

702P08851
Revised Update: May 2023
Initial Release: March 2023

Xerox® VersaLink® C625 **Multifunction Color Printer** **Service Manual**

Xerox®VersaLink®C625 Color MFP

Service Manual

Xerox®VersaLink® C625 Color MFP Service Manual

705P01470

Revised Update: May 2023

Initial Release: March 2023

Prepared for:

Xerox Corporation

800 Phillips Road

Webster, New York 14580

© 2022 Xerox Corporation. All Rights Reserved. Xerox®, Xerox, and VersaLink® are trademarks of Xerox Corporation in the United States and/or other countries.

Other company trademarks are also acknowledged.

NOTICE

While every care has been taken in the preparation of this manual, no liability will be accepted by Xerox arising out of any inaccuracies or omissions.

All service documentation is supplied to Xerox external customers for informational purposes only. Xerox service documentation is intended for use by certified, product trained service personnel only. Xerox does not warrant or represent that it will notify or provide to such customer any future change to this documentation. Customer performed service of equipment, or modules, components or parts of such equipment may affect whether Xerox is responsible to fix machine defects under the warranty offered by Xerox with respect to such equipment. You should consult the applicable warranty for its terms regarding customer or third-party provided service.

Introduction

About This Manual ii
How To Use This Manual ii
Change Historyiii
Mod/Tag Identification v
Voltages Resistances and Tolerancesvi
Safety Informationvii
Health and Safety Incident reporting viii
Translation of Warningsix

About This Manual

This manual is part of a multinational service documentation system that is structured in the standard Xerox service manual format.

Organization

The service manual is the document used as the primary information source for repairing and maintaining this family of products and is available as EDOC on a CDROM, or in PDF format on a CDROM. The information within the manual is divided into an introduction and 8 other sections.

Section 1 Service Call Procedures

This section is used to start and complete a service call. The procedures in this section will either direct you to a Repair Analysis Procedure (RAP), or identify a faulty component or subassembly.

Section 2 Status Indicator Repair Analysis Procedures

This section contains the Repair Analysis Procedures (RAPs) and checkouts necessary to diagnose, isolate and repair faults other than image quality faults.

Section 3 Image Quality

This section contains the Image Quality Repair Analysis Procedures (IQ RAPs), checkouts and setup procedures necessary to diagnose, isolate and repair image quality faults.

Section 4 Repairs and Adjustments

This section contains the instructions for removal, replacement, and adjustment of parts within the machine.

Section 5 Parts List

This section contains the detailed and illustrated spare parts list. Any part that is spared or that must be removed to access a spared part is illustrated.

Section 6 General Procedures and Information

This section contains all other procedures, product specifications and general information. It also contains Tag/MOD information. The abbreviations used in this Manual are in [GP 40 Glossary of Terms, Acronyms and Abbreviations](#).

Section 7 Wiring Data

This section contains the PJ locations, wiring diagrams and block schematic diagrams (BSDs).

Section 8 Product Technical Overview

This section contains technical details of the machine.

Publication Comments Sheet

A Publication Comment Sheet is provided at the rear of the PDF version of the manual.

How To Use This Manual

Always start with the Service Call Procedures, Section 1. Perform Initial Actions to verify the problem, then follow the directions given.

How to Differentiate Between Machine Variants

When a procedure, parts list description, artwork, or other reference is unique across different machine variants, the applicable variant is identified. For example, VLC625:

1. VL = VersaLink
2. C = Color
3. 6 = Workteam High Laser Printer
4. 2 = 2nd Family
5. 5 = MultiFunctional Printer (MFP)

VLC625 includes the following model variants:

- Xerox® VersaLink® C625 Color MultiFunctional Printer

Warnings, Cautions And Notes



WARNING: A warning is used whenever an operating or maintenance procedure, practice, condition or statement, if not strictly observed, could result in personal injury.

A translated version of all warnings is in [Translation of Warnings](#).



CAUTION: A caution is used whenever an operation or maintenance procedure, practice, condition or statement, if not strictly observed, could result in damage to the equipment.

Note: A note is used where it is essential to highlight a procedure, practice, condition or statement.

Use of the Wiring Diagrams, P/J Maps, and Sensor Locations

Wiring diagrams, P/J maps, and sensor locations are included in [7. Wiring Data](#):

- [Wiring Diagrams](#), show the connections of the electrical circuitry to all electromechanical, power, and data transmission throughout the machine.
- [P/J Maps](#), define the connections between components and the PWB the item is connected at.
- [Sensor Locations](#), identify the location of all sensors within the machine.

Change History

Change History provides changes to the service manual after the launch version, initial release.

May 2023

Introduction

- How to Use this Manual

Section 1 Service Call Procedures

- SCP 4 Subsystem Maintenance

Section 2 RAPs

- 303-317-00 to 303-319-00 IOT NVM Error RAP
- 303-380-00 to 303-383-00 Distribution PWBA is Missing or Disconnected RAP
- 303-403-00 Extended FAX Not Detected or Confirmed RAP
- 303-417-00 Incompatible FAX SW Detected at Power Up RAP
- 316E Network Fault Checkout RAP
- 316-000-09 to 316-010-99, 316-015-14 to 316-016-99 Network Faults 1
- 316-012-00 Rolling Reboot Has Been Detected RAP
- 316-023-09 to 316-154-19 Network Faults 2 RAP
- 316-156-19 to 316-436-00 Network Faults 3 RAP
- 316-501-00 to 316-544-00 Network Faults 4 RAP
- 316-600-35 to 316-608-68 Network Faults 5 RAP
- 316-609-105 to 316-612-68 Network Faults 6 RAP
- 316-613-09 to 316-617-19 Network Faults 7 RAP
- 316-621-00 to 316-625-67 Network Faults 8 RAP
- 316-636-35 to 316-647-26 Network Faults 10 RAP
- 316-650-35 to 316-668-95 Network Faults 11 RAP
- 316-669-28 to 316-730-00 Network Faults 12 RAP
- 316-718-00, 316-720-02 to 316-720-05, 316-722-01, 316-722-02, 316-726-00, 316-727-00 Hard Disk Faults RAP
- 316-732-01 to 316-750-95 Network Faults 13 RAP
- 316-742-19 Hard Disk ODIO Failure RAP

- 316-745-00 Optional Drive not detected RAP
- 316-746-00 Optional drive pairing unsuccessful RAP
- 316-751-11 to 316-753-95 Network Faults 14 RAP
- 316-754-09 to 316-756-93 Network Faults 15 RAP
- 316-757-09 to 316-760-99 Network Faults 16 RAP
- 316-761-14 to 316-765-93 Network Faults 17 RAP
- 316-766-19 to 316-772-95 Network Faults 18 RAP
- 316-773-19 to 316-779-95 Network Faults 19 RAP
- 316-780-19 to 316-789-19 Network Faults 20 RAP
- 316-790-19 to 316-799-47 Network Faults 21 RAP
- 316-800-09 to 316-809-47 Network Faults 22 RAP
- 316-810-09 to 316-839-47 Network Faults 23 RAP
- 316-840-47 to 316-879-47 Network Faults 24 RAP
- 316-880-47 to 316-929-19 Network Faults 25 RAP
- 316-930-19 to 316-971-19 Network Faults 26 RAP
- 316-972-08 to 316-986-19 Network Faults 27 RAP
- 316-990-00 to 316-997-00 Network Faults 28 RAP
- 317A Ethernet or USB WIFI Connection Fault RAP
- 319-410-00 Mark Output Timeout RAP
- 319-410-01 Mark Output Timeout/Video Decompressor Fault RAP
- 319-410-02 Compress Image Timeout RAP
- 319-410-03 Decompress Image Timeout RAP
- 319-410-04 Merge Image Timeout RAP
- 319-410-05 Rotate Image Timeout RAP
- 319-410-08 Scan Input Failure RAP
- 319-476-01 to 319-476-03 Band Fault RAP
- 319-752-00 Image Rotation Detected RAP
- 319-754-00 Image Disk Configuration Changed At Power Up RAP
- 320-250-00 IRFax Analog Wrong Jack Error RAP
- 320-322-00

- 320–340–00
 - 320-347-00, 320-347-01, 320–348–00, 320–348–01 Fax Card 1 & 2 Modem Firmware Upgrade Failure RAP
 - 320-701–00 Fax Phone Book Download Fault RAP
 - 320-710–00 Fax Image Overwrite Error RAP
 - 320–711–00 ODIO Error RAP
 - 322-310-04 to 322-318-04 Paper Supply Errors RAP
 - 322–319–04 Integrity Problem While Printing a Job RAP
 - 322-328–00 Incomplete System Information RAP
 - 322-352-00 Serial Number Missing From Memory RAP
 - 322-365-00 Engine Serial number needs Recovery RAP
 - 322-370–00 Unable To Communicate With XSA Database RAP
 - 322-750-04 Output Device Configuration Mismatch RAP
 - 322-751-04 Paper Tray Configuration Mismatch RAP
 - 322-701-04, 322–720–00, 322–721–00, 322–751–04, 322– 754–17 Configuration Mismatch Fault RAP
 - 341-371-00 Speed Update Required RAP
 - 395–001–00 The DC software failed to upgrade
 - 395-002-00 Software Upgrade Failure : DC Application RAP
 - 395-008-00 Software Upgrade Failure : DC OS RAP
 - 395-009-00 Software Upgrade Failure : DC CIPS RAP
 - 395-011-00 Software Upgrade Failure : XUI Application RAP
 - 395-019-00 Software Upgrade Failure : UI Panel Firmware RAP
 - 395-038-00 Software Upgrade Failure : Embedded Fax LCF Application RAP
 - 395-042-00 Software Upgrade Failure : IOT Application RAP
 - 395-140-00 Software Upgrade Failure : DC NC Applications RAP
 - 395-168-00 Software Upgrade Failure : DADH Single Pass RAP
 - 395-216-00 Software Upgrade Failure : DC Glue RAP
 - 395-226-00 Software Upgrade Failure : SOK RAP
 - 395-255-00 Software Upgrade Failure : DC SCD RAP
 - 395-305-00 Software Upgrade Failure : Platform Synchronisation Error RAP
 - 395-306-00 Software Upgrade Failure : CCS Platform Synchronisation Error RAP
 - 395-307-00 Software Upgrade Failure : NC Platform Synchronisation Error RAP
 - 395-308-00 Software Upgrade Failure : UI Platform Synchronisation Error RAP
 - 395-309-00 Software Upgrade Failure : IIT Platform Synchronisation Error RAP
 - 395-310-00 Software Upgrade Failure : IOT Platform Synchronisation Error RAP
 - 395-311-00 Software Upgrade Failure : Finisher Platform Synchronisation Error RAP
 - 395-312-00 Software Upgrade Failure : Feeder Platform Synchronisation Error RAP
 - 395-314-00 Software Upgrade Failure :SDCARD Full Error RAP
 - 395-315-00 Software Upgrade Failure : Bios RAP
 - 395-316-00 Software Upgrade Failure : FPGA RAP
 - 395-319-00 Software Upgrade Failure : USB pendrive not detected 2nd time RAP
 - 395-324-00 Disk is blank or cannot be mounted RAP
- Section 4 Repairs/Adjustments
- REP 3.2 Controller PWB
- Section 6 General Procedures / Diagnostics / Information
- General Procedures
- GP 3 Service Information
 - GP 4 Software Upgrade
 - GP 10 How to Switch Off the Machine or Switch On the Machine
 - GP 13 Cloning Machine Settings
 - GP 16 Installation Space Requirements
 - GP 17 Electrical Power Requirement
 - GP 19 Obtaining Audit and Device Logs
 - GP 20 First Copy/Print Out Time and Power On Time
 - GP 21 Restriction of Hazardous Substances (RoHS)
 - GP 22 Backup & Restore Settings
 - GP 23 Customer Administration Tools
 - GP 26 PagePack Plan Activation

- GP 27 Intermittent or Noise Problem
- GP 28 System Administrator Password Reset
- GP 30 Paper and Media Size Specifications
- GP 31 Environmental Data
- GP 32 Device Specification
- GP 33 Restoring Customer Mode
- GP 34 How to Re-Enter Optional Feature Installation Keys
- GP 35 Serial Number Synchronization Procedure
- GP 36 Xerox USB Wireless Printing Troubleshooting
- GP 37 Supplies Plan Conversion

Diagnostics

- dC131 NVM Read/Write
- dC132 Machine Serial Number
- dC301 NVM Initialization
- dC330 Component Control
- dC361 NVM Save and Restore
- dC927 Toner Patch Sensor (TPS) Setup

Mod/Tag Identification

Figure 1 shows the Mod/Tag identification symbols.



F-1-0628-A

Figure 1 Mod/Tag identification symbols

Voltages Resistances and Tolerances

DC Voltage Levels and Tolerances

DC voltages should be measured between an available test point and a machine ground. Table 1 shows the range of the common voltages.

Table 1 DC Voltage Levels

Nominal Voltage	Voltage Tolerance Range
0V	0.00 to 0.10V
+3.3V standby	+3.23V to +3.43V
+3.3V	+3.23V to +3.43V
+5V and +5V standby	+4.75V to +5.25V
+12V	+11.4V to +12.6V
+24V	+23.28V to +25.73V

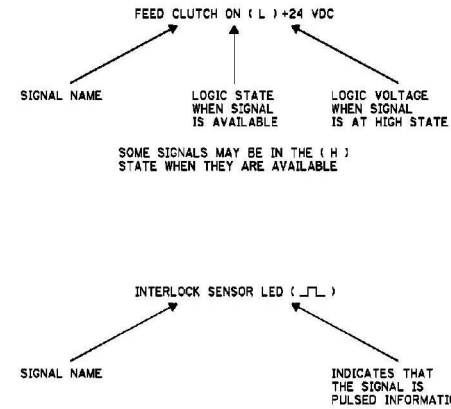
Non-standard voltage levels will be quoted on the relevant wiring diagram or BSD. All other voltage levels are plus or minus 10 %.

Resistance Tolerances

All resistance measurement tolerances are plus or minus 10 %, unless otherwise stated in the procedure.

DC Signal Nomenclature

Figure 1 shows the signal nomenclature used in the BSDs.



TF-1-0629-A

Figure 1 Signal Nomenclature

Table 2 shows the signal tolerances.

Table 2 Signal tolerances

Signal Voltage	(H) Logic Level	(L) Logic Level
+5V	+3.85V or greater	At or near 0.8V
+3.3V	+2V or greater	At or near 0.8V

Non standard signal tolerances will be quoted on the relevant circuit diagram.

Note: The logic level shown with the signal name will be the actual signal as measured with a service meter. This will not necessarily be the same as the logic state shown on the diagnostic screen.

Safety Information

The WARNING that follows is for general guidance when live working.



WARNING: Do not work in a confined space. 1m (39 inches) space is needed for safe working.

Safety Icons

The safety icons that follow are displayed on the machine:

ESD Caution Symbol



CAUTION: Certain components in this product are susceptible to damage from electrostatic discharge. Observe all ESD procedures to avoid component damage.

Location Arrow Symbol

The location arrow symbol points to the location to install, to gain access to, or to release an object.



Hot Surface Symbol

This symbol indicates hot surfaces. Take care when servicing the machine.



Lethal Voltage Symbol

This symbol indicates potentially lethal voltages. Take care when servicing the machine when the power cord is connected.



Toner Cartridge

The product contains a toner cartridge that is recyclable. Under various state and local laws, it may be illegal to dispose of the cartridge into the municipal waste. Check with the local waste officials for details on recycling options or the proper disposal procedures.

Fuses



WARNING: Do not install a fuse of a different type or rating. Installing the wrong type or rating of fuse can cause overheating and a risk of fire.

Part Replacement

Only use genuine Xerox approved spare parts or components to maintain compliance with legislation and safety certification.

Disassembly Precautions

Do not leave the machine with any covers removed at a customer location.

Reassembly Precautions

Use extreme care during assembly. Check all harnesses to ensure they do not contact moving parts and do not get trapped between components.

General Procedures

Observe all warnings displayed on the machine and written in the service procedures. Do not attempt to perform any task that is not specified in the service procedures.

Health and Safety Incident reporting

I. Summary

This section defines requirements for notification of health and safety incidents involving Xerox products (equipment and materials) at customer locations.

II. Scope

Xerox Corporation and subsidiaries worldwide.

III. Objective

To enable prompt resolution of health and safety incidents involving Xerox products and to ensure Xerox regulatory compliance.

IV. Definitions

Incident:

An event or condition occurring in a customer account that has resulted in injury, illness or property damage. Examples of incidents include machine fires, smoke generation, physical injury to an operator or service representative. Alleged events and product conditions are included in this definition.

V. Requirements

Initial Report:

1. Xerox organizations shall establish a process for individuals to report product incidents to Xerox Environment Health and Safety within 24 hours of becoming aware of the event.
2. The information to be provided at the time of reporting is contained in Appendix A (Health and Safety Incident Report involving a Xerox product).
3. The initial notification may be made by the method that follows:
 - Email Xerox EH&S at: usa.product.incident@xerox.com.
 - Fax Xerox EH&S at: 585-422-2249.

Note: If sending a fax, please also send the original via internal mail.

Responsibilities for resolution:

1. Business Groups/Product Design Teams responsible for the product involved in the incident shall:
 - a. Manage field bulletins, customer correspondence, product recalls, safety retrofits.
 - b. Fund all field retrofits.
2. Field Service Operations shall:

- a. Preserve the Xerox product involved and the scene of the incident inclusive of any associated equipment located in the vicinity of the incident.
 - b. Return any affected equipment/part(s) to the location designated by Xerox EH&S and/or the Business Division.
 - c. Implement all safety retrofits.
3. Xerox EH&S shall:
 - a. Manage and report all incident investigation activities.
 - b. Review and approve proposed product corrective actions and retrofits, if necessary.
 - c. Manage all communications and correspondence with government agencies.
 - d. Define actions to correct confirmed incidents.

VI. Appendices

The Health and Safety Incident Report involving a Xerox Product (Form # EH&S-700) is available in the following location:

- [GSN Library 1789](#)

Translation of Warnings



WARNING: A warning is used whenever an operating or maintenance procedure, practice, condition or statement, if not strictly observed, could result in personal injury.

DANGER: Une note Danger est utilisée chaque fois qu'une procédure d'utilisation ou de maintenance peut être cause de blessure si elle n'est pas strictement respectée.

AVVERTENZA: Un segnale di avvertenza è utilizzato ogni volta che una procedura operativa o di manutenzione, una pratica, una condizione o un'istruzione, se non strettamente osservata, potrebbe causare lesioni personali.

VORSICHT: Weist darauf hin, dass ein Abweichen von den angeführten Arbeits- und Wartungsanweisungen gesundheitliche Schäden, möglicherweise sogar schwere Verletzungen zur Folge haben kann.

AVISO: Un aviso se utiliza siempre que un procedimiento de operación o mantenimiento, práctica o condición puede causar daños personales si no se respetan estrictamente.



WARNING: Do not work in a confined space. 1 m (39 inches) space is needed for safe working.

DANGER : Ne pas travailler dans un espace restreint. 1 mètre d'espace est nécessaire pour un dépannage en toute sécurité.

AVVERTENZA: Non lavorare in uno spazio limitato; è necessario uno spazio di almeno un metro attorno alla macchina per la sicurezza dell'operatore.

VORSICHT: Nur mit ausreichendem Bewegungsspielraum (1 m) arbeiten.

AVISO: No trabaje en un espacio reducido. Se necesita 1 metro de espacio para trabajar con seguridad.



WARNING: Do not install a fuse of a different type or rating. Installing the wrong type or rating of fuse can cause overheating and a risk of fire.

DANGER : Ne pas installer de fusible de type ou de calibre différent. Il existe un risque de surchauffe voire d'incendie.

AVVERTENZA: per evitare rischi di surriscaldamento o d'incendio, non installare un fusibile di tipo o carica diversi da quelli esistenti.

VORSICHT: Keine Sicherungen anderer Art oder anderer Leistung auf dem IOT-PWB installieren - Überhitzungs- und Brandgefahr.

AVISO: No instale un fusible de potencia o tipo distinto. Un fusible de potencia o tipo distinto puede producir sobrecalentamiento y el riesgo de incendio.



WARNING: Ensure that the electricity to the machine is switched off while performing tasks that do not need electricity. Refer to GP XX. Disconnect the power cord. Electricity can cause death or injury. Moving parts can cause injury.

DANGER : Assurez-vous que la machine est hors tension lorsque vous effectuez des tâches ne nécessitant pas d'alimentation électrique. Reportez-vous à GP XX. Débranchez le câble d'alimentation pour prévenir tout risque d'électrocution. Les chocs électriques peuvent présenter un danger de mort ou entraîner des blessures graves. De plus, certaines pièces, lorsqu'elles sont en mouvement, peuvent être source de blessures graves.

AVVERTENZA: Accertarsi di isolare la macchina dall'alimentazione elettrica quando si eseguono attività che non richiedono elettricità. Vedere GP XX. Scollegare il cavo di alimentazione. L'elettricità può causare morte o lesioni personali. Le parti in movimento possono causare lesioni personali.

VORSICHT: Sicherstellen, dass die Stromversorgung des Geräts bei Arbeiten, die keinen Strom erfordern, ausgeschaltet ist. Siehe auch GP XX. Den Netzstecker ziehen. Andernfalls besteht Stromschlaggefahr und Verletzungsgefahr durch bewegliche Teile.

AVISO: Asegúrese de mantener la máquina aislada de la energía eléctrica mientras realiza tareas que no necesitan electricidad. Consulte GP XX. Desconecte el cable de alimentación. La energía eléctrica puede producir lesiones o incluso la muerte. Las piezas sueltas pueden producir lesiones.



WARNING: Switch off the electricity to the machine. Refer to **GP 10** . Disconnect the power cord from the customer supply while performing tasks that do not need electricity. Electricity can cause death or injury. Moving parts can cause injury.

DANGER : Mettez la machine hors tension. Reportez-vous à **GP 10** . Déconnectez le cordon d'alimentation de l'alimentation du client lorsque vous réalisez des tâches qui ne nécessitent pas d'électricité. L'électricité peut être à l'origine de blessures, voire d'un accident mortel. Les pièces amovibles peuvent être à l'origine de blessures.

AVVERTENZA: Spegner la macchina. Vedere **GP 10** . Scollegare il cavo di alimentazione dall'alimentatore quando si eseguono attività che non richiedono elettricità. L'elettricità può causare morte o lesioni personali. Le parti in movimento possono causare lesioni personali.

VORSICHT: Schalten Sie die Stromversorgung der Maschine ab. Siehe auch **GP 10** . Ziehen Sie das Stromkabel ab, wenn Sie Aufgaben ausführen, für die keine Stromversorgung benötigt wird. Stromschläge können Todesfällen oder Verletzungen verursachen. Bewegliche Teile können zu Verletzungen führen.

AVISO: Apague la electricidad de la máquina. Consulte el **GP 10** . Desconecte el cable de alimentación eléctrica de la toma de pared mientras esté realizando tareas que no necesiten corriente. La electricidad puede causar daños o la muerte. Las partes móviles pueden causar daños.



WARNING: Take care when measuring AC mains (line) voltage. Electricity can cause death or injury.

DANGER : Prendre des précautions lors du relevé de la tension de la prise de courant alternatif. L'électricité peut entraîner des blessures graves voire mortelles.

AVVERTENZA: Procedere con cautela durante la misurazione della tensione CA della rete. L'elettricità può causare infortuni o morte.

VORSICHT: Bei der Netzspannungsprüfung stets vorsichtig vorgehen

AVISO: Tenga cuidado al medir la tensión de la línea de alimentación de corriente alterna. La electricidad puede causar lesiones e incluso la muerte.



WARNING: Ensure that the electricity to the machine is switched off while performing tasks that do not need electricity. Refer to **GP 10** . Disconnect the power cord. Electricity can cause death or injury. Moving parts can cause injury.

DANGER : Assurez-vous que la machine est hors tension lorsque vous effectuez des tâches ne nécessitant pas d'alimentation électrique. Reportez-vous à **GP 10** . Débranchez le câble d'alimentation pour prévenir tout risque d'électrocution. Les chocs électriques peuvent présenter un danger de mort ou entraîner des blessures graves. De plus, certaines pièces, lorsqu'elles sont en mouvement, peuvent être source de blessures graves.

AVVERTENZA: Accertarsi di isolare la macchina dall'alimentazione elettrica quando si eseguono attività che non richiedono elettricità. Vedere **GP 10** . Scollegare il cavo di alimentazione. L'elettricità può causare morte o lesioni personali. Le parti in movimento possono causare lesioni personali.

VORSICHT: Sicherstellen, dass die Stromversorgung des Geräts bei Arbeiten, die keinen Strom erfordern, ausgeschaltet ist. Siehe auch **GP 10** . Den Netzstecker ziehen. Andernfalls besteht Stromschlaggefahr und Verletzungsgefahr durch bewegliche Teile.

AVISO: Asegúrese de mantener la máquina aislada de la energía eléctrica mientras realiza tareas que no necesitan electricidad. Consulte **GP XX** . Desconecte el cable de alimentación. La energía eléctrica puede producir lesiones o incluso la muerte. Las piezas sueltas pueden producir lesiones.



WARNING: Do not touch the fuser while it is hot.

DANGER : Ne pas toucher au four pendant qu'il est encore chaud.

AVVERTENZA: Non toccare il fonditore quando è caldo.

VORSICHT: Fixierbereich erst berühren, wenn dieser abgekühlt ist.

AVISO: No toque el fusor mientras está caliente.



WARNING: Do not touch the fuser while it is hot.

DANGER : Ne pas toucher au four pendant qu'il est encore chaud.

AVVERTENZA: Non toccare il fonditore quando è caldo.

VORSICHT: Fixierbereich erst berühren, wenn dieser abgekühlt ist.

AVISO: No toque el fusor mientras está caliente.



WARNING: Take care during this procedure. Sharp edges may be present that can cause injury.

DANGER : Exécuter cette procédure avec précaution. La présence de bords tranchants peut entraîner des blessures.

AVVERTENZA: procedere con cautela durante questa procedura. Possono essere presenti oggetti con bordi taglienti pericolosi.

VORSICHT: Bei diesem Vorgang vorsichtig vorgehen, damit keine Verletzungen durch die scharfen Kanten entstehen.

AVISO: Tenga cuidado al efectuar este procedimiento. Puede haber bordes afilados que podrían producir lesiones.



WARNING: Do not use the power button as a safety disconnect device. The power button is not a disconnect device. Disconnect the power cord from the supply to isolate the equipment.

DANGER : Ne vous servez pas de l'interrupteur comme d'un dispositif de déconnexion. L'interrupteur n'est pas un dispositif de déconnexion. Débranchez le câble d'alimentation de la prise électrique pour isoler l'appareil.

AVVERTENZA: L'interruttore di alimentazione non è un dispositivo di disconnessione di sicurezza e pertanto non va utilizzato come tale. Per isolare la macchina, scollegare il cavo di alimentazione dalla presa elettrica.

VORSICHT: Zur Unterbrechung der Gerätestromzufuhr nicht den Betriebsschalter verwenden, sondern das Netzkabel aus der Steckdose ziehen, an die das Gerät angeschlossen ist. Nur dann ist der Drucker vollständig vom Stromnetz getrennt.

AVISO: No utilice el botón de encendido/apagado como dispositivo de desconexión de seguridad. El botón de encendido/apagado no es un dispositivo de desconexión. Desconecte el cable de alimentación de la fuente de energía para aislar el equipo.

1 Service Call Procedures

SCP 1 Initial Actions.....13
SCP 2 Call Actions13
SCP 3 Fault Analysis14
SCP 4 Subsystem Maintenance.....15
SCP 5 Final Actions16

SCP 1 Initial Actions

Service Call Procedures are used at the beginning of a service call. Use Initial Actions to collect information about the machine performance.

Procedure



WARNING: Switch off the electricity to the machine, [GP 10](#). Disconnect the power lead from the customer supply while performing tasks that do not need electricity. Electricity can cause the death or injury. Moving components can cause the injury.



CAUTION: Do not work in a confined space. 1m (39 inches) space is needed for safe working.

1. Take note of problems, error messages or error codes. If necessary, refer to [dC122](#) Fault Codes and History Files.
2. Switch off, then switch on the machine, [GP 10](#).
3. Ask the operator to describe or demonstrate the problem.
4. If the problem is the result of an incorrect action by the operator, refer the operator to the user documentation.
5. Check the steps that follow:
 - a. The power lead is connected to the wall outlet and to the machine.
 - b. The paper is loaded correctly.
 - c. All paper trays are closed.
 - d. All doors are closed.
6. Check the machine service log book for previous actions that are related to this call.
7. Go to [SCP 2](#) Call Actions.

SCP 2 Call Actions

Use Call Actions to perform any general actions before starting to diagnose the fault.

Procedure

1. If this is the first service call to this machine, if possible, perform the actions that follow:
 - a. Check the machine configuration with the customer. Check that all the required hardware and software is installed. Check that all the required hardware and software is enabled.
 - b. Check that all the machine settings are entered correctly.
 - c. Mark off the hardware options, software options or Tags installed on the Tag matrix cards.
 - d. Enter the machine information and the customer information in the service log book.
2. Review the print samples.
3. Ensure the user access settings are correct. If necessary refer to the user documentation.
4. If necessary, perform [GP 13](#) Cloning Network Configurations.

Note: The clone file must be taken whenever the customer changes the network controller setting or after the system software is changed.
5. Before switching off the machine or clearing the memory, check for a customer job in the memory.
6. Check and record the total impressions usage counter.
7. Go to [SCP 3](#) Fault Analysis.

SCP 3 Fault Analysis

Use Fault Analysis to identify the appropriate RAP to perform based on the machine fault or symptoms.

- For network printing issues refer to, [OF 8](#), Network Printing Problems RAP.

Procedure



CAUTION: Do not expose the drum cartridges, to light for more than 30 minutes. If necessary, remove the drum cartridges, then place in a black bag.

Fault Codes

If a fault code is displayed, go to the relevant RAP.

Image Quality Defects

If the image quality is defective, go to the [IQ 1](#) IOT Image Quality Entry RAP.

Unresolved Faults

If a fault cannot be resolved using the appropriate RAP, and only if instructed by next level support, obtain a device log. Refer to [GP 19](#), Obtaining Audit and Device Logs. Escalate the problem to next level support.

Other Problems

- For suspected power distribution faults, refer to the following:
 - [PJ and Sensor Locations](#)
 - [C625 Wiring Diagrams](#)
- If the customer requires a billing plan change, go to [GP 26](#), PagePack (Supplies Plan) Plan Conversion.

Additional Information

If necessary, refer to the general procedures and information that follow:

- [GP 1](#) Diagnostics Entry
- [GP 2](#) Fault Codes and Fault History
- [GP 3](#) Service Information.
- [GP 4](#) Machine Software
- [GP 5](#) Miscellaneous Checks
- [GP 6](#) How to Check a Motor
- [GP 7](#) How to Check a Sensor
- [GP 8](#) How to Check a Solenoid or Clutch
- [GP 9](#) How to Check a Switch
- [GP 10](#) How to Switch Off the Machine or Switch On the Machine
- [GP 11](#) How to Safely Lift or Move Heavy Modules
- [GP 12](#) Machine Lubrication
- [GP 13](#) Network Clone Procedure
- [GP 14](#) Printing Reports
- [GP 15](#) Cleaning the Printhead Lenses
- [GP 16](#) Installation Space Requirements

- [GP 17](#) Electrical Power Requirements
- [GP 18](#) Cleaning the Scanner
- [GP 19](#) Obtaining Audit and Device Logs
- [GP 20](#) First Copy/Print Out Time and Power On Time
- [GP 21](#) Restriction of Hazardous Substances (RoHS)
- [GP 22](#) Back Up and Restore Settings
- [GP 23](#) Customer Administration Tools
- [GP 24](#) How to Set the Date and Time
- [GP 25](#) Ethernet Crossover Cable Setup
- [GP 26](#) PagePack (Supplies Plan) Plan Conversion
- [GP 27](#) Intermittent or Noise Problem
- [GP 28](#) System Administrator Password Reset
- [GP 29](#) Print/Copy Orientation Definitionst
- [GP 30](#) Paper and Media Size Specifications
- [GP 31](#) Environmental Data
- [GP 32](#) Device Specification
- [GP 33](#) Restoring Customer Mode
- [GP 34](#) How to Re-Enter Optional Feature Installation Keys
- [GP 35](#) Serial Number Synchronization Procedure
- [GP 36](#) Xerox USB Wireless Printing Troubleshooting
- [GP 40](#) Glossary of Terms, Acronyms and Abbreviations

SCP 4 Subsystem Maintenance

Use Subsystem Maintenance to identify potentially worn components that should be replaced to prevent further faults, and to perform routine cleaning and lubrication of the machine.

Procedure



WARNING: Switch off the electricity to the machine, GP 10 . Disconnect the power lead from the customer supply while performing tasks that do not need electricity. Electricity can cause the death or injury. Moving components can cause the injury.

Go to the correct procedure:

- [Service Checks](#)
- [HFSI](#)
- [How to Clean the Machine](#)
- [Drum Cartridge Handling](#)

Service Checks

Perform the actions in [Table 1](#) at the indicated service interval.

Table 1 Service actions

Servicing Items	Service Details	Service Interval
IQ check	Check the overall print quality using a test chart. Check for uneven density, blank areas, drum scratches, heat roll scratches, etc. in A3 halftone.	Every visit
Clean the machine interior	Check and clean the paper transport roller (including the bypass tray). Clean any toner residue in the paper transport path. Clean any contamination and paper dust from the jam sensors.	150K feeds
	Clean the operating parts around the toner cartridges.	Every visit
Safety Check	Ensure that the power cords are not damaged and no wires are exposed. Ensure that an extension cord with insufficient length or power cord outside the specification, such as an off-the-shelf power strip, is not being used. Ensure that a single socket does not have multiple power plugs plugged into it.	Every visit

HFSI

For High Frequency Service Items (HFSI), refer to [dC135](#) HFSI Counters and [Table 2](#), below.

Table 2 HFSI

Part Name	Part Number	Kit Contents	Life	Manual Counter Reset	PL Ref.
Fuser Maintenance Kit (110V)	115R00159	Fuser (110V)	150K prints	Yes**	PL 10.10
Fuser Maintenance Kit (220V)	115R00160	Fuser (220V)	150K prints	Yes**	PL 10.10
Paper Tray Maintenance Kit*	116R00038	Separator Block Tray Pick Roller	150K prints	Yes**	PL 70.10
DADF Maintenance Kit	116R00039	Separator Assembly DADF Pick Roller Assembly	110K	Yes**	PL 5.10
Bypass Tray Maintenance Kit	116R00040	MPF (bypass) Pick Roller	150K feeds	Yes**	PL 70.10
* Kit is for a single tray only; Kit is common with optional trays. ** Customers will reset counters in Admin menu: Device > Tools > Supplies > Supply Counter Reset > select the counter to reset > Reset Counter. Service will reset counters in Diagnostics, dC135					

How to Clean the Machine

Use a dry lint free cloth or a lint free cloth moistened with water for all cleaning unless directed otherwise. Wipe with a dry lint free cloth if a moistened cloth is used.

1. Feed Components (Rolls and Pads)

Use a dry lint free cloth or a lint free cloth moistened with water. Wipe with a dry lint free cloth if a moistened cloth is used.

2. Toner Dispense Units

Vacuum the toner dispense units.

3. Jam Sensors

Clean the sensors with a dry cotton swab.

Drum Cartridge Handling

- The drum cartridges must be protected from light shock and mechanical damage.
- Do not expose the photoreceptor drum to bright lights for extended periods.
- Whenever the drum cartridge is removed, place the drum cartridge in the black plastic bag supplied with the machine. Store the drum cartridge in a safe place on a clean flat surface, to avoid damage to the photoreceptor drum surface.
- Place the drum cartridge in the black bag if the left door is opened for long periods.

SCP 5 Final Actions

Use Final Actions to verify the correct operation of the machine and to complete the service call.

Procedure

Perform the steps that follow. If a fault is identified, go to [SCP 3 Fault Analysis](#):

1. If necessary, re-connect the machine to the customer's network.
2. If necessary, perform [GP 13 Cloning Network Configurations](#).
Note: The clone file will need to be taken whenever the system software is changed.
3. Perform the relevant maintenance procedures. Refer to [SCP 4 Subsystem Maintenance](#).
4. Ensure that the machine has the latest available software loaded.
5. Operate the machine in all modes. Make the copies and prints from all trays.
6. Make prints from all trays. Check the registration quality. To reset the registration, perform [dC126 System Registration Adjustment](#).
7. Make a proof print of a customer document.
8. If some of the customer's selections were changed, return the selections to the customer settings.
9. Mark off the hardware options, software options or Tags installed on the Tag matrix cards.
10. If some changes were made to the configuration or options were added, print the configuration report. Store the configuration report with the machine log book. Discard the previous version of the configuration report.
11. Log the usage counters.
12. If necessary, provide the customer with training.
13. Remove and destroy all copies of test patterns.
14. Ensure the machine and service area are clean.

2 Status Indicator RAPs

Chain 302	23	310-401-00 PH Thermistor Reading Out Of Range Error RAP	52
302-315-00 Service Registry Bad Data / Corrupted RAP	23	310-405-00 Cavity/TPS Thermistor Reading Out Of Range Error RAP	52
302-316-00 and 302-317-00 Service Registry Not Responding RAP	24	310-418-00, 310-419-00, 310-422-00 to 310-430-00, 310-486-00 to 310-488-00 The Printhead Error RAPS	53
302-318-00 Touch Device not Available RAP	24	310-473-00, 310-474-00 NVRAM Chip Fail Error RAPS	54
302-321-00 XEIP Browser Dead RAP	25	310-475-00, 310-476-00, 340-167-00 to 340-169-00, 340-171-00 to 340-184-00 Option Device Communication Error RAPS	55
302-380-00 and 302-381-00 UI Communication Fault RAP	25	310-494-00 Fuser Bubble Sensor Covered at Warmup Error RAP	56
Chain 303	26	310-495-00, 310-498-00, 310-501-00, 310-504-00, 310-507-00, 310-510-00 Fuser Decurl Sensor Error RAPS	57
303-306-00 Downgrade Not Permitted	26	310-496-00, 310-499-00, 310-502-00, 310-505-00, 310-508-00, 310-511-00, 310-513-00 Fuser Decurl Sensor Error RAPS	58
303-307-00 Upgrade Synchronization Failure	27	310-497-00, 310-500-00, 310-503-00, 310-506-00, 310-509-00, 310-512-00 Fuser Decurl Sensor Error RAPS	59
303-315-00 DC Platform Internal Interface Fault RAP	27	305-211-00, 305-212-00, 310-514-00, 371-329-00, 372-322-00, 373-322-00, 374-328-00, 375-328-00 Unknown Error RAP	60
303-316-00 CCM Cannot Communicate With IOT RAP	28	310-515-00, 310-516-00, 391-900-00 Drive Software Error Rap	60
303-317-00 IOT NVM Save Failure	28	310-670-00 Weather Station Data Not Valid RAP	61
303-318-00 IOT NVM Init Failure	29	Chain 316	61
303-319-00 IOT NVM Restore Failure	29	316E Network Fault Checkout RAP	62
303-320-00 Incompatible Product Type	30	316-000-09 to 316-010-99, 316-015-14 to 316-016-99 Network Faults 1	62
303-324-00 Software Upgrade File Transfer Failure	30	316-012-00 Rolling Reboot Has Been Detected RAP	63
303-325-00 Wall Clock Time-out During Power Up	31	316-023-09 to 316-154-19 Network Faults 2 RAP	64
303-326-00 Upgrade is not Required	31	316-156-19 to 316-436-00 Network Faults 3 RAP	64
303-327-00 Upgrade Failure	32	316-501-00 to 316-544-00 Network Faults 4 RAP	65
303-329-00 Upgrade Request During Diagnostics	32	316-600-35 to 316-608-68 Network Faults 5 RAP	65
303-330-00 Upgrade Request During Active Security Feature	33	316-609-105 to 316-612-68 Network Faults 6 RAP	66
303-331-00 Communication Fault With NC	33	316-613-09 to 316-617-19 Network Faults 7 RAP	67
303-332-00 NC Communications Timeout	34	316-621-00 to 316-625-67 Network Faults 8 RAP	67
303-333-00 Invalid Value Detected for NVM 616-004 RAP	34	316-626-00 to 316-635-99 Network Faults 9 RAP	68
303-338-00 Main Controller Has Been Reset	35	316-636-35 to 316-647-26 Network Faults 10 RAP	69
303-346-00 Communication Fault with UI	35	316-650-35 to 316-668-95 Network Faults 11 RAP	70
303-347-00 UI Communications Lost RAP	36	316-669-28 to 316-730-00 Network Faults 12 RAP	71
303-355-00 CCM POST Failure During NVM Integrity Test	36	316-718-00, 316-720-02 to 316-720-05, 316-722-01, 316-722-02, 316-726-00, 316-727-00 Hard Disk Faults RAP	72
303-397 System Configuration is Lost	37	316-732-01 to 316-750-95 Network Faults 13 RAP	72
303-401 Basic FAX Not Detected or Confirmed	37	316-742-19 Hard Disk ODIO Failure RAP	73
303-403 Extended FAX Not Detected or Confirmed	38	316-751-11 to 316-753-95 Network Faults 14 RAP	73
303-405-00 Failed to Recover Machine Class	38	316-754-09 to 316-756-93 Network Faults 15 RAP	74
303-417-00 Incompatible FAX SW Detected at Power Up	39	316-757-09 to 316-760-99 Network Faults 16 RAP	75
303-450-00 Unexpected IOT reset RAP	39	316-761-14 to 316-765-93 Network Faults 17 RAP	76
303-777 Power Loss Detected	40	316-766-19 to 316-772-95 Network Faults 18 RAP	77
303-788 Failed to Exit Power Save Mode	40	316-773-19 to 316-779-95 Network Faults 19 RAP	78
303-790 Time Zone File Cannot be Set	41	316-780-19 to 316-789-19 Network Faults 20 RAP	78
Chain 305	41	316-790-19 to 316-799-47 Network Faults 21 RAP	79
305-101-00, 305-102-00, 305-124-00 to 305-127-00, 305-129-00, 305-175-00 to 305-177-00, 305-906-00, 305-922-00 DADF Paper Jam Error RAP	42	316-800-09 to 316-809-47 Network Faults 22 RAP	79
305-103-00 Scanner Disabled Error RAP	43	316-810-09 to 316-839-47 Network Faults 23 RAP	80
305-121-00 Feed Sensor Off Error RAP	44	316-840-47 to 316-879-47 Network Faults 24 RAP	81
305-210-00 Image Pipe Error RAP	45	316-880-47 to 316-929-19 Network Faults 25 RAP	82
305-211-00, 305-212-00, 310-514-00, 371-329-00, 372-322-00, 373-322-00, 374-328-00, 375-328-00 Unknown Error RAP	47	316-930-19 to 316-971-19 Network Faults 26 RAP	83
305-253-01, 362-397-00 to 362-399-00 IIT- DADH Communication Error RAP	47	316-972-08 to 316-986-19 Network Faults 27 RAP	84
305-300-00 Platen Cover Interlock Opened During Run Error RAP	48	316-990-00 to 316-997-00 Network Faults 28 RAP	84
305-305-00 Document Feeder Top Cover Open During Scan Error RAP	49	Chain 319	85
305-309-00 DADF No Paper Detected Error RAP	49	319-300-00 and 319-301-00 Hard Disk Read/Write Error RAP	85
Chain 310	50		
310-327-00, 310-330-00, 310-341-00, 310-360-00 to 310-364-00, 310-368-00, 310-369-00, 310-370-00, 310-372-00 to 310-379-00, 310-383-00, 310-407-00, 310-457-00, 310-460-00, 310-461-00, 310-464-00 to 310-466-00, 310-489-00, 310-490-00 to 310-493-00 Fuser Error RAPS	51		

319-340-00 SIC Crash RAP	86	322-309-04 NO Accepts Received Fault RAP	115
319-350-00 Missing Side 2 Calibration File at Reboot RAP	86	322-310-04 to 322-318-04 Paper Supply Errors RAP	115
319-401 Out Of Memory Caused By Stress Document	87	322-311-04 Sequencer Response Fault RAP	116
319-402 Out Of Memory Caused By Stress Job	87	322-314-04 Module Registration Error RAP	116
319-403-00 Out Of Memory With More Than 1 Job In EPC	88	322-316-04, 322-317-04, 322-318-04 Job Requirement Error RAP	117
319-409-01 Video Integrity Overflow Fault RAP	88	322-319-04 IOT Integrity Problem While Printing a Job RAP	118
319-409-02 Video Integrity Underflow Fault RAP	89	322-320-04 to 322-327-00, 322-335-00 to 322-340-00 Software Install Failed RAP	118
319-409-03 Video Integrity No Block List Fault RAP	89	322-328-00 Incomplete System Information	119
319-409-04 Video Integrity End Of Block List Fault RAP	90	322-330-00 and 322-332-00 Supplies Plan Errors RAP	119
319-410-00 Mark Output Timeout	90	322-350-02 Software detects non-valid Xerox SOK 2 or 3 RAP	120
319-410-01 Mark Output Timeout/Video Decompressor Fault RAP	91	322-352-00 Serial Number Missing From Memory RAP	120
319-410-02 Compress Image Timeout	91	322-360-00 to 322-363-00 3-way Sync (Service Plan) Faults RAP	121
319-410-03 Decompress Image Timeout	92	322-364-00 Critical Parameters Restored from Mirror RAP	122
319-410-04 Merge Image Timeout	92	322-365-00 Engine Serial Number Needs Recovery RAP	122
319-410-05 Rotate Image Timeout	93	322-370-00 Unable To Communicate With XSA Database	123
319-410-06 Network Input Failure	93	322-371-00, 322-407-00, 322-417-00, 322-419-00, 322-421-00 Embedded Fax Errors RAP	123
319-410-07 E-Fax Send/Receive Failure	94	322-701-04, 322-720-00, 322-721-00, 322-751-04, 322-754-17 Configuration Mismatch Fault RAP	124
319-410-08 Scan Input Failure RAP	94	Chain 341	124
319-410-09 Byte Count Error	95	341-368-00, 341-369-00 Firmware Mismatch Fail RAP	125
319-410-10 Setup Too Late	95	341-371-00 Speed Update Required Fault RAP	125
319-410-11 DMA Master Abort	96	Chain 342	126
319-410-12 Huffman Error	96	342-200-00 to 342-202-00, 342-204-00, 342-208-00 LVPS Error RAP	126
319-410-13 EOR Error	97	342-209-00 HVPS Error RAP	127
319-410-14 Scan Output Timeout Fault RAP	97	342-210-00 to 342-213-00 LVPS Fuser Fan Error RAP	127
319-410-15 Image Path Response Error From CIPS RAP	98	Chain 343	128
319-410-17 Insufficient Memory Allocation RAP	98	343-360-00 to 343-362-00, 343-364-00 to 343-366-00, 343-463-00 PC Motor Error RAP	128
319-410-18 Video Fatal error from CIPS RAP	99	Chain 344	129
319-411-01 Scan Image Capture DMA Setup Too Late RAP	99	344-217-00 to 344-223-00, 364-217-00 to 364-223-00 Staging Motor Error RAP	130
319-411-02 Scan Image Capture IIT Setup Too Early RAP	100	344-224-00 to 344-230-00, 364-222-00 to 364-230-00 Redrive Motor Error RAP	131
319-411-03 Scan Image Capture DMA Overflow RAP	100	344-231-00 to 344-244-00, 364-231-00 to 364-237-00, 377-350-00 to 377-356-00 Motor (DU- PLEX/MPF) Error RAP	132
319-411-04 Scan Image Capture DMA Incomplete RAP	101	344-245-00 to 344-251-00 Black Only Retract Motor Error RAPs	133
319-411-05 Scan Image Capture DMA Timeout RAP	101	344-252-00 to 344-258-00, 377-343-00 to 377-349-00 Transport Motor (Feed Separator) Error RAP	134
319-411-06 Scan Image Capture Planar Data Missing RAP	102	Chain 352	135
319-411-07 Scan Image Capture DMA Failure Due To Master Abort	102	352-214-00, 352-216-00, 352-218-00, 352-220-00, 352-222-00, 352-224-00, 352-226-00, 352-228- 00, 353-214-00, 353-216-00, 353-218-00, 353-220-00, 353-222-00, 353-224-00, 353-226-00, 353- 228-00, 354-214-00, 354-216-00, 354-218-00, 354-220-00, 354-222-00, 354-224-00, 354-226-00, 354-228-00, 355-224-00 to 355-231-00 Tray 2, 3, 4, 5 Motor (Pick / Lift) Lifting Error RAP	135
319-411-08 Scan Image Capture Setup Failure RAP	103	352-314-00, 352-316-00, 352-318-00, 352-320-00, 352-322-00, 352-326-10, 352-328-00, 353-314- 00, 353-316-00, 353-318-00, 353-320-00, 353-322-00, 353-326-10, 353-328-00, 354-314-00, 354- 316-00, 354-318-00, 354-320-00, 354-322-00, 354-326-10, 354-328-00, 355-232-00 to 355-238- 00 Motor (Pass-Through Tray 2, 3, 4, 5) Stall Error RAP	137
319-412-01 Scan Image Capture IIT Line Sync Integrity Error RAP	103	Chain 353	138
319-420 Image Processing Error At Power UP RAP	104	352-214-00, 352-216-00, 352-218-00, 352-220-00, 352-222-00, 352-224-00, 352-226-00, 352-228- 00, 353-214-00, 353-216-00, 353-218-00, 353-220-00, 353-222-00, 353-224-00, 353-226-00, 353- 228-00, 354-214-00, 354-216-00, 354-218-00, 354-220-00, 354-222-00, 354-224-00, 354-226-00, 354-228-00, 355-224-00 to 355-231-00 Tray 2, 3, 4, 5 Motor (Pick / Lift) Lifting Error RAP	138
319-422 Image Processing Error At Standby RAP	104	352-314-00, 352-316-00, 352-318-00, 352-320-00, 352-322-00, 352-326-10, 352-328-00, 353-314- 00, 353-316-00, 353-318-00, 353-320-00, 353-322-00, 353-326-10, 353-328-00, 354-314-00, 354- 316-00, 354-318-00, 354-320-00, 354-322-00, 354-326-10, 354-328-00, 355-232-00 to 355-238- 00 Motor (Pass-Through Tray 2, 3, 4, 5) Stall Error RAP	137
319-424 Image Processing Error With Job RAP	105	Chain 354	139
319-426 Image Processing Error During Print RAP	105	352-214-00, 352-216-00, 352-218-00, 352-220-00, 352-222-00, 352-224-00, 352-226-00, 352-228- 00, 353-214-00, 353-216-00, 353-218-00, 353-220-00, 353-222-00, 353-224-00, 353-226-00, 353- 228-00, 354-214-00, 354-216-00, 354-218-00, 354-220-00, 354-222-00, 354-224-00, 354-226-00, 354-228-00, 355-224-00 to 355-231-00 Tray 2, 3, 4, 5 Motor (Pick / Lift) Lifting Error RAP	138
319-476-00 PageNotAvailable Fault RAP	106	352-314-00, 352-316-00, 352-318-00, 352-320-00, 352-322-00, 352-326-10, 352-328-00, 353-314- 00, 353-316-00, 353-318-00, 353-320-00, 353-322-00, 353-326-10, 353-328-00, 354-314-00, 354- 316-00, 354-318-00, 354-320-00, 354-322-00, 354-326-10, 354-328-00, 355-232-00 to 355-238- 00 Motor (Pass-Through Tray 2, 3, 4, 5) Stall Error RAP	137
319-476-01 to 319-476-03 Band Fault RAP	106	Chain 355	139
319-750 EPC Memory Size Changed Configuration At Power Up RAP	107	352-214-00, 352-216-00, 352-218-00, 352-220-00, 352-222-00, 352-224-00, 352-226-00, 352-228- 00, 353-214-00, 353-216-00, 353-218-00, 353-220-00, 353-222-00, 353-224-00, 353-226-00, 353- 228-00, 354-214-00, 354-216-00, 354-218-00, 354-220-00, 354-222-00, 354-224-00, 354-226-00, 354-228-00, 355-224-00 to 355-231-00 Tray 2, 3, 4, 5 Motor (Pick / Lift) Lifting Error RAP	138
319-752 Image Rotation Detected RAP	107	352-314-00, 352-316-00, 352-318-00, 352-320-00, 352-322-00, 352-326-10, 352-328-00, 353-314- 00, 353-316-00, 353-318-00, 353-320-00, 353-322-00, 353-326-10, 353-328-00, 354-314-00, 354- 316-00, 354-318-00, 354-320-00, 354-322-00, 354-326-10, 354-328-00, 355-232-00 to 355-238- 00 Motor (Pass-Through Tray 2, 3, 4, 5) Stall Error RAP	137
319-754 Image Disk Configuration Changed At Power Up	108	Chain 356	140
319-760-00 Test Patterns Missing From EPC RAP	108	352-214-00, 352-216-00, 352-218-00, 352-220-00, 352-222-00, 352-224-00, 352-226-00, 352-228- 00, 353-214-00, 353-216-00, 353-218-00, 353-220-00, 353-222-00, 353-224-00, 353-226-00, 353- 228-00, 354-214-00, 354-216-00, 354-218-00, 354-220-00, 354-222-00, 354-224-00, 354-226-00, 354-228-00, 355-224-00 to 355-231-00 Tray 2, 3, 4, 5 Motor (Pick / Lift) Lifting Error RAP	138
Chain 320	109	352-314-00, 352-316-00, 352-318-00, 352-320-00, 352-322-00, 352-326-10, 352-328-00, 353-314- 00, 353-316-00, 353-318-00, 353-320-00, 353-322-00, 353-326-10, 353-328-00, 354-314-00, 354- 316-00, 354-318-00, 354-320-00, 354-322-00, 354-326-10, 354-328-00, 355-232-00 to 355-238- 00 Motor (Pass-Through Tray 2, 3, 4, 5) Stall Error RAP	137
320-250-00 IR Fax Analog Wrong Jack: Line Connected in Wrong Jack RAP	109	Chain 357	141
320-302-00 to 320-345-00, 320-713-00 Fax Errors RAP	110	352-214-00, 352-216-00, 352-218-00, 352-220-00, 352-222-00, 352-224-00, 352-226-00, 352-228- 00, 353-214-00, 353-216-00, 353-218-00, 353-220-00, 353-222-00, 353-224-00, 353-226-00, 353- 228-00, 354-214-00, 354-216-00, 354-218-00, 354-220-00, 354-222-00, 354-224-00, 354-226-00, 354-228-00, 355-224-00 to 355-231-00 Tray 2, 3, 4, 5 Motor (Pick / Lift) Lifting Error RAP	138
320-347-00, 320-347-01, 320-348-00, 320-348-01 Fax Card 1 & 2 Modem Firmware Upgrade Fail- ure RAP	111	352-314-00, 352-316-00, 352-318-00, 352-320-00, 352-322-00, 352-326-10, 352-328-00, 353-314- 00, 353-316-00, 353-318-00, 353-320-00, 353-322-00, 353-326-10, 353-328-00, 354-314-00, 354- 316-00, 354-318-00, 354-320-00, 354-322-00, 354-326-10, 354-328-00, 355-232-00 to 355-238- 00 Motor (Pass-Through Tray 2, 3, 4, 5) Stall Error RAP	137
320-324-00 and 320-349-00 Fax Failure Error RAP	111	Chain 358	142
320-701-00 Fax Phone Book Download Fault RAP	112	352-214-00, 352-216-00, 352-218-00, 352-220-00, 352-222-00, 352-224-00, 352-226-00, 352-228- 00, 353-214-00, 353-216-00, 353-218-00, 353-220-00, 353-222-00, 353-224-00, 353-226-00, 353- 228-00, 354-214-00, 354-216-00, 354-218-00, 354-220-00, 354-222-00, 354-224-00, 354-226-00, 354-228-00, 355-224-00 to 355-231-00 Tray 2, 3, 4, 5 Motor (Pick / Lift) Lifting Error RAP	138
320-710-00 and 320-711-00 Fax Image Overwrite Error RAP	113	352-314-00, 352-316-00, 352-318-00, 352-320-00, 352-322-00, 352-326-10, 352-328-00, 353-314- 00, 353-316-00, 353-318-00, 353-320-00, 353-322-00, 353-326-10, 353-328-00, 354-314-00, 354- 316-00, 354-318-00, 354-320-00, 354-322-00, 354-326-10, 354-328-00, 355-232-00 to 355-238- 00 Motor (Pass-Through Tray 2, 3, 4, 5) Stall Error RAP	137
Chain 322	113	Chain 359	143
322-300-05, 322-300-10, 322-301-05, 322-315-04 Image Transfer Errors RAP	114	352-214-00, 352-216-00, 352-218-00, 352-220-00, 352-222-00, 352-224-00, 352-226-00, 352-228- 00, 353-214-00, 353-216-00, 353-218-00, 353-220-00, 353-222-00, 353-224-00, 353-226-00, 353- 228-00, 354-214-00, 354-216-00, 354-218-00, 354-220-00, 354-222-00, 354-224-00, 354-226-00, 354-228-00, 355-224-00 to 355-231-00 Tray 2, 3, 4, 5 Motor (Pick / Lift) Lifting Error RAP	138
322-300-16 Clock Overflow Fault	114	352-314-00, 352-316-00, 352-318-00, 352-320-00, 352-322-00, 352-326-10, 352-328-00, 353-314- 00, 353-316-00, 353-318-00, 353-320-00, 353-322-00, 353-326-10, 353-328-00, 354-314-00, 354- 316-00, 354-318-00, 354-320-00, 354-322-00, 354-326-10, 354-328-00, 355-232-00 to 355-238- 00 Motor (Pass-Through Tray 2, 3, 4, 5) Stall Error RAP	137

316-00, 354-318-00, 354-320-00, 354-322-00, 354-326-10, 354-328-00, 355-232-00 to 355-238-00 Motor (Pass-Through Tray 2, 3, 4, 5) Stall Error RAP.....	140	371-344-00 Tray 1 S1 Sensor Cleared By Page Too Soon Error RAP.....	168
Chain 354	141	371-345-00 Tray 1 S1 Sensor Never Cleared By Trailing Edge Error RAP.....	169
352-214-00, 352-216-00, 352-218-00, 352-220-00, 352-222-00, 352-224-00, 352-226-00, 352-228-00, 353-214-00, 353-216-00, 353-218-00, 353-220-00, 353-222-00, 353-224-00, 353-226-00, 353-228-00, 354-214-00, 354-216-00, 354-218-00, 354-220-00, 354-222-00, 354-224-00, 354-226-00, 354-228-00, 355-224-00 to 355-231-00 Tray 2, 3, 4, 5 Motor (Pick / Lift) Lifting Error RAP.....	141	371-537-00 Tray Empty Sensor Cable Unplugged RAP.....	170
352-314-00, 352-316-00, 352-318-00, 352-320-00, 352-322-00, 352-326-10, 352-328-00, 353-314-00, 353-316-00, 353-318-00, 353-320-00, 353-322-00, 353-326-10, 353-328-00, 354-314-00, 354-316-00, 354-318-00, 354-320-00, 354-322-00, 354-326-10, 354-328-00, 355-232-00 to 355-238-00 Motor (Pass-Through Tray 2, 3, 4, 5) Stall Error RAP.....	143	Chain 372	170
Chain 355	144	372-010-00 to 372-012-00, 373-010-00 to 373-012-00, 374-010-00 to 374-012-00, 375-010-00 to 375-012-00 TRAY 2, 3, 4, 5 Invalid Product ID, Board ID, Option Type Error RAP.....	171
352-214-00, 352-216-00, 352-218-00, 352-220-00, 352-222-00, 352-224-00, 352-226-00, 352-228-00, 353-214-00, 353-216-00, 353-218-00, 353-220-00, 353-222-00, 353-224-00, 353-226-00, 353-228-00, 354-214-00, 354-216-00, 354-218-00, 354-220-00, 354-222-00, 354-224-00, 354-226-00, 354-228-00, 355-224-00 to 355-231-00 Tray 2, 3, 4, 5 Motor (Pick / Lift) Lifting Error RAP.....	144	372-100-00, 372-150-00, 372-330-00, 372-333-00, 372-338-00, 373-100-00, 373-150-00, 373-332-00, 373-341-00, 374-150-00, 374-341-00, 375-246-00, 375-343-00, 377-277-00 Tray 2, 3, 4, 5 Fail To Pick Error RAP.....	172
352-314-00, 352-316-00, 352-318-00, 352-320-00, 352-322-00, 352-326-10, 352-328-00, 353-314-00, 353-316-00, 353-318-00, 353-320-00, 353-322-00, 353-326-10, 353-328-00, 354-314-00, 354-316-00, 354-318-00, 354-320-00, 354-322-00, 354-326-10, 354-328-00, 355-232-00 to 355-238-00 Motor (Pass-Through Tray 2, 3, 4, 5) Stall Error RAP.....	146	372-102-00, 372-108-00, 372-142-00, 372-144-00, 372-223-00, 372-331-00, 372-334-00, 372-902-00, 373-102-00, 373-142-00, 373-144-00, 373-330-00, 373-333-00, 373-339-00, 373-900-00, 374-142-00, 374-143-00, 374-334-00, 374-335-00, 374-339-00, 375-142-00, 375-242-00, 375-334-00, 375-335-00, 375-339-00, 377-149-00, 377-274-00, 377-279-00 Early Arriving Jam And Static Jam RAP.....	174
Chain 362	147	372-105-00, 372-112-00, 372-148-00, 372-337-00, 373-105-00, 373-148-00, 374-112-00, 374-148-00, 374-338-00, 375-240-00, 375-244-00, 375-338-00, 375-342-00, 377-276-00 Late Leaving Jam Tray (3, 4, 5) RAP.....	175
362-358-00 Backside Cable Error RAP.....	147	372-114-00, 372-116-00, 372-118-00, 372-120-00, 372-122-00, 372-124-00, 372-126-00, 373-116-00, 373-118-00, 373-120-00, 373-122-00, 373-124-00, 373-126-00, 373-321-00, 374-114-00, 374-116-00, 374-118-00, 374-120-00, 374-122-00, 374-124-00, 374-126-00, 375-247-00 to 375-249-00, 375-251-00 to 375-253-00, 375-560-00 Tray 2, 3, 4, 5 Transport (550) or Lift (HCIT) Motor Error RAP.....	177
305-253-01, 362-397-00 to 362-399-00 IIT- DADH Communication Error RAP.....	148	372-128-00, 372-130-00, 372-132-00, 372-134-00, 372-138-00, 372-140-00, 372-321-00, 373-128-00, 373-130-00, 373-132-00, 373-134-00, 373-136-00, 373-138-00, 373-140-00, 374-128-00, 374-130-00, 374-132-00, 374-134-00, 374-136-00, 374-138-00, 374-140-00, 375-254-00 to 375-259-00, 375-250-00 Tray 2, 3, 4, 5 Motor Error RAP.....	179
362-463-00 DADF Feed/Exit Drive Error RAP.....	149	371-107-00 to 371-108-00, 372-151-00 to 372-152-00, 373-153-00 to 373-154-00, 374-100-01, 374-950-00, 375-100-01, 375-950-00, 375-951-00, 376-104-00 to 376-105-00, 377-950-00, 377-951-00 Load tray 1,2,3,4,5 with media Error RAPS.....	180
362-476-01 Flatbed CIS Scanner Home Position Error RAP.....	149	372-210-00, 372-212-00, 372-214-00, 372-216-00, 372-218-00, 372-220-00, 372-222-00, 373-210-00, 373-212-00, 373-214-00, 373-216-00, 373-218-00, 373-220-00, 373-222-00, 374-218-00 to 374-224-00, 375-232-00 to 375-238-00 Motor (Tray 2, 3, 4, 5 Pick/Lift) Error RAP.....	181
Chain 364	150	373-146-00, 373-328-00, 374-147-00, 375-239-00 Never Arriving Jam From Normal Path Tray (3, 4, 5) RAP.....	182
344-217-00 to 344-223-00, 364-217-00 to 364-223-00 Staging Motor Error RAP.....	151	371-302-00, 371-310-00, 371-318-00, 371-324-00, 371-327-00, 372-226-00, 374-318-00, 374-329-00, 375-318-00, 375-329-00 Tray 2, 3, 4, 5 Sensor Failed To Arrive Error RAP.....	184
344-224-00 to 344-230-00, 364-222-00 to 364-230-00 Redrive Motor Error RAP.....	152	372-300-00, 372-302-00, 372-304-00, 372-306-00, 372-308-00, 372-310-00, 372-312-00, 373-300-00, 373-302-00, 373-304-00, 373-306-00, 373-308-00, 373-310-00, 373-312-00, 374-225-00 to 374-231-00, 375-225-00 to 375-231-00 Tray 2, 3, 4, 5 Transport Motor Error RAP.....	186
344-231-00 to 344-244-00, 364-231-00 to 364-237-00, 377-350-00 to 377-356-00 Motor (DU- PLEX/MPF) Error RAP.....	153	371-339-00, 372-305-00, 373-305-00, 374-305-00, 375-305-00 Tray 1, 2, 3, 4, 5 S1/Input Sensor Cleared Error RAP.....	187
364-238-00, 364-225-00 to 364-230-00 Motor (Tray 1 Pick/Lift) Lifting Error RAP.....	154	372-313-00, 372-314-00, 372-315-00, 372-316-00, 372-317-00, 372-318-00, 372-319-00 Tray 2 Lift Motor Error RAP.....	188
Chain 371	154	305-211-00, 305-212-00, 310-514-00, 371-329-00, 372-322-00, 373-322-00, 374-328-00, 375-328-00 Unknown Error RAP.....	189
371-107-00 to 371-108-00, 372-151-00 to 372-152-00, 373-153-00 to 373-154-00, 374-100-01, 374-950-00, 375-100-01, 375-950-00, 375-951-00, 376-104-00 to 376-105-00, 377-950-00, 377-951-00 Load tray 1,2,3,4,5 with media Error RAPS.....	155	372-324-00, 372-325-00, 372-326-00, 372-327-00 Bump Exit Sensor Error RAP.....	189
371-210-00, 371-212-00, 371-214-00, 371-216-00, 371-218-00, 371-220-00, 371-222-00, 351-214-00, 351-216-00, 351-218-00, 351-220-00, 351-222-00, 351-224-10, 351-226-10, 351-228-00 Motor (Tray 1, Autocomp Pick/Lift) Lifting Error RAP.....	156	372-328-00, 372-329-00, 372-332-00, 372-336-00, 372-339-00, 373-329-00, 373-331-00, 373-338-00, 373-340-00, 374-337-00, 374-340-00, 374-342-00, 375-337-00, 375-341-00 Early Leaving Jam Sensor Tray (2, 3, 4, 5) Error RAPS.....	190
371-302-00, 371-310-00, 371-318-00, 371-324-00, 371-327-00, 372-226-00, 374-318-00, 374-329-00, 375-318-00, 375-329-00 Tray 2, 3, 4, 5 Sensor Failed To Arrive Error RAP.....	157	Chain 373	191
371-304-00, 371-312-00, 371-320-00, 371-326-00, 374-320-00, 375-320-00 Tray 1, 2, 3, 4, 5 Sensor Failed To Clear Page Error RAP.....	159	372-010-00 to 372-012-00, 373-010-00 to 373-012-00, 374-010-00 to 374-012-00, 375-010-00 to 375-012-00 TRAY 2, 3, 4, 5 Invalid Product ID, Board ID, Option Type Error RAP.....	192
371-308-00, 371-316-00, 371-322-00, 374-300-00, 375-306-00 S1/Input Sensor Covered Error RAP.....	160		
371-317-00, 371-346-00, 374-317-00 Autocomp Motor Under Speed Error RAP.....	161		
371-319-00 Tray1 Pass-Through Sensor Covered During Warm Up Error RAP.....	162		
371-328-00 S1/Input Sensor Covered At Warmup Error RAP.....	163		
305-211-00, 305-212-00, 310-514-00, 371-329-00, 372-322-00, 373-322-00, 374-328-00, 375-328-00 Unknown Error RAP.....	164		
371-338-00 Sensor Never Made By Leading Edge After A Paper Pick.....	164		
371-339-00, 372-305-00, 373-305-00, 374-305-00, 375-305-00 Tray 1, 2, 3, 4, 5 S1/Input Sensor Cleared Error RAP.....	166		
371-340-00, 371-341-00, 371-342-00, 371-347-00 Bump Exit Sensor Error RAP.....	167		
371-343-00 S1 Sensor Covered To Soon Error RAP.....	167		

372-100-00, 372-150-00, 372-330-00, 372-333-00, 372-338-00, 373-100-00, 373-150-00, 373-332-00, 373-341-00, 374-150-00, 374-341-00, 375-246-00, 375-343-00, 377-277-00 Tray 2, 3, 4, 5 Fail To Pick Error RAP 193

372-102-00, 372-108-00, 372-142-00, 372-144-00, 372-223-00, 372-331-00, 372-334-00, 372-902-00, 373-102-00, 373-142-00, 373-144-00, 373-330-00, 373-333-00, 373-339-00, 373-900-00, 374-142-00, 374-143-00, 374-334-00, 374-335-00, 374-339-00, 375-142-00, 375-242-00, 375-334-00, 375-335-00, 375-339-00, 377-149-00, 377-274-00, 377-279-00 Early Arriving Jam And Static Jam RAP 195

372-105-00, 372-112-00, 372-148-00, 372-337-00, 373-105-00, 373-148-00, 374-112-00, 374-148-00, 374-338-00, 375-240-00, 375-244-00, 375-338-00, 375-342-00, 377-276-00 Late Leaving Jam Tray (3, 4, 5) RAP 196

372-114-00, 372-116-00, 372-118-00, 372-120-00, 372-122-00, 372-124-00, 372-126-00, 373-116-00, 373-118-00, 373-120-00, 373-122-00, 373-124-00, 373-126-00, 373-321-00, 374-114-00, 374-116-00, 374-118-00, 374-120-00, 374-122-00, 374-124-00, 374-126-00, 375-247-00 to 375-249-00, 375-251-00 to 375-253-00, 375-560-00 Tray 2, 3, 4, 5 Transport (550) or Lift (HCIT) Motor Error RAP 198

372-128-00, 372-130-00, 372-132-00, 372-134-00, 372-138-00, 372-140-00, 372-321-00, 373-128-00, 373-130-00, 373-132-00, 373-134-00, 373-136-00, 373-138-00, 373-140-00, 374-128-00, 374-130-00, 374-132-00, 374-134-00, 374-136-00, 374-138-00, 374-140-00, 375-254-00 to 375-259-00, 375-250-00 Tray 2, 3, 4, 5 Motor Error RAP 200

373-146-00, 373-328-00, 374-147-00, 375-239-00 Never Arriving Jam From Normal Path Tray (3, 4, 5) RAP 201

371-107-00 to 371-108-00, 372-151-00 to 372-152-00, 373-153-00 to 373-154-00, 374-100-01, 374-950-00, 375-100-01, 375-950-00, 375-951-00, 376-104-00 to 376-105-00, 377-950-00, 377-951-00 Load tray 1,2,3,4,5 with media Error RAPS 203

372-210-00, 372-212-00, 372-214-00, 372-216-00, 372-218-00, 372-220-00, 372-222-00, 373-210-00, 373-212-00, 373-214-00, 373-216-00, 373-218-00, 373-220-00, 373-222-00, 374-218-00 to 374-224-00, 375-232-00 to 375-238-00 Motor (Tray 2, 3, 4, 5 Pick/Lift) Error RAP 204

372-300-00, 372-302-00, 372-304-00, 372-306-00, 372-308-00, 372-310-00, 372-312-00, 373-300-00, 373-302-00, 373-304-00, 373-306-00, 373-308-00, 373-310-00, 373-312-00, 374-225-00 to 374-231-00, 375-225-00 to 375-231-00 Tray 2, 3, 4, 5 Transport Motor Error RAP 205

371-339-00, 372-305-00, 373-305-00, 374-305-00, 375-305-00 Tray 1, 2, 3, 4, 5 S1/Input Sensor Cleared Error RAP 206

305-211-00, 305-212-00, 310-514-00, 371-329-00, 372-322-00, 373-322-00, 374-328-00, 375-328-00 Unknown Error RAP 208

373-324-00, 373-325-00, 373-326-00, 373-327-00 Bump Exit Sensor Error RAP 208

372-328-00, 372-329-00, 372-332-00, 372-336-00, 372-339-00, 373-329-00, 373-331-00, 373-338-00, 373-340-00, 374-337-00, 374-340-00, 374-342-00, 375-337-00, 375-341-00 Early Leaving Jam Sensor Tray (2, 3, 4, 5) Error RAPS 209

Chain 374 **210**

374-100-01 Change Tray 4 to Different Media RAP 211

372-010-00 to 372-012-00, 373-010-00 to 373-012-00, 374-010-00 to 374-012-00, 375-010-00 to 375-012-00 TRAY 2, 3, 4, 5 Invalid Product ID, Board ID, Option Type Error RAP 211

371-107-00 to 371-108-00, 372-151-00 to 372-152-00, 373-153-00 to 373-154-00, 374-100-01, 374-950-00, 375-100-01, 375-950-00, 375-951-00, 376-104-00 to 376-105-00, 377-950-00, 377-951-00 Load tray 1,2,3,4,5 with media Error RAPS 212

372-105-00, 372-112-00, 372-148-00, 372-337-00, 373-105-00, 373-148-00, 374-112-00, 374-148-00, 374-338-00, 375-240-00, 375-244-00, 375-338-00, 375-342-00, 377-276-00 Late Leaving Jam Tray (3, 4, 5) RAP 213

372-114-00, 372-116-00, 372-118-00, 372-120-00, 372-122-00, 372-124-00, 372-126-00, 373-116-00, 373-118-00, 373-120-00, 373-122-00, 373-124-00, 373-126-00, 373-321-00, 374-114-00, 374-116-00, 374-118-00, 374-120-00, 374-122-00, 374-124-00, 374-126-00, 375-247-00 to 375-249-00, 375-251-00 to 375-253-00, 375-560-00 Tray 2, 3, 4, 5 Transport (550) or Lift (HCIT) Motor Error RAP 215

372-128-00, 372-130-00, 372-132-00, 372-134-00, 372-138-00, 372-140-00, 372-321-00, 373-128-00, 373-130-00, 373-132-00, 373-134-00, 373-136-00, 373-138-00, 373-140-00, 374-128-00, 374-130-00, 374-132-00, 374-134-00, 374-136-00, 374-138-00, 374-140-00, 375-254-00 to 375-259-00, 375-250-00 Tray 2, 3, 4, 5 Motor Error RAP 217

372-102-00, 372-108-00, 372-142-00, 372-144-00, 372-223-00, 372-331-00, 372-334-00, 372-902-00, 373-102-00, 373-142-00, 373-144-00, 373-330-00, 373-333-00, 373-339-00, 373-900-00, 374-142-00, 374-143-00, 374-334-00, 374-335-00, 374-339-00, 375-142-00, 375-242-00, 375-334-00, 375-335-00, 375-339-00, 377-149-00, 377-274-00, 377-279-00 Early Arriving Jam And Static Jam RAP 218

372-110-00, 372-146-00, 372-225-00, 372-335-00, 374-146-00 Never Arriving Jam From Normal Path Tray (2, 3, 4, 5) RAP 220

373-146-00, 373-328-00, 374-147-00, 375-239-00 Never Arriving Jam From Normal Path Tray (3, 4, 5) RAP 222

372-100-00, 372-150-00, 372-330-00, 372-333-00, 372-338-00, 373-100-00, 373-150-00, 373-332-00, 373-341-00, 374-150-00, 374-341-00, 375-246-00, 375-343-00, 377-277-00 Tray 2, 3, 4, 5 Fail To Pick Error RAP 224

372-210-00, 372-212-00, 372-214-00, 372-216-00, 372-218-00, 372-220-00, 372-222-00, 373-210-00, 373-212-00, 373-214-00, 373-216-00, 373-218-00, 373-220-00, 373-222-00, 374-218-00 to 374-224-00, 375-232-00 to 375-238-00 Motor (Tray 2, 3, 4, 5 Pick/Lift) Error RAP 226

372-300-00, 372-302-00, 372-304-00, 372-306-00, 372-308-00, 372-310-00, 372-312-00, 373-300-00, 373-302-00, 373-304-00, 373-306-00, 373-308-00, 373-310-00, 373-312-00, 374-225-00 to 374-231-00, 375-225-00 to 375-231-00 Tray 2, 3, 4, 5 Transport Motor Error RAP 227

377-270-00, 377-404-00, 377-407-00, 377-410-00, 374-232-00, 377-421-00, 377-419-00 S1/Input/Stage Sensor RAP 228

377-402-00, 377-405-00, 377-408-00, 377-411-00, 374-233-00, 377-422-00, 377-420-00 S1/Input/Stage Sensor RAP 229

371-308-00, 371-316-00, 371-322-00, 374-300-00, 375-306-00S1/Input Sensor Covered Error RAP 230

371-339-00, 372-305-00, 373-305-00, 374-305-00, 375-305-00 Tray 1, 2, 3, 4, 5 S1/Input Sensor Cleared Error RAP 231

371-317-00, 371-346-00, 374-317-00 Autocomp Motor Under Speed Error RAP 232

371-302-00, 371-310-00, 371-318-00, 371-324-00, 371-327-00, 372-226-00, 374-318-00, 374-329-00, 375-318-00, 375-329-00 Tray 2, 3, 4, 5 Sensor Failed To Arrive Error RAP 233

371-304-00, 371-312-00, 371-320-00, 371-326-00, 374-320-00, 375-320-00 Tray 1, 2, 3, 4, 5 Sensor Failed To Clear Page Error RAP 235

374-321-00, 374-322-00, 374-323-00, 374-324-00, 374-325-00, 374-326-00, 374-327-00 Tray 4 Lift Motor Error RAP 236

305-211-00, 305-212-00, 310-514-00, 371-329-00, 372-322-00, 373-322-00, 374-328-00, 375-328-00 Unknown Error RAP 237

374-330-00, 374-331-00, 374-332-00, 374-333-00 Bump Exit Sensor Error RAP 237

374-336-00, 375-243-00, 375-336-00, 375-340-00, 377-275-00 Tray (4, 5) Never Arriving Jam From Normal Path Error RAPS 238

372-328-00, 372-329-00, 372-332-00, 372-336-00, 372-339-00, 373-329-00, 373-331-00, 373-338-00, 373-340-00, 374-337-00, 374-340-00, 374-342-00, 375-337-00, 375-341-00 Early Leaving Jam Sensor Tray (2, 3, 4, 5) Error RAPS 240

374-343-00, 375-345-00 Late Arriving Jam RAP 241

374-951-00 Change Tray 4 To Different Media (Orientation Supported) RAP 243

Chain 375 **244**

372-010-00 to 372-012-00, 373-010-00 to 373-012-00, 374-010-00 to 374-012-00, 375-010-00 to 375-012-00 TRAY 2, 3, 4, 5 Invalid Product ID, Board ID, Option Type Error RAP 244

371-107-00 to 371-108-00, 372-151-00 to 372-152-00, 373-153-00 to 373-154-00, 374-100-01, 374-950-00, 375-100-01, 375-950-00, 375-951-00, 376-104-00 to 376-105-00, 377-950-00, 377-951-00 Load tray 1,2,3,4,5 with media Error RAPS 245

372-102-00, 372-108-00, 372-142-00, 372-144-00, 372-223-00, 372-331-00, 372-334-00, 372-902-00, 373-102-00, 373-142-00, 373-144-00, 373-330-00, 373-333-00, 373-339-00, 373-900-00, 374-142-00, 374-143-00, 374-334-00, 374-335-00, 374-339-00, 375-142-00, 375-242-00, 375-334-00, 375-335-00, 375-339-00, 377-149-00, 377-274-00, 377-279-00 Early Arriving Jam And Static Jam RAP	246	377-130-00, 377-132-00, 377-134-00, 377-136-00, 377-293-00, 377-297-00 Duplex Stage Sensor Error RAP	277
372-300-00, 372-302-00, 372-304-00, 372-306-00, 372-308-00, 372-310-00, 372-312-00, 373-300-00, 373-302-00, 373-304-00, 373-306-00, 373-308-00, 373-310-00, 373-312-00, 374-225-00 to 374-231-00, 375-225-00 to 375-231-00 Tray 2, 3, 4, 5 Transport Motor Error RAP	248	377-131-00, 377-133-00, 377-135-00, 377-137-00, 377-291-00, 377-295-00, 377-299-00 Tray 1, 2, 3, 4, 5 Duplex Stage Sensor Error RAP	279
372-210-00, 372-212-00, 372-214-00, 372-216-00, 372-218-00, 372-220-00, 372-222-00, 373-210-00, 373-212-00, 373-214-00, 373-216-00, 373-218-00, 373-220-00, 373-222-00, 374-218-00 to 374-224-00, 375-232-00 to 375-238-00 Motor (Tray 2, 3, 4, 5 Pick/Lift) Error RAP	249	377-138-00, 377-139-00 Duplex Entry Sensor Cable Unplugged RAP	280
373-146-00, 373-328-00, 374-147-00, 375-239-00 Never Arriving Jam From Normal Path Tray (3, 4, 5) RAP	250	377-140-00 Fuser Bubble Sensor Unplugged RAP	281
372-105-00, 372-112-00, 372-148-00, 372-337-00, 373-105-00, 373-148-00, 374-112-00, 374-148-00, 374-338-00, 375-240-00, 375-244-00, 375-338-00, 375-342-00, 377-276-00 Late Leaving Jam Tray (3, 4, 5) RAP	252	377-141-00 Narrow Media Sensor Cable Unplugged RAP	281
374-336-00, 375-243-00, 375-336-00, 375-340-00, 377-275-00 Tray (4, 5) Never Arriving Jam From Normal Path Error RAPs	254	377-142-00, 377-144-00 Alt-S1 Sensor Unplugged RAP	282
372-100-00, 372-150-00, 372-330-00, 372-333-00, 372-338-00, 373-100-00, 373-150-00, 373-332-00, 373-341-00, 374-150-00, 374-341-00, 375-246-00, 375-343-00, 377-277-00 Tray 2, 3, 4, 5 Fail To Pick Error RAP	256	377-145-00 Bump Exit Sensor Cable Unplugged RAP	282
372-114-00, 372-116-00, 372-118-00, 372-120-00, 372-122-00, 372-124-00, 372-126-00, 373-116-00, 373-118-00, 373-120-00, 373-122-00, 373-124-00, 373-126-00, 373-321-00, 374-114-00, 374-116-00, 374-118-00, 374-120-00, 374-122-00, 374-124-00, 374-126-00, 375-247-00 to 375-249-00, 375-251-00 to 375-253-00, 375-560-00 Tray 2, 3, 4, 5 Transport (550) or Lift (HCIT) Motor Error RAP	258	372-102-00, 372-108-00, 372-142-00, 372-144-00, 372-223-00, 372-331-00, 372-334-00, 372-902-00, 373-102-00, 373-142-00, 373-144-00, 373-330-00, 373-333-00, 373-339-00, 373-900-00, 374-142-00, 374-143-00, 374-334-00, 374-335-00, 374-339-00, 375-142-00, 375-242-00, 375-334-00, 375-335-00, 375-339-00, 377-149-00, 377-274-00, 377-279-00 Early Arriving Jam And Static Jam RAP	283
372-128-00, 372-130-00, 372-132-00, 372-134-00, 372-138-00, 372-140-00, 372-321-00, 373-128-00, 373-130-00, 373-132-00, 373-134-00, 373-136-00, 373-138-00, 373-140-00, 374-128-00, 374-130-00, 374-132-00, 374-134-00, 374-136-00, 374-138-00, 374-140-00, 375-254-00 to 375-259-00, 375-250-00 Tray 2, 3, 4, 5 Motor Error RAP	259	377-150-00 Stage Sensor Cable Is Unplugged RAP	284
371-339-00, 372-305-00, 373-305-00, 374-305-00, 375-305-00 Tray 1, 2, 3, 4, 5 S1/Input Sensor Cleared Error RAP	261	377-184-00 Bin Full Sensor Cable Unplugged RAP	285
371-308-00, 371-316-00, 371-322-00, 374-300-00, 375-306-00S1/Input Sensor Covered Error RAP	262	377-185-00 Sensor (Duplex/MPF Input) Appears To Be Disconnected RAP	285
371-302-00, 371-310-00, 371-318-00, 371-324-00, 371-327-00, 372-226-00, 374-318-00, 374-329-00, 375-318-00, 375-329-00 Tray 2, 3, 4, 5 Sensor Failed To Arrive Error RAP	263	377-186-00 MPF Paper Present Sensor Unplugged RAP	286
371-304-00, 371-312-00, 371-320-00, 371-326-00, 374-320-00, 375-320-00 Tray 1, 2, 3, 4, 5 Sensor Failed To Clear Page Error RAP	265	377-206-00, 377-207-00 Fuser Exit Sensor Error RAP	286
375-321-00, 375-322-00, 375-323-00, 375-324-00, 375-325-00, 375-326-00, 375-327-00 Tray 5 Lift Motor Error RAP	266	377-211-00 Tray Module Kind Mismatch RAP	287
305-211-00, 305-212-00, 310-514-00, 371-329-00, 372-322-00, 373-322-00, 374-328-00, 375-328-00 Unknown Error RAP	266	377-218-00 Duplex Entry/Park Sensor Covered Warmup Error RAP	287
375-330-00, 375-331-00, 375-332-00, 375-333-00 Bump Exit Sensor Error RAP	267	377-219-00 to 377-225-00 Tray 1, 2, 3, 4, 5 S1/Input Sensor Error RAP	288
372-328-00, 372-329-00, 372-332-00, 372-336-00, 372-339-00, 373-329-00, 373-331-00, 373-338-00, 373-340-00, 374-337-00, 374-340-00, 374-342-00, 375-337-00, 375-341-00 Early Leaving Jam Sensor Tray (2, 3, 4, 5) Error RAPs	267	377-235-00, 377-237-00, 377-239-00, 377-241-00, 377-243-00, 377-245-00 Fuser exit sensor RAP	289
375-344-00, 377-278-00 Sensor Did Not Clear Error RAP	269	377-236-00, 377-238-00, 377-240-00, 377-242-00, 377-244-00, 377-247-00 Fuser Exit Sensor RAP	290
374-343-00, 375-345-00 Late Arriving Jam RAP	270	377-251-00, 377-254-00, 377-258-00, 377-262-00, 377-267-00, 377-285-00 Duplex Entry/Park Sensor RAP	291
Chain 377	272	377-252-00, 377-256-00, 377-260-00, 377-264-00, 377-269-00, 377-286-00 Duplex Entry/Park Sensor RAP	293
377-102-00, 377-105-00, 377-106-00, 377-109-00, 377-204-00, 377-246-00 Fuser Exit Sensor RAP	273	377-270-00, 377-404-00, 377-407-00, 377-410-00, 374-232-00, 377-421-00, 377-419-00 S1/Input/Stage Sensor RAP	294
377-103-00, 377-108-00, 377-111-00, 377-205-00, 377-248-00 Fuser Exit Sensor Never Cleared By Trailing Edge Of Page RAP	275	377-271-00, 377-324-00, 377-327-00, 377-329-00, 377-331-00, 377-333-00 Alt S1 Sensor RAP	296
377-112-00 Fuser Exit Sensor Covered Warmup RAP	276	377-272-00, 377-273-00 MPF Motor RAP	297
		374-336-00, 375-243-00, 375-336-00, 375-340-00, 377-275-00 Tray (4, 5) Never Arriving Jam From Normal Path Error RAPs	298
		372-105-00, 372-112-00, 372-148-00, 372-337-00, 373-105-00, 373-148-00, 374-112-00, 374-148-00, 374-338-00, 375-240-00, 375-244-00, 375-338-00, 375-342-00, 377-276-00 Late Leaving Jam Tray (3, 4, 5) RAP	300
		372-100-00, 372-150-00, 372-330-00, 372-333-00, 372-338-00, 373-100-00, 373-150-00, 373-332-00, 373-341-00, 374-150-00, 374-341-00, 375-246-00, 375-343-00, 377-277-00 Tray 2, 3, 4, 5 Fail To Pick Error RAP	302
		375-344-00, 377-278-00 Sensor Did Not Clear Error RAP	304
		377-283-00, 377-284-00 Bump Exit Sensor Error RAP	305
		377-287-00, 377-288-00, 377-290-00, 377-294-00, 377-298-00 Duplex Stage Sensor RAP	306
		377-289-00, 377-292-00, 377-296-00 Duplex Stage Sensor RAP	307
		377-320-00 All Feed Tray Broken RAP	308
		377-321-00 Duplex Stage Sensor Covered Warm Up RAP	308
		377-322-00, 377-323-00, 377-325-00 Alt S1 Sensor Error RAP	309
		377-326-00 Tray 2 Alt S1 Sensor RAP	310
		377-328-00 Alt S1 Sensor Tray 3 RAP	311
		377-330-00 Alt S1 Sensor Tray 4 RAP	312
		377-332-00 Alt S1 Sensor Tray 5 RAP	314
		377-334-00 MPF Motor Stall RAP	316
		377-335-00 Alt S1 sensor covered on warm up - RAP	317

377-336-00 Alt S1 Sensor Never Uncovered After Picking A Page From Tray X- Source = Unknown RAP	318
377-337-00, 377-338-00, 377-339-00, 377-340-00, 377-341-00, 377-342-00, 377-358-00 Duplex Diverter Motor Error RAP	318
344-252-00 to 344-258-00, 377-343-00 to 377-349-00 Transport Motor (Feed Separator) Error RAP	319
344-231-00 to 344-244-00, 364-231-00 to 364-237-00, 377-350-00 to 377-356-00 Motor (DU- PLEX/MPF) Error RAP	320
377-357-00 Alt S1 Never Reached On Pick From MPF RAP	321
377-402-00, 377-405-00, 377-408-00, 377-411-00, 374-233-00, 377-422-00, 377-420-00 S1/Input/ Stage Sensor RAP	322
377-602 OHP Sensor Fail RAP	323
371-107-00 to 371-108-00, 372-151-00 to 372-152-00, 373-153-00 to 373-154-00, 374-100-01, 374-950-00, 375-100-01, 375-950-00, 375-951-00, 376-104-00 to 376-105-00, 377-950-00, 377- 951-00 Load tray 1,2,3,4,5 with media Error RAPS	324
Chain 393	325
391-100-00 to 391-105-00, 391-940-00, 393-100-00 to 393-105-00, 393-947-00 to 393-955-00, 393-957-00, 393-958-00, 393-968-00, 393-969-00, 393-986-00, 393-985-00, 393-962-00 Toner Bottle Unsupported Error RAP	325
393-337-00, 393-337-01 Toner CRUM M Auth IC Error RAP	327
393-426-00 to 393-428-00, 393-438-00 to 393-442-00, 393-444-00 to 393-464-00 Cartridge Quan- ta Error RAPS	327
393-443-00 Replace Black Cartridge - Fresh Toner RAP	328
393-901-00 WTB Smartchip Or Sensor Commo Problem - Missing RAP	329
393-964-00, 393-964-01, 393-965-00, 393-965-01, 393-966-00, 393-966-01, 393-967-00, 393-967- 01 Toner Meter Cycle Error RAPS	329
393-975-00, 393-976-00, 393-977-00 Null String Error RAP	330
393-978-00, 393-979-00, 393-980-00, 393-981-00 Non-Xerox String Error RAP	330
393-987-00 Non-genuine Supply - Color (CMY) Imaging Unit Or Kit, Or Photoconductor RAP	331
393-988-00 Magenta Toner Bottle Smartchip Or Sensor Common Problem RAP	331
Chain 395	332
395-001-00 to 395-168-00 and 395-216 to 395-324-00 Software Upgrade Failure RAP	332
395-171-00, 395-172-00, 395-173-00 Software Upgrade Failure Error RAP	333
Chain 399	334
399-350-00, 399-355-00, 399-364-00, 399-373-00, 399-375-00, 399-377-00, 399-395-00 Fuser Motor RAP	334
Chain OF	335
OF1 Machine Not Ready RAP	336
OF2 UI Touch Screen Failure RAP	336
OF3 AC Power RAP	337
OF4 +5VDC Power Fault RAP	337
OF5 +24VDC Power Fault RAP	338
OF8 Network Printing Problems RAP	338
OF9 TCP/IP Checkout RAP	340
OF10 Problem Printing Job RAP	341
OF 11 Job Prints Incorrectly RAP	341
OF12 Modem/Fax PWB Service RAP	342
OF13 Secure Access RAP	343

302-315-00 Service Registry Bad Data / Corrupted RAP

302-315-00 is an internal machine fault code, and is never displayed or logged in the fault history.

Procedure



WARNING: Switch off the electricity to the machine, GP 10. Disconnect the power lead from the customer supply while performing tasks that do not need electricity. Electricity can cause the death or injury. Moving components can cause the injury.

1. Switch OFF, then switch ON the machine, GP 10.
2. Enter Diagnostics, GP 1.
 - a. Touch **Adjustments**, then touch **dC301**.
 - b. Follow the procedures to initialize NVM.
3. If the fault persists, perform Software Upgrade, GP 4, using the USB FORCED_ALTBOOT method.

302-316-00 and 302-317-00 Service Registry Not Responding RAP

302-316-00 SRS returns to UI “invalid fields, invalid data, or missing data”.

302-317-00 UI gets no response from SRS.

Procedure



WARNING: Switch off the electricity to the machine, GP 10 . Disconnect the power lead from the customer supply while performing tasks that do not need electricity. Electricity can cause the death or injury. Moving components can cause the injury.

Perform the following in order:

1. Upgrade software, GP 4.
2. Install a new Controller PWB, PL 3.05 item 2.

302-318-00 Touch Device not Available RAP

LUI gets stuck after upgrade or popo (home/power button works).

Procedure



WARNING: Switch off the electricity to the machine, GP 10 . Disconnect the power lead from the customer supply while performing tasks that do not need electricity. Electricity can cause the death or injury. Moving components can cause the injury.

Switch OFF, then switch ON the machine, GP 10. If the fault persists, call 2nd level support.

302-321-00 XEIP Browser Dead RAP

Set by the XUI when the XEIP browser does not respond or is known to be dead.

Procedure



WARNING: Switch off the electricity to the machine, GP 10 . Disconnect the power lead from the customer supply while performing tasks that do not need electricity. Electricity can cause the death or injury. Moving components can cause the injury.

Perform the following in order:

1. Switch OFF, then switch ON the machine, GP 10
2. Upgrade the software, GP 4 .
3. Install a new Controller PWB, PL 3.05 item 2.

302-380-00 and 302-381-00 UI Communication Fault RAP

302-380-00 Communication via H-H USB netpath connection between SBC and UI panel is not working.

302-381-00 Communication via USB connection between CC and UI panel is not working.

Procedure



WARNING: Switch off the electricity to the machine, GP 10 . Disconnect the power lead from the customer supply while performing tasks that do not need electricity. Electricity can cause the death or injury. Moving components can cause the injury.

Perform the following in order:

1. Switch OFF, then switch ON the machine, GP 10.
2. Upgrade the software, GP 4.
3. Install a new control panel cable, PL 2.10 item 4.
4. Install a new Controller PWB, PL 3.05 item 2.

303–306–00 Downgrade Not Permitted

Downgrade not permitted. A Customer upgrade was attempted, which would result in a software downgrade, which is not allowed.

Procedure



WARNING: Switch off the electricity to the machine, [GP 10](#). Disconnect the power lead from the customer supply while performing tasks that do not need electricity. Electricity can cause the death or injury. Moving components can cause the injury.



CAUTION: Software downgrades cannot be performed by a customer. When using the FORCED_ALTBOOT method, follow the procedure in [GP 4](#), Software Upgrade. Inform the customer that customer data will not be retained using the FORCED_ALTBOOT method for downgrading machine software.

If a software downgrade is required by the customer, perform the downgrade using the FORCED_ALTBOOT method, [GP 4](#).

303-307–00 Upgrade Synchronization Failure

SW Upgrade Synchronization Failure. Customer or CSE tried to perform upgrade resulting in a SW Upgrade Synchronization problem.

Initial Actions



WARNING: Switch off the electricity to the machine, [GP 10](#). Disconnect the power lead from the customer supply while performing tasks that do not need electricity. Electricity can cause the death or injury. Moving components can cause the injury.



CAUTION: Software downgrades cannot be performed by a customer. When using the FORCED_ALTBOOT method, follow the procedure in [GP 4](#), Software Upgrade. Inform the customer that customer data will not be retained using the FORCED_ALTBOOT method for downgrading machine software.

Switch off, then switch on the machine [GP 10](#).

Procedure

Perform the following in order:

1. Check connections and cables and perform Software Upgrade again using Altboot in [GP 10](#).
2. If the upgrade fails again, use Altboot to upgrade the SW version that existed on the machine prior to attempting the upgrade.
3. If the previous version loads correctly, download the upgrade SW again, verify that the files are correct for the machine, and attempt the upgrade using different media.

303-315–00 DC Platform Internal Interface Fault RAP

303-315-00 The DC platform software interface has timed out.

Procedure



WARNING: Switch off the electricity to the machine, [GP 10](#). Disconnect the power lead from the customer supply while performing tasks that do not need electricity. Electricity can cause the death or injury. Moving components can cause the injury.

Check the fault history file for other 303-XXX fault codes.

303-XXX fault codes occur randomly.

Y	N	
		Switch OFF, then switch ON the machine, GP 10 .
		The fault persists.
Y	N	
		Perform SCP 5 Final Actions.

The cause may be due to electrical noise, perform the [GP 28](#) Intermittent Failure RAP.

303–316–00 CCM Cannot Communicate With IOT RAP

C625 Wiring Diagrams

Controller cannot communicate with IOT.

Scanning and FAX are available, printing and copying are disabled.

Procedure



WARNING: Switch off the electricity to the machine, GP 10 . Disconnect the power lead from the customer supply while performing tasks that do not need electricity. Electricity can cause the death or injury. Moving components can cause the injury.



CAUTION: Software downgrades cannot be performed by a customer. When using the FORCED_ALTBOOT method, follow the procedure in GP 4, Software Upgrade. Inform the customer that customer data will not be retained using the FORCED_ALTBOOT method for downgrading machine software.

Switch OFF, then switch ON the machine. If the problem continues, perform a Forced Altboot using GP 10.

If the fault persists, install new components as required:



CAUTION: Never install a new drive PWB, new controller PWB, or black toner cartridge at the same time. First install one of the parts, then switch on the machine, GP 10. If the installation is successful, switch off the machine, then install another part item if necessary.

1. Install a new drive PWB, PL 1.10, (C625 only)
2. Install a new controller PWB, PL 3.05.

303–317–00 IOT NVM Save Failure

303–317–00 IOT NVM Save Failure

Procedure



WARNING: Switch off the electricity to the machine, GP 10 . Disconnect the power lead from the customer supply while performing tasks that do not need electricity. Electricity can cause the death or injury. Moving components can cause the injury.

Switch OFF, then switch ON the machine GP 10.

Fault Code 303-317 is still declared.

Y N

If intermittent performance is suspected, inspect the Drive PWB for loose connections or any obvious electrical/mechanical cause for malfunction.

This fault can be caused by IOT software corruption or a software version mismatch between the IOT module and the rest of the software:

- If the fault occurred after replacing the Drive PWB, it is probably a software mismatch; perform a Software Upgrade GP 4.
- If the fault is unrelated to Drive PWB replacement it may be corrupt software; perform a Forced Upgrade.

If this does not resolve the problem replace the following in order,

1. Upgrade SW using GP 4
2. Install a new Drive PWB, PL 1.10 item 3.

303–318–00 IOT NVM Init Failure

303–318–00 IOT NVM Init Failure



WARNING: Switch off the electricity to the machine, GP 10 . Disconnect the power lead from the customer supply while performing tasks that do not need electricity. Electricity can cause the death or injury. Moving components can cause the injury.

Initial Actions

- Disconnect any Foreign Interface devices.
- Obtain all of the following information:
 - Saved Machine Settings, if possible.
 - NVM value factory setting report (typically it is located in the Tray 1 pocket)
 - Any customer setting Auditron account from the system administrator
 - Any setting changes (specifically NVM settings) shown on the machine's service log.
 - Any customer settings in the Tools mode.
- If possible, save Critical NVM dC361 .

Procedure

Perform dC301 NVM Initialization for the IOT.

After the initialization is complete, use the data accumulated in Initial Action to restore the machine to its previous configuration.

303–319–00 IOT NVM Restore Failure

303–319–00 IOT NVM Restore Failure



WARNING: Switch off the electricity to the machine, GP 10 . Disconnect the power lead from the customer supply while performing tasks that do not need electricity. Electricity can cause the death or injury. Moving components can cause the injury.

Procedure

Perform dC361 NVM Restore for the IOT Critical NVM.

If this does not resolve the problem replace the following in order,

1. Install a new Drive PWB PL 1.10 item 3.

303–320–00 Incompatible Product Type

Incompatible Product Type. SW Upgrade Aborted due to incompatible product type - software set does not match hardware.



WARNING: Switch off the electricity to the machine, GP 10 . Disconnect the power lead from the customer supply while performing tasks that do not need electricity. Electricity can cause the death or injury. Moving components can cause the injury.

Procedure

Perform GP 4 Software Upgrade with the correct Software module or select the correct .dlm file using the Web UI to upgrade the machine.

303–324–00 Software Upgrade File Transfer Failure

SW Upgrade File Transfer failure

Initial Actions



WARNING: Switch off the electricity to the machine, GP 10 . Disconnect the power lead from the customer supply while performing tasks that do not need electricity. Electricity can cause the death or injury. Moving components can cause the injury.

Switch OFF, then switch ON the machine GP 10.

Procedure

Perform the following in order:

1. Check connections and cables and perform SW Upgrade again using Altboot in GP 4.
2. Download and upgrade the SW again, verify that the files are correct for the machine, and attempt the upgrade using different media.

303–325–00 Wall Clock Time-out During Power Up

System detects that the Wall Clock has not incremented within 1.5 seconds during Power On.

Procedure



WARNING: Switch off the electricity to the machine, GP 10 . Disconnect the power lead from the customer supply while performing tasks that do not need electricity. Electricity can cause the death or injury. Moving components can cause the injury.

Switch OFF, then switch ON the machine GP 10.

If the problem continues, call service support for assistance.

303–326–00 Upgrade is not Required

Upgrade not required, since the SW Upgrade version is the same as the SW version on the machine.



WARNING: Switch off the electricity to the machine, GP 10 . Disconnect the power lead from the customer supply while performing tasks that do not need electricity. Electricity can cause the death or injury. Moving components can cause the injury.



CAUTION: Software downgrades cannot be performed by a customer. When using the FORCED_ALTBOOT method, follow the procedure in GP 4, Software Upgrade. Inform the customer that customer data will not be retained using the FORCED_ALTBOOT method for downgrading machine software.

Procedure

If a software reinstallation is required, perform GP 4 using Forced Altboot Method.

303–327–00 Upgrade Failure

Upgrade Failed. this problem could be caused by an internal timing issue (Front side BUS speed set incorrectly), hardware error, user error and others.

Initial Actions



WARNING: Switch off the electricity to the machine, GP 10 . Disconnect the power lead from the customer supply while performing tasks that do not need electricity. Electricity can cause the death or injury. Moving components can cause the injury.



CAUTION: Software downgrades cannot be performed by a customer. When using the FORCED_ALTBOOT method, follow the procedure in GP 4, Software Upgrade. Inform the customer that customer data will not be retained using the FORCED_ALTBOOT method for downgrading machine software.

Check connections and reconnect Drive PWB, and Controller PWB and attempt another upgrade using GP 4 Forced Altboot for the system or platform that failed.

Procedure

The problem is still present:

Y N
 | |
 | | Return to Service Call Procedures.
 Call service support for assistance.

303–329–00 Upgrade Request During Diagnostics

Upgrade request received during active diagnostics.



WARNING: Switch off the electricity to the machine, GP 10 . Disconnect the power lead from the customer supply while performing tasks that do not need electricity. Electricity can cause the death or injury. Moving components can cause the injury.

Procedure

Exit Diagnostics and perform GP 4 Software Upgrade.

303–330–00 Upgrade Request During Active Security Feature

Upgrade request received during active Security function.



WARNING: Switch off the electricity to the machine, GP 10 . Disconnect the power lead from the customer supply while performing tasks that do not need electricity. Electricity can cause the death or injury. Moving components can cause the injury.

Procedure

Wait until Security function (Image Overwrite) is completed and perform GP 4 Software Upgrade.

303–331–00 Communication Fault With NC

Main controller board cannot communicate with Network Controller and unable to reestablish communications for 12 minutes. This problem could be caused by loose connections or improperly seated PWBs.



WARNING: Switch off the electricity to the machine, GP 10 . Disconnect the power lead from the customer supply while performing tasks that do not need electricity. Electricity can cause the death or injury. Moving components can cause the injury.

Procedure

The printer is currently busy. Normal operations should resume momentarily. The controller will continue to try to re-establish communication for 12 minutes.

If the fault persists, go to [303-332-00](#).

303–332–00 NC Communications Timeout

CCS unable to reestablish communication with the Network Controller after 5 minutes.

Procedure



WARNING: Switch off the electricity to the machine, GP 10 . Disconnect the power lead from the customer supply while performing tasks that do not need electricity. Electricity can cause the death or injury. Moving components can cause the injury.

1. Switch OFF, then switch ON the machine, GP 10
2. Remove, then reseal all connections on the controller PWB.
3. Install a new controller PWB, PL 3.05 item 2.

303-333–00 Invalid Value Detected for NVM 616-004 RAP

Invalid value has been detected for NVM 616–004 System configuration.

Initial Actions



WARNING: Switch off the electricity to the machine, GP 10 . Disconnect the power lead from the customer supply while performing tasks that do not need electricity. Electricity can cause the death or injury. Moving components can cause the injury.

Power OFF and power ON the machine GP 10.

Procedure

Enter diagnostics and check the 616–004 NVM value

- Default = 1
- Min = 0
- Max = 8
- 0 = Unknown (not set)
- 1 = ST (Networked)
- 8 = Network Suppressed

If the value is not correct perform the following-

1. NVM Initialization dC301
2. NVM save and restore dC361

303–338–00 Main Controller Has Been Reset

CCS has been reset; either the watch dog timer timed out or the application SW wrote to an illegal address.

Initial Actions

Check that the customer does not have another device configured with the same IP address.

Procedure



WARNING: Switch off the electricity to the machine, GP 10 . Disconnect the power lead from the customer supply while performing tasks that do not need electricity. Electricity can cause the death or injury. Moving components can cause the injury.

Switch OFF, then switch On the machine GP 10.

Perform dC361 to restore NVM.

If the problem continues, perform GP 4 SW upgrade.

303–346–00 Communication Fault with UI

UI dead- Unable to establish communication with the UI after 5 minutes

Procedure



WARNING: Switch off the electricity to the machine, GP 10 . Disconnect the power lead from the customer supply while performing tasks that do not need electricity. Electricity can cause the death or injury. Moving components can cause the injury.

Perform RAP 303-347-00, Communication Fault with UI.

303–347–00 UI Communications Lost RAP

WD1 Controller PWB Wiring Diagram

C625 Wiring Diagrams

The controller PWB cannot communicate with UI PWBA.

If communication is not reestablished within 30 seconds, fault code 303-346–00 will be declared.

Procedure



WARNING: Switch off the electricity to the machine, GP 10 . Disconnect the power lead from the customer supply while performing tasks that do not need electricity. Electricity can cause the death or injury. Moving components can cause the injury.

Note: This fault can occur if the UI software version is not compatible with the Controller software version.

1. Switch OFF, then switch ON the machine,GP 10.
2. Perform GP 4, Software Upgrade using the USB installation method if the UI is not available.
3. If the fault persists perform OF 2, UI Touch Screen Failure RAP.

303–355–00 CCM POST Failure During NVM Integrity Test

Power On Self-Test failure detected during the NVM Integrity Test.

An error message will be displayed on the LUI for the power on cycle when the fault is raised.

Initial Actions



WARNING: Switch off the electricity to the machine, GP 10 . Disconnect the power lead from the customer supply while performing tasks that do not need electricity. Electricity can cause the death or injury. Moving components can cause the injury.

Switch OFF, then switch ON the machine GP 10.

Procedure

Report the Billing Meter reset GP 26.

303–397 System Configuration is Lost

This fault occurs when the System Configuration is lost and an attempted recovery made.



WARNING: Switch off the electricity to the machine, GP 10 . Disconnect the power lead from the customer supply while performing tasks that do not need electricity. Electricity can cause the death or injury. Moving components can cause the injury.

Procedure

Refer to GP 8

303–401 Basic FAX Not Detected or Confirmed

Basic FAX not detected/confirmed

Procedure



WARNING: Switch off the electricity to the machine, GP 10 . Disconnect the power lead from the customer supply while performing tasks that do not need electricity. Electricity can cause the death or injury. Moving components can cause the injury.

Switch the power OFF then ON GP 10. If the problem continues, go to the OF 12.

303–403 Extended FAX Not Detected or Confirmed

Extended FAX not detected/confirmed

Procedure



WARNING: Switch off the electricity to the machine, GP 10 . Disconnect the power lead from the customer supply while performing tasks that do not need electricity. Electricity can cause the death or injury. Moving components can cause the injury.

Switch the power OFF then ON GP 10. If the problem continues, go to the OF 12.

303–405–00 Failed to Recover Machine Class

Machine Class not set (unknown). Failed to recover machine class

Procedure



WARNING: Switch off the electricity to the machine, GP 10 . Disconnect the power lead from the customer supply while performing tasks that do not need electricity. Electricity can cause the death or injury. Moving components can cause the injury.

Set machine class - dC131 NVM [616-328].

- Value of 1 = chassis speed 30/35
- Value of 2 = chassis speed 45/55
- Value of 3 =chassis speed 70.

303–417–00 Incompatible FAX SW Detected at Power Up

Incompatible FAX software detected at power on

Procedure



WARNING: Switch off the electricity to the machine, GP 10 . Disconnect the power lead from the customer supply while performing tasks that do not need electricity. Electricity can cause the death or injury. Moving components can cause the injury.

Switch OFF, then switch ON the machine. If the problem continues, reload FAX software GP 10.

303–450–00 Unexpected IOT reset RAP

Unexpected IOT reset has occurred.

Procedure



WARNING: Switch off the electricity to the machine, GP 10 . Disconnect the power lead from the customer supply while performing tasks that do not need electricity. Electricity can cause the death or injury. Moving components can cause the injury.

Switch OFF, then switch ON the machine. If the problem persists, reload System software GP 10.

303–777 Power Loss Detected

Input Power loss detected or software corruption.

Power on Self test has detected that the previous shutdown was abnormal. Possible causes include the following:



WARNING: Switch off the electricity to the machine, GP 10 . Disconnect the power lead from the customer supply while performing tasks that do not need electricity. Electricity can cause the death or injury. Moving components can cause the injury.

- The main power switch was used to power off the machine instead of the software switch
- Power outage / unplugging power cord / poor voltage quality

Procedure

- Verify customer power outlet voltage is correct.
- Perform customer training on proper power down process

Note: Inform the customer that improper power off has the potential to cause file system corruption

303–788 Failed to Exit Power Save Mode

CCS Runtime could not enter power saver mode S3.

Note: The CC USB could not re-enumerate the UI panel coming out of sleep, which keeps parts of the system in power saver mode S3 and parts awake. This prevents system entry into power saver mode S3 at the next attempt to do so.

Procedure



WARNING: Switch off the electricity to the machine, GP 10 . Disconnect the power lead from the customer supply while performing tasks that do not need electricity. Electricity can cause the death or injury. Moving components can cause the injury.

Switch OFF, then switch ON the machine to allow system to enter power save GP 10.

303–790 Time Zone File Cannot be Set

Timezone file cannot be set. At power up, the time zone setting is not valid due to NVM corruption, or OS file system problem. Time Zone overridden to GMT: DST Disabled.

Procedure



WARNING: Switch off the electricity to the machine, GP 10 . Disconnect the power lead from the customer supply while performing tasks that do not need electricity. Electricity can cause the death or injury. Moving components can cause the injury.

1. Switch OFF, then switch ON GP 10.
2. Perform dC361 to restore NVM.
3. If the problem continues, perform GP 4 SW upgrade.

305-101-00, 305-102-00, 305-124-00 to 305-127-00, 305-129-00, 305-175-00 to 305-177-00, 305-906-00, 305-922-00 DADF Paper Jam Error RAP

WD2 Drive PWB Wiring Diagram

C625 Wiring Diagrams

305-101-00 First Scan Sensor not reached RAP

305-102-00 First Scan Sensor not Cleared RAP

305-124-00 First Scan Off Jam RAP

305-125-00 First Scan On Jam RAP

305-126-00 Second Scan Duplex Off Jam RAP

305-127-00 Second Scan Duplex On Jam RAP

305-129-00 Remainder Duplex / Second Scan Jam RAP

305-175-00 Remainder Jam - Second Scan/Duplex Sensor RAP

305-176-00 Second Scan/Duplex Sensor not reached RAP

305-177-00 Second Scan/Duplex Sensor not cleared RAP

305-906-00 Remainder Jam First Scan RAP

305-922-00 Remainder Jam - First Scan Sensor RAP



WARNING: Switch off the electricity to the machine, GP 10 . Disconnect the power lead from the customer supply while performing tasks that do not need electricity. Electricity can cause the death or injury. Moving components can cause the injury.

Procedure

Action	Yes	No
Step 1 Resend the scan job. The fault persists.	Go to step 2.	The problem is solved.
Step 2 Check the paper path for paper jams and fragments. The paper path is free of fragments and debris.	Go to step 4.	Go to step 3.
Step 3 Remove the paper jams and fragments. The fault persists.	Go to step 4.	The problem is solved.
Step 4 Check if the paper feeds into the DADF. The paper feeds into the DADF.	Go to step 6.	Go to step 5.

Action	Yes	No
Step 5 Check for and clear any obstruction or foreign material in the paper path, then refeed the paper in the DADF. The fault persists.	Go to step 6.	The problem is solved.
Step 6 Check if the paper has a bent or curled leading edge. The paper have a bent or curled leading edge.	Go to step 7.	Go to step 10.
Step 7 Replace the paper, and then resend the scan job. The fault persists.	Go to step 8.	The problem is solved.
Step 8 Check if the paper is damp or heavy. The paper damp or heavy.	Go to step 9.	Go to step 10.
Step 9 Replace the paper, and then resend the scan job. The fault persists.	Go to step 10.	The problem is solved.
Step 10 1 Enter the Diagnostics menu GP 1, and then navigate to: Scanner diagnostics > Motor tests > DADF pick 2 Touch Start . 3 Enter the Diagnostics menu GP 1, and then navigate to: Scanner diagnostics > Motor tests > DADF transport 4 Touch Start . The motors will run.	Go to step 12.	Go to step 11.
Step 11 1 Reconnect the JADF2 connector on the controller board. 2 Reconnect the DADF cables on the DADF. The fault persists.	Go to step 12.	The problem is solved.
Step 12	Go to step 16.	Go to step 13.

Action	Yes	No
<p>1 Enter the Diagnostics menu GP 1, and then navigate to:</p> <p>Scanner diagnostics > Sensor tests</p> <p>2 Find the following sensors:</p> <ol style="list-style-type: none"> 1 Sensor (DADF media present) 2 Sensor (DADF 1st scan) 3 Sensor (DADF 2nd scan) <p>The status of each sensor will change while toggling the sensors.</p>		
<p>Step 13 Check the affected sensor for dirt and debris. The sensor is free of dirt and debris.</p>	Go to step 16.	Go to step 14.
<p>Step 14 Clean the sensor. The fault persists.</p>	Go to step 15.	The problem is solved.
<p>Step 15 Check if the actuator is stuck or damaged. The actuator stuck or damaged.</p>	Go to step 17.	Go to step 16.
<p>Step 16</p> <ol style="list-style-type: none"> 1 Reconnect the JADF2 connector on the controller board. 2 Reconnect the DADF cables on the DADF. <p>The fault persists.</p>	Go to step 17.	The problem is solved.
<p>Step 17 Install a new DADF. See REP 5.3. The fault persists.</p>	Contact the next level of support.	The problem is solved.

305–103–00 Scanner Disabled Error RAP

WD1 Controller PWB Wiring Diagram

C625 Wiring Diagrams

305-103-00 Scanner Disabled Error RAP



WARNING: Switch off the electricity to the machine, **GP 10**. Disconnect the power lead from the customer supply while performing tasks that do not need electricity. Electricity can cause the death or injury. Moving components can cause the injury.

Procedure

Action	Yes	No
<p>Step 1</p> <ol style="list-style-type: none"> 1 From the Home screen, navigate to: Settings > Device > Maintenance > Configuration Menu > Scanner Configuration > Disable Scanner > No 2 Reset the printer, and then perform an DADF scan job. The fault persists. 	Go to step 2.	The problem is solved.
<p>Step 2</p> <ol style="list-style-type: none"> 1 From the Home screen, navigate to: Settings > Device > Maintenance > Configuration Menu > Scanner Configuration > Disable Scanner > Yes 2 Restart the printer, and then perform an DADF scan job. The display indicate that the DADF is disabled. 	Go to step 3.	Go to step 4.
<p>Step 3</p> <ol style="list-style-type: none"> 1 Reconnect the JADF1 connector on the controller board. 2 Reconnect the DADF cables on the DADF. 3 Repeat step 1. The fault persists. 	Go to step 4.	The problem is solved.
<p>Step 4</p> <ol style="list-style-type: none"> 1 Install a new DADF. See PL 5.10 item 1. 2 Repeat step 1. The fault persists. 	Go to step 5.	The problem is solved.

Action	Yes	No
Step 5 Reconnect the JFB1, JFBM1, and JHS1 connectors on the controller board. The fault persists.	Go to step 6.	The problem is solved.
Step 6 1 Install a new scanner. See PL 5.10 item 5. 2 Repeat step 1. The fault persists.	Go to step 7.	The problem is solved.
Step 7 Install a new controller board. See PL 3.05 item 2. The fault persists.	Contact the next level of support.	The problem is solved.

305-121-00 Feed Sensor Off Error RAP

[WD1 Controller PWB Wiring Diagram](#)

[C625 Wiring Diagrams](#)

305-121-00 Feed Sensor Off RAP



WARNING: Switch off the electricity to the machine, [GP 10](#). Disconnect the power lead from the customer supply while performing tasks that do not need electricity. Electricity can cause the death or injury. Moving components can cause the injury.

Procedure

Action	Yes	No
Step 1 Ensure that the paper is properly loaded in the DADF tray. The fault persists.	Go to step 2.	The problem is solved.
Step 2 1 Enter the Diagnostics menu GP 1 , and then navigate to: Scanner diagnostics > Sensor tests 2 Find the sensor (DADF media present). The status of each sensor will change while toggling the sensors.	Go to step 6.	Go to step 3.
Step 3 Check the sensor for dirt and debris. The sensor is free of dirt and debris.	Go to step 5.	Go to step 4.
Step 4 Clean the sensor. The fault persists.	Go to step 5.	The problem is solved.
Step 5 Check if the actuator is stuck or damaged. The actuator is stuck or damaged.	Go to step 8.	Go to step 6.
Step 6 Reconnect the JADF2 connector on the controller board. The fault persists.	Go to step 7.	The problem is solved.

Action	Yes	No
Step 7 Reconnect the DADF cables on the DADF. The fault persists.	Go to step 8.	The problem is solved.
Step 8 Install a new DADF. See PL 5.10 item 1. The fault persists.	Contact the next level of support.	The problem is solved.

305-210-00 Image Pipe Error RAP

BSD-Reference: [WD1 Controller PWB Wiring Diagram](#) and [C625 Wiring Diagrams](#)

305-210-00 ImagePipe Error RAP

Procedure



WARNING: Switch off the electricity to the machine, GP 10 . Disconnect the power lead from the customer supply while performing tasks that do not need electricity. Electricity can cause the death or injury. Moving components can cause the injury.

305-210-00 ImagePipe Error RAP

Table 1 RAP Procedure

Action	Yes	No
Step 1 Check if multiple pages can feed into the DADF. Multiple pages feed into the DADF.	Go to step 5.	Go to step 2.
Step 2 Check the DADF separator roller and DADF pick roller for dirt. The DADF rollers clean.	Go to step 4.	Go to step 3.
Step 3 Use a lint-free cloth and iso-propyl alcohol to clean the DADF separator roller and DADF pick roller. The fault persists.	Go to step 4.	The problem is solved.
Step 4 Install a new DADF rollers. See PL 5.10 item 4 The fault persists.	Go to step 5.	The problem is solved.
Step 5 Check if the document that fed into the DADF is skewed. The document is skewed.	Go to step 6.	Go to step 7.
Step 6 Set the DADF tray guides correctly. The fault persists.	Go to step 7.	The problem is Solved.
Step 7 Make sure that the DADF top cover is closed completely. The fault persists.	Go to step 8.	The problem is Solved.
Step 8 Check if the document has a wrinkled or torn leading edge.	Go to step 9.	Go to step 10.

Action	Yes	No
The document have a wrinkled or torn leading edge.		
Step 9 Replace the document, and then resend the scan job. The fault persists.	Go to step 10.	The problem is Solved.
Step 10 1 Enter the Diagnostics menu GP 1, and then navigate to: Scanner diagnostics > Motor tests 2 Test the following motors. • ADF pick • ADF transport The motors will run.	Go to step 12.	Go to step 11.
Step 11 1 Reconnect the JADF1 connector on the controller board. 2 Reconnect the DADF cables on the DADF. The fault persists.	Go to step 12.	The problem is solved.
Step 12 1 Enter the Diagnostics menu GP 1, and then navigate to: Scanner diagnostics > Sensor tests 2 Find the sensor (DADF media present). The sensor status will change while toggling the sensor.	Go to step 16.	Go to step 13.
Step 13 Check if the actuator is dirty or stuck. The actuator dirty or stuck.	Go to step 14.	Go to step 15.
Step 14 Clean the actuator. The fault persists.	Go to step 15.	The problem is solved.
Step 15 1 Reconnect the JADF1 connector on the controller board. 2 Reconnect the DADF cables on the DADF. The fault persists.	Go to step 16.	The problem is solved.

Action	Yes	No
Step 16 Install a new DADF. See REP 5.3. The fault persists.	Go to step 17.	The problem is solved.
Step 17 Install a new controller board. See REP 3.2. The fault persists.	Contact the next level of support.	The problem is solved.

305-211-00, 305-212-00, 310-514-00, 371-329-00, 372-322-00, 373-322-00, 374-328-00, 375-328-00 Unknown Error RAP

305-211-00 Laser Safety interlock RAP

305-212-00 Mirror motor lock fail RAP

310-514-00 Facet Map failure due to kernel failure - May be due to low memory situations - RAP

371-329-00 Tray 1 fails to become input source ready for picking RAP

372-322-00 Tray 2 fails to become input source ready for picking RAP

373-322-00 Tray 3 fails to become input source ready for picking RAP

374-328-00 Tray 4 fails to become input source ready for picking RAP

375-328-00 Tray 5 fails to become input source ready for picking RAP

Procedure



WARNING: Switch off the electricity to the machine, GP 10 . Disconnect the power lead from the customer supply while performing tasks that do not need electricity. Electricity can cause the death or injury. Moving components can cause the injury.

Action	Yes	No
Restart the print job. The fault persists.	Contact the next level of support.	The problem is solved.

305-253-01, 362-397-00 to 362-399-00 IIT- DADH Communication Error RAP

WD1 Controller PWB Wiring Diagram

C625 Wiring Diagrams

305-253-01 IIT- DADH Communication Error RAP

362-397-00 IIT Comm Failure - Logical Protocol RAP

362-398-00 Scanner Comm Failure- HW Protocol RAP

362-399-00 IIT Comm Failure - No Response RAP



WARNING: Switch off the electricity to the machine, GP 10 . Disconnect the power lead from the customer supply while performing tasks that do not need electricity. Electricity can cause the death or injury. Moving components can cause the injury.

Procedure

Action	Yes	No
Step 1 Reconnect the JADF1 connector on the controller board. The fault persists.	Go to step 2.	The problem is solved.
Step 2 Reconnect the JFB1 connector on the controller board. The fault persists.	Go to step 3.	The problem is solved.
Step 3 Install a new DADF. See REP 5.3. The fault persists.	Go to step 4.	The problem is solved.
Step 4 Install a new DADF scanner. See REP 5.4. The fault persists.	Go to step 5.	The problem is solved.
Step 5 Install a new controller board. See REP 3.2. The fault persists.	Contact the next level of support.	The problem is solved.

305-300-00 Platen Cover Interlock Opened During Run Error RAP

WD1 Controller PWB Wiring Diagram

C625 Wiring Diagrams

305-300-00 Platen cover interlock opened during run RAP



WARNING: Switch off the electricity to the machine, GP 10. Disconnect the power lead from the customer supply while performing tasks that do not need electricity. Electricity can cause the death or injury. Moving components can cause the injury.

Procedure

Action	Yes	No
Step 1 Ensure that the scanner cover is properly closed. The fault persists.	Go to step 2.	The problem is solved.
Step 2 Restart the printer, and then perform a DADF scan job. The fault persists.	Go to step 3.	The problem is solved.
Step 3 1 Enter the Diagnostics menu GP 1, and then navigate to: Scanner diagnostics > Sensor tests 2 Find the sensor (DADF closed). The sensor status will change while toggling the sensor.	Go to step 5.	Go to step 4.
Step 4 Check the sensor actuator for misalignment and damage. The actuator is misaligned or damaged.	Go to step 5.	Go to step 6.
Step 5 1 Reconnect the JADF2 connector on the controller board. 2 Reconnect the DADF cables on the DADF. The fault persists.	Go to step 6.	The problem is solved.

Action	Yes	No
Step 6 Install a new DADF. See REP 5.3. The fault persists.	Go to step 7.	The problem is solved.
Step 7 Perform an DADF scan job. The fault persists.	Contact the next level of support.	The problem is solved.

305–305–00 Document Feeder Top Cover Open During Scan Error RAP

305-305-00 Document Feeder Top Cover open during scan RAP

Procedure



WARNING: Switch off the electricity to the machine, GP 10 . Disconnect the power lead from the customer supply while performing tasks that do not need electricity. Electricity can cause the death or injury. Moving components can cause the injury.

Action	Yes	No
Step 1 1 Enter the Diagnostics menu, and then navigate to: Additional input trays adjustments/tests > Additional input tray motors 2 Select Pass-through (tray [x]) , and then touch Start . Note: [x] is the tray number. Does the motor run?	Go to step 4.	Go to step 2.
Step 2 Make sure that the motor cable is properly connected. Does the problem remain?	Go to step 3.	The problem is solved.
Step 3 Check the motor for noise. Does the motor sound abnormal or do the gears make a grinding sound?	Go to step 5.	Go to step 4.
Step 4 Perform a print job. Does the problem remain?	Go to step 5.	The problem is solved.
Step 5 Replace the optional tray. See <i>Part number</i> . Does the problem remain?	Contact the next level of support.	The problem is solved.

305–309–00 DADF No Paper Detected Error RAP

WD1 Controller PWB Wiring Diagram

C625 Wiring Diagrams

305-309-00 DADF No Paper Detected RAP



WARNING: Switch off the electricity to the machine, GP 10 . Disconnect the power lead from the customer supply while performing tasks that do not need electricity. Electricity can cause the death or injury. Moving components can cause the injury.

Procedure

Action	Yes	No
Step 1 Ensure that the paper is properly loaded in the DADF tray. The fault persists.	Go to step 2.	The problem is solved.
Step 2 1 Enter the Diagnostics menu GP 1, and then navigate to: Scanner diagnostics > Sensor tests 2 Find the sensor (DADF media present). The status of each sensor will change while toggling the sensors.	Go to step 6.	Go to step 3.
Step 3 Check the sensor for dirt and debris. The sensor is free of dirt and debris.	Go to step 5.	Go to step 4.
Step 4 Clean the sensor. The fault persists.	Go to step 5.	The problem is solved.
Step 5 Check if the actuator is stuck or damaged. The actuator is stuck or damaged.	Go to step 8.	Go to step 6.
Step 6 Reconnect the JADF2 connector on the controller board. The fault persists.	Go to step 7.	The problem is solved.

Action	Yes	No
Step 7 Reconnect the DADF cables on the DADF The fault persists.	Go to step 8.	The problem is solved.
Step 8 Install a new DADF. See REP 5.3 . The fault persists.	Contact the next level of support.	The problem is solved.

310-327-00, 310-330-00, 310-341-00, 310-360-00 to 310-364-00, 310-368-00, 310-369-00, 310-370-00, 310-372-00 to 310-379-00, 310-383-00, 310-407-00, 310-457-00, 310-460-00, 310-461-00, 310-464-00 to 310-466-00, 310-489-00, 310-490-00 to 310-493-00 Fuser Error RAPs

WD1 Controller PWB Wiring Diagram

C625 Wiring Diagrams

- 310-327-00 Fusing On Time Fail RAP
- 310-330-00 Fuser Install Fail RAP
- 310-341-00 Fuser Power Up Fail RAP
- 310-360-00 Fuser Hardware Mismatch RAP
- 310-361-00 Fuser Relay comm Fail RAP
- 310-362-00 Fuser Relay Open Fail RAP
- 310-363-00 Fuser Low Temp Error RAP
- 310-364-00 Fuser Warmup Fail RAP
- 310-368-00 Fuser EWC line Temp Fail RAP
- 310-369-00 Fuser EWC / Line Long RAP
- 310-370-00 Fuser EWC / Line To Fast RAP
- 310-372-00 Fuser power up undertemp too long RAP
- 310-373-00 Fuser feed undertemp too long RAP
- 310-374-00 Fuser under temp fail RAP
- 310-375-00 Fuser relay under temp RAP
- 310-376-00 Fuser under temp check RAP
- 310-377-00 Fuser On Time Fail RAP
- 310-378-00 Fuser Main temp fail RAP
- 310-379-00 Fuser Main therm open RAP
- 310-383-00 Fuser Heater Was To Cold When Page Entered Fuser nip RAP
- 310-407-00 Fuser or Maintenance Kit smartchip or sensor common problem RAP
- 310-457-00 Open fuser relay detected- RAP
- 310-460-00 Temperature out of range (Edge thermistor) RAP
- 310-461-00 Temperature change rate out of range (Edge thermistor) RAP
- 310-464-00 Temperature out of range (Narrow media thermistor) RAP

- 310-465-00 Temperature change rate out of range (Narrow media thermistor)
- 310-466-00 Open fuser edge thermistor- RAP
- 310-489-00 Fuser Was Under Temp When Page Was in Fuser
- 310-490-00 Fuser mech did not see expected cam sensor transition RAP
- 310-491-00 Temperature out of range (Middle thermistor) RAP
- 310-492-00 Temperature change rate out of range (Middle thermistor) RAP
- 310-493-00 Open fuser middle heater thermistor- RAP



WARNING: Switch off the electricity to the machine, GP 10 . Disconnect the power lead from the customer supply while performing tasks that do not need electricity. Electricity can cause the death or injury. Moving components can cause the injury.

Procedure

ACTION	YES	NO
Step 1 Ensure that the fuser is properly installed. The fault persists.	Go to step 2.	The problem is solved .
Step 2 Ensure that the JLVPS1 connector is properly connected to the Drive PWB and LVPS PWB. The fault persists.	Go to step 3.	The problem is solved .
Step 3 Ensure that the JFSNS1 connector is properly connected to the Drive PWB and fuser. The fault persists.	Go to step 4.	The problem is solved.
Step 4 Install a new fuser. See REP 10.1. The fault persists.	Go to step 5 .	The problem is solved .
Step 5 Install a new LVPS. See REP 1.2. The fault persists.	Go to step 6.	The problem is solved .
Step 6 Install a new Drive PWB. See REP 1.4Part number. The fault persists.	Contact the next level of support .	The problem is solved .

310-401-00 PH Thermistor Reading Out Of Range Error RAP

310-401-00 PH thermistor reading out of range RAP

Procedure



WARNING: Switch off the electricity to the machine, GP 10 . Disconnect the power lead from the customer supply while performing tasks that do not need electricity. Electricity can cause the death or injury. Moving components can cause the injury.

Action	Yes	No
Step 1 Restart the printer. Does the problem remain?	Go to step 2 .	The problem is solved.
Step 2 1 Make sure that the print-head cable is properly connected. 2 Make sure that the following connectors on the engine board are properly connected. • JMIRR1 or JMIRR2 • JPH1 Does the problem remain?	Go to step 3 .	The problem is solved .
Step 3 Replace the printhead. See Part number. Does the problem remain?	Go to step 4 .	The problem is solved.
Step 4 Replace the engine board. See Part number. Does the problem remain?	Contact the next level of support .	The problem is solved.

310-405-00 Cavity/TPS Thermistor Reading Out Of Range Error RAP

WD2 Drive PWB Wiring Diagram

C625 Wiring Diagrams

310-405-00 Cavity/TPS Thermistor Reading Out of Range RAP



WARNING: Switch off the electricity to the machine, GP 10 . Disconnect the power lead from the customer supply while performing tasks that do not need electricity. Electricity can cause the death or injury. Moving components can cause the injury.

Procedure

Action	YES	NO
Step 1 Ensure that the sensor (TPS) is properly connected. The fault persists.	Go to step 2.	The problem is solved .
Step 2 Install a new sensor (TPS), The fault persists.	Contact the next level of support.	The problem is solved.

310-418-00, 310-419-00, 310-422-00 to 310-430-00, 310-486-00 to 310-488-00 The Printhead Error RAPs

WD1 Controller PWB Wiring Diagram

C625 Wiring Diagrams

- 310-418-00 Mirror motor lock is asserted before the motor is turned on RAP
- 310-419-00 The printhead +5v power was not on when starting the laser servo RAP
- 310-422-00 The printhead error (no first Hsync) was detected - RAP
- 310-423-00 The printhead error (lost first Hsync) was detected - RAP
- 310-424-00 The printhead error (lost first Hsync) was detected during servo - RAP
- 310-425-00 The printhead error (mirror motor lost lock) was detected - RAP
- 310-426-00 The printhead error (mirror motor no first lock) was detected - RAP
- 310-427-00 The printhead error (mirror motor never stabilized) was detected - RAP
- 310-428-00 Unable to determine printhead type from printhead NVRAM RAP
- 310-429-00 Failure to read NVRAM RAP
- 310-430-00 Printhead NVRAM contents are incorrect - RAP
- 310-486-00 Bad Facet time measurement RAP
- 310-487-00 Bad facet time reading RAP
- 310-488-00 Printhead NVRAM checksum mismatch - The calculated checksum does not match the checksum stored in the printhead NVRAM - RAP



WARNING: Switch off the electricity to the machine, GP 10. Disconnect the power lead from the customer supply while performing tasks that do not need electricity. Electricity can cause the death or injury. Moving components can cause the injury.

Procedure

Action	Yes	No
Step 1 Restart the printer. The fault persists.	Go to step 2.	The problem is solved.
Step 2 1 Ensure that the printhead cable is properly connected. 2 Ensure that the following connectors on the Drive PWB are properly connected. <ul style="list-style-type: none"> • JMIRR1 or JMIRR2 • JPH1 The fault persists.	Go to step 3.	The problem is solved.

Action	Yes	No
Step 3 Install a new printhead. See REP 60.2. The fault persists.	Go to step 4.	The problem is solved.
Step 4 Install a new Drive PWB. See REP 1.4. The fault persists.	Contact the next level of support.	The problem is solved.

310-473-00, 310-474-00 NVRAM Chip Fail Error RAPs

[WD1 Controller PWB Wiring Diagram](#)

[WD2 Drive PWB Wiring Diagram](#)

[C625 Wiring Diagrams](#)

310-473-00 NVRAM chip failure with mirror part RAP

310-474-00 System Board NAND Failure RAP



WARNING: Switch off the electricity to the machine, [GP 10](#). Disconnect the power lead from the customer supply while performing tasks that do not need electricity. Electricity can cause the death or injury. Moving components can cause the injury.

Procedure

Action	Yes	No
Step 1 Verify if the drive PWB has been replaced. The drive PWB has been replaced.	Go to step 2.	Go to step 3.
Step 2 Install a new drive PWB . See REP 1.4 . The fault persist.	Go to step 3.	The problem is solved.
Step 3 Verify if the controller PWB has been replaced. The controller PWB has been replaced.	Go to step 4.	Go to step 5.
Step 4 Install a new controller PWB. See REP 3.2 . The fault persists.	Go to step 5.	The problem is solved.
Step 5 1 Turn the printer off for ten or more seconds. 2 Turn the printer back on. The fault persists.	Go to step 6.	The problem is solved.
Step 6 Restore the printer to factory defaults to clear the NVRAM. The fault persists.	Go to step 7.	The problem is solved.

Action	Yes	No
Step 7 Install a new drive PWB. See REP 1.4 . The fault persists.	Go to step 8.	The problem is solved.
Step 8 Install a new controller PWB. See REP 3.2 . The fault persists.	Contact the next level of support.	The problem is solved.

310-475-00, 310-476-00, 340-167-00 to 340-169-00, 340-171-00 to 340-184-00 Option Device Communication Error RAPs

310-475-00 The engine timed out waiting for a mechanical reset or an intervention required clear to complete after tray insert RAP

310-476-00 The engine timed out waiting for an option to quiescent RAP

340-167-00 Paper port communication device detected a validation failure RAP

340-168-00 Paper port communication device detected a framing error or the receive buffer overflowed RAP

340-169-00 Paper port communication device timed out during communication RAP

340-171-00 An option did not echo the last communication byte sent within the allotted time RAP

340-172-00 An option declared a link reset RAP

340-173-00 Command response error on the paper port - Response is too large for the communications buffer RAP

340-174-00 The Printer has detected a hot plug of an optional device-Low-level error on paper port RAP

340-175-00 Invalid Paper port protocol RAP

340-176-00 Paper port Framing Error RAP

340-177-00 Paper port Overrun Error RAP

340-178-00 Paper port parity Error RAP

340-179-00 Paper port Other Paper port Error RAP

340-180-00 Paper port encountered multiple communication error RAP

340-181-00 Invalid Paper port Echo RAP

340-182-00 Unsupported Paper port command RAP

340-183-00 Invalid paper port parameter RAP

340-184-00 Option device software error RAP



WARNING: Switch off the electricity to the machine, [GP 10](#). Disconnect the power lead from the customer supply while performing tasks that do not need electricity. Electricity can cause the death or injury. Moving components can cause the injury.

Procedure

Action	Yes	No
Step 1 1 Check if the software is updated, and then update the software if necessary. 2 Ensure that the printer supports the accessory. Refer to, GP 32 Device Specifications, for listed accessories. 3 Ensure that the accessory is properly attached to the printer or adjacent accessory. 4 Reset the printer. The fault persists.	Go to step 2.	Perform, SCP 5 Final Actions.
Step 2 Reconnect the accessory interface cable on the drive PWB, PL 1.10 item 3. The fault persists.	Go to step 3.	Perform, SCP 5 Final Actions.
Step 3 Do the following to each accessory: 1 Install the accessory again. 2 Print a test page, and then check if the accessory is defective. All accessories are properly working.	Perform, SCP 5 Final Actions.	Go to Step 4.
Step 4 Install a new accessory. Refer to, PL 25.05 , Accessories. The fault persists.	Contact the next level of support	Perform, SCP 5 Final Actions.

310-494-00 Fuser Bubble Sensor Covered at Warmup Error RAP

WD2 Drive PWB Wiring Diagram

C625 Wiring Diagrams

310-494-00 Fuser Bubble Sensor Covered at Warmup RAP



WARNING: Switch off the electricity to the machine, GP 10 . Disconnect the power lead from the customer supply while performing tasks that do not need electricity. Electricity can cause the death or injury. Moving components can cause the injury.

Procedure

Action	Yes	No
Step 1 1 From the Home screen, touch Settings > Device > Preferences . 2 Check if the paper size matches the size set on the tray guides. The paper size will match the size set on the tray.	Go to step 3.	Go to step 2.
Step 2 Change the paper size or adjust the size setting in the tray. The fault persists.	Go to step 3.	The problem is solved.
Step 3 Check the paper path for partially fed or jammed paper. The paper path is free of partially fed or jammed paper.	Go to step 5.	Go to step 4.
Step 4 Remove the partially fed or jammed paper. Note: The fuser nip may not release if the printer is still powered on. Make sure to close all doors, and then turn off the printer to release the fuser nip. The fault persists.	Go to step 5.	The problem is solved.
Step 5 1 Enter the Diagnostics menu GP 1, and then navigate to: Printer diagnostics & adjustments > Sensor tests 2 Find the sensor (Fuser buckle).	Contact the next level of support.	Go to step 6.

Action	Yes	No
The sensor status will change while toggling the sensor.		
Step 6 1 Ensure that the sensor cable is properly connected. 2 Check the sensor for damage. The sensor is free of damage.	Go to step 8.	Go to step 7.
Step 7 Install a new sensor. See REP 10.5. The fault persists.	Go to step 8.	The problem is solved.
Step 8 Perform a print job. The fault persists.	Contact the next level of support.	The problem is solved.

310-495-00, 310-498-00, 310-501-00, 310-504-00, 310-507-00, 310-510-00 Fuser Decurl Sensor Error RAPs

WD2 Drive PWB Wiring Diagram

C625 Wiring Diagrams

310-495-00 MPF Fuser decurl sensor was not made in time RAP

310-498-00 Tray 1 Fuser decurl sensor was not made in time RAP

310-501-00 Tray 2 Fuser decurl sensor was not made in time RAP

310-504-00 Tray 3 Fuser decurl sensor was not made in time RAP

310-507-00 Tray 4 Fuser decurl sensor was not made in time RAP

310-510-00 Tray 5 Fuser decurl sensor was not made in time RAP



WARNING: Switch off the electricity to the machine, GP 10. Disconnect the power lead from the customer supply while performing tasks that do not need electricity. Electricity can cause the death or injury. Moving components can cause the injury.

Procedure

Action	Yes	No
Step 1 Check the fuser and exit paper path for paper jams and obstructions. The paper path is free of jams and obstructions.	Go to step 3.	Go to step 2.
Step 2 Remove the jams and obstructions. The fault persists.	Go to step 3.	The problem is solved.
Step 3 Check the duplex paper path for paper jams and obstructions. The paper path is free of jams and obstructions.	Go to step 5.	Go to step 4.
Step 4 Remove the jams and obstructions. The fault persists.	Go to step 5.	The problem is solved.
Step 5 Inspect the ribs on the top frame base cover for wear, nicks, or other damage that could obstruct the paper path. If any damage persists.	Go to step 6.	Go to step 9.

Action	Yes	No
Step 6 Install a new top frame base cover. See REP 28.7. The fault persists.	Go to step 7.	The problem is solved.
Step 7 1 Enter the Diagnostics menu GP 1, and then navigate to: Printer diagnostics & adjustments > Sensor tests 2 Find the sensor (Redrive/ Duplex Path 1). The sensor status will change while toggling the sensor.	Go to step 9.	Go to step 8.
Step 8 Install a new sensor. See REP 10.5. The fault persists.	Go to step 9.	The problem is solved.
Step 9 1 Enter the Diagnostics menu GP 1, and then navigate to: Printer diagnostics & adjustments > Motor tests > Fuser 2 Select a setting, and then touch Start . The motor will run.	Contact the next level of support.	Go to step 10.
Step 10 Ensure that the JFDRV1 connector on the drive PWB is properly connected. The fault persists.	Go to step 11.	The problem is solved.
Step 11 1 Install a new motor. See REP 10.2 2 Perform a print job. The fault persists.	Contact the next level of support.	The problem is solved.

310-496-00, 310-499-00, 310-502-00, 310-505-00, 310-508-00, 310-511-00, 310-513-00 Fuser Decurl Sensor Error RAPs

WD2 Drive PWB Wiring Diagram

C625 Wiring Diagrams

310-496-00 MPF Fuser decurl sensor uncovered too soon - indicates suck back jam RAP

310-499-00 Tray 1 Fuser decurl sensor uncovered too soon - indicates suck back jam RAP

310-502-00 Tray 2 Fuser decurl sensor uncovered too soon - indicates suck back jam RAP

310-505-00 Tray 3 Fuser decurl sensor uncovered too soon - indicates suck back jam RAP

310-508-00 Tray 4 Fuser decurl sensor uncovered too soon - indicates suck back jam RAP

310-511-00 Tray 5 Fuser decurl sensor uncovered too soon - indicates suck back jam RAP

310-513-00 Fuser decurl sensor uncovered too soon - indicates suck back jam RAP



WARNING: Switch off the electricity to the machine, GP 10. Disconnect the power lead from the customer supply while performing tasks that do not need electricity. Electricity can cause the death or injury. Moving components can cause the injury.

Procedure

Action	Yes	No
Step 1 Check the fuser and exit paper path for paper jams and obstructions. The paper path is free of jams and obstructions.	Go to step 3.	Go to step 2.
Step 2 Remove the jams and obstructions. The fault persists.	Go to step 3.	The problem is solved.
Step 3 Check the duplex paper path for paper jams and obstructions. The paper path is free of jams and obstructions.	Go to step 5.	Go to step 4.
Step 4 Remove the jams and obstructions. The fault persists.	Go to step 5.	The problem is solved.
Step 5 1 Enter the Diagnostics menu GP 1, and then navigate to: Printer diagnostics & adjustments > Sensor tests	Go to step 7.	Go to step 6.

Action	Yes	No
2 Find the sensor (Redrive/ Duplex Path 1). The sensor status will change while toggling the sensor.		
Step 6 Install a new sensor. See REP 10.5. The fault persists.	Go to step 7.	The problem is solved.
Step 7 1 Enter the Diagnostics menu GP 1, and then navigate to: Printer diagnostics & adjustments > Motor tests > Redrive 2 Select a setting, and then touch Start . The motor will run.	Go to step 10.	Go to step 8.
Step 8 Ensure that the JOUTDC1 connector on the drive PWB is properly connected. The fault persists.	Go to step 9.	The problem is solved.
Step 9 Install a new the motor (exit/redrive). See REP 10.4. The fault persists.	Contact the next level of support.	The problem is solved.

310-497-00, 310-500-00, 310-503-00, 310-506-00, 310-509-00, 310-512-00 Fuser Decurl Sensor Error RAPs

WD2 Drive PWB Wiring Diagram

C625 Wiring Diagrams

310-497-00 MPF Fuser decurl sensor was not cleared in time source RAP

310-500-00 Tray 1 Fuser decurl sensor was not cleared in time source RAP

310-503-00 Tray 2 Fuser decurl sensor was not cleared in time source RAP

310-506-00 Tray 3 Fuser decurl sensor was not cleared in time source RAP

310-509-00 Tray 4 Fuser decurl sensor was not cleared in time source RAP

310-512-00 Tray 5 Fuser decurl sensor was not cleared in time source RAP



WARNING: Switch off the electricity to the machine, GP 10. Disconnect the power lead from the customer supply while performing tasks that do not need electricity. Electricity can cause the death or injury. Moving components can cause the injury.

Procedure

Action	Yes	No
Step 1 Check the fuser and exit paper path for paper jams and obstructions. The paper path is free of jams and obstructions.	Go to step 3.	Go to step 2.
Step 2 Remove the jams and obstructions. The fault persists.	Go to step 3.	The problem is solved.
Step 3 1 Enter the Diagnostics menu GP 1, and then navigate to: Printer diagnostics & adjustments > Sensor tests 2 Find the sensor (Redrive/Duplex path 1). The sensor status will change while toggling the sensor.	Go to step 6.	Go to step 4.
Step 4 1 Ensure that the sensor cable is properly connected. 2 Check the sensor for damage. The sensor is free of damage.	Go to step 6.	Go to step 5.
Step 5	Go to step 6.	The problem is solved.

Action	Yes	No
Install a new sensor. See REP 10.5. The fault persists.		
Step 6 1 Enter the Diagnostics menu GP 1, and then navigate to: Printer diagnostics & adjustments > Motor tests > Redrive 2 Select a setting, and then touch Start . The motor will run.	Contact the next level of support.	Go to step 7.
Step 7 1 Ensure that the motor cable is properly connected. 2 Check the motor for damage. The motor is free of damage.	Contact the next level of support.	Go to step 8.
Step 8 1 Install a new motor. See REP 10.4. 2 Perform a print job. The fault persists.	Contact the next level of support.	The problem is solved.

305-211-00, 305-212-00, 310-514-00, 371-329-00, 372-322-00, 373-322-00, 374-328-00, 375-328-00 Unknown Error RAP

305-211-00 Laser Safety interlock RAP

305-212-00 Mirror motor lock fail RAP

310-514-00 Facet Map failure due to kernel failure - May be due to low memory situations - RAP

371-329-00 Tray 1 fails to become input source ready for picking RAP

372-322-00 Tray 2 fails to become input source ready for picking RAP

373-322-00 Tray 3 fails to become input source ready for picking RAP

374-328-00 Tray 4 fails to become input source ready for picking RAP

375-328-00 Tray 5 fails to become input source ready for picking RAP

Procedure



WARNING: Switch off the electricity to the machine, GP 10 . Disconnect the power lead from the customer supply while performing tasks that do not need electricity. Electricity can cause the death or injury. Moving components can cause the injury.

Action	Yes	No
Restart the print job. The fault persists.	Contact the next level of support.	The problem is solved.

310-515-00, 310-516-00, 391-900-00 Drive Software Error Rap

310-515-00 Failed to talk to engine card EEPROM RAP

310-516-00 Service Engine Communication Error: in a 2 Jake ASIC system, Jake1 could not communicate with Jake2 RAP

391-900-00 Supplies security is not enabled- RAP

Procedure



WARNING: Switch off the electricity to the machine, GP 10 . Disconnect the power lead from the customer supply while performing tasks that do not need electricity. Electricity can cause the death or injury. Moving components can cause the injury.

Action	Yes	No
Step 1 1 Remove the controller PWB shield. See REP 3.1. 2 Make sure that the controller PWB and Drive PWB cables are properly connected. Does the problem remain?	Go to step 2.	The problem is solved.
Step 2 Replace the Drive PWB. See REP 1.4. Does the problem remain?	Go to step 3.	The problem is solved.
Step 3 Replace the controller PWB. See REP 3.2. Does the problem remain?	Contact the next level of support.	The problem is solved.

310-670-00 Weather Station Data Not Valid RAP

310-670-00 Weather station data not valid RAP

Procedure

Step 1 Check the sensor cable for proper connection and damage, and replace if necessary. The fault persists.	Go to step 2.	The problem is solved.
Step 2 Install a new Sensor. See REP 10.5 The fault persists.	Contact the next level of support.	The problem is solved .

316E Network Fault Checkout RAP

Initial Actions

Switch off, then switch on the machine, [GP 10](#).

Procedure

Refer to the Active Messages and Fault History to determine under what situation the fault is occurring.

The fault is related to a specific job, client or Page Description Language (PDL).

Y N
| Reload the software, [GP 4](#).

The fault persists.

Y N
| Perform [SCP 5](#) Final Actions.

Install new components as necessary:

- Optional 500+GB Hard Disk, if installed, [PL 25.05 item 2](#).
- Controller PWBPL [3.05](#).

If the fault persists, perform the [OF 1](#) Machine Not Ready RAP.

The fault occurs on one particular job from one particular client.

Y N
| **The fault occurs on all jobs sent from one client.**

Y N
| **The fault occurs with one job from any client.**

Y N
| Install new components as necessary:

- Optional 500+GB Hard Disk, if installed, [PL 25.05 item 2](#).
- Controller PWBPL [3.05](#).

If the fault persists, perform the [OF 1](#) Machine Not Ready RAP.

Another VersaLink® machine is available.

Y N
| Escalate the service call.

Perform the job causing the fault on another VersaLink® machine

The fault is repeatable on both machines.

Y N
| Reload the software, [GP 4](#), on the faulty machine. If the fault persists, escalate the service call.

Contact next level support, then explain that a Software Problem Action Report (SPAR) needs to be generated.

Ask the System Administrator to:

- Check the network configuration on the client (compare to a working client).
- Ensure that the client has the required resources.
- Reload the print driver on the client.

If the fault persists, ask the customer to contact the customer support centre.

Ask the customer to reload the print driver on the affected workstation.

316-000-09 to 316-010-99, 316-015-14 to 316-016-99 Network Faults 1

316-000-09 Cannot create RPC connection with ENS.

316-000-19 Unable to Create RPC Connection with ENS.

316-001-09 Unable to do startup synchronization.

316-001-14 Unable to do startup synchronization.

316-001-19 Unable to do start up synchronization.

316-001-26 Unable to Start up and Sync with SC.

316-001-47 Unable to do Start Up Synchronization.

316-002-09 Unable to register as RPC server.

316-002-14 Unable to register as RPC server.

316-002-19 Unable to Register as an RPC Server.

316-002-26 Could not become an RPC Server.

316-003-09 Too many IPC Handles.

316-003-14 Too many IPC Handles.

316-003-19 Too many IPC Handlers.

316-004-14 RPC call failure to NC registration service.

316-004-19 RPC Connect Failure to NC Registration Service.

316-005-14 RPC call failure to NC registration service.

316-005-19 RPC Call Failure to NC Registration Service.

316-005-68 RPC Call Failure to NC Registration Service.

316-005-92 RPC Call Failure to NC Registration Service.

316-006-09 Cannot register for events.

316-006-19 Cannot register for events.

316-009-09 Invalid IPC Data Received.

316-010-14 Unable to send IPC.

316-010-99 IPC open, create, signal queue failed.

316-015-14 SESS data store environmental variable not set.

316-015-19 SESS data store environmental variable not set.

316-016-14 Data Store init- failed.

316-016-19 Data Store init- failed.

316-016-99 Data Store init- failed.

Procedure

1. If a single occurrence, take no action.
2. For multiple occurrences, perform, [316E Network Fault Checkout RAP](#).

316-012-00 Rolling Reboot Has Been Detected RAP

316-012-00 Rolling reboot has been detected.

Procedure



WARNING: Switch off the electricity to the machine, [GP 10](#). Disconnect the power lead from the customer supply while performing tasks that do not need electricity. Electricity can cause the death or injury. Moving components can cause the injury.

1. If a single occurrence, take no action.
2. For multiple occurrences perform, [316E Network Fault Checkout RAP](#)

316-023-09 to 316-154-19 Network Faults 2 RAP

316-023-09 RPC Call Failure to ENS.

316-026-09 Memory allocation failure.

316-026-14 MALLOC error.

316-030-19 Unable to Obtain Client RPC handle to EJS.

316-031-09 Invalid Event Notification Received.

316-048-09 Unable to set binding.

316-048-14 Can not set NC client binding.

316-048-99 Unable to set client binding.

316-101-93 Swap memory usage exceeds 90 percent.

316-150-19 Unable to sync peer (within NC) infrastructure services.

316-150-26 Fault Service Failed to Write to Log.

316-151-09 Invalid IPC command.

316-151-26 Fault Service Failed to get a Log Handle.

316-152-09 Internal IPC failure.

316-152-14 Empty internal event received by ENS.

316-152-19 Unable to send request to SESS.

316-152-26 Fault Service could not open Fault Log.

316-153-09 Unable to obtain IPC queue.

316-153-14 Can not initialize internal event list.

316-153-19 NVM Save Failure.

316-154-14 Cannot create internal event queue.

316-154-19 NVM Read Failure.

Procedure

1. If a single occurrence, take no action.
2. For multiple occurrences, perform, [316E Network Fault Checkout RAP](#).

316-156-19 to 316-436-00 Network Faults 3 RAP

316-156-19 Service Run loop failed.

316-161-09 Cannot send registration event.

316-164-09 List access failure (Create, Add, Find, delete).

316-165-01 SLC wear level at 90 %.

316-165-02 MLC wear level at 90 %.

316-165-03 SLC wear level at 100 %.

316-165-04 MLC wear level at 100 %.

316-330-00 System Startup Process Crash.

316-331-00 UI Panel Communication Failure.

316-331-01 UI Panel Communication Failure After Retry.

316-333-00 Device DLM process unloaded after causing repeated resets.

316-338-00 NC Platform Death.

316-339-00 UI Platform Death.

316-340-00 UI Power On Failure.

316-400-19 NVM Connection Failure.

316-428-00 NVM Save to FPGA Failure.

316-435-00 UI thread not running 10s warning.

316-435-01 UI thread not running 30s warning.

316-436-00 UI Serial Comm Not Present.

Procedure

1. If a single occurrence, take no action.
2. For multiple occurrences, perform, [316E Network Fault Checkout RAP](#).

316-501-00 to 316-544-00 Network Faults 4 RAP

- 316-501-00 Ethernet cable not connected.
- 316-502-00 USB WiFi adapter not installed.
- 316-503-00 Ethernet 802.1X connection failure.
- 316-504-00 WiFi connection failure. Cannot connect to the WiFi network.
- 316-505-00 WiFi connection lost.
- 316-506-00 Ethernet DHCP/BOOTP Error: DHCP/BOOTP failure.
- 316-507-00 Ethernet DHCP/BOOTP Error: DHCP/BOOTP failure.
- 316-508-00 Ethernet DHCP/BOOTP Error: DHCP/BOOTP failure.
- 316-509-00 Ethernet DHCP/BOOTP Error: DHCP/BOOTP failure.
- 316-514-00 Ethernet DHCP/BOOTP Error: DHCP/BOOTP failed to obtain an address.
- 316-517-00 WiFi DHCP/BOOTP Error: DHCP/BOOTP failed to obtain an address.
- 316-518-00 Ethernet DHCP/BOOTP Error: DHCP/BOOTP failed to obtain an address.
- 316-519-00 WiFi DHCP/BOOTP Error: DHCP/BOOTP failed to obtain an address.
- 316-524-00 Ethernet: Duplicate IPv4 address detected.
- 316-525-00 WiFi Duplicate IPv4 address detected.
- 316-526-00 Ethernet: No IPv4 router configured.
- 316-527-00 WiFi: No IPv4 router configured.
- 316-528-00 Ethernet: No IPv6 router advertisement. No routable IPv6 address configured.
- 316-529-00 WiFi: No IPv6 router advertisement. No routable IPv6 address configured.
- 316-531-00 Ethernet: Duplicate IPv6 address detected.
- 316-533-00 WiFi: Duplicate IPv6 address detected.
- 316-535-00 Ethernet DHCPv6 Error: DHCPv6 failed to obtain an address.
- 316-536-00 WiFi DHCPv6 Error: DHCPv6 failed to obtain an address.
- 316-540-00 Ethernet DHCPv6 Error: DHCPv6 failed to obtain an address.
- 316-544-00 WiFi DHCPv6 Error: DHCPv6 failed to obtain an address.

Procedure

1. If a single occurrence, take no action.
2. For multiple occurrences, perform, [316E Network Fault Checkout RAP](#).

316-600-35 to 316-608-68 Network Faults 5 RAP

- 316-600-35 Can not create RPC connection to ENS.
- 316-600-66 Unable to Create RPC Connection with ENS.
- 316-600-67 Unable to Create RPC Connection with ENS.
- 316-601-19 Client Bridge Communication Timeout (EAGAIN).
- 316-601-26 Fault Service Failed IPC Queue Setup.
- 316-601-35 System Control initialization failed.
- 316-601-47 Diag Service Failed IPC Queue Setup.
- 316-601-66 Unable to do start up synchronization.
- 316-601-67 Unable to do start up synchronization.
- 316-601-68 Unable to start up and sync with SC.
- 316-602-105 Unable to Register as an RPC Server.
- 316-602-19 UI Client Bridge Communication Timeout (EAGAIN).
- 316-602-28 RPC Server Registration failed.
- 316-602-35 RPC Server Registration.
- 316-602-38 RPC Server Registration Failed.
- 316-602-66 Unable to Register as an RPC Server.
- 316-602-67 Unable to Register as an RPC Server.
- 316-602-68 Unable to Register as an RPC Server.
- 316-603-105 RPC call failure to NC registration service.
- 316-603-11 Replace Handler call failed.
- 316-603-28 Replace Handler call failed.
- 316-603-66 Too many IPC Handlers.
- 316-603-67 Too many IPC Handlers.
- 316-603-68 Replace Handler call failed.
- 316-604-105 SESS data store environmental variable not set.
- 316-604-14 RPC call failure to NC registration service.
- 316-604-38 Could not register with Registration Service.
- 316-604-99 Could not register with Registration Service.
- 316-605-14 RPC call failure to NC registration service.
- 316-605-26 Fault Service timed out registering with registration service.
- 316-605-35 RPC Call Failure to NC Registration Service.

316-605-47 RPC Call Failure to NC Registration Service.
316-605-66 RPC Call Failure to NC Registration Service.
316-605-67 RPC Call Failure to NC Registration Service.
316-606-105 OS problem.
316-606-19 Corrupt System Event Log detected.
316-606-35 Can not register for events.
316-606-99 Cannot register for events.
316-607-105 Service Run loop failed.
316-607-19 Invalid RPC Data Received.
316-607-47 Invalid RPC disk diagnostics Data Received.
316-607-92 Invalid RPC Data Received.
316-608-09 Unable to free IPC resources.
316-608-105 Build UI SVC obtain client failed.
316-608-14 Unable to free IPC resources.
316-608-26 Fault Service Failed to Unbind with SC.
316-608-28 IPC un-register failure.
316-608-35 Unable to Free IPC Resources.
316-608-66 Unable to Free IPC resources.
316-608-67 Unable to Free IPC resources.
316-608-68 Unable to Free IPC Resources.

Procedure

1. If a single occurrence, take no action.
2. For multiple occurrences, perform, [316E Network Fault Checkout RAP](#).

316-609-105 to 316-612-68 Network Faults 6 RAP

316-609-105 Too many IPC Handlers.
316-609-19 Invalid IPC Data Received.
316-609-26 Fault Service Encountered Error Trying to get IPC Message.
316-609-47 Invalid IPC Data Received- Get SC diag handle failed.
316-609-92 Invalid IPC Data Received.
316-610-00 IPC send failure to NC Triple A service for queue command authorization.
316-610-09 Cannot send IPC message to NC Platform Manage.
316-610-11 IPC communication failed.
316-610-19 Unable to Send IPC Message.
316-610-26 Unable to ; Send IPC Message.
316-610-28 IPC communication failed.
316-610-35 Unable to send IPC Message.
316-610-92 Failure to send Queue Status.
316-610-99 Unable to send IPC Message.
316-611-14 Cannot remove RPC connection.
316-611-19 Unable to Remove RPC Connection.
316-611-26 Cannot Remove RPC Connection.
316-611-38 Client Removal Failed.
316-611-47 Cannot remove RPC connection.
316-611-66 Unable to Remove RPC Connection.
316-611-67 Unable to Remove RPC Connection.
316-611-99 Cannot remove RPC connection.
316-612-09 Unable to do shutdown synchronization.
316-612-14 Unable to do shutdown synchronization.
316-612-35 Unable to do shutdown synchronization.
316-612-68 Unable to do shutdown synchronization.

Procedure

1. If a single occurrence, take no action.
2. For multiple occurrences, perform, [316E Network Fault Checkout RAP](#).

316-613-09 to 316-617-19 Network Faults 7 RAP

316-613-09 DC Registration synchronization error.

316-613-14 DC ENS synchronization error.

316-613-19 DC Sys Mgr sync error.

316-614-09 DC Registration communications error.

316-614-14 Digital Copier ENS registration error.

316-614-19 DC Sys Mgr communications error.

316-615-35 SESS Data Store Environmental Variable not set.

316-615-66 SESS data store environmental variable not set.

316-615-67 SESS data store environmental variable not set.

316-616-35 Data Store initialization failure.

316-616-38 Error - Shared Memory Failure.

316-616-67 Submission of Email or IFax Job Failed.

316-617-19 Send Event Failure Unable to send event to NC ENS.

Procedure

1. If a single occurrence, take no action.
2. For multiple occurrences, perform, [316E Network Fault Checkout RAP](#).

316-621-00 to 316-625-67 Network Faults 8 RAP

316-621-00 Unable to get host name.

316-621-11 Unable to get host name.

316-621-28 Unable to get host name.

316-621-35 Get Host Name failed.

316-621-38 Unable to get host name.

316-621-47 Get Host Name failed.

316-621-66 Unable to get the host name.

316-621-67 Unable to get the host name.

316-621-93 Unable to get host name.

316-621-99 Get Host Name failed.

316-623-35 RPC Call Failure to ENS.

316-623-47 RPC Call Failure to ENS.

316-625-35 Invalid IPC Type.

316-625-66 Invalid IPC message Type.

316-625-67 Invalid IPC message Type.

Procedure

1. If a single occurrence, take no action.
2. For multiple occurrences, perform, [316E Network Fault Checkout RAP](#).

316-626-00 to 316-635-99 Network Faults 9 RAP

316-626-00 Memory Allocation Error.

316-626-11 Can't allocate memory to load a template.

316-626-38 Memory Allocation Error.

316-626-47 Memory Allocation Error.

316-626-66 Memory allocation failed.

316-626-67 Memory allocation failed.

316-628-09 Unable to complete RPC call.

316-628-35 Range String calculation failed.

316-628-66 Cannot get range environment variable.

316-628-67 Cannot get range environment variable.

316-629-11 RPC call failure.

316-629-26 Fault Service Call to PSW Callback failed.

316-629-66 No acknowledgement for RPC message.

316-629-67 No acknowledgement for RPC message.

316-629-68 No acknowledgement for RPC message.

316-629-92 No Acknowledgment to RPC Message- RPC timeout.

316-629-93 No Acknowledgment to RPC Message- RPC timeout.

316-630-26 Fault Service Failed to get RPC Client Handle.

316-630-35 Unable to Get RPC Client Handle.

316-630-38 Client Create Failed.

316-630-47 Unable to Get RPC Client Handle.

316-630-66 Unable to get RPC client handle.

316-630-67 Unable to get RPC client handle.

316-630-68 Unable to get RPC client handle.

316-630-99 Unable to Get RPC Client Handle.

316-631-19 Invalid Event Notification Received.

316-633-19 NVM Detach Error.

316-635-35 Can not free XDR data.

316-635-99 Can not free XDR data.

Procedure

1. If a single occurrence, take no action.

2. For multiple occurrences, perform, [316E Network Fault Checkout RAP](#).

316-636-35 to 316-647-26 Network Faults 10 RAP

316-636-35 Unable to unmarshall XDR data.

316-636-99 Unable to unmarshall XDR data.

316-637-11 Can't open template cache file.

316-637-26 Unable to open file- RAP.

316-637-38 Unable to Open File for Write.

316-637-47 Failed to Open File.

316-637-66 File I/O Error.

316-637-67 File I/O Error.

316-637-93 Unable to open local file.

316-637-95 Unable to open local file.

316-638-66 Unable to initialize with Queue Library.

316-638-67 Unable to initialize with Queue Library.

316-639-38 Create Thread Fault.

316-640-00 System date is invalid for the Apache HTTPS device certificate.

316-640-35 RPC send.

316-641-26 Cannot log fault to ess fault log.

316-642-47 Invalid Internal Parameters

316-643-19 Unable to close file.

316-643-26 Unable to close file.

316-643-47 Failed to Close File.

316-644-11 Can't read template cache file.

316-644-26 Unable to read from file.

316-644-47 SWVerify Get_next_proc failed.

316-644-66 File I/O Error.

316-644-67 File I/O Error.

316-645-11 Can't write updated template cache file.

316-645-26 Unable to write to file.

316-645-47 Failed to Write File.

316-645-66 File I/O Error.

316-645-67 File I/O Error.

316-646-26 Failed to delete file.

316-647-19 Unable to get Time and Date.

316-647-26 Unable to become Client of Diag Service.

Procedure

1. If a single occurrence, take no action.
2. For multiple occurrences, perform, [316E Network Fault Checkout RAP](#).

316-650-35 to 316-668-95 Network Faults 11 RAP

316-650-35 Invalid service attribute requested.

316-650-68 Network or authentication server setup problem.

316-650-99 Invalid service attribute requested.

316-651-19 Cannot register for SESS Events.

316-651-35 Can not register for SESS events.

316-651-99 SPI register failed.

316-652-38 Unable to Enroll Spi Callbacks.

316-652-68 Device configuration of remote server may be incorrect.

316-652-99 SPI enroll failed.

316-653-38 Error - Invalid Job Handle Fault.

316-653-68 Smart card error.

316-654-14 Log_Init/Log_Close Fault.

316-654-38 Return from spi_register Fault.

316-654-99 Return from Log_init Fault.

316-655-38 Return from spi_register Fault.

316-656-38 RPC Processing Fault.

316-656-68 OCSP Error.

316-657-68 Certificate is not FIPS 140 compliant.

316-658-68 Expired certificate.

316-659-11 Parser Utility open failure.

316-659-28 Parser Utility open failure.

316-659-68 Certificate key length error.

316-659-93 Parser Utility open failure.

316-659-95 Parser Utility open failure.

316-660-68 Card is locked.

316-660-95 Cannot read local directory entries.

316-660-99 Service initialization failed.

316-661-95 Cannot create spool directory.

316-662-11 Parser utility template failed to parse.

316-662-28 Parser utility template failed to parse.

316-662-68 Authentication credentials locked.

316-662-93 Parser utility template failed to parse.

316-662-95 Parser utility template failed to parse.

316-663-11 Parser utility destroy template failed.

316-663-28 Parser utility destroy template failed.

316-663-68 Authentication server clock mismatch.

316-663-93 Parser utility destroy template failed.

316-663-95 Parser utility destroy template failed.

316-664-11 Parser utility parser closing failed.

316-664-28 Parser utility parser closing failed.

316-664-68 Invalid authentication server certificate.

316-664-93 Parser utility parser closing failed.

316-664-95 Parser utility parser closing failed.

316-665-95 Unable to detach from child thread.

316-666-11 Parser utility invocation failed.

316-666-28 Parser utility invocation failed.

316-666-93 Parser utility invocation failed.

316-666-95 Parser utility invocation failed.

316-667-11 Parser utility set status failed.

316-667-28 Parser utility set status failed.

316-667-68 SMB local system error.

316-667-95 Parser utility set status failed.

316-668-68 SMB remote system error.

316-668-93 Unable to determine local file statistics.

316-668-95 Unable to determine local file statistics.

Procedure

1. If a single occurrence, take no action.
2. For multiple occurrences, perform, [316E Network Fault Checkout RAP](#).

316-669-28 to 316-730-00 Network Faults 12 RAP

316-669-28 Unable to write job template file to NC disk.

316-669-68 Parameter error to SMB client.

316-669-93 Unable to write job template file to NC disk.

316-669-95 Unable to write job template file to NC disk.

316-670-00 Unable to lock/unlock data store.

316-670-11 Unable to decode template file.

316-670-28 Unable to decode template file.

316-670-68 SMB internal system error.

316-670-93 Unable to decode template file.

316-671-00 Sort jobs failed.

316-671-68 SMB server error.

316-671-93 Unable to encode template file.

316-671-95 Unable to encode template file.

316-672-09 Unable to remove file from system.

316-672-68 SMB authentication error.

316-672-95 Unable to remove file from system.

316-673-95 Cannot remove local directory.

316-679-68 Device user database unavailable.

316-697-68 Kerberos error.

316-698-68 LDAP Error.

316-699-68 Failed to open Azure IoT Hub Connection.

316-700-00 Unknown Attribute Requested.

316-700-68 gSOAP Server Error.

316-701-110 Unable to communicate with XSA Database.

316-701-68 Unable to communicate with Postgre database.

316-701-99 Unable to communicate with XSA database.

316-702-68 gSOAP Client Error.

316-702-95 Unable to communicate with XSA database.

316-703-68 GetSecurityToken error.

316-707-00 Unknown Queue Request received.

316-710-00 NC Internal Communication Failure

316-716-00 Data Store init failed.

316-728-00 Unable to compute Range String.

316-730-00 Unable to create Client Handle.

Procedure

1. If a single occurrence, take no action.
2. For multiple occurrences, perform, [316E Network Fault Checkout RAP](#).

316-718-00, 316-720-02 to 316-720-05, 316-722-01, 316-722-02, 316-726-00, 316-727-00 Hard Disk Faults RAP

316-718-00 Data Store Threshold Exceeded.

316-720-02 Disk Partition /opt Threshold Exceeded

316-720-03 Disk Partition /tmp Threshold Exceeded

316-720-04 Disk Partition /persistent Threshold Exceeded

316-720-05 Disk Partition /var/log Threshold Exceeded

316-722-01 Disk Partition /var Threshold Exceeded.

316-722-02 Disk Partition /var/userdata Threshold Exceeded.

316-726-00 RPC connections exhausted.

316-727-00 RPC connections approaching limit.

Procedure



WARNING: Switch off the electricity to the machine, GP 10 . Disconnect the power lead from the customer supply while performing tasks that do not need electricity. Electricity can cause the death or injury. Moving components can cause the injury.

1. If a single occurrence, take no action.
2. For multiple occurrences, perform, [316E Network Fault Checkout RAP](#).

316-732-01 to 316-750-95 Network Faults 13 RAP

316-732-01 Disk Partition /var/spool/nc/scan Threshold Exceeded.

316-732-02 Disk Partition /var/spool/nc/image_store: "File Cabinet Service" Threshold Exceeded.

316-732-03 Disk Partition /var/spool/nc/image_store: "Transfer service" Threshold Exceeded.

316-732-05 Disk Partition /var/spool/CIPS/image_store Threshold Exceeded.

316-732-06 Disk Partition /var/spool/nc/net Threshold Exceeded.

316-732-07 Disk Partition /var/fonts Threshold Exceeded.

316-740-19 Error - NC Hard Disk IIO Failure.

316-743-19 SSD Data Removal failure.

316-747-00 Productivity Kit Error.

316-748-00 Remote Services Download Failed.

316-750-11 Template cache file is missing.

316-750-19 Invalid Online/ Offline request.

316-750-26 Invalid number of faults requested.

316-750-35 Queue Service library Initialization failed.

316-750-38 Error - SPI Init Fault.

316-750-47 SC Diag Startup failed.

316-750-66 Failure to set service state.

316-750-67 Failure to set service state.

316-750-92 Bad file descriptor.

316-750-93 IFS error when requesting memory.

316-750-95 Local Spool area does not exist.

Procedure

1. If a single occurrence, take no action.
2. For multiple occurrences, perform, [316E Network Fault Checkout RAP](#).

316-742-19 Hard Disk ODIO Failure RAP

316-742-19 Hard disk ODIO failure.

Procedure



WARNING: Switch off the electricity to the machine, GP 10 . Disconnect the power lead from the customer supply while performing tasks that do not need electricity. Electricity can cause the death or injury. Moving components can cause the injury.

1. Print a configuration report.
2. If the configuration report shows Image Overwrite as installed/disabled, perform the following:
 - a. Enter Customer Administration Tools, GP 2.
 - b. Select the **Tools** tab.
 - c. Select **Security Settings**.
 - d. Select **Image Overwrite Security**.
 - e. Enable the required feature.

316-751-11 to 316-753-95 Network Faults 14 RAP

316-751-11 Initialization procedure fails.

316-751-112 Database Error or Service Registry not available.

316-751-14 SESS SC event registration failed.

316-751-19 Unable to set time / date.

316-751-26 Unrecognized Fault Code.

316-751-28 Template attributes are invalid, or syntax error.

316-751-35 Failure to initialize with DM Agent.

316-751-38 Warning - Unknown Attribute.

316-751-47 SWVerify RepairDir failed.

316-751-66 Unable to send event to NC ENS.

316-751-92 Job State Fault.

316-751-93 Invalid template attribute.

316-752-09 Attempt to register too many services.

316-752-14 Retry SESS Sys Control event registration.

316-752-19 Cannot Acknowledge System Mode Change.

316-752-26 Unrecognized SESS Error Code.

316-752-28 Template cache file is missing.

316-752-35 Failure to initialize with PrintSpi

316-752-47 Invalid Test Pattern Source.

316-752-66 Scan to FAX services registration error.

316-752-67 Scan to Distribution services registration error.

316-752-92 Printsipi can't read frame type from data store.

316-752-93 Error accessing job(s) in job list.

316-752-95 File transfer operation failure.

316-753-14 Invalid event number error received by ENS.

316-753-19 Unable to send event to NC ENS.

316-753-26 Unable to become Client of PSW.

316-753-28 Cannot communicate with UI for template list request.

316-753-35 Unable to change EJS state to OFF line.

316-753-47 Failed to Close Directory.

316-753-66 Data Store Read Failure.

316-753-67 Data Store Read Failure.

316-753-92 Printsip can't read frame type from data store.

316-753-93 Error adding job(s) in job list.

316-753-95 Requested transfer protocol not supported.

Procedure

1. If a single occurrence, take no action.
2. For multiple occurrences, perform, [316E Network Fault Checkout RAP](#).

316-754-09 to 316-756-93 Network Faults 15 RAP

316-754-19 Shutdown Request Reason Unknown.

316-754-26 Fault Service encountered error reading fault log.

316-754-35 Can not generate SESS event.

316-754-47 SWVerify Repair file failed.

316-754-66 OS problem.

316-754-68 Initialization procedure fails.

316-754-92 Consumer Interface Fault.

316-754-93 Error deleting job(s) from job list.

316-754-95 Unable to remove advisory lock on network server.

316-755-09 Unable to register requested service.

316-755-112 Unable to initialize the Service Registry Table.

316-755-14 Event notification via IPC error - full queue.

316-755-19 Unable to provide new s/w config- to SESS.

316-755-26 Fault Service failed to Clear Fault Log.

316-755-28 Cancel Request Failed.

316-755-35 Unable to update Data Store attribute.

316-755-47 SWVerify Repair permission failed.

316-755-67 Cancel Request Failed.

316-755-92 Invalid IPC Data Received.

316-755-93 Unable to initialize with IFS.

316-755-99 Unable to abort job fault.

316-756-14 RPC creation error: unable to create RPC communication to client services.

316-756-26 Memory Allocation Failure.

316-756-28 Range String Error.

316-756-35 Unable to read NVM value.

316-756-47 SC Run Diagnostic failed.

316-756-67 Unable to read NVM value.

316-756-92 Invalid IPC Data Received.

316-756-93 IPA operation failed.

Procedure

WARNING: Switch off the electricity to the machine, GP 10 . Disconnect the power lead from the customer supply while performing tasks that do not need electricity. Electricity can cause the death or injury. Moving components can cause the injury.

1. If a single occurrence, take no action.
2. For multiple occurrences, perform, 316E Network Fault Checkout RAP

316-757-09 to 316-760-99 Network Faults 16 RAP

- 316-757-09 Invalid RPC parameters.
- 316-757-14 RPC Control error.
- 316-757-19 System Manager callback sm_operation _complete failed.
- 316-757-26 Fault Service could not close Fault Log
- 316-757-28 Unknown Message Received.
- 316-757-35 Unable to write NVM value.
- 316-757-47 SWVerify Repair chksum failed.
- 316-757-66 Unable to write NVM value.
- 316-757-67 Unable to write NVM value.
- 316-757-92 Invalid IPC Data Received.
- 316-757-92 Invalid IPC Data Received.
- 316-757-93 Unable to set ICS document state.
- 316-758-14 RPC communication error to client.
- 316-758-26 Fault Service Encountered Error Trying to access its own queue ID.
- 316-758-28 State Error.
- 316-758-35 Unable to change EJS state to OFF line.
- 316-758-47 Error Finding Job Id.
- 316-758-66 ServiceRun loop failed.
- 316-758-67 ServiceRun loop failed.
- 316-758-93 Unable to obtain data store object handle.
- 316-759-14 Request for wildcard from non-NC.
- 316-759-19 NC Failed Cold Reset 3 Times in a Row.
- 316-759-26 Unrecognized Service ID requesting Fault Information.
- 316-759-28 SC Init Fault.
- 316-759-47 Failed to Abort Process.
- 316-759-66 OA Event register Failed.
- 316-759-67 OA Event register Failed.
- 316-759-93 Unable to create -DAT file.
- 316-760-26 Unable to become Client of RDT.
- 316-760-28 Unable to Ack SC.
- 316-760-47 Incorrect Checksum partition 1.

316-760-67 Create List Failed.

316-760-68 SRS returns to Login Service "invalid fields, invalid data, or missing data".

316-760-93 Job report failure from CCM.

316-760-99 Request for system policy failed.

Procedure

1. If a single occurrence, take no action.
2. For multiple occurrences, perform, [316E Network Fault Checkout RAP](#).

316-761-14 to 316-765-93 Network Faults 17 RAP

316-761-14 Invalid RPC data.

316-761-26 Unable to become Client of UI.

316-761-28 Unable to submit a job.

316-761-47 SWVerify Init File failed.

316-761-67 Failed to Retrieve Public List.

316-761-68 Login gets no response from SRS.

316-761-93 Image conversion to TIFF failed.

316-761-95 Unable to read template pool configuration information.

316-762-14 Invalid internal table type.

316-762-19 DC Platform Mgr Comm Error.

316-762-26 Unable to become client of SCS Diag Service.

316-762-28 Scan Image Compressor Error.

316-762-47 Missing File.

316-762-67 Invalid Index for Recipient List.

316-762-68 Service Registry Bad data / Corrupted.

316-762-93 IFSImageDoneX call failed.

316-762-95 Unable to read document repository configuration information.

316-763-14 Reached internal limit for events.

316-763-19 System Manager Comm Error.

316-763-26 No acknowledgment to RPC message- RPC time-out.

316-763-47 Invalid Permission.

316-763-67 Failed to Retrieve LDAP List.

316-763-93 Document image count not found.

316-763-95 Internal destination error.

316-764-14 Internal Logic error.

316-764-19 Set Up of the SIGALRM Signal failed.

316-764-26 Fault Service Encountered Error Trying to get IPC Message.

316-764-47 Incorrect Checksum partition 2.

316-764-67 Create List Failed.

316-765-19 SystemMgr call failed.

316-765-26 Fault Service Call to PSW Callback failed.

316-765-67 Failed to Retrieve Recipient List.

316-765-93 Unable to access data store.

Procedure

1. If a single occurrence, take no action.
2. For multiple occurrences, perform, [316E Network Fault Checkout RAP](#).

316-766-19 to 316-772-95 Network Faults 18 RAP

316-766-19 DM admin error.

316-766-26 Fault Service Call to UI Callback failed.

316-766-47 No Servers Responded.

316-766-67 Failed to Bind to LDAP Server.

316-766-93 TIFF handle has become null.

316-766-95 Cannot create Image file name.

316-767-19 Request to cancel spooling job error.

316-767-26 Fault Service Call to RDT Callback failed.

316-767-47 Server in Config list not up.

316-767-67 Error performing LDAP search.

316-767-93 Get Document Image Count failed.

316-767-95 Cannot determine filing policy for transfer.

316-768-19 Hold/release of jobs error.

316-768-47 NC Not Attached to Server.

316-768-67 Error performing Public search.

316-768-93 Increment image count failed.

316-768-95 Cannot get Network advisory lock file name.

316-769-47 NC Not Attached to print queue.

316-769-67 Failed to Cancel Search Request

316-769-93 IFS deregister call failed.

316-769-95 Cannot determine appropriate lock name/address.

316-770-19 Online/Offline request time out.

316-770-47 Attached to Queue and Server.

316-770-67 Required attribute missing.

316-771-19 Online/Offline callback failure.

316-772-19 Failure to set NC Platform Manager service state.

316-772-47 RPC Failure for communication.

316-772-95 Invalid transfer request.

Procedure

1. If a single occurrence, take no action.
2. For multiple occurrences, perform, [316E Network Fault Checkout RAP](#).

316-773-19 to 316-779-95 Network Faults 19 RAP

316-773-19 Unknown client requested online/offline.

316-774-19 Can not obtain RPC connection.

316-775-19 Can not obtain Data Store handle for server object.

316-775-95 Cannot create temporary file name.

316-776-19 Can not delete jobs using Job Map library.

316-776-95 Cannot clean up after job completion.

316-777-19 Can not access Data Store element.

316-777-95 Cannot log into requested network server.

316-778-19 Invalid Enable Demo Job setting.

316-778-95 Cannot generate confirmation sheet.

316-779-19 System Manager callback sm power saver completed failed.

316-779-95 Cannot create the template / job log name.

Procedure

1. If a single occurrence, take no action.
2. For multiple occurrences, perform, [316E Network Fault Checkout RAP](#).

316-780-19 to 316-789-19 Network Faults 20 RAP

316-780-19 Power Saver request time out.

316-780-95 Cannot determine the remote directory.

316-781-19 Network Upgrade Checksum Error.

316-782-09 NC Configuration Synchronization process failure.

316-782-19 SW Upgrade manifest mismatch.

316-783-09 Unable to send sc_proc_disable.

316-783-19 NC Failure to enter upgrade mode.

316-784-19 SW Upgrade aborted - IOT failed to enter Upgrade Mode.

316-785-09 NC SNMP Agent process failure.

316-785-19 SW Upgrade aborted - UI failed to enter Upgrade Mode.

316-786-19 NC failure to uncompress upgrade file.

316-787-19 IOT SW Upgrade failed.

316-788-19 NC PM Failed to install Scan to File.

316-789-19 NC PM Failed to install LAN FAX.

Procedure

1. If a single occurrence, take no action.
2. For multiple occurrences, perform, [316E Network Fault Checkout RAP](#).

316-790-19 to 316-799-47 Network Faults 21 RAP

316-790-19 NC PM Failed to install Job Based Accounting.

316-790-47 SESS Banyan test unknown error.

316-791-19 Scan to File DLM is not defined.

316-791-47 SESS Banyan test no network.

316-792-19 Lan Fax DLM is not defined.

316-792-47 SESS Banyan test open failure.

316-793-19 Job Based Accounting DLM is not defined.

316-793-47 SESS Banyan test echo failure.

316-794-09 Cross platform synchronization error.

316-794-19 Install Password mismatch.

316-794-47 SESS Banyan test no servers.

316-795-19 NC PM Failed to remove LAN FAX.

316-795-47 SESS NetBIOS test no lanas found.

316-796-19 NC PM Failed to remove Scan to File.

316-796-47 SESS NetBIOS test invalid command.

316-797-19 NC PM Failed to remove Job Based Accounting.

316-797-47 SESS NetBIOS test interface busy.

316-798-19 Option already enabled.

316-798-47 SESS NetBIOS test too many commands.

316-799-19 Option already enabled.

316-799-47 SESS NetBIOS test invalid adapter.

Procedure

1. If a single occurrence, take no action.
2. For multiple occurrences, perform, [316E Network Fault Checkout RAP](#).

316-800-09 to 316-809-47 Network Faults 22 RAP

316-800-09 List access failure (Create, add, find, delete).

316-800-19 Option not supported.

316-800-47 SESS NetBIOS test cannot cancel.

316-801-09 Invalid SESS event/IPC error.

316-801-19 Serial Number mismatch.

316-801-47 SESS NetBIOS test oem x (unusual network problem).

316-802-19 Counters do not match.

316-802-47 SESS NetBIOS test adapter malfunction.

316-803-47 SESS NetBIOS test cannot init token ring.

316-804-47 SESS NetBIOS test no cable connected to board.

316-805-19 Accounting install failed.

316-805-47 SESS NetBIOS test could not join ring.

316-806-09 CPI service unavailable.

316-806-19 Counters did not increment.

316-806-47 SESS NetBIOS test cable not connected to MAU.

316-807-09 Job Log service unavailable.

316-807-19 State change failed.

316-807-47 SESS NetBIOS test memory allocation error.

316-808-09 JobTracker service unavailable.

316-808-47 SESS NetBIOS test no more minor devices available.

316-809-09 Kerberos service unavailable.

316-809-47 SESS NetBIOS test token ring board was stopped.

Procedure

1. If a single occurrence, take no action.
2. For multiple occurrences, perform, [316E Network Fault Checkout RAP](#).

316-810-09 to 316-839-47 Network Faults 23 RAP

316-810-09 Scan Service unavailable.

316-810-19 Failed to remove Accounting.

316-810-47 SESS NetBIOS test network is bad.

316-811-09 SMB service unavailable.

316-811-19 Failed to initiate operation.

316-811-47 SESS NetBIOS test command timed out.

316-812-19 Failed to change the enable upgrade flag.

316-812-47 SESS NetBIOS test message incomplete.

316-813-09 Scan Service unavailable.

316-813-19 DEF error occurred on NC.

316-813-47 SESS NetBIOS test no resources on local adapter

316-814-09 Scan Compressor service unavailable.

316-814-19 DEF was enabled on the NC.

316-814-47 SESS NetBIOS test duplicate name in local name table.

316-815-47 SESS NetBIOS test name table is full.

316-816-09 EIP Service not responding.

316-816-47 SESS NetBIOS test unexpected protocol received.

316-817-47 SESS NetBIOS test NetBIOS/ix being reset.

316-818-47 SESS NetBIOS test NetBIOS/ix being stopped.

316-819-47 SESS NetBIOS test NetBIOS/ix not loaded.

316-820-47 SESS NetBIOS test NetBIOS/ix not running.

316-821-47 SESS NetBIOS test MAC driver went offline.

316-822-47 SESS NetBIOS test error during reset.

316-823-47 SESS NetBIOS test unknown error.

316-824-47 SESS UNIX test unknown error.

316-825-47 Echo Test Failure; SESS diag name not found.

316-830-47 GetNetData IP Diagnostic - failed to get default router.

316-831-47 GetNetData IP Diagnostic - failed to get subnet mask.

316-832-47 GetNetData IP Diagnostic - failed to get local devices

316-833-47 GetNetData IP Diagnostic - failed on ARP.

316-837-47 GetNetData - Diagnostic Name not found.

316-838-47 SWVerify Setup Alarm Failed.

316-839-47 SWVerify Repair File length Failed.

Procedure

1. If a single occurrence, take no action.
2. For multiple occurrences, perform, [316E Network Fault Checkout RAP](#).

316-840-47 to 316-879-47 Network Faults 24 RAP

316-840-47 System call failed.

316-841-47 SWVerify Missing Directory.

316-842-47 SWVerify Process Not Running.

316-843-47 SWVerify Repair Timeout.

316-844-47 Failed to save data to NVM.

316-845-47 Failed to initialize NVM.

316-846-47 Failed to restore contents of NVM.

316-847-47 Failed to write value to NVM.

316-848-47 Failed to read faults.

316-849-47 Failed to create command array.

316-850-47 Failed to add substitution string.

316-851-47 Failed calling stream editor.

316-852-47 Failed to process fault for error report.

316-853-47 Failed to get last reset time.

316-854-47 Failed on call to fault service.

316-855-47 Failed on call send event.

316-856-47 Failed on system command.

316-857-47 Failed to find process.

316-858-47 Failed to dump log.

316-859-47 Failed on software verify.

316-860-47 No response for IP Ping Test.

316-861-47 Registration Monitor Failure.

316-862-47 SESS NETBIOS test invalid cancel command.

316-863-47 SESS NETBIOS test illegal buffer length.

316-864-47 SESS NETBIOS test illegal local session number.

316-865-47 SESS NETBIOS test session closed.

316-866-47 SESS NETBIOS test command canceled.

316-867-47 SESS NETBIOS test name deregistered.

316-868-47 SESS NETBIOS test local session table full.

316-869-47 SESS NETBIOS test no listen in remote computer.

316-870-47 SESS NETBIOS test illegal name number.

316-871-47 SESS NETBIOS test cannot find name or no answer.

316-872-47 SESS NETBIOS test name in use.

316-873-47 SESS NETBIOS test name deleted.

316-874-47 SESS NETBIOS test session abended.

316-875-47 SESS NETBIOS test name conflict.

316-876-47 SW verify setup SIGTERM Failed.

316-877-47 SESS PCI test unknown error.

316-878-47 SESS PCI test failed to open driver.

316-879-47 SESS PCI test failed flushing stream buffer.

Procedure

1. If a single occurrence, take no action.
2. For multiple occurrences, perform, [316E Network Fault Checkout RAP](#).

316-880-47 to 316-929-19 Network Faults 25 RAP

316-880-47 SESS PCI test failed on put msg call.

316-881-47 SESS PCI test invalid argument.

316-882-47 SESS PCI test failed on put msg call.

316-883-47 SESS PCI test failed on ioctl call.

316-884-47 SESS PCI test control flag area too small.

316-885-47 SESS PCI test driver not initialized.

316-886-47 SESS PCI test info request failed.

316-887-47 SESS PCI test driver failed to register.

316-888-47 SESS PCI test driver failed to unregister.

316-889-47 SW verify get data failed.

316-890-47 SW verify get next proc failed.

316-891-19 Remote Services failed to register.

316-891-47 Invalid RPC submit job Data Received.

316-891-89 Edge server auto registration failed.

316-892-19 Remote Services cannot contact Remote Services datacenter.

316-892-47 Invalid RPC Data Received; Unknown diagnostic action.

316-892-89 Edge server communication failed.

316-893-47 Invalid RPC Data Received; Invalid job type.

316-894-47 Invalid RPC disk diagnostics Data Received.

316-896-00 Remote Services Sync Failed.

316-896-01 Remote Services Data Push Failed.

316-896-02 Remote Services Data Collection Incomplete.

316-900-19 Failed to open on SMC driver.

316-901-19 Failed to make ioctl call using SMC driver.

316-903-19 Result from ioctl does not match FD.

316-904-19 Invalid ioctl request.

316-905-19 Unknown ioctl failure.

316-906-19 Malloc failed for net upgrade.

316-907-19 Attempt to get pinned memory failed.

316-908-19 Error opening File.

316-909-19 Error transfer data to CCM.

316-910-19 Failed to untar File.

316-911-19 Error changing directory.

316-912-19 Install script did not execute.

316-913-19 Write failure to File.

316-914-19 Shared memory was corrupted.

316-915-19 Open failed.

316-916-19 CRC Failed.

316-917-19 Failed to close on checksum.

316-918-19 CRC comparison failed.

316-919-19 Restart request failed.

316-920-19 ELT Daemon start failed.

316-922-19 NVM store failed.

316-923-19 Failed saving persistent data.

316-924-19 Failed in restoring persistent data.

316-925-19 Failed saving web config data.

316-926-19 Failed to save data store values.

316-927-19 Failed to restore web config data.

316-928-19 Failed to install files.

316-929-19 Failed to restore data store values.

Procedure

1. If a single occurrence, take no action.
2. For multiple occurrences, perform, [316E Network Fault Checkout RAP](#).

316-930-19 to 316-971-19 Network Faults 26 RAP

316-930-19 Failed to remove jobs.

316-931-19 Failed to close on SMC driver.

316-932-19 NVM write failure.

316-933-19 Failed to remove File.

316-934-19 Job Based Accounting not enough dc memory.

316-935-19 Auto-Upgrade failed Cannot read/write attributes to machine.

316-936-19 Auto-Upgrade failed Cannot connect to remote server.

316-937-19 Auto-Upgrade failed Cannot login to remote server.

316-938-19 Auto-Upgrade failed Cannot access directory on remote server.

316-939-19 Auto-Upgrade failed Multiple upgrade files found on remote server.

316-940-19 Auto-Upgrade failed Machine is in diagnostics mode.

316-941-19 Auto-Upgrade failed Network controller cannot communicate with main controller.

316-942-19 Auto-Upgrade failed Upgrade file is invalid - Incompatible with main controller.

316-944-19 Auto-Upgrade failed Upgrade file is invalid - File corruption detected.

316-945-19 Auto-Upgrade failed Upgrade file is invalid - File is not appropriate for current machine software.

316-946-19 Failed to install Scan to Email.

316-947-19 Failed to install internet Fax.

316-948-19 Remove of Scan to Email option failed.

316-949-19 Remove of Internet Fax option failed.

316-950-19 Scan to Email image processing hardware not available.

316-951-19 Internet fax image processing hardware not available.

316-952-19 Scan to Email memory size error.

316-953-19 Internet fax memory size error.

316-958-19 Failed to install Kerberos.

316-959-19 Failed to install SMB.

316-960-19 Failed to install SMTP.

316-961-19 Failed to remove Kerberos.

316-962-19 Failed to remove SMB.

316-963-19 Failed to remove SMTP.

316-964-19 Failed to Cancel operation.

316-965-19 Failed to send Platform Unavailable.

316-966-19 Failed to install job tracker.

316-967-19 Failed to remove job tracker.

316-968-19 Failed to install POP3.

316-969-19 Failed to remove POP3.

316-970-19 Over allocation of contiguous memory.

316-971-19 Auto-Upgrade not attempted due to machine being offline.

Procedure

1. If a single occurrence, take no action.
2. For multiple occurrences, perform, [316E Network Fault Checkout RAP](#).

316-972-08 to 316-986-19 Network Faults 27 RAP

316-972-08 Bootmgr's SW verify failed.

316-972-09 SWUP Signature Verification Fails.

316-972-15 DLM signature fails.

316-975-19 Failed to install Disk Overwrite.

316-976-19 Failed to install Immediate Image Overwrite.

316-977-00 Queue List Jobs failure.

316-977-19 NC PM failed to remove Disk Overwrite.

316-978-19 NC PM failed to remove Job Overwrite.

316-979-19 NC PM failed to remove Embedded Fax.

316-980-19 NC PM failed to install G4.

316-981-00 Unable to Obtain Job Handle.

316-982-19 Failed to remove Embedded Fax.

316-983-19 Failed to remove G4.

316-984-19 CPSR Memory Size Error.

316-985-19 Workflow Scanning Application Registration Error.

316-986-19 Workflow Scanning Application Un-Registration Error.

Procedure

1. If a single occurrence, take no action.
2. For multiple occurrences, perform, [316E Network Fault Checkout RAP](#).

316-990-00 to 316-997-00 Network Faults 28 RAP

316-990-00 Promote Response from DM received with errors.

316-990-19 Lockdown Security Remediation Failed.

316-991-00 Request to DM to promote Job Failed.

316-991-19 Xerox Configuration Watchdog Remediation Failed.

316-992-00 Unable to build SESS Job Identifier for promote.

316-992-19 A security-related item being monitored by the Xerox Configuration Watchdog feature has changed.

316-994-00 Cancel Response from DM received with errors.

316-995-00 Request to DM to Cancel Job Failed.

316-997-00 Unable to get admin - name from data store.

Procedure

1. If a single occurrence, take no action.
2. For multiple occurrences, perform, [316E Network Fault Checkout RAP](#).

319-300-00 and 319-301-00 Hard Disk Read/Write Error RAP

319-300-00 Unable to read or write data from the Image Disk

319-301-00 Unable to write data to the Image Disk RAP

Procedure



WARNING: Switch off the electricity to the machine, **GP 10**. Disconnect the power lead from the customer supply while performing tasks that do not need electricity. Electricity can cause the death or injury. Moving components can cause the injury.

Switch OFF, then switch ON the machine, **GP 10**.

The fault persists.

Y N

- | Perform, **SCP 5** Final Actions, then log the problem in the **Logbook**.
- Perform Software Upgrade, **GP 4**.
- If installed, verify the harness between the optional 500Gb+ hard disk, **PL 25.05 item 2**, and the controller PWB **PL 3.05**, is fully seated and has no damage. Repair any damage to the harness as required.
- If the fault persists, install new components as required:
 1. Optional 500Gb+ hard disk, **PL 25.05 item 2**
 2. Controller PWB, **PL 3.05**.

319-340-00 SIC Crash RAP

Scan Image Controller (SIC) detects that it has recovered from a crash.

Procedure



WARNING: Switch off the electricity to the machine, GP 10 . Disconnect the power lead from the customer supply while performing tasks that do not need electricity. Electricity can cause the death or injury. Moving components can cause the injury.

Switch OFF, then switch ON the machine, GP 10. If the fault persists, call 2nd level support.

319-350-00 Missing Side 2 Calibration File at Reboot RAP

319-350-00 Missing side 2 calibration file at reboot RAP

Procedure



WARNING: Switch off the electricity to the machine, GP 10 . Disconnect the power lead from the customer supply while performing tasks that do not need electricity. Electricity can cause the death or injury. Moving components can cause the injury.

1. Switch OFF, then switch ON the machine, GP 10.
2. If the fault persists, perform dC945, IIT Calibration.

319-401 Out Of Memory Caused By Stress Document

Out of memory caused by a stress document

Procedure



WARNING: Switch off the electricity to the machine, GP 10 . Disconnect the power lead from the customer supply while performing tasks that do not need electricity. Electricity can cause the death or injury. Moving components can cause the injury.

No action is required. If 319-401 remains for more than 5 minutes, Switch OFF, then switch ON the machine, GP 10. If the problem continues, reload software using GP 4.

319-402 Out Of Memory Caused By Stress Job

Out of memory caused by a stress job

Procedure



WARNING: Switch off the electricity to the machine, GP 10 . Disconnect the power lead from the customer supply while performing tasks that do not need electricity. Electricity can cause the death or injury. Moving components can cause the injury.



CAUTION: Software downgrades cannot be performed by a customer. When using the FORCED_ALTBOOT method, follow the procedure in GP 4, Software Upgrade. Inform the customer that customer data will not be retained using the FORCED_ALTBOOT method for downgrading machine software.

No action is required. If the fault remains for more than 5 minutes, Switch OFF, then switch ON the machine, GP 10. If the problem continues, go to GP 4 and perform the Regular AltBoot procedure.

319-403–00 Out Of Memory With More Than 1 Job In EPC

Out of memory with greater than one job in EPC.

Procedure



WARNING: Switch off the electricity to the machine, [GP 10](#) . Disconnect the power lead from the customer supply while performing tasks that do not need electricity. Electricity can cause the death or injury. Moving components can cause the injury.



CAUTION: Software downgrades cannot be performed by a customer. When using the FORCED_ALTBOOT method, follow the procedure in [GP 4](#), Software Upgrade. Inform the customer that customer data will not be retained using the FORCED_ALTBOOT method for downgrading machine software.

No action is required. If the fault remains for more than 5 minutes, Switch OFF, then switch ON the machine, [GP 10](#). If the problem continues, go to [GP 4](#) and perform the Regular AltBoot procedure.

319-409-01 Video Integrity Overflow Fault RAP

Video Integrity not Guaranteed due to an Overflow Condition.

Procedure



WARNING: Switch off the electricity to the machine, [GP 10](#) . Disconnect the power lead from the customer supply while performing tasks that do not need electricity. Electricity can cause the death or injury. Moving components can cause the injury.

Switch OFF, then switch ON the machine [GP 10](#). Rerun uncompleted jobs.

319-409-02 Video Integrity Underflow Fault RAP

Video Integrity not guaranteed due to an Underflow Condition.

Procedure



WARNING: Switch off the electricity to the machine, GP 10 . Disconnect the power lead from the customer supply while performing tasks that do not need electricity. Electricity can cause the death or injury. Moving components can cause the injury.

Switch OFF, then switch ON the machineGP 10. Rerun uncompleted jobs.

319-409-03 Video Integrity No Block List Fault RAP

Video Integrity not guaranteed due to a No Block List error.

Procedure



WARNING: Switch off the electricity to the machine, GP 10 . Disconnect the power lead from the customer supply while performing tasks that do not need electricity. Electricity can cause the death or injury. Moving components can cause the injury.

Switch OFF, then switch ON the machineGP 10. Rerun uncompleted jobs.

319-409-04 Video Integrity End Of Block List Fault RAP

Video Integrity not guaranteed due to End of Block List Error.

Procedure



WARNING: Switch off the electricity to the machine, GP 10 . Disconnect the power lead from the customer supply while performing tasks that do not need electricity. Electricity can cause the death or injury. Moving components can cause the injury.

Switch OFF, then switch ON the machineGP 10. Rerun uncompleted jobs.

319-410-00 Mark Output Timeout

Mark Output Timeout. Incomplete image data transfer within the prescribed period. Machine will attempt to recover (may take more then 30 sec.).

Procedure



WARNING: Switch off the electricity to the machine, GP 10 . Disconnect the power lead from the customer supply while performing tasks that do not need electricity. Electricity can cause the death or injury. Moving components can cause the injury.

Switch OFF, then switch ON the machineGP 10. Rerun uncompleted jobs.

319-410-01 Mark Output Timeout/Video Decompressor Fault RAP

Incomplete image data transfer within the prescribed period.

Procedure



WARNING: Switch off the electricity to the machine, GP 10 . Disconnect the power lead from the customer supply while performing tasks that do not need electricity. Electricity can cause the death or injury. Moving components can cause the injury.

1. Switch OFF, then switch ON the machine GP 10.
2. Run the job creating the fault. If the fault persists, upgrade the software, GP 4.

319-410-02 Compress Image Timeout

Compress Image timeout. Incomplete image data transfer within the prescribed period. Job has been deleted.

Procedure



WARNING: Switch off the electricity to the machine, GP 10 . Disconnect the power lead from the customer supply while performing tasks that do not need electricity. Electricity can cause the death or injury. Moving components can cause the injury.



CAUTION: Software downgrades cannot be performed by a customer. When using the FORCED_ALTBOOT method, follow the procedure in GP 4, Software Upgrade. Inform the customer that customer data will not be retained using the FORCED_ALTBOOT method for downgrading machine software.

Perform the following in order:

1. Switch OFF, then switch ON the machine GP 10 and rerun the job.
2. Go to GP 9 and perform the Regular AltBoot procedure.

319-410-03 Decompress Image Timeout

Decompress Image timeout. Incomplete image data transfer within the prescribed period. Job has been deleted.

Procedure



WARNING: Switch off the electricity to the machine, GP 10 . Disconnect the power lead from the customer supply while performing tasks that do not need electricity. Electricity can cause the death or injury. Moving components can cause the injury.

Switch OFF, then switch ON the machineGP 10. Rerun uncompleted jobs.

319-410-04 Merge Image Timeout

Merge Image timeout. Incomplete image data transfer within the prescribed period. Job has been deleted.

Procedure



WARNING: Switch off the electricity to the machine, GP 10 . Disconnect the power lead from the customer supply while performing tasks that do not need electricity. Electricity can cause the death or injury. Moving components can cause the injury.

Switch OFF , then switch ON the machineGP 10. Rerun uncompleted jobs.

319-410-05 Rotate Image Timeout

Rotate Image timeout. Incomplete image data transfer within the prescribed period. Job has been deleted.

Procedure



WARNING: Switch off the electricity to the machine, GP 10 . Disconnect the power lead from the customer supply while performing tasks that do not need electricity. Electricity can cause the death or injury. Moving components can cause the injury.

Switch OFF, then switch ON the machineGP 10. Rerun uncompleted jobs.

319-410-06 Network Input Failure

Network Input Failure. Incomplete image data transfer. Job has been deleted.

Procedure



WARNING: Switch off the electricity to the machine, GP 10 . Disconnect the power lead from the customer supply while performing tasks that do not need electricity. Electricity can cause the death or injury. Moving components can cause the injury.

Switch OFF, then switch ON the machineGP 10. Rerun uncompleted jobs.

319-410-07 E-Fax Send/Receive Failure

E-Fax Send/Receive Failure. Incomplete image data transfer. Job has been deleted.

Procedure



WARNING: Switch off the electricity to the machine, GP 10 . Disconnect the power lead from the customer supply while performing tasks that do not need electricity. Electricity can cause the death or injury. Moving components can cause the injury.

Switch OFF, then switch ON the machineGP 10. Rerun uncompleted jobs.

319-410-08 Scan Input Failure RAP

Scan Input Failure. Incomplete image data transfer. Job has been deleted.

Procedure



WARNING: Switch off the electricity to the machine, GP 10 . Disconnect the power lead from the customer supply while performing tasks that do not need electricity. Electricity can cause the death or injury. Moving components can cause the injury.

1. Switch OFF, then switch ON the machineGP 10.
2. Run the job creating the fault. If the fault persists, upgrade the software, GP 4.

319-410-09 Byte Count Error

Byte Count Error. Incomplete image data transfer. Job has been deleted.

Procedure



WARNING: Switch off the electricity to the machine, GP 10 . Disconnect the power lead from the customer supply while performing tasks that do not need electricity. Electricity can cause the death or injury. Moving components can cause the injury.

Switch OFF, then switch ON the machineGP 10. Rerun uncompleted jobs.

319-410-10 Setup Too Late

Set Up Too Late. Incomplete image data transfer. Job has been deleted.

Procedure



WARNING: Switch off the electricity to the machine, GP 10 . Disconnect the power lead from the customer supply while performing tasks that do not need electricity. Electricity can cause the death or injury. Moving components can cause the injury.

Switch OFF, then switch ON the machineGP 10. Rerun uncompleted jobs.

319-410-11 DMA Master Abort

DMA Master Abort. Incomplete image data transfer. Job has been deleted.

Procedure



WARNING: Switch off the electricity to the machine, GP 10 . Disconnect the power lead from the customer supply while performing tasks that do not need electricity. Electricity can cause the death or injury. Moving components can cause the injury.

Switch OFF, then switch ON the machineGP 10. Rerun uncompleted jobs.

319-410-12 Huffman Error

Huffman Error. Incomplete image data transfer. Job has been deleted.

Procedure



WARNING: Switch off the electricity to the machine, GP 10 . Disconnect the power lead from the customer supply while performing tasks that do not need electricity. Electricity can cause the death or injury. Moving components can cause the injury.

Switch OFF, then switch ON the machineGP 10. Rerun uncompleted jobs.

319-410-13 EOR Error

EOR Error. Incomplete image data transfer. Job has been deleted.

Procedure



WARNING: Switch off the electricity to the machine, GP 10 . Disconnect the power lead from the customer supply while performing tasks that do not need electricity. Electricity can cause the death or injury. Moving components can cause the injury.

Switch OFF, then switch ON the machineGP 10. Rerun uncompleted jobs.

319-410-14 Scan Output Timeout Fault RAP

Intel IAP did not return from function call for Set Scan Path

Procedure



WARNING: Switch off the electricity to the machine, GP 10 . Disconnect the power lead from the customer supply while performing tasks that do not need electricity. Electricity can cause the death or injury. Moving components can cause the injury.

Switch OFF, then switch ON the machineGP 10. Rerun uncompleted jobs.

319-410-15 Image Path Response Error From CIPS RAP

Image Path Response Error from CIPS

Procedure



WARNING: Switch off the electricity to the machine, GP 10 . Disconnect the power lead from the customer supply while performing tasks that do not need electricity. Electricity can cause the death or injury. Moving components can cause the injury.

Switch OFF, then switch ON the machine GP 10. Rerun uncompleted jobs.

319-410-17 Insufficient Memory Allocation RAP

CIPS is not able to allocate enough memory when CCS requests buffer for mark image path set up.

Procedure



WARNING: Switch off the electricity to the machine, GP 10 . Disconnect the power lead from the customer supply while performing tasks that do not need electricity. Electricity can cause the death or injury. Moving components can cause the injury.

Switch OFF, then switch ON the machine, GP 10. Rerun the uncompleted jobs.

319-410-18 Video Fatal error from CIPS RAP

319-410-18 Video Fatal error from CIPS RAP

Procedure



WARNING: Switch off the electricity to the machine, GP 10 . Disconnect the power lead from the customer supply while performing tasks that do not need electricity. Electricity can cause the death or injury. Moving components can cause the injury.

1. Delete all files possible from memory.
2. Switch OFF, then switch ON the machine, GP 10. If the fault persists, call 2nd level support.

319-411-01 Scan Image Capture DMA Setup Too Late RAP

Scan Image Capture DMA is not setup in time and does not capture all of the data.

Procedure



WARNING: Switch off the electricity to the machine, GP 10 . Disconnect the power lead from the customer supply while performing tasks that do not need electricity. Electricity can cause the death or injury. Moving components can cause the injury.

Switch OFF, then switch ON the machine GP 10. Rerun uncompleted jobs.

319-411-02 Scan Image Capture IIT Setup Too Early RAP

The image input terminal has started transferring a scan image before the previous image has completed transferring.

Procedure



WARNING: Switch off the electricity to the machine, GP 10 . Disconnect the power lead from the customer supply while performing tasks that do not need electricity. Electricity can cause the death or injury. Moving components can cause the injury.

Switch OFF, then switch ON the machineGP 10. Rerun uncompleted jobs.

319-411-03 Scan Image Capture DMA Overflow RAP

The Scan Image Capture DMA was not able to pull data fast enough from its buffers which results in the buffers overflowing.

Procedure



WARNING: Switch off the electricity to the machine, GP 10 . Disconnect the power lead from the customer supply while performing tasks that do not need electricity. Electricity can cause the death or injury. Moving components can cause the injury.

Switch OFF, then switch ON the machineGP 10. Rerun uncompleted jobs.

319-411-04 Scan Image Capture DMA Incomplete RAP

The Scan Image Capture DMA failed to receive all the data expected.

Procedure



WARNING: Switch off the electricity to the machine, GP 10 . Disconnect the power lead from the customer supply while performing tasks that do not need electricity. Electricity can cause the death or injury. Moving components can cause the injury.

Switch OFF, then switch ON the machineGP 10. Rerun uncompleted jobs.

319-411-05 Scan Image Capture DMA Timeout RAP

The Scan Image Capture DMA didn't complete in the prescribed period.

Procedure



WARNING: Switch off the electricity to the machine, GP 10 . Disconnect the power lead from the customer supply while performing tasks that do not need electricity. Electricity can cause the death or injury. Moving components can cause the injury.

Switch OFF, then switch ON the machineGP 10. Rerun uncompleted jobs.

319-411-06 Scan Image Capture Planar Data Missing RAP

The Scan Image Capture software error. Data captured but lost in software.

Procedure



WARNING: Switch off the electricity to the machine, GP 10 . Disconnect the power lead from the customer supply while performing tasks that do not need electricity. Electricity can cause the death or injury. Moving components can cause the injury.

Switch OFF, then switch ON the machineGP 10. Rerun uncompleted jobs.

319-411-07 Scan Image Capture DMA Failure Due To Master Abort

The Scan Image Capture DMA failed to receive all the data expected, due to Master Abort triggered on channels.

Procedure



WARNING: Switch off the electricity to the machine, GP 10 . Disconnect the power lead from the customer supply while performing tasks that do not need electricity. Electricity can cause the death or injury. Moving components can cause the injury.

Switch OFF, then switch ON the machineGP 10. Rerun uncompleted jobs.

319-411-08 Scan Image Capture Setup Failure RAP

The scan image capture setup failed due to the SIC buffer allocation failure.

Procedure



WARNING: Switch off the electricity to the machine, GP 10 . Disconnect the power lead from the customer supply while performing tasks that do not need electricity. Electricity can cause the death or injury. Moving components can cause the injury.

Switch OFF, then switch ON the machine, GP 4. Rerun the uncompleted jobs.

319-412-01 Scan Image Capture IIT Line Sync Integrity Error RAP

Unexpected IIT Page Sync that typically indicates noise on the line.

Procedure



WARNING: Switch off the electricity to the machine, GP 10 . Disconnect the power lead from the customer supply while performing tasks that do not need electricity. Electricity can cause the death or injury. Moving components can cause the injury.

Switch OFF, then switch ON the machine GP 10. Rerun uncompleted jobs.

319-420 Image Processing Error At Power UP RAP

Unable to communicate with image processing service at power up.

Procedure



WARNING: Switch off the electricity to the machine, GP 10 . Disconnect the power lead from the customer supply while performing tasks that do not need electricity. Electricity can cause the death or injury. Moving components can cause the injury.

Switch OFF, then switch ON the machine, GP 10. Rerun uncompleted jobs.

319-422 Image Processing Error At Standby RAP

Communication with image processing service is lost.

Procedure



WARNING: Switch off the electricity to the machine, GP 10 . Disconnect the power lead from the customer supply while performing tasks that do not need electricity. Electricity can cause the death or injury. Moving components can cause the injury.

Switch OFF, then switch ON the machine, GP 10. Rerun uncompleted jobs.

319-424 Image Processing Error With Job RAP

Communication with image processing service is lost during a job. Current copy/scan jobs may have been deleted.

Procedure



WARNING: Switch off the electricity to the machine, GP 10 . Disconnect the power lead from the customer supply while performing tasks that do not need electricity. Electricity can cause the death or injury. Moving components can cause the injury.

Switch OFF, then switch ON the machine, GP 10. Rerun uncompleted jobs.

319-426 Image Processing Error During Print RAP

Communication with image processing service is lost during a print/fax job.

Procedure



WARNING: Switch off the electricity to the machine, GP 10 . Disconnect the power lead from the customer supply while performing tasks that do not need electricity. Electricity can cause the death or injury. Moving components can cause the injury.

Switch OFF, then switch ON the machine, GP 10. Rerun uncompleted jobs.

319–476–00 PageNotAvailable Fault RAP

The RIP did not make the page's imaging parameters available by the time the imaging needed to begin.

Procedure

1. Delete the job, then perform the same operation again.
2. If fault persists, switch OFF, then switch ON the machine, [GP 10](#)
3. Upgrade the software, [GP 4](#).
4. Perform the operation again.

319-476-01 to 319–476–03 Band Fault RAP

319-476-01 Band Not Available Fault RAP

319-476-02 Band Error Fault RAP

319-476-03 Incomplete Error RAP

Similar to Page Not Available, but for an individual band. The imaging was set up and may have partially completed, but incoming image data was not available by the time it needed to be sent to the laser.

DMA of a band to the laser failed. This can be caused by the RIP sending unsupported image parameters, a band of incorrect size, or a software error in the engine that caused a real-time deadline to be missed.

Imaging stopped successfully before sending all the lines of an image. This can happen if the paper is physically shorter than the incoming image data.

Procedure



WARNING: Switch off the electricity to the machine, [GP 10](#). Disconnect the power lead from the customer supply while performing tasks that do not need electricity. Electricity can cause the death or injury. Moving components can cause the injury.

1. Delete all jobs, then run the job causing the fault.
2. Switch OFF, then switch ON the machine, [GP 10](#). Run the job again causing the fault.
3. If the fault persists, upgrade the software, [GP 4](#).

319-750 EPC Memory Size Changed Configuration At Power Up RAP

The System detects that the EPC Memory Size configuration has changed during the Power On sequence.

Procedure



WARNING: Switch off the electricity to the machine, **GP 10**. Disconnect the power lead from the customer supply while performing tasks that do not need electricity. Electricity can cause the death or injury. Moving components can cause the injury.

Switch OFF, then switch ON the machine, **GP 10**. Rerun uncompleted jobs.

319-752 Image Rotation Detected RAP

The system detected that the image rotation configuration had changed during the Power On sequence.

Procedure



WARNING: Switch off the electricity to the machine, **GP 10**. Disconnect the power lead from the customer supply while performing tasks that do not need electricity. Electricity can cause the death or injury. Moving components can cause the injury.

1. Switch OFF, then switch ON the machine, **GP 10**. Run the job again causing the fault.
2. If the fault persists, upgrade the software, **GP 4**.

319-754 Image Disk Configuration Changed At Power Up

The System detects that the Image Disk Configuration (present vs. not present) has changed during the Power On sequence

Procedure



WARNING: Switch off the electricity to the machine, GP 10 . Disconnect the power lead from the customer supply while performing tasks that do not need electricity. Electricity can cause the death or injury. Moving components can cause the injury.

1. Switch OFF, then switch ON the machine, GP 10. Run the job again causing the fault.
2. If the fault persists, upgrade the software, GP 4.

319-760–00 Test Patterns Missing From EPC RAP

Unable to communicate with image processing service at power up.

Procedure



WARNING: Switch off the electricity to the machine, GP 10 . Disconnect the power lead from the customer supply while performing tasks that do not need electricity. Electricity can cause the death or injury. Moving components can cause the injury.

Switch OFF, then switch ON the machine,GP 10. Rerun uncompleted jobs.

320-250-00 IR Fax Analog Wrong Jack: Line Connected in Wrong Jack RAP

320-250-00 IRFaxAnalogWrongJack: Line connected in wrong jack RAP



WARNING: Switch off the electricity to the machine, GP 10 . Disconnect the power lead from the customer supply while performing tasks that do not need electricity. Electricity can cause the death or injury. Moving components can cause the injury.

Procedure

ACTION	YES	NO
Step 1 Reconnect the telephone cable on the LINE port of the printer and on the wall jack. The fault persists.	Go to step 2.	The problem is solved.
Step 2 Check if the telephone cable sends and receives calls. The cable will send and receive calls.	Go to step 4.	Go to step 3.
Step 3 Connect the telephone cable to a working wall jack. The fault persists.	Go to step 4.	The problem is solved.
Step 4 Reconnect the modem card ribbon cable on the modem card and on the JFAX1 connector on the controller PWB. The fault persists.	Go to step 5.	The problem is solved.
Step 5 Check the modem card ribbon cable for continuity. The cable have continuity.	Go to step 7.	Go to step 6.
Step 6 Install a new modem card ribbon cable. The fault persists.	Go to step 7.	The problem is solved.
Step 7 Measure the voltages of pins 4, 5, and 7 of the JFAX1 connector on the controller PWB. Are the voltages of pins 4 and 5 equal to +3.3 V DC and pin 7 equal to +5 V DC?	Go to step 8.	Go to step 9.

ACTION	YES	NO
Step 8 Install a new fax card. The fault persists.	Go to step 9.	The problem is solved.
Step 9 Install a new controller PWB. See PL 3.05 . The fault persists.	Contact the next level of support.	The problem is solved.

320-302-00 to 320-345-00, 320-713-00 Fax Errors RAP

C625 Wiring Diagrams

320-302-00 Fax Unexpected Reset

320-303-00 Fax Basic Card Unrecoverable Fault

320-305-00 Fax System Low Memory Unrecoverable Fault

320-320-00 5 instances of an unrecoverable fax fault and has not been cleared by a card reset

320-322-00 NV device not fitted to basic fax card

320-323-00 Fax system memory is low

320-331-00 No comms via PSTN1 port

320-332-00 No comms via PSTN2 port

320-338-00 Fax communication error at power up or re-boot

320-339-00 Internal fax card fault

320-340-00 FaxPort2ModemFailure

320-341-00 Miscellaneous Basic Card problems

320-342-00 Error accessing file on a NV device

320-345-00 FaxPort1ModemFailure

320-713-00 Fax Job Data Removal Error

Initial Actions

Print a Configuration Sheet.

Procedure



WARNING: Switch off the electricity to the machine, [GP 10](#) . Disconnect the power lead from the customer supply while performing tasks that do not need electricity. Electricity can cause the death or injury. Moving components can cause the injury.

Perform, [OF 12](#), Modem/Fax PWB Service RAP

320-347-00, 320-347-01, 320-348-00, 320-348-01 Fax Card 1 & 2 Modem Firmware Upgrade Failure RAP

C625 Wiring Diagrams

320-347-00 Failed to upgrade the Faxcard1 modem firmware.

320-347-01 Failed to upgrade the Faxcard2 modem firmware.

320-348-00 Failed to put Fax Modem 1 into upgrade mode

320-348-01 Failed to put Fax Modem 2 into upgrade mode

Initial Actions

Print a Configuration Sheet and a Software Failure Report. Refer to, [GP 14](#) Printing Reports.

Procedure



WARNING: Switch off the electricity to the machine, [GP 10](#). Disconnect the power lead from the customer supply while performing tasks that do not need electricity. Electricity can cause the death or injury. Moving components can cause the injury.



CAUTION: Software downgrades cannot be performed by a customer. When using the FORCED_ALTBOOT method, follow the procedure in [GP 4](#), Software Upgrade. Inform the customer that customer data will not be retained using the FORCED_ALTBOOT method for downgrading machine software.

1. Ensure the FAX is enabled.
2. Check that the FAX phone wire is securely connected between the wall jack and the machine fax port. There may be an **Input** and an **Output** line connection, verify the cable is in the **Input** line connection on the fax PWB.
3. Perform, [OF 12](#) Modem/Fax PWB Service RAP, to verify fax settings are correct.
4. Perform a FORCED_ALTBOOT software installation, [GP 4](#).
5. If the fault persists, install a new fax PWB [PL 20.10](#) item 1.

320-324-00 and 320-349-00 Fax Failure Error RAP

C625 Wiring Diagrams

320-324-00 Not enough memory to use Fax Service RAP

320-349-00 IR Fax Analog Missing: No analog phone line RAP



WARNING: Switch off the electricity to the machine, [GP 10](#). Disconnect the power lead from the customer supply while performing tasks that do not need electricity. Electricity can cause the death or injury. Moving components can cause the injury.

Procedure

ACTION	YES	NO
Step 1 Turn off the printer, wait for about 10 seconds, and then turn on the printer. The fault persists.	Go to step 2.	The problem is solved.
Step 2 1 Ensure that the telephone cable is properly connected to the line port of the printer. 2 Ensure that the other end of the cable is connected to an active analog wall jack. Contact the analog phone service provider if necessary. The fault persists.	Go to step 3.	The problem is solved.
Step 3 Check the line port connector pins of the fax card for corrosion and damage. Note: The telephone cable must properly fit with the line port. The fax card is connector free of damage.	Go to step 4.	The problem is solved.
Step 4 Check the Software version. The Software is updated to the latest version.	Go to step 6.	Go to step 5.
Step 5 Update the Software. The fault persists.	Go to step 6.	The problem is solved.
Step 6 Ensure that the controller PWB is properly installed.	Go to step 7.	The problem is solved.

ACTION	YES	NO
Reconnect all the cables on the controller PWB. The fault persists.		
Step 7 Check the controller PWB and its connector pins for damage. The controller PWB and its connectors are free of damage.	Contact the next level of support.	Go to step 8.
Step 8 Install a new controller PWB. See PL 3.05 item 1 . The fault persists.	Contact the next level of support.	The problem is solved.

320-701-00 Fax Phone Book Download Fault RAP

Phone book download failed

Initial Actions

Print a Configuration Sheet and a Software Failure Report. Refer to, [GP 14](#) Printing Reports.

Procedure



WARNING: Switch off the electricity to the machine, [GP 10](#). Disconnect the power lead from the customer supply while performing tasks that do not need electricity. Electricity can cause the death or injury. Moving components can cause the injury.

1. Perform Software Upgrade, [GP 4](#), using the FORCED_ALTBOOT method.
2. If the fault persists, install a new fax PWB, [PL 20.10 item 1](#).

320-710-00 and 320-711-00 Fax Image Overwrite Error RAP

C625 Wiring Diagrams

320-710-00 IIO Error has occurred on the fax card when overwriting the job

320-711-00 ODIO Error has occurred on the fax card when overwriting the compact flash memory

Initial Actions

Print a Configuration Sheet and a Software Failure Report. Refer to, [GP 14](#) Printing Reports.

Procedure



WARNING: Switch off the electricity to the machine, [GP 10](#) . Disconnect the power lead from the customer supply while performing tasks that do not need electricity. Electricity can cause the death or injury. Moving components can cause the injury.

1. Ensure the FAX is enabled
2. Perform, [GP 4](#) Software Upgrade, using the FORCED_ALTBOOT method.
3. Perform, [OF 12](#) Modem/Fax PWB Service RAP, to verify the Fax settings are correct
4. If the fault persists, install a new fax PWB [PL 20.10 item 1](#).

322-300-05, 322-300-10, 322-301-05, 322-315-04 Image Transfer Errors RAP

322-300-05 Image Complete not received from video.

322-300-10 Failed to transfer image due to decoding error.

322-301-05 Scan resources not available.

322-315-04 One or more e modules did not respond with completion message.

Initial Actions

Rerun job after the machine recovers

Check the Service Log for the frequency of occurrence of this fault.

Check dC122 Fault History for the frequency of occurrence of this fault

Procedure



WARNING: Switch off the electricity to the machine, GP 10 . Disconnect the power lead from the customer supply while performing tasks that do not need electricity. Electricity can cause the death or injury. Moving components can cause the injury.

Switch OFF, then switch ON the machineGP 10. Rerun job.

The fault persists.

Y N

Return to SCP 3.

Note: Record the fault in the Logbook. If the same fault recurs frequently, perform the actions listed in the Y branch of this RAP.

Perform the following in order:

1. Upgrade SW using GP 4.

322-300-16 Clock Overflow Fault

When machine determines that it needs to do a reset in order to avoid an impending real time clock overflow

Procedure



WARNING: Switch off the electricity to the machine, GP 10 . Disconnect the power lead from the customer supply while performing tasks that do not need electricity. Electricity can cause the death or injury. Moving components can cause the injury.

Switch OFF, then switch ON the machineGP 10.

The fault persists.

Y N

Return to SCP 3.

Note: Record the fault in the Logbook. If the same fault recurs frequently, perform the actions listed in the Y branch of this RAP.

Perform the following in order:

1. Upgrade SW using GP 4.
2. Initiaize NVM using dC301
3. Install a new controller PWBPL 3.05 item 2

322-309-04 NO Accepts Received Fault RAP

Consecutive NO accepts received from a module exceeds threshold value (currently 20).

Five consecutive 322-309-04 will cause 322-319-04.

Procedure

Switch OFF, then switch ON the machine GP 10.

If the fault persists, go to the [322-319-04](#) IOT Integrity Problem While Printing a Job RAP.

322-310-04 to 322-318-04 Paper Supply Errors RAP

322-310-04 Pages received from extended job service out of sequence.

322-311-04 Sequencer failed to respond with proposal within the required time.

322-314-04 Module registration error.

322-315-04 One or more modules failed to respond with a completion message.

322-316-04 Job required paper tray that does not exist.

322-317-04 Job required finishing capability that does not exist.

322-318-04 Job required an IOT capability that does not exist.

Procedure



WARNING: Switch off the electricity to the machine, GP 10 . Disconnect the power lead from the customer supply while performing tasks that do not need electricity. Electricity can cause the death or injury. Moving components can cause the injury.

1. Verify the UI control panel tray settings and the tray configuration are correct for the job requested.
2. Switch OFF, then switch ON the machine, GP 10.
3. Delete the original job, then rerun the job causing the fault.

322-311-04 Sequencer Response Fault RAP

Sequencer did not respond with proposal within the required time

Initial Actions

Check the Service Log for the frequency of occurrence of this fault.

Check dC122 Fault History for the frequency of occurrence of this fault.

Procedure



WARNING: Switch off the electricity to the machine, GP 10 . Disconnect the power lead from the customer supply while performing tasks that do not need electricity. Electricity can cause the death or injury. Moving components can cause the injury.

Switch OFF, then switch ON the machine GP 10.

The fault persists.

Y N

Return to SCP 3.

Note: Record the fault in the Logbook. If the same fault recurs frequently, perform the actions listed in the Y branch of this RAP.

Perform the following in order:

1. Perform Software Upgrade, GP 4.
2. Install a new drive PWB, PL 1.10 item 3
3. Install a new controller PWB, PL 3.05 item 2

322-314-04 Module Registration Error RAP

Module registration message was received beyond required time window.

Initial Actions

Check the Service Log for the frequency of occurrence of this fault.

Check dC122 Fault History for the frequency of occurrence of this fault

Procedure

Switch OFF, then switch ON the machine, GP 10.

322-316-04, 322-317-04, 322-318-04 Job Requirement Error RAP

322-316-04 Job Requires Paper Tray that does not exist.

322-317-04 Job requires finishing capability that does not exist

322-318-04 Job requires an IOT capability that does not exist

Initial Actions

Verify the settings in the UI and the paper in the trays match the job requested.

Check the Service Log for the frequency of occurrence of this fault.

Check [dC122](#) Fault History, for the frequency of occurrence of this fault

Procedure



WARNING: Switch off the electricity to the machine, [GP 10](#). Disconnect the power lead from the customer supply while performing tasks that do not need electricity. Electricity can cause the death or injury. Moving components can cause the injury.

Switch OFF, then switch ON the machine, [GP 10](#), then perform the same operation causing the fault.

The fault persists.

Y N

Return to [SCP 3](#).

Note: Record the fault in the [Logbook](#). If the same fault recurs frequently, perform the actions listed in the Y branch of this RAP.

The Job is a copy job.

Y N

Perform the same operation causing the fault from a different computer. If the fault persists, perform Software Upgrade, [GP 4](#), using the FORCED_ALTBOOT method.

Perform the following in order:

- perform Software Upgrade, [GP 4](#), using the FORCED_ALTBOOT method.
- Verify the harness between the scanner assembly, [PL 60.05 item 1](#), and the controller PWB, [PL 3.05 item 2](#), is correctly seated, no damage exists, and no kinks in the harness path. Correct as required.
- Enter Diagnostics, [GP 1](#). Enter [dC330](#) Component Control, touch [[dC330 Print Engine](#)] > [[Print Engine Tests](#)].

Test the following sensors:

Tray: sensors will show for the trays installed.

- Tray 1 Media Out
- Media size (tray 1) switch 1
- Media size (tray 1) switch 2
- Media size (tray 1) switch 3
- Media size (tray 1) switch 4
- Tray 2 media size switch 1

- Tray 2 media size switch 2
- Tray 2 media size switch 3
- Tray 2 media size switch 4
- Tray 3 media size switch 1
- Tray 3 media size switch 2
- Tray 3 media size switch 3
- Tray 3 media size switch 4
- Tray 4 media size switch 1
- Tray 4 media size switch 2
- Tray 4 media size switch 3
- Tray 4 media size switch 4
- Tray 5 media size switch 1
- Tray 5 media size switch 2
- Tray 5 media size switch 3
- Tray 5 media size switch 4

Close the Print Engine tests, then touch [[Scanner Diagnostics](#)] > [Scanner \[Feed\]](#):

- Select paper size
- Feed test

Repair or install new sensors as required.

- If the fault persists, install new components as required:



CAUTION: Never install a new drive PWB, new controller PWB, or black toner cartridge at the same time. First install one of the parts, then switch on the machine, [GP 10](#). If the installation is successful, switch off the machine, then install another part item if necessary.



CAUTION: The serial number is stored and synchronized between the controller PWB, drive PWB, and black toner cartridge. Always install these items individually. After installation of one of these items, switch on the machine, [GP 1](#), to allow the serial number to synchronize before proceeding to install the next part. Refer to [dC132](#) Machine Serial Number.

- Drive PWB, [PL 1.10 item 3](#).
- Controller PWB, [PL 3.05 item 2](#).

322-319-04 IOT Integrity Problem While Printing a Job RAP

Mark Service broadcasts an event identifying the Job ID and the reason for the time out:

1. If the deleted job is a Copy job, the UI uses the event information to inform the user that the job has been deleted and needs to be rescanned.
2. If the deleted job is a Print Job, the ESS uses the information to delete the job.
3. Early versions of the C625 and B625 machine may fault if there is an open tray above the tray used by the job.

This fault can result in two ways:

1. IOT Cycles down and back up 10 times without printing a page within the same job causing a 322-319-04 fault.
2. Five consecutive 322-309-04 faults will also cause a 322-319-04 fault.

Procedure

1. Switch OFF, then switch ON the machine [GP 10](#).
2. If the fault persists, check fault history for 322-309-04. Perform RAP [322-309-04](#) to resolve the fault.

322-320-04 to 322-327-00, 322-335-00 to 322-340-00 Software Install Failed RAP

322-320-00 SM Failed to install scan to file.

322-321-00 SM Failed to remove Scan to file.

322-322-00 SM Failed to install LAN FAX.

322-323-00 SM Failed to remove LAN FAX.

322-324-00 SM Failed to install Scan to Email.

322-325-00 SM Failed to remove Scan to Email.

322-326-00 SM Failed to install IFAX.

322-327-00 SM Failed to remove IFAX.

322-335-00 SM Failed to install Job Based Accounting.

322-336-00 SM Failed to remove Job Based Accounting.

322-337-00 SM Failed to install disk overwrite.

322-338-00 SM Failed to remove Disk Overwrite.

322-339-00 SM Failed to install Job Overwrite.

322-340-00 SM Failed to remove Job Overwrite.

Initial Actions

Check the Service Log for the frequency of occurrence of this fault.

Check [dC122](#) Fault History for the frequency of occurrence of this fault

Procedure



WARNING: Switch off the electricity to the machine, [GP 10](#) . Disconnect the power lead from the customer supply while performing tasks that do not need electricity. Electricity can cause the death or injury. Moving components can cause the injury.

Switch OFF, then switch ON the machine, [GP 10](#).

The fault persists.

Y N

Return to [SCP 3](#).

Note: Record the fault in the [Logbook](#). If the same fault recurs frequently, perform the actions listed in the Y branch of this RAP.

1. Perform, Software Upgrade [GP 4](#), using the FORCED_ALTBOOT method.
2. Install a new controller PWB, [PL 3.05](#).

322-328–00 Incomplete System Information

Incomplete System Information.

Procedure

Restart the machine, [GP 10](#) How to Switch Off, or Switch On the Machine.

332–330–00 and 322-332–00 Supplies Plan Errors RAP

322-330-00 PagePack PIN (Supplies Plan Activation Code) Entry Locked RAP

322-332-00 Invalid Plan Conversion RAP

Plan conversion invalid due to repeated incorrect entry attempts.

Initial Actions

Ensure that this fault code did not occur during an attempt to perform plan conversion. Refer to, [GP 26](#) PagePack (Supplies Plan) Plan Conversion.

Check the [Service Log](#) for the frequency of occurrence of this fault.

Check [dC122](#) Fault History for the frequency of occurrence of this fault

Procedure



WARNING: Switch off the electricity to the machine, [GP 10](#) . Disconnect the power lead from the customer supply while performing tasks that do not need electricity. Electricity can cause the death or injury. Moving components can cause the injury.

Switch OFF, then switch ON the machine, [GP 10](#).

The fault persists.

Y N

Return to, [SCP 3](#).

Note: Record the fault in the, [Service Log](#). If fault recurs frequently, perform the actions listed in the Y branch of this RAP.

Perform the following in order:

1. Upgrade the software, [GP 4](#).
2. Install a new controller PWB, [PL 3.05](#).

If the fault persists, contact next level support.

322-350-02 Software detects non-valid Xerox SOK 2 or 3 RAP

322-350-02 Software detects non-valid Xerox SOK 2 or 3 RAP

Procedure

1. Remove all requested options from the SOK.
2. Switch off, then switch on the machine, [GP 10](#). If the fault persists, call 2nd level support.

322-352-00 Serial Number Missing From Memory RAP

Serial Number Update Required or Serial number lost/missing. A password routine may be required to write serial number to machine.

Initial Actions

1. Confirm that the machine serial number displayed on the UI and on the label on machine frame match. If they do not match notify the FE/NTS.
 - a. Select, **Machine Status > Machine Information Screen**.
 - b. Print a Configuration Sheet, [GP 14](#) Printing Reports, if the UI is unavailable.

Check all P/J connectors for loose or unseated connectors on the following PWBs.

1. Drive PWB, [PL 1.10 item 3](#).
2. Controller PWB, [PL 3.05 item 2](#).
3. Check the Fault History, [dC122](#), for communications faults. These can prevent serial number synchronization and must be addressed before proceeding.
4. Enter Diagnostics, [GP 1](#), then touch **[Clear Counters]**. **[Exit and Reboot]** at Diagnostics Exit.
5. If the fault persists, order new PWBs as per listed below before troubleshooting the fault.
 - Drive PWB, [PL 1.10 item 3](#).
 - Controller PWB, [PL 3.05 item 2](#).



WARNING: Do not swap PWBs between machines.



WARNING: Do not remove the batteries from any PWBs while making voltage checks in this RAP.



CAUTION: The serial number is stored and synchronized between the controller PWB, drive PWB, and black toner cartridge. Always install these items individually. After installation of one of these items, switch on the machine, [GP 1](#), to allow the serial number to synchronize before proceeding to install the next part. Refer to [dC132](#) Machine Serial Number.



CAUTION: Never install a new drive PWB, new controller PWB, or black toner cartridge at the same time. First install one of the parts, then switch on the machine, [GP 10](#). If the installation is successful, switch off the machine, then install another part item if necessary.



WARNING: Switch off the electricity to the machine, [GP 10](#). Disconnect the power lead from the customer supply while performing tasks that do not need electricity. Electricity can cause the death or injury. Moving components can cause the injury.

Switch OFF, then switch ON the machine, [GP 10](#). If the fault persists, wait 5 minutes, then perform [GP 10](#) again.

Procedure

Match the serial numbers on the UI. Select, **[Machine Status > Machine Information]**, and the serial number on the plate inside the front cover and the Configuration Report printed at the beginning of this RAP.



WARNING: Do not remove the black (K) toner cartridge or the imaging unit from the machine unless instructed to do so. Removing may cause the serial number synchronization to fail. The black (K) CRUM holds serial number information and is synced with the drive PWB and controller PWB.

The serial numbers match.

Y N

1. Switch OFF the machine, [GP 10](#), then disconnect the power cord for the source.
2. Contact next level support, then go to [GP 35](#) Serial Number Synchronization Procedure.

A new drive PWB and controller PWB were installed at the same time.

Y N

Install the original controller PWB back into the machine, then perform, [GP 10](#).

The fault persists.

Y N

1. Check the Fault History, [dC122](#). If no other fault codes exist perform, [SCP 5](#) Final Actions.
2. If more faults are listed, perform the corresponding RAP to clear the fault.

Reseat all connectors between the controller PWB, [PL 3.05 item 2](#) and the drive PWB, [PL 1.10 item 3](#).

The fault persists.

Y N

Perform, [SCP 5](#) Final Actions.
Perform, [dC132](#) to restore serial number integrity.

The fault persists.

Y N

1. Check the Fault History, [dC122](#). If no other fault codes exist perform, [SCP 5](#) Final Actions.
2. If more faults are listed, perform the corresponding RAP to clear the fault.

1. Enter Diagnostics, [GP 1](#), then perform [dC122](#). If other fault codes are present, go to the specific fault code RAP.
2. Switch off the machine, [GP 10](#).
3. Install the original drive PWB back into the machine.
4. Perform, [dC132](#) to restore serial number integrity.
5. Perform Software Upgrade, [GP 4](#). If the fault persists, contact next level support for assistance.
6. Check the fault log for fault code 322-365-00. If the fault is listed, perform RAP, [322-365-00](#) Engine Serial Number Needs Recovery RAP.
7. Perform, [SCP 5](#), Final Actions.

322-360-00 to 322-363-00 3-way Sync (Service Plan) Faults RAP

322-360-00 Service Plan Mismatch

Three way sync of Service Plan could not be resolved or is associated with incorrect Region.

322-361-00 Product ID Mismatch RAP

Three way sync of ProductID could not be resolved

322-362-00 Product Class Mismatch RAP

Three way sync of Product Class could not be resolved

322-363-00 Billing Counter Mismatch RAP

Three way sync of Billing Counters could not be resolved

Primary Causes

Typically these faults are caused by the installation of a new controller PWB, new drive PWB, black (K) toner cartridge, or a combination of these installed in the same task.

Procedure

1. Perform, [GP 35](#), Serial Number Synchronization Procedure.
2. If the fault persists, contact next level support.

322-364-00 Critical Parameters Restored from Mirror RAP

Three way sync determined that the primary NVM storage has been replaced or corrupted.

Procedure

1. Perform, [GP 35](#) Serial Number Synchronization Procedure.

322-365-00 Engine Serial Number Needs Recovery RAP

Three way sync determined that the engine Critical Parameter File is lost or corrupted.

Procedure

- Perform [GP 35](#) Serial Number Synchronization Procedure.

322-370-00 Unable To Communicate With XSA Database

XSA communication lost, SW issue internal to the device.

Procedure



WARNING: Switch off the electricity to the machine, GP 10. Disconnect the power lead from the customer supply while performing tasks that do not need electricity. Electricity can cause the death or injury. Moving components can cause the injury.

Switch OFF, then switch ON the machine GP 10.

322-371-00, 322-407-00, 322-417-00, 322-419-00, 322-421-00 Embedded Fax Errors RAP

322-371-00 Fax Application Registration Error RAP

322-407-00 SM Failed To Install Embedded Fax RAP

322-417-00 SM Failed To Removal Embedded Fax RAP

322-419-00 SM Failed To Enable Embedded Fax RAP

322-421-00 SM Failed To Disable Embedded Fax RAP

Set by Fax Service when it gets no response from Service Registry when trying to Register.

Initial Actions

- If the Fax Card is installed, go to OF 12.
- Check the Service Log for the frequency of occurrence of this fault.
- Check dC122 Fault History for the frequency of occurrence of this fault

Procedure



WARNING: Switch off the electricity to the machine, GP 10. Disconnect the power lead from the customer supply while performing tasks that do not need electricity. Electricity can cause the death or injury. Moving components can cause the injury.

Switch OFF, then switch ON the machine GP 10.

The fault code reappears.

Y N

Return to SCP 3.

Note: Record the fault in the Logbook. If the same fault recurs frequently, perform the actions listed in the Y branch of this RAP.

Perform the following in order:

1. Upgrade SW using GP 4.
2. Install a new Fax PWB, PL 20.10 item 1.
3. Install a new controller PWB, PL 3.05.

322-701-04, 322-720-00, 322-721-00, 322-751-04, 322-754-17 Configuration Mismatch Fault RAP

322-701-04 Module completion message received after IOT returned to standby.

322-720-00 Service Registry Bad data / Corrupted.

322-721-00 Triple A gets no response from SRS.

322-751-04 Paper Tray Configuration Mismatch.

322-754-17 When the System detects the UI Configuration has changed during the Power On Sequence.

Procedure



WARNING: Switch off the electricity to the machine, **GP 10**. Disconnect the power lead from the customer supply while performing tasks that do not need electricity. Electricity can cause the death or injury. Moving components can cause the injury.

1. Verify the tray configuration is the same in the UI control panel as is physically configured in the machine.
2. Change the UI control panel configuration to match the job required.
3. Switch OFF, then switch ON the machine, **GP 10**.
4. Check the UI control panel input tray required is set correctly, then run the job again causing the fault.
5. If the fault persists, contact next level support.

341–368–00, 341–369–00 Firmware Mismatch Fail RAP

[WD1 Controller PWB Wiring Diagram](#)

341-368-00 MCU-SW Firmware Mismatch RAP

341-369-00 MD Type Mismatch RAP

Procedure

Perform Software Upgrade, [GP 4](#), using the FORCED_ALTBOOT method.

341–371–00 Speed Update Required Fault RAP

FIK needed to set machine speed (ppm not set).

Procedure

Contact next level support.

342-200-00 to 342-202-00, 342-204-00, 342-208-00 LVPS Error RAP

WD2 Drive PWB Wiring Diagram

C625 Wiring Diagrams

342-200-00 LVPS/controller (switched power rails that determine the PGOOD signal state) dropped while not sleeping RAP

342-201-00 LVPS/controller (switched power rails that determine the PGOOD signal state) line not up by time out from POR/sleep exit RAP

342-202-00 Sensor rail down at POR RAP

342-204-00 Line Frequency outside operating range of device RAP

342-208-00 LVPS relay is stuck closed- RAP



WARNING: Switch off the electricity to the machine, GP 10. Disconnect the power lead from the customer supply while performing tasks that do not need electricity. Electricity can cause the death or injury. Moving components can cause the injury.

Procedure

ACTION	YES	NO
<p>Step 1 1 Turn OFF the printer, and then disconnect it from the electrical outlet for more than five seconds. 2 Restart the printer. The fault persists.</p>	<p>Go to step 2</p>	<p>The problem is solved.</p>
<p>Step 2 Ensure that the JLVP51 connector on the drive PWB, PL 1.10 item 3, and the LVPS, PL 1.10 item 7, is properly connected. The fault persists.</p>	<p>Go to step 3.</p>	<p>The problem is solved</p>
<p>Step 3 Install a new LVPS, PL 1.10 item 7. The fault persists.</p>	<p>Go to step 4.</p>	<p>The problem is solved.</p>
<p>Step 4 Install a new drive PWB, PL 1.10 item 3. The fault persists.</p>	<p>Contact the next level of support.</p>	<p>The problem is solved</p>

342-209-00 HVPS Error RAP

WD2 Drive PWB Wiring Diagram

C625 Wiring Diagrams

342-209-00 First HVPS is not detected RAP



WARNING: Switch off the electricity to the machine, GP 10 . Disconnect the power lead from the customer supply while performing tasks that do not need electricity. Electricity can cause the death or injury. Moving components can cause the injury.

Procedure

ACTION	YES	NO
Step 1 Restart the printer. The fault persists.	Go to step 2.	The problem is solved.
Step 2 Ensure that the JHVPS1 connector on the Drive PWB is properly connected to the HVPS. The fault persists.	Go to step 3.	The problem is solved.
Step 3 Install a new HVPS. See PL 1.10 item 5. The fault persists.	Go to step 4	The problem is solved.
Step 4 Install a new Drive PWB. See PL 1.10 item 3. The fault persists.	Contact the next level of support.	The problem is solved

342-210-00 to 342-213-00 LVPS Fuser Fan Error RAP

342-210-00 LVPS Fan Error - Ramp error (motor failed to achieve expected speed).

342-211-00 LVPS Fan Error - Stall detect error (motor loss of encoders during operation or intentional motor stall occurs prior to expected time).

342-212-00 LVPS Fan Error - PWM overflow (motor under speed).

342-213-00 LVPS Fan Error - PWM underflow (motor over speed).

Procedure

Check that the fuser fan area is clear of obstructions.

The fault persists.

Y N
| Perform SCP 5, Final Actions.

Check that the JFAN1 connector on the drive PWB, PL 1.10 item 3, is properly connected to the fan.

The fault persists.

Y N
| Perform SCP 5, Final Actions.

Install a new fuser Fan, PL 40.15 item 2.

The fault persists.

Y N
| Perform SCP 5, Final Actions.

Install a new drive PWB, PL 1.10 item 3.

The fault persists.

Y N
| Perform SCP 5, Final Actions.

Contact 2nd Level Support.

343-360-00 to 343-362-00, 343-364-00 to 343-366-00, 343-463-00 PC Motor Error RAP

WD2 Drive PWB Wiring Diagram

C625 Wiring Diagrams

343-360-00 PC Motor On Fail RAP

343-361-00 PC Motor Off Fail RAP

343-362-00 PC Motor Speed Fail RAP

343-364-00 PC Motor low speed RAP

343-365-00 PC Motor high speed RAP

343-366-00 PC Motor long Fail RAP

343-463-00 PC Motor Stall RAP



WARNING: Switch off the electricity to the machine, [GP 10](#). Disconnect the power lead from the customer supply while performing tasks that do not need electricity. Electricity can cause the death or injury. Moving components can cause the injury.

Procedure

Action	Yes	No
Step 1 Restart the printer. The fault persists.	Go to step 2.	The problem is solved.
Step 2 1 Remove the imaging kit. See REP 60.1 . 2 Remove the transfer module. See REP 90.9 . 3 Enter the Diagnostics menu GP 1 , and then navigate to: Printer diagnostics & adjustments > Motor tests > CMY developer 4 Touch Start . The motor will run.	Go to step 5.	Go to step 3.
Step 3 Ensure that the JCDRV1 connector on the Drive PWB is properly connected to the motor (CMY). The fault persists.	Go to step 4.	The problem is solved.
Step 4 Install a new motor (CMY). See PL 40.10 item 3 . The fault persists.	Go to step 5.	The problem is solved.

Action	Yes	No
Step 5 1 Check if the CMY imaging kit has reached end-of-life. 2 Check the CMY imaging kit for damage. The CMY imaging kit will be functional and free of damage.	Go to step 7.	Go to step 6.
Step 6 Install the new CMY imaging kit. See PL 26.05 item 2 . The fault persists.	Go to step 7.	The problem is solved.
Step 7 Manually turn the drive gears. The CMY drive gears freely turn.	Go to step 9.	Go to step 8.
Step 8 Install a new EP drive gearbox. See PL 40.10 item 2 . The fault persists.	Go to step 9.	The problem is solved.
Step 9 Install a new Drive PWB. See PL 1.10 item 3 . The fault persists.	Contact the next level of support.	The problem is solved.

344-217-00 to 344-223-00, 364-217-00 to 364-223-00 Staging Motor Error RAP

- 344-217-00 Staging Motor does not turn on RAP
- 344-218-00 Staging Motor does not turn off RAP
- 344-219-00 Staging Motor failed to achieve expected speed RAP
- 344-220-00 Staging Motor loss of encoders (motor stall) RAP
- 344-221-00 Staging Motor under speed RAP
- 344-222-00 Staging Motor over speed RAP
- 344-223-00 Staging Motor moved too long RAP
- 364-217-00 Staging Motor does not turn on RAP
- 364-218-00 Staging Motor does not turn off RAP
- 364-219-00 Staging Motor failed to achieve expected speed RAP
- 364-220-00 Staging Motor loss of encoders (motor stall) RAP
- 364-221-00 Staging Motor under speed RAP
- 364-222-00 Staging Motor overs peed RAP
- 364-223-00 Staging Motor moved too long RAP

Procedure

Action	Yes	No
Step 1 Restart the printer. The fault persists.	Go to step 2.	The problem is solved.
Step 2 1 Enter the Diagnostics menu GP 1, and then navigate to: Printer diagnostics & adjustments > Motor tests > Deskew 2 Touch Start . The motor will run.	Go to step 5.	Go to step 3.
Step 3 Ensure that the JMTR1 connector on the Drive PWB is properly connected to the motor. The fault persists.	Go to step 4.	Contact the next level of support.
Step 4 Install a new motor. See PL 40.10 item 1. The fault persists.	Go to step 5.	Contact the next level of support.

Action	Yes	No
Step 5 Manually turn the aligner rollers. There is binding or uneven movement when turning the rollers.	Go to step 6.	Go to step 7.
Step 6 Check the aligner rollers and drivetrain for damage. The aligner roller and drivetrain are free of damage.	Go to step 8.	Go to step 7.
Step 7 Install a new aligner roller or drivetrain. See PL 80.05 item 8. The fault persists.	Go to step 8.	The problem is solved.
Step 8 Install a new Drive PWB. See PL 1.10 item 3. The fault persists.	Contact the next level of support.	The problem is solved.

344-224-00 to 344-230-00, 364-222-00 to 364-230-00 Re-drive Motor Error RAP

WD2 Drive PWB Wiring Diagram

C625 Wiring Diagrams

344-224-00 Redrive Motor does not turn on.

344-225-00 Redrive Motor does not turn off.

344-226-00 Redrive Motor failed to achieve expected speed.

344-227-00 Redrive Motor loss of encoders (motor stall).

344-228-00 Redrive Motor under speed.

344-229-00 Redrive Motor over speed.

344-230-00 Redrive Motor moved too long.

364-225-00 Redrive Motor does not turn off.

364-226-00 Redrive Motor failed to achieve expected speed.

364-227-00 Redrive Motor loss of encoders (motor stall).

364-228-00 Redrive Motor under speed.

364-229-00 Redrive Motor over speed.

364-230-00 Redrive Motor moved too long.



WARNING: Switch off the electricity to the machine, GP 10 . Disconnect the power lead from the customer supply while performing tasks that do not need electricity. Electricity can cause the death or injury. Moving components can cause the injury.

Procedure

ACTION	YES	NO
Step 1 Restart the printer. The fault persists.	Go to step 2.	The problem is solved.
Step 2 Ensure that the JOUTDC1 connector on the drive PWB, PL 1.10 item 3, is properly connected to the motor (exit/redrive), PL 80.05 item 10. The fault persists.	Go to step 3.	The problem is solved.
Step 3 Restart the printer. The fault persists.	Go to step 4.	The problem is solved.
Step 4 Install a new motor (exit/redrive), PL 80.05 item 10.	Go to step 5.	The problem is solved.

ACTION	YES	NO
The fault persists.		
Step 5 Restart the printer. The fault persists.	Go to step 6.	The problem is solved.
Step 6 Install a new drive PWB. See PL 1.10 item 3. The fault persists.	Contact the next level of support.	The problem is solved.

344-231-00 to 344-244-00, 364-231-00 to 364-237-00, 377-350-00 to 377-356-00 Motor (DUPLEX/MPF) Error RAP

WD2 Drive PWB Wiring Diagram

C625 Wiring Diagrams

- 344-231-00 Duplex Motor does not turn on RAP
- 344-232-00 Duplex Motor does not turn off RAP
- 344-233-00 Duplex Motor failed to achieve expected speed RAP
- 344-234-00 Duplex Motor loss of encoders (motor stall) RAP
- 344-235-00 Duplex Motor under speed RAP
- 344-236-00 Duplex Motor over speed RAP
- 344-237-00 Duplex Motor moved too long RAP
- 344-238-00 MPF Motor does not turn on RAP
- 344-239-00 MPF Motor does not turn off RAP
- 344-240-00 MPF Motor failed to achieve expected speed RAP
- 344-241-00 MPF Motor loss of encoders (motor stall) RAP
- 344-242-00 MPF Motor under speed RAP
- 344-243-00 MPF Motor over speed RAP
- 344-244-00 MPF Motor moved too long RAP
- 364-231-00 Duplex Motor does not turn on RAP
- 364-232-00 Duplex Motor does not turn off RAP
- 364-233-00 Duplex Motor failed to achieve expected speed RAP
- 364-234-00 Duplex Motor loss of encoders (motor stall) RAP
- 364-235-00 Duplex Motor under speed RAP
- 364-236-00 Duplex Motor over speed RAP
- 364-237-00 Duplex Motor moved too long RAP
- 377-350-00 MPF Motor does not turn on RAP
- 377-351-00 MPF Motor does not turn off RAP
- 377-352-00 MPF Motor failed to achieve expected speed RAP
- 377-353-00 MPF Motor loss of encoders (motor stall) RAP
- 377-354-00 MPF Motor under speed RAP
- 377-355-00 MPF Motor over speed RAP
- 377-356-00 MPF Motor moved too long RAP



WARNING: Switch off the electricity to the machine, **GP 10**. Disconnect the power lead from the customer supply while performing tasks that do not need electricity. Electricity can cause the death or injury. Moving components can cause the injury.

Procedure

Action	Yes	No
Step 1 Restart the printer. The fault persists.	Go to step 2.	The problem is solved.
Step 2 1 Enter the Diagnostics menu GP 1 , and then navigate to: Printer diagnostics & adjustments > Motor tests > Duplex/MPF 2 Touch Start . The motor will run.	Go to step 6.	Go to step 3.
Step 3 Ensure that the JMTR1 connector is properly connected to the Drive PWB. The fault persists.	Go to step 4.	The problem is solved.
Step 4 Open the front door, and then manually turn the duplex/MPF drive gears. The gears will move freely.	Go to step 6.	Go to step 5.
Step 5 Install a new motor. See PL 80.05 item 6 . The fault persists.	Go to step 6.	The problem is solved.
Step 6 Install a new Drive PWB. See PL 1.10 item 3 . The fault persists.	Contact the next level of support.	The problem is solved.

344-245-00 to 344-251-00 Black Only Retract Motor Error RAPs

WD2 Drive PWB Wiring Diagram

C625 Wiring Diagrams

344-245-00 Black only retract Motor does not turn on RAP

344-246-00 Black only retract Motor does not turn off RAP

344-247-00 Black only retract Motor failed to achieve expected speed RAP

344-248-00 Black only retract Motor loss of encoders (motor stall) RAP

344-249-00 Black only retract Motor under speed RAP

344-250-00 Black only retract Motor over speed RAP

344-251-00 Black only retract Motor moved too long RAP



WARNING: Switch off the electricity to the machine, GP 10 . Disconnect the power lead from the customer supply while performing tasks that do not need electricity. Electricity can cause the death or injury. Moving components can cause the injury.

Procedure

ACTION	YES	NO
Step 1 Restart the printer. The fault persists.	Go to step 2.	The problem is solved.
Step 2 1 Remove the transfer module. See REP 90.9. 2 Enter the Diagnostics menu GP 1, and then navigate to: Printer diagnostics & adjustments > Motor tests > Black only retract 3 Touch Start . The motor will run.	Go to step 5.	Go to step 3
Step 3 Ensure that the JBOR1 connector on the Drive PWB is properly connected to the motor. The fault persists.	Go to step 4	The problem is solved.
Step 4 Install a new motor. See PL 80.05 item 9. The fault persists.	Go to step 5.	The problem is solved
Step 5	Contact the next level of support	Go to step 6.

ACTION	YES	NO
Manually turn the BOR gear on the transfer module. The gear will freely turn.	.	
Step 6 Install a new transfer module. See PL 90.10 item 2. The fault persists.	Go to step 7.	The problem is solved.
Step 7 Install a new Drive PWB. See PL 1.10 item 3. The fault persists.	Contact the next level of support.	The problem is solved.

344–252–00 to 344–258–00, 377-343-00 to 377-349-00 Transport Motor (Feed Separator) Error RAP

WD2 Drive PWB Wiring Diagram

C625 Wiring Diagrams

- 344-252-00 Transport motor (Feed separator) does not turn on.
- 344-253-00 Transport motor (Feed separator) does not turn off.
- 344-254-00 Transport motor (Feed separator) failed to achieve expected speed.
- 344-255-00 Transport motor (Feed separator) loss of encoders (motor stall).
- 344-256-00 Transport motor (Feed separator) under speed.
- 344-257-00 Transport motor (Feed separator) over speed.
- 344-258-00 Transport motor (Feed separator) moved too long.
- 377-343-00 Transport (Feed separator) Motor does not turn on.
- 377-344-00 Transport (Feed separator) Motor does not turn off.
- 377-345-00 Transport (Feed separator) Motor failed to achieve expected speed.
- 377-346-00 Transport (Feed separator) Motor loss of encoders (motor stall).
- 377-347-00 Transport (Feed separator) Motor under speed.
- 377-348-00 Transport (Feed separator) Motor over speed.
- 377-349-00 Transport (Feed separator) Motor moved too long.



WARNING: Switch off the electricity to the machine, GP 10 . Disconnect the power lead from the customer supply while performing tasks that do not need electricity. Electricity can cause the death or injury. Moving components can cause the injury.

Procedure

Action	Yes	No
Step 1 Reset the printer. The fault persists.	Go to step 2.	The problem is solved.
Step 2 1 Enter the Diagnostics menu GP 1, and then navigate to: Printer diagnostics & adjustments > Motor tests > Isolation 2 Touch Start . The motor will run.	Go to step 3.	Go to step 4.
Step 3 Ensure that the JMTR1 connector on the drive PWB, PL	Go to step 4.	The problem is solved.

Action	Yes	No
1.10 item 3, is properly connected to the paper feeder, PL 70.10 item 8. The fault persists.		
Step 4 Manually turn the registration rollers and the alternate registration rollers. The rollers will move freely.	Go to step 6.	Go to step 5.
Step 5 Install a new registration chute, PL 80.10 item 4. The fault persists.	Go to step 6.	The problem is solved.
Step 6 Install a new drive PWB, PL 1.10 item 3. The fault persists.	Contact the next level of support.	The problem is solved.

352-214-00, 352-216-00, 352-218-00, 352-220-00, 352-222-00, 352-224-00, 352-226-00, 352-228-00, 353-214-00, 353-216-00, 353-218-00, 353-220-00, 353-222-00, 353-224-00, 353-226-00, 353-228-00, 354-214-00, 354-216-00, 354-218-00, 354-220-00, 354-222-00, 354-224-00, 354-226-00, 354-228-00, 355-224-00 to 355-231-00 Tray 2, 3, 4, 5 Motor (Pick / Lift) Lifting Error RAP

352-214-00 Tray 2 Pick Motor failed to achieve expected speed RAP

352-216-00 Tray 2 Pick Motor loss of encoders (motor stall) RAP

352-218-00 Tray 2 pick Motor under speed RAP

352-220-00 Tray 2 Pick Motor over speed RAP

352-222-00 Tray 2 pick Motor moved too long RAP

352-224-10 Tray 2 Autocomp Pick / Lift Motor did not lift properly since the lift plate sensor never changed state RAP

352-226-10 Tray 2 Pick Motor does not turn on RAP

352-228-00 Tray 2 Pick Motor does not turn off RAP

353-214-00 Tray 3 Pick Motor failed to achieve expected speed RAP

353-216-00 Tray 3 pick Motor loss of encoders (motor stall) RAP

353-218-00 Tray 3 pick Motor under speed RAP

353-220-00 Tray 3 Pick Motor over speed RAP

353-222-00 Tray 3 Pick Motor moved too long RAP

353-224-10 Tray 3 Autocomp Pick / Lift Motor did not lift properly since the lift plate sensor never changed state RAP

353-226-10 Tray 3 pick Motor does not turn on RAP

353-228-00 Tray 3 Pick Motor does not turn off RAP

354-214-00 Tray 4 pick Motor failed to achieve expected speed RAP

354-216-00 Tray 4 Pick Motor loss of encoders (motor stall) RAP

354-218-00 Tray 4 pick Motor under speed RAP

354-220-00 Tray 4 pick Motor over speed RAP

354-222-00 Tray 4 Pick Motor moved too long RAP

354-224-10 Tray 4 Autocomp Pick / Lift Motor did not lift properly since the lift plate sensor never changed state RAP

354-226-10 Tray 4 Pick Motor does not turn on RAP

354-228-00 Tray 4 pick Motor does not turn off RAP

355-224-00 Tray 5 Autocomp Pick / Lift Motor did not lift properly since the lift plate sensor never changed state RAP

355-225-00 Tray 5 Pick Motor does not turn on RAP

355-226-00 Tray 5 Pick Motor does not turn off RAP

355-227-00 Tray 5 Pick Motor failed to achieve expected speed RAP

355-228-00 Tray 5 Pick Motor loss of encoders (motor stall) RAP

355-229-00 Tray 5 Pick Motor under speed RAP

355-230-00 Tray 5 Pick Motor over speed RAP

355-231-00 Tray 5 Pick Motor moved too long RAP

Procedure



WARNING: Switch off the electricity to the machine, GP 10 . Disconnect the power lead from the customer supply while performing tasks that do not need electricity. Electricity can cause the death or injury. Moving components can cause the injury.

Action	Yes	No
Step 1 Restart the printer. The fault persists.	Go to step 2.	The problem is solved.
Step 2 Ensure that the tray insert is properly seated or fully inserted. The fault persists.	Go to step 3.	The problem is solved.
Step 3 1 Enter the Diagnostics menu GP 1, and then navigate to: Additional input trays adjustments/tests > Additional input tray sensors 2 Find the sensor (Pick roller index (tray [x])). Note: [x] is the tray number. The sensor status will change while toggling the sensor.	Go to step 5.	Go to step 4.
Step 4 Ensure that the sensor cable is properly connected. The fault persists.	Go to step 5.	The problem is solved.
Step 5 Check the affected motor for proper operation and noise.	Go to step 8.	Go to step 6.

Action	Yes	No
1 Remove the tray insert. 2 Enter the Diagnostics menu, and then navigate to: Additional input trays adjustments/tests > Additional input tray motors 3 Select Pick (tray [x]) , and then touch Start . Note: [x] is the tray number. The motor runs or it sound normal.		
Step 6 Ensure that the motor cable is properly connected. The fault persists.	Go to step 7.	The problem is solved.
Step 7 Install a new optional tray. See PL 70.15 item 1. The fault persists.	Go to step 8.	The problem is solved.
Step 8 Restart the printer. The fault persists.	Contact the next level of support.	The problem is solved.

352-314-00, 352-316-00, 352-318-00, 352-320-00, 352-322-00, 352-326-10, 352-328-00, 353-314-00, 353-316-00, 353-318-00, 353-320-00, 353-322-00, 353-326-10, 353-328-00, 354-314-00, 354-316-00, 354-318-00, 354-320-00, 354-322-00, 354-326-10, 354-328-00, 355-232-00 to 355-238-00 Motor (Pass-Through Tray 2, 3, 4, 5) Stall Error RAP

- 352-314-00 Tray 2 Pass Through Motor failed to achieve expected speed RAP
- 352-316-00 Tray 2 Pass Through Motor loss of encoders (motor stall) RAP
- 352-318-00 Tray 2 Pass Through Motor underspeed RAP
- 352-320-00 Tray 2 Pass Through Motor overspeed RAP
- 352-322-00 Tray 2 Pass Through Motor moved too long RAP
- 352-326-10 Tray 2 Pass Through Motor does not turn on RAP
- 352-328-00 Tray 2 Pass Through Motor does not turn off RAP
- 353-314-00 Tray 3 Pass Through Motor failed to achieve expected speed RAP
- 353-316-00 Tray 3 Pass Through Motor loss of encoders (motor stall) RAP
- 353-318-00 Tray 3 Pass Through Motor underspeed RAP
- 353-320-00 Tray 3 Pass Through Motor overspeed RAP
- 353-322-00 Tray 3 Pass Through Motor moved too long RAP
- 353-326-10 Tray 3 Pass Through Motor does not turn on RAP
- 353-328-00 Tray 3 Pass Through Motor does not turn off RAP
- 354-314-00 Tray 4 Pass Through Motor failed to achieve expected speed RAP
- 354-316-00 Tray 4 Pass Through Motor loss of encoders (motor stall) RAP
- 354-318-00 Tray 4 Pass Through Motor underspeed RAP
- 354-320-00 Tray 4 Pass Through Motor overspeed RAP
- 354-322-00 Tray 4 Pass Through Motor moved too long RAP
- 354-326-10 Tray 4 Pass Through Motor does not turn on RAP
- 354-328-00 Tray 4 Pass Through Motor does not turn off RAP
- 355-232-00 Tray 5 Pass Through Motor does not turn on RAP
- 355-233-00 Tray 5 Pass Through Motor does not turn off RAP
- 355-234-00 Tray 5 Pass Through Motor failed to achieve expected speed RAP
- 355-235-00 Tray 5 Pass Through Motor loss of encoders (motor stall) RAP
- 355-236-00 Tray 5 Pass Through Motor underspeed RAP
- 355-237-00 Tray 5 Pass Through Motor overspeed RAP

355-238-00 Tray 5 Pass Through Motor moved too long RAP

Procedure



WARNING: Switch off the electricity to the machine, GP 10 . Disconnect the power lead from the customer supply while performing tasks that do not need electricity. Electricity can cause the death or injury. Moving components can cause the injury.

Action	Yes	No
<p>Step 1</p> <p>1 Enter the Diagnostics menu GP 1, and then navigate to:</p> <p>Additional input trays adjustments/tests > Additional input tray motors</p> <p>2 Select Pass-through (tray [x]), and then touch Start.</p> <p>Note: [x] is the tray number.</p> <p>The motor will run.</p>	Go to step 4.	Go to step 2.
<p>Step 2</p> <p>Ensure that the motor cable is properly connected.</p> <p>The fault persists.</p>	Go to step 3.	The problem is solved.
<p>Step 3</p> <p>Check the motor for noise.</p> <p>The motor sounds abnormal or the gears make a grinding sound.</p>	Go to step 5.	Go to step 4.
<p>Step 4</p> <p>Perform a print job.</p> <p>The fault persists.</p>	Go to step 5.	The problem is solved.
<p>Step 5</p> <p>Install a new optional tray.</p> <p>See PL 70.15 item 1.</p> <p>The fault persists.</p>	Contact the next level of support.	The problem is solved.

352-214-00, 352-216-00, 352-218-00, 352-220-00, 352-222-00, 352-224-00, 352-226-00, 352-228-00, 353-214-00, 353-216-00, 353-218-00, 353-220-00, 353-222-00, 353-224-00, 353-226-00, 353-228-00, 354-214-00, 354-216-00, 354-218-00, 354-220-00, 354-222-00, 354-224-00, 354-226-00, 354-228-00, 355-224-00 to 355-231-00 Tray 2, 3, 4, 5 Motor (Pick / Lift) Lifting Error RAP

352-214-00 Tray 2 Pick Motor failed to achieve expected speed RAP

352-216-00 Tray 2 Pick Motor loss of encoders (motor stall) RAP

352-218-00 Tray 2 pick Motor under speed RAP

352-220-00 Tray 2 Pick Motor over speed RAP

352-222-00 Tray 2 pick Motor moved too long RAP

352-224-10 Tray 2 Autocomp Pick / Lift Motor did not lift properly since the lift plate sensor never changed state RAP

352-226-10 Tray 2 Pick Motor does not turn on RAP

352-228-00 Tray 2 Pick Motor does not turn off RAP

353-214-00 Tray 3 Pick Motor failed to achieve expected speed RAP

353-216-00 Tray 3 pick Motor loss of encoders (motor stall) RAP

353-218-00 Tray 3 pick Motor under speed RAP

353-220-00 Tray 3 Pick Motor over speed RAP

353-222-00 Tray 3 Pick Motor moved too long RAP

353-224-10 Tray 3 Autocomp Pick / Lift Motor did not lift properly since the lift plate sensor never changed state RAP

353-226-10 Tray 3 pick Motor does not turn on RAP

353-228-00 Tray 3 Pick Motor does not turn off RAP

354-214-00 Tray 4 pick Motor failed to achieve expected speed RAP

354-216-00 Tray 4 Pick Motor loss of encoders (motor stall) RAP

354-218-00 Tray 4 pick Motor under speed RAP

354-220-00 Tray 4 pick Motor over speed RAP

354-222-00 Tray 4 Pick Motor moved too long RAP

354-224-10 Tray 4 Autocomp Pick / Lift Motor did not lift properly since the lift plate sensor never changed state RAP

354-226-10 Tray 4 Pick Motor does not turn on RAP

354-228-00 Tray 4 pick Motor does not turn off RAP

355-224-00 Tray 5 Autocomp Pick / Lift Motor did not lift properly since the lift plate sensor never changed state RAP

355-225-00 Tray 5 Pick Motor does not turn on RAP

355-226-00 Tray 5 Pick Motor does not turn off RAP

355-227-00 Tray 5 Pick Motor failed to achieve expected speed RAP

355-228-00 Tray 5 Pick Motor loss of encoders (motor stall) RAP

355-229-00 Tray 5 Pick Motor under speed RAP

355-230-00 Tray 5 Pick Motor over speed RAP

355-231-00 Tray 5 Pick Motor moved too long RAP

Procedure



WARNING: Switch off the electricity to the machine, GP 10 . Disconnect the power lead from the customer supply while performing tasks that do not need electricity. Electricity can cause the death or injury. Moving components can cause the injury.

Action	Yes	No
Step 1 Restart the printer. The fault persists.	Go to step 2.	The problem is solved.
Step 2 Ensure that the tray insert is properly seated or fully inserted. The fault persists.	Go to step 3.	The problem is solved.
Step 3 1 Enter the Diagnostics menu GP 1, and then navigate to: Additional input trays adjustments/tests > Additional input tray sensors 2 Find the sensor (Pick roller index (tray [x])). Note: [x] is the tray number. The sensor status will change while toggling the sensor.	Go to step 5.	Go to step 4.
Step 4 Ensure that the sensor cable is properly connected. The fault persists.	Go to step 5.	The problem is solved.
Step 5 Check the affected motor for proper operation and noise.	Go to step 8.	Go to step 6.

Action	Yes	No
1 Remove the tray insert. 2 Enter the Diagnostics menu, and then navigate to: Additional input trays adjustments/tests > Additional input tray motors 3 Select Pick (tray [x]) , and then touch Start . Note: [x] is the tray number. The motor runs or it sound normal.		
Step 6 Ensure that the motor cable is properly connected. The fault persists.	Go to step 7.	The problem is solved.
Step 7 Install a new optional tray. See PL 70.15 item 1. The fault persists.	Go to step 8.	The problem is solved.
Step 8 Restart the printer. The fault persists.	Contact the next level of support.	The problem is solved.

352-314-00, 352-316-00, 352-318-00, 352-320-00, 352-322-00, 352-326-10, 352-328-00, 353-314-00, 353-316-00, 353-318-00, 353-320-00, 353-322-00, 353-326-10, 353-328-00, 354-314-00, 354-316-00, 354-318-00, 354-320-00, 354-322-00, 354-326-10, 354-328-00, 355-232-00 to 355-238-00 Motor (Pass-Through Tray 2, 3, 4, 5) Stall Error RAP

- 352-314-00 Tray 2 Pass Through Motor failed to achieve expected speed RAP
- 352-316-00 Tray 2 Pass Through Motor loss of encoders (motor stall) RAP
- 352-318-00 Tray 2 Pass Through Motor underspeed RAP
- 352-320-00 Tray 2 Pass Through Motor overspeed RAP
- 352-322-00 Tray 2 Pass Through Motor moved too long RAP
- 352-326-10 Tray 2 Pass Through Motor does not turn on RAP
- 352-328-00 Tray 2 Pass Through Motor does not turn off RAP
- 353-314-00 Tray 3 Pass Through Motor failed to achieve expected speed RAP
- 353-316-00 Tray 3 Pass Through Motor loss of encoders (motor stall) RAP
- 353-318-00 Tray 3 Pass Through Motor underspeed RAP
- 353-320-00 Tray 3 Pass Through Motor overspeed RAP
- 353-322-00 Tray 3 Pass Through Motor moved too long RAP
- 353-326-10 Tray 3 Pass Through Motor does not turn on RAP
- 353-328-00 Tray 3 Pass Through Motor does not turn off RAP
- 354-314-00 Tray 4 Pass Through Motor failed to achieve expected speed RAP
- 354-316-00 Tray 4 Pass Through Motor loss of encoders (motor stall) RAP
- 354-318-00 Tray 4 Pass Through Motor underspeed RAP
- 354-320-00 Tray 4 Pass Through Motor overspeed RAP
- 354-322-00 Tray 4 Pass Through Motor moved too long RAP
- 354-326-10 Tray 4 Pass Through Motor does not turn on RAP
- 354-328-00 Tray 4 Pass Through Motor does not turn off RAP
- 355-232-00 Tray 5 Pass Through Motor does not turn on RAP
- 355-233-00 Tray 5 Pass Through Motor does not turn off RAP
- 355-234-00 Tray 5 Pass Through Motor failed to achieve expected speed RAP
- 355-235-00 Tray 5 Pass Through Motor loss of encoders (motor stall) RAP
- 355-236-00 Tray 5 Pass Through Motor underspeed RAP
- 355-237-00 Tray 5 Pass Through Motor overspeed RAP

355-238-00 Tray 5 Pass Through Motor moved too long RAP

Procedure



WARNING: Switch off the electricity to the machine, GP 10 . Disconnect the power lead from the customer supply while performing tasks that do not need electricity. Electricity can cause the death or injury. Moving components can cause the injury.

Action	Yes	No
<p>Step 1</p> <p>1 Enter the Diagnostics menu GP 1, and then navigate to:</p> <p>Additional input trays adjustments/tests > Additional input tray motors</p> <p>2 Select Pass-through (tray [x]), and then touch Start.</p> <p>Note: [x] is the tray number. The motor will run.</p>	Go to step 4.	Go to step 2.
<p>Step 2</p> <p>Ensure that the motor cable is properly connected. The fault persists.</p>	Go to step 3.	The problem is solved.
<p>Step 3</p> <p>Check the motor for noise. The motor sounds abnormal or the gears make a grinding sound.</p>	Go to step 5.	Go to step 4.
<p>Step 4</p> <p>Perform a print job. The fault persists.</p>	Go to step 5.	The problem is solved.
<p>Step 5</p> <p>Install a new optional tray. See PL 70.15 item 1. The fault persists.</p>	Contact the next level of support.	The problem is solved.

352-214-00, 352-216-00, 352-218-00, 352-220-00, 352-222-00, 352-224-00, 352-226-00, 352-228-00, 353-214-00, 353-216-00, 353-218-00, 353-220-00, 353-222-00, 353-224-00, 353-226-00, 353-228-00, 354-214-00, 354-216-00, 354-218-00, 354-220-00, 354-222-00, 354-224-00, 354-226-00, 354-228-00, 355-224-00 to 355-231-00 Tray 2, 3, 4, 5 Motor (Pick / Lift) Lifting Error RAP

352-214-00 Tray 2 Pick Motor failed to achieve expected speed RAP

352-216-00 Tray 2 Pick Motor loss of encoders (motor stall) RAP

352-218-00 Tray 2 pick Motor under speed RAP

352-220-00 Tray 2 Pick Motor over speed RAP

352-222-00 Tray 2 pick Motor moved too long RAP

352-224-10 Tray 2 Autocomp Pick / Lift Motor did not lift properly since the lift plate sensor never changed state RAP

352-226-10 Tray 2 Pick Motor does not turn on RAP

352-228-00 Tray 2 Pick Motor does not turn off RAP

353-214-00 Tray 3 Pick Motor failed to achieve expected speed RAP

353-216-00 Tray 3 pick Motor loss of encoders (motor stall) RAP

353-218-00 Tray 3 pick Motor under speed RAP

353-220-00 Tray 3 Pick Motor over speed RAP

353-222-00 Tray 3 Pick Motor moved too long RAP

353-224-10 Tray 3 Autocomp Pick / Lift Motor did not lift properly since the lift plate sensor never changed state RAP

353-226-10 Tray 3 pick Motor does not turn on RAP

353-228-00 Tray 3 Pick Motor does not turn off RAP

354-214-00 Tray 4 pick Motor failed to achieve expected speed RAP

354-216-00 Tray 4 Pick Motor loss of encoders (motor stall) RAP

354-218-00 Tray 4 pick Motor under speed RAP

354-220-00 Tray 4 pick Motor over speed RAP

354-222-00 Tray 4 Pick Motor moved too long RAP

354-224-10 Tray 4 Autocomp Pick / Lift Motor did not lift properly since the lift plate sensor never changed state RAP

354-226-10 Tray 4 Pick Motor does not turn on RAP

354-228-00 Tray 4 pick Motor does not turn off RAP

355-224-00 Tray 5 Autocomp Pick / Lift Motor did not lift properly since the lift plate sensor never changed state RAP

355-225-00 Tray 5 Pick Motor does not turn on RAP

355-226-00 Tray 5 Pick Motor does not turn off RAP

355-227-00 Tray 5 Pick Motor failed to achieve expected speed RAP

355-228-00 Tray 5 Pick Motor loss of encoders (motor stall) RAP

355-229-00 Tray 5 Pick Motor under speed RAP

355-230-00 Tray 5 Pick Motor over speed RAP

355-231-00 Tray 5 Pick Motor moved too long RAP

Procedure



WARNING: Switch off the electricity to the machine, GP 10 . Disconnect the power lead from the customer supply while performing tasks that do not need electricity. Electricity can cause the death or injury. Moving components can cause the injury.

Action	Yes	No
Step 1 Restart the printer. The fault persists.	Go to step 2.	The problem is solved.
Step 2 Ensure that the tray insert is properly seated or fully inserted. The fault persists.	Go to step 3.	The problem is solved.
Step 3 1 Enter the Diagnostics menu GP 1, and then navigate to: Additional input trays adjustments/tests > Additional input tray sensors 2 Find the sensor (Pick roller index (tray [x])). Note: [x] is the tray number. The sensor status will change while toggling the sensor.	Go to step 5.	Go to step 4.
Step 4 Ensure that the sensor cable is properly connected. The fault persists.	Go to step 5.	The problem is solved.
Step 5 Check the affected motor for proper operation and noise.	Go to step 8.	Go to step 6.

Action	Yes	No
1 Remove the tray insert. 2 Enter the Diagnostics menu, and then navigate to: Additional input trays adjustments/tests > Additional input tray motors 3 Select Pick (tray [x]) , and then touch Start . Note: [x] is the tray number. The motor runs or it sound normal.		
Step 6 Ensure that the motor cable is properly connected. The fault persists.	Go to step 7.	The problem is solved.
Step 7 Install a new optional tray. See PL 70.15 item 1. The fault persists.	Go to step 8.	The problem is solved.
Step 8 Restart the printer. The fault persists.	Contact the next level of support.	The problem is solved.

352-314-00, 352-316-00, 352-318-00, 352-320-00, 352-322-00, 352-326-10, 352-328-00, 353-314-00, 353-316-00, 353-318-00, 353-320-00, 353-322-00, 353-326-10, 353-328-00, 354-314-00, 354-316-00, 354-318-00, 354-320-00, 354-322-00, 354-326-10, 354-328-00, 355-232-00 to 355-238-00 Motor (Pass-Through Tray 2, 3, 4, 5) Stall Error RAP

- 352-314-00 Tray 2 Pass Through Motor failed to achieve expected speed RAP
- 352-316-00 Tray 2 Pass Through Motor loss of encoders (motor stall) RAP
- 352-318-00 Tray 2 Pass Through Motor underspeed RAP
- 352-320-00 Tray 2 Pass Through Motor overspeed RAP
- 352-322-00 Tray 2 Pass Through Motor moved too long RAP
- 352-326-10 Tray 2 Pass Through Motor does not turn on RAP
- 352-328-00 Tray 2 Pass Through Motor does not turn off RAP
- 353-314-00 Tray 3 Pass Through Motor failed to achieve expected speed RAP
- 353-316-00 Tray 3 Pass Through Motor loss of encoders (motor stall) RAP
- 353-318-00 Tray 3 Pass Through Motor underspeed RAP
- 353-320-00 Tray 3 Pass Through Motor overspeed RAP
- 353-322-00 Tray 3 Pass Through Motor moved too long RAP
- 353-326-10 Tray 3 Pass Through Motor does not turn on RAP
- 353-328-00 Tray 3 Pass Through Motor does not turn off RAP
- 354-314-00 Tray 4 Pass Through Motor failed to achieve expected speed RAP
- 354-316-00 Tray 4 Pass Through Motor loss of encoders (motor stall) RAP
- 354-318-00 Tray 4 Pass Through Motor underspeed RAP
- 354-320-00 Tray 4 Pass Through Motor overspeed RAP
- 354-322-00 Tray 4 Pass Through Motor moved too long RAP
- 354-326-10 Tray 4 Pass Through Motor does not turn on RAP
- 354-328-00 Tray 4 Pass Through Motor does not turn off RAP
- 355-232-00 Tray 5 Pass Through Motor does not turn on RAP
- 355-233-00 Tray 5 Pass Through Motor does not turn off RAP
- 355-234-00 Tray 5 Pass Through Motor failed to achieve expected speed RAP
- 355-235-00 Tray 5 Pass Through Motor loss of encoders (motor stall) RAP
- 355-236-00 Tray 5 Pass Through Motor underspeed RAP
- 355-237-00 Tray 5 Pass Through Motor overspeed RAP

355-238-00 Tray 5 Pass Through Motor moved too long RAP

Procedure



WARNING: Switch off the electricity to the machine, GP 10 . Disconnect the power lead from the customer supply while performing tasks that do not need electricity. Electricity can cause the death or injury. Moving components can cause the injury.

Action	Yes	No
<p>Step 1</p> <p>1 Enter the Diagnostics menu GP 1, and then navigate to:</p> <p>Additional input trays adjustments/tests > Additional input tray motors</p> <p>2 Select Pass-through (tray [x]), and then touch Start.</p> <p>Note: [x] is the tray number. The motor will run.</p>	Go to step 4.	Go to step 2.
<p>Step 2</p> <p>Ensure that the motor cable is properly connected. The fault persists.</p>	Go to step 3.	The problem is solved.
<p>Step 3</p> <p>Check the motor for noise. The motor sounds abnormal or the gears make a grinding sound.</p>	Go to step 5.	Go to step 4.
<p>Step 4</p> <p>Perform a print job. The fault persists.</p>	Go to step 5.	The problem is solved.
<p>Step 5</p> <p>Install a new optional tray. See PL 70.15 item 1. The fault persists.</p>	Contact the next level of support.	The problem is solved.

352-214-00, 352-216-00, 352-218-00, 352-220-00, 352-222-00, 352-224-00, 352-226-00, 352-228-00, 353-214-00, 353-216-00, 353-218-00, 353-220-00, 353-222-00, 353-224-00, 353-226-00, 353-228-00, 354-214-00, 354-216-00, 354-218-00, 354-220-00, 354-222-00, 354-224-00, 354-226-00, 354-228-00, 355-224-00 to 355-231-00 Tray 2, 3, 4, 5 Motor (Pick / Lift) Lifting Error RAP

352-214-00 Tray 2 Pick Motor failed to achieve expected speed RAP

352-216-00 Tray 2 Pick Motor loss of encoders (motor stall) RAP

352-218-00 Tray 2 pick Motor under speed RAP

352-220-00 Tray 2 Pick Motor over speed RAP

352-222-00 Tray 2 pick Motor moved too long RAP

352-224-10 Tray 2 Autocomp Pick / Lift Motor did not lift properly since the lift plate sensor never changed state RAP

352-226-10 Tray 2 Pick Motor does not turn on RAP

352-228-00 Tray 2 Pick Motor does not turn off RAP

353-214-00 Tray 3 Pick Motor failed to achieve expected speed RAP

353-216-00 Tray 3 pick Motor loss of encoders (motor stall) RAP

353-218-00 Tray 3 pick Motor under speed RAP

353-220-00 Tray 3 Pick Motor over speed RAP

353-222-00 Tray 3 Pick Motor moved too long RAP

353-224-10 Tray 3 Autocomp Pick / Lift Motor did not lift properly since the lift plate sensor never changed state RAP

353-226-10 Tray 3 pick Motor does not turn on RAP

353-228-00 Tray 3 Pick Motor does not turn off RAP

354-214-00 Tray 4 pick Motor failed to achieve expected speed RAP

354-216-00 Tray 4 Pick Motor loss of encoders (motor stall) RAP

354-218-00 Tray 4 pick Motor under speed RAP

354-220-00 Tray 4 pick Motor over speed RAP

354-222-00 Tray 4 Pick Motor moved too long RAP

354-224-10 Tray 4 Autocomp Pick / Lift Motor did not lift properly since the lift plate sensor never changed state RAP

354-226-10 Tray 4 Pick Motor does not turn on RAP

354-228-00 Tray 4 pick Motor does not turn off RAP

355-224-00 Tray 5 Autocomp Pick / Lift Motor did not lift properly since the lift plate sensor never changed state RAP

355-225-00 Tray 5 Pick Motor does not turn on RAP

355-226-00 Tray 5 Pick Motor does not turn off RAP

355-227-00 Tray 5 Pick Motor failed to achieve expected speed RAP

355-228-00 Tray 5 Pick Motor loss of encoders (motor stall) RAP

355-229-00 Tray 5 Pick Motor under speed RAP

355-230-00 Tray 5 Pick Motor over speed RAP

355-231-00 Tray 5 Pick Motor moved too long RAP

Procedure



WARNING: Switch off the electricity to the machine, GP 10 . Disconnect the power lead from the customer supply while performing tasks that do not need electricity. Electricity can cause the death or injury. Moving components can cause the injury.

Action	Yes	No
Step 1 Restart the printer. The fault persists.	Go to step 2.	The problem is solved.
Step 2 Ensure that the tray insert is properly seated or fully inserted. The fault persists.	Go to step 3.	The problem is solved.
Step 3 1 Enter the Diagnostics menu GP 1, and then navigate to: Additional input trays adjustments/tests > Additional input tray sensors 2 Find the sensor (Pick roller index (tray [x])). Note: [x] is the tray number. The sensor status will change while toggling the sensor.	Go to step 5.	Go to step 4.
Step 4 Ensure that the sensor cable is properly connected. The fault persists.	Go to step 5.	The problem is solved.
Step 5 Check the affected motor for proper operation and noise.	Go to step 8.	Go to step 6.

Action	Yes	No
1 Remove the tray insert. 2 Enter the Diagnostics menu, and then navigate to: Additional input trays adjustments/tests > Additional input tray motors 3 Select Pick (tray [x]) , and then touch Start . Note: [x] is the tray number. The motor runs or it sound normal.		
Step 6 Ensure that the motor cable is properly connected. The fault persists.	Go to step 7.	The problem is solved.
Step 7 Install a new optional tray. See PL 70.15 item 1. The fault persists.	Go to step 8.	The problem is solved.
Step 8 Restart the printer. The fault persists.	Contact the next level of support.	The problem is solved.

352-314-00, 352-316-00, 352-318-00, 352-320-00, 352-322-00, 352-326-10, 352-328-00, 353-314-00, 353-316-00, 353-318-00, 353-320-00, 353-322-00, 353-326-10, 353-328-00, 354-314-00, 354-316-00, 354-318-00, 354-320-00, 354-322-00, 354-326-10, 354-328-00, 355-232-00 to 355-238-00 Motor (Pass-Through Tray 2, 3, 4, 5) Stall Error RAP

352-314-00 Tray 2 Pass Through Motor failed to achieve expected speed RAP

352-316-00 Tray 2 Pass Through Motor loss of encoders (motor stall) RAP

352-318-00 Tray 2 Pass Through Motor underspeed RAP

352-320-00 Tray 2 Pass Through Motor overspeed RAP

352-322-00 Tray 2 Pass Through Motor moved too long RAP

352-326-10 Tray 2 Pass Through Motor does not turn on RAP

352-328-00 Tray 2 Pass Through Motor does not turn off RAP

353-314-00 Tray 3 Pass Through Motor failed to achieve expected speed RAP

353-316-00 Tray 3 Pass Through Motor loss of encoders (motor stall) RAP

353-318-00 Tray 3 Pass Through Motor underspeed RAP

353-320-00 Tray 3 Pass Through Motor overspeed RAP

353-322-00 Tray 3 Pass Through Motor moved too long RAP

353-326-10 Tray 3 Pass Through Motor does not turn on RAP

353-328-00 Tray 3 Pass Through Motor does not turn off RAP

354-314-00 Tray 4 Pass Through Motor failed to achieve expected speed RAP

354-316-00 Tray 4 Pass Through Motor loss of encoders (motor stall) RAP

354-318-00 Tray 4 Pass Through Motor underspeed RAP

354-320-00 Tray 4 Pass Through Motor overspeed RAP

354-322-00 Tray 4 Pass Through Motor moved too long RAP

354-326-10 Tray 4 Pass Through Motor does not turn on RAP

354-328-00 Tray 4 Pass Through Motor does not turn off RAP

355-232-00 Tray 5 Pass Through Motor does not turn on RAP

355-233-00 Tray 5 Pass Through Motor does not turn off RAP

355-234-00 Tray 5 Pass Through Motor failed to achieve expected speed RAP

355-235-00 Tray 5 Pass Through Motor loss of encoders (motor stall) RAP

355-236-00 Tray 5 Pass Through Motor underspeed RAP

355-237-00 Tray 5 Pass Through Motor overspeed RAP

355-238-00 Tray 5 Pass Through Motor moved too long RAP

Procedure



WARNING: Switch off the electricity to the machine, GP 10 . Disconnect the power lead from the customer supply while performing tasks that do not need electricity. Electricity can cause the death or injury. Moving components can cause the injury.

Action	Yes	No
<p>Step 1</p> <p>1 Enter the Diagnostics menu GP 1, and then navigate to:</p> <p>Additional input trays adjustments/tests > Additional input tray motors</p> <p>2 Select Pass-through (tray [x]), and then touch Start.</p> <p>Note: [x] is the tray number.</p> <p>The motor will run.</p>	Go to step 4.	Go to step 2.
<p>Step 2</p> <p>Ensure that the motor cable is properly connected.</p> <p>The fault persists.</p>	Go to step 3.	The problem is solved.
<p>Step 3</p> <p>Check the motor for noise.</p> <p>The motor sounds abnormal or the gears make a grinding sound.</p>	Go to step 5.	Go to step 4.
<p>Step 4</p> <p>Perform a print job.</p> <p>The fault persists.</p>	Go to step 5.	The problem is solved.
<p>Step 5</p> <p>Install a new optional tray.</p> <p>See PL 70.15 item 1.</p> <p>The fault persists.</p>	Contact the next level of support.	The problem is solved.

362-358-00 Backside Cable Error RAP

WD1 Controller PWB Wiring Diagram

C625 Wiring Diagrams

362-358-00 Backside Cable error RAP

Procedure



WARNING: Switch off the electricity to the machine, GP 10 . Disconnect the power lead from the customer supply while performing tasks that do not need electricity. Electricity can cause the death or injury. Moving components can cause the injury.

Action	Yes	No
<p>Step 1 Check the DADF paper path for paper fragments, partially fed paper, and obstructions.</p> <ul style="list-style-type: none"> • Under the DADF top cover • Under the DADF • DADF bin <p>The paper path is free of paper fragments, partially fed paper, and obstructions.</p>	Go to step 3.	Go to step 2.
<p>Step 2 Remove the paper fragments, partially fed paper, and obstructions. The fault persists.</p>	Go to step 3.	The problem is solved.
<p>Step 3</p> <ol style="list-style-type: none"> 1 Enter the Diagnostics menu GP 1, and then navigate to: Scanner diagnostics > Motor tests 2 Select DADF transport, and then start the test. The motor will run. 	Go to step 5.	Go to step 4.
<p>Step 4</p> <ol style="list-style-type: none"> 1 Ensure that the ADF is properly installed. Lift the ADF, and then check if it closes properly. 2 Check the ADF for damage. The ADF is free of damage. 	Go to step 5.	Go to step 7.
<p>Step 5</p> <ol style="list-style-type: none"> 1 Enter the Diagnostics menu GP 1, and then navigate to: 	Go to step 8.	Go to step 6.

Action	Yes	No
Scanner diagnostics > Sensor tests 2 Run the test on the following sensors: <ul style="list-style-type: none"> DADF media present DADF 1st scan The sensor status will change while toggling the sensors.		
Step 6 Check the affected sensor and its flag for damage. The sensor is free of damage.	Go to step 8.	Go to step 7.
Step 7 1 Reconnect the scanner cables and JADF1 connector on the controller PWB. 2 Reseat the DADF cables on the DADF. The fault persists.	Go to step 8.	The problem is solved.
Step 8 Check the cables for damage. The cables are free of damage.	Go to step 10.	Go to step 9.
Step 9 Install a new affected scanner or DADF cable. The fault persists.	Go to step 10.	The problem is solved.
Step 10 Check if the scanner lamp lights up during scanning. The scanner lamp is functional.	Go to step 12.	Go to step 11.
Step 11 Install a new scanner. See PL 60.05 item 1 . The fault persists.	Contact the next level of support.	The problem is solved.
Step 12 Install a new DADF. See PL 5.10 item 1 . The fault persists.	Contact the next level of support.	The problem is solved.

305-253-01, 362-397-00 to 362-399-00 IIT- DADH Communication Error RAP

WD1 Controller PWB Wiring Diagram

C625 Wiring Diagrams

305-253-01 IIT- DADH Communication Error RAP

362-397-00 IIT Comm Failure - Logical Protocol RAP

362-398-00 Scanner Comm Failure- HW Protocol RAP

362-399-00 IIT Comm Failure - No Response RAP



WARNING: Switch off the electricity to the machine, [GP 10](#). Disconnect the power lead from the customer supply while performing tasks that do not need electricity. Electricity can cause the death or injury. Moving components can cause the injury.

Procedure

Action	Yes	No
Step 1 Reconnect the JADF1 connector on the controller board. The fault persists.	Go to step 2.	The problem is solved.
Step 2 Reconnect the JFB1 connector on the controller board. The fault persists.	Go to step 3.	The problem is solved.
Step 3 Install a new DADF. See REP 5.3 . The fault persists.	Go to step 4.	The problem is solved.
Step 4 Install a new DADF scanner. See REP 5.4 . The fault persists.	Go to step 5.	The problem is solved.
Step 5 Install a new controller board. See REP 3.2 . The fault persists.	Contact the next level of support.	The problem is solved.

362-463-00 DADF Feed/Exit Drive Error RAP

WD1 Controller PWB Wiring Diagram

C625 Wiring Diagrams

362-463-00 IIT Mech Failure - DADF RAP

Procedure



WARNING: Switch off the electricity to the machine, GP 10 . Disconnect the power lead from the customer supply while performing tasks that do not need electricity. Electricity can cause the death or injury. Moving components can cause the injury.

Action	Yes	No
Step 1 Manually turn the DADF feed/exit roller. The fault persists.	Go to step 2.	The problem is solved.
Step 2 1 Enter the Diagnostics menu GP 1, and then navigate to: Scanner diagnostics > Motor tests 2 Select DADF transport , and then touch Start . The motors will run.	Go to step 4.	Go to step 3.
Step 3 1 Reconnect the JADF2 connector on the controller PWB. 2 REconnect the DADF cables on the DADF. The fault persists.	Go to step 4.	The problem is solved.
Step 4 Install a new DADF. See PL 5.10 item 1. The fault persists.	Contact the next level of support.	The problem is solved.

362-476-01 Flatbed CIS Scanner Home Position Error RAP

WD1 Controller PWB Wiring Diagram

C625 Wiring Diagrams

362-476-01 IIT Mech Failure - Flatbed carriage failed to home RAP

Procedure



WARNING: Switch off the electricity to the machine, GP 10 . Disconnect the power lead from the customer supply while performing tasks that do not need electricity. Electricity can cause the death or injury. Moving components can cause the injury.

Action	Yes	No
Step 1 Turn off the printer. The CIS scanner move and return to the home position.	The problem is solved.	Go to step 2.
Step 2 1 Enter the Diagnostics menu GP 1, and then navigate to: Scanner diagnostics> Sensor tests 2 Find the sensor (FB CCD home). The sensor status will change while toggling the sensor.	Go to step 4.	Go to step 3.
Step 3 REconnect the JHS1 connector on the controller PWB. The fault persists.	Go to step 4.	The problem is solved.
Step 4 Reconnect the JFBM1 connector on the controller PWB. The fault persists.	Go to step 5.	The problem is solved.
Step 5 Measure the voltage of pin 1 of the JFBM1 connector on the controller PWB. The voltage is equal to +24 V AC.	Go to step 6.	Go to step 7.

Action	Yes	No
<p>Step 6 Measure the voltage of pin 1 of the JHS1 connector on the controller PWB.</p> <p>Note: Pin 2 is GND. The voltage is equal to +5 V AC.</p>	Contact the next level of support.	Go to step 7.
<p>Step 7 Install a new scanner. See PL 60.05 item 1. The fault persists.</p>	Contact the next level of support.	The problem is solved.

344-217-00 to 344-223-00, 364-217-00 to 364-223-00 Staging Motor Error RAP

- 344-217-00 Staging Motor does not turn on RAP
- 344-218-00 Staging Motor does not turn off RAP
- 344-219-00 Staging Motor failed to achieve expected speed RAP
- 344-220-00 Staging Motor loss of encoders (motor stall) RAP
- 344-221-00 Staging Motor under speed RAP
- 344-222-00 Staging Motor over speed RAP
- 344-223-00 Staging Motor moved too long RAP
- 364-217-00 Staging Motor does not turn on RAP
- 364-218-00 Staging Motor does not turn off RAP
- 364-219-00 Staging Motor failed to achieve expected speed RAP
- 364-220-00 Staging Motor loss of encoders (motor stall) RAP
- 364-221-00 Staging Motor under speed RAP
- 364-222-00 Staging Motor overs peed RAP
- 364-223-00 Staging Motor moved too long RAP

Procedure

Action	Yes	No
Step 1 Restart the printer. The fault persists.	Go to step 2.	The problem is solved.
Step 2 1 Enter the Diagnostics menu GP 1, and then navigate to: Printer diagnostics & adjustments > Motor tests > Deskew 2 Touch Start . The motor will run.	Go to step 5.	Go to step 3.
Step 3 Ensure that the JMTR1 connector on the Drive PWB is properly connected to the motor. The fault persists.	Go to step 4.	Contact the next level of support.
Step 4 Install a new motor. See PL 40.10 item 1. The fault persists.	Go to step 5.	Contact the next level of support.

Action	Yes	No
Step 5 Manually turn the aligner rollers. There is binding or uneven movement when turning the rollers.	Go to step 6.	Go to step 7.
Step 6 Check the aligner rollers and drivetrain for damage. The aligner roller and drive-train are free of damage.	Go to step 8.	Go to step 7.
Step 7 Install a new aligner roller or drivetrain. See PL 80.05 item 8. The fault persists.	Go to step 8.	The problem is solved.
Step 8 Install a new Drive PWB. See PL 1.10 item 3. The fault persists.	Contact the next level of support.	The problem is solved.

344-224-00 to 344-230-00, 364-222-00 to 364-230-00 Redrive Motor Error RAP

WD2 Drive PWB Wiring Diagram

C625 Wiring Diagrams

344-224-00 Redrive Motor does not turn on.

344-225-00 Redrive Motor does not turn off.

344-226-00 Redrive Motor failed to achieve expected speed.

344-227-00 Redrive Motor loss of encoders (motor stall).

344-228-00 Redrive Motor under speed.

344-229-00 Redrive Motor over speed.

344-230-00 Redrive Motor moved too long.

364-225-00 Redrive Motor does not turn off.

364-226-00 Redrive Motor failed to achieve expected speed.

364-227-00 Redrive Motor loss of encoders (motor stall).

364-228-00 Redrive Motor under speed.

364-229-00 Redrive Motor over speed.

364-230-00 Redrive Motor moved too long.



WARNING: Switch off the electricity to the machine, GP 10 . Disconnect the power lead from the customer supply while performing tasks that do not need electricity. Electricity can cause the death or injury. Moving components can cause the injury.

Procedure

ACTION	YES	NO
Step 1 Restart the printer. The fault persists.	Go to step 2.	The problem is solved.
Step 2 Ensure that the JOUTDC1 connector on the drive PWB, PL 1.10 item 3, is properly connected to the motor (exit/redrive), PL 80.05 item 10. The fault persists.	Go to step 3.	The problem is solved.
Step 3 Restart the printer. The fault persists.	Go to step 4.	The problem is solved.
Step 4 Install a new motor (exit/redrive), PL 80.05 item 10.	Go to step 5.	The problem is solved.

ACTION	YES	NO
The fault persists.		
Step 5 Restart the printer. The fault persists.	Go to step 6.	The problem is solved.
Step 6 Install a new drive PWB. See PL 1.10 item 3. The fault persists.	Contact the next level of support.	The problem is solved.

344-231-00 to 344-244-00, 364-231-00 to 364-237-00, 377-350-00 to 377-356-00 Motor (DUPLEX/MPF) Error RAP

WD2 Drive PWB Wiring Diagram

C625 Wiring Diagrams

- 344-231-00 Duplex Motor does not turn on RAP
- 344-232-00 Duplex Motor does not turn off RAP
- 344-233-00 Duplex Motor failed to achieve expected speed RAP
- 344-234-00 Duplex Motor loss of encoders (motor stall) RAP
- 344-235-00 Duplex Motor under speed RAP
- 344-236-00 Duplex Motor over speed RAP
- 344-237-00 Duplex Motor moved too long RAP
- 344-238-00 MPF Motor does not turn on RAP
- 344-239-00 MPF Motor does not turn off RAP
- 344-240-00 MPF Motor failed to achieve expected speed RAP
- 344-241-00 MPF Motor loss of encoders (motor stall) RAP
- 344-242-00 MPF Motor under speed RAP
- 344-243-00 MPF Motor over speed RAP
- 344-244-00 MPF Motor moved too long RAP
- 364-231-00 Duplex Motor does not turn on RAP
- 364-232-00 Duplex Motor does not turn off RAP
- 364-233-00 Duplex Motor failed to achieve expected speed RAP
- 364-234-00 Duplex Motor loss of encoders (motor stall) RAP
- 364-235-00 Duplex Motor under speed RAP
- 364-236-00 Duplex Motor over speed RAP
- 364-237-00 Duplex Motor moved too long RAP
- 377-350-00 MPF Motor does not turn on RAP
- 377-351-00 MPF Motor does not turn off RAP
- 377-352-00 MPF Motor failed to achieve expected speed RAP
- 377-353-00 MPF Motor loss of encoders (motor stall) RAP
- 377-354-00 MPF Motor under speed RAP
- 377-355-00 MPF Motor over speed RAP
- 377-356-00 MPF Motor moved too long RAP



WARNING: Switch off the electricity to the machine, GP 10. Disconnect the power lead from the customer supply while performing tasks that do not need electricity. Electricity can cause the death or injury. Moving components can cause the injury.

Procedure

Action	Yes	No
Step 1 Restart the printer. The fault persists.	Go to step 2.	The problem is solved.
Step 2 1 Enter the Diagnostics menu GP 1, and then navigate to: Printer diagnostics & adjustments > Motor tests > Duplex/MPF 2 Touch Start . The motor will run.	Go to step 6.	Go to step 3.
Step 3 Ensure that the JMTR1 connector is properly connected to the Drive PWB. The fault persists.	Go to step 4.	The problem is solved.
Step 4 Open the front door, and then manually turn the duplex/MPF drive gears. The gears will move freely.	Go to step 6.	Go to step 5.
Step 5 Install a new motor. See PL 80.05 item 6. The fault persists.	Go to step 6.	The problem is solved.
Step 6 Install a new Drive PWB. See PL 1.10 item 3. The fault persists.	Contact the next level of support.	The problem is solved.

364-238-00, 364-225-00 to 364-230-00 Motor (Tray 1 Pick/Lift) Lifting Error RAP

WD2 Drive PWB Wiring Diagram

C625 Wiring Diagrams

364-238-00 -80 = Redrive Motor does not turn on RAP

364-225-00 Redrive Motor does not turn off RAP

364-226-00 Redrive Motor failed to achieve expected speed RAP

364-227-00 Redrive Motor loss of encoders (motor stall) RAP

364-228-00 Redrive Motor underspeed RAP

364-229-00 Redrive Motor overspeed RAP

364-230-00 Redrive Motor moved too long RAP

Procedure



WARNING: Switch off the electricity to the machine, GP 10 . Disconnect the power lead from the customer supply while performing tasks that do not need electricity. Electricity can cause the death or injury. Moving components can cause the injury.

Action	Yes	No
Step 1 Restart the printer. The fault persists.	Go to step 2.	The problem is solved.
Step 2 Ensure that the JOUTDC1 connector on the Drive PWB is properly connected to the motor. The fault persists.	Go to step 3.	The problem is solved.
Step 3 Restart the printer. The fault persists.	Go to step 4.	The problem is solved.
Step 4 Install a new motor. See PL 80.05 item 10. The fault persists.	Go to step 5.	The problem is solved.
Step 5 Restart the printer. The fault persists.	Go to step 6.	The problem is solved.
Step 6 Install a new Drive PWB. See PL 1.10 item 3. The fault persists.	Contact the next level of support.	The problem is solved.

371-107-00 to 371-108-00, 372-151-00 to 372-152-00, 373-153-00 to 373-154-00, 374-100-01, 374-950-00, 375-100-01, 375-950-00, 375-951-00, 376-104-00 to 376-105-00, 377-950-00, 377-951-00 Load tray 1,2,3,4,5 with media Error RAPs

WD2 Drive PWB Wiring Diagram

C625 Wiring Diagrams

- 371-107-00 IRLoad: Load tray 1 with media (orientation not supported) RAP
- 371-108-00 IRLoad: Load tray 1 with media (orientation supported) RAP
- 372-151-00 IRLoad: Load tray 2 with media (orientation not supported) RAP
- 372-152-00 IRLoad: Load tray 2 with media (orientation supported) RA
- 373-153-00 IRLoad: Load tray 3 with media (orientation not supported) RAP
- 373-154-00 IRLoad: Load tray 3 with media (orientation supported) RAP
- 374-100-01 Change tray 4 to different media (orientation supported) RAP
- 374-950-00 IRChange: Load tray 4 to different media (orientation not supported) RAP
- 375-100-01 Change tray 5 to different media (orientation supported) RAP
- 375-950-00 Change tray 5 to different media (orientation not supported) RAP
- 375-951-00 IRChange: Load tray 5 to different media (orientation not supported) RAP
- 377-950-00 Change MP feeder to different media (orientation not supported) RAP
- 377-951-00 Change MP feeder to different media (orientation supported) RAP



WARNING: Switch off the electricity to the machine, GP 10 . Disconnect the power lead from the customer supply while performing tasks that do not need electricity. Electricity can cause the death or injury. Moving components can cause the injury.

Procedure

Action	Yes	No
<p>Step 1</p> <p>1 From the Home screen, touch Settings > Device > Preferences.</p> <p>2 Check if the paper size matches the size set on the tray guides. The paper size will match the size set on the tray.</p>	Go to step 3.	Go to step 2.
<p>Step 2</p> <p>Change the paper size or adjust the size setting in the tray. The fault persists.</p>	Go to step 3.	The problem is solved.

Action	Yes	No
<p>Step 3</p> <p>Check the drive PWB and its pins for damage. The drive PWB is free of damage.</p>	Contact the next level of support.	Go to step 4.
<p>Step 4</p> <p>Install a new drive PWB, PL 1.10 item 3. The fault persists.</p>	Contact the next level of support.	The problem is solved.

371-210-00, 371-212-00, 371-214-00, 371-216-00, 371-218-00, 371-220-00, 371-222-00, 351-214-00, 351-216-00, 351-218-00, 351-220-00, 351-222-00, 351-224-10, 351-226-10, 351-228-00 Motor (Tray 1, Autocomp Pick/Lift) Lifting Error RAP

371-210-00 Tray 1 Lift On Fail RAP

371-212-00 Tray 1 Lift Off Fail RAP

371-214-00 Autocomp Pick / Lift Motor failed to achieve expected speed RAP

371-216-00 Autocomp Pick / Lift Motor loss of encoders (motor stall) RAP

371-218-00 Autocomp Pick / Lift Motor under speed RAP

371-220-00 Autocomp Pick / Lift Motor over speed RAP

371-222-00 Autocomp Pick / Lift Motor moved too long RAP

351-214-00 Autocomp Pick / Lift Motor failed to achieve expected speed RAP

351-216-00 Autocomp Pick / Lift Motor loss of encoders (motor stall) RAP

351-218-00 Autocomp Pick / Lift Motor under speed RAP

351-220-00 Autocomp Pick / Lift Motor over speed RAP

351-222-00 Autocomp Pick / Lift Motor moved too long RAP

351-224-10 Tray 1 Autocomp Pick / Lift Motor did not lift properly since the lift plate sensor never changed state RAP

351-226-10 Autocomp Pick / Lift Motor does not turn on RAP

351-228-00 Autocomp Pick / Lift Motor does not turn off RAP

Procedure



WARNING: Switch off the electricity to the machine, GP 10 . Disconnect the power lead from the customer supply while performing tasks that do not need electricity. Electricity can cause the death or injury. Moving components can cause the injury.

Action	Yes	No
Step 1 Restart the printer. The fault persists.	Go to step 2.	The problem is solved.
Step 2 Ensure that the tray insert is properly seated or fully inserted. The fault persists.	Go to step 3.	The problem is solved.
Step 3	Go to step 5.	Go to step 4.

Action	Yes	No
<p>1 Enter the Diagnostics menu GP 1, and then navigate to: Printer diagnostics & adjustments > Sensor tests</p> <p>2 Find the sensor (Pick roller index (tray 1)). The sensor status will change while toggling the sensor.</p>		
<p>Step 4 Ensure that the JMTR1 connector on the engine board is properly connected to the sensor. The fault persists.</p>	Go to step 5.	The problem is solved.
<p>Step 5 Check the motor (tray 1 pick) for proper operation and noise.</p> <p>1 Remove the tray insert. 2 Enter the Diagnostics menu GP 1, and then navigate to: Printer diagnostics & adjustments > Motor tests > Pick (tray 1)</p> <p>3 Select Pick (tray 1) lifting, and then touch Start. The motor will run or does it sound normal.</p>	Go to step 8.	Go to step 6.
<p>Step 6 Ensure that the JMTR1 connector on the engine board is properly connected to the motor. The fault persists.</p>	Go to step 7.	The problem is solved.
<p>Step 7 Install a new paper feeder. See PL 70.10 item 8. The fault persists.</p>	Go to step 8.	The problem is solved.
<p>Step 8 Restart the printer. The fault persists.</p>	Contact the next level of support.	The problem is solved.

371-302-00, 371-310-00, 371-318-00, 371-324-00, 371-327-00, 372-226-00, 374-318-00, 374-329-00, 375-318-00, 375-329-00 Tray 2, 3, 4, 5 Sensor Failed To Arrive Error RAP

WD2 Drive PWB Wiring Diagram

C625 Wiring Diagrams

371-302-00 Sensor never made by leading edge of page RAP

371-310-00 Sensor never made by leading edge of page RAP

371-318-00 Tray 2 Jam at S1/Input/stage - never reached s1/Input/stage sensor RAP

371-324-00 Tray 3 Jam at Bump Exit - never reached bump exit sensor RAP

371-327-00 Tray 3 S1/Input sensor never made by leading edge after pick RAP

372-226-00 Tray 2 S1/Input sensor never made by leading edge after pick RAP

374-318-00 Tray 4 Jam at Bump Exit - never reached bump exit sensor RAP

374-329-00 Tray 4 S1/Input sensor never made by leading edge after pick RAP

375-318-00 Tray 5 Jam at Bump Exit - never reached bump exit sensor RAP

375-329-00 Tray 5 S1/Input sensor never made by leading edge after pick RAP

Procedure



WARNING: Switch off the electricity to the machine, **GP 10**. Disconnect the power lead from the customer supply while performing tasks that do not need electricity. Electricity can cause the death or injury. Moving components can cause the injury.

Action	Yes	No
Step 1 1 From the Home screen, touch Settings > Device > Preferences . 2 Check if the paper type and size settings match the paper type and size set on the tray. The paper size will match the size set on the tray.	Go to step 3.	Go to step 2.
Step 2 Change the paper size or adjust the size setting in the tray. The fault persists.	Go to step 3.	The problem is solved.
Step 3 Check the paper path for paper jams and fragments.	Go to step 5.	Go to step 4.

Action	Yes	No
Note: If necessary, remove the transfer module to properly see the paper path. The paper path is free of jams and fragments.		
Step 4 Remove the jams and fragments. The fault persists.	Go to step 5.	The problem is solved.
Step 5 Check the tray insert and its paper path guides and drive gears for damage. The tray insert is free of damage.	Go to step 7.	Go to step 6.
Step 6 Install a new tray insert. See PL 70.10 item 4 . The fault persists.	Go to step 7.	The problem is solved.
Step 7 1 Ensure that the pick roller is properly installed. Note: Firmly press the pick roller to its shaft to make sure that it is properly engaged. 2 Check the pick roller for excess wear, contamination, and damage. The pick roller is free from excess wear, contamination, and damage.	Go to step 9.	Go to step 8.
Step 8 Install a new pick roller. See PL 70.10 item 10 . The fault persists.	Go to step 9.	The problem is solved.
Step 9 1 Enter the Diagnostics menu GP 1 , and then navigate to: Printer diagnostics and adjustments > Motor tests > Pick (tray 1) 2 Select a setting, and then touch Start . The motor will run.	Go to step 12.	Go to step 10.

Action	Yes	No
Step 10 1 Ensure that the motor cable is properly connected. 2 Check the motor and the other paper feeder components PL 70.10 item 8 for damage. The motor and paper feeder is free of damage.	Go to step 12.	Go to step 11.
Step 11 1 Install a new paper feeder. See . 2 Perform a print job. The fault persists.	Go to step 12.	The problem is solved.
Step 12 1 Enter the Diagnostics menu GP 1 , and then navigate to: Printer diagnostics & adjustments >Sensor tests 2 Find the sensor (Input). The sensor status will change while toggling the sensor	Go to step 15.	Go to step 13.
Step 13 1 Ensure that the sensor cable is properly connected. 2 Check the sensor for damage. The sensor is free of damage.	Go to step 15.	Go to step 14.
Step 14 Install a new sensor. See PL 80.05 item 7 . The fault persists.	Go to step 15.	The problem is solved.
Step 15 1 Enter the Diagnostics menu, and then navigate to: Printer diagnostics & adjustments >Motor tests > Isolation 2 Touch Start , and then listen to the sound of the motor. 3 Check if the sound of the motor (isolation) is similar. The motor will create a similar grinding sound	Go to step 17.	Go to step 16.
Step 16	Go to step 18.	Go to step 17.

Action	Yes	No
Check the motor and its cable for damage. The motor and its cable is free of damage		
Step 17 Install a new isolation unit. See PL 80.10 item 4 . The fault persists.	Contact the next level of support.	The problem is solved.
Step 18 1 Enter the Diagnostics menu GP 1 , and then navigate to: Printer diagnostics & adjustments >Motor tests > Deskew 2 Touch Start . The motor will run.	Contact the next level of support.	Go to step 19.
Step 19 1 Ensure that the motor cable is properly connected. 2 Check the motor (deskew) for damage. The motor is free of damage.	Contact the next level of support.	Go to step 20.
Step 20 Install a new motor (deskew). See PL 40.10 item 1 . The fault persists.	Contact the next level of support.	The problem is solved.

371–304–00, 371–312–00, 371–320–00, 371–326–00, 374–320–00, 375–320–00 Tray 1, 2, 3, 4, 5 Sensor Failed To Clear Page Error RAP

WD2 Drive PWB Wiring Diagram

C625 Wiring Diagrams

371-304-00 S1/Input/Stage sensor never cleared by trailing edge of page (bump exit sensor for CA/MM) RAP

371-312-00 Tray 1 Bump exit/stage sensor never cleared by trailing edge of page RAP

371-320-00 Tray 2 S1/Input sensor never cleared by trailing edge of page RAP

371-326-00 Tray 3 S1/Input sensor never cleared by trailing edge of page RAP

374-320-00 Tray 4 S1/Input sensor never cleared by trailing edge of page RAP

375-320-00 Tray 5 S1/Input sensor never cleared by trailing edge of page RAP

Procedure



WARNING: Switch off the electricity to the machine, GP 10. Disconnect the power lead from the customer supply while performing tasks that do not need electricity. Electricity can cause the death or injury. Moving components can cause the injury.

Action	Yes	No
Step 1 1 From the Home screen, touch Settings > Device > Preferences . 2 Check if the paper size matches the size set on the tray guides. The paper size will match the size set on the tray.	Go to step 3.	Go to step 2.
Step 2 Change the paper size or adjust the size setting in the tray. The fault persists.	Go to step 3.	The problem is solved.
Step 3 Check the paper path for paper jams and obstructions. Note: If necessary, remove the transfer module to properly see the paper path. The paper path is free of jams and obstructions.	Go to step 5.	Go to step 4.
Step 4 Remove the jams and obstructions.	Go to step 5.	The problem is solved.

Action	Yes	No
The fault persists.		
Step 5 1 Enter the Diagnostics menu, GP 1 and then navigate to: Printer diagnostics & adjustments > Sensor tests 2 Find the sensor (Input). The sensor status will change while toggling the sensor.	Go to step 8.	Go to step 6.
Step 6 1 Ensure that the sensor cable is properly connected. 2 Check the sensor for damage. The sensor is free of damage.	Go to step 8.	Go to step 7.
Step 7 Install a new sensor. See PL 80.05 item 7. The fault persists.	Go to step 8.	The problem is solved.
Step 8 1 Enter the Diagnostics menu GP 1, and then navigate to: Printer diagnostics & adjustments Motor tests > Deskew 2 Touch Start . The motor will run.	Contact the next level of support.	Go to step 9.
Step 9 1 Ensure that the motor cable is properly connected. 2 Check the motor (deskew) for damage. The motor is free of damage.	Contact the next level of support.	Go to step 10.
Step 10 Install a new motor (deskew). See PL 40.10 item 1. The fault persists.	Contact the next level of support.	The problem is solved.

371-308-00, 371-316-00, 371-322-00, 374-300-00, 375-306-00S1/Input Sensor Covered Error RAP

371-308-00 Tray 1 Bump exit sensor covered too soon RAP

371-316-00 Tray 2 S1/Input sensor covered too soon RAP

371-322-00 Tray 3 S1/Input sensor covered too soon RAP

374-300-00 Tray 4 S1/Input sensor covered too soon RAP

375-306-00 Tray 5 S1/Input sensor covered too soon RAP

Procedure



WARNING: Switch off the electricity to the machine, GP 10 . Disconnect the power lead from the customer supply while performing tasks that do not need electricity. Electricity can cause the death or injury. Moving components can cause the injury.

Action	Yes	No
Step 6 Clean the paper path. The fault persists.	Go to step 7.	The problem is solved.
Step 7 Perform a print job. The fault persists.	Contact the next level of support.	The problem is solved.

Action	Yes	No
Step 1 1 From the Home screen, touch Settings >Device > Preferences . 2 Check if the paper size matches the size set on the tray guides. The paper size will match the size set on the tray.	Go to step 3.	Go to step 2.
Step 2 Change the paper size or adjust the size setting in the tray. The fault persists.	Go to step 3.	The problem is solved.
Step 3 Check the tray for overfilling. The tray is overfilled.	Go to step 4.	Go to step 5.
Step 4 Remove the excess paper from the tray. The fault persists.	Go to step 5.	The problem is solved.
Step 5 Check the paper path along the tray exit. The paper path is free of fragments and contamination.	Go to step 7.	Go to step 6.

371-317-00, 371-346-00, 374-317-00 Autocomp Motor Under Speed Error RAP

WD2 Drive PWB Wiring Diagram

C625 Wiring Diagrams

371-317-00 Tray 2 - Autocomp Motor under speed RAP

371-346-00 Tray 1- Autocomp Motor under speed RAP

374-317-00 Autocomp Motor under speed RAP

Procedure



WARNING: Switch off the electricity to the machine, GP 10 . Disconnect the power lead from the customer supply while performing tasks that do not need electricity. Electricity can cause the death or injury. Moving components can cause the injury.

Action	Yes	No
Step 1 Check the tray for overfilling. The tray is overfilled.	Go to step 2.	Go to step 3.
Step 2 Remove the excess paper from the tray. The fault persists.	Go to step 3.	The problem is solved.
Step 3 Check the paper condition in the tray. The paper is crumpled or damaged.	Go to step 4.	Go to step 5.
Step 4 Replace the crumpled or damaged paper. The problem persists.	Go to step 5.	The problem is solved.
Step 5 Check the tray exit paper path for fragments and contamination The paper path is free of fragments and contamination.	Go to step 7.	Go to step 6.
Step 6 Clean the paper path. The fault persists.	Go to step 7.	The problem is solved.
Step 7 1 Enter the Diagnostics menu GP 1, and then navigate to:	Contact the next level of support.	Go to step 8.

Action	Yes	No
Printer diagnostics and adjustments > Motor tests > Pick (tray 1) 2 Select a setting, and then touch Start . The motor will run.		
Step 8 1 Ensure that the motor cable is properly connected. 2 Check the motor and the other paper feeder components for damage. The motor and paper feeder is free of damage	Contact the next level of support.	Go to step 9.
Step 9 1 Install a new paper feeder. See PL 70.10 item 8. 2 Perform a print job. The fault persists.	Contact the next level of support.	The problem is solved.

371-319-00 Tray1 Pass-Through Sensor Covered During Warm Up Error RAP

WD2 Drive PWB Wiring Diagram

C625 Wiring Diagrams

371-319-00 Tray1 Pass-through sensor covered during warm up RAP

Procedure



WARNING: Switch off the electricity to the machine, GP 10. Disconnect the power lead from the customer supply while performing tasks that do not need electricity. Electricity can cause the death or injury. Moving components can cause the injury.

Action	Yes	No
Step 1 1 From the Home screen, touch Settings > Device > Preferences . 2 Check if the paper size matches the size set on the tray guides. The paper size will match the size set on the tray.	Go to step 3.	Go to step 2.
Step 2 Change the paper size or adjust the size setting in the tray. The fault persists.	Go to step 3.	The problem is solved.
Step 3 1 Enter the Diagnostics menu GP 1, and then navigate to: Printer diagnostics & adjustments > Sensor tests 2 Find the sensor (Tray 1 pick). The sensor status will change while toggling the sensor.	Contact the next level of support.	Go to step 4.

Action	Yes	No
Step 4 1 Ensure that the sensor cable is properly connected. 2 Check the sensor and the other isolation units for damage. The sensor and isolation unit is free of damage.	Contact the next level of support.	Go to step 5.
Step 5 1 Install a new isolation unit. See PL 80.10 item 4. 2 Perform a print job. The fault persists.	Contact the next level of support.	The problem is solved.

371–328–00 S1/Input Sensor Covered At Warmup Error RAP

C625 Wiring Diagrams

WD2 Drive PWB Wiring Diagram

371-328-00 S1/Input sensor covered at warm up RAP



WARNING: Switch off the electricity to the machine, GP 10 . Disconnect the power lead from the customer supply while performing tasks that do not need electricity. Electricity can cause the death or injury. Moving components can cause the injury.

Procedure

Action	Yes	No
Step 1 1 From the Home screen, touch Settings > Device > Preferences . 2 Check if the paper size matches the size set on the tray guides. The paper size will match the size set on the tray.	Go to step 3.	Go to step 2.
Step 2 Change the paper size or adjust the size setting in the tray. The fault persists.	Go to step 3.	The problem is solved.
Step 3 Check the paper path for partially fed or jammed paper. Note: If necessary, remove the transfer module to properly see the paper path. The paper path is free of partially fed or jammed paper.	Go to step 5.	Go to step 4.
Step 4 Remove the partially fed or jammed paper. The fault persists.	Go to step 5.	The problem is solved.
Step 5 1 Enter the Diagnostics menu GP 1, and then navigate to: Printer diagnostics & adjustments >Sensor tests 2 Find the sensor (Input). The sensor status will change while toggling the sensor.	Go to step 8.	Go to step 6.
Step 6	Go to step 8.	Go to step 7.

Action	Yes	No
1 Ensure that the sensor cable is properly connected. 2 Check the sensor for damage. The sensor is free of damage.		
Step 7 Install a new sensor. See PL 80.05 item 7. The fault persists.	Go to step 8.	The problem is solved.
Step 8 Perform a print job. The fault persists.	Contact the next level of support.	The problem is solved.

305-211-00, 305-212-00, 310-514-00, 371-329-00, 372-322-00, 373-322-00, 374-328-00, 375-328-00 Unknown Error RAP

305-211-00 Laser Safety interlock RAP

305-212-00 Mirror motor lock fail RAP

310-514-00 Facet Map failure due to kernel failure - May be due to low memory situations - RAP

371-329-00 Tray 1 fails to become input source ready for picking RAP

372-322-00 Tray 2 fails to become input source ready for picking RAP

373-322-00 Tray 3 fails to become input source ready for picking RAP

374-328-00 Tray 4 fails to become input source ready for picking RAP

375-328-00 Tray 5 fails to become input source ready for picking RAP

Procedure



WARNING: Switch off the electricity to the machine, GP 10 . Disconnect the power lead from the customer supply while performing tasks that do not need electricity. Electricity can cause the death or injury. Moving components can cause the injury.

Action	Yes	No
Restart the print job. The fault persists.	Contact the next level of support.	The problem is solved.

371-338-00 Sensor Never Made By Leading Edge After A Paper Pick

371-338-00 S1 sensor never made by leading edge after picking a page from tray 1 RAP

Procedure



WARNING: Switch off the electricity to the machine, GP 10 . Disconnect the power lead from the customer supply while performing tasks that do not need electricity. Electricity can cause the death or injury. Moving components can cause the injury.

Action	Yes	No
Step 1 1 From the Home screen, touch Settings > Device > Preferences 2 Check if the paper size matches the size set on the tray guides.	Go to step 3.	Go to step 2.
Step 2 Change the paper size or adjust the size setting in the tray. The Problem persists.	Go to step 3.	The problem is solved.
Step 3 Check if the paper size matches the size set on the tray guides. The paper size will match the size set on the tray.	Go to step 5.	Go to step 4.
Step 4 Insert a new paper or change the paper size setting in the tray. The fault persists.	Go to step 5.	The problem is solved.
Step 5 Check the paper tray for overfilling. The paper tray is overfilled.	Go to step 6.	Go to step 7.
Step 6 Remove the excess paper from the tray. The fault persists.	Go to step 7.	The problem is solved.
Step 7 Check the paper condition in the tray. The paper is crumpled or damaged.	Go to step 8.	Go to step 9.
Step 8	Go to step 9.	The problem is solved.

Action	Yes	No
Check that the damaged paper is removed and insert the new paper. The fault persists.		
Step 9 1 Ensure that the tray pick roller is properly installed. Note: Firmly press the pick roller to its shaft to make sure that it is properly engaged. 1 Check the tray pick roller for excess wear, contamination, and damage. The tray pick roller is free from excess wear, contamination, and damage.	Go to step 11.	Go to step 10.
Step 10 Install a new pick roller. See PL 70.10 item 10 . The fault persists.	Go to step 11.	The problem is solved.
Step 11 Check the tray exit paper path for paper fragments and contamination. The paper path is free of paper fragments and contamination.	Go to step 15.	Go to step 12.
Step 12 Clean the paper path. The fault persists.	Go to step 13.	The problem is solved.
Step 13 1 Enter the Diagnostics menu GP 1 , and then navigate to: Printer diagnostics & adjustments > Sensor tests 2 Find the sensor (Tray 1 pick).	Go to step 15.	Go to step 14.
Step 14 1 Ensure that the sensor cable is properly connected. 2 Ensure that the sensor is properly installed. 3 Check the sensor and the other optional tray components for damage The sensor and optional tray are free of damage.	Go to step 15.	Go to step 17.

Action	Yes	No
Step 15 1 Enter the Diagnostics menu GP 1 , and then navigate to: Printer diagnostics & adjustments > Motor tests > Pick (tray 1) 2 Select a setting, and then touch Start . The motor will run.	Go to step 18.	Go to step 16.
Step 16 1 Ensure that the motor cable is properly connected. 2 Check the motor and the other paper feeder components for damage The motor and paper feeder is free of damage.	Go to step 18.	Go to step 17.
Step 17 1 Install a new paper feeder. See PL 70.10 item 8 2 Perform a print job. The fault persists.	Go to step 18.	The problem is solved.
Step 18 Perform a print test. The fault persists.	Contact the next level of support.	The problem is solved.

371-339-00, 372-305-00, 373-305-00, 374-305-00, 375-305-00 Tray 1, 2, 3, 4, 5 S1/Input Sensor Cleared Error RAP

C625 Wiring Diagrams

WD2 Drive PWB Wiring Diagram

371-339-00 Tray 1 Bump exit sensor cleared by page too soon RAP

372-305-00 Tray 2 S1/Input sensor cleared by page too soon RAP

373-305-00 Tray 3 S1/Input sensor cleared by page too soon RAP

374-305-00 Tray 4 S1/Input sensor cleared by page too soon RAP

375-305-00 Tray 5 S1/Input sensor cleared by page too soon RAP

Procedure



WARNING: Switch off the electricity to the machine, GP 10. Disconnect the power lead from the customer supply while performing tasks that do not need electricity. Electricity can cause the death or injury. Moving components can cause the injury.

Action	Yes	No
Step 1 1 From the Home screen, touch Settings >Device > Preferences . 2 Check if the paper size matches the size set on the tray guides. The paper size will match the size set on the tray.	Go to step 3.	Go to step 2.
Step 2 Change the paper size or adjust the size setting in the tray. The fault persists.	Go to step 3.	The problem is solved.
Step 3 Check the tray for overfilling. The tray is overfilled.	Go to step 4.	Go to step 5.
Step 4 Remove the excess paper from the tray. The fault persists.	Go to step 5.	The problem is solved.
Step 5 Check the paper condition in the tray. The paper is crumpled or damaged?	Go to step 6.	Go to step 7.
Step 6	Go to step 7.	The problem is solved.

Action	Yes	No
Install a new crumpled or damaged paper. The fault persists.		
Step 7 1 Enter the Diagnostics menu, GP 1 and then navigate to: Printer diagnostics & adjustments> Sensor tests 2 Find the sensor (Input). The sensor status will change while toggling the sensor.	Go to step 9.	The problem is solved.
Step 8 1 Ensure that the sensor cable is properly connected. 2 Check the sensor for damage. The sensor is free of damage.	Go to step 9.	Go to step 9.
Step 9 Install a new sensor. See PL 80.05 item 7. The fault persists.	Go to step 10.	The problem is solved.
Step 10 Perform a print job. The fault persists.	Contact the next level of support.	The problem is solved.

371-340-00, 371-341-00, 371-342-00, 371-347-00 Bump Exit Sensor Error RAP

371-340-00 Bump exit sensor never made by leading edge of page- Source is tray 1- RAP

371-341-00 Bump exit sensor cleared by page too soon- Source is tray 1- RAP

371-342-00 Bump exit sensor never cleared by trailing edge of page- Source is tray 1- RAP

371-347-00 Bump exit sensor covered too soon- Source is tray 1- RAP



WARNING: Switch off the electricity to the machine, GP 10. Disconnect the power lead from the customer supply while performing tasks that do not need electricity. Electricity can cause the death or injury. Moving components can cause the injury.

Switch OFF, then switch ON the machine,GP 10. If the fault persists, contact 2nd Level Support.

371-343-00 S1 Sensor Covered To Soon Error RAP

371-343-00 Tray 1 S1 sensor covered too soon RAP

Procedure



WARNING: Switch off the electricity to the machine, GP 10. Disconnect the power lead from the customer supply while performing tasks that do not need electricity. Electricity can cause the death or injury. Moving components can cause the injury.

Action	Yes	No
Step 1 1 From the Home screen, touch Settings >Device > Preferences . 2 Check if the paper size matches the size set on the tray guides. The paper size will match the size set on the tray.	Go to step 3.	Go to step 2.
Step 2 Change the paper size or adjust the size setting in the tray. The fault persists.	Go to step 3.	The problem is solved.
Step 3 Check the tray for overfilling. The tray is overfilled.	Go to step 4.	Go to step 5.
Step 4 Remove the excess paper from the tray. The fault persists.	Go to step 5.	The problem is solved.
Step 5 Check the tray exit paper path for fragments and contamination. The paper path is free of fragments and contamination.	Go to step 7.	Go to step 6.
Step 6 Clean the paper path. The fault persists.	Go to step 7.	The problem is solved.
Step 7 Perform a print job. The fault persists.	Contact the next level of support.	The problem is solved.

371–344–00 Tray 1 S1 Sensor Cleared By Page Too Soon Error RAP

WD2 Drive PWB Wiring Diagram

C625 Wiring Diagrams

371-344-00 Tray 1 S1 sensor cleared by page too soon RAP

Procedure



WARNING: Switch off the electricity to the machine, GP 10. Disconnect the power lead from the customer supply while performing tasks that do not need electricity. Electricity can cause the death or injury. Moving components can cause the injury.

Action	Yes	No
Step 1 1 From the Home screen, touch Settings > Device > Preferences . 2 Check if the paper size matches the size set on the tray guides. The paper size will match the size set on the tray.	Go to step 3.	Go to step 2.
Step 2 Change the paper size or adjust the size setting in the tray. The fault persists.	Go to step 3.	The problem is solved.
Step 3 Check the tray for overfilling. The tray is overfilled.	Go to step 4.	Go to step 5.
Step 4 Remove the excess paper from the tray. The fault persists.	Go to step 5.	The problem is solved.
Step 5 Check the paper condition in the tray. The paper is crumpled or damaged.	Go to step 6.	Go to step 7.
Step 6 Check whether crumpled or damaged paper. is removed and insert new paper. The fault persists.	Go to step 7.	The problem is solved.
Step 7	Go to step 9.	The problem is solved.

Action	Yes	No
1 Enter the Diagnostics menu GP 1, and then navigate to: Printer diagnostics & adjustments > Sensor tests 2 Find the sensor (Input). The sensor status will change while toggling the sensor.		
Step 8 1 Ensure that the sensor cable is properly connected. 2 Check the sensor for damage. The sensor is free of damage.	Go to step 9.	Go to step 9.
Step 9 Install a new sensor. See PL 80.05 item 7. The fault persists.	Go to step 10.	The problem is solved.
Step 10 Perform a print job. The fault persists.	Contact the next level of support.	The problem is solved.

371–345–00 Tray 1 S1 Sensor Never Cleared By Trailing Edge Error RAP

WD2 Drive PWB Wiring Diagram

C625 Wiring Diagrams

371-345-00 Tray 1 S1 sensor never cleared by trailing edge of page RAP

Procedure



WARNING: Switch off the electricity to the machine, GP 10. Disconnect the power lead from the customer supply while performing tasks that do not need electricity. Electricity can cause the death or injury. Moving components can cause the injury.

Action	Yes	No
Step 1 1 From the Home screen, touch Settings >Device > Preferences . 2 Check if the paper size matches the size set on the tray guides. The paper size will match the size set on the tray.	Go to step 3.	Go to step 2.
Step 2 Change the paper size or adjust the size setting in the tray. The fault persists.	Go to step 3.	The problem is solved.
Step 3 Check the paper path for paper jams and fragments. The paper path is free of jams and fragments.	Go to step 5.	Go to step 4.
Step 4 Remove the paper jams and fragments. The fault persists.	Go to step 5.	The problem is solved.
Step 5 Check the tray insert and its paper path guides and drive gears for damage. The tray insert is free of damage.	Go to step 7.	Go to step 6.
Step 6 Install a new tray insert. See PL 70.10 item 4. The fault persists.	Go to step 7.	The problem is solved.
Step 7	Go to step 10.	Go to step 8.

Action	Yes	No
1 Enter the Diagnostics menu GP 1, and then navigate to: Printer diagnostics & adjustments >Sensor tests 2 Find the sensor (Input). The sensor status will change while toggling the sensor.		
Step 8 1 Ensure that the sensor cable is properly connected. 2 Check the sensor for damage. The sensor is free of damage.	Go to step 10.	Go to step 9.
Step 9 Install a new sensor. See PL 80.05 item 7. The fault persists.	Go to step 10.	The problem is solved.
Step 10 1 Enter the Diagnostics menu GP 1, and then navigate to: Printer diagnostics & adjustments >Motor tests > Isolation 2 Touch Start . The motor will run.	Contact the next level of support.	Go to step 11.
Step 11 1 Ensure that the motor cable is properly connected. 2 Check the motor and isolation unit for damage. The motor and isolation unit are free of damage.	Contact the next level of support.	Go to step 12.
Step 12 1 Install a new isolation unit. See PL 80.10 item 4. 2 Perform a print job. The fault persists.	Contact the next level of support.	The problem is solved.

371-537-00 Tray Empty Sensor Cable Unplugged RAP

371-537-00 Tray empty sensor cable unplugged RAP



WARNING: Switch off the electricity to the machine, GP 10. Disconnect the power lead from the customer supply while performing tasks that do not need electricity. Electricity can cause the death or injury. Moving components can cause the injury.

Switch OFF, then switch ON the machine, GP 10. If the fault persists, contact 2nd Level Support.

372-010-00 to 372-012-00, 373-010-00 to 373-012-00, 374-010-00 to 374-012-00, 375-010-00 to 375-012-00 TRAY 2, 3, 4, 5 Invalid Product ID, Board ID, Option Type Error RAP

WD2 Drive PWB Wiring Diagram

C625 Wiring Diagrams

372-010-00 Tray 2 Invalid Product ID RAP

372-011-00 Tray 2 Invalid Board ID RAP

372-012-00 Tray 2 Invalid Option Type RAP

373-010-00 Tray 3 Invalid Product ID RAP

373-011-00 Tray 3 Invalid Board ID RAP

373-012-00 Tray 3 Invalid Option Type RAP

374-010-00 Tray 4 Invalid Product ID RAP

374-011-00 Tray 4 Invalid Board ID RAP

374-012-00 Tray 4 Invalid Option Type RAP

375-010-00 Tray 5 Invalid Product ID RAP

375-011-00 Tray 5 Invalid Board ID RAP

375-012-00 Tray 5 Invalid Option Type RAP

Procedure



WARNING: Switch off the electricity to the machine, GP 10 . Disconnect the power lead from the customer supply while performing tasks that do not need electricity. Electricity can cause the death or injury. Moving components can cause the injury.

Action	Yes	No
Step 1 1 Ensure that the latest firmware is installed. 2 Ensure that the options configuration is supported. See the Printer, Option, and Stand Compatibility Guide. 3 Restart the printer. The fault persists.	Go to step 2.	The problem is solved.
Step 2 Reinstall the optional tray. The fault persists.	Go to step 3.	The problem is solved.

Action	Yes	No
Step 3 Install a new optional tray. See PL 70.15 item 1. The fault persists.	Go to step 4 .	The problem is solved.
Step 4 Restart the printer. The fault persists.	Contact the next level of support.	The problem is solved.

372-100-00, 372-150-00, 372-330-00, 372-333-00, 372-338-00, 373-100-00, 373-150-00, 373-332-00, 373-341-00, 374-150-00, 374-341-00, 375-246-00, 375-343-00, 377-277-00
Tray 2, 3, 4, 5 Fail To Pick Error RAP

WD2 Drive PWB Wiring Diagram

C625 Wiring Diagrams

372-100-00 Tray 2 Mis feed_ Empty RAP

372-150-00 Fail To Pick From Tray. Option declared jam, or warm up jam with unknown page RAP

372-330-00 Tray 3 Fail To Pick From Tray (Paper did not reach first sensor; Miss-feed, tray empty) RAP

372-333-00 Tray 4 Fail To Pick From Tray (Paper did not reach first sensor; Miss-feed, tray empty) RAP

372-338-00 Tray 5 Fail To Pick From Tray (Paper did not reach first sensor; Miss-feed, tray empty) RAP

373-100-00 Tray 3 Mis feed_ Empty RAP

373-150-00 Fail To Pick From Tray Option declared jam, or warm up jam with unknown page RAP

373-332-00 Tray 4 Fail To Pick From Tray RAP

373-341-00 Tray 5 Fail To Pick From Tray (Paper did not reach first sensor; Miss-feed, tray empty) RAP

374-150-00 Tray 4 Fail To Pick From Tray (Paper did not reach first sensor; Miss-feed, tray empty) RAP

374-341-00 Tray 5 Fail To Pick From Tray (Paper did not reach first sensor; Miss-feed, tray empty) RAP

375-246-00 Tray 5 Fail To Pick From Tray (Paper did not reach first sensor; Miss-feed, tray empty) RAP

375-343-00 Fail To Pick From Tray. Option declared jam, or warm up jam with unknown page RAP

377-277-00 Fail To Pick From Tray. Option declared jam, or warm up jam with unknown page RAP

Procedure



WARNING: Switch off the electricity to the machine, GP 10 . Disconnect the power lead from the customer supply while performing tasks that do not need electricity. Electricity can cause the death or injury. Moving components can cause the injury.

Action	Yes	No
Step 1 1 From the Home screen, touch Settings >Device > Preferences. 2 Check if the paper size matches the size set on the tray guides. The paper size will match the size set on the tray.	Go to step 3.	Go to step 2.
Step 2 Change the paper size or adjust the size setting in the tray. The fault persists.	Go to step 3.	The problem is solved.
Step 3 Check if the paper size matches the size set on the tray guides. The paper size will match the size set on the tray.	Go to step 5.	Go to step 4.
Step 4 Insert new paper or change the paper size setting in the tray. The fault persists.	Go to step 5.	The problem is solved.
Step 5 Check the paper tray for overfilling. The paper tray overfilled.	Go to step 6.	Go to step 7.
Step 6 Remove the excess paper from the tray. The fault persists.	Go to step 7.	The problem is solved.
Step 7 Check the paper condition in the tray. The paper crumpled or damaged.	Go to step 8.	Go to step 9.
Step 8 Check whether the crumbled or damaged paper is removed and insert new paper. The fault persists.	Go to step 9.	The problem is solved.
Step 9	Go to step 11.	Go to step 10.

Action	Yes	No
<p>1 Ensure that the optional tray pick roller is properly installed.</p> <p>Note: Firmly press the pick roller to its shaft to make sure that is properly engaged.</p> <p>2 Check the optional tray pick roller for excess wear, contamination, and damage.</p> <p>The optional tray pick roller is free from excess wear, contamination, and damage.</p>		
<p>Step 10 Install a new pick roller. See PL 70.10 item 7. The fault persists.</p>	Go to step 11.	The problem is solved.
<p>Step 11 Check the tray exit paper path for paper fragments and contamination. The paper path is free of paper fragments and contamination.</p>	Go to step 15.	Go to step 12.
<p>Step 12 Clean the paper path. The fault persists.</p>	Go to step 13.	The problem is solved.
<p>Step 13</p> <p>1 Enter the Diagnostics menu GP 1, and then navigate to: Additional input trays adjustments/tests > Additional input tray sensors</p> <p>2 Find the sensor (Trailing edge (tray [x])).</p> <p>Note: [x] is the tray number. The sensor status will change while toggling the sensor.</p>	Go to step 15.	Go to step 14.
<p>Step 14</p> <p>1 Ensure that the sensor cable is properly connected.</p> <p>2 Ensure that the sensor is properly installed.</p>	Go to step 15.	Go to step 17.

Action	Yes	No
<p>3 Check the sensor and the other optional tray components for damage. The sensor and optional tray are free of damage.</p>		
<p>Step 15</p> <p>1 Enter the Diagnostics menu, GP 1 and then navigate to: Additional input tray diagnostics > Motor tests</p> <p>2 Select Pick (tray [x]), and then touch Start. The motor will run.</p>	Go to step 18.	Go to step 16.
<p>Step 16</p> <p>1 Ensure that the motor cable is properly connected.</p> <p>2 Ensure that the motor is properly installed.</p> <p>3 Check the motor and the other optional tray components for damage. The motor and the optional tray are free of damage.</p>	Go to step 18.	Go to step 17.
<p>Step 17 Install a new optional tray. See PL 70.15 item 1. The fault persists.</p>	Go to step 18.	The problem is solved.
<p>Step 18 Perform a print test. The fault persists.</p>	Contact the next level of support.	The problem is solved.

372-102-00, 372-108-00, 372-142-00, 372-144-00, 372-223-00, 372-331-00, 372-334-00, 372-902-00, 373-102-00, 373-142-00, 373-144-00, 373-330-00, 373-333-00, 373-339-00, 373-900-00, 374-142-00, 374-143-00, 374-334-00, 374-335-00, 374-339-00, 375-142-00, 375-242-00, 375-334-00, 375-335-00, 375-339-00, 377-149-00, 377-274-00, 377-279-00
Early Arriving Jam And Static Jam RAP

WD2 Drive PWB Wiring Diagram

C625 Wiring Diagrams

- 372-102-00 Tray 2 EARLY ARRIVING JAM (Paper reaches the sensor too soon, or unexpected) RAP
- 372-108-00 Tray 3 EARLY ARRIVING JAM (Paper reaches the sensor too soon, or unexpected) RAP
- 372-142-00 STATIC JAM. Option declared jam, or warm up jam with no known page source - RAP
- 372-144-00 EARLY ARRIVING JAM. Option declared jam, or warm up jam with no known page source - RAP
- 372-223-00 Tray 2 STATIC JAM (Paper at sensor at start, cover closed or idle - Jam not cleared) RAP
- 372-331-00 Tray 4 EARLY ARRIVING JAM (Paper reaches the sensor too soon, or unexpected) RAP
- 372-334-00 Tray 5 EARLY ARRIVING JAM (Paper reaches the sensor too soon, or unexpected) RAP
- 372-902-00 Tray 3 STATIC JAM (Paper at sensor at start, cover closed or idle - Jam not cleared) RAP
- 373-102-00 Tray 3 early jam RAP
- 373-142-00 STATIC JAM. Option declared jam, or warm up jam with no known page source RAP
- 373-144-00 EARLY ARRIVING JAM. Option declared jam, or warm up jam with no known page source - RAP
- 373-330-00 Tray 4 EARLY ARRIVING JAM (Paper reaches the sensor too soon, or unexpected) RAP
- 373-333-00 Tray 5 STATIC JAM (Paper at sensor at start, cover closed or idle - Jam not cleared) RAP
- 373-339-00 Tray 5 EARLY ARRIVING JAM (Paper reaches the sensor too soon, or unexpected) RAP
- 373-900-00 Tray 3 static jam RAP
- 374-142-00 Tray 4 STATIC JAM (Paper at sensor at start, cover closed or idle - Jam not cleared) RAP
- 374-143-00 Tray 4 STATIC JAM (Paper at sensor at start, cover closed or idle - Jam not cleared) RAP
- 374-334-00 Tray 4 STATIC JAM (Paper at sensor at start, cover closed or idle - Jam not cleared) RAP
- 374-335-00 Tray 4 EARLY ARRIVING JAM (Paper reaches the sensor too soon, or unexpected) RAP
- 374-339-00 Tray 5 EARLY ARRIVING JAM (Paper reaches the sensor too soon, or unexpected) RAP
- 375-142-00 Tray 5 STATIC JAM (Paper at sensor at start, cover closed or idle - Jam not cleared) RAP
- 375-242-00 Tray 5 STATIC JAM (Paper at sensor at start, cover closed or idle - Jam not cleared) RAP
- 375-334-00 Tray 5 STATIC JAM (Paper at sensor at start, cover closed or idle - Jam not cleared) RAP

- 375-335-00 Tray 5 EARLY ARRIVING JAM (Paper reaches the sensor too soon, or unexpected) RAP
- 375-339-00 EARLY ARRIVING JAM. Option declared jam, or warm up jam with no known page source RAP
- 377-149-00 STATIC JAM. Option declared jam, or warm up jam with no known page source RAP
- 377-274-00 EARLY ARRIVING JAM. Option declared jam, or warm up jam with no known page source RAP
- 377-279-00 STATIC JAM. Option declared jam, or warm up jam with no known page source RAP

Procedure



WARNING: Switch off the electricity to the machine, GP 10 . Disconnect the power lead from the customer supply while performing tasks that do not need electricity. Electricity can cause the death or injury. Moving components can cause the injury.

Action	Yes	No
Step 1 1 From the Home screen, touch Settings >Device > Preferences . 2 Check if the paper size matches the size set on the tray guides. The paper size will match the size set on the tray.	Go to step 3.	Go to step 2.
Step 2 Change the paper size or adjust the size setting in the tray. The fault persists.	Go to step 3.	The problem is solved.
Step 3 Check the paper path for partially fed or jammed paper. The paper path is free of partially fed or jammed paper.	Go to step 5.	Go to step 4.
Step 4 Remove the partially fed or jammed paper. The fault persists.	Go to step 5.	The problem is solved.
Step 5 1 Enter the Diagnostics menu GP 1 , and then navigate to: Additional input trays adjustments/tests >Additional input tray sensors 2 Find the sensor (Trailing edge (tray [x])).	Go to step 7.	Go to step 6.

Action	Yes	No
<p>Note: [x] is the tray number. The sensor status will change while toggling the sensor.</p>		
<p>Step 6 1 Ensure that the sensor cable is properly connected. 2 Ensure that the sensor is properly installed. 3 Check the sensor for damage. The sensor is free of damage.</p>	Go to step 7.	Go to step 9.
<p>Step 7 1 Enter the Diagnostics menu GP 1, and then navigate to: Additional input trays adjustments/tests >Additional input tray sensors 2 Find the sensor (Pass-through (tray [x])). Note: [x] is the tray number. The sensor status will change while toggling the sensor.</p>	Go to step 10.	Go to step 8.
<p>Step 8 1 Ensure that the sensor cable is properly connected. 2 Ensure that the sensor is properly installed. 3 Check the sensor and the other optional tray components for damage. The sensor is free of damage.</p>	Go to step 10.	Go to step 9.
<p>Step 9 Install a new 550-sheet optional tray, PL 25.05 item 1. The fault persists.</p>	Go to step 10.	The problem is solved.
<p>Step 10 Perform a print test. The fault persists.</p>	Contact the next level of support.	The problem is solved.

372-105-00, 372-112-00, 372-148-00, 372-337-00, 373-105-00, 373-148-00, 374-112-00, 374-148-00, 374-338-00, 375-240-00, 375-244-00, 375-338-00, 375-342-00, 377-276-00
Late Leaving Jam Tray (3, 4, 5) RAP

WD2 Drive PWB Wiring Diagram

C625 Wiring Diagrams

372-105-00 Tray 2 Late jam RAP

372-112-00 Tray 3 Late Leaving Jam (Paper reaches sensor but clears it late-(Long media, double feed) RAP

372-148-00 Late Leaving Jam. Option declared jam, or warm up jam with no known page source RAP

372-337-00 Tray 5 Late Leaving Jam (Paper reaches sensor but clears it late-(Long media, double feed) RAP

373-105-00 Tray 3 Regi Sensor On Jam RAP

373-148-00 Late Leaving Jam. Option declared jam, or warm up jam with no known page source RAP

374-112-00 Tray 4 Late Leaving Jam (Paper reaches sensor but clears it late-(Long media, double feed) RAP

374-148-00 Tray 4 Late Leaving Jam (Paper reaches sensor but clears it late-(Long media, double feed) RAP

374-338-00 Tray 4 Late Leaving Jam (Paper reaches sensor but clears it late-(Long media, double feed) RAP

375-240-00 Tray 5 Late Leaving Jam (Paper reaches sensor but clears it late-(Long media, double feed) RAP

375-244-00 Tray 5 Late Leaving Jam (Paper reaches sensor but clears it late-(Long media, double feed) RAP

375-338-00 Tray 5 Late Leaving Jam (Paper reaches sensor but clears it late-(Long media, double feed) RAP

375-342-00 Late Leaving Jam. Option declared jam, or warm up jam with no known page source RAP

377-276-00 Late Leaving Jam. Option declared jam, or warm up jam with no known page source RAP

Procedure



WARNING: Switch off the electricity to the machine, **GP 10**. Disconnect the power lead from the customer supply while performing tasks that do not need electricity. Electricity can cause the death or injury. Moving components can cause the injury.

Action	Yes	No
<p>Step 1</p> <p>1 From the Home screen, touch Settings >Device > Preferences.</p> <p>2 Check if the paper size matches the size set on the tray guides. The paper size will match the size set on the tray.</p>	Go to step 3.	Go to step 2.
<p>Step 2</p> <p>Change the paper size or adjust the size setting in the tray. The fault persists.</p>	Go to step 3.	The problem is solved.
<p>Step 3</p> <p>Check if the paper size matches the size set on the tray guides. The paper size will match the size set on the tray.</p>	Go to step 5.	Go to step 4.
<p>Step 4</p> <p>Insert new paper or change the paper size setting in the tray. The fault persists.</p>	Go to step 5.	The problem is solved.
<p>Step 5</p> <p>Check the primary paper path for paper jams and obstructions. The paper path is free of jams and obstructions.</p>	Go to step 7.	Go to step 6.
<p>Step 6</p> <p>Remove the paper jams and obstructions. The fault persists.</p>	Go to step 7.	The problem is solved.
<p>Step 7</p> <p>1 Enter the Diagnostics menu GP 1, and then navigate to: Additional input trays adjustments/tests >Additional input tray sensors</p> <p>2 Find the sensor (Trailing edge (tray [x])).</p> <p>Note: [x] is the tray number.</p>	Go to step 9.	Go to step 8.

Action	Yes	No
<p>The sensor status will change while toggling the sensor.</p>		
<p>Step 8</p> <p>1 Ensure that the sensor cable is properly connected.</p> <p>2 Ensure that the sensor is properly installed.</p> <p>3 Check the sensor and the other optional tray components for damage. The sensor is free of damage.</p>	Go to step 9.	Go to step 13.
<p>Step 9</p> <p>1 Enter the Diagnostics menu GP 1, and then navigate to: Additional input trays adjustments/tests >Additional input tray sensors</p> <p>2 Find the sensor (Pass-through (tray [x])).</p> <p>Note: [x] is the tray number. The sensor status will change while toggling the sensor.</p>	Go to step 11.	Go to step 10.
<p>Step 10</p> <p>1 Ensure that the sensor cable is properly connected.</p> <p>2 Ensure that the sensor is properly installed.</p> <p>3 Check the sensor and the other optional tray components for damage. The sensor and the optional tray are free of damage.</p>	Go to step 11.	Go to step 11.
<p>Step 11</p> <p>1 Enter the Diagnostics menu GP 1, and then navigate to: Additional input trays adjustments/tests >Additional input tray motors</p> <p>2 Select Pass-through (tray [x]), and then touch Start.</p> <p>Note: [x] is the tray number.</p>	Go to step 14.	Go to step 12.

Action	Yes	No
The motor will run.		
Step 12 1 Ensure that the motor cable is properly connected. 2 Ensure that the motor is properly installed. 3 Check the motor and the other optional tray components for damage. The motor and the optional tray are free of damage.	Go to step 14.	Go to step 13.
Step 13 Install a new optional tray. See PL 70.15 item 1 . The fault persists.	Go to step 14.	The problem is solved.
Step 14 1 Enter the Diagnostics menu GP 1 , and then navigate to: Printer diagnostics & adjustments > Motor tests 2 Select Duplex/MPF , and then touch Start . The motor will run.	Go to step 17.	Go to step 15.
Step 15 Reseat the motor cable, and then check the motor form is alignment and damage. The motor is properly installed and free of damage.	Go to step 17.	Go to step 16.
Step 16 Install a new motor. See PL 80.05 item 6 . The fault persists.	Go to step 17.	The problem is solved.
Step 17 Perform a print test. The fault persists.	Contact the next level of support.	The problem is solved.

372-114-00, 372-116-00, 372-118-00, 372-120-00, 372-122-00, 372-124-00, 372-126-00, 373-116-00, 373-118-00, 373-120-00, 373-122-00, 373-124-00, 373-126-00, 373-321-00, 374-114-00, 374-116-00, 374-118-00, 374-120-00, 374-122-00, 374-124-00, 374-126-00, 375-247-00 to 375-249-00, 375-251-00 to 375-253-00, 375-560-00 Tray 2, 3, 4, 5 Transport (550) or Lift (HCIT) Motor Error RAP

WD2 Drive PWB Wiring Diagram

C625 Wiring Diagrams

- 372-114-00 Tray 2 Transport (550) or lift (HCIT) Motor does not turn on RAP
- 372-116-00 Tray 2 Transport (550) or lift (HCIT) Motor does not turn off RAP
- 372-118-00 Tray 2 Transport (550) or lift (HCIT) Motor failed to achieve expected speed RAP
- 372-120-00 Tray 2 Transport (550) or lift (HCIT) Motor loss of encoders (motor stall) RAP
- 372-122-00 Tray 2 Transport (550) or lift (HCIT) Motor under speed RAP
- 372-124-00 Tray 2 Transport (550) or lift (HCIT) Motor overs peed RAP
- 372-126-00 Tray 2 Transport (550) or lift (HCIT) Motor moved too long RAP
- 373-116-00 Tray 3 Transport (550) or lift (HCIT) Motor does not turn off RAP
- 373-118-00 Tray 3 Transport (550) or lift (HCIT) Motor failed to achieve expected speed RAP
- 373-120-00 Tray 3 Transport (550) or lift (HCIT) Motor loss of encoders (motor stall) RAP
- 373-122-00 Tray 3 Transport (550) or lift (HCIT) Motor under speed RAP
- 373-124-00 Tray 3 Transport (550) or lift (HCIT) Motor over speed RAP
- 373-126-00 Tray 3 Transport (550) or lift (HCIT) Motor moved too long RAP
- 373-321-00 Tray 3 Transport (550) or lift (HCIT) Motor does not turn on RAP
- 374-114-00 -70 = Tray 4 Transport (550) or lift (HCIT) Motor does not turn on RAP
- 374-116-00 -71 = Tray 4 Transport (550) or lift (HCIT) Motor does not turn off RAP
- 374-118-00 -72 = Tray 4 Transport (550) or lift (HCIT) Motor failed to achieve expected speed RAP
- 374-120-00 -73 = Tray 4 Transport (550) or lift (HCIT) Motor loss of encoders (motor stall) RAP
- 374-122-00 -74 = Tray 4 Transport (550) or lift (HCIT) Motor under speed RAP
- 374-124-00 -75 = Tray 4 Transport (550) or lift (HCIT) Motor over speed RAP
- 374-126-00 -76 = Tray 4 Transport (550) or lift (HCIT) Motor moved too long RAP
- 375-247-00 Tray 5 Transport (550) or lift (HCIT) Motor does not turn on RAP
- 375-248-00 Tray 5 Transport (550) or lift (HCIT) Motor does not turn off RAP
- 375-249-00 Tray 5 Transport (550) or lift (HCIT) Motor failed to achieve expected speed RAP

375-251-00 Tray 5 Transport (550) or lift (HCIT) Motor under speed RAP

375-252-00 Tray 5 Transport (550) or lift (HCIT) Motor over speed RAP

375-253-00 Tray 5 Transport (550) or lift (HCIT) Motor moved too long RAP

375-560-00 Tray 5 Transport (550) or lift (HCIT) Motor loss of encoders (motor stall) RAP

Procedure



WARNING: Switch off the electricity to the machine, GP 10 . Disconnect the power lead from the customer supply while performing tasks that do not need electricity. Electricity can cause the death or injury. Moving components can cause the injury.

Action	Yes	No
Step 1 Check the paper path and trays for paper fragments and partially fed paper. The paper path is free of paper fragments and partially fed paper.	Go to step 3.	Go to step 2.
Step 2 Remove the paper fragments and partially fed paper. The fault persists.	Go to step 3.	The problem is solved.
Step 3 Ensure that all the trays and tray inserts are properly installed. The fault persists.	Go to step 4.	The problem is solved.
Step 4 Enter the Diagnostics menu GP 1, and then navigate to: Input tray quick print >select source tray > Single The fault persists.	Go to step 5.	The problem is solved.
Step 5 1 Enter the Diagnostics menu GP 1, and then navigate to: Additional input tray adjustments/tests > Additional input tray motors 2 Select Pass-through (tray [x]) , and then touch Start . Note: [x] is the tray number. The motor will run.	Go to step 7.	Go to step 6.
Step 6	Go to step 7.	The problem is solved.

Action	Yes	No
Reseat the cable on the motor and on the optional tray controller board. The fault persists.		
Step 7 Remove the source tray insert, and then check if the following components are functional and free of damage: <ul style="list-style-type: none"> • Paper guides • Lift plate • Note: Move the components or turn gears to check for proper mechanisms. The tray insert and its components are functional and free of damage.	Go to step 9.	Go to step 8.
Step 8 Install a new tray insert.PL 70.10 item 4 The fault persists.	Go to step 9.	The problem is solved.
Step 9 Ensure that the controller board of the affected tray is properly installed. Reseat all the cables on the controller board. The fault persists.	Go to step 10.	The problem is solved.
Step 10 Check the affected tray controller board and its connector pins for damage. The tray controller board and its connectors are free of damage.	Contact the next level of support.	The problem is solved.
Step 11 Install a new optional tray. See PL 70.15 item 1 The fault persists.	Contact the next level of support.	The problem is solved.

372-128-00, 372-130-00, 372-132-00, 372-134-00, 372-138-00, 372-140-00, 372-321-00, 373-128-00, 373-130-00, 373-132-00, 373-134-00, 373-136-00, 373-138-00, 373-140-00, 374-128-00, 374-130-00, 374-132-00, 374-134-00, 374-136-00, 374-138-00, 374-140-00, 375-254-00 to 375-259-00, 375-250-00 Tray 2, 3, 4, 5 Motor Error RAP

WD2 Drive PWB Wiring Diagram

C625 Wiring Diagrams

- 372-128-00 Tray 2 Motor does not turn on RAP
- 372-130-00 Tray 2 Motor does not turn off RAP
- 372-132-00 Tray 2 Motor failed to achieve expected speed RAP
- 372-134-00 Tray 2 Motor loss of encoders (motor stall) RAP
- 372-138-00 Tray 2 Motor over speed RAP
- 372-140-00 Tray 2 Motor moved too long RAP
- 372-321-00 Tray 2 Motor under speed RAP
- 373-128-00 Tray 3 Motor does not turn on RAP
- 373-130-00 Tray 3 Motor does not turn off RAP
- 373-132-00 Tray 3 Motor failed to achieve expected speed RAP
- 373-134-00 Tray 3 Motor loss of encoders (motor stall) RAP
- 373-136-00 Tray 3 Motor under speed RAP
- 373-138-00 Tray 3 Motor over speed RAP
- 373-140-00 Tray 3 Motor moved too long RAP
- 374-128-00-80 = Tray 4 Motor does not turn on RAP
- 374-130-00-81 = Tray 4 Motor does not turn off RAP
- 374-132-00-82 = Tray 4 Motor failed to achieve expected speed RAP
- 374-134-00-83 = Tray 4 Motor loss of encoders (motor stall) RAP
- 374-136-00-84 = Tray 4 Motor under speed RAP
- 374-138-00-85 = Tray 4 Motor over speed RAP
- 374-140-00-86 = Tray 4 Motor moved too long RAP
- 375-254-00 Tray 5 Pick Motor does not turn on RAP
- 375-255-00 Tray 5 Pick Motor does not turn off RAP
- 375-256-00 Tray 5 Pick Motor failed to achieve expected speed RAP
- 375-257-00 Tray 5 Pick Motor loss of encoders (motor stall) RAP

- 375-258-00 Tray 5 Pick Motor under speed RAP
- 375-259-00 Tray 5 Pick Motor over speed RAP
- 375-250-00 Tray 5 Pick Motor moved to long RAP

Procedure



WARNING: Switch off the electricity to the machine, GP 10 . Disconnect the power lead from the customer supply while performing tasks that do not need electricity. Electricity can cause the death or injury. Moving components can cause the injury.

Action	Yes	No
Step 1 Check the paper path and trays for paper fragments and partially fed paper. The paper is path free of paper fragments and partially fed paper.	Go to step 3.	Go to step 2.
Step 2 Remove the paper fragments and partially fed paper. The fault persists.	Go to step 3.	The problem is solved.
Step 3 Ensure that all the trays and tray inserts are properly installed. The fault persists.	Go to step 4.	The problem is solved.
Step 4 Enter the Diagnostics menu GP 1, and then navigate to: Input tray quick print >select source tray > Single The fault persists.	Go to step 5.	The problem is solved.
Step 5 1 Enter the Diagnostics menu GP 1, and then navigate to: Additional input tray diagnostics >Motor tests 2 Select Pick (tray [x]) , and then touch Start . Note: [x] is the tray number. The motor will run.	Go to step 7.	Go to step 6.
Step 6 Reseat the cable on the motor and on the optional tray controller board. The fault persists.	Go to step 7.	The problem is solved.

Action	Yes	No
Step 7 Check the source tray controller board and its connector pins for damage. The tray controller board and its connectors free of damage.	Contact the next level of support.	The problem is solved.
Step 8 Install a new optional tray. See PL 70.15 item 1 . The fault persists.	Contact the next level of support.	The problem is solved.

371-107-00 to 371-108-00, 372-151-00 to 372-152-00, 373-153-00 to 373-154-00, 374-100-01, 374-950-00, 375-100-01, 375-950-00, 375-951-00, 376-104-00 to 376-105-00, 377-950-00, 377-951-00 Load tray 1,2,3,4,5 with media Error RAPs

WD2 Drive PWB Wiring Diagram

C625 Wiring Diagrams

371-107-00 IRLoad: Load tray 1 with media (orientation not supported) RAP

371-108-00 IRLoad: Load tray 1 with media (orientation supported) RAP

372-151-00 IRLoad: Load tray 2 with media (orientation not supported) RAP

372-152-00 IRLoad: Load tray 2 with media (orientation supported) RA

373-153-00 IRLoad: Load tray 3 with media (orientation not supported) RAP

373-154-00 IRLoad: Load tray 3 with media (orientation supported) RAP

374-100-01 Change tray 4 to different media (orientation supported) RAP

374-950-00 IRChange: Load tray 4 to different media (orientation not supported) RAP

375-100-01 Change tray 5 to different media (orientation supported) RAP

375-950-00 Change tray 5 to different media (orientation not supported) RAP

375-951-00 IRChange: Load tray 5 to different media (orientation not supported) RAP

377-950-00 Change MP feeder to different media (orientation not supported) RAP

377-951-00 Change MP feeder to different media (orientation supported) RAP



WARNING: Switch off the electricity to the machine, [GP 10](#). Disconnect the power lead from the customer supply while performing tasks that do not need electricity. Electricity can cause the death or injury. Moving components can cause the injury.

Procedure

Action	Yes	No
Step 1 1 From the Home screen, touch Settings > Device > Preferences . 2 Check if the paper size matches the size set on the tray guides. The paper size will match the size set on the tray.	Go to step 3.	Go to step 2.
Step 2 Change the paper size or adjust the size setting in the tray. The fault persists.	Go to step 3.	The problem is solved.

Action	Yes	No
Step 3 Check the drive PWB and its pins for damage. The drive PWB is free of damage.	Contact the next level of support.	Go to step 4.
Step 4 Install a new drive PWB, PL 1.10 item 3. The fault persists.	Contact the next level of support.	The problem is solved.

372-210-00, 372-212-00, 372-214-00, 372-216-00, 372-218-00, 372-220-00, 372-222-00, 373-210-00, 373-212-00, 373-214-00, 373-216-00, 373-218-00, 373-220-00, 373-222-00, 374-218-00 to 374-224-00, 375-232-00 to 375-238-00 Motor (Tray 2, 3, 4, 5 Pick/Lift) Error RAP

[WD2 Drive PWB Wiring Diagram](#)

[C625 Wiring Diagrams](#)

372-210-00 Tray 2 Lift ON Fail RAP

372-212-00 Tray 2 Lift Off Fail RAP

372-214-00 Tray 2 Pick Motor failed to achieve expected speed RAP

372-216-00 Tray 2 Pick Motor loss of encoders (motor stall) RAP

372-218-00 Tray 2 pick Motor under speed RAP

372-220-00 Tray 2 Pick Motor over speed RAP

372-222-00 Tray 2 pick Motor moved too long RAP

373-210-00 Tray 3 Lift On Fail RAP

373-212-00 Tray 3 Off Fail RAP

373-214-00 Tray 3 Pick Motor failed to achieve expected speed RAP

373-216-00 Tray 3 pick Motor loss of encoders (motor stall) RAP

373-218-00 Tray 3 pick Motor under speed RAP

373-220-00 Tray 3 Pick Motor over speed RAP

373-222-00 Tray 3 Pick Motor moved too long RAP

374-218-00 Tray 4 Pick Motor does not turn on RAP

374-219-00 Tray 4 pick Motor does not turn off RAP

374-220-00 Tray 4 pick Motor failed to achieve expected speed RAP

374-221-00 Tray 4 Pick Motor loss of encoders (motor stall) RAP

374-222-00 Tray 4 pick Motor under speed RAP

374-223-00 Tray 4 pick Motor over speed RAP

374-224-00 Tray 4 Pick Motor moved too long RAP

375-232-00 Tray 5 Motor does not turn on RAP

375-233-00 Tray 5 Motor does not turn off RAP

375-234-00 Tray 5 Motor failed to achieve expected speed RAP

375-235-00 Tray 5 Motor loss of encoders (motor stall) RAP

375-236-00 Tray 5 Motor under speed RAP

375-237-00 Tray 5 Motor over speed RAP

375-238-00 Tray 5 Motor moved too long RAP

Procedure



WARNING: Switch off the electricity to the machine, GP 10 . Disconnect the power lead from the customer supply while performing tasks that do not need electricity. Electricity can cause the death or injury. Moving components can cause the injury.

Action	Yes	No
Step 1 Check the pick roller for misalignment and damage. The pick roller is properly installed and free of damage.	Go to step 3.	Go to step 2.
Step 2 Ensure that the motor cable is properly connected. The fault persists.	Go to step 3.	The problem is solved.
Step 3 Restart the printer. The fault persists.	Go to step 4.	The problem is solved.
Step 4 Install a new optional tray. See PL 70.15 item 1. The fault persists.	Contact the next level of support.	The problem is solved.

373-146-00, 373-328-00, 374-147-00, 375-239-00 Never Arriving Jam From Normal Path Tray (3, 4, 5) RAP

WD2 Drive PWB Wiring Diagram

C625 Wiring Diagrams

373-146-00 Never Arriving Jam From Normal Path (Paper didn't reach the specified sensor, but did reach the previous sensor)-Option declared jam, or warm up jam with no known page source - RAP

373-328-00 Never Arriving Jam From Normal Path (Paper didn't reach the specified sensor, but did reach the previous sensor)-Source was tray 3 - RAP

374-147-00 Never Arriving Jam From Normal Path (Paper didn't reach the specified sensor, but did reach the previous sensor)-Source was tray 4 - RAP

375-239-00 Never Arriving Jam From Normal Path (Paper didn't reach the specified sensor, but did reach the previous sensor)-Source was tray 5 - RAP

Procedure



WARNING: Switch off the electricity to the machine, GP 10 . Disconnect the power lead from the customer supply while performing tasks that do not need electricity. Electricity can cause the death or injury. Moving components can cause the injury.

Action	Yes	No
Step 1 1 From the Home screen, touch Settings > Device > Preferences . 2 Check if the paper size matches the size set on the tray guides. The paper size will match the size set on the tray.	Go to step 3.	Go to step 2.
Step 2 Change the paper size or adjust the size setting in the tray. The fault persists.	Go to step 3.	The problem is solved.
Step 3 Check if the paper size matches the size set on the tray guides. The paper size will match the size set on the tray.	Go to step 5.	Go to step 4.
Step 4 Insert new paper or change the paper size setting in the tray. The fault persists.	Go to step 5.	The problem is solved.
Step 5	Go to step 6.	Go to step 7.

Action	Yes	No
Check the paper tray for overfilling. The paper tray overfilled.		
Step 6 Remove the excess paper from the tray. The fault persists.	Go to step 7.	The problem is solved.
Step 7 Check the paper condition in the tray. The paper is crumpled or damaged.	Go to step 8.	Go to step 9.
Step 8 Check whether the crumpled or damaged paper is removed and insert new paper. The fault persists.	Go to step 9.	The problem is solved.
Step 9 Check the paper path for partially fed or jammed paper. The paper path is free of partially fed or jammed paper.	Go to step 11.	Go to step 10.
Step 10 Remove the partially fed or jammed paper. The fault persists.	Go to step 11.	The problem is solved.
Step 11 1 Enter the Diagnostics menu GP 1 , and then navigate to: Additional input trays adjustments/tests > Additional input tray sensors 2 Find the sensor (Pass-through (tray 3)). The sensor status will change while toggling the sensor.	Go to step 13.	Go to step 12.
Step 12 1 Ensure that the sensor cable is properly connected. 2 Ensure that the sensor is properly installed. 3 Check the sensor and the other optional tray components for damage. The sensor is free of damage.	Go to step 13.	Go to step 15.

Action	Yes	No
Step 13 1 Enter the Diagnostics menu GP 1 , and then navigate to: Additional input trays adjustments/tests > Additional input tray motors 2 Select Pass-through (tray 3) , and then touch Start . The motor will run.	Go to step 16.	Go to step 14.
Step 14 1 Ensure that the motor cable is properly connected. 2 Ensure that the motor is properly installed. 3 Check the motor and the other optional tray components for damage. The motor and the optional tray are free of damage.	Go to step 16.	Go to step 15.
Step 15 Install a new optional tray. See PL 70.15 item 1 The fault persists.	Go to step 16.	The problem is solved.
Step 16 1 Enter the Diagnostics menu GP 1 , and then navigate to: Additional input trays adjustments/tests > Additional input tray motors 2 Select Pass-through (tray 4) , and then touch Start . The motor will run.	Go to step 19.	Go to step 17.
Step 17 1 Ensure that the motor cable is properly connected. 2 Ensure that the motor is properly installed. 3 Check the motor and the other optional tray components for damage. The motor and optional tray are free of damage.	Go to step 19.	Go to step 18.

Action	Yes	No
Step 18 Install a new optional tray. See PL 70.15 item 1 . The fault persists.	Go to step 19.	The problem is solved.
Step 19 Perform a print test. The fault persists.	Contact the next level of support.	The problem is solved.

371-302-00, 371-310-00, 371-318-00, 371-324-00, 371-327-00, 372-226-00, 374-318-00, 374-329-00, 375-318-00, 375-329-00 Tray 2, 3, 4, 5 Sensor Failed To Arrive Error RAP

[WD2 Drive PWB Wiring Diagram](#)

[C625 Wiring Diagrams](#)

371-302-00 Sensor never made by leading edge of page RAP

371-310-00 Sensor never made by leading edge of page RAP

371-318-00 Tray 2 Jam at S1/Input/stage - never reached s1/Input/stage sensor RAP

371-324-00 Tray 3 Jam at Bump Exit - never reached bump exit sensor RAP

371-327-00 Tray 3 S1/Input sensor never made by leading edge after pick RAP

372-226-00 Tray 2 S1/Input sensor never made by leading edge after pick RAP

374-318-00 Tray 4 Jam at Bump Exit - never reached bump exit sensor RAP

374-329-00 Tray 4 S1/Input sensor never made by leading edge after pick RAP

375-318-00 Tray 5 Jam at Bump Exit - never reached bump exit sensor RAP

375-329-00 Tray 5 S1/Input sensor never made by leading edge after pick RAP

Procedure



WARNING: Switch off the electricity to the machine, [GP 10](#). Disconnect the power lead from the customer supply while performing tasks that do not need electricity. Electricity can cause the death or injury. Moving components can cause the injury.

Action	Yes	No
Step 1 1 From the Home screen, touch Settings > Device > Preferences . 2 Check if the paper type and size settings match the paper type and size set on the tray. The paper size will match the size set on the tray.	Go to step 3.	Go to step 2.
Step 2 Change the paper size or adjust the size setting in the tray. The fault persists.	Go to step 3.	The problem is solved.
Step 3 Check the paper path for paper jams and fragments.	Go to step 5.	Go to step 4.

Action	Yes	No
Note: If necessary, remove the transfer module to properly see the paper path. The paper path is free of jams and fragments.		
Step 4 Remove the jams and fragments. The fault persists.	Go to step 5.	The problem is solved.
Step 5 Check the tray insert and its paper path guides and drive gears for damage. The tray insert is free of damage.	Go to step 7.	Go to step 6.
Step 6 Install a new tray insert. See PL 70.10 item 4 . The fault persists.	Go to step 7.	The problem is solved.
Step 7 1 Ensure that the pick roller is properly installed. Note: Firmly press the pick roller to its shaft to make sure that it is properly engaged. 2 Check the pick roller for excess wear, contamination, and damage. The pick roller is free from excess wear, contamination, and damage.	Go to step 9.	Go to step 8.
Step 8 Install a new pick roller. See PL 70.10 item 10 . The fault persists.	Go to step 9.	The problem is solved.
Step 9 1 Enter the Diagnostics menu GP 1 , and then navigate to: Printer diagnostics and adjustments > Motor tests > Pick (tray 1) 2 Select a setting, and then touch Start . The motor will run.	Go to step 12.	Go to step 10.

Action	Yes	No
Step 10 1 Ensure that the motor cable is properly connected. 2 Check the motor and the other paper feeder components PL 70.10 item 8 for damage. The motor and paper feeder is free of damage.	Go to step 12.	Go to step 11.
Step 11 1 Install a new paper feeder. See . 2 Perform a print job. The fault persists.	Go to step 12.	The problem is solved.
Step 12 1 Enter the Diagnostics menu GP 1 , and then navigate to: Printer diagnostics & adjustments > Sensor tests 2 Find the sensor (Input). The sensor status will change while toggling the sensor	Go to step 15.	Go to step 13.
Step 13 1 Ensure that the sensor cable is properly connected. 2 Check the sensor for damage. The sensor is free of damage.	Go to step 15.	Go to step 14.
Step 14 Install a new sensor. See PL 80.05 item 7 . The fault persists.	Go to step 15.	The problem is solved.
Step 15 1 Enter the Diagnostics menu, and then navigate to: Printer diagnostics & adjustments > Motor tests > Isolation 2 Touch Start , and then listen to the sound of the motor. 3 Check if the sound of the motor (isolation) is similar. The motor will create a similar grinding sound	Go to step 17.	Go to step 16.
Step 16	Go to step 18.	Go to step 17.

Action	Yes	No
Check the motor and its cable for damage. The motor and its cable is free of damage		
Step 17 Install a new isolation unit. See PL 80.10 item 4 . The fault persists.	Contact the next level of support.	The problem is solved.
Step 18 1 Enter the Diagnostics menu GP 1 , and then navigate to: Printer diagnostics & adjustments > Motor tests > Deskew 2 Touch Start . The motor will run.	Contact the next level of support.	Go to step 19.
Step 19 1 Ensure that the motor cable is properly connected. 2 Check the motor (deskew) for damage. The motor is free of damage.	Contact the next level of support.	Go to step 20.
Step 20 Install a new motor (deskew). See PL 40.10 item 1 . The fault persists.	Contact the next level of support.	The problem is solved.

372-300-00, 372-302-00, 372-304-00, 372-306-00, 372-308-00, 372-310-00, 372-312-00, 373-300-00, 373-302-00, 373-304-00, 373-306-00, 373-308-00, 373-310-00, 373-312-00, 374-225-00 to 374-231-00, 375-225-00 to 375-231-00 Tray 2, 3, 4, 5 Transport Motor Error RAP

[WD2 Drive PWB Wiring Diagram](#)

[C625 Wiring Diagrams](#)

- 372-300-00 Tray 2 transport Motor On Fail RAP
- 372-302-00 Tray 2 transport Motor Off Fail RAP
- 372-304-00 Tray 2 transport Motor Speed Fail RAP
- 372-306-00 Tray 2 transport Motor loss of encoders (motor stall) RAP
- 372-308-00 Tray 2 transport Motor under speed RAP
- 372-310-00 Tray 2 transport Motor over speed RAP
- 372-312-00 Tray 2 transport Motor moved too long RAP
- 373-300-00 Tray 3 transport Motor On Fail RAP
- 373-302-00 Tray 3 transport Motor Off Fail RAP
- 373-304-00 Tray 3 transport Motor Speed Fail RAP
- 373-306-00 Tray 3 transport Motor loss of encoders (motor stall) RAP
- 373-308-00 Tray 3 transport Motor under speed RAP
- 373-310-00 Tray 3 transport Motor over speed RAP
- 373-312-00 Tray 3 transport Motor moved too long RAP
- 374-225-00 Tray 4 transport Motor does not turn on RAP
- 374-226-00 Tray 4 transport Motor does not turn off RAP
- 374-227-00 Tray 4 transport Motor failed to achieve expected speed RAP
- 374-228-00 Tray 4 transport Motor loss of encoders (motor stall) RAP
- 374-229-00 Tray 4 transport Motor under speed RAP
- 374-230-00 Tray 4 transport Motor over speed RAP
- 374-231-00 Tray 4 transport Motor moved too long RAP
- 375-225-00 Tray 5 transport Motor does not turn on RAP
- 375-226-00 Tray 5 transport Motor does not turn off RAP
- 375-227-00 Tray 5 transport Motor failed to achieve expected speed RAP
- 375-228-00 Tray 5 transport Motor loss of encoders (motor stall) RAP

375-229-00 Tray 5 transport Motor under speed RAP

375-230-00 Tray 5 transport Motor over speed RAP

375-231-00 Tray 5 transport Motor moved too long RAP

Procedure



WARNING: Switch off the electricity to the machine, GP 10 . Disconnect the power lead from the customer supply while performing tasks that do not need electricity. Electricity can cause the death or injury. Moving components can cause the injury.

Action	Yes	No
Step 1 Restart the printer The fault persists.	Go to step 2.	The problem is solved.
Step 2 Ensure that the motor cable is properly connected. The fault persists.	Go to step 3.	The problem is solved.
Step 3 Restart the printer. The fault persists.	Go to step 4.	The problem is solved.
Step 4 Install a new optional tray. See PL 70.15 item 1. The fault persists.	Contact the next level of support.	The problem is solved.

371-339-00, 372-305-00, 373-305-00, 374-305-00, 375-305-00 Tray 1, 2, 3, 4, 5 S1/Input Sensor Cleared Error RAP

C625 Wiring Diagrams

WD2 Drive PWB Wiring Diagram

371-339-00 Tray 1 Bump exit sensor cleared by page too soon RAP

372-305-00 Tray 2 S1/Input sensor cleared by page too soon RAP

373-305-00 Tray 3 S1/Input sensor cleared by page too soon RAP

374-305-00 Tray 4 S1/Input sensor cleared by page too soon RAP

375-305-00 Tray 5 S1/Input sensor cleared by page too soon RAP

Procedure



WARNING: Switch off the electricity to the machine, GP 10 . Disconnect the power lead from the customer supply while performing tasks that do not need electricity. Electricity can cause the death or injury. Moving components can cause the injury.

Action	Yes	No
Step 1 1 From the Home screen, touch Settings >Device > Preferences . 2 Check if the paper size matches the size set on the tray guides. The paper size will match the size set on the tray.	Go to step 3.	Go to step 2.
Step 2 Change the paper size or adjust the size setting in the tray. The fault persists.	Go to step 3.	The problem is solved.
Step 3 Check the tray for overfilling. The tray is overfilled.	Go to step 4.	Go to step 5.
Step 4 Remove the excess paper from the tray. The fault persists.	Go to step 5.	The problem is solved.
Step 5 Check the paper condition in the tray. The paper is crumpled or damaged?	Go to step 6.	Go to step 7.
Step 6	Go to step 7.	The problem is solved.

Action	Yes	No
Install a new crumpled or damaged paper. The fault persists.		
Step 7 1 Enter the Diagnostics menu, GP 1 and then navigate to: Printer diagnostics & adjustments > Sensor tests 2 Find the sensor (Input). The sensor status will change while toggling the sensor.	Go to step 9.	The problem is solved.
Step 8 1 Ensure that the sensor cable is properly connected. 2 Check the sensor for damage. The sensor is free of damage.	Go to step 9.	Go to step 9.
Step 9 Install a new sensor. See PL 80.05 item 7 . The fault persists.	Go to step 10.	The problem is solved.
Step 10 Perform a print job. The fault persists.	Contact the next level of support.	The problem is solved.

372-313-00, 372-314-00, 372-315-00, 372-316-00, 372-317-00, 372-318-00, 372-319-00 Tray 2 Lift Motor Error RAP

372-313-00 Tray 2 lift Motor does not turn on RAP

372-314-00 Tray 2 lift Motor does not turn off RAP

372-315-00 Tray 2 lift Motor failed to achieve expected speed RAP

372-316-00 Tray 2 lift Motor loss of encoders (motor stall) RAP

372-317-00 Tray 2 lift Motor underspeed RAP

372-318-00 Tray 2 lift Motor overspeed RAP

372-319-00 Tray 2 lift Motor moved too long RAP



WARNING: Switch off the electricity to the machine, **GP 10**. Disconnect the power lead from the customer supply while performing tasks that do not need electricity. Electricity can cause the death or injury. Moving components can cause the injury.

Switch OFF, then switch ON the machine, **GP 10**. If the fault persists, contact 2nd Level Support.

305-211-00, 305-212-00, 310-514-00, 371-329-00, 372-322-00, 373-322-00, 374-328-00, 375-328-00 Unknown Error RAP

305-211-00 Laser Safety interlock RAP

305-212-00 Mirror motor lock fail RAP

310-514-00 Facet Map failure due to kernel failure - May be due to low memory situations - RAP

371-329-00 Tray 1 fails to become input source ready for picking RAP

372-322-00 Tray 2 fails to become input source ready for picking RAP

373-322-00 Tray 3 fails to become input source ready for picking RAP

374-328-00 Tray 4 fails to become input source ready for picking RAP

375-328-00 Tray 5 fails to become input source ready for picking RAP

Procedure



WARNING: Switch off the electricity to the machine, GP 10 . Disconnect the power lead from the customer supply while performing tasks that do not need electricity. Electricity can cause the death or injury. Moving components can cause the injury.

Action	Yes	No
Restart the print job. The fault persists.	Contact the next level of support.	The problem is solved.

372-324-00, 372-325-00, 372-326-00, 372-327-00 Bump Exit Sensor Error RAP

372-324-00 Bump exit sensor covered too soon- Source is tray 2 RAP

372-325-00 Bump exit sensor never made by leading edge of page- Source is tray 2 RAP

372-326-00 Bump exit sensor cleared by page too soon- Source is tray 2 RAP

372-327-00 Bump exit sensor never cleared by trailing edge of page- Source is tray 2 RAP



WARNING: Switch off the electricity to the machine, GP 10 . Disconnect the power lead from the customer supply while performing tasks that do not need electricity. Electricity can cause the death or injury. Moving components can cause the injury.

Switch OFF, then switch ON the machine,GP 10. If the fault persists, contact 2nd Level Support.

372-328-00, 372-329-00, 372-332-00, 372-336-00, 372-339-00, 373-329-00, 373-331-00, 373-338-00, 373-340-00, 374-337-00, 374-340-00, 374-342-00, 375-337-00, 375-341-00
Early Leaving Jam Sensor Tray (2, 3, 4, 5) Error RAPs

WD2 Drive PWB Wiring Diagram

C625 Wiring Diagrams

372-328-00 Tray 2 Early Leaving Jam RAP

372-329-00 Tray 3 Early Leaving Jam RAP

372-332-00 Tray 4 Early Leaving Jam RAP

372-336-00 Tray 5 Early Leaving Jam RAP

372-339-00 Early Leaving Jam RAP. Option declared jam, or warm up jam with no known page source.

373-329-00 Tray 3 Early Leaving Jam RAP

373-331-00 Tray 4 Early Leaving Jam RAP

373-338-00 Early Leaving Jam RAP. Option declared jam, or warm up jam with no known page source.

373-340-00 Tray 5 Early Leaving Jam RAP

374-337-00 Tray 4 Early Leaving Jam RAP

374-340-00 Tray 5 Early Leaving Jam RAP

374-342-00 Early Leaving Jam RAP. Option declared jam, or warm up jam with no known page source.

375-337-00 Tray 5 Early Leaving Jam RAP

375-341-00 Early Leaving Jam RAP. Option declared jam, or warm up jam with no known page source.



WARNING: Switch off the electricity to the machine, GP 10 . Disconnect the power lead from the customer supply while performing tasks that do not need electricity. Electricity can cause the death or injury. Moving components can cause the injury.

Procedure

Action	Yes	No
Step 1 1 From the Home screen, touch Settings >Device > Preferences . 2 Check if the paper size matches the size set on the tray guides. The paper size match the size set on the tray.	Go to step 3.	Go to step 2.
Step 2 Change the paper size or adjust the size setting in the tray. The fault persists.	Go to step 3.	The problem is solved.
Step 3 Check if the paper size matches the size set on the tray guides. The paper size will match the size set on the tray.	Go to step 5.	Go to step 4.
Step 4 Replace the paper or change the paper size setting in the tray. The fault persists.	Go to step 5.	The problem is solved.
Step 5 Check the paper tray for overfilling. The paper tray is overfilled.	Go to step 6.	Go to step 7.
Step 6 Remove the excess paper from the tray. The fault persists.	Go to step 7.	The problem is solved.
Step 7 Check the paper condition in the tray. The paper is crumpled or damaged.	Go to step 8.	Go to step 9.
Step 8 Replace the crumpled or damaged paper. The fault persists.	Go to step 9.	The problem is solved.
Step 9 1 Enter the Diagnostics menu GP 1 , and then navigate to:	Go to step 11.	Go to step 10.

Action	Yes	No
<p>Additional input trays adjustments/tests > Additional input tray sensors</p> <p>2 Find the sensor (Trailing edge (tray [x])).</p> <p>Note: [x] is the tray number.</p> <p>The sensor status will change while toggling the sensor.</p>		
<p>Step 10</p> <p>1 Ensure that the sensor cable is properly connected.</p> <p>2 Ensure that the sensor is properly installed.</p> <p>3 Check the sensor for damage.</p> <p>The sensor is free of damage.</p>	Go to step 11.	Go to step 13.
<p>Step 11</p> <p>1 Enter the Diagnostics menu GP 1, and then navigate to:</p> <p>Additional input trays adjustments/tests > Additional input tray sensors</p> <p>2 Find the sensor (Pass-through (tray [x])).</p> <p>Note: [x] is the tray number.</p> <p>The sensor status will change while toggling the sensor.</p>	Go to step 14.	Go to step 12.
<p>Step 12</p> <p>1 Ensure that the sensor cable is properly connected.</p> <p>2 Ensure that the sensor is properly installed.</p> <p>3 Check the sensor and the other optional tray components for damage.</p> <p>The sensor is free of damage.</p>	Go to step 14.	Go to step 13.
<p>Step 13</p> <p>Install a new 550 sheet optional tray, PL 25.05 item 10.</p> <p>The fault persists.</p>	Go to step 14.	The problem is solved.
<p>Step 14</p> <p>Perform a print test.</p> <p>The fault persists.</p>	Contact the next level of support.	The problem is solved.

372-010-00 to 372-012-00, 373-010-00 to 373-012-00, 374-010-00 to 374-012-00, 375-010-00 to 375-012-00 TRAY 2, 3, 4, 5 Invalid Product ID, Board ID, Option Type Error RAP

WD2 Drive PWB Wiring Diagram

C625 Wiring Diagrams

372-010-00 Tray 2 Invalid Product ID RAP

372-011-00 Tray 2 Invalid Board ID RAP

372-012-00 Tray 2 Invalid Option Type RAP

373-010-00 Tray 3 Invalid Product ID RAP

373-011-00 Tray 3 Invalid Board ID RAP

373-012-00 Tray 3 Invalid Option Type RAP

374-010-00 Tray 4 Invalid Product ID RAP

374-011-00 Tray 4 Invalid Board ID RAP

374-012-00 Tray 4 Invalid Option Type RAP

375-010-00 Tray 5 Invalid Product ID RAP

375-011-00 Tray 5 Invalid Board ID RAP

375-012-00 Tray 5 Invalid Option Type RAP

Procedure



WARNING: Switch off the electricity to the machine, GP 10 . Disconnect the power lead from the customer supply while performing tasks that do not need electricity. Electricity can cause the death or injury. Moving components can cause the injury.

Action	Yes	No
Step 1 1 Ensure that the latest firmware is installed. 2 Ensure that the options configuration is supported. See the Printer, Option, and Stand Compatibility Guide. 3 Restart the printer. The fault persists.	Go to step 2.	The problem is solved.
Step 2 Reinstall the optional tray. The fault persists.	Go to step 3.	The problem is solved.

Action	Yes	No
Step 3 Install a new optional tray. See PL 70.15 item 1. The fault persists.	Go to step 4 .	The problem is solved.
Step 4 Restart the printer. The fault persists.	Contact the next level of support.	The problem is solved.

372-100-00, 372-150-00, 372-330-00, 372-333-00, 372-338-00, 373-100-00, 373-150-00, 373-332-00, 373-341-00, 374-150-00, 374-341-00, 375-246-00, 375-343-00, 377-277-00
Tray 2, 3, 4, 5 Fail To Pick Error RAP

WD2 Drive PWB Wiring Diagram

C625 Wiring Diagrams

372-100-00 Tray 2 Mis feed_ Empty RAP

372-150-00 Fail To Pick From Tray. Option declared jam, or warm up jam with unknown page RAP

372-330-00 Tray 3 Fail To Pick From Tray (Paper did not reach first sensor; Miss-feed, tray empty) RAP

372-333-00 Tray 4 Fail To Pick From Tray (Paper did not reach first sensor; Miss-feed, tray empty) RAP

372-338-00 Tray 5 Fail To Pick From Tray (Paper did not reach first sensor; Miss-feed, tray empty) RAP

373-100-00 Tray 3 Mis feed_ Empty RAP

373-150-00 Fail To Pick From Tray Option declared jam, or warm up jam with unknown page RAP

373-332-00 Tray 4 Fail To Pick From Tray RAP

373-341-00 Tray 5 Fail To Pick From Tray (Paper did not reach first sensor; Miss-feed, tray empty) RAP

374-150-00 Tray 4 Fail To Pick From Tray (Paper did not reach first sensor; Miss-feed, tray empty) RAP

374-341-00 Tray 5 Fail To Pick From Tray (Paper did not reach first sensor; Miss-feed, tray empty) RAP

375-246-00 Tray 5 Fail To Pick From Tray (Paper did not reach first sensor; Miss-feed, tray empty) RAP

375-343-00 Fail To Pick From Tray. Option declared jam, or warm up jam with unknown page RAP

377-277-00 Fail To Pick From Tray. Option declared jam, or warm up jam with unknown page RAP

Procedure



WARNING: Switch off the electricity to the machine, GP 10 . Disconnect the power lead from the customer supply while performing tasks that do not need electricity. Electricity can cause the death or injury. Moving components can cause the injury.

Action	Yes	No
Step 1 1 From the Home screen, touch Settings >Device > Preferences. 2 Check if the paper size matches the size set on the tray guides. The paper size will match the size set on the tray.	Go to step 3.	Go to step 2.
Step 2 Change the paper size or adjust the size setting in the tray. The fault persists.	Go to step 3.	The problem is solved.
Step 3 Check if the paper size matches the size set on the tray guides. The paper size will match the size set on the tray.	Go to step 5.	Go to step 4.
Step 4 Insert new paper or change the paper size setting in the tray. The fault persists.	Go to step 5.	The problem is solved.
Step 5 Check the paper tray for overfilling. The paper tray overfilled.	Go to step 6.	Go to step 7.
Step 6 Remove the excess paper from the tray. The fault persists.	Go to step 7.	The problem is solved.
Step 7 Check the paper condition in the tray. The paper crumpled or damaged.	Go to step 8.	Go to step 9.
Step 8 Check whether the crumbled or damaged paper is removed and insert new paper. The fault persists.	Go to step 9.	The problem is solved.
Step 9	Go to step 11.	Go to step 10.

Action	Yes	No
<p>1 Ensure that the optional tray pick roller is properly installed.</p> <p>Note: Firmly press the pick roller to its shaft to make sure that is properly engaged.</p> <p>2 Check the optional tray pick roller for excess wear, contamination, and damage.</p> <p>The optional tray pick roller is free from excess wear, contamination, and damage.</p>		
<p>Step 10 Install a new pick roller. See PL 70.10 item 7. The fault persists.</p>	Go to step 11.	The problem is solved.
<p>Step 11 Check the tray exit paper path for paper fragments and contamination. The paper path is free of paper fragments and contamination.</p>	Go to step 15.	Go to step 12.
<p>Step 12 Clean the paper path. The fault persists.</p>	Go to step 13.	The problem is solved.
<p>Step 13</p> <p>1 Enter the Diagnostics menu GP 1, and then navigate to: Additional input trays adjustments/tests > Additional input tray sensors</p> <p>2 Find the sensor (Trailing edge (tray [x])).</p> <p>Note: [x] is the tray number. The sensor status will change while toggling the sensor.</p>	Go to step 15.	Go to step 14.
<p>Step 14</p> <p>1 Ensure that the sensor cable is properly connected.</p> <p>2 Ensure that the sensor is properly installed.</p>	Go to step 15.	Go to step 17.

Action	Yes	No
<p>3 Check the sensor and the other optional tray components for damage. The sensor and optional tray are free of damage.</p>		
<p>Step 15</p> <p>1 Enter the Diagnostics menu, GP 1 and then navigate to: Additional input tray diagnostics > Motor tests</p> <p>2 Select Pick (tray [x]), and then touch Start. The motor will run.</p>	Go to step 18.	Go to step 16.
<p>Step 16</p> <p>1 Ensure that the motor cable is properly connected.</p> <p>2 Ensure that the motor is properly installed.</p> <p>3 Check the motor and the other optional tray components for damage. The motor and the optional tray are free of damage.</p>	Go to step 18.	Go to step 17.
<p>Step 17 Install a new optional tray. See PL 70.15 item 1. The fault persists.</p>	Go to step 18.	The problem is solved.
<p>Step 18 Perform a print test. The fault persists.</p>	Contact the next level of support.	The problem is solved.

372-102-00, 372-108-00, 372-142-00, 372-144-00, 372-223-00, 372-331-00, 372-334-00, 372-902-00, 373-102-00, 373-142-00, 373-144-00, 373-330-00, 373-333-00, 373-339-00, 373-900-00, 374-142-00, 374-143-00, 374-334-00, 374-335-00, 374-339-00, 375-142-00, 375-242-00, 375-334-00, 375-335-00, 375-339-00, 377-149-00, 377-274-00, 377-279-00
Early Arriving Jam And Static Jam RAP

WD2 Drive PWB Wiring Diagram

C625 Wiring Diagrams

- 372-102-00 Tray 2 EARLY ARRIVING JAM (Paper reaches the sensor too soon, or unexpected) RAP
- 372-108-00 Tray 3 EARLY ARRIVING JAM (Paper reaches the sensor too soon, or unexpected) RAP
- 372-142-00 STATIC JAM. Option declared jam, or warm up jam with no known page source - RAP
- 372-144-00 EARLY ARRIVING JAM. Option declared jam, or warm up jam with no known page source - RAP
- 372-223-00 Tray 2 STATIC JAM (Paper at sensor at start, cover closed or idle - Jam not cleared) RAP
- 372-331-00 Tray 4 EARLY ARRIVING JAM (Paper reaches the sensor too soon, or unexpected) RAP
- 372-334-00 Tray 5 EARLY ARRIVING JAM (Paper reaches the sensor too soon, or unexpected) RAP
- 372-902-00 Tray 3 STATIC JAM (Paper at sensor at start, cover closed or idle - Jam not cleared) RAP
- 373-102-00 Tray 3 early jam RAP
- 373-142-00 STATIC JAM. Option declared jam, or warm up jam with no known page source RAP
- 373-144-00 EARLY ARRIVING JAM. Option declared jam, or warm up jam with no known page source - RAP
- 373-330-00 Tray 4 EARLY ARRIVING JAM (Paper reaches the sensor too soon, or unexpected) RAP
- 373-333-00 Tray 5 STATIC JAM (Paper at sensor at start, cover closed or idle - Jam not cleared) RAP
- 373-339-00 Tray 5 EARLY ARRIVING JAM (Paper reaches the sensor too soon, or unexpected) RAP
- 373-900-00 Tray 3 static jam RAP
- 374-142-00 Tray 4 STATIC JAM (Paper at sensor at start, cover closed or idle - Jam not cleared) RAP
- 374-143-00 Tray 4 STATIC JAM (Paper at sensor at start, cover closed or idle - Jam not cleared) RAP
- 374-334-00 Tray 4 STATIC JAM (Paper at sensor at start, cover closed or idle - Jam not cleared) RAP
- 374-335-00 Tray 4 EARLY ARRIVING JAM (Paper reaches the sensor too soon, or unexpected) RAP
- 374-339-00 Tray 5 EARLY ARRIVING JAM (Paper reaches the sensor too soon, or unexpected) RAP
- 375-142-00 Tray 5 STATIC JAM (Paper at sensor at start, cover closed or idle - Jam not cleared) RAP
- 375-242-00 Tray 5 STATIC JAM (Paper at sensor at start, cover closed or idle - Jam not cleared) RAP
- 375-334-00 Tray 5 STATIC JAM (Paper at sensor at start, cover closed or idle - Jam not cleared) RAP

- 375-335-00 Tray 5 EARLY ARRIVING JAM (Paper reaches the sensor too soon, or unexpected) RAP
- 375-339-00 EARLY ARRIVING JAM. Option declared jam, or warm up jam with no known page source RAP
- 377-149-00 STATIC JAM. Option declared jam, or warm up jam with no known page source RAP
- 377-274-00 EARLY ARRIVING JAM. Option declared jam, or warm up jam with no known page source RAP
- 377-279-00 STATIC JAM. Option declared jam, or warm up jam with no known page source RAP

Procedure



WARNING: Switch off the electricity to the machine, GP 10 . Disconnect the power lead from the customer supply while performing tasks that do not need electricity. Electricity can cause the death or injury. Moving components can cause the injury.

Action	Yes	No
Step 1 1 From the Home screen, touch Settings >Device > Preferences . 2 Check if the paper size matches the size set on the tray guides. The paper size will match the size set on the tray.	Go to step 3.	Go to step 2.
Step 2 Change the paper size or adjust the size setting in the tray. The fault persists.	Go to step 3.	The problem is solved.
Step 3 Check the paper path for partially fed or jammed paper. The paper path is free of partially fed or jammed paper.	Go to step 5.	Go to step 4.
Step 4 Remove the partially fed or jammed paper. The fault persists.	Go to step 5.	The problem is solved.
Step 5 1 Enter the Diagnostics menu GP 1 , and then navigate to: Additional input trays adjustments/tests >Additional input tray sensors 2 Find the sensor (Trailing edge (tray [x])).	Go to step 7.	Go to step 6.

Action	Yes	No
<p>Note: [x] is the tray number. The sensor status will change while toggling the sensor.</p>		
<p>Step 6 1 Ensure that the sensor cable is properly connected. 2 Ensure that the sensor is properly installed. 3 Check the sensor for damage. The sensor is free of damage.</p>	Go to step 7.	Go to step 9.
<p>Step 7 1 Enter the Diagnostics menu GP 1, and then navigate to: Additional input trays adjustments/tests > Additional input tray sensors 2 Find the sensor (Pass-through (tray [x])). Note: [x] is the tray number. The sensor status will change while toggling the sensor.</p>	Go to step 10.	Go to step 8.
<p>Step 8 1 Ensure that the sensor cable is properly connected. 2 Ensure that the sensor is properly installed. 3 Check the sensor and the other optional tray components for damage. The sensor is free of damage.</p>	Go to step 10.	Go to step 9.
<p>Step 9 Install a new 550-sheet optional tray, PL 25.05 item 1. The fault persists.</p>	Go to step 10.	The problem is solved.
<p>Step 10 Perform a print test. The fault persists.</p>	Contact the next level of support.	The problem is solved.

372-105-00, 372-112-00, 372-148-00, 372-337-00, 373-105-00, 373-148-00, 374-112-00, 374-148-00, 374-338-00, 375-240-00, 375-244-00, 375-338-00, 375-342-00, 377-276-00
Late Leaving Jam Tray (3, 4, 5) RAP

WD2 Drive PWB Wiring Diagram

C625 Wiring Diagrams

372-105-00 Tray 2 Late jam RAP

372-112-00 Tray 3 Late Leaving Jam (Paper reaches sensor but clears it late-(Long media, double feed) RAP

372-148-00 Late Leaving Jam. Option declared jam, or warm up jam with no known page source RAP

372-337-00 Tray 5 Late Leaving Jam (Paper reaches sensor but clears it late-(Long media, double feed) RAP

373-105-00 Tray 3 Regi Sensor On Jam RAP

373-148-00 Late Leaving Jam. Option declared jam, or warm up jam with no known page source RAP

374-112-00 Tray 4 Late Leaving Jam (Paper reaches sensor but clears it late-(Long media, double feed) RAP

374-148-00 Tray 4 Late Leaving Jam (Paper reaches sensor but clears it late-(Long media, double feed) RAP

374-338-00 Tray 4 Late Leaving Jam (Paper reaches sensor but clears it late-(Long media, double feed) RAP

375-240-00 Tray 5 Late Leaving Jam (Paper reaches sensor but clears it late-(Long media, double feed) RAP

375-244-00 Tray 5 Late Leaving Jam (Paper reaches sensor but clears it late-(Long media, double feed) RAP

375-338-00 Tray 5 Late Leaving Jam (Paper reaches sensor but clears it late-(Long media, double feed) RAP

375-342-00 Late Leaving Jam. Option declared jam, or warm up jam with no known page source RAP

377-276-00 Late Leaving Jam. Option declared jam, or warm up jam with no known page source RAP

Procedure



WARNING: Switch off the electricity to the machine, **GP 10**. Disconnect the power lead from the customer supply while performing tasks that do not need electricity. Electricity can cause the death or injury. Moving components can cause the injury.

Action	Yes	No
Step 1 1 From the Home screen, touch Settings >Device > Preferences . 2 Check if the paper size matches the size set on the tray guides. The paper size will match the size set on the tray.	Go to step 3.	Go to step 2.
Step 2 Change the paper size or adjust the size setting in the tray. The fault persists.	Go to step 3.	The problem is solved.
Step 3 Check if the paper size matches the size set on the tray guides. The paper size will match the size set on the tray.	Go to step 5.	Go to step 4.
Step 4 Insert new paper or change the paper size setting in the tray. The fault persists.	Go to step 5.	The problem is solved.
Step 5 Check the primary paper path for paper jams and obstructions. The paper path is free of jams and obstructions.	Go to step 7.	Go to step 6.
Step 6 Remove the paper jams and obstructions. The fault persists.	Go to step 7.	The problem is solved.
Step 7 1 Enter the Diagnostics menu GP 1 , and then navigate to: Additional input trays adjustments/tests >Additional input tray sensors 2 Find the sensor (Trailing edge (tray [x])). Note: [x] is the tray number.	Go to step 9.	Go to step 8.

Action	Yes	No
The sensor status will change while toggling the sensor.		
Step 8 1 Ensure that the sensor cable is properly connected. 2 Ensure that the sensor is properly installed. 3 Check the sensor and the other optional tray components for damage. The sensor is free of damage.	Go to step 9.	Go to step 13.
Step 9 1 Enter the Diagnostics menu GP 1 , and then navigate to: Additional input trays adjustments/tests >Additional input tray sensors 2 Find the sensor (Pass-through (tray [x])). Note: [x] is the tray number. The sensor status will change while toggling the sensor.	Go to step 11.	Go to step 10.
Step 10 1 Ensure that the sensor cable is properly connected. 2 Ensure that the sensor is properly installed. 3 Check the sensor and the other optional tray components for damage. The sensor and the optional tray are free of damage.	Go to step 11.	Go to step 11.
Step 11 1 Enter the Diagnostics menu GP 1 , and then navigate to: Additional input trays adjustments/tests >Additional input tray motors 2 Select Pass-through (tray [x]) , and then touch Start . Note: [x] is the tray number.	Go to step 14.	Go to step 12.

Action	Yes	No
The motor will run.		
Step 12 1 Ensure that the motor cable is properly connected. 2 Ensure that the motor is properly installed. 3 Check the motor and the other optional tray components for damage. The motor and the optional tray are free of damage.	Go to step 14.	Go to step 13.
Step 13 Install a new optional tray. See PL 70.15 item 1 . The fault persists.	Go to step 14.	The problem is solved.
Step 14 1 Enter the Diagnostics menu GP 1 , and then navigate to: Printer diagnostics & adjustments > Motor tests 2 Select Duplex/MPF , and then touch Start . The motor will run.	Go to step 17.	Go to step 15.
Step 15 Reseat the motor cable, and then check the motor form is alignment and damage. The motor is properly installed and free of damage.	Go to step 17.	Go to step 16.
Step 16 Install a new motor. See PL 80.05 item 6 . The fault persists.	Go to step 17.	The problem is solved.
Step 17 Perform a print test. The fault persists.	Contact the next level of support.	The problem is solved.

372-114-00, 372-116-00, 372-118-00, 372-120-00, 372-122-00, 372-124-00, 372-126-00, 373-116-00, 373-118-00, 373-120-00, 373-122-00, 373-124-00, 373-126-00, 373-321-00, 374-114-00, 374-116-00, 374-118-00, 374-120-00, 374-122-00, 374-124-00, 374-126-00, 375-247-00 to 375-249-00, 375-251-00 to 375-253-00, 375-560-00 Tray 2, 3, 4, 5 Transport (550) or Lift (HCIT) Motor Error RAP

WD2 Drive PWB Wiring Diagram

C625 Wiring Diagrams

- 372-114-00 Tray 2 Transport (550) or lift (HCIT) Motor does not turn on RAP
- 372-116-00 Tray 2 Transport (550) or lift (HCIT) Motor does not turn off RAP
- 372-118-00 Tray 2 Transport (550) or lift (HCIT) Motor failed to achieve expected speed RAP
- 372-120-00 Tray 2 Transport (550) or lift (HCIT) Motor loss of encoders (motor stall) RAP
- 372-122-00 Tray 2 Transport (550) or lift (HCIT) Motor under speed RAP
- 372-124-00 Tray 2 Transport (550) or lift (HCIT) Motor overs peed RAP
- 372-126-00 Tray 2 Transport (550) or lift (HCIT) Motor moved too long RAP
- 373-116-00 Tray 3 Transport (550) or lift (HCIT) Motor does not turn off RAP
- 373-118-00 Tray 3 Transport (550) or lift (HCIT) Motor failed to achieve expected speed RAP
- 373-120-00 Tray 3 Transport (550) or lift (HCIT) Motor loss of encoders (motor stall) RAP
- 373-122-00 Tray 3 Transport (550) or lift (HCIT) Motor under speed RAP
- 373-124-00 Tray 3 Transport (550) or lift (HCIT) Motor over speed RAP
- 373-126-00 Tray 3 Transport (550) or lift (HCIT) Motor moved too long RAP
- 373-321-00 Tray 3 Transport (550) or lift (HCIT) Motor does not turn on RAP
- 374-114-00 -70 = Tray 4 Transport (550) or lift (HCIT) Motor does not turn on RAP
- 374-116-00 -71 = Tray 4 Transport (550) or lift (HCIT) Motor does not turn off RAP
- 374-118-00 -72 = Tray 4 Transport (550) or lift (HCIT) Motor failed to achieve expected speed RAP
- 374-120-00 -73 = Tray 4 Transport (550) or lift (HCIT) Motor loss of encoders (motor stall) RAP
- 374-122-00 -74 = Tray 4 Transport (550) or lift (HCIT) Motor under speed RAP
- 374-124-00 -75 = Tray 4 Transport (550) or lift (HCIT) Motor over speed RAP
- 374-126-00 -76 = Tray 4 Transport (550) or lift (HCIT) Motor moved too long RAP
- 375-247-00 Tray 5 Transport (550) or lift (HCIT) Motor does not turn on RAP
- 375-248-00 Tray 5 Transport (550) or lift (HCIT) Motor does not turn off RAP
- 375-249-00 Tray 5 Transport (550) or lift (HCIT) Motor failed to achieve expected speed RAP

375-251-00 Tray 5 Transport (550) or lift (HCIT) Motor under speed RAP

375-252-00 Tray 5 Transport (550) or lift (HCIT) Motor over speed RAP

375-253-00 Tray 5 Transport (550) or lift (HCIT) Motor moved too long RAP

375-560-00 Tray 5 Transport (550) or lift (HCIT) Motor loss of encoders (motor stall) RAP

Procedure



WARNING: Switch off the electricity to the machine, GP 10 . Disconnect the power lead from the customer supply while performing tasks that do not need electricity. Electricity can cause the death or injury. Moving components can cause the injury.

Action	Yes	No
Step 1 Check the paper path and trays for paper fragments and partially fed paper. The paper path is free of paper fragments and partially fed paper.	Go to step 3.	Go to step 2.
Step 2 Remove the paper fragments and partially fed paper. The fault persists.	Go to step 3.	The problem is solved.
Step 3 Ensure that all the trays and tray inserts are properly installed. The fault persists.	Go to step 4.	The problem is solved.
Step 4 Enter the Diagnostics menu GP 1, and then navigate to: Input tray quick print >select source tray > Single The fault persists.	Go to step 5.	The problem is solved.
Step 5 1 Enter the Diagnostics menu GP 1, and then navigate to: Additional input tray adjustments/tests > Additional input tray motors 2 Select Pass-through (tray [x]) , and then touch Start . Note: [x] is the tray number. The motor will run.	Go to step 7.	Go to step 6.
Step 6	Go to step 7.	The problem is solved.

Action	Yes	No
Reseat the cable on the motor and on the optional tray controller board. The fault persists.		
Step 7 Remove the source tray insert, and then check if the following components are functional and free of damage: <ul style="list-style-type: none"> • Paper guides • Lift plate • Note: Move the components or turn gears to check for proper mechanisms. The tray insert and its components are functional and free of damage.	Go to step 9.	Go to step 8.
Step 8 Install a new tray insert.PL 70.10 item 4 The fault persists.	Go to step 9.	The problem is solved.
Step 9 Ensure that the controller board of the affected tray is properly installed. Reseat all the cables on the controller board. The fault persists.	Go to step 10.	The problem is solved.
Step 10 Check the affected tray controller board and its connector pins for damage. The tray controller board and its connectors are free of damage.	Contact the next level of support.	The problem is solved.
Step 11 Install a new optional tray. See PL 70.15 item 1 The fault persists.	Contact the next level of support.	The problem is solved.

372-128-00, 372-130-00, 372-132-00, 372-134-00, 372-138-00, 372-140-00, 372-321-00, 373-128-00, 373-130-00, 373-132-00, 373-134-00, 373-136-00, 373-138-00, 373-140-00, 374-128-00, 374-130-00, 374-132-00, 374-134-00, 374-136-00, 374-138-00, 374-140-00, 375-254-00 to 375-259-00, 375-250-00 Tray 2, 3, 4, 5 Motor Error RAP

WD2 Drive PWB Wiring Diagram

C625 Wiring Diagrams

- 372-128-00 Tray 2 Motor does not turn on RAP
- 372-130-00 Tray 2 Motor does not turn off RAP
- 372-132-00 Tray 2 Motor failed to achieve expected speed RAP
- 372-134-00 Tray 2 Motor loss of encoders (motor stall) RAP
- 372-138-00 Tray 2 Motor over speed RAP
- 372-140-00 Tray 2 Motor moved too long RAP
- 372-321-00 Tray 2 Motor under speed RAP
- 373-128-00 Tray 3 Motor does not turn on RAP
- 373-130-00 Tray 3 Motor does not turn off RAP
- 373-132-00 Tray 3 Motor failed to achieve expected speed RAP
- 373-134-00 Tray 3 Motor loss of encoders (motor stall) RAP
- 373-136-00 Tray 3 Motor under speed RAP
- 373-138-00 Tray 3 Motor over speed RAP
- 373-140-00 Tray 3 Motor moved too long RAP
- 374-128-00-80 = Tray 4 Motor does not turn on RAP
- 374-130-00-81 = Tray 4 Motor does not turn off RAP
- 374-132-00-82 = Tray 4 Motor failed to achieve expected speed RAP
- 374-134-00-83 = Tray 4 Motor loss of encoders (motor stall) RAP
- 374-136-00-84 = Tray 4 Motor under speed RAP
- 374-138-00-85 = Tray 4 Motor over speed RAP
- 374-140-00-86 = Tray 4 Motor moved too long RAP
- 375-254-00 Tray 5 Pick Motor does not turn on RAP
- 375-255-00 Tray 5 Pick Motor does not turn off RAP
- 375-256-00 Tray 5 Pick Motor failed to achieve expected speed RAP
- 375-257-00 Tray 5 Pick Motor loss of encoders (motor stall) RAP

- 375-258-00 Tray 5 Pick Motor under speed RAP
- 375-259-00 Tray 5 Pick Motor over speed RAP
- 375-250-00 Tray 5 Pick Motor moved to long RAP

Procedure



WARNING: Switch off the electricity to the machine, GP 10 . Disconnect the power lead from the customer supply while performing tasks that do not need electricity. Electricity can cause the death or injury. Moving components can cause the injury.

Action	Yes	No
Step 1 Check the paper path and trays for paper fragments and partially fed paper. The paper is path free of paper fragments and partially fed paper.	Go to step 3.	Go to step 2.
Step 2 Remove the paper fragments and partially fed paper. The fault persists.	Go to step 3.	The problem is solved.
Step 3 Ensure that all the trays and tray inserts are properly installed. The fault persists.	Go to step 4.	The problem is solved.
Step 4 Enter the Diagnostics menu GP 1, and then navigate to: Input tray quick print >select source tray > Single The fault persists.	Go to step 5.	The problem is solved.
Step 5 1 Enter the Diagnostics menu GP 1, and then navigate to: Additional input tray diagnostics >Motor tests 2 Select Pick (tray [x]) , and then touch Start . Note: [x] is the tray number. The motor will run.	Go to step 7.	Go to step 6.
Step 6 Reseat the cable on the motor and on the optional tray controller board. The fault persists.	Go to step 7.	The problem is solved.

Action	Yes	No
Step 7 Check the source tray controller board and its connector pins for damage. The tray controller board and its connectors free of damage.	Contact the next level of support.	The problem is solved.
Step 8 Install a new optional tray. See PL 70.15 item 1 . The fault persists.	Contact the next level of support.	The problem is solved.

373-146-00, 373-328-00, 374-147-00, 375-239-00 Never Arriving Jam From Normal Path Tray (3, 4, 5) RAP

WD2 Drive PWB Wiring Diagram

C625 Wiring Diagrams

373-146-00 Never Arriving Jam From Normal Path (Paper didn't reach the specified sensor, but did reach the previous sensor)-Option declared jam, or warm up jam with no known page source - RAP

373-328-00 Never Arriving Jam From Normal Path (Paper didn't reach the specified sensor, but did reach the previous sensor)-Source was tray 3 - RAP

374-147-00 Never Arriving Jam From Normal Path (Paper didn't reach the specified sensor, but did reach the previous sensor)-Source was tray 4 - RAP

375-239-00 Never Arriving Jam From Normal Path (Paper didn't reach the specified sensor, but did reach the previous sensor)-Source was tray 5 - RAP

Procedure



WARNING: Switch off the electricity to the machine, [GP 10](#). Disconnect the power lead from the customer supply while performing tasks that do not need electricity. Electricity can cause the death or injury. Moving components can cause the injury.

Action	Yes	No
Step 1 1 From the Home screen, touch Settings > Device > Preferences . 2 Check if the paper size matches the size set on the tray guides. The paper size will match the size set on the tray.	Go to step 3.	Go to step 2.
Step 2 Change the paper size or adjust the size setting in the tray. The fault persists.	Go to step 3.	The problem is solved.
Step 3 Check if the paper size matches the size set on the tray guides. The paper size will match the size set on the tray.	Go to step 5.	Go to step 4.
Step 4 Insert new paper or change the paper size setting in the tray. The fault persists.	Go to step 5.	The problem is solved.
Step 5	Go to step 6.	Go to step 7.

Action	Yes	No
Check the paper tray for overfilling. The paper tray overfilled.		
Step 6 Remove the excess paper from the tray. The fault persists.	Go to step 7.	The problem is solved.
Step 7 Check the paper condition in the tray. The paper is crumpled or damaged.	Go to step 8.	Go to step 9.
Step 8 Check whether the crumpled or damaged paper is removed and insert new paper. The fault persists.	Go to step 9.	The problem is solved.
Step 9 Check the paper path for partially fed or jammed paper. The paper path is free of partially fed or jammed paper.	Go to step 11.	Go to step 10.
Step 10 Remove the partially fed or jammed paper. The fault persists.	Go to step 11.	The problem is solved.
Step 11 1 Enter the Diagnostics menu GP 1 , and then navigate to: Additional input trays adjustments/tests > Additional input tray sensors 2 Find the sensor (Pass-through (tray 3)). The sensor status will change while toggling the sensor.	Go to step 13.	Go to step 12.
Step 12 1 Ensure that the sensor cable is properly connected. 2 Ensure that the sensor is properly installed. 3 Check the sensor and the other optional tray components for damage. The sensor is free of damage.	Go to step 13.	Go to step 15.

Action	Yes	No
Step 13 1 Enter the Diagnostics menu GP 1 , and then navigate to: Additional input trays adjustments/tests > Additional input tray motors 2 Select Pass-through (tray 3) , and then touch Start . The motor will run.	Go to step 16.	Go to step 14.
Step 14 1 Ensure that the motor cable is properly connected. 2 Ensure that the motor is properly installed. 3 Check the motor and the other optional tray components for damage. The motor and the optional tray are free of damage.	Go to step 16.	Go to step 15.
Step 15 Install a new optional tray. See PL 70.15 item 1 The fault persists.	Go to step 16.	The problem is solved.
Step 16 1 Enter the Diagnostics menu GP 1 , and then navigate to: Additional input trays adjustments/tests > Additional input tray motors 2 Select Pass-through (tray 4) , and then touch Start . The motor will run.	Go to step 19.	Go to step 17.
Step 17 1 Ensure that the motor cable is properly connected. 2 Ensure that the motor is properly installed. 3 Check the motor and the other optional tray components for damage. The motor and optional tray are free of damage.	Go to step 19.	Go to step 18.

Action	Yes	No
Step 18 Install a new optional tray. See PL 70.15 item 1 . The fault persists.	Go to step 19.	The problem is solved.
Step 19 Perform a print test. The fault persists.	Contact the next level of support.	The problem is solved.

371-107-00 to 371-108-00, 372-151-00 to 372-152-00, 373-153-00 to 373-154-00, 374-100-01, 374-950-00, 375-100-01, 375-950-00, 375-951-00, 376-104-00 to 376-105-00, 377-950-00, 377-951-00 Load tray 1,2,3,4,5 with media Error RAPs

WD2 Drive PWB Wiring Diagram

C625 Wiring Diagrams

371-107-00 IRLoad: Load tray 1 with media (orientation not supported) RAP

371-108-00 IRLoad: Load tray 1 with media (orientation supported) RAP

372-151-00 IRLoad: Load tray 2 with media (orientation not supported) RAP

372-152-00 IRLoad: Load tray 2 with media (orientation supported) RA

373-153-00 IRLoad: Load tray 3 with media (orientation not supported) RAP

373-154-00 IRLoad: Load tray 3 with media (orientation supported) RAP

374-100-01 Change tray 4 to different media (orientation supported) RAP

374-950-00 IRChange: Load tray 4 to different media (orientation not supported) RAP

375-100-01 Change tray 5 to different media (orientation supported) RAP

375-950-00 Change tray 5 to different media (orientation not supported) RAP

375-951-00 IRChange: Load tray 5 to different media (orientation not supported) RAP

377-950-00 Change MP feeder to different media (orientation not supported) RAP

377-951-00 Change MP feeder to different media (orientation supported) RAP



WARNING: Switch off the electricity to the machine, [GP 10](#). Disconnect the power lead from the customer supply while performing tasks that do not need electricity. Electricity can cause the death or injury. Moving components can cause the injury.

Procedure

Action	Yes	No
Step 1 1 From the Home screen, touch Settings > Device > Preferences . 2 Check if the paper size matches the size set on the tray guides. The paper size will match the size set on the tray.	Go to step 3.	Go to step 2.
Step 2 Change the paper size or adjust the size setting in the tray. The fault persists.	Go to step 3.	The problem is solved.

Action	Yes	No
Step 3 Check the drive PWB and its pins for damage. The drive PWB is free of damage.	Contact the next level of support.	Go to step 4.
Step 4 Install a new drive PWB, PL 1.10 item 3. The fault persists.	Contact the next level of support.	The problem is solved.

372-210-00, 372-212-00, 372-214-00, 372-216-00, 372-218-00, 372-220-00, 372-222-00, 373-210-00, 373-212-00, 373-214-00, 373-216-00, 373-218-00, 373-220-00, 373-222-00, 374-218-00 to 374-224-00, 375-232-00 to 375-238-00 Motor (Tray 2, 3, 4, 5 Pick/Lift) Error RAP

[WD2 Drive PWB Wiring Diagram](#)

[C625 Wiring Diagrams](#)

372-210-00 Tray 2 Lift ON Fail RAP

372-212-00 Tray 2 Lift Off Fail RAP

372-214-00 Tray 2 Pick Motor failed to achieve expected speed RAP

372-216-00 Tray 2 Pick Motor loss of encoders (motor stall) RAP

372-218-00 Tray 2 pick Motor under speed RAP

372-220-00 Tray 2 Pick Motor over speed RAP

372-222-00 Tray 2 pick Motor moved too long RAP

373-210-00 Tray 3 Lift On Fail RAP

373-212-00 Tray 3 Off Fail RAP

373-214-00 Tray 3 Pick Motor failed to achieve expected speed RAP

373-216-00 Tray 3 pick Motor loss of encoders (motor stall) RAP

373-218-00 Tray 3 pick Motor under speed RAP

373-220-00 Tray 3 Pick Motor over speed RAP

373-222-00 Tray 3 Pick Motor moved too long RAP

374-218-00 Tray 4 Pick Motor does not turn on RAP

374-219-00 Tray 4 pick Motor does not turn off RAP

374-220-00 Tray 4 pick Motor failed to achieve expected speed RAP

374-221-00 Tray 4 Pick Motor loss of encoders (motor stall) RAP

374-222-00 Tray 4 pick Motor under speed RAP

374-223-00 Tray 4 pick Motor over speed RAP

374-224-00 Tray 4 Pick Motor moved too long RAP

375-232-00 Tray 5 Motor does not turn on RAP

375-233-00 Tray 5 Motor does not turn off RAP

375-234-00 Tray 5 Motor failed to achieve expected speed RAP

375-235-00 Tray 5 Motor loss of encoders (motor stall) RAP

375-236-00 Tray 5 Motor under speed RAP

375-237-00 Tray 5 Motor over speed RAP

375-238-00 Tray 5 Motor moved too long RAP

Procedure



WARNING: Switch off the electricity to the machine, GP 10 . Disconnect the power lead from the customer supply while performing tasks that do not need electricity. Electricity can cause the death or injury. Moving components can cause the injury.

Action	Yes	No
Step 1 Check the pick roller for misalignment and damage. The pick roller is properly installed and free of damage.	Go to step 3.	Go to step 2.
Step 2 Ensure that the motor cable is properly connected. The fault persists.	Go to step 3.	The problem is solved.
Step 3 Restart the printer. The fault persists.	Go to step 4.	The problem is solved.
Step 4 Install a new optional tray. See PL 70.15 item 1. The fault persists.	Contact the next level of support.	The problem is solved.

372-300-00, 372-302-00, 372-304-00, 372-306-00, 372-308-00, 372-310-00, 372-312-00, 373-300-00, 373-302-00, 373-304-00, 373-306-00, 373-308-00, 373-310-00, 373-312-00, 374-225-00 to 374-231-00, 375-225-00 to 375-231-00 Tray 2, 3, 4, 5 Transport Motor Error RAP

WD2 Drive PWB Wiring Diagram

C625 Wiring Diagrams

372-300-00 Tray 2 transport Motor On Fail RAP

372-302-00 Tray 2 transport Motor Off Fail RAP

372-304-00 Tray 2 transport Motor Speed Fail RAP

372-306-00 Tray 2 transport Motor loss of encoders (motor stall) RAP

372-308-00 Tray 2 transport Motor under speed RAP

372-310-00 Tray 2 transport Motor over speed RAP

372-312-00 Tray 2 transport Motor moved too long RAP

373-300-00 Tray 3 transport Motor On Fail RAP

373-302-00 Tray 3 transport Motor Off Fail RAP

373-304-00 Tray 3 transport Motor Speed Fail RAP

373-306-00 Tray 3 transport Motor loss of encoders (motor stall) RAP

373-308-00 Tray 3 transport Motor under speed RAP

373-310-00 Tray 3 transport Motor over speed RAP

373-312-00 Tray 3 transport Motor moved too long RAP

374-225-00 Tray 4 transport Motor does not turn on RAP

374-226-00 Tray 4 transport Motor does not turn off RAP

374-227-00 Tray 4 transport Motor failed to achieve expected speed RAP

374-228-00 Tray 4 transport Motor loss of encoders (motor stall) RAP

374-229-00 Tray 4 transport Motor under speed RAP

374-230-00 Tray 4 transport Motor over speed RAP

374-231-00 Tray 4 transport Motor moved too long RAP

375-225-00 Tray 5 transport Motor does not turn on RAP

375-226-00 Tray 5 transport Motor does not turn off RAP

375-227-00 Tray 5 transport Motor failed to achieve expected speed RAP

375-228-00 Tray 5 transport Motor loss of encoders (motor stall) RAP

375-229-00 Tray 5 transport Motor under speed RAP

375-230-00 Tray 5 transport Motor over speed RAP

375-231-00 Tray 5 transport Motor moved too long RAP

Procedure



WARNING: Switch off the electricity to the machine, GP 10 . Disconnect the power lead from the customer supply while performing tasks that do not need electricity. Electricity can cause the death or injury. Moving components can cause the injury.

Action	Yes	No
Step 1 Restart the printer The fault persists.	Go to step 2.	The problem is solved.
Step 2 Ensure that the motor cable is properly connected. The fault persists.	Go to step 3.	The problem is solved.
Step 3 Restart the printer. The fault persists.	Go to step 4.	The problem is solved.
Step 4 Install a new optional tray. See PL 70.15 item 1. The fault persists.	Contact the next level of support.	The problem is solved.

371-339-00, 372-305-00, 373-305-00, 374-305-00, 375-305-00 Tray 1, 2, 3, 4, 5 S1/Input Sensor Cleared Error RAP

C625 Wiring Diagrams

WD2 Drive PWB Wiring Diagram

371-339-00 Tray 1 Bump exit sensor cleared by page too soon RAP

372-305-00 Tray 2 S1/Input sensor cleared by page too soon RAP

373-305-00 Tray 3 S1/Input sensor cleared by page too soon RAP

374-305-00 Tray 4 S1/Input sensor cleared by page too soon RAP

375-305-00 Tray 5 S1/Input sensor cleared by page too soon RAP

Procedure



WARNING: Switch off the electricity to the machine, GP 10 . Disconnect the power lead from the customer supply while performing tasks that do not need electricity. Electricity can cause the death or injury. Moving components can cause the injury.

Action	Yes	No
Step 1 1 From the Home screen, touch Settings >Device > Preferences. 2 Check if the paper size matches the size set on the tray guides. The paper size will match the size set on the tray.	Go to step 3.	Go to step 2.
Step 2 Change the paper size or adjust the size setting in the tray. The fault persists.	Go to step 3.	The problem is solved.
Step 3 Check the tray for overfilling. The tray is overfilled.	Go to step 4.	Go to step 5.
Step 4 Remove the excess paper from the tray. The fault persists.	Go to step 5.	The problem is solved.
Step 5 Check the paper condition in the tray. The paper is crumpled or damaged?	Go to step 6.	Go to step 7.
Step 6	Go to step 7.	The problem is solved.

Action	Yes	No
Install a new crumpled or damaged paper. The fault persists.		
Step 7 1 Enter the Diagnostics menu, GP 1 and then navigate to: Printer diagnostics & adjustments> Sensor tests 2 Find the sensor (Input). The sensor status will change while toggling the sensor.	Go to step 9.	The problem is solved.
Step 8 1 Ensure that the sensor cable is properly connected. 2 Check the sensor for damage. The sensor is free of damage.	Go to step 9.	Go to step 9.
Step 9 Install a new sensor. See PL 80.05 item 7 . The fault persists.	Go to step 10.	The problem is solved.
Step 10 Perform a print job. The fault persists.	Contact the next level of support.	The problem is solved.

373-314-00, 373-315-00, 373-316-00, 373-317-00, 373-318-00, 373-319-00, 373-320-00 Tray 3 Lift Motor Error RAP

305-211-00, 305-212-00, 310-514-00, 371-329-00, 372-322-00, 373-322-00, 374-328-00, 375-328-00 Unknown Error RAP

305-211-00 Laser Safety interlock RAP

305-212-00 Mirror motor lock fail RAP

310-514-00 Facet Map failure due to kernel failure - May be due to low memory situations - RAP

371-329-00 Tray 1 fails to become input source ready for picking RAP

372-322-00 Tray 2 fails to become input source ready for picking RAP

373-322-00 Tray 3 fails to become input source ready for picking RAP

374-328-00 Tray 4 fails to become input source ready for picking RAP

375-328-00 Tray 5 fails to become input source ready for picking RAP

Procedure



WARNING: Switch off the electricity to the machine, GP 10 . Disconnect the power lead from the customer supply while performing tasks that do not need electricity. Electricity can cause the death or injury. Moving components can cause the injury.

Action	Yes	No
Restart the print job. The fault persists.	Contact the next level of support.	The problem is solved.

373-324-00, 373-325-00, 373-326-00, 373-327-00 Bump Exit Sensor Error RAP

373-324-00 Bump exit sensor covered too soon- Source is tray 3 RAP

373-325-00 Bump exit sensor never made by leading edge of page- Source is tray 3 RAP

373-326-00 Bump exit sensor cleared by page too soon- Source is tray 3 RAP

373-327-00 Bump exit sensor never cleared by trailing edge of page- Source is tray 3 RAP



WARNING: Switch off the electricity to the machine, GP 10 . Disconnect the power lead from the customer supply while performing tasks that do not need electricity. Electricity can cause the death or injury. Moving components can cause the injury.

Switch OFF, then switch ON the machine, GP 10. If the fault persists, contact the 2nd Level Support.

372-328-00, 372-329-00, 372-332-00, 372-336-00, 372-339-00, 373-329-00, 373-331-00, 373-338-00, 373-340-00, 374-337-00, 374-340-00, 374-342-00, 375-337-00, 375-341-00
 Early Leaving Jam Sensor Tray (2, 3, 4, 5) Error RAPs

WD2 Drive PWB Wiring Diagram

C625 Wiring Diagrams

372-328-00 Tray 2 Early Leaving Jam RAP

372-329-00 Tray 3 Early Leaving Jam RAP

372-332-00 Tray 4 Early Leaving Jam RAP

372-336-00 Tray 5 Early Leaving Jam RAP

372-339-00 Early Leaving Jam RAP. Option declared jam, or warm up jam with no known page source.

373-329-00 Tray 3 Early Leaving Jam RAP

373-331-00 Tray 4 Early Leaving Jam RAP

373-338-00 Early Leaving Jam RAP. Option declared jam, or warm up jam with no known page source.

373-340-00 Tray 5 Early Leaving Jam RAP

374-337-00 Tray 4 Early Leaving Jam RAP

374-340-00 Tray 5 Early Leaving Jam RAP

374-342-00 Early Leaving Jam RAP. Option declared jam, or warm up jam with no known page source.

375-337-00 Tray 5 Early Leaving Jam RAP

375-341-00 Early Leaving Jam RAP. Option declared jam, or warm up jam with no known page source.



WARNING: Switch off the electricity to the machine, GP 10. Disconnect the power lead from the customer supply while performing tasks that do not need electricity. Electricity can cause the death or injury. Moving components can cause the injury.

Procedure

Action	Yes	No
Step 1 1 From the Home screen, touch Settings >Device > Preferences . 2 Check if the paper size matches the size set on the tray guides. The paper size match the size set on the tray.	Go to step 3.	Go to step 2.
Step 2 Change the paper size or adjust the size setting in the tray. The fault persists.	Go to step 3.	The problem is solved.
Step 3 Check if the paper size matches the size set on the tray guides. The paper size will match the size set on the tray.	Go to step 5.	Go to step 4.
Step 4 Replace the paper or change the paper size setting in the tray. The fault persists.	Go to step 5.	The problem is solved.
Step 5 Check the paper tray for overfilling. The paper tray is overfilled.	Go to step 6.	Go to step 7.
Step 6 Remove the excess paper from the tray. The fault persists.	Go to step 7.	The problem is solved.
Step 7 Check the paper condition in the tray. The paper is crumpled or damaged.	Go to step 8.	Go to step 9.
Step 8 Replace the crumpled or damaged paper. The fault persists.	Go to step 9.	The problem is solved.
Step 9 1 Enter the Diagnostics menu GP 1, and then navigate to:	Go to step 11.	Go to step 10.

Action	Yes	No
<p>Additional input trays adjustments/tests > Additional input tray sensors</p> <p>2 Find the sensor (Trailing edge (tray [x])).</p> <p>Note: [x] is the tray number.</p> <p>The sensor status will change while toggling the sensor.</p>		
<p>Step 10</p> <p>1 Ensure that the sensor cable is properly connected.</p> <p>2 Ensure that the sensor is properly installed.</p> <p>3 Check the sensor for damage.</p> <p>The sensor is free of damage.</p>	Go to step 11.	Go to step 13.
<p>Step 11</p> <p>1 Enter the Diagnostics menu GP 1, and then navigate to:</p> <p>Additional input trays adjustments/tests > Additional input tray sensors</p> <p>2 Find the sensor (Pass-through (tray [x])).</p> <p>Note: [x] is the tray number.</p> <p>The sensor status will change while toggling the sensor.</p>	Go to step 14.	Go to step 12.
<p>Step 12</p> <p>1 Ensure that the sensor cable is properly connected.</p> <p>2 Ensure that the sensor is properly installed.</p> <p>3 Check the sensor and the other optional tray components for damage.</p> <p>The sensor is free of damage.</p>	Go to step 14.	Go to step 13.
<p>Step 13</p> <p>Install a new 550 sheet optional tray, PL 25.05 item 10. The fault persists.</p>	Go to step 14.	The problem is solved.
<p>Step 14</p> <p>Perform a print test. The fault persists.</p>	Contact the next level of support.	The problem is solved.

374-100-01 Change Tray 4 to Different Media RAP

374-100-01 The media in tray 4 is incorrect for the specified job.

Initial Actions

Verify the UI settings for tray 4 and the media, and orientation of the media, in tray 4 are correct for the job specified .

Procedure



WARNING: Switch off the electricity to the machine, GP 10 . Disconnect the power lead from the customer supply while performing tasks that do not need electricity. Electricity can cause the death or injury. Moving components can cause the injury.

1. Switch OFF, then switch ON the machine, GP 10.
2. Perform Software Upgrade, GP 4.
3. Verify the settings in the UI for tray 4, the media and orientation of the media, in tray 4 are correct for the specified job. Change the UI settings or media in tray 4 as required.
4. If the fault persists, install a new controller PWB, PL 3.05 item 2.

372-010-00 to 372-012-00, 373-010-00 to 373-012-00, 374-010-00 to 374-012-00, 375-010-00 to 375-012-00 TRAY 2, 3, 4, 5 Invalid Product ID, Board ID, Option Type Error RAP

WD2 Drive PWB Wiring Diagram

C625 Wiring Diagrams

- 372-010-00 Tray 2 Invalid Product ID RAP
- 372-011-00 Tray 2 Invalid Board ID RAP
- 372-012-00 Tray 2 Invalid Option Type RAP
- 373-010-00 Tray 3 Invalid Product ID RAP
- 373-011-00 Tray 3 Invalid Board ID RAP
- 373-012-00 Tray 3 Invalid Option Type RAP
- 374-010-00 Tray 4 Invalid Product ID RAP
- 374-011-00 Tray 4 Invalid Board ID RAP
- 374-012-00 Tray 4 Invalid Option Type RAP
- 375-010-00 Tray 5 Invalid Product ID RAP
- 375-011-00 Tray 5 Invalid Board ID RAP
- 375-012-00 Tray 5 Invalid Option Type RAP

Procedure



WARNING: Switch off the electricity to the machine, GP 10 . Disconnect the power lead from the customer supply while performing tasks that do not need electricity. Electricity can cause the death or injury. Moving components can cause the injury.

Action	Yes	No
Step 1 1 Ensure that the latest firmware is installed. 2 Ensure that the options configuration is supported. See the Printer, Option, and Stand Compatibility Guide. 3 Restart the printer. The fault persists.	Go to step 2.	The problem is solved.
Step 2 Reinstall the optional tray. The fault persists.	Go to step 3.	The problem is solved.

Action	Yes	No
Step 3 Install a new optional tray. See PL 70.15 item 1 . The fault persists.	Go to step 4	The problem is solved.
Step 4 Restart the printer. The fault persists.	Contact the next level of support.	The problem is solved.

371-107-00 to 371-108-00, 372-151-00 to 372-152-00, 373-153-00 to 373-154-00, 374-100-01, 374-950-00, 375-100-01, 375-950-00, 375-951-00, 376-104-00 to 376-105-00, 377-950-00, 377-951-00 Load tray 1,2,3,4,5 with media Error RAPs

WD2 Drive PWB Wiring Diagram

C625 Wiring Diagrams

371-107-00 IRLoad: Load tray 1 with media (orientation not supported) RAP

371-108-00 IRLoad: Load tray 1 with media (orientation supported) RAP

372-151-00 IRLoad: Load tray 2 with media (orientation not supported) RAP

372-152-00 IRLoad: Load tray 2 with media (orientation supported) RA

373-153-00 IRLoad: Load tray 3 with media (orientation not supported) RAP

373-154-00 IRLoad: Load tray 3 with media (orientation supported) RAP

374-100-01 Change tray 4 to different media (orientation supported) RAP

374-950-00 IRChange: Load tray 4 to different media (orientation not supported) RAP

375-100-01 Change tray 5 to different media (orientation supported) RAP

375-950-00 Change tray 5 to different media (orientation not supported) RAP

375-951-00 IRChange: Load tray 5 to different media (orientation not supported) RAP

377-950-00 Change MP feeder to different media (orientation not supported) RAP

377-951-00 Change MP feeder to different media (orientation supported) RAP



WARNING: Switch off the electricity to the machine, [GP 10](#). Disconnect the power lead from the customer supply while performing tasks that do not need electricity. Electricity can cause the death or injury. Moving components can cause the injury.

Procedure

Action	Yes	No
Step 1 1 From the Home screen, touch Settings > Device > Preferences . 2 Check if the paper size matches the size set on the tray guides. The paper size will match the size set on the tray.	Go to step 3.	Go to step 2.
Step 2 Change the paper size or adjust the size setting in the tray. The fault persists.	Go to step 3.	The problem is solved.

Action	Yes	No
Step 3 Check the drive PWB and its pins for damage. The drive PWB is free of damage.	Contact the next level of support.	Go to step 4.
Step 4 Install a new drive PWB, PL 1.10 item 3. The fault persists.	Contact the next level of support.	The problem is solved.

372-105-00, 372-112-00, 372-148-00, 372-337-00, 373-105-00, 373-148-00, 374-112-00, 374-148-00, 374-338-00, 375-240-00, 375-244-00, 375-338-00, 375-342-00, 377-276-00
Late Leaving Jam Tray (3, 4, 5) RAP

WD2 Drive PWB Wiring Diagram

C625 Wiring Diagrams

372-105-00 Tray 2 Late jam RAP

372-112-00 Tray 3 Late Leaving Jam (Paper reaches sensor but clears it late-(Long media, double feed) RAP

372-148-00 Late Leaving Jam. Option declared jam, or warm up jam with no known page source RAP

372-337-00 Tray 5 Late Leaving Jam (Paper reaches sensor but clears it late-(Long media, double feed) RAP

373-105-00 Tray 3 Regi Senor On Jam RAP

373-148-00 Late Leaving Jam. Option declared jam, or warm up jam with no known page source RAP

374-112-00 Tray 4 Late Leaving Jam (Paper reaches sensor but clears it late-(Long media, double feed) RAP

374-148-00 Tray 4 Late Leaving Jam (Paper reaches sensor but clears it late-(Long media, double feed) RAP

374-338-00 Tray 4 Late Leaving Jam (Paper reaches sensor but clears it late-(Long media, double feed) RAP

375-240-00 Tray 5 Late Leaving Jam (Paper reaches sensor but clears it late-(Long media, double feed) RAP

375-244-00 Tray 5 Late Leaving Jam (Paper reaches sensor but clears it late-(Long media, double feed) RAP

375-338-00 Tray 5 Late Leaving Jam (Paper reaches sensor but clears it late-(Long media, double feed) RAP

375-342-00 Late Leaving Jam. Option declared jam, or warm up jam with no known page source RAP

377-276-00 Late Leaving Jam. Option declared jam, or warm up jam with no known page source RAP

Procedure



WARNING: Switch off the electricity to the machine, GP 10. Disconnect the power lead from the customer supply while performing tasks that do not need electricity. Electricity can cause the death or injury. Moving components can cause the injury.

Action	Yes	No
<p>Step 1</p> <p>1 From the Home screen, touch Settings >Device > Preferences.</p> <p>2 Check if the paper size matches the size set on the tray guides. The paper size will match the size set on the tray.</p>	Go to step 3.	Go to step 2.
<p>Step 2</p> <p>Change the paper size or adjust the size setting in the tray. The fault persists.</p>	Go to step 3.	The problem is solved.
<p>Step 3</p> <p>Check if the paper size matches the size set on the tray guides. The paper size will match the size set on the tray.</p>	Go to step 5.	Go to step 4.
<p>Step 4</p> <p>Insert new paper or change the paper size setting in the tray. The fault persists.</p>	Go to step 5.	The problem is solved.
<p>Step 5</p> <p>Check the primary paper path for paper jams and obstructions. The paper path is free of jams and obstructions.</p>	Go to step 7.	Go to step 6.
<p>Step 6</p> <p>Remove the paper jams and obstructions. The fault persists.</p>	Go to step 7.	The problem is solved.
<p>Step 7</p> <p>1 Enter the Diagnostics menu GP 1, and then navigate to: Additional input trays adjustments/tests >Additional input tray sensors</p> <p>2 Find the sensor (Trailing edge (tray [x])).</p> <p>Note: [x] is the tray number.</p>	Go to step 9.	Go to step 8.

Action	Yes	No
<p>The sensor status will change while toggling the sensor.</p>		
<p>Step 8</p> <p>1 Ensure that the sensor cable is properly connected.</p> <p>2 Ensure that the sensor is properly installed.</p> <p>3 Check the sensor and the other optional tray components for damage. The sensor is free of damage.</p>	Go to step 9.	Go to step 13.
<p>Step 9</p> <p>1 Enter the Diagnostics menu GP 1, and then navigate to: Additional input trays adjustments/tests >Additional input tray sensors</p> <p>2 Find the sensor (Pass-through (tray [x])).</p> <p>Note: [x] is the tray number. The sensor status will change while toggling the sensor.</p>	Go to step 11.	Go to step 10.
<p>Step 10</p> <p>1 Ensure that the sensor cable is properly connected.</p> <p>2 Ensure that the sensor is properly installed.</p> <p>3 Check the sensor and the other optional tray components for damage. The sensor and the optional tray are free of damage.</p>	Go to step 11.	Go to step 11.
<p>Step 11</p> <p>1 Enter the Diagnostics menu GP 1, and then navigate to: Additional input trays adjustments/tests >Additional input tray motors</p> <p>2 Select Pass-through (tray [x]), and then touch Start.</p> <p>Note: [x] is the tray number.</p>	Go to step 14.	Go to step 12.

Action	Yes	No
The motor will run.		
Step 12 1 Ensure that the motor cable is properly connected. 2 Ensure that the motor is properly installed. 3 Check the motor and the other optional tray components for damage. The motor and the optional tray are free of damage.	Go to step 14.	Go to step 13.
Step 13 Install a new optional tray. See PL 70.15 item 1 . The fault persists.	Go to step 14.	The problem is solved.
Step 14 1 Enter the Diagnostics menu GP 1 , and then navigate to: Printer diagnostics & adjustments > Motor tests 2 Select Duplex/MPF , and then touch Start . The motor will run.	Go to step 17.	Go to step 15.
Step 15 Reseat the motor cable, and then check the motor form is alignment and damage. The motor is properly installed and free of damage.	Go to step 17.	Go to step 16.
Step 16 Install a new motor. See PL 80.05 item 6 . The fault persists.	Go to step 17.	The problem is solved.
Step 17 Perform a print test. The fault persists.	Contact the next level of support.	The problem is solved.

372-114-00, 372-116-00, 372-118-00, 372-120-00, 372-122-00, 372-124-00, 372-126-00, 373-116-00, 373-118-00, 373-120-00, 373-122-00, 373-124-00, 373-126-00, 373-321-00, 374-114-00, 374-116-00, 374-118-00, 374-120-00, 374-122-00, 374-124-00, 374-126-00, 375-247-00 to 375-249-00, 375-251-00 to 375-253-00, 375-560-00 Tray 2, 3, 4, 5 Transport (550) or Lift (HCIT) Motor Error RAP

WD2 Drive PWB Wiring Diagram

C625 Wiring Diagrams

- 372-114-00 Tray 2 Transport (550) or lift (HCIT) Motor does not turn on RAP
- 372-116-00 Tray 2 Transport (550) or lift (HCIT) Motor does not turn off RAP
- 372-118-00 Tray 2 Transport (550) or lift (HCIT) Motor failed to achieve expected speed RAP
- 372-120-00 Tray 2 Transport (550) or lift (HCIT) Motor loss of encoders (motor stall) RAP
- 372-122-00 Tray 2 Transport (550) or lift (HCIT) Motor under speed RAP
- 372-124-00 Tray 2 Transport (550) or lift (HCIT) Motor overs peed RAP
- 372-126-00 Tray 2 Transport (550) or lift (HCIT) Motor moved too long RAP
- 373-116-00 Tray 3 Transport (550) or lift (HCIT) Motor does not turn off RAP
- 373-118-00 Tray 3 Transport (550) or lift (HCIT) Motor failed to achieve expected speed RAP
- 373-120-00 Tray 3 Transport (550) or lift (HCIT) Motor loss of encoders (motor stall) RAP
- 373-122-00 Tray 3 Transport (550) or lift (HCIT) Motor under speed RAP
- 373-124-00 Tray 3 Transport (550) or lift (HCIT) Motor over speed RAP
- 373-126-00 Tray 3 Transport (550) or lift (HCIT) Motor moved too long RAP
- 373-321-00 Tray 3 Transport (550) or lift (HCIT) Motor does not turn on RAP
- 374-114-00 -70 = Tray 4 Transport (550) or lift (HCIT) Motor does not turn on RAP
- 374-116-00 -71 = Tray 4 Transport (550) or lift (HCIT) Motor does not turn off RAP
- 374-118-00 -72 = Tray 4 Transport (550) or lift (HCIT) Motor failed to achieve expected speed RAP
- 374-120-00 -73 = Tray 4 Transport (550) or lift (HCIT) Motor loss of encoders (motor stall) RAP
- 374-122-00 -74 = Tray 4 Transport (550) or lift (HCIT) Motor under speed RAP
- 374-124-00 -75 = Tray 4 Transport (550) or lift (HCIT) Motor over speed RAP
- 374-126-00 -76 = Tray 4 Transport (550) or lift (HCIT) Motor moved too long RAP
- 375-247-00 Tray 5 Transport (550) or lift (HCIT) Motor does not turn on RAP
- 375-248-00 Tray 5 Transport (550) or lift (HCIT) Motor does not turn off RAP
- 375-249-00 Tray 5 Transport (550) or lift (HCIT) Motor failed to achieve expected speed RAP

375-251-00 Tray 5 Transport (550) or lift (HCIT) Motor under speed RAP

375-252-00 Tray 5 Transport (550) or lift (HCIT) Motor over speed RAP

375-253-00 Tray 5 Transport (550) or lift (HCIT) Motor moved too long RAP

375-560-00 Tray 5 Transport (550) or lift (HCIT) Motor loss of encoders (motor stall) RAP

Procedure



WARNING: Switch off the electricity to the machine, GP 10 . Disconnect the power lead from the customer supply while performing tasks that do not need electricity. Electricity can cause the death or injury. Moving components can cause the injury.

Action	Yes	No
Step 1 Check the paper path and trays for paper fragments and partially fed paper. The paper path is free of paper fragments and partially fed paper.	Go to step 3.	Go to step 2.
Step 2 Remove the paper fragments and partially fed paper. The fault persists.	Go to step 3.	The problem is solved.
Step 3 Ensure that all the trays and tray inserts are properly installed. The fault persists.	Go to step 4.	The problem is solved.
Step 4 Enter the Diagnostics menu GP 1, and then navigate to: Input tray quick print >select source tray > Single The fault persists.	Go to step 5.	The problem is solved.
Step 5 1 Enter the Diagnostics menu GP 1, and then navigate to: Additional input tray adjustments/tests > Additional input tray motors 2 Select Pass-through (tray [x]) , and then touch Start . Note: [x] is the tray number. The motor will run.	Go to step 7.	Go to step 6.
Step 6	Go to step 7.	The problem is solved.

Action	Yes	No
Reseat the cable on the motor and on the optional tray controller board. The fault persists.		
Step 7 Remove the source tray insert, and then check if the following components are functional and free of damage: <ul style="list-style-type: none"> • Paper guides • Lift plate • Note: Move the components or turn gears to check for proper mechanisms. The tray insert and its components are functional and free of damage.	Go to step 9.	Go to step 8.
Step 8 Install a new tray insert.PL 70.10 item 4 The fault persists.	Go to step 9.	The problem is solved.
Step 9 Ensure that the controller board of the affected tray is properly installed. Reseat all the cables on the controller board. The fault persists.	Go to step 10.	The problem is solved.
Step 10 Check the affected tray controller board and its connector pins for damage. The tray controller board and its connectors are free of damage.	Contact the next level of support.	The problem is solved.
Step 11 Install a new optional tray. See PL 70.15 item 1 The fault persists.	Contact the next level of support.	The problem is solved.

372-128-00, 372-130-00, 372-132-00, 372-134-00, 372-138-00, 372-140-00, 372-321-00, 373-128-00, 373-130-00, 373-132-00, 373-134-00, 373-136-00, 373-138-00, 373-140-00, 374-128-00, 374-130-00, 374-132-00, 374-134-00, 374-136-00, 374-138-00, 374-140-00, 375-254-00 to 375-259-00, 375-250-00 Tray 2, 3, 4, 5 Motor Error RAP

WD2 Drive PWB Wiring Diagram

C625 Wiring Diagrams

- 372-128-00 Tray 2 Motor does not turn on RAP
- 372-130-00 Tray 2 Motor does not turn off RAP
- 372-132-00 Tray 2 Motor failed to achieve expected speed RAP
- 372-134-00 Tray 2 Motor loss of encoders (motor stall) RAP
- 372-138-00 Tray 2 Motor over speed RAP
- 372-140-00 Tray 2 Motor moved too long RAP
- 372-321-00 Tray 2 Motor under speed RAP
- 373-128-00 Tray 3 Motor does not turn on RAP
- 373-130-00 Tray 3 Motor does not turn off RAP
- 373-132-00 Tray 3 Motor failed to achieve expected speed RAP
- 373-134-00 Tray 3 Motor loss of encoders (motor stall) RAP
- 373-136-00 Tray 3 Motor under speed RAP
- 373-138-00 Tray 3 Motor over speed RAP
- 373-140-00 Tray 3 Motor moved too long RAP
- 374-128-00-80 = Tray 4 Motor does not turn on RAP
- 374-130-00-81 = Tray 4 Motor does not turn off RAP
- 374-132-00-82 = Tray 4 Motor failed to achieve expected speed RAP
- 374-134-00-83 = Tray 4 Motor loss of encoders (motor stall) RAP
- 374-136-00-84 = Tray 4 Motor under speed RAP
- 374-138-00-85 = Tray 4 Motor over speed RAP
- 374-140-00-86 = Tray 4 Motor moved too long RAP
- 375-254-00 Tray 5 Pick Motor does not turn on RAP
- 375-255-00 Tray 5 Pick Motor does not turn off RAP
- 375-256-00 Tray 5 Pick Motor failed to achieve expected speed RAP
- 375-257-00 Tray 5 Pick Motor loss of encoders (motor stall) RAP

- 375-258-00 Tray 5 Pick Motor under speed RAP
- 375-259-00 Tray 5 Pick Motor over speed RAP
- 375-250-00 Tray 5 Pick Motor moved to long RAP

Procedure



WARNING: Switch off the electricity to the machine, GP 10 . Disconnect the power lead from the customer supply while performing tasks that do not need electricity. Electricity can cause the death or injury. Moving components can cause the injury.

Action	Yes	No
Step 1 Check the paper path and trays for paper fragments and partially fed paper. The paper is path free of paper fragments and partially fed paper.	Go to step 3.	Go to step 2.
Step 2 Remove the paper fragments and partially fed paper. The fault persists.	Go to step 3.	The problem is solved.
Step 3 Ensure that all the trays and tray inserts are properly installed. The fault persists.	Go to step 4.	The problem is solved.
Step 4 Enter the Diagnostics menu GP 1, and then navigate to: Input tray quick print >select source tray > Single The fault persists.	Go to step 5.	The problem is solved.
Step 5 1 Enter the Diagnostics menu GP 1, and then navigate to: Additional input tray diagnostics >Motor tests 2 Select Pick (tray [x]) , and then touch Start . Note: [x] is the tray number. The motor will run.	Go to step 7.	Go to step 6.
Step 6 Reseat the cable on the motor and on the optional tray controller board. The fault persists.	Go to step 7.	The problem is solved.

Action	Yes	No
Step 7 Check the source tray controller board and its connector pins for damage. The tray controller board and its connectors free of damage.	Contact the next level of support.	The problem is solved.
Step 8 Install a new optional tray. See PL 70.15 item 1 . The fault persists.	Contact the next level of support.	The problem is solved.

372-102-00, 372-108-00, 372-142-00, 372-144-00, 372-223-00, 372-331-00, 372-334-00, 372-902-00, 373-102-00, 373-142-00, 373-144-00, 373-330-00, 373-333-00, 373-339-00, 373-900-00, 374-142-00, 374-143-00, 374-334-00, 374-335-00, 374-339-00, 375-142-00, 375-242-00, 375-334-00, 375-335-00, 375-339-00, 377-149-00, 377-274-00, 377-279-00
Early Arriving Jam And Static Jam RAP

WD2 Drive PWB Wiring Diagram

C625 Wiring Diagrams

- 372-102-00 Tray 2 EARLY ARRIVING JAM (Paper reaches the sensor too soon, or unexpected) RAP
- 372-108-00 Tray 3 EARLY ARRIVING JAM (Paper reaches the sensor too soon, or unexpected) RAP
- 372-142-00 STATIC JAM. Option declared jam, or warm up jam with no known page source - RAP
- 372-144-00 EARLY ARRIVING JAM. Option declared jam, or warm up jam with no known page source - RAP
- 372-223-00 Tray 2 STATIC JAM (Paper at sensor at start, cover closed or idle - Jam not cleared) RAP
- 372-331-00 Tray 4 EARLY ARRIVING JAM (Paper reaches the sensor too soon, or unexpected) RAP
- 372-334-00 Tray 5 EARLY ARRIVING JAM (Paper reaches the sensor too soon, or unexpected) RAP
- 372-902-00 Tray 3 STATIC JAM (Paper at sensor at start, cover closed or idle - Jam not cleared) RAP
- 373-102-00 Tray 3 early jam RAP
- 373-142-00 STATIC JAM. Option declared jam, or warm up jam with no known page source RAP
- 373-144-00 EARLY ARRIVING JAM. Option declared jam, or warm up jam with no known page source - RAP
- 373-330-00 Tray 4 EARLY ARRIVING JAM (Paper reaches the sensor too soon, or unexpected) RAP
- 373-333-00 Tray 5 STATIC JAM (Paper at sensor at start, cover closed or idle - Jam not cleared) RAP
- 373-339-00 Tray 5 EARLY ARRIVING JAM (Paper reaches the sensor too soon, or unexpected) RAP
- 373-900-00 Tray 3 static jam RAP
- 374-142-00 Tray 4 STATIC JAM (Paper at sensor at start, cover closed or idle - Jam not cleared) RAP
- 374-143-00 Tray 4 STATIC JAM (Paper at sensor at start, cover closed or idle - Jam not cleared) RAP
- 374-334-00 Tray 4 STATIC JAM (Paper at sensor at start, cover closed or idle - Jam not cleared) RAP
- 374-335-00 Tray 4 EARLY ARRIVING JAM (Paper reaches the sensor too soon, or unexpected) RAP
- 374-339-00 Tray 5 EARLY ARRIVING JAM (Paper reaches the sensor too soon, or unexpected) RAP
- 375-142-00 Tray 5 STATIC JAM (Paper at sensor at start, cover closed or idle - Jam not cleared) RAP
- 375-242-00 Tray 5 STATIC JAM (Paper at sensor at start, cover closed or idle - Jam not cleared) RAP
- 375-334-00 Tray 5 STATIC JAM (Paper at sensor at start, cover closed or idle - Jam not cleared) RAP

375-335-00 Tray 5 EARLY ARRIVING JAM (Paper reaches the sensor too soon, or unexpected) RAP

375-339-00 EARLY ARRIVING JAM. Option declared jam, or warm up jam with no known page source RAP

377-149-00 STATIC JAM. Option declared jam, or warm up jam with no known page source RAP

377-274-00 EARLY ARRIVING JAM. Option declared jam, or warm up jam with no known page source RAP

377-279-00 STATIC JAM. Option declared jam, or warm up jam with no known page source RAP

Procedure



WARNING: Switch off the electricity to the machine, GP 10. Disconnect the power lead from the customer supply while performing tasks that do not need electricity. Electricity can cause the death or injury. Moving components can cause the injury.

Action	Yes	No
<p>Step 1</p> <p>1 From the Home screen, touch Settings >Device > Preferences.</p> <p>2 Check if the paper size matches the size set on the tray guides. The paper size will match the size set on the tray.</p>	Go to step 3.	Go to step 2.
<p>Step 2</p> <p>Change the paper size or adjust the size setting in the tray. The fault persists.</p>	Go to step 3.	The problem is solved.
<p>Step 3</p> <p>Check the paper path for partially fed or jammed paper. The paper path is free of partially fed or jammed paper.</p>	Go to step 5.	Go to step 4.
<p>Step 4</p> <p>Remove the partially fed or jammed paper. The fault persists.</p>	Go to step 5.	The problem is solved.
<p>Step 5</p> <p>1 Enter the Diagnostics menu GP 1, and then navigate to: Additional input trays adjustments/tests >Additional input tray sensors</p> <p>2 Find the sensor (Trailing edge (tray [x])).</p>	Go to step 7.	Go to step 6.

Action	Yes	No
<p>Note: [x] is the tray number. The sensor status will change while toggling the sensor.</p>		
<p>Step 6</p> <p>1 Ensure that the sensor cable is properly connected.</p> <p>2 Ensure that the sensor is properly installed.</p> <p>3 Check the sensor for damage. The sensor is free of damage.</p>	Go to step 7.	Go to step 9.
<p>Step 7</p> <p>1 Enter the Diagnostics menu GP 1, and then navigate to: Additional input trays adjustments/tests >Additional input tray sensors</p> <p>2 Find the sensor (Pass-through (tray [x])).</p> <p>Note: [x] is the tray number. The sensor status will change while toggling the sensor.</p>	Go to step 10.	Go to step 8.
<p>Step 8</p> <p>1 Ensure that the sensor cable is properly connected.</p> <p>2 Ensure that the sensor is properly installed.</p> <p>3 Check the sensor and the other optional tray components for damage. The sensor is free of damage.</p>	Go to step 10.	Go to step 9.
<p>Step 9</p> <p>Install a new 550-sheet optional tray, PL 25.05 item 1. The fault persists.</p>	Go to step 10.	The problem is solved.
<p>Step 10</p> <p>Perform a print test. The fault persists.</p>	Contact the next level of support.	The problem is solved.

372-110-00, 372-146-00, 372-225-00, 372-335-00, 374-146-00 Never Arriving Jam From Normal Path (2, 3, 4, 5) RAP

WD2 Drive PWB Wiring Diagram

C625 Wiring Diagrams

372-110-00 Tray 3 Never Arriving Jam From Normal Path (Paper didn't reach the specified sensor, but did reach the previous sensor) RAP

372-146-00 Never Arriving Jam From Normal Path. Option declared jam, or warm up jam with no known page source RAP

372-225-00 Tray 2 Never Arriving Jam From Normal Path (Paper didn't reach the specified sensor, but did reach the previous sensor) RAP

372-335-00 Tray 5 Never Arriving Jam From Normal Path (Paper didn't reach the specified sensor, but did reach the previous sensor) RAP

374-146-00 Tray 4 Never Arriving Jam From Normal Path (Paper didn't reach the specified sensor, but did reach the previous sensor) RAP

Procedure



WARNING: Switch off the electricity to the machine, GP 10. Disconnect the power lead from the customer supply while performing tasks that do not need electricity. Electricity can cause the death or injury. Moving components can cause the injury.

Action	Yes	No
Step 1 1 From the Home screen, touch Settings > Device > Preferences . 2 Check if the paper size matches the size set on the tray guides. The paper size will match the size set on the tray.	Go to step 3.	Go to step 2.
Step 2 Change the paper size or adjust the size setting in the tray. The fault persists.	Go to step 3.	The problem is solved.
Step 3 Check if the paper size matches the size set on the tray guides. The paper size will match the size set on the tray.	Go to step 5.	Go to step 4.
Step 4 Ensure the paper is removed and insert new paper or change the paper size setting in the tray.	Go to step 5.	The problem is solved.

Action	Yes	No
The fault persists.		
Step 5 Check the paper tray for overfilling. The paper tray is overfilled.	Go to step 6.	Go to step 7.
Step 6 Remove the excess paper from the tray. The fault persists.	Go to step 7.	The problem is solved.
Step 7 Check the paper condition in the tray. The paper is crumpled or damaged.	Go to step 8.	Go to step 9.
Step 8 Ensure that the crumpled or damaged paper is removed and insert new paper. The fault persists.	Go to step 9.	The problem is solved.
Step 9 Check the paper path for partially fed or jammed paper. The paper path is free of partially fed or jammed paper.	Go to step 11.	Go to step 10.
Step 10 Remove the partially fed or jammed paper. The fault persists.	Go to step 11.	The problem is solved.
Step 11 1 Enter the Diagnostics menu GP 1, and then navigate to: Additional input trays adjustments/tests > Additional input tray sensors 2 Find the sensor (Pass-through (tray 2)). The sensor status will change while toggling the sensor.	Go to step 13.	Go to step 12.
Step 12 1 Ensure that the sensor cable is properly connected. 2 Ensure that the sensor is properly installed.	Go to step 13.	Go to step 15.

Action	Yes	No
3 Check the sensor and the other optional tray components for damage. The sensor is free of damage.		
Step 13 1 Enter the Diagnostics menu GP 1 , and then navigate to: Additional input trays adjustments/tests >Additional input tray motors 2 Select Pass-through (tray 2) , and then touch Start . The motor will run.	Go to step 16.	Go to step 14.
Step 14 1 Ensure that the motor cable is properly connected. 2 Ensure that the motor is properly installed. 3 Check the motor and the other optional tray components for damage. The motor and the optional tray is free of damage.	Go to step 16.	Go to step 15.
Step 15 Install a new 550-sheet optional tray, PL 25.05 item 10 . The fault persists.	Go to step 16.	The problem is solved.
Step 16 1 Enter the Diagnostics menu GP 1 , and then navigate to: Additional input trays adjustments/tests >Additional input tray motors 2 Select Pass-through (tray 3) , and then touch Start . The motor will run.	Go to step 19.	Go to step 17.
Step 17 1 Ensure that the motor cable is properly connected. 2 Ensure that the motor is properly installed. 3 Check the motor and the other optional tray components for damage.	Go to step 19.	Go to step 18.

Action	Yes	No
The motor and optional tray is free of damage.		
Step 18 Install a new 550-sheet optional tray, PL 25.05 item 10 . The fault persists.	Go to step 19.	The problem is solved.
Step 19 Perform a print test. The fault persists.	Contact the next level of support.	The problem is solved.

373-146-00, 373-328-00, 374-147-00, 375-239-00 Never Arriving Jam From Normal Path Tray (3, 4, 5) RAP

WD2 Drive PWB Wiring Diagram

C625 Wiring Diagrams

373-146-00 Never Arriving Jam From Normal Path (Paper didn't reach the specified sensor, but did reach the previous sensor)-Option declared jam, or warm up jam with no known page source - RAP

373-328-00 Never Arriving Jam From Normal Path (Paper didn't reach the specified sensor, but did reach the previous sensor)-Source was tray 3 - RAP

374-147-00 Never Arriving Jam From Normal Path (Paper didn't reach the specified sensor, but did reach the previous sensor)-Source was tray 4 - RAP

375-239-00 Never Arriving Jam From Normal Path (Paper didn't reach the specified sensor, but did reach the previous sensor)-Source was tray 5 - RAP

Procedure



WARNING: Switch off the electricity to the machine, GP 10 . Disconnect the power lead from the customer supply while performing tasks that do not need electricity. Electricity can cause the death or injury. Moving components can cause the injury.

Action	Yes	No
Step 1 1 From the Home screen, touch Settings > Device > Preferences . 2 Check if the paper size matches the size set on the tray guides. The paper size will match the size set on the tray.	Go to step 3.	Go to step 2.
Step 2 Change the paper size or adjust the size setting in the tray. The fault persists.	Go to step 3.	The problem is solved.
Step 3 Check if the paper size matches the size set on the tray guides. The paper size will match the size set on the tray.	Go to step 5.	Go to step 4.
Step 4 Insert new paper or change the paper size setting in the tray. The fault persists.	Go to step 5.	The problem is solved.
Step 5	Go to step 6.	Go to step 7.

Action	Yes	No
Check the paper tray for overfilling. The paper tray overfilled.		
Step 6 Remove the excess paper from the tray. The fault persists.	Go to step 7.	The problem is solved.
Step 7 Check the paper condition in the tray. The paper is crumpled or damaged.	Go to step 8.	Go to step 9.
Step 8 Check whether the crumpled or damaged paper is removed and insert new paper. The fault persists.	Go to step 9.	The problem is solved.
Step 9 Check the paper path for partially fed or jammed paper. The paper path is free of partially fed or jammed paper.	Go to step 11.	Go to step 10.
Step 10 Remove the partially fed or jammed paper. The fault persists.	Go to step 11.	The problem is solved.
Step 11 1 Enter the Diagnostics menu GP 1, and then navigate to: Additional input trays adjustments/tests > Additional input tray sensors 2 Find the sensor (Pass-through (tray 3)). The sensor status will change while toggling the sensor.	Go to step 13.	Go to step 12.
Step 12 1 Ensure that the sensor cable is properly connected. 2 Ensure that the sensor is properly installed. 3 Check the sensor and the other optional tray components for damage. The sensor is free of damage.	Go to step 13.	Go to step 15.

Action	Yes	No
<p>Step 13</p> <p>1 Enter the Diagnostics menu GP 1, and then navigate to:</p> <p>Additional input trays adjustments/tests > Additional input tray motors</p> <p>2 Select Pass-through (tray 3), and then touch Start. The motor will run.</p>	Go to step 16.	Go to step 14.
<p>Step 14</p> <p>1 Ensure that the motor cable is properly connected.</p> <p>2 Ensure that the motor is properly installed.</p> <p>3 Check the motor and the other optional tray components for damage. The motor and the optional tray are free of damage.</p>	Go to step 16.	Go to step 15.
<p>Step 15</p> <p>Install a new optional tray. See PL 70.15 item 1 The fault persists.</p>	Go to step 16.	The problem is solved.
<p>Step 16</p> <p>1 Enter the Diagnostics menu GP 1, and then navigate to:</p> <p>Additional input trays adjustments/tests > Additional input tray motors</p> <p>2 Select Pass-through (tray 4), and then touch Start. The motor will run.</p>	Go to step 19.	Go to step 17.
<p>Step 17</p> <p>1 Ensure that the motor cable is properly connected.</p> <p>2 Ensure that the motor is properly installed.</p> <p>3 Check the motor and the other optional tray components for damage. The motor and optional tray are free of damage.</p>	Go to step 19.	Go to step 18.

Action	Yes	No
<p>Step 18</p> <p>Install a new optional tray. See PL 70.15 item 1. The fault persists.</p>	Go to step 19.	The problem is solved.
<p>Step 19</p> <p>Perform a print test. The fault persists.</p>	Contact the next level of support.	The problem is solved.

372-100-00, 372-150-00, 372-330-00, 372-333-00, 372-338-00, 373-100-00, 373-150-00, 373-332-00, 373-341-00, 374-150-00, 374-341-00, 375-246-00, 375-343-00, 377-277-00
Tray 2, 3, 4, 5 Fail To Pick Error RAP

WD2 Drive PWB Wiring Diagram

C625 Wiring Diagrams

372-100-00 Tray 2 Mis feed_ Empty RAP

372-150-00 Fail To Pick From Tray. Option declared jam, or warm up jam with unknown page RAP

372-330-00 Tray 3 Fail To Pick From Tray (Paper did not reach first sensor; Miss-feed, tray empty) RAP

372-333-00 Tray 4 Fail To Pick From Tray (Paper did not reach first sensor; Miss-feed, tray empty) RAP

372-338-00 Tray 5 Fail To Pick From Tray (Paper did not reach first sensor; Miss-feed, tray empty) RAP

373-100-00 Tray 3 Mis feed_ Empty RAP

373-150-00 Fail To Pick From Tray Option declared jam, or warm up jam with unknown page RAP

373-332-00 Tray 4 Fail To Pick From Tray RAP

373-341-00 Tray 5 Fail To Pick From Tray (Paper did not reach first sensor; Miss-feed, tray empty) RAP

374-150-00 Tray 4 Fail To Pick From Tray (Paper did not reach first sensor; Miss-feed, tray empty) RAP

374-341-00 Tray 5 Fail To Pick From Tray (Paper did not reach first sensor; Miss-feed, tray empty) RAP

375-246-00 Tray 5 Fail To Pick From Tray (Paper did not reach first sensor; Miss-feed, tray empty) RAP

375-343-00 Fail To Pick From Tray. Option declared jam, or warm up jam with unknown page RAP

377-277-00 Fail To Pick From Tray. Option declared jam, or warm up jam with unknown page RAP

Procedure



WARNING: Switch off the electricity to the machine, GP 10 . Disconnect the power lead from the customer supply while performing tasks that do not need electricity. Electricity can cause the death or injury. Moving components can cause the injury.

Action	Yes	No
Step 1 1 From the Home screen, touch Settings >Device > Preferences. 2 Check if the paper size matches the size set on the tray guides. The paper size will match the size set on the tray.	Go to step 3.	Go to step 2.
Step 2 Change the paper size or adjust the size setting in the tray. The fault persists.	Go to step 3.	The problem is solved.
Step 3 Check if the paper size matches the size set on the tray guides. The paper size will match the size set on the tray.	Go to step 5.	Go to step 4.
Step 4 Insert new paper or change the paper size setting in the tray. The fault persists.	Go to step 5.	The problem is solved.
Step 5 Check the paper tray for overfilling. The paper tray overfilled.	Go to step 6.	Go to step 7.
Step 6 Remove the excess paper from the tray. The fault persists.	Go to step 7.	The problem is solved.
Step 7 Check the paper condition in the tray. The paper crumpled or damaged.	Go to step 8.	Go to step 9.
Step 8 Check whether the crumbled or damaged paper is removed and insert new paper. The fault persists.	Go to step 9.	The problem is solved.
Step 9	Go to step 11.	Go to step 10.

Action	Yes	No
<p>1 Ensure that the optional tray pick roller is properly installed.</p> <p>Note: Firmly press the pick roller to its shaft to make sure that is properly engaged.</p> <p>2 Check the optional tray pick roller for excess wear, contamination, and damage.</p> <p>The optional tray pick roller is free from excess wear, contamination, and damage.</p>		
<p>Step 10 Install a new pick roller. See PL 70.10 item 7. The fault persists.</p>	Go to step 11.	The problem is solved.
<p>Step 11 Check the tray exit paper path for paper fragments and contamination. The paper path is free of paper fragments and contamination.</p>	Go to step 15.	Go to step 12.
<p>Step 12 Clean the paper path. The fault persists.</p>	Go to step 13.	The problem is solved.
<p>Step 13</p> <p>1 Enter the Diagnostics menu GP 1, and then navigate to: Additional input trays adjustments/tests > Additional input tray sensors</p> <p>2 Find the sensor (Trailing edge (tray [x])).</p> <p>Note: [x] is the tray number. The sensor status will change while toggling the sensor.</p>	Go to step 15.	Go to step 14.
<p>Step 14</p> <p>1 Ensure that the sensor cable is properly connected.</p> <p>2 Ensure that the sensor is properly installed.</p>	Go to step 15.	Go to step 17.

Action	Yes	No
<p>3 Check the sensor and the other optional tray components for damage. The sensor and optional tray are free of damage.</p>		
<p>Step 15</p> <p>1 Enter the Diagnostics menu, GP 1 and then navigate to: Additional input tray diagnostics > Motor tests</p> <p>2 Select Pick (tray [x]), and then touch Start. The motor will run.</p>	Go to step 18.	Go to step 16.
<p>Step 16</p> <p>1 Ensure that the motor cable is properly connected.</p> <p>2 Ensure that the motor is properly installed.</p> <p>3 Check the motor and the other optional tray components for damage. The motor and the optional tray are free of damage.</p>	Go to step 18.	Go to step 17.
<p>Step 17 Install a new optional tray. See PL 70.15 item 1. The fault persists.</p>	Go to step 18.	The problem is solved.
<p>Step 18 Perform a print test. The fault persists.</p>	Contact the next level of support.	The problem is solved.

372-210-00, 372-212-00, 372-214-00, 372-216-00, 372-218-00, 372-220-00, 372-222-00, 373-210-00, 373-212-00, 373-214-00, 373-216-00, 373-218-00, 373-220-00, 373-222-00, 374-218-00 to 374-224-00, 375-232-00 to 375-238-00 Motor (Tray 2, 3, 4, 5 Pick/Lift) Error RAP

WD2 Drive PWB Wiring Diagram

C625 Wiring Diagrams

- 372-210-00 Tray 2 Lift ON Fail RAP
- 372-212-00 Tray 2 Lift Off Fail RAP
- 372-214-00 Tray 2 Pick Motor failed to achieve expected speed RAP
- 372-216-00 Tray 2 Pick Motor loss of encoders (motor stall) RAP
- 372-218-00 Tray 2 pick Motor under speed RAP
- 372-220-00 Tray 2 Pick Motor over speed RAP
- 372-222-00 Tray 2 pick Motor moved too long RAP
- 373-210-00 Tray 3 Lift On Fail RAP
- 373-212-00 Tray 3 Off Fail RAP
- 373-214-00 Tray 3 Pick Motor failed to achieve expected speed RAP
- 373-216-00 Tray 3 pick Motor loss of encoders (motor stall) RAP
- 373-218-00 Tray 3 pick Motor under speed RAP
- 373-220-00 Tray 3 Pick Motor over speed RAP
- 373-222-00 Tray 3 Pick Motor moved too long RAP
- 374-218-00 Tray 4 Pick Motor does not turn on RAP
- 374-219-00 Tray 4 pick Motor does not turn off RAP
- 374-220-00 Tray 4 pick Motor failed to achieve expected speed RAP
- 374-221-00 Tray 4 Pick Motor loss of encoders (motor stall) RAP
- 374-222-00 Tray 4 pick Motor under speed RAP
- 374-223-00 Tray 4 pick Motor over speed RAP
- 374-224-00 Tray 4 Pick Motor moved too long RAP
- 375-232-00 Tray 5 Motor does not turn on RAP
- 375-233-00 Tray 5 Motor does not turn off RAP
- 375-234-00 Tray 5 Motor failed to achieve expected speed RAP
- 375-235-00 Tray 5 Motor loss of encoders (motor stall) RAP

- 375-236-00 Tray 5 Motor under speed RAP
- 375-237-00 Tray 5 Motor over speed RAP
- 375-238-00 Tray 5 Motor moved too long RAP

Procedure



WARNING: Switch off the electricity to the machine, GP 10 . Disconnect the power lead from the customer supply while performing tasks that do not need electricity. Electricity can cause the death or injury. Moving components can cause the injury.

Action	Yes	No
Step 1 Check the pick roller for misalignment and damage. The pick roller is properly installed and free of damage.	Go to step 3.	Go to step 2.
Step 2 Ensure that the motor cable is properly connected. The fault persists.	Go to step 3.	The problem is solved.
Step 3 Restart the printer. The fault persists.	Go to step 4.	The problem is solved.
Step 4 Install a new optional tray. See PL 70.15 item 1. The fault persists.	Contact the next level of support.	The problem is solved.

372-300-00, 372-302-00, 372-304-00, 372-306-00, 372-308-00, 372-310-00, 372-312-00, 373-300-00, 373-302-00, 373-304-00, 373-306-00, 373-308-00, 373-310-00, 373-312-00, 374-225-00 to 374-231-00, 375-225-00 to 375-231-00 Tray 2, 3, 4, 5 Transport Motor Error RAP

WD2 Drive PWB Wiring Diagram

C625 Wiring Diagrams

- 372-300-00 Tray 2 transport Motor On Fail RAP
- 372-302-00 Tray 2 transport Motor Off Fail RAP
- 372-304-00 Tray 2 transport Motor Speed Fail RAP
- 372-306-00 Tray 2 transport Motor loss of encoders (motor stall) RAP
- 372-308-00 Tray 2 transport Motor under speed RAP
- 372-310-00 Tray 2 transport Motor over speed RAP
- 372-312-00 Tray 2 transport Motor moved too long RAP
- 373-300-00 Tray 3 transport Motor On Fail RAP
- 373-302-00 Tray 3 transport Motor Off Fail RAP
- 373-304-00 Tray 3 transport Motor Speed Fail RAP
- 373-306-00 Tray 3 transport Motor loss of encoders (motor stall) RAP
- 373-308-00 Tray 3 transport Motor under speed RAP
- 373-310-00 Tray 3 transport Motor over speed RAP
- 373-312-00 Tray 3 transport Motor moved too long RAP
- 374-225-00 Tray 4 transport Motor does not turn on RAP
- 374-226-00 Tray 4 transport Motor does not turn off RAP
- 374-227-00 Tray 4 transport Motor failed to achieve expected speed RAP
- 374-228-00 Tray 4 transport Motor loss of encoders (motor stall) RAP
- 374-229-00 Tray 4 transport Motor under speed RAP
- 374-230-00 Tray 4 transport Motor over speed RAP
- 374-231-00 Tray 4 transport Motor moved too long RAP
- 375-225-00 Tray 5 transport Motor does not turn on RAP
- 375-226-00 Tray 5 transport Motor does not turn off RAP
- 375-227-00 Tray 5 transport Motor failed to achieve expected speed RAP
- 375-228-00 Tray 5 transport Motor loss of encoders (motor stall) RAP

- 375-229-00 Tray 5 transport Motor under speed RAP
- 375-230-00 Tray 5 transport Motor over speed RAP
- 375-231-00 Tray 5 transport Motor moved too long RAP

Procedure



WARNING: Switch off the electricity to the machine, GP 10 . Disconnect the power lead from the customer supply while performing tasks that do not need electricity. Electricity can cause the death or injury. Moving components can cause the injury.

Action	Yes	No
Step 1 Restart the printer The fault persists.	Go to step 2.	The problem is solved.
Step 2 Ensure that the motor cable is properly connected. The fault persists.	Go to step 3.	The problem is solved.
Step 3 Restart the printer. The fault persists.	Go to step 4.	The problem is solved.
Step 4 Install a new optional tray. See PL 70.15 item 1. The fault persists.	Contact the next level of support.	The problem is solved.

377-270-00, 377-404-00, 377-407-00, 377-410-00, 374-232-00, 377-421-00, 377-419-00 S1/Input/Stage Sensor RAP

WD2 Drive PWB Wiring Diagram

C625 Wiring Diagrams

377-270-00 MPF S1/Input/stage sensor never made by leading edge of page during duplex pass RAP

377-404-00 Tray 1 S1/Input/stage sensor never made by leading edge of page during duplex pass RAP

377-407-00 Tray 2 S1/Input/stage sensor never made by leading edge of page during duplex pass RAP

377-410-00 Tray 3 S1/Input/stage sensor never made by leading edge of page during duplex pass RAP

374-232-00 Tray 4 S1/Input/stage sensor never made by leading edge of page during duplex pass RAP

377-421-00 Tray 5 S1/Input/stage sensor never made by leading edge of page during duplex pass RAP

377-419-00 Unknown S1/Input/stage sensor never made by leading edge of page during duplex pass RAP

Procedure



WARNING: Switch off the electricity to the machine, GP 10. Disconnect the power lead from the customer supply while performing tasks that do not need electricity. Electricity can cause the death or injury. Moving components can cause the injury.

Action	Yes	No
Step 1 Check the duplex paper path for paper jams and obstructions. The paper path is free of jams and obstructions.	Go to step 3.	Go to step 2.
Step 2 Remove the jams and obstructions. The fault persists.	Go to step 3.	The problem is solved.
Step 3 Check the sensor (MPF/pass-through) area for paper jams and obstructions. The paper path is free of jams and obstructions.	Go to step 5.	Go to step 4.
Step 4 Remove the jams and obstructions. The fault persists.	Go to step 5.	The problem is solved.

Action	Yes	No
Step 5 1 Enter the Diagnostics menu GP 1, and then navigate to: Printer diagnostics & adjustments >Sensor tests 2 Find the sensor (MPF/pass-through). The sensor status will change while toggling the sensor.	Go to step 8.	Go to step 6.
Step 6 1 Ensure that the sensor cable is properly connected. 2 Check the sensor and its flag for damage. 3 Check the isolation unit components for damage. The sensor and isolation unit components are free of damage.	Go to step 8.	Go to step 7.
Step 7 Install a new isolation unit. See PL 80.10 item 3. The fault persists.	Go to step 8.	The problem is solved.
Step 8 1 Enter the Diagnostics menu GP 1, and then navigate to: Printer diagnostics & adjustments >Motor tests > Duplex/MPF 2 Select a setting, and then touch Start . The motor will run.	Go to step 11.	Go to step 9.
Step 9 1 Ensure that the motor cable is properly connected. 2 Check the motor for damage. The motor is free of damage.	Go to step 11.	Go to step 10.
Step 10 1 Install a new motor. See PL 80.05 item 6. 2 Perform a print job. The fault persists.	Go to step 11.	The problem is solved.

Action	Yes	No
Step 11 Check the duplex inner guide and its gears, belts, and rollers for damage. The duplex inner guide and its components are free of damage.	Contact the next level of support.	Go to step 12.
Step 12 1 Install a new duplex inner guide. See PL 80.15 item 1 . 2 Perform a print job. The fault persists.	Contact the next level of support.	The problem is solved.

377-402-00, 377-405-00, 377-408-00, 377-411-00, 374-233-00, 377-422-00, 377-420-00 S1/Input/Stage Sensor RAP

WD2 Drive PWB Wiring Diagram

C625 Wiring Diagrams

377-402-00 MPF S1/Input/stage sensor never cleared by trailing edge of page during duplex pass RAP

377-405-00 Tray 1 S1/Input/stage sensor never cleared by trailing edge of page during duplex pass RAP

377-408-00 Tray 2 S1/Input/stage sensor never cleared by trailing edge of page during duplex pass RAP

377-411-00 Tray 3 S1/Input/stage sensor never cleared by trailing edge of page during duplex pass RAP

374-233-00 Tray 4 S1/Input/stage sensor never cleared by trailing edge of page during duplex pass RAP

377-422-00 Tray 5 S1/Input/stage sensor never cleared by trailing edge of page during duplex pass RAP

377-420-00 Unknown S1/Input/stage sensor never cleared by trailing edge of page during duplex pass RAP

Procedure



WARNING: Switch off the electricity to the machine, [GP 10](#). Disconnect the power lead from the customer supply while performing tasks that do not need electricity. Electricity can cause the death or injury. Moving components can cause the injury.

Action	Yes	No
Step 1 Check the duplex paper path for paper jams and obstructions. The paper path is free of jams and obstructions.	Go to step 3.	Go to step 2.
Step 2 Remove the jams and obstructions. The fault persists.	Go to step 3.	The problem is solved.
Step 3 1 Enter the Diagnostics menu GP 1 , and then navigate to: Printer diagnostics & adjustments > Sensor tests 2 Find the sensor (MPF/pass-through). The sensor status will change while toggling the sensor.	Go to step 6.	Go to step 4.

Action	Yes	No
Step 4 1 Ensure that the sensor cable is properly connected. 2 Check the sensor and its flag for damage. 3 Check the isolation unit components for damage. The sensor and isolation unit components are free of damage.	Go to step 6.	Go to step 5.
Step 5 Install a new isolation unit. See PL 80.10 item 4 . The fault persists.	Go to step 6.	The problem is solved.
Step 6 1 Enter the Diagnostics menu GP 1 , and then navigate to: Printer diagnostics & adjustments > Motor tests > Deskew 2 Touch Start . The motor will run.	Contact the next level of support.	Go to step 7.
Step 7 1 Ensure that the motor cable is properly connected. 2 Check the motor for damage. The fault persists.	Contact the next level of support.	Go to step 8.
Step 8 1 Install a new motor (deskew). See PL 40.10 item 1 . 2 Perform a print job. The fault persists.	Contact the next level of support.	The problem is solved.

371-308-00, 371-316-00, 371-322-00, 374-300-00, 375-306-00S1/Input Sensor Covered Error RAP

371-308-00 Tray 1 Bump exit sensor covered too soon RAP

371-316-00 Tray 2 S1/Input sensor covered too soon RAP

371-322-00 Tray 3 S1/Input sensor covered too soon RAP

374-300-00 Tray 4 S1/Input sensor covered too soon RAP

375-306-00 Tray 5 S1/Input sensor covered too soon RAP

Procedure



WARNING: Switch off the electricity to the machine, [GP 10](#). Disconnect the power lead from the customer supply while performing tasks that do not need electricity. Electricity can cause the death or injury. Moving components can cause the injury.

Action	Yes	No
Step 1 1 From the Home screen, touch Settings > Device > Preferences . 2 Check if the paper size matches the size set on the tray guides. The paper size will match the size set on the tray.	Go to step 3.	Go to step 2.
Step 2 Change the paper size or adjust the size setting in the tray. The fault persists.	Go to step 3.	The problem is solved.
Step 3 Check the tray for overfilling. The tray is overfilled.	Go to step 4.	Go to step 5.
Step 4 Remove the excess paper from the tray. The fault persists.	Go to step 5.	The problem is solved.
Step 5 Check the paper path along the tray exit. The paper path is free of fragments and contamination.	Go to step 7.	Go to step 6.

Action	Yes	No
Step 6 Clean the paper path. The fault persists.	Go to step 7.	The problem is solved.
Step 7 Perform a print job. The fault persists.	Contact the next level of support.	The problem is solved.

371-339-00, 372-305-00, 373-305-00, 374-305-00, 375-305-00 Tray 1, 2, 3, 4, 5 S1/Input Sensor Cleared Error RAP

C625 Wiring Diagrams

WD2 Drive PWB Wiring Diagram

371-339-00 Tray 1 Bump exit sensor cleared by page too soon RAP

372-305-00 Tray 2 S1/Input sensor cleared by page too soon RAP

373-305-00 Tray 3 S1/Input sensor cleared by page too soon RAP

374-305-00 Tray 4 S1/Input sensor cleared by page too soon RAP

375-305-00 Tray 5 S1/Input sensor cleared by page too soon RAP

Procedure



WARNING: Switch off the electricity to the machine, GP 10 . Disconnect the power lead from the customer supply while performing tasks that do not need electricity. Electricity can cause the death or injury. Moving components can cause the injury.

Action	Yes	No
Step 1 1 From the Home screen, touch Settings >Device > Preferences . 2 Check if the paper size matches the size set on the tray guides. The paper size will match the size set on the tray.	Go to step 3.	Go to step 2.
Step 2 Change the paper size or adjust the size setting in the tray. The fault persists.	Go to step 3.	The problem is solved.
Step 3 Check the tray for overfilling. The tray is overfilled.	Go to step 4.	Go to step 5.
Step 4 Remove the excess paper from the tray. The fault persists.	Go to step 5.	The problem is solved.
Step 5 Check the paper condition in the tray. The paper is crumpled or damaged?	Go to step 6.	Go to step 7.
Step 6	Go to step 7.	The problem is solved.

Action	Yes	No
Install a new crumpled or damaged paper. The fault persists.		
Step 7 1 Enter the Diagnostics menu, GP 1 and then navigate to: Printer diagnostics & adjustments > Sensor tests 2 Find the sensor (Input). The sensor status will change while toggling the sensor.	Go to step 9.	The problem is solved.
Step 8 1 Ensure that the sensor cable is properly connected. 2 Check the sensor for damage. The sensor is free of damage.	Go to step 9.	Go to step 9.
Step 9 Install a new sensor. See PL 80.05 item 7 . The fault persists.	Go to step 10.	The problem is solved.
Step 10 Perform a print job. The fault persists.	Contact the next level of support.	The problem is solved.

371-317-00, 371-346-00, 374-317-00 Autocomp Motor Under Speed Error RAP

WD2 Drive PWB Wiring Diagram

C625 Wiring Diagrams

371-317-00 Tray 2 - Autocomp Motor under speed RAP

371-346-00 Tray 1- Autocomp Motor under speed RAP

374-317-00 Autocomp Motor under speed RAP

Procedure



WARNING: Switch off the electricity to the machine, **GP 10**. Disconnect the power lead from the customer supply while performing tasks that do not need electricity. Electricity can cause the death or injury. Moving components can cause the injury.

Action	Yes	No
Step 1 Check the tray for overfilling. The tray is overfilled.	Go to step 2.	Go to step 3.
Step 2 Remove the excess paper from the tray. The fault persists.	Go to step 3.	The problem is solved.
Step 3 Check the paper condition in the tray. The paper is crumpled or damaged.	Go to step 4.	Go to step 5.
Step 4 Replace the crumpled or damaged paper. The problem persists.	Go to step 5.	The problem is solved.
Step 5 Check the tray exit paper path for fragments and contamination The paper path is free of fragments and contamination.	Go to step 7.	Go to step 6.
Step 6 Clean the paper path. The fault persists.	Go to step 7.	The problem is solved.
Step 7 1 Enter the Diagnostics menu GP 1 , and then navigate to:	Contact the next level of support.	Go to step 8.

Action	Yes	No
<p>Printer diagnostics and adjustments > Motor tests > Pick (tray 1)</p> <p>2 Select a setting, and then touch Start. The motor will run.</p>		
<p>Step 8</p> <p>1 Ensure that the motor cable is properly connected. 2 Check the motor and the other paper feeder components for damage. The motor and paper feeder is free of damage</p>	Contact the next level of support.	Go to step 9.
<p>Step 9</p> <p>1 Install a new paper feeder. See PL 70.10 item 8. 2 Perform a print job. The fault persists.</p>	Contact the next level of support.	The problem is solved.

371-302-00, 371-310-00, 371-318-00, 371-324-00, 371-327-00, 372-226-00, 374-318-00, 374-329-00, 375-318-00, 375-329-00 Tray 2, 3, 4, 5 Sensor Failed To Arrive Error RAP

WD2 Drive PWB Wiring Diagram

C625 Wiring Diagrams

- 371-302-00 Sensor never made by leading edge of page RAP
- 371-310-00 Sensor never made by leading edge of page RAP
- 371-318-00 Tray 2 Jam at S1/Input/stage - never reached s1/Input/stage sensor RAP
- 371-324-00 Tray 3 Jam at Bump Exit - never reached bump exit sensor RAP
- 371-327-00 Tray 3 S1/Input sensor never made by leading edge after pick RAP
- 372-226-00 Tray 2 S1/Input sensor never made by leading edge after pick RAP
- 374-318-00 Tray 4 Jam at Bump Exit - never reached bump exit sensor RAP
- 374-329-00 Tray 4 S1/Input sensor never made by leading edge after pick RAP
- 375-318-00 Tray 5 Jam at Bump Exit - never reached bump exit sensor RAP
- 375-329-00 Tray 5 S1/Input sensor never made by leading edge after pick RAP

Procedure



WARNING: Switch off the electricity to the machine, [GP 10](#). Disconnect the power lead from the customer supply while performing tasks that do not need electricity. Electricity can cause the death or injury. Moving components can cause the injury.

Action	Yes	No
<p>Step 1</p> <p>1 From the Home screen, touch Settings > Device > Preferences. 2 Check if the paper type and size settings match the paper type and size set on the tray. The paper size will match the size set on the tray.</p>	Go to step 3.	Go to step 2.
<p>Step 2</p> <p>Change the paper size or adjust the size setting in the tray. The fault persists.</p>	Go to step 3.	The problem is solved.
<p>Step 3</p> <p>Check the paper path for paper jams and fragments.</p>	Go to step 5.	Go to step 4.

Action	Yes	No
<p>Note: If necessary, remove the transfer module to properly see the paper path. The paper path is free of jams and fragments.</p>		
<p>Step 4 Remove the jams and fragments. The fault persists.</p>	Go to step 5.	The problem is solved.
<p>Step 5 Check the tray insert and its paper path guides and drive gears for damage. The tray insert is free of damage.</p>	Go to step 7.	Go to step 6.
<p>Step 6 Install a new tray insert. See PL 70.10 item 4. The fault persists.</p>	Go to step 7.	The problem is solved.
<p>Step 7 1 Ensure that the pick roller is properly installed. <p>Note: Firmly press the pick roller to its shaft to make sure that it is properly engaged.</p> 2 Check the pick roller for excess wear, contamination, and damage. The pick roller is free from excess wear, contamination, and damage.</p>	Go to step 9.	Go to step 8.
<p>Step 8 Install a new pick roller. See PL 70.10 item 10. The fault persists.</p>	Go to step 9.	The problem is solved.
<p>Step 9 1 Enter the Diagnostics menu GP 1, and then navigate to: Printer diagnostics and adjustments > Motor tests > Pick (tray 1) 2 Select a setting, and then touch Start. The motor will run.</p>	Go to step 12.	Go to step 10.

Action	Yes	No
<p>Step 10 1 Ensure that the motor cable is properly connected. 2 Check the motor and the other paper feeder components PL 70.10 item 8 for damage. The motor and paper feeder is free of damage.</p>	Go to step 12.	Go to step 11.
<p>Step 11 1 Install a new paper feeder. See . 2 Perform a print job. The fault persists.</p>	Go to step 12.	The problem is solved.
<p>Step 12 1 Enter the Diagnostics menu GP 1, and then navigate to: Printer diagnostics & adjustments > Sensor tests 2 Find the sensor (Input). The sensor status will change while toggling the sensor</p>	Go to step 15.	Go to step 13.
<p>Step 13 1 Ensure that the sensor cable is properly connected. 2 Check the sensor for damage. The sensor is free of damage.</p>	Go to step 15.	Go to step 14.
<p>Step 14 Install a new sensor. See PL 80.05 item 7. The fault persists.</p>	Go to step 15.	The problem is solved.
<p>Step 15 1 Enter the Diagnostics menu, and then navigate to: Printer diagnostics & adjustments > Motor tests > Isolation 2 Touch Start, and then listen to the sound of the motor. 3 Check if the sound of the motor (isolation) is similar. The motor will create a similar grinding sound</p>	Go to step 17.	Go to step 16.
<p>Step 16</p>	Go to step 18.	Go to step 17.

Action	Yes	No
Check the motor and its cable for damage. The motor and its cable is free of damage		
Step 17 Install a new isolation unit. See PL 80.10 item 4 . The fault persists.	Contact the next level of support.	The problem is solved.
Step 18 1 Enter the Diagnostics menu GP 1 , and then navigate to: Printer diagnostics & adjustments > Motor tests > Deskew 2 Touch Start . The motor will run.	Contact the next level of support.	Go to step 19.
Step 19 1 Ensure that the motor cable is properly connected. 2 Check the motor (deskew) for damage. The motor is free of damage.	Contact the next level of support.	Go to step 20.
Step 20 Install a new motor (deskew). See PL 40.10 item 1 . The fault persists.	Contact the next level of support.	The problem is solved.

371-304-00, 371-312-00, 371-320-00, 371-326-00, 374-320-00, 375-320-00 Tray 1, 2, 3, 4, 5 Sensor Failed To Clear Page Error RAP

WD2 Drive PWB Wiring Diagram

C625 Wiring Diagrams

371-304-00 S1/Input/Stage sensor never cleared by trailing edge of page (bump exit sensor for CA/MM) RAP

371-312-00 Tray 1 Bump exit/stage sensor never cleared by trailing edge of page RAP

371-320-00 Tray 2 S1/Input sensor never cleared by trailing edge of page RAP

371-326-00 Tray 3 S1/Input sensor never cleared by trailing edge of page RAP

374-320-00 Tray 4 S1/Input sensor never cleared by trailing edge of page RAP

375-320-00 Tray 5 S1/Input sensor never cleared by trailing edge of page RAP

Procedure



WARNING: Switch off the electricity to the machine, [GP 10](#). Disconnect the power lead from the customer supply while performing tasks that do not need electricity. Electricity can cause the death or injury. Moving components can cause the injury.

Action	Yes	No
Step 1 1 From the Home screen, touch Settings > Device > Preferences . 2 Check if the paper size matches the size set on the tray guides. The paper size will match the size set on the tray.	Go to step 3.	Go to step 2.
Step 2 Change the paper size or adjust the size setting in the tray. The fault persists.	Go to step 3.	The problem is solved.
Step 3 Check the paper path for paper jams and obstructions. Note: If necessary, remove the transfer module to properly see the paper path. The paper path is free of jams and obstructions.	Go to step 5.	Go to step 4.
Step 4 Remove the jams and obstructions.	Go to step 5.	The problem is solved.

Action	Yes	No
The fault persists.		
Step 5 1 Enter the Diagnostics menu, GP 1 and then navigate to: Printer diagnostics & adjustments > Sensor tests 2 Find the sensor (Input). The sensor status will change while toggling the sensor.	Go to step 8.	Go to step 6.
Step 6 1 Ensure that the sensor cable is properly connected. 2 Check the sensor for damage. The sensor is free of damage.	Go to step 8.	Go to step 7.
Step 7 Install a new sensor. See PL 80.05 item 7 . The fault persists.	Go to step 8.	The problem is solved.
Step 8 1 Enter the Diagnostics menu GP 1 , and then navigate to: Printer diagnostics & adjustments Motor tests > Deskew 2 Touch Start . The motor will run.	Contact the next level of support.	Go to step 9.
Step 9 1 Ensure that the motor cable is properly connected. 2 Check the motor (deskew) for damage. The motor is free of damage.	Contact the next level of support.	Go to step 10.
Step 10 Install a new motor (deskew). See PL 40.10 item 1 . The fault persists.	Contact the next level of support.	The problem is solved.

374-321-00, 374-322-00, 374-323-00, 374-324-00, 374-325-00, 374-326-00, 374-327-00 Tray 4 Lift Motor Error RAP

374-321-00 Tray 4 lift Motor does not turn on RAP

374-322-00 Tray 4 lift Motor does not turn off RAP

374-323-00 Tray 4 lift Motor failed to achieve expected speed RAP

374-324-00 Tray 4 lift Motor loss of encoders (motor stall) RAP

374-325-00 Tray 4 lift Motor underspeed RAP

374-326-00 Tray 4 lift Motor overspeed RAP

374-327-00 Tray 4 lift Motor moved too long RAP



WARNING: Switch off the electricity to the machine, **GP 10**. Disconnect the power lead from the customer supply while performing tasks that do not need electricity. Electricity can cause the death or injury. Moving components can cause the injury.

Switch OFF, then switch ON the machine, **GP 10**. If the fault persists, contact 2nd Level Support.

305-211-00, 305-212-00, 310-514-00, 371-329-00, 372-322-00, 373-322-00, 374-328-00, 375-328-00 Unknown Error RAP

305-211-00 Laser Safety interlock RAP

305-212-00 Mirror motor lock fail RAP

310-514-00 Facet Map failure due to kernel failure - May be due to low memory situations - RAP

371-329-00 Tray 1 fails to become input source ready for picking RAP

372-322-00 Tray 2 fails to become input source ready for picking RAP

373-322-00 Tray 3 fails to become input source ready for picking RAP

374-328-00 Tray 4 fails to become input source ready for picking RAP

375-328-00 Tray 5 fails to become input source ready for picking RAP

Procedure



WARNING: Switch off the electricity to the machine, GP 10 . Disconnect the power lead from the customer supply while performing tasks that do not need electricity. Electricity can cause the death or injury. Moving components can cause the injury.

Action	Yes	No
Restart the print job. The fault persists.	Contact the next level of support.	The problem is solved.

374-330-00 , 374-331-00, 374-332-00, 374-333-00 Bump Exit Sensor Error RAP

374-330-00 Bump exit sensor covered too soon- Source is tray 4 RAP

374-331-00 Bump exit sensor never made by leading edge of page- Source is tray 4 RAP

374-332-00 Bump exit sensor cleared by page too soon- Source is tray 4 RAP

374-333-00 Bump exit sensor never cleared by trailing edge of page- Source is tray 4 RAP



WARNING: Switch off the electricity to the machine, GP 10 . Disconnect the power lead from the customer supply while performing tasks that do not need electricity. Electricity can cause the death or injury. Moving components can cause the injury.

Switch OFF, then switch ON the machine, GP 10. If the fault persists, contact 2nd Level Support.

374-336-00, 375-243-00, 375-336-00, 375-340-00, 377-275-00 Tray (4, 5) Never Arriving Jam From Normal Path Error RAPs

WD2 Drive PWB Wiring Diagram

C625 Wiring Diagrams

374-336-00 Tray 4 Never Arriving Jam From Normal Path RAP

375-243-00 Tray 5 Never Arriving Jam From Normal Path RAP

375-336-00 Tray 5 Never Arriving Jam From Normal Path RAP

375-340-00 Never Arriving Jam From Normal Path RAP. Option declared jam, or warm up jam with no known page source.

377-275-00 Never Arriving Jam From Normal Path RAP. Option declared jam, or warm up jam with no known page source.



WARNING: Switch off the electricity to the machine, GP 10. Disconnect the power lead from the customer supply while performing tasks that do not need electricity. Electricity can cause the death or injury. Moving components can cause the injury.

Procedure

Action	Yes	No
Step 1 1 From the Home screen, touch Settings >Device > Preferences . 2 Check if the paper size matches the size set on the tray guides. The paper size will match the size set on the tray.	Go to step 3.	Go to step 2.
Step 2 Change the paper size or adjust the size setting in the tray. The fault persists.	Go to step 3.	The problem is solved.
Step 3 Check if the paper size matches the size set on the tray guides. The paper size will match the size set on the tray.	Go to step 5.	Go to step 4.
Step 4 Install the new paper or change the paper size setting in the tray. The fault persists.	Go to step 5.	The problem is solved.
Step 5	Go to step 6.	Go to step 7.

Action	Yes	No
Check the paper tray for overfilling. The paper tray is overfilled.		
Step 6 Remove the excess paper from the tray. The fault persists.	Go to step 7.	The problem is solved.
Step 7 Check the paper condition in the tray. The paper is crumpled or damaged.	Go to step 8.	Go to step 9.
Step 8 Replace the crumpled or damaged paper. The fault persists.	Go to step 9.	The problem is solved.
Step 9 Check the paper path for partially fed or jammed paper. The paper path is free of partially fed or jammed paper.	Go to step 11.	Go to step 10.
Step 10 Remove the partially fed or jammed paper. The fault persists.	Go to step 11.	The problem is solved.
Step 11 1 Enter the Diagnostics menu GP 1, and then navigate to: Additional input trays adjustments/tests >Additional input tray sensors 2 Find the sensor (Pass-through (tray 4)). The sensor status will change while toggling the sensor.	Go to step 13.	Go to step 12.
Step 12 1 Ensure that the sensor cable is properly connected. 2 Ensure that the sensor is properly installed. 3 Check the sensor and the other optional tray components for damage. The sensor is free of damage.	Go to step 13.	Go to step 15.

Action	Yes	No
Step 13 1 Enter the Diagnostics menu GP 1 , and then navigate to: Additional input trays adjustments/tests >Additional input tray motors 2 Select Pass-through (tray 4) , and then touch Start . The motor will run.	Go to step 16.	Go to step 14.
Step 14 1 Ensure that the motor cable is properly connected. 2 Ensure that the motor is properly installed. 3 Check the motor and the other optional tray components for damage. The motor and the optional tray are free of damage.	Go to step 16.	Go to step 15.
Step 15 Install the new 550 optional tray. See PL 70.15 item 1 . The fault persists.	Go to step 16.	The problem is solved.
Step 16 1 Enter the Diagnostics menu GP 1 , and then navigate to: Additional input trays adjustments/tests >Additional input tray motors 2 Select Pass-through (tray 5) , and then touch Start . The motor will run.	Go to step 19.	Go to step 17.
Step 17 1 Ensure that the motor cable is properly connected. 2 Ensure that the motor is properly installed. 3 Check the motor and the other optional tray components for damage. The motor and optional tray is free of damage.	Go to step 19.	Go to step 18.

Action	Yes	No
Step 18 Install a new 550 sheet optional tray. See PL 70.15 item 1 . The fault persists.	Go to step 19.	The problem is solved.
Step 19 Perform a print test. The fault persists.	Contact the next level of support.	The problem is solved.

372-328-00, 372-329-00, 372-332-00, 372-336-00, 372-339-00, 373-329-00, 373-331-00, 373-338-00, 373-340-00, 374-337-00, 374-340-00, 374-342-00, 375-337-00, 375-341-00
Early Leaving Jam Sensor Tray (2, 3, 4, 5) Error RAPs

WD2 Drive PWB Wiring Diagram

C625 Wiring Diagrams

372-328-00 Tray 2 Early Leaving Jam RAP

372-329-00 Tray 3 Early Leaving Jam RAP

372-332-00 Tray 4 Early Leaving Jam RAP

372-336-00 Tray 5 Early Leaving Jam RAP

372-339-00 Early Leaving Jam RAP. Option declared jam, or warm up jam with no known page source.

373-329-00 Tray 3 Early Leaving Jam RAP

373-331-00 Tray 4 Early Leaving Jam RAP

373-338-00 Early Leaving Jam RAP. Option declared jam, or warm up jam with no known page source.

373-340-00 Tray 5 Early Leaving Jam RAP

374-337-00 Tray 4 Early Leaving Jam RAP

374-340-00 Tray 5 Early Leaving Jam RAP

374-342-00 Early Leaving Jam RAP. Option declared jam, or warm up jam with no known page source.

375-337-00 Tray 5 Early Leaving Jam RAP

375-341-00 Early Leaving Jam RAP. Option declared jam, or warm up jam with no known page source.



WARNING: Switch off the electricity to the machine, GP 10 . Disconnect the power lead from the customer supply while performing tasks that do not need electricity. Electricity can cause the death or injury. Moving components can cause the injury.

Procedure

Action	Yes	No
Step 1 1 From the Home screen, touch Settings >Device > Preferences . 2 Check if the paper size matches the size set on the tray guides. The paper size match the size set on the tray.	Go to step 3.	Go to step 2.
Step 2 Change the paper size or adjust the size setting in the tray. The fault persists.	Go to step 3.	The problem is solved.
Step 3 Check if the paper size matches the size set on the tray guides. The paper size will match the size set on the tray.	Go to step 5.	Go to step 4.
Step 4 Replace the paper or change the paper size setting in the tray. The fault persists.	Go to step 5.	The problem is solved.
Step 5 Check the paper tray for overfilling. The paper tray is overfilled.	Go to step 6.	Go to step 7.
Step 6 Remove the excess paper from the tray. The fault persists.	Go to step 7.	The problem is solved.
Step 7 Check the paper condition in the tray. The paper is crumpled or damaged.	Go to step 8.	Go to step 9.
Step 8 Replace the crumpled or damaged paper. The fault persists.	Go to step 9.	The problem is solved.
Step 9 1 Enter the Diagnostics menu GP 1, and then navigate to:	Go to step 11.	Go to step 10.

Action	Yes	No
<p>Additional input trays adjustments/tests > Additional input tray sensors</p> <p>2 Find the sensor (Trailing edge (tray [x])).</p> <p>Note: [x] is the tray number.</p> <p>The sensor status will change while toggling the sensor.</p>		
<p>Step 10</p> <p>1 Ensure that the sensor cable is properly connected.</p> <p>2 Ensure that the sensor is properly installed.</p> <p>3 Check the sensor for damage.</p> <p>The sensor is free of damage.</p>	Go to step 11.	Go to step 13.
<p>Step 11</p> <p>1 Enter the Diagnostics menu GP 1, and then navigate to:</p> <p>Additional input trays adjustments/tests > Additional input tray sensors</p> <p>2 Find the sensor (Pass-through (tray [x])).</p> <p>Note: [x] is the tray number.</p> <p>The sensor status will change while toggling the sensor.</p>	Go to step 14.	Go to step 12.
<p>Step 12</p> <p>1 Ensure that the sensor cable is properly connected.</p> <p>2 Ensure that the sensor is properly installed.</p> <p>3 Check the sensor and the other optional tray components for damage.</p> <p>The sensor is free of damage.</p>	Go to step 14.	Go to step 13.
<p>Step 13</p> <p>Install a new 550 sheet optional tray, PL 25.05 item 10.</p> <p>The fault persists.</p>	Go to step 14.	The problem is solved.
<p>Step 14</p> <p>Perform a print test.</p> <p>The fault persists.</p>	Contact the next level of support.	The problem is solved.

374-343-00, 375-345-00 Late Arriving Jam RAP

WD2 Drive PWB Wiring Diagram

C625 Wiring Diagrams

374-343-00 Late Arriving Jam (Paper reached sensor, but outside of time window)-Option declared jam, or warm up jam with no known page source - RAP

375-345-00 Late Arriving Jam (Paper reached sensor, but outside of time window)-Option declared jam, or warm up jam with no known page source - RAP

Procedure



WARNING: Switch off the electricity to the machine, GP 10 . Disconnect the power lead from the customer supply while performing tasks that do not need electricity. Electricity can cause the death or injury. Moving components can cause the injury.

Action	Yes	No
<p>Step 1</p> <p>1 From the home screen, touch Settings > Device > Preferences.</p> <p>2 Check if the paper size matches the size set on the tray guides.</p> <p>The paper size will match the size set on the tray.</p>	Go to step 3.	Go to step 2.
<p>Step 2</p> <p>Change the paper size or adjust the size setting in the tray.</p> <p>The fault persists.</p>	Go to step 3.	The problem is solved.
<p>Step 3</p> <p>Check if the paper size matches the size set on the tray guides.</p> <p>The paper size will match the size set on the tray.</p>	Go to step 5.	Go to step 4.
<p>Step 4</p> <p>Insert a new paper or change the paper size setting in the tray.</p> <p>The fault persists.</p>	Go to step 5.	The problem is solved.
<p>Step 5</p> <p>Check the primary paper path for paper jams and obstructions.</p> <p>The paper path is free of jams and obstructions.</p>	Go to step 7.	Go to step 6.
<p>Step 6</p>	Go to step 7.	The problem is solved.

Action	Yes	No
Remove the paper jams and obstructions. The fault persists.		
Step 7 1 Enter the Diagnostics menu GP 1 , and then navigate to: Additional input trays adjustments/tests >Additional input tray sensors 2 Find the sensor (Trailing edge (tray [x])). Note: [x] is the tray number. The sensor status will change while toggling the sensor.	Go to step 9.	Go to step 8.
Step 8 1 Ensure that the sensor cable is properly connected. 2 Ensure that the sensor is properly installed. 3 Check the sensor and the other optional tray components for damage. The sensor is free of damage.	Go to step 9.	Go to step 13.
Step 9 1 Enter the Diagnostics menu GP 1 , and then navigate to: Additional input trays adjustments/tests >Additional input tray sensors 2 Find the sensor (Pass-through (tray [x])). Note: [x] is the tray number. The sensor status will change while toggling the sensor.	Go to step 11.	Go to step 10.
Step 10 1 Ensure that the sensor cable is properly connected. 2 Ensure that the sensor is properly installed. 3 Check the sensor and the other optional tray components for damage.	Go to step 11.	Go to step 11.

Action	Yes	No
The sensor and the optional tray are free of damage.		
Step 11 1 Enter the Diagnostics menu GP 1 , and then navigate to: Additional input trays adjustments/tests >Additional input tray motors 2 Select Pass-through (tray [x]) , and then touch Start . Note: [x] is the tray number. The motor will run.	Go to step 14.	Go to step 12.
Step 12 1 Ensure that the motor cable is properly connected. 2 Ensure that the motor is properly installed. 3 Check the motor and the other optional tray components for damage. The motor and the optional tray are free of damage.	Go to step 14.	Go to step 13.
Step 13 Install a new optional tray. See PL 70.15 item 1 The fault persists.	Go to step 14.	The problem is solved.
Step 14 1 Enter the Diagnostics menu GP 1 , and then navigate to: Printer diagnostics & adjustments >Motor tests 2 Select Duplex/MPF , and then touch Start . The motor will run.	Go to step 17.	Go to step 15.
Step 15 Reseat the motor cable, and then check the motor for misalignment and damage. The motor is properly installed and free of damage.	Go to step 17.	Go to step 16.

Action	Yes	No
Step 16 Install a new motor. See PL 80.05 item 6 The fault persists.	Go to step 17.	The problem is solved.
Step 17 Perform a print test. The fault persists.	Contact the next level of support.	The problem is solved.

374-951-00 Change Tray 4 To Different Media (Orientation Supported) RAP

374-951-00 Change tray 4 to different media (orientation supported) RAP



WARNING: Switch off the electricity to the machine, GP 10. Disconnect the power lead from the customer supply while performing tasks that do not need electricity. Electricity can cause the death or injury. Moving components can cause the injury.

Switch OFF, then switch ON the machine, GP 10. If the fault persists, contact 2nd Level Support.

**372-010-00 to 372-012-00, 373-010-00 to 373-012-00,
374-010-00 to 374-012-00, 375-010-00 to 375-012-00
TRAY 2, 3, 4, 5 Invalid Product ID, Board ID, Option Type Error
RAP**

WD2 Drive PWB Wiring Diagram

C625 Wiring Diagrams

372-010-00 Tray 2 Invalid Product ID RAP

372-011-00 Tray 2 Invalid Board ID RAP

372-012-00 Tray 2 Invalid Option Type RAP

373-010-00 Tray 3 Invalid Product ID RAP

373-011-00 Tray 3 Invalid Board ID RAP

373-012-00 Tray 3 Invalid Option Type RAP

374-010-00 Tray 4 Invalid Product ID RAP

374-011-00 Tray 4 Invalid Board ID RAP

374-012-00 Tray 4 Invalid Option Type RAP

375-010-00 Tray 5 Invalid Product ID RAP

375-011-00 Tray 5 Invalid Board ID RAP

375-012-00 Tray 5 Invalid Option Type RAP

Procedure



WARNING: Switch off the electricity to the machine, GP 10 . Disconnect the power lead from the customer supply while performing tasks that do not need electricity. Electricity can cause the death or injury. Moving components can cause the injury.

Action	Yes	No
Step 1 1 Ensure that the latest firmware is installed. 2 Ensure that the options configuration is supported. See the Printer, Option, and Stand Compatibility Guide. 3 Restart the printer. The fault persists.	Go to step 2.	The problem is solved.
Step 2 Reinstall the optional tray. The fault persists.	Go to step 3.	The problem is solved.

Action	Yes	No
Step 3 Install a new optional tray. See PL 70.15 item 1 . The fault persists.	Go to step 4 .	The problem is solved.
Step 4 Restart the printer. The fault persists.	Contact the next level of support.	The problem is solved.

371-107-00 to 371-108-00, 372-151-00 to 372-152-00, 373-153-00 to 373-154-00, 374-100-01, 374-950-00, 375-100-01, 375-950-00, 375-951-00, 376-104-00 to 376-105-00, 377-950-00, 377-951-00 Load tray 1,2,3,4,5 with media Error RAPs

WD2 Drive PWB Wiring Diagram

C625 Wiring Diagrams

371-107-00 IRLoad: Load tray 1 with media (orientation not supported) RAP

371-108-00 IRLoad: Load tray 1 with media (orientation supported) RAP

372-151-00 IRLoad: Load tray 2 with media (orientation not supported) RAP

372-152-00 IRLoad: Load tray 2 with media (orientation supported) RA

373-153-00 IRLoad: Load tray 3 with media (orientation not supported) RAP

373-154-00 IRLoad: Load tray 3 with media (orientation supported) RAP

374-100-01 Change tray 4 to different media (orientation supported) RAP

374-950-00 IRChange: Load tray 4 to different media (orientation not supported) RAP

375-100-01 Change tray 5 to different media (orientation supported) RAP

375-950-00 Change tray 5 to different media (orientation not supported) RAP

375-951-00 IRChange: Load tray 5 to different media (orientation not supported) RAP

377-950-00 Change MP feeder to different media (orientation not supported) RAP

377-951-00 Change MP feeder to different media (orientation supported) RAP



WARNING: Switch off the electricity to the machine, [GP 10](#). Disconnect the power lead from the customer supply while performing tasks that do not need electricity. Electricity can cause the death or injury. Moving components can cause the injury.

Procedure

Action	Yes	No
Step 1 1 From the Home screen, touch Settings > Device > Preferences . 2 Check if the paper size matches the size set on the tray guides. The paper size will match the size set on the tray.	Go to step 3.	Go to step 2.
Step 2 Change the paper size or adjust the size setting in the tray. The fault persists.	Go to step 3.	The problem is solved.

Action	Yes	No
Step 3 Check the drive PWB and its pins for damage. The drive PWB is free of damage.	Contact the next level of support.	Go to step 4.
Step 4 Install a new drive PWB, PL 1.10 item 3. The fault persists.	Contact the next level of support.	The problem is solved.

372-102-00, 372-108-00, 372-142-00, 372-144-00, 372-223-00, 372-331-00, 372-334-00, 372-902-00, 373-102-00, 373-142-00, 373-144-00, 373-330-00, 373-333-00, 373-339-00, 373-900-00, 374-142-00, 374-143-00, 374-334-00, 374-335-00, 374-339-00, 375-142-00, 375-242-00, 375-334-00, 375-335-00, 375-339-00, 377-149-00, 377-274-00, 377-279-00
Early Arriving Jam And Static Jam RAP

WD2 Drive PWB Wiring Diagram

C625 Wiring Diagrams

- 372-102-00 Tray 2 EARLY ARRIVING JAM (Paper reaches the sensor too soon, or unexpected) RAP
- 372-108-00 Tray 3 EARLY ARRIVING JAM (Paper reaches the sensor too soon, or unexpected) RAP
- 372-142-00 STATIC JAM. Option declared jam, or warm up jam with no known page source - RAP
- 372-144-00 EARLY ARRIVING JAM. Option declared jam, or warm up jam with no known page source - RAP
- 372-223-00 Tray 2 STATIC JAM (Paper at sensor at start, cover closed or idle - Jam not cleared) RAP
- 372-331-00 Tray 4 EARLY ARRIVING JAM (Paper reaches the sensor too soon, or unexpected) RAP
- 372-334-00 Tray 5 EARLY ARRIVING JAM (Paper reaches the sensor too soon, or unexpected) RAP
- 372-902-00 Tray 3 STATIC JAM (Paper at sensor at start, cover closed or idle - Jam not cleared) RAP
- 373-102-00 Tray 3 early jam RAP
- 373-142-00 STATIC JAM. Option declared jam, or warm up jam with no known page source RAP
- 373-144-00 EARLY ARRIVING JAM. Option declared jam, or warm up jam with no known page source - RAP
- 373-330-00 Tray 4 EARLY ARRIVING JAM (Paper reaches the sensor too soon, or unexpected) RAP
- 373-333-00 Tray 5 STATIC JAM (Paper at sensor at start, cover closed or idle - Jam not cleared) RAP
- 373-339-00 Tray 5 EARLY ARRIVING JAM (Paper reaches the sensor too soon, or unexpected) RAP
- 373-900-00 Tray 3 static jam RAP
- 374-142-00 Tray 4 STATIC JAM (Paper at sensor at start, cover closed or idle - Jam not cleared) RAP
- 374-143-00 Tray 4 STATIC JAM (Paper at sensor at start, cover closed or idle - Jam not cleared) RAP
- 374-334-00 Tray 4 STATIC JAM (Paper at sensor at start, cover closed or idle - Jam not cleared) RAP
- 374-335-00 Tray 4 EARLY ARRIVING JAM (Paper reaches the sensor too soon, or unexpected) RAP
- 374-339-00 Tray 5 EARLY ARRIVING JAM (Paper reaches the sensor too soon, or unexpected) RAP
- 375-142-00 Tray 5 STATIC JAM (Paper at sensor at start, cover closed or idle - Jam not cleared) RAP
- 375-242-00 Tray 5 STATIC JAM (Paper at sensor at start, cover closed or idle - Jam not cleared) RAP
- 375-334-00 Tray 5 STATIC JAM (Paper at sensor at start, cover closed or idle - Jam not cleared) RAP

375-335-00 Tray 5 EARLY ARRIVING JAM (Paper reaches the sensor too soon, or unexpected) RAP

375-339-00 EARLY ARRIVING JAM. Option declared jam, or warm up jam with no known page source RAP

377-149-00 STATIC JAM. Option declared jam, or warm up jam with no known page source RAP

377-274-00 EARLY ARRIVING JAM. Option declared jam, or warm up jam with no known page source RAP

377-279-00 STATIC JAM. Option declared jam, or warm up jam with no known page source RAP

Procedure



WARNING: Switch off the electricity to the machine, GP 10. Disconnect the power lead from the customer supply while performing tasks that do not need electricity. Electricity can cause the death or injury. Moving components can cause the injury.

Action	Yes	No
<p>Step 1</p> <p>1 From the Home screen, touch Settings >Device > Preferences.</p> <p>2 Check if the paper size matches the size set on the tray guides. The paper size will match the size set on the tray.</p>	Go to step 3.	Go to step 2.
<p>Step 2</p> <p>Change the paper size or adjust the size setting in the tray. The fault persists.</p>	Go to step 3.	The problem is solved.
<p>Step 3</p> <p>Check the paper path for partially fed or jammed paper. The paper path is free of partially fed or jammed paper.</p>	Go to step 5.	Go to step 4.
<p>Step 4</p> <p>Remove the partially fed or jammed paper. The fault persists.</p>	Go to step 5.	The problem is solved.
<p>Step 5</p> <p>1 Enter the Diagnostics menu GP 1, and then navigate to: Additional input trays adjustments/tests >Additional input tray sensors</p> <p>2 Find the sensor (Trailing edge (tray [x])).</p>	Go to step 7.	Go to step 6.

Action	Yes	No
<p>Note: [x] is the tray number. The sensor status will change while toggling the sensor.</p>		
<p>Step 6</p> <p>1 Ensure that the sensor cable is properly connected.</p> <p>2 Ensure that the sensor is properly installed.</p> <p>3 Check the sensor for damage. The sensor is free of damage.</p>	Go to step 7.	Go to step 9.
<p>Step 7</p> <p>1 Enter the Diagnostics menu GP 1, and then navigate to: Additional input trays adjustments/tests >Additional input tray sensors</p> <p>2 Find the sensor (Pass-through (tray [x])).</p> <p>Note: [x] is the tray number. The sensor status will change while toggling the sensor.</p>	Go to step 10.	Go to step 8.
<p>Step 8</p> <p>1 Ensure that the sensor cable is properly connected.</p> <p>2 Ensure that the sensor is properly installed.</p> <p>3 Check the sensor and the other optional tray components for damage. The sensor is free of damage.</p>	Go to step 10.	Go to step 9.
<p>Step 9</p> <p>Install a new 550-sheet optional tray, PL 25.05 item 1. The fault persists.</p>	Go to step 10.	The problem is solved.
<p>Step 10</p> <p>Perform a print test. The fault persists.</p>	Contact the next level of support.	The problem is solved.

372-300-00, 372-302-00, 372-304-00, 372-306-00, 372-308-00, 372-310-00, 372-312-00, 373-300-00, 373-302-00, 373-304-00, 373-306-00, 373-308-00, 373-310-00, 373-312-00, 374-225-00 to 374-231-00, 375-225-00 to 375-231-00 Tray 2, 3, 4, 5 Transport Motor Error RAP

WD2 Drive PWB Wiring Diagram

C625 Wiring Diagrams

- 372-300-00 Tray 2 transport Motor On Fail RAP
- 372-302-00 Tray 2 transport Motor Off Fail RAP
- 372-304-00 Tray 2 transport Motor Speed Fail RAP
- 372-306-00 Tray 2 transport Motor loss of encoders (motor stall) RAP
- 372-308-00 Tray 2 transport Motor under speed RAP
- 372-310-00 Tray 2 transport Motor over speed RAP
- 372-312-00 Tray 2 transport Motor moved too long RAP
- 373-300-00 Tray 3 transport Motor On Fail RAP
- 373-302-00 Tray 3 transport Motor Off Fail RAP
- 373-304-00 Tray 3 transport Motor Speed Fail RAP
- 373-306-00 Tray 3 transport Motor loss of encoders (motor stall) RAP
- 373-308-00 Tray 3 transport Motor under speed RAP
- 373-310-00 Tray 3 transport Motor over speed RAP
- 373-312-00 Tray 3 transport Motor moved too long RAP
- 374-225-00 Tray 4 transport Motor does not turn on RAP
- 374-226-00 Tray 4 transport Motor does not turn off RAP
- 374-227-00 Tray 4 transport Motor failed to achieve expected speed RAP
- 374-228-00 Tray 4 transport Motor loss of encoders (motor stall) RAP
- 374-229-00 Tray 4 transport Motor under speed RAP
- 374-230-00 Tray 4 transport Motor over speed RAP
- 374-231-00 Tray 4 transport Motor moved too long RAP
- 375-225-00 Tray 5 transport Motor does not turn on RAP
- 375-226-00 Tray 5 transport Motor does not turn off RAP
- 375-227-00 Tray 5 transport Motor failed to achieve expected speed RAP
- 375-228-00 Tray 5 transport Motor loss of encoders (motor stall) RAP

- 375-229-00 Tray 5 transport Motor under speed RAP
- 375-230-00 Tray 5 transport Motor over speed RAP
- 375-231-00 Tray 5 transport Motor moved too long RAP

Procedure



WARNING: Switch off the electricity to the machine, GP 10 . Disconnect the power lead from the customer supply while performing tasks that do not need electricity. Electricity can cause the death or injury. Moving components can cause the injury.

Action	Yes	No
Step 1 Restart the printer The fault persists.	Go to step 2.	The problem is solved.
Step 2 Ensure that the motor cable is properly connected. The fault persists.	Go to step 3.	The problem is solved.
Step 3 Restart the printer. The fault persists.	Go to step 4.	The problem is solved.
Step 4 Install a new optional tray. See PL 70.15 item 1. The fault persists.	Contact the next level of support.	The problem is solved.

372-210-00, 372-212-00, 372-214-00, 372-216-00, 372-218-00, 372-220-00, 372-222-00, 373-210-00, 373-212-00, 373-214-00, 373-216-00, 373-218-00, 373-220-00, 373-222-00, 374-218-00 to 374-224-00, 375-232-00 to 375-238-00 Motor (Tray 2, 3, 4, 5 Pick/Lift) Error RAP

WD2 Drive PWB Wiring Diagram

C625 Wiring Diagrams

372-210-00 Tray 2 Lift ON Fail RAP

372-212-00 Tray 2 Lift Off Fail RAP

372-214-00 Tray 2 Pick Motor failed to achieve expected speed RAP

372-216-00 Tray 2 Pick Motor loss of encoders (motor stall) RAP

372-218-00 Tray 2 pick Motor under speed RAP

372-220-00 Tray 2 Pick Motor over speed RAP

372-222-00 Tray 2 pick Motor moved too long RAP

373-210-00 Tray 3 Lift On Fail RAP

373-212-00 Tray 3 Off Fail RAP

373-214-00 Tray 3 Pick Motor failed to achieve expected speed RAP

373-216-00 Tray 3 pick Motor loss of encoders (motor stall) RAP

373-218-00 Tray 3 pick Motor under speed RAP

373-220-00 Tray 3 Pick Motor over speed RAP

373-222-00 Tray 3 Pick Motor moved too long RAP

374-218-00 Tray 4 Pick Motor does not turn on RAP

374-219-00 Tray 4 pick Motor does not turn off RAP

374-220-00 Tray 4 pick Motor failed to achieve expected speed RAP

374-221-00 Tray 4 Pick Motor loss of encoders (motor stall) RAP

374-222-00 Tray 4 pick Motor under speed RAP

374-223-00 Tray 4 pick Motor over speed RAP

374-224-00 Tray 4 Pick Motor moved too long RAP

375-232-00 Tray 5 Motor does not turn on RAP

375-233-00 Tray 5 Motor does not turn off RAP

375-234-00 Tray 5 Motor failed to achieve expected speed RAP

375-235-00 Tray 5 Motor loss of encoders (motor stall) RAP

375-236-00 Tray 5 Motor under speed RAP

375-237-00 Tray 5 Motor over speed RAP

375-238-00 Tray 5 Motor moved too long RAP

Procedure



WARNING: Switch off the electricity to the machine, GP 10 . Disconnect the power lead from the customer supply while performing tasks that do not need electricity. Electricity can cause the death or injury. Moving components can cause the injury.

Action	Yes	No
Step 1 Check the pick roller for misalignment and damage. The pick roller is properly installed and free of damage.	Go to step 3.	Go to step 2.
Step 2 Ensure that the motor cable is properly connected. The fault persists.	Go to step 3.	The problem is solved.
Step 3 Restart the printer. The fault persists.	Go to step 4.	The problem is solved.
Step 4 Install a new optional tray. See PL 70.15 item 1. The fault persists.	Contact the next level of support.	The problem is solved.

373-146-00, 373-328-00, 374-147-00, 375-239-00 Never Arriving Jam From Normal Path Tray (3, 4, 5) RAP

WD2 Drive PWB Wiring Diagram

C625 Wiring Diagrams

373-146-00 Never Arriving Jam From Normal Path (Paper didn't reach the specified sensor, but did reach the previous sensor)-Option declared jam, or warm up jam with no known page source - RAP

373-328-00 Never Arriving Jam From Normal Path (Paper didn't reach the specified sensor, but did reach the previous sensor)-Source was tray 3 - RAP

374-147-00 Never Arriving Jam From Normal Path (Paper didn't reach the specified sensor, but did reach the previous sensor)-Source was tray 4 - RAP

375-239-00 Never Arriving Jam From Normal Path (Paper didn't reach the specified sensor, but did reach the previous sensor)-Source was tray 5 - RAP

Procedure



WARNING: Switch off the electricity to the machine, GP 10. Disconnect the power lead from the customer supply while performing tasks that do not need electricity. Electricity can cause the death or injury. Moving components can cause the injury.

Action	Yes	No
Step 1 1 From the Home screen, touch Settings > Device > Preferences . 2 Check if the paper size matches the size set on the tray guides. The paper size will match the size set on the tray.	Go to step 3.	Go to step 2.
Step 2 Change the paper size or adjust the size setting in the tray. The fault persists.	Go to step 3.	The problem is solved.
Step 3 Check if the paper size matches the size set on the tray guides. The paper size will match the size set on the tray.	Go to step 5.	Go to step 4.
Step 4 Insert new paper or change the paper size setting in the tray. The fault persists.	Go to step 5.	The problem is solved.
Step 5	Go to step 6.	Go to step 7.

Action	Yes	No
Check the paper tray for overfilling. The paper tray overfilled.		
Step 6 Remove the excess paper from the tray. The fault persists.	Go to step 7.	The problem is solved.
Step 7 Check the paper condition in the tray. The paper is crumpled or damaged.	Go to step 8.	Go to step 9.
Step 8 Check whether the crumpled or damaged paper is removed and insert new paper. The fault persists.	Go to step 9.	The problem is solved.
Step 9 Check the paper path for partially fed or jammed paper. The paper path is free of partially fed or jammed paper.	Go to step 11.	Go to step 10.
Step 10 Remove the partially fed or jammed paper. The fault persists.	Go to step 11.	The problem is solved.
Step 11 1 Enter the Diagnostics menu GP 1, and then navigate to: Additional input trays adjustments/tests > Additional input tray sensors 2 Find the sensor (Pass-through (tray 3)). The sensor status will change while toggling the sensor.	Go to step 13.	Go to step 12.
Step 12 1 Ensure that the sensor cable is properly connected. 2 Ensure that the sensor is properly installed. 3 Check the sensor and the other optional tray components for damage. The sensor is free of damage.	Go to step 13.	Go to step 15.

Action	Yes	No
<p>Step 13</p> <p>1 Enter the Diagnostics menu GP 1, and then navigate to:</p> <p>Additional input trays adjustments/tests > Additional input tray motors</p> <p>2 Select Pass-through (tray 3), and then touch Start. The motor will run.</p>	Go to step 16.	Go to step 14.
<p>Step 14</p> <p>1 Ensure that the motor cable is properly connected.</p> <p>2 Ensure that the motor is properly installed.</p> <p>3 Check the motor and the other optional tray components for damage. The motor and the optional tray are free of damage.</p>	Go to step 16.	Go to step 15.
<p>Step 15</p> <p>Install a new optional tray. See PL 70.15 item 1 The fault persists.</p>	Go to step 16.	The problem is solved.
<p>Step 16</p> <p>1 Enter the Diagnostics menu GP 1, and then navigate to:</p> <p>Additional input trays adjustments/tests > Additional input tray motors</p> <p>2 Select Pass-through (tray 4), and then touch Start. The motor will run.</p>	Go to step 19.	Go to step 17.
<p>Step 17</p> <p>1 Ensure that the motor cable is properly connected.</p> <p>2 Ensure that the motor is properly installed.</p> <p>3 Check the motor and the other optional tray components for damage. The motor and optional tray are free of damage.</p>	Go to step 19.	Go to step 18.

Action	Yes	No
<p>Step 18</p> <p>Install a new optional tray. See PL 70.15 item 1. The fault persists.</p>	Go to step 19.	The problem is solved.
<p>Step 19</p> <p>Perform a print test. The fault persists.</p>	Contact the next level of support.	The problem is solved.

372-105-00, 372-112-00, 372-148-00, 372-337-00, 373-105-00, 373-148-00, 374-112-00, 374-148-00, 374-338-00, 375-240-00, 375-244-00, 375-338-00, 375-342-00, 377-276-00 Late Leaving Jam Tray (3, 4, 5) RAP

WD2 Drive PWB Wiring Diagram

C625 Wiring Diagrams

372-105-00 Tray 2 Late jam RAP

372-112-00 Tray 3 Late Leaving Jam (Paper reaches sensor but clears it late-(Long media, double feed) RAP

372-148-00 Late Leaving Jam. Option declared jam, or warm up jam with no known page source RAP

372-337-00 Tray 5 Late Leaving Jam (Paper reaches sensor but clears it late-(Long media, double feed) RAP

373-105-00 Tray 3 Regi Senor On Jam RAP

373-148-00 Late Leaving Jam. Option declared jam, or warm up jam with no known page source RAP

374-112-00 Tray 4 Late Leaving Jam (Paper reaches sensor but clears it late-(Long media, double feed) RAP

374-148-00 Tray 4 Late Leaving Jam (Paper reaches sensor but clears it late-(Long media, double feed) RAP

374-338-00 Tray 4 Late Leaving Jam (Paper reaches sensor but clears it late-(Long media, double feed) RAP

375-240-00 Tray 5 Late Leaving Jam (Paper reaches sensor but clears it late-(Long media, double feed) RAP

375-244-00 Tray 5 Late Leaving Jam (Paper reaches sensor but clears it late-(Long media, double feed) RAP

375-338-00 Tray 5 Late Leaving Jam (Paper reaches sensor but clears it late-(Long media, double feed) RAP

375-342-00 Late Leaving Jam. Option declared jam, or warm up jam with no known page source RAP

377-276-00 Late Leaving Jam. Option declared jam, or warm up jam with no known page source RAP

Procedure



WARNING: Switch off the electricity to the machine, GP 10 . Disconnect the power lead from the customer supply while performing tasks that do not need electricity. Electricity can cause the death or injury. Moving components can cause the injury.

Action	Yes	No
Step 1 1 From the Home screen, touch Settings >Device > Preferences. 2 Check if the paper size matches the size set on the tray guides. The paper size will match the size set on the tray.	Go to step 3.	Go to step 2.
Step 2 Change the paper size or adjust the size setting in the tray. The fault persists.	Go to step 3.	The problem is solved.
Step 3 Check if the paper size matches the size set on the tray guides. The paper size will match the size set on the tray.	Go to step 5.	Go to step 4.
Step 4 Insert new paper or change the paper size setting in the tray. The fault persists.	Go to step 5.	The problem is solved.
Step 5 Check the primary paper path for paper jams and obstructions. The paper path is free of jams and obstructions.	Go to step 7.	Go to step 6.
Step 6 Remove the paper jams and obstructions. The fault persists.	Go to step 7.	The problem is solved.
Step 7 1 Enter the Diagnostics menu GP 1 , and then navigate to: Additional input trays adjustments/tests >Additional input tray sensors 2 Find the sensor (Trailing edge (tray [x])). Note: [x] is the tray number.	Go to step 9.	Go to step 8.

Action	Yes	No
The sensor status will change while toggling the sensor.		
Step 8 1 Ensure that the sensor cable is properly connected. 2 Ensure that the sensor is properly installed. 3 Check the sensor and the other optional tray components for damage. The sensor is free of damage.	Go to step 9.	Go to step 13.
Step 9 1 Enter the Diagnostics menu GP 1 , and then navigate to: Additional input trays adjustments/tests > Additional input tray sensors 2 Find the sensor (Pass-through (tray [x])). Note: [x] is the tray number. The sensor status will change while toggling the sensor.	Go to step 11.	Go to step 10.
Step 10 1 Ensure that the sensor cable is properly connected. 2 Ensure that the sensor is properly installed. 3 Check the sensor and the other optional tray components for damage. The sensor and the optional tray are free of damage.	Go to step 11.	Go to step 11.
Step 11 1 Enter the Diagnostics menu GP 1 , and then navigate to: Additional input trays adjustments/tests > Additional input tray motors 2 Select Pass-through (tray [x]) , and then touch Start . Note: [x] is the tray number.	Go to step 14.	Go to step 12.

Action	Yes	No
The motor will run.		
Step 12 1 Ensure that the motor cable is properly connected. 2 Ensure that the motor is properly installed. 3 Check the motor and the other optional tray components for damage. The motor and the optional tray are free of damage.	Go to step 14.	Go to step 13.
Step 13 Install a new optional tray. See PL 70.15 item 1 . The fault persists.	Go to step 14.	The problem is solved.
Step 14 1 Enter the Diagnostics menu GP 1 , and then navigate to: Printer diagnostics & adjustments > Motor tests 2 Select Duplex/MPF , and then touch Start . The motor will run.	Go to step 17.	Go to step 15.
Step 15 Reseat the motor cable, and then check the motor form is alignment and damage. The motor is properly installed and free of damage.	Go to step 17.	Go to step 16.
Step 16 Install a new motor. See PL 80.05 item 6 . The fault persists.	Go to step 17.	The problem is solved.
Step 17 Perform a print test. The fault persists.	Contact the next level of support.	The problem is solved.

374-336-00, 375-243-00, 375-336-00, 375-340-00, 377-275-00 Tray (4, 5) Never Arriving Jam From Normal Path Error RAPs

WD2 Drive PWB Wiring Diagram

C625 Wiring Diagrams

374-336-00 Tray 4 Never Arriving Jam From Normal Path RAP

375-243-00 Tray 5 Never Arriving Jam From Normal Path RAP

375-336-00 Tray 5 Never Arriving Jam From Normal Path RAP

375-340-00 Never Arriving Jam From Normal Path RAP. Option declared jam, or warm up jam with no known page source.

377-275-00 Never Arriving Jam From Normal Path RAP. Option declared jam, or warm up jam with no known page source.



WARNING: Switch off the electricity to the machine, GP 10. Disconnect the power lead from the customer supply while performing tasks that do not need electricity. Electricity can cause the death or injury. Moving components can cause the injury.

Procedure

Action	Yes	No
Step 1 1 From the Home screen, touch Settings >Device > Preferences . 2 Check if the paper size matches the size set on the tray guides. The paper size will match the size set on the tray.	Go to step 3.	Go to step 2.
Step 2 Change the paper size or adjust the size setting in the tray. The fault persists.	Go to step 3.	The problem is solved.
Step 3 Check if the paper size matches the size set on the tray guides. The paper size will match the size set on the tray.	Go to step 5.	Go to step 4.
Step 4 Install the new paper or change the paper size setting in the tray. The fault persists.	Go to step 5.	The problem is solved.
Step 5	Go to step 6.	Go to step 7.

Action	Yes	No
Check the paper tray for overfilling. The paper tray is overfilled.		
Step 6 Remove the excess paper from the tray. The fault persists.	Go to step 7.	The problem is solved.
Step 7 Check the paper condition in the tray. The paper is crumpled or damaged.	Go to step 8.	Go to step 9.
Step 8 Replace the crumpled or damaged paper. The fault persists.	Go to step 9.	The problem is solved.
Step 9 Check the paper path for partially fed or jammed paper. The paper path is free of partially fed or jammed paper.	Go to step 11.	Go to step 10.
Step 10 Remove the partially fed or jammed paper. The fault persists.	Go to step 11.	The problem is solved.
Step 11 1 Enter the Diagnostics menu GP 1, and then navigate to: Additional input trays adjustments/tests >Additional input tray sensors 2 Find the sensor (Pass-through (tray 4)). The sensor status will change while toggling the sensor.	Go to step 13.	Go to step 12.
Step 12 1 Ensure that the sensor cable is properly connected. 2 Ensure that the sensor is properly installed. 3 Check the sensor and the other optional tray components for damage. The sensor is free of damage.	Go to step 13.	Go to step 15.

Action	Yes	No
Step 13 1 Enter the Diagnostics menu GP 1 , and then navigate to: Additional input trays adjustments/tests >Additional input tray motors 2 Select Pass-through (tray 4) , and then touch Start . The motor will run.	Go to step 16.	Go to step 14.
Step 14 1 Ensure that the motor cable is properly connected. 2 Ensure that the motor is properly installed. 3 Check the motor and the other optional tray components for damage. The motor and the optional tray are free of damage.	Go to step 16.	Go to step 15.
Step 15 Install the new 550 optional tray. See PL 70.15 item 1 . The fault persists.	Go to step 16.	The problem is solved.
Step 16 1 Enter the Diagnostics menu GP 1 , and then navigate to: Additional input trays adjustments/tests >Additional input tray motors 2 Select Pass-through (tray 5) , and then touch Start . The motor will run.	Go to step 19.	Go to step 17.
Step 17 1 Ensure that the motor cable is properly connected. 2 Ensure that the motor is properly installed. 3 Check the motor and the other optional tray components for damage. The motor and optional tray is free of damage.	Go to step 19.	Go to step 18.

Action	Yes	No
Step 18 Install a new 550 sheet optional tray. See PL 70.15 item 1 . The fault persists.	Go to step 19.	The problem is solved.
Step 19 Perform a print test. The fault persists.	Contact the next level of support.	The problem is solved.

372-100-00, 372-150-00, 372-330-00, 372-333-00, 372-338-00, 373-100-00, 373-150-00, 373-332-00, 373-341-00, 374-150-00, 374-341-00, 375-246-00, 375-343-00, 377-277-00
Tray 2, 3, 4, 5 Fail To Pick Error RAP

WD2 Drive PWB Wiring Diagram

C625 Wiring Diagrams

372-100-00 Tray 2 Mis feed_ Empty RAP

372-150-00 Fail To Pick From Tray. Option declared jam, or warm up jam with unknown page RAP

372-330-00 Tray 3 Fail To Pick From Tray (Paper did not reach first sensor; Miss-feed, tray empty) RAP

372-333-00 Tray 4 Fail To Pick From Tray (Paper did not reach first sensor; Miss-feed, tray empty) RAP

372-338-00 Tray 5 Fail To Pick From Tray (Paper did not reach first sensor; Miss-feed, tray empty) RAP

373-100-00 Tray 3 Mis feed_ Empty RAP

373-150-00 Fail To Pick From Tray Option declared jam, or warm up jam with unknown page RAP

373-332-00 Tray 4 Fail To Pick From Tray RAP

373-341-00 Tray 5 Fail To Pick From Tray (Paper did not reach first sensor; Miss-feed, tray empty) RAP

374-150-00 Tray 4 Fail To Pick From Tray (Paper did not reach first sensor; Miss-feed, tray empty) RAP

374-341-00 Tray 5 Fail To Pick From Tray (Paper did not reach first sensor; Miss-feed, tray empty) RAP

375-246-00 Tray 5 Fail To Pick From Tray (Paper did not reach first sensor; Miss-feed, tray empty) RAP

375-343-00 Fail To Pick From Tray. Option declared jam, or warm up jam with unknown page RAP

377-277-00 Fail To Pick From Tray. Option declared jam, or warm up jam with unknown page RAP

Procedure



WARNING: Switch off the electricity to the machine, GP 10 . Disconnect the power lead from the customer supply while performing tasks that do not need electricity. Electricity can cause the death or injury. Moving components can cause the injury.

Action	Yes	No
Step 1 1 From the Home screen, touch Settings >Device > Preferences. 2 Check if the paper size matches the size set on the tray guides. The paper size will match the size set on the tray.	Go to step 3.	Go to step 2.
Step 2 Change the paper size or adjust the size setting in the tray. The fault persists.	Go to step 3.	The problem is solved.
Step 3 Check if the paper size matches the size set on the tray guides. The paper size will match the size set on the tray.	Go to step 5.	Go to step 4.
Step 4 Insert new paper or change the paper size setting in the tray. The fault persists.	Go to step 5.	The problem is solved.
Step 5 Check the paper tray for overfilling. The paper tray overfilled.	Go to step 6.	Go to step 7.
Step 6 Remove the excess paper from the tray. The fault persists.	Go to step 7.	The problem is solved.
Step 7 Check the paper condition in the tray. The paper crumpled or damaged.	Go to step 8.	Go to step 9.
Step 8 Check whether the crumbled or damaged paper is removed and insert new paper. The fault persists.	Go to step 9.	The problem is solved.
Step 9	Go to step 11.	Go to step 10.

Action	Yes	No
<p>1 Ensure that the optional tray pick roller is properly installed.</p> <p>Note: Firmly press the pick roller to its shaft to make sure that is properly engaged.</p> <p>2 Check the optional tray pick roller for excess wear, contamination, and damage.</p> <p>The optional tray pick roller is free from excess wear, contamination, and damage.</p>		
<p>Step 10 Install a new pick roller. See PL 70.10 item 7. The fault persists.</p>	Go to step 11.	The problem is solved.
<p>Step 11 Check the tray exit paper path for paper fragments and contamination. The paper path is free of paper fragments and contamination.</p>	Go to step 15.	Go to step 12.
<p>Step 12 Clean the paper path. The fault persists.</p>	Go to step 13.	The problem is solved.
<p>Step 13</p> <p>1 Enter the Diagnostics menu GP 1, and then navigate to: Additional input trays adjustments/tests > Additional input tray sensors</p> <p>2 Find the sensor (Trailing edge (tray [x])).</p> <p>Note: [x] is the tray number. The sensor status will change while toggling the sensor.</p>	Go to step 15.	Go to step 14.
<p>Step 14</p> <p>1 Ensure that the sensor cable is properly connected.</p> <p>2 Ensure that the sensor is properly installed.</p>	Go to step 15.	Go to step 17.

Action	Yes	No
<p>3 Check the sensor and the other optional tray components for damage. The sensor and optional tray are free of damage.</p>		
<p>Step 15</p> <p>1 Enter the Diagnostics menu, GP 1 and then navigate to: Additional input tray diagnostics > Motor tests</p> <p>2 Select Pick (tray [x]), and then touch Start. The motor will run.</p>	Go to step 18.	Go to step 16.
<p>Step 16</p> <p>1 Ensure that the motor cable is properly connected.</p> <p>2 Ensure that the motor is properly installed.</p> <p>3 Check the motor and the other optional tray components for damage. The motor and the optional tray are free of damage.</p>	Go to step 18.	Go to step 17.
<p>Step 17 Install a new optional tray. See PL 70.15 item 1. The fault persists.</p>	Go to step 18.	The problem is solved.
<p>Step 18 Perform a print test. The fault persists.</p>	Contact the next level of support.	The problem is solved.

372-114-00, 372-116-00, 372-118-00, 372-120-00, 372-122-00, 372-124-00, 372-126-00, 373-116-00, 373-118-00, 373-120-00, 373-122-00, 373-124-00, 373-126-00, 373-321-00, 374-114-00, 374-116-00, 374-118-00, 374-120-00, 374-122-00, 374-124-00, 374-126-00, 375-247-00 to 375-249-00, 375-251-00 to 375-253-00, 375-560-00 Tray 2, 3, 4, 5 Transport (550) or Lift (HCIT) Motor Error RAP

WD2 Drive PWB Wiring Diagram

C625 Wiring Diagrams

- 372-114-00 Tray 2 Transport (550) or lift (HCIT) Motor does not turn on RAP
- 372-116-00 Tray 2 Transport (550) or lift (HCIT) Motor does not turn off RAP
- 372-118-00 Tray 2 Transport (550) or lift (HCIT) Motor failed to achieve expected speed RAP
- 372-120-00 Tray 2 Transport (550) or lift (HCIT) Motor loss of encoders (motor stall) RAP
- 372-122-00 Tray 2 Transport (550) or lift (HCIT) Motor under speed RAP
- 372-124-00 Tray 2 Transport (550) or lift (HCIT) Motor overs peed RAP
- 372-126-00 Tray 2 Transport (550) or lift (HCIT) Motor moved too long RAP
- 373-116-00 Tray 3 Transport (550) or lift (HCIT) Motor does not turn off RAP
- 373-118-00 Tray 3 Transport (550) or lift (HCIT) Motor failed to achieve expected speed RAP
- 373-120-00 Tray 3 Transport (550) or lift (HCIT) Motor loss of encoders (motor stall) RAP
- 373-122-00 Tray 3 Transport (550) or lift (HCIT) Motor under speed RAP
- 373-124-00 Tray 3 Transport (550) or lift (HCIT) Motor over speed RAP
- 373-126-00 Tray 3 Transport (550) or lift (HCIT) Motor moved too long RAP
- 373-321-00 Tray 3 Transport (550) or lift (HCIT) Motor does not turn on RAP
- 374-114-00 -70 = Tray 4 Transport (550) or lift (HCIT) Motor does not turn on RAP
- 374-116-00 -71 = Tray 4 Transport (550) or lift (HCIT) Motor does not turn off RAP
- 374-118-00 -72 = Tray 4 Transport (550) or lift (HCIT) Motor failed to achieve expected speed RAP
- 374-120-00 -73 = Tray 4 Transport (550) or lift (HCIT) Motor loss of encoders (motor stall) RAP
- 374-122-00 -74 = Tray 4 Transport (550) or lift (HCIT) Motor under speed RAP
- 374-124-00 -75 = Tray 4 Transport (550) or lift (HCIT) Motor over speed RAP
- 374-126-00 -76 = Tray 4 Transport (550) or lift (HCIT) Motor moved too long RAP
- 375-247-00 Tray 5 Transport (550) or lift (HCIT) Motor does not turn on RAP
- 375-248-00 Tray 5 Transport (550) or lift (HCIT) Motor does not turn off RAP
- 375-249-00 Tray 5 Transport (550) or lift (HCIT) Motor failed to achieve expected speed RAP

- 375-251-00 Tray 5 Transport (550) or lift (HCIT) Motor under speed RAP
- 375-252-00 Tray 5 Transport (550) or lift (HCIT) Motor over speed RAP
- 375-253-00 Tray 5 Transport (550) or lift (HCIT) Motor moved too long RAP
- 375-560-00 Tray 5 Transport (550) or lift (HCIT) Motor loss of encoders (motor stall) RAP

Procedure



WARNING: Switch off the electricity to the machine, GP 10 . Disconnect the power lead from the customer supply while performing tasks that do not need electricity. Electricity can cause the death or injury. Moving components can cause the injury.

Action	Yes	No
Step 1 Check the paper path and trays for paper fragments and partially fed paper. The paper path is free of paper fragments and partially fed paper.	Go to step 3.	Go to step 2.
Step 2 Remove the paper fragments and partially fed paper. The fault persists.	Go to step 3.	The problem is solved.
Step 3 Ensure that all the trays and tray inserts are properly installed. The fault persists.	Go to step 4.	The problem is solved.
Step 4 Enter the Diagnostics menu GP 1, and then navigate to: Input tray quick print >select source tray > Single The fault persists.	Go to step 5.	The problem is solved.
Step 5 1 Enter the Diagnostics menu GP 1, and then navigate to: Additional input tray adjustments/tests >Additional input tray motors 2 Select Pass-through (tray [x]) , and then touch Start . Note: [x] is the tray number. The motor will run.	Go to step 7.	Go to step 6.
Step 6	Go to step 7.	The problem is solved.

Action	Yes	No
Reseat the cable on the motor and on the optional tray controller board. The fault persists.		
Step 7 Remove the source tray insert, and then check if the following components are functional and free of damage: <ul style="list-style-type: none"> • Paper guides • Lift plate • <p>Note: Move the components or turn gears to check for proper mechanisms.</p> The tray insert and its components are functional and free of damage.	Go to step 9.	Go to step 8.
Step 8 Install a new tray insert. PL 70.10 item 4 The fault persists.	Go to step 9.	The problem is solved.
Step 9 Ensure that the controller board of the affected tray is properly installed. Reseat all the cables on the controller board. The fault persists.	Go to step 10.	The problem is solved.
Step 10 Check the affected tray controller board and its connector pins for damage. The tray controller board and its connectors are free of damage.	Contact the next level of support.	The problem is solved.
Step 11 Install a new optional tray. See PL 70.15 item 1 The fault persists.	Contact the next level of support.	The problem is solved.

372-128-00, 372-130-00, 372-132-00, 372-134-00, 372-138-00, 372-140-00, 372-321-00, 373-128-00, 373-130-00, 373-132-00, 373-134-00, 373-136-00, 373-138-00, 373-140-00, 374-128-00, 374-130-00, 374-132-00, 374-134-00, 374-136-00, 374-138-00, 374-140-00, 375-254-00 to 375-259-00, 375-250-00 Tray 2, 3, 4, 5 Motor Error RAP

WD2 Drive PWB Wiring Diagram

C625 Wiring Diagrams

- 372-128-00 Tray 2 Motor does not turn on RAP
- 372-130-00 Tray 2 Motor does not turn off RAP
- 372-132-00 Tray 2 Motor failed to achieve expected speed RAP
- 372-134-00 Tray 2 Motor loss of encoders (motor stall) RAP
- 372-138-00 Tray 2 Motor over speed RAP
- 372-140-00 Tray 2 Motor moved too long RAP
- 372-321-00 Tray 2 Motor under speed RAP
- 373-128-00 Tray 3 Motor does not turn on RAP
- 373-130-00 Tray 3 Motor does not turn off RAP
- 373-132-00 Tray 3 Motor failed to achieve expected speed RAP
- 373-134-00 Tray 3 Motor loss of encoders (motor stall) RAP
- 373-136-00 Tray 3 Motor under speed RAP
- 373-138-00 Tray 3 Motor over speed RAP
- 373-140-00 Tray 3 Motor moved too long RAP
- 374-128-00-80 = Tray 4 Motor does not turn on RAP
- 374-130-00-81 = Tray 4 Motor does not turn off RAP
- 374-132-00-82 = Tray 4 Motor failed to achieve expected speed RAP
- 374-134-00-83 = Tray 4 Motor loss of encoders (motor stall) RAP
- 374-136-00-84 = Tray 4 Motor under speed RAP
- 374-138-00-85 = Tray 4 Motor over speed RAP
- 374-140-00-86 = Tray 4 Motor moved too long RAP
- 375-254-00 Tray 5 Pick Motor does not turn on RAP
- 375-255-00 Tray 5 Pick Motor does not turn off RAP
- 375-256-00 Tray 5 Pick Motor failed to achieve expected speed RAP
- 375-257-00 Tray 5 Pick Motor loss of encoders (motor stall) RAP

375-258-00 Tray 5 Pick Motor under speed RAP

375-259-00 Tray 5 Pick Motor over speed RAP

375-250-00 Tray 5 Pick Motor moved to long RAP

Procedure



WARNING: Switch off the electricity to the machine, GP 10 . Disconnect the power lead from the customer supply while performing tasks that do not need electricity. Electricity can cause the death or injury. Moving components can cause the injury.

Action	Yes	No
Step 1 Check the paper path and trays for paper fragments and partially fed paper. The paper is path free of paper fragments and partially fed paper.	Go to step 3.	Go to step 2.
Step 2 Remove the paper fragments and partially fed paper. The fault persists.	Go to step 3.	The problem is solved.
Step 3 Ensure that all the trays and tray inserts are properly installed. The fault persists.	Go to step 4.	The problem is solved.
Step 4 Enter the Diagnostics menu GP 1, and then navigate to: Input tray quick print >select source tray > Single The fault persists.	Go to step 5.	The problem is solved.
Step 5 1 Enter the Diagnostics menu GP 1, and then navigate to: Additional input tray diagnostics >Motor tests 2 Select Pick (tray [x]) , and then touch Start . Note: [x] is the tray number. The motor will run.	Go to step 7.	Go to step 6.
Step 6 Reseat the cable on the motor and on the optional tray controller board. The fault persists.	Go to step 7.	The problem is solved.

Action	Yes	No
Step 7 Check the source tray controller board and its connector pins for damage. The tray controller board and its connectors free of damage.	Contact the next level of support.	The problem is solved.
Step 8 Install a new optional tray. See PL 70.15 item 1 The fault persists.	Contact the next level of support.	The problem is solved.

371-339-00, 372-305-00, 373-305-00, 374-305-00, 375-305-00 Tray 1, 2, 3, 4, 5 S1/Input Sensor Cleared Error RAP

C625 Wiring Diagrams

WD2 Drive PWB Wiring Diagram

371-339-00 Tray 1 Bump exit sensor cleared by page too soon RAP

372-305-00 Tray 2 S1/Input sensor cleared by page too soon RAP

373-305-00 Tray 3 S1/Input sensor cleared by page too soon RAP

374-305-00 Tray 4 S1/Input sensor cleared by page too soon RAP

375-305-00 Tray 5 S1/Input sensor cleared by page too soon RAP

Procedure



WARNING: Switch off the electricity to the machine, GP 10. Disconnect the power lead from the customer supply while performing tasks that do not need electricity. Electricity can cause the death or injury. Moving components can cause the injury.

Action	Yes	No
Step 1 1 From the Home screen, touch Settings >Device > Preferences . 2 Check if the paper size matches the size set on the tray guides. The paper size will match the size set on the tray.	Go to step 3.	Go to step 2.
Step 2 Change the paper size or adjust the size setting in the tray. The fault persists.	Go to step 3.	The problem is solved.
Step 3 Check the tray for overfilling. The tray is overfilled.	Go to step 4.	Go to step 5.
Step 4 Remove the excess paper from the tray. The fault persists.	Go to step 5.	The problem is solved.
Step 5 Check the paper condition in the tray. The paper is crumpled or damaged?	Go to step 6.	Go to step 7.
Step 6	Go to step 7.	The problem is solved.

Action	Yes	No
Install a new crumpled or damaged paper. The fault persists.		
Step 7 1 Enter the Diagnostics menu, GP 1 and then navigate to: Printer diagnostics & adjustments> Sensor tests 2 Find the sensor (Input). The sensor status will change while toggling the sensor.	Go to step 9.	The problem is solved.
Step 8 1 Ensure that the sensor cable is properly connected. 2 Check the sensor for damage. The sensor is free of damage.	Go to step 9.	Go to step 9.
Step 9 Install a new sensor. See PL 80.05 item 7. The fault persists.	Go to step 10.	The problem is solved.
Step 10 Perform a print job. The fault persists.	Contact the next level of support.	The problem is solved.

371-308-00, 371-316-00, 371-322-00, 374-300-00, 375-306-00S1/Input Sensor Covered Error RAP

371-308-00 Tray 1 Bump exit sensor covered too soon RAP

371-316-00 Tray 2 S1/Input sensor covered too soon RAP

371-322-00 Tray 3 S1/Input sensor covered too soon RAP

374-300-00 Tray 4 S1/Input sensor covered too soon RAP

375-306-00 Tray 5 S1/Input sensor covered too soon RAP

Procedure



WARNING: Switch off the electricity to the machine, GP 10 . Disconnect the power lead from the customer supply while performing tasks that do not need electricity. Electricity can cause the death or injury. Moving components can cause the injury.

Action	Yes	No
Step 1 1 From the Home screen, touch Settings >Device > Preferences . 2 Check if the paper size matches the size set on the tray guides. The paper size will match the size set on the tray.	Go to step 3.	Go to step 2.
Step 2 Change the paper size or adjust the size setting in the tray. The fault persists.	Go to step 3.	The problem is solved.
Step 3 Check the tray for overfilling. The tray is overfilled.	Go to step 4.	Go to step 5.
Step 4 Remove the excess paper from the tray. The fault persists.	Go to step 5.	The problem is solved.
Step 5 Check the paper path along the tray exit. The paper path is free of fragments and contamination.	Go to step 7.	Go to step 6.

Action	Yes	No
Step 6 Clean the paper path. The fault persists.	Go to step 7.	The problem is solved.
Step 7 Perform a print job. The fault persists.	Contact the next level of support.	The problem is solved.

371-302-00, 371-310-00, 371-318-00, 371-324-00, 371-327-00, 372-226-00, 374-318-00, 374-329-00, 375-318-00, 375-329-00 Tray 2, 3, 4, 5 Sensor Failed To Arrive Error RAP

WD2 Drive PWB Wiring Diagram

C625 Wiring Diagrams

371-302-00 Sensor never made by leading edge of page RAP

371-310-00 Sensor never made by leading edge of page RAP

371-318-00 Tray 2 Jam at S1/Input/stage - never reached s1/Input/stage sensor RAP

371-324-00 Tray 3 Jam at Bump Exit - never reached bump exit sensor RAP

371-327-00 Tray 3 S1/Input sensor never made by leading edge after pick RAP

372-226-00 Tray 2 S1/Input sensor never made by leading edge after pick RAP

374-318-00 Tray 4 Jam at Bump Exit - never reached bump exit sensor RAP

374-329-00 Tray 4 S1/Input sensor never made by leading edge after pick RAP

375-318-00 Tray 5 Jam at Bump Exit - never reached bump exit sensor RAP

375-329-00 Tray 5 S1/Input sensor never made by leading edge after pick RAP

Procedure



WARNING: Switch off the electricity to the machine, **GP 10**. Disconnect the power lead from the customer supply while performing tasks that do not need electricity. Electricity can cause the death or injury. Moving components can cause the injury.

Action	Yes	No
Step 1 1 From the Home screen, touch Settings > Device > Preferences . 2 Check if the paper type and size settings match the paper type and size set on the tray. The paper size will match the size set on the tray.	Go to step 3.	Go to step 2.
Step 2 Change the paper size or adjust the size setting in the tray. The fault persists.	Go to step 3.	The problem is solved.
Step 3 Check the paper path for paper jams and fragments.	Go to step 5.	Go to step 4.

Action	Yes	No
Note: If necessary, remove the transfer module to properly see the paper path. The paper path is free of jams and fragments.		
Step 4 Remove the jams and fragments. The fault persists.	Go to step 5.	The problem is solved.
Step 5 Check the tray insert and its paper path guides and drive gears for damage. The tray insert is free of damage.	Go to step 7.	Go to step 6.
Step 6 Install a new tray insert. See PL 70.10 item 4 . The fault persists.	Go to step 7.	The problem is solved.
Step 7 1 Ensure that the pick roller is properly installed. Note: Firmly press the pick roller to its shaft to make sure that it is properly engaged. 2 Check the pick roller for excess wear, contamination, and damage. The pick roller is free from excess wear, contamination, and damage.	Go to step 9.	Go to step 8.
Step 8 Install a new pick roller. See PL 70.10 item 10 . The fault persists.	Go to step 9.	The problem is solved.
Step 9 1 Enter the Diagnostics menu GP 1 , and then navigate to: Printer diagnostics and adjustments > Motor tests > Pick (tray 1) 2 Select a setting, and then touch Start . The motor will run.	Go to step 12.	Go to step 10.

Action	Yes	No
Step 10 1 Ensure that the motor cable is properly connected. 2 Check the motor and the other paper feeder components PL 70.10 item 8 for damage. The motor and paper feeder is free of damage.	Go to step 12.	Go to step 11.
Step 11 1 Install a new paper feeder. See . 2 Perform a print job. The fault persists.	Go to step 12.	The problem is solved.
Step 12 1 Enter the Diagnostics menu GP 1 , and then navigate to: Printer diagnostics & adjustments >Sensor tests 2 Find the sensor (Input). The sensor status will change while toggling the sensor	Go to step 15.	Go to step 13.
Step 13 1 Ensure that the sensor cable is properly connected. 2 Check the sensor for damage. The sensor is free of damage.	Go to step 15.	Go to step 14.
Step 14 Install a new sensor. See PL 80.05 item 7 . The fault persists.	Go to step 15.	The problem is solved.
Step 15 1 Enter the Diagnostics menu, and then navigate to: Printer diagnostics & adjustments >Motor tests > Isolation 2 Touch Start , and then listen to the sound of the motor. 3 Check if the sound of the motor (isolation) is similar. The motor will create a similar grinding sound	Go to step 17.	Go to step 16.
Step 16	Go to step 18.	Go to step 17.

Action	Yes	No
Check the motor and its cable for damage. The motor and its cable is free of damage		
Step 17 Install a new isolation unit. See PL 80.10 item 4 . The fault persists.	Contact the next level of support.	The problem is solved.
Step 18 1 Enter the Diagnostics menu GP 1 , and then navigate to: Printer diagnostics & adjustments >Motor tests > Deskew 2 Touch Start . The motor will run.	Contact the next level of support.	Go to step 19.
Step 19 1 Ensure that the motor cable is properly connected. 2 Check the motor (deskew) for damage. The motor is free of damage.	Contact the next level of support.	Go to step 20.
Step 20 Install a new motor (deskew). See PL 40.10 item 1 . The fault persists.	Contact the next level of support.	The problem is solved.

371-304-00, 371-312-00, 371-320-00, 371-326-00, 374-320-00, 375-320-00 Tray 1, 2, 3, 4, 5 Sensor Failed To Clear Page Error RAP

WD2 Drive PWB Wiring Diagram

C625 Wiring Diagrams

371-304-00 S1/Input/Stage sensor never cleared by trailing edge of page (bump exit sensor for CA/MM) RAP

371-312-00 Tray 1 Bump exit/stage sensor never cleared by trailing edge of page RAP

371-320-00 Tray 2 S1/Input sensor never cleared by trailing edge of page RAP

371-326-00 Tray 3 S1/Input sensor never cleared by trailing edge of page RAP

374-320-00 Tray 4 S1/Input sensor never cleared by trailing edge of page RAP

375-320-00 Tray 5 S1/Input sensor never cleared by trailing edge of page RAP

Procedure



WARNING: Switch off the electricity to the machine, GP 10. Disconnect the power lead from the customer supply while performing tasks that do not need electricity. Electricity can cause the death or injury. Moving components can cause the injury.

Action	Yes	No
Step 1 1 From the Home screen, touch Settings > Device > Preferences . 2 Check if the paper size matches the size set on the tray guides. The paper size will match the size set on the tray.	Go to step 3.	Go to step 2.
Step 2 Change the paper size or adjust the size setting in the tray. The fault persists.	Go to step 3.	The problem is solved.
Step 3 Check the paper path for paper jams and obstructions. Note: If necessary, remove the transfer module to properly see the paper path. The paper path is free of jams and obstructions.	Go to step 5.	Go to step 4.
Step 4 Remove the jams and obstructions.	Go to step 5.	The problem is solved.

Action	Yes	No
The fault persists.		
Step 5 1 Enter the Diagnostics menu, GP 1 and then navigate to: Printer diagnostics & adjustments > Sensor tests 2 Find the sensor (Input). The sensor status will change while toggling the sensor.	Go to step 8.	Go to step 6.
Step 6 1 Ensure that the sensor cable is properly connected. 2 Check the sensor for damage. The sensor is free of damage.	Go to step 8.	Go to step 7.
Step 7 Install a new sensor. See PL 80.05 item 7. The fault persists.	Go to step 8.	The problem is solved.
Step 8 1 Enter the Diagnostics menu GP 1, and then navigate to: Printer diagnostics & adjustments Motor tests > Deskew 2 Touch Start . The motor will run.	Contact the next level of support.	Go to step 9.
Step 9 1 Ensure that the motor cable is properly connected. 2 Check the motor (deskew) for damage. The motor is free of damage.	Contact the next level of support.	Go to step 10.
Step 10 Install a new motor (deskew). See PL 40.10 item 1. The fault persists.	Contact the next level of support.	The problem is solved.

375-321-00, 375-322-00, 375-323-00, 375-324-00, 375-325-00, 375-326-00, 375-327-00 Tray 5 Lift Motor Error RAP

375-321-00 Tray 5 lift Motor does not turn on RAP

375-322-00 Tray 5 lift Motor does not turn off RAP

375-323-00 Tray 5 lift Motor failed to achieve expected speed RAP

375-324-00 Tray 5 lift Motor loss of encoders (motor stall) RAP

375-325-00 Tray 5 lift Motor underspeed RAP

375-326-00 Tray 5 lift Motor overspeed RAP

375-327-00 Tray 5 lift Motor moved too long RAP



WARNING: Switch off the electricity to the machine, GP 10. Disconnect the power lead from the customer supply while performing tasks that do not need electricity. Electricity can cause the death or injury. Moving components can cause the injury.

Switch OFF, then switch ON the machine, GP 10. If the fault persists, contact 2nd Level Support.

305-211-00, 305-212-00, 310-514-00, 371-329-00, 372-322-00, 373-322-00, 374-328-00, 375-328-00 Unknown Error RAP

305-211-00 Laser Safety interlock RAP

305-212-00 Mirror motor lock fail RAP

310-514-00 Facet Map failure due to kernel failure - May be due to low memory situations - RAP

371-329-00 Tray 1 fails to become input source ready for picking RAP

372-322-00 Tray 2 fails to become input source ready for picking RAP

373-322-00 Tray 3 fails to become input source ready for picking RAP

374-328-00 Tray 4 fails to become input source ready for picking RAP

375-328-00 Tray 5 fails to become input source ready for picking RAP

Procedure



WARNING: Switch off the electricity to the machine, GP 10. Disconnect the power lead from the customer supply while performing tasks that do not need electricity. Electricity can cause the death or injury. Moving components can cause the injury.

Action	Yes	No
Restart the print job. The fault persists.	Contact the next level of support.	The problem is solved.

375-330-00 , 375-331-00, 375-332-00, 375-333-00 Bump Exit Sensor Error RAP

375-330-00 Bump exit sensor covered too soon- Source is tray 5 RAP

375-331-00 Bump exit sensor never made by leading edge of page- Source is tray 5 RAP

375-332-00 Bump exit sensor cleared by page too soon- Source is tray 5 RAP

375-333-00 Bump exit sensor never cleared by trailing edge of page- Source is tray 5 RAP



WARNING: Switch off the electricity to the machine, GP 10. Disconnect the power lead from the customer supply while performing tasks that do not need electricity. Electricity can cause the death or injury. Moving components can cause the injury.

Switch OFF, then switch ON the machine, GP 10. If the fault persists, contact 2nd Level Support.

372-328-00, 372-329-00, 372-332-00, 372-336-00, 372-339-00, 373-329-00, 373-331-00, 373-338-00, 373-340-00, 374-337-00, 374-340-00, 374-342-00, 375-337-00, 375-341-00 Early Leaving Jam Sensor Tray (2, 3, 4, 5) Error RAPs

WD2 Drive PWB Wiring Diagram

C625 Wiring Diagrams

372-328-00 Tray 2 Early Leaving Jam RAP

372-329-00 Tray 3 Early Leaving Jam RAP

372-332-00 Tray 4 Early Leaving Jam RAP

372-336-00 Tray 5 Early Leaving Jam RAP

372-339-00 Early Leaving Jam RAP. Option declared jam, or warm up jam with no known page source.

373-329-00 Tray 3 Early Leaving Jam RAP

373-331-00 Tray 4 Early Leaving Jam RAP

373-338-00 Early Leaving Jam RAP. Option declared jam, or warm up jam with no known page source.

373-340-00 Tray 5 Early Leaving Jam RAP

374-337-00 Tray 4 Early Leaving Jam RAP

374-340-00 Tray 5 Early Leaving Jam RAP

374-342-00 Early Leaving Jam RAP. Option declared jam, or warm up jam with no known page source.

375-337-00 Tray 5 Early Leaving Jam RAP

375-341-00 Early Leaving Jam RAP. Option declared jam, or warm up jam with no known page source.



WARNING: Switch off the electricity to the machine, GP 10 . Disconnect the power lead from the customer supply while performing tasks that do not need electricity. Electricity can cause the death or injury. Moving components can cause the injury.

Procedure

Action	Yes	No
Step 1 1 From the Home screen, touch Settings >Device > Preferences . 2 Check if the paper size matches the size set on the tray guides. The paper size match the size set on the tray.	Go to step 3.	Go to step 2.
Step 2 Change the paper size or adjust the size setting in the tray. The fault persists.	Go to step 3.	The problem is solved.
Step 3 Check if the paper size matches the size set on the tray guides. The paper size will match the size set on the tray.	Go to step 5.	Go to step 4.
Step 4 Replace the paper or change the paper size setting in the tray. The fault persists.	Go to step 5.	The problem is solved.
Step 5 Check the paper tray for overfilling. The paper tray is overfilled.	Go to step 6.	Go to step 7.
Step 6 Remove the excess paper from the tray. The fault persists.	Go to step 7.	The problem is solved.
Step 7 Check the paper condition in the tray. The paper is crumpled or damaged.	Go to step 8.	Go to step 9.
Step 8 Replace the crumpled or damaged paper. The fault persists.	Go to step 9.	The problem is solved.
Step 9 1 Enter the Diagnostics menu GP 1 , and then navigate to:	Go to step 11.	Go to step 10.

Action	Yes	No
Additional input trays adjustments/tests >Additional input tray sensors 2 Find the sensor (Trailing edge (tray [x])). Note: [x] is the tray number. The sensor status will change while toggling the sensor.		
Step 10 1 Ensure that the sensor cable is properly connected. 2 Ensure that the sensor is properly installed. 3 Check the sensor for damage. The sensor is free of damage.	Go to step 11.	Go to step 13.
Step 11 1 Enter the Diagnostics menu GP 1 , and then navigate to: Additional input trays adjustments/tests >Additional input tray sensors 2 Find the sensor (Pass-through (tray [x])). Note: [x] is the tray number. The sensor status will change while toggling the sensor.	Go to step 14.	Go to step 12.
Step 12 1 Ensure that the sensor cable is properly connected. 2 Ensure that the sensor is properly installed. 3 Check the sensor and the other optional tray components for damage. The sensor is free of damage.	Go to step 14.	Go to step 13.
Step 13 Install a new 550 sheet optional tray, PL 25.05 item 10 . The fault persists.	Go to step 14.	The problem is solved.
Step 14 Perform a print test. The fault persists.	Contact the next level of support.	The problem is solved.

375-344-00, 377-278-00 Sensor Did Not Clear Error RAP

WD2 Drive PWB Wiring Diagram

C625 Wiring Diagrams

375-344-00 Sensor Did Not Clear (Previous sheet did not clear sensor so next sheet could look for an input make) RAP

377-278-00 Sensor Did Not Clear (Previous sheet did not clear sensor so next sheet could look for an input make) RAP



WARNING: Switch off the electricity to the machine, GP 10 . Disconnect the power lead from the customer supply while performing tasks that do not need electricity. Electricity can cause the death or injury. Moving components can cause the injury.

Procedure

Action	Yes	No
Step 1 1 From the Home screen, touch Settings >Device > Preferences . 2 Check if the paper size matches the size set on the tray guides. The paper size will match the size set on the tray.	Go to step 3.	Go to step 2.
Step 2 Change the paper size or adjust the size setting in the tray. The fault persists.	Go to step 3.	The problem is solved.
Step 3 Check the paper path for partially fed or jammed paper. The paper path is free of partially fed or jammed paper.	Go to step 5.	Go to step 4.
Step 4 Remove the partially fed or jammed paper. The fault persists.	Go to step 5.	The problem is solved.
Step 5 1 Enter the Diagnostics menu GP 1, and then navigate to: Additional input trays adjustments/tests >Additional input tray sensors 2 Find the sensor (Trailing edge (tray [x])).	Go to step 7.	Go to step 6.

Action	Yes	No
Note: [x] is the tray number. The sensor status will change while toggling the sensor.		
Step 6 1 Ensure that the sensor cable is properly connected. 2 Ensure that the sensor is properly installed. 3 Check the sensor for damage. The is sensor free of damage.	Go to step 7.	Go to step 11.
Step 7 1 Enter the Diagnostics menu GP 1, and then navigate to: Additional input trays adjustments/tests >Additional input tray sensors 2 Find the sensor (Pass-through (tray [x])). Note: [x] is the tray number. The sensor status will change while toggling the sensor.	Go to step 9.	Go to step 8.
Step 8 1 Ensure that the sensor cable is properly connected. 2 Ensure that the sensor is properly installed. 3 Check the sensor and the other optional tray components for damage. The sensor is free of damage.	Go to step 9.	Go to step 11.
Step 9 1 Enter the Diagnostics menu GP 1, and then navigate to: Additional input trays adjustments/tests >Additional input tray motors 2 Select Pass-through (tray [x]) , and then touch Start . Note: [x] is the tray number. The motor will run.	Go to step 12.	Go to step 10.

Action	Yes	No
Step 10 1 Ensure that the motor cable is properly connected. 2 Ensure that the motor is properly installed. 3 Check the motor and the other optional tray components for damage. The motor and 550 sheet optional tray are free of damage.	Go to step 12.	Go to step 11.
Step 11 Install a new 550 sheet optional tray. See PL 70.15 item 1 . The fault persists.	Go to step 12.	The problem is solved.
Step 12 1 Enter the Diagnostics menu GP 1 , and then navigate to: Printer diagnostics & adjustments > Motor tests 2 Find the motor (Duplex/MPF), and then touch Start . The motor will run.	Go to step 15.	Go to step 13.
Step 13 Reconnect the motor cable, and then check the motor for misalignment and damage. The motor properly is installed and free of damage.	Go to step 15.	Go to step 14.
Step 14 Install a new motor. See PL 80.05 item 6 . The fault persists.	Go to step 15.	The problem is solved.
Step 15 Perform a print test. The fault persists.	Contact the next level of support.	The problem is solved.

374-343-00, 375-345-00 Late Arriving Jam RAP

WD2 Drive PWB Wiring Diagram

C625 Wiring Diagrams

374-343-00 Late Arriving Jam (Paper reached sensor, but outside of time window)-Option declared jam, or warm up jam with no known page source - RAP

375-345-00 Late Arriving Jam (Paper reached sensor, but outside of time window)-Option declared jam, or warm up jam with no known page source - RAP

Procedure



WARNING: Switch off the electricity to the machine, [GP 10](#). Disconnect the power lead from the customer supply while performing tasks that do not need electricity. Electricity can cause the death or injury. Moving components can cause the injury.

Action	Yes	No
Step 1 1 From the home screen, touch Settings > Device > Preferences . 2 Check if the paper size matches the size set on the tray guides. The paper size will match the size set on the tray.	Go to step 3.	Go to step 2.
Step 2 Change the paper size or adjust the size setting in the tray. The fault persists.	Go to step 3.	The problem is solved.
Step 3 Check if the paper size matches the size set on the tray guides. The paper size will match the size set on the tray.	Go to step 5.	Go to step 4.
Step 4 Insert a new paper or change the paper size setting in the tray. The fault persists.	Go to step 5.	The problem is solved.
Step 5 Check the primary paper path for paper jams and obstructions. The paper path is free of jams and obstructions.	Go to step 7.	Go to step 6.
Step 6	Go to step 7.	The problem is solved.

Action	Yes	No
Remove the paper jams and obstructions. The fault persists.		
Step 7 1 Enter the Diagnostics menu GP 1 , and then navigate to: Additional input trays adjustments/tests >Additional input tray sensors 2 Find the sensor (Trailing edge (tray [x])). Note: [x] is the tray number. The sensor status will change while toggling the sensor.	Go to step 9.	Go to step 8.
Step 8 1 Ensure that the sensor cable is properly connected. 2 Ensure that the sensor is properly installed. 3 Check the sensor and the other optional tray components for damage. The sensor is free of damage.	Go to step 9.	Go to step 13.
Step 9 1 Enter the Diagnostics menu GP 1 , and then navigate to: Additional input trays adjustments/tests >Additional input tray sensors 2 Find the sensor (Pass-through (tray [x])). Note: [x] is the tray number. The sensor status will change while toggling the sensor.	Go to step 11.	Go to step 10.
Step 10 1 Ensure that the sensor cable is properly connected. 2 Ensure that the sensor is properly installed. 3 Check the sensor and the other optional tray components for damage.	Go to step 11.	Go to step 11.

Action	Yes	No
The sensor and the optional tray are free of damage.		
Step 11 1 Enter the Diagnostics menu GP 1 , and then navigate to: Additional input trays adjustments/tests >Additional input tray motors 2 Select Pass-through (tray [x]) , and then touch Start . Note: [x] is the tray number. The motor will run.	Go to step 14.	Go to step 12.
Step 12 1 Ensure that the motor cable is properly connected. 2 Ensure that the motor is properly installed. 3 Check the motor and the other optional tray components for damage. The motor and the optional tray are free of damage.	Go to step 14.	Go to step 13.
Step 13 Install a new optional tray. See PL 70.15 item 1 The fault persists.	Go to step 14.	The problem is solved.
Step 14 1 Enter the Diagnostics menu GP 1 , and then navigate to: Printer diagnostics & adjustments >Motor tests 2 Select Duplex/MPF , and then touch Start . The motor will run.	Go to step 17.	Go to step 15.
Step 15 Reseat the motor cable, and then check the motor for misalignment and damage. The motor is properly installed and free of damage.	Go to step 17.	Go to step 16.

Action	Yes	No
Step 16 Install a new motor. See PL 80.05 item 6 The fault persists.	Go to step 17.	The problem is solved.
Step 17 Perform a print test. The fault persists.	Contact the next level of support.	The problem is solved.

377-102-00, 377-105-00, 377-106-00, 377-109-00, 377-204-00, 377-246-00 Fuser Exit Sensor RAP

[WD2 Drive PWB Wiring Diagram](#)

[WD3 LVPS Wiring Diagram](#)

[C625 Wiring Diagrams](#)

377-106-00 Fuser Exit Sensor Early (MPF) RAP

377-105-00 Fuser Exit late (Tray 1) RAP

377-102-00 Fuser exit sensor never made by leading edge of page - Source is tray 2 RAP

377-109-00 Fuser Exit Sensor late (Tray 3) RAP

377-204-00 Fuser exit sensor never made by leading edge of page - Source is tray 4 RAP

377-246-00 Fuser exit sensor never made by leading edge of page - Source is tray 5 RAP

Procedure



WARNING: Switch off the electricity to the machine, [GP 10](#). Disconnect the power lead from the customer supply while performing tasks that do not need electricity. Electricity can cause the death or injury. Moving components can cause the injury.

Action	Yes	No
Step 1 1 From the home screen, touch Settings > Device > Preferences . 2 Check if the paper size matches the size set on the tray guides. The paper size will match the size set on the tray.	Go to step 3.	Go to step 2.
Step 2 Change the paper size or adjust the size setting in the tray. The fault persists.	Go to step 3.	The problem is solved.
Step 3 Check the paper path for paper jams and fragments. The paper path is free of jams and fragments.	Go to step 5.	Go to step 4.
Step 4 Remove the jams and fragments.	Go to step 5.	The problem is solved.

Action	Yes	No
Note: The fuser nip may not release if the printer is still powered on. Make sure to close all doors, and then turn off the printer to release the fuser nip. The fault persists.		
Step 5 Check the fuser for obstructions. The fuser is free from obstructions.	Go to step 7.	Go to step 6.
Step 6 Remove the obstructions in the fuser area. The fault persists.	Go to step 7.	The problem is solved.
Step 7 1 Ensure that the fuser life has not ended. 2 Check the fuser for damage. The fuser is free of damage.	Go to step 9.	Go to step 8.
Step 8 Install a new fuser. See PL 10.10 item 1 . The fault persists.	Go to step 9.	The problem is solved.
Step 9 1 Enter the Diagnostics menu GP 1 , and then navigate to: Printer diagnostics & adjustments > Sensor tests 2 Find the sensor (Fuser exit). The sensor status will change while toggling the sensor.	Go to step 12.	Go to step 10.
Step 10 1 Ensure that the fuser is properly seated. 2 Ensure that the JFSNS1 connector on the engine board is properly connected. 3 Check the sensor for damage. The sensor is free of damage.	Go to step 12.	Go to step 11.
Step 11	Go to step 12.	The problem is solved.

Action	Yes	No
Install a new fuser. See PL 10.10 item 1 . The fault persists.		
Step 12 Check the transfer module for damage. The transfer module is free of damage.	Go to step 14.	Go to step 13.
Step 13 Install a new transfer module. See PL 90.10 item 2 . The fault persists.	Go to step 14.	The problem is solved.
Step 14 1 Enter the Diagnostics menu GP 1 , and then navigate to: Printer diagnostics & adjustments > Motor tests > Fuser 2 Select a setting, and then touch Start . The motor will run.	Go to step 17.	Go to step 15.
Step 15 Ensure that the JFDRV1 connector on the engine board is properly connected. The fault persists.	Go to step 16.	The problem is solved.
Step 16 1 Install a new motor. See PL 80.05 item 6 . 2 Perform a print job. The fault persists.	Go to step 17.	The problem is solved.
Step 17 1 Remove the transfer module. See PL 90.10 item 2 . 2 Close the front door or bypass the door interlock switch. 3 Enter the Diagnostics menu GP 1 , and then navigate to: Printer diagnostics & adjustments > Motor tests > K developer/transfer 4 Touch Start . The motor will run.	Contact the next level of support.	Go to step 18.

Action	Yes	No
Step 18 Ensure that the JKDRV1 connector on the engine board is properly connected. The fault persists.	Go to step 19.	The problem is solved.
Step 19 1 Install a new motor (K/transfer belt). See PL 40.10 item 2 . 2 Perform a print job. The fault persists.	Contact the next level of support.	The problem is solved.

377-103-00, 377-108-00, 377-111-00, 377-205-00, 377-248-00 Fuser Exit Sensor Never Cleared By Trailing Edge Of Page RAP

[WD2 Drive PWB Wiring Diagram](#)

[C625 Wiring Diagrams](#)

[WD3 LVPS Wiring Diagram](#)

377-103-00 Fuser Exit trail edge (MPF) RAP

377-108-00 Fuser exit sensor never cleared by trailing edge of page - Source is tray 2 RAP

377-111-00 Fuser exit sensor never cleared by trailing edge of page - Source is tray 3 RAP

377-205-00 Fuser exit sensor never cleared by trailing edge of page - Source is tray 4 RAP

377-248-00 Fuser exit sensor never cleared by trailing edge of page - Source is tray 5 RAP

Procedure



WARNING: Switch off the electricity to the machine, GP 10. Disconnect the power lead from the customer supply while performing tasks that do not need electricity. Electricity can cause the death or injury. Moving components can cause the injury.

Action	Yes	No
Step 1 1 From the Home screen, touch Settings >Device > Preferences . 2 Check if the paper size matches the size set on the tray guides. The paper size will match the size set on the tray.	Go to step 3.	Go to step 2.
Step 2 Change the paper size or adjust the size setting in the tray. The fault persists.	Go to step 3.	The problem is solved.
Step 3 Check the paper path for paper jams and fragments. The paper path is free of jams and fragments.	Go to step 5.	Go to step 4.
Step 4 Remove the jams and fragments.	Go to step 5.	The problem is solved.

Action	Yes	No
Note: The fuser nip may not release if the printer is still powered on. Make sure to close all doors, and then turn off the printer to release the fuser nip. The fault persists.		
Step 5 Check the fuser for obstructions. The fuser is free from obstructions.	Go to step 7.	Go to step 6.
Step 6 Remove the obstructions in the fuser area. The fault persists.	Go to step 7.	The problem is solved.
Step 7 Check the fuser for damage or life expiration, and install a new fuser if necessary. See PL 10.10 item 1. The fault persists.	Go to step 8.	The problem is solved.
Step 8 1 Enter the Diagnostics menu GP 1, and then navigate to: Printer diagnostics & adjustments >Sensor tests 2 Find the sensor (Fuser exit). The sensor status will change while toggling the sensor.	Go to step 11.	Go to step 9.
Step 9 1 Ensure that the fuser is properly seated. 2 Ensure that the JFSNS1 connector on the engine board is properly connected. 3 Check the sensor for damage. The sensor is free of damage.	Go to step 11.	Go to step 10.
Step 10 Install a new fuser. See PL 10.10 item 1. The fault persists.	Go to step 11.	The problem is solved.

Action	Yes	No
Step 11 1 Enter the Diagnostics menu GP 1 , and then navigate to: Printer diagnostics & adjustments >Motor tests > Fuser 2 Select a setting, and then touch Start . The motor will run.	Contact the next level of support.	Go to step 12.
Step 12 Ensure that the motor cable is properly connected. The fault persists.	Go to step 13.	The problem is solved.
Step 13 1 Install a new motor. See PL 80.05 item 6 . 2 Perform a print job. The fault persists.	Contact the next level of support.	The problem is solved.

377-112-00 Fuser Exit Sensor Covered Warmup RAP

C625 Wiring Diagrams

WD3 LVPS Wiring Diagram

377-112-00 Fuser exit sensor covered at warmup RAP

Procedure



WARNING: Switch off the electricity to the machine, **GP 10**. Disconnect the power lead from the customer supply while performing tasks that do not need electricity. Electricity can cause the death or injury. Moving components can cause the injury.

Action	Yes	No
Step 1 1 From the Home screen, touch Settings >Device > Preferences . 2 Check if the paper size matches the size set on the tray guides. The paper size will match the size set on the tray.	Go to step 3.	Go to step 2.
Step 2 Change the paper size or adjust the size setting in the tray. The fault persists.	Go to step 3.	The problem is solved.
Step 3 Check the paper path for partially fed or jammed paper. The paper path is free of partially fed or jammed paper.	Go to step 5.	Go to step 4.
Step 4 Remove the partially fed or jammed paper. Note: The fuser nip may not release if the printer is still powered on. Make sure to close all doors, and then turn off the printer to release the fuser nip. The fault persists.	Go to step 5.	The problem is solved.
Step 5 1 Enter the Diagnostics menu GP 1 , and then navigate to: Printer diagnostics & adjustments >Sensor tests 2 Find the sensor (Fuser exit).	Contact the next level of support.	Go to step 6.

Action	Yes	No
The sensor status will change while toggling the sensor.		
Step 6 1 Ensure that the fuser is properly seated. 2 Ensure that the JFSNS1 connector on the engine board is properly connected. 3 Check the sensor for damage. The sensor is free of damage.	Go to step 7.	The problem is solved.
Step 7 Install a new fuser. See PL 10.10 item 1. The fault persists.	Contact the next level of support.	The problem is solved.

377-130-00, 377-132-00, 377-134-00, 377-136-00, 377-293-00, 377-297-00 Duplex Stage Sensor Error RAP

[WD2 Drive PWB Wiring Diagram](#)

[C625 Wiring Diagrams](#)

[WD3 LVPS Wiring Diagram](#)

377-130-00 Duplex Path lead edge jam RAP

377-132-00 Tray 1 Duplex stage sensor never made by leading edge of page RAP

377-134-00 Tray 2 Duplex stage sensor never made by leading edge of page RAP

377-136-00 Tray 3 Duplex stage sensor never made by leading edge of page RAP

377-293-00 Tray 4 Duplex stage sensor never made by leading edge of page RAP

377-297-00 Tray 5 Duplex stage sensor never made by leading edge of page RAP

Procedure



WARNING: Switch off the electricity to the machine, GP 10 . Disconnect the power lead from the customer supply while performing tasks that do not need electricity. Electricity can cause the death or injury. Moving components can cause the injury.

Action	Yes	No
Step 1 1 From the Home screen, touch Settings >Device > Preferences . 2 Check if the paper size matches the size set on the tray guides. The paper size will match the size set on the tray.	Go to step 3.	Go to step 2.
Step 2 Change the paper size or adjust the size setting in the tray. The fault persists.	Go to step 3.	The problem is solved.
Step 3 Check the duplex paper path for paper jams and obstructions. The paper path is free of jams and obstructions.	Go to step 5.	Go to step 4.
Step 4 Remove the jams and obstructions. The fault persists.	Go to step 5.	The problem is solved.
Step 5	Go to step 8.	Go to step 6.

Action	Yes	No
<p>1 Enter the Diagnostics menu GP 1, and then navigate to: Printer diagnostics & adjustments >Sensor tests</p> <p>2 Find the sensor (Duplex path 2). The sensor status will change while toggling the sensor.</p>		
<p>Step 6</p> <p>1 Ensure that the sensor cable is properly connected.</p> <p>2 Check the sensor for damage. The sensor is free of damage.</p>	Go to step 8.	Go to step 7.
<p>Step 7</p> <p>Install a new sensor (duplex staging).PL 80.15 item 1 The fault persists.</p>	Go to step 8.	The problem is solved.
<p>Step 8</p> <p>1 Enter the Diagnostics menu GP 1, and then navigate to: Printer diagnostics & adjustments >Motor tests > Duplex/MPF</p> <p>2 Select a setting, and then touch Start. The motor will run.</p>	Go to step 11.	Go to step 9.
<p>Step 9</p> <p>1 Ensure that the motor cable is properly connected.</p> <p>2 Check the motor for damage. The motor is free of damage.</p>	Go to step 11.	Go to step 10.
<p>Step 10</p> <p>1 Install a new motor. See PL 80.05 item 6.</p> <p>2 Perform a print job. The fault persists.</p>	Go to step 11.	The problem is solved.

Action	Yes	No
<p>Step 11</p> <p>Check the duplex inner guide and its gears, belts, and rollers for damage. The duplex inner guide and its components are free of damage.</p>	Contact the next level of support.	The problem is solved.
<p>Step 12</p> <p>1 Install a new duplex inner guide. See PL 80.15 item 1.</p> <p>2 Perform a print job. The fault persists.</p>	Contact the next level of support.	The problem is solved.

377-131-00, 377-133-00, 377-135-00, 377-137-00, 377-291-00, 377-295-00, 377-299-00 Tray 1, 2, 3, 4, 5 Duplex Stage Sensor Error RAP

WD2 Drive PWB Wiring Diagram

C625 Wiring Diagrams

377-131-00 Duplex Path trail edge jam RAP

377-133-00 Tray 1 Duplex stage sensor never cleared by trailing edge of page RAP

377-135-00 Tray 2 Duplex stage sensor never cleared by trailing edge of page RAP

377-137-00 Tray 3 Duplex stage sensor never cleared by trailing edge of page RAP

377-291-00 Tray 3 Duplex stage sensor never cleared by trailing edge of page RAP

377-295-00 Tray 4 Duplex stage sensor never cleared by trailing edge of page RAP

377-299-00 Tray 5 Duplex stage sensor never cleared by trailing edge of page RAP

Procedure



WARNING: Switch off the electricity to the machine, GP 10. Disconnect the power lead from the customer supply while performing tasks that do not need electricity. Electricity can cause the death or injury. Moving components can cause the injury.

Action	Yes	No
Step 1 1 From the Home screen, touch Settings > Device > Preferences . 2 Check if the paper size matches the size set on the tray guides. The paper size will match the size set on the tray.	Go to step 3.	Go to step 2.
Step 2 Change the paper size or adjust the size setting in the tray. The fault persists.	Go to step 3.	The problem is solved.
Step 3 Check if the paper size matches the size set on the tray guides. The paper size will match the size set on the tray.	Go to step 5.	Go to step 4.
Step 4 Change the paper size or adjust the size setting in the tray. The fault persists.	Go to step 5.	The problem is solved.

Action	Yes	No
Step 5 Check the paper path for paper jams and obstructions. The paper path is free of jams and obstructions.	Go to step 7.	Go to step 6.
Step 6 Remove the jams and obstructions. The fault persists.	Go to step 7.	The problem is solved.
Step 7 1 Enter the Diagnostics menu GP 1, and then navigate to: Printer diagnostics & adjustments > Sensor tests 2 Find the sensor (Duplex path 2). The sensor status will change while toggling the sensor.	Go to step 10.	Go to step 8.
Step 8 1 Ensure that the sensor cable is properly connected. 2 Check the sensor for damage. The sensor is free of damage.	Go to step 10.	Go to step 9.
Step 9 Install a new sensor (duplex staging) PL 80.15 item 1. The fault persists.	Go to step 10.	The problem is solved.
Step 10 1 Enter the Diagnostics menu GP 1, and then navigate to: Printer diagnostics & adjustments > Motor tests > Isolation 2 Touch Start . The motor will run.	Contact the next level of support.	Go to step 11.

Action	Yes	No
Step 11 1 Ensure that the motor cable is properly connected. 2 Check the motor and isolation unit for damage. The motor and isolation unit are free of damage.	Contact the next level of support.	Go to step 12.
Step 12 1 Install a new isolation unit. See PL 80.10 item 4 . 2 Perform a print job. The fault persists.	Contact the next level of support.	The problem is solved.

377-138-00, 377-139-00 Duplex Entry Sensor Cable Unplugged RAP

377-138-00 Duplex entry sensor cable unplugged RAP

377-139-00 Duplex stage sensor unplugged RAP

Procedure



WARNING: Switch off the electricity to the machine, [GP 10](#). Disconnect the power lead from the customer supply while performing tasks that do not need electricity. Electricity can cause the death or injury. Moving components can cause the injury.

Switch OFF, then switch ON the machine, [GP 10](#). If the fault persists, call 2nd level support.

377-140-00 Fuser Bubble Sensor Unplugged RAP

377-140-00 Fuser bubble sensor unplugged RAP



WARNING: Switch off the electricity to the machine, GP 10. Disconnect the power lead from the customer supply while performing tasks that do not need electricity. Electricity can cause the death or injury. Moving components can cause the injury.

Switch OFF, then switch ON the machine, GP 10. If the fault persists, contact 2nd Level Support.

377-141-00 Narrow Media Sensor Cable Unplugged RAP

377-141-00 Narrow media sensor cable unplugged RAP



WARNING: Switch off the electricity to the machine, GP 10. Disconnect the power lead from the customer supply while performing tasks that do not need electricity. Electricity can cause the death or injury. Moving components can cause the injury.

Switch OFF, then switch ON the machine, GP 10. If the fault persists, contact 2nd Level Support.

377-142-00, 377-144-00 Alt-S1 Sensor Unplugged RAP

377-142-00 Alt-S1 bump exit and staging sensor are all unplugged RAP

377-144-00 Alt-S1 sensor unplugged RAP



WARNING: Switch off the electricity to the machine, GP 10. Disconnect the power lead from the customer supply while performing tasks that do not need electricity. Electricity can cause the death or injury. Moving components can cause the injury.

Switch OFF, then switch ON the machine, GP 10. If the fault persists, contact 2nd Level Support.

377-145-00 Bump Exit Sensor Cable Unplugged RAP

377-145-00 Bump exit sensor cable unplugged RAP



WARNING: Switch off the electricity to the machine, GP 10. Disconnect the power lead from the customer supply while performing tasks that do not need electricity. Electricity can cause the death or injury. Moving components can cause the injury.

Switch OFF, then switch ON the machine, GP 10. If the fault persists, contact 2nd Level Support.

372-102-00, 372-108-00, 372-142-00, 372-144-00, 372-223-00, 372-331-00, 372-334-00, 372-902-00, 373-102-00, 373-142-00, 373-144-00, 373-330-00, 373-333-00, 373-339-00, 373-900-00, 374-142-00, 374-143-00, 374-334-00, 374-335-00, 374-339-00, 375-142-00, 375-242-00, 375-334-00, 375-335-00, 375-339-00, 377-149-00, 377-274-00, 377-279-00
Early Arriving Jam And Static Jam RAP

WD2 Drive PWB Wiring Diagram

C625 Wiring Diagrams

- 372-102-00 Tray 2 EARLY ARRIVING JAM (Paper reaches the sensor too soon, or unexpected) RAP
- 372-108-00 Tray 3 EARLY ARRIVING JAM (Paper reaches the sensor too soon, or unexpected) RAP
- 372-142-00 STATIC JAM. Option declared jam, or warm up jam with no known page source - RAP
- 372-144-00 EARLY ARRIVING JAM. Option declared jam, or warm up jam with no known page source - RAP
- 372-223-00 Tray 2 STATIC JAM (Paper at sensor at start, cover closed or idle - Jam not cleared) RAP
- 372-331-00 Tray 4 EARLY ARRIVING JAM (Paper reaches the sensor too soon, or unexpected) RAP
- 372-334-00 Tray 5 EARLY ARRIVING JAM (Paper reaches the sensor too soon, or unexpected) RAP
- 372-902-00 Tray 3 STATIC JAM (Paper at sensor at start, cover closed or idle - Jam not cleared) RAP
- 373-102-00 Tray 3 early jam RAP
- 373-142-00 STATIC JAM. Option declared jam, or warm up jam with no known page source RAP
- 373-144-00 EARLY ARRIVING JAM. Option declared jam, or warm up jam with no known page source - RAP
- 373-330-00 Tray 4 EARLY ARRIVING JAM (Paper reaches the sensor too soon, or unexpected) RAP
- 373-333-00 Tray 5 STATIC JAM (Paper at sensor at start, cover closed or idle - Jam not cleared) RAP
- 373-339-00 Tray 5 EARLY ARRIVING JAM (Paper reaches the sensor too soon, or unexpected) RAP
- 373-900-00 Tray 3 static jam RAP
- 374-142-00 Tray 4 STATIC JAM (Paper at sensor at start, cover closed or idle - Jam not cleared) RAP
- 374-143-00 Tray 4 STATIC JAM (Paper at sensor at start, cover closed or idle - Jam not cleared) RAP
- 374-334-00 Tray 4 STATIC JAM (Paper at sensor at start, cover closed or idle - Jam not cleared) RAP
- 374-335-00 Tray 4 EARLY ARRIVING JAM (Paper reaches the sensor too soon, or unexpected) RAP
- 374-339-00 Tray 5 EARLY ARRIVING JAM (Paper reaches the sensor too soon, or unexpected) RAP
- 375-142-00 Tray 5 STATIC JAM (Paper at sensor at start, cover closed or idle - Jam not cleared) RAP
- 375-242-00 Tray 5 STATIC JAM (Paper at sensor at start, cover closed or idle - Jam not cleared) RAP
- 375-334-00 Tray 5 STATIC JAM (Paper at sensor at start, cover closed or idle - Jam not cleared) RAP

- 375-335-00 Tray 5 EARLY ARRIVING JAM (Paper reaches the sensor too soon, or unexpected) RAP
- 375-339-00 EARLY ARRIVING JAM. Option declared jam, or warm up jam with no known page source RAP
- 377-149-00 STATIC JAM. Option declared jam, or warm up jam with no known page source RAP
- 377-274-00 EARLY ARRIVING JAM. Option declared jam, or warm up jam with no known page source RAP
- 377-279-00 STATIC JAM. Option declared jam, or warm up jam with no known page source RAP

Procedure



WARNING: Switch off the electricity to the machine, GP 10 . Disconnect the power lead from the customer supply while performing tasks that do not need electricity. Electricity can cause the death or injury. Moving components can cause the injury.

Action	Yes	No
Step 1 1 From the Home screen, touch Settings >Device > Preferences. 2 Check if the paper size matches the size set on the tray guides. The paper size will match the size set on the tray.	Go to step 3.	Go to step 2.
Step 2 Change the paper size or adjust the size setting in the tray. The fault persists.	Go to step 3.	The problem is solved.
Step 3 Check the paper path for partially fed or jammed paper. The paper path is free of partially fed or jammed paper.	Go to step 5.	Go to step 4.
Step 4 Remove the partially fed or jammed paper. The fault persists.	Go to step 5.	The problem is solved.
Step 5 1 Enter the Diagnostics menu GP 1 , and then navigate to: Additional input trays adjustments/tests >Additional input tray sensors 2 Find the sensor (Trailing edge (tray [x])).	Go to step 7.	Go to step 6.

Action	Yes	No
<p>Note: [x] is the tray number. The sensor status will change while toggling the sensor.</p>		
<p>Step 6 1 Ensure that the sensor cable is properly connected. 2 Ensure that the sensor is properly installed. 3 Check the sensor for damage. The sensor is free of damage.</p>	Go to step 7.	Go to step 9.
<p>Step 7 1 Enter the Diagnostics menu GP 1, and then navigate to: Additional input trays adjustments/tests > Additional input tray sensors 2 Find the sensor (Pass-through (tray [x])). Note: [x] is the tray number. The sensor status will change while toggling the sensor.</p>	Go to step 10.	Go to step 8.
<p>Step 8 1 Ensure that the sensor cable is properly connected. 2 Ensure that the sensor is properly installed. 3 Check the sensor and the other optional tray components for damage. The sensor is free of damage.</p>	Go to step 10.	Go to step 9.
<p>Step 9 Install a new 550-sheet optional tray, PL 25.05 item 1. The fault persists.</p>	Go to step 10.	The problem is solved.
<p>Step 10 Perform a print test. The fault persists.</p>	Contact the next level of support.	The problem is solved.

377-150-00 Stage Sensor Cable Is Unplugged RAP

377-150-00 Stage sensor cable is unplugged RAP



WARNING: Switch off the electricity to the machine, **GP 10**. Disconnect the power lead from the customer supply while performing tasks that do not need electricity. Electricity can cause the death or injury. Moving components can cause the injury.

Switch OFF, then switch ON the machine, **GP 10**. If the fault persists, contact 2nd Level Support.

377-184-00 Bin Full Sensor Cable Unplugged RAP

377-184-00 Bin full sensor cable unplugged RAP



WARNING: Switch off the electricity to the machine, GP 10. Disconnect the power lead from the customer supply while performing tasks that do not need electricity. Electricity can cause the death or injury. Moving components can cause the injury.

Switch OFF, then switch ON the machine, GP 10. If the fault persists, contact 2nd Level Support.

377-185-00 Sensor (Duplex/MPF Input) Appears To Be Disconnected RAP

377-185-00 MPF Paper present, Duplex stage sensor, fuser bubble sensor, and narrow media sensors appear to be disconnected RAP



WARNING: Switch off the electricity to the machine, GP 10. Disconnect the power lead from the customer supply while performing tasks that do not need electricity. Electricity can cause the death or injury. Moving components can cause the injury.

Switch OFF, then switch ON the machine, GP 10. If the fault persists, contact 2nd Level Support.

377-186-00 MPF Paper Present Sensor Unplugged RAP

377-186-00 MPF Paper present sensor unplugged RAP



WARNING: Switch off the electricity to the machine, GP 10. Disconnect the power lead from the customer supply while performing tasks that do not need electricity. Electricity can cause the death or injury. Moving components can cause the injury.

Switch OFF, then switch ON the machine, GP 10. If the fault persists, contact 2nd Level Support.

377-206-00, 377-207-00 Fuser Exit Sensor Error RAP

377-206-00 Fuser exit sensor never made by page found over input sensor that triggered a flush action RAP

377-207-00 Fuser exit sensor never cleared by trailing edge of page - Source is Unknown RAP



WARNING: Switch off the electricity to the machine, GP 10. Disconnect the power lead from the customer supply while performing tasks that do not need electricity. Electricity can cause the death or injury. Moving components can cause the injury.

Switch OFF, then switch ON the machine, GP 10. If the fault persists, contact 2nd Level Support.

377-211-00 Tray Module Kind Mismatch RAP

377-211-00 A tray module mismatch has occurred.

Procedure



WARNING: Switch off the electricity to the machine, GP 10 . Disconnect the power lead from the customer supply while performing tasks that do not need electricity. Electricity can cause the death or injury. Moving components can cause the injury.

Perform the steps that follow:

1. Check the correct tray module (2TM/TTM) is installed. Install the correct tray module desired.
2. Check the connections between the tray module and the machine.
3. Switch OFF, then switch ON the machine, GP 10.
4. If the fault persists, enter dC131 to ensure the tray module type is correctly set in NVM value 743-147:
 - 2TM = 4
 - TTM = 5

377-218-00 Duplex Entry/Park Sensor Covered Warmup Error RAP

WD2 Drive PWB Wiring Diagram

C625 Wiring Diagrams

377-218-00 Duplex entry/park sensor covered at warm up RAP

Procedure



WARNING: Switch off the electricity to the machine, GP 10 . Disconnect the power lead from the customer supply while performing tasks that do not need electricity. Electricity can cause the death or injury. Moving components can cause the injury.

Action	Yes	No
Step 1 1 From the Home screen, touch Settings >Device > Preferences. 2 Check if the paper size matches the size set on the tray guides. The paper size will match the size set on the tray.	Go to step 3.	Go to step 2.
Step 2 Change the paper size or adjust the size setting in the tray. The fault persists.	Go to step 3.	The problem is solved.
Step 3 Check the paper path for partially fed or jammed paper. The paper path is free of partially fed or jammed paper.	Go to step 5.	Go to step 4.
Step 4 Remove the partially fed or jammed paper. The fault persists.	Go to step 5.	The problem is solved.
Step 5 1 Enter the Diagnostics menu GP 1, and then navigate to: Printer diagnostics & adjustments > Sensor tests 2 Find the sensor (Redrive/ Duplex path 1). The sensor status will change while toggling the sensor.	Contact the next level of support.	Go to step 6.

Action	Yes	No
Step 6 1 Ensure that the JDSNS1 connector on the engine board is properly connected. 2 Check the sensor for damage. The sensor free of damage.	Go to step 7.	The problem is solved.
Step 7 Install a new sensor. See PL 80.10 item 2 . The fault persists.	Contact the next level of support.	The problem is solved.

377-219-00 to 377-225-00 Tray 1, 2, 3, 4, 5 S1/Input Sensor Error RAP

WD2 Drive PWB Wiring Diagram

C625 Wiring Diagrams

377-219-00 MPF S1/Input sensor cleared too soon by trailing edge of page during duplexpass RAP

377-220-00 Tray 1 S1/Input sensor cleared too soon by trailing edge of page during duplexpass RAP

377-221-00 Tray 2 S1/Input sensor cleared too soon by trailing edge of page during duplexpass RAP

377-222-00 Tray 3 S1/Input sensor cleared too soon by trailing edge of page during duplexpass RAP

377-223-00 Tray 4 S1/Input sensor cleared too soon by trailing edge of page during duplexpass RAP

377-224-00 Tray 5 S1/Input sensor cleared too soon by trailing edge of page during duplexpass RAP

377-225-00 Unknown S1/Input sensor cleared too soon by trailing edge of page during duplexpass RAP

Procedure



WARNING: Switch off the electricity to the machine, [GP 10](#) . Disconnect the power lead from the customer supply while performing tasks that do not need electricity. Electricity can cause the death or injury. Moving components can cause the injury.

Action	Yes	No
Step 1 Check the duplex inner guide and its gears, belts, and rollers for damage. The duplex inner guide and its components are free of damage.	Go to step 3.	Go to step 2.
Step 2 1 Install a new duplex inner guide. See PL 80.15 item 1 . 2 Perform a print job. The fault persists.	Go to step 3.	The problem is solved.
Step 3 1 Enter the Diagnostics menu GP 1 , and then navigate to: Printer diagnostics & adjustments > Sensor tests 2 Find the sensor (MPF/pass-through).	Go to step 6.	Go to step 4.

Action	Yes	No
The sensor status will change while toggling the sensor.		
Step 4 1 Ensure that the sensor cable is properly connected. 2 Check the sensor for damage. The sensor is free of damage.	Go to step 6.	Go to step 5.
Step 5 Install a new isolation unit. See PL 80.10 item 4. The fault persists.	Go to step 6.	The problem is solved.
Step 6 Perform a print job. The fault persists.	Contact the next level of support.	The problem is solved.

377-235-00, 377-237-00, 377-239-00, 377-241-00, 377-243-00, 377-245-00 Fuser exit sensor RAP

C625 Wiring Diagrams

WD3 LVPS Wiring Diagram

377-235-00 MPF/Manual Fuser exit sensor covered too soon RAP

377-237-00 Tray 1 Fuser exit sensor covered too soon RAP

377-239-00 Tray 2 Fuser exit sensor covered too soon RAP

377-241-00 Tray 3 Fuser exit sensor covered too soon RAP

377-243-00 Tray 4 Fuser exit sensor covered too soon RAP

377-245-00 Tray 5 Fuser exit sensor covered too soon RAP

Procedure



WARNING: Switch off the electricity to the machine, GP 10. Disconnect the power lead from the customer supply while performing tasks that do not need electricity. Electricity can cause the death or injury. Moving components can cause the injury.

Action	Yes	No
Step 1 1 From the Home screen, touch Settings > Device > Preferences . 2 Check if the paper size matches the size set on the tray guides. The paper size will match the size set on the tray.	Go to step 3.	Go to step 2.
Step 2 Change the paper size or adjust the size setting in the tray. The fault persists.	Go to step 3.	The problem is solved.
Step 3 Check the paper path just before the fuser for paper jams and fragments. The paper path is free of fragments and contamination.	Go to step 5.	Go to step 4.
Step 4 Remove the paper jams and fragments.	Go to step 5.	The problem is solved.

Action	Yes	No
Note: The fuser nip may not release if the printer is still powered on. Make sure to close all doors, and then turn off the printer to release the fuser nip. The fault persists.		
Step 5 Check the fuser rollers for damage. The rollers are free of damage.	Go to step 7.	Go to step 6.
Step 6 Install a new fuser. See PL 10.10 item 1. The fault persists.	Go to step 7.	The problem is solved.
Step 7 Perform a print job. The fault persists.	Contact the next level of support.	The problem is solved.

377-236-00, 377-238-00, 377-240-00, 377-242-00, 377-244-00, 377-247-00 Fuser Exit Sensor RAP

C625 Wiring Diagrams

WD3 LVPS Wiring Diagram

377-236-00 Page trailing edge left exit sensor too soon - possible fuser wrap jam RAP

377-238-00 Tray 1 Fuser exit sensor cleared by page too soon RAP

377-240-00 Tray 2 Fuser exit sensor cleared by page too soon RAP

377-242-00 Tray 3 Fuser exit sensor cleared by page too soon RAP

377-244-00 Tray 4 Fuser exit sensor cleared by page too soon RAP

377-247-00 Tray 5 Fuser exit sensor cleared by page too soon RAP

Procedure



WARNING: Switch off the electricity to the machine, GP 10 . Disconnect the power lead from the customer supply while performing tasks that do not need electricity. Electricity can cause the death or injury. Moving components can cause the injury.

Action	Yes	No
Step 1 1 From the Home screen, touch Settings > Device > Preferences . 2 Check if the paper size matches the size set on the tray guides. The paper size will match the size set on the tray.	Go to step 3.	Go to step 2.
Step 2 Change the paper size or adjust the size setting in the tray. The fault persists.	Go to step 3.	The problem is solved.
Step 3 Check the fuser rollers for damage. The rollers are free of damage.	Go to step 5.	Go to step 4.
Step 4 Install a new fuser. See PL 10.10 item 1. The fault persists.	Go to step 5.	The problem is solved.
Step 5 1 Enter the Diagnostics menu GP 1, and then navigate to:	Go to step 8.	Go to step 6.

Action	Yes	No
Printer diagnostics & adjustments > Sensor tests 2 Find the sensor (Fuser exit). The sensor status will change while toggling the sensor.		
Step 6 Ensure that the sensor cable is properly connected. The fault persists.	Go to step 7.	The problem is solved.
Step 7 Install a new fuser. See PL 10.10 item 1. The fault persists.	Go to step 8.	The problem is solved.
Step 8 Perform a print job. The fault persists.	Contact the next level of support.	The problem is solved.

377-251-00, 377-254-00, 377-258-00, 377-262-00, 377-267-00, 377-285-00 Duplex Entry/Park Sensor RAP

WD2 Drive PWB Wiring Diagram

C625 Wiring Diagrams

377-251-00 MPF Duplex entry/park sensor never made by leading edge of page RAP

377-254-00 Tray 1 Duplex park sensor never made by leading edge of page RAP

377-258-00 Tray 2 Duplex park sensor never hit RAP

377-262-00 Tray 3 Duplex park sensor never hit RAP

377-285-00 Tray 4 Duplex entry sensor never hit RAP

377-267-00 Tray 5 Duplex park sensor never hit RAP

Procedure



WARNING: Switch off the electricity to the machine, GP 10. Disconnect the power lead from the customer supply while performing tasks that do not need electricity. Electricity can cause the death or injury. Moving components can cause the injury.

Action	Yes	No
Step 1 1 From the Home screen, touch Settings > Device > Preferences . 2 Check if the paper size matches the size set on the tray guides. The paper size will match the size set on the tray.	Go to step 3.	Go to step 2.
Step 2 Change the paper size or adjust the size setting in the tray. The fault persists.	Go to step 3.	The problem is solved.
Step 3 Check the redrive paper path for paper jams and obstructions. The paper path is free of jams and obstructions.	Go to step 5.	Go to step 4.
Step 4 Remove the jams and obstructions. The fault persists.	Go to step 5.	The problem is solved.
Step 5 Check the duplex paper path for paper jams and obstructions.	Go to step 7.	Go to step 6.

Action	Yes	No
The paper path free of jams and obstructions.		
Step 6 Remove the jams and obstructions. The fault persists.	Go to step 7.	The problem is solved.
Step 7 Inspect the ribs on the top frame base cover for wear, nicks, or other damage that could obstruct the paper path. There is any damage.	Go to step 8.	Go to step 9.
Step 8 Install a new top frame base cover. See REP 28.7 . The fault persists.	Go to step 9.	The problem is solved.
Step 9 Check the diverter for smooth movement. The diverter will freely move without interference.	Go to step 11.	Go to step 10.
Step 10 Install a new diverter. See PL 80.10 item 1 . The fault persists.	Go to step 11.	The problem is solved.
Step 11 1 Enter the Diagnostics menu GP 1 , and then navigate to: Printer diagnostics & adjustments >Sensor tests 2 Find the sensor (Redrive/ Duplex Path 1). The sensor status will change while toggling the sensor.	Go to step 13.	Go to step 12.
Step 12 Install a new sensor. See PL 80.10 item 2 . The fault persists.	Go to step 13.	The problem is solved.
Step 13 1 Enter the Diagnostics menu GP 1 , and then navigate to:	Go to step 15.	Go to step 14.

Action	Yes	No
Printer diagnostics & adjustments >Motor tests > Redrive 2 Select a setting, and then touch Start . The motor will run.		
Step 14 Ensure that the JOUTDC1 connector on the engine board is properly connected. The fault persists.	Go to step 15.	The problem is solved.
Step 15 Install a new motor (exit/re-drive). See PL 80.05 item 10 . The fault persists.	Contact the next level of support.	The problem is solved.

377-252-00, 377-256-00, 377-260-00, 377-264-00, 377-269-00, 377-286-00 Duplex Entry/Park Sensor RAP

WD2 Drive PWB Wiring Diagram

C625 Wiring Diagrams

377-252-00 MPF Duplex entry/park sensor never cleared by trailing edge of page RAP

377-256-00 Tray 1 Duplex park sensor never cleared by trailing edge of page RAP

377-260-00 Tray 2 Duplex park sensor never cleared by trailing edge of page RAP

377-264-00 Tray 3 Duplex park sensor never cleared by trailing edge of page RAP

377-286-00 Tray 4 Duplex entry sensor never cleared by trailing edge of page RAP

377-269-00 Tray 5 Duplex park sensor never cleared by trailing edge of page RAP

Procedure



WARNING: Switch off the electricity to the machine, GP 10. Disconnect the power lead from the customer supply while performing tasks that do not need electricity. Electricity can cause the death or injury. Moving components can cause the injury.

Action	Yes	No
Step 1 1 From the Home screen, touch Settings >Device > Preferences . 2 Check if the paper size matches the size set on the tray guides. The paper size will match the size set on the tray.	Go to step 3.	Go to step 2.
Step 2 Change the paper size or adjust the size setting in the tray. The fault persists.	Go to step 3.	The problem is solved.
Step 3 Check if the paper size matches the size set on the tray guides. The paper will size match the size set on the tray.	Go to step 5.	Go to step 4.
Step 4 Change the paper size or adjust the size setting in the tray. The fault persists.	Go to step 5.	The problem is solved.
Step 5	Go to step 7.	Go to step 6.

Action	Yes	No
Check the paper path for paper jams and obstructions. The paper path is free of jams and obstructions.		
Step 6 Remove the jams and obstructions. The fault persists.	Go to step 7.	The problem is solved.
Step 7 1 Enter the Diagnostics menu GP 1, and then navigate to: Printer diagnostics & adjustments >Sensor tests 2 Find the sensor (Redrive/ Duplex path 1). The sensor status will change while toggling the sensor.	Go to step 10.	Go to step 8.
Step 8 1 Ensure that the sensor cable is properly connected. 2 Check the sensor for damage. The sensor is free of damage.	Go to step 10.	Go to step 9.
Step 9 Install a new sensor. See PL 80.10 item 2. The fault persists.	Go to step 10.	The problem is solved.
Step 10 1 Enter the Diagnostics menu GP 1, and then navigate to: Printer diagnostics & adjustments >Motor tests > Duplex/MPF 2 Select a setting, and then touch Start . The motor will run.	Contact the next level of support.	Go to step 11.

Action	Yes	No
Step 11 1 Ensure that the motor cable is properly connected. 2 Check the motor for damage. The motor is free of damage.	Contact the next level of support.	Go to step 12.
Step 12 1 Install a new motor. See PL 80.05 item 6 . 2 Perform a print job. The fault persists.	Contact the next level of support.	The problem is solved.

377-270-00, 377-404-00, 377-407-00, 377-410-00, 374-232-00, 377-421-00, 377-419-00 S1/Input/Stage Sensor RAP

WD2 Drive PWB Wiring Diagram

C625 Wiring Diagrams

377-270-00 MPF S1/Input/stage sensor never made by leading edge of page during duplex pass RAP

377-404-00 Tray 1 S1/Input/stage sensor never made by leading edge of page during duplex pass RAP

377-407-00 Tray 2 S1/Input/stage sensor never made by leading edge of page during duplex pass RAP

377-410-00 Tray 3 S1/Input/stage sensor never made by leading edge of page during duplex pass RAP

374-232-00 Tray 4 S1/Input/stage sensor never made by leading edge of page during duplex pass RAP

377-421-00 Tray 5 S1/Input/stage sensor never made by leading edge of page during duplex pass RAP

377-419-00 Unknown S1/Input/stage sensor never made by leading edge of page during duplex pass RAP

Procedure



WARNING: Switch off the electricity to the machine, [GP 10](#). Disconnect the power lead from the customer supply while performing tasks that do not need electricity. Electricity can cause the death or injury. Moving components can cause the injury.

Action	Yes	No
Step 1 Check the duplex paper path for paper jams and obstructions. The paper path is free of jams and obstructions.	Go to step 3.	Go to step 2.
Step 2 Remove the jams and obstructions. The fault persists.	Go to step 3.	The problem is solved.
Step 3 Check the sensor (MPF/pass-through) area for paper jams and obstructions. The paper path is free of jams and obstructions.	Go to step 5.	Go to step 4.
Step 4 Remove the jams and obstructions. The fault persists.	Go to step 5.	The problem is solved.

Action	Yes	No
<p>Step 5</p> <p>1 Enter the Diagnostics menu GP 1, and then navigate to:</p> <p>Printer diagnostics & adjustments >Sensor tests</p> <p>2 Find the sensor (MPF/pass-through).</p> <p>The sensor status will change while toggling the sensor.</p>	Go to step 8.	Go to step 6.
<p>Step 6</p> <p>1 Ensure that the sensor cable is properly connected.</p> <p>2 Check the sensor and its flag for damage.</p> <p>3 Check the isolation unit components for damage.</p> <p>The sensor and isolation unit components are free of damage.</p>	Go to step 8.	Go to step 7.
<p>Step 7</p> <p>Install a new isolation unit. See PL 80.10 item 3.</p> <p>The fault persists.</p>	Go to step 8.	The problem is solved.
<p>Step 8</p> <p>1 Enter the Diagnostics menu GP 1, and then navigate to:</p> <p>Printer diagnostics & adjustments >Motor tests > Duplex/MPF</p> <p>2 Select a setting, and then touch Start.</p> <p>The motor will run.</p>	Go to step 11.	Go to step 9.
<p>Step 9</p> <p>1 Ensure that the motor cable is properly connected.</p> <p>2 Check the motor for damage.</p> <p>The motor is free of damage.</p>	Go to step 11.	Go to step 10.
<p>Step 10</p> <p>1 Install a new motor. See PL 80.05 item 6.</p> <p>2 Perform a print job.</p> <p>The fault persists.</p>	Go to step 11.	The problem is solved.

Action	Yes	No
<p>Step 11</p> <p>Check the duplex inner guide and its gears, belts, and rollers for damage.</p> <p>The duplex inner guide and its components are free of damage.</p>	Contact the next level of support.	Go to step 12.
<p>Step 12</p> <p>1 Install a new duplex inner guide. See PL 80.15 item 1.</p> <p>2 Perform a print job.</p> <p>The fault persists.</p>	Contact the next level of support.	The problem is solved.

377-271-00, 377-324-00, 377-327-00, 377-329-00, 377-331-00, 377-333-00 Alt S1 Sensor RAP

WD2 Drive PWB Wiring Diagram

C625 Wiring Diagrams

377-271-00 MPF Pass through sensor never cleared by trailing edge of page from RAP

377-324-00 Tray 1 Alt S1 sensor never uncovered after picking a page from tray X - source RAP

377-327-00 Tray 2 Alt S1 sensor never uncovered after picking a page from tray X - source RAP

377-329-00 Tray 3 Alt S1 sensor never uncovered after picking a page from tray X - source RAP

377-331-00 Tray 4 Alt S1 sensor never uncovered after picking a page from tray X - source RAP

377-333-00 Tray 5 Alt S1 sensor never uncovered after picking a page from tray X - source RAP

Procedure



WARNING: Switch off the electricity to the machine, GP 10 . Disconnect the power lead from the customer supply while performing tasks that do not need electricity. Electricity can cause the death or injury. Moving components can cause the injury.

Action	Yes	No
Step 1 1 From the Home screen, touch Settings > Device > Preferences . 2 Check if the paper size matches the size set on the tray guides. The paper size will match the size set on the tray.	Go to step 3.	Go to step 2.
Step 2 Change the paper size or adjust the size setting in the tray. The fault persists.	Go to step 3.	The problem is solved.
Step 3 Check the duplex and MPF paper paths for paper jams and obstructions. The paper paths are free of jams and obstructions.	Go to step 5.	Go to step 4.
Step 4 Remove the paper jams and obstructions. The fault persists.	Go to step 5.	The problem is solved.
Step 5	Go to step 7.	Go to step 6.

Action	Yes	No
Check the tray insert and its paper path guides and drive gears for damage. The tray insert is free of damage.		
Step 6 Install a new tray insert. See PL 70.10 item 4 . The fault persists.	Go to step 7.	The problem is solved.
Step 7 1 Enter the Diagnostics menu GP 1 , and then navigate to: Printer diagnostics & adjustments > Sensor tests 2 Find the sensor (MPF/pass-through). The sensor status will change while toggling the sensor.	Contact the next level of support.	Go to step 8.
Step 8 1 Ensure that the sensor cable is properly connected. 2 Check the sensor and its flag for damage. 3 Check the isolation unit components for damage. The sensor and isolation unit components are free of damage.	Contact the next level of support.	Go to step 9.
Step 9 Install a new isolation unit. See PL 80.10 item 4 . The fault persists.	Contact the next level of support.	The problem is solved.

377-272-00, 377-273-00 MPF Motor RAP

WD2 Drive PWB Wiring Diagram

C625 Wiring Diagrams

377-272-00 MPF Motor Stall RAP

377-273-00 MPF Motor Under Speed RAP

Procedure



WARNING: Switch off the electricity to the machine, GP 10. Disconnect the power lead from the customer supply while performing tasks that do not need electricity. Electricity can cause the death or injury. Moving components can cause the injury.

Action	Yes	No
Step 1 Check if the MPF is the source tray used during the error. The MPF is the source tray.	Go to step 2.	Go to step 6.
Step 2 Check the MPF for overfilling. The tray is overfilled.	Go to step 3.	Go to step 4.
Step 3 Remove the excess paper from the MPF. The fault persists.	Go to step 4.	The problem is solved.
Step 4 Check the paper condition in the MPF. Check whether the paper crumpled or damaged.	Go to step 5.	Go to step 6.
Step 5 Check whether the crumpled or damaged paper is removed and insert new paper. The fault persists.	Go to step 6.	The problem is solved.
Step 6 Check the duplex and MPF paper path guides along the tray 1 exit area. The paper path is free of paper fragments and contamination.	Go to step 7.	Go to step 8.
Step 7 Clean the paper path. The fault persists.	Go to step 8.	The problem is solved.
Step 8	Contact the next level of support.	Go to step 9.

Action	Yes	No
<ol style="list-style-type: none"> 1 Enter the Diagnostics menu GP 1, and then navigate to: Printer diagnostics & adjustments > Motor tests > Duplex/MPF 2 Select a setting, and then touch Start. The motor will run. 		
Step 9 <ol style="list-style-type: none"> 1 Ensure that the motor cable JMTR1 on the engine board is properly connected. 2 Check the motor for damage. The motor is free of damage. 	Contact the next level of support.	Go to step 10.
Step 10 <ol style="list-style-type: none"> 1 Install a new motor. See PL 80.05 item 6. 2 Perform a print job. The fault persists. 	Contact the next level of support.	The problem is solved.

374-336-00, 375-243-00, 375-336-00, 375-340-00, 377-275-00 Tray (4, 5) Never Arriving Jam From Normal Path Error RAPs

WD2 Drive PWB Wiring Diagram

C625 Wiring Diagrams

374-336-00 Tray 4 Never Arriving Jam From Normal Path RAP

375-243-00 Tray 5 Never Arriving Jam From Normal Path RAP

375-336-00 Tray 5 Never Arriving Jam From Normal Path RAP

375-340-00 Never Arriving Jam From Normal Path RAP. Option declared jam, or warm up jam with no known page source.

377-275-00 Never Arriving Jam From Normal Path RAP. Option declared jam, or warm up jam with no known page source.



WARNING: Switch off the electricity to the machine, GP 10. Disconnect the power lead from the customer supply while performing tasks that do not need electricity. Electricity can cause the death or injury. Moving components can cause the injury.

Procedure

Action	Yes	No
Step 1 1 From the Home screen, touch Settings >Device > Preferences . 2 Check if the paper size matches the size set on the tray guides. The paper size will match the size set on the tray.	Go to step 3.	Go to step 2.
Step 2 Change the paper size or adjust the size setting in the tray. The fault persists.	Go to step 3.	The problem is solved.
Step 3 Check if the paper size matches the size set on the tray guides. The paper size will match the size set on the tray.	Go to step 5.	Go to step 4.
Step 4 Install the new paper or change the paper size setting in the tray. The fault persists.	Go to step 5.	The problem is solved.
Step 5	Go to step 6.	Go to step 7.

Action	Yes	No
Check the paper tray for overfilling. The paper tray is overfilled.		
Step 6 Remove the excess paper from the tray. The fault persists.	Go to step 7.	The problem is solved.
Step 7 Check the paper condition in the tray. The paper is crumpled or damaged.	Go to step 8.	Go to step 9.
Step 8 Replace the crumpled or damaged paper. The fault persists.	Go to step 9.	The problem is solved.
Step 9 Check the paper path for partially fed or jammed paper. The paper path is free of partially fed or jammed paper.	Go to step 11.	Go to step 10.
Step 10 Remove the partially fed or jammed paper. The fault persists.	Go to step 11.	The problem is solved.
Step 11 1 Enter the Diagnostics menu GP 1, and then navigate to: Additional input trays adjustments/tests >Additional input tray sensors 2 Find the sensor (Pass-through (tray 4)). The sensor status will change while toggling the sensor.	Go to step 13.	Go to step 12.
Step 12 1 Ensure that the sensor cable is properly connected. 2 Ensure that the sensor is properly installed. 3 Check the sensor and the other optional tray components for damage. The sensor is free of damage.	Go to step 13.	Go to step 15.

Action	Yes	No
Step 13 1 Enter the Diagnostics menu GP 1 , and then navigate to: Additional input trays adjustments/tests >Additional input tray motors 2 Select Pass-through (tray 4) , and then touch Start . The motor will run.	Go to step 16.	Go to step 14.
Step 14 1 Ensure that the motor cable is properly connected. 2 Ensure that the motor is properly installed. 3 Check the motor and the other optional tray components for damage. The motor and the optional tray are free of damage.	Go to step 16.	Go to step 15.
Step 15 Install the new 550 optional tray. See PL 70.15 item 1 . The fault persists.	Go to step 16.	The problem is solved.
Step 16 1 Enter the Diagnostics menu GP 1 , and then navigate to: Additional input trays adjustments/tests >Additional input tray motors 2 Select Pass-through (tray 5) , and then touch Start . The motor will run.	Go to step 19.	Go to step 17.
Step 17 1 Ensure that the motor cable is properly connected. 2 Ensure that the motor is properly installed. 3 Check the motor and the other optional tray components for damage. The motor and optional tray is free of damage.	Go to step 19.	Go to step 18.

Action	Yes	No
Step 18 Install a new 550 sheet optional tray. See PL 70.15 item 1 . The fault persists.	Go to step 19.	The problem is solved.
Step 19 Perform a print test. The fault persists.	Contact the next level of support.	The problem is solved.

372-105-00, 372-112-00, 372-148-00, 372-337-00, 373-105-00, 373-148-00, 374-112-00, 374-148-00, 374-338-00, 375-240-00, 375-244-00, 375-338-00, 375-342-00, 377-276-00 Late Leaving Jam Tray (3, 4, 5) RAP

WD2 Drive PWB Wiring Diagram

C625 Wiring Diagrams

372-105-00 Tray 2 Late jam RAP

372-112-00 Tray 3 Late Leaving Jam (Paper reaches sensor but clears it late-(Long media, double feed) RAP

372-148-00 Late Leaving Jam. Option declared jam, or warm up jam with no known page source RAP

372-337-00 Tray 5 Late Leaving Jam (Paper reaches sensor but clears it late-(Long media, double feed) RAP

373-105-00 Tray 3 Regi Senor On Jam RAP

373-148-00 Late Leaving Jam. Option declared jam, or warm up jam with no known page source RAP

374-112-00 Tray 4 Late Leaving Jam (Paper reaches sensor but clears it late-(Long media, double feed) RAP

374-148-00 Tray 4 Late Leaving Jam (Paper reaches sensor but clears it late-(Long media, double feed) RAP

374-338-00 Tray 4 Late Leaving Jam (Paper reaches sensor but clears it late-(Long media, double feed) RAP

375-240-00 Tray 5 Late Leaving Jam (Paper reaches sensor but clears it late-(Long media, double feed) RAP

375-244-00 Tray 5 Late Leaving Jam (Paper reaches sensor but clears it late-(Long media, double feed) RAP

375-338-00 Tray 5 Late Leaving Jam (Paper reaches sensor but clears it late-(Long media, double feed) RAP

375-342-00 Late Leaving Jam. Option declared jam, or warm up jam with no known page source RAP

377-276-00 Late Leaving Jam. Option declared jam, or warm up jam with no known page source RAP

Procedure



WARNING: Switch off the electricity to the machine, GP 10 . Disconnect the power lead from the customer supply while performing tasks that do not need electricity. Electricity can cause the death or injury. Moving components can cause the injury.

Action	Yes	No
Step 1 1 From the Home screen, touch Settings >Device > Preferences. 2 Check if the paper size matches the size set on the tray guides. The paper size will match the size set on the tray.	Go to step 3.	Go to step 2.
Step 2 Change the paper size or adjust the size setting in the tray. The fault persists.	Go to step 3.	The problem is solved.
Step 3 Check if the paper size matches the size set on the tray guides. The paper size will match the size set on the tray.	Go to step 5.	Go to step 4.
Step 4 Insert new paper or change the paper size setting in the tray. The fault persists.	Go to step 5.	The problem is solved.
Step 5 Check the primary paper path for paper jams and obstructions. The paper path is free of jams and obstructions.	Go to step 7.	Go to step 6.
Step 6 Remove the paper jams and obstructions. The fault persists.	Go to step 7.	The problem is solved.
Step 7 1 Enter the Diagnostics menu GP 1 , and then navigate to: Additional input trays adjustments/tests >Additional input tray sensors 2 Find the sensor (Trailing edge (tray [x])). Note: [x] is the tray number.	Go to step 9.	Go to step 8.

Action	Yes	No
The sensor status will change while toggling the sensor.		
Step 8 1 Ensure that the sensor cable is properly connected. 2 Ensure that the sensor is properly installed. 3 Check the sensor and the other optional tray components for damage. The sensor is free of damage.	Go to step 9.	Go to step 13.
Step 9 1 Enter the Diagnostics menu GP 1 , and then navigate to: Additional input trays adjustments/tests > Additional input tray sensors 2 Find the sensor (Pass-through (tray [x])). Note: [x] is the tray number. The sensor status will change while toggling the sensor.	Go to step 11.	Go to step 10.
Step 10 1 Ensure that the sensor cable is properly connected. 2 Ensure that the sensor is properly installed. 3 Check the sensor and the other optional tray components for damage. The sensor and the optional tray are free of damage.	Go to step 11.	Go to step 11.
Step 11 1 Enter the Diagnostics menu GP 1 , and then navigate to: Additional input trays adjustments/tests > Additional input tray motors 2 Select Pass-through (tray [x]) , and then touch Start . Note: [x] is the tray number.	Go to step 14.	Go to step 12.

Action	Yes	No
The motor will run.		
Step 12 1 Ensure that the motor cable is properly connected. 2 Ensure that the motor is properly installed. 3 Check the motor and the other optional tray components for damage. The motor and the optional tray are free of damage.	Go to step 14.	Go to step 13.
Step 13 Install a new optional tray. See PL 70.15 item 1 . The fault persists.	Go to step 14.	The problem is solved.
Step 14 1 Enter the Diagnostics menu GP 1 , and then navigate to: Printer diagnostics & adjustments > Motor tests 2 Select Duplex/MPF , and then touch Start . The motor will run.	Go to step 17.	Go to step 15.
Step 15 Reseat the motor cable, and then check the motor form is alignment and damage. The motor is properly installed and free of damage.	Go to step 17.	Go to step 16.
Step 16 Install a new motor. See PL 80.05 item 6 . The fault persists.	Go to step 17.	The problem is solved.
Step 17 Perform a print test. The fault persists.	Contact the next level of support.	The problem is solved.

372-100-00, 372-150-00, 372-330-00, 372-333-00, 372-338-00, 373-100-00, 373-150-00, 373-332-00, 373-341-00, 374-150-00, 374-341-00, 375-246-00, 375-343-00, 377-277-00
Tray 2, 3, 4, 5 Fail To Pick Error RAP

WD2 Drive PWB Wiring Diagram

C625 Wiring Diagrams

372-100-00 Tray 2 Mis feed_ Empty RAP

372-150-00 Fail To Pick From Tray. Option declared jam, or warm up jam with unknown page RAP

372-330-00 Tray 3 Fail To Pick From Tray (Paper did not reach first sensor; Miss-feed, tray empty) RAP

372-333-00 Tray 4 Fail To Pick From Tray (Paper did not reach first sensor; Miss-feed, tray empty) RAP

372-338-00 Tray 5 Fail To Pick From Tray (Paper did not reach first sensor; Miss-feed, tray empty) RAP

373-100-00 Tray 3 Mis feed_ Empty RAP

373-150-00 Fail To Pick From Tray Option declared jam, or warm up jam with unknown page RAP

373-332-00 Tray 4 Fail To Pick From Tray RAP

373-341-00 Tray 5 Fail To Pick From Tray (Paper did not reach first sensor; Miss-feed, tray empty) RAP

374-150-00 Tray 4 Fail To Pick From Tray (Paper did not reach first sensor; Miss-feed, tray empty) RAP

374-341-00 Tray 5 Fail To Pick From Tray (Paper did not reach first sensor; Miss-feed, tray empty) RAP

375-246-00 Tray 5 Fail To Pick From Tray (Paper did not reach first sensor; Miss-feed, tray empty) RAP

375-343-00 Fail To Pick From Tray. Option declared jam, or warm up jam with unknown page RAP

377-277-00 Fail To Pick From Tray. Option declared jam, or warm up jam with unknown page RAP

Procedure



WARNING: Switch off the electricity to the machine, GP 10 . Disconnect the power lead from the customer supply while performing tasks that do not need electricity. Electricity can cause the death or injury. Moving components can cause the injury.

Action	Yes	No
Step 1 1 From the Home screen, touch Settings >Device > Preferences. 2 Check if the paper size matches the size set on the tray guides. The paper size will match the size set on the tray.	Go to step 3.	Go to step 2.
Step 2 Change the paper size or adjust the size setting in the tray. The fault persists.	Go to step 3.	The problem is solved.
Step 3 Check if the paper size matches the size set on the tray guides. The paper size will match the size set on the tray.	Go to step 5.	Go to step 4.
Step 4 Insert new paper or change the paper size setting in the tray. The fault persists.	Go to step 5.	The problem is solved.
Step 5 Check the paper tray for overfilling. The paper tray overfilled.	Go to step 6.	Go to step 7.
Step 6 Remove the excess paper from the tray. The fault persists.	Go to step 7.	The problem is solved.
Step 7 Check the paper condition in the tray. The paper crumpled or damaged.	Go to step 8.	Go to step 9.
Step 8 Check whether the crumbled or damaged paper is removed and insert new paper. The fault persists.	Go to step 9.	The problem is solved.
Step 9	Go to step 11.	Go to step 10.

Action	Yes	No
<p>1 Ensure that the optional tray pick roller is properly installed.</p> <p>Note: Firmly press the pick roller to its shaft to make sure that is properly engaged.</p> <p>2 Check the optional tray pick roller for excess wear, contamination, and damage.</p> <p>The optional tray pick roller is free from excess wear, contamination, and damage.</p>		
<p>Step 10 Install a new pick roller. See PL 70.10 item 7. The fault persists.</p>	Go to step 11.	The problem is solved.
<p>Step 11 Check the tray exit paper path for paper fragments and contamination. The paper path is free of paper fragments and contamination.</p>	Go to step 15.	Go to step 12.
<p>Step 12 Clean the paper path. The fault persists.</p>	Go to step 13.	The problem is solved.
<p>Step 13</p> <p>1 Enter the Diagnostics menu GP 1, and then navigate to: Additional input trays adjustments/tests > Additional input tray sensors</p> <p>2 Find the sensor (Trailing edge (tray [x])).</p> <p>Note: [x] is the tray number. The sensor status will change while toggling the sensor.</p>	Go to step 15.	Go to step 14.
<p>Step 14</p> <p>1 Ensure that the sensor cable is properly connected.</p> <p>2 Ensure that the sensor is properly installed.</p>	Go to step 15.	Go to step 17.

Action	Yes	No
<p>3 Check the sensor and the other optional tray components for damage. The sensor and optional tray are free of damage.</p>		
<p>Step 15</p> <p>1 Enter the Diagnostics menu, GP 1 and then navigate to: Additional input tray diagnostics > Motor tests</p> <p>2 Select Pick (tray [x]), and then touch Start. The motor will run.</p>	Go to step 18.	Go to step 16.
<p>Step 16</p> <p>1 Ensure that the motor cable is properly connected.</p> <p>2 Ensure that the motor is properly installed.</p> <p>3 Check the motor and the other optional tray components for damage. The motor and the optional tray are free of damage.</p>	Go to step 18.	Go to step 17.
<p>Step 17 Install a new optional tray. See PL 70.15 item 1. The fault persists.</p>	Go to step 18.	The problem is solved.
<p>Step 18 Perform a print test. The fault persists.</p>	Contact the next level of support.	The problem is solved.

375-344-00, 377-278-00 Sensor Did Not Clear Error RAP

WD2 Drive PWB Wiring Diagram

C625 Wiring Diagrams

375-344-00 Sensor Did Not Clear (Previous sheet did not clear sensor so next sheet could look for an input make) RAP

377-278-00 Sensor Did Not Clear (Previous sheet did not clear sensor so next sheet could look for an input make) RAP



WARNING: Switch off the electricity to the machine, GP 10 . Disconnect the power lead from the customer supply while performing tasks that do not need electricity. Electricity can cause the death or injury. Moving components can cause the injury.

Procedure

Action	Yes	No
Step 1 1 From the Home screen, touch Settings >Device > Preferences . 2 Check if the paper size matches the size set on the tray guides. The paper size will match the size set on the tray.	Go to step 3.	Go to step 2.
Step 2 Change the paper size or adjust the size setting in the tray. The fault persists.	Go to step 3.	The problem is solved.
Step 3 Check the paper path for partially fed or jammed paper. The paper path is free of partially fed or jammed paper.	Go to step 5.	Go to step 4.
Step 4 Remove the partially fed or jammed paper. The fault persists.	Go to step 5.	The problem is solved.
Step 5 1 Enter the Diagnostics menu GP 1, and then navigate to: Additional input trays adjustments/tests >Additional input tray sensors 2 Find the sensor (Trailing edge (tray [x])).	Go to step 7.	Go to step 6.

Action	Yes	No
Note: [x] is the tray number. The sensor status will change while toggling the sensor.		
Step 6 1 Ensure that the sensor cable is properly connected. 2 Ensure that the sensor is properly installed. 3 Check the sensor for damage. The is sensor free of damage.	Go to step 7.	Go to step 11.
Step 7 1 Enter the Diagnostics menu GP 1, and then navigate to: Additional input trays adjustments/tests >Additional input tray sensors 2 Find the sensor (Pass-through (tray [x])). Note: [x] is the tray number. The sensor status will change while toggling the sensor.	Go to step 9.	Go to step 8.
Step 8 1 Ensure that the sensor cable is properly connected. 2 Ensure that the sensor is properly installed. 3 Check the sensor and the other optional tray components for damage. The sensor is free of damage.	Go to step 9.	Go to step 11.
Step 9 1 Enter the Diagnostics menu GP 1, and then navigate to: Additional input trays adjustments/tests >Additional input tray motors 2 Select Pass-through (tray [x]) , and then touch Start . Note: [x] is the tray number. The motor will run.	Go to step 12.	Go to step 10.

Action	Yes	No
Step 10 1 Ensure that the motor cable is properly connected. 2 Ensure that the motor is properly installed. 3 Check the motor and the other optional tray components for damage. The motor and 550 sheet optional tray are free of damage.	Go to step 12.	Go to step 11.
Step 11 Install a new 550 sheet optional tray. See PL 70.15 item 1 . The fault persists.	Go to step 12.	The problem is solved.
Step 12 1 Enter the Diagnostics menu GP 1 , and then navigate to: Printer diagnostics & adjustments > Motor tests 2 Find the motor (Duplex/MPF), and then touch Start . The motor will run.	Go to step 15.	Go to step 13.
Step 13 Reconnect the motor cable, and then check the motor for misalignment and damage. The motor properly is installed and free of damage.	Go to step 15.	Go to step 14.
Step 14 Install a new motor. See PL 80.05 item 6 . The fault persists.	Go to step 15.	The problem is solved.
Step 15 Perform a print test. The fault persists.	Contact the next level of support.	The problem is solved.

377-283-00, 377-284-00 Bump Exit Sensor Error RAP

377-283-00 Bump exit sensor never cleared by trailing edge of page- Source is tray MPF RAP

377-284-00 Bump exit sensor covered at warmup RAP



WARNING: Switch off the electricity to the machine, [GP 10](#). Disconnect the power lead from the customer supply while performing tasks that do not need electricity. Electricity can cause the death or injury. Moving components can cause the injury.

Switch OFF, then switch ON the machine, [GP 10](#). If the fault persists, contact 2nd Level Support.

377-287-00, 377-288-00, 377-290-00, 377-294-00, 377-298-00 Duplex Stage Sensor RAP

WD2 Drive PWB Wiring Diagram

C625 Wiring Diagrams

377-287-00 Tray 1 Duplex stage sensor cleared by page too soon RAP

377-288-00 Tray 2 Duplex stage sensor cleared by page too soon RAP

377-290-00 Tray 3 Duplex stage sensor cleared by page too soon RAP

377-294-00 Tray 4 Duplex stage sensor cleared by page too soon RAP

377-298-00 Tray 5 Duplex stage sensor cleared by page too soon RAP

Procedure



WARNING: Switch off the electricity to the machine, GP 10. Disconnect the power lead from the customer supply while performing tasks that do not need electricity. Electricity can cause the death or injury. Moving components can cause the injury.

Action	Yes	No
Step 1 1 From the Home screen, touch Settings > Device > Preferences . 2 Check if the paper size matches the size set on the tray guides. The paper size will match the size set on the tray.	Go to step 3.	Go to step 2.
Step 2 Change the paper size or adjust the size setting in the tray. The fault persists.	Go to step 3.	The problem is solved.
Step 3 Check the duplex inner guide and its gears, belts, and rollers for damage. The duplex inner guide and its components are free of damage.	Go to step 5.	Go to step 4.
Step 4 1 Install a new duplex inner guide. See PL 80.15 item 1. 2 Perform a print job. The fault persists.	Go to step 5.	The problem is solved.
Step 5	Go to step 8.	Go to step 6.

Action	Yes	No
1 Enter the Diagnostics menu GP 1, and then navigate to: Printer diagnostics & adjustments > Sensor tests 2 Find the sensor (Duplex path 2). The sensor status will change while toggling the sensor.		
Step 6 1 Ensure that the sensor cable is properly connected. 2 Check the sensor for damage. The sensor is free of damage.	Go to step 8.	Go to step 7.
Step 7 Install a new sensor (duplex staging). See PL 80.15 item 1. The fault persists.	Go to step 8.	The problem is solved.
Step 8 Perform a print job. The fault persists.	Contact the next level of support.	The problem is solved.

377-289-00, 377-292-00, 377-296-00 Duplex Stage Sensor RAP

377-289-00 Tray 3 Duplex stage sensor covered too soon RAP

377-292-00 Tray 4 Duplex stage sensor covered too soon RAP

377-296-00 Tray 5 Duplex stage sensor covered too soon RAP

Procedure



WARNING: Switch off the electricity to the machine, GP 10. Disconnect the power lead from the customer supply while performing tasks that do not need electricity. Electricity can cause the death or injury. Moving components can cause the injury.

Action	Yes	No
Step 1 1 From the Home screen, touch Settings > Device > Preferences . 2 Check if the paper size matches the size set on the tray guides. The paper size will match the size set on the tray.	Go to step 3.	Go to step 2.
Step 2 Change the paper size or adjust the size settings in the tray. The fault persists.	Go to step 3.	The problem is solved.
Step 3 1 From the Home screen, touch Settings > Device > Preferences . 2 Check if the paper settings matches the paper in the tray guides. The paper settings will match the paper in the tray.	Go to step 5.	Go to step 4.
Step 4 Change the paper size and type, or adjust the size settings in the tray to match the paper size. The fault persists.	Go to step 5.	The problem is solved.

Action	Yes	No
Step 5 Check the duplex paper path for paper jams and obstructions. The paper path is free of jams and obstructions.	Go to step 6.	Go to step 6.
Step 6 Remove the jams and obstructions. The fault persists.	Contact the next level of support.	The problem is solved.

377-320-00 All Feed Tray Broken RAP

All the Feed Trays that are connected to the IOT were detected to have malfunctioned.

Procedure



WARNING: Switch off the electricity to the machine, GP 10 . Disconnect the power lead from the customer supply while performing tasks that do not need electricity. Electricity can cause the death or injury. Moving components can cause the injury.

Enter dC122 Fail History. Go to the RAP of the affected Paper Tray.

377-321-00 Duplex Stage Sensor Covered Warm Up RAP

[WD2 Drive PWB Wiring Diagram](#)

[C625 Wiring Diagrams](#)

377-321-00 Duplex stage sensor covered at warm up RAP

Procedure



WARNING: Switch off the electricity to the machine, GP 10 . Disconnect the power lead from the customer supply while performing tasks that do not need electricity. Electricity can cause the death or injury. Moving components can cause the injury.

Action	Yes	No
Step 1 1 From the Home screen, touch Settings >Device > Preferences . 2 Check if the paper size matches the size set on the tray guides. The paper size will match the size set on the tray.	Go to step 3.	Go to step 2.
Step 2 Change the paper size or adjust the size setting in the tray. The fault persists.	Go to step 3.	The problem is solved.
Step 3 Check the paper path for partially fed or jammed paper. The paper path is free of partially fed or jammed paper.	Go to step 5.	Go to step 4.
Step 4 Remove the partially fed or jammed paper. The fault persists.	Go to step 5.	The problem is solved.
Step 5 1 Enter the Diagnostics menu GP 1, and then navigate to: Printer diagnostics & adjustments >Sensor tests 2 Find the sensor (Duplex path 2). The sensor status will change while toggling the sensor.	Contact the next level of support.	Go to step 6.

Action	Yes	No
Step 6 1 Ensure that the sensor cable is properly connected. 2 Check the sensor for damage. The sensor is free of damage.	Contact the next level of support.	Go to step 7.
Step 7 1 Install a new sensor (duplex staging). See PL 80.15 item 1. 2 Perform a print job. The fault persists.	Contact the next level of support.	The problem is solved.

377-322-00, 377-323-00, 377-325-00 Alt S1 Sensor Error RAP

377-322-00 Alt S1 sensor covered too soon- Source is tray 1- RAP

377-323-00 Alt S1 sensor cleared by page too soon- Source is tray 1- RAP

377-325-00 Alt S1 sensor never made by leading edge after picking a page from tray 1- RAP



WARNING: Switch off the electricity to the machine, GP 10 . Disconnect the power lead from the customer supply while performing tasks that do not need electricity. Electricity can cause the death or injury. Moving components can cause the injury.

Switch OFF, then switch ON the machine, GP 10. If the fault persists, contact 2nd Level Support.

377–326–00 Tray 2 Alt S1 Sensor RAP

WD2 Drive PWB Wiring Diagram

C625 Wiring Diagrams

377-326-00 Tray 2 Alt S1 sensor never made by leading edge after picking a page RAP

Procedure



WARNING: Switch off the electricity to the machine, GP 10. Disconnect the power lead from the customer supply while performing tasks that do not need electricity. Electricity can cause the death or injury. Moving components can cause the injury.

Action	Yes	No
Step 1 1 From the Home screen, touch Settings >Device > Preferences . 2 Check if the paper size matches the size set on the tray guides. The paper size will match the size set on the tray.	Go to step 3.	Go to step 2.
Step 2 Change the paper size or adjust the size setting in the tray. The fault persists.	Go to step 3.	The problem is solved.
Step 3 Check the tray for overfilling. The tray is overfilled.	Go to step 4.	Go to step 5.
Step 4 Remove the excess paper from the tray. The fault persists.	Go to step 5.	The problem is solved.
Step 5 Check the paper condition in the tray. The paper is crumpled or damaged.	Go to step 6.	Go to step 7.
Step 6 Check whether the crumpled or damaged paper is removed and insert new paper. The fault persists.	Go to step 7.	The problem is solved.
Step 7 1 Ensure that the tray 2 pick roller is properly installed.	Go to step 9.	Go to step 8.

Action	Yes	No
Note: Firmly press the pick roller to its shaft to make sure that is properly engaged. 2 Check the tray 2 pick roller for excess wear, contamination, and damage. The tray 2 pick roller is free from excess wear, contamination, and damage.		
Step 8 Install a new tray 2 pick roller. See PL 70.15 item 5. The fault persists.	Go to step 9.	The problem is solved.
Step 9 Check the tray exit paper path for fragments and contamination. The paper path is free of fragments and contamination.	Go to step 11.	Go to step 10.
Step 10 Clean the paper path. The fault persists.	Go to step 11.	The problem is solved.
Step 11 1 Enter the Diagnostics menu GP 1, and then navigate to: Printer diagnostics & adjustments >Sensor tests 2 Find the sensor (MPF/pass-through). The sensor status will change while toggling the sensor.	Go to step 14.	Go to step 12.
Step 12 1 Ensure that the sensor cable is properly connected. 2 Check the sensor and its flag for damage. 3 Check the isolation unit components for damage. The sensor and isolation unit components are free of damage.	Go to step 14.	Go to step 13.
Step 13 Install a new isolation unit. See PL 80.10 item 4. The fault persists.	Go to step 14.	The problem is solved.

Action	Yes	No
<p>Step 14</p> <p>1 Enter the Diagnostics menu GP 1, and then navigate to:</p> <p>Additional input trays adjustments/tests > Additional input tray motors > Pick (tray 2)</p> <p>2 Select a setting, and then touch Start.</p> <p>The motor will run.</p>	Go to step 16.	Go to step 15.
<p>Step 15</p> <p>1 Ensure that the motor cable is properly connected.</p> <p>2 Check the motor and the other optional tray components for damage.</p> <p>The motor and the optional tray are free of damage.</p>	Go to step 16.	Go to step 17.
<p>Step 16</p> <p>Install a new tray insert. See PL 70.10 item 4.</p> <p>The fault persists.</p>	Go to step 17.	The problem is solved.
<p>Step 17</p> <p>1 Install a new optional tray. See PL 70.15 item 1.</p> <p>2 Perform a print job.</p> <p>The fault persists.</p>	Contact the next level of support.	The problem is solved.

377-328-00 Alt S1 Sensor Tray 3 RAP

WD2 Drive PWB Wiring Diagram

C625 Wiring Diagrams

377-328-00 Alt S1 sensor never made by leading edge after picking a page from tray 3 - RAP

Procedure



WARNING: Switch off the electricity to the machine, **GP 10**. Disconnect the power lead from the customer supply while performing tasks that do not need electricity. Electricity can cause the death or injury. Moving components can cause the injury.

Action	Yes	No
<p>Step 1</p> <p>1 From the Home screen, touch Settings > Device > Preferences.</p> <p>2 Check if the paper size matches the size set on the tray guides.</p> <p>The paper size will match the size set on the tray.</p>	Go to step 3.	Go to step 2.
<p>Step 2</p> <p>Change the paper size or adjust the size setting in the tray.</p> <p>The fault persists.</p>	Go to step 3.	The problem is solved.
<p>Step 3</p> <p>1 Enter the Diagnostics menu GP 1, and then navigate to:</p> <p>Printer diagnostics & adjustments > Sensor tests</p> <p>2 Find the sensor (MPF/pass-through).</p> <p>The sensor status will change while toggling the sensor.</p>	Go to step 6.	Go to step 4.
<p>Step 4</p> <p>1 Ensure that the sensor cable is properly connected.</p> <p>2 Check the sensor and its flag for damage.</p> <p>3 Check the isolation unit components for damage.</p> <p>The sensor and isolation unit are free of damage.</p>	Go to step 6.	Go to step 5.
<p>Step 5</p> <p>Install a new isolation unit. See PL 80.10 item 4.</p> <p>The fault persists.</p>	Go to step 6.	The problem is solved.

Action	Yes	No
<p>Step 6</p> <p>1 Enter the Diagnostics menu GP 1, and then navigate to:</p> <p>Additional input trays adjustments/tests > Additional input tray sensors</p> <p>2 Find the sensor (Pass-through (tray 2)). The sensor status will change while toggling the sensor.</p>	Go to step 8.	Go to step 7.
<p>Step 7</p> <p>1 Ensure that the sensor cable is properly connected.</p> <p>2 Check the sensor and the other optional tray components for damage. The sensor and the optional tray are free of damage.</p>	Go to step 8.	Go to step 10.
<p>Step 8</p> <p>1 Enter the Diagnostics menu GP 1, and then navigate to:</p> <p>Additional input trays adjustments/tests > Additional input tray motors > Pass-through (tray 2)</p> <p>2 Select a setting, and then touch Start. The motor will run.</p>	Contact the next level of support.	Go to step 9.
<p>Step 9</p> <p>1 Ensure that the motor cable is properly connected.</p> <p>2 Check the motor and the other optional tray components for damage. The motor and the optional tray are free of damage.</p>	Contact the next level of support.	Go to step 10.
<p>Step 10</p> <p>1 Install a new optional tray. See PL 70.15 item 1.</p> <p>2 Perform a print job. The fault persists.</p>	Contact the next level of support.	The problem is solved.

377-330-00 Alt S1 Sensor Tray 4 RAP

WD2 Drive PWB Wiring Diagram

C625 Wiring Diagrams

377-330-00 Alt S1 sensor never made by leading edge after picking a page from tray 4 - RAP

Procedure



WARNING: Switch off the electricity to the machine, **GP 10**. Disconnect the power lead from the customer supply while performing tasks that do not need electricity. Electricity can cause the death or injury. Moving components can cause the injury.

Action	Yes	No
<p>Step 1</p> <p>1 From the Home screen, touch Settings > Device > Preferences.</p> <p>2 Check if the paper size matches the size set on the tray guides. The paper size will match the size set on the tray.</p>	Go to step 3.	Go to step 2.
<p>Step 2</p> <p>Change the paper size or adjust the size setting in the tray. The fault persists.</p>	Go to step 3.	The problem is solved.
<p>Step 3</p> <p>Check the paper path in tray 3 for paper jams and fragments. The paper path is free of jams and fragments.</p>	Go to step 5.	Go to step 4.
<p>Step 4</p> <p>Remove the paper jams and fragments. The fault persists.</p>	Go to step 5.	The problem is solved.
<p>Step 5</p> <p>1 Enter the Diagnostics menu GP 1, and then navigate to:</p> <p>Printer diagnostics & adjustments > Sensor tests</p> <p>2 Find the sensor (MPF/pass-through). The sensor status will change while toggling the sensor.</p>	Go to step 8.	Go to step 6.
<p>Step 6</p>	Go to step 8.	Go to step 7.

Action	Yes	No
1 Ensure that the sensor cable is properly connected. 2 Check the sensor and its flag for damage. 3 Check the isolation unit components for damage. The sensor and isolation unit are free of damage.		
Step 7 Install a new isolation unit. See PL 80.10 item 4 . The fault persists.	Go to step 8.	The problem is solved.
Step 8 1 Enter the Diagnostics menu GP 1 , and then navigate to: Additional input trays adjustments/tests > Additional input tray sensors 2 Find the sensor (Pass-through (tray 2)). The sensor status will change while toggling the sensor.	Go to step 10.	Go to step 9.
Step 9 1 Ensure that the sensor cable is properly connected. 2 Check the sensor and the other optional tray components for damage. The sensor and the optional tray are free of damage.	Go to step 10.	Go to step 12.
Step 10 1 Enter the Diagnostics menu GP 1 , and then navigate to: Additional input trays adjustments/tests > Additional input tray motors > Pass-through (tray 2) 2 Select a setting, and then touch Start . The motor will run.	Go to step 13.	Go to step 11.
Step 11 1 Ensure that the motor cable is properly connected.	Go to step 13.	Go to step 12.

Action	Yes	No
2 Check the motor and the other optional tray components for damage. The motor and the optional tray are free of damage.		
Step 12 Install a new optional tray. See PL 70.15 item 1 . The fault persists.	Go to step 13.	The problem is solved.
Step 13 1 Enter the Diagnostics menu GP 1 , and then navigate to: Additional input trays adjustments/tests > Additional input tray sensors 2 Find the sensor (Pass-through (tray 3)). The sensor status will change while toggling the sensor.	Go to step 15.	Go to step 14.
Step 14 1 Ensure that the sensor cable is properly connected. 2 Check the sensor and the other optional tray components for damage. The sensor and the optional tray are free of damage.	Go to step 15.	Go to step 17.
Step 15 1 Enter the Diagnostics menu GP 1 , and then navigate to: Additional input trays adjustments/tests > Additional input tray motors > Pass-through (tray 3) 2 Select a setting, and then touch Start . The motor will run.	Contact the next level of support.	Go to step 16.

Action	Yes	No
Step 16 1 Ensure that the motor cable is properly connected. 2 Check the motor and the other optional tray components for damage. The motor and the optional tray are free of damage.	Contact the next level of support.	Go to step 17.
Step 17 Install a new optional tray. See PL 70.15 item 1. The fault persists.	Contact the next level of support.	The problem is solved.

377-332-00 Alt S1 Sensor Tray 5 RAP

WD2 Drive PWB Wiring Diagram

C625 Wiring Diagrams

377-332-00 Alt S1 sensor never made by leading edge after picking a page from tray 5 - RAP

Procedure



WARNING: Switch off the electricity to the machine, GP 10 . Disconnect the power lead from the customer supply while performing tasks that do not need electricity. Electricity can cause the death or injury. Moving components can cause the injury.

Action	Yes	No
Step 1 1 From the Home screen, touch Settings >Device > Preferences . 2 Check if the paper size matches the size set on the tray guides. The paper size will match the size set on the tray.	Go to step 3.	Go to step 2.
Step 2 Change the paper size or adjust the size setting in the tray. The fault persists.	Go to step 3.	The problem is solved.
Step 3 Check the paper path in tray 4 for paper jams and fragments. The paper path is free of jams and fragments.	Go to step 5.	Go to step 4.
Step 4 Remove the paper jams and fragments. The fault persists.	Go to step 5.	The problem is solved.
Step 5 1 Enter the Diagnostics menu GP 1, and then navigate to: Printer diagnostics & adjustments >Sensor tests 2 Find the sensor (MPF/pass-through). The sensor status will change while toggling the sensor.	Go to step 8.	Go to step 6.
Step 6	Go to step 8.	Go to step 7.

Action	Yes	No
1 Ensure that the sensor cable is properly connected. 2 Check the sensor and its flag for damage. 3 Check the isolation unit components for damage. The sensor and isolation unit are free of damage.		
Step 7 Install a new isolation unit. See .PL 80.10 item 4 The fault persists.	Go to step 8.	The problem is solved.
Step 8 1 Enter the Diagnostics menu GP 1 , and then navigate to: Additional input trays adjustments/tests > Additional input tray sensors 2 Find the sensor (Pass-through (tray 3)). The sensor status will change while toggling the sensor.	Go to step 10.	Go to step 9.
Step 9 1 Ensure that the sensor cable is properly connected. 2 Check the sensor and the other optional tray components for damage. The sensor and the optional tray are free of damage.	Go to step 10.	Go to step 12.
Step 10 1 Enter the Diagnostics menu GP 1 , and then navigate to: Additional input trays adjustments/tests > Additional input tray motors > Pass-through (tray 3) 2 Select a setting, and then touch Start . The motor will run.	Go to step 13.	Go to step 11.
Step 11 1 Ensure that the motor cable is properly connected.	Go to step 13.	Go to step 12.

Action	Yes	No
2 Check the motor and the other optional tray components for damage. The motor and the optional tray are free of damage.		
Step 12 Install a new optional tray. See PL 70.15 item 1 . The fault persists.	Go to step 13.	The problem is solved.
Step 13 1 Enter the Diagnostics menu GP 1 , and then navigate to: Additional input trays adjustments/tests > Additional input tray sensors 2 Find the sensor (Pass-through (tray 4)). The sensor status will change while toggling the sensor.	Go to step 15.	Go to step 14.
Step 14 1 Ensure that the sensor cable is properly connected. 2 Check the sensor and the other optional tray components for damage. The sensor and the optional tray are free of damage.	Go to step 15.	Go to step 17.
Step 15 1 Enter the Diagnostics menu GP 1 , and then navigate to: Additional input trays adjustments/tests > Additional input tray motors > Pass-through (tray 4) 2 Select a setting, and then touch Start . The motor will run.	Contact the next level of support.	Go to step 16.

Action	Yes	No
Step 16 1 Ensure that the motor cable is properly connected. 2 Check the motor and the other optional tray components for damage. The motor and the optional tray are free of damage.	Contact the next level of support.	Go to step 17.
Step 17 Install a new optional tray. See PL 70.15 item 1 The fault persists.	Contact the next level of support.	The problem is solved.

377-334-00 MPF Motor Stall RAP

377-334-00 MPF Motor stall RAP



WARNING: Switch off the electricity to the machine, [GP 10](#). Disconnect the power lead from the customer supply while performing tasks that do not need electricity. Electricity can cause the death or injury. Moving components can cause the injury.

Switch OFF, then switch ON the machine, [GP 10](#). If the fault persists, contact 2nd Level Support.

377–335–00 Alt S1 sensor covered on warm up - RAP

[WD2 Drive PWB Wiring Diagram](#)

[C625 Wiring Diagrams](#)

377-335-00 Alt S1 sensor covered on warm up - RAP

Procedure



WARNING: Switch off the electricity to the machine, [GP 10](#). Disconnect the power lead from the customer supply while performing tasks that do not need electricity. Electricity can cause the death or injury. Moving components can cause the injury.

Action	Yes	No
Step 1 1 From the Home screen, touch Settings >Device > Preferences . 2 Check if the paper size matches the size set on the tray guides. The paper size will match the size set on the tray.	Go to step 3.	Go to step 2.
Step 2 Change the paper size or adjust the size setting in the tray. The fault persists.	Go to step 3.	The problem is solved.
Step 3 1 Enter the Diagnostics menu GP 1 , and then navigate to: Printer diagnostics & adjustments >Sensor tests 2 Find the sensor (MPF/pass-through). The sensor status will change while toggling the sensor.	Contact the next level of support.	Go to step 4.

Action	Yes	No
Step 4 1 Ensure that the sensor cable is properly connected. 2 Check the sensor and its flag for damage. 3 Check the isolation unit components for damage. The sensor and isolation unit are free of damage.	Contact the next level of support.	Go to step 5.
Step 5 1 Install a new isolation unit. See PL 80.10 item 4 . 2 Perform a print job. The fault persists.	Contact the next level of support.	The problem is solved.

377-336-00 Alt S1 Sensor Never Uncovered After Picking A Page From Tray X- Source = Unknown RAP

377-336-00 Alt S1 sensor never uncovered after picking a page from tray X- source = unknown RAP



WARNING: Switch off the electricity to the machine, GP 10 . Disconnect the power lead from the customer supply while performing tasks that do not need electricity. Electricity can cause the death or injury. Moving components can cause the injury.

Switch OFF, then switch ON the machine, GP 10. If the fault persists, contact 2nd Level Support.

377-337-00, 377-338-00, 377-339-00, 377-340-00, 377-341-00, 377-342-00, 377-358-00 Duplex Diverter Motor Error RAP

377-337-00 Duplex Diverter Motor does not turn off RAP

377-338-00 Duplex Diverter Motor failed to achieve expected speed RAP

377-339-00 Duplex Diverter Motor loss of encoders (motor stall) RAP

377-340-00 Duplex Diverter Motor underspeed RAP

377-341-00 Duplex Diverter Motor overspeed RAP

377-342-00 Duplex Diverter Motor moved too long RAP

377-358-00 Duplex Diverter Motor does not turn on RAP



WARNING: Switch off the electricity to the machine, GP 10 . Disconnect the power lead from the customer supply while performing tasks that do not need electricity. Electricity can cause the death or injury. Moving components can cause the injury.

Switch OFF, then switch ON the machine, GP 10. If the fault persists, contact 2nd Level Support.

344–252–00 to 344–258–00, 377-343-00 to 377-349-00 Transport Motor (Feed Separator) Error RAP

WD2 Drive PWB Wiring Diagram

C625 Wiring Diagrams

- 344-252-00 Transport motor (Feed separator) does not turn on.
- 344-253-00 Transport motor (Feed separator) does not turn off.
- 344-254-00 Transport motor (Feed separator) failed to achieve expected speed.
- 344-255-00 Transport motor (Feed separator) loss of encoders (motor stall).
- 344-256-00 Transport motor (Feed separator) under speed.
- 344-257-00 Transport motor (Feed separator) over speed.
- 344-258-00 Transport motor (Feed separator) moved too long.
- 377-343-00 Transport (Feed separator) Motor does not turn on.
- 377-344-00 Transport (Feed separator) Motor does not turn off.
- 377-345-00 Transport (Feed separator) Motor failed to achieve expected speed.
- 377-346-00 Transport (Feed separator) Motor loss of encoders (motor stall).
- 377-347-00 Transport (Feed separator) Motor under speed.
- 377-348-00 Transport (Feed separator) Motor over speed.
- 377-349-00 Transport (Feed separator) Motor moved too long.



WARNING: Switch off the electricity to the machine, GP 10 . Disconnect the power lead from the customer supply while performing tasks that do not need electricity. Electricity can cause the death or injury. Moving components can cause the injury.

Procedure

Action	Yes	No
Step 1 Reset the printer. The fault persists.	Go to step 2.	The problem is solved.
Step 2 1 Enter the Diagnostics menu GP 1, and then navigate to: Printer diagnostics & adjustments > Motor tests > Isolation 2 Touch Start . The motor will run.	Go to step 3.	Go to step 4.
Step 3 Ensure that the JMTR1 connector on the drive PWB, PL	Go to step 4.	The problem is solved.

Action	Yes	No
1.10 item 3, is properly connected to the paper feeder, PL 70.10 item 8. The fault persists.		
Step 4 Manually turn the registration rollers and the alternate registration rollers. The rollers will move freely.	Go to step 6.	Go to step 5.
Step 5 Install a new registration chute, PL 80.10 item 4. The fault persists.	Go to step 6.	The problem is solved.
Step 6 Install a new drive PWB, PL 1.10 item 3. The fault persists.	Contact the next level of support.	The problem is solved.

344-231-00 to 344-244-00, 364-231-00 to 364-237-00, 377-350-00 to 377-356-00 Motor (DUPLEX/MPF) Error RAP

WD2 Drive PWB Wiring Diagram

C625 Wiring Diagrams

- 344-231-00 Duplex Motor does not turn on RAP
- 344-232-00 Duplex Motor does not turn off RAP
- 344-233-00 Duplex Motor failed to achieve expected speed RAP
- 344-234-00 Duplex Motor loss of encoders (motor stall) RAP
- 344-235-00 Duplex Motor under speed RAP
- 344-236-00 Duplex Motor over speed RAP
- 344-237-00 Duplex Motor moved too long RAP
- 344-238-00 MPF Motor does not turn on RAP
- 344-239-00 MPF Motor does not turn off RAP
- 344-240-00 MPF Motor failed to achieve expected speed RAP
- 344-241-00 MPF Motor loss of encoders (motor stall) RAP
- 344-242-00 MPF Motor under speed RAP
- 344-243-00 MPF Motor over speed RAP
- 344-244-00 MPF Motor moved too long RAP
- 364-231-00 Duplex Motor does not turn on RAP
- 364-232-00 Duplex Motor does not turn off RAP
- 364-233-00 Duplex Motor failed to achieve expected speed RAP
- 364-234-00 Duplex Motor loss of encoders (motor stall) RAP
- 364-235-00 Duplex Motor under speed RAP
- 364-236-00 Duplex Motor over speed RAP
- 364-237-00 Duplex Motor moved too long RAP
- 377-350-00 MPF Motor does not turn on RAP
- 377-351-00 MPF Motor does not turn off RAP
- 377-352-00 MPF Motor failed to achieve expected speed RAP
- 377-353-00 MPF Motor loss of encoders (motor stall) RAP
- 377-354-00 MPF Motor under speed RAP
- 377-355-00 MPF Motor over speed RAP
- 377-356-00 MPF Motor moved too long RAP



WARNING: Switch off the electricity to the machine, [GP 10](#). Disconnect the power lead from the customer supply while performing tasks that do not need electricity. Electricity can cause the death or injury. Moving components can cause the injury.

Procedure

Action	Yes	No
Step 1 Restart the printer. The fault persists.	Go to step 2.	The problem is solved.
Step 2 1 Enter the Diagnostics menu GP 1 , and then navigate to: Printer diagnostics & adjustments > Motor tests > Duplex/MPF 2 Touch Start . The motor will run.	Go to step 6.	Go to step 3.
Step 3 Ensure that the JMTR1 connector is properly connected to the Drive PWB. The fault persists.	Go to step 4.	The problem is solved.
Step 4 Open the front door, and then manually turn the duplex/MPF drive gears. The gears will move freely.	Go to step 6.	Go to step 5.
Step 5 Install a new motor. See PL 80.05 item 6 . The fault persists.	Go to step 6.	The problem is solved.
Step 6 Install a new Drive PWB. See PL 1.10 item 3 . The fault persists.	Contact the next level of support.	The problem is solved.

377–357–00 Alt S1 Never Reached On Pick From MPF RAP

WD2 Drive PWB Wiring Diagram

C625 Wiring Diagrams

377-357-00 Alt S1 never reached on pick from MPF RAP

Procedure



WARNING: Switch off the electricity to the machine, GP 10. Disconnect the power lead from the customer supply while performing tasks that do not need electricity. Electricity can cause the death or injury. Moving components can cause the injury.

Action	Yes	No
Step 1 1 From the Home screen, touch Settings > Device > Preferences . 2 Check if the paper size matches the size set on the MPF guides. The paper size will match the size set on the MPF.	Go to step 3.	Go to step 2.
Step 2 Change the paper size or adjust the size setting in the MPF. The fault persists.	Go to step 3.	The problem is solved.
Step 3 Check the MPF for overfilling. The MPF is overfilled.	Go to step 4.	Go to step 5.
Step 4 Remove the excess paper from the MPF. The fault persists.	Go to step 5.	The problem is solved.
Step 5 Check the paper condition in the MPF. The paper is crumpled or damaged.	Go to step 6.	Go to step 7.
Step 6 Check whether the crumpled or damaged paper is removed and insert new paper. The fault persists.	Go to step 7.	The problem is solved.
Step 7 1 Ensure that the MPF pick roller is properly installed. Note: Firmly press the pick roller to its shaft to	Go to step 9.	Go to step 8.

Action	Yes	No
make sure that is properly engaged. 2 Check the MPF pick roller for excess wear, contamination, and damage. The MPF pick roller is free from excess wear, contamination, and damage.		
Step 8 Install a new MPF pick roller. See PL 70.10 item 11. The fault persists.	Go to step 9.	The problem is solved.
Step 9 Check the tray exit paper path for paper fragments and contamination.. The paper path is free of fragments and contamination.	Go to step 11.	Go to step 10.
Step 10 Clean the paper path. The fault persists.	Go to step 11.	The problem is solved.
Step 11 Check the tray insert and its paper path guides and drive gears for damage. The tray insert is free of damage.	Go to step 13.	Go to step 12.
Step 12 Install a new tray insert. See PL 70.10 item 4. The fault persists.	Go to step 13.	The problem is solved.
Step 13 1 Enter the Diagnostics menu GP 1, and then navigate to: Printer diagnostics & adjustments > Sensor tests 2 Find the sensor (MPF/pass-through). The sensor status will change while toggling the sensor.	Go to step 16.	Go to step 14.
Step 14 1 Ensure that the sensor cable is properly connected. 2 Check the sensor and its flag for damage.	Go to step 16.	Go to step 15.

Action	Yes	No
3 Check the isolation unit components for damage. The sensor and isolation unit components are free of damage.		
Step 15 Install a new isolation unit. See PL 80.10 item 4 . The fault persists.	Go to step 16.	The problem is solved.
Step 16 1 Enter the Diagnostics menu GP 1 , and then navigate to: Printer diagnostics & adjustments > Motor tests > Duplex/MPF 2 Select a setting, and then touch Start . The motor will run.	Contact the next level of support.	Go to step 17.
Step 17 1 Ensure that the motor cable is properly connected. 2 Check the motor for damage. The motor is free of damage.	Contact the next level of support.	The problem is solved.
Step 18 1 Install a new motor. See PL 80.05 item 6 . 2 Perform a print job. The fault persists.	Contact the next level of support.	The problem is solved.

377-402-00, 377-405-00, 377-408-00, 377-411-00, 374-233-00, 377-422-00, 377-420-00 S1/Input/Stage Sensor RAP

WD2 Drive PWB Wiring Diagram

C625 Wiring Diagrams

377-402-00 MPF S1/Input/stage sensor never cleared by trailing edge of page during duplex pass RAP

377-405-00 Tray 1 S1/Input/stage sensor never cleared by trailing edge of page during duplex pass RAP

377-408-00 Tray 2 S1/Input/stage sensor never cleared by trailing edge of page during duplex pass RAP

377-411-00 Tray 3 S1/Input/stage sensor never cleared by trailing edge of page during duplex pass RAP

374-233-00 Tray 4 S1/Input/stage sensor never cleared by trailing edge of page during duplex pass RAP

377-422-00 Tray 5 S1/Input/stage sensor never cleared by trailing edge of page during duplex pass RAP

377-420-00 Unknown S1/Input/stage sensor never cleared by trailing edge of page during duplex pass RAP

Procedure



WARNING: Switch off the electricity to the machine, [GP 10](#). Disconnect the power lead from the customer supply while performing tasks that do not need electricity. Electricity can cause the death or injury. Moving components can cause the injury.

Action	Yes	No
Step 1 Check the duplex paper path for paper jams and obstructions. The paper path is free of jams and obstructions.	Go to step 3.	Go to step 2.
Step 2 Remove the jams and obstructions. The fault persists.	Go to step 3.	The problem is solved.
Step 3 1 Enter the Diagnostics menu GP 1 , and then navigate to: Printer diagnostics & adjustments > Sensor tests 2 Find the sensor (MPF/pass-through). The sensor status will change while toggling the sensor.	Go to step 6.	Go to step 4.

Action	Yes	No
Step 4 1 Ensure that the sensor cable is properly connected. 2 Check the sensor and its flag for damage. 3 Check the isolation unit components for damage. The sensor and isolation unit components are free of damage.	Go to step 6.	Go to step 5.
Step 5 Install a new isolation unit. See PL 80.10 item 4 . The fault persists.	Go to step 6.	The problem is solved.
Step 6 1 Enter the Diagnostics menu GP 1 , and then navigate to: Printer diagnostics & adjustments > Motor tests > Deskew 2 Touch Start . The motor will run.	Contact the next level of support.	Go to step 7.
Step 7 1 Ensure that the motor cable is properly connected. 2 Check the motor for damage. The fault persists.	Contact the next level of support.	Go to step 8.
Step 8 1 Install a new motor (deskew). See PL 40.10 item 1 . 2 Perform a print job. The fault persists.	Contact the next level of support.	The problem is solved.

377-602 OHP Sensor Fail RAP

While adjusting LED power, PWM output was reduced to 59.5%, but the sensor output (Volt) did not fall to 0.5V.

.LED power adjustment did not complete within a specified period of time.

Procedure

Note: To power down the machine, press the UI Power Button and then respond to the on-screen prompts. Wait until the Power Button LED turns off, then switch off the machine, [GP 10](#).

Power Off then Power On.

371-107-00 to 371-108-00, 372-151-00 to 372-152-00, 373-153-00 to 373-154-00, 374-100-01, 374-950-00, 375-100-01, 375-950-00, 375-951-00, 376-104-00 to 376-105-00, 377-950-00, 377-951-00 Load tray 1,2,3,4,5 with media Error RAPs

WD2 Drive PWB Wiring Diagram

C625 Wiring Diagrams

- 371-107-00 IRLoad: Load tray 1 with media (orientation not supported) RAP
- 371-108-00 IRLoad: Load tray 1 with media (orientation supported) RAP
- 372-151-00 IRLoad: Load tray 2 with media (orientation not supported) RAP
- 372-152-00 IRLoad: Load tray 2 with media (orientation supported) RA
- 373-153-00 IRLoad: Load tray 3 with media (orientation not supported) RAP
- 373-154-00 IRLoad: Load tray 3 with media (orientation supported) RAP
- 374-100-01 Change tray 4 to different media (orientation supported) RAP
- 374-950-00 IRChange: Load tray 4 to different media (orientation not supported) RAP
- 375-100-01 Change tray 5 to different media (orientation supported) RAP
- 375-950-00 Change tray 5 to different media (orientation not supported) RAP
- 375-951-00 IRChange: Load tray 5 to different media (orientation not supported) RAP
- 377-950-00 Change MP feeder to different media (orientation not supported) RAP
- 377-951-00 Change MP feeder to different media (orientation supported) RAP



WARNING: Switch off the electricity to the machine, GP 10 . Disconnect the power lead from the customer supply while performing tasks that do not need electricity. Electricity can cause the death or injury. Moving components can cause the injury.

Procedure

Action	Yes	No
<p>Step 1</p> <p>1 From the Home screen, touch Settings > Device > Preferences.</p> <p>2 Check if the paper size matches the size set on the tray guides. The paper size will match the size set on the tray.</p>	Go to step 3.	Go to step 2.
<p>Step 2</p> <p>Change the paper size or adjust the size setting in the tray. The fault persists.</p>	Go to step 3.	The problem is solved.

Action	Yes	No
<p>Step 3</p> <p>Check the drive PWB and its pins for damage. The drive PWB is free of damage.</p>	Contact the next level of support.	Go to step 4.
<p>Step 4</p> <p>Install a new drive PWB, PL 1.10 item 3. The fault persists.</p>	Contact the next level of support.	The problem is solved.

391-100-00 to 391-105-00, 391-940-00, 393-100-00 to 393-105-00, 393-947-00 to 393-955-00, 393-957-00, 393-958-00, 393-968-00, 393-969-00, 393-986-00, 393-985-00, 393-962-00 Toner Bottle Unsupported Error RAP

WD2 Drive PWB Wiring Diagram

C625 Wiring Diagrams

391-100-00 Black IU or Photoconductor Unsupported Error: Unsupported memory map version in smartchip.

391-101-00 Black IU or Photoconductor Unsupported Error: Fail capacity class/model compatibility check.

391-102-00 Black IU or Photoconductor Unsupported Error: Fail OEM check.

391-103-00 Black IU or Photoconductor Unsupported Error: Fail SWE marriage check.

391-104-00 Black IU or Photoconductor Unsupported Error: Supply is on the revoked list.

391-105-00 Black IU or Photoconductor Unsupported Error: IU is MICR, and this FW release does not support MICR.

393-100-00 Black Toner Bottle Unsupported Error: Unsupported memory map version in smartchip.

393-101-00 Black Toner Bottle Unsupported Error: Fail capacity class/model compatibility check.

393-102-00 Black Toner Bottle Unsupported Error: Fail OEM check.

393-103-00 Black Toner Bottle Unsupported Error: Fail SWE marriage check.

393-104-00 Black Toner Bottle Unsupported Error: Supply is on the revoked list.

393-105-00 Black Toner Bottle Unsupported Error: Bottle is MICR, and this FW release does not support MICR.

393-947-00 Cyan Toner Bottle Unsupported Error

393-948-00 Cyan Toner Bottle Unsupported Error: Fail OEM check.

393-949-00 Cyan Toner Bottle Unsupported Error: - Supply is on the revoked list.

393-950-00 Cyan Toner Bottle Unsupported Error: - IU is MICR, and this FW release does not support MICR.

393-951-00 Magenta Toner Bottle Unsupported Error: - Unsupported memory map version in smartchip.

393-952-00 Magenta Toner Bottle Unsupported Error: - Fail OEM check.

393-953-00 Magenta Toner Bottle Unsupported Error: - Supply is on the revoked list.

393-954-00 Magenta Toner Bottle Unsupported Error: - IU is MICR, and this FW release does not support MICR.

393-955-00 Yellow Toner Bottle Unsupported Error: - Unsupported memory map version in smartchip.

393-968-00 Yellow Toner Bottle Unsupported Error: - Fail OEM check.

393-957-00 Yellow Toner Bottle Unsupported Error: - Supply is on the revoked list.

393-958-00 Yellow Toner Bottle Unsupported Error: - IU is MICR, and this FW release does not support MICR.

393-969-00 Color IU or Photoconductor Unsupported Error: - Unsupported memory map version in smartchip.

393-986-00 Color IU or Photoconductor Unsupported Error: - Fail OEM check.

393-985-00 Color IU or Photoconductor Unsupported Error: - Supply is on the revoked list.

393-986-00 Color IU or Photoconductor Unsupported Error: - Fail OEM check.

393-962-00 Color IU or Photoconductor Unsupported Error: - IU is MICR, and this FW release does not support MICR.

391-940-00 Non-genuine supply - Black imaging unit or kit, or photoconductor.

Procedure

Action	Yes	No
Step 1 1 Ensure that the toner cartridges, black imaging unit, and CMY imaging kit are all completely installed. 2 Ensure that the toner cartridges, black imaging unit, and CMY imaging kit are genuine and supported. The fault persists.	Go to step 2.	The problem is solved.
Step 2 1 Ensure that the toner cartridges, black imaging unit, and CMY imaging kit are properly installed. 2 Ensure that the imaging kit cable is properly connected. The fault persists.	Go to step 3.	The problem is solved.
Step 3 Check the TMC card contacts for damage. The TMC card contacts is free of damage?	Go to step 5.	Go to step 4.
Step 4 Install a new TMC card. See PL 1.10 item 4 . The fault persists.	Go to step 5.	The problem is solved.

Action	Yes	No
Step 5 Check the Drive PWB and its pins for damage. The Drive PWB is free of damage.	Contact the next level of support.	Go to step 6.
Step 6 Install a new Drive PWB . See PL 1.10 item 3 . The fault persists.	Contact the next level of support.	The problem is solved.

393-337-00, 393-337-01 Toner CRUM M Auth IC Error RAP

393-337-00 Toner CRUM M Auth IC Error RAP

393-337-01 Toner CRUM M Auth IC Error RAP



WARNING: Switch off the electricity to the machine, GP 10 . Disconnect the power lead from the customer supply while performing tasks that do not need electricity. Electricity can cause the death or injury. Moving components can cause the injury.

Switch OFF, then switch ON the machine, GP 10.

1. Pull the Toner Cartridge CRUM M.
2. If the fault persists, contact 2nd Level Support.

393-426-00 to 393-428-00, 393-438-00 to 393-442-00, 393-444-00 to 393-464-00 Cartridge Quanta Error RAPS

WD2 Drive PWB Wiring Diagram

C625 Wiring Diagrams

393-426-00 Cartridge out of Quanta - Toner very Low RAP

393-427-00 Cartridge out of Quanta - Toner Life Ended RAP

393-439-00 Black Cartridge out of Quanta (very low) RAP

393-438-00 Cyan Cartridge out of Quanta (very low) RAP

393-440-00 Magent a Cartridge out of Quanta (very low) RAP

393-441-00 Yellow Cartridge out of Quanta (very low) RAP

393-442-00 Replace Cyan cartridge – fresh toner RAP

393-444-00 Replace Magenta cartridge – fresh toner RAP

393-445-00 Replace Yellow cartridge – fresh toner RAP

393-447-00 The black toner cartridge is at end-of-life.

393-448-00 Magenta Cartridge at End of Life via Failure to Replenish Image Unit RAP

393-449-00 Yellow Cartridge at End of Life via Failure to Replenish Image Unit RAP

393-451-00 Black Cartridge out of Quanta (end of life) RAP

393-450-00 Cyan Cartridge out of Quanta (end of life) RAP

393-452-00 Magenta Cartridge out of Quanta (end of life) RAP

393-453-00 Yellow Cartridge out of Quanta (end of life) RAP

393-455-00 Replace Black cartridge – fresh toner – hard stop RAP

393-454-00 Replace Cyan cartridge – fresh toner – hard stop RAP

393-456-00 Replace Magenta cartridge – fresh toner – hard stop RAP

393-457-00 Replace Yellow cartridge – fresh toner – hard stop RAP

393-459-00 Black Cartridge at Absolute End of Life via Failure to Replenish Image Unit RAP

393-458-00 Cyan Cartridge at Absolute End of Life via Failure to Replenish Image Unit RAP

393-460-00 Magenta Cartridge at Absolute End of Life via Failure to Replenish Image Unit RAP

393-461-00 Yellow Cartridge at Absolute End of Life via Failure to Replenish Image Unit RAP

393-428-00 Replace cartridge – quanta – hard stop RAP

393-462-00 Replace Cyan cartridge – quanta – hard stop (absolute end of life) RAP

393-463-00 Replace Magenta cartridge – quanta – hard stop (absolute end of life) RAP

393-464-00 Replace Yellow cartridge – quanta – hard stop (absolute end of life) RAP

Procedure



WARNING: Switch off the electricity to the machine, [GP 10](#) . Disconnect the power lead from the customer supply while performing tasks that do not need electricity. Electricity can cause the death or injury. Moving components can cause the injury.

Action	Yes	No
<p>Step 1</p> <p>1 Ensure that the toner cartridges, black imaging unit, and CMY imaging kit are all completely installed.</p> <p>2 Ensure that the toner cartridges, black imaging unit, and CMY imaging kit are genuine and supported.</p> <p>The fault persists.</p>	Go to step 2.	The problem is solved.
<p>Step 2</p> <p>1 Ensure that the toner cartridges, black imaging unit, and CMY imaging kit are properly installed.</p> <p>2 Ensure that the imaging kit cable is properly connected.</p> <p>The fault persists.</p>	Go to step 3.	The problem is solved.
<p>Step 3</p> <p>Check the TMC card contacts for damage.</p> <p>The TMC card contacts are free of damage.</p>	Go to step 5.	Go to step 4.
<p>Step 4</p> <p>Install a new TMC card. See PL 1.10 item 4.</p> <p>The fault persists.</p>	Go to step 5.	The problem is solved.
<p>Step 5</p> <p>Check the engine board and its pins for damage.</p> <p>The engine board is free of damage.</p>	Contact the next level of support.	Go to step 6.
<p>Step 6</p> <p>Install a new dDrive PWB. See PL 1.10 item 3.</p> <p>The fault persists.</p>	Contact the next level of support.	The problem is solved.

393-443-00 Replace Black Cartridge - Fresh Toner RAP

393-443-00 Replace Black cartridge – fresh toner RAP



WARNING: Switch off the electricity to the machine, [GP 10](#) . Disconnect the power lead from the customer supply while performing tasks that do not need electricity. Electricity can cause the death or injury. Moving components can cause the injury.

Switch OFF, then switch ON the machine, [GP 10](#) . If the fault persists, contact 2nd Level Support.

393-901-00 WTB Smartchip Or Sensor Commo Problem - Missing RAP

393-901-00 WTB smartchip or sensor commo problem - Missing RAP



WARNING: Switch off the electricity to the machine, **GP 10** . Disconnect the power lead from the customer supply while performing tasks that do not need electricity. Electricity can cause the death or injury. Moving components can cause the injury.

Switch OFF, then switch ON the machine, **GP 10**. If the fault persists, contact 2nd Level Support.

393-964-00,393-964-01, 393-965-00, 393-965-01, 393-966-00,393-966-01, 393-967-00, 393-967-01 Toner Meter Cycle Error RAPs

393-964-00 Black Bottle Toner Meter Cycle Error: z = Y: 1st error, Recoverable RAP

393-964-01 Black Bottle Toner Meter Cycle Error: z = Z: 2nd error, Non-Recoverable RAP

393-965-00 Cyan Bottle Toner Meter Cycle Error: z = Y: 1st error, Recoverable RAP

393-965-01 Cyan Bottle Toner Meter Cycle Error: z = Z: 2nd error, Non-Recoverable RAP

393-966-00 Magenta Bottle Toner Meter Cycle Error: z = Y: 1st error, Recoverable RAP

393-966-01 Magenta Bottle Toner Meter Cycle Error: z = Z: 2nd error, Non-Recoverable RAP

393-967-00 Yellow Bottle Toner Meter Cycle Error: z = Y: 1st error, Recoverable RAP

393-967-01 Yellow Bottle Toner Meter Cycle Error: z = Z: 2nd error, Non-Recoverable RAP

Procedure

Action	Yes	No
<p>Step 1</p> <p>1 Enter the Diagnostics menu, and then navigate to: Printer diagnostics & adjustments >Sensor tests</p> <p>2 Find the sensor (toner meter) of the affected color. The sensor status will change while toggling the sensor.</p>	Go to step 2.	Go to step 3.
<p>Step 2</p> <p>Install a new toner cartridge. The fault persists.</p>	Go to step 3.	The problem is solved.
<p>Step 3</p> <p>Install a new TMC card. See PL 1.10 item 4. The fault persists.</p>	Contact the next level of support.	The problem is solved.

393-975-00, 393-976-00, 393-977-00 Null String Error RAP

393-975-00 Null string read on new C unit RAP

393-976-00 Null string read on new M unit RAP

393-977-00 Null string read on new Y unit RAP



WARNING: Switch off the electricity to the machine, GP 10 . Disconnect the power lead from the customer supply while performing tasks that do not need electricity. Electricity can cause the death or injury. Moving components can cause the injury.

Switch OFF, then switch ON the machine, GP 10. If the fault persists, contact 2nd Level Support.

393-978-00, 393-979-00, 393-980-00, 393-981-00 Non-Xerox String Error RAP

393-978-00 Non-Xerox string read on new K unit RAP

393-979-00 Non-Xerox string read on new C unit RAP

393-980-00 Non-Xerox string read on new M unit RAP

393-981-00 Non-Xerox string read on new Y unit RAP



WARNING: Switch off the electricity to the machine, GP 10 . Disconnect the power lead from the customer supply while performing tasks that do not need electricity. Electricity can cause the death or injury. Moving components can cause the injury.

Switch OFF, then switch ON the machine, GP 10. If the fault persists, contact 2nd Level Support.

393-987-00 Non-genuine Supply - Color (CMY) Imaging Unit Or Kit, Or Photoconductor RAP

393-987-00 Non-genuine supply - Color (CMY) imaging unit or kit, or photoconductor RAP



WARNING: Switch off the electricity to the machine, GP 10 . Disconnect the power lead from the customer supply while performing tasks that do not need electricity. Electricity can cause the death or injury. Moving components can cause the injury.

Switch OFF, then switch ON the machine, GP 10. If the fault persists, contact 2nd Level Support.

393-988-00 Magenta Toner Bottle Smartchip Or Sensor Common Problem RAP

393-988-00 Magenta Toner Bottle smartchip or sensor common problem RAP



WARNING: Switch off the electricity to the machine, GP 10 . Disconnect the power lead from the customer supply while performing tasks that do not need electricity. Electricity can cause the death or injury. Moving components can cause the injury.

Switch OFF, then switch ON the machine, GP 10. If the fault persists, contact 2nd Level Support.

395-001-00 to 395-168-00 and 395-216 to 395-324-00 Software Upgrade Failure RAP

395-001-00 Software Upgrade Failure : DC software failed to upgrade.

395-002-00 Software Upgrade Failure : DC Application RAP.

395-008-00 Software Upgrade Failure : DC OS RAP

395-009-00 Software Upgrade Failure : DC CIPS RAP

395-011-00 Software Upgrade Failure : XUI Application RAP

395-019-00 Software Upgrade Failure : UI Panel Firmware RAP

395-038-00 Software Upgrade Failure : Embedded Fax LCF Application RAP

395-042-00 Software Upgrade Failure : IOT Application RAP

395-140-00 Software Upgrade Failure : DC NC Applications RAP

395-168-00 Software Upgrade Failure : DADH Single Pass RAP

395-216-00 Software Upgrade Failure : DC Glue RAP

395-226-00 Software Upgrade Failure : SOK RAP

395-255-00 Software Upgrade Failure : DC SCD RAP

395-300-00 Software Upgrade Failure : Incompatible Product RAP

395-301-00 Software Upgrade Failure : Incompatible Hardware RAP

395-302-00 Software Upgrade Failure : Incompatible Firmware RAP

395-303-00 Software Upgrade Failure : DLM Downgrade RAP

395-304-00 Software Upgrade Failure : DLM Sidegrade RAP

395-305-00 Software Upgrade Failure : Platform Synchronisation Error RAP

395-306-00 Software Upgrade Failure : CCS Platform Synchronisation Error RAP

395-307-00 Software Upgrade Failure : NC Platform Synchronisation Error RAP

395-308-00 Software Upgrade Failure : UI Platform Synchronisation Error RAP

395-309-00 Software Upgrade Failure : IIT Platform Synchronisation Error RAP

395-310-00 Software Upgrade Failure : IOT Platform Synchronisation Error RAP

395-311-00 Software Upgrade Failure : Finisher Platform Synchronisation Error RAP

395-312-00 Software Upgrade Failure : Feeder Platform Synchronisation Error RAP

395-313-00 Differential DLM Installation Failure: Launch DLM Missing RAP

395-313-01 Differential DLM Installation Failure: Launch DLM Corrupt RAP

395-313-02 Differential DLM Installation Failure: Launch DLM MISMATCH RAP

395-313-03 Launch DLM installation failure RAP

395-314-00 Software Upgrade Failure :SDCARD Full Error RAP
 395-315-00 Software Upgrade Failure : Bios RAP
 395-316-00 Software Upgrade Failure : FPGA RAP
 395-318-00 Software Upgrade Failure : USB pendrive not detected RAP
 395-319-00 Software Upgrade Failure : USB pendrive not detected 2nd time RAP
 395-321-00 Software Upgrade Failure : Failure to revert flash contents RAP
 395-322-00 USB drive filesystem unsupported RAP
 395-323-00 Multiple USB drives detected RAP
 395-324-00 Disk is blank or cannot be mounted RAP
 316-745 -00 Optional Drive not detected
 316-746 -00 Optional drive pairing unsuccessful

Procedure



WARNING: Switch off the electricity to the machine, [GP 10](#) . Disconnect the power lead from the customer supply while performing tasks that do not need electricity. Electricity can cause the death or injury. Moving components can cause the injury.



CAUTION:

1. Ensure you are using the correct DLM for the device you are upgrading.
 2. Obtain the correct Launch DLM Recovery patch (LDRP) for the device you are upgrading from GSN Library 16910 or Library 500 for Approved Service Providers
1. Perform a Software Upgrade, [GP 4](#), using the FORCED_ALTBOOT method.
 2. If the 500+GB Hard Disk, [PL 25.05 item 2](#) is installed, check the connections at the controller PWB are firmly seated and no damage to the harness exists. Repair or install a new 500+GB Hard Disk as required.
 3. If the fault persists install a new controller PWB, [PL 3.05 item 1](#).

395–171–00, 395–172–00, 395–173–00 Software Upgrade Failure Error RAP

395–171–00 Device does not have enough RAM to continue with upgrade.

395–172–00 Device does not have enough storage memory to continue with upgrade.

395–173–00 Device could not decrypt the DLM.

Procedure



WARNING: Switch off the electricity to the machine, [GP 10](#) . Disconnect the power lead from the customer supply while performing tasks that do not need electricity. Electricity can cause the death or injury. Moving components can cause the injury.

1. Switch off, then switch on the machine, [GP 10](#).
2. Perform a Software Upgrade, [GP 4](#) using the FORCED_ALTBOOT method.
3. If the fault persists, use the FORCED_ALTBOOT method with DISABLE_DATA_BACKUP flag.

399-350-00, 399-355-00, 399-364-00, 399-373-00, 399-375-00, 399-377-00, 399-395-00 Fuser Motor RAP

WD2 Drive PWB Wiring Diagram

C625 Wiring Diagrams

WD3 LVPS Wiring Diagram

399-350-00 Fuser Motor does not turn on RAP

399-355-00 Fuser Motor does not turn off RAP

399-364-00 Fuser Motor Stall RAP

399-373-00 Fuser Motor under speed RAP

399-375-00 Fuser Motor over speed RAP

399-377-00 Fuser Motor moved too long RAP

399-395-00 Fusing Mot Current Fail RAP

Procedure



WARNING: Switch off the electricity to the machine, GP 10 . Disconnect the power lead from the customer supply while performing tasks that do not need electricity. Electricity can cause the death or injury. Moving components can cause the injury.

Action	Yes	No
Step 1 Restart the printer. The fault persists.	Go to step 2.	The problem is solved.
Step 2 1 Check if the fuser has reached end-of-life. 2 Check the fuser for damage. The fuser is still functional and free of damage.	Go to step 4 .	Go to step 3.
Step 3 Install a new fuser. See PL 10.10 item 1. The fault persists.	Go to step 4.	Go to step 4.
Step 4 Ensure that the JFDRV1 connector on the Drive PWB is properly connected. The fault persists.	Go to step 5.	The problem is solved.
Step 5 Remove the fuser, and then manually turn the fuser drive gear. The gear will freely turn.	Go to step 7.	Go to step 6.

Action	Yes	No
Step 6 Install a new fuser drive gear. The fault persists.	Go to step 7 .	The problem is solved.
Step 7 Install a new motor (fuser). See PL 80.05 item 4 . The fault persists.	Go to step 8 .	The problem is solved.
Step 8 Install a new Drive PWB . See PL 1.10 item 3 . The fault persists.	Contact the next level of support.	The problem is solved.

OF1 Machine Not Ready RAP

PJ and Sensor Locations

C625 Wiring Diagrams

Machine Not Ready, is defined as any condition where the machine is not capable of performing its basic tasks (Copy or Print). **Not Ready**, ranges from a machine that is totally inert, without any indication of power, to a machine that appears ready but does not respond to either Control Panel commands or network input.

Initial Actions

- Switch off the machine, [GP 10](#).
- Check all connections on the LVPS, [PL 1.10 item 7](#), Drive PWB, and Controller PWB, [PL 3.05 item 2](#).

Procedure

The first step is to categorize the problem. Decide which of the following condition best describes the problem:

- [Dead Machine](#)
- [Boots up; does not respond to Control Panel](#)
- [Boots up; does not print \(or other Network problem\)](#)

Dead Machine

1. If the machine shows no sign of power (fans or motors running, backlight on UI display, LEDs on Control Panel), check for AC line voltage at the customer supply outlet. Refer to, [OF 3](#).
2. If AC voltage is measured within specifications, [GP 17](#), measure the voltage at the connector on the LVPS.
3. If the voltage is within specification, measure the voltage at the connector on the drive PWB, [PL 1.10 item 7](#).
4. If the voltage at each connector is within specification, measure the voltage at [JPWR2](#), and [JPWR1](#) on the Controller PWB.

Install new components as required:

1. LVPS, [PL 1.10 item 7](#).
2. Drive PWB, [PL 1.10 item 3](#).
3. Controller PWB, [PL 3.05 item 2](#).

Boots up; does not respond to Control Panel

Perform the following:

1. Switch off, then switch on the machine, [GP 10](#)
2. Perform RAP, [OF 2](#).
3. Install new components as required:
 - Control panel display, [PL 2.10 item 1](#).
 - Controller PWB, [PL 3.05 item 2](#).

Boots up; does not print (or other Network problem)

Perform RAP, [OF 11](#), Job Prints Incorrectly RAP.

OF2 UI Touch Screen Failure RAP

PJ and Sensor Locations

C625 Wiring Diagrams

Use this RAP to solve user interface touch screen problems when the machine has power but either the display is Black, blank, too dark, responds incorrectly or does not refresh.

Procedure

1. Switch OFF, then switch ON the machine, [GP 10](#).
2. Check the, control panel harness, [PL 2.10 item 4](#), is fully seated at the control panel and the controller PWB. Verify no damage or severe creasing to the FFC exists and the connector-ends are not frayed. Install a new components as required:
 - a. Control panel cable, [PL 2.10 item 4](#).
 - a.
 - If no problems are found, install new components as required:
 - Control panel cable, [PL 2.10 item 4](#).
 - Controller PWB, [PL 3.05 item 2](#).
 - Control panel, [PL 2.10 item 4](#).

OF3 AC Power RAP

PJ and Sensor Locations

C625 Wiring Diagrams

Use this procedure to identify AC power input and output failures.

Procedure



WARNING: Switch off the electricity to the machine, [GP 10](#). Disconnect the power lead from the customer supply while performing tasks that do not need electricity. Electricity can cause the death or injury. Moving components can cause the injury.



WARNING: Take care when measuring AC mains (line) voltage. Electricity can cause death or injury.

1. Switch off the machine, [GP 10](#).
2. Measure the voltage connecting the LVPS, [PL 1.10 item 7](#) to the drive PWB, [PL 1.10 item 4](#).

The voltage measured is within electrical power requirements, [GP 11](#).

Y N
| Disconnect the power cord from the outlet. Check the AC mains (line) voltage at the customer's power outlet.

The voltage measured is within electrical power requirements, [GP 17](#).

Y N
| The voltage is incorrect, or the wiring of the main supply is found to be defective, inform your technical manager and the customer. Do not attempt to repair or adjust the customer supply.

Verify the power cord is not frayed or damaged and is fully seated into the machine socket.

The main power cord is good.

Y N
| Install a new power cord.
| Install a new LVPS, [PL 1.10 item 7](#).

1. Switch ON the machine, [GP 10](#).
2. Measure the voltage connecting the LVPS, [PL 1.10 item 7](#) to the drive PWB, [PL 1.10 item 3](#).

The AC power supply is within specification, [GP 17](#).

Y N
| Install a new LVPS, [PL 1.10 item 7](#).

- Install a new drive PWB, [PL 1.10 item 3](#).
- Install a new controller PWB, [PL 3.05 item 2](#).

OF4 +5VDC Power Fault RAP

PJ and Sensor Locations

C625 Wiring Diagrams

Procedure



WARNING: Switch off the electricity to the machine, [GP 10](#). Disconnect the power lead from the customer supply while performing tasks that do not need electricity. Electricity can cause the death or injury. Moving components can cause the injury.



WARNING: Take care when measuring AC mains (line) voltage. Electricity can cause death or injury.

Check the voltage between the LVPS pin 1 and ground.

+5VDC is measured.

Y N
| Check the voltage between pin 1 and pin 4 on the LVPS, [PL 1.10 item 7](#).
| The AC power supply is within specification, [GP 17](#).

Y N
| Perform the [OF 3 AC Power RAP](#).

Switch off the machine, [GP 10](#). Disconnect the harness from the LVPS. Wait 15 seconds, then switch on the machine, [GP 10](#). Check the voltage between the LVPS [PL 1.10 item 7](#), pin 1 and ground.

+5VDC is measured.

Y N
| Install a new LVPS, [PL 1.10 item 7](#).

Check the +5VDC circuit for a short circuit to frame.

Check the wiring of the suspect component for an open circuit or poor contact.

OF5 +24VDC Power Fault RAP

PJ and Sensor Locations

C625 Wiring Diagrams

Procedure



WARNING: Switch off the electricity to the machine, [GP 10](#) . Disconnect the power lead from the customer supply while performing tasks that do not need electricity. Electricity can cause the death or injury. Moving components can cause the injury.



WARNING: Take care when measuring AC mains (line) voltage. Electricity can cause death or injury.

Check the voltage between the LVPS pin 1 and ground.

+24VDC is measured.

Y N

Check the voltage between pin 1 and pin 4 on the LVPS, [PL 1.10 item 7](#).

The AC power supply is within specification, [GP 17](#).

Y N

Perform the [OF 3 AC Power RAP](#).

Switch off the machine, [GP 10](#) . Disconnect the harness from the LVPS. Wait 15 seconds, then switch on the machine, [GP 10](#) . Check the voltage between the LVPS pin 1 and ground.

+24VDC is measured.

Y N

Install a new LVPS, [PL 1.10 item 7](#).

Check the +24VDC circuit for a short circuit to frame.

Check the wiring of the suspect component for an open circuit or poor contact.

OF8 Network Printing Problems RAP

This Procedure is provided to help identify and diagnose network printing problems.

Initial Actions

- Ensure the machine is online.
- Ensure that no IOT faults exist that prevent the IOT from functioning. That is, copies can be made, or prints can be printed from the UI.

Determine the following:

- Are any jobs printing on the printer?
- Is the problem related to one workstation?
- Is the problem related to one job?
- Have any changes been made to the network prior to a printing problem?
- Was a backup log of network configuration data created? If so, was it last created by a CSE or the customer/SA?

If there are multiple protocols enabled on the printer, and the problems are ONLY occurring with one network protocol, go to the procedure appropriate for that protocol:

- Switch OFF, then switch ON the machine, [GP 10](#).
- TCP/IP: [OF 9](#), TCP/IP Checkout RAP.

Procedure

No printing occurs (jobs won't print, can't see printer, or can't connect to printer)

Y N

If, instead of job printing normally, there is a literal printing of the PDL (many pages of code, or the job prints, but looks wrong fonts, missing fonts, other image quality problems), go to the [OF 10](#).

The problem occurs in all print jobs from all clients.

Y N

The problem occurs in a specific job from all clients.

Y N

The problem occurs in all jobs from a specific client or group of clients,

Y N

If the problem is with a specific job from a specific client, the problem is likely with the client; either not connected to the network, wrong or old driver, bad application files or a hardware failure in the client.

If no printing can be done from a specific client or group, while other clients or group function normally, the likely cause is a problem in the customer's network.

If the problem is specific to a single application or group of applications, ensure that current drivers are loaded.

If the problem occurs in only one job, go to the [OF 10](#).

Check that the printer is physically connected to the network cable and that the cable/connections are OK. Disconnect and reseal the cable at both ends. Check to see if the problem is corrected.

The fault persists.

Y N

Return to [SCP 1](#).

Go to [GP 14](#) (Network Printing Simulation) and send a print job.

An acceptable print is produced:

Y N

- verify machine settings .
- reload system software, [GP 9](#).
- If the fault persists, install a new, Controller PWB [PL 3.05 item 1](#).

Print out a Configuration Report, [GP 14](#). Review the, TCP/IP, and Microsoft Networking (NETBIOS) settings.

At least one networking protocol is enabled.

Y N

The printer is not installed properly. Inform the customer/system administrator that the printer needs to be installed and setup for the appropriate networking protocol.

Enter Diagnostics, [GP 1](#), then go to [dC312](#). Check for a selectable protocol (not grayed out).

There is at least one selectable protocol.

Y N

Switch OFF, then switch ON the machine, [GP 10](#). When machine is ready, reenter Diagnostics, [GP 1](#), the select [dC312](#) again. Check for a selectable protocol (not grayed out).

There is at least one selectable protocol.

Y N

Open software update, [GP 4](#), then perform the Regular AltBoot procedure.

If the fault persists, return to the start of this procedure.

Select **Start**. Observe the test results.

The test passed.

Y N

Enter Diagnostics, [GP 1](#), then go to [dC312](#). Check for a selectable protocol (not grayed out).

The test passed.

Y N

Perform the following:

- Ask the system administrator to test the network port.
- Open software update, [GP 4](#), then perform the Regular AltBoot procedure.
- Install a new Ethernet cable from the machine to the source connector.
- Check fault history for faults related to networking, then perform the RAP associated with any faults listed.
- TCP/IP: [OF 9](#), TCP/IP Checkout RAP
- If the fault persists, install a new Controller PWB, [PL 3.05](#).

Verify that the problem is corrected. If the problem continues, go to [GP 4](#) and perform the Regular AltBoot procedure.



CAUTION: The AltBoot procedure in Software Upgrade, [GP 4](#), will delete all stored data on the System Disk Drive, including E-mail addresses, Xerox Standard Accounting data, and network configuration information. **ALWAYS** backup the machine, [GP 22](#), if possible, before performing AltBoot. If the machine failure is such that cloning is not possible, ensure that the customer is aware of the data loss.

Reload software via AltBoot, [GP 4](#).

The problem continues.

Y N

Return to [SCP 1](#).

Select the most appropriate from the following:

- Jobs Won't Print, Can't See Printer, Can't Connect to Printer

– TCP/IP: [OF 9](#), TCP/IP Checkout RAP

- A particular job isn't printing, go to the Problem Printing Job RAP, [OF 10](#)
- Instead of job printing normally, there is a literal printing of the PDL (many pages of cryptic code) - Go to the [OF 10](#)
- Job prints, but looks wrong. Wrong fonts, missing fonts, other image quality problems - Go to the [OF 11](#)

OF9 TCP/IP Checkout RAP

Use this RAP if the printer is enabled for TCP/IP protocol, but there are problems printing to it.

Initial Actions

- Perform [OF 8](#), Network Printing Problems RAP.
- It is assumed that before entering here that the IOT is known to be OK.
- Ensure that the printer is properly configured for the TCP/IP Network. Verify with the system administrator that the following printer settings are correct:
 - Printer IP address
 - Subnet mask
 - Broadcast Address
 - Default Gateway
- For Solaris 2.5 and above, the key operator or system administrator must have root privilege to install the printer.
- For SunOs, have the system administrator ensure that the /etc/printcap file is properly configured.
- Switch OFF, then switch ON the machine, [GP 10](#).

Procedure

Determine if problem is occurring on multiple workstations.

Only one workstation is unable to print (answer no if unsure)

Y	N	
		Print a Configuration Report, GP 14 . Review the TCP/IP settings.
		TCP/IP is enabled.
		Y N
		Inform the customer's system administrator that the printer needs TCP/IP added.
		Enter Diagnostics, GP 1 . Select dC312 , then check if TCP/IP is selectable.
		TCP/IP is selectable (not grayed out).
		Y N
		Switch OFF, then switch ON the machine, GP 10 . Reenter Diagnostics, GP 1 . When machine is ready, select dC312 again. Check if TCP/IP is selectable.
		TCP/IP is selectable (not grayed out).
		Y N
		Go to GP 4 , then perform the Regular AltBoot procedure.
		If the fault persists, return to the start of this procedure.
		Enter Diagnostics, GP 1 . Select dC312 , select TCP/IP and select Start . Observe the test results.
		The test passed.
		Y N
		In Echo Test, dC312 , select Internal TCP/IP and select Start .
		Observe the test results.
		The test passed.
		B

A

A

B

Y

N

Perform the following:

- There may be a problem with the network port. Ask the system administrator to test the port.
- If the fault persists, request the customer's system administrator install a new Ethernet cable.
- Go to [GP 4](#) and perform the Regular AltBoot procedure.
- If the fault persists, install a new Controller PWB, [PL 3.05](#).

Request the system administrator install the printer.

- Ensure that all configurations and IP addresses are valid.

Request the system administrator install the printer.

- Ensure that all configurations and IP addresses are valid.

The problem occurs only on one job

Y

N

Have the customer's system administrator Ping the IP address of the printer from the affected workstation.

Observe results.

The workstation can ping the printer successfully.

Y

N

Have the customer's system administrator Ping another known good static IP address on the network.

The workstation can successfully ping another static IP address on the network.

Y

N

Inform the customer's system administrator there is a problem with the workstation.

Request the system administrator check the workstation configuration is correct for the network.

Request the system administrator check the workstation configuration is correct for the network.

The same job prints ok from another workstation.

Y

N

Have the customer's system administrator reload the print driver on the affected workstation. If the problem continues, escalate the call to the Customer Service Center (CSC).

There is an application problem. Request the customer contact the Customer Service Center.

OF10 Problem Printing Job RAP

Use this RAP when a particular job won't print. Other jobs print OK.

Procedure

Check the output to see if a PDL error sheet was printed.

An error sheet was printed.

Y N

On the machine UI, select Job Status, Other Queues, All Completed Jobs, Save.

Check the queue for the job in question.

The job is in the log.

Y N

Select Other Queues, All Incomplete Jobs, Save.

The job is stuck in the queue.

Y N

Check for a fault listed against the job in question.

There is a fault(s) listed with the job.

Y N

Go to Software Upgrade, [GP 4](#), and perform the Regular AltBoot procedure.

Go to the appropriate RAP for the fault(s) listed with the job.

Switch the machine power off/on to reboot the SBC PWB.

The job printed OK.

Y N

Inform the customer the job must be deleted. Delete the job. Instruct the customer to recreate and re-send the job.

The job printed OK.

Y N

Go to Software Upgrade, [GP 4](#), and perform the Regular AltBoot procedure.

If the problem continues, there may be a problem with the job. See if other jobs print OK. If not, instruct the customer/System administrator to reload the print driver on the affected workstation.

If the problem continues have the customer call the Customer Service Center.

Done. Return to [SCP 1](#).

Done. Return to [SCP 1](#).

The job must have been printed. Check for the possibility that the job was removed from the printer by another user.

Go to Software Upgrade, [GP 4](#), and perform the Regular AltBoot procedure.

If the problem continues, there may be a problem with the job. See if other jobs print OK. If not, instruct the customer/System administrator to reload the print driver on the affected workstation.

If the problem continues have the customer call the Customer Service Center.

OF 11 Job Prints Incorrectly RAP

The job prints, but incorrectly.

Procedure

Discuss the problem with the customer and/or inspect the incorrect output.

There is a font problem.

Y N

The problem is occurring on all jobs from all clients.

Y N

The problem is occurring on jobs from one particular client.

Y N

The problem is related to a particular job. Have the customer call the Customer Support Center.

There may be a problem with the client workstation. Check/perform the following:

- See if problem is related to a particular job. If so, go to the [OF 10](#).
- Ensure that the client meets minimum specifications for the Embedded Web Server software drivers.
- Ensure the latest printer drivers are loaded.
- Have the customer/System administrator reload the printer driver.

Have the customer/system administrator replace the print drivers. Ensure that the latest drivers available are loaded.

The problem persists.

Y N

Return to [SCP 3](#).

Go to [GP 4](#) and perform the Regular AltBoot procedure.

Have the customer view the job in Print Preview of the application.

The problem appears in Print Preview.

Y N

There may be a font substitution that is not acceptable to the customer. In the Printer Setup for the print driver, if Always Send to Printer is selected, the actual fonts will be sent to the printer from the workstation. This will slow down the printer performance, but will usually solve the font problem.

There may be a problem with the client workstation. Check/perform the following:

- See if problem is related to a particular job. If so, go to the [OF 10](#).
- Ensure the client meets minimum specifications for the Embedded Web Server drivers.
- Ensure the latest printer drivers are loaded.
- Have the customer/System administrator reload the printer driver.

OF12 Modem/Fax PWB Service RAP

There is a problem with the FAX. The primary causes of Fax problems, **in order of likelihood**, are:

- Phone line problems
- Customer operation problems
- PBX setup problems
- Machine configuration problems
- Fax hardware problems

Initial Actions

- If the problem is FAX not printing the Date and Time stamp, enter **dC131** and change the setting in NVM location 200-143 from a 0 to a 1.
- Check the phone line connection is active.
- Check the Configuration Sheet to confirm that the FAX PWB is detected.
- If the FAX icon is not present, check cable connection from the FAX PWB to the Controller PWB.
- Verify the presence of the FAX PWB.
- If the fault persists, or the FAX is inoperable, proceed to the following procedure.

Procedure



WARNING: Switch off the electricity to the machine, **GP 10**. Disconnect the power lead from the customer supply while performing tasks that do not need electricity. Electricity can cause the death or injury. Moving components can cause the injury.

Actions	Yes	No
Step 1 Reseat the telephone cable on the LINE port of the printer and on the wall jack. The fault persists.	Go to step 2.	Perform SCP 5 , Call Closeout.
Step 2 Check if the telephone cable sends and receives calls. Does the cable send and receive calls?	Go to step 4.	Go to step 3.
Step 3 Connect the telephone cable to a working wall jack. The fault persists.	Go to step 4.	Perform SCP 5 Final Actions.
Step 4 Reseat the fax PWB harness and on the JFAX1 connector, PJ Controller PWB , on the controller PWB, PL 3.05 item 1 . The fault persists.	Go to step 5.	Perform SCP 5 Final Actions.
Step 5 Check the fax PWB harness for continuity.	Go to step 7.	Go to step 6.

Actions	Yes	No
Does the cable have continuity?		
Step 6 Install a new fax PWB, PL 20.10 item 1 . Note: The fax PWB harness is not separately spared. The fax PWB harness is part of the fax PWB. The fault persists.	Go to step 7.	Perform SCP 5 Final Actions.
Step 7 Measure the voltages of pins 4, 5, and 7 of the JFAX1 connector, PJ Controller PWB , on the controller PWB, PL 3.05 item 1 . Note: Pins 9, 11, 13, 15, 17, and 19 are GND. Are the voltages of pins 4 and 5 equal to +3.3VDC and pin 7 equal to +5VDC?	Go to step 8.	Go to step 9.
Step 8 Install a new fax PWB, PL 20.10 item 1 . The fault persists.	Go to step 9.	Perform SCP 5 Final Actions.
Step 9 Install a new controller PWB, PL 3.05 item 1 . The fault persists.	Contact the next level of support.	Perform SCP 5 Final Actions.

OF13 Secure Access RAP

Overview

Xerox Secure Access uses an external device, such as a card reader or biometric device, to authorize access to the machine. This reader then passes the information to the controller, which handles the authentication process including, which GUI screens are displayed, accepting GUI responses, that defines their content and order. The controller can pass user identities and passwords directly to the machine after gathering the data from an external server. All communication is via a secure network link, [Figure 1 Network Diagnostic](#).

Xerox Secure Access shall be controlled via the Embedded Web Server GUI. The active status is displayed in tools within Access Control. If communication cannot be established with the Xerox Secure Access Server the service may be temporarily disabled by touching the now enabled Off button within the Xerox Secure Access tools window. Once communication is reestablished the stored Xerox Secure Access setting shall be restored.

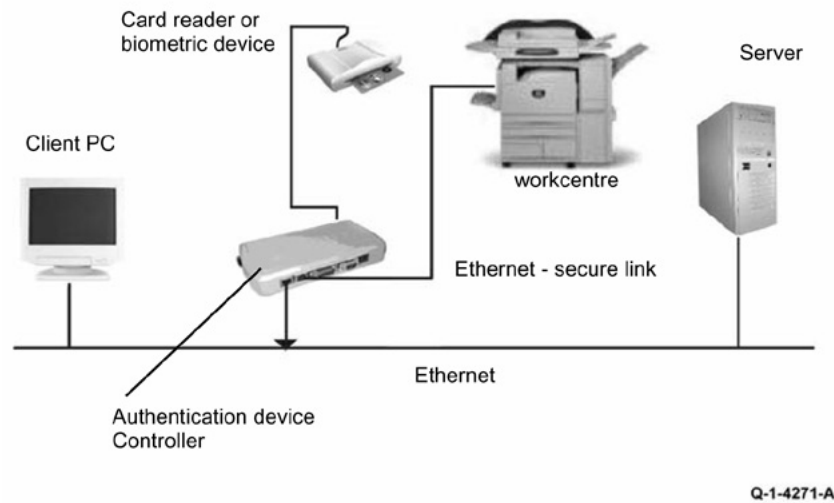


Figure 1 Network Diagnostic

Initial Action

Before working on the Xerox Secure Access, check out the machine in the service mode to insure no faults are displayed and that the machine is functioning properly. If it is not, repair any problems before proceeding with diagnosing the Secure Access Accessory. Diagnostics can be entered to test copier functionality when Secure Access is installed.

Note: To power down the machine, press the UI Power Button and then respond to the on-screen prompts. Wait until the Power Button LED turns off, then switch off the Main Power Switch (GP 4).

Perform the following steps

- Check the connection between the Card Reader and the Secure Access Authentication Device.
- Check for the LEDs are on or blinking on the Secure Access Authentication Device. If the LEDs on the Secure Access Authentication Device are not operating, go to Secure Access Authentication Device Failure.
- Check for the LEDs are on or blinking on the Card Reader. If the LEDs on the Card Reader are not operating, go to Card Reader Failure.

- If customers have problems of install / setting up, or any other problems related to their Secure Access Administrator, they should refer to the Secure Access System Administrator's Guide or contact Xerox Technical Support.

Secure Access Authentication Device Failure

The primary failure modes are power problems or failed hardware components. The symptom of these failures can be detected by observing the LEDs on the Secure Access Authentication Device, [Figure 2](#).

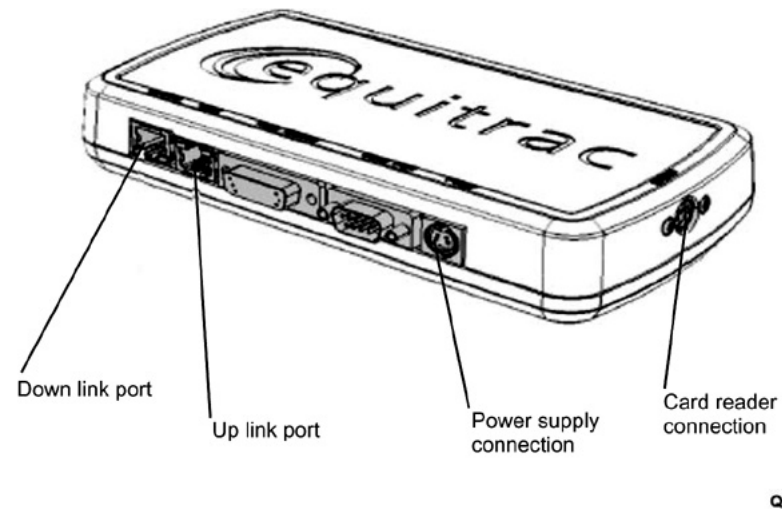


Figure 2 Authentication Device

Check the power to the Secure Access Authentication Device.

- Check the power supply at the wall socket. If there is no power at the wall socket, have the customer restore power and continue when confirmed.
- Disconnect the power cord from the wall socket and the power supply. Check the power cord for continuity and damage. If necessary install a new power cord. Disconnect the power cord from the power supply and plug the power cord into the wall outlet. Using a multi meter, check for line voltage at the end of the power cord disconnected from the power supply. If there is power at the wall but not at the end of the power cord. Install a new power cord.
- Disconnect the small power cord from the Secure Access Authentication Device. Check there is +5V at the connector that plugs into the Secure Access Authentication Device. If there is no +5V, install a new power supply.
- There is a 'Keyed' switch on the end of the Secure Access Authentication Device. Obtain the key from the customer. Insert the key into the 'keyed' switch and cycle the switch 1 quarter turn clockwise and then back to its start position. Observe the LEDs and listen for an audible tone.
- If the LEDs on the Secure Access Authentication Device "Uplink" and "Downlink" Ethernet ports do not cycle on and off as the controller goes through its boot-up process, or if the audible tone is not heard. Install a new Secure Access Authentication Device.

Note: A new device will require the Secure Access Administrator to reconfigure the server with the new MAC address for the new part. Be sure to inform the Secure Access Administrator of the MAC address of the device being removed and the MAC address of the new device.

Card Reader Failure

The primary failure modes are power problems or failed hardware components. The symptom of these failures can be detected by observing the LED on the Card Reader. Refer to [Figure 2](#).

- The Green LED on the Card Reader is On
- The Green LED on the Card Reader Flashes Rapidly
- The Red LED on the Card Reader is On
- The Red LED on Card Reader Flashes Slowly
- The Red LED on Card Reader Flashes Rapidly
- The Card Reader LEDs are not On or Blinking

Table 1 Fault Indications

When the LED on the card Reader is	Description
Red	The authentication device is in idle mode; there is no active session.
Green	The authentication device is in ready mode; a session is active.
Slow Flashing Red	The authentication device has no connection to the server.
Slow Flashing Green	The authentication device is communicating to the server.
Fast flashing red	Invalid card / password; access denied.

The Green LED on the Card Reader is On

- This indicates an active Secure Access Session and the Card Read correctly corresponds to a valid Secure Access Account.
- If the UI on the machine is locked, check with the customer for a second PIN number for additional security. This PIN number will need to be entered via the soft keys on the UI.
- Ensure that the card corresponds to a valid Secure Access Account.

The Green LED on the Card Reader Flashes Rapidly

- This indicates a valid card swipe and in the process of authentication on the server.
- If the UI on the machine is locked, check with the customer for a second PIN number for additional security. This PIN number will need to be entered via the soft keys on the UI.
- If the UI on the machine is locked and no secondary PIN is required. Check that the Xerox Secure Access is installed correctly, and ask customer to check the configuration at the server.

The Red LED on the Card Reader is On

- This indicates the Card Reader is in an idle state. If the red LED remains on, and the UI remains locked after a card is swiped, re-orient the card and re-swipe.
- Try a known good card in the reader. If the other card is working on the problem Card Reader. Ask customer to make sure the card corresponds to a valid Secure Access Account.
- Try the card in a known good reader. If the card is working on a known good Card Reader, it may be a problem with the Secure Access Authentication Device. Check to see if the LEDs on the Secure Access Authentication Device are on.

The Red LED on Card Reader Flashes Slowly

- This indicates the reader is connected to the controller but the controller is not connected to the server. Check the Ethernet green LED on the Authentication Device.

- If the Ethernet green LED on the Authentication Device is off, make sure the connectors of the LAN connections are working properly. If the connections are working, this indicates the network may not work properly. Ask customer to check with Network Administrator.
- If the Ethernet green LED on the Authentication Device is either on or flashing, contact the Secure Access Administrator

The Red LED on Card Reader Flashes Rapidly

- This indicates a valid card but does not correspond to a valid Secure Access Account at the server, test with a known valid user's card.
- If all cards react the same way, this indicates the Server Configuration may not be correct. Ask customer to check the Server Configuration.
- If all the card react this way, this indicates the cards are not valid. Ask customer to check the Server Configuration

The Card Reader LEDs are not On or Blinking

- Check to see if the Secure Access is correctly installed.
- If there is still no LED on the Card Reader, install a new the Card Reader.

Note: If there is another working card reader available, the readers can be switched to confirm failure. If the Card Reader is not functioning, the web page of the machine has a setting that will enable UI keypad access. If the users know their card access number, they can use the machine by manually entering their number. The process is as follows:

1. Go to the machine web page under properties and then security and check the box that says "Allow local user interface initiation".
2. Enable the keypad and test with valid credentials. This will validate the rest of the secure access function.
3. Leave it in this mode until the new card reader can be installed.

3 Image Quality

Image Quality RAPs	346
IQ1 IOT Image Quality Entry RAP.....	346
IQ2 IIT Image Quality Entry RAP.....	348
IQ3 Blank Or White Pages Check RAP.....	349
IQ4 Dark Print Rap.....	351
IQ5 Ghost Images RAP.....	353
IQ6 Gray Or Colored Background RAP.....	354
IQ7 Horizontal Colored Lines or Banding RAP.....	355
IQ8 Light Print RAP.....	356
IQ9 Marks on Leading or Trailing Edges RAP.....	358
IQ10 Mottled Print and Dots RAP.....	359
IQ11 Print Crooked or Skewed RAP.....	360
IQ12 Repeating Defects RAP.....	361
IQ13 Solid Color or Black Image RAP.....	363
IQ14 Text or Images Cut Off RAP.....	364
IQ15 Toner Easily Rubs Off RAP.....	365
IQ16 Uneven Print Density RAP.....	366
IQ17 Vertical Colored Lines or Banding RAP.....	367
IQ18 Vertical White Lines RAP.....	367
IQ19 Blurred Print or Misaligned Color RAP.....	368
IQ20 Gapping or Half Color Page RAP.....	369
IQ21 Image Void Process Direction RAP.....	371
IQ22 Image Void Scan Direction RAP.....	372
IQ23 Missing Color RAP.....	373
IQ24 Random Marks RAP.....	375
Scan Quality RAPs	376
SQ1 Dark Image Quality (using the DADF or scanner) RAP.....	377
SQ2 Vertical Lines (process direction using the DADF) RAP.....	377
SQ3 Spots (using the flatbed scanner) RAP.....	378
SQ4 DADF Skew Check RAP.....	379
SQ5 Media Damage (using the DADF) RAP.....	380
SQ6 Black Or Blank Page Copy RAP.....	380

IQ1 IOT Image Quality Entry RAP

Use this RAP to identify the causes of Image Quality defects and provides steps to working through each Image Quality RAP.

Copy and Print Mode Definitions:

- Print Mode document images are submitted electronically from a Fax, USB, or network source. They do not use any of the IIT components (DADF or Scanner) and there is no hard copy original.
- Copy Mode document images are made from a hard copy original. They use the IIT components (DADF and/or Scanner) to introduce the image into the machine.
- For Copy Mode images made using the DADF, side 1 is defined as the visible side of the document as it sits in the DADF document tray. Side 2 is the side that faces the document tray and is not visible without removing the document from the tray and turning it over. It is useful to label the two sides on the originals used for testing.
- For Copy Mode images made using the Platen Glass, some different parts of the IIT are used to make the image.

Initial Actions

During initial actions, a set of copies and prints are produced. These, along with any copies or prints from the customer, enable you to analyze and correct image quality problems.

1. Ensure that fresh dry paper that meets Xerox specifications is loaded in all paper trays. If necessary, refer to the User Guide to find the approved list of papers and part numbers. 8.5 x 11 and A4 should be loaded. If possible, use paper listed in, [Table 1 Recommended Papers](#).
2. Set the machine UI settings to the corresponding settings listed in, [Table 2 Basic Copier Mode Settings](#), to ensure that the machine is set to a standard state.
3. Make copies of hard copy originals to check for copy mode problems. If a customer original is not available, make the copies from the Color Test Pattern 82E13120
 - a. Make 2-sided copies using the DADF. Use the following process to ensure that both the scanner (for side 1) and the CIS (for side 2) are tested. Set the Copy mode for 2-sided to 2-sided copying.

Set the number of copies to 10.

 1. If possible, use a 2-sided original. If the customer original is not 2 sided, use the Color Test Pattern and feed it through the DADF twice. When using the Color Test Pattern use the following process. Be sure to keep track of whether the copies are side one or side two.
 - 1) Place the Test Pattern in the DADF document tray face up with the top on the left. This will produce a set of side 1 copies.
 - 2) Place the Test Pattern in the DADF document tray face down with the top on the left. This will produce a set of side 2 copies.
 2. Make copies using the platen. Be sure to register the original correctly on the platen with the top on the left. Use either the customer original, or the Color Test Pattern.
4. Ask the customer to make ten 2-sided prints of the file that is showing the defect. If possible, ask that the file be printed from several different computers.
5. If step 4 cannot be completed, make ten 2-sided prints of an appropriate test pattern using [dC612](#).

Table 1 Recommended Papers

Paper	Size / Weight
Bold Digital Printing	8.5 x11 or A4
ColoTech Plus Gold	8.5 x 11 or A4

Table 2 Basic Copier Mode Settings

Item Name	Sub-Item	Sub-Item	Setting
Output Color	-	-	Auto Detect
Reduce/Enlarge	-	-	Auto
Original Type	More	Content Type	Photo and Text
Original Type	More	How Original was Produced	Printed Original
Lighten/Darken	-	-	Normal
Sharpness	-	-	Normal
Saturation	-	-	Normal
Automatic Background Suppression	-	-	Off (unchecked)
Contrast	Contrast: Manual Contrast	-	Normal
Color Presets	-	-	Off
Color Balance	-	-	Normal
Image Shift	-	-	Off

Procedure

Check the set of copies and prints for the presence of the defect in Copy Mode and in Print Mode.

If the problem only occurs in Copy Mode, go to the [IQ2 RAP](#).

1. Check machine customer selectable image quality settings on the UI and the Print Driver. Determine if adjustments to these settings should be made to tune image output to meet customer IQ requirements.
2. Refer the customer to user documentation to review settings that affect copy and print image quality. In particular, ask that they review the following settings for Copy image quality:
 - Output Color
 - Original Type
 - Lighten / Darken
 - Sharpness
 - Saturation

- Automatic Background Suppression
 - Color Presets
 - Color Balance
3. Make a set of prints using dC612 to aid in further defect analysis.
 4. Examine the complete set of copies and prints to determine which Image Quality RAP to perform listed in, [Table 3 Image Quality Defects: Process \(Slow Scan\) Direction Streaks and Lines](#).

Table 3 Image Quality Defects: Process (Slow Scan) Direction Streaks and Lines

Defect	Description	Corrective Action
IQ3 Blank Or White Pages Check RAP	Full page blank or white print.	Go to the RAP IQ3
IQ4 Dark Print Rap	The page appears horizontal dark gradient starting from top to bottom.	Go to the RAP IQ4
IQ5 Ghost Images RAP	Images appear washed out and overlaid.	Go to the RAP IQ5
IQ6 Gray Or Colored Background RAP	The page background appears greyed or having a tint of color.	Go to the RAP IQ6
IQ7 Horizontal Colored Lines or Banding RAP	Horizontal lines appear across the page at intervals top to bottom.	Go to the RAP IQ7
IQ8 Light Print RAP	The print is washed out at 20% to 30% print density.	Go to the RAP IQ8
IQ9 Marks on Leading or Trailing Edges RAP	Dots and irregular print appearing at the top and bottom of the page.	Go to the RAP IQ9
IQ10 Mottled Print and Dots RAP	Dots and irregular print appearing at the at random and in the middle of the page.	Go to the RAP IQ10
IQ11 Print Crooked or Skewed RAP	The print is skewed or crooked.	Go to the RAP IQ11
IQ12 Repeating Defects RAP	Lines or dots repeat at regular intervals down the page.	Go to the RAP IQ12
IQ13 Solid Color or Black Image RAP	The page prints a solid color or black.	Go to the RAP IQ13
IQ14 Text or Images Cut Off RAP	The print is incomplete or cut off the page.	Go to the RAP IQ14
IQ15 Toner Easily Rubs Off RAP	The print is poorly fused to the page.	Go to the RAP IQ15
IQ16 Uneven Print Density RAP	The print is unevenly delivered to the page.	Go to the RAP IQ16

Defect	Description	Corrective Action
IQ17 Vertical Colored Lines or Banding RAP	Colored lines or bands appear vertically across the page.	Go to the RAP IQ17
IQ18 Vertical White Lines RAP	Vertical white lines or missing print appears on the page.	Go to the RAP IQ18
IQ19 Blurred Print or Misaligned Color RAP	The color print is blurred and not crisp.	Go to the RAP IQ19
IQ20 Gapping or Half Color Page RAP	Gaps in the fused toner or only half the page prints.	Go to the RAP IQ20
IQ21 Image Void Process Direction RAP	Images on the page appear missing vertically top to bottom.	Go to the RAP IQ21
IQ22 Image Void Scan Direction RAP	Colors missing are very faded.	Go to the RAP IQ22
IQ23 Missing Color RAP	The print is skewed or crooked.	Go to the RAP IQ23
IQ24 Random Marks RAP	The page has marks across the page at random with no clear pattern or repetition.	Go to the RAP IQ24

IQ2 IIT Image Quality Entry RAP

Use this RAP to troubleshoot scanner and DADF problems only. Before proceeding verify that the defect is present in Copy mode only. If the defect is present on the page printed from the IOT go to, [IQ 1 Image Quality Entry RAP](#).

Initial Actions

1. Clean the scanner, [GP 18](#).
2. Recheck for the problem by repeating the copy mode print generation process from [IQ 1](#). If the problem remains continue with this procedure. Otherwise return to Call Flow.

Procedure

Examine the copies made during Initial Actions of [IQ 1](#). Compare the defective copies with the descriptions listed in [Table 1](#). Perform the corrective action listed for that defect.

Note: The defects listed in [Table 1](#) are for problems that occur in copy mode only. If the problem occurs in both copy and print mode, refer to [IQ 1](#).

Table 1 IIT/IPS Image Quality Problems

Defect	SubSystem	Corrective Action	Description
Dark image quality (using the DADF or scanner)	DADF or Scanner	Check print quality samples Correct any print quality issues using RAP, IQ 1 Image Quality Entry RAP Clean the scanner Clean the white reference strips Perform a copy job using the DADF Perform a copy using the scanner If the fault persists, install a new controller PWB, PL 3.05 item 2	The image is dark using either the DADF or the scanner.
Vertical lines (process direction using the DADF) check	ADF	Clean the Platen Glass Clean the Platen Cushion Calibrate the IIT dC945 . Perform RAP IQ17	Vertical lines appear on the page.
Spots (using the flatbed scanner) check	Scanner	Perform RAP IQ 1 Image Quality Entry RAP	Spots on the printed page appear after scanning a document.
DADF skew check	DADF	Clean the CIS Install a new scanner assembly, PL 60.05 item 1	Images and print are skewed or crooked.



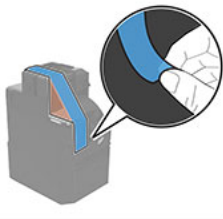

Defect	SubSystem	Corrective Action	Description
Media Damage (using the DADF)	DADF	Check the DADF paper path for debris or foreign objects. Clean the DADF pick and separator rollers. Install new DADF rollers, PL 5.10 item 4	Highlight density too light
Black Or Blank Page Copy	DADF/Scanner	Perform RAP IQ3 for blank pages. Perform IQ13 for black pages.	Highlight density too dark

IQ3 Blank Or White Pages Check RAP



Figure 1 Blank Page

Note: Before performing this print quality check, print the Print Quality Test Pages. From the control panel, navigate to **Settings > Troubleshooting > Print Quality Test Pages**, and then perform the initial print quality check. See [IQ 1](#)

Action	Yes	No
<p>Step 1 Ensure that all the packing materials on the printer are removed.</p> <ul style="list-style-type: none"> Inside the printer   <ul style="list-style-type: none"> Toner cartridges and imaging unit   <p>The fault persists.</p>	Go to step 2.	The problem is solved.
<p>Step 2</p> <ol style="list-style-type: none"> Enter the Diagnostics menu GP 1, and then navigate to: Advanced Print Quality Samples > Advanced Print Quality Test Pages Check the test page. One color is missing. 	Go to step 3.	Go to step 5.

Action	Yes	No
<p>Step 3 Check the toner cartridge and imaging unit contacts of the affected color. The contacts are clean.</p>	Go to step 5.	Go to step 4.
<p>Step 4 Clean the contacts. The fault persists.</p>	Go to step 5.	The problem is solved.
<p>Step 5 Check whether the affected imaging kit or imaging unit is removed and install new imaging kit or imaging unit. The fault persists.</p>	Go to step 6.	The problem is solved.
<p>Step 6</p> <ol style="list-style-type: none"> Remove the transfer module. See REP 90.9. Close the front door or bypass the door interlock switch. Enter the Diagnostics menu GP 1, and then navigate to: Printer diagnostics & adjustments > Motor tests Select the motor of the affected color, and then touch Start. The motor runs. 	Go to step 8.	Go to step 7.
<p>Step 7 Install a new affected motor (EP drive). See PL 40.10 item 2. The fault persists.</p>	Go to step 8.	The problem is solved.
<p>Step 8</p> <ol style="list-style-type: none"> Manually turn the motor (EP drive). While turning the motor, check if the corresponding couplers that drive the affected toner cartridge or imaging unit move. The couplers move. 	Go to step 10.	Go to step 9.
<p>Step 9 Install a new EP drive gear-box. See PL 40.10 item 2. The fault persists.</p>	Go to step 10.	The problem is solved.

Action	Yes	No
Step 10 Check if the pins on the HVPS freely move. The pins can freely move.	Go to step 12.	Go to step 11.
Step 11 Install a new HVPS. See PL 1.10 item 5 . The fault persists.	Go to step 12.	The problem is solved.
Step 12 Check the continuity of the cable on the JWTH_SC1 connector on the engine board. The cable have continuity.	Go to step 14.	Go to step 13.
Step 13 Install a new cable. The fault persists.	Go to step 14.	The problem is solved.
Step 14 Ensure that the printhead cables on the Drive PWB are properly connected. The fault persists.	Go to step 15.	The problem is solved.
Step 15 Ensure that the JTH1 and JPWR1 cables are properly connected to the controller PWB and Drive PWB. The fault persists.	Go to step 16.	The problem is solved.
Step 16 Install a new printhead. See PL 60.10 item 1 . The fault persists.	Go to step 17.	The problem is solved.
Step 17 Install a new Drive PWB. See PL 1.10 item 3 . The fault persists.	Contact the next level of support.	The problem is solved.

IQ4 Dark Print Rap

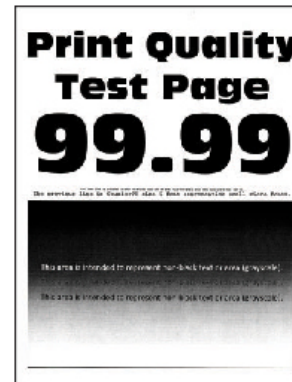


Figure 1 Dark Print

Note: Before performing this print quality check, print the Print Quality Test Pages. From the control panel, navigate to **Settings > Troubleshooting > Print Quality Test Pages**, and then perform the initial print quality check. See [IQ 1](#)

Procedure

Action	Yes	No
Step 1 1 From the Home screen, touch Settings > Print > Quality > Toner Darkness . 2 Check the toner darkness setting value. Note: The default value for toner darkness is 4. The darkness setting is too high.	Go to step 2.	Go to step 3.
Step 2 Adjust the darkness setting to the proper value. The fault persists.	Go to step 3.	The problem is solved.
Step 3 1 Enter the Diagnostics menu GP 1 , and then navigate to: Printer diagnostics & adjustments > Printer Setup > EP Setup > Toner Patch Sensor Adjust 2 Ensure that Calibration reference values are set to default.	Go to step 4.	The problem is solved.

Action	Yes	No
<p>Note: Default value for Black and CMY settings is 0. The fault persists.</p>		
<p>Step 4 1 Enter the Diagnostics menu GP 1, and then navigate to: Advanced Print Quality Samples > Advanced Print Quality Test Pages 2 Check the test page. If color affected.</p>	Go to step 5.	Go to step 8.
<p>Step 5 If the affected color is black, then do the following: 1 Remove the black imaging unit from the imaging kit. 2 Reinstall the black imaging unit. If the affected color is C, M, or Y, then do the following: 1 Remove the affected color imaging unit from the imaging kit. 2 Reinstall the affected color imaging unit. The fault persists.</p>	Go to step 6.	The problem is solved.
<p>Step 6 Check whether the affected imaging unit or imaging kit is removed and install a new imaging unit or imaging kit. The fault persists.</p>	Go to step 7.	The problem is solved.
<p>Step 7 1 Enter the Diagnostics menu GP 1, and then navigate to: Printer diagnostics & adjustments > Color alignment adjust 2 On the AA adjustment row, touch Start. 3 From the Home screen, touch Settings > Print > Quality > Advanced Imaging > Color Adjust. The fault persists.</p>	Go to step 8.	The problem is solved.

Action	Yes	No
<p>Step 8 Perform the toner patch sensing service check. See dC927. The fault persists.</p>	Go to step 9.	The problem is solved.
<p>Step 9 Reconnect the HVPS cable on the Drive PWB. The fault persists.</p>	Go to step 10.	The problem is solved.
<p>Step 10 Install a new HVPS. See PL 1.10 item 5. The fault persists.</p>	Contact the next level of support.	The problem is solved.

IQ5 Ghost Images RAP

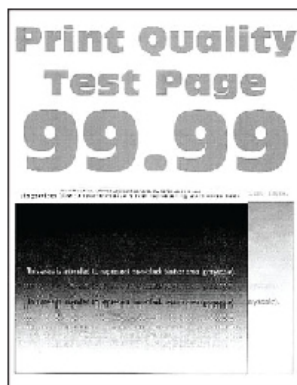


Figure 1 Ghost Image

Note: Before performing this print quality check, print the Print Quality Test Pages. From the control panel, navigate to **Settings > Troubleshooting > Print Quality Test Pages**, and then perform the initial print quality check. See [IQ 1](#)

Procedure

Action	Yes	No
Step 1 1 From the Home screen, touch Settings > Paper > Tray Configuration > Default Source . 2 Select the paper source. 3 Check if the paper type and size settings match the paper type and size set on the tray. If the settings match.	Go to step 3.	Go to step 2.
Step 2 Change the paper size and type, or adjust the size settings in the tray to match the paper size. The fault persists.	Go to step 3.	The problem is solved.
Step 3 Note: Ghost images may occur when printing to a full-width media immediately after print jobs with long narrow media. The issue occurs right after printing from long narrow media to a full-width media.	Go to step 4.	Go to step 5.

Action	Yes	No
Step 4 Wait for several printing cycles before doing a print job on a full-width media. If necessary, contact the next level of support for the engine setting to make the printer wait longer. The fault persists.	Go to step 5.	The problem is solved.
Step 5 1 From the Home screen, touch Status/Supplies . 2 Check the status of the black and color supplies. If any of the supplies are low.	Go to step 6.	Go to step 7.
Step 6 Check whether affected supply is removed and install a new supply. The fault persists.	Go to step 7.	The problem is solved.
Step 7 Measure the distance from one point of the original image to the same point on the ghost image. Note: Defects that repeat after 43.6 mm are most likely caused by the developer roller. The distance is 43.6 mm.	Go to step 8.	Go to step 9.
Step 8 Check whether the affected imaging kit or imaging unit is removed and install a new imaging kit or imaging unit. The fault persists.	Go to step 9.	The problem is solved.
Step 9 Measure the distance from one point of the original image to the same point on the ghost image. Note: Defects that repeat after 94.5 mm are most likely caused by the photo conductor drum. The distance is 94.5 mm.	Go to step 10.	Go to step 11.
Step 10	Go to step 11.	The problem is solved.

Action	Yes	No
Check whether the affected imaging kit or imaging unit is removed and install a new imaging kit or imaging unit. The fault persists.		
Step 11 1 From the Home screen, touch Settings > Reports > Menu Settings Page . Note: Perform this step twice to clear any debris. 2 Check the fuser area for toner contamination. If there is toner contamination.	Go to step 12.	Contact the next level of support.
Step 12 Install a new fuser. See PL 10.10 item 1 . The fault persists.	Contact the next level of support.	The problem is solved.

IQ6 Gray Or Colored Background RAP

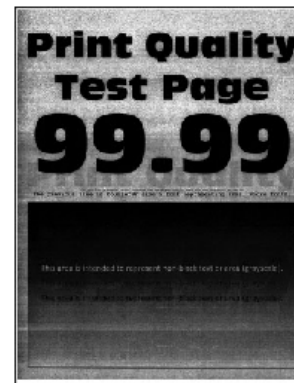


Figure 1 Gray Background

Note: Before performing this print quality check, print the Print Quality Test Pages. From the control panel, navigate to **Settings > Troubleshooting > Print Quality Test Pages**, and then perform the initial print quality check. See [IQ 1](#)

Procedure

Action	Yes	No
Step 1 1 From the Home screen, touch Status/Supplies . 2 Check the status of the toner cartridges or imaging unit if any were recently replaced. If any of the toner cartridges or imaging unit recently replaced.	Go to step 2.	Go to step 3.
Step 2 Install a new toner cartridges or imaging unit. See REP 60.1 . The fault persists.	Go to step 3.	The problem is solved.
Step 3 Check if black is the only color producing the background of the print job. Is black the only color producing the background.	Go to step 4.	Go to step 5.
Step 4 Install a new black imaging unit. The fault persists.	Go to step 5.	The problem is solved.
Step 5	Go to step 6.	The problem is solved.

Action	Yes	No
Install a new imaging kit. See REP 60.1 . The fault persists.		
Step 6 Reconnect the HVPS cable on the HVPS and on the JHVPS1 connector on the Drive PWB . The fault persists.	Go to step 7.	The problem is solved.
Step 7 Check the contact pins connecting the HVPS to the transfer module for damage. The contact pins are damaged.	Go to step 8.	Go to step 9.
Step 8 Install a new HVPS. See PL 1.10 item 5 . The fault persists.	Go to step 9.	The problem is solved.
Step 9 Ensure that the printhead cables on the Drive PWB are properly connected. The fault persists.	Go to step 10.	The problem is solved.
Step 10 Install a new printhead. See PL 60.10 item 1 . The fault persists.	Contact the next level of support.	The problem is solved.

IQ7 Horizontal Colored Lines or Banding RAP



Figure 1 Horizontal Colored Lines

Note: Before performing this print quality check, print the Print Quality Test Pages. From the control panel, navigate to **Settings > Troubleshooting > Print Quality Test Pages**, and then perform the initial print quality check. See [IQ 1](#)

Procedure

Action	Yes	No
Step 1 Check if the lines on the print quality test page are white. The lines are white.	Go to step 2.	Go to step 3.
Step 2 Perform the repeating defects check. See IQ12 . The fault persists.	Go to step 3.	The problem is solved.
Step 3 Check if the lines appear only on the leading or trailing edge. The issue occurred only on the leading or trailing edge.	Go to step 4.	Go to step 5.
Step 4 Perform the Marks on leading or trailing edges check. See IQ9 . The fault persists.	Go to step 5.	The problem is solved.
Step 5 1 Enter the Diagnostics menu GP 1 , and then navigate to:	Go to step 6.	Go to step 7.

Action	Yes	No
<p>Advanced Print Quality Samples > Advanced Print Quality Test Pages</p> <p>2 Check if the lines appear on the same area of the page. The lines appear on the same area.</p>		
<p>Step 6 Perform the repeating defects check. See IQ12. The fault persists.</p>	Go to step 7.	The problem is solved.
<p>Step 7 Check the pages right after the defective page. The lines appearing after two consecutive normal pages were printed</p>	Go to step 8.	The problem is solved.
<p>Step 8 Check the transfer module for contamination. The transfer module is free of contamination.</p>	Contact the next level of support.	Go to step 9.
<p>Step 9 Clean or install a new transfer module. See PL 90.10 item 2. The fault persists.</p>	Contact the next level of support.	The problem is solved.

IQ8 Light Print RAP

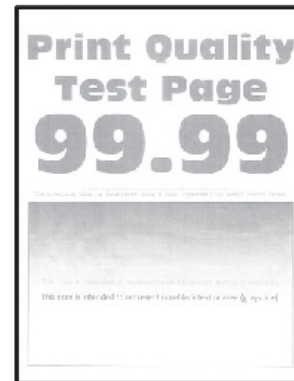



Figure 1 Light Print

Note: Before performing this print quality check, print the Print Quality Test Pages. From the control panel, navigate to **Settings > Troubleshooting > Print Quality Test Pages**, and then perform the initial print quality check. See [IQ 1](#)

Procedure

Action	Yes	No
<p>Step 1</p> <p>1 From the Home screen, touch Settings > Print > Quality.</p> <p>2 Check the Toner darkness setting value.</p> <p>Note: The default value for toner darkness is 4. The darkness setting is too low.</p>	Go to step 2.	Go to step 3.
<p>Step 2 Adjust the darkness setting to the proper value. The fault persists.</p>	Go to step 3.	The problem is solved.
<p>Step 3</p> <p>1 From the Home screen, touch Device > Eco-mode > Print.</p> <p>2 Ensure that the Color saver setting is set to Off. The fault persists.</p>	Go to step 4.	The problem is solved.
<p>Step 4 Ensure that there is no paper wrapping around the second transfer roller</p>	Go to step 5.	The problem is solved.

Action	Yes	No
The fault persists.		
Step 5 1 Remove the transfer module. See REP 90.9 . 2 Check if the three contacts are visible and if they freely move. The contacts are visible and Check if they freely move.	Go to step 7.	Go to step 6.
Step 6 Check if the index pin behind the transfer module retract arm is visible and properly aligned.  <small>W0406L 008</small> The index pin is visible and properly aligned.	Go to step 8.	Go to step 7.
Step 7 1 Reconnect the HVPS. 2 Ensure that the contacts are visible and can freely move. 3 Ensure that the index pin is properly aligned. The fault persists.	Go to step 8.	The problem is solved.
Step 8 1 Enter the Diagnostics menu GP 1 , and then navigate to: Advanced Print Quality Samples > Advanced Print Quality Test Pages 2 Check the test page. If only one color affected.	Go to step 9.	Go to step 17.
Step 9 Check the toner cartridge of the affected color for proper installation.	Go to step 11.	Go to step 10.

Action	Yes	No
<ul style="list-style-type: none"> Ensure that there are no packing materials still on it. Check for misalignment. The toner cartridge is properly installed. 		
Step 10 Reinstall the toner cartridge. The fault persists.	Go to step 11.	The problem is solved.
Step 11 Check the cartridge toner level. The cartridge is empty.	Go to step 12.	Go to step 13.
Step 12 Install a new toner cartridge. The fault persists.	Go to step 13.	The problem is solved.
Step 13 Remove, and then reinstall the imaging kit or imaging unit of the affected color. The fault persists.	Go to step 14.	The problem is solved.
Step 14 1 Remove the transfer module. See REP 90.9 . 2 Close the front door or bypass the door interlock switch. 3 Enter the Diagnostics menu GP 1 , and then navigate to: Printer diagnostics & adjustments > Motor tests 4 Select the motor of the affected color, and then touch Start . The motor will run.	Go to step 17.	Go to step 15.
Step 15 Reconnect the motor cable. The fault persists.	Go to step 16.	The problem is solved.
Step 16 Remove the affected motor (EP drive) and install a new motor. See PL 40.10 item 2 . The fault persists.	Go to step 17.	The problem is solved.
Step 17	Go to step 19.	Go to step 18.

Action	Yes	No
Remove the imaging kit, and then check the printhead lenses for dust or debris. See REP 60.1 . The lenses are free of dust or debris.		
Step 18 Clean the printhead lenses. The fault persists.	Go to step 19.	The problem is solved.
Step 19 Check the HVPS cable on the HVPS and on the JHVPS1 connector on the engine board for proper connection. The cable is properly connected at both ends.	Go to step 21.	Go to step 20.
Step 20 Reconnect the cable. The fault persists.	Go to step 21.	The problem is solved.
Step 21 Install a new transfer module. See REP 90.9 . The fault persists.	Go to step 22.	The problem is solved.
Step 22 Install a new HVPS. See PL 1.10 item 5 . The fault persists.	Contact the next level of support.	The problem is solved.

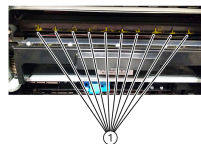
IQ9 Marks on Leading or Trailing Edges RAP



Figure 1 Marks on Leading or Trailing Edges

Note: Before performing this print quality check, print the Print Quality Test Pages. From the control panel, navigate to **Settings > Troubleshooting > Print Quality Test Pages**, and then perform the initial print quality check. See [IQ 1](#)

Procedure

Action	Yes	No
<p>1 Use a dry and lint-free cloth to clean the ribs (1) on the transfer module cleaning assembly housing.</p> <p>Note: Do not remove the transfer belt to clean the housing.</p> 	Contact the next level of support.	The problem is solved.
<p>2 Use a toner vacuum to remove the remaining toner.</p> <p>3 Perform a print job. The fault persists.</p>		

IQ10 Mottled Print and Dots RAP



Figure 1 Random Dark Spots

Note: Before performing this print quality check, print the Print Quality Test Pages. From the control panel, navigate to **Settings > Troubleshooting > Print Quality Test Pages**, and then perform the initial print quality check. See [IQ 1](#)

Procedure

Action	Yes	No
Step 1 1 From the Home screen, touch Settings > Device > Preferences . 2 Check if the paper type and size settings match the paper type and size set on the tray. The settings will match.	Go to step 3.	Go to step 2.
Step 2 Change the paper size and type, or adjust the size settings in the tray to match the paper size. The fault persists.	Go to step 3.	The problem is solved.
Step 3 Check the paper for texture or rough finish. The paper is textured or rough.	Go to step 4.	Go to step 5.
Step 4	Go to step 5.	The problem is solved.

Action	Yes	No
Replace the textured or rough paper with plain paper. The fault persists.		
Step 5 Check the printer for toner leaks. If there is any toner leaks.	Go to step 6.	Go to step 7.
Step 6 1 Clean the printer thoroughly using a toner vacuum. 2 Perform a print job to clear the remaining toner from the imaging components. The fault persists.	Go to step 7.	The problem is solved.
Step 7 Check whether the affected imaging kit or imaging unit is removed and install a new imaging kit or imaging unit. The fault persists.	Go to step 8.	The problem is solved.
Step 8 Check the transfer module for improper installation and damage. The transfer module is properly installed and free of damage.	Go to step 10.	Go to step 9.
Step 9 Install a new transfer module. See PL 90.10 item 2 . The fault persists.	Go to step 10.	The problem is solved.
Step 10 1 Remove the fuser. See REP 10.1 . 2 Check the fuser for debris and damage. The fuser is free of debris and damage.	Contact the next level of support.	Go to step 11.
Step 11 Clean or install a new fuser. See PL 10.10 item 1 . The fault persists.	Contact the next level of support.	The problem is solved.

IQ11 Print Crooked or Skewed RAP

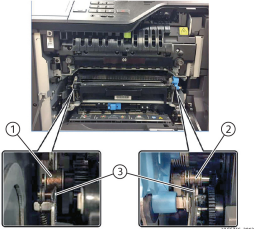
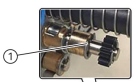
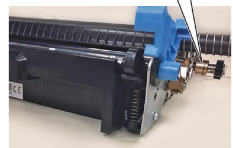




Figure 1 Skewed Print

Note: Before performing this print quality check, print the Print Quality Test Pages. From the control panel, navigate to **Settings > Troubleshooting > Print Quality Test Pages**, and then perform the initial print quality check. See [IQ 1](#)

Procedure

Action	Yes	No
Step 1 Ensure that the paper is properly loaded and free of damage. The fault persists.	Go to step 2.	The problem is solved.
Step 2 1 From the Home screen, touch Settings > Device > Preferences . 2 Check if the paper type and size settings match the paper type and size set on the tray. If settings matches.	Go to step 4.	Go to step 3.
Step 3 Change the paper size and type, or adjust the size settings in the tray to match the paper size. The fault persists.	Go to step 4.	The problem is solved.
Step 4 <ul style="list-style-type: none"> Check if the transfer module bearings are properly seated on the frame. Ensure that the bearings sit on top of their slots. 	Go to step 5.	The problem is solved.

Action	Yes	No								
 <table border="1" data-bbox="1123 430 1354 617"> <thead> <tr> <th>#</th> <th>Part</th> </tr> </thead> <tbody> <tr> <td>1</td> <td>Left bearing</td> </tr> <tr> <td>2</td> <td>Right bearing</td> </tr> <tr> <td>3</td> <td>Frame</td> </tr> </tbody> </table> <ul style="list-style-type: none"> If necessary, install a new transfer module. See PL 90.10 item 2 The fault persists.	#	Part	1	Left bearing	2	Right bearing	3	Frame		
#	Part									
1	Left bearing									
2	Right bearing									
3	Frame									
Step 5 <ul style="list-style-type: none"> Ensure that the transfer module E-clip (1) is not missing.   <ul style="list-style-type: none"> Ensure that the transfer module bearing (1) is properly seated.   The fault persists.	Go to step 6.	The problem is solved.								

Action	Yes	No
Step 6 Check the isolation unit for dust or debris. The isolation unit is free of dust or debris.	Go to step 8.	Go to step 7.
Step 7 Remove the dust or debris. The fault persists.	Go to step 8.	The problem is solved.
Step 8 1 Enter the Diagnostics menuGP 1, and then navigate to: Printer diagnostics & adjustments > Motor tests > Deskew 2 Touch Start . The motor will run.	Go to step 11.	Go to step 9.
Step 9 Check the cable on the JMTR1 connector on the controller PWB for proper connection and damage, and replace if necessary. The fault persists.	Go to step 10.	The problem is solved.
Step 10 Install a new motor (deskew). See PL 40.10 item 1. The fault persists.	Go to step 11.	The problem is solved.
Step 11 Check the condition of the aligner rollers. The rollers are free from excess wear, contamination, and damage.	Contact the next level of support.	Go to step 12.
Step 12 Clean or install a new rollers. See PL 80.05 item 8. The fault persists.	Contact the next level of support.	The problem is solved.

IQ12 Repeating Defects RAP



Figure 1 Repeating Defects

Note: Before performing this print quality check, print the Print Quality Test Pages. From the control panel, navigate to **Settings > Troubleshooting > Print Quality Test Pages**, and then perform the initial print quality check. See [IQ 1](#)

Procedure

Action	Yes	No
Step 1 Check the printer rollers for dust or debris. The rollers are free of dust or debris.	Go to step 3.	Go to step 2.
Step 2 Remove the dust or debris. The fault persists.	Go to step 3.	The problem is solved.
Step 3 Measure the distance between the repeating marks. Note: A distance of 43.6 mm is likely caused by the developer roller. A distance of 45 mm is likely caused by the toner add roller. The distance between the marks is either 43.6 mm or 45 mm.	Go to step 4.	Go to step 5.
Step 4 Check whether the affected imaging kit or imaging unit is removed and install a new imaging kit or imaging unit. The fault persists.	Contact the next level of support.	The problem is solved.

Action	Yes	No
<p>Step 5 Measure the distance between the repeating marks.</p> <p>Note: A distance of 29.9 mm is likely caused by the charge roller. A distance of 23.2 mm is likely caused by the charge roller cleaner. A distance of 94.5 mm is likely caused by the photo conductor drum. The distance between the marks is either 29.9 mm, 23.2 mm, or 94.5 mm.</p>	Go to step 6.	Go to step 7.
<p>Step 6 Check whether the affected imaging kit or imaging unit is removed and install a new imaging kit or imaging unit. The fault persists.</p>	Contact the next level of support.	The problem is solved.
<p>Step 7 Measure the distance between the repeating marks.</p> <p>Note: A distance of 95 mm is likely caused by the fuser roller or belt. The distance between the marks is 95 mm or 110 mm.</p>	Go to step 8.	Go to step 9.
<p>Step 8 Install a new fuser. See PL 10.10 item 1. The fault persists.</p>	Contact the next level of support.	The problem is solved.
<p>Step 9 Measure the distance between the repeating marks.</p> <p>Note: Distances of 37.7 mm, 54.6 mm, and 78.5 mm points to the transfer module as the likely cause. The distance between the marks is either 37.7 mm, 54.6 mm, or 78.5 mm.</p>	Go to step 11.	Go to step 10.

Action	Yes	No
<p>Step 10 Check the marks that appear on a multi-page print job. The marks appear on every other page.</p>	Go to step 11.	Contact the next level of support.
<p>Step 11 Install a new transfer module. See PL 90.10 item 2. The fault persists.</p>	Contact the next level of support.	The problem is solved.

IQ13 Solid Color or Black Image RAP



Figure 1 Solid Color or Black Image

Note: Before performing this print quality check, print the Print Quality Test Pages. From the control panel, navigate to **Settings > Troubleshooting > Print Quality Test Pages**, and then perform the initial print quality check. See [IQ 1](#)

Procedure

Action	Yes	No
<p>Step 1</p> <p>1 Place a narrow strip of paper over the gap between the developer rollers.</p> <p>Note: Ensure that the paper stays in place when reinstalling the imaging unit to he laser from discharging the photo conductor.</p> <p>2 From the Home screen, touch Settings > Troubleshooting > Print Quality Pages.</p> <p>3 Check the test page. If there is vertical banding.</p>	Go to step 2.	Go to step 6.
<p>Step 2</p> <p>1 Ensure that the cables are properly connected on the printhead and Drive PWB.</p> <p>2 Ensure that the cables from the Drive PWB are connected to the controller PWB.</p> <p>The fault persists.</p>	Go to step 3.	The problem is solved.

Action	Yes	No
<p>Step 3</p> <p>Install a new printhead. See PL 60.10 item 1.</p> <p>The fault persists.</p>	Go to step 4.	The problem is solved.
<p>Step 4</p> <p>Install a new Drive PWB. See PL 1.10 item 3.</p> <p>The fault persists.</p>	Go to step 5.	The problem is solved.
<p>Step 5</p> <p>Install a new controller PWB. See PL 3.05 item 2.</p> <p>The fault persists.</p>	Contact the next level of support.	The problem is solved.
<p>Step 6</p> <p>Check whether the affected imaging unit or imaging kit are removed and install a new imaging unit or imaging kit.</p> <p>The fault persists.</p>	Go to step 7.	The problem is solved.
<p>Step 7</p> <p>Turn off the printer, and then check the continuity of the HVPS cable.</p> <p>The cable have continuity.</p>	Go to step 9.	Go to step 8.
<p>Step 8</p> <p>Install a new HVPS cable.</p> <p>The fault persists.</p>	Go to step 9.	The problem is solved.
<p>Step 9</p> <p>Install a new HVPS. See PL 1.10 item 5.</p> <p>The fault persists.</p>	Contact the next level of support.	The problem is solved.

IQ14 Text or Images Cut Off RAP



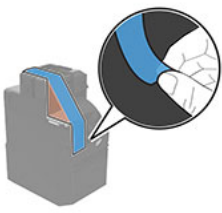



Figure 1 Image Cut Off

Note: Before performing this print quality check, print the Print Quality Test Pages. From the control panel, navigate to **Settings > Troubleshooting > Print Quality Test Pages**, and then perform the initial print quality check. See [IQ 1](#)

Procedure

Action	Yes	No
<p>Step 1</p> <p>1 From the Home screen, touch Settings > Device > Preferences.</p> <p>2 Check if the paper type and size settings match the paper type and size set on the tray. If the settings matches.</p>	Go to step 3.	Go to step 2.
<p>Step 2</p> <p>Change the paper size and type, or adjust the size settings in the tray to match the paper size. The fault persists.</p>	Go to step 3.	The problem is solved.

Action	Yes	No
<p>Step 3</p> <p>Ensure that all the packing materials on the printer are removed.</p> <ul style="list-style-type: none"> Inside the printer   <ul style="list-style-type: none"> Toner cartridges and imaging unit   <p>The fault persists.</p>	Go to step 4.	The problem is solved.
<p>Step 4</p> <p>Ensure that the black imaging unit and CMY imaging kit have not reached end-of-life. The fault persists.</p>	Contact the next level of support.	The problem is solved.

IQ15 Toner Easily Rubs Off RAP



Figure 1 Toner Easily Rubs Off

Note: Before performing this print quality check, print the Print Quality Test Pages. From the control panel, navigate to **Settings > Troubleshooting > Print Quality Test Pages**, and then perform the initial print quality check. See [IQ 1](#)

Procedure

Action	Yes	No
Step 1 1 From the Home screen, touch Settings > Device > Preferences . 2 Check if the paper type and size settings match the paper type and size set on the tray. The settings matches.	Go to step 3.	Go to step 2.
Step 2 Change the paper size and type, or adjust the size settings in the tray to match the paper size. The fault persists.	Go to step 3.	The problem is solved.
Step 3 Check the paper for texture or rough finish. The paper is textured or rough.	Go to step 4.	Go to step 5.
Step 4 Install a new textured or rough paper with plain paper. The fault persists.	Go to step 5.	The problem is solved.
Step 5	Go to step 6.	The problem is solved.

Action	Yes	No
Remove, and then install a new fuser. See PL 10.10 item 1 . The fault persists.		
Step 6 Install a new fuser. See PL 10.10 item 1 . The fault persists.	Go to step 7.	The problem is solved.
Step 7 1 From the Home screen, touch Settings > Device > Maintenance > Configuration Menu > Reports > Event Log . 2 Check the log history for fuser error codes. Fuser error codes is there on the event log.	Go to step 8.	Go to step 9.
Step 8 Perform the service check for the error code found. The fault persists.	Go to step 9.	The problem is solved.
Step 9 Install a new LVPS. See PL 1.10 item 7 . The fault persists.	Contact the next level of support.	The problem is solved.

IQ16 Uneven Print Density RAP



Figure 1 Uneven Print

Note: Before performing this print quality check, print the Print Quality Test Pages. From the control panel, navigate to **Settings > Troubleshooting > Print Quality Test Pages**, and then perform the initial print quality check. See [IQ 1](#)

Procedure

Action	Yes	No
Step 1 1 From the Home screen, touch Settings > Device > Preferences . 2 Check if the paper type and size settings match the paper type and size set on the tray. If the settings matches.	Go to step 3.	Go to step 2.
Step 2 Change the paper size and type, or adjust the size settings in the tray to match the paper size. The fault persists.	Go to step 3.	The problem is solved.
Step 3 Check the paper for texture or rough finish. The paper is textured or rough.	Go to step 4.	Go to step 5.
Step 4 Remove the textured or rough paper and insert new plain paper. The fault persists.	Go to step 5.	The problem is solved.

Action	Yes	No
Step 5 1 Remove the imaging kit. See REP 60.1 . 2 Inspect and clean the print head lenses. 3 Print a test page. The fault persists.	Go to step 6.	The problem is solved.
Step 6 1 Remove the CMY developer units from the imaging kit, and then install them back to the imaging kit. 2 Remove the black imaging unit from the imaging kit, and then install it back to the imaging kit. The fault persists.	Go to step 7.	The problem is solved.
Step 7 Check whether the affected imaging unit or imaging kit is removed and install a new imaging unit or imaging kit. The fault persists.	Contact the next level of support.	The problem is solved.

IQ17 Vertical Colored Lines or Banding RAP



Figure 1 Vertical Colored Lines

Note: Before performing this print quality check, print the Print Quality Test Pages. From the control panel, navigate to **Settings > Troubleshooting > Print Quality Test Pages**, and then perform the initial print quality check. See [IQ 1](#)

Procedure

Action	Yes	No
Step 1 1 Enter the Diagnostics menu GP 1 , and then navigate to: Advanced Print Quality Samples > Advanced Print Quality Test Pages 2 Check the test page. If only one color producing the defect.	Go to step 2.	Go to step 3.
Step 2 Check whether the affected imaging unit or imaging kit is removed and install a new imaging unit or imaging kit. The fault persists.	Go to step 3.	The problem is solved.
Step 3 Install a new transfer module. See PL 90.10 item 2 . The fault persists.	Go to step 4.	The problem is solved.
Step 4 Install a new fuser. See PL 10.10 item 1 . The fault persists.	Contact the next level of support.	The problem is solved.

IQ18 Vertical White Lines RAP



Figure 1 Vertical White Lines

Note: Before performing this print quality check, print the Print Quality Test Pages. From the control panel, navigate to **Settings > Troubleshooting > Print Quality Test Pages**, and then perform the initial print quality check. See [IQ 1](#)

Procedure

Action	Yes	No
Step 1 1 Remove the imaging kit. See REP 60.1 . 2 Inspect and clean the print head lenses. 3 Print a test page. The fault persists.	Go to step 2.	The problem is solved.
Step 2 1 Enter the Diagnostics menu GP 1 , and then navigate to: Advanced Print Quality Samples Advanced Print Quality Test Pages 2 Check the test page. The print defect appears on all the pages.	Go to step 3.	Go to step 3.
Step 3 Check whether the affected imaging unit or imaging kit is removed and install a new imaging unit or imaging kit. The fault persists.	Go to step 4.	The problem is solved.
Step 4	Go to step 5.	Go to step 5.

Action	Yes	No
Check the transfer module for improper installation and damage. The transfer module is properly installed and free of damage.		
Step 5 Install a new transfer module. See PL 90.10 item 2 . The fault persists.	Go to step 6.	The problem is solved.
Step 6 Install a new print head. See PL 60.10 item 1 . The fault persists.	Contact the next level of support.	The problem is solved.

IQ19 Blurred Print or Misaligned Color RAP

Note: Before performing this print quality check, print the Print Quality Test Pages. From the control panel, navigate to **Settings > Troubleshooting > Print Quality Test Pages**, and then perform the initial print quality check. See [IQ 1](#)

Procedure



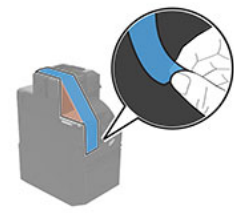

Action	Yes	No
Step 1 Check the print quality test page if it has one color that is blurred or misaligned. If only one color blurred or misaligned.	Go to step 2.	Go to step 3.
Step 2 Perform the color alignment adjustment on the misaligned color. See dC919 . The fault persists.	Go to step 3.	The problem is solved.
Step 3 Perform color alignment adjustment on all color. See dC919 . The fault persists.	Go to step 4.	The problem is solved.
Step 4 Perform the Auto alignment service check. See dC919 . The fault persists.	Go to step 5.	The problem is solved.
Step 5 Enter the Diagnostics menu GP 1 , and then navigate to: Advanced Print Quality Samples > Advanced Print Quality Test Page . The fault persists.	Go to step 6.	The problem is solved.
Step 6 Remove the imaging kit, and then clean the print head lenses. See GP 15 . The fault persists.	Go to step 7.	The problem is solved.
Step 7 Replace the motor (K/transfer belt). See REP 40.1 . The fault persists.	Go to step 8.	The problem is solved.

Action	Yes	No
Step 8 Install a new print head. See PL 60.10 item 1 . The fault persists.	Go to step 9.	The problem is solved.
Step 9 Install a new Drive PWB. See PL 1.10 item 3 . The fault persists.	Contact the next level of support.	The problem is solved.

IQ20 Gapping or Half Color Page RAP

Note: Before performing this print quality check, print the Print Quality Test Pages. From the control panel, navigate to **Settings > Troubleshooting > Print Quality Test Pages**, and then perform the initial print quality check. See [IQ 1](#)

Procedure



Action	Yes	No
<p>Step 1 Ensure that all the packing materials on the printer are removed.</p> <ul style="list-style-type: none"> Inside the printer   <ul style="list-style-type: none"> Toner cartridges and imaging unit   <p>The fault persists.</p>	Go to step 2.	The problem is solved.
<p>Step 2</p> <ol style="list-style-type: none"> 1 Reinstall the toner cartridges and imaging unit. 2 Reinstall the imaging kit. 3 Enter the Diagnostics menu GP 1, and then navigate to: 	Go to step 3.	The problem is solved.

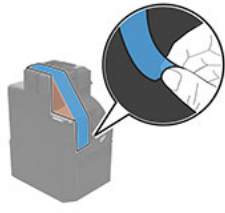

Action	Yes	No
<p>Advanced Print Quality Samples > Advanced Print Quality Test Pages</p> <p>4 Check the test page. The fault persists.</p>		
<p>Step 3 Check the developer hold down arms and their springs for damage. The developer hold down arms are damaged.</p>	Go to step 4.	Go to step 5.
<p>Step 4 Remove the affected developer hold down arm and install a new developer hold down arm. See PL 90.05 item 1. The fault persists.</p>	Go to step 5.	The problem is solved.
<p>Step 5 Check whether the affected imaging unit or imaging kit is removed and install a new imaging unit or imaging kit. The fault persists.</p>	Contact the next level of support.	The problem is solved.

IQ21 Image Void Process Direction RAP

Note: Before performing this print quality check, print the Print Quality Test Pages. From the control panel, navigate to **Settings > Troubleshooting > Print Quality Test Pages**, and then perform the initial print quality check. See [IQ 1](#)

Procedure

Action	Yes	No
<p>Step 1 Load paper from a fresh package.</p> <p>Note: Paper may absorb moisture due to high humidity. Store paper in its original wrapper until it is ready to be used. The fault persists.</p>	Go to step 2.	The problem is solved.
<p>Step 2 Ensure that all the packing materials on the printer are removed.</p> <p>1 Inside the printer</p>   <p>2 Toner cartridges and imaging unit</p>	Go to step 3.	The problem is solved.

Action	Yes	No
  <p>The fault persists.</p>		
<p>Step 3</p> <ol style="list-style-type: none"> 1 Reconnect the imaging kit. 2 Perform a print job. <p>The fault persists.</p>	Go to step 4.	The problem is solved.
<p>Step 4 Check if the problem appears only on one side of the page. If the problem appear only on one side.</p>	Go to step 5.	Go to step 8.
<p>Step 5 Check the developer hold down arms for damage or loose springs. The developer hold down arms are free of damage and loose springs.</p>	Go to step 7.	The problem is solved.
<p>Step 6 Install a new developer hold down arms. See PL 90.05 item 1. The fault persists.</p>	Go to step 7.	The problem is solved.
<p>Step 7 Check for missing colors. If only one color missing.</p>	Go to step 9.	Go to step 8.
<p>Step 8 Remove the imaging kit, and then clean the printhead lenses. See GP 15. The fault persists.</p>	Go to step 9.	The problem is solved.

Action	Yes	No
Step 9 <ul style="list-style-type: none"> If the affected color is cyan, magenta, or yellow, then replace the developer unit of the affected color. If the affected color is black, then replace the imaging unit. The fault persists.	Go to step 10.	The problem is solved.
Step 10 Install a new printhead. See PL 60.10 item 1 . The fault persists.	Go to step 11.	The problem is solved.
Step 11 Install a new Drive PWB. See PL 1.10 item 3 . The fault persists.	Contact the next level of support.	The problem is solved.

IQ22 Image Void Scan Direction RAP

Note: Before performing this print quality check, print the Print Quality Test Pages. From the control panel, navigate to **Settings > Troubleshooting > Print Quality Test Pages**, and then perform the initial print quality check. See [IQ 1](#)



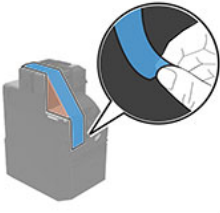

Procedure

Action	Yes	No
Step 1 Load paper from a fresh package. Note: Paper may absorb moisture due to high humidity. Store paper in its original wrapper until it is ready to be used. The fault persists.	Go to step 2.	The problem is solved.
Step 2 Reconnect the imaging kit, and then perform a print job. The fault persists.	Go to step 3.	The problem is solved.
Step 3 Check if the problem affects only one color. If the problem affect only one color.	Go to step 4.	Go to step 5.
Step 4 Check whether the affected imaging unit or imaging kit is removed and install a new imaging unit or imaging kit. The fault persists.	Go to step 5.	The problem is solved.
Step 5 Measure the interval between every defect. The defect occurs in 55-mm intervals.	Contact the next level of support.	Go to step 6.
Step 6 Install a new transfer module. See PL 90.10 item 2 . The fault persists.	Go to step 7.	Go to step 5.
Step 7 Reconnect the HVPS cable on the controller PWB. The fault persists.	Go to step 8.	The problem is solved.
Step 8 Install a new HVPS. See PL 1.10 item 5 .	Go to step 9.	The problem is solved.

Action	Yes	No
The fault persists.		
Step 9 Install a new Drive PWB. See PL 1.10 item 3 . The fault persists.	Go to step 10.	The problem is solved.
Step 10 Install a new printhead. See PL 60.10 item 1 . The fault persists.	Contact the next level of support.	The problem is solved.

IQ23 Missing Color RAP

Procedure

Action	Yes	No
<p>Step 1 Ensure that all the packing materials on the printer are removed.</p> <ul style="list-style-type: none"> Inside the printer   <p>Toner cartridges and imaging unit</p>   <p>The fault persists.</p>	Go to step 2.	The problem is solved.
<p>Step 2 Ensure that all supplies are properly installed. The fault persists.</p>	Go to step 3.	The problem is solved.

Action	Yes	No
Step 3 Install a new imaging unit and imaging kit. The fault persists.	Go to step 4.	The problem is solved.
Step 4 Reconnect the printhead cable on the drive PWB. The fault persists.	Go to step 5.	The problem is solved.
Step 5 Check the contacts on the imaging unit or imaging kit of the missing color for dust or debris. The contacts are free of dust or debris.	Go to step 7.	Go to step 6.
Step 6 Clean the contacts. The fault persists.	Go to step 7.	The problem is solved.
Step 7 Check if the missing color is yellow. If the affected color is yellow.	Go to step 8.	Go to step 9.
Step 8 Ensure that the cleaning blade on the transfer belt is facing the proper direction. If the blade has flipped (and is now facing the wrong direction), replace the transfer module. Note: Look at the corner edge of the blade to determine the direction. FIG FIG The fault persists.	Go to step 9.	The problem is solved.
Step 9 Check whether the affected imaging unit or imaging kit is removed and install a new imaging unit or imaging kit. The fault persists.	Go to step 8.	The problem is solved.
Step 10 Check if the spring-loaded pins in the HVPS freely move	Go to step 10.	Go to step 9.

Action	Yes	No
in and out with an equal amount of spring force. The pins can freely move.		
Step 11 Install a new HVPS. See PL 1.10 item 5 . The fault persists.	Go to step 10.	The problem is solved.
Step 12 1 Remove the transfer module. See PL 90.10 item 2 . 2 Close the front door or bypass the door interlock switch. 3 Enter the Diagnostics menu GP 1 , and then navigate to: Printer diagnostics & adjustments > Motor tests 4 Select the motor of the affected color, and then touch Start . If the motor runs.	Go to step 12.	Go to step 11.
Step 13 Remove the affected motor (EP drive) and install a new motor (EP drive). See PL 40.10 item 2 . The fault persists.	Go to step 12.	The problem is solved.
Step 14 While manually turning the motors, check if the corresponding couplers move. If the couplers move.	Go to step 14.	Go to step 13.
Step 15 Install a new EP drive gearbox. See PL 40.10 item 2 . The fault persists.	Go to step 14.	The problem is solved.
Step 16 1 Ensure that the printhead cables are properly connected to the Drive PWB. 2 Ensure that the JTH1 and JPWR1 cables are properly connected to the controller PWB and Drive PWB. The fault persists.	Go to step 15.	The problem is solved.

Action	Yes	No
Step 17 Install a new printhead. See PL 60.10 item 1 . The fault persists.	Go to step 16.	The problem is solved.
Step 18 Install a new Drive PWB. See PL 1.10 item 3 . The fault persists.	Contact the next level of support.	The problem is solved.

IQ24 Random Marks RAP

Note: Before performing this print quality check, print the Print Quality Test Pages. From the control panel, navigate to **Settings > Troubleshooting > Print Quality Test Pages**, and then perform the initial print quality check. See [IQ 1](#)

Procedure

Action	Yes	No
Step 1 Check the printer for toner leaks. If there is any toner leaks.	Go to step 2.	Go to step 3.
Step 2 1 Clean the printer thoroughly using a toner vacuum. 2 Perform a print job to clear the remaining toner from the imaging components. The fault persists.	Go to step 3.	The problem is solved.
Step 3 Remove the imaging kit, and then check it for debris and fragments. See REP 60.1 . The imaging kit is free of debris and fragments.	Go to step 5.	Go to step 4.
Step 4 Remove the debris and fragments. The fault persists.	Go to step 5.	The problem is solved.
Step 5 1 Remove the transfer module. See REP 90.9 . 2 Check the transfer module for debris and fragments. The transfer module is free of debris and fragments.	Go to step 7.	Go to step 6.
Step 6 Remove the debris and fragments. The fault persists.	Contact the next level of support.	The problem is solved.

Action	Yes	No
<p>Step 7</p> <p>1 Remove the fuser. See REP 10.1.</p> <p>2 Check the fuser for debris and damage.</p> <p>The fuser is free of debris and damage.</p>	Contact the next level of support.	Go to step 8.
<p>Step 8</p> <p>Install a new fuser. See PL 10.10 item 1.</p> <p>The fault persists.</p>	Contact the next level of support.	The problem is solved.

SQ1 Dark Image Quality (using the DADF or scanner) RAP

Procedure

Action	Yes	No
Step 1 Enter the Diagnostics menu GP 1 , and then navigate to: Advanced Print Quality Samples > Advanced Print Quality Test Pages The scan defects are seen on the print quality samples.	Go to step 2.	Go to step 3.
Step 2 Identify, and then resolve the print quality defect. See IQ 1 . The fault persists.	Go to step 3.	The problem is solved.
Step 3 From the Home screen, touch Settings > Print > Quality > Advanced Imaging > Color Adjust . The fault persists.	Go to step 4.	The problem is solved.
Step 4 Clean the following parts. See GP 18 . <ul style="list-style-type: none"> • DADF glass • Scanner glass • DADF glass pad • Scanner glass pad • DADF glass pad in door C • DADF glass in door C The fault persists.	Go to step 5.	The problem is solved.
Step 5 1 Perform a copy job using the DADF. 2 Perform a copy job using the scanner. The fault persists.	Go to step 6.	The problem is solved.
Step 6 Install a new printer controller PWB. See PL 3.05 item 2 . The fault persists.	Contact the next level of support.	The problem is solved.

SQ2 Vertical Lines (process direction using the DADF) RAP

Procedure

Action	Yes	No
Step 1 Enter the Diagnostics menu GP 1 , and then navigate to: Advanced Print Quality Samples > Advanced Print Quality Test Pages The scan defects are seen on the print quality samples.	Go to step 2.	Go to step 3.
Step 2 Identify, and then resolve the print quality defect. See IQ 1 . The fault persists.	Go to step 3.	The problem is solved.
Step 3 Clean the following parts. See GP 18 . <ul style="list-style-type: none"> • DADF glass • DADF glass pad • DADF glass pad in door C • DADF glass in door C The fault persists.	Go to step 4.	The problem is solved.
Step 4 Check the DADF glass on the scanner for cracks or damage. The scanner is free of cracks and damage.	Go to step 5.	Go to step 8.
Step 5 Check inside the flatbed scanner for dust and contamination. The flatbed scanner is free of dust and contamination.	Contact the next level of support.	Go to step 8.
Step 6 Perform a two-sided copy job using the DADF, and then check if the issue occurs on the front side. If the issue occur on the front side.	Go to step 8.	Go to step 7.
Step 7 Check if the issue occurs on the back side. If the issue occur on the back side.	Go to step 9.	The problem is solved.

Action	Yes	No
Step 8 Install a new flatbed scanner. See PL 60.05 item 1 . The fault persists.	Contact the next level of support.	The problem is solved.
Step 9 Install a new DADF. See PL 5.10 item 1 . The fault persists.	Contact the next level of support.	The problem is solved.

SQ3 Spots (using the flatbed scanner) RAP

Procedure

Action	Yes	No
Step 1 Enter the Diagnostics menu GP 1 , and then navigate to: Advanced Print Quality Samples > Advanced Print Quality Test Pages The scan defecta are seen on the print quality samples.	Go to step 2.	Go to step 3.
Step 2 Identify, and then resolve the print quality defect. See IQ 1 . The fault persists.	Go to step 3.	The problem is solved.
Step 3 Clean the following parts. See GP 18 . <ul style="list-style-type: none"> Scanner glass Scanner glass pad The fault persists.	Go to step 4.	The problem is solved.
Step 4 <ol style="list-style-type: none"> 1 Install a new scanner glass pad. See PL 5.10 item 5. 2 Perform a copy job using the scanner. The fault persists.	Go to step 5.	The problem is solved.
Step 5 Check inside the flatbed scanner for dust and contamination. The flatbed scanner is free of dust and contamination.	Contact the next level of support.	Go to step 6.
Step 6 <ol style="list-style-type: none"> 1 Install a new flatbed scanner. See PL 60.05 item 1. 2 Perform a copy job using the scanner. The fault persists.	Contact the next level of support.	The problem is solved.

SQ4 DADF Skew Check RAP

Procedure

Action	Yes	No
Step 1 Enter the Diagnostics menu GP 1, and then navigate to: Advanced Print Quality Samples > Advanced Print Quality Test Pages The scan defects are seen on the print quality samples.	Go to step 2.	Go to step 3.
Step 2 Identify, and then resolve the print quality defect. See IQ 1. The fault persists.	Go to step 3.	The problem is solved.
Step 3 Ensure that the printer is placed on a flat, sturdy, and stable surface. The fault persists.	Go to step 4.	The problem is solved.
Step 4 1 Ensure that the document is properly loaded in the DADF tray. Note: The DADF guide positions should match the width of the document. 2 Perform a copy job using the DADF. The fault persists.	Go to step 5.	The problem is solved.
Step 5 Clear the DADF paper path of obstructions. The fault persists.	Go to step 6.	The problem is solved.
Step 6 Open, and then properly close the DADF top cover. The fault persists.	Go to step 7.	The problem is solved.
Step 7 From the Home screen, navigate to: Settings > Device > Maintenance > Configuration Menu > Scanner Configuration > DADF Deskew > DADF Electronic Deskew > On	Go to step 8.	The problem is solved.

Action	Yes	No
The fault persists.		
Step 8 Check the DADF pick roller and separator roller for wear and damage. The rollers are free of wear and damage.	Contact the next level of support.	Go to step 10.
Step 9 Install a new DADF rollers. See PL 5.10 item 4 . The fault persists.	Contact the next level of support.	The problem is solved.

SQ5 Media Damage (using the DADF) RAP

Procedure

Action	Yes	No
Step 1 Ensure that the document is properly loaded in the DADF tray. Note: The DADF guide positions should match the width of the document. The fault persists.	Go to step 2.	The problem is solved.
Step 2 Clear the DADF paper path of any obstructions. The fault persists.	Go to step 3.	The problem is solved.
Step 3 Open, and then properly close the DADF top cover. The fault persists.	Go to step 4.	The problem is solved.
Step 4 Check the DADF pick roller and separator roller for wear and damage. The rollers are free of wear and damage.	Contact the next level of support.	Go to step 5.
Step 5 Install a new DADF rollers. See PL 5.10 item 4 . The fault persists.	Contact the next level of support.	The problem is solved.

SQ6 Black Or Blank Page Copy RAP

Procedure

Action	Yes	No
Step 1 Print a test page. Check whether blank page is there.	Go to step 2.	Go to step 3.
Step 2 Resolve the print quality issue. See IQ3 . The fault persists.	Go to step 3.	The problem is solved.
Step 3 Ensure that the orientation of the original document is correct. Note: <ul style="list-style-type: none"> When copying from the DADF, load the document faceup. When copying from the flatbed scanner, load the document facedown. The fault persists.	Go to step 4.	The problem is solved.
Step 4 1 Ensure that the DADF FFC is properly connected to the DADF and controller PWB. 2 Ensure that the flatbed scanner FFC is properly connected to the flatbed scanner and controller PWB. The fault persists.	Go to step 5.	The problem is solved.
Step 5 Check the DADF and flatbed scanner FFC cables for damage. The FFC cables are free of damage.	Go to step 7.	Go to step 6.
Step 6 Remove the damaged cables and install new cables. The fault persists.	Go to step 7.	The problem is solved.

Action	Yes	No
Step 7 Install a new flatbed scanner. See PL 60.05 item 1 . Note: If the backside scan is blank, Install a new DADF. The fault persists.	Go to step 8.	The problem is solved.
Step 8 Install a new controller PWB. See PL 3.05 item 2 . The fault persists.	Contact the next level of support.	The problem is solved.

4 Repairs- Adjustments

Chain 1 REPs - Standby Power	383	REP 40.1 EP Drive Motor	434
REP 1.1 HVPS PWB	383	REP 40.2 EP Drive Gearbox	435
REP 1.2 LVPS PWB	385	REP 40.3 BOR Motor (deskew)	436
REP 1.3 LVPS Cage.....	386	REP 40.4 Deskew Motor	436
REP 1.4 Drive PWB.....	388	REP 40.5 Exit/Redrive Motor	437
REP 1.5 Power Connector	389	Chain 60 REPs - Imaging and NOHAD	438
Chain 2 REPs - User Interface	390	REP 60.1 Imaging Unit.....	438
REP 2.1 UI Control Panel Assembly	391	REP 60.2 Print Head	439
REP 2.2 UI FFC Cable.....	392	REP 60.3 Main Fan	440
REP 2.3 Speaker/USB Cable	393	REP 60.4 Fuser Fan	441
Chain 3 REPs - Machine Run Control	394	Chain 70 REPs- Paper Supply	442
REP 3.1 Controller PWB Shield	394	REP 70.1 Tray 1/2 Paper Size Sensor	443
REP 3.2 Controller PWB	395	REP 70.2 MPF/Bypass Present Sensor	444
Chain 5 REPs- DADF	396	REP 70.3 Tray Rail	445
REP 5.1 Scanner Glass Pad Removal.....	397	REP 70.4 Pick Roller.....	446
REP 5.2 DADF Rollers Removal.....	398	REP 70.5 Paper Feeder	447
REP 5.3 DADF Removal.....	400	REP 70.6 Paper Out Actuator Spring	448
REP 5.4 Scanner Removal	401	REP 70.7 Aligner Rollers	449
REP 5.5 DADF Cables Removal.....	403	Chain 80 REPs- Paper Transport	453
REP 5.6 DADF FFC Removal.....	405	REP 80.1 Exit Roller Gear.....	454
REP 5.7 DADF Cable Covers Removal.....	405	REP 80.2 Exit Roller	454
REP 5.8 DADF Top Cover Removal.....	406	REP 80.3 MPF/Duplex Motor.....	455
REP 5.9 DADF Right Hinge Removal.....	407	REP 80.4 Input Sensor.....	456
REP 5.10 DADF Left Hinge Removal.....	407	REP 80.5 Diverter	457
REP 5.11 Scanner Tilt.....	408	REP 80.6 Duplex Staging Sensor.....	458
Chain 10 REPs- Print Transport and Fusing	409	REP 80.7 Fuser Buckle And Narrow Media Sensors	459
REP 10.1 Fuser	409	REP 80.8 Tensioner belt	460
REP 10.2 Fuser Motor	410	REP 80.9 Duplex Outer Guide.....	461
REP 10.3 Fuser Drive Gear.....	411	REP 80.10 Pivot Shaft	462
REP 10.4 Motor (exit/redrive)	412	REP 80.11 Bin Full Sensor	462
REP 10.5 Sensor (redrive)	413	REP 80.12 Bin Flag	464
REP 10.6 Redrive Guide	414	REP 80.13 Duplex Inner Guide	465
REP 10.7 Fuser AC Harness.....	415	Chain 90 REPs- Xerographics	465
Chain 28 REPs Covers	416	REP 90.1 TMC Card.....	466
REP 28.1 Right Cover	416	REP 90.2 Developer Hold Down Arm	467
REP 28.2 Toner Cover.....	417	REP 90.3 Waste Toner Bottle.....	468
REP 28.3 Toner Door Mount Bracket	418	REP 90.4 Waste Toner Bottle Idler Gear.....	469
REP 28.4 USB Cover	419	REP 90.5 Waste Toner Sensor	469
REP 28.5 Headphone and USB Cables	419	REP 90.6 Sensor (weather station)	470
REP 28.6 Upper Front Door	421	REP 90.7 Sensor (TPS).....	470
REP 28.7 Top Frame Base Cover	422	REP 90.8 Isolation Unit	471
REP 28.8 Top Cover	422	REP 90.9 Transfer Module.....	473
REP 28.9 Not Used	424	Chain 5 ADJs - DADF/Scanner	474
REP 28.10 Front Door	424	ADJ 5.1 DADF Registration Adjustment	474
REP 28.11 Motor Cover.....	425	Chain 60 ADJs - Imaging	474
REP 28.12 Bin Cover	426	ADJ 60.1 Scanner Manual Registration	474
REP 28.13 Face Cover	427	ADJ 60.2 Flatbed Registration Adjustment	475
REP 28.14 Bin Exit Cover	428	Chain 90 ADJs - Xerographics	475
REP 28.15 Bin Flag	429	ADJ 90.1 Printhead alignment adjustment	475
REP 28.16 Scanner Front Cover.....	430	ADJ 90.2 Registration Adjustment.....	476
REP 28.17 Left Cover	431		
Chain 40 REPs - Main Drives	433		

REP 1.1 HVPS PWB

Parts List on [PL 1.10](#)

Removal



WARNING: Switch off the electricity to the machine, [GP 10](#) . Disconnect the power lead from the customer supply while performing tasks that do not need electricity. Electricity can cause the death or injury. Moving components can cause the injury.



Figure 1 ESD Symbol

1. Remove the left cover, [REP 28.17](#)
2. Remove the right cover, [REP 28.1](#)
3. Remove the controller PWB shield, [REP 3.1](#).
4. Press the latch (1) to release it, and then disconnect the cable (2).

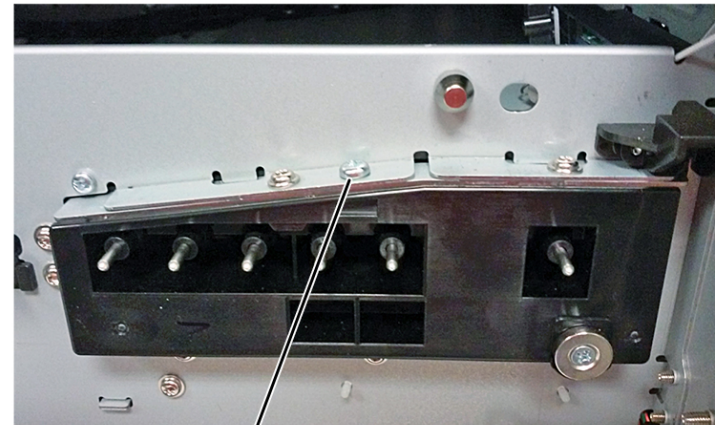


VLC625S_4075



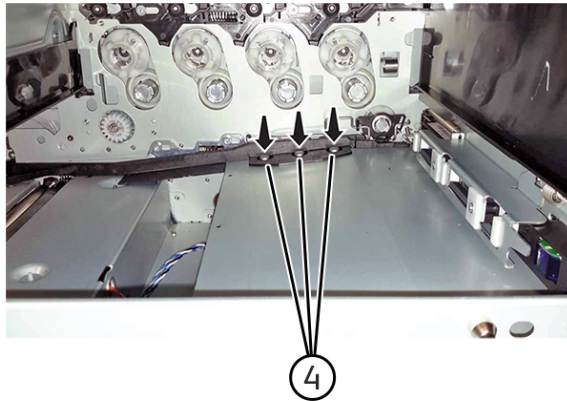
VLC625S_4076

5. Remove the screw (3) securing the HVPS.



VLC625S_4077

6. At the opposite end of the HVPS, press down on the latch (4) and slide the HVPS inwards to release it.
7. Remove the HVPS.



VLC625S_4078

Note: Press on the side of the toner contacts while removing the HVPS to fully release it.

REP 1.2 LVPS PWB

Parts List on [PL 1.10](#)

Removal

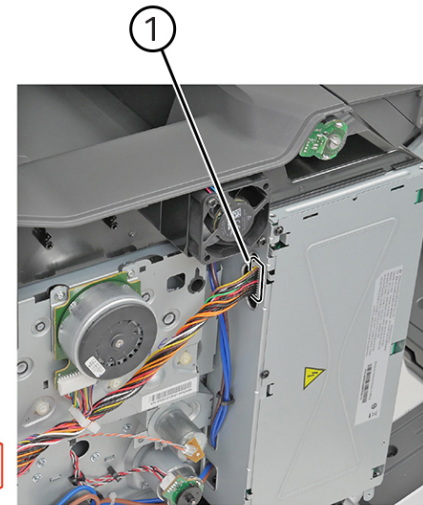


WARNING: Switch off the electricity to the machine, [GP 10](#). Disconnect the power lead from the customer supply while performing tasks that do not need electricity. Electricity can cause the death or injury. Moving components can cause the injury.



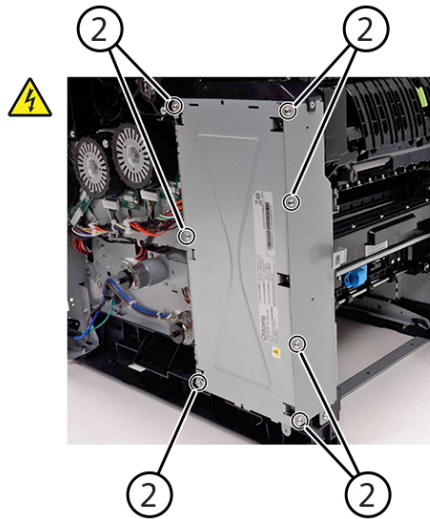
Figure 1 ESD Symbol

1. Remove the left cover. See [REP 28.17](#).
2. Disconnect the cable (1).

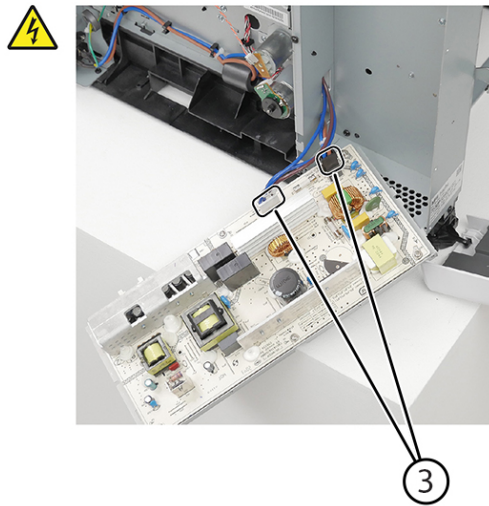


VLC625S_4021

3. Remove the seven screws (2), and then pull the LVPS.



4. Disconnect the cables (3).



5. Remove the LVPS.

VLC625S_4022

VLC625S_4023

REP 1.3 LVPS Cage

Parts List on [PL 1.10](#)

Removal



WARNING: Switch off the electricity to the machine, [GP 10](#). Disconnect the power lead from the customer supply while performing tasks that do not need electricity. Electricity can cause the death or injury. Moving components can cause the injury.



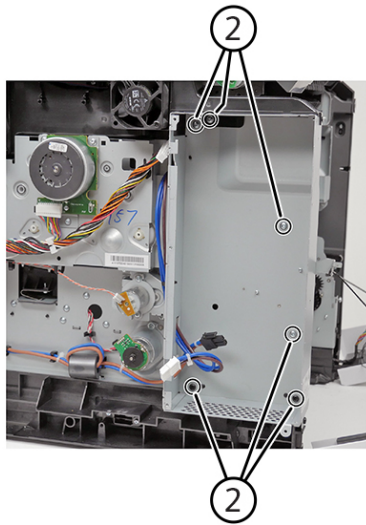
Figure 1 ESD Symbol

1. Remove the fuser. See [REP 10.1](#).
2. Remove the transfer module. See [REP 90.9](#).
3. Remove the left cover. See [REP 28.17](#).
4. Remove the LVPS. See [REP 1.2](#).
5. Remove the two screws (1).



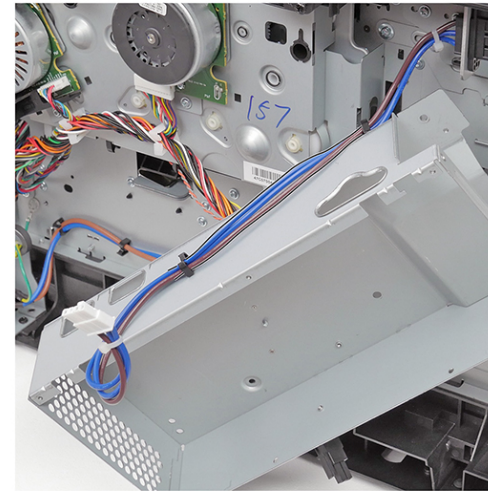
6. Remove the six screws (2).

VLC625S_4041



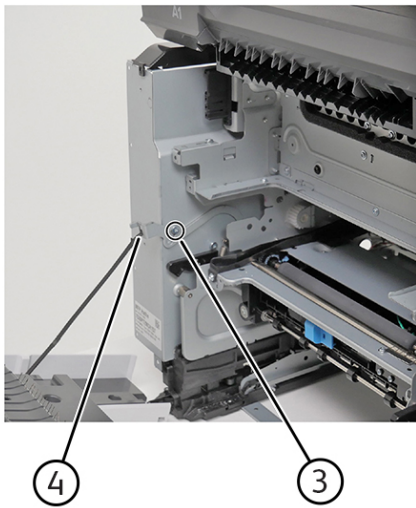
VLC625S_4042

7. Remove the screw (3), and then release the strap (4).



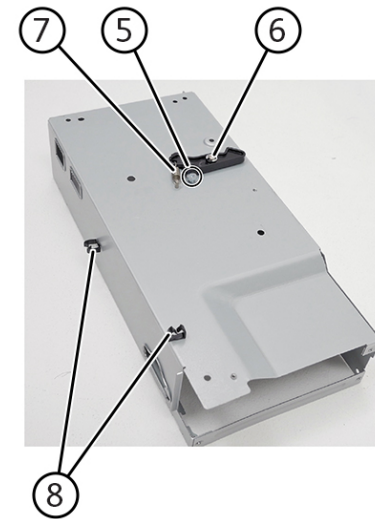
VLC625S_4044

9. Remove the screw (5), E-clip (6), spring (7), and guides (8) from the cage.



VLC625S_4043

8. Release the cable from its guides, and then remove the cage.



VLC625S_4045

REP 1.4 Drive PWB

Parts List on [PL 1.10](#)



CAUTION: The serial number is stored and synchronized between the controller PWB, drive PWB, and black toner cartridge. Always install these items individually. After installation of one of these items, switch on the machine, [GP 1](#), to allow the serial number to synchronize before proceeding to install the next part. Refer to [dC132](#) Machine Serial Number.

Initial Actions

Pre-Removal Requirements

1. Check the UI control panel, if available, for any active faults. Resolve as required in the corresponding RAP.
2. Enter Diagnostics, [GP 1](#). Perform, [dC361](#) NVM Save and Restore, to **Save** customer settings to the hard drive.
3. While still in [dC361](#), click on each file listed, then select **Copy to USB device** as a second backup.
4. Exit Diagnostics, [GP 1](#).
5. Shutdown the machine, [GP 10](#).

Removal



WARNING: Switch off the electricity to the machine, [GP 10](#). Disconnect the power lead from the customer supply while performing tasks that do not need electricity. Electricity can cause the death or injury. Moving components can cause the injury.



Figure 1 ESD Symbol



CAUTION: Mark to identify the original PWBs and Black Toner Cartridge, if removed from machine. DO NOT dispose of or return those items until the machine is completely recovered.

1. Remove the controller PWB shield, [REP 3.1](#).
2. Disconnect all cables, then remove six screws (1).



VLC625S_4150

3. Remove the drive PWB.

Replacement



CAUTION: The serial number is stored and synchronized between the controller PWB, drive PWB, and black toner cartridge. Always install these items individually. After installation of one of these items, switch on the machine, [GP 1](#), to allow the serial number to synchronize before proceeding to install the next part. Refer to [dC132](#) Machine Serial Number.

The replacement is the reverse of the removal procedure.

Post—Replacement Requirements

Perform the following steps to return the machine to **Customer Mode** after installation of a new controller PWB.

1. Switch on the machine, [GP 10](#).
 - Note:** While the machine is booting up for the first time after a new drive PWB is installed, encryption will initiate. Allow time for encryption to complete before the machine comes to **Ready**.
2. After the machine completes encryption and comes to **Ready**, perform, [GP 4](#) Software Upgrade, using the **Special ALTBOOT** procedure.
3. After the machine restarts from the software upgrade, enter Diagnostics, [GP 1](#).
4. Enter [dC131](#) NVM Read/Write.
 - a. Enter the chain-link [\[616–014\]](#), then change the value to **4** and save.
 - b. Exit Diagnostics, [GP 1](#).
5. Restart the machine, [GP 10](#).

REP 1.5 Power Connector

Parts List on [PL 1.10](#)

Removal

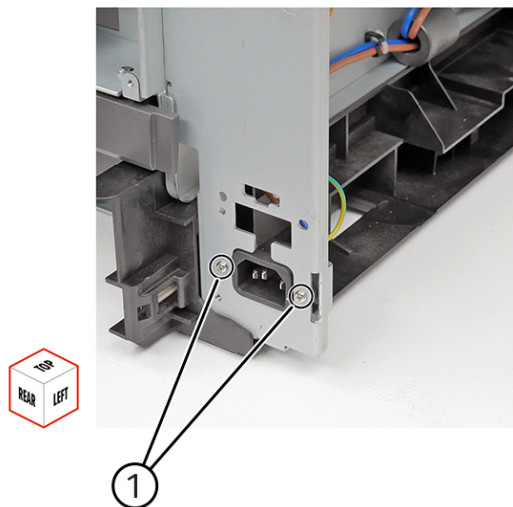


WARNING: Switch off the electricity to the machine, [GP 10](#) . Disconnect the power lead from the customer supply while performing tasks that do not need electricity. Electricity can cause the death or injury. Moving components can cause the injury.



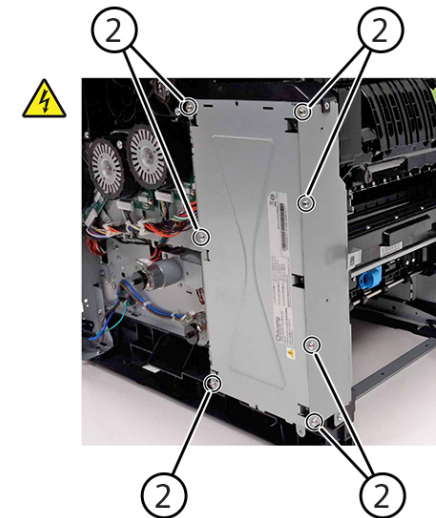
Figure 1 ESD Symbol

1. Remove the left cover. See [REP 28.17](#).
2. Remove the two screws (1), and then release the socket.



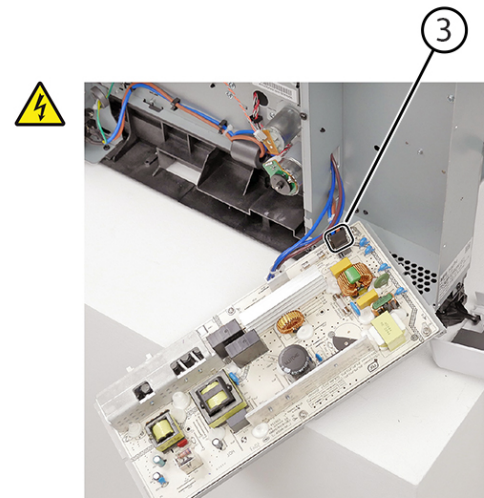
VLC625S_4035

3. Remove the seven screws (2), and then pull the LVPS.



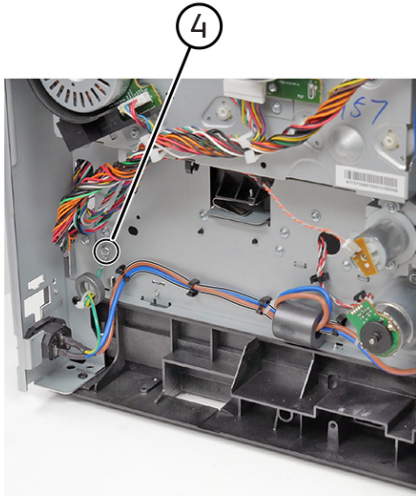
VLC625S_4022

4. Disconnect the cable (3).



VLC625S_4036

5. Remove the ground screw (4), and then remove the cable from its guides. Installation note: Pay attention to the cable route.



VLC625S_4037

REP 2.1 UI Control Panel Assembly

Parts List on [PL 2.10](#)

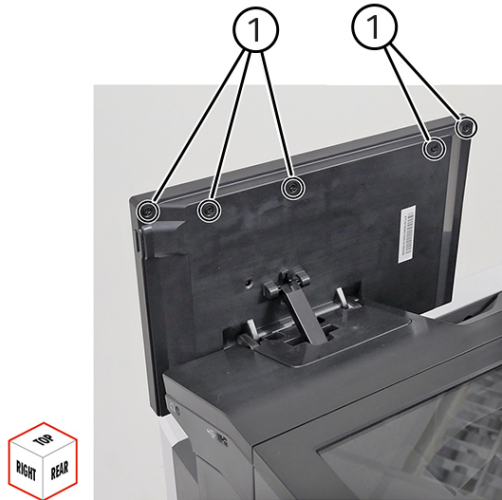
Removal

Procedure



WARNING: Switch off the electricity to the machine, [GP 10](#). Disconnect the power lead from the customer supply while performing tasks that do not need electricity. Electricity can cause the death or injury. Moving components can cause the injury.

1. Remove the five screws (1) behind the control panel.



VLC625S_4110

2. Pry the control panel display to release, and then pull it to access the cable. Warning—Potential Damage: The FFC may get damaged if the control panel display is dropped. Make sure to hold

the control panel display after releasing it.



VLC625S_4111

3. Unlock the clip, and then disconnect the cable.



VLC625S_4112

4. Remove two screws (1), then remove the control panel base.



VLC625S_4113

REP 2.2 UI FFC Cable

Parts List on [PL 2.10](#)

Removal

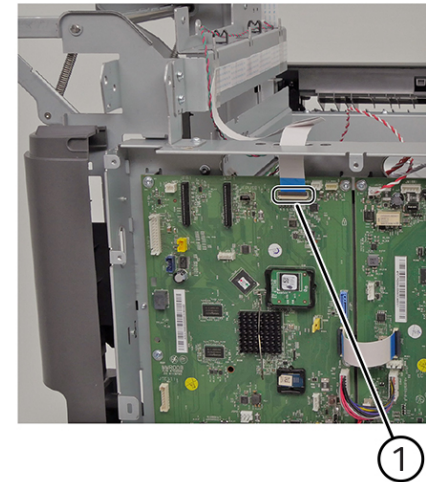


WARNING: Switch off the electricity to the machine, [GP 10](#). Disconnect the power lead from the customer supply while performing tasks that do not need electricity. Electricity can cause the death or injury. Moving components can cause the injury.



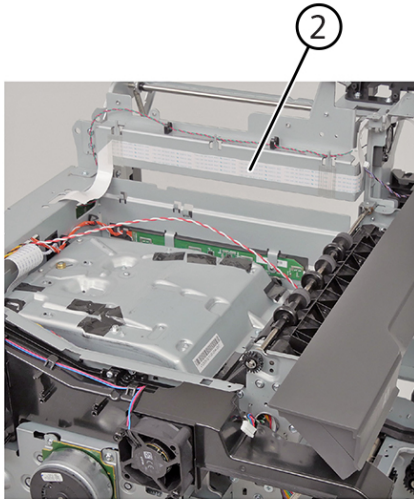
Figure 1 ESD Symbol

1. Remove the scanner rear right cover.
2. Remove the scanner rear left cover.
3. Remove the DADF. See [REP 5.4](#).
4. Remove the controller PWB shield. See [REP 3.1](#).
5. Remove the flatbed scanner. See [REP 5.4](#).
6. Remove the bin cover. See [REP 28.12](#).
7. Remove the top cover.
8. Disconnect the cable (1).



VLC625S_4163

9. Remove the cable (2). Installation note: Pay attention to the cable route.



VLC625S_4164

REP 2.3 Speaker/USB Cable

Parts List on [PL 2.10](#)

Removal

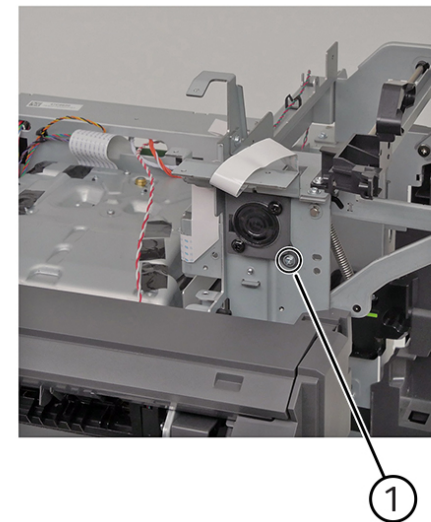


WARNING: Switch off the electricity to the machine, [GP 10](#). Disconnect the power lead from the customer supply while performing tasks that do not need electricity. Electricity can cause the death or injury. Moving components can cause the injury.



Figure 1 ESD Symbol

1. Remove the USB cover. See [REP 28.4](#).
2. Remove the scanner front cover. See [REP 28.13](#).
3. Remove two screws (1).



VLC625S_4114

4. Disconnect the cable.
5. Remove the speaker.

REP 3.1 Controller PWB Shield

Parts List on [PL 3.05](#)

Removal

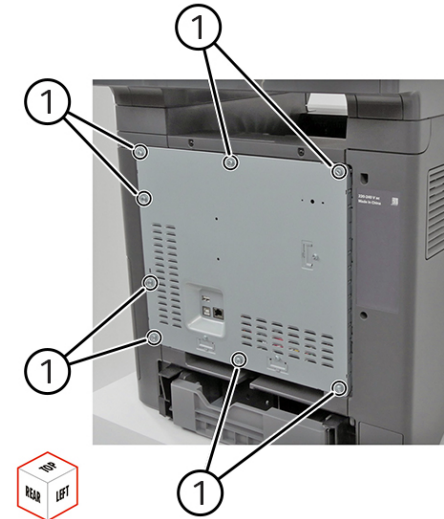


WARNING: Switch off the electricity to the machine, [GP 10](#). Disconnect the power lead from the customer supply while performing tasks that do not need electricity. Electricity can cause the death or injury. Moving components can cause the injury.



Figure 1 ESD Symbol

1. Remove the eight screws (1).



VLC625S_4146

2. Remove the shield. Installation warning: The screws may damage the board cables. Make sure that the board cables are out of the way before screwing the shield in place.

REP 3.2 Controller PWB

Parts List on [PL 3.05](#)



CAUTION: The serial number is stored and synchronized between the controller PWB, drive PWB, and black toner cartridge. Always install these items individually. After installation of one of these items, switch on the machine, [GP 1](#), to allow the serial number to synchronize before proceeding to install the next part. Refer to [dC132](#) Machine Serial Number.

Initial Actions

Pre-Removal Requirements

1. Check the UI control panel, if available, for any active faults. Resolve as required in the corresponding RAP.
2. Enter Diagnostics, [GP 1](#). Enter, [dC361](#) NVM Save and Restore, then touch **Machine NVM** to save all device platform settings to the hard drive.
3. While still in [dC361](#), click on each file listed, then select **Copy to USB device** as a second backup.
4. Exit Diagnostics, [GP 1](#).
5. Shutdown the machine, [GP 10](#).

Removal

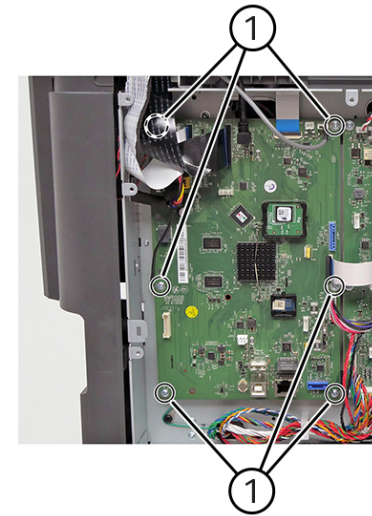


WARNING: Switch off the electricity to the machine, [GP 10](#). Disconnect the power lead from the customer supply while performing tasks that do not need electricity. Electricity can cause the death or injury. Moving components can cause the injury.



Figure 1 ESD Symbol

1. Remove the controller PWB shield, [REP 3.1](#).
2. Disconnect six cables, then remove six screws (1).



VLC625S_4149

3. Remove the controller PWB.



CAUTION: When removing and inserting the ribbon cables into the connector, take care not to damage the ends of the ribbon cables. Also, take notice of the lock orientation when removing to ensure the lock is correct after insertion.

Replacement



CAUTION: The serial number is stored and synchronized between the controller PWB, drive PWB, and black toner cartridge. Always install these items individually. After installation of one of these items, switch on the machine, [GP 1](#), to allow the serial number to synchronize before proceeding to install the next part. Refer to [dC132](#) Machine Serial Number.

The replacement is the reverse of the removal procedure.

Post—Replacement Requirements

Perform the following steps to return the machine to **Customer Mode** after installation of a new controller PWB.

1. Switch on the machine, [GP 10](#).

Note: While the machine is booting up for the first time after a new controller PWB is installed, encryption will initiate. Allow time for encryption to complete before the machine comes to **Ready**.

2. After the machine completes encryption and comes to **Ready**, perform, [GP 4](#) Software Upgrade, using the **Special ALTBOOT** procedure.
3. After the machine restarts from the software upgrade, enter Diagnostics, [GP 1](#).
4. Enter [dC131](#) NVM Read/Write.
 - a. Enter the chain-link **[616–014]**, then change the value to **4** and save.
 - b. Exit Diagnostics, [GP 1](#).

5. Restart the machine, GP 10.

Troubleshooting Possible Restart Faults

In the early releases of the C625 MFP printer, there may be software issues resulting in failed restarts after installing a new controller PWB. The following flowchart, [Controller PWB Installation Troubleshooting Flowchart](#), is provided to troubleshoot and resolve these issues when they arise.

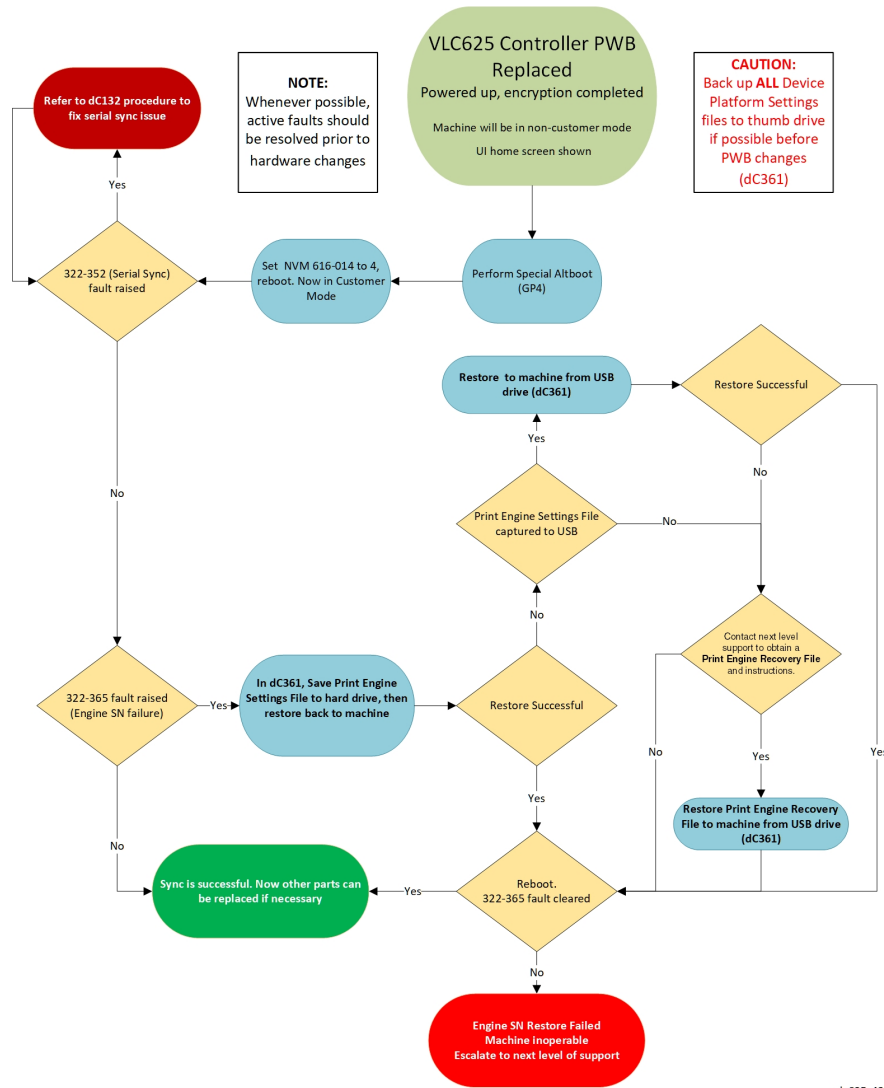


Figure 2 Controller PWB Installation Troubleshooting Flowchart

REP 5.1 Scanner Glass Pad Removal

Parts List on [PL 5.10](#)

Removal

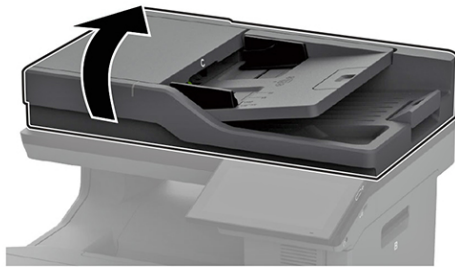


WARNING: Switch off the electricity to the machine, [GP 10](#). Disconnect the power lead from the customer supply while performing tasks that do not need electricity. Electricity can cause the death or injury. Moving components can cause the injury.



Figure 1 ESD Symbol

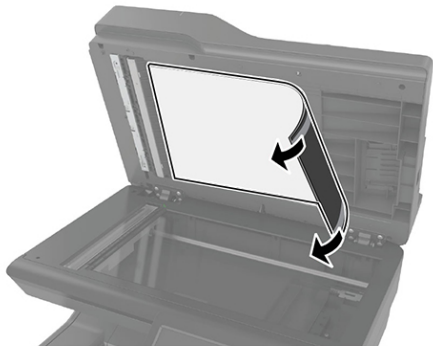
1. Open the scanner cover.



VLC625S_4189

2. Slowly remove the scanner glass pad.

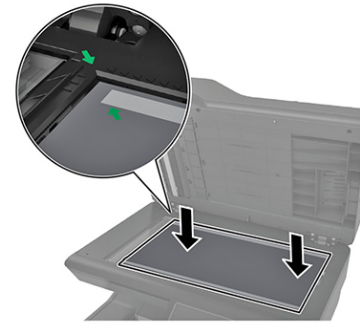
Note: The adhesive should not tear off the pad.



VLC625S_4190

Installation notes:

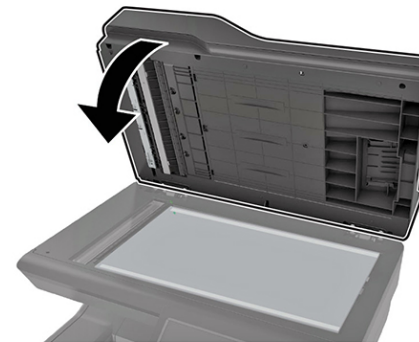
- a. Place the white area of the new scanner glass pad facedown on the scanner glass, and then remove the backing on the tape.



VLC625S_4191

Note: Make sure that the scanner glass pad is aligned correctly on the edges of the scanner glass.

- b. Close the scanner cover to stick the new scanner glass pad to the cover.



VLC625S_4192

- c. Open the scanner cover to check if the new scanner glass pad is properly attached to the cover.

REP 5.2 DADF Rollers Removal

Parts List on [PL 5.10](#)

Removal

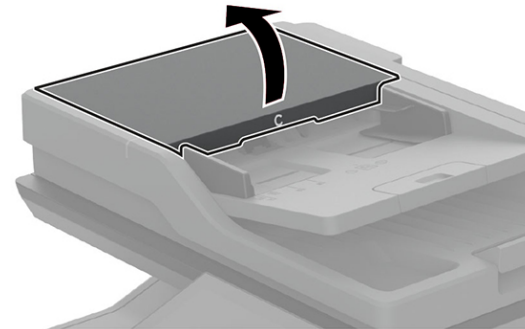


WARNING: Switch off the electricity to the machine, [GP 10](#). Disconnect the power lead from the customer supply while performing tasks that do not need electricity. Electricity can cause the death or injury. Moving components can cause the injury.



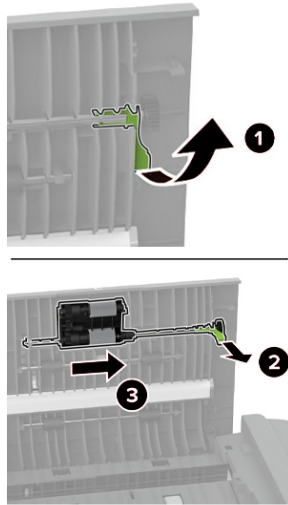
Figure 1 ESD Symbol

1. Open door C. **Warning—Potential Damage:** To prevent damage from electrostatic discharge, touch any exposed metal frame of the printer before accessing or touching interior areas of the printer.



VLC625S_4193

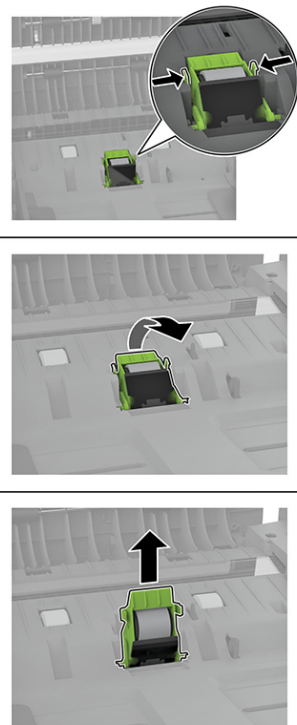
2. Remove the DADF pick roller.



3. Remove the DADF separator roller.

VLC625S_4194

4. Installation warning: To avoid damage and poor printer performance, make sure that your hands are clean when handling the parts.



VLC625S_4195

REP 5.3 DADF Removal

Parts List on [PL 5.10](#)

Removal



WARNING: Switch off the electricity to the machine, [GP 10](#). Disconnect the power lead from the customer supply while performing tasks that do not need electricity. Electricity can cause the death or injury. Moving components can cause the injury.



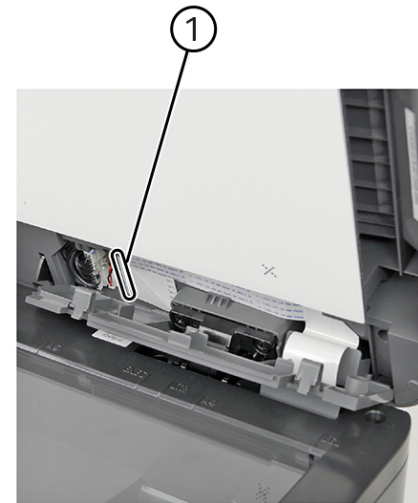
Figure 1 ESD Symbol

1. Release the latches, and then remove the cover.



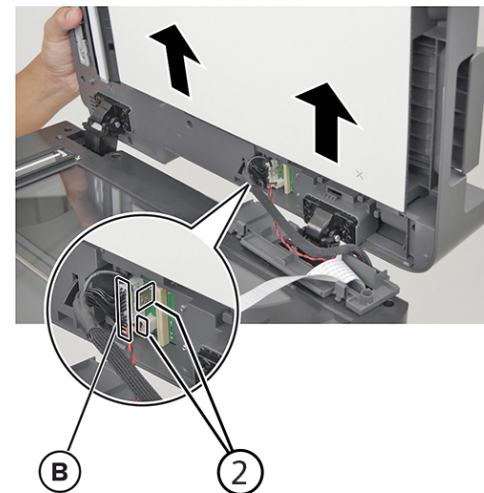
VLC625S_4196

2. Disconnect the FFC (1).



VLC625S_4197

3. Slightly lift the DADF, and then disconnect the cables (2).



VLC625S_4198

4. Remove the DADF.

REP 5.4 Scanner Removal

Parts List on [PL 5.10](#)

Removal

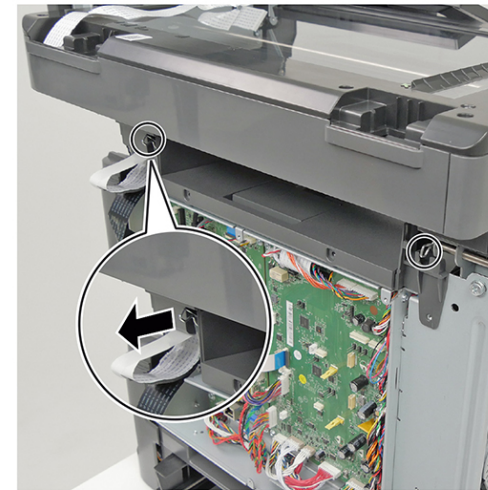


WARNING: Switch off the electricity to the machine, [GP 10](#) . Disconnect the power lead from the customer supply while performing tasks that do not need electricity. Electricity can cause the death or injury. Moving components can cause the injury.



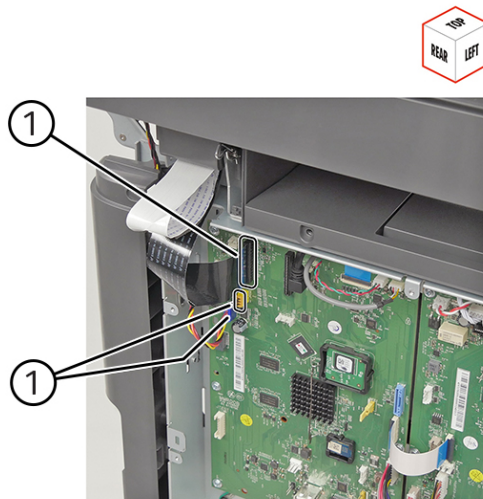
Figure 1 ESD Symbol

1. Remove the scanner rear right cover, [PL 28.15 item 9](#).
2. Remove the scanner rear left cover, [PL 28.15 item 8](#).
3. Remove the DADF. See [REP 5.3](#).
4. Remove the controller PWB shield. See [REP 3.1](#).
5. Disconnect the cables (1).



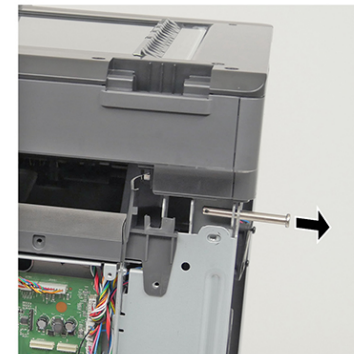
VLC625S_4200

7. Remove the locking pins.



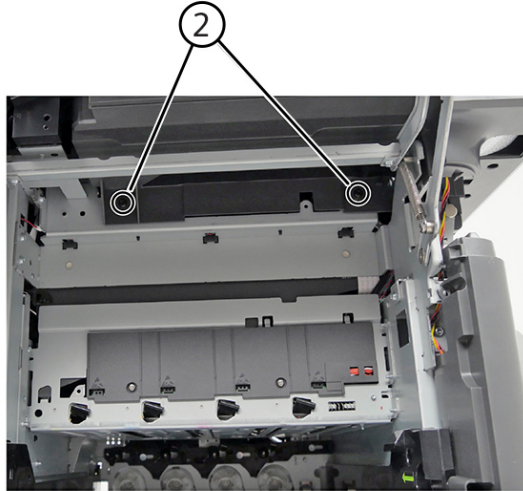
VLC625S_4199

6. Using pliers, remove the two retainers.



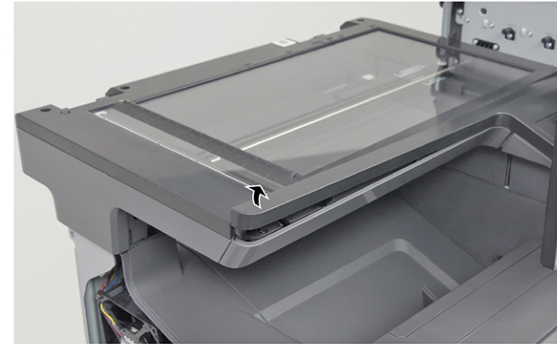
VLC625S_4201

8. Open the cartridge door, and then remove the two screws (2).



VLC625S_4202

9. Pry the cover to release, and then remove the flatbed scanner.



VLC625S_4203

REP 5.5 DADF Cables Removal

Parts List on [PL 5.10](#)

Removal

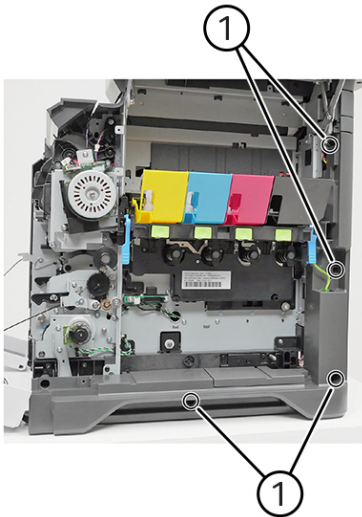


WARNING: Switch off the electricity to the machine, [GP 10](#) . Disconnect the power lead from the customer supply while performing tasks that do not need electricity. Electricity can cause the death or injury. Moving components can cause the injury.



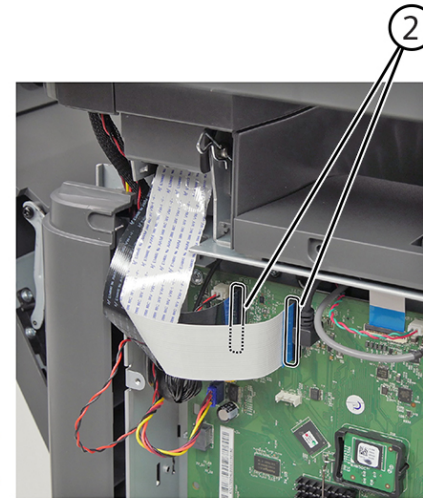
Figure 1 ESD Symbol

1. Remove the scanner rear right cover.
2. Remove the DADF. See [REP 5.3](#).
3. Remove the scanner. See [REP 5.4](#).
4. Remove the controller PWB shield. See [REP 3.1](#).
5. Remove the four screws (1) to loosen the right cover.



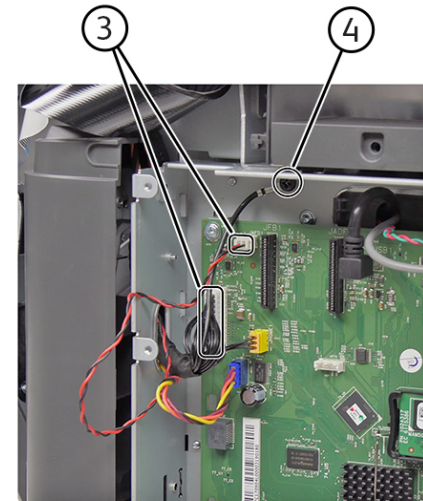
VLC625S_4204

6. Disconnect the cables (2).



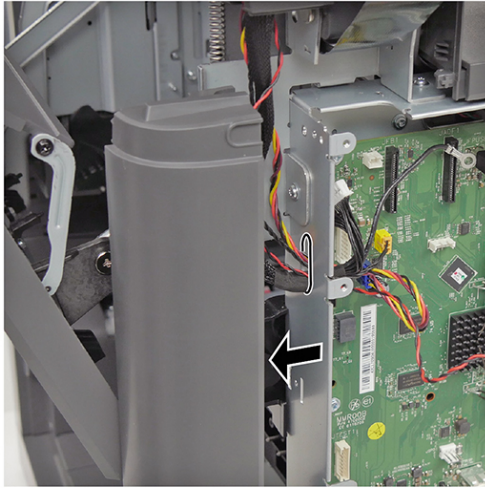
VLC625S_4205

7. Disconnect the cables (3), and then remove the ground screw (4).



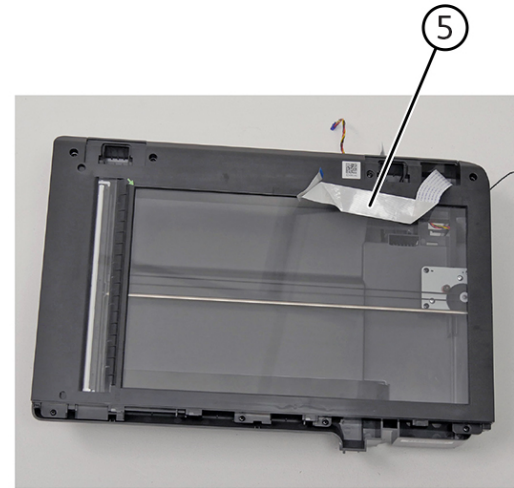
VLC625S_4206

8. Slightly pull the right cover, and then pull the cables out of the hole.

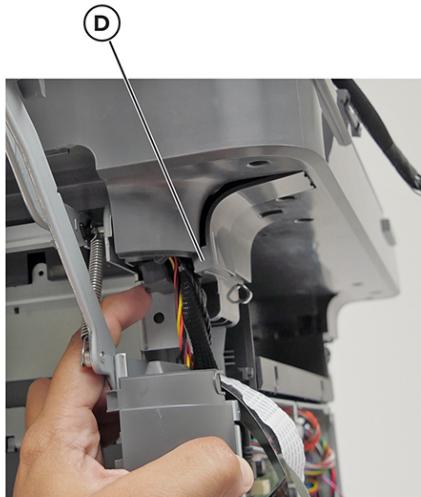


VLC625S_4207

9. Release the latch, remove the cable cover (4), and then remove the cables.



VLC625S_4209



VLC625S_4208

10. Remove the FFC (5) from the scanner.

REP 5.6 DADF FFC Removal

Parts List on [PL 5.10](#)

Removal

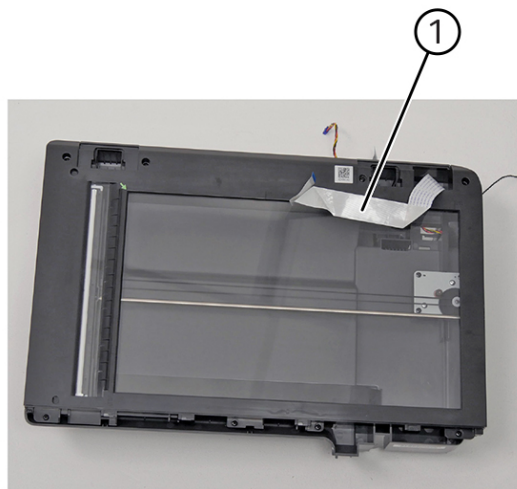


WARNING: Switch off the electricity to the machine, [GP 10](#) . Disconnect the power lead from the customer supply while performing tasks that do not need electricity. Electricity can cause the death or injury. Moving components can cause the injury.



Figure 1 ESD Symbol

1. Remove the scanner rear right cover.
2. Remove the scanner rear left cover.
3. Remove the DADF. See [REP 5.3](#).
4. Remove the controller PWB shield. See [REP 3.1](#).
5. Remove the flatbed scanner. See [REP 5.4](#).
6. Remove the FFC (1).



VLC625S_4210

REP 5.7 DADF Cable Covers Removal

Parts List on [PL 5.10](#)

Removal

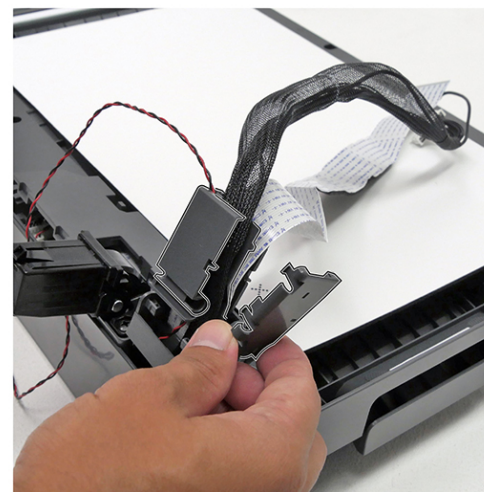


WARNING: Switch off the electricity to the machine, [GP 10](#) . Disconnect the power lead from the customer supply while performing tasks that do not need electricity. Electricity can cause the death or injury. Moving components can cause the injury.



Figure 1 ESD Symbol

1. Remove the DADF. See [REP 5.3](#).
2. Release, and then remove the covers.



VLC625S_4211

REP 5.8 DADF Top Cover Removal

Parts List on [PL 5.10](#)

Removal



WARNING: Switch off the electricity to the machine, [GP 10](#). Disconnect the power lead from the customer supply while performing tasks that do not need electricity. Electricity can cause the death or injury. Moving components can cause the injury.



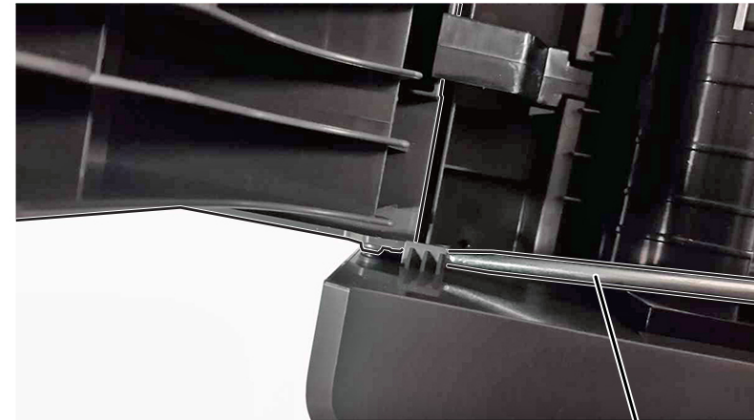
Figure 1 ESD Symbol

1. Open the DADF top cover. Note: Pay attention to the position of the tabs (1).



VLC625S_4212

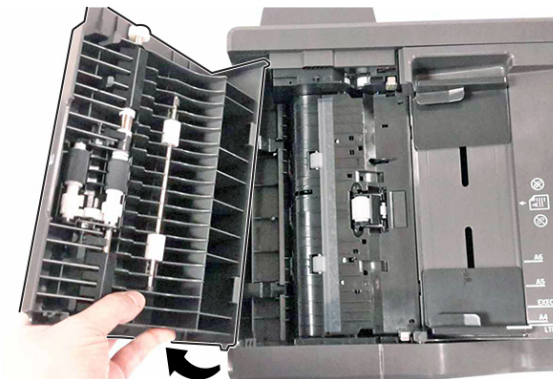
2. Using a flat-head screwdriver (2), push the cover away from the DADF.



2

VLC625S_4213

3. Remove the cover.



VLC625S_4214

REP 5.9 DADF Right Hinge Removal

Parts List on [PL 5.10](#)

Removal

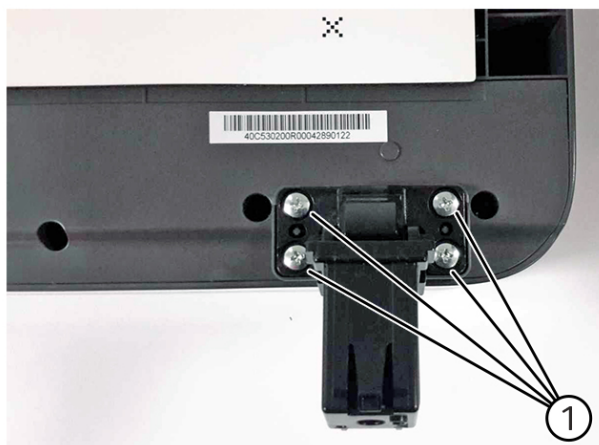


WARNING: Switch off the electricity to the machine, [GP 10](#) . Disconnect the power lead from the customer supply while performing tasks that do not need electricity. Electricity can cause the death or injury. Moving components can cause the injury.



Figure 1 ESD Symbol

1. Remove the DADF. See [REP 5.3](#).
2. Remove the four screws (1), and then remove the hinge.



VLC625S_4215

REP 5.10 DADF Left Hinge Removal

Parts List on [PL 5.10](#)

Removal

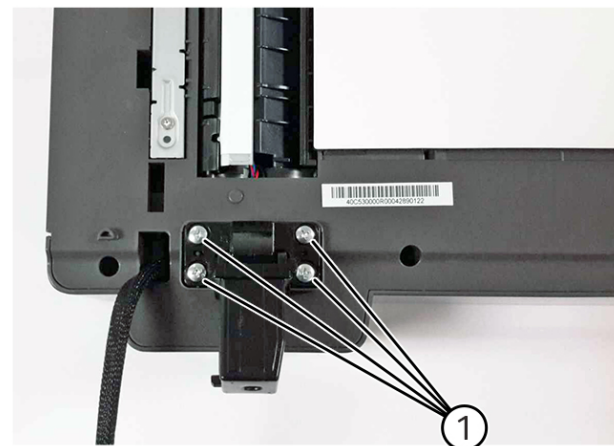


WARNING: Switch off the electricity to the machine, [GP 10](#) . Disconnect the power lead from the customer supply while performing tasks that do not need electricity. Electricity can cause the death or injury. Moving components can cause the injury.



Figure 1 ESD Symbol

1. Remove the DADF. See [REP 5.3](#).
2. Remove the four screws (1), and then remove the hinge.



VLC625S_4216

REP 5.11 Scanner Tilt

Parts List on [PL 5.10](#)

Removal

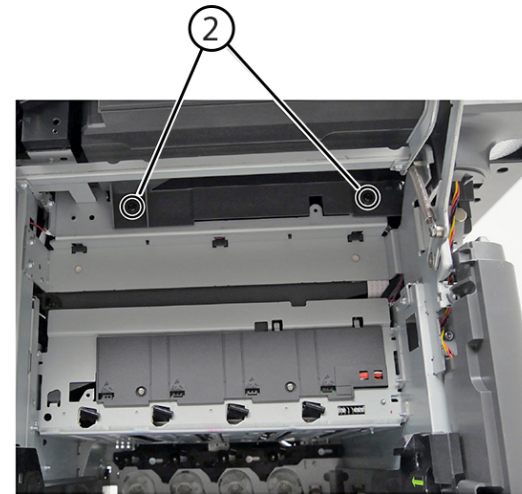


WARNING: Switch off the electricity to the machine, [GP 10](#) . Disconnect the power lead from the customer supply while performing tasks that do not need electricity. Electricity can cause the death or injury. Moving components can cause the injury.



Figure 1 ESD Symbol

1. Remove the scanner rear right cover, [PL 28.15 item 9](#).
2. Remove the scanner rear left cover, [PL 28.15 item 8](#)
3. Remove the waste toner bottle, [REP 90.3](#).
4. Remove the imaging kit, [REP 60.1](#).
5. Remove or loosen the right cover, [REP 28.1](#)
6. Remove the USB cover, [REP 28.4](#)
7. Remove the scanner front cover, [REP 28.16](#)
8. Remove the control panel, [REP 2.1](#)
9. Remove the control panel base, [REP 2.2](#)
10. Remove two screws below the control panel base.
11. Open the cartridge door, then remove two screws (2).



VLC625S_4202

12. Carefully lift the DADF and flatbed scanner to access the parts underneath it.

REP 10.1 Fuser

Parts List on [PL 10.10](#)

Removal

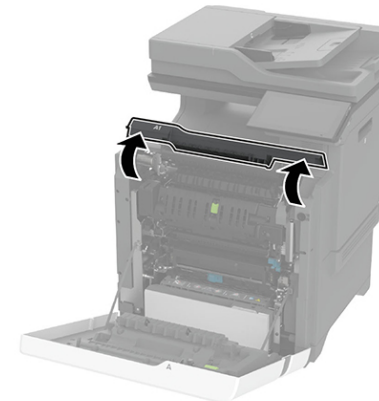
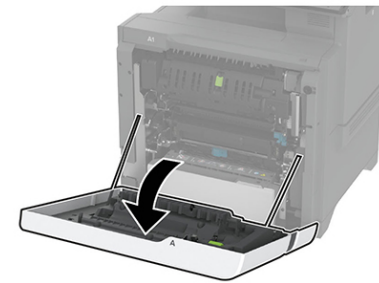


WARNING: Switch off the electricity to the machine, [GP 10](#). Disconnect the power lead from the customer supply while performing tasks that do not need electricity. Electricity can cause the death or injury. Moving components can cause the injury.



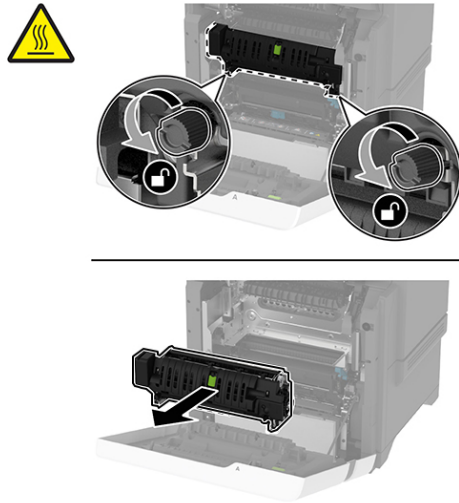
Figure 1 ESD Symbol

1. Open door A, and then open door A1.



VLC625S_4100

2. Remove the fuser.



VLC625S_4101

Note: After installing a new fuser, reset the HFSI counters, [dC135](#).

REP 10.2 Fuser Motor

Parts List on [PL 80.05](#)

Removal

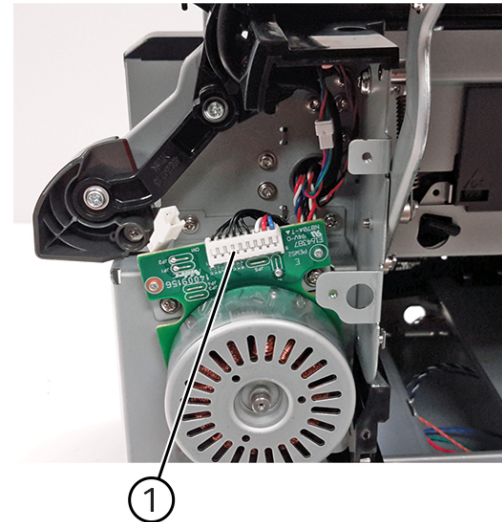


WARNING: Switch off the electricity to the machine, [GP 10](#). Disconnect the power lead from the customer supply while performing tasks that do not need electricity. Electricity can cause the death or injury. Moving components can cause the injury.



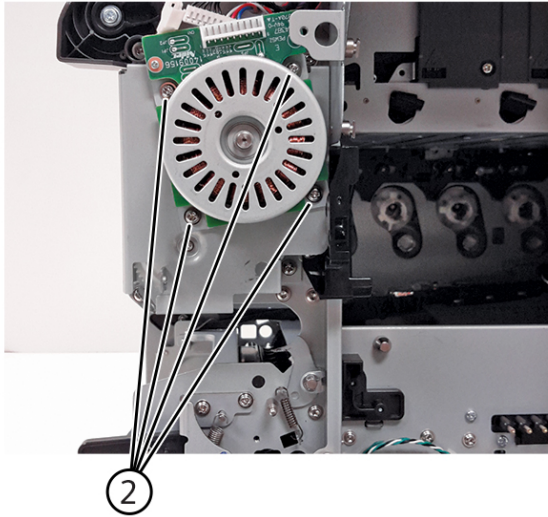
Figure 1 ESD Symbol

1. Remove the motor cover. See [REP 28.11](#).
2. Disconnect the motor cable (1).



VLC625S_4069

3. Remove the four screws (2), and then remove the motor.



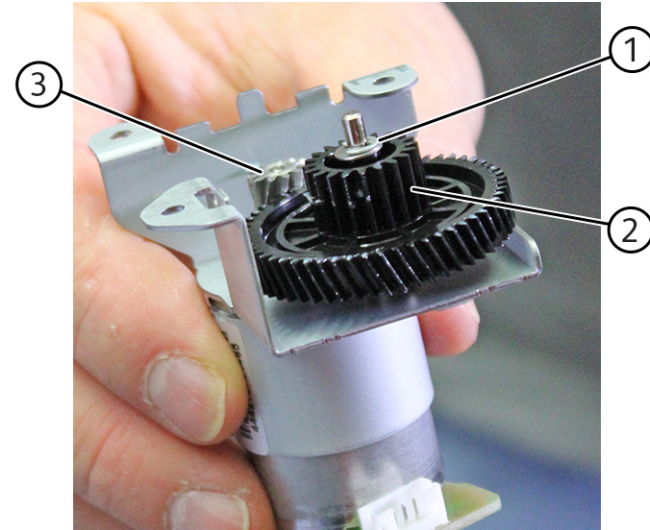
VLC625S_4070

REP 10.3 Fuser Drive Gear

Parts List on [PL 80.05](#)

Removal

1. Remove the fuser motor, [REP 10.2](#).
2. Remove the C-clip (1), plastic drive gears (2), then the metal drive gear (3).



VLC625S_4224

Figure 1 Fuser drive gear removal

REP 10.4 Motor (exit/redrive)

Parts List on [PL 80.05](#)

Removal

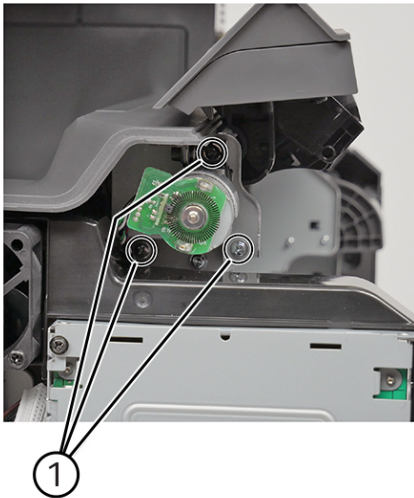


WARNING: Switch off the electricity to the machine, [GP 10](#) . Disconnect the power lead from the customer supply while performing tasks that do not need electricity. Electricity can cause the death or injury. Moving components can cause the injury.



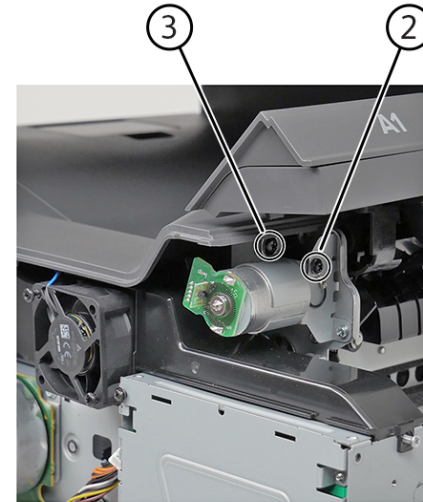
Figure 1 ESD Symbol

1. Remove the left cover. See [REP 28.17](#).
2. Open door A1, and then remove the three screws (1).



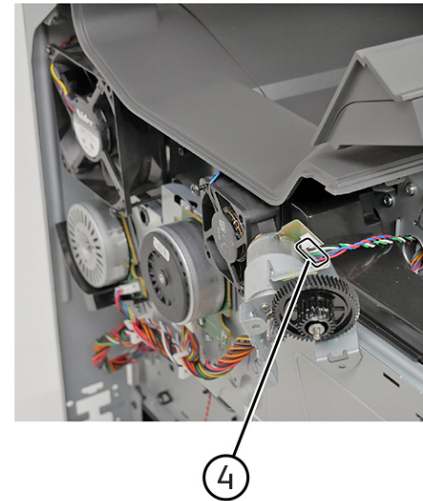
VLC625S_4038

3. Remove the ground screw (2) and the other screw (3).



VLC625S_4039

4. Disconnect the cable (4), and then remove the motor.



VLC625S_4040

REP 10.5 Sensor (redrive)

Parts List on [PL 80.10](#)

Removal

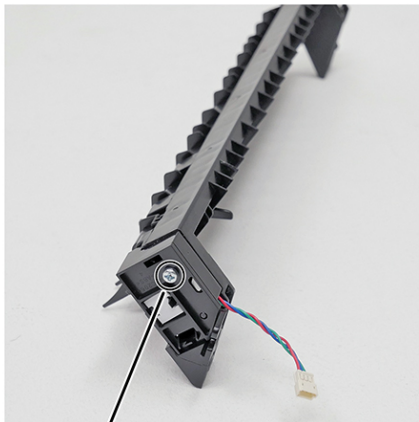


WARNING: Switch off the electricity to the machine, [GP 10](#). Disconnect the power lead from the customer supply while performing tasks that do not need electricity. Electricity can cause the death or injury. Moving components can cause the injury.



Figure 1 ESD Symbol

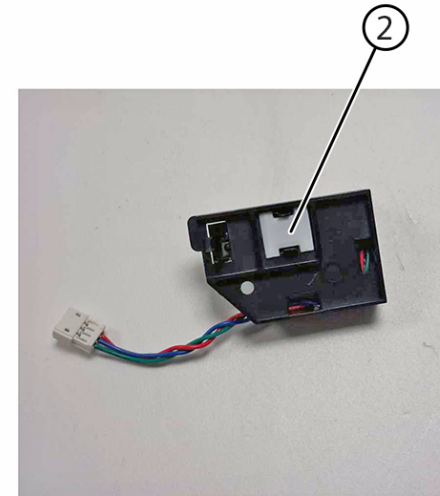
1. Remove the fuser. See [REP 10.1](#).
2. Remove the top frame cover. See [REP 28.6](#).
3. Remove the top frame base cover. See [REP 28.7](#).
4. Remove the diverter. See [REP 80.5](#).
5. Remove the screw (1), and then remove the sensor bracket.



1

VLC625S_4106

6. Remove the retainer (2), and then remove the sensor from its bracket. Installation note: Make sure that the retainer is installed with the replacement sensor.



VLC625S_4107

REP 10.6 Redrive Guide

Parts List on [PL 80.10](#)

Removal

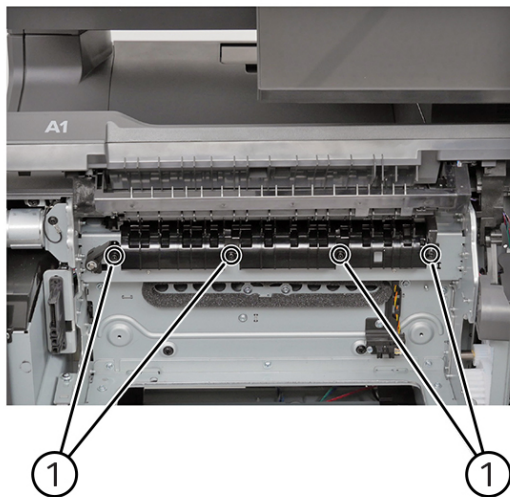


WARNING: Switch off the electricity to the machine, [GP 10](#). Disconnect the power lead from the customer supply while performing tasks that do not need electricity. Electricity can cause the death or injury. Moving components can cause the injury.



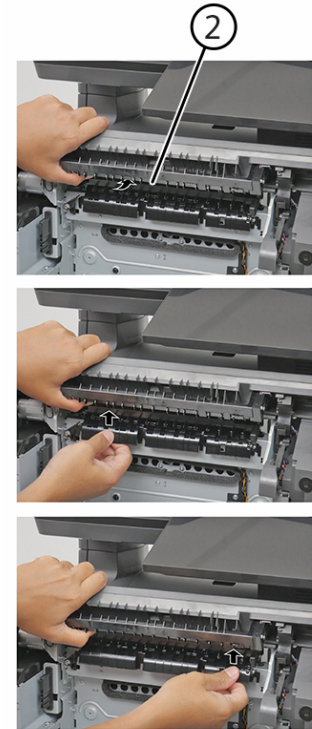
Figure 1 ESD Symbol

1. Remove the fuser. See [REP 10.1](#).
2. Remove the four screws (1).



VLC625S_4102

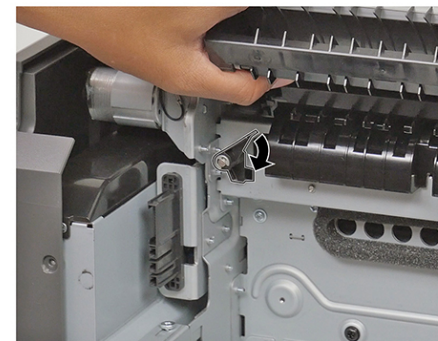
3. Move the diverter (2) out of the way, and then release the cover from its frame.



VLC625S_4103

4. Remove the cover.

Note: If necessary, turn the lever to make way for the cover.



VLC625S_4104

REP 10.7 Fuser AC Harness

Parts List on [PL 31.10](#)

Removal

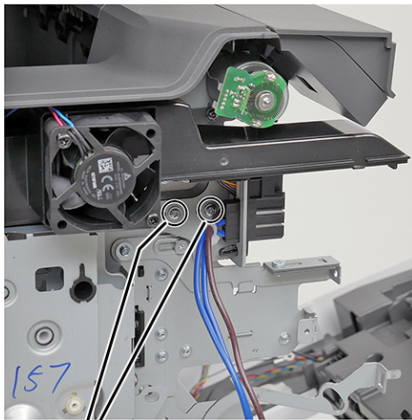


WARNING: Switch off the electricity to the machine, [GP 10](#). Disconnect the power lead from the customer supply while performing tasks that do not need electricity. Electricity can cause the death or injury. Moving components can cause the injury.



Figure 1 ESD Symbol

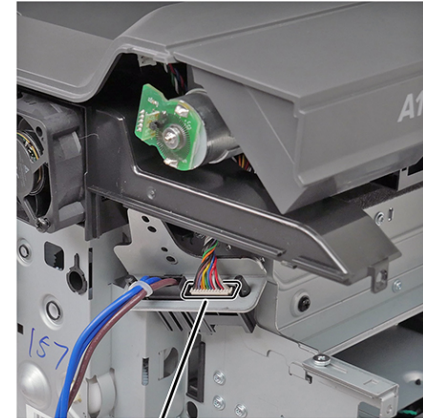
1. Remove the fuser. See [REP 10.1](#).
2. Remove the transfer module. See [REP 90.9](#).
3. Remove the left cover. See [REP 28.17](#).
4. Remove the LVPS. See [REP 1.2](#).
5. Remove the LVPS cage. See [REP 1.3](#).
6. Remove the two screws (1), and then pull the bracket.



1

VLC625S_4046

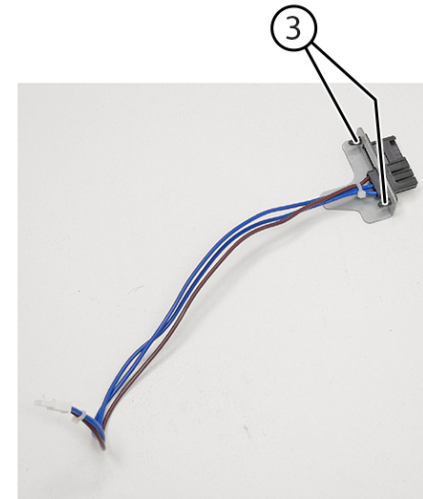
7. Disconnect the cable (2), and then remove the bracket.



2

VLC625S_4047

8. Release the pins (3) from the bracket using a pliers, and then remove the cable.



3

VLC625S_4048

REP 28.1 Right Cover

Parts List on [PL 28.10](#)

Removal

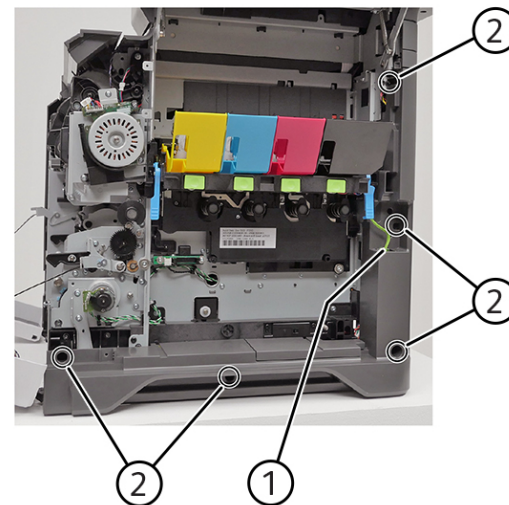


WARNING: Switch off the electricity to the machine, [GP 10](#). Disconnect the power lead from the customer supply while performing tasks that do not need electricity. Electricity can cause the death or injury. Moving components can cause the injury.



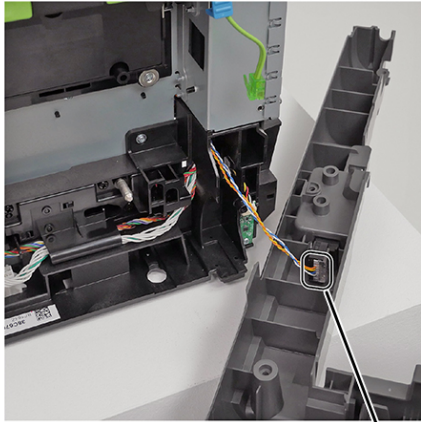
Figure 1 ESD Symbol

1. Remove the waste toner bottle. See [REP 90.3](#).
2. Remove the motor cover. See [REP 28.11](#).
3. Disconnect the cable (1), and then remove the five screws (2).



4. Pull the cover, and then disconnect the cable (3).

VLC625S_4051



3

5. Remove the cover.

VLC625S_4052

REP 28.2 Toner Cover

Parts List on [PL 28.10](#)

Removal

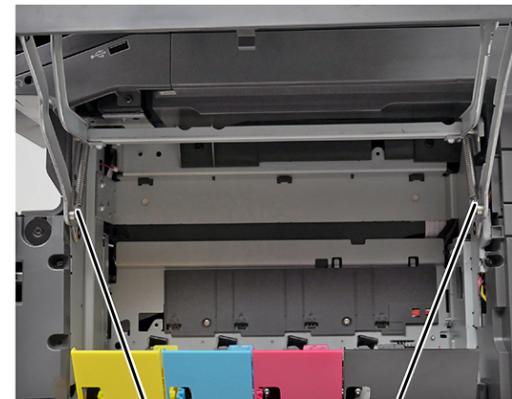


WARNING: Switch off the electricity to the machine, [GP 10](#). Disconnect the power lead from the customer supply while performing tasks that do not need electricity. Electricity can cause the death or injury. Moving components can cause the injury.



Figure 1 ESD Symbol

1. Open the cartridge door.
2. Release the springs (1).

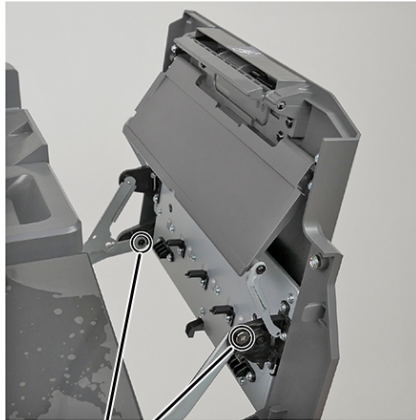


1

1

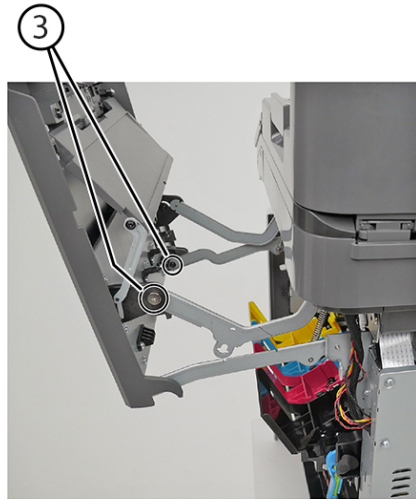
3. Remove the two screws (2).

VLC625S_4053



2

4. Remove the two screws (3).



3

5. Remove the toner cover.

REP 28.3 Toner Door Mount Bracket

Parts List on [PL 28.10](#)

Removal



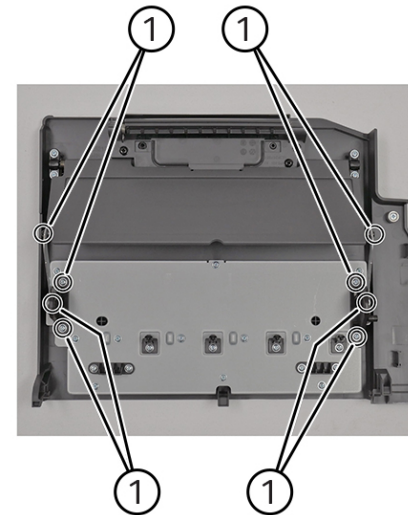
WARNING: Switch off the electricity to the machine, [GP 10](#). Disconnect the power lead from the customer supply while performing tasks that do not need electricity. Electricity can cause the death or injury. Moving components can cause the injury.



Figure 1 ESD Symbol

1. Remove the toner door. See [REP 28.2](#).
2. Remove the eight screws (1).

VLC625S_4054



1

1

1

1

3. Remove the brackets.

VLC625S_4055

VLC625S_4056

REP 28.4 USB Cover

Parts List on [PL 28.10](#)

Removal



WARNING: Switch off the electricity to the machine, [GP 10](#) . Disconnect the power lead from the customer supply while performing tasks that do not need electricity. Electricity can cause the death or injury. Moving components can cause the injury.



Figure 1 ESD Symbol

1. Open the cartridge door.
2. Remove the screw (1), and then remove the cover.



VLC625S_4057

REP 28.5 Headphone and USB Cables

Parts List on [PL 28.10](#)

Removal



WARNING: Switch off the electricity to the machine, [GP 10](#) . Disconnect the power lead from the customer supply while performing tasks that do not need electricity. Electricity can cause the death or injury. Moving components can cause the injury.



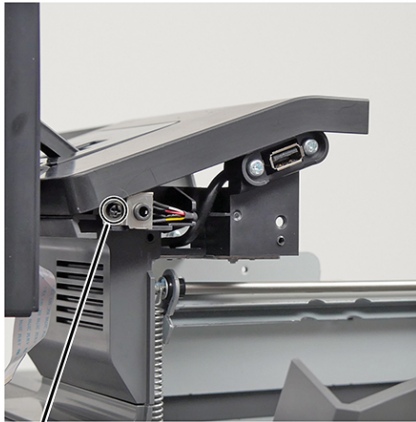
Figure 1 ESD Symbol

1. Remove the scanner rear right cover. See [PL 28.15 item 9](#)
2. Remove the scanner rear left cover. See [PL 28.15 item 8](#)
3. Remove the DADF. See [REP 5.3](#).
4. Remove the controller PWB shield. See [REP 3.1](#).
5. Remove the flatbed scanner. See [REP 5.4](#).
6. Remove or loosen the top cover. See [REP 28.8](#).
7. Remove the screw (1), and then remove the cover.



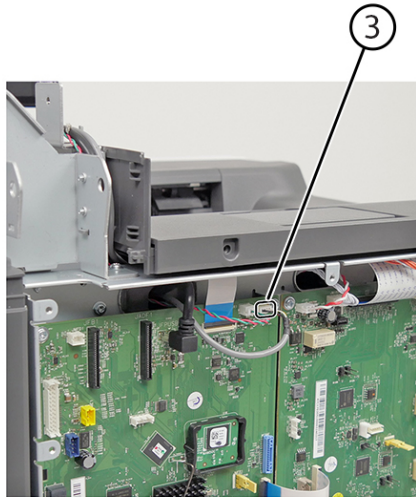
VLC625S_4058

8. Remove the screw (2), and then release the headphone socket.



2

9. Disconnect the cable (3).



3

10. Remove the cable.

USB socket cable removal

Removal

1. Remove the scanner rear right cover. See [PL 28.15 item 9](#)
2. Remove the scanner rear left cover. See [PL 28.15 item 8](#)
3. Remove the DADF. See [REP 5.3](#).

VLC625S_4059

VLC625S_4060

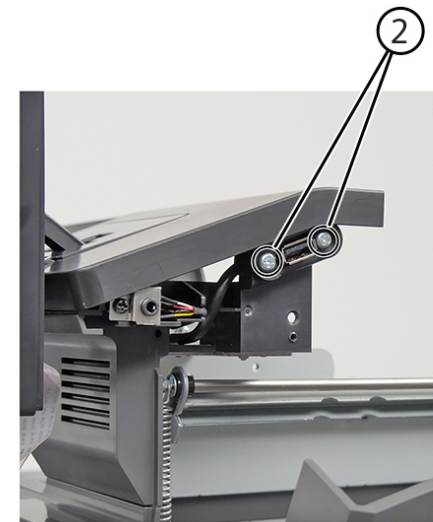
4. Remove the controller PWB shield. See [REP 3.1](#).
5. Remove the flatbed scanner. See [REP 5.4](#).
6. Remove or loosen the top cover. See [REP 28.8](#).
7. Remove the screw (1), then remove the cover, Figure 2



1

Figure 2 Cover screw removal

8. Remove two screws (2), then release the USB socket, Figure 3.



2

Figure 3 USB socket screws removal

VLC625S_4058

VLC625S_4061

9. Disconnect the cable (3), Figure 4.

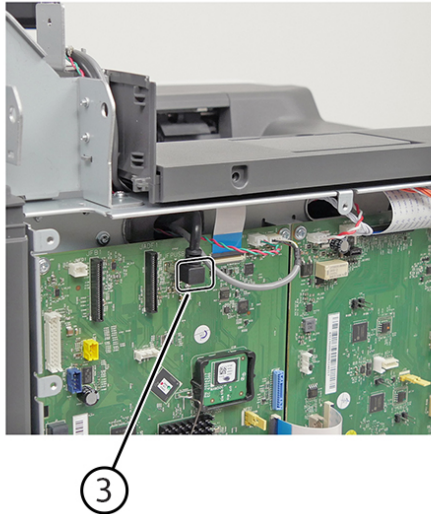


Figure 4 USB cable disconnect

10. Remove the cable.

REP 28.6 Upper Front Door

Parts List on [PL 28.15](#)

Removal



WARNING: Switch off the electricity to the machine, [GP 10](#). Disconnect the power lead from the customer supply while performing tasks that do not need electricity. Electricity can cause the death or injury. Moving components can cause the injury.

1. Open the front door and door A1.
2. Remove the two screws (1), and then release the two latches (2).

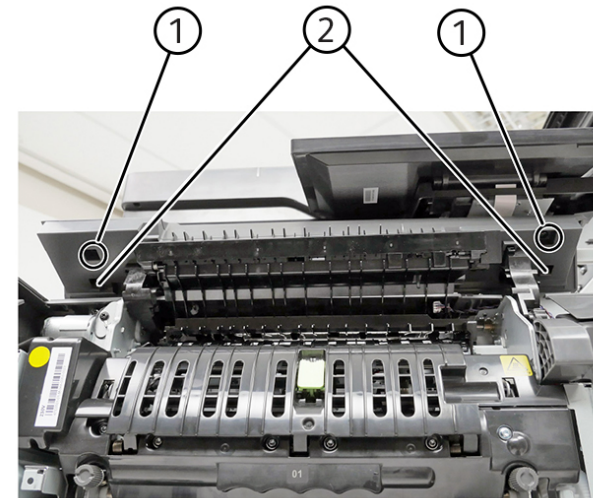


Figure 1 Upper front door removal

3. Remove the upper front door.

VLC625S_4062

VLC625S_4153

REP 28.7 Top Frame Base Cover

Removal

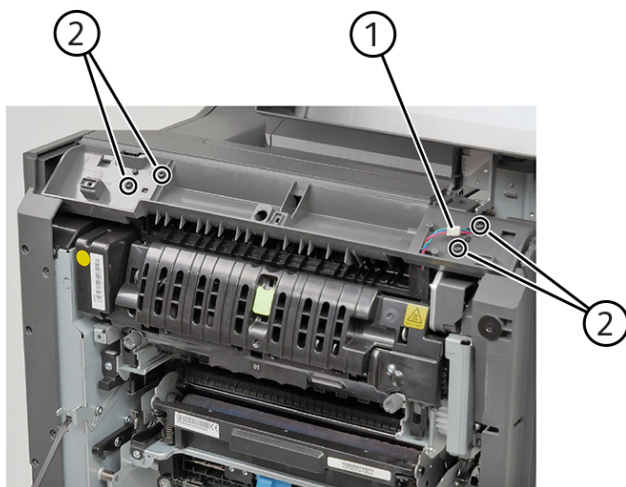


WARNING: Switch off the electricity to the machine, [GP 10](#) . Disconnect the power lead from the customer supply while performing tasks that do not need electricity. Electricity can cause the death or injury. Moving components can cause the injury.



Figure 1 ESD Symbol

1. Remove the top frame cover. See [REP 28.6](#).
2. Disconnect the cable (1), and then remove the four screws (2).



VLC625S_4154

3. Remove the cover.

REP 28.8 Top Cover

Parts List on [PL 28.15](#)

Removal



WARNING: Switch off the electricity to the machine, [GP 10](#) . Disconnect the power lead from the customer supply while performing tasks that do not need electricity. Electricity can cause the death or injury. Moving components can cause the injury.



Figure 1 ESD Symbol

1. Remove the scanner rear right cover.
2. Remove the scanner rear left cover.
3. Remove the waste toner bottle. See [REP 90.3](#)
4. Remove the imaging kit. See [REP 60.1](#)
5. Remove the motor cover. See [REP 28.11](#)
6. Remove or loosen the right cover. See [REP 28.1](#)
7. Remove the USB cover. See [REP 28.4](#)
8. Remove the scanner front cover. See [REP 28.16](#)
9. Remove the control panel. See [REP 2.1](#)
10. Remove the control panel base. See [REP 2.2](#)
11. Remove the façade cover. See [REP 28.15](#)
12. Remove the DADF. See [REP 5.3](#).
13. Remove the controller PWB shield. See [REP 3.1](#).
14. Remove the flatbed scanner. See [REP 5.4](#).
15. Remove the bin cover. See [REP 28.12](#).
16. Remove two screws (1).

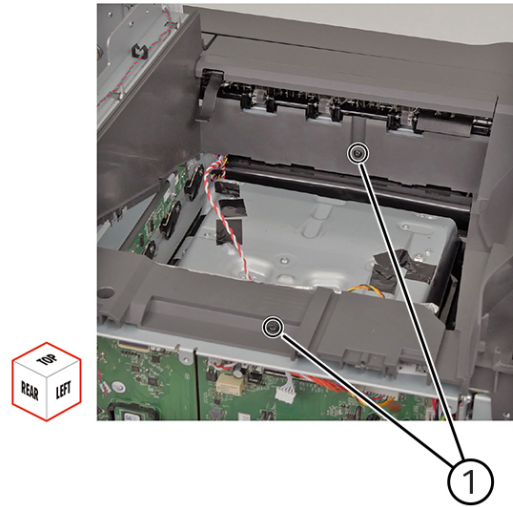


Figure 2 Screw removal
17. Remove the screw (2).

VLC625S_4157

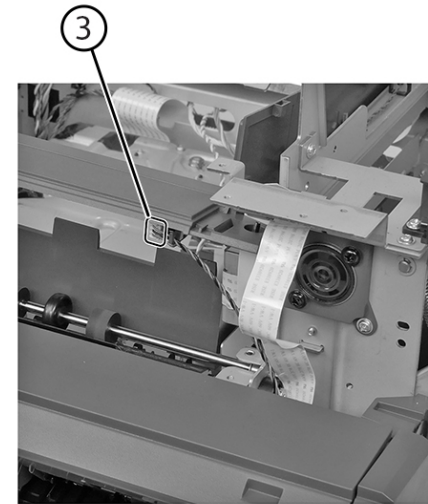


Figure 4 Disconnect the sensor
19. Remove the sensor retainer (4), and then remove the sensor from the cover.

VLC625S_4159

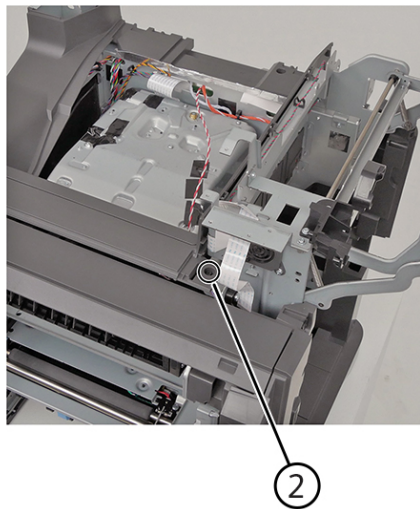


Figure 3 screw removal
18. Lift the cover, and then disconnect the sensor cable (3).

VLC625S_4158

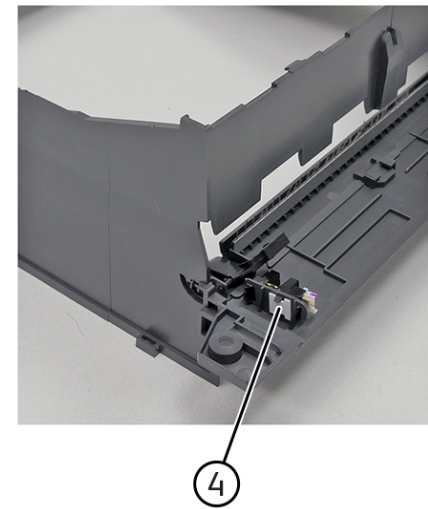


Figure 5 Sensor removal

VLC625S_4160

REP 28.9 Not Used

REP 28.10 Front Door

Parts List on [PL 28.10](#)

Removal

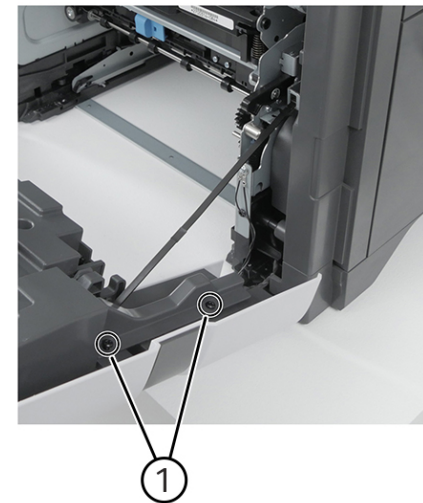


WARNING: Switch off the electricity to the machine, [GP 10](#) . Disconnect the power lead from the customer supply while performing tasks that do not need electricity. Electricity can cause the death or injury. Moving components can cause the injury.



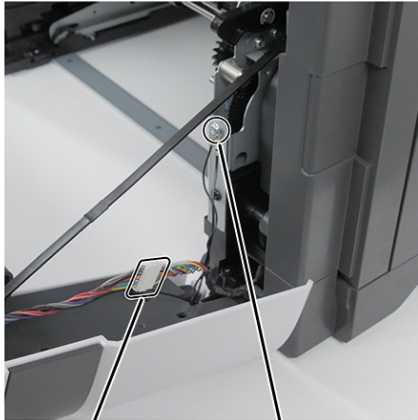
Figure 1 ESD Symbol

1. Remove the screw, and then remove the cover.
2. Remove the two screws (1), and then remove the cover.



3. Disconnect the cable (2), and then remove the ground screw (3).

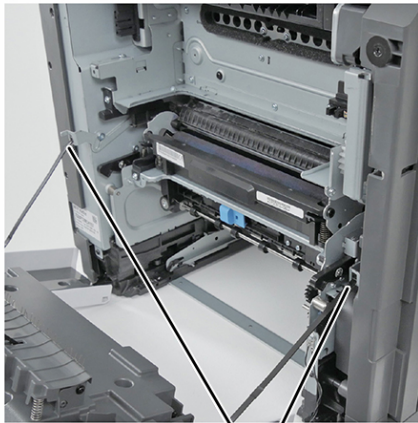
VLC625S_4085



2 3

VLC625S_4086

4. Release the straps (4), and then remove the door. Warning—Potential Damage: Make sure that the door does not fall.



4

VLC625S_4087

REP 28.11 Motor Cover

Parts List on [PL 28.10](#)

Removal

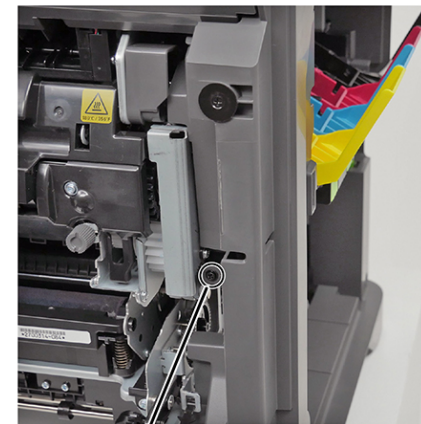


WARNING: Switch off the electricity to the machine, [GP 10](#). Disconnect the power lead from the customer supply while performing tasks that do not need electricity. Electricity can cause the death or injury. Moving components can cause the injury.



Figure 1 ESD Symbol

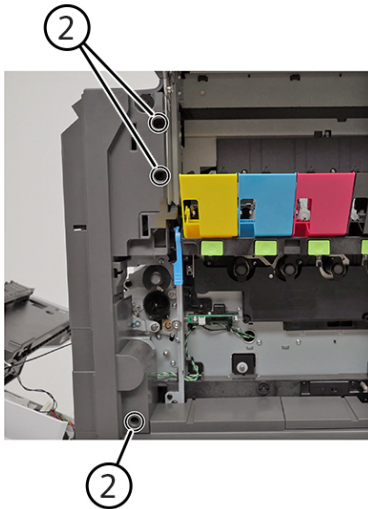
1. Open the front door and cartridge door.
2. Remove the screw (1).



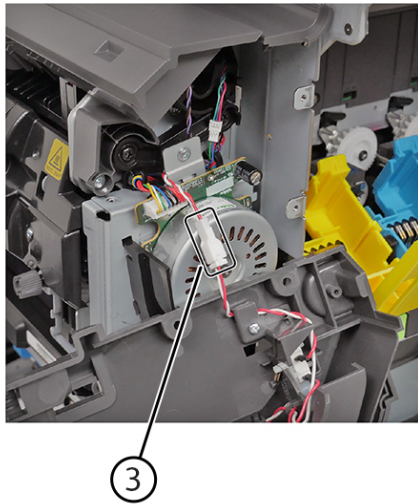
1

VLC625S_4088

3. Remove the three screws (2).



4. Disconnect the switch cable (3).



5. Remove the cover.

REP 28.12 Bin Cover

Parts List on [PL 28.15](#)

Removal



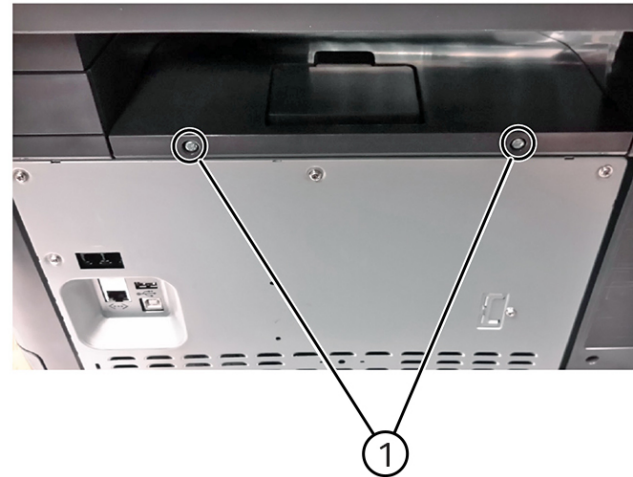
WARNING: Switch off the electricity to the machine, [GP 10](#). Disconnect the power lead from the customer supply while performing tasks that do not need electricity. Electricity can cause the death or injury. Moving components can cause the injury.



Figure 1 ESD Symbol

1. From the rear, remove the two screws (1).

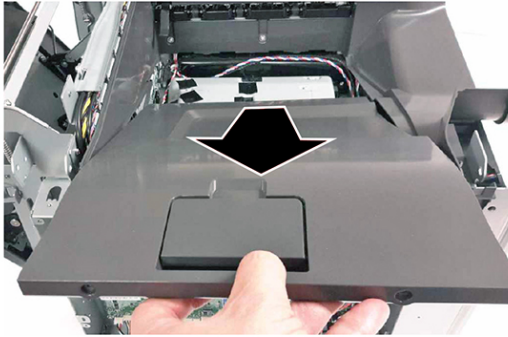
VLC625S_4089



VLC625S_4151

2. Remove the cover.

VLC625S_4090



VLC625S_4152

REP 28.13 Face Cover

Parts List on [PL 28.15](#)

Removal

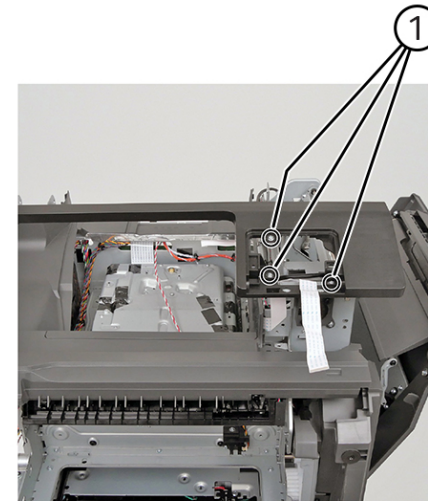


WARNING: Switch off the electricity to the machine, [GP 10](#). Disconnect the power lead from the customer supply while performing tasks that do not need electricity. Electricity can cause the death or injury. Moving components can cause the injury.



Figure 1 ESD Symbol

1. Remove the USB cover. See [REP 28.4](#).
2. Remove the scanner front cover. See [REP 28.16](#)
3. Remove the control panel. See [REP 2.1](#).
4. Remove the control panel base. See [REP 2.2](#).
5. Remove the three screws (1).



VLC625S_4165

6. Remove the cover.

REP 28.14 Bin Exit Cover

Parts List on [PL 28.10](#)

Removal

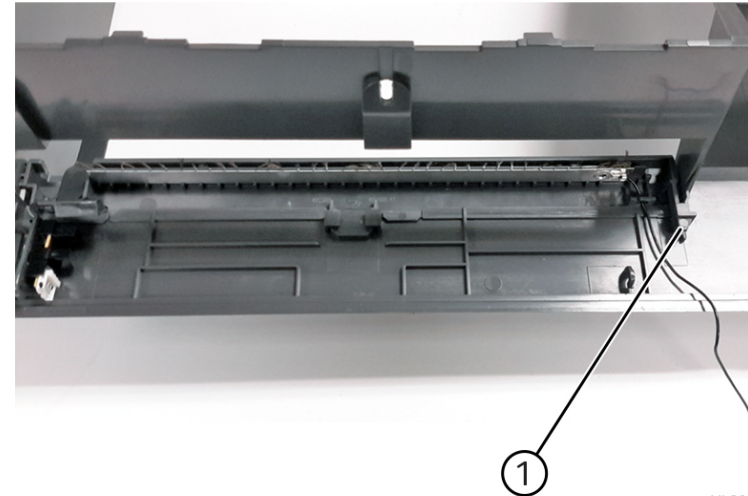


WARNING: Switch off the electricity to the machine, [GP 10](#). Disconnect the power lead from the customer supply while performing tasks that do not need electricity. Electricity can cause the death or injury. Moving components can cause the injury.



Figure 1 ESD Symbol

1. Remove the scanner rear right cover. See [PL 28.15 item 9](#)
2. Remove the scanner rear left cover. See [PL 28.15 item 8](#)
3. Remove the waste toner bottle. See [REP 90.3](#)
4. Remove the imaging kit. See [REP 60.1](#)
5. Remove the motor cover. See [REP 28.11](#)
6. Remove or loosen the right cover. See [REP 28.1](#)
7. Remove the USB cover. See [REP 28.4](#)
8. Remove the scanner front cover. See [REP 28.16](#)
9. Remove the control panel. See [REP 2.1](#)
10. Remove the control panel base. See [REP 2.2](#)
11. Remove the façade cover. See [REP 28.15](#)
12. Remove the DADF. See [REP 5.3](#).
13. Remove the flatbed scanner. See [REP 5.4](#).
14. Remove the controller PWB shield. See [REP 3.1](#)
15. Remove the bin cover. See [REP 28.12](#).
16. Remove the top cover. See [REP 28.8](#).
17. Disengage the tab (1), and then remove the cable from the tabs.



VLC625S_4166

18. Remove the cover.



VLC625S_4167

REP 28.15 Bin Flag

Parts List on [PL 28.10](#)

Removal

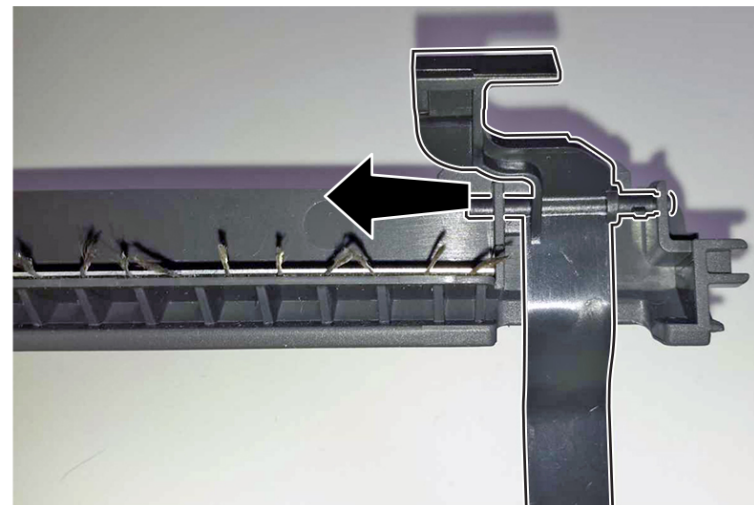


WARNING: Switch off the electricity to the machine, [GP 10](#) . Disconnect the power lead from the customer supply while performing tasks that do not need electricity. Electricity can cause the death or injury. Moving components can cause the injury.



Figure 1 ESD Symbol

1. Remove the scanner rear right cover. See [PL 28.15 item 9](#)
2. Remove the scanner rear left cover. See [PL 28.15 item 8](#)
3. Remove the waste toner bottle. See [REP 90.3](#)
4. Remove the imaging kit. See [REP 60.1](#)
5. Remove the motor cover. See [REP 28.11](#)
6. Remove or loosen the right cover. See [REP 28.1](#)
7. Remove the USB cover. See [REP 28.4](#)
8. Remove the scanner front cover. See [REP 28.16](#)
9. Remove the control panel. See [REP 2.1](#)
10. Remove the control panel base. See [REP 2.2](#)
11. Remove the façade cover. See [REP 28.15](#)
12. Remove the DADF. See [REP 5.3](#).
13. Remove the controller PWB shield. See [REP 3.1](#).
14. Remove the flatbed scanner. See [REP 5.4](#).
15. Remove the bin cover. See [REP 28.12](#).
16. Remove the top cover. See [REP 28.8](#).
17. Remove the bin exit cover. See [REP 28.16](#).
18. Slide the flag to the left to remove.



VLC625S_4168

REP 28.16 Scanner Front Cover

Parts List on [PL 28.15](#)

Removal



WARNING: Switch off the electricity to the machine, [GP 10](#) . Disconnect the power lead from the customer supply while performing tasks that do not need electricity. Electricity can cause the death or injury. Moving components can cause the injury.



Figure 1 ESD Symbol

1. Remove the USB cover. See [REP 28.4](#).
2. Remove the badge cover.



VLC625S_4091

3. Remove the screw (1).



1

VLC625S_4092

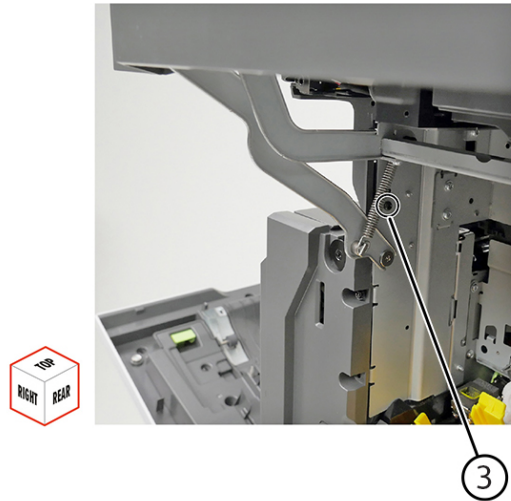
4. Remove the screw (2).



2

VLC625S_4093

5. Open the cartridge door, and then remove the screw (3).



6. Remove the cover.

VLC625S_4094

REP 28.17 Left Cover

Parts List on [PL 28.10](#)

Removal



WARNING: Switch off the electricity to the machine, [GP 10](#). Disconnect the power lead from the customer supply while performing tasks that do not need electricity. Electricity can cause the death or injury. Moving components can cause the injury.



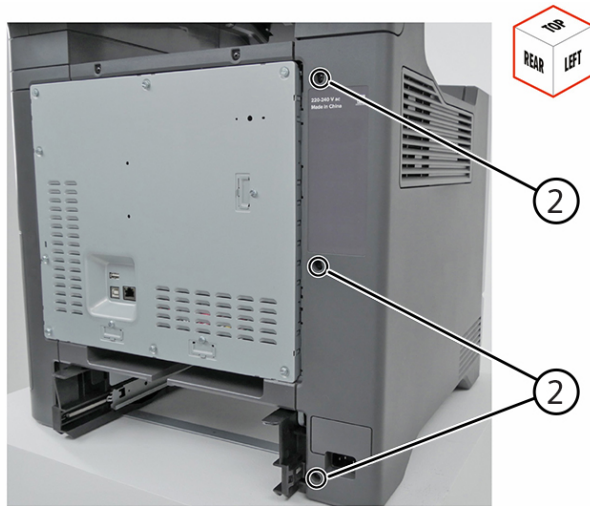
Figure 1 ESD Symbol

1. Remove one screw (1).



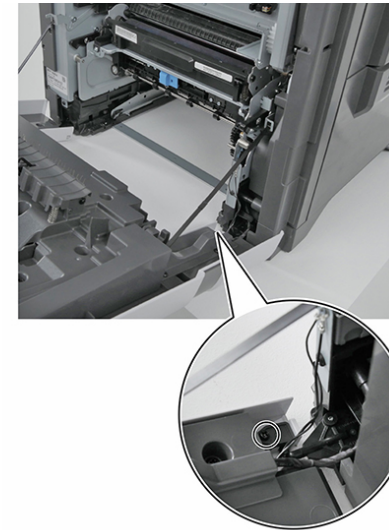
VLC625S_4015

2. Remove three screws (2).



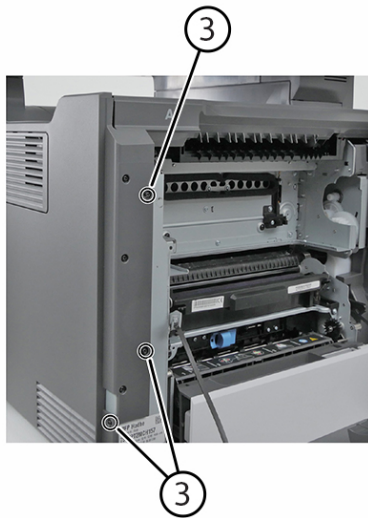
VLC625S_4016

3. Remove three screws (3).



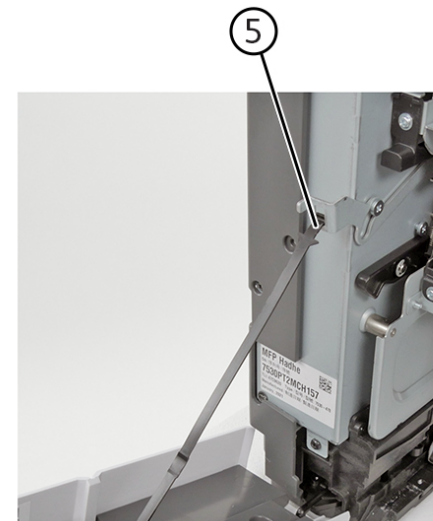
VLC625S_4018

5. Release the left strap.



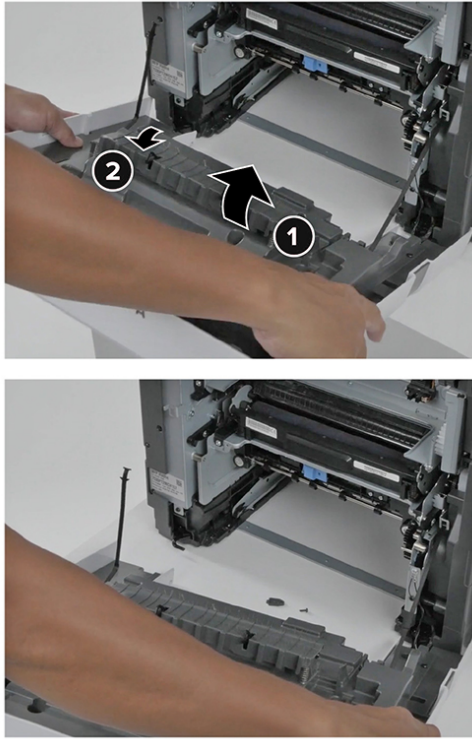
VLC625S_4017

4. Remove one screw, then remove the cover.



VLC625S_4019

6. Release the front door, and then move it out of the way.



VLC625S_4020

7. Remove the left cover.

REP 40.1 EP Drive Motor

Parts List on [PL 40.10](#)

Removal

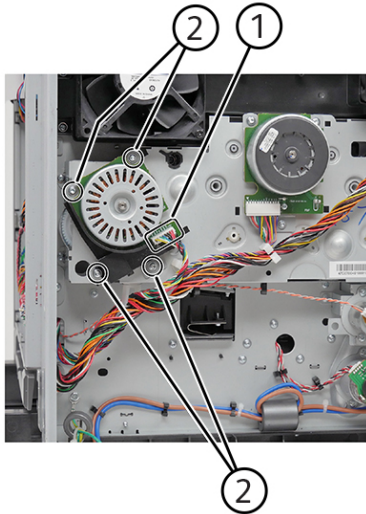


WARNING: Switch off the electricity to the machine, [GP 10](#). Disconnect the power lead from the customer supply while performing tasks that do not need electricity. Electricity can cause the death or injury. Moving components can cause the injury.



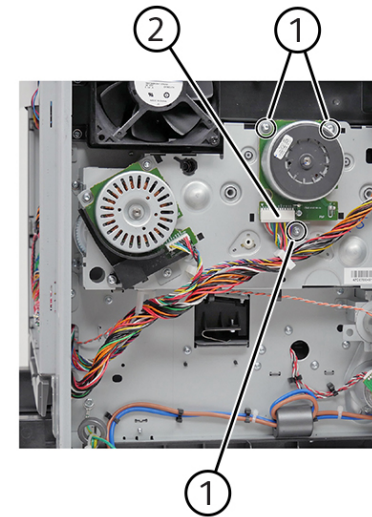
Figure 1 ESD Symbol

1. Remove the left cover. See [REP 3.1](#).
2. Disconnect the cable (1), and then remove the screws (2).
 - Motor (K/transfer belt)



VLC625S_4029

- Motor (CMY)



VLC625S_4030

3. Remove the motor.

REP 40.2 EP Drive Gearbox

Parts List on [PL 40.10](#)

Removal

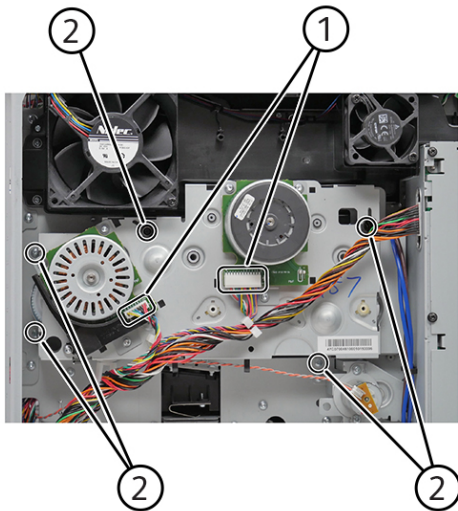


WARNING: Switch off the electricity to the machine, [GP 10](#). Disconnect the power lead from the customer supply while performing tasks that do not need electricity. Electricity can cause the death or injury. Moving components can cause the injury.

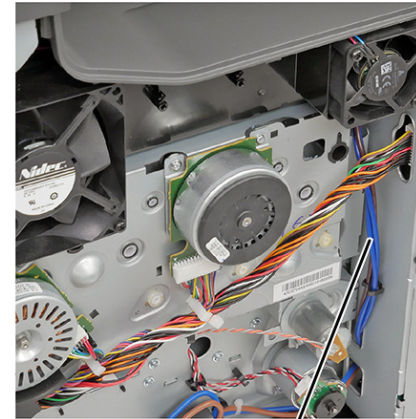


Figure 1 ESD Symbol

1. Remove the left cover. See [REP 28.17](#).
2. Disconnect the cables (1), and then remove the five screws (2).



VLC625S_4031



1

VLC625S_4032

Installation note: Make sure to align the locating tabs with their corresponding slots.

3. Remove the gearbox. Warning—Potential Damage: The right edge of the gearbox may be sharp. Be careful not to cut the cables (1).

REP 40.3 BOR Motor (deskew)

Parts List on [PL 40.10](#)

Removal

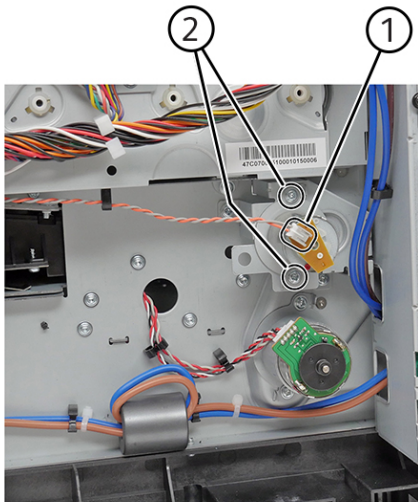


WARNING: Switch off the electricity to the machine, [GP 10](#) . Disconnect the power lead from the customer supply while performing tasks that do not need electricity. Electricity can cause the death or injury. Moving components can cause the injury.



Figure 1 ESD Symbol

1. Remove the left cover. See [REP 28.17](#).
2. Disconnect the cable (1), and then remove the two screws (2).



VLC625S_4033

3. Remove the motor.

REP 40.4 Deskew Motor

Parts List on [PL 40.10](#)

Removal

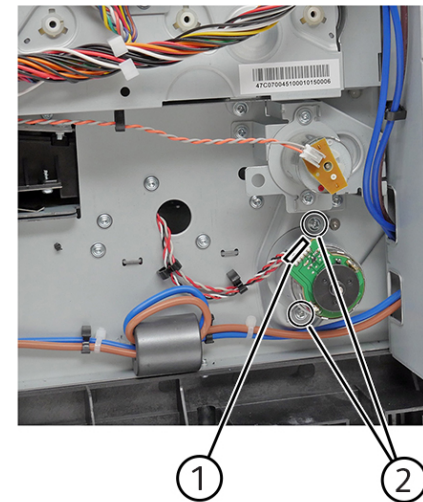


WARNING: Switch off the electricity to the machine, [GP 10](#) . Disconnect the power lead from the customer supply while performing tasks that do not need electricity. Electricity can cause the death or injury. Moving components can cause the injury.



Figure 1 ESD Symbol

1. Remove the left cover. See [REP 28.17](#).
2. Disconnect the cable (1), and then remove the two screws (2).



VLC625S_4034

3. Remove the motor.

REP 40.5 Exit/Redrive Motor

Parts List on [PL 40.10](#)

Removal

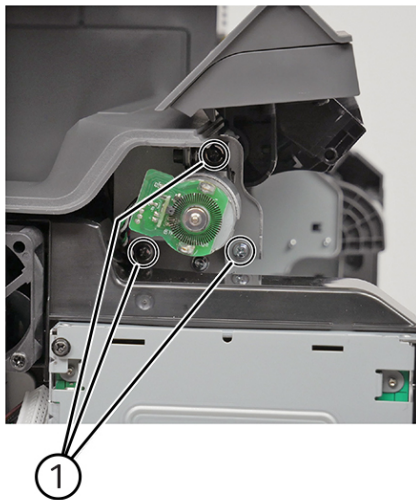


WARNING: Switch off the electricity to the machine, [GP 10](#). Disconnect the power lead from the customer supply while performing tasks that do not need electricity. Electricity can cause the death or injury. Moving components can cause the injury.



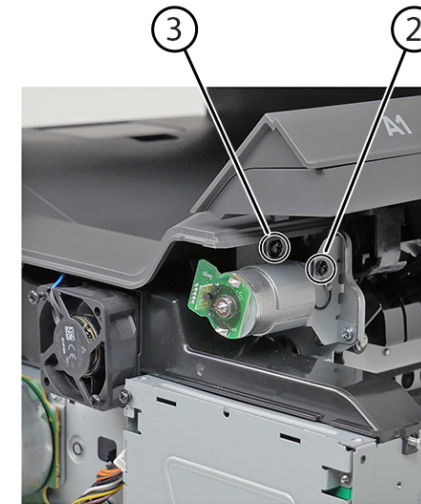
Figure 1 ESD Symbol

1. Remove the left cover. See [REP 28.17](#).
2. Open door A1, and then remove the three screws (1).



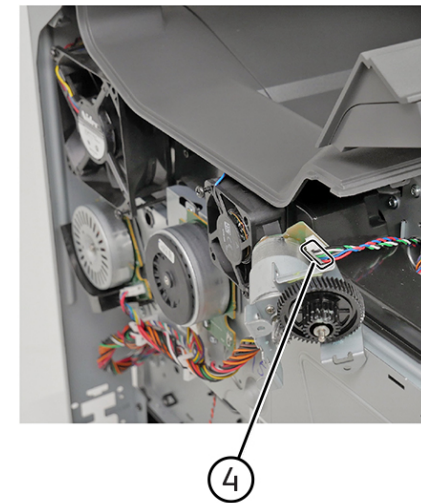
VLC625S_4038

3. Remove the ground screw (2) and the other screw (3).



VLC625S_4039

4. Disconnect the cable (4), and then remove the motor.



VLC625S_4040

REP 60.1 Imaging Unit

Removal



WARNING: Switch off the electricity to the machine, [GP 10](#). Disconnect the power lead from the customer supply while performing tasks that do not need electricity. Electricity can cause the death or injury. Moving components can cause the injury.



Figure 1 ESD Symbol

1. Remove the waste toner bottle. See [REP 90.3](#)Waste toner bottle removal.
2. Disconnect the imaging kit cable.

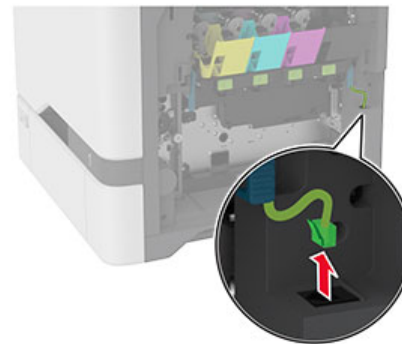
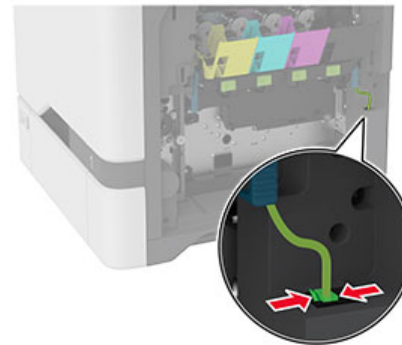


Figure 2 Imaging kit cable

3. Remove the imaging kit.

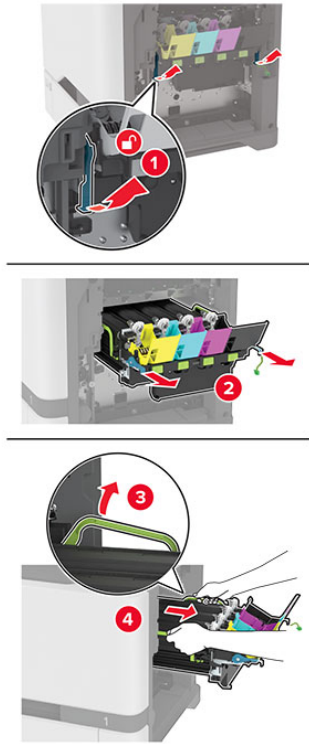


Figure 3 Imaging kit removal

Note: To avoid scratching the imaging kit or damaging the photoconductor drum, place the imaging kit in an uplifted position.

REP 60.2 Print Head

Parts List on [PL 60.10](#)

Removal

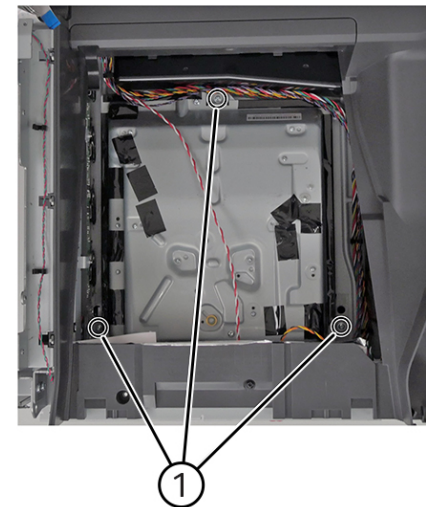


WARNING: Switch off the electricity to the machine, [GP 10](#). Disconnect the power lead from the customer supply while performing tasks that do not need electricity. Electricity can cause the death or injury. Moving components can cause the injury.



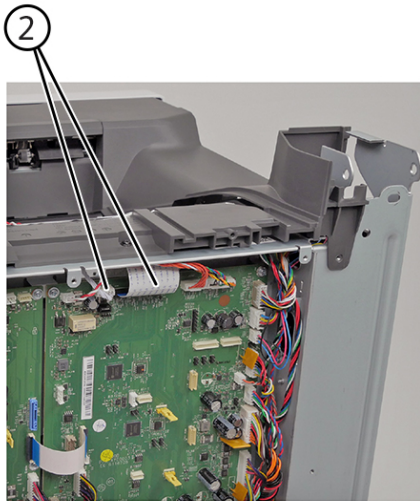
Figure 1 ESD Symbol

1. Remove the scanner rear right cover, See [PL 28.15 item 9](#)
2. Remove the scanner rear left cover, See [PL 28.15 item 8](#)
3. Remove the DADF. See [REP 5.3](#).
4. Remove the controller PWB shield. See [REP 3.1](#).
5. Remove the flatbed scanner. See [REP 5.4](#).
6. Remove the bin cover. See [REP 28.12](#).
7. Remove the three screws (1).



8. Disconnect the cables (2).

VLC625S_4155



VLC625S_4156

9. Remove the printhead.

Installation notes:

- a. When installing the printhead, replace the screws but do not tighten them right away. After installing the screws, turn the printhead clockwise until it stops.
- b. Enter the Diagnostics menu, and then navigate to:
Printer diagnostics & adjustments > Registration adjust > Quick test
- c. If the printhead needs alignment, perform a printhead alignment adjustment. See [ADJ 90.1](#).
- d. Tighten the screws.
- e. Perform a color alignment adjustment. See [dC919](#).

REP 60.3 Main Fan

Parts List on [PL 60.05](#)

Removal

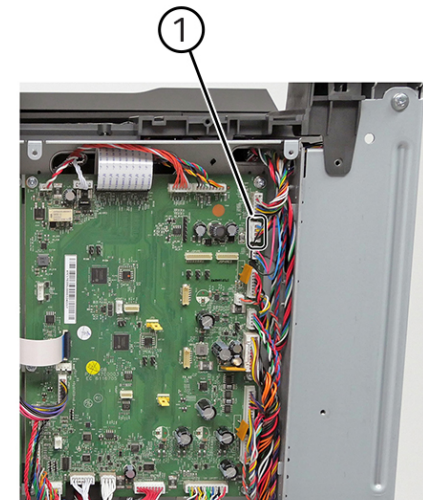


WARNING: Switch off the electricity to the machine, [GP 10](#). Disconnect the power lead from the customer supply while performing tasks that do not need electricity. Electricity can cause the death or injury. Moving components can cause the injury.



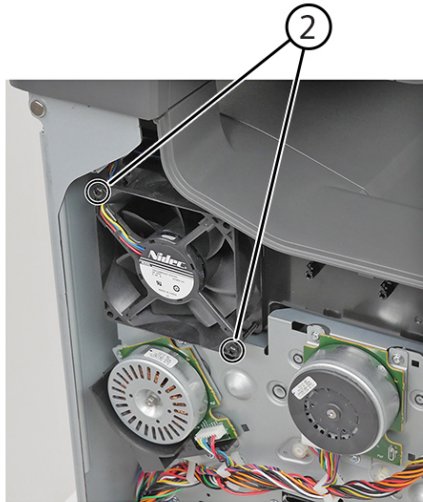
Figure 1 ESD Symbol

1. Remove the left cover. See [REP 28.17](#).
2. Remove the controller board shield. See [REP 3.1](#).
3. Disconnect the cable (1).



VLC625S_4024

4. Remove the two screws (2).



5. Remove the fan.

VLC625S_4025

REP 60.4 Fuser Fan

Parts List on [PL 60.05](#)

Removal

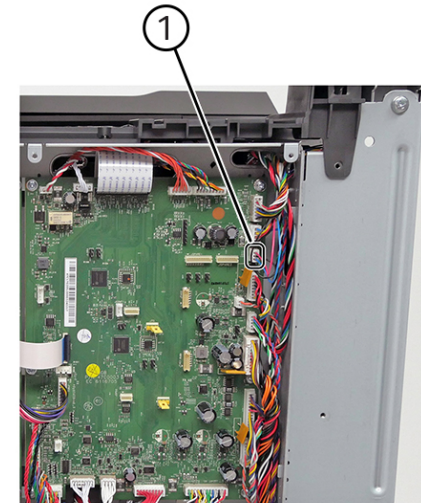


WARNING: Switch off the electricity to the machine, [GP 10](#). Disconnect the power lead from the customer supply while performing tasks that do not need electricity. Electricity can cause the death or injury. Moving components can cause the injury.



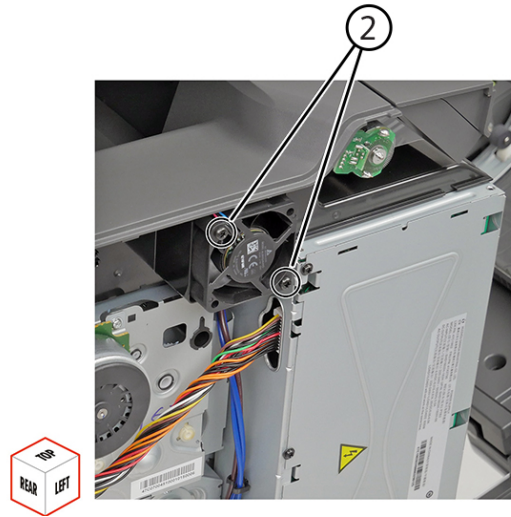
Figure 1 ESD Symbol

1. Remove the left cover, [REP 28.17](#).
2. Remove the controller board shield, [REP 3.1](#).
3. Disconnect one cable (1).



4. Remove two screws (2).

VLC625S_4026



VLC625S_4027

5. Release the cable from its guides, and then remove the fan.

Note: Pay attention to the cable route.



VLC625S_4028

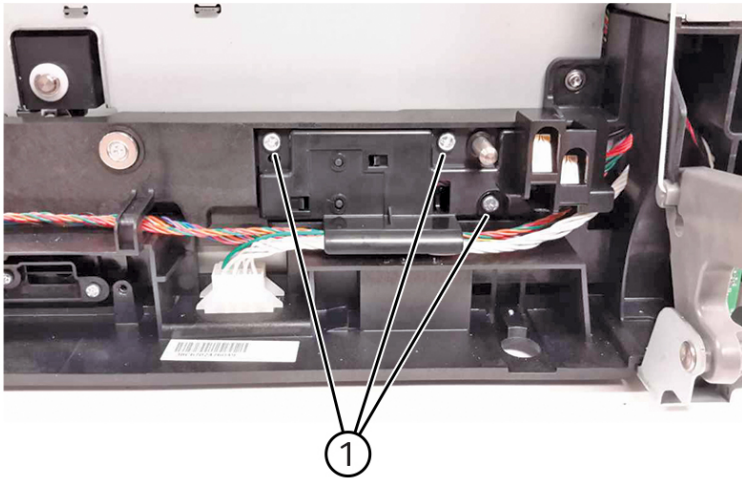
REP 70.1 Tray 1/2 Paper Size Sensor

Removal



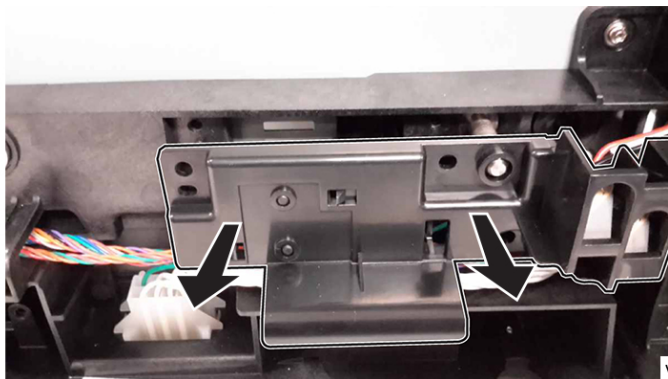
WARNING: Switch off the electricity to the machine, **GP 10**. Disconnect the power lead from the customer supply while performing tasks that do not need electricity. Electricity can cause the death or injury. Moving components can cause the injury.

1. Remove the waste toner bottle. See [REP 90.3](#).
2. Remove the motor cover. See [REP 28.11](#).
3. Remove the right cover. See [REP 28.1](#).
4. Remove the three screws (1).



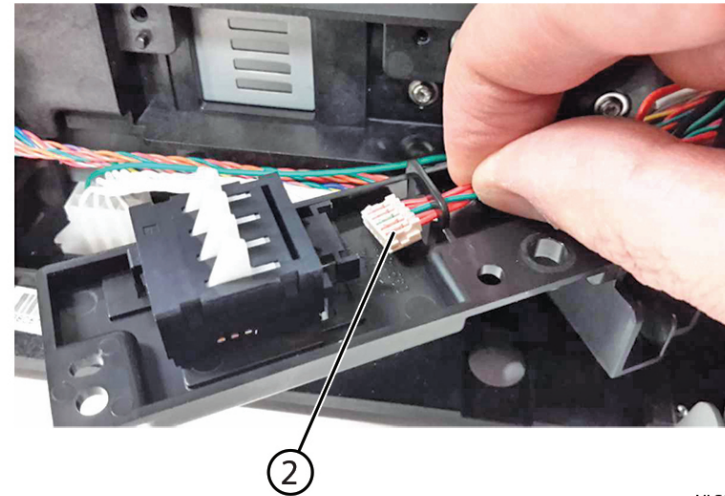
VLC625S_4065

5. Pull the mounting assembly away from the printer.



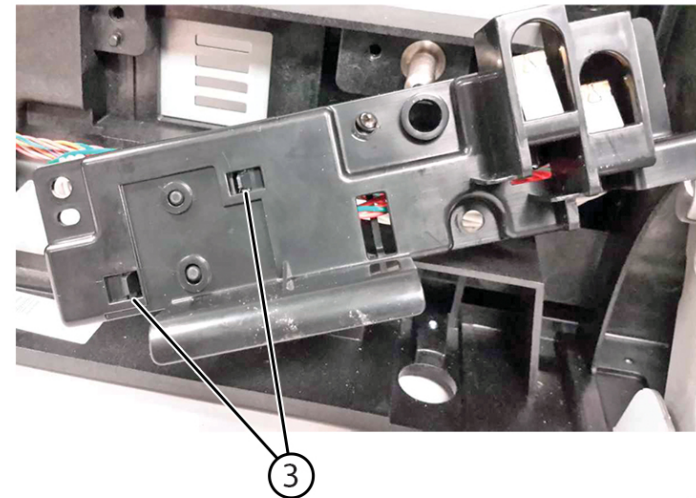
VLC625S_4066

6. Disconnect the sensor cable (2).



VLC625S_4067

7. Release the two tabs (3) from the mounting assembly, and then remove the sensor.



VLC625S_4068

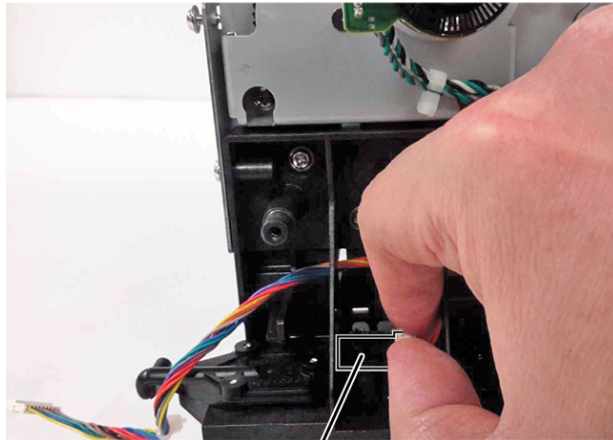
REP 70.2 MPF/Bypass Present Sensor

Removal



WARNING: Switch off the electricity to the machine, **GP 10**. Disconnect the power lead from the customer supply while performing tasks that do not need electricity. Electricity can cause the death or injury. Moving components can cause the injury.

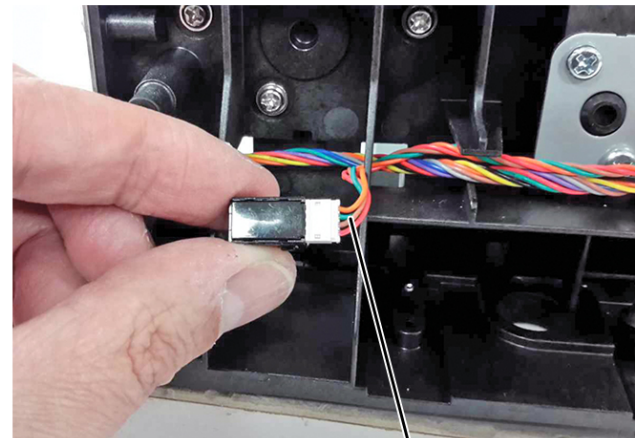
1. Remove the waste toner bottle. See [REP 90.3](#).
2. Remove the motor cover. See [REP 28.11](#).
3. Remove the right cover. See [REP 28.1](#).
4. Pull the sensor (1) out of the printer.



1

VLC625S_4080

5. Disconnect the sensor cable (2), and then remove the sensor.



2

VLC625S_4081

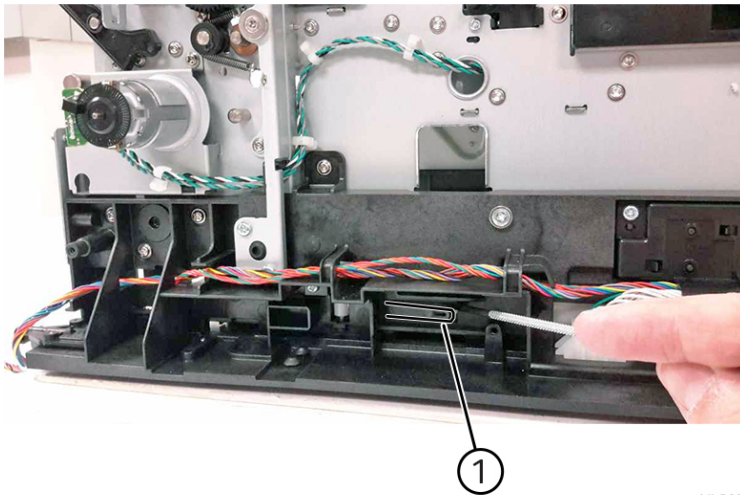
6. Pry the sensor (C) out of the printer.
7. Disconnect the sensor cable (D), and then remove the sensor.

REP 70.3 Tray Rail



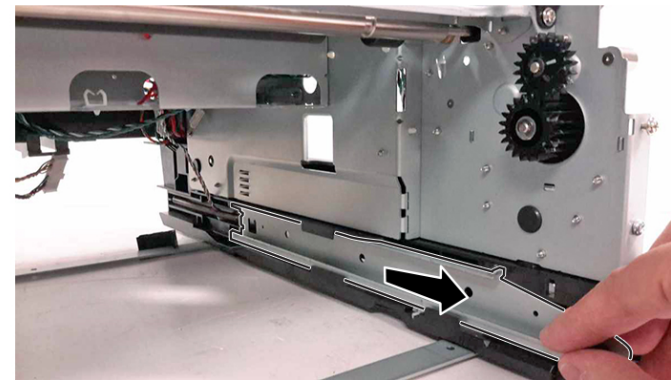
WARNING: Switch off the electricity to the machine, **GP 10**. Disconnect the power lead from the customer supply while performing tasks that do not need electricity. Electricity can cause the death or injury. Moving components can cause the injury.

1. Remove the waste toner bottle. See [REP 90.3](#).
2. Remove the tray insert.
3. Remove the left cover. See [REP 28.17](#).
4. Remove the motor cover. See [REP 28.11](#).
5. Remove the right cover. See [REP 28.1](#).
6. Pull the tab (1) on the rail.
 - Right side



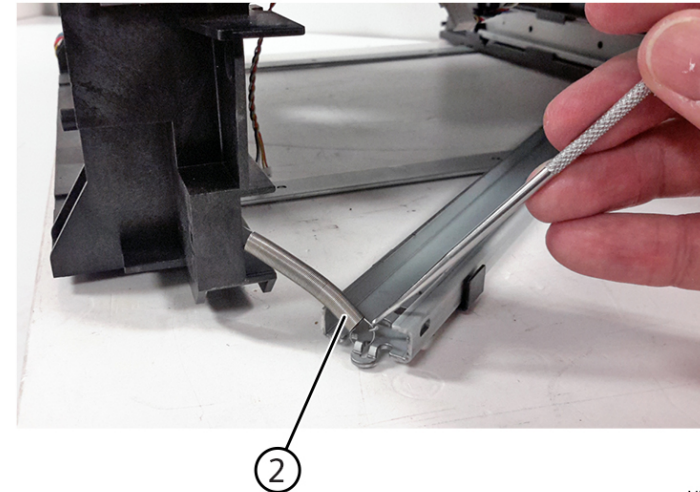
VLC625S_4177

- Left side
7. Hold the tab in place, and then slide the rail to the front of the printer to remove.



VLC625S_4178

8. Remove the spring (2) from the rail.
 - Right side



VLC625S_4179

- Left side

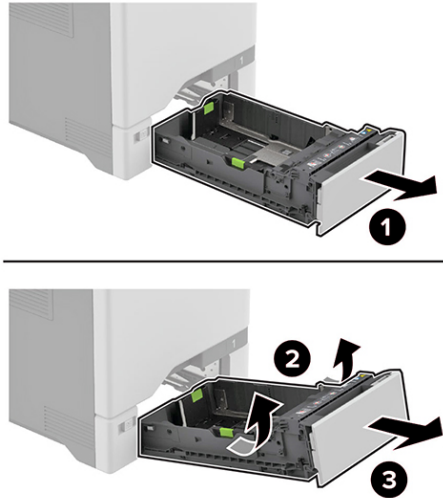
REP 70.4 Pick Roller



WARNING: Switch off the electricity to the machine, GP 10 . Disconnect the power lead from the customer supply while performing tasks that do not need electricity. Electricity can cause the death or injury. Moving components can cause the injury.

Tray 1 pick roller removal

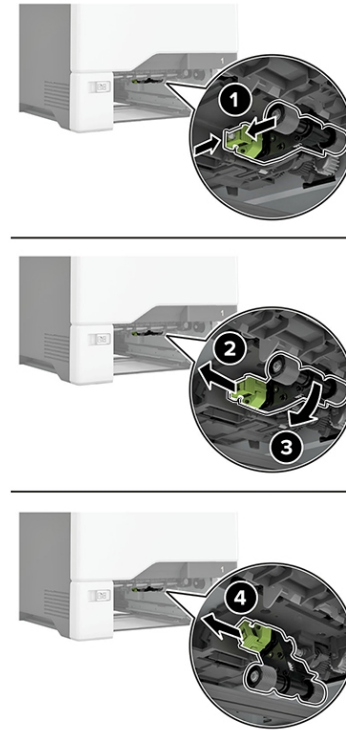
1. Remove the tray.



VLC625S_4171

2. Remove the pick roller.

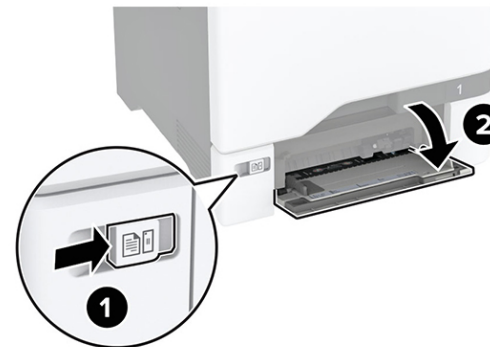
Tray 1 pick roller removal (continued)



VLC625S_4174

MPF pick roller removal

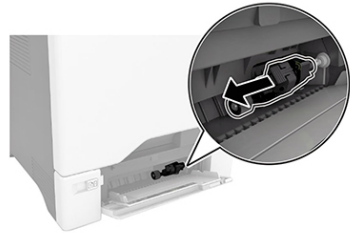
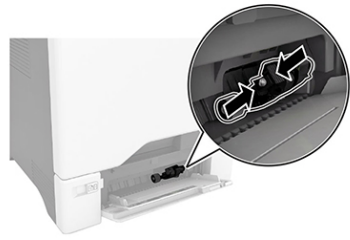
1. Open the multipurpose feeder.



VLC625S_4175

2. Remove the pick roller

MPF pick roller removal (continued)



VLC625S_4176

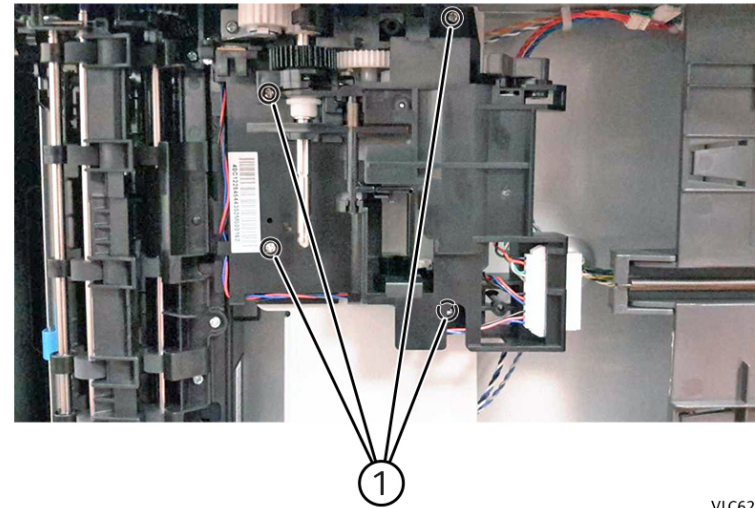
REP 70.5 Paper Feeder



WARNING: Switch off the electricity to the machine, GP 10 . Disconnect the power lead from the customer supply while performing tasks that do not need electricity. Electricity can cause the death or injury. Moving components can cause the injury.

Warning—Potential Damage: Remove the waste toner bottle and imaging kit first before removing the paper feeder. Failure to do this can lead to toner spillage and damage to the printer.

1. Remove the waste toner bottle. See REP 90.3.
2. Remove the imaging kit. See REP 60.1.
3. Remove the tray insert.
4. Remove the tray 1 pick roller. See REP 70.5.
5. Place the printer on its back, and then disconnect the cables.
6. Remove the four screws (1), and then remove the paper feeder.



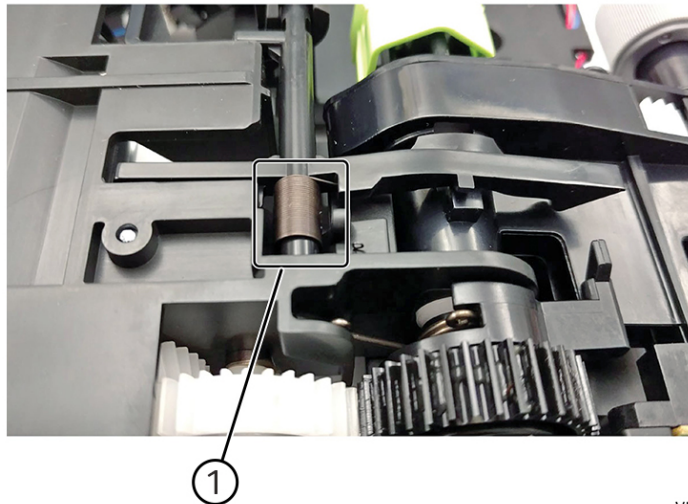
VLC625S_4180

REP 70.6 Paper Out Actuator Spring



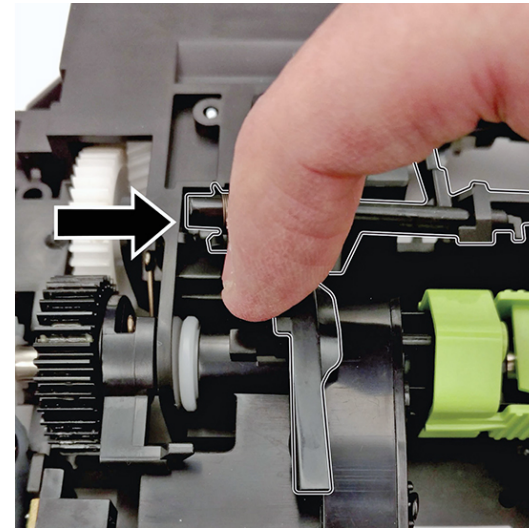
WARNING: Switch off the electricity to the machine, GP 10 . Disconnect the power lead from the customer supply while performing tasks that do not need electricity. Electricity can cause the death or injury. Moving components can cause the injury.

1. Remove the waste toner bottle. See REP 90.3.
2. Remove the imaging kit. See REP 60.1.
3. Remove the tray insert.
4. Remove the tray 1 pick roller. See REP 70.5.
5. Remove the paper feeder. See REP 70.6.
6. Pay attention to the position of the paper out actuator spring (1).



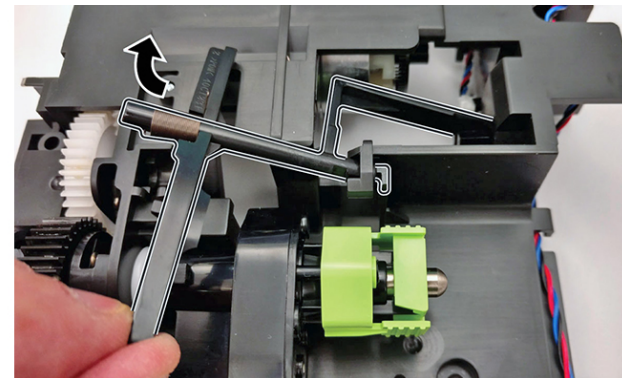
VLC625S_4181

7. Move the actuator to the right, and then release it.



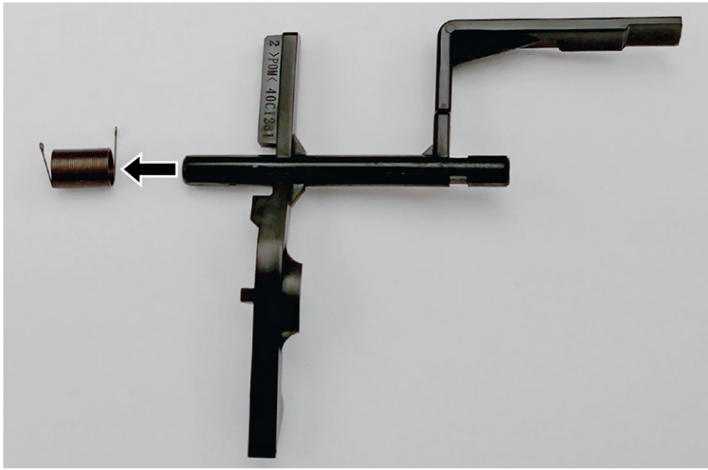
VLC625S_4182

8. Remove the actuator.



VLC625S_4183

9. Remove the spring.



VLC625S_4184

Installation note: When installing the spring, make sure to install it as shown in step 6.

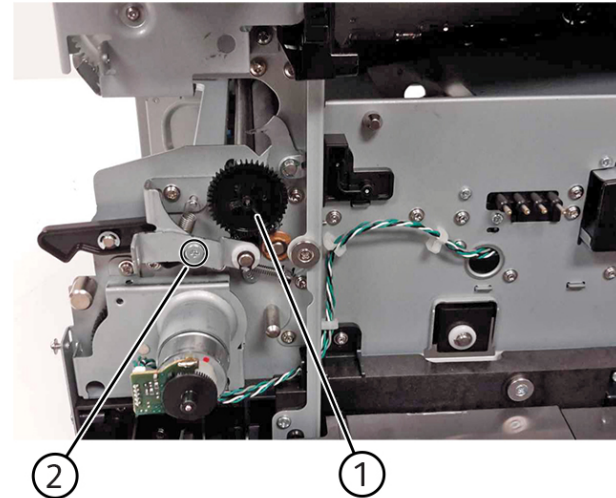
REP 70.7 Aligner Rollers



WARNING: Switch off the electricity to the machine, GP 10 . Disconnect the power lead from the customer supply while performing tasks that do not need electricity. Electricity can cause the death or injury. Moving components can cause the injury.

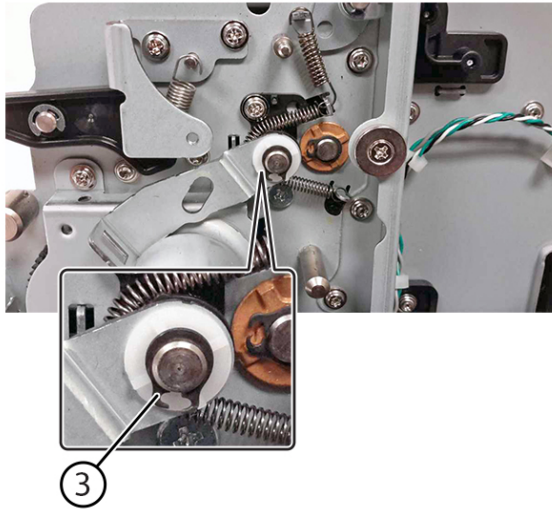
Note: There are two types of aligner rollers used on this printer. The solid rubber roller uses C-clips to fasten the aligner roller. Printers using the segmented rubber roller use E-clips to fasten the aligner roller. The parts are not interchangeable. Replace both rollers.

1. Remove the fuser. See REP 10.1.
2. Remove the transfer module. See REP 90.9.
3. Remove the left cover. See REP 28.17.
4. Remove the LVPS. See REP 1.2.
5. Remove the LVPS cage. See REP 1.3.
6. Remove the motor cover. See REP 28.11.
7. Remove the right cover. See REP 28.1.
8. Remove the sensor (input). See REP 80.4.
9. On the right side of the printer, remove the gear (1), and then remove the screw (2).



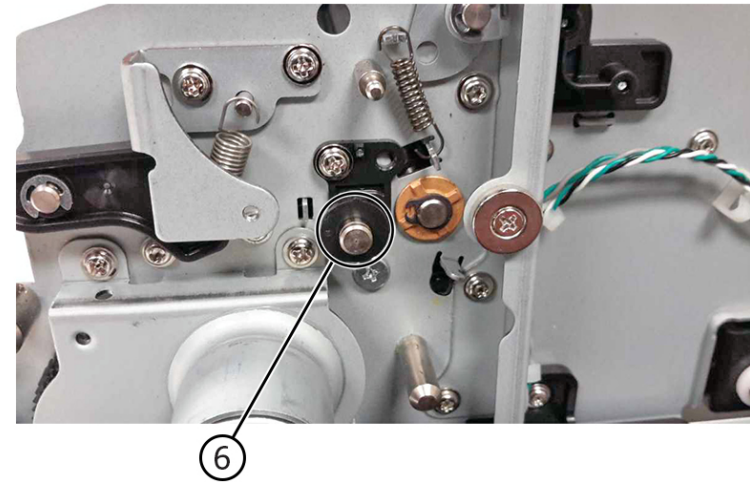
VLC625S_4123

10. Remove the C-clip (3), and then remove the spacer. Warning—Potential Damage: Be careful not to overextend the clip when removing or installing.



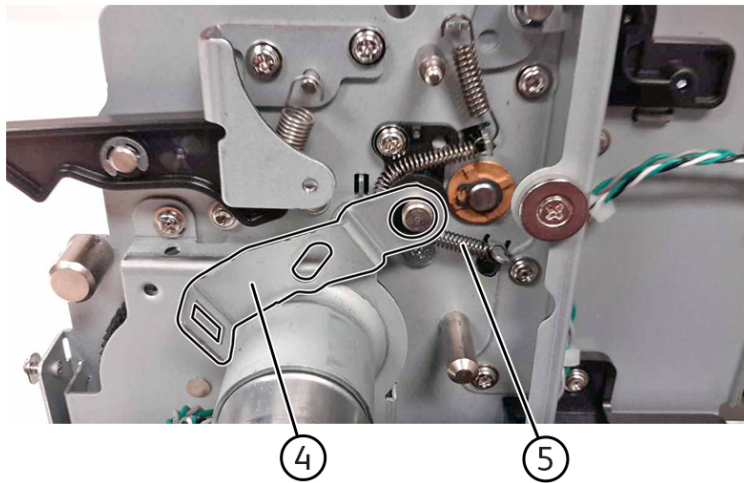
VLC625S_4124

11. Remove the bracket (4), and then release the spring (5).



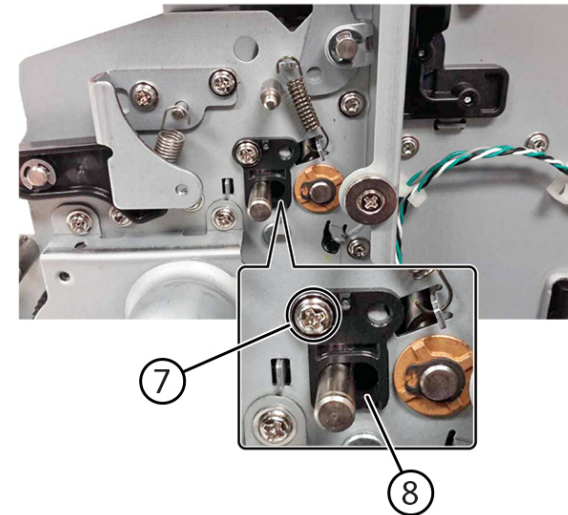
VLC625S_4126

13. Remove the screw (7), and then remove the guide (8).



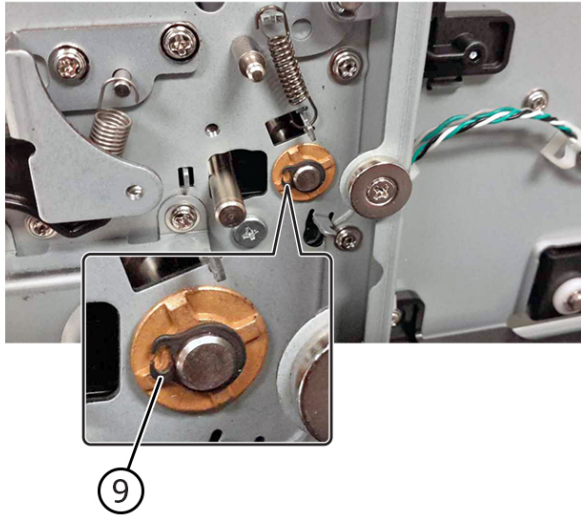
VLC625S_4125

12. Remove the spacer (6).



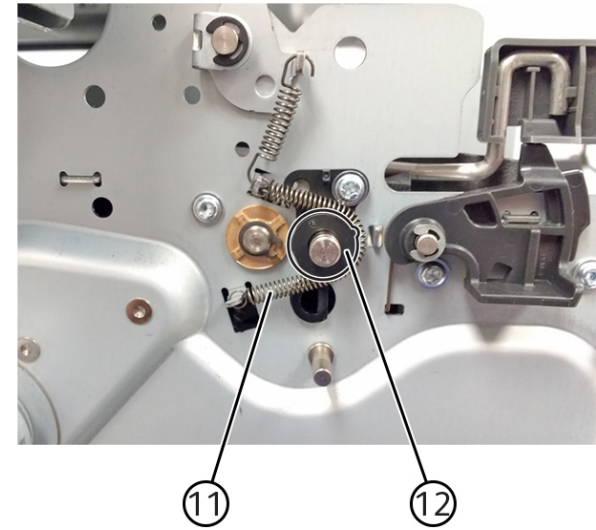
VLC625S_4127

14. Remove the C-clip (9), and then remove the bushing.



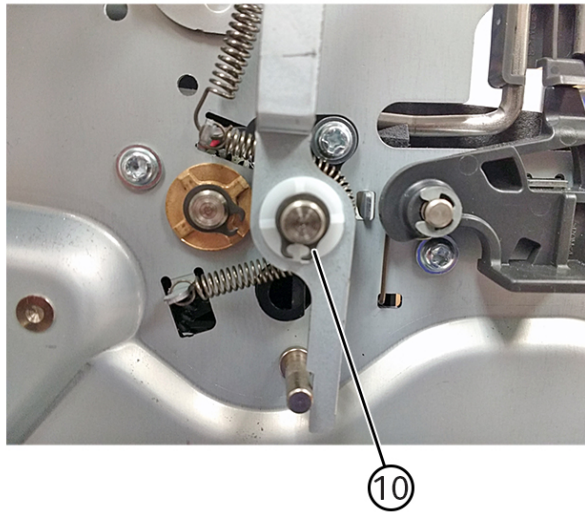
15. Remove the C-clip (10), and then remove the spacer.

VLC625S_4128



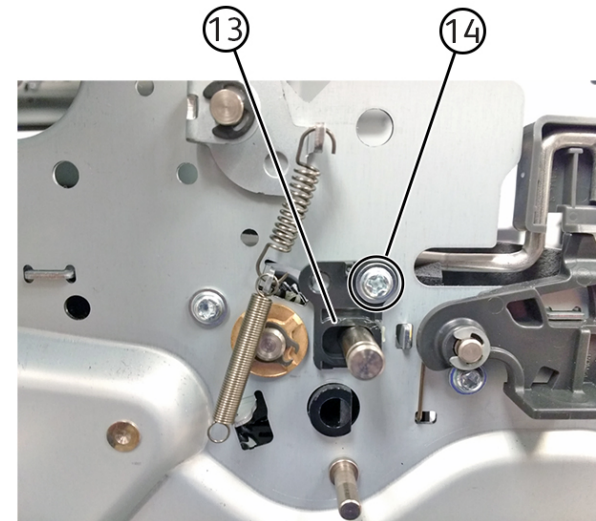
17. Remove the screw (13), and then remove the guide (14).

VLC625S_4130



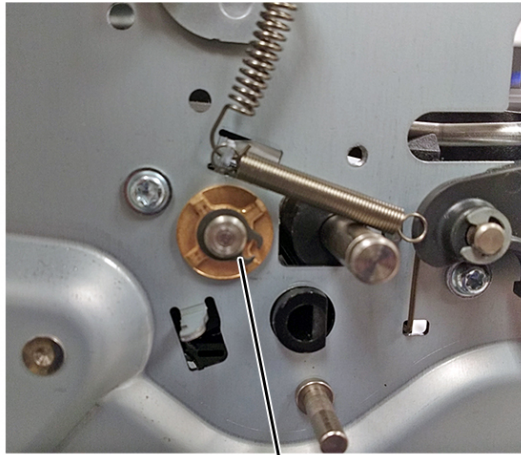
16. Remove the spring (11), and then remove the spacer (12).

VLC625S_4129



18. Remove the C-clip (15), and then remove the bushing.

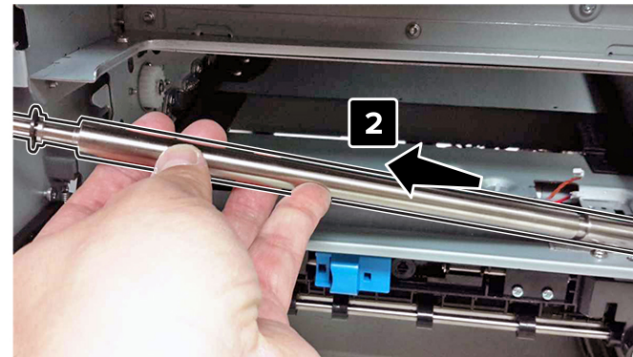
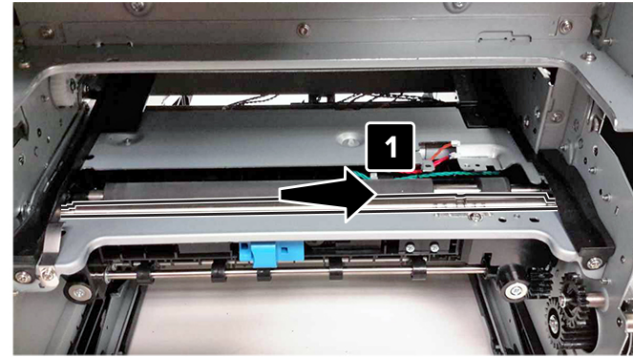
VLC625S_4131



19. Slide the front aligner roller to the right to remove.

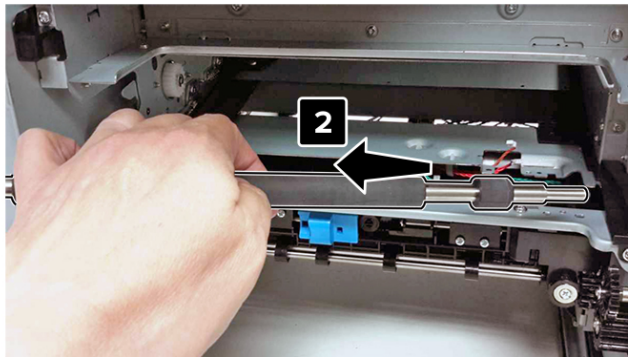
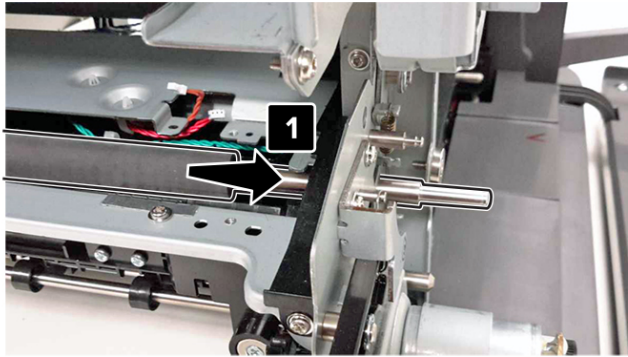
Note: Be careful not to drop or lose the washer on the left side of the shaft.

VLC625S_4132



VLC625S_4133

20. Slide the rear aligner roller to the right to remove.



VLC625S_4134

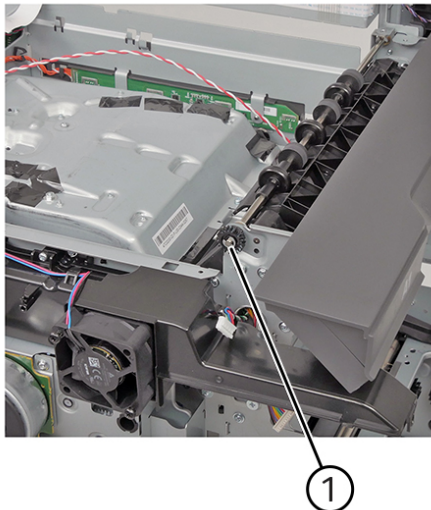
REP 80.1 Exit Roller Gear

Removal



WARNING: Switch off the electricity to the machine, [GP 10](#) . Disconnect the power lead from the customer supply while performing tasks that do not need electricity. Electricity can cause the death or injury. Moving components can cause the injury.

1. Remove the scanner rear right cover. See [PL 28.15 item 9L](#).
2. Remove the scanner rear left cover. See [PL 28.15 item 8](#).
3. Remove the waste toner bottle. See [REP 90.3](#).
4. Remove the imaging unit. See [REP 60.1](#).
5. Remove the motor cover. See [REP 28.11](#).
6. Remove or loosen the right cover. See [REP 28.1](#).
7. Remove the controller PWB shield. See [REP 3.1](#).
8. Remove the USB cover. See [REP 28.4](#).
9. Remove the scanner front cover. See [REP 28.16](#).
10. Remove the control panel. See [REP 2.1](#).
11. Remove the UI control panel base. See [REP 2.2](#).
12. Remove the facade cover. See [REP 28.15](#).
13. Remove the DADF and flatbed scanner. See [PL 5.10](#).
14. Remove the bin cover. See [REP 28.12](#).
15. Remove the top cover. See [REP 28.8](#).
16. Remove the E-clip, and then remove the gear.



VLC625S_4161

REP 80.2 Exit Roller

Removal

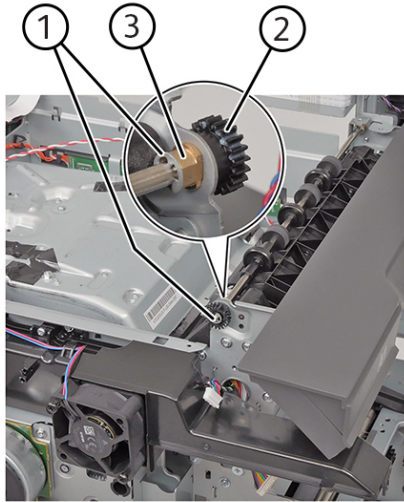


WARNING: Switch off the electricity to the machine, [GP 10](#) . Disconnect the power lead from the customer supply while performing tasks that do not need electricity. Electricity can cause the death or injury. Moving components can cause the injury.



Figure 1 ESD Symbol

1. Remove the scanner rear right cover. See [PL 28.15 item 9](#)
2. Remove the scanner rear left cover. See [PL 28.15 item 8](#).
3. Remove the waste toner bottle. See [REP 90.3](#).
4. Remove the imaging unit. See [REP 60.1](#).
5. Remove the motor cover. See [REP 28.11](#).
6. Remove or loosen the right cover. See [REP 28.1](#).
7. Remove the controller PWB shield. See [REP 3.1](#).
8. Remove the USB cover. See [REP 28.4](#).
9. Remove the scanner front cover. See [REP 28.16](#).
10. Remove the control panel. See [REP 2.1](#).
11. Remove the UI control panel base. See [REP 2.2](#).
12. Remove the facade cover. See [REP 28.15](#).
13. Remove the DADF and flatbed scanner. See [PL 5.10](#).
14. Remove the bin cover. See [REP 28.12](#).
15. Remove the top cover. See [REP 28.8](#).
16. Remove the two E-clips (1), and then remove the gear (2) and bushing (3).



17. Remove the roller.

VLC625S_4162

REP 80.3 MPF/Duplex Motor

Removal

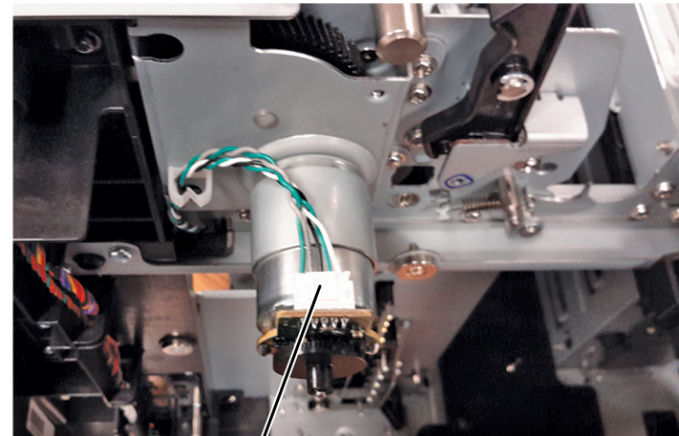


WARNING: Switch off the electricity to the machine, GP 10 . Disconnect the power lead from the customer supply while performing tasks that do not need electricity. Electricity can cause the death or injury. Moving components can cause the injury.



Figure 1 ESD Symbol

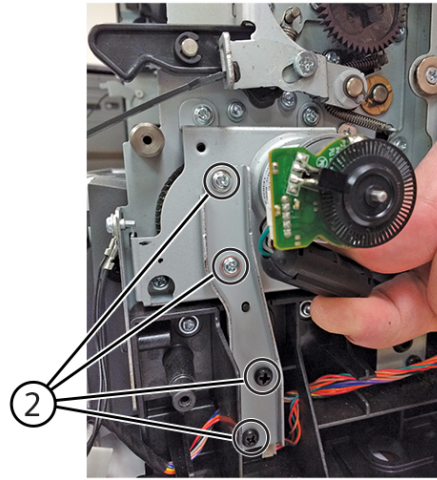
1. Remove the motor cover. See REP 28.11.
2. Remove the right cover. See REP 28.1.
3. Disconnect the cable (1).



1

VLC625S_4072

4. Remove the four screws (2), and then remove the motor.



VLC6255_4073

REP 80.4 Input Sensor

Removal

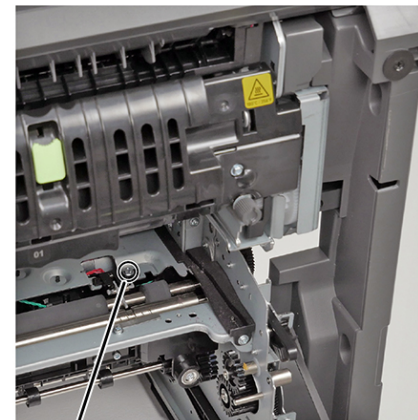


WARNING: Switch off the electricity to the machine, [GP 10](#). Disconnect the power lead from the customer supply while performing tasks that do not need electricity. Electricity can cause the death or injury. Moving components can cause the injury.



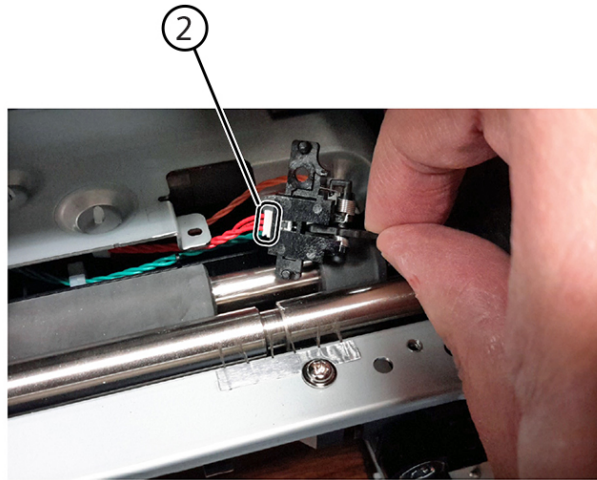
Figure 1 ESD Symbol

1. Remove the waste toner bottle. See [REP 90.3](#)
2. Remove the imaging kit. See [REP 60.1](#)
3. Remove the transfer module. See [REP 90.9](#)
4. Remove the screw (1), and then lift the sensor.



VLC6255_4098

5. Disconnect the cable (2), and then remove the sensor.



VLC625S_4099

REP 80.5 Diverter

Parts List on [PL 80.10](#)

Removal

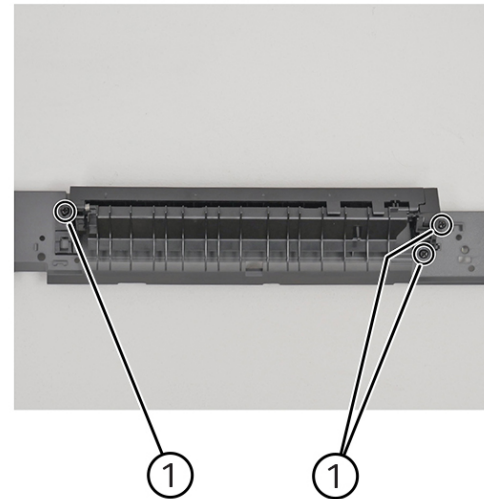


WARNING: Switch off the electricity to the machine, [GP 10](#). Disconnect the power lead from the customer supply while performing tasks that do not need electricity. Electricity can cause the death or injury. Moving components can cause the injury.



Figure 1 ESD Symbol

1. Remove the fuser. See [REP 10.1](#).
2. Remove the top frame cover. See [REP 28.6](#).
3. Remove the top frame base cover. See [REP 28.7](#).
4. Remove the three screws (1).



VLC625S_4105

5. Remove the diverter.

REP 80.6 Duplex Staging Sensor

Removal

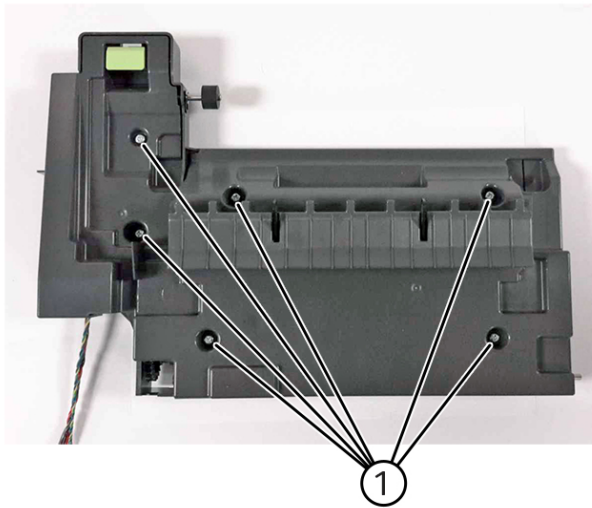


WARNING: Switch off the electricity to the machine, **GP 10**. Disconnect the power lead from the customer supply while performing tasks that do not need electricity. Electricity can cause the death or injury. Moving components can cause the injury.



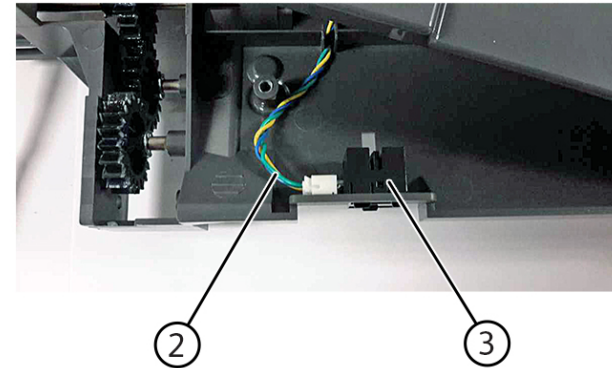
Figure 1 ESD Symbol

1. Remove the front door. See [REP 28.10](#).
2. Remove the pivot shaft. See [REP 80.10](#).
3. Remove the duplex inner guide. See [REP 80.13](#).
4. Remove the six screws (1).



VLC625S_4137

5. Disconnect the cable (2), and then remove the sensor (3).



VLC625S_4138

REP 80.7 Fuser Buckle And Narrow Media Sensors

Removal

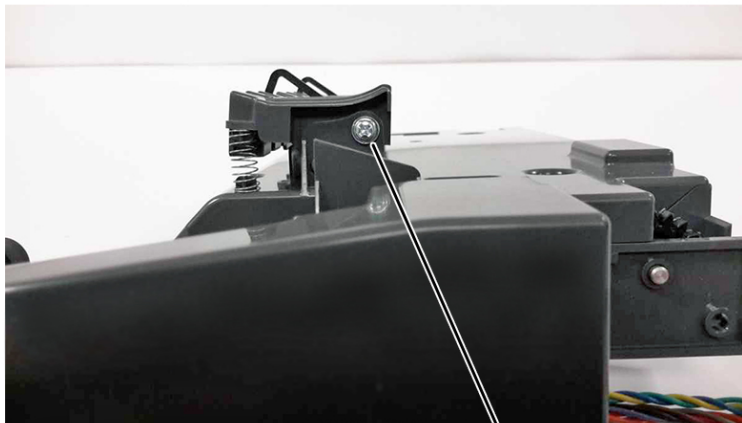


WARNING: Switch off the electricity to the machine, [GP 10](#) . Disconnect the power lead from the customer supply while performing tasks that do not need electricity. Electricity can cause the death or injury. Moving components can cause the injury.



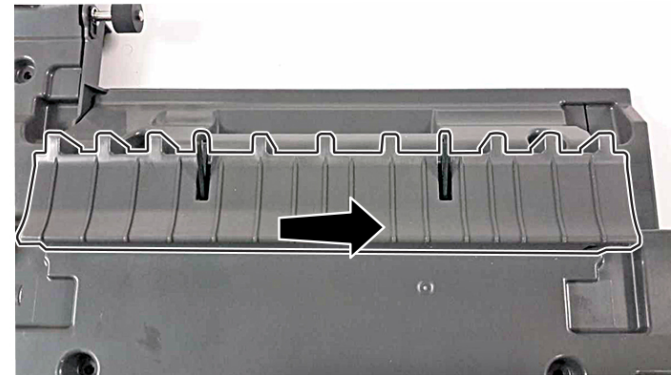
Figure 1 ESD Symbol

1. Open the front door.
2. Remove the screw (1).



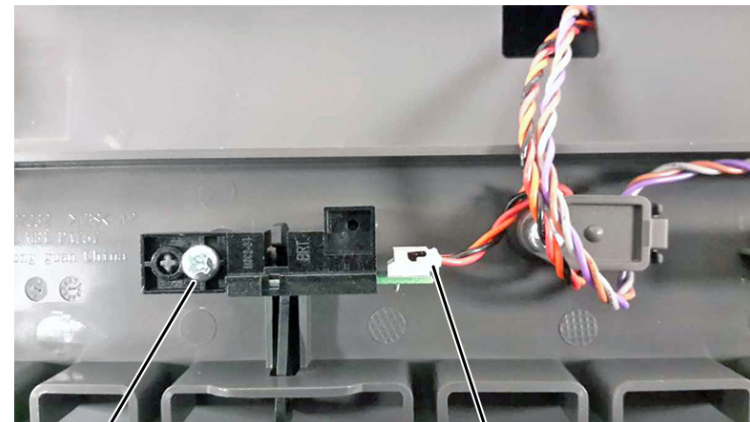
VLC625S_4139

3. Slide the paper guide to the right to remove.



VLC625S_4140

4. Disconnect the sensor cable (2), remove the screw (3), and then remove the sensors.
Note: The left sensor is the sensor (fuser buckle). The right sensor is the sensor (narrow media). For more information, see [REP 10.3](#)



VLC625S_4141

REP 80.8 Tensioner belt

Removal

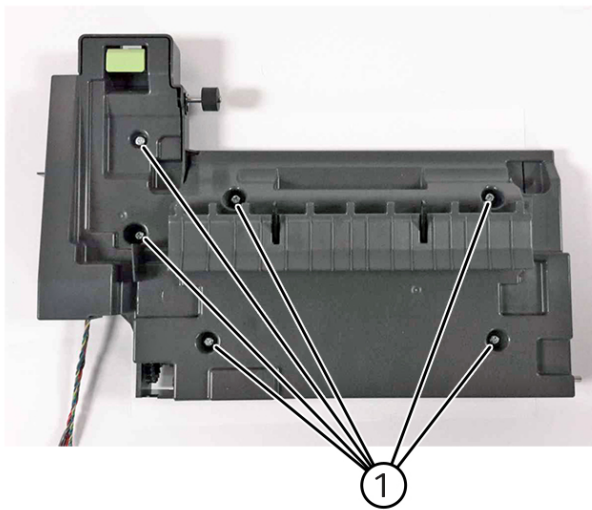


WARNING: Switch off the electricity to the machine, **GP 10** . Disconnect the power lead from the customer supply while performing tasks that do not need electricity. Electricity can cause the death or injury. Moving components can cause the injury.



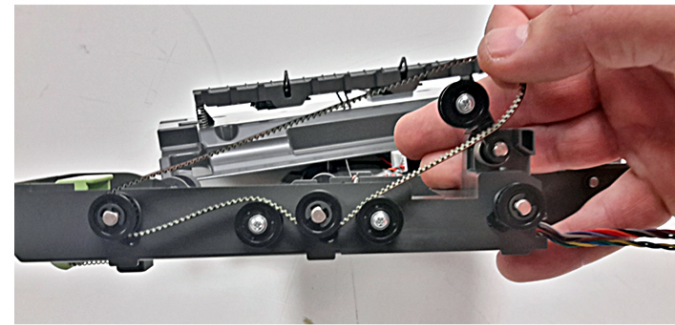
Figure 1 ESD Symbol

1. Remove the front door. See [REP 28.10](#).
2. Remove the pivot shaft. See [REP 80.11](#).
3. Remove the duplex inner guide. See [REP 80.13](#).
4. Remove the six screws (1), and then remove the cover.



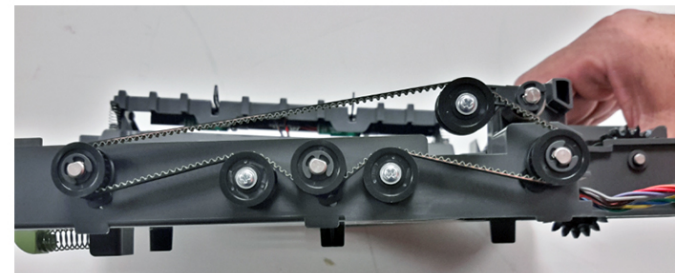
VLC625S_4137

5. Remove the belt.



VLC625S_4142

Note: Pay attention to the belt path before removing the belt.



VLC625S_4143

REP 80.9 Duplex Outer Guide

Removal



WARNING: Switch off the electricity to the machine, **GP 10**. Disconnect the power lead from the customer supply while performing tasks that do not need electricity. Electricity can cause the death or injury. Moving components can cause the injury.



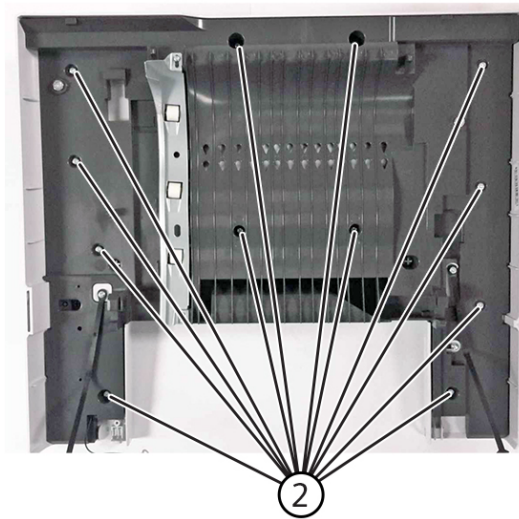
Figure 1 ESD Symbol

1. Remove the front door. See [REP 28.10](#).
2. Remove the pivot shaft. See [REP 80.10](#).
3. Remove duplex inner guide. See [REP 80.13](#).
4. Remove the tray indicator (1).



VLC625S_4144

5. Remove the 12 screws (2), and then remove the duplex outer guide.



VLC625S_4145

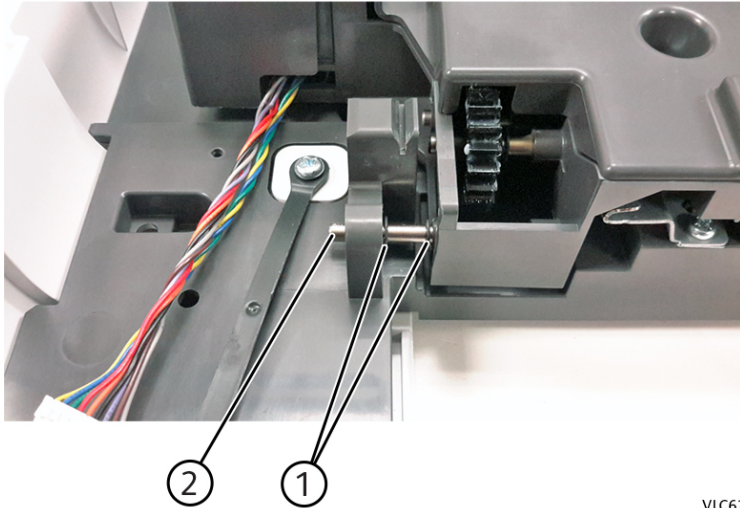
REP 80.10 Pivot Shaft

Removal



WARNING: Switch off the electricity to the machine, GP 10 . Disconnect the power lead from the customer supply while performing tasks that do not need electricity. Electricity can cause the death or injury. Moving components can cause the injury.

1. Remove the front door. See REP 28.10.
2. Remove the two E-clips (1), and then remove the shaft (2).



VLC625S_4135

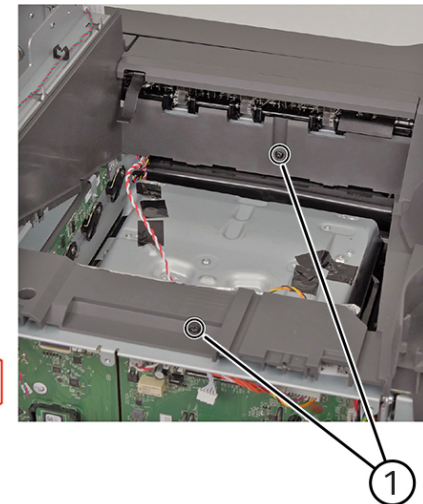
REP 80.11 Bin Full Sensor

Removal



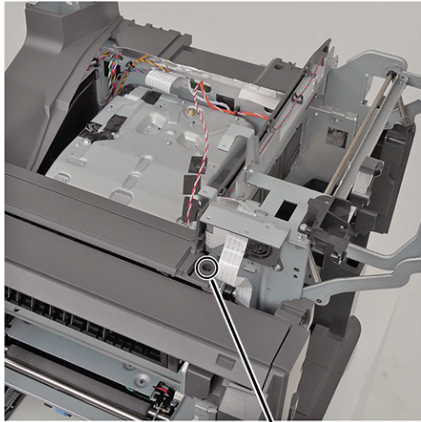
WARNING: Switch off the electricity to the machine, GP 10 . Disconnect the power lead from the customer supply while performing tasks that do not need electricity. Electricity can cause the death or injury. Moving components can cause the injury.

1. Remove the scanner rear right cover. See PL 28.15 item 9.
2. Remove the scanner rear left cover. See PL 28.15 item 8L.
3. Remove the waste toner bottle. See REP 90.3.
4. Remove the imaging unit. See REP 60.1.
5. Remove the motor cover. See REP 28.11.
6. Remove or loosen the right cover. See REP 28.1.
7. Remove the controller PWB shield. See REP 3.1.
8. Remove the USB cover. See REP 28.4.
9. Remove the scanner front cover. See REP 28.16L.
10. Remove the control panel. See REP 2.1.
11. Remove the UI control panel base. See REP 2.2L.
12. Remove the facade cover. See REP 28.15.
13. Remove the DADF and flatbed scanner. See PL 5.10.
14. Remove the bin cover. See REP 28.12.
15. Remove the two screws (1).



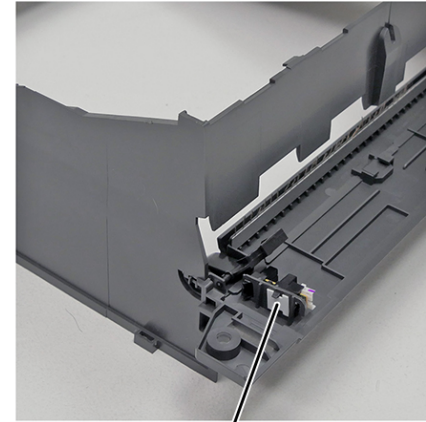
VLC625S_4157

16. Remove the screw (2).



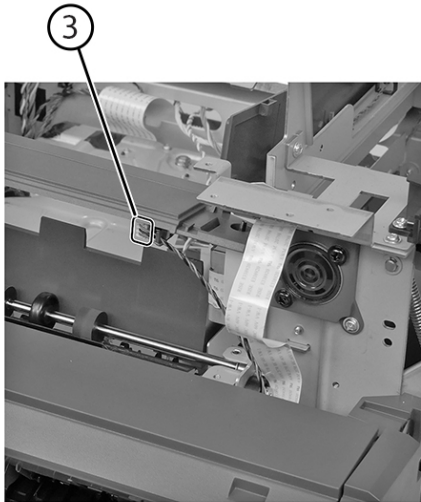
2

17. Lift the cover, and then disconnect the sensor cable (3).



4

VLC625S_4160



3

18. Remove the sensor retainer (4), and then remove the sensor from the cover.

VLC625S_4158

VLC625S_4159

REP 80.12 Bin Flag

Removal

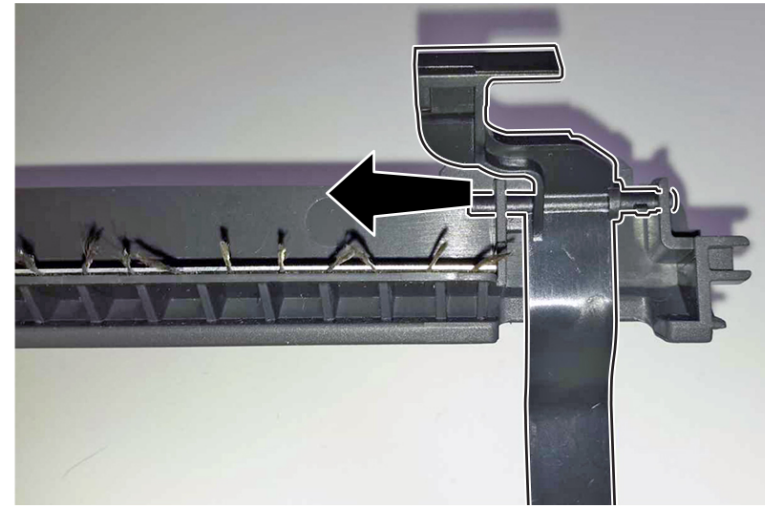


WARNING: Switch off the electricity to the machine, **GP 10**. Disconnect the power lead from the customer supply while performing tasks that do not need electricity. Electricity can cause the death or injury. Moving components can cause the injury.



Figure 1 ESD Symbol

1. Remove the scanner rear right cover. See [PL 28.15 item 9](#).
2. Remove the scanner rear left cover. See [PL 28.15 item 8](#).
3. Remove the waste toner bottle. See [REP 90.3](#).
4. Remove the imaging unit. See [REP 60.1](#).
5. Remove the motor cover. See [REP 28.11](#).
6. Remove or loosen the right cover. See [REP 28.1](#).
7. Remove the controller PWB shield. See [REP 3.1](#).
8. Remove the USB cover. See [REP 28.4](#).
9. Remove the scanner front cover. See [REP 28.16](#).
10. Remove the control panel. See [REP 2.1](#).
11. Remove the UI control panel base. See [REP 2.2](#).
12. Remove the facade cover. See [REP 28.15](#).
13. Remove the DADF and flatbed scanner. See [PL 5.10](#).
14. Remove the bin cover. See [REP 28.12](#).
15. Remove the top cover. See [REP 28.8](#).
16. Remove the bin exit cover. See [REP 28.14](#).
17. Slide the flag to the left to remove.



VLC625S_4168

REP 80.13 Duplex Inner Guide

Parts List on [PL 5.10](#)

Removal

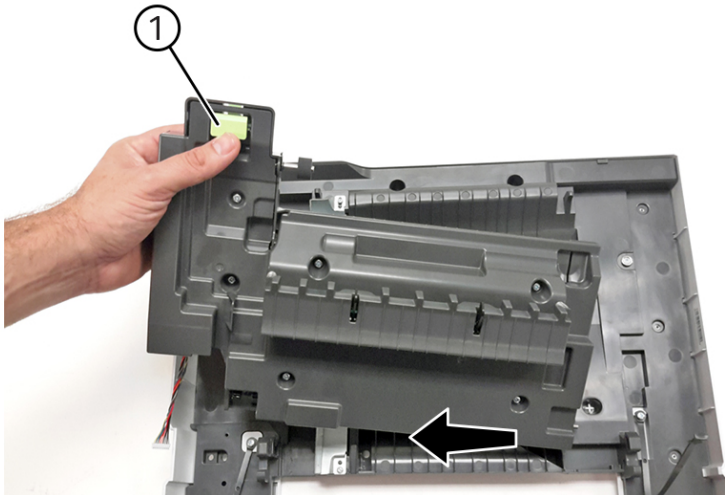


WARNING: Switch off the electricity to the machine, [GP 10](#). Disconnect the power lead from the customer supply while performing tasks that do not need electricity. Electricity can cause the death or injury. Moving components can cause the injury.



Figure 1 ESD Symbol

1. Remove the front door. See [REP 28.10](#).
2. Remove the pivot shaft. See [REP 80.11](#).
3. Release the latch (1), and then slide the guide to remove.



VLC6255_4136

REP 90.1 TMC Card

Removal

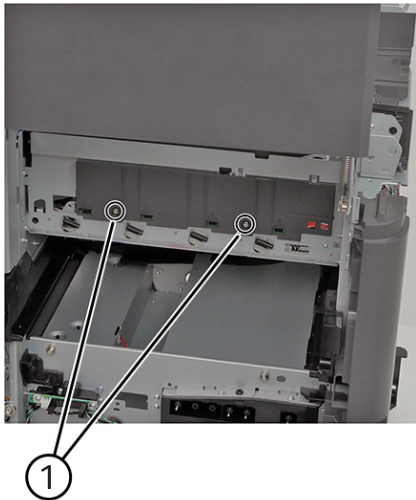


WARNING: Switch off the electricity to the machine, [GP 10](#) . Disconnect the power lead from the customer supply while performing tasks that do not need electricity. Electricity can cause the death or injury. Moving components can cause the injury.



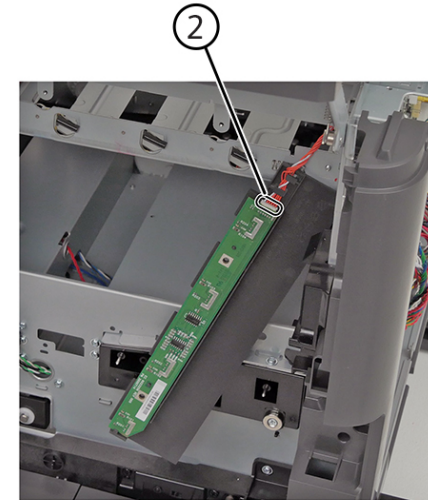
Figure 1 ESD Symbol

1. Remove the waste toner bottle, [REP 90.3](#).
2. Remove the imaging unit, [REP 60.1](#).
3. Remove the two screws (1), and then pull the cover.



VLC625S_4063

4. Disconnect the cable (2), and then remove the card.



VLC625S_4064

Replacement

Replacement is the reverse of the removal procedure.

REP 90.2 Developer Hold Down Arm

Removal

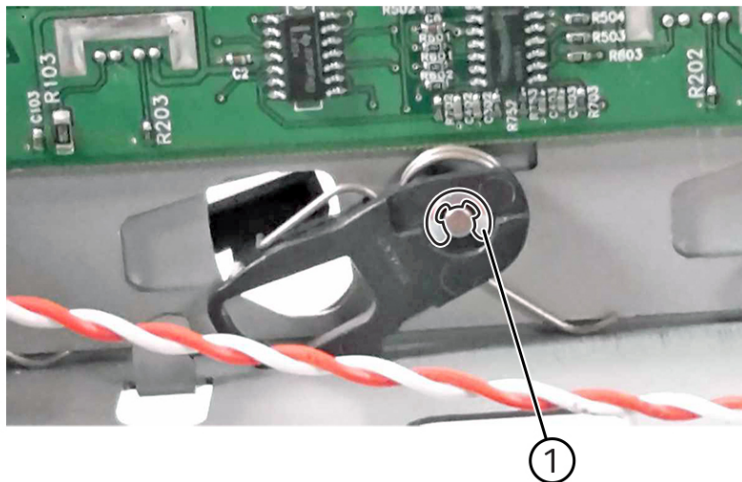


WARNING: Switch off the electricity to the machine, [GP 10](#) . Disconnect the power lead from the customer supply while performing tasks that do not need electricity. Electricity can cause the death or injury. Moving components can cause the injury.



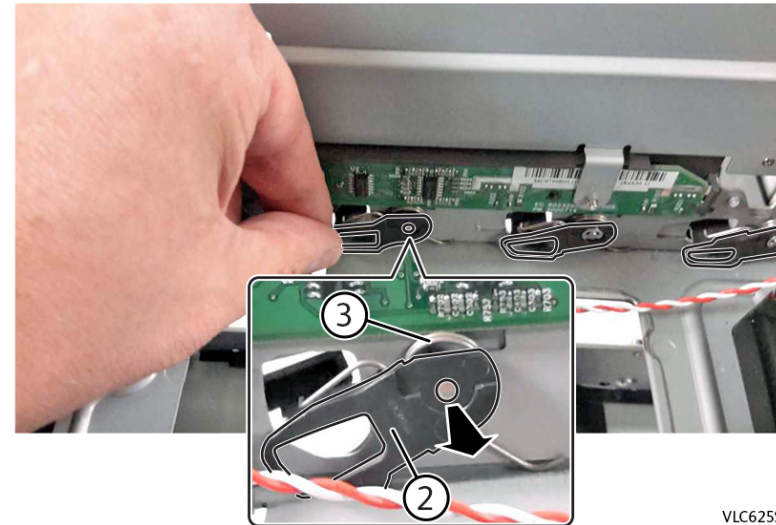
Figure 1 ESD Symbol

1. Remove the scanner rear right cover, [PL 28.15 item 9](#).
2. Remove the scanner rear left cover. See [PL 28.15 item 8](#).
3. Remove the DADF, [REP 5.3](#).
4. Remove the controller PWB shield, [REP 3.1](#).
5. Remove the scanner, [REP 5.4](#).
6. Remove the bin cover, [REP 28.12](#).
7. Remove the printhead, [REP 60.2](#).
8. Remove the E-clip (1).



VLC625S_4169

9. Pull the bell crank (2) and spring (3) off the mounting pin, and then remove the developer hold down arm.



VLC625S_4170

Replacement

Replacement is the reverse of the removal procedure.

REP 90.3 Waste Toner Bottle

Removal

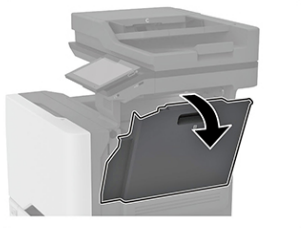


WARNING: Switch off the electricity to the machine, GP 10 . Disconnect the power lead from the customer supply while performing tasks that do not need electricity. Electricity can cause the death or injury. Moving components can cause the injury.



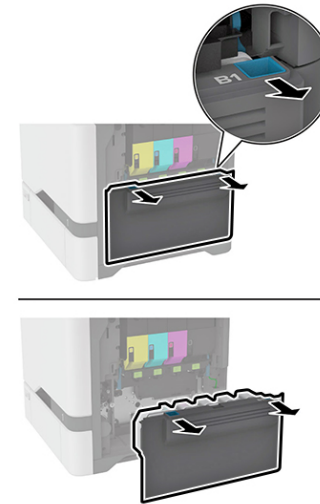
Figure 1 ESD Symbol

1. Open door B.



2. Remove the waste toner bottle.

VLC625S_4049



VLC625S_4050

Note: To avoid spilling the toner, place the bottle in an upright position.

Replacement

Replacement is the reverse of the removal procedure.

REP 90.4 Waste Toner Bottle Idler Gear

Removal

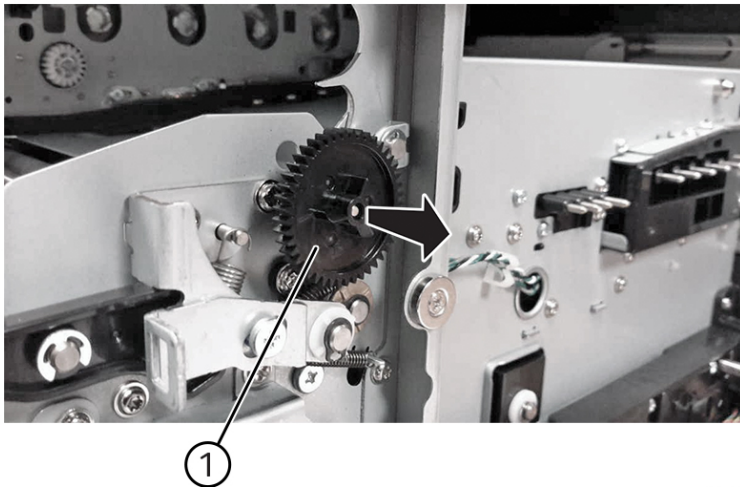


WARNING: Switch off the electricity to the machine, [GP 10](#) . Disconnect the power lead from the customer supply while performing tasks that do not need electricity. Electricity can cause the death or injury. Moving components can cause the injury.



Figure 1 ESD Symbol

1. Remove the waste toner bottle. See [REP 90.3](#).
2. Remove the gear.



VLC625S_4071

REP 90.5 Waste Toner Sensor

Removal



WARNING: Switch off the electricity to the machine, [GP 10](#) . Disconnect the power lead from the customer supply while performing tasks that do not need electricity. Electricity can cause the death or injury. Moving components can cause the injury.



Figure 1 ESD Symbol

1. Remove the waste toner bottle. See [REP 90.3](#).
2. Disconnect the cable (1), and then remove the two screws (2).

REP 90.6 Sensor (weather station)

Removal

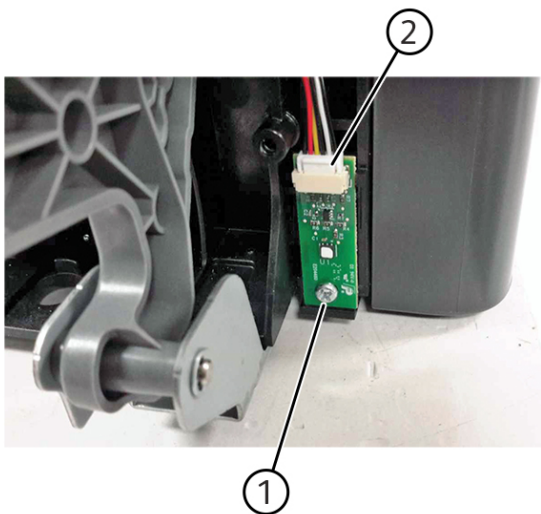


WARNING: Switch off the electricity to the machine, [GP 10](#) . Disconnect the power lead from the customer supply while performing tasks that do not need electricity. Electricity can cause the death or injury. Moving components can cause the injury.



Figure 1 ESD Symbol

1. Remove the waste toner bottle. See [REP 90.3](#).
2. Remove the motor cover. See [REP 28.11](#).
3. Remove the right cover. See [REP 28.1](#).
4. Remove the screw (1), disconnect the cable (2), and then remove the sensor.



VLC625S_4074

REP 90.7 Sensor (TPS)

Removal

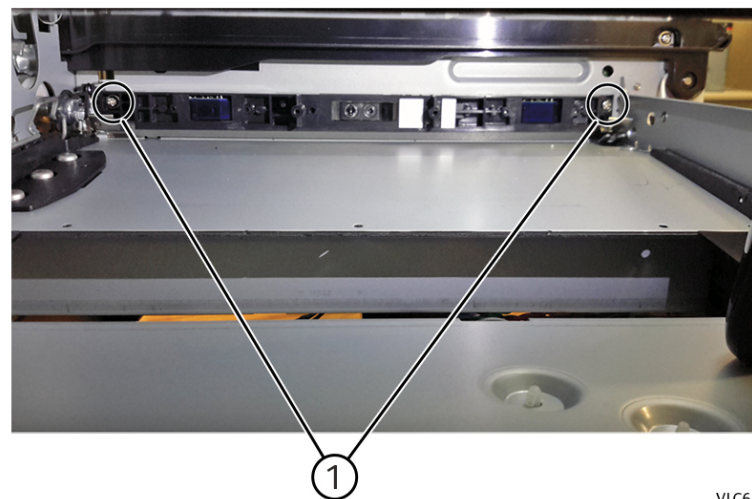


WARNING: Switch off the electricity to the machine, [GP 10](#) . Disconnect the power lead from the customer supply while performing tasks that do not need electricity. Electricity can cause the death or injury. Moving components can cause the injury.



Figure 1 ESD Symbol

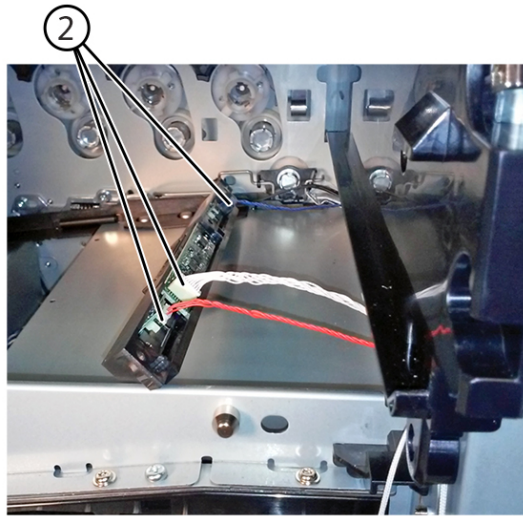
1. Remove the waste toner bottle. See [REP 90.3](#).
2. Remove the imaging Unit. See [REP 60.1](#).
3. Remove the transfer module. See [REP 90.9](#)
4. Remove the two screws (1).



VLC625S_4082

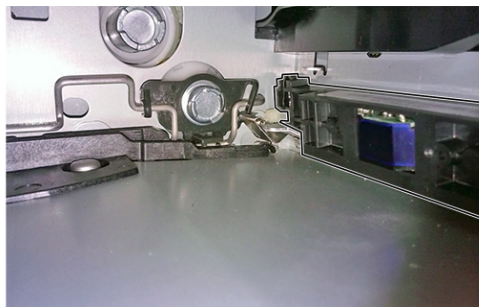
5. Disconnect the three cables (2).

Warning-Potential Damage: Press the tab, before disconnecting the cable



VLC625S_4083

6. Remove the sensor.
7. **Installation note:** When installing a new sensor (TPS), perform the TPS characterization data entry as instructed in the accompanying FRU sheet.



VLC625S_4084

REP 90.8 Isolation Unit



WARNING: Switch off the electricity to the machine, GP 10 . Disconnect the power lead from the customer supply while performing tasks that do not need electricity. Electricity can cause the death or injury. Moving components can cause the injury.

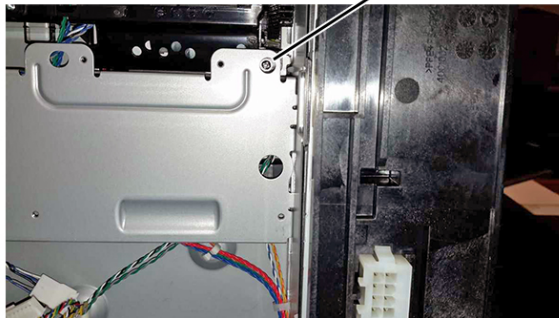
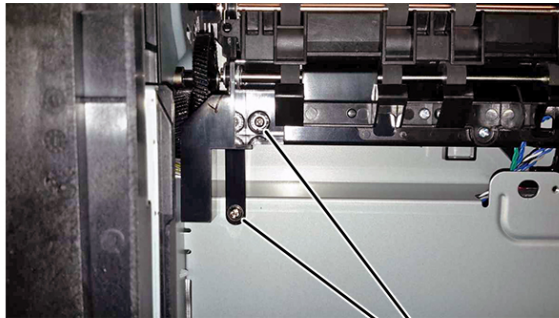


WARNING: Potential Damage: Remove the waste toner bottle and imaging kit first before removing the isolation unit. Failure to do this can lead to toner spillage and damage to the printer.



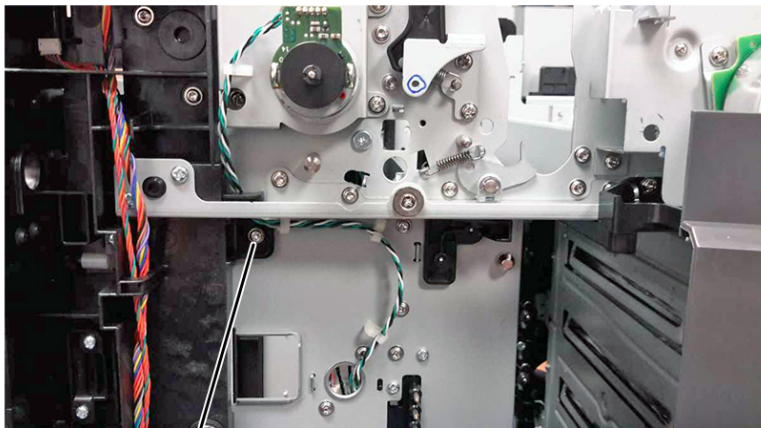
Figure 1 ESD Symbol

1. Remove the waste toner bottle, REP 90.3.
2. Remove the imaging kit, REP 60.1.
3. Remove the 550-sheet tray insert, PL 70.10 item 4
4. Remove the tray 1 pick roller, REP 70.4.
5. Remove the paper feeder, REP 70.5.
6. Remove the three screws (1) securing the isolation unit.



VLC625S_4185

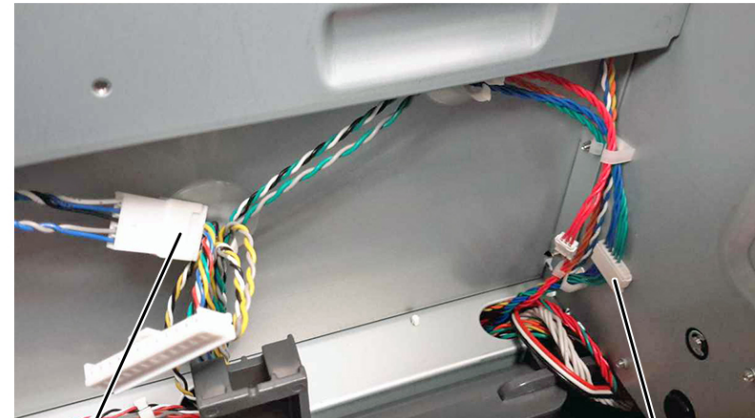
7. Remove the biasing screw (2).



VLC625S_4186

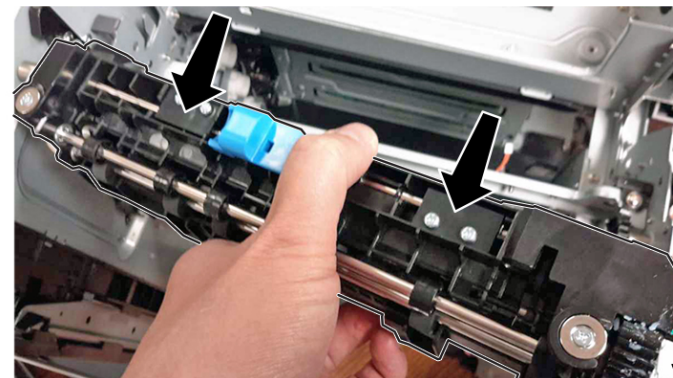
Installation note: Make sure to install the biasing screw first before installing the other three screws.

8. Disconnect the motor cable (3) and sensor cable (4).



VLC625S_4187

9. Tilt the right portion of the isolation unit to the front, and then remove the unit.



VLC625S_4188

10. Release the isolation unit cables from the printer.

REP 90.9 Transfer Module

Parts List on [PL 90.10](#)

Removal

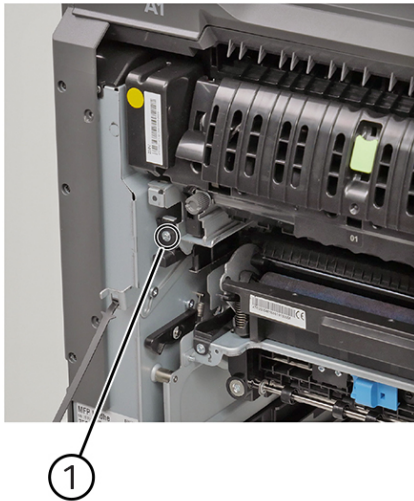


WARNING: Switch off the electricity to the machine, [GP 10](#). Disconnect the power lead from the customer supply while performing tasks that do not need electricity. Electricity can cause the death or injury. Moving components can cause the injury.



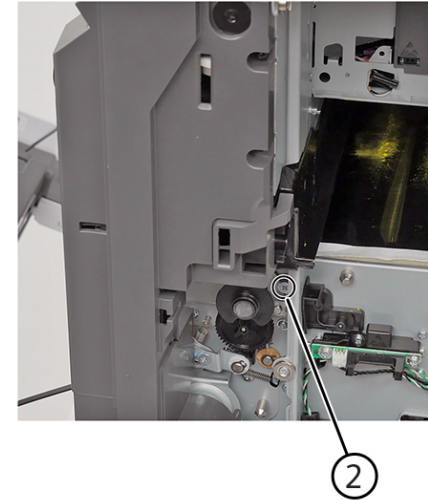
Figure 1 ESD Symbol

1. Remove the waste toner bottle, [REP 90.3](#).
2. Remove the imaging unit, [REP 60.1](#).
3. Open the front door.
4. Remove the screw (1), and then remove the transfer module retainer.



VLC625S_4095

5. Open the cartridge door, and then remove the screw (2).



VLC625S_4096

6. Remove the transfer module.



VLC625S_4097

Installation notes:

- a. Check if the transfer module bearings are properly seated on the frame. Make sure that the bearings sit on top of their slots.
- b. Reset the transfer module counter. See **Transfer module reset**.
- c. Align the top and bottom margins. See [ADJ 90.2](#).

ADJ 5.1 DADF Registration Adjustment

1. From the home screen, navigate to:
Settings > Device > Maintenance > Configuration Menu > Scanner Configuration > Scanner Manual Registration
2. From the Print Quick Test section, touch **Start**.
3. Place the test page faceup on the ADF, and then select **Front ADF Registration**.
4. From the Copy Quick Test section, touch **Start**.
5. Compare the pages from the print quick and copy quick tests.
6. Adjust the value of the horizontal adjust, top margin, and vertical magnification settings.
7. Apply the changes.
8. Repeat step 2 through step 7 to make further adjustments.
9. From the Print Quick Test section, touch **Start**.
10. Place the quick test page facedown on the ADF, and then select **Rear ADF Registration**.
11. From the Copy Quick Test section, touch **Start**.
12. Compare the pages from the print quick and copy quick tests.
13. Adjust the value of the horizontal adjust and top margin settings.
14. Apply the changes.
15. Repeat step 9 through step 14 to make further adjustments.

ADJ 60.1 Scanner Manual Registration

Use this setting to register the flatbed and ADF on the scanner. Perform a registration adjustment whenever the ADF, flatbed, or controller board is replaced.

Note: This setting does not appear if the Disable Scanner setting is set to Auto Disabled.

For more information on adjusting the scanner registration, see [ADJ 5.1](#), and [ADJ 60.2](#)

ADJ 60.2 Flatbed Registration Adjustment

1. From the home screen, navigate to:
Settings > Device > Maintenance > Configuration Menu > Scanner Configuration > Scanner Manual Registration
2. From the Print Quick Test section, touch **Start**.
3. Place the test page on the flatbed, and then select **Flatbed Registration**.
4. From the Copy Quick Test section, touch **Start**.
5. Compare the pages from the print quick and copy quick tests.
6. Adjust the value of the top margin, left margin, and vertical magnification settings.
7. Apply the changes.
8. Repeat steps 2 through step 7 to make further adjustments.

ADJ 90.1 Printhead alignment adjustment

Printhead misalignment may cause crooked or skewed print. Perform this procedure after replacing the printhead or if there are skewed print issues.

Checking the test page for alignment

1. Enter the Diagnostics menu, and then navigate to:
Printer diagnostics & adjustments > Registration adjust > Quick test

2. Check the test page.

The following test page result shows a properly aligned printhead:

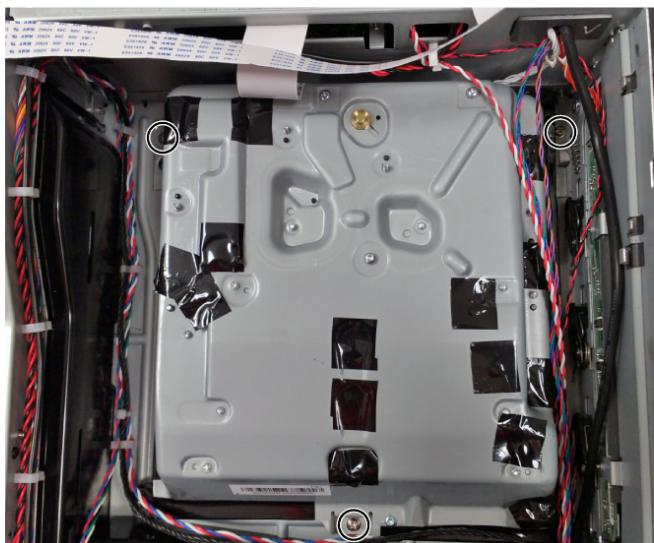


Aligning a printhead skewed in the counterclockwise direction

In most cases, the printhead is skewed counterclockwise, as shown in the following test page result.

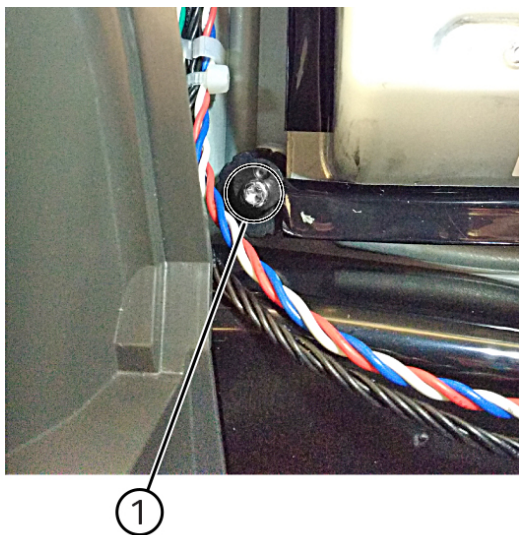


1. Tilt the scanner, [REP 5.11](#).
2. Lift the scanner, and then remove the bin cover. See [REP 28.12](#).
3. Loosen the three screws.



VLC625S_4011

4. Adjust the printhead until the front left corner of the printhead touches the alignment pin (1).



VLC625S_4012

5. Print another test page, and then check if the printhead is aligned.
6. Repeat step 4 through step 5 until the printhead is aligned.
7. Tighten the three screws.

ADJ 90.2 Registration Adjustment

Image misalignments can occur after printhead replacement. Perform this procedure to correct the position of the image relative to the paper edges.

Note: You cannot perform mechanical registration or skew adjustments on this printhead.

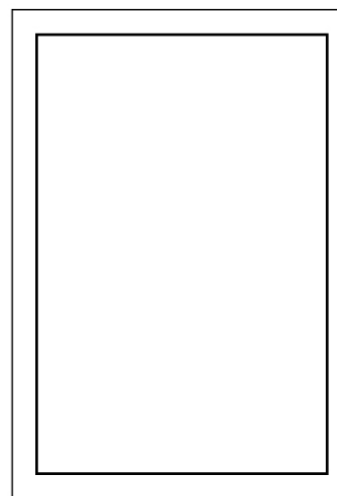
Before performing the procedure, make sure that the tray guides are properly set and the paper settings on the printer match the paper size loaded in the tray.

ADJ 90.2.1 Adjusting the skew

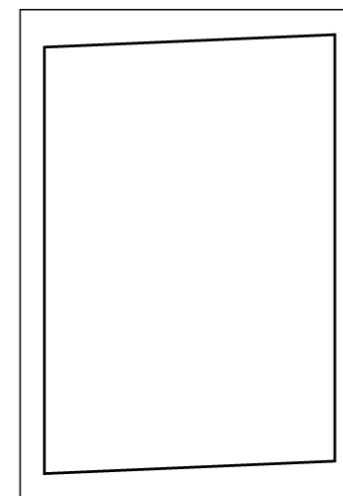
The skew adjustment changes the angle of the horizontal lines so that the lines can be aligned with the leading edge of the page. As the skew setting is changed, the top line on the test page stays in place at the left end, while its right end tilts up or down. All horizontal lines on the page will tilt at that same angle while the vertical lines will remain vertical. Changing the skew setting moves the right edge of the page up and down, and changes the angle of the top and bottom lines. If the skew is properly adjusted, the horizontal lines at the top of the page will be parallel to the leading edge of the page.

To check for skew:

1. Enter the Diagnostics menu, and then navigate to:
Printer diagnostics & adjustments > Registration adjust
2. Select **Quick Test**, and then touch **Start**.
The printer prints a test page.



Normal



Skewed

vlc625s_4013

Note: If there is no skew on the page, then see [Adjusting the Top and Bottom Margins](#).

To adjust the skew:

1. Enter the Diagnostics menu, and then navigate to:

Printer diagnostics & adjustments > Registration adjust > Top skew

- Specify the value. The value range is from -100 to 100.

Note:

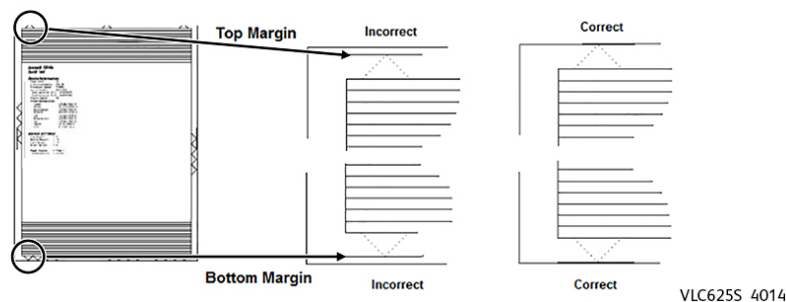
- Raising the value of the skew rotates the horizontal lines clockwise. The left end of the line remains in the same place and the right end moves downward.
 - Decreasing the value of the skew rotates the horizontal lines counter clockwise. The left end of the line remains in the same place and the right end moves upward.
- Touch **OK**.
 - Print a Quick test page to verify the change.
 - Repeat step 1 through step 4 until the horizontal line is properly aligned with the leading edge of the page.
 - Check for proper margin alignment. see [Adjusting the Top and Bottom Margins](#).

ADJ 90.2.2 Adjusting the Top and Bottom Margins

- Load Letter- or A4-size paper into tray 1.
- From the home screen, touch **Settings > Paper > Tray Configuration > Default Source > Tray 1**.
- Verify that the paper type and size settings match the paper type and size loaded in the tray.
- Enter the Diagnostics menu, and then navigate to **Printer diagnostics & adjustments > Registration adjust**.
- Touch **Quick Test**, and then touch **Start**.
The printer prints a test page.
- Check the top and bottom margins of the test page for correct alignment.

Note:

- The arrows should be completely visible along the edges.
- The tip of the arrows should point to the edges of the paper.



- Change the value of the top margin or bottom margin as needed.
 - Select the margin that needs adjustment.
 - Enter a value in the field.

Note:

- The value range is from -80 to 80.
- Increasing the value of the top margin pushes the top edge of the image downward. Increasing the value of the bottom margin pushes the bottom edge of the image upward.

- Touch **Start**.
- Print a test page to verify the changes.
 - Repeat step 7 through step 8 as needed.
 - Check for proper color alignment. See [Adjusting the Color Alignment](#).

ADJ 90.2.3 Adjusting the Color Alignment

- Enter the Diagnostics menu, and then navigate to:
Printer diagnostics & adjustments > Color alignment adjust
On the AA Adjustment row, touch **Start**.

Note: Note: The Color alignment procedure is performed on the cyan, magenta, and yellow colors

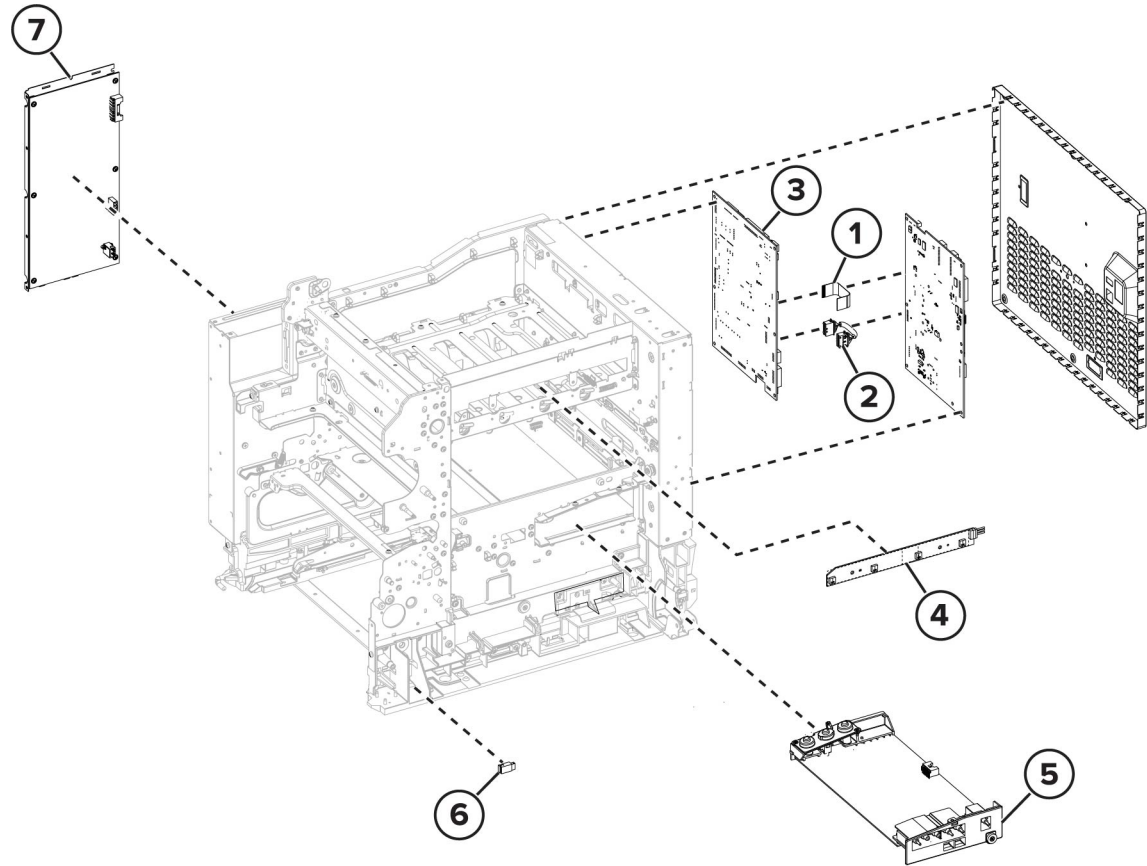
- Enter the Diagnostics menu, and then navigate to:
Printer diagnostics & adjustments > Color alignment adjust > Cyan > Quick test
Check the alignment markings on the test page generated. Follow the instructions on the test page to correct the color misalignment.
- Enter the Diagnostics menu, and then navigate to:
Printer diagnostics & adjustments > Color alignment adjust > Yellow > Quick test
Check the alignment markings on the test page generated. Follow the instructions on the test page to correct the color misalignment.
- Enter the Diagnostics menu, and then navigate to:
Printer diagnostics & adjustments > Color alignment adjust > Magenta > Quick test
Check the alignment markings on the test page generated. Follow the instructions on the test page to correct the color misalignment.
- If color misalignment still occurs, then repeat step 1 through step 4.

5 Parts List

5 Parts Lists	479
PL 1 - Standby Power	480
PL 1.10 Electrical	481
PL 2 - User Interface	482
PL 2.10 User Interface	483
PL 3 - Machine Run Control	484
PL 3.05 Controller PWB Assembly	485
PL 5 - DADF	486
PL 5.10 DADF Components	487
PL 10 - Print Transport and Fusing	488
PL 10.10 Fuser	489
PL 20 - Fax	490
PL 20.10 Fax PWB	491
PL 25 - Accessories	492
PL 25.05 Accessories	493
PL 26- Consumables and Tools	494
PL 26.05 Consumables and Tools	495
PL 28- Covers	496
PL 28.10 Covers 1	497
PL 28.15 Covers 2	498
PL 31 – Maintenance/Installation/Removal Kits	499
PL 31.10 Left Side Harness	500
PL 31.15 Middle Harness	501
PL 31.20 Right Side Harness	502
PL 40 – Drive Assembly	503
PL 40.10 Drive Components	504
PL 40.15 NOHAD	505
PL 60 - Imaging	506
PL 60.05 Scanner	507
PL 60.10 Print Head	508
PL 70 - Paper Supply	509
PL 70.10 Paper Feed	510
PL 70.15 Optional 550-Sheet Tray	511
PL 80 - Paper Transport	512
PL 80.05 Paper Path 1	513
PL 80.10 Paper Path 2	514
PL 80.15 Duplex Paper Path	515
PL 90 - Xerographics	516
PL 90.05 Xerographic Components	517
PL 90.10 Transfer Module Assembly	518

PL 1.10 Electrical

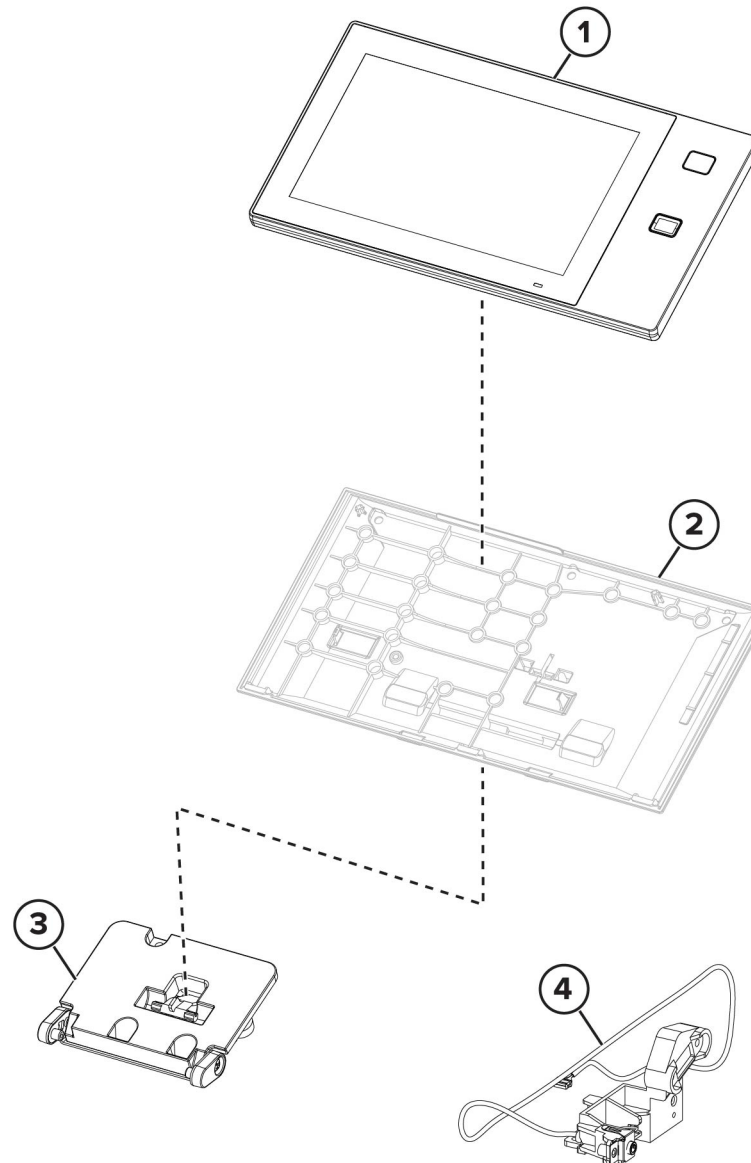
Item	Part	Description
1	117N02388	Print data harness
2	117N02387	Controller power harness (REP 1.5)
3	140N63947	Drive PWB (REP 1.4)
4	128N00558	TMC Card
5	105N02405	HVPS (REP 1.1)
6	130N01989	Sensor (MFP media present)
7	105N02406	LVPS, 110 V (REP 1.3)
—	105N02407	LVPS, 220 V (REP 1.3)



vlc625s_5001-A

PL 2.10 User Interface

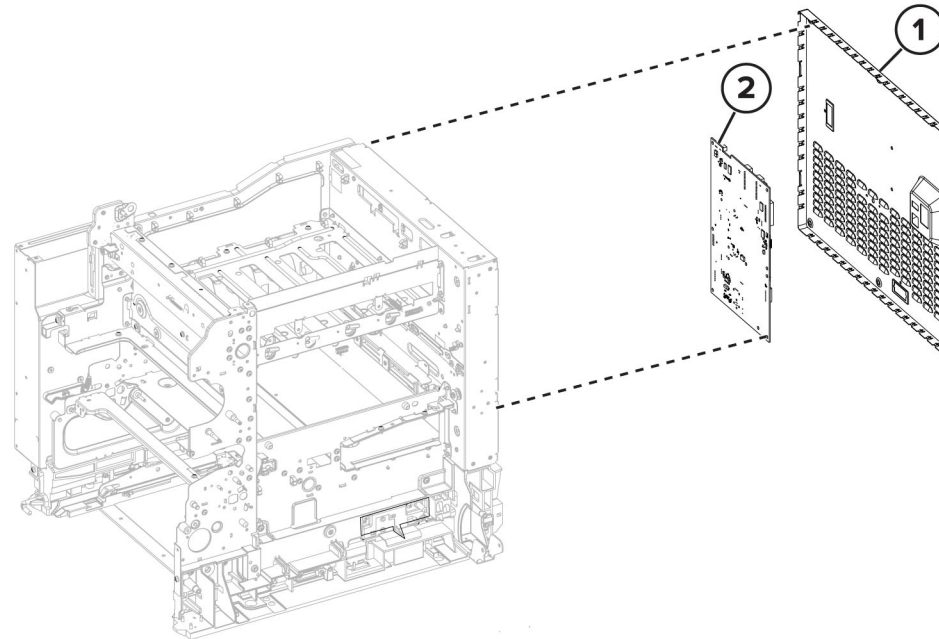
Item	Part	Description
1	002N03701	Control panel display, 7-inch (REP 2.1)
2	—	Control panel (7-inch display) rear cover
3	003N01203	Control panel hinge
4	117N02391	Control panel harness



vlc625s_5004-A

PL 3.05 Controller PWB Assembly

Item	Part	Description
1	—	Controller PWB Shield (REP 3.1)
2	109N00908	Controller PWB (REP 3.2)

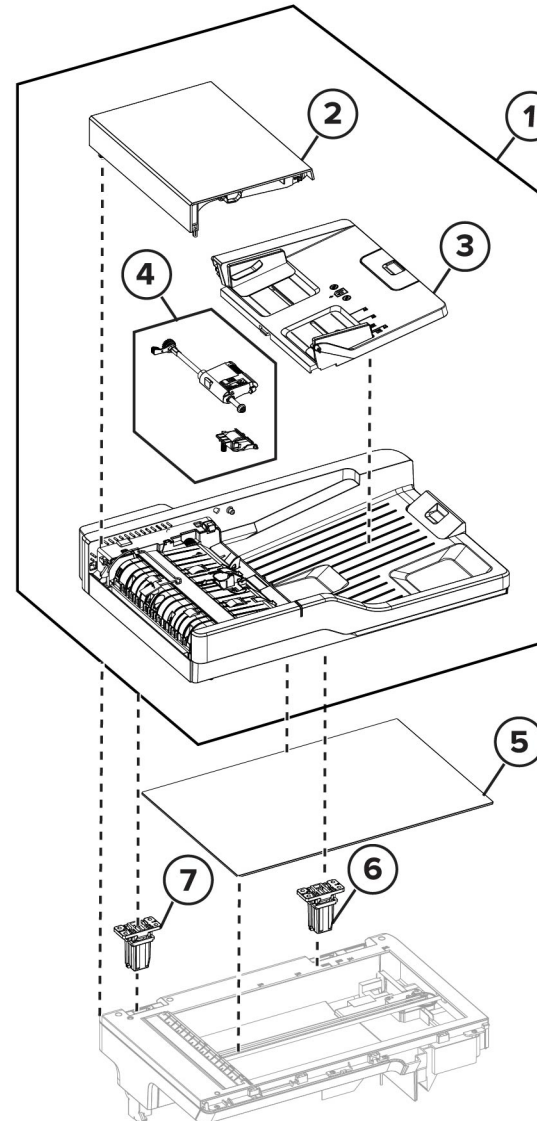


vlc625s_5002-A

PL 5.10 DADF Components

Item	Part	Description
1	022N02961	DADF (REP 5.3)
2	002N03700	DADF top cover (P/O PL 5.10 Item 1) (REP 5.8)
3	050N00757	DADF tray (P/O PL 5.10 Item 1)
4	116R00039	DADF Maintenance Kit (See NOTE) (P/O PL 5.10 Item 1) (REP 5.2)
5	019N01167	Scanner glass pad (REP 5.1)
6	003N01200	DADF right hinge (REP 5.9)
7	003N01202	DADF left hinge (REP 5.10)
8	117N02389	DADF harness with Covers (Not Shown) (REP 5.7)

Note: HFSI. To reset HFSI counter, refer to [dC135](#)

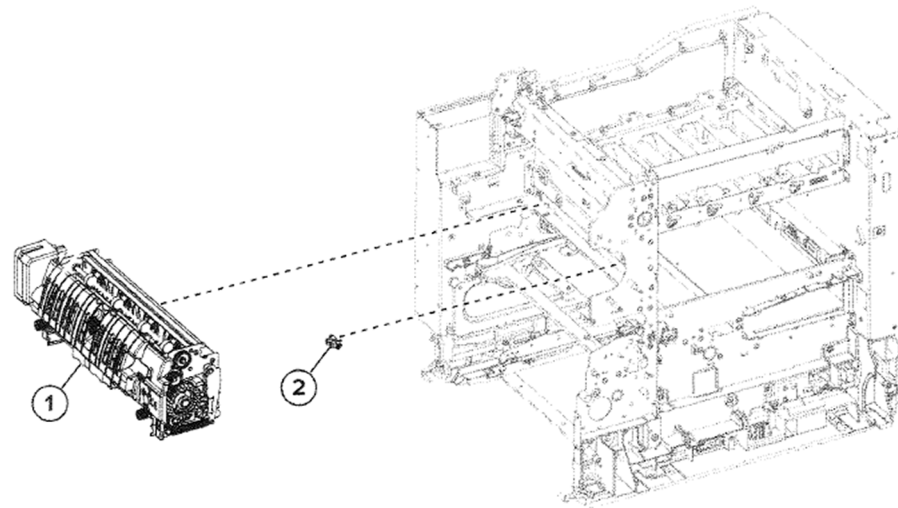


vlc625s5003a

PL 10.10 Fuser

Item	Part	Description
1	115R00159	Fuser, 110V (REP 10.1) (See NOTE)
—	115R00160	Fuser, 220V (REP 10.1) (See NOTE)
2	130N01897	Sensor (Fuser Nip) (REP 10.5)

Note: HFSI. To reset HFSI counter, refer to [dC135](#)

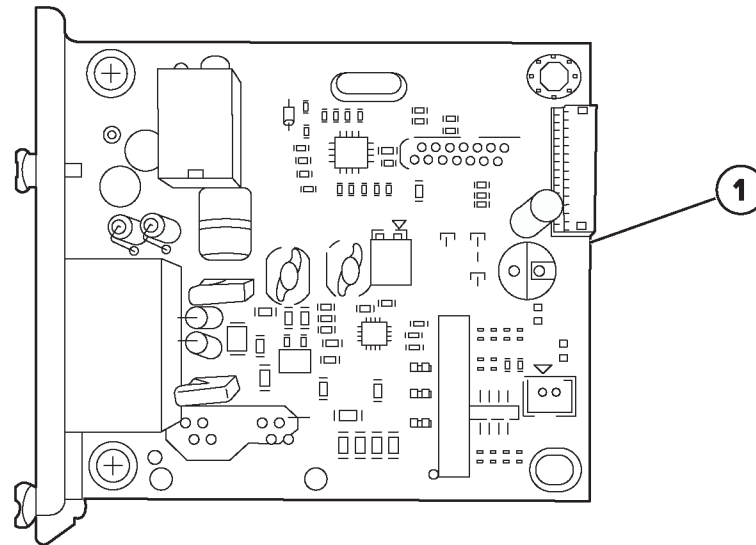


vlc625s5014a

PL 20.10 Fax PWB

Item	Part	Description
1	091N80391	Fax PWB
2	497K24460	Optional fax disable kit (See Note)
3	497K24470	Optional fax removal kit (See Note)

Note: For special request only.



v1b625s5039a

PL 25.05 Accessories

Item	Part	Description
1	097N02444	Wifi Network Adapter
2	097N02443	500+GB Hard Disk
3	097S05244	Printer Stand
4	497N07994	Adjustable stand
5	017N00320	Adjustable stand non-locking caster
6	017N00319	Adjustable stand locking caster
7	097N02442	Convenience Stapler (110v)
8	097N02463	Convenience Stapler (220v)
9	019N01170	Staple cartridge holder (staples included)
10	097N02441	550 Sheet tray

**No exploded
View Provided**

vlc625s5031a

PL 26.05 Consumables and Tools

Item	Part	Description
1	008R13347	Staple Cartridges
2	013R00697	Black Imaging Kit
3	013R00698	3 Color Imaging Kit
4	008R13334	Waste Toner Bottle
5	006R04648	Black WW Metered
6	006R04616	Black Std-Capacity NA/XE Sold
7	006R04620	Black Std-Capacity DMO Sold
8	006R04636	Black High-Capacity NA/XE Sold
9	006R04644	Black High-Capacity DMO Sold
10	006R04664	Black WW Sold (See Note)
11	006R04651	Yellow WW Metered
12	006R04619	Yellow Std-Capacity NA/XE Sold
13	006R04623	Yellow Std-Capacity DMO Sold
14	006R04639	Yellow High-Capacity NA/XE Sold
15	006R04647	Yellow High-Capacity DMO Sold
16	006R04667	Yellow WW Sold (See Note)
17	006R04650	Magenta WW Metered
18	006R04618	Magenta Std-Capacity NA/XE Sold
19	006R04622	Magenta Std-Capacity DMO Sold
20	006R04638	Magenta High-Capacity NA/XE Sold
21	006R04646	Magenta High-Capacity DMO Sold
22	006R04666	Magenta WW Sold (See Note)
23	006R04649	Cyan WW Metered
24	006R04617	Cyan Std-Capacity NA/XE Sold
25	006R04621	Cyan Std-Capacity DMO Sold
26	006R04637	Cyan High-Capacity NA/XE Sold
27	006R04645	Cyan High-Capacity DMO Sold
28	006R04665	Cyan WW Sold (See Note)

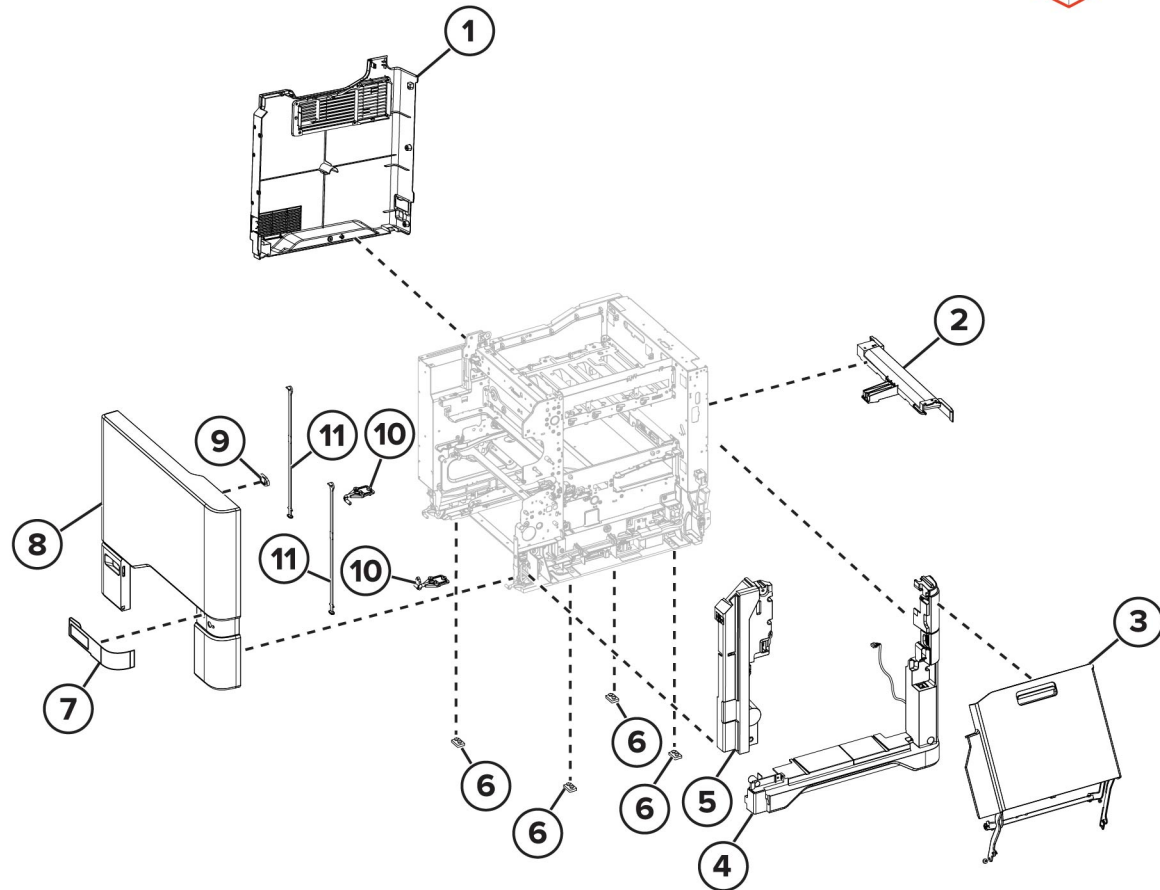
**No exploded
View Provided**

Note: Not widely distributed. For specific accounts only.

vlc625s5031a

PL 28.10 Covers 1

Item	Part	Description
1	—	Left cover (REP 28.17)
2	—	Rear handle cover
3	002N03707	Toner cover (REP 28.2)
4	002N03702	Right cover (REP 28.1)
5	—	Motor cover (REP 28.11)
6	—	Rubber feet
7	—	Tray indicator
8	002N03703	Front door cover (REP 28.10)
9	002N03696	Front door bracket
10	003N01201	Front door hinges (See NOTE)
11	002N03694	Front door straps

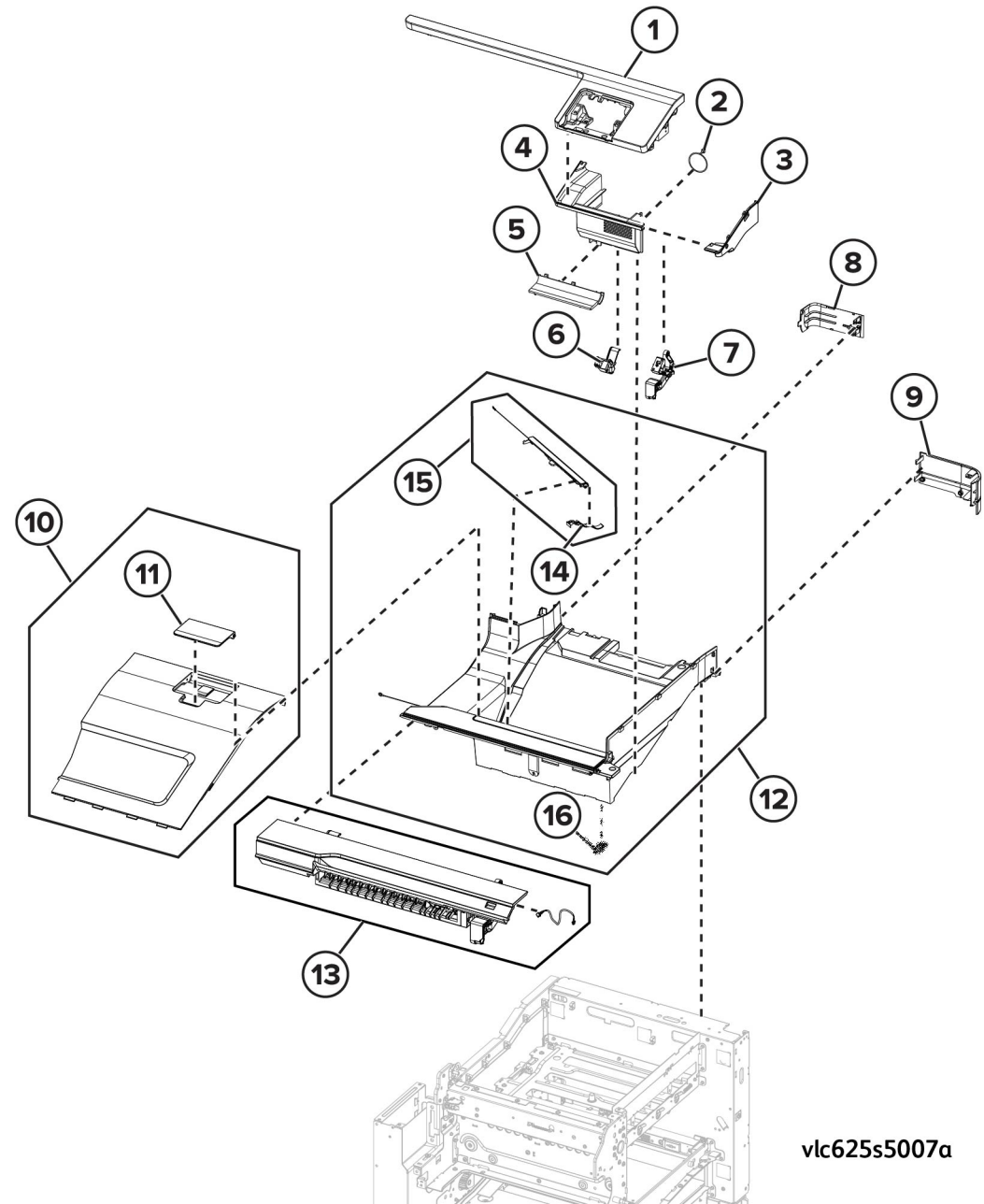


Note: Includes left hinge-and right hinge

vlc625s5006a

PL 28.15 Covers 2

Item	Part	Description
1	002N03710	Face cover
2	—	Speaker
3	—	USB cover (REP 28.4)
4	002N03709	Scanner front cover (REP 28.16)
5	—	Badge cover
6	002N03697	Control panel left arm
7	002N03698	Control panel right arm
8	—	Scanner rear left cover
9	—	Scanner rear right cover
10	002N03706	Bin cover (REP 28.12)
11	—	Bin extender (P/O PL 28.15 Item 10)
12	002N03704	Top cover (REP 28.8)
13	002N03708	Upper front door (with harness)
14	—	Bin flag (P/O PL 28.15 Item 15) (REP 28.15)
15	002N03705	Bin exit cover (P/O PL 28.15 Item 12) (REP 28.14)
16	130N02006	Sensor (binfull) (P/O PL 28.15 Item 12)



PL 31.10 Left Side Harness

Item	Part	Description
1	117N02383	Left side harness
2	—	LVPS harness (P/O PL 31.10 Item 1)
3	—	AC line in harness (P/O PL 31.10 Item 1)
4	—	CMY motor harness (P/O PL 31.10 Item 1)
5	—	Fuser AC harness (P/O PL 31.10 Item 1)
6	—	BOR motor harness (P/O PL 31.10 Item 1)
7	—	Fuser DC harness (P/O PL 31.10 Item 1)
8	—	K Motor harness (P/O PL 31.10 Item 1)
9	—	Exit/redrive motor harness (P/O PL 31.10 Item 1)

**No exploded
View Provided**

vlc625s5031a

PL 31.15 Middle Harness

Item	Part	Description
1	117N02384	Middle section harnesss
2	—	HVPS harness (P/O PL 31.15 Item 1)
3	—	Aligner sensor harnesss,(P/O PL 31.15 Item 1)
4	—	Upper paper path sensor harnesss (P/O PL 31.15 Item 1)
5	—	Fuser buckle sensor harness (P/O PL 31.15 Item 1)
6	—	TPS harness (P/O PL 31.15 Item 1)
7	—	Paper path motor harnesss (P/O PL 31.15 Item 1)
8	—	Fuser motor harnesss (P/O PL 31.15 Item 1)
9	—	Waste toner sensor harness (P/O PL 31.15 Item 1)

**No exploded
View Provided**

vlc625s5031a

PL 31.20 Right Side Harness

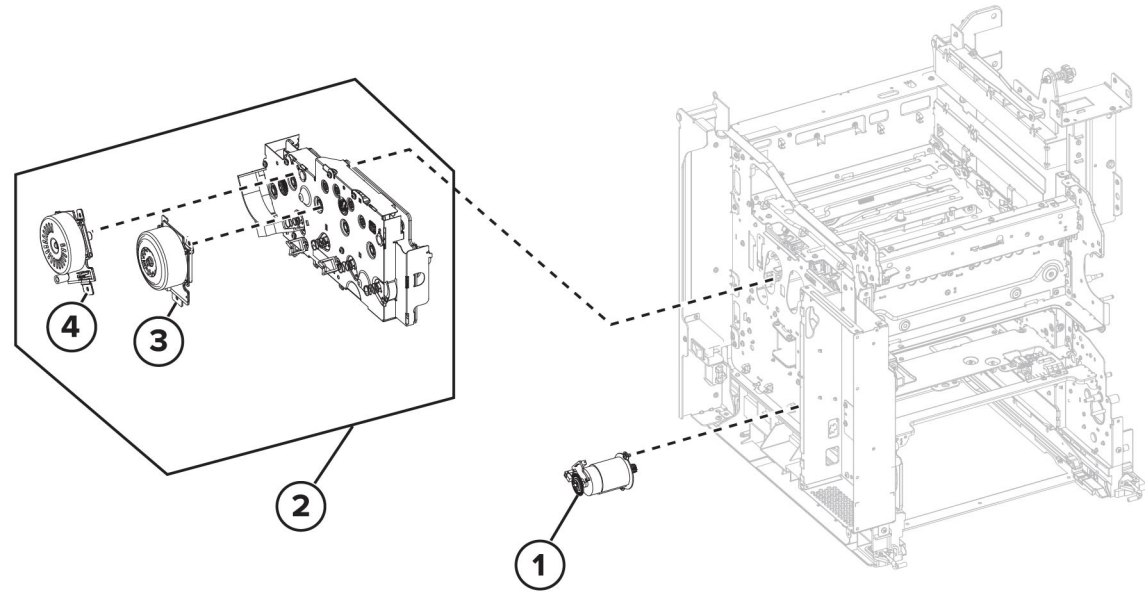
Item	Part	Description
1	117N02385	Right side harness
2	—	Front door sensor harness (P/O PL 31.20 Item 1)
3	—	TMC card harness (P/O PL 31.20 Item 1)
4	—	Weather station sensor harness (P/O PL 31.20 Item 1)
5	—	Interlock switch harness (P/O PL 31.20 Item 1)
6	—	Optional tray harness (P/O PL 31.20 Item 1)

**No exploded
View Provided**

v1c625s5031a

PL 40.10 Drive Components

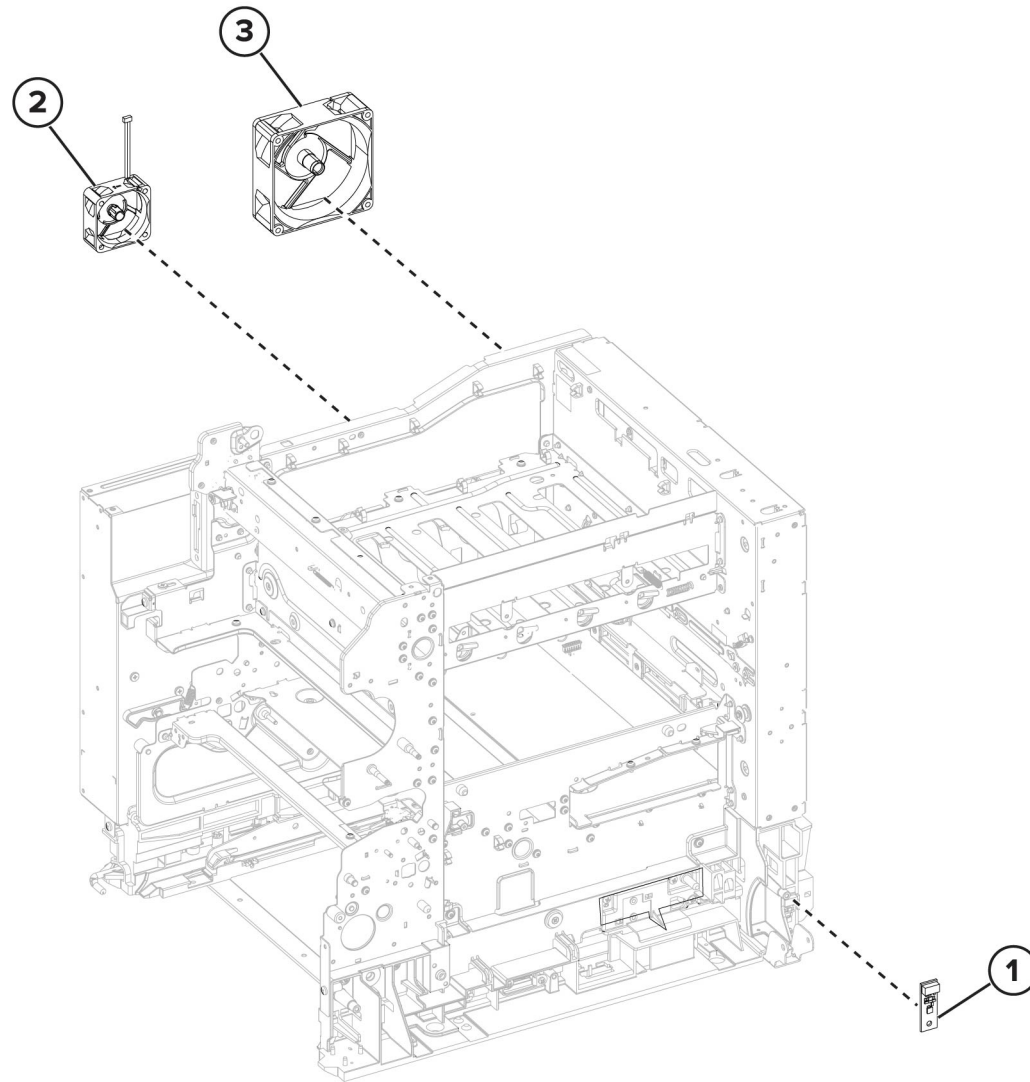
Item	Part	Description
1	127N08058	Motor (deskew) (REP 40.4)
2	007N01924	EP drive gearbox (REP 40.2)
3	—	Motor (CMY) (P/O PL 40.10 Item 2)
4	—	Motor (K/transfer belt) (P/O PL 40.10 Item 2)



vlc625s_5015-A

PL 40.15 NOHAD

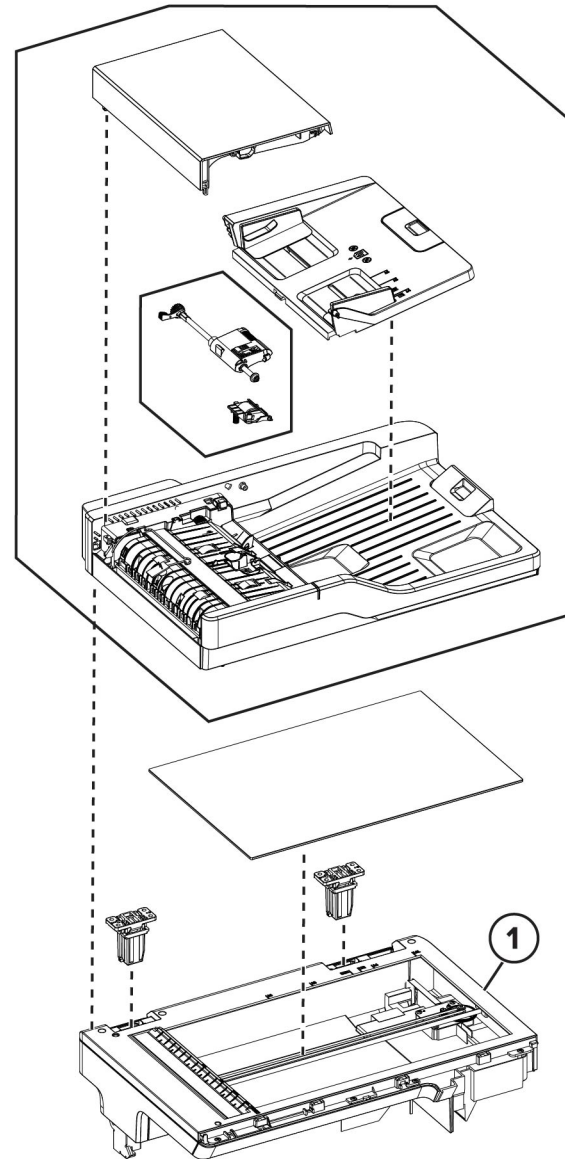
Item	Part	Description
1	130N01991	Temperature Sensor
2	127N08060	Fuser fan
3	127N07965	System fan



vlc625s_5019-A

PL 60.05 Scanner

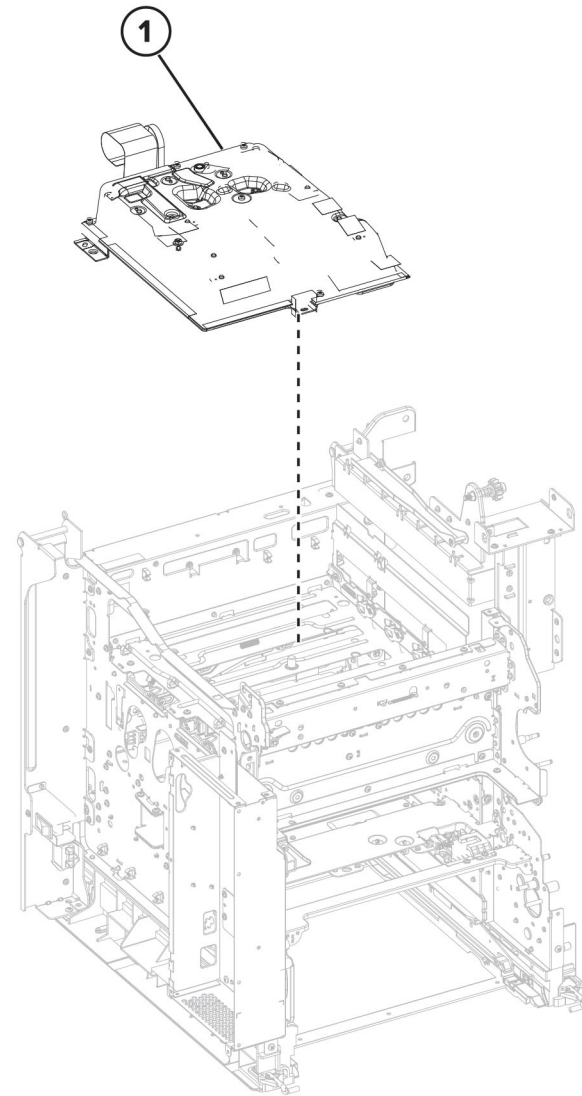
Item	Part	Description
1	109N00907	Scanner Assembly



vlc625s_5018-A

PL 60.10 Print Head

Item	Part	Description
1	046N00246	Print head (REP 60.1)

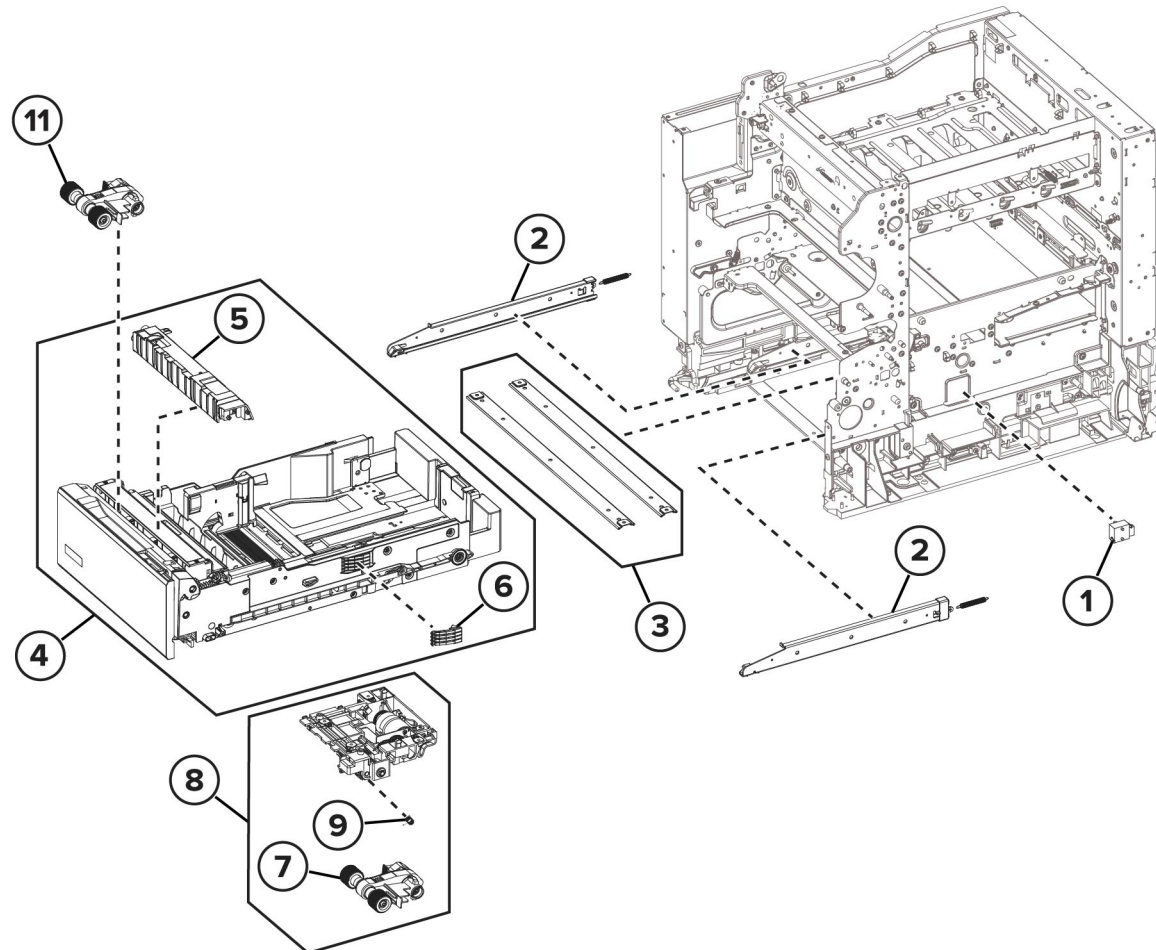


vlc625s_5012-A

PL 70.10 Paper Feed

Item	Part	Description
1	130N01984	Sensor (paper size) (REP 70.1)
2	—	Tray rails (REP 70.3)
3	—	Support straps
4	050N00758	550-sheet tray insert
5	—	Separator bracket (P/O PL 70.10 Item 4) (P/O PL 70.10 Item 10)
6	120N00588	Paper size sensor actuators (P/O PL 70.10 Item 4)
7	—	Pick roller (REP 70.4) (P/O PL 70.10 Item 8) (P/O PL 70.10 Item 10)
8	022N02965	Paper feeder (REP 70.5)
9	009N01772	Paper actuator spring (REP 70.6) (P/O PL 70.10 Item 8)
10	116R00038	Paper Tray Maintenance Kit (See NOTE)
11	022N02982	MPF Pick Roller (REP 70.4) (See NOTE)

Note: HFSI. To reset HFSI counter, refer to dC135

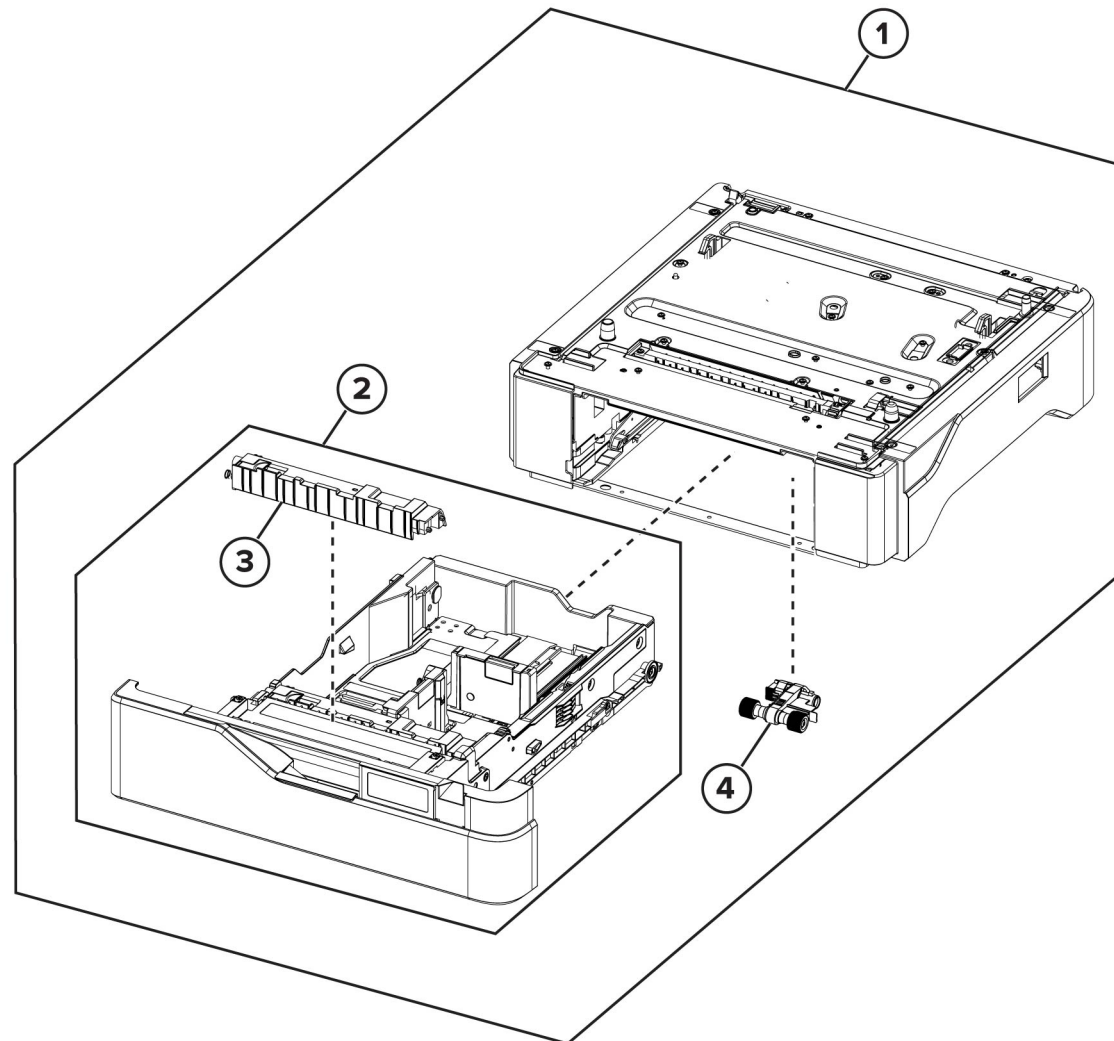


vlc625s5017a

PL 70.15 Optional 550-Sheet Tray

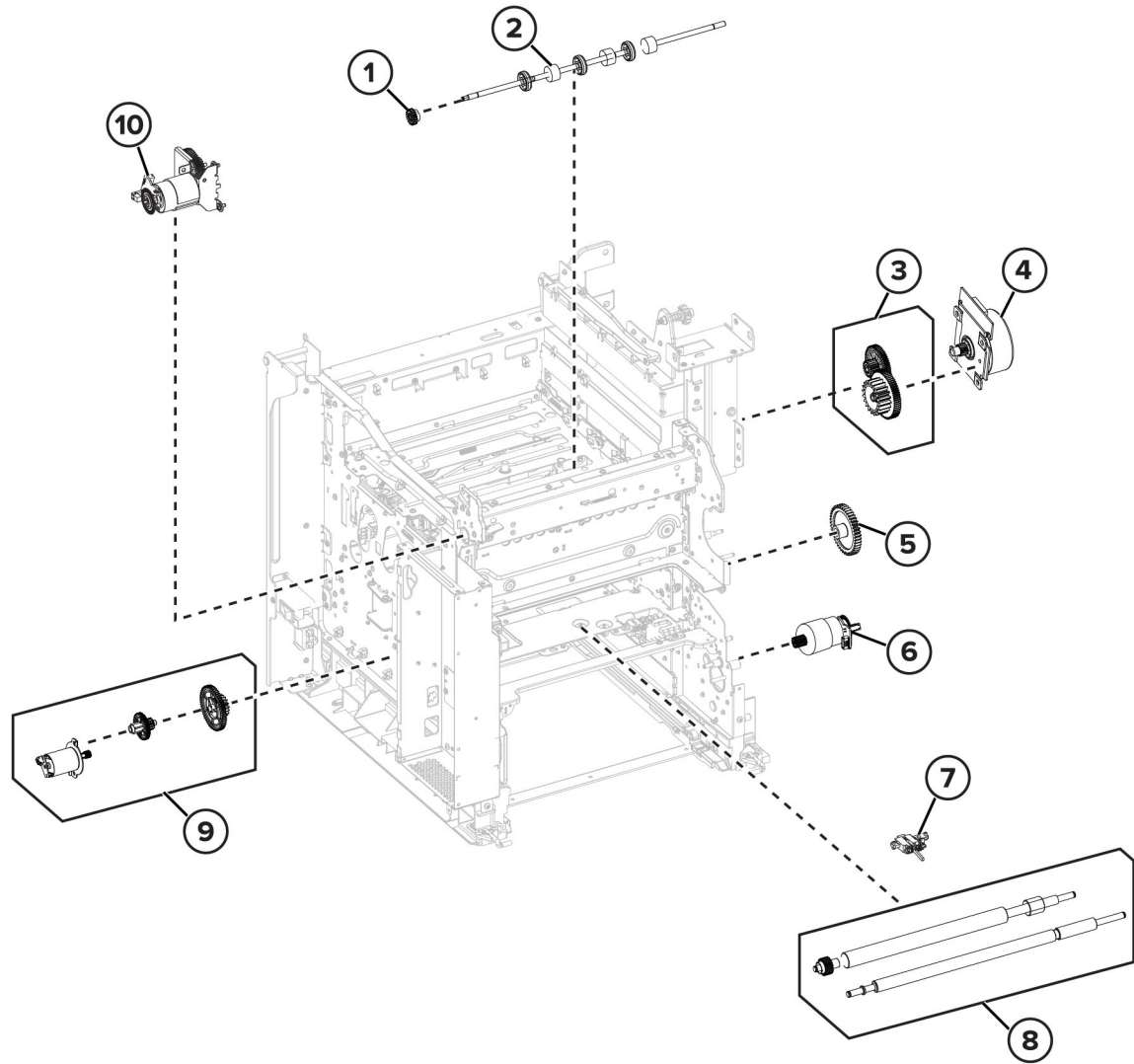
Item	Part	Description
1	—	Optional 550 sheet tray
2	050N00759	Optional 550 sheet tray insert (P/O PL 70.15 Item 1)
3	—	Separation Block (P/O PL 70.15 Item 2) (P/O PL 70.15 Item 5)
4	—	Pick roller (REP 70.4) (P/O PL 70.15 Item 1) (P/O PL 70.15 Item 5)
5	116R00038	Paper tray maintenance kit (See NOTE)

Note: HFSI. To reset HFSI counter, refer to [dC135](#)



PL 80.05 Paper Path 1

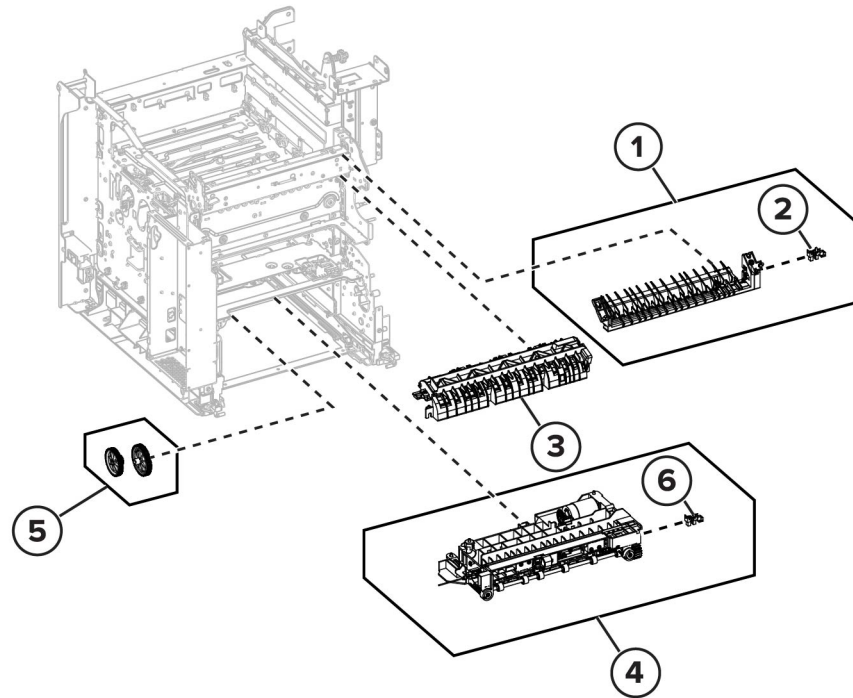
Item	Part	Description
1	007N01916	Exit roller gear (REP 80.1)
2	022N02956	Exit roller (REP 80.2)
3	126N00508	Fuser drive gear
4	127N08063	Fuser Motor
5	007N01917	Waste toner bottle idler gear
6	127N08057	Motor (duplex/MPF) (REP 80.3)
7	130N01987	Sensor (input) (REP 80.4)
8	022N02955	Aligner rollers
9	127N08062	Motor (Black Only Retract)
10	127N08059	Motor (exit/redrive)



vlc625s_5010-A

PL 80.10 Paper Path 2

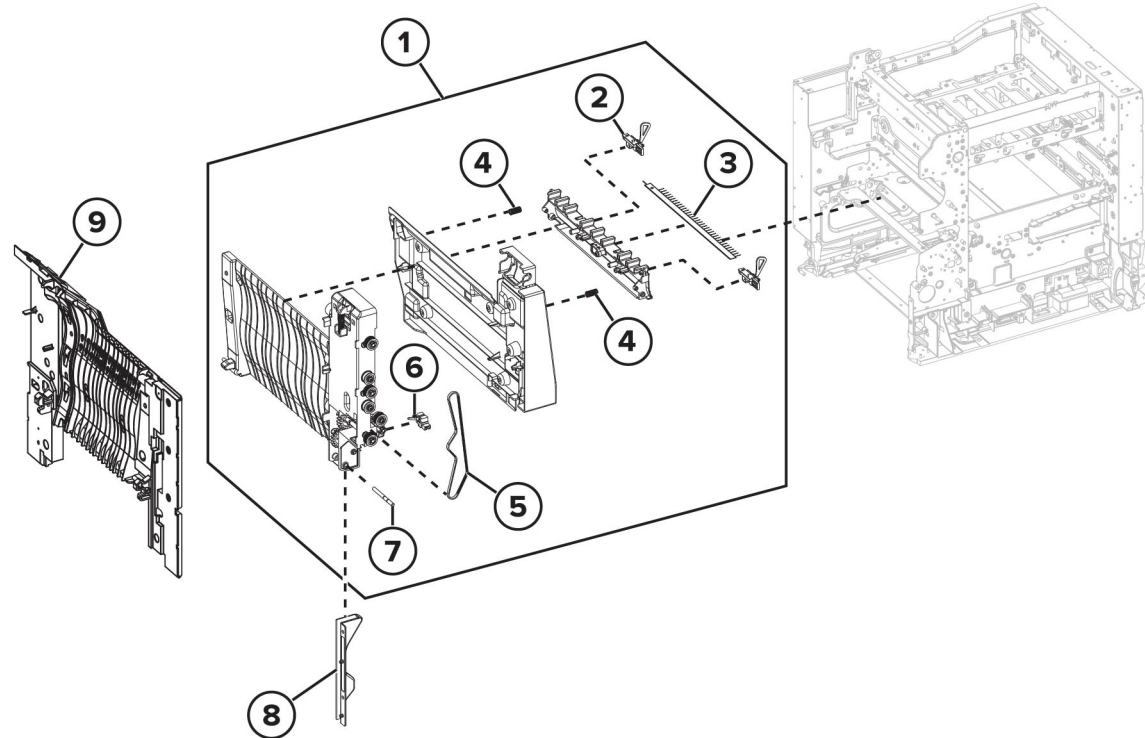
Item	Part	Description
1	121N01281	Diverter (REP 80.5)
2	130N02006	Sensor (Redrive) (P/O PL 80.10 Item 1)
3	032N00584	Redrive guide
4	007N01925	Registration Chute
5	007N01918	Aligner drivetrain kit
6	—	Sensor (MPF Pass through) (P/O PL 80.10 Item 4)



vlc625s5011a

PL 80.15 Duplex Paper Path

Item	Part	Description
1	032N00583	Duplex inner guide (REP 80.13)
2	—	Sensor (fuser buckle) (P/O PL 80.15 Item 1)
—	—	Sensor (narrow media) (P/O PL 80.15 Item 1)
3	—	Static brush (P/O PL 80.15 Item 1)
4	—	Guide springs (P/O PL 80.15 Item 1)
5	—	Tensioner belt (REP 80.8) (P/O PL 80.15 Item 1)
6	—	Sensor (duplex staging) (REP 80.6) (P/O PL 80.15 Item 1)
7	—	Pivot shaft (REP 80.10) (P/O PL 80.15 Item 1)
8	002N03695	harness cover
9	—	Duplex outer guide (REP 80.9)

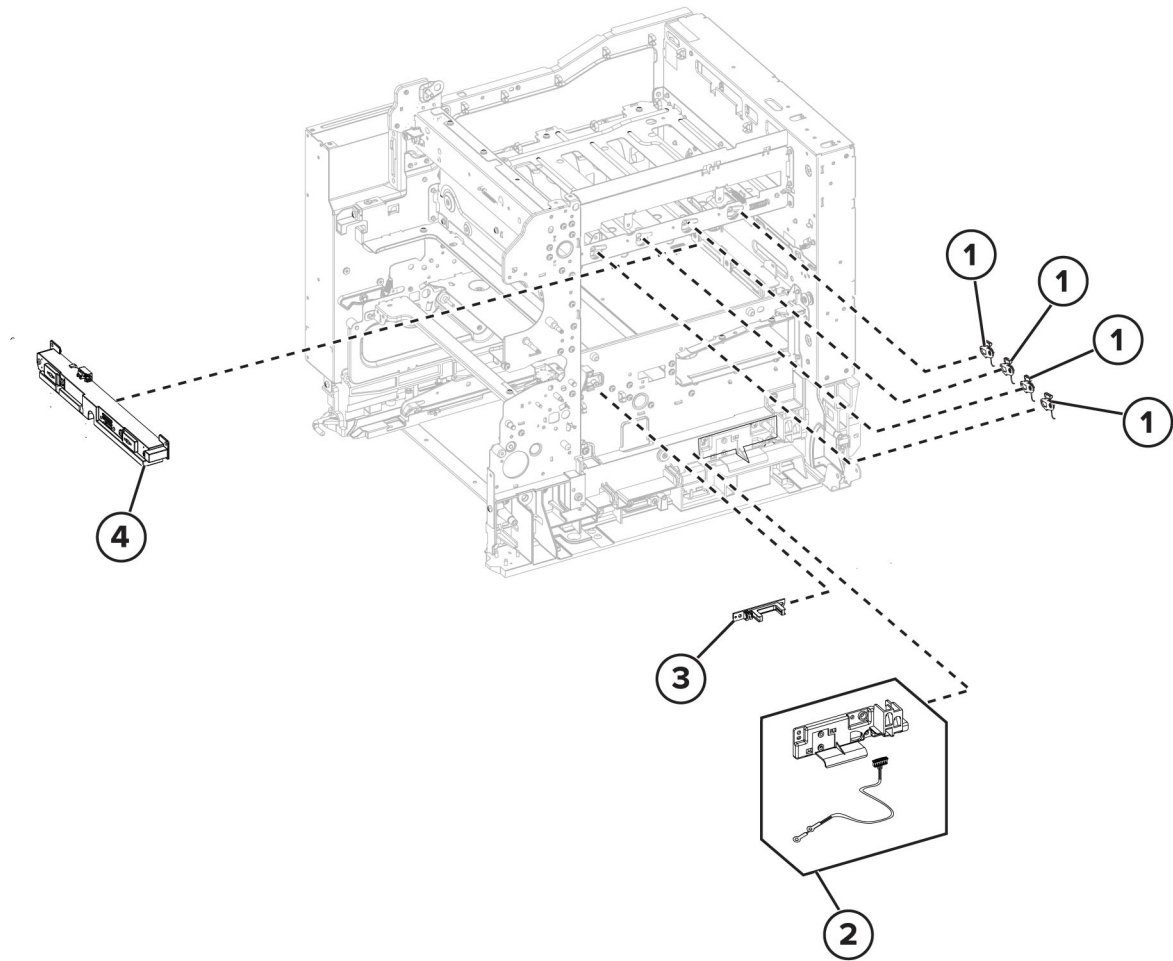


vlc625s_5008-A

PL 90.05 Xerographic Components

Item	Part	Description
1	031N00258	Developer hold down arm (REP 90.2)
2	130N01988	Sensor (waste toner contact)
3	130N02005	Sensor (waste toner) (REP 90.5)
4	130N02009	Toner Patch Sensor (See NOTE)

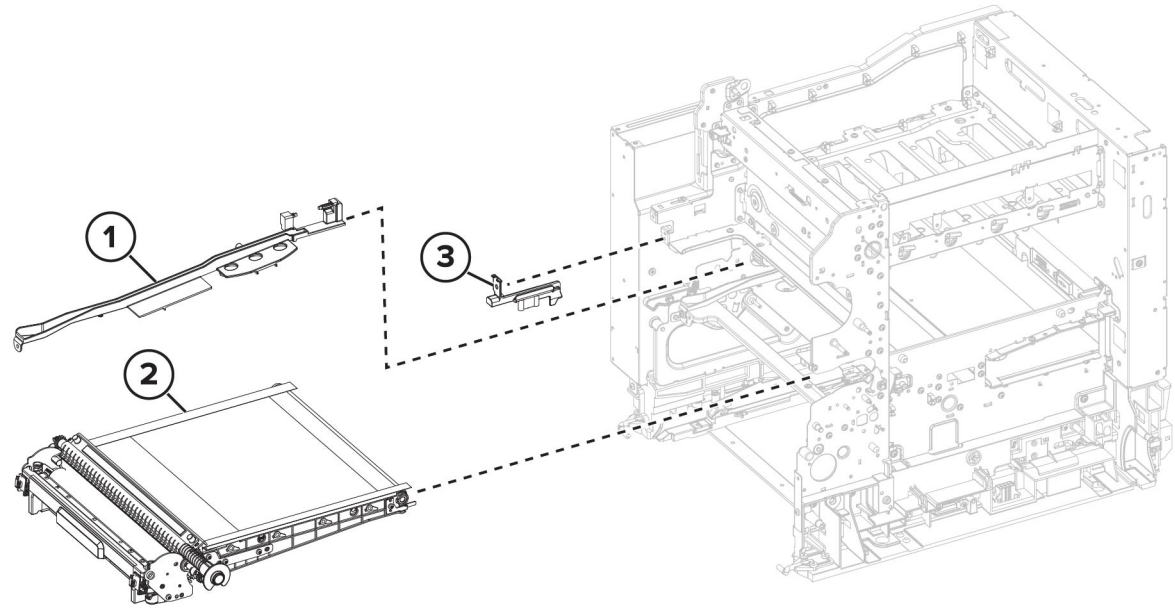
Note: This part has a FRU sheet.



vlc625s_5016-A

PL 90.10 Transfer Module Assembly

Item	Part	Description
1	—	Transfer module guide rail
2	133N23277	Transfer module
3	120N00590	Transfer module retainer



vlc625s_5013-A

6 General Procedures and Information

General Procedures	520	dC330 Component Control	601
GP 1 Diagnostics Mode Entry	520	dC361 NVM Save and Restore	608
GP 2 Fault Codes and History Files	522	dC612 Print Test Patterns	609
GP 3 Service Information	523	dC727 Tray Quick Print Tests	610
GP 4 Software Upgrade	524	dC919 Color Balance Adjustment	611
GP 5 Miscellaneous Checks	540	dC925 Printer Setup	612
GP 6 How to Check a Motor	541	dC927 Toner Patch Sensor (TPS) Setup	613
GP 7 How to Check a Switch	542	dC945 IIT Calibration	614
GP 8 How to Check a Solenoid or Clutch	543	Change Tags	615
GP 9 How to Check a Sensor	544	Change Tags	615
GP 10 How to Switch Off the Machine or Switch On the Machine	545		
GP 11 How to Safely Lift or Move Heavy Modules	546		
GP 12 Machine Lubrication	546		
GP 13 Cloning Machine Settings	547		
GP 14 Printing Reports	547		
GP 15 Cleaning the Printhead Lense	549		
GP 16 Installation Space Requirements	550		
GP 17 Electrical Power Requirements	552		
GP 18 Cleaning the Scanner	555		
GP 19 Obtaining Audit and Device Logs	556		
GP 20 First Copy/Print Out Time and Power On Time	558		
GP 21 Restriction of Hazardous Substances (RoHS)	559		
GP 22 Backup & Restore Settings	559		
GP 23 Customer Administration Tools	561		
GP 24 How to Set the Date and Time	562		
GP 25 Ethernet Crossover Cable Setup	562		
GP 26 PagePack Plan Activation	564		
GP 27 Intermittent or Noise Problem	568		
GP 28 System Administrator Password Reset	569		
GP 29 Print/Copy Orientation Definitions	571		
GP 30 Paper and Media Size Specifications	572		
GP 31 Environmental Data	578		
GP 32 Device Specification	579		
GP 33 Restoring Customer Mode	581		
GP 34 How to Re-Enter Optional Feature Installation Keys	582		
GP 35 Serial Number Synchronization Procedure	583		
GP 36 Xerox USB Wireless Printing Troubleshooting	584		
GP 37 Supplies Plan Conversion	585		
GP 40 Glossary of Terms, Acronyms and Abbreviations	588		
Reference Library	593		
VLB625 and VLC625 NVM Tables	594		
Log Book	594		
Safety Information	595		
Diagnostics	596		
Service Copy (Tools) Mode	596		
dC104 Usage Counters	596		
dC108 Software Version	597		
dC122 Fault History	597		
dC126 Paper Registration	598		
dC131 NVM Read/Write	598		
dC132 Machine Serial Number	599		
dC135 HFSI Counters	600		
dC301 NVM Initialization	600		
dC312 Network Echo Tests	601		

GP 1 Diagnostics Mode Entry

Purpose

This procedure describes how to enter and exit diagnostics mode and the available diagnostics routines.

Note: When diagnostics mode is entered, all existing copy jobs are cancelled and an 'Offline' screen message is displayed.

How to Enter Service Mode

Note: Do not enter diagnostics mode if the Replace Toner Cartridge dialog box is displayed. Entry to diagnostics mode with the dialog box displayed will stop the machine printing test patterns. Confirm either yes or no, then enter diagnostics mode.

1. Switch on the machine, [GP 10](#).
2. When the machine is ready press and hold the **Home** button for 7 seconds. The passcode screen will display when the button is released.
3. Enter the passcode, 6789. Press the **OK** button on the UI.

Note: Five incorrect entries cause the entry screen to lock for 3 minutes.

4. Select the relevant tab:
 - [General Information Tab](#)
 - [Service Information Tab](#)
 - [Diagnostics Tab](#)
 - [Adjustments Tab](#)
 - [Maintenance Tab](#)

Call Closeout Button

Note: Do not exit service mode until the machine has recovered from all diagnostic routines.

1. Select the Call Closeout button to exit service mode.
2. If necessary, select Reset Counters.
3. Select Exit or Exit and Reboot.

General Information Tab

- Product code:
- Serial number:
- Total images:

- Images since last call:
- System software version:
- IPV4 address:
- Device name:
- IPV6 address:

Service Information Tab

The service info tab contains routines used to track; use counts, SW versions, fault history, and consumable status. Refer to [Table 1](#) Service Information Tab.

Table 1 Service Information Tab

Routine	Description
dC104 dC104	Usage Counters
dC108 dC108	Software Version
dC122 dC122	Fault History
dC135 dC135	CRU / HSF1 Status

Diagnostics Tab

The diagnostic tab contains routines used to test specific areas of the machine. Refer to [Table 2](#) Diagnostics Tab.

Table 2 Diagnostics Tab

Routine	Description
dC312 dC312	Network Echo Test
dC330 dC330	Component Control (Fax Engine)
dC330 dC330	Component Control (Print Engine)
dC330 dC330	Component Control (Scan Engine)

Routine	Description
dC612 dC612	Print Test Pattern
dC727 dC727	Tray Quick Print Tests

Adjustments Tab

The adjustment tab contains routines used to modify the set-up or to calibrate specific areas of the machine. Refer to [Table 3 Adjustments Tab](#).

Table 3 Adjustments Tab

Routine	Description
dC126 dC126	System Registration
dC131 dC131	NVM Read/Write
dC301 dC301	NVM Initialization
dC361 dC361	NVM Save and Restore
dC919 dC919	Color Balance Adjustment
dC925 dC925	Printer Setup
dC927 dC927	Toner Patch Sensor Setup
dC945 dC945	IIT Calibration

Maintenance Tab

The maintenance tab contains routines that give information about the fault history of the machine, serial number, and consumable. Refer to [Table 4 Maintenance Tab](#).

Table 4 Maintenance Tab

Routine	Description
dC122 dC122	Fault History
dC132 dC132	Machine Serial Number
dC135 dC135	CRU / HSF1

Service Copy Mode

Service copy mode provides access to the machine that is greater than that of a user, but less than that of the System Administrator. This mode allows the CSE to perform a number of checks and run copies without compromising the customer's security settings. This mode can be used if the Administrator user name and passcode are not at the default, and the Administrator is not available to enter the admin passcode. Perform the steps that follow:

1. Press and hold the **Home** button for 7 seconds. The passcode screen will display when the button is released.
2. Enter the passcode 2732. press the **OK** button on the UI.
3. The **Log In** button will change to display **CSE**.

Note: Five incorrect entries cause the entry screen to lock for 3 minutes.

Note: The tools available in this mode are a subset of those available in Administrator mode. CSE service copy mode remains active until the **login/CSE** button is pressed again. When finished with always log out of service copy mode by pressing the **CSE** button and confirming log out.

GP 2 Fault Codes and History Files

Purpose

To describe access to fault history information and explain the fault code structure.

- Fault History files can be accessed from the UI:

1. Touch Device > Notifications > Fault History.

Fault Data Available from Service Mode

1. Enter Service Mode, [GP 1](#):
2. Touch Service Information > dC122 Fault History, [dC122](#).

Function, Fault, Component Codes

Refer to, [Table 1](#), Function and fault code prefixes. Also known as the chain code.

For example. displayed code 373-215-00, Tray 3 hoist failure.

- 3 - Indicates that this is an Atlantis software platform fault code.
- 73 - The fault is located in chain 7 — paper supply, tray 3.
- 215 - This is the link code.
- 00 - This is the extension code.

Table 1 Function and fault code prefixes

Chain Code	Function
301	Standby power
302	User interface
303	Machine run control
305	Document transportation
310	Fusing and copy/print transportation
312	Finishers
316	Network controller
319	Video image manipulation
320	Fax
322	System Errors
340	Main drives
36X	LED print head, scanners

Chain Code	Function
37X (X = tray No.)	Paper supply (paper trays and bypass)
38X	Paper feed and transport
39X	Xerographics
395	Software upgrade errors

GP 3 Service Information

Purpose

To provide machine hardware and software information.

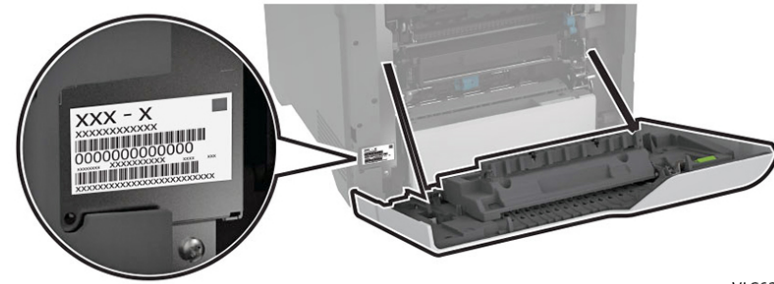
Diagnostics Mode Screen

Enter service/diagnostics mode, [GP 1](#). The screen displays the following selections:

- **Initial View:**
 - [General Information Tab.](#)
 - [Service Information Tab.](#)
 - [Diagnostics Tab](#)
 - [Adjustments Tab.](#)
 - [Maintenance Tab.](#)
- **General Information:**
 - Product Code:
 - Serial Number:
 - Total Images:
 - Images Since Last Call:
 - System Software Version:
 - IPV4 Address:
 - Device Name:
 - IPV6 Address:
- **Service Information:**
 - [dC104](#) Usage Counters
 - [dC108](#) Software Version
 - [dC122](#) Fault History
 - [dC135](#) CRU/HFSI

Machine Serial Number

To locate the machine serial number, open the front door, the serial number plate is located on the lower left frame of the machine, [Figure 1](#).



VLC625S_6004

Figure 1 Machine Serial Number

The serial number for the NA markets is in the format: XXX #####. Where XXX is the product code (see [Product Code](#)) and ##### is the serial number.

The serial number for the XE markets is in the format: MMM#####C. MMM is the manufacturing location code, ##### is the serial number and C is the check digit, for example 2327020103.

Product Code


The machine product codes are shown below, [Table 1](#).

Table 1 Machine product codes

Machine Configuration	Product Code	Comments
C625_DN, (110VAC)	UQA	
C625V_DN, (220VAC)	UQC	
C625_YDN, (110VAC)	UQAN	TAA configuration
C625V_YDN, (220VAC)	UQCN	TAA configuration

GP 4 Software Upgrade

Preparation

 **CAUTION:** The Altboot procedure may delete all stored data on the System Disk Drive, including e-mail addresses, Xerox Standard Accounting data, and network configuration information. If possible, clone the machine, [GP 13](#), and back up customer settings, [GP 22](#), before performing Altboot. If the machine failure is such that a Backup and Restore cannot be performed, notify the customer that data will be lost.

Perform the following, if possible:

1. Save NVM to a USB drive, [dC361](#).
2. Print a Configuration Report, [GP 14](#).
3. Clone the network configuration, [GP 13](#).
4. Create a backup file of customer settings, [GP 22](#).

Purpose

This procedure provides installation instructions for upgrading, downgrading, or restoring system software:

Additional software installation options are available using EWS when software updates are enabled. Customers can upload system software using EWS or they can configure EWS to monitor an FTP site and automatically upgrade when a newer version is detected. [Table 1](#) lists the available software installation procedures and their effects on each module.

Note: If a newly installed component has a different version of software than the software set that is on the controller PWB, the software on the new component may be upgraded or downgraded at system startup.

Note: To power down the machine, press the UI Power Button and then respond to the on-screen prompts. Wait until the Power Button LED turns off, then switch off the Main Power Switch, [GP 10](#).

Table 1 Software Loading Options

Full DLM download location: GSN Library 17800		Phase 1 - BIOS / Flash Update			Phase 2 - Platform Upgrade									
Software Platform	Procedure Overview	Controller (SBC)												
Platform Components		OS kernel & FPGAs	SW Upgrade	BIOS	Network Controller	Fax	Copy Controller	UI App	OS	OS kernel & FPGAs	UI Panel Firmware	IIT Apps	DADF	IOT
HW Location	Physical location of the software component.	eMMC	eMMC	eMMC							UI PWB	eMMC	DADF PWB	Controller PWB
<p>USB Altboot (Standard Altboot)</p> <p>Used for software upgrade or downgrade.</p> <p>Based on the drive setup, the printer reads the folders, finds the Altboot folder, checks the versions of software against the .DLM file, and then installs the .DLM file associated with the printer. The printer retains the customer data.</p>	<p>DLM file placed in "Altboot" folder on a USB drive then inserted into the machine.</p> <ul style="list-style-type: none"> Place a .DLM software file on a USB drive. Insert the USB into an active port. Hold down the Home button and reboot the printer. Release the Home button when the Install File message appears. [Revert to Previous Settings] file is automatically created and is automatically restored. Do not partition the USB drive. Format the USB drive for FAT32 (other formats not supported). Only place one .DLM file per product number in the folder (both VersaLink C625 and B625 are OK). Altboot .DLMs are larger files. USB Port must be Enabled. 	Upgrade Downgrade Reload											none	
<p>Forced USB Altboot:</p> <p>Method used for failed SW Upgrade recovery.</p>	<p>DLM file placed in "Altboot" folder on a USB drive inserted prior to powering on the machine.</p> <ul style="list-style-type: none"> Skips version check forcing installation of the file in the \alboot folder. Resets all machine settings to default. Uses full sized ALTBOOT DLM Flag labeled [FORCED_UPGRADE] added to the altboot folder. Flag labeled [DISABLE_DATA_BACKUP] can be added to the altboot folder to prevent any data saving. USB Ports must be Enabled Customer data/configuration should be retained. As a precaution, create, or have customer create, a Backup file through EWS (GP 22). 	Upgrade Downgrade Reload												

Full DLM download location: GSN Library 17800		Phase 1 - BIOS / Flash Update	Phase 2 - Platform Upgrade
	<ul style="list-style-type: none"> [Revert to Previous Settings] file is automatically created, but it is NOT automatically restored. Restore customer settings via Tools [Device > Login > Tools > General > Revert To Previous Settings] 		
<p>Special Altboot: Use in the event of EMMC or Controller Board failure, the machine may lose the encryption keys for the EMMC.</p>	<p>DLM file placed in "Altboot" folder on a USB drive inserted prior to powering on the machine.</p> <ul style="list-style-type: none"> This file is version and product specific, download the current version of the DLM file. Both the DLM and swup_usb files are packaged together in the same download. In USB drive, copy DLM file inside ALTBOOT folder and copy a swup_usb file inside the root folder. The swup_usb file can be extracted from the CKUSBBootZip file. In pen drive has the following folder structure (the last file is an empty file that is part of the CKUSBBootZip file that is only used to remind the operator what version of CKUSBBootZip was used since these are product-specific). <ul style="list-style-type: none"> /Altboot /Altboot/XeroxVersaLink_X625_ALTBOOT_system-sw#11802400227150#.DLM (example only) /swup_usb /XeroxVersaLink_X625_118.024.002.27150 Connect the pen drive to one of the working USB ports of MFP. Power on the device and hold the "Home" button on LUI panel till upgrade screen display on LUI. Device will go for upgrade and after upgrade completed device will go for several reboots . After the upgrade an Upgrade Report will be printed. 		Upgrade Downgrade Reload
<p>PWS ALTBOOT: Allows upgrade when USB is not available at the customer site.</p>	<p>DLM file is loaded using a PWS laptop and Ethernet crossover cable.</p> <ul style="list-style-type: none"> Ethernet crossover cable required. <p>Note: The laptop and printer must be on the same subnet. IPv4 addresses must be assigned in the same subnet Set the printer IPv4 address back to its original address when done.</p> <ul style="list-style-type: none"> Uses the PWS Altboot Utility to upgrade the software. <p>Settings in the utility for:</p> <ul style="list-style-type: none"> Standard Altboot FORCED_ALTBOOT SPECIAL_ALTBOOT 		Upgrade Downgrade Reload

Full DLM download location: GSN Library 17800		Phase 1 - BIOS / Flash Update			Phase 2 - Platform Upgrade																				
Other software upgrade methods (for reference only).																									
Normal USB Upgrade Note: Recommended CSE method, customer data should always be preserved.	DLM file placed in \Upgrade folder on a USB drive and inserted after the machine has come to ready. <ul style="list-style-type: none"> • Uses smaller 'differential' DLM (only changes from Launch DLM) • Machine must be Online • USB Ports must be Enabled • Software Upgrade must be enabled 	Version Check: Up/Down	Version Check: Up/Down	Version Check: Up/Down	Up/Down / Re-load	Up / Down / Re-load	Up/Down/Reload	Up/Down/Reload	Up / Down / Re-load	Up / Down / Re-load	Up / Down / Re-load	Up/Down / Re-load	Version Check: Up Only	Version Check: Up Only											
Customer Manual Upgrade via EWS	DLM file is loaded through [EWS Properties > General Setup > Machine Software > Manual Upgrade] <ul style="list-style-type: none"> • Both the Customer DLM, downloaded from Xerox.com, and the full DLM file types can be used during EWS upgrade. • Machine must be Online • Software Upgrade must be enabled 																								
SWUP Utility	DLM file is loaded through SWUP utility. <ul style="list-style-type: none"> • Uses smaller differential DLM (only changes from Launch DLM) • Machine must be Online • Software Upgrade must be enabled 																								
Customer Automatic FTP Upgrade	DLM file is placed on an FTP server and EWS is configured [Properties > General Setup > Machine Software > Auto Upgrade] to periodically check the FTP site for updated SW. <ul style="list-style-type: none"> • Uses smaller 'differential' DLM (only changes from Launch DLM) • Machine must be Online • Software Upgrade must be enabled 																								
Remote Services	New major SW releases are automatically pushed to connected machines. <ul style="list-style-type: none"> • Uses smaller 'differential' DLM (only changes from Launch DLM) • Machine must be Online • Software Upgrade via Remote Services must be enabled with device communicating with Xerox. 																								

Full DLM download location: GSN Library 17800		Phase 1 - BIOS / Flash Update			Phase 2 - Platform Upgrade													
Fleet Orchestrator	Contents of the different platform behaviors (upgrade/downgrade/reload) is same as all customer upgrades (EWS/Normal USB upgrade/Etc).																	

Software Installation Types

- [Loading Software Using a USB Flash Drive](#)
- [Embedded Web Server \(EWS\) upgrade using the network](#)
- [Altboot Software Loading using a USB Flash Drive](#)
 - [Standard Altboot Procedure](#)
 - [Forced Altboot Procedure](#)
 - [Special Altboot Procedure](#)
- [PWS Altboot Procedure using PWS Altboot tools](#)

Additional Tools

- [Troubleshooting](#)
- [Fleet Orchestrator](#)

System software sets are compilations of software modules and a software compatibility database (SCD). The SCD lists software versions suitable for the system and its installed options. System software is supplied as a .DLM file.

Two versions of the software DLM file are available.



CAUTION: The full DLM is required for all forms of Altboot Software Updates.

1. The full Altboot versions of the DLM files will be made available on the TCIP Site and [GSN Library 17800](#) for Service to use during Altboot upgrades:

Note: Example: XeroxVersaLink_X625_ALTBOOT_system-sw#11802400220120#.DLM (The X will be B if mono, C if Color)

- Product Type: VersaLink
- Product Number: X625
- Version number is a numeric series to identify product, version, and release date.
- ENG_MOD is not part of the file name.



CAUTION: The software will not load if no pound (#) signs appear in the file name.



CAUTION: Do not attempt to open this file. Attempting to open the file may corrupt it, making it unusable.

Note: The Altboot DLM can be used even when the shipped DLM is missing in the machine.

2. The smaller, Thin/BDC or Customer File, DLM files downloaded from Xerox.com, contain changes from the manufactured release software that ships in the machine:

Note: Example: XeroxVersaLink_X625_system-sw#11902500304611# (The X will be B if mono, C if Color)

- Product Type: VersaLink
- Product Number: X625

- Version number is a numeric series to identify product, version, and release date.
- ENG_MOD appears in the file name.
- If the Launch DLM is missing from the drive, the BDC upgrade will fail and the launch DLM recovery patch (LDRP) will be required.
- Software upgrade instructions and instructions on how to recover from failed upgrades are posted with the upgrade files on Xerox.com.

Note: Software version information appears in **Service Information > Service Mode, dC108** .

Note: If the screen displays the message **The device is in non-customer mode** after completing Power On, it will be necessary to perform **GP 33** to restore the machine to customer mode. If the Billing Counters have been lost, follow **GP 26** to report Billing Meter reset.

At Power On, the system checks the version information for each installed module and compares it to locally stored SCDs.

Software Installation Procedures

Note: Depending on the procedure used, the software installation could require up to 60 minutes. If the installation fails, refer to **OF 1, Machine Not Ready RAP** .

Initial Actions:

- Verify the machine is fully operational, if possible. Clear any active faults or jams.
- Obtain a USB Flash drive with a minimum capacity of 1GB, formatted for FAT32.
- Print a Configuration Report, if possible, to check the software version on the machine.
- Download the current version .dlm file from Xerox.com
- USB port must be enabled.
- Software updating must be enabled.

Software Upgrade Installation

Customer USB DLM Software Upgrade

1. Either allow all pending print jobs to finish or delete the.

Note: If the print jobs cannot be deleted, inform the customer that all pending jobs will be lost.



CAUTION:

Check the Release Notes to ensure upgrades can be applied.

Note: Before inserting the USB drive, ensure the machine is in a **[Ready]** state.

2. Log in as Admin.
3. Enable SW Upgrade via UI Tools or the EWS.
4. Connect the USB Flash drive containing the .DLM file to one of the USB ports.



CAUTION: The USB should only contain the DLM for the machine being updated. No other DLM should exist.

Note: Use a USB thumb drive that is compatible with Xerox approved models.

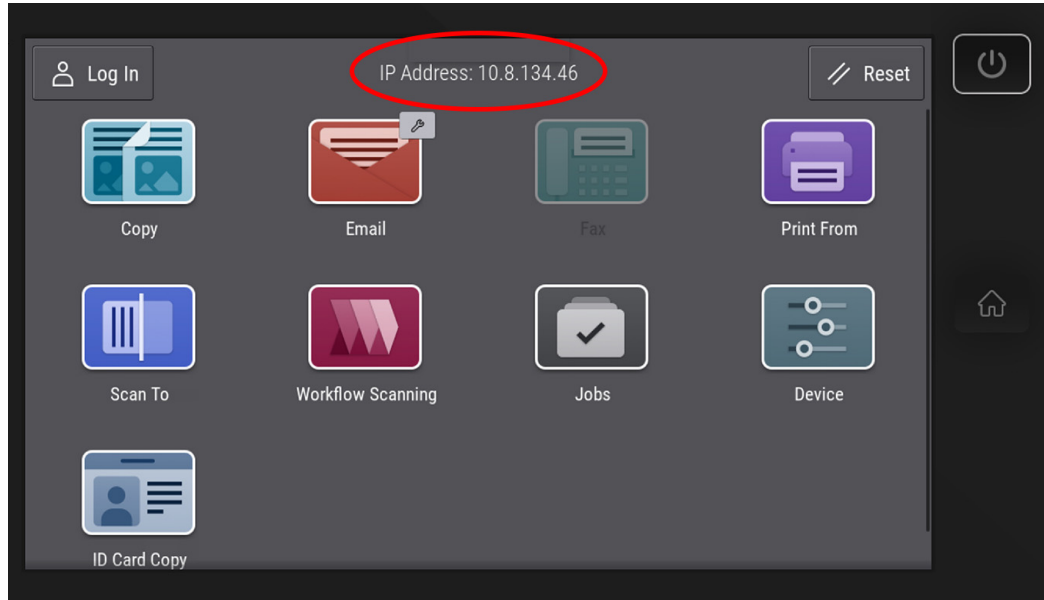
Note: It is not necessary to switch off the system to perform a software upgrade.

5. Touch **[Install File]** on the USB Drive Detected popup, then select the .DLM file for the upgrade to initiate.
6. Do not remove the USB drive until the message **[Software upgrade is completed. Remove the USB drive to restart the system]**, displays on the UI.
7. If the upgrade fails, use the **Forced Altboot** procedure to recover.
8. The system may restart several times completing the installation before returning to a ready state.
9. After the software has been upgraded a software upgrade report will print automatically.

Embedded Web Server (EWS) upgrade using the network

1. Open a web browser, enter the machine IP address in the address field, then press **Enter** on the keyboard. The system EWS will open.

Note: The machine IP address is listed at the top-center of the UI screen.



vlc625s6005

Figure 1 UI Home Screen IP Address

2. Click **[Properties]**, then login as Admin.
3. Select **General Setup > Software Upgrade**.
The Screen will open to **[Fleet Orchestrator]**.

4. Select **Create / Install File**.
5. Select **Software Upgrade File**
6. Scroll to **[Details] > [Installation Policy]**. Verify the link is set to **[Allowed]**.
To set to Allowed from Not Allowed:
 - a. Click on the link, **[Not Allowed]**.
 - b. Check the box **[Allow Software Upgrade]**.
 - c. Click **[Apply]**.
7. Select **Install a File**, then **Browse**. Select the .DLM file from the upgrade directory.

Note: Both the Customer DLM downloaded from Xerox.com and the full DLM file types can be used for EWS upgrade. Download the full DLM file here: [GSN Library 17800](#).

8. Select **Install**.

Note: All network connectivity is lost. Progress can be monitored from the UI.

9. The system reboots several times before returning to a ready state.

Altboot Software Installation

There are four altboot software configurations. Each is listed below:

- [Loading Software Using a USB Flash Drive](#)
- [Embedded Web Server \(EWS\) upgrade using the network](#)
- [Altboot Software Loading using a USB Flash Drive](#)
 - [Standard Altboot Procedure](#)
 - [Forced Altboot Procedure](#)
 - [Special Altboot Procedure](#)
- [PWS Altboot Procedure using PWS Altboot tools](#)

Additional Tools

- [Troubleshooting](#)
- [Fleet Orchestrator](#)

Altboot Software Loading using a USB Flash Drive


Altboot reloads system software. It is used to upgrade, downgrade, or reload software on systems that will not come to a ready state. It also can be used to upgrade or downgrade the software on system options.



CAUTION: Altboot should only be used when a loss of operation occurs and the standard customer software upgrade is not possible.

Note: If the customer purchased Adobe PS or McAfee Integrity Control features, perform the following:

- Login as Admin. Refer to, [GP 23](#).
- Install features as required. Refer to, [GP 35](#) How to Re-Enter Optional Feature Installation Keys.

 **CAUTION:** The system may appear to hang during the Altboot process while loading software in the background. Wait a minimum of 10 minutes before switching the system off. Switching the system off while software is loading will corrupt the software installation requiring the Altboot installation to be restarted.

Standard Altboot Procedure

1. Perform [dC361](#) NVM Save and Restore.
2. USB Port must be **[Enabled]**.
3. Format the USB drive for **FAT32** (other formats not supported).

Note: Do not partition the USB drive.

4. Confirm USB file and directory structure is configured correctly. The below structure is required in the root level of the USB drive.

Note: It is best practice to start the procedure with a clean formatted USB drive having no files or folders.

Table 2 USB structure at root level

```

\...

\Altboot\XeroxVersaLink_X625_ALTBOOT_system-sw#11802400227150#.DLM (example only)

```

Note: Ensure the Microsoft Windows Safely remove hardware procedure is followed before the USB Flash drive is removed.

5. Copy the required .DLM software file into the \altboot folder of the USB drive.


Note: Typically, only one .DLM file per product number should be in the folder.

6. Insert the USB into an active port in the machine.
7. Restart the printer.
8. Press and hold the **[Home]** button as soon as the printer restarts.
9. When the **[Install File]** message appears, release the **[Home]** button .
10. Touch the altboot file to be installed, then touch **[OK]**.
11. The UI control panel will instruct to remove the USB device to restart the printer and continue the installation.


Note: The printer may restart several times during the installation.

Note: A **[Revert to Previous Settings]** file is automatically created and is automatically restored.

Forced Altboot Procedure

 **CAUTION:** Use Forced Altboot with extreme caution! Forced Altboot replaces boot and application code. Power failure during a Forced Altboot may result in PWBs becoming unrecoverable.

1. Perform [dC361](#) NVM Save and Restore.
2. Start with a USB drive as per the [Standard Altboot Procedure](#).
3. Create a flag labeled **FORCED_UPGRADE** inside the `\altboot` folder.

 **CAUTION:** Forced Altboot uses the available .DLM file to upgrade or downgrade every component in the system, regardless of installed software. Forced Altboot is required to recover from corrupt application code for all machine devices.

Note: This is an empty file and must not have an extension. The Altboot routine checks to see that a file with this name is present.

4. How to create the flag:
 - a. Open the `\altboot` folder on USB drive.
 - b. Right click on a blank area of the screen and select **New**.
 - c. Select **Text Document**.
 - d. The name [New Text Document.txt] will be highlighted.
 - e. Type **FORCED_UPGRADE** (the file name is case sensitive), then press **Enter**.
 - f. A pop-up with the message, **If you change a file name extension, the file might become unusable. Are you sure you want to change it?**, will appear.
 - g. Click **Yes**.
 - h. The folder structure should be as below:


Table 3 Structure at root level

```

\...
\altboot\XeroxVersaLink_X625_ALTBOOT_system-sw#11802400227150#.DLM (example only)
\altboot\FORCED_UPGRADE

```

5. **Installation of the altboot .DLM:**
 - a. Switch OFF the machine, [GP 10](#)
 - b. Insert the USB drive into an available USB port on the machine.
 - c. Switch on the machine, immediately press and hold the **[HOME]** button.
 - d. Release the **[HOME]** button when the UI screen shows the installation starting.
 - e. The installation progress indicator appears on the UI.
 - f. When the installation is complete, the UI will state, **Remove the USB drive for the system to restart**.
 - g. When the installation is complete and the machine is at Ready, on the UI control panel touch the **Device** icon, then touch **Tools > General > Revert to previous settings**.

 **CAUTION:** A Forced Altboot enables the **Revert to previous settings** feature to display. This feature restores machine-specific information, **IF**, the **DISABLE_DATA_BACKUP** flag was not used. The **DISABLE_DATA_BACKUP** intentionally prevents backup of the data on the machine. There is nothing for the **Revert to previous settings** operation to restore.

- h. The machine will restart to the ready UI screen.

Special Altboot Procedure

Perform this step **ONLY** if executing a Special Altboot:



CAUTION: Only perform Special Altboot procedure when a new Optional Hard Disk Drive (HDD) or controller PWB is installed or the files have become corrupted

1. Download the **SpecialAltboot\X625_SpecialAltboot_.zip** (example) file that is specific to the product from [GSN Library 17800](#).

Note: Example: X625_105.0xx.009.34422_SpecialAltboot.zip. These files are product specific and **MUST** match the Altboot system software DLM being used.

Note: Special Altboot files will only be provided for general releases. Recovering to a SPAR is a two step upgrade.

2. Extract the SpecialAltboot.zip content into the root folder of USB drive, **not the \altboot folder**.

Note: The default extract location for a specific unzip tool used may not be at the root level. Verify the root level of the USB drive is the destination for the extracted files before proceeding.

3. **Perform this step ONLY if executing a Disable data backup:** This prevents the NC from keeping data normally retained through an Altboot. This file is used to eliminate backup of corrupt customer settings

To create the DISABLE_DATA_BACKUP flag:

- a. Open the \altboot folder
 - b. In a blank area of the screen, right click and select **New**.
 - c. Select **Text Document**.
 - d. The name **New Text Document.txt** will be highlighted.
 - e. Type **DISABLE_DATA_BACKUP** (the file name is case sensitive), then press **Enter**.
 - f. A pop-up with the message, **If you change a file name extension, the file might become unusable. Are you sure you want to change it?** will appear.
 - g. Click on **Yes**.
 - h.
4. **Confirm USB file and directory structure is configured correctly. Below structure is required in the root level of the USB drive.**

Confirm:

Note: It is best practice to start the procedure with a clean formatted USB drive having no files or folders.

Table 4 Structure at root level

\...

\altboot\XeroxVersaLink_X625_ALTBOOT_system-sw#11802400227150#.DLM (example only)

\altboot\FORCED_ALTBOOT

\altboot\DISABLE_DATA_BACKUP

\\swup_usb

\\XeroxVersaLink_X625_118.024.002.27150 (example only)

Note: Ensure the Microsoft Windows Safely remove hardware procedure is followed before the USB Flash drive is removed.

5. Insert the USB Flash drive into the system.
6. Save the NVM settings, [dC361](#). Verify that the NVM data were saved to the USB Flash drive before proceeding.

Note: The same USB Flash drive that has the .dlm file can be used to store NVM data.

7. Perform Backup and Restore of customer settings through EWS, [GP 22](#).
8. Complete or delete all pending print jobs. If the jobs cannot be deleted, inform the customer that all pending jobs will be lost.
9. Switch OFF, then switch ON the machine, [GP 10](#). The Altboot process starts automatically. No button presses are required to initiate the Altboot.
10. The upgrade start screen displays.
- 11.

Note: If the USB Flash drive is incompatible with the system, the upgrade start screen will display continuously. If the screen has not changed after 10 minutes, use a different known compatible USB drive, then restart the process.

12. The upgrade begins and the progress screen opens in about 2 minutes.

Note: If the upgrade process screen is not displayed after 4 minutes, restart the process.

13. The Altboot process may take up to 60 minutes to complete. When the Altboot complete screen opens, follow the on screen instructions.
14. If the Altboot process fails, the Altboot failed screen opens. Follow the on screen instructions. Restart the procedure and troubleshoot as necessary.

Note: Do not switch the machine Off unless directed to on the UI.

15. The system may reboot several times before returning to a ready state.
16. Check that the software set has installed. Refer to the printed software upgrade report or press the **Status** button.
17. Restore the customer settings, [GP 12](#).
18. When performing a Forced Altboot, select the **Device** icon, then **Tools > General > Revert to previous settings**.



CAUTION: A Forced Altboot enables the **Revert to previous settings** feature to display. This feature restores machine-specific information, **IF**, the **DISABLE_DATA_BACKUP** flag was not used. The **DISABLE_DATA_BACKUP** intentionally prevents backup of the data on the machine. There is nothing for the **Revert to previous settings** operation to restore.

PWS Altboot Procedure using PWS Altboot tools

PWS-Altboot function is to perform full functional recovery of an MFP or printer with damaged SW and other recovery methods had failed. Also, it is used to provide a viable solution for customers that do not allow thumb drives and/or internet connectivity to perform software upgrades.

Before beginning the procedure perform the following:

1. Go to [GSN Library 17800](#), then download the following items:

- **VersaLink_X625X_Family_Altboot_Tool_PWS**
- **Altboot_SW_and_support_files_VersaLink_X625X_system_sw**. Download the version for the machine you are working on and store it in a folder named **Altboot_SW_and_support_files** on the PWS. The support files are paired with the software version. The support files will only work for that specific software version.

2. Connect an Ethernet crossover cable to the PWS Ethernet port and to the printer Ethernet port.

3. Install the Altboot tool downloaded in Step 1 on the PWS. Use the instructions in the Readme file included with the tool.

Note: Before loading system software, the system should be fully operational and the UI control panel fully operational. If possible, clear any active faults or jams before starting this procedure.

1. Perform an NVM Save, [dC361](#).

2. Back up customer settings, [GP 22](#).

3. Print a Configuration Report, [GP 14](#).

4. If possible, complete or delete all pending print jobs. If jobs cannot be deleted, warn the customer that all pending jobs will be lost.

5. If the machine is equipped with a Wireless Network Interface, enter Tools mode using CSE Tools (Service Copy Mode), [Service Copy \(Tools\) Mode](#), disable wireless, then Switch OFF and Switch ON the Machine, [GP 10](#).

6. Use these steps to configure a PWS LAN connection so the PWS can communicate with the system Network Controller. Once established, settings remain in effect until changed.



CAUTION: Record the original data for every place you make a change. You may or may not need to reset the IP address, depending on PWS usage and local network practice.

a. Right click on the **My Network Places** icon.

b. Select **Properties** to bring up the Network and Dial-up Connections window.

c. Right click on **Local Area Connection** and select **Properties**.

d. Select the **General** tab and scroll down to Internet Protocol (TCP/IP). Highlight **TCP/IP** and select **Properties**.

e. Select the **Use the following IP address** radio button.

f. Enter the IP address 192.168.0.2.

g. Enter 255.255.255.0 for Subnet mask.

h. Select **OK** to close the **TCP/IP Properties** window

i. Select **OK** to close the **Local Area Connection Properties** window.

j. You may need to reboot the PWS to load the settings.

7. Disable the customer's WiFi network connection if enabled.

8. Connect the PWS to the printer Ethernet port using an Ethernet crossover cable.

9. Start the PWS Altboot tool on the PWS and follow the instruction in the file AltaLink-PWS-Altboot-Instructions.pdf to configure the Altboot tool. The file is in the Altboot tool package that was downloaded at the beginning of the PWS Altboot Procedure.

10. Switch on the machine using the Main Power Switch. After approximately 10 seconds, the transfer of the uImage and uboot files begins.
11. After file transfer, the settings menu appears in the terminal window. Check that the 'Received packet' line is displayed and that the IP address is set one digit away from the packet was received from address.
Press **Y** at the prompt and continue. If the valid netmask is not set, press **n** and change it to 255.255.255.0
12. From the next menu, select **5 > Install SBC software**.
13. At the **Proceed?** prompt, select **Y**.
14. At the second **Proceed?** prompt, select **Y**.
15. From the next menu, select **4 > Continue**.
16. A list will display the .DLM file in the directory identified in step 2, select the DLM file to download to the machine. A transfer progress window will then open.
17. After the DLM file has been downloaded to the machine, the Software Upgrade start screen will display on the UI.
18. After approximately 1 minute the upgrade will begin and the Software Upgrade in progress screen will open. If the upgrade process screen is not displayed after 2 minutes, restart the process.
19. The Altboot process should complete after approximately 5 minutes, and the Upgrade Complete screen will open. Ignore the instruction to remove the USB flash drive, only press **0** to continue.
20. The machine will reboot several times before returning to a ready state. During the reboot, the Hard Disk Drive is encrypted. Switching off the machine can cause only partial encryption of the Hard Disk's partitions. The Altboot process may need to be re-run if power is removed at this step. The UI displays the Data Encryption/Decryption in Progress screen.
21. After the reboots have finished the machine will come to ready. In the SBC-AlternateBoot window on the PWS should display SBC System is OPERATIONAL.
22. Disconnect the crossover Ethernet cable from the PWS network and the machine.
23. Connect the customer's network cable to the machine or re-enable the WiFi card adapter if installed.
24. Compare the configuration report printed at the start of the procedure to the software version in the **[Device]** UI control panel settings to verify the software upgrade is successful.
25. Perform an NVM Restore, [dC361](#).
26. Restore the customer settings, [GP 22](#).

Note: If the screen displays the message the device is in a non-customer mode, perform [GP 33](#) Restoring Customer Mode.

Additional Tools

- [Troubleshooting](#)
- [Fleet Orchestrator](#)

Troubleshooting

Listed below are possible problems that may stop Altboot software loading:

Possible causes and solutions are:

- Incompatible/or not working USB drive. Change the USB drive to a known good USB drive, or, use a Xerox approved model of USB drive.
- Corrupt.dlm file. Install a new .dlm file.
- Incorrect spelling of the \altboot directory on USB drive. Correct the spelling of the \altboot folder.

- Altboot and upgrade folders on the USB drive.
- Bad data connection to the optional hard disk drive. Reseat the optional hard disk drive harnesses.
- Hard disk drive corruption or failure.
- USB port or cable damage. Use a different USB port or cable.
- UI failure. Troubleshoot the UI control panel failure to resolve.
- Controller PWB failure. Troubleshoot the controller PWB.
- Check the +5V supply to the USB ports on the controller PWB. Troubleshoot the controller PWB.
- Failure to disable wireless networking when using a PWS. Disable the WiFi card.
- Pound [#] signs missing from the .dlm file name. Correct the .dlm file name.

Fleet Orchestrator

The Fleet Orchestrator feature allows you to configure many devices in similar ways, automatically. After you configure one device, you can distribute any of the configuration settings to other devices, as needed. You can set up schedules to share configuration settings regularly and automatically. The Fleet Orchestrator feature enables you to share the following types of configuration files

- **Software upgrade files:** A software upgrade file contains the latest firmware for the device. Xerox releases upgrades when needed. **Refer to the System Administrator Guide**
- **Clone files:** A clone file contains configuration settings from a device. When you install a clone file on another device, the clone file changes the configuration settings to match the settings on the cloned device. **Refer to the System Administrator Guide**
- **1-Touch Add-On files:** A 1-Touch Add-On file adds workflows to a device without overwriting existing apps or workflows. **Refer to the System Administrator Guide**

Software Upgrade Files: When Xerox releases a new version of software for the device, Fleet Orchestrator can be used to install the software upgrade file. Software upgrade files do not overwrite printer configuration settings.

GP 5 Miscellaneous Checks

Purpose

To indicate which types of problems to look for when checking or inspecting parts of the machine.

Procedure

1. Assess the fault. Check if the part is broken, too loose or too tight. Check if it needs cleaning or lubricating.
2. Check the components that follow as appropriate:
 - [Actuators](#)
 - [Bearings](#)
 - [Drive Belts](#)
 - [Gears](#)
 - [Gravity Fingers and Stripper Fingers](#)
 - [Harnesses and Wiring](#)
 - [Rollers](#)
 - [Shafts](#)

Actuators

- Free movement.
- Damage
- Contamination.

Bearings

- Wear.
- Damage.
- Contamination.

Drive Belts

- Wear.
- Damaged teeth.
- Correct tension.
- Contamination of tension rollers and support shafts.

Gears

- Contamination.

- Chips or cracks.
- Wear.
- Misalignment.

Gravity Fingers and Stripper Fingers

- Free movement.
- Missing fingers.
- Damage.
- Contamination on the fingers, rollers or on the pivot shaft.

Harnesses and Wiring

- Continuity.
- Short circuits caused by physical damage or contamination of conductors, terminals or connectors.
- Overheated insulation.
- Damaged insulation near moving parts and sharp edges.
- Pin and receptacle damage on connectors.

Rollers

- Flats.
- Tears.
- Contamination.
- Secure E-clips and other retainers.

Shafts

- Contamination.
- Misalignment.
- Rotates without binding.

GP 6 How to Check a Motor

This procedure describes how to check a motor:

Initial Actions



WARNING: Isolate the machine from the electrical supply while performing tasks that do not need electricity. Refer to GP 10. Electricity can cause death or injury. Moving parts can cause injury.

1. Check that the motor is free to rotate.
2. Check that all the motors mechanisms are clean, free to move and lubricated correctly.
3. Enable 24V with chain-link 041-001 and test motor operability using dC330. Run the motor for 30 seconds, if the motor shows signs of or can be heard to slow down, the motor is defective. Install a new motor.
4. Perform the appropriate procedure:
 - Two Wire DC Motor
 - DC Motor with Integral Encoder
 - Four Wire Stepper Motor

Note: The voltages, PJ numbers, pin numbers and PWB names shown are an example only. Go to the wiring diagram associated with the RAP for the correct information.

Note: In cases where the motor may be driven forward or backward, the same two feed wires are used, but the voltages on them are reversed, to reverse the motor direction. Such motors may have two component control codes, for forward and reverse. A typical application is a tray lift motor with a tray-up and a tray-down direction.

1. Check the drive voltage when the component control code for the motor is entered. If the drive voltage is present at the motor, but the motor does not turn, install a new motor. If the drive voltage is not present, go to step 2.
2. Check that the drive voltage is correct at the driver output pins of the PWB when the component control code for the motor is entered. If the drive voltage is present, check the wiring and connectors to the motor. If the drive voltage is not present, check the power to the driver PWB. If the power to the PWB is good, install a new driver PWB.

Note: This type of motor has the normal drive voltages for a DC motor, plus the +3.3VDC and 0V lines for the encoder. The encoder has two outputs, A and B, producing pulses when the motor is on. When the motor is running in one direction, the encoder A pulses lead the encoder B pulses. In the other direction, encoder B pulses lead encoder A pulses. In this way the controller can detect that the motor is running in the correct direction.

Check the operation of the motor as follows:

1. Check the drive voltage when the component control code for the motor is entered. If the drive voltage is present at the motor, but the motor does not turn, install a new motor. If the drive voltage is not present, go to step 2.
2. Check that the drive voltage is correct at the output pins of the driver PWB when the component control code for the motor is entered. If the drive voltage is present, check the wiring and connectors to the motor. If the drive voltage is not present, check the power to the driver PWB. If the power to the PWB is good, install a new driver PWB.

Note: When checking for pulses, use a standard digital multimeter. Using the DC volts range, or the AC volts range, expect to obtain a reading greater than 1V and less than 4 volts, while the motor is running. The actual value depends on the meter's reaction to square waves and to the particular frequency of the pulses. It is common to obtain a reading of 2 to 3 volts. If the meter has a minimum and maximum recording facility, expect a maximum value of around +4.9 volts DC, and a minimum value of around +0.2 volts DC.

Check the operation of the encoder as follows:

Check for pulses when the motor is running. If pulses are present at the motor, but not present at the PWB, check the wiring to the motor and repair or install new wiring. If pulses are present at the PWB, but there is still an error indicating that the motor is failing, install a new driver PWB.

Note: A stepper motor with an internal open circuit may appear to be fully functional under dC330 component control. However, under normal operation it will run with intermittent failure. Use the multimeter to check stepper motor coil resistance.

1. Refer to Figure 1 as an example. Disconnect PJ111. Check the +24VDC supply and the phase pulses to GND when the component control code for the motor is entered. If the supply and pulses are present, install a new motor.
2. Check the connectors and wiring to the motor. Repair or install new wiring, as necessary.
3. Disconnect PJ11. Check the +24VDC. If +24VDC is not present, check the power to the PWB. If the power is good, install a new PWB. Check the phase pulses at the PWB. If the phase pulses are not present at the PWB, install a new PWB.

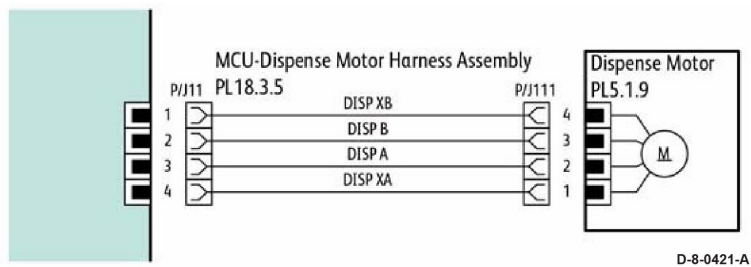


Figure 1 Motor wiring diagram

GP 7 How to Check a Switch

Use this procedure to check the operation of a switch.

Note: Figure 1 shows an interlock switch actuated by the closing of a door.

Initial Actions



WARNING: Isolate the machine from the electrical supply while performing tasks that do not need electricity. Refer to GP 10. Electricity can cause death or injury. Moving parts can cause injury.

Manually check that the switch operates. Ensure that the magnet or other actuator has enough mechanical movement to operate the switch.

Note: The voltages, PJ numbers, pin numbers and PWB names shown are an example only. Go to the wiring diagram associated with the RAP for the correct information.

Procedure

1. Enter Diagnostics, GP 1, then dC330 to enable the switch to test. Actuate the switch. If the display changes, the switch operates correctly. If the display does not change, perform the following steps.
2. Inspect the mechanism intended to actuate the switch. Adjust, repair or install a new part as needed if it is not actuating the switch.
3. Disconnect the switch and measure the resistance between the two connector pins. If it does not change from infinite to 0 ohms as the switch is actuated, install a new switch. If the resistance changes correctly, go to the next step.
4. Check the continuity of the wire harness between the switch and its control PWB. If open, repair or install a new harness.
5. If the switch and wire harness have tested good, install a new PWB that the switch is connected to.

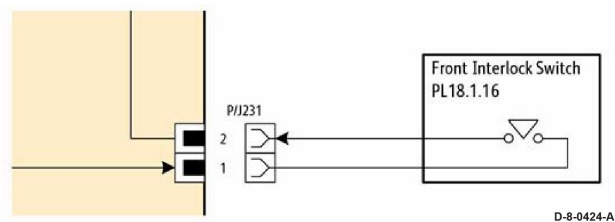


Figure 1 Switch wiring diagram

GP 8 How to Check a Solenoid or Clutch

Use this procedure to check a clutch or solenoid.

Initial Actions



WARNING: Isolate the machine from the electrical supply while performing tasks that do not need electricity. Refer to GP 10. Electricity can cause death or injury. Moving parts can cause injury.

1. For a clutch, check that the shafts, gears, rolls etc., associated with the clutch are free to rotate, clean and lubricated where applicable.
2. For a solenoid, check that the solenoid is free to actuate and that the mechanisms associated with the solenoid are free to move.

Procedure

Note: The voltages, PJ numbers, pin numbers and PWB names shown are an example only. Go to the wiring diagram associated with the RAP for the correct information.

Note: When a solenoid is energized in diagnostics, movement is seen. When a clutch is energized in diagnostics, the sound of the clutch action is heard. If possible, run the motor connected to the clutch to confirm when the clutch is energized.

1. Enter the dC330 output code for the clutch or solenoid. If the clutch or solenoid does not energize, continue with step 2.
2. Refer to Figure 1 (as an example). Disconnect PJ17, check for +24VDC at pin 1 on the wiring side of the connector. If the voltage is correct, install a new solenoid or clutch.
3. Reconnect PJ17, enter the dC330 output code for the clutch or solenoid, while measuring the voltage between pin 1 and ground. If the voltage does not change when the code is entered, install a new PWB.
4. If the fault is intermittent, perform the actions that follow:
 - a. Check the wiring. Repair or replace as necessary.
 - b. Operate the clutch or solenoid under normal running conditions. If the clutch or solenoid operates intermittently or with hesitation, install new parts.
 - c. Check that the clutch or solenoid has enough drive to operate the mechanism to which it is attached; if necessary, install a new clutch or solenoid.

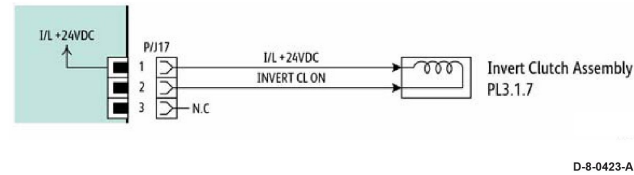


Figure 1 Clutch wiring diagram

GP 9 How to Check a Sensor

Use this procedure to check the operation of all types of sensors.

Note: Some sensors have a resistor within the sensor and other sensors require a resistor on the PWB. The resistor limits the current through the LED. The voltage to the sensor LED with an external resistor, is typically 1.2V

Note: The voltages, PJ numbers, pin numbers and PWB names shown are an example only. Go to the wiring diagram associated with the RAP for the correct information.

Note: In some cases, two sensors are used to form an interruptible beam of light. In these cases, the LED of one sensor and the sensing element of the other sensor are used. Treat the two sensors as if they were housed in the same body for diagnostic purposes, ignoring the unused part of each sensor. If the combined sensors do not operate correctly and the beam path is clear of obstruction, it may be necessary to install both new sensors.

Quick Sensor Check

Enter the component control code for the sensor, refer to [dC330](#). Actuate the sensor. If the display changes, the sensor operates correctly. If the display does not change, perform the procedure.

Procedure



WARNING: Isolate the machine from the electrical supply while performing tasks that do not need electricity. Refer to [GP 10](#). Electricity can cause death or injury. Moving parts can cause injury.

For the sensor in the example wiring diagram shown in [Figure 1](#) :

1. Actuate the sensor and check for a change in voltage at PJ27, pin 3. If the voltage changes, install a new PWB. If the voltage does not change, continue to the next step.
2. Disconnect PJ271 at the sensor. Check for +3.3VDC and 0V (GND) on the harness (between pins 2 and 3). If the voltage is correct, install a new sensor. If voltage is not present, go to the next step.
3. Disconnect PJ27 and PJ271. Check the harness and the connectors for continuity. Repair or install a new harness if continuity test indicates an open wire. If harness is good, go to the next step.
4. Check for +3.3VDC and 0V (GND) between pins 2 and 3. If voltage is not correct, install a new PWB.

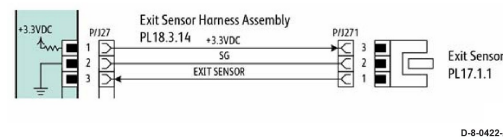


Figure 1 Sensor wiring diagram

GP 10 How to Switch Off the Machine or Switch On the Machine

Purpose

To properly instruct the user, how to switch off, or switch on the machine. The following procedures will provide the greatest security of customer data or damage to the machine.

Refer to:

- [Switch Off Procedure](#)
- [Shutdown Procedure](#)
- [Quick Restart](#)
- [Switch On Procedure](#)
- [Restart](#)
- [Sleep Mode](#)

Switch Off Procedure

1. Press and hold the **power button** on the UI control panel for 5 seconds, then release the **power button**.
2. After 5 seconds from releasing the power button, the machine shuts down automatically

Shutdown Procedure

Note: Do not disconnect the power cord or interrupt the electricity supply before the power down is complete unless advised. The data and software can become damaged.

1. Press then release the **power button** on the UI control panel. The **Power Down Options window** will display.
2. Touch **Power Off**.
3. When the power button stops blinking and is fully dark, remove the power cord from the customer's power supply outlet.

Quick Restart

The quick restart causes the system to reset the software of the controller PWB, the drive PWB and the UI.

1. Press the **power button** on the UI control panel. The **Power Down Options window** will display.
2. Touch **quick restart** on the UI touch screen.

Switch On Procedure

Note:

- After the machine has been switched off, wait a **minimum of 2 minutes** before the machine is switched on.
 - After a service call, ensure that all service tools are removed from the machine.
1. Connect the power cord from the customer's power supply outlet to the machine.
 2. Press the **power button** on the UI control panel.
 3. The machine will perform a power on self test (POST) as it comes to Ready.

Restart

Restart is selected from the **Power Down Options** window.

Note: The machine will restart within 2–3 minutes.

Sleep Mode

Sleep is selected from the **Power Down Options** window.

Note: When sleep is touched, the machine should immediately enter sleep mode.

Note: Issues that may cause the machine to not enter sleep mode:

1. There is an active fault or status needing attention. Check the UI for a page up arrow or UI fault log for active faults.
2. The system is busy doing something in the back ground (e.g. a data push, or there is a software bug and some process is hung).
3. An active job is in process of completion. Check the UI Jobs for activity.
4. Check the DADF for paper in the feeder and remove if found.

GP 11 How to Safely Lift or Move Heavy Modules

Purpose

Use this procedure when lifting or moving heavy modules.

Procedure

When removing heavy modules from the machine, the instructions that follow must be observed:

1. Ensure that a suitable stable surface to support the module after removal is located in close proximity to the machine.

Note: Other parts of the machine are not a suitable stable surface.

2. Ensure that the height of the support surface is between 750mm and 1000mm (30 inches and 39 inches).
3. Ensure that there are no hazards or obstacles between the machine and the support surface.
4. If instructed to remove the module toward the rear of the machine and only 1 person is available, the module must be removed while standing at the rear of the machine. If 2 people are available, the module may be removed while standing at the front of the machine.
5. Two people are required if the module is to be lifted on to the floor or lifted from the floor.

GP 12 Machine Lubrication

Purpose

To give information on the use of lubricants.

Procedure



WARNING: Switch off the electricity to the machine, GP 10. Disconnect the power lead from the customer supply while performing tasks that do not need electricity. Electricity can cause the death or injury. Moving components can cause the injury.



CAUTION: Only use lubricants as directed. Incorrect use of lubricants could seriously affect the performance of the machine.

Take the precautions that follow when performing machine lubrication:

- Wear disposable gloves.
- Only use lubricants that are specified in the Parts List.
- Only lubricate parts of the machine as directed in the relevant RAPs, Repairs, Adjustments and General Procedures.
- Apply only the smallest amount of lubricant, sufficient to lubricate the parts. To prevent contamination, remove any surplus lubricant before the machine is run.
- Take great care not to contaminate other parts of the machine with the lubricant.

GP 13 Cloning Machine Settings

Purpose

Use this procedure to overwrite existing machine settings on one machine or multiple same-machines from a common settings machine via EWS in a web browser.

Procedure

Refer to the relevant procedure:

- [Creating the Clone File.](#)
- [Using the Clone File.](#)

Creating the Clone File

1. Refer to [GP 22 Backup & Restore Settings](#).
2. Follow the procedure, [Create & Import Backup File](#) to create the clone DLM.

Using the Clone File

1. Open EWS on the target machine.
2. Login as **admin**; click admin in the upper right corner of the screen, the Login screen appears.
3. enter the username [**admin**], password [**1111**], then click **OK**.

Note: The Login icon is now changed to admin in the upper right of the screen.

4. Scroll to the bottom of the **Home** screen, then click on **Cloning**.
5. The **Install Configuration File** screen appears and **Clone File** is selected.
6. The **Details** sections provides information on:
 - **Last Attempt** Clone DLM.
 - **Last Attempt Status** if a clone file installation has been attempted the status will show success or failed.
 - **Installation Policy** shows two policies:
 - Cloning **Allowed or Not Allowed** — click the link to jump to the **Installation Policies** to change as required.
 - Cloning via **Print Submission** — Print Submission Allowed or Not Allowed.

Note: Print Submission is not the recommended mechanism for deliver of cloned DLM files. Print Submission allows the device to receive clone files via the print path? This may result in unauthenticated clone files being installed on this device. Consider turning this feature on temporarily when needed.

GP 14 Printing Reports

Reports can be produced by two methods:

1. Through use of Embedded Web Server (refer to the User Guide or the System Administrator Guide for more information).
2. From the local UI.

Purpose

To list reports available from the UI:

Note: It is not necessary to enter SA mode (log in) in order to perform this procedure.

- [Basic Configuration Report](#)
- [Detailed Configuration Report](#)
- [Billing Summary](#)
- [Getting Started](#)
- [Troubleshooting Print Quality](#)
- [Supplies Usage Page](#)
- [Graphics Demo Page](#)
- [PCL Font List](#)
- [PostScript Font List](#)

Procedure

At the UI panel **Home** screen:

1. Touch **Device** icon on the UI.
2. Touch **Information Pages**.
3. Touch the report required, then press **Print**.

Basic Configuration Report

Detailed Configuration Report

The Detailed Configuration Report lists the current state of system configuration parameters including installed options and network settings.

Billing Summary

The Billing Summary Report lists Device Information, Billing Meter impression counters (for customers on billing meter supplies plans only) and Sheet Count by Paper Type.

Getting Started

Troubleshooting Print Quality

Supplies Usage Page

The Supplies Usage report includes the current status of printer consumables and routine maintenance items. Installation dates and replacement part numbers are listed.

Graphics Demo Page

This report shows a brief synopsis of the device.

PCL Font List

This report provides a list of the installed PCL fonts.

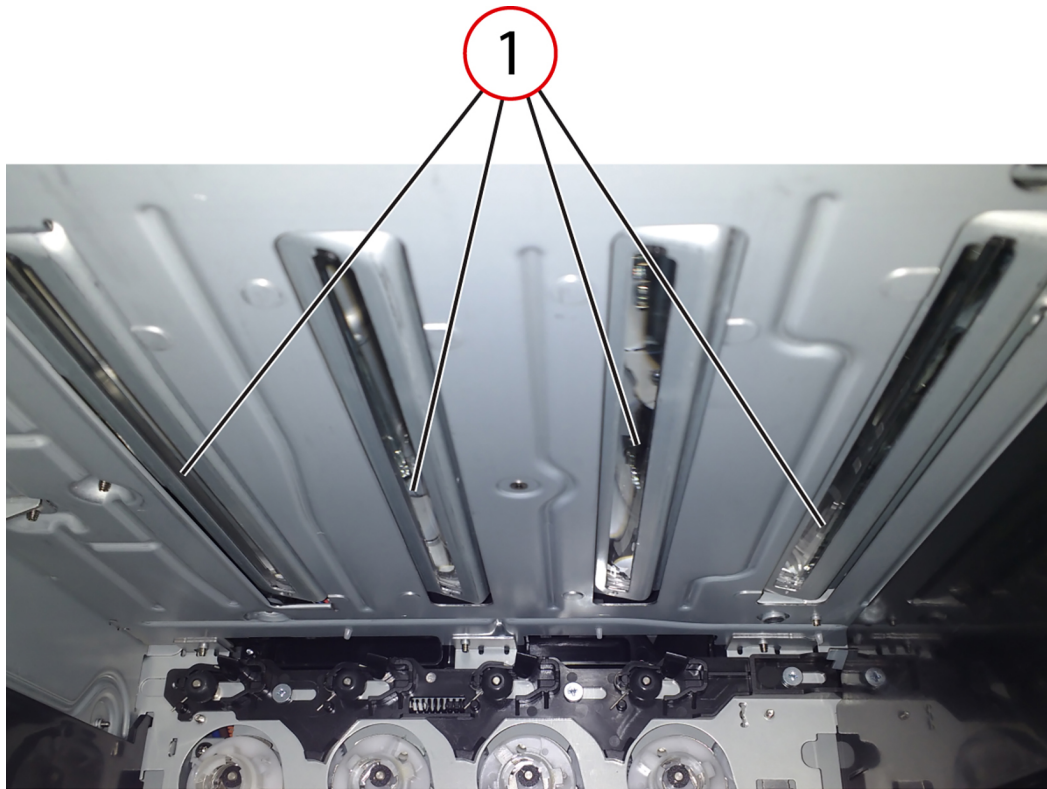
PostScript Font List

This report provides a list of the installed PostScript fonts.

GP 15 Cleaning the Printhead Lens

Cleaning the Printhead Lens

1. Remove the waste toner bottle, [REP 90.3](#)
2. Remove the imaging kits:
 - Black Imaging Kit (150K) [013R00697]
 - 3 Color Imaging Kit (150K) [013R00698]
3. Using a lint-free cloth, wipe the printhead lenses (1).



vlc625s_6006

Figure 1 Printhead lenses

GP 16 Installation Space Requirements

Purpose

To outline the general space requirements to enable safe use and adequate access for service.



WARNING: Do not work in a confined space. 1 m (39 inches) space is needed for safe working.



WARNING: USA and Canada. Do not install this machine in a hallway or exit route that does not have 1.12 m (44 inches) of space additional to the normal space requirements in front of the machine. To conform with fire regulations this additional 1.12 m (44 inches) of space is needed in front of the machine in hallway and exit routes

Machine Height

- IOT+DADF with the DADF lowered = 621mm (24.44 inches).
- IOT+DADF with the DADF raised = 863.6mm (34.0 inches).
- IOT + DADF + Optional 550–Sheet Tray DADF lowered = 739.14mm (29.1 inches).
- IOT + DADF + Optional 550–Sheet Tray DADF raised = 982mm (38.66 inches).

Machine Weight

- IOT+DADF = 32.2kg (71lb).
- IOT + DADF + Optional 550–Sheet Tray = 39kg (86lb).

Paper Trays

- Optional 550–Sheet Tray = 6.8kg (15lb).

Machine Dimensions and Installation Space Requirements

Table 1, Dimensions and Space Requirements, shows the dimensions and the installation space required for safe operation.

Note: The installation dimensions in Table 1, Dimensions and Space Requirements, allow for a 1 metre (39.4 inches) minimum safety work space around the machine. To acquire this minimum safety work space, it may be necessary to move the machine within the area specified. A gap of 100mm (4 inches) is required at the rear for airflow to fans. This is also sufficient for the DADF when raised.

Figure 1, Installation Plan, represents a plan view of a machine installation and is to be read in conjunction with this information.

Table 1 Dimensions and space requirements

Configuration	Machine Width mm/inches	Machine Depth mm/inches	Machine Height mm/inches
IOT+DADF	1140 / 45	1143 / 45	920 / 36
IOT+DADF+Optional 550-Sheet Tray	1140 / 45	1143 / 45	1039 / 41

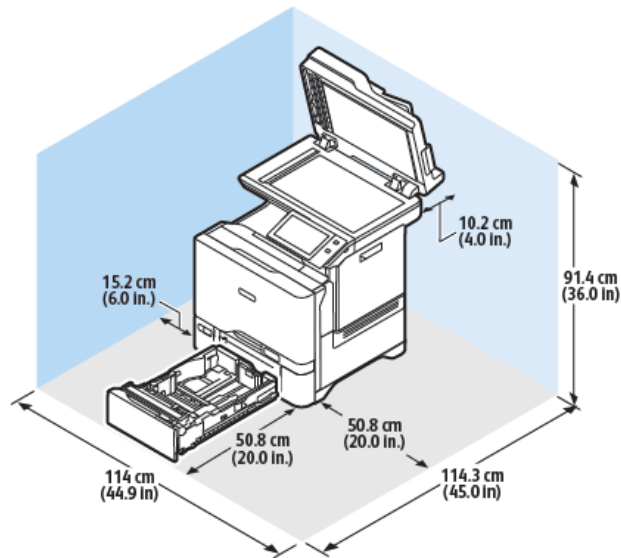


Figure 1 Installation Plan

GP 17 Electrical Power Requirements

List of Tables:

1. [Table 1](#), Electrical Power Usage.
2. [Table 2](#), Power Modes, supports up to six (6) power modes.
3. [Table 3](#), Operation Modes.

Power Usage

Table 1 Power Usage

Power State	Value
Off (W)	0.1
Hibernate (W)	0.1
Sleep State (W)	1
Ready Low Power State - Tier 2 (W)	31.5
Ready State - Tier 1/ first ~5 min (W)	61
Simplex Printing (W)	630
Duplex Printing (W)	520
Typical Electricity Consumption (kwh) Default Mode	0.55
Average Current While Operating 100-110V (A)	8.7
Average Current While Operating 110-127V (A)	7.51
Average Current While Operating 220-240V (A)	3.55
Rated (Maximum) Current 100-110V (A)	11
Rated (Maximum) Current 110-127V (A)	10
Rated (Maximum) Current 220-240V (A)	5

Power Modes

Table 2 Operation modes

Mode	State
Active Mode: <ul style="list-style-type: none"> Machine producing output. 	<ul style="list-style-type: none"> Power Used: Varies with job and includes maximum AC power. Active Mode Entry: From Ready or Sleep Modes, upon receipt of a print or scan job Active Mode Exit: Upon job complete UI state: By default, the UI is active, with backlight on, and indicator light blinking blue.
Ready Mode: <ul style="list-style-type: none"> Machine can respond to jobs with minimal delay. 	<ul style="list-style-type: none"> Ready Mode Entry: <ul style="list-style-type: none"> From Active Mode, on job completion. From Sleep Mode upon wake event* From Hibernate Mode, upon scheduled wake, or touch of Power Button From Off Mode via touch of Power Button Ready Mode Exit: <ul style="list-style-type: none"> To Sleep Mode, upon Power Button touch, Sleep timeout of scheduled Sleep event. To Hibernate Mode, upon scheduled event To Off Mode, via a 5 second press of the Power Button UI state: At home screen, by default, with the indicator light illuminated blue.
Sleep Mode: <ul style="list-style-type: none"> Primary power saving mode. UI dark. Machine can respond to jobs with some delay. 	<ul style="list-style-type: none"> Sleep Mode Entry <ul style="list-style-type: none"> From Ready Mode only, via Sleep mode timeout, power button press, or scheduled day/time. Sleep Mode Exit <ul style="list-style-type: none"> To Ready Mode, via wake events*, or cycling AC power. To Deep Sleep Mode, via a 6 minute timeout from entering Sleep mode To Hibernate Mode, via scheduled Hibernate, or Hibernate inactivity timeout. To Off Mode, via a 5 second press of the Power Button. UI State: <ul style="list-style-type: none"> Indicator light is lit solid amber with panel dark Touch screen is active, in Sleep
Deep Sleep Mode: <ul style="list-style-type: none"> Enhanced power saving mode. UI is dark. Machine can respond to jobs with some delay. 	<ul style="list-style-type: none"> Deep Sleep Mode Entry <ul style="list-style-type: none"> From Sleep Mode only, via 6-minute timeout after entering Sleep Mode Deep Sleep Mode Exit <ul style="list-style-type: none"> To Ready Mode, via wake events*, or cycling AC power. To Hibernate Mode, via scheduled Hibernate, or Hibernate inactivity timeout To Off Mode, via a 5 second press of the Power Button UI State: <ul style="list-style-type: none"> Indicator light blinks amber, with panel dark

Mode	State
	<ul style="list-style-type: none"> Touch screen is active, in Deep Sleep
Hibernate Mode: <ul style="list-style-type: none"> Panel not lit. Touch not active. Minimal wake events recognized. MACHINE IS NOT RESPONSIVE TO PRINT OR FAX JOBS IN THE HIBERNATE STATE. Supports ultra-low power, via scheduled times when printer is not being actively used. 	<ul style="list-style-type: none"> Hibernate Mode Entry <ul style="list-style-type: none"> Via scheduled date/time Via inactivity timeout. <ul style="list-style-type: none"> 3 days, by default By default, the inactivity timer is disabled, if the machine is connected via network, USB, or FAX Hibernate Mode Exit <ul style="list-style-type: none"> Press of the Power Button Scheduled Wake Cycling AC power. UI State: The indicator light will pulse amber, otherwise, the machine appears to be unpowered.

Mode	State
<p>Off (Soft Off) Mode:</p> <ul style="list-style-type: none"> Lowest Power machine state. MACHINE IS NOT RESPONSIVE TO PRINT OR FAX JOBS IN THE OFF MODE. 	<ul style="list-style-type: none"> Off Mode Entry: <ul style="list-style-type: none"> Via sustained, five second, Power Button Press <ul style="list-style-type: none"> After five second press, UI will turn off If the machine is in Off Mode, and AC power is cycled <ul style="list-style-type: none"> Machine will return to Off Mode The Power Button LED will pulse for 30 seconds, after AC power is reapplied, before the machine re-enters Off Mode. Off Mode Exit to Ready Mode: <ul style="list-style-type: none"> Via momentary Power Button press only. UI State: Panel, buttons, and all lights, are off, in Off Mode. The machine is unpowered, except for low power uC and some portions of the Low Voltage Power Supply (LVPS).
<p>Wake:</p> <ul style="list-style-type: none"> The device is in the Wake state during printing, scanning, copying, or any time the display is active. Responsiveness and performance are most important in Wake, thus fewer power savings features are enabled in this state. 	<p>Device may transition to a Wake state upon:</p> <ul style="list-style-type: none"> Physical activity: <ul style="list-style-type: none"> Wake sources vary depending on prior state, but may include <ul style="list-style-type: none"> Cover/Door open Touch Screen Press Power Button Press: always active Print or Scan Jobs initiated via USB, Ethernet, WiFi, FAX <ul style="list-style-type: none"> Note that some devices support ISP's (Internal Solutions Ports) to provide IEEE 1284 Parallel Port, Serial, and Fiber. These would also remain active during Sleep and wake the machine upon job receipt.

Sub-System	Run Mode	Ready Mode	Low Power Mode	Sleep Mode	Sub Power Off Mode
Print Head Assembly	Operating state	Off	Off	Off	Off
Fusing Fan	Temperature controlled slow or fast rotation	Temperature control in stop or rotate (slow)	Temperature control in stop or rotate (slow)	Off	Off
Marking Fan	Temperature controlled, either stopped or slow or fast rotation	Temperature control led either stop or slow rotation	Temperature control led either stop or slow rotation	Off	Off
ESS (Reference only)	Operating state	Standby	Standby	Ready to receive	Inactive

Table 3 IOT states

Sub-System	Run Mode	Ready Mode	Low Power Mode	Sleep Mode	Sub Power Off Mode
Fuser	Maintaining operating temperature	Maintaining standby temperature	Maintaining low temperature	Off	Off
Xerographics	Operating state	Off	Off	Off	Off

GP 18 Cleaning the Scanner

Procedure

1. Lift the scanner cover, [Figure 1](#).

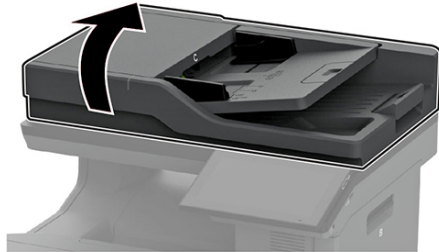


Figure 1 DADF

2. Using a damp, soft, lint-free cloth, wipe the following areas:

- DADF glass pad, [Figure 2](#).

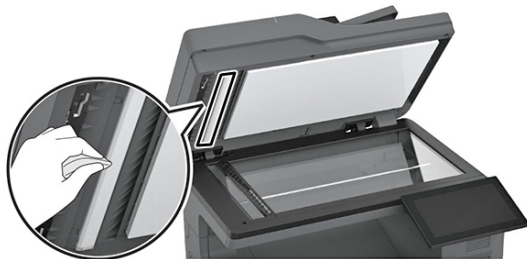


Figure 2 DADF glass pad

- Scanner glass pad, [Figure 3](#).



Figure 3 Scanner glass pad

- DADF glass, [Figure 4](#).



Figure 4 DADF glass

- Scanner glass, [Figure 5](#).



Figure 5 Scanner glass

3. Close the scanner cover.

4. Open door C.

5. Using a damp, soft, lint-free cloth, wipe the following areas:

- DADF glass pad in door C, [Figure 6](#).

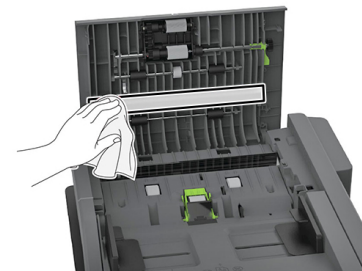


Figure 6 DADF glass pad in door C

- DADF glass in door C, [Figure 7](#).



VLC625S_1007

Figure 7 DADF glass in door C

6. Close door C.

GP 19 Obtaining Audit and Device Logs

Purpose

To obtain then download device data for analysis by 2nd level support. The machine needs to be out of Diagnostics [GP 1](#), if you need to enable HTTPS or you will get an error.

Note: It may not be possible to obtain a device log if the device executed a reboot after an error occurred. To enable the device log collection enter Diagnostics, enter [dC131](#), then set the NVM chain-link code 700-530 value to 0. Repeat the device log procedure then reset the NVM chain-link code 700-530 value back to 1.

Initial Actions

- Print a configuration report, [GP 14](#) Printing Reports, to locate the machine's IPv4 address.
- The machine IPv4 address is also located at the top of the UI screen.

Procedure

User Panel (UI) on the Machine

1. Login as Admin.
2. Touch, **Device > Tools > Network Settings > Advanced Network Settings > HTTP Settings**.
3. Verify HTTP is **[Enabled]**.

Audit Log

- Enter the **IPv4 address** from the Configuration Report, into the address line in a web browser, then press **Enter** on the keyboard to access the WebUI.

Note: The computer accessing the WebUI must be on the same TCP/IP network address as the machine.

- Within the WebUI, login to admin mode, [GP 23](#) Customer Administration Tools.

1. Click the tab, **[Properties]**, at the top of the screen.
2. On the left side of the screen click, **Connectivity > Setup**.
3. Scroll down to **[Protocol]**, then **[HTTP]**, verify the **[Enabled]** box is checked.

If unchecked:

- a. Click **[Edit]**, to open the HTTP settings.
- b. In the **[Configuration]** section, click **[Enabled]**.
- c. Enter the port number, **[80]** is the default.
- d. **[Force Traffic over Secure Connection (HTTPS)]**, check **[Yes]**, port number **[443]** is default.
- e. Click **[Save]** to save settings.

1. Within EWS, click the tab, **[Properties]**, at the top of the screen.
2. On the left side of the screen, open the **Security** menu.
3. Open the **[Logs]** menu, then click **[Audit Log]**.
 - a. Click the **Export Audit Log** radio button.
 - b. Click the **Download Log** link. A file named [UQA188055_2022-12-28T15_46-0800_auditfile.zip], **example**, is downloaded to the **Downloads** folder on the computer.

Note: The instructions state to **Right click on the link to download**. This is a typo and should be ignored. Left click the link to download the log file.
 - c. Extract the zip file, then find the file named "auditfile.txt".

Note: To view the file, open with a text editor such as; Notepad, Notepad ++, Wordpad, or other text editing/viewing application.
4. If uploading to the **SFTP Transfer Server**, check the box to enable **[Automatic Log Transfer]**.
 - a. Enter the **[Log Transfer SFTP Server]**:
 - **[IPv4 Address]**, [xxx][xxx][xxx][xxx] and port :[xxxx].or
 - **[Host Name]**, [xxx.xxx.xxx.xxx] :[xxxx].
 - b. **[Path]**, enter the HTTPS server address, if known.
 - c. **[Authentication]**, select the appropriate method.
 - d. Enter the **[Login Name]** and **[Password]**.
 - e. Click, **[Apply]**.

Support Logs

1. Obtain the machine's IP address by printing a configuration report. Refer to [GP 14](#) Printing Reports.
2. Access the web UI by entering the IP address into a web browser on a PC on the same network as the machine.
3. Log in to the web UI as an administrator. Refer to [GP 23](#) Customer Administration Tools.
4. Click **Properties**, at the top of the screen.
5. On the left side screen menu, click **Security > Logs > Support Logs**.
6. Click **Start Download**.

7. Click **Download File Now**. A file named [UMQ000530_20230208_153932.zip], **example** is downloaded to the **Downloads** folder on the computer.
8. Support Logs can also be downloaded to a USB drive by using the Control Panel (UI):
 - a. Login as admin.
 - b. At the Control Panel (UI), Touch; **Device > Tools > Network Settings > Support Logs > Download Log Files**.

Note: If a USB drive is not detected, the **USB Drive Not Found** screen appears. Insert a USB drive or remove, then insert the USB drive again. Select **OK**, the download will begin to the USB drive.

GP 20 First Copy/Print Out Time and Power On Time

Refer to [Table 1](#). The first copy out time (FCOT) is the duration from the start copy request to the delivery of the first copy to the output destination. Values are based on a standard job where the original is copied at 100% from the document glass or DADF onto A4 LEF paper fed from tray 1.

The first print out time (FPOT) is the duration from the print job request to the delivery of the print in the centre catch tray. Values are based on paper fed from tray 1.

Setting preferences using the Embedded Web Server

Use the Embedded Web Server to change **preferences settings** :

1. Open Embedded Web Server in a browser, then Login as admin.
2. Select **[Apps > Copy]** .
3. Select **[General Settings and Policies > Background Suppression]** .
4. Select **[Color Copy Preferences > High Speed]**
5. Select **[Black and White Copy Preferences > High Speed]**

Setting priority using the Embedded Web Server

Use the Embedded Web Server to change priority settings:

1. Open Embedded Web Server in a browser, then Login as admin.
2. Select **[System/Defaults & Policies]** .
3. Select **[Common > First Page Printing Optimization]** . Set for Color **OR** Black and White as required for the job.
4. Select **[Common > Color Printing Optimization]** . Set for Color **OR** Black and White as required for the job.
5. Select **[Close]** .

Table 1 First Copy Output Times (FCOT)

Versalink	C625 (time in seconds)
ADF Text/Photo Letter Standby/Ready Mono	5.7
ADF Text/Photo Letter Standby/Ready Color	6.3
Flatbed Text/Photo Letter Standby/Ready Mono	5.5
Flatbed Text/Photo Letter Standby/Ready Color	6.1
ADF Text/Photo Letter Sleep Mono	12.9

Versalink	C625 (time in seconds)
ADF Text/Photo Letter Sleep Color	12.9
Flatbed Text/Photo Letter Sleep Mono	13
Flatbed Text/Photo Letter Sleep Color	13
ADF Text/Photo A4 Standby/Ready Mono	5.8
ADF Text/Photo A4 Standby/Ready Color	6.3
Flatbed Text/Photo A4 Standby/Ready Mono	5.6
Flatbed Text/Photo A4 Standby/Ready Color	6.2
ADF Text/Photo A4 Sleep Mono	12.9
ADF Text/Photo A4 Sleep Color	13.2
Flatbed Text/Photo A4 Sleep Mono	13
Flatbed Text/Photo A4 Sleep Color	13.3

GP 21 Restriction of Hazardous Substances (RoHS)

Purpose

To provide information on the RoHS Directive.

The RoHS Directive restricts the use of certain hazardous substances in electrical and electronic equipment. It applies to equipment placed in the European Union (EU) market. The directive takes effect from 1st July 2006.

Note: Currently these restrictions are only for the European Union (EU) market and some associated countries. For more information go to www.Xerox.com. However, Xerox has mandated that all Xerox® VersaLink® machines must be maintained as RoHS compliant.

The hazardous substances are:

- Lead (Pb)
- Mercury (Hg)
- Cadmium (Cd)
- Hexavalent Chromium (Cr 6+, Cr [VI])
- Polybrominated Diphenyl Ethers (PBDEs)
- Polybrominated Biphenyls (PBBs)

Identification of a RoHS Compliant Machine

Xerox will maintain a central list of RoHS compliant machines.

All Xerox® VersaLink® machines are RoHS compliant at time of manufacture.

Procedure



CAUTION: Failure to comply with RoHS guidelines can result in product recalls, imprisonment, fines or penalties.

Use only spares that are listed in the Xerox® VersaLink® Spare Parts List. Do not use spare parts from other similar machines, even if the parts look identical. All Xerox® VersaLink® machines are RoHS compliant at time of manufacture and must be maintained as RoHS compliant.

GP 22 Backup & Restore Settings

Purpose

The Backup & Restore feature takes a snapshot of your device's settings and saves them as a backup file to the device itself. Xerox recommends backing up your device settings when the device is operating as desired. This practice is useful for restoring (applying settings) to your device, such as when the settings have changed in error. Note that settings contained in the Daily backup file will be reapplied after a software upgrade. Updating this file before upgrading software will maintain your device's most recent settings.

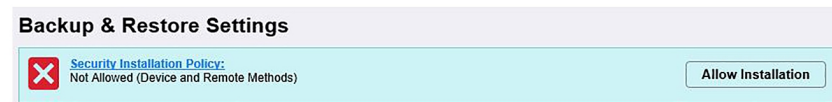


CAUTION: Before starting the procedure, inform the system administrator when any service procedure may result in the loss of saved customer settings.

Procedure

Setting the Security Installation Policy for Backup & Restore

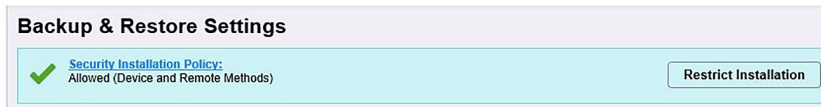
1. Open a web browser, then enter the machine IP address in the browser address line.
2. When EWS loads, click on **admin** in the upper right of the screen.
3. Enter the username [**admin**] and password [**1111**] to log in as admin.
4. Click **Properties > Security > Installation Policies**.
5. **Backup & Restore** is the first policy listed. Check the box, then click **Take me there...**, to the right.
6. The first line, highlighted in blue, lists the active Security Installation Policy.
 - **Figure 1**, shows backup and restore as not allowed. Click the **Allow Installation** button to allow installation.



Q-1-0017-A

Figure 1 Allow Installation

- **Figure 2**, shows backup and restore is allowed. Click the **Restrict Installation** button to not allow installation.



Q-1-0016-A

Figure 2 Restrict Installation Locally Stored Backup Files

Backup files stored in the machine's memory are listed by Date/Time and action, [Figure 3](#).

File Type	Backup Date/Time	Backup	Restore	Other actions
Daily	2023-04-24T00-00-13	Update Now	Restore	
Automatic - Upgrade	2023-02-21T13-47-31		Restore	
Manual	2023-04-24T15-05-10	Update Now	Restore	Delete

Figure 3 Locally Stored Backup Files and Actions

Available actions that can be performed:

- **Backup**
 - Backup/update files immediately.
- **Restore**
 - Restore files immediately.
- **Other Actions**
 - Delete Manual backups immediately.

Import & Restore Backup File

1. In the Embedded Web Server, click **Properties > General Setup > Backup & Restore Settings**.
2. Click **Browse**, then navigate to the file to be restored. The file name appears in the **[Choose File]** window.
3. Click the **Import & Restore** button to restore the machine settings from the selected file.

Create & Export Backup File Creating and Downloading a Backup File

1. In the Embedded Web Server, click **Properties > General Setup > Backup & Restore Settings**.

2. Click **Create and Export**.
3. The **Backup Instructions** page appears with a checked box stating **The backup file has been successfully created**.
4. To download the new backup file, left click the file name link **[2023-04-24T15-47-49_UPQ100574.bkup]** example. The file begins downloading to the computer's Downloads folder.

GP 23 Customer Administration Tools

Purpose

To gain access to Customer Administration Tools in the UI control panel or to login as an administrator via the Embedded Web Server (EWS).

Refer to the relevant procedure:

- [How to Enter Customer Administration Tools](#)
- [How to Enter Admin Mode via the EWS](#)

How to Enter Customer Administration Tools

1. Switch on the machine, [GP 10](#).
2. When the machine completes startup to ready, touch **Log In** in the top left corner of the UI.
3. Touch the keys in the UI to type the user name, **admin**, in the box.
4. Touch **Next**.
5. Enter the password **1111** (default setting).

Note: If the administrator password is not 1111, ask the customer for the current password. If the administrator password is unknown, perform [GP 29](#) System Administrator Password Reset.

6. Touch **Done**.
7. The user **Admin** is displayed in the top left corner of the UI control panel.

Call Closeout

1. Touch **Admin** in the top left corner of the UI control panel.
2. Touch **Log Out**, then at the next screen touch:
 - a. **Cancel** to remain in admin mode.
 - b. **Log Out** to exit admin mode.

How to Enter Admin Mode via the EWS

1. Type the device IP address into a web browser.

Note: The machine IP address can be found:

- At the top center of the UI control panel.
 - The EWS Home Screen.
 - The machine Configuration Report, refer to [GP 14](#) Printing Reports.
2. Select **Login** at the top right corner.
 3. The **Login** screen is displayed:

- a. In the **User ID** box enter **admin**.
 - b. In the **Password** box enter **1111**.
 - c. Click **Login**.
4. The user **admin** is displayed in the top right corner of the EWS screen.

Note: If the admin password is not 1111, ask the customer for the current password. If the admin password is unknown, perform [GP 29](#) System Administrator Password Reset.

Note: A new device will have a default password of the device Serial Number (case sensitive).

Note: If the customer set password is changed during call, return the password to the customer password from the admin pull down menu, before logout. Refer to, [GP 29](#) System Administrator Password Reset.

Call Closeout

1. Select **admin** in the top right corner of the UI control panel.
2. Select **Logout** from the pull down menu.

GP 24 How to Set the Date and Time

Purpose

To set the machine's date and time.

Procedure

Perform the steps that follow:

1. Enter Customer Administration Tools, [GP 23](#).
2. Touch Device.
3. Touch General.
4. Touch Date & Time.
5. Again, touch Date & Time.
6. Correctly set the date and time. Touch OK.
7. Log out of Customer Administration Tools.

GP 25 Ethernet Crossover Cable Setup

Purpose

To connect and then configure the PWS to communicate with a device via a ethernet crossover cable (600T02252).

Procedure



WARNING: Switch off the electricity to the machine, [GP 10](#) . Disconnect the power lead from the customer supply while performing tasks that do not need electricity. Electricity can cause the death or injury. Moving components can cause the injury.

1. Print a configuration report, [GP 14](#).
2. Ensure that Windows firewall and wireless network connectivity on the PWS are turned off.
3. Record the IP address and Subnet Mask of the PWS.



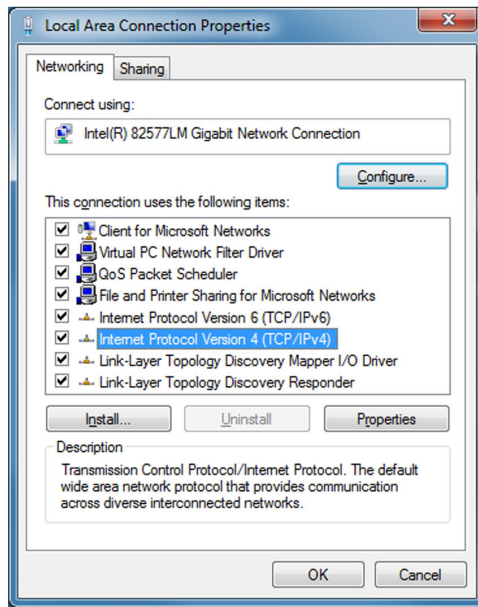
CAUTION: Before changing the value of a setting ensure the original value is recorded. All the original values will need to be restored to the PWS at the end of the procedure.

- a. Open a command window on the PWS:
 - Select **Start** and in the Search box above the Start button, type **CMD**, then press **Enter**.
- b. Type **ipconfig** at the command prompt, then record the Local Area Connection: IPv4 Address and Subnet Mask.
4. Configure the LAN connection of the PWS to enable communication with the device. Go to the relevant procedure:
 - [Windows 7](#).
 - [Windows 10](#).

Windows 7

Perform the steps that follow:

1. Select the Windows **Start** button, then **Control Panel**, then **Network and Sharing Center**.
2. From the left pane, select **Change adapter settings** .
3. Right-click on the **Local Area Connection icon** . Select **Properties**. The Local Area Connection Properties window will open.
4. Select **Internet Protocol Version 4 (TCP/IPv4)** . Select **Properties**, [Figure 1](#). The Internet Protocol Version 4 (TCP/IPv4) Properties window will open.



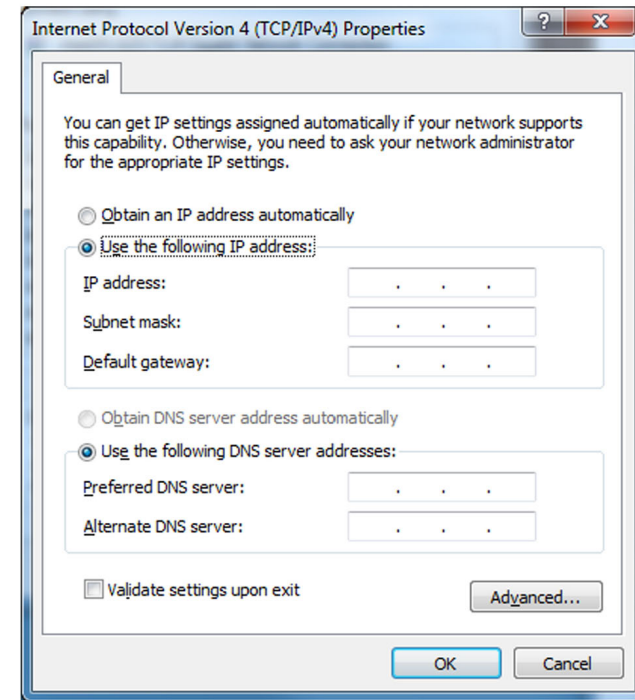
Y-1-0546-A

Figure 1 Properties window

5. Double-click the entry **Internet Protocol Version 4 (TCP/IPv4)**.
6. Select **Use the following IP address**, then enter the IP address and subnet mask.

Refer to the configuration report then:

- Set the IP address of the laptop one number higher than the device. For example, if the IP address of the device is 192.168.196.112, set the IP address of the laptop to 192.168.196.113.
- Set the Subnet mask of the laptop to the same as the Subnet mask of the device, [Figure 2](#).



Y-1-0547-A

Figure 2 Properties window

7. Click on **OK** to close the properties dialog box, then **OK** to close the second properties dialog box.
8. Close the Local Area Connection Status dialog box.
9. Connect the ethernet crossover cable to the device, then continue with your procedure.

Windows 10

Perform the steps that follow:

1. Select the Windows **Start** button, then select **Settings**.
2. Select **Network & Internet**.
3. Under Related settings select **Network and Sharing Center**, then from the task list on the left of the screen select **Change adapter settings**.
4. Right click on **Local Area Connection (Ethernet)**, then select **Properties**.

5. Select **Internet Protocol Version 4(TCP/IPv4)**, then select **Properties**. The Internet Protocol Version 4 (TCP/IPv4) Properties window will open.
6. Select **Use the following IP address**, then enter the IP address and subnet mask.

Refer to the configuration report then:

- Set the IP address of the laptop one number higher than the device. For example, if the IP address of the device is 192.168.196.112, set the IP address of the laptop to 192.168.196.113.
 - Set the Subnet mask of the laptop to the same as the Subnet mask of the device.
7. Select **OK** to close the properties dialog box, then **OK** to close the second properties dialog box.
 8. Close the Local Area Connection Status dialog box.
 9. Connect the ethernet crossover cable to the device, then continue with your procedure.

GP 26 PagePack Plan Activation

Purpose

To assist in activation of a new or changed PagePack Plan.

Introduction

The machine is typically shipped with a Neutral and Factory supplies plan coded CRUM in the toner cartridge. Refer to, [Table 1](#), Supplies Plan Variables and Regional Differentiations. When the first replacement toner cartridge is installed, the Regional Differentiation Code and Toner Cartridge Type in the machine settings are automatically changed to the same settings as the cartridge.

Note: Factory Learning Mode is Service Plan = **Neutral** and Regional Differentiation = **Factory**. It is also possible on this product to be in Regional Learning Mode, where a Service Plan = Sold or Metered and the Region = Factory.

Note: US devices will automatically set to metered without a PIN entry when a metered toner is inserted as the first toner after SWE.

Note: When a device has been set to sold, possibly upon a Sold cartridge inserted as the first toner after SWE, then any metered toner should be disallowed. Once Sold is set, only a PagePack PIN or a Plan Conversion, [GP 37](#), can be used to set Metered/PagePack.

There are four service Plan Variables and six Regional Differentiations:

Plan Variables

- Neutral — as shipped
- Sold
- Metered
- PagePack

Regional Differentiations

- NA
- XE
- NAXE
- DMO
- Metered
- Factory — as shipped

Note: Refer to, [PL 26.05](#) for part numbers.

Verify the current machine PagePack (Supplies Plan) configuration:

At the Machine UI:

1. Print a Configuration Report [GP 14](#).
2. The supplies plan is shown on the configuration report under the General Setup heading.

In EWS:

1. Open a web browser.

2. Enter the machine IP address.
3. On the **Home** screen scroll to the bottom and select **Configuration Report**.
4. The screen displays the configuration report in alphabetical order. Select **General Setup**.
5. The **Service Plan** is shown in the list. Typical **as shipped** service plan is **Neutral**.

Note: Do not attempt to change the NVM settings in [Table 1](#), they are for reference only.

Table 1 Supplies Plan Variables and Regional Differentiations

Device Configuration	Xerox Toner						
Plan Variables: Neutral Sold Metered PagePack Regional Differentiation: NA XE NAXE DMO Factory	SWE (Starter) Sold PagePack	Metered Metered_Learning	Sold NA	Sold XE	Sold DMO	Sold NAXE	Sold Sold_Learning
Metered_Learning Metered_NA Metered_XE Metered_NA/XE Metered_DMO	Y	Y	Y	Y	Y	Y	Y
Sold_NA	Y	N	Y	N	N	Y	Y
Sold_XE	Y	N	N	Y	N	Y	Y
Sold_DMO	Y	N	N	N	Y	N	Y
Sold_Learning	Y	N	Y	Y	Y	Y	Y
Sold_NA/XE	Y	N	Y	Y	N	Y	Y

Note: If a problem occurs after several toner replacements, the customer may have received the wrong toner in a consumable order; either because the wrong part number was ordered, or the shipment did not match the order. Resolution in this case is simple; the customer should exchange the toner for the correct part.

Note: If an incorrect toner cartridge was installed at the first toner replacement after install, or if the machine's configuration changed due to software or NVM corruption, resolve the issue, then perform the following procedure:

Note: 220VAC machines:

- May ask for a PagePack Supplies Activation Code with a courtesy print time.
- This may happen when a metered toner is inserted into a neutral machine still running on SWE toner.
- This will appear automatically in Europe.
- A PagePack Activation Code can also be entered at any time by navigating through the following procedures.

Obtaining a PagePack Activation Code

- **XE:** Contact: office.europe.page.pack.pin@xerox.com.
- **NA:** Follow Local Process.

Note: The machine Serial Number and the PagePack Sequence number are required.

PagePack Activation via Web UI (EWS)

1. In the Embedded Web Server window, enter the machine IP address, then login as **[admin]**.
2. Select the **[Properties]** tab, then in the left column select **[General Setup]**.
3. Select **[Supplies Plan Activation Code]**.



CAUTION: Compare the serial number on the screen with the serial number on the configuration report to ensure the correct machine is being changed.

4. Enter the 6-character PagePack Supplies Plan Activation Code provided above, in **[Supplies Plan Activation Code]**, then select **[Apply]**.

The Geographic Differentiation Code and Toner Cartridge Type will be reset to the values of the customer's agreed-to supplies plan.

PagePack Activation via Remote Control Panel (RPC)

1. Open a browser window, then enter the machine IP address to open Embedded Web Server.

2. Scroll down to remote control panel and start remote session, then login at the admin login screen.
3. At the **[Home]** screen, select **[Device]**.
4. Select **[Tools]**.
5. Select **[Device Settings]**.
6. Scroll down, touch **[Supplies]**, then select **[Enter PagePack Activation Code]**.



CAUTION: Compare the serial number on the screen with the serial number on the configuration report to ensure the correct machine is being changed.

7. Enter the 6-character PagePack Activation Code provided.
8. Select **[OK]**.

The Geographic Differentiation Code and Toner Cartridge Type will be reset to the values of the customer's agreed-to supplies plan.

PagePack Activation via Machine UI

1. At the **[Home]** screen, (Log In to Admin mode is not required).
2. Touch **[Device]** on the UI, touch **[Tools]**.
3. Touch **[Device Settings]**.
4. Scroll down, touch **[Supplies]**, then touch **[Enter PagePack Activation Code]**.



CAUTION: Compare the serial number on the screen with the serial number on the configuration report to ensure the correct machine is being changed.

5. Enter the 6-character PagePack Supplies Plan Activation Code provided in step above.
6. Touch **[OK]**.

The Geographic Differentiation Code and Toner Cartridge Type will be reset to the values of the customer's agreed-to supplies plan.

GP 27 Intermittent or Noise Problem

Purpose

The purpose of this RAP is to provide guidance for resolving an intermittent or noise problem. This is not an exact procedure, but a set of recommended actions that use the resources of the service manual to help locate the cause of an intermittent or noise problem.

Procedure

1. Check the service log. Recent service actions may provide information about the problem. For example, a component that was recently replaced to correct another problem may be the cause of the new intermittent problem.
2. Noise problems may be due to improper installation. Check for packing materials that have not been removed. Check for loose or missing hardware.
3. Run the machine in a mode that vigorously exercises the function that is suspected. The machine may fail more frequently or may fail completely under these conditions. Look for signs of failure or abnormal operation.

An intermittent problem can usually be associated with a RAP, since when it does fail, it results in a fault code, a jam code, or some other observable symptom.

4. Using the RAP that is associated with the symptom of the intermittent problem, examine all of the components that are referenced in the RAP. Look for:
 - contamination, such as a feed roller that has a build up of dirt or toner
 - wear, such as gear teeth that are rounded or have excessive backlash
 - HFSI, even if they are not near or have not exceeded the SPEC LIFE or COPY COUNT value
 - wires chafing against components of the machine, especially against moving components
 - misaligned, maladjusted, or incorrectly installed components
 - slow or slipping clutches; slow or binding solenoids
 - damaged components
 - excessive heat, or symptoms of excessive heat, such as the discoloration of a component
 - loose cables or wires
5. Using the RAP that is associated with the symptom of the intermittent problem, perform all of the adjustments for the components or functions that are referred to in the RAP. Check to ensure that the adjustment can be made and that there is an adequate range of adjustment, and that it can be set to or near the nominal value. Any abnormality that is observed may be an

indication of the cause of the problem. For example, a component can be adjusted to the nominal value, but it is at the limit of the adjustment range. This is not normal and may be an indication of the cause of the problem.

6. Operate all of the components in the appropriate RAP that is associated with the symptom of the intermittent problem with Component Control. Observe the components for any symptoms of abnormal operation, such as a hesitation or an unusual sound.
7. Check that the AC and DC power are within specification.
8. Get technical advice or assistance when it is appropriate. This will depend upon the situation and the established local procedures.
9. Examine the components that are not in the RAP, but are associated with the function that is failing. Refer to the BSDs. Look for:
 - contamination, such as a feed roller that has a build up of dirt or toner
 - wear, such as gear teeth that are rounded or have excessive backlash
 - HFSI, even if they are not near or have not exceeded the SPEC LIFE or COPY COUNT value
 - wires chafing against components of the machine, especially against moving components
 - misaligned, maladjusted, or incorrectly installed components
 - slow or slipping clutches; slow or binding solenoids
 - damaged components
 - excessive heat, or symptoms of excessive heat, such as the discoloration of a component
 - loose cables or wires
10. Perform the adjustments for the components that are not in the RAP, but are associated with the function that is failing. Refer to the BSDs. Check to ensure that the adjustment CAN BE MADE and that there is an adequate range of adjustment, and that it can be set to or near the nominal value. Any abnormality that is observed may be an indication of the cause of the problem. For example, a component can be adjusted to the nominal value, but it is at the limit of the adjustment range. This is not normal and may be an indication of the cause of the problem.
11. Operate all of the components that are not in the RAP, but are associated with the function that is failing with Component Control. Refer to the BSDs. Observe the components for any symptoms of abnormal operation, such as a hesitation, or an unusual sound.
12. Replace any components or consumables that are known to be a frequent cause of the problem. When doing this, consider the cost and time required. If the suspected item is inexpensive, can be installed quickly, and has a high probability of resolving the problem, then it is reasonable to replace it.

13. Leave an accurate and detailed record of your actions in the service log. Describe what you have observed, what actions you took, and the recommended next steps.

GP 28 System Administrator Password Reset

When a customer requires a new administrator password, the customer must call the Welcome Center and request an administrator password reset.

Note: Check to see if the machine password is set at the default. The default password is the Serial Number and is case sensitive.

1. The Welcome Center will request the machine serial number and current copy count.
2. The Welcome Center generates a 12 digit Feature Key number.
3. Press the **Device** icon, then select **Tools**.
4. If necessary, select **Device Settings**, then select **General > Feature Installation**.

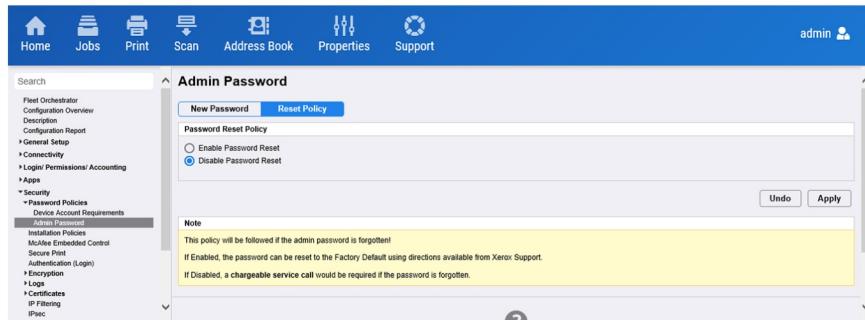
Note: The UI control panel **Feature Installation** menu is accessible without logging in to the admin account.

5. Enter the Feature Key on the Feature Installation Key screen to reset the admin log in credentials to the default values **admin** and **1111**.



CAUTION: The next step calls for a Forced AltBoot procedure to be performed. In this case, **DO NOT** back up or restore customer settings using, [GP 22](#). Doing so will relock the administrator password. Instead, tell the customer that the settings will need to be restored manually. Ask the customer to record all appropriate settings so that they can restore them after the procedure is complete.

6. After performing Steps 1–5 above, the password is not reset, check EWS to verify the password reset has been disabled by the customer, [Figure 1](#). The password can only be reset by a CSE arriving on site and performing a **Forced AltBoot**. Refer to, [GP 4](#) Software Upgrade.



Q-1-0015-A

Figure 1 Disable Password Reset EWS screen

GP 29 Print/Copy Orientation Definitions

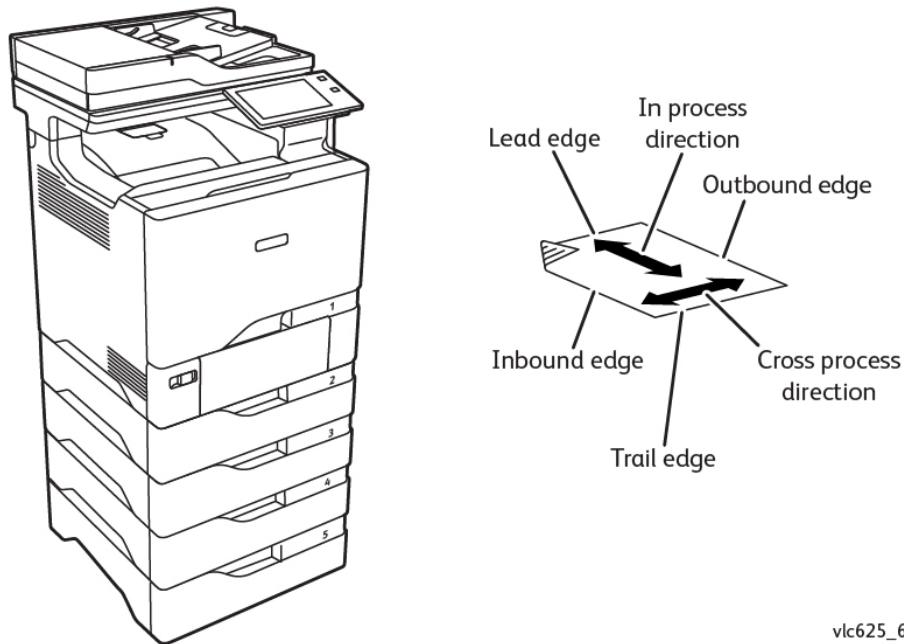
Purpose

To describe the print/copy orientation definitions.

Definitions

Refer to [Figure 1](#). Be aware of the points that follow:

- **Inboard edge** - can also be described as the top edge or side edge.
- **In process direction** - can also be described as the slow scan direction.
- **Cross process direction** - can also be described as the fast scan direction.



vlc625_6007

Figure 1 Print/copy orientation definitions

GP 30 Paper and Media Size Specifications

Purpose

As a reference of Xerox supported I/O media capacities, media types, media sizes, and media bonds and weights.

Specifications

Note: Check that the paper tray settings match the paper size in the tray.

Refer to the tables that follow:

- [Table 1](#) Input/Output Media Capacities.
- [Table 2](#) Media Sizes.
- [Table 3](#) Media Bonds and Weights.

Table 1 Input/Output Media Capacities

Input/Output Capacity by Media and Source			
Source	Media	Stack Height	Approximate Reference Capacity
Input			
Standard Trays ² : 550-sheet Tray	Plain Paper ¹	59 mm	550 sheets (75 g/m ²)
	Labels		200 labels ³
Optional Trays ² : 550-sheet Tray	Plain Paper ¹	59 mm	550 sheets (75 g/m ²)
	Labels		200 labels ³
Multi-Purpose Feeder Tray ²	Plain paper ¹	11 mm	100 sheets (75 g/m ²)
	Envelopes, Other		Various quantities ⁴
Output			
Standard output bin - MFP ^{1,2}	Plain Paper	~ 44 mm	300 sheets (75 g/m ²)
¹ 20 lb. xerographic paper at ambient environment ² Capacity may vary and is subject to media specifications and printer operating environment. ³ Capacity will vary with label material and construction. ⁴ Capacity will vary depending on weight and type of media			

Table 2 Media Sizes

Name	Duplex	550-sheet Tray	Bypass Tray	Output Tray	550-sheet Option Tray	DADF Detection	Plate Detection
Letter (8.5 x 11") 215.9mm x 279.4mm	•	•	•	•	•	•	•1
Legal (8.5 x 14") 215.9mm x 355.6mm	•	•	•	•	•	•	•2
3 x 5" 76.2mm x 127.0mm			•	•			
Postcard (4 x 6") 101.6mm x 152.4mm			•	•			
Postcard (4.25 x 5.5") 108.0mm x 139.7mm			•	•			
5 x 7" 127.0mm x 177.8mm	•	•	•	•	•		
Statement (5.5 x 8.5") 139.7mm x 215.9mm	•	•	•	•	•		
Executive (7.25 x 10.5") 187.2mm x 266.7mm	•	•	•	•	•		
8 x 10" 202.3mm x 254.0mm	•	•	•	•	•		
8.5 x 13" 215.9mm x 330.2mm	•	•	•	•	•	•	•2
8.5 x 13.4" 215.9mm x 340.2mm	•	•	•	•	•	•	•2
A4 (210 x 297 mm)	•	•	•	•	•	•	•1
A5 (148 x 210 mm)	•	•	•	•	•		
A5 (148 x 210 mm)	•	•	•	•	•		
A6 (105 x 148 mm)	•	•	•	•	•		
B5 (176 x 250 mm)	•	•	•	•	•		
JIS B5 (182 x 257 mm)	•	•	•	•	•		
215 x 315 mm	•	•	•	•	•		•2

Name	Duplex	550-sheet Tray	Bypass Tray	Output Tray	550-sheet Option Tray	DADF Detection	Plate Detection
C5 Envelope (162 x 229 mm)		•	•	•	•		
C6 Envelope (114 x 162 mm)		•	•	•	•		
DL Envelope (110 x 220 mm)		•	•	•	•		
Envelope (6 x 9") 152.4mm x 228.6mm		•	•	•	•		
Monarch Envelope (3.9 x 7.5") 98.4mm x 190.5mm			•	•			
No. 9 Envelope (3.9 x 8.9") 98.4mm x 225.4mm			•	•			
No. 10 Envelope (4.1 x 9.5") 104.8mm x 241.3mm		•	•	•	•		
<p>Note: These constraints apply only to size. In respect of Envelopes, the size may be able to be duplex or invert, where the type may not. To fully understand the constraint for a given media, both size and type must be taken into account.</p>						<ol style="list-style-type: none"> 1 The size detected will be based on the Paper Size Preference setting 2 The size detected will be based on the Default Legal Size setting. 	

Table 3 Media Bonds and Weights.

Media Types	Weight Range	Duplex	550-sheet Tray	Bypass Tray	Output Tray	550-sheet Option Trays	DADF
Plain	75 - 90 gsm	•	•	•	•	•	•
Hole Punched	75 - 90 gsm	•	•	•	•	•	•
Letterhead	75 - 105 gsm	•	•	•	•	•	•
Lightweight Cardstock	120 - 162 gsm	•	•	•	•	•	
Cardstock	163 - 200 gsm		•	•	•	•	
Recycled	75 - 90 gsm	•	•	•	•	•	•
Bond	75 - 105 gsm	•	•	•	•	•	•
Labels	75 - 131 gsm		•	•	•	•	
Pre-Printed	75 - 90 gsm	•	•	•	•	•	•
Envelope	60 - 105 gsm		•	•	•	•	
Light Glossy Cardstock	105 - 162 gsm	•	•	•	•	•	
Glossy Cardstock	163 - 200 gsm		•	•	•	•	
Lightweight	60 - 74 gsm	•	•	•	•	•	•
Custom Type 1	75 - 90 gsm	•	•	•	•	•	
Custom Type 2	75 - 90 gsm	•	•	•	•	•	
Custom Type 3	75 - 90 gsm	•	•	•	•	•	
Custom Type 4	75 - 90 gsm	•	•	•	•	•	
Custom Type 5	75 - 90 gsm	•	•	•	•	•	
Custom Type 6	75 - 90 gsm	•	•	•	•	•	

Custom Type 7	75 - 90 gsm	
<p>Note: These constraints apply only to type. In respect of Envelopes, the size may be able to be duplex or invert, where the type may not. To fully understand the constraint for a given media, both size and type must be taken into account.</p>							<p>Note: The weight range supported in the DADF shall be from 52–120 gsm and must be non-coated media</p>

GP 31 Environmental Data

Operating Environment

Table 1 Temperature and Humidity, lists the minimum and maximum range of temperature and humidity limitations during normal operation of the machine.

Table 1 Temperature and Humidity

Environment	Specifications
Operating Temperature and Relative Humidity	10 to 32.2°C (50 to 90°F) and 15 to 80% RH 15.6 to 32.2°C (60 to 90°F) and 8 to 80% RH Maximum wet-bulb temperature (2): 22.8°C (73°F) Non-condensing environment
Operating Altitude	TBD
Printer / Cartridge / IU Long-Term Storage (1)	15.6 to 32.2°C (60 to 90°F) and 8 to 80% RH Maximum wet-bulb temperature (2): 22.8°C (73°F)
Printer / Cartridge / IU Short-Term Shipping	-40 to 40°C (-40 to 104°F)

¹ Supplies shelf life is approximately 2 years.

Note: This shelf-life estimate is based on storage in standard office environment at 72°F (22.2°C) and 45% humidity.

² Wet-bulb temperature is determined by the air temperature and the relative humidity.

Noise

- **Table 2** Sound Pressure Levels, contains the maximum sound pressure in decibels.
- **Table 3** Sound Power Levels, contains the maximum audible power in decibels during operation.

Table 2 Sound Pressure Levels

Sound Pressure Levels	dB Value
Idle	14
Simplex Print - Mono	53
Simplex Print - Color	53
Duplex Print - Mono	55
Duplex Print - Mono	55

Quiet Mode Print (Simplex) Mono	47
Quiet Mode Print (Simplex) Color	47
Scan to file - Mono	51
Scan to file - Color	45
ADF Copy - Mono	56
ADF Copy - Color	52

Table 3 Sound Power Levels

Sound Power Levels	dB Value
Idle	3.1
Simplex Print - Mono	6.7
Simplex Print - Color	6.8
Duplex Print - Mono	7
Duplex Print - Mono	7
Quiet Mode Print (Simplex) Mono	6.2
Quiet Mode Print (Simplex) Color	6.2
ADF Scan to file - Mono	6.8
ADF Scan to file - Color	6.6
ADF Copy - Mono	7.1
ADF Copy - Color	6.8

GP 32 Device Specification

Configuration Options

The Xerox® VersaLink® C625 Color Multifunction Printer is available as a basic machine with tray 1. It is also available in various configurations using the options that follow:

General

For the space requirements, environment range and the print out time. Refer to:

- [GP 16](#) Installation Space Requirements.
- [GP 31](#) Environmental Data.
- [GP 20](#) First Copy / Print Out Time and Power On / Off Time.

Paper Supply and Paper Handling Options

- One 550 sheet paper tray (tray 1).
- 100 sheet bypass tray.
- 100 sheet document feeder (DADF).
- Optional 550 sheet single tray module (STM) (tray 2, 3, 4, 5).

Accessories and Kits

- Wifi Network Adapter.
- 500+GB Hard Disk.
- Printer stand
- Adjustable stand
- Adjustable stand non-locking caster
- Adjustable stand locking caster
- Convenience Stapler (110v)
- Convenience Stapler (220v)
- Staple cartridge holder (staples included)
- 550 Sheet tray

Machine Identification

The diagrams that follow illustrate some of the machine configurations:

- Xerox® VersaLink® C625 (MFP)

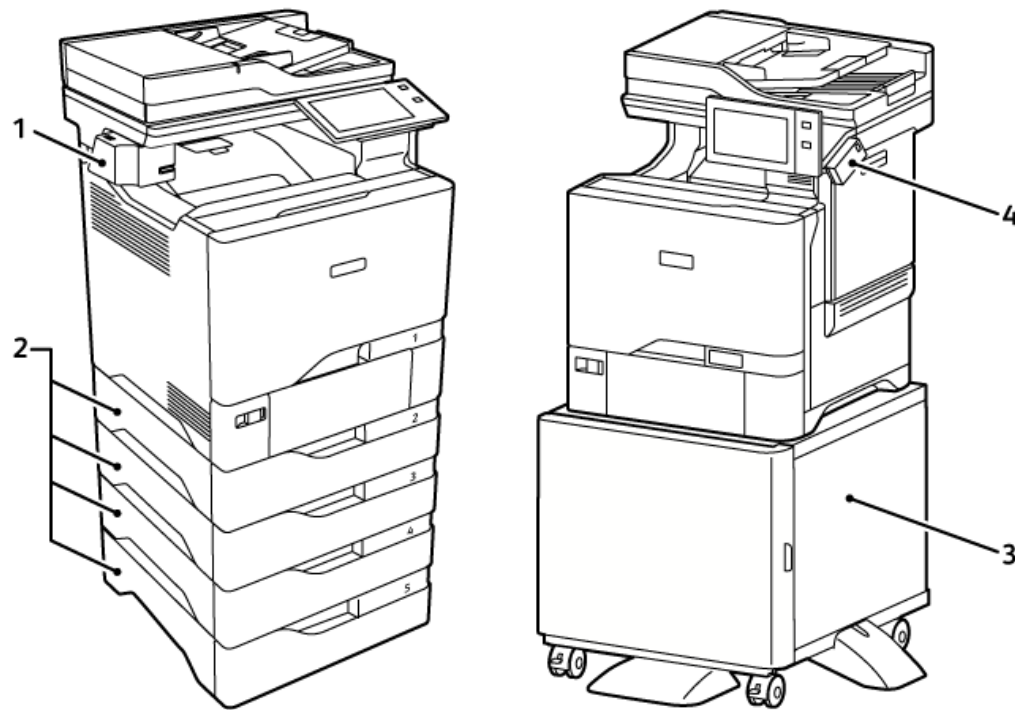


Figure 1 VLC625 with print and finishing options

1. Convenience stapler, [PL 25.05 item 7](#).
2. Optional 550 Sheet trays, [PL 25.05 item 10](#).
3. Printer stand, [PL 25.05 item 3](#).
4. Wifi Network Adapter, [PL 25.05 item 1](#).

GP 33 Restoring Customer Mode

Purpose

This procedure provides a method to restore normal customer mode in the event that a procedure such as a software load, or NVM initialization has reset NVM 616-014 system install phase to the default value of 0 (non-customer mode).



CAUTION: NEVER change the controller PWB, control panel display, or start the machine with the black toner cartridge out of the machine while NVM 616-014 is set to 0, as three-way synchronization is not performed.

Overview

During some service procedures, NVM 616-014 may be set to the default value of 0. When this occurs, the screen will display the message **The device is in a non-customer mode**, Figure 1.

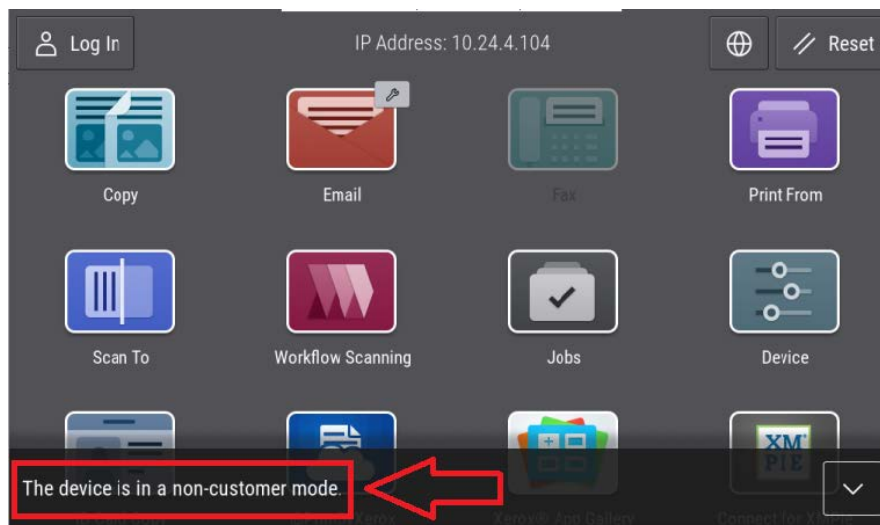


Figure 1 UI Display

The EWS UI screen will show no serial number, Figure 2.

xerox™ VersaLink® C625 Color MFP



Figure 2 EWS UI Screen

When the NVM value is reset to 2, using the procedure listed below, it will cause the machine to re-start in Install Wizard mode. Re-running the Install Wizard will restore other customer data that also may have been lost.

After the Install Wizard completes, the value of NVM 616-014 is automatically set to 4.



CAUTION: POSU will NOT run if the machine is in non-customer mode, even though it may appear that SW load has completed successfully. For some SW upgrades, it is necessary for POSU to run to finish installing upgrades in all platforms.

Procedure

1. Enter Diagnostics, GP 1.
2. Select **Adjustments**.
3. Select **dC131**.
4. Enter **616-014** and select **Read**.
5. Set the NVM value to 2. Figure 3.

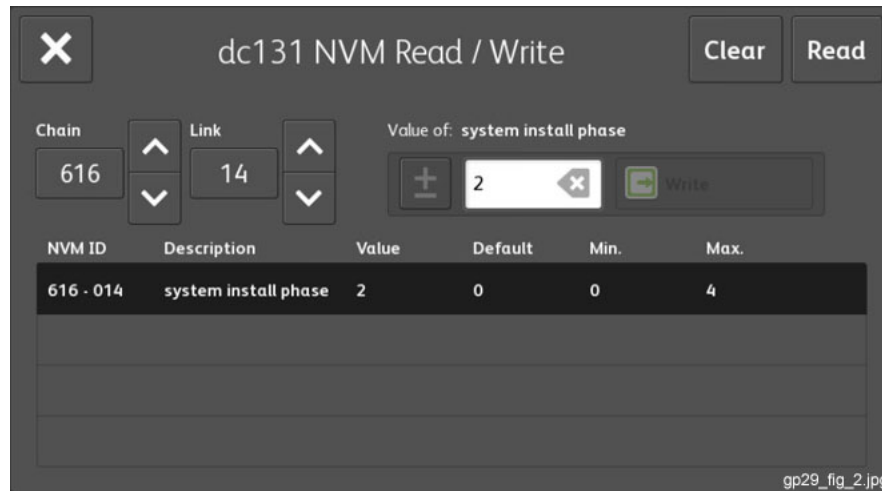


Figure 3 NVM 616-014 set to 2

6. Touch **Write**.
7. Touch the **X** to close , then select the **Call Closeout** button.
8. Select **Exit & Reboot**.

When the machine completes rebooting the Install Wizard will prompt to enter the initial settings. Follow the instructions on the screen to enter appropriate values as required. When the Install Wizard process completes the machine will reboot and the value of **NVM 616-014** will automatically be set to 4 (customer mode). During this reboot, if POSU is required, it will be performed.

Note: There is no indication on the screen when the machine is in customer mode. The only time any indication appears on the UI screen is when the machine is in non-customer mode.

GP 34 How to Re-Enter Optional Feature Installation Keys

Purpose

To explain how to re-enter optional feature installation keys.

Procedure

Perform the following:

1. Obtain the valid Feature Installation key(s) by either:
 - a. Asking the customer.
 - b. Logging into the SWAP portal, <https://www.xeroxlicensing.xerox.com/fik/>.
From the Welcome screen, select **Find** and existing key.
Enter the machine serial number in the window, then select **Next**.
 - c. Contacting the Licensing Admin Centre (USSG/XCL) or the Xerox sales representative (XE/DMO).
2. Enter the Feature Installation keys(s). Perform the following:
 - a. Select the **Device** icon on the UI.
 - b. Select **Tools**.
 - c. Select **Device Settings > General**.
 - d. Select **Feature Installation**. Enter the Feature Installation key, then select **OK**. If necessary, enter the second Feature Installation key.

GP 35 Serial Number Synchronization Procedure

Purpose

This procedure is used to maintain serial number and billing data integrity when certain PWBs must be replaced. This data is stored at three locations; drive PWB , controller PWB , and the black (K) toner cartridge. This procedure instructs how the data in all three locations is synchronized when one or more of the part items is replaced, or when data corruption associated when the 322–352-00 Serial Number Missing From Memory fault occurs.

Initial Actions

If possible, print a Configuration Report. Refer to, [GP 14 Printing Reports](#).

Note: Compare the serial number displayed on the control panel display with the serial number on the configuration report and the serial number on the data plate inside the front cover. If the serial numbers do not match, contact next level support.

Procedure



CAUTION: Check the machine is in **Customer Mode** before removing the controller PWB, control panel display, or the black toner cartridge. Refer to, [GP 33](#).



CAUTION: To maintain the integrity of the serial number and billing data, never install all three part items listed below in the same task.

- Drive PWB, [PL 1.10 item 3](#).
- Controller PWB, [PL 3.05 item 2](#).
- Black (K) Toner Cartridge.

Install **ONE ITEM AT A TIME**, as per the following procedure steps.



CAUTION: Installing all three part items in the same task **will cause** unrecoverable NVM corruption. After installing **one of the new part items**, restart the machine, [GP 10](#), then check the machine for the fault cleared. If the fault persists, reinstall the original part item, restart the machine, [GP 10](#), then if required re-enter the serial number, [dC132 Machine Serial Number](#), before attempting installation of the next part item.

Controller PWB Replacement Precautions



CAUTION: Spare controller PWBs are shipped in Manufacturing Mode NVM **616–14**, value = **0**.

1. When a machine is in Manufacturing Mode, three way sync is inhibited.
 - a. During the install phase, NVM 616-14 is Saved and Restored, as long as, [dC361](#) is performed restoring from the USB drive backup immediately after installing a new controller PWB.
 - b. The install phase should return to Customer Mode, NVM **616–14 = 4**.
 - c. the system will sync thereafter.
2. In the case that a new controller PWB was installed:
 - a. An immediate machine startup and [dC361](#) must immediately be performed for the NVM change to take affect and cause a sync to occur.
3. In the event that a machine is found in such a condition that an NVM Save cannot be performed before any work on the machine is done, then a manual NVM write to **616-14 = 4** will be necessary following the installation of a new controller PWB. Refer to, [dC131 NVM Read/Write](#).

1. Check the fault log on the control panel display, [PL 2.10 item 1](#), if available, for any active faults. Resolve all faults possible before removing the controller PWB, control panel display, or black toner cartridge, as required in the corresponding RAP.



CAUTION:

- a. When fault code 322–352–00 is active, reinstall the **original** controller PWB, control panel display, black toner cartridge, or any combination of these as required, then restart the machine to allow synchronization.
 - b. if the fault persists, continue this procedure as outlined below.
2. Enter Diagnostics, [GP 1](#). Enter, [dC361 NVM Save and Restore](#), then touch **Machine NVM** to save all device platform settings to the hard drive.
 3. While still in [dC361](#), click on each file listed, then select each device platform setting and **Copy to USB device** as a second backup.
 4. Exit Diagnostics, [GP 1](#).
 5. Shutdown the machine, [GP 10](#).
 6. Remove the suspect failed part, then install the new part in the machine.



CAUTION: Mark the original part item removed from the machine, if replaced.

7. Install the first suspected failed item, switch ON the machine, GP 10, then check the machine for the fault cleared.
8. If the installation is successful and no fault remains, compare the serial number displayed on the control panel display with the serial number on the configuration report and the serial number on the data plate inside the front cover.

Note: When any one of the following conditions occurs, escalate the call to next level support:

- The serial number displayed on the control panel display does not match the data plate inside the front cover of the machine.
 - The serial number displayed on the control panel display does not match the configuration report printed in, **Initial Actions**.
 - Fault code 322–365–00 is raised.
9. If the fault persists, or, the fault code 322–365–00 is raised, reinstall the original part item, restart the machine, GP 10, then if required, re-enter the serial number, dC132 Machine Serial Number, before attempting installation of the next part item.

Fault code 322–365–00 may flag when the device platform settings restore is unsuccessful or the

Note: When any one of the following conditions occurs, escalate the call to next level support:

- The serial number displayed on the control panel display does not match the data plate inside the front cover of the machine.
- The serial number displayed on the control panel display does not match the configuration report printed in, **Initial Actions**.
- Fault code 322–365–00 is raised.

After contacting next level support, perform, dC132 Machine Serial Number.

GP 36 Xerox USB Wireless Printing Troubleshooting

Use this troubleshooting guide when the customer reports wireless network failures when using the Xerox wireless print kit.

Initial Actions

Consult your manager before troubleshooting the customer's network, as the policy varies according to region.

Procedure

Perform the following:

1. Check that the USB wireless network adapter is plugged into a USB port on the machine.
2. If the USB wireless network adapter is connected using the USB extension cable, check that the extension cable is also plugged into a USB port on the machine.
3. Print a configuration report.
 - a. Check with the customer that printing of configuration reports is enabled. If necessary, ask the customer to enable printing of the configuration report.
4. Ensure that the USB ports are enabled.
 - a. Check the configuration report under the heading Connectivity Physical Connections.
 - b. If Software Tools is not listed next to USB Connection Mode, ask the customer to enable USB.
 1. Refer to the System Administrator Guide > USB Port Security Setting Check.
 2. Refer to the System Administrator Guide > Configuring USB Settings and set USB Connection Mode.
5. Confirm the USB port is functional.
 - a. Check that the LED on the wireless network adapter flashes when the machine is in standby.
 - b. Connect the wireless network adapter to a different USB port if available.
 - c. Insert a USB flash drive into the USB port, then perform dC361 NVM Save and Restore to test the port functionality.

Note: If the NVM can be saved to a USB flash drive, the USB port is functional.

Note: It is not necessary to perform the NVM restore procedure.
6. Ensure that the machine is configured for wireless printing.

- a. Check the configuration report under the heading **Connectivity Physical Connections**.
 - b. If wireless is disabled, ask the customer to enable wireless printing. Or enter Customer Administration Tools:
 1. Touch **Network Settings**.
 2. Touch **Network Connectivity**.
 3. Touch **Wireless**.
 4. Touch **OK**.
 - c. Check the network name listed next to SSID on the configuration report.
 - d. If the network name does not match the customer's wireless network, ask the customer to configure the wireless network setup before continuing.
 - e. Check the network name under the heading **Connectivity Protocols**.
 - f. If an IP address is not listed under TCP/IPv4 or TCP/IPv6, ask the customer to configure the wireless network setup before continuing.
7. Confirm that the customer's wireless network can be detected at the machine's location.
- a. Ask the customer to confirm that the wireless network is switched on and can be received at the machine's location. You the PWS or a smartphone to detect the customer's wireless network.
8. If the wireless network signal strength is weak, ensure that the wireless network adapter is connected via the USB extension lead. If possible change the mounting position of the adapter to improve the reception. To view the signal strength, enter System Administration Tools and perform the following:
- a. Touch **Network Settings**.
 - b. Touch **Network Connectivity**.
 - c. Touch **Wireless**.
 - d. The signal strength is displayed in the text frame.
 - e. Move the wireless network adapter and extension lead until the strongest signal strength is found.
9. Install a new wireless network adapter.

GP 37 Supplies Plan Conversion

Purpose

The procedure explains how to convert the supplies plan from Sold to Metered or Metered to Sold.

Introduction

Unless special ordered, machines are shipped with Factory-Neutral toner cartridges. The machine supplies plan is set by the toner cartridges. When toner cartridges are first replaced, the Geographic Differentiation Code and Toner Cartridge Type in NVM are automatically changed to the same settings as the replacement cartridge. Once these NVM are set, the toner configuration can only be changed with a Supplies Plan Conversion PIN

Table 1 Supplies Plan Variables and Regional Differentiations

Device Configuration	Xerox Toner						
Plan Variables: Neutral Sold Metered PagePack Regional Differentiation: NA XE NAXE DMO Factory	SWE (Starter) Sold PagePack	Metered Metered_Learning	Sold NA	Sold XE	Sold DMO	Sold NAXE	Sold Sold_Learning
Metered_Learning Metered_NA Metered_XE Metered_NA/XE Metered_DMO	Y	Y	Y	Y	Y	Y	Y
Sold_NA	Y	N	Y	N	N	Y	Y
Sold_XE	Y	N	N	Y	N	Y	Y
Sold_DMO	Y	N	N	N	Y	N	Y
Sold_Learning	Y	N	Y	Y	Y	Y	Y
Sold_NA/XE	Y	N	Y	Y	N	Y	Y

Check the current Supply Plan:

At the Machine UI:

1. Print Configuration Report [GP 14](#).
2. The supplies plan is shown on the configuration report under the **General Setup** heading.

At the Web UI:

1. Enter the machine IP address.
2. On the **Home** screen scroll to the bottom and select **Configuration Report**.
3. The screen displays the configuration report in alphabetical order. Select **General Setup**.
4. The **Supplies Plan** is shown in the list. Typical **as shipped** supplies plan is **Neutral**.

Obtain the Supplies Plan Conversion PIN

1. Press the **Device** icon on the UI and select **About**.
2. Record the Serial Number.
3. Select **X**
4. Select **Billing/Usage** and record the number of Total Impressions
5. Contact the relevant OPCO, provide the machine Serial Number and the number of Total Impressions.
 - **US:** Call Xerox Corporate Licensing Systems (XDSS) directly on 1-800-890-3260 or 1-800-635-8054 prompt 8 (license strings) for toner conversions. Provide the machine serial number and the number of total impressions.
 - **Xerox Business Solution (XBS):** All requests for such conversions must be approved by the XBS Headquarter VP of Service. Technicians should request that their field service manager contact their XBS Company VP of Service for directions. The XBS Core Company VP of Service will require authorization to convert the machine from sold to metered and provide a status of your request. Do not call field engineering to obtain a Service Plan Conversion PIN.
 - **US Authorized Service Provider (ASP):** Call PageConnect at 1-888-892-6483 or send an email to pageconnectprogram@xerox.com requesting a PIN. Provide the machine serial number and the total number of impressions.
 - **Canada:** Call the Customer Delivery Organization (CDO) field support number 1-800-647-1331 prompt 8 (license strings) for a Supplies Plan Conversion PIN. Provide the machine serial number and the total number of impressions.
 - **LATAM (Latin America):** Follow Local Process.

6. You will be given a 6-character Supplies Plan Conversion PIN.

Note: The Supplies Plan Conversion PIN must be entered within 500 Total Impressions counts of when it was issued, or it will not be valid.

Supplies Plan Conversion via Machine UI

1. Log in to **Admin** mode.
2. At the **Home** screen touch **Device > Tools > Device Settings > Supplies**.
3. Touch **Enter Plan Conversion**.

Note: The current Service Plan and Supplies Plan Number are listed.

4. Touch **+ Convert Supplies Plan**.
5. Enter the 6-character **Convert Supplies Plan** PIN provided.
6. Select **OK**.

The Geographic Differentiation Code and Toner Cartridge Type will be reset to the values of the customer's agreed-to supplies plan.

Supplies Plan Conversion via Remote Control Panel

1. Open a web browser then enter the machine IP in the address bar.
2. At the EWS Home screen, click on **Support > Remote Control Panel > Start Remote Session**.
3. Log in to **Admin** mode.
4. At the **Home** screen touch **Device > Tools > Device Settings > Supplies**.
5. Touch **Enter Plan Conversion**.

Note: The current Service Plan and Supplies Plan Number are listed.

6. Touch **+ Convert Supplies Plan**.
7. Enter the 6-character **Convert Supplies Plan** PIN provided.
8. Select **OK**.

The Geographic Differentiation Code and Toner Cartridge Type will be reset to the values of the customer's agreed-to supplies plan.

GP 40 Glossary of Terms, Acronyms and Abbreviations

Where possible unit designations as appear in ISO 1000 (International Organization for Standardization) and Xerox Standard MN2-905 have been used. All measurements appear in ISO units followed by any conversion in brackets e.g.; 22.5mm (0.885 inches)

Refer to [Table 1](#).

Table 1 Abbreviations

Term	Description
1TM	One Tray Module
3TM	Three Tray Module
AAA	Authentication, Authorisation and Accounting
ABS	Automatic Background Suppression.
AC	Alternating Current
ACAST	Anti Counterfeiting Activities Support/Strategy Team
ACL	Alternating Current Live
ACN	Alternating Current Neutral
AGC	Automatic Gain Control
AHA	Advanced Hardware Architecture
AMPV	Average Monthly Print Volume
ANSAM	Answer Tone, Amplitude Modulated
APS	Auto Paper Selection
ARP	Address Resolution Protocol. Converts an IP address to a MAC address. See RARP.
ASIC	Application Specific Integrated Circuit
B	Bels (applies to sound power level units)
Binding	Part of the communication between modules.
BM	Booklet Maker
BootP	Boot Protocol. AN IP protocol for automatically assigning IP addresses.
BPS	Bits Per Second
BS	Behavior Specification

Term	Description
BT	Busy Tone
BCR	Bias Charge Roll
BTR	Bias Transfer Roll
C	Celsius
CAT	Customer Admin Tool
CBC	Customer Business Center
CCD	Charged Coupled Device
CCM	Copy Controller Module
CCS	Copy Controller Service
CentreWare	CentreWare internet services is the embedded HTTP server application that is available on network enabled machines. It enables access to printing, faxing and scanning over the internet.
CIPS	Common Image Path Software
CIS	Contact Image Sensor
CL	Copy Lighter. A copy density setting
CQ	Copy Quality
CRC	Cyclic Redundancy Check
CRU	Customer Replaceable Unit
CRUM	Customer Replaceable Unit Monitor
CSE	Customer Service Engineer
CVT	Constant Velocity Transport
CWIS	CentreWare Internet Services (also known as Web UI)
DADF	Dual Auto Document Feeder
dB	Decibel (applies to sound pressure level units)
dC	Diagnostic code
DC	Device Controller, generic term for any module that acts as a image handling device e.g., SIP. Digital Copier
DC	Direct Current
DCN	Disconnect

Term	Description
DCS	Digital Command Signal
DDNS	Dynamic Domain Name System
DH	Document Handler
DHCP	Dynamic Host Config Protocol (similar to BootP)
DIMM	Dual In-line Memory Module
DIP	Dual In-line Package (switch)
DIS	Digital Identification Signal
DLM	Dynamically Loadable Module
DM	Document Manager
DMA	Direct Memory Access
DMO	Developing Markets Operations
DMO-E	Developing Markets Operations East
DMO-W	Developing Markets Operations West
DPI	Dots per inch
DRAM	Dynamic Random Access Memory
DST	Daylight Saving Time
DT	Dial Tone
DTMF	Dual Tone Multiple Frequency
DTS	Detack Saw
Dust Off	Routine to return machine to pre-install state
DVMA	Direct Virtual Memory Access
EH&S	Environmental Health and Safety
EJS	Easy Java Simulation
ELT	Extract, Load, Transform
Embedded Fax	A fax system included in a system device
EMC	Electromagnetic Compatibility
EME	Electromagnetic Emission

Term	Description
ENS	Event Notification Service. Used by a software module to alert another module of an event.
EOM	End Of Message
EOP	End Of Procedure
EOR	End Of Retransmission
EPA	Environmental Protection Agency
EPC	Electronic Page Collation (memory dedicated to temporary retention of images captured from the scanner and network controller)
EPROM	Erasable / Programmable Read Only Memory
ERR	End Retransmission Response
ERU	Engineer Replaceable Unit
ESD	Electrostatic Discharge
ESS	Electronic Sub-System (equivalent to NC)
EU	European Union
EUR	Europe
FAR	Fully Active Retard feeder
Fax	Facsimile
FCOT	First Copy Out Time
FDI	Foreign Device Interface
FIFO	First In First Out
Firmware	Software in a ROM
FLASH	On board erasable and re-programmable non volatile memory
FOIP	Fax Over Internet Protocol
FPGA	Field Programmable Gate Array
FPOT	First Print Out Time
FRU	Field Replaceable Unit
FRU	Fuser Replacement Unit
FTP	File Transfer Protocol

Term	Description
FX	Fuji Xerox
G3	Group 3
GMT	Greenwich Mean Time
GND	Ground
GSM	Grams per square metre
GUI	Graphical User Interface
HCF	High Capacity Feeder
HDD	Hard Disk Drive
HFSI	High Frequency Service Intervals
HTTP	Hyper Text Transfer Protocol
HVPS	High Voltage Power Supply
Hz	Hertz
I/O	Input/Output
I2C-bus	Inter Integrated Circuit bus. This provides a simple bidirectional 2-wire bus for efficient inter-IC control. All I2C-bus compatible devices incorporate an interface which allows them to communicate directly with each other via the I2C-bus.
ID	Identification
IDG	Inter document gap
IFax	Internet Fax
IIT	Image Input Terminal
Intlk	Interlock
ioctl	input/output control
IOT	Image Output Terminal
IP	Internet Protocol
IPA	Image Processing Accelerator. Used by the machine scanning services to convert scanned images to a standard format e.g. for scan to file / scan to E-mail for network transmission.
IPS	Image Processing Service
IPSec	Internet Protocol Security

Term	Description
IPX	Internetwork Protocol eXchange
IQ	Image Quality
IQS	Image Quality Specification
IR	Intelligent Ready
ISDN	Integrated Services Digital Network / International Standard Data Network
ISO	International Standards Organization
ITP	Internal Test Pattern
JBA	Job Based Accounting (Network Accounting)
JIS	Japanese Industrial Standards
kg	kilogram
kHz	kilohertz
Kill All	Routine to return all NVM, including protected NVM, to a virgin state. Factory use only
KO	Key Operator
LAN	Local Area Network
LCD	Liquid Crystal Display
LCSS	Low Capacity Stapler Stacker
LDAP	Lightweight Directory Access Protocol (allows sharing of corporate phone book information)
LE	Lead edge
LED	Light Emitting Diode
LEF	Long Edge Feed
LOA	Load Object Attributes
LPD	Line Printer Daemon
LPH	LED Print Head. An LED array in close proximity to and the same width as the photoreceptor. Individual LEDs are switched on/off to develop the image on the xerographic drum.
lpi	Lines per inch
LVF BM	Low Volume Finisher Booklet maker

Term	Description
LVDS	Low Voltage Differential Signal
LVPS	Low Voltage Power Supply
LUI	Local user Interface
m	metre
MAC Address	Media Access Code. This is the basic, unique identifier of a networked device. An incoming message is analysed and an address in another form, such as an IP address, is resolved by a lookup table to a MAC address. The message is then directed to, and accepted by the equipment thus identified. It is the burnt-in, hardware address of a NIC.
Mark Service	Mark Service is the software module that tells the hardware to put toner on paper.
MB	Megabyte (one MB = 1,048,576 bytes = 1024 kilobytes). Mail Box
Mb	Mega bit (one million bits)
MCF	Message Confirmation
MF	Multifunction
mm	millimeter
Modem	MOdulator/DEModulator. Hardware unit that converts the 'one' and 'zero' binary values from the computer to 2 frequencies for transmission over the public telephone network (modulation). It also converts the 2 frequencies received from the telephone network to the binary values for the computer (demodulation).
Moire	Image quality defect caused by interference between patterned originals and the digital imaging process. Moire patterns are repetitive and visible as bands, plaids or other texture.
MSG	Management Steering Group
ms	millisecond
N	Newton
NA	North America
NC	Network Controller (equivalent to ESS)
NC	Normal Contrast. Copy contrast setting
NCR	No Copying Required
NetBIOS	Network Basic Input / Output System. Software developed by IBM that provides the interface between the PC operating system, the I/O bus, and the network. Since its design, NetBIOS has become a de facto standard.

Term	Description
Nm	Newton metre
NOHAD	Noise, Ozone, Heat, Airflow and Dust
NTP	Network Time Protocol
NVM	Non-Volatile Memory
OA	Open Architecture
OCT	Offsetting Catch Tray
ODIO	On Demand Image Overwrite
OEM	Original Equipment Manufacturer
OPC	Organic Photo Conductor
OpCo	Operating Company
OS	Operating System
P/R	Photoreceptor
PABX	Private Automatic Branch Exchange
PC	Personal Computer
PC Fax	Personal Computer Fax
PCI	Peripheral Component Interface
PCL	Printer Control Language
PDF	Adobe Acrobat Portable Document Format
PFM	Paper Feed Module
PIN	Procedural Interrupt Negative
PIN	Personal Identification Number
ping	Packet InterNet Groper. Tool to test connections between nodes by sending and returning test data.
PME	Power Management Event
POPO	Power Off Power On
POO or P of O	Principles of Operation
POST	Power On Self Test

Term	Description
POTS	Plain Old Telephone System
PPM	Prints per minute / Parts Per Million
PR	Photo-Receptor
Process Death	A process has stopped working.
PS	Post Script
PS	Power Supply
PSTN	Private Switched Telephone Network
PSW	Portable Service Workstation
Pthread	Process Thread. A very low level operating system concept for code execution.
PWB	Printed Wiring Board
PWBA	Printed Wiring Board Assembly
PWM	Pulse-Width Modulation
PWS	Portable Work Station
RAM	Random Access Memory
RARP	Reverse Address Resolution. Reverse of ARP. Converts a MAC address to an IP address. The document centre resolves its address using RARP. See also MAC, NIC and ARP.
RDT	Remote Data Transfer
Reg	Registration
Registration Service	Monitors when RPC services go on and offline.
RF	Radio Frequency
RFID	Radio Frequency Identification
RPC	Remote Procedure Call. How the device communicates internally between software modules.
RH	Relative humidity
RMS	Root Mean Square (AC effective voltage)
RNR	Receive Not Ready
RoHS	Restriction of Hazardous Substances

Term	Description
ROM	Read Only Memory
RR	Receive Ready
RS-232, RS-423, RS-422, RS-485	Series of standards for serial communication of data by wire. RS-232 operates at 20kbits/s, RS-423 operates at 100kbits/s, RS-422 and RS-485 operate at 10Mbits/s. See FireWire and USB.
RTC	Real Time Clock
Rx	Receive
S2F	Scan-to-File
SA	Systems Administration
SAKO	Systems Administration Key Operator
SAR	Semi-Active Retard feeder
SBC	Single board controller. Copy, print and UI controllers all on one PWB within the image processing module.
SCD	Software Compatibility Database
SD	Secure Digital, memory card format
Server Fax	A fax system that uses a remote Fax server. Faxes transmit as a Scan to File job sent to the server. Fax receive as print jobs submitted to the Connection Device.
SEF	Short Edge Feed
Semaphore	A variable or abstract data type.
SESS	Strategic Electronic Sub-System
SH	Staple Head
SIM	Subscriber Identity Module (also known as a SOK-Software Option Key)
SIM	Scanner Input Module
SIP	Scanning and Image Processing
SIR	Standard Image Reference
SLP	Service Location Protocol (finds servers)
SM	Scheduled Maintenance
SMART	Systematic Material Acquisition Release Technique
SMB	Server Message Block. Microsoft Server / Client Communications protocol

Term	Description
SMP	Service Maintenance Pack (contains a software package)
SNMP	Simple Network Management Protocol
Snr	Sensor
SOK	Software Option Key (also known as a SOIM-Subscriber Identity Module)
SPAR	Software Problem Action Request
spi	Spots per inch
SPI	Service Provider Interface. Steps to process a job.
SR	Service Representative
SRS	Service Registry Service
SS or S/S	Sub System
SSDP	Simple Service Discovery Protocol
SSID	Service Set Identifier (wireless network name)
STM	Single Tray Module
SU	Staple Unit
SW	Switch
SW or S/W	Software
sync	synchronize
TAR	Take Away Roll
TAR or tar	An archive file format, derived from Tape ARchive
TBC	To Be Confirmed
TBD	To Be Defined
TC	Toner Concentration
TCF	Training Check Field
TCO	Thermal Cutout
TCP/IP	Transmission Control Protocol/Internet Protocol
TE	Trail Edge
Template	A collection of Scan to File attributes that can be conveniently re-used.

Term	Description
TIFF	Tagged Image File Format
TP	Test Point
TRC	Toner Reproduction Curve
TTM	Tandem Tray Module
TTY	Teletype Terminal
Tx	Transmit
UART	Universal Asynchronous Receiver Transmitter
U-boot	Universal Boot Loader
UI	User Interface (display screen)
UK	United Kingdom
UM	Unscheduled Maintenance
USB	Universal Serial Bus. High speed successor to parallel port for local device communications. Operates at 12Mbps/s. See FireWire and RS-232.
USCO	United States Customer Operations
USSG	United States Solutions Group
V.17 / V.29 / V.34	Modem standards
VOIP	Voice Over Internet Protocol
WC	WorkCentre
WEB UI	CentreWare Internet Services
XCL	Xerox Canada Limited
XE	Xerox Europe
XEIP	Xerox Extensible Interface Platform
XLA	Xerox Latin America
XML	eXtensible Markup Language
XPS	XML Paper Specification (printing format)
XRU	Xerographic Replacement Unit
XSA	Xerox Standard Accounting

VLC625 NVM Tables

[C625 NVM Tables](#)

EHS 700 - Health & Safety Incident Report Form

[Safety](#)

Log Book

[Log Book](#)

Safety Information

The WARNING that follows is for general guidance when live working.



WARNING: Do not work in a confined space. 1m (39 inches) space is needed for safe working.

Safety Icons

The safety icons that follow are displayed on the machine:

ESD Caution Symbol



CAUTION: Certain components in this product are susceptible to damage from electrostatic discharge. Observe all ESD procedures to avoid component damage.

Location Arrow Symbol

The location arrow symbol points to the location to install, to gain access to, or to release an object.



Hot Surface Symbol

This symbol indicates hot surfaces. Take care when servicing the machine.



Lethal Voltage Symbol

This symbol indicates potentially lethal voltages. Take care when servicing the machine when the power cord is connected.



Toner Cartridge

The product contains a toner cartridge that is recyclable. Under various state and local laws, it may be illegal to dispose of the cartridge into the municipal waste. Check with the local waste officials for details on recycling options or the proper disposal procedures.

Fuses



WARNING: Do not install a fuse of a different type or rating. Installing the wrong type or rating of fuse can cause overheating and a risk of fire.

Part Replacement

Only use genuine Xerox approved spare parts or components to maintain compliance with legislation and safety certification. Also refer to [GP 26](#) Restriction of Hazardous Substances (RoHS).

Disassembly Precautions

Do not leave the machine with any covers removed at a customer location.

Reassembly Precautions

Use extreme care during assembly. Check all harnesses to ensure they do not contact moving parts and do not get trapped between components.

General Procedures

Observe all warnings displayed on the machine and written in the service procedures. Do not attempt to perform any task that is not specified in the service procedures.

Service Copy (Tools) Mode

Service Copy Mode

Service copy mode provides access to the machine that is greater than that of a user, but less than that of the System Administrator. This mode allows the CSE to perform a number of checks and run copies without compromising the customer's security settings. This mode can be used if the Administrator user name and passcode are not at the default, and the Administrator is not available to enter the admin passcode. Perform the steps that follow:

1. Press and hold the **Home** button for 7 seconds. The passcode screen will display when the button is released.
2. Enter the passcode 2732, press the **OK** button on the UI.

Note: Five incorrect entries cause the entry screen to lock for 3 minutes.

3. The **Log In** button will change to display **CSE**.

Note: The tools available in this mode are a subset of those available in Administrator mode. CSE service copy mode remains active until the **login/CSE** button is pressed again. When finished with always log out of service copy mode by pressing the **CSE** button and confirming log out.

dC104 Usage Counters

Purpose

Displays a history of system usage.

Procedure

1. Enter **GP 1**.
2. Select **Service Information**.
3. Select **dc104 Usage Counters**.
4. Touch the **Diagnostic Counters** button to filter the results:
 - **Diagnostic Counters** - lists sheet counters for service operations and tray totals.
 - **Impression Counters** - lists all impressions, categorized by B/W, Color, Large, Small, Print, Copy.
 - **Sheet Counters** - Color and B/W for copied and printed sheets.
 - **Images Sent Counters** - Server Fax, Internet Fax, E-mail images, and Network Scan.
 - **Fax Impressions Counters** - If Fax is enabled, lists the number of received Faxes that were printed.
 - **All Usage Counters** - all the above.

Press the **Update** button for the most current count.

dC108 Software Version

Purpose

Displays the installed software versions for the various modules installed in the system.

Procedure

1. Enter **GP 1**.
2. Select **Service Information**.
3. Select **dc108 Software Version**. Depending on installed options, software version information appears for these modules:
 - Software Upgrade
 - Copy Controller
 - Copy Controller OS
 - UI Panel Firmware
 - Fax
 - Imaging Output Terminal
 - Network Controller
 - Image Input Terminal
 - Document Feeder
 - User Interface
 - XUI Language Version
 - Finisher

dC122 Fault History

Purpose

Displays the Last 40 faults.

Note:

1. Faults detected while in Service Mode are not counted.
2. An Interlock open while the machine is stopped is not counted.
3. If multiple faults occurred in the machine, the primary fault is recorded.

Procedure

1. Enter **GP 1**.
2. Select **Service Information**.
3. Select **dc122 Fault History**.

Note: In dC122 Fault History, you can print in the right upper corner depending on software release 105.xxx.009.34422.

4. A five-column table will appear, listing the **Fault Name**, **Code**, **Date/Time**, **Total Impression**, and **Size** of the last 40 machine faults.
5. To clear the fault history, select **Reset Counters** on the **Call Closeout** screen.

dC126 Paper Registration

Purpose

This procedure is used to align the Lead Edge and Side Edge of the developed image with media fed from the various paper trays.

For instructions, refer to [ADJ 90.1](#).

dC131 NVM Read/Write

Note: NVM values are listed in the procedures where they are called out.

To access the complete [VCL625 and VLB625 NVM Tables](#).

Procedure

1. Enter Diagnostics, [GP 1](#).
2. Select **Adjustments**.
3. Select **dc131 NVM Read/Write**.
4. Enter the NVM Chain and Link in the **Chain** and **Link** windows.

Note: It is not necessary to re-enter NVM locations that have already been entered. You can select previously entered locations by touching the row in the table where that location is listed. If more than four NVM locations are entered, a scroll bar will appear on the right side of the table.

5. Select the **Read** button.

Note: When an NVM is displayed in the table, it will remain displayed until **Clear** is selected. The **Clear** button only clears the table display, not an NVM value.

6. Touch the **Value of:** window and use the keypad to enter the new NVM Value. Use the **+/-** button to enter negative numbers.
7. Select **Write** to load the new value.

dC132 Machine Serial Number

Purpose

This procedure synchronizes the serial number information on the components where it is stored.

Serial number information is stored at these locations:

- **Controller PWB**, PL 3.05.
- **Drive PWB**, PL 1.10.



CAUTION: When installing a new Controller PWB and Drive PWB in the same call, each must be installed independently, then the machine restarted to see if the fault persists. The new component's serial number data will synchronize automatically with the data on the other components. In such instances, dC132 need not be performed. **When both PWBs are installed at the same time, then the machine restarted, serial number mismatch and machine inoperability will occur, and dC132 must be performed.**

Initial Action

Check dC122 for Communications faults (Chain 303 and 316). These faults can prevent serial number synchronization. Resolve these faults before continuing. Please obtain a serial number re-synchronization request form from GSN Library 15053.

Procedure

Part 1 - Notify service support.

Note: It may take up to 24 – 72 hours to receive a password from A-CAST.

1. Enter GP 1.
2. Select **Maintenance**.
3. Select **dc132 Machine Serial Number**.
4. Select **Generate New Identifier Code**. Record the Unique Machine Identifier.



CAUTION: After the Unique Machine Identifier is generated, **DO NOT** touch the **Generate New Identifier Code** button a second time, as this will invalidate the Password that will be provided.

5. Contact service support for instructions on how to complete the form.

Note: Follow all instructions included in the form. You must complete the form, print it, obtain required signatures and data, then scan it. There is a cost for this service.

6. Have the National Technical Specialist (NTS, RSE or FE) forward a copy of service log and proof of the location of the machine to A-CAST. This information must indicate machine location, customer name and address.

The proof must be a screen capture of the NTS/FE/RSE customer support database (account management database), FWSS, ICSS, DFM BT, VQMS, VALE, STPR, eSAP, etc. The information on the proof must match the information on the form.

Part 2 - Re-serialize machine

1. Enter Diagnostics, GP 1.
2. Select **Maintenance**.
3. Select **dc132 Machine Serial Number**.
4. Select **Enter Passcode**.
5. Enter the Passcode received from A-CAST in the box named **Enter Passcode**.
6. Select **OK**.
7. Please verify UI screen indicated **Serial Number Verification Complete, Your machine serial number has been verified**.
8. Exit Diagnostic mode and select Reboot.
9. Print a configuration report and verify that the serial number is corrected. The serial numbers are now synchronized.

dC135 HFSI Counters

Purpose

This routine displays the percentage of service life remaining for periodic replacement parts.

Procedure

1. Enter Diagnostics, [GP 1](#).
2. Select **Maintenance**.
3. Select **dc135 CRU/HFSI**.
4. The CRU/HFSI screen lists the serviceable items and displays **Estimated Pages Remaining**.
5. Refer to [SCP 4](#) Subsystem Maintenance. Perform the listed Service Action for all HFSI counters that are at or near end of life.
6. To reset the count after replacing the parts, select the appropriate HFSI item, then select **Reset Counter**.

dC301 NVM Initialization

Purpose

This procedure may be needed when the machine cannot recover for some unknown reason, including problems such as producing blank copies/prints, continuously declaring system faults, etc.



CAUTION: Before Initializing NVM on any subsystem, perform [dC361](#) NVM Save and Restore. Performing NVM Initialization on any subsystem may cause damage or degradation of machine performance.

Initial Actions

- Disconnect any Foreign Interface devices.
- Obtain all of the following information:
 - Save Machine Settings, if possible.
 - NVM value factory setting report (typically it is located in the Tray 1 pocket).
 - Any customer setting Auditron account from the system administrator.
 - Any setting changes (specifically NVM settings) shown on the machine's service log.
 - Any customer settings in the Tools mode.
- If possible, perform [dC361](#) NVM Save and Restore.

Procedure

1. Enter Diagnostics, [GP 1](#).
2. Select **Adjustments**.
3. Select **dC301 NVM Initialization**.
4. Select the desired **Controller** and **NVM Data** using the features on the UI screen.
5. Select **Initialize** to run the routine. Select the **[X]** button to exit the routine without running it.
6. When prompted by the message **Are you sure you want to initialize NVM?**, select **Initialize**.

Note: If the screen displays the message **The device is in a non-customer mode** after completing this step, perform [dC361](#) to restore the machine to customer mode.

7. After the initialization is complete, the machine will restart into the Startup Wizard.

dC312 Network Echo Tests

Purpose

Tests the machine's ability to communicate on the network.

Procedure

1. Enter Diagnostics, [GP 1](#).
2. Select **Diagnostics**.
3. Select **dC312 Network Echo Test**.
4. Select the **Protocol** to be tested.

Note: Protocols not available will be greyed out.

5. Select the **Start Network Echo Test** button. The test will run. A message will be displayed on the UI indicating whether the test was successful.

dC330 Component Control

Purpose

To show the status of input components e.g. sensors, and to run or energize output components e.g. motors, solenoids.

Description

Output and input component codes are entered into the Component Control Table on the UI, and then checked individually or in permitted groups. The codes in the tables are grouped in function chain order. Refer to [GP 2](#) Fault Codes and History Files.

Go to the appropriate procedure:

- [Input Components](#)
- [Output Components](#)

Input Components

Component control codes are not used with the VLC625 dC330 procedures. Direct access to components are listed in the dC330 procedures of the Control Panel interface.

The displayed status of the input component can be changed by causing the component status to change, e.g. operating a sensor with a sheet of paper.

Output Components

Component control codes are not used with the VLC625 dC330 procedures. Direct access to components are listed in the dC330 procedures of the Control Panel interface.

Procedure

1. Enter Diagnostics, [GP 1](#).
2. Touch Diagnostics.
3. Touch:
 - a. dC330 Component Control (Fax Engine).
 - b. dC330 Component Control (Print Engine).
 - c. dC330 Component Control (Scan Engine).
1. Touch the dC330 component control list desired.
2. Scroll the list for the component to be checked.
3. Touch the component name.
4. Touch Start.

Note:

- Some motors require automatic deactivation in order to avoid secondary issues such as possible damage and contamination.
 - Some tests require a special action to activate a motor such as removing a major component.
 - If the motor fails, the test failure may not indicate a failed motor. Further troubleshooting may be required. Check PWBs and cables for possible issues.
 - The component status.
 - The component change state.
 - Operation counter.
5. Toggle Cyclic Motion to repeat the operation.
 6. Touch Stop All to stop component operation.
 7. Touch Close to return to the Diagnostics screen.
 8. Exit diagnostics, [GP 1](#).

Fax Engine Tests

Table 1 Fax Engine Tests

Test	Sub Menu	Sub Menu	Action	General
Agency Test				
	Go Off-Hook		Start	
	Ring Detect		Touch Start	
	Generate Tones	Generate GNC Tone 1100 Hz	Touch To Open Tones Menu	
		Generate ANS Tone 2100 Hz		
		Generate ANSam Tone		
		Generate DTMF Tone 0-9, *, #		
	Generate Modulations	V.21 300 bps	Touch To Open Modulations Menu	

Test	Sub Menu	Sub Menu	Action	General
		V.22 1200 bps ORG		
		V.22 1200 bps ANS		
		V.27ter 2400 bps		
		V.27ter 4800 bps		
		V.29 7200 bps		
		V.29 9600 bps		
		V.17 7200 bps		
		V.17 9600 bps		
		V.17 12000 bps		
		V.17 14400 bps		
		V.22 1200 bps org		
		V.22 1200 bps ans		
		V.34 2400 bps		
		V.34 4800 bps		
		V.34 7200 bps		
		V.34 9600 bps		
		V.34 12000 bps		
		V.34 14400 bps		
		V.34 16800 bps		
		V.34 19200 bps		
		V.34 21600 bps		
		V.34 24000 bps		
		V.34 26400 bps		
		V.34 28800 bps		

Test	Sub Menu	Sub Menu	Action	General
		V.34 31200 bps		
		V.34 33600 bps		
Fax Settings				
	General User Settings		Touch to Open	
		Behind PABX	Enable/Disable	
		Single Ring	Enable/Disable	
		Double Ring	Enable/Disable	
		Triple Ring	Enable/Disable	
		Enable Line Connection Detection	Enable/Disable	
		Enable Line In Wrong Jack Detection	Enable/Disable	
		Enable Extension Support	Enable/Disable	
	Homologation General Settings		Touch to Open	
		Detect EOLs	Increase/Decrease: Range 0 – 6	
		Dial Wait Time	Increase/Decrease: Range -255 – 255	
		Pause Timeout	Increase/Decrease: Range 0 – 255	
		Pulse Dial Type	Normal/One Pulse/ Ten Mins	
		Caller ID Pattern	None/DTAS_FSK/ RPAS_FSK/LR_FSK/	

Test	Sub Menu	Sub Menu	Action	General
			NTT/FSK/LR_DTFM/ DTFM	
		Fax Low Power	Auto/DisableSleep/ PermitSleep	
		JBIG	Enable/Disable	
		JBIG2	Enable/Disable	
		MMR	Enable/Disable	
		MR	Enable/Disable	
		Fax Image Confirmation	Enable/Disable	
		Partial Page Heartbeat	Enable/Disable	
		Partial Page Heartbeat Interval		
		Fax Image Width		
		Fax Receive Resolutions		
		Disable Sending CRP		
		Send Max Speed		
		Send - Allow V.34		
		Send - Allow V.17		
		Send - Allow V.29		
		Send - Allow V.27		
		Receive Max Speed		
		Receive - Allow V.34		
		Receive - Allow V.17		
		Receive - Allow V.29		

Test	Sub Menu	Sub Menu	Action	General
		Receive - Allow V.27		
	Homologation Con- exant Settings	Dial Tone Timeout	Touch to Open	
		Max Busy Check		
		Positive Twist Control		
		Negative Twist Control		
		ARA EQM Bias		
		Pulse Interdigit Delay		
		Enable CEQ		
		Disable V.17 TX Filter		
		Digital Line Guard		
		Digital Line Threshold		
		Off Hook Line Settle Time		
		Volume Level Low		
		Volume Level Medium		
		Volume Level High		
		Dial Timeout		
		Transmit Level		
		Receive Threshold		
		DTMF Low Power Level		
		DTMF High Power Level		

Test	Sub Menu	Sub Menu	Action	General
		Progress Threshold		
		Dial Tone Threshold		
		Adjust Power FSK		
		DC Characteristics		
		Impedance		
		High Ring Impedance		
		Pulse Make Time		
		Pulse Break Time		
		Pulse Fall Time		
		Busy Tone - Cycles		
		Busy Tone - Min On Time		
		Busy Tone - Max On Time		
		Busy Tone - Min Off Time		
		Busy Tone - Max Off Time		
		Congest Tone - Cycles		
		Congest Tone - Min On Time		
		Congest Tone - Max On Time		
		Congest Tone - Min Off Time		
		Congest Tone - Max Off Time		
Reset Fax Settings	Reset Fax User Settings			

Test	Sub Menu	Sub Menu	Action	General
	Reset Fax Modem Settings			
	Reset All Fax Settings			
	Reset to Compatibility Mode			
Fax Logs	Clear All T.30 Logs			
	Clear All T.30 Error Logs			
	Clear Fax Call Log			
	Clear Caller ID Log			

Print Engine Tests

Table 2 Print Engine Tests

Test	Sub Menu	Action	Sub Menu	General
Sensor Tests				
	MPF Media Present			
	Pick Roller Index (tray 1)			
	Tray 1 Media Out			
	Tray 1 pick			
	Tray 1 Pass-through			
	Input			
	Narrow media			

Test	Sub Menu	Action	Sub Menu	General
	Fuser exit			
	Duplex path			
	Duplex interlock			
	Output bin full			
	Front door interlock			
	Rear door interlock			
	Media size (tray 1) switch 1			
	Media size (tray 1) switch 2			
	Media size (tray 1) switch 3			
	Media size (tray 1) switch 4			
Additional Trays Sensor Tests				
	Tray 2 pick roller index			
	Tray 2 media out			

Test	Sub Menu	Action	Sub Menu	General
	Tray 2 pass-through			
	Tray 2 media size switch 1			
	Tray 2 media size switch 2			
	Tray 2 media size switch 3			
	Tray 2 media size switch 4			
Motor Tests				
	MPF pick			
	Pick (tray 1) picking			
	Pick (tray 1) lifting			
	Fuser (fusing)			
	Fuser (retracing)			
	Redrive (forward)			
	Redrive (reverse)			
	Imaging unit			
	K toner add			
	Fan (main)			

Test	Sub Menu	Action	Sub Menu	General
	Fan (cartridge)			
Additional Trays Motor Tests				
	Pick (tray 2) picking			
	Pick (tray 2) lifting			
	Pass-through (tray 2)			

Scanner Diagnostics

Table 3 Scanner diagnostics

Test	Sub Menu	Sub Menu	Action	General
Sensor Tests			Start	
Motor				
	Flatbed scanner		Start	
	ADF Transport			

Test	Sub Menu	Sub Menu	Action	General
		Run DADF transport forward	Start	
		Run DADF transport backward	Start	
		DADF stop transport	Start	
	DADF Pick		Start	
	DADF Tray Lift			
		Raise DADF Tray	Start	
		Lower DADF Tray	Start	
	DADF Deskew			
		DADF Deskew On	Start	
		DADF Deskew Off	Start	
	DADF Calibration		Start	
Feed				
	Select paper size			
	Feed test			
DA-DF Rolling Cleaning Cycle			Start	

FAX diagnostics

Table 4 FAX diagnostics

Test	Sub Menu	Sub Menu	Action	General
Agency Test				
	Go Off Hook		Start	
	Ring Detect		Start	
	Generate Tones			
	Modulations			
FAX Settings				
	Fax Modulations			
	Miscellaneous Settings			
	Reset Fax Settings			
Modem Settings				

Test	Sub Menu	Sub Menu	Action	General
	Caller ID Pattern Note: Changing the value of this setting also changes the value of the Caller ID setting in the Fax Settings.			
	Pulse Dial Type			
	Disable Sending CRP			
Reboot System	N/A			

dC361 NVM Save and Restore

Purpose

1. To capture the state of NVM to a file stored on the machine's controller PWB.
2. Copy the selected NVM to a USB device or restore NVM back to the device when required.

This routine supports the save and restore of the following NVM platforms:

- Print Engine
- Fax
- Fax Engine
- Scan Engine
- Copy Controller

Procedure



CAUTION: In this procedure it is important to follow the steps in order, read and understand all notes, and perform all actions correctly for each step. Failure to do so may result in saving an old and/or incorrect NVM file, then inadvertently reloading it when NVM is restored.

Note:

- NVM data files are first saved to the controller PWB.
Saved NVM platforms can be copied to a USB device by selecting the saved platform, then selecting **[Copy to USB Device]**.
- When an AltBoot or Forced AltBoot is performed, the files are first copied to the controller PWB from the USB drive, then written to the machine.

Note: Always save NVM data to a USB drive before performing an AltBoot or Forced AltBoot. Performing an AltBoot or Forced AltBoot deletes all data from the controller PWB.

To Save NVM

1. Enter Diagnostics, **GP 1**.
2. If you are saving NVM to a USB device, connect the USB device to one of the USB ports on the machine.
3. Select **[Adjustments]**.
4. Select **[dc361 NVM Save and Restore]**.

Note: The top line represents the NVM data stored in the various locations in the machine. Subsequent lines represent the NVM platform saved in the controller PWB. Each time NVM is saved to the controller PWB a new file is created on the controller PWB. Each file displays as a separate line in the window with a unique date and time. Upon controller PWB replacement or a AltBoot or Forced AltBoot is performed, these files persist each time dc361 is accessed. When inserted, the USB device files are listed at the bottom.

5. Touch the **[Machine NVM]** line. A popup menu will open.
6. Select **[Save To Hard Drive]** from the popup menu.
A screen with a progress bar will display and the NVM data will be saved to the HDD/SSD immediately. No confirmation popup displays.
7. New line(s) are added to the screen in date and time order.
8. If it is necessary to copy the NVM files to a USB drive, touch the **[Hard Drive]** line from the save you just made. A popup menu displays.
9. Select **[Copy To USB Device]** from the popup menu.
A screen with a progress bar will display and the NVM data will be saved to the USB device immediately. No confirmation popup displays.

To Restore NVM

1. Enter Diagnostics, [GP 1](#).
2. If restoring NVM from a USB drive, connect the USB Drive to a USB port on the machine.
3. Select **[Adjustments]**.
4. Select **[dc361 NVM Save and Restore]**.

Note: The top line represents the NVM data stored in the various locations in the machine. Subsequent lines represent the data stored on the controller PWB and USB drive. Each time NVM is saved to the controller PWB a new file is created on the controller PWB. Each file displays as a separate line in the window with a unique date and time. Unless the controller PWB is replaced, or an AltBoot or Forced AltBoot is performed, these files persist each time dc361 is accessed. The USB Device files are always listed at the bottom.

5. Touch the **[Hard Drive]** line corresponding to either the save made previously or to the copy just made from the USB drive.
6. Select **[Restore Machine NVM]**.

Note: You must switch OFF, then switch ON the machine, [GP 10](#).

dC612 Print Test Patterns

Purpose

Prints the built-in test patterns to help identify Image Quality problems, [Table 1](#).

Procedure

1. Enter Diagnostics, [GP 1](#).
2. Select **Diagnostics**.
3. Select **dc612 Print Test Patterns**.
4. Select **[Start]** from the **[Advanced Print Quality Samples]** menu.

Table 1 Test Patterns

#	Description	Paper Size	Color Mode
1	Vertically repeating defects - [Print Cartridges]	8.5x11/A4	Y, M, C, K
2	Vertically repeating defects - [Transfer Module]	8.5x11/A4	Y, M, C, K
3	PQTEST-A	8.5x11/A4	Y, M, C, K
4	PQTEST-B	8.5x11/A4	C
5	PQTEST-C	8.5x11/A4	M
6	PQTEST-D	8.5x11/A4	Y
7	PQTEST-E	8.5x11/A4	K
8	PQTEST-F	8.5x11/A4	Blank
9	PQTEST-G	8.5x11/A4	Y, M, C, K
10	PQTEST-H	8.5x11/A4	Y, M, C, K
11	PQTEST-I	8.5x11/A4	Y, M, C, K
12	PQTEST-J	8.5x11/A4	Y, M, C, K

dC727 Tray Quick Print Tests

Purpose

Performs a single or continuous Quick Print Test.

Procedure

1. Enter Diagnostics, [GP 1](#).
2. Touch **[Diagnostics]** to open the diagnostics procedures menu.
3. Touch **[dc727 Tray Quick Print Tests]**.
4. Select the desired test from one of the three available options:
 - a. Touch **>Duplex**, to open the Duplex Quick Print Test menu.
 1. **[Paper size]**, touch the button to change the paper size.
 - Letter (default).
 - A4
 2. Two quick print test options are available:
 - **[Single]**, prints a single page.
 - **[Continuous]**, prints a minimum of 20 continuous pages.

Note: Load the MPF tray with a minimum of 20 sheets of the desired paper size, **[Letter]** or **[A4]**, before touching **[Start]**.
 3. **[Single]**, touch **[Start]** to print a single quick print test page.
 4. **[Continuous]**, touch **[Start]** to print continuous quick print test pages.
 - b. Touch **>MPF Tray**, to open the MPF Tray tests:
 1. Two quick print test options are available:
 - **[Single]**, prints a single page.
 - **[Continuous]**, prints a minimum of 20 pages.

Note: Load Tray 1 with a minimum of 20 sheets of the desired paper size, **[Letter]** or **[A4]**, before touching **[Start]**.
 2. **[Single]**, touch **[Start]** to print a single quick print test page.
 3. **[Continuous]**, touch **[Start]** to print continuous quick print test pages.

- A4
2. Two quick print test options are available:
 - **[Single]**, prints a single page.
 - **[Continuous]**, prints a minimum of 20 continuous pages.

Note: Load the MPF tray with a minimum of 20 sheets of the desired paper size, **[Letter]** or **[A4]**, before touching **[Start]**.
3. **[Single]**, touch **[Start]** to print a single quick print test page.
4. **[Continuous]**, touch **[Start]** to print continuous quick print test pages.
- c. Touch **>Tray 1**, to open the Tray 1 tests:
 1. Two quick print test options are available:
 - **[Single]**, prints a single page.
 - **[Continuous]**, prints a minimum of 20 continuous pages.

Note: Load Tray 1 with a minimum of 20 sheets of the desired paper size, **[Letter]** or **[A4]**, before touching **[Start]**.
 2. **[Single]**, touch **[Start]** to print a single quick print test page.
 3. **[Continuous]**, touch **[Start]** to print continuous quick print test pages.

dc919 Color Balance Adjustment

Purpose

Adjustment of color alignment and to print or reset the default settings.

Procedure

1. Enter the Diagnostics, [GP 1](#).
2. Touch **[Adjustments]** to open the adjustments list.
3. Touch **[dc919 Color Balance Adjustment]**.
4. The following settings are available:

- **Color alignment adjust**
 - Touch the **[next]** button to open the procedure.

The color alignment adjust provides seven adjustments for each color C,Y,M,K independently. Perform the required adjustment for the color required.

- a. Select the required color for adjustment: **Cyan, Magenta, Yellow, or Black**:
 - **Top margin**, touch the **[+]** or **[-]** to the desired setting, then touch **[Save]**. The range is –100 to 100.
 - **Left margin**, touch the **[+]** or **[-]** to the desired setting, then touch **[Save]**. The range is –600 to 600.
 - **Right margin**, touch the **[+]** or **[-]** to the desired setting, then touch **[Save]**. The range is –600 to 600.
 - **Skew**, touch the **[+]** or **[-]** to the desired setting, then touch **[Save]**. The range is –50 to 50.
 - **Bow**, touch the **[+]** or **[-]** to the desired setting, then touch **[Save]**. The range is –50 to 50.
 - **Linearity**, touch the **[next]** button to open the linearity menu.
 - ◆ **Left adjustment**, touch the **[+]** or **[-]** to the desired setting, then touch **[Save]**. The range is –65 to 65.
 - ◆ **Center adjustment**, touch the **[+]** or **[-]** to the desired setting, then touch **[Save]**. The range is –65 to 65.
 - ◆ **Right adjustment**, touch the **[+]** or **[-]** to the desired setting, then touch **[Save]**. The range is –65 to 65.
 - ◆ **Quick test**, touch **[Start]** to initiate the Quick Test.

- **Quick test**, touch **[Start]** to initiate the Quick Test.
 - **Factory manual**, touch **[Start]** to begin the adjustment.
 - **Reset auto alignment margin**, touch **[Start]** to begin the adjustment.
 - **AA adjustment**, touch **[Start]** to begin the adjustment.
 - **Print AA information page**, touch **[Start]** to begin the adjustment.
5. Touch **[Back]**.
 6. Touch **[Call Closeout]**.
 7. Touch **[Exit & Reboot]**.

dC925 Printer Setup

Purpose

Adjusts the EP settings of the printer and calibrates the waste tone sensor for optimal accuracy.

Procedure

Three adjustments can be performed in dC925 Printer Setup:

1. Enter Diagnostics, [GP 1](#).
2. Scroll to **[Adjustments > dc925 Printer Setup]**, then touch **[dc925 Printer Setup]** to open the menu.
3. Touch the adjustment required:
 - a. **Engine Settings:** Not Used.
 - b. **EP Setup:** increase or reduce bias voltage on the drum from the bias charge roll.

Two settings are available for either **[Charge Adjust]** or **[Developer Adjust]**:

- **Charge Adjust:**

1. Black (DC bias votage)
 - 1) Touch the button to change the black bias voltage as required:
 - **[Low]**
 - **[Normal]** (default)
 - **[High]**
 - 2) Touch **[Save]** to set the change active.

2. Color (DC bias votage)

- 1) Touch the button to change the color bias voltage as required:
 - **[Low]**
 - **[Normal]** (default)
 - **[High]**
- 2) Touch **[Save]** to set the change active.

- **Developer Adjust:**

1. Black (DC bias votage)
 - 1) Touch the button to change the black bias voltage as required:

- **[Low]**
 - **[Normal]** (default)
 - **[High]**
- 2) Touch **[Save]** to set the change active.

2. Color (DC bias votage)

- 1) Touch the button to change the color bias voltage as required:
 - **[Low]**
 - **[Normal]** (default)
 - **[High]**
- 2) Touch **[Save]** to set the change active.

- c. **Waste toner sensor calibration:** calibrates the waste toner sensor, ensuring the accuracy of the waste toner level detection.

1. Touch **[Start]** to begin the sensor calibration.

4. Exit Diagnostics, [GP 1](#).

dC927 Toner Patch Sensor (TPS) Setup

The Toner Patch Sensor (TPS) regulates the density of the toner fused to the print medium. dC927 is used when a new TPS sensor is installed or when toner density needs adjusting beyond the customer TPS setup allows.

Diagnostics Entry

Enter Diagnostics, [GP 1](#).

Calibration Frequency Preference

1. Touch the adjustment button to change the frequency of the auto-calibration process:
 - **[Disable]** stops auto-calibration entirely.
 - **[Fewest color adjustments]** sets the frequency of adjustment to the lowest number of auto-calibrations.
 - **[Fewer color adjustments]** sets the frequency of adjustment to a next lower number of auto-calibrations.
 - **[Normal]** sets the frequency of adjustment to the default number of auto-calibrations.
 - **[Better color accuracy]** sets the frequency of adjustment to a higher number of auto-calibrations.
 - **[Best color accuracy]** sets the frequency of adjustment to the highest number of auto-calibrations.
2. Touch **[Save]** to save settings.

TPS Characterization Data.



CAUTION: TPS characterization data is only used when a new TPS sensor kit is to be installed. Changing these values for any other reason could result in decreased print quality, possible damage, or machine failure.

1. Touch the **[next page]** button.
2. Enter the characterization data.

Note: The characterization data is provided with the TPS sensor kit.

- Select **[Left Sensor Data]**, then enter the corresponding strings.
- Select **[Right Sensor Data]**, then enter the corresponding strings.
- Select **[Shared Sensor Data]**, then enter the corresponding strings.
- Select **[Serial Number]**, then enter the corresponding strings.
- Select **[Save all TPS Sensor Data]**, then touch **[Start]**.

3. Remaining in dC927 Toner Patch Sensor Setup:
 - Touch **[Start]** to run the automated routine **[Sensor Gain Characterization]**.

Note: Engine will start up and stop to complete this automated routine, but no physical pages will be printed.

- Touch **[Start]** to run the automated routine **[Sensor Gain Verification]**.

Note: Check for red text indicating errors on the page printed by this automated routine. Contact the next level of support if needed.

- Touch **[Start]** to run the automated routine **[Full Calibration]**.

Note: Engine will start up and stop to complete this automated routine, but no physical pages will be printed.

Full Calibration

Touch **[Start]** to initiate all calibration procedures available for the TPS sensor.

Gap Calibration

Touch **[Start]** to initiate gap calibration procedures available for the TPS sensor.

Print TPS information page

Touch **[Start]** to print TPS sensor details.

Print Test Pages

Touch **[Start]** to print TPS sensor test pages.

Calibration Reference

Calibration reference decreases or increases the darkness of the print.

The Calibration reference section provides a menu for Black (K) and a menu for CMY.

- A negative number makes the print darker.
- A positive number makes the print lighter.

Note: Calibration Reference has CMY combined because the developer voltage controls are combined.

1. **Black:**
 - a. Touch **[-]** to make the print darker.
 - b. Touch **[+]** to make the print lighter.
2. **CMY:**

- a. Touch [-] to make the print darker.
- b. Touch [+] to make the print lighter.

Note: Make small adjustments, then test prints are suggested.

3. Touch [Save] to save changes.

Halftone Reference

Halftone reference increases or decreases the halftone darkness of the print.

Note: Halftone reference has four individual settings, One for C, one for M, one for Y, and one for K. This is because the laser power controls are all independent.

1. Touch the adjustment button for the desired color:

Note: Make small adjustments, then test prints are suggested.

- **[Low]** reduces the halftone reference.
- **[Normal]** is the default halftone reference.
- **[High]** increases the halftone reference.

2. Touch **[Save]** after each adjustment to save changes.

Reset Color Calibration

Touch **[Start]** to reset color calibration settings to default.

Sensor Gain Characterization

Touch **[Start]** to auto-adjust the TPS sensor gain characteristics.

Sensor Gain Verification

Touch **[Start]** to initiate system verification of the TPS sensor gain settings.

Exit Diagnostics, [GP 1](#).

dC945 IIT Calibration

Purpose

The purpose of this procedure is to calibrate the optics in the IIT for optimal performance.

This procedure provides two functions:

1. Scanner Calibration Reset
2. Controller Calibration

Procedure

1. Enter Diagnostics, [GP 1](#).
2. Touch the desired operation, then touch **[Start]** to begin.
3. Exit Diagnostics, [GP 1](#), when complete.

Change Tags

Change Tag Introduction

This section describes tags associated with the printer, as well as multinational applicability, classification codes, and permanent or temporary modification information. Important modifications to the printer are identified by a tag number which is recorded on a tag matrix inside the front door.

Classification Codes

A tag number may be required to identify differences between parts that cannot be interchanged, or differences in diagnostic, repair, installation, or adjustment procedures.

A tag number may also be required to identify the presence of optional hardware, special non-volatile memory programming, or whether mandatory modifications have been installed. Each tag number is given a classification code to identify the type of change that the tag has made. The classification codes and their descriptions are listed in [Table 1](#).

Table 1 Classification codes

Classification Code	Description
M	Mandatory tag.
N	Tag not installed in the field.
O	Optional tag.
R	Repair tag.

7 Wiring Data

Plug/Jack and Sensor Locations.....	617
C625 PJ and Sensor Locations.....	617
Wiring Diagrams.....	621
Wiring Diagrams.....	622

C625 PJ and Sensor Locations

PJ and Sensor Location Tables:

To locate a connector, go to the appropriate table.

- Controller PWB Connectors, [Table 1](#).
- Drive PWB Connectors, [Table 2](#).
- LVPS Connectors, [Table 3](#).
- Sensor Locations, [Table 4](#)

P/J and Sensor Location Figures:

- Controller PWB Connectors, [Figure 1](#).
- Drive PWB Connectors, [Figure 2](#).
- LVPS Connectors, [Figure 3](#).
- Sensor Locations, [Figure 4](#)

Table 1 Controller PWB Connectors

Connector	Connects to
J61	Wireless module
J65	Connector jumper
JADF1	ADF back side scan module
JADF2	<ul style="list-style-type: none"> • ADF sensors • Motor (ADF pick) • Motor (ADF transport)
JBUSB1	Rear USB port
JETH1	Ethernet port
JFAX1	Fax card
JFB1	Scanner front side scan module
JFBM1	Motor (flatbed CIS scanner)
JFUSB1	Front USB port
JHS1	Sensor (flatbed CIS scanner)
JISP1	Internal Solutions Port
JLCD1	Control panel display
JMFD1	Sensor (ADF multifeed)

Connector	Connects to
JMFP1	Connector jumper
JPHONE1	Headphones
JPWR1	Drive PWB, power connection
JSPKR1	Speaker
JTH1	Drive PWB, data connection
JTPM	Trusted Platform Module
JUSB1	USB printer port

Table 2 Drive PWB Connectors

Connector	Connects to
J72	Connector jumper
JBOR1	Motor (BOR)
JCDRV1	Motor (CMY)
JCTM1	TMC card
JCVR1	Interlock switches
JDSNS1	<ul style="list-style-type: none"> • Sensor (redrive) • Sensor (exit/bin full)
JFAN2	Main fan
JFDRV1	Motor (fuser)
JFSNS1	Sensor (fuser present)
JHVPS1	HVPS
JKDRV1	Motor (K/transfer belt)
JLVPS1	LVPS
JMIRR1	Printhead mirror
JMIRR2	Printhead mirror
JMSPZ1	<ul style="list-style-type: none"> • Sensor (tray 1 paper size) • Sensor (MPF paper present) • Front door sensors <ul style="list-style-type: none"> • Sensor (duplex staging) • Sensor (fuser buckle)

Connector	Connects to
	<ul style="list-style-type: none"> Sensor (narrow media)
JMTR1	<ul style="list-style-type: none"> Pick drive Motor (tray 1 pick) Sensor (tray 1 pick position) Sensor (tray 1 paper present) Motor (deskew) Motor (duplex/MPF) Isolation unit Motor (isolation)
JMTREN2	Connector jumper
JOPT1	Optional tray
JOUTDC1	Motor (exit/redrive)
JPH1	Printhead
JKSNS1	<ul style="list-style-type: none"> Sensor (waste toner contact) Sensor (input) Isolation unit Sensor (tray 1 pick) Sensor (MPF/pass-through)
JPWR2	Controller PWB, power connection
JTH2	Controller PWB, data connection
JTPS_C1	Sensor (TPS)
JWTH_SC1	<ul style="list-style-type: none"> Sensor (weather station) Imaging unit and imaging kit

Table 3 LVPS Connectors

Connector	Connects to	Pin no.	Signal
CN201	Drive PWB	1	+25V
		2	GND
		3	+25V
		4	GND
		5	+25V

Connector	Connects to	Pin no.	Signal		
		6	GND		
		7	+25V		
		8	GND		
		9	+25V		
		10	GND		
		11	+25V		
		12	GND		
		13	+25V		
		14	GND		
		15	+25V		
		16	GND		
		17	GND		
		18	GND		
		19	Zero_Cross		
		20	Heat_On2		
		21	Heat_On1		
		22	Main_On_Off		
		23	Tx_PwrMtr		
		24	Relay_Drive		
		25	Ground		
		26	+6.5V		
		27	+6.5V		
		28	+6.5V		
		29	Rx_PwrMtr		
		30	Heat_On3		
		CN1	Fuser	1	AC Common
				2	AC Out 3
				3	AC Out 2

Connector	Connects to	Pin no.	Signal
		4	AC Out 1
AC1	AC line in	1	Phase
		2	Neutral

Table 4 Sensor Locations

1	Sensor (Toner Patch Sensor (TPS)), PL 90.05 item 4
2	Sensor (weather station), PL 40.15 item 1
3A	Sensor (tray 1 paper present) (not spared), P/O Paper Feeder, PL 70.10 item 8
3B	Sensor (pick position) (not spared), P/O Paper Feeder, PL 70.10 item 8
4	Sensor (MPF media present), PL 1.10 item 6
5	Sensor (input), PL 80.05 item 7
6	Sensor (tray 1 pick) (not spared) P/O Registration Chute, PL 80.10 item 4
7	Sensor (MPF/pass-through), PL 80.10 item 6
8	Sensor (duplex staging, PL 80.15 item 6, P/O Duplex Inner Guide, PL 80.15 item 1
9	Sensor (narrow media), PL 80.15 item 2, P/O Duplex Inner Guide, PL 80.15 item 1
10	Sensor (fuser buckle), PL 80.15 item 2, P/O Duplex Inner Guide, PL 80.15 item 1
11	Sensor (fuser nip), PL 10.10 item 2.
12	Sensor (redrive), PL 80.10 item 2, P/O Diverter, PL 80.10 item 1
13	Sensor (exit/bin full), PL 28.15 item 16

Controller PWB

Location: PL 3.05 item 2

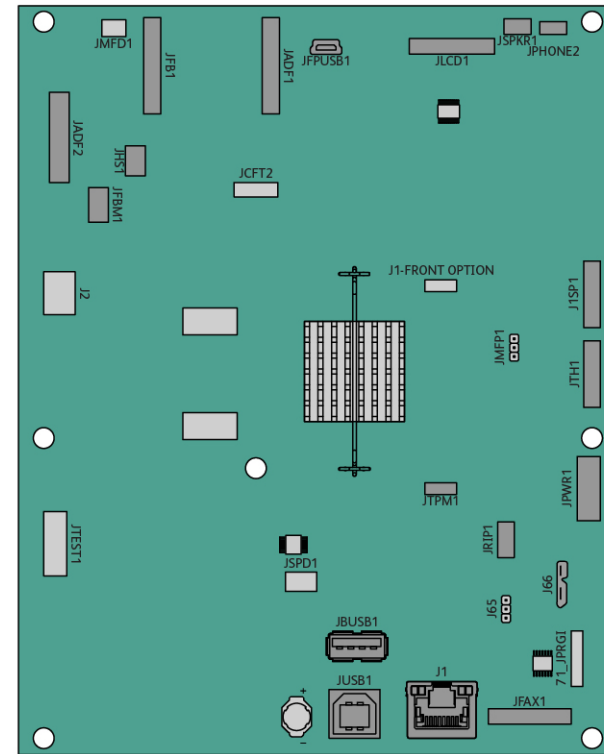
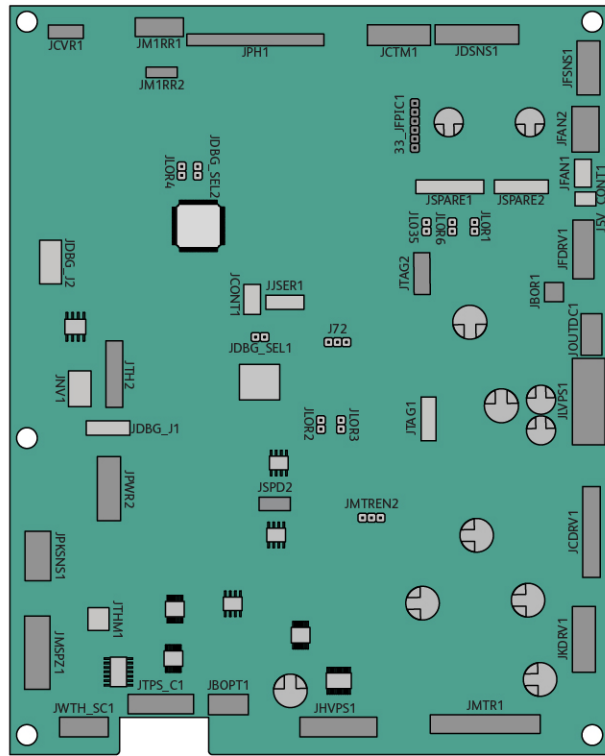


Figure 1 Controller PWB

Motor Drive PWB

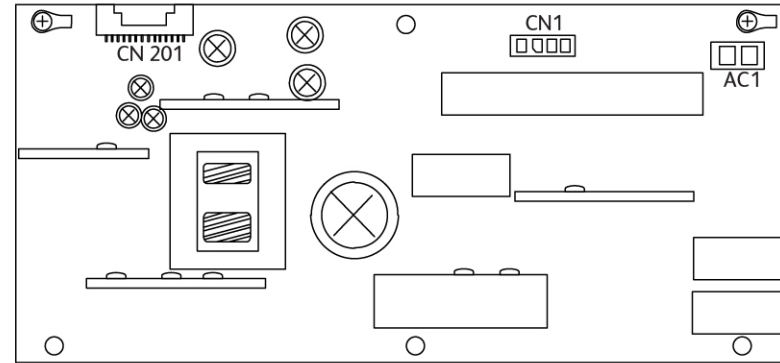
Location: PL 1.10 item 3



VLC625S_7005

Figure 2 Motor Drive PWB
LVPS

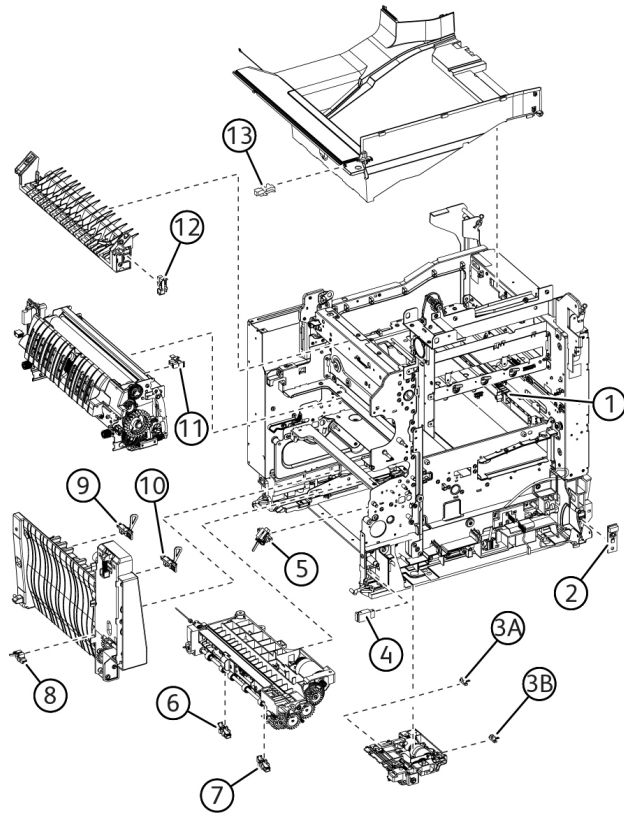
Location: [PL 1.10 item 7](#)



VLC625S_7001

Figure 3 LVPS

Sensor Locations



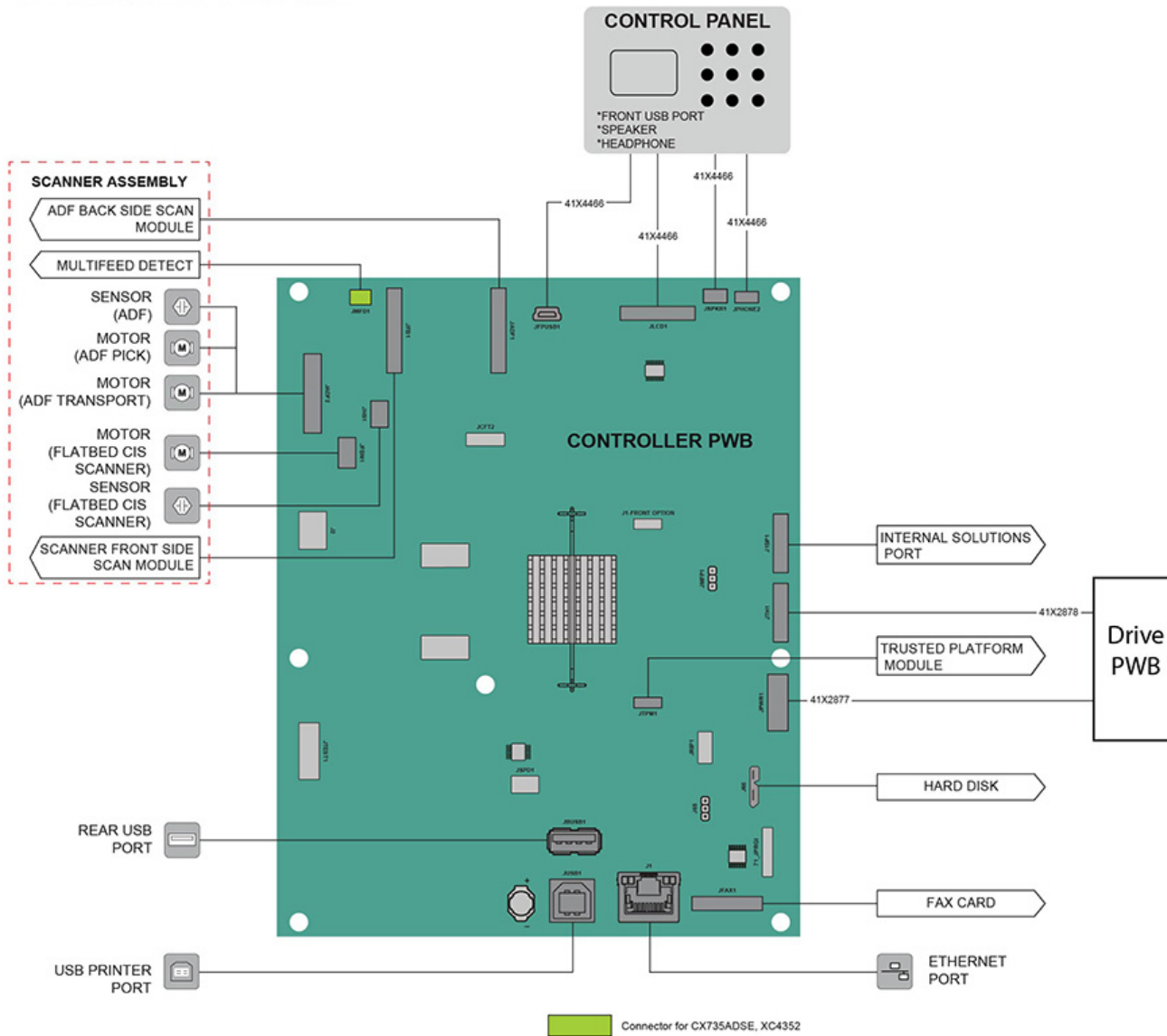
VLC6255_7003

Figure 4 Sensor Locations

Wiring Diagrams

WD1 Controller PWB Wiring Diagram

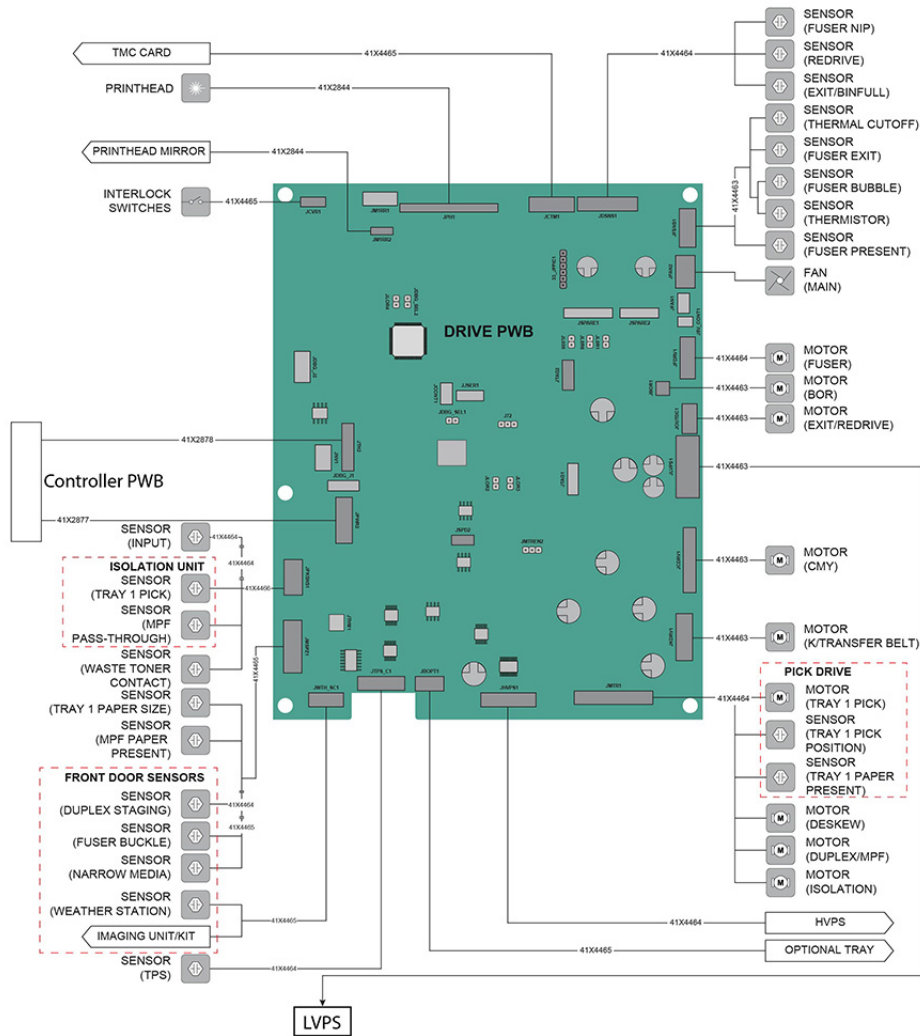
WD1 - Controller PWB Wiring Diagram



C625S_7007

WD2 Drive PWB Wiring Diagram

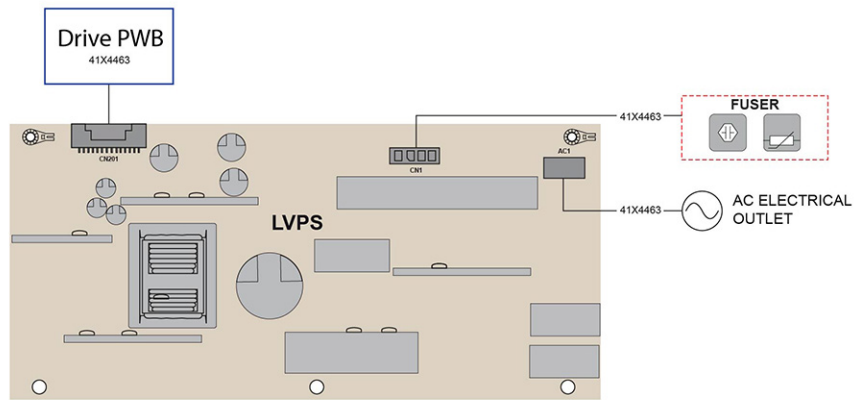
WD2 - Drive PWB Wiring Diagram



C6255_7008

WD3 LVPS Wiring Diagram

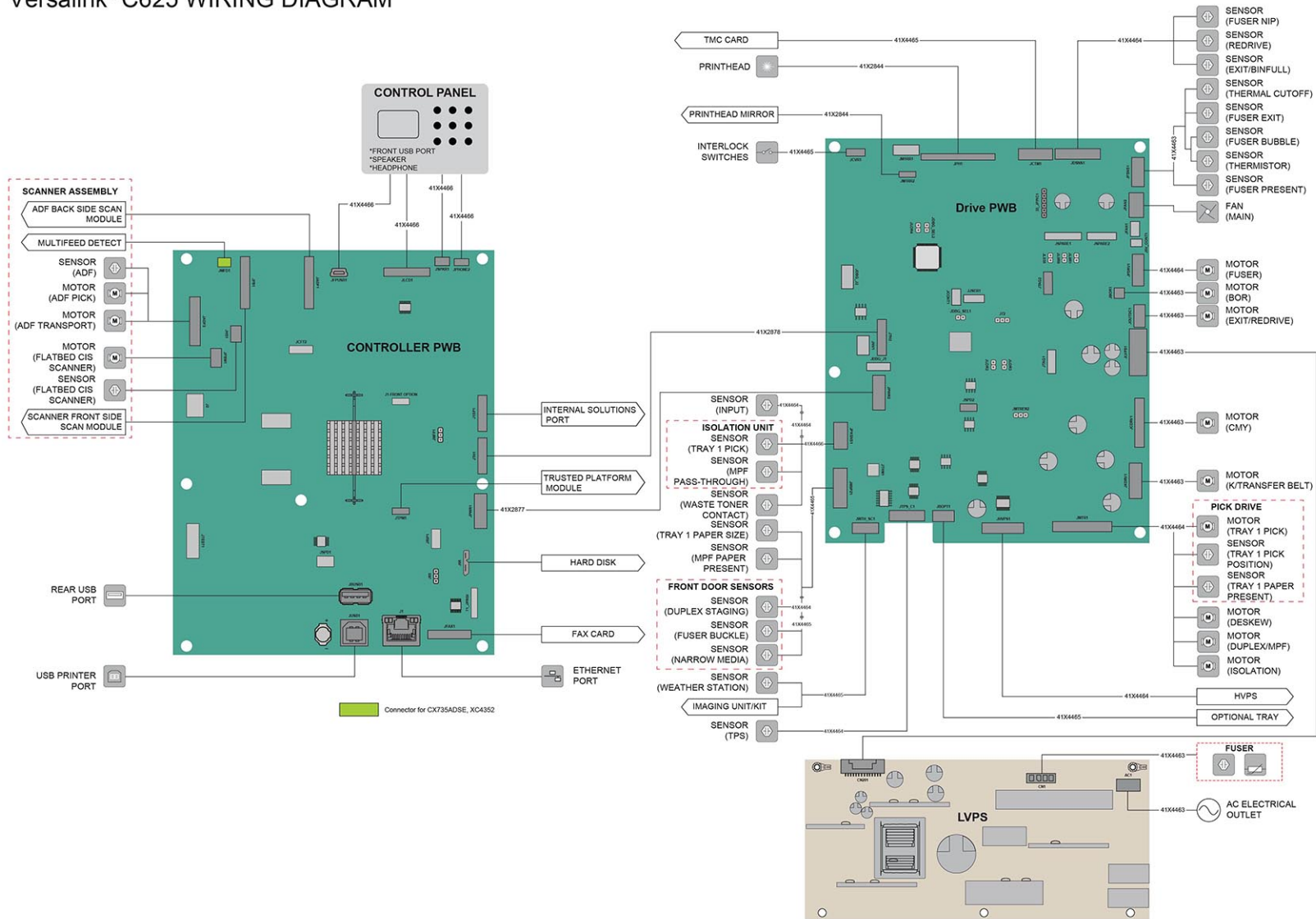
WD3 - LVPS Wiring Diagram



C625S_7009

WD4 C625 Wiring Diagram

Versalink® C625 WIRING DIAGRAM



VLC625S_7006

NVMID- Index	Tools		Display Mode	dc131 Display Name	Category	Type	Reset After Forced Alboot Software Installation	External Reference	Version	Machine Configure Parameter	Is part of Diagnostics Database?
	Description	Setting Information									
600-009	BlockSize in K		RW	BlockSize in K	NVMConfiguration	natural	No		1.686		
600-012	Frame Size		RW	Frame Size	NVMConfiguration	natural	No		1.686		
600-015	Fault Counter 19-750-00: VideoEPCSizeMisMatchCntr		RW	Ram Size Mismatch FaultFC	NVMFaultCounter	shortNatural	No	Fault Counter:19-750-00:	1.813		
600-016	Fault Counter 19-754-00: VideoDiskMismatchCntr		RW	Disk Mode Mismatch FaultFC	NVMFaultCounter	shortNatural	No	Fault Counter:19-754-00:	1.813		
600-017	Fault Counter 19-401-00: Out of Memory Fault - Stress Document		RW	Out Memory Fault - StrNC docFC	NVMFaultCounter	shortNatural	No	Fault Counter:19-401-00: Out of Memory Fault - Stress	1.153		
600-018	Fault Counter 19-402-00: FaultVideoDVMSTimeOutFault		RW	Compressor DVMA Timeout FaultFC	NVMFaultCounter	shortNatural	No	Fault Counter:19-402-00:	1.153		
600-020	Fault Counter 22-300-10: AHA End of Record Fault		RW	AHA End of Record Fault	NVMFaultCounter	shortNatural	No	Fault Counter:22-300-10: AHA End of Record Fault	1.000		
600-059	Toner Coverage Plane1-2		RO	Toner Coverage Plane1-2	NVMSystemUsageCounter	longNatural	No	System Usage	1.813		
600-060	Toner Coverage Plane1-3		RO	Toner Coverage Plane1-3	NVMSystemUsageCounter	longNatural	No	System Usage	1.813		
600-061	Toner Coverage Plane1-4		RO	Toner Coverage Plane1-4	NVMSystemUsageCounter	longNatural	No	System Usage	1.813		
600-071	Toner Coverage Plane1-14		RO	Toner Coverage Plane1-14	NVMSystemUsageCounter	longNatural	No	System Usage	1.813		
600-073	Toner Coverage Plane1-16		RO	Toner Coverage Plane1-16	NVMSystemUsageCounter	longNatural	No	System Usage Counter:226: Black	1.813		
600-074	Toner Coverage Plane1-17		RO	Toner Coverage Plane1-17	NVMSystemUsageCounter	longNatural	No	System Usage Counter:227: Black	1.813		
600-076	Toner Coverage Plane1-19		RO	Toner Coverage Plane1-19	NVMSystemUsageCounter	longNatural	No	System Usage Counter:229: Black >90 to 100% Area Coverage Impressions	1.813		
600-117	Toner Coverage Plane4-3		RO	Toner Coverage Plane4-3	NVMSystemUsageCounter	longNatural	No	System Usage Counter:278: Yellow >2 to 3% Area Coverage	1.813		
600-209	Fault Counter 19-420: Image Processing	no. of faults	RW	Fault Counter 19-420	NVMFaultCounter	shortNatural	No	Fault Counter:19-420-	1.660		
600-210	Fault Counter 19-422: Image Processing	no of faults	RW	Fault Counter 19-422	NVMFaultCounter	shortNatural	No	Fault Counter:19-422-	1.660		
600-211	Fault Counter 19-424: Image Processing	no of faults	RW	Fault Counter 19-424	NVMFaultCounter	shortNatural	No	Fault Counter:19-424-	1.660		
600-212	Fault Counter 19-426: Image Processing	no of faults	RW	Fault Counter 19-426	NVMFaultCounter	shortNatural	No	Fault Counter:19-426-	1.663		
600-213	Fault Counter 19-410-14: Scan Output	no of faults	RW	Fault Counter 19-410-14	NVMFaultCounter	shortNatural	No	Fault Counter:19-410-	1.668		
600-214	Fault Counter 19-340 :SIC Crash	no of faults	RW	Fault Counter 19-340-00	NVMFaultCounter	shortNatural	No	Fault Counter:19-340-	1.813		
603-002	Determines whether APS requires input to		RW	APSSStandardSizeRequired	NVMSAKOSetting	boolean	No		1.000		
603-013	Counter-COPYLargeSheets		ND		NVMBillingCounter	byteArray	No	Billing Counter:16:	1.799		
603-041	Counter-COPYLargeColorSheets		ND		NVMBillingCounter	byteArray	No	Billing Counter:19: Color Copied Large Sheets	1.799		
604-025	Counter-CollatedSheets		ND		NVMSystemUsageCounter	byteArray	No	System Usage Counter:186: All collated sheets	1.799		

604-028	Counter-DualStaples		ND		NVMSystemUsageCounter	byteArray	No	System Usage Counter:192: All dual staples	1.799		
604-037	Counter-PunchedSheets		ND		NVMSystemUsageCounter	byteArray	No	System Usage Counter:187: All punched sheets	1.799		
604-046	Counter-StapledSheets		ND		NVMSystemUsageCounter	byteArray	No	System Usage Counter:189: All stapled sheets	1.799		
604-055	Counter-All Uncollated Stapled sheets		ND		NVMSystemUsageCounter	byteArray	No	System Usage Counter:188: All uncollated stapled sheets	1.799		
604-061	Counter-DualPitchImages		ND		NVMSystemUsageCounter	byteArray	No	System Usage Counter:56: Number of developed dual-pitch images	1.799		
604-064	Counter-Stapled2_15		ND		NVMSystemUsageCounter	byteArray	No	System Usage Counter:180: Number of stapled output sets with 2 to 15 sheets	1.799		
604-067	Counter-Stapled16_30		ND		NVMSystemUsageCounter	byteArray	No	System Usage Counter:181: Number of stapled output sets with 16 to 30 sheets	1.799		
604-090	-Images During Service Call		ND		NVMDiagCounter	byteArray	No	Diagnostic Counter:299: Images During Service	1.799		
604-092	-Images Between Service Calls		ND		NVMDiagCounter	byteArray	No	Diagnostic Counter:300: Images Between Service	1.000		
604-094	Fault Counter 22-310-04:PageTKTSOutOfOrder (SheetsOutOfSequence)	no. of faults	ND		NVMFaultCounter	byteArray	No	Fault Counter:22-310-04: PageTKTSOutOfOrder	1.153		
604-099	Fault Counter 22-314-04: ModuleRegistrationError	no. of faults	ND		NVMFaultCounter	byteArray	No	Fault Counter:22-314-04: ModuleRegistrationError	1.000		
604-101	Fault Counter 22-315-04: NoCompletionsError	no. of faults	ND		NVMFaultCounter	byteArray	No	Fault Counter:22-315-04: NoCompletionsError	1.143		
604-105	Fault Counter 22-701-04: CompletionWhileIdle	no. of faults	ND		NVMFaultCounter	byteArray	No	Fault Counter:22-701-04: CompletionWhileIdle	1.000		

604-107	Fault Counter 22-316-04: trayDoesNotExist	no. of faults	ND		NVMFaultCounter	byteArray	No	Fault Counter:22-316-04: trayDoesNotExist	1.000		
604-109	Fault Counter 22-317-04: noFinisherCapabilityFound	no. of faults	ND		NVMFaultCounter	byteArray	No	Fault Counter:22-317-04: noFinisherCapabilityFound	1.000		
604-111	Fault Counter 22-318-04: noIOTCapabilityFound	no. of faults	ND		NVMFaultCounter	byteArray	No	Fault Counter:22-318-04: noIOTCapabilityFound	1.000		
604-127	Enable Offset policy	Enable Offset policy 0=Off 1=On	RW	MsoffsetEnabledPolicy	NVMSAKOSetting	boolean	No		1.754		
604-132	ProdCfgNvm	Northwood	RW	ProdCfgNvm	NVMConfiguration	shortNatural	No		1.266		
604-132	ProdCfgNvm	Burgundy	RW	ProdCfgNvm	NVMConfiguration	shortNatural	No		1.507		
604-132	ProdCfgNvm	Barolo	RW	ProdCfgNvm	NVMConfiguration	shortNatural	No		1.507		
604-135	Counter-Stapled31_50		ND		NVMSystemUsageCounter	byteArray	No	System Usage Counter:182: Number of stapled output sets with 31 to 50 sheets	1.799		
604-136	Counter-Stapled51_100		ND		NVMSystemUsageCounter	byteArray	No	System Usage Counter:183: Number of stapled output sets with 51 to 100 sheets	1.799		
604-160	Fault Counter 03-316: CCMCannotCommunicateWithlotFC		RW	CCMCannotCommunicateWithlotFC	NVMFaultCounter	shortNatural	No	Fault Counter:03-316-00: CCMCannotCommunicateWithlotFC	1.813		
604-161	Fault Counter 10-311: FuserHeatRollStsDisconnectFailCountFC		RW	FuserHeatRollStsDisconnectFC	NVMFaultCounter	shortNatural	No	Fault Counter:10-311-00: FuserHeatRollStsDisconnectFailCountFC	1.159		
604-162	Fault Counter 10-319: FuserNcSnrDifferentialFailCountFC		RW	FuserNcSnrDifferentialFC	NVMFaultCounter	shortNatural	No	Fault Counter:10-319-00: FuserNcSnrDifferentialFailCountFC	1.159		
604-163	Fault Counter 10-320: HeatRolloverTempFailCountFC		RW	HeatRolloverTempFailCountFC	NVMFaultCounter	shortNatural	No	Fault Counter:10-320-00: HeatRolloverTempFailCountFC	1.159		
604-164	Fault Counter 10-321: FuserNipFailCountFC		RW	FuserNipFailCountFC	NVMFaultCounter	shortNatural	No	Fault Counter:10-321-00: FuserNipFailCountFC	1.159		

604-165	Fault Counter 10-323: FuserRearNcSnrDisconnectFailCountFC		RW	FuserRearNcSnrDisconnectFC	NVMFaultCounter	shortNatural	No	Fault Counter:10-323-00: FuserRearNcSnrDisconnectFailCountFC	1.159		
604-166	Fault Counter 10-324: FuserNvmFailCountFC		RW	FuserNvmFailCountFC	NVMFaultCounter	shortNatural	No	Fault Counter:10-324-00: FuserNvmFailCountFC	1.159		
604-167	Fault Counter 10-326: WaitHeatRollFuserOnTimeFailCountFC		RW	WaitHeatRollFuserOnTimeFC	NVMFaultCounter	shortNatural	No	Fault Counter:10-326-00: WaitHeatRollFuserOnTimeFailCountFC	1.159		
604-168	Fault Counter 10-327: StandbyHeatRollFuserOnTimeFailCountFC		RW	StandbyHeatRollFuserOnTimeFC	NVMFaultCounter	shortNatural	No	Fault Counter:10-327-00: StandbyHeatRollFuserOnTimeFailCountFC	1.159		
604-169	Fault Counter 10-330: FuserMotorFailFC		RW	FuserMotorFailFC	NVMFaultCounter	shortNatural	No	Fault Counter:10-330-00: FuserMotorFailFC	1.813		
604-170	Fault Counter 12-112: HxportEntSnrOnJamFaultCountFC		RW	HxportEntSnrOnJamFaultCountFC	NVMFaultCounter	shortNatural	No	Fault Counter:12-112-00: HxportEntSnrOnJamFaultCountFC	1.813		
604-171	Fault Counter 12-113: BookletInSnrOnJamFaultCountFC		RW	BookletInSnrOnJamFaultCountFC	NVMFaultCounter	shortNatural	No	Fault Counter:12-113-00: BookletInSnrOnJamFaultCountFC	1.813		
604-172	Fault Counter 12-114: BookletInSnrOffJamFaultCountFC		RW	BookletInSnrOffJamFaultCountFC	NVMFaultCounter	shortNatural	No	Fault Counter:12-114-00: BookletInSnrOffJamFaultCountFC	1.813		
604-173	Fault Counter 12-115: BookletFolderRollExitSnrOnJamFaultCountFC		RW	BookletFolderRollExitSnrOnJamFC	NVMFaultCounter	shortNatural	No	Fault Counter:12-115-00: BookletFolderRollExitSnrOnJamFaultCountFC	1.813		
604-174	Fault Counter 12-125: GateSnrOnJamFaultCountFC		RW	GateSnrOnJamFaultCountFC	NVMFaultCounter	shortNatural	No	Fault Counter:12-125-00: GateSnrOnJamFaultCountFC	1.521		
604-175	Fault Counter 12-132: XportEntSnrOnJamFaultCountFC		RW	XportEntSnrOnJamFaultCountFC	NVMFaultCounter	shortNatural	No	Fault Counter:12-132-00: XportEntSnrOnJamFaultCountFC	1.813		
604-176	Fault Counter 12-142: BufferPathSnrOnJamFaultCountFC		RW	BufferPathSnrOnJamFaultCountFC	NVMFaultCounter	shortNatural	No	Fault Counter:12-142-00: BufferPathSnrOnJamFaultCountFC	1.521		
604-177	Fault Counter 12-151: CompileExitSnrOffJamFaultCountFC		RW	CompileExitSnrOffJamFC	NVMFaultCounter	shortNatural	No	Fault Counter:12-151-00: CompileExitSnrOffJamFaultCountFC	1.813		

604-178	Fault Counter 12-152: CompileExitSnrOnJamFaultCountFC		RW	CompileExitSnrOnJamFaultCountFC	NVMFaultCounter	shortNatural	No	Fault Counter:12-152-00: CompileExitSnrOnJamFaultCountFC	1.813		
604-179	Fault Counter 12-161: SetEjectJamFaultCountFC		RW	SetEjectJamFaultCountFC	NVMFaultCounter	shortNatural	No	Fault Counter:12-161-00: SetEjectJamFaultCountFC	1.813		
604-180	Fault Counter 12-162: HxportExitSnrOnJamFaultCountFC		RW	HxportExitSnrOnJamFaultCountFC	NVMFaultCounter	shortNatural	No	Fault Counter:12-162-00: HxportExitSnrOnJamFaultCountFC	1.521		
604-181	Fault Counter 12-171: TopTrayExitSnrOnJamFaultCountFC		RW	TopTrayExitSnrOnJamFaultCountFC	NVMFaultCounter	shortNatural	No	Fault Counter:12-171-00: TopTrayExitSnrOnJamFaultCountFC	1.813		
604-182	Fault Counter 12-172: TopTrayExitSnrOffJamFaultCountFC		RW	TopTrayExitSnrOffJamFaultCountFC	NVMFaultCounter	shortNatural	No	Fault Counter:12-172-00: TopTrayExitSnrOffJamFaultCountFC	1.813		
604-183	Fault Counter 12-180: BookletFolderRollExitSnrOffJamFaultCountFC		RW	BookletFolderRollExitSnrOffJamFC	NVMFaultCounter	shortNatural	No	Fault Counter:12-180-00: BookletFolderRollExitSnrOffJamFaultCountFC	1.813		
604-184	Fault Counter 12-211: StackerTrayFailFaultCountFC		RW	StackerTrayFailFaultCountFC	NVMFaultCounter	shortNatural	No	Fault Counter:12-211-00: StackerTrayFailFaultCountFC	1.813		
604-185	Fault Counter 12-212: StackerUpperLimitFailFaultCountFC		RW	StackerUpperLimitFailFC	NVMFaultCounter	shortNatural	No	Fault Counter:12-212-00: StackerUpperLimitFailFaultCountFC	1.813		
604-186	Fault Counter 12-213: StackerLowerLimitFailFaultCountFC		RW	StackerLowerLimitFailFC	NVMFaultCounter	shortNatural	No	Fault Counter:12-213-00: StackerLowerLimitFailFaultCountFC	1.813		
604-187	Fault Counter 12-221: FrontTamperHomeSnrOnFailFaultCountFC		RW	FrontTamperHomeSnrOnFailFC	NVMFaultCounter	shortNatural	No	Fault Counter:12-221-00: FrontTamperHomeSnrOnFailFaultCountFC	1.813		
604-188	Fault Counter 12-223: FrontTamperHomeSnrOffFailFaultCountFC		RW	FrontTamperHomeSnrOffFailFC	NVMFaultCounter	shortNatural	No	Fault Counter:12-223-00: FrontTamperHomeSnrOffFailFaultCountFC	1.813		
604-189	Fault Counter 12-224: RearTamperHomeSnrOffFailFaultCountFC		RW	RearTamperHomeSnrOffFailFC	NVMFaultCounter	shortNatural	No	Fault Counter:12-224-00: RearTamperHomeSnrOffFailFaultCountFC	1.813		
604-190	Fault Counter 12-225: BookletTamperFHomeSnrOnFailFaultCountFC		RW	BookletTamperFHomeSnrOnFailFC	NVMFaultCounter	shortNatural	No	Fault Counter:12-225-00: BookletTamperFHomeSnrOnFailFaultCountFC	1.813		

604-191	Fault Counter 12-226: BookletTamperFHomeSnrOffFailFaultCountFC		RW	BookletTamperFHomeSnrOffFailFC	NVMFaultCounter	shortNatural	No	Fault Counter:12-226-00: BookletTamperFHomeSnrOffFailFaultCountF	1.521		
604-192	Fault Counter 12-227: BookletEndGuideHomeSnrOffFailFaultCountFC		RW	BookletEndGuideHomeSnrOffFailFC	NVMFaultCounter	shortNatural	No	Fault Counter:12-227-00: BookletEndGuideHomeSnrOffFailFaultCount	1.813		
604-193	Fault Counter 12-228: BookletEndGuideHomeSnrOnFailFaultCountFC		RW	BookletEndGuideHomeSnrOnFailFC	NVMFaultCounter	shortNatural	No	Fault Counter:12-228-00: BookletEndGuideHomeSnrOnFailFaultCount	1.813		
604-194	Fault Counter 12-229: BookletTamperRHomeSnrOnFailFaultCountFC		RW	BookletTamperRHomeSnrOnFailFC	NVMFaultCounter	shortNatural	No	Fault Counter:12-229-00: BookletTamperRHomeSnrOnFailFaultCountF	1.521		
604-195	Fault Counter 12-230: BookletTamperRHomeSnrOffFailFaultCountFC		RW	BookletTamperRHomeSnrOffFailFC	NVMFaultCounter	shortNatural	No	Fault Counter:12-230-00: BookletTamperRHomeSnrOffFailFaultCountF	1.521		
604-196	Fault Counter 12-243: BookletKnifeHomeSnrOnFailFaultCountFC		RW	BookletKnifeHomeSnrOnFailFC	NVMFaultCounter	shortNatural	No	Fault Counter:12-243-00:	1.521		
604-197	Fault Counter 12-246: BookletStaplerFailCountFC		RW	BookletStaplerFailCountFC	NVMFaultCounter	shortNatural	No	Fault Counter:12-246-00: BookletStaplerFailCountFC	1.813		
604-198	Fault Counter 12-247: SideRegiSnrOffFailFaultCountFC		RW	SideRegiSnrOffFailFaultCountFC	NVMFaultCounter	shortNatural	No	Fault Counter:12-247-00:	1.813		
604-199	Fault Counter 12-260: EjectClampHomeSnrOnFailFaultCountFC		RW	EjectClampHomeSnrOnFailFC	NVMFaultCounter	shortNatural	No	Fault Counter:12-260-00: EjectClampHomeSnrOnFailFaultCountFC	1.813		
604-200	Fault Counter 12-261: BookletKnifeFoldingSnrFailFaultCountFC		RW	BookletKnifeFoldingSnrFailFC	NVMFaultCounter	shortNatural	No	Fault Counter:12-261-00: BookletKnifeFoldingSnrFailFaultCountFC	1.521		
604-201	Fault Counter 12-263: RearTsmperHomeSnrOnFailFaultCountFC		RW	RearTsmperHomeSnrOnFailFC	NVMFaultCounter	shortNatural	No	Fault Counter:12-263-00: RearTsmperHomeSnrOnFailFaultCountFC	1.813		
604-202	Fault Counter 12-264: BookletDrawerBrokenFailFaultCountFC		RW	BookletDrawerBrokenFailFC	NVMFaultCounter	shortNatural	No	Fault Counter:12-264-00: BookletDrawerBrokenFailFaultCountFC	1.521		
604-203	Fault Counter 12-265: BookletKnifeHomeSnrOffFailFaultCountFC		RW	BookletKnifeHomeSnrOffFailFC	NVMFaultCounter	shortNatural	No	Fault Counter:12-265-00:	1.813		
604-204	Fault Counter 12-266: BookletCompilerNoPaperSnrFailFaultCountFC		RW	BookletCompilerNoPaperSnrFailFC	NVMFaultCounter	shortNatural	No	Fault Counter:12-266-00: BookletCompilerNoPaperSnrFailFaultCountFC	1.813		
604-205	Fault Counter 12-270: TopOffsetHomeSnrOnFailCountFC		RW	TopOffsetHomeSnrOnFailCountFC	NVMFaultCounter	shortNatural	No	Fault Counter:12-270-00: TopOffsetHomeSnrOnFailCountFC	1.810		

604-205	Fault Counter 12-601: TopOffsetHomeSnrOnFailCountFC		RW	TopOffsetHomeSnrOnFailCountFC	NVMFaultCounter	shortNatural	No	Fault Counter:12-601-00: TopOffsetHomeSnrOnFailCountFC	1.813		
604-206	Fault Counter 12-271: TopOffsetHomeSnrOffFailCountFC		RW	TopOffsetHomeSnrOffFailCountFC	NVMFaultCounter	shortNatural	No	Fault Counter:12-271-00: TopOffsetHomeSnrOffFailCountFC	1.810		
604-206	Fault Counter 12-602: TopOffsetHomeSnrOffFailCountFC		RW	TopOffsetHomeSnrOffFailCountFC	NVMFaultCounter	shortNatural	No	Fault Counter:12-602-00: TopOffsetHomeSnrOffFailCountFC	1.813		
604-207	Fault Counter 12-282: EjectClampHomeSnrOffFailFaultCountFC		RW	EjectClampHomeSnrOffFailFC	NVMFaultCounter	shortNatural	No	Fault Counter:12-282-00: EjectClampHomeSnrOffFailFaultCountFC	1.813		
604-208	Fault Counter 12-283: SetClampHomeSnrOnFailFaultCountFC		RW	SetClampHomeSnrOnFailFC	NVMFaultCounter	shortNatural	No	Fault Counter:12-283-00: SetClampHomeSnrOnFailFaultCountFC	1.813		
604-209	Fault Counter 12-284: SetClampHomeSnrOffFailFaultCountFC		RW	SetClampHomeSnrOffFC	NVMFaultCounter	shortNatural	No	Fault Counter:12-284-00: SetClampHomeSnrOffFailFaultCountFC	1.813		
604-210	Fault Counter 12-291: StapleFailCountFC		RW	StapleFailCountFC	NVMFaultCounter	shortNatural	No	Fault Counter:12-291-00: StapleFailCountFC	1.813		
604-211	Fault Counter 12-295: StaplerMovePositionSnrOnFailFaultCountFC		RW	StaplerMovePositionSnrOnFailFC	NVMFaultCounter	shortNatural	No	Fault Counter:12-295-00: StaplerMovePositionSnrOnFailFaultCountFC	1.813		
604-212	Fault Counter 12-296: StaplerMovePositionSnrOffFailFaultCountFC		RW	StaplerMovePositionSnrOffFailFC	NVMFaultCounter	shortNatural	No	Fault Counter:12-296-00: StaplerMovePositionSnrOffFailFaultCountFC	1.813		
604-213	Fault Counter 12-320: PunchHomeSnrOnFailFaultCountFC		RW	PunchHomeSnrOnFailFaultCountFC	NVMFaultCounter	shortNatural	No	Fault Counter:12-320-00: PunchHomeSnrOnFailFaultCountFC	1.813		
604-214	Fault Counter 12-321: PunchHomeSnrOffFailFaultCountFC		RW	PunchHomeSnrOffFailFaultCountFC	NVMFaultCounter	shortNatural	No	Fault Counter:12-321-00: PunchHomeSnrOffFailFaultCountFC	1.813		
604-215	Fault Counter 12-322: PuncherMoveHomeSnrOffFailFaultCountFC		RW	PuncherMoveHomeSnrOffFailFC	NVMFaultCounter	shortNatural	No	Fault Counter:12-322-00: PuncherMoveHomeSnrOffFailFaultCountFC	1.813		
604-216	Fault Counter 12-323: PuncherMoveHomeSnrOnFailFaultCountFC		RW	PuncherMoveHomeSnrOnFailFC	NVMFaultCounter	shortNatural	No	Fault Counter:12-323-00: PuncherMoveHomeSnrOnFailFaultCountFC	1.813		

604-217	Fault Counter 12-330: DeculerHomeSnrOffFailFaultCountFC		RW	DeculerHomeSnrOffFailFC	NVMFaultCounter	shortNatural	No	Fault Counter:12-330-00: DeculerHomeSnrOffFailFaultCountFC	1.521		
604-218	Fault Counter 12-332: DecurlerHomeSnrOnFailFaultCountFC		RW	DecurlerHomeSnrOnFailFC	NVMFaultCounter	shortNatural	No	Fault Counter:12-332-00: DecurlerHomeSnrOnFailFaultCountFC	1.521		
604-219	Fault Counter 12-334: FinisherDownLoadFailCountFC		RW	FinisherDownLoadFailCountFC	NVMFaultCounter	shortNatural	No	Fault Counter:12-334-00: FinisherDownLoadFailCountFC	1.813		
604-220	SPARE (was Fault Counter 12-335: BookletSubCpuCommFailFaultCountFC)		RW	SPARE 604-220	NVMFaultCounter	shortNatural	No	Fault Counter:12-335-00: BookletSubCpuCommFailFaultCountFC	1.687		
604-221	Fault Counter 13-902: PaperRemainAtBookletCompileNoPaperSnrFaultCountFC		RW	PaperAtBookletCompileNoPaperSnrFC	NVMFaultCounter	shortNatural	No	Fault Counter:13-902-00: PaperRemainAtBookletCompileNoPaperSnrFa	1.159		
604-222	Fault Counter 13-903: PaperRemainAtBookletFolderRollExitSnrFaultCountFC		RW	PaperAtBookletFolderRollExitSnrFC	NVMFaultCounter	shortNatural	No	Fault Counter:13-903-00: PaperRemainAtBookletFolderRollExitSnrFault	1.159		
604-223	Fault Counter 42-313: RearCoolingFanFailCountFC		RW	RearCoolingFanFailCountFC	NVMFaultCounter	shortNatural	No	Fault Counter:42-313-00: RearCoolingFanFailCountFC	1.159		
604-224	Fault Counter 42-320: DrumMotorYFailCountFC		RW	DrumMotorYFailCountFC	NVMFaultCounter	shortNatural	No	Fault Counter:42-320-00: DrumMotorYFailCountFC	1.813		
604-225	Fault Counter 42-321: DrumMotorMFailCountFC		RW	DrumMotorMFailCountFC	NVMFaultCounter	shortNatural	No	Fault Counter:42-321-00: DrumMotorMFailCountFC	1.743		
604-226	Fault Counter 42-322: DrumMotorCFailCountFC		RW	DrumMotorCFailCountFC	NVMFaultCounter	shortNatural	No	Fault Counter:42-322-00: DrumMotorCFailCountFC	1.743		
604-227	Fault Counter 42-323: DrumMotorKFailCountFC		RW	DrumMotorKFailCountFC	NVMFaultCounter	shortNatural	No	Fault Counter:42-323-00: DrumMotorKFailCountFC	1.813		
604-228	Fault Counter 42-324: IBTDriveMotorFailCountFC		RW	IBTDriveMotorFailCountFC	NVMFaultCounter	shortNatural	No	Fault Counter:42-324-00: IBTDriveMotorFailCountFC	1.813		
604-229	Fault Counter 42-325: MainMotorFailCountFC		RW	MainMotorFailCountFC	NVMFaultCounter	shortNatural	No	Fault Counter:42-325-00: MainMotorFailCountFC	1.813		

604-230	Fault Counter 42-326: BeltHomePositionTooLongCountFC		RW	BeltHomePositionTooLongCountFC	NVMFaultCounter	shortNatural	No	Fault Counter:42-326-00: BeltHomePositionTooLongCountFC	1.159		
604-231	Fault Counter 42-327: BeltPositionFailCountFC		RW	BeltPositionFailCountFC	NVMFaultCounter	shortNatural	No	Fault Counter:42-327-00: BeltPositionFailCountFC	1.159		
604-232	Fault Counter 42-328: BeltEdgeSnrFailFC		RW	BeltEdgeSnrFailFC	NVMFaultCounter	shortNatural	No	Fault Counter:42-328-00: BeltEdgeSnrFailFC	1.159		
604-233	Fault Counter 42-330: FuserExhaustFanFailCountFC		RW	FuserExhaustFanFailCountFC	NVMFaultCounter	shortNatural	No	Fault Counter:42-330-00: FuserExhaustFanFailCountFC	1.813		
604-234	Fault Counter 42-331: BlowerMotorFanFailCountFC		RW	BlowerMotorFanFailCountFC	NVMFaultCounter	shortNatural	No	Fault Counter:42-331-00: BlowerMotorFanFailCountFC	1.159		
604-235	Fault Counter 42-600: BeltWalkFailCountFC		RW	BeltWalkFailCountFC	NVMFaultCounter	shortNatural	No	Fault Counter:42-600-00: BeltWalkFailCountFC	1.159		
604-236	Fault Counter 42-601: BeltEdgeLearnFailCountFC		RW	BeltEdgeLearnFailCountFC	NVMFaultCounter	shortNatural	No	Fault Counter:42-601-00: BeltEdgeLearnFailCountFC	1.159		
604-237	Fault Counter 42-602: BeltEdgeCheckFailCountFC		RW	BeltEdgeCheckFailCountFC	NVMFaultCounter	shortNatural	No	Fault Counter:42-602-00: BeltEdgeCheckFailCountFC	1.159		
604-238	Fault Counter 42-603: SuctionFilterLifeFailCountFC		RW	SuctionFilterLifeFailCountFC	NVMFaultCounter	shortNatural	No	Fault Counter:42-603-00: SuctionFilterLifeFailCountFC	1.159		
604-239	Fault Counter 45-310: ImageReadyNgCountFC		RW	ImageReadyNgCountFC	NVMFaultCounter	shortNatural	No	Fault Counter:45-310-00: ImageReadyNgCountFC	1.813		
604-240	Fault Counter 45-311: ControllerCommFailCountFC		RW	ControllerCommFailCountFC	NVMFaultCounter	shortNatural	No	Fault Counter:45-311-00:	1.813		
604-241	Fault Counter 47-210:		RW	OctOffsetFailCountFC	NVMFaultCounter	shortNatural	No	Fault Counter:47-210-	1.153		
604-241	Fault Counter 12-701: OctOffsetFailCountFC		RW	OctOffsetFailCountFC	NVMFaultCounter	shortNatural	No	Fault Counter:12-701-00: OutputFinisherCommFailCountFC	1.521		
604-242	Fault Counter 47-310: OutputFinisherCommFailCountFC		RW	OutputFinisherCommFailCountFC	NVMFaultCounter	shortNatural	No	Fault Counter:47-310-00: OutputFinisherCommFailCountFC	1.813		
604-243	Fault Counter 61-600: RosDataYFailCountFC		RW	RosDataYFailCountFC	NVMFaultCounter	shortNatural	No	Fault Counter:61-600-00: RosDataYFailCountFC	1.766		

604-244	Fault Counter 61-601: RosDataYFailCountFC		RW	RosDataMFailCountFC	NVMFaultCounter	shortNatural	No	Fault Counter:61-601-00: RosDataMFailCountFC	1.766		
604-245	Fault Counter 61-602: RosDataCFailCountFC		RW	RosDataCFailCountFC	NVMFaultCounter	shortNatural	No	Fault Counter:61-602-00: RosDataCFailCountFC	1.766		
604-246	Fault Counter 61-603: RosDataKFailCountFC		RW	RosDataKFailCountFC	NVMFaultCounter	shortNatural	No	Fault Counter:61-603-00: RosDataKFailCountFC	1.159		
604-247	Fault Counter 61-310: Clapper1FailCountFC		RW	Clapper1FailCountFC	NVMFaultCounter	shortNatural	No	Fault Counter:61-310-00: Clapper1FailCountFC	1.159		
604-248	Fault Counter 61-311: Clapper2FailCountFC		RW	Clapper2FailCountFC	NVMFaultCounter	shortNatural	No	Fault Counter:61-311-00: Clapper2FailCountFC	1.159		
604-249	Fault Counter 61-313: SOSLongMFailCountFC		RW	SOSLongMFailCountFC	NVMFaultCounter	shortNatural	No	Fault Counter:61-313-00: SOSLongMFailCountFC	1.159		
604-250	Fault Counter 61-315: SOSLongKFailCountFC		RW	SOSLongKFailCountFC	NVMFaultCounter	shortNatural	No	Fault Counter:61-315-00: SOSLongKFailCountFC	1.159		
604-251	Fault Counter 61-317: SOSShortMFailCountFC		RW	SOSShortMFailCountFC	NVMFaultCounter	shortNatural	No	Fault Counter:61-317-00: SOSShortMFailCountFC	1.159		
604-252	Fault Counter 61-319: SOSShortKFailCountFC		RW	SOSShortKFailCountFC	NVMFaultCounter	shortNatural	No	Fault Counter:61-319-00: SOSShortKFailCountFC	1.159		
604-253	Fault Counter 61-320: PolygonMotor1FailCountFC		RW	PolygonMotor1FailCountFC	NVMFaultCounter	shortNatural	No	Fault Counter:61-320-00: PolygonMotor1FailCountFC	1.159		
604-254	Fault Counter 61-321: PolygonMotor2FailCountFC		RW	PolygonMotor2FailCountFC	NVMFaultCounter	shortNatural	No	Fault Counter:61-321-00: PolygonMotor2FailCountFC	1.159		
604-255	Fault Counter 61-323: NoSOSMFailCountFC		RW	NoSOSMFailCountFC	NVMFaultCounter	shortNatural	No	Fault Counter:61-323-00: NoSOSMFailCountFC	1.159		
604-256	Fault Counter 61-325: NoSOSKFailCountFC		RW	NoSOSKFailCountFC	NVMFaultCounter	shortNatural	No	Fault Counter:61-325-00: NoSOSKFailCountFC	1.159		

604-257	Fault Counter 61-326: ROSCConnectYFailCountFC		RW	ROSCConnectYFailCountFC	NVMFaultCounter	shortNatural	No	Fault Counter:61-326-00: ROSCConnectYFailCountFC	1.766		
604-258	Fault Counter 61-327: ROSCConnectMFailCountFC		RW	ROSCConnectMFailCountFC	NVMFaultCounter	shortNatural	No	Fault Counter:61-327-00: ROSCConnectMFailCou	1.766		
604-259	Fault Counter 61-328: ROSCConnectCFailCountFC		RW	ROSCConnectCFailCountFC	NVMFaultCounter	shortNatural	No	Fault Counter:61-328-00: ROSCConnectCFailCou	1.766		
604-260	Fault Counter 61-329: ROSCConnectKFailCountFC		RW	ROSCConnectKFailCountFC	NVMFaultCounter	shortNatural	No	Fault Counter:61-329-00: ROSCConnectKFailCou	1.159		
604-261	Fault Counter 61-334: ROSYMVddFailCountFC		RW	ROSYMVddFailCountFC	NVMFaultCounter	shortNatural	No	Fault Counter:61-334-00:	1.159		
604-262	Fault Counter 61-335: ROSCKVddFailCountFC		RW	ROSCKVddFailCountFC	NVMFaultCounter	shortNatural	No	Fault Counter:61-335-00: ROSCKVddFailCountF	1.159		
604-263	Fault Counter 61-336: ROSYMVddDownFailCountFC		RW	ROSYMVddDownFailCountFC	NVMFaultCounter	shortNatural	No	Fault Counter:61-336-00: ROSYMVddDownFailC ountFC	1.159		
604-264	Fault Counter 61-337: ROSCKVddDownFailCountFC		RW	ROSCKVddDownFailCountFC	NVMFaultCounter	shortNatural	No	Fault Counter:61-337-00: ROSCKVddDownFailC ountFC	1.159		

604-265	Fault Counter 61-338: SOSStopMFailCountFC		RW	SOSStopMFailCountFC	NVMFaultCounter	shortNatural	No	Fault Counter:61-338-00: SOSStopMFailCountFC	1.159		
604-266	Fault Counter 61-339: SOSStopKFailCountFC		RW	SOSStopKFailCountFC	NVMFaultCounter	shortNatural	No	Fault Counter:61-339-00: SOSStopKFailCountFC	1.159		
604-267	Fault Counter 61-604: LDAalarmYCountFC		RW	LDAalarmYCountFC	NVMFaultCounter	shortNatural	No	Fault Counter:61-604-00: LDAalarmYCountFC	1.766		
604-268	Fault Counter 61-605: LDAalarmMCountFC		RW	LDAalarmMCountFC	NVMFaultCounter	shortNatural	No	Fault Counter:61-605-00: LDAalarmMCountFC	1.766		
604-269	Fault Counter 61-606: LDAalarmCCountFC		RW	LDAalarmCCountFC	NVMFaultCounter	shortNatural	No	Fault Counter:61-606-00: LDAalarmCCountFC	1.766		
604-270	Fault Counter 61-607: LDAalarmKCountFC		RW	LDAalarmKCountFC	NVMFaultCounter	shortNatural	No	Fault Counter:61-607-00: LDAalarmKCountFC	1.159		
604-271	Fault Counter 71-101: Tray1MisfeedJamCountFC		RW	Tray1MisfeedJamCountFC	NVMFaultCounter	shortNatural	No	Fault Counter:71-101-00: Tray1MisfeedJamCountFC	1.159		
604-272	Fault Counter 71-104: Tray1PreRegiSnrOnJamCountFC		RW	Tray1PreRegiSnrOnJamCountFC	NVMFaultCounter	shortNatural	No	Fault Counter:71-104-00:	1.159		
604-273	Fault Counter 71-105: Tray1RegiSnrOnJamCountFC		RW	Tray1RegiSnrOnJamCountFC	NVMFaultCounter	shortNatural	No	Fault Counter:71-105-00: Tray1RegiSnrOnJamCountFC	1.813		
604-274	Fault Counter 71-210: Tray1LiftUpFailCountFC		RW	Tray1LiftUpFailCountFC	NVMFaultCounter	shortNatural	No	Fault Counter:71-210-00: Tray1LiftUpFailCountFC	1.813		
604-275	Fault Counter 72-101:		RW	Tray2MisfeedJamCountFC	NVMFaultCounter	shortNatural	No	Fault Counter:72-101-	1.810		
604-276	Fault Counter 72-102: Tray2FeedOutSnr1OnJamCountFC		RW	Tray2FeedOutSnr1OnJamCountFC	NVMFaultCounter	shortNatural	No	Fault Counter:72-102-00: Tray2FeedOutSnr1OnJ	1.159		
604-277	Fault Counter 72-104:		RW	Tray2PreRegiSnrOnJamCountFC	NVMFaultCounter	shortNatural	No	Fault Counter:72-104-	1.159		
604-278	Fault Counter 72-105:		RW	Tray2RegiSnrOnJamCountFC	NVMFaultCounter	shortNatural	No	Fault Counter:72-105-	1.159		
604-279	Fault Counter 72-210: Tray2LiftUpFailCountFC		RW	Tray2LiftUpFailCountFC	NVMFaultCounter	shortNatural	No	Fault Counter:72-210-00: Tray2LiftUpFailCountFC	1.813		
604-280	Fault Counter 73-101:		RW	Tray3MisfeedJamCountFC	NVMFaultCounter	shortNatural	No	Fault Counter:73-101-	1.813		
604-281	Fault Counter 73-102:		RW	Tray3FeedOutSnr1OnJamCountFC	NVMFaultCounter	shortNatural	No	Fault Counter:73-102-	1.813		
604-282	Fault Counter 73-104:		RW	Tray3PreRegiSnrOnJamCountFC	NVMFaultCounter	shortNatural	No	Fault Counter:73-104-	1.159		
604-283	Fault Counter 73-105:		RW	Tray3RegiSnrOnJamCountFC	NVMFaultCounter	shortNatural	No	Fault Counter:73-105-	1.159		
604-284	Fault Counter 73-210:		RW	Tray3LiftUpFailCountFC	NVMFaultCounter	shortNatural	No	Fault Counter:73-210-	1.813		
604-285	Fault Counter 74-101:		RW	Tray4MisfeedJamCountFC	NVMFaultCounter	shortNatural	No	Fault Counter:74-101-	1.813		
604-286	Fault Counter 74-102:		RW	Tray4FeedOutSnr1OnJamCountFC	NVMFaultCounter	shortNatural	No	Fault Counter:74-102-	1.159		
604-287	Fault Counter 74-103:		RW	Tray4FeedOutSnr3OnJamCountFC	NVMFaultCounter	shortNatural	No	Fault Counter:74-103-	1.159		

604-288	Fault Counter 74-104: Tray4PreRegiSnrOnJamCountFC		RW	Tray4PreRegiSnrOnJamCountFC	NVMFaultCounter	shortNatural	No	Fault Counter:74-104-00: Tray4PreRegiSnrOnJamCountFC	1.159		
604-289	Fault Counter 74-105: Tray4RegiSnrOnJamCountFC		RW	Tray4RegiSnrOnJamCountFC	NVMFaultCounter	shortNatural	No	Fault Counter:74-105-00: Tray4RegiSnrOnJamCountFC	1.159		
604-290	Fault Counter 74-210: Tray4LiftUpFailCountFC		RW	Tray4LiftUpFailCountFC	NVMFaultCounter	shortNatural	No	Fault Counter:74-210-00: Tray4LiftUpFailCountFC	1.813		
604-291	Fault Counter 75-100:		RW	MSIMisfeedJamCountFC	NVMFaultCounter	shortNatural	No	Fault Counter:75-100-	1.813		
604-292	Fault Counter 75-109:		RW	MSIPreRegiSnrOnJamCountFC	NVMFaultCounter	shortNatural	No	Fault Counter:75-109-	1.159		
604-293	Fault Counter 75-135:		RW	MSIRegiSnrOnJamCountFC	NVMFaultCounter	shortNatural	No	Fault Counter:75-135-	1.813		
604-294	Fault Counter 75-210: MSILiftUpFailCountFC		RW	MSILiftUpFailCountFC	NVMFaultCounter	shortNatural	No	Fault Counter:75-210-00:	1.159		
604-295	Fault Counter 75-211:		RW	MSILiftDownFailCountFC	NVMFaultCounter	shortNatural	No	Fault Counter:75-211-	1.159		
604-296	Fault Counter 77-103: FuserExitSnrOffJamStraightCountFC		RW	FuserExitSnrOffJamStraightFC	NVMFaultCounter	shortNatural	No	Fault Counter:77-103-00: FuserExitSnrOffJamStraightCountFC	1.159		
604-297	Fault Counter 77-106: FuserExitSnrOnJamCountFC		RW	FuserExitSnrOnJamCountFC	NVMFaultCounter	shortNatural	No	Fault Counter:77-106-00: FuserExitSnrOnJamCountFC	1.159		
604-298	Fault Counter 77-107: FuserExitSnrOffJamInvertCountFC		RW	FuserExitSnrOffJamInvertCountFC	NVMFaultCounter	shortNatural	No	Fault Counter:77-107-00: FuserExitSnrOffJamInvertCountFC	1.159		
604-299	Fault Counter 77-109: IOTExitSnrOnJamStraightCountFC		RW	IOTExitSnrOnJamStraightCountFC	NVMFaultCounter	shortNatural	No	Fault Counter:77-109-00: IOTExitSnrOnJamStraightCountFC	1.813		
604-300	Fault Counter 77-111: IOTExitSnrOnJamInvertCountFC		RW	IOTExitSnrOnJamInvertCountFC	NVMFaultCounter	shortNatural	No	Fault Counter:77-111-00: IOTExitSnrOnJamInvertCountFC	1.159		
604-301	Fault Counter 77-113: IOTExitSnrOffJamStraightCountFC		RW	IOTExitSnrOffJamStraightCountFC	NVMFaultCounter	shortNatural	No	Fault Counter:77-113-00: IOTExitSnrOffJamStraightCountFC	1.159		

604-302	Fault Counter 77-115: IOTExitSnrOffJamInvertCountFC		RW	IOTExitSnrOffJamInvertCountFC	NVMFaultCounter	shortNatural	No	Fault Counter:77-115-00: IOTExitSnrOffJamInvertCountFC	1.159		
604-303	Fault Counter 77-118:		RW	PreRegiSnrOnDuplexJamCountFC	NVMFaultCounter	shortNatural	No	Fault Counter:77-118-	1.159		
604-304	Fault Counter 77-120: Post2ndBTRSnrOnJamCountFC		RW	Post2ndBTRSnrOnJamCountFC	NVMFaultCounter	shortNatural	No	Fault Counter:77-120-00: Post2ndBTRSnrOnJamCountFC	1.159		
604-305	Fault Counter 77-123: RegiSnrOnDuplexJamCountFC		RW	RegiSnrOnDuplexJamCountFC	NVMFaultCounter	shortNatural	No	Fault Counter:77-123-00:	1.159		
604-306	Fault Counter 77-129:		RW	DuplexInSnrOnJamCountFC	NVMFaultCounter	shortNatural	No	Fault Counter:77-129-	1.159		
604-307	Fault Counter 77-130: DuplexOutSnrOnJamCountFC		RW	DuplexOutSnrOnJamCountFC	NVMFaultCounter	shortNatural	No	Fault Counter:77-130-00: DuplexOutSnrOnJamC	1.813		
604-308	Fault Counter 77-312: FeederCommFailCountFC		RW	FeederCommFailCountFC	NVMFaultCounter	shortNatural	No	Fault Counter:77-312-00:	1.813		
604-309	Fault Counter 77-909: IOTStaticJamCountFC		RW	IOTStaticJamCountFC	NVMFaultCounter	shortNatural	No	Fault Counter:77-909-00:	1.159		
604-310	Fault Counter 78-100: HCF1PreRegiSnrOnJamCountFC		RW	HCF1PreRegiSnrOnJamCountFC	NVMFaultCounter	shortNatural	No	Fault Counter:78-100-00:	1.159		
604-311	Fault Counter 78-101: HCF1FeedOutSnr1OnJamCountFC		RW	HCF1FeedOutSnr1OnJamCountFC	NVMFaultCounter	shortNatural	No	Fault Counter:78-101-00: HCF1FeedOutSnr1On	1.159		
604-312	Fault Counter 78-102: HCF1RegiSnrOnJamCountFC		RW	HCF1RegiSnrOnJamCountFC	NVMFaultCounter	shortNatural	No	Fault Counter:78-102-00:	1.159		
604-313	Fault Counter 78-151: HCF1FeedOutSnrOnJamCountFC		RW	HCF1FeedOutSnrOnJamCountFC	NVMFaultCounter	shortNatural	No	Fault Counter:78-151-00: HCF1FeedOutSnrOnJ	1.813		
604-314	Fault Counter 78-250: HCF1TrayLiftUpFailCountFC		RW	HCF1TrayLiftUpFailCountFC	NVMFaultCounter	shortNatural	No	Fault Counter:78-250-00:	1.813		
604-315	Fault Counter 78-901: HCF1FeedOutSnrStaticJamFC		RW	HCF1FeedOutSnrStaticJamFC	NVMFaultCounter	shortNatural	No	Fault Counter:78-901-00: HCF1FeedOutSnrStati	1.813		
604-316	Fault Counter 89-600: RCSampleLateralFailA1CountFC		RW	RCSampleLateralFailA1CountFC	NVMFaultCounter	shortNatural	No	Fault Counter:89-600-00: RCSampleLateralFailA	1.813		
604-317	Fault Counter 89-601: RCSampleBlockFailA1InCountFC		RW	RCSampleBlockFailA1InCountFC	NVMFaultCounter	shortNatural	No	Fault Counter:89-601-00: RCSampleBlockFailA1InCountFC	1.813		
604-318	Fault Counter 89-602: RCSampleBlockFailA1CntCountFC		RW	RCSampleBlockFailA1CntCountFC	NVMFaultCounter	shortNatural	No	Fault Counter:89-602-00:	1.159		
604-319	Fault Counter 89-603: RCSampleBlockFailA1OutCountFC		RW	RCSampleBlockFailA1OutCountFC	NVMFaultCounter	shortNatural	No	Fault Counter:89-603-00:	1.813		
604-320	Fault Counter 89-604: RCSampleBlockFailB1InCountFC		RW	RCSampleBlockFailB1InCountFC	NVMFaultCounter	shortNatural	No	Fault Counter:89-604-00:	1.813		
604-321	Fault Counter 89-605: RCSampleBlockFailB1CntCountFC		RW	RCSampleBlockFailB1CntCountFC	NVMFaultCounter	shortNatural	No	Fault Counter:89-605-00:	1.159		
604-322	Fault Counter 89-606: RCSampleBlockFailB1OutCountFC		RW	RCSampleBlockFailB1OutCountFC	NVMFaultCounter	shortNatural	No	Fault Counter:89-606-00:	1.813		

604-323	Fault Counter 89-607: RCSampleBlockFailB2InCountFC		RW	RCSampleBlockFailB2InCountFC	NVMFaultCounter	shortNatural	No	Fault Counter:89-607-00: RCSampleBlockFailB2I	1.813		
604-324	Fault Counter 89-608: RCSampleBlockFailB2CntCountFC		RW	RCSampleBlockFailB2CntCountFC	NVMFaultCounter	shortNatural	No	Fault Counter:89-608-00: RCSampleBlockFailB2	1.159		
604-325	Fault Counter 89-609: RCSampleBlockFailB2OutCountFC		RW	RCSampleBlockFailB2OutCountFC	NVMFaultCounter	shortNatural	No	Fault Counter:89-609-00:	1.813		
604-326	Fault Counter 89-610: RCSampleBlockFailB3InCountFC		RW	RCSampleBlockFailB3InCountFC	NVMFaultCounter	shortNatural	No	Fault Counter:89-610-00: RCSampleBlockFailB3I	1.813		
604-327	Fault Counter 89-611: RCSampleBlockFailB3CntCountFC		RW	RCSampleBlockFailB3CntCountFC	NVMFaultCounter	shortNatural	No	Fault Counter:89-611-00: RCSampleBlockFailB3 CntCountFC	1.159		
604-328	Fault Counter 89-612: RCSampleBlockFailB3OutCountFC		RW	RCSampleBlockFailB3OutCountFC	NVMFaultCounter	shortNatural	No	Fault Counter:89-612-00: RCSampleBlockFailB3	1.813		
604-329	Fault Counter 89-613: RCSampleBlockFailB4InCountFC		RW	RCSampleBlockFailB4InCountFC	NVMFaultCounter	shortNatural	No	Fault Counter:89-613-00: RCSampleBlockFailB4I	1.813		
604-330	Fault Counter 89-614: RCSampleBlockFailB4CntCountFC		RW	RCSampleBlockFailB4CntCountFC	NVMFaultCounter	shortNatural	No	Fault Counter:89-614-00: RCSampleBlockFailB4 CntCountFC	1.159		
604-331	Fault Counter 89-615: RCSampleBlockFailB4OutCountFC		RW	RCSampleBlockFailB4OutCountFC	NVMFaultCounter	shortNatural	No	Fault Counter:89-615-00: RCSampleBlockFailB4 OutCountFC	1.813		
604-332	Fault Counter 89-616: RCDataOverFlowFailCountFC		RW	RCDataOverFlowFailCountFC	NVMFaultCounter	shortNatural	No	Fault Counter:89-616-00: RCDataOverFlowFailC ountFC	1.813		
604-333	Fault Counter 89-617: RCDataOverRangeFailCountFC		RW	RCDataOverRangeFailCountFC	NVMFaultCounter	shortNatural	No	Fault Counter:89-617-00: RCDataOverRangeFail CountFC	1.813		
604-334	Fault Counter 91-311: BCRCCCleanerMotorFailCountFC		RW	BCRCCCleanerMotorFailCountFC	NVMFaultCounter	shortNatural	No	Fault Counter:91-311-00: BCRCCCleanerMotorF	1.159		
604-335	Fault Counter 91-312: CCHvpsBrokenFailCountFC		RW	CCHvpsBrokenFailCountFC	NVMFaultCounter	shortNatural	No	Fault Counter:91-312-00: CCHvpsBrokenFailCou	1.159		
604-336	Fault Counter 91-313:		RW	CrumAsicCommFailCountFC	NVMFaultCounter	shortNatural	No	Fault Counter:91-313-	1.813		
604-337	Fault Counter 91-320:		RW	CCWireCutFailCountFC	NVMFaultCounter	shortNatural	No	Fault Counter:91-320-	1.159		
604-338	Fault Counter 91-914:		RW	DrumKCrumCommFailCountFC	NVMFaultCounter	shortNatural	No	Fault Counter:91-914-	1.813		
604-339	Fault Counter 91-917: DrumYCrumCommFailCountFC		RW	DrumYCrumCommFailCountFC	NVMFaultCounter	shortNatural	No	Fault Counter:91-917-00:	1.813		
604-340	Fault Counter 91-918:		RW	DrumMCrumCommFailCountFC	NVMFaultCounter	shortNatural	No	Fault Counter:91-918-	1.813		
604-341	Fault Counter 91-919:		RW	DrumCCrumCommFailCountFC	NVMFaultCounter	shortNatural	No	Fault Counter:91-919-	1.813		
604-342	Fault Counter 92-649: ADCShutterOpenFailCountFC		RW	ADCShutterOpenFailCountFC	NVMFaultCounter	shortNatural	No	Fault Counter:92-649-00: ADCShutterOpenFailC ountFC	1.813		
604-343	Fault Counter 92-650:		RW	ADCShutterCloseFailCountFC	NVMFaultCounter	shortNatural	No	Fault Counter:92-650-	1.813		

604-344	Fault Counter 92-651:		RW	ADCSensorFailCountFC	NVMFaultCounter	shortNatural	No	Fault Counter:92-651-	1.813		
604-345	Fault Counter 92-652:		RW	ADCPatchFailCountFC	NVMFaultCounter	shortNatural	No	Fault Counter:92-652-	1.159		
604-346	Fault Counter 92-653:		RW	ATCSensorYOutputFailCountFC	NVMFaultCounter	shortNatural	No	Fault Counter:92-653-	1.766		
604-347	Fault Counter 92-654:		RW	ATCSensorMOutputFailCountFC	NVMFaultCounter	shortNatural	No	Fault Counter:92-654-	1.766		
604-348	Fault Counter 92-655:		RW	ATCSensorCOutputFailCountFC	NVMFaultCounter	shortNatural	No	Fault Counter:92-655-	1.766		
604-349	Fault Counter 92-656:		RW	ATCSensorKOutputFailCountFC	NVMFaultCounter	shortNatural	No	Fault Counter:92-656-	1.159		
604-350	Fault Counter 92-657:		RW	ATCSensorYAmplitudeFailCountFC	NVMFaultCounter	shortNatural	No	Fault Counter:92-657-	1.766		
604-351	Fault Counter 92-658:		RW	ATCSensorMAmplitudeFailCountFC	NVMFaultCounter	shortNatural	No	Fault Counter:92-658-	1.766		
604-352	Fault Counter 92-659:		RW	ATCSensorCAmplitudeFailCountFC	NVMFaultCounter	shortNatural	No	Fault Counter:92-659-	1.766		
604-353	Fault Counter 92-660:		RW	ATCSensorKAmplitudeFailCountFC	NVMFaultCounter	shortNatural	No	Fault Counter:92-660-	1.813		
604-354	Fault Counter 92-661:		RW	EnvironTemperatureSnrFailCountFC	NVMFaultCounter	shortNatural	No	Fault Counter:92-661-	1.813		
604-355	Fault Counter 92-662:		RW	EnvironHumiditySensorFailCountFC	NVMFaultCounter	shortNatural	No	Fault Counter:92-662-	1.813		
604-356	Fault Counter 92-663:		RW	MiniSetupADCFailCountFC	NVMFaultCounter	shortNatural	No	Fault Counter:92-663-	1.159		
604-357	Fault Counter 94-320:		RW	FistBTRRetractFailCountFC	NVMFaultCounter	shortNatural	No	Fault Counter:94-320-	1.159		
604-358	Fault Counter 94-321:		RW	FirstBTRContactFailCountFC	NVMFaultCounter	shortNatural	No	Fault Counter:94-321-	1.159		
604-359	Fault Counter 94-322:		RW	SecondBTRRetractFailCountFC	NVMFaultCounter	shortNatural	No	Fault Counter:94-322-	1.159		
604-360	Fault Counter 94-323:		RW	SecondBTRContactFailCountFC	NVMFaultCounter	shortNatural	No	Fault Counter:94-323-	1.159		
604-361	Fault Counter 12-100:		RW	DFinDeculerInSnrOnJamFC	NVMFaultCounter	shortNatural	No	Fault Counter:12-100-	1.521		
604-362	Fault Counter 12-101:		RW	DFinDeculerOutSnrOnJamFC	NVMFaultCounter	shortNatural	No	Fault Counter:12-101-	1.521		
604-363	Fault Counter 12-102:		RW	DFinPunchOutSnrOnJamFC	NVMFaultCounter	shortNatural	No	Fault Counter:12-102-	1.521		
604-364	Fault Counter 12-103:		RW	DFinPunchOutSnrOffJamFC	NVMFaultCounter	shortNatural	No	Fault Counter:12-103-	1.521		
604-365	Fault Counter 12-104:		RW	DFinInterposeFeedOutSnrOnJamFC	NVMFaultCounter	shortNatural	No	Fault Counter:12-104-	1.521		
604-366	Fault Counter 12-108:		RW	DFinFolderPathSnr3OffJamFC	NVMFaultCounter	shortNatural	No	Fault Counter:12-108-	1.813		
604-367	Fault Counter 12-109:		RW	DFinInterposerFeedOutSnrOffJamF	NVMFaultCounter	shortNatural	No	Fault Counter:12-109-	1.521		
604-368	Fault Counter 12-117:		RW	DFinFolderPathExitSnrOnJamFC	NVMFaultCounter	shortNatural	No	Fault Counter:12-117-	1.813		
604-369	Fault Counter 12-118: DFinFolderPathSnr2OnJamFC		RW	DFinFolderPathSnr2OnJamFC	NVMFaultCounter	shortNatural	No	Fault Counter:12-118- 00: DFinFolderPathSnr2O nJamFC	1.813		
604-370	Fault Counter 12-119: DFi FolderPathSnr3OnJamFC		RW	DFi FolderPathSnr3OnJamFC	NVMFaultCounter	shortNatural	No	Fault Counter:12-119- 00: DFi FolderPathSnr3OnJam FC	1.813		
604-371	Fault Counter 12-120: DFinFolderPathSnr4OnJamFC		RW	DFinFolderPathSnr4OnJamFC	NVMFaultCounter	shortNatural	No	Fault Counter:12-120- 00: DFinFolderPathSnr4O nJamFC	1.813		
604-372	Fault Counter 12-141: DFinBufferPathSnrOffJam FC		RW	DFinBufferPathSnrOffJam FC	NVMFaultCounter	shortNatural	No	Fault Counter:12-141- 00: DFinBufferPathSnrOffJ	1.521		
604-373	Fault Counter 12-159: DFinEjectSnrOnJamFC		RW	DFinEjectSnrOnJamFC	NVMFaultCounter	shortNatural	No	Fault Counter:12-159- 00: DFinEjectSnrOnJamF C	1.521		
604-374	Fault Counter 12-160:		RW	DFinEjectSnrOffJamFC	NVMFaultCounter	shortNatural	No	Fault Counter:12-160-	1.521		
604-375	Fault Counter 12-214: DFinEndWallHomeSnrOffFailFC		RW	DFinEndWallHomeSnrOffFailFC	NVMFaultCounter	shortNatural	No	Fault Counter:12-214- 00: DFinEndWallHomeSnr OffFailFC	1.521		
604-376	Fault Counter 12-215: DFinEndWallOpenSnrOnFailFC		RW	DFinEndWallOpenSnrOnFailFC	NVMFaultCounter	shortNatural	No	Fault Counter:12-215- 00: DFinEndWallOpenSnr OnFailFC	1.521		

604-377	Fault Counter 12-216: DFinEndWallHomeSnrOnFailFC		RW	DFinEndWallHomeSnrOnFailFC	NVMFaultCounter	shortNatural	No	Fault Counter:12-216-00: DFinEndWallHomeSnrOnFailFC	1.521		
604-378	Fault Counter 12-217: DFinEndWallOpenSnrOffFailFC		RW	DFinEndWallOpenSnrOffFailFC	NVMFaultCounter	shortNatural	No	Fault Counter:12-217-00: DFinEndWallOpenSnrOffFailFC	1.521		
604-379	Fault Counter 12-218: DFinShelfHomeSnrOnFailFC		RW	DFinShelfHomeSnrOnFailFC	NVMFaultCounter	shortNatural	No	Fault Counter:12-218-00: DFinShelfHomeSnrOnFailFC	1.521		
604-380	Fault Counter 12-219: DFinShelfHomeSnrOffFailFC		RW	DFinShelfHomeSnrOffFailFC	NVMFaultCounter	shortNatural	No	Fault Counter:12-219-00: DFinShelfHomeSnrOffFailFC	1.521		
604-381	Fault Counter 12-235: DFinStapleMoveHomeSnrOffFailFC		RW	DFinStapleMoveHomeSnrOffFailFC	NVMFaultCounter	shortNatural	No	Fault Counter:12-235-00: DFinStapleMoveHomeSnrOffFailFC	1.521		
604-382	Fault Counter 12-236: DFinStapleMoveHomeSnrOnFailFC		RW	DFinStapleMoveHomeSnrOnFailFC	NVMFaultCounter	shortNatural	No	Fault Counter:12-236-00: DFinStapleMoveHomeSnrOnFailFC	1.521		
604-383	Fault Counter 12-237: DFinStapleCenterPositionSnrOnFailFC		RW	DFinStapleCenterPositionSnrOnFailFC	NVMFaultCounter	shortNatural	No	Fault Counter:12-237-00: DFinStapleCenterPositionSnrOnFailFC	1.521		
604-384	Fault Counter 12-238: DFinStapleCenterPositionSnrOffFailFC		RW	DFinStapleCenterPositionSnrOffFailFC	NVMFaultCounter	shortNatural	No	Fault Counter:12-238-00: DFinStapleCenterPositionSnrOffFailFC	1.521		
604-385	Fault Counter 12-239: DFinSubPaddleHomeSnrOnFailFC		RW	DFinSubPaddleHomeSnrOnFailFC	NVMFaultCounter	shortNatural	No	Fault Counter:12-239-00: DFinSubPaddleHomeSnrOnFailFC	1.521		
604-386	Fault Counter 12-240: DFinSubPaddleHomeSnrOffFailFC		RW	DFinSubPaddleHomeSnrOffFailFC	NVMFaultCounter	shortNatural	No	Fault Counter:12-240-00: DFinSubPaddleHomeSnrOffFailFC	1.521		
604-387	Fault Counter 12-241: DFinBookletKnifeFoldingSnrFailFC		RW	DFinBookletKnifeFoldingSnrFailFC	NVMFaultCounter	shortNatural	No	Fault Counter:12-241-00: DFinBookletKnifeFoldingSnrFailFC	1.521		
604-388	Fault Counter 12-248: DFinCompileStackerTrayOffsetFailFC		RW	DFinCompileStackerTrayOffsetFailFC	NVMFaultCounter	shortNatural	No	Fault Counter:12-248-00: DFinCompileStackerTrayOffsetFailFC	1.521		
604-389	Fault Counter 12-250: DFinEndGuideMot1StartFailFC		RW	DFinEndGuideMot1StartFailFC	NVMFaultCounter	shortNatural	No	Fault Counter:12-250-00: DFinEndGuideMot1StartFailFC	1.521		
604-390	Fault Counter 12-251: DFinEndGuideMot2StartFailFC		RW	DFinEndGuideMot2StartFailFC	NVMFaultCounter	shortNatural	No	Fault Counter:12-251-00: DFinEndGuideMot2StartFailFC	1.521		

604-391	Fault Counter 12-252: DFinEndGuideMot1HomeFailFC		RW	DFinEndGuideMot1HomeFailFC	NVMFaultCounter	shortNatural	No	Fault Counter:12-252-00: DFinEndGuideMot1HomeFailFC	1.521		
604-392	Fault Counter 12-253: DFinEndGuideMot2HomeFailFC		RW	DFinEndGuideMot2HomeFailFC	NVMFaultCounter	shortNatural	No	Fault Counter:12-253-00:	1.521		
604-393	Fault Counter 12-254: DFinEnvelopeFolderTrayBrokenFC		RW	DFinEnvelopeFolderTrayBrokenFC	NVMFaultCounter	shortNatural	No	Fault Counter:12-254-00: DFinEnvelopeFolderTrayBrokenFC	1.813		
604-394	Fault Counter 12-255: DFinInterposerTrayUpFailFC		RW	DFinInterposerTrayUpFailFC	NVMFaultCounter	shortNatural	No	Fault Counter:12-255-00: DFinInterposerTrayUpFailFC	1.521		
604-395	Fault Counter 12-324: DFinSideRegiHomeSnrOffFailFC		RW	DFinSideRegiHomeSnrOffFailFC	NVMFaultCounter	shortNatural	No	Fault Counter:12-324-00: DFinSideRegiHomeSnrOffFailFC	1.521		
604-396	Fault Counter 12-325: DFinSideRegiHomeSnrOnFailFC		RW	DFinSideRegiHomeSnrOnFailFC	NVMFaultCounter	shortNatural	No	Fault Counter:12-325-00: DFinSideRegiHomeSnrOnFailFC	1.521		
604-402	KnownJamsinFinishingdevicesC31- KnownJamsinFinishingdevicesC31		ND		NVMBillingCounter	byteArray	No	Billing Counter:302: Known Jams in Finishing Devices	1.799		
604-403	AllsheetsfedfromTray1- AllsheetsfedfromTray1		ND		NVMDiagCounter	byteArray	No	Diagnostic Counter:59: All sheets fed from Tray #1	1.799		
604-404	AllsheetsfedfromTray2- AllsheetsfedfromTray2		ND		NVMDiagCounter	byteArray	No	Diagnostic Counter:60: All sheets fed from Tray #2	1.799		
604-405	AllsheetsfedfromTray3- AllsheetsfedfromTray3		ND		NVMDiagCounter	byteArray	No	Diagnostic Counter:61: All sheets fed from Tray #3	1.799		
604-406	AllsheetsfedfromTray4- AllsheetsfedfromTray4		ND		NVMDiagCounter	byteArray	No	Diagnostic Counter:62: All sheets fed from Tray #4	1.810		
604-407	AllsheetsfedfromBypassTray- AllsheetsfedfromBypassTray		ND		NVMDiagCounter	byteArray	No	Diagnostic Counter:41: All sheets fed from MSI	1.813		
604-408	TotalSheetsside1-TotalSheetsside1		ND		NVMDiagCounter	byteArray	No	Diagnostic Counter:184: Total Sheets (Side 1)	1.799		

604-409	TotalSheetsside1and2- TotalSheetsside1and2		ND		NVMDiagCounter	byteArray	No	Diagnostic Counter:185: Total Sheets (Side 1 and 2)	1.799		
604-415	# of bins		RW	MSDefaultPrintBin	NVMSAKOSetting	shortNatural	No		1.260		
604-415	# of bins		RW	MSDefaultPrintBin	NVMSAKOSetting	shortNatural	No		1.416		
604-416	# of bins		RW	MSDefaultCopyBin	NVMSAKOSetting	shortNatural	No		1.260		
604-416	# of bins		RW	MSDefaultCopyBin	NVMSAKOSetting	shortNatural	No		1.416		
604-416	# of bins		RW	MSDefaultCopyBin	NVMSAKOSetting	shortNatural	No		1.574		
604-417	# of bins		RW	MSDefaultFaxBin	NVMSAKOSetting	shortNatural	No		1.260		
604-417	# of bins		RW	MSDefaultFaxBin	NVMSAKOSetting	shortNatural	No		1.802		
604-418	# of bins		RW	MSDefaultOtherBin	NVMSAKOSetting	shortNatural	No		1.260		
604-418	# of bins		RW	MSDefaultOtherBin	NVMSAKOSetting	shortNatural	No		1.416		
604-438	-OCT Total Sheets		ND		NVMSystemUsageCounter	byteArray	No	System Usage	1.799		
604-439	1 Tiered billing (Traditional):	Stores the count of all	ND		NVMBillingCounter	byteArray	No	Billing Counter:8: Black	1.799		
604-441	TOTAL MARK COUNTER: Tier 1	TOTAL MARK	ND		NVMBillingCounter	byteArray	No	Billing Counter:10:	1.000		
604-442	Media Order Group	1 = MSGXc 2 = MSGXe 3 = MSGFx 4 = MSGFxap 5 = MSGGco	RW	MSMediaSizeGroup	NVMSAKOSetting	shortNatural	No		1.796		
604-444	Conditional Finisher Offset Policy OFF /	0=Off (No conditional	RW	ConditionalFinisherOffsetPolicy	NVMSAKOSetting	boolean	No		1.799		
604-833	Fault Counter 12-024: Paddle Home Fault	no. of faults	RW	PaddleHomeFC	NVMFaultCounter	shortNatural	No	Fault Counter:12-024-	1.521		
604-834	Fault Counter 12-025: Paddle Move Fault	no. of faults	RW	PaddleMoveFC	NVMFaultCounter	shortNatural	No	Fault Counter:12-025-	1.521		
604-835	Fault Counter 12-043: Hole Punch Motor Move Fault	no. of faults	RW	PunchMotorMoveFC	NVMFaultCounter	shortNatural	No	Fault Counter:12-043-00: Hole Punch Motor	1.521		

604-836	Fault Counter 12-044: Hole Punch Head	no. of faults	RW	PunchHeadHomeFC	NVMFaultCounter	shortNatural	No	Fault Counter:12-044-	1.521		
604-837	Fault Counter 12-045: Hole Punch Head Move Fault	no. of faults	RW	PunchHeadMoveFC	NVMFaultCounter	shortNatural	No	Fault Counter:12-045-00: Hole Punch Head	1.521		
604-838	Fault Counter 12-046: Hole Punch Motor Home Fault	no. of faults	RW	PunchMotorHomeFC	NVMFaultCounter	shortNatural	No	Fault Counter:12-046-00: Hole Punch Motor	1.521		
604-839	Fault Counter 12-047: Punch Unit Move Fault	no. of faults	RW	PunchUnitMoveFC	NVMFaultCounter	shortNatural	No	Fault Counter:12-047-00: Punch Unit Move	1.521		
604-840	Fault Counter 12-056: Inserter Bottom Plate Home Fault	no. of faults	RW	InserterBottPltHomeFC	NVMFaultCounter	shortNatural	No	Fault Counter:12-056-00: Inserter Bottom	1.521		
604-841	Fault Counter 12-057: Inserter Bottom Plate Lift Fault	no. of faults	RW	InserterBottPltLiftFC	NVMFaultCounter	shortNatural	No	Fault Counter:12-057-00: Inserter Bottom	1.521		
604-842	Fault Counter 12-061: Crease Blade Move	no. of faults	RW	CreaseBladeMoveFFC	NVMFaultCounter	shortNatural	No	Fault Counter:12-061-	1.521		
604-843	Fault Counter 12-062: Crease Roll Motor	no. of faults	RW	CreaseRollMotorFailFC	NVMFaultCounter	shortNatural	No	Fault Counter:12-062-	1.521		
604-844	Fault Counter 12-063: Booklet Maker	no. of faults	RW	BMStaplerMoveFC	NVMFaultCounter	shortNatural	No	Fault Counter:12-063-	1.521		
604-845	Fault Counter 12-065: Back Stop Motor	no. of faults	RW	BackStopMotorMoveFC	NVMFaultCounter	shortNatural	No	Fault Counter:12-065-	1.521		
604-846	Fault Counter 12-066: Tamper Move Fault	no. of faults	RW	TampermoveFC	NVMFaultCounter	shortNatural	No	Fault Counter:12-066-00: Tamper Move Fault	1.521		
604-847	Fault Counter 12-083: Paper Pusher Motor Stalled	no. of faults	RW	PaperPushMotorStalledFC	NVMFaultCounter	shortNatural	No	Fault Counter:12-083-00: Paper Pusher	1.521		
604-848	Fault Counter 12-126: Entrance Sensor OFF Jam	no. of faults	RW	EntSnsOfJamFC	NVMFaultCounter	shortNatural	No	Fault Counter:12-126-00: Entrance Sensor	1.521		
604-849	Fault Counter 12-127: Punch Sensor ON Jam	no. of faults	RW	PunchSnrOnJamFC	NVMFaultCounter	shortNatural	No	Fault Counter:12-127-00: Punch Sensor ON	1.521		
604-850	Fault Counter 12-157: Buffer Point Sensor ON Jam	no. of faults	RW	BuffPointSnsOnJamFC	NVMFaultCounter	shortNatural	No	Fault Counter:12-157-00: Buffer Point Sensor	1.521		
604-851	Fault Counter 12-158: Buffer Point Sensor OFF Jam	no. of faults	RW	BuffPointSnsOffJamFC	NVMFaultCounter	shortNatural	No	Fault Counter:12-158-00: Buffer Point Sensor	1.521		
604-852	Fault Counter 12-166: Booklet Compiler Exit Sensor OFF Jam	no. of faults	RW	BookletCompExitSenOffJamFC	NVMFaultCounter	shortNatural	No	Fault Counter:12-166-00: Booklet Compiler	1.521		
604-853	Fault Counter 12-181: Booklet Maker Exit	no. of faults	RW	BMExitSnrOnJamFC	NVMFaultCounter	shortNatural	No	Fault Counter:12-181-	1.521		
604-854	Fault Counter 12-182: Booklet Maker Exit Sensor OFF Jam	no. of faults	RW	BMExitSnrOffJamFC	NVMFaultCounter	shortNatural	No	Fault Counter:12-182-00: Booklet Maker Exit	1.521		
604-855	Fault Counter 12-183: Booklet Maker	no. of faults	RW	BMUnexpectedSheetFC	NVMFaultCounter	shortNatural	No	Fault Counter:12-183-	1.678		
604-856	Fault Counter 12-184: Booklet Maker Stray Sheet	no. of faults	RW	BMStraySheetFC	NVMFaultCounter	shortNatural	No	Fault Counter:12-184-00: BMStraySheet	1.678		
604-857	Fault Counter 12-185: Trifold Exit Sensor ON Jam	no. of faults	RW	TrifoldExitSnrOnJFC	NVMFaultCounter	shortNatural	No	Fault Counter:12-185-00: Trifold Exit Sensor	1.521		
604-858	Fault Counter 12-186: Trifold Exit Sensor OFF Jam	no. of faults	RW	TrifoldExitSnrOffJFC	NVMFaultCounter	shortNatural	No	Fault Counter:12-186-00: Trifold Exit Sensor	1.521		
604-859	Fault Counter 12-187: Trifold Assist Sensor ON Jam	no. of faults	RW	TrifoldAssistSnrOnJFC	NVMFaultCounter	shortNatural	No	Fault Counter:12-187-00: Trifold Assist	1.521		
604-860	Fault Counter 12-190: Sheet late to BB	no. of faults	RW	LELateBBEntrySnrFC	NVMFaultCounter	shortNatural	No	Fault Counter:12-190-	1.521		
604-861	Fault Counter 12-191: Lead edge late to	no. of faults	RW	LELateToInserterTabStandbySFC	NVMFaultCounter	shortNatural	No	Fault Counter:12-191-	1.521		
604-862	Fault Counter 12-192: Sheet late from BB	no. of faults	RW	TELateFromBBEntrySFC	NVMFaultCounter	shortNatural	No	Fault Counter:12-192-	1.521		
604-863	Fault Counter 12-193: Trail edge late from	no. of faults	RW	TELateInserterTabSnrFC	NVMFaultCounter	shortNatural	No	Fault Counter:12-193-	1.521		
604-864	Fault Counter 12-194: Lead edge late to Inserter Pick Up Sensor	no. of faults	RW	LeadedgelatetoInserterPickUpSFC	NVMFaultCounter	shortNatural	No	Fault Counter:12-194-00: Lead edge late to	1.521		
604-865	Fault Counter 12-196: Trail edge late from Inserter Tray Pick Up Sensor	no. of faults	RW	TELateFromInserterPickUpSFC	NVMFaultCounter	shortNatural	No	Fault Counter:12-196-00: Trail edge late from	1.521		
604-866	Fault Counter 12-198: Stray sheet is detected after jam clearance	no. of faults	RW	FinStraySheetFC	NVMFaultCounter	shortNatural	No	Fault Counter:12-198-00: Stray sheet is	1.521		
604-867	Fault Counter 12-199: Unexpected Sheet at Finisher Entry	no. of faults	RW	UnexpectedSheetatFinEntFC	NVMFaultCounter	shortNatural	No	Fault Counter:12-199-00: Unexpected Sheet	1.521		
604-868	Fault Counter 12-273: Offset Unit Init Fault	no. of faults	RW	OffsetUnitInitFC	NVMFaultCounter	shortNatural	No	Fault Counter:12-273-00: Offset Unit Init	1.521		

604-869	Fault Counter 12-274: Offset Unit Home Fault	no. of faults	RW	OffsetUnitHomeFC	NVMFaultCounter	shortNatural	No	Fault Counter:12-274-00: Offset Unit Home	1.521		
604-870	Fault Counter 12-275: Offset Unit Home	no. of faults	RW	OffsetUnitHomeMvFC	NVMFaultCounter	shortNatural	No	Fault Counter:12-275-	1.521		
604-871	Fault Counter 12-276: Offset Unit Away	no. of faults	RW	OffsetUnitAwayHomeFC	NVMFaultCounter	shortNatural	No	Fault Counter:12-276-	1.521		
604-872	Fault Counter 12-277: Offset Unit Away	no. of faults	RW	OffsetUnitAwayHomeMvFC	NVMFaultCounter	shortNatural	No	Fault Counter:12-277-	1.521		
604-873	Fault Counter 12-288: Nip Split Failure	no. of faults	RW	NipSplitFC	NVMFaultCounter	shortNatural	No	Fault Counter:12-288-	1.521		
604-874	Fault Counter 12-289: Nip Home Failure	no. of faults	RW	NipHomeFC	NVMFaultCounter	shortNatural	No	Fault Counter:12-289-	1.521		
604-875	Fault Counter 12-310: Finisher Undocked	no. of faults	RW	FinUndockedDuringRFC	NVMFaultCounter	shortNatural	No	Fault Counter:12-310-	1.521		
604-876	Fault Counter 12-312: Top Cover Open in Run	no. of faults	RW	TopCoverOpeninRFC	NVMFaultCounter	shortNatural	No	Fault Counter:12-312-00: Top Cover Open in	1.521		
604-877	Fault Counter 12-313: Finisher Door Open	no. of faults	RW	FinDoorOpenInRFC	NVMFaultCounter	shortNatural	No	Fault Counter:12-313-	1.521		
604-878	Fault Counter 12-316: Inserter Top Cover	no. of faults	RW	InserterTopCoverOpenInRFC	NVMFaultCounter	shortNatural	No	Fault Counter:12-316-	1.521		
604-879	Fault Counter 12-317: Trifold Cover Open In Run	no. of faults	RW	TrifoldCoverOpenInRFC	NVMFaultCounter	shortNatural	No	Fault Counter:12-317-00: Trifold Cover Open	1.521		
604-880	Fault Counter 12-318: Trifold Front Door Open In Run	no. of faults	RW	TrifoldFDOpenInRFC	NVMFaultCounter	shortNatural	No	Fault Counter:12-318-00: Trifold Front Door	1.521		
604-881	Fault Counter 12-319: Inserter Hand Door Open In run	no. of faults	RW	InserterHandDoorOpenInRFC	NVMFaultCounter	shortNatural	No	Fault Counter:12-319-00: Inserter Hand Door	1.521		
604-882	Fault Counter 12-340: Compiler Home Fault	no. of faults	RW	CompHomeFC	NVMFaultCounter	shortNatural	No	Fault Counter:12-340-00: Compiler Home	1.521		
604-883	Fault Counter 12-341: Compiler Out Fault	no. of faults	RW	CompOutFC	NVMFaultCounter	shortNatural	No	Fault Counter:12-341-	1.521		
604-884	Fault Counter 12-342: Compiler Move	no. of faults	RW	CompMvFC	NVMFaultCounter	shortNatural	No	Fault Counter:12-342-	1.521		
604-885	Fault Counter 12-371: Stapler Move Fault	no. of faults	RW	StapleMvFC	NVMFaultCounter	shortNatural	No	Fault Counter:12-371-	1.521		
604-886	Fault Counter 12-372: Stapler Home Fault	no. of faults	RW	StapleHomeFC	NVMFaultCounter	shortNatural	No	Fault Counter:12-372-00: Stapler Home Fault	1.521		
604-887	Fault Counter 12-373: Stapler Middle	no. of faults	RW	StapleMiddleHomeFC	NVMFaultCounter	shortNatural	No	Fault Counter:12-373-	1.521		
604-888	Fault Counter 12-374: Stapler Middle	no. of faults	RW	StapleMiddleMvFC	NVMFaultCounter	shortNatural	No	Fault Counter:12-374-	1.521		
604-889	Fault Counter 12-375: Stapler Jaw Home	no. of faults	RW	StapleJawHomeFC	NVMFaultCounter	shortNatural	No	Fault Counter:12-375-	1.521		
604-890	Fault Counter 12-376: Stapler Jaw Move	no. of faults	RW	StapleJawMvFC	NVMFaultCounter	shortNatural	No	Fault Counter:12-376-	1.521		
604-891	Fault Counter 12-377: Stapler Priming Fault	no. of faults	RW	StaplePrimingFC	NVMFaultCounter	shortNatural	No	Fault Counter:12-377-00: Stapler Priming	1.521		
604-892	Fault Counter 12-378: LCSS Stapler index	no. of faults	RW	LCSSStapleIndexFC	NVMFaultCounter	shortNatural	No	Fault Counter:12-378-	1.521		
604-893	Fault Counter 12-380: Punch Unit Side	no. of faults	RW	PunchUnitSideEdgeDetectFC	NVMFaultCounter	shortNatural	No	Fault Counter:12-380-	1.521		
604-894	Fault Counter 12-383: Back Stop Home	no. of faults	RW	BackStopHomeFFC	NVMFaultCounter	shortNatural	No	Fault Counter:12-383-	1.521		
604-895	Fault Counter 12-384: Tamper Home Fault	no. of faults	RW	TampHomeFC	NVMFaultCounter	shortNatural	No	Fault Counter:12-384-	1.521		
604-896	Fault Counter 12-392: Front Tamper Move	no. of faults	RW	FTampMvFC	NVMFaultCounter	shortNatural	No	Fault Counter:12-392-	1.521		
604-897	Fault Counter 12-393: Front Tamper	no. of faults	RW	FTampHomeFC	NVMFaultCounter	shortNatural	No	Fault Counter:12-393-	1.521		
604-898	Fault Counter 12-394: Front Tamper Away	no. of faults	RW	FTampAwayFromHomeFC	NVMFaultCounter	shortNatural	No	Fault Counter:12-394-	1.521		
604-899	Fault Counter 12-395: Front Tamper Away	no. of faults	RW	FTampAwayFromHomeMvFC	NVMFaultCounter	shortNatural	No	Fault Counter:12-395-	1.521		
604-900	Fault Counter 12-396: Rear Tamper Move	no. of faults	RW	RTampMvFC	NVMFaultCounter	shortNatural	No	Fault Counter:12-396-	1.521		
604-901	Fault Counter 12-397: Rear Tamper Home	no. of faults	RW	RTampHomeFC	NVMFaultCounter	shortNatural	No	Fault Counter:12-397-	1.521		
604-902	Fault Counter 12-398: Rear Tamper Away	no. of faults	RW	RTampAwayFromHomeMvFC	NVMFaultCounter	shortNatural	No	Fault Counter:12-398-	1.521		
604-903	Fault Counter 12-399: Rear Tamper Away	no. of faults	RW	RTampAwayFromHomeFC	NVMFaultCounter	shortNatural	No	Fault Counter:12-399-	1.521		
604-904	Fault Counter 12-403: Booklet Staple	no. of faults	RW	BMStapleHead2MvFC	NVMFaultCounter	shortNatural	No	Fault Counter:12-403-	1.521		
604-905	Fault Counter 12-411: Booklet Stapler	no. of faults	RW	BMStapleHomeFC	NVMFaultCounter	shortNatural	No	Fault Counter:12-411-	1.521		
604-906	Fault Counter 12-413: Booklet Staple	no. of faults	RW	BMStapleHead2HomeFC	NVMFaultCounter	shortNatural	No	Fault Counter:12-413-	1.521		
604-907	Fault Counter 12-414: Booklet Stapler Not	no. of faults	RW	BMStapleNotHomeForInFC	NVMFaultCounter	shortNatural	No	Fault Counter:12-414-	1.521		
604-908	Fault Counter 12-415: Roll Gate Home	no. of faults	RW	RollGateHomeFC	NVMFaultCounter	shortNatural	No	Fault Counter:12-415-	1.521		
604-909	Fault Counter 12-416: Crease Blade Home Fault	no. of faults	RW	CreaseBladeHomeFC	NVMFaultCounter	shortNatural	No	Fault Counter:12-416-00: Crease Blade	1.521		
604-910	Fault Counter 12-417: Booklet Maker	no. of faults	RW	BMFlapperHomeFC	NVMFaultCounter	shortNatural	No	Fault Counter:12-417-	1.521		
604-911	Fault Counter 12-418: Booklet Maker	no. of faults	RW	BMFlappermvFC	NVMFaultCounter	shortNatural	No	Fault Counter:12-418-	1.521		
604-912	Fault Counter 12-419: Booklet Maker	no. of faults	RW	BMTamp2HomeFC	NVMFaultCounter	shortNatural	No	Fault Counter:12-419-	1.521		

604-913	Fault Counter 12-420: Booklet Maker	no. of faults	RW	BMTamp2MvFC	NVMFaultCounter	shortNatural	No	Fault Counter:12-420-	1.521		
604-914	Fault Counter 12-440: Paper Pusher	no. of faults	RW	PapPushHomeFC	NVMFaultCounter	shortNatural	No	Fault Counter:12-440-	1.521		
604-915	Fault Counter 12-441: Paper Pusher	no. of faults	RW	PapPushHomeMvFC	NVMFaultCounter	shortNatural	No	Fault Counter:12-441-	1.521		
604-916	Fault Counter 12-442: Paper Pusher Away	no. of faults	RW	PapPushAwayHomeFC	NVMFaultCounter	shortNatural	No	Fault Counter:12-442-	1.521		
604-917	Fault Counter 12-443: Paper Pusher Away	no. of faults	RW	PapPushAwayHomeMvFC	NVMFaultCounter	shortNatural	No	Fault Counter:12-443-	1.521		
604-918	Fault Counter 12-450: Ejector Module	no. of faults	RW	EjectModMotorStallFC	NVMFaultCounter	shortNatural	No	Fault Counter:12-450-	1.521		
604-919	Fault Counter 12-451: Ejector Plate Motor	no. of faults	RW	EjectPlateMotorStallFC	NVMFaultCounter	shortNatural	No	Fault Counter:12-451-	1.521		
604-920	Fault Counter 12-452: Ejector Plate Home	no. of faults	RW	EjectPlateHomeFC	NVMFaultCounter	shortNatural	No	Fault Counter:12-452-	1.521		
604-921	Fault Counter 12-453: Ejector Plate Move	no. of faults	RW	EjectPlateMvFC	NVMFaultCounter	shortNatural	No	Fault Counter:12-453-	1.521		
604-922	Fault Counter 12-454: Lower Paddle Home	no. of faults	RW	LwrPaddHomeFC	NVMFaultCounter	shortNatural	No	Fault Counter:12-454-	1.521		
604-923	Fault Counter 12-455: Lower Paddle Move	no. of faults	RW	LwrPaddMvFC	NVMFaultCounter	shortNatural	No	Fault Counter:12-455-	1.521		
604-924	Fault Counter 12-456: Ejector Module Home Fault	no. of faults	RW	EjectModHomeFC	NVMFaultCounter	shortNatural	No	Fault Counter:12-456-00: Ejector Module Home Fault	1.521		
604-925	Fault Counter 12-457: Ejector Module Home Move Fault	no. of faults	RW	EjectModHomeMvFC	NVMFaultCounter	shortNatural	No	Fault Counter:12-457-00: Ejector Module	1.521		
604-926	Fault Counter 12-458: Ejector Module Out	no. of faults	RW	EjectModOutPosFC	NVMFaultCounter	shortNatural	No	Fault Counter:12-458-	1.521		
604-927	Fault Counter 12-459: Ejector Module Out Position Move Fault	no. of faults	RW	EjectModOutPosMvFC	NVMFaultCounter	shortNatural	No	Fault Counter:12-459-00: Ejector Module	1.521		
604-928	Fault Counter 12-460: Stacker Bin 1 Motor Stall	no. of faults	RW	StackBin1MotorStallFC	NVMFaultCounter	shortNatural	No	Fault Counter:12-460-00: Stacker Bin 1	1.521		
604-929	Fault Counter 12-461: Stacker Bin 1 Level Fault	no. of faults	RW	StackBin1LevelFC	NVMFaultCounter	shortNatural	No	Fault Counter:12-461-00: Stacker Bin 1Level Fault	1.521		
604-930	Fault Counter 12-462: Stacker Bin 1 Elevator Failure	no. of faults	RW	StackBin1ElevatorFC	NVMFaultCounter	shortNatural	No	Fault Counter:12-462-00: Stacker Bin 1 Elevator Failure	1.521		
604-931	Fault Counter 12-463: Booklet Maker Power Not Present Fault	no. of faults	RW	BMPwrNotPresentFC	NVMFaultCounter	shortNatural	No	Fault Counter:12-463-00: Booklet Maker	1.521		
604-932	Fault Counter 12-464: Booklet Maker Power Fault	no. of faults	RW	BMPwrFC	NVMFaultCounter	shortNatural	No	Fault Counter:12-464-00: Booklet Maker	1.521		
604-933	Fault Counter 12-465: Paddle Upper Position Fault	no. of faults	RW	PaddUpprPosFC	NVMFaultCounter	shortNatural	No	Fault Counter:12-465-00: Paddle Upper	1.521		
604-934	Fault Counter 12-466: Paddle Upper Position Move Fault	no. of faults	RW	PaddUpprPosMvFC	NVMFaultCounter	shortNatural	No	Fault Counter:12-466-00: Paddle Upper	1.521		
604-935	Fault Counter 12-467: Paddle Lower Position Fault	no. of faults	RW	PaddLwrPosFC	NVMFaultCounter	shortNatural	No	Fault Counter:12-467-00: Paddle Lower	1.521		
604-936	Fault Counter 12-468: Paddle Lower Position Move Fault	no. of faults	RW	PaddLwrPosMvFC	NVMFaultCounter	shortNatural	No	Fault Counter:12-468-00: Paddle Lower	1.521		
604-937	Fault Counter 12-469: Curl Suppressor Home Fault	no. of faults	RW	CurlSupprHomeFC	NVMFaultCounter	shortNatural	No	Fault Counter:12-469-00: Curl Suppressor	1.521		
604-938	Fault Counter 12-470: Curl Suppressor Move Fault	no. of faults	RW	CurlSupprMvFC	NVMFaultCounter	shortNatural	No	Fault Counter:12-470-00: Curl Suppressor	1.521		
604-939	Fault Counter 12-471: Curl Suppressor	no. of faults	RW	CurlSupprAwayPosFC	NVMFaultCounter	shortNatural	No	Fault Counter:12-471-	1.521		
604-940	Fault Counter 12-472: Curl Suppressor	no. of faults	RW	CurlSupprAwayPosMvFC	NVMFaultCounter	shortNatural	No	Fault Counter:12-472-	1.521		
604-941	Fault Counter 12-473: Pressing Motor Init	no. of faults	RW	PressMotorInitFC	NVMFaultCounter	shortNatural	No	Fault Counter:12-473-	1.521		
604-942	Fault Counter 12-474: Pressing Motor Init	no. of faults	RW	PressMotorInitMvFC	NVMFaultCounter	shortNatural	No	Fault Counter:12-474-	1.521		
604-943	Fault Counter 12-475: Pressing Motor Home Fault	no. of faults	RW	PressMotorHomeFC	NVMFaultCounter	shortNatural	No	Fault Counter:12-475-00: Pressing Motor	1.521		

604-944	Fault Counter 12-476: Pressing Motor Home Move Fault	no. of faults	RW	PressMotorHomeMvFC	NVMFaultCounter	shortNatural	No	Fault Counter:12-476-00: Pressing Motor	1.521		
604-945	Fault Counter 12-477: Pressing Motor Out Position Fault	no. of faults	RW	PressMotorOutPosFC	NVMFaultCounter	shortNatural	No	Fault Counter:12-477-00: Pressing Motor Out	1.521		
604-946	Fault Counter 12-478: Pressing Motor Out Position Move Fault	no. of faults	RW	PressMtrOutPosMvFC	NVMFaultCounter	shortNatural	No	Fault Counter:12-478-00: Pressing Motor Out	1.521		
604-947	Fault Counter 12-479: Insert Sheet Too Short	no. of faults	RW	InsShitTooShortFC	NVMFaultCounter	shortNatural	No	Fault Counter:12-479-00: Insert Sheet Too	1.521		
604-951	Total no. of Black and Color Duplex (Copy sheets +	Stores the count when	ND		NVMBillingCounter	byteArray	No		1.810		
604-952	Total no. of Black and Color Simplex (Copy sheets +	Stores the count when	ND		NVMBillingCounter	byteArray	No		1.810		
604-953	Total no. of Black simplex and duplex (Copy sheets + Print Sheets , including Blank and Banner Sheets	Stores the count when traditional billing	ND		NVMBillingCounter	byteArray	No		1.810		
604-954	Total number of (embedded Fax Images Successfully Sent and Scanned Image using Platen	Stores the count when traditional billing	ND		NVMBillingCounter	byteArray	No		1.810		
604-979	Finisher Hole Punch Configuration		RW	HolePunchConfiguration	NVMConfiguration	shortNatural	No		1.299		
604-979	Finisher Hole Punch Configuration	Corvo and Kiska uses finisher NVM 763-605	RW	HolePunchConfiguration	NVMConfiguration	shortNatural	No		1.769		
604-980	Fault Counter 12-762-00: Cannot communicate with finisher.	no. of faults	RW	ImeFinCommsFailFC	NVMFaultCounter	shortNatural	No	Fault Counter:12-762-00: Cannot communicate with	1.521		
604-981	Fault Counter 12-764-00: Finisher is not present.	no. of faults	RW	ImeFinMissingFC	NVMFaultCounter	shortNatural	No	Fault Counter:12-764-00: Finisher is not present.	1.521		
604-995	Fault Counter 12-492-00: CDI communications failure with finisher.	no. of faults	RW	FINISHERCDICOMMSFAILFC	NVMFaultCounter	shortNatural	No	Fault Counter:12-492-00: CDI communications failure	1.521		
604-996	Fault Counter 12-493-00: Finisher failure to Cycle Up in time	no. of faults	RW	FINISHERFAILCYCLEUPFC	NVMFaultCounter	shortNatural	No	Fault Counter:12-493-00: Finisher failure to Cycle Up in time	1.521		
604-997	Fault Counter 12-494-00: Finisher failure to return prep time	no. of faults	RW	FINISHERFAILPREPTIMEFC	NVMFaultCounter	shortNatural	No	Fault Counter:12-494-00: Finisher failure to	1.521		
604-998	Fault Counter 12-100-00: Finisher Late to Entry Sensor	no. of faults	RW	DfFnlinkLateToEntry	NVMFaultCounter	shortNatural	No	Fault Counter:12-100-00: Finisher Late to	1.521		
604-999	Fault Counter 12-102-00: Late IME Exit	no. of faults	RW	DfFnlinkLateImeExit	NVMFaultCounter	shortNatural	No	Fault Counter:12-102-00: Late IME Exit	1.521		
605-011	Counter-MFPRINTLargeSheets		ND		NVMBillingCounter	byteArray	No	Billing Counter:31: Black Printed Large Sheets	1.799		
605-015	Counter-PrintIFAXJobs		ND		NVMSystemUsageCounter	byteArray	No	System Usage Counter:48: Total	1.799		
605-025	Counter-MFPRINTLargeColorSheets		ND		NVMBillingCounter	byteArray	No	Billing Counter:34: Color Printed Large	1.799		
605-027	Counter-MFPRINTSuccessfulFaxImagesReceived		ND		NVMBillingCounter	byteArray	No	Billing Counter:12: Internet Fax	1.799		
606-003	Tray 1 Media Weight		RW	Tray 1 Media Weight	NVMSAKOSetting	shortNatural	No		1.042		
606-005	Tray 1 Priority		RW	Tray 1 Priority	NVMSAKOSetting	shortNatural	No		1.730		
606-006	Tray 1 Width	Range and default size in	RW	Tray 1 Width	NVMSAKOSetting	natural	No		1.333		
606-006	Tray 1 Width	Range and default size in	RW	Tray 1 Width	NVMSAKOSetting	natural	No		1.380		
606-006	Tray 1 Width	Range and default size in	RW	Tray 1 Width	NVMSAKOSetting	natural	No		1.488		
606-006	Tray 1 Width	Range and default size in	RW	Tray 1 Width	NVMSAKOSetting	natural	No		1.495		
606-006	Tray 1 Width	Range and default size in	RW	Tray 1 Width	NVMSAKOSetting	natural	No		1.696		

606-007	Tray 1 Length	Range and default size in	RW	Tray 1 Length	NVMSAKOSetting	natural	No		1.333		
606-007	Tray 1 Length	Range and default size in	RW	Tray 1 Length	NVMSAKOSetting	natural	No		1.380		
606-007	Tray 1 Length	Range and default size in mm	RW	Tray 1 Length	NVMSAKOSetting	natural	No		1.629		
606-007	Tray 1 Length	Range and default size in	RW	Tray 1 Length	NVMSAKOSetting	natural	No		1.495		
606-007	Tray 1 Length	Range and default size in	RW	Tray 1 Length	NVMSAKOSetting	natural	No		1.568		
606-007	Tray 1 Length	Range and default size in	RW	Tray 1 Length	NVMSAKOSetting	natural	No		1.696		
606-007	Tray 1 Length	Range and default size in	RW	Tray 1 Length	NVMSAKOSetting	natural	No		1.787		
606-007	Tray 1 Length	Range and default size in	RW	Tray 1 Length	NVMSAKOSetting	natural	No		1.804		
606-023	Tray 2 Media Weight		RW	Tray 2 Media Weight	NVMSAKOSetting	shortNatural	No		1.042		
606-025	Tray 2 Priority		RW	Tray 2 Priority	NVMSAKOSetting	shortNatural	No		1.730		
606-026	Tray 2 Width		RW	Tray 2 Width	NVMSAKOSetting	natural	No		1.253		
606-026	Tray 2 Width	Range and default size in	RW	Tray 2 Width	NVMSAKOSetting	natural	No		1.380		
606-026	Tray 2 Width	Range and default size in	RW	Tray 2 Width	NVMSAKOSetting	natural	No		1.640		
606-026	Tray 2 Width		RW	Tray 2 Width	NVMSAKOSetting	natural	No		1.495		
606-026	Tray 2 Width		RW	Tray 2 Width	NVMSAKOSetting	natural	No		1.696		
606-026	Tray 2 Width	Range and default size in	RW	Tray 2 Width	NVMSAKOSetting	natural	No		1.787		
606-027	Tray 2 Length	Range and default size in	RW	Tray 2 Length	NVMSAKOSetting	natural	No		1.253		
606-027	Tray 2 Length	Range and default size in mm	RW	Tray 2 Length	NVMSAKOSetting	natural	No		1.380		
606-027	Tray 2 Length	Range and default size in	RW	Tray 2 Length	NVMSAKOSetting	natural	No		1.640		
606-027	Tray 2 Length	Range and default size in	RW	Tray 2 Length	NVMSAKOSetting	natural	No		1.495		
606-027	Tray 2 Length	Range and default size in	RW	Tray 2 Length	NVMSAKOSetting	natural	No		1.568		
606-027	Tray 2 Length	Range and default size in	RW	Tray 2 Length	NVMSAKOSetting	natural	No		1.696		
606-027	Tray 2 Length	Range and default size in mm	RW	Tray 2 Length	NVMSAKOSetting	natural	No		1.787		
606-027	Tray 2 Length	Range and default size in mm	RW	Tray 2 Length	NVMSAKOSetting	natural	No		1.804		
606-032	Tray 2 Usage: Standard Tray / Envelope	specialMaterials = 0,	RW	Tray 2 Usage:Standard/Envelope	NVMSAKOSetting	shortNatural	No		1.524		
606-043	Tray 3 Media Weight		RW	Tray 3 Media Weight	NVMSAKOSetting	shortNatural	No		1.042		
606-045	Tray 3 Priority		RW	Tray 3 Priority	NVMSAKOSetting	shortNatural	No		1.730		
606-045	Tray 3 Priority		RW	Tray 3 Priority	NVMSAKOSetting	shortNatural	No		1.462		
606-045	Tray 3 Priority		RW	Tray 3 Priority	NVMSAKOSetting	shortNatural	No		1.507		
606-045	Tray 3 Priority		RW	Tray 3 Priority	NVMSAKOSetting	shortNatural	No		1.561		
606-046	Tray 3 Width	Range and default size in mm	RW	Tray 3 Width	NVMSAKOSetting	natural	No		1.042		
606-046	Tray 3 Width	Range and default size in	RW	Tray 3 Width	NVMSAKOSetting	natural	No		1.380	Yes	
606-046	Tray 3 Width	Range and default size in	RW	Tray 3 Width	NVMSAKOSetting	natural	No		1.495		

606-046	Tray 3 Width	Range and default size in	RW	Tray 3 Width	NVMSAKOSetting	natural	No		1.787		
606-047	Tray 3 Length	Range and default size in	RW	Tray 3 Length	NVMSAKOSetting	natural	No		1.615		
606-047	Tray 3 Length	Range and default size in	RO	Tray 3 Length	NVMSAKOSetting	natural	No		1.380	Yes	
606-047	Tray 3 Length	Range and default size in	RW	Tray 3 Length	NVMSAKOSetting	natural	No		1.495		
606-047	Tray 3 Length	Range and default size in	RW	Tray 3 Length	NVMSAKOSetting	natural	No		1.787		
606-047	Tray 3 Length	Range and default size in	RW	Tray 3 Length	NVMSAKOSetting	natural	No		1.804		
606-049	Tray 3 User Type	0 = TAFixed 1 = TAAadjustableAll	RW	Tray 3 User Type	NVMSAKOSetting	shortNatural	No		1.448		
606-063	Tray 4 Media Weight		RW	Tray 4 Media Weight	NVMSAKOSetting	shortNatural	No		1.042		
606-065	Tray 4 Priority		RW	Tray 4 Priority	NVMSAKOSetting	shortNatural	No		1.730		
606-065	Tray 4 Priority		RW	Tray 4 Priority	NVMSAKOSetting	shortNatural	No		1.462		
606-065	Tray 4 Priority		RW	Tray 4 Priority	NVMSAKOSetting	shortNatural	No		1.507		
606-066	Tray 4 Width	Range and default size in	RW	Tray 4 Width	NVMSAKOSetting	natural	No		1.042		
606-066	Tray 4 Width	Range and default size in	RW	Tray 4 Width	NVMSAKOSetting	natural	No		1.380	Yes	
606-066	Tray 4 Width	Range and default size in	RW	Tray 4 Width	NVMSAKOSetting	natural	No		1.495		
606-066	Tray 4 Width	Range and default size in	RW	Tray 4 Width	NVMSAKOSetting	natural	No		1.787		
606-067	Tray 4 Length	Range and default size in mm	RW	Tray 4 Length	NVMSAKOSetting	natural	No		1.615		
606-067	Tray 4 Length	Range and default size in	RW	Tray 4 Length	NVMSAKOSetting	natural	No		1.380	Yes	
606-067	Tray 4 Length	Range and default size in mm	RW	Tray 4 Length	NVMSAKOSetting	natural	No		1.495		
606-067	Tray 4 Length	Range and default size in mm	RW	Tray 4 Length	NVMSAKOSetting	natural	No		1.787		
606-067	Tray 4 Length	Range and default size in mm	RW	Tray 4 Length	NVMSAKOSetting	natural	No		1.804		
606-069	Tray 4 User Type	0 = TAFixed 1 = TAAadjustableAll	RW	Tray 4 User Type	NVMSAKOSetting	shortNatural	No		1.380		
606-083	Tray 5 Media Weight		RW	Tray 5 Media Weight	NVMSAKOSetting	shortNatural	No		1.042		
606-084	Tray 5 Direct Select	TSDirectOnly = 0, TSDirectAndAuto = 1	RW	Tray 5 Direct Select	NVMSAKOSetting	shortNatural	No		1.380		
606-085	Tray 5 Priority		RW	Tray 5 Priority	NVMSAKOSetting	shortNatural	No		1.793		
606-085	Tray 5 Priority Note: Tray 5 is manual feed slot on		RW	Tray 5 Priority	NVMSAKOSetting	shortNatural	No		1.814		
606-086	Tray 5 Width	Range and default size in mm	RW	Tray 5 Width	NVMSAKOSetting	natural	No		1.332		
606-086	Tray 5 Width	Range and default size in mm	RW	Tray 5 Width	NVMSAKOSetting	natural	No		1.380		
606-086	Tray 5 Width	Range and default size in	RW	Tray 5 Width	NVMSAKOSetting	natural	No		1.495		
606-086	Tray 5 Width	Range and default size in	RW	Tray 5 Width	NVMSAKOSetting	natural	No		1.629		
606-086	Tray 5 Width	Range and default size in	RW	Tray 5 Width	NVMSAKOSetting	natural	No		1.629		
606-086	Tray 5 Width	Range and default size in mm	RW	Tray 5 Width	NVMSAKOSetting	natural	No		1.700		
606-086	Tray 5 Width	Range and default size in mm	RW	Tray 5 Width	NVMSAKOSetting	natural	No		1.793		
606-087	Tray 5 Length	Range and default size in mm	RW	Tray 5 Length	NVMSAKOSetting	natural	No		1.332		
606-087	Tray 5 Length	Range and default size in mm	RW	Tray 5 Length	NVMSAKOSetting	natural	No		1.380		
606-087	Tray 5 Length	Range and default size in mm	RW	Tray 5 Length	NVMSAKOSetting	natural	No		1.495		
606-087	Tray 5 Length	Range and default size in mm	RW	Tray 5 Length	NVMSAKOSetting	natural	No		1.629		

606-087	Tray 5 Length	Range and default size in mm	RW	Tray 5 Length	NVMSAKOSetting	natural	No		1.675		
606-087	Tray 5 Length	Range and default size in mm	RW	Tray 5 Length	NVMSAKOSetting	natural	No		1.793		
606-088	Tray 5 Percent Full		RW	Tray 5 Percent Full	NVMSAKOSetting	shortNatural	No		1.016		
606-089	Tray 5 User Type	TAFixed = 0,	RW	Tray 5 User Type	NVMSAKOSetting	shortNatural	No		1.793		
606-103	Tray 6 Media Weight		RW	Tray 6 Media Weight	NVMSAKOSetting	shortNatural	No		1.042		
606-104	Tray 6 Direct Select	TSDirectOnly = 0,	RW	Tray 6 Direct Select	NVMSAKOSetting	shortNatural	No		1.340		
606-105	Tray 6 Priority		RW	Tray 6 Priority	NVMSAKOSetting	shortNatural	No		1.793		
606-105	Tray 6 Priority		RW	Tray 6 Priority	NVMSAKOSetting	shortNatural	No		1.380		
606-106	Tray 6 Width	Range and default size in mm	RW	Tray 6 Width	NVMSAKOSetting	natural	No		1.253		
606-106	Tray 6 Width	Range and default size in mm	RW	Tray 6 Width	NVMSAKOSetting	natural	No		1.610	Yes	
606-106	Tray 6 Width	Range and default size in mm	RW	Tray 6 Width	NVMSAKOSetting	natural	No		1.610	Yes	
606-106	Tray 6 Width Note: In Melody tray 6 is Optional HCF 2	Range and default size in mm	RW	Tray 6 Width	NVMSAKOSetting	natural	No		1.793		
606-107	Tray 6 Length	Range and default size in mm	RW	Tray 6 Length	NVMSAKOSetting	natural	No		1.042		
606-107	Tray 6 Length	Range and default size in mm	RW	Tray 6 Length	NVMSAKOSetting	natural	No		1.610	Yes	
606-107	Tray 6 Length	Range and default size in mm	RW	Tray 6 Length	NVMSAKOSetting	natural	No		1.610	Yes	
606-107	Tray 6 Length	Range and default size in mm	RW	Tray 6 Length	NVMSAKOSetting	natural	No		1.793		
606-109	Tray 6 User Type	TAFixed = 0,	RW	Tray 6 User Type	NVMSAKOSetting	shortNatural	No		1.793		
606-109	Tray 6 User Type	TAFixed = 0,	RW	Tray 6 User Type	NVMSAKOSetting	shortNatural	No		1.268		
606-109	Tray 6 User Type	TAFixed = 0,	RW	Tray 6 User Type	NVMSAKOSetting	shortNatural	No		1.610		
606-121	Tray 7 Media Type	MTStandard = 0,	RW	Tray 7 Media Type	NVMSAKOSetting	shortNatural	No		1.670		
606-122	Tray 7 Media Color	MCWhite = 0,	RW	Tray 7 Media Color	NVMSAKOSetting	shortNatural	No		1.670		
606-123	Tray 7 Media Weight		RW	Tray 7 Media Weight	NVMSAKOSetting	shortNatural	No		1.268		
606-123	Tray 7 Media Weight		RW	Tray 7 Media Weight	NVMSAKOSetting	shortNatural	No		1.670		
606-124	Tray 7 Direct Select	TSDirectOnly = 0,	RW	Tray 7 Direct Select	NVMSAKOSetting	shortNatural	No		1.793		
606-125	Tray 7 Priority		RW	Tray 7 Priority	NVMSAKOSetting	shortNatural	No		1.380		
606-125	Tray 7 Priority		RW	Tray 7 Priority	NVMSAKOSetting	shortNatural	No		1.670		
606-125	Tray 7 Priority		RW	Tray 7 Priority	NVMSAKOSetting	shortNatural	No		1.793		
606-126	Tray 7 Width	Range and default size in mm	RW	Tray 7 Width	NVMSAKOSetting	natural	No		1.380		
606-126	Tray 7 Width Note : In FX product, this Tray 7 NVM's is	Range and default size in mm	RW	Tray 7 Width	NVMSAKOSetting	natural	No		1.670		
606-126	Tray 7 Width	Range and default size in mm	RW	Tray 7 Width	NVMSAKOSetting	natural	No		1.696		
606-126	Tray 7 Width	Range and default size in mm	RW	Tray 7 Width	NVMSAKOSetting	natural	No		1.793		
606-127	Tray 7 Length	Range and default size in mm	RW	Tray 7 Length	NVMSAKOSetting	natural	No		1.380		
606-127	Tray 7 Length Note : In FX product, this Tray 7 NVM's is	Range and default size in mm	RW	Tray 7 Length	NVMSAKOSetting	natural	No		1.670		
606-127	Tray 7 Length Note : In FX product, this Tray 7 NVM's is used by 3TM tray config for Tray 3 setting.	Range and default size in mm	RW	Tray 7 Length	NVMSAKOSetting	natural	No		1.696		
606-127	Tray 7 Length Note : In Melody, tray 7 is Optional HCF 3	Range and default size in mm	RW	Tray 7 Length	NVMSAKOSetting	natural	No		1.793		

606-128	Tray 7 Percent Full Note : In FX product, this Tray 7 NVM's is used by 3TM tray config for Tray 3 setting. TTM tray config will use the Tray 3 NVM similar to other products.		RW	Tray 7 Percent Full	NVMSAKOSetting	shortNatural	No		1.670		
606-129	Tray 7 User Type	TAFixed = 0, TAAdjustableAll = 1,	RW	Tray 7 User Type	NVMSAKOSetting	shortNatural	No		1.380		
606-129	Tray 7 User Type	TAFixed = 0,	RW	Tray 7 User Type	NVMSAKOSetting	shortNatural	No		1.793		
606-130	Tray 7 Modulus Note : In FX product, this Tray 7 NVM's is		RW	Tray 7 Modulus	NVMSAKOSetting	shortNatural	No		1.670		
606-131	Tray 7 Modulus Position Note : In FX product, this Tray 7 NVM's is		RW	Tray 7 Modulus Position	NVMSAKOSetting	shortNatural	No		1.670		
606-141	Tray 8 Media Type	MTStandard = 0,	RW	Tray 8 Media Type	NVMSAKOSetting	shortNatural	No		1.670		
606-142	Tray 8 Media Color Note : In FX product, this Tray 8 NVM's is	MCWhite = 0, MCGreen = 1,	RW	Tray 8 Media Color	NVMSAKOSetting	shortNatural	No		1.670		
606-143	Tray 8 Media Weight Note : In FX product, this Tray 8 NVM's is		RW	Tray 8 Media Weight	NVMSAKOSetting	shortNatural	No		1.670		
606-144	Tray 8 Direct Select Note : In FX product, this Tray 8 NVM's is	TSDirectOnly = 0, TSDirectAndAuto = 1	RW	Tray 8 Direct Select	NVMSAKOSetting	shortNatural	No		1.793		
606-145	Tray 8 Priority		RW	Tray 8 Priority	NVMSAKOSetting	shortNatural	No		1.670		
606-145	Tray 8 Priority Note : In Melody, Tray 8 is Optional HCF 4		RW	Tray 8 Priority	NVMSAKOSetting	shortNatural	No		1.793		
606-146	Tray 8 Width	Range and default size in	RW	Tray 8 Width	NVMSAKOSetting	natural	No		1.670		
606-146	Tray 8 Width	Range and default size in	RW	Tray 8 Width	NVMSAKOSetting	natural	No		1.696		
606-146	Tray 8 Width Note : In Melody, Tray 8 is Optional HCF 4	Range and default size in mm	RW	Tray 8 Width	NVMSAKOSetting	natural	No		1.793		
606-147	Tray 8 Length Note : In FX product, this Tray 8 NVM's is	Range and default size in mm	RW	Tray 8 Length	NVMSAKOSetting	natural	No		1.670		
606-147	Tray 8 Length Note : In FX product, this Tray 8 NVM's is	Range and default size in mm	RW	Tray 8 Length	NVMSAKOSetting	natural	No		1.696		
606-147	Tray 8 Length	Range and default size in	RW	Tray 8 Length	NVMSAKOSetting	natural	No		1.793		
606-148	Tray 8 Percent Full Note : In FX product, this Tray 8 NVM's is used by 3TM tray config for Tray 4 setting. TTM tray config will use the Tray 4 NVM similar to other products.		RW	Tray 8 Percent Full	NVMSAKOSetting	shortNatural	No		1.670		
606-149	Tray 8 User Type	TAFixed = 0,	RW	Tray 8 User Type	NVMSAKOSetting	shortNatural	No		1.793		
606-150	Tray 8 Modulus Note : In FX product, this Tray 8 NVM's is		RW	Tray 8 Modulus	NVMSAKOSetting	shortNatural	No		1.670		
606-151	Tray 8 Modulus Position Note : In FX product, this Tray 8 NVM's is		RW	Tray 8 Modulus Position	NVMSAKOSetting	shortNatural	No		1.670		
606-190	Plain Large Sheets Used Total of large size Plain media sheets since activation date numLargePlainMedia	Plain Large Sheets Used Total of large size Plain media sheets since activation date numLargePlainMedia	ND	Plain Large Sheets Used	NVMSystemUsageCounter	byteArray	No	System Usage Counter:98: Plain Large Sheets Used	1.799		
606-191	Bond Large Sheets Used Total of large size Bond media sheets since activation date	Bond Large Sheets Used Total of large size Bond media sheets since	ND	Bond Large Sheets Used	NVMSystemUsageCounter	byteArray	No	System Usage Counter:99: Bond Large Sheets Used	1.799		

606-192	LetterHead Large Sheets Used Total of large size Leterhead media sheets	LetterHead Large Sheets Used	ND	LetterHead Large Sheets Used	NVMSystemUsageCounter	byteArray	No	System Usage Counter:100:	1.799		
606-193	Pre-Printed Large Sheets Used Total of large size Pre-Printed media	Pre-Printed Large Sheets Used	ND	Pre-Printed Large Sheets Used	NVMSystemUsageCounter	byteArray	No	System Usage Counter:101: Pre-	1.799		
606-199	Gloss Coating Large Sheets Used Total of large size Gloss Coating media	Gloss Coating Large Sheets Used	ND	Gloss Coating Large Sheets Used	NVMSystemUsageCounter	byteArray	No	System Usage Counter:108: Gloss	1.799		
606-205	Recycled Large Sheets Used Total of large size Recycled media sheets	Recycled Large Sheets Used	ND	Recycled Large Sheets Used	NVMSystemUsageCounter	byteArray	No	System Usage Counter:114: Recycled	1.799		
606-206	Hole Punched Large Sheets Used Total of large size Holepunched media	Hole Punched Large Sheets Used	ND	Hole Punched Large Sheets Used	NVMSystemUsageCounter	byteArray	No	System Usage Counter:115: Punched	1.799		
606-207	Other Paper Type Large Sheets Used Total of large size Other media (not	Other Paper Type Large Sheets Used	ND	Other Paper Type Large Sheets	NVMSystemUsageCounter	byteArray	No	System Usage Counter:116: Other	1.799		
606-209	Tabloid (11 x 17") Sheets Used Total of 11x17" sheets since activation	Tabloid (11 x 17") Sheets Used	ND	Tabloid Sheets Used	NVMSystemUsageCounter	byteArray	No	System Usage Counter:118: Tabloid	1.799		
606-214	12 x 18" Sheets Used	12 x 18" Sheets Used	ND	12 x 18 Sheets Used	NVMSystemUsageCounter	byteArray	No	System Usage	1.799		
606-215	12 x 19" Sheets Used Total of 12x19" sheets since activation	12 x 19" Sheets Used Total of 12x19" sheets	ND	12 x 19 Sheets Used	NVMSystemUsageCounter	byteArray	No	System Usage Counter:124: 12 x 19"	1.799		
606-218	A3 Sheets Used Total of A3 sheets since activation date numA3Sheets	A3 Sheets Used Total of A3 sheets since activation date	ND	A3 Sheets Used	NVMSystemUsageCounter	byteArray	No	System Usage Counter:127: A3 Sheets Used	1.061		
606-219	SRA3 Sheets Used	SRA3 Sheets Used	ND	SRA3 Sheets Used	NVMSystemUsageCounter	byteArray	No	System Usage	1.799		
606-249	All sheets fed from Tray #7	All sheets fed from Tray	ND	All sheets fed from Tray #7	NVMSystemUsageCounter	byteArray	No	System Usage	1.061		
606-250	All sheets fed from Tray #8	All sheets fed from Tray	ND	All sheets fed from Tray #8	NVMSystemUsageCounter	byteArray	No	System Usage	1.061		
606-269	Service Plan (Contract - with leaning mode	Sold = 0, Metered =	RO	Service Plan	NVMcontrolledAccess	shortNatural	No		1.790	Yes	Yes, as Text
606-399	SPARED (was Tray 7 Jams - Usage	Tray 7 Jams	ND	SPARE 606-399	NVMSystemUsageCounter	longNatural	No	System Usage	1.044		
606-400	Tray 8 Jams - Usage Counter	Tray 8 Jams	RO	Tray 8 Jams	NVMSystemUsageCounter	longNatural	No	System Usage	1.044		
606-403	Protocol comm faults counter	Protocol comm faults	RO	Protocol comm faults counter	NVMSystemUsageCounter	longNatural	No	System Usage	1.678		
606-483	Tray 7 (PPI) Feed Rolls life counter	Feeds - counted by	RW	Tray7FeedRollsLifeCount	NVMHFSICounter	longNatural	No		1.426		
606-488	Tray 6 (PFP) Feed Rolls life counter	Feeds - counted by	RW	Tray6FeedRollsLifeCount	NVMHFSICounter	longNatural	No		1.426		
606-493	Tray 7 (PPI) Feed Rolls replacement counter	Replacements - incremented when user resets life counter	RW	Tray7FeedRollsRepCount	NVMSystemUsageCounter	natural	No	Unknown	1.426		
606-494	Tray 1 Feed Rolls replacement counter	Replacements - incremented when user resets life counter	RW	Tray1FeedRollsRepCount	NVMSystemUsageCounter	natural	No	Unknown	1.426		
606-495	Tray 2 Feed Rolls replacement counter	Replacements - incremented when user resets life counter	RW	Tray2FeedRollsRepCount	NVMSystemUsageCounter	natural	No	Unknown	1.426		
606-496	Tray 3 Feed Rolls replacement counter	Replacements - incremented when user resets life counter	RW	Tray3FeedRollsRepCount	NVMSystemUsageCounter	natural	No	Unknown	1.426		
606-497	Tray 5 (MSI) Feed Rolls replacement counter	Replacements - incremented when user	RW	Tray5FeedRollsRepCount	NVMSystemUsageCounter	natural	No	Unknown	1.426		
606-498	Tray 6 (PFP) Feed Rolls replacements	Replacements - incremented when user resets life counter	RW	Tray6FeedRollsRepCount	NVMSystemUsageCounter	natural	No	Unknown	1.426		
606-513	Transfer Roller replacements	system increments counter	RO	XferRollReplacements	NVMSystemUsageCounter	natural	No	Unknown	1.265		
606-514	Transfer Belt replacements	system increments	RO	XferBeltReplacements	NVMSystemUsageCounter	natural	No	Unknown	1.799		
606-514	Transfer Belt Cleaner replacements	system increments counter	RO	BeltCleanerReplacements	NVMSystemUsageCounter	natural	No	Unknown	1.799		

606-516	SPDH Feed Roll Life Expectancy	Modifiable via DC131	RW	SPDHRollLife	NVMConfiguration	longNatural	No		1.434		
606-516	SPDH Feed Roll Life Expectancy	Modifiable via DC131	RW	SPDHRollLife	NVMConfiguration	longNatural	No		1.600		
606-516	ADF Roller- Forward Roller – Separation	Feeds - adjustable by	RW	SPDHRollLife	NVMConfiguration	longNatural	No		1.805		
606-517	Tray 7 (PPI) Feed Rolls Life Expectancy	Feeds - adjustable by CSE	RW	Tray7FeedRollsExpLife	NVMConfiguration	longNatural	No		1.434		
606-518	Tray 1 Feed Rolls life expectancy	Feeds - adjustable by CSE	RW	Tray1FeedRollsExpLife	NVMConfiguration	longNatural	No		1.434		
606-518	Tray 1 Pick & Separator Roller life expectancy	Feeds - adjustable by CSE	RW	Tray1FeedRollsExpLife	NVMConfiguration	longNatural	No		1.805		
606-519	Tray 2 Feed Rolls life expectancy	Feeds - adjustable by CSE	RW	Tray2FeedRollsExpLife	NVMConfiguration	longNatural	No		1.434		
606-519	Tray 2 Pick & Separator Roller life expectancy	Feeds - adjustable by CSE	RW	Tray2FeedRollsExpLife	NVMConfiguration	longNatural	No		1.805		
606-520	Tray 3 Feed Rolls Life Expectancy	Feeds - adjustable by CSE	RW	Tray3FeedRollsExpLife	NVMConfiguration	longNatural	No		1.434		
606-520	Tray 3 Pick & Separator Roller Life Expectancy	Feeds - adjustable by CSE	RW	Tray3FeedRollsExpLife	NVMConfiguration	longNatural	No		1.805		
606-521	Tray 5 (MSI) Feed Rolls life expectancy	Feeds - adjustable by CSE	RW	Tray5FeedRollsExpLife	NVMConfiguration	longNatural	No		1.434		
606-522	Tray 6 (PFP) Feed Rolls life expectancy	Feeds - adjustable by CSE	RW	Tray6FeedRollsExpLife	NVMConfiguration	longNatural	No		1.434		
606-523	Fuser Life Expectancy	Modifiable via DC131	RW	FuserLife	NVMConfiguration	longNatural	No		1.206		
606-523	Fuser Life Expectancy	Modifiable via DC131	RW	FuserLife	NVMConfiguration	longNatural	No		1.805		
606-527	Tray 7 (PPI) Feed Rolls install date	unix timedate - set when user resets count	ND	Tray7FeedRollsInstDate	NVMConfiguration	longNatural	No		1.667		
606-528	Tray 1 Feed Rolls install date	unix timedate - set when user resets count	ND	Tray1FeedRollsInstDate	NVMConfiguration	longNatural	No		1.667		
606-529	Tray 2 Feed Rolls install date	unix timedate - set when user resets count	ND	Tray2FeedRollsInstDate	NVMConfiguration	longNatural	No		1.667		
606-530	Tray 3 Feed Rolls install date	unix timedate - set when user resets count	ND	Tray3FeedRollsInstDate	NVMConfiguration	longNatural	No		1.667		
606-531	Tray 5 (MSI) Feed Rolls install date	unix timedate - set when user resets count	ND	Tray5FeedRollsInstDate	NVMConfiguration	longNatural	No		1.667		
606-532	Tray 6 (PFP) Feed Rolls install date	unix timedate - set when user resets count	ND	Tray6FeedRollsInstDate	NVMConfiguration	longNatural	No		1.667		
606-538	Label Enablement for T1 / T2	0=disabled 1=enabled	RW	T1/ T2 Label Enablement	NVMConfiguration	shortNatural	No		1.510		

606-540	Bias Transfer Roll Install Date	Bias Transfer Roller installation date	ND		NVMConfiguration	longNatural	No		1.667		
606-572	Fault Counter 12-098: FinisherFlashROMFailFC	no. of faults	RW	FinisherFlashROMFailFC	NVMFaultCounter	shortNatural	No	Fault Counter:12-098-00:	1.521		
606-573	Fault Counter 12-099: FinisherCommErrorFC	no. of faults	RW	FinisherCommErrorFC	NVMFaultCounter	shortNatural	No	Fault Counter:12-099-00:	1.521		
606-578	Fault Counter 12-480:	no. of faults	RW	FinisherElevationDriveFailFC	NVMFaultCounter	shortNatural	No	Fault Counter:12-480-	1.521		
606-579	Fault Counter 12-481: FinisherPaperPressDriveFailFC	no. of faults	RW	FinisherPaperPressDriveFailFC	NVMFaultCounter	shortNatural	No	Fault Counter:12-481-00: FinisherPaperPressDriveFailFC	1.521		
606-580	Fault Counter 12-482: FinisherAlignPlateDriveFailFC	no. of faults	RW	FinisherAlignPlateDriveFailFC	NVMFaultCounter	shortNatural	No	Fault Counter:12-482-00: FinisherAlignPlateDriveFailFC	1.521		
606-581	Fault Counter 12-483: FinisherEjectRollerContactFailFC	no. of faults	RW	FinisherEjectRollerContactFailFC	NVMFaultCounter	shortNatural	No	Fault Counter:12-483-00: FinisherEjectRollerContactFailFC	1.521		
606-582	Fault Counter 12-484: FinisherStorageBeltContactFailFC	no. of faults	RW	FinisherStorageBeltContactFailFC	NVMFaultCounter	shortNatural	No	Fault Counter:12-484-00: FinisherStorageBeltContactFailFC	1.521		
606-583	Fault Counter 12-485: FinisherBundleEjectMotorFailFC	no. of faults	RW	FinisherBundleEjectMotorFailFC	NVMFaultCounter	shortNatural	No	Fault Counter:12-485-00: FinisherBundleEjectMo	1.521		
606-604	Fault Counter 12-487: JamFinisherTransportAreaFC	no. of faults	RW	JamFinisherTransportAreaFC	NVMFaultCounter	shortNatural	No	Fault Counter:12-487-00: JamFinisherTransport	1.521		
606-605	Fault Counter 12-488: JamFinisherUpperOutputTrayFC	no. of faults	RW	JamFinisherUpperOutputTrayFC	NVMFaultCounter	shortNatural	No	Fault Counter:12-488-00: JamFinisherUpperOutp	1.521		
606-606	Fault Counter 12-489: JamFinisherStackerOutputTrayFC	no. of faults	RW	JamFinisherStackerOutputTrayFC	NVMFaultCounter	shortNatural	No	Fault Counter:12-489-00: JamFinisherStackerOu	1.521		
606-607	Fault Counter 12-491: StaplerJamFC	no. of faults	RW	StaplerJamFC	NVMFaultCounter	shortNatural	No	Fault Counter:12-491-00: StaplerJamFC	1.521		
606-629	IOTTOTALXCRUREPLACEMENTS_C This supports the AIF counter Color Drum Cartridge in Position R2		ND		NVMSystemUsageCounter	natural	No	System Usage Counter:342: Color Drum Cartridge in	1.799		
606-630	IOTTOTALXCRUREPLACEMENTS_M This supports the AIF counter Color Drum Cartridge in Position R3		ND		NVMSystemUsageCounter	natural	No	System Usage Counter:343: Color Drum Cartridge in	1.799		
606-631	IOTTOTALXCRUREPLACEMENTS_Y This supports the AIF counter Color Drum Cartridge in Position R4		ND		NVMSystemUsageCounter	natural	No	System Usage Counter:344: Color Drum Cartridge in	1.799		
606-787	Default is the version number of the Excel	Table Version used to	RW	FS23.201 Table Version	NVMConfiguration	natural	No		1.707		
606-787	Default is the version number of the Excel	Table Version used to	RW	FS23.201 Table Version	NVMConfiguration	natural	No		1.781		
606-787	Default is the version number of the Excel table used to create the NVM	Table Version used to create the NVM ie V1.234 = 1234	RW	FS23.201 Table Version	NVMConfiguration	natural	No		1.781		
606-787	Default is the version number of the Excel table used to create the NVM	Table Version used to create the NVM ie V1.234	RW	FS23.201 Table Version	NVMConfiguration	natural	No		1.781		

606-787	Default is the version number of the Excel table used to create the NVM	Table Version used to create the NVM ie V1.774 = 1774	RW	FS23.201 Table Version	NVMConfiguration	natural	No		1.800		
606-787	Default is the version number of the Excel table used to create the NVM	Table Version used to create the NVM ie V1.774 = 1774	RW	FS23.201 Table Version	NVMConfiguration	natural	No		1.800		
606-787	Default is the version number of the Excel table used to create the NVM	Table Version used to create the NVM ie V1.765 = 1765	RW	FS23.201 Table Version	NVMConfiguration	natural	No		1.816		
606-787	Default is the version number of the Excel table used to create the NVM	Table Version used to create the NVM ie V1.791 = 1791	RW	FS23.201 Table Version	NVMConfiguration	natural	No		1.807		
606-801	Fault Counter 12-444: Paper Pusher Switch Fault	no. of faults	RW	PapPusherSwitchFC	NVMFaultCounter	shortNatural	No	Fault Counter:12-444-00: Paper Pusher	1.521		
606-806	Default Staple position (HVF only)	1 = Staple head moves to	RW	Default Staple Position	NVMSAKOSetting	shortNatural	No		1.189		
606-820	Number of Grams of toner in a Standard size cartridge - Burgundy	Grams	RW	TonerGramsStd	NVMConfiguration	natural	No		1.526		
606-821	Number of Grams of toner in a High Capacity cartridge - Burgundy	Grams	RW	TonerGramsHiCap	NVMConfiguration	natural	No		1.526		
606-821	Number of Grams of toner in a High Capacity cartridge - Barolo	Grams	RW	TonerGramsHiCap	NVMConfiguration	natural	No		1.526		
606-834	B4 Sheets Used Total of B4 sheets since activation date	B4 Sheets Used Total of B4 sheets since	ND	B4 Sheets Used	NVMSystemUsageCounter	byteArray	No	System Usage Counter:???: B4	1.799		
606-838	Number of Grams of toner in a Standard size cartridge - Yellow	Grams	RW	TonerGramsStdYellow	NVMConfiguration	natural	No		1.572		
606-839	Number of Grams of toner in a Standard size cartridge - Magenta	Grams	RW	TonerGramsStdMagenta	NVMConfiguration	natural	No		1.572		
606-840	Number of Grams of toner in a Standard size cartridge - Cyan	Grams	RW	TonerGramsStdCyan	NVMConfiguration	natural	No		1.572		
606-842	Number of Grams of toner in a High Capacity cartridge - Yellow	Grams	RW	TonerGramsHiCapYellow	NVMConfiguration	natural	No		1.572		
606-843	Number of Grams of toner in a High Capacity cartridge - Magenta	Grams	RW	TonerGramsHiCapMagenta	NVMConfiguration	natural	No		1.572		

606-844	Number of Grams of toner in a High Capacity cartridge - Cyan	Grams	RW	TonerGramsHiCapCyan	NVMConfiguration	natural	No		1.572		
606-845	Number of Grams of toner in a High Capacity cartridge - Black	Grams	RW	TonerGramsHiCapBlack	NVMConfiguration	natural	No		1.572		
606-867	Tray 1 Envelopes: Width	Range and default size in mm	RW	Tray 1 Envelopes: Width	NVMSAKOSetting	natural	No		1.354		
606-868	Tray 1 Envelopes: Length	Range and default size in mm	RW	Tray 1 Envelopes: Length	NVMSAKOSetting	natural	No		1.354		

606-874	Fault Counter 12-259-00: EJECTHOMESENSORONFAILCTR	no. of faults	RW	EjectHomeSensorONFail	NVMFaultCounter	shortNatural	No	Fault Counter:12-259-00:EJECTHOMESENSORONFAILCTR	1.813		
606-875	Fault Counter 12-280-00: EJECTHOMESENSOROFFFAILCTR	no. of faults	RW	EjectHomeSensorOFFFail	NVMFaultCounter	shortNatural	No	Fault Counter:12-280-00:EJECTHOMESENSOROFFFAILCTR	1.813		
606-876	Fault Counter 12-917-00: STACKERTRAYSTAPLESETOVERCOUN	no. of faults	RW	StackerTrayStapleSetOverCount	NVMFaultCounter	shortNatural	No	Fault Counter:12-917-00:STACKERTRAYST	1.521		
606-877	Fault Counter 12-928-00:	no. of faults	RW	ScratchSheetCompile	NVMFaultCounter	shortNatural	No	Fault Counter:12-928-	1.521		
606-878	Fault Counter 12-976-00: STAPLENGCTR	no. of faults	RW	StapleNG	NVMFaultCounter	shortNatural	No	Fault Counter:12-976-00:STAPLENGCTR	1.813		
606-879	Fault Counter 12-977-00:	no. of faults	RW	StaplerFeedReadyFail	NVMFaultCounter	shortNatural	No	Fault Counter:12-977-	1.813		
606-880	Fault Counter 12-982-00:	no. of faults	RW	StackerLowerSafetyWarning	NVMFaultCounter	shortNatural	No	Fault Counter:12-982-	1.521		

606-881	Fault Counter 12-269-00: BOOKLETSSUBCPUCOMMFAILCTR	no. of faults	RW	BookletSubCPUCommFail	NVMFaultCounter	shortNatural	No	Fault Counter:12-269-00:BOOKLETSSUBCPU COMMFAILCTR	1.813		
606-882	Fault Counter 12-111-00: H_XPORTENTSNROFFJAMCTR	no. of faults	RW	H_XportEntSnrOFFJam	NVMFaultCounter	shortNatural	No	Fault Counter:12-111-00:H_XPORTENTSNR OFFJAMCTR	1.521		

606-883	Fault Counter 12-249-00: BOOKLETFRONTSTAPLERFAILCTR	no. of faults	RW	BookletFrontStaplerFail	NVMFaultCounter	shortNatural	No	Fault Counter:12-249-00:BOOKLETFRONTST	1.813		
606-884	Fault Counter 12-268-00: BOOKLETREARSTAPLERFAILCTR	no. of faults	RW	BookletRearStaplerFail	NVMFaultCounter	shortNatural	No	Fault Counter:12-268-00:BOOKLETREARST	1.813		
606-885	Fault Counter 12-212-00: BOOKLETSTAPLEMOVEPOSI_SNRONF	no. of faults	RW	BookletStapleMovePosi_SnrONFail	NVMFaultCounter	shortNatural	No	Fault Counter:12-212-00:BOOKLETSTAPLE	1.813		
606-886	Fault Counter 12-213-00:	no. of faults	RW	BookletStapleMovePosi_SnrOFFFail	NVMFaultCounter	shortNatural	No	Fault Counter:12-213-	1.813		
606-887	IBT Cleaner Install Date	System sets this upon new unit detection or confirmation	ND		NVMConfiguration	longNatural	No		1.751		
606-887	IBT Cleaner Install Date	System sets this upon	ND		NVMConfiguration	longNatural	No		1.751		
606-888	Second BTR Unit Install Date	System sets this upon	ND		NVMConfiguration	longNatural	No		1.751		
606-888	Second BTR Unit Install Date	System sets this upon new unit detection or confirmation	ND		NVMConfiguration	longNatural	No		1.751		
606-922	Number of Grams of toner in a Extra High Capacity cartridge - Burgundy	Grams	RW	TonerGramsExtraHiCap	NVMConfiguration	natural	No		1.526		
606-923	Number of Grams of toner in previous cartridge - Burgundy	Grams	RW	TonerGramsPrevious	NVMConfiguration	natural	No		1.526		
606-923	Number of Grams of toner in previous K	Grams	RW	TonerGramsPreviousK	NVMConfiguration	natural	No		1.572		
606-925	Number of Grams of toner in previous Y cartridge - Barolo Default is Starter cartridge Size	Grams	RW	TonerGramsPreviousY	NVMConfiguration	natural	No		1.572		
606-926	Number of Grams of toner in previous M	Grams	RW	TonerGramsPreviousM	NVMConfiguration	natural	No		1.572		

606-927	Number of Grams of toner in previous C	Grams	RW	TonerGramsPreviousC	NVMConfiguration	natural	No		1.572		
606-928	Fan Filter replacements	system increments counter	RO	FanFilterReplacements	NVMSystemUsageCounter	natural	No	System Usage Counter:???: FANFILTERREPLACEMENTS	1.799		
606-930	Counter-DualStapleFreeStapled		ND		NVMSystemUsageCounter	byteArray	No	System Usage Counter 10884: All dual Staple Free Staples	1.799		
606-931	Counter-StapleFreeStapledSheets		ND		NVMSystemUsageCounter	byteArray	No	System Usage Counter:10883: All	1.799		
606-932	Counter-All Uncollated StapleFreeStapled		ND		NVMSystemUsageCounter	byteArray	No	System Usage	1.799		
606-933	Counter-StapleFreeStapled2_15		ND		NVMSystemUsageCounter	byteArray	No	System Usage	1.799		
606-934	Total of 3xA4 Long Banner Sheet Used that is Larger than A3 Total of 3xA4 Long Banner Sheet Used since activation date	3xA4 Long Sheets Used that is Larger than A3 Total of Long 3xA4 sheets since activation date	ND	3xA4 Long Sheets	NVMSystemUsageCounter	byteArray	No		1.799		
606-935	Total of 4xA4 Long Banner Sheet Used	4xA4 Long Sheets Used	ND	4xA4 Long Sheets	NVMSystemUsageCounter	byteArray	No		1.799		
606-936	Total of 5xA4 Long Banner Sheet Used	5xA4 Long Sheets Used	ND	5xA4 Long Sheets	NVMSystemUsageCounter	byteArray	No		1.799		

606-937	Total of 6xA4 Long Banner Sheet Used that is Larger than A3 Total of 6xA4 Long Banner Sheet Used since activation date	6xA4 Long Sheets Used that is Larger than A3 Total of Long 6xA4 sheets since activation date	ND	6xA4 Long Sheets	NVMSystemUsageCounter	byteArray	No		1.799		
606-938	Total of Extra Long Black Banner Sheet made that is Larger than A3 Total of Extra Long Black Banner Sheet made since activation date	Black Banner Sheets Used that is Larger than A3 Total of Black Banner sheets since activation date	ND	Black Extra Long Sheets	NVMSystemUsageCounter	byteArray	No		1.799		

606-939	Total of Extra Long Color Banner Sheet Made that is Larger than A3 Total of Extra Long Color Banner Sheet Made since activation date	Color Banner Sheets Used that is Larger than A3 Total of Color Banner sheets since activation	ND	Color Extra Long Sheets	NVMSystemUsageCounter	byteArray	No		1.799		
606-940	Fault Counter 12-128: H-tra ExtSnrOnJamFaultCountFC	no.of times fault occurred	RW	H-tra ExtSnrOnJamFaultCountFC	NVMFaultCounter	shortNatural	No	Fault Counter:12-128-00:	1.813		
606-941	Fault Counter 12-129: H-tra ExtSnrOnJamFaultCountFC	no.of times fault occurred	RW	S-tra ExtSnrOnJamFaultCountFC	NVMFaultCounter	shortNatural	No	Fault Counter:12-129-00: H-tra	1.813		
606-942	Fault Counter 12-110: H-tra	no.of times fault occurred	RW	V-tra ExtSnrOnJamFaultCountFC	NVMFaultCounter	shortNatural	No	Fault Counter:12-110-	1.813		
606-943	Fault Counter 12-355-00: STAPLELESSSUBCPUDOWNLOADMODEFAILFAULTCOUNT	no.of times fault occurred	RW	STAPLELESSCPUDOWNLOADMOD	NVMFaultCounter	shortNatural	No	Fault Counter:12-355-00: STAPLELESSSUBCPUDOWNLOADMODEFAILFAULTCOUNT	1.813		
606-944	Fault Counter 12-333-00:	no.of times fault occurred	RW	PUNCHCPUDOWNLOADMODEFAI	NVMFaultCounter	shortNatural	No	Fault Counter:12-333-	1.813		
606-945	Fault Counter 12-250-00:	no.of times fault occurred	RW	PUNCHSUBCPUCOMMFAILFAULT	NVMFaultCounter	shortNatural	No	Fault Counter:12-250-	1.813		
606-946	Fault Counter 12-991-00: STAPLELESSSUBCPUCOMMUNICATIONFAILFAULTCOUNT	no.of times fault occurred	RW	STAPLELESSSUBCPUCOMMFAILFAULTCNT	NVMFaultCounter	shortNatural	No	Fault Counter:12-991-00: STAPLELESSSUBCPUCOMMUNICATIONFAILFAULT	1.813		

606-947	Fault Counter 12-990-00: HNSTAPLEFAILFAULTCOUNT	no.of times fault occurred	RW	HNSTAPLEFAILFAULTCOUNT	NVMFaultCounter	shortNatural	No	Fault Counter:12-990-00: HNSTAPLEFAILFAULT	1.813		
606-948	Fault Counter 13-210-00: BOOKLETSTAPLEMOVEPOSITIONSNRONFAILFAULTCOUNT	no.of times fault occurred	RW	BOOKLETSTAPLEMOVEPOSSNRO NFAILFC	NVMFaultCounter	shortNatural	No	Fault Counter:13-210-00: BOOKLETSTAPLEMOVEPOSITIONSNRONFAILFAULT	1.813		
606-949	Fault Counter 13-211-00: BOOKLETSTAPLEMOVEPOSITIONSNROFFFAILFAULTCOUNT	no.of times fault occurred	RW	BOOKLETSTAPLEMOVEPOSSNRO FFFAILFC	NVMFaultCounter	shortNatural	No	Fault Counter:13-210-00: BOOKLETSTAPLEMOVEPOSITIONSNROFFFAILFAULT	1.813		
606-950	Fault Counter 12-992-00: HN Stacker Stapler Move Position SNR ON Fail	no.of times fault occurred	RW	HNSTACKERSTAPLEMOVEPOSSNRONFC	NVMFaultCounter	shortNatural	No	Fault Counter:12-992-00: HNSTACKERSTAPLEMOVEPOSSNRONFAULT	1.813		
606-951	Fault Counter 12-993-00: Stacker Stapler Move Position SNR OFF Fail	no.of times fault occurred	RW	STACKERSTAPLEMOVEPOSSNRO FFFC	NVMFaultCounter	shortNatural	No	Fault Counter:12-993-00: STACKERSTAPLEMOVEPOSSNROFFFAULT	1.813		

606-952	No. of Print calibration attempts		RW	Print Calibration attempts	NVMSystemUsageCounter	natural	No		1.808		
606-953	No. of Copy calibration attempts		RW	Copy Calibration attempts	NVMSystemUsageCounter	natural	No		1.808		

606-954	Toner Darkness Control for Alexandra Mono Engines	1 (Lightest) to 10 (Darkest) Default = 8	RW	TonerDarknessCtrl	NVMSAKOSetting	shortNatural	No		1.797		
606-959	Bias Transfer Roller (BTR) Life Counter	Feeds - counted by system	RW	BTRLifeCount	NVMHFSICounter	longNatural	No		1.813		
606-960	Bias Transfer Roller (BTR) Life Expectancy	Modifiable via DC131	RW	BTRExpLife	NVMConfiguration	longNatural	No		1.805		
608-411	Fault Counter 12-370-00: Stapler End Home Failure	no. of faults	RW	Stapler End Home Failure	NVMFaultCounter	shortNatural	No	Fault Counter:12-370-00: Stapler End Home	1.521		
608-412	Fault Counter 12-369-00: Stapler Return End Home Failure	no. of faults	RW	Stapler Return End Home Failure	NVMFaultCounter	shortNatural	No	Fault Counter:12-369-00: Stapler Return End Home Failure	1.521		
608-413	Fault Counter 12-368-00: Punch Unit paper side edge 2 detecting failure	no. of faults	RW	Punch - side edge2 detect fail	NVMFaultCounter	shortNatural	No	Fault Counter:12-368-00: Punch Unit paper side edge 2 detecting failure	1.521		
608-414	Fault Counter 12-367-00: Punch Unit paper side edge 3 detecting failure	no. of faults	RW	Punch - side edge3 detect fail	NVMFaultCounter	shortNatural	No	Fault Counter:12-367-00: Punch Unit paper side edge 3 detecting failure	1.521		
608-565	Fault Counter 45-321-00:MK_Panel_NG	no. of faults	RW	MK_Panel_NG	NVMFaultCounter	shortNatural	No	Fault Counter:45-321-	1.254		
608-566	Fault Counter 45-322-00:MK_Pitch_NG	no. of faults	RW	MK_Pitch_NG	NVMFaultCounter	shortNatural	No	Fault Counter:45-322-	1.254		
608-567	Fault Counter 45-331-00:MK_MKIF_MSG_Reject	no. of faults	RW	MK_MKIF_MSG_Reject	NVMFaultCounter	shortNatural	No	Fault Counter:45-331-00:MK_MKIF_MSG_Reject	1.254		
608-568	Fault Counter 45-332-00:MK_MMIF_MSG_Reject	no. of faults	RW	MK_MMIF_MSG_Reject	NVMFaultCounter	shortNatural	No	Fault Counter:45-332-00:	1.254		
608-569	Fault Counter 45-350-00:MK_Emergency_Over_Wait	no. of faults	RW	MK_Emergency_Over_Wait	NVMFaultCounter	shortNatural	No	Fault Counter:45-350-00:	1.254		
608-570	Fault Counter 45-351-00:MK_Emergency_No_Timer	no. of faults	RW	MK_Emergency_No_Timer	NVMFaultCounter	shortNatural	No	Fault Counter:45-351-00:	1.254		
608-571	Fault Counter 45-352-00:MK_Emergency_Enforced_Stop	no. of faults	RW	MK_Emergency_Enforced_Stop	NVMFaultCounter	shortNatural	No	Fault Counter:45-352-00:	1.254		
608-572	Fault Counter 45-313-00:ENG_LOGIC_FAIL	no. of faults	RW	ENG_LOGIC_FAIL	NVMFaultCounter	shortNatural	No	Fault Counter:45-313-00:ENG_LOGIC_FAIL	1.254		
608-573	Fault Counter 72-108-00:Feed Out	no. of faults	RW	Feed Out Sensor2 On Jam_Tray3/4	NVMFaultCounter	shortNatural	No	Fault Counter:72-108-	1.254		
608-574	Fault Counter 72-109-00:Regi Sensor On	no. of faults	RW	Regi Sensor On Jam_Tray1-4	NVMFaultCounter	shortNatural	No	Fault Counter:72-109-	1.254		
608-575	Fault Counter 77-200-00:POB Sensor On	no. of faults	RW	POB Sensor On Jam	NVMFaultCounter	shortNatural	No	Fault Counter:77-200-	1.813		
608-576	Fault Counter 77-101-00:Regi Sensor Off Jam	no. of faults	RW	Regi Sensor Off Jam	NVMFaultCounter	shortNatural	No	Fault Counter:77-201-00: Regi Sensor Off Jam	1.813		
608-577	Fault Counter 77-202-00:Exit Sensor1 On	no. of faults	RW	Exit Sensor1 On Jam	NVMFaultCounter	shortNatural	No	Fault Counter:77-202-	1.254		
608-578	Fault Counter 77-203-00:Exit Sensor2 On	no. of faults	RW	Exit Sensor2 On Jam	NVMFaultCounter	shortNatural	No	Fault Counter:77-203-	1.254		

608-579	Fault Counter 77-204-00:Exit Sensor1 Off	no. of faults	RW	Exit Sensor1 Off Jam_Long	NVMFaultCounter	shortNatural	No	Fault Counter:77-204-	1.254		
608-580	Fault Counter 77-104-00:Exit Sensor1 Off	no. of faults	RW	Exit Sensor1 Off Jam_Short	NVMFaultCounter	shortNatural	No	Fault Counter:77-104-	1.813		
608-581	Fault Counter 77-105-00:Exit Sensor2 Off	no. of faults	RW	Exit Sensor2 Off Jam	NVMFaultCounter	shortNatural	No	Fault Counter:77-105-	1.813		
608-582	Fault Counter 77-131-00:Duplex Path	no. of faults	RW	Duplex Path Sensor On Jam	NVMFaultCounter	shortNatural	No	Fault Counter:77-131-	1.813		
608-583	Fault Counter 77-900-00:IOT Static Jam	no. of faults	RW	IOT Static Jam_Regi Sensor	NVMFaultCounter	shortNatural	No	Fault Counter:77-900-	1.813		
608-584	Fault Counter 77-903-00:IOT Static Jam	no. of faults	RW	IOT Static Jam_POB Sensor	NVMFaultCounter	shortNatural	No	Fault Counter:77-903-	1.813		
608-585	Fault Counter 77-901-00:IOT Static Jam	no. of faults	RW	IOT Static Jam_Exit Sensor1	NVMFaultCounter	shortNatural	No	Fault Counter:77-901-	1.813		
608-586	Fault Counter 77-902-00:IOT Static Jam (@Exit Sensor2)	no. of faults	RW	IOT Static Jam_Exit Sensor2	NVMFaultCounter	shortNatural	No	Fault Counter:77-902-00: IOT Static Jam (@Exit Sensor2)	1.813		
608-587	Fault Counter 77-907-00:IOT Static Jam (@Duplex Path Sensor)	no. of faults	RW	IOT StaticJam Duplex Path Sensor	NVMFaultCounter	shortNatural	No	Fault Counter:77-907-00: IOT Static Jam (@Duplex Path Sensor)	1.813		
608-588	Fault Counter 78-214-00:TTM #2 3 Lift Up Fail	no. of faults	RW	TTM #2 3 Lift Up Fail	NVMFaultCounter	shortNatural	No	Fault Counter:78-214-00: TTM #2 3 Lift Up Fail	1.254		
608-589	Fault Counter 78-211-00:TTM #3 4 Lift Up Fail	no. of faults	RW	TTM #3 4 Lift Up Fail	NVMFaultCounter	shortNatural	No	Fault Counter:78-211-00: TTM #3 4 Lift Up Fail	1.254		
608-590	Fault Counter 71-940-00:#1 Lift Up NG	no. of faults	RW	#1 Lift Up NG	NVMFaultCounter	shortNatural	No	Fault Counter:71-940-00: #1 Lift Up NG	1.254		
608-591	Fault Counter 72-940-00:#2 Lift Up NG	no. of faults	RW	#2 Lift Up NG	NVMFaultCounter	shortNatural	No	Fault Counter:72-940-00: #2 Lift Up NG	1.254		
608-592	Fault Counter 73-940-00:#3 Lift Up NG	no. of faults	RW	#3 Lift Up NG	NVMFaultCounter	shortNatural	No	Fault Counter:73-940-00: #3 Lift Up NG	1.254		
608-593	Fault Counter 74-940-00:#4 Lift Up NG	no. of faults	RW	#4 Lift Up NG	NVMFaultCounter	shortNatural	No	Fault Counter:74-940-00: #4 Lift Up NG	1.254		
608-594	Fault Counter 78-945-00:TTM #2 3 Lift Up NG	no. of faults	RW	TTM #2 3 Lift Up NG	NVMFaultCounter	shortNatural	No	Fault Counter:78-945-00: TTM #2 3 Lift Up NG	1.254		
608-595	Fault Counter 78-946-00:TTM #3 4 Lift Up NG	no. of faults	RW	TTM #3 4 Lift Up NG	NVMFaultCounter	shortNatural	No	Fault Counter:78-946-00: TTM #3 4 Lift Up NG	1.254		
608-596	Fault Counter 47-211-00:Exit1 OCT Home Fail	no. of faults	RW	Exit1 OCT Home Fail	NVMFaultCounter	shortNatural	No	Fault Counter:47-211-00: Exit1 OCT Home Fail	1.813		

608-597	Fault Counter 47-212-00:Exit2 OCT Home Fail	no. of faults	RW	Exit2 OCT Home Fail	NVMFaultCounter	shortNatural	No	Fault Counter:47-212-00: Exit2 OCT Home Fail	1.813		
608-598	Fault Counter 71-212-00:TRAY1 Sensor Fail	no. of faults	RW	TRAY1 Sensor Fail	NVMFaultCounter	shortNatural	No	Fault Counter:71-212-00: TRAY1 Sensor Fail	1.813		
608-599	Fault Counter 72-212-00:TRAY2 Sensor Fail	no. of faults	RW	TRAY2 Sensor Fail	NVMFaultCounter	shortNatural	No	Fault Counter:72-212-00: TRAY2 Sensor Fail	1.813		
608-600	Fault Counter 73-212-00:TRAY3 Sensor Fail	no. of faults	RW	TRAY3 Sensor Fail	NVMFaultCounter	shortNatural	No	Fault Counter:73-212-00: TRAY3 Sensor Fail	1.813		
608-601	Fault Counter 74-212-00:TRAY4 Sensor Fail	no. of faults	RW	TRAY4 Sensor Fail	NVMFaultCounter	shortNatural	No	Fault Counter:74-212-00: TRAY4 Sensor Fail	1.813		
608-602	Fault Counter 77-214-00:P/H Module Logic Fail	no. of faults	RW	P/H Module Logic Fail	NVMFaultCounter	shortNatural	No	Fault Counter:77-214-00: P/H Module Logic Fail	1.813		
608-603	Fault Counter 77-215-00:Tray Module Comm Fail	no. of faults	RW	Tray Module Comm Fail	NVMFaultCounter	shortNatural	No	Fault Counter:77-215-00: Tray Module Comm Fail	1.813		
608-604	Fault Counter 77-602-00:OHP Sensor Fail	no. of faults	RW	OHP Sensor Fail	NVMFaultCounter	shortNatural	No	Fault Counter:77-602-00: OHP Sensor Fail	1.813		
608-605	Fault Counter 77-212-00:Tray Module Reset Fail	no. of faults	RW	Tray Module Reset Fail	NVMFaultCounter	shortNatural	No	Fault Counter:77-212-00: Tray Module Reset	1.813		
608-606	Fault Counter 77-214-00:Tray Module Logic Fail	no. of faults	RW	Tray Module Logic Fail	NVMFaultCounter	shortNatural	No	Fault Counter:77-214-00: Tray Module Logic Fail	1.813		
608-607	Fault Counter 77-211-00:Tray Module Kind Mismatch	no. of faults	RW	Tray Module Kind Mismatch	NVMFaultCounter	shortNatural	No	Fault Counter:77-211-00: Tray Module Kind Mismatch	1.813		
608-608	Fault Counter 78-216-00:HCF Logic Fail	no. of faults	RW	HCF Logic Fail	NVMFaultCounter	shortNatural	No	Fault Counter:78-216-00: HCF Logic Fail	1.813		
608-609	Fault Counter 77-320-00:ALL Feed Tray Broken	no. of faults	RW	ALL Feed Tray Broken	NVMFaultCounter	shortNatural	No	Fault Counter:77-320-00: ALL Feed Tray Broken	1.813		
608-610	Fault Counter 47-320-00:ALL Destination Tray Broken	no. of faults	RW	ALL Destination Tray Broken	NVMFaultCounter	shortNatural	No	Fault Counter:47-320-00: ALL Destination Tray Broken	1.813		

608-611	Fault Counter 94-300-00:IBT Front Cover	no. of faults	RW	IBT Front Cover	NVMFaultCounter	shortNatural	No	Fault Counter:94-300-00: IBT Front Cover	1.254		
608-612	Fault Counter 78-219-00:HCF PF2 Soft Download Fail	no. of faults	RW	HCF PF2 Soft Download Fail	NVMFaultCounter	shortNatural	No	Fault Counter:78-219-00: HCF PF2 Soft Download Fail	1.813		
608-613	Fault Counter 78-213-00:Finisher Kind Mismatch	no. of faults	RW	Finisher Kind Mismatch	NVMFaultCounter	shortNatural	No	Fault Counter:78-213-00: Finisher Kind Mismatch	1.813		
608-614	Fault Counter 75-103-00:MSI Feed Out Sensor Off Jam	no. of faults	RW	MSI Feed Out Sensor Off Jam	NVMFaultCounter	shortNatural	No	Fault Counter:75-103-00: MSI Feed Out Sensor Off Jam	1.813		
608-615	Fault Counter 94-400-00:1st BTR Contact/Retract Fail	no. of faults	RW	1st BTR Contact/Retract Fail	NVMFaultCounter	shortNatural	No	Fault Counter:94-400-00: 1st BTR Contact/Retract Fail	1.813		
608-616	Fault Counter 94-401-00:2nd BTR Contact/Retract Fail	no. of faults	RW	2nd BTR Contact/Retract Fail	NVMFaultCounter	shortNatural	No	Fault Counter:94-401-00: 2nd BTR Contact/Retract Fail	1.254		
608-617	Fault Counter 94-417-00:IBT Unit Near End Warning	no. of faults	RW	IBT Unit Near End Warning	NVMFaultCounter	shortNatural	No	Fault Counter:94-417-00: IBT Unit Near End Warning	1.254		
608-618	Fault Counter 94-418-00:IBT CLN Unit Near End Warning	no. of faults	RW	IBT CLN Unit Near End Warning	NVMFaultCounter	shortNatural	No	Fault Counter:94-418-00: IBT CLN Unit Near End Warning	1.254		
608-619	Fault Counter 94-419-00:2nd BTR Unit Near End Warning	no. of faults	RW	2nd BTR Unit Near End Warning	NVMFaultCounter	shortNatural	No	Fault Counter:94-419-00: 2nd BTR Unit Near End Warning	1.254		
608-620	Fault Counter 94-420-00:IBT Unit End Warning	no. of faults	RW	IBT Unit End Warning	NVMFaultCounter	shortNatural	No	Fault Counter:94-420-00: IBT Unit End Warning	1.254		
608-621	Fault Counter 94-421-00:IBT CLN Unit End Warning	no. of faults	RW	IBT CLN Unit End Warning	NVMFaultCounter	shortNatural	No	Fault Counter:94-421-00: IBT CLN Unit End Warning	1.254		
608-622	Fault Counter 94-422-00:2nd BTR Unit End Warning	no. of faults	RW	2nd BTR Unit End Warning	NVMFaultCounter	shortNatural	No	Fault Counter:94-422-00: 2nd BTR Unit End Warning	1.254		
608-623	Fault Counter 91-310-00:Auger Broken	no. of faults	RW	Auger Broken	NVMFaultCounter	shortNatural	No	Fault Counter:91-310-00: Auger Broken	1.254		
608-624	Fault Counter 10-371-00:Heat Belt STS Center Disconnection Fail	no. of faults	RW	HeatBelt STSCenterDisconnectFail	NVMFaultCounter	shortNatural	No	Fault Counter:10-371-00: Heat Belt STS Center Disconnection Fail	1.813		

608-625	Fault Counter 10-372-00:Heat Belt STS Center Over Temperature Fail	no. of faults	RW	HeatBelt STSCenterOverTempFail	NVMFaultCounter	shortNatural	No	Fault Counter:10-372-00: Heat Belt STS Center Over Temperature Fail	1.813		
608-626	Fault Counter 10-375-00:Heat Belt STS Center Warm Up Time Fail	no. of faults	RW	HeatBeltSTSCenterWarmUpTimeFail	NVMFaultCounter	shortNatural	No	Fault Counter:10-375-00: Heat Belt STS Center Warm Up Time Fail	1.813		
608-627	Fault Counter 10-376-00:Heat Belt STS Rear Warm Up Time Fail	no. of faults	RW	HeatBeltSTSRearWarmUpTimeFail	NVMFaultCounter	shortNatural	No	Fault Counter:10-376-00: Heat Belt STS Rear Warm Up Time Fail	1.813		
608-628	Fault Counter 10-378-00:Heat Belt Rotation Fail	no. of faults	RW	Heat Belt Rotation Fail	NVMFaultCounter	shortNatural	No	Fault Counter:10-378-00: Heat Belt Rotation Fail	1.813		
608-629	Fault Counter 10-380-00:P/Roll Latch Motor Fail	no. of faults	RW	P/Roll Latch Motor Fail	NVMFaultCounter	shortNatural	No	Fault Counter:10-380-00: P/Roll Latch Motor Fail	1.813		
608-630	Fault Counter 10-381-00:Fuser Assy Illegal Fail	no. of faults	RW	Fuser Assy Illegal Fail	NVMFaultCounter	shortNatural	No	Fault Counter:10-381-00: Fuser Assy Illegal Fail	1.813		
608-631	Fault Counter 10-382-00:Fuser Thermostat Fail	no. of faults	RW	Fuser Thermostat Fail	NVMFaultCounter	shortNatural	No	Fault Counter:10-382-00: Fuser Thermostat Fail	1.813		
608-632	Fault Counter 61-350-00:LPH Power On Fail Y	no. of faults	RW	LPH Power On Fail Y	NVMFaultCounter	shortNatural	No	Fault Counter:61-350-00: LPH Power On Fail Y	1.813		
608-633	Fault Counter 61-351-00:LPH Power On Fail M	no. of faults	RW	LPH Power On Fail M	NVMFaultCounter	shortNatural	No	Fault Counter:61-351-00: LPH Power On Fail M	1.813		
608-634	Fault Counter 61-352-00:LPH Power On Fail C	no. of faults	RW	LPH Power On Fail C	NVMFaultCounter	shortNatural	No	Fault Counter:61-352-00: LPH Power On Fail C	1.813		
608-635	Fault Counter 61-353-00:LPH Power On Fail K	no. of faults	RW	LPH Power On Fail K	NVMFaultCounter	shortNatural	No	Fault Counter:61-353-00: LPH Power On Fail K	1.813		
608-636	Fault Counter 45-370-00:LPH Power On Fail Multi	no. of faults	RW	LPH Power On Fail Multi	NVMFaultCounter	shortNatural	No	Fault Counter:45-370-00: LPH Power On Fail Multi	1.813		

608-637	Fault Counter 61-354-00:LPH Download Data Fail Y	no. of faults	RW	LPH Download Data Fail Y	NVMFaultCounter	shortNatural	No	Fault Counter:61-354-00: LPH Download Data Fail Y	1.813		
608-638	Fault Counter 61-355-00:LPH Download Data Fail M	no. of faults	RW	LPH Download Data Fail M	NVMFaultCounter	shortNatural	No	Fault Counter:61-355-00: LPH Download Data Fail M	1.813		
608-639	Fault Counter 61-356-00:LPH Download Data Fail C	no. of faults	RW	LPH Download Data Fail C	NVMFaultCounter	shortNatural	No	Fault Counter:61-356-00: LPH Download Data Fail C	1.813		
608-640	Fault Counter 61-357-00:LPH Download Data Fail K	no. of faults	RW	LPH Download Data Fail K	NVMFaultCounter	shortNatural	No	Fault Counter:61-357-00: LPH Download Data Fail K	1.813		
608-641	Fault Counter 45-371-00:LPH Download Data Fail Multi	no. of faults	RW	LPH Download Data Fail Multi	NVMFaultCounter	shortNatural	No	Fault Counter:45-371-00: LPH Download Data Fail Multi	1.813		
608-642	Fault Counter 61-358-00:LPH Mismatch Fail Y	no. of faults	RW	LPH Mismatch Fail Y	NVMFaultCounter	shortNatural	No	Fault Counter:61-358-00: LPH Mismatch Fail Y	1.813		
608-643	Fault Counter 61-359-00:LPH Mismatch Fail M	no. of faults	RW	LPH Mismatch Fail M	NVMFaultCounter	shortNatural	No	Fault Counter:61-359-00: LPH Mismatch Fail M	1.813		
608-644	Fault Counter 61-360-00:LPH Mismatch Fail C	no. of faults	RW	LPH Mismatch Fail C	NVMFaultCounter	shortNatural	No	Fault Counter:61-360-00: LPH Mismatch Fail C	1.813		
608-645	Fault Counter 61-361-00:LPH Mismatch Fail K	no. of faults	RW	LPH Mismatch Fail K	NVMFaultCounter	shortNatural	No	Fault Counter:61-361-00: LPH Mismatch Fail K	1.813		
608-646	Fault Counter 45-372-00:LPH Mismatch Fail Multi	no. of faults	RW	LPH Mismatch Fail Multi	NVMFaultCounter	shortNatural	No	Fault Counter:45-372-00: LPH Mismatch Fail Multi	1.813		
608-647	Fault Counter 61-362-00:LPH Read Fail Y	no. of faults	RW	LPH Read Fail Y	NVMFaultCounter	shortNatural	No	Fault Counter:61-362-00: LPH Read Fail Y	1.813		
608-648	Fault Counter 61-363-00:LPH Read Fail M	no. of faults	RW	LPH Read Fail M	NVMFaultCounter	shortNatural	No	Fault Counter:61-363-00: LPH Read Fail M	1.813		

608-649	Fault Counter 61-364-00:LPH Read Fail C	no. of faults	RW	LPH Read Fail C	NVMFaultCounter	shortNatural	No	Fault Counter:61-364-00: LPH Read Fail C	1.813		
608-650	Fault Counter 61-365-00:LPH Read Fail K	no. of faults	RW	LPH Read Fail K	NVMFaultCounter	shortNatural	No	Fault Counter:61-365-00: LPH Read Fail K	1.813		
608-651	Fault Counter 45-373-00:LPH Read Fail Multi	no. of faults	RW	LPH Read Fail Multi	NVMFaultCounter	shortNatural	No	Fault Counter:45-373-00: LPH Read Fail Multi	1.813		
608-652	Fault Counter 61-366-00:LPH Write Fail Y	no. of faults	RW	LPH Write Fail Y	NVMFaultCounter	shortNatural	No	Fault Counter:61-366-00: LPH Write Fail Y	1.813		
608-653	Fault Counter 61-367-00:LPH Write Fail M	no. of faults	RW	LPH Write Fail M	NVMFaultCounter	shortNatural	No	Fault Counter:61-367-00: LPH Write Fail M	1.813		
608-654	Fault Counter 61-368-00:LPH Write Fail C	no. of faults	RW	LPH Write Fail C	NVMFaultCounter	shortNatural	No	Fault Counter:61-368-00: LPH Write Fail C	1.813		
608-655	Fault Counter 61-369-00:LPH Write Fail K	no. of faults	RW	LPH Write Fail K	NVMFaultCounter	shortNatural	No	Fault Counter:61-369-00: LPH Write Fail K	1.813		
608-656	Fault Counter 45-374-00:LPH Write Fail Multi	no. of faults	RW	LPH Write Fail Multi	NVMFaultCounter	shortNatural	No	Fault Counter:45-374-00: LPH Write Fail Multi	1.813		
608-657	Fault Counter 61-370-00:LPH Act Fail Y	no. of faults	RW	LPH Act Fail Y	NVMFaultCounter	shortNatural	No	Fault Counter:61-370-00: LPH Act Fail Y	1.813		
608-658	Fault Counter 61-371-00:LPH Act Fail M	no. of faults	RW	LPH Act Fail M	NVMFaultCounter	shortNatural	No	Fault Counter:61-371-00: LPH Act Fail M	1.813		
608-659	Fault Counter 61-372-00:LPH Act Fail C	no. of faults	RW	LPH Act Fail C	NVMFaultCounter	shortNatural	No	Fault Counter:61-372-00: LPH Act Fail C	1.813		
608-660	Fault Counter 61-373-00:LPH Act Fail K	no. of faults	RW	LPH Act Fail K	NVMFaultCounter	shortNatural	No	Fault Counter:61-373-00: LPH Act Fail K	1.813		
608-661	Fault Counter 45-375-00:LPH Act Fail Multi	no. of faults	RW	LPH Act Fail Multi	NVMFaultCounter	shortNatural	No	Fault Counter:45-375-00: LPH Act Fail Multi	1.813		
608-662	Fault Counter 61-374-00:LPH Chip Fail Y	no. of faults	RW	LPH Chip Fail Y	NVMFaultCounter	shortNatural	No	Fault Counter:61-374-00: LPH Chip Fail Y	1.813		

608-663	Fault Counter 61-375-00:LPH Chip Fail M	no. of faults	RW	LPH Chip Fail M	NVMFaultCounter	shortNatural	No	Fault Counter:61-375-00: LPH Chip Fail M	1.813		
608-664	Fault Counter 61-376-00:LPH Chip Fail C	no. of faults	RW	LPH Chip Fail C	NVMFaultCounter	shortNatural	No	Fault Counter:61-376-00: LPH Chip Fail C	1.813		
608-665	Fault Counter 61-377-00:LPH Chip Fail K	no. of faults	RW	LPH Chip Fail K	NVMFaultCounter	shortNatural	No	Fault Counter:61-377-00: LPH Chip Fail K	1.813		
608-666	Fault Counter 61-378-00:LPH Ltrg Fail Y	no. of faults	RW	LPH Ltrg Fail Y	NVMFaultCounter	shortNatural	No	Fault Counter:61-378-00: LPH Ltrg Fail Y	1.813		
608-667	Fault Counter 61-379-00:LPH Ltrg Fail M	no. of faults	RW	LPH Ltrg Fail M	NVMFaultCounter	shortNatural	No	Fault Counter:61-379-00: LPH Ltrg Fail M	1.813		
608-668	Fault Counter 61-384-00:LPH Ltrg Fail C	no. of faults	RW	LPH Ltrg Fail C	NVMFaultCounter	shortNatural	No	Fault Counter:61-384-00: LPH Ltrg Fail C	1.813		
608-669	Fault Counter 61-385-00:LPH Ltrg Fail K	no. of faults	RW	LPH Ltrg Fail K	NVMFaultCounter	shortNatural	No	Fault Counter:61-385-00: LPH Ltrg Fail K	1.813		
608-670	Fault Counter 61-386-00:LPH PLL Lock Fail Y	no. of faults	RW	LPH PLL Lock Fail Y	NVMFaultCounter	shortNatural	No	Fault Counter:61-386-00: LPH PLL Lock Fail Y	1.813		
608-671	Fault Counter 61-387-00:LPH PLL Lock Fail M	no. of faults	RW	LPH PLL Lock Fail M	NVMFaultCounter	shortNatural	No	Fault Counter:61-387-00: LPH PLL Lock Fail M	1.813		
608-672	Fault Counter 61-388-00:LPH PLL Lock Fail C	no. of faults	RW	LPH PLL Lock Fail C	NVMFaultCounter	shortNatural	No	Fault Counter:61-388-00: LPH PLL Lock Fail C	1.813		
608-673	Fault Counter 61-389-00:LPH PLL Lock Fail K	no. of faults	RW	LPH PLL Lock Fail K	NVMFaultCounter	shortNatural	No	Fault Counter:61-389-00: LPH PLL Lock Fail K	1.813		
608-674	Fault Counter 45-376-00:LPH PLL Lock Fail Multi	no. of faults	RW	LPH PLL Lock Fail Multi	NVMFaultCounter	shortNatural	No	Fault Counter:45-376-00: LPH PLL Lock Fail Multi	1.813		
608-675	Fault Counter 61-390-00:LPH FFC Connect Posi Fail Y	no. of faults	RW	LPH FFC Connect Posi Fail Y	NVMFaultCounter	shortNatural	No	Fault Counter:61-390-00: LPH FFC Connect Posi Fail Y	1.813		
608-676	Fault Counter 61-391-00:LPH FFC Connect Posi Fail M	no. of faults	RW	LPH FFC Connect Posi Fail M	NVMFaultCounter	shortNatural	No	Fault Counter:61-391-00: LPH FFC Connect Posi Fail M	1.813		
608-677	Fault Counter 61-392-00:LPH FFC Connect Posi Fail C	no. of faults	RW	LPH FFC Connect Posi Fail C	NVMFaultCounter	shortNatural	No	Fault Counter:61-392-00: LPH FFC Connect Posi Fail C	1.813		
608-678	Fault Counter 61-393-00:LPH FFC Connect Posi Fail K	no. of faults	RW	LPH FFC Connect Posi Fail K	NVMFaultCounter	shortNatural	No	Fault Counter:61-393-00: LPH FFC Connect Posi Fail K	1.813		
608-679	Fault Counter 61-394-00:LPH FFC Connect Nega Fail Y	no. of faults	RW	LPH FFC Connect Nega Fail Y	NVMFaultCounter	shortNatural	No	Fault Counter:61-394-00: LPH FFC Connect Nega Fail Y	1.813		
608-680	Fault Counter 61-395-00:LPH FFC Connect Nega Fail M	no. of faults	RW	LPH FFC Connect Nega Fail M	NVMFaultCounter	shortNatural	No	Fault Counter:61-395-00: LPH FFC Connect Nega Fail M	1.813		
608-681	Fault Counter 61-396-00:LPH FFC Connect Nega Fail C	no. of faults	RW	LPH FFC Connect Nega Fail C	NVMFaultCounter	shortNatural	No	Fault Counter:61-396-00: LPH FFC Connect Nega Fail C	1.813		

608-682	Fault Counter 61-397-00:LPH FFC Connect Nega Fail K	no. of faults	RW	LPH FFC Connect Nega Fail K	NVMFaultCounter	shortNatural	No	Fault Counter:61-397-00: LPH FFC Connect Nega Fail K	1.813		
608-683	Fault Counter 61-398-00:BITZ1 Initialize Fail	no. of faults	RW	BITZ1 Initialize Fail	NVMFaultCounter	shortNatural	No	Fault Counter:61-398-00: BITZ1 Initialize Fail	1.813		
608-684	Fault Counter 61-399-00:BITZ2 Initialize Fail	no. of faults	RW	BITZ2 Initialize Fail	NVMFaultCounter	shortNatural	No	Fault Counter:61-399-00: BITZ2 Initialize Fail	1.813		
608-685	Fault Counter 61-610-00:Bitz1 CONTIF Fail	no. of faults	RW	Bitz1 CONTIF Fail	NVMFaultCounter	shortNatural	No	Fault Counter:61-610-00: Bitz1 CONTIF Fail	1.813		
608-686	Fault Counter 61-611-00:Bitz2 CONTIF Fail	no. of faults	RW	Bitz2 CONTIF Fail	NVMFaultCounter	shortNatural	No	Fault Counter:61-611-00: Bitz2 CONTIF Fail	1.813		
608-687	Fault Counter 10-360-00:IH Driver Input High Voltage Fail	no. of faults	RW	IH Driver Input HighVoltage Fail	NVMFaultCounter	shortNatural	No	Fault Counter:10-360-00: IH Driver Input High Voltage Fail	1.813		
608-688	Fault Counter 10-361-00:IH Driver Input Low Voltage Fail	no. of faults	RW	IH Driver Input LowVoltage Fail	NVMFaultCounter	shortNatural	No	Fault Counter:10-361-00: IH Driver Input Low Voltage Fail	1.813		

608-689	Fault Counter 10-362-00:IH Driver Surge Fail	no. of faults	RW	IH Driver Surge Fail	NVMFaultCounter	shortNatural	No	Fault Counter:10-362-00: IH Driver Surge Fail	1.813		
608-690	Fault Counter 10-363-00:IGBT High Temperature Fail	no. of faults	RW	IGBT High Temperature Fail	NVMFaultCounter	shortNatural	No	Fault Counter:10-363-00: IGBT High Temperature Fail	1.813		
608-691	Fault Counter 10-364-00:IGBT Temperature Sensor Fail	no. of faults	RW	IGBT Temperature Sensor Fail	NVMFaultCounter	shortNatural	No	Fault Counter:10-364-00: IGBT temperature disconnect	1.813		
608-692	Fault Counter 10-367-00:Input Low Current Fail	no. of faults	RW	Input Low Current Fail	NVMFaultCounter	shortNatural	No	Fault Counter:10-367-00: Input Low Current Fail	1.813		
608-693	Fault Counter 10-368-00:Encoder Pulse Fail	no. of faults	RW	Encoder Pulse Fail	NVMFaultCounter	shortNatural	No	Fault Counter:10-368-00: Encoder Pulse Fail	1.813		
608-694	Fault Counter 10-369-00:IH Driver Communication Fail	no. of faults	RW	IH Driver Communication Fail	NVMFaultCounter	shortNatural	No	Fault Counter:10-369-00: IH Driver Communication Fail	1.813		

608-695	Fault Counter 10-370-00:IH Driver Freeze Fail	no. of faults	RW	IH Driver Freeze Fail	NVMFaultCounter	shortNatural	No	Fault Counter:10-370-00: IH Driver Freeze Fail	1.813		
608-696	Fault Counter 92-670-00:ADC Patch Fail [Y]	no. of faults	RW	ADC Patch Fail [Y]	NVMFaultCounter	shortNatural	No	Fault Counter:92-670-00: ADC Patch Fail [Y]	1.751		
608-697	Fault Counter 92-671-00:ADC Patch Fail [M]	no. of faults	RW	ADC Patch Fail [M]	NVMFaultCounter	shortNatural	No	Fault Counter:92-671-00: ADC Patch Fail [M]	1.751		
608-698	Fault Counter 92-672-00:ADC Patch Fail [C]	no. of faults	RW	ADC Patch Fail [C]	NVMFaultCounter	shortNatural	No	Fault Counter:92-672-00: ADC Patch Fail [C]	1.751		
608-699	Fault Counter 92-673-00:ADC Patch Fail [K]	no. of faults	RW	ADC Patch Fail [K]	NVMFaultCounter	shortNatural	No	Fault Counter:92-673-00: ADC Patch Fail [K]	1.813		
608-700	Fault Counter 92-675-00:ADC_MiniSetup_Fail [Y]	no. of faults	RW	ADC_MiniSetup_Fail [Y]	NVMFaultCounter	shortNatural	No	Fault Counter:92-675-00: ADC_MiniSetup_Fail [Y]	1.766		
608-701	Fault Counter 92-676-00:ADC_MiniSetup_Fail [M]	no. of faults	RW	ADC_MiniSetup_Fail [M]	NVMFaultCounter	shortNatural	No	Fault Counter:92-676-00: ADC_MiniSetup_Fail [M]	1.766		
608-702	Fault Counter 92-677-00:ADC_MiniSetup_Fail [C]	no. of faults	RW	ADC_MiniSetup_Fail [C]	NVMFaultCounter	shortNatural	No	Fault Counter:92-677-00: ADC_MiniSetup_Fail [C]	1.766		

608-703	Fault Counter 92-678-00:ADC_MiniSetup_Fail [K]	no. of faults	RW	ADC_MiniSetup_Fail [K]	NVMFaultCounter	shortNatural	No	Fault Counter:92-678-00: ADC_MiniSetup_Fail [K]	1.813		
608-704	Fault Counter 89-621-00:RC Temp Sensor Fail	no. of faults	RW	RC Temp Sensor Fail	NVMFaultCounter	shortNatural	No	Fault Counter:89-621-00: RC Temp Sensor Fail	1.254		
608-705	Fault Counter 89-622-00:RC Data Linearity Fail	no. of faults	RW	RC Data Linearity Fail	NVMFaultCounter	shortNatural	No	Fault Counter:89-622-00: RC Data Linearity Fail	1.254		
608-706	Fault Counter 89-624-00:PS Zphase Sensor Fail	no. of faults	RW	PS Zphase Sensor Fail	NVMFaultCounter	shortNatural	No	Fault Counter:89-624-00: PS Zphase Sensor Fail	1.254		
608-707	Fault Counter 89-625-00:RC Data Linearity Fail-#1	no. of faults	RW	RC Data Linearity Fail-#1	NVMFaultCounter	shortNatural	No	Fault Counter:89-625-00: RC Data Linearity Fail-#1	1.813		
608-708	Fault Counter 89-626-00:RC Data Linearity Fail-#2	no. of faults	RW	RC Data Linearity Fail-#2	NVMFaultCounter	shortNatural	No	Fault Counter:89-626-00: RC Data Linearity Fail-#2	1.813		
608-709	Fault Counter 89-627-00:RC Data Linearity Fail-#3	no. of faults	RW	RC Data Linearity Fail-#3	NVMFaultCounter	shortNatural	No	Fault Counter:89-627-00: RC Data Linearity Fail-#3	1.813		

608-710	Fault Counter 89-628-00:RC Data Linearity Fail-#4	no. of faults	RW	RC Data Linearity Fail-#4	NVMFaultCounter	shortNatural	No	Fault Counter:89-628-00: RC Data Linearity Fail-#4	1.813		
608-711	Fault Counter 42-319-00:Drum YMC Motor Fail	no. of faults	RW	Drum YMC Motor Fail	NVMFaultCounter	shortNatural	No	Fault Counter:42-319-00: Drum YMC Motor Fail	1.813		
608-712	Fault Counter 42-605-00:Drive Fan Fail	no. of faults	RW	Drive Fan Fail	NVMFaultCounter	shortNatural	No	Fault Counter:42-605-00: Drive Fan Fail	1.813		
608-713	Fault Counter 42-334-00:IBT Fan Fail	no. of faults	RW	IBT Fan Fail	NVMFaultCounter	shortNatural	No	Fault Counter:42-334-00: IBT Fan Fail	1.813		
608-714	Fault Counter 42-335-00:Process1 Fan Fail	no. of faults	RW	Process1 Fan Fail	NVMFaultCounter	shortNatural	No	Fault Counter:42-335-00: Process1 Fan Fail	1.813		
608-715	Fault Counter 42-336-00:Process2 Fan Fail	no. of faults	RW	Process2 Fan Fail	NVMFaultCounter	shortNatural	No	Fault Counter:42-336-00: Process2 Fan Fail	1.813		

608-716	Fault Counter 42-343-00:Rear Bottom Fan Fail	no. of faults	RW	Rear Bottom Fan Fail	NVMFaultCounter	shortNatural	No	Fault Counter:42-343-00: Rear Bottom Fan Fail	1.813		
608-717	Fault Counter 42-338-00:LVPS Exhaust Fan Fail	no. of faults	RW	LVPS Exhaust Fan Fail	NVMFaultCounter	shortNatural	No	Fault Counter:42-338-00: LVPS Exhaust Fan Fail	1.813		
608-718	Fault Counter 42-340-00:Cartridge Fan Fail	no. of faults	RW	Cartridge Fan Fail	NVMFaultCounter	shortNatural	No	Fault Counter:42-340-00: Cartridge Fan Fail	1.813		
608-719	Fault Counter 42-341-00:MHVPS Fan Fail	no. of faults	RW	MHVPS Fan Fail	NVMFaultCounter	shortNatural	No	Fault Counter:42-341-00: MHVPS Fan Fail	1.254		
608-720	Fault Counter 42-342-00:Suction Fan Fail	no. of faults	RW	Suction Fan Fail	NVMFaultCounter	shortNatural	No	Fault Counter:42-342-00: Suction Fan Fail	1.254		
608-721	Fault Counter 42-316-00:Front Fan Fail	no. of faults	RW	Front Fan Fail	NVMFaultCounter	shortNatural	No	Fault Counter:42-316-00: Front Fan Fail	1.254		
608-722	Fault Counter 43-344-00:C Exhaust Fan Fail	no. of faults	RW	C Exhaust Fan Fail	NVMFaultCounter	shortNatural	No	Fault Counter:43-344-00: C Exhaust Fan Fail	1.813		
608-723	Fault Counter 42-332-00:IH INTAKE Fan Fail	no. of faults	RW	IH INTAKE Fan Fail	NVMFaultCounter	shortNatural	No	Fault Counter:42-332-00: IH INTAKE Fan Fail	1.813		
608-724	Fault Counter 42-604-00:NOHAD Temperature Sensor Fail	no. of faults	RW	NOHAD Temperature Sensor Fail	NVMFaultCounter	shortNatural	No	Fault Counter:42-604-00: NOHAD Temperature Sensor Fail	1.813		
608-725	Fault Counter 42-337-00:NOHAD Logic Fail	no. of faults	RW	NOHAD Logic Fail	NVMFaultCounter	shortNatural	No	Fault Counter:42-337-00: NOHAD Logic Fail	1.254		
608-726	Fault Counter 42-609-00:B Fan Fail	no. of faults	RW	B Fan Fail	NVMFaultCounter	shortNatural	No	Fault Counter:42-609-00: B Fan Fail	1.254		

608-727	Fault Counter 42-400-00: Fan Filter Life End	no. of faults	RW	Fan Filter Life End	NVMFaultCounter	shortNatural	No	Fault Counter:42-400-00: FANFILTEREOLCOUN T	1.813		
608-825	Tray 1 Detected Width	Tray 1 Detected Width (Custom Size Support)	RW	Tray 1 Detected Width	NVMSAKOSetting	natural	No		1.503		
608-826	Tray 1 Detected Length	Tray 1 Detected Length (Custom Size Support)	RW	Tray 1 Detected Length	NVMSAKOSetting	natural	No		1.503		
608-827	Tray 2 Detected Width	Tray 2 Detected Width (Custom Size Support)	RW	Tray 2 Detected Width	NVMSAKOSetting	natural	No		1.503		
608-828	Tray 2 Detected Length	Tray 2 Detected Length (Custom Size Support)	RW	Tray 2 Detected Length	NVMSAKOSetting	natural	No		1.503		
608-829	Tray 3 Detected Width	Tray 3 Detected Width (Custom Size Support)	RW	Tray 3 Detected Width	NVMSAKOSetting	natural	No		1.503		
608-830	Tray 3 Detected Length	Tray 3 Detected Length (Custom Size Support)	RW	Tray 3 Detected Length	NVMSAKOSetting	natural	No		1.503		
608-831	Tray 4 Detected Width	Tray 4 Detected Width (Custom Size Support)	RW	Tray 4 Detected Width	NVMSAKOSetting	natural	No		1.503		
608-832	Tray 4 Detected Length	Tray 4 Detected Length (Custom Size Support)	RW	Tray 4 Detected Length	NVMSAKOSetting	natural	No		1.503		

608-931	Fault Counter 12-765-00: Incompatible Finisher detected.	no. of faults	RW	ImelIncompatibleFinisherFC	NVMFaultCounter	shortNatural	No	Fault Counter:12-765-00: Incompatible Finisher detected.	1.521		
608-933	Fault Counter 12-195: Paper Detect Sensor not made Jam	no. of faults	RW	PaperDetectSensorNotMade	NVMFaultCounter	shortNatural	No	Fault Counter:12-195-00: PaperDetectSensorNot Made	1.521		
608-934	Fault Counter 12-125: Finisher Entry Sensor not made Jam	no. of faults	RW	LELateEntrySensor	NVMFaultCounter	shortNatural	No	Fault Counter:12-125-00: Finisher Entry Sensor not made Jam	1.521		
608-935	Fault Counter 12-101: Finisher Entry Sensor no cleared Jam	no. of faults	RW	TELateEntrySensor	NVMFaultCounter	shortNatural	No	Fault Counter:12-125-00: Finisher Entry Sensor not made Jam	1.521		
608-936	Fault Counter 12-336: Rear Staple Door Opened in Run	no. of faults	RW	StapleDoorOpenIR	NVMFaultCounter	shortNatural	No	Fault Counter:12-125-00: Finisher Entry Sensor not made Jam	1.521		
608-937	Fault Counter 12-283: Ejector Clamp Motor Stall Failure	no. of faults	RW	EjectorClampMotorStall	NVMFaultCounter	shortNatural	No	Fault Counter:12-125-00: Finisher Entry Sensor not made Jam	1.521		
608-938	Fault Counter 12-284: Ejector Clamp Return Home Failure	no. of faults	RW	EjectorClampReturnHome	NVMFaultCounter	shortNatural	No	Fault Counter:12-125-00: Finisher Entry Sensor not made Jam	1.521		

608-939	Fault Counter 12-950: Preparation time violation on finisher entry sensor	no. of faults	RW	LEEntrySensorTriggered	NVMFaultCounter	shortNatural	No	Fault Counter:12-125-00: Finisher Entry Sensor not made Jam	1.521		
608-943	Lightweight Large Sheets Used Total of large size Lightweight media sheets since activation date numLargeLWMedia	Lightweight Large Sheets Used Total of large size Lightweight media sheets	ND	Lightweight Large Sheets Used	NVMSystemUsageCounter	byteArray	No	System Usage Counter:909: Heavyweight Large Sheets Used	1.799		
608-951	Tray 1 Top Edge Reg Simp (FD 3.2.2)	pixels (600 dpi)	RW	Top Edge Reg Tray 1 Simplex	NVMMachVarRegistration	natural	No		1.362		
608-951	Tray 1 Top Edge Reg Simp (FS23.604)	pixels (600 dpi)	RW	Top Edge Reg Tray 1 Simplex	NVMMachVarRegistration	natural	No		1.485		
608-952	Tray 2 Top Edge Reg Simp (FD 3.2.2)	pixels (600 dpi)	RW	Top Edge Reg Tray 2 Simplex	NVMMachVarRegistration	natural	No		1.362		
608-952	Tray 2 Top Edge Reg Simp (FS23.604)	pixels (600 dpi)	RW	Top Edge Reg Tray 2 Simplex	NVMMachVarRegistration	natural	No		1.485		
608-953	Tray 3 Top Edge Reg Simp (FD 3.2.2)	pixels (600 dpi)	RW	Top Edge Reg Tray 3 Simplex	NVMMachVarRegistration	natural	No		1.362		
608-953	Tray 3 Top Edge Reg Simp (FS23.604)	pixels (600 dpi)	RW	Top Edge Reg Tray 3 Simplex	NVMMachVarRegistration	natural	No		1.485		
608-954	Tray 4 Top Edge Reg Simp (FD 3.2.2)	pixels (600 dpi)	RW	Top Edge Reg Tray 4 Simplex	NVMMachVarRegistration	natural	No		1.362		
608-954	Tray 4 Top Edge Reg Simp (FS23.604)	pixels (600 dpi)	RW	Top Edge Reg Tray 4 Simplex	NVMMachVarRegistration	natural	No		1.485		
608-955	Tray 5 (MSI) Top Edge Reg Simp (FD 3.2.2)	pixels (600 dpi)	RW	Top Edge Reg Tray 5 Simplex	NVMMachVarRegistration	natural	No		1.438		

608-955	Tray 5 (MSI) Top Edge Reg Simp (FS23.604)	pixels (600 dpi)	RW	Top Edge Reg Tray 5 Simplex	NVMMachVarRegistration	natural	No		1.485		
608-956	Tray 6 (PFP) Top Edge Reg Simp (FD 3.2.2)	pixels (600 dpi)	RW	Top Edge Reg Tray 6 Simplex	NVMMachVarRegistration	natural	No		1.438		
608-956	Tray 6 (PFP) Top Edge Reg Simp (FS23.604)	pixels (600 dpi)	RW	Top Edge Reg Tray 6 Simplex	NVMMachVarRegistration	natural	No		1.485		
608-957	Tray 1 Top Edge Reg Dup (FD 3.2.2)	pixels (600 dpi)	RW	Top Edge Reg Tray 1 Duplex	NVMMachVarRegistration	natural	No		1.362		
608-957	Tray 1 Top Edge Reg Dup (FS23.604)	pixels (600 dpi)	RW	Top Edge Reg Tray 1 Duplex	NVMMachVarRegistration	natural	No		1.485		
608-958	Tray 2 Top Edge Reg Dup (FD 3.2.2)	pixels (600 dpi)	RW	Top Edge Reg Tray 2 Duplex	NVMMachVarRegistration	natural	No		1.362		
608-958	Tray 2 Top Edge Reg Dup (FS23.604)	pixels (600 dpi)	RW	Top Edge Reg Tray 2 Duplex	NVMMachVarRegistration	natural	No		1.485		

608-959	Tray 3 Top Edge Reg Dup (FD 3.2.2)	pixels (600 dpi)	RW	Top Edge Reg Tray 3 Duplex	NVMMachVarRegistration	natural	No		1.362		
608-959	Tray 3 Top Edge Reg Dup (FS23.604)	pixels (600 dpi)	RW	Top Edge Reg Tray 3 Duplex	NVMMachVarRegistration	natural	No		1.485		
608-960	Tray 4 Top Edge Reg Dup (FD 3.2.2)	pixels (600 dpi)	RW	Top Edge Reg Tray 4 Duplex	NVMMachVarRegistration	natural	No		1.362		
608-960	Tray 4 Top Edge Reg Dup (FS23.604)	pixels (600 dpi)	RW	Top Edge Reg Tray 4 Duplex	NVMMachVarRegistration	natural	No		1.485		
608-961	Tray 5 (MSI) Top Edge Reg Dup (FD 3.2.2)	pixels (600 dpi)	RW	Top Edge Reg Tray 5 Duplex	NVMMachVarRegistration	natural	No		1.438		
608-961	Tray 5 (MSI) Top Edge Reg Dup (FS23.604)	pixels (600 dpi)	RW	Top Edge Reg Tray 5 Duplex	NVMMachVarRegistration	natural	No		1.485		
608-962	Tray 6 (PFP) Top Edge Reg Dup (FD 3.2.2)	pixels (600 dpi)	RW	Top Edge Reg Tray 6 Duplex	NVMMachVarRegistration	natural	No		1.438		
608-962	Tray 6 (PFP) Top Edge Reg Dup (FS23.604)	pixels (600 dpi)	RW	Top Edge Reg Tray 6 Duplex	NVMMachVarRegistration	natural	No		1.485		

608-963	IOT Lead Edge Reg Simp (FD 23.110)	scan lines	RW	IOT LE Reg Simp	NVMMachVarRegistration	natural	No		1.362		
608-963	IOT Lead Edge Reg Simp (FS23.604)	scan lines @600dpi	RW	IOT LE Reg Simp	NVMMachVarRegistration	natural	No		1.485		
608-964	IOT Lead Edge Reg Dup (FD 23.110)	scan lines	RW	IOT LE Reg Dup	NVMMachVarRegistration	natural	No		1.362		
608-964	IOT Lead Edge Reg Dup (FS23.604)	scan lines @600dpi	RW	IOT LE Reg Dup	NVMMachVarRegistration	natural	No		1.485		
608-976	Fault Counter 12-484-00: BMENDSTOPMIDHOMESENSORNOTMADE	no. of faults	RW	BMENDSTOPMIDHOMESENSORNOTMADE	NVMFaultCounter	shortNatural	No	Fault Counter:12-484-00: BMENDSTOPMIDHOMESENSORNOTMADE	1.678		
608-977	Fault Counter 12-486-00: BMENDSTOPMIDHOMESENSORNOTCLEARED	no. of faults	RW	BMENDSTOPMIDHOMESENSORNOTCLEARED	NVMFaultCounter	shortNatural	No	Fault Counter:12-486-00: BMENDSTOPMIDHOMESENSORNOTCLEARED	1.678		
608-978	Fault Counter 12-488-00: BMSTAPLEUNITMOVETOHOMEFAULT	no. of faults	RW	BMSTAPLEUNITMOVETOHOMEFAULT	NVMFaultCounter	shortNatural	No	Fault Counter:12-488-00: BMSTAPLEUNITMOVETOHOMEFAULT	1.678		

608-979	Fault Counter 12-490-00: BMSTAPLEUNITMOVETOAWAYFAULT	no. of faults	RW	BMSTAPLEUNITMOVETOAWAYFA ULT	NVMFaultCounter	shortNatural	No	Fault Counter:12-490- 00: BMSTAPLEUNITMOV ETOAWAYFAULT	1.678		
608-980	Fault Counter 11-492-00: BMSTAPLEUNITNOTHOMEFAULT	no. of faults	RW	Fault Counter 11-492-00	NVMFaultCounter	shortNatural	No	Fault Counter:11-492- 00: BMSTAPLEUNITNOT HOMEFAULT	1.417		
608-981	Toner CRU install date	System sets this upon new unit detection or confirmation	ND		NVMConfiguration	longNatural	No		1.417		
608-982	XRU CRU install date	unix time (seconds since start of 1970)	ND	XruInstallDate	NVMSAKOSetting	longNatural	No		1.421		
608-993	Toner Waste Control	Set/changed by a tools setting. 0=disabled, 1=enabled	RW	TonerWasteControlEnabled	NVMConfiguration	boolean	No		1.443		
608-996	Custom display names - Custom media type List initialized flag	Refer to FS 16.027	RO	CMT List Initialized	NVMSAKOSetting	boolean	No		1.693		

608-999	Display Media Resource Screen for jobs held for resources	Refer to FS 16.020 0 = Disabled (SR3 Status, no pop-up) 1 = Enabled (SR3 Status and pop-up)	ND		NVMSAKOSetting	shortNatural	No		1.796		
609-001	Fault Counter 01-300-00: FrontCoverOpenInRunFault	no. of faults	RW	FrontCoverOpenInRunFC	NVMFaultCounter	shortNatural	No	Fault Counter:01-300-00: FrontCoverOpenInRun Fault	1.370		
609-002	Fault Counter 01-305-00: SideCoverOpenInRunFault	no. of faults	RW	SideCoverOpenInRunFC	NVMFaultCounter	shortNatural	No	Fault Counter:01-305-00: SideCoverOpenInRun Fault	1.370		
609-003	Fault Counter 10-101-00: LeadEdgeLateToPostFuserSensorSimpFault	no. of faults	RW	LELateToPostFuserSnsrSimpFC	NVMFaultCounter	shortNatural	No	Fault Counter:10-101-00: LeadEdgeLateToPostFuserSensorSimpFault	1.370		
609-004	Fault Counter 10-102-00: LeadEdgeLateToPostFuserSensorDup1Fault	no. of faults	RW	LELateToPostFuserSnsrDup1FC	NVMFaultCounter	shortNatural	No	Fault Counter:10-102-00: LeadEdgeLateToPostFuserSensorDup1Fault	1.370		
609-005	Fault Counter 10-103-00: LeadEdgeLateToPostFuserSensorDup2Fault	no. of faults	RW	LELateToPostFuserSnsrDup2FC	NVMFaultCounter	shortNatural	No	Fault Counter:10-103-00: LeadEdgeLateToPostFuserSensorDup2Fault	1.370		
609-006	Fault Counter 10-107-00: TrailEdgeLateFromPostFuserSensorSimpNonInvFault	no. of faults	RW	TELateFmPostFuseSnsrSimpNonInvFC	NVMFaultCounter	shortNatural	No	Fault Counter:10-107-00: TrailEdgeLateFromPostFuserSensorSimpNonInvFault	1.370		
609-007	Fault Counter 10-108-00: TrailEdgeLateFromPostFuserSensorSimpInvFault	no. of faults	RW	TELateFmPostFuserSnsrSimpInvFC	NVMFaultCounter	shortNatural	No	Fault Counter:10-108-00:	1.370		
609-008	Fault Counter 10-109-00:	no. of faults	RW	TELateFmPostFuserSnsrDup1FC	NVMFaultCounter	shortNatural	No	Fault Counter:10-109-	1.370		

609-009	Fault Counter 10-110-00: TrailEdgeLateFromPostFuserSensorDup2 Fault	no. of faults	RW	TELateFmPostFuserSnsrDup2FC	NVMFaultCounter	shortNatural	No	Fault Counter:10-110-00: TrailEdgeLateFromPostFuserSensorDup2Fault	1.370		
609-010	Fault Counter 10-120-00: LeadEdgeLateTolotExitSensorInvFault	no. of faults	RW	LELateTolotExitSnsrInvFC	NVMFaultCounter	shortNatural	No	Fault Counter:10-120-00: LeadEdgeLateTolotExitSensorInvFault	1.370		
609-011	Fault Counter 10-121-00: LeadEdgeLateTolotExitSensorNonInvFault	no. of faults	RW	LELateTolotExitSnsrNonInvFC	NVMFaultCounter	shortNatural	No	Fault Counter:10-121-00: LeadEdgeLateTolotExitSensorNonInvFault	1.370		
609-012	Fault Counter 10-126-00: TrailEdgeLateFromlotExitSensorFault	no. of faults	RW	TELateFmlotExitSnsrFC	NVMFaultCounter	shortNatural	No	Fault Counter:10-126-00:	1.370		
609-013	Fault Counter 10-130-00: LeadEdgeLateToTopExitSensorFault	no. of faults	RW	LELateToTopExitSnsrFC	NVMFaultCounter	shortNatural	No	Fault Counter:10-130-00: LeadEdgeLateToTopExitSensorFault	1.370		
609-014	Fault Counter 10-131-00: TrailEdgeLateFromTopExitSensorFault	no. of faults	RW	TELateFmTopExitSnsrFC	NVMFaultCounter	shortNatural	No	Fault Counter:10-131-00: TrailEdgeLateFromTopExitSensorFault	1.370		

609-015	Fault Counter 10-132-00: LeadEdgeLateToInvertSensorSimpFault	no. of faults	RW	LELateToInvertSnsrSimpFC	NVMFaultCounter	shortNatural	No	Fault Counter:10-132-00: LeadEdgeLateToInvertSensorSimpFault	1.370		
609-016	Fault Counter 10-133-00: LeadEdgeLateToInvertSensorDup1Fault	no. of faults	RW	LELateToInvertSnsrDup1FC	NVMFaultCounter	shortNatural	No	Fault Counter:10-133-00: LeadEdgeLateToInvertSensorDup1Fault	1.370		
609-017	Fault Counter 10-134-00: LeadEdgeLateToInvertSensorDup2Fault	no. of faults	RW	LELateToInvertSnsrDup2FC	NVMFaultCounter	shortNatural	No	Fault Counter:10-134-00: LeadEdgeLateToInvertSensorDup2Fault	1.370		
609-018	Fault Counter 10-135-00: TrailEdgeLateFromInvertSensorSimpNonInvertFault	no. of faults	RW	TELateFmInvertSnsrSimpNonInvFC	NVMFaultCounter	shortNatural	No	Fault Counter:10-135-00: TrailEdgeLateFromInvertSensorSimpNonInvertFault	1.370		
609-019	Fault Counter 10-136-00: TrailEdgeLateFromInvertSensorSimpInvFault	no. of faults	RW	TELateFmInvertSnsrSimpInvFC	NVMFaultCounter	shortNatural	No	Fault Counter:10-136-00: TrailEdgeLateFromInvertSensorSimpInvFault	1.370		
609-020	Fault Counter 10-137-00: TrailEdgeLateFromInvertSensorDup1Fault	no. of faults	RW	TELateFmInvertSnsrDup1FC	NVMFaultCounter	shortNatural	No	Fault Counter:10-137-00: TrailEdgeLateFromInvertSensorDup1Fault	1.370		

609-021	Fault Counter 10-138-00: TrailEdgeLateFromInvertSensorDup2Fault	no. of faults	RW	TELateFmInvertSnsrDup2FC	NVMFaultCounter	shortNatural	No	Fault Counter:10-138-00: TrailEdgeLateFromInvertSensorDup2Fault	1.370		
609-022	Fault Counter 10-315-00: FuserThermFaultFault	no. of faults	RW	FuserThermFCFC	NVMFaultCounter	shortNatural	No	Fault Counter:10-315-00: FuserThermFaultFault	1.370		
609-023	Fault Counter 10-320-00: FuserControlFailureFault	no. of faults	RW	FuserCtrlFailFC	NVMFaultCounter	shortNatural	No	Fault Counter:10-320-00: FuserControlFailureFault	1.370		
609-024	Fault Counter 10-321-00: FuserControlFailureStandbyOverTempFault	no. of faults	RW	FuserCtrlFailStandbyOverTempFC	NVMFaultCounter	shortNatural	No	Fault Counter:10-321-00: FuserControlFailureStandbyOverTempFault	1.370		
609-025	Fault Counter 10-322-00: FuserControlFailureStandbyUnderTempFault	no. of faults	RW	FuserCtrlFailStandbyUnderTempFC	NVMFaultCounter	shortNatural	No	Fault Counter:10-322-00: FuserControlFailureStandbyUnderTempFault	1.370		
609-026	Fault Counter 10-323-00: FuserControlFailureRunOverTempFault	no. of faults	RW	FuserCtrlFailRunOverTempFC	NVMFaultCounter	shortNatural	No	Fault Counter:10-323-00: FuserControlFailureRunOverTempFault	1.370		

609-027	Fault Counter 10-324-00: FuserControlFailureRunUnderTempFault	no. of faults	RW	FuserCtrlFailRunUnderTempFC	NVMFaultCounter	shortNatural	No	Fault Counter:10-324-00: FuserControlFailureRunUnderTempFault	1.370		
609-028	Fault Counter 10-325-00:	no. of faults	RW	FuserNotBeingCtrlledFC	NVMFaultCounter	shortNatural	No	Fault Counter:10-325-	1.370		
609-029	Fault Counter 10-330-00: FuserWarmupFailureFault	no. of faults	RW	FuserWarmupFailFC	NVMFaultCounter	shortNatural	No	Fault Counter:10-330-00: FuserWarmupFailureFault	1.370		
609-030	Fault Counter 10-340-00: FuserAOverTemperatureFault	no. of faults	RW	FuserAOverTemperatureFC	NVMFaultCounter	shortNatural	No	Fault Counter:10-340-00: FuserAOverTemperatureFault	1.370		
609-031	Fault Counter 10-350-00: FuserOverTempOrShortCircuitFault	no. of faults	RW	FuserOverTempOrShortCircuitFC	NVMFaultCounter	shortNatural	No	Fault Counter:10-350-00: FuserOverTempOrSho	1.370		
609-032	Fault Counter 10-360-00: FuserBOverTemperatureFault	no. of faults	RW	FuserBOverTemperatureFC	NVMFaultCounter	shortNatural	No	Fault Counter:10-360-00: FuserBOverTemperatureFault	1.370		
609-033	Fault Counter 10-365-00: FuserCOverTemperatureFault	no. of faults	RW	FuserCOverTemperatureFC	NVMFaultCounter	shortNatural	No	Fault Counter:10-365-00: FuserCOverTemperatureFault	1.370		

609-034	Fault Counter 10-370-00: FuserPowerSaveControlFailureFault	no. of faults	RW	FuserPowerSaveCtrlFailFC	NVMFaultCounter	shortNatural	No	Fault Counter:10-370-00: FuserPowerSaveControlFailureFault	1.370		
609-035	Fault Counter 10-380-00: FuserTempGradientTooHighFault	no. of faults	RW	FuserTempGradientTooHighFC	NVMFaultCounter	shortNatural	No	Fault Counter:10-380-00: FuserTempGradientTooHighFault	1.370		
609-036	Fault Counter 10-399-00: FruAuthorisationFailureFault	no. of faults	RW	FruAuthorisationFailFC	NVMFaultCounter	shortNatural	No	Fault Counter:10-399-00: FruAuthorisationFailureFault	1.370		
609-037	Fault Counter 10-821-00: SorFuserControlFailureStandbyOverTempFault	no. of faults	RW	SFuserCtrlFailStandbyOverTempFC	NVMFaultCounter	shortNatural	No	Fault Counter:10-821-00: SorFuserControlFailureStandbyOverTempFault	1.370		
609-038	Fault Counter 10-822-00: SorFuserControlFailureStandbyUnderTempFault	no. of faults	RW	SFuserCtrlFailStandbyUnderTempFC	NVMFaultCounter	shortNatural	No	Fault Counter:10-822-00: SorFuserControlFailureStandbyUnderTempFault	1.370		
609-039	Fault Counter 41-350-00: PfmCommsFailureFault	no. of faults	RW	PfmCommsFailFC	NVMFaultCounter	shortNatural	No	Fault Counter:41-350-00: PfmCommsFailureFault	1.370		
609-040	Fault Counter 41-351-00: PfmFeedBufferOverflowFault	no. of faults	RW	PfmFeedBufferOverflowFC	NVMFaultCounter	shortNatural	No	Fault Counter:41-351-00:	1.370		

609-041	Fault Counter 41-354-00: PfmI2CFrameFailureFault	no. of faults	RW	PfmI2CFrameFailFC	NVMFaultCounter	shortNatural	No	Fault Counter:41-354-00: PfmI2CFrameFailureFault	1.370		
609-042	Fault Counter 41-359-00: HcfCommsFailureFault	no. of faults	RW	FinisherCommsFailFC	NVMFaultCounter	shortNatural	No	Fault Counter:41-359-00:	1.370		
609-043	Fault Counter 03-360-00: FinisherCommsFailureFault	no. of faults	RW	FINCOMMSFAILFLT	NVMFaultCounter	shortNatural	No	Fault Counter:03-360-00: FINCOMMSFAILFLT	1.678		
609-044	Fault Counter 41-363-00: FinToBmCommsFailureFault	no. of faults	RW	PfpCommsFailFC	NVMFaultCounter	shortNatural	No	Fault Counter:41-363-00: FinToBmCommsFailureFault	1.370		
609-045	Fault Counter 03-350-00: PfpCommsFailureFault	no. of faults	RW	FruCommsFailFC	NVMFaultCounter	shortNatural	No	Fault Counter:03-350-00: PfpCommsFailure	1.678		
609-046	Fault Counter 41-371-00: FruCommsFailureFault	no. of faults	RW	XruCommsFailFC	NVMFaultCounter	shortNatural	No	Fault Counter:41-371-00: FruCommsFailureFault	1.370		

609-047	Fault Counter 41-372-00: XruCommsFailureFault	no. of faults	RW	IOTCycledInWithoutPrintingFC	NVMFaultCounter	shortNatural	No	Fault Counter:41-372-00: XruCommsFailureFault	1.370		
609-048	Fault Counter 41-395-00: IOTCycledInWithoutPrintingFault	no. of faults	RW	LaserOnWithoutPrTurningFC	NVMFaultCounter	shortNatural	No	Fault Counter:41-395-00: IOTCycledInWithoutPrintingFault	1.370		
609-049	Fault Counter 41-396-00: LaserOnWithoutPrTurningFault	no. of faults	RW	MainMtrNotBeingCtrlledFC	NVMFaultCounter	shortNatural	No	Fault Counter:41-396-00: LaserOnWithoutPrTurningFault	1.370		
609-050	Fault Counter 41-397-00: MainMotorNotBeingControlledFault	no. of faults	RW	HcfCommsFailFC	NVMFaultCounter	shortNatural	No	Fault Counter:41-397-00: MainMotorNotBeingControlledFault	1.370		
609-051	Fault Counter 41-423-00: PrintCommandLateToPageSyncSimplex3 Fault	no. of faults	RW	PrintCmdLateToPageSyncSplx3FC	NVMFaultCounter	shortNatural	No	Fault Counter:41-423-00: PrintCommandLateToPageSyncSimplex3Fault	1.370		
609-052	Fault Counter 41-480-00: Failure24VFault	no. of faults	RW	Fail24VFC	NVMFaultCounter	shortNatural	No	Fault Counter:41-480-00: Failure24VFault	1.370		

609-053	Fault Counter 41-805-00: IgnorestatFault	no. of faults	RW	IgnorestatFC	NVMFaultCounter	shortNatural	No	Fault Counter:41-805-00: IgnorestatFault	1.370		
609-054	Fault Counter 41-852-00: OutOfTimersFault	no. of faults	RW	OutOfTmrsFC	NVMFaultCounter	shortNatural	No	Fault Counter:41-852-00: OutOfTimersFault	1.370		
609-055	Fault Counter 91-365-00: IOTRelativeHumiditySensorFault	no. of faults	RW	IOTRelativeHumiditySnsrFC	NVMFaultCounter	shortNatural	No	Fault Counter:91-365-00: FAULT9_365	1.678		
609-056	Fault Counter 91-375-00: IOTAmbientTemperatureSensorFault	no. of faults	RW	IOTAmbientTemperatureSnsrFC	NVMFaultCounter	shortNatural	No	Fault Counter:91-375-00: FAULT9_375	1.678		
609-057	Fault Counter 46-060-00: HighVoltagePowerSupplyFailureFault	no. of faults	RW	HighVoltagePowerSupplyFailFC	NVMFaultCounter	shortNatural	No	Fault Counter:46-060-00: HighVoltagePowerSupplyFailureFault	1.370		

609-058	Fault Counter 61-020-00: RosMotorFailureFault	no. of faults	RW	RosMtrFailFC	NVMFaultCounter	shortNatural	No	Fault Counter:61-020-00: RosMotorFailureFault	1.370		
609-059	Fault Counter 61-340-00: RosSystemFailureFault	no. of faults	RW	RosSystemFailFC	NVMFaultCounter	shortNatural	No	Fault Counter:61-340-00: RosSystemFailureFault	1.370		
609-060	Fault Counter 61-350-00: RosLaserNotBeingControlledFault	no. of faults	RW	RosLaserNotBeingCtrlledFC	NVMFaultCounter	shortNatural	No	Fault Counter:61-350-00: RosLaserNotBeingControlledFault	1.370		
609-061	Fault Counter 92-399-00: XruAuthorisationFailureFault	no. of faults	RW	XruAuthorisationFailFC	NVMFaultCounter	shortNatural	No	Fault Counter:92-399-00: XruAuthorisationFailureFault	1.370		

609-062	Fault Counter 93-310-00: ReplenisherLevelSensorFailureFault	no. of faults	RW	ReplenisherLevelSnsrFailFC	NVMFaultCounter	shortNatural	No	Fault Counter:93-310-00: ReplenisherLevelSensorFailureFault	1.370		
609-063	Fault Counter 93-360-00: TonerConcentrationSensorFailureFault	no. of faults	RW	TonerConcSnsrFailFC	NVMFaultCounter	shortNatural	No	Fault Counter:93-360-00: TonerConcentrationSensorFailureFault	1.370		
609-064	Fault Counter 93-361-00: TonerConcentrationControlFailureLowFault	no. of faults	RW	TonerConcCtrlFailLowFC	NVMFaultCounter	shortNatural	No	Fault Counter:93-361-00: TonerConcentrationControlFailureLowFault	1.370		
609-065	Fault Counter 93-362-00: TonerConcentrationControlFailureHighFault	no. of faults	RW	TonerConcCtrlFailHighFC	NVMFaultCounter	shortNatural	No	Fault Counter:93-362-00: TonerConcentrationControlFailureHighFault	1.370		

609-066	Fault Counter 93-363-00: TonerConcentrationIsolatedControlFailLowFault	no. of faults	RW	TonerConclsolatedCtrlFailLowFC	NVMFaultCounter	shortNatural	No	Fault Counter:93-363-00: TonerConcentrationIsolatedControlFailLowFault	1.370		
609-067	Fault Counter 93-380-00: WasteTonerBottleMissingFault	no. of faults	RW	WasteTonerBottleMissingFC	NVMFaultCounter	shortNatural	No	Fault Counter:93-380-00: WasteTonerBottleMissingFault	1.370		
609-068	Fault Counter 93-390-00: TonerCartridgeEmptyFault	no. of faults	RW	TonerCartridgeEmptyFC	NVMFaultCounter	shortNatural	No	Fault Counter:93-390-00: TonerCartridgeEmptyFault	1.370		
609-069	Fault Counter 94-341-00: ScrotronCleaningFailedFault	no. of faults	RW	ScrotronCleaningFailedFC	NVMFaultCounter	shortNatural	No	Fault Counter:94-341-00: ScrotronCleaningFailedFault	1.370		

609-070	Fault Counter 94-342-00: ScorotronCleanngWarningFault	no. of faults	RW	ScorotronCleanngWarningFC	NVMFaultCounter	shortNatural	No	Fault Counter:94-342-00: ScorotronCleanngWarningFault	1.370		
609-071	Fault Counter 94-345-00: TransferDetackCleaningFailedFault	no. of faults	RW	TransferDetackCleaningFailedFC	NVMFaultCounter	shortNatural	No	Fault Counter:94-345-00: TransferDetackCleaningFailedFault	1.370		
609-072	Fault Counter 94-346-00: TransferDetackCleanngWarningFault	no. of faults	RW	TransferDetackCleanngWarningFC	NVMFaultCounter	shortNatural	No	Fault Counter:94-346-00: TransferDetackCleanngWarningFault	1.370		
609-073	Fault Counter 94-350-00: PhotoreceptorEraseLampFailureFault	no. of faults	RW	PhotoreceptorEraseLampFailFC	NVMFaultCounter	shortNatural	No	Fault Counter:94-350-00: PhotoreceptorEraseLampFailureFault	1.370		
609-074	Fault Counter 94-370-00: IOTDeveloperTemperatureSensorFault	no. of faults	RW	IOTDeveloperTemperatureSnsrFC	NVMFaultCounter	shortNatural	No	Fault Counter:94-370-00: IOTDeveloperTemperatureSensorFault	1.370		
609-075	Fault Counter 81-100-00: LeadEdgeLateToPfmWaitPointSensorFault	no. of faults	RW	LELateToPfmWaitPointSnsrFC	NVMFaultCounter	shortNatural	No	Fault Counter:81-100-00: LeadEdgeLateToPfmWaitPointSensorFault	1.374		
609-076	Fault Counter 81-101-00: LeadEdgeLateToTray1FeedSensorFault	no. of faults	RW	LELateToTray1FeedSnsrFC	NVMFaultCounter	shortNatural	No	Fault Counter:81-101-00: LeadEdgeLateToTray1FeedSensorFault	1.374		
609-077	Fault Counter 81-102-00: LeadEdgeLateToTray2FeedSensorFault	no. of faults	RW	LELateToTray2FeedSnsrFC	NVMFaultCounter	shortNatural	No	Fault Counter:81-102-00:	1.374		

609-078	Fault Counter 81-103-00: LeadEdgeLateToTray3FeedSensorFault	no. of faults	RW	LELateToTray3FeedSnsrFC	NVMFaultCounter	shortNatural	No	Fault Counter:81-103-00: LeadEdgeLateToTray3	1.374		
609-079	Fault Counter 81-104-00: LeadEdgeLateToTray4FeedSensorFault	no. of faults	RW	LELateToTray4FeedSnsrFC	NVMFaultCounter	shortNatural	No	Fault Counter:81-104-00: LeadEdgeLateToTray4	1.374		
609-080	Fault Counter 81-106-00: LeadEdgeLateToTray1SensorFromTray2Fault	no. of faults	RW	LELateToTray1SnsrFmTray2FC	NVMFaultCounter	shortNatural	No	Fault Counter:81-106-00: LeadEdgeLateToTray1	1.374		
609-081	Fault Counter 81-107-00: LeadEdgeLateToTray4SensorFromTray3Fault	no. of faults	RW	LELateToTray4SnsrFmTray3FC	NVMFaultCounter	shortNatural	No	Fault Counter:81-107-00: LeadEdgeLateToTray4	1.374		
609-082	Fault Counter 81-108-00: LeadEdgeLateToTray2SensorFromTray4Fault	no. of faults	RW	LELateToTray2SnsrFmTray4FC	NVMFaultCounter	shortNatural	No	Fault Counter:81-108-00: LeadEdgeLateToTray2	1.374		
609-083	Fault Counter 81-111-00: TrailEdgeLateFromTray1FeedSensorFault	no. of faults	RW	TELateFmTray1FeedSnsrFC	NVMFaultCounter	shortNatural	No	Fault Counter:81-111-00: TrailEdgeLateFromTra	1.374		
609-084	Fault Counter 81-112-00: TrailEdgeLateFromTray2FeedSensorFault	no. of faults	RW	TELateFmTray2FeedSnsrFC	NVMFaultCounter	shortNatural	No	Fault Counter:81-112-00: TrailEdgeLateFromTra	1.374		
609-085	Fault Counter 81-113-00: TrailEdgeLateFromTray3FeedSensorFault	no. of faults	RW	TELateFmTray3FeedSnsrFC	NVMFaultCounter	shortNatural	No	Fault Counter:81-113-00: TrailEdgeLateFromTra	1.374		
609-086	Fault Counter 81-114-00: TrailEdgeLateFromTray4FeedSensorFault	no. of faults	RW	TELateFmTray4FeedSnsrFC	NVMFaultCounter	shortNatural	No	Fault Counter:81-114-00: TrailEdgeLateFromTra	1.374		
609-087	Fault Counter 71-100-00: Tray1HoistFailureFault	no. of faults	RW	Tray1HoistFailFC	NVMFaultCounter	shortNatural	No	Fault Counter:71-100-00: Tray1HoistFailureFault	1.374		
609-088	Fault Counter 71-500-00: Tray1OpenWhileFeedingFault	no. of faults	RW	Tray1OpenWhileFeedingFC	NVMFaultCounter	shortNatural	No	Fault Counter:71-500-00:	1.374		
609-089	Fault Counter 72-100-00: Tray2HoistFailureFault	no. of faults	RW	Tray2HoistFailFC	NVMFaultCounter	shortNatural	No	Fault Counter:72-100-00: Tray2HoistFailureFault	1.374		
609-090	Fault Counter 72-500-00: Tray2OpenWhileFeedingFault	no. of faults	RW	Tray2OpenWhileFeedingFC	NVMFaultCounter	shortNatural	No	Fault Counter:72-500-00: Tray2OpenWhileFeedi	1.374		
609-091	Fault Counter 73-100-00: Tray3HoistFailureFault	no. of faults	RW	Tray3HoistFailFC	NVMFaultCounter	shortNatural	No	Fault Counter:73-100-00: Tray3HoistFailureFault	1.374		
609-092	Fault Counter 73-500-00: Tray3OpenWhileFeedingFault	no. of faults	RW	Tray3OpenWhileFeedingFC	NVMFaultCounter	shortNatural	No	Fault Counter:73-500-00: Tray3OpenWhileFeedi	1.374		
609-093	Fault Counter 74-100-00: Tray4HoistFailureFault	no. of faults	RW	Tray4HoistFailFC	NVMFaultCounter	shortNatural	No	Fault Counter:74-100-00: Tray4HoistFailureFault	1.374		
609-094	Fault Counter 74-500-00: Tray4OpenWhileFeedingFault	no. of faults	RW	Tray4OpenWhileFeedingFC	NVMFaultCounter	shortNatural	No	Fault Counter:74-500-00: Tray4OpenWhileFeedi	1.374		

609-095	Fault Counter 76-100-00: PfpTrayHoistFailureFault	no. of faults	RW	PfpTrayHoistFailFC	NVMFaultCounter	shortNatural	No	Fault Counter:76-100-00: PfpTrayHoistFailureFa	1.374		
609-096	Fault Counter 76-101-00: PfpTrayLowerFailureFault	no. of faults	RW	PfpTrayLowerFailFC	NVMFaultCounter	shortNatural	No	Fault Counter:76-101-00: PfpTrayLowerFailure	1.678		
609-097	Fault Counter 76-500-00: PfpOpenWhileFeedingFault	no. of faults	RW	PfpOpenWhileFeedingFC	NVMFaultCounter	shortNatural	No	Fault Counter:76-500-00: PfpOpenWhileFeeding	1.678		
609-098	Fault Counter 76-510-00: PfpUndockedInRunFault	no. of faults	RW	PfpUndockedInRunFC	NVMFaultCounter	shortNatural	No	Fault Counter:76-510-00: PfpUndockedInRun	1.678		
609-099	Fault Counter 81-115-00: LeadEdgeLateToPfpWaitPointSensorFault	no. of faults	RW	LELateToPfpWaitPointSnsrFC	NVMFaultCounter	shortNatural	No	Fault Counter:81-115-00: LeadEdgeLateToPfpW aitPointSensorFault	1.374		
609-100	Fault Counter 81-117-00: LeadEdgeLateToPfpFeedSensorFault	no. of faults	RW	LELateToPfpFeedSnsrFC	NVMFaultCounter	shortNatural	No	Fault Counter:81-117-00: LeadEdgeLateToPfpFe edSensorFault	1.374		
609-101	Fault Counter 81-150-00: LeadEdgeLateToRegistrationSensorFrom PfmFault	no. of faults	RW	LELateToRegSnsrFmPfmFC	NVMFaultCounter	shortNatural	No	Fault Counter:81-150-00: LeadEdgeLateToRegis trationSensorFromPfm Fault	1.374		
609-102	Fault Counter 81-151-00: TrailEdgeLateToRegSensorAfterClutchOn Fault	no. of faults	RW	TELateToRegSnsrAfterClutchOnFC	NVMFaultCounter	shortNatural	No	Fault Counter:81-151-00: TrailEdgeLateToRegS ensorAfterClutchOnFa ult	1.374		
609-103	Fault Counter 81-155-00: LeadEdgeLateToRegistrationSensorFrom MsiFault	no. of faults	RW	LELateToRegSnsrFmMsiFC	NVMFaultCounter	shortNatural	No	Fault Counter:81-155-00: LeadEdgeLateToRegis trationSensorFromMsi Fault	1.374		
609-104	Fault Counter 81-156-00: StraySheetFromMsiAtRegSensorFault	no. of faults	RW	StrayShtFmMsiAtRegSnsrFC	NVMFaultCounter	shortNatural	No	Fault Counter:81-156-00: StraySheetFromMsiAt RegSensorFault	1.374		
609-105	Fault Counter 81-171-00: UnexpectedTimeoutForSheetTypeFault	no. of faults	RW	UnexpTmoutForShtTypeFC	NVMFaultCounter	shortNatural	No	Fault Counter:81-171-00: UnexpectedTimeoutFo rSheetTypeFault	1.374		
609-106	Fault Counter 81-174-00: PpMissingPreReleasedSheetFault	no. of faults	RW	PpMissingPreReleasedShtFC	NVMFaultCounter	shortNatural	No	Fault Counter:81-174-00: PpMissingPreReleased SheetFault	1.374		
609-107	Fault Counter 81-180-00: UnableToFeedNextSheetFault	no. of faults	RW	UnableToFeedNextShtFC	NVMFaultCounter	shortNatural	No	Fault Counter:81-180-00: UnableToFeedNextSh	1.374		

609-108	Fault Counter 83-160-00: LeadEdgeLateToDuplexSensorFault	no. of faults	RW	LELateToDplxSnsrFC	NVMFaultCounter	shortNatural	No	Fault Counter:83-160-00: LeadEdgeLateToDuple	1.374		
609-109	Fault Counter 83-161-00: TrailEdgeLateToDuplexSensorAfterClutch	no. of faults	RW	TELateToDplxSnsrAfterClutchOnFC	NVMFaultCounter	shortNatural	No	Fault Counter:83-161-00:	1.374		
609-110	Fault Counter 83-181-00: PpUnexpectedTimeoutForSheetTypeSimplInvFault	no. of faults	RW	PpUnexpTmoutForShtTypeSimplInvFC	NVMFaultCounter	shortNatural	No	Fault Counter:83-181-00: PpUnexpectedTimeoutForSheetTypeSimplInvFault	1.374		
609-111	Fault Counter 83-182-00: PpUnexpectedTimeoutForSheetTypeDuplexFault	no. of faults	RW	PpUnexpTmoutForShtTypeDplxFC	NVMFaultCounter	shortNatural	No	Fault Counter:83-182-00: PpUnexpectedTimeoutForSheetTypeDuplexFault	1.374		
609-112	Fault Counter 83-190-00: StraySheetDetectedPostJamClearanceFault	no. of faults	RW	StrayShtDetectPostJamClearFC	NVMFaultCounter	shortNatural	No	Fault Counter:83-190-00: StraySheetDetectedPo	1.374		
609-113	Fault Counter 01-310-00: TopCoverOpenInRunFault	no. of faults	RW	TopCoverOpenInRunFC	NVMFaultCounter	shortNatural	No	Fault Counter:01-310-00: TopCoverOpenInRunF	1.374		
609-114	Fault Counter 11-005-00: FinTamper1FrontMoveFailureFault	no. of faults	RW	FinTamp1FrontMoveFailFC	NVMFaultCounter	shortNatural	No	Fault Counter:11-005-00: FinTamper1FrontMove	1.374		
609-115	Fault Counter 11-006-00: FinTamper1RearMoveFailureFault	no. of faults	RW	FinTamp1RearMoveFailFC	NVMFaultCounter	shortNatural	No	Fault Counter:11-006-00: FinTamper1RearMove	1.374		
609-116	Fault Counter 11-007-00: FinTamper2FrontMoveFailureFault	no. of faults	RW	FinTamp2FrontMoveFailFC	NVMFaultCounter	shortNatural	No	Fault Counter:11-007-00: FinTamper2FrontMove	1.374		
609-117	Fault Counter 11-008-00: FinTamper2RearMoveFailureFault	no. of faults	RW	FinTamp2RearMoveFailFC	NVMFaultCounter	shortNatural	No	Fault Counter:11-008-00: FinTamper2RearMove	1.374		
609-118	Fault Counter 11-012-00: FinCompilerCarriageHomeFailureFault	no. of faults	RW	FinCompilerCarriageHomeFailFC	NVMFaultCounter	shortNatural	No	Fault Counter:11-012-00: FinCompilerCarriageH	1.374		

609-119	Fault Counter 11-014-00: FinCompilerCarriageMoveFailureFault	no. of faults	RW	FinCompilerCarriageMoveFailFC	NVMFaultCounter	shortNatural	No	Fault Counter:11-014-00: FinCompilerCarriageM	1.374		
609-120	Fault Counter 11-024-00: FinPaddleRollHomeFailureFault	no. of faults	RW	FinPaddleRollHomeFailFC	NVMFaultCounter	shortNatural	No	Fault Counter:11-024-00: FinPaddleRollHomeFai	1.374		
609-121	Fault Counter 11-025-00: FinPaddleRollCycleFailureFault	no. of faults	RW	FinPaddleRollCycleFailFC	NVMFaultCounter	shortNatural	No	Fault Counter:11-025-00: FinPaddleRollCycleFail	1.374		
609-122	Fault Counter 11-026-00: FinPaddleRollerNotHomeFailureFault	no. of faults	RW	FinPaddleRollerNotHomeFailFC	NVMFaultCounter	shortNatural	No	Fault Counter:11-026-00: FinPaddleRollerNotHomeFailureFault	1.374		
609-123	Fault Counter 11-030-00: FinBin1MoveFailureFault	no. of faults	RW	FinBin1MoveFailFC	NVMFaultCounter	shortNatural	No	Fault Counter:11-030-00:	1.374		
609-124	Fault Counter 11-031-00: FinBin1OffsetMoveFailureFault	no. of faults	RW	FinBin1OffsetMoveFailFC	NVMFaultCounter	shortNatural	No	Fault Counter:11-031-00: FinBin1OffsetMoveFailureFault	1.374		
609-125	Fault Counter 11-036-00: FinBin2MoveFailureFault	no. of faults	RW	FinBin2MoveFailFC	NVMFaultCounter	shortNatural	No	Fault Counter:11-036-00: FinBin2MoveFailureFault	1.374		
609-126	Fault Counter 11-040-00: FinBin2OffsetMoveFailureFault	no. of faults	RW	FinBin2OffsetMoveFailFC	NVMFaultCounter	shortNatural	No	Fault Counter:11-040-00: FinBin2OffsetMoveFailureFault	1.374		
609-127	Fault Counter 11-043-00: FinPunchHeadCycleFailureFault	no. of faults	RW	FinPunchHeadCycleFailFC	NVMFaultCounter	shortNatural	No	Fault Counter:11-043-00: FinPunchHeadCycleFailureFault	1.374		

609-128	Fault Counter 11-044-00: FinPunchHeadReturnHomeFailureFault	no. of faults	RW	FinPunchHeadRtrnHomeFailFC	NVMFaultCounter	shortNatural	No	Fault Counter:11-044-00: FinPunchHeadReturnHomeFailureFault	1.374		
609-129	Fault Counter 11-045-00: FinPunchHeadStuckHomeFailureFault	no. of faults	RW	FinPunchHeadStuckHomeFailFC	NVMFaultCounter	shortNatural	No	Fault Counter:11-045-00:	1.374		
609-130	Fault Counter 11-046-00: FinPunchUnitHomeFlagFailureFault	no. of faults	RW	FinPunchUnitHomeFlagFailFC	NVMFaultCounter	shortNatural	No	Fault Counter:11-046-00:	1.374		
609-131	Fault Counter 11-047-00: FinPunchUnitHomeFailureFault	no. of faults	RW	FinPunchUnitHomeFailFC	NVMFaultCounter	shortNatural	No	Fault Counter:11-047-00: FinPunchUnitHomeFail	1.374		
609-132	Fault Counter 11-050-00: FinStapleHead1CycleFailureFault	no. of faults	RW	FinStapleHead1CycleFailFC	NVMFaultCounter	shortNatural	No	Fault Counter:11-050-00: FinStapleHead1CycleF ailureFault	1.374		
609-133	Fault Counter 11-053-00: FinStapleUnit1MoveFailureFault	no. of faults	RW	FinStapleUnit1MoveFailFC	NVMFaultCounter	shortNatural	No	Fault Counter:11-053-00: FinStapleUnit1MoveFai lureFault	1.374		
609-134	Fault Counter 11-056-00: FinPPIBottomPlateHomeFailureFault	no. of faults	RW	FinPPIBottomPlateHomeFailFC	NVMFaultCounter	shortNatural	No	Fault Counter:11-056-00: FinPPIBottomPlateHo meFailureFault	1.374		
609-135	Fault Counter 11-057-00: FinPPIBottomPlateLiftFailureFault	no. of faults	RW	FinPPIBottomPlateLiftFailFC	NVMFaultCounter	shortNatural	No	Fault Counter:11-057-00: FinPPIBottomPlateLiftF ailureFault	1.374		
609-136	Fault Counter 11-061-00: FinBBCreaseBladeMoveFailureFault	no. of faults	RW	FinBBCreaseBladeMoveFailFC	NVMFaultCounter	shortNatural	No	Fault Counter:11-061-00: FinBBCreaseBladeMov eFailureFault	1.374		
609-137	Fault Counter 11-062-00: FinBBCreaseRollFailureFault	no. of faults	RW	FinBBCreaseRollFailFC	NVMFaultCounter	shortNatural	No	Fault Counter:11-062-00: FinBBCreaseRollFailur eFault	1.374		
609-138	Fault Counter 11-063-00: FinBBStapleHead1MoveFailureFault	no. of faults	RW	FinBBStapleHead1MoveFailFC	NVMFaultCounter	shortNatural	No	Fault Counter:11-063-00: FinBBStapleHead1Mov eFailureFault	1.374		
609-139	Fault Counter 11-065-00: FinBBBackStopStartFailureFault	no. of faults	RW	FinBBBackStopStartFailFC	NVMFaultCounter	shortNatural	No	Fault Counter:11-065-00: FinBBBackStopStartFa ilureFault	1.374		
609-140	Fault Counter 11-066-00: FinBBTamp1MoveFailureFault	no. of faults	RW	FinBBTamp1MoveFailFC	NVMFaultCounter	shortNatural	No	Fault Counter:11-066-00: FinBBTamp1MoveFa ilureFault	1.374		
609-141	Fault Counter 11-072-00: FinBBTapeFeedMoveFaultFault	no. of faults	RW	FinBBTapeFeedMoveFCFC	NVMFaultCounter	shortNatural	No	Fault Counter:11-072-00: FinBBTapeFeedMoveF aultFault	1.374		

609-142	Fault Counter 11-073-00: FinBBCoolingFanFault	no. of faults	RW	FinBBCoolingFanFCFC	NVMFaultCounter	shortNatural	No	Fault Counter:11-073-00:	1.374		
609-143	Fault Counter 11-077-00:	no. of faults	RW	FinBBHeaterUnderTemperatureFC	NVMFaultCounter	shortNatural	No	Fault Counter:11-077-	1.374		
609-144	Fault Counter 11-078-00:	no. of faults	RW	FinBBHeaterOverTemperatureFC	NVMFaultCounter	shortNatural	No	Fault Counter:11-078-	1.374		
609-145	Fault Counter 11-083-00:	no. of faults	RW	FinPaperPusherMtrStalledFC	NVMFaultCounter	shortNatural	No	Fault Counter:11-083-	1.374		
609-146	Fault Counter 11-100-00:	no. of faults	RW	LELateToFinEntrySnsrFC	NVMFaultCounter	shortNatural	No	Fault Counter:11-100-	1.374		
609-147	Fault Counter 11-101-00:	no. of faults	RW	FinTELateFmEntranceSnsrFC	NVMFaultCounter	shortNatural	No	Fault Counter:11-101-	1.374		
609-148	Fault Counter 11-110-00:	no. of faults	RW	LELateToFinPunchSnsrFC	NVMFaultCounter	shortNatural	No	Fault Counter:11-110-	1.374		
609-149	Fault Counter 11-120-00:	no. of faults	RW	LELateToFinCompilerEntrySnsrFC	NVMFaultCounter	shortNatural	No	Fault Counter:11-120-	1.374		
609-150	Fault Counter 11-122-00: TrailEdgeLateFromFinCompilerEntrySnsrFault	no. of faults	RW	TELateFmFinCompilerEntrySnsrFC	NVMFaultCounter	shortNatural	No	Fault Counter:11-122-00: TrailEdgeLateFromFin	1.374		
609-151	Fault Counter 11-130-00: LeadEdgeLateToFinTopExitSensorFault	no. of faults	RW	LELateToFinTopExitSnsrFC	NVMFaultCounter	shortNatural	No	Fault Counter:11-130-00: LeadEdgeLateToFinTo	1.374		
609-152	Fault Counter 11-132-00: TrailEdgeLateFromFinTopExitSensorFault	no. of faults	RW	TELateFmFinTopExitSnsrFC	NVMFaultCounter	shortNatural	No	Fault Counter:11-132-00: TrailEdgeLateFromFin	1.374		
609-153	Fault Counter 11-140-00: LeadEdgeLateToFin2ndTopExitSensorFault	no. of faults	RW	LELateToFin2ndTopExitSnsrFC	NVMFaultCounter	shortNatural	No	Fault Counter:11-140-00: LeadEdgeLateToFin2n	1.374		
609-154	Fault Counter 11-142-00: TrailEdgeLateFromFin2ndTopExitSensorFault	no. of faults	RW	TELateFmFin2ndTopExitSnsrFC	NVMFaultCounter	shortNatural	No	Fault Counter:11-142-00: TrailEdgeLateFromFin	1.374		
609-155	Fault Counter 11-150-00: LeadEdgeLateToFin3rdTopExitSensorFault	no. of faults	RW	LELateToFin3rdTopExitSnsrFC	NVMFaultCounter	shortNatural	No	Fault Counter:11-150-00: LeadEdgeLateToFin3r	1.374		
609-156	Fault Counter 11-152-00: TrailEdgeLateFromFin3rdTopExitSensorFault	no. of faults	RW	TELateFmFin3rdTopExitSnsrFC	NVMFaultCounter	shortNatural	No	Fault Counter:11-152-00: TrailEdgeLateFromFin	1.374		
609-157	Fault Counter 11-157-00: FinLELateToBufferPositionSensorFault	no. of faults	RW	FinLELateToBufferPosSnsrFC	NVMFaultCounter	shortNatural	No	Fault Counter:11-157-00: FinLELateToBufferPosi	1.374		
609-158	Fault Counter 11-158-00: FinLELateToExitHVFIntoBMSensorFault	no. of faults	RW	FinLELateToExitHVFIntoBMSnsrFC	NVMFaultCounter	shortNatural	No	Fault Counter:11-158-00: FinLELateToExitHVFIn toBMSensorFault	1.374		
609-159	Fault Counter 12-160-00: LeadEdgeLateToBBEntrySensorFault	no. of faults	RW	LELateToBBEntrySnsrFC	NVMFaultCounter	shortNatural	No	Fault Counter:12-160-00: FAULT11_160	1.678		
609-160	Fault Counter 11-161-00: FinTELateFromBufferPositionSensorFault	no. of faults	RW	FinTELateFmBufferPosSnsrFC	NVMFaultCounter	shortNatural	No	Fault Counter:11-161-00: FinTELateFromBufferP ositionSensorFault	1.374		
609-161	Fault Counter 12-162-00: TrailEdgeLateFromBBEntrySensorFault	no. of faults	RW	TELateFmBBEntrySnsrFC	NVMFaultCounter	shortNatural	No	Fault Counter:12-162-00: TrailEdgeLateFromBB	1.678		
609-162	Fault Counter 11-163-00: FinTELateFromExitHVFIntoBMSensorFault	no. of faults	RW	FinTELateFmExitHVFIntoBMSnsrFC	NVMFaultCounter	shortNatural	No	Fault Counter:11-163-00: FinTELateFromExitHV	1.374		
609-163	Fault Counter 11-164-00: FinTELateFromBufferPathSensorFault	no. of faults	RW	FinTELateFmBufferPathSnsrFC	NVMFaultCounter	shortNatural	No	Fault Counter:11-164-00: FinTELateFromBufferP	1.374		

609-164	Fault Counter 11-165-00: FinLELateToBufferPathSensorFault	no. of faults	RW	FinLELateToBufferPathSnsrFC	NVMFaultCounter	shortNatural	No	Fault Counter:11-165-00: FinLELateToBufferPat	1.374		
609-165	Fault Counter 11-170-00: LeadEdgeLateToBBCompilerExitSensorFault	no. of faults	RW	LELateToBBCompilerExitSnsrFC	NVMFaultCounter	shortNatural	No	Fault Counter:11-170-00: LeadEdgeLateToBBCo	1.374		
609-166	Fault Counter 11-172-00: TrailEdgeLateFromBBCompilerSensorFault	no. of faults	RW	TELateFmBBCompilerSnsrFC	NVMFaultCounter	shortNatural	No	Fault Counter:11-172-00: TrailEdgeLateFromBB CompilerSensorFault	1.374		
609-167	Fault Counter 11-173-00: FinOffsetUnitInitializationFailureFault	no. of faults	RW	FinOffsetUnitInitFailFC	NVMFaultCounter	shortNatural	No	Fault Counter:11-173-00: FinOffsetUnitInitializati onFailureFault	1.374		
609-168	Fault Counter 11-174-00: FinOffsetUnitReturnHomeFailureFault	no. of faults	RW	FinOffsetUnitRtrnHomeFailFC	NVMFaultCounter	shortNatural	No	Fault Counter:11-174-00: FinOffsetUnitReturnHo	1.374		
609-169	Fault Counter 11-175-00: FinOffsetUnitHomeFailureFault	no. of faults	RW	FinOffsetUnitHomeFailFC	NVMFaultCounter	shortNatural	No	Fault Counter:11-175-00: FinOffsetUnitHomeFail ureFault	1.374		
609-170	Fault Counter 11-176-00: FinOffsetUnitReturnAwayHomeFailureFault	no. of faults	RW	FinOffsetUnitRtrnAwayHomeFailFC	NVMFaultCounter	shortNatural	No	Fault Counter:11-176-00: FinOffsetUnitReturnAw ayHomeFailureFault	1.374		
609-171	Fault Counter 11-177-00: FinOffsetUnitAwayHomeFailureFault	no. of faults	RW	FinOffsetUnitAwayHomeFailFC	NVMFaultCounter	shortNatural	No	Fault Counter:11-177-00: FinOffsetUnitAwayHom eFailureFault	1.374		
609-172	Fault Counter 12-180-00: LeadEdgeLateToBBExitSensorFault	no. of faults	RW	LELateToBBExitSnsrFC	NVMFaultCounter	shortNatural	No	Fault Counter:12-180-00: FAULT11_180	1.678		
609-173	Fault Counter 11-182-00: TrailEdgeLateFromBBExitSensorFault	no. of faults	RW	TELateFmBBExitSnsrFC	NVMFaultCounter	shortNatural	No	Fault Counter:11-182-00: TrailEdgeLateFromBB ExitSensorFault	1.374		
609-174	Fault Counter 11-183-00: FinBMUnexpectedSheetDetectedFault	no. of faults	RW	FinBMUnexpShtDetectFC	NVMFaultCounter	shortNatural	No	Fault Counter:11-183-00: FinBMUnexpectedShe etDetectedFault	1.374		
609-175	Fault Counter 11-184-00: FinBMStraySheetDetectedPostJamClearanceFault	no. of faults	RW	FinBMStryShtDetectPostJamClearFC	NVMFaultCounter	shortNatural	No	Fault Counter:11-184-00: FinBMStraySheetDetec	1.374		
609-176	Fault Counter 11-185-00: FinLELateToTFExitSensorFault	no. of faults	RW	FinLELateToTFExitSnsrFC	NVMFaultCounter	shortNatural	No	Fault Counter:11-185-00: FinLELateToTFExitSen	1.374		
609-177	Fault Counter 11-186-00: FinTELateFromTFExitSensorFault	no. of faults	RW	FinTELateFmTFExitSnsrFC	NVMFaultCounter	shortNatural	No	Fault Counter:11-186-00: FinTELateFromTFExit SensorFault	1.374		

609-178	Fault Counter 11-187-00: FinLELateToTFAssistSensorFault	no. of faults	RW	FinLELateToTFAssistSnsrFC	NVMFaultCounter	shortNatural	No	Fault Counter:11-187-00: FinLELateToTFAssistS	1.374		
609-179	Fault Counter 11-188-00: FinNipSplitFailureFault	no. of faults	RW	FinNipSplitFailFC	NVMFaultCounter	shortNatural	No	Fault Counter:11-188-00: FinNipSplitFailureFault	1.374		
609-180	Fault Counter 11-189-00: FinNipHomeFailureFault	no. of faults	RW	FinNipHomeFailFC	NVMFaultCounter	shortNatural	No	Fault Counter:11-189-00: FinNipHomeFailureFau lt	1.374		
609-181	Fault Counter 11-191-00: FinLELateToPPITabStandbySensorFault	no. of faults	RW	FinLELateToPPITabStandbySnsrFC	NVMFaultCounter	shortNatural	No	Fault Counter:11-191-00: FinLELateToPPITabSt	1.374		
609-182	Fault Counter 11-193-00: FinTELateFromPPITabStandbySensorFau lt	no. of faults	RW	FinTELateFmPPITabStandbySnsrFC	NVMFaultCounter	shortNatural	No	Fault Counter:11-193-00: FinTELateFromPPITab StandbySensorFault	1.374		
609-183	Fault Counter 11-194-00: FinLELateToPPIPickupSensorFault	no. of faults	RW	FinLELateToPPIPickupSnsrFC	NVMFaultCounter	shortNatural	No	Fault Counter:11-194-00: FinLELateToPPIPickup	1.374		
609-184	Fault Counter 11-196-00: FinTELateFromPPITrayPickupSensorFault	no. of faults	RW	FinTELateFmPPITrayPickupSnsrFC	NVMFaultCounter	shortNatural	No	Fault Counter:11-196-00: FinTELateFromPPITra yPickupSensorFault	1.374		
609-185	Fault Counter 11-198-00: FinStraySheetDetectedPostJamClearance Fault	no. of faults	RW	FinStrayShtDetectPostJamClearFC	NVMFaultCounter	shortNatural	No	Fault Counter:11-198-00: FinStraySheetDetected PostJamClearanceFaul t	1.374		
609-186	Fault Counter 11-199-00: UnexpectedSheetDetectedFault	no. of faults	RW	UnexpShtDetectFC	NVMFaultCounter	shortNatural	No	Fault Counter:11-199-00: UnexpectedSheetDete ctedFault	1.374		
609-187	Fault Counter 11-300-00: FinUnDockedInterlockInRunFault	no. of faults	RW	FinUnDockedIntlckInRunFC	NVMFaultCounter	shortNatural	No	Fault Counter:11-300-00: FinUnDockedInterlockl nRunFault	1.374		

609-188	Fault Counter 11-301-00: FinEntryGateInterlockOpenInRunFault	no. of faults	RW	FinEntryGateIntlckOpenInRunFC	NVMFaultCounter	shortNatural	No	Fault Counter:11-301-00: FinEntryGateInterlock OpenInRunFault	1.374		
609-189	Fault Counter 11-302-00: FinTopCoverInterlockOpenInRunFault	no. of faults	RW	FinTopCoverIntlckOpenInRunFC	NVMFaultCounter	shortNatural	No	Fault Counter:11-302-00: FinTopCoverInterlockO	1.374		
609-190	Fault Counter 11-303-00: FinFrontDoorInterlockOpenInRunFault	no. of faults	RW	FinFrontDoorIntlckOpenInRunFC	NVMFaultCounter	shortNatural	No	Fault Counter:11-303-00: FinFrontDoorInterlock	1.374		
609-191	Fault Counter 11-304-00: FinTopGateInterlockOpenInRunFault	no. of faults	RW	FinTopGateIntlckOpenInRunFC	NVMFaultCounter	shortNatural	No	Fault Counter:11-304-00: FinTopGateInterlockO	1.374		
609-192	Fault Counter 11-305-00: FinBottomExitGateInterlockOpenInRunFault	no. of faults	RW	FinBotExitGateIntlckOpenInRunFC	NVMFaultCounter	shortNatural	No	Fault Counter:11-305-00: FinBottomExitGateInter	1.374		
609-193	Fault Counter 11-306-00: FinPPITopCoverInterlockOpenInRunFault	no. of faults	RW	FinPPITopCoverIntlckOpenInRunFC	NVMFaultCounter	shortNatural	No	Fault Counter:11-306-00: FinPPITopCoverInterlo	1.374		
609-194	Fault Counter 11-307-00: FinTrifoldTopCoverOpenInRunFault	no. of faults	RW	FinTrifoldTopCoverOpenInRunFC	NVMFaultCounter	shortNatural	No	Fault Counter:11-307-00: FinTrifoldTopCoverOp enInRunFault	1.374		
609-195	Fault Counter 11-308-00: FinTrifoldFrontDoorOpenInRunFault	no. of faults	RW	FinTrifoldFrontDoorOpenInRunFC	NVMFaultCounter	shortNatural	No	Fault Counter:11-308-00:	1.374		
609-196	Fault Counter 11-309-00: FinInserterLeftHandDoorOpenInRunFault	no. of faults	RW	FinInsLeftHandDoorOpenInRunFC	NVMFaultCounter	shortNatural	No	Fault Counter:11-309-00: FinInserterLeftHandDo	1.374		
609-197	Fault Counter 11-310-00: FinTamper1FrontHomeFailureFault	no. of faults	RW	FinTamp1FrontHomeFailFC	NVMFaultCounter	shortNatural	No	Fault Counter:11-310-00: FinTamper1FrontHom	1.374		
609-198	Fault Counter 11-311-00: FinTamper1RearHomeFailureFault	no. of faults	RW	FinTamp1RearHomeFailFC	NVMFaultCounter	shortNatural	No	Fault Counter:11-311-00: FinTamper1RearHome	1.374		
609-199	Fault Counter 11-312-00: FinTamper2FrontHomeFailureFault	no. of faults	RW	FinTamp2FrontHomeFailFC	NVMFaultCounter	shortNatural	No	Fault Counter:11-312-00: FinTamper2FrontHom eFailureFault	1.374		
609-200	Fault Counter 11-313-00: FinTamper2RearHomeFailureFault	no. of faults	RW	FinTamp2RearHomeFailFC	NVMFaultCounter	shortNatural	No	Fault Counter:11-313-00: FinTamper2RearHome	1.374		
609-201	Fault Counter 11-315-00: FinCompilerCarriageOverTravelFailureUp Fault	no. of faults	RW	FinComplerCarriageTravelFailUpFC	NVMFaultCounter	shortNatural	No	Fault Counter:11-315-00: FinCompilerCarriageO	1.374		
609-202	Fault Counter 11-316-00: FinCompilerCarriageOverTravelFailureLo wFault	no. of faults	RW	FinComplrCarriageTravelFailLowFC	NVMFaultCounter	shortNatural	No	Fault Counter:11-316-00: FinCompilerCarriageO verTravelFailureLowFa	1.374		

609-203	Fault Counter 11-319-00: FinRearTamperAwayHomeSensorFailureFault	no. of faults	RW	FinRearTampAwayHomeSnsrFailFC	NVMFaultCounter	shortNatural	No	Fault Counter:11-319-00: FinRearTamperAwayHomeSensorFailureFault	1.374		
609-204	Fault Counter 11-320-00: FinCompilerEjectorHomeFailureFault	no. of faults	RW	FinCompilerEjectorHomeFailFC	NVMFaultCounter	shortNatural	No	Fault Counter:11-320-00: FinCompilerEjectorHo	1.374		
609-205	Fault Counter 11-322-00: FinCompilerEjectorCycleFailureFault	no. of faults	RW	FinCompilerEjectorCycleFailFC	NVMFaultCounter	shortNatural	No	Fault Counter:11-322-00: FinCompilerEjectorCyc	1.374		
609-206	Fault Counter 11-334-00: FinBin1OverTravelFailureUpperFault	no. of faults	RW	FinBin1OverTravelFailUpperFC	NVMFaultCounter	shortNatural	No	Fault Counter:11-334-00: FinBin1OverTravelFail	1.374		
609-207	Fault Counter 11-335-00: FinBin1OverTravelFailureLowerFault	no. of faults	RW	FinBin1OverTravelFailLowerFC	NVMFaultCounter	shortNatural	No	Fault Counter:11-335-00: FinBin1OverTravelFail	1.374		
609-208	Fault Counter 11-336-00: FinBin1HomeFailureFault	no. of faults	RW	FinBin1HomeFailFC	NVMFaultCounter	shortNatural	No	Fault Counter:11-336-00: FinBin1HomeFailureFault	1.374		
609-209	Fault Counter 11-337-00: FinBin1OffsetHomeFailureFault	no. of faults	RW	FinBin1OffsetHomeFailFC	NVMFaultCounter	shortNatural	No	Fault Counter:11-337-00: FinBin1OffsetHomeFailureFault	1.374		
609-210	Fault Counter 11-344-00: FinBin2OverTravelFailureUpperFault	no. of faults	RW	FinBin2OverTravelFailUpperFC	NVMFaultCounter	shortNatural	No	Fault Counter:11-344-00: FinBin2OverTravelFailureUpperFault	1.374		
609-211	Fault Counter 11-345-00: FinBin2OverTravelFailureLowerFault	no. of faults	RW	FinBin2OverTravelFailLowerFC	NVMFaultCounter	shortNatural	No	Fault Counter:11-345-00: FinBin2OverTravelFailureLowerFault	1.374		
609-212	Fault Counter 11-346-00: FinBin2HomeFailureFault	no. of faults	RW	FinBin2HomeFailFC	NVMFaultCounter	shortNatural	No	Fault Counter:11-346-00: FinBin2HomeFailureFault	1.374		
609-213	Fault Counter 11-347-00: FinBin2OffsetHomeFailureFault	no. of faults	RW	FinBin2OffsetHomeFailFC	NVMFaultCounter	shortNatural	No	Fault Counter:11-347-00: FinBin2OffsetHomeFailureFault	1.374		
609-214	Fault Counter 11-350-00: FinPunchHeadHomeFailureFault	no. of faults	RW	FinPunchHeadHomeFailFC	NVMFaultCounter	shortNatural	No	Fault Counter:11-350-00: FinPunchHeadHomeFailureFault	1.374		
609-215	Fault Counter 11-360-00:	no. of faults	RW	FinStapleHead1HomeFailFC	NVMFaultCounter	shortNatural	No	Fault Counter:11-360-	1.374		

609-216	Fault Counter 11-364-00: FinStapleHead1NotPrimedFault	no. of faults	RW	FinStapleHead1NotPrimedFC	NVMFaultCounter	shortNatural	No	Fault Counter:11-364-00: FinStapleHead1NotPri	1.374		
609-217	Fault Counter 11-370-00: FinStapleUnit1HomeFailureFault	no. of faults	RW	FinStapleUnit1HomeFailFC	NVMFaultCounter	shortNatural	No	Fault Counter:11-370-00: FinStapleUnit1HomeFa	1.374		
609-218	Fault Counter 11-371-00:	no. of faults	RW	FinStaplerHomeFailFC	NVMFaultCounter	shortNatural	No	Fault Counter:11-371-	1.374		
609-219	Fault Counter 11-372-00: FinStaplerReturnHomeFailureFault	no. of faults	RW	FinStaplerRtrnHomeFailFC	NVMFaultCounter	shortNatural	No	Fault Counter:11-372-00:	1.374		
609-220	Fault Counter 11-373-00: FinStaplerMiddleHomeFailureFault	no. of faults	RW	FinStaplerMiddleHomeFailFC	NVMFaultCounter	shortNatural	No	Fault Counter:11-373-00: FinStaplerMiddleHome	1.374		
609-221	Fault Counter 11-374-00: FinStaplerStuckMiddleHomeFailureFault	no. of faults	RW	FinStaplerStuckMiddleHomeFailFC	NVMFaultCounter	shortNatural	No	Fault Counter:11-374-00: FinStaplerStuckMiddle	1.374		
609-222	Fault Counter 11-375-00: FinStaplerJawHomeFailureFault	no. of faults	RW	FinStaplerJawHomeFailFC	NVMFaultCounter	shortNatural	No	Fault Counter:11-375-00: FinStaplerJawHomeFai	1.374		
609-223	Fault Counter 11-376-00: FinStaplerJawStuckHomeFailureFault	no. of faults	RW	FinStaplerJawStuckHomeFailFC	NVMFaultCounter	shortNatural	No	Fault Counter:11-376-00:	1.374		
609-224	Fault Counter 11-377-00: FinStaplerPrimingFailureFault	no. of faults	RW	FinStaplerPrimingFailFC	NVMFaultCounter	shortNatural	No	Fault Counter:11-377-00: FinStaplerPrimingFailu reFault	1.374		
609-225	Fault Counter 11-380-00: FinPunchUnitPaperSideEdgeDetectingFail ureFault	no. of faults	RW	FinPunchPaprSideEdgeDetectFailFC	NVMFaultCounter	shortNatural	No	Fault Counter:11-380-00: FinPunchUnitPaperSid eEdgeDetectingFailure	1.374		
609-226	Fault Counter 11-383-00: FinBBBackStopHomeFailureFault	no. of faults	RW	FinBBBackStopHomeFailFC	NVMFaultCounter	shortNatural	No	Fault Counter:11-383-00: FinBBBackStopHomeF ailureFault	1.374		
609-227	Fault Counter 11-384-00: FinBBTamper1HomeFailureFault	no. of faults	RW	FinBBTamp1HomeFailFC	NVMFaultCounter	shortNatural	No	Fault Counter:11-384-00: FinBBTamper1HomeF ailureFault	1.374		
609-228	Fault Counter 11-391-00: FinBBFlapperHomeFailureFault	no. of faults	RW	FinBBFlapperHomeFailFC	NVMFaultCounter	shortNatural	No	Fault Counter:11-391-00: FinBBFlapperHomeFail ureFault	1.374		
609-229	Fault Counter 11-392-00: FinFrontTamperTrayHomeFailureFault	no. of faults	RW	FinFrontTampTrayHomeFailFC	NVMFaultCounter	shortNatural	No	Fault Counter:11-392-00: FinFrontTamperTrayH omeFailureFault	1.374		
609-230	Fault Counter 11-393-00: FinFrontTamperTrayReturnHomeFailureF ault	no. of faults	RW	FinFrontTampTrayRtrnHomeFailFC	NVMFaultCounter	shortNatural	No	Fault Counter:11-393-00: FinFrontTamperTrayR eturnHomeFailureFault	1.374		
609-231	Fault Counter 11-394-00: FinFrontTamperTrayAwayHomeFailureFa ult	no. of faults	RW	FinFrontTampTrayAwayHomeFailFC	NVMFaultCounter	shortNatural	No	Fault Counter:11-394-00: FinFrontTamperTrayA wayHomeFailureFault	1.374		

609-232	Fault Counter 11-395-00: FinFrontTamperTrayStuckAwayHomeFailureFault	no. of faults	RW	FinFrontTampStuckAwayHomeFailFC	NVMFaultCounter	shortNatural	No	Fault Counter:11-395-00: FinFrontTamperTrayStuckAwayHomeFailureF	1.374		
609-233	Fault Counter 11-396-00: FinRearTamperTrayHomeFailureFault	no. of faults	RW	FinRearTampTrayHomeFailFC	NVMFaultCounter	shortNatural	No	Fault Counter:11-396-00:	1.374		
609-234	Fault Counter 11-397-00: FinRearTamperTrayReturnHomeFailureFault	no. of faults	RW	FinRearTampTrayRtrnHomeFailFC	NVMFaultCounter	shortNatural	No	Fault Counter:11-397-00: FinRearTamperTrayRe	1.374		
609-235	Fault Counter 11-398-00: FinRearTamperTrayAwayHomeFailureFault	no. of faults	RW	FinRearTampTrayAwayHomeFailFC	NVMFaultCounter	shortNatural	No	Fault Counter:11-398-00:	1.374		
609-236	Fault Counter 11-399-00: FinRearTamperTrayReturnAwayHomeFailureFault	no. of faults	RW	FinRearTampRtrnAwayHomeFailFC	NVMFaultCounter	shortNatural	No	Fault Counter:11-399-00: FinRearTamperTrayRe	1.374		
609-237	Fault Counter 11-403-00: FinBBStapleHead2MoveFailureFault	no. of faults	RW	FinBBStapleHead2MoveFailFC	NVMFaultCounter	shortNatural	No	Fault Counter:11-403-00: FinBBStapleHead2MoveFailureFault	1.374		
609-238	Fault Counter 11-411-00: FinBBStapleHead1HomeFailureFault	no. of faults	RW	FinBBStapleHead1HomeFailFC	NVMFaultCounter	shortNatural	No	Fault Counter:11-411-00: FinBBStapleHead1HomeFailureFault	1.374		
609-239	Fault Counter 11-413-00: FinBBStapleHead2HomeFailureFault	no. of faults	RW	FinBBStapleHead2HomeFailFC	NVMFaultCounter	shortNatural	No	Fault Counter:11-413-00: FinBBStapleHead2HomeFailureFault	1.374		
609-240	Fault Counter 11-414-00: FinBMStaplerModuleHomeFault	no. of faults	RW	FinBMStaplerModuleHomeFC	NVMFaultCounter	shortNatural	No	Fault Counter:11-414-00: FinBMStaplerModuleHomeFault	1.374		
609-241	Fault Counter 11-415-00: FinBBCreaseRollGateHomeFailureFault	no. of faults	RW	FinBBCreaseRollGateHomeFailFC	NVMFaultCounter	shortNatural	No	Fault Counter:11-415-00: FinBBCreaseRollGate	1.374		
609-242	Fault Counter 11-416-00: FinBBCreaseBladeHomeFailureFault	no. of faults	RW	FinBBCreaseBladeHomeFailFC	NVMFaultCounter	shortNatural	No	Fault Counter:11-416-00: FinBBCreaseBladeHomeFailureFault	1.374		
609-243	Fault Counter 11-417-00: FinBMFlapperHomeFailureFault	no. of faults	RW	FinBMFlapperHomeFailFC	NVMFaultCounter	shortNatural	No	Fault Counter:11-417-00: FinBMFlapperHomeFailureFault	1.374		
609-244	Fault Counter 11-418-00: FinBMFlapperMoveFailureFault	no. of faults	RW	FinBMFlapperMoveFailFC	NVMFaultCounter	shortNatural	No	Fault Counter:11-418-00: FinBMFlapperMoveFailureFault	1.374		
609-245	Fault Counter 11-419-00: FinBMTamper2HomeFailureFault	no. of faults	RW	FinBMTamp2HomeFailFC	NVMFaultCounter	shortNatural	No	Fault Counter:11-419-00: FinBMTamper2HomeFailureFault	1.374		
609-246	Fault Counter 11-420-00: FinBMTamper2MoveFailureFault	no. of faults	RW	FinBMTamp2MoveFailFC	NVMFaultCounter	shortNatural	No	Fault Counter:11-420-00: FinBMTamper2MoveFailureFault	1.374		

609-247	Fault Counter 11-430-00: FinKickerCycleFailureFault	no. of faults	RW	FinKickerCycleFailFC	NVMFaultCounter	shortNatural	No	Fault Counter:11-430-00: FinKickerCycleFailureFault	1.374		
609-248	Fault Counter 11-440-00: FinPaperPusherReturnHomeFailureFault	no. of faults	RW	FinPaperPusherRtrnHomeFailFC	NVMFaultCounter	shortNatural	No	Fault Counter:11-440-00: FinPaperPusherReturnHomeFailureFault	1.374		
609-249	Fault Counter 11-441-00: FinPaperPusherHomeFailureFault	no. of faults	RW	FinPaperPusherHomeFailFC	NVMFaultCounter	shortNatural	No	Fault Counter:11-441-00: FinPaperPusherHomeFailureFault	1.374		
609-250	Fault Counter 11-442-00: FinPaperPusherReturnAwayHomeFailureFault	no. of faults	RW	FinPaperPusherRtrnAwayHomeFailFC	NVMFaultCounter	shortNatural	No	Fault Counter:11-442-00: FinPaperPusherReturnAwayHomeFailureFault	1.374		
609-251	Fault Counter 11-443-00: FinPaperPusherAwayHomeFailureFault	no. of faults	RW	FinPaperPusherAwayHomeFailFC	NVMFaultCounter	shortNatural	No	Fault Counter:11-443-00: FinPaperPusherAwayHomeFailureFault	1.374		
609-252	Fault Counter 11-450-00: FinEjectorModuleMotorStallFault	no. of faults	RW	FinEjectorModuleMtrStallFC	NVMFaultCounter	shortNatural	No	Fault Counter:11-450-00: FinEjectorModuleMotorStallFault	1.374		
609-253	Fault Counter 11-451-00: FinEjectorPlateMotorStallFailureFault	no. of faults	RW	FinEjectorPlateMtrStallFailFC	NVMFaultCounter	shortNatural	No	Fault Counter:11-451-00: FinEjectorPlateMotorStallFailureFault	1.374		
609-254	Fault Counter 11-452-00: FinEjectorPlateReturnHomeFailureFault	no. of faults	RW	FinEjectorPlateRtrnHomeFailFC	NVMFaultCounter	shortNatural	No	Fault Counter:11-452-00: FinEjectorPlateReturnHomeFailureFault	1.374		
609-255	Fault Counter 11-453-00: FinEjectorPlateHomeFailureFault	no. of faults	RW	FinEjectorPlateHomeFailFC	NVMFaultCounter	shortNatural	No	Fault Counter:11-453-00: FinEjectorPlateHomeFailureFault	1.374		
609-256	Fault Counter 11-454-00: FinLowerPaddleReturnHomeFailureFault	no. of faults	RW	FinLowerPaddleRtrnHomeFailFC	NVMFaultCounter	shortNatural	No	Fault Counter:11-454-00: FinLowerPaddleReturnHomeFailureFault	1.374		
609-257	Fault Counter 11-455-00: FinLowerPaddleHomeFailureFault	no. of faults	RW	FinLowerPaddleHomeFailFC	NVMFaultCounter	shortNatural	No	Fault Counter:11-455-00: FinLowerPaddleHomeFailureFault	1.374		
609-258	Fault Counter 11-456-00: FinEjectorModuleReturnHomeFailureFault	no. of faults	RW	FinEjectorModuleRtrnHomeFailFC	NVMFaultCounter	shortNatural	No	Fault Counter:11-456-00: FinEjectorModuleReturnHomeFailureFault	1.374		

609-259	Fault Counter 11-457-00: FinEjectorModuleHomeFailureFault	no. of faults	RW	FinEjectorModuleHomeFailFC	NVMFaultCounter	shortNatural	No	Fault Counter:11-457-00: FinEjectorModuleHomeFailureFault	1.374		
609-260	Fault Counter 11-458-00: FinEjectorModuleReturnOutFailureFault	no. of faults	RW	FinEjectorModuleRtrnOutFailFC	NVMFaultCounter	shortNatural	No	Fault Counter:11-458-00: FinEjectorModuleReturnOutFailureFault	1.374		
609-261	Fault Counter 11-459-00: FinEjectorModuleOutFailureFault	no. of faults	RW	FinEjectorModuleOutFailFC	NVMFaultCounter	shortNatural	No	Fault Counter:11-459-00: FinEjectorModuleOutFailureFault	1.374		
609-262	Fault Counter 11-460-00: FinStackerMotorStallFailureFault	no. of faults	RW	FinStackerMtrStallFailFC	NVMFaultCounter	shortNatural	No	Fault Counter:11-460-00: FinStackerMotorStallF	1.374		
609-263	Fault Counter 11-461-00: FinStackerBinHomeFailureFault	no. of faults	RW	FinStackerBinHomeFailFC	NVMFaultCounter	shortNatural	No	Fault Counter:11-461-00: FinStackerBinHomeFai	1.374		
609-264	Fault Counter 11-462-00: FinStackerBinMoveFailureFault	no. of faults	RW	FinStackerBinMoveFailFC	NVMFaultCounter	shortNatural	No	Fault Counter:11-462-00: FinStackerBinMoveFailureFault	1.374		
609-265	Fault Counter 11-463-00: FinBM24vUnavailableAtInputFault	no. of faults	RW	FinBM24vUnavailableAtInputFC	NVMFaultCounter	shortNatural	No	Fault Counter:11-463-00: FinBM24vUnavailableA	1.374		
609-266	Fault Counter 11-464-00: FinBM24vInternalFailureFault	no. of faults	RW	FinBM24vInternalFailFC	NVMFaultCounter	shortNatural	No	Fault Counter:11-464-00:	1.374		
609-267	Fault Counter 11-465-00: FinPaddleUnitReturnUpperFailureFault	no. of faults	RW	FinPaddleUnitRtrnUpperFailFC	NVMFaultCounter	shortNatural	No	Fault Counter:11-465-00: FinPaddleUnitReturnUpperFailureFault	1.374		
609-268	Fault Counter 11-466-00: FinPaddleUnitNotUpperFailureFault	no. of faults	RW	FinPaddleUnitNotUpperFailFC	NVMFaultCounter	shortNatural	No	Fault Counter:11-466-00: FinPaddleUnitNotUpperFailureFault	1.374		
609-269	Fault Counter 11-467-00: FinPaddleUnitReturnLowerFailureFault	no. of faults	RW	FinPaddleUnitRtrnLowerFailFC	NVMFaultCounter	shortNatural	No	Fault Counter:11-467-00: FinPaddleUnitReturnLowerFailureFault	1.374		
609-270	Fault Counter 11-468-00: FinPaddleUnitNotLowerFailureFault	no. of faults	RW	FinPaddleUnitNotLowerFailFC	NVMFaultCounter	shortNatural	No	Fault Counter:11-468-00: FinPaddleUnitNotLowerFailureFault	1.374		

609-271	Fault Counter 11-469-00: FinCurlSuppressorReturnHomeFailureFault	no. of faults	RW	FinCurlSuppressorRtrnHomeFailFC	NVMFaultCounter	shortNatural	No	Fault Counter:11-469-00: FinCurlSuppressorReturnHomeFailureFault	1.374		
609-272	Fault Counter 11-470-00: FinCurlSuppressorHomeFailureFault	no. of faults	RW	FinCurlSuppressorHomeFailFC	NVMFaultCounter	shortNatural	No	Fault Counter:11-470-00: FinCurlSuppressorHo	1.374		
609-273	Fault Counter 11-471-00: FinCurlSuppressorReturnAwayFailureFault	no. of faults	RW	FinCurlSuppressorRtrnAwayFailFC	NVMFaultCounter	shortNatural	No	Fault Counter:11-471-00: FinCurlSuppressorRet	1.374		
609-274	Fault Counter 11-472-00: FinCurlSuppressorAwayFailureFault	no. of faults	RW	FinCurlSuppressorAwayFailFC	NVMFaultCounter	shortNatural	No	Fault Counter:11-472-00: FinCurlSuppressorAwa yFailureFault	1.374		
609-275	Fault Counter 11-473-00: FinPressingSupportMotorReturnInitFailureFault	no. of faults	RW	FinPressSupportMtrRtrnInitFailFC	NVMFaultCounter	shortNatural	No	Fault Counter:11-473-00: FinPressingSupportMo torReturnInitFailureFau lt	1.374		
609-276	Fault Counter 11-474-00: FinPressingSupportMotorInitFailureFault	no. of faults	RW	FinPressSupportMtrInitFailFC	NVMFaultCounter	shortNatural	No	Fault Counter:11-474-00: FinPressingSupportMo torInitFailureFault	1.374		
609-277	Fault Counter 11-475-00: FinPressingSupportMotorReturnHomeFailureFault	no. of faults	RW	FinPressSupportMtrRtrnHomeFailFC	NVMFaultCounter	shortNatural	No	Fault Counter:11-475-00: FinPressingSupportMo torReturnHomeFailure Fault	1.374		
609-278	Fault Counter 11-476-00: FinPressingSupportMotorHomeFailureFault	no. of faults	RW	FinPressSupportMtrHomeFailFC	NVMFaultCounter	shortNatural	No	Fault Counter:11-476-00: FinPressingSupportMo torHomeFailureFault	1.374		
609-279	Fault Counter 11-477-00: FinPressingSupportMotorReturnOutFailureFault	no. of faults	RW	FinPressSupportMtrRtrnOutFailFC	NVMFaultCounter	shortNatural	No	Fault Counter:11-477-00: FinPressingSupportMo torReturnOutFailureFa ult	1.374		
609-280	Fault Counter 11-478-00: FinPressingSupportMotorOutFailureFault	no. of faults	RW	FinPressSupportMtrOutFailFC	NVMFaultCounter	shortNatural	No	Fault Counter:11-478-00: FinPressingSupportMo torOutFailureFault	1.374		
609-281	Fault Counter 11-479-00: FinShortSheetFedFromInserterFault	no. of faults	RW	FinShortShtFedFmInserterFC	NVMFaultCounter	shortNatural	No	Fault Counter:11-479-00: FinShortSheetFedFro mInserterFault	1.374		

609-282	Fault Counter 11-701-00: OctNotInIndexPositionFault	no. of faults	RW	OctNotInIndexPosFC	NVMFaultCounter	shortNatural	No	Fault Counter:11-701-00: OctNotInIndexPosition Fault	1.374		
609-283	Tray 9 Media Type	MTStandard = 0, MTDrilled = 1, MTEvelope = 3, ... MTRoughStock = 58,	RW	Tray 9 Media Type	NVMSAKOSetting	shortNatural	No		1.554		
609-284	Tray 9 Media Color	MCWhite = 0, MCGreen = 1, MCBuff = 2, ... MCCustom6 = 19,	RW	Tray 9 Media Color	NVMSAKOSetting	shortNatural	No		1.380		
609-285	Tray 9 Media Weight		RW	Tray 9 Media Weight	NVMSAKOSetting	shortNatural	No		1.380		
609-286	Tray 9 Direct Select	TSDirectOnly = 0, TSDirectAndAuto = 1	RW	Tray 9 Direct Select	NVMSAKOSetting	shortNatural	No		1.380		
609-287	Tray 9 Priority		RW	Tray 9 Priority	NVMSAKOSetting	shortNatural	No		1.380		
609-288	Tray 9 Width	Range and default size in mm	RW	Tray 9 Width	NVMSAKOSetting	natural	No		1.380		
609-289	Tray 9 Length	Range and default size in mm	RW	Tray 9 Length	NVMSAKOSetting	natural	No		1.380		
609-290	Tray 9 Percent Full		RW	Tray 9 Percent Full	NVMSAKOSetting	shortNatural	No		1.380		
609-291	Tray 9 User Type	TAFixed = 0, TAAdjustableAll = 1, ----- [TAAdjustableSizeOnly = 2]	RW	Tray 9 User Type	NVMSAKOSetting	shortNatural	No		1.380		
609-292	Tray 9 Modulus		RW	Tray 9 Modulus	NVMSAKOSetting	shortNatural	No		1.380		
609-293	Tray 9 Modulus Position		RW	Tray 9 Modulus Position	NVMSAKOSetting	shortNatural	No		1.380		

609-294	Tray 10 Media Type	MTStandard = 0, MTDrilled = 1, MTEvelope = 3,	RW	Tray 10 Media Type	NVMSAKOSetting	shortNatural	No		1.554		
609-295	Tray 10 Media Color	MCWhite = 0, MCGreen = 1, MCBuff = 2, ... MCCustom6 = 19,	RW	Tray 10 Media Color	NVMSAKOSetting	shortNatural	No		1.380		
609-296	Tray 10 Media Weight		RW	Tray 10 Media Weight	NVMSAKOSetting	shortNatural	No		1.380		
609-297	Tray 10 Direct Select	TSDirectOnly = 0, TSDirectAndAuto = 1	RW	Tray 10 Direct Select	NVMSAKOSetting	shortNatural	No		1.380		
609-298	Tray 10 Priority		RW	Tray 10 Priority	NVMSAKOSetting	shortNatural	No		1.380		
609-299	Tray 10 Width	Range and default size in mm	RW	Tray 10 Width	NVMSAKOSetting	natural	No		1.380		
609-300	Tray 10 Length	Range and default size in mm	RW	Tray 10 Length	NVMSAKOSetting	natural	No		1.380		
609-301	Tray 10 Percent Full		RW	Tray 10 Percent Full	NVMSAKOSetting	shortNatural	No		1.380		
609-302	Tray 10 User Type	TAFixed = 0, TAAdjustableAll = 1, ----- [TAAdjustableSizeOnly =	RW	Tray 10 User Type	NVMSAKOSetting	shortNatural	No		1.380		
609-303	Tray 10 Modulus		RW	Tray 10 Modulus	NVMSAKOSetting	shortNatural	No		1.380		
609-304	Tray 10 Modulus Position		RW	Tray 10 Modulus Position	NVMSAKOSetting	shortNatural	No		1.380		
609-305	Tray 11 Media Type	MTStandard = 0, MTDrilled = 1, MTEvelope = 3, ...	RW	Tray 11 Media Type	NVMSAKOSetting	shortNatural	No		1.554		
609-306	Tray 11 Media Color	MCWhite = 0, MCGreen = 1, MCBuff = 2, ...	RW	Tray 11 Media Color	NVMSAKOSetting	shortNatural	No		1.380		

609-307	Tray 11 Media Weight		RW	Tray 11 Media Weight	NVMSAKOSetting	shortNatural	No		1.380		
609-308	Tray 11 Direct Select	TSDirectOnly = 0, TSDirectAndAuto = 1	RW	Tray 11 Direct Select	NVMSAKOSetting	shortNatural	No		1.380		
609-309	Tray 11 Priority		RW	Tray 11 Priority	NVMSAKOSetting	shortNatural	No		1.380		
609-310	Tray 11 Width	Range and default size in mm	RW	Tray 11 Width	NVMSAKOSetting	natural	No		1.380		
609-311	Tray 11 Length	Range and default size in mm	RW	Tray 11 Length	NVMSAKOSetting	natural	No		1.380		
609-312	Tray 11 Percent Full		RW	Tray 11 Percent Full	NVMSAKOSetting	shortNatural	No		1.380		
609-313	Tray 11 User Type	TAFixed = 0, TAAdjustableAll = 1, ----- [TAAdjustableSizeOnly = 2]	RW	Tray 11 User Type	NVMSAKOSetting	shortNatural	No		1.380		
609-314	Tray 11 Modulus		RW	Tray 11 Modulus	NVMSAKOSetting	shortNatural	No		1.380		
609-315	Tray 11 Modulus Position		RW	Tray 11 Modulus Position	NVMSAKOSetting	shortNatural	No		1.380		
609-316	PFP Kit Type installed in PFP	0=Standard (A4 & Letter LEF) 1=Kit A (A3 SEF & A4 LEF) 2=Kit A (11x17 SEF &	RW	PFP Kit Type	NVMSAKOSetting	shortNatural	No		1.380		
609-319	Tray 4 Feed Rolls life expectancy	Feeds - adjustable by CSE	RW	Tray4FeedRollsExpLife	NVMConfiguration	longNatural	No		1.434		
609-319	Tray 4 Pick & Separator Roller life expectancy	Feeds - adjustable by CSE	RW	Tray4FeedRollsExpLife	NVMConfiguration	longNatural	No		1.805		
609-320	Tray 4 Feed Rolls install date	unix timedate - set when	ND	Tray4FeedRollsInstDate	NVMConfiguration	longNatural	No		1.667		

609-321	Tray 4 Feed Rolls replacement counter	Replacements - incremented when user	RW	Tray4FeedRollsRepCount	NVMSystemUsageCounter	natural	No	Unknown	1.426		
609-322	Tray 1 Transport Rolls life counter	Feeds - counted by	RW	Tray1TransportRollsLifeCount	NVMHFSICounter	longNatural	No		1.426		
609-323	Tray 1 Transport Rolls life expectancy	Feeds - adjustable by	RW	Tray1TransportRollsExpLife	NVMConfiguration	longNatural	No		1.426		
609-324	Tray 1 Transport Rolls install date	unix timedate - set when user resets count	ND	Tray1TransportRollsInstDate	NVMConfiguration	longNatural	No		1.667		
609-325	Tray 1 Transport Rolls replacement counter	Replacements - incremented when user resets life counter	RW	Tray1TransportRollsRepCount	NVMSystemUsageCounter	natural	No	Unknown	1.426		
609-326	Tray 2 Transport Rolls life counter	Feeds - counted by system	RW	Tray2TransportRollsLifeCount	NVMHFSICounter	longNatural	No		1.426		
609-327	Tray 2 Transport Rolls life expectancy	Feeds - adjustable by CSE	RW	Tray2TransportRollsExpLife	NVMConfiguration	longNatural	No		1.426		
609-328	Tray 2 Transport Rolls install date	unix timedate - set when user resets count	ND	Tray2TransportRollsInstDate	NVMConfiguration	longNatural	No		1.667		
609-329	Tray 2 Transport Rolls replacement counter	Replacements - incremented when user resets life counter	RW	Tray2TransportRollsRepCount	NVMSystemUsageCounter	natural	No	Unknown	1.426		
609-330	Tray 3/4 Transport Rolls life counter	Feeds - counted by system	RW	Tray3/4TransportRollsLifeCount	NVMHFSICounter	longNatural	No		1.426		
609-331	Tray 3/4 Transport Rolls life expectancy	Feeds - adjustable by CSE	RW	Tray3/4TransportRollsLimit	NVMConfiguration	longNatural	No		1.426		
609-332	Tray 3/4 Transport Rolls install date	unix timedate - set when user resets count	ND	Tray3/4TransportRollsInstDate	NVMConfiguration	longNatural	No		1.667		

609-333	Tray 3/4 Transport Rolls replacement counter	Replacements - incremented when user resets life counter	RW	Tray3/4TransportRollsRepCount	NVMSystemUsageCounter	natural	No	Unknown	1.426		
609-334	Split Drive Rolls life counter	Feeds - counted by system	RW	SplitDriveRollsLifeCount	NVMHFSICounter	longNatural	No		1.426		
609-335	Split Drive Rolls life expectancy	Feeds - adjustable by CSE	RW	SplitDriveRollsExpLife	NVMConfiguration	longNatural	No		1.426		
609-336	Split Drive Rolls install date	unix timedate - set when user resets count	ND	SplitDriveRollsInstDate	NVMConfiguration	longNatural	No		1.667		
609-337	Split Drive Rolls replacement counter	Replacements - incremented when user resets life counter	RW	SplitDriveRollsRepCount	NVMSystemUsageCounter	natural	No	Unknown	1.426		
609-338	Duplex Sensor Rolls life counter	Feeds - counted by system	RW	DuplexSensorRollsLifeCount	NVMHFSICounter	longNatural	No		1.426		
609-339	Duplex Sensor Rolls life expectancy	Feeds - adjustable by CSE	RW	DuplexSensorRollsExpLife	NVMConfiguration	longNatural	No		1.426		

609-340	Duplex Sensor Rolls install date	unix timedate - set when user resets count	ND	DuplexSensorRollsInstDate	NVMConfiguration	longNatural	No		1.667		
609-341	Duplex Sensor Rolls replacement counter	Replacements - incremented when user resets life counter	RW	DuplexSensorRollsRepCount	NVMSystemUsageCounter	natural	No	Unknown	1.426		
609-342	Bias Foam life counter	Feeds - counted by system	RW	BiasFoamLifeCount	NVMHFSICounter	longNatural	No		1.426		
609-343	Bias Foam life expectancy	Feeds - adjustable by CSE	RW	BiasFoamExpLife	NVMConfiguration	longNatural	No		1.434		
609-344	Bias Foam install date	unix timedate - set when user resets count	ND	BiasFoamInstDate	NVMConfiguration	longNatural	No		1.667		
609-345	Bias Foam replacement counter	Replacements - incremented when user resets life counter	RW	BiasFoamRepCount	NVMSystemUsageCounter	natural	No	Unknown	1.426		
609-346	Developer Drive Gear life counter	Feeds - counted by system	RW	DeveloperDriveGearLifeCount	NVMHFSICounter	longNatural	No		1.426		
609-347	Developer Drive Gear life expectancy	Feeds - adjustable by CSE	RW	DeveloperDriveGearExpLife	NVMConfiguration	longNatural	No		1.426		
609-348	Developer Drive Gear install date	unix timedate - set when user resets count	ND	DeveloperDriveGearInstDate	NVMConfiguration	longNatural	No		1.667		
609-349	Developer Drive Gear replacement counter	Replacements - incremented when user resets life counter	RW	DeveloperDriveGearRepCount	NVMSystemUsageCounter	natural	No	Unknown	1.426		

609-350	Post Fuser Rolls life counter	Feeds - counted by system	RW	PostFuserRollsLifeCount	NVMHFSICounter	longNatural	No		1.426		
609-351	Post Fuser Rolls life expectancy	Feeds - adjustable by CSE	RW	PostFuserRollsExpLife	NVMConfiguration	longNatural	No		1.426		
609-352	Post Fuser Rolls install date	unix timedate - set when user resets count	ND	PostFuserRollsInstDate	NVMConfiguration	longNatural	No		1.667		
609-353	Post Fuser Rolls replacement counter	Replacements - incremented when user	RW	PostFuserRollsRepCount	NVMSystemUsageCounter	natural	No	Unknown	1.426		
609-354	HVF Paddle life counter	Feeds - counted by system	RW	HVFPaddleLifeCount	NVMHFSICounter	longNatural	No		1.426		
609-355	HVF Paddle life expectancy	Feeds - adjustable by CSE	RW	HVFPaddleExpLife	NVMConfiguration	longNatural	No		1.434		
609-356	HVF Paddle install date	unix timedate - set when user resets count	ND	HVFPaddleInstDate	NVMConfiguration	longNatural	No		1.667		
609-357	HVF Paddle replacement counter	Replacements - incremented when user resets life counter	RW	HVFPaddleRepCount	NVMSystemUsageCounter	natural	No	Unknown	1.426		
609-358	Fault Counter 12-494-00: BMLELateToBMDetectSensor	no. of faults	RW	BMLELateToBMDetectSensor	NVMFaultCounter	shortNatural	No	Fault Counter:12-494-00:	1.678		
609-359	Fault Counter 12-496-00: BMTELateFromBMDetectSensor	no. of faults	RW	BMTELateFromBMDetectSensor	NVMFaultCounter	shortNatural	No	Fault Counter:12-496-00:	1.678		
609-364	Total since activation date	Total since activation date	ND	LW Cardstock Large Sheets Used	NVMSystemUsageCounter	byteArray	No	System Usage Counter 926: Lightweight Cardstock Large Sheets Used	1.799		
609-368	Total since activation date	Total since activation date	ND	Cardstock Large Sheets Used	NVMSystemUsageCounter	byteArray	No	System Usage Counter 928: Cardstock Large Sheets Used	1.799		
609-372	Total since activation date	Total since activation date	ND	HW Cardstock Large Sheets Used	NVMSystemUsageCounter	byteArray	No	System Usage Counter 930: Heavyweight Cardstock Large	1.799		
609-373	Total since activation date	Total since activation date	ND	HW Cardstock LG Reload Sheets	NVMSystemUsageCounter	byteArray	No	System Usage Counter 931: Heavyweight Cardstock Reloaded	1.799		
609-374	Stores local density adjustment for DC1037	Degrees (Range -3 to +3)	RW	Density Adjustment	NVMSAKOSetting	shortInteger	No		1.513		
609-375	Fault Counter 12-352-00: BMSTAPLEHEAD1PRIMINGFAULT	no. of faults	RW	BMSTAPLEHEAD1PRIMINGFAULT	NVMFaultCounter	shortNatural	No	Fault Counter:12-352-00: BMSTAPLEHEAD1PRI	1.515		
609-376	Fault Counter 12-353-00: BMSTAPLEHEAD2PRIMINGFAULT	no. of faults	RW	BMSTAPLEHEAD2PRIMINGFAULT	NVMFaultCounter	shortNatural	No	Fault Counter:12-353-00: BMSTAPLEHEAD2PRI	1.515		

609-377	Fault Counter 61-100-00: LEDPRINTEADDDATAINTEGRITYFAILURE	no. of faults	RW	LEDPRINTEADDDATAINTEGRITYFAILURE	NVMFaultCounter	shortNatural	No	Fault Counter:61-100-00: LEDPRINTEADDDATA	1.515		
609-378	Fault Counter 10-702-00: OFFSETCENTRETRAYMOTORFAILURE	no. of faults	RW	OFFSETCENTRETRAYMOTORFAILURE	NVMFaultCounter	shortNatural	No	Fault Counter:10-702-00: OFFSETCENTRETRA	1.515		
609-379	Fault Counter 93-364-00: TCNOTINRANGEFAULT	no. of faults	RW	TCNOTINRANGEFAULT	NVMFaultCounter	shortNatural	No	Fault Counter:93-364-00: TCNOTINRANGEFAU	1.515		
609-380	Fault Counter 10-170-00: LELATETO HORIZONTALTRANSPORT	no. of faults	RW	LELATETO HORIZONTALTRANSPORT	NVMFaultCounter	shortNatural	No	Fault Counter:10-170-00: LELATETO HORIZONTAL	1.515		
609-381	Fault Counter 10-171-00: TELATEFROMHORIZONTALTRANSPORT	no. of faults	RW	TELATEFROMHORIZONTALTRANSPORT	NVMFaultCounter	shortNatural	No	Fault Counter:10-171-00: TELATEFROMHORIZ	1.515		
609-382	Fault Counter 10-338-00: HORIZONTALTRANSPORTOPENINRUN	no. of faults	RW	HORIZONTALTRANSPORTOPENINRUN	NVMFaultCounter	shortNatural	No	Fault Counter:10-338-00: HORIZONTALTRANSPORTOPENINRUN	1.515		
609-383	Fault Counter 81-151-00: LELATETO REGSENSORSIMPLEX	no. of faults	RW	LELATETO REGSENSORSIMPLEX	NVMFaultCounter	shortNatural	No	Fault Counter:81-151-00: LELATETO REGSENS	1.515		
609-384	Fault Counter 81-152-00:	no. of faults	RW	TELATETO REGSENSORSIMPLEX	NVMFaultCounter	shortNatural	No	Fault Counter:81-152-	1.515		
609-385	Fault Counter 10-153-00:	no. of faults	RW	LELATETOPOSTFUSERSENSORSIMPLEX	NVMFaultCounter	shortNatural	No	Fault Counter:10-153-	1.515		
609-386	Fault Counter 10-154-00: TELATETOPOSTFUSERSENSORSIMPLEX	no. of faults	RW	TELATETOPOSTFUSERSENSORSIMPLEX	NVMFaultCounter	shortNatural	No	Fault Counter:10-154-00:	1.515		
609-387	Fault Counter 83-155-00: LELATETODUPLEXSENSOR	no. of faults	RW	LELATETODUPLEXSENSOR	NVMFaultCounter	shortNatural	No	Fault Counter:83-155-00:	1.515		
609-388	Fault Counter 83-156-00: TELATETODUPLEXSENSOR	no. of faults	RW	TELATETODUPLEXSENSOR	NVMFaultCounter	shortNatural	No	Fault Counter:83-156-00: TELATETODUPLEXSENSOR	1.515		
609-389	Fault Counter 81-136-00: LELATETOFEEDHCFLH	no. of faults	RW	LELATETOFEEDHCFLH	NVMFaultCounter	shortNatural	No	Fault Counter:81-136-00: LELATETOFEEDHCFL	1.515		
609-390	Fault Counter 81-137-00: TELATETOFEEDHCFLH	no. of faults	RW	TELATETOFEEDHCFLH	NVMFaultCounter	shortNatural	No	Fault Counter:81-137-00: TELATETOFEEDHCF	1.515		
609-391	Fault Counter 81-159-00: LELATETOHCXFEXITFROMTRAY3	no. of faults	RW	LELATETOHCXFEXITFROMTRAY3	NVMFaultCounter	shortNatural	No	Fault Counter:81-159-00: LELATETOHCXFEXITF	1.515		
609-392	Fault Counter 81-160-00: TELATETOFEEDERRHTARSENSOR	no. of faults	RW	TELATETOFEEDERRHTARSENSOR	NVMFaultCounter	shortNatural	No	Fault Counter:81-160-00: TELATETOFEEDERR	1.515		
609-393	Fault Counter 81-146-00: LELATETOFEEDHCFRH	no. of faults	RW	LELATETOFEEDHCFRH	NVMFaultCounter	shortNatural	No	Fault Counter:81-146-00:	1.515		
609-394	Fault Counter 81-147-00: TELATETOFEEDHCFRH	no. of faults	RW	TELATETOFEEDHCFRH	NVMFaultCounter	shortNatural	No	Fault Counter:81-147-00:	1.515		

609-395	Fault Counter 81-106-00: LELATETOTAR1SENSORFROMTRAY1	no. of faults	RW	LELATETOTAR1SENSORFROMTRAY1	NVMFaultCounter	shortNatural	No	Fault Counter:81-106-00: LELATETOTAR1SENSORFROMTRAY1	1.515		
609-396	Fault Counter 81-126-00:	no. of faults	RW	LELATETOTAR2SENSORFROMTRAY1	NVMFaultCounter	shortNatural	No	Fault Counter:81-126-00:	1.515		
609-397	Fault Counter 81-107-00: TELATETOTAR1SENSORFROMTRAY1	no. of faults	RW	TELATETOTAR1SENSORFROMTRAY1	NVMFaultCounter	shortNatural	No	Fault Counter:81-107-00: TELATETOTAR1SEN	1.515		
609-398	Fault Counter 81-127-00: TELATETOTAR2SENSORFROMTRAY2	no. of faults	RW	TELATETOTAR2SENSORFROMTRAY2	NVMFaultCounter	shortNatural	No	Fault Counter:81-127-00: TELATETOTAR2SEN	1.515		
609-399	Fault Counter 10-400-00: FRUMISSINGORCOMMSFAILUREFAULT	no. of faults	RW	FRUMISSINGORCOMMSFAILUREFAULT	NVMFaultCounter	shortNatural	No	Fault Counter:10-400-00: FRUMISSINGORCOM	1.515		
609-400	Fault Counter 92-400-00: PCMISSINGORCOMMSFAILUREFAULT	no. of faults	RW	PCMISSINGORCOMMSFAILUREFAULT	NVMFaultCounter	shortNatural	No	Fault Counter:92-400-00: PCMISSINGORCOMM	1.515		
609-401	Fault Counter 10-163-00: LELATETOPOSTFUSERSENSORDUPL X	no. of faults	RW	LELATETOPOSTFUSERSENSORDUPL X	NVMFaultCounter	shortNatural	No	Fault Counter:10-163-00: LELATETOPOSTFUS ERSENSORDUPL X	1.515		
609-402	Fault Counter 10-164-00: TELATETOPOSTFUSERSENSORDUPL X	no. of faults	RW	TELATETOPOSTFUSERSENSORDUPL X	NVMFaultCounter	shortNatural	No	Fault Counter:10-164-00: TELATETOPOSTFUS ERSENSORDUPL X	1.515		
609-403	Fault Counter 71-217-00: TRAY1BUMPUPFAILURE	no. of faults	RW	TRAY1BUMPUPFAILURE	NVMFaultCounter	shortNatural	No	Fault Counter:71-217-00: TRAY1BUMPUPFAILU RE	1.515		
609-404	Fault Counter 81-161-00: LELATETOREGSENSORDUPL X	no. of faults	RW	LELATETOREGSENSORDUPL X	NVMFaultCounter	shortNatural	No	Fault Counter:81-161-00: LELATETOREGSENS	1.515		
609-405	Fault Counter 81-162-00: TELATETOREGSENSORDUPL X	no. of faults	RW	TELATETOREGSENSORDUPL X	NVMFaultCounter	shortNatural	No	Fault Counter:81-162-00: TELATETOREGSENS ORDUPL X	1.515		
609-406	Fault Counter 81-167-00: LELATETOHCFTTRANSPORT	no. of faults	RW	LELATETOHCFTTRANSPORT	NVMFaultCounter	shortNatural	No	Fault Counter:81-167-00: LELATETOHCFTTRAN SPORT	1.515		

609-407	SPARED (was Fault Counter 81-168-00: TELATETOHCFTTRANSPORT)	no. of faults	ND	SPARE 609-407	NVMFaultCounter	shortNatural	No	Fault Counter:81-168-00: TELATETOHCFTTRANSPORT	1.515		
609-408	Fault Counter 10-399-00: FUSERINCOMPATIBLEFAULT	no. of faults	RW	FUSERINCOMPATIBLEFAULT	NVMFaultCounter	shortNatural	No	Fault Counter:10-399-00: FUSERINCOMPATIBLEFAULT	1.515		
609-409	Fault Counter 10-340-00: FUSERTEMPERATUREREADINGFAILURE	no. of faults	RW	FUSERTEMPERATUREREADINGFAILURE	NVMFaultCounter	shortNatural	No	Fault Counter:10-340-00: FUSERTEMPERATUREREADINGFAILURE	1.515		
609-410	Fault Counter 81-155-00: LELATETOREGSENSORFROMTRAY5	no. of faults	RW	LELATETOREGSENSORFROMTRAY5	NVMFaultCounter	shortNatural	No	Fault Counter:81-155-00: LELATETOREGSENSORFROMTRAY5	1.515		
609-411	Fault Counter 93-401-00: TONEBOTTLERMISSINGFAULT	no. of faults	RW	TONEBOTTLERMISSINGFAULT	NVMFaultCounter	shortNatural	No	Fault Counter:93-401-00: TONEBOTTLERMISSINGFAULT	1.515		
609-412	Fault Counter 93-399-00: TONERCARTRIDGEINCOMPATIBLEFAULT	no. of faults	RW	TONERCARTRIDGEINCOMPATIBLEFAULT	NVMFaultCounter	shortNatural	No	Fault Counter:93-399-00: TONERCARTRIDGEINCOMPATIBLEFAULT	1.515		
609-413	Fault Counter 93-365-00: HIGHACMODERECOVERYFAULT	no. of faults	RW	HIGHACMODERECOVERYFAULT	NVMFaultCounter	shortNatural	No	Fault Counter:93-365-00: HIGHACMODERECOVERYFAULT	1.515		
609-414	Fault Counter 81-190-00: LELATETOREGFROMTRAY1	no. of faults	RW	LELATETOREGFROMTRAY1	NVMFaultCounter	shortNatural	No	Fault Counter:81-190-00: LELATETOREGFROMTRAY1	1.515		
609-415	Fault Counter 81-191-00: LELATETOREGFROMTRAY2	no. of faults	RW	LELATETOREGFROMTRAY2	NVMFaultCounter	shortNatural	No	Fault Counter:81-191-00: LELATETOREGFROMTRAY2	1.515		
609-416	Fault Counter 81-192-00: LELATETOREGFROMTRAY3	no. of faults	RW	LELATETOREGFROMTRAY3	NVMFaultCounter	shortNatural	No	Fault Counter:81-192-00: LELATETOREGFROMTRAY3	1.515		
609-417	Fault Counter 81-193-00: LELATETOREGFROMTRAY4	no. of faults	RW	LELATETOREGFROMTRAY4	NVMFaultCounter	shortNatural	No	Fault Counter:81-193-00: LELATETOREGFROMTRAY4	1.515		
609-418	Fault Counter 81-194-00: LELATETOTAR1FROMTRAY2	no. of faults	RW	LELATETOTAR1FROMTRAY2	NVMFaultCounter	shortNatural	No	Fault Counter:81-194-00: LELATETOTAR1FROMTRAY2	1.515		
609-419	Fault Counter 81-195-00: LELATETOTAR1FROMTRAY3	no. of faults	RW	LELATETOTAR1FROMTRAY3	NVMFaultCounter	shortNatural	No	Fault Counter:81-195-00: LELATETOTAR1FROMTRAY3	1.515		

609-420	Fault Counter 81-196-00: LELATETOTAR1FROMTRAY4	no. of faults	RW	LELATETOTAR1FROMTRAY4	NVMFaultCounter	shortNatural	No	Fault Counter:81-196-00: LELATETOTAR1FRO	1.515		
609-421	Fault Counter 81-197-00: LELATETOTAR2FROMTRAY3	no. of faults	RW	LELATETOTAR2FROMTRAY3	NVMFaultCounter	shortNatural	No	Fault Counter:81-197-00: LELATETOTAR2FRO	1.515		
609-422	Fault Counter 81-198-00: LELATETOTAR2FROMTRAY4	no. of faults	RW	LELATETOTAR2FROMTRAY4	NVMFaultCounter	shortNatural	No	Fault Counter:81-198-00: LELATETOTAR2FRO	1.515		
609-423	Fault Counter 81-199-00: LELATETOHCXFEXITFROMTRAY4	no. of faults	RW	LELATETOHCXFEXITFROMTRAY4	NVMFaultCounter	shortNatural	No	Fault Counter:81-199-00: LELATETOHCXFEXITF	1.515		
609-424	Fault Counter 81-200-00: UNEXPECTEDSHEETATREG	no. of faults	RW	UNEXPECTEDSHEETATREG	NVMFaultCounter	shortNatural	No	Fault Counter:81-200-00: UNEXPECTEDSHEET ATREG	1.515		
609-425	Fault Counter 10-201-00: UNEXPECTEDSHEETATPOSTFUSER	no. of faults	RW	UNEXPECTEDSHEETATPOSTFUSER	NVMFaultCounter	shortNatural	No	Fault Counter:10-201-00: UNEXPECTEDSHEET ATPOSTFUSER	1.678		
609-426	Fault Counter 83-157-00: UNEXPECTEDSHEETATDUPLEX	no. of faults	RW	UNEXPECTEDSHEETATDUPLEX	NVMFaultCounter	shortNatural	No	Fault Counter:83-157-00: UNEXPECTEDSHEET	1.515		
609-427	Fault Counter 10-172-00: UNEXPECTEDSHEETATFINXPORT	no. of faults	RW	UNEXPECTEDSHEETATFINXPORT	NVMFaultCounter	shortNatural	No	Fault Counter:10-172-00: UNEXPECTEDSHEET ATFINXPORT	1.515		
609-428	Fault Counter 75-100-00: TRAY5(MSI)HOISTFAILURE	no. of faults	RW	TRAY5(MSI)HOISTFAILURE	NVMFaultCounter	shortNatural	No	Fault Counter:75-100-00: TRAY5(MSI)HOISTFAI LURE	1.515		
609-429	Fault Counter 03-800-00: FINISHERCOMMSRESETAFTERACRASH	no. of faults	RW	FINISHERCOMMSRESETAFTERACRASH	NVMFaultCounter	shortNatural	No	Fault Counter:03-800-00: FINISHERCOMMSRE SETAFTERACRASH	1.678		
609-430	Fault Counter 12-984-00: BOOKLETLOWSTAPLEFRONTFAULTCOUNT	no. of faults	RW	BOOKLETLOWSTAPLEFRONTFAULTCOUNT	NVMFaultCounter	shortNatural	No	Fault Counter:12-984-00: BOOKLETLOWSTAPL EFRONTFAULTCOUN T	1.813		
609-431	Fault Counter 12-989-00: BOOKLETLOWSTAPLEREARFAULTCOUNT	no. of faults	RW	BOOKLETLOWSTAPLEREARFAULTCOUNT	NVMFaultCounter	shortNatural	No	Fault Counter:12-989-00: BOOKLETLOWSTAPL EREARFAULTCOUNT	1.813		

609-432	Fault Counter 12-130-00: FOLDERPATHSNR1ONJAMFAULTCOUNT	no. of faults	RW	FOLDERPATHSNR1ONJAMFAULTCOUNT	NVMFaultCounter	shortNatural	No	Fault Counter:12-130-00: FOLDERPATHSNR1ONJAMFAULTCOUNT	1.813		
609-433	Fault Counter 12-131-00: COMPILEEXITSNRONJAMBUFFERFAULTCOUNT	no. of faults	RW	COMPILEEXITSNRONJAMBUFFERFAULTCOUNT	NVMFaultCounter	shortNatural	No	Fault Counter:12-131-00: COMPILEEXITSNRONJAMBUFFERFAULTCOUNT	1.813		
609-434	Fault Counter 12-135-00: COMPILEEXITSNRONJAMSTRBUFFERFAULTCOUNT	no. of faults	RW	COMPILEEXITSNRONJAMSTRBUFFERFAULTCOUNT	NVMFaultCounter	shortNatural	No	Fault Counter:12-135-00: COMPILEEXITSNRONJAMSTRBUFFERFAULTCOUNT	1.813		
609-435	Fault Counter 12-136-00: FOLDEREXITSNRONJAMFOLDFAULTCOUNT	no. of faults	RW	FOLDEREXITSNRONJAMFOLDFAULTCOUNT	NVMFaultCounter	shortNatural	No	Fault Counter:12-136-00: FOLDEREXITSNRONJAMFOLDFAULTCOUNT	1.813		
609-436	Fault Counter 12-222-00: UPENDGUIDEHOMESNROFFFAILFAULTCOUNT	no. of faults	RW	UPENDGUIDEHOMESNROFFFAILFAULTCOUNT	NVMFaultCounter	shortNatural	No	Fault Counter:12-222-00: UPENDGUIDEHOMESNROFFFAILFAULTCOUNT	1.813		
609-437	Fault Counter 12-274-00: LOWENDGUIDEHOMESNROFFFAILFAULTCOUNT	no. of faults	RW	LOWENDGUIDEHOMESNROFFFAILFAULTCOUNT	NVMFaultCounter	shortNatural	No	Fault Counter:12-274-00: LOWENDGUIDEHOMESNROFFFAILFAULTCOUNT	1.813		
609-438	Fault Counter 12-279-00: UPENDGUIDEHOMESNRONFAILFAULTCOUNT	no. of faults	RW	UPENDGUIDEHOMESNRONFAILFAULTCOUNT	NVMFaultCounter	shortNatural	No	Fault Counter:12-279-00: UPENDGUIDEHOMESNRONFAILFAULTCOUNT	1.813		
609-439	Fault Counter 12-288-00: LOWENDGUIDEHOMESNRONFAILFAULTCOUNT	no. of faults	RW	LOWENDGUIDEHOMESNRONFAILFAULTCOUNT	NVMFaultCounter	shortNatural	No	Fault Counter:12-288-00: LOWENDGUIDEHOMESNRONFAILFAULTCOUNT	1.813		
609-440	Fault Counter 12-289-00: FOLDERFANBROKENFAILFAULTCOUNT	no. of faults	RW	FOLDERFANBROKENFAILFAULTCOUNT	NVMFaultCounter	shortNatural	No	Fault Counter:12-289-00: FOLDERFANBROKENFAILFAULTCOUNT	1.813		
609-441	Fault Counter 12-290-00: INTERLOCK24VDISCONNECTFAULTCOUNT	no. of faults	RW	INTERLOCK24VDISCONNECTFAULTCOUNT	NVMFaultCounter	shortNatural	No	Fault Counter:12-290-00: INTERLOCK24VDISCONNECTFAULTCOUNT	1.813		
609-442	Fault Counter 12-292-00: BOOKLETTAMPERHOMESNRONFAILFAULTCOUNT	no. of faults	RW	BOOKLETTAMPERHOMESNRONFAILFAULTCOUNT	NVMFaultCounter	shortNatural	No	Fault Counter:12-292-00: BOOKLETTAMPERHOMESNRONFAILFAULTCOUNT	1.813		
609-443	Fault Counter 12-297-00: BOOKLETTAMPERHOMESNROFFFAILFAULTCOUNT	no. of faults	RW	BOOKLETTAMPERHOMESNROFFFAILFAULTCOUNT	NVMFaultCounter	shortNatural	No	Fault Counter:12-297-00: BOOKLETTAMPERHOMESNROFFFAILFAULTCOUNT	1.813		

609-444	Fault Counter 12-298-00: FOLDERSUBCPUCOMMFAILFAULTCOU	no. of faults	RW	FOLDERSUBCPUCOMMFAILFAULT	NVMFaultCounter	shortNatural	No	Fault Counter:12-298-00:	1.813		
609-445	Fault Counter 12-299-00: COMPILENOPAPERSNRONFAILFAULTC	no. of faults	RW	COMPILENOPAPERSNRONFAILFAI	NVMFaultCounter	shortNatural	No	Fault Counter:12-299-00:	1.813		
609-446	Fault Counter 12-319-00: BOOKLETSCPUDOWNLOADMODEFAI LFAULTCOUNT	no. of faults	RW	BOOKLETSCPUDOWNLOADMODEFAI	NVMFaultCounter	shortNatural	No	Fault Counter:12-319-00: BOOKLETSCPUDOWN LOADMODEFAILF AULTCOUNT	1.813		
609-447	Fault Counter 12-326-00: FOLDERSUBCPUDOWNLOADMODEFAI	no. of faults	RW	FOLDERCPUDOWNLOADMODEFAI	NVMFaultCounter	shortNatural	No	Fault Counter:12-326-00:	1.813		
609-448	Fault Counter 12-912-00: FINISHERSTATICJAMFAULTCOUNT	no. of faults	RW	FINISHERSTATICJAMFAULTCOUN	NVMFaultCounter	shortNatural	No	Fault Counter:12-912-00:	1.813		
609-449	Fault Counter 13-300-00: FOLDERFRONTDOOROPENFAULTCOU	no. of faults	RW	FOLDERFRONTDOOROPENFAULT	NVMFaultCounter	shortNatural	No	Fault Counter:13-300-00:	1.813		
609-450	Punch errors	Punch errors	RO	Punch errors	NVMSystemUsageCounter	longNatural	No	System Usage Counter:933:	1.813		
609-455	Defines the period of time before beeping occurs when left side door is open.	seconds	RW	LSDOpenTimeBeforeBeep	NVMConfiguration	shortNatural	No		1.529		
609-456	Enables/Disables 3mm border on print	0= disable border, 1= enable border (default)	RW	IMAGEBORDERENABLE	NVMSAKOSetting	boolean	No		1.535		
609-457	Fault Counter 91-377: PC cooling event	no. of faults	RW	PcCoolingEventFC	NVMFaultCounter	shortNatural	No	Fault Counter:91-377-00: PcCoolingEvent	1.697		
609-459	Lead Edge Registration		RW	LE Registration	NVMMachVarRegistration	integer	No		1.543		
609-469	Provides capability for manufacturing to adjust color registration and also allows a CSE to set it via DC131.		RW	ManRegiConLeftYellow	NVMMachVarRegistration	shortInteger	No		1.565		
609-470	Provides capability for manufacturing to adjust color registration and also allows a CSE to set it via DC131.		RW	ManRegiConLeftMagenta	NVMMachVarRegistration	shortInteger	No		1.565		
609-471	Provides capability for manufacturing to adjust color registration and also allows a CSE to set it via DC131.		RW	ManRegiConLeftCyan	NVMMachVarRegistration	shortInteger	No		1.565		
609-472	Provides capability for manufacturing to adjust color registration and also allows a CSE to set it via DC131.		RW	ManRegiConRightYellow	NVMMachVarRegistration	shortInteger	No		1.565		
609-473	Provides capability for manufacturing to adjust color registration and also allows a CSE to set it via DC131.		RW	ManRegiConRightMagenta	NVMMachVarRegistration	shortInteger	No		1.565		
609-474	Provides capability for manufacturing to adjust color registration and also allows a CSE to set it via DC131.		RW	ManRegiConRightCyan	NVMMachVarRegistration	shortInteger	No		1.565		
609-475	Provides capability for manufacturing to adjust color registration and also allows a CSE to set it via DC131.		RW	ManRegiConProcessLeftYellow	NVMMachVarRegistration	shortInteger	No		1.565		
609-476	Provides capability for manufacturing to adjust color registration and also allows a CSE to set it via DC131.		RW	ManRegiConProcessLeftMagenta	NVMMachVarRegistration	shortInteger	No		1.565		
609-477	Provides capability for manufacturing to adjust color registration and also allows a CSE to set it via DC131.		RW	ManRegiConProcessLeftCyan	NVMMachVarRegistration	shortInteger	No		1.565		
609-478	Provides capability for manufacturing to adjust color registration and also allows a CSE to set it via DC131.		RW	ManRegiConProcessRightYellow	NVMMachVarRegistration	shortInteger	No		1.565		

609-479	Provides capability for manufacturing to adjust color registration and also allows a CSE to set it via DC131.		RW	ManRegiConProcessRightMagenta	NVMMachVarRegistration	shortInteger	No		1.565		
609-480	Provides capability for manufacturing to adjust color registration and also allows a CSE to set it via DC131.		RW	ManRegiConProcessRightCyan	NVMMachVarRegistration	shortInteger	No		1.565		
609-481	Fault Counter 81-132-00: LELATETOHCXFEXITSENSORFROMTRAY3	no. of faults	RW	LELATETOHCXFEXITSENSORFROMTRAY3	NVMFaultCounter	shortNatural	No	Fault Counter:81-132-00: LELATETOHCXFEXITSENSORFROMTRAY3	1.573		
609-482	Fault Counter 81-133-00: LELATETOHCXFEXITSENSORFROMTRAY4	no. of faults	RW	LELATETOHCXFEXITSENSORFROMTRAY4	NVMFaultCounter	shortNatural	No	Fault Counter:81-133-00: LELATETOHCXFEXITSENSORFROMTRAY4	1.573		
609-483	Fault Counter 93-974-00: GENUINETONERNULLSTRINGCOUNTERK		RO	NullStringCounterK	NVMFaultCounter	shortNatural	No	Fault Counter:93-974-00: GENUINETONERNULLSTRINGCOUNTERK	1.584		
609-484	Fault Counter 93-975-00: GENUINETONERNULLSTRINGCOUNTERC		RO	NullStringCounterC	NVMFaultCounter	shortNatural	No	Fault Counter:93-975-00: GENUINETONERNULLSTRINGCOUNTERC	1.810		
609-485	Fault Counter 93-976-00: GENUINETONERNULLSTRINGCOUNTERM		RO	NullStringCounterM	NVMFaultCounter	shortNatural	No	Fault Counter:93-976-00: GENUINETONERNULLSTRINGCOUNTERM	1.810		
609-486	Fault Counter 93-974-00: GENUINETONERNULLSTRINGCOUNTERY		RO	NullStringCounterY	NVMFaultCounter	shortNatural	No	Fault Counter:93-974-00: GENUINETONERNULLSTRINGCOUNTERY	1.810		
609-487	Fault Counter 93-974-00: GENUINETONERNONXEROXSTRINGCOUNTERK		RO	NonGenuineStringCounterK	NVMFaultCounter	shortNatural	No	Fault Counter:93-974-00: GENUINETONERNONXEROXSTRINGCOUNTERK	1.584		
609-488	Fault Counter 93-974-00: GENUINETONERNONXEROXSTRINGCOUNTERC		RO	NonGenuineStringCounterC	NVMFaultCounter	shortNatural	No	Fault Counter:93-974-00: GENUINETONERNONXEROXSTRINGCOUNTERC	1.810		
609-489	Fault Counter 93-974-00: GENUINETONERNONXEROXSTRINGCOUNTERM		RO	NonGenuineStringCounterM	NVMFaultCounter	shortNatural	No	Fault Counter:93-974-00: GENUINETONERNONXEROXSTRINGCOUNTERM	1.810		
609-490	Fault Counter 93-974-00: GENUINETONERNONXEROXSTRINGCOUNTERY		RO	NonGenuineStringCounterY	NVMFaultCounter	shortNatural	No	Fault Counter:93-974-00: GENUINETONERNONXEROXSTRINGCOUNTERY	1.810		
609-491	IOTCommunicationsTimeout If the IOT fails to respond within the period defined by this NVM then communication	Timer in milliseconds	RW	IOTCommunicationsTimeout	NVMcrashRecoveryType	natural	No		1.589		
609-492	Fault Counter 81-180-00: LELATETOTAR1FROMTRAY6	no. of faults	RW	LELateToTAR1FromTray6	NVMFaultCounter	shortNatural	No	Fault Counter:81-180-00: LELATETOTAR1FROMTRAY6	1.616		
609-493	Fault Counter 81-182-00: LELATETOREGFROMTRAY6	no. of faults	RW	LELateToRegFromTray6	NVMFaultCounter	shortNatural	No	Fault Counter:81-182-00: LELATETOREGFROMTRAY6	1.616		
609-494	Fault Counter 81-184-00: LELATETOFEEDTRAY6	no. of faults	RW	LELateToFEEDTray6	NVMFaultCounter	shortNatural	No	Fault Counter:81-184-00: LELATETOFEEDTRAY6	1.616		
609-496	Enable JobOffset policy	Enable JobOffset policy 0=Off 1=On	RW	MSJobOffsetEnabledPolicy	NVMSAKOSetting	boolean	No		1.754		

609-497	Tray 1 detected width Min	Range and default size in mm	RW	Tray 1 detected width Min	NVMSAKOSetting	natural	No		1.669		
609-498	Tray 1 detected width Max	Range and default size in mm	RW	Tray 1 detected width Max	NVMSAKOSetting	natural	No		1.669		
609-499	Tray 1 detected Length Min	Range and default size in mm	RW	Tray 1 detected Length Min	NVMSAKOSetting	natural	No		1.669		
609-500	Tray 1 detected Length Max	Range and default size in mm	RW	Tray 1 detected Length Max	NVMSAKOSetting	natural	No		1.669		
609-501	Tray 2 detected width Min	Range and default size in mm	RW	Tray 2 detected width Min	NVMSAKOSetting	natural	No		1.669		
609-502	Tray 2 detected width Max	Range and default size in mm	RW	Tray 2 detected width Max	NVMSAKOSetting	natural	No		1.669		
609-503	Tray 2 detected Length Min	Range and default size in mm	RW	Tray 2 detected Length Min	NVMSAKOSetting	natural	No		1.669		
609-504	Tray 2 detected Length Max	Range and default size in mm	RW	Tray 2 detected Length Max	NVMSAKOSetting	natural	No		1.669		
609-505	Tray 3 detected width Min	Range and default size in mm	RW	Tray 3 detected width Min	NVMSAKOSetting	natural	No		1.669		
609-506	Tray 3 detected width Max	Range and default size in mm	RW	Tray 3 detected width Max	NVMSAKOSetting	natural	No		1.669		
609-507	Tray 3 detected Length Min	Range and default size in mm	RW	Tray 3 detected Length Min	NVMSAKOSetting	natural	No		1.669		
609-508	Tray 3 detected Length Max	Range and default size in mm	RW	Tray 3 detected Length Max	NVMSAKOSetting	natural	No		1.669		
609-509	Tray 4 detected width Min	Range and default size in mm	RW	Tray 4 detected width Min	NVMSAKOSetting	natural	No		1.669		

609-510	Tray 4 detected width Max	Range and default size in mm	RW	Tray 4 detected width Max	NVMSAKOSetting	natural	No		1.669		
609-511	Tray 4 detected Length Min	Range and default size in mm	RW	Tray 4 detected Length Min	NVMSAKOSetting	natural	No		1.669		
609-512	Tray 4 detected Length Max	Range and default size in mm	RW	Tray 4 detected Length Max	NVMSAKOSetting	natural	No		1.669		
609-513	Tray 5 detected Length Min	Range and default size in mm	RW	Tray 5 detected Length Min	NVMSAKOSetting	natural	No		1.669		
609-514	Tray 5 detected Length Max	Range and default size in mm	RW	Tray 5 detected Length Max	NVMSAKOSetting	natural	No		1.669		

609-515	Tray 7 detected width	Range and default size in mm	RW	Tray 7 Last detected width	NVMSAKOSetting	natural	No		1.669		
609-516	Tray 7 detected Length	Range and default size in mm	RW	Tray 7 Last detected Length	NVMSAKOSetting	natural	No		1.669		
609-518	Fault Counter 03-450:IOT crash unexpectedly	no of faults	RW	Fault Counter 03-450	NVMFaultCounter	shortNatural	No	Fault Counter:03-450-00: IOTCRASHCOUNT	1.658		
609-519	Fault Counter 74-900: Tray4SheetOverFeedFault	no of faults	RW	Fault Counter 74-900	NVMFaultCounter	shortNatural	No	Fault Counter:74-900-00: TRAY4SHEETOVERFEEDSNRCOUNT	1.664		

609-520	Fault Counter 76-900: Tray6SheetOverFeedFault	no.of faults	RW	Fault Counter 76-900	NVMFaultCounter	shortNatural	No	Fault Counter:76-900-00: TRAY6SHEETOVERFEEDSNRCOUNT	1.664		
609-521	Transport Drive Belt replacement counter	Replacements - incremented when user	RW	TransportDriveBeltRepCount	NVMSystemUsageCounter	natural	No	Unknown	1.677		
609-522	Transport Roll replacement counter	Replacements -	RW	TransportRollRepCount	NVMSystemUsageCounter	natural	No	Unknown	1.677		
609-523	Drive Pulley replacement counter	Replacements - incremented when user	RW	DrivePulleyRepCount	NVMSystemUsageCounter	natural	No	Unknown	1.677		
609-524	Pressure Blade replacement counter	Replacements -	RW	PressureBladeRepCount	NVMSystemUsageCounter	natural	No	Unknown	1.677		
609-525	Transport Drive Belt Life Counter	Feeds - counted by system	RW	TransportDriveBeltLifeCount	NVMHFSICounter	longNatural	No	Unknown	1.677		
609-526	Transport Drive Belt Life Expectancy	Modifiable via DC131	RW	TransportDriveBeltExpLife	NVMConfiguration	longNatural	No	Unknown	1.677		
609-527	Transport Drive Belt Install Date	Transport Belt install date	ND	TransportDriveBeltInstallDate	NVMConfiguration	longNatural	No	Unknown	1.677		
609-528	Transport Roll Life Counter	Feeds - counted by system	RW	TransportRollLifeCount	NVMHFSICounter	longNatural	No	Unknown	1.677		
609-529	Transport Roll Life Expectancy	Modifiable via DC131	RW	TransportRollExpLife	NVMConfiguration	longNatural	No	Unknown	1.677		
609-530	Transport Roll Install Date	Transport Belt install date	ND	TransportRollInstallDate	NVMConfiguration	longNatural	No	Unknown	1.677		
609-531	Drive Pulley Life Counter	Feeds - counted by	RW	DrivePulleyLifeCount	NVMHFSICounter	longNatural	No	Unknown	1.677		
609-532	Drive Pulley Life Expectancy	Modifiable via DC131	RW	DrivePulleyExpLife	NVMConfiguration	longNatural	No	Unknown	1.677		

609-533	Drive Pulley Install Date	Transport Belt install date	ND	DrivePulleyInstallDate	NVMConfiguration	longNatural	No	Unknown	1.677		
609-534	Pressure Blade Life Counter	Feeds - counted by	RW	PressureBladeLifeCount	NVMHFSICounter	longNatural	No	Unknown	1.677		
609-535	Pressure Blade Life Expectancy	Modifiable via DC131	RW	PressureBladeExpLife	NVMConfiguration	longNatural	No	Unknown	1.677		
609-536	Pressure Blade Install Date	Transport Belt install date	ND	PressureBladeInstallDate	NVMConfiguration	longNatural	No	Unknown	1.677		
609-537	Fault Counter 72-217-00: TRAY2BUMPUPFAILURE	no. of faults	RW	TRAY2BUMPUPFAILURE	NVMFaultCounter	shortNatural	No	Fault Counter:72-217-00: T2BUMPUPFAILUREC OUNT	1.678		
609-538	Fault Counter 73-217-00: TRAY3BUMPUPFAILURE	no. of faults	RW	TRAY3BUMPUPFAILURE	NVMFaultCounter	shortNatural	No	Fault Counter:73-217-00: T3BUMPUPFAILUREC OUNT	1.678		
609-539	Fault Counter 74-217-00: TRAY4BUMPUPFAILURE	no. of faults	RW	TRAY4BUMPUPFAILURE	NVMFaultCounter	shortNatural	No	Fault Counter:74-217-00: T4BUMPUPFAILUREC OUNT	1.678		
609-540	Fault Counter 10-316: Fuser T1 or T2	no. of faults	RW	FUSERT1ORT2EXCEED250DEGC	NVMFaultCounter	shortNatural	No	Fault Counter:10-316-	1.810		
609-541	Fault Counter 10-317: Fuser T1 or T2 sensor reached or exceeded soft cycle out	no. of faults	RW	FUSERT1ORT2BEYONDCYCLOUT THRSHLD	NVMFaultCounter	shortNatural	No	Fault Counter:10-317-00:	1.679		
609-542	Fault Counter 10-318: Fuser T1 or T2 have not dropped to run temperature after	no. of faults	RW	FUSERT1ORT2NOTATRUNTMPAF TRCOOLNG	NVMFaultCounter	shortNatural	No	Fault Counter:10-318-00:	1.679		
609-543	Fault Counter 91-379: PC cooling event timeout	no. of faults	RW	PcCoolingTimeoutFC	NVMFaultCounter	shortNatural	No	Fault Counter:91-379-00: PcCoolingTimeout	1.697		
609-545	Enable OCT offset policy	Enable OCT Offset policy 0=Off	RW	OCT offset enablement	NVMSAKOSetting	boolean	No		1.761		
609-546	Plain paper type setting	KisyuPlainTypes PlainA = 0,	RW	Plain paper type setting	NVMConfiguration	shortNatural	No		1.741		
610-005	Auto Contrast level for platen		RW	Copy Auto Contrast Level Platen	NVMSAKOSetting	shortNatural	No		1.807		
610-006	Auto Contrast level for DADH		RW	Copy Auto Contrast Level DADH	NVMSAKOSetting	shortNatural	No		1.807		
610-007	Auto Color detection window fast scan start, defined in tenth of percentage point of document fast scan dimension. Values from 0 to 1000 (e.g. 1% is 10, 10% is 100,		ND	Copy Auto Color Detect FS Start	NVMSAKOSetting	natural	No		1.622		
610-007	Auto Color detection window fast scan start, defined in tenth of percentage point of document fast scan dimension. Values		ND	Copy Auto Color Detect FS Start	NVMSAKOSetting	natural	No		1.737		
610-008	Auto Color detection window slow scan start, defined in tenth of percentage point of document slow scan dimension. Values from 0 to 1000 (e.g. 1% is 10, 10% is 100,		ND	Copy Auto Color Detect SS Start	NVMSAKOSetting	natural	No		1.622		

610-008	Auto Color detection window slow scan start, defined in tenth of percentage point of document slow scan dimension. Values from 0 to 1000 (e.g. 1% is 10, 10% is 100,		ND	Copy Auto Color Detect SS Start	NVMSAKOSetting	natural	No		1.737		
610-009	Auto Color Detection Level for platen at pixel level. Defines a value that dictates how chromatic a pixel has to be in order to		ND	Copy Auto Color Level Pixel Plat	NVMSAKOSetting	shortNatural	No		1.737		
610-011	Auto Color Detection Level for DADH at pixel level. Defines a value that dictates how many color pixels have to be on a		ND	Copy Auto Color Level Pixel DADH	NVMSAKOSetting	shortNatural	No		1.737		
610-015	Defines the type of paper used		ND	Copy White Reference	NVMSAKOSetting	shortNatural	No		1.622		
610-021	Auto Contrast level for platen		RW	Scan Auto Contrast Level Platen	NVMSAKOSetting	shortNatural	No		1.807		
610-022	Auto Contrast level for DADH		RW	Scan Auto Contrast Level DADH	NVMSAKOSetting	shortNatural	No		1.807		
610-030	Defines the type of paper used (4024, 4200, Xpressions, recyclable, etc)		ND	Scan White Reference	NVMSAKOSetting	shortNatural	No		1.622		
610-035	Auto Contrast level for platen		RW	Fax Auto Contrast Level Platen	NVMSAKOSetting	shortNatural	No		1.019		
610-036	Auto Contrast level for DADH		RW	Fax Auto Contrast Level DADH	NVMSAKOSetting	shortNatural	No		1.019		
610-037	Photo/Text Segmentation Threshold will control the Galileo segmentation. When it changes, the part of the input that will be		ND	Fax Photo/Text Segment'n Control	NVMSAKOSetting	shortNatural	No		1.622		
610-038	Defines the type of paper used		ND	Fax White Reference	NVMSAKOSetting	shortNatural	No		1.622		
610-047	Defines the binary vs. contone image path/printing	1 to 16	RW	Print ImagePath Type (bit depth)	NVMConfiguration	shortNatural	No		1.019		
610-052	Toner Saver Mode	0=standard 1=eco	RW	Toner Saver Mode	NVMConfiguration	shortNatural	No		1.477		
610-053	Scan Graph with CST2	0 - Without CST2 1 - With CST2	RW	IQ PARAMETER FAMILY	NVMConfiguration	natural	No		1.714		
612-001	Fault Counter 22-330-02: Queue To ESSPrint Timeout		RW	Queue To NC Print TimeoutFC	NVMFaultCounter	shortNatural	No	Fault Counter:22-330-02: Queue To ESSPrint Timeout	1.153		
612-002	Fault Counter 22-330-03: Queue To S2F Timeout		RW	Queue To S2F Timeout	NVMFaultCounter	shortNatural	No	Fault Counter:22-330-03: Queue To S2F Timeout	1.000		
612-003	Fault Counter 22-330-04: Queue To FaxSend Timeout		RW	Queue To FaxSend Timeout	NVMFaultCounter	shortNatural	No	Fault Counter:22-330-04: Queue To FaxSend Timeout	1.000		
612-004	Fault Counter 22-330-05: Queue To DCCopy Timeout		RW	Queue To DCCopy Timeout	NVMFaultCounter	shortNatural	No	Fault Counter:22-330-05: Queue To DCCopy Timeout	1.000		

612-005	Fault Counter 22-330-06: Queue To S2Distr Timeout		RW	Queue To S2Distr Timeout	NVMFaultCounter	shortNatural	No	Fault Counter:22-330-06: Queue To S2Distr Timeout	1.000		
616-001	Defines market region	Market Region settings: 0=US (North America) 1=XCL(Canada)	RO	Market Region	NVMcontrolledAccess	shortNatural	No		1.324	Yes	
616-002	Enable Power Saver feature - Most Programs	0=Disabled 1=Enabled	RW	power saver enabled	NVMSAKOSetting	boolean	No		1.631		
616-003	Northwood Family - Defines Machine PPM Speed (Product Configuration) 255 (PC0) = No Run. Speed set according to the SIM or via Mfg tool	255 = No Run 119 = 30 ppm 120 = 35 ppm 121 = 45 ppm	RO	Product Configuration	NVMcontrolledAccess	shortNatural	No		1.266		
616-003	Luminance Family - Defines Product Configuration	Machine Speed (Nominal ppm NOT ACTUAL): 32 = A1 class 32ppm (PCF32)	RO	Product Configuration	NVMcontrolledAccess	shortNatural	No		1.390	Yes	
616-003	Burgundy Family - Defines Machine PPM Speed (Product Configuration) See also ID250	152 = 47 ppm standard 153 = 47 ppm with Fax	RO	Product Configuration	NVMcontrolledAccess	shortNatural	No		1.507		
616-003	Brilliance Family - Defines Product Configuration	Machine Speed (Nominal ppm NOT ACTUAL): 145 = 40ppm (PCB40)	RO	Product Configuration	NVMcontrolledAccess	shortNatural	No		1.476	Yes	
616-003	Barolo Family - Defines Machine PPM Speed (Product Configuration) See also ID250	154 = 36ppm	RO	Product Configuration	NVMcontrolledAccess	shortNatural	No		1.507		
616-003	Snowdon Family - Defines Product Configuration	Machine Speed (Nominal ppm NOT ACTUAL): 163 = 45ppm (PCSN45)	RO	Product Configuration	NVMcontrolledAccess	shortNatural	No		1.732	Yes	
616-003	Snowdon2 Family - Defines Product Configuration	Machine Speed (Nominal ppm NOT ACTUAL): 174 = 45ppm (PCSN245)	RO	Product Configuration	NVMcontrolledAccess	shortNatural	No		1.732	Yes	
616-004	Lexington family - Defines system Configuration (type of System)	0 = Unknown (Not set) 1 = ST (Networked) 8 = Network Suppressed	RW	System Configuration	NVMConfiguration	shortNatural	No		1.099		
616-004	Defines System Configuration (type of system)	0 = Unknown (Not set) 1 = ST (Networked) 8 = Network Suppressed	RW	System Configuration	NVMConfiguration	shortNatural	No		1.028		
616-010	Defines time in "normal" mode where system has been idle to enabled transition into power saver.	The idle time in minutes before the machine will enter Low power	RW	powersaver idletime	NVMSAKOSetting	shortNatural	No		1.790		Yes, as Integer Value
616-010	Defines time in "normal" mode where system has been idle to enabled transition into power saver.	The idle time in minutes before the machine will enter Low power	RW	powersaver idletime	NVMSAKOSetting	shortNatural	No		1.790		Yes, as Integer Value
616-010	Defines time in "normal" mode where system has been idle to enabled transition into power saver.	The idle time in minutes before the machine will enter Low power	RW	powersaver idletime	NVMSAKOSetting	shortNatural	No		1.790		Yes, as Integer Value
616-010	Defines time in "normal" mode where system has been idle to enabled transition into power saver.	The idle time in minutes before the machine will enter Low power	RW	powersaver idletime	NVMSAKOSetting	shortNatural	No		1.790		Yes, as Integer Value
616-010	Defines time in "normal" mode where system has been idle to enabled transition into power saver.	The idle time in minutes before the machine will enter Low power	RW	powersaver idletime	NVMSAKOSetting	shortNatural	No		1.790		Yes, as Integer Value

616-011	Defines time in "mode 1" before transitioning to "mode 3" for appropriate configurations.	The idle time in minutes the machine will remain in Low power before entering	RW	power saver in mode 1 time	NVMSAKOSetting	shortNatural	No		1.321		
616-011	Defines time in "mode 1" before transitioning to "mode 3" for appropriate	The idle time in minutes the machine will remain in	RW	power saver in mode 1 time	NVMSAKOSetting	shortNatural	No		1.531		
616-014	Defines system's current installation phase.	0 = Manufacturing 2 = Pre Install (Default) 4 = Complete	RW	system install phase	NVMConfiguration	shortNatural	No		1.820	Yes	
616-015	SMFCustomerServiceNumber		ND		NVMSAKOSetting	byteArray	No		1.000		
616-052	Product Identifier (e.g. Marketing product name)	0 = Unknown (Not set) Lexington Family 89 to	RW	Product Identifier	NVMcontrolledAccess	natural	No	Device Profile:403: Model	1.155	Yes	
616-052	Product Identifier (e.g. Marketing product name)	1000 = Unknown (Not set) (Luminance values) 191 = 35	RW	Product Identifier	NVMcontrolledAccess	natural	No	Device Profile:403: Model	1.357	Yes	
616-052	Product Identifier (e.g. Marketing product name)	1000 = Unknown (Not set) (Brilliance values) 204 = 40 (note that this	RO	Product Identifier	NVMcontrolledAccess	natural	No	Device Profile:403: Model	1.582	Yes	
616-052	Product Identifier (e.g. Marketing product name)	1000 = Unknown (Not set) (Snowdon values) 227 = 45	RO	Product Identifier	NVMcontrolledAccess	natural	No	Device Profile:403: Model	1.598	Yes	
616-052	Product Identifier (e.g. Marketing product name)	1000 = Unknown (Not set) (Skylight values) 221=25	RO	Product Identifier	NVMcontrolledAccess	natural	No	Device Profile:403: Model	1.734	Yes	
616-052	Product Identifier (e.g. Marketing product name)	1000 = Unknown (Not set) (Snowdon2 values) 238 = 45	RO	Product Identifier	NVMcontrolledAccess	natural	No	Device Profile:403: Model	1.598	Yes	
616-052	Product Identifier (e.g. Marketing product name)	1000 = Unknown (Not set) (Kiska values)	RO	Product Identifier	NVMcontrolledAccess	natural	No	Device Profile:403: Model	1.734		
616-166	Intelligent Ready Yesterday's Activity IR1b array	Byte array containing 24 hourly activity bins (hr0 -->	ND	Yesterday's Activity IR1b array	NVMSAKOSetting	byteArray	No		1.781		
616-167	Intelligent Ready Yesterday's Activity IR2b	Byte array containing 24	ND	Yesterday's Activity IR2b array	NVMSAKOSetting	byteArray	No		1.781		
616-168	Intelligent Ready Today's Activity IR1b array	Byte array containing 24 hourly activity bins (hr0 --> hr23)	ND	Today's Activity IR1b array	NVMSAKOSetting	byteArray	No		1.781		
616-169	Intelligent Ready Today's Activity IR2b array	Byte array containing 24 hourly activity bins (hr0 --> hr23)	ND	Today's Activity IR2b array	NVMSAKOSetting	byteArray	No		1.781		
616-170	Intelligent Ready IR3 week array	Byte array containing 168 hourly activity bins (hr0 --> hr167, 00=first bin Sunday 00hrs AM)	ND	IR3 week array	NVMSAKOSetting	byteArray	No		1.781		
616-171	Intelligent Ready Low Power Timeout	Used by IR1 algorithm	ND	IR Low Power Timeout	NVMSAKOSetting	shortNatural	No		1.781		
616-172	Intelligent Ready Sleep Timeout	Used by IR2 algorithm	ND	IR Sleep Timeout	NVMSAKOSetting	shortNatural	No		1.781		

616-173	Intelligent Ready - pre-populated array daily usage flags	Byte array containing 7 values indicating weekday use of IR3 data or initial pre-populated data	ND	IR pre-populated usage flags	NVMSAKOSetting	byteArray	No		1.781		
616-200	Fault Counter 22-330: number of times page pack pin has been locked out	no. of faults	RW	NumTimesPagePackPinlockedFC	NVMFaultCounter	shortNatural	No	Fault Counter:22-330-00: number of times page pack pin has been locked out	1.045		
616-206	Disk Encryption enabled/disabled	0 = disabled, 1 = enabled	RW	Disk Encryption Enabled/Disabled	NVMcontrolledAccess	boolean	No		1.130		
616-206	Disk Encryption enabled/disabled	0 = disabled, 1 = enabled	RW	Disk Encryption Enabled/Disabled	NVMcontrolledAccess	boolean	No		1.527		
616-206	Disk Encryption enabled/disabled	0 = disabled, 1 = enabled	RW	Disk Encryption Enabled/Disabled	NVMcontrolledAccess	boolean	No		1.744		
616-213	defines system manager full ODIO timeout	90 minutes	RW	FullODIOTimeout	NVMDebug	shortNatural	No		1.135		
616-214	defines system manager standard ODIO timeout	30 minutes	RW	StandardODIOTimeout	NVMDebug	shortNatural	No		1.135		
616-217	PagePack Grace Prints Left	0-6000	ND		NVMcontrolledAccess	longInteger	No		1.823		
616-217	PagePack Grace Prints Left	0-2000	ND		NVMcontrolledAccess	longInteger	No		1.341		
616-224	Intelligent Ready History Log	Byte array containing a circular log of Intelligent Ready bin values updated on a daily basis. Sized for	ND	IR log data	NVMSAKOSetting	byteArray	No		1.179		
616-225	IR1a byte array	Byte array containing IR1a: quarter hourly values for a day	ND	IR1a values day array	NVMSAKOSetting	byteArray	No		1.781		
616-226	IR2a byte array	Byte array containing IR2a: hourly values for a day	ND	IR2a values day array	NVMSAKOSetting	byteArray	No		1.781		
616-227	IR1a last updated binId	Identifies last bin updated with Ir1a value for the day	ND	IR1a last bin updated	NVMSAKOSetting	shortNatural	No		1.781		
616-228	IR2a last updated binId	Identifies last bin updated with Ir2a value for the day	ND	IR2a last bin updated	NVMSAKOSetting	shortNatural	No		1.781		
616-229	When the CCS instructs the IME to enter Snooze mode, it needs to remember that snooze was initiated since the IME does not report this mode. When a new unit is detected, the flag should be reset. Note	0 = IME Not in Snooze mode, 1 = IME in snooze mode	RW	Display Snooze Message	NVMConfiguration	boolean	No		1.183		

616-232	Defines time in "normal" mode where system has been idle to enabled transition into power saver WITH fast resume set. Only for Solid Ink programmes.	The idle time in minutes before the machine will enter Low power with Fast resume set	RW	powersaver fast resume idletime	NVMSAKOSetting	shortNatural	No		1.238		
616-233	Defines time in "mode 1" before transitioning to "mode 3" WITH fast resume set. Only for Solid Ink programmes; Only for Solid Ink	The idle time in minutes the machine will remain in Low power before entering Sleep with Fast Resume	RW	powersaver fast resume in mode1	NVMSAKOSetting	shortNatural	No		1.238		
616-234	UI system Timeout value	seconds	RW	UI system Timeout value	NVMSAKOSetting	integer	Yes		1.552		
616-235	Regional Differentiator value	NA_Classic = 1 (Default) NA_Enterprise = 2 XE_Classic = 3 XE_Enterprise = 4	RO	RegDiff	NVMcontrolledAccess	shortNatural	No		1.819		
616-241	Control for UI display of Energy Star Logo splash screen. Factory Default is not to display Logo and the appropriate value is set by the MITS tool as required per programme.	0 = Not ES compliant OR unknown - do not display ES Logo on LUI. 1 = ES compliant - do display ES Logo on LUI.	RO	Energy Star Compliant status	NVMcontrolledAccess	boolean	No		1.729		
616-242	S-Config Enablement Status. This was developed for Mamba+ and used to interact with ID5612 but is no longer required. DEPRECATED FOR D3.6.		RO	S-Config EStarEnablement status	NVMSAKOSetting	boolean	No		1.673		
616-245	Install Wizard (FS22.020):SIM Required screen	Set by CCS when a SIM is required but not yet detected. For Northwood this is whenever Market =	ND	#	NVMConfiguration	boolean	No		1.733	Yes	
616-255	S/W UGD Fault Counter 95-011-00: XUI Application	no. of faults	RW	Fault Counter 95-011-00	NVMFaultCounter	shortNatural	No	Fault Counter:95-011-00:XUI Application	1.813		
616-256	S/W UGD Fault Counter 95-001-00: DCSWUPCODEERROR	no. of faults	RW	Fault Counter 95-001-00	NVMFaultCounter	shortNatural	No	Fault Counter:95-001-00:DCSWUPCODEERROR	1.636		
616-257	S/W UGD Fault Counter 95-002-00: DCAPPERROR	no. of faults	RW	Fault Counter 95-002-00	NVMFaultCounter	shortNatural	No	Fault Counter:95-002-00:DCAPPERROR	1.636		
616-258	S/W UGD Fault Counter 95-008-00: DCOSERROR	no. of faults	RW	Fault Counter 95-008-00	NVMFaultCounter	shortNatural	No	Fault Counter:95-008-00:DCOSERROR	1.813		
616-259	S/W UGD Fault Counter 95-009-00: DCCIPSEERROR	no. of faults	RW	Fault Counter 95-009-00	NVMFaultCounter	shortNatural	No	Fault Counter:95-009-00:DCCIPSEERROR	1.636		
616-260	S/W UGD Fault Counter 95-019-00: SUIH8ERROR	no. of faults	RW	Fault Counter 95-019-00	NVMFaultCounter	shortNatural	No	Fault Counter:95-019-00:SUIH8ERROR	1.813		

616-261	S/W UGD Fault Counter 95-020-00: DADHAPPERROR	no. of faults	RW	Fault Counter 95-020-00	NVMFaultCounter	shortNatural	No	Fault Counter:95-020-00:DADHAPPERROR	1.810		
616-262	S/W UGD Fault Counter 95-038-00: EMBEDFAXERROR	no. of faults	RW	Fault Counter 95-038-00	NVMFaultCounter	shortNatural	No	Fault Counter:95-038-00:EMBEDFAXERROR	1.813		
616-263	S/W UGD Fault Counter 95-040-00: IOTBOOTSTRAPERROR	no. of faults	RW	Fault Counter 95-040-00	NVMFaultCounter	shortNatural	No	Fault Counter:95-040-00:IOTBOOTSTRAPERROR	1.636		
616-264	S/W UGD Fault Counter 95-041-00: IOTBOOTLOADERERROR	no. of faults	RW	Fault Counter 95-041-00	NVMFaultCounter	shortNatural	No	Fault Counter:95-041-00:IOTBOOTLOADERERROR	1.636		
616-265	S/W UGD Fault Counter 95-042-00: IOTAPPERROR	no. of faults	RW	Fault Counter 95-042-00	NVMFaultCounter	shortNatural	No	Fault Counter:95-042-00:IOTAPPERROR	1.813		
616-266	S/W UGD Fault Counter 95-060-00: LCSS2KAPPERROR	no. of faults	RW	Fault Counter 95-060-00	NVMFaultCounter	shortNatural	No	Fault Counter:95-060-00:LCSS2KAPPERROR	1.636		
616-267	S/W UGD Fault Counter 95-140-00: DCNCAPPERROR	no. of faults	RW	Fault Counter 95-140-00	NVMFaultCounter	shortNatural	No	Fault Counter:95-140-00:DCNCAPPERROR	1.813		
616-268	S/W UGD Fault Counter 95-150-00: IITAPPERROR	no. of faults	RW	Fault Counter 95-150-00	NVMFaultCounter	shortNatural	No	Fault Counter:95-150-00:IITAPPERROR	1.813		
616-269	S/W UGD Fault Counter 95-153-00: IITKERNELError	no. of faults	RW	Fault Counter 95-153-00	NVMFaultCounter	shortNatural	No	Fault Counter:95-153-00:IITKERNELError	1.813		
616-270	S/W UGD Fault Counter 95-180-00: HCFWWMODERROR	no. of faults	RW	Fault Counter 95-180-00	NVMFaultCounter	shortNatural	No	Fault Counter:95-180-00:HCFWWMODERROR	1.813		
616-271	S/W UGD Fault Counter 95-191-00: PFPWWMODERROR	no. of faults	RW	Fault Counter 95-191-00	NVMFaultCounter	shortNatural	No	Fault Counter:95-191-00:PFPWWMODERROR	1.636		
616-272	S/W UGD Fault Counter 95-192-00: HVFAPPERROR	no. of faults	RW	Fault Counter 95-192-00	NVMFaultCounter	shortNatural	No	Fault Counter:95-192-00:HVFAPPERROR	1.636		
616-273	S/W UGD Fault Counter 95-193-00: HVFBMAPPERROR	no. of faults	RW	Fault Counter 95-193-00	NVMFaultCounter	shortNatural	No	Fault Counter:95-193-00:HVFBMAPPERROR	1.636		
616-274	S/W UGD Fault Counter 95-195-00: HVFBMBCERROR	no. of faults	RW	Fault Counter 95-195-00	NVMFaultCounter	shortNatural	No	Fault Counter:95-195-00:HVFBMBCERROR	1.636		

616-275	S/W UGD Fault Counter 95-200-00: CFINAPPERROR	no. of faults	RW	Fault Counter 95-200-00	NVMFaultCounter	shortNatural	No	Fault Counter:95-200-00:CFINAPPERROR	1.636		
616-276	S/W UGD Fault Counter 95-007-00: CHFINAPPERROR	no. of faults	RW	Fault Counter 95-007-00	NVMFaultCounter	shortNatural	No	Fault Counter:95-007-00:CHFINAPPERROR	1.813		
616-277	S/W UGD Fault Counter 95-203-00: AFINAPPERROR	no. of faults	RW	Fault Counter 95-203-00	NVMFaultCounter	shortNatural	No	Fault Counter:95-203-00:AFINAPPERROR	1.813		
616-278	S/W UGD Fault Counter 95-204-00: SBFINAPPERROR	no. of faults	RW	Fault Counter 95-204-00	NVMFaultCounter	shortNatural	No	Fault Counter:95-204-00:SBFINAPPERROR	1.813		
616-279	S/W UGD Fault Counter 95-161-00: IITSINDOHBCERROR	no. of faults	RW	Fault Counter 95-161-00	NVMFaultCounter	shortNatural	No	Fault Counter:95-161-00:IITSINDOHBCERR	1.636		
616-280	S/W UGD Fault Counter 95-162-00: IITSINDOH2APPERROR	no. of faults	RW	Fault Counter 95-162-00	NVMFaultCounter	shortNatural	No	Fault Counter:95-162-00:IITSINDOH2APPERROR	1.636		
616-281	S/W UGD Fault Counter 95-163-00: SPDHBOOTSINDOHERRO	no. of faults	RW	Fault Counter 95-163-00	NVMFaultCounter	shortNatural	No	Fault Counter:95-163-00:IITSINDOH1FPGAE	1.636		
616-282	S/W UGD Fault Counter 95-164-00: SPDHAPPSINDOHERRO	no. of faults	RW	Fault Counter 95-164-00	NVMFaultCounter	shortNatural	No	Fault Counter:95-164-00:IITSINDOHFPGAE	1.636		
616-283	S/W UGD Fault Counter 95-228-00: DADHSPB0DAPPERROR	no. of faults	RW	Fault Counter 95-228-00	NVMFaultCounter	shortNatural	No	Fault Counter:95-228-00:DADHSPB0DAPPE	1.636		
616-284	S/W UGD Fault Counter 95-229-00: DADHSPB0DBCERROR	no. of faults	RW	Fault Counter 95-229-00	NVMFaultCounter	shortNatural	No	Fault Counter:95-229-00:DADHSPB0DBCER	1.636		
616-285	S/W UGD Fault Counter 95-216-00: DCGLUEERROR	no. of faults	RW	Fault Counter 95-216-00	NVMFaultCounter	shortNatural	No	Fault Counter:95-216-00:DCGLUEERROR	1.813		
616-286	S/W UGD Fault Counter 95-168-00: DADHSPERROR	no. of faults	RW	Fault Counter 95-168-00	NVMFaultCounter	shortNatural	No	Fault Counter:95-168-00:DADHSPERROR	1.813		
616-287	S/W UGD Fault Counter 95-152-00: SICAPPERROR	no. of faults	RW	Fault Counter 95-152-00	NVMFaultCounter	shortNatural	No	Fault Counter:95-152-00:SICAPPERROR	1.813		
616-288	S/W UGD Fault Counter 95-226-00: SOKAPPERROR	no. of faults	RW	Fault Counter 95-226-00	NVMFaultCounter	shortNatural	No	Fault Counter:95-226-00:SOKAPPERROR	1.813		
616-289	S/W UGD Fault Counter 95-222-00: LVFAPPERROR	no. of faults	RW	Fault Counter 95-222-00	NVMFaultCounter	shortNatural	No	Fault Counter:95-222-00:LVFAPPERROR	1.810		
616-290	S/W UGD Fault Counter 95-224-00: DCSCDERROR	no. of faults	RW	Fault Counter 95-224-00	NVMFaultCounter	shortNatural	No	Fault Counter:95-224-00:DCSCDERROR	1.810		
616-291	S/W UGD Fault Counter 95-255-00: DCSCDERROR	no. of faults	RW	Fault Counter 95-255-00	NVMFaultCounter	shortNatural	No	Fault Counter:95-255-00:DCSCDERROR	1.636		
616-292	S/W UGD Fault Counter 95-306-00: CCSSYNCERROR	no. of faults	RW	Fault Counter 95-306-00	NVMFaultCounter	shortNatural	No	Fault Counter:95-306-00:CCSSYNCERROR	1.813		

616-293	S/W UGD Fault Counter 95-307-00: NCSYNCERROR	no. of faults	RW	Fault Counter 95-307-00	NVMFaultCounter	shortNatural	No	Fault Counter:95-307-00:NCSYNCERROR	1.813		
616-294	S/W UGD Fault Counter 95-308-00: UISYNCERROR	no. of faults	RW	Fault Counter 95-308-00	NVMFaultCounter	shortNatural	No	Fault Counter:95-308-00:UISYNCERROR	1.813		
616-295	S/W UGD Fault Counter 95-309-00: IITSYNCERROR	no. of faults	RW	Fault Counter 95-309-00	NVMFaultCounter	shortNatural	No	Fault Counter:95-309-00:IITSYNCERROR	1.813		
616-296	S/W UGD Fault Counter 95-310-00: IOTSYNCERROR	no. of faults	RW	Fault Counter 95-310-00	NVMFaultCounter	shortNatural	No	Fault Counter:95-310-00:IOTSYNCERROR	1.813		
616-297	S/W UGD Fault Counter 95-311-00: FINSYNCERROR	no. of faults	RW	Fault Counter 95-311-00	NVMFaultCounter	shortNatural	No	Fault Counter:95-311-00:FINSYNCERROR	1.813		
616-298	S/W UGD Fault Counter 95-312-00: FDRSYNCERROR	no. of faults	RW	Fault Counter 95-312-00	NVMFaultCounter	shortNatural	No	Fault Counter:95-312-00:FDRSYNCERROR	1.813		
616-299	S/W UGD Fault Counter 95-300-00: SWUPINCOMPATPRODERROR	no. of faults	RW	Fault Counter 95-300-00	NVMFaultCounter	shortNatural	No	Fault Counter:95-300-00:SWUPINCOMPATPRODERROR	1.636		
616-300	S/W UGD Fault Counter 95-301-00: SWUPINCOMPATHWERROR	no. of faults	RW	Fault Counter 95-301-00	NVMFaultCounter	shortNatural	No	Fault Counter:95-301-00:SWUPINCOMPATHWERROR	1.636		
616-301	S/W UGD Fault Counter 95-302-00: SWUPINCOMPATFWERROR	no. of faults	RW	Fault Counter 95-302-00	NVMFaultCounter	shortNatural	No	Fault Counter:95-302-00:SWUPINCOMPATFWERROR	1.636		
616-302	S/W UGD Fault Counter 95-303-00: SWUPDLMDOWNGRADEERROR	no. of faults	RW	Fault Counter 95-303-00	NVMFaultCounter	shortNatural	No	Fault Counter:95-303-00:SWUPDLMDOWNGRADEERROR	1.636		
616-303	S/W UGD Fault Counter 95-304-00: SWUPDLMSIDEGRADEERROR	no. of faults	RW	Fault Counter 95-304-00	NVMFaultCounter	shortNatural	No	Fault Counter:95-304-00:SWUPDLMSIDEGRADEERROR	1.636		
616-304	S/W UGD Fault Counter 95-305-00: SWUPPLATSYNCEERROR	no. of faults	RW	Fault Counter 95-305-00	NVMFaultCounter	shortNatural	No	Fault Counter:95-305-00:SWUPPLATSYNCEERROR	1.636		
616-305	SPARE was s/w upgrade fault counter		ND	SPARE	NVMMachVar	shortNatural	No		1.636		

616-306	SPARE was s/w upgrade fault counter		ND	SPARE	NVMMachVar	shortNatural	No		1.636		
616-307	SPARE was s/w upgrade fault counter		ND	SPARE	NVMMachVar	shortNatural	No		1.636		
616-308	SPARE was s/w upgrade fault counter		ND	SPARE	NVMMachVar	shortNatural	No		1.636		
616-309	SPARE was s/w upgrade fault counter		ND	SPARE	NVMMachVar	shortNatural	No		1.636		
616-310	SPARE was s/w upgrade fault counter		ND	SPARE	NVMMachVar	shortNatural	No		1.636		
616-311	SPARE was s/w upgrade fault counter		ND	SPARE	NVMMachVar	shortNatural	No		1.636		
616-312	SPARE was s/w upgrade fault counter		ND	SPARE	NVMMachVar	shortNatural	No		1.636		
616-313	SPARE was s/w upgrade fault counter		ND	SPARE	NVMMachVar	shortNatural	No		1.636		
616-314	SPARE was s/w upgrade fault counter		ND	SPARE	NVMMachVar	shortNatural	No		1.636		
616-315	SPARE was s/w upgrade fault counter		ND	SPARE	NVMMachVar	shortNatural	No		1.636		
616-316	SPARE was s/w upgrade fault counter		ND	SPARE	NVMMachVar	shortNatural	No		1.636		
616-317	SPARE was s/w upgrade fault counter		ND	SPARE	NVMMachVar	shortNatural	No		1.636		
616-318	SPARE was s/w upgrade fault counter		ND	SPARE	NVMMachVar	shortNatural	No		1.636		
616-319	SPARE was s/w upgrade fault counter		ND	SPARE	NVMMachVar	shortNatural	No		1.636		

616-320	SPARE was s/w upgrade fault counter		ND	SPARE	NVMMachVar	shortNatural	No		1.636		
616-321	SPARE was s/w upgrade fault counter		ND	SPARE	NVMMachVar	shortNatural	No		1.636		
616-322	SPARE was s/w upgrade fault counter		ND	SPARE	NVMMachVar	shortNatural	No		1.636		
616-323	SPARE was s/w upgrade fault counter		ND	SPARE	NVMMachVar	shortNatural	No		1.636		
616-324	SPARE was s/w upgrade fault counter		ND	SPARE	NVMMachVar	shortNatural	No		1.636		
616-325	SPARE was s/w upgrade fault counter		ND	SPARE	NVMMachVar	shortNatural	No		1.636		
616-326	SPARE was s/w upgrade fault counter		ND	SPARE	NVMMachVar	shortNatural	No		1.636		
616-327	SPARE was s/w upgrade fault counter		ND	SPARE	NVMMachVar	shortNatural	No		1.636		
616-339	For Blue Angel when the energy saver is set to 0 minutes the system will take a	seconds	RW	power saver grace period	NVMSAKOSetting	shortNatural	No		1.726		
616-346	Touch Volume		RW	Touch Volume	NVMSAKOSetting	shortNatural	No		1.741		
616-347	Fault / Alert Volume		RW	Fault / Alert Volume	NVMSAKOSetting	shortNatural	No		1.741		
616-348	Job Completion Volume		RW	Job Completion Volume	NVMSAKOSetting	shortNatural	No		1.741		

616-349	Energy Saver Volume		RW	Energy Saver Volume	NVMSAKOSetting	shortNatural	No		1.741		
616-350	Power Volume		RW	Power Volume	NVMSAKOSetting	shortNatural	No		1.741		
616-351	Log In Volume		RW	Log In Volume	NVMSAKOSetting	shortNatural	No		1.741		
616-352	AirPrint Feature unhide/hide (for use in Manufacturing)	0 = Hidden 1 = Unhidden	ND		NVMcontrolledAccess	boolean	No		1.790		Yes, as Text
616-352	AirPrint Feature unhide/hide (for use in Manufacturing)	0 = Hidden 1 = Unhidden	ND		NVMcontrolledAccess	boolean	No		1.790		Yes, as Text
616-352	AirPrint Feature unhide/hide (for use in Manufacturing)	0 = Hidden 1 = Unhidden	ND		NVMcontrolledAccess	boolean	No		1.790		Yes, as Text
616-355	Policy for AdjustableTrayConfirmation Prompt	0 - Always show 1 - Delayed Close 2 - Auto confirmation	RW	AdjustableTrayConfirmationPolicy	NVMSAKOSetting	shortNatural	No		1.817		
616-361	Enable / Disable of the Reduced Power Print feature. (Default = disabled for D3.6-D4.0 programmes).	0=Disabled 1=Enabled	RW	Lower Power Print Feature Enable	NVMSAKOSetting	boolean	No		1.701	Yes	
616-363	Control for UI display of Energy Star Logo splash screen. Factory Default is not to display Logo and the appropriate value is set by the MITS tool as required for 22ppm machines	0 = Not ES compliant OR unknown - do not display ES Logo on LUI. 1 = ES compliant - do display ES Logo on LUI.	RO	Energy Star Compliant status 22	NVMcontrolledAccess	boolean	No		1.792	Yes	
616-364	Control for UI display of Energy Star Logo splash screen. Factory Default is not to display Logo and the appropriate value is set by the MITS tool as required for 25ppm	0 = Not ES compliant OR unknown - do not display ES Logo on LUI. 1 = ES compliant - do	RO	Energy Star Compliant status 25	NVMcontrolledAccess	boolean	No		1.792	Yes	
616-365	Control for UI display of Energy Star Logo splash screen. Factory Default is not to display Logo and the appropriate value is set by the MITS tool as required for 28ppm	0 = Not ES compliant OR unknown - do not display ES Logo on LUI. 1 = ES compliant - do	RO	Energy Star Compliant status 28	NVMcontrolledAccess	boolean	No		1.792	Yes	
616-366	Control for UI display of Energy Star Logo splash screen. Factory Default is not to display Logo and the appropriate value is set by the MITS tool as required for 35ppm machines	0 = Not ES compliant OR unknown - do not display ES Logo on LUI. 1 = ES compliant - do display ES Logo on LUI.	RO	Energy Star Compliant status 30	NVMcontrolledAccess	boolean	No		1.792	Yes	
616-367	Control for UI display of Energy Star Logo splash screen. Factory Default is not to display Logo and the appropriate value is set by the MITS tool as required for 35ppm machines	0 = Not ES compliant OR unknown - do not display ES Logo on LUI. 1 = ES compliant - do display ES Logo on LUI.	RO	Energy Star Compliant status 35	NVMcontrolledAccess	boolean	No		1.750	Yes	
616-368	Control for UI display of Energy Star Logo splash screen. Factory Default is not to display Logo and the appropriate value is set by the MITS tool as required for 45ppm	0 = Not ES compliant OR unknown - do not display ES Logo on LUI. 1 = ES compliant - do	RO	Energy Star Compliant status 45	NVMcontrolledAccess	boolean	No		1.750	Yes	

616-369	Control for UI display of Energy Star Logo splash screen. Factory Default is not to display Logo and the appropriate value is set by the MITS tool as required for 55ppm machines	0 = Not ES compliant OR unknown - do not display ES Logo on LUI. 1 = ES compliant - do display ES Logo on LUI.	RO	Energy Star Compliant status 55	NVMcontrolledAccess	boolean	No		1.750	Yes	
616-370	Control for UI display of Energy Star Logo splash screen. Factory Default is not to display Logo and the appropriate value is set by the MITS tool as required for 70ppm	0 = Not ES compliant OR unknown - do not display ES Logo on LUI. 1 = ES compliant - do	RO	Energy Star Compliant status 70	NVMcontrolledAccess	boolean	No		1.750	Yes	
616-372	Control for UI display of Energy Star Logo splash screen. Factory Default is not to	0 = Not ES compliant OR unknown - do not display	RO	Energy Star Compliant status 60	NVMcontrolledAccess	boolean	No		1.792	Yes	
616-373	Control for UI display of Energy Star Logo splash screen. Factory Default is not to display Logo and the appropriate value is set by the MITS tool as required for 65ppm	0 = Not ES compliant OR unknown - do not display ES Logo on LUI. 1 = ES compliant - do	RO	Energy Star Compliant status 65	NVMcontrolledAccess	boolean	No		1.792	Yes	
616-374	Control for UI display of Energy Star Logo splash screen. Factory Default is not to display Logo and the appropriate value is set by the MITS tool as required for 75ppm	0 = Not ES compliant OR unknown - do not display ES Logo on LUI. 1 = ES compliant - do	RO	Energy Star Compliant status 75	NVMcontrolledAccess	boolean	No		1.750	Yes	
616-375	Control for UI display of Energy Star Logo splash screen. Factory Default is not to display Logo and the appropriate value is set by the MITS tool as required for 90ppm machines	0 = Not ES compliant OR unknown - do not display ES Logo on LUI. 1 = ES compliant - do display ES Logo on LUI.	RO	Energy Star Compliant status 90	NVMcontrolledAccess	boolean	No		1.750	Yes	
616-377	Control for UI display of Energy Star Logo splash screen. Factory Default is not to display Logo and the appropriate value is set by the MITS tool as required for 42ppm	0 = Not ES compliant OR unknown - do not display ES Logo on LUI. 1 = ES compliant - do	RO	Energy Star Compliant status 42	NVMcontrolledAccess	boolean	No		1.816	Yes	
616-378	Control for UI display of Energy Star Logo splash screen. Factory Default is not to display Logo and the appropriate value is set by the MITS tool as required for 50ppm machines	0 = Not ES compliant OR unknown - do not display ES Logo on LUI. 1 = ES compliant - do display ES Logo on LUI.	RO	Energy Star Compliant status 50	NVMcontrolledAccess	boolean	No		1.792	Yes	
616-384	Starter cartridge inserted count: Cyan	Cyan: To store the number of times the starter cartridge inserted count.	RO	CyanStrtrCartInstCnt	NVMSystemUsageCounter	shortNatural	No		1.764		
616-385	Starter cartridge inserted count: Magenta	Magenta: To store the number of times the	RO	MagStrtrCartInstCnt	NVMSystemUsageCounter	shortNatural	No		1.764		
616-386	Starter cartridge inserted count: Yellow	Yellow: To store the number of times the starter cartridge inserted count.	RO	YelStrtrCartInstCnt	NVMSystemUsageCounter	shortNatural	No		1.764		
616-387	Starter cartridge inserted count: Black	Black: To store the number of times the starter cartridge inserted count.	RO	BlkStrtrCartInstCnt	NVMSystemUsageCounter	shortNatural	No		1.764		

616-388	Toner billing mode	Stores the billing mode value that comes from the IOT. Enum TonerBillingMode	RO	TonerBillingMode	NVMcontrolledAccess	shortNatural	No		1.764		
616-389	Toner service plan mode	Stores the service plan value that comes from the IOT.	RO	TonerSvcPlanMode	NVMcontrolledAccess	shortNatural	No		1.764		
616-390	Toner regional differentiator	Stores the toner regional differentiator value that comes from the IOT.	RO	TonerRgnDifferentiator	NVMcontrolledAccess	shortNatural	No		1.764		
616-398	Fault Counter 16-972-15:DLM signature fails	no. of faults	RW	DLMSIGFAILSFAULT	NVMFaultCounter	shortNatural	No	Fault Counter:16-972-15:DLM signature fails	1.768		
616-399	Fault Counter 16-972-08:Bootmgr's SW verify failed.	no. of faults	RW	SWVERIFYBOOTFAILED	NVMFaultCounter	shortNatural	No	Fault Counter:16-972-08:Bootmgr's SW verify failed.	1.771		
616-400	Fault Counter 16-972-09:SWUP Signature Verification Fails	no. of faults	RW	SWUPSIGNATUREVERIFICATION FAILS	NVMFaultCounter	shortNatural	No	Fault Counter:16-972-09:SWUP Signature Verification Fails	1.768		
616-402	Type of fuser	0 = Letter Fuser 1 = A4 Fuser	RO	FuserType	NVMcontrolledAccess	shortNatural	No		1.803	Yes	Yes, as Text
617-001	Displayed faults-Fault Log		ND	Displayable Fault Log	NVMFaultLog	byteArray	No	Log Data:657: Last 250 Faults	1.707		
617-008	Hidden faults-Fault Log		ND	Hidden Fault Log	NVMFaultLog	byteArray	No	Unknown	1.707		
620-034	Fault Counter 05-110:		RW	05-110 counter	NVMFaultCounter	shortNatural	No	Fault Counter:05-110-00: Unknown	1.159		
620-035	Fault Counter 05-111: SPARED (was IIT fault counter)		ND	SPARE 620-035	NVMFaultCounter	shortNatural	No	Fault Counter:05-111-00: Unknown	1.159		
620-036	Fault Counter 05-112:		RW	05-112 counter	NVMFaultCounter	shortNatural	No	Fault Counter:05-112-00: Unknown	1.159		
620-037	Fault Counter 05-113: SPARED (was IIT fault counter)		ND	SPARE 620-037	NVMFaultCounter	shortNatural	No	Fault Counter:05-113-00: Unknown	1.159		

620-038	Fault Counter 05-115: SPARED (was IIT fault counter)		ND	SPARE 620-038	NVMFaultCounter	shortNatural	No	Fault Counter:05-115-00: Unknown	1.159		
620-039	Fault Counter 05-116: SPARED (was IIT fault counter)		ND	SPARE 620-039	NVMFaultCounter	shortNatural	No	Fault Counter:05-116-00: Unknown	1.159		
620-040	Fault Counter 05-121:		RW	05-121 counter	NVMFaultCounter	shortNatural	No	Fault Counter:05-121-00: Unknown	1.159		
620-041	Fault Counter 05-122:		RW	05-122 counter	NVMFaultCounter	shortNatural	No	Fault Counter:05-122-00: Unknown	1.159		
620-042	Fault Counter 05-123:		RW	05-123 counter	NVMFaultCounter	shortNatural	No	Fault Counter:05-123-00: Unknown	1.159		
620-043	Fault Counter 05-124:		RW	05-124 counter	NVMFaultCounter	shortNatural	No	Fault Counter:05-124-00: Unknown	1.159		
620-044	Fault Counter 05-125:		RW	05-125 counter	NVMFaultCounter	shortNatural	No	Fault Counter:05-125-00: Unknown	1.159		
620-045	Fault Counter 05-126:		RW	05-126 counter	NVMFaultCounter	shortNatural	No	Fault Counter:05-126-00: Unknown	1.813		
620-046	Fault Counter 05-127:		RW	05-127 counter	NVMFaultCounter	shortNatural	No	Fault Counter:05-127-00: Unknown	1.813		
620-047	Fault Counter 05-128:		RW	05-128 counter	NVMFaultCounter	shortNatural	No	Fault Counter:05-128-00: Unknown	1.813		
620-048	Fault Counter 05-129:		RW	05-129 counter	NVMFaultCounter	shortNatural	No	Fault Counter:05-129-00: Unknown	1.813		
620-049	Fault Counter 05-130:		RW	05-130 counter	NVMFaultCounter	shortNatural	No	Fault Counter:05-130-00: Unknown	1.813		
620-050	Fault Counter 05-133: SPARED (was IIT fault counter)		ND	SPARE 620-050	NVMFaultCounter	shortNatural	No	Fault Counter:05-133-00: Unknown	1.159		
620-051	Fault Counter 05-135:		RW	05-135 counter	NVMFaultCounter	shortNatural	No	Fault Counter:05-135-00: Unknown	1.813		

620-052	Fault Counter 05-136:		RW	05-136 counter	NVMFaultCounter	shortNatural	No	Fault Counter:05-136-00: Unknown	1.813		
620-053	Fault Counter 05-137: SPARED (was IIT fault counter)		ND	SPARE 620-053	NVMFaultCounter	shortNatural	No	Fault Counter:05-137-00: Unknown	1.159		
620-054	Fault Counter 05-138: SPARED (was IIT fault counter)		ND	SPARE 620-054	NVMFaultCounter	shortNatural	No	Fault Counter:05-138-00: Unknown	1.159		
620-055	Fault Counter 05-141:		RW	05-141 counter	NVMFaultCounter	shortNatural	No	Fault Counter:05-141-00: Unknown	1.813		
620-056	Fault Counter 05-142: SPARED (was IIT fault counter)		ND	SPARE 620-056	NVMFaultCounter	shortNatural	No	Fault Counter:05-142-00: Unknown	1.159		
620-057	Fault Counter 05-143: SPARED (was IIT fault counter)		ND	SPARE 620-057	NVMFaultCounter	shortNatural	No	Fault Counter:05-143-00: Unknown	1.159		
620-058	Fault Counter 05-144:		RW	05-144 counter	NVMFaultCounter	shortNatural	No	Fault Counter:05-144-00: Unknown	1.159		
620-059	Fault Counter 05-150: SPARED (was IIT fault counter)		ND	SPARE 620-059	NVMFaultCounter	shortNatural	No	Fault Counter:05-150-00: Unknown	1.159		
620-060	Fault Counter 05-151: SPARED (was IIT fault counter)		ND	SPARE 620-060	NVMFaultCounter	shortNatural	No	Fault Counter:05-151-00: Unknown	1.159		
620-061	Fault Counter 05-152: SPARED (was IIT fault counter)		ND	SPARE 620-061	NVMFaultCounter	shortNatural	No	Fault Counter:05-152-00: Unknown	1.159		
620-062	Fault Counter 05-153:		RW	05-153 counter	NVMFaultCounter	shortNatural	No	Fault Counter:05-153-00: Unknown	1.159		
620-063	Fault Counter 05-154: SPARED (was IIT fault counter)		ND	SPARE 620-063	NVMFaultCounter	shortNatural	No	Fault Counter:05-154-00: Unknown	1.159		
620-064	Fault Counter 05-155: SPARED (was IIT fault counter)		ND	SPARE 620-064	NVMFaultCounter	shortNatural	No	Fault Counter:05-155-00: Unknown	1.159		
620-065	Fault Counter 05-156: SPARED (was IIT		ND	SPARE 620-065	NVMFaultCounter	shortNatural	No	Fault Counter:05-156-	1.159		

620-066	Fault Counter 05-157: SPARED (was IIT fault counter)		ND	SPARE 620-066	NVMFaultCounter	shortNatural	No	Fault Counter:05-157-00: Unknown	1.159		
620-067	Fault Counter 05-158: SPARED (was IIT fault counter)		ND	SPARE 620-067	NVMFaultCounter	shortNatural	No	Fault Counter:05-158-00: Unknown	1.159		
620-068	Fault Counter 05-160:		RW	05-160 counter	NVMFaultCounter	shortNatural	No	Fault Counter:05-160-00: Unknown	1.159		
620-069	Fault Counter 05-190: SPARED (was IIT fault counter)		ND	SPARE 620-069	NVMFaultCounter	shortNatural	No	Fault Counter:05-190-00: Unknown	1.159		
620-070	Fault Counter 05-194:		RW	05-194 counter	NVMFaultCounter	shortNatural	No	Fault Counter:05-194-00: Unknown	1.813		
620-071	Fault Counter 05-195: SPARED (was IIT fault counter)		ND	SPARE 620-071	NVMFaultCounter	shortNatural	No	Fault Counter:05-195-00: Unknown	1.159		
620-072	Fault Counter 05-196:		RW	05-196 counter	NVMFaultCounter	shortNatural	No	Fault Counter:05-196-00: Unknown	1.813		
620-073	Fault Counter 05-197:		RW	05-197 counter	NVMFaultCounter	shortNatural	No	Fault Counter:05-197-00: Unknown	1.813		
620-074	Fault Counter 05-198:		RW	05-198 counter	NVMFaultCounter	shortNatural	No	Fault Counter:05-198-00: Unknown	1.813		
620-075	Fault Counter 05-199:		RW	05-199 counter	NVMFaultCounter	shortNatural	No	Fault Counter:05-199-00: Unknown	1.813		
620-076	Fault Counter 05-280:		RW	05-280 counter	NVMFaultCounter	shortNatural	No	Fault Counter:05-280-00: Unknown	1.813		
620-077	Fault Counter 05-304: SPARED (was IIT fault counter)		ND	SPARE 620-077	NVMFaultCounter	shortNatural	No	Fault Counter:05-304-00: Unknown	1.159		
620-078	Fault Counter 05-305:		RW	05-305 counter	NVMFaultCounter	shortNatural	No	Fault Counter:05-305-00: Unknown	1.159		

620-079	Fault Counter 05-306: SPARED (was IIT fault counter)		ND	SPARE 620-079	NVMFaultCounter	shortNatural	No	Fault Counter:05-306-00: Unknown	1.159		
620-080	Fault Counter 05-309:		RW	05-309 counter	NVMFaultCounter	shortNatural	No	Fault Counter:05-309-00: Unknown	1.159		
620-081	Fault Counter 05-900:		RW	05-900 counter	NVMFaultCounter	shortNatural	No	Fault Counter:05-900-00: Unknown	1.159		
620-082	Fault Counter 05-902: SPARED (was IIT fault counter)		ND	SPARE 620-082	NVMFaultCounter	shortNatural	No	Fault Counter:05-902-00: Unknown	1.159		
620-083	Fault Counter 05-903: SPARED (was IIT fault counter)		ND	SPARE 620-083	NVMFaultCounter	shortNatural	No	Fault Counter:05-903-00: Unknown	1.159		
620-084	Fault Counter 05-904: SPARED (was IIT fault counter)		ND	SPARE 620-084	NVMFaultCounter	shortNatural	No	Fault Counter:05-904-00: Unknown	1.159		
620-085	Fault Counter 05-906:		RW	05-906 counter	NVMFaultCounter	shortNatural	No	Fault Counter:05-906-00: Unknown	1.159		
620-086	Fault Counter 05-907:		RW	05-907 counter	NVMFaultCounter	shortNatural	No	Fault Counter:05-907-00: Unknown	1.159		
620-087	Fault Counter 05-908:		RW	05-908 counter	NVMFaultCounter	shortNatural	No	Fault Counter:05-908-00: Unknown	1.813		
620-088	Fault Counter 05-909:		RW	05-909 counter	NVMFaultCounter	shortNatural	No	Fault Counter:05-909-00: Unknown	1.813		
620-089	Fault Counter 05-910:		RW	05-910 counter	NVMFaultCounter	shortNatural	No	Fault Counter:05-910-00: Unknown	1.813		
620-090	Fault Counter 05-911:		RW	05-911 counter	NVMFaultCounter	shortNatural	No	Fault Counter:05-911-00: Unknown	1.813		
620-091	Fault Counter 05-912: SPARED (was IIT fault counter)		ND	SPARE 620-091	NVMFaultCounter	shortNatural	No	Fault Counter:05-912-00: Unknown	1.159		
620-092	Fault Counter 05-913:		RW	05-913 counter	NVMFaultCounter	shortNatural	No	Fault Counter:05-913-00: Unknown	1.813		

620-093	Fault Counter 05-914: SPARED (was IIT fault counter)		ND	SPARE 620-093	NVMFaultCounter	shortNatural	No	Fault Counter:05-914-00: Unknown	1.159		
620-094	Fault Counter 05-918: SPARED (was IIT fault counter)		ND	SPARE 620-094	NVMFaultCounter	shortNatural	No	Fault Counter:05-918-00: Unknown	1.159		
620-095	Fault Counter 05-919:		RW	05-919 counter	NVMFaultCounter	shortNatural	No	Fault Counter:05-919-00: Unknown	1.159		
620-096	Fault Counter 62-211: SPARED (was IIT fault counter)		ND	SPARE 620-096	NVMFaultCounter	shortNatural	No	Fault Counter:62-211-00: Unknown	1.159		
620-097	Fault Counter 62-277:		RW	62-277 counter	NVMFaultCounter	shortNatural	No	Fault Counter:62-277-00: Unknown	1.813		
620-098	Fault Counter 62-278: SPARED (was IIT fault counter)		ND	SPARE 620-098	NVMFaultCounter	shortNatural	No	Fault Counter:62-278-00: Unknown	1.159		
620-099	Fault Counter 62-310:		RW	62-310 counter	NVMFaultCounter	shortNatural	No	Fault Counter:62-310-00: Unknown	1.813		
620-100	Fault Counter 62-311:		RW	62-311 counter	NVMFaultCounter	shortNatural	No	Fault Counter:62-311-00: Unknown	1.810		
620-511	200 x 100 Scanned Lifetime Documents Number of jobs (not impressions) since activation that were scanned where the user selected 200 x 100 resolution	200 x 100 Scanned Lifetime Documents Number of jobs (not impressions) since	ND	200 x 100 Scanned Lifetime Docs	NVMSystemUsageCounter	byteArray	No	System Usage Counter:469: 200 x 100 Scanned Lifetime Documents	1.061		
620-522	Fault Counter 05-300: DADH open during run	DADH down sensor detects DADH opened whilst DADH in operation	RW	DADH OpenDuringRunFC	NVMFaultCounter	shortNatural	No	Fault Counter:05-300-00: DADH open during run	1.037		
620-523	Fault Counter 05-307: DADH LH cover interlock opened during run	24 V LH cover interlock opened during DADH in operation.	RW	DADHLHCovIntlockOpenDuringRunFC	NVMFaultCounter	shortNatural	No	Fault Counter:05-307-00: DADH LH cover interlock opened during run	1.037		
620-524	Fault Counter 05-310: DADH Source Doc Too Short For DADH	DADH ReportsDocument <110mm in length. See FD 8.3	RW	DADH Source Doc Too Short FC	NVMFaultCounter	shortNatural	No	Fault Counter:05-310-00: DADH Source Doc Too Short For DADH	1.037		
620-525	Fault Counter 05-330: LE late to post feed sensor S5 (misfeed)	Lead edge of original does not make the post feed sensor S5 in time window	RW	LE late to post feed sensorS5 FC	NVMFaultCounter	shortNatural	No	Fault Counter:05-330-00: LE late to post feed sensor S5 (misfeed)	1.037		
620-526	Fault Counter 05-331: TE late to post feed sensor S5 (multifeed)	Trail edge of original does not make the post feed sensor S5 in time window	RW	TE late to post feed sensorS5 FC	NVMFaultCounter	shortNatural	No	Fault Counter:05-331-00: TE late to post feed sensor S5 (multifeed)	1.037		
620-527	Fault Counter 05-335: LE late to TAR sensor S6	Lead edge of original does not make the TAR sensor S6 in time window	RW	LE late to TAR sensor S6 FC	NVMFaultCounter	shortNatural	No	Fault Counter:05-335-00: LE late to TAR sensor S6	1.037		
620-528	Fault Counter 05-340: LE late to Reg. Sensor S7	Lead edge of original does not make the Reg. sensor S7 in time window	RW	LE late to Reg. Sensor S7 FC	NVMFaultCounter	shortNatural	No	Fault Counter:05-340-00: LE late to Reg. Sensor S7	1.037		
620-529	Fault Counter 05-342: IIT/Scan LE late to mid-scan sensor	Trail edge of original does not make the Reg. sensor	RW	LE late to Exit sensor S8 FC	NVMFaultCounter	shortNatural	No	Fault Counter:05-345-00: LE late to Exit	1.810		
620-530	Fault Counter 05-346: TE late to Exit sensor S8 (FWD)	Trail edge of original does not make the Reg. sensor S8 in time window	RW	TE late to Exit sensor S8 FC	NVMFaultCounter	shortNatural	No	Fault Counter:05-346-00: TE late to Exit sensor S8 (FWD)	1.037		

620-531	Fault Counter 05-350: LE late to CVT sensor S10 (FWD)	Lead edge (FWD) of original does not make CVT sensor S10 in time window.	RW	LE late to CVT sensor S10 FWD FC	NVMFaultCounter	shortNatural	No	Fault Counter:05-350-00: LE late to CVT sensor S10 (FWD)	1.037		
620-532	Fault Counter 05-352: LE late to CVT sensor S10 (REV)	Lead edge (REV) of original does not make CVT sensor S10 in time window.	RW	LE late to CVT sensor S10 REV FC	NVMFaultCounter	shortNatural	No	Fault Counter:05-352-00: LE late to CVT sensor S10 (REV)	1.037		
620-548	Fault Counter 05-250-00: Kernel Checksum Error	DADH m/c corrupted flash memory	RW	KernelChecksumErrorFC	NVMFaultCounter	shortNatural	No	Fault Counter:05-250-00: Kernel Checksum Error	1.092		
620-549	Fault Counter 05-251-00: Application checksum error	DADH m/c corrupted flash memory	RW	ApplicationChecksumErrorFC	NVMFaultCounter	shortNatural	No	Fault Counter:05-251-00: Application checksum error	1.092		
620-550	Fault Counter 05-252-00: Stepper Controller Comms Error	Error when communicating between the stepper motor and DADH	RW	StepperControllerCommsErrorFC	NVMFaultCounter	shortNatural	No	Fault Counter:05-252-00: Stepper Controller Comms Error	1.092		
620-551	Fault Counter 05-253-00: IIT- DADH Comms Error	Error in comms between IIT and DADH	RW	IIT-DADHcommsErrorFC	NVMFaultCounter	shortNatural	No	Fault Counter:05-253-00: IIT- DADH Comms Error	1.721		
620-552	Fault Counter 05-254-00: Comms Sequence Error	When communications between IIT and DADH are out of sequence.	RW	CommsSequenceErrorFC	NVMFaultCounter	shortNatural	No	Fault Counter:05-254-00: Comms Sequence Error	1.092		
620-553	Fault Counter 05-259-00: DADH Hotline Error	The DADH hotline is in the wrong state during the scan	RW	DADHhotlineErrorFC	NVMFaultCounter	shortNatural	No	Fault Counter:05-259-00: DADH Hotline Error	1.092		
620-554	Fault Counter 05-260-00: DADH not in standby	The DADH is not in standby at the start of the job	RW	DADHnotInStandbyFC	NVMFaultCounter	shortNatural	No	Fault Counter:05-260-00: DADH not in standby	1.092		
620-577	BES2toS1Calibration_1	For S1 to S2 color matching routine	RW	BES2toS1Calibration_1	NVMMachVar	natural	No		1.738		
620-578	BES2toS1Calibration_2	For S1 to S2 color matching routine	RW	BES2toS1Calibration_2	NVMMachVar	natural	No		1.738		
620-579	BES2toS1Calibration_3	For S1 to S2 color matching routine	RW	BES2toS1Calibration_3	NVMMachVar	natural	No		1.738		
620-580	BES2toS1Calibration_4	For S1 to S2 color matching routine	RW	BES2toS1Calibration_4	NVMMachVar	natural	No		1.738		

620-581	BES2toS1Calibration_5	For S1 to S2 color matching routine	RW	BES2toS1Calibration_5	NVMMachVar	natural	No		1.738		
620-582	BES2toS1Calibration_6	For S1 to S2 color matching routine	RW	BES2toS1Calibration_6	NVMMachVar	natural	No		1.738		
620-583	BES2toS1Calibration_7	For S1 to S2 color matching routine	RW	BES2toS1Calibration_7	NVMMachVar	natural	No		1.738		
620-584	BES2toS1Calibration_8	For S1 to S2 color matching routine	RW	BES2toS1Calibration_8	NVMMachVar	natural	No		1.738		
620-585	BES2toS1Calibration_9	For S1 to S2 color matching routine	RW	BES2toS1Calibration_9	NVMMachVar	natural	No		1.738		
620-588	Fault Counter 05-966-00: DOCNOTFULLYINSERTED	no. of faults	RW	Fault Counter 05-966-00	NVMFaultCounter	shortNatural	No	Fault Counter:05-966-00: Unknown	1.581		
620-589	Fault Counter 05-100: IIT/Scan IIT SPDH EEPROM	no. of faults	RW	Fault Counter 05-100	NVMFaultCounter	shortNatural	No	Fault Counter:05-100-00:	1.643		
620-590	Fault Counter 05-131: IIT/Scan CVT Invert Sensor On Jam while inverting (PF2)	no. of faults	RW	Fault Counter 05-131	NVMFaultCounter	shortNatural	No	Fault Counter:05-131-00: CVTINVERTSNRONPF2JAMINVERTINGCOUNT	1.813		
620-591	Fault Counter 05-132: IIT/Scan CVT Invert Sensor On Jam (PF2)	no. of faults	RW	Fault Counter 05-132	NVMFaultCounter	shortNatural	No	Fault Counter:05-132-00: CVTINVERTSNRONPF2JAM	1.813		
620-592	Fault Counter 05-134: IIT/Scan CVT Invert Sensor Off Jam (Inv) (PF2)	no. of faults	RW	Fault Counter 05-134	NVMFaultCounter	shortNatural	No	Fault Counter:05-134-00: CVTINVERTSNROFFPF2JAM	1.813		
620-593	Fault Counter 05-139: IIT/Scan CVT Invert Sensor Off Jam (PF2)	no. of faults	RW	Fault Counter 05-139	NVMFaultCounter	shortNatural	No	Fault Counter:05-139-00: CVTINVERTSNRPF2OFFJAMCOUNT	1.813		
620-594	Fault Counter 05-145: IIT/Scan CVT-DADF Registration Sensor Off - Jam on inverting	no. of faults	RW	Fault Counter 05-145	NVMFaultCounter	shortNatural	No	Fault Counter:05-145-00: CVTREGSNROFFINVERTINGJAMCOUNT	1.813		
620-595	Fault Counter 05-146: IIT/Scan CVT-DADF Pre Registration Sensor Off Jam	no. of faults	RW	Fault Counter 05-146	NVMFaultCounter	shortNatural	No	Fault Counter:05-146-00: CVTPREREKSNROFFJAMCOUNT	1.813		
620-596	Fault Counter 05-147: IIT/Scan CVT-DADF Pre Registration Sensor Off Jam - Jam on inverting	no. of faults	RW	Fault Counter 05-147	NVMFaultCounter	shortNatural	No	Fault Counter:05-147-00: CVTPREREKSNROFFINVERTINGJAMCOUNT	1.813		
620-597	Fault Counter 05-210: IIT/Scan DADF Download Fail	no. of faults	RW	Fault Counter 05-210	NVMFaultCounter	shortNatural	No	Fault Counter:05-210-00: DADFDOWNLOADFAILCOUNT	1.643		

620-598	Fault Counter 05-336: IIT/Scan Document Feeder: IIT/Scan Paper jam at TAR sensor.	no. of faults	RW	Fault Counter 05-336	NVMFaultCounter	shortNatural	No	Fault Counter:05-336-00: IITARSNRJAMCOUNT	1.643		
620-599	Fault Counter 05-341: IIT/Scan Document Feeder: IIT/Scan Paper jam at Pre-Scan sensor.	no. of faults	RW	Fault Counter 05-341	NVMFaultCounter	shortNatural	No	Fault Counter:05-341-00: IITPRESCANSNRJAMCOUNT	1.643		
620-600	Fault Counter 05-343: IIT/Scan Document Feeder: IIT/Scan Paper jam at Mid Scan sensor.	no. of faults	RW	Fault Counter 05-343	NVMFaultCounter	shortNatural	No	Fault Counter:05-343-00: IITMIDSCANSNRJAMCOUNT	1.643		
620-601	Fault Counter 05-905: IIT/Scan CVT Feedout Sensor Static Jam (PF1.5 & PF2.02)	no. of faults	RW	Fault Counter 05-905	NVMFaultCounter	shortNatural	No	Fault Counter:05-905-00: CVTFEEDSNRJAMCOUNT	1.813		
620-602	Fault Counter 05-915: IIT/Scan CVT APS No.1 Sensor Static Jam (PF2 & 2.01 & PF2.02 & PF2.03 & PF3.01)	no. of faults	RW	Fault Counter 05-915	NVMFaultCounter	shortNatural	No	Fault Counter:05-915-00: CVTAPS1SNRJAMCOUNT	1.813		
620-603	Fault Counter 05-916: IIT/Scan CVT APS No.2 Sensor Static Jam (PF2 & 2.01 & PF2.02 & PF2.03 & PF3.01)	no. of faults	RW	Fault Counter 05-916	NVMFaultCounter	shortNatural	No	Fault Counter:05-916-00: CVTAPS2SNRJAMCOUNT	1.813		
620-604	Fault Counter 05-917: IIT/Scan CVT APS No.3 Sensor Static Jam(PF2 & 2.01 & PF2.02 & PF2.03	no. of faults	RW	Fault Counter 05-917	NVMFaultCounter	shortNatural	No	Fault Counter:05-917-00: CVTAPS3SNRJAMCOUNT	1.813		
620-605	Fault Counter 05-940: IIT/Scan DADF Feeder Tray Empty Fail	no. of faults	RW	Fault Counter 05-940	NVMFaultCounter	shortNatural	No	Fault Counter:05-940-00: DADFFEEDTRAYEMPTYFAILCOUNT	1.813		
620-606	Fault Counter 05-941: IIT/Scan Not Enough Originals detected in the DADF during DADF Fault Recovery	no. of faults	RW	Fault Counter 05-941	NVMFaultCounter	shortNatural	No	Fault Counter:05-941-00: LESSORIGINALSINDADFA TFAULTRECVRYCOUNT	1.813		
620-607	Fault Counter 05-945: IIT/Scan Fast Scan - size mismatch	no. of faults	RW	Fault Counter 05-945	NVMFaultCounter	shortNatural	No	Fault Counter:05-945-00: IITFSSIZEMISMATCHCOUNT	1.813		
620-608	Fault Counter 05-946: IIT/Scan Slow Scan - size	no. of faults	RW	Fault Counter 05-946	NVMFaultCounter	shortNatural	No	Fault Counter:05-946-00:	1.813		
620-609	Fault Counter 05-947: IIT/Scan CVT FS - size mismatch	no. of faults	RW	Fault Counter 05-947	NVMFaultCounter	shortNatural	No	Fault Counter:05-947-00: CVTFSSIZEMISMATCHCOUNT	1.813		
620-610	Fault Counter 05-948: IIT/Scan CVT SS - size mismatch	no. of faults	RW	Fault Counter 05-948	NVMFaultCounter	shortNatural	No	Fault Counter:05-948-00: CVTSSSIZEMISMATCHCO	1.813		
620-611	Fault Counter 05-958: IIT/Scan Nisca Document Feeder: IIT/Scan Lift Home Sensor Error.	no. of faults	RW	Fault Counter 05-958	NVMFaultCounter	shortNatural	No	Fault Counter:05-958-00: IITLIFTHOMESNRFAILCOUNT	1.643		
620-612	Fault Counter 05-959: IIT/Scan Nisca Document	no. of faults	RW	Fault Counter 05-959	NVMFaultCounter	shortNatural	No	Fault Counter:05-959-00:	1.643		
620-613	Fault Counter 05-961: IIT/Scan Nisca Document Feeder: IIT/Scan Motor Fan Lock Alarm.	no. of faults	RW	Fault Counter 05-961	NVMFaultCounter	shortNatural	No	Fault Counter:05-961-00: IITMTRFANLOCKALARMCOUNT	1.643		
620-615	Fault Counter 62-396: Side1 IIT/Scan CIS 1	no. of faults	RW	Fault Counter 62-396	NVMFaultCounter	shortNatural	No	Fault Counter:62-396-00:	1.643		
620-616	Fault Counter 62-397: Side1 IIT/Scan CIS1 pixel clock missing	no. of faults	RW	Fault Counter 62-397	NVMFaultCounter	shortNatural	No	Fault Counter:62-397-00: IITCIS1PXLCLKMISSINGCOUNT	1.813		
620-617	Fault Counter 62-398: Side1 IIT/Scan IIT-Cont I/O Cable Connection Fail	no. of faults	RW	Fault Counter 62-398	NVMFaultCounter	shortNatural	No	Fault Counter:62-398-00: IITIOCABLECONNECTFAILCOUNT	1.643		
620-618	Fault Counter 62-399: Side1 IIT/Scan NISCA DADF	no. of faults	RW	Fault Counter 62-399	NVMFaultCounter	shortNatural	No	Fault Counter:62-399-00:	1.643		
620-619	Fault Counter 62-450: Side1 IIT/Scan Calibration	no. of faults	RW	Fault Counter 62-450	NVMFaultCounter	shortNatural	No	Fault Counter:62-450-00:	1.813		
620-620	Fault Counter 62-451: Side1 IIT/Scan Calibration	no. of faults	RW	Fault Counter 62-451	NVMFaultCounter	shortNatural	No	Fault Counter:62-451-00:	1.813		

620-621	Fault Counter 62-452: Side1 IIT/Scan Calibration Pixel Offset Not Clear	no. of faults	RW	Fault Counter 62-452	NVMFaultCounter	shortNatural	No	Fault Counter:62-452-00: IITCALSIDE1PXLOFFSETN OTCLEARCOUNT	1.813		
620-622	Fault Counter 62-453: Side1 IIT/Scan Calibration Pixel Offset Not Done	no. of faults	RW	Fault Counter 62-453	NVMFaultCounter	shortNatural	No	Fault Counter:62-453-00: IITCALSIDE1PXLOFFSETN OTDONECOUNT	1.813		
620-623	Fault Counter 62-454: Side1 IIT/Scan Calibration Gain Range Not Clear	no. of faults	RW	Fault Counter 62-454	NVMFaultCounter	shortNatural	No	Fault Counter:62-454-00: IITCALSIDE1GAINRNGNOT	1.813		
620-624	Fault Counter 62-455: Side1 IIT/Scan Calibration	no. of faults	RW	Fault Counter 62-455	NVMFaultCounter	shortNatural	No	Fault Counter:62-455-00:	1.813		
620-625	Fault Counter 62-457: Side1 IIT/Scan Calibration Pixel Gain Not Done	no. of faults	RW	Fault Counter 62-457	NVMFaultCounter	shortNatural	No	Fault Counter:62-457-00: IITCALSIDE1PXLGAINNOT DONECOUNT	1.813		
620-626	Fault Counter 62-458: Side1 IIT/Scan Calibration Dark Range Errors	no. of faults	RW	Fault Counter 62-458	NVMFaultCounter	shortNatural	No	Fault Counter:62-458-00: IITCALSIDE1PXLOFFSETN OTDONECOUNT	1.813		
620-627	Fault Counter 62-459: Side1 IIT/Scan Calibration Pixel Offset Hi Errors	no. of faults	RW	Fault Counter 62-459	NVMFaultCounter	shortNatural	No	Fault Counter:62-459-00: IITCALSIDE1PXLOFFSETHI GHERRORCOUNT	1.813		
620-628	Fault Counter 62-460: Side1 IIT/Scan Calibration	no. of faults	RW	Fault Counter 62-460	NVMFaultCounter	shortNatural	No	Fault Counter:62-460-00:	1.813		
620-629	Fault Counter 62-461: Side1 IIT/Scan Calibration Gain Range Errors	no. of faults	RW	Fault Counter 62-461	NVMFaultCounter	shortNatural	No	Fault Counter:62-461-00: IITCALSIDE1GAINRNGERR	1.813		
620-630	Fault Counter 62-462: Side1 IIT/Scan Calibration Pixel Gain Hi Errors	no. of faults	RW	Fault Counter 62-462	NVMFaultCounter	shortNatural	No	Fault Counter:62-462-00: IITCALSIDE1PXLGAINHIGH ERRORCOUNT	1.813		
620-631	Fault Counter 62-463: Side1 IIT/Scan Calibration Pixel Gain Lo Errors	no. of faults	RW	Fault Counter 62-463	NVMFaultCounter	shortNatural	No	Fault Counter:62-463-00: IITCALSIDE1PXLGAINLOW ERRORCOUNT	1.813		
620-632	Fault Counter 62-466: Side1 IIT/Scan Dark Range Rail Error	no. of faults	RW	Fault Counter 62-466	NVMFaultCounter	shortNatural	No	Fault Counter:62-466-00: IITSIDE1DARKRNGRAILER RORCOUNT	1.813		
620-633	Fault Counter 62-467: Side1 IIT/Scan Gain Range Rail Error	no. of faults	RW	Fault Counter 62-467	NVMFaultCounter	shortNatural	No	Fault Counter:62-467-00: IITSIDE1GAINRNGRAILER RORCOUNT	1.813		
620-634	Fault Counter 62-468: Side1 IIT/Scan Color State Errors	no. of faults	RW	Fault Counter 62-468	NVMFaultCounter	shortNatural	No	Fault Counter:62-468-00: IITSIDE1COLORSTATEER RORCOUNT	1.813		
620-635	Fault Counter 62-476: Side1 IIT/Scan Stepper Home Error	no. of faults	RW	Fault Counter 62-476	NVMFaultCounter	shortNatural	No	Fault Counter:62-476-00: IITSTEPPERHOMEERROR	1.813		

620-636	Fault Counter 62-481: Side1 IIT/Scan DADH Client Time Out	no. of faults	RW	Fault Counter 62-481	NVMFaultCounter	shortNatural	No	Fault Counter:62-481-00: DADHCLIENTTIMEOUTCOUNT	1.813		
620-637	Fault Counter 62-486: Side1 IIT/Scan Supply 24 Volt Error	no. of faults	RW	Fault Counter 62-486	NVMFaultCounter	shortNatural	No	Fault Counter:62-486-00: IIT24VERRORCOUNT	1.813		
620-638	Fault Counter 62-490: Side1 IIT/Scan Data Steerer Error - Taurus 1	no. of faults	RW	Fault Counter 62-490	NVMFaultCounter	shortNatural	No	Fault Counter:62-490-00: IITSIDE1DATASTEERERERRORCOUNT	1.813		
620-639	Fault Counter 62-491: Side1 IIT/Scan Data Steerer Tx Error - Taurus 1	no. of faults	RW	Fault Counter 62-491	NVMFaultCounter	shortNatural	No	Fault Counter:62-491-00: IITSIDE1DATASTEERERTXERRORCOUNT	1.813		
620-640	Fault Counter 62-492: Side1 IIT/Scan video failure	no. of faults	RW	Fault Counter 62-492	NVMFaultCounter	shortNatural	No	Fault Counter:62-492-00: IITSIDE1VIDEOFAILCOUNT	1.643		
620-641	Fault Counter 62-779: Side1 IIT/Scan FPGA not loaded	no. of faults	RW	Fault Counter 62-779	NVMFaultCounter	shortNatural	No	Fault Counter:62-779-00: IITSIDE1FPGANOTLOADEDFAILCOUNT	1.813		
620-642	Fault Counter 62-780: Side1 IIT/Scan FPGA CRC Error	no. of faults	RW	Fault Counter 62-780	NVMFaultCounter	shortNatural	No	Fault Counter:62-780-00: IITSIDE1FPGACRCERRORCOUNT	1.813		
620-643	Fault Counter 62-781: Side1 IIT/Scan IIT Remote Nvm Out of Range	no. of faults	RW	Fault Counter 62-781	NVMFaultCounter	shortNatural	No	Fault Counter:62-781-00: IITSIDE1REMOTENVMOUOFNRNGCOUNT	1.813		
620-644	Fault Counter 62-782: Side1 IIT/Scan IIT Remote Nvm Read Timeout	no. of faults	RW	Fault Counter 62-782	NVMFaultCounter	shortNatural	No	Fault Counter:62-782-00: IITSIDE1REMOTENVMRDTIMEOUTCOUNT	1.813		
620-645	Fault Counter 62-783: Side1 IIT/Scan SPDH hotline error.	no. of faults	RW	Fault Counter 62-783	NVMFaultCounter	shortNatural	No	Fault Counter:62-783-00: IITSIDE1SPDHHOTLINEERROR	1.813		
620-646	Fault Counter 62-784: Side1 IIT/Scan IIT Platen hotline error	no. of faults	RW	Fault Counter 62-784	NVMFaultCounter	shortNatural	No	Fault Counter:62-784-00: IITSIDE1PLATENHOTLINEERROR	1.813		
620-647	Fault Counter 62-785: Side1 IIT/Scan Taurus 2 capability retry	no. of faults	RW	Fault Counter 62-785	NVMFaultCounter	shortNatural	No	Fault Counter:62-785-00: IITSIDE1TAURUS2CAPBLTYRETRYCOUNT	1.813		
620-648	Fault Counter 62-786: Side1 IIT/Scan Taurus 2 capability timeout	no. of faults	RW	Fault Counter 62-786	NVMFaultCounter	shortNatural	No	Fault Counter:62-786-00: IITSIDE1TAURUS2CAPBLTYTIMEOUTCOUNT	1.813		
620-649	Fault Counter 62-790: Side1 IIT/Scan Side 1 doorbell reject	no. of faults	RW	Fault Counter 62-790	NVMFaultCounter	shortNatural	No	Fault Counter:62-790-00: IITSIDE1DOORBELLREJE	1.773		
620-650	Fault Counter 62-791: Side1 IIT/Scan Side 1 doorbell timeout	no. of faults	RW	Fault Counter 62-791	NVMFaultCounter	shortNatural	No	Fault Counter:62-791-00: IITSIDE1DOORBELLTIMEOUTCOUNT	1.813		
620-651	Fault Counter 62-792: Side1 IIT/Scan Side 1 doorbell failure	no. of faults	RW	Fault Counter 62-792	NVMFaultCounter	shortNatural	No	Fault Counter:62-792-00: IITSIDE1DOORBELLFAILC	1.773		
620-652	Fault Counter 66-396: Side2 IIT/Scan CIS 2 Communication failure	no. of faults	RW	Fault Counter 66-396	NVMFaultCounter	shortNatural	No	Fault Counter:66-396-00: IITCIS2COMMFAILCOUNT	1.772		
620-653	Fault Counter 66-397: Side2 IIT/Scan CIS 2 Pixel clock missing	no. of faults	RW	Fault Counter 66-397	NVMFaultCounter	shortNatural	No	Fault Counter:66-397-00: IITCIS2PXLCLKMISSINGC	1.813		
620-654	Fault Counter 66-450: Side2 IIT/Scan Calibration Dark Range Not Clear	no. of faults	RW	Fault Counter 66-450	NVMFaultCounter	shortNatural	No	Fault Counter:66-450-00: IITSIDE2CALDARKRNGNO	1.813		
620-655	Fault Counter 66-451: Side2 IIT/Scan Calibration Dark Range Not Done	no. of faults	RW	Fault Counter 66-451	NVMFaultCounter	shortNatural	No	Fault Counter:66-451-00: IITSIDE2CALDARKRNGNO	1.813		
620-656	Fault Counter 66-452: Side2 IIT/Scan Calibration Pixel Offset Not Clear	no. of faults	RW	Fault Counter 66-452	NVMFaultCounter	shortNatural	No	Fault Counter:66-452-00: IITCALSIDE2PXLOFFSETN	1.813		

620-657	Fault Counter 66-453: Side2 IIT/Scan Calibration Pixel Offset Not Done	no. of faults	RW	Fault Counter 66-453	NVMFaultCounter	shortNatural	No	Fault Counter:66-453-00: IITCALSIDE2PXLOFFSETN	1.813		
620-658	Fault Counter 66-454: Side2 IIT/Scan Calibration Gain Range Not Clear	no. of faults	RW	Fault Counter 66-454	NVMFaultCounter	shortNatural	No	Fault Counter:66-454-00: IITCALSIDE2GAINRNGNOT	1.813		
620-659	Fault Counter 66-455: Side2 IIT/Scan Calibration Gain Range Not Done	no. of faults	RW	Fault Counter 66-455	NVMFaultCounter	shortNatural	No	Fault Counter:66-455-00: IITCALSIDE2GAINRNGNOT DONECOUNT	1.813		
620-660	Fault Counter 66-457: Side2 IIT/Scan Calibration Pixel Gain Not Done	no. of faults	RW	Fault Counter 66-457	NVMFaultCounter	shortNatural	No	Fault Counter:66-457-00: IITCALSIDE2PXLGAINNOT DONECOUNT	1.813		
620-661	Fault Counter 66-458: Side2 IIT/Scan Calibration Dark Range Errors	no. of faults	RW	Fault Counter 66-458	NVMFaultCounter	shortNatural	No	Fault Counter:66-458-00: IITCALSIDE2PXLOFFSETN	1.813		
620-662	Fault Counter 66-459: Side2 IIT/Scan Calibration Pixel Offset Hi Errors	no. of faults	RW	Fault Counter 66-459	NVMFaultCounter	shortNatural	No	Fault Counter:66-459-00: IITCALSIDE2PXLOFFSETHIGHERRORCOUNT	1.813		
620-663	Fault Counter 66-460: Side2 IIT/Scan Calibration Pixel Offset Lo Errors	no. of faults	RW	Fault Counter 66-460	NVMFaultCounter	shortNatural	No	Fault Counter:66-460-00: IITCALSIDE2PXLOFFSETL	1.813		
620-664	Fault Counter 66-461: Side2 IIT/Scan Calibration Gain Range Errors	no. of faults	RW	Fault Counter 66-461	NVMFaultCounter	shortNatural	No	Fault Counter:66-461-00: IITCALSIDE2GAINRNGERRORCOUNT	1.813		
620-665	Fault Counter 66-462: Side2 IIT/Scan Calibration Pixel Gain Hi Errors	no. of faults	RW	Fault Counter 66-462	NVMFaultCounter	shortNatural	No	Fault Counter:66-462-00: IITCALSIDE2PXLGAINHIGH ERRORCOUNT	1.813		
620-666	Fault Counter 66-463: Side2 IIT/Scan Calibration Pixel Gain Lo Errors	no. of faults	RW	Fault Counter 66-463	NVMFaultCounter	shortNatural	No	Fault Counter:66-463-00: IITCALSIDE2PXLGAINLOW ERRORCOUNT	1.813		
620-667	Fault Counter 66-466: Side2 IIT/Scan Dark Range Rail Error	no. of faults	RW	Fault Counter 66-466	NVMFaultCounter	shortNatural	No	Fault Counter:66-466-00: IITSIDE2DARKRNGRAILER RORCOUNT	1.813		
620-668	Fault Counter 66-467: Side2 IIT/Scan Gain Range Rail Error	no. of faults	RW	Fault Counter 66-467	NVMFaultCounter	shortNatural	No	Fault Counter:66-467-00: IITSIDE2GAINRNGRAILER RORCOUNT	1.813		
620-669	Fault Counter 66-468: Side2 IIT/Scan Color State Errors	no. of faults	RW	Fault Counter 66-468	NVMFaultCounter	shortNatural	No	Fault Counter:66-468-00: IITSIDE2COLORSTATEER RORCOUNT	1.813		

CONFIDENTIAL
(When filled in)



EHS 700 - Health & Safety Incident Report Form For Incidents Involving a Xerox Product

For incidents in Canada: PIPEDA consent given	<input type="checkbox"/> YES <input type="checkbox"/> NO	EH&S Office Use ONLY EH&S Incident Reference Number:
PIPEDA is the Canadian "Personal Information Protection and Electronic Documents Act."		
For incidents in the EU: Safe Harbour Complaint	<input type="checkbox"/> YES <input type="checkbox"/> NO	

*Date Of Incident (mm / dd / yyyy):		
Product Description		
*Model No. or Product Name:		
Product Serial Number:	Serial Number(s) of Accessory(ies):	
Installation Date:	Total Copy Meter:	
Date of last service maintenance:		
List damaged and affected part(s) of the machine by description and part number:		
*Description	Part Number	
*Location of product and affected part(s):		
Customer Identification		
*Customer Name:		*Name of Customer Contact Person:
*Address:	E-mail:	*Telephone:
		Fax:
Customer Service Engineer Identification		
*Name (required for Xerox serviced equipment):	Employee:	E-mail:
Location:	*Phone (required for Xerox serviced equipment):	
Individual Providing Notification		
*Name:	*Title:	*Telephone Number:
*Organization:	E-Mail:	
Mailing Address:	*Date Report Submitted:	

Details of Incident

***Description Of Incident: (Check all that apply)**

Smoke

Describe quantity and duration of smoke:

Fire with open flames seen

Electric shock to operator or service representative

Physical injury/illness to operator or service representative

Describe:

Other, describe:

MANDATORY DESCRIPTION (above): Provide a detailed description of all valid factors that may have contributed to the incident. Hardware involved in the incident should be preserved and retained for further investigation should investigation be deemed necessary by EH&S.

LIST INCIDENT DESCRIPTIONS AND SUPPORT DIAGRAMS/DATA INCLUDED OR ATTACHED:

***Any damage to customer property?** No Yes Describe:

***Did external emergency response provider(s) such as a fire department, ambulance, etc. respond?**

No Yes Identify: (i.e., source, names of individuals)

Apparent cause of incident (identify part that is suspected to be responsible for the incident)

***Preliminary actions taken to mitigate incident:**

Instructions: E-mail or fax both pages of this completed form to EH&S:

e-mail: usa.product.incident@xerox.com or fax 585-422-2249

* Required information is preceded by asterisk, **title shown in red** with a tan wash background



Machine Log Book

602E91901

Service Record

Date: Time:	Eng. No.: Name:	Type of Call:	
Meter 1	2	3	4
Problem/Cause/Solution		Parts Replaced	
Notes:			

Date: Time:	Eng. No.: Name:	Type of Call:	
Meter 1	2	3	4
Problem/Cause/Solution		Parts Replaced	
Notes:			

Service Record

Date: Time:	Eng. No.: Name:	Type of Call:	
Meter 1	2	3	4
Problem/Cause/Solution		Parts Replaced	
Notes:			

Date: Time:	Eng. No.: Name:	Type of Call:	
Meter 1	2	3	4
Problem/Cause/Solution		Parts Replaced	
Notes:			

Service Record

Date: Time:	Eng. No.: Name:	Type of Call:	
Meter 1 _____	2 _____	3 _____	4 _____
Problem/Cause/Solution		Parts Replaced	
Notes:			

Date: Time:	Eng. No.: Name:	Type of Call:	
Meter 1 _____	2 _____	3 _____	4 _____
Problem/Cause/Solution		Parts Replaced	
Notes:			

Service Record

Date: Time:	Eng. No.: Name:	Type of Call:	
Meter 1 _____	2 _____	3 _____	4 _____
Problem/Cause/Solution		Parts Replaced	
Notes:			

Date: Time:	Eng. No.: Name:	Type of Call:	
Meter 1 _____	2 _____	3 _____	4 _____
Problem/Cause/Solution		Parts Replaced	
Notes:			

Service Record

Date: Time:	Eng. No.: Name:	Type of Call:	
Meter 1	2	3	4
Problem/Cause/Solution		Parts Replaced	
Notes:			

Date: Time:	Eng. No.: Name:	Type of Call:	
Meter 1	2	3	4
Problem/Cause/Solution		Parts Replaced	
Notes:			

Service Record

Date: Time:	Eng. No.: Name:	Type of Call:	
Meter 1	2	3	4
Problem/Cause/Solution		Parts Replaced	
Notes:			

Date: Time:	Eng. No.: Name:	Type of Call:	
Meter 1	2	3	4
Problem/Cause/Solution		Parts Replaced	
Notes:			

Service Record

Date: Time:	Eng. No.: Name:	Type of Call:	
Meter 1	2	3	4
Problem/Cause/Solution		Parts Replaced	
Notes:			

Date: Time:	Eng. No.: Name:	Type of Call:	
Meter 1	2	3	4
Problem/Cause/Solution		Parts Replaced	
Notes:			

Service Record

Date: Time:	Eng. No.: Name:	Type of Call:	
Meter 1	2	3	4
Problem/Cause/Solution		Parts Replaced	
Notes:			

Date: Time:	Eng. No.: Name:	Type of Call:	
Meter 1	2	3	4
Problem/Cause/Solution		Parts Replaced	
Notes:			

Service Record

Date: Time:	Eng. No.: Name:	Type of Call:	
Meter 1	2	3	4
Problem/Cause/Solution		Parts Replaced	
Notes:			

Date: Time:	Eng. No.: Name:	Type of Call:	
Meter 1	2	3	4
Problem/Cause/Solution		Parts Replaced	
Notes:			

Service Record

Date: Time:	Eng. No.: Name:	Type of Call:	
Meter 1 _____	2 _____	3 _____	4 _____
Problem/Cause/Solution		Parts Replaced	
Notes:			

Date: Time:	Eng. No.: Name:	Type of Call:	
Meter 1 _____	2 _____	3 _____	4 _____
Problem/Cause/Solution		Parts Replaced	
Notes:			

Service Record

Date: Time:	Eng. No.: Name:	Type of Call:	
Meter 1	2	3	4
Problem/Cause/Solution		Parts Replaced	
Notes:			

Date: Time:	Eng. No.: Name:	Type of Call:	
Meter 1	2	3	4
Problem/Cause/Solution		Parts Replaced	
Notes:			

Service Record

Date: Time:	Eng. No.: Name:	Type of Call:	
Meter 1	2	3	4
Problem/Cause/Solution		Parts Replaced	
Notes:			

Date: Time:	Eng. No.: Name:	Type of Call:	
Meter 1	2	3	4
Problem/Cause/Solution		Parts Replaced	
Notes:			

Service Record

Date: Time:	Eng. No.: Name:	Type of Call:	
Meter 1	2	3	4
Problem/Cause/Solution		Parts Replaced	
Notes:			

Date: Time:	Eng. No.: Name:	Type of Call:	
Meter 1	2	3	4
Problem/Cause/Solution		Parts Replaced	
Notes:			

Service Record

Date: Time:	Eng. No.: Name:	Type of Call:	
Meter 1	2	3	4
Problem/Cause/Solution		Parts Replaced	
Notes:			

Date: Time:	Eng. No.: Name:	Type of Call:	
Meter 1	2	3	4
Problem/Cause/Solution		Parts Replaced	
Notes:			

