

**Error codes** and **Fault Codes** are in 2 columns, **Chain** and **Link**; so instead of searching for **094-911**, search for **094** or **911**. See sample below...

Chain Link	
071	921
072	921
075	921

# Phaser® 6600 and WorkCentre® 6605 Service Manual **Updated 10/14/15 DAW**



Prepared By:

Xerox Corporation  
Content Development and Language Services  
26600 SW Parkway  
Wilsonville, OR 97070

© 2012 by Xerox Corporation. All rights reserved.

XEROX® and XEROX and Design®, Phaser®, CentreWare®, PrintingScout®, Walk-Up®, WorkCentre®, FreeFlow®, SMARTsend®, Scan to PC Desktop®, ColorQube, Global Print Driver®, and Mobile Express Driver are trademarks of Xerox Corporation in the United States and/or other countries

Unpublished rights reserved under the copyright laws of the United States. Contents of this publication may not be reproduced in any form without permission of Xerox Corporation.

Copyright protection claimed includes all forms and matters of copyrightable materials and information now allowed by statutory or judicial law or hereinafter granted, including without limitation, material generated from the software programs which are displayed on the screen such as styles, templates, icons, screen displays, looks, etc.

Xerox technical training materials and service manuals are intended for use by authorized Xerox service technicians and service partners only and are not for resale. These materials may not be distributed, copied, or otherwise reproduced without prior written consent from Xerox Corporation.

Adobe Reader®, Adobe Type Manager®, ATM™, and PostScript® are trademarks of Adobe Systems Incorporated in the United States and/or other countries.

Apple®, AppleTalk®, Bonjour®, EtherTalk®, LaserWriter®, LocalTalk®, Macintosh®, Mac OS®, and TrueType® are trademarks of Apple Computer, Inc. in the United States and/or other countries.

HP-GL®, HP-UX®, and PCL® are trademarks of Hewlett-Packard Corporation in the United States and/or other countries.

Windows®, Vista™, and Windows Server™ are trademarks of Microsoft Corporation in the United States and/or other countries.

Novell®, NetWare®, NDPS®, NDS®, Novell Directory Services®, IPX™, and Novell Distributed Print Services™ are trademarks of Novell, Incorporated in the United States and/or other countries.

Sun<sup>SM</sup>, Sun Microsystems™, and Solaris™ are trademarks of Sun Microsystems, Incorporated in the United States and/or other countries.

SWOP® is a trademark of SWOP, Inc.

UNIX® is a registered trademark in the US and other countries, licensed exclusively through X/Open Company Limited.

PANTONE® Colors generated may not match PANTONE-identified standards. Consult current PANTONE Publications for accurate color. PANTONE® and other Pantone, Inc. trademarks are the property of Pantone, Inc. © Pantone, Inc., 2000.

As an ENERGY STAR® partner, Xerox Corporation has determined that this product meets the ENERGY STAR guidelines for energy efficiency. The ENERGY STAR name and logo are registered U.S. marks.





# Contents

## 1 General Information

About this Service Manual .....	1-2
Manual Terms .....	1-2
Manual Organization .....	1-3
Symbols Marked on the Product .....	1-4
Product Terms .....	1-4
Power Safety Precautions .....	1-5
Power Source .....	1-5
Disconnecting Power .....	1-5
Electrostatic Discharge (ESD) Precautions .....	1-6
Service Safety Summary .....	1-7
General Guidelines .....	1-7
Servicing Electrical Components .....	1-7
Servicing Mechanical Components .....	1-8
Servicing Fuser Components .....	1-8
Warning/caution Labels .....	1-8
Health and Safety Incident Reporting .....	1-14
Regulatory .....	1-16
United States (FCC Regulations) .....	1-16
Canada (Regulations) .....	1-16
European Union .....	1-16
Introduction and Overview .....	1-18
Technical Support Information .....	1-18
Configurations .....	1-19
Parts of the Printer .....	1-20
Phaser 6600 Front View .....	1-20
Phaser 6600 Rear View .....	1-20
Phaser 6600 Internal Parts .....	1-21
WorkCentre 6605 Front View .....	1-21
WorkCentre 6605 Rear and Side Views .....	1-22
WorkCentre 6605 Internal Parts .....	1-23
Control Panel .....	1-24
Phaser 6600 Control Panel Button Descriptions .....	1-24
WorkCentre 6605 Control Panel Button Descriptions .....	1-25

Media Path .....	1-26
Paper Path Layout .....	1-26
Feeding from Paper Cassette .....	1-26
Feeding from Bypass Tray .....	1-28
Feeding to Registration Section .....	1-29
Transfer/Fusing/Exit .....	1-31
Duplex Feeding (Optional) .....	1-32
Paper Path of DADF (Simplex) .....	1-33
Paper Path of DADF (Duplex) .....	1-34
Major Functional Components .....	1-35
Laser Unit .....	1-36
Drive .....	1-37
NOHAD & Waste Toner Collection .....	1-38
Dispenser .....	1-39
Xerographics & Transfer .....	1-40
Fusing .....	1-42
Paper Transport .....	1-44
Bypass Tray .....	1-45
Exit .....	1-46
Electrical .....	1-47
Option Feeder .....	1-48
UI (User Interface) and MFP Engine .....	1-49
Scanner .....	1-50
Consumables & Maintenance Items .....	1-54
Specifications .....	1-57
Configuration of Printer .....	1-57
Electrical Properties .....	1-60
Mechanical Properties .....	1-61
Functions .....	1-66
Operating Environment .....	1-70
Safety / Environment Conditions .....	1-70
Print Image Quality .....	1-71
Option .....	1-71
ESS Specification .....	1-72
IIT (Image Input Terminal) Specifications .....	1-79
FAX Specifications .....	1-80

## 2 Error Troubleshooting

Introduction .....	2-2
Initial Actions .....	2-2
Display Problems .....	2-2
Printing Problems.....	2-3
Copy/Scan Problems.....	2-3
DADF Problems.....	2-4
Fax Problems.....	2-4
Media-Based Problems.....	2-5
Servicing Instructions.....	2-7
Service Mode .....	2-8
How To Enter Service Mode .....	2-8
Using Diagnostics .....	2-10
How to Exit Service Mode .....	2-10
Service Mode Menu Maps.....	2-11
Service Mode Functions Overview.....	2-14
Service Mode Diagnostic Tests .....	2-19
ESS Diag .....	2-19
Engine Diag.....	2-23
Print Info .....	2-33
Installation Settings (Installation).....	2-35
Print Function Test (Test Print) .....	2-40
Parameter Setting (Parameter).....	2-52
Board Diag (Board Test) .....	2-55
Information.....	2-60
Scanner Maintenance.....	2-61
System Data Setting (Parameter).....	2-65
Backup (BackUP Data).....	2-86
Error Messages.....	2-89
Error Message Abbreviations .....	2-89
Error History Report.....	2-90
Error Code Tables.....	2-90
Phaser 6600 Error Code List .....	2-91
WorkCentre 6605 Error Code List .....	2-112
Error Code Fault Isolation Procedures.....	2-177
Level 1 FIP .....	2-177
Level 2 FIP .....	2-210
Other Fault Isolation Procedures .....	2-225
Abnormal Noise .....	2-225
Fault Isolation Procedure for FAX.....	2-227
Other FAX Problems .....	2-228

### 3 Image Quality

Initial Steps for Image Quality Troubleshooting .....	3-2
Image Quality Troubleshooting Chart .....	3-3
Image Quality FIP .....	3-4

### 4 Service Parts Disassembly

Preface .....	4-2
General notes .....	4-4
Standard Orientation of the SFP .....	4-5
Standard Orientation of the MFP .....	4-6
UICC .....	4-7
SFP Control Panel Assembly .....	4-7
MFP Control Panel Assembly .....	4-8
Laser Unit .....	4-10
Laser Unit Assembly .....	4-10
Drive .....	4-11
SFP Drive Assembly .....	4-11
MFP Drive Assembly .....	4-16
Drive Shaft Assembly .....	4-21
NOHAD .....	4-23
Toner Full Sensor .....	4-23
Left Rear Latch / Right Rear Latch .....	4-26
Dispenser .....	4-27
Upper Dispenser Motor Assembly .....	4-27
Dispenser Motor .....	4-31
Dispenser Assemblies Y, M, C, K .....	4-34
Toner Cartridges Y, M, C, K .....	4-37
Transfer .....	4-38
Transfer Belt Assembly .....	4-38
Waste Cartridge Lock .....	4-39
Left Transfer Belt Guide Assembly .....	4-40
CTD Spring / CTD Sensor Assembly .....	4-41
Transfer Belt Right Latch Kit .....	4-43
Coupling Kit .....	4-45
Fuser .....	4-46
Fuser Assembly .....	4-46
Xerographic .....	4-47
Transfer CRUM Connector Assembly .....	4-47
Imaging Units Y, M, C, K .....	4-48
Cleaner Assembly / Cleaner Assembly Base .....	4-49
Waste Cartridge .....	4-50
Tray .....	4-51
Tray Retard Holder Assembly .....	4-51
Feed Roller Assembly .....	4-52



Option Feeder.....	4-53
Optional 550-Sheet Feeder / Joint Screw .....	4-53
550 Option Left-Side Cover.....	4-54
550 Option Cassette Stopper.....	4-55
550 Option Feed Clutch Assembly .....	4-56
550 Option Drive Assembly .....	4-57
550 Option Feeder Board .....	4-58
550 Size Switch Assembly .....	4-59
550 Option Main Feed Assembly .....	4-60
550 Option Regi Clutch Assembly.....	4-61
550 Option Feed Roller Assembly.....	4-62
Bypass Tray.....	4-63
TA1 Roller Assembly .....	4-63
TA2 Roller Assembly .....	4-64
Bypass Tray Frame Assembly.....	4-65
Bypass Tray No Paper Sensor.....	4-66
Bypass Tray Sensor .....	4-67
Feed Roller Assembly .....	4-68
Roller Kit Assembly .....	4-69
Bypass Tray Feed Solenoid / Bypass Tray Feed Gear .....	4-70
Bypass Tray Assembly .....	4-71
Bypass Tray Cover Assembly .....	4-72
Bypass Tray Lower Cover.....	4-73
Bypass Tray Chute Assembly .....	4-74
Retard Holder Assembly.....	4-75
Bypass Tray Pinch Roller .....	4-76
Duplex.....	4-77
Duplex Assembly .....	4-77
Transfer Roller.....	4-79
Registration / Feeder .....	4-80
Upper Transfer Belt Chute Assembly.....	4-80
Regi Clutch Assembly .....	4-81
Cassette Stopper .....	4-83
Duplex Chute Assembly Kit.....	4-84
Lower Regi Chute / Opt 550 Regi Chute .....	4-85
Regi Chute Assembly / Rear Hinge Bracket .....	4-86
Right Regi Bearing.....	4-89
Duplex Clutch Assembly.....	4-90
Feed Clutch Assembly.....	4-91
Feed Roller Assembly .....	4-92
Exit.....	4-93
Exit Assembly .....	4-93
Stack Full Actuator .....	4-94
Exit Drive Assembly .....	4-95

Electrical.....	4-97
Fax Board (MFP only).....	4-97
MCU Board.....	4-98
Development HVPS Board.....	4-99
Hard Disk Package Kit.....	4-100
SFP IP Board.....	4-102
MFP IP Board.....	4-104
Wireless Kit.....	4-107
Transfer HVPS Board.....	4-108
AC Inlet Assembly.....	4-111
LVPS.....	4-112
Varistor Assembly.....	4-114
Covers.....	4-115
SFP Top Cover Assembly.....	4-115
MFP Top Cover Assembly.....	4-118
MFP Left Hand Inner Pole Cover.....	4-120
USB Hub Board.....	4-121
MFP Upper Right Hand Pole Cover.....	4-122
MFP Right Hand Inner Pole Cover.....	4-123
MFP Lower Left Hand Rear Cover.....	4-124
Exit Cover.....	4-125
SFP Left Sub-top Cover.....	4-126
Right Interlock Switch Assembly.....	4-127
Front Door Assembly.....	4-128
Rear Door Assembly.....	4-129
Right Side Door Assembly.....	4-130
Right Cover Assembly.....	4-131
SFP Left Cover Assembly.....	4-134
MFP Left Cover Assembly.....	4-136
Scanner.....	4-138
Scanner Assembly.....	4-138
DADF Assembly / IIT Assembly.....	4-143
IIT Pick-up Module.....	4-145
L Hinge/ R Hinge.....	4-147
Harness.....	4-148
Drive Harness Assembly.....	4-148
Main Harness Assembly.....	4-149
SFP Top Harness Assembly.....	4-150

## 5 Parts Lists

Serial Number Location and Range .....	5-2
Using the Parts List .....	5-3
Parts Navigation: Phaser 6600 .....	5-4
Parts Navigation: WorkCentre 6605 .....	5-7
Parts Lists .....	5-10
Parts List 1.1 Phaser 6600 UI (Control Panel) .....	5-11
Parts List 1.1 WorkCentre 6605 UI (Control Panel) .....	5-12
Parts List 2.1 Laser Unit .....	5-13
Parts List 3.1 Drive .....	5-14
Parts List 4.1 NOHAD .....	5-15
Parts List 5.1 Dispenser .....	5-17
Parts List 6.1 Transfer .....	5-19
Parts List 7.1 Fuser .....	5-21
Parts List 8.1 Xerographic .....	5-22
Parts List 9.1 Tray .....	5-24
Parts List 10.1 Option Feeder .....	5-27
Parts List 10.2 Option Feeder .....	5-29
Parts List 10.3 Option Feeder .....	5-30
Parts List 13.1 Bypass Tray (MSI) .....	5-32
Parts List 13.2 Bypass Tray (MSI) .....	5-34
Parts List 13.3 Bypass Tray (MSI) .....	5-36
Parts List 14.1 Duplex .....	5-38
Parts List 15.1 Registration / Feeder .....	5-39
Parts List 15.2 Registration / Feeder .....	5-41
Parts List 17.1 Exit .....	5-43
Parts List 18.1 Phaser 6600 Electrical (1/2) .....	5-45
Parts List 18.1 WorkCentre 6605 Electrical (1/2) .....	5-48
Parts List 18.2 Electrical (2/2) .....	5-51
Parts List 19.1 Phaser 6600 Covers .....	5-53
Parts List 19.1 WorkCentre 6605 Covers .....	5-56
Parts List 51.1 WorkCentre 6605 Scanner .....	5-60
Xerox Supplies and Accessories .....	5-62
Hardware Kit .....	5-62
Consumables .....	5-62
Routine Maintenance Items .....	5-63

## 6 Maintenance

Service Maintenance Procedure .....	6-2
Recommended Tools .....	6-2
Cleaning .....	6-3
General Precautions .....	6-3
Recommended Tools .....	6-3
Cleaning the Exterior .....	6-4
Cleaning the Scanner (MFP Only) .....	6-4
Cleaning the Interior .....	6-7
Moving the Printer .....	6-16

Adjustments and Maintenance Procedures.....	6-18
Color Registration .....	6-18
Adjusting the Transfer Roller Bias.....	6-21
Adjusting the Transfer Belt Offsets .....	6-22
Adjusting Altitude .....	6-22
Adjusting the Fuser .....	6-23
Updating Firmware .....	6-24
<b>7 Wiring</b>	
Printer Plug/Jack Designations .....	7-2
Phaser 6600 Plug/Jack Designators .....	7-2
Phaser 6600 Plug/Jack Locations .....	7-6
WorkCentre 6605 Plug/Jack Designators .....	7-11
WorkCentre 6605 Plug/Jack Locations .....	7-15
System Wiring .....	7-21
Notations Used in the Wiring Diagrams.....	7-21
Connection Details .....	7-24
Phaser 6600 General Wiring Diagram.....	7-26
WorkCentre 6605 General Wiring Diagram.....	7-28
AC Power .....	7-30
Fuser .....	7-32
Drive.....	7-33
Bypass Tray (MSI) .....	7-35
Laser Unit.....	7-36
SFP Controller .....	7-38
MFP Controller .....	7-40
Paper Transport .....	7-42
HVPS .....	7-43
Xerographic.....	7-45
Developer.....	7-47
Exit .....	7-48
550 Feeder.....	7-49
Scanner.....	7-51
<b>A Reference</b>	
Acronyms and Abbreviations.....	A-2
Phaser 6600 Menu Map .....	A-6
E, H, & S Incident Report Form .....	A-7
<b>Index</b>	

# General Information

# 1

## In this chapter...

- About this Service Manual
- Manual Organization
- Symbols Marked on the Product
- Power Safety Precautions
- Electrostatic Discharge (ESD) Precautions
- Service Safety Summary
- Regulatory
- Introduction and Overview
- Configurations
- Parts of the Printer
- Control Panel
- Media Path
- Major Functional Components
- Consumables & Maintenance Items
- Specifications

# About this Service Manual

The Phaser 6600 & WorkCentre 6605 MFP Service Manual is the primary document used for repairing, maintaining, and troubleshooting the printer. Use this manual as your primary resource for understanding the operational characteristics of the printer and all available options. This manual describes specifications and the diagnosis and repair of problems occurring in the printer and attached options. Also included are detailed replacement procedures, parts lists, and wiring diagrams.

## Manual Terms

Various terms are used throughout this manual to either provide additional information on a specific topic or to warn of possible danger present during a procedure or action. Be aware of all symbols and terms when they are used, and always read Note, Caution, and Warning statements.



**WARNING:** A warning indicates an operating or maintenance procedure, practice or condition that, if not strictly observed, results in injury or loss of life.



**CAUTION:** A caution indicates an operating or maintenance procedure, practice or condition that, if not strictly observed, results in damage to, or destruction of, equipment.

**Replacement Note:** A replacement note provides important information related to parts replacement. When needed, replacement notes appear at the end of the disassembly procedure.

**Note:** A note indicates an operating or maintenance procedure, practice or condition that is necessary to efficiently accomplish a task. A note can provide additional information related to a specific subject or add a comment on the results achieved through a previous action.

# Manual Organization

The Phaser 6600 & WorkCentre 6605 MFP Service Manual contains these sections:

**Introductory, Safety, and Regulatory Information:** This section contains important safety information and regulatory requirements.

**Chapter 1 - General Information:** This section contains an overview of the printer's operation, configuration, specifications, and consumables.

**Chapter 2 - Error Codes and Troubleshooting:** This section provides detailed troubleshooting procedures for error messages and codes generated by resident diagnostics. Troubleshooting covers the operation of Power On Self Test (POST) and Service Diagnostics. In addition, this section includes troubleshooting methods for situations where error indicator is not available.

**Chapter 3 - Image Quality Troubleshooting:** This section focuses on techniques to correct image quality problems associated with the printer output.

**Chapter 4 - Service Parts Disassembly:** This section contains removal procedures for spare parts listed in the Parts List. A replacement procedure is included when necessary.

**Chapter 5 - Parts List:** This section contains exploded views of the print engine and optional Field Replaceable Units (FRUs), as well as part numbers for orderable parts.

**Chapter 6 - Maintenance:** This section provides periodic cleaning procedures for the printer. This section also provides procedures for the adjustment of print engine components

**Chapter 7 - Wiring:** This section contains the plug/jack locations and wiring diagrams for the printer.

**Appendix - Reference:** This section provides a list of acronyms and their definitions, and a menu map for the Phaser 6600.

## Symbols Marked on the Product



Hot surface on or in the printer. Use caution to avoid personal injury.



Use caution (or draws attention to a particular component). Refer to the manual(s) for information.



It may take 40 minutes for the Fuser to cool down.



Do not touch the item.



Do not expose the item to sunlight.



Do not expose the item to light.

## Product Terms

**Caution:** A personal injury hazard exists that may not be apparent. For example, a panel may cover the hazardous area.

**Danger:** A personal injury hazard exists in the area where you see the sign.



# Power Safety Precautions

## Power Source

For 115 VAC printers, do not apply more than 127 volts RMS between the supply conductors or between either supply conductor and ground. For 230 VAC printers, do not apply more than 254 volts RMS between the supply conductors or between either supply conductor and ground. Use only the specified power cord and connector. This manual assumes that the reader is a qualified service technician.

Plug the three-wire power cord (with grounding prong) into a grounded AC outlet only. If necessary, contact a licensed electrician to install a properly grounded outlet. If the product loses its ground connection, contact with conductive parts may cause an electrical shock. A protective ground connection by way of the grounding conductor in the power cord is essential for safe operation.

## Disconnecting Power

**WARNING:** Turning the power Off using the power switch does not completely de-energize the printer. You must also disconnect the Power Cord from the printer's Alternating Current (AC) inlet. Disconnect the Power Cord by pulling the plug, not the cord.

Disconnect the Power Cord in the following cases:

- if the power cord or plug is frayed or otherwise damaged,
- if any liquid or foreign material is spilled into the product,
- if the printer is exposed to any excess moisture,
- if the printer is dropped or damaged,
- if you suspect that the product needs servicing or repair,
- whenever you clean the product.

## Electrostatic Discharge (ESD) Precautions

Some semiconductor components, and the respective sub-assemblies that contain them, are vulnerable to damage by Electrostatic Discharge (ESD). These components include Integrated Circuits (ICs), Large-Scale Integrated circuits (LSIs), field-effect transistors, and other semiconductor chip components. The following techniques will reduce the occurrence of component damage caused by static electricity.

Be sure the power is Off and observe these other safety precautions.

- Immediately before handling any semiconductor component assemblies, drain the electrostatic charge from your body. This can be accomplished by touching an earth ground source or by wearing a wrist strap device connected to an earth ground source. Wearing a wrist strap will also prevent accumulation of additional bodily static charges. Be sure to remove the wrist strap before applying power to the unit under test to avoid potential shock.
- After removing a static sensitive assembly from its anti-static bag, place it on a grounded conductive surface. If the anti-static bag is conductive, you may ground the bag and use it as a conductive surface.
- Do not use freon-propelled chemicals. These can generate electrical charges sufficient to damage some devices.
- Do not remove a replacement component or electrical sub-assembly from its protective package until you are ready to install it.
- Immediately before removing the protective material from the leads of a replacement device, touch the protective material to the chassis or circuit assembly into which the device will be installed.
- Minimize body motions when handling unpacked replacement devices. Motion such as your clothes brushing together, or lifting a foot from a carpeted floor can generate enough static electricity to damage an electro-statically sensitive device.
- Handle ICs and Erasable Programmable Read-Only Memories (EPROM's) carefully to avoid bending pins.
- Pay attention to the direction of parts when mounting or inserting them on Circuit Boards.

# Service Safety Summary

## General Guidelines

**For qualified service personnel only:** Refer also to the preceding [Power Safety Precautions](#) on page 1-5.

**Avoid servicing alone:** Do not perform internal service or adjustment of this product unless another person capable of rendering first aid or resuscitation is present.

**Use care when servicing with power:** Dangerous voltages may exist at several points in this product. To avoid personal injury, do not touch exposed connections and components while power is On. Disconnect power before removing the power supply shield or replacing components.

**Do not wear jewelry:** Remove jewelry prior to servicing. Rings, necklaces and other metallic objects could come into contact with dangerous voltages and currents.

## Warning Labels

Read and obey all posted warning labels. Throughout the printer, warning labels are displayed on potentially dangerous components. As you service the printer, check to make certain that all warning labels remain in place.

## Safety Interlocks

Make sure all covers are in place and all Interlock Switches are functioning correctly after you have completed a printer service call. If you bypass an Interlock Switch during a service call, use extreme caution when working on or around the printer.

## Servicing Electrical Components


Before starting any service procedure, switch the printer power Off and unplug the power cord from the wall outlet. If you must service the printer with power applied, be aware of the potential for electrical shock.

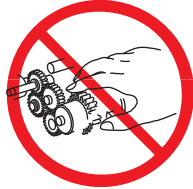
 **WARNING:** Do not touch any electrical component unless you are instructed to do so by a service procedure.




## Servicing Mechanical Components

When servicing mechanical components within the printer, manually rotate the Drive Assemblies, Rollers, and Gears.

 **WARNING:** Do not try to manually rotate or manually stop the drive assemblies while any motor is running.



## Servicing Fuser Components

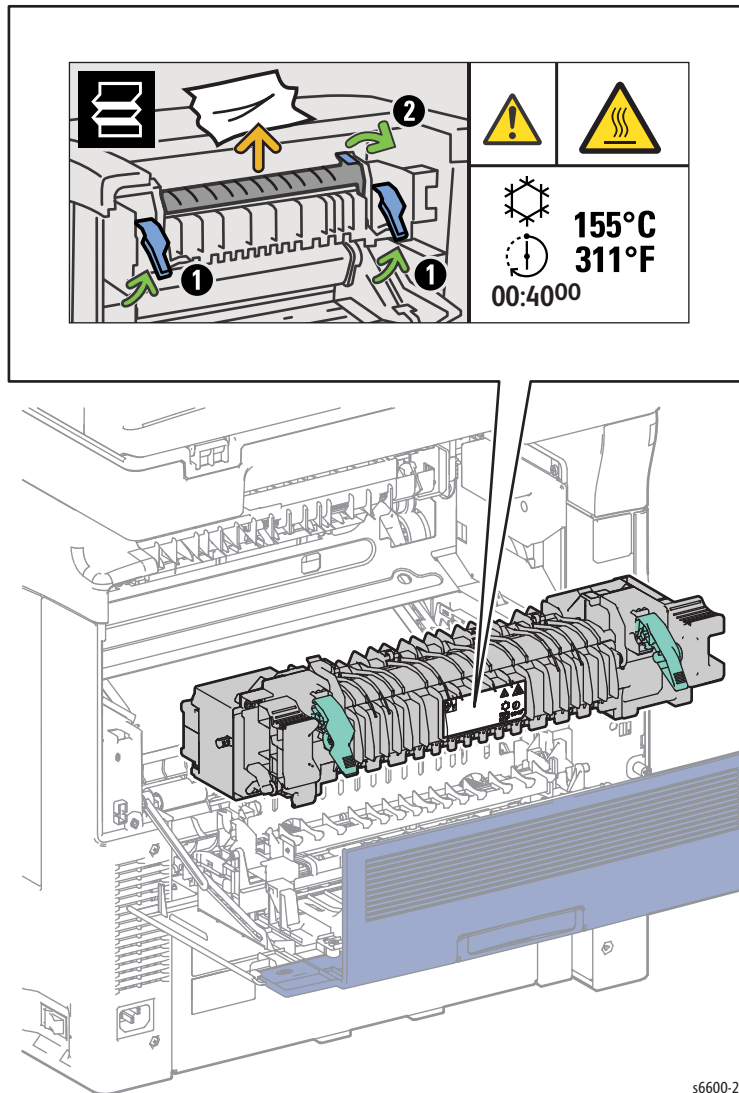
 **WARNING:** This printer uses heat to fuse the image to the media. During operating, the Fuser is very hot. Allow the Fuser to cool before you attempt to service the Fuser or adjacent components.

## Warning/caution Labels

Warning labels and caution labels are attached to this laser printer to prevent accidents. Check those labels for their peeling or stains when servicing the printer.

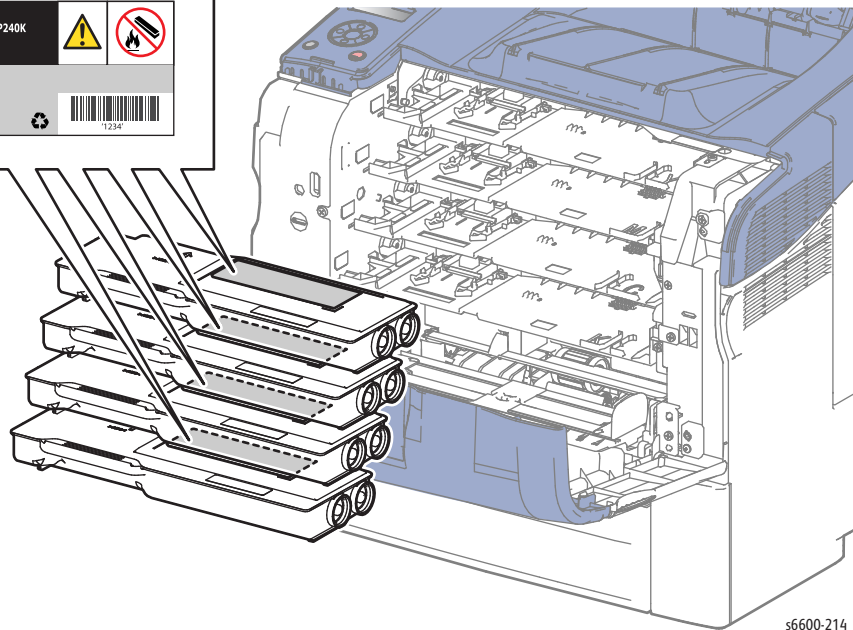
## Caution label for high-temperature units

This picture shows the location and content of the caution label on the Fuser for both the SFP and MFP.



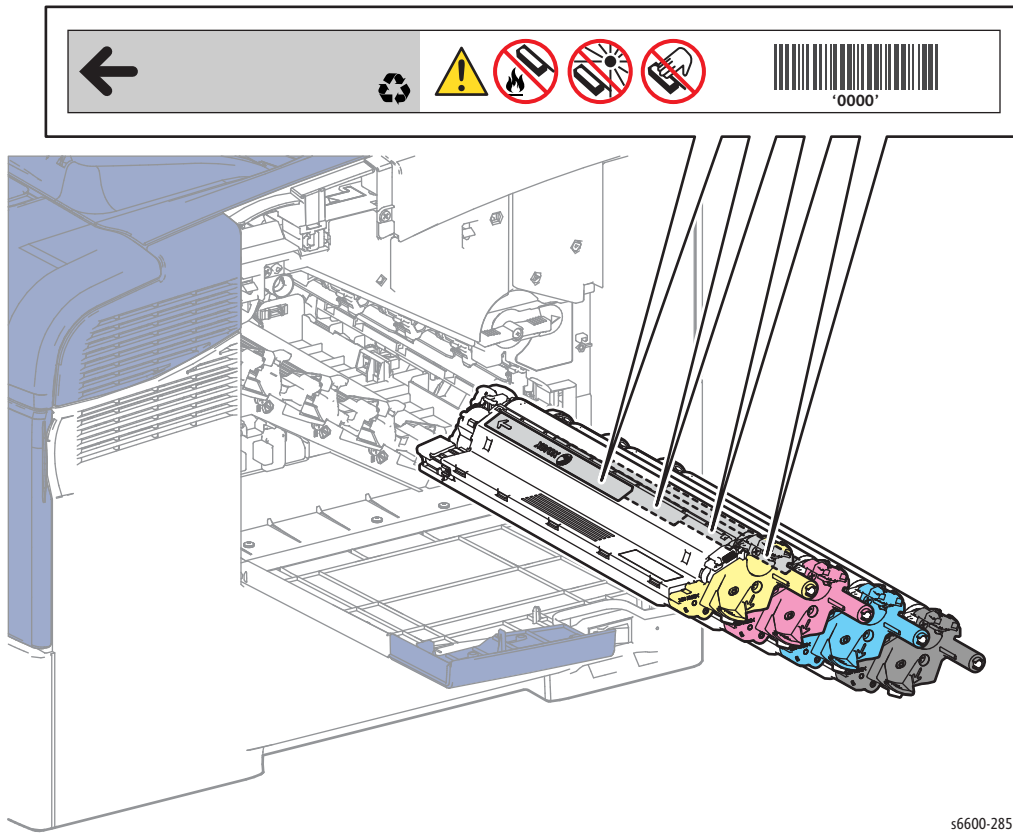
s6600-235

## Caution label for toner cartridges



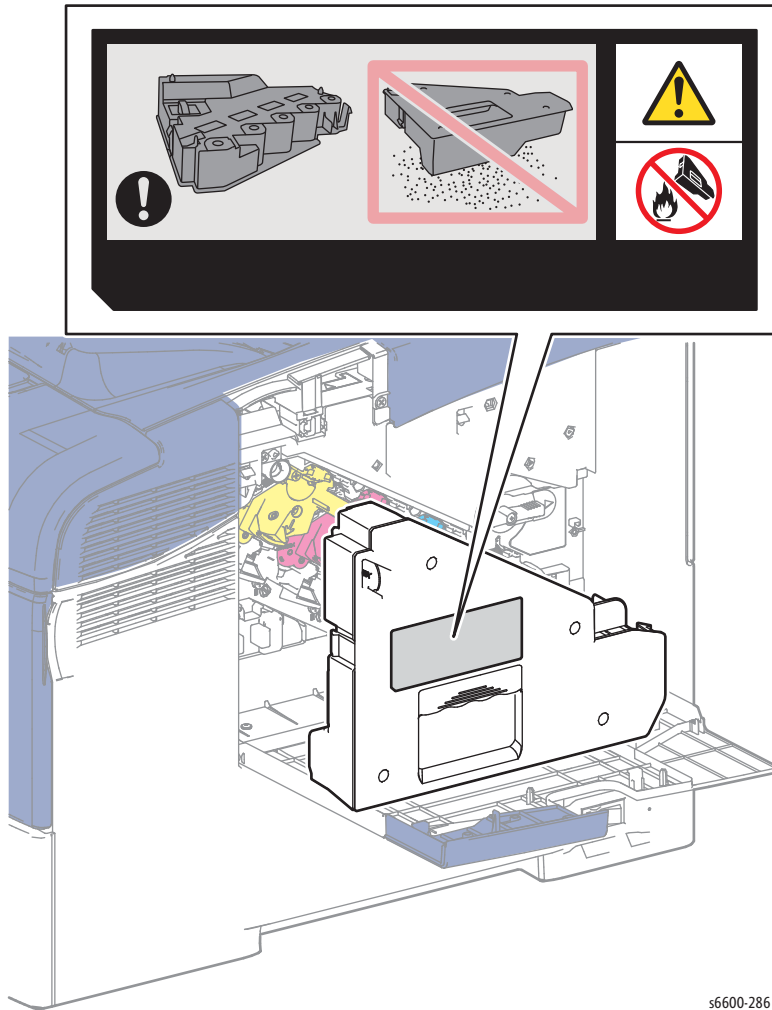
s6600-214

## Caution label for Imaging Units



s6600-285

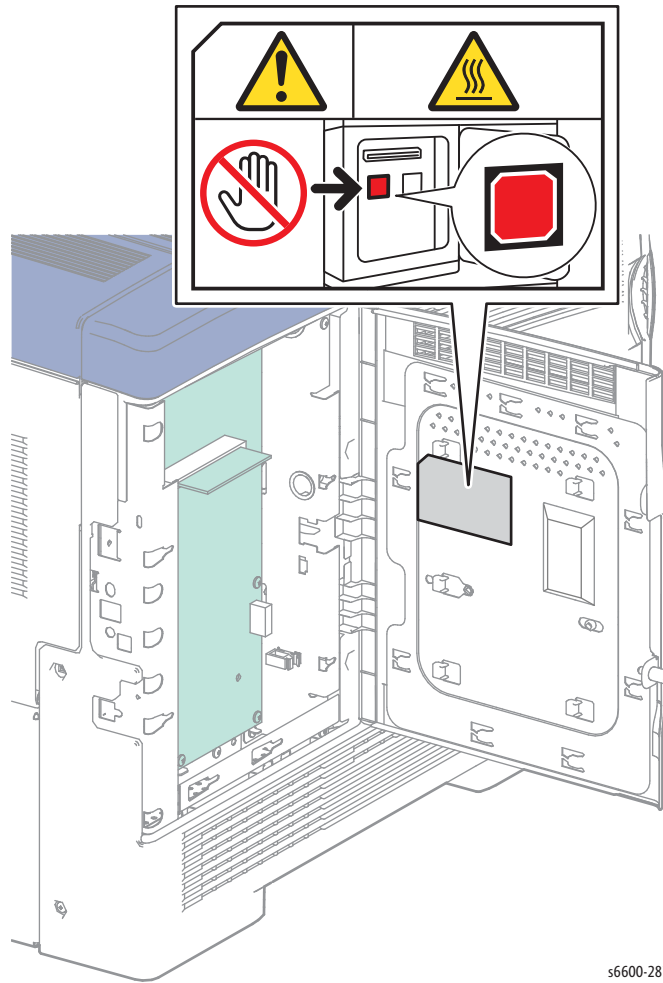
## Caution label for Waste Cartridge



s6600-286



### Caution label for IP Board



s6600-287

## Health and Safety Incident Reporting

This section defines requirements for notification of health and safety incidents involving Xerox products (equipment and materials) at customer locations worldwide. These requirements apply to Xerox Corporation and its subsidiaries worldwide.

### Objective

To enable prompt resolution of health and safety incidents involving Xerox products and to ensure Xerox regulatory compliance.

### Definitions

Incident:

An event or condition occurring in a customer account that has resulted in injury, illness or property damage. Examples of incidents include machine fires, smoke generation, physical injury to an operator or service representative. Alleged events and product conditions are included in this definition.

### Requirements

Initial Report:

1. Xerox organizations have established a process for individuals to report product incidents to Xerox Environment Health & Safety within 24 hours of becoming aware of the event.
2. The information to be provided at the time of reporting is outlined in the Health and Safety Incident Report form.

The Health and Safety Incident Report form used to report incidents involving Xerox products is available on Xerox Global Service Net at <https://www.xrxgsn.com/secure/main.pl?CatId=1789>. If you are unable to download the form, request a form when reporting the incident by phone, electronic mail or Fax. You can also see the form at “E, H, & S Incident Report Form” on page A-7.

3. The initial notification may be made by any of the methods that follow:
  - For incidents in North America and Developing Markets West (Brazil, Mexico, Latin American North and Latin American South):
    - Phone\* Xerox EH&S at: +1-800-828-6571.
    - Electronic mail Xerox EH&S at: [usa.xerox.ehs@xerox.com](mailto:usa.xerox.ehs@xerox.com).
    - Fax Xerox EH&S at: +1-585-216-8817 [intelnet 8-219-8817].
  - For incidents in Europe and Developing Markets East (Middle East, Africa, India, China and Hong Kong):
    - Phone\* Xerox EH&S at: +44 (0) 1707 353434.
    - Electronic mail Xerox EH&S at: [ehs-europe@xerox.com](mailto:ehs-europe@xerox.com).
    - Fax Xerox EH&S at: +44 (0) 1707 353914 [intelnet 8 668 3914].

**Note:** Initial notification made by phone must be followed within 24 hours by a completed Health and Safety Incident Report form sent to the indicated electronic mail address or fax number. If sending a fax, please also send the original form by internal mail.

Responsibilities for resolution:

1. Business Groups / Product Design Teams responsible for the product involved in the incident shall:
  - a. Manage field bulletins, customer correspondence, product recalls, safety retrofits.
  - b. Fund all field retrofits.
2. Field Service Operations shall:
  - a. Preserve the Xerox product involved and the scene of the incident inclusive of any associated equipment located in the vicinity of the incident.
  - b. Return any affected equipment/part(s) to the location designated by Xerox EH&S and/or the Business Division.
  - c. Implement all safety retrofits.
3. Xerox EH&S shall:
  - a. Manage and report all incident investigation activities.
  - b. Review and approve proposed product corrective actions and retrofits, if necessary.
  - c. Manage all communications and correspondence with government agencies.
  - d. Define actions to correct confirmed incidents.

## Regulatory

Xerox has tested this product to electromagnetic emission and immunity standards. These standards are designed to mitigate interference caused or received by this product in a typical office environment.

### United States (FCC Regulations)

This equipment has been tested and found to comply with the limits for a Class A digital device, pursuant to Part 15 of the Federal Communications Commission (FCC) Rules. These limits are designed to provide reasonable protection against harmful interference in a residential installation. This equipment generates, uses, and can radiate radio frequency energy. If it is not installed and used in accordance with these instructions, it may cause harmful interference to radio communications. However, there is no guarantee that interference will not occur in a particular installation. If this equipment does cause harmful interference to radio or television reception, which can be determined by turning the equipment Off and On, the user is encouraged to try to correct the interference by one or more of the following measures:

- Reorient or relocate the receiver (device being interfered with).
- Increase the separation between the printer and the receiver.
- Connect the equipment into an outlet on a circuit different from that which the receiver is connected.
- Consult the dealer or an experienced radio/television technician for help.

Any changes or modifications not expressly approved by Xerox could void the user's authority to operate the equipment. To ensure compliance with Part 15 of the FCC rules, use shielded interface cables.

### Canada (Regulations)

This Class A digital apparatus complies with Canadian ICES-003.

Cet appareil numérique de la classe A est conforme à la norme NMB-003 du Canada.

### European Union

The CE mark applied to this product symbolizes Xerox's declaration of conformity with the following applicable Directives of the European Union as of the dates indicated:



December 12, 2006: Low Voltage Directive 2006/95/EC

December 15, 2004: Electromagnetic Compatibility Directive 2004/108/EC

March 9, 1999: Electromagnetic Compatibility Directive 99/5/EC

This product, if used properly in accordance with the user's instructions, is neither dangerous for the consumer nor for the environment.

To ensure compliance with European Union regulations, use shielded interface cables.

A signed copy of the Declaration of Conformity for this product can be obtained from Xerox.

## Introduction and Overview

The Phaser 6600 and WorkCentre 6605 are color laser devices built around a common print engine. The Phaser 6600 Printer is a single function machine, while the WorkCentre 6605 is a multifunction printer that adds copy, scan, and fax functions to the print function.

### Technical Support Information

The Xerox Service Manual is the primary document used for repairing, maintaining, and troubleshooting the printer. To ensure complete understanding of this product, participation in Xerox Service Training is strongly recommended. To service this product, certification for this product is required.

For updates to the Service Manual, Service Bulletins, knowledge base, etc., go to:

- Xerox Global Service Net - <https://www.xrxgsn.com/secure/main.p>

For further technical support, contact your assigned Xerox Technical Support for this product.

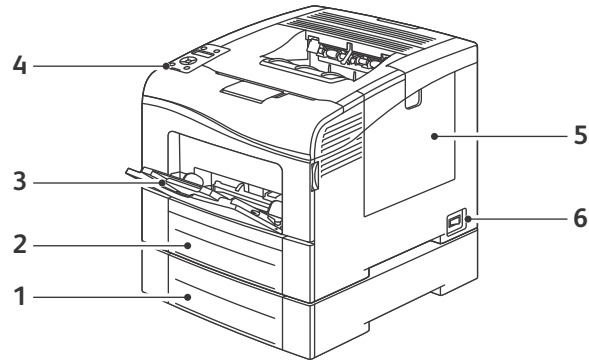
# Configurations

This table lists Phaser 6600 & WorkCentre 6605 MFP configurations

Features	Phaser 6600	WorkCentre 6605
Processor Speed	533 MHz	533 MHz
Memory Configuration	256 MB	512 MB
Print Speed (Letter)	36 ppm simplex/ 24 ipm duplex	36 ppm simplex/ 24 ipm duplex
Print Speed (A4)	35 ppm simplex/ 24 ipm duplex	35 ppm simplex/ 24 ipm duplex
<b>Print Resolutions (dpi)</b>		
Standard	600 x 600	
Enhanced & Photo	600 x 600 x 4 (1200 x 1200 enhanced image quality)	
USB 2.0 Support	Yes	Yes
Ethernet Interface 10/100/1000 Base-TX	Yes	Yes
Wireless Interface IEEE802.11b/g/n	Optional	Optional
Multi-sheet Inserter(<150 sheets)	Standard	Standard
Main Tray (550 Sheets)	Yes	Yes
DADF (50 sheets)	No	Yes
Duplex	DN configuration only	DN configuration only

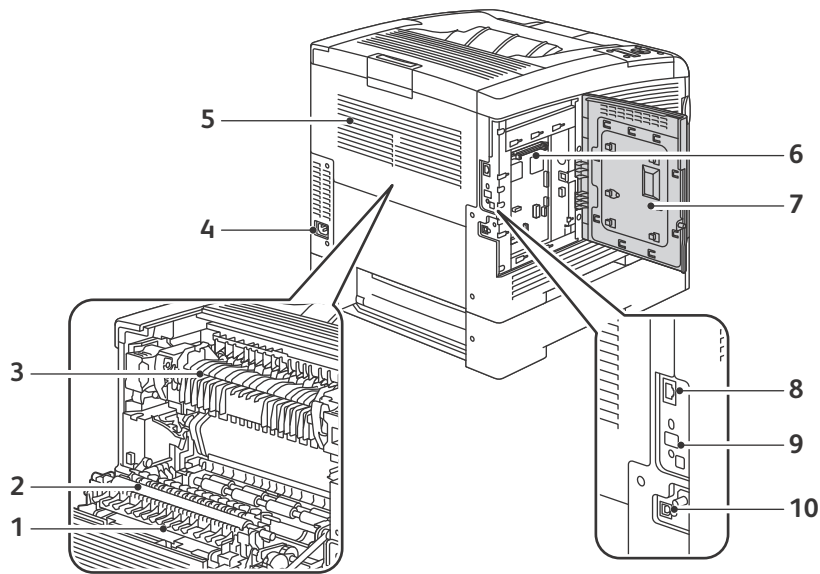
# Parts of the Printer

## Phaser 6600 Front View



- |                      |                    |
|----------------------|--------------------|
| 1. Tray 2 (Optional) | 4. Control Panel   |
| 2. Tray 1            | 5. Right Side Door |
| 3. Bypass Tray       | 6. Power Switch    |

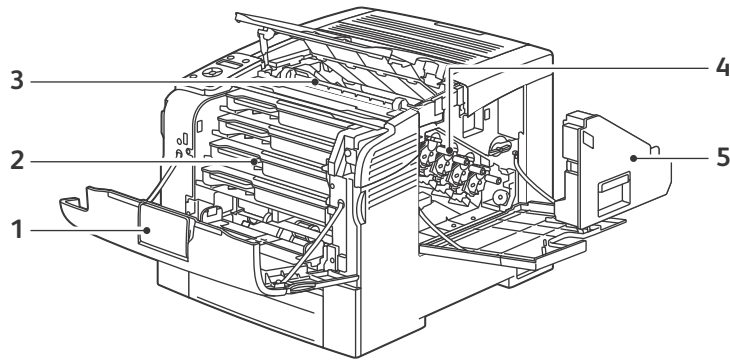
## Phaser 6600 Rear View



- |                    |                                  |
|--------------------|----------------------------------|
| 1. Duplex Unit     | 6. IP Board                      |
| 2. Transfer Roller | 7. Left Side Door                |
| 3. Fuser           | 8. Ethernet Connection           |
| 4. Power Connector | 9. Wireless Network Adapter Port |
| 5. Rear Cover      | 10. USB Port                     |

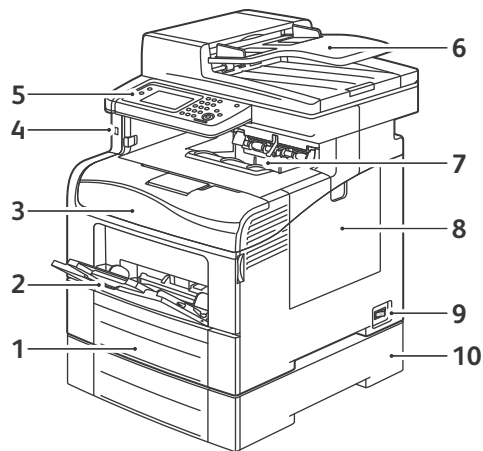


## Phaser 6600 Internal Parts



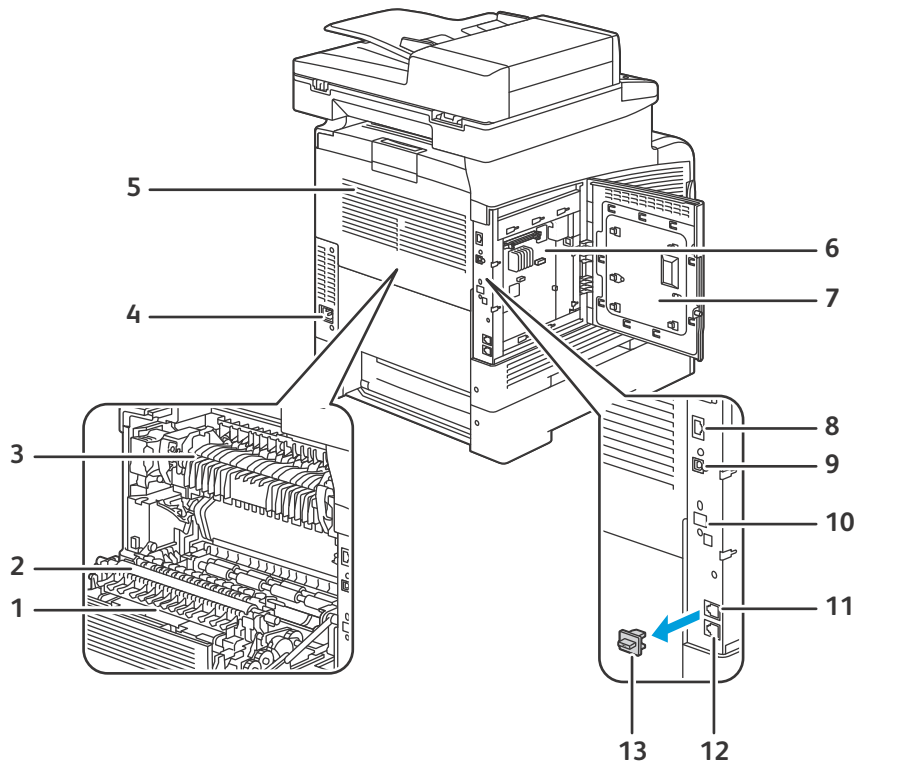
- |                     |                    |
|---------------------|--------------------|
| 1. Front Cover      | 4. Imaging Unit    |
| 2. Toner Cartridges | 5. Waste Cartridge |
| 3. Transfer Belt    |                    |

## WorkCentre 6605 Front View



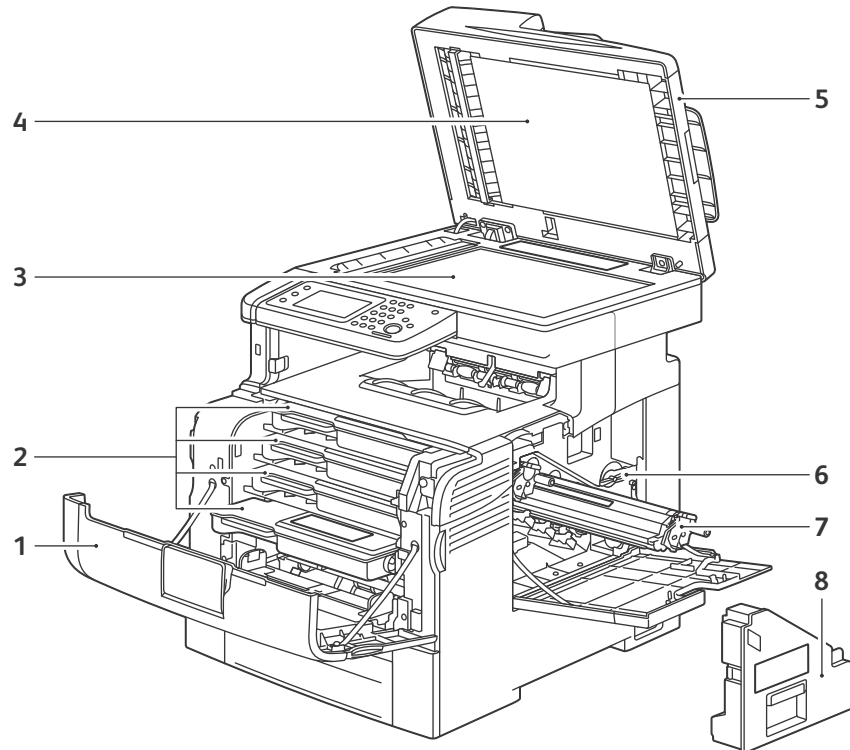
- |                    |                                       |
|--------------------|---------------------------------------|
| 1. Tray 1          | 6. Duplex Automatic Document Feeder   |
| 2. Bypass Tray     | 7. Output Tray                        |
| 3. Front Door      | 8. Right Side Door                    |
| 4. USB Memory Port | 9. Power Switch                       |
| 5. Control Panel   | 10. Tray 2, Optional 550-Sheet Feeder |

## WorkCentre 6605 Rear and Side Views



- |                    |                                   |
|--------------------|-----------------------------------|
| 1. Duplex Unit     | 8. Ethernet Connection            |
| 2. Transfer Roller | 9. USB Port                       |
| 3. Fuser           | 10. Wireless Network Adapter Port |
| 4. Power Connector | 11. Phone Connector               |
| 5. Rear Door       | 12. Fax Line Connector            |
| 6. IP Board        | 13. Phone Line Cover              |
| 7. Left Side Door  |                                   |

## WorkCentre 6605 Internal Parts

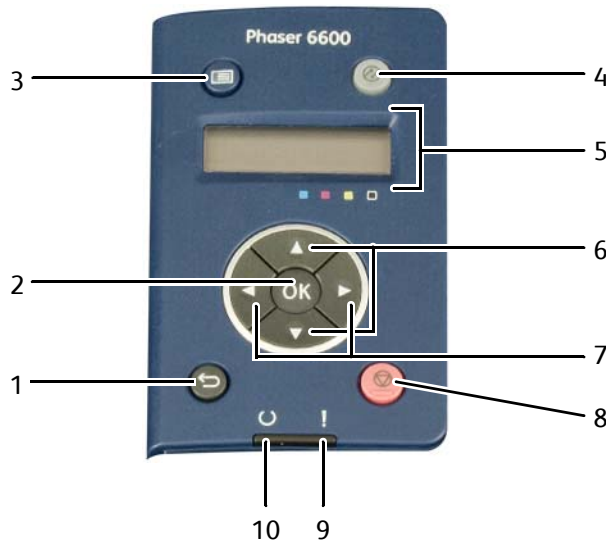


- |    |                  |    |                                  |
|----|------------------|----|----------------------------------|
| 1. | Front Door       | 5. | Duplex Automatic Document Feeder |
| 2. | Toner Cartridges | 6. | Waste Cartridge Lock             |
| 3. | Document Glass   | 7. | Imaging Units                    |
| 4. | Document Cover   | 8. | Waste Cartridge                  |

# Control Panel

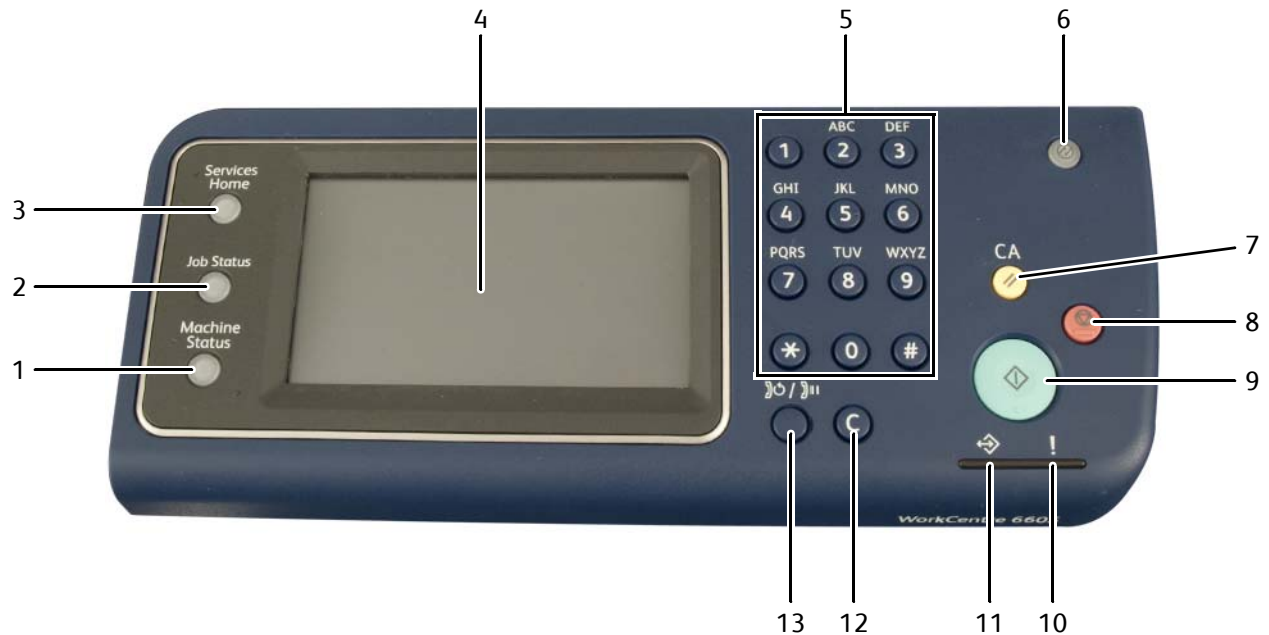
The Control Panel consists of multiple LEDs, a display, and several function buttons. These buttons are used to navigate the menu system, perform functions, and select modes of operation.

## Phaser 6600 Control Panel Button Descriptions



- |     |                              |  |
|-----|------------------------------|--|
| 1.  | Back/Return                  | Goes up one level in the menu.   |
| 2.  | OK                           | Displays the selected menu or selects the current menu option.   |
| 3.  | Menu                         | Displays the Information Pages, Billing Meters, Admin, Tray Settings, and Panel Language menus.  |
| 4.  | Power Saver                  | Enters and exits low-power mode.   |
| 5.  | Display                      | Provides information about settings, and status or error messages. An asterisk (*) next to a menu option indicates the current default setting.  |
| 6.  | Up and Down Arrow Buttons    | Navigate to the next menu, item, or option.  |
| 7.  | Left and Right Arrow Buttons | Move forward and back through sub-menus or number fields. To display the Walk-up Features menu and list Secure Jobs and Saved Jobs, press the <b>Left</b> arrow button   |
| 8.  | Cancel                       | Ends printing jobs.  |
| 9.  | Error indicator              | <ul style="list-style-type: none"> <li>• Lights red to indicate an error condition or warning that requires your attention.</li> <li>• Blinks red when an error occurs that requires technical support.</li> </ul> |
| 10. | Ready indicator              | <ul style="list-style-type: none"> <li>• Lights green when the printer is ready to receive data.</li> <li>• Blinks green when the printer is busy receiving data.</li> </ul>                                       |

## WorkCentre 6605 Control Panel Button Descriptions



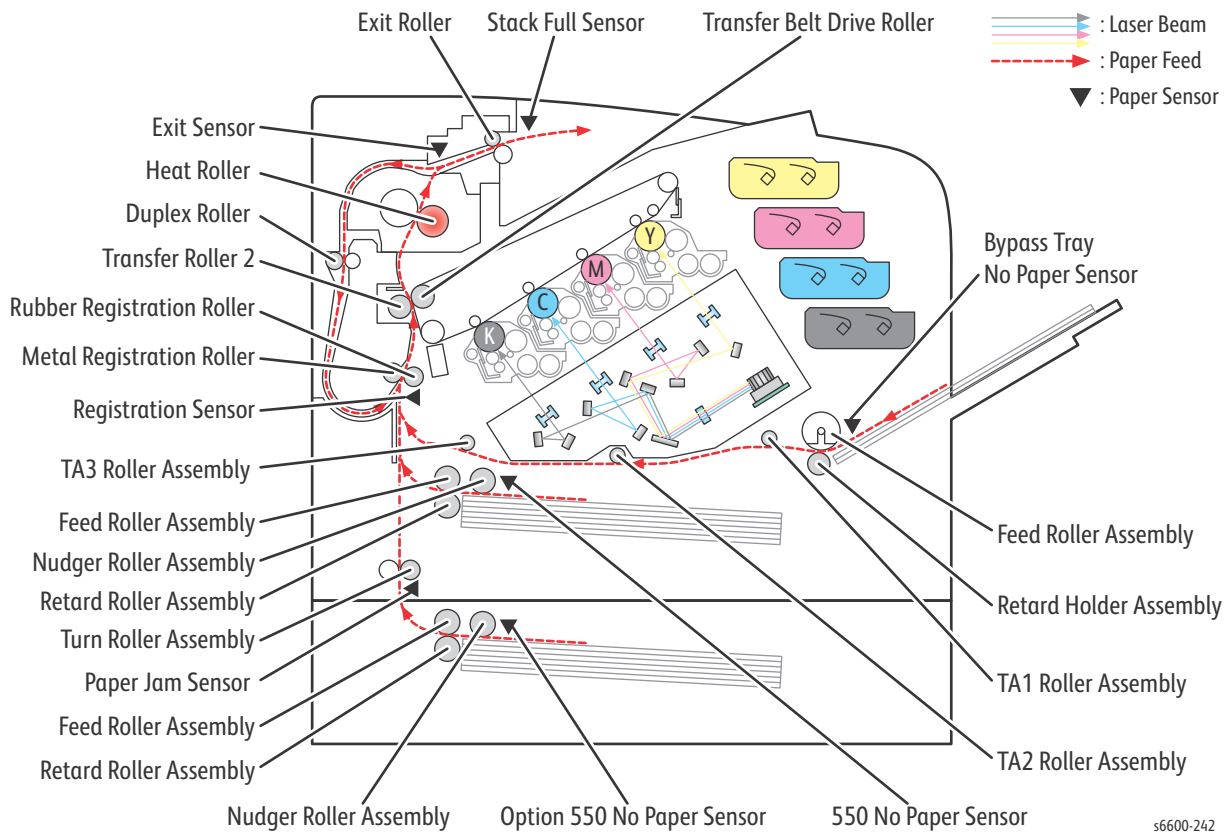
- |                         |   |
|-------------------------|---|
| 1. Machine Status       | Switches the display to the System menus.   |
| 2. Job Status           | Displays the active jobs, Secure Print Jobs, and Secure Fax Jobs available in Job Status on the touch screen.   |
| 3. Services Home        | Invokes the Services home menu for access to printer features, such as copy, scan, and fax.   |
| 4. Touch screen Display | Displays information and provides access to printer functions.  |
| 5. Alphanumeric Keypad  | Enters alphanumeric information such as phone numbers, quantities, text.  |
| 6. Power Saver          | Enters and exits low-power mode.  |
| 7. Clear All            | Clears previous and changed settings for the current selection.   |
| 8. Stop                 | Cancels the current job.  |
| 9. Start                | Starts the selected copy, scan, fax, or Print From job, such as Print from USB  |
| 10. Error indicator     | <ul style="list-style-type: none"> <li>• Lights red to indicate an error condition or warning that requires attention.</li> <li>• Blinks red when an error occurs that requires technical support.</li> </ul> |
| 11. Ready indicator     | <ul style="list-style-type: none"> <li>• Lights green when the printer is ready to receive data.</li> <li>• Blinks green when the printer is busy receiving data.</li> </ul>                                  |
| 12. Clear               | Clears a number field or clears the last number of a numeric entry.   |
| 13. Redial/Pause        | Recalls the last fax number used or inserts pauses in fax numbers.  |

# Media Path

This section describes the paper feed path of the entire device and the paper feed process in the each feed section.

## Paper Path Layout

The following shows the paper feed layout when the duplex print unit and the tray module are installed, and the components relevant to paper feed.



## Feeding from Paper Cassette

The paper loaded in the paper cassette is fed between the Feed Roller and the Retard Roller by the Nudger Roller, and fed farther to the registration section by the rotation of the Feed Roller and the Retard Roller.

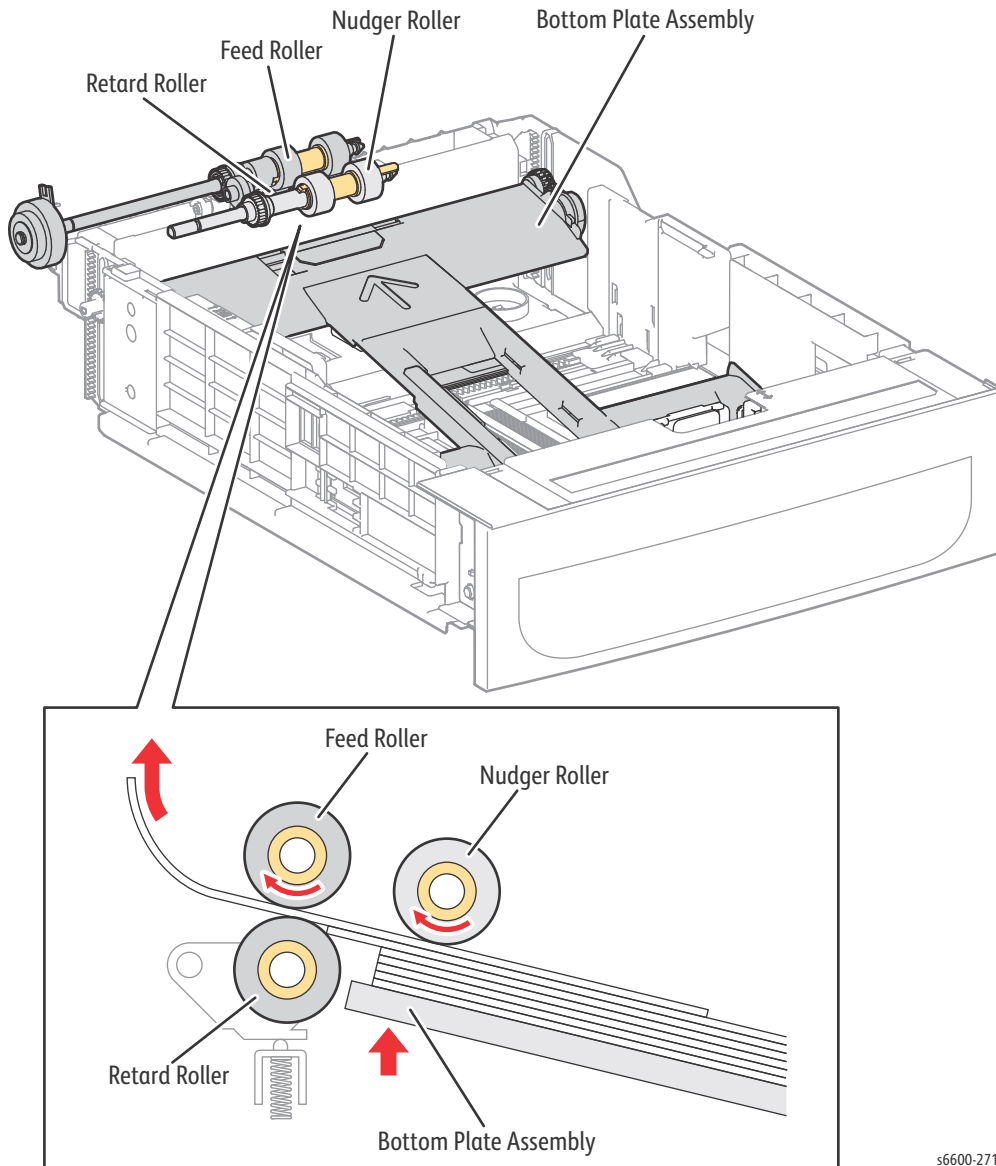
The Nudger Roller and the Feed Roller are rotated by the torque of the Paper Transport Motor via the Feed Roller Clutch.

The Retard Roller, pressed from underneath by the spring pressure and forced to the Feed Roller, plays a role of fanning a sheet by the rotation friction.

When the sheet is lapped over, the break force of the torque limiter combined with the Retard Roller separates and feeds only the sheet on the top.

The Bottom Plate Assembly is the mechanism driven with the gear located on the side of the paper cassette. Unless the interlock gear is unlocked, the Bottom Plate Assembly keeps the state that it is not lowered or elevated from the arbitrary position. The sheet is fed at this position.

As the paper feed is proceeded and several sheets of paper on the top of the paper loaded are decreased, the Nudger Roller lowers down and the lever unlocks the gear, and then the Bottom Plate Assembly is elevated.



s6600-271

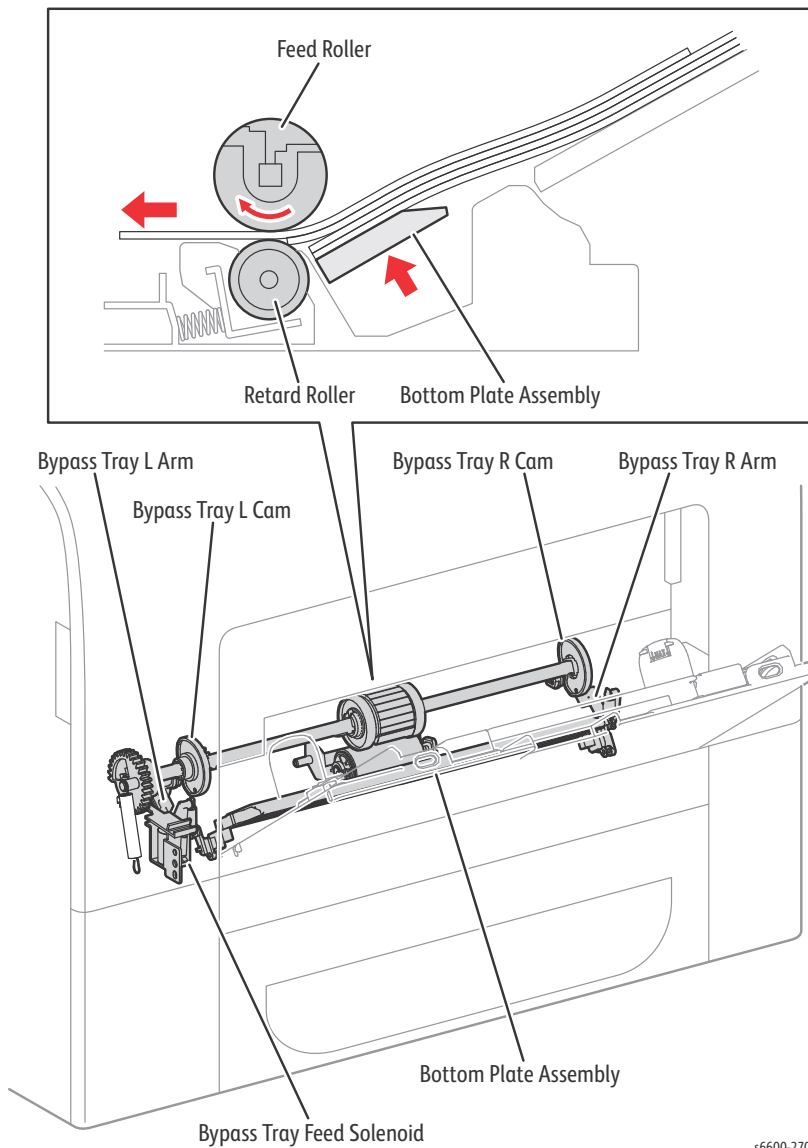
## Feeding from Bypass Tray

When sheet feeding from the Bypass Tray starts, the Feed Roller rotates, driven by the Paper Transport Motor and controlled by the Bypass Tray Feed Solenoid, to feed the sheet to the position where it is nipped between the Feed Roller and the Retard Roller.

As the Feed Roller rotates, the Left and Right Bypass Tray Cams also rotate to lift the Bottom Plate Assembly via the Left and Right Bypass Tray Arms to the position for sheet feeding.

Normally, when only one sheet is fed, both the Feed Roller and Retard Roller rotate to allow the sheet to pass. However, when two sheets are fed concurrently, only the Feed Roller rotates and the Retard Roller is locked thereby allowing the upper sheet to pass by being separated from the lower sheet that is stopped by the friction with the Retard Roller at rest.

The Retard Roller is being pushed toward the Feed Roller by spring pressure, and controlled by the torque limiter (Friction Clutch Assembly) with which it is coupled.



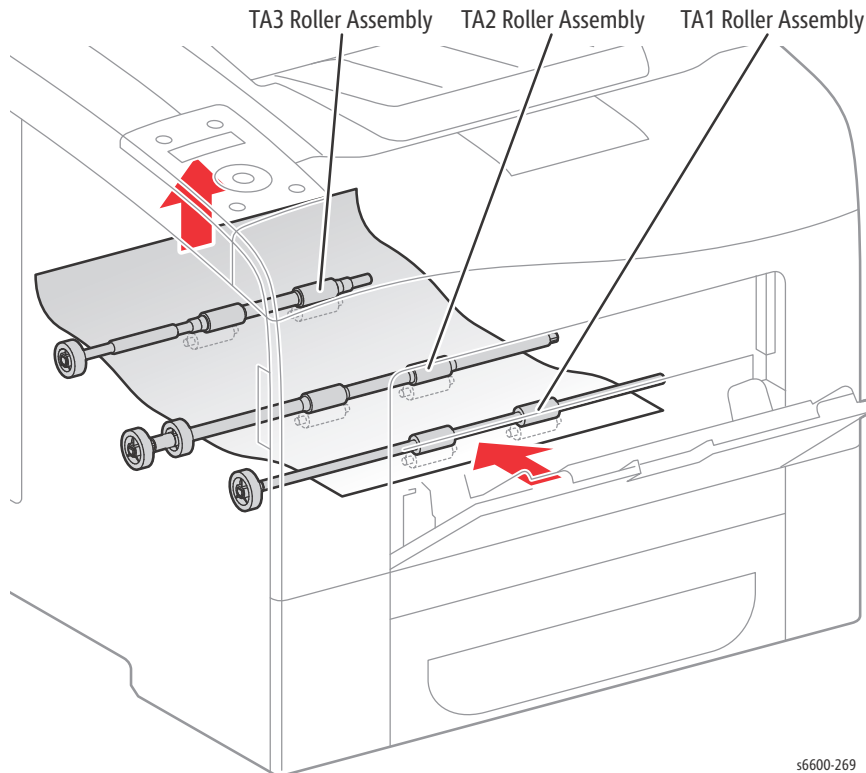
s6600-270



## Feeding to Registration Section

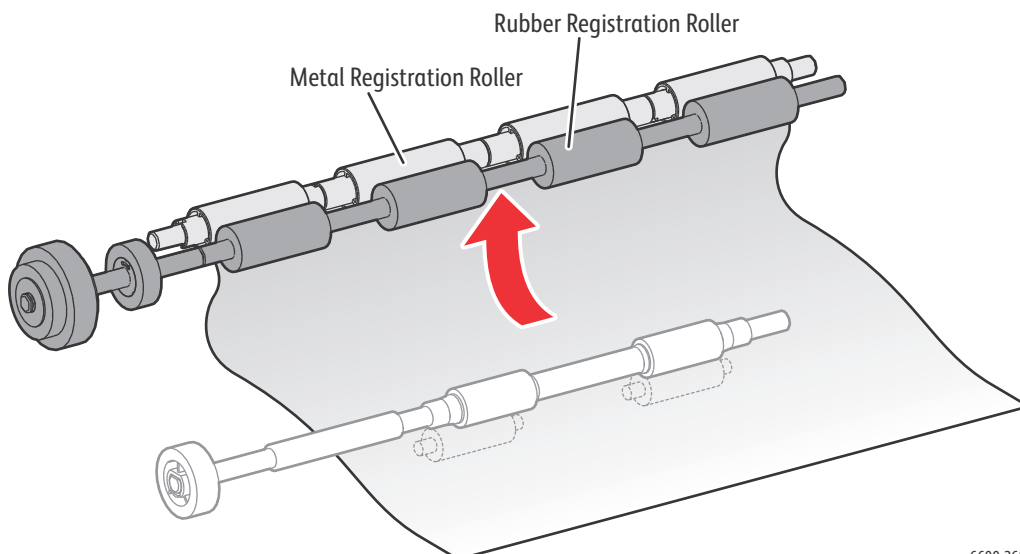
Paper is fed to the printer's Registration section from either the Bypass Tray or from the paper cassettes.

A sheet coming from the Bypass Tray is fed to the registration section by the Takeaway rollers, TA1, TA2, and TA3, all driven by the Paper Transport Motor.



s6600-269

The sheet coming from the paper cassette passes through the chute directly and is fed to the registration section.



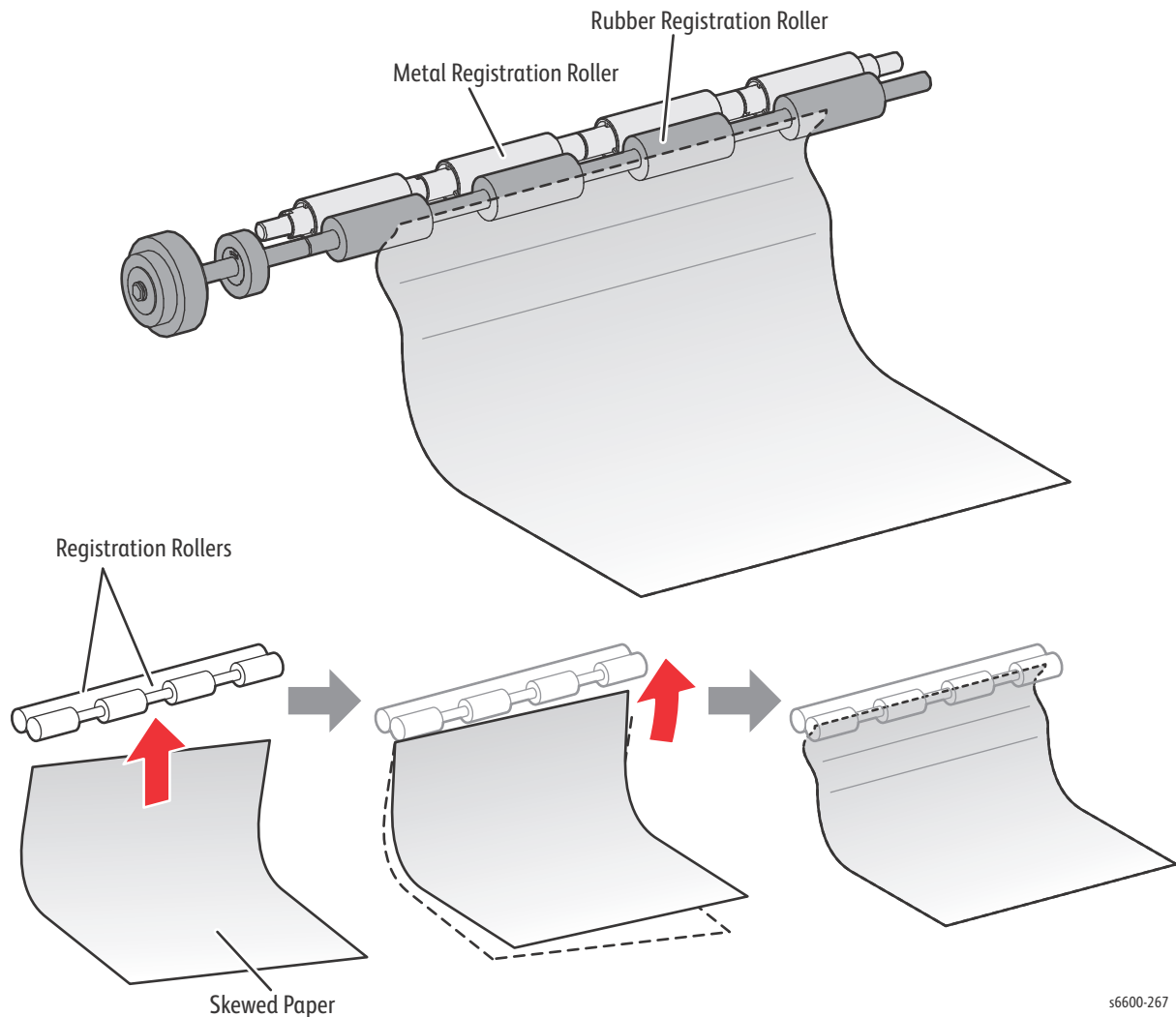
s6600-268

## Lead-edge Registration

When a sheet fed out of the Bypass Tray or cassette directly reaches the toner transfer section, the toner image may not be transferred at the correct position on the sheet due to misalignment of lead edges in the Bypass Tray or Tray.

To avoid this problem, the lead edge position of the sheet needs to be corrected at the registration section before the sheet is forwarded to the toner transfer section.

By thrusting the edge of the sheet fed out of the Bypass Tray or Tray against the Regi Roller that is locked, the lead edge position of the sheet is corrected.



s6600-267

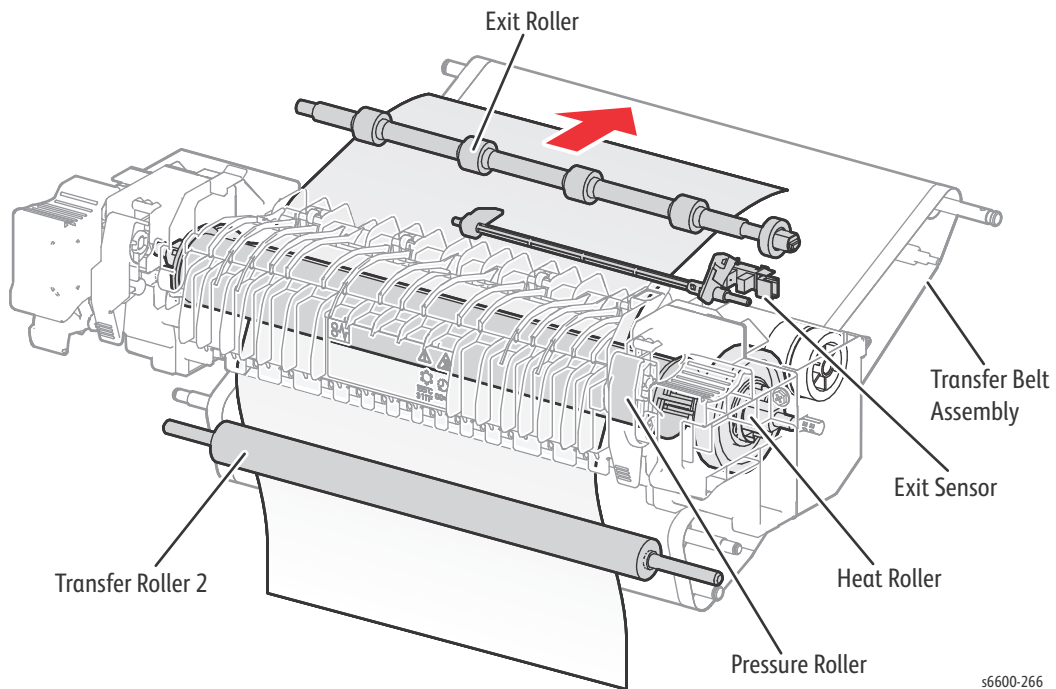
## Feeding From Registration Section

The sheet is fed to the toner transfer section by the rotation of the Regi Roller at the proper timing, after the lead edge position of the sheet fed is corrected in the registration section.

The Regi Roller is rotated by the drive from the Paper Transport Motor via the Regi Clutch.

## Transfer/Fusing/Exit

On the sheet passed through the registration section, the toner image on the intermediate transfer belt is transferred by the intermediate transfer belt and the Transfer Roller rotated by the drive of the Developer Motor. Then, the sheet is fed to the exit section while its toner image is being fused by the Heat Roller that rotated by the drive of the Main Motor. Also, the drive of the Main Motor is transmitted to the Exit Clutch 1, and the Exit Roller is rotated in the sheet exit direction, and the print completed sheet is ejected from the printer. The completion of the sheet exit is detected by the Exit Sensor.

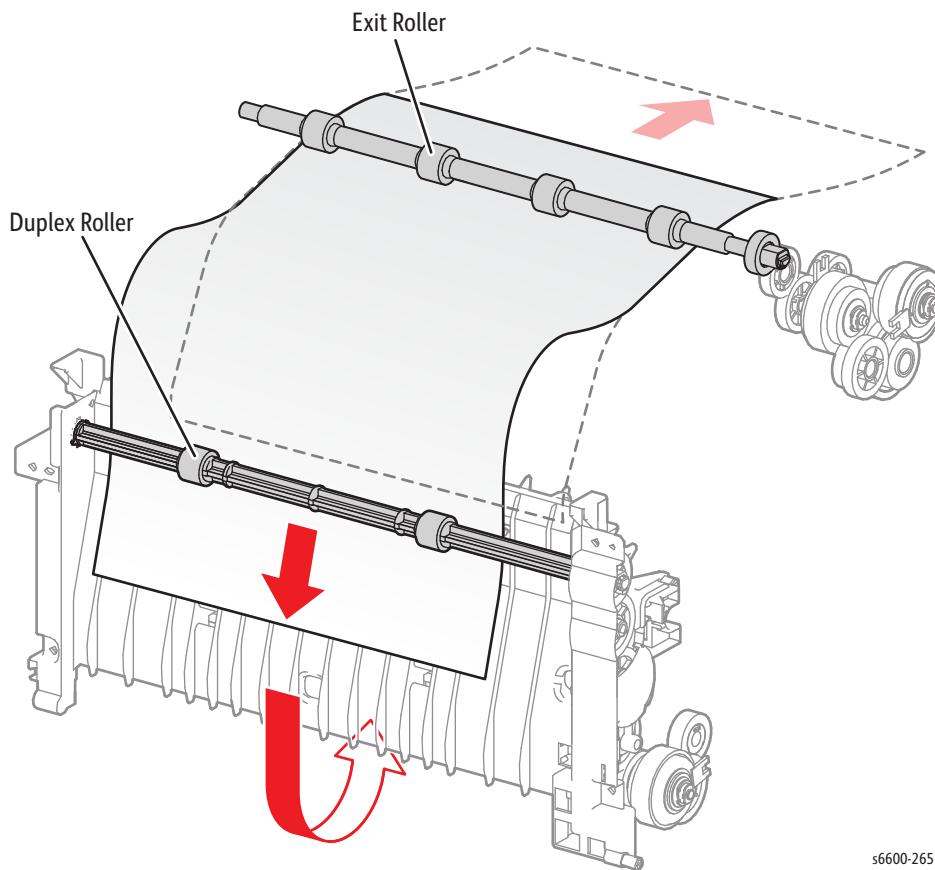


## Duplex Feeding (Optional)

After the sheet is passed through the Heat Roller and the printing on the side 1 is completed, the rotation direction of the Exit Roller is changed to the duplex feed direction at the proper timing, and the sheet is nipped in the Duplex Assembly.

When the drive of the Main Motor is transferred to the Exit Clutch 2, the Exit Roller is rotated in the duplex direction.

Also, the Duplex Roller is rotated by the drive of the Paper Transport Motor, and the sheet is fed to the registration position.



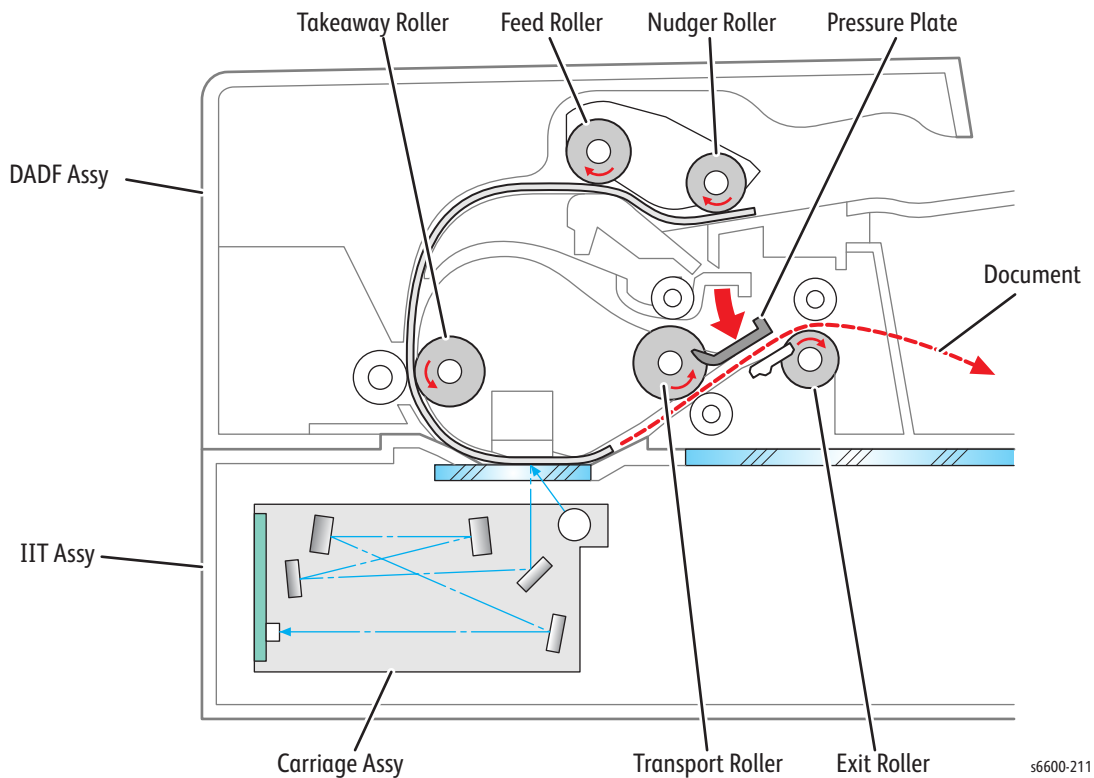
s6600-265

## Paper Path of DADF (Simplex)

When the sheet feeding from the Document Feeder Tray of the DADF starts, the Nudger Roll and the Feed Roll that rotate driven by the torque from the DADF Motor. The sheet is nipped between the Feed Roll and the Retard Pad while being fed into the DADF.

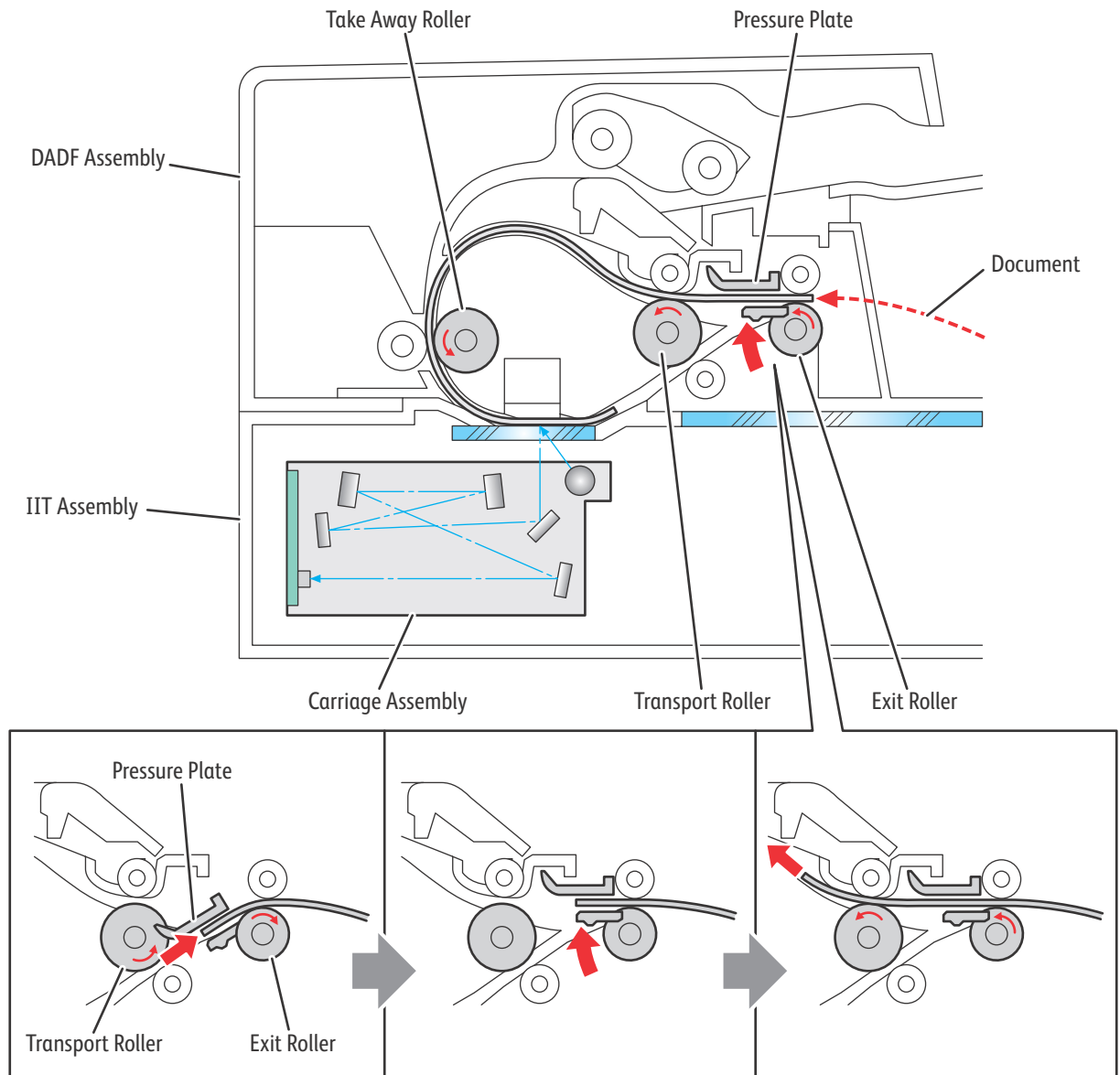
Inside the DADF, the sheet is fed by the Takeaway Roll that rotates by the torque from the DADF Motor to the Scanner Home (CVT: Constant Velocity Transport) Position in the Carriage Assembly, and is scanned.

After being scanned, the sheet is ejected to the Document Output Tray of the DADF by the Transport Roll and Exit Roll that rotates by the torque from the DADF Motor.



## Paper Path of DADF (Duplex)

After scanning a document is completed and the rear edge of the document is passed through the Transport Roll, switch the position of the Pressure Plate to above. Then, the Exit Roll is reversed by the reverse drive of the DADF Motor, and the document is nipped into the DADF. The document is reversed at this time. When the position of the Pressure Plate is switched, the gear to drive the Transfer Roll is switched, so the rotation is in a positive manner although the DADF Motor rotates in a negative manner. When the document is fed near side of the Take away Roll, switch the position of the Pressure Plate to below to make the DADF Motor return to the positive rotation drive, and the document is fed to the Scanner Home Position (CVT Position) by the torque from the Transport Roll. The document scanned at the CVT Position is fed to the Document Output Tray of the DADF by the Transport Roll and the Exit Roll.



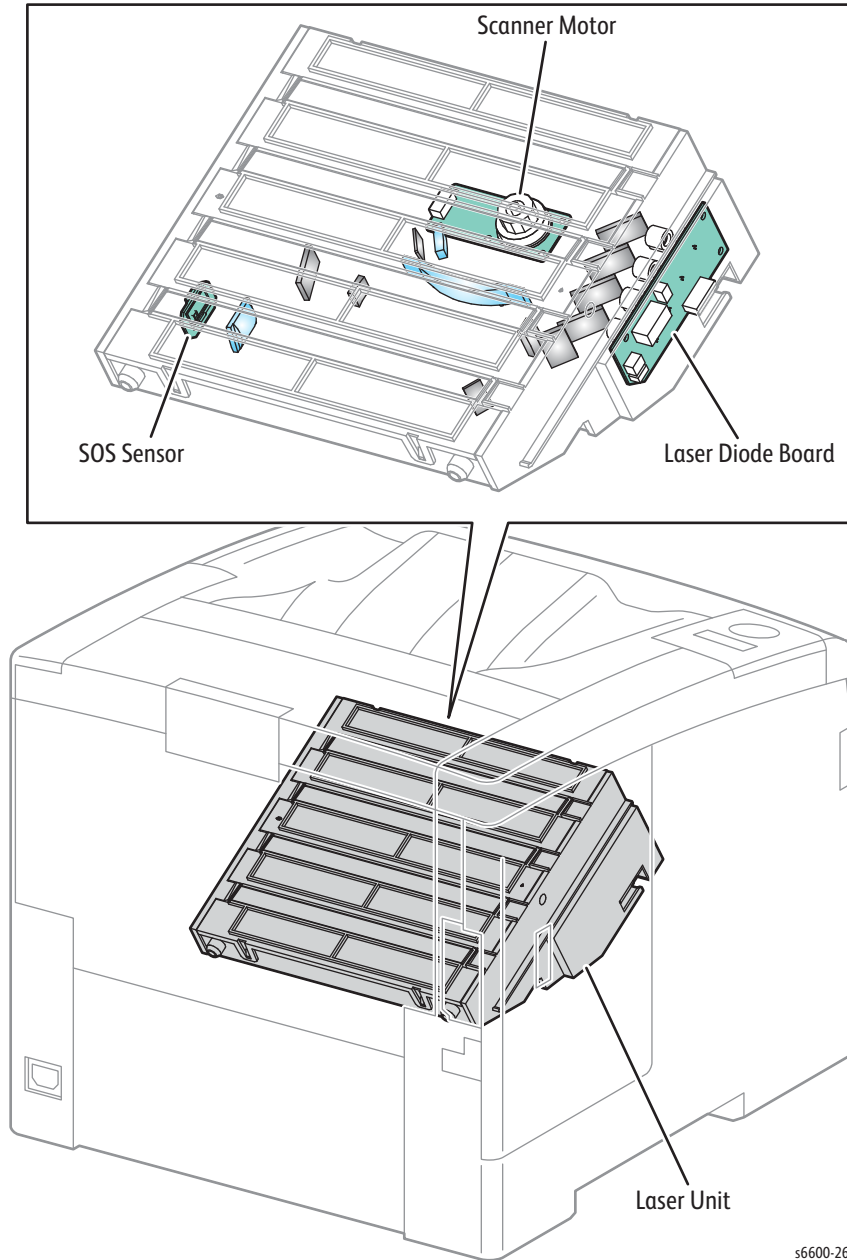
s6600-237

# Major Functional Components

This section describes the major functional components of the printer with corresponding illustrations. These components are classified into the following blocks based on the configuration of the printer.

- Laser Unit
- Drive
- NOHAD & Waste Toner Collection
- Dispenser
- Xerographics & Transfer
- Fusing
- Paper Transport
- Bypass Tray
- Exit
- Electrical
- Option Feeder

## Laser Unit



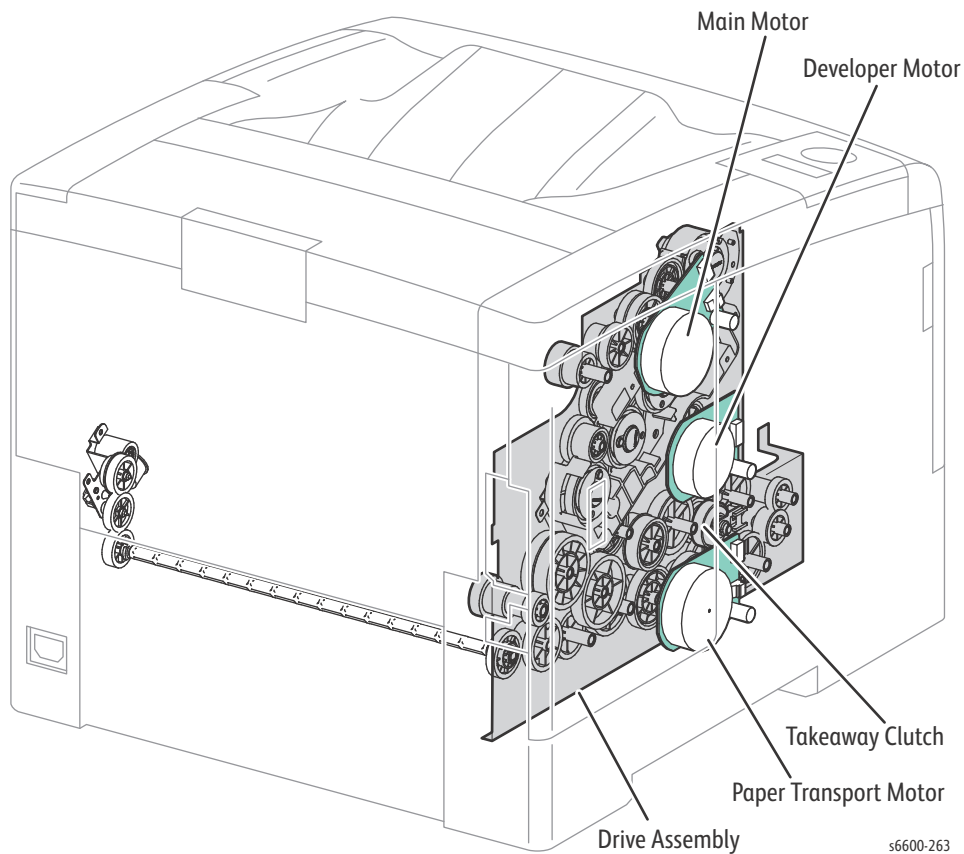
s6600-264

The Laser Unit (PL2.1.1) is an exposure device that outputs laser beams to form an electrostatic latent image on the drum surface. The Laser Unit consists of the following parts.

- Scanner Motor — spins the Polygon Mirror
- Laser Diode Board — holds the Laser Diodes, converts the image data into laser beams, and controls the other components in the Laser Unit.
- Humidity/Temperature Sensor
- SOS Sensor — detects the laser beam at the scan starting point, and sends a signal to the MCU Board.



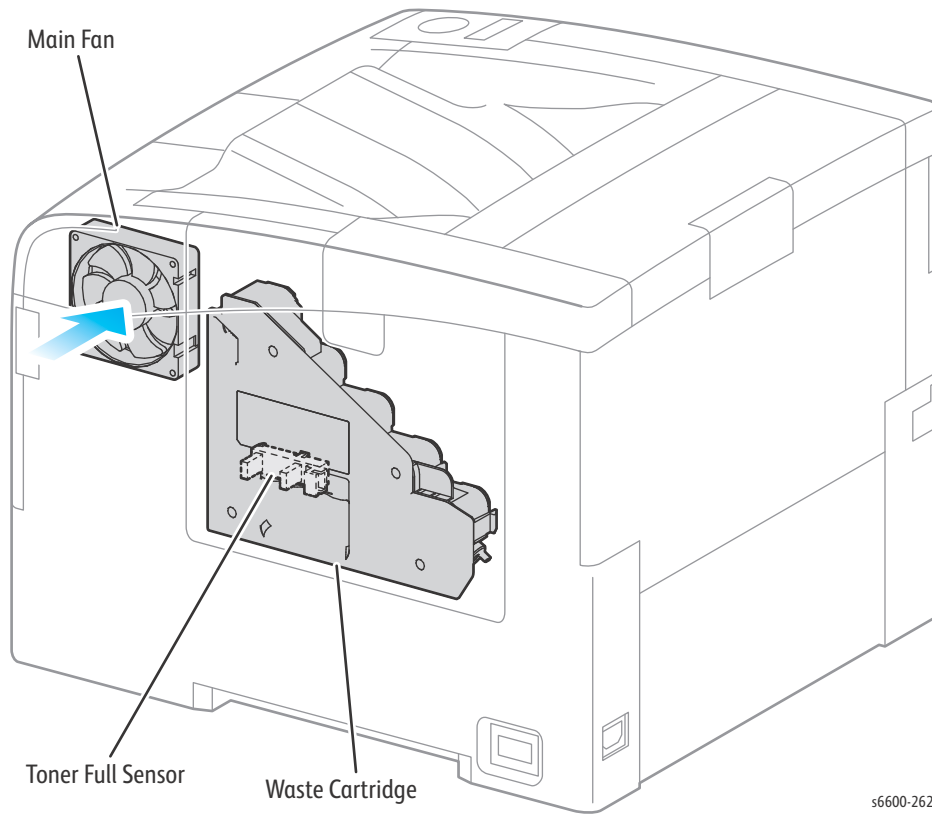
## Drive



The Drive Assembly (PL3.1.1) consists of the following parts.

- **Main Motor**  
The DC motor that drives the Heat Roller in the Fuser, the Exit Roller Assembly in the exit section, the drum in the Imaging Unit of each color, the magnet Roller in the Imaging Unit K (black), and the belt and cleaner in the Transfer Belt Assembly.
- **Paper Transport Motor**  
The DC motor that drives each roller of the paper feed section (feed from the Bypass Tray/tray, registration, and duplex feed). Also, drives the Drive Shaft Assembly and the Auger in the Waste Cartridge via the gear.
- **Developer Motor**  
The DC motor that drives the magnet Roller in the Imaging Unit Y/M/C (Yellow/Magenta/Cyan).
- **Takeaway Clutch**  
Transfers the drive of the Paper Transport Motor to the Takeaway Roller.

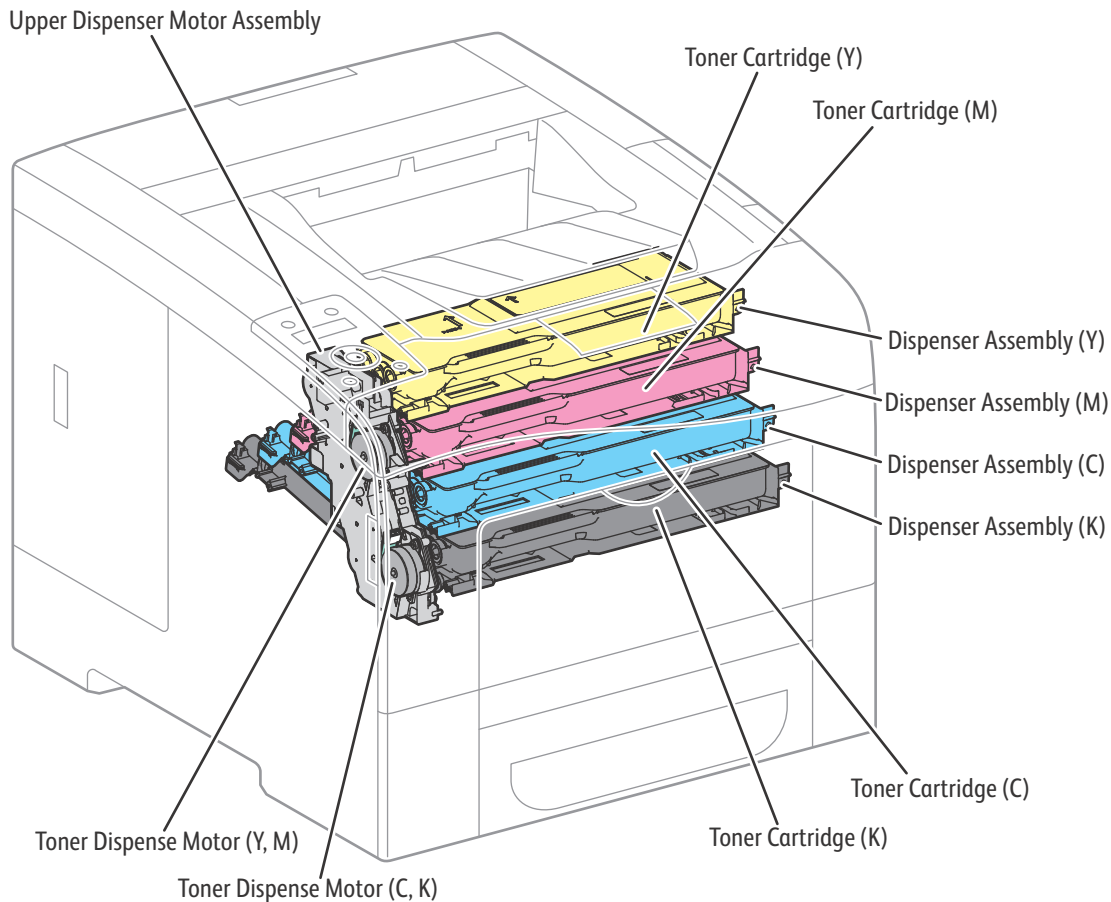
## NOHAD & Waste Toner Collection



The Main Fan (PL4.1.13) — Draws air from outside the machine, and prevents temperature rise inside the machine.

Toner Full Sensor (PL4.1.17) — Detects when the Waste Cartridge is full.

## Dispenser



s6600-261

Upper Dispenser Motor Assembly (PL5.1.1) drives the paddle in the Toner Cartridge and the auger of the Dispenser Assembly and feeds toner to the development section in the Imaging Unit.

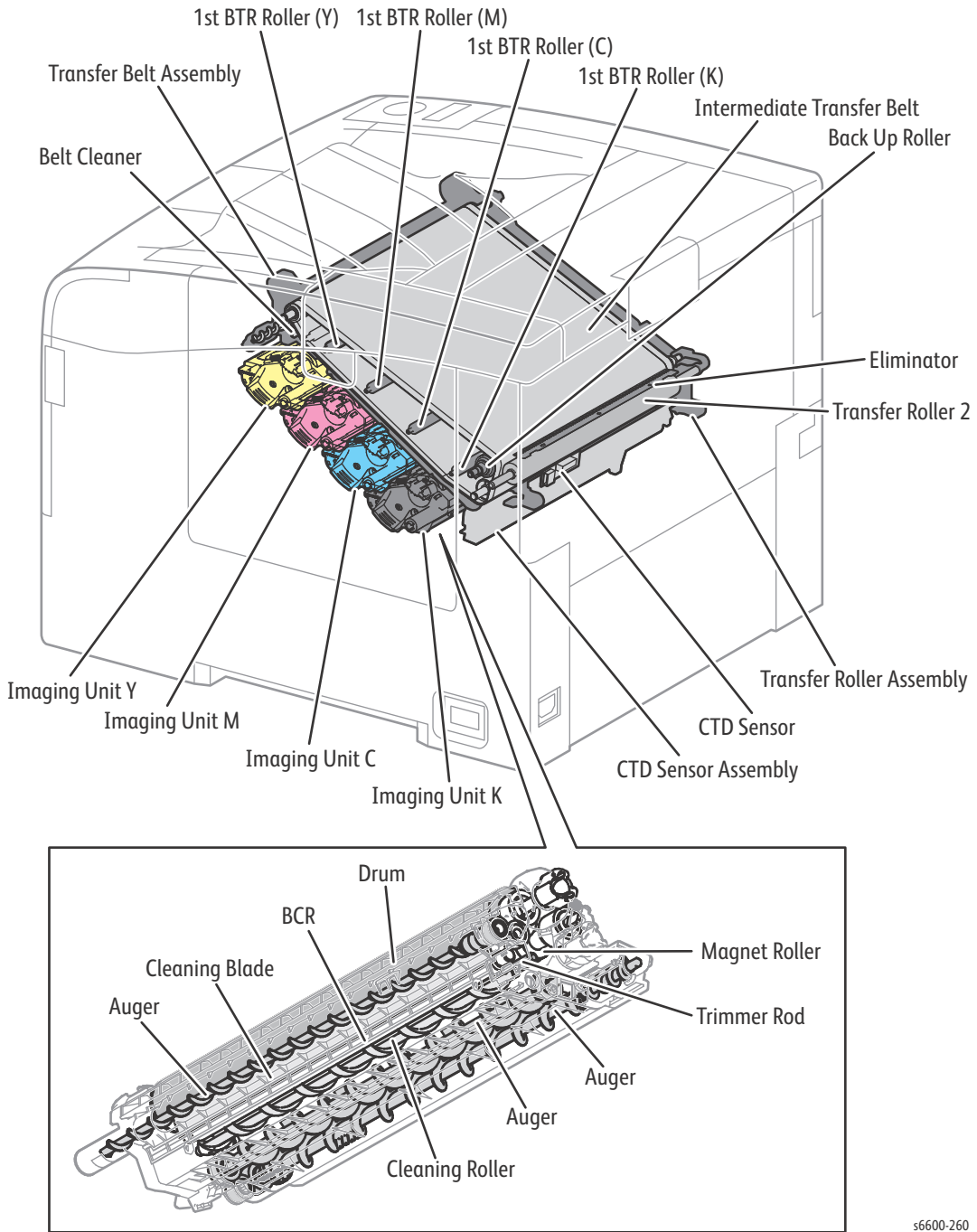
The Upper Dispenser Motor Assembly consists of the following parts.

- Toner Dispense Motor (Y,M)  
Drives the yellow and magenta Toner Cartridges and the Dispenser Assembly via the gear.
- Toner Dispense Motor (C,K)  
Drives the cyan and black Toner Cartridges and the Dispenser Assembly via the gear.

Toner Cartridges Y (PL5.1.8), M (PL5.1.9), C (PL5.1.10), K (PL5.1.11) store toner and a small amount of carrier.

The Dispenser Assemblies (Y (PL5.1.4), M (PL5.1.5), C (PL5.1.6), K (PL5.1.7)) feed toner to the developer.

## Xerographics & Transfer



s6600-260

### **CTD Sensor Assembly (PL6.1.14)**

Includes the CTD Sensor.

- CTD Sensor — The reflective color toner density sensor. Irradiates light from the LED in the sensor to the intermediate transfer belt, detects the reflected light from the intermediate transfer belt with the light receiving element, and outputs the electric signal corresponding with the light intensity. Before the secondary transfer, detects the toner patch density on the intermediate transfer belt.

### **Imaging Units Y, M, C, K (PL8.1.2-5)**

Consists of the drum to form the static latent image and toner image, and the developer to develop toner to the drum. Placed in yellow, magenta, cyan, and black color each.

- Drum — Forms the static latent image and the toner image.
- BCR — Bias charging roller — charges the drum.
- Cleaning Roller — Cleans toner on the BCR surface.
- Cleaning Blade — Cleans the remaining toner from the drum after the toner image is transferred to the sheet.
- Magnet Roller — Contacts the drum and forms the toner image on the drum.
- Auger — Stirs toner.
- Trimmer Rod — Equalizes toner and carriers on the Magnet Roller.

### **Transfer Belt Assembly (PL6.1.1)**

The primary transfer unit that transfers the toner image on the drum surface of each color to the intermediate transfer belt.

The Transfer Belt Assembly mainly consists of the following components.

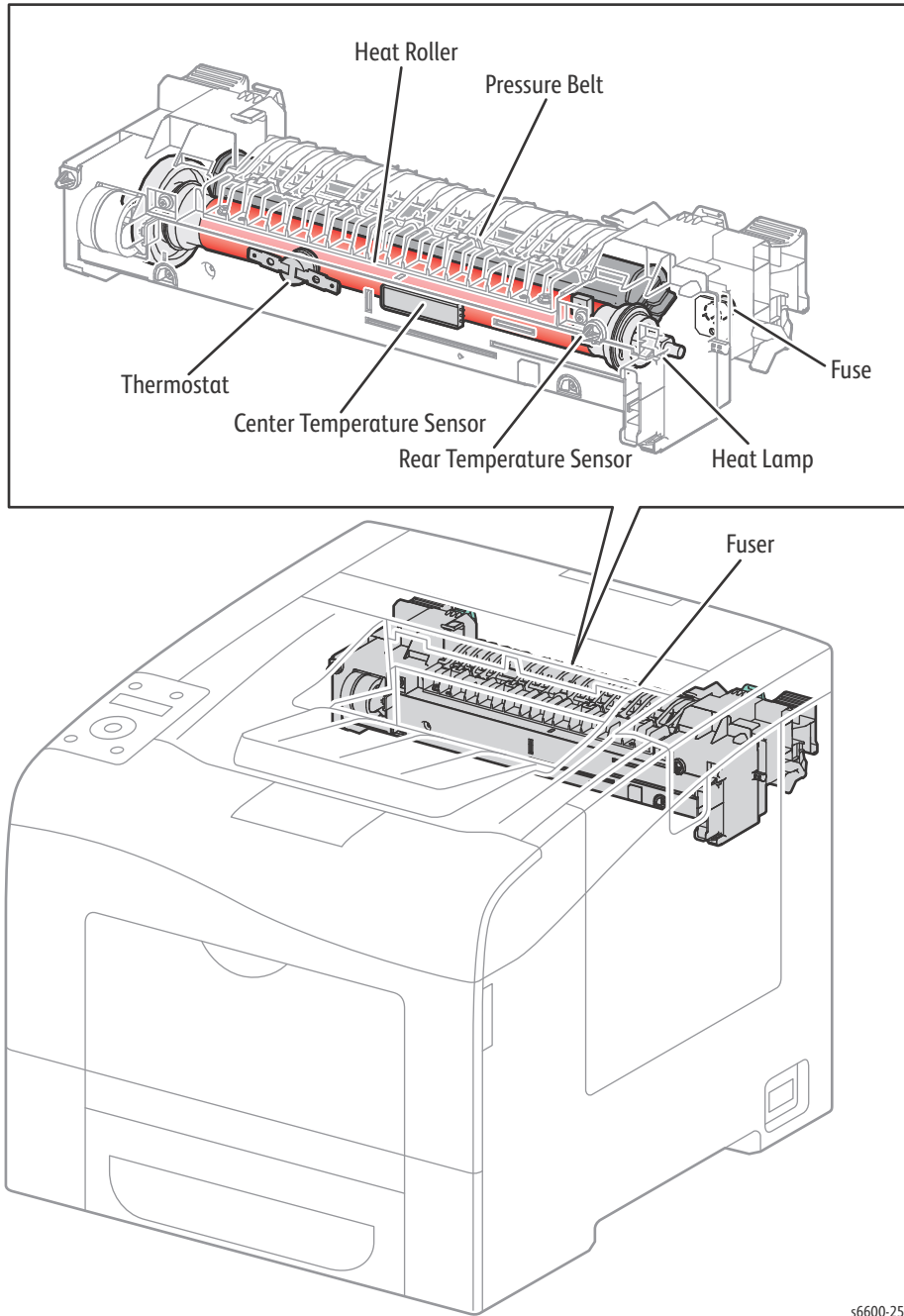
- 1st BTR Roller Y/M/C/K — Impresses the positive electric charge on the reverse side of the intermediate transfer belt in printing, and transfers the toner image formed on the drum to the intermediate transfer belt.
- Intermediate Transfer Belt — Reduplicates and transfers the toner image formed in the drums of each color.
- Back Up Roller — Contacts with the Transfer Roller via the intermediate transfer belt in the secondary transfer, and transfers the toner image on the transfer belt to the sheet.
- Belt Cleaner — After the toner image is transferred on the sheet, cleans the remaining toner in the intermediate transfer belt.

### **Transfer Roller Assembly**

The Transfer Roller Assembly consists of the following components.

- Transfer Roller — Contacts with the reverse side of the toner transfer face on the sheet, and transfers the toner image formed in the belt to the sheet.
- Eliminator — Neutralizes the sheet.

## Fusing



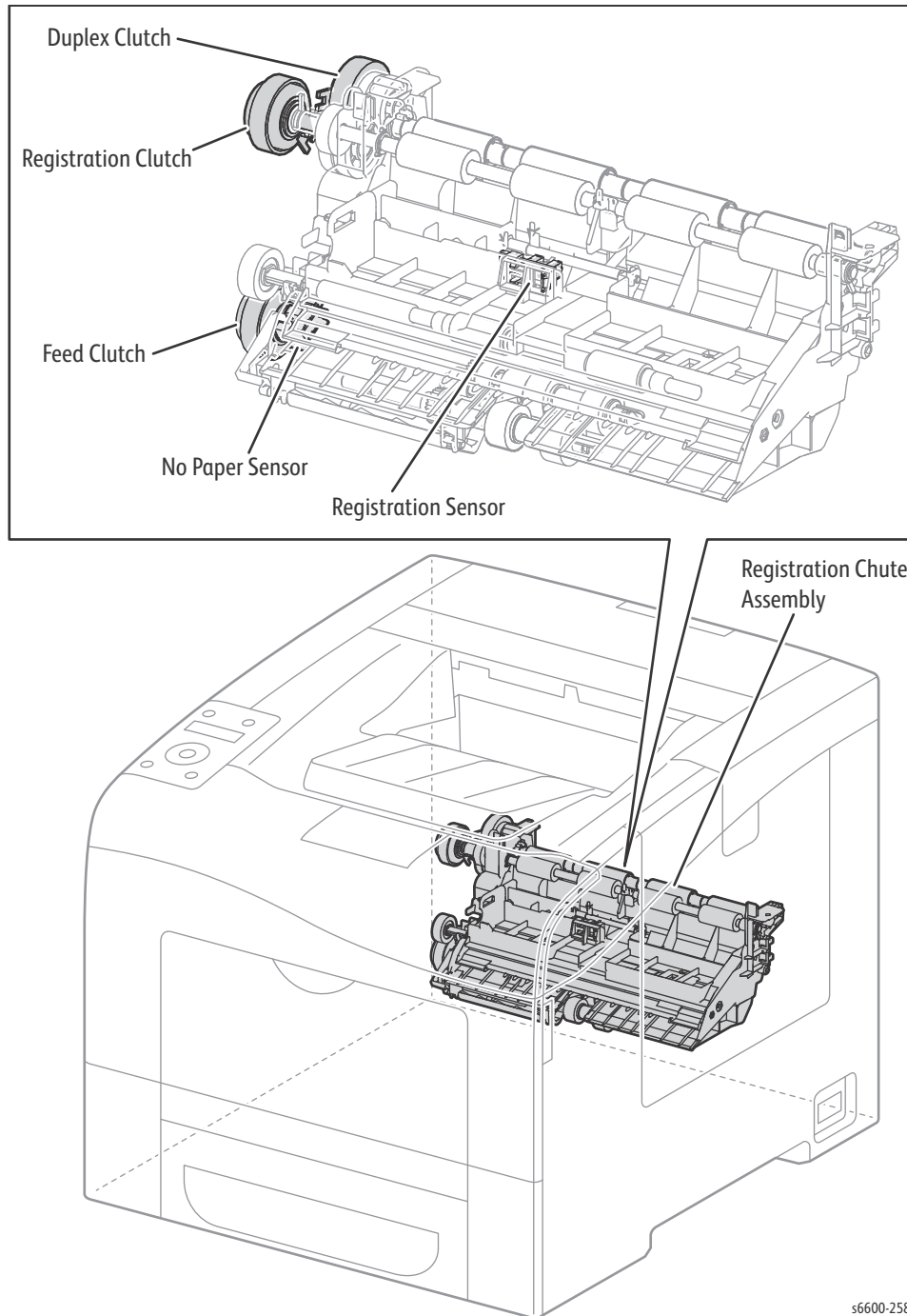
s6600-259

**Fuser (PL7.1.1)**

The Fuser is a unit that fuses the complete toner image transferred on the sheet with the sheet by heat and pressure. The Fuser consists of the following components.

- Heat Roller — A spouted metal Roller, which has the surface for giving heat to fuse toner on a sheet covered by the tube.
- Pressure Belt — A belt contained the pressurization system inside. Paired up with the Heat Roller, impresses toner on the sheet.
- Heater Lamp — A lamp that seals the heat coil as a heat source in the Heat Roller and that is stored inside the Heat Roller. A heating element that heats up the Heat Roller.
- Center Temp. Sensor (contactless type) — A thermistor as an electric resistor that reacts corresponding with temperature changes, located in the Heat Roller contactlessly, and detects the surface temperature on the Heat Roller. Based on the temperature detected, controls ON (power distribution: lighting) / OFF (Extinction).
- Rear Temp. Sensor (contact type) — A thermistor as an electric resistor that reacts corresponding with temperature changes, located in contact with the Heat Roller, and detects the surface temperature on the Heat Roller. Prevents the abnormally high temperature of the Heat Roller.
- Thermostat — Located in series with the power source of the Heater Lamp, and prevents the secondary excess rise of temperature by the open interface when the temperature excess rise preventions (primary) by Temp. Sensor (thermistor) fails and temperature on the interface part reaches to a certain level.
- First Time Fuse — Resets page count on fuser installation.

## Paper Transport



s6600-258

The Regi Clutch (PL15.1.8) transfers the drive of the Paper Transport Motor to the Regi Roller.

The Regi Chute Assembly (PL15.2.1) mainly consists of the following components.

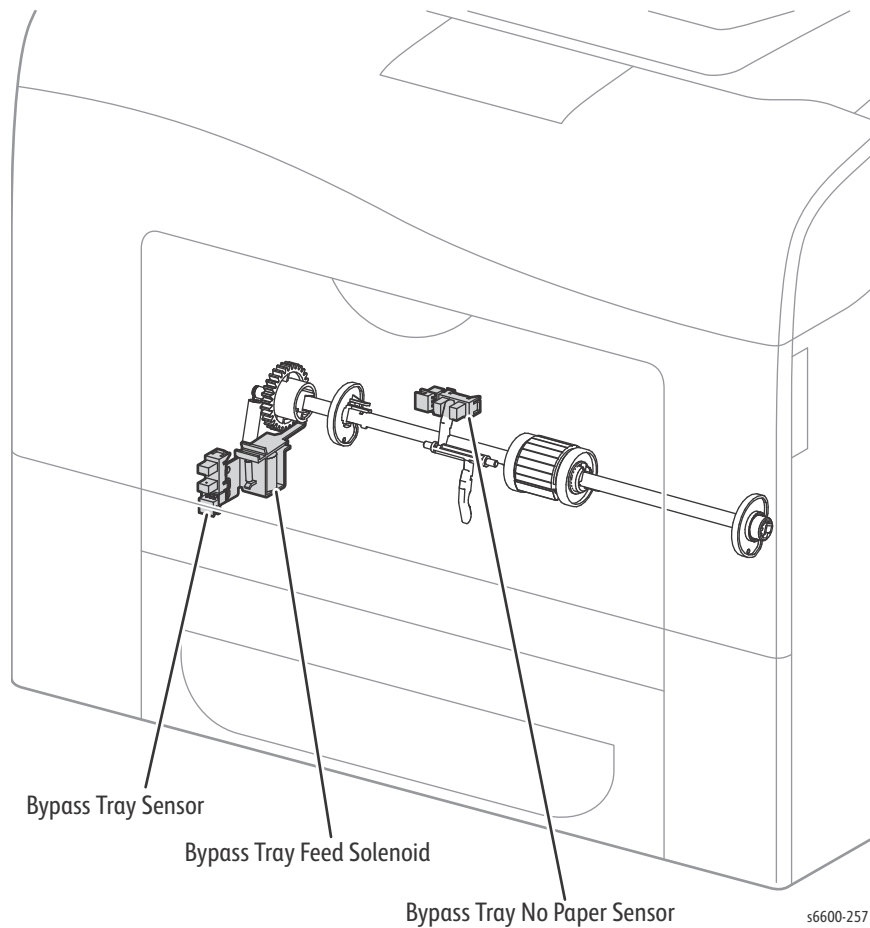
- No Paper Sensor — By change of the actuator, detects presence or absence of paper in the paper cassette.
- Regi Sensor — Detects that a lead edge of a sheet is reached to the registration section.



The Feed Clutch (PL15.2.6) transfers the drive of the Paper Transport Motor to the Feed Roller.

The Duplex Clutch (PL15.2.5) transfers the drive of the Paper Transport Motor to the Duplex Roller inside the Duplex Assembly.

## Bypass Tray

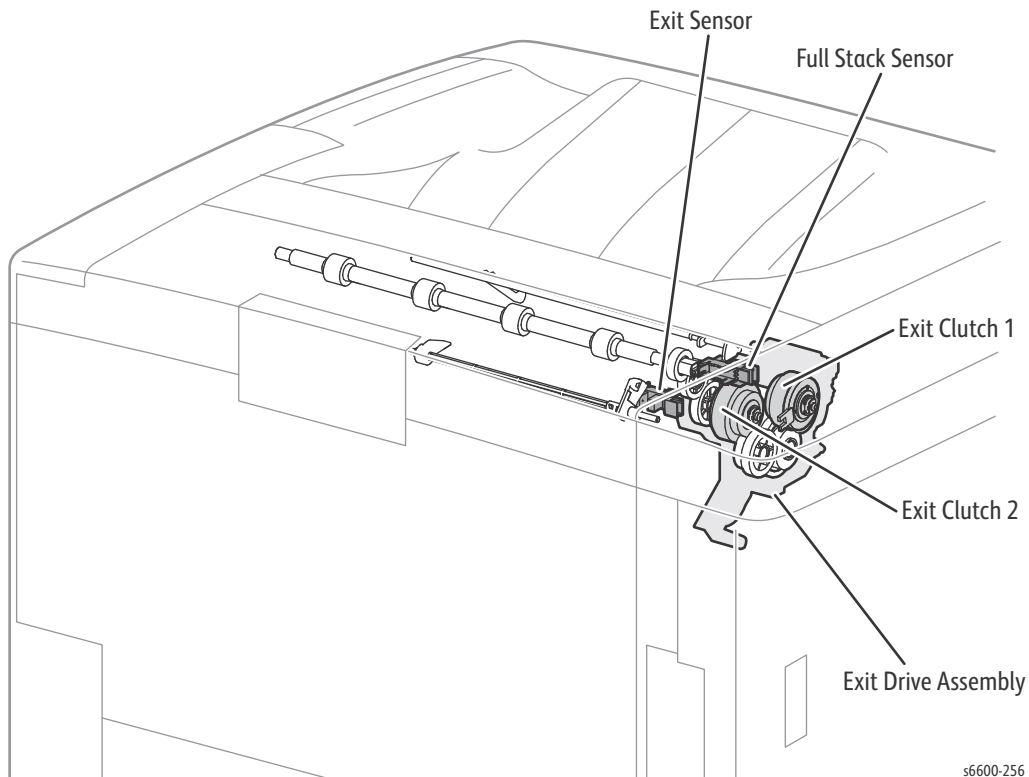


The Bypass Tray Sensor (PL13.2.4) detects the installation of the Bypass Tray.

The Bypass Tray No Paper Sensor (PL13.2.4) by change of the actuator, detects presence or absence of paper in the Bypass Tray.

The Bypass Tray Feed Solenoid (PL13.2.9) transfers the drive of the Paper Transport Motor to the Bypass Tray Feed Roller.

## Exit



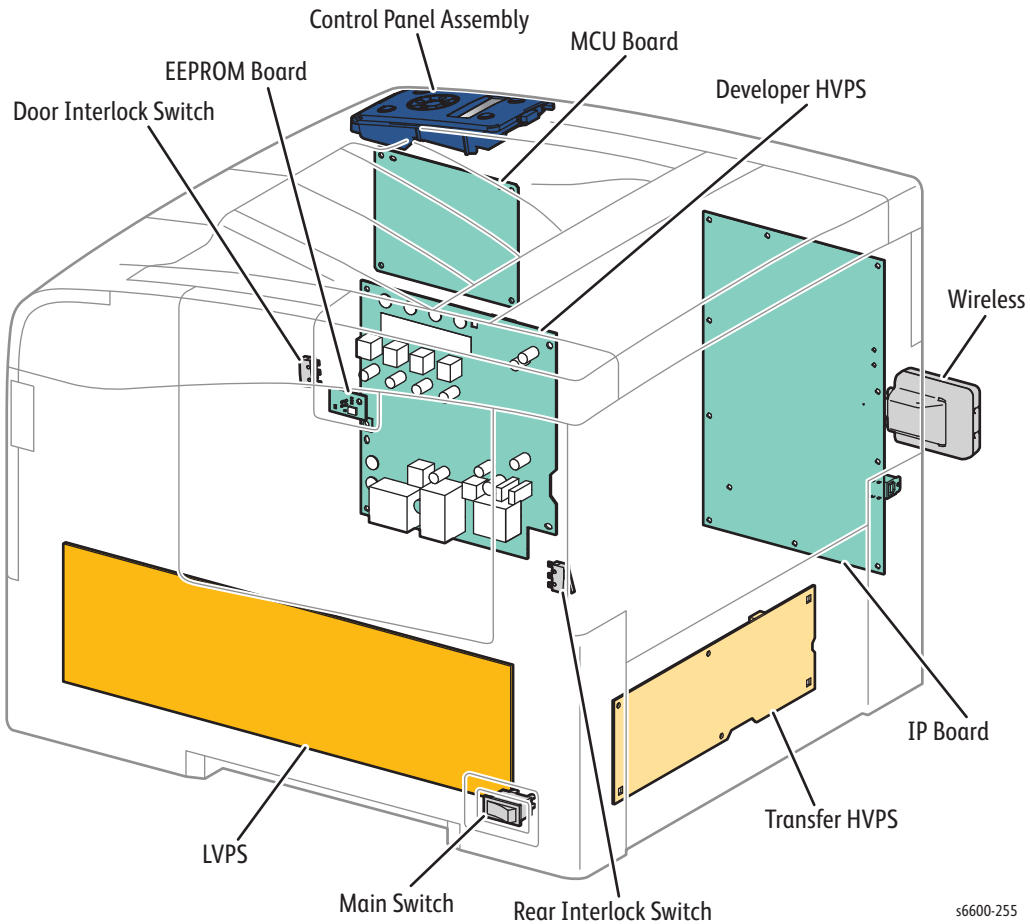
The Exit Sensor (PL17.1.11) detects when media is present in the fuser.

The Full Stack Sensor (PL17.1.11) detects when the output tray is full.

The Exit Drive Assembly (PL17.1.21) consists of the following components.

- Exit Clutch 1 — Transfers the drive of the Main Motor to the Exit Roller. The Exit Roller rotates in the paper exit direction.
- Exit Clutch 2 — Transfers the drive of the Main Motor to the Exit Roller. The Exit Roller rotates in the duplex feed direction.

## Electrical



The Control Panel Assembly (PL1.1.1) consists of the LCD, LED, and the switch. The assembly displays the status of the machine with the LCD and LED, and controls the machine using the switch.

The Rear Interlock Switch (PL14.1.3) detects the opening/closing of the Rear Cover.

Door Interlock Switch (PL19.1.21) detects the opening/closing of the Top Cover.

The Main Switch (PL18.1.31) controls AC power to the printer.

The MCU Board (PL18.1.13) communicates with the IP Board and controls each component in printing.

The IP Board (PL18.1.22) is the printer controller. It controls printing by communicating with the MCU Board, Laser Unit, and Control Panel (UI).

The LVPS (PL18.1.34) generates +24VDC, +5VDC, and +3.3VDC from the AC power source to supply each component.

The Transfer HVPS (PL18.1.28) provides high voltage to the 1st BTRs, which are part of the Transfer Belt Assembly.

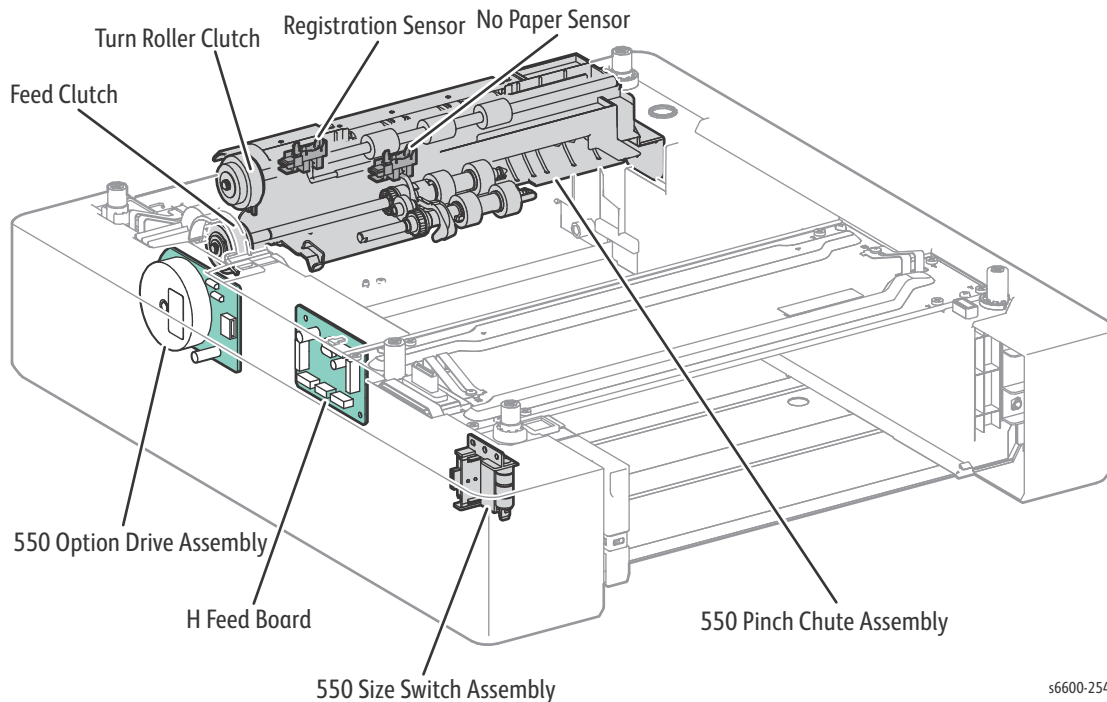
## General Information

The Developer HVPS (PL18.1.14) provides high voltage to the Magnet Roller and BCR found in each Imaging Unit.

The EEPROM Board (PL18.1.43) is non-volatile memory that stores machine information.

The Wireless Kit (PL18.1.27) is the adapter that controls the interface to the Wireless Network.

## Option Feeder



s6600-254

550 Option Feeder Board (PL10.1.10) controls each component in the optional tray.

The Turn Roller Clutch (PL10.1.8) transfers the drive of the 550 Option Drive Assembly to the Turn Roller.

550 Size Switch Assembly (PL10.1.11) detects paper size, and presence or absence of paper in the 550 paper cassette.

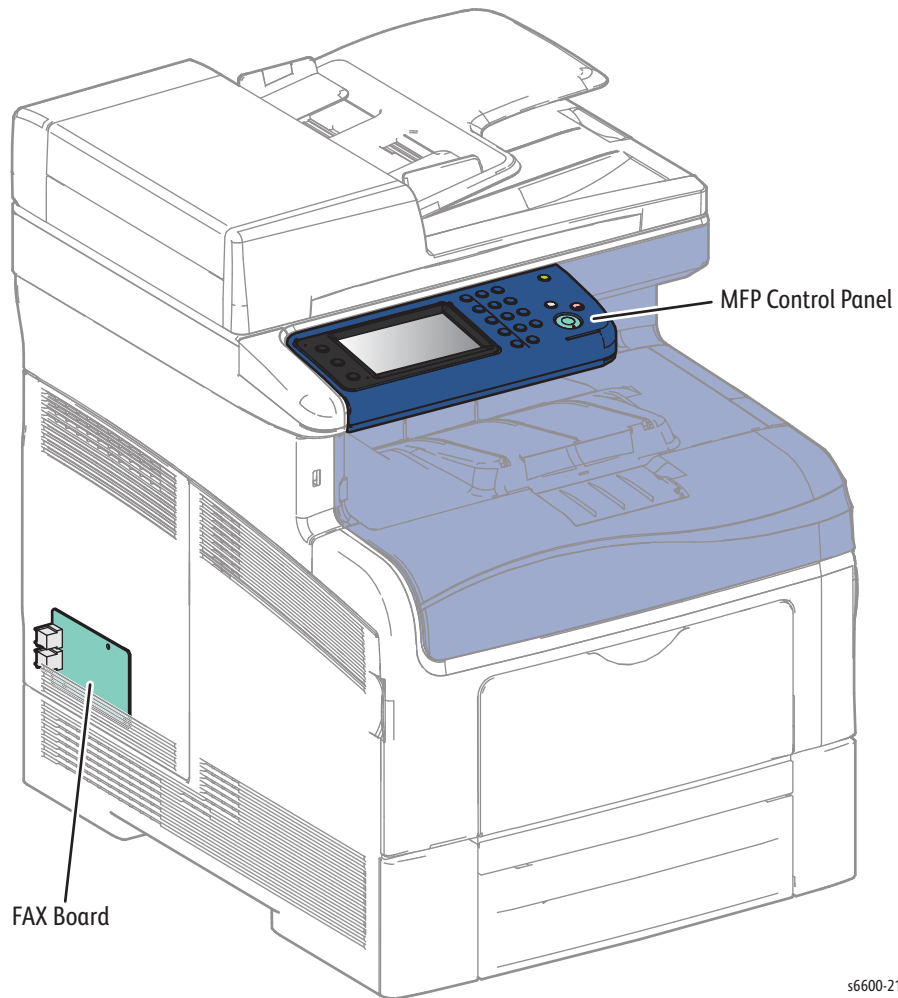
550 Option Drive Assembly (PL10.1.9) consists of a DC motor that drives each Roller of the paper feed section in the optional tray.

### 550 Pinch Chute Assembly (PL10.2.1)

The 550 Pinch Chute Assembly mainly consists of the following components.

- No Paper Sensor  
By changes of the actuator, detects presence or absence in the paper cassette.
- Regi Sensor  
Detects that a lead edge of a sheet has reached the registration section.
- Feed Clutch (PL10.2.2)  
Transfers the drive of the 550 Option Drive Assembly to the Feed Roller.

## UI (User Interface) and MFP Engine



s6600-216

### **MFP Control Panel (PL1.1.1)**

The MFP Console Assembly displays the state of the printer and fax using LCD and LED, and operates the printer and fax using the buttons.

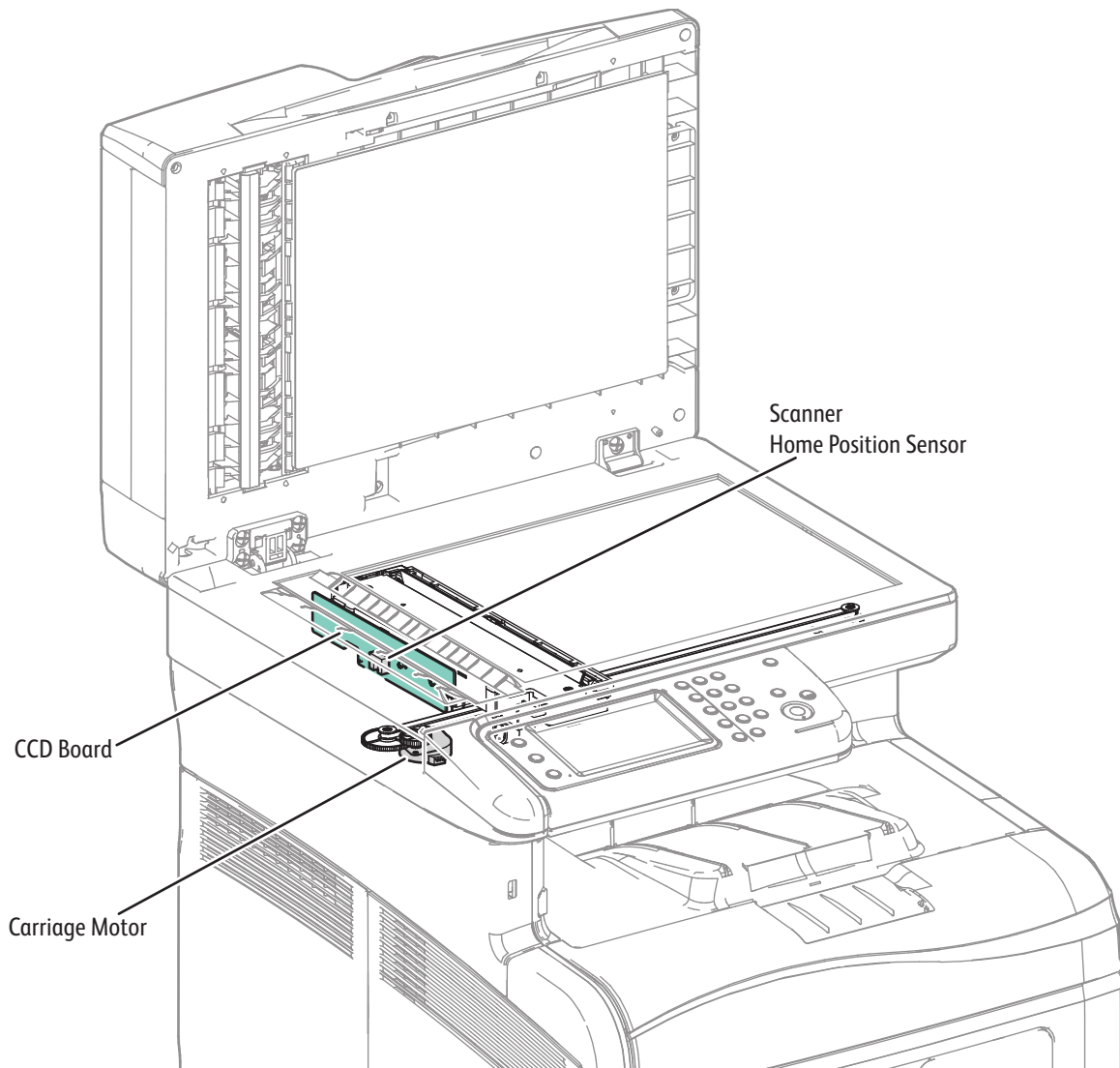
FAX Board (PL18.1.41) controls the FAX signal.

## Scanner

The Scanner Assembly is made up of two separate assemblies, the IIT Assembly, and the DADF Assembly.

### IIT Assembly (PL51.1.3)

- Carriage Motor  
The stepping motor that drives the Scanner Carriage.
- Scanner Home Position Sensor/CVT Position  
The part on the rear side of the Scanner Carriage frame that interrupts the Scanner Home Position Sensor, thus detecting when the carriage is in the Home or CVT Position.
- CCD PWB  
The PWB mounted with the CCD Image Sensor that inputs the image data.

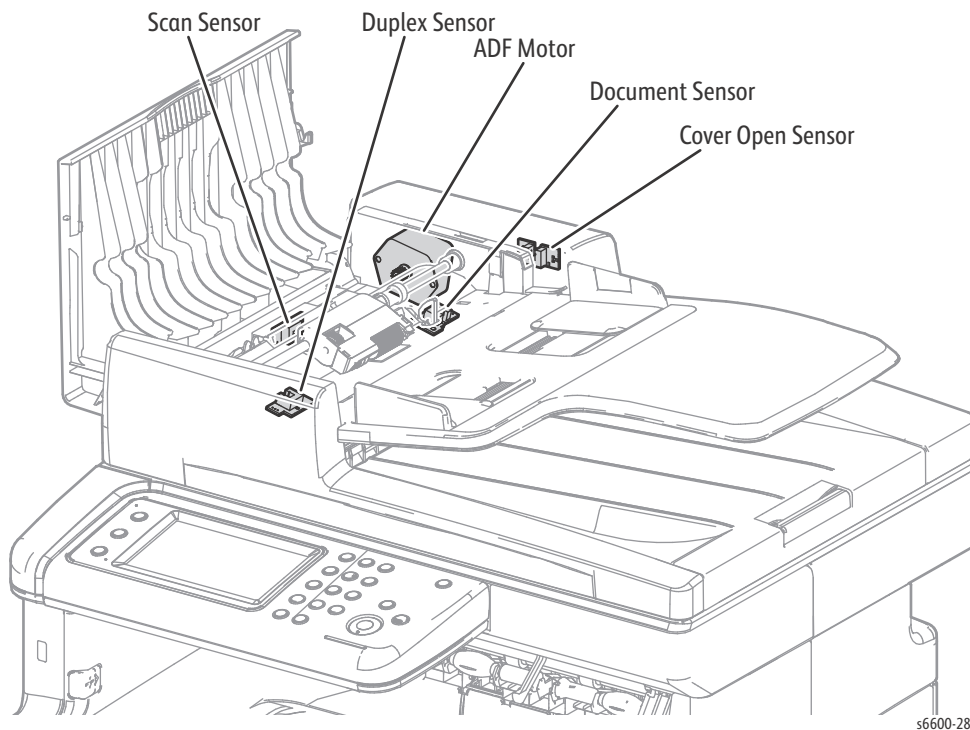


s6600-218

## DADF Assembly (PL51.1.2)

### Sensors and Motor

- Document Sensor  
A sensor that detects the presence or absence of a document on the DADF Document Tray.  
(Presence: entrance of light, absence: NO entrance of light)
- Cover Open Sensor  
A switch that detects whether or not the DADF Top Cover is open.  
(Open: entrance of light, close: NO entrance of light)
- Scan Sensor  
Located near side of the Takeaway Roll and detects the scanning timing.  
(Presence: entrance of light, absence: NO entrance of light)
- Duplex Sensor  
Detects that a reverse side of a document is nipped into the duplex feed path by the torque of the Transport Roll, after scanning the front side of the document is completed and then the document is reversed. (Presence: entrance of light, absence: NO entrance of light)
- DADF Motor  
The DADF Motor rotates the Nudger Roll, Feed Roll, Takeaway Roll, Transfer Roll, and Exit Roll.

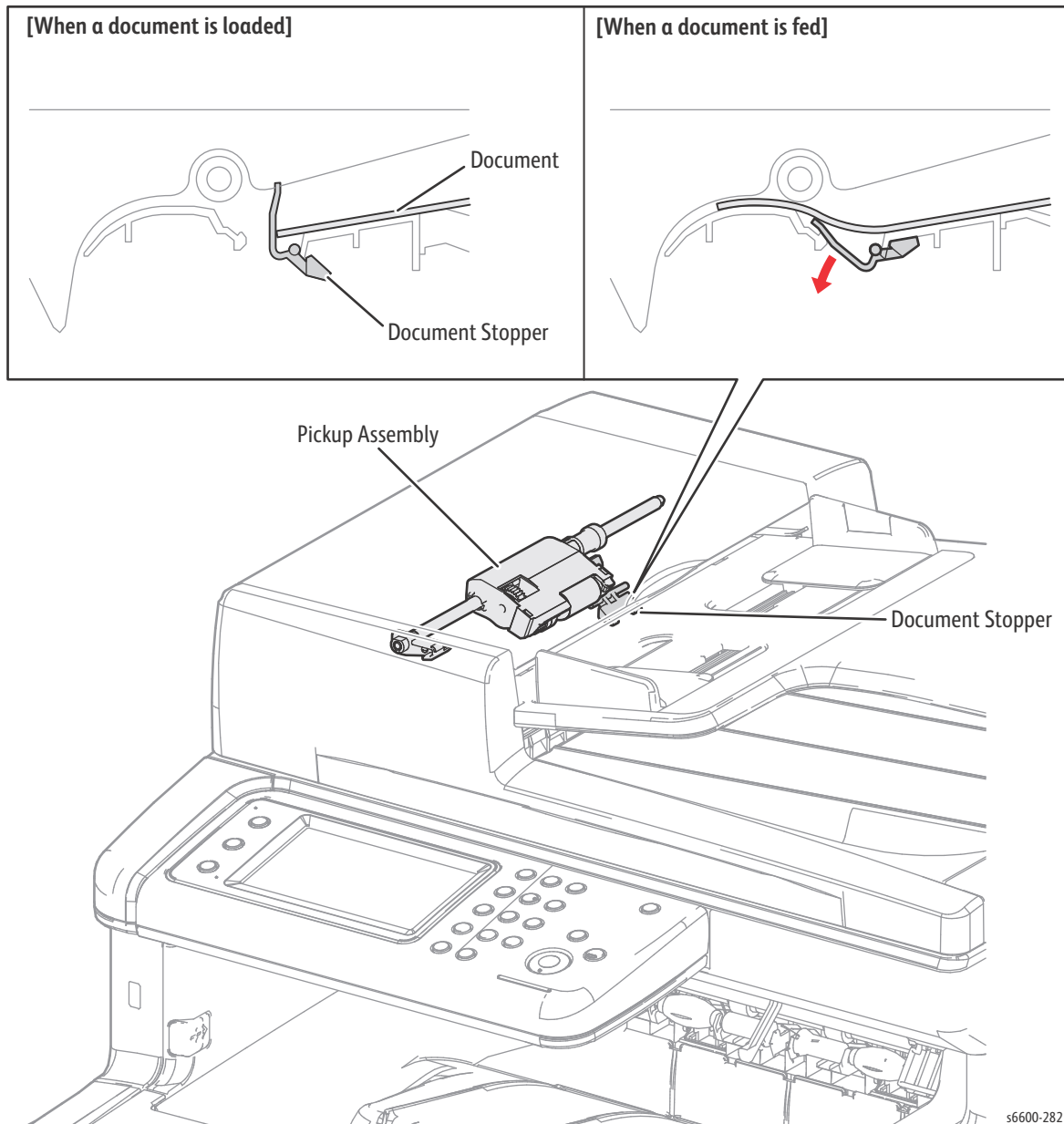


## Document Stopper

When a document is loaded in the DADF, the Document Stopper is locked to prevent the document from being moved forward.

When the DADF starts feeding, the front portion of the Pickup Assembly is lowered. This unlocks the Document Stopper that blocks the document, and the Document Stopper is pressed by the lead edge of the document in the feed direction and the document is fed.

When the paper feed is completed, the Pickup Assembly returns to its original position.

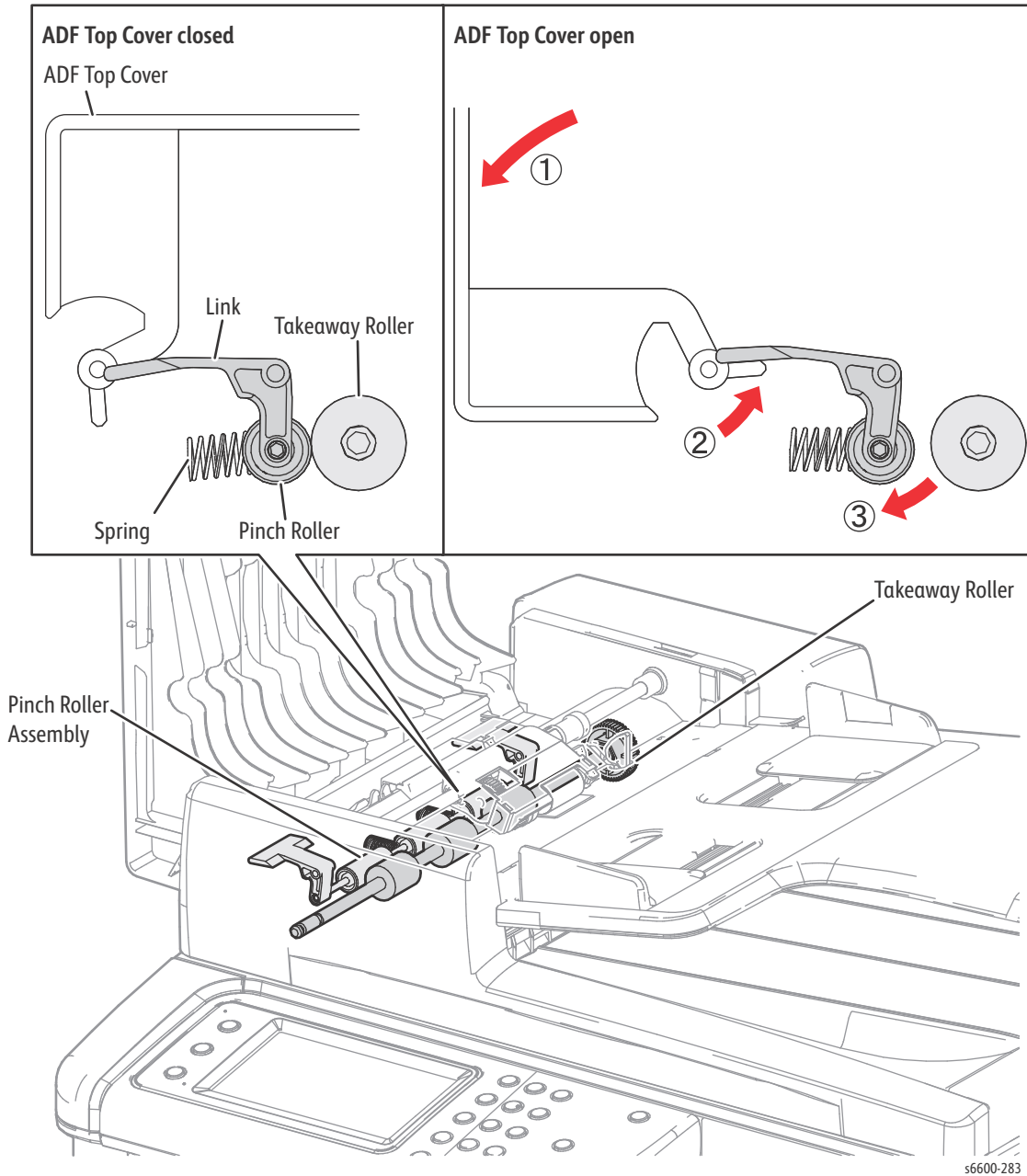




### Pinch Roller Assembly

The Pinch Roller Assembly is normally pressed against the direction of the Takeaway Roller by the spring pressure. Documents are fed through between the Pinch Rollers and the Takeaway Roller to the CVT Window by the rotation of the Takeaway Roller.

If a jam occurs between the Pinch Roller Assembly and the Takeaway Roller, it is hard to retrieve documents due to the high spring pressure of Pinch Roller Assembly. In order to retrieve jammed documents, open the DADF Cover Assembly to release the spring pressure, and make enough clearance between the Pinch Rollers and the Takeaway Roller.



## Consumables & Maintenance Items

Consumables consist of C, M, Y, and K Toner Cartridges, C, M, Y, and K Imaging Units, and the Waste Cartridge.

Each Toner Cartridge (except starter cartridges) has a CRUM (Customer Replaceable Unit Monitor) to record regional and toner usage information. The CRUM maintains a count of the amount of toner consumed. When the count reaches set values, warning and error messages appear to notify the user when near and end of life status is reached.

Like the Toner Cartridges, each Imaging Unit has a CRUM to maintain a page count. When the count reaches a set value, warning and error messages appear to notify the user that the Imaging Unit has reached near or end of life status.

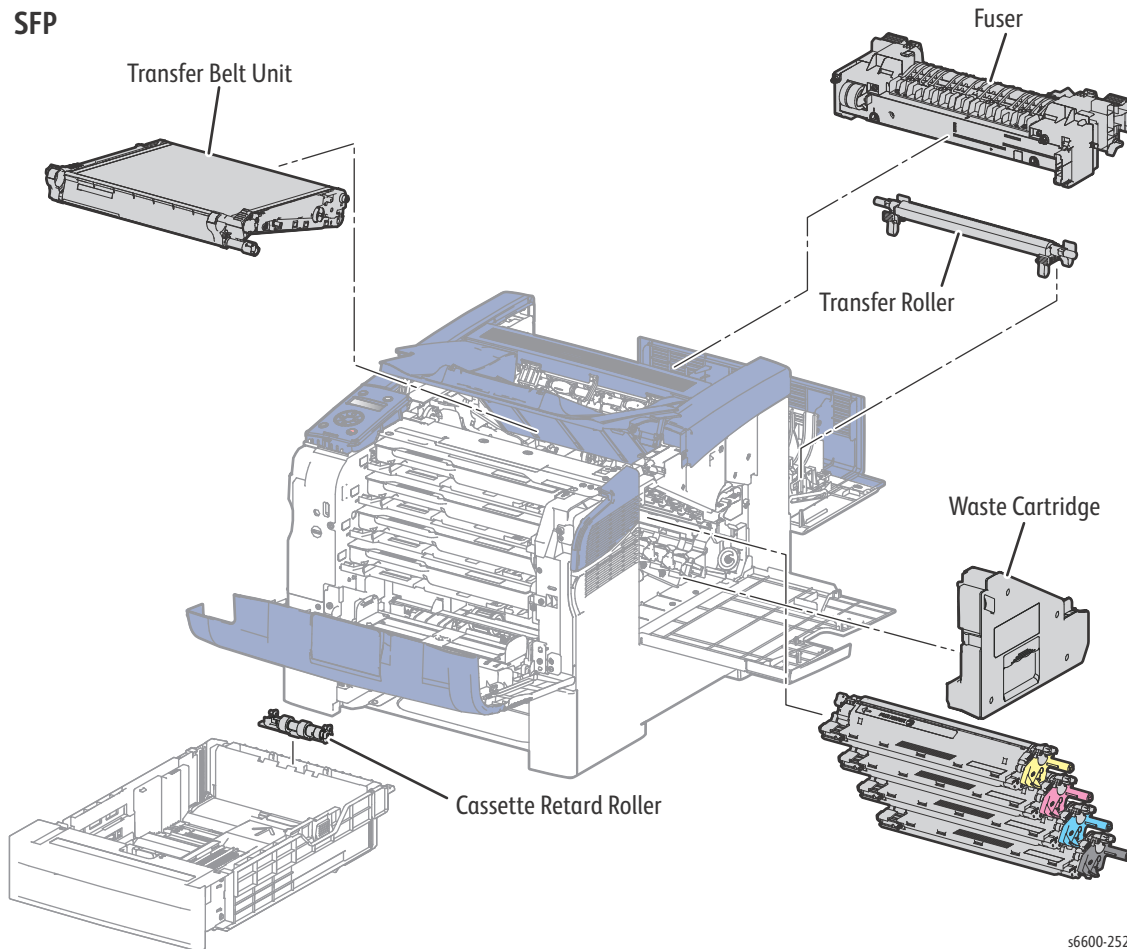
Life ratings are based on ISO/IEC 19798.

Consumables	Capacity
CMYK Standard Capacity Toner Cartridges	2,000 color / 3,000 mono
CMYK High Capacity Toner Cartridges	6,000 color / 8,000 mono
CMYK Imaging Unit	60,000
Waste Cartridge	30,000

## Routine Maintenance Items

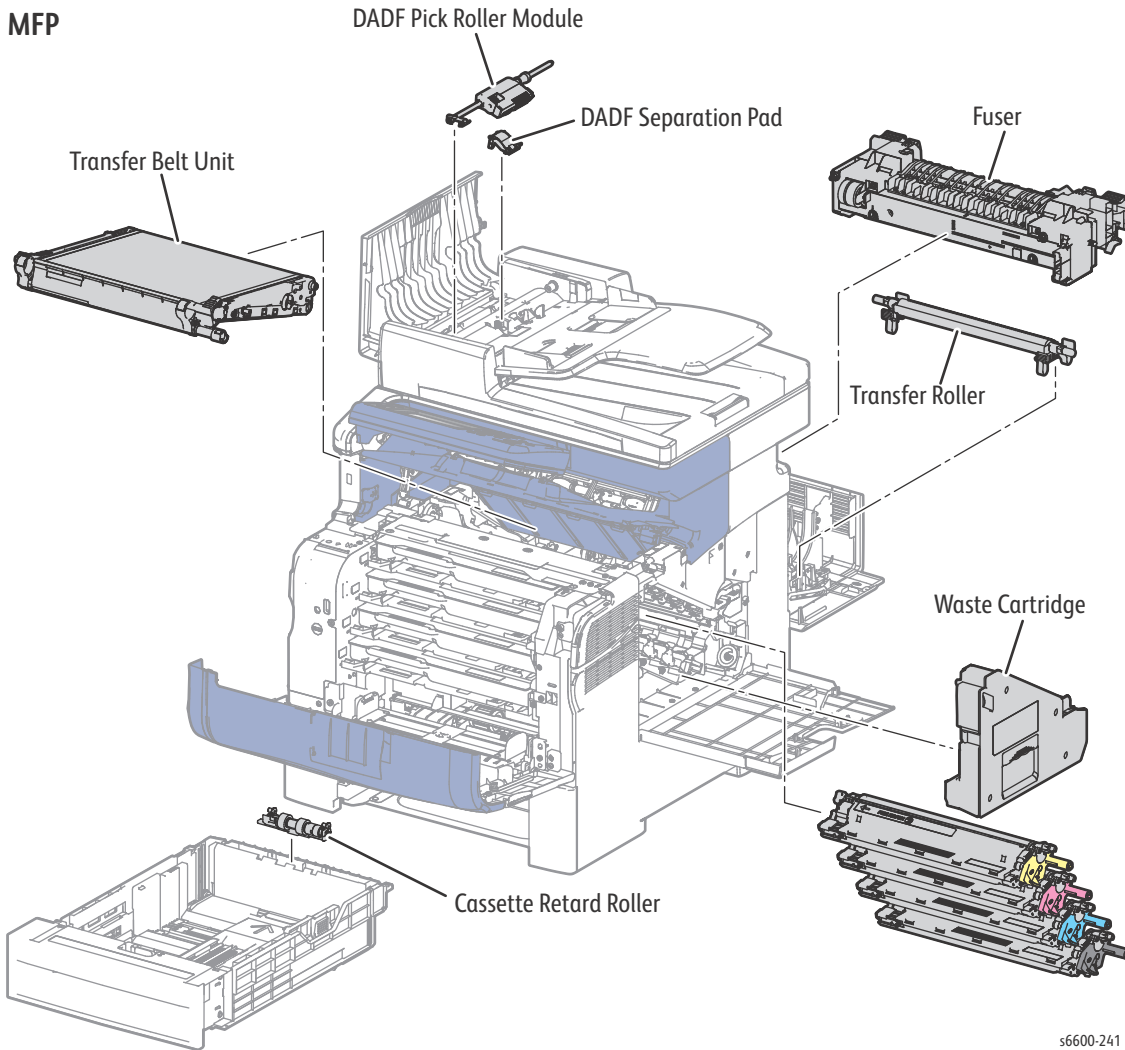
- Fuser (110V / 220V): 100kPV or 5 years (B50)
- Transfer Belt unit + Transfer Roller unit + Cassette Retard Roller: 100kPV (B10)
- DADF Pick roller module and separation pad (MFP only): 35kPV

### SFP



General Information

MFP



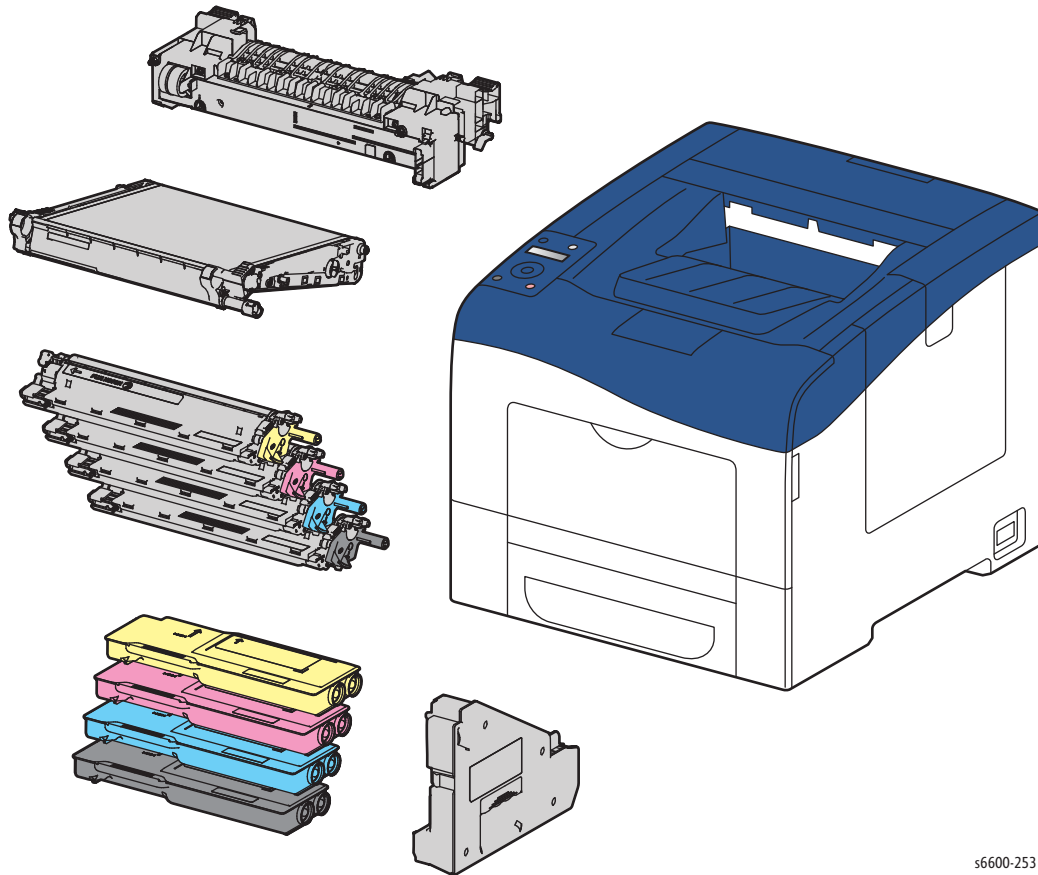
# Specifications

## Configuration of Printer

### Basic Configuration

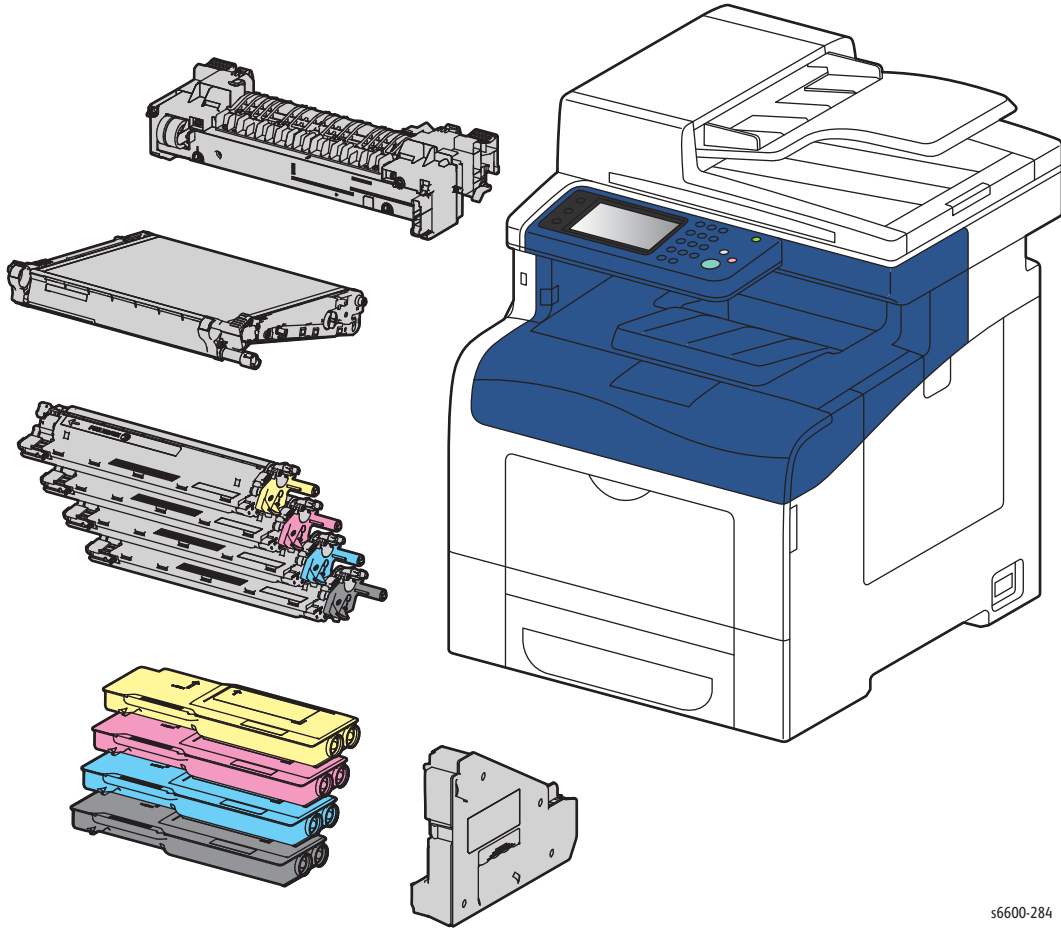
The printer has the following basic configurations depending on the destination.

- print engine main unit (MSI and 550 feeder unit as the standard paper feeding)
- consumables (CRU)



s6600-253

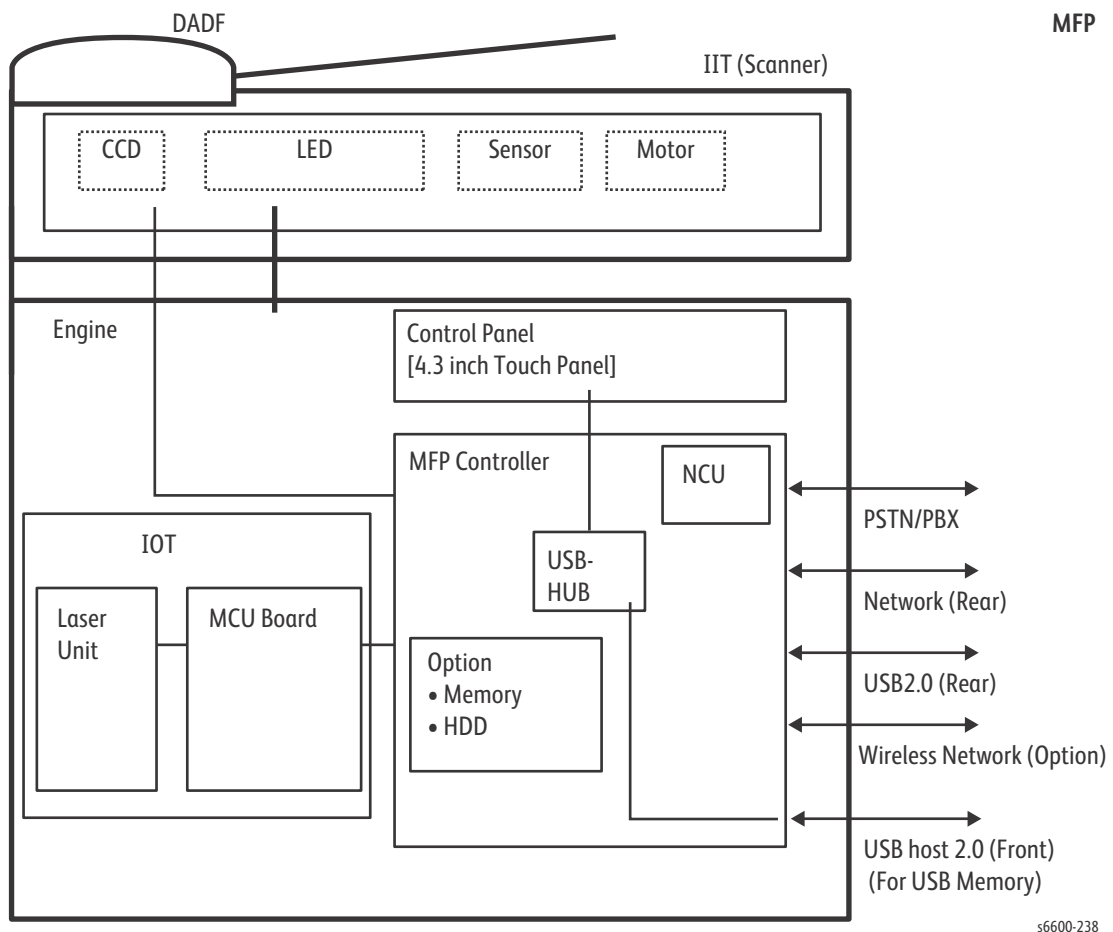
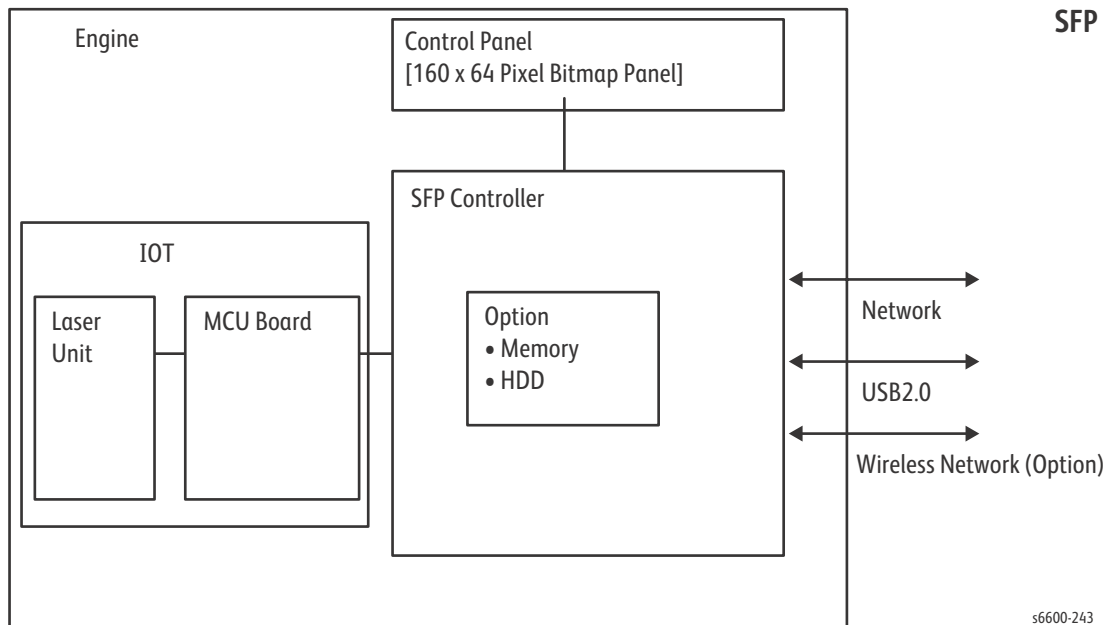
General Information



s6600-284

## Functional Configuration

Functional configurations of the Phaser 6600 and WorkCentre 6605 printers are shown below.



## Electrical Properties

### Power Source

Two types of power source as follows are available for this printer, which are selected according to the specifications.

- 110 M/C: ---voltage: 100-127VAC  $\pm 10\%$  (90 ~ 140V), frequency: 50/60Hz  $\pm 3$ Hz
- 220 M/C: ---voltage: 220-240VAC  $\pm 10\%$  (198 ~ 264V), frequency: 50/60Hz  $\pm 3$ Hz

### Power Consumption

Power consumption in each operation mode at rated voltage input

Operation mode	Phaser 6600	WorkCentre 6605
Power off	0 W	0 W
Printing	535 W	560 W
Ready	65 W	72 W
Sleep	4 W	6 W

### Rush Current

When the power switch is turned on, the inrush current shall be maximum 50Amp (Cold start)/135Amp (Hot start) at first 2.5msec, and 80Amp (120V/220V/240V) / 85Amp (100V) within 10msec.



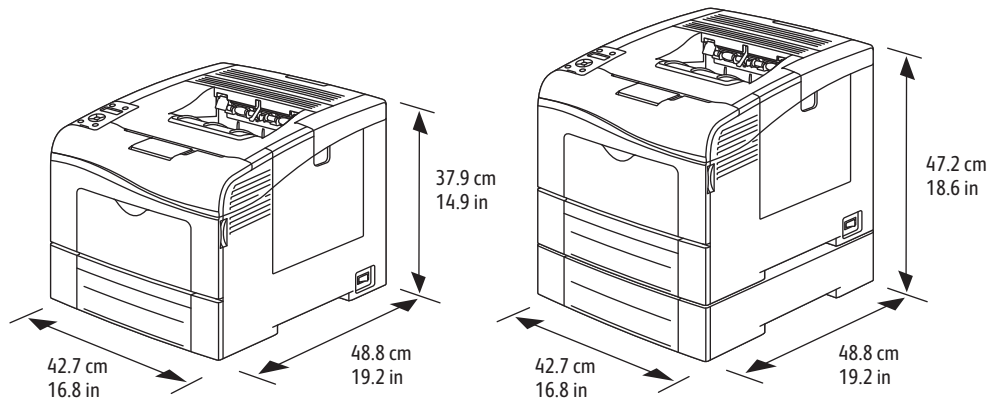
## Mechanical Properties

### Dimensions/Mass of Printer

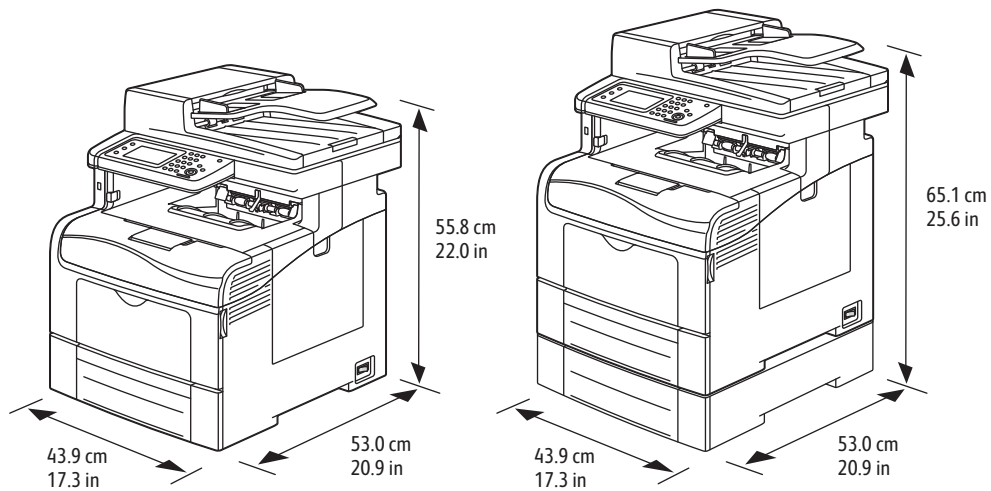
The dimensions listed are with Bypass Tray cover, ejection stacker, and scanner cover closed.

	Width	Depth	Height	Mass
Phaser 6600	430 mm (16.9 in.)	488 mm (19.2 in.)	384 mm (15.1 in.)	25.5 kg (56.2 lb.)
Phaser 6600 w/ 550-sheet feeder	430 mm (16.9 in.)	488 mm (19.2 in.)	477 mm (18.8 in.)	28.1 kg (61.8 lb.)
WorkCentre 6605	430 mm (16.9 in.)	530 mm (20.8 in.)	560 mm (22.0 in.)	32.5 kg (71.7 lb.)
WorkCentre 6605 w/ 550-sheet feeder	430 mm (16.9 in.)	530 mm (20.8 in.)	653 mm (25.7 in.)	35.1 kg (77.3 lb.)

#### Phaser 6600

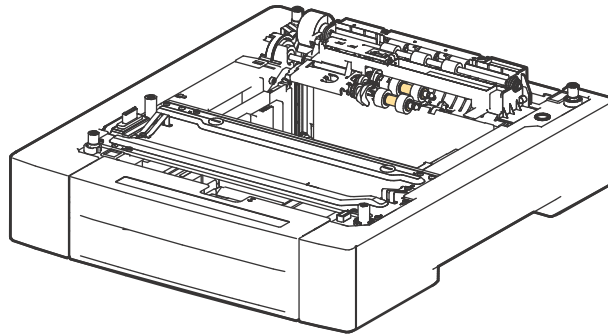


#### WorkCentre 6605



## Dimensions/Mass of Paper Tray

Width	Depth	Height	Mass
430 mm (16.9 in.)	488 mm (19.2 in.)	138 mm (5.4 in.)	2.6 kg (5.7 lb.)

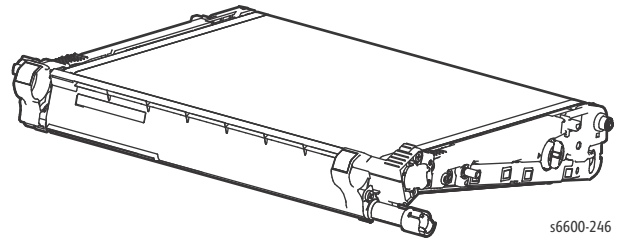


s6600-245

## Dimensions/Mass of Consumables and CRUs

### Transfer Belt

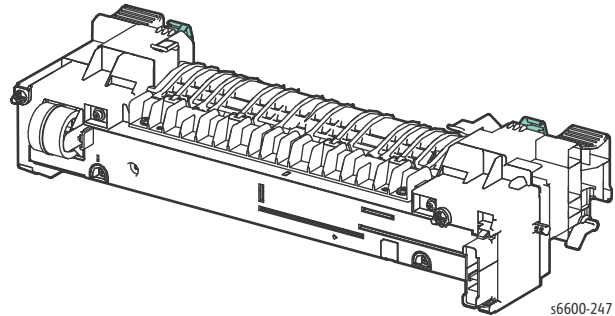
- Width: 318.1mm
- Depth: 256.7mm
- Height: 51mm
- Mass: 1.5kg



s6600-246

### Fuser

- Width: 370mm
- Depth: 140mm
- Height: 92mm
- Mass: 1.3kg



s6600-247

**Standard & High Capacity Toner cartridges  
(Y, M, C, K)**

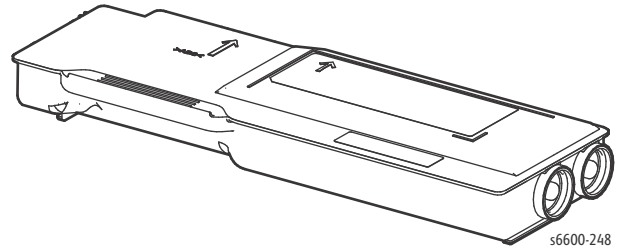
Width: 273.4mm

Depth: 87.7mm

Height: 37.3mm

Mass: 0.4kg

Reference: Each toner cartridge (except starters) has a CRUM (CRU memory) to record information.



**Imaging Unit (Y, M, C, K)**

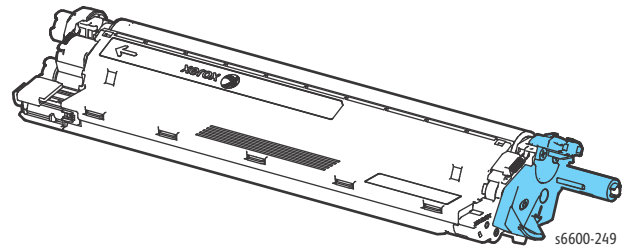
Width: 333.4mm

Depth: 81.3mm

Height: 51.3mm

Mass: 3.06 kg

Reference: Each Imaging Unit has a CRUM (CRU memory) to record information.



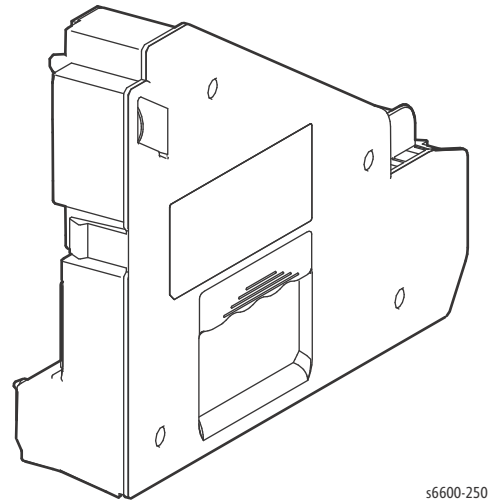
**Waste cartridge**

Width: 232.9mm

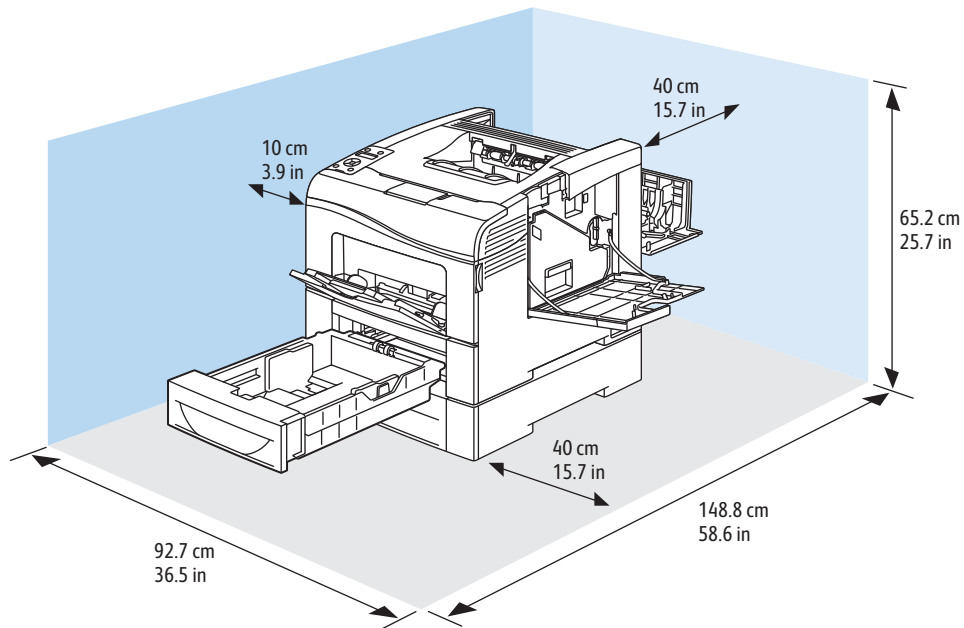
Depth: 183.6mm

Height: 66.5mm

Mass: 0.3kg

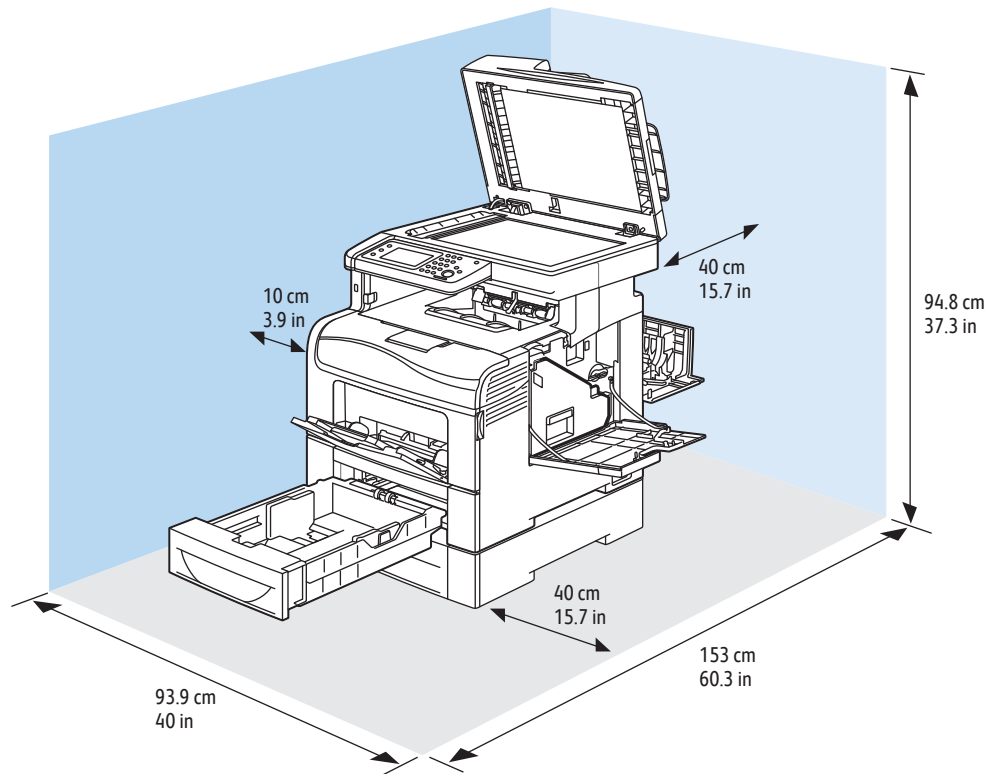


## Phaser 6600 Installation Clearance Requirements



	Phaser 6600DN Color Printer	Phaser 6600DN Color Printer with Optional 550-Sheet Feeder
Width	927 mm (36.4 in.)	927 mm (36.4 in.)
Depth	1488 mm (58.6 in.)	1488 mm (58.6 in.)
Height	559 mm (22 in.)	652 mm (25.7 in.)

## WorkCentre 6605 Installation Clearance Requirements



	<b>WorkCentre 6605DN Color Multifunction Printer</b>	<b>WorkCentre 6605DN Color Multifunction Printer with Optional 550-Sheet Feeder</b>
Width	930 mm (36.6 in.)	930 mm (36.6 in.)
Depth	1528 mm (60.2 in.)	1528 mm (60.2 in.)
Height	855 mm (33.7 in.)	948 mm (37.3 in.)

## Functions

### Resolution

Line Density in Fast Scan Direction: 600 dots/25.4mm

Line Density in Slow Scan Direction: 600 dots/25.4mm (fixed)

### Operation Mode

#### **Power-off State**

The power switch is off and no power is supplied. The machine does not operate.

#### **Ready (Standby) Mode**

When the system starts up by power-on, it shifts from the power-off state to the Ready mode.

After pressing “Power Saver button” on the operator panel, the machine enters the Energy Saver Mode to save more power consumption.

### Running Mode

There are the Print mode, Scan mode, and FAX communication mode in which the IOT, IIT, and FAX communication operate respectively.

#### **Print Mode**

In this mode, the IOT is operating for printing and report printing.

#### **Scan Mode (MFP only)**

In this mode, the IIT is operating for copy scanning, local scanning, network scanning, and FAX scanning.

#### **FAX Communication Mode (MFP only)**

In this mode, FAX sending/receiving is in progress.

## Energy Saver (Sleep) Mode

When no jobs are executed for a certain period of time, the machine enters Energy Saver mode to reduce electricity consumption. The user can set the time that the printer spends idle in Ready mode before it shifts to Energy Saver mode for a period of 1 to 60 minutes. The factory default is 5 minutes for the MFP, and 10 minutes for the SFP.

After one minute in Energy Saver mode, the printer automatically enters Deep Sleep mode for a further reduction in power consumption.

The following conditions trigger the printer to exit Energy Saver or Deep Sleep mode and return to Ready mode:

- Pressing “Energy Saver button” on the operator panel
- Receiving a print job
- Receiving a FAX job (MFP only)
- Receiving Direct Fax job (MFP only)
- Report printing directions from CWIS.
- Start sending or polling data at the communication, if start time specified by the operator (MFP only)

## Machine State

State	Exposure	Developer and transfer	Fusing Unit	Cooling fan	IIT (MFP only)	MCU	Operation panel	Controller	Interface Port <sup>a</sup>
Initializing	Working during calibration		Rest	Rest	Working	Working	Working	Working	Working
Running	Working	Working	Working	Working					
Ready	Rest	Rest	Standby Temp.	Working (Half)					
Sleep			Rest	Rest	Rest	Power Saver button LED Only			
Deep Sleep					Rest				Working

a. Interface Port: USB Port (Type B), Ethernet Port

## Warm-up Time

Event	State transition	Warm up time	Condition
Power On	Power off to Ready	As few as 12 seconds	20°C/60 % RH, Rated voltage. Power On after seasoning for 3 hours or more.
Wake up from Sleep mode	Sleep to Ready	As few as 3 seconds.	20°C/60 % RH, Rated voltage, Plain paper job in Deep Sleep Mode shift and 1 hour.
Wake up from Deep Sleep mode	Deep sleep to Ready		

## FPOT (First Print Output Time)

The time required for the first sheet of paper to exit the printer after clicking **OK** in the driver.

Color Mode	FPOT (Ready)	FPOT (Power Saver/Sleep)
B/W	As fast as 9 seconds	30.3 sec. or less (TBD)
Color	As fast as 10 seconds	30.3 sec. or less (TBD)

## Input Capacities

Input	Capacity
Cassette Tray	550 sheets or under 59.4mm of standard paper
Bypass Tray	150 sheets or under 15mm of standard paper

## Output Properties

- Paper delivery system: Face up delivery
- Paper delivery capacity: 250 sheets (Letter/A4 standard paper)
- Delivery paper size/mass: All paper sizes applicable to this printer
- Full stack detection: There is a sensor to detect a full stack.



## Paper

	550-Sheet Cassette	Bypass Tray <sup>b</sup>
Preset Paper size	A4 SEF, B5 SEF <sup>a</sup> , A5 SEF, Letter SEF, Executive SEF, Folio (8.5" x 13") SEF, Legal SEF	A4 SEF, B5 SEF <sup>+1</sup> , A5 SEF, Letter SEF, Executive SEF, Folio (8.5" x 13") SEF, Legal SEF, Com-10 SEF, Monarch, DL, C5 SEF
Custom paper size	Width: 148 to 215.9mm (A5 to 8.5") Length: 210 to 355.6mm (A5 to 14")	Width: 76.2mm to 215.9mm (3" to 8.5") Length: 127mm to 355.6mm (5" to 14")
Paper mass	60 to 216 g/m <sup>2</sup> (16 lb to 80 lb)	60 to 216 g/m <sup>2</sup> (16 lb to 80 lb)

- a. JIS B5 SEF supports  
b. Supports the same paper sizes as 550-sheet tray except for Monarch LEF and DL LEF.

## Operating Environment

Characteristic	Specification
Installation Temperature / Humidity	Installation temperature and humidity on the condition without condensation is as follows. Operating: 10-32°C, 10-85 % RH (No condensation) Storage: minus 20-40°C, 5-85 % RH (No condensation)
Installation Altitude	0 to 3,100m
Installation Horizontality	Longitudinal levelness of table surface on which the printer is installed: 1 degree or under Lateral levelness of table surface on which the printer is installed: 1 degree or under
Storage Temperature of a Toner Cartridge	The guaranteed period of the Toner Cartridge before unpacked is as follows: Normal conditions: 24 months under 0 to 35°C, 15 to 80 % RH. Harsh conditions: 1 month under -20 to 0°C and 35 to 40°C, 5 to 15 % RH and 80 to 95 % RH. The storage altitude shall be 0 to 3,100m. Can be extended to 0 to 15,000m when shipped by air. (Provided that the cargo bay is pressurized to 70.9275Kpa or higher.

## Safety / Environment Conditions

	100-127V M/C	220-240V M/C
Safety Standard	UL60950-1, CSA 22.2 60950	IEC60950-1 / EN60950-1
Laser Safety Standard	FDA21CFR Chapter 1, Subchapter J, Section 1010, 1040	IEC60825-1 Amendment 1 + Amendment 2 / EN60825-1 Amendment 1 + Amendment 2 Class 1 Laser Product
EMI	FCC Part15 Subpart B, Class B	EN55022:2006, Class B

## Noise Levels

Mode		Sound Power Level (B)	
		LWA	LWAD
Running	Color	7.15	7.2
	B&W	6.95	7.25
Standby	Color	4.69	4.8
	B&W	4.69	4.99

## Print Image Quality

### Image Quality Guarantee Conditions

The image quality is specified and guaranteed under the following conditions.

Item	Specification
Environmental conditions	Environment condition for evaluating image quality Temperature: 15-28°C Humidity: 20-70 % RH
Guaranteed paper	The print quality defined in this chapter is guaranteed when standard paper is used in the tray.
Paper condition	The paper used is fresh paper immediately after unpacked, which has been left in the operating environment for 12 hours before unpacking.
Printer condition	The print image quality specified in this section is guaranteed with the printer in normal condition.
Image quality guaranteed area	The print image quality specified in this section is guaranteed in the guaranteed image quality area specified in this manual.
Criterion	The print image quality is guaranteed with the Spec. In rate = 90 % ( $\gamma = 90\%$ ).

## Option

### Options to be Installed by Users

Users can install the following units.

- Expansion Memory (512MB)
- Wireless Adapter
- HDD Unit (160GB or larger)
- Optional 550-Sheet Feeder
- Wireless Adapter and HDD Unit (160GB or larger)

## ESS Specification

### Support OS

The machine supports the following operation systems with the latest service pack.

- Microsoft Windows XP (32bit / 64bit)
- Microsoft Windows Server 2003 (32bit / 64bit)
- Microsoft Windows Vista (32bit / 64bit)
- Microsoft Windows Server 2008 (32bit / 64bit)
- Microsoft Windows Server 2008 R2 (64bit)
- Microsoft Windows 7 (32bit / 64bit)
- Mac OS X 10.3.9/10.4/10.5 (PPC/x86)
- Mac OS X 10.6/10.7 (x86/x64)
- Red Hat Enterprise Linux 5/6 Desktop (x86)
- SUSE Linux Enterprise Desktop 10/11 (x86)

### Interface Port

#### USB

Item	Specification
Connector	One Type-B connector
Protocol	Hi-speed USB2.0 compatible

Item	Specification
Connector	One Type-A connector
Protocol	Hi-speed USB2.0 compatible
Supported Class	USB Mass Storage Class

#### Ethernet

Item	Specification
Connector	One RJ-45 connector
Protocol	10 Base-T / 100 Base-TX / 1000 Base-T compatible

## Wireless

Wireless Adapter is required.

Item	Specification
Conectivity Technology	Wireless
Compliant Standards	IEEE802.11 n/g/b
Band width	2.4GHz
Data Transfer Rate	IEEE802.11n mode: 65 Mbps IEEE802.11g mode: 54, 48, 36, 24, 18, 12, 9, 6 Mbps IEEE802.11b mode: 11, 5.5, 2, 1 Mbps
Protocol	See "Network Protocol" for details
Device Type	Wireless Adapter
Security Protocol	64(40-bit key)/128(104-bit key) WEP,WPA-PSK(TKIP,AES), WPA2-PSK(AES), WPA-Enterprise(TKIP,AES), WPA2-Enterprise(AES) (EAP method supports PEAPv0 only)
Wifi Protected Setup (WPS)	Push Button Configuration (PBC), Personal Identification Number (PIN)

**Note:** Connection to the Linux machine is not guaranteed. Only for infrastructure connection and when Linux terminal is connected with Wired LAN connection.

## Network Protocol

### Printing Protocol

Protocol	Transport	Maximum sessions	Remarks
Port9100	TCP/IP	1	Windows XP/Server2003/Vista/ Server2008/ 7/Server2008 R2 Mac OS X
LPD	TCP/IP	10	Windows XP/Server2003/Vista/ Server2008/ 7/Server2008 R2 Mac OS X Linux
IPP/IPPS <sup>a</sup>	TCP/IP	5	Windows XP/Server2003/Vista/ Server2008/ 7/Server2008 R2 Mac OS X
SMB	TCP/IP	5	Windows XP/Server2003/Vista/ Server2008/ 7/Server2008 R2
Web Services on Devices	TCP/IP	2	[Print]:Windows Vista / Server2008/ 7 / Server2008 R2 [Scan] : Windows Vista / 7

a. Requires HDD Option

### Control and Management Protocol

Protocol	Transport	Application / Usage	Remarks
HTTP/HTTPS	TCP/IP	EWS	
SMTP	TCP/IP	E-Mail Alert	
SNMP v1/v2c/v3	UDP/IP	Driver, Installer, Management	SNMP v3 Default OFF
DHCP	UDP/IP	IP setup	
BOOTP	UDP/IP	IP setup	
RARP	TCP/IP	IP management	
AutoIP	TCP/IP	Installer (Device discovery)	
WINS	TCP/IP	IP setup	
Telnet	TCP/IP	IP management	
Bonjour (mDNS)	UDP/IP	IP setup for Mac	
LDAP	TCP/IP	Address Book,ColorTrack Pro1.1	
LDAPS	TCP/IP	Address Book,ColorTrack Pro1.1	Need HDD Option
DNS	TCP/IP	IP management	
DDNS	TCP/IP	IP management	Default OFF
SNTP	TCP/IP	IP management	Default OFF
FTP	TCP/IP	IP management	

## MIB

The following MIBs are supported.

- RFC1213 MIB-II
- RFC1514 HostResources
- RFC1759 Printer MIB
- Printer port monitor MIB
- XCMIB MIB

## Decomposer

### PDL

PDL	Interface		Remark
	USB I/F, Net	USB Storage	
PCL 5c	Yes <sup>a</sup>	No	
PCL 6	Yes	No	SupportOS: Windows XP/Server 2003/Vista/Server 2008/ 7 / Server2008 R2
PostScript	Yes	No	SupportOS: Mac OS X(10.3.9/10.4/10.5/10.6/10.7), Linux, Windows XP/Server2003/ Vista / Server2008 / 7 / Server2008 R2
FX-PDF	Yes	Yes	Ver1.6
TIFF	No	Yes	
JPEG	No	Yes	
HBPL	Yes	No	

a. Yes: Supported No: Not supported

### Font

81 fonts and 36 Symbol Sets for PCL, 16 fonts for PDF and 136 fonts for PS3 are available as built-in font.

## Image Area

Area definition	Specification
Usable Area (maximum paper size)	215.9 <sup>a</sup> x 355.6mm
Un-printable Area	Default: 4.1mm each from four edges of paper <sup>b</sup>
Printable Area	207.7 x 347.4 mm <sup>c</sup>
Print quality guaranteed Area	Same as Printable Area

a. Maximum width 220mm for Envelope (DL LEF)

b. Can be enabled in printer driver up to 4.0mm

c. Maximum printable width of paper which paper width is more than 215.9mm is 210.9mm. therefore Maximum printable area is 210.9 x 361.6mm.

## Job Control

### Print Cancel

A print job in progress can be cancelled from the operator panel.

### Job Recovery

When a print job fails due to a recoverable error such as paper jam, the machine recovers the job automatically after the jammed paper is removed.

### Job Timeout

When a print job is stopped for a certain period of time (time can be changed at the operator panel, and unlimited also can be selected), the print data of the job is deleted as an error.

### ColorTrack Pro1.1

Color Track is a function to designate the use of color printing and control print volume per user.

Only the administrator can set restrictions from the EWS.

The user name and password are embedded in the print job to confirm from whom the job is sent. In addition, the user name and password are entered by user from the printer driver.

The printer can support maximum 50 accounts.

When “ColorTrack Mode” is set to “Off”, “Automatic Color to Monochrome Print” setting applies to all users. When “ColorTrack Mode” is set to “Internal Mode” or “External Mode”, “Automatic Color to Monochrome Print” setting applies to Registered Users with “Monochrome Print Only” rights and Non Registered Users.



**Secure Print**

When the expansion memory (512MB) or HDD is attached, the printer holds print data in memory, including a user password (1~12 digits), a user name and a document name specified in the printer driver. The data is not printed until the same password, user name and document name are specified at the printer UI. The data is cleared after being printed. The data remains in the printer as long as it is not cleared. The data on the memory is cleared when the printer is turned off. The data on the HDD is not cleared even the printer is turned off.

**Proof Print**

When the expansion memory (512MB) or HDD is attached, the proof print can be selected only. When multiple sets of prints are specified in the printer driver, the printer prints only the first set of the print data. Then the user can select whether the remaining sets are printed or not (the remaining data is cleared) when the same user name and document name are entered at the Panel UI. The data remains in the printer as long as it is not cleared. The data on the memory is cleared when the printer is turned off. The data on the HDD is not cleared even the printer is turned off.

**IP Filter**

The user can select to accept or reject jobs for the specified IP address. Up to 5 IP addresses can be specified. IP filter is available only to LPD and Port 9100.

**Virtual Mail Box**

When the expansion memory (512MB) or HDD is attached, the Virtual Mail Box can be selected only. There are two type of Virtual Mail Box.

**Public Virtual Mail Box**

When print job is selected Public (password not needed) in the Stored Print menu on the driver, everyone can print job from operator panel if know user name or file name. And this print job remains till deleted intentionally.

**Private Virtual Mail Box**

When print job is selected Private (password needed) in the Stored Print menu on the driver, everyone cannot print job from operator panel if unknown password. And this print job remains till deleted intentionally.

**Public Mail Box**

When the expansion memory (512MB) or HDD is attached, the Public Mail Box can be selected only. When print job is selected "Public Mail Box" in the Job Type menu on the driver, everyone cannot print job from operator panel if unknown password. And this print job remains till deleted intentionally. The data on the memory is cleared when the printer is turned off. The data on the HDD is not cleared even the printer is turned off.

## Logging

### Job Logging

The machine can retain up to 20 job logs.

Job log is printed instantly by user's request or automatically when the number of the retained job logs has reached 20.

Job log includes the following information.

- Job finish date and time
- Job type (Print/File/FaxSend/FaxReceived/Copy/Scan) — MFP only
- Input interface (USB, LPD, Port9100)
- Document name (File name)
- Output color
- User name/Host name
- Number of printed sheets (Color, B&W)
- Number of printed impressions (Color, B&W)
- Paper size
- Result (Successful, Error, etc.)

### Error Logging

The machine can retain the following errors.

Fatal error: 42 errors at the maximum (10 errors at the minimum)

Jam error: 42 errors

The user can print the error log by the panel operation.

Jam error log includes the following information.

- Date and time when jam has occurred
- Jam name Fatal error log includes the following information.
- Date and time when error has occurred
- Error code

### Billing Counter

The PV counter counts the number of sheets printed properly (Similar to Odometer).

Counter	Description
Color PV (7 digits)(KCMY)	Count the number of paper printed in color.
B&W PV (7 digits)(K only)	Count the number of paper printed in B&W.
Total PV (7 digits)	Count the total number of paper printed in color and B&W.

## ID Print

User name can be printed. The printing position can be selected from upper right, upper left, lower right and lower left (Only for PCL6). The user selects using the operator panel whether user name is printed or not and where it is printed.

## Non-Genuine Mode

When a Toner Cartridge has reached end-of-life, the printer stops accepting print requests (Toner Cartridge life is counted by the counter in CRUM). Taking into consideration that some users use refilled Toner Cartridges they get from remanufacturers, the printer can accept a print request by the user's panel operation even if the life of the Toner Cartridge has ended. Settings of Toner Cartridge can be made separately (settings of Toner Cartridge can not be made by color). When the mode has changed so that the printer does not stop even after life of Toner Cartridge ends, the printer displays a message on the operator panel to inform the user of the mode change. When the printer operates in this mode, print image quality is not guaranteed. Also, remaining toner level is not displayed (as CRUM data can not be guaranteed).

## IIT (Image Input Terminal) Specifications

These specifications apply only to the WorkCentre 6605.

### Scanner

Scanning Method Platen: Document-fixed flatbed scanning method

DADF: Carriage-fixed, document-feeding scanning method (2- side scanning)

Optical Resolution 1200 x 1200 dots / 25.4mm (max)

Light Source LED

Maximum Scanning Guarantee Area

Platen: 215.9mm x 297mm

DADF: 215.9mm x 355.6mm

Scanning Halftone Level

Output from the CCD has the following halftone level.

Gray: 16bit x 2ch (CDD/EVEN)

Color: 16bit x 3ch (R/G/B)

### Platen

Platen Glass Size: 221mm x 300mm (Flat glass area)

Document Image Area (Platen mode).

Max: 215.9mm (8.5") x 297mm

## General Information

### DADF

Document Condition	Sheets without tears, wrinkles, or folds.
Document Thickness	Simplex: 50g/m <sup>2</sup> - 125g/m <sup>2</sup> Duplex: 60g/m <sup>2</sup> - 125g/m <sup>2</sup>
Auto Document Size Detection	None
Retention Angle / Open Angle of Platen Cover with DADF	Maximum open angle: ≤ 70 deg Platen cover can be retained at any angle: 15 ± 5 through 65 ± 5 deg Platen cover self-weight drop angle: 15 ± 5 deg or less
Document Setting	Center Registration
Document Tray Capacity	50 sheets of standard document(document stack height is ≤ 8 mm).  Document shall not be creased/folded/swollen, etc.

### FAX Specifications

#### Fax Send/Receive Buffer

FlashROM: 4MB

#### Connectable Network

The MFP can be connected to the following communication networks:

- PSTN
- PBX
- Leased line (3.4KHz/2-wire)

The MFP *cannot* be connected to the following communication networks:

- ISDN communication network
- VoIP network

## Mutual Communication Ability

Characteristic	Specification
Communication Mode	Priority 1: ITU-T Super G3 Priority 2: ITU-T G3 ECM Priority 3: ITU-T G3 <b>Note:</b> ITU: International Telecommunication Union ITU-T: ITU Telecommunication Standardization Sector ECM: Error Correction Mode
Modem Signal Processing	The following communication standards are supported: <ul style="list-style-type: none"> <li>• V.34 (33.6 /31.2 /28.8 /26.4 /24 /21.6 /19.2 /16.8 /14.4 /12 /9.6 /7.2 /4.8 /2.4kbps)</li> <li>• V.17 (14.4 /12 /9.6 /7.2kbps)</li> <li>• V.29 (9.6 /7.2kbps)</li> <li>• V.27ter (4.8 /2.4kbps)</li> </ul>
Pixel Transmission Density (on the supported transmission path)	<b>B/W:</b> <ul style="list-style-type: none"> <li>• R16 x 15.4 line/mm</li> <li>• R8 x 15.4 line/mm</li> <li>• R8 x 7.7 line/mm</li> <li>• R8 x 3.85 line/mm</li> <li>• 400 x 400 pixel/25.4mm</li> <li>• 300 x 300 pixel/25.4mm</li> <li>• 200 x 200 pixel/25.4mm,</li> <li>• 200 x 100 pixel/25.4mm</li> </ul>
	<b>Color:</b> Not supported.
Communication Image Size	Fast scan direction size on communication: 215 mm +/- 1 %
Halftone/Compression Method	<b>B/W:</b> 1bit, JBIG, MMR, MR, MH encoding
	<b>Color:</b> Not supported.
Communication Control Procedure	Comply with ITU-T recommendation T.30.
Nonstandard Function	Not supported.

**Transmission Time**

Transmission time ( $T_p$ ) of image data in G3 mode is as follows.

Resolution conversion is not performed during transmission, and density is normal.

Specified value condition: ECM (No data error)

Chart		14.4Kbps (MMR)	28.8Kbps (MMR)	33.6Kbps (JBIG) <sup>a</sup>
IIEEJ No.4	Super Fine	56 sec. or less	29 sec. or less	22 sec. or less
	Fine	26 sec. or less	13 sec. or less	11 sec. or less
	Standard	19 sec. or less	10 sec. or less	7 sec. or less
ITU-T No.1	Super Fine	30 sec. or less	15 sec. or less	12 sec. or less
	Fine	15 sec. or less	8 sec. or less	6 sec. or less
	Standard	11 sec. or less	6 sec. or less	4 sec. or less
FX English Sales Text	Standard	7 sec. or less	4 sec. or less	2 sec. or less
FX Japanese Sales Text	Standard	9 sec. or less	5 sec. or less	4 sec. or less
IIEEJ No.1	Standard	75 sec. or less	38 sec. or less	20 sec. or less

a. Reference value

**Protocol Control Time**

When no data error occurs, protocol control time ( $T_m, T_n, T_u$ ) is as follows.

V.17, V.29, V.27ter

Mode	Before messages: $T_m$	Between messages: $T_n$	After messages: $T_u$	Total
Standard protocol	16.4 sec. or less	3.2 sec. or less	4.4 sec. or less	24.0 sec. or less

-V.34

Mode	Before messages: $T_m$	Between messages: $T_n$	After messages: $T_u$	Total
Standard protocol	9.9 sec. or less	1.0 sec. or less	0.9 sec. or less	11.8 sec. or less

In G3 mode, when a data error that exceeds the threshold occurs,  $T_n$  increases by about 6 seconds.

In ECM (Error Correction Mode), according to the number of resending operations performed for the occurred data error,  $T_n$  increases by about  $T_n+1$  seconds for each resending operation.

## Throughput

The sending time is calculated in the following formula:

Sending time = Call setup time +  $T_m$  +  $(N \times T_p)$  +  $\{(N-1) \times T_n\}$  +  $T_u$  (sec)

(N: Send quantity;  $T_p$ : Image transmission time)

## Cable Characteristics

With pseudo cable from 0 to 15km, the highest speed shall be guaranteed for communication with V.17, V.29, and V.27ter. For V.34, 33600bps communication speed shall be guaranteed from 0 to 2km, 31200bps or higher communication speed from 2 to 9km, and 19200bps or higher communication speed from 9 to 15km.

## Communication Load Characteristics

Data error characteristics for noise and cable loss during communication are as follows:

Error rate (Error frequency/Total communication quantity)  $\leq 1/500$

## Incoming Call Level

Under ideal conditions (flat line, no noise, and no other line stress), normal communication shall be guaranteed in the range from -3 through -43dBm.

For V.17, V.29, and V.27ter, the highest speed shall be guaranteed in the range from -6 through -43dBm. For V.34, 33600bps communication speed shall be guaranteed in the range from -9 through -19dBm, and 16800bps or higher communication speed in the range from -19 through -43dBm.

For V.34, normal communication shall be guaranteed in the range from -9 through -43dBm.





# Error Troubleshooting

# 2

## In this chapter...

- Introduction
- Servicing Instructions
- Service Mode
- Service Mode Diagnostic Tests
- Error Messages
- Error Code Fault Isolation Procedures
- Other Fault Isolation Procedures

# Introduction

This chapter describes error messages displayed on the Control Panel or listed on the Error History page, Service Diagnostics used to test system operation and troubleshooting procedures to correct problems. Troubleshooting print quality problems is covered in Chapter 3, Image Quality.

## Initial Actions

Some problems are easy to resolve. Use these Steps in an attempt to quickly isolate the problem.

1. Turn Off the printer, wait 10 seconds, then turn On the printer. This often [solves problems](#) related to power transients, ESD, and software errors.
2. If a message appears on the Control Panel, see “Error Messages” on page 2-89 for specific procedures related to error messages.
3. Check the power cord. Is the power cord plugged into the printer and a properly grounded electrical outlet? Is the power cord damaged?
4. Check the electrical outlet. Is the outlet turned off by a switch or breaker?
5. Does other electrical equipment plugged into the outlet operate?

## Display Problems

If the Control Panel is blank:

1. Turn the printer Off, wait 10 seconds, then turn the printer On.
2. When tests complete, **Ready to Print** should appear on the display.

If the problem persists:

1. Check the connections to the Control Panel.  
SFP: Verify the connection at the Control Panel, and at P/J12 on the IP Board.  
MFP: Verify the connections at P/J820 and P/J830 on the USB Hub Board, and at P/J810 on the IP Board.
2. Check +3.3 and +5 VDC from the LVPS.
3. Replace the Control Panel.
4. Replace the IP Board.

## Printing Problems

If menu settings entered from the Control Panel have no effect, change or disable print settings from the print driver, the print utilities, or the application.

**Note:** Settings made in the application, print driver, or print utilities override settings made from the Control Panel.

If a job did not print correctly or incorrect characters were printed, check the following:

1. Check that the printer is in a “Ready to Print” state before sending a print job.
2. Check the loaded media.
3. Check the print driver.
4. Check the printer connections to Ethernet or USB.
5. Verify that the correct print media size is selected.
6. If using a print spooler, verify that the spooler has not stalled.
7. Check the printer’s interface configuration. Determine the host interface you are using. Print a Configuration Report to verify that the current settings are correct.

## Copy/Scan Problems

If the scanner does not work or operates slowly, check the following:

1. Ensure that you place the document to be scanned face down from the document feeder glass, or face up in the DADF.
2. There may not be enough available memory to hold the document you want to scan. Try the Prescan function to see if that works. Try lowering the scan resolution rate.
3. Check that the USB cable is connected properly.
4. Ensure that the USB cable is not defective. Switch the cable with a known good cable. If necessary, replace the cable.
5. Check that the scanner is configured correctly. Check the application you want to use to make certain that the scanner job is being sent to the correct port.
6. Graphics are scanned more slowly than text when using the Scan to E-mail or Scan to Network feature.
7. Communication speed becomes slow in scan mode because of the large amount of memory required to analyze and reproduce the scanned image.
8. Scanning images at a high resolution takes more time than scanning at a low resolution.

## DADF Problems

If document misfeeds or multiple feeds occur in the Duplexing Automatic Document Feeder (DADF), check and try the following actions.

1. Check whether the DADF roller assembly is installed properly.
2. Ensure the document's paper type meets the specifications for the printer.
3. Check whether the document is properly loaded in the DADF.
4. Ensure that the document guides are adjusted properly.
5. Ensure that the number of document sheets do not exceed the maximum capacity of the DADF.
6. Ensure that the document is not curled.

## Fax Problems

If printer does not properly send or receive faxes, check the following:

1. Check your scan glass for marks and clean it.
2. The other fax machine may be turned off, out of paper, or cannot answer incoming calls. Speak with the other machine operator and ask her/him to sort out the problem.
3. The FAX mode should be selected.
4. Ensure that there is paper in the paper tray.
5. Check to see if the display shows Memory Full.
6. Ensure that the document is loaded in the DADF or on the document glass.
7. Sending should show up on the display.
8. A noisy phone line can cause line errors.
9. Check your printer by making a copy.
10. The toner cartridge may be empty. Replace the toner cartridge.
11. The fax machine sending you the fax may be faulty.

## Media-Based Problems

1. Check that the correct type of media is being used; for the correct media types and weights, refer to the “Supplies” page on the Xerox web site. The customer should be using a quality laser printer paper. The printer may have trouble picking glossy or overly smooth paper.
2. Inspect the paper for bent, torn, or folded corners.
3. Check the media path for obstructions or debris.
4. Ensure that the correct media type is set at the Control Panel.
5. Ensure that the media guides are set correctly.
6. Ensure that the media is a supported type for the tray.
7. Load a fresh ream of paper in the tray.

## Multiple-Sheet Pick or Mis-Pick

1. Check the media. Is the media in good condition and listed as supported media? Quality office laser printer paper works best.
2. Check that the printer is printing within its environmental specifications by printing and review the environmental information on the Information page.
3. Remove, fan, and then reload the media. Ensure that the guides are securely against the media and the tray has not been over filled.
4. Try loading paper from a fresh ream, fan the paper, and then insert into the tray or flip existing paper over.
5. Check the tray’s Separator Roller for damage.
6. Clean the Feed Rollers with a clean, dry, lint-free wipe.
7. Replace the Feed Rollers.

## Skewed Image

1. The image area is not parallel, skewed, with the sides of the page but the printer neither jams nor displays an error code.
2. Remove the tray and ensure the paper guides are set correctly.
3. Check that the correct type of media for the tray is being used.
4. Ensure that the tray has not been over filled. (Skewed images are a common defect when the tray is overfilled.)
5. Verify the Feed Rollers are installed correctly.
6. Clean the Feed and Separator Rollers with a clean, dry, lint-free wipe.

## Damaged Prints

The printed page exits the printer either wrinkled, creased, or torn. The printer neither jams nor displays an error code.

1. Stop the sheet at various points in the media path to determine where the media is damaged.
2. Try using the next heaviest type of paper.

3. Feed paper through the printer from each of the available trays. Is the paper damaged when fed out of one tray but not when fed out of the others? If so, inspect the tray for damage, ensure that the media guides are set correctly and verify that the proper media is being used.
4. If media shows damage from all trays, check the registration rollers.
5. Inspect the tray and media path for debris or broken components.

## Wrinkled Envelopes

Envelope wrinkling of varying severity can sometimes occur. In general, envelope wrinkling is considered a technology limitation due to the fusing process which relies on heat and pressure to bond toner to the media. The #10 Commercial envelopes are particularly susceptible to wrinkling.

1. Check the media path for obstructions or debris.
2. Check that the media guides are set correctly.
3. Test envelopes from other manufacturers to find the best result.

## Fuser Jams

1. Check that the Fuser is properly seated, locked, and operates normally.
2. Ensure that the paper is in good condition and is listed as supported media. Try loading new media from a fresh ream.
3. Ensure that only supported transparency film is being used.
4. Check that the printer is operating within its environmental specifications by printing the Information page.
5. Ensure that the loaded media matches the Control Panel settings.
6. Are the margins on the page greater than 4.1 mm?
7. Check the Fuser area for debris.
8. Visually inspect the Fuser for burrs.

## Exit Jams

1. Check that the correct type of media is being used; refer to the “Supplies” page on the Xerox web site.
2. Ensure the printer is within its operating environmental specifications.
3. If media is showing excessive curl when exiting, try turning the media over, loading new media from a fresh ream, or a different type of media.
4. Ensure that the loaded media matches the Control Panel settings.
5. Is the jam caused by a heavy, stiff paper being used for two-sided printing? In such cases, a lighter grade of paper should be used.
6. If debris is visible, clean the printer with a clean, dry, lint-free wipe.
7. Turn the printer off and then back on. The exit roller in the Fuser should turn for a few seconds.

# Servicing Instructions

This checklist outlines the path a service technician should take when servicing the printer.

## Step 1: Identify the Problem

1. Verify the reported problem does exist.
2. Check for any error codes and write them down.
3. Print normal customer prints and service test prints.
4. Make note of any print-quality problems in the test prints.
5. Make note of any mechanical or electrical abnormalities present.
6. Make note of any unusual noise or smell coming from the printer.
7. View the System Fail History and Paper Jam History on the Error History Report.
8. Verify the AC input power supply is within proper specifications by measuring the voltage at the electric outlet while the printer is running.

## Step 2: Inspect and Clean the Printer

1. Turn the printer power Off.
2. Disconnect the AC power cord from the wall outlet.
3. Verify the power cord is free from damage or short circuit and is connected properly.
4. Remove the Toner Cartridges, Waste Cartridge, and Imaging Units.
5. Inspect the printer interior and remove any foreign matter such as paper clips, staples, pieces of paper, dust, or loose toner.
6. Do not use solvents or chemical cleaners to clean the printer interior.
7. Do not use any type of oil or lubricant on printer parts.
8. Use only an approved toner vacuum.
9. Clean all rubber rollers with a lint-free cloth, dampened slightly with cold water and mild detergent.
10. Inspect the interior of the printer for damaged wires, loose connections, toner leakage, and damaged or obviously worn parts.
11. If any of the Toner Cartridges, Imaging Units, or the Waste Cartridge are damaged, replace with a new one.

## Step 3: Find the Cause of the Problem

1. Use the Error Messages and Codes and troubleshooting procedures to find the cause of the problem.
2. Use Service Diagnostics to check the printer and optional components.
3. Use the Wiring Diagrams and Plug/Jack Locator to locate test points.
4. Take voltage readings as instructed in the appropriate troubleshooting procedure.

## Step 4: Correct the Problem

1. Use the Parts List to locate a part number.
2. Use the Disassembly procedures to replace the part.

## Step 5: Final Checkout

Test the printer to be sure you have corrected the initial problem and there are no additional problems present.

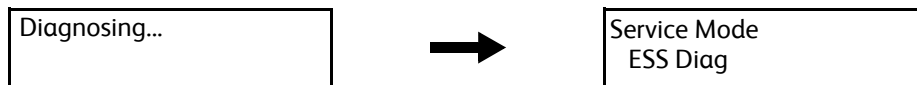
# Service Mode

Service Mode in the Phaser 6600 and Phaser 6600/WorkCentre 6605 printers provides service engineers with diagnostic routines for testing electromechanical components, displaying status, and accessing NVRAM. Additionally, the WorkCentre 6605 has diagnostic tests for the Fax and Scanner subsystems. Use these tests to diagnose problems and isolate which component or sub assembly part needs replacement.

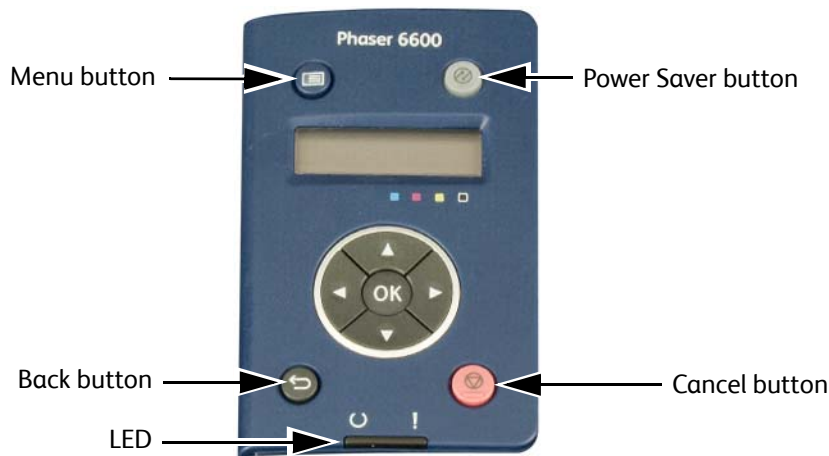
## How To Enter Service Mode

### Phaser 6600

1. Hold down the [▲] and [▼] buttons and turn on the power of the printer.



After Service Mode is started, use the buttons on the control panel and the messages displayed in the LCD to operate Service Mode.



LCD Display: Displays the menu, setting values, and test result.

[▲]: Moves upward one by one. Pressing this at the top of the list will return to the bottom.

[▼]: Moves downward one by one. Pressing this at the bottom of the list will return to the top.

[◀]: Moves the cursor to the left by one.

[▶]: Moves the cursor to the right by one.

**OK:** Press the **OK** button to confirm the selection or execute the processing.

**Cancel, Back:** Press the [Cancel] or [Back] button to cancel the selection or stop the processing.

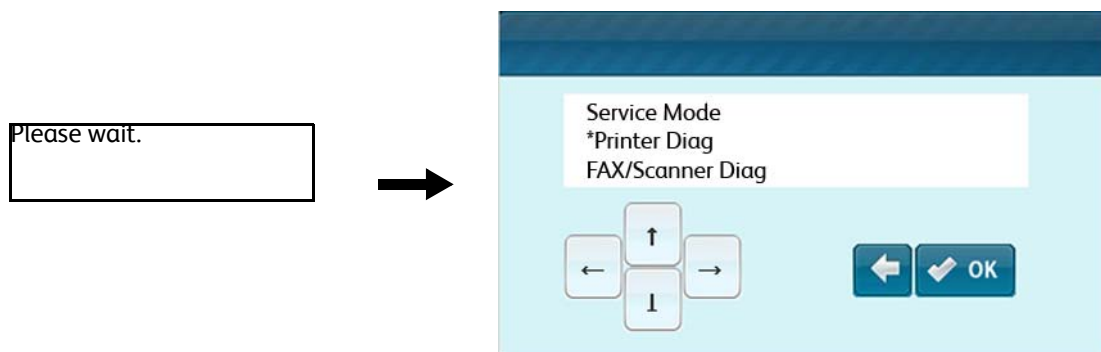


## WorkCentre 6605

1. Start Service Mode by holding down the [2] and [8] buttons on the control panel while turning on the printer.



2. After Service Mode is started, use the buttons displayed in the touch panel to operate Service Mode.





[▲] : Moves upward one by one. Pressing this at the top of the list will return to the bottom.

[▼] : Moves downward one by one. Pressing this at the bottom of the list will return to the top.

[◀] : Moves the cursor to the left by one.

[▶] : Moves the cursor to the right by one.

**OK** (  ) button : Press this button to confirm a selection or execute a process.

**Back** (  ) button : Press this button to cancel a selection or stop a process.

## Using Diagnostics

Service Diagnostics for the Phaser 6600/WorkCentre 6605 printers consist of two separate sets: the Printer diagnostics that test the print engine on both machines, and the Fax/Scanner diagnostics that test the copy, scan, and Fax functions of the WorkCentre 6605.

**Note:** To switch between Printer Diag mode and Fax/Scanner Diag mode, you must exit Service Mode and restart it to select the other mode.

Most diagnostic tests are straightforward and require no additional explanation, but there are some that require specific conditions be met to achieve meaningful results. These instructions cover each of the test groups, listing special instructions, conditions, or other information necessary to successfully interpret the results of the diagnostic tests.

### Overview of Service Mode Operation

1. Use the [▲] and [▼] buttons to select the diagnostic item to execute.
2. Press the **OK** button to confirm the item selected.
3. Follow the message and keep holding down the **OK** button until the diagnosis is started.  
If the diagnosis requires changing the parameter value, use the [▲] and [▼] buttons and then press the **OK** button.

To execute the diagnosis for other items, press the **Back** button until the screen returns to the item to evaluate.

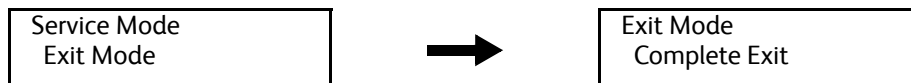
If an error occurs while in the diagnosis or in the middle of selecting parameter values, an error message will appear and the processing will stop.

To cancel the error message and return to the menu screen, press the **Back** button or the **OK** button.

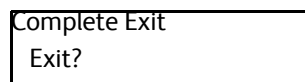
### How to Exit Service Mode

Use this procedure to exit Service Mode:

1. Return to the top level — Service Mode on the SFP; Printer Diag or Fax/Scanner Diag on the MFP— and use the [▲] or [▼] button until [Exit Mode] appears, and then press the **OK** button.



2. Press the **OK** button.

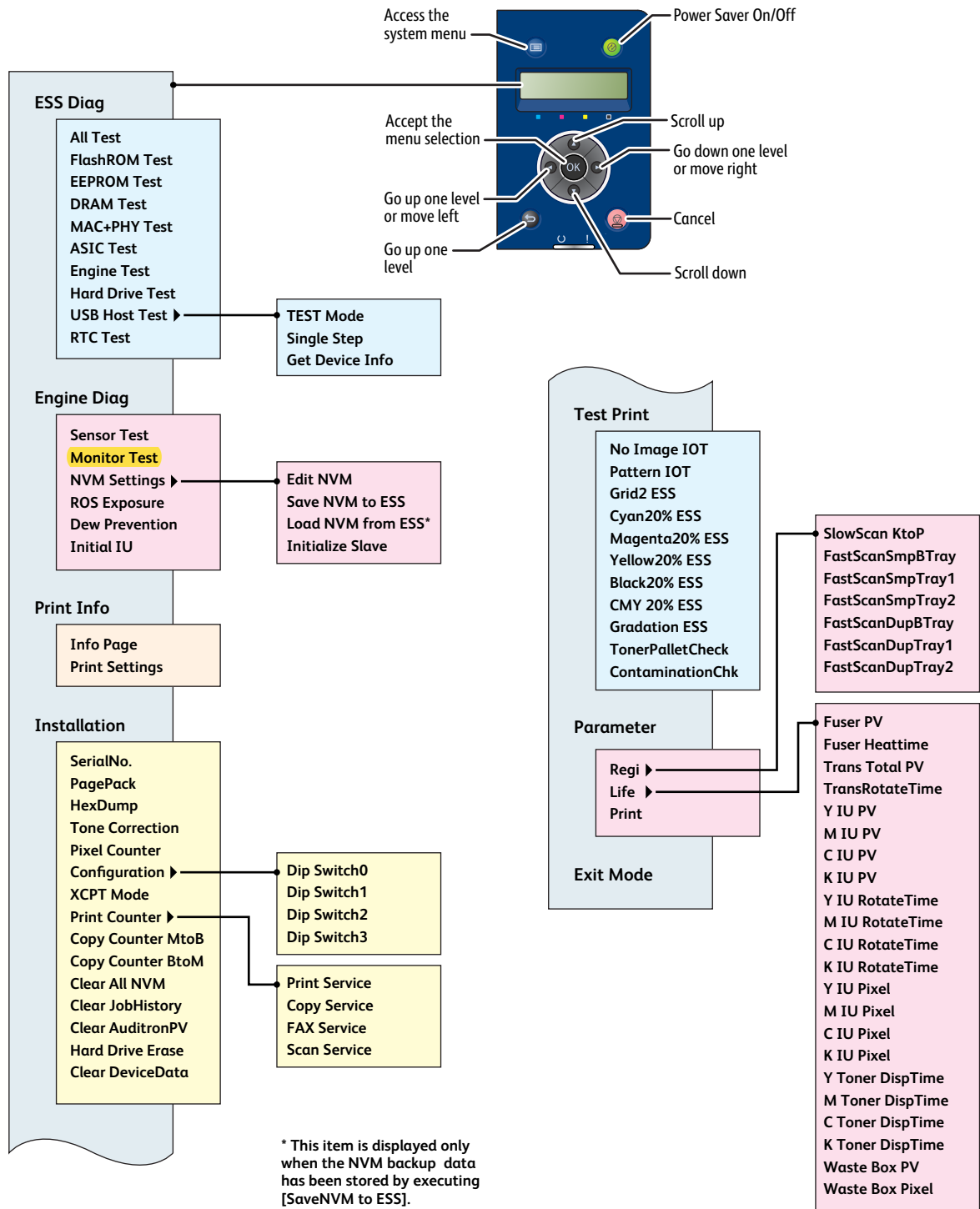


3. Press the **OK** button again, and the printer will exit Service Mode and re-start (same as the power on).

## Service Mode Menu Maps

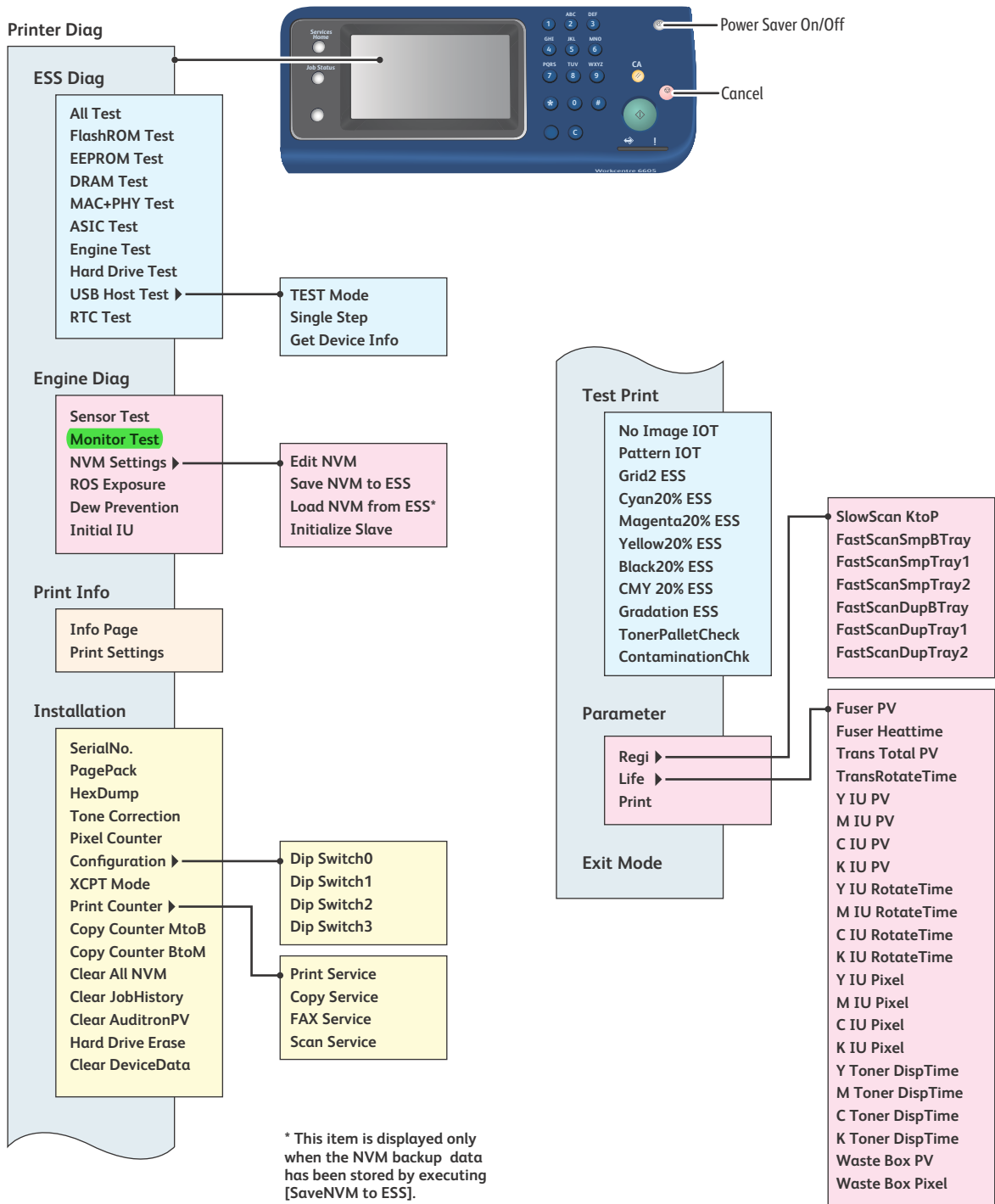
Use these maps to assist you in navigating through the diagnostic routines.

### Phaser 6600 Service Mode Menu Map



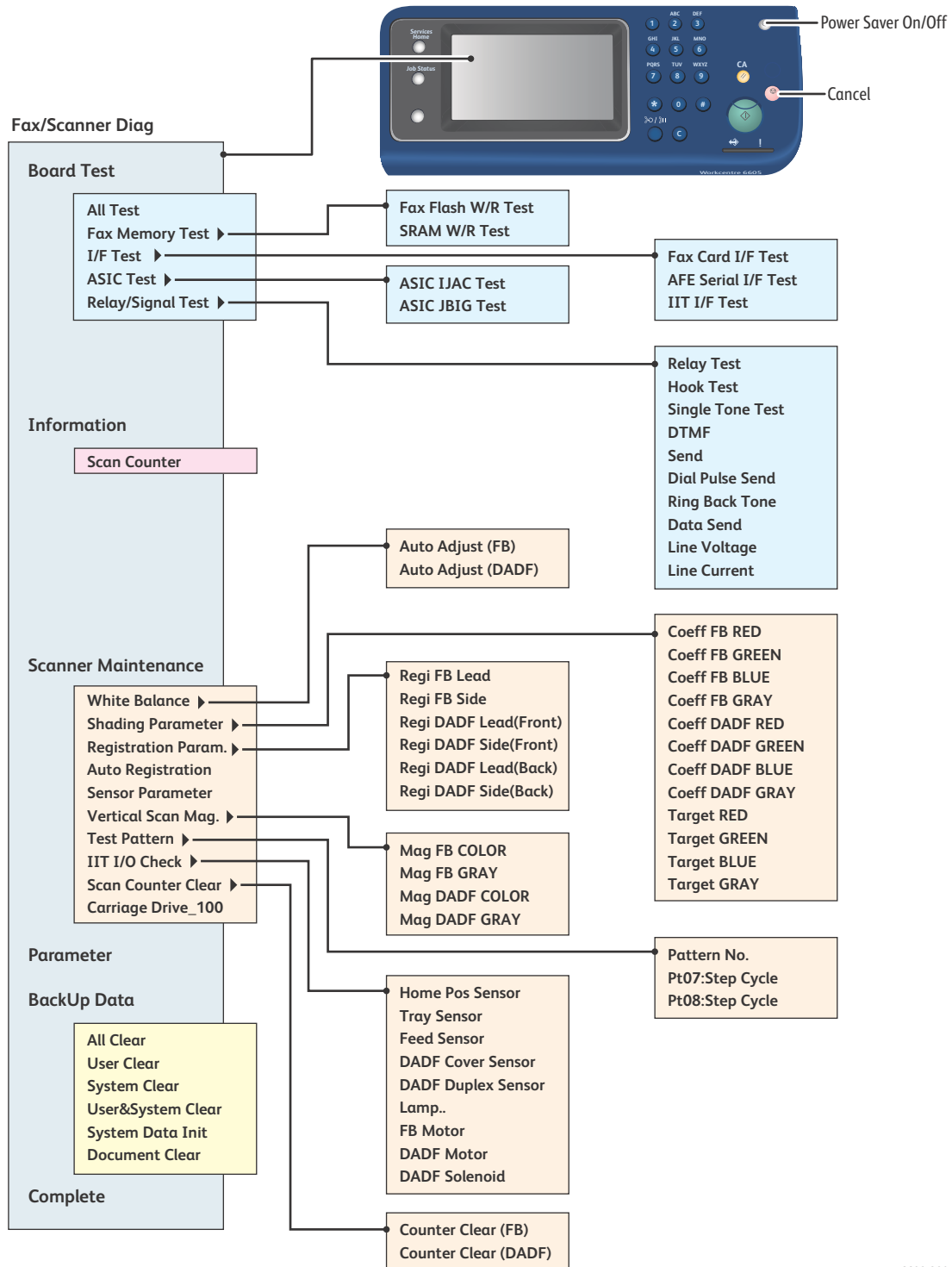
s6600-220

## WorkCentre 6605 Printer Diag Menu Map



s6600-288

## WorkCentre 6605 Fax/Scanner Diag Menu Map



s6600-289

## Service Mode Functions Overview

The following tables list the tests available in the Service Mode diagnostics and describe each function.

### Printer Diag Function Names and Details

Function		Description	See	
ESS Diag	All Test	Performs all ESS Diag tests except for MAC+PHY/USB Host/RTC.	2-19	
	FlashROM Test	Calculates the checksum per Flash ROM header area and compares the result with the each area's prepared checksum stored in the ROM.	2-20	
	EEPROM Test	Writes/reads/verifies the test pattern in the EEPROM area to be evaluated.	2-20	
	DRAM Test	Writes the test data in the DRAM area to be evaluated. (Values will be overwritten with the original value after the test)	2-20	
	MAC+PHY Test	Performs the loopback test for MAC (Media Access Control) and PHY (Physical Layer).	2-20	
	ASIC Test	Performs the Regi check test.	2-21	
	Engine Test	Performs the communication test between IOT.	2-21	
	Hard Drive Test (when the optional HD is installed)	Performs the Hard Disk test.	2-21	
	USB Host Test (only when the optional USB is installed)	Checks the communication between a USB Host port and the USB devices connected to the USB Host port.	2-21	
	RTC Test	Performs the RTC test.	2-23	
Engine Diag	Sensor Test	Checks the IOT switch and sensor operation.	2-23	
	Monitor Test	Checks the clutch, solenoid, and motor drive operation.	2-25	
	NVM Settings	Edit NVM	Writes the NVM values.	2-28
		Save NVM to ESS	Saves the IOT NVM information in the ESS NVM.	2-30
		Load NVM from ESS	Loads all the NVM information in the ESS NVM into the IOT.	2-30
		Initialize Slave		2-31
	ROS Exposure	Corrects the variation in the read-Regi of the Laser Unit.	2-31	
	Dew Prevention	Specifies whether to set the Dew Prevention mode to ON or OFF.	2-32	
Initial IU		2-32		

## Printer Diag Function Names and Details

Function		Description	See	
Print Info	Info Page	Prints the printer configuration information on A4 paper.	2-33	
	Print Settings	Prints the printer setting information on A4 paper.	2-34	
Installation	Serial No.	Displays/specifies the serial number.	2-35	
	PagePack	Displays the current PagePack status (Enable or Disable).		
	HexDump	Specifies whether to set HexDump to ON or OFF.		
	Tone Correction (IOT tone correction)	Specifies whether to set IOT Tone Correction to ON or OFF.		
	Pixel Counter	Displays the last print pixel coverage (%) for 4 mm square meter in A4 paper, per Y/M/C/K color.		
	Configuration	Operates the DIP switches on the NVM in ESS.		
	XCPT Mode	Displays/Specifies the XCPT Mode setting.		
	Print Counter	Print Service		Displays the current count of the Print Service.
		Copy Service		Displays the current count of the Copy Service.
		FAX Service		Displays the current count of the FAX Service.
		Scan Service		Displays the current count of the Scan Service.
	Copy Counter M to B	Copies the Master NVM values to the Backup NVM.		
	Copy Counter B to M	Copies the Backup NVM values to the Master NVM.		
	Clear All NVM	Initializes NVM.		
	Clear JobHistory	Initializes the job data (log).		
	Clear AuditronPV	Clears the AuditronPV data such as billing counter, user account and user restriction settings.		
Hard Drive Erase (when the optional HD is installed)	Deletes all data from the Hard Disk.			
Clear DeviceData	Deletes all data in the devices (EEPROM, SRAM, Fax Memory, Hard Disk).			

## Printer Diag Function Names and Details

	Function	Description	See
Test Print	No Image IOT	Prints the IOT built-in test pattern.	2-40
	Pattern IOT	Prints the IOT built-in test pattern.	
	Grid 2 ESS	Prints the ESS built-in grid pattern.	
	Cyan 20 % ESS	Fills one side of paper in the density of 20 % of cyan.	
	Magenta 20 % ESS	Fills one side of paper in the density of 20 % of magenta.	
	Yellow 20 % ESS	Fills one side of paper in the density of 20 % of yellow.	
	Black 20 % ESS	Fills one side of paper in the density of 20 % of black.	
	CMY 20 % ESS	Fills one side of paper in the density of 20 % of the mixture of cyan, magenta, and yellow.	
	Gradation ESS	Prints the ESS built-in gradation pattern.	
	Toner Pallet Check	Prints four bars, filled with 100 % density of each color (C/M/Y/K), lined on the paper. * Use this for checking the density of each toner cartridge.	
	Contamination Chk	Prints 5 sheets of paper with the pattern of millimeter scale on the top/left edges and inch scale on the bottom/right edges, each filed with Y/M/C/K color of 20 % density, and the one that identifies defects.	
Parameter	Regi	Displays/specifies the Regi current set value.	2-52
	Life	Displays the current counter of the consumables life.	2-53
	Print	Prints the parameter of the IOT and the error count.	2-54
Exit Mode	Exit Mode	Exits Service Mode and restarts the printer.	



## Fax/Scanner Diag Function Names and Details

Function		Description	See	
Board Diag	All Test	Continually performs the Fax Memory, Fax Card I/F, AFE Serial I/F, IIT I/F, and ASIC tests.	2-55	
	Fax Memory Test	Fax Flash W/R Test	Performs write/read tests of the Fax Flash Memory.	2-56
		SRAM W/R Test	Performs write/read tests of the Fax SRAM.	
	I/F Test	Performs the communication test between Fax Card, AFE, and IIT.	2-56	
	ASIC Test	Performs the ASIC built-in IJAC/JBIG test.	2-56	
	Relay/ Signal Test	Relay Test	Toggles the Relay signal at the specified frequency.	2-57
		Hook Test	Toggles the Hook signal at the specified frequency.	
		Single Tone Test	Continuously sends the tone at the selected frequency.	
		DTMF Send	Continuously sends the DTMF signal.	
		Dial Pulse Send	Sends the multi-digits Dial Pulse (10/20pps) signal.	
Ring Back Tone		Sends the ringback tone.		
Data Send		Specifies the speed and pattern for checking data forwarding (no pattern for V.34)		
Line Voltage		Checks the status of the Line Voltage.		
Line Current	Checks the status of the Line Current.			
Information	Scan Counter	Displays the Scan counter value.	2-60	

**Fax/Scanner Diag Function Names and Details**

	<b>Function</b>	<b>Description</b>	<b>See</b>
Scanner Maintenance	White Balance	Adjusts the white balance automatically.	2-61
	Shading Parameter	Specifies the Shading factor setting.	2-61
	Registration Param.	Adjusts the Registration.	2-62
	Auto Registration	Specifies whether the Auto Reg adjust function to set to ON or OFF.	2-62
	Sensor Parameter	Specifies the power control value of the Feed Sensor.	2-62
	Vertical Scan Mag.	Specifies the parameter setting of the magnification for the vertical scanning.	2-62
	Test Pattern	Specifies the test pattern and the parameter setting.	2-63
	IIT I/O Check	Checks the input and output of the scanner components.	2-63
	Scan Counter Clear	Clear the scan counter.	2-64
	Carriage Drive_100		2-64
Parameter		Specifies the system data setting using ChainLink.	
Backup Data	All Clear	Deletes the SRAM/EEPROM backup data.	
	User Clear	Deletes the SRAM/EEPROM backup data.	
	System Clear	Deletes the SRAM/EEPROM backup data.	
	User&System Clear	Deletes the SRAM/EEPROM backup data.	
	System Data Init	Deletes the SRAM/EEPROM backup data.	
	Document Clear	Deletes the document data in the Fax Flash Memory.	
Complete	Complete	Exits Service Mode and restarts the printer.	

# Service Mode Diagnostic Tests

The diagnostic test procedures for the Phaser 6600 and WorkCentre 6605 printers are documented in this section of the chapter. In the procedures that follow, the screen displays shown are for the MFP. The Printer Diag tests for the MFP are the same as the Service Mode tests for the SFP. Therefore, if you are working with an SFP, you can ignore the step to confirm that Printer Diag is selected, and you can substitute the term Service Mode for Printer Diag.

## ESS Diag

This section explains the details of the ESS Diag tests.

### All Test

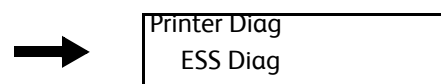
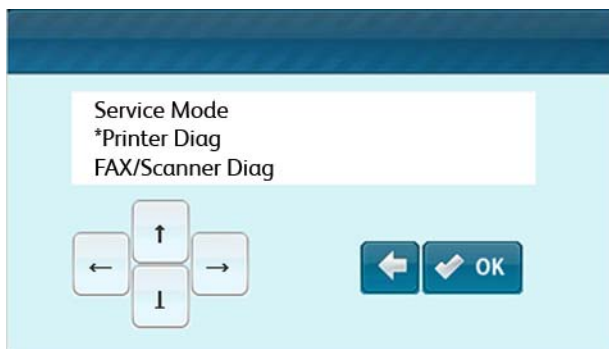
All Test allows you to execute a series of FlashROM, EEPROM, DRAM, ASIC, IOT, and HD tests in one go. (MAC+PHY/PANEL/USB Host/RTC tests are not carried out.)

### Displayed Test Results

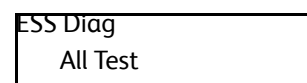
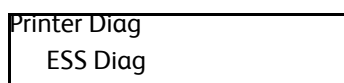
Normal	Error	Note
CHECK OK	*** Error	***: Displays the name of the test ended in error. (Flash ROM / EEPROM / DRAM / ASIC / IOT / Hard Disk)

### Procedure

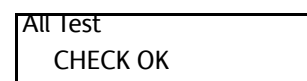
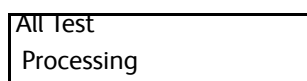
1. Enter Service Mode. See “How To Enter Service Mode” on page 2-8.
2. **(MFP only)** Confirm that the [Printer Diag] is selected, and then press the **OK** button.



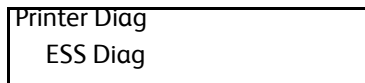
3. Press the **OK** button.



4. Press the **OK** button to start the test.



- Press the **OK** button to return to the SFP Service Mode or MFP Printer Diag screen.



- Exit Service Mode. See “How to Exit Service Mode” on page 2-10.

### Flash ROM Test

Flash ROM Test calculates the checksum per Flash ROM header area and compares the result with the each area's checksum prepared in ROM. The status will be regarded as “normal” when the all results coincide with the checksums stored in ROM.

Normal	Error
CHECK OK	FlashROM ERROR xxxxxx

### EEPROM Test

EEPROM Test allows you to execute read/write/verify of the test pattern (0xff, 0xaa, 0x55, 0x00) from the head of the EEPROM for one byte in every 0 x 400.

Normal	Error
CHECK OK	EEPROM ID* ERROR (*: 1, 2)

### DRAM Test

DRAM Test checks whether the writing of the test data, 4-byte unit (0x00000000 -> 0x55555555 -> 0xaaaaaaaa -> 0xffffffff -> 0x00000000 -> ...), in the area available for the diagnosis is possible or not.

Values will be overwritten with the original value after the test.

Area available for the diagnosis: Work areas other than the stack area and the task acquiring area.

Normal	Error
CHECK OK	DRAM slot* ERROR (*: 0, 1)

### MAC+PHY Test

MAC+PHY Test allows you to perform the loopback test for MAC (Media Access Control) and PHY (Physical Layer).

Normal	Error
CHECK OK	MAC+PHY ERROR

## ASIC Test

ASIC Test reads the device ID of the REMORA-EX via ZoranQuatro4530 and performs the Zoran Quatro4530 and REMORA-EX tests.

Normal	Error
CHECK OK	ASIC CHECK NG

## Engine Test

IOT Test provides the communication test between the IOT. In this communication test, the IOT status register is read for checking whether the commands are exchanged normally.

Normal	Error
CHECK OK	IOT ERROR

## Hard Drive Test

Use the Device Diagnostic Command to perform the Hard Disk Test.

Normal	Error
CHECK OK	Hard Disk ERROR

## USB Host Test

USB Host Test checks the communication between a USB Host port and the USB devices connected to the USB Host port.

\* This test menu is for obtaining the USB authentication. To use this test, you will need the devices approved by the certification authority.

## Test Mode

Test Mode (when the optional USB Host is installed)

Item		Description
TEST MODE	TEST J	Keeps J state for the DownStream port of the Host Controller.
	TEST K	Keeps K state for the DownStream port of the Host Controller.
	TEST SE0	Keeps SE0 state for the DownStream port of the Host Controller.
	TEST PACKET	Repeatedly sends the test packet form the DownStream port of the Host Controller.

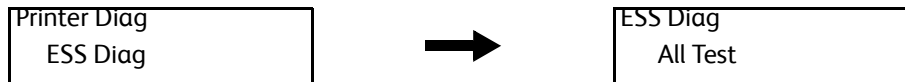
**Note:** To complete the test mode, restart the printer.

## Single Step

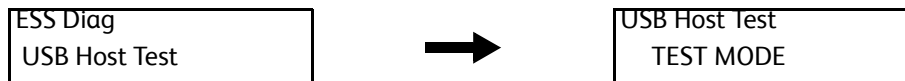
Single Step allows you to collect Device Descriptor from the device you specify.

### Procedure

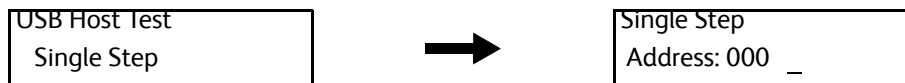
1. Enter Service Mode. See “How To Enter Service Mode” on page 2-8.
2. Confirm that the [Printer Diag] is selected, and then press the **OK** button.
3. Press the **OK** button.



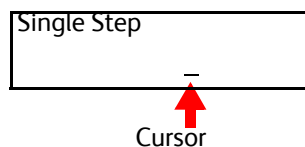
4. Use the [▼] button to select [USB Host Test], and press the **OK** button.



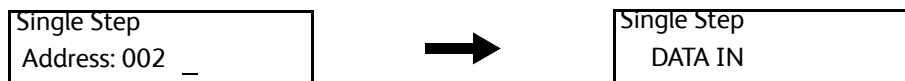
5. Use the [▼] button to select [Single Step], and press the **OK** button.



6. Specify the device address. (Available addresses are 0 to 127.)  
 Use the [◀] and [▶] buttons to move the cursor to right and left.  
 Use the [▲] and [▼] buttons to increase or decrease the value where the cursor is placed.



7. Press the **OK** button to transfer a request to the device specified.



8. Press the **OK** button to obtain data from the device specified.
9. [CHECK OK] will appear when the data is obtained normally.  
When the data is not obtained normally, [CHECK NG] will appear, and when the request was not transferred to the device, [Send Error] will appear.

Single Step CHECK OK
-------------------------

10. Press the **Back** button to return to the [Printer Diag] screen.

Printer Diag ESS Diag
--------------------------

11. Exit Service Mode. See “How to Exit Service Mode” on page 2-10.

## Get Device Info

Get Device Info displays the VID, PID, Add, and Prt information of the device connected. [Read Error] will appear when the device information is not obtained.

- VID: [Vendor ID] value of a device collected by the Device Descriptor
- PID: [Product ID] value of a device collected by the Device Descriptor
- Add: [Device Address] assigned to the device
- Prt: The port number of a connected controller or the downstream port number of the hub

## RTC Test

RTC Test checks the time by backing up the current time and writing the default values, and then checking, after a certain period of time, whether the time reaches the expected time.

\* Performing RTC Test will delay the internal clock of the printer by 2 seconds.

Normal	Error
CHECK OK	RTC ERROR

## Engine Diag

### Sensor Test

Digital Input checks whether the digital input (DI) components function properly.

The display shows [0] when the digital input test is started, and the value will be increased when the DI components are switched from OFF to ON, which is used for confirming that the component functions normally. The test targets all DI components.

**Sensor Test Parameter Table**

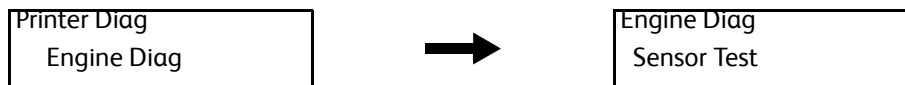
Chain	Link	Component
010	200	Fusing Relay Enable
010	201	Fusing Fuse Sensor
041	300	Interlock, Side Cover
041	301	Interlock, Rear Cover
041	302	Front Cover Sensor
042	200	LVPS Fan Alarm
071	100	Bypass Tray No Paper Sensor
071	101	Tray1 No Paper Sensor
071	102	Bypass Tray Detect Sensor
071	103	Regi Sensor
071	104	Exit Sensor
071	105	Full Stack Sensor
071	109	Option Feeder1 Size Sensor0
071	110	Option Feeder1 Size Sensor1
071	111	Option Feeder1 Size Sensor2
071	112	Option Feeder2 Size Sensor0 (not in use)
071	113	Option Feeder2 Size Sensor1 (not in use)
071	114	Option Feeder2 Size Sensor2 (not in use)
071	115	Option Feeder1 No Paper Sensor
071	116	Option Feeder2 No Paper Sensor (not in use)
071	117	Option Feeder1 Path Sensor
071	118	Option Feeder2 Path Sensor (not in use)
071	200	Main Motor Alarm
071	201	Paper Transport Motor Alarm
071	202	Option Feeder1 Motor Alarm
071	203	Option Feeder2 Motor Alarm (not in use)
093	200	Developer Motor Alarm
094	202	Waste Toner Box Full Sensor



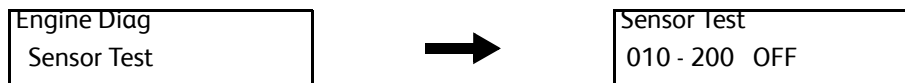
## Sensor Test Example

This section explains Digital Input Testing using [041-302: Front Cover Sensor] as an example.

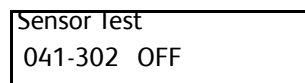
1. Enter Service Mode. See “How To Enter Service Mode” on page 2-8.
2. Confirm that the [Printer Diag] is selected, and then press the **OK** button.
3. Use the [▼] button to select [Engine Diag], and press the **OK** button.



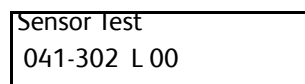
4. Press the **OK** button.



5. Use the [▲] or [▼] button to select [041-302].



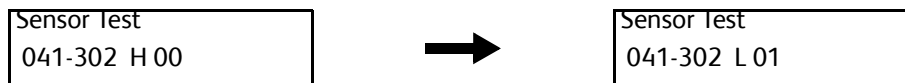
6. Press the **OK** button.



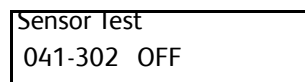
7. Open and shut the front cover to check that the display changes as shown below.

Cover Open

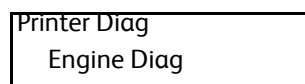
Cover Close



8. Press the **Back** button to stop the test.



9. Press the **Back** button to return to the [Printer Diag] screen.



10. Exit Service Mode. See “How to Exit Service Mode” on page 2-10.

## Monitor Test

Digital Output checks whether the digital output (DO) components function properly.

You can switch each DO component to ON and check the operation separately, which helps you judge which component functions normally.

You can operate all components at one time in the Digital Output Test. If you open the interlock while a motor test is being executed, the operation of each component will be stopped.

**Note:** Except for 010-001, 042-001, 042-002, set LVPS 24V to On (041-001) first.

Monitor Test Parameter Table

Chain	Link	Component
010	001	Fusing Relay
041	001	Low Voltage Power Supply 24V
042	001	Main Fan (Normal)
042	002	Main Fan (Half)
061	001	ROS Motor
071	001	Main Motor (Normal)
071	002	Main Motor (Half)
071	004	Paper Transport Motor (Normal)
071	005	Paper Transport Motor (Half)
071	007	Bypass Tray Feed Solenoid
071	008	Tray1 Feed Clutch
071	009	Take Away2 Clutch
071	010	Regi Clutch
071	011	Exit Clutch
071	012	Exit Clutch2
071	013	Duplex Clutch
071	014	Option Feeder1 Motor (Normal)
071	015	Option Feeder1 Motor (Half)
071	017	Option Feeder2 Motor (Normal) (not in use)
071	018	Option Feeder2 Motor (Half) (not in use)
071	020	Option Feeder1 Feed Clutch
071	021	Option Feeder2 Feed Clutch (not in use)
071	022	Option Feeder1 Take Away Clutch
071	023	Option Feeder2 Take Away Clutch (not in use)
093	001	Developer Motor (Normal)
093	002	Developer Motor (Half)
093	004	Yellow Toner Dispense Motor (Normal)
093	005	Yellow Toner Dispense Motor (Half)
093	006	Magenta Toner Dispense Motor (Normal)
093	007	Magenta Toner Dispense Motor (Half)

Note: Except for 010-001, 042-001, 042-002, set LVPS 24V to On (041-001) first, or the motors/clutches won't work in Diagnostics.

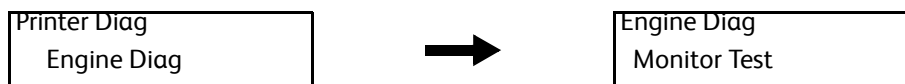
### Monitor Test Parameter Table

Chain	Link	Component
093	008	Cyan Toner Dispense Motor (Normal)
093	009	Cyan Toner Dispense Motor (Half)
093	010	Black Toner Dispense Motor (Normal)
093	011	Black Toner Dispense Motor (Half)

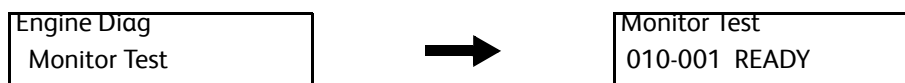
### Monitor Test Example

This section explains Digital Output Testing using [071-002: Main Motor (Half)] and [071-010: Regi Clutch] as an example.

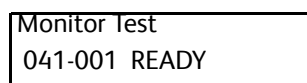
1. Enter Service Mode. See “How To Enter Service Mode” on page 2-8.
2. Confirm that the [Printer Diag] is selected, and then press the **OK** button.
3. Use the [▼] button to select [Engine Diag], and press the **OK** button.



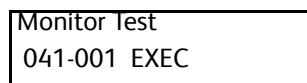
4. Use the [▼] button to select [Monitor Test], and press the **OK** button.



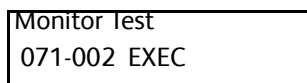
5. To set LVPS 24V to On, use the [▲] or [▼] button and select [041-001]



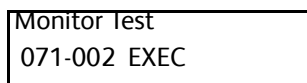
6. Press the **OK** button, and check the operation sound



7. To carry on checking the operation of Main Motor (Half), do not press the **Back** button. Use the [▲] or [▼] button to display [071-002].



8. Press the **OK** button, and check the operation sound.



**Note:** Press the **Back** button to stop the test.

9. To carry on checking the operation of Regi Clutch, do not press the **Back** button. Use the [▲] or [▼] button to display [071-010].

Monitor Test  
071-010 READY

10. Press the **OK** button, and check the operation sound.

Monitor Test  
071-010 EXEC

11. Press the **Back** button to stop the Regi Clutch operation.

Monitor Test  
071-010 READY

12. To stop the Main Motor (Half) operation, use the [▼] button to select [071-002], and then press the **Back** button.

Monitor Test  
071-002 READY

13. To set LVPS 24V to Off, use the [▼] button and select [041-001], and then press the **Back** button.

Monitor Test  
041-001 READY

14. Press the **Back** button to return to the [Printer Diag] screen.

Printer Diag  
Engine Diag

15. Exit Service Mode. See “How to Exit Service Mode” on page 2-10.

## NVM Settings

You can access the NVM (IOT EEPROM) using the keys on the touch panel.

The following functions are provided.

- Reading and writing of the data in the IOT NVM
- Saving the IOT NVM information to ESS
- Returning all NVM information saved in ESS to the IOT NVM

## NVM Read and Write (Edit NVM)

NVM Edit allows you to read or write the IOT NVM.

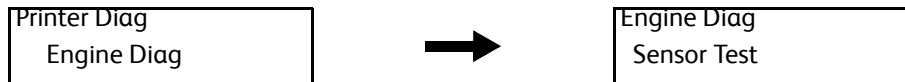


**CAUTION:** NVM Read and Write (NVM Edit) is for changing settings peculiar to the device, and therefore requires you a precise attention, otherwise you might lose the essential setting of the printer or give the printer an unrecoverable failure.

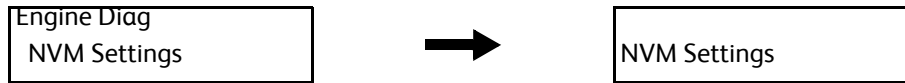
### Procedure

1. Enter Service Mode. See “How To Enter Service Mode” on page 2-8.
2. Confirm that the [Printer Diag] is selected, and then press the **OK** button.

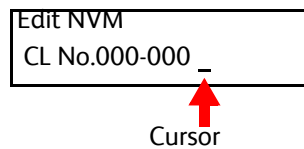
3. Use the [▼] button to select [Engine Diag], and press the **OK** button.



4. Use the [▼] button to select [NVM Settings], and press the **OK** button.



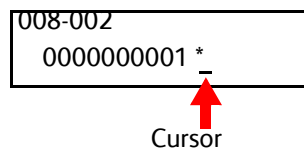
5. Press the **OK** button.
6. Enter the Chain-Link number.  
Use the [◀] and [▶] buttons to move the cursor to right and left.  
Use the [▲] and [▼] buttons to increase or decrease the value where the cursor is placed.



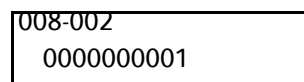
7. Press the **OK** button to confirm the Chain-Link number.  
When there is a relevant Chain-Link No., the screen displays the current NVM value and the cursor.  
When there is no relevant Chain-Link No., the screen displays "NG". In this case, press the **Back** button to enter the Chain-Link No. again.



8. Specify the NVM value.  
Use the [◀] and [▶] buttons to move the cursor to right and left.  
Use the [▲] and [▼] buttons to increase or decrease the value where the cursor is placed.



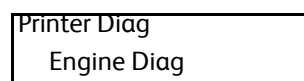
9. Press the **OK** button to start writing the new NVM value.



10. Press the **Back** button to return to the previous screen.

**Back**

11. Press the **Back** button to return to the [Printer Diag] screen.



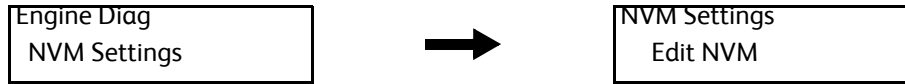
12. Exit Service Mode. See "How to Exit Service Mode" on page 2-10.

## NVM Saving (SaveNVM to ESS)

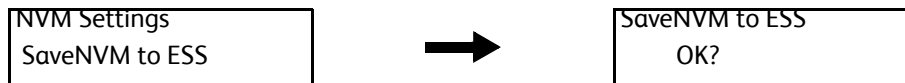
SaveNVM to ESS allows you to save the IOT NVM information to ESS.

### Procedure

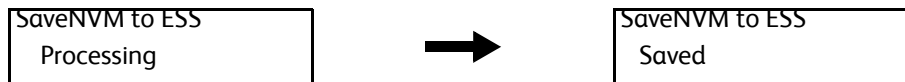
1. Enter Service Mode to select [Engine Diag] > [NVM Settings], and press the **OK** button. See “How To Enter Service Mode” on page 2-8.



2. Use the [▼] button to select [SaveNVM to ESS], and press the **OK** button.



3. Press the **OK** button.



4. Press the **OK** button to return to the [Printer Diag] screen, and then exit Service Mode. See “How to Exit Service Mode” on page 2-10.

## NVM Loading (Load NVM from ESS)

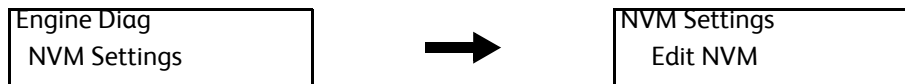
Initialize Slave allows you to load all NVM information saved in ESS to the IOT NVM.



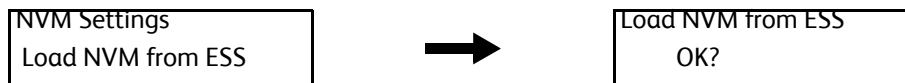
**CAUTION:** Do not execute "NVM Loading" unless "NVM Saving" has been executed. Doing so will damage PWBA MCU.

### Procedure

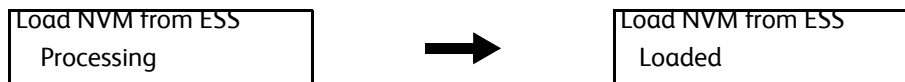
1. Enter Service Mode to select [Engine Diag] > [NVM Settings], and press the **OK** button. See “How To Enter Service Mode” on page 2-8.



2. Use the [▼] button to select [Load NVM from ESS], and press the **OK** button.



3. Press the **OK** button.

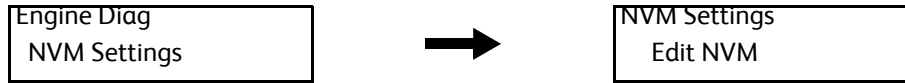


4. Press the **Back** button to return to the [Printer Diag] screen, and then exit Service Mode. See “How to Exit Service Mode” on page 2-10.

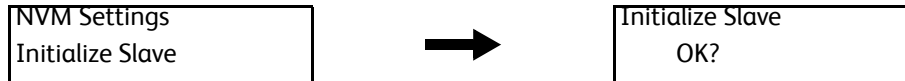
## Initialize Slave

### Procedure

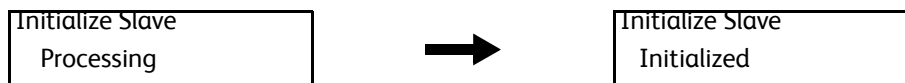
1. Enter Service Mode to select [Engine Diag] > [NVM Settings], and press the **OK** button. See “How To Enter Service Mode” on page 2-8.



2. Use the [▼] button to select [Initialize Slave], and press the **OK** button.



3. Press the **OK** button.



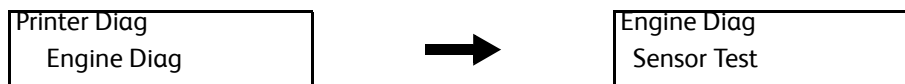
4. Press the **Back** button to return to the [Printer Diag] screen, and then exit Service Mode. See “How to Exit Service Mode” on page 2-10.

## ROS Exposure

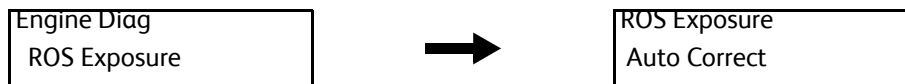
ROS Exposure corrects the ROS read registration when it has variation.

### Procedure

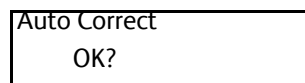
1. Enter Service Mode. See “How To Enter Service Mode” on page 2-8
2. Confirm that the [Printer Diag] is selected, and press the **OK** button.
3. Use the [▼] button to select [Engine Diag], and press the **OK** button.



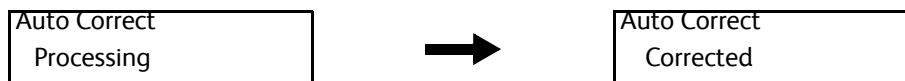
4. Use the [▼] button to select [ROS Exposure], and press the **OK** button.



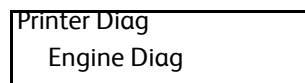
5. Press the **OK** button.



6. Press the **OK** button.



7. Press the **Back** button to return to the [Printer Diag] screen.



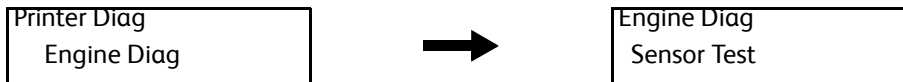
8. Exit Service Mode. See “How to Exit Service Mode” on page 2-10.

## Dew Prevention

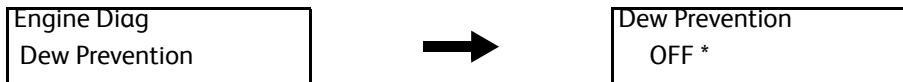
You can specify whether to set the Dew Prevention mode to ON or OFF.

### Procedure

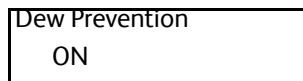
1. Enter Service Mode. See “How To Enter Service Mode” on page 2-8.
2. Confirm that the [Printer Diag] is selected, and then press the **OK** button.
3. Use the [▼] button to select [Engine Diag], and press the **OK** button.



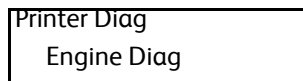
4. Use the [▼] button to select [Dew Prevention], and press the **OK** button.



5. Use the [▲] or [▼] button to switch to ON or OFF, and press the **OK** button.



6. Press the **Back** button to return to the [Printer Diag] screen.

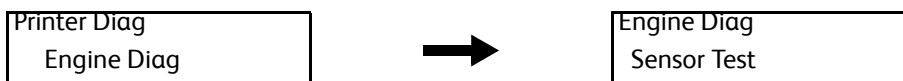


7. Exit Service Mode. See “How to Exit Service Mode” on page 2-10.

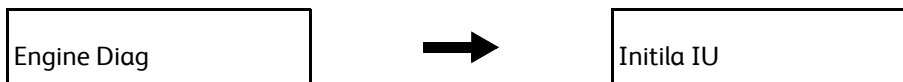
## Initial IU

### Procedure

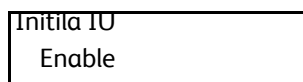
1. Enter Service Mode. See “How To Enter Service Mode” on page 2-8.
2. Confirm that the [Printer Diag] is selected, and then press the **OK** button.
3. Use the [▼] button to select [IOT Diag], and press the **OK** button.



4. Use the [▼] button to select [Initial IU], and press the **OK** button.

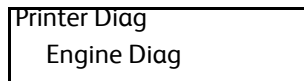


5. Use the [▲] or [▼] button to select [Disable] or [Enable], and press the **OK** button to confirm the setting.





- Press the **Back** button to return to the [Printer Diag] screen.



- Exit Service Mode. See “How to Exit Service Mode” on page 2-10

## Print Info

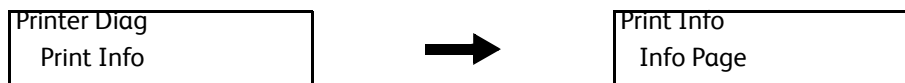
### Printing Printer Configuration Report (Info Page)

You can print the following printer configuration information (A4 size paper is supported) .

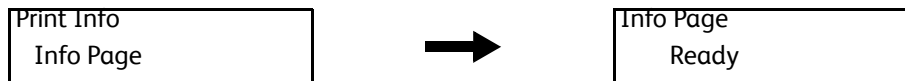
- IOT Installed Tray
- IOT ROM Version
- IOT NVM Version

#### Procedure

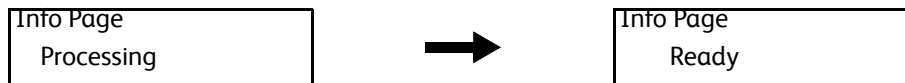
- Enter Service Mode. See “How To Enter Service Mode” on page 2-8.
- Confirm that the [Printer Diag] is selected, and then press the **OK** button.
- Use the [▼] button to select [Print Info], and press the **OK** button.



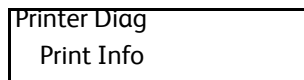
- Press the **OK** button.



- Press the **OK** button to print the printer configuration report. The screen will return to the [Ready] screen after print.



- Press the **Back** button to return to the [Printer Diag] screen.



- Exit Service Mode. See “How to Exit Service Mode” on page 2-10.

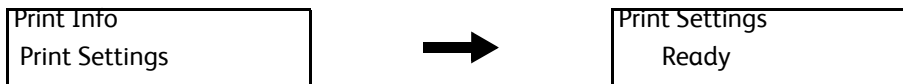
## Printing Printer Settings Report (Print Settings)

You can print the following printer settings report (A4 size paper is supported).

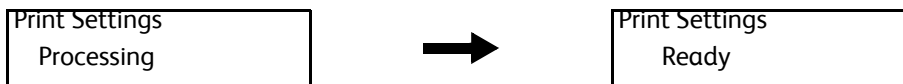
- Serial No.
- HexDump ON/OFF Information
- IOT Tone Correction ON/OFF Information
- Full Color Print Count
- Toner Saver Print Count
- Specific Color Print Count
- Monochrome Print Count
- Total Print Count
- Full Color Print Count Backup
- Toner Saver Print Count Backup
- Specific Color Print Count Backup
- Monochrome Print Count Backup
- Total Print Count Backup
- Full Color Error Print Count
- Toner Saver Error Print Count
- Specific Color Error Print Count
- Monochrome Error Print Count

### Procedure

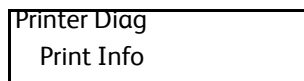
1. Enter Service Mode, and select [Print Info] > [Print Settings], and press the **OK** button. See “How To Enter Service Mode” on page 2-8.



2. Press the **OK** button to print the printer setting information. The screen will return to the [Ready] screen after print.



1. Press the **Back** button to return to the [Printer Diag] screen.



2. Exit Service Mode. See “How to Exit Service Mode” on page 2-10.

## Installation Settings (Installation)

Set the parameter as indicated in the following table.

Item		Range	Description
Serial No.		9 digits	Displays or changes the 9 digits serial number.
PagePack		Enable, Disable	Displays the current PagePack status (Enable or Disable).
HexDump		ON,OFF	Specifies whether HexDump to set to ON or OFF.
Tone Correction (IOT tone control)		ON,OFF	Specifies whether IOT Tone Correction to set to ON or OFF.
Pixel Counter		0-100 %	Displays the last print pixel coverage ( %) for 4 mm square meter in A4 paper, per Y/M/C/K color.
Configuration	Dip Switch0	-	Operates the DIP switches on the NVM in ESS.
	Dip Switch1		
	Dip Switch2		
	Dip Switch3		
XCPT Mode		Legacy, XCPT	Displays/Specifies the XCPT Mode setting. Legacy: Follows the rule of the existing print service. XCPT: Follows the XCPT (XFCI) rule.

Item	Range	Description
Print Counter (Print Service)	Full Color Full color print counter	- Displays the current count of the following. - Normal Full Color Print Count - Toner Saver Print Count - Specific Color Print Count
	B/W Monochrome print counter	- Displays the current count of the following. - Normal Monochrome Print Count - Toner Saver Monochrome Print Count - Report Print Count
	Total Total print counter	- Displays the total count of the full color print and the monochrome print.
	Full Color Backup Full color print counter backup	- Displays the current count of the following. - Full Color Print Count Backup - Toner Saver Print Count Backup - Specific Color Print Count Backup
	B/W Backup Monochrome print counter backup	- Displays the count backup of the monochrome print.
	Total Backup Total print counter backup	- Displays the total count backup of the full color print and the monochrome print.
	Full Color Error Full color print error counter	- Displays the following (“error print count” is the number of auto-recoveries performed when the number of the print is different from the count backup). - Full Color Error Print Count - Toner Saver Error Print Count - Specific Color Error Print Count
	B/W Error Monochrome print error counter	- Displays the number of auto-recoveries performed when the number of the monochrome print is different from the count backup.

Item	Range	Description
Print Counter (Copy Service)	Full Color Full color copy counter	- Displays the count of the full color (4 colors) copy count.
	Color 2 Single color, dual color copy counter	- Displays the count of the single color or the dual color print.
	B/W Monochrome copy counter	- Displays the monochrome copy count.
	Total Total copy counter	- Displays the total count of the full color, the single color, the dual color, and the monochrome copy.
	Full Color Backup Full counter counter backup	- Displays the count backup of the full color (4 colors) copy.
	Color 2 Backup Single color, dual color copy counter backup	- Displays the count backup of the single color and the dual color copy.
	B/W Backup Monochrome copy counter backup	- Displays the count backup of the monochrome copy.
	Total Backup Total copy counter backup	- Displays the total count backup of the full color, the single color, the dual color, and the monochrome copy.
	Full Color Error Full color copy counter backup	- Displays the number of auto-recoveries performed when the number of the full color copy counter is different from the count backup.
	Color 2 Error Single color, dual color error copy counter	- Displays the number of auto-recoveries performed when the number of the single/dual color copy is different from the count backup.
	B/W Error Monochrome error copy counter	- Displays the number of auto-recoveries performed when the number of monochrome copy is different from the count backup.

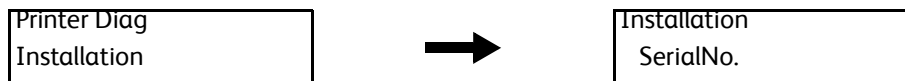
Item		Range	Description
Print Counter (FAX Service)	B/W Monochrome fax reception counter	-	Displays the count of the monochrome FAX received.
	B/W Backup Monochrome fax reception counter backup	-	Displays the count backup of the monochrome FAX received.
	B/W Error Monochrome fax reception error counter	-	Displays the number of auto-recoveries performed when the number of the FAX received is different from the count backup.
Print Counter (Scan Service)	SMB/FTP SMB/FTP counter	-	Displays the count of pages transferred via Scan To SMB and Scan To FTP.
	Email Email counter	-	Displays the count of pages transferred via Scan To Email.
	SMB/FTP Backup SMB/FTP counter backup	-	Displays the SMB/FTP count backup.
	Email Backup Email counter backup	-	Displays the Email count backup.
	SMB/FTP Error SMB/FTP error counter	-	Displays the number of auto-recoveries performed when the number of SMB/FTP count is different from the count backup.
	Email Error Email error counter	-	Displays the number of auto-recoveries performed when the number of E-mail count is different from the count backup.
Copy Counter M to B		-	Copies from the ESS Master NVM to the Backup NVM.
Copy Counter B to M		-	Copies from the ESS Backup NVM to the Master NVM.
Clear All NVM		-	Initializes NVM (ESS NVM all delete (= 0 clear))
Clear JobHistory		-	Initializes the job data (log) (JobHistory data deletion (= 0 clear))
Clear AuditronPV		-	Clears the AuditronPV data such as billing counter, user account and user restriction settings.
Hard Drive Erase (when the optional HD is installed)		-	Deletes the Hard Disk data.

Item	Range	Description	
Clear DeviceData	Error Log	-	Deletes the E2PROM Error Log data.
	Jam Log	-	Deletes the E2PROM Jam Log data.
	Job Log	-	Deletes the E2PROM Job Log data.
	FW Parameter	-	Deletes the E2PROM FW Parameter data.
	NET Parameter	-	Deletes the E2PROM NET Parameter data.
	Auditron/PV	-	Deletes the E2PROM Auditron/each user's Print Volume data.
	SRAM Adrs	-	Deletes the SRAM address data.
	FAX Log	-	Deletes the FAT data in the Fax System Data File System of the SRAM/Fax Memory, and it also deletes all files via the File System.
	Hard Disk (when the optional HD is installed)	-	Deletes the Hard Disk data.

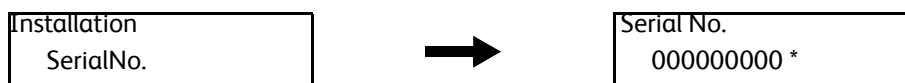
### Serial Number Setting (Serial No.)

The procedure below explains how to change the parameter using [Serial No.] as an example.

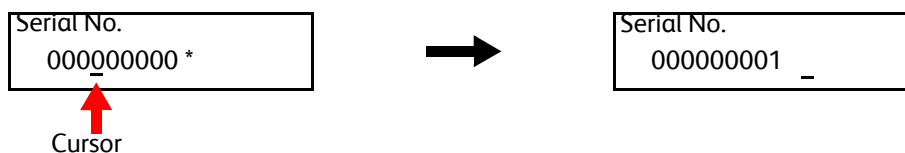
1. Enter Service Mode. See "How To Enter Service Mode" on page 2-8.
2. Confirm that the [Printer Diag] is selected, and then press the **OK** button.
3. Use the [▼] button to select [Installation], and press the **OK** button.



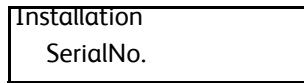
4. Use the [▼] button to select [SerialNo.], and press the **OK** button.



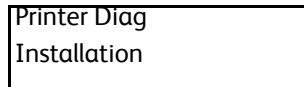
5. Change the serial number.  
Use the [◀] and [▶] buttons to move the cursor to right and left.  
Use the [▲] and [▼] buttons to increase or decrease the value where the cursor is placed.  
The asterisk (\*) will disappear when the number is changed from the current number.



6. Press the **OK** button.  
The number changed will be written in and the screen returns to the previous screen.



7. Press the **Back** button to return to the [Printer Diag] screen.



8. Exit Service Mode. See “How to Exit Service Mode” on page 2-10.

## Print Function Test (Test Print)

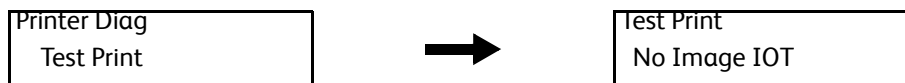
You can perform the Test Print using the prepared patterns for the print test. In the event of paper jam or out of paper, wait until the error is released.

**Note:** Do not remove the cassette while the test is being executed. Before the print test, check that the paper tray contains enough paper.

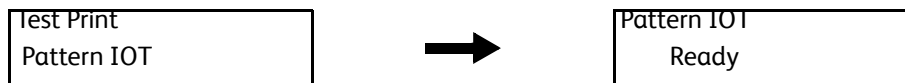
### Procedure for the Print Function Test

This section explains how to print a test pattern using Pattern IOT as an example.

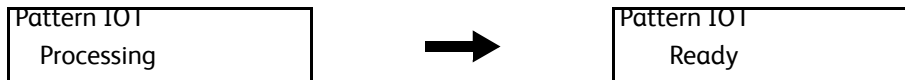
1. Enter Service Mode. See “How To Enter Service Mode” on page 2-8.
2. Confirm that [Printer Diag] is selected, and press the **OK** button.
3. Use the [▼] button to select [Test Print], and press the **OK** button.



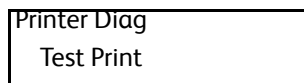
4. Use the [▼] button to select [Pattern IOT], and press the **OK** button.



5. Press the **OK** button to print the test pattern.  
The screen will return to the [Ready] screen after printing.



6. Press the **Back** button to return to the [Printer Diag] screen.

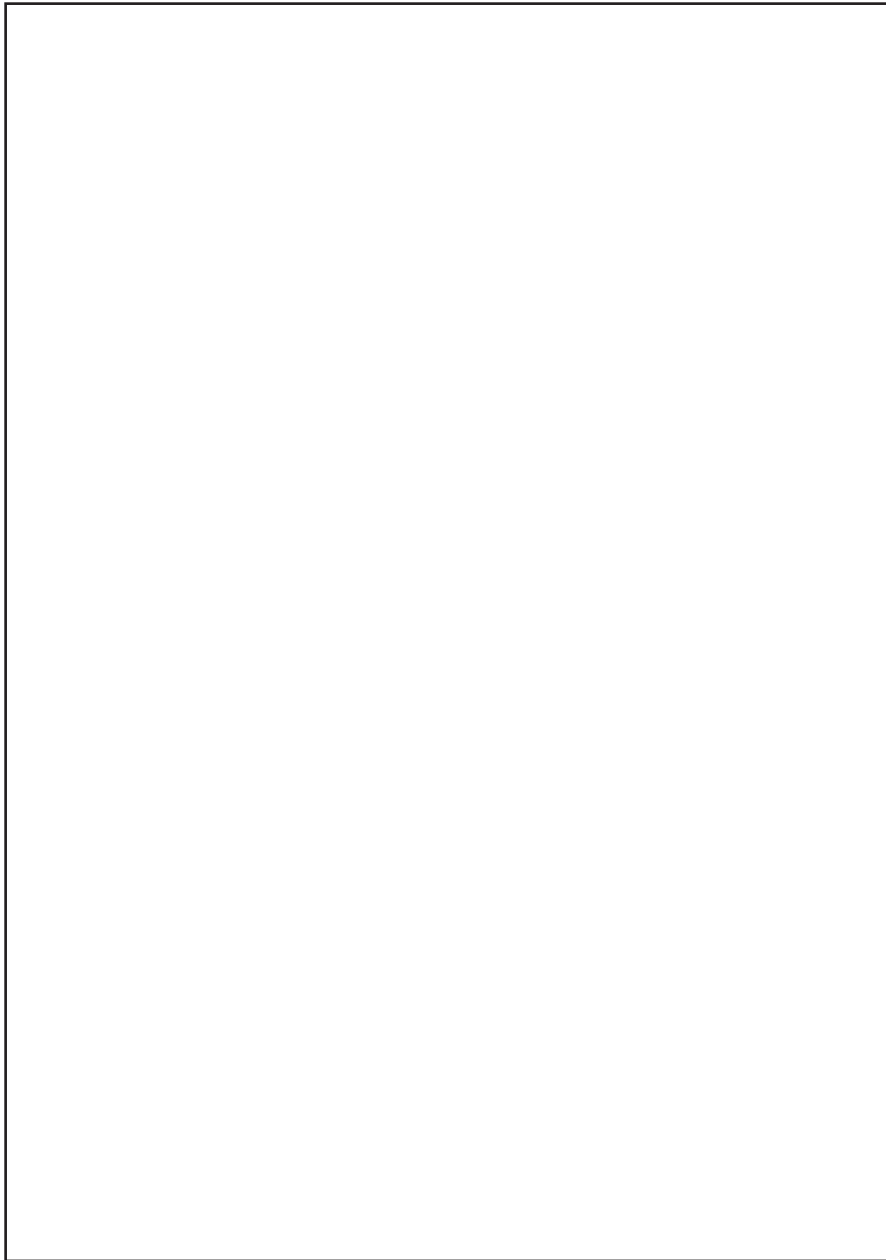


7. Exit Service Mode. See “How to Exit Service Mode” on page 2-10.



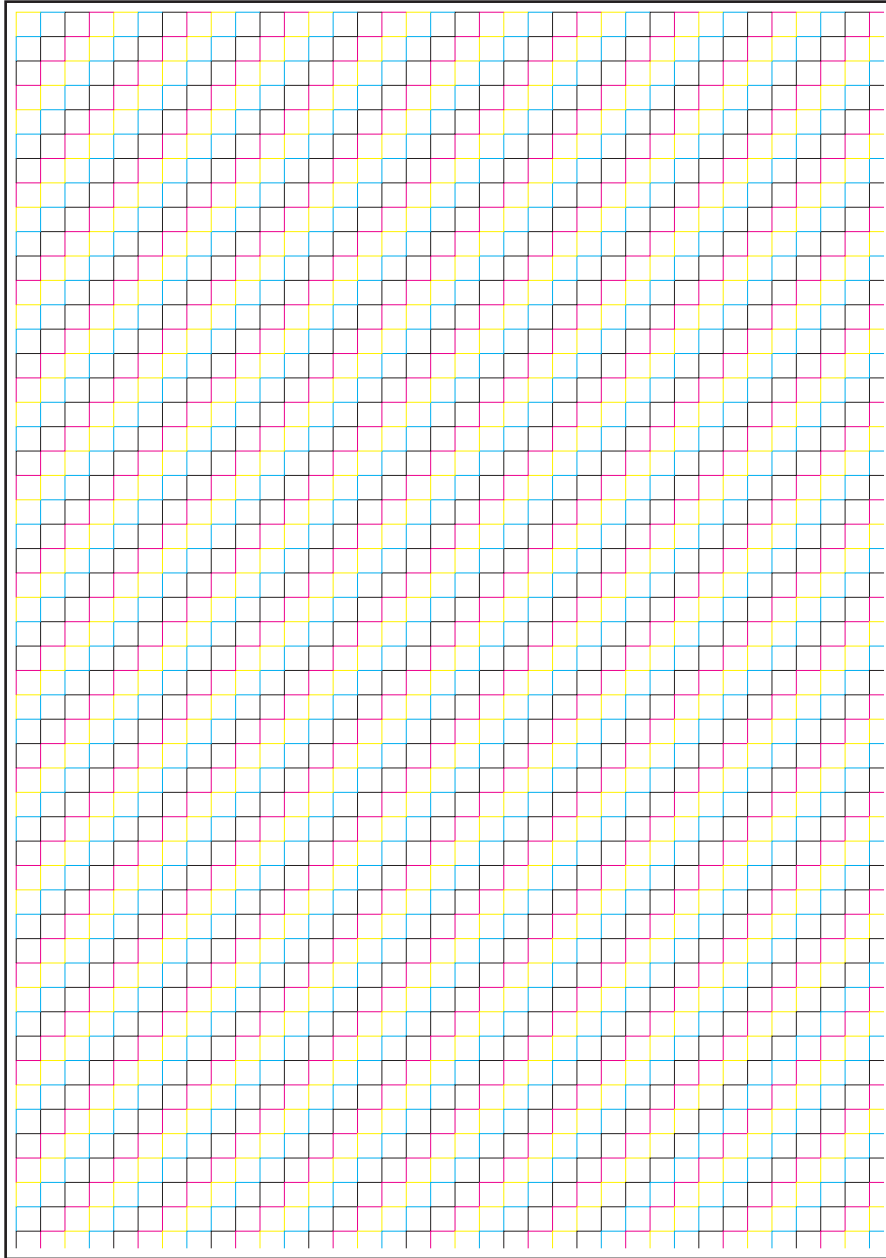
## Test Pattern (No Image IOT)

The No Image IOT Test Pattern prints the IOT built-in blank page pattern on a side of paper (IOT print functionality check).



### Test Pattern (Pattern IOT)

The Pattern IOT Test Pattern prints the IOT built-in test pattern 600 dpi on a side of paper (IOT print functionality check).



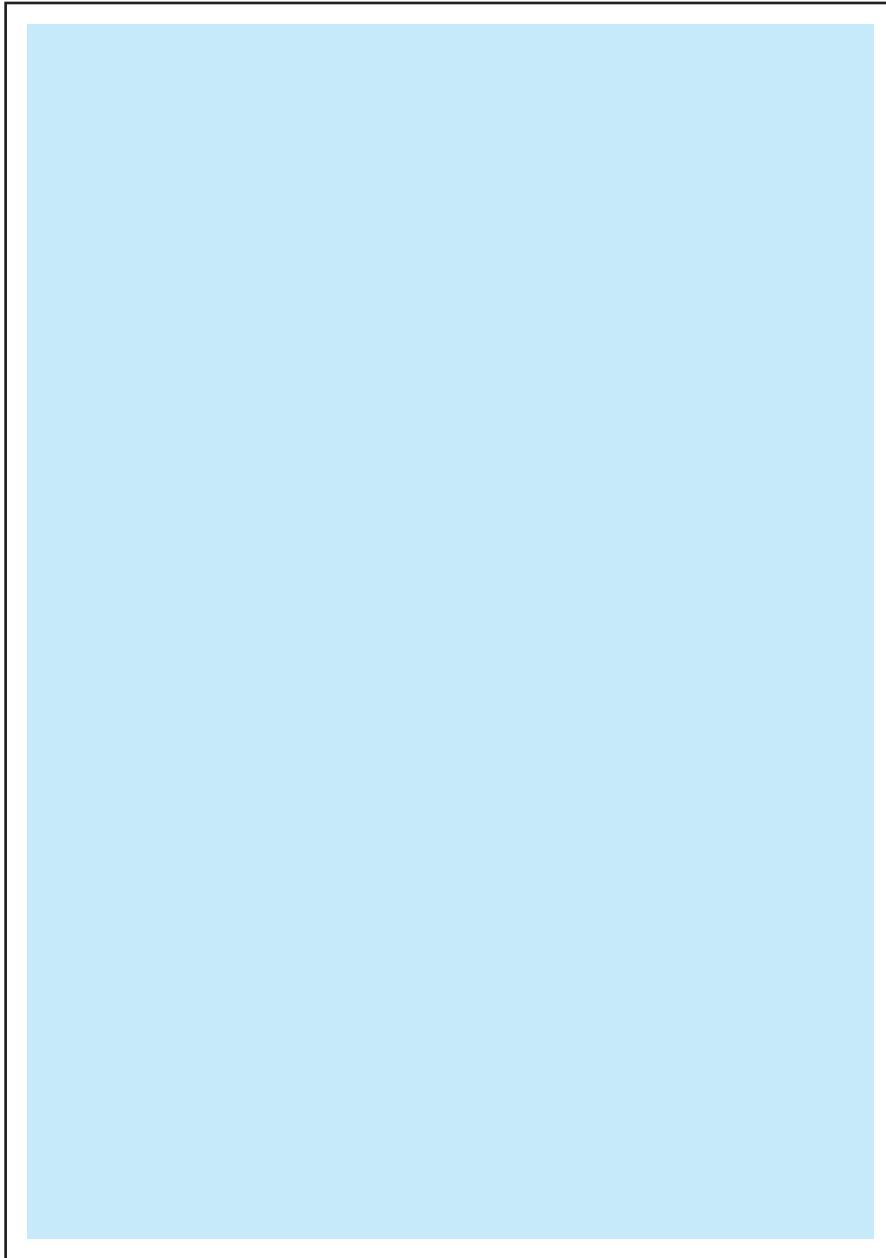
## Grid Pattern (Grid 2 ESS)

The ESS built-in Grid 2 Pattern (Grid2) prints the grid pattern on a side of paper.



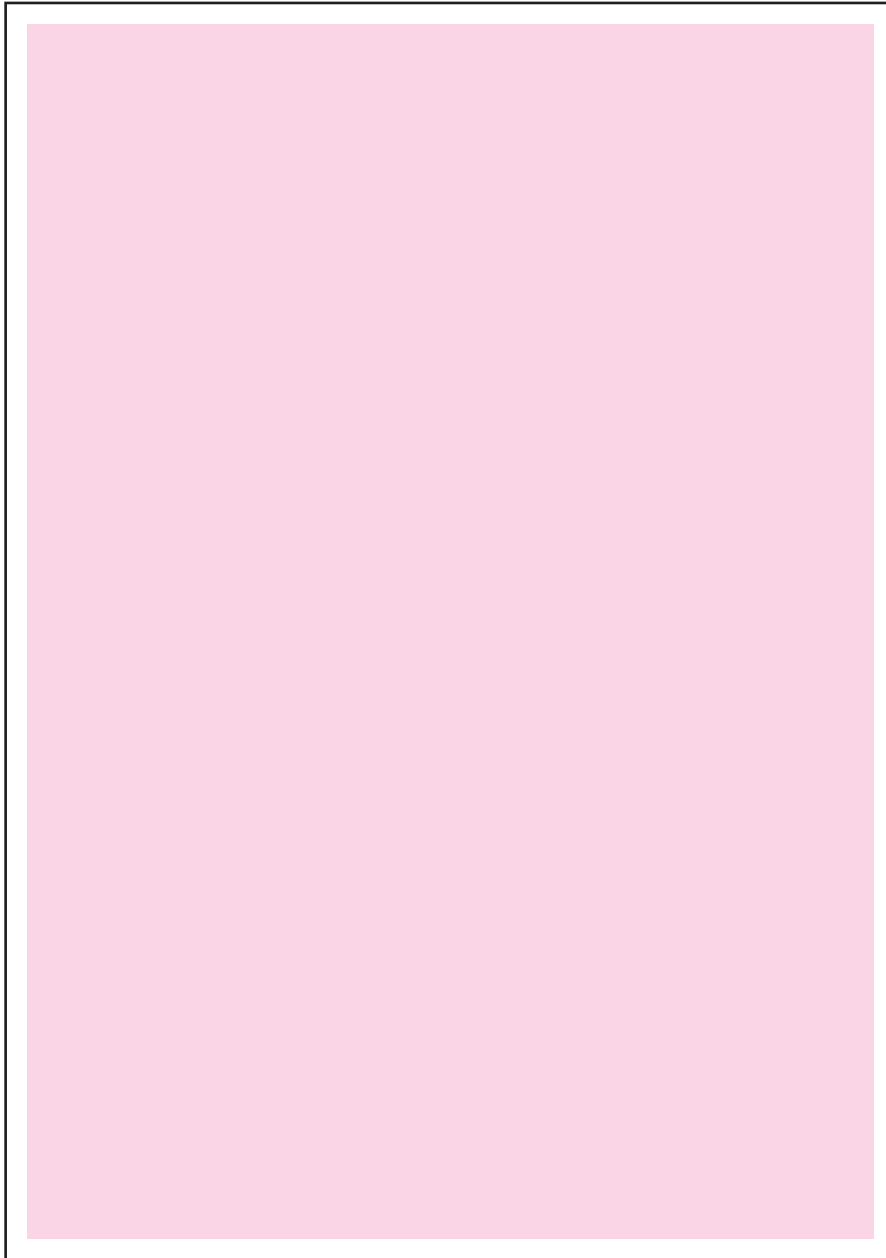
## Cyan 20% ESS

The Cyan 20 % (ESS built-in test pattern) fills one side of paper with 20 % density cyan.



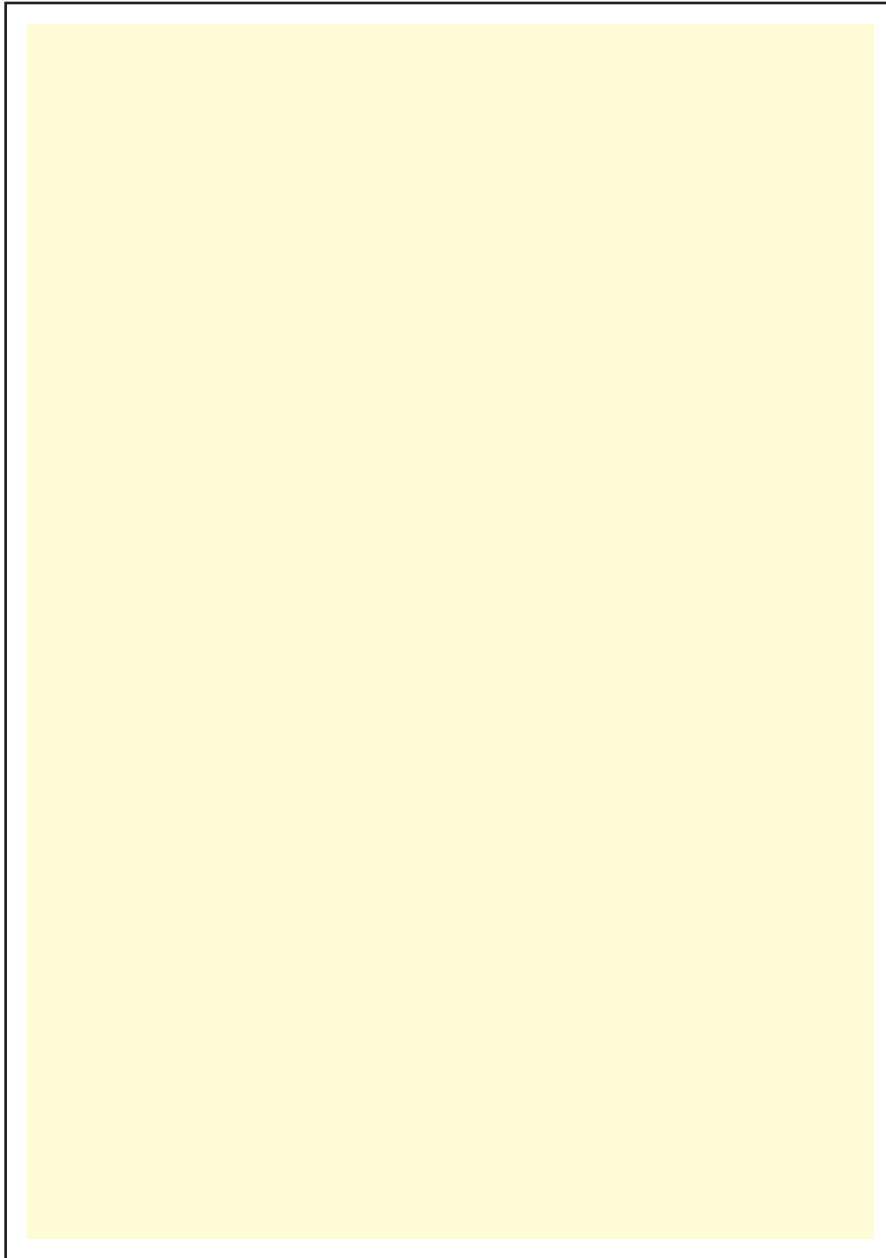
## Magenta 20% ESS

The Magenta 20% (ESS built-in test pattern) fills one side of paper with 20% density magenta.



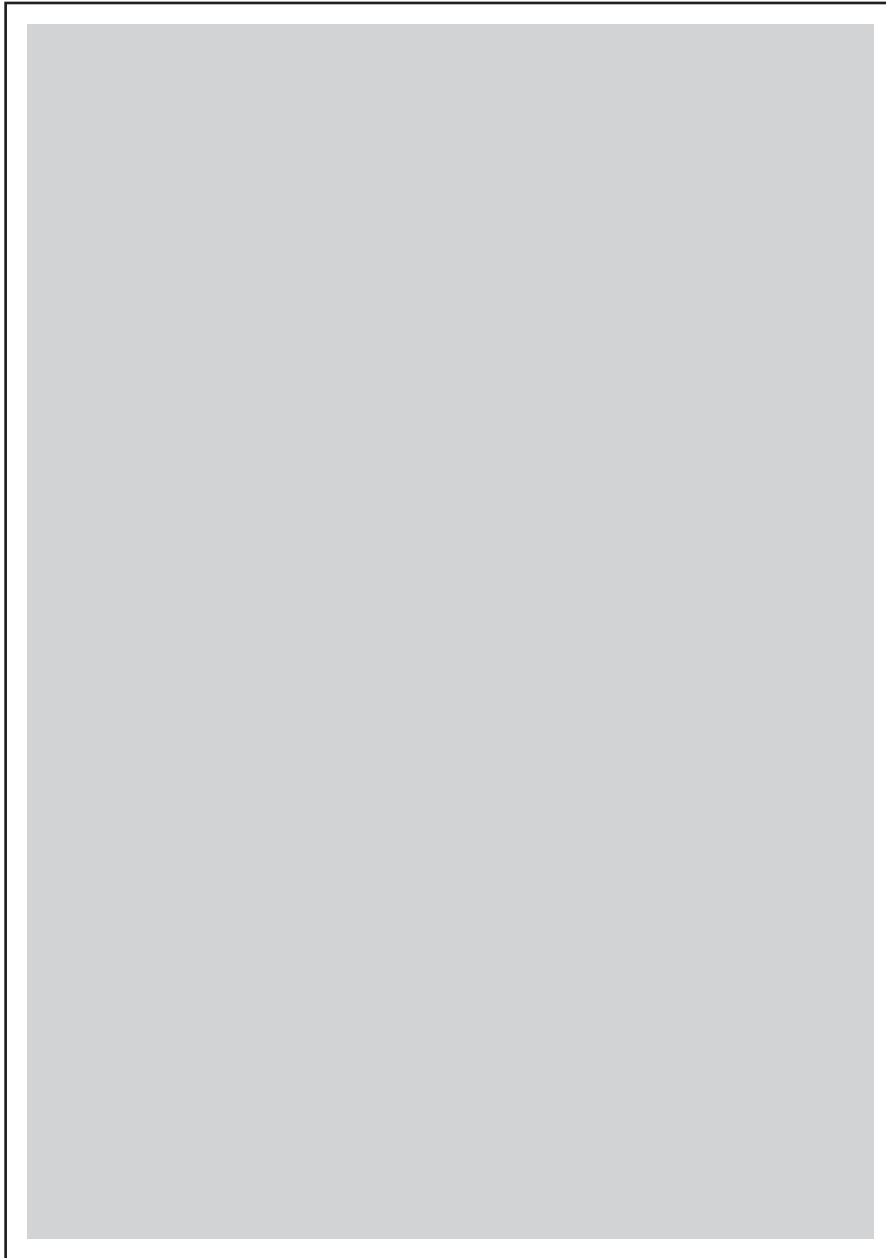
## Yellow 20% ESS

The Yellow 20 % (ESS built-in test pattern) fills one side of paper with 20 % density yellow.



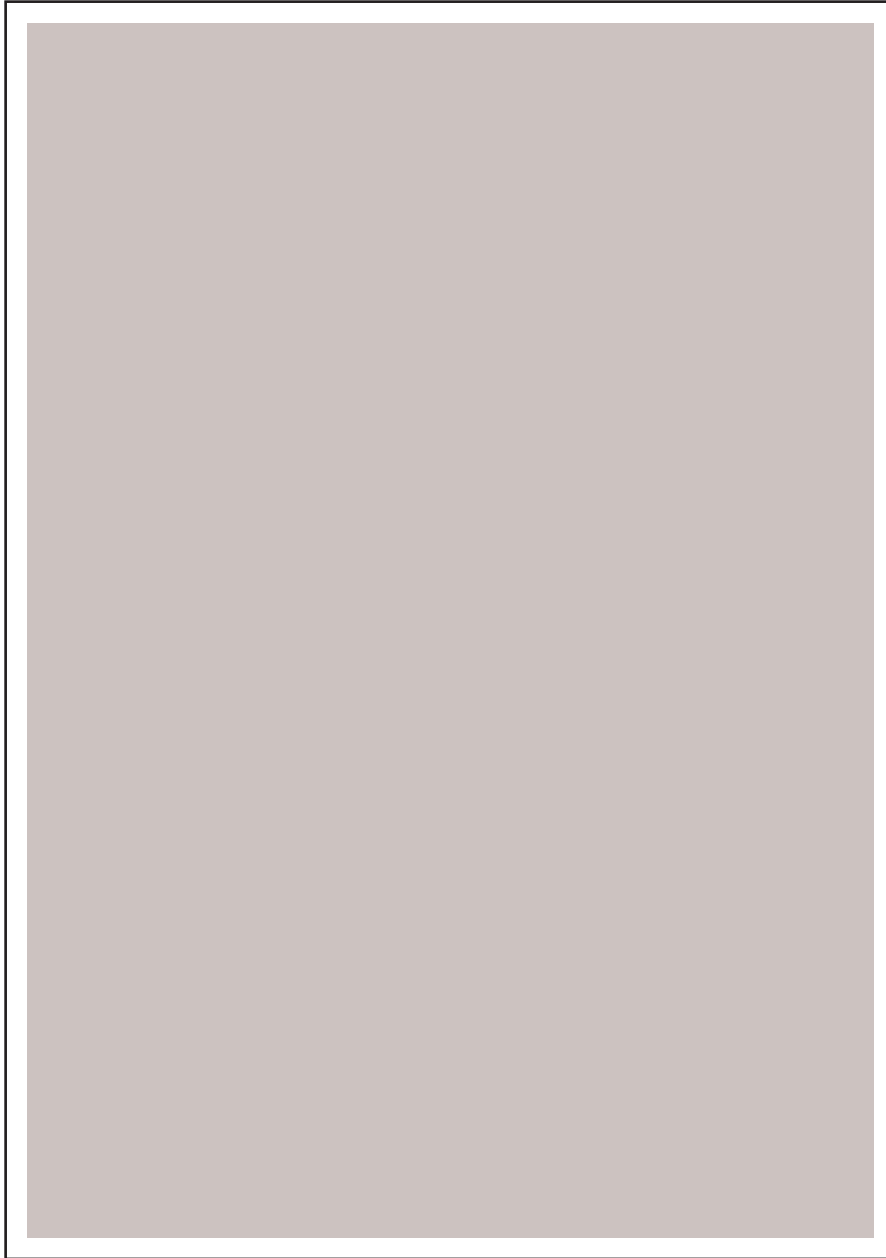
## Black 20% ESS

The Black 20% (ESS built-in test pattern) fills one side of paper with 20% density black.



## CMY 20% ESS

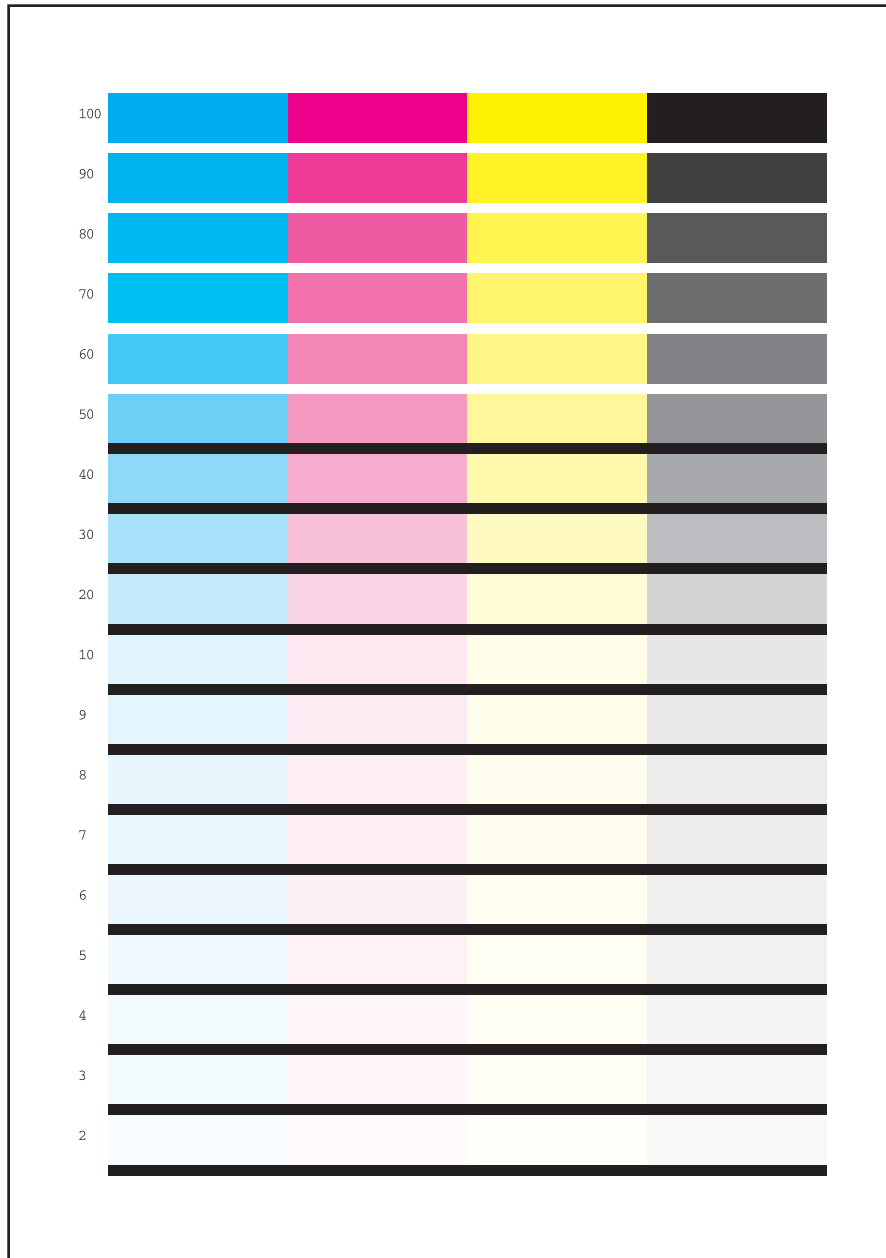
The CMY 20 % (ESS built-in test pattern) fills one side of paper with 20 % density of the mixture of cyan, magenta, and yellow.





## Gradation ESS

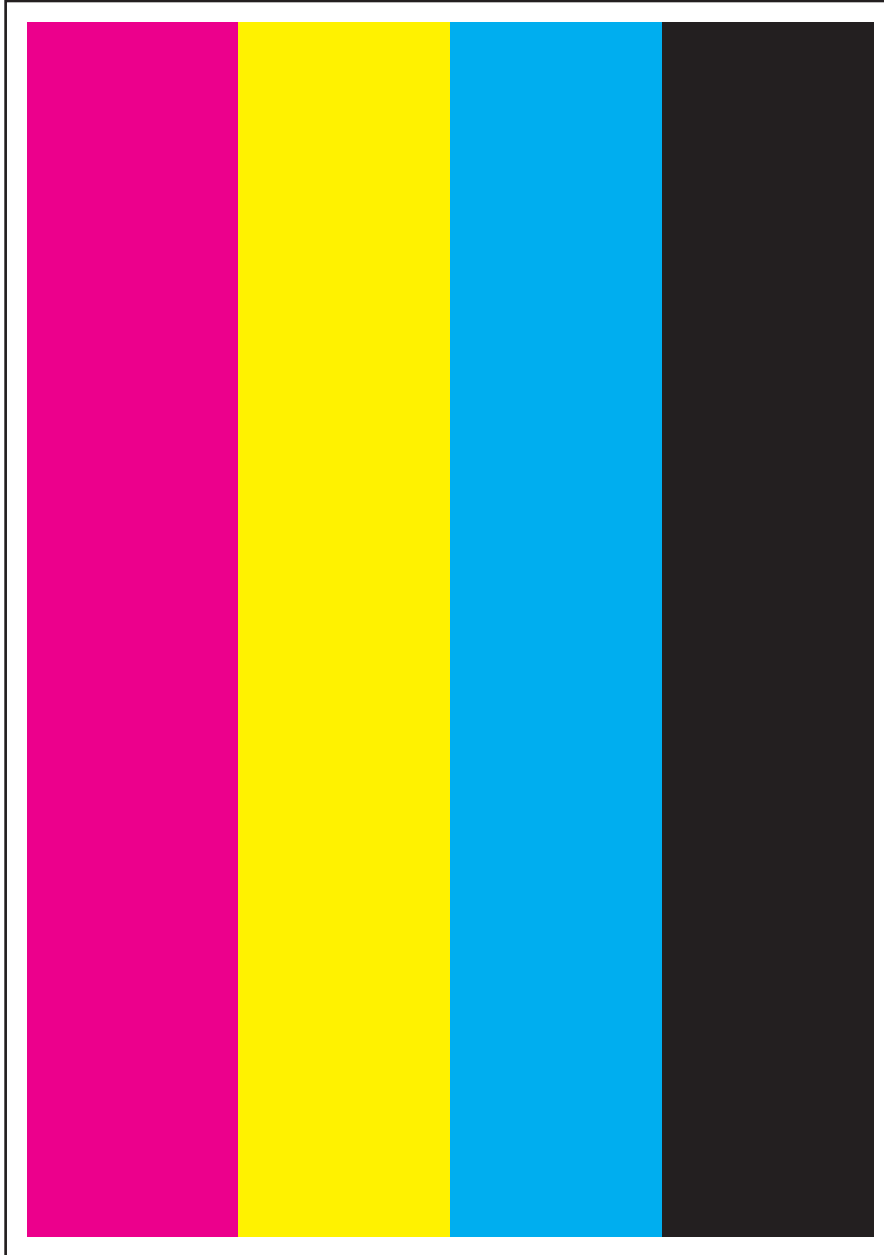
The Gradation (ESS built-in test pattern) prints the broken border patterns with the density of 0 to 100% cyan, magenta, yellow, and black.



## Toner Pallet Check

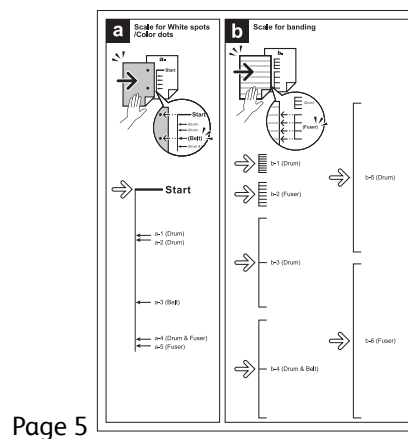
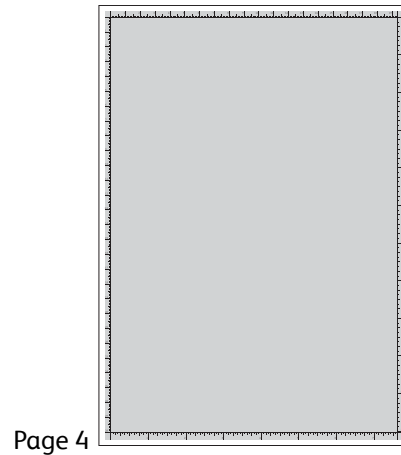
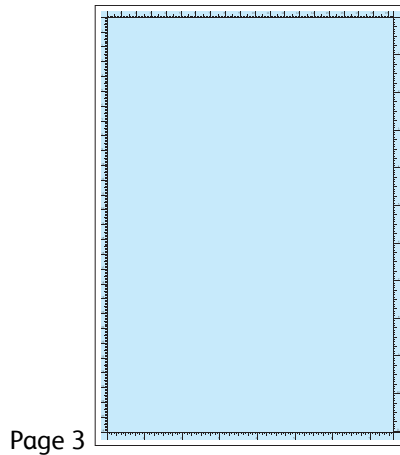
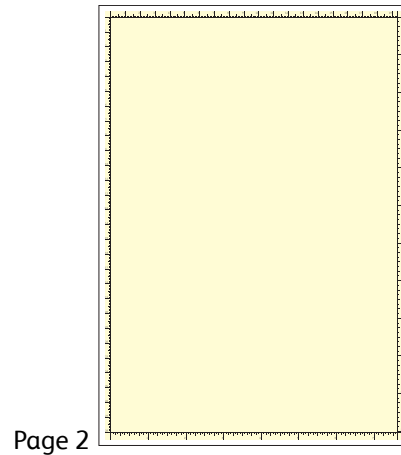
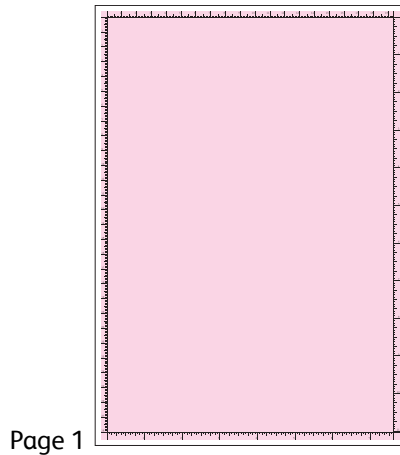
The Toner Pallet Check (ESS built-in test pattern) prints four bars, filled with 100 % density of each color (C/M/Y/K), lined on the paper .

Use this test for checking the density of each toner cartridge.



## Contamination Check

The Contamination Check prints 5 sheets of paper with the pattern of millimeter scale on the top/left edges and inch scale on the bottom/right edges, each filed with Y/M/C/K color of 20 % density, and the one with defect list (which helps finding defects such as lines, streaks, smudges, and scaling the size of the defect to identify the part to be replaced).



## Parameter Setting (Parameter)

Use Parameter to read and write the parameters in the IOT parameters.

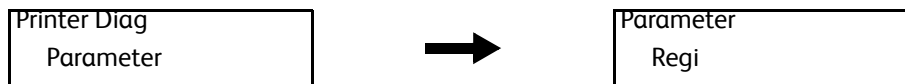
### Registration Parameter Settings (Regi)

Item	Range	
Regi	Slow Scan K to P	-15 - +15
	Fast Scan Smp BTray	-15 - +15
	Fast Scan Smp Tray1	-15 - +15
	Fast Scan Smp Tray2 (when Tray2 is installed)	-15 - +15
	Fast Scan Dup BTray	-15 - +15
	Fast Scan Dup Tray1	-15 - +15
	Fast Scan Dup Tray2 (when Tray2 is installed)	-15 - +15

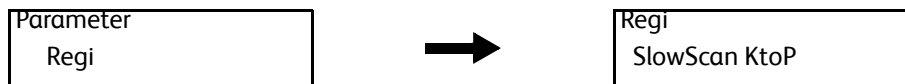
#### Procedure

This procedure explains how to change the registration value using [Fast Scan Smp BTray] as an example.

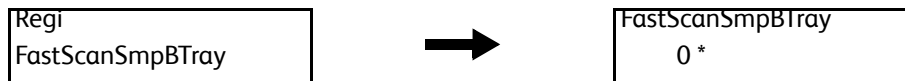
1. Enter Service Mode. See “How To Enter Service Mode” on page 2-8.
2. Confirm that the [Printer Diag] is selected, and then press the **OK** button.
3. Use the [▼] button to select [Parameter], and press the **OK** button.



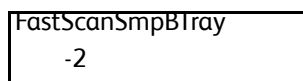
4. Press the **OK** button.



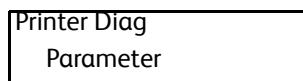
5. Use the [▼] button to select [FastScanSmpBTray], and press the **OK** button.



6. Use the [▲] or [▼] button to change the value, and press the **OK** button.



7. Press the **Back** button to return to the [Printer Diag] screen.



8. Exit Service Mode. See “How to Exit Service Mode” on page 2-10.

## Life Counter Display and Counter Initialization (Life)

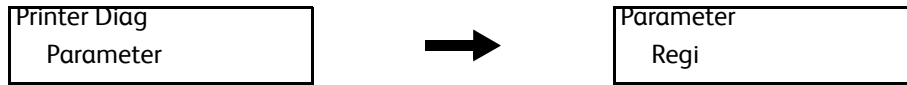
You can display the life counter of the IOT and initialize the life counter value.

Item	
Life	Fuser PV
	Fuser Heat Time
	Trans Total PV
	Trans Rotate Time
	Y IU PV
	M IU PV
	C IU PV
	K IU PV
	Y IU Rotate Time
	M IU Rotate Time
	C IU Rotate Time
	K IU Rotate Time
	Y IU Pixel
	M IU Pixel
	C IU Pixel
	K IU Pixel
	Y Toner Disp Time
	M Toner Disp Time
	C Toner Disp Time
	K Toner Disp Time
Waste Box PV	
Waste Box Pixel	

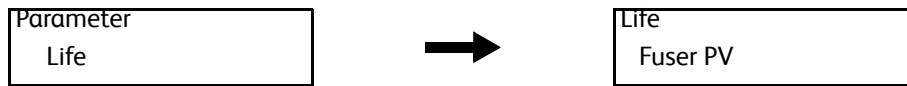
### Procedure

This procedure explains how to confirm the value of the life counter using [Trans Total PV] as an example.

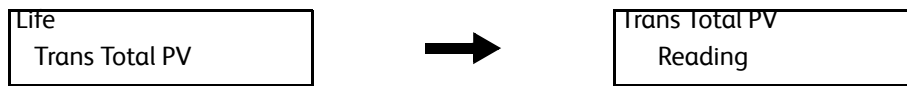
1. Enter Service Mode. See “How To Enter Service Mode” on page 2-8.
2. Confirm that the [Printer Diag] is selected, and then press the **OK** button.
3. Use the [▼] button to select [Parameter], and press the **OK** button.



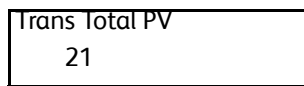
4. Use the [▼] button to select [Life], and press the **OK** button.



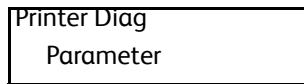
5. Use the [▼] button to select [Trans Total PV], and press the **OK** button.



6. Press the **OK** button to display the value.  
Initialize the life counter of Belt Total PV, select [Initializing], and press the **OK** button.



7. Press the **Back** button to return to the [Printer Diag] screen.



8. Exit Service Mode. See “How to Exit Service Mode” on page 2-10.

### Parameter List Print (Print)

You can print the values of the parameter of the IOT, the error count, and the life count.

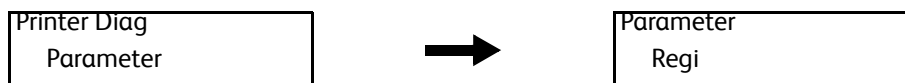


**CAUTIONS:** When you print the parameter list, check that the Tray 1 contains A4 paper (Only A4 paper is supported). If the parameter list is printed on the paper of other than A4, some part of the image might be lost.

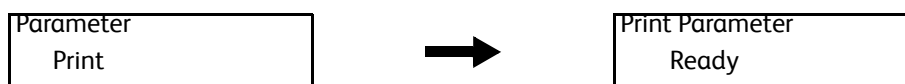
- The printer will display [Processing] and suspend the parameter list from printing, if the paper size other than A4 is set as the default paper tray setting.
- In this case, switch off the printer once, and on again, specify A4 for the paper tray setting, enter Service Mode, and then print the list.

**Procedure**

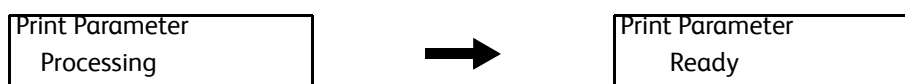
1. Enter Service Mode. See “How To Enter Service Mode” on page 2-8.
2. Confirm that the [Printer Diag] is selected, and then press the **OK** button.
3. Use the [▼] button to select [Parameter], and then press the **OK** button.



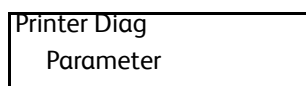
4. Use the [▼] button to select [Print], and press the **OK** button.



5. Press the **OK** button to print the parameter list.  
?The screen will return to the [Ready] screen when the parameter list print is complete.



6. Press the **Back** button to return to the [Printer Diag] screen.



7. Exit Service Mode. See “How to Exit Service Mode” on page 2-10.

**Board Diag (Board Test)**

This section explains the details of the Board Diag.

**All Test**

All Test allows you to execute a series of Fax Memory, Fax Card I/F, AFE Serial I/F, IIT I/F, ASIC in one go.

Display After Diag		Note
Normal	Error	
CHECK OK	*** Test Check NG	***: Displays the name of the test ended in error. (Fax Flash W/R / SRAM W/R / Fax Card I/F / AFE Serial I/F / IIT I/F / ASIC IJAC / ASIC JBIG)

## Fax Memory Test

Fax Memory Test allows you to check the read and write ability of the Fax memory.

Display After Diag		Note
Normal	Error	
CHECK OK	*** Test Check NG	***: Displays the name of the test ended in error. (Fax Flash W/R / SRAM W/R)

## I/F Test

I/F Test provides the communication test between Fax Card, AFE Serial I/F, and IIT.

Display After Diag		Note
Normal	Error	
CHECK OK	*** Test Check NG	***: Displays the name of the test ended in error. (Fax Card I/F / AFE Serial I/F / IIT I/F)

## ASIC Test

Provides the ASIC built-in IJAC and JBIG tests.

Display After Diag		Note
Normal	Error	
CHECK OK	*** Test Check NG	***: Displays the name of the test ended in error. (ASIC IJAC / ASIC JBIG)



## Relay/Signal Test

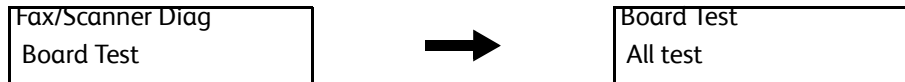
Item		Range	Description
Relay Test	Relay Toggle Test	0150 - 9999	Toggles the Relay signal within the specified frequency.
	Relay Set Test	ON, OFF	Outputs the Relay signal at a specified level.
Hook Test	Hook Toggle Test	0150 - 9999	Toggles the Hook signal within the specified frequency.
	Hook Set Test	ON, OFF	Outputs the Hook signal at a specified level.
Single Tone Send	0Hz	-	Continuously sends the selected frequency tone.
	400Hz		
	462Hz		
	1080Hz		
	1100Hz		
	1300Hz		
	1500Hz		
	1650Hz		
	1850Hz		
	2100Hz		
	500Hz		
	600Hz		
	900Hz		
	1000Hz		
DTMF Send	DTMF Continuous	0 - 9, A - D, *, #	Continuously sends the DTMF signal.
	DTMF Individually	16 digits (each digit 0 - 9, A - D, *, #)	Sends the multiple digits DTMF signal.
Dial Pulse Send	DP10 Individually	10 digits (each digit: 0 - 9)	Sends the multiple digits dial pulse (10pps) signal.
	DP20 Individually	10 digits (each digit: 0 - 9)	Sends the multiple digits dial pulse (20pps) signal.
Ring Back Tone		-	Sends the ringback tone.

Item		Range	Description
Data Send	V.34 33600bps	-	Sends the data specified with speed and pattern (no pattern for V.34).
	V.34 31200bps		
	V.34 28800bps		
	V.34 26400bps		
	V.34 24000bps		
	V.34 21600bps		
	V.34 19200bps		
	V.34 31200bps		
	V.34 16800bps		
	V.34 14400bps		
	V.34 12000bps		
	V.34 9600bps		
	V.34 7200bps		
	V.34 4800bps		
	V.34 2400bps		
V.29 7200bps	5 patterns	Sends the data specified with speed and pattern.	
V.29 4800bps			
V.27ter 4800bps	5 patterns	Sends the data specified with speed and pattern.	
V.27ter 2400bps			
V.21 300bps	5 patterns	Sends the data specified with speed and pattern.	
V.17 14400bps	5 patterns	Sends the data specified with speed and pattern.	
V.17 12000bps			
V.17 9600bps			
V.17 7200bps			
Line Voltage		-	Checks the Line Voltage status.
Line Current		-	Checks the Line Current status.

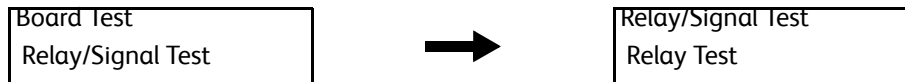
## Procedure

The procedure below explains [DTMF Send] > [DTMF Continuous] as an example.

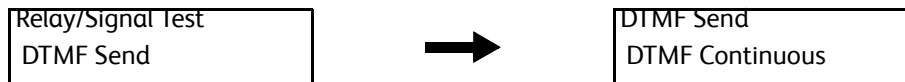
1. Enter Service Mode. See “How To Enter Service Mode” on page 2-8.
2. Use the [▼] button to select [Fax/Scanner Diag], and press the **OK** button.
3. Press the **OK** button.



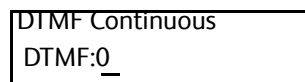
4. Use the [▼] button to select [Relay/Signal Test], and press the **OK** button.



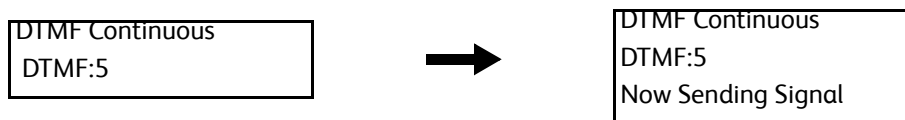
5. Use the [▼] button to select [DTMF Send], and press the **OK** button.



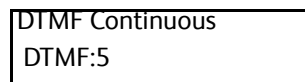
6. Press the **OK** button.



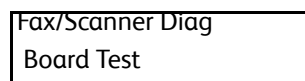
7. Use the [▲] or [▼] button to change the value and then press the **OK** button to start sending the signal.



8. To stop sending the signal, press the **Back** button.



9. Press the **Back** button to return to the [Fax Scanner Diag] screen.



10. Exit Service Mode. See “How to Exit Service Mode” on page 2-10.

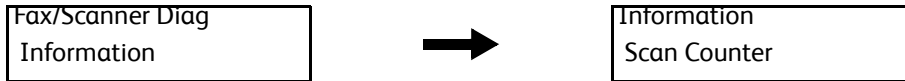
## Information

### Scan Counter

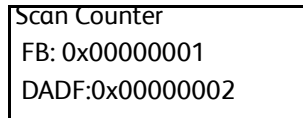
Displays the scan counter value.

#### Procedure

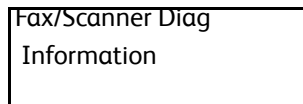
1. Enter Service Mode. See “How To Enter Service Mode” on page 2-8.
2. Use the [▼] button to select [Fax/Scanner Diag], and press the **OK** button.
3. Use the [▼] button to select [Information], and press the **OK** button.



4. Press the **OK** button.



5. Press the **Back** button to return to the [Fax Scanner Diag] screen.



6. Exit Service Mode. See “How to Exit Service Mode” on page 2-10.

## Scanner Maintenance

### White Balance

Adjusts the White Balance.

Item	Display After Diag	
	Normal	Error
Auto Adjust(FB)	Adjust OK	Auto Adjust(FB) Adjust NG
Auto Adjust(DADF)	Adjust OK	Auto Adjust(DADF) Adjust NG

### Shading Parameter

Specifies the Shading factor.

Item	Range
Coeff FB RED	4 digits (hexadecimal) (each digit 0 - 9, A - F)
Coeff FB GREEN	
Coeff FB BLUE	
Coeff FB GRAY	
Coeff DADF RED	4 digits (hexadecimal) (each digit 0 - 9, A - F)
Coeff DADF GREEN	
Coeff DADF BLUE	
Coeff DADF GRAY	
Target RED	2 digits (hexadecimal) (each digit 0 - 9, A - F)
Target GREEN	
Target BLUE	
Target GRAY	

## Registration Parameter

Specifies the parameter value of the registration.

Item	Range
Regi FB Lead	3 digits (each digit 0 - 9)
Regi FB Side	
Regi DADF Lead (Front)	
Regi DADF Side (Front)	
Regi DADF Lead (Back)	
Regi DADF Side (Back)	

## Auto Registration

Specifies whether to set Auto Registration to ON or OFF.

Item	Range
Auto Registration	ON, OFF

## Sensor Parameter

Specifies the setting value of the Sensor Parameter.

Item	Range
Feed Sensor	3 digits (each digit 0 - 9)

## Vertical Scan Mag.

Specifies the parameter value of the Vertical Scan magnification.

Item	Range
Mag FB COLOR	2 digits (hexadecimal) (each digit 0 - 9, A - F)
Mag FB GRAY	
Mag DADF COLOR	
Mag DADF GRAY	

## Test Pattern

Specifies the test pattern and the parameter value of the test.

Item	Range
Pattern No.	3 digits (each digit 0 - 9)
Pt07:Step Cycle	4 digits (hexadecimal) (each digit 0 - 9, A - F)
Pt08:Step Cycle	

## IIT I/O Check

Checks the IIT I/O components operation.

Item	Sensor Status
Home Pos Sensor	ON or OFF
Tray Sensor	
Feed Sensor	
DADF Cover Sensor	
DADF Duplex Sensor	

Item		Display After Diag		Description
		Normal	Error	
Lamp..	Set ON	Check OK	-	The lamp is set to ON.
	Set OFF			The lamp is set to OFF.
FB Motor	Forward	Now Driving	Check NG	Turns the FB Motor to the forward direction.
	Reverse			Turns the FB Motor to the reverse direction.
DADF Motor	Forward	Now Driving	Check NG	Turns the DADF Motor to the forward direction.
	Reverse			Turns the DADF Motor to the reverse direction.
DADF Solenoid	Set ON	Check OK	-	The DADF Solenoid is set to ON.
	Set OFF			The DADF Solenoid is set to OFF.

## Scan Counter Clear

Item	Sensor Status
Counter Clear (FB)	Clears the value of the FB scan counter.
Counter Clear (DADF)	Clears the value of the DADF scan counter.

## Carriage Drive\_100

Carriage Drive\_100 is the IIT jig for the ORT which continuously operates the carriage 100 times a test. If the lump error or the home position error is detected, the display shows the message [Abnormal End].

Item	Display After Diag	
	Normal	Error
Carriage Drive_100	Complete	Abnormal End

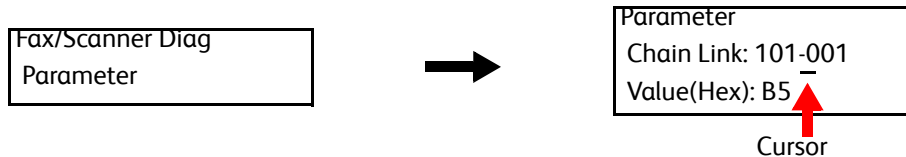


## System Data Setting (Parameter)

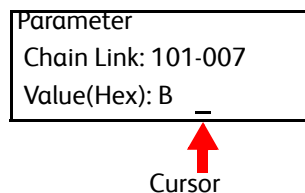
You can specify the Fax and Scan system data settings.

### Procedure

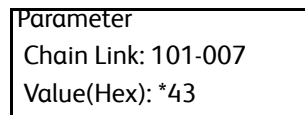
1. Enter Service Mode. See “How To Enter Service Mode” on page 2-8.
2. Use the [▼] button to select [Fax/Scanner Diag], and press the **OK** button.
3. Use the [▼] button to select [Parameter], and press the **OK** button.



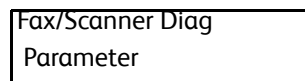
4. Change the Chain Link number, and press the **OK** button.  
Use the [◀] and [▶] buttons to move the cursor to right and left.  
Use the [▲] and [▼] buttons to increase or decrease the value where the cursor is placed.  
Press the **OK** button, and the Chain Link number changed will appear.



5. Change the setting value, and press the **OK** button.  
\* (asterisk) will appear when the value is set.



6. Press the **Back** button to return the [Fax Scanner Diag] screen.



7. Exit Service Mode. See “How to Exit Service Mode” on page 2-10.

## Parameter List

Chain Link	Parameter	Name	Range	Fac'y Def'lt	Note	
840	001	SYS_DEF_SCN_START_DOT	Scanner Fast Scan Start Pixel	0-255	128	0 - 255: ± 12.8 mm (in increments of 0.1 mm)
840	002	SYS_DEF_SCN_START_LINE	Scanner Slow Scan Start Position	0-255	128	0 - 255: ± 12.8 mm (in increments of 0.1 mm)
840	003	SYS_DEF_SCN_MAG_C	Scanner Magnification (Color)	0-255	128	0 - 255: ± 6.4 mm (in increments of 0.05 %)
840	101	SYS_DEF_SCN_MAG_G	Scanner Magnification (Gray)	0-255	128	0 - 255: ± 6.4 mm (in increments of 0.05 %)
840	004	SYS_DEF_SCN_CARRIGE_POS	Scanner Carriage Position	0-60	0	0 - 60
840	005	SYS_DEF_ADF_START_DOT	ADF Fast Scan Start Pixel	0-255	128	0 - 255: ± 12.8 mm (in increments of 0.1 mm)
840	008	SYS_DEF_ADF_START_DOT2	ADF Fast Scan Start Pixel (Side 2)	0-255	128	0 - 255: ± 12.8 mm (in increments of 0.1 mm)
840	006	SYS_DEF_ADF_START_LINE	ADF Slow Scan Start Position	0-255	159	0 - 255: ± 12.8 mm (in increments of 0.1 mm)
840	009	SYS_DEF_ADF_START_LINE2	ADF Slow Scan Start Position (Side 2)	0-255	153	0 - 255: ± 12.8 mm (in increments of 0.1 mm)
840	007	SYS_DEF_ADF_MAG_C	ADF Magnification (Color)	0-255	144	0 - 255: ± 6.4 mm (in increments of 0.05 %)
840	102	SYS_DEF_ADF_MAG_G	ADF Magnification (Gray)	0-255	144	0 - 255: ± 6.4 mm (in increments of 0.05 %)
700	003	SYS_DEF_FBC2_CLR_R	FB C2 Paper ColorR Correction Factor	0-65535	36213	0 - 2 <sup>16</sup> -1
700	004	SYS_DEF_FBC2_CLR_G	FB C2 Paper ColorG Correction Factor	0-65535	37734	0 - 2 <sup>16</sup> -1

## Parameter List

Chain Link	Parameter	Name	Range	Fac'y Def'lt	Note	
700	005	SYS_DEF_FBC2_CLR_B	FB C2 Paper ColorB Correction Factor	0-65535	36786	0 - 2^16-1
700	006	SYS_DEF_FBC2_MONO	FB C2 Paper Mono Correction Factor	0-65535	37636	0 - 2^16-1
700	007	SYS_DEF_ADCF2_CLR_R	ADF C2 Paper ColorR Correction Factor	0-65535	36874	0 - 2^16-1
700	008	SYS_DEF_ADCF2_CLR_G	ADF C2 Paper ColorG Correction Factor	0-65535	37813	0 - 2^16-1
700	009	SYS_DEF_ADCF2_CLR_B	ADF C2 Paper ColorB Correction Factor	0-65535	37159	0 - 2^16-1
700	010	SYS_DEF_ADCF2_MONO	ADF C2 Paper Mono Correction Factor	0-65535	38557	0 - 2^16-1
700	101	SYS_DEF_ASTGT_CLR_R	Auto Shading ColorR Correction Factor	0-255	240	0 - 255
700	102	SYS_DEF_ASTGT_CLR_G	Auto Shading ColorG Correction Factor	0-255	240	0 - 255
700	103	SYS_DEF_ASTGT_CLR_B	Auto Shading ColorB Correction Factor	0-255	240	0 - 255
700	104	SYS_DEF_ASTGT_MONO	Auto Shading Mono Correction Factor	0-255	240	0 - 255
700	105	SYS_DEF_FAX_ADFCUT	Fax Store ADF Scan Size Reduce Length (Feed Sensor Output Correction Value)	0-10	0	0 mm - 10 mm
700	106	SYS_DEF_IIT_AUTOREG	IIT Auto Register Adjustment On/Off	0,1	0	0: Enable 1: Disable

## Parameter List

Chain Link		Parameter	Name	Range	Fac'y Def'lt	Note
700	107	SYS_DEF_ADFC2_CLR_R_DW	Auto Shading ColorR DADF Correction Factor (DW)	0-65535	31402	
700	108	SYS_DEF_ADFC2_CLR_G_DW	Auto Shading ColorG DADF Correction Factor (DW)	0-65535	32085	
700	109	SYS_DEF_ADFC2_CLR_B_DW	Auto Shading ColorB DADF Correction Factor (DW)	0-65535	32358	
700	110	SYS_DEF_ADFC2_MONO_DW	Auto Shading Mono DADF Correction Factor (DW)	0-65535	31948	
950	100	IIT_AFE_REG_VERSION	Scanner AFE Register Version	0,1	1	0:M0-1 1:M0-1mod
950	101	IMAGE_PREPRM_THROUGH1	PreIPS Through Setting 1	0-255	192	bit0 0: AFE bit1 1: Shading Correction bit2 2: GAP Correction bit3 3: Mirror Processing bit4 4: Masking Processing bit5 5: White Balance Machine Difference Correction bit6 6: Lamp Initial Start Up Attribute Correction bit7 7: DADF Lamp Time Variation Attribute Correction
950	102	IMAGE_PREPRM_THROUGH2	PreIPS Through Setting 2	0-255	0	bit0 0: SS400 -> 600 dpi Conversion (to FX-I/F)

## Parameter List

Chain Link		Parameter	Name	Range	Fac'y Def'lt	Note
950	103	IMAGE_PARAM_THROUGH1	Image Quality Parameter Through Setting 1		0	bit0 0: ENL Conversion bit1 1: RGB 3x9 Filter bit2 2: Enlarge/Reduce bit3 3: 3x9 Color Conversion bit4 4: Background Suppression bit5 5: NSP bit6 6: NSP (Saturation Conversion Factor) bit7 7: Color Adjustment (Linear Conversion)
950	104	IMAGE_PARAM_THROUGH2	Image Quality Parameter Through Setting 2	0-255	0	Continued from "Image Quality Parameter Through Setting 1" bit0 8: Color Adjustment (L* INLUT) bit1 9: 4-Color DLUT Color Conversion bit2 10: 3-Color DLUT Color Conversion bit3 11: JPEG Compression bit4 12: K 5x5 Filter bit5 13: Resolution Conversion bit6 14: Delete Border bit7 15: TRC
950	105	IMAGE_PARAM_THROUGH3	Image Quality Parameter Through Setting 3	0-255	0	Continued from "Image Quality Parameter Through Setting 1, 2" bit7 16 - 23: Reserve

## Parameter List

Chain Link	Parameter	Name	Range	Fac'y Def'lt	Note	
950	106	IMAGE_PARAM_THROUGH4	Image Quality Parameter Through Setting 4	0-255	0	Continued from "Image Quality Parameter Through Setting 1, 2, 3" bit7 24 - 31: Reserve
950	107	DIAG_IMG_PATH	Select Test Pattern	0-255	0	0 = Normal Operation 1 = Raw Image Output 1 2 = Raw Image Output 2 3 = 1 Dot Grid Output 4 = Vertical Gradation Output 5 = Horizontal Gradation Output 6 = Solid Color Output 7 = Lamp On Silent Image Output 8 = Lamp Off Silent Image Output 9 = Shading Memory Silent Image Output 10 = FXIF Test 11 = Patch Pattern 12 = AFE: Maximum Transient Status 13 = AFE: Lamp 14 = AFE: Fixed Data?Output
950	108	DIAG_IMG03_GRID_SIZE	Test Pattern 3 Parameter	0-1023	200	1 Dot Grid Size
950	109	DIAG_IMG04_GRADATION	Test Pattern 4 Parameter	1-255	10	Vertical Gradation Step
950	110	DIAG_IMG05_GRADATION	Test Pattern 5 Parameter	1-255	10	Horizontal Gradation Step
950	111	DIAG_IMG06_R_LV	Test Pattern 6 Parameter R	0-255	128	Image Path R Level
950	112	DIAG_IMG06_G_LV	Test Pattern 6 Parameter G	0-255	128	Image Path G Level

## Parameter List

Chain Link	Parameter	Name	Range	Fac'y Def'lt	Note	
950	113	DIAG_IMG06_B_LV	Test Pattern 6 Parameter B	0-255	128	Image Path B Level
950	114	DIAG_IMG07_STEP	Test Pattern 7 Parameter	0-65535	0	Output Thinning Cycle (x100line)
950	115	DIAG_IMG08_STEP	Test Pattern 8 Parameter	0-65535	0	Output Thinning Cycle (x100line)
950	116	DIAG_IMG09_TEMP	Test Pattern 9 Parameter	0	0	Reserve
950	117	DIAG_IMG11_R_LV	Test Pattern 11 Parameter	0	0	Image Path R Level
790	308	FAX_DEF_CL	Fax Default Color	0,1	0	0: Black & White 1: Color
790	304	FAX_DEF_RESO	Fax Default Resolution	0-3	0	0: Standard 1: Fine 2: Super Fine 3: Photo
790	302	FAX_DEF_ORIG_TYPE	Fax Default Original Type	0-2	0	0: Text 1: Text & Photo 2: Photo
790	301	FAX_DEF_DENSITY	Fax Default Density	-3-+3	0	-3 (Lighter3) - +3 (Darker3)
790	306	FAX_DEF_DELAY_H	Fax Default Specified Time - Hour	0-23	21	0 h - 23 h
790	307	FAX_DEF_DELAY_M	Fax Default Specified Time - Minute	0-59	0	0 min - 59 min
701	006	SYS_SET_FAX_TRANS	SystemSetting Sent/Unsent Report	0-2	1	0: Do Not Deliver 1: Deliver Upon Error 2: Always Deliver
701	007	SYS_SET_FAX_BROAD	SystemSetting Broadcast Report	0-2	2	0: Do Not Deliver 1: Deliver Upon Error 2: Always Deliver
701	008	SYS_SET_FAX_PROTOCOL	SystemSetting Protocol Monitor	0-2	0	0: Do Not Deliver 1: Deliver Upon Error 2: Always Deliver

## Parameter List

Chain Link	Parameter	Name	Range	Fac'y Def'lt	Note	
790	305	FAX_SET_SD_HEAD	FaxSetting Sender Record	0,1	1	0: Do Not Record 1: Record
825	200	FAX_COVER_NOTE	FaxSetting Add Cover Note	0,1	0	0: Disable 1: Enable
701	001	FAX_SET_COUNTRY	FaxSetting Country Setting	cFaxCntryUnknown	cFaxCntyUnitedStates	Unknown
821	205	FAX_SET_CL_FAX	FaxSetting Color Fax Enable/Disable	0,1		0: Disable 1: Enable
821	403	FAX_SET_DUSCARD_SIZE	FaxSetting Discard Size	0-2		0: New Page 1: Cut Without New Page 2: Auto Reduce
821	407	FAX_SET_DUP_PRT	FaxSetting Receive Print - 2 Sided Print	0,1		0: 1 Sided 1: 2 Sided
821	411	SYS_SET_FAX_ACT	SystemSetting Communication Management Report	0,1		0: No Auto Delivery 1: Always Deliver
825	002	FAX_SET_LINE_TYPE	FaxSetting Line Type	0,1		0: PSTN 1: PBX
825	003	FAX_SET_DIAL_TYPE	FaxSetting Dial Type	0-2		0: PB 1: DP (10PPS) 2: DP (20PPS)
825	006	FAX_SET_DRPD	FaxSetting DRPD Pattern Setting	0-7		0: Disable 1: Pattern1 2: Pattern2 3: Pattern3 4: Pattern4 5: Pattern5 6: Pattern6 7: Pattern7
825	014	FAX_SET_RCV_MODE	FaxSetting Switch Receive Mode	0-4		0: For Tel Only 1: For Fax Only 2: Switch Tel/Fax 3: Switch Ans/Fax 4: DRPD Mode



## Parameter List

Chain Link	Parameter	Name	Range	Fac'y Def'lt	Note	
825	017	FAX_SET_AT_TELFAX	FaxSetting AutoAnswerTel / Fax Call Time	0-255		0 - 255 sec
825	018	FAX_SET_AT_ANSFAX	FaxSetting AutoAnswerAns/ Fax Call Time	0-255		0 - 255 sec
825	019	FAX_SET_AT_FAX	FaxSetting AutoAnswer Fax Call Time	0-255		0 - 255 sec
825	031	FAX_SET_RESND	FaxSetting Resend Times	0-5		0 - 5 times
825	032	FAX_SET_REDIAL	FaxSetting Redial Times	0-13		0 - 13 times
825	034	FAX_SET_INT_REDIAL	FaxSetting Redial Interval	1-15		1 - 15 min
825	035	FAX_SET_INT_TIMER	FaxSetting Communication Interval Timer	3-255		3 - 255 sec
825	054	FAX_SET_HOOK_THRESH	FaxSetting OnHook Detect Threshold Value			Lower Normal Higher
825	060	FAX_SET_DM_PRE	FaxSetting DM Prevent Feature	0,1		0: Do Not Prevent 1: Prevent
825	083	FAX_SET_RING_VOL	FaxSetting Incoming Sound Volume	0-3		0: OFF 1: Min 2: Middle 3: Max
825	096	FAX_SET_RMT_RCV	FaxSetting Remote Receive	0,1		0: Disable 1: Enable
825	097	FAX_SET_RMT_RCV_TONE1	FaxSetting Remote Receive Tone 1st Digit	0-9		
825	098	FAX_SET_RMT_RCV_TONE2	FaxSetting Remote Receive Tone 2nd Digit	0-9		
825	102	FAX_SET_PREFIX_SET	FaxSetting Add Prefix Dial	0,1		0: Do Not Add 1: Add

Parameter List

Chain Link	Parameter	Name	Range	Fac'y Def'lt	Note
825	103	FAX_SET_PREFIX_NUM	FaxSetting Prefix Dial Number		UINT8*5
825	602	FAX_SET_LINE_MONI	FaxSetting Line Monitor Sound Volume	0-3	0: OFF 1: Min 2: Middle 3: Max
825	635	FAX_SET_CAPAB_ECM	FaxSetting ECM Setting	0,1	0: Disable 1: Enable
825	701	FAX_SET_UI_FAX_SPEED	On-Panel Fax Communication Speed	0-4	0 :2400 1: 4800 2: 9600 3: 14400 4: 33600
701	10	FAX_SET_FOWD_SET	FaxSetting Fax Receive Print Transfer	0,2	0: Do Not Transfer 2: Always Transfer
701	11	FAX_SET_FOWD_PRT	FaxSetting Print Setting Upon Fax Receive Print Transfer	0,1	0: Do Not Print 1: Print
701	12	FAX_SET_FWD_ERR_PRT	FaxSetting Print Upon Fwd. Error Print	0,1	0: Do Not Print 1: Print
820	001	DIAG_DIALLING_TYPE	Dial Type	0-2	
821	101	DIAG_SYS_MACHINE_MODE	Operation Mode	0,1	Specify [1] to output the monitor sound from the speaker upon fax communication. 0: Normal Mode 1: Maintenance Mode

## Parameter List

Chain Link	Parameter	Name	Range	Fac'y Def'lt	Note
821	201	DIAG_CONTINUE_ILLEGAL	Operation after Error such as Send Store Insufficient Memory, etc.	0	Specify whether to send all the scanned pages of fax ([1]) or to delete all the scanned pages of fax ([0]) upon error during Send Store. 0: Delete All 1: Send Stored Document
821	202	DIAG_THRESH_MEMRX	Stop Fax Receive, Disable Fax Receive (when Color Fax is disabled)	0-100	
821	203	DIAG_THRESH_RXPRINT	Transit to Immediate Receive	0-99	
821	204	DIAG_THRESH_MEMTX	Stop Send Store, Disable Send Store Start	0-100	
821	206	DIAG_THRESH_COLOR_FAX_RX	FAX Receive Disable (when Color Fax is enabled)	0-2	
821	207	DIAG_THRESH_GC_START	Start Garbage Correction	0-99	
821	401	DIAG_PAGE_MARGIN	Page Split Margin (Reduction: OFF)	0-127	
821	406	DIAG_COLOR_RX_PAGE_LIMIT	Maximum Value of 1 Page Data Upon Color Receive	0-64	
701	009	DIAG_SEL_OPP_NAME	Recipient Channel Second Priority Notation Setting of Communication Management Report	0,1	0: Name of Recipient Channel (to be displayed when an individual protocol is used.) 1: Phone Number

## Parameter List

Chain Link	Parameter	Name	Range	Fac'y Def'lt	Note	
790	401	DIAG_G3M_RX_RESO	Resolution Setting Upon Receive	0-128		0x00: Normal 0x80: R8x3.85
821	412	DIAG_PAGE_MARGIN_REDUCTION	Page Split Margin (Reduction: ON)	0-127		
825	001	DIAG_NCU_TYPE	NCU Type	0,1		
825	004	DIAG_DP_RELAY_DELAY	Interval Until Relay Switch (Interval Until Steady Line) Upon Pulse Dial	0-255		
825	005	DIAG_DRPD_ENABLE	Allow/Restrict DRPD Setting	0,1		
825	013	DIAG_DIS_DP_20PPS	20PPS Pulse Dial	0,1		
825	015	DIAG_CNG_DETECT_TIME	CNG Detect Time	0-255		
825	016	DIAG_AUTO_ANSWER_TIME	External Phone Calling Time (Time to output ringing sound from speaker when unable to detect CNG after starting to call)	0-255		
825	025	DIAG_RING_CYCLE_MIN	(14/0.5) Ring Signal Cycle Minimum Value	0-255		
825	026	DIAG_RING_CYCLE_MAX	(100/0.5) Ring Signal Cycle Maximum Value	8-255		
825	027	DIAG_SELECT_DIALTONE	Dial Tone Frequency	0-3		
825	028	DIAG_BUSY_TONE_FREQ	Busy Tone Frequency	0-4		
825	029	DIAG_BUSY_TONE_PATTERN	Busy Tone Pattern	0-8		
825	030	DIAG_BUSY_TONE_DETECTION	Allow/Restrict Busy Tone Detection Upon Calling	0,1		

## Parameter List

Chain Link	Parameter	Name	Range	Fac'y Def'lt	Note
825	033	DIAG_NUMBER_OF_REDIAL_M AX	Maximum Redial Times	0-255	
825	036	DIAG_CAPAB_NUM_CHECK	Check Same Recipient Upon Recalling	0,1	
825	037	DIAG_NUM_CHECK_TIMER	Interval Until Resending to Same Recipient	1-255	
825	045	DIAG_DAA_REG730	RingThreshold	0-255	
825	046	DIAG_DAA_REG731	Complex	0-2	
825	047	DIAG_DAA_REG733	DCCurve	0-4	
825	048	DIAG_DAA_REG734	Rmake	0-255	
825	049	DIAG_DAA_REG74F	FastEdgePulseDia l	0,1	
825	050	DIAG_DAA_MODE	SiDAA Operation Mode	0-255	
825	062	DIAG_NUM_DIAL_PULSE	Number of Dial Pulses	0-2	
825	063	DIAG_PB_TONE_TIME	PB Transmission Time	0-255	
825	064	DIAG_PB_INTERDIGIT	PB Pause Time	0-255	
825	065	DIAG_PB_ATT_LEVEL	DTMF Transmission Attenuator Level	4-15	
825	066	DIAG_PB_LEVEL_SUB	Difference of DTMF High- Pass/Low-Pass Level	0-15	
825	067	DIAG_MAKE_10PPS	10PPS Make Time	1-106	
825	068	DIAG_BREAK_10PPS	10PPS Break Time	1-106	
825	069	DIAG_MAKE_20PPS	20PPS Make Time	1-106	
825	070	DIAG_BREAK_20PPS	20PPS Break Time	1-106	

## Parameter List

Chain Link	Parameter	Name	Range	Fac'y Def'lt	Note
825	071	DIAG_DP_INTERDIGIT	DP Interdigit Pause Time	0-255	
825	072	DIAG_PAUSE_TIME	(4/0.1) Pause Time	0-255	
825	073	DIAG_BLIND_TIME	Blind Dial Time	0-255	
825	074	DIAG_TIME_TO_DETECT_DIALT ONE	Interval Until Dial Tone Detection Timeout	0-255	
825	079	DIAG_ONHOOK_DETECT_TIME	ONHOOK Detect Time	10-255	
825	080	DIAG_OFFHOOK_DETECT_TIME	OFFHOOK Detect Time Upon No Online RING Signal	15-255	
825	081	DIAG_OFFHOOK_DETECT_TIME _RING	OFFHOOK Detect Time Upon Online RING Signal	15-255	
825	084	DIAG_EX_RINGER_FREQ_ON_TI ME	External Phone Calling Frequency: ON	6250-65535	6250 - 65535:3125 $\mu$ s - 31250 $\mu$ s
825	085	DIAG_EX_RINGER_FREQ_OFF_T IME	External Phone Calling Frequency: OFF	6250-65535	6250 - 65535:3125 $\mu$ s - 31250 $\mu$ s
825	086	DIAG_EX_RINGER_ON_T1	External Phone Calling ON Time T1	5-250	
825	087	DIAG_EX_RINGER_OFF_T2	External Phone Calling OFF Time T2	5-250	
825	088	DIAG_EX_RINGER_ON_T3	External Phone Calling ON Time T3	5-250	
825	089	DIAG_EX_RINGER_OFF_T4	External Phone Calling OFF Time T4	5-250	
825	090	DIAG_DIS_DIALTONE_PSTN	Detect Dial Tone on Public Line	0,1	

## Parameter List

Chain Link	Parameter	Name	Range	Fac'y Def'lt	Note
825	092	DIAG_MANUAL_CED_START_TIME	CED Signal Transmission Start Time Upon Manual Send	0-255	
825	093	DIAG_CNG_SEND_START_TIME	CNG Signal Transmission Start Time	0-255	
825	094	DIAG_MANUAL_CNG_START_TIME	CNG Transmission Start Time Upon Manual Send	0-255	
825	099	DIAG_RING_ON_JUDGE	Ring ON Judge Time	0-255	
825	100	DIAG_RING_OFF_JUDGE	Ring OFF Judge Time	0-255	
825	101	DIAG_RING_OFFMAX	Time to Judge Ring Disappeared from Line	0-255	
825	103	DIAG_PREFIX_NUM_1	Prefix Dial Number1	0-255	
825	104	DIAG_PREFIX_NUM_2	PrefixDial Number2	0-255	
825	105	DIAG_PREFIX_NUM_3	PrefixDial Number3	0-255	
825	106	DIAG_PREFIX_NUM_4	PrefixDial Number4	0-255	
825	107	DIAG_PREFIX_NUM_5	PrefixDial Number5	0-255	
825	108	DIAG_SIDAA_MANUAL_CALIBRATION	SiDAA Manual Calibration	0,1	
825	110	DIAG_DIS_DIALTONE_PATTERN	Detect Dial Tone Pattern	0,1	
825	111	DIAG_DIALTONE_ONOFFPTN_MIN	Minimum Time of Dial Tone ON/OFF	0-255	
825	112	DIAG_DIALTONE_ONOFFPTN_MAX	Maximum Time of Dial Tone ON/OFF	8-255	

## Parameter List

Chain Link	Parameter	Name	Range	Fac'y Def'lt	Note
825	201	DIAG_NCU_COUNTRY_RELAY	NCU Country Setting - Relay Setting	0,1	
825	202	DIAG_DAA_REG732	FastEdgePulseDial2	0,2	
825	203	DIAG_DAA_REG_EMI	DAA SSD Register 0x02 Setting	0-255	
825	601	DIAG_LINE_MONITOR_ENABLE	Line Monitor Setting	0,1	
825	604	DIAG_CED_DETECT_TIMER	CED Detect Time	25-255	
825	666	DIAG_MANUAL_CNG_SIGNAL	Manual Send CNG Transmission	0,1	
825	605	DIAG_CNG_STOP_SELECT	CNG Transmission Stop Judge Selection	0,2	
825	608	DIAG_RTN_TX_RATE	RTN Command Transmission Standard (Rate)	0-100	
825	609	DIAG_RTN_TX_LINE	RTN Command Transmission Standard (Serial Line Number)	0-255	
825	610	DIAG_G3M_CALL_T1_TIMER	T1 Timer Value Soon After Calling	0-255	
825	611	DIAG_G3M_TX_T1_TIMER	T1 Timer Value Upon Sending	0-255	
825	612	DIAG_G3M_RX_T1_TIMER	T1 Timer Value Upon Receiving	0-255	
825	613	DIAG_G3M_T2_TIMER	T2 Timer Value	0-255	
825	614	DIAG_G3M_T3_TIMER	T3 Timer Value	0-255	
825	615	DIAG_G3M_AUTO_T4_TIMER	Auto Send/Receive T4 Timer Value	0-255	



## Parameter List

Chain Link	Parameter	Name	Range	Fac'y Def'lt	Note
825	616	DIAG_G3M_MAN_T4_TIMER	Manual Send/Receive T4 Timer Value	0-255	
825	617	DIAG_G3M_IVL_TIMER	Silent Time Timer Value	0-255	
825	618	DIAG_G3M_FSK_CHK_TIMER	FSK Observation Timer Value	0-255	
825	619	DIAG_ITUT_PIX_DELAY	Image Information Send Delay Time	0-255	
825	620	DIAG_G3M_DROP_OUT_TIMER	Image Information Receive Dropout Observation Timer Value	0-255	
825	621	DIAG_G3M_NSF_DIS_TIME	NSF/DIS Transmission Time	0-3	
825	622	DIAG_G3M_TX_MODEM_SPEED	Communication Mode Upon Sending (Speed)	0-5	
825	623	DIAG_G3M_RX_MODEM_SPEED	Communication Mode Upon Receiving (Speed)	0-5	
825	625	DIAG_G3M_DIS_IGNORE_NO	DIS Ignore Times	0-255	
825	626	DIAG_G3M_TSI_CIG_MODE	TSI/CIG Send Timing	0-2	
825	627	DIAG_G3M_WITH_CSI	CSI Send	0,1	
825	628	DIAG_G3M_FTT_FALLBACK	Number of FTT Until Fallback	0-2	
825	629	DIAG_G3M_TCF_CHECK	TCF Signal Judge Standard	0,1	
825	630	DIAG_G3M_TX_CABLE_EQU	Send Cable Equalizer	0-3	
825	631	DIAG_G3M_RX_CABLE_EQU	Receive Cable Equalizer	0-4	
825	632	DIAG_G3M_TAP_HOLD	TAP HOLD	0,1	
825	633	DIAG_G3M_V29_EPT	EP Tone	0,1	

## Parameter List

Chain Link	Parameter	Name	Range	Fac'y Def'lt	Note
825	634	DIAG_EXTENDED_DIS_DTC	DIS/DTC FIF Transmission Bytes	0-10	
825	636	DIAG_G3M_CTC_NO	ECM/CTC Transmission Times	0-7	
825	637	DIAG_G3M_T5_TIMER	RNR Signal Timer	0-255	
825	638	DIAG_G3M_EQM_48	4800bps EQM Comparison Value	0-127	
825	639	DIAG_G3M_EQM_72	7200bps EQM Comparison Value	0-127	
825	640	DIAG_G3M_EQM_96	9600bps EQM Comparison Value	0-127	
825	641	DIAG_G3M_EQM_120	12000bps EQM Comparison Value	0-127	
825	642	DIAG_G3M_EQM_144	14400bps EQM Comparison Value	0-127	
825	643	DIAG_G3M_EQM_TCM72	TCM7200bps EQM Comparison Value	0-127	
825	644	DIAG_G3M_EQM_TCM96	TCM9600bps EQM Comparison Value	0-127	
825	645	DIAG_G3M_V34_MAX_SYMBOL_RATE	Symbol Speed Maximum Allowed Value (Enable Upon Receiving)	0-5	
825	646	DIAG_G3M_V34_MAX_BIT_RATE	Bit Speed Maximum Value	1-14	
825	647	DIAG_G3M_V34_SYM_RATE_ENABLE1	Symbol Speed Enable Command	0-61	
825	648	DIAG_G3M_V34_BIT_RATE_ENABLE1	Bit Speed Enable Command 1	0-255	

## Parameter List

Chain Link	Parameter	Name	Range	Fac'y Def'lt	Note
825	649	DIAG_G3M_V34_BIT_RATE_ENABLE2	Bit Speed Enable Command 2	0-63	
825	650	DIAG_G3M_V34_CTRL_BIT_RATE	Control Channel Bit Speed	0,1	
825	653	DIAG_G3M_V34_BIT_RATE_THRESHOLD	Bit Speed Selection Threshold Value	0-255	
825	655	DIAG_G3M_V8_TE_TIME	V8Te Time	0-255	
825	656	DIAG_G3M_V34_CC_TIMER	Interval From V34 Mode (Phase2) Until Control Channel	5-255	
825	657	DIAG_G3M_V34_SHIFT_G3	Setting Whether to Transit to G3 Mode Upon V34_CC_TIMER Timeout	0,1	
825	658	DIAG_CAPAB_V34	V34 Capability	0,1	
825	659	DIAG_ANSAM_SEND_TIME	ANSam Signal Maximum Transmission Time	1-255	
825	660	DIAG_ANSAM_START_TIME	Interval From Line Close Until ANSam Signal Transmission	22-255	
825	661	DIAG_G3M_TX_CODING	Upon Sending Coding Method	0-3	
825	662	DIAG_G3M_RX_CODING	Upon Receiving Coding Method	0-3	
825	664	DIAG_RX_GAIN_ADJUSTMENT	Receive Gain Correction Value	0-255	
825	665	DIAG_G3M_V34_FRAME_SIZE	V34 1 Frame Size	0,1	
825	667	DIAG_TONE_TX_ATT	Tone Transmission Level	0-15	
825	668	DIAG_RX_ATT	Incoming Level	0-3	

## Parameter List

Chain Link	Parameter	Name	Range	Fac'y Def'lt	Note
825	669	DIAG_SAVE_ERROR_RX_DATA	Store Decode Error Page	0,1	
825	673	DIAG_DFAULT_JBIG_LRLTWO	LRLTWO (Reference Line) Value	0,1	
825	702	DIAG_EXTEL_HOOK_THRESH_0	Threshold Value 0 for External Phone HOOK Detection	0-255	
825	703	DIAG_EXTEL_HOOK_THRESH_1	Threshold Value 1 for External Phone HOOK Detection	0-255	
825	704	DIAG_EXTEL_HOOK_THRESH_2	Threshold Value 2 for External Phone HOOK Detection	0-255	
825	705	DIAG_CAPAB_EXTEL_HOOK_SUPPLEMENT	Support ETSI Standard (Enable/Disable Start)	0,1	0: Disable 1: Enable
825	706	DIAG_EXTEL_HOOK_SUPPLEMENT_VOLTRESH	Support ETSI Standard (Voltage to Decide External Phone OFFHOOK)	10-20	10, 15, 20 (V)
950	001	DIAG_FORGET_ERROR_SECRET		0-255	
950	002	DIAG_CODE_CHECK_SECRET		0-255	
950	003	DIAG_PMQAT_BOARD_SECRET		0-255	
950	004	DIAG_DONT_DEL_TXFILE		0,1	
950	005	DIAG_DONT_PR_RCVFILE		0,1	
950	006	DIAG_MON_SPEED_38400		0,1	
950	007	DIAG_COMM_TIME_MEASURE		0,1	
950	008	DIAG_WITHOUT_ICM		0,1	
950	009	DIAG_COMM_PARAM		0,1	
950	010	DIAG_EQM_READ		0,1	
950	011	DIAG_AGCVAL_READ		0,1	

## Parameter List

Chain Link	Parameter	Name	Range	Fac'y Def'lt	Note
950	012	DIAG_FAXCOM_DEBUG_INFO		0,1	
950	013	DIAG_G3M_V8_SHIFT_G3		0,1	
950	014	DIAG_SERIMON_RX_ENABLE		0,1	
950	015	DIAG_CODEEC_DEBUG_DISP		0,1	
950	016	DIAG_WARMBOOT_DISABLE		0,1	
950	017	DIAG_FORCED_POLLING		0,1	
950	018	DIAG_REMOTE_DIAG		0,1	
950	019	DIAG_ECM_RX_64	Frame Size Setting Upon ECM Sending	0,1	
950	020	DIAG_ECM_TX_64	Frame Size Setting Upon ECM Receiving	0,1	
950	021	DIAG_SELECT_LN	Select Maximum Record Paper Length	0-2	
950	022	DIAG_CAPAB_FULLCOLOR		0,1	
950	118	DIAG_FREQ_DETECT_LEVEL	Frequency Detect Level (For Filter)	0-3	
825	708	DIAG_ANSWER_DELAY_MINIMUM	Minimum Call Time in Auto Receive Mode (FAX only, TEL/FAX, ANS/FAX)	0-255	0: Disable 1 - 255 sec
825	709	DIAG_ANSWER_DELAY_MAXIMUM	Maximum Call Time in Auto Receive Mode (FAX only, DRPD)	0-255	0: Disable 1 - 255 sec
825	710	DIAG_DIS_DP	Restrict Dial Pulse	0,1	0: Allow DP 1: Restrict DP
825	707	DIAG_FAXLINE_TEST_VOLTAGE_THRESH	Voltage Threshold Value for Line Voltage Detection	10-50	10 - 50 1Step/1V

## Backup (BackUP Data)

Backup data in SRAM and EEPROM can be cleared using one of these methods:

- All Clear
- User Clear
- System Clear
- User & System Clear
- System Data Init
- Document Clear

The table below indicates which data items are cleared with each method. The procedure that follows explains how to clear data using the User Clear method as an example.

### Initialization Data

Data	All	User	System	User& System	Docu-ment	System Data
EEPROM System Data	0	0	0	0		0
SRAM System Data	0	0	0	0		0
System Error History	0		0	0		
SW Bug History	0		0	0		
Diag History	0		0	0		
Local ID G3	0	0		0		
Local Name	0	0		0		
TX Header Logo	0	0		0		
Forward Dial Number	0	0		0		
System Counter	0					
Speed Dial Block (Speed Dial Control Block)	0	0		0		
Dial Group Block (Group Dial Registration Block)	0	0		0		
SCAN to FTP/SMB Address Book	0	0		0		
SCAN to Email Address Book	0	0		0		
Email Group Block (E-mail Group Registration Block)	0	0		0		
Email Subject	0	0		0		
Email Text	0	0		0		
Block for Communication Result Registration	0		0	0		
Communication Result Registration for Protocol Monitor Report	0		0	0		
Backup Check Data1	0					

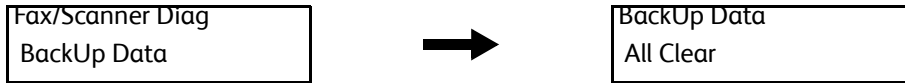
## Initialization Data

Data	All	User	System	User& System	Docu-ment	System Data
Calling Table	0	0	0	0	0	
Broadcast CRB Document Number	0		0	0		
Management Data in Broadcast 1 Job	0		0	0		
Broadcast 1 Job Result	0		0	0		
Substitute Queue	0	0	0	0	0	
Receiving Document Information	0	0	0	0	0	
Document Number	0	0	0	0	0	
Document Management Table	0	0	0	0	0	
Directory Management Table	0	0	0	0	0	
FAT Chain Table	0	0	0	0	0	
FAT Chain Save Range	0	0	0	0	0	
FAT Delete Status Table	0	0	0	0	0	
Table of Number of Sector Erase Times	0					
Garbage Correction Information	0	0	0	0	0	
Sector for Garbage Correction	0	0	0	0	0	
Garbage Correction Preparation Sector	0	0	0	0	0	
Fax Communication Speed Counter	0					
DADF Scan Counter	0					
Platen Scan Counter	0					
Total Signal Number	0		0	0		
Signal Data Buffer Pointer	0		0	0		
Signal Information Table	0		0	0		
Signal Data Buffer	0		0	0		
Number of SCJL Job Log Registrations	0		0	0		
SCJL Job Log Data	0		0	0		
Backup Check Data 2	0					
Backup Data Status	0					
Backup RAM Bottom	0					

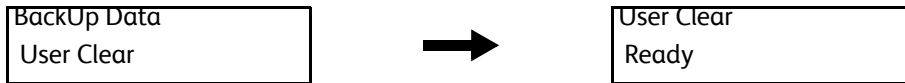
**Procedure**

The following procedure explains how to clear the data using [User Clear] as an example.

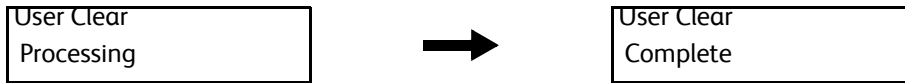
1. Enter Service Mode. See “How To Enter Service Mode” on page 2-8.
2. Use the [▼] button to select [Fax/Scanner Diag], and press the **OK** button.
3. Use the [▼] button to select [BackUp Data], and press the **OK** button.



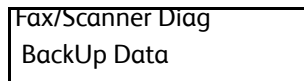
4. Use the [▼] button to select [User Clear], and press the **OK** button.



5. Press the **OK** button.



6. Press the **Back** button to return to the [Fax Scanner Diag] screen.



7. Exit Service Mode. See “How to Exit Service Mode” on page 2-10.



## Error Messages

Error messages generated by the printer's operating system are the lead-in to the troubleshooting procedures that follow in subsequent pages. This section correlates the output of the printer's diagnostic aids and provides the troubleshooting procedures to locate and correct the reported errors.

### Error Message Abbreviations

Due to limited display space, some error messages include abbreviations. The most common abbreviations used throughout this chapter are listed here.

ADC	Automatic Density Control
ASIC	Application-Specific Integrated Circuit
COMM	Communication
CRT	Cartridge
CRUM	Customer Replaceable Unit Monitor
ER/ERR	Error
ENV	Environment
FUNC	Function
IBT	Transfer Belt
K	Black
MACaddress	Media Access Control Address
MCU	Machine Control Unit
NVM	Non-Volatile Memory. Used instead of NVRAM.
NVRAM	Non-Volatile Random Access Memory
PDL	Page Description Language
RAM	Random Access Memory
REGI	Registration
ROM	Read Only Memory

## Error History Report

The Error History Report provides a list of error messages and codes relating to jams and system errors.

The Error History page contains two types of history information.

- System Fail History contains: Date, Time, Chain-Link code, and Error Information.
- Paper Jam History contains: Date, Time, Chain-Link code and Paper Jam Type.

### Printing the Error History Report with the Printer Settings Utility

1. From the Start Menu, select Programs > Xerox Office Printing > Phaser 6600 > Printer Settings Utility.
2. On the Printer Settings Report tab, select Information Pages.
3. Press the Error History button.  
The Error History Report is printed.

**Note:** If the Error History Report will not print due to printer failure, see “Error Code Tables” on page 2-90.

### Printing the Error History Report at the Control Panel

1. At the Control Panel, press the System button.
2. Select Information Pages, press OK.
3. Press the Up or Down arrow button to find Error History. Press OK.

## Error Code Tables

The Error Code Tables list possible errors, along with the corresponding code, and page reference for the corrective procedure. There are two separate tables, one for the Phaser 6600 and one for the WorkCentre 6605.

- The Chain Link column lists the code associated with the error.
- The Error Message column shows the error history message when the error occurs during normal operation.
- The Error column lists the error title.
- The Error Details column describes the error in more detail.
- The Control Panel Messages column contains the messages that appear in either the MFP touch panel or the SFP LCD panel.
- The FIP Location column links to the Fault Isolation Procedure related to the error.

## Phaser 6600 Error Code List

## Phaser 6600 Error Code List

Chain Link	Error	Error Details	Control Panel Messages	FIP location	
004	310	IOT Feeder I/F Failure	IOT-FEEDER communication error	Reseat Feeder Power Off/On  Error 004-310 Power Off/On	Page 2-178
010	317	IOT Fuser Detached	Detect Fuser Detached	Insert Fuser 010-317  Insert Fuser Power Off/On	Page 2-189
010	351	IOT Fuser Life Over	Detect Fuser Life Over	Replace Fuser 010-351  Turn off and Replace Fuser  Reset Fuser Are You Sure?  (Press <b>OK</b> to reset counter.)  Turn off and Replace Fuser	Page 2-189
010	397	IOT Fuser Failure	Detect Fuser Error	Fuser Error Power Off/On  Error 010-397 Power Off/On	Page 2-189
010	420	IOT Fuser Near End Warning	Fuser Near End Warning	XXXXXXXXXXXXXXXXXX Fuser Life Low  XXXXXXXXXXXXXXXXXX Replace soon	Replace the Fuser Assembly.
010	421	IOT Fuser Life Pre Warning	Detect Fuser Life Warning	XXXXXXXXXXXXXXXXXX Fuser Life Low  XXXXXXXXXXXXXXXXXX Order Fuser	Replace the Fuser Assembly.
016	338	Wi-Fi Option Error	Wi-Fi Driver starting error.	Reseat Wi-Fi Contact Admin.  Error 016-338 Power Off/On	Replace the IP Board.
016	369	UI Panel - ESS Communication Fail	Communication Fail with a UI Panel and ESS F/W.	Error 016-369 Power Off/On	Replace the IP Board.

## Phaser 6600 Error Code List

Chain Link	Error	Error Details	Control Panel Messages	FIP location	
016	404	Certificate DB Error	Certificate DB access error	Certificate Fail Init Certificate  Error 016-404 Are You Sure?	Replace the IP Board.
016	405	Certificate DB Error	Invalid security setting error	Certificate Fail Init Certificate  Error 016-405 Are You Sure?	Replace the IP Board.
016	500	DOWNLOAD DELETE ERROR	Flash delete error in download.	Flash Erase Err Power Off/On  Error 016-500 Power Off/On	Replace the IP Board.
016	501	DOWNLOAD WRITE ERROR	Flash write error in download.	Flash Write Err Power Off/On  Error 016-501 Power Off/On	Replace the IP Board.
016	502	DOWNLOAD VERIFY ERROR	Flash verify error in download.	Flash ROM Err Power Off/On  Error 016-502 Power Off/On	Replace the IP Board.
016	520	Ipsec Certificate Error	Self device certificate error	Certificate Fail Contact Admin.  Error 016-520 Power Off/On	Replace the IP Board.
016	521	Ipsec Certificate Error	Remote device certification verification error	Certificate Fail Contact Admin.  Error 016-521 Power Off/On	Replace the IP Board.
016	522	LDAP Certificate Error	No client certificate exists	Certificate Fail Contact Admin.  Error 016-522 Power Off/On	Replace the IP Board.
016	523	LDAP Certificate Error	Server certificate verification error.	Certificate Fail Contact Admin.  Error 016-523 Power Off/On	Replace the IP Board.

## Phaser 6600 Error Code List

Chain Link	Error	Error Details	Control Panel Messages	FIP location	
016	524	LDAP Certificate Error	No server certificate exists	Certificate Fail Contact Admin.  Error 016-524 Power Off/On	Replace the IP Board.
016	527	LDAP Certificate Error	SSL authentication internal error	Certificate Fail Contact Admin.  Error 016-527 Power Off/On	Replace the IP Board.
016	541	Wi-Fi Certificate Error	No certificate exists.	Certificate Fail Contact Admin.  Error 016-541 Power Off/On	Replace the IP Board.
016	542	Wi-Fi Certificate Error	Server certificate error.	Certificate Fail Contact Admin.  Error 016-542 Power Off/On	Replace the IP Board.
016	543	Wi-Fi Certificate Error	Certificate corruption error	Certificate Fail Contact Admin.  Error 016-543 Power Off/On	Replace the IP Board.
016	570	Job Ticket Out Of Memory	XPIF parser detects insufficient memory in the processing of XCPT (XPIF) interpretation.	Print Job Error Press Ok Button  Error 016-570 Press Ok Button	Replace the IP Board.
016	571	Job ticket wrong param	Print instruction contents that the device cannot execute are detected.	Print Job Error Press Ok Button  Error 016-571 Press Ok Button	Replace the IP Board.
016	572	Job ticket media error	The paper attribute specified by XCPT (XPIF) cannot solve paper selection.	Print Job Error Press Ok Button  Error 016-572 Press Ok Button	Replace the IP Board.
016	573	Job ticket parse error	XPIF parser detects error other than those listed above.	Print Job Error Press Ok Button  Error 016-573 Press Ok Button	Replace the IP Board.

## Phaser 6600 Error Code List

Chain Link	Error	Error Details	Control Panel Messages	FIP location	
016	602	System NVM Initialize	At POWON start-up, execute NVM clear.	Initialize NVM Initializing...	-
016	603	ESS-NVM Parameter Recover	Executed ESS-NVM Parameter Recovery	-	-
016	604	ESS-NVM Parameter Copy	Executed ESS-NVM Parameter Copy	-	-
016	606	Clear Job History	Clear Job History	-	-
016	610	Panel Destination Mismatch (only for Production Line)	Tried to apply JP setting to non-JP panel, or tried to apply non-JP setting to JP panel.	Error 016-610 Power Off/On	Replace the IP Board.
016	612	Invalid MAC Address	MAC address is invalid (only for production line)	Error 016-612 Power Off/On	Replace the IP Board.
016	718	Memory Overflow		Out of Memory Press Ok Button  Error 016-718 Press Ok Button	Replace the IP Board.
016	720	PDL Error		Print Job Error Press Ok Button  Error 016-720 Press Ok Button	Replace the IP Board.
016	737	DOWNLOAD FORMAT ERROR	Download file format is invalid.	Format Error Press Ok Button  Error 016-737 Press Ok Button	Replace the IP Board.
016	741	DOWNLOAD PROTECT ERROR	Performed FW download although FW update is prohibited by panel settings.	Protection Error Press Ok Button  Error 016-741 Press Ok Button	Replace the IP Board.
016	742	DOWNLOAD ID ERROR	Download file ID is invalid.	Invalid ID Press Ok Button  Error 016-742 Press Ok Button	Replace the IP Board.

## Phaser 6600 Error Code List

Chain Link	Error	Error Details	Control Panel Messages	FIP location	
016	743	DOWNLOAD RANGE ERROR	At download, write-in destination address is invalid. Range check error.	Range Chk Error Press Ok Button  Error 016-743 Press Ok Button	Replace the IP Board.
016	744	DOWNLOAD CHECKSUM ERROR	Download file checksum is invalid.	Check Sum Error Press Ok Button  Error 016-744 Press Ok Button	Replace the IP Board.
016	745	DOWNLOAD HEADER ERROR	Download file header is invalid	Header Error Press Ok Button  Error 016-745 Press Ok Button	Replace the IP Board.
016	746	DOWNLOAD PROHIBIT ERROR		ProhibitionError Press Ok Button  Error 016-746 Press Ok Button	Replace the IP Board.
016	750		PDF print job ticket description error.	PDF Job Error Press Ok Button  Error 016-750 Press Ok Button	Replace the IP Board.
016	753		PDF password error	Wrong Password Press Ok Button  Error 016-753 Press Ok Button	Replace the IP Board.
016	755		PDF print is not allowed.	PDF Print Disabled  Error 016-755 Press Ok Button	Replace the IP Board.
016	757	Auditron - Invalid User	Account is not registered.	Invalid User Press Ok Button  Error 016-757 Press Ok Button	Replace the IP Board.
016	758	Auditron - Disabled Function	Detect invalid account.	Acct. Restricted Press Ok Button  Error 016-758 Press Ok Button	Replace the IP Board.

## Phaser 6600 Error Code List

Chain Link	Error	Error Details	Control Panel Messages	FIP location	
016	759	Auditron - Reached Limit	Reached the limit of the number of registered users.	Limit Exceeded Press Ok Button  Error 016-759 Press Ok Button	Replace the IP Board.
016	799	Job Environment Violation	Print condition conflicts with other condition.	Invalid Job Press Ok Button  Error 016-799 Press Ok Button	Replace the IP Board.
016	920	Wireless Setting Error Timeout Error		Wi-Fi Timeout Press Ok Button  Error 016-920 Press Ok Button	Replace the IP Board.
016	921	Wireless Setting Error Download Error		Wi-Fi DL Error Press Ok Button  Error 016-921 Press Ok Button	Replace the IP Board.
016	922	Wireless Setting Error Session Overlap Error		Wi-Fi SessionErr Press Ok Button  Error 016-922 Press Ok Button	Replace the IP Board.
016	923	Wireless Password Error	Wireless Password is wrong	Wi-Fi Password Error  Error 016-923 Press Ok Button	Replace the IP Board.
016	930	Warning when unsupported device is installed to USB host	<ul style="list-style-type: none"> <li>• Detect installation of device of which class driver cannot be found.</li> <li>• Detect installation of device that class driver judges not to support.</li> <li>• Detect installation of Low-Speed device.</li> </ul>	USB Memory Error Unsupported  Error 016-930 Unsupported	Replace the IP Board.
016	931	Warning to installation of hub that cannot be used to USB host.	Detect installation of hubs in more than supported number of stacks.	USB Memory Error Unsupported  Error 016-931 Unsupported	Replace the IP Board.



## Phaser 6600 Error Code List

Chain Link	Error	Error Details	Control Panel Messages	FIP location	
016	982	Disk Full		RAM Disk Full Press Ok Button  Error 016-982 Press Ok Button	Replace the IP Board.
024	340	IOT Firmware Error	Detect Firmware Error	MCU Firmware Err Power Off/On  Error 024-340 Power Off/On	Page 2-178
024	360	MCU DownLoad Error	MCU-F/W download failure	Download Error Send FW Data  Error 024-360 Send FW Data	-
024	362	IOT Start Image Marking Timeout	IOT internal error.	IOT Start Error Power Off/On  Error 024-362 Power Off/On	Page 2-190
024	371	IOT-ESS Communication Fail	Communication fail between IOT and ESS.	MCU Comm. Error Power Off/On  Error 024-371 Power Off/On	Replace the IP Board.
024	920	<IOT Standard Stacker Full>	Center Tray Full is Detected.	Output Tray Full Remove Paper	Page 2-190
024	927	Mono only mode reached Limit	Mono only mode (plural color toners are empty) reached Limit	PluralTonerEmpty ReplaceCartridge	Replace Toner Cartridges.
024	947 948	Tray Detached	Tray 1 : 947 Tray 2 : 948	TrayN Missing Insert TrayN  Error 024-xxx Insert TrayN	Insert the tray.
027	446	IPv6 duplicate	At start-up, detect duplicate IPv6 address on network.	XXXXXXXXXXXXXXXXXX IPv6 Duplicate	Replace the IP Board.
027	452	IPv4 duplicate	At start-up, detect duplicate IPv4 address on network.	XXXXXXXXXXXXXXXXXX IPv4 Duplicate	Replace the IP Board.

## Phaser 6600 Error Code List

Chain Link	Error	Error Details	Control Panel Messages	FIP location	
041	340	IOT NVRAM Error	Detect NVRAM Error	MCU NVRAM Error Power Off/On  Error 041-340 Power Off/On	Page 2-178
041	347	IOT I/F Failure	MCU Internal Error(I/F part)	MCU Int. Error Power Off/On  Error 041-347 Power Off/On	Replace the MCU Board.
042	313	IOT Fan Motor Failure	Detect Fan Motor Error	Fan Motor Error Power Off/On  Error 042-313 Power Off/On	Page 2-177
042	325	IOT Motor Failure	Detect Motor Failure	Motor Error Power Off/On  Error 042-325 Power Off/On	Page 2-180
042	326	IOT Motor Failure	Detect Motor Failure	Motor Error Power Off/On  Error 042-326 Power Off/On	Page 2-181
042	700	IOT Over Heat Stop	IOT Over Heat Stop	Printer Error Power Off/On  Error 042-700 Power Off/On	Page 2-189
046	310	IOT HVPS Error	Detect HVPS Error	HVPS Error Power Off/On  Error 046-310 Power Off/On	Page 2-191
050	111	IOT Rear Cover	Paper Jam Detected Zone IOT RearCover	Paper Jam Open Rear Cover and remove jammed paper	1. Open the Rear Cover 2. Remove any jammed paper 3. Close the Rear Cover

## Phaser 6600 Error Code List

Chain Link	Error	Error Details	Control Panel Messages	FIP location	
050	112	MSI	Paper Jam Detected Zone MSI	Paper Jam Open BypassTray and Tray1, remove paper.	1. Pull out papers on the Bypass Tray 2. Pull out Bypass Tray 3. Pull out Tray1 4. Remove any jammed paper 5. Push Tray1 back in 6. Push Bypass Tray back in
050	121	IOT Remain Zone 1T JAM	Paper Jam Detected Zone 1T	Paper Jam Open Tray1 and remove paper PressOK to start	Open Tray1 & Remove paper
050	122	IOT Remain Zone 2T JAM	Paper Jam Detected Zone 2T	Paper Jam Open Tray2 and remove paper	Open Tray2 & Remove paper

## Phaser 6600 Error Code List

Chain Link	Error	Error Details	Control Panel Messages	FIP location	
050	129	IOT Rear Cover and MSI	Paper Jam Detected Zone IOT RearCover and MSI	Paper Jam Open BypassTray, Tray1, RearCover and remove paper	1. Pull out papers on the Bypass Tray 2. Pull out Bypass Tray 3. Pull out Tray1 4. Remove any jammed paper 5. Push Tray1 back in 6. Push Bypass Tray back in 7. Open the Rear Cover if cannot remove any jammed paper 8. Remove any jammed paper 9. Close the Rear Cover
061	370	IOT ROS Failure	Detect ROS Failure	Laser Error Power Off/On  Error 061-370 Power Off/On	Page 2-179
071	100	IOT Tray1 Misfeed JAM	Detect Tray1 Misfeed JAM	no message	Page 2-192
072	100	IOT Tray2 Misfeed JAM	Detect Tray2 Misfeed	no message	Page 2-193
072	101	IOT Path2 SNS On JAM	Detect Path2 SNS On JAM	no message	Page 2-193
072	211	IOT Option Feeder2 Failure	Detect Feeder2 Failure	Tray2 Error Power Off/On  Error 072-211 Power Off/On	Page 2-178
075	100	MSI Misfeed JAM	Detect VSYNC On JAM(TBD)	no message	Page 2-195

## Phaser 6600 Error Code List

Chain Link	Error	Error Details	Control Panel Messages	FIP location	
075	910	MSI Detached	MSI Detached	Bypass Tray Missing Error 075-910 Insert the Tray	Page 2-196
077	101	VSYNC ON JAM	Detect VSYNC On JAM	no message	Replace the MCU Board.
077	104	RegOff JAM	Detect RegOff JAM	no message	Page 2-197
077	106	Exit ON JAM	Detect Exit ON JAM	no message	Page 2-197
077	107	Duplex ON JAM	Detect Duplex ON JAM(TBD)	no message	Page 2-198
077	108	ExitOff early JAM	Detect ExitOff early JAM	no message	Page 2-198
077	109	ExitOff JAM	Detect IOT Exit Sensor Off JAM	no message	Page 2-198
077	215	IOT Duplexer Error		Duplexer Error Power Off/On Error 077-215 Power Off/On	-
077	217	Duplex Mis-configuration	Duplex Mis-configuration	Duplexer Error Power Off/On Error 077-217 Power Off/On	Replace the MCU Board.
077	300	IOT Cover Front Open	FrontCover Open. Beep sounds after FrontCover remains open for 3 minutes.	Front Cover Open Close FrontCover	Page 2-199
077	301	<IOT Side Cover Open>	Side Cover is open.	Side Door Open Close Side Door	Page 2-199
077	304	IOT Cover Rear Open	Rear Cover Open	Rear Cover Open Close Rear Cover	Page 2-200
077	312	Tray Configure Error	Combination of trays was illegal.	Tray Config Err. Power Off/On Error 077-312 Power Off/On	-
091	400	IOT Waste Toner Box Near Life	Detect Waste Toner Box Near Life	XXXXXXXXXXXXXXXXXX Waste Toner Box XXXXXXXXXXXXXXXXXX Replace Soon	Page 2-200

**Phaser 6600 Error Code List**

Chain Link	Error	Error Details	Control Panel Messages	FIP location	
091	402	IOT Drum Cartridge Kit Life Pre Warning	Detect Drum Life Warning	XXXXXXXXXXXXXXXXXX IU Kit Life Low  XXXXXXXXXXXXXXXXXX Replace Soon	Replace the Imaging Unit.
091	911	IOT Waste Toner Box Life Over	Detect Waste Toner Box Life Over	Replace Waste Toner Box	Page 2-200
091	914	IOT K Drum Comm Fail	Detect Black Drum Comm Fail	Blk - IU Error Reseat IU  Error 091-914 Reseat IU	Page 2-201
091	915	DRUM UnitK CRUM Data Broken Fail	Wrong data in CRUM of drum K	Blk - IU Error Reseat IU  Error 091-915 Reseat IU	Page 2-203
091	917	IOT Y Drum Comm Fail	Detect Yellow Drum Comm Fail	Y - IU Error Reseat IU  Error 091-917 Reseat IU	Page 2-201
091	918	IOT M Drum Comm Fail	Detect Magenta Drum Comm Fail	M - IU Error Reseat IU  Error 091-918 Reseat IU	Page 2-202
091	919	IOT C Drum Comm Fail	Detect Cyan Drum Comm Fail	C - IU Error Reseat IU  Error 091-919 Reseat IU	Page 2-203
091	920	DRUM Y CRUM Data Broken Fail	Wrong data in CRUM of drum Y	Y - IU Error Reseat IU  Error 091-920 Reseat IU	Page 2-204
091	921	IOT K Drum Detached	Black	Insert Black Imaging Unit	Reinsert the Black Imaging Unit.
091	922	DRUM M CRUM Data Broken Fail	Wrong data in CRUM of drum M	M - IU Error Reseat IU  Error 091-922 Reseat IU	Page 2-204

## Phaser 6600 Error Code List

Chain Link	Error	Error Details	Control Panel Messages	FIP location	
091	923	DRUM C CRUM Data Broken Fail	Wrong data in CRUM of drum C	C - IU Error Reseat IU  Error 091-923 Reseat IU	Page 2-204
091	927	IOT Y Drum Detached	Yellow	Insert Yellow Imaging Unit	Reinsert the Yellow Imaging Unit.
091	928	IOT M Drum Detached	Magenta	Insert Magenta Imaging Unit	Reinsert the Magenta Imaging Unit.
091	929	IOT C Drum Detached	Cyan	Insert Cyan Imaging Unit	Reinsert the Cyan Imaging Unit.
091	935	IOT Drum Cartridge Kit Life Over	Detect Drum Cartridge Kit Life Over	Replace Imaging Unit Kit	Replace the Imaging Unit.
091	960	IOT X CRUM ID Error	Detect Y Drum CRUM ID Warning	Invalid Yellow Imaging Unit	Page 2-204
091	961	IOT X CRUM ID Error	Detect M Drum CRUM ID Warning	Invalid Magenta Imaging Unit	Page 2-204
091	962	IOT X CRUM ID Error	Detect C Drum CRUM ID Warning	Invalid Cyan Imaging Unit	Page 2-204
091	963	IOT X CRUM ID Error	Detect K Drum CRUM ID Warning	Invalid Black Imaging Unit	Page 2-203
092	310	IOT CTD Sensor Error	Detect CTD Sensor Error	CTD Sensor Error Power Off/On  Error 092-310 Power Off/On	Page 2-183
092	410	CTD Sensor Dustiness	Detect CTD Sensor Warning	XXXXXXXXXXXXXXXXXX Clean CTD Sensor	Clean the CTD Sensor.
092	661	IOT Environment Sensor Error	Detect Environment Sensor Error	Env Sensor Error Power Off/On  Error 092-661 Power Off/On	Page 2-179

**Phaser 6600 Error Code List**

Chain Link	Error	Error Details	Control Panel Messages	FIP location
092	670	Yellow Patch Error	IOT could not recovery toner density.  Y Test Patch Err Power Off/On  Error 092-670 Power Off/On	Page 2-205
092	671	Magenta Patch Error	IOT could not recovery toner density.  M Test Patch Err Power Off/On  Error 092-671 Power Off/On	Page 2-205
092	672	Cyan Patch Error	IOT could not recovery toner density.  C Test Patch Err Power Off/On  Error 092-672 Power Off/On	Page 2-207
092	673	Black Patch Error	IOT could not recovery toner density.  K Test Patch Err Power Off/On  Error 092-673 Power Off/On	Page 2-207
093	320	IOT Deve Motor Fail	Detect Developer Motor Failure  Deve Motor Error Power Off/On  Error 093-320 Power Off/On	Page 2-182
093	423	IOT X Toner Near Life	Y  XXXXXXXXXXXXXXXXXX Yellow Low  XXXXXXXXXXXXXXXXXX Replace Soon	Replace the Yellow Toner Cartridge.
093	424	IOT X Toner Near Life	M  XXXXXXXXXXXXXXXXXX Magenta Low  XXXXXXXXXXXXXXXXXX Replace Soon	Replace the Magenta Toner Cartridge.
093	425	IOT X Toner Near Life	C  XXXXXXXXXXXXXXXXXX Cyan Low  XXXXXXXXXXXXXXXXXX Replace Soon	Replace the Cyan Toner Cartridge.
093	426	IOT X Toner Near Life	K  XXXXXXXXXXXXXXXXXX Black Low  XXXXXXXXXXXXXXXXXX Replace Soon	Replace the Black Toner Cartridge.



## Phaser 6600 Error Code List

Chain Link	Error	Error Details	Control Panel Messages	FIP location	
093	925	IOT X CRUM Error	Detect Black CRUM Error	Blk - CRUM Error Reseat Cartridge  Error 093-925 Reseat Cartridge	Page 2-187
093	926	IOT X CRUM ID Error	Detect K Toner CRUM ID Warning	Invalid Black	Page 2-188
093	928	IOT K Toner Type Error	Black Toner Type Error	Blk - Type Error Reseat Cartridge  Error 093-928 Reseat Cartridge	Page 2-188
093	930	IOT X Toner Life Over	Y	Replace Yellow Cartridge	Replace the Yellow Toner Cartridge.
093	931	IOT X Toner Life Over	M	Replace Magenta Cartridge	Replace the Magenta Toner Cartridge.
093	932	IOT X Toner Life Over	C	Replace Cyan Cartridge	Replace the Cyan Toner Cartridge.
093	933	IOT X Toner Life Over	K	Replace Black Cartridge	Replace the Black Toner Cartridge.
093	950	IOT X CRUM Error	Detect Yellow CRUM Error	Y - CRUM Error Reseat Cartridge  Error 093-950 Reseat Cartridge	Page 2-184
093	951	IOT X CRUM Error	Detect Magenta CRUM Error	M - CRUM Error Reseat Cartridge  Error 093-951 Reseat Cartridge	Page 2-185
093	952	IOT X CRUM Error	Detect Cyan CRUM Error	C - CRUM Error Reseat Cartridge  Error 093-952 Reseat Cartridge	Page 2-186
093	960	IOT X CRUM ID Error	Detect Y Toner CRUM ID Warning	Invalid Yellow	Page 2-187
093	961	IOT X CRUM ID Error	Detect M Toner CRUM ID Warning	Invalid Magenta	Page 2-188

## Phaser 6600 Error Code List

Chain Link	Error	Error Details	Control Panel Messages	FIP location	
093	962	IOT X CRUM ID Error	Detect C Toner CRUM ID Warning	Invalid Cyan	Page 2-188
093	970	IOT X Toner Detached	Y	Insert Yellow Cartridge	Reinsert the Yellow Imaging Unit.
093	971	IOT X Toner Detached	M	Insert Magenta Cartridge	Reinsert the Magenta Imaging Unit.
093	972	IOT X Toner Detached	C	Insert Cyan Cartridge	Reinsert the Cyan Imaging Unit.
093	973	IOT X Toner Detached	K	Insert Black Cartridge	Reinsert the Black Imaging Unit.
093	980	IOT Y Toner Type Error	Yellow Toner Type Error	Y - Type Error Reseat Cartridge  Error 093-980 Reseat Cartridge	Page 2-187
093	981	IOT M Toner Type Error	magenta Toner Type Error	M - Type Error Reseat Cartridge  Error 093-981 Reseat Cartridge	Page 2-188
093	982	IOT C Toner Type Error	Cyan Toner Type Error	C - Type Error Reseat Cartridge  Error 093-982 Reseat Cartridge	Page 2-188
094	417	Belt Unit Near End Warning	Transfer Belt Unit Near End Warning	XXXXXXXXXXXXXXXXXX TransferUnitLife  XXXXXXXXXXXXXXXXXX Replace Soon	-
094	420	Belt Unit End Warning	Transfer Belt Unit End Warning	XXXXXXXXXXXXXXXXXX Replace Trans	-
094	910	Belt Detached	Belt Detached is detected.	Insert Transfer Unit	Reinsert the Transfer Belt Unit.

## Phaser 6600 Error Code List

Chain Link	Error	Error Details	Control Panel Messages	FIP location	
094	911	IOT Belt Unit Life Over	Detect Belt Unit Life Over	Replace Transfer Unit  Has Trans Unit been replaced?  (Press <b>OK</b> to counter reset.)	Replace the Transfer Belt Unit.
116	210	USB Host Error	Fatal error of USB Host driver	USB Host Error Power Off/On  Error 116-210 Power Off/On	Replace the IP Board.
116	312	Encryption Key Error	Encryption key mismatch	HDD Error Power Off/On  Error 116-312 Power Off/On	Replace the IP Board.
116	313	Encryption Setting Error	Encryption setting mismatch	HDD Error Power Off/On  Error 116-313 Power Off/On	Replace the IP Board.
116	314	On Board Network MAC Address Checksum Error		MAC Addr. Error Power Off/On  Error 116-314 Power Off/On	Replace the IP Board.
116	315	ESS On Board RAM W/R Check Fail	Detected by On Board RAM W/R Check at the time of initialization.	RAM Error Power Off/On  Error 116-315 Power Off/On	Replace the IP Board.
116	316	ESS DIMM Slot RAM W/R Check Fail	Detected by DIMM Slot RAM W/R Check at the time of initialization.	DIMM RAM Error Reseat Memory  Error 116-316 Power Off/On	Replace the IP Board.
116	317	ESS ROM Check(Main) Fail	Main Program ROM checksum error	Controller Error Power Off/On  Error 116-317 Power Off/On	Replace the IP Board.
116	320	ESS DIMM Slot RAM Error	Occurs when unusable DIMM is inserted in DIMM slot in initialization processing at power-on.	DIMM Error Reseat Memory  Error 116-320 Power Off/On	Replace the IP Board.

## Phaser 6600 Error Code List

Chain Link	Error	Error Details	Control Panel Messages	FIP location	
116	323	ESS NVRAM1 W/R Check Fail	Detected by master NVRAM W/R check	NVRAM Error Power Off/On  Error 116-323 Power Off/On	Replace the IP Board.
116	324	ESS Illegal Exception	CPU illegal exception	Controller Error Power Off/On  Error 116-324 Power Off/On	Replace the IP Board.
116	325	ESS NVRAM3 W/R Check Fail	It detects with the W/Rcheck of a Slave NVRAM at the time of initialization.	NVRAM Error Power Off/On  Error 116-325 Power Off/On	Replace the IP Board.
116	326	Reserved(For NVRAM2)		NVRAM Error Power Off/On  Error 116-326 Power Off/On	Replace the IP Board.
116	327	ESS Instruction Cache Error	CPU instruction cache error	Controller Error Power Off/On  Error 116-327 Power Off/On	Replace the IP Board.
116	328	ESS Data Cache Error	CPU data cache error	Controller Error Power Off/On  Error 116-328 Power Off/On	Replace the Fuser Assembly.
116	343	ASIC Fail	TBD	ASIC Error Power Off/On  Error 116-343 Power Off/On	Replace the IP Board.
116	350	On Board Network Communication Fail	Communication fail between 1 CPU network and ESS F/W.	Network Error Power Off/On  Error 116-350 Power Off/On	Replace the IP Board.
116	351	On Board Network Ethernet BIST parity/RAM R/W Error		Network Error Power Off/On  Error 116-351 Power Off/On	Replace the IP Board.

## Phaser 6600 Error Code List

Chain Link	Error	Error Details	Control Panel Messages	FIP location
116	352	On Board Network Internal Loopback Error	Network Error Power Off/On  Error 116-352 Power Off/On	Replace the IP Board.
116	353	ESS HD Fail	Detect HDD Error  HDD Error Power Off/On  Error 116-353 Power Off/On	Replace the IP Board.
116	355	On Board Network Fatal Error	Network Error Power Off/On  Error 116-355 Power Off/On	Replace the IP Board.
116	356	HDD Overwrite Error	Error has occurred during HDD overwrite.  HDD Error Power Off/On  Error 116-356 Power Off/On	Replace the IP Board.
116	361	PCI Bus#0 Error Detected	PCI Bus#0 Uncorrectable Error Detected * Connected with RemoraEX(x4 port)  PCI Error Power Off/On  Error 116-361 Power Off/On	Replace the IP Board.
116	362	PCI Bus#0 Host Bridge Controller Error	PCI Bus#0 Host Bridge Controller Error (Connected with RemoraEX port)  PCI Error Power Off/On  Error 116-362 Power Off/On	Replace the IP Board.
116	363	PCI Bus#1 Host Bridge Controller Error	PCI Bus#1 Host Bridge Controller Error (Connected with RemoraEX port)  PCI Error Power Off/On  Error 116-363 Power Off/On	Replace the IP Board.
116	364	Timer Fail	Timer error is detected  Clock Error Power Off/On  Error 116-364 Power Off/On	Replace the IP Board.
116	366	PCI Bus#1 Error Detected	PCI Bus#1 Uncorrectable Error Detected * Connected with RemoraEX(x1 port)  PCI Error Power Off/On  Error 116-366 Power Off/On	Replace the IP Board.

**Phaser 6600 Error Code List**

Chain Link	Error	Error Details	Control Panel Messages	FIP location	
116	368	PCI Error Messages received from Bus#0-Device#1	RemoraEX PCI x1 port Error * DeviceID 0x65 (x1)	PCI Error Power Off/On  Error 116-368 Power Off/On	Replace the IP Board.
116	369	PCI Error Messages received from Bus#0-Device#0	RemoraEX PCI x4 port Error * DeviceID 0x64 (x4)	PCI Error Power Off/On  Error 116-369 Power Off/On	Replace the IP Board.
116	390	ESS NVRAM1 SIZE And ID Check Fail	Detected by consistency check between NVRAM size requested by the system and actual size and consistency check of ID recorded at the first power-on.	NVRAM Error Power Off/On  Error 116-390 Power Off/On	Replace the IP Board.
116	719	XPIF Parameter Cancelled	Due to conflict among multiple print instructions, print instructions are ignored.	-	Replace the IP Board.
116	721	Collate Full		Memory Full Press Ok Button  Error 116-721 Press Ok Button	Replace the IP Board.
124	310	IOT XPC Error	Detect XPC Error	IOT XPC Error Power Off/On  Error 124-310 Power Off/On	Replace the IP Board.
124	313	Serial No Fail	Serial No Fail	Serial No. Fail Power Off/On  P/J 251 on the EEPROM board not plugged in.	Replace the IP Board.
142	700	IOT Over Heat Forced Half Speed	IOT change half speed due to over heat.	XXXXXXXXXXXXXXXXXX Over Heating  XXXXXXXXXXXXXXXXXX Run Half-speed	-
193	700	Custom Toner Mode	Custom Toner Mode	XXXXXXXXXXXXXXXXXX Non-Xerox Toner	-

## Phaser 6600 Error Code List

Chain Link		Error	Error Details	Control Panel Messages	FIP location
024	910	IOT Paper Size Mismatch	Detect Paper Size Mismatch	Load NNN XXX	-
024	911				
024	958			BypassTray : 958 Tray 1 : 910 Tray 2 : 911	
024	959	No Suitable Paper	<ul style="list-style-type: none"> <li>• Displayed when any of the following errors occurs and tray setting needs to be changed after paper is loaded.</li> <li>• When paper source auto selection is selected, paper sizes of all existing trays do not match. (All Tray Size Mismatch?)</li> <li>• When a tray is specified, no paper is loaded in the specified tray. (Specified Tray Empty?)</li> <li>• When a tray is specified, paper size loaded in the specified tray does not match. (Specified Tray Size Mismatch?)</li> <li>• When Substitute Tray is Off and a paper type is specified, there is no tray loading the specified paper type. (Specified Tray Media Mismatch)</li> </ul>	Load NNN XXX	-
024	960				
024	963			BypassTray : 963 Tray 1 : 959 Tray 2 : 960	
071	920	Waiting for side 2 to be set for manual duplex print(Tray)	Tray 1 : 071 Tray 2 : 072 Manual Feed : 075	Insert Output to NNN	-
072	920				
075	920				

### Phaser 6600 Error Code List

Chain Link	Error	Error Details	Control Panel Messages	FIP location	
071 072 075	921	Waiting for dashdashSetdash key to be pressed after setting side 2 for manual duplex print(Tray)	Tray Tray 1 : 071 Tray 2 : 072 Manual Feed : 075	Press Ok Button to continue	-

### WorkCentre 6605 Error Code List

#### WorkCentre 6605 Error Code List

Chain Link	Error	Error Details	Control Panel Messages	FIP location	
004	310	IOT Feeder I/F Failure	IOT-FEEDER communication error	Optional Feeder Error 004-310 Reset Optional Feeder. Power Off/On the Printer. If this failure occurs again, please contact customer support.	Page 2-178
005	110	PICKUP JAM	Detect PICKUPJAM	Paper Jam Open the Document Feeder Cover and remove paper.  <After Jam recovery> Reload the original that was removed from the Document Feeder and press the Start button. N Scanned	Page 2-208
005	121	ADF JAM	Detect ADFJAM	Paper Jam Open the Document Feeder Cover and remove paper.  <After Jam recovery> Reload the original that was removed from the Document Feeder and press the Start button. N Scanned	Page 2-208
005	124	Virtual JAM	Detect HARFJAM	Document Feeder Jam Job Canceled. Open Document Feeder Cover and Remove Jammed Paper.	Page 2-208
005	301	ADF Cover Open	ADF cover open	Document Feeder Cover Open Close Document Feeder Cover.	Page 2-209



## WorkCentre 6605 Error Code List

Chain Link	Error	Error Details	Control Panel Messages	FIP location	
010	317	IOT Fuser Detached	Detect Fuser Detached	Fuser Connection Error 010-317 Turn off the printer and reseal the Fuser.	Page 2-189
010	351	IOT Fuser Life Over	Detect Fuser Life Over	Fuser End of Life 010-351 Turn off the printer and replace the Fuser. Pressing <b>OK</b> will reset the counter due to the use of a new fuser. * Fault screen with <b>OK</b> button  -> (Press <b>OK</b> to counter reset.)  Fuser End of Life Reset is completed. Switch off the power and ensure that you replace the fuser.	Page 2-189
010	397	IOT Fuser Failure	Detect Fuser Error	Fuser Error 010-397 Power Off/On the Printer. If this failure occurs again, please contact customer support. Code:xxxxxxxh	Page 2-189
010	420	IOT Fuser Near End Warning	Fuser Near End Warning	XXXXXXXXXXXXXXXXXX Fuser Near End of Life, Replace Soon	Replace the Fuser Assembly.
010	421	IOT Fuser Life Pre Warning	Detect Fuser Life Warning	XXXXXXXXXXXXXXXXXX Fuser Near End of Life	Replace the Fuser Assembly.
016	338	Wi-Fi Option Error	Wi-Fi Driver starting error.	Reseat Wi-Fi Option 016-338 Power Off/On the Printer and contact the administrator if problem persists after reboot.	Replace the IP Board.
016	369	UI Panel - ESS Communication Fail	Communication Fail with a UI Panel and ESS F/W.	Control Panel Error 016-369 Power Off/On the Printer. If this failure occurs again, please contact customer support.	Replace the IP Board.

## WorkCentre 6605 Error Code List

Chain Link	Error	Error Details	Control Panel Messages	FIP location	
016	404	Certificate DB Error	Certificate DB access error	Certificate Failure 016-404 Contact the administrator. Initialization required. Press <b>OK</b> to start certificate initialization. After initialization, reboot the printer.  * Fault screen with <b>OK</b> button	Replace the IP Board.
016	405	Certificate DB Error	Invalid security setting error	Certificate Failure 016-405 Contact the administrator. Initialization required. Press <b>OK</b> to start certificate initialization. After initialization, reboot the printer.  * Fault screen with <b>OK</b> button	Replace the IP Board.
016	500	DOWNLOAD DELETE ERROR	Flash delete error in download.	Flash ROM Erase Error 016-500 Job canceled. Power Off/On the Printer.	Replace the IP Board.
016	501	DOWNLOAD WRITE ERROR	Flash write error in download.	Flash ROM Write Error 016-501 Job canceled. Power Off/On the Printer.	Replace the IP Board.
016	502	DOWNLOAD VERIFY ERROR	Flash verify error in download.	Flash ROM Verification Error 016-502 Job canceled. Power Off/On the Printer.	Replace the IP Board.
016	503	SMTP Server Address Resolution Fail for Maillib	SMTP server name resolution for email send failed. MAIL F2N_ERR_MAIL_INVALID_SMTP_SVR	Scan to Email Error 016-503 Unable to resolve Email SMTP Server hostname. Please check the SMTP and DNS Server settings, or contact your System Administrator. Job canceled.  * Caution screen with [Close] button	Replace the IP Board.

## WorkCentre 6605 Error Code List

Chain Link	Error	Error Details	Control Panel Messages	FIP location	
016	504	POP Server Address Resolution Fail for Maillib	POP3 server name resolution for email send failed. MAIL F2N_ERR_MAIL_INVALID_POP3_SVR	Scan to Email Error 016-504 Unable to resolve Email POP3 Server Hostname. Please check the POP3 and DNS Server settings, or contact your System Administrator. Job canceled.  * Caution screen with [Close] button	Replace the IP Board.
016	505	POP Authentication Fail for Maillib	Cannot login to POP3 server to send email. MAIL F2N_ERR_MAIL_INVALID_POP3_PASS	Scan to Email Error 016-505 Email POP3 Server Login Error. Please check the POP3 Server settings and confirm the login details, or contact your System Administrator. Job canceled.  * Caution screen with [Close] button	Replace the IP Board.
016	506	Required user entry item is empty	Some item is not set. MAIL F2N_ERR_MAIL_EMPTY_P ARAM	Scan to Email Error 016-506 SMTP Server not configured. Please configure the Email SMTP Server Settings on the printer's Web Interface. Job canceled.  * Caution screen with [Close] button	Replace the IP Board.
016	507	SMTP Authentication Fail for Maillib	Cannot login to SMTP server to send email. MAIL F2N_ERR_MAIL_INVALID_SMTP_PASS	Scan to Email Error 016-507 Email SMTP Server Login Error. Please check the SMTP Server settings and confirm the login details, or contact your System Administrator. Job canceled.  * Caution screen with [Close] button	Replace the IP Board.
016	520	Ipssec Certificate Error	Self device certificate error	Certificate Failure 016-520 Power Off/On the Printer and contact the administrator if problem persists after reboot.	Replace the IP Board.

## WorkCentre 6605 Error Code List

Chain Link	Error	Error Details	Control Panel Messages	FIP location	
016	521	Ipssec Certificate Error	Remote device certification verification error	Certificate Failure 016-521 Power Off/On the Printer and contact the administrator if problem persists after reboot.	Replace the IP Board.
016	522	LDAP Certificate Error	No client certificate exists	Certificate Failure 016-522 Power Off/On the Printer and contact the administrator if problem persists after reboot.	Replace the IP Board.
016	523	LDAP Certificate Error	Server certificate verification error.	Certificate Failure 016-523 Power Off/On the Printer and contact the administrator if problem persists after reboot.	Replace the IP Board.
016	524	LDAP Certificate Error	No server certificate exists	Certificate Failure 016-524 Power Off/On the Printer and contact the administrator if problem persists after reboot.	Replace the IP Board.
016	527	LDAP Certificate Error	SSL authentication internal error	Certificate Failure 016-527 Power Off/On the Printer and contact the administrator if problem persists after reboot.	Replace the IP Board.
016	530	LDAP Address Book - Access Error	LDAP Address Book Other Access Errors.	Certificate Error 016-530 Job canceled. Power Off/On the Printer.	Replace the IP Board.
016	541	Wi-Fi Certificate Error	No certificate exists.	Certificate Failure 016-541 Power Off/On the Printer and contact the administrator if problem persists after reboot.	Replace the IP Board.
016	542	Wi-Fi Certificate Error	Server certificate error.	Certificate Failure 016-542 Power Off/On the Printer and contact the administrator if problem persists after reboot.	Replace the IP Board.
016	543	Wi-Fi Certificate Error	Certificate corruption error	Certificate Failure 016-543 Power Off/On the Printer and contact the administrator if problem persists after reboot.	Replace the IP Board.

## WorkCentre 6605 Error Code List

Chain Link	Error	Error Details	Control Panel Messages	FIP location	
016	570	Job Ticket Out Of Memory	XPIF parser detects insufficient memory in the processing of XCPT (XPIF) interpretation.	Print Job Processing Error 016-570 Insufficient Memory for Job Ticket Processing Job canceled.  * Caution screen with [Close] button	Replace the IP Board.
016	571	Job ticket wrong param	Print instruction contents that the device cannot execute are detected.	Print Job Processing Error 016-571 Invalid Job Ticket Command Job canceled.  * Caution screen with [Close] button	Replace the IP Board.
016	572	Job ticket media error	The paper attribute specified by XCPT (XPIF) cannot solve paper selection.	Print Job Processing Error 016-572 Invalid Job Ticket Parameter Job canceled.  * Caution screen with [Close] button	Replace the IP Board.
016	573	Job ticket parse error	XPIF parser detects error other than those listed above.	Print Job Processing Error 016-573 Job Ticket Error Job canceled.  * Caution screen with [Close] button	Replace the IP Board.
016	602	System NVM Initialize	At POWON start-up, execute NVM clear.	Initialize NVM Initializing...	-
016	603	ESS-NVM Parameter Recover	Executed ESS-NVM Parameter Recovery	-	-
016	604	ESS-NVM Parameter Copy	Executed ESS-NVM Parameter Copy	-	-
016	605	ESS-NVM Parameter Copy	Executed ESS-NVM Parameter Copy	-	-
016	606	Clear Job History	Clear Job History	-	-

## WorkCentre 6605 Error Code List

Chain Link	Error	Error Details	Control Panel Messages	FIP location	
016	610	Panel Destination Mismatch (only for Production Line)	Tried to apply JP setting to non-JP panel, or tried to apply non-JP setting to JP panel.	Control Panel Error 016-610 Power Off/On the Printer. If this failure occurs again, please contact customer support.	Replace the IP Board.
016	612	Invalid MAC Address	MAC address is invalid (only for production line)	Invalid MAC Address 016-612 Power Off/On the Printer. If this failure occurs again, please contact customer support.	Replace the IP Board.
016	718	Memory Overflow		Job exceeded memory capacity. 016-718 Job canceled.  * Caution screen with [Close] button	Replace the IP Board.
016	720	PDL Error		Print Job Processing Error 016-720 Job canceled.  * Caution screen with [Close] button	Replace the IP Board.
016	737	DOWNLOAD FORMAT ERROR	Download file format is invalid.	File Format Error 016-737 Job canceled.  * Caution screen with [Close] button	Replace the IP Board.
016	741	DOWNLOAD PROTECT ERROR	Performed FW download although FW update is prohibited by panel settings.	File Protection Error 016-741 Job canceled.  * Caution screen with [Close] button	Replace the IP Board.
016	742	DOWNLOAD ID ERROR	Download file ID is invalid.	Invalid File ID 016-742 Job canceled.  * Caution screen with [Close] button	Replace the IP Board.
016	743	DOWNLOAD RANGE ERROR	At download, write-in destination address is invalid. Range check error.	Range Check Error 016-743 Job canceled.  * Caution screen with [Close] button	Replace the IP Board.

## WorkCentre 6605 Error Code List

Chain Link	Error	Error Details	Control Panel Messages	FIP location	
016	744	DOWNLOAD CHECKSUM ERROR	Download file checksum is invalid.	Check Sum Error 016-744 Job canceled.  * Caution screen with [Close] button	Replace the IP Board.
016	745	DOWNLOAD HEADER ERROR	Download file header is invalid	File Header Error 016-745 Job canceled.  * Caution screen with [Close] button	Replace the IP Board.
016	746	DOWNLOAD PROHIBIT ERROR		Prohibition Error 016-746 Job canceled.  * Caution screen with [Close] button	Verify that Software Download is enabled in CWIS.
016	750		PDF print job ticket description error.	PDF Job Processing Error 016-750 Invalid Job Ticket PDF Description. Job canceled.  * Caution screen with [Close] button	Replace the IP Board.
016	753		PDF password error	Wrong PDF Password 016-753 Job canceled.  * Caution screen with [Close] button	Replace the IP Board.
016	755		PDF print is not allowed.	Direct PDF Print Disabled 016-755 Job canceled.  * Caution screen with [Close] button	Replace the IP Board.
016	757	Auditron - Invalid User	Account is not registered.	Invalid User Account 016-757 Job canceled.  * Caution screen with [Close] button	Replace the IP Board.
016	758	Auditron - Disabled Function	Detect invalid account.	User Account Restriction 016-758 Job canceled.  * Caution screen with [Close] button	Replace the IP Board.

## WorkCentre 6605 Error Code List

Chain Link	Error	Error Details	Control Panel Messages	FIP location	
016	759	Auditron - Reached Limit	Reached the limit of the number of registered users.	User Account Limit Exceeded 016-759 Job canceled.  * Caution screen with [Close] button	Replace the IP Board.
016	764	SMTP Server Connection Error	Error occurs when connecting to SMTP server. MAIL F2N_ERR_MAIL_SVR_CONN_FAIL	Scan to Email Error 016-764 Unable to connect to Email SMTP Server. Please check the SMTP Server settings or contact your System Administrator. Job canceled.  * Caution screen with [Close] button	Replace the IP Board.
016	765	SMTP Server HD Full	Capacity of SMTP server is not enough. MAIL F2N_ERR_MAIL_SVR_SHORT_RESOURCE	Scan to Email Error 016-765 Email SMTP Server Capacity Exceeded. Contact System Administrator. Job canceled.  * Caution screen with [Close] button	Replace the IP Board.
016	766	SMTP Server File System Error	Error in SMTP server. MAIL F2N_ERR_MAIL_EXCEED_SVR_SIZE	Scan to Email Error 016-766 Email exceeds SMTP Server size restriction. Contact SMTP Server Administrator. Job canceled.  * Caution screen with [Close] button	Replace the IP Board.
016	767	Invalid Recipient Email Address	Recipient email address is incorrect. MAIL F2N_ERR_MAIL_INVALID_MAIL_ADDR	Scan to Email Error 016-767 Invalid Recipient Email Address. Please check the recipient Email Address and try again. Job canceled.  * Caution screen with [Close] button	Replace the IP Board.



## WorkCentre 6605 Error Code List

Chain Link	Error	Error Details	Control Panel Messages	FIP location	
016	768	Invalid Sender Address (Login Error)	Sender email address is incorrect. MAIL F2N_ERR_MAIL_INVALID_MAIL_FROM_A DDR	Scan to Email Error 016-768 Invalid Sender Email Address. Please check the sender Email Address and try again. Job canceled.  * Caution screen with [Close] button	Replace the IP Board.
016	786	Data Send/Receive Timeout Error	Timeout error occurs in scan data send/receive. MAIL/SMB/FTP F2N_ERR_TMO	Network Scan Timeout Error 016-786 Job canceled.  * Caution screen with [Close] button	Replace the IP Board.
016	790	F2N Module Starting-up	F2N module task is starting up, or IP address is not determined. F2N_ERR_F2N_INITIALIZING	Network Connection Error 016-790 Check network cable connection and the network status. If problem persists, contact network administrator.  * Caution screen with [Close] button	Replace the IP Board.
016	791	USB Memory Removal Error (During Read)	USB memory is removed while memory reading job is being executed.	USB Memory Read Error 016-791 Job canceled. Please insert USB memory and restart job.  * Caution screen with [Close] button	Replace the IP Board.
016	799	Job Environment Violation	Print condition conflicts with other condition.	Invalid Job 016-799 Job canceled.  * Caution screen with [Close] button	Replace the IP Board.
016	920	Wireless Setting Error Timeout Error		Wi-Fi Timeout Error 016-920 Try again.  * Caution screen with [Close] button	Replace the IP Board.
016	921	Wireless Setting Error Download Error		Wi-Fi Download Error 016-921 Try again.  * Caution screen with [Close] button	Replace the IP Board.

## WorkCentre 6605 Error Code List

Chain Link	Error	Error Details	Control Panel Messages	FIP location
016	922	Wireless Setting Error Session Overlap Error	Wireless Setting Error 016-922 Try again.  * Caution screen with [Close] button	Replace the IP Board.
016	923	Wireless Password Error	Wireless Password is wrong  Wi-Fi Password Error 016-923 Try again.  * Caution screen with [Close] button	Replace the IP Board.
016	930	Warning when unsupported device is installed to USB host	?Detect installation of device of which class driver cannot be found. ?Detect installation of device that class driver judges not to support. ?Detect installation of Low-Speed device.	Replace the IP Board.
016	931	Warning to installation of hub that cannot be used to USB host.	Detect installation of hubs in more than supported number of stacks.	Replace the IP Board.
016	982	Disk Full	RAM Disk Full 016-982 Job canceled.  * Caution screen with [Close] button	Replace the IP Board.
016	985	Mail Size Error	Exceed the max mail size specified on the menu. MAIL	Replace the IP Board.
016	986	File Size Error	As a result of conversion to the specified format, exceed the max file size specified for each format. MAIL/SMB/FTP	Replace the IP Board.

## WorkCentre 6605 Error Code List

Chain Link	Error	Error Details	Control Panel Messages	FIP location	
017	600	AddressInfo Sum Check Fail	At POWON start-up, check phone book and address book data and initializing incorrect data automatically.	Initialize User Data Initializing...	-
017	970		AIOC memory run out.	Fax Memory Error 017-970 Fax Memory Full. Check Job Status for pending fax jobs. Job canceled. Please try again later.  * Caution screen with [Close] button	Replace the IP Board.
017	971		Write error of image data storage FlashROM	Fax Controller Error 017-971 Write Error in FlashROM Image Data Storage Job canceled. Please try again.  * Caution screen with [Close] button	Replace the IP Board.
017	972		Erase error of image data storage FlashROM	Fax Controller Error 017-972 Erase Error in FlashROM Image Data Storage Job canceled. Please try again.  * Caution screen with [Close] button	Replace the IP Board.
017	973		Suspend error of image data storage FlashROM	Fax Controller Error 017-973 Suspend Error in FlashROM Image Data Storage. Job canceled. Please try again.  * Caution screen with [Close] button	Replace the IP Board.
017	974		Resume error of image data storage FlashROM	Fax Controller Error 017-974 Resume Error in FlashROM Image Data Storage Job canceled. Please try again.  * Caution screen with [Close] button	Replace the IP Board.

## WorkCentre 6605 Error Code List

Chain Link	Error	Error Details	Control Panel Messages	FIP location
017	975	Exceed the maximum number of file handles.	Fax Controller Error 017-975 Maximum number of file handles exceeded. Job canceled. Please restart device and try again.  * Caution screen with [Close] button	Replace the IP Board.
017	976	Exceed the maximum number of controlled files.	Fax Controller Error 017-976 Maximum number of controlled files exceeded. Job canceled. Please try again later.  * Caution screen with [Close] button	Replace the IP Board.
017	977	Exceed the maximum number of controlled documents.	Fax Controller Error 017-977 Maximum number of controlled documents exceeded. Job canceled. Please try again later.  * Caution screen with [Close] button	Replace the IP Board.
017	978	Exceed the maximum number of pages in document.	Fax Controller Error 017-978 Maximum number of pages exceeded. Job canceled. Please re-load document and try again.  * Caution screen with [Close] button	Replace the IP Board.
017	979	File multi-open	Fax Controller Error 017-979 Multiple Files Open Job canceled. Please restart device and try again.  * Caution screen with [Close] button	Replace the IP Board.
017	980	Report File Open/Close Error	Report job fails to open/close report file.  Fax Report Error 017-980 Failed to Open/Close Report File Job canceled.  * Caution screen with [Close] button	Replace the IP Board.

## WorkCentre 6605 Error Code List

Chain Link	Error	Error Details	Control Panel Messages	FIP location	
017	983	EEPROM R/W Error	At system boot, EEPROM Read/Write check error (sumcheck error)	Initialize NVM Initializing...	-
017	986		Create empty file (0Byte)	Fax Controller Error 017-986 Empty File created Job canceled. Please restart device and try again.  * Caution screen with [Close] button	Replace the IP Board.
017	987		Cannot read file because it is bigger than read destination buffer.	Fax Controller Error 017-987 File exceeds destination buffer size Job canceled. Please try again later.  * Caution screen with [Close] button	Replace the IP Board.
017	988		Timeout at start of ScanToApplicaion	Scan Job Timeout Error 017-988 Job canceled. Restart Scan Job.  * Caution screen with [Close] button	Replace the IP Board.
017	989		Stop writing because size of file to be written is bigger than read destination buffer (even if file writing is continued, it is impossible to read the file).	Fax Controller Error 017-989 File to be written exceeds destination buffer size Job canceled. Please try again later.  * Caution screen with [Close] button	Replace the IP Board.
017	990	IIT Auto Registration Adjustment Fail	Fail to adjust IIT registration automatically at start-up. Set to default value and continue processing.	no error Record to ErrorLog.	-
017	991	IIT Level Adjustment Fail	At the start of IIT read job, fail to adjust IIT level. Set to default value and continue processing.	no error Record to ErrorLog.	-

## WorkCentre 6605 Error Code List

Chain Link	Error	Error Details	Control Panel Messages	FIP location	
024	340	IOT Firmware Error	Detect Firmware Error	Engine Controller Error 024-340 Power Off/On the Printer. If this failure occurs again, please contact customer support. Code:xxxxxxxxh	Page 2-178
024	360	MCU DownLoad Error	MCU-F/W download failure	Engine Code DownLoad Error 024-360 Power Off/On Printer and Send Firmware Data again.	-
024	362	IOT Start Image Marking Timeout	IOT internal error.	Print Engine Start Error 024-362 Power Off/On the Printer. If this failure occurs again, please contact customer support.	Page 2-190
024	371	IOT-ESS Communication Fail	Communication fail between IOT and ESS.	Engine Communication Error 024-371 Power Off/On the Printer. If this failure occurs again, please contact customer support.	Replace the IP Board.
024	920	<IOT Standard Stacker Full>	Center Tray Full is Detected.	Output Tray Full Remove Paper from Output Tray.	Page 2-190
024	927	Mono only mode reached Limit	Mono only mode(plural color toners are empty) reached Limit	Multiple Toner Cartridges Empty Open the Front Cover. Then, replace Toner Cartridges.	Replace Toner Cartridges.
024	947 948	Tray Detached	Tray 1 : 947 Tray 2 : 948	Tray N Missing 024-xxx Insert Tray N.	Insert the tray.
026	720	USB Memory Full	Writing to USB memory failed.	USB Memory Full 026-720 Job canceled.  * Caution screen with [Close] button	Replace the IP Board.
026	721	USB Memory Write Error	Writing to USB memory failed.	USB Memory Write Error 026-721 Job canceled.  * Caution screen with [Close] button	Replace the IP Board.
027	446	IPv6 duplicate	At start-up, detect duplicate IPv6 address on network.	XXXXXXXXXXXXXXXXXXXX Duplicate IPv6 Addr, Reconfigure	Replace the IP Board.

## WorkCentre 6605 Error Code List

Chain Link	Error	Error Details	Control Panel Messages	FIP location	
027	452	IPv4 duplicate	At start-up, detect duplicate IPv4 address on network.	XXXXXXXXXXXXXXXXXX Duplicate IPv4 Addr, Reconfigure	Replace the IP Board.
031	521	In SMB scan, login-able workstation is restricted.	In SMB scan, login-able workstation is restricted. SMB F2N_ERR_SMB_RESTRICTED_WORKSTATION_FOR_LOGIN	Scan to SMB Error 031-521 SMB Server Login Error. Please check the SMB Server settings and confirm the login details, or contact your System Administrator. Job canceled.  * Caution screen with [Close] button	Replace the IP Board.
031	522	SMB user authentication fail or SMBScanener login fail	In SMB scan, login access is rejected. Request is not allowed. SMB F2N_ERR_SMB_PROTOCOL_ERR_1_005	Scan to SMB Error 031-522 SMB Server Login Error. Please check the SMB Server settings and confirm the login details, or contact your System Administrator. Job canceled.  * Caution screen with [Close] button	Replace the IP Board.
031	523	Problem with share name in SMB scan server.	Problem with share name in SM scan server. SMB F2N_ERR_SMB_SHARE_NAME	Scan to SMB Error 031-523 Invalid SMB Share name specified. Please check the SMB Server settings and confirm the Share name, or contact your System Administrator. Job canceled.  * Caution screen with [Close] button	Replace the IP Board.
031	524	SMB Scan User Overlimit	Exceed the upper limit of the number of SMB scan users. SMB F2N_ERR_SMB_USER_NUMBER_LIMIT	Scan to SMB Error 031-524 SMB Server user account limit exceeded. Contact your System Administrator. Job canceled.  * Caution screen with [Close] button	Replace the IP Board.

## WorkCentre 6605 Error Code List

Chain Link	Error	Error Details	Control Panel Messages	FIP location	
031	525	SMB scan client has no access right (Win9x)	SMB scan client has no access right. SMB F2N_ERR_SMB_CLIENT_RIGHT_TO_ACCESS	Scan to SMB Error 031-525 SMB destination client permission error. Please check the SMB Server settings and confirm the login details, or contact your System Administrator. Job canceled.  * Caution screen with [Close] button	Replace the IP Board.
031	526	SMB Scan Host Name Resolution Fail	SMB server name resolution failed SMB F2N_ERR_SMB_SERVER_NAME_SOLUTION	Scan to SMB Error 031-526 Unable to resolve SMB Server hostname. Please check the SMB and DNS Server settings, or contact your System Administrator.  * Caution screen with [Close] button	Replace the IP Board.
031	527	SMB Scan DNS Server Not Set	DNS server is not set. SMB F2N_ERR_SMB_DNSSERVER_SETUP	Scan to SMB Error 031-527 Unable to resolve SMB Server hostname. Please check the DNS Server settings or contact your System Administrator. Job canceled.  * Caution screen with [Close] button	Replace the IP Board.
031	528	In SMB scan, server connection error	Cannot find SMB server. SMB F2N_ERR_SMB_SERVER_NOT_FOUND	Scan to SMB Error 031-528 Unable to connect to SMB Server. Please check the SMB Server settings and confirm the SMB Server, or contact your System Administrator. Job canceled.  * Caution screen with [Close] button	Replace the IP Board.



## WorkCentre 6605 Error Code List

Chain Link	Error	Error Details	Control Panel Messages	FIP location	
031	529	Problem with SMB scan login name or password	Invalid password.(Win9x) SMB F2N_ERR_SMB_LOGIN_P ASSWD	Scan to SMB Error 031-529 SMB Server login error, invalid password. Please check the SMB Server settings and confirm the login password, or contact your System Administrator. Job canceled.  * Caution screen with [Close] button	Replace the IP Board.
031	530	Problem with storage location of scanned image in SMB scan server.	Problem with storage location. SMB F2N_ERR_SMB_SCAN_PL ACE_OF_DATA_SAVE	Scan to SMB Error 031-530 SMB Share folder was not found on the specified SMB server. Please check the SMB Server settings and confirm the SMB Server and Share name, or contact your System Administrator.  * Caution screen with [Close] button	Replace the IP Board.
031	531	Couldn't get file/folder name of SMB scan server.	Couldn't get file/folder name of server. SMB F2N_ERR_SMB_GET_FILE _OR_FOLDER_NAME_FRO M_SERVER	Scan to SMB Error 031-531 Unable to get file/folder name on SMB Server. Please check the SMB Server settings and confirm the SMB Server and Share name, or contact your System Administrator. Job canceled.  * Caution screen with [Close] button	Replace the IP Board.
031	532	Suffix of SMB scan file name/folder name is overlimit.	Suffix of file name/folder name is overlimit. SMB F2N_ERR_SMB_OVERLIM IT_SUFFIX_OF_FILE_OR_ FOLDER_NAME	Scan to SMB Error 031-532 SMB scan file/folder name limit exceeded. Reduce the SMB file/folder name length, or contact your System Administrator. Job canceled.  * Caution screen with [Close] button	Replace the IP Board.

## WorkCentre 6605 Error Code List

Chain Link	Error	Error Details	Control Panel Messages	FIP location	
031	533	SMB Scan File Creation Fail	Fail to create file. SMB F2N_ERR_SMB_SCAN_MK_FILE	Scan to SMB Error 031-533 Unable write file in SMB Server. Please check the SMB Server settings or contact your System Administrator. Job canceled.  * Caution screen with [Close] button	Replace the IP Board.
031	534	SMB Scan Folder Creation Fail	Fail to create folder. SMB F2N_ERR_SMB_SCAN_MK_FOLDER	Scan to SMB Error 031-534 Unable to create folder on SMB Server. Please check the SMB Server settings or contact your System Administrator. Job canceled.  * Caution screen with [Close] button	Replace the IP Board.
031	535	SMB Scan File Deletion Fail	Fail to delete file. SMB F2N_ERR_SMB_SCAN_DELETE_FILE	Scan to SMB Error 031-535 Unable to delete file on SMB Server. Please check if the file is currently in use and try again. Job canceled.  * Caution screen with [Close] button	Replace the IP Board.
031	536	SMB Scan Folder Deletion Fail	Fail to delete folder. SMB F2N_ERR_SMB_SCAN_DELETE_FOLDER	Scan to SMB Error 031-536 Unable to delete folder on SMB Server. Please check if the folder is currently in use and try again. Job canceled.  * Caution screen with [Close] button	Replace the IP Board.
031	537	No free space in storage location on SMB scan data server	Storage location has no free space. SMB F2N_ERR_SMB_SCAN_DISK_FULL	Scan to SMB Error 031-537 SMB Server Capacity Exceeded. Contact your System Administrator. Job canceled.  * Caution screen with [Close] button	Replace the IP Board.

## WorkCentre 6605 Error Code List

Chain Link	Error	Error Details	Control Panel Messages	FIP location	
031	539	Invalid SMB server (NetBIOS) name is specified.	Invalid SMB server (NetBIOS) name is specified. SMB F2N_ERR_SMB_SPECIFICATION_OF_SERVER_NAME	Scan to SMB Error 031-539 Invalid SMB server specified. Please check SMB Server settings and confirm the Server name, or contact your System Administrator. Job canceled.  * Caution screen with [Close] button	Replace the IP Board.
031	540	SMB protocol error(4-007)Invalid scan domain name is specified.	Invalid domain name is specified (User name is specified in domain user form) SMB F2N_ERR_SMB_PROTOCOL_ERR_4_007	Scan to SMB Error 031-540 Invalid domain name specified. Please check the SMB Server settings or contact your System Administrator. Job canceled.  * Caution screen with [Close] button	Replace the IP Board.
031	541	SMB protocol error (4-008) Invalid scan user name is specified.	Invalid scan user name is specified. SMB F2N_ERR_SMB_PROTOCOL_ERR_4_008	Scan to SMB Error 031-541 Invalid user name specified for SMB Server. Please check the SMB Server settings and confirm the login user, or contact your System Administrator. Job canceled.  * Caution screen with [Close] button	Replace the IP Board.
031	542	SMB(TCP/IP) is not active	SMB(TCP/IP) is not active. SMB F2N_ERR_SMB_TCPIP_NOT_INIT	Scan to SMB Error 031-542 TCP/IP not initialized. Job canceled. Please try again later.  * Caution screen with [Close] button	Replace the IP Board.
031	543	SMB protocol error(4-045) Scan login prohibited time	Login prohibited time. SMB F2N_ERR_SMB_PROTOCOL_ERR_4_045	Scan to SMB Error 031-543 SMB Server Login Error. Please check the SMB Server settings and confirm the login details, or contact your System Administrator. Job canceled.  * Caution screen with [Close] button	Replace the IP Board.

## WorkCentre 6605 Error Code List

Chain Link	Error	Error Details	Control Panel Messages	FIP location
031	544	SMB protocol error(4-046) Password expired.	<p>Password expired. SMB F2N_ERR_SMB_PROTOCOL_ERR_4_046</p> <p>Scan to SMB Error 031-544 SMB Server Login Error, password has expired. Please check the SMB Server settings and confirm the login password, or contact your System Administrator. Job canceled.</p> <p>* Caution screen with [Close] button</p>	Replace the IP Board.
031	545	SMB protocol error(4-047) Password change is required.	<p>Password change is required. SMB F2N_ERR_SMB_PROTOCOL_ERR_4_047</p> <p>Scan to SMB Error 031-545 SMB Server Login Error, a password change is required. Please check the SMB Server settings and update the login password, or contact your System Administrator. Job canceled.</p> <p>* Caution screen with [Close] button</p>	Replace the IP Board.
031	546	SMB protocol error(4-048) User is invalid	<p>User is invalid. SMB F2N_ERR_SMB_PROTOCOL_ERR_4_048</p> <p>Scan to SMB Error 031-546 SMB Server Login Error, invalid User specified. Please check the SMB Server settings and confirm the login user, or contact your System Administrator. Job canceled.</p> <p>* Caution screen with [Close] button</p>	Replace the IP Board.
031	547	SMB protocol error(4-049) Lock-out	<p>User is locked out. SMB F2N_ERR_SMB_PROTOCOL_ERR_4_049</p> <p>Scan to SMB Error 031-547 SMB Server Login Error, user specified is restricted. Please check the SMB Server settings and confirm the login user, or contact your System Administrator. Job canceled.</p> <p>* Caution screen with [Close] button</p>	Replace the IP Board.

## WorkCentre 6605 Error Code List

Chain Link	Error	Error Details	Control Panel Messages	FIP location	
031	548	SMB protocol error (4-050) User is expired.	User is expired. SMB F2N_ERR_SMB_PROTOCOL_ERR_4_050	Scan to SMB Error 031-548 SMB Server Login Error, user specified has expired. Please check the SMB Server settings and confirm the login user, or contact your System Administrator. Job canceled.  * Caution screen with [Close] button	Replace the IP Board.
031	549	SMB protocol error(4-051) User is restricted. Null password is prohibited.	User is restricted. Null password is prohibited. SMB F2N_ERR_SMB_PROTOCOL_ERR_4_051	Scan to SMB Error 031-549 SMB Server Login Error. User specified is restricted, null password is prohibited. Please check the SMB Server settings and confirm the login details, or contact your System Administrator. Job canceled.  * Caution screen wit	Replace the IP Board.
031	550	SMB Scan Append Command Fail	Have no append access right to the file. Server does not support SMB append command. SMB F2N_ERR_SMB_APPEND	Scan to SMB Error 031-550 Append command not supported by SMB Server. Contact your System Administrator. Job canceled.  * Caution screen with [Close] button	Replace the IP Board.
031	551	SMB Scan Rename Command Fail	Have no rename access right to the file. Server does not support SMB rename command. SMB F2N_ERR_SMB_RENAME	Scan to SMB Error 031-551 Rename command not supported by SMB Server. Contact your System Administrator. Job canceled.  * Caution screen with [Close] button	Replace the IP Board.

## WorkCentre 6605 Error Code List

Chain Link	Error	Error Details	Control Panel Messages	FIP location	
031	552	In SMB scan, "Cancel" is selected for processing in the case of file name duplication, and job is cancelled because of file name duplication.	"Cancel" is selected for processing in the case of file name duplication, and job is cancelled because of file name duplication. SMB F2N_ERR_SMB_SCAN_CANCEL_BECAUSE_OF_DUPLICATE	Scan to SMB Error 031-552 Job canceled.  * Caution screen with [Close] button	Replace the IP Board.
031	574	FTP Scan Host Name Resolution Fail	DNS library call error FTP F2N_ERR_FTP_SERVER_NAME_RESOLUTION	Scan to FTP Error 031-574 Unable to resolve FTP Server hostname. Please check the FTP and DNS Server settings, or contact your System Administrator. Job canceled.  * Caution screen with [Close] button	Replace the IP Board.
031	575	FTP Scan DNS Server Not Set	DNS library call error FTP F2N_ERR_FTP_DNSSERVER_SETUP	Scan to FTP Error 031-575 Unable to resolve FTP Server hostname. Please check the DNS Server settings, or contact System Administrator. Job canceled.  * Caution screen with [Close] button	Replace the IP Board.
031	576	Server Connection Error in FTP Scan	Network connection failed. FTP F2N_ERR_FTP_SERVER_NOT_FOUND	Scan to FTP Error 031-576 Unable to connect to FTP Server. Please check FTP Server settings or contact your System Administrator. Job canceled.  * Caution screen with [Close] button	Replace the IP Board.

## WorkCentre 6605 Error Code List

Chain Link	Error	Error Details	Control Panel Messages	FIP location	
031	578	FTP Scan Login Name or Password Error	<p>USER./PASS command failed.</p> <p>FTP</p> <p>F2N_ERR_FTP_LOGIN_USERNAME_OR_PASSWD</p>	<p>Scan to FTP Error 031-578</p> <p>FTP Server Login Error. Please check the FTP Server settings and confirm the login details, or contact your System Administrator.</p> <p>Job canceled.</p> <p>* Caution screen with [Close] button</p>	Replace the IP Board.
031	579	Problem with Location FTP-scanned Image is Saved in.	<p>Fail to move data to RepositoryPath.</p> <p>FTP</p> <p>F2N_ERR_FTP_SCAN_PLACE_OF_DATA_SAVE</p>	<p>Scan to FTP Error 031-579</p> <p>Invalid FTP Subdirectory Path. Please check the FTP Server settings and confirm the Subdirectory Path, or contact your System Administrator.</p> <p>Job canceled.</p> <p>* Caution screen with [Close] button</p>	Replace the IP Board.
031	580	Fail to get file name/folder name of FTP scan server	<p>NLST command failed.</p> <p>FTP</p> <p>F2N_ERR_FTP_GET_FILE_OR_FOLDER_NAME_FROM_SERVER</p>	<p>Scan to FTP Error 031-580</p> <p>Failed to obtain file/folder Name of FTP Server. NLST command failure.</p> <p>Contact System Administrator.</p> <p>Job canceled.</p> <p>* Caution screen with [Close] button</p>	Replace the IP Board.
031	581	Suffix of FTP scan file name/folder name is overlimit.	<p>Same as left.</p> <p>FTP</p> <p>F2N_ERR_FTP_OVERLIMIT_SUFFIX_OF_FILE_OR_FOLDER_NAME</p>	<p>Scan to FTP Error 031-581</p> <p>FTP scan file/folder name limit exceeded. Reduce the file/folder name length, or contact your System Administrator.</p> <p>Job canceled.</p> <p>* Caution screen with [Close] button</p>	Replace the IP Board.

## WorkCentre 6605 Error Code List

Chain Link	Error	Error Details	Control Panel Messages	FIP location	
031	582	FTP Scan File Creation Fail	STOR command failed. FTP F2N_ERR_FTP_SCAN_MK_FILE	Scan to FTP Error 031-582 Unable to write scan file to FTP Server location. STOR command failure. Contact your System Administrator. Job canceled.  * Caution screen with [Close] button	Replace the IP Board.
031	584	FTP Scan Folder Creation Fail	MKD command failed. FTP F2N_ERR_FTP_SCAN_MK_FOLDER	Scan to FTP Error 031-584 Unable to create scan folder on FTP Server. MKD command failure. Contact your System Administrator. Job canceled.  * Caution screen with [Close] button	Replace the IP Board.
031	585	FTP Scan File Deletion Fail	DEL command failed. FTP F2N_ERR_FTP_SCAN_DELETE_FILE	Scan to FTP Error 031-585 Unable to delete file on FTP Server. DEL command failure. Contact your System Administrator. Job canceled.  * Caution screen with [Close] button	Replace the IP Board.
031	587	FTP Scan Folder Deletion Fail	RMD command failed. FTP F2N_ERR_FTP_SCAN_DELETE_FOLDER	Scan to FTP Error 031-587 Unable to delete folder on FTP Server. RMD command failure. Contact your System Administrator. Job canceled.  * Caution screen with [Close] button	Replace the IP Board.
031	588	FTP Scan Server Data Write Fail	write( ) failed. FTP F2N_ERR_FTP_SCAN_DATA_WRITE_FOR_SERVER	Scan to FTP Error 031-588 Unable to write file in FTP Server location. Contact your System Administrator. Job canceled.  * Caution screen with [Close] button	Replace the IP Board.



## WorkCentre 6605 Error Code List

Chain Link	Error	Error Details	Control Panel Messages	FIP location	
031	590	In FTP scan, "Cancel" is selected for processing in the case of file name duplication, and job is cancelled because of file name duplication.	"Cancel" is selected for processing in the case of file name duplication, and job is cancelled because of file name duplication. FTP F2N_ERR_FTP_SCAN_CANCEL_BECAUSE_OF_DUPLICATE	Scan to FTP Error 031-590 Job canceled.  * Caution screen with [Close] button	Replace the IP Board.
031	594	FTP Scan TYPE Command Fail (Network Error)	TYPE command failed. FTP F2N_ERR_FTP_SCAN_TYPE_COMMAND	Scan to FTP Error 031-594 FTP transfer TYPE command failure. Contact your System Administrator. Job canceled.  * Caution screen with [Close] button	Replace the IP Board.
031	595	FTP Scan PORT Command Fail (Network Error)	PORT command failed. FTP F2N_ERR_FTP_SCAN_PORT_COMMAND	Scan to FTP Error 031-595 FTP data PORT command failure. Contact your System Administrator. Job canceled.  * Caution screen with [Close] button	Replace the IP Board.
031	598	FTP Scan Append Command Fail	APPE command failed. FTP F2N_ERR_FTP_APPEND	Scan to FTP Error 031-598 FTP append data APPE command failure. Contact your System Administrator. Job canceled.  * Caution screen with [Close] button	Replace the IP Board.
031	599	FTP Scan Rename Command Fail	RNFR command or RNTO command failed. FTP F2N_ERR_FTP_RENAME	Scan to FTP Error 031-599 FTP rename file RNFR command failure. Contact your System Administrator. Job canceled.  * Caution screen with [Close] button	Replace the IP Board.

## WorkCentre 6605 Error Code List

Chain Link	Error	Error Details	Control Panel Messages	FIP location	
033	500	FAX RX JPEG Data Limit Over	In FAX receive, JPEG encode data volume exceeds system data (COLOR_RX_PAGE_LIMIT)	Fax Codec Error 033-500 JBIG Compression error. FAX RX JPEG Data Limit exceeded. Job canceled. Please try again.  * Caution screen with [Close] button	Replace the Fax Board.
033	501		Cancel Codec processing due to error of read part during manual send.	Fax Codec Error 033-501 Codec processing canceled during manual send. Job canceled. Please try again.  * Caution screen with [Close] button	Replace the Fax Board.
033	502	File Open Error	File open errorT_RCV_STBY	Fax Error 033-502 Unable to open File Job canceled.  * Caution screen with [Close] button	Replace the Fax Board.
033	503	Memory Full	In receive, memory full. (under THRESH_MEMRX)	Device Memory Full 033-503 Job canceled. Remote device will try again.  * Caution screen with [Close] button	Replace the Fax Board.
033	510		In JBIG data decode, error in the number of decode line in one stripe.	Fax Codec Error 033-510 JBIG Compression error. Error in the number of decode lines. Job canceled. Please try again.  * Caution screen with [Close] button	Replace the Fax Board.
033	511		Result of MH,HR,MMR receive decode is 0Line.	Fax Codec Error 033-511 No lines received for decode Job canceled. Remote device will try again.  * Caution screen with [Close] button	Replace the Fax Board.

## WorkCentre 6605 Error Code List

Chain Link	Error	Error Details	Control Panel Messages	FIP location
033	512	Modem Parameter Exchange Error	Modem Parameter Exchange Error  Fax Communication Error 033-512 Modem parameter error Job canceled.  * Caution screen with [Close] button	Replace the Fax Board.
033	513		Communication shutdown due to memory full.  Fax Communication Error 033-513 Communication stopped due to memory full Job canceled. Please try again later.  * Caution screen with [Close] button	Replace the Fax Board.
033	514	JPEG DNL/SOF0 Error	In JPEG receive, cannot get data on the number of lines.  Fax Codec Error 033-514 JPEG receive number of lines error Job canceled. Remote device will try again.  * Caution screen with [Close] button	Replace the Fax Board.
033	515	JBIG Nf Error	In JPEG receive, cannot get color/monochrome multi-level data.  Fax Codec Error 033-515 JPEG receive did not get proper multi-level data Job canceled. Remote device will try again.  * Caution screen with [Close] button	Replace the Fax Board.
033	516	JPEG EOI Error	In JPEG receive, cannot detect EOI from encode data.  Fax Codec Error 033-516 JPEG received encoded data error Job canceled. Remote device will try again.  * Caution screen with [Close] button	Replace the Fax Board.
033	517	DFAX Password Error	Mismatch between DFAX Password and Fax/Scan Lock Password.  Incorrect Password 033-517 Please confirm password Job canceled.  * Caution screen with [Close] button	Replace the Fax Board.

## WorkCentre 6605 Error Code List

Chain Link	Error	Error Details	Control Panel Messages	FIP location	
033	518	DFAX:Fax Country is not set correctly.	When DFAX job is executed, Fax Country code is "Unknown".	Fax Country is not Set 033-518 Please set Country code to correct region Job canceled.  * Caution screen with [Close] button	Replace the Fax Board.
033	519	DFAX:Fax Function is not available.	When DFAX job is executed, Fax function is not Enabled. *When this error occurs at the same time as 033-518, 033-519 is displayed preferentially.	Fax Function is Disabled 033-519 Please confirm Fax is Enabled Job canceled.  * Caution screen with [Close] button	Replace the Fax Board.
033	520	JBF_ERROR_CALLBACK	Callback function returns error.	Fax Codec Error 033-520 Callback returned error Job canceled. Please try again.  * Caution screen with [Close] button	Replace the Fax Board.
033	521	JBF_ERROR_MARKER_ABORT	Detect ABORT marker.	Fax Codec Error 033-521 Detected Terminate Marker Job canceled.  * Caution screen with [Close] button	Replace the Fax Board.
033	522	JBF_ERROR_MARKER_UNKNOWN	Detect invalid marker.	Fax Codec Error 033-522 Invalid Marker detected Job canceled.  * Caution screen with [Close] button	Replace the Fax Board.
033	523	JBF_ERROR_MARKER_NOT_FOUND	Predetermined marker cannot be found.	Fax Codec Error 033-523 Marker can not be found Job canceled.  * Caution screen with [Close] button	Replace the Fax Board.
033	524	JBF_ERROR_MARKER_BAD_ATTRIBUTE	Adaptive template is moved incorrectly.	Fax Codec Error 033-524 Adaptive template incorrect Job canceled.  * Caution screen with [Close] button	Replace the Fax Board.

## WorkCentre 6605 Error Code List

Chain Link	Error	Error Details	Control Panel Messages	FIP location	
033	525	JBF_ERROR_MARKER_BAD_NEWLEN	Image height is changed incorrectly.	Fax Codec Error 033-525 Image height is incorrect Job canceled.  * Caution screen with [Close] button	Replace the Fax Board.
033	526	JBF_ERROR_BIH	BIH data error	Fax Codec Error 033-526 Data Error Job canceled.  * Caution screen with [Close] button	Replace the Fax Board.
033	751	Over Run	Modem receive data overrun	Fax Communication Error 033-751  Fax Modem receive data overrun. Sender will retransmitt as required. Job canceled.  * Caution screen with [Close] button	Replace the Fax Board.
033	752	During Call Busy Tone	In Tel/Fax mode, detect busy tone while calling external phone.	Fax Communication Error 033-752  Fax Recipient Line is Busy. Job canceled. Please try again.  * Caution screen with [Close] button	Replace the Fax Board.
033	753	CJ Not Detection	CJ undetected	Fax Communication Error 033-753  CJ undetected to terminate the call menu. Job canceled. Please try again.  * Caution screen with [Close] button	Replace the Fax Board.
033	754	V8 Error	V8 error	Fax Communication Error 033-754  Fax V8 Communication Error Job canceled. Please try again.  * Caution screen with [Close] button	Replace the Fax Board.

## WorkCentre 6605 Error Code List

Chain Link	Error	Error Details	Control Panel Messages	FIP location	
033	755	Phase2 Error	Phase2(Line Probing) error	Fax Communication Error 033-755 Phase 2 Communication Line Error. Job canceled. Please try again, if error persists check Fax line quality.  * Caution screen with [Close] button	Replace the Fax Board.
033	756	Phase3 Error	Phase3(Primary Channel Equalizer Training) error	Fax Communication Error 033-756 Phase 3 Training Error Job canceled. Please try again.  * Caution screen with [Close] button	Replace the Fax Board.
033	757	Primary Channel Synchronization Error	Primary channel resynchronization error	Fax Communication Error 033-757 Primary Channel Synchronization Error Job canceled. Please try again.  * Caution screen with [Close] button	Replace the Fax Board.
033	758	Control Channel Synchronization Error	Control channel resynchronization error	Fax Communication Error 033-758 Control Channel Synchronization Error Job canceled. Please try again.  * Caution screen with [Close] button	Replace the Fax Board.
033	759	Control Channel Retrain Error	Control channel retrain error	Fax Communication Error 033-759 Control Channel Retrain Error Job canceled. Please try again.  * Caution screen with [Close] button	Replace the Fax Board.
033	760	Control Channel OFF Time Out	Control channel OFF timeout	Fax Communication Error 033-760 Control Channel OFF Timeout Job canceled. Please try again.  * Caution screen with [Close] button	Replace the Fax Board.

## WorkCentre 6605 Error Code List

Chain Link	Error	Error Details	Control Panel Messages	FIP location	
033	761	Primary Channel OFF Time Out	Primary channel OFF timeout	Fax Communication Error 033-761 Primary Channel OFF Timeout Job canceled. Please try again.  * Caution screen with [Close] button	Replace the Fax Board.
033	762	DM Prevention Function Receive Refuse	DM prevention function rejects to receive data.	Fax Communication Error 033-762 Invalid Fax command received Job canceled.  * Caution screen with [Close] button	Disable Junk Fax Filter  Replace the Fax Board.
033	763	Manual Transmission Read Manuscript Not Do	In manual send, cannot make document read on time.	Fax Communication Error 033-763 Manual Fax transmission error Job canceled. Please re-load document and try again.  * Caution screen with [Close] button	Replace the Fax Board.
033	764	Draw Data Create Not Do	When sending, cannot make image data creation on time.	Fax Communication Error 033-764 Fax Data error Job canceled. Please try again.  * Caution screen with [Close] button	Replace the Fax Board.
033	765	File Pointer Error	In encode/decode, Read/Write file pointer error.	Fax Codec Error 033-765 File Pointer Error Job canceled. Please restart device and try again.  * Caution screen with [Close] button	Replace the Fax Board.
033	766	Target File Opening	In decode, encoding target file open.	Fax Codec Error 033-766 Target File Opening Job canceled. Please restart device and try again.  * Caution screen with [Close] button	Replace the Fax Board.

## WorkCentre 6605 Error Code List

Chain Link	Error	Error Details	Control Panel Messages	FIP location	
033	767	MMR MN86064 Decode Error	In MMR decode, MN86064 decode error.	Fax Codec Error 033-767 MMR MN86064 Decode Error Job canceled. Please restart device and try again.  * Caution screen with [Close] button	Replace the Fax Board.
033	768	ATMove Counter Over	The number of ATMove is 5 or more in one stripe.	Fax Codec Error 033-768 ATMove Counter Over Job canceled. Please restart device and try again.  * Caution screen with [Close] button	Replace the Fax Board.
033	769	JBIG NEWLEN Marker Error	NEWLEN marker undetected.	Fax Codec Error 033-769 JBIG Compression error. NEWLEN marker not detected. Job canceled. Please try again.  * Caution screen with [Close] button	Replace the Fax Board.
033	770	YD Error	Detect YD error in JBIG data decode.	Fax Codec Error 033-770 JBIG Compression error. YD error detected in JBIG data decode. Job canceled. Please try again.  * Caution screen with [Close] button	Replace the Fax Board.
033	771	Abort Marker Error	Detect abort marker error in JBIG data decode.	Fax Codec Error 033-771 JBIG Compression error. Terminate marker error detected in JBIG data decode. Job canceled. Please try again.  * Caution screen with [Close] button	Replace the Fax Board.
033	772	Undefined Marker Error	Detect undefined marker	Fax Codec Error 033-772 JBIG Compression error. Undefined marker detected. Job canceled. Please try again.  * Caution screen with [Close] button	Replace the Fax Board.



## WorkCentre 6605 Error Code List

Chain Link	Error	Error Details	Control Panel Messages	FIP location	
033	773	BIH Error	BIH error in JBIG data decode.	Fax Codec Error 033-773 JBIG Compression error. BIH Error in JBIG data decode. Job canceled. Please try again.  * Caution screen with [Close] button	Replace the Fax Board.
033	774	FAX TX Encode Output Buffer Over	In FAX send, JBIG encode output buffer overflow.	Fax Codec Error 033-774 JBIG Compression error. FAX TX Encode Output Buffer exceeded. Job canceled. Please try again.  * Caution screen with [Close] button	Replace the Fax Board.
033	775	FAX RX Encode Output Buffer Over	In FAX receive, JBIG encode output buffer overflow.	Fax Codec Error 033-775 JBIG Compression error. FAX RX Encode Output Buffer exceeded. Job canceled.  * Caution screen with [Close] button	Replace the Fax Board.
033	776	SCAN Encode Output Buffer Over	In FAX scan and D-FAX scan, JBIG encode output buffer overflow.	Fax Codec Error 033-776 JBIG Compression error. SCAN Encode Output Buffer exceeded. Job canceled. Please try again.  * Caution screen with [Close] button	Replace the Fax Board.
033	777	FAX RX Decode Input Buffer Over	In FAX receive, when copying from ECM buffer to JBIG decode input buffer, input buffer overflow.	Fax Codec Error 033-777 JBIG Compression error. FAX RX Decode Input Buffer exceeded. Job canceled. Please try again.  * Caution screen with [Close] button	Replace the Fax Board.
033	779	Log File Create Fail	Cannot create log file of communication result.	Fax Report Error 033-779 Log file creation error Job canceled. Please restart device and try again.  * Caution screen with [Close] button	Replace the Fax Board.

## WorkCentre 6605 Error Code List

Chain Link	Error	Error Details	Control Panel Messages	FIP location	
033	782	NSS/DCS Function disagreement	Received NSS/DCS function disagrees with capability of own terminal.	Fax Communication Error 033-782 Incompatible NSS/DCS function received Job canceled. Please try again. * Caution screen with [Close] button	Replace the Fax Board.
033	784		In FAX receive, JBIG decode output buffer overflow.	Fax Codec Error 033-784 JBIG Compression error. JBIG decode output buffer exceeded. Job canceled. Please try again. * Caution screen with [Close] button	Replace the Fax Board.
033	786		In JBIG data decode, discrepancy between the number of decode line and the number of BIH line.	Fax Codec Error 033-786 JBIG Compression error. The number of decode lines do not match the number of BIH lines. Job canceled. Please try again. * Caution screen with [Close] button	Replace the Fax Board.
033	787		Calling table full.	Fax Memory Error 033-787 Maximum number of pending fax jobs has been exceeded. Job canceled. * Caution screen with [Close] button	Replace the Fax Board.
033	788		Flash full. (for DFAX)	Fax Memory Full 033-788 Job canceled. * Caution screen with [Close] button	Replace the Fax Board.
033	789	Cancel	Cancel	Fax Job Canceled 033-789 * Caution screen with [Close] button	Replace the Fax Board.
033	790	Cancel	Cancel	Fax Job Canceled 033-790 * Caution screen with [Close] button	Replace the Fax Board.

## WorkCentre 6605 Error Code List

Chain Link	Error	Error Details	Control Panel Messages	FIP location	
033	791	Cancel	Cancel	Fax Job Canceled 033-791 * Caution screen with [Close] button	Replace the Fax Board.
033	795	FAX Send Count Limit	Reach the upper limit of Fax send accumulation pages.	Fax Send Error 033-795 Maximum number of send pages has been exceeded. Job canceled. Please wait then try again. * Caution screen with [Close] button	Replace the Fax Board.
033	799		In MH,HR,MMR receive, exceed the maximum number of received lines for 1 page.	Fax Codec Error 033-799 Maximum number of received lines for one page exceeded. Job canceled. Remote device will try again. * Caution screen with [Close] button	Replace the Fax Board.
034	508	Command Refuse Signal Send	Send command refuse signal to stop communication.	Fax Communication Error 034-508 Refused command signal sent Job canceled. Please try again. * Caution screen with [Close] button	Replace the Fax Board.
034	515	DIS DCS Illegal Command Receive	Receive illegal command such as DIS, DCS receive from calling terminal in spite of having no ability to receive.	Fax Communication Error 034-515 Digital identification signal or Digital command signal had illegal command. Job canceled. Remote device will try again. * Caution screen with [Close] button	Replace the Fax Board.
034	791	Check Line Connection	Fax Line fail. Check the plug and connection.	No Answer 034-791 Check Line Connection. Please disconnect and reconnect fax line to insure proper connection. Job canceled. * Caution screen with [Close] button	Replace the Fax Board.

## WorkCentre 6605 Error Code List

Chain Link	Error	Error Details	Control Panel Messages	FIP location	
034	799	No Dial Data	Auto dial is activated but no dial data exist.	Fax Number Error 034-799 No dial Data, please confirm and enter fax number or try again. Job canceled.  * Caution screen with [Close] button	Replace the Fax Board.
035	701	Send T1 Time Out	In send, T1 timeout	Target Fax is Not Answering 035-701 T1 time out, no response detected from remote device. Job canceled. Confirm fax number and contact receiving party if issue persists.  * Caution screen with [Close] button	Replace the Fax Board.
035	702	Receive DCN	DCN receive	Fax Communication Error 035-702 Disconnect signal received from remote device. Job canceled. Remote device will try again.  * Caution screen with [Close] button	Replace the Fax Board.
035	704	Not Send Ability	Remote device has no ability to send.	Fax Communication Error 035-704 Please check remote device if error persists. Job canceled.  * Caution screen with [Close] button	Replace the Fax Board.
035	705	DCS/NSS Resend Over	DCS/NSS resend over.	Fax Communication Error 035-705 Digital Command Signal/Non-standard Setup error. Job canceled. Please try again.  * Caution screen with [Close] button	Replace the Fax Board.

## WorkCentre 6605 Error Code List

Chain Link	Error	Error Details	Control Panel Messages	FIP location	
035	706	Fall Back Error	Fall back error.	Fax Communication Error 035-706 Faliure to negotiate fall back. Job canceled. Please try again.  * Caution screen with [Close] button	Replace the Fax Board.
035	708	Post Message Resend Over	Post message resend over.	Fax Communication Error 035-708 Post message response Error. Job canceled. Please try again.  * Caution screen with [Close] button	Replace the Fax Board.
035	709	G3 Send RTN/PIN Receive	In G3 send, receive RTN/PIN.	Fax Communication Error 035-709 Retrain error received Job canceled. Please try again.  * Caution screen with [Close] button	Replace the Fax Board.
035	710	Receive PIN	PIN receive (excl. EOR)	Fax Communication Error 035-710 Procedural interrupt negative received Job canceled. Please try again.  * Caution screen with [Close] button	Replace the Fax Board.
035	716	T2 Time Out	T2 timeout.	Fax Communication Error 035-716 T2 time out - Timing between commands exceeded 6 seconds Job canceled. Please try again.  * Caution screen with [Close] button	Replace the Fax Board.

## WorkCentre 6605 Error Code List

Chain Link	Error	Error Details	Control Panel Messages	FIP location	
035	717	G3 Receive RTN Send	In G3 receive, send RTN.	Fax Communication Error 035-717 Retrain signal sent Job canceled. Sender will try again. * Caution screen with [Close] button	Replace the Fax Board.
035	718	Receive T1 Time Out	In receive, T1 timeout.	Target Fax is Not Answering 035-718 T1 timeout, no response from sender received. Job canceled. Remote device will try again. * Caution screen with [Close] button	Replace the Fax Board.
035	720	Not Receive Ability	Remote device has no ability to receive.	Fax Communication Error 035-720 Remote device unable to receive. Job canceled. Please try again later. Remote device may be full. * Caution screen with [Close] button	Replace the Fax Board.
035	728	G3 EOL Not Receive	In G3 image data receive, cannot receive EOL for 13 sec(default).	Fax Communication Error 035-728 No end of line signal received within 13 seconds. Job canceled. Sender will try again. * Caution screen with [Close] button	Replace the Fax Board.
035	729	Career Cut	Career cut.	Fax Communication Error 035-729 Job canceled. * Caution screen with [Close] button	Replace the Fax Board.

## WorkCentre 6605 Error Code List

Chain Link	Error	Error Details	Control Panel Messages	FIP location	
035	730	RS Request CS NOT ON	In high-speed training, modem CS does not become ON against RS request.	Fax Communication Error 035-730 High speed training error. Job canceled. Please try again.  * Caution screen with [Close] button	Replace the Fax Board.
035	737	CTC/EOR Resend Over	CTC/EOR resend over.	Fax Communication Error 035-737 Continue to correct / End of transmission resend over. Job canceled. Please try again.  * Caution screen with [Close] button	Replace the Fax Board.
035	739	T5 Time Out	T5 timeout	Fax Communication Error 035-739 T5 Time out for Error Correction Mode exceeded. Job canceled. Please try again.  * Caution screen with [Close] button	Replace the Fax Board.
035	740	ECM Send EOR-Q Send	IN ECM send, send EOR-Q.	Fax Communication Error 035-740 End of retransmission ECM error Job canceled. Please try again.  * Caution screen with [Close] button	Replace the Fax Board.
035	742	ECM Receive EOR-Q Receive	IN ECM receive, receive EOR-Q.	Fax Communication Error 035-742 Received ECM error Job canceled. Remote device will try again.  * Caution screen with [Close] button	Replace the Fax Board.
035	746	Before Dial Dial Tone	Cannot detect dial tone before dialing.	No Dial Tone 035-746 Please check that fax line is connected and working Job canceled.  * Caution screen with [Close] button	Replace the Fax Board.

## WorkCentre 6605 Error Code List

Chain Link	Error	Error Details	Control Panel Messages	FIP location	
035	779	FAX FWD document change error	FAX forward document change error	Fax Communication Error 035-779 Fax forward document error Job canceled. * Caution screen with [Close] button	Replace the Fax Board.
035	781		Detect busy tone after dialing.	Target Fax Busy 035-781 Busy tone detected Job canceled. * Caution screen with [Close] button	Replace the Fax Board.
035	792	JM Not Detection	JM undetected	Fax Communication Error 035-792 Joint Menu signal not Detected Job canceled. Please try again. * Caution screen with [Close] button	Replace the Fax Board.
035	793	Digital Line Detection	Connected to digital line and cannot connect. (Detect when connecting to line)	Fax Communication Error 035-793 Digital line detected, an analog line is required Job canceled. Please confirm fax line is Analog and not Digital. If error persists, contact phone provider. * Caution screen with [Close] button	Replace the Fax Board.
041	340	IOT NVRAM Error	Detect NVRAM Error	Engine NVRAM Error 041-340 Power Off/On the Printer. If this failure occurs again, please contact customer support. Code:xxxxxxxh	Page 2-178
041	347	IOT I/F Failure	MCU Internal Error(I/F part)	Engine Controller Error 041-347 Power Off/On the Printer. If this failure occurs again, please contact customer support.	Replace the MCU Board.



## WorkCentre 6605 Error Code List

Chain Link	Error	Error Details	Control Panel Messages	FIP location	
042	313	IOT Fan Motor Failure	Detect Fan Motor Error	Fan Motor Error 042-313 Power Off/On the Printer. If this failure occurs again, please contact customer support.	Page 2-177
042	325	IOT Motor Failure	Detect Motor Failure	Main Motor Error 042-325 Power Off/On the Printer. If this failure occurs again, please contact customer support.	Page 2-180
042	326	IOT Motor Failure	Detect Motor Failure	Main Motor Error 042-326 Power Off/On the Printer. If this failure occurs again, please contact customer support.	Page 2-181
042	700	IOT Over Heat Stop	IOT Over Heat Stop	Printer Error 042-700 Power Off/On the Printer. If this failure occurs again, please contact customer support.	Page 2-189
046	310	IOT HVPS Error	Detect HVPS Error	High Voltage Power Supply Error 046-310 Power Off/On the Printer. If this failure occurs again, please contact customer support.	Page 2-191
050	111	IOT Rear Cover	Paper Jam Detected Zone IOT Rear Cover	Paper Jam Open the Rear Cover and remove any jammed paper.	1. Open the Rear Cover 2. Remove any jammed paper 3. Close the Rear Cover

**WorkCentre 6605 Error Code List**

Chain Link	Error	Error Details	Control Panel Messages	FIP location	
050	112	MSI	Paper Jam Detected Zone MSI	<p>Paper Jam</p> <p>Open Bypass Tray and Tray 1, and remove any jammed paper.</p>	<ol style="list-style-type: none"> <li>1. Pull out papers on the Bypass Tray</li> <li>2. Pull out Bypass Tray</li> <li>3. Pull out Tray1</li> <li>4. Remove any jammed paper</li> <li>5. Push Tray1 back in</li> <li>6. Push Bypass Tray back in</li> </ol>
050	121	IOT Remain Zone 1T JAM	Paper Jam Detected Zone 1T	<p>Paper Jam</p> <ol style="list-style-type: none"> <li>1. Pull out Tray 1 and remove any jammed paper.</li> <li>2. Insert Tray 1 and press [Start].</li> </ol>	Open Tray1 & Remove paper
050	122	IOT Remain Zone 2T JAM	Paper Jam Detected Zone 2T	<p>Paper Jam</p> <p>Pull out Tray 2 and remove any jammed paper.</p>	Open Tray2 & Remove paper

## WorkCentre 6605 Error Code List

Chain Link	Error	Error Details	Control Panel Messages	FIP location	
050	129	IOT Rear Cover and MSI	Paper Jam Detected Zone IOT RearCover and MSI	<p>Paper Jam</p> <p>Pull out Bypass Tray, Tray 1, and Open Rear Cover to remove any jammed paper.</p>	<ol style="list-style-type: none"> <li>1. Pull out papers on the Bypass Tray</li> <li>2. Pull out Bypass Tray</li> <li>3. Pull out Tray1</li> <li>4. Remove any jammed paper</li> <li>5. Push Tray1 back in</li> <li>6. Push Bypass Tray back in</li> <li>7. Open the Rear Cover if cannot remove any jammed paper</li> <li>8. Remove any jammed paper</li> <li>9. Close the Rear Cover</li> </ol>
061	370	IOT ROS Failure	Detect ROS Failure	<p>Laser Unit Error 061-370</p> <p>Power Off/On the Printer.</p> <p>If this failure occurs again, please contact customer support.</p> <p>Code:xxxxxxxh</p>	Page 2-179
062	320	Scanner Error	Scanning error	<p>Scanner Error 062-320</p> <p>Power Off/On the Printer.</p> <p>If this failure occurs again, please contact customer support.</p>	Page 2-209
062	321		Unexecutable error. (carriage is at the locked position, etc.)	<p>Scanner Error 062-321</p> <p>Power Off/On the Printer.</p> <p>If this failure occurs again, please contact customer support.</p>	Page 2-209

## WorkCentre 6605 Error Code List

Chain Link	Error	Error Details	Control Panel Messages	FIP location	
062	322		Parameter error	Scanner Error 062-322 Power Off/On the Printer. If this failure occurs again, please contact customer support.	Page 2-209
062	360	HPSensor Error	Carriage home position error	Scanner Home Position Sensor Error 062-360 Power Off/On the Printer. If this failure occurs again, please contact customer support.	Page 2-209
062	371		IIT failure Lamp error	Scanner Lamp Error 062-371 Power Off/On the Printer. If this failure occurs again, please contact customer support.	Page 2-209
062	393	CcdAsic Error	CcdAsic communication error	Scanner Error 062-393 Power Off/On the Printer. If this failure occurs again, please contact customer support.	Page 2-209
062	790	Copy Limit	Copy limit	Copy Limit Error Last sheet not copied.  * Caution screen with [Close] button	Page 2-209
071	100	IOT Tray1 Misfeed JAM	Detect Tray1 Misfeed JAM	no message	Page 2-192
072	100	IOT Tray2 Misfeed JAM	Detect Tray2 Misfeed	no message	Page 2-193
072	101	IOT Path2 SNS On JAM	Detect Path2 SNS On JAM	no message	Page 2-193
072	211	IOT Option Feeder2 Failure	Detect Feeder2 Failure	Tray 2 Error 072-211 Power Off/On the Printer. If this failure occurs again, please contact customer support. Code:xxxxxxxh	Page 2-178
075	100	MSI Misfeed JAM	Detect VSYNC On JAM(TBD)	no message	Page 2-195
075	910	MSI Detached	MSI Detached	Bypass Tray Missing 075-910 Insert Bypass Tray.	Page 2-196
077	101	VSYNC?ON?JAM	Detect VSYNC On JAM	no message	Replace the MCU Board.

## WorkCentre 6605 Error Code List

Chain Link	Error	Error Details	Control Panel Messages	FIP location	
077	104	RegOff JAM	Detect RegOff JAM	no message	Page 2-197
077	106	Exit ON JAM	Detect Exit ON JAM	no message	Page 2-197
077	107	Duplex ON JAM	Detect Duplex ON JAM(TBD)	no message	Page 2-198
077	108	ExitOff early JAM	Detect ExitOff early JAM	no message	Page 2-198
077	109	ExitOff JAM	Detect IOT Exit Sensor Off JAM	no message	Page 2-198
077	215	IOT Duplexer Error		Duplex Unit Error 077-215 Reset Duplex Unit and Power Off/On the Printer. If this failure occurs again, please contact customer support.	-
077	217	Duplex Mis-configuration	Duplex Mis-configuration	Duplexer Error 077-217 Power Off/On the Printer. If this failure occurs again, please contact customer support.	Replace the MCU Board.
077	300	IOT Cover Front Open	FrontCover Open. Beep sounds after FrontCover remains open for 3 minutes.	Front Cover Open Close Front Cover.	Page 2-199
077	301	<IOT Side Cover Open>	Side Cover is open.	Right Side Door Open Close Right Side Door.	Page 2-199
077	304	IOT Cover Rear Open	Rear Cover Open	Rear Cover Open Close Rear Cover.	Page 2-200
077	312	Tray Configure Error	Combination of trays was illegal.	Tray Configuration Error 077-312 Power Off/On the Printer. If this failure occurs again, please contact customer support. Code:xxxxxxxxh	-
091	400	IOT Waste Toner Box Near Life	Detect Waste Toner Box Near Life	XXXXXXXXXXXXXXXXXX Replace Waste Toner Box, Near Full	Page 2-200
091	402	IOT Drum Cartridge Kit Life Pre Warning	Detect Drum Life Warning	XXXXXXXXXXXXXXXXXX Imaging Unit Kit Near End of Life	Replace the Imaging Unit.
091	911	IOT Waste Toner Box Life Over	Detect Waste Toner Box Life Over	Waste Toner Box End of Life Open the Right Side Door. Then, replace the Waste Toner Box.	Page 2-200

## WorkCentre 6605 Error Code List

Chain Link	Error	Error Details	Control Panel Messages	FIP location	
091	914	IOT K Drum Comm Fail	Detect Black Drum Comm Fail	Black Imaging Unit Error 091-914 Open the Right Side Door. Then, reseal Black Imaging Unit or replace the Imaging Unit Kit.	Page 2-201
091	915	DRUM UnitK CRUM Data Broken Fail	Wrong data in CRUM of drum K	Black Imaging Unit Error 091-915 Open the Right Side Door. Then, reseal Black Imaging Unit or replace the Imaging Unit Kit.	Page 2-203
091	917	IOT Y Drum Comm Fail	Detect Yellow Drum Comm Fail	Yellow Imaging Unit Error 091-917 Open the Right Side Door. Then, reseal Yellow Imaging Unit or replace the Imaging Unit Kit.	Page 2-201
091	918	IOT M Drum Comm Fail	Detect Magenta Drum Comm Fail	Magenta Imaging Unit Error 091-918 Open the Right Side Door. Then, reseal Magenta Imaging Unit or replace the Imaging Unit Kit.	Page 2-202
091	919	IOT C Drum Comm Fail	Detect Cyan Drum Comm Fail	Cyan Imaging Unit Error 091-919 Open the Right Side Door. Then, reseal Cyan Imaging Unit or replace the Imaging Unit Kit.	Page 2-203
091	920	DRUM Y CRUM Data Broken Fail	Wrong data in CRUM of drum Y	Yellow Imaging Unit Error 091-920 Open the Right Side Door. Then, reseal Yellow Imaging Unit or replace the Imaging Unit Kit.	Page 2-204
091	921	IOT K Drum Detached	Black	Black Imaging Unit Missing Open the Right Side Door. Then, insert the Black Imaging Unit.	Reinsert the Black Imaging Unit.
091	922	DRUM M CRUM Data Broken Fail	Wrong data in CRUM of drum M	Magenta Imaging Unit Error 091-922 Open the Right Side Door. Then, reseal Magenta Imaging Unit or replace the Imaging Unit Kit.	Page 2-204

## WorkCentre 6605 Error Code List

Chain Link	Error	Error Details	Control Panel Messages	FIP location	
091	923	DRUM C CRUM Data Broken Fail	Wrong data in CRUM of drum C	Cyan Imaging Unit Error 091-923 Open the Right Side Door. Then, reseal Cyan Imaging Unit or replace the Imaging Unit Kit.	Page 2-204
091	927	IOT Y Drum Detached	Yellow	Yellow Imaging Unit Missing Open the Right Side Door. Then, insert the Yellow Imaging Unit.	Reinsert the Yellow Imaging Unit.
091	928	IOT M Drum Detached	Magenta	Magenta Imaging Unit Missing Open the Right Side Door. Then, insert the Magenta Imaging Unit.	Reinsert the Magenta Imaging Unit.
091	929	IOT C Drum Detached	Cyan	Cyan Imaging Unit Missing Open the Right Side Door. Then, insert the Cyan Imaging Unit.	Reinsert the Cyan Imaging Unit.
091	935	IOT Drum Cartridge Kit Life Over	Detect Drum Cartridge Kit Life Over	Imaging Unit Kit End of Life Open the Right Side Door. Then, replace the Imaging Unit Kit.	Replace the Imaging Unit.
091	960	IOT X CRUM ID Error	Detect Y Drum CRUM ID Warning	Invalid Imaging Unit Open the Right Side Door. Then, reseal/replace the Yellow Imaging Unit.	Page 2-204
091	961	IOT X CRUM ID Error	Detect M Drum CRUM ID Warning	Invalid Imaging Unit Open the Right Side Door. Then, reseal/replace the Magenta Imaging Unit.	Page 2-204
091	962	IOT X CRUM ID Error	Detect C Drum CRUM ID Warning	Invalid Imaging Unit Open the Right Side Door. Then, reseal/replace the Cyan Imaging Unit.	Page 2-204
091	963	IOT X CRUM ID Error	Detect K Drum CRUM ID Warning	Invalid Imaging Unit Open the Right Side Door. Then, reseal/replace the Black Imaging Unit.	Page 2-203

## WorkCentre 6605 Error Code List

Chain Link	Error	Error Details	Control Panel Messages	FIP location	
092	310	IOT CTD Sensor Error	Detect CTD Sensor Error	Density Sensor Error 092-310 Power Off/On the Printer. If this failure occurs again, please contact customer support. Code:xxxxxxx	Page 2-204
092	410	CTD Sensor Dustiness	Detect CTD Sensor Warning	XXXXXXXXXXXXXXXXXX Clean Density Sensor	Clean the CTD Sensor.
092	661	IOT Environment Sensor Error	Detect Environment Sensor Error	Temperature/Humidity Sensor Error 092-661 Power Off/On the Printer. If this failure occurs again, please contact customer support.	Page 2-179
092	670	Yellow Patch Error	IOT could not recovery toner density.	Yellow Test Patch Error 092-670 Power Off/On the Printer. If this failure occurs again, please contact customer support.	Page 2-205
092	671	Magenta Patch Error	IOT could not recovery toner density.	Magenta Test Patch Error 092-671 Power Off/On the Printer. If this failure occurs again, please contact customer support.	Page 2-205
092	672	Cyan Patch Error	IOT could not recovery toner density.	Cyan Test Patch Error 092-672 Power Off/On the Printer. If this failure occurs again, please contact customer support.	Page 2-207
092	673	Black Patch Error	IOT could not recovery toner density.	Black Test Patch Error 092-673 Power Off/On the Printer. If this failure occurs again, please contact customer support.	Page 2-207
093	320	IOT Deve Motor Fail	Detect Developer Motor Failure	Developer Motor Error 093-320 Power Off/On the Printer. If this failure occurs again, please contact customer support.	Page 2-182
093	423	IOT X Toner Near Life	Y	XXXXXXXXXXXXXXXXXX Yellow Toner Low	Replace the Yellow Toner Cartridge.
093	424	IOT X Toner Near Life	M	XXXXXXXXXXXXXXXXXX Magenta Toner Low	Replace the Magenta Toner Cartridge.



## WorkCentre 6605 Error Code List

Chain Link	Error	Error Details	Control Panel Messages	FIP location	
093	425	IOT X Toner Near Life	C	XXXXXXXXXXXXXXXXXX Cyan Toner Low	Replace the Cyan Toner Cartridge.
093	426	IOT X Toner Near Life	K	XXXXXXXXXXXXXXXXXX Black Toner Low	Replace the Black Toner Cartridge.
093	925	IOT X CRUM Error	Detect Black CRUM Error	Black Toner Chip Error 093-925 Open the Front Cover. Then, reseal/replace the Black Cartridge.	Page 2-187
093	926	IOT X CRUM ID Error	Detect K Toner CRUM ID Warning	Invalid Black Toner Cartridge Open the Front Cover. Then, reseal/replace the Black Toner Cartridge.	Page 2-188
093	928	IOT K Toner Type Error	Black Toner Type Error	Black Toner Type Error 093-928 Open the Front Cover. Then, reseal/replace the Black Cartridge.	Page 2-188
093	930	IOT X Toner Life Over	Y	Yellow Toner Empty Open the Front Cover. Then, replace the Yellow Toner Cartridge.	Replace the Yellow Toner Cartridge.
093	931	IOT X Toner Life Over	M	Magenta Toner Empty Open the Front Cover. Then, replace the Magenta Toner Cartridge.	Replace the Magenta Toner Cartridge.
093	932	IOT X Toner Life Over	C	Cyan Toner Empty Open the Front Cover. Then, replace the Cyan Toner Cartridge.	Replace the Cyan Toner Cartridge.
093	933	IOT X Toner Life Over	K	Black Toner Empty Open the Front Cover. Then, replace the Black Toner Cartridge.	Replace the Black Toner Cartridge.
093	950	IOT X CRUM Error	Detect Yellow CRUM Error	Yellow Toner Chip Error 093-950 Open the Front Cover. Then, reseal/replace the Yellow Cartridge.	Page 2-184

## WorkCentre 6605 Error Code List

Chain Link	Error	Error Details	Control Panel Messages	FIP location	
093	951	IOT X CRUM Error	Detect Magenta CRUM Error	Magenta Toner Chip Error 093-951 Open the Front Cover. Then, reseal/replace the Magenta Cartridge.	Page 2-185
093	952	IOT X CRUM Error	Detect Cyan CRUM Error	Cyan Toner Chip Error 093-952 Open the Front Cover. Then, reseal/replace the Cyan Cartridge.	Page 2-186
093	960	IOT X CRUM ID Error	Detect Y Toner CRUM ID Warning	Invalid Yellow Toner Cartridge Open the Front Cover. Then, reseal/replace the Yellow Toner Cartridge.	Page 2-187
093	961	IOT X CRUM ID Error	Detect M Toner CRUM ID Warning	Invalid Magenta Toner Cartridge Open the Front Cover. Then, reseal/replace the Magenta Toner Cartridge.	Page 2-188
093	962	IOT X CRUM ID Error	Detect C Toner CRUM ID Warning	Invalid Cyan Toner Cartridge Open the Front Cover. Then, reseal/replace the Cyan Toner Cartridge.	Page 2-188
093	970	IOT X Toner Detached	Y	Yellow Toner Cartridge Missing Open the Front Cover. Then, insert the Yellow Toner Cartridge.	Reinsert the Yellow Imaging Unit.
093	971	IOT X Toner Detached	M	Magenta Toner Cartridge Missing Open the Front Cover. Then, insert the Magenta Toner Cartridge.	Reinsert the Magenta Imaging Unit.
093	972	IOT X Toner Detached	C	Cyan Toner Cartridge Missing Open the Front Cover. Then, insert the Cyan Toner Cartridge.	Reinsert the Cyan Imaging Unit.
093	973	IOT X Toner Detached	K	Black Toner Cartridge Missing Open the Front Cover. Then, insert the Black Toner Cartridge.	Reinsert the Black Imaging Unit.

## WorkCentre 6605 Error Code List

Chain Link	Error	Error Details	Control Panel Messages	FIP location	
093	980	IOT Y Toner Type Error	Yellow Toner Type Error	Yellow Toner Type Error 093-980 Open the Front Cover. Then, reseal/replace the Yellow Cartridge.	Page 2-187
093	981	IOT M Toner Type Error	magenta Toner Type Error	Magenta Toner Type Error 093-981 Open the Front Cover. Then, reseal/replace the Magenta Cartridge.	Page 2-188
093	982	IOT C Toner Type Error	Cyan Toner Type Error	Cyan Toner Type Error 093-982 Open the Front Cover. Then, reseal/replace the Cyan Cartridge.	Page 2-188
094	417	Belt Unit Near End Warning	Transfer Belt Unit Near End Warning	XXXXXXXXXXXXXXXXXX Transfer Unit Near End of Life	-
094	420	Belt Unit End Warning	Transfer Belt Unit End Warning	XXXXXXXXXXXXXXXXXX Replace Transfer Unit	-
094	910	Belt Detached	Belt Detached is detected.	Transfer Unit Missing Open all covers. Then, insert the Transfer Unit.	Reinsert the Transfer Belt Unit.
094	911	IOT Belt Unit Life Over	Detect Belt Unit Life Over	Transfer Unit End of Life Open all covers. Then, replace the Transfer Unit. Pressing <b>OK</b> will reset the counter due to the use of a new Transfer Unit.  When the replacement is done, press <b>OK</b> .  * Fault screen with <b>OK</b> button  (Press <b>OK</b> to counter reset.)	Replace the Transfer Belt Unit.
116	210	USB Host Error	Fatal error of USB Host driver	USB Host Error 116-210 Power Off/On the Printer. If this failure occurs again, please contact customer support.	Replace the IP Board.
116	312	Encryption Key Error	Encryption key mismatch	Hard Disk Error 116-312 Power Off/On the Printer. If this failure occurs again, please contact customer support.	Replace the IP Board.

## WorkCentre 6605 Error Code List

Chain Link	Error	Error Details	Control Panel Messages	FIP location	
116	313	Encryption Setting Error	Encryption setting mismatch	Hard Disk Error 116-313 Power Off/On the Printer. If this failure occurs again, please contact customer support.	Replace the IP Board.
116	314	On Board Network MAC Address Checksum Error		MAC Address Error 116-314 Power Off/On the Printer. If this failure occurs again, please contact customer support.	Replace the IP Board.
116	315	ESS On Board RAM W/R Check Fail	Detected by On Board RAM W/R Check at the time of initialization.	Controller Memory RAM Error 116-315 Power Off/On the Printer. If this failure occurs again, please contact customer support.	Replace the IP Board.
116	316	ESS DIMM Slot RAM W/R Check Fail	Detected by DIMM Slot RAM W/R Check at the time of initialization.	Controller Optional Memory RAM Error 116-316 Reseat Memory and Power Off/On the Printer. If this failure occurs again, please contact customer support.	Replace the IP Board.
116	317	ESS ROM Check(Main) Fail	Main Program ROM checksum error	Controller ROM Error 116-317 Power Off/On the Printer. If this failure occurs again, please contact customer support.	Replace the IP Board.
116	320	ESS DIMM Slot RAM Error	Occurs when unusable DIMM is inserted in DIMM slot in initialization processing at power-on.	Incompatible DIMM RAM Error 116-320 Reseat or Replace Memory and Power Off/On the Printer. If this failure occurs again, please contact customer support.	Replace the IP Board.
116	323	ESS NVRAM1 W/R Check Fail	Detected by master NVRAM W/R check	Controller NVRAM Error 116-323 Power Off/On the Printer. If this failure occurs again, please contact customer support.	Replace the IP Board.
116	324	ESS Illegal Exception	CPU illegal exception	Controller Error 116-324 Power Off/On the Printer. If this failure occurs again, please contact customer support.	Replace the IP Board.

## WorkCentre 6605 Error Code List

Chain Link	Error	Error Details	Control Panel Messages	FIP location	
116	326	Reserved(For NVRAM2)		Controller NVRAM Error 116-326 Power Off/On the Printer. If this failure occurs again, please contact customer support.	Replace the IP Board.
116	327	ESS Instruction Cache Error	CPU instruction cache error	Controller Error 116-327 Power Off/On the Printer. If this failure occurs again, please contact customer support.	Replace the IP Board.
116	328	ESS Data Cache Error	CPU data cache error	Controller Error 116-328 Power Off/On the Printer. If this failure occurs again, please contact customer support.	Replace the Fuser Assembly.
116	343	ASIC Fail	TBD	Controller ASIC Error 116-343 Power Off/On the Printer. If this failure occurs again, please contact customer support.	Replace the IP Board.
116	350	On Board Network Communication Fail	Communication fail between 1 CPU network and ESS F/W.	Network Error 116-350 Power Off/On the Printer. If this failure occurs again, please contact customer support.	Replace the IP Board.
116	351	On Board Network Ethernet BIST parity/RAM R/W Error		Network Error 116-351 Power Off/On the Printer. If this failure occurs again, please contact customer support.	Replace the IP Board.
116	352	On Board Network Internal Loopback Error		Network Error 116-352 Power Off/On the Printer. If this failure occurs again, please contact customer support.	Replace the IP Board.
116	353	ESS HD Fail	Detect HDD Error	Hard Disk Error 116-353 Power Off/On the Printer. If this failure occurs again, please contact customer support.	Replace the IP Board.
116	355	On Board Network Fatal Error		Network Error 116-355 Power Off/On the Printer. If this failure occurs again, please contact customer support.	Replace the IP Board.

## WorkCentre 6605 Error Code List

Chain Link	Error	Error Details	Control Panel Messages	FIP location	
116	356	HDD Overwrite Error	Error has occurred during HDD overwrite.	Hard Disk Error 116-356 Power Off/On the Printer. If this failure occurs again, please contact customer support.	Replace the IP Board.
116	361	PCI Bus#0 Error Detected	PCI Bus#0 Uncorrectable Error Detected * Connected with RemoraEX(x4 port)	Controller PCI Error 116-361 Power Off/On the Printer. If this failure occurs again, please contact customer support.	Replace the IP Board.
116	362	PCI Bus#0 Host Bridge Controller Error	PCI Bus#0 Host Bridge Controller Error (Connected with RemoraEX port)	Controller PCI Error 116-362 Power Off/On the Printer. If this failure occurs again, please contact customer support.	Replace the IP Board.
116	363	PCI Bus#1 Host Bridge Controller Error	PCI Bus#1 Host Bridge Controller Error (Connected with RemoraEX port)	Controller PCI Error 116-363 Power Off/On the Printer. If this failure occurs again, please contact customer support.	Replace the IP Board.
116	364	Timer Fail	Timer error is detected	Controller Clock Error 116-364 Power Off/On the Printer. If this failure occurs again, please contact customer support.	Replace the IP Board.
116	366	PCI Bus#1 Error Detected	PCI Bus#1 Uncorrectable Error Detected * Connected with RemoraEX(x1 port)	Controller PCI Error 116-366 Power Off/On the Printer. If this failure occurs again, please contact customer support.	Replace the IP Board.
116	368	PCI Error Messages received from Bus#0-Device#1	RemoraEX PCI x1 port Error * DeviceID 0x65 (x1)	Controller PCI Error 116-368 Power Off/On the Printer. If this failure occurs again, please contact customer support.	Replace the IP Board.
116	369	PCI Error Messages received from Bus#0-Device#0	RemoraEX PCI x4 port Error * DeviceID 0x64 (x4)	Controller PCI Error 116-369 Power Off/On the Printer. If this failure occurs again, please contact customer support.	Replace the IP Board.
116	390	ESS NVRAM1 SIZE And ID Check Fail	Detected by consistency check between NVRAM size requested by the system and actual size and consistency check of ID recorded at the first power-on.	Controller NVRAM Error 116-390 Power Off/On the Printer. If this failure occurs again, please contact customer support.	Replace the IP Board.

## WorkCentre 6605 Error Code List

Chain Link	Error	Error Details	Control Panel Messages	FIP location	
116	396	Fatal Error Related to Maillib Other Errors(of File2Net Library)	S/W bug F2N_ERR_MAIL_SYS_FAIL MAIL/SMB/FTP F2N_ERR_SYS_FAIL F2N_ERR_STATE F2N_ERR_BAD_LEN F2N_ERR_BAD_PORTNO F2N_ERR_INVALID_PARAM F2N_ERR_INIT_FTP F2N_ERR_INIT_SMB F2N_ERR_INIT_MAIL F2N_ERR_OTHER	Network Scan Error 116-396 Power Off/On the Printer. If this failure occurs again, please contact customer support.	Replace the IP Board.
116	719	XPIF Parameter Cancelled	Due to conflict among multiple print instructions, print instructions are ignored.	-	Replace the IP Board.
116	721	Collate Full		Memory Full 116-721 Job too large to Collate. Job canceled.  * Caution screen with [Close] button	Replace the IP Board.
116	722	WSD Scan address error	WSD Scan suspended due to Host PC down.	WSD Scan Destination Error 116-722 Job canceled. Check Destination PC and Restart Scan Job.  * Caution screen with [Close] button	Replace the IP Board.
116	987	Fatal Error Related to Format Library	S/W bug MAIL/SMB/FTP	Scanner Error 116-987 Power Off/On the Printer. If this failure occurs again, please contact customer support.	Replace the IP Board.
117	315	EEPROM Driver Error	EEPROM Driver program error	Fax EEPROM Error 117-315 Power Off/On the Printer. If this failure occurs again, please contact customer support.	Replace the IP Board.

## WorkCentre 6605 Error Code List

Chain Link	Error	Error Details	Control Panel Messages	FIP location	
117	331	DSP-related Program Internal Error	In relation to DSP, the following internal error has occurred. ?OS function return value error ?DSP program load fail	Scanner Controller Error 117-331 Power Off/On the Printer. If this failure occurs again, please contact customer support.	Replace the IP Board.
117	340		HOOK task error	Fax Controller Error 117-340 Power Off/On the Printer. If this failure occurs again, please contact customer support.	Replace the IP Board.
117	344		FLASHFILE task error	Fax Error 117-344 Power Off/On the Printer. If this failure occurs again, please contact customer support.	Replace the IP Board.
117	350		Task initialization (start) error	Fax Controller Error 117-350 Power Off/On the Printer. If this failure occurs again, please contact customer support.	Replace the IP Board.
117	361	IIT Parameter Verify NG (The IIT Parameter setting value is checked only at the production process. )	IIT registration adjustment value verification NG. (Checked only at production process)	Scanner Parameter Error 117-361 Power Off/On the Printer. If this failure occurs again, please contact customer support.	Replace the IP Board.
117	362	EEPROM Sum Check Error	EEPROM sumcheck value error	Fax EEPROM Error 117-362 Power Off/On the Printer. If this failure occurs again, please contact customer support.	Replace the IP Board.
117	363	NVM Sum Check Error	NVM sumcheck value error	Fax NVRAM Error 117-363 Power Off/On the Printer. If this failure occurs again, please contact customer support.	Replace the IP Board.
117	365	Low Voltage	RTC detected Low Voltage. RTC clock setting and content of SRAM are invalid. Initialize them.	Controller Clock Voltage Low Error 117-365 Power Off/On the Printer. If this failure occurs again, please contact customer support.	Replace the IP Board.



## WorkCentre 6605 Error Code List

Chain Link	Error	Error Details	Control Panel Messages	FIP location	
117	367	FXIF Error	FXIF Error	Scanner Controller Error 117-367 Power Off/On the Printer. If this failure occurs again, please contact customer support.	Replace the IP Board.
123	314	Panel Power On Error	Communication error at panel power on. Startup sequence does not start from AIOC within 1 minute after panel power on.	Control Panel Error 123-314 Power Off/On the Printer. If this failure occurs again, please contact customer support.	Replace the IP Board.
123	333	UI Panel - ESS Initialize Error	Transmission Fail at initialization.	Control Panel Error 123-333 Power Off/On the Printer. If this failure occurs again, please contact customer support.	Replace the IP Board.
123	399	Panel Device Reboot Error	UI Panel was rebooted by unexpected event(ex. static electricity)	Control Panel Error 123-399 Power Off/On the Printer. If this failure occurs again, please contact customer support.	Replace the IP Board.
124	310	IOT XPC Error	Detect XPC Error	Print Engine XPC Error 124-310 Power Off/On the Printer. If this failure occurs again, please contact customer support.	Replace the IP Board.
124	313	Serial No Fail	Serial No Fail	Serial Number Failure 124-313 Power Off/On the Printer. P/J 251 on the EEPROM board not plugged in.	Replace the IP Board.
131	397	File2Net Fatal Error	File2Net fatal error S/W bug F2N_ERR_OTHER F2N_ERR_BAD_LEN F2N_ERR_BAD_PORTNO F2N_ERR_STATE F2N_ERR_BUFF_INSUFFICIENT F2N_ERR_INVALID_PARAMETER	Scanner Error 131-397 Power Off/On the Printer. If this failure occurs again, please contact customer support.	Replace the IP Board.
131	398	SMBclient Fatal Error	SMBClient fatal error SMB F2N_ERR_SMB_SYS_FAIL F2N_ERR_INIT_SMB	Network Scan Error 131-398 Power Off/On the Printer. If this failure occurs again, please contact customer support.	Replace the IP Board.

## WorkCentre 6605 Error Code List

Chain Link	Error	Error Details	Control Panel Messages	FIP location	
131	399	FTPclient Fatal Error	FTPClient fatal error F2N_ERR_FTP_SYS_FAIL F2N_ERR_INIT_FTP	Network Scan Error 131-399 Power Off/On the Printer. If this failure occurs again, please contact customer support.	Replace the IP Board.
133	231	T_FAXCOM Data Receive I/F Error	T_FAXCOM<->Data processing I/F error	Fax Communication Error 133-231 Power Off/On the Printer. If this failure occurs again, please contact customer support.	Replace the Fax Board.
133	234	JBIG Parameter Error	JBIG parameter error	Fax Error 133-234 Power Off/On the Printer. If this failure occurs again, please contact customer support.	Replace the Fax Board.
133	235	MHR Parameter Error	MHR parameter error	Fax Error 133-235 Power Off/On the Printer. If this failure occurs again, please contact customer support.	Replace the Fax Board.
133	236	MHR Encode Error	MHR encode error	Fax Error 133-236 Power Off/On the Printer. If this failure occurs again, please contact customer support.	Replace the Fax Board.
133	237	MHR Input Buffer Error	Data error of MHR input buffer	Fax Codec Error 133-237 Power Off/On the Printer. If this failure occurs again, please contact customer support.	Replace the Fax Board.
133	238	MHR Output Buffer Error	Data error of MHR output buffer	Fax Codec Error 133-238 Power Off/On the Printer. If this failure occurs again, please contact customer support.	Replace the Fax Board.
133	239	FAX ECM Buffer Address Error	At FAX send/receive, address to get from and write in ECM buffer is wrong.	Fax Error 133-239 Power Off/On the Printer. If this failure occurs again, please contact customer support.	Replace the Fax Board.
133	240	Resolution Change Error	Resolution error in FAX send resolution conversion.	Fax Error 133-240 Power Off/On the Printer. If this failure occurs again, please contact customer support.	Replace the Fax Board.

## WorkCentre 6605 Error Code List

Chain Link	Error	Error Details	Control Panel Messages	FIP location	
133	241	Memory Pool Get Error	Memory pool get error (OS error)	Fax Error 133-241 Power Off/On the Printer. If this failure occurs again, please contact customer support.	Replace the Fax Board.
133	242	Memory Pool Release Error	Memory pool release error (OS error)	Fax Error 133-242 Power Off/On the Printer. If this failure occurs again, please contact customer support.	Replace the Fax Board.
133	243	Message Send Error	Message send error (OS error)	Fax Error 133-243 Power Off/On the Printer. If this failure occurs again, please contact customer support.	Replace the Fax Board.
133	244	Message Receive Error	Message receive error (OS error)	Fax Error 133-244 Power Off/On the Printer. If this failure occurs again, please contact customer support.	Replace the Fax Board.
133	246	Memory Pool Get Error	Memory pool get error (OS error)	Fax Error 133-246 Power Off/On the Printer. If this failure occurs again, please contact customer support.	Replace the Fax Board.
133	247	Message Send Error	Message send error (OS error)	Fax Error 133-247 Power Off/On the Printer. If this failure occurs again, please contact customer support.	Replace the Fax Board.
133	248	Memory Pool Release Error	Memory pool release error (OS error)	Fax Error 133-248 Power Off/On the Printer. If this failure occurs again, please contact customer support.	Replace the Fax Board.
133	249	Message Receive Error	Message receive error (OS error)	Fax Error 133-249 Power Off/On the Printer. If this failure occurs again, please contact customer support.	Replace the Fax Board.
133	251	File Open Error	File open error	Fax Error 133-251 Power Off/On the Printer. If this failure occurs again, please contact customer support.	Replace the Fax Board.

## WorkCentre 6605 Error Code List

Chain Link	Error	Error Details	Control Panel Messages	FIP location	
133	252	File Close Error	File close error	Fax Error 133-252 Power Off/On the Printer. If this failure occurs again, please contact customer support.	Replace the Fax Board.
133	253	File Erase Error	File erase error	Fax Error 133-253 Power Off/On the Printer. If this failure occurs again, please contact customer support.	Replace the Fax Board.
133	254	Mem Full	Cannot secure memory necessary to print.	Fax Error 133-254 Power Off/On the Printer. If this failure occurs again, please contact customer support.	Replace the Fax Board.
133	259	OS Call Error	OS Call error	Fax Error 133-259 Power Off/On the Printer. If this failure occurs again, please contact customer support.	Replace the Fax Board.
133	260	File Open Error	File open error	Fax Error 133-260 Power Off/On the Printer. If this failure occurs again, please contact customer support.	Replace the Fax Board.
133	261	File Close Error	File close error	Fax Error 133-261 Power Off/On the Printer. If this failure occurs again, please contact customer support.	Replace the Fax Board.
133	269	File Close Error	File close error	Fax Error 133-269 Power Off/On the Printer. If this failure occurs again, please contact customer support.	Replace the Fax Board.
133	271	Memory Pool Get Error	Memory pool get error (OS error)	Fax Error 133-271 Power Off/On the Printer. If this failure occurs again, please contact customer support.	Replace the Fax Board.
133	272	Message Send Error	Message send error (OS error)	Fax Error 133-272 Power Off/On the Printer. If this failure occurs again, please contact customer support.	Replace the Fax Board.

## WorkCentre 6605 Error Code List

Chain Link	Error	Error Details	Control Panel Messages	FIP location	
133	273	Memory Pool Release Error	Memory pool release error (OS error)	Fax Error 133-273 Power Off/On the Printer. If this failure occurs again, please contact customer support.	Replace the Fax Board.
133	274	Message Receive Error	Message receive error (OS error)	Fax Error 133-274 Power Off/On the Printer. If this failure occurs again, please contact customer support.	Replace the Fax Board.
133	275	OS Call Error	OS Call error	Fax Error 133-275 Power Off/On the Printer. If this failure occurs again, please contact customer support.	Replace the Fax Board.
133	276	File Open Error	File open error	Fax Error 133-276 Power Off/On the Printer. If this failure occurs again, please contact customer support.	Replace the Fax Board.
133	277	File Close Error	File close error	Fax Error 133-277 Power Off/On the Printer. If this failure occurs again, please contact customer support.	Replace the Fax Board.
133	278	File Erase Error	File erase error	Fax Error 133-278 Power Off/On the Printer. If this failure occurs again, please contact customer support.	Replace the Fax Board.
133	279	FAX CODEC I/F Error	FAX CODEC I/F error	Fax Error 133-279 Power Off/On the Printer. If this failure occurs again, please contact customer support.	Replace the Fax Board.
133	280	ERR_FAX_TIME	FAX timer error	Fax Error 133-280 Power Off/On the Printer. If this failure occurs again, please contact customer support.	Replace the Fax Board.
133	281	Power Off Report Create Fail	Failed in creating power-off report.	Fax Report Error 133-281 Power Off/On the Printer. If this failure occurs again, please contact customer support.	Replace the Fax Board.

## WorkCentre 6605 Error Code List

Chain Link	Error	Error Details	Control Panel Messages	FIP location	
133	282	Memory Pool Get Error	Memory pool get error (OS error)	Fax Error 133-282 Power Off/On the Printer. If this failure occurs again, please contact customer support.	Replace the Fax Board.
133	283	Message Send Error	Message send error (OS error)	Fax Error 133-283 Power Off/On the Printer. If this failure occurs again, please contact customer support.	Replace the Fax Board.
133	286	OS Call Error	OS Call error	Fax Error 133-286 Power Off/On the Printer. If this failure occurs again, please contact customer support.	Replace the Fax Board.
133	287	File Open Error	File open error	Fax Error 133-287 Power Off/On the Printer. If this failure occurs again, please contact customer support.	Replace the Fax Board.
133	288	File Close Error	File close error	Fax Error 133-288 Power Off/On the Printer. If this failure occurs again, please contact customer support.	Replace the Fax Board.
133	289	File Erase Error	File erase error	Fax Error 133-289 Power Off/On the Printer. If this failure occurs again, please contact customer support.	Replace the Fax Board.
133	290	Print Decode Error	At JBIG data print decode, decode error occurred three successive times.	Fax Error 133-290 Power Off/On the Printer. If this failure occurs again, please contact customer support.	Replace the Fax Board.
134	211	Fax Card Modem Error	Fax Card parts error (MODEM error)	Fax Error 134-211 Power Off/On the Printer. If this failure occurs again, please contact customer support.	Replace the Fax Board.
142	700	IOT Over Heat Forced Half Speed	IOT change half speed due to over heat.	XXXXXXXXXXXXXXXXXX Over Heating. Running Half-speed mode.	-
193	700	Custom Toner Mode	Custom Toner Mode	XXXXXXXXXXXXXXXXXX Non-Xerox Toner Cartridge Installed	-

## WorkCentre 6605 Error Code List

Chain Link	Error	Error Details	Control Panel Messages	FIP location	
024 024 024	910 911 958	IOT Paper Size Mismatch	Detect Paper Size Mismatch  BypassTray : 958 Tray 1 : 910 Tray 2 : 911	<Bypass Tray/Tray1> Paper Size Mismatch Load paper in NNN. XXX YYY  <Option Tray> Paper Size Mismatch Load paper in Tray 2. XXX YYY Or check that the paper guide is correctly set.	-
024 024 024	959 960 963	No Suitable Paper	<ul style="list-style-type: none"> <li>Displayed when any of the following errors occurs and tray setting needs to be changed after paper is loaded.</li> <li>When paper source auto selection is selected, paper sizes of all existing trays do not match. (All Tray Size Mismatch?)</li> <li>When a tray is specified, no paper is loaded in the specified tray. (Specified Tray Empty?)</li> <li>When a tray is specified, paper size loaded in the specified tray does not match. (Specified Tray Size Mismatch?)</li> <li>When Substitute Tray is Off and a paper type is specified, there is no tray loading the specified paper type. (Specified Tray Media Mismatch)</li> </ul> BypassTray : 963 Tray 1 : 959 Tray 2 : 960	<Bypass Tray/Tray1> Paper not available Load paper XXX / YYY in NNN.  <Option Tray> Paper not available Load paper XXX / YYY in Tray 2. Or check that the paper guide is correctly set.	-

**WorkCentre 6605 Error Code List**

Chain Link		Error	Error Details	Control Panel Messages	FIP location
071 072 075	920 920 920	Waiting for side 2 to be set for manual duplex print(Tray)	Tray 1 : 071 Tray 2 : 072 Manual Feed : 075	Manual 2-Sided Print Waiting to Print Side 2. Load Printed Pages into NNN.	-
071 072 075	921 921 921	Waiting for "Set" key to be pressed after setting side 2 for manual duplex print(Tray)	Tray 1 : 071 Tray 2 : 072 Manual Feed : 075	Manual 2-Sided Print Press the Start Button to Continue.	-



# Error Code Fault Isolation Procedures

## Level 1 FIP

### 042-313 IOT Fan Motor Failure

Step	Check	Yes	No
	Possible causative parts: <ul style="list-style-type: none"> <li>• Main Fan (PL4.1.13)</li> <li>• Top Harness Assembly (PL18.2.5)</li> <li>• LVPS (PL18.1.34)</li> <li>• MCU Board (PL18.1.13)</li> </ul>		
1	Check the Main Fan operation Execute Digital Output diagnostic test 042-001, and check the Main Fan rotation. Does the Main Fan function normally?	Replace the MCU Board.	Go to step 2.
2	Check the Main Fan installation Rotate the Main Fan manually. Is there an overload?	Reinstall the Main Fan appropriately.	Go to step 3.
3	Check the Main Fan connection Check the connection between the Main Fan and the LVPS. Is P/J503 connected securely?	Go to step 4.	Reconnect P/J503 securely.
4	Check the connections between the LVPS and the MCU Board Are P/J501 and P/J29 connected securely?	Go to step 5.	Reconnect P/J501 and P/J29 securely.
5	Check the continuity between the LVPS and the MCU Board Is each cable of P/J501 <=> P/J29 continuous?	Go to step 6.	Replace the Top Harness Assembly.
6	Check after replacing the Main Fan Replace the Main Fan. Does the error still occur?	Replace the LVPS.	Finished.

## 024-340 IOT Firmware Error

Step	Check	Yes	No
	Possible causative parts: <ul style="list-style-type: none"> <li>MCU Board (PL18.1.13)</li> </ul>		
1	Check the version of the MCU Board firmware Is the MCU Board firmware of the latest version?	Replace the MCU Board.	Upgrade the firmware of the MCU Board.

## 041-340 IOT NVRAM Error

Step	Check	Yes	No
	Possible causative parts: <ul style="list-style-type: none"> <li>MCU Board (PL18.1.13)</li> </ul>		
1	Check the EEPROM connection Is the EEPROM on the MCU Board installed properly?	Replace the MCU Board.	Install the EEPROM PWB properly.

## 004-310 IOT Feeder I/F Failure

### 072-211 IOT Option Feeder2 Failure

Step	Check	Yes	No
	Possible causative parts: <ul style="list-style-type: none"> <li>Main Harness Assembly (PL18.2.3)</li> <li>Drawer 1 Feeder Harness Assembly (PL10.1.13)</li> <li>550 Option Feeder Board (PL10.1.10)</li> <li>MCU Board (PL18.1.13)</li> </ul>		
1	Check the connections between the 550 Option Feeder Board and the MCU Board Are P/J27, DP/DJ271, and P/J419 connected securely?	Go to step 2.	Connect P/J27, DP/DJ271, and P/J419 securely.
2	Check the continuity between the 550 Option Feeder Board and the drawer connector Is each cable of P/J419<=>DP/DJ271 continuous?	Go to step 3.	Replace the Drawer 1 Feeder Harness Assembly.
3	Check the continuity between the MCU Board and the drawer connector Is each cable of P/J27<=>DP/DJ271 continuous?	Go to step 4.	Replace the Main Harness Assembly.
4	Check after replacing the 550 Option Feeder Board Replace the 550 Option Feeder Board. Does the error still occur?	Replace the MCU Board.	Finished.

## 061-370 IOT ROS Failure

### 092-661 IOT Environment Sensor Error

Step	Check	Yes	No
	Possible causative parts: <ul style="list-style-type: none"> <li>• Laser Unit (PL2.1.1)</li> <li>• Top Harness Assembly (PL18.2.5)</li> <li>• LVPS (PL18.1.34)</li> <li>• MCU Board (PL18.1.13)</li> </ul>		
1	Check the Laser Unit connection Check the connection between the Laser Unit and the MCU Board, and the connection between the Laser Unit and the PWBA LVPS. Are P/J36, P/J11, and PJ43 connected securely?	Go to step 2.	Connect P/J36, P/J11, and PJ43 securely.
2	Check the continuity between the LVPS and the Laser Unit Is each cable of P/J43<=>P/J431 continuous?	Go to step 3.	Replace the Top Harness Assembly.
3	Check the power to the Laser Unit (+5 VDC) Close the interlock switch(es), and check if the voltage between the LVPS ground and the P/J43-2 pin is about +5 VDC.	Go to step 4.	Replace the LVPS.
4	Check the power to the Laser Unit (+24 VDC) Close the interlock switch(es), and check if the voltage between the MCU Board ground and the P/J36-1 pin is about +24 VDC.	Go to step 5.	Refer to “+24 VDC Power FIP” on page 2-222.
5	Check the power to the Laser Unit (+3.3 VDC) Check if the voltage between the MCU Board ground and the P/J11-1 pin is about +3.3 VDC.	Go to step 6.	Refer to “+3.3 VDC Power FIP” on page 2-224.
6	Check after replacing the Laser Unit Replace the Laser Unit. Does the error still occur?	Replace the MCU Board.	Finished.

## 042-325 IOT Motor Failure

Step	Check	Yes	No
	Possible causative parts: <ul style="list-style-type: none"> <li>• Main Motor [Drive Assembly] (PL3.1.1)</li> <li>• Drive Harness Assembly (PL18.2.2)</li> <li>• Top Harness Assembly (PL18.2.5)</li> <li>• LVPS (PL18.1.34)</li> <li>• MCU Board (PL18.1.13)</li> </ul>		
1	Check the Main Motor operation Execute Digital Output diagnostic test 071-001, and check the Main Motor rotation. Does the Main Motor function normally?	Replace the MCU Board.	Go to step 2.
2	Check the Main Motor connection Check the connection between the Main Motor and the LVPS, and the connection between the Main Motor and the MCU Board. Are P/J311, P/J509, P/J171 and P/J17 connected securely?	Go to step 3.	Connect P/J311, P/J509, P/J171, and P/J17 securely.
3	Check the continuity between the Main Motor and the MCU Board Is each cable of P/J171<=>P/J17 continuous?	Go to step 4.	Replace the Drive Harness Assembly.
4	Check the continuity between the Main Motor and the LVPS Is each cable of P/J311<=>P/J509 continuous?	Go to step 5.	Replace the Top Harness Assembly.
5	Check the power to the Main Motor (+24 VDC) Close the interlock switch(es), and check if the voltage between the LVPS ground and the P/J509-1 pin is about +24 VDC.	Replace the Drive Assembly.	Replace the LVPS.

## 042-326 IOT Motor Failure

Step	Check	Yes	No
	Possible causative parts: <ul style="list-style-type: none"> <li>• Paper Transport Motor [Drive Assembly] (PL3.1.1)</li> <li>• Drive Harness Assembly (PL18.2.2)</li> <li>• Top Harness Assembly (PL18.2.5)</li> <li>• LVPS (PL18.1.34)</li> <li>• MCU Board (PL18.1.13)</li> </ul>		
1	Check the Paper Transport Motor operation Execute Digital Output diagnostic test 071-004, and check the Paper Transport Motor rotation. Does the Paper Transport Motor function normally?	Replace the MCU Board.	Go to step 2.
2	Check the Paper Transport Motor connection Check the connection between the Paper Transport Motor and the LVPS, and the connection between the Paper Transport Motor and the MCU Board. Are P/J312, P/J509, P/J172, and P/J17 connected securely?	Go to step 3.	Connect P/J312, P/J509, P/J172, and P/J17 securely.
3	Check the continuity between the Paper Transport Motor and the MCU Board Is each cable of P/J172<=>P/J17 continuous?	Go to step 4.	Replace the Drive Harness Assembly.
4	Check the continuity between the Paper Transport Motor and the LVPS Is each cable of P/J312<=>P/J509 continuous?	Go to step 5.	Replace the Top Harness Assembly.
5	Check the power to the Paper Transport Motor (+24 VDC) Close the interlock switch(es), and check if the voltage between the LVPS ground and the P/J509-3 pin is about +24 VDC.	Replace the Drive Assembly.	Replace the LVPS.

## 093-320 IOT Developer Motor Fail

Step	Check	Yes	No
	Possible causative parts: <ul style="list-style-type: none"> <li>• Developer Motor [Drive Assembly] (PL3.1.1)</li> <li>• Drive Harness Assembly (PL18.2.2)</li> <li>• Top Harness Assembly (PL18.2.5)</li> <li>• LVPS (PL18.1.34)</li> <li>• MCU Board (PL18.1.13)</li> </ul>		
1	Check the Developer Motor operation Execute Digital Output diagnostic test 093-001, and check the Developer Motor rotation. Does the Developer Motor function normally?	Replace the MCU Board.	Go to step 2.
2	Check the Developer Motor connection Check the connection between the Developer Motor and the MCU Board. Are P/J331 and P/J33 connected securely?	Go to step 3.	Connect P/J331 and P/J33 securely.
3	Check the continuity between the Developer Motor and the MCU Board Is each cable of P/J331 <=> P/J33 continuous?	Go to step 4.	Replace the Drive Harness Assembly.
4	Check the power to the Developer Motor (+24 VDC) Close the interlock switch(es), and check if the voltage between the MCU Board ground and the P/J33-2 pin, and the voltage between the MCU Board ground and the P/J33-4 pin is about +24 VDC.	Replace the Drive Assembly.	Replace the LVPS.

## 092-310 IOT CTD Sensor Error

Step	Check	Yes	No
	Possible causative parts: <ul style="list-style-type: none"> <li>• CTD Sensor Assembly (PL6.1.14)</li> <li>• Regi Harness Assembly (PL15.2.8)</li> <li>• MCU Board (PL18.1.13)</li> </ul>		
1	Check the CTD Sensor surface for any smears or foreign objects Are there any smears or foreign objects on the surface of the CTD Sensor, which is a part of the CTD Sensor Assembly.	Clean the CTD Sensor surface <sup>a</sup> or remove the foreign objects.	Go to step 2.
2	Check the CTD Sensor Assembly installation Is the CTD Sensor Assembly installed properly?	Go to step 3.	Reinstall the CTD Sensor Assembly.
3	Check the CTD Sensor Assembly connection Check the connection between the CTD Sensor Assembly and the MCU Board. Are P/J131 and P/J13 connected securely?	Go to step 4.	Connect P/J131 and P/J13 securely.
4	Check the continuity between the CTD Sensor Assembly and the MCU Board Is each cable of P/J131 <=> P/J13 continuous?	Go to step 5.	Replace the Regi Harness Assembly.
5	Check the power to the CTD Sensor Assembly (+5 VDC) Check if the voltage between the MCU Board ground and the P/J13-1 pin is about +5 VDC.	Go to step 6.	Refer to “+5 VDC Power FIP” on page 2-223.
6	Check after replacing the CTD Sensor Assembly Replace the CTD Sensor Assembly. Does the error still occur?	Replace the MCU Board.	Finished.

a. Wipe it with a dry, soft cloth (without alcohol).

093-950 IOT X CRUM Error (Y Toner)

Step	Check	Yes	No
	Possible causative parts: <ul style="list-style-type: none"> <li>• Yellow Toner Cartridge (PL5.1.8)</li> <li>• Dispenser Assembly Y (PL5.1.4)</li> <li>• Top Harness Assembly (PL18.2.5)</li> <li>• MCU Board (PL18.1.13)</li> </ul>		
1	Check the Toner Cartridge installation Is the connection part between the CRUM and the Dispenser Assembly Y inside the Yellow Toner Cartridge clean (without any foreign objects)? And, is the Yellow Toner Cartridge installed properly?	Go to step 2.	Reinstall the Yellow Toner Cartridge.
2	Check the CRUM of the Toner Cartridge Is the connection terminal of the CRUM inside the Yellow Toner Cartridge broken?	Replace the Yellow Toner Cartridge.	Go to step 3.
3	Check the Dispenser Assembly Y Is the connection terminal of the Dispenser Assembly Y broken?	Replace the Dispenser Assembly Y.	Go to step 4.
4	Check the Dispenser Assembly Y connection Check the connection between the Dispenser Assembly Y and the MCU Board. Are P/J191 and P/J19 connected securely?	Go to step 5.	Connect P/J191 and P/J19 securely.
5	Check the continuity between the Dispenser Assembly Y and the MCU Board Is each cable of P/J191 <=> P/J19 continuous?	Replace the MCU Board.	Replace the Top Harness Assembly.



## 093-951 IOT X CRUM Error (M Toner)

Step	Check	Yes	No
	Possible causative parts: <ul style="list-style-type: none"> <li>• Magenta Toner Cartridge (PL5.1.9)</li> <li>• Dispenser Assembly M (PL5.1.5)</li> <li>• Top Harness Assembly (PL18.2.5)</li> <li>• MCU Board (PL18.1.13)</li> </ul>		
1	Check the Toner Cartridge installation Is the connection part between the CRUM and the Dispenser Assembly M inside the Magenta Toner Cartridge clean (without any foreign objects)? And, is the Magenta Toner Cartridge installed properly?	Go to step 2.	Reinstall the Magenta Toner Cartridge.
2	Check the CRUM of the Toner Cartridge Is the connection terminal of the CRUM inside the Magenta Toner Cartridge broken?	Replace the Magenta Toner Cartridge.	Go to step 3.
3	Check the Dispenser Assembly M Is the connection terminal of the Dispenser Assembly M broken?	Replace the Dispenser Assembly M.	Go to step 4.
4	Check the Dispenser Assembly M connection Check the connection between the Dispenser Assembly M and the MCU Board. Are P/J192 and P/J19 connected securely?	Go to step 5.	Connect P/J192 and P/J19 securely.
5	Check the continuity between the Dispenser Assembly M and the MCU Board Is each cable of P/J192<=>P/J19 continuous?	Replace the MCU Board.	Replace the Top Harness Assembly.

## 093-952 IOT X CRUM Error (C Toner)

Step	Check	Yes	No
	Possible causative parts: <ul style="list-style-type: none"> <li>• Cyan Toner Cartridge (PL5.1.10)</li> <li>• Dispenser Assembly C (PL5.1.6)</li> <li>• Top Harness Assembly (PL18.2.5)</li> <li>• MCU Board (PL18.1.13)</li> </ul>		
1	Check the Toner Cartridge installation Is the connection part between the CRUM and the Dispenser Assembly C inside the Cyan Toner Cartridge clean (without any foreign objects)? And, is the Cyan Toner Cartridge installed properly?	Go to step 2.	Reinstall the Cyan Toner Cartridge.
2	Check the CRUM of the Toner Cartridge Is the connection terminal of the CRUM inside the Cyan Toner Cartridge broken?	Replace the Cyan Toner Cartridge.	Go to step 3.
3	Check the Dispenser Assembly C. Is the connection terminal of the Dispenser Assembly C broken?	Replace the Dispenser Assembly C.	Go to step 4.
4	Check the Dispenser Assembly C connection Check the connection between the Dispenser Assembly C and the MCU Board. Are P/J193 and P/J19 connected securely?	Go to step 5.	Connect P/J193 and P/J19 securely.
5	Check the continuity between the Dispenser Assembly C and the MCU Board Is each cable of P/J193<=>P/J19 continuous?	Replace the MCU Board.	Replace the Top Harness Assembly.

## 093-925 SFP / 093-953 MFP IOT X CRUM Error (K Toner)

Step	Check	Yes	No
	Possible causative parts: <ul style="list-style-type: none"> <li>Black Toner Cartridge (PL5.1.11)</li> <li>Dispenser Assembly K (PL5.1.7)</li> <li>Top Harness Assembly (PL18.2.5)</li> <li>MCU Board (PL18.1.13)</li> </ul>		
1	Check the Toner Cartridge installation Is the connection part between the CRUM and the Dispenser Assembly K inside the Black Toner Cartridge clean (without any foreign objects)? And, is the Black Toner Cartridge installed properly?	Go to step 2.	Reinstall the Black Toner Cartridge.
2	Check the CRUM of the Toner Cartridge Is the connection terminal of the CRUM inside the Black Toner Cartridge broken?	Replace the Black Toner Cartridge.	Go to step 3.
3	Check the Dispenser Assembly K Is the connection terminal of the Dispenser Assembly K broken?	Replace the Dispenser Assembly K.	Go to step 4.
4	Check the Dispenser Assembly K connection Check the connection between the Dispenser Assembly K and the MCU Board. Are P/J194 and P/J19 connected securely?	Go to step 5.	Connect P/J194 and P/J19 securely.
5	Check the continuity between the Dispenser Assembly Y and the MCU Board Is each cable of P/J194<=>P/J19 continuous?	Replace the MCU Board.	Replace the Top Harness Assembly.

## 093-980 IOT Y Toner Type Error

## 093-960 IOT X CRUM ID Error (Y Toner)

Step	Check	Yes	No
	Possible causative parts: <ul style="list-style-type: none"> <li>Yellow Toner Cartridge (PL5.1.8)</li> </ul>		
1	Check the Toner Cartridge installation Is a Toner Cartridge other than a Yellow Toner Cartridge installed? Or, is the installed Toner Cartridge for another printer?	Install the right Yellow Toner Cartridge.	Reinstall the Yellow Toner Cartridge.

**093-981 IOT M Toner Type Error****093-961 IOT X CRUM ID Error (M Toner)**

Step	Check	Yes	No
	Possible causative parts: <ul style="list-style-type: none"> <li>• Magenta Toner Cartridge (PL5.1.9)</li> </ul>		
1	Check the Toner Cartridge installation Is a Toner Cartridge other than a Magenta Toner Cartridge installed? Or, is the installed Toner Cartridge for another printer?	Install the right Magenta Toner Cartridge.	Reinstall the Magenta Toner Cartridge.

**093-982 IOT C Toner Type Error****093-962 IOT X CRUM ID Error (C Toner)**

Step	Check	Yes	No
	Possible causative parts: <ul style="list-style-type: none"> <li>• Cyan Toner Cartridge (PL5.1.10)</li> </ul>		
1	Check the Toner Cartridge installation Is a Toner Cartridge other than a Cyan Toner Cartridge installed? Or, is the installed Toner Cartridge for another printer?	Install the right Cyan Toner Cartridge.	Reinstall the Cyan Toner Cartridge.

**093-928 IOT K Toner Type Error****093-926 IOT X CRUM ID Error (K Toner)**

Step	Check	Yes	No
	Possible causative parts: <ul style="list-style-type: none"> <li>• Black Toner Cartridge (PL5.1.11)</li> </ul>		
1	Check the Toner Cartridge installation Is a Toner Cartridge other than a Black Toner Cartridge installed? Or, is the installed Toner Cartridge for another printer?	Install the right Black Toner Cartridge.	Reinstall the Black Toner Cartridge.

## 010-317 IOT Fuser Detached

## 010-351 IOT Fuser Life Over

## 010-397 IOT Fuser Failure

## 042-700 IOT Over Heat Stop

Step	Check	Yes	No
	Possible causative parts: <ul style="list-style-type: none"> <li>• Fuser Assembly (PL7.1.1)</li> <li>• Heater Harness Assembly (PL7.1.5)</li> <li>• Top Harness Assembly (PL18.2.5)</li> <li>• LVPS (PL18.1.34)</li> <li>• MCU Board (PL18.1.13)</li> </ul>		
1	Check the Fuser Assembly installation Are the Fuser Assembly, and the drawer connector (DP/J281) of the printer installed properly (without a bent pin, or any foreign or burnt objects, etc.)?	Go to step 2.	Reinstall the Fuser Assembly.
2	Check the Fuser Assembly connection Check the connection between the Fuser Assembly and the MCU Board, and the connection between the Fuser Assembly and the LVPS. Are P/J281, P/J28, and P/J47 connected securely?	Go to step 3.	Connect P/J281, P/J28, and P/J47 securely.
3	Check the connections between LVPS and the MCU Board Check the connection between the LVPS and the MCU Board. Are P/J508 and P/J29 connected securely?	Go to step 4.	Connect P/J508 and P/J29 securely.
4	Check the Heater Harness Assembly continuity. Is each cable of P/J281 <=> P/J47 continuous?	Go to step 5.	Replace the Heater Harness Assembly.
5	Check the Top Harness Assembly continuity. Is each cable of P/J281 <=> P/J28 continuous?	Go to step 6.	Replace the Top Harness Assembly.
6	Check the power to the Fuser Assembly (+5 VDC) Check if the voltage between the MCU Board ground and the P/J28-2 pin is about +5 VDC.	Go to step 7.	Refer to “+5 VDC Power FIP” on page 2-223.
7	Check after replacing the Fuser Assembly Replace the Fuser Assembly. Does the error still occur?	Go to step 8.	Finished.
8	Check after replacing the LVPS Replace the LVPS. Does the error still occur?	Replace the MCU Board.	Finished.

## 024-362 IOT Start Image Marking Timeout

Step	Check	Yes	No
	Possible causative parts: <ul style="list-style-type: none"> <li>• MCU Board (PL18.1.13)</li> <li>• IP Board (PL18.1.22)</li> </ul>		
1	Check after replacing the MCU Board Replace the MCU Board. Does the error still occur?	Replace the IP Board.	Finished.

## 024-920 IOT Standard Stacker Full

Step	Check	Yes	No
	Possible causative parts: <ul style="list-style-type: none"> <li>• Full Stack Sensor (PL17.1.11)</li> <li>• Sensor Harness Assembly (PL17.1.23)</li> <li>• MCU Board (PL18.1.13)</li> </ul>		
1	Check the Full Stack Sensor operation Execute Digital Input diagnostic test 071-105, and check the Full Stack Sensor operation. Does it function normally?	Replace the MCU Board.	Go to step 2.
2	Check the Full Stack Sensor connection Check the connection between the Full Stack Sensor and the MCU Board. Are P/J154 and P/J15 connected securely?	Go to step 3.	Connect P/J154 and P/J15 securely.
3	Check the continuity between the Full Stack Sensor and the MCU Board Is each cable of P/J154<=>P/J15 continuous?	Go to step 4.	Replace the Sensor Harness Assembly.
4	Check the power to the Full Stack Sensor (+5 VDC) Check if the voltage between the MCU Board ground and the P/J15-4 pin is about +5 VDC.	Replace the Full Stack Sensor.	Refer to “+5 VDC Power FIP” on page 2-223.

## 046-310 IOT HVPS Error

Step	Check	Yes	No
	Possible causative parts: <ul style="list-style-type: none"> <li>• Transfer HVPS Board (PL18.1.28)</li> <li>• Development HVPS Board (PL18.1.14)</li> <li>• MCU-HVPS Flat Flex Cable (PL18.2.7)</li> <li>• HVPS Harness Assembly (PL18.2.6)</li> <li>• MCU Board (PL18.1.13)</li> </ul>		
1	Check the Transfer HVPS Board connection Check the connection between the Transfer HVPS Board and the Development HVPS Board. Are P/J1821 and P/J182 connected securely?	Go to step 2.	Connect P/J1821 and P/J182 securely.
2	Check the continuity between the Transfer HVPS Board and the Development HVPS Board Is each cable of P/J1821<=>P/J182 continuous?	Go to step 3.	Replace the HVPS Harness Assembly.
3	Check the Development HVPS Board connection Check the connection between the Development HVPS Board and the MCU Board. Are P/J181 and P/J18 connected securely?	Go to step 4.	Connect P/J181 and P/J18 securely.
4	Check after replacing the MCU-HVPS Flat Flex Cable Replace the MCU-HVPS Flat Flex Cable. Does the error still occur?	Go to step 5.	Finished.
5	Check after replacing the Transfer HVPS Board Replace the Transfer HVPS Board. Does the error still occur?	Go to step 6.	Finished.
6	Check after replacing the Development HVPS Board Replace the Development HVPS Board. Does the error still occur?	Replace the MCU Board.	Finished.

## 071-100 IOT Tray1 Misfeed JAM

Step	Check	Yes	No
	Possible causative parts: <ul style="list-style-type: none"> <li>• Regi Sensor [Regi Chute Assembly] (PL15.2.1)</li> <li>• Feed Clutch (PL15.2.6)</li> <li>• Paper Transport Motor [Drive Assembly] (PL3.1.1)</li> <li>• Feed Roller Assembly (PL15.2.7)</li> <li>• Tray Retard Holder Assembly (PL9.1.3)</li> <li>• Regi Harness Assembly (PL15.2.8)</li> <li>• MCU Board (PL18.1.13)</li> </ul>		
1	Check the Tray 1 installation Is Tray 1 installed properly?	Go to step 2.	Install Tray 1 properly.
2	Check the paper path Are there any foreign objects, or paper pieces, etc. on the paper path?	Remove the foreign objects, or paper pieces, etc.	Go to step 3.
3	Check the paper feed roller Is the paper feed roller (the roller on the possible causative parts list) installed properly?	Go to step 4.	Reinstall the paper feed roller.
4	Check the paper feed roller Is the paper feed roller (the roller on the possible causative parts list) deformed or worn out?	Replace the paper feed roller.	Go to step 5.
5	Check the Regi Sensor operation Execute Digital Input diagnostic test 071-103, and check the Regi Sensor operation. Does the Regi Sensor function normally?	Go to step 6.	Refer to page 2-211.
6	Check the Feed Clutch operation Execute Digital Output diagnostic test 071-008, and check the Feed Clutch operation. Does the Feed Clutch function normally?	Go to step 7.	Refer to page 2-211
7	Check the Paper Transport Motor operation Execute Digital Output diagnostic test 071-004, and check the Paper Transport Motor rotation. Does the Paper Transport Motor function normally?	Replace the MCU Board.	Refer to page 2-181.



## 072-100 IOT Tray2 Misfeed JAM

## 072-101 IOT Path2 SNS On JAM

Step	Check	Yes	No
	Possible causative parts: <ul style="list-style-type: none"> <li>• Path Sensor [550 Option Main Feed Assembly] (PL10.2.1)</li> <li>• 550 Option Regi Clutch Assembly (PL10.2.2)</li> <li>• 550 Option Feed Clutch Assembly (PL10.1.8)</li> <li>• 550 Option Drive Assembly (PL10.1.9)</li> <li>• Feed Roller Assembly (PL10.2.3)</li> <li>• Tray Retard Holder Assembly (PL10.3.3)</li> <li>• C2 Size Harness Assembly (PL10.1.14)</li> <li>• C2 Turn Harness Assembly (PL10.1.15)</li> <li>• Feeder Motor Harness Assembly (PL10.1.16)</li> <li>• 550 Option Feeder Board (PL10.1.10)</li> <li>• MCU Board (PL18.1.13)</li> </ul>		
1	Check the Tray 2 installation Is Tray 2 installed properly?	Go to step 2.	Install Tray 2 properly.
2	Check the paper path Are there any foreign objects, or paper pieces, etc. on the paper path?	Remove the foreign objects, or paper pieces, etc.	Go to step 3.
3	Check the paper feed roller Is the paper feed roller (the roller on the possible causative parts list) installed properly?	Go to step 4.	Reinstall the paper feed roller.
4	Check the paper feed roller Is the paper feed roller (the roller on the possible causative parts list) deformed or worn out?	Replace the paper feed roller.	Go to step 5.
5	Check the Path Sensor operation Execute Digital Input diagnostic test 071-117, and check the Path Sensor operation. Does the Path Sensor function normally?	Go to step 6.	Refer to page 2-213.
6	Check the 550 Option Regi Clutch Assembly operation Execute Digital Output diagnostic test 071-020, and check the 550 Option Regi Clutch Assembly operation. Does the 550 Option Regi Clutch Assembly function normally?	Go to step 7.	Refer to page 2-214.
7	Check the 550 Option Feed Clutch Assembly operation Execute Digital Output diagnostic test 071-022, and check the 550 Option Feed Clutch Assembly operation. Does the 550 Option Feed Clutch Assembly function normally?	Go to step 8.	Refer to page 2-216.

Step	Check	Yes	No
8	Check the 550 Option Drive Assembly operation Execute Digital Output diagnostic test 071-014, and check the 550 Option Drive Assembly rotation. Does the 550 Option Drive Assembly function normally?	Replace the MCU Board.	Refer to page 2-218.

## 075-100 MSI (Bypass Tray) Misfeed JAM

Step	Check	Yes	No
	Possible causative parts: <ul style="list-style-type: none"> <li>• Regi Sensor [Regi Chute Assembly] (PL15.2.1)</li> <li>• Bypass Tray Feed Solenoid (PL13.2.9)</li> <li>• Paper Transport Motor [Drive Assembly] (PL3.1.1)</li> <li>• Feed Roller Assembly (PL13.2.10)</li> <li>• Retard Holder Assembly (PL13.3.14)</li> <li>• TA1 Roller Assembly (PL13.1.2)</li> <li>• TA2 Roller Assembly (PL13.1.3)</li> <li>• Bypass Tray Harness Assembly (PL13.2.5)</li> <li>• MCU Board (PL18.1.13)</li> </ul>		
1	Check the Bypass Tray installation Is the Bypass Tray installed properly?	Go to step 2.	Install the Bypass Tray properly.
2	Check the paper path Are there any foreign objects, or paper pieces, etc. in the paper path?	Remove foreign objects, or paper pieces, etc.	Go to step 3.
3	Check the paper feed roller Is the paper feed roller (the roller on the possible causative parts list) installed properly?	Go to step 4.	Reinstall the paper feed roller.
4	Check the paper feed roller Is the paper feed roller (the roller on the possible causative parts list) deformed or worn out?	Replace the paper feed roller.	Go to step 5.
5	Check the Regi Sensor operation Execute Digital Input diagnostic test 071-103, and check the Regi Sensor operation. Does the Regi Sensor function normally?	Go to step 6.	Refer to page 2-211.
6	Check the Bypass Tray Feed Solenoid operation Execute Digital Output diagnostic test 071-007, and check the Bypass Tray Feed Solenoid operation. Does the Bypass Tray Feed Solenoid function normally?	Go to step 7.	Refer to page 2-219.
7	Check the Paper Transport Motor operation Execute Digital Output diagnostic test 071-004, and check the Paper Transport Motor rotation. Does the Paper Transport Motor function normally?	Replace the MCU Board.	Refer to page 2-181.

## 075-910 MSI (Bypass Tray) Detached

Step	Check	Yes	No
	Possible causative parts: <ul style="list-style-type: none"> <li>• Bypass Tray No Paper Sensor (PL13.2.4)</li> <li>• Bypass Tray Cover Assembly (PL13.3.2)</li> <li>• Bypass Tray Harness Assembly (PL13.2.5)</li> <li>• MCU Board (PL18.1.13)</li> </ul>		
1	Check the Bypass Tray installation Is the Bypass Tray installed properly?	Go to step 2.	Install the Bypass Tray properly.
2	Check the Bypass Tray Cover Assembly Is the Bypass Tray Cover Assembly broken?	Replace the Bypass Tray Cover Assembly.	Go to step 3.
3	Check the Bypass Tray No Paper Sensor operation Execute Digital Input diagnostic test 071-102, and check the Bypass Tray No Paper Sensor operation. Does the Bypass Tray No Paper Sensor function normally?	Replace the MCU Board.	Go to step 4.
4	Check the connections between Bypass Tray No Paper Sensor and the MCU Board Check the connection between the Bypass Tray No Paper Sensor and the MCU Board. Are P/J211 and P/J21 connected securely?	Go to step 5.	Connect P/J211 and P/J21 securely.
5	Check the Bypass Tray Harness Assembly continuity. Is each cable of P/J211 <=> P/J21 continuous?	Go to step 6.	Replace the Bypass Tray Harness Assembly.
6	Check the power to the Bypass Tray No Paper Sensor (+5 VDC) Check if the voltage between the MCU Board ground and the P/J21- 1 pin is about +5 VDC.	Replace the Bypass Tray No Paper Sensor.	Refer to page 2-223.

**077-104 RegOff JAM**  
**077-106 Exit ON JAM**

Step	Check	Yes	No
	Possible causative parts: <ul style="list-style-type: none"> <li>• Regi Sensor [Regi Chute Assembly] (PL15.2.1)</li> <li>• Exit Sensor (PL17.1.11)</li> <li>• Regi Clutch (PL15.1.8)</li> <li>• Paper Transport Motor / Main Motor [Drive Assembly] (PL3.1.1)</li> <li>• Regi Harness Assembly (PL15.2.8)</li> <li>• MCU Board (PL18.1.13)</li> </ul>		
1	Check the paper path Are there any foreign objects, or paper pieces, etc. on the paper path?	Remove the foreign objects, or paper pieces, etc.	Go to step 2.
2	Check the paper feed roller Is the paper feed roller (the roller on the possible causative parts list) installed properly?	Go to step 3.	Reinstall the paper feed roller.
3	Check the paper feed roller Is the paper feed roller (the roller on the possible causative parts list) deformed or worn out?	Replace the paper feed roller.	Go to step 4.
4	Check the Regi Sensor operation Execute Digital Input diagnostic test 071-103, and check the Regi Sensor operation. Does the Regi Sensor function normally?	Go to step 5.	Refer to page 2-211.
5	Check the Regi Clutch operation Execute Digital Output diagnostic test 071-010, and check the Regi Clutch operation. Does the Regi Clutch function normally?	Go to step 6.	Refer to page 2-212.
6	Check the Paper Transport Motor operation Execute Digital Output diagnostic test 071-004, and check the Paper Transport Motor rotation. Does the Paper Transport Motor function normally?	Go to step 7.	Refer to page 2-181.
7	Check the Exit Sensor operation Execute Digital Input diagnostic test 071-104, and check the Exit Sensor operation. Does the Exit Sensor function normally?	Go to step 8.	Refer to page 2-220.
8	Check the Main Motor operation Execute Digital Output diagnostic test 071-001, and check the Main Motor rotation. Does the Main Motor function normally?	Replace the MCU Board.	Refer to page 2-180.

**077-109 ExitOff JAM**  
**077-108 ExitOff early JAM**  
**077-107 Duplex ON JAM**

Step	Check	Yes	No
	Possible causative parts: <ul style="list-style-type: none"> <li>Exit Sensor (PL17.1.11)</li> <li>Exit Clutch 1 / Exit Clutch 2 [Exit Drive Assembly](PL17.1.21)</li> <li>Main Motor [Drive Assembly] (PL3.1.1)</li> <li>Exit Sensor Harness Assembly (PL17.1.18)</li> <li>Sensor Harness Assembly (PL17.1.23)</li> <li>MCU Board (PL18.1.13)</li> </ul>		
1	Check the paper path Are there any foreign objects, or paper pieces, etc. on the paper path?	Remove the foreign objects, or paper pieces, etc.	Go to step 2.
2	Check the paper feed roller Is the paper feed roller (the roller on the possible causative parts list) installed properly?	Go to step 3.	Reinstall the paper feed roller.
3	Check the paper feed roller Is the paper feed roller (the roller on the possible causative parts list) deformed or worn out?	Replace the paper feed roller.	Go to step 4.
4	Check the Exit Sensor operation Execute Digital Input diagnostic test 071-104, and check the Exit Sensor operation. Does the Exit Sensor function normally?	Go to step 5.	Refer to page 2-220.
5	Check the Exit Clutch 1 operation Execute Digital Output diagnostic test 071-011, and check the Exit Clutch 1 operation. Does the Exit Clutch 1 function normally?	Go to step 6.	Refer to page 2-221.
6	Check the Exit Clutch 2 operation Execute Digital Output diagnostic test 071-012, and check the Exit Clutch 2 operation. Does the Exit Clutch 2 function normally?	Go to step 6.	Refer to page 2-221.
7	Check the Main Motor operation Execute Digital Output diagnostic test 071-001, and check the Main Motor rotation. Does the Main Motor function normally?	Replace the MCU Board.	Refer to page 2-180.

## 077-300 IOT Cover Front Open

Step	Check	Yes	No
	Possible causative parts: <ul style="list-style-type: none"> <li>• Front Cover Sensor (PL18.1.45)</li> <li>• MCU Board (PL18.1.13)</li> </ul>		
1	Check the Front Cover Sensor operation Execute Digital Input diagnostic test 041-302, and check the Front Cover Sensor operation. Does it function normally?	Replace the MCU Board.	Go to step 2.
2	Check the Front Cover Sensor connection Check the connection between the Front Cover Sensor and the MCU Board. Are P/J145 and P/J14 connected securely?	Go to step 3.	Connect P/J145 and P/J14 securely.
3	Check the power to the Front Cover Sensor (+5 VDC) Check if the voltage between the MCU Board ground and the P/J14-9 pin is about +5 VDC.	Replace the Front Cover Sensor.	Refer to page 2-223.

## 077-301 IOT Side Cover Open

Step	Check	Yes	No
	Possible causative parts: <ul style="list-style-type: none"> <li>• Door Interlock Switch (PL19.1.21)</li> <li>• LVPS (PL18.1.34)</li> </ul>		
1	Check the Door Interlock Switch operation Execute Digital Input diagnostic test 041-300, and check the Door Interlock Switch operation. Does it function normally?	Replace the MCU Board.	Go to step 2.
2	Check the Door Interlock Switch connection Check the connection between the Door Interlock Switch and the LVPS. Is P/J42 connected securely?	Go to step 3.	Connect P/J42 securely.
3	Check after replacing the Door Interlock Switch Replace the Door Interlock Switch. Does the error still occur?	Replace the LVPS.	Finished.

## 077-304 IOT Cover Rear Open

Step	Check	Yes	No
	Possible causative parts: <ul style="list-style-type: none"> <li>Rear Interlock Switch (PL19.1.21)</li> <li>LVPS (PL18.1.34)</li> </ul>		
1	Check the Rear Interlock Switch operation Execute Digital Input diagnostic test 041-301, and check the Rear Interlock Switch operation. Does it function normally?	Replace the MCU Board.	Go to step 2.
2	Check the Rear Interlock Switch connection Check the connection between the Rear Interlock Switch and the LVPS. Is P/J41 connected securely?	Go to step 3.	Connect P/J41 securely.
3	Check after replacing the Rear Interlock Switch Replace the Rear Interlock Switch. Does the error still occur?	Replace the LVPS.	Finished.

## 091-400 IOT Waste Toner Box Near Life

## 091-911 IOT Waste Toner Box Life Over

Step	Check	Yes	No
	Possible causative parts: <ul style="list-style-type: none"> <li>Toner Full Sensor (PL4.1.17)</li> <li>MCU Board (PL18.1.13)</li> </ul>		
1	Check the Toner Full Sensor operation Execute Digital Input diagnostic test 094-202, and check the Toner Full Sensor operation. Does it function normally?	Replace the MCU Board.	Go to step 2.
2	Check the Toner Full Sensor connection Check the connection between the Toner Full Sensor and the MCU Board. Are P/J203 and P/J29 connected securely?	Go to step 3.	Connect P/J203 and P/J29 securely.
3	Check the power to the Toner Full Sensor (+5 VDC) Check if the voltage between the MCU Board ground and the P/J29-20 pin is about +5 VDC.	Replace the Toner Full Sensor.	Refer to page 2-223.



## 091-914 IOT K Drum Comm Fail

Step	Check	Yes	No
	Possible causative parts: <ul style="list-style-type: none"> <li>Black Imaging Unit (PL8.1.5)</li> <li>CRUM Connector Assembly (PL8.1.1)</li> <li>MCU Board (PL18.1.13)</li> </ul>		
1	Check the Imaging Unit installation Is the connection part between the CRUM and the CRUM Connector Assembly inside the Black Imaging Unit clean (without any foreign objects)? And, is the Black Imaging Unit installed properly?	Go to step 2.	Reinstall the Black Imaging Unit.
2	Check the Imaging Unit CRUM Is the connection terminal of the CRUM inside the Black Imaging Unit broken?	Replace the Black Imaging Unit.	Go to step 3.
3	Check the CRUM Connector Assembly Is the connection terminal of the CRUM Connector Assembly broken?	Replace the CRUM Connector Assembly.	Go to step 4.
4	Check the CRUM Connector Assembly connection Check the connection between the CRUM Connector Assembly and the MCU Board. Are P/J124 and P/J12 connected securely?	Go to step 5.	Connect P/J124 and P/J12 securely.
5	Check the continuity between the CRUM Connector Assembly and the MCU Board Is each cable of P/J124<=>P/J12 continuous?	Replace the MCU Board.	Replace the CRUM Connector Assembly.

## 091-917 IOT Y Drum Comm Fail

Step	Check	Yes	No
	Possible causative parts: <ul style="list-style-type: none"> <li>Yellow Imaging Unit (PL8.1.2)</li> <li>CRUM Connector Assembly (PL8.1.1)</li> <li>MCU Board (PL18.1.13)</li> </ul>		
1	Check the Imaging Unit installation Is the connection part between the CRUM and the CRUM Connector Assembly inside the Yellow Imaging Unit clean (without any foreign objects)? And, is the Yellow Imaging Unit installed properly?	Go to step 2.	Reinstall the Yellow Imaging Unit.
2	Check the Imaging Unit CRUM Is the connection terminal of the CRUM inside the Yellow Imaging Unit broken?	Replace the Yellow Imaging Unit.	Go to step 3.

Step	Check	Yes	No
3	Check the CRUM Connector Assembly Is the connection terminal of the CRUM Connector Assembly broken?	Replace the CRUM Connector Assembly.	Go to step 4.
4	Check the CRUM Connector Assembly connection Check the connection between the CRUM Connector Assembly and the MCU Board. Are P/J121 and P/J12 connected securely?	Go to step 5.	Connect P/J121 and P/J12 securely.
5	Check the continuity between the CRUM Connector Assembly and the MCU Board Is each cable of P/J121<=>P/J12 continuous?	Replace the MCU Board.	Replace the CRUM Connector Assembly.

### 091-918 IOT M Drum Comm Fail

Step	Check	Yes	No
	Possible causative parts: <ul style="list-style-type: none"> <li>• Magenta Imaging Unit (PL8.1.3)</li> <li>• CRUM Connector Assembly (PL8.1.1)</li> <li>• MCU Board (PL18.1.13)</li> </ul>		
1	Check the Imaging Unit installation Is the connection part between the CRUM and the CRUM Connector Assembly inside the Magenta Imaging Unit clean (without any foreign objects)? And, is the Magenta Imaging Unit installed properly?	Go to step 2.	Reinstall the Magenta Imaging Unit.
2	Check the Imaging Unit CRUM Is the connection terminal of the CRUM inside the Magenta Imaging Unit broken?	Replace the Magenta Imaging Unit.	Go to step 3.
3	Check the CRUM Connector Assembly Is the connection terminal of the CRUM Connector Assembly broken?	Replace the CRUM Connector Assembly.	Go to step 4.
4	Check the CRUM Connector Assembly connection Check the connection between the CRUM Connector Assembly and the MCU Board. Are P/J122 and P/J12 connected securely?	Go to step 5.	Connect P/J122 and P/J12 securely.
5	Check the continuity between the CRUM Connector Assembly and the MCU Board Is each cable of P/J122<=>P/J12 continuous?	Replace the MCU Board.	Replace the CRUM Connector Assembly.

## 091-919 IOT C Drum Comm Fail

Step	Check	Yes	No
	Possible causative parts: <ul style="list-style-type: none"> <li>• Cyan Imaging Unit (PL8.1.4)</li> <li>• CRUM Connector Assembly (PL8.1.1)</li> <li>• MCU Board (PL18.1.13)</li> </ul>		
1	Check the Imaging Unit installation Is the connection part between the CRUM and the CRUM Connector Assembly inside the Cyan Imaging Unit clean (without any foreign objects)? And, is the Cyan Imaging Unit installed properly?	Go to step 2.	Reinstall the Cyan Imaging Unit.
2	Check the Imaging Unit CRUM Is the connection terminal of the CRUM inside the Cyan Imaging Unit broken?	Replace the Cyan Imaging Unit.	Go to step 3.
3	Check the CRUM Connector Assembly Is the connection terminal of the CRUM Connector Assembly broken?	Replace the CRUM Connector Assembly.	Go to step 4.
4	Check the CRUM Connector Assembly connection Check the connection between the CRUM Connector Assembly and the MCU Board. Are P/J123 and P/J12 connected securely?	Go to step 5.	Connect P/J123 and P/J12 securely.
5	Check the continuity between the CRUM Connector Assembly and the MCU Board Is each cable of P/J123<=>P/J12 continuous?	Replace the MCU Board.	Replace the CRUM Connector Assembly.

## 091-915 DRUM UnitK CRUM Data Broken Fail 091-963 IOT X CRUM ID Error (K DRUM)

Step	Check	Yes	No
	Possible causative parts: <ul style="list-style-type: none"> <li>• Black Imaging Unit (PL8.1.5)</li> </ul>		
1	Check the Imaging Unit installation Is an Imaging Unit other than a Black Imaging Unit installed? Or, is the installed Imaging Unit for another printer?	Install the right Black Imaging Unit.	Reinstall the Black Imaging Unit.

**091-920 DRUM Y CRUM Data Broken Fail**  
**091-960 IOT X CRUM ID Error (Y DRUM)**

Step	Check	Yes	No
	Possible causative parts: <ul style="list-style-type: none"> <li>Yellow Imaging Unit (PL8.1.2)</li> </ul>		
1	Check the Imaging Unit installation Is an Imaging Unit other than a Yellow Imaging Unit installed? Or, is the installed Imaging Unit for another printer?	Install the right Yellow Imaging Unit.	Reinstall the Yellow Imaging Unit.

**091-922 DRUM M CRUM Data Broken Fail**  
**091-961 IOT X CRUM ID Error (M DRUM)**

Step	Check	Yes	No
	Possible causative parts: <ul style="list-style-type: none"> <li>Magenta Imaging Unit (PL8.1.3)</li> </ul>		
1	Check the Imaging Unit installation Is an Imaging Unit other than a Magenta Imaging Unit installed? Or, is the installed Imaging Unit for another printer?	Install the right Magenta Imaging Unit.	Reinstall the Magenta Imaging Unit.

**091-923 DRUM C CRUM Data Broken Fail**  
**091-962 IOT X CRUM ID Error (C DRUM)**

Step	Check	Yes	No
	Possible causative parts: <ul style="list-style-type: none"> <li>Cyan Imaging Unit (PL8.1.3)</li> </ul>		
1	Check the Imaging Unit installation Is an Imaging Unit other than a Cyan Imaging Unit installed? Or, is the installed Imaging Unit for another printer?	Install the right Cyan Imaging Unit.	Reinstall the Cyan Imaging Unit.

## 092-670 Yellow Patch Error

Step	Check	Yes	No
	Possible causative parts: <ul style="list-style-type: none"> <li>• Yellow Imaging Unit (PL8.1.2)</li> <li>• Yellow Toner Cartridge (PL5.1.8)</li> <li>• MCU Board (PL18.1.13)</li> </ul>		
1	Check after reinstalling the Toner Cartridge Pull out and shake the Yellow Toner Cartridge, and then reinstall it. Does the error still occur?	Go to step 2.	Finished.
2	Check after replacing the Toner Cartridge Replace the Yellow Toner Cartridge. Does the error still occur?	Go to step 3.	Finished.
3	Check the Imaging Unit installation Take out the Yellow Imaging Unit. Is the connection part of the Yellow Imaging Unit clean? And, is the Yellow Imaging Unit touching against the guides on the left and right sides, and installed properly?	Go to step 4.	Clean the connection part. Reinstall the Yellow Imaging Unit.
4	Check after replacing the Yellow Imaging Unit Replace the Yellow Imaging Unit. Does the error still occur?	Replace the MCU Board.	Finished.

## 092-671 Magenta Patch Error

Step	Check	Yes	No
	Possible causative parts: <ul style="list-style-type: none"> <li>• Magenta Imaging Unit (PL8.1.3)</li> <li>• Magenta Toner Cartridge (PL5.1.9)</li> <li>• MCU Board (PL18.1.13)</li> </ul>		
1	Check after reinstalling the Toner Cartridge Pull out and shake the Magenta Toner Cartridge, and then reinstall it. Does the error still occur?	Go to step 2.	Finished.
2	Check after replacing the Toner Cartridge Replace the Magenta Toner Cartridge. Does the error still occur?	Go to step 3.	Finished.
3	Check the Imaging Unit installation Take out the Magenta Imaging Unit. Is the connection part of the Magenta Imaging Unit clean? And, is the Magenta Imaging Unit touching against the guides on the left and right sides, and installed properly?	Go to step 4.	Clean the connection part. Reinstall the Magenta Imaging Unit.

Step	Check	Yes	No
4	Check after replacing the Magenta Imaging Unit Replace the Magenta Imaging Unit. Does the error still occur?	Replace the MCU Board.	Finished.

## 092-672 Cyan Patch Error

Step	Check	Yes	No
	Possible causative parts: <ul style="list-style-type: none"> <li>• Cyan Imaging Unit (PL8.1.4)</li> <li>• Cyan Toner Cartridge (PL5.1.10)</li> <li>• MCU Board (PL18.1.13)</li> </ul>		
1	Check after reinstalling the Toner Cartridge Pull out and shake the Cyan Toner Cartridge, and then reinstall it. Does the error still occur?	Go to step 2.	Finished.
2	Check after replacing the Toner Cartridge Replace the Cyan Toner Cartridge. Does the error still occur?	Go to step 3.	Finished.
3	Check the Imaging Unit installation Take out the Cyan Imaging Unit. Is the connection part of the Cyan Imaging Unit clean? And, is the Cyan Imaging Unit touching against the guides on the left and right sides, and installed properly?	Go to step 4.	Clean the connection part. Reinstall the Cyan Imaging Unit.
4	Check after replacing the Cyan Imaging Unit Replace the Cyan Imaging Unit. Does the error still occur?	Replace the MCU Board.	Finished.

## 092-673 Black Patch Error

Step	Check	Yes	No
	Possible causative parts: <ul style="list-style-type: none"> <li>• Black Imaging Unit (PL8.1.5)</li> <li>• Black Toner Cartridge (PL5.1.11)</li> <li>• MCU Board (PL18.1.13)</li> </ul>		
1	Check after reinstalling the Toner Cartridge Pull out and shake the Black Toner Cartridge, and then reinstall it. Does the error still occur?	Go to step 2.	Finished.
2	Check after replacing the Toner Cartridge Replace the Black Toner Cartridge. Does the error still occur?	Go to step 3.	Finished.
3	Check the Imaging Unit installation Take out the Black Imaging Unit. Is the connection part of the Black Imaging Unit clean? And, is the Black Imaging Unit touching against the guides on the left and right sides, and installed properly?	Go to step 4.	Clean the contact point. Reinstall the Black Imaging Unit.

Step	Check	Yes	No
4	Check after replacing the Black Imaging Unit Replace the Black Imaging Unit. Does the error still occur?	Replace the MCU Board.	Finished.

### 005-110 Pickup Jam

### 005-121 ADF Jam

### 005-124 Virtual Jam

Step	Check	Yes	No
	Possible causative parts: <ul style="list-style-type: none"> <li>DADF Assembly (PL51.1.2)</li> <li>IIT Pick-up Module Kit (PL51.1.4)</li> <li>IP Board (PL18.1.22)</li> </ul>		
1	Check the document Does the document meet the specifications of the printer?	Go to step 2.	Use the right document.
2	Check the DADF Assembly Is the DADF Assembly closed properly against the platen glass?	Go to step 3.	Close the DADF Assembly properly.
3	Check the DADF Assembly connection Check the connection between the DADF Assembly and the IP Board. Is P/J1502 connected securely?	Go to step 4.	Connect P/J1502 securely.
4	Check the document path Open the DADF cover and check the document path. Are there any foreign objects, or paper pieces, etc. on the document path?	Remove the foreign objects, or paper pieces, etc.	Go to step 5.
5	Check the IIT Pick-up Module Kit Is the IIT Pick-up Module Kit installed properly?	Go to step 3.	Reinstall the IIT Pick-up Module Kit.
6	Check the IIT Pick-up Module Kit Is the IIT Pick-up Module Kit deformed or worn out?	Replace the KIT IIT Pick-up Module.	Go to step 7.
7	Check after replacing the DADF Assembly Replace the DADF Assembly. Does the error still occur?	Replace the IP Board.	Finished.



## 005-301 ADF Cover Open

Step	Check	Yes	No
	Possible causative parts: <ul style="list-style-type: none"> <li>DADF Assembly (PL51.1.2)</li> <li>IP Board (PL18.1.22)</li> </ul>		
1	Check the DADF cover Is the DADF cover closed properly?	Go to step 2.	Close the DADF cover properly.
2	Check the DADF Assembly connection Check the connection between the DADF Assembly and the IP Board. Is P/J1502 connected securely?	Go to step 3.	Connect P/J1502 securely.
3	Check after replacing the DADF Assembly Replace the DADF Assembly. Does the error still occur?	Replace the IP Board.	Finished.

## 062-320 Scanning error

## 062-321 Unexecutable error

## 062-322 Parameter error

## 062-360 Carriage home position error

## 062-371 IIT Failure Lamp error

## 062-393 CcdAsic communication error

## 062-790 Copy limit

Step	Check	Yes	No
	Possible causative parts: <ul style="list-style-type: none"> <li>IIT Assembly (PL51.1.3)</li> <li>IP Board (PL18.1.22)</li> </ul>		
1	Check the IIT Assembly connection Check the connection between the IIT Assembly and the IP Board. Are P/J1401 and P/J1501 connected securely?	Go to step 2.	Connect P/J1401 and P/J1501 securely.
2	Check after replacing the IIT Assembly Replace the IIT Assembly. Does the error still occur?	Replace the IP Board.	Finished.

## Level 2 FIP

## Regi Sensor [Regi Chute Assembly] (PL15.2.1)

Step	Check	Yes	No
	Possible causative parts: <ul style="list-style-type: none"> <li>• Regi Sensor [Regi Chute Assembly] (PL15.2.1)</li> <li>• Regi Harness Assembly (PL15.2.8)</li> <li>• MCU Board (PL18.1.13)</li> </ul>		
1	Check the Regi Sensor operation Execute Digital Input diagnostic test 071-103, and check the Regi Sensor operation. Does the Regi Sensor function normally?	Replace the MCU Board.	Go to step 2.
2	Check the Regi Sensor connection Check the connection between the Regi Sensor and the MCU Board. Are P/J232 and P/J23 connected securely?	Go to step 3.	Connect P/J232 and P/J23 securely.
3	Check the continuity between the Regi Sensor and the MCU Board Is each cable of P/J232<=>P/J23 continuous?	Go to step 4.	Replace the Regi Harness Assembly.
4	Check the power to the Regi Sensor (+5 VDC) Check if the voltage between the MCU Board ground and the P/J23-6 pin is about +5 VDC.	Replace the Regi Sensor [Regi Chute Assembly].	Refer to page 2-223.

## Feed Clutch (PL15.2.6)

Step	Check	Yes	No
	Possible causative parts: <ul style="list-style-type: none"> <li>• Feed Clutch (PL15.2.6)</li> <li>• Regi Harness Assembly (PL15.2.8)</li> <li>• MCU Board (PL18.1.13)</li> </ul>		
1	Check the Feed Clutch operation Execute Digital Output diagnostic test 071-008, and check the Feed Clutch operation. Does the Feed Clutch function normally?	Replace the MCU Board.	Go to step 2.
2	Check the Feed Clutch connection Check the connection between the Feed Clutch and the MCU Board. Are P/J392 and P/J39 connected securely?	Go to step 3.	Connect P/J392 and P/J39 securely.
3	Check the Feed Clutch resistance value Turn off the power, take off the Feed Clutch, and check the wire wound resistance between both terminals. Is the wire wound resistance value 240 ohm (20 degrees C)?	Go to step 4.	Replace the Feed Clutch.

Step	Check	Yes	No
4	Check the power to the Feed Clutch (+24 VDC) Close the interlock switch(es), and check if the voltage between the MCU Board ground and the P/J39-3 pin is about +24 VDC.	Replace the Feed Clutch.	Refer to “+24 VDC Power FIP” on page 2-222.

### Regi Clutch (PL15.1.8)

Step	Check	Yes	No
	Possible causative parts: <ul style="list-style-type: none"> <li>• Regi Clutch (PL15.1.8)</li> <li>• Regi Harness Assembly (PL15.2.8)</li> <li>• MCU Board (PL18.1.13)</li> </ul>		
1	Check the Regi Clutch operation Execute Digital Output diagnostic test 071-010, and check the Regi Clutch operation. Does the Regi Clutch function normally?	Replace the MCU Board.	Go to step 2.
2	Check the Regi Clutch connection Check the connection between the Regi Clutch and the MCU Board. Are P/J234 and P/J23 connected securely?	Go to step 3.	Connect P/J234 and P/J23 securely.
3	Check the Regi Clutch resistance value Turn off the power, take off the Regi Clutch, and check the wire wound resistance between both terminals. Is the wire wound resistance value 240 ohm (20 degrees C)?	Go to step 4.	Replace the Regi Clutch.
4	Check the power to the Regi Clutch (+24 VDC) Close the interlock switch(es), and check if the voltage between the MCU Board ground and the P/J23-1 pin is about +24 VDC.	Replace the Regi Clutch.	Refer to “+24 VDC Power FIP” on page 2-222.

## Path Sensor [550 Option Main Feed Assembly] (PL10.2.1)

Step	Check	Yes	No
	Possible causative parts: <ul style="list-style-type: none"> <li>• Path Sensor [550 Option Main Feed Assembly] (PL10.2.1)</li> <li>• C2 Size Harness Assembly (PL10.1.14)</li> <li>• Drawer 1 Feeder Harness Assembly (PL10.1.13)</li> <li>• Main Harness Assembly (PL18.2.3)</li> <li>• 550 Option Feeder Board (PL10.1.10)</li> <li>• MCU Board (PL18.1.13)</li> </ul>		
1	Check the Path Sensor operation Execute Digital Input diagnostic test 071-117, and check the Path Sensor operation. Does the Path Sensor function normally?	Replace the MCU Board.	Go to step 2.
2	Check the Path Sensor connection Check the connection between the Path Sensor and the 550 Option Feeder Board. Are P/J4214 and P/J421 connected securely?	Go to step 3.	Connect P/J4214 and P/J421 securely.
3	Check the continuity between the Path Sensor and the 550 Option Feeder Board Is each cable of P/J4214 $\leftrightarrow$ P/J421 continuous?	Go to step 4.	Replace the C2 Size Harness Assembly.
4	Check the power to the Path Sensor (+3.3 VDC) Check if the voltage between the 550 Option Feeder Board ground and the P/J23-6 pin is about +3.3 VDC.	Replace the Path Sensor [550 Option Main Feed Assembly].	Go to step 5.
5	Check the power to the 550 Option Feeder Board (+3.3 VDC) Check if the voltage between the 550 Option Feeder Board ground and the P/J419-4 pin is about +3.3 VDC.	Replace the 550 Option Feeder Board.	Go to step 6.
6	Check the power from the MCU Board (+3.3 VDC) Check if the voltage between the MCU Board ground and the P/J27-7 pin is about +3.3 VDC.	Go to step 7.	Refer to “+3.3 VDC Power FIP” on page 2-224.
7	Check the PWBA Assembly FEED connection Check the connection between the PWBA Assembly FEED and the MCU Board. Are P/J419, DP/J271, and P/J27 connected securely?	Replace the Drawer 1 Feeder Harness Assembly and the Main Harness Assembly.	Connect P/J419, DP/J271, and P/J27 securely.

## 550 Option Regi Clutch Assembly (PL10.2.2)

Step	Check	Yes	No
	Possible causative parts: <ul style="list-style-type: none"> <li>• 550 Option Regi Clutch Assembly (PL10.2.2)</li> <li>• C2 Size Harness Assembly (PL10.1.14)</li> <li>• Drawer 1 Feeder Harness Assembly (PL10.1.13)</li> <li>• Main Harness Assembly (PL18.2.3)</li> <li>• 550 Option Feeder Board (PL10.1.10)</li> <li>• MCU Board (PL18.1.13)</li> </ul>		
1	Check the 550 Option Regi Clutch Assembly operation Execute Digital Output diagnostic test 071-020, and check the 550 Option Regi Clutch Assembly operation. Does the 550 Option Regi Clutch Assembly function normally?	Replace the MCU Board.	Go to step 2.
2	Check the 550 Option Regi Clutch Assembly connection Check the connection between the 550 Option Regi Clutch Assembly and the 550 Option Feeder Board. Are P/J4213 and P/J421 connected securely?	Go to step 3.	Connect P/J4213 and P/J421 securely.
3	Check the continuity between the 550 Option Regi Clutch Assembly and the 550 Option Feeder Board Is each cable of P/J4213<=>P/J421 continuous?	Go to step 4.	Replace the C2 Size Harness Assembly.
4	Check the 550 Option Regi Clutch Assembly resistance value Turn off the power, take off the 550 Option Regi Clutch Assembly, and check the wire wound resistance between both terminals. Is the wire wound resistance value 240 ohm (20 degrees C)?	Go to step 5.	Replace the 550 Option Regi Clutch Assembly.
5	Check the power to the 550 Option Regi Clutch Assembly (+24 VDC) Close the interlock switch(es), and check if the voltage between the PWBA FEED ground and the P/J421-1 pin is about +24 VDC.	Replace the 550 Option Regi Clutch Assembly.	Go to step 6.
6	Check the power to the 550 Option Feeder Board (+24 VDC) Close the interlock switch(es), and check if the voltage between the 550 Option Feeder Board ground and the P/J419-6 pin, and the voltage between the 550 Option Feeder Board ground and the P/J419-7 pin is about +24 VDC.	Replace the 550 Option Feeder Board.	Go to step 7.
7	Check the power from the MCU Board (+24 VDC) Close the interlock switch(es), and check if the voltage between the MCU Board ground and the P/J271-4 pin, and the voltage between the MCU Board ground and the P/J27-5 pin is about +24 VDC.	Go to step 8.	Refer to “+24 VDC Power FIP” on page 2-222.

Step	Check	Yes	No
8	Check the PWBA Assembly FEED connection Check the connection between the PWBA Assembly FEED and the MCU Board. Are P/J419, DP/J271, and P/J27 connected securely?	Replace the Drawer 1 Feeder Harness Assembly and the Main Harness Assembly.	Connect P/J419, DP/J271, and P/J27 securely.

## 550 Option Feed Clutch Assembly (PL10.1.8)

Step	Check	Yes	No
	Possible causative parts: <ul style="list-style-type: none"> <li>• 550 Option Feed Clutch Assembly (PL10.1.8)</li> <li>• C2 Turn Harness Assembly (PL10.1.15)</li> <li>• Drawer 1 Feeder Harness Assembly (PL10.1.13)</li> <li>• Main Harness Assembly (PL18.2.3)</li> <li>• 550 Option Feeder Board (PL10.1.10)</li> <li>• MCU Board (PL18.1.13)</li> </ul>		
1	Check the 550 Option Feed Clutch Assembly operation Execute Digital Output diagnostic test 071-022, and check the 550 Option Feed Clutch Assembly operation. Does the 550 Option Feed Clutch Assembly function normally?	Replace the MCU Board.	Go to step 2.
2	Check the 550 Option Feed Clutch Assembly connection Check the connection between the 550 Option Feed Clutch Assembly and the 550 Option Feeder Board. Are P/J4201 and P/J420 connected securely?	Go to step 3.	Connect P/J4201 and P/J420 securely.
3	Check the continuity between the 550 Option Feed Clutch Assembly and the 550 Option Feeder Board Is each cable of P/J4201<=>P/J420 continuous?	Go to step 4.	Replace the C2 Turn Harness Assembly.
4	Check the 550 Option Feed Clutch Assembly resistance value Turn off the power, take off the 550 Option Feed Clutch Assembly, and check the wire wound resistance between both terminals. Is the wire wound resistance value 240 ohm (20 degrees C)?	Go to step 5.	Replace the 550 Option Feed Clutch Assembly.
5	Check the power to the 550 Option Feed Clutch Assembly (+24 VDC) Close the interlock switch(es), and check if the voltage between the PWBA FEED ground and the P/J421-1 pin is about +24 VDC.	Replace the 550 Option Feed Clutch Assembly.	Go to step 6.
6	Check the power to the 550 Option Feeder Board (+24 VDC) Close the interlock switch(es), and check if the voltage between the 550 Option Feeder Board ground and the P/J419-6 pin, and the voltage between the 550 Option Feeder Board ground and the P/J419-7 pin is about +24 VDC.	Replace the 550 Option Feeder Board.	Go to step 7.
7	Check the power from the MCU Board (+24 VDC) Close the interlock switch(es), and check if the voltage between the MCU Board ground and the P/J271-4 pin, and the voltage between the MCU Board ground and the P/J27-5 pin is about +24 VDC.	Go to step 8.	Refer to “+24 VDC Power FIP” on page 2-222.



Step	Check	Yes	No
8	Check the PWBA Assembly FEED connection Check the connection between the PWBA Assembly FEED and the MCU Board. Are P/J419, DP/J271, and P/J27 connected securely?	Replace the Drawer 1 Feeder Harness Assembly and the Main Harness Assembly.	Connect P/J419, DP/J271, and P/J27 securely.

## 550 Option Drive Assembly (PL10.1.9)

Step	Check	Yes	No
	Possible causative parts: <ul style="list-style-type: none"> <li>• 550 Option Drive Assembly (PL10.1.9)</li> <li>• Feeder Motor Harness Assembly (PL10.1.16)</li> <li>• Drawer 1 Feeder Harness Assembly (PL10.1.13)</li> <li>• Main Harness Assembly (PL18.2.3)</li> <li>• 550 Option Feeder Board (PL10.1.10)</li> <li>• MCU Board (PL18.1.13)</li> </ul>		
1	Check the 550 Option Drive Assembly operation Execute Digital Output diagnostic test 071-014, and check the 550 Option Drive Assembly rotation. Does the 550 Option Drive Assembly function normally?	Replace the MCU Board.	Go to step 2.
2	Check the 550 Option Drive Assembly installation Rotate the 550 Option Drive Assembly manually. Is there an overload?	Reinstall the 550 Option Drive Assembly appropriately.	Go to step 3.
3	Check the 550 Option Drive Assembly connection Check the connection between the 550 Option Drive Assembly and the 550 Option Feeder Board. Are P/J4221 and P/J422 connected securely?	Go to step 4.	Connect P/J4221, and P/J422 securely.
4	Check the continuity between the 550 Option Drive Assembly and the 550 Option Feeder Board Is each cable of P/J4221 <=> P/J422 continuous?	Go to step 5.	Replace the Feeder Motor Harness Assembly.
5	Check the power to the 550 Option Drive Assembly (+24 VDC) Close the interlock switch(es), and check if the voltage between the 550 Option Feeder Board ground and the P/J422-6 pin is about +24 VDC.	Replace the 550 Option Drive Assembly.	Go to step 6.
6	Check the power to the 550 Option Feeder Board (+24 VDC) Close the interlock switch(es), and check if the voltage between the 550 Option Feeder Board ground and the P/J419-6 pin, and the voltage between the 550 Option Feeder Board ground and the P/J419-7 pin is about +24 VDC.	Replace the 550 Option Feeder Board.	Go to step 7.
7	Check the power from the MCU Board (+24 VDC) Close the interlock switch(es), and check if the voltage between the MCU Board ground and the P/J271-4 pin, and the voltage between the MCU Board ground and the P/J27-5 pin is about +24 VDC.	Go to step 8.	Refer to “+24 VDC Power FIP” on page 2-222.

Step	Check	Yes	No
8	Check the PWBA Assembly FEED connection Check the connection between the PWBA Assembly FEED and the MCU Board. Are P/J419, DP/J271, and P/J27 connected securely?	Replace the Drawer 1 Feeder Harness Assembly and the Main Harness Assembly.	Connect P/J419, DP/J271, and P/J27 securely.

### Bypass Tray Feed Solenoid (PL13.2.9)

Step	Check	Yes	No
	Possible causative parts: <ul style="list-style-type: none"> <li>• Bypass Tray Feed Solenoid (PL13.2.9)</li> <li>• Bypass Tray Harness Assembly (PL13.2.5)</li> <li>• MCU Board (PL18.1.13)</li> </ul>		
1	Check the Bypass Tray Feed Solenoid operation Execute Digital Output diagnostic test 071-007, and check the Bypass Tray Feed Solenoid operation. Does the Bypass Tray Feed Solenoid function normally?	Replace the MCU Board.	Go to step 2.
2	Check the Bypass Tray Feed Solenoid connection Check the connection between the Bypass Tray Feed Solenoid and the MCU Board. Are P/J214 and P/J21 connected securely?	Go to step 3.	Connect P/J214 and P/J21 securely.
3	Check the continuity between the Bypass Tray Feed Solenoid and the MCU Board Is each cable of P/J214<=>P/J21 continuous?	Go to step 4.	Replace the Bypass Tray Harness Assembly.
4	Check the power to the Bypass Tray Feed Solenoid (+24 VDC) Close the interlock switch(es), and check if the voltage between the MCU Board ground and the P/J21-9 pin is about +24 VDC.	Replace the Bypass Tray Feed Solenoid.	Refer to “+24 VDC Power FIP” on page 2-222.

## Exit Sensor (PL17.1.11)

Step	Check	Yes	No
	Possible causative parts: <ul style="list-style-type: none"> <li>Exit Sensor (PL17.1.11)</li> <li>Exit Sensor Harness Assembly (PL17.1.18)</li> <li>Sensor Harness Assembly (PL17.1.23)</li> <li>MCU Board (PL18.1.13)</li> </ul>		
1	Check the Exit Sensor operation Execute Input Output diagnostic test [071-104], and check the Exit Sensor operation. Does the Exit Sensor function normally?	Replace the MCU Board.	Go to step 2.
2	Check the Exit Sensor connection Check the connection between the Exit Sensor and the MCU Board. Are P/J155, P/J151, and P/J15 connected securely?	Go to step 3.	Connect P/J155, P/J151, and P/J15 securely.
3	Check the continuity between the Exit Sensor and the relay connector Is each cable of P/J155<=>P/J151 continuous?	Go to step 4.	Replace the Exit Sensor Harness Assembly.
4	Check the continuity between the relay connector and the MCU Board Is each cable of P/J151<=>P/J15 continuous?	Go to step 5.	Replace the Sensor Harness Assembly.
5	Check the power to the Exit Sensor (+5 VDC) Check if the voltage between the MCU Board ground and the P/J15-1 pin is about +5 VDC.	Replace the Exit Sensor.	Refer to "+5 VDC Power FIP" on page 2-223.

### Exit Clutch 1 [Exit Drive Assembly] (PL17.1.21)

Step	Check	Yes	No
	Possible causative parts: <ul style="list-style-type: none"> <li>Exit Clutch 1 [Exit Drive Assembly] (PL17.1.21)</li> <li>MCU Board (PL18.1.13)</li> </ul>		
1	Check the Exit Clutch 1 operation Execute Digital Output diagnostic test 071-011, and check the Exit Clutch 1 operation. Does the Exit Clutch 1 function normally?	Replace the MCU Board.	Go to step 2.
2	Check the Exit Clutch 1 connection Check the connection between the Exit Clutch 1 and the MCU Board. Is P/J40 connected securely?	Go to step 3.	Connect P/J40 securely.
3	Check the power to the Exit Clutch 1 (+24 VDC) Close the interlock switch(es), and check if the voltage between the MCU Board ground and the P/J40-1 pin is about +24 VDC.	Replace the Exit Clutch 1.	Refer to “+24 VDC Power FIP” on page 2-222.

### Exit Clutch 2 [Exit Drive Assembly] (PL17.1.21)

Step	Check	Yes	No
	Possible causative parts: <ul style="list-style-type: none"> <li>Exit Clutch 2 [Exit Drive Assembly] (PL17.1.21)</li> <li>MCU Board (PL18.1.13)</li> </ul>		
1	Check the Exit Clutch 2 operation Execute Digital Output diagnostic test 071-012, and check the Exit Clutch 2 operation. Does Exit Clutch 2 function normally?	Replace the MCU Board.	Go to step 2.
2	Check the Exit Clutch 2 connection Check the connection between the Exit Clutch 2 and the MCU Board. Is P/J38 connected securely?	Go to step 3.	Connect P/J38 securely.
3	Check the power to the Exit Clutch 2 (+24 VDC) Close the interlock switch(es), and check if the voltage between the MCU Board ground and the P/J38-1 pin is about +24 VDC.	Replace the Exit Clutch 2.	Refer to “+24 VDC Power FIP” on page 2-222.

**+24 VDC Power FIP**

Step	Check	Yes	No
	Possible causative parts: <ul style="list-style-type: none"> <li>• Top Harness Assembly (PL18.2.5)</li> <li>• AC Inlet (PL18.1.31)</li> <li>• LVPS (PL18.1.34)</li> <li>• MCU Board (PL18.1.13)</li> </ul>		
1	Check the connections between LVPS and the MCU Board Check the connection between the LVPS and the MCU Board. Are P/J501 and P/J29 connected securely?	Go to step 2.	Reconnect P/J501 and P/J29 securely.
2	Check the continuity between the LVPS and the MCU Board Is each cable of P/J501 <=> P/J29 continuous?	Go to step 3.	Replace the Top Harness Assembly.
3	Check the power from the LVPS (+24 VDC) Close the interlock switch(es), and check if the voltage between the LVPS ground and the P/J501-2 pin, and the voltage between the LVPS ground and the P/J501-1 pin is about +24 VDC.	Replace the MCU Board.	Go to step 4.
4	Check the power (off/on) Turn the power off, wait a while, and turn the power on again. Does the error still occur?	Go to step 5.	Finished.
5	Check the AC power to the LVPS Is the voltage between the P/J48-1 pin and the P/J48-3 pin of the LVPS 100 VAC?	Replace the LVPS.	Replace the AC Inlet.

**+5 VDC Power FIP**

Step	Check	Yes	No
	Possible causative parts: <ul style="list-style-type: none"> <li>• Top Harness Assembly (PL18.2.5)</li> <li>• AC Inlet (PL18.1.31)</li> <li>• LVPS (PL18.1.34)</li> <li>• MCU Board (PL18.1.13)</li> </ul>		
1	Check the connections between LVPS and the MCU Board Check the connection between the LVPS and the MCU Board. Are P/J501 and P/J29 connected securely?	Go to step 2.	Reconnect P/J501 and P/J29 securely.
2	Check the continuity between the LVPS and the MCU Board Is each cable of P/J501 <=> P/J29 continuous?	Go to step 3.	Replace the Top Harness Assembly.
3	Check the power from the LVPS (+5 VDC) Check if the voltage between the LVPS ground and the P/J501-3 pin is about +5 VDC.	Replace the MCU Board.	Go to step 4.
4	Check the power (off/on) Turn the power off, wait a while, and turn the power on again. Does the error still occur?	Go to step 5.	Finished.
5	Check the AC power to the LVPS Is the voltage between the P/J48-1 pin and the P/J48-3 pin of the LVPS 100 VAC?	Replace the LVPS.	Replace the AC Inlet.

**+3.3 VDC Power FIP**



Step	Check	Yes	No
	Possible causative parts: <ul style="list-style-type: none"> <li>• Top Harness Assembly (PL18.2.5)</li> <li>• AC Inlet (PL18.1.31)</li> <li>• LVPS (PL18.1.34)</li> <li>• MCU Board (PL18.1.13)</li> </ul>		
1	Check the connections between the LVPS and the MCU Board Check the connection between the LVPS and the MCU Board. Are P/J501 and P/J29 connected securely?	Go to step 2.	Reconnect P/J501 and P/J29 securely.
2	Check the continuity between the LVPS and the MCU Board Is each cable of P/J501 <=> P/J29 continuous?	Go to step 3.	Replace the Top Harness Assembly.
3	Check the power from the LVPS (+5 VDC) Check if the voltage between the LVPS ground and the P/J501-5 pin is about +3.3 VDC.	Replace the MCU Board.	Go to step 4.
4	Check the power (off/on) Turn the power off, wait a while, and turn the power on again. Does the error still occur?	Go to step 5.	Finished.
5	Check the AC power to the LVPS Is the voltage between the P/J48-1 pin and the P/J48-3 pin of the LVPS 100 VAC?	Replace the LVPS.	Replace the AC Inlet.




# Other Fault Isolation Procedures

## Abnormal Noise

### FIP-N1 Abnormal Noise: When Power is Turned On

Step	Check	Yes	No
	Possible causative parts: <ul style="list-style-type: none"> <li>• Toner Cartridge (Y, M, C, K) (PL5.1.8?PL5.1.11)</li> <li>• Dispenser Motor (Y,M,C,K) [Upper Dispenser Motor Assembly] (PL5.1.1)</li> <li>• Main Motor [Drive Assembly] (PL3.1.1)</li> </ul>		
1	Check the Dispense Motor operation Execute Digital Output diagnostic test 093-004(Y), 093-006(M), 093-008(C), and 093-010(K), and check the Dispenser Motor rotation. Is the device making an abnormal noise?   <b>CAUTION:</b> Stop the Motor operation within 3 seconds, or the device will be damaged.	Go to step 2.	Go to step 3.
2	Check the Toner Cartridge installation Reinstall the Toner Cartridge.  Turn the power off, and then on again. Is the device making an abnormal noise?	Replace the Toner Cartridge. If the trouble still exists, replace the device.	Finished.
3	Check the Main Motor operation Execute Digital Output diagnostic test 071-001, and check the Main Motor rotation. Is the device making an abnormal noise?   <b>CAUTION:</b> Stop the Motor operation within 3 seconds, or the device will be damaged.	Replace the Main Motor [Drive Assembly].	Finished.

### FIP-N2 Abnormal Noise: During Standby

Step	Check	Yes	No
	Possible causative parts: <ul style="list-style-type: none"> <li>Main Fan (PL4.1.13)</li> </ul>		
1	<p>Check the Main Fan operation Execute Digital Output diagnostic test 042-001, and check the Main Fan rotation. Is the device making an abnormal noise?</p> <p> <b>CAUTION:</b> Stop the Motor operation within 3 seconds, or the device will be damaged.</p>	Replace the Main Fan.	Finished.

### FIP-N3 Abnormal Noise: During Printing

Step	Check	Yes	No
	Possible causative parts: <ul style="list-style-type: none"> <li>Bypass Tray Feed Solenoid (PL13.2.9)</li> <li>Regi Clutch (PL15.1.8)</li> </ul>		
1	<p>Check after replacing the Bypass Tray Feed Solenoid Replace the Bypass Tray Feed Solenoid. Does the MPF (PSI) make an abnormal noise when feeding paper?</p>	Go to step 2.	Finished.
2	<p>Check after replacing the Regi Clutch Replace the Regi Clutch. Is the device making an abnormal noise?</p>	Refer to “FIP-N1 Abnormal Noise: When Power is Turned On” on page 2-225.	Finished.

### FIP - Multiple Feed

Step	Check	Yes	No
	Possible causative parts: <ul style="list-style-type: none"> <li>Retard Holder Assembly (PL13.3.14)</li> </ul>		
1	<p>Check the Retard Holder Assembly installation Reinstall the Retard Holder Assembly. Does multiple feed still occur?</p>	Replace the Retard Holder Assembly.	Finished.

## Fault Isolation Procedure for FAX

Because a FAX is composed of multiple blocks, pinpointing a fault is problematic.

### Fault Occurs

First, try using the copy function. If the copy function's printing results are correct, the probability of a fault in the FAX itself is low. The fault is likely in the telephone line or receiving FAX.

If the fault is in the telephone line, first retry sending. If there is no improvement, contact the telephone company.

If the copy function's printing results are incorrect, it can be determined if the fault is in the scanner or printer by operating each unit separately via a computer.

### Send Fault

Problem with printing quality at receiving a FAX, such as corrupt image, lines in image, or top/bottom cut off.

- If copy function is normal

**Cause:** Degraded telephone line connection caused by noise, etc.; or a fault in receiving FAX's printer.

**Corrective Action:** Determine whether fault is in telephone line or at receiving FAX by trying copy function at receiving FAX.

#### Notes:

- If the telephone line condition is degraded, white horizontal lines, missing rows, and/or cut-off top/bottom may occur.
- Branch connections or incoming call (call waiting) may also cause image corruption.
- If copy function is faulty
 

**Cause:** Dirt or fault in scanner.

**Corrective Action:** Clean platen glass or repair scanner. If the original is being sent from the DADF, try executing a copy with the original placed on the platen glass. If this solves the problem, the fault is in the DADF.

Cannot dial

**Cause:** Incorrect connection. Incorrect setup of dial type and/or line type.

**Corrective Action:** Correct the connection. Reset the dial type and/or line type to correct settings.

#### Notes:

- If the telephone line condition is degraded, white horizontal lines, missing rows, and/or cut-off top/bottom may occur.
- Branch connections or incoming call (call waiting) may also cause image corruption.

## Receive Fault

Problem with printing quality, such as corrupt image, lines in image, top/bottom cut off.

- If copy function is normal

**Cause:** Degraded telephone line connection caused by noise, etc.; or a fault in sending FAX's scanner.

**Corrective Action:** Determine whether fault is in telephone line or at sending FAX by trying copy function at receiving FAX.

### Notes:

- If the telephone line condition is degraded, white horizontal lines, missing rows, and/or cut-off top/bottom may occur.
  - Branch connections or incoming call (call waiting) may also cause image corruption.
- If copy function is faulty  
**Cause:** Dirt or fault in printer.  
**Corrective Action:** Clean all parts of printer or repair printer.

Does not emit response signal

**Cause:** Incorrect connection. Incorrect setup of dial type, line type, and/or reception mode.

**Corrective Action:** Correct the connection. Reset the dial type, line type, and/or receive mode to correct settings.

**Note:** If a call is made to the FAX from a telephone, and the FAX does not emit its ringing sound, a telephone line fault is highly probable.

## Other FAX Problems

### Branch Connection (Parallel Connection)

During FAX reception, if the handset of another telephone on a branch connection is lifted, the received image may be corrupted or a transmission error may occur. Branch connection may also interfere with caller identification, call waiting, the receiving operation of connected telephones.

### Call Waiting

If a call comes in during FAX sending/reception, as with branch connections the image may be corrupted.

### DSL (Digital Subscriber Line)

DSL, a high-speed digital transmission method using existing telephone lines, has several types. These include ADSL (Asymmetric Digital Subscriber Line) with differing upstream and downstream transmission speeds, SDSL (Symmetric Digital Subscriber Line) with symmetrical upstream and downstream transmission speeds, and VDSL (Very high bit rate Digital Subscriber Line) which features higher speed. However, because the line is used for both voice and data transmission, various problems may occur, such as noise during spoken conversation, low sound volume, and mis-dialing. Replacing the splitter may improve the situation.

## Noise

If electronic equipment (television, computer, microwave, etc.) or devices equipped with motors are located near a FAX, noise from them may degrade the line condition.

Also, a telephone line, acting as an antenna, may absorb electric waves generated from wireless or broadcasting equipment.

Because FAX data is audio data, the line quality affects the quality/stability of image data as well as that of conversation.



# Image Quality

# 3

## In this chapter...

- Initial Steps for Image Quality Troubleshooting
- Image Quality Troubleshooting Chart
- Image Quality FIP

# Initial Steps for Image Quality Troubleshooting

In order to resolve an end user's image quality problem, it is necessary to clearly understand the nature of the problem (streaks, color deterioration, and blanks). To determine the cause of the print problem faced by the end user, first confirm the following items to grasp the status of use by the end user.

1. Is the paper matched with the Print Media Guidelines?
2. Is the remaining amount of the toner sufficient?
3. Has the printer been cleaned up lately?

## Confirm the Printer Status

### Toner

When the remaining amount of the toner is low, image quality problems such as faint print, streaks, white lines, and blanks) occur. Ask the end user to print the lower-capacity document using a different application, confirm the problem repeatability, and then check that the remaining amount of the toner is sufficient for printing. When a document is printed by an end user, the dialog box indicating the remaining amount of the toner appears on the laser printer status monitor.

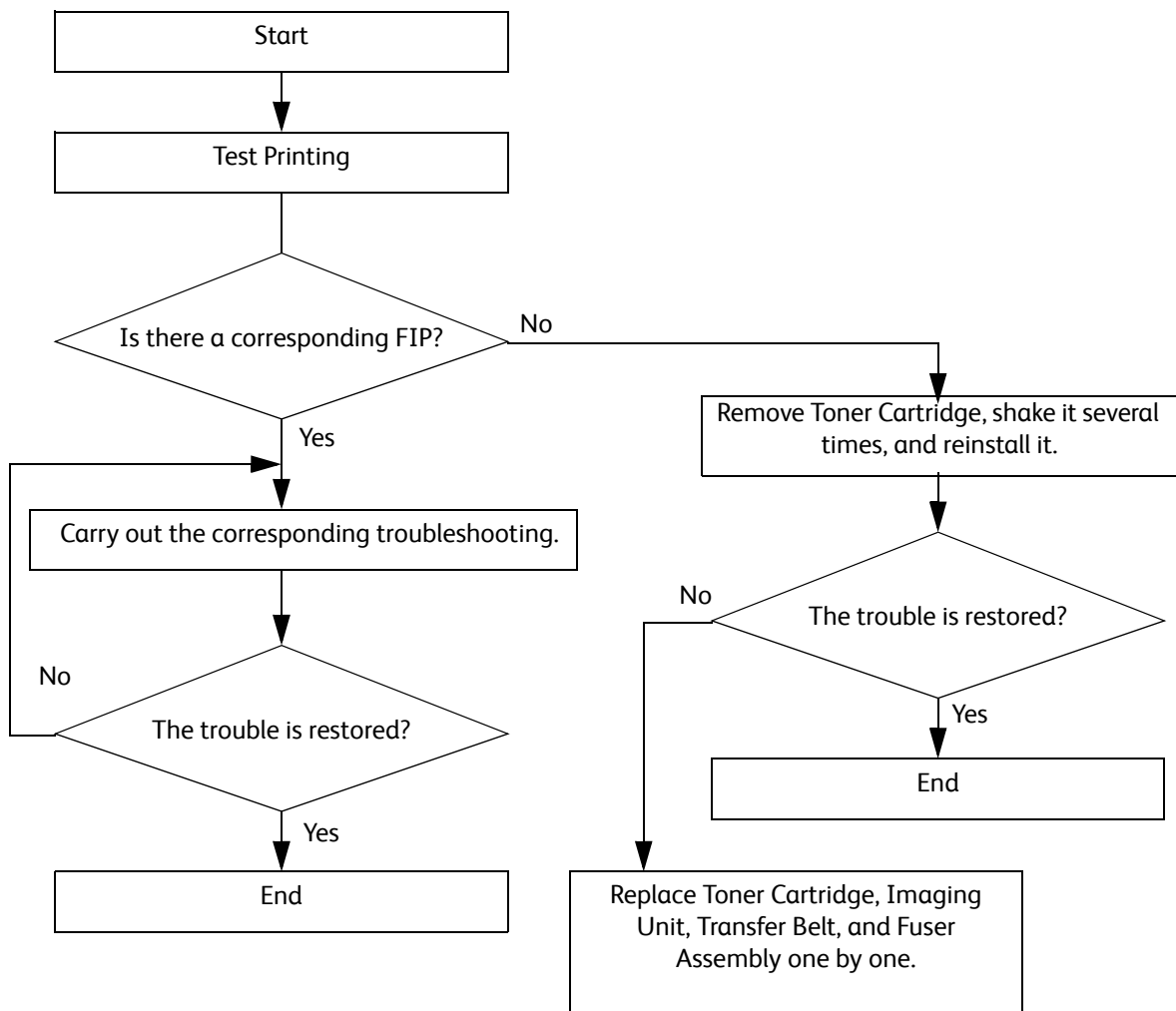
When the remaining amount of the toner is low, the end user can extend the life of the toner cartridge slightly by removing the cartridge from the printer, shaking it right and left slowly (this softens the firm toner), and reinstalling the cartridge.

### Cleaning

Image quality problems such as smears and toner spots might occur when particles of paper, toner, or dust is piled up in the printer. Cleaning the inside of the printer can prevent the problems.



# Image Quality Troubleshooting Chart



When an image quality problem occurs during printing, output a sample print to determine and grasp the nature of the problem, then use the list of problem descriptions on page 3-4 to select a troubleshooting procedure from the Image Quality FIP.

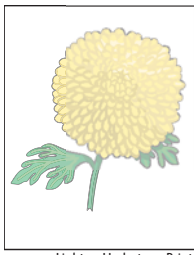
If the problem persists even after the troubleshooting with the Image Quality FIP, check using the Image Quality FIP again, and then replace the "Possible causative parts" listed in the Image Quality FIP one by one, and also troubleshoot using the procedures in Chapter 2, *Error Troubleshooting*.

## Image Quality FIP

This section describes the following image quality problems:

- The output is too light - 3-5
- Toner smears or print comes off - 3-7
- Random spots/Blurred images - 3-8
- Blank output - 3-9
- Streaked output - 3-11
- Partial or entire black output - 3-12
- Pitched color dots - 3-13
- Vertical blanks - 3-14
- Ghosting - 3-15
- Light-induced fatigue - 3-16
- Fog - 3-17
- Bead-Carry-Out (BCO) - 3-18
- Jagged characters - 3-18
- Banding - 3-19
- Auger mark - 3-20
- Wrinkled/Stained paper - 3-20
- Leading edge paper damage - 3-22
- Incorrect top and side margins - 3-23
- Color registration is out of alignment - 3-24
- Images are skewed - 3-25

## The output is too light



Light or Undertone Print

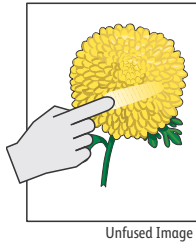
### Possible causative parts

- Toner Cartridge Y/M/C/K (PL5.1.8/PL5.1.9/PL5.1.10/PL5.1.11)
- Imaging Unit Y/M/C/K (PL8.1.2/PL8.1.3/PL8.1.4/PL8.1.5)
- Transfer Roller (PL14.1.99)
- CTD Sensor Assembly (PL6.1.14)
- Development HVPS Board (PL18.1.14)
- Transfer HVPS Board (PL18.1.28)

	Action	Yes	No
1	The toner cartridges may be low or need to be replaced. Confirm the amount of toner left in each toner cartridge. 1. Check the toner level. 2. Replace the toner cartridges as necessary. Does this solve your problem?	The task is complete.	Go to action 2.
2	Disable the <b>Draft Mode</b> setting in the printer driver. 1. On the Advanced tab, ensure that Draft Mode is set to Off. Does this solve your problem?	The task is complete.	Go to action 3.
3	The print media surface may be uneven. Try changing the <b>Paper Type</b> setting in the printer driver. For example, change the plain paper to thick. 1. On the <b>Printing Options</b> tab, change the <b>Paper Type</b> setting. Does this solve your problem?	The task is complete.	Go to action 4.
4	Verify that the correct print media is being used. If not, use the print media recommended for the printer. Does this solve your problem?	The task is complete.	Go to action 5.
5	Clean the Laser lenses as described in “Cleaning the Laser Lenses” on page 6-7. Does this solve your problem?	The task is complete.	Go to action 6.
6	Replace the Imaging Units. Does this solve your problem?	The task is complete.	Go to action 7.
7	Check the installation status of the CTD Sensor Assembly. Is the Sensor Assembly installed correctly?	Go to action 8.	Reinstall the CTD Sensor Assembly. See “CTD Spring / CTD Sensor Assembly” on page 4-41

Action		Yes	No
8	Check dirt and foreign substances on the CTD Sensor surface. Is the CTD Sensor Assembly Sensor surface dirty, or are there any foreign substances on the surface?	Clean the CTD Sensor surface. See “Cleaning the Color Toner Density Sensors” on page 6-11.	Go to action 9.
9	Check the Transfer Roller. Is Transfer Roller not contaminated, damaged, or worn, and does it work correctly?	Go to action 10.	Reinstall Transfer Roller.
10	Check the Transfer Roller. Is Transfer Roller not contaminated, damaged, or worn, and does it work correctly?	Go to action 11.	Replace Transfer Roller.
11	Check the Transfer HVPS Board connector connection. Is the Transfer HVPS Board connector connected correctly?	Go to action 12.	Connect the connector.
12	Check the Development HVPS Board connector connection. Is the Development HVPS Board connector connected correctly?	Replace the Development HVPS Board.	Connect the connector.

## Toner smears or print comes off

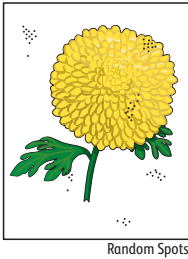


### Possible causative parts

- Toner Cartridge Y/M/C/K (PL5.1.8/PL5.1.9/PL5.1.10/PL5.1.11)
- Imaging Unit Y/M/C/K (PL8.1.2/PL8.1.3/PL8.1.4/PL8.1.5)
- Fuser Assembly (PL7.1.1)
- Transfer Belt Assembly (PL6.1.1)
- Transfer Roller (PL14.1.99)

	Action	Yes	No
1	The print media surface may be uneven. Try changing the <b>Paper Type</b> setting in the printer driver. For example, change the plain paper to thick. 1. On the <b>Printing Options</b> tab, change the <b>Paper Type</b> setting. Does this solve your problem?	The task is complete.	Go to action 2.
2	Verify that the correct print media is being used. If not, use the print media recommended for the printer. Does this solve your problem?	The task is complete.	Go to action 3.
3	Replace the Imaging Units. 1. Replace the Imaging Units. 2. After you replace the Imaging Units, test print your document again. Does this solve your problem?	The task is complete.	Go to action 4.
4	Replace the Fuser Assembly. Does this solve your problem?	The task is complete.	Go to action 5.
5	Replace the Transfer Belt Assembly, the Transfer Roller, and the retard roller. Does this solve your problem?	The task is complete.	Go to action 6.

## Random spots/Blurred images

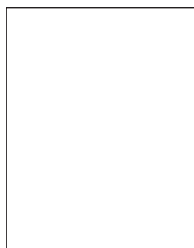


### Possible causative parts

- Toner Cartridge Y/M/C/K (PL5.1.8/PL5.1.9/PL5.1.10/PL5.1.11)
- Imaging Unit Y/M/C/K (PL8.1.2/PL8.1.3/PL8.1.4/PL8.1.5)
- Transfer Roller (PL14.1.99)
- Transfer Belt Assembly (PL6.1.1)
- Development HVPS Board (PL18.1.14)
- Transfer HVPS Board (PL18.1.28)

Action		Yes	No
1	Ensure that the toner cartridges are installed correctly. Does this solve your problem?	The task is complete.	Go to action 2.
2	Ensure that the Imaging Units are installed correctly. Does this solve your problem?	The task is complete.	Go to action 3.
3	Replace the Imaging Units. Does this solve your problem?	The task is complete.	Go to action 4.
4	Check the Transfer Roller. Is Transfer Roller not contaminated, damaged, or worn, and does it work correctly?	Go to action 5.	Reinstall Transfer Roller.
5	Check the Transfer Roller. Is Transfer Roller not contaminated, damaged, or worn, and does it work correctly?	Go to action 6.	Replace Transfer Roller.
6	Check the Transfer HVPS Board connector connection. Is the Transfer HVPS Board connector connected correctly?	Go to action 7.	Connect the connector.
7	Check the Development HVPS Board connector connection status. Is the Development HVPS Board connector connected correctly?	Go to action 8.	Connect the connector.
8	Check the intermediate transfer belt. Is the Transfer Belt Assembly not contaminated, damaged, or worn, and does it work correctly?	Contact Xerox Technical Support.	Replace the Transfer Belt Assembly.

## Blank output



Blank Print

## Possible causative parts

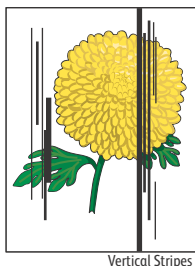
- Toner Cartridge Y/M/C/K (PL5.1.8/PL5.1.9/PL5.1.10/PL5.1.11)
- Imaging Unit Y/M/C/K (PL8.1.2/PL8.1.3/PL8.1.4/PL8.1.5)
- Laser Unit (PL2.1.1)
- Transfer Roller (PL14.1.99)
- Transfer Belt Assembly (PL6.1.1)
- Development HVPS Board (PL18.1.14)
- Transfer HVPS Board (PL18.1.28)

Action		Yes	No
1	The toner cartridges may be low or need to be replaced. Confirm the amount of toner left in each toner cartridge. 1. Check the toner level in the <b>Status</b> tab in the Status Monitor. 2. Replace the toner cartridges as necessary. Does this solve your problem?	The task is complete.	Go to action 2.
2	Disable the <b>Draft Mode</b> setting in the printer driver. 1. On the Advanced tab, ensure that Draft Mode is set to Off. Does this solve your problem?	The task is complete.	Go to action 3.
3	The print media surface may be uneven. Try changing the <b>Paper Type</b> setting in the printer driver. For example, change the plain paper to thick. 1. On the <b>Printing Options</b> tab, change the <b>Paper Type</b> setting. Does this solve your problem?	The task is complete.	Go to action 4.
4	Verify that the correct print media is being used. If not, use the print media recommended for the printer. Does this solve your problem?	The task is complete.	Go to action 5.
5	Replace the Imaging Units. Does this solve your problem?	The task is complete.	Go to action 6.
6	Check the laser beam path. Are there any foreign substances between the Laser Unit and the Y/M/C/K drum?	Remove the foreign substance.	Go to action 7.
7	Check the installation status of the intermediate Transfer Belt Assembly. Is the Transfer Belt Assembly HV terminal not dirty, and is it contacted to the spring correctly?	Go to action 9.	Clean the HV terminal. Reinstall the Transfer Belt Assembly.
8	Check the installation status of the Transfer Roller. Is Transfer Roller installed correctly?	Go to action 10.	Reinstall the Transfer Roller.

Action		Yes	No
9	Check the Transfer HVPS Board connector connection. Is the Transfer HVPS Board connector connected correctly?	Go to action 10.	Connect the connector.
10	Check the Development HVPS Board connector connection. Is the Development HVPS Board connector connected correctly?	Go to action 11.	Connect the connector.
11	Check the Laser Unit connection. Check the connection between the Laser Unit and MCU Board. Are the P/J36 and P/J11 connected correctly?	Go to action 12.	Connect the P/J36 and P/J11 correctly.
12	Check after replacing the Laser Unit. Replace the Laser Unit. Does an error occur?	Contact Xerox Technical Support.	The task is complete.



## Streaked output



### Possible causative parts

- Toner Cartridge Y/M/C/K (PL5.1.8/PL5.1.9/PL5.1.10/PL5.1.11)
- Imaging Unit Y/M/C/K (PL8.1.2/PL8.1.3/PL8.1.4/PL8.1.5)
- Transfer Belt Assembly (PL6.1.1)
- Scanner Assembly (PL51.1.1)

Action		Yes	No
	Is the unit under test an MFP?	Go to action 1.	Go to action 4.
1	Check the error mode. Does the error occur when copying or scanning?	Go to action 2.	Go to action 4.
2	Check the original. Is the original color clean?	Go to action 3.	Change the original.
3	Clean up ADF Glass and White strip of the Scanner with a clean dry cotton swab.  Does the error occur when copying or scanning?	Go to action 4.	End.
4	The toner cartridges may be low or need to be replaced. Confirm the amount of toner left in each toner cartridge. Replace the toner cartridges as necessary. Does this solve your problem?	The task is complete.	Go to action 5.
5	Replace the Imaging Units. Does this solve your problem?	The task is complete.	Go to action 6
6	Check the intermediate transfer belt. Is the Transfer Belt Assembly not dirty, damaged, or worn, and does it work correctly?	Contact Xerox Technical Support.	Replace the Transfer Belt Assembly.

## Partial or entire black output



Black Print

### Possible causative parts

- Toner Cartridge Y/M/C/K (PL5.1.8/PL5.1.9/PL5.1.10/PL5.1.11)
- Imaging Unit Y/M/C/K (PL8.1.2/PL8.1.3/PL8.1.4/PL8.1.5)
- Laser Unit (PL2.1.1)
- Development HVPS Board (PL18.1.14)

	Action	Yes	No
1	Ensure that the Imaging Units are installed correctly. Does this solve your problem?	The task is complete.	Go to action 2.
2	Ensure that the printer driver is set to print color output. 1. On the <b>Image Options</b> tab, ensure that the <b>Xerox Black and White Conversion</b> button is <i>not</i> checked. Does this solve your problem?	The task is complete.	Go to action 3.
3	Replace the Imaging Units. Does this solve your problem?	The task is complete.	Go to action 4.
4	Check the drum charge status. Cover the Laser Unit window with a sheet of paper and perform a test print. Is the test print result black? (If the drum is charged correctly, the test print result is white.)	Replace the Development HVPS Board.	Go to action 5.
5	Check the Laser Unit. Cover the half of the Laser Unit window with a sheet of paper and perform a test print. Is the half page of the test print result white and the other half page is black? (If the Laser Unit is normal, the other half page is not black but test patterned.)	Replace the Laser Unit.	Contact Xerox Technical Support.

## Pitched color dots



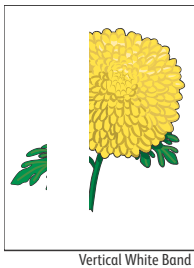
Repeating Defect, Deve Roller

### Possible causative parts

- Toner Cartridge Y/M/C/K (PL5.1.8/PL5.1.9/PL5.1.10/PL5.1.11)
- Imaging Unit Y/M/C/K (PL8.1.2/PL8.1.3/PL8.1.4/PL8.1.5)
- Fuser Assembly (PL7.1.1)
- Transfer Roller (PL14.1.99)
- Transfer Belt Assembly (PL6.1.1)
- Development HVPS Board (PL18.1.14)
- Transfer HVPS Board (PL18.1.28)

Action		Yes	No
1	Determine the cause of the problem using the Contamination Check test prints. 1. Enter Service Mode and run "Contamination Check" on page 2-51 to print the test pages. 2. Compare the pitch of the color spots on your output with that on the "Scale for White spots/Color dots", and determine which part is causing the problem. Can you determine the part that is causing the problem?	Proceed to the action that corresponds to the problem part: Imaging Unit - 2 Fuser - 3 Transfer Belt - 4	Go to action 2.
2	Replace the Imaging Units. Does this solve your problem?	The task is complete.	Go to action 3.
3	Replace the Fuser Assembly. Does this solve your problem?	The task is complete.	Go to action 4.
4	Replace the Transfer Belt Assembly, the Transfer Roller, and the retard roller. Does this solve your problem?	The task is complete.	Go to action 5.
5	Check the Development HVPS Board connector connection. Is the Development HVPS Board connector connected correctly?	Go to action 6.	Connect the connector.
6	Check the installation of the Transfer Belt Assembly. Is the Transfer Belt Assembly HV terminal clean, and does it contact the spring correctly?	Go to action 7.	Clean the HV terminal. Reinstall the Transfer Belt Assembly.
7	Check the Transfer Belt Assembly. Is the Transfer Belt Assembly dirty, damaged, or worn, and does it work correctly?	Replace the Transfer Belt Assembly.	Go to action 8.
8	Check the Transfer HVPS Board connector connection. Is the Transfer HVPS Board connector connected correctly?	Contact Xerox Technical Support.	Connect the connector.

## Vertical blanks



## Possible causative parts

- Toner Cartridge Y/M/C/K (PL5.1.8/PL5.1.9/PL5.1.10/PL5.1.11)
- Imaging Unit Y/M/C/K (PL8.1.2/PL8.1.3/PL8.1.4/PL8.1.5)
- Laser Unit (PL2.1.1)
- Transfer Roller (PL14.1.99)
- Transfer Belt Assembly (PL6.1.1)
- Scanner Assembly (PL51.1.1)

Action		Yes	No
	Is the unit under test an MFP?	Go to action 1.	Go to action 4.
1	Check the error mode. Does the error occur when copying or scanning?	Go to action 2.	Go to action 4.
2	Check the original. Is the original color clean?	Go to action 3.	Change the original.
3	Clean the Scanner document glass and CVT glass Does this solve your problem?	The task is complete.	Go to action 4.
4	Clean the Laser lenses as described in “Cleaning the Laser Lenses” on page 6-7. Does this solve your problem?	The task is complete.	Go to action 5.
5	Check the laser beam path. Are there any foreign substances between the Laser Unit and the Y/M/C/K drum? Particularly, check if any fibers and others are not under around the development roller bottom cover.	Remove the foreign substance.	Go to action 6.
6	Check the paper transfer path. Are there any smears or foreign substances on the path between the paper entrance and the paper exit? When the vertical blanks problem occurs, check if there are problems such as foreign substances or rib deformation in the corresponding location.	Remove the foreign substance. Replace the causative part.	Go to action 7.
7	Replace the Imaging Units. Does this solve your problem?	The task is complete.	Go to action 8.
8	Check the intermediate transfer belt. Is the Transfer Belt Assembly dirty, damaged, or torn, and does it work correctly?	Replace the Transfer Belt Assembly.	Go to action 9.
9	Check the Transfer Roller. Is Transfer Roller contaminated, damaged, or worn, and does it work correctly?	Replace Transfer Roller.	Contact Xerox Technical Support.

## Ghosting



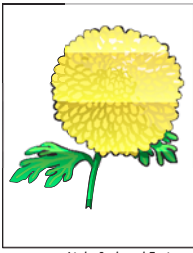
Residual Image/Ghosting

### Possible causative parts

- Imaging Unit Y/M/C/K (PL8.1.2/PL8.1.3/PL8.1.4/PL8.1.5)
- Transfer Belt Assembly (PL6.1.1)

Action		Yes	No
1	If you are using non-recommended print media, switch to the print media recommended for the printer. Does this solve your problem?	The task is complete.	Go to action 2.
2	Replace the Imaging Units. Does this solve your problem?	The task is complete.	Go to action 3.
3	Adjust the Transfer Belt Offset. Decrease the K Offset or YMC Offset as appropriate. Refer to "Adjusting the Transfer Belt Offsets" on page 6-22. Does this solve your problem?	The task is complete.	Go to action 4.
4	Check the installation status of the Transfer Belt Assembly. Is the Transfer Belt Assembly HV terminal clean, and is it contacted to the spring correctly?	Go to action 5.	Clean the HV terminal. Reinstall the Transfer Belt Assembly.
5	Replace the Transfer Belt Assembly. Does the problem persist even after the Transfer Belt Assembly is replaced with a new one?	Contact Xerox Technical Support.	The task is complete.

## Light-induced fatigue



Light Induced Fatigue

### Possible causative parts

- Imaging Unit Y/M/C/K (PL8.1.2/PL8.1.3/PL8.1.4/PL8.1.5)

	Action	Yes	No
1	<p>Determine the cause of the light fatigue pattern using the Contamination Check test prints.</p> <ol style="list-style-type: none"> <li>1. Enter Service Mode and run “Contamination Check” on page 2-51 to print the test pages.</li> <li>2. Compare the pitch of the light fatigue pattern on your output with that on the “Scale for banding”, and determine which part is causing the problem.</li> </ol> <p>Does the pattern on the output match with that on the scale?</p>	Go to action 2.	Contact Xerox Technical Support.
2	<p>Replace the Imaging Units.</p> <p>Does this solve your problem?</p>	The task is complete.	Contact Xerox Technical Support.

## Fog



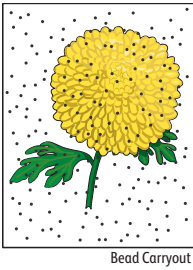
Background Contamination

## Possible causative parts

- Toner Cartridge Y/M/C/K (PL5.1.8/PL5.1.9/PL5.1.10/PL5.1.11)
- Imaging Unit Y/M/C/K (PL8.1.2/PL8.1.3/PL8.1.4/PL8.1.5)
- CTD Sensor Assembly (PL6.1.14)
- Development HVPS Board (PL18.1.14)

	Action	Yes	No
1	Check if a problem occurs repeatedly. Print a variety of images for 30 pages. Does the problem still persist?	Go to action 2.	The task is complete.
2	Check the installation status of the Imaging Unit. Remove the Imaging Unit Y/M/C/K. Is the Imaging Unit Y/M/C/K interface not deformed, dirty, and is it contacted to the right and left guides, and installed correctly?	Go to action 3.	Restore and clean the interface. Reinstall the Imaging Unit Y/M/C/K.
3	Replace the Imaging Units. Does this solve your problem?	The task is complete.	Go to action 4.
4	Check dirt and foreign substances on the CTD Sensor surface. Is the CTD Sensor Assembly not dirty, or are there any foreign substances on the surface?	Clean the CTD sensor surface or remove the foreign substance.	Go to action 5.
5	Check the Development HVPS Board connector connection. Is the Development HVPS Board connector connected correctly?	Replace the Development HVPS Board.	Connect the connector.

## Bead-Carry-Out (BCO)



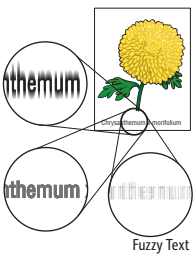
Bead Carryout

### Possible causative parts

- Imaging Unit Y/M/C/K (PL8.1.2/PL8.1.3/PL8.1.4/PL8.1.5)
- Development HVPS Board (PL18.1.14)

	Action	Yes	No
1	If the printer is installed in a high altitude location, set the altitude of the location. 1. Adjust the printer for the correct altitude. See “Adjusting Altitude” on page 6-22 Does this solve your problem?	The task is complete.	Go to action 2.
2	Replace the Imaging Units. Does this solve your problem?	The task is complete.	Go to action 3.
3	Check the Development HVPS Board connector connection. Is the Development HVPS Board connector connected correctly?	Replace the Development HVPS Board.	Connect the connector.

## Jagged characters



Fuzzy Text

### Possible causative parts

- IP Board (PL18.1.22)

	Action	Yes	No
1	On the <b>Printing Options</b> tab, set <b>Print Quality</b> to <b>Enhanced</b> . Does this solve your problem?	The task is complete.	Go to action 2.
2	If using a downloaded font, ensure that the font is recommended for the printer, operating system, and the application being used. Does this solve your problem?	The task is complete.	Replace the IP Board.



## Banding



Horizontal Band, Void, or Streaks

### Possible causative parts

- Toner Cartridge Y/M/C/K (PL5.1.8/PL5.1.9/PL5.1.10/PL5.1.11)
- Imaging Unit Y/M/C/K (PL8.1.2/PL8.1.3/PL8.1.4/PL8.1.5)
- Fuser Assembly (PL7.1.1)
- Transfer Roller (PL14.1.99)
- Transfer Belt Assembly (PL6.1.1)

	Action	Yes	No
1	<p>Determine the cause of the problem using the Contamination Check test prints.</p> <ol style="list-style-type: none"> <li>1. Enter Service Mode and run “Contamination Check” on page 2-51 to print the test pages.</li> <li>2. Compare the pitch of the banding on your output with that on the “Scale for White spots/Color dots”, and determine which part is causing the problem.</li> </ol> <p>Can you determine the part that is causing the problem?</p>	<p>Proceed to the action that corresponds to the problem part:</p> <p>Imaging Unit - 2 Fuser - 3 Transfer Belt - 4</p>	Go to action 2.
2	<p>Replace the Imaging Units.</p> <p>Does this solve your problem?</p>	The task is complete.	Go to action 3.
3	<p>Replace the Fuser Assembly.</p> <p>Does this solve your problem?</p>	The task is complete.	Go to action 4.
4	<p>Replace the Transfer Belt Assembly, the Transfer Roller, and the retard roller.</p> <p>Does this solve your problem?</p>	The task is complete.	Contact Xerox Technical Support.

## Auger mark

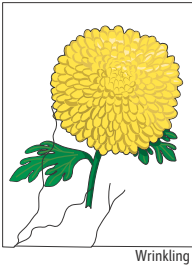


### Possible causative parts

- Imaging Unit Y/M/C/K (PL8.1.2/PL8.1.3/PL8.1.4/PL8.1.5)

Action		Yes	No
1	Replace the Imaging Units. Does this solve your problem?	The task is complete.	Contact Xerox Technical Support.


## Wrinkled/Stained paper



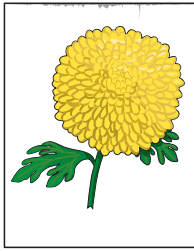
### Possible causative parts

- Transfer Roller (PL14.1.99)
- Fuser Assembly (PL7.1.1)
- Retard Holder Assembly (PL13.3.14)
- Feed Roller Assembly (PL13.2.10)
- Retard Holder Assembly (PL10.3.3)
- TA1 Roller Assembly (PL13.1.2)
- TA2 Roller Assembly (PL13.1.3)
- Regi Chute Assembly (PL15.2.1)
- Exit Roller Assembly (PL17.1.14)

Action		Yes	No
1	Verify that the correct print media is being used. If not, use the print media recommended for the printer. Does this solve your problem?	The task is complete.	If printing on an envelope, go to action 2. If printing on print media other than envelopes, Go to action 4.
2	Check the wrinkle. Is the wrinkle within 30 mm of the four edges of the envelope?	This type of wrinkle is considered normal. Your printer is not at fault.	Go to action 3.

Action		Yes	No
3	Load the envelopes in the Bypass Tray properly. Does this solve your problem?	The task is complete.	Go to action 4.
4	Check the paper loaded in the paper cassette. Remove the paper cassette, adjust the paper guides, and reload the paper correctly. Reinstall the paper cassette correctly, and perform a test print. Is the image printed correctly?	The task is complete.	Go to action 5.
5	Check the paper humidity conditioning effect. Load the unopened (or sealed and stored under humidity control) and recommended paper, and then perform a test print. Is the image printed correctly?	The task is complete.	Go to action 6.
6	Check the paper type setting. Is the paper type setting corresponding with the paper printed?	Go to action 7.	Set the correct paper type.
7	Check the paper transfer path. Are there any smears or foreign substances on the path between the paper entrance and the paper exit?	Remove the foreign substance.	Go to action 8.
8	Check the paper feed path roller. Is the roller on the paper feed path not dirty, damaged, or worn, and does it work correctly? Also, is the roller installed correctly?	Go to action 9.	Clean or replace the corresponding roller, and reinstall it.
9	Check the installation status of the Transfer Roller. Is Transfer Roller installed correctly?	Go to action 10.	Reinstall Transfer Roller.
10	Check the Fuser Assembly. Is the Fuser Assembly installed correctly?	Go to action 11.	Reinstall the Fuser Assembly.
11	Check the Fuser Assembly.  <b>WARNING:</b> Start the operation after the Fuser has cooled down. Remove the Fuser Assembly. Turn the gear by hand, and examine the Heat Roll section. Is the Heat Roll section not dirty or damaged, and does it work correctly?	Contact Xerox Technical Support.	Replace the Fuser Assembly.

## Leading edge paper damage



Leading Edge Damage

### Possible causative parts

- Transfer Roller (PL14.1.99)
- Fuser Assembly (PL7.1.1)
- Retard Holder Assembly (PL13.3.14)
- Feed Roller Assembly (PL13.2.10)
- Retard Holder Assembly (PL10.3.3)
- TA1 Roller Assembly (PL13.1.2)
- TA2 Roller Assembly (PL13.1.3)
- Regi Chute Assembly (PL15.2.1)
- Exit Roller Assembly (PL17.1.14)

Action		Yes	No
1	When you use the Bypass Tray, reverse the paper and then try again. When you use any of the trays, change the paper and then try again. Does this solve your problem?	The task is complete.	(Bypass Tray) Go to action 2. (trays) Go to action 4.
2	Try again with a different sheet of paper. Does this solve your problem?	The task is complete.	Go to action 3.
3	Use any of the trays in place of the Bypass Tray. Does this solve your problem?	The task is complete.	Go to action 4.
4	Check the paper loaded in the paper cassette. Remove the paper cassette, adjust the paper guides, and reload the paper correctly. Reinstall the paper cassette correctly, and perform a test print. Is the image printed correctly?	The task is complete.	Go to action 5.
5	Check the paper humidity conditioning effect. Load the unopened (or stored and sealed under humidity control) and recommended paper, and then perform a test print. Is the image printed correctly?	The task is complete.	Go to action 6.
6	Check the paper type setting. Is the paper type setting corresponding with the paper printed?	Go to action 7.	Set the correct paper type.
7	Check the paper transfer path. Are there any dirt or foreign substances on the paper transfer path?	Remove the foreign substance.	Go to action 8.
8	Check the paper feed path roller. Is the roller on the paper feed path not dirty, damaged, or worn, and does it work correctly? Also, is the paper feed path roller installed correctly?	Go to action 9.	Clean or replace the corresponding roller, and reinstall it.
9	Check the installation status of the Transfer Roller. Is Transfer Roller installed correctly?	Go to action 10.	Reinstall Transfer Roller.

Action		Yes	No
10	Check the installation status of the Fuser Assembly. Is the Fuser Assembly installed correctly?	Go to action 11.	Reinstall the Fuser Assembly.
11	<p>Check the Fuser Assembly.</p> <p><b>!</b> <b>WARNING:</b> Start the operation after the Fuser Assembly has cooled down.</p> <p>Remove the Fuser Assembly. Turn the gear by hand, and examine the Heat Roll section.</p> <p>Is the Heat Roll section not dirty or damaged, and does it work correctly?</p>	Replace the?device.	Replace the Fuser Assembly.

## Incorrect top and side margins

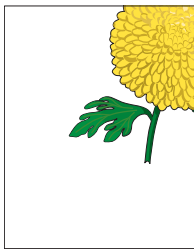


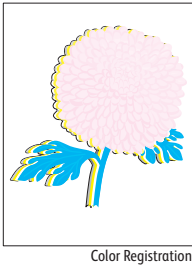
Image Not Centered

### Possible causative parts

- MCU Board (PL18.1.13)
- IP Board (PL18.1.22)

Action		Yes	No
1	Ensure that the margins are set correctly on the application being used. Does this solve your problem?	The task is complete.	Replace the possible causative parts one by one.

## Color registration is out of alignment



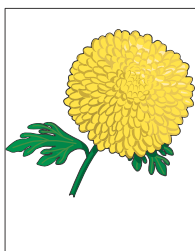
### Possible causative parts

- Imaging Unit Y/M/C/K (PL8.1.2/PL8.1.3/PL8.1.4/PL8.1.5)
- CTD Sensor Assembly (PL6.1.14)
- Transfer Belt Assembly (PL6.1.1)
- Laser Unit (PL2.1.1)

Action		Yes	No
1	Adjust the settings of the paper type on the printer driver to those of the tray. Does this solve your problem?	The task is complete.	Go to action 2.
2	Perform the auto color registration adjustment described in “Performing an Automatic Color Registration Adjustment” on page 6-18. Does this solve your problem?	The task is complete.	Go to action 3.
3	Manually correct the color registration using “Performing a Manual Color Registration Adjustment” on page 6-19. Does this solve your problem?	The task is complete.	Go to action 4.
4	Check the installation status of the drum unit. Remove the Imaging Unit Y/M/C/K. Is each imaging unit installed correctly, and are the contacts at each end of the imaging units clean and free of deformation?	Go to action 5.	Restore and clean the interface. Reinstall the Imaging Unit Y/M/C/K.
5	Replace the Imaging Units. Does this solve your problem?	The task is complete.	Go to action 6.
6	Check dirt and foreign substances on the CTD Sensor surface. Is the CTD Sensor Assembly sensor surface dirty, or are there any foreign substances on the surface?	Clean the CTD sensor surface or remove the foreign substance. <sup>a</sup>	Go to action 7.
7	Replace the Transfer Belt Assembly. Does the problem persist even after the Transfer Belt Assembly is replaced with a new one?	Go to action 8.	The task is complete.
8	Replace the Laser Unit. Does the problem persist even after the Laser Unit is replaced with a new one?	Contact Xerox Technical Support.	The task is complete.

a. Wipe with a cotton swab. (Do not use alcohol.)

## Images are skewed



Skew 2

### Possible causative parts

- Transfer Roller (PL14.1.99)
- Fuser Assembly (PL7.1.1)
- Transfer Belt Assembly (PL6.1.1)
- Retard Holder Assembly (PL13.3.14)
- Feed Roller Assembly (PL13.2.10)
- Retard Holder Assembly (PL10.3.3)
- TA1 Roller Assembly (PL13.1.2)
- TA2 Roller Assembly (PL13.1.3)
- Regi Chute Assembly (PL15.2.1)
- Exit Roller Assembly (PL17.1.14)

Action		Yes	No
1	Adjust the paper guides properly. Does this solve your problem?	The task is complete.	Go to action 2.
2	Install the Transfer Belt Assembly according to an appropriate procedure. Does this solve your problem?	The task is complete.	Go to action 3.
3	Check the paper humidity conditioning effect. Load the unopened (or stored and sealed under humidity control) and recommended paper, and then perform a test print. Is the image printed correctly?	The task is complete.	Go to action 4.
4	Check the paper type setting. Is the paper type setting corresponding with the paper printed?	Go to action 5.	Set the correct paper type.
5	Check the paper transfer path. Are there any dirt or foreign substances on the paper transfer path between the paper entrance and the paper exit?	Remove the foreign substance.	Go to action 6.
6	Check the paper feed path roller. Is the roller on the paper feed path not dirty, damaged, or worn, and does it work correctly? Also, is the roller installed correctly?	Go to action 7.	Clean or replace the corresponding roller, and reinstall it.
7	Check the installation status of the Transfer Roller. Is Transfer Roller installed correctly?	Go to action 8.	Reinstall Transfer Roller.
8	Check the installation status of the Fuser Assembly. Is the Fuser Assembly installed correctly?	Contact Xerox Technical Support.	Reinstall the Fuser Assembly.





# Service Parts Disassembly

## In this chapter...

- Preface
- UICC
- Laser Unit
- Drive
- NOHAD
- Dispenser
- Transfer
- Fuser
- Xerographic
- Tray
- Option Feeder
- Bypass Tray
- Duplex
- Registration / Feeder
- Exit
- Electrical
- Covers
- Scanner
- Harness

## Preface

This section contains the removal procedures for field-replaceable parts listed in the Parts List. In most cases, the replacement procedure is simply the reverse of the removal procedure. In some instances, additional steps are necessary and are provided for replacement of the parts. For specific assemblies and parts, refer to Chapter 5. Parts removal and replacement procedures are divided into seventeen categories that correspond to the parts list categories.

- PL1 UI (SFP: page 5-11; MFP: page 5-12)
- PL2 Laser Unit (page 5-13)
- PL3 Drive (page 5-14)
- PL4 NOHAD (page 5-15)
- PL5 Dispenser (page 5-17)
- PL6 Transfer (page 5-19)
- PL7 Fuser (page 5-21)
- PL8 Xerographic (page 5-22)
- PL9 Tray (page 5-24)
- PL10 Option Feeder (page 5-27, 5-29, 5-30)
- PL13 Bypass Tray (page 5-32, 5-34, 5-36)
- PL14 Duplex (page 5-38)
- PL15 Registration / Feeder (page 5-39, 5-41)
- PL17 Exit (page 5-43)
- PL18 Electrical (SFP: page 5-45; MFP: page 5-48; Both: page 5-51)
- PL19 Cover (SFP: page 5-53; MFP: page 5-56)
- PL51 Scanner (page 5-60)

### Notes:

- When working on an item which is controlled as a spare part but the procedure therefore is not described, observe carefully how the part is attached before removing the item.
- As a general rule, remove optional items from the machine first, especially if they interfere with access to a part.

## Before starting service work



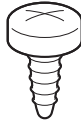
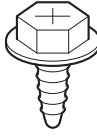
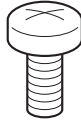
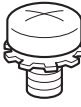
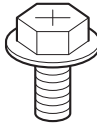
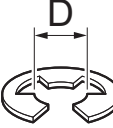
### **WARNINGS:**

- To avoid injury or death due to electrical shock, unplug the power cord from the wall outlet.
- To avoid burns, allow the Fuser to cool before performing service operations around it.



**CAUTION:** Many parts are secured by plastic tabs. Do not excessively flex or force these parts. Do not over-torque screws threaded into plastic.

- If necessary, remove Imaging Units (Xero Deve Assembly) before disassembling the printer.
- Avoid using excessive force when removing or installing parts to prevent possible malfunction or breakage.
- Since various types of screws are used, ensure that the right screws are replace in the correct positions.  
Be careful not to confuse screws for plastic with screws for sheet metal. Using the wrong type of screw may result in damage to the screw threads or other troubles.
- At the locations with "TAP" marked on the base material and sheet metal, use the tap screw for plastic.

Type	Shape	PL No.	Size	PARTS No.
Screw for plastic Silver,tapping		ST1	M3X8mm	153W 27878
Screw for plastic Silver,tapping,with flange		ST10	M3X10mm	153W 18088
Machine screw for metal Silver		SM3	M4X6mm	113W 35688
		SM18	M3X6mm	116W 27678
		SM19	M3X32mm	826E 11030
Machine screw for metal Silver,with an external tooth washer		SM5	M4X6mm	826E 25760
Machine screw for metal Silver,with flange		SM15	M4X8mm	133W 35878
Ring-E		E1	D3	354W 21278
		E2	D4	354W 24278
		E3	D5	354W 26278

**! CAUTION:** Screws you should not loosen are painted red. Never remove the red screws because the equipment may not operate correctly.

### General notes

- Wear an anti-static wristband or the like to remove static electricity from your body.
- The string "(PL X.Y.Z)" suffixed to the part name in the procedure denotes that the part corresponds to the plate (PL) "X.Y", item "Z" of [Engineering Parts list], and its shape and fitting position can be checked in [Chapter 5 Parts List].
- Use a Phillips-head (crossslot) screwdriver to remove screws shown in the illustrations, unless otherwise specified.
- Black arrows shown in the illustrations indicate the motion for removing parts. When numbers are assigned to these arrows, they refer to the order in the procedure.
- Refer to [7.1 Plug/Jack (P/J) Connector Locations] for the positions of connectors (P/J).

- The installation procedures are basically the reverse order of removal. There are notes at the "Replacement" section for items which require special caution.

## Standard Orientation of the SFP

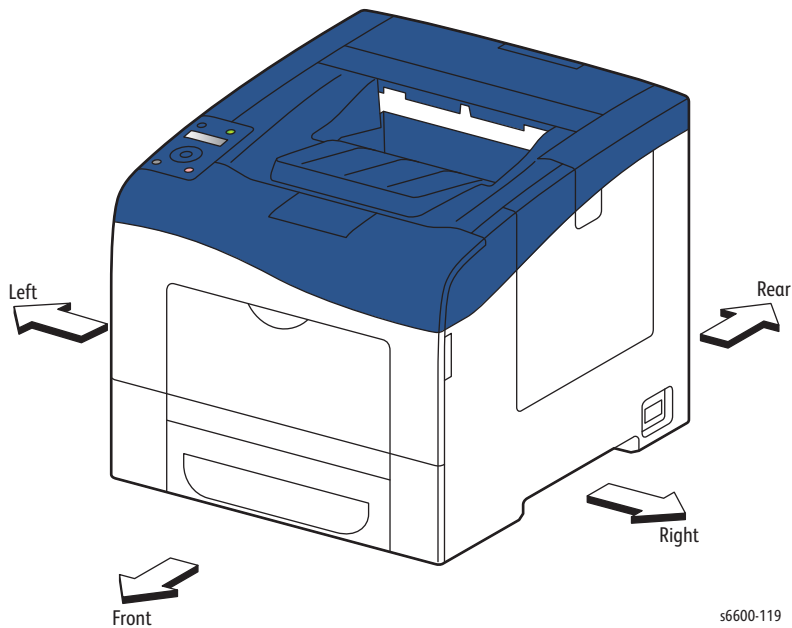
Directional descriptions used in the procedures are defined as follows:

Front: Direction toward you when facing the front of the printer.

Rear: Direction opposite to the front when facing the front of the printer.

Left: Left-hand direction when facing the front of the printer.

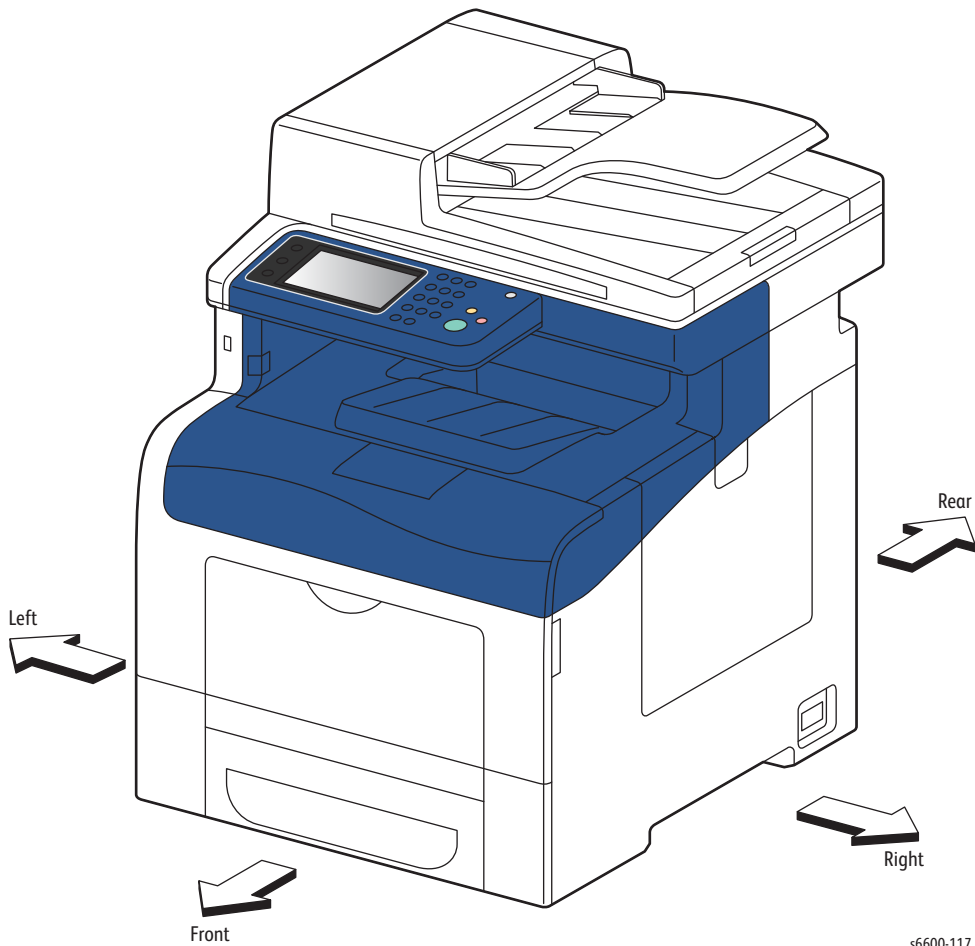
Right: Right-hand direction when facing the front of the printer.



## Standard Orientation of the MFP

Directional descriptions used in the procedures are defined as follows:

- Front: Direction toward you when facing the front of the printer.
- Rear: Direction opposite to the front when facing the front of the printer.
- Left: Left-hand direction when facing the front of the printer.
- Right: Right-hand direction when facing the front of the printer.



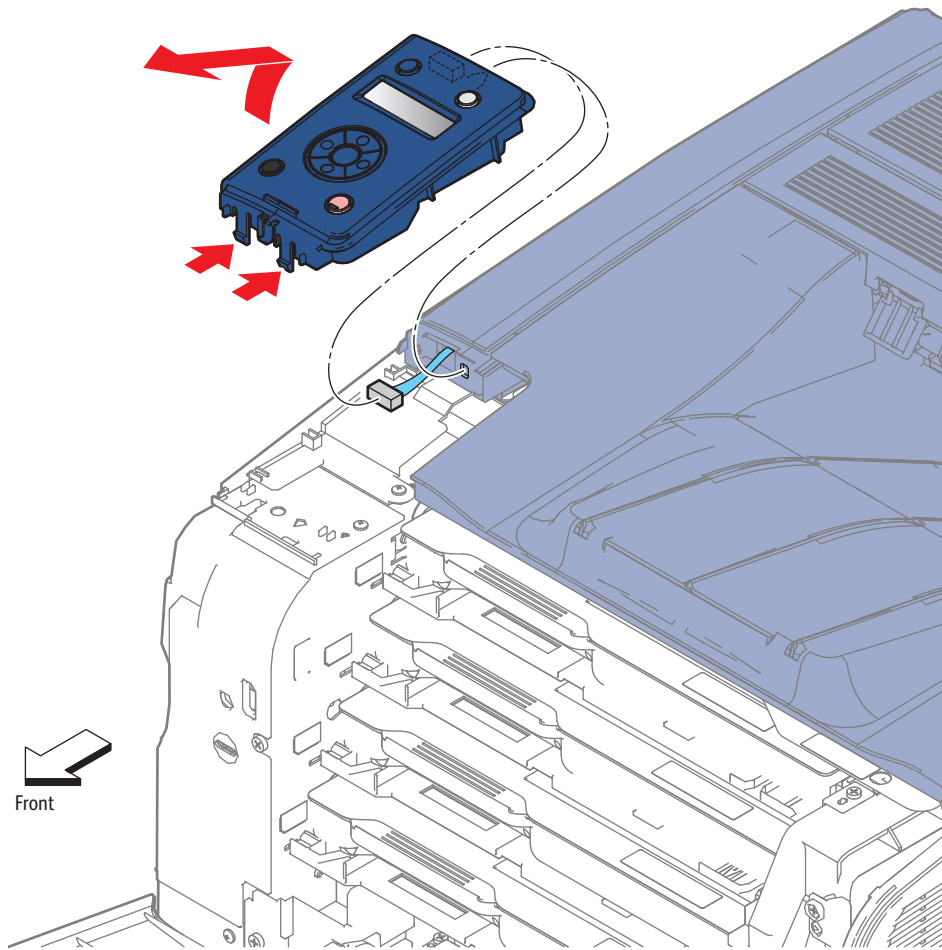
s6600-117

# UICC

## SFP Control Panel Assembly

### PL1.1.1

1. Open the Front Door Assembly (page 4-128).
2. Raise the front end of the Control Panel Assembly while releasing the two latches holding it using a flatblade screwdriver or similar tool, and remove the assembly by releasing the two hooks on the rear end from the holes on the printer.
3. Unplug the connector from the Control Panel Assembly and remove it.

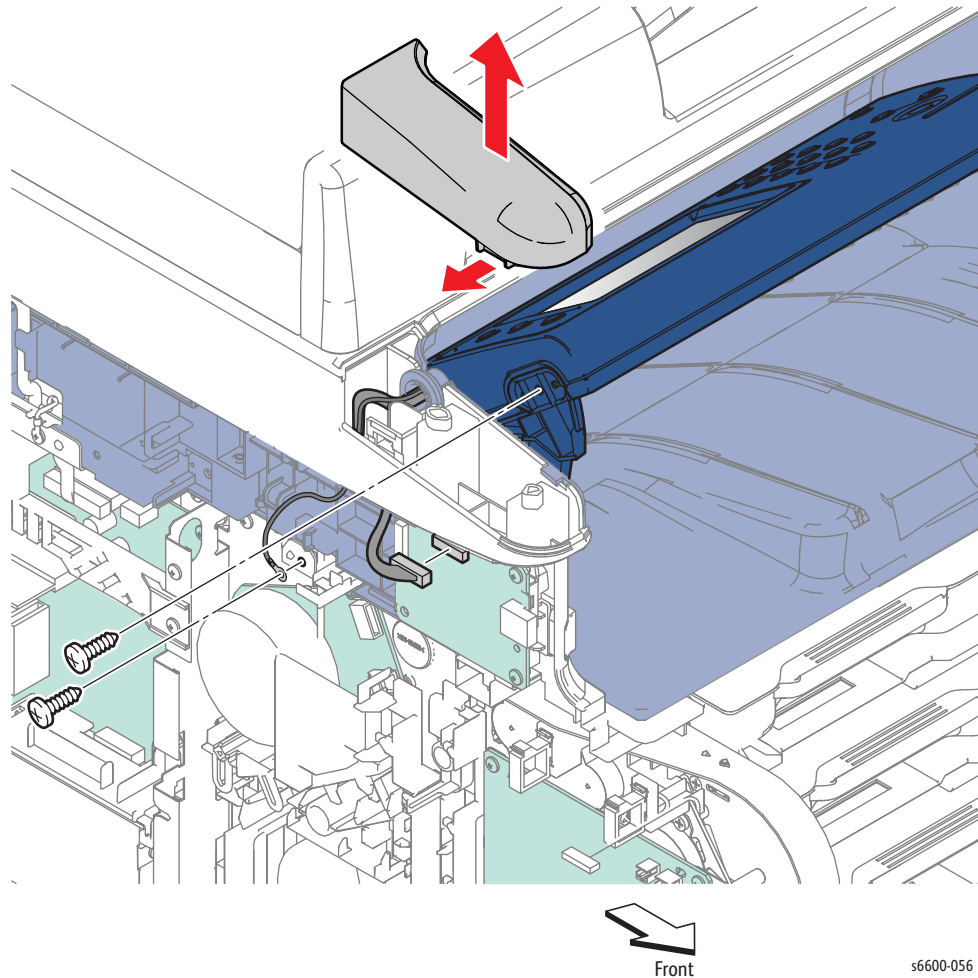


s6600-134

## MFP Control Panel Assembly

### PL1.1.1

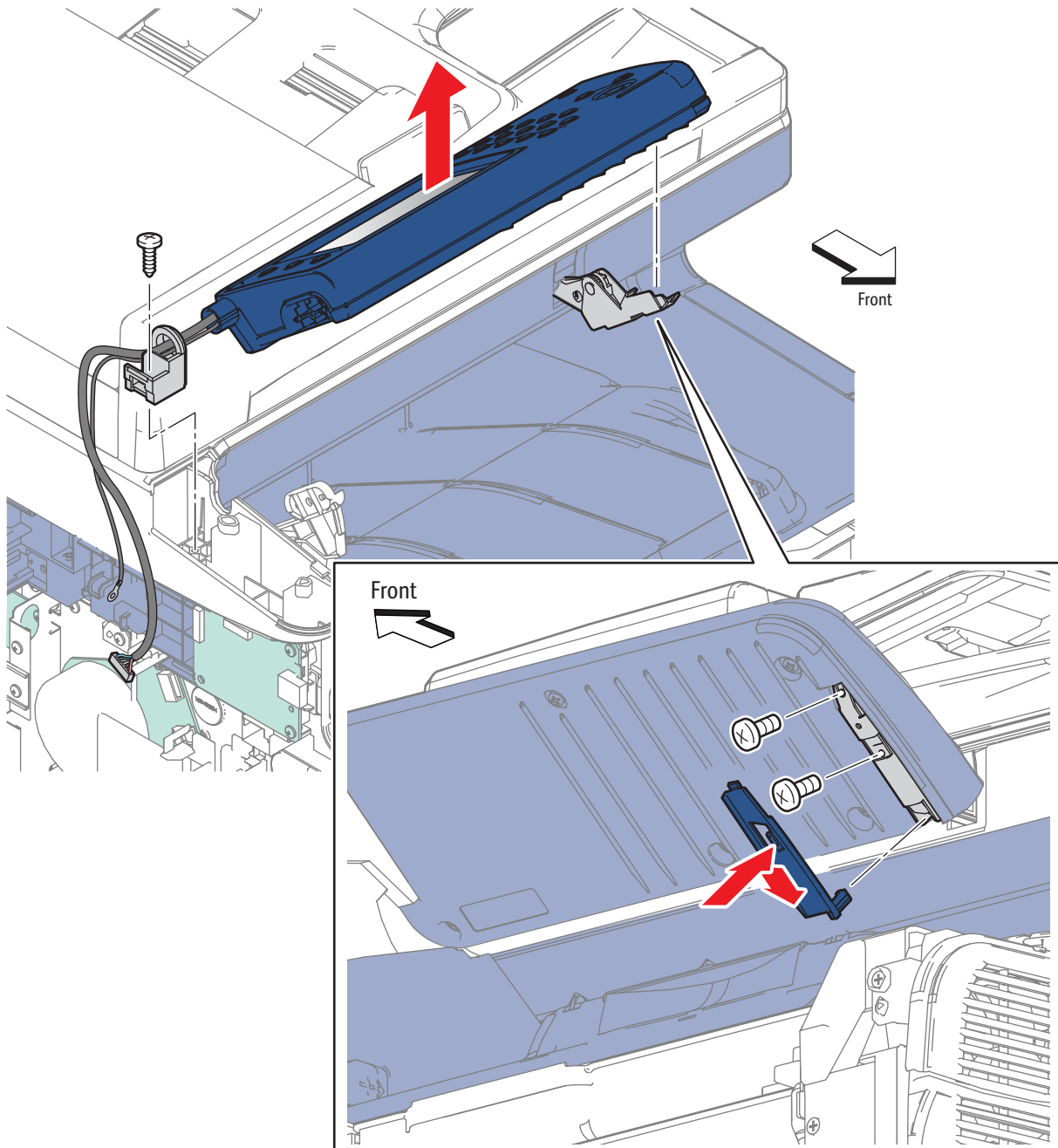
1. Remove the Front Door Assembly. (page 4-128)
2. Remove the Left Cover Assembly. (page 4-136)
3. Unplug connector P/J 830 from the USB Hub Board (page 4-121), and release the harness from the harness guide.
4. Remove the screw that attaches the ground wire to the frame.
5. Release the hook and lift the Control Panel Hinge Cover off the printer.



s6600-056



6. Remove the screw (silver, 6mm) that attaches the MFP Control Panel Pivot Holder (PL19.1.58) to the printer, and lift the pivot holder off the boss on the frame.
7. Push the boss on right-side Bracket Cover to release it from the bracket, and slide the Bracket Cover to the rear and off the Control Panel.
8. Remove the two screws (silver, 6mm) that attach the Control Panel Assembly to the bracket.
9. Remove the Control Panel Assembly.



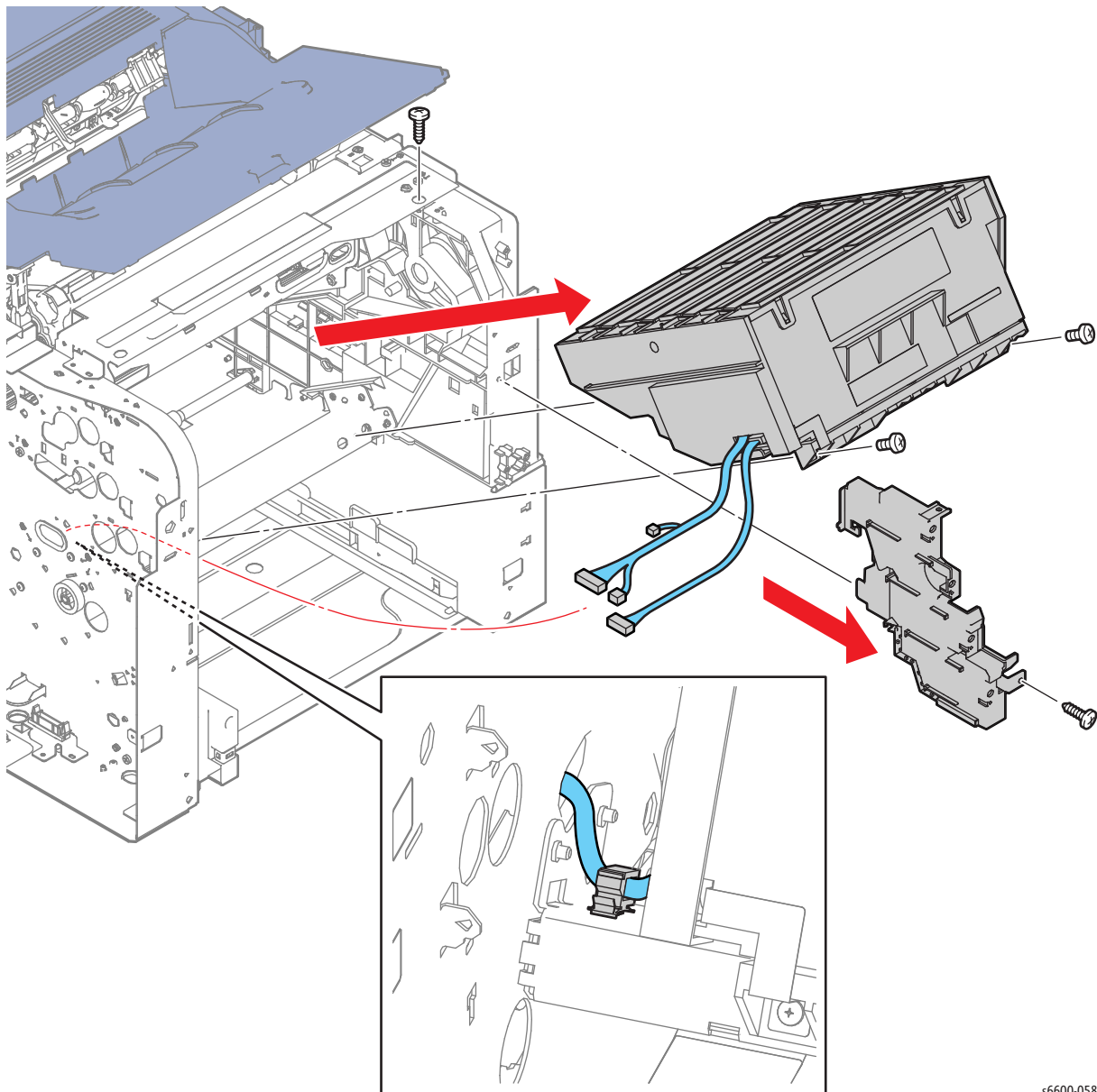
s6600-057

# Laser Unit

## Laser Unit Assembly

### PL2.1.1

1. Remove all the Dispenser Assemblies Y, M, C, K. (page 4-34)
2. Remove the two screws (silver, tapping, 8mm) that attach the Base Duct (PL4.1.2) to the printer and remove the duct. One screw is at the top, the other at the front.
3. Release the clamp holding the harness to the Laser Unit Assembly.
4. Remove the two screws (silver, 6mm) that attach the Laser Unit Assembly and remove the Laser Unit Assembly while pulling the harness out of the hole on the frame.



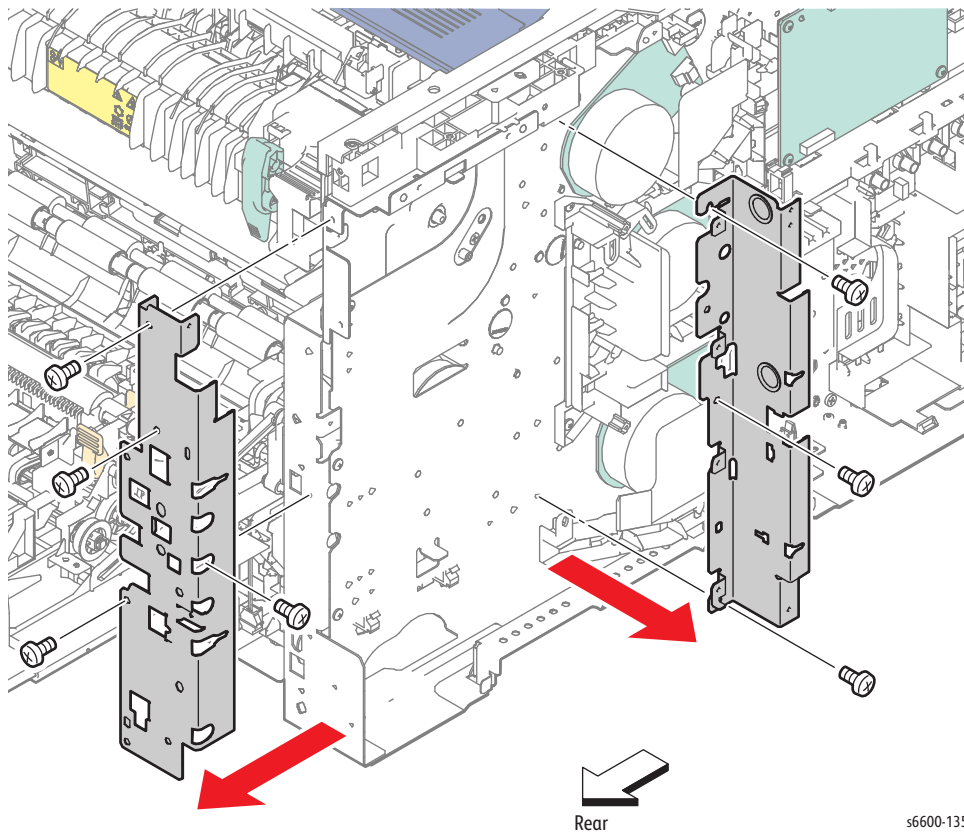
s6600-058

# Drive

## SFP Drive Assembly

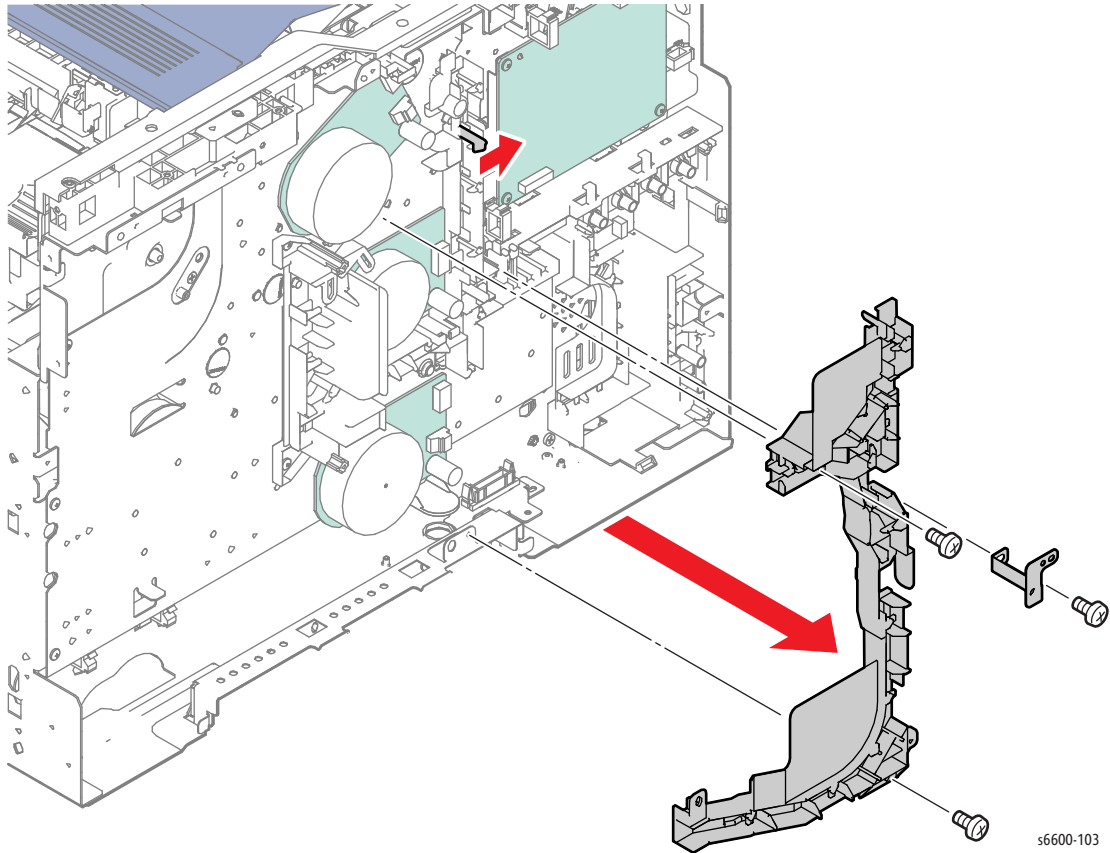
### PL3.1.1

1. Remove the Development HVPS Board. (page 4-99)
2. Remove the IP Board. (page 4-102)
3. Release and remove the wiring harnesses from the Front IP Board Plate (PL 18.1.23).
4. Remove the three screws (silver, 6mm) that attach the Front IP Board Plate to the printer and remove the plate.
5. Remove the four screws (silver, 6mm) that attach the Rear IP Board Plate (PL18.1.24) to the printer and remove the plate.

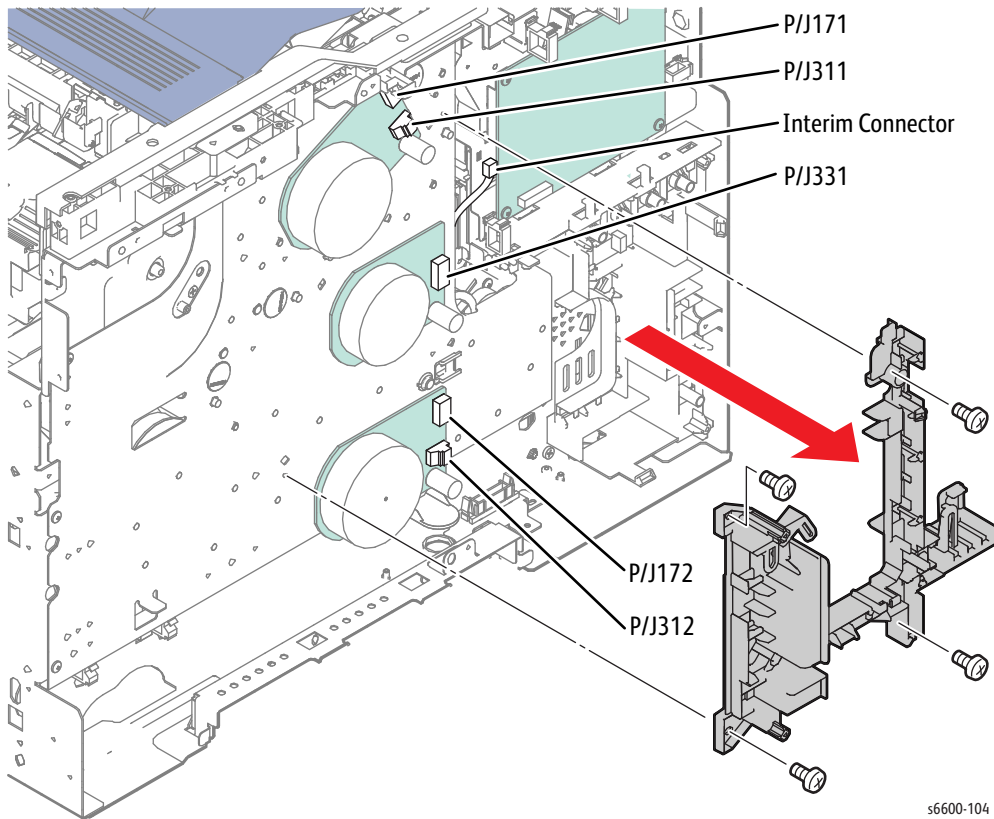


## Service Parts Disassembly

6. Remove the screw (silver, 6mm) that attaches the HV Ground Plate (PL18.1.15) to the printer and remove the plate (if not already removed).
7. Release the harness from the Left Harness Guide (PL18.1.11).
8. Remove the two screws (silver, 6mm) that attach the Left Harness Guide to the printer.
9. Release the pawl holding the Left Harness Guide and remove the guide.



10. Release the harness from the Video Harness Guide (PL18.1.10).
11. Disconnect plugs P/J171, P/J311, P/J172, P/J312, P/J331, P/J213 from the three drive motors and the interim connector from the jack inside the the Drive Assembly (PL3.1.1).
12. Release the harnesses from the clamps at the bottom of the Drive Assembly.
13. Remove the four screws (silver, 6mm) that attach the Video Harness Guide to the printer and remove the guide.

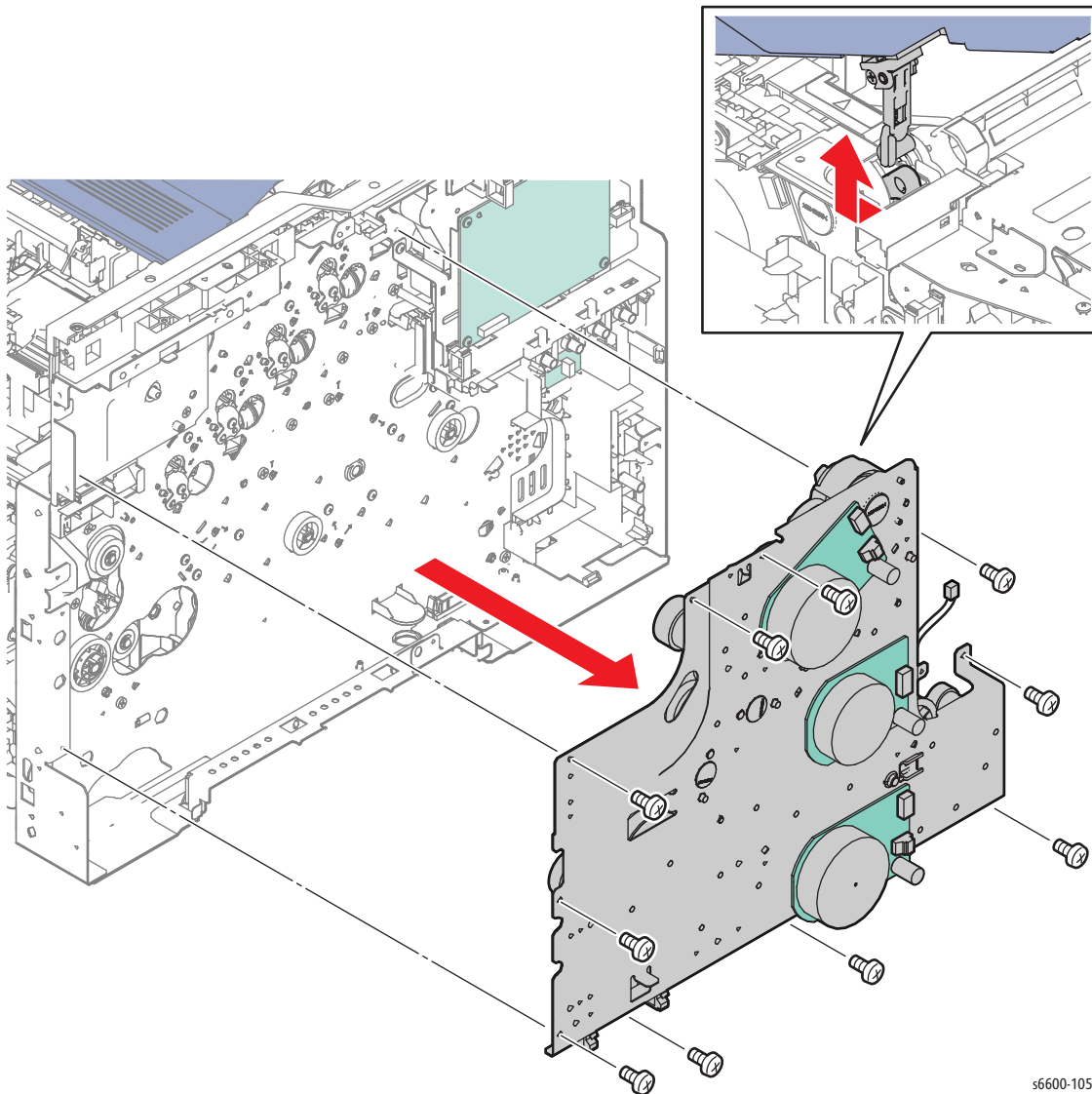


14. Remove the screw (silver, 6mm) that attaches the Left Sub-Top Cover (PL 19.1.10) and remove it.
15. Remove the Transfer 2 Link (PL19.1.4) from the Transfer Coupling Link.

**!** **CAUTION:** When performing the following step to remove the Drive Assembly, use caution not to drop the gears.

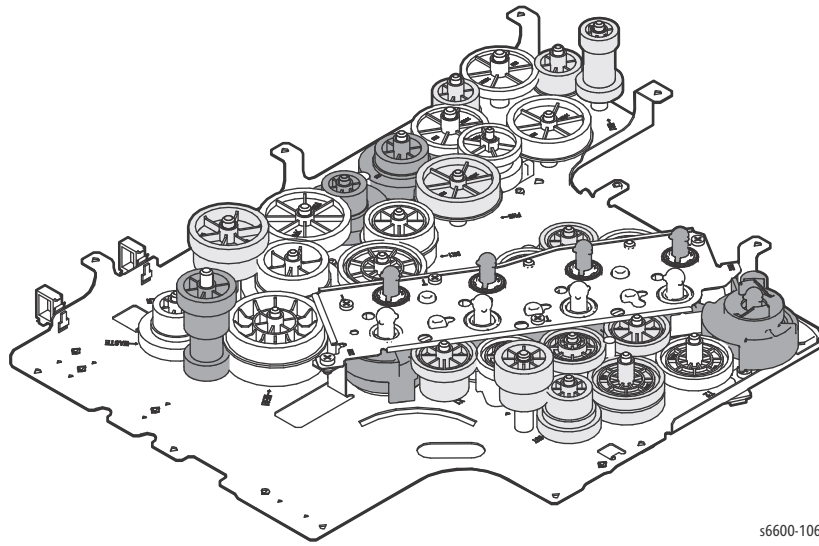
16. Remove the ten screws (silver, 6mm) that attach the Drive Assembly to the printer and remove the drive assembly.

**Note:** When placing the Drive Assembly on the workbench, face the gear side upward to prevent the gears from falling off.



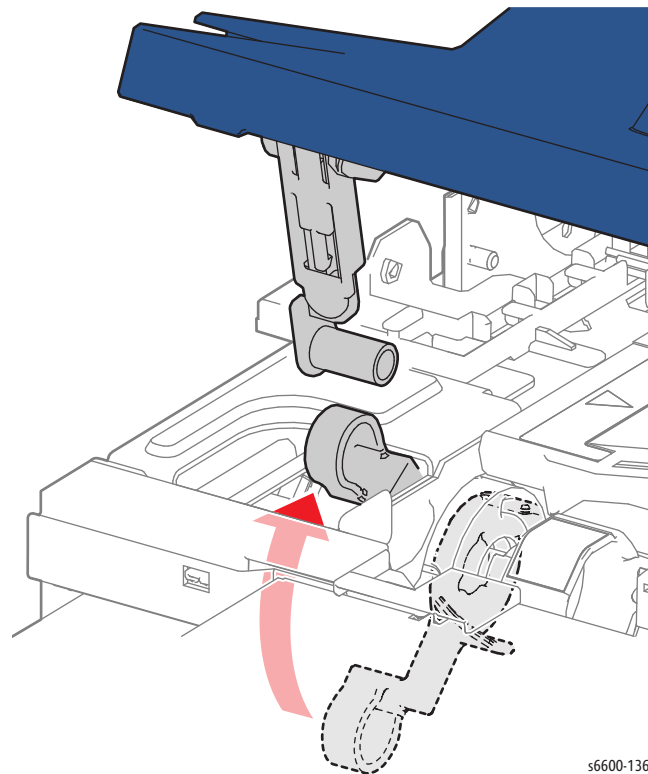
s6600-105

**Note:** The following figure shows how the gears are installed to the Drive Assembly.



s6600-106

**Replacement Note:** If the installation hole of the Transfer 2 Link for the Transfer Link Coupling is lowered, raise it by accessing the Transfer Link Coupling from inside the frame.

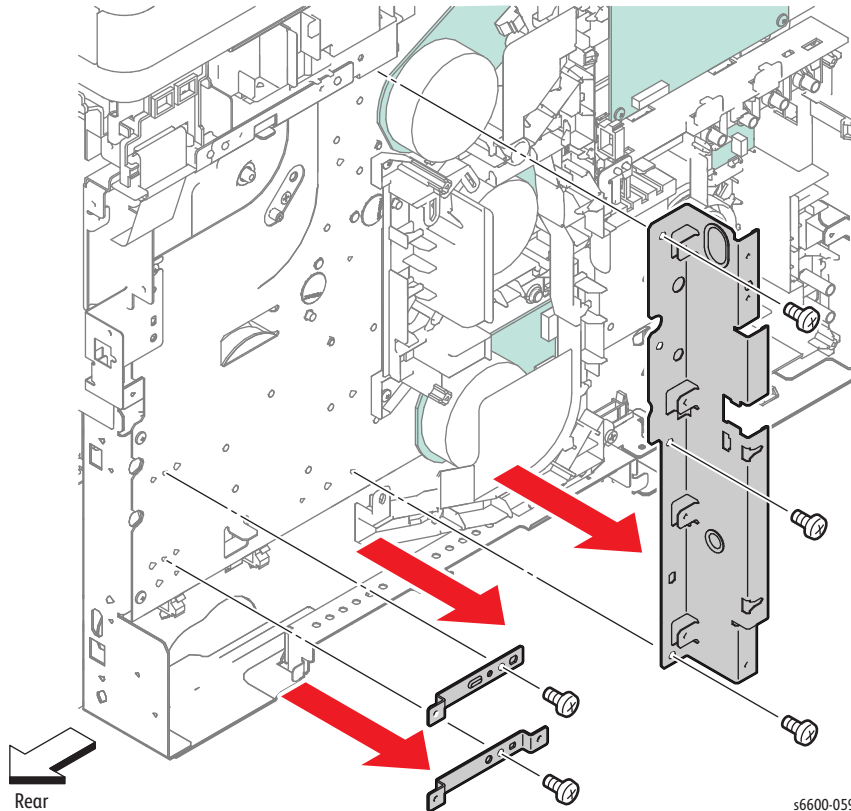


s6600-136

## MFP Drive Assembly

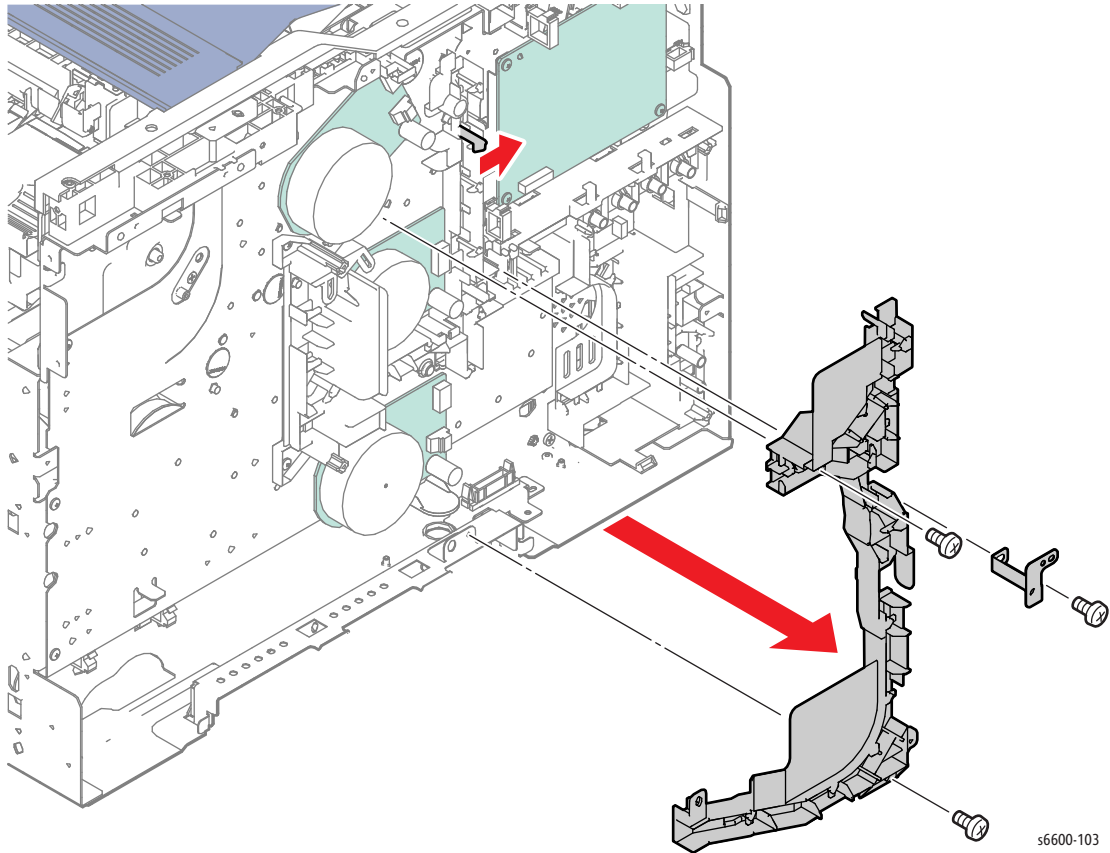
### PL3.1.1

1. Remove the Development HVPS Board. (page 4-99)
2. Remove the IP Board. (page 4-104)
3. Remove the three screws (silver, 6mm) that attach the MFP Front IP Board Plate (PL18.1.23) to the printer and remove the plate.
4. Remove the IP Board Bracket (PL18.1.38) and the MFP IP Board Bracket (PL18.1.46) by removing the screw (silver, 6mm) that attaches each bracket.

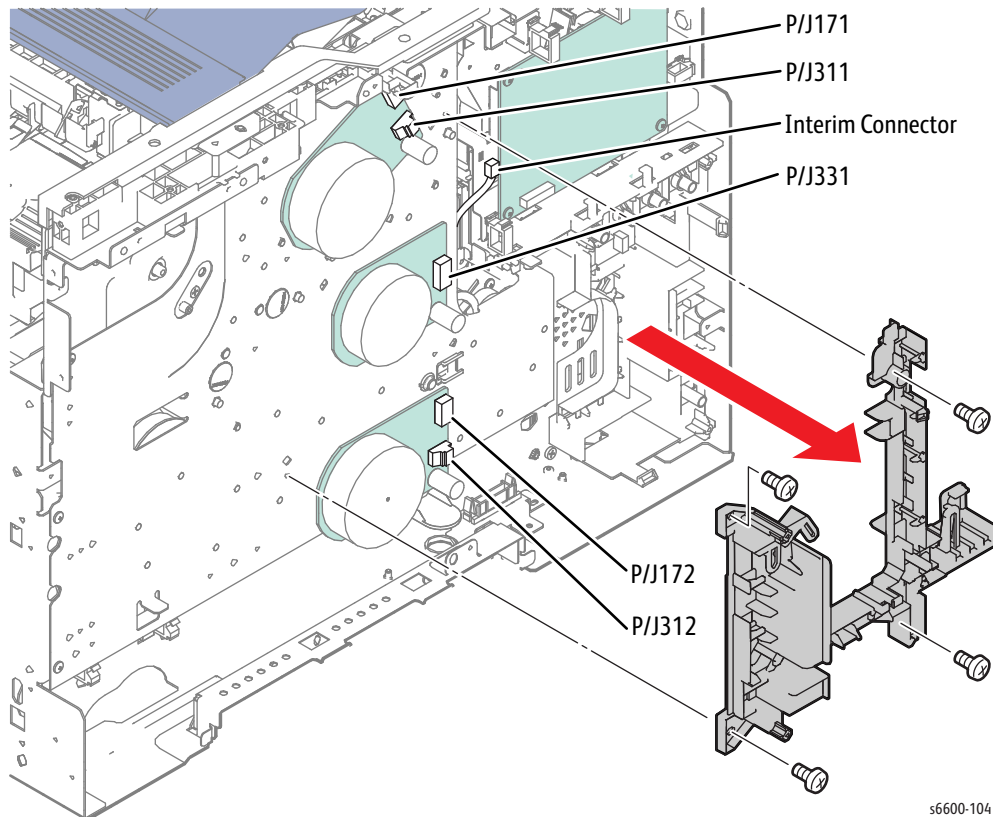




5. Remove the screw (silver, 6mm) that attaches the HV Ground Plate (PL18.1.15) to the printer and remove the plate.
6. Release the harness from the Left Harness Guide (PL18.1.11).
7. Remove the two screws (silver, 6mm) that attach the Left Harness Guide to the printer.
8. Release the pawl holding the Left Harness Guide and remove the guide.



9. Release the harness from the Video Harness Guide (PL18.1.10).
10. Disconnect plugs P/J171, P/J311, P/J172, P/J312, P/J331, P/J213 from the three drive motors and the interim connector from the jack inside the the Drive Assembly (PL3.1.1).
11. Release the harnesses from the clamps at the bottom of the Drive Assembly.
12. Remove the four screws (silver, 6mm) that attach the Video Harness Guide to the printer and remove the guide.



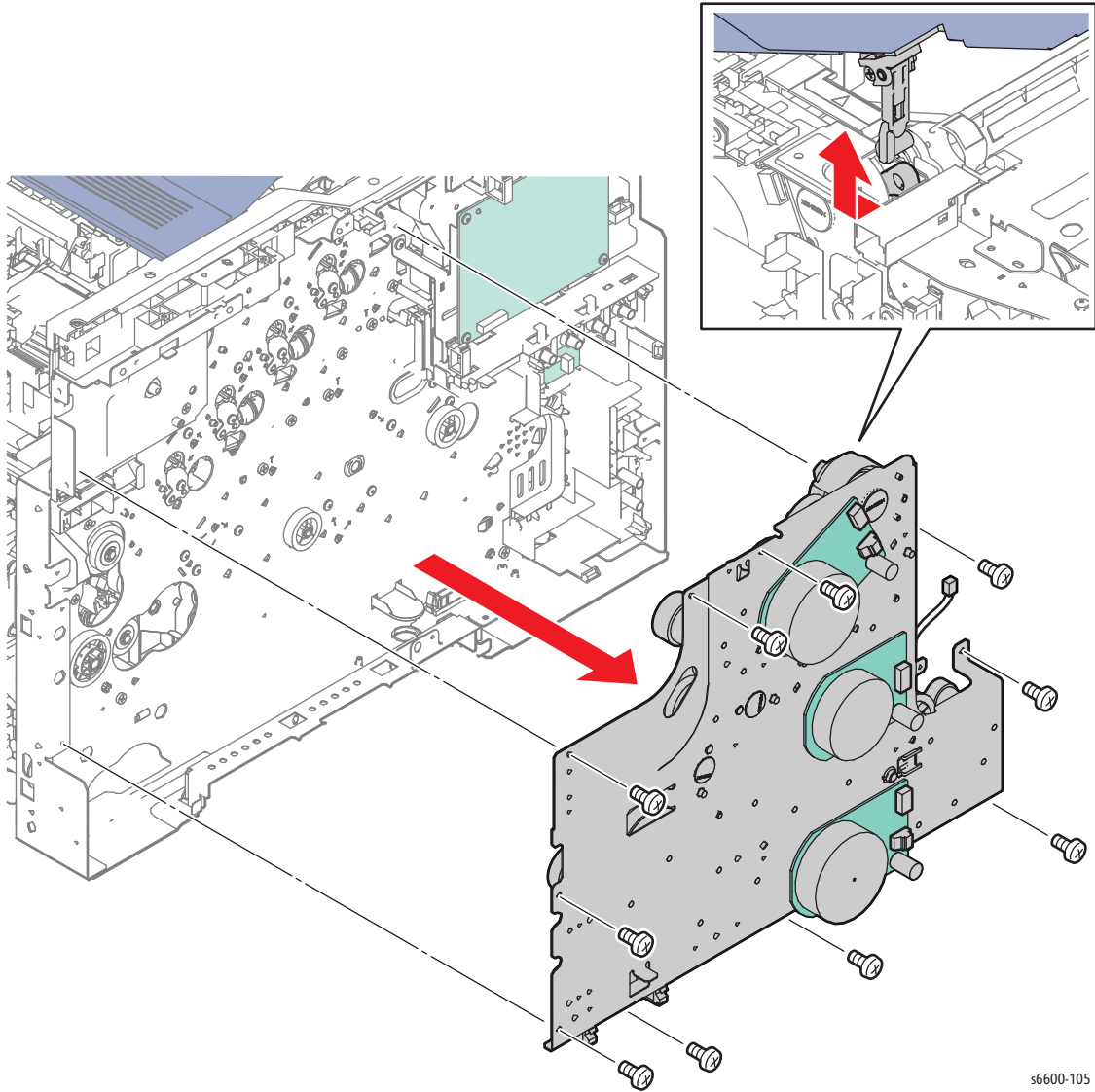
13. Remove the screw (silver, 6mm) that attaches the Left Sub-Top Cover (PL 19.1.10) and remove it.
14. Remove the Transfer 2 Link (PL19.1.4) from the Transfer Coupling Link.



**CAUTION:** When performing the following step to remove the Drive Assembly, use caution not to drop the gears.

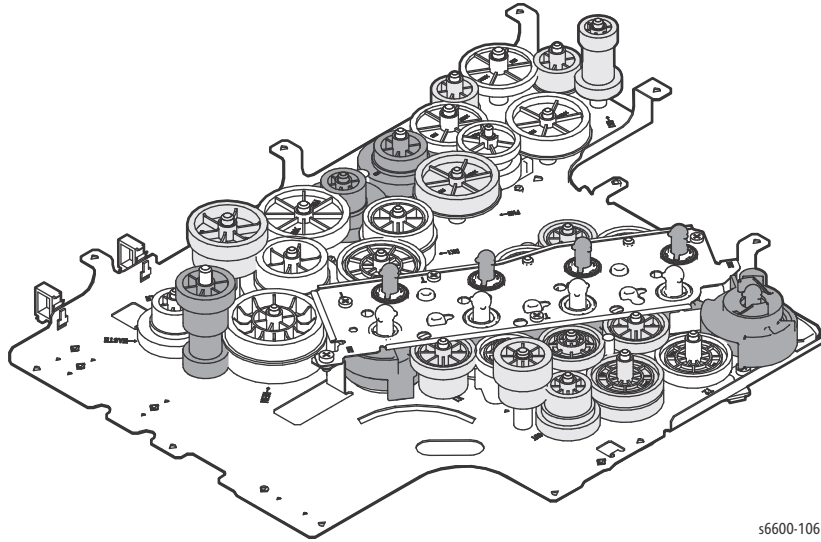
15. Remove the ten screws (silver, 6mm) that attach the Drive Assembly to the printer and remove the assembly.

**Note:** When placing the Drive Assembly on the workbench, face the gear side upward to prevent the gears from falling off.

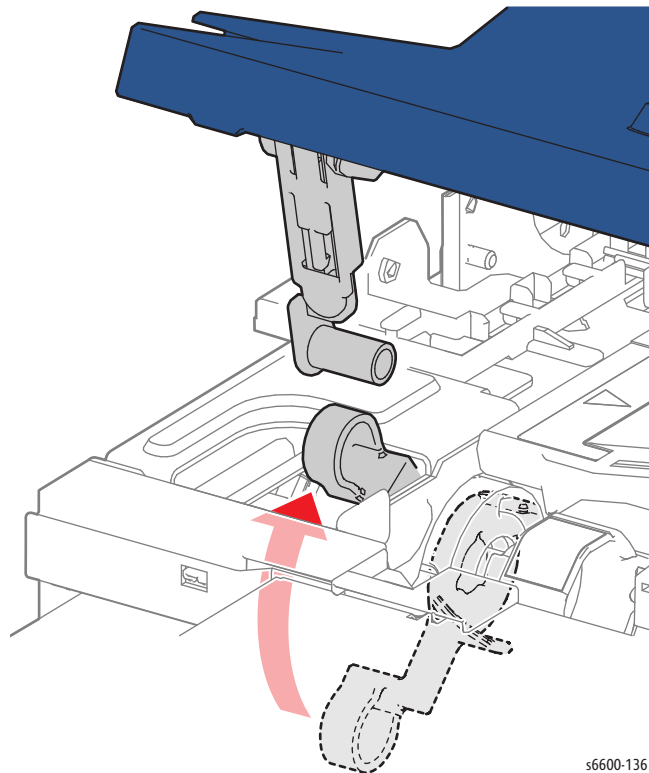


s6600-105

**Note:** The following figure shows how the gears are installed to the Drive Assembly.



**Replacement Note:** When the installation hole of the Transfer 2 Link for the Transfer Link Coupling is lowered, raise it by accessing the Transfer Link Coupling from inside the frame.

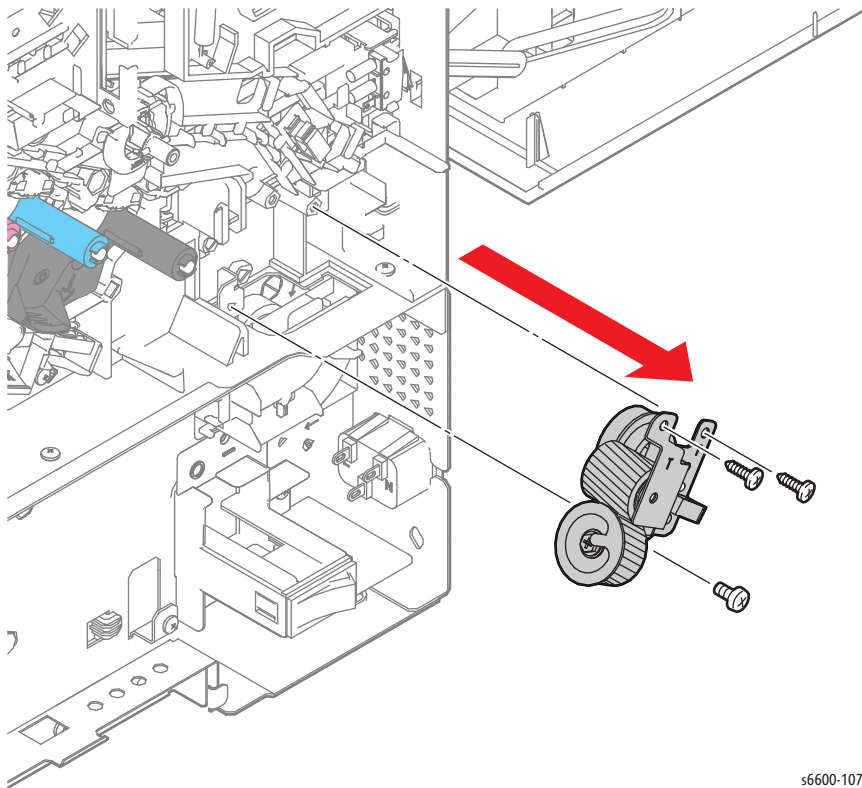


## Waste Drive Assembly

### PL3.1.2

**!** **WARNING:** The Fuser is very hot. Take added care when handling the fuser to avoid being burned.

1. Remove the Right Cover Assembly. (page 4-131)
2. Release the harness from the clamp installed on the Waste Drive Assembly.
3. Remove two screws (silver, tapping, 8mm) and one screw (silver, 6mm) that attaches the Waste Drive Assembly to the printer and remove the Waste Drive Assembly.



s6600-107

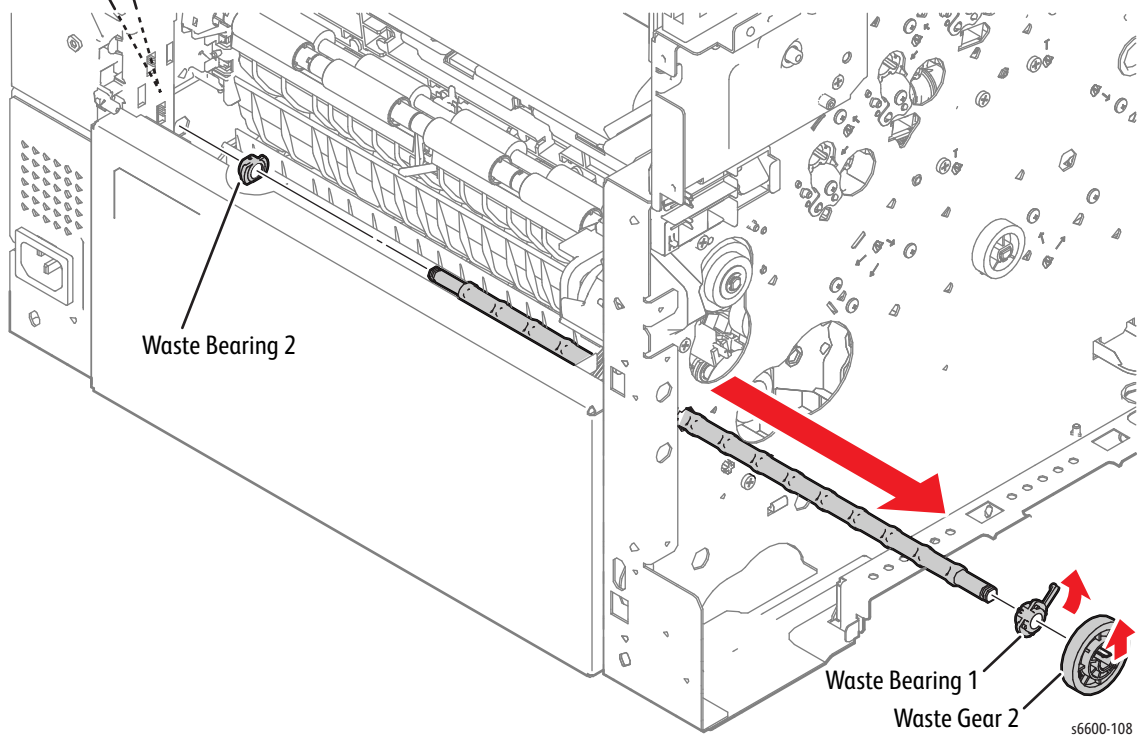
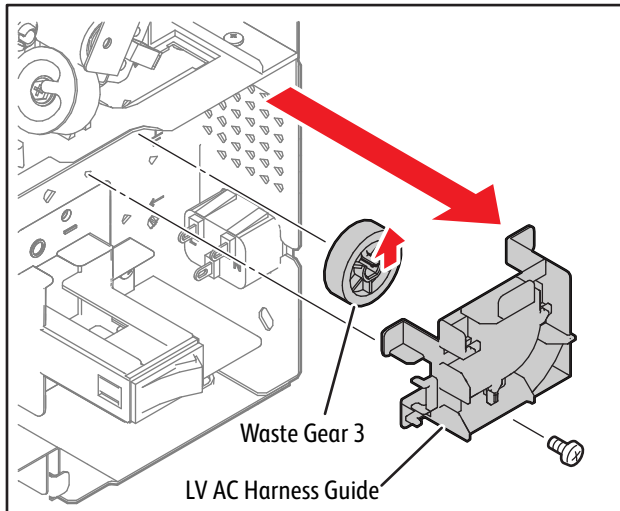
## Drive Shaft Assembly

### PL3.1.8

**!** **WARNING:** The Fuser is very hot. Take added care when handling the fuser to avoid being burned.

1. Remove the Drive Assembly. (SFP page 4-11; MFP page 4-16)
2. Remove the Duplex Chute Assembly Kit. (page 4-84)

3. Release the harness from the LV AC Harness Guide (PL18.1.32).
4. Remove the screw (silver, 6mm) that attaches the LV AC Harness Guide to the printer and remove the guide.
5. Release the hook of Waste Gear 3 (PL3.1.7) and remove the gear.
6. Release the hook of Waste Gear 2 (PL3.1.3) and remove the gear.
7. Unlock Waste Bearing 1 (PL3.1.4) and rotate the bearing to remove it.
8. Remove the Waste Idler Shaft (PL3.1.5) by pulling it out of the hole on the frame.
9. Remove Waste Bearing 2 (PL3.1.6).

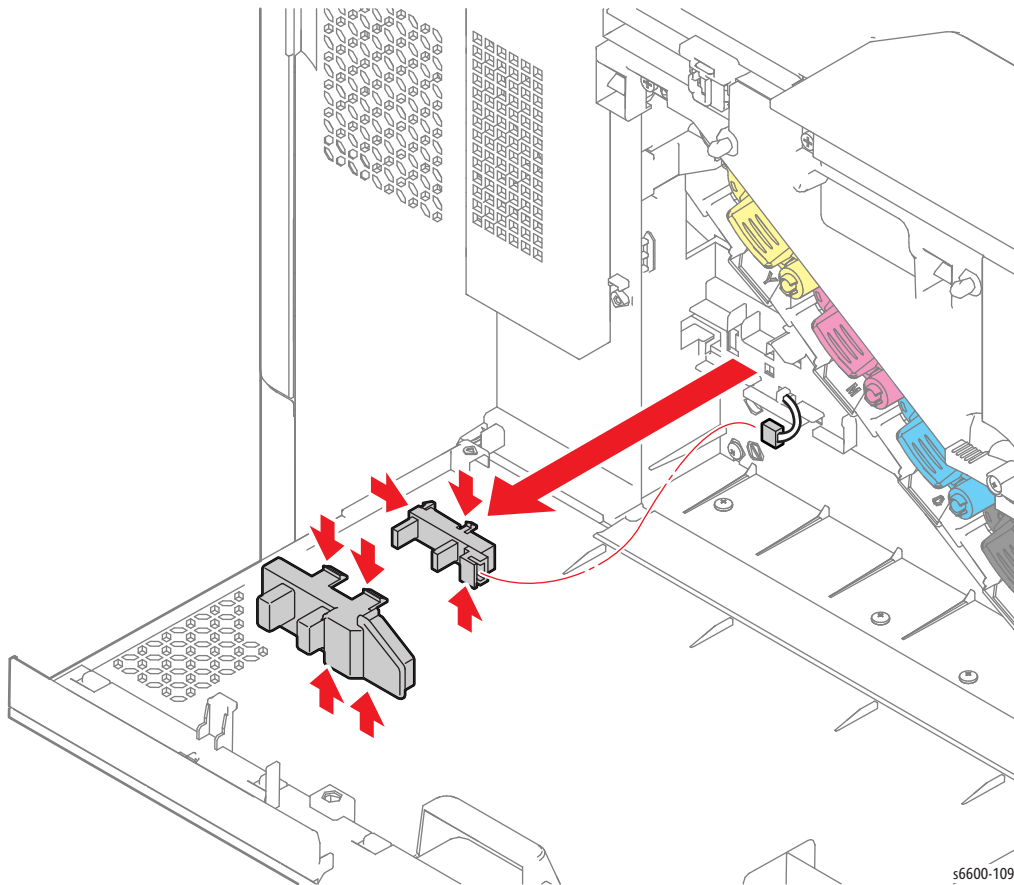


# NOHAD

## Toner Full Sensor

### PL4.1.17

1. Remove the Waste Cartridge. (page 4-50)
2. Release the four hooks holding the Waste Sensor Cover (PL4.1.11) and remove the cover.
3. Disengage connector P/J203 of the Toner Full Sensor (PL4.1.17).
4. Release the hook holding the Toner Full Sensor and remove the sensor.

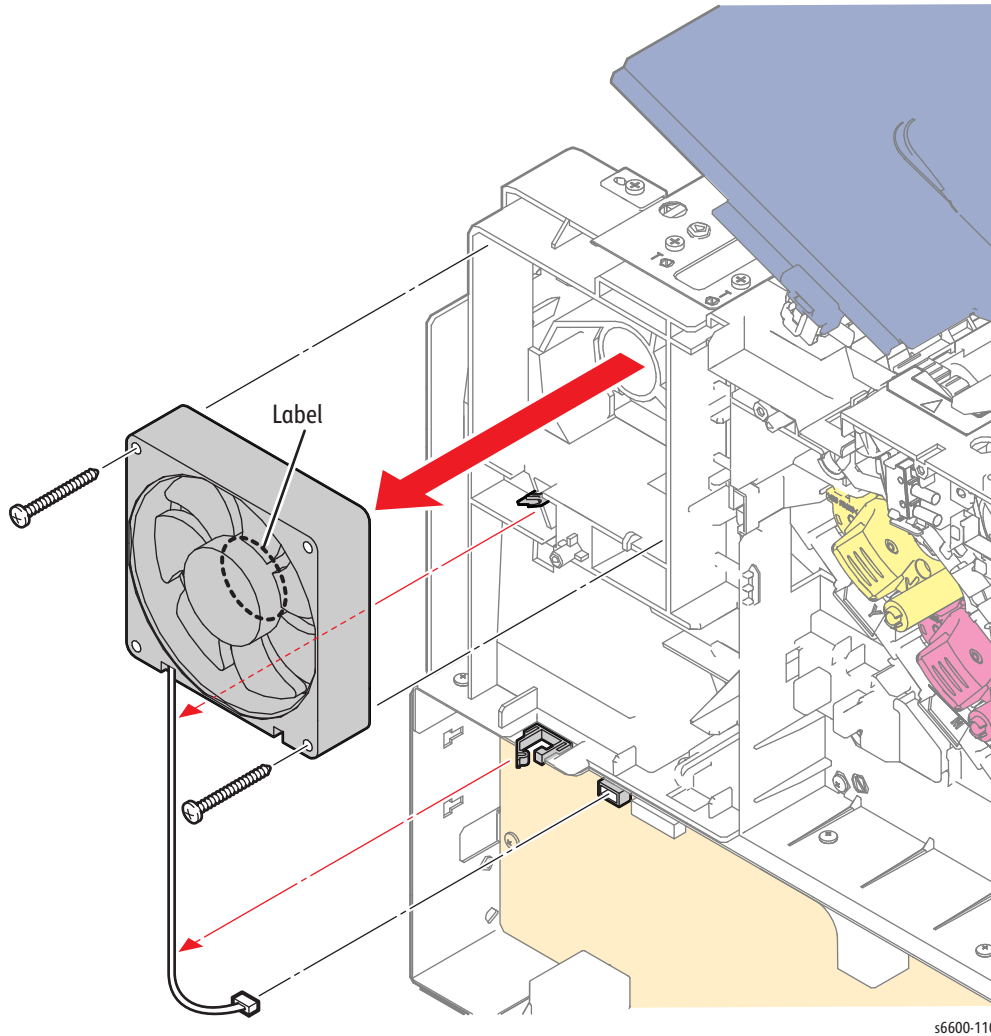


## Main Fan

PL4.1.13

**!** **WARNING:** The Fuser is very hot. Take added care when handling the fuser to avoid being burned.

1. Remove the Right Cover Assembly. (page 4-131)
2. Unplug connector P/J503 from the LVPS (PL18.1.34), and release the harness from the clamp.
3. Remove the two screws (silver, tapping, 30mm) that attach the Main Fan (PL4.1.13) to the printer and remove the fan.



**Replacement Note:** Orient the Main Fan during installation so that the label side faces inward.



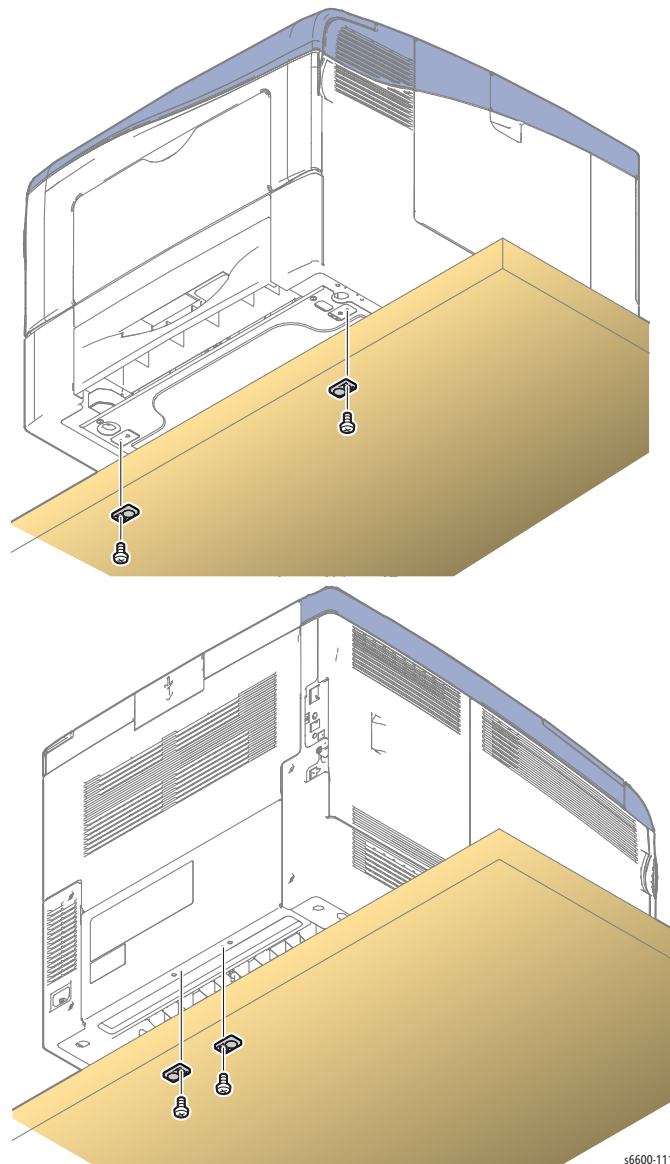
## Bottom Foot

### PL4.1.15

**!** **CAUTION:** When positioning the printer to overhang the edge of the workbench, make the overhang as small as possible to prevent the printer from falling off.

1. Position the front of the printer to overhang the edge of the workbench.
2. Remove the screws (silver, 6mm) that attach the Bottom Feet on the front, and replace the feet.
3. Reposition the printer so that the rear of the printer overhangs the edge of the workbench.
4. Remove the screws (silver, 6mm) that attach the Bottom Feet on the rear, and replace the feet.

**Note:** Although the illustration shows the SFP, the MFP Bottom Feet are in the same locations and removed in the same manner.



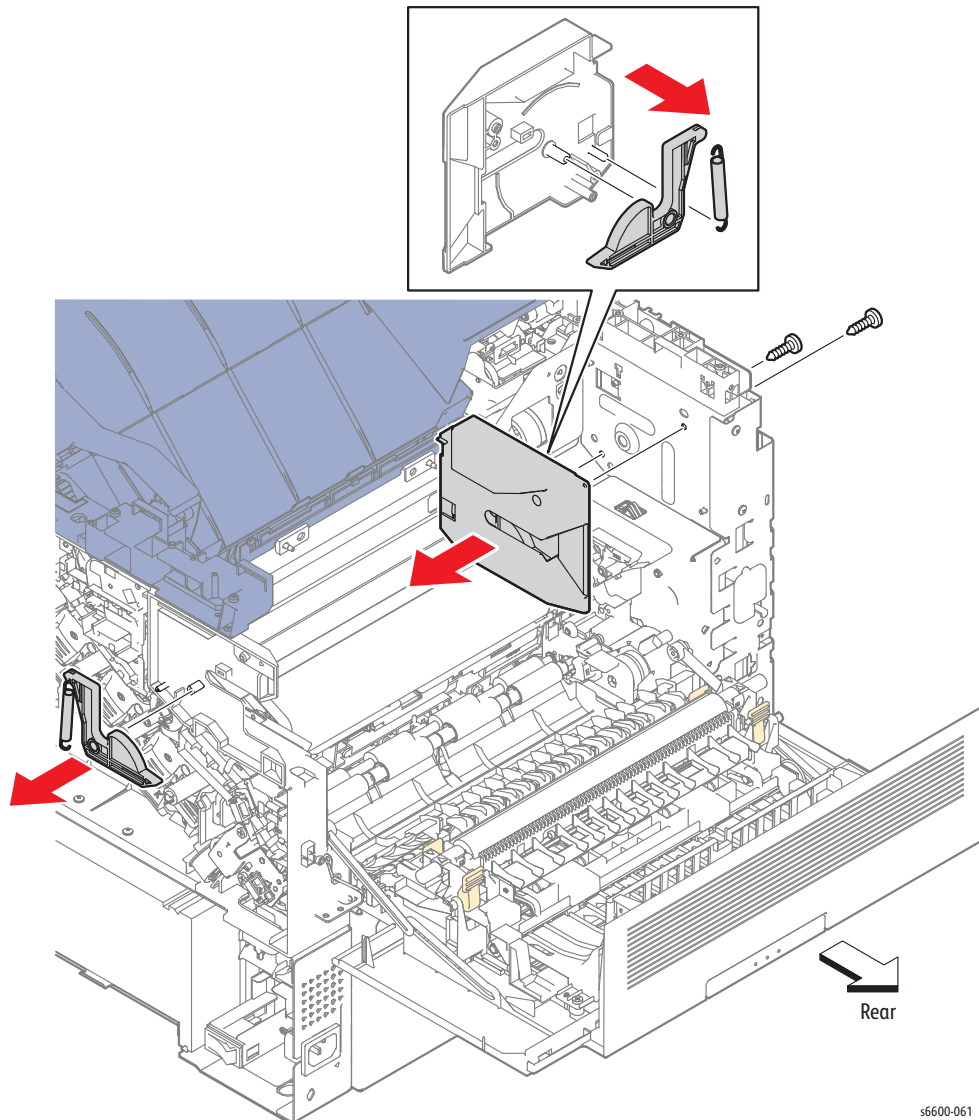
s6600-111

## Left Rear Latch / Right Rear Latch

### PL4.1.97 / PL4.1.99

**!** **WARNING:** The Fuser is very hot. Take added care when handling the fuser to avoid being burned.

1. Remove the Exit Assembly. (page 4-93)
2. Remove the IP Board. (SFP page 4-102; MFP page 4-104)
3. Remove the two screws (silver, tapping, 8mm) that attach the Left Latch Bracket (PL4.1.5) to the printer and remove the Left Latch Bracket.
4. Remove the Latch Spring (PL4.1.3) on the left side of the printer from the Left Latch Bracket and remove the Left Rear Latch (PL4.1.18).
5. Remove the Latch Spring (PL4.1.3) on the right side of the printer and remove the Right Rear Latch (PL4.1.4).



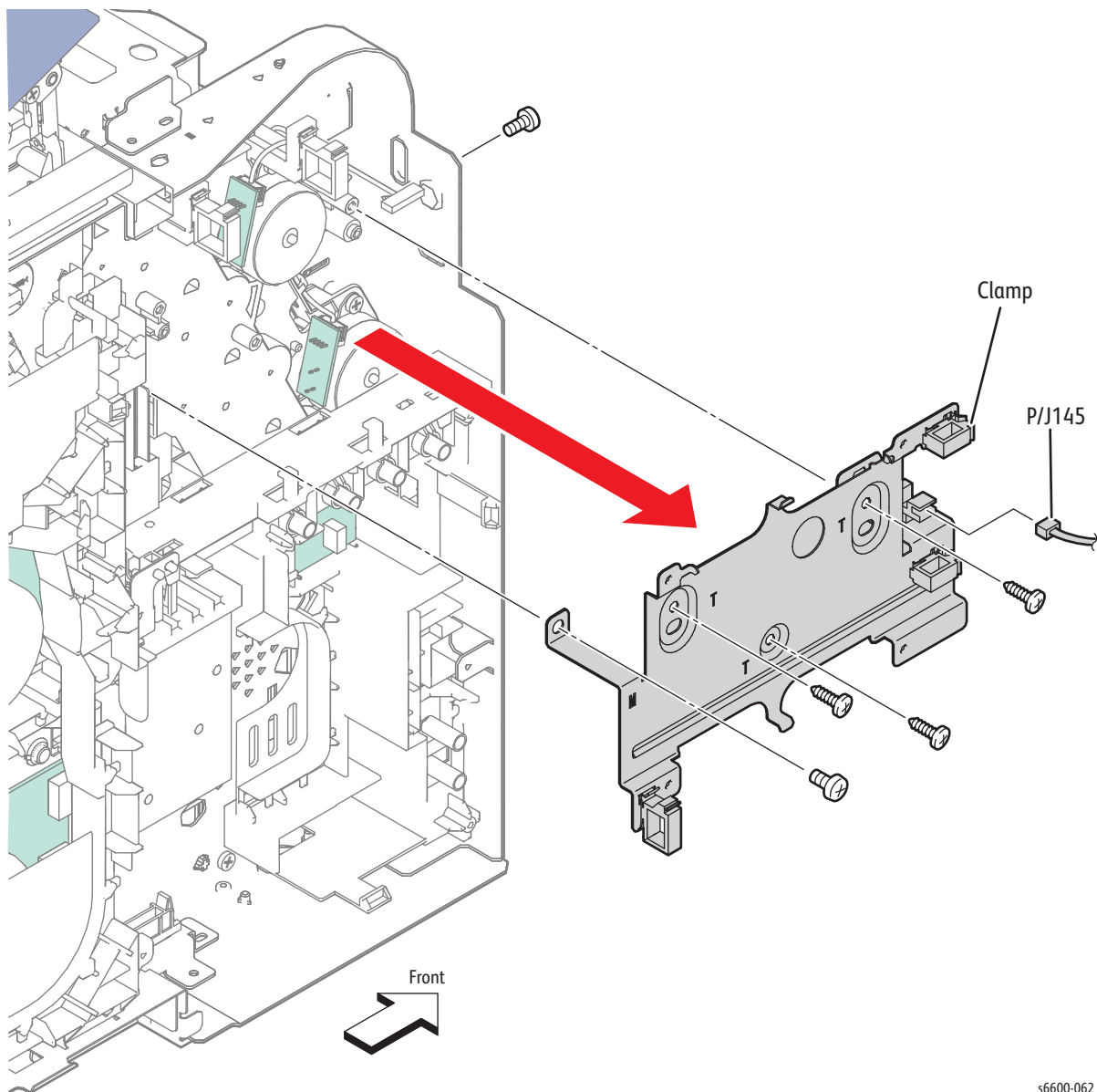
s6600-061

# Dispenser

## Upper Dispenser Motor Assembly

### PL5.1.1

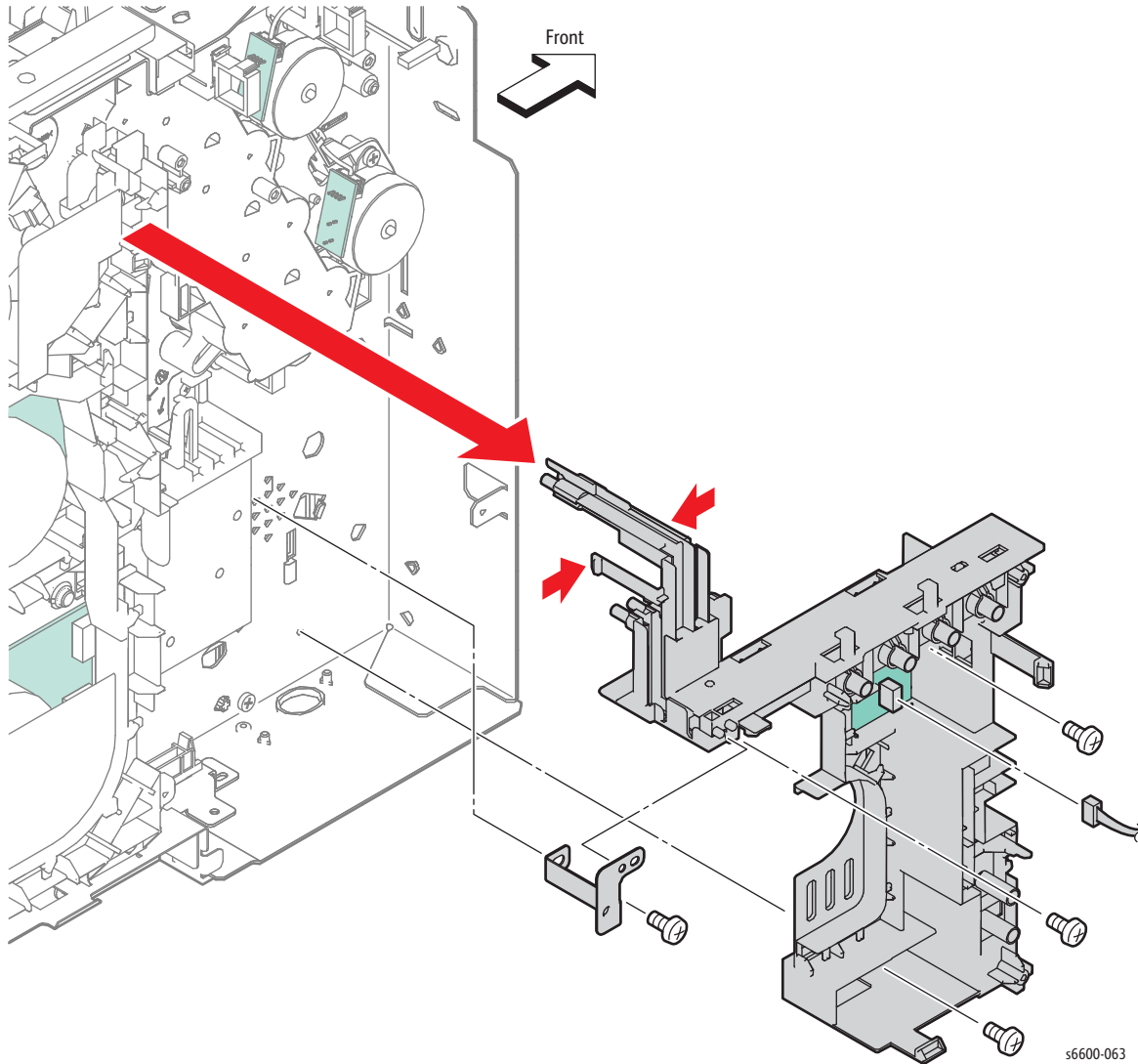
1. Remove the MCU Board. (page 4-98)
2. Remove the Development HVPS Board. (page 4-99)
3. Unplug connector P/J145 of the Front Door Open Sensor (Interlock Photo Sensor - PL18.1.45).
4. Release the harness from the clamp installed on the MCU Plate (PL18.1.12).
5. Remove three screws (silver, tapping, 8mm) and two screws (silver, 6mm) that attach the MCU Plate to the printer and remove the plate.



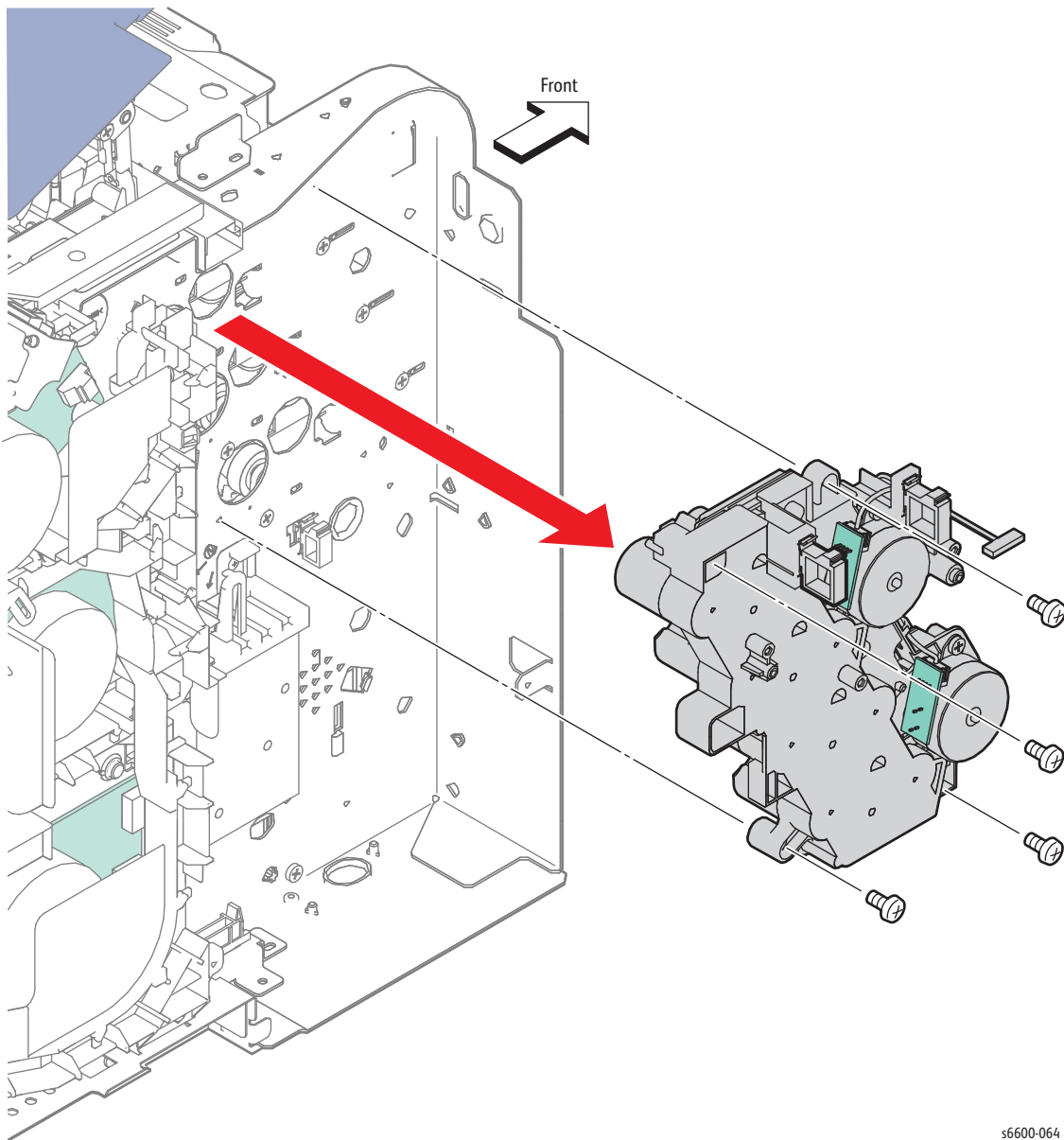
s6600-062

6. Unplug connector P/J251 from the EEPROM Board (PL18.1.43).
7. Remove the screw (silver, 6mm) that attaches the HV Ground Plate (PL18.1.15) to the printer and remove the plate.
8. Release the harness from the harness guide of the Outer Developer Charge Housing Assembly (PL18.1.9).
9. Remove the three screws (silver, 6mm) that attach the Outer Developer Charge Housing Assembly and remove it.

**Note:** Do NOT remove the tapping screw that holds together the two pieces of the Outer Developer Charge Housing Assembly.

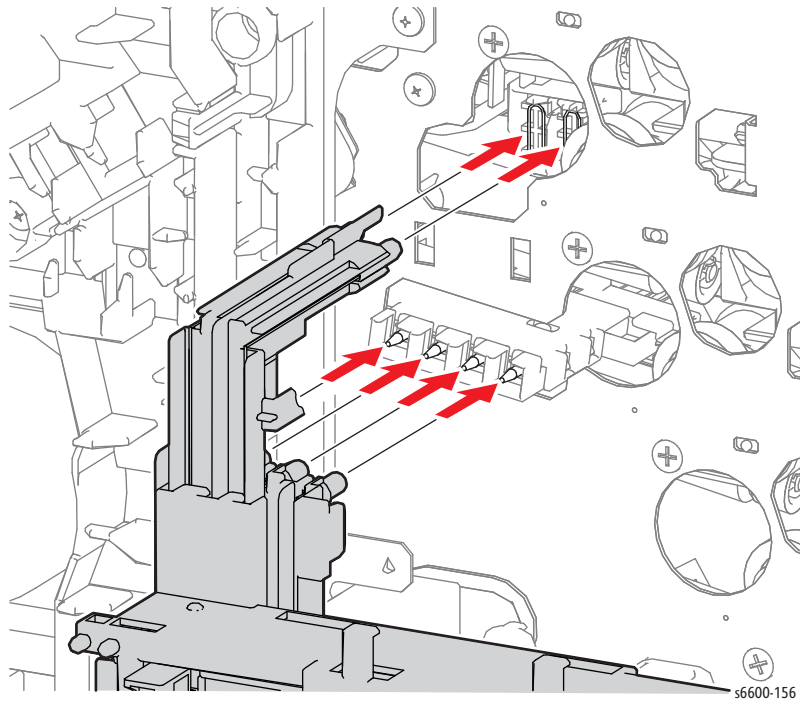


10. Release the clamp of the Upper Dispenser Motor Assembly (PL5.1.1), and release the harness.
11. Remove the four screws (silver, 6mm) that attach the Upper Dispenser Motor Assembly to the printer and remove the assembly.



s6600-064

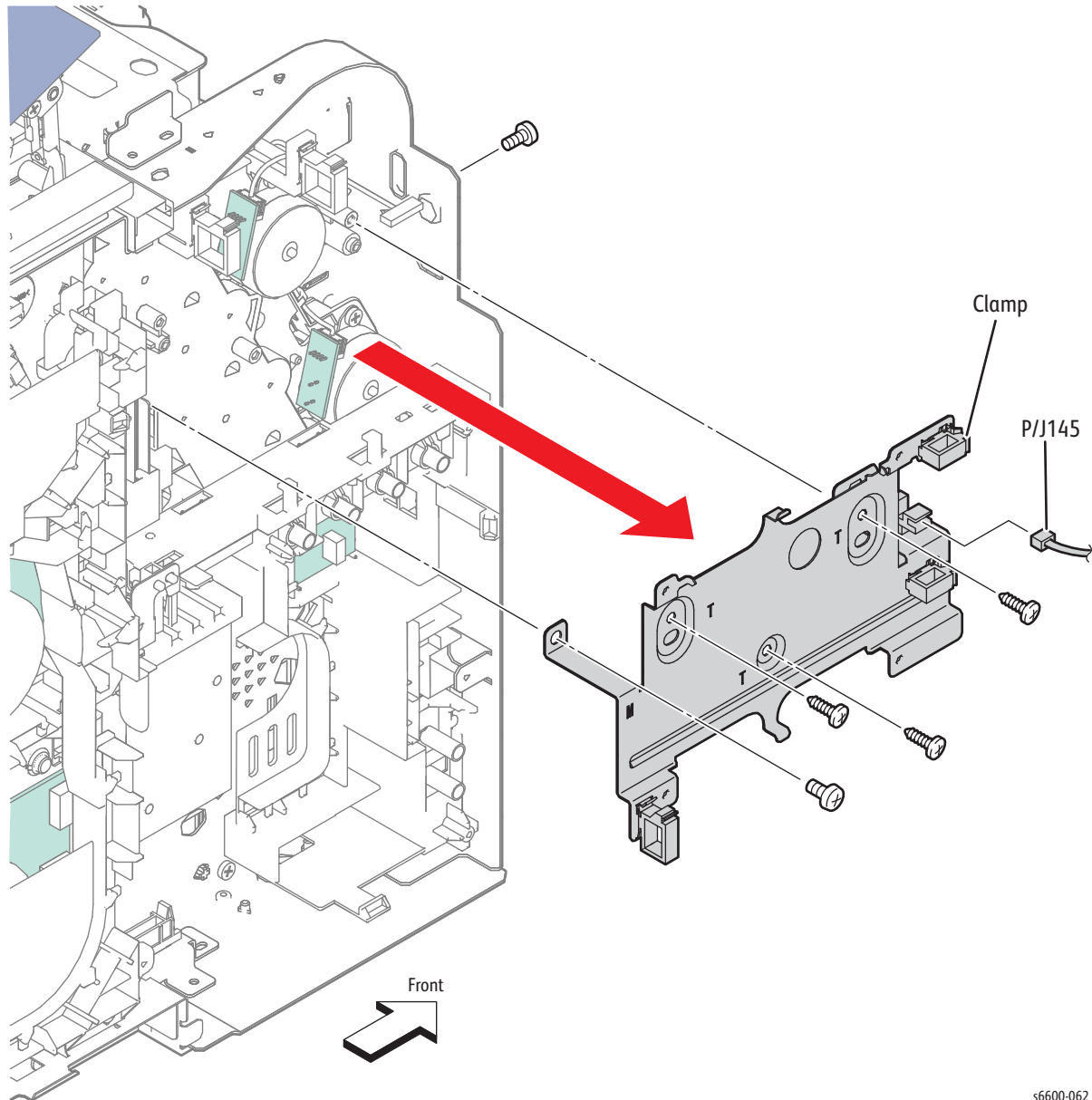
**Replacement Note:** When installing the Outer Developer Charge Housing Assembly, make sure that the tips of the six springs are correctly in place. (The Upper Dispenser Motor Assembly is not shown in the following figure for the sake of clarity.)



## Dispenser Motor

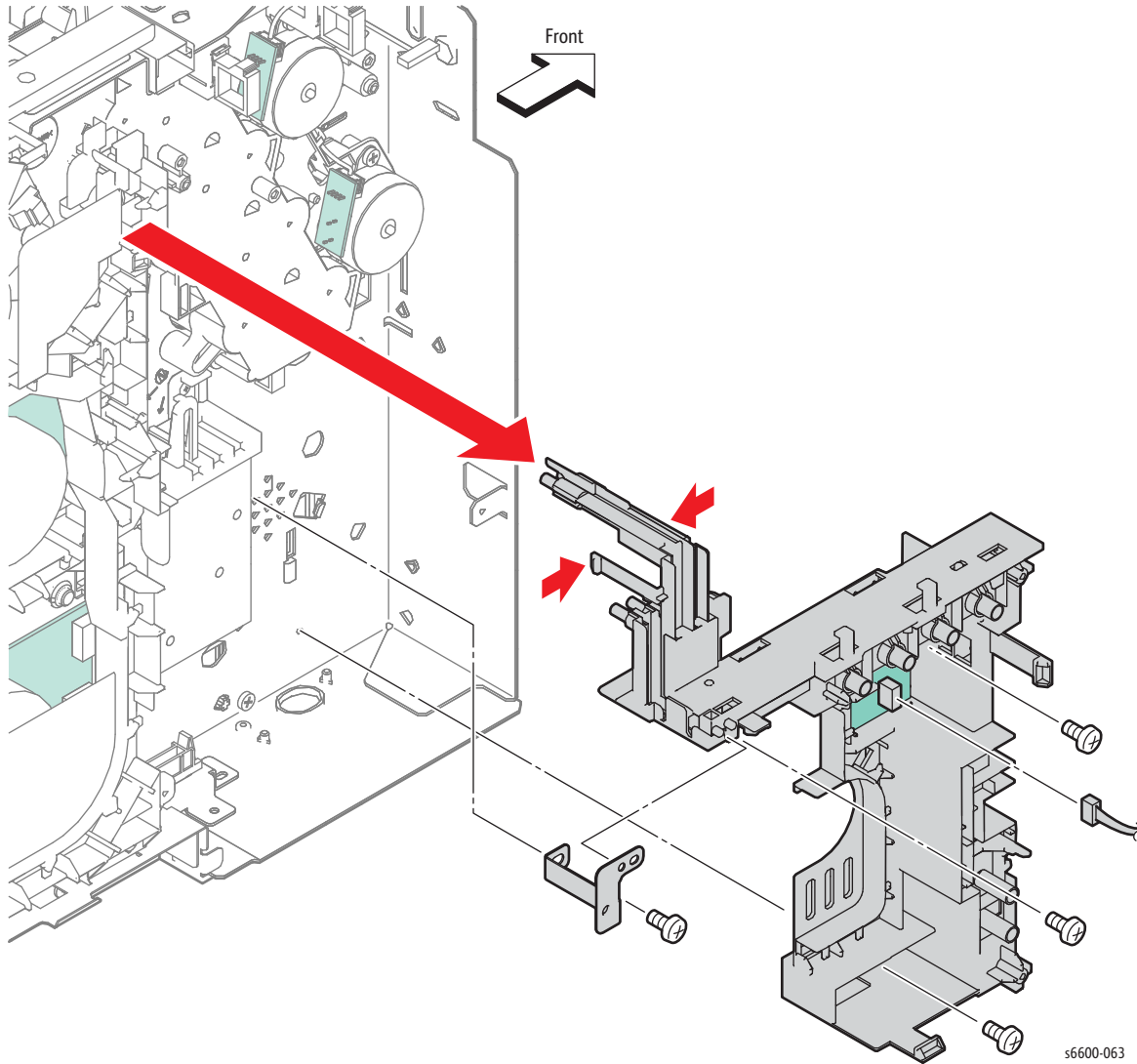
### PL5.1.2

1. Remove the MCU Board. (page 4-98)
2. Remove the Development HVPS Board. (page 4-99)
3. Unplug connector P/J145 of the Front Door Open Sensor (Interlock Photo Sensor - PL18.1.45).
4. Release the harness from the clamp installed on the MCU Plate (PL18.1.12).
5. Remove the three screws (silver, tapping, 8mm) and the two screws (silver, 6mm) that attach the MCU Plate to the printer and remove the plate.



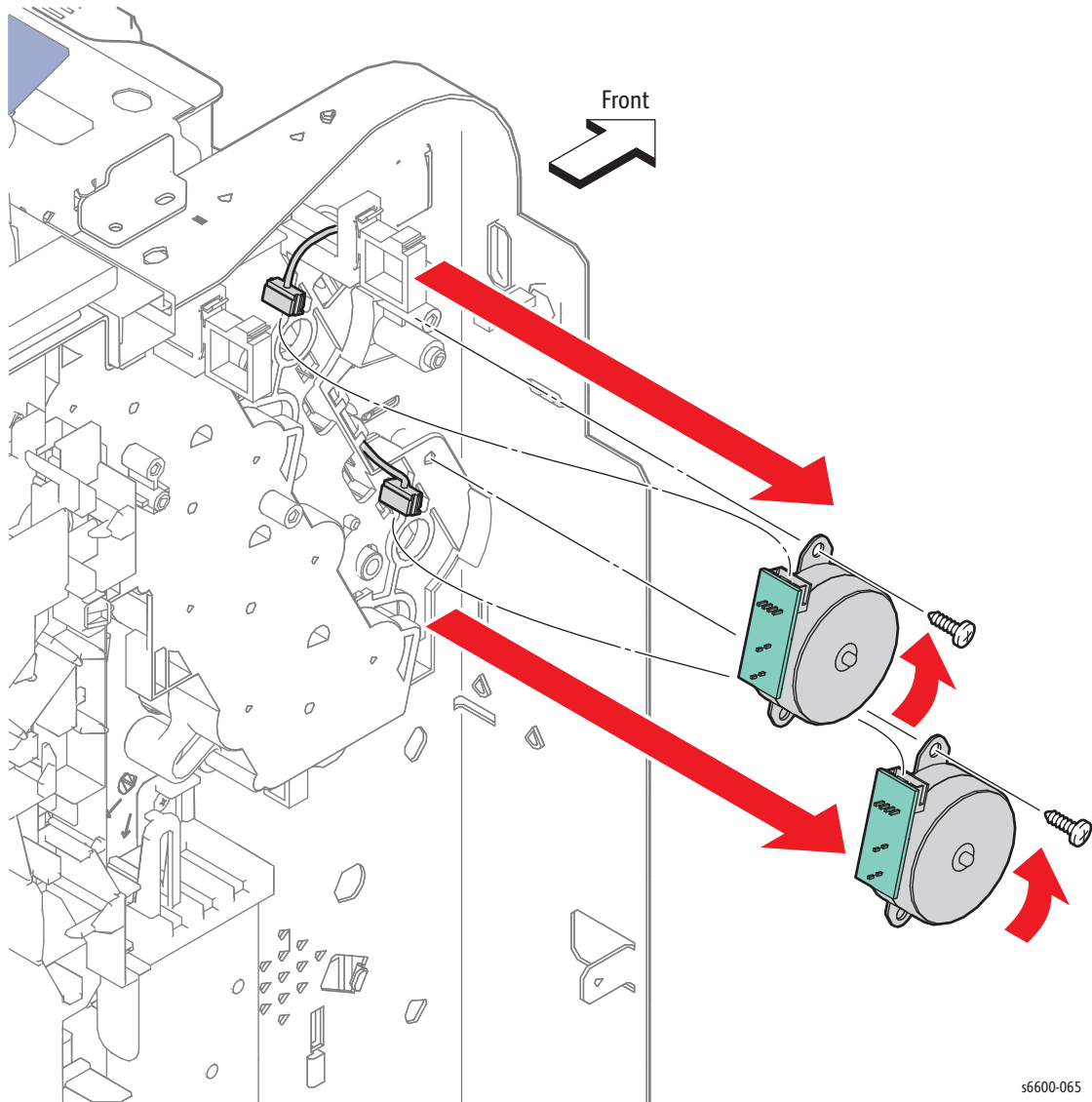
s6600-062

6. Unplug connector P/J251 from the EEPROM Board (PL18.1.43).
7. Remove the screw (silver, 6mm) that attaches the HV Ground Plate (PL18.1.15) to the printer and remove the plate.
8. Release the harness from the harness guide of the Outer Developer Charge Housing Assembly (PL18.1.9).
9. Remove the three screws (silver, 6mm) that attach the Outer Developer Charge Housing Assembly and remove it.





10. Unplug connectors P/J141 and P/J144 connected to the two Dispenser Motors (PL5.1.2).
11. Remove the screw that attaches the Dispenser Motor (silver, tapping, 8mm) and remove the Dispenser Motor by rotating it counterclockwise.

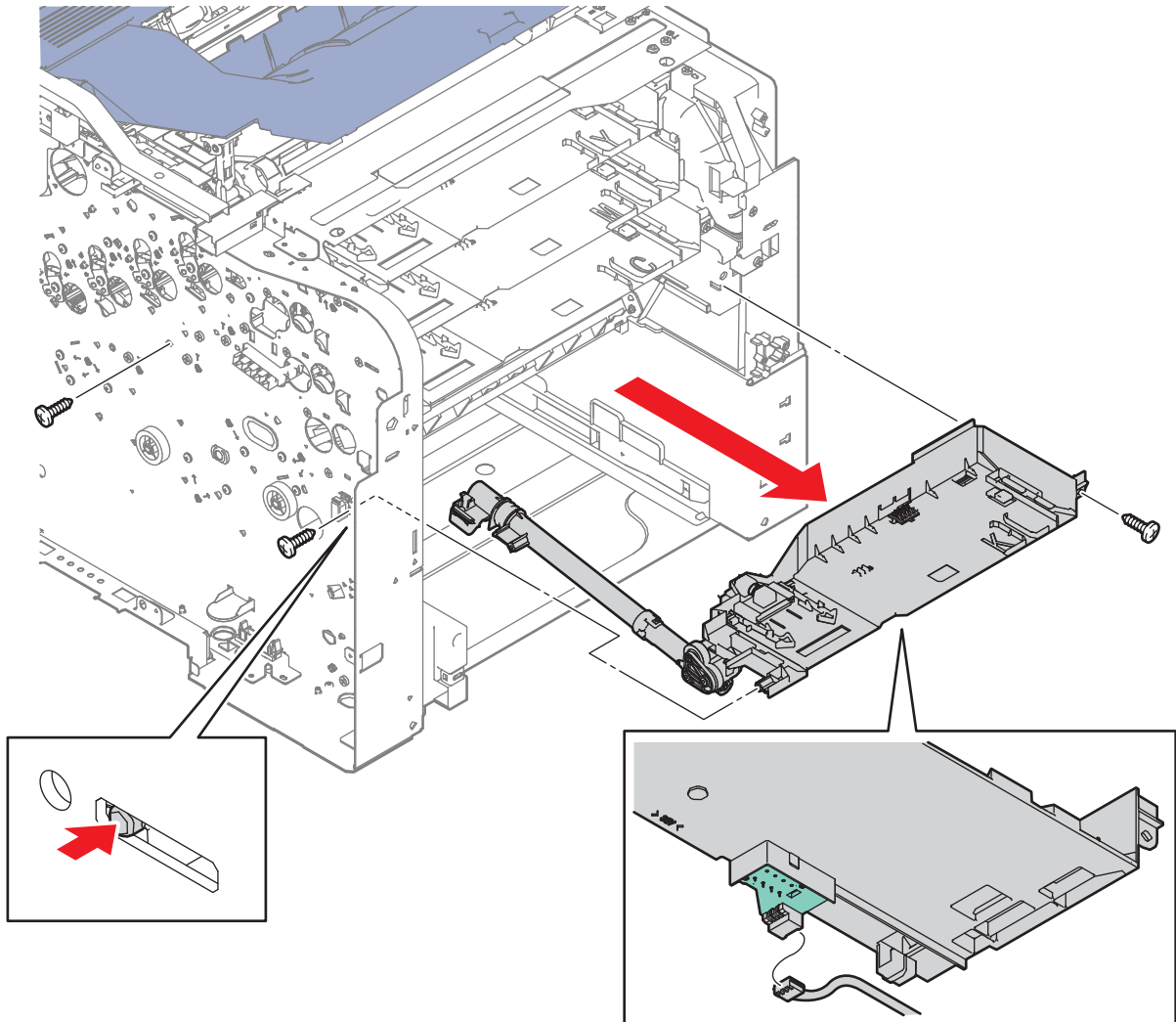


## Dispenser Assemblies Y, M, C, K

### PL5.1.4-7

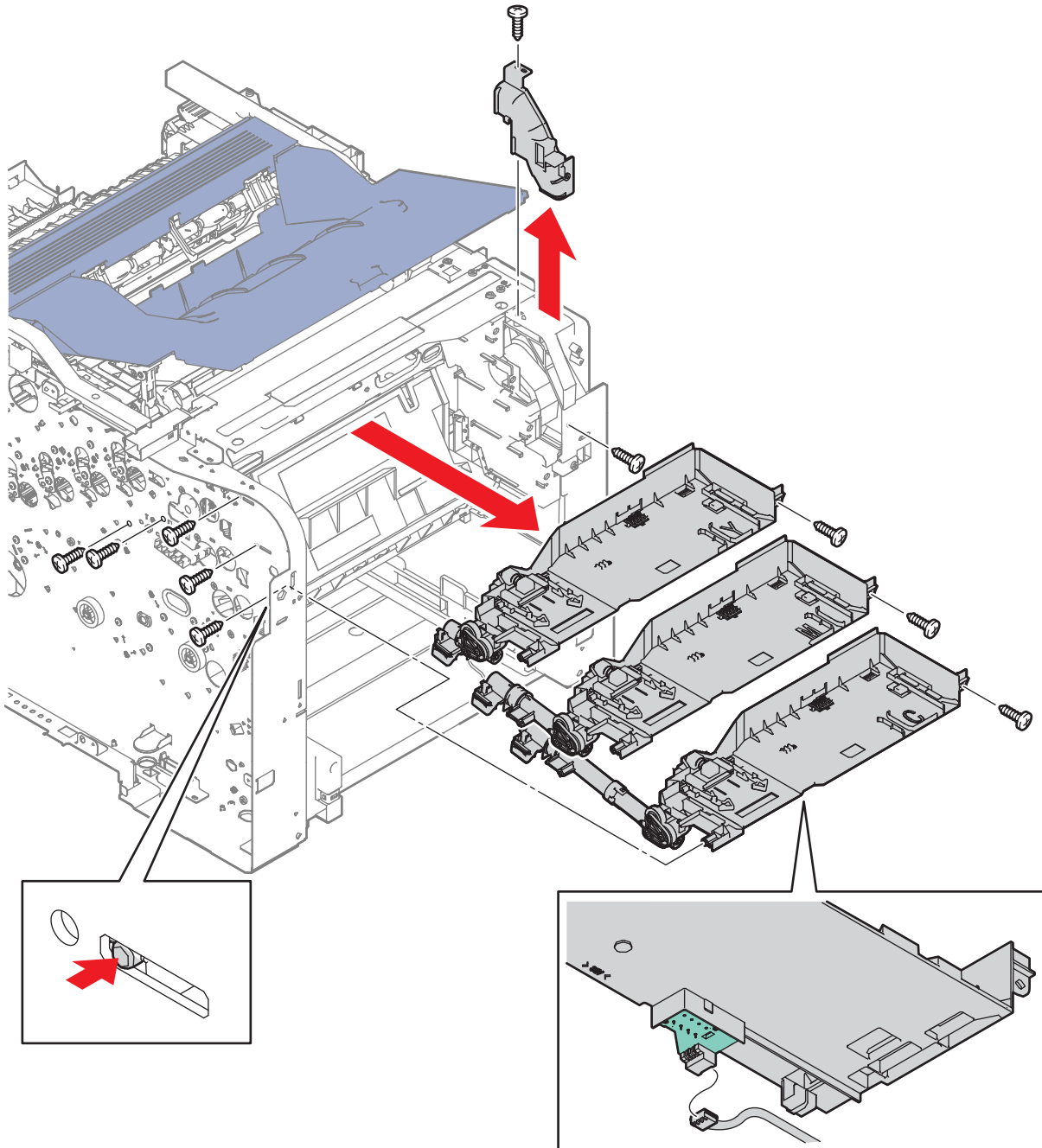
**Note:** The Dispenser Assemblies must be removed in order from the bottom, K, C, M, Y.

1. Remove the Toner Cartridges Y, M, C, K. (page 4-37)
2. Remove the Transfer Belt Assembly. (page 4-38)
3. Remove the Imaging Units Y, M, C, K. (page 4-48)
4. Remove the Upper Dispenser Motor Assembly. (page 4-27)
5. Remove the Bypass Tray Frame Assembly. (page 4-65)
6. Disengage the connector of the Dispenser Assembly K.
7. Remove the three screws (silver, tapping, 8mm) that attach the Dispenser Assembly K and pull the Dispenser Assembly K to the front while pressing the lug on the left side inward with a screwdriver.



56600-066

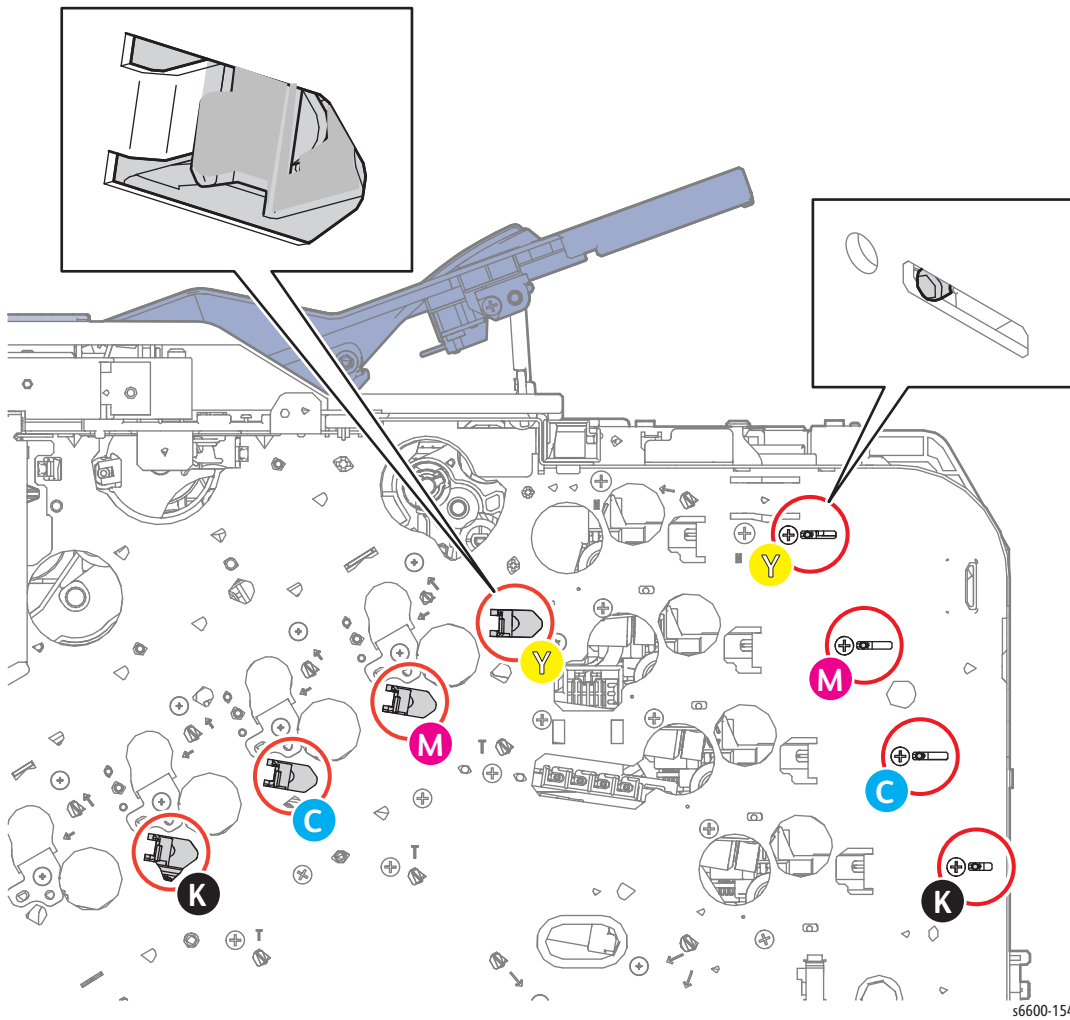
8. Remove the two screws (silver, tapping, 8mm) that attach the Frame Duct (PL4.1.1) to the printer and remove the duct.
9. Disengage the connectors connected to the Dispenser Assemblies in the order of C, M, and Y. Remove the three screws (silver, tapping, 8mm) that attach each Dispenser Assembly, and pull the Dispenser Assemblies to the front in the order of C, M, and Y while pressing the lug on the left side inward with a screwdriver.



s6600-067

Replacement Notes:

- The Dispenser Assemblies must be installed in Y, M, C, K order from top to bottom.
- When installing the Dispenser Assemblies, make sure that the lug on the front and the hook on the rear are correctly in place as shown in the drawing.
- Reconnect the harness for each dispenser before fully seating the dispenser in the frame.

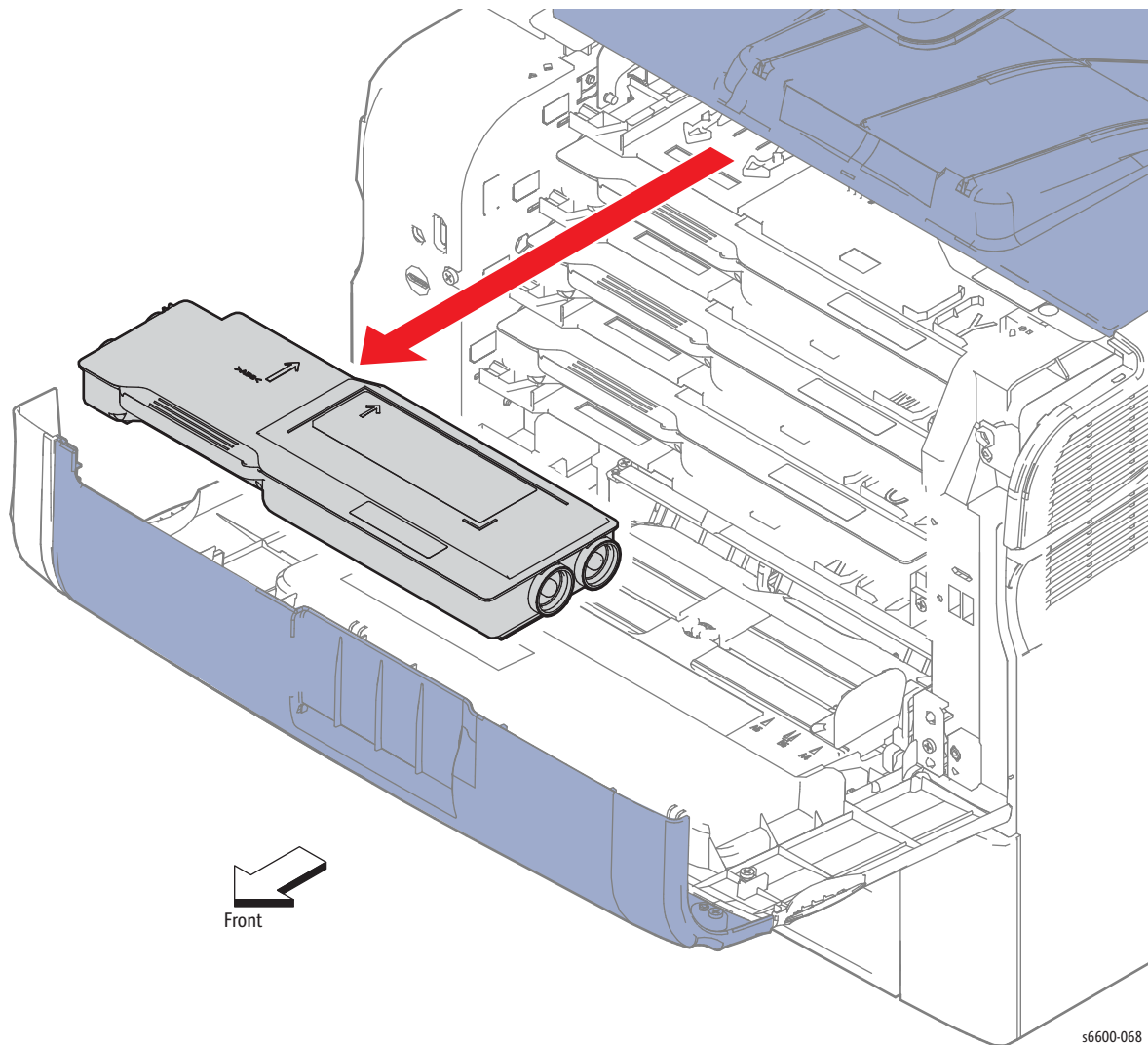


## Toner Cartridges Y, M, C, K

### PL5.1.8-11

#### Notes:

- The illustration shows the SFP, but the procedure is the same for the MFP.
  - Since the removal procedure is the same for all the toner cartridges, this procedure describes removal of Toner Cartridge Y only.
  - When removing a Toner Cartridge, be careful not to spill toner.
1. Open the Front Door Assembly (PL19.1.34).
  2. Pull out the Toner Cartridge Y to the front by the handle.



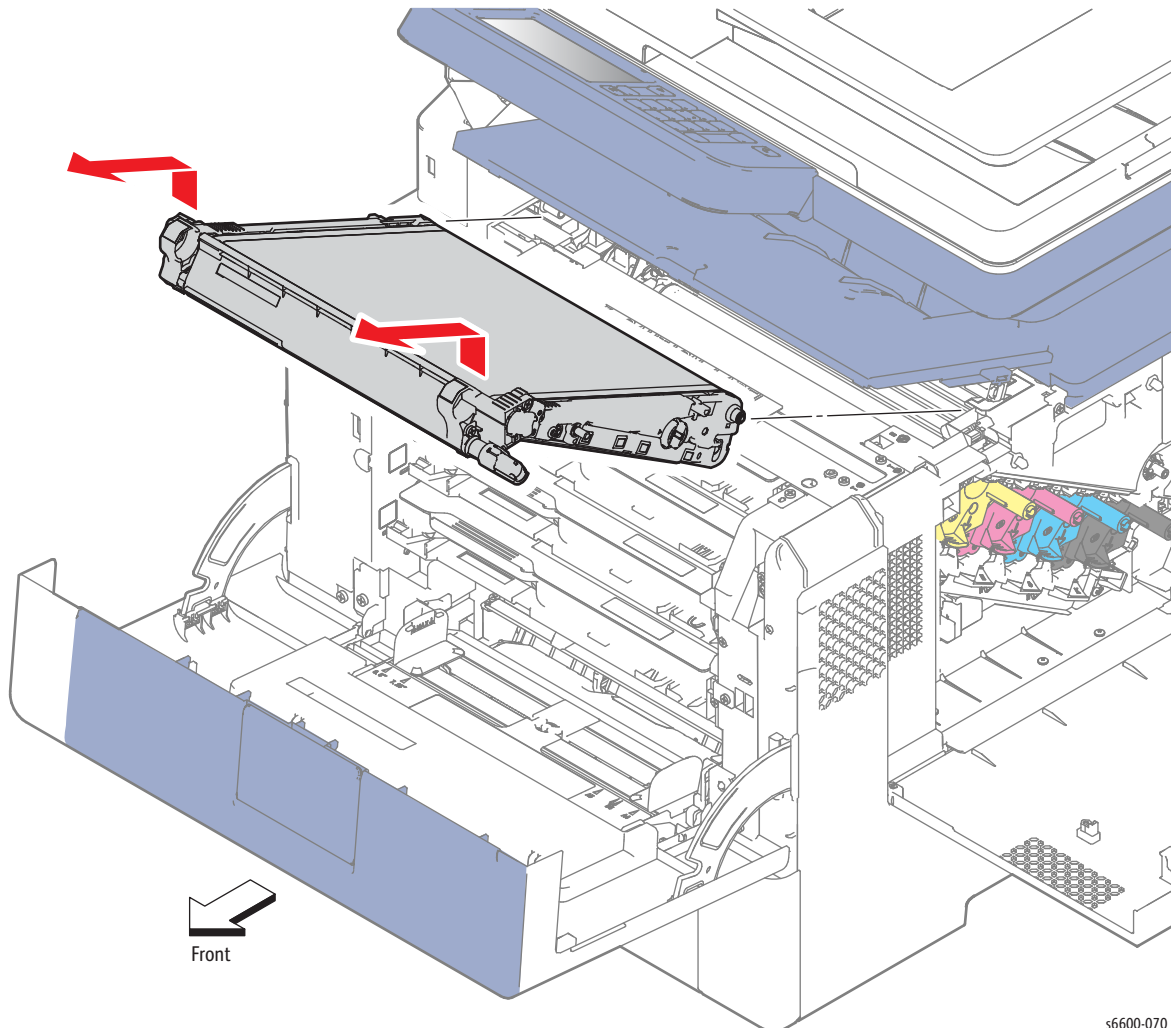
# Transfer

## Transfer Belt Assembly

### PL6.1.1

**Note:** Make sure that the belt surface of the Transfer Belt Assembly is never touched.

1. Open the Front Door Assembly (PL19.1.34).
2. Open the Right Side Door (PL19.1.96).
3. Open the Rear Door Assembly (PL19.1.95).
4. Open the Top Cover Assembly (PL19.1.1).
5. Remove the Waste Cartridge. (page 4-50)
6. Lift the Transfer Belt Assembly (PL6.1.1) by the handles on the left and right sides, and then pull it out to the front.



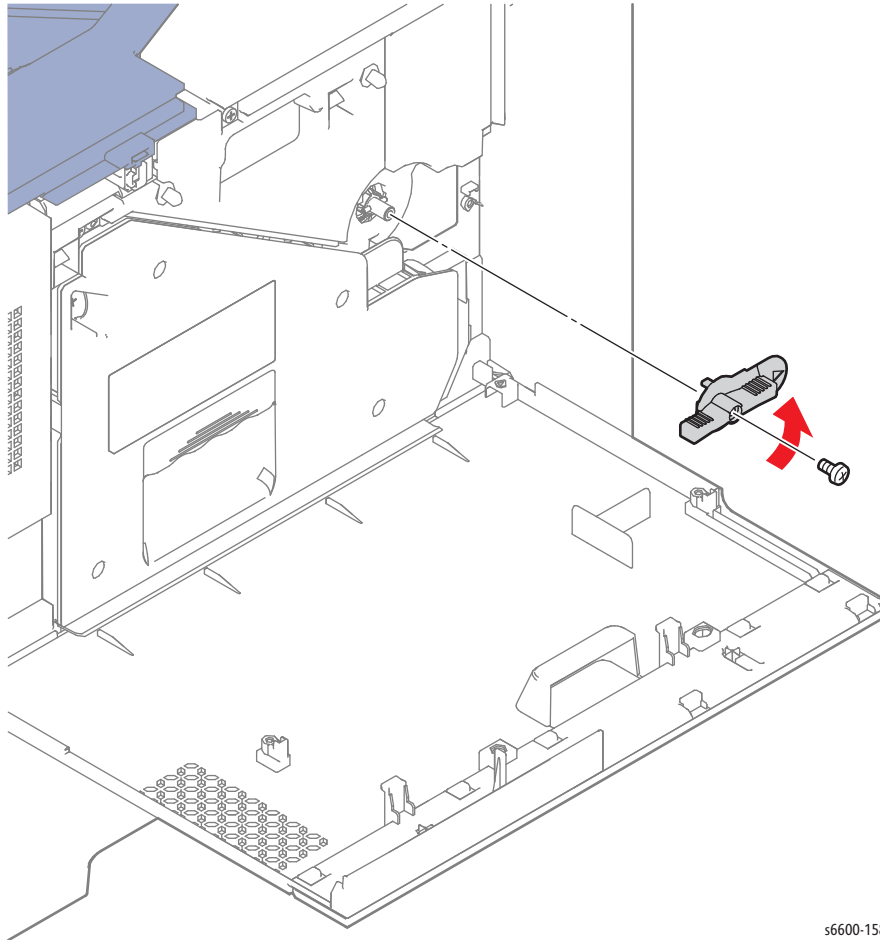
s6600-070

**Note:** Keep the Transfer Belt Assembly on a flat workbench free of foreign substances.

## Waste Cartridge Lock

### PL6.1.5


1. Open the Right Side Door (PL19.1.96).
2. Rotate the Waste Cartridge Lock (PL6.1.5) counterclockwise.
3. Remove the screw (silver, 6mm) that holds the Waste Cartridge Lock on the shaft and remove the handle.



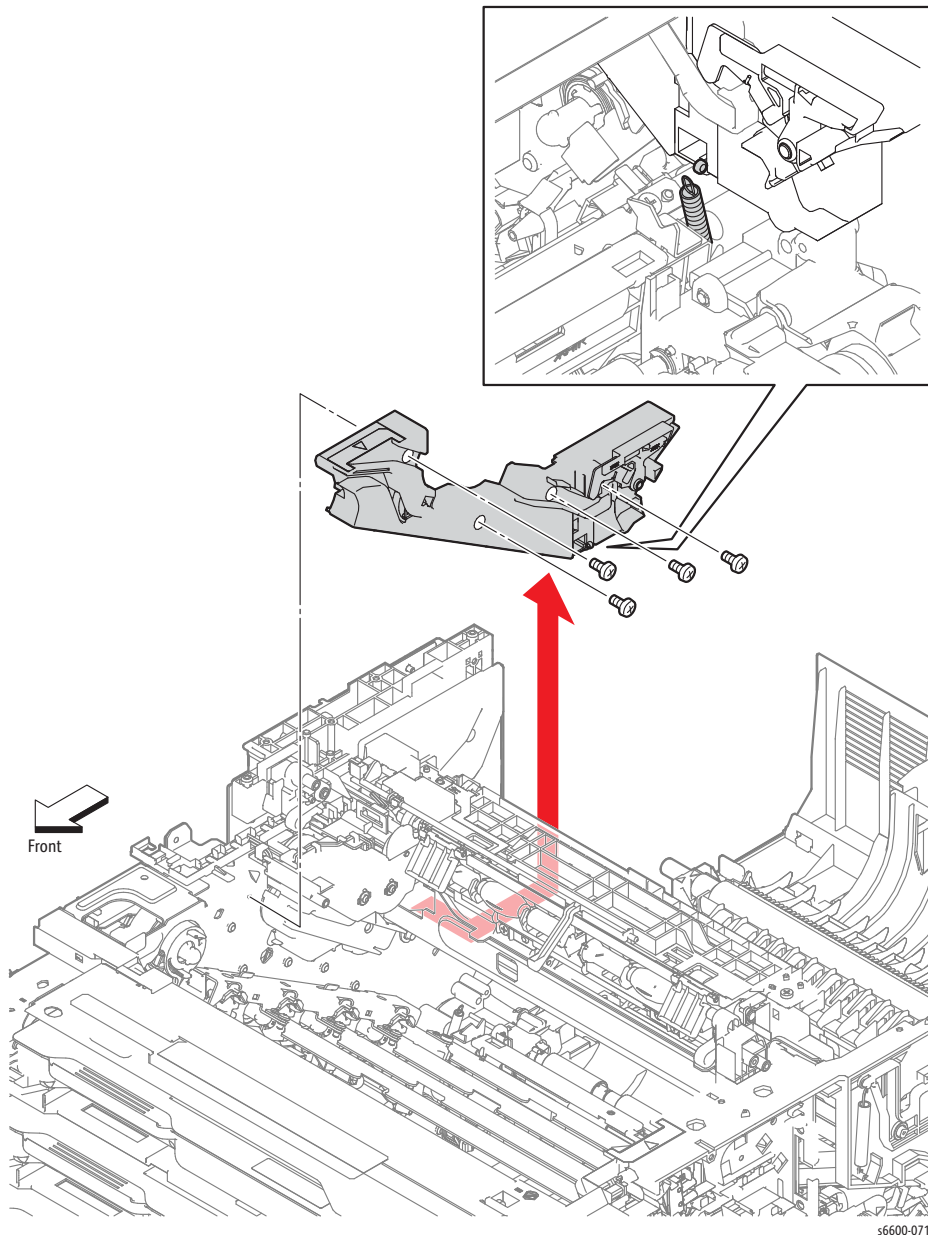
s6600-158

## Left Transfer Belt Guide Assembly

PL6.1.6

 **WARNING:** The Fuser is very hot. Take added care when handling the fuser to avoid being burned.

1. Remove the Transfer Belt Assembly. (page 4-38)
2. Remove the Imaging Units Y, M, C, K. (page 4-48)
3. Remove the Top Cover Assembly. (SFP page 4-115; MFP page 4-118)
4. Release the CTD Spring (PL6.1.13) from the Left Transfer Belt Guide Assembly (PL6.1.6).
5. Remove the four screws (silver, 6mm) that attach the Left Transfer Belt Guide Assembly to the printer and remove the guide Assembly.





## CTD Spring / CTD Sensor Assembly

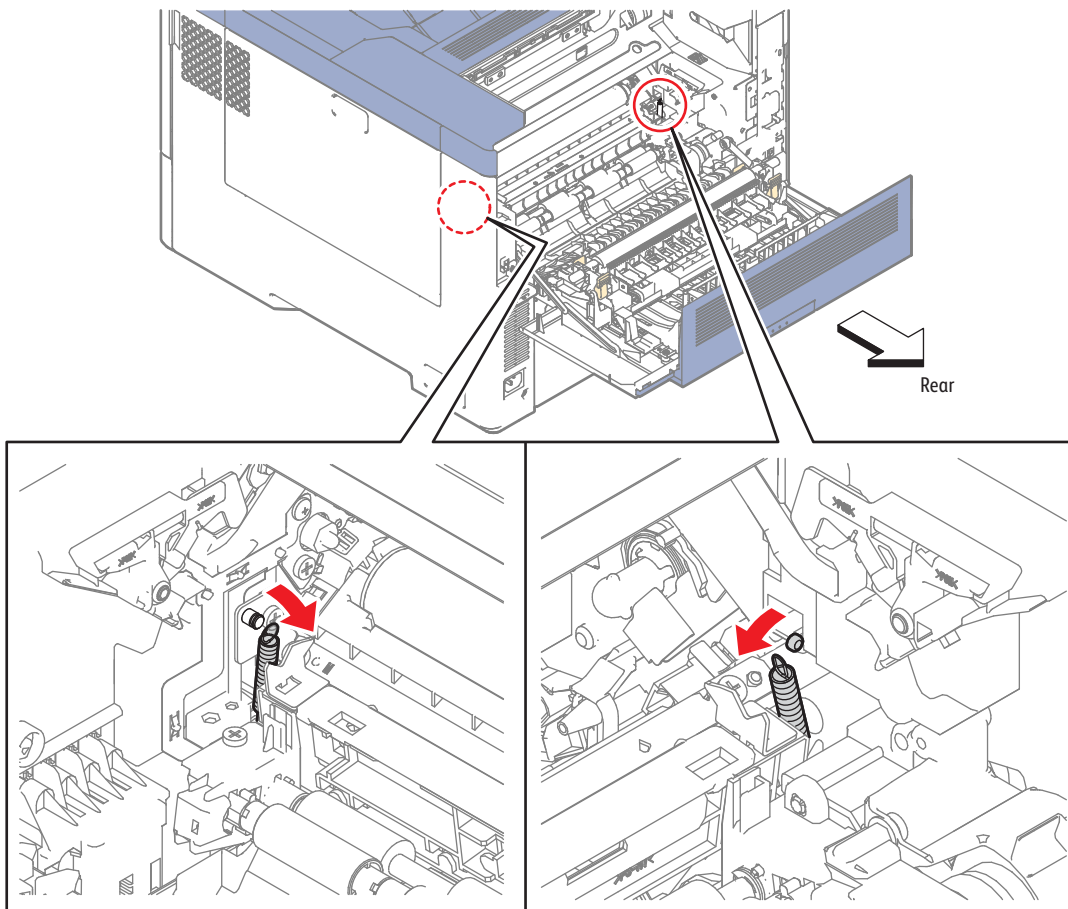
### PL6.1.13/PL6.1.14

**!** **WARNING:** The Fuser is very hot. Take added care when handling the fuser to avoid being burned.

1. Remove the Upper Transfer Belt Chute Assembly. (page 4-80)

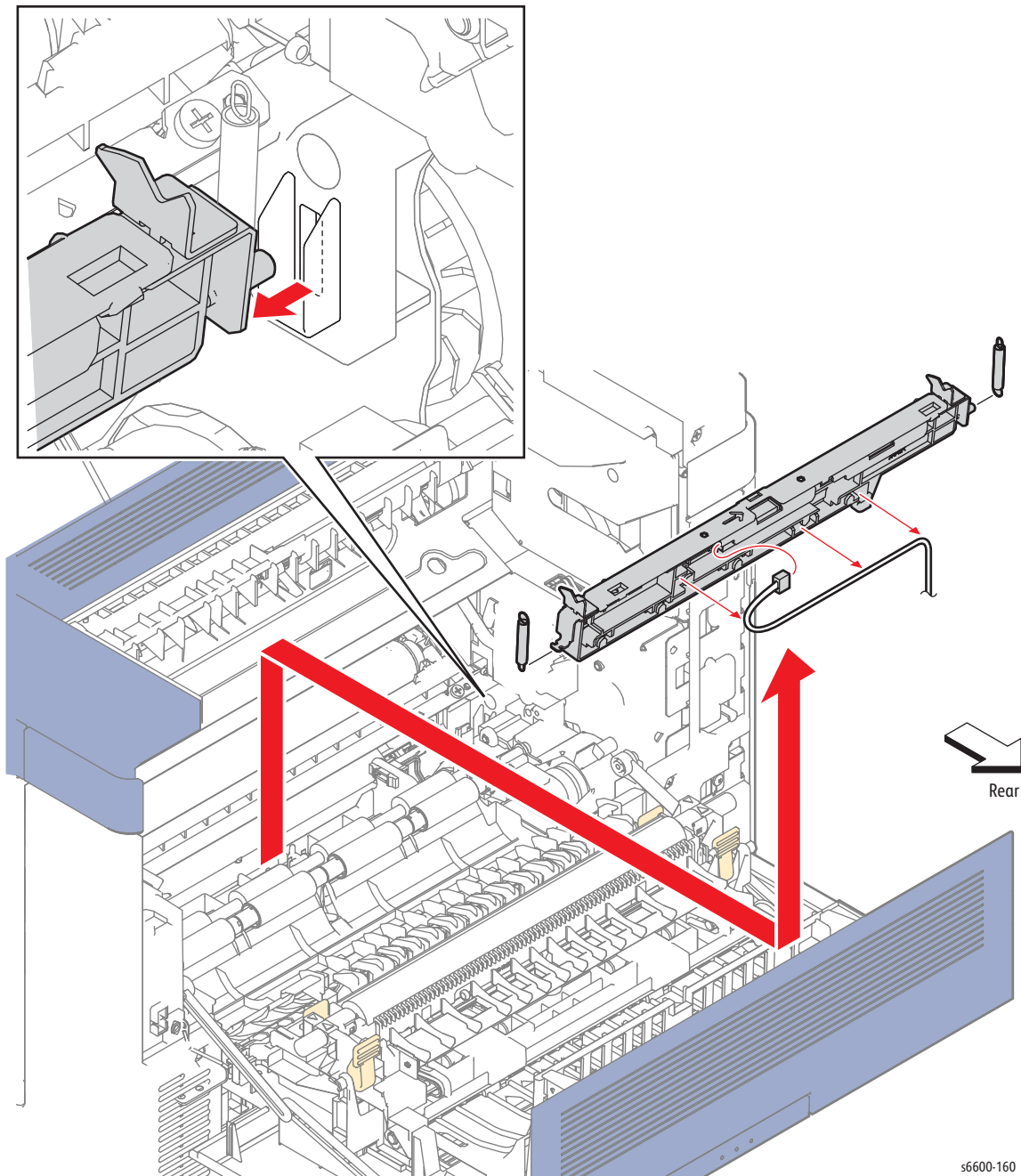
**Note:** When performing the following step, use caution not to drop and lose the CTD Spring (PL6.1.13).

2. Remove the CTD Spring (PL6.1.13) from the Left Transfer Belt Guide Assembly (PL6.1.6).
3. Remove the CTD Spring from the frame.



s6600-159

4. Raise the left side of the CTD Sensor Assembly (PL6.1.14), pull the shaft on the right side out of the hole on the guide, and then raise the CTD Sensor Assembly.
5. Release the harness from the harness guide of the CTD Sensor Assembly.
6. Unplug the connector and remove the CTD Sensor Assembly.
7. Remove the CTD Spring from the CTD Sensor Assembly.



s6600-160

## Transfer Belt Right Latch Kit

### PL6.1.98

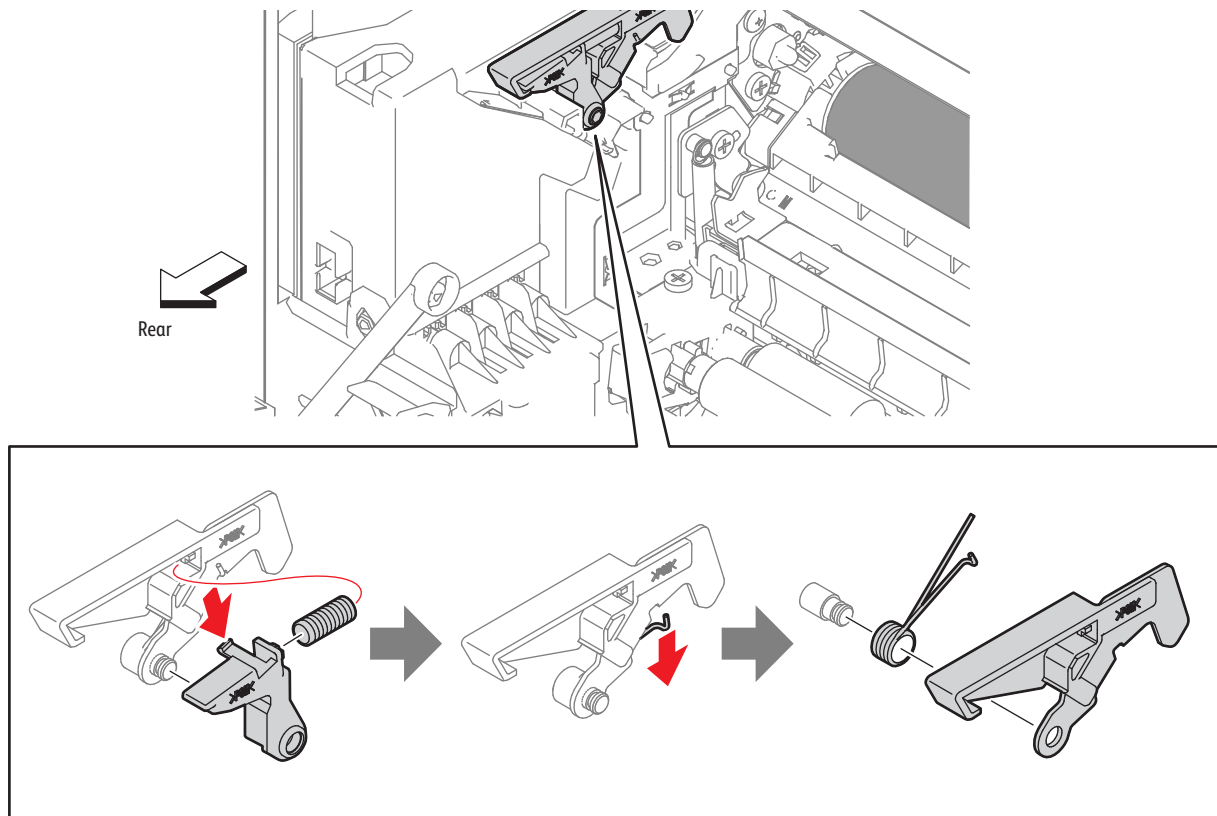
**Note:** The Transfer Belt Right Latch Kit includes the Transfer Belt Right Latch Housing, Transfer Belt Latch Spring, Transfer Belt Right Rear Spring, Transfer Belt Latch Plate, and Transfer Belt Right Latch Arm

**! WARNING:** The Fuser is very hot. Take added care when handling the fuser to avoid being burned.

1. Remove the Fuser Assembly. (page 4-46)
2. Remove the Waste Cartridge. (page 4-50)
3. Remove the Transfer Belt Assembly. (page 4-38)

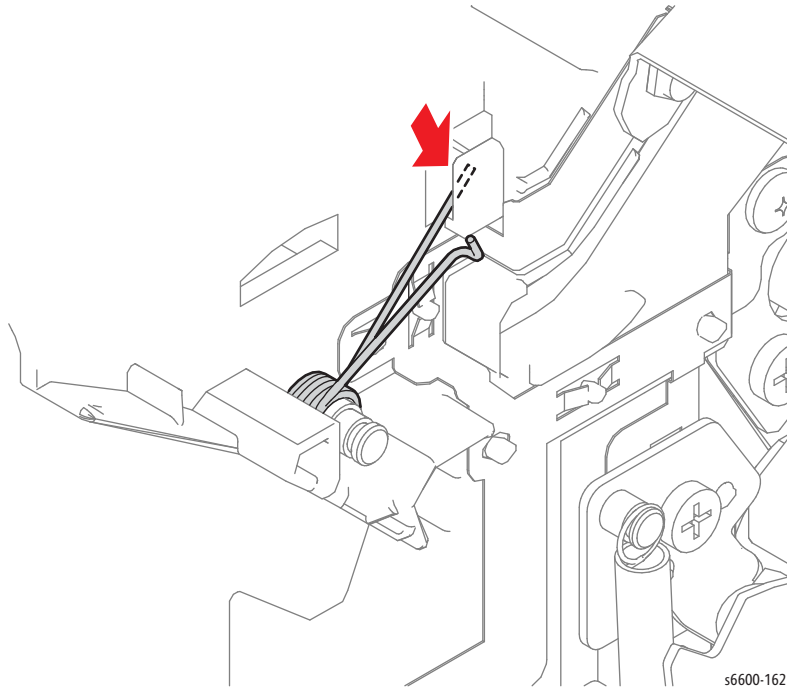
**! CAUTION:** When performing the following step, use caution not to drop and lose the Transfer Belt Latch Spring (PL6.1.8).

4. Release the hook on the Transfer Belt Right Latch Arm (PL6.1.11), and pull it out of the shaft while removing the Transfer Belt Latch Spring.
5. Release the Transfer Belt Right Rear Spring (PL6.1.9) from the Transfer Belt Latch Plate (PL6.1.10).
6. Remove the Transfer Belt Latch Plate from the shaft.
7. Remove the Transfer Belt Right Rear Spring from the shaft.



s6600-161

**Replacement Note:** When installing the Transfer Belt Right Rear Spring, make sure that one end of the spring is hooked on the frame.



## Coupling Kit

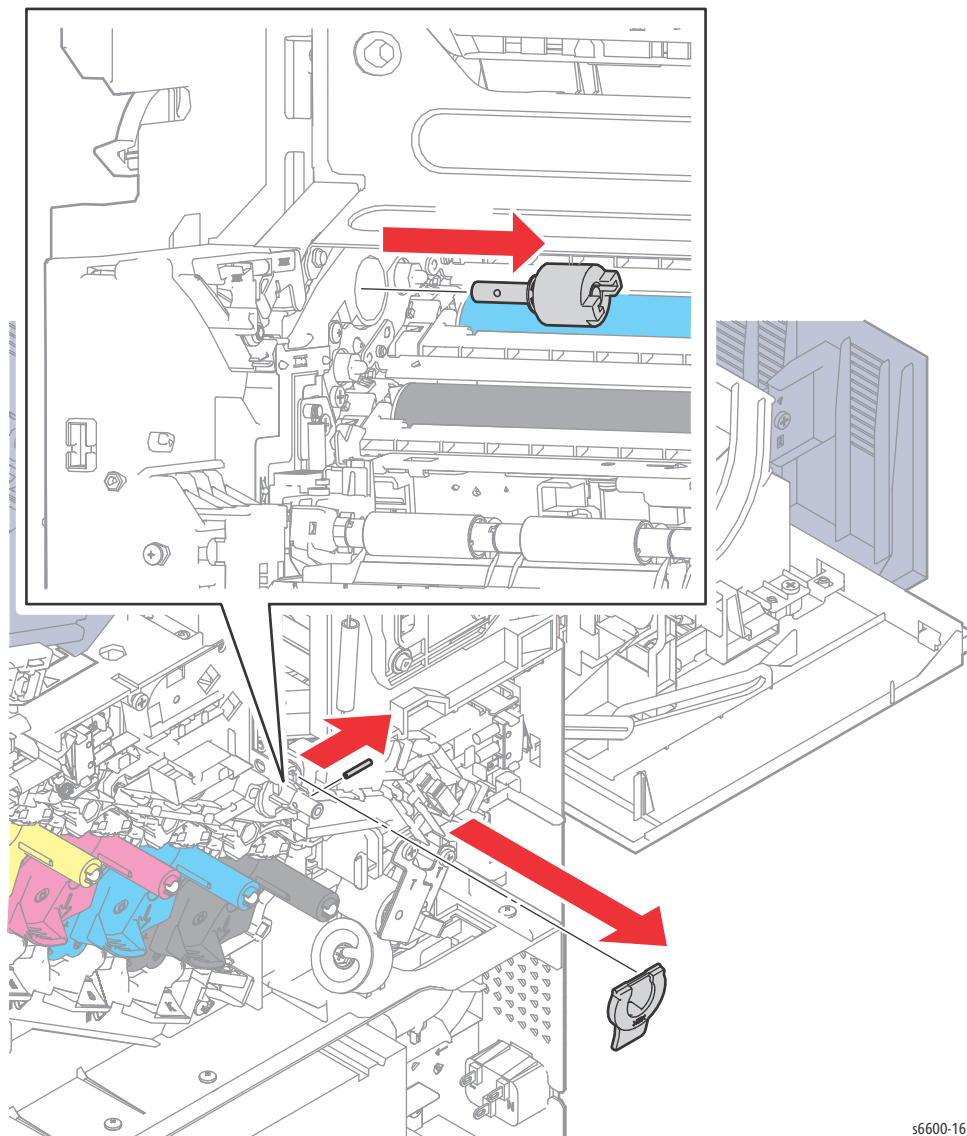
### PL6.1.99

**!** **WARNING:** The Fuser is very hot. Take added care when handling the fuser to avoid being burned.

1. Remove the Transfer Belt Assembly. (page 4-38)
2. Remove the Right Cover Assembly. (page 4-131)

**Note:** When performing the following step, use caution not to drop the Dowel Pin (PL6.1.15).

3. Remove the Coupling Actuator (PL6.1.4).
4. Pull out the Dowel Pin.
5. Remove the Coupling Kit (PL6.1.99).



s6600-163

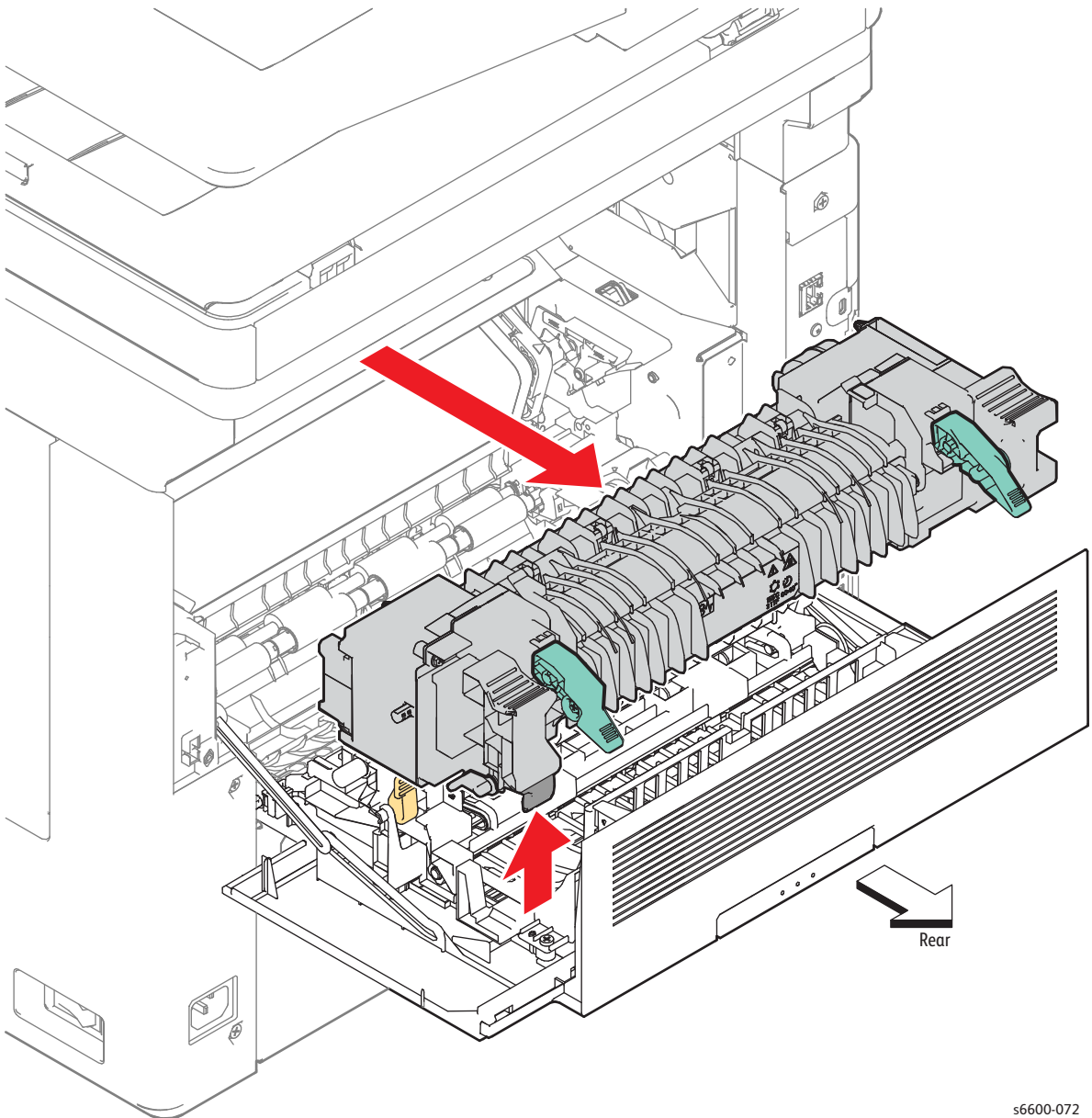
# Fuser

## Fuser Assembly

### PL7.1.1

**!** **WARNING:** The Fuser is very hot. Take added care when handling the fuser to avoid being burned.

1. Open the Rear Door Assembly (PL19.1.95).
2. Press up on the Fuser latch release at the lower-left to unlock the Fuser Assembly, and pull it out to the rear by the handles on the left and right sides.



s6600-072

# Xerographic

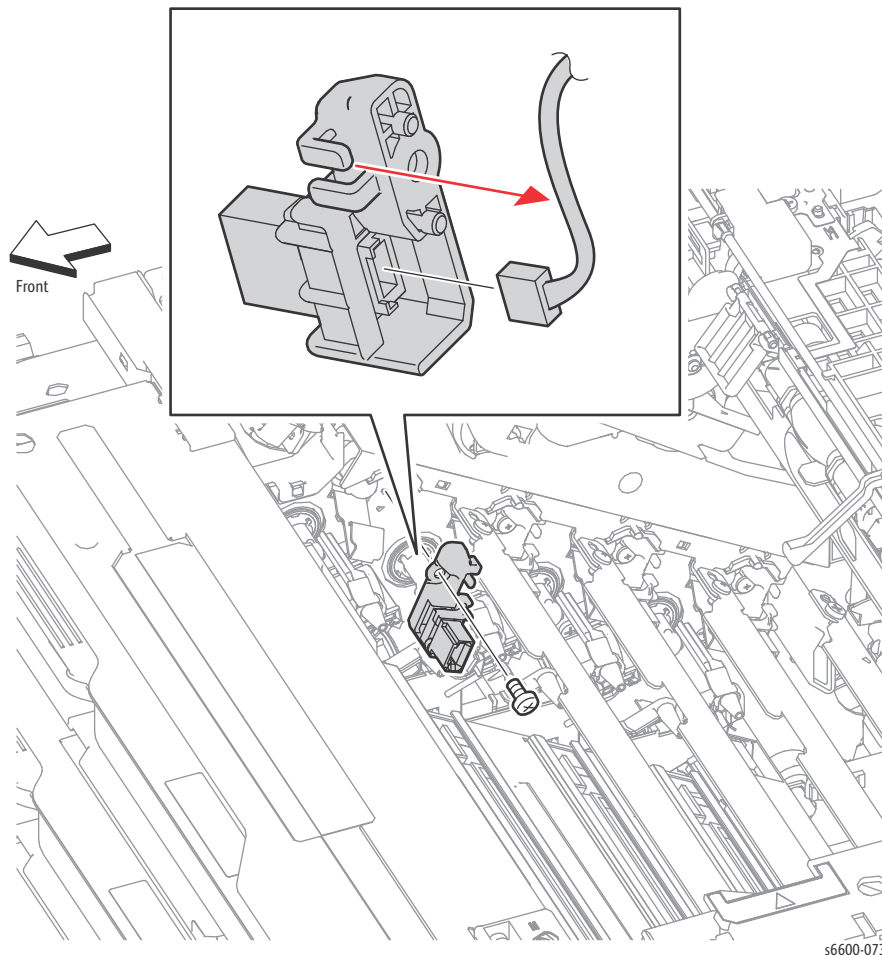
## Transfer CRUM Connector Assembly

### PL8.1.1

**Note:** Since the removal procedure is common among the four Transfer CRUM Connector Assemblies (PL8.1.1), this section describes only the removal procedure of the Transfer CRUM Connector Assembly connected to the Imaging Unit Y.

**! WARNING:** The Fuser is very hot. Take added care when handling the fuser to avoid being burned.

1. Remove the Transfer Belt Assembly. (page 4-38)
2. Remove the Imaging Units Y, M, C, K. (page 4-48)
3. Remove the Top Cover Assembly. (SFP page 4-115; MFP page 4-118)
4. Remove the screw (silver, 6mm) that attaches the Transfer CRUM Connector Assembly.
5. Release the harness from the harness guide on the Transfer CRUM Connector Assembly, unplug the connectors and remove the Transfer CRUM Connector Assembly.

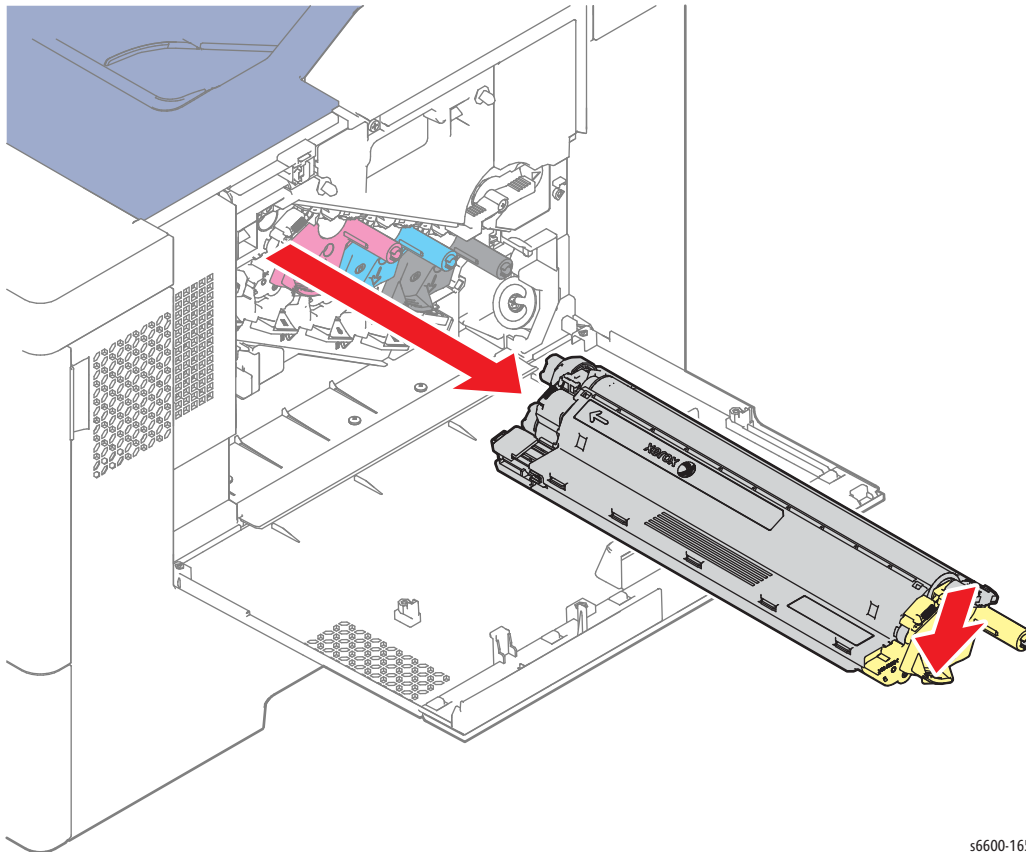


## Imaging Units Y, M, C, K

### PL8.1.2-5

**Note:** Since the removal is the same for all four Imaging Units, this procedure describes the removal of the Imaging Unit Y only.

1. Remove the Waste Cartridge. (page 4-50)
2. Press down on the the handle, and then pull out the Imaging Unit Y.



s6600-165

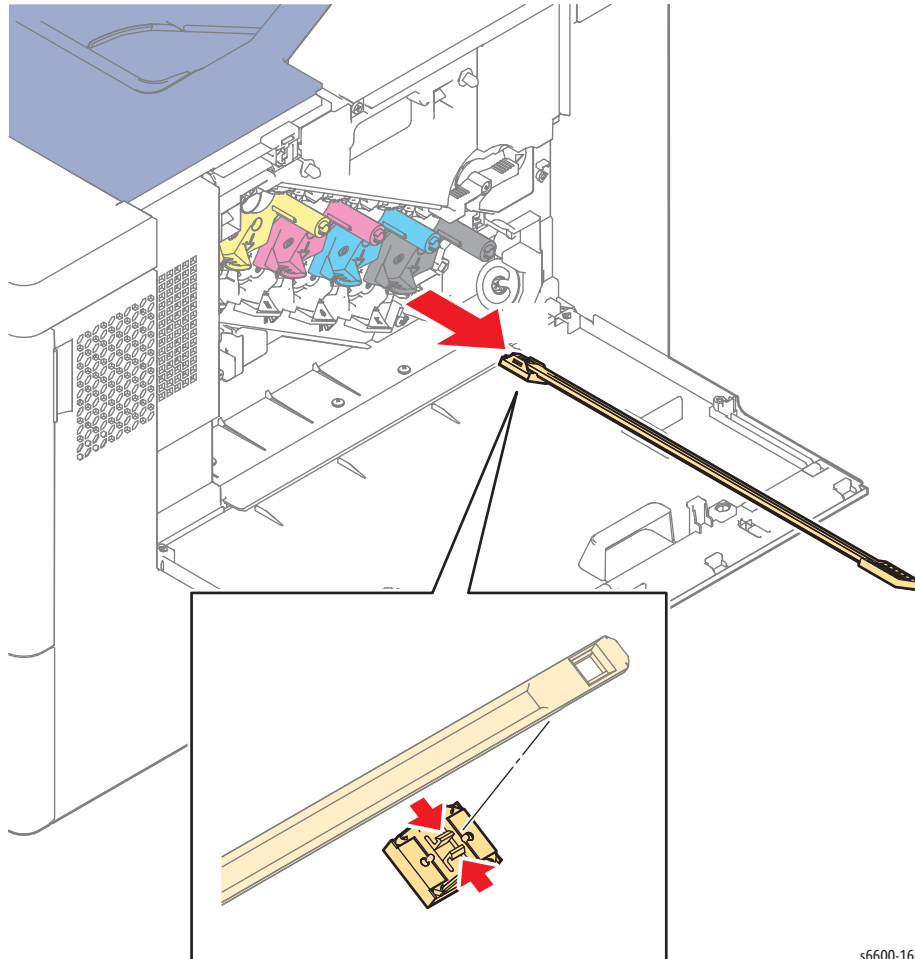
**CAUTION:** Store the Imaging Unit in a drawer, cabinet, or light-shielded cover to avoid damaging the drum while the Imaging Unit is out of the printer.



## Cleaner Assembly / Cleaner Assembly Base

### PL8.1.6 / PL8.1.9

1. Remove the Waste Cartridge. (page 4-50)
2. Pull out the Cleaner Assembly (PL8.1.6).
3. Release the hook holding the Cleaner Assembly Base (PL8.1.9) and remove it.

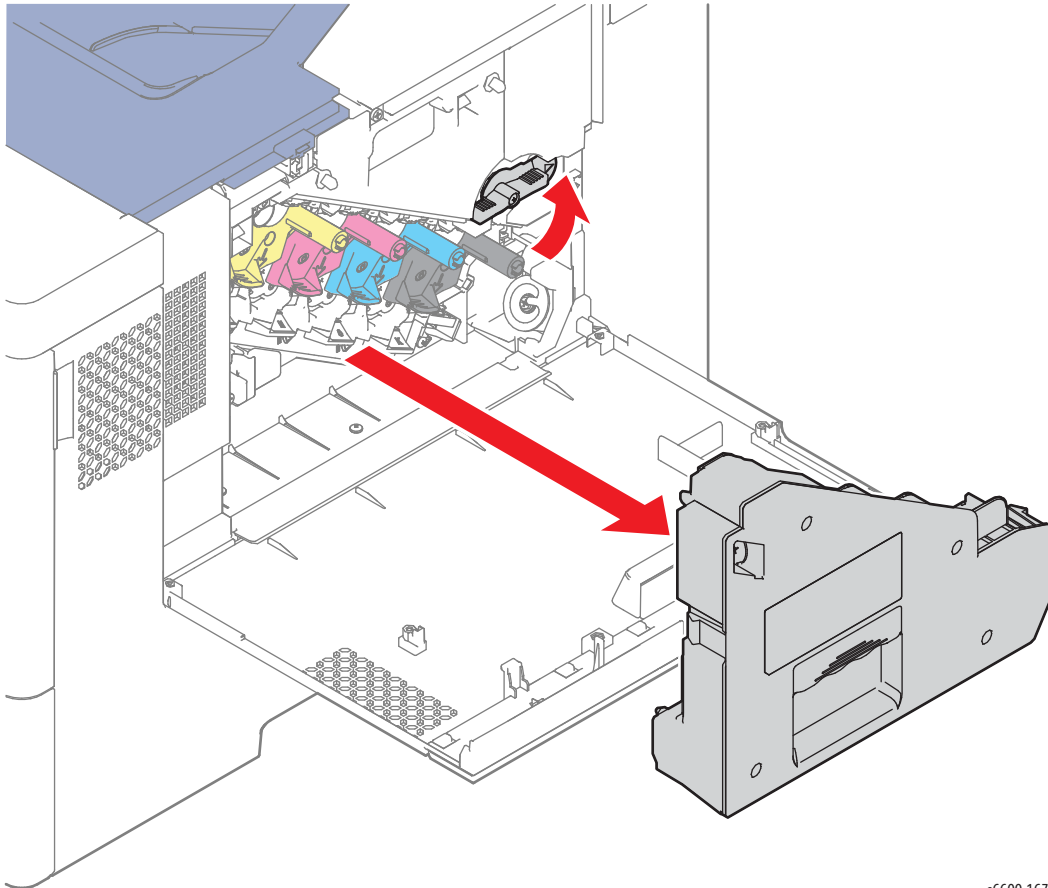


s6600-166

## Waste Cartridge

### (PL8.1.7)

1. Open the Right Side Door (PL19.1.96).
2. Rotate the Waste Cartridge Lock (PL6.1.5) counterclockwise.
3. Pull out the Waste Cartridge (PL8.1.7) toward you.



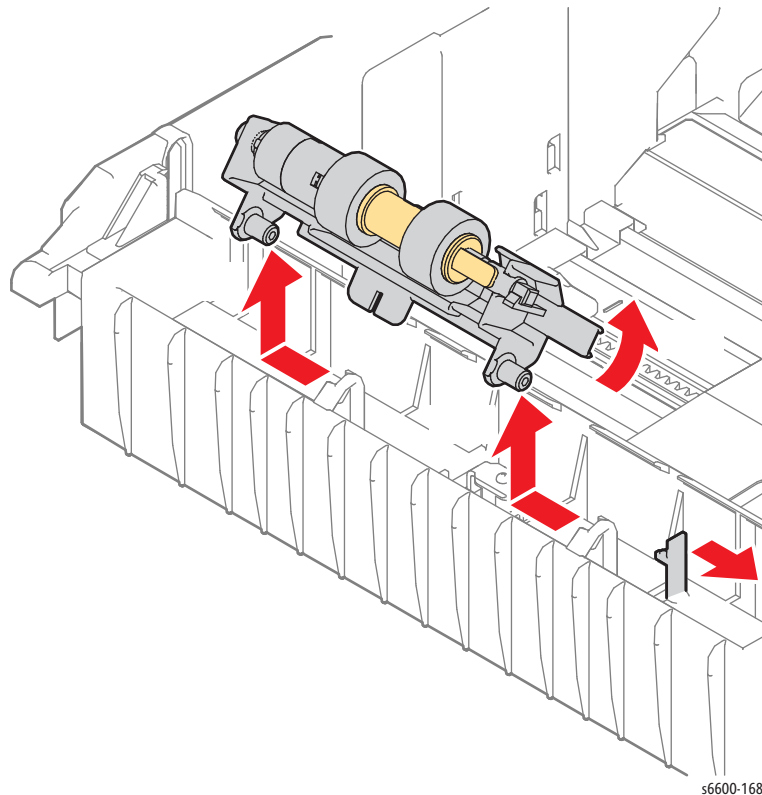
s6600-167

# Tray

## Tray Retard Holder Assembly

### PL9.1.3, PL10.3.3

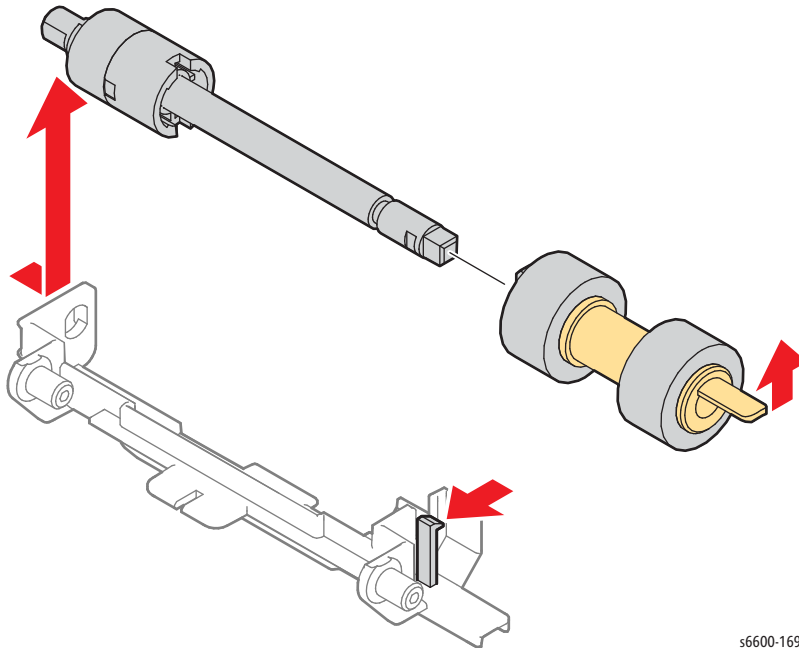
1. Remove the 550 Cassette Assembly from the printer.
2. Release the hook on the rear of the Housing Base (PL9.1.25 or PL10.3.25) and remove the Tray Retard Holder Assembly (PL9.1.3) (PL10.3.3) by swinging it upward and then by pulling it out sideways.



## Feed Roller Assembly

### PL9.1.4, PL10.3.4

1. Remove the 550 Cassette Assembly from the printer.
2. Remove the Tray Retard Holder Assembly. (page 4-51)
3. Release the hook holding the Tray Retard Shaft (PL9.1.6) (PL10.3.6) and remove the shaft together with the Feed Roller Assembly (PL9.1.4) (PL10.3.4) by pulling it out sideways.
4. Release the hook that holds the Feed Roller Assembly and slide the roller off the shaft.



s6600-169

# Option Feeder

## Optional 550-Sheet Feeder / Joint Screw

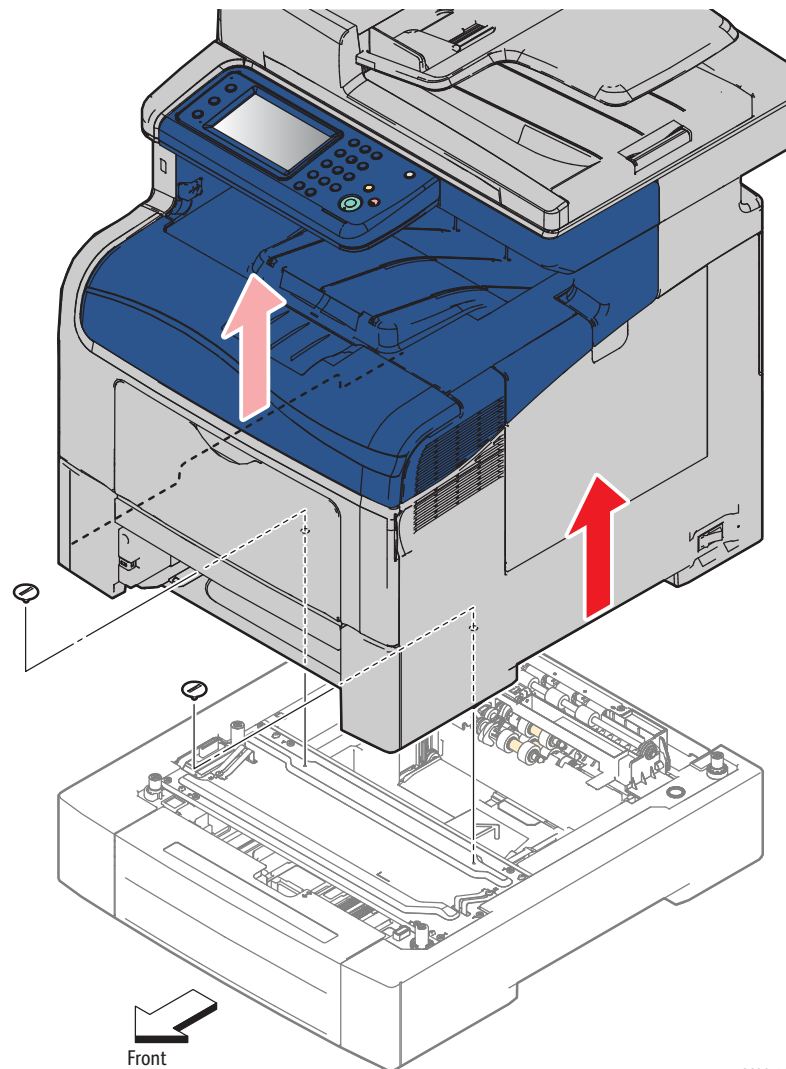
### PL10.1.1 / PL10.1.17

1. Remove the 550-sheet Paper Tray from the printer.
2. Remove the two Joint Screws (PL10.1.17) that attach the Optional 550-Sheet Feeder (PL10.1.1) to the printer.

**!** **WARNING:** The Fuser is very hot. Take added care when handling the fuser to avoid being burned.

3. Raise the printer while holding the recessed areas on both sides, and separate it from the Optional 550-Sheet Feeder.

**Note:** Although the illustration shows the MFP, the procedure details apply equally to the SFP.



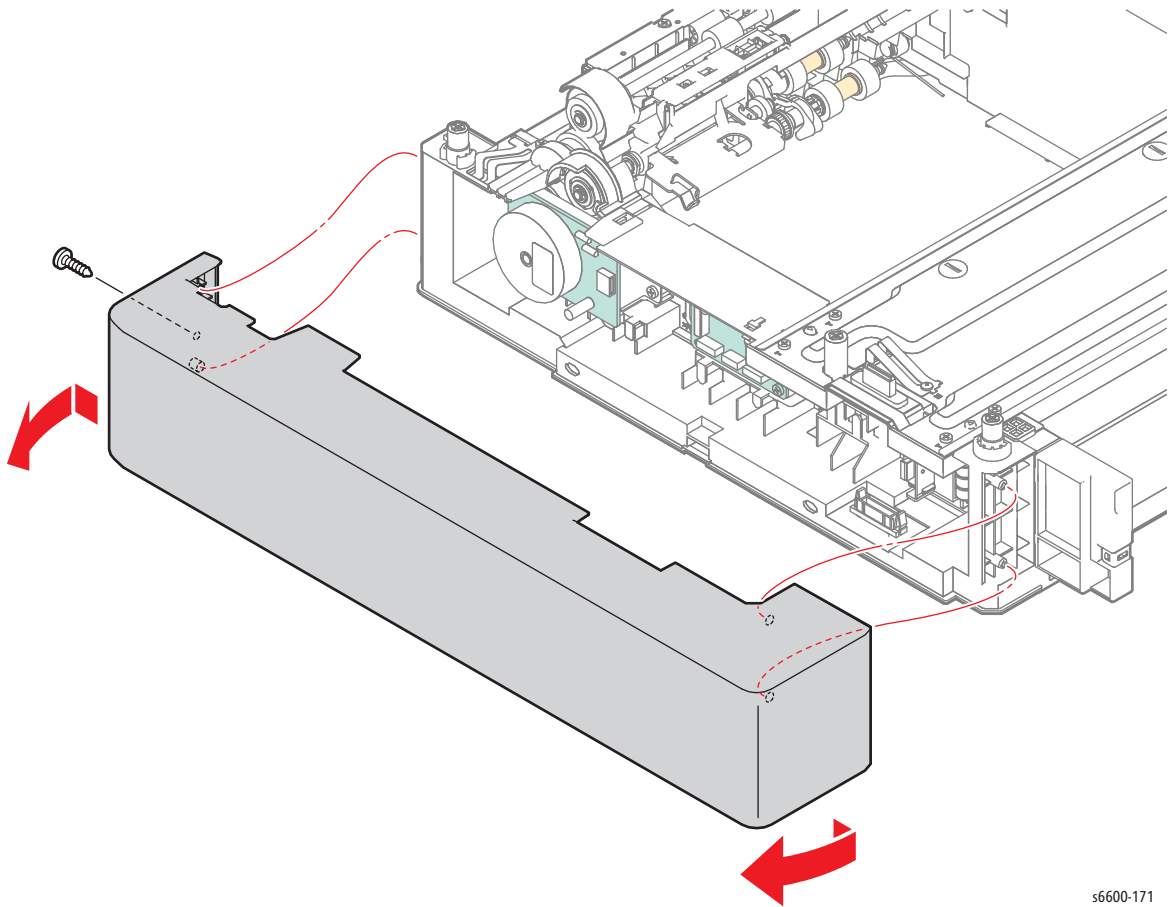
s6600-118

## 550 Option Left-Side Cover

### PL10.1.2

**Note:** When installing or removing this part, you do not need to separate the printer from the Optional 550-Sheet Feeder.

1. Remove the 550 Option Cassette Assembly from the Optional 550-Sheet Feeder.
2. Remove the screw (silver, tapping, 8mm) that attaches the 550 Option Left-Side Cover (PL10.1.2) to the feeder.
3. Remove the 550 Option Left-Side Cover by releasing the two bosses on its rear and then the two bosses on its front while flexing its rear end outward.

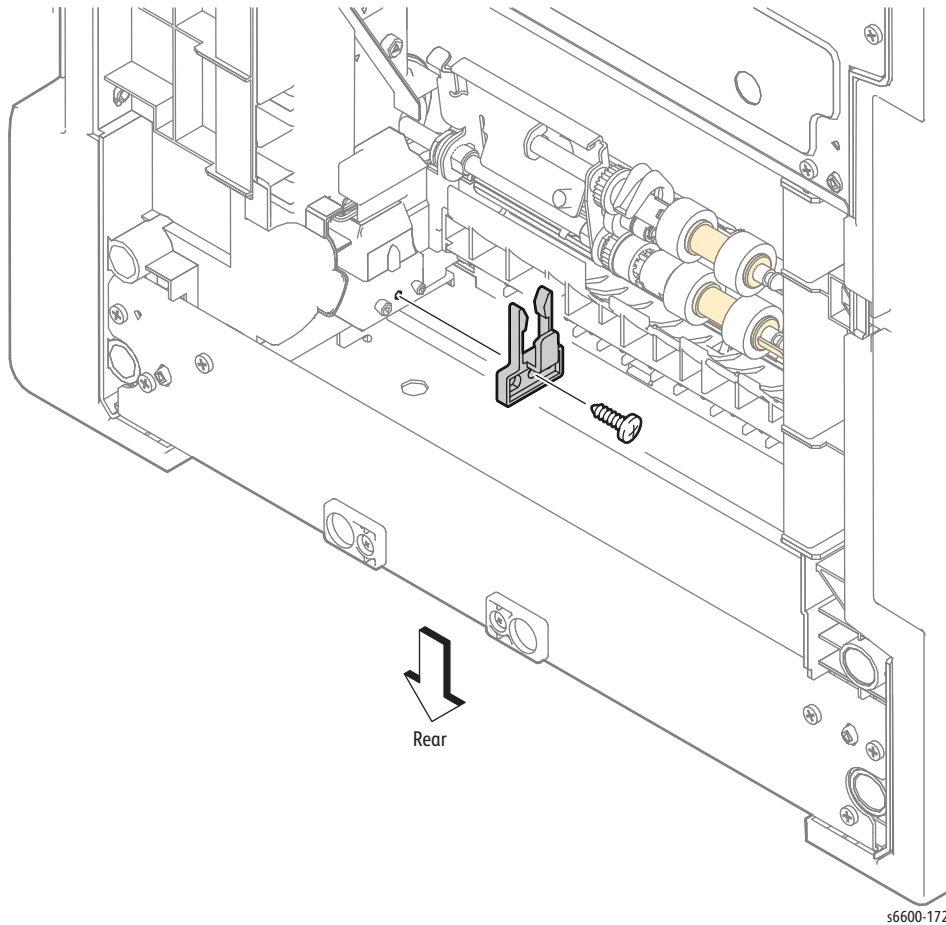


s6600-171

## 550 Option Cassette Stopper

### PL10.1.6

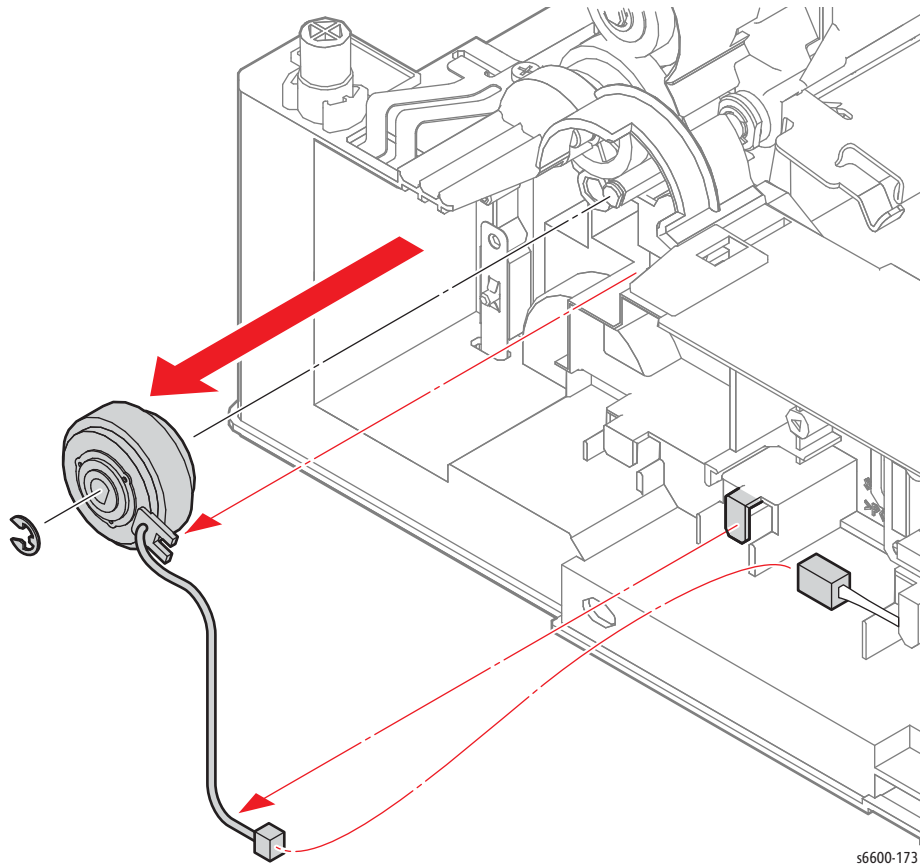
1. Remove the Optional 550-Sheet Feeder from the printer. (page 4-53)
2. Remove the 550 Cassette Assembly from the Optional 550-Sheet Feeder.
3. Turn the Optional 550-Sheet Feeder over.
4. Remove the screw (silver, tapping, 8mm) that attaches the Cassette Stopper (PL10.1.6) to the feeder and remove the stopper.



## 550 Option Feed Clutch Assembly

### PL10.1.8

1. Remove the 550 Option Drive Assembly. (page 4-57)
2. Unplug connector P/J4213 on the harness coming out of the 550 Option Feed Clutch Assembly (PL10.1.8), and then release the harness from the harness guide.
3. Remove the E-ring holding the the 550 Option Feed Clutch Assembly, and then pull the 550 Option Feed Clutch Assembly off of the shaft.



**Replacement Note:** When installing the 550 Option Feed Clutch Assembly, align the recess on the 550 Option Feed Clutch Assembly with the lug on the frame.

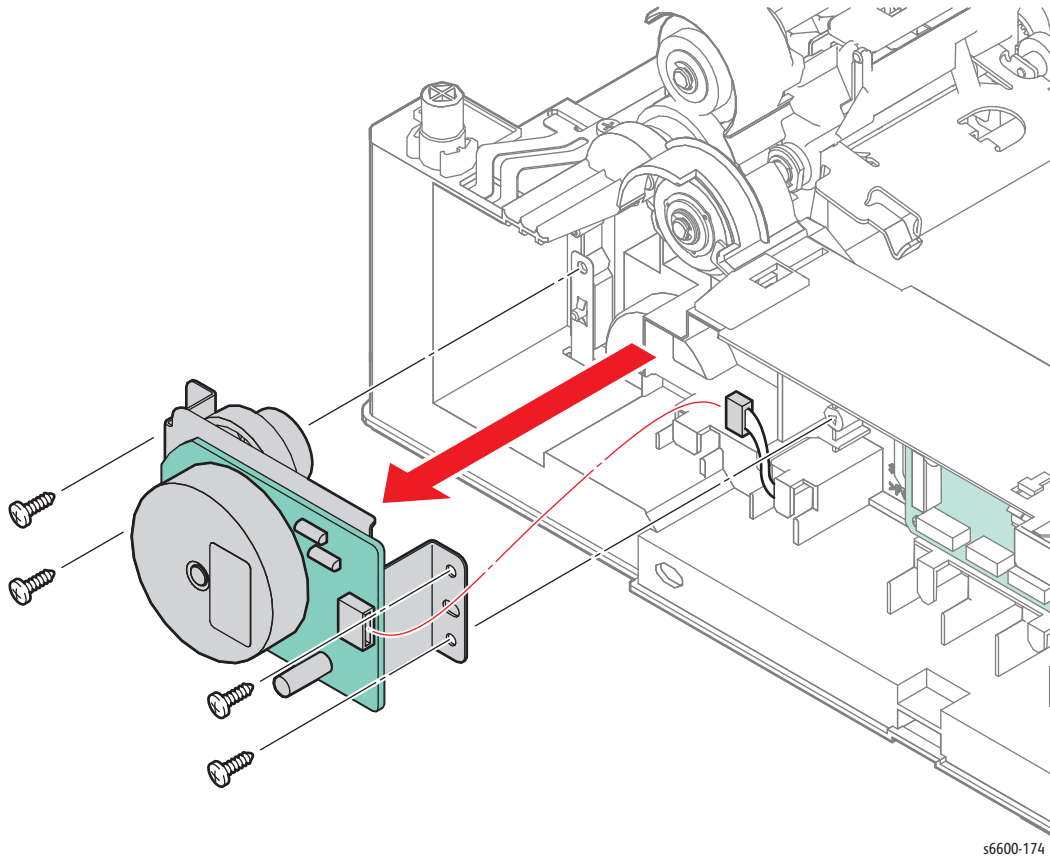


## 550 Option Drive Assembly

### PL10.1.9

**Note:** When installing or removing this part, you do not need to separate the printer from the Optional 550-Sheet Feeder.

1. Remove the 550 Option Cassette Assembly from the Optional 550-Sheet Feeder.
2. Remove the 550 Option Left-Side Cover. (page 4-54)
3. Unplug connector P/J4221 from the 550 Option Drive Assembly (PL10.1.9).
4. Remove the four screws (silver, tapping, 8mm) that attach the 550 Option Drive Assembly to the feeder and remove the drive assembly.

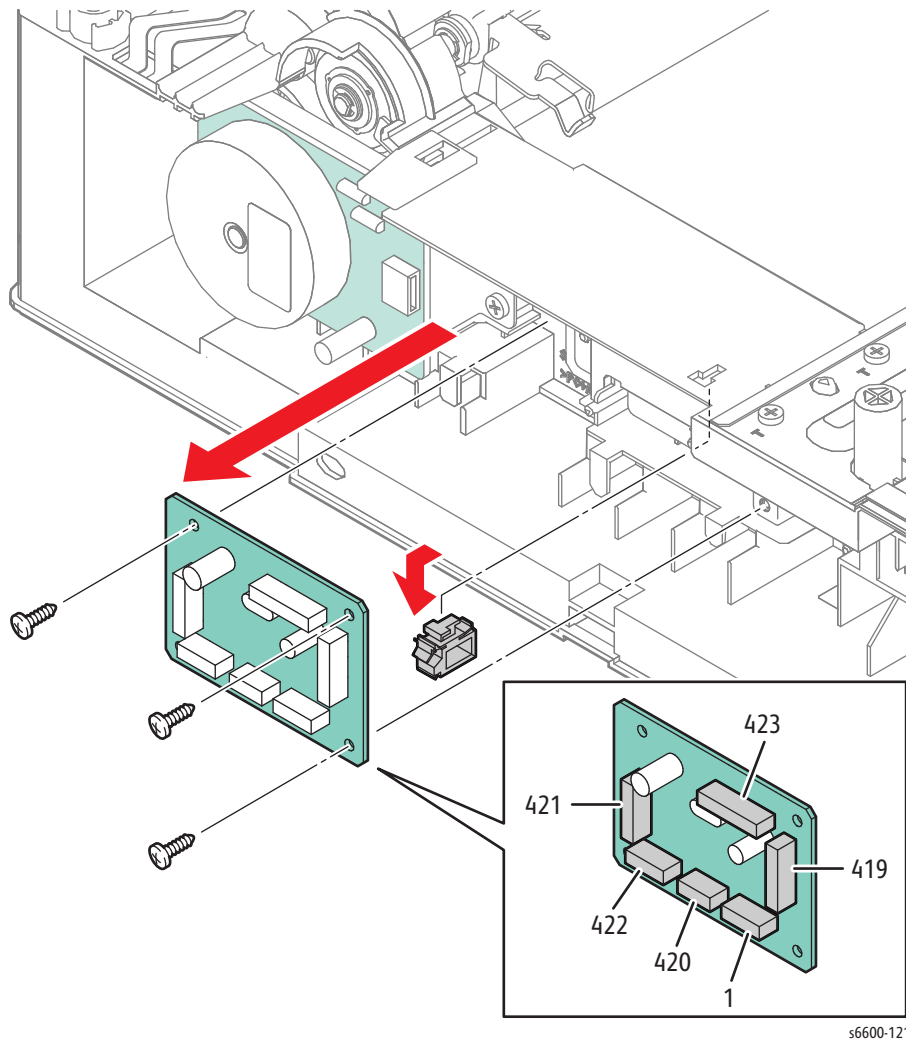


## 550 Option Feeder Board

### PL10.1.10

**Note:** When installing or removing this part, you do not need to separate the printer from the Optional 550-Sheet Feeder.

1. Remove the 550 Option Cassette Assembly from the Optional 550-Sheet Feeder.
2. Remove the 550 Option Left-Side Cover. (page 4-54)
3. Disengage the all connectors on the 550 Option Feeder Board (PL10.1.10).
4. Remove the clamp secured on the frame by sliding it to the left.
5. Remove the three screws (silver, tapping, 8mm) that attach the 550 Option Feeder Board to the feeder and remove the board.

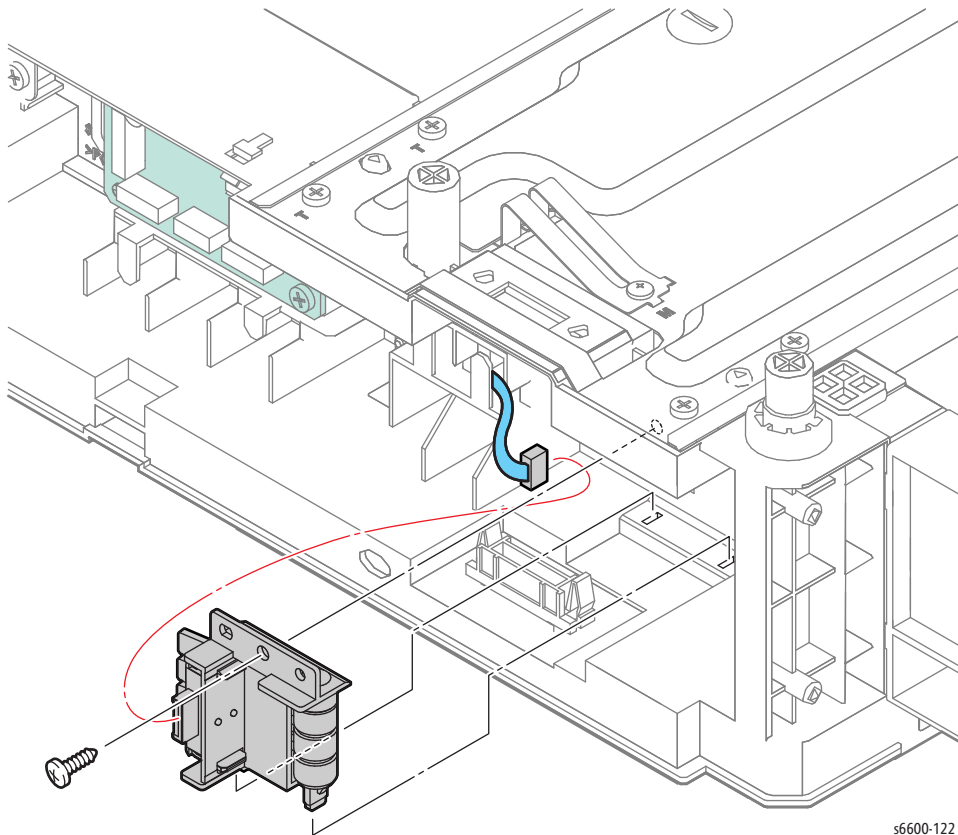


## 550 Size Switch Assembly

### PL10.1.11

**Note:** When installing or removing this part, you do not need to separate the printer from the Optional 550-Sheet Feeder.

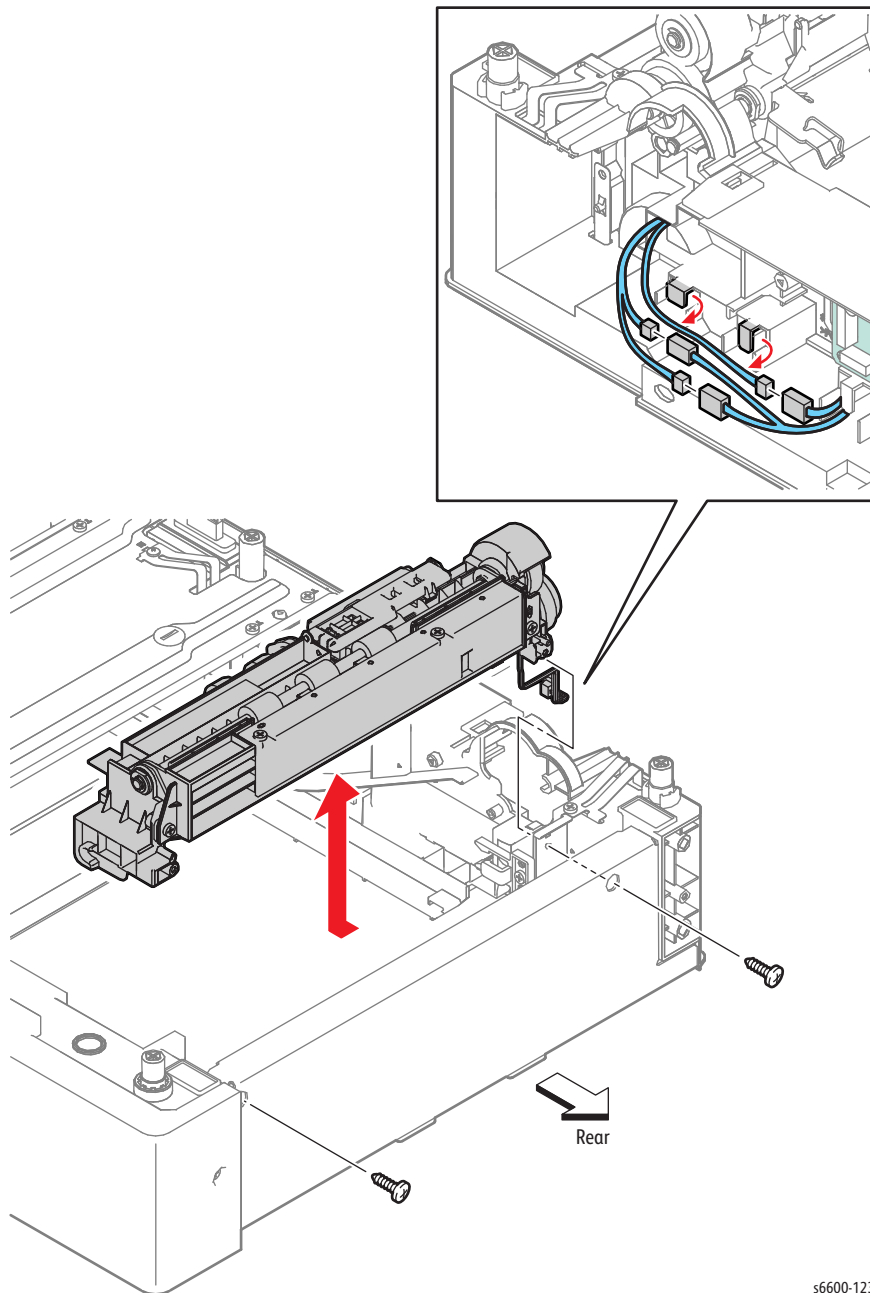
1. Remove the 550 Option Left-Side Cover. (page 4-54)
2. Unplug connector P/J4211 from the 550 Size Switch Assembly (PL10.1.11).
3. Remove the screw (silver, tapping, 8mm) that attaches the 550 Size Switch Assembly to the feeder and remove the switch assembly.



## 550 Option Main Feed Assembly

### PL10.2.1

1. Remove the Optional 550-Sheet Feeder from the printer. (page 4-53)
2. Remove the 550 Option Feed Clutch Assembly. (page 4-56)
3. Unplug connectors P/J4201, P/J4202, and P/J4214 on the harness coming from the 550 Option Main Feed Assembly (PL10.2.1), and then release the harness from the harness guide.
4. Remove the two screws (silver, tapping, 8mm) that attach the 550 Option Main Feed Assembly and remove the 550 Option Main Feed Assembly while pulling the harness out of the hole on the frame.

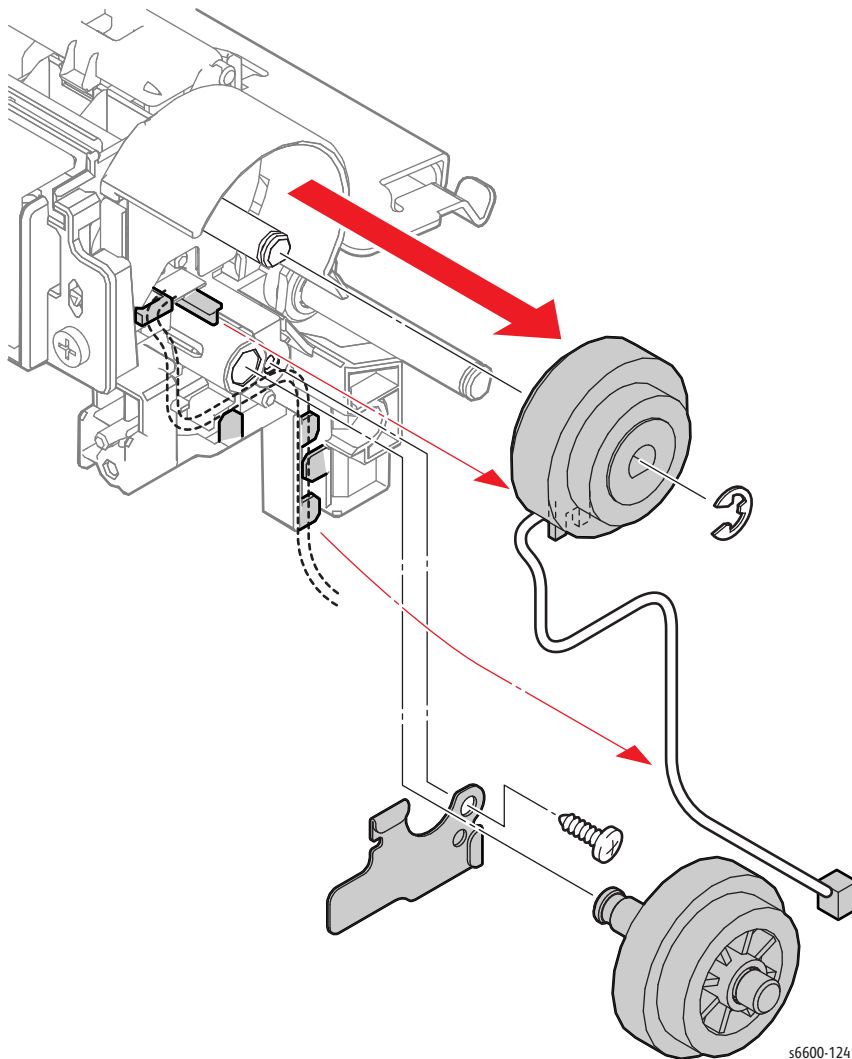


s6600-123

## 550 Option Regi Clutch Assembly

### PL10.2.2

1. Remove the Optional 550-Sheet Feeder from the printer. (page 4-53)
2. Remove the 550 Option Main Feed Assembly. (page 4-60)
3. Pull out the 550 Option Feeder Gear together with the shaft.
4. Remove the screw (silver, tapping, 8mm) that attaches the Nudger 2 Spring Bracket to the printer and remove the bracket.
5. Release the harness coming out of the 550 Option Regi Clutch Assembly from the harness guide.
6. Remove the E-ring holding the the 550 Option Regi Clutch Assembly, and then pull the clutch Assembly off of the shaft.

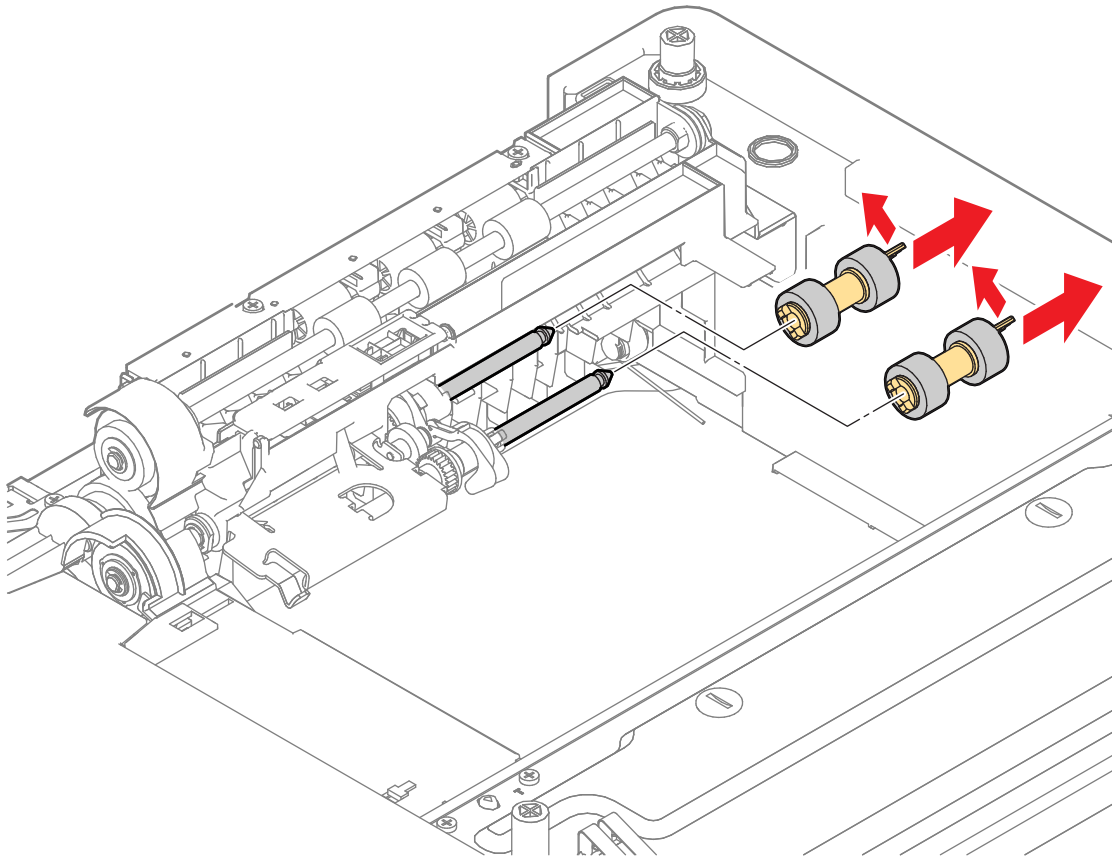


**Replacement Note:** When installing the 550 Option Regi Clutch Assembly, align the recess on the clutch Assembly with the lug on the frame.

## 550 Option Feed Roller Assembly

### PL10.2.3

1. Remove the Optional 550-Sheet Feeder from the printer. (page 4-53)
2. Remove the 550 Option Cassette Assembly from the Optional 550-Sheet Feeder.
3. Release the hook holding the Feed Roller Assembly (PL10.2.3), and slide the assembly off the shaft.



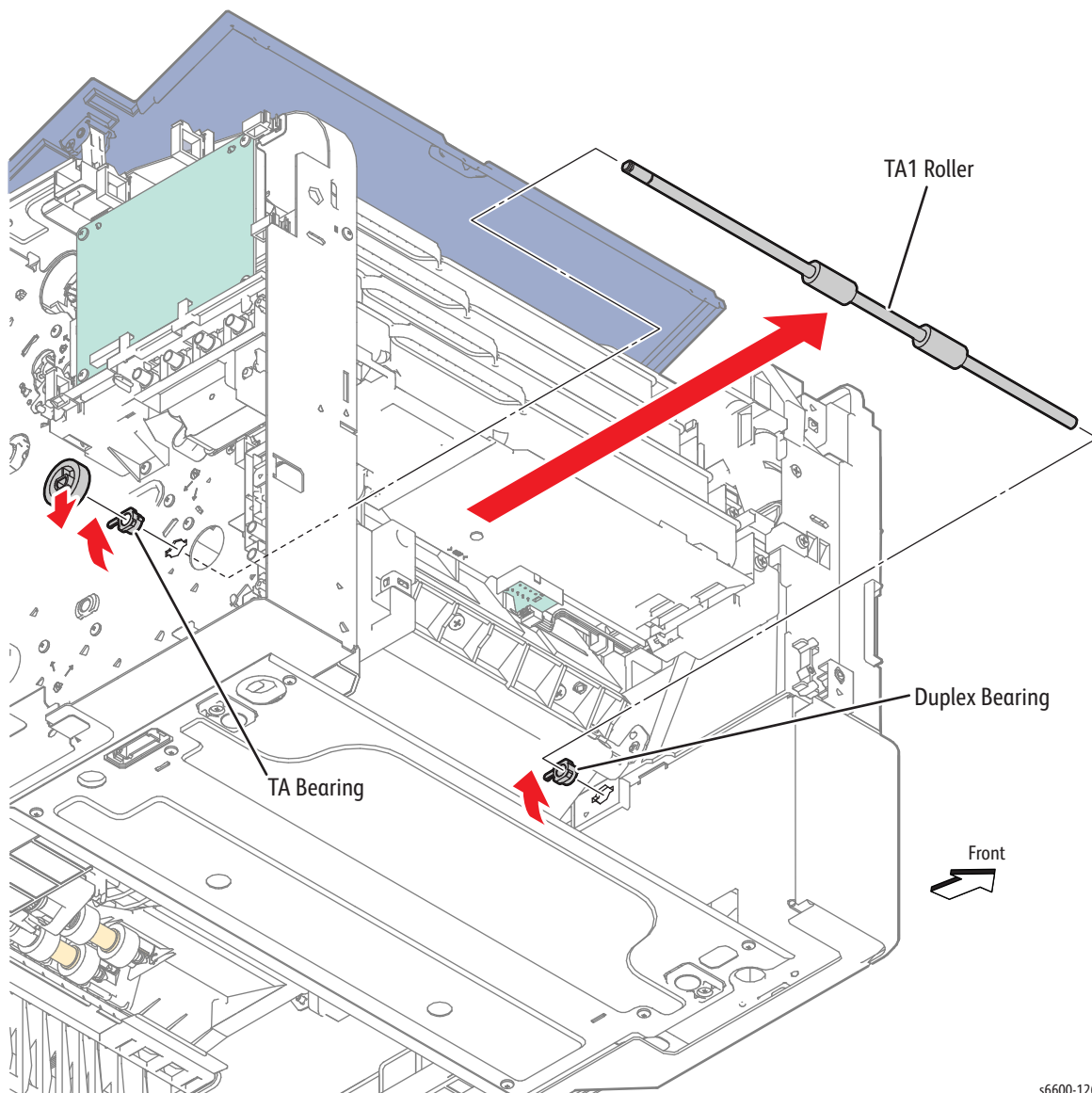
s6600-125

# Bypass Tray

## TA1 Roller Assembly

### PL13.1.2

1. Remove the Bypass Tray Frame Assembly. (page 4-65)
2. Release the hook holding the Turn Gear (PL13.1.7) and remove the gear.
3. Unlock the TA Bearing (PL13.1.6) and remove it by rotating it.
4. Unlock the Duplex Bearing (PL13.1.1), rotate it, and then slide it onto the shaft.
5. Slide the TA1 Roller Assembly (PL13.1.2) to the left and remove it from the end of the right shaft.

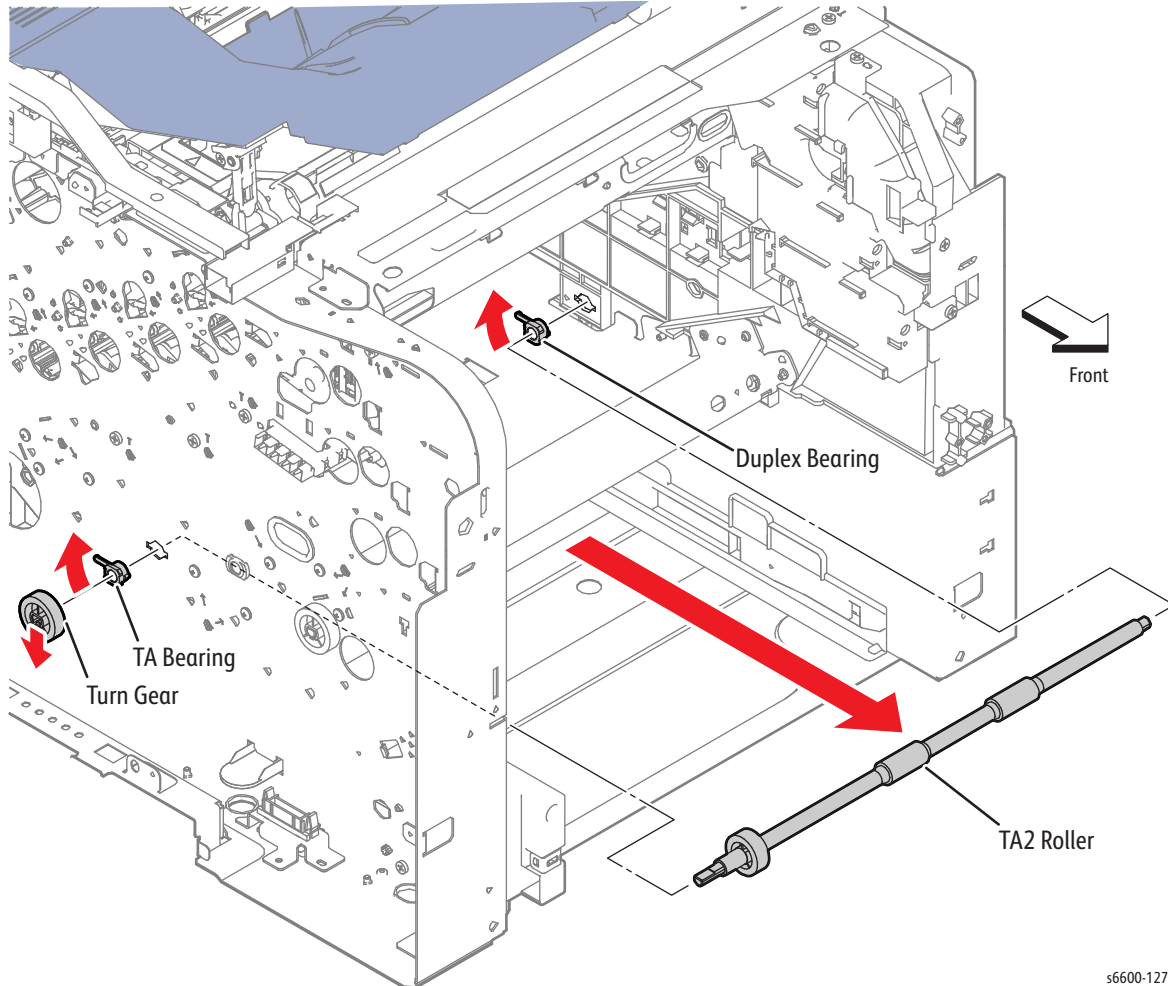


s6600-126

## TA2 Roller Assembly

### PL13.1.3

1. Remove the Laser Unit Assembly. (page 4-10)
2. Release the hook holding the Turn Gear (PL13.1.7) and remove the gear.
3. Unlock the TA Bearing (PL13.1.6) and remove it by rotating it.
4. Unlock the Duplex Bearing (PL13.1.1), rotate it, and then slide it onto the shaft.
5. Slide the TA2 Roller Assembly (PL13.1.3) to the left and remove it from the end of the right shaft.



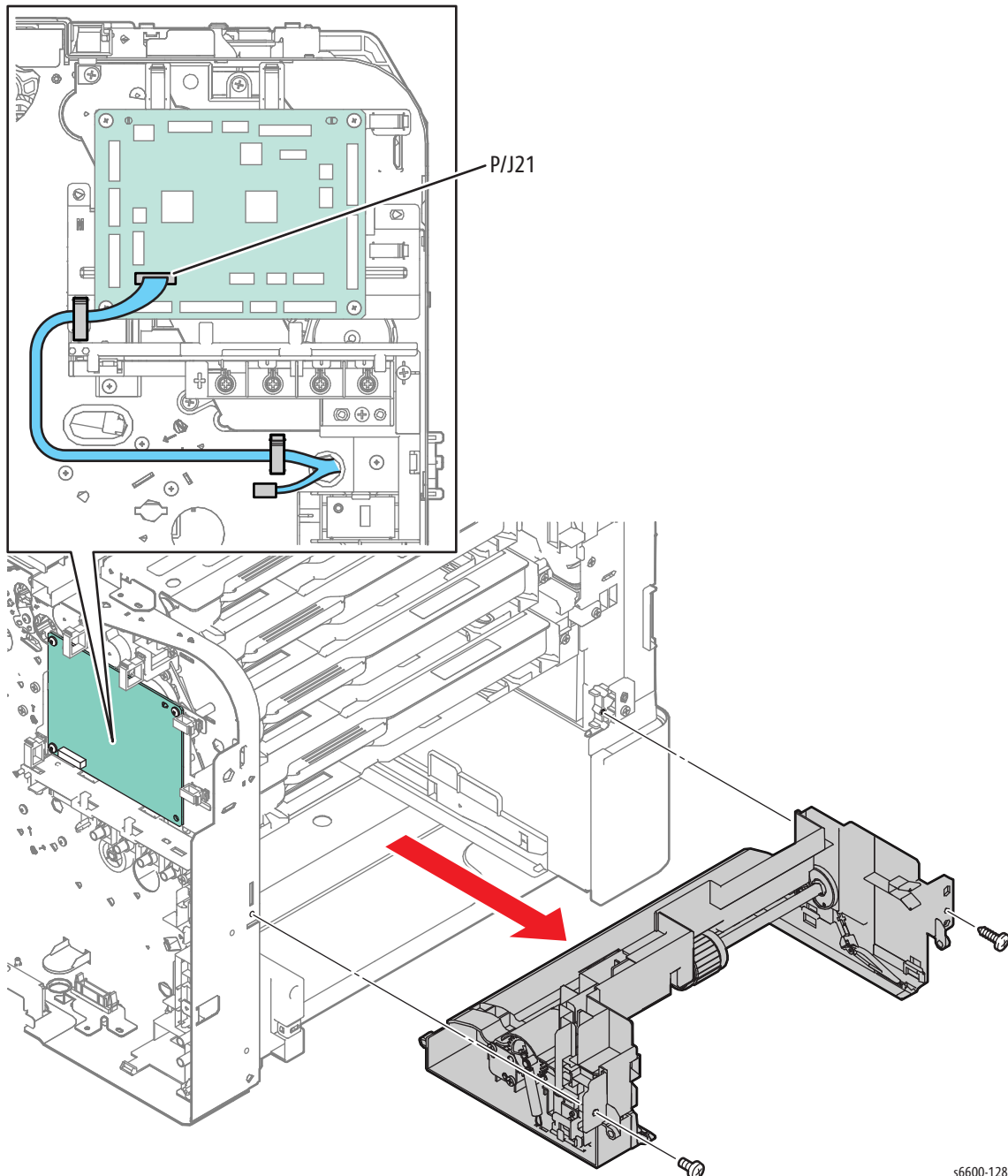
s6600-127



## Bypass Tray Frame Assembly

### PL13.2.1

1. Remove the Bypass Tray Assembly. (page 4-71)
2. Remove the Drive Assembly. (SFP page 4-11; MFP page 4-16)
3. Unplug connector P/J21 from the MCU Board, and release the harness from the clamps.
4. Remove the two screws (silver, 6mm) (silver, tapping, 8mm) that attach the Bypass Tray Frame Assembly (PL13.2.1).
5. Remove the Bypass Tray Frame Assembly while guiding the harness through the hole in the frame.

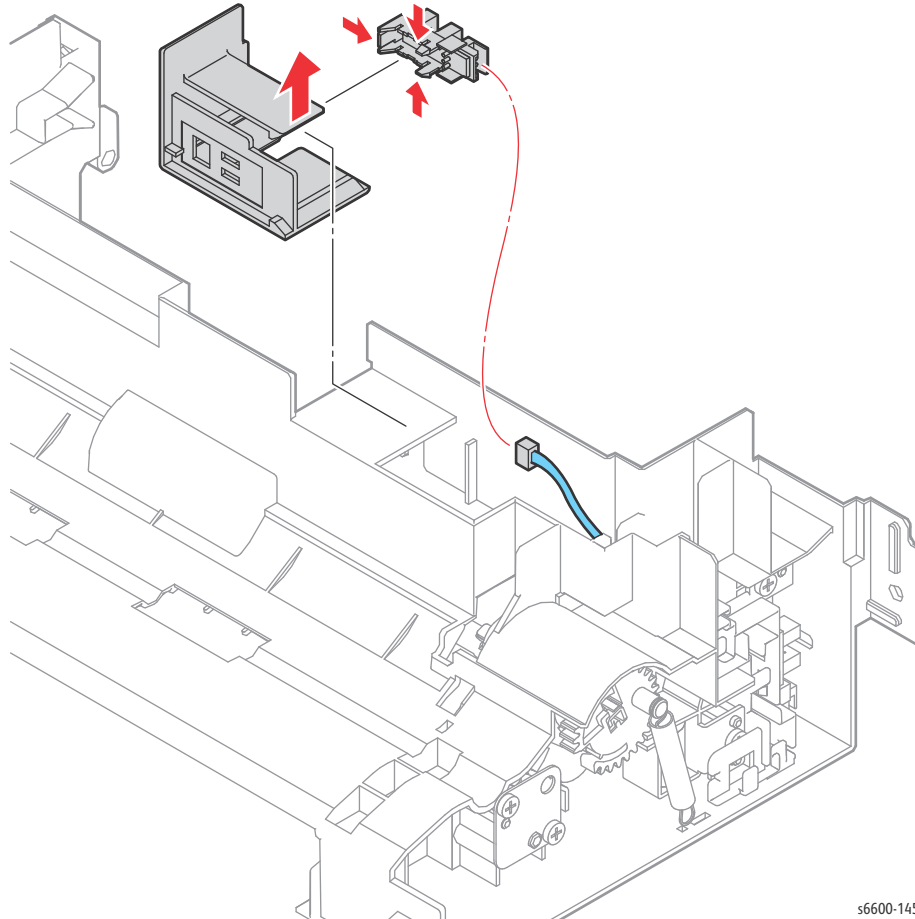


s6600-128

## Bypass Tray No Paper Sensor

### PL13.2.4

1. Remove the Bypass Tray Frame Assembly. (page 4-65)
2. Unplug connector P/J212 of the Bypass Tray No Paper Sensor (Interlock Photo Sensor - PL13.2.4).
3. Release the hook holding the Bypass Tray No Paper Bracket (PL13.2.3) and remove the Bypass Tray No Paper Bracket together with the Bypass Tray No Paper Sensor.
4. Release the hook holding the Bypass Tray No Paper Sensor and remove it.

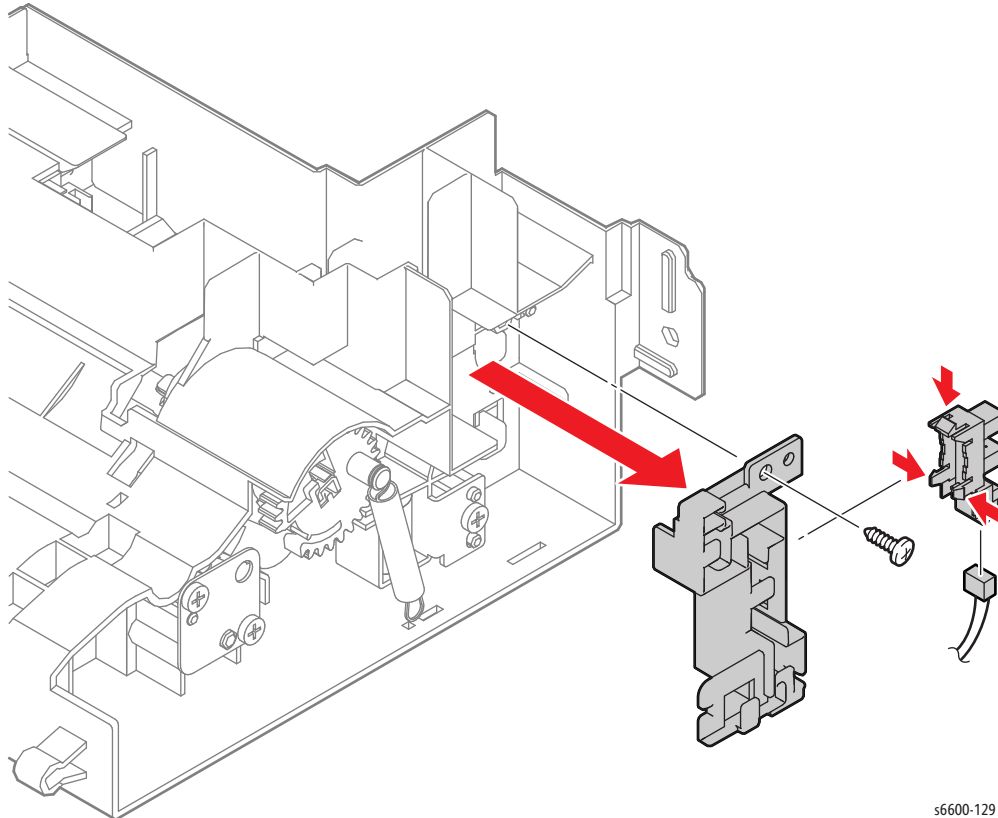


s6600-145

## Bypass Tray Sensor

### PL13.2.4

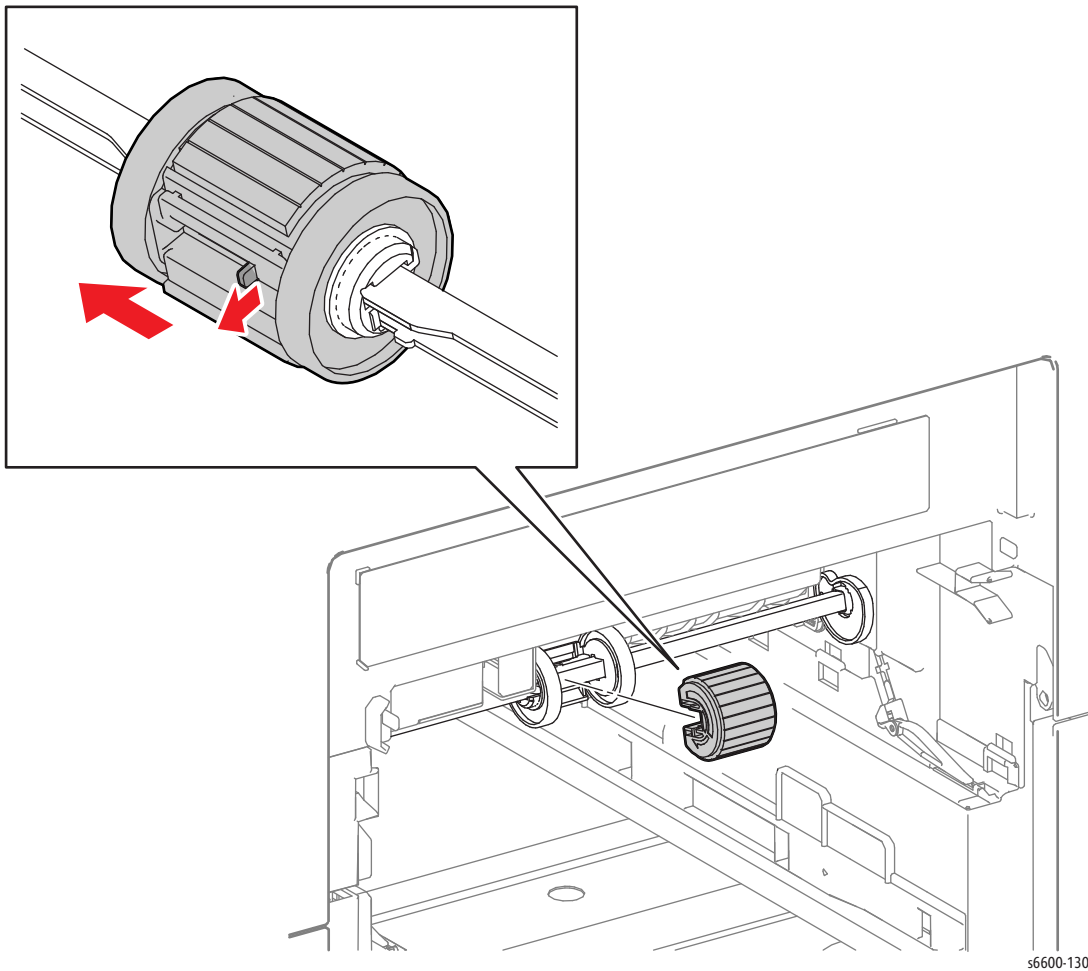
1. Remove the Bypass Tray Frame Assembly. (page 4-65)
2. Remove the screw (silver, tapping, 8mm) that attaches the Bypass Tray Harness Guide (PL13.2.6) and remove the Bypass Tray Harness Guide together with the Bypass Tray Sensor (Interlock Photo Sensor - PL13.2.4).
3. Unplug connector P/J211 of the Bypass Tray Sensor.
4. Release the hook holding the Bypass Tray Sensor and remove the sensor.



## Feed Roller Assembly

### PL13.2.10

1. Remove the 550-sheet Paper Tray (PL9.1.1).
2. Remove the Bypass Tray Assembly. (page 4-71)
3. Release the hook holding the Feed Roller Assembly and remove the Feed Roller Assembly by sliding it to the right.



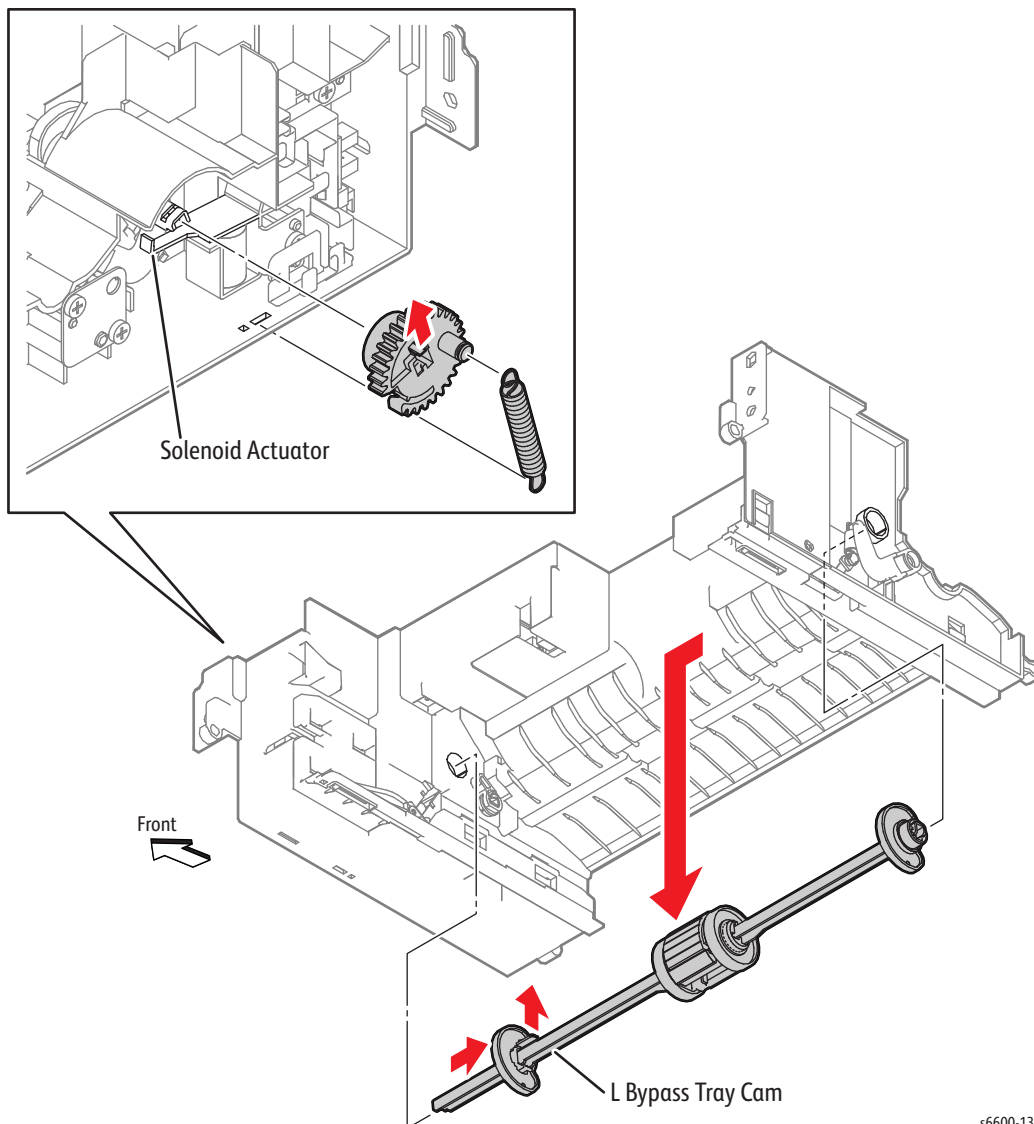
s6600-130

## Roller Kit Assembly

### (PL13.2.98)

1. Remove the Bypass Tray Frame Assembly (page 4-65).
2. Remove the Feed Spring (PL13.2.7).
3. Release the hook holding the Bypass Tray Feed Gear (PL13.2.8) and remove the gear from the Bypass Tray Feed Shaft (PL13.2.14).
4. Release the hook holding the Left Bypass Tray Cam (PL13.2.11), and slide the cam to the right.
5. Slide the Roller Kit Assembly (PL13.2.98) to the left to release the right end of the shaft, and then swing the right end of the shaft toward the front while shifting the shaft to the right in order to free the left end.

**Replacement Note:** Make sure that the solenoid actuator is below the shaft when reinstalling the Roller Kit Assembly.

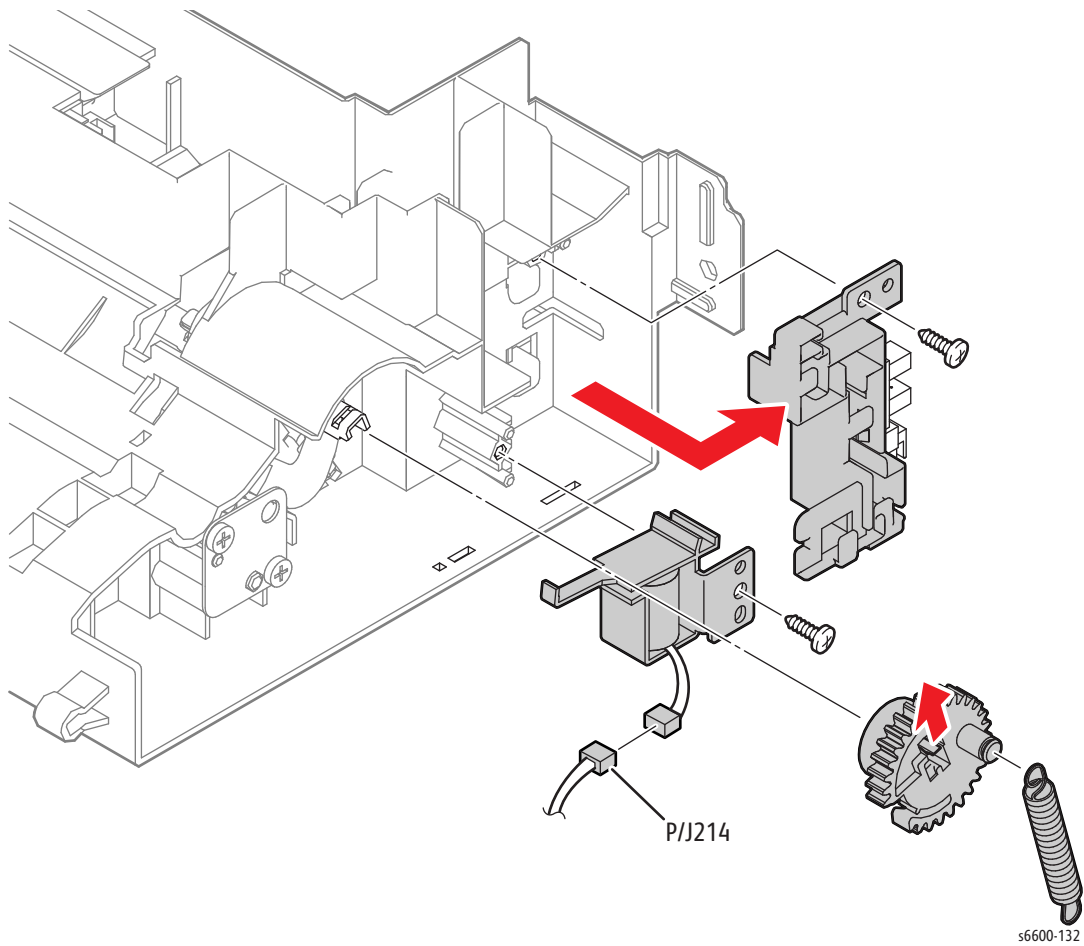


s6600-131

## Bypass Tray Feed Solenoid / Bypass Tray Feed Gear

### PL13.2.9 / PL13.2.8

1. Remove the Bypass Tray Frame Assembly. (page 4-65)
2. Remove the Feed Spring (PL13.2.7).
3. Release the hook holding the Bypass Tray Feed Gear and remove the gear from the Bypass Tray Feed Shaft (PL13.2.14).
4. Remove the screw (silver, tapping, 8mm) that attaches the Bypass Tray Harness Guide (PL13.2.6), and then move the Bypass Tray Harness Guide sideways together with Bypass Tray Sensor (PL13.2.4).
5. Unplug connector P/J214 on the harness coming from the Bypass Tray Feed Solenoid.
6. Remove the screw (silver, tapping, 8mm) that attaches the Bypass Tray Feed Solenoid to the printer and remove the solenoid.

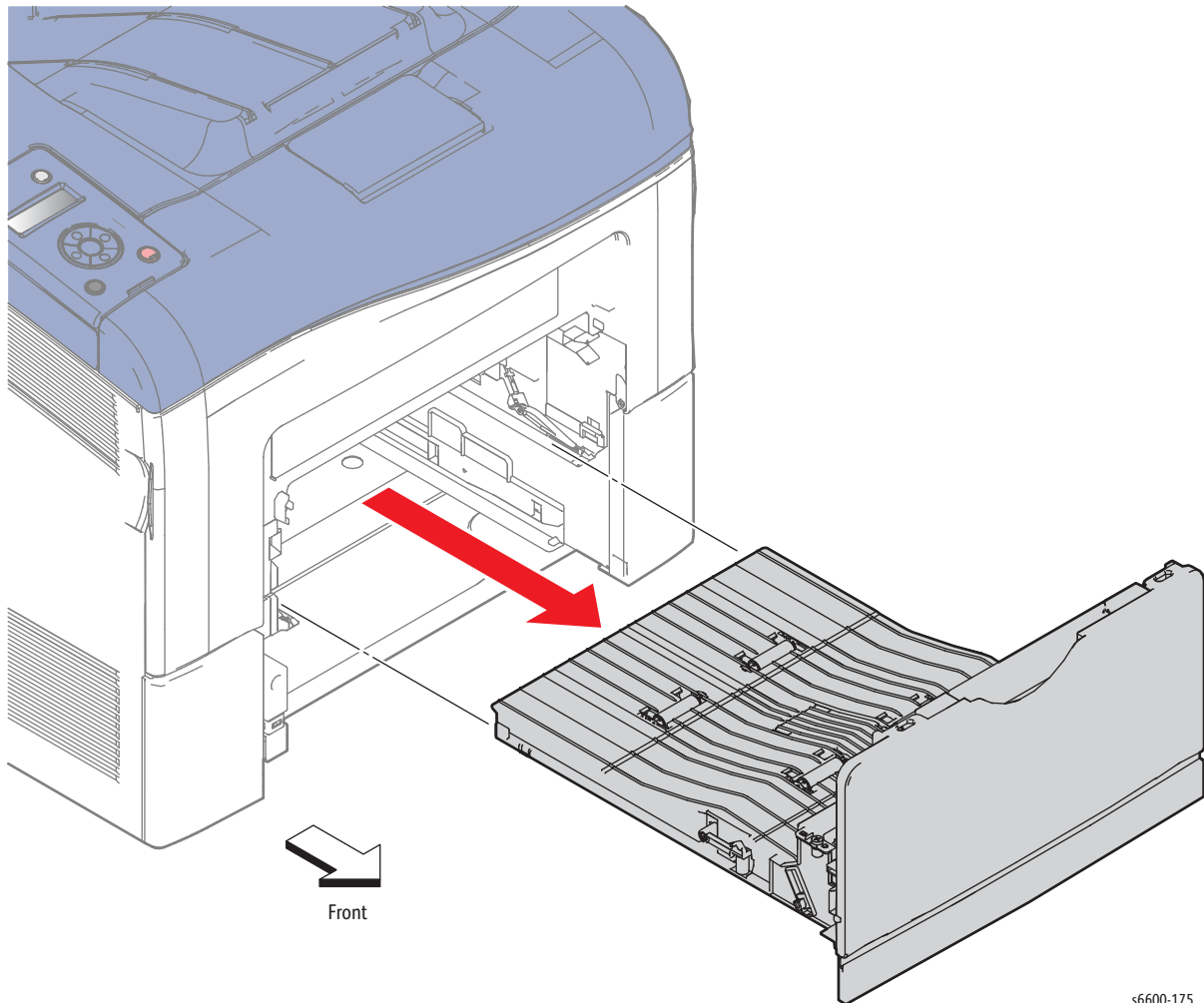


## Bypass Tray Assembly

### PL13.3.1

1. Remove the 550-sheet Paper Tray (PL9.1.1) from the printer.
2. Pull the Bypass Tray Assembly (PL13.3.1) out toward you.

**Note:** The SFP is shown here, but the procedure is exactly the same for the MFP.

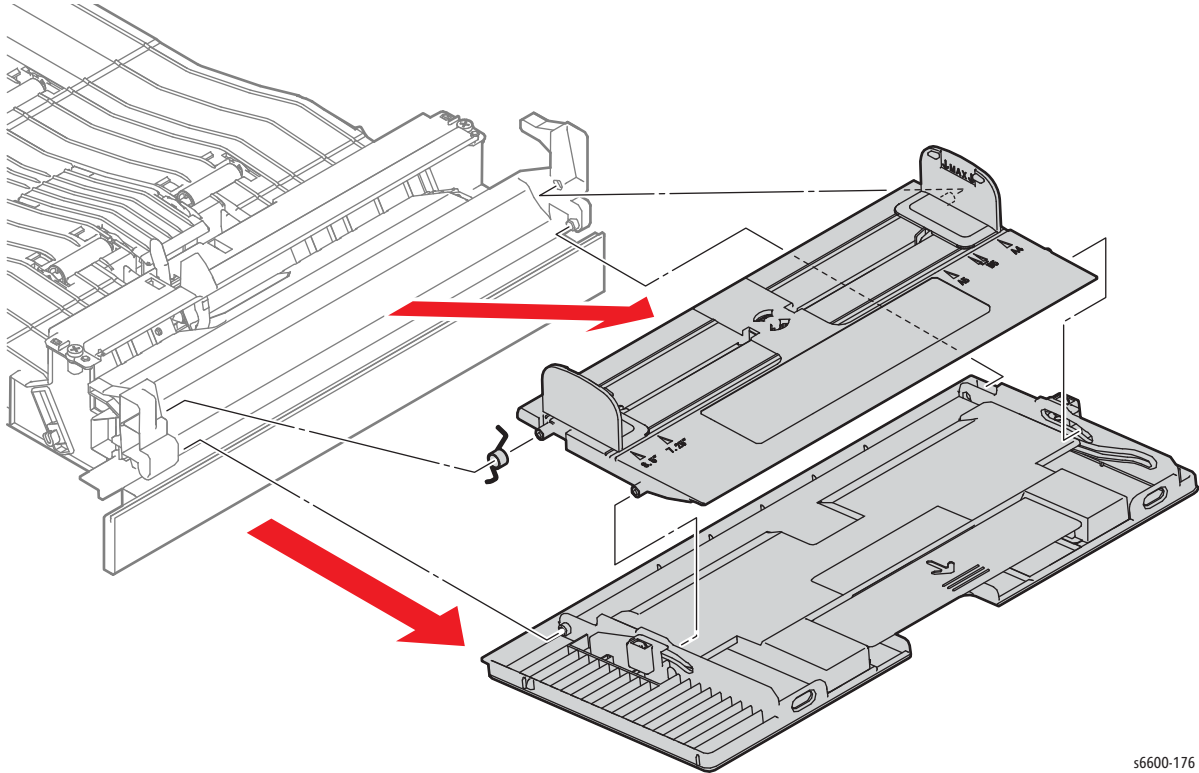


s6600-175

## Bypass Tray Cover Assembly

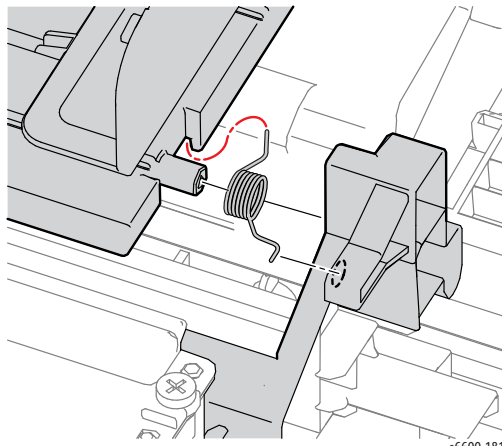
### PL13.3.2

1. Remove the Bypass Tray Assembly. (page 4-71)
2. Open the Bypass Tray Cover Assembly (PL13.3.2).
3. Remove the paper guide from the cover by flexing the paper guide to release the bosses from the holes in both the cover and the tray assembly, and by releasing the Damper Spring (PL13.3.3).
4. Remove the Bypass Tray Cover Assembly (PL13.3.2) by flexing it to release the bosses from the holes.



s6600-176

**Replacement Note:** Check that the Damper Spring is correctly in place.



s6600-181



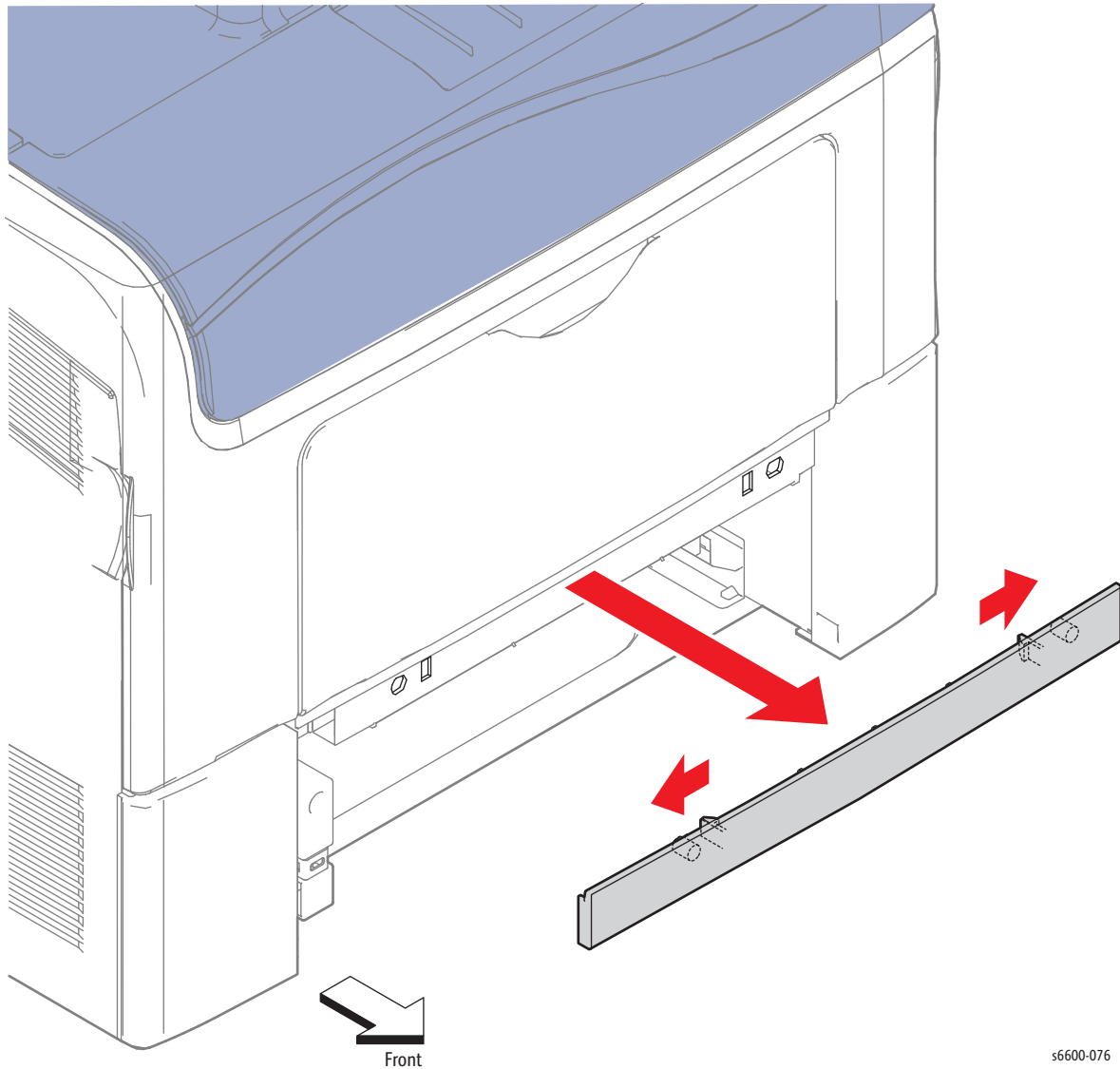
## Bypass Tray Lower Cover

### PL13.3.4

1. Remove the 550 Cassette Assembly from the printer.

**Note:** If the hook position is difficult to locate in the following step, this step can be performed after the removing the Bypass Tray Assembly (page 4-71).

2. Release the two hooks holding the Bypass Tray Lower Cover (PL13.3.4) and remove the cover.



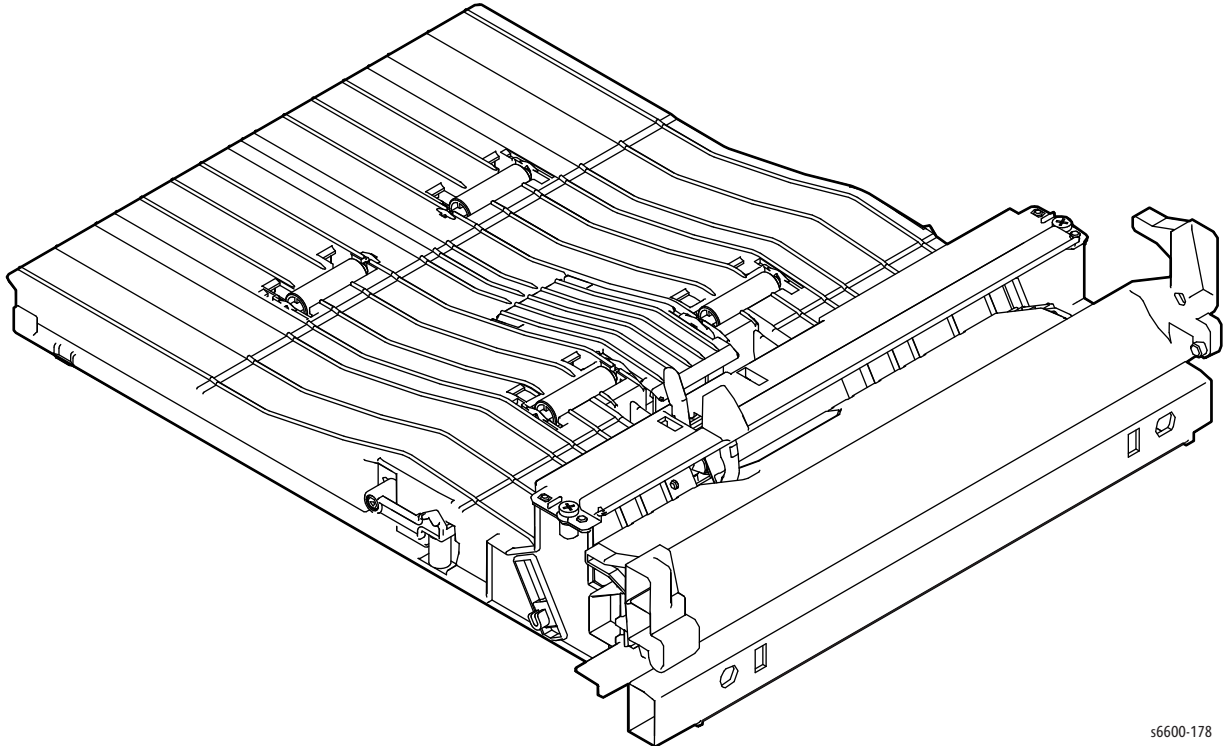
s6600-076

## Bypass Tray Chute Assembly

### (PL13.3.5)

1. Remove the Bypass Tray Assembly. (page 4-71)
2. Remove the Bypass Tray Cover Assembly. (page 4-72)
3. Remove the Bypass Tray Lower Cover. (page 4-73)

**Note:** This figure shows the Bypass Tray Chute Assembly (PL13.3.5) as it appears after the covers are removed.

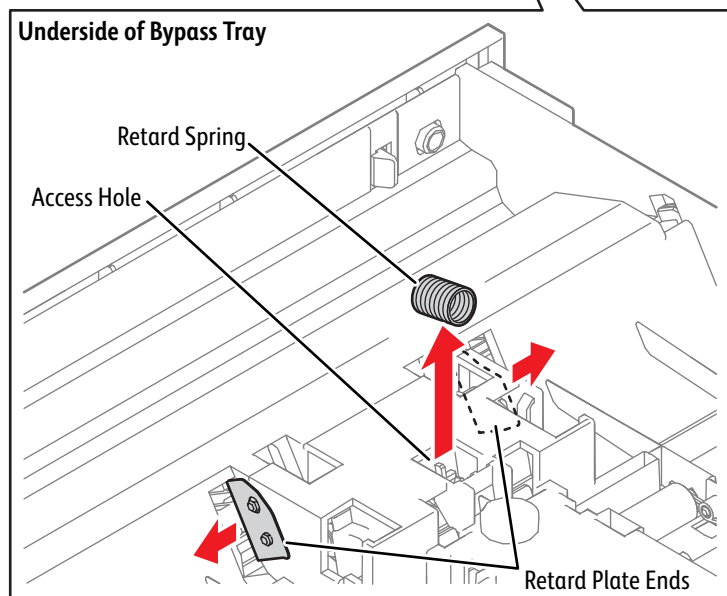
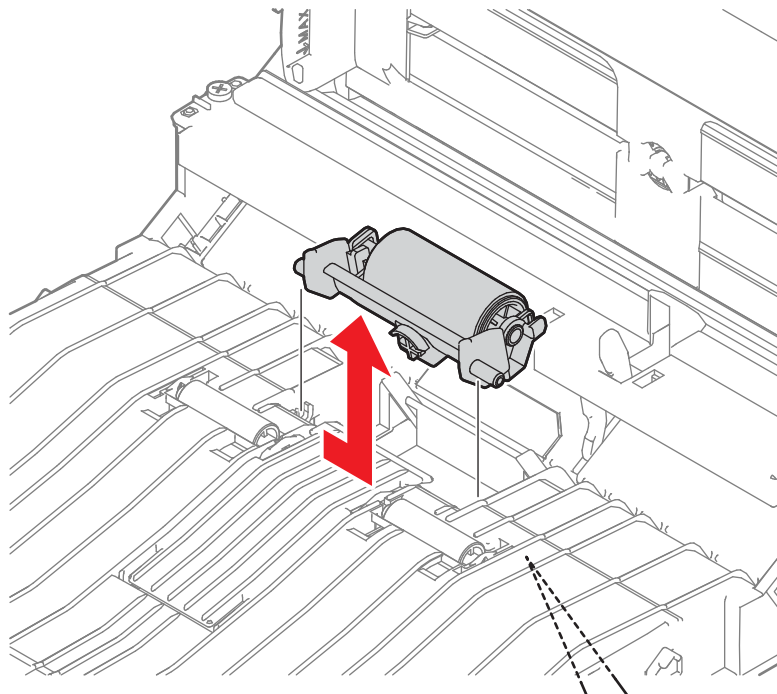


s6600-178

## Retard Holder Assembly

### (PL13.3.14)

1. Remove the Bypass Tray Assembly. (page 4-71)
2. Remove the Bypass Tray Retard Spring (PL13.3.13) through the access hole on the underside of the tray.
3. Release the ends of the Bypass Tray Retard Plate Assembly from the bosses, and move the plate as far forward as possible.
4. Slide the Retard Holder Assembly (PL13.3.14) to the left and remove it upward by releasing the right shaft first.

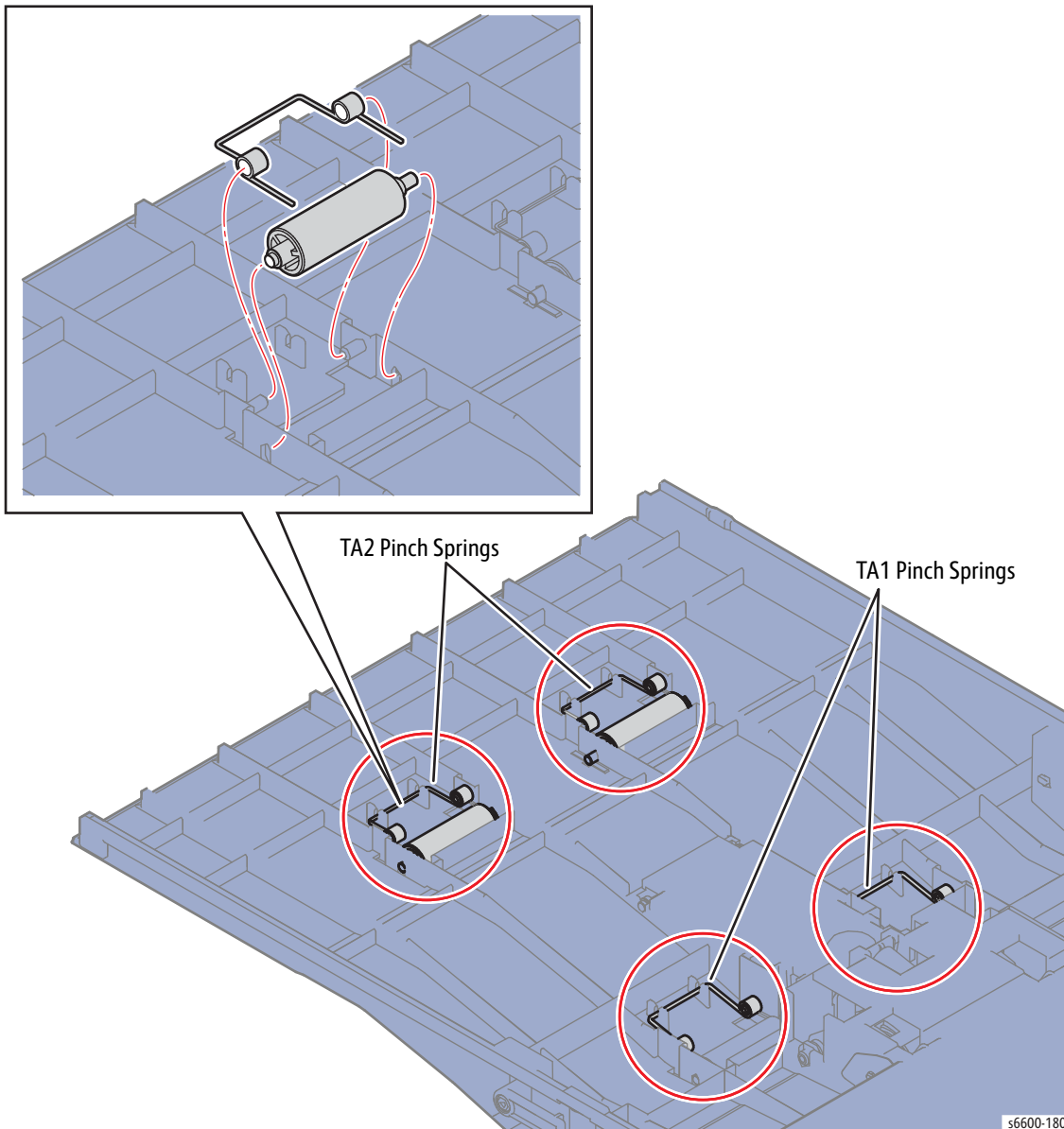


s6600-179

## Bypass Tray Pinch Roller

### (PL13.3.9)

1. Remove the Bypass Tray Assembly. (page 4-71)
2. Turn over the Bypass Tray Assembly.
3. Remove the pinch spring from the roller being removed.
4. Remove the Bypass Tray Pinch Roller (PL13.3.9).



**Replacement Note:** The TA1 and TA2 Pinch Springs are not the same. Carefully note the difference in the springs when removing, and use caution not to confuse the springs when reinstalling.

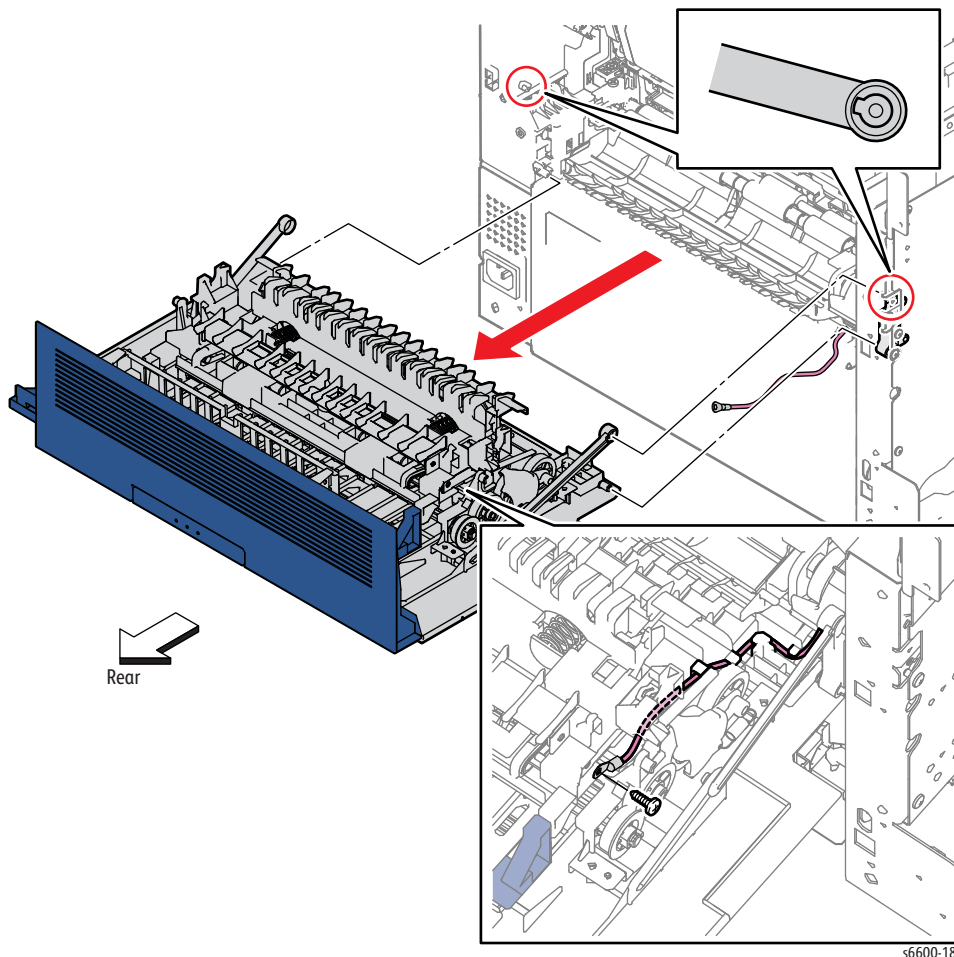
# Duplex

## Duplex Assembly

### PL14.1.1

**! WARNING:** The Fuser is very hot. Take added care when handling the fuser to avoid being burned.

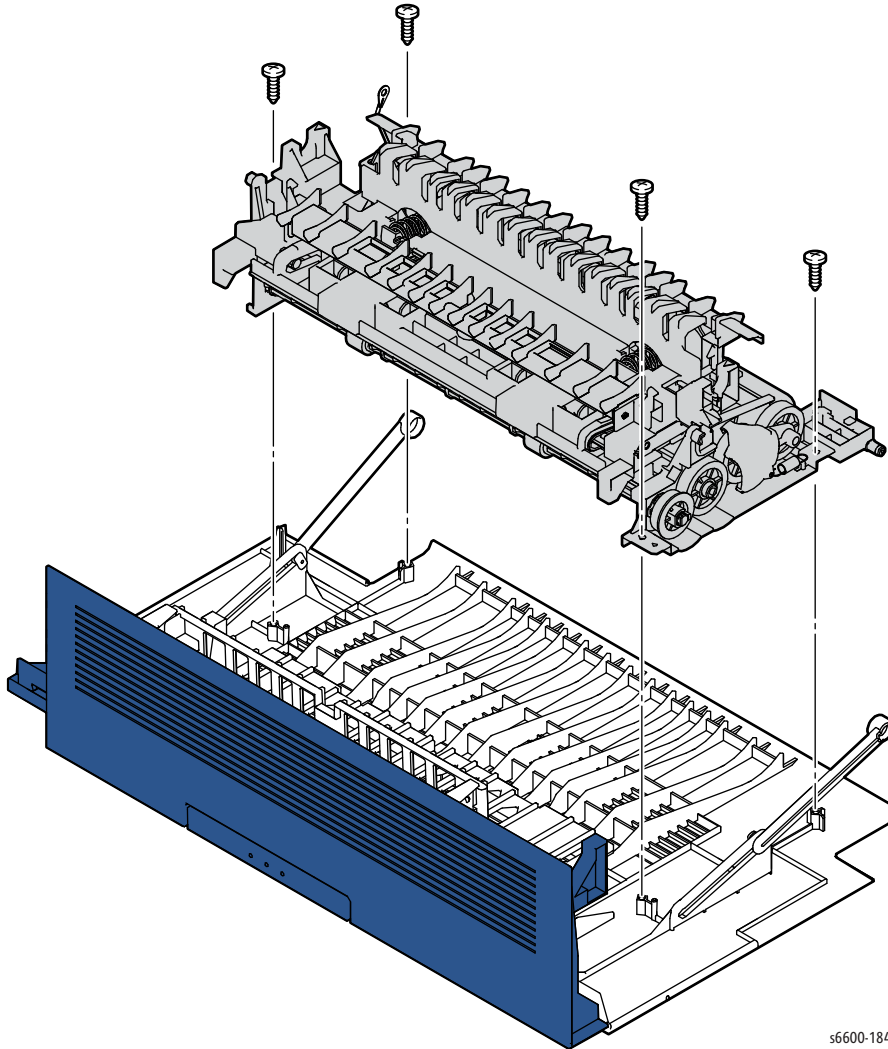
1. Open the Rear Door Assembly (PL19.1.95).
2. Remove the Transfer Roller. (page 4-79)
3. Remove the screw (silver, tapping, 8mm) that attaches the power supply (pink wire) to the Duplex Assembly (PL14.1.1), and release the wire from the harness guide.
4. Remove the Rear Cover Links by raising the Rear Cover slightly so that the holes on the Rear Cover Links can be released from the keyed bosses on the left and right.
5. Raise the steel hinge pin on the left side and slide the pin to the right to remove it.
6. Swing the right side of the assembly out so that the corner is clear of the frame, then move the assembly to the left to disengage the hinge pin on the right side. When the grounding spring is clear of the hinge pin, lift the Rear Cover/Duplex Assembly away from the printer.



s6600-183

**Note:** Perform the following step only if you need to separate the Duplex Assembly from the Rear Door Assembly.

7. Remove the four screws (silver, tapping, 8mm) that attach the Duplex Assembly to the Rear Cover and remove the assembly.

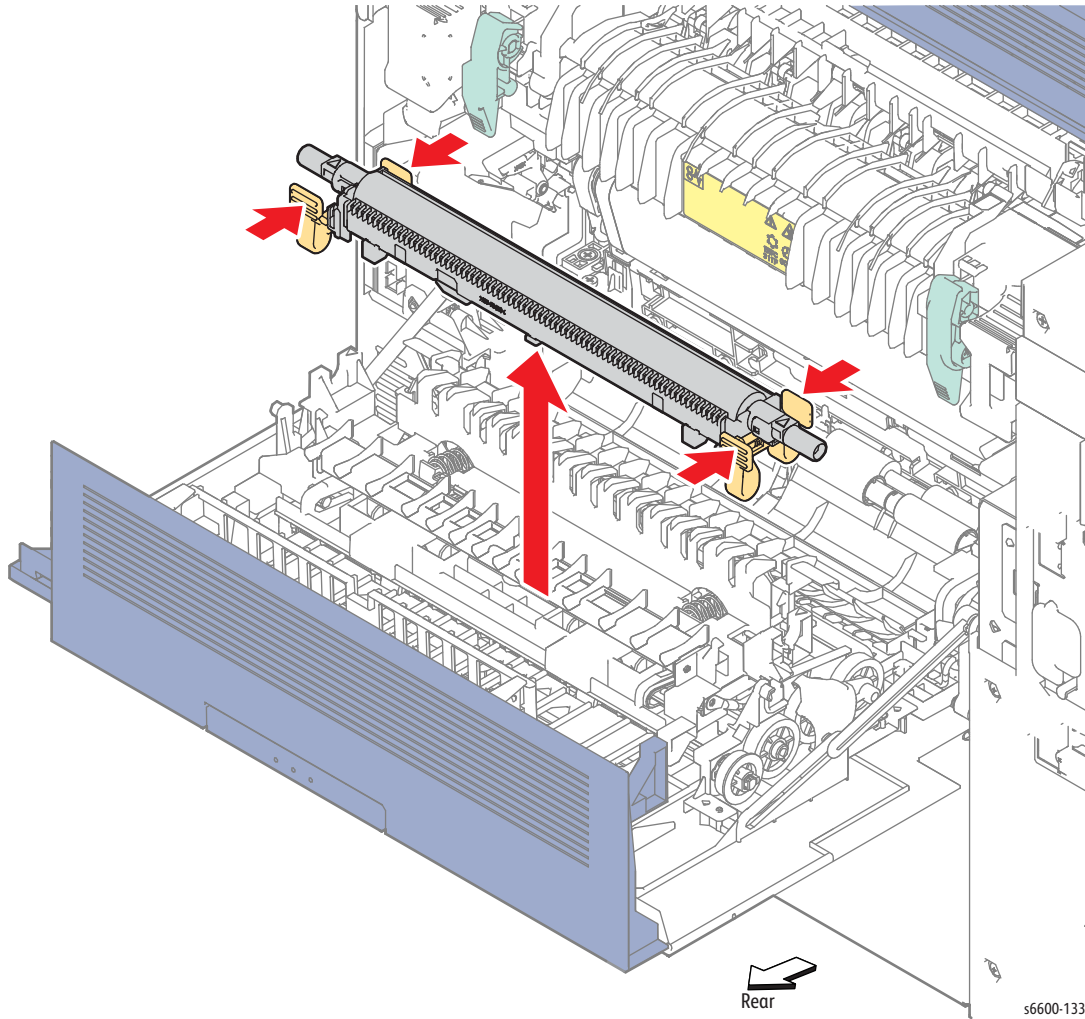


56600-184

## Transfer Roller

(PL14.1.2)

1. Open the Rear Door Assembly (PL19.1.95).
2. Remove the Transfer Roller upward while squeezing the tabs holding it.



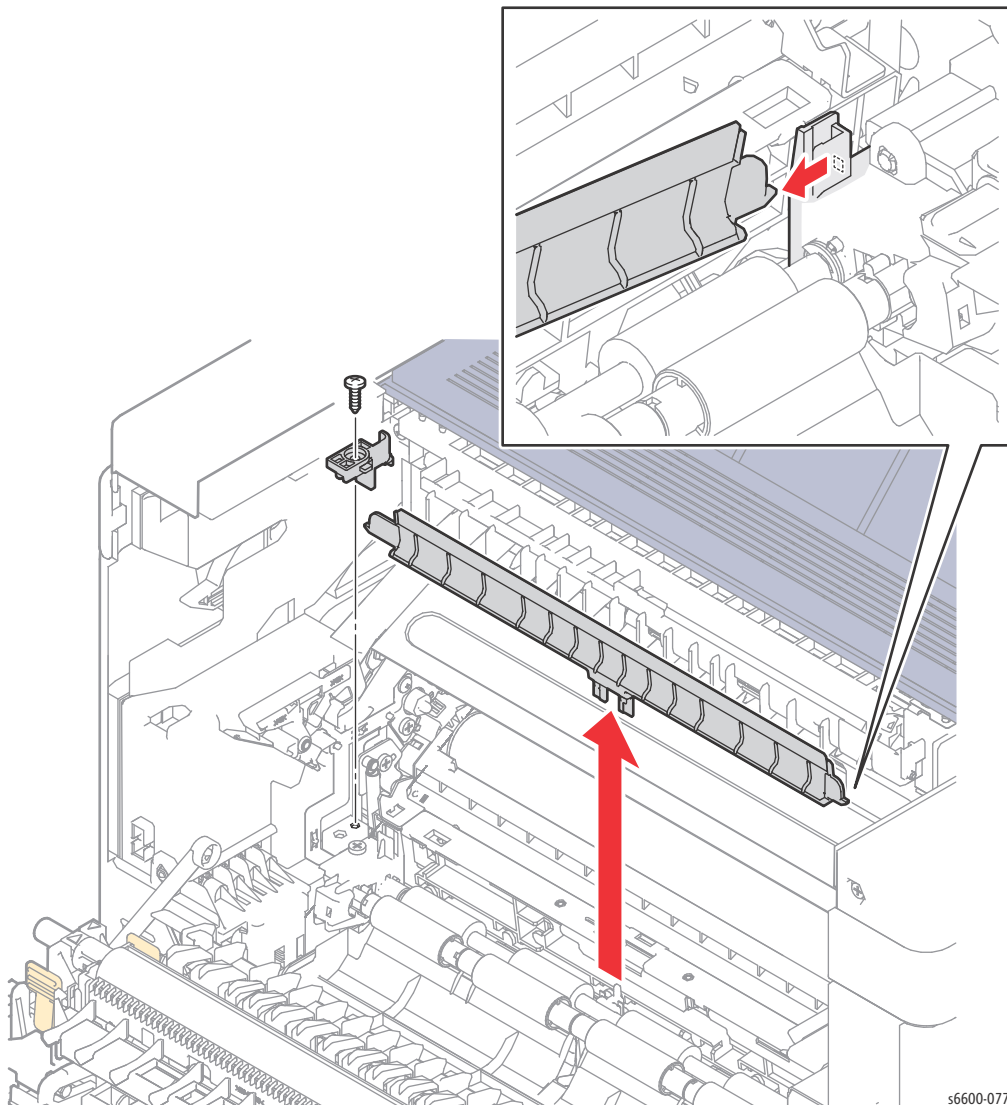
## Registration / Feeder

### Upper Transfer Belt Chute Assembly

#### PL15.1.6

**!** **WARNING:** The Fuser is very hot. Take added care when handling the fuser to avoid being burned.

1. Remove the Fuser Assembly. (page 4-46)
2. Remove the Transfer Belt Assembly. (page 4-38)
3. Remove the screw (silver, tapping, 8mm) that attaches the R CTD Guide (PL6.1.12) to the printer and remove the guide.
4. Raise the right end of the Upper Transfer Belt Chute Assembly (PL15.1.6), release the hook on the left from the hole and remove the Upper Transfer Belt Chute Assembly.



s6600-077

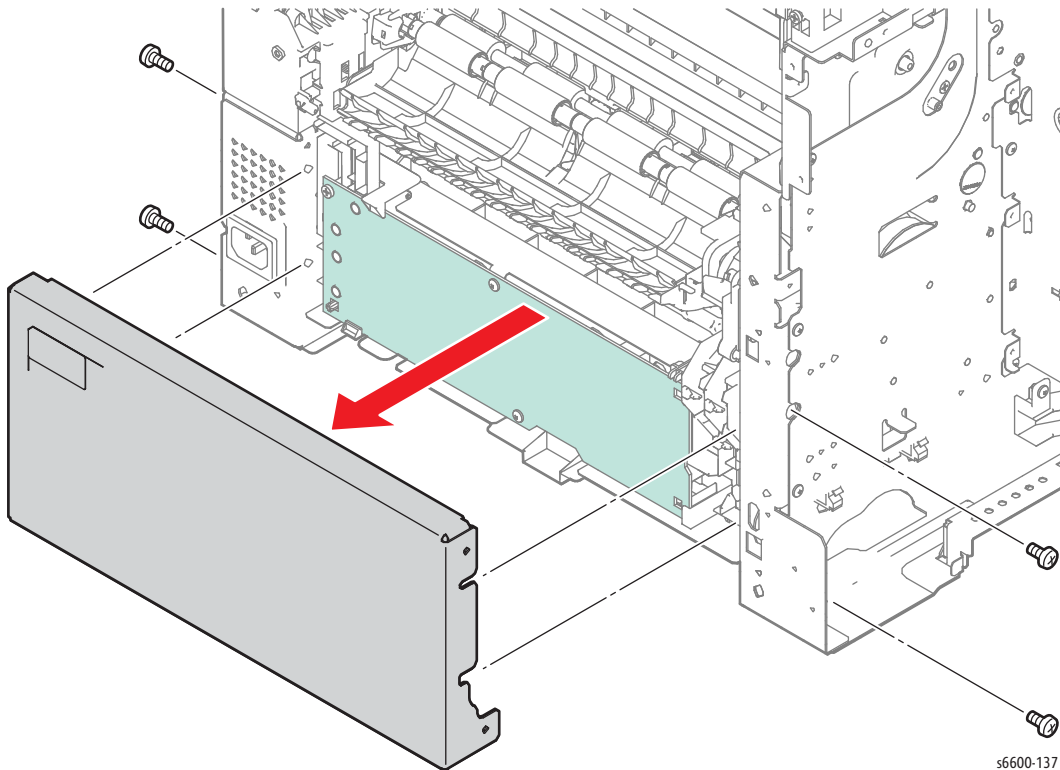


## Regi Clutch Assembly

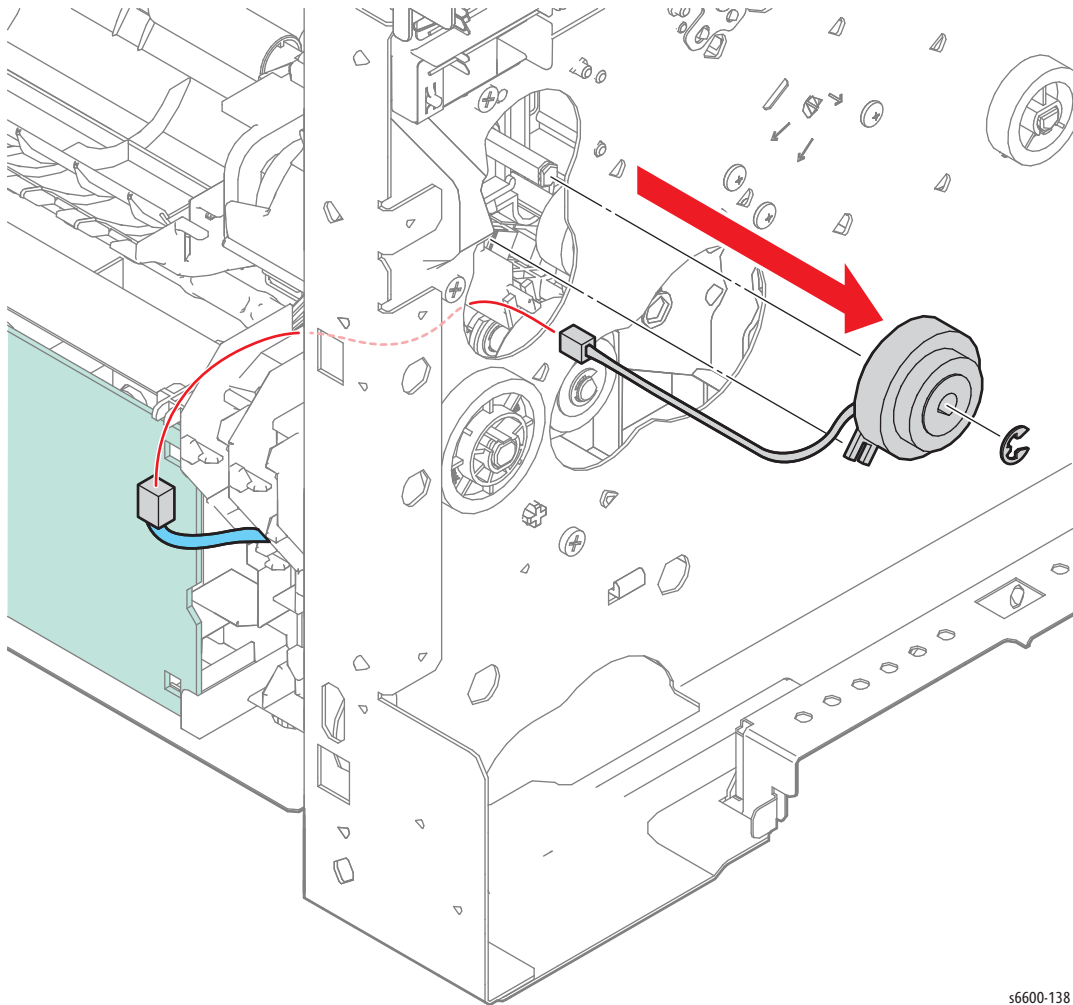
### PL15.1.8

**!** **WARNING:** The Fuser is very hot. Take added care when handling the fuser to avoid being burned.

1. Remove the Fuser Assembly. (page 4-46)
2. Remove the Transfer Roller. (page 4-79)
3. Remove the Waste Cartridge. (page 4-50)
4. Remove the Waste Cartridge Lock. (page 4-39)
5. Remove the Development HVPS Board. (page 4-99)
6. Remove the IP Board. (SFP page 4-102; MFP page 4-104)
7. Remove the Drive Assembly. (SFP page 4-11; MFP page 4-16)
8. Remove the Duplex Assembly. (page 4-77)
9. Remove the four screws (silver, 6mm) that attach the S3 Rear Frame (PL4.1.6) to the printer and remove the frame.



10. Unplug connector P/J234 on the harness coming from the Regi Clutch Assembly (PL15.1.8), and release the harness from the harness guide.
11. Remove the E-ring holding the Regi Clutch Assembly, and pull the assembly off the shaft.



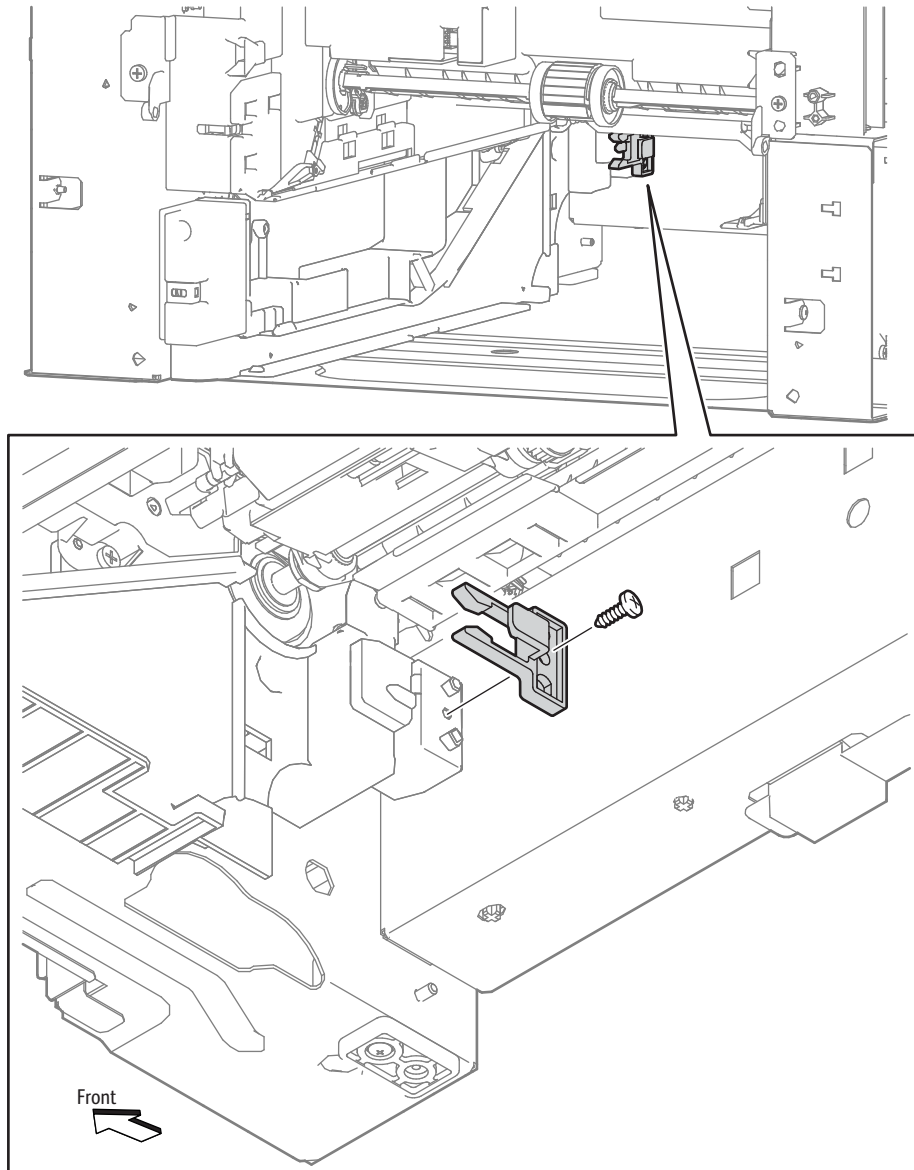
s6600-138

## Cassette Stopper

### PL15.1.10

**!** **WARNING:** The Fuser is very hot. Take added care when handling the fuser to avoid being burned.

1. Remove the Lower Regi Chute / Opt 550 Regi Chute. (page 4-85)
2. Remove the screw (silver, tapping, 8mm) that attaches the CST Stopper (PL15.1.10) to the printer and remove the stopper.



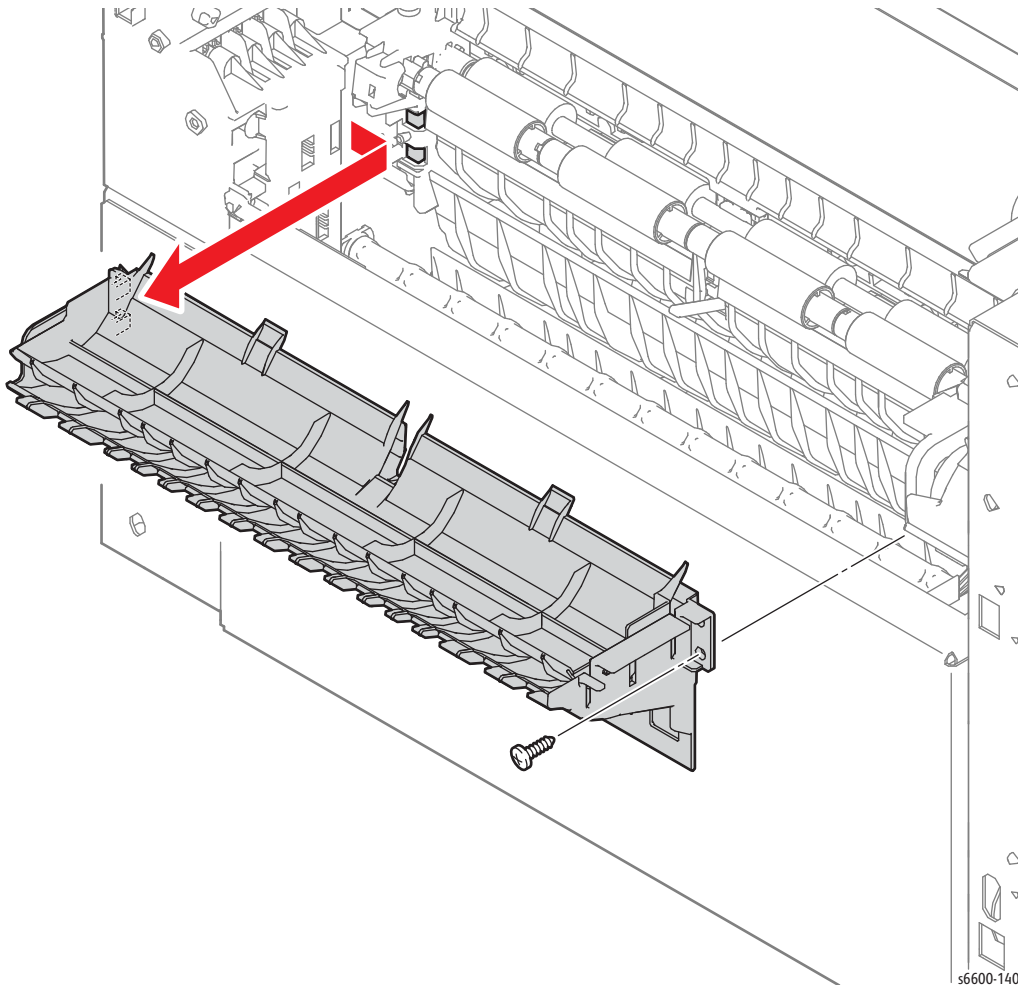
s6600-139

## Duplex Chute Assembly Kit

(PL15.1.2) / (PL15.1.3)

**!** **WARNING:** The Fuser is very hot. Take added care when handling the fuser to avoid being burned.

1. Remove the Fuser Assembly. (page 4-46)
2. Remove the Transfer Roller. (page 4-79)
3. Remove the Waste Cartridge. (page 4-50)
4. Remove the Waste Cartridge Lock. (page 4-39)
5. Remove the Front Door Assembly. (page 4-128)
6. Remove the Right Cover Assembly. (page 4-131)
7. Remove the Left Cover Assembly. (SFP page 4-134; MFP page 4-136)
8. Remove the IP Board. (SFP page 4-102; MFP page 4-104)
9. Remove the Duplex Assembly. (page 4-77)
10. Release the screw (silver, tapping, 8mm) that attaches the Lower A Duplex Chute (PL15.1.3), release the two hooks and remove the Upper Duplex Chute together with the Lower A Duplex Chute.

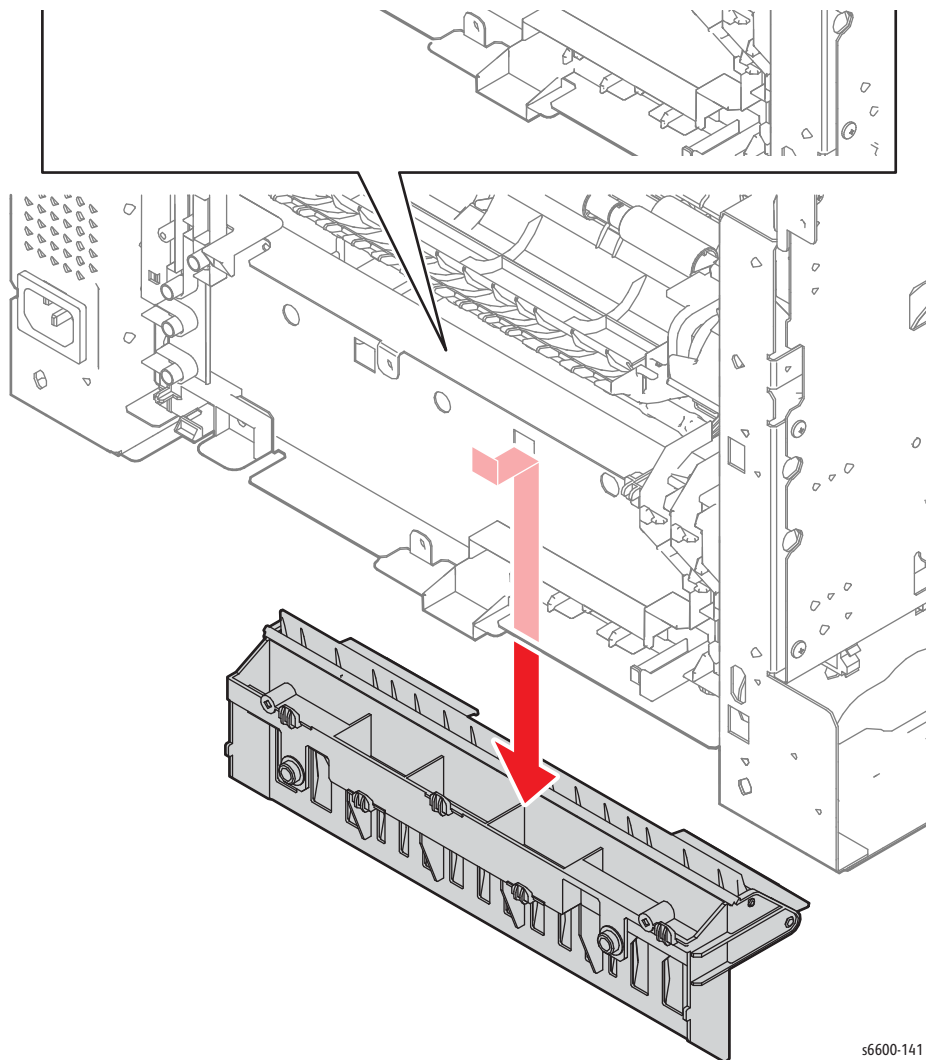


## Lower Regi Chute / Opt 550 Regi Chute

### PL15.1.4 / PL15.1.5

**!** **WARNING:** The Fuser is very hot. Take added care when handling the fuser to avoid being burned.

1. Remove the 550 Cassette Assembly from the printer.
2. Remove the Transfer Roller. (page 4-79)
3. Remove the Duplex Assembly. (page 4-77)
4. Remove the Transfer HVPS Board. (page 4-108)
5. Remove the Opt 550 Regi Chute by releasing the two bosses and by sliding the Opt 550 Regi Chute downward to release the hook.



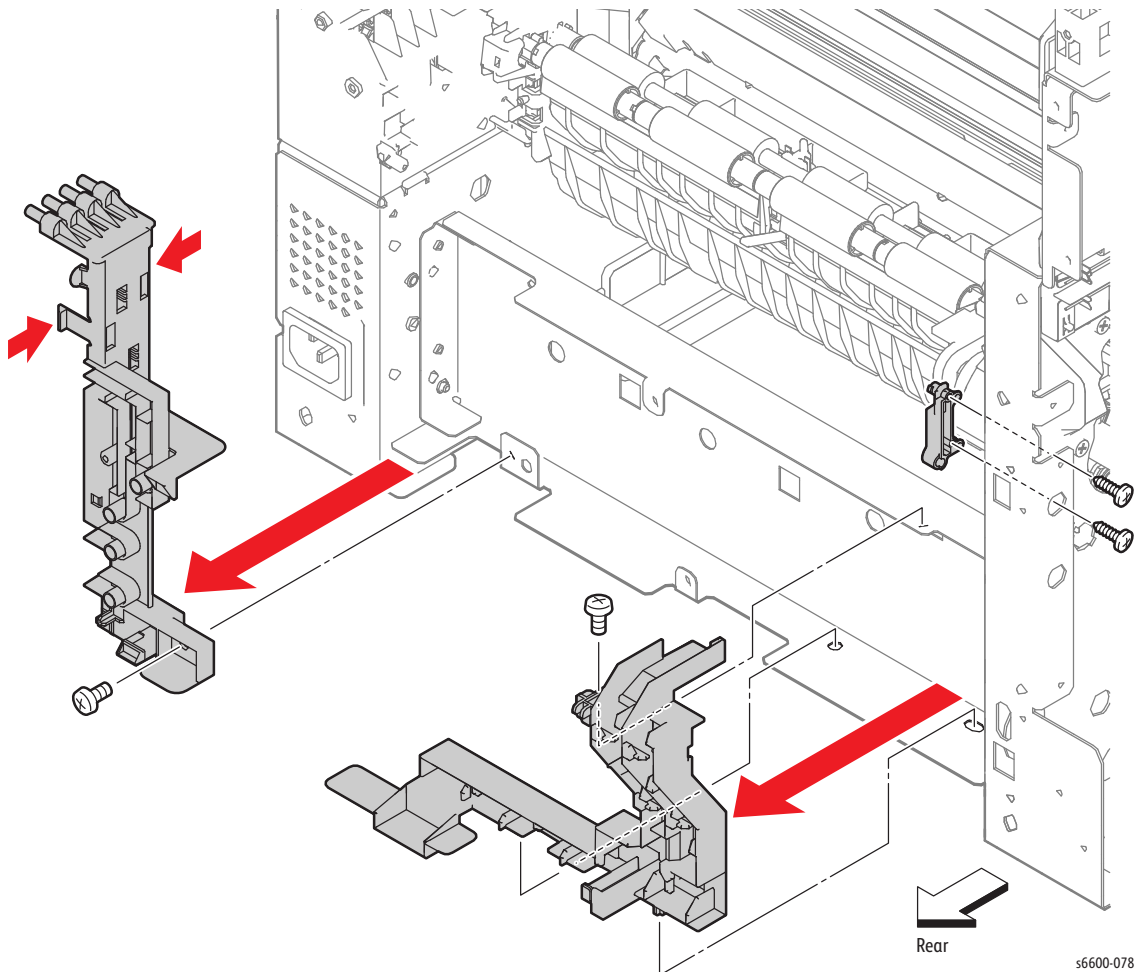
56600-141

## Regi Chute Assembly / Rear Hinge Bracket

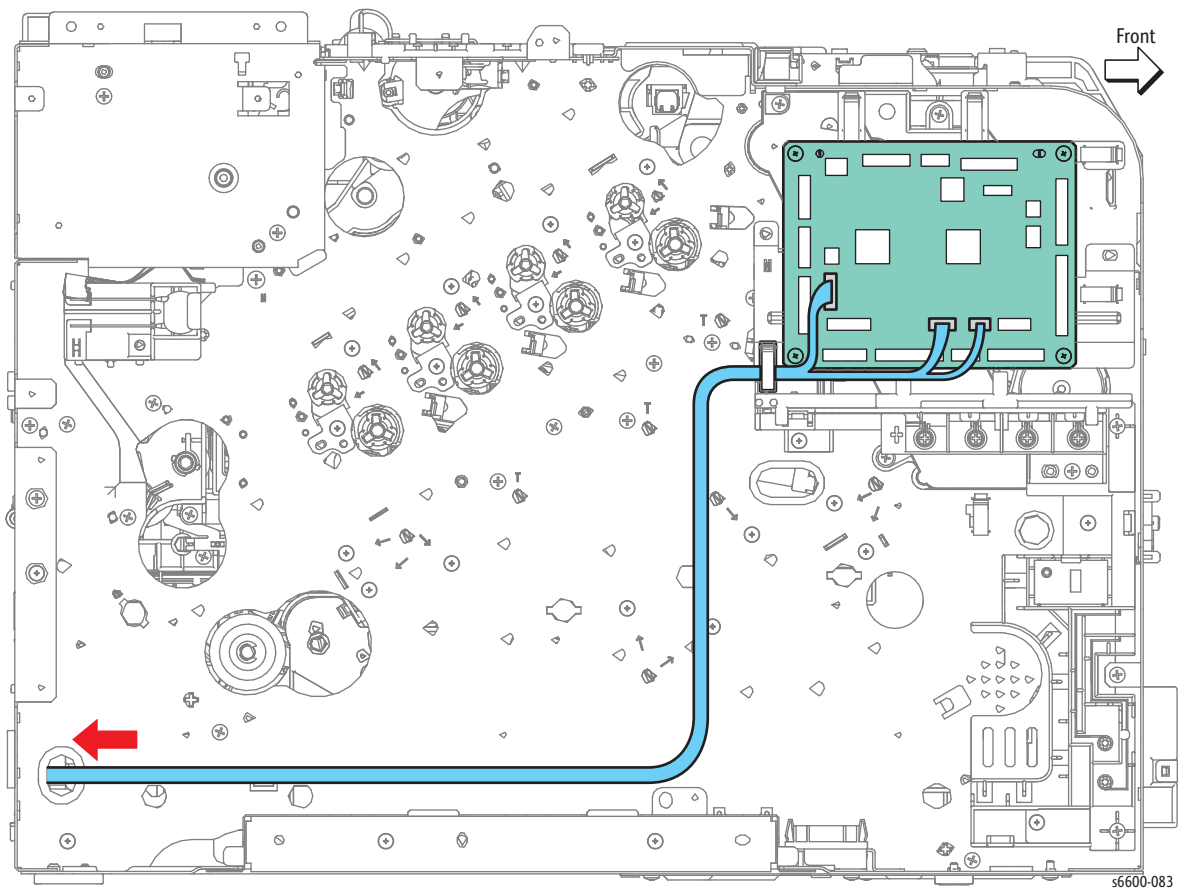
### PL15.2.1 / PL14.1.4

**! WARNING:** The Fuser is very hot. Take added care when handling the fuser to avoid being burned.

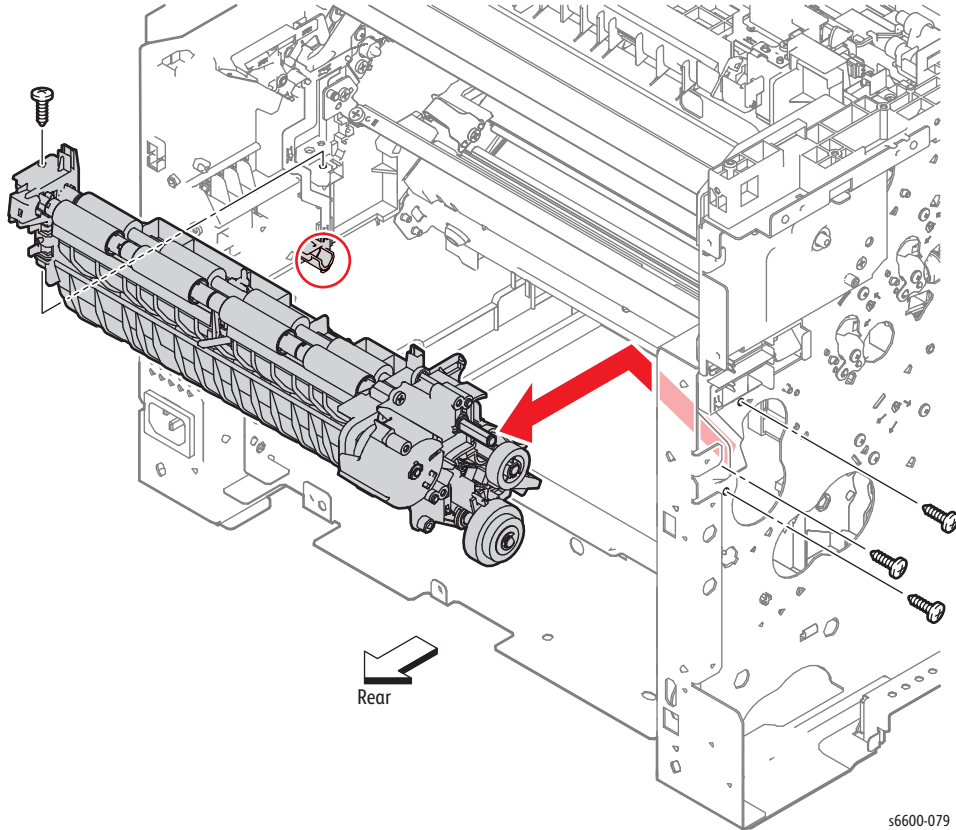
1. Remove the Left Transfer Belt Guide Assembly. (page 4-40)
2. Remove the CTD Sensor Assembly. (page 4-41)
3. Remove the Drive Shaft Assembly. (page 4-21)
4. Remove the Lower Regi Chute / Opt 550 Regi Chute. (page 4-85)
5. Remove the Regi Clutch Assembly. (page 4-81)
6. Remove the Inner Transfer Wire Housing Assembly (PL18.1.30) by removing the screw (silver, 6mm) near the bottom, and by releasing the two hooks on the sides.
7. Release the harness from the PH Harness Guide (PL18.1.29).
8. Remove the PH Harness Guide by removing the screw (silver, 6mm) that attaches the PH Harness Guide and by releasing the two hooks.
9. Remove the two screws (silver, tapping, 8mm) that attach the Rear Hinge Bracket (PL14.1.4) and remove the Rear Hinge Bracket.



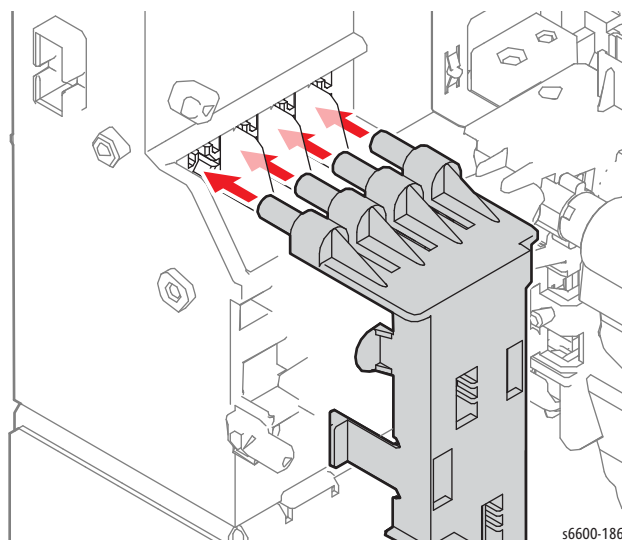
10. Unplug connectors P/J13, P/J23, and P/J39 from the MCU Board (PL18.1.13), and release the harness from the clamp.
11. Pull the harness out of the hole on the frame.



12. Remove the four screws (silver, tapping, 8mm) that attach the Regi Chute Assembly.
13. Remove the two screws (silver, tapping, 8mm) that attach the Rear Hinge Bracket (PL14.1.4) and remove the Rear Hinge Bracket.
14. Remove the Regi Chute Assembly by releasing its right lug from the recess while moving the shaft end of the Regi Clutch Assembly along the recess on the left frame of the printer.



**Replacement Note:** When installing the Inner Transfer Wire Housing Assembly, check that the ends of the four springs fit correctly into the holes.



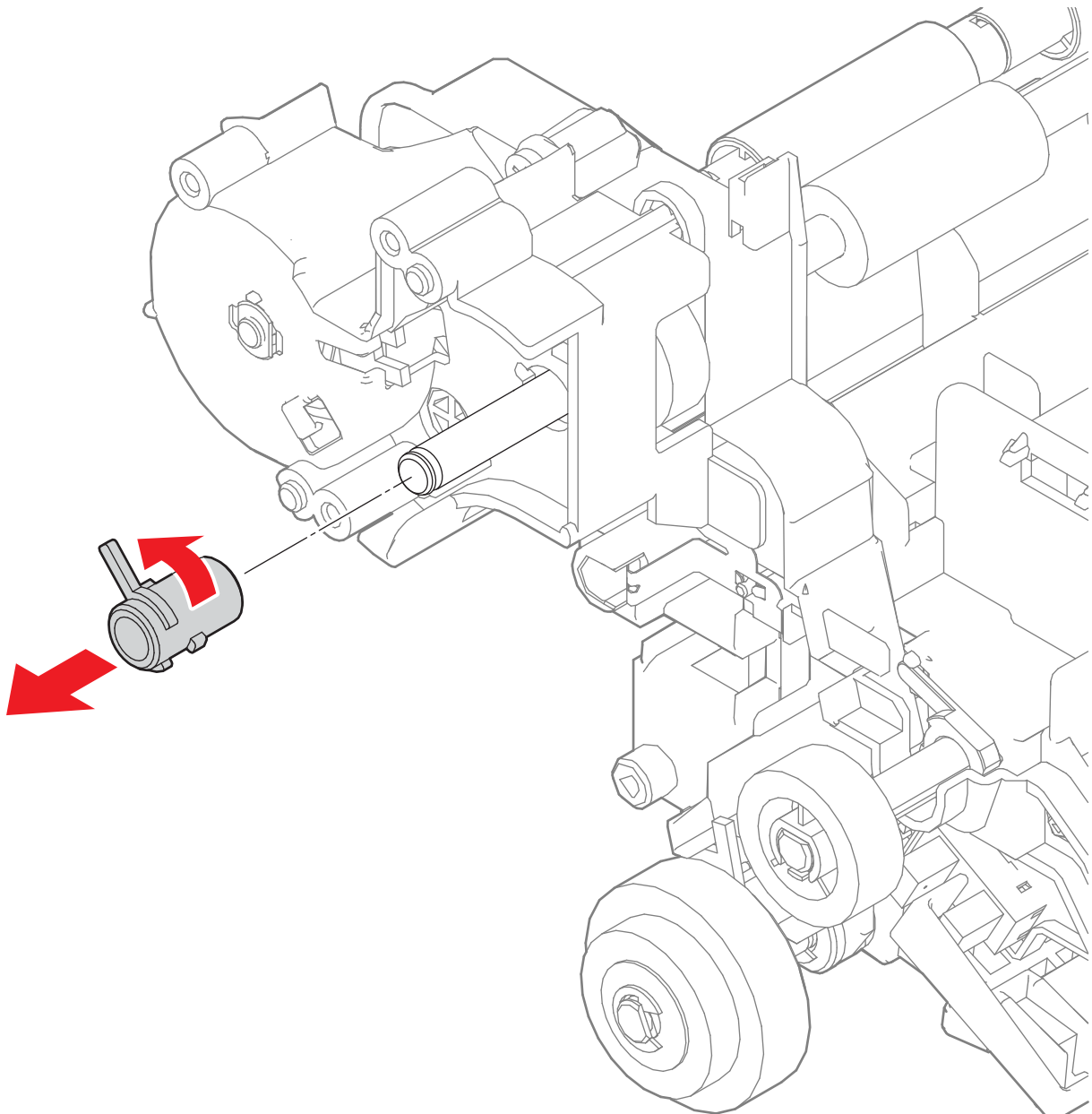


## Right Regi Bearing

### PL15.2.2

**!** **WARNING:** The Fuser is very hot. Take added care when handling the fuser to avoid being burned.

1. Remove the Regi Chute Assembly. (page 4-86)
2. Unlock the Right Regi Bearing (PL15.2.2) by rotating it counterclockwise and remove it.



## Duplex Clutch Assembly

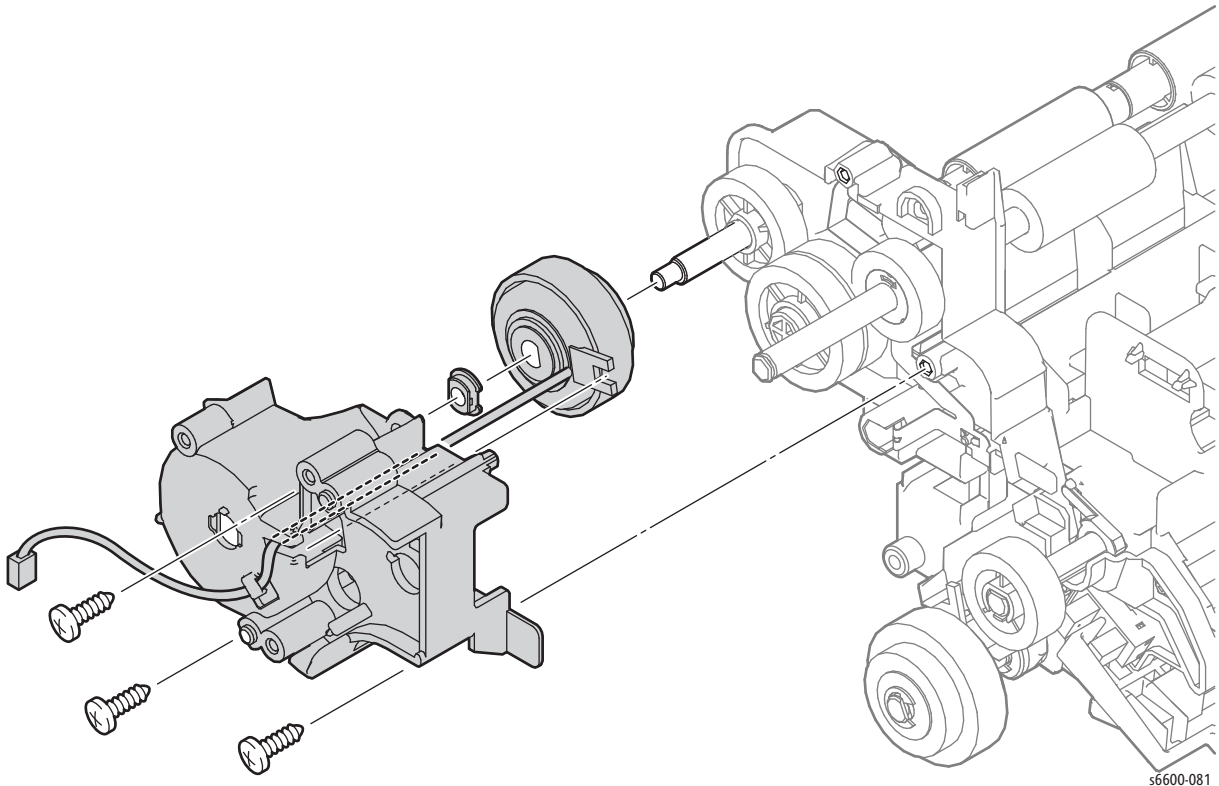
### PL15.2.5

**! WARNING:** The Fuser is very hot. Take added care when handling the fuser to avoid being burned.

1. Remove the Right Regi Bearing. (page 4-89)
2. Release the harness from the harness guide of the Duplex Gear Cover (PL15.2.3).
3. Remove the three screws (silver, tapping, 8mm) that attach the Duplex Gear Cover to the printer and remove the cover.

**! CAUTION:** The gears and shafts of the Duplex Clutch Assembly easily fall off of the assembly. Use care when removing to avoid losing or damaging any of the parts.

4. Remove the Duplex Clutch Assembly (PL15.2.5) from the shaft.



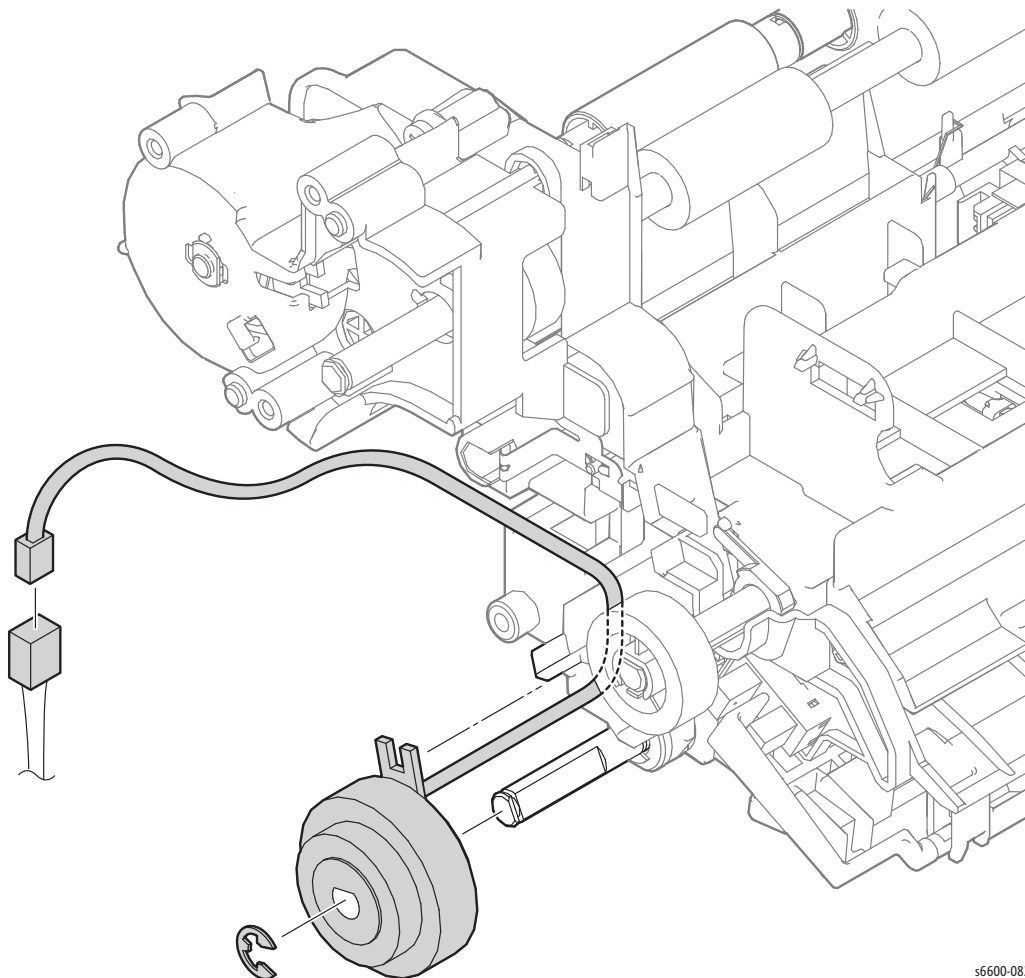
s6600-081

## Feed Clutch Assembly

### PL15.2.6 (Same as PL 10.1.8)

**!** **WARNING:** The Fuser is very hot. Take added care when handling the fuser to avoid being burned.

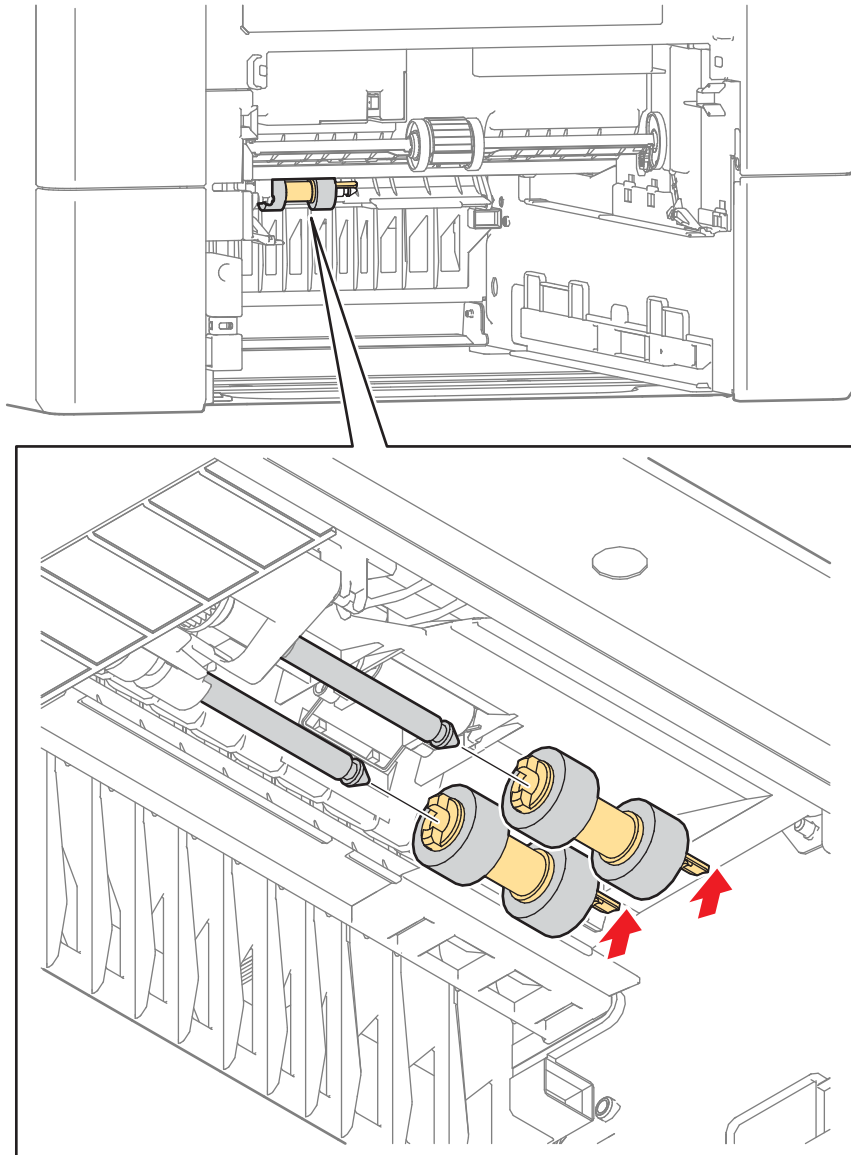
1. Remove the Regi Chute Assembly. (page 4-86)
2. Unplug connector P/J392 on the harness coming from the Feed Clutch Assembly, and release the harness from the harness guide.
3. Remove the E-ring holding the the Feed Clutch Assembly, and then pull the clutch off of the shaft.



## Feed Roller Assembly

### PL15.2.7

1. Remove the 550 Cassette Assembly from the printer.
2. Remove the Bypass Tray Assembly. (page 4-71)
3. Release the latch that holds the Feed Roller Assembly on the shaft, and slide the roller to the right off the shaft.



s6600-185

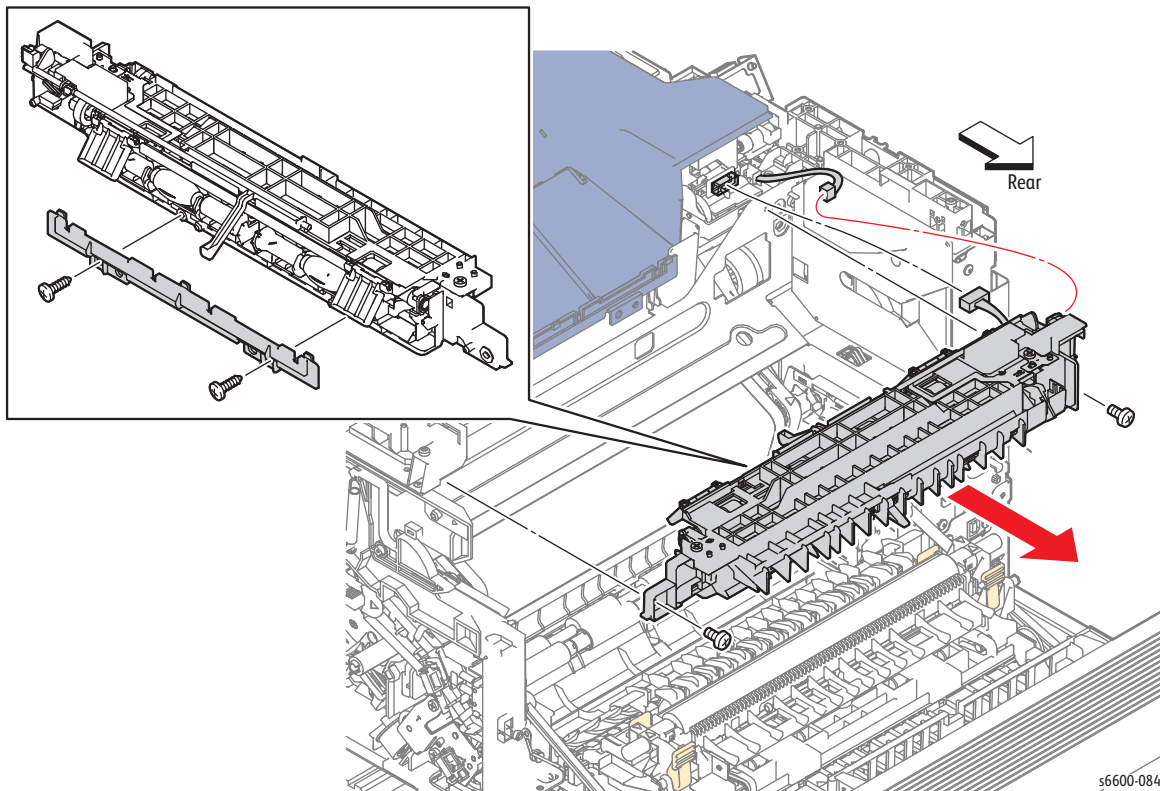
# Exit

## Exit Assembly

(PL17.1.1)

**! WARNING:** The Fuser is very hot. Take added care when handling the fuser to avoid being burned.

1. Remove the Right Cover Assembly. (page 4-131)
2. Remove the Exit Cover. (page 4-125)
3. Remove the two screws (silver, 6mm) that attach the Exit Assembly (PL17.1.1) to the printer and remove the Exit Assembly.
4. Unplug connectors P/J151 and P/J154 of the Exit Assembly.
5. Remove the two screws (silver, tapping, 8mm) that attach the Exit Tray Cover (PL17.1.20) to the Exit Assembly and remove the cover.

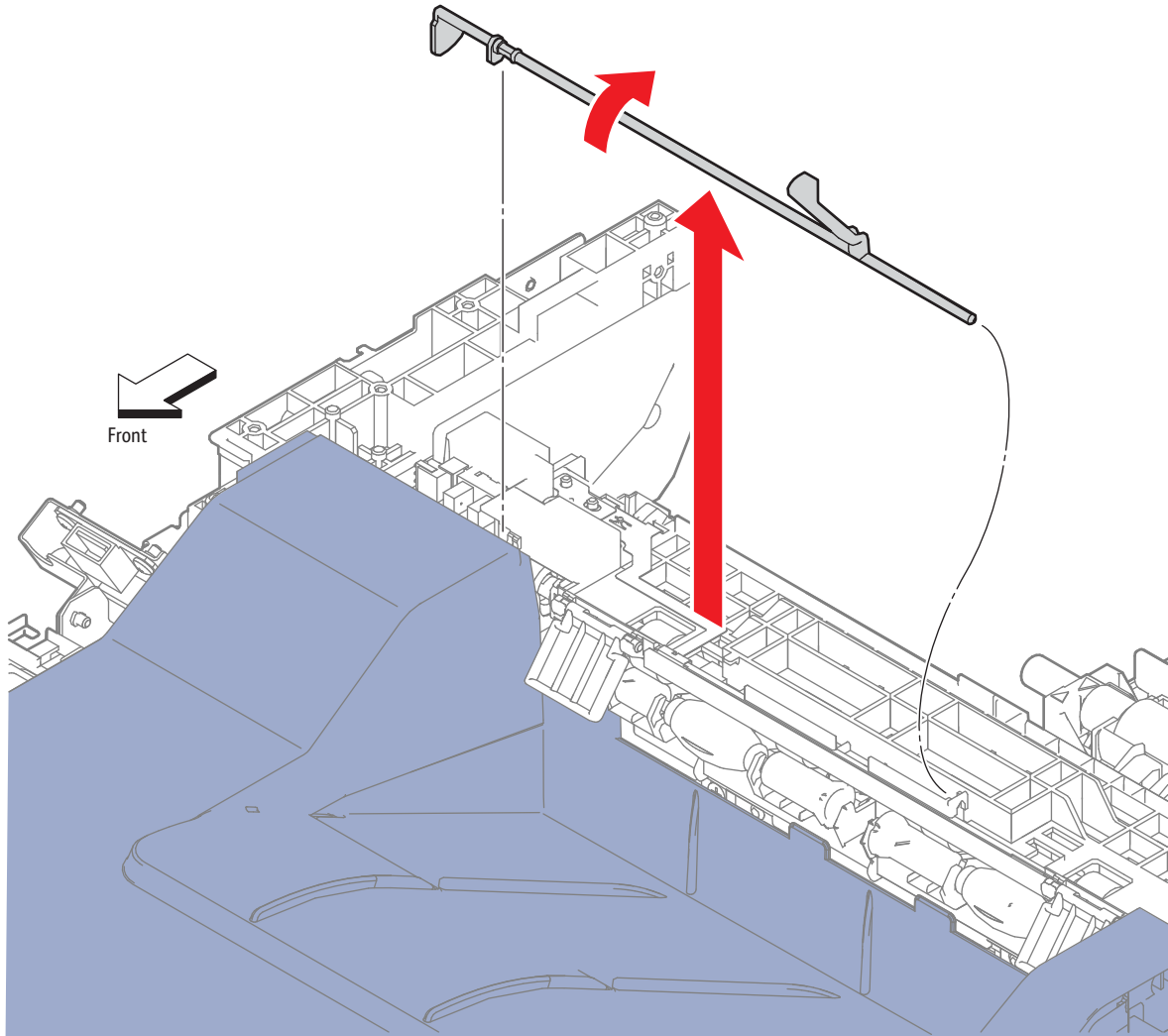


## Stack Full Actuator

### PL17.1.10

**!** **WARNING:** The Fuser is very hot. Take added care when handling the fuser to avoid being burned.


1. Remove the Exit Cover. (page 4-125)
2. Remove the Stack Full Actuator (PL17.1.10) by swinging it 90° upward, and by releasing the left end, and then by releasing the right end from the hole.



s6600-085

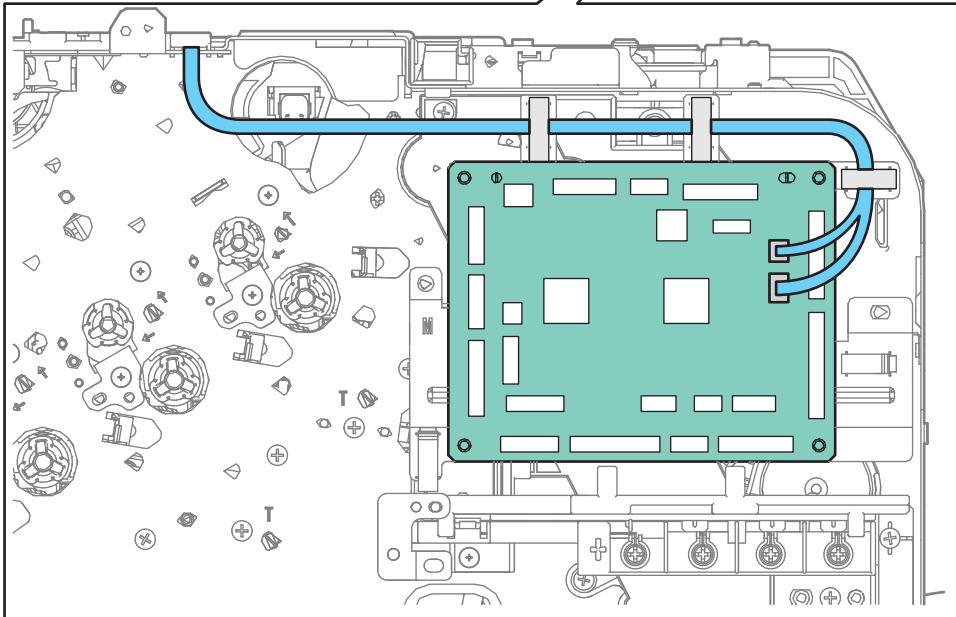
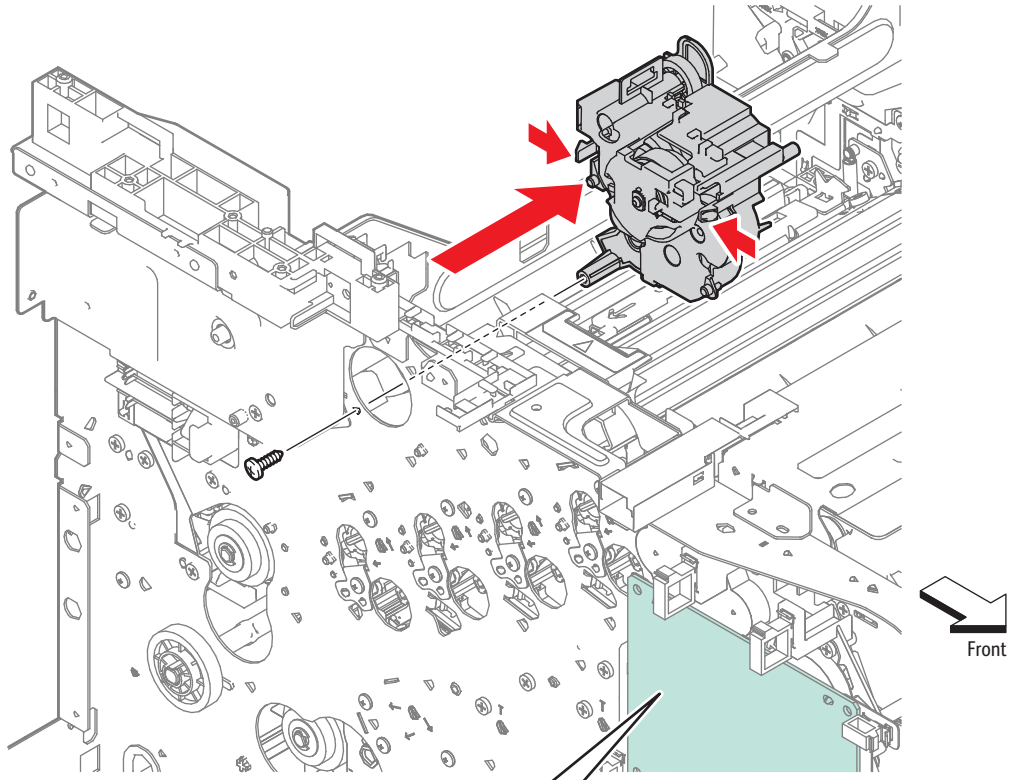
## Exit Drive Assembly

(PL17.1.21)

 **WARNING:** The Fuser is very hot. Take added care when handling the fuser to avoid being burned.

1. Remove the Transfer Belt Assembly. (page 4-38)
2. Remove the Top Cover Assembly. (SFP page 4-115; MFP page 4-118)
3. Remove the Development HVPS Board. (page 4-99)
4. Remove the IP Board. (SFP page 4-102; MFP page 4-104)
5. Remove the Drive Assembly. (SFP page 4-11; MFP page 4-16)
6. Remove the Exit Assembly. (page 4-93)
7. Unplug connectors P/J38 and P/J40 connected to the MCU Board (PL18.1.13), and release the harness from the clamp and the harness guide.
8. Unplug the harness from the interim connector on top of the Exit Drive Assembly.

9. Remove the screw (silver, tapping, 8mm) that attaches the Exit Drive Assembly.
10. Release the two latches holding the Exit Drive Assembly and remove the exit assembly.



56600-086

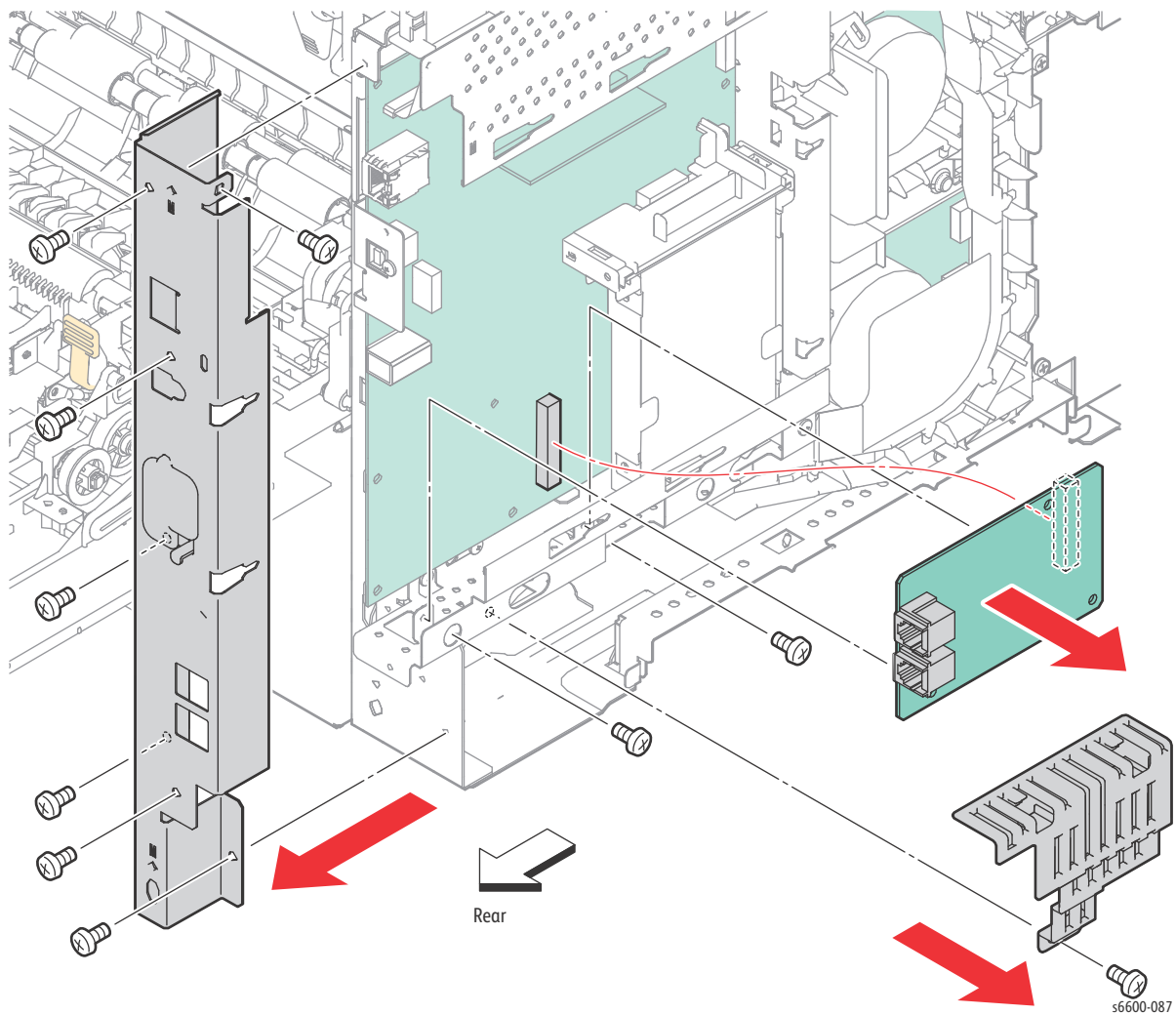


# Electrical

## Fax Board (MFP only)

### (PL18.1.41)

1. Remove the Front Door Assembly. (page 4-128)
2. Remove the Left Cover Assembly. (page 4-136)
3. Remove the Lower Left Hand Rear Cover. (page 4-124)
4. Remove the seven screws (silver, 6mm) that attach the MFP Rear IP Board Plate (PL18.1.24) to the printer and remove the plate.
5. Remove the screw (silver, 6mm) that attaches the MFP Bottom IP Board Guard to the printer and remove the guard.
6. Remove the two screws (silver, 6mm) that attach the Fax Board (PL18.1.41), disengage the connectors and remove the board.



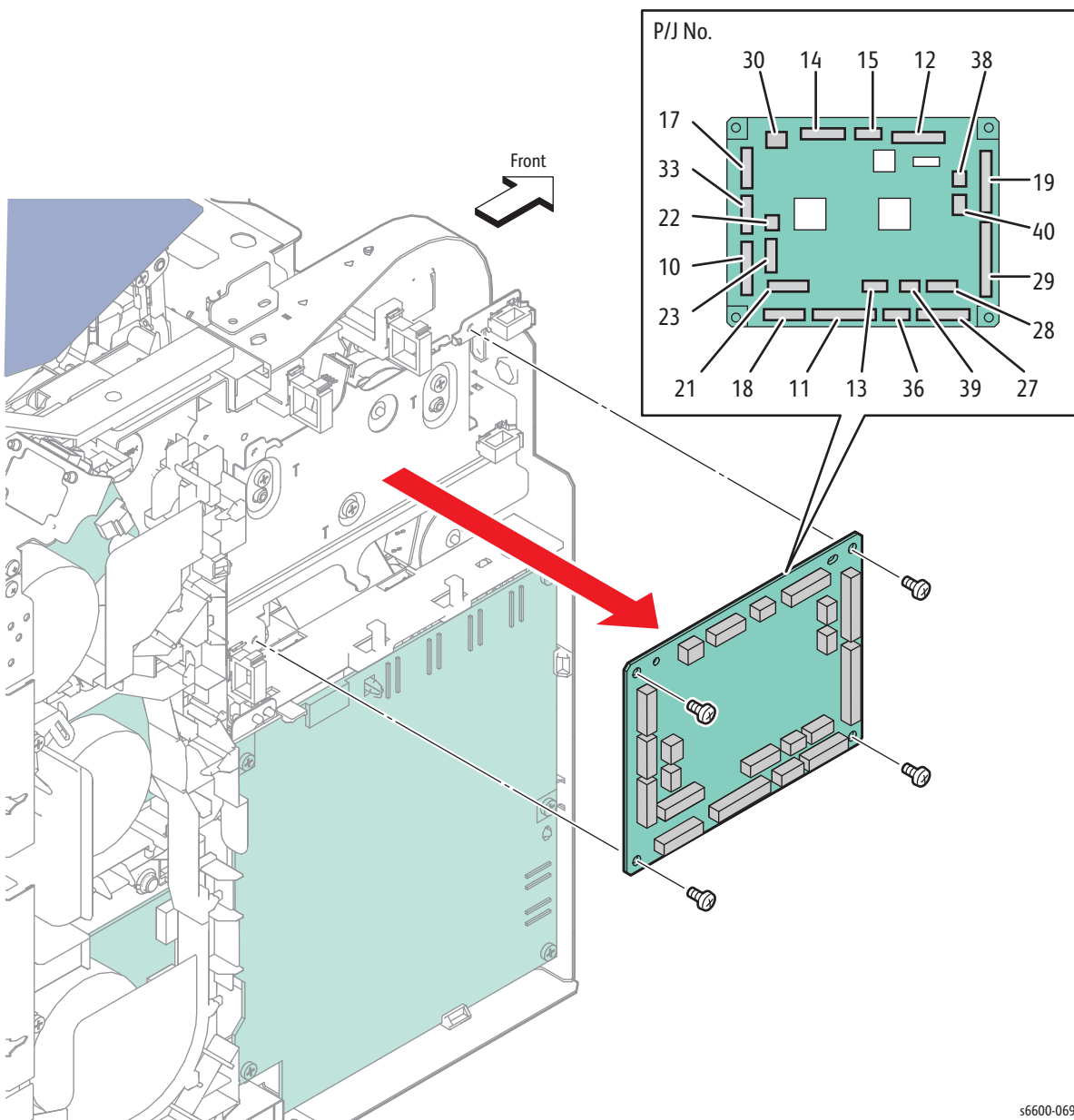
## MCU Board

### PL18.1.13

1. Enter Service Mode and perform “NVM Saving (SaveNVM to ESS)” on page 2-30.
2. Remove the Front Door Assembly. (page 4-128)
3. Remove the Left Cover Assembly. (SFP page 4-134; MFP page 4-136)

**Tip:** Release the harnesses from the clamps to ease unplugging the connectors on the MCU Board.

4. Unplug all connectors from the MCU Board (PL18.1.13).
5. Remove the four screws (silver, 6mm) that attach the MCU Board to the printer and remove the board.
6. After replacing the board, enter Service Mode and perform “Initialize Slave” on page 2-31.

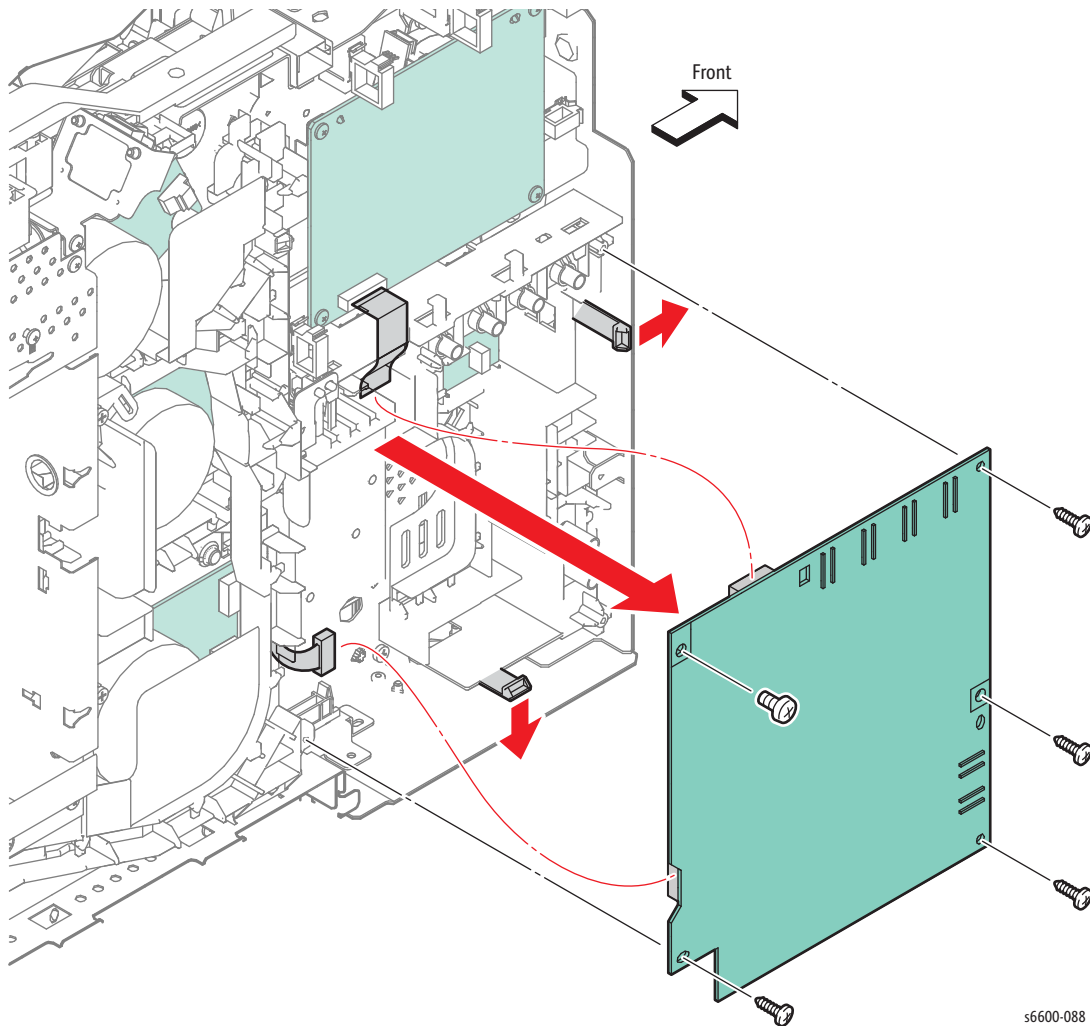


s6600-069

## Development HVPS Board

### PL18.1.14

1. Remove the Front Door Assembly. (page 4-128)
2. Remove the Left Cover Assembly. (SFP page 4-134; MFP page 4-136)
3. Remove the five screws (silver, tapping, 8mm) (silver, 6mm) that attach the Development HVPS Board (PL18.1.14) and remove the Development HVPS Board while releasing the two hooks.
4. Unplug connectors P/J181 and P/J182 from the Development HVPS Board and remove the board.

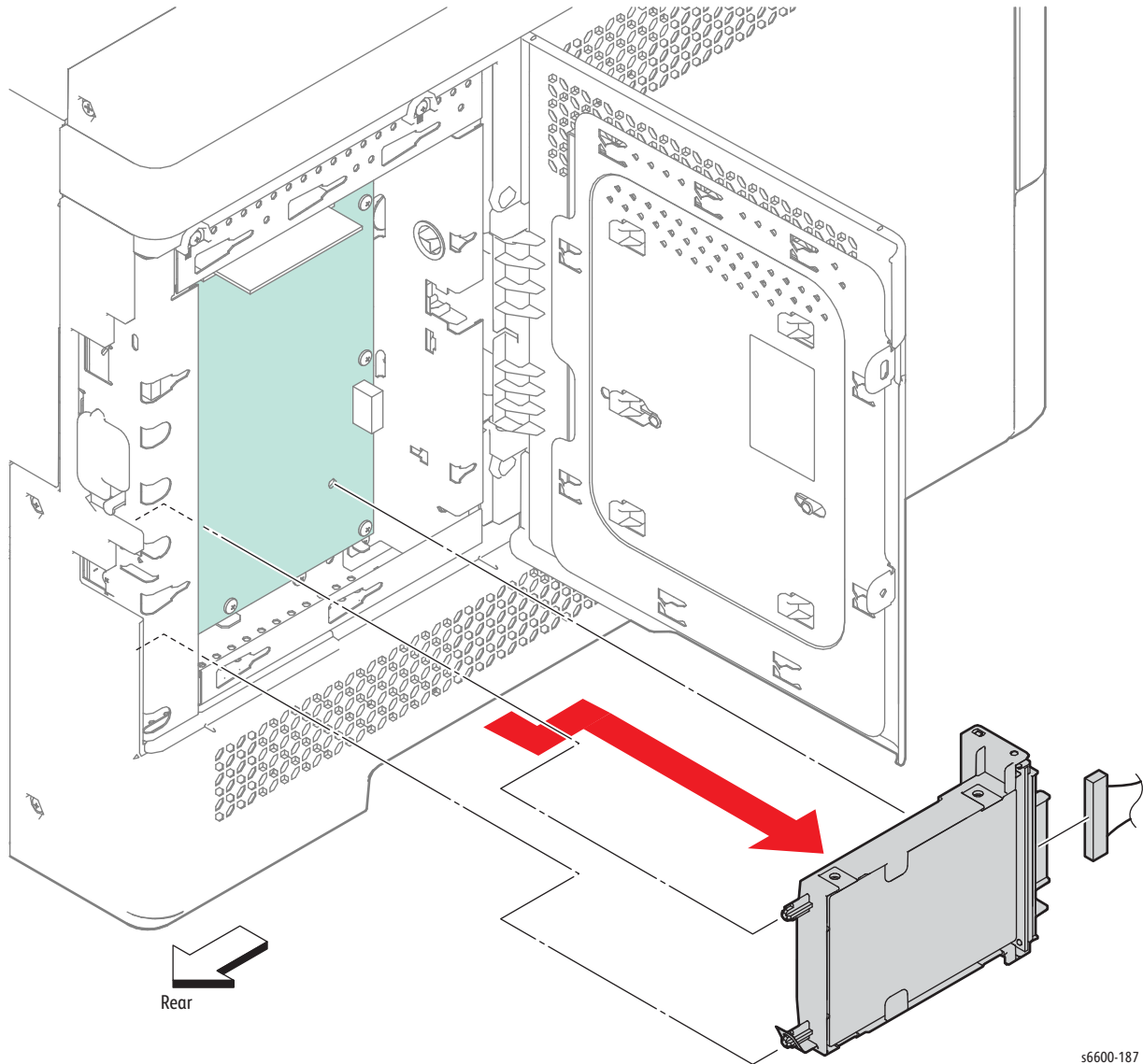


**Note:** When installing the Development HVPS Board, check that the six springs are correctly in contact with the Development HVPS Board.

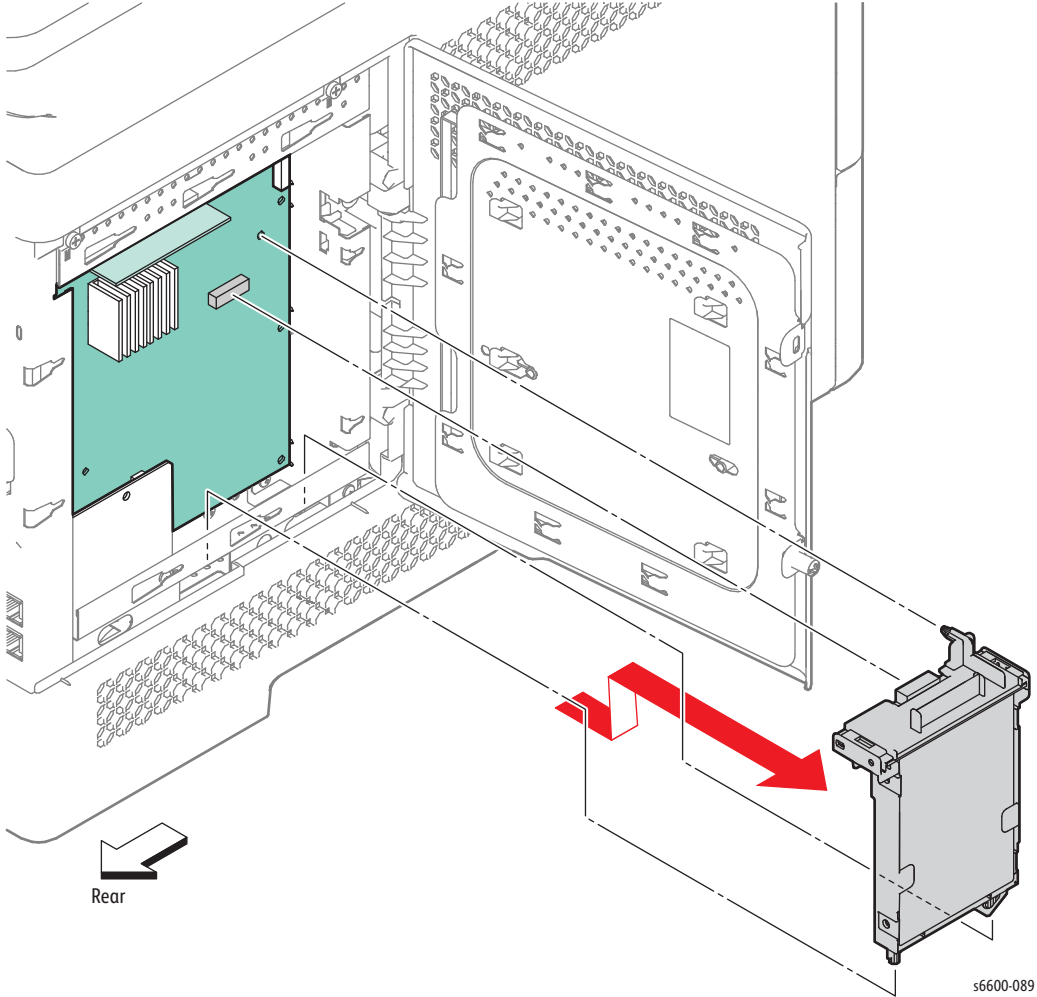
## Hard Disk Package Kit

### PL18.1.21

1. Open the IP Board Cover.
2. Unplug the connector from the Hard Disk Package Kit (PL18.1.21).
3. **SFP:** Remove the Hard Disk Package Kit by pulling out to release the front lug, then sliding forward to release the two rear lugs.  
**MFP:** Remove the Hard Disk Package Kit by pulling out to release the upper lug, then sliding upward to release the two lower lugs.



s6600-187

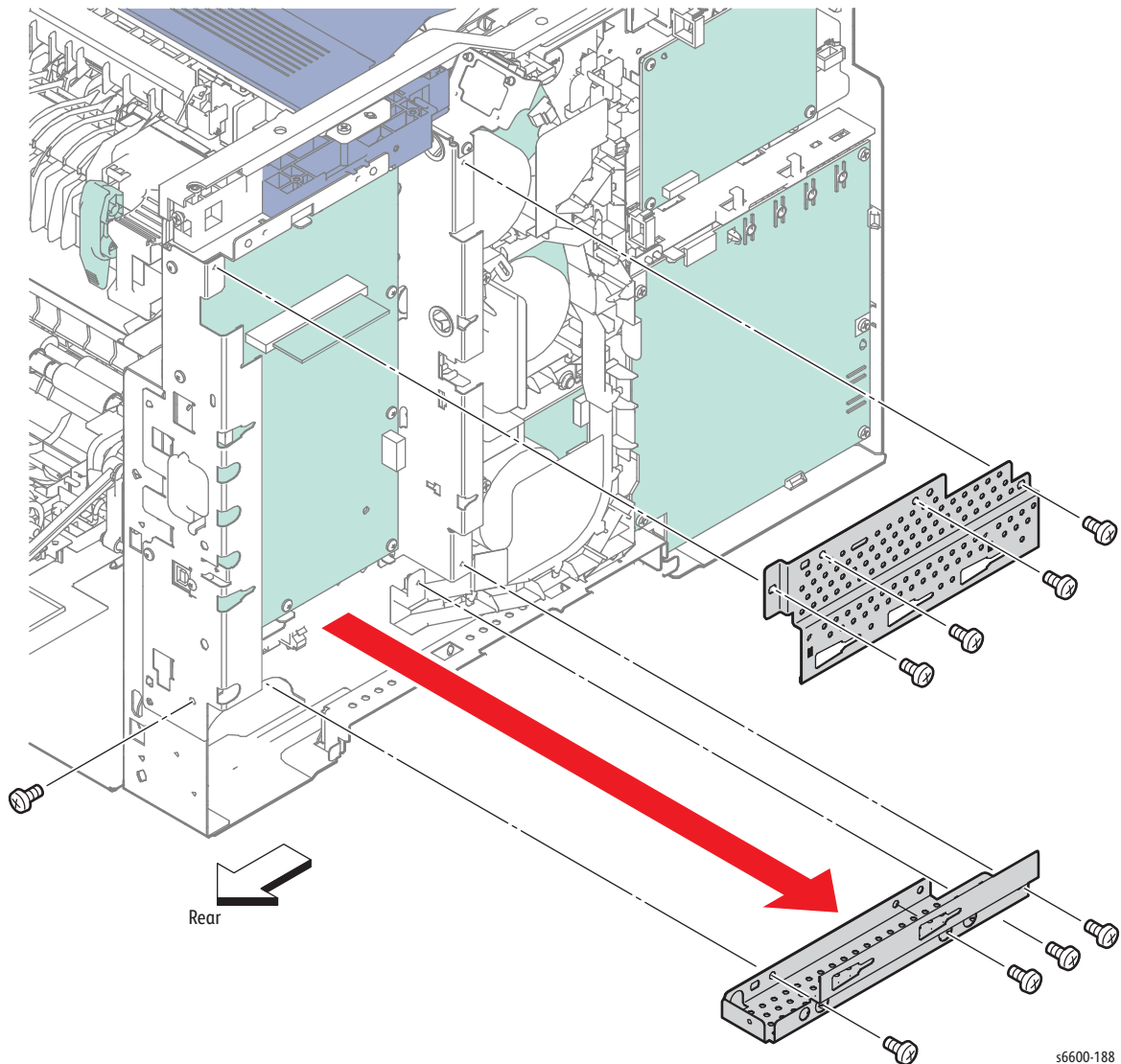


## SFP IP Board

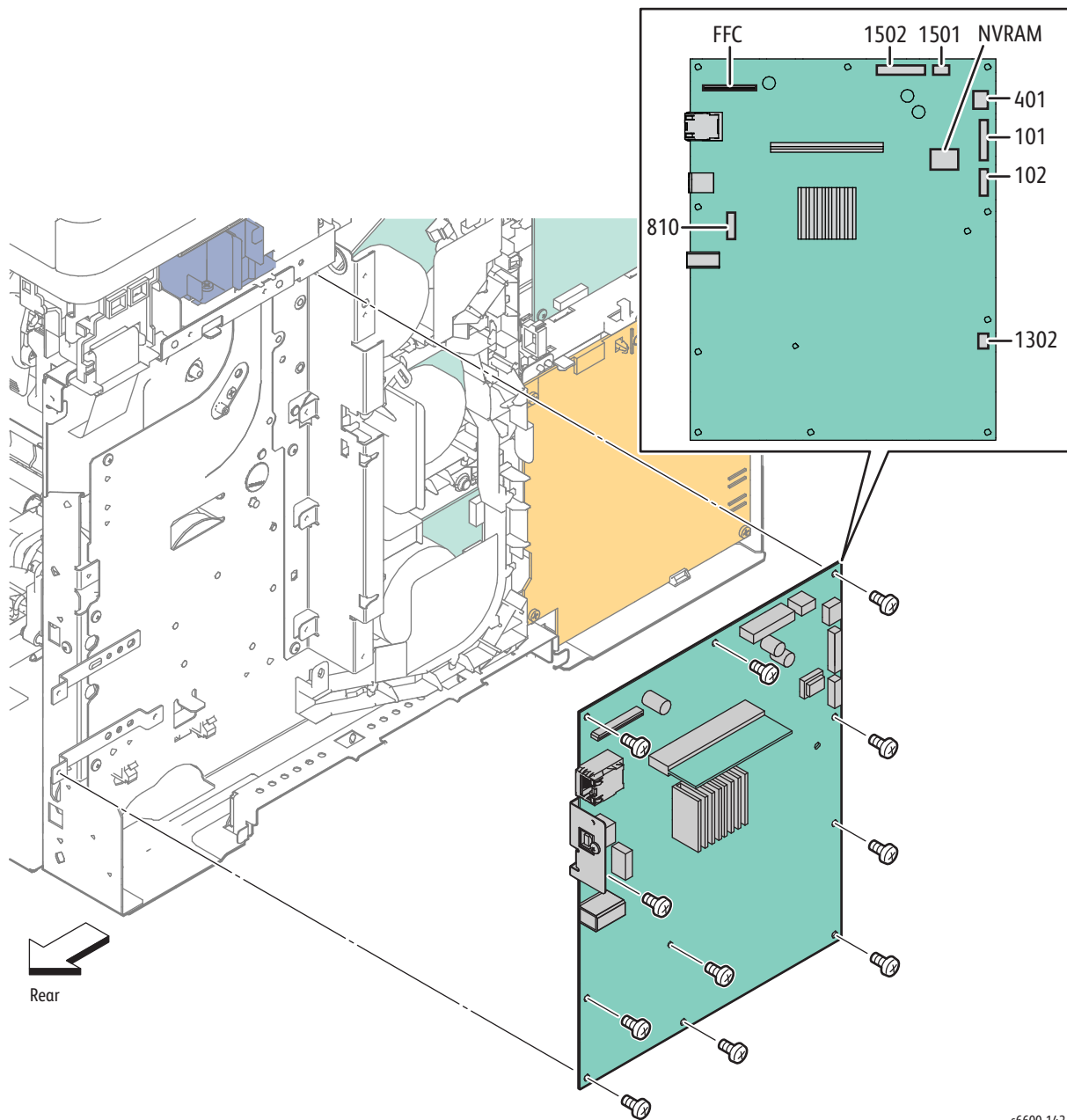
### (PL18.1.22)

**Note:** When replacing the IP Board, be sure to transfer the NVRAM and, if installed, Optional RAM, Hard Disk or Wireless Kit to the new IP Board.

1. Remove the Control Panel Assembly. (page 4-7)
2. Remove the Front Door Assembly. (page 4-128)
3. Remove the Left Cover Assembly. (page 4-134)
4. Remove the Hard Disk and/or Wireless Kit (if installed).
5. Remove the four screws (silver, 6mm) that attach the IP Board Top Plate (PL18.1.19) to the printer and remove the plate.
6. Remove the five screws (silver, 6mm) that attach the IP Board Bottom Plate (PL18.1.20) to the printer (four on the side, one on the rear) and remove the plate.



7. Unplug all connectors from the IP Board.
8. Remove the eleven screws (silver, 6mm) that attach the IP Board to the printer (ten from the board, one from the USB port at the rear) and remove the board.



s6600-142

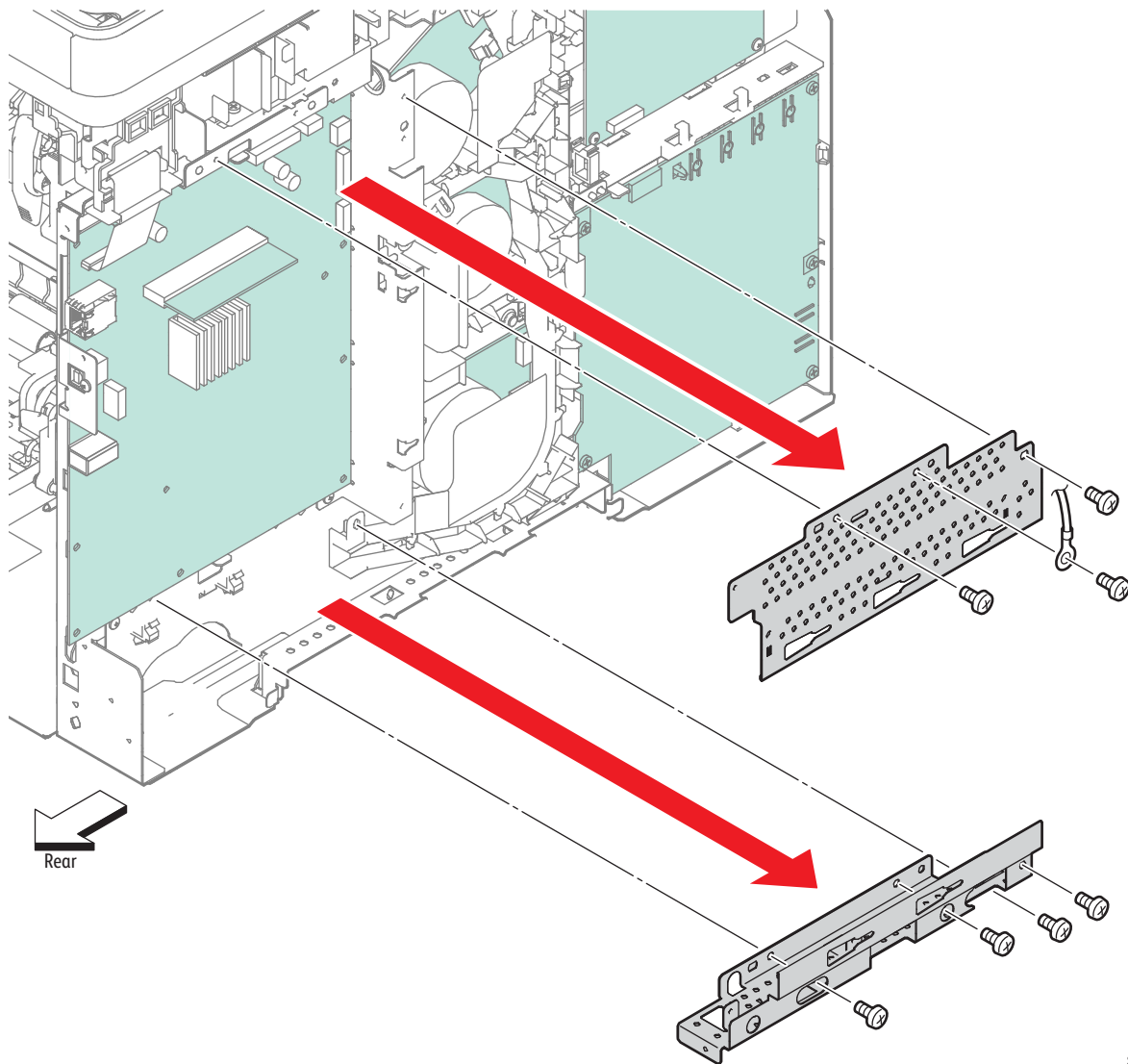
**Replacement Note:** Make sure the top edge of the board is under the metal hook at the top.

## MFP IP Board

### (PL18.1.22)

**Note:** When replacing the IP Board, be sure to transfer the NVRAM and, if installed, Optional RAM, Hard Disk or Wireless Kit to the new IP Board.

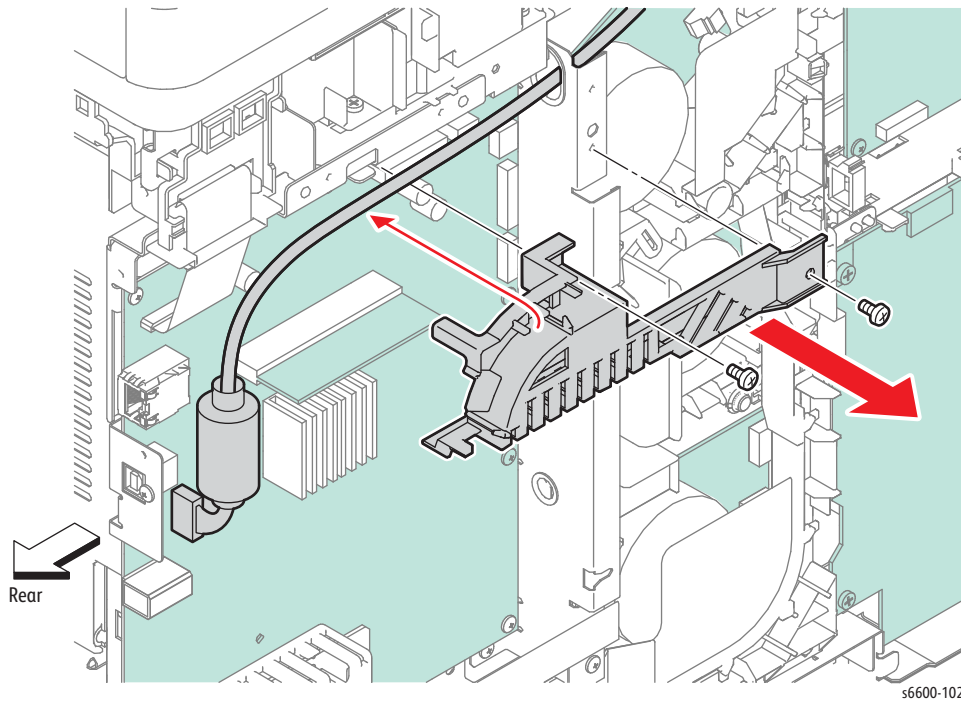
1. Remove the Front Door Assembly. (page 4-128)
2. Remove the Left Cover Assembly. (page 4-136)
3. Remove the Lower Left Hand Rear Cover. (page 4-124)
4. Remove the Fax Board. (page 4-97)
5. Remove the three screws (silver, 6mm) that attach the MFP Top IP Board Plate (PL18.1.19) and remove the plate by removing the grounding wire.
6. Remove the four screws (silver, 6mm) that attach the IP Board Bottom Plate (PL18.1.20) to the printer and remove the plate.



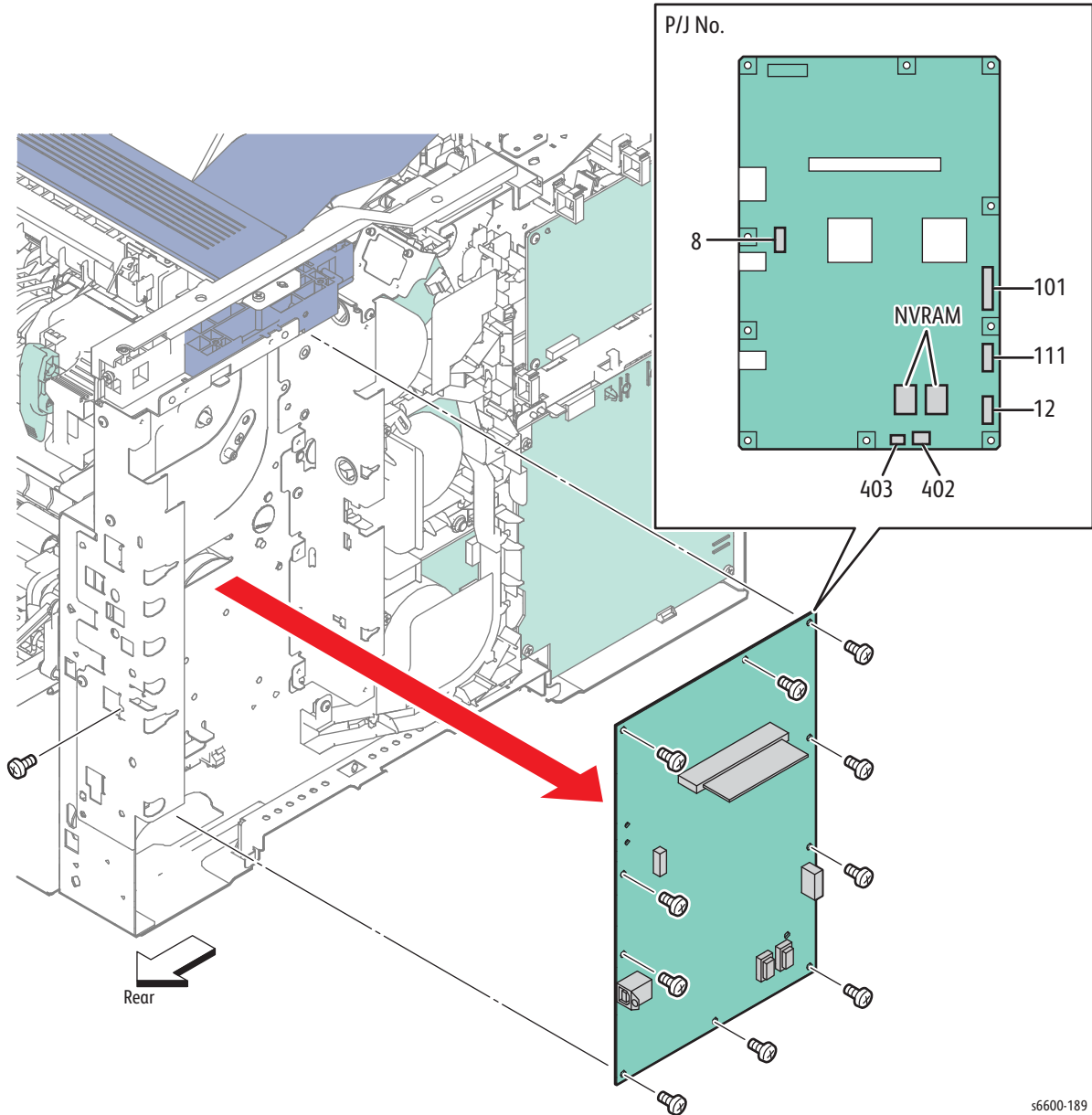
s6600-116



7. Release the harness from the IP Board Top Guard (Bypass Tray Harness Guide).
8. Remove the two screws (silver, 6mm) that attach the IP Board Top Guard (Bypass Tray Harness Guide) to the printer and remove the guard.



9. Unplug all connectors from the IP Board.
10. Remove the eleven screws (silver, 6mm) that attach the IP Board to the printer (ten from the board, one from the USB port at the rear) and remove the board.
11. When replacing the IP Board with a new one, transfer the two NVRAM chips, U71 and 72, and any optional memory to the replacement board.



s6600-189

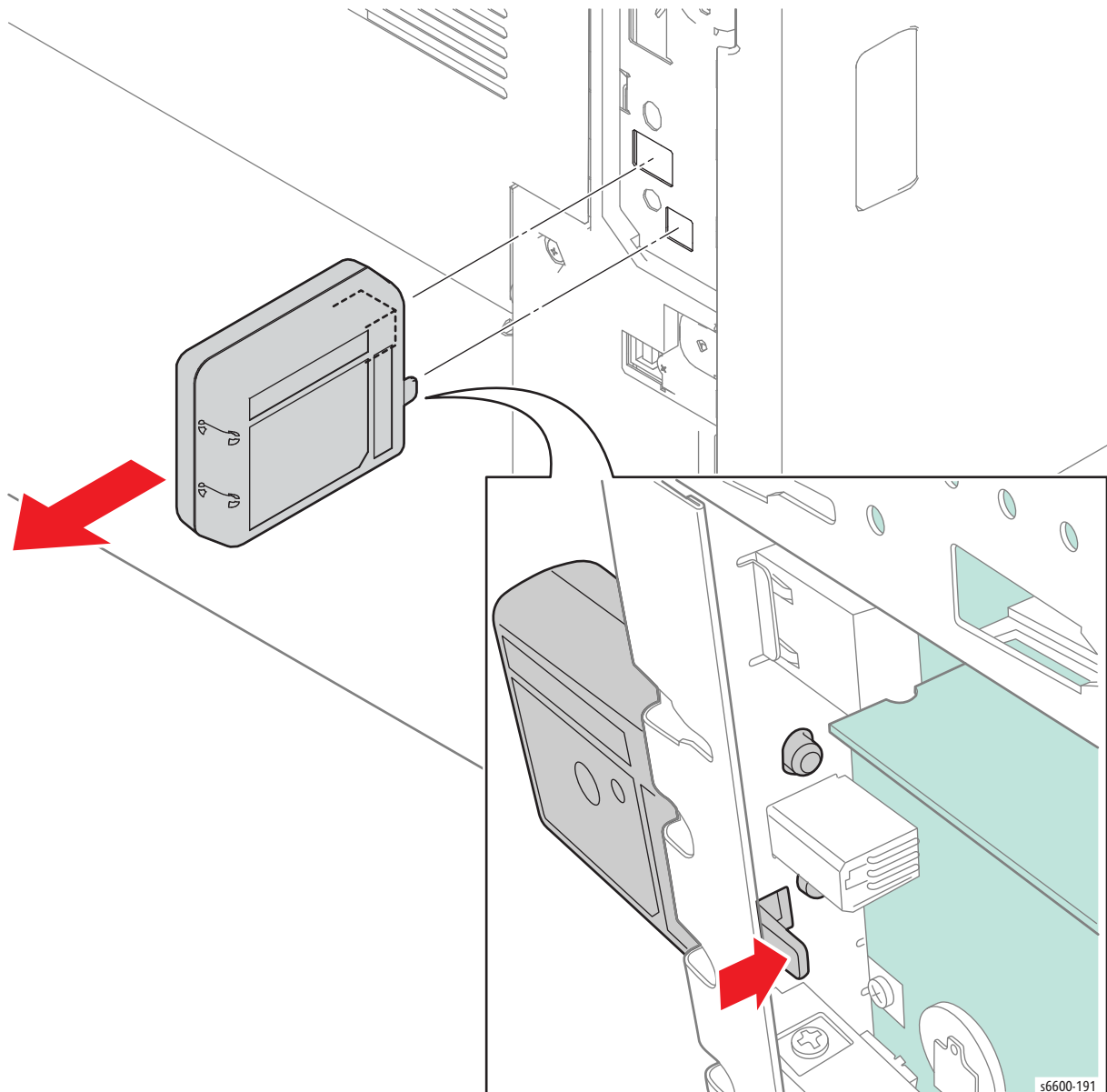
## Wireless Kit

(PL18.1.27)

1. Open the IP Board Cover.

**!** **CAUTION:** Use of excessive force during removal can damage the Wireless Kit. Be sure to fully release the latch to avoid damage to the Wireless Kit.

2. Press and hold the latch release while pulling the Wireless Kit to unplug it.

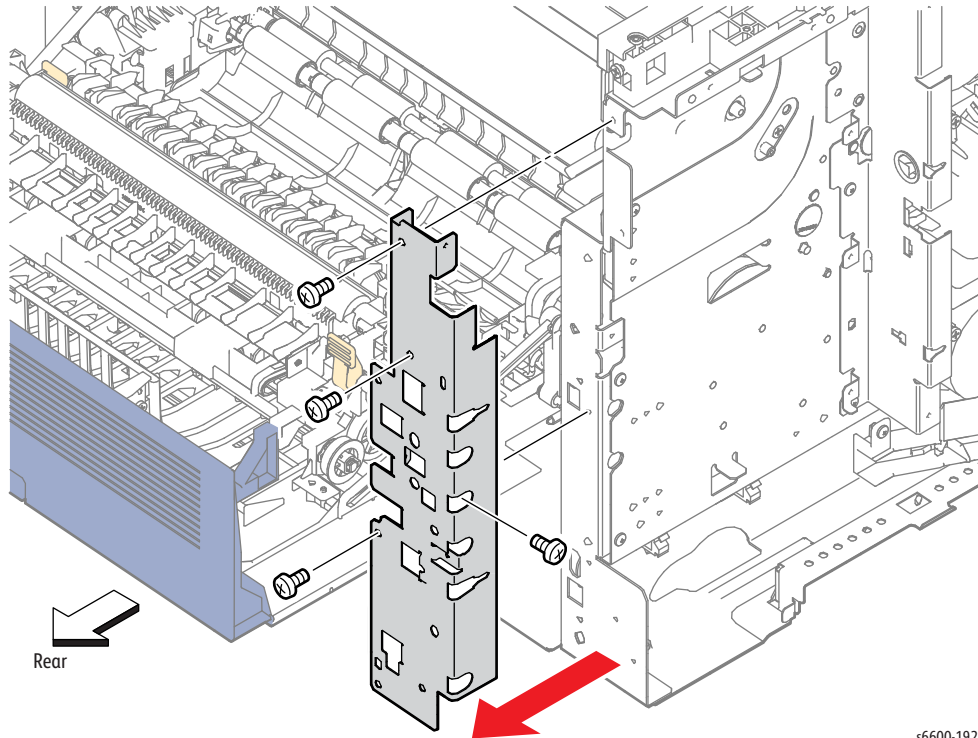


## Transfer HVPS Board

(PL18.1.28)

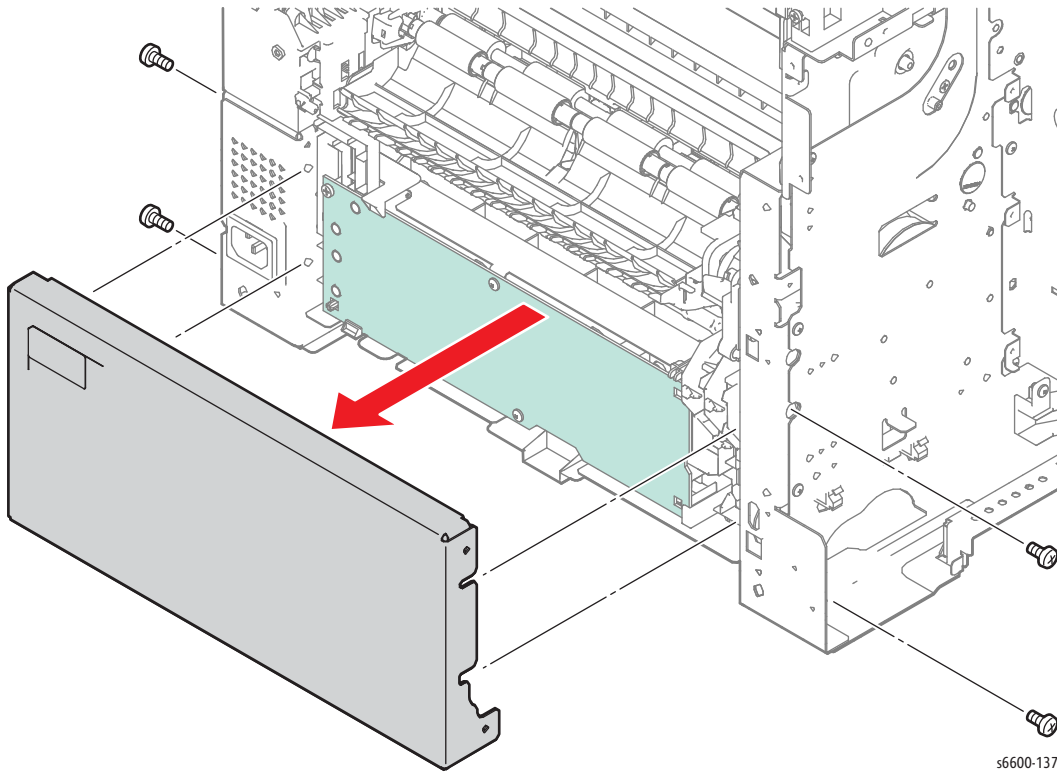
**!** **WARNING:** The Fuser is very hot. Take added care when handling the fuser to avoid being burned.

1. Remove the Fuser Assembly. (page 4-46)
2. Remove the Waste Cartridge. (page 4-50)
3. Remove the Waste Cartridge Lock. (page 4-39)
4. Remove the Front Door Assembly. (page 4-128)
5. Remove the Right Cover Assembly. (page 4-131)
6. Remove the Left Cover Assembly. (SFP page 4-134; MFP page 4-136)
7. **MFP only:** Remove the FAX Board. (page 4-97)
8. Remove the IP Board. (SFP page 4-102; MFP page 4-104)
9. **SFP only:** Remove the four screws (silver, 6mm) that attach the Rear IP Board Plate (PL18.1.24) to the printer and remove the plate.



s6600-192

10. Remove the four screws (silver, 6mm) that attach the S3 Rear Frame (PL4.1.6) to the printer and remove the frame.

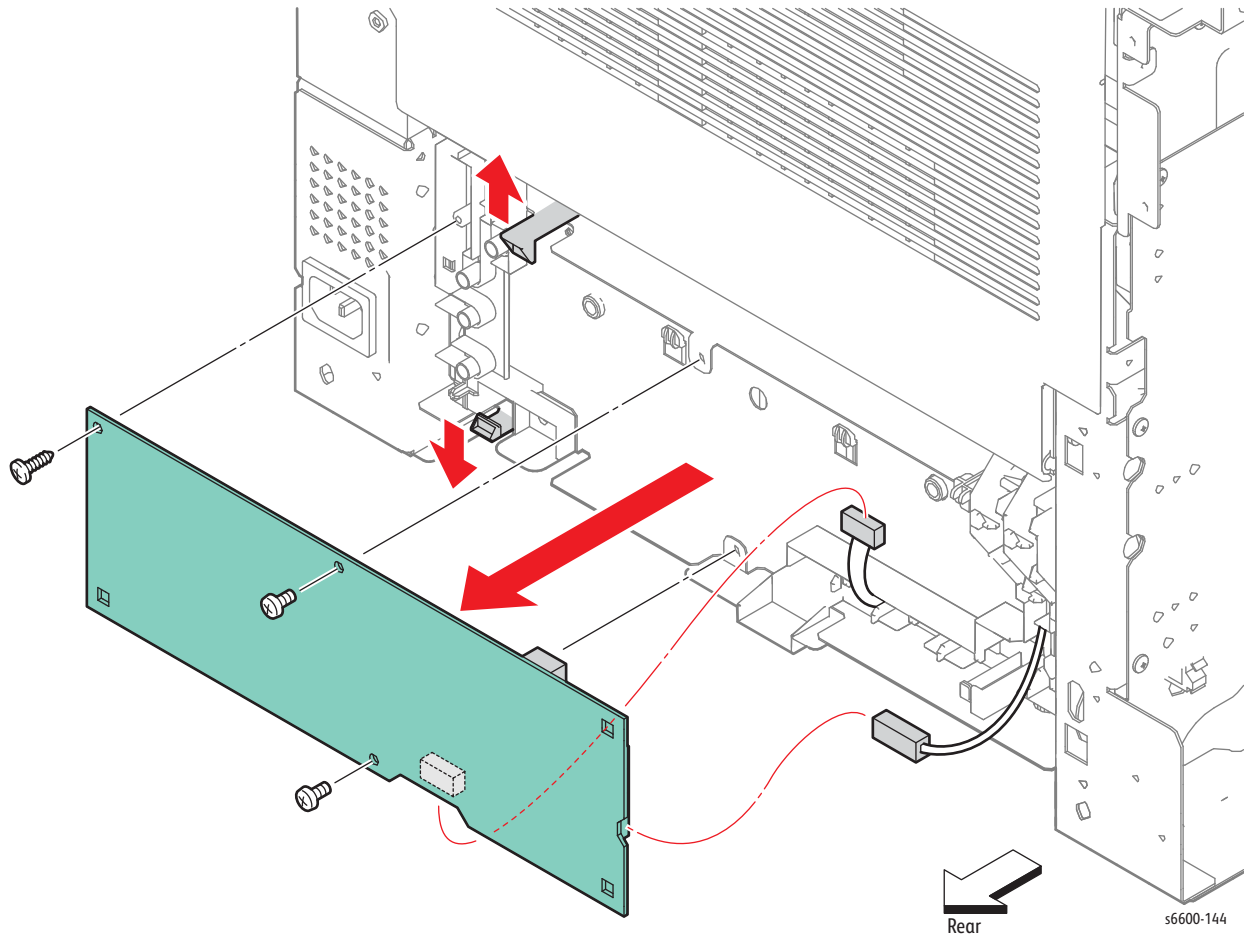


11. Remove the three screws (one, silver, tapping, 8mm; two, silver, 6mm) that attach the Transfer HVPS Board (PL18.1.28).
12. Release the two hooks that attach the Transfer HVPS Board, and move the board away from the frame enough to access the connectors.

**!** **CAUTION:** The harnesses connected to the Transfer HVPS Board have little slack. Pull carefully on the board to avoid damage to the connectors or wires.

**Note:** Release the harness from the guide to allow enough slack to unplug the connector.

13. Unplug P/J1821 and the Faston connector from the Transfer HVPS Board and remove the board.

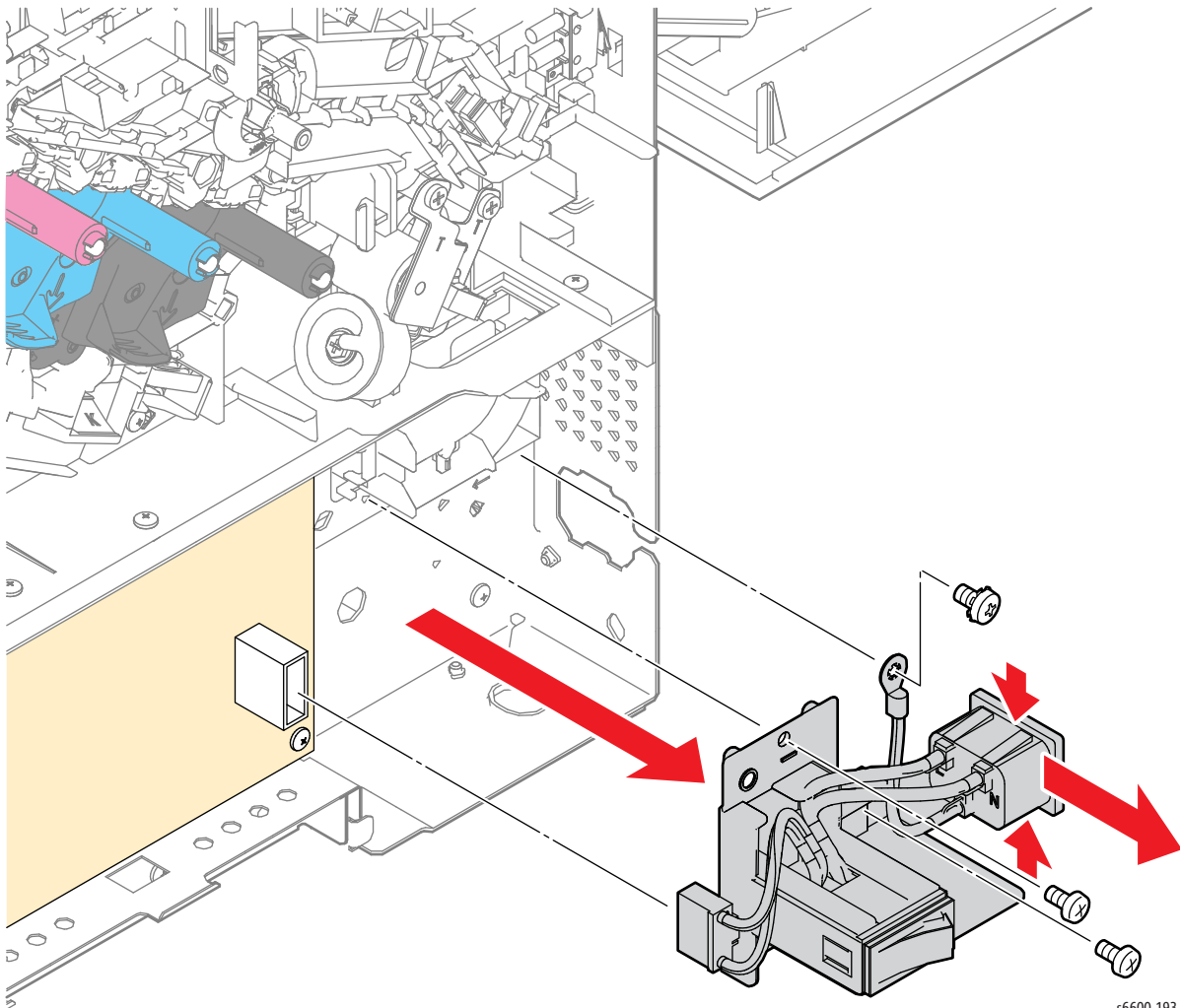


## AC Inlet Assembly

### PL18.1.31

**!** **WARNING:** The Fuser is very hot. Take added care when handling the fuser to avoid being burned.

1. Remove the Fuser Assembly. (page 4-46)
2. Remove the Waste Cartridge. (page 4-50)
3. Remove the Waste Cartridge Lock. (page 4-39)
4. Remove the Front Door Assembly. (page 4-128)
5. Remove the Right Cover Assembly. (page 4-131)
6. Unplug connector P/J48 of the LVPS.
7. Remove the screw and the grounding wire.
8. Remove the two screws (silver, 6mm) that attach the Inlet Harness Guide to the printer and remove the guide.
9. Release the two hooks holding the AC Inlet and remove the AC Inlet.



## LVPS

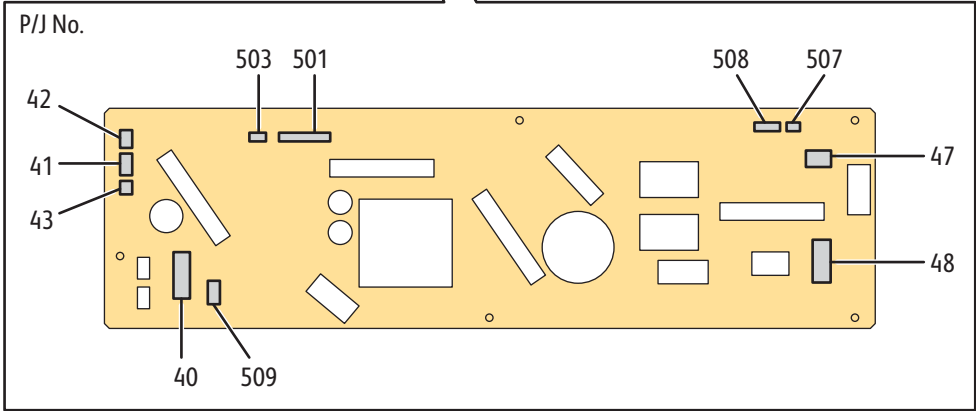
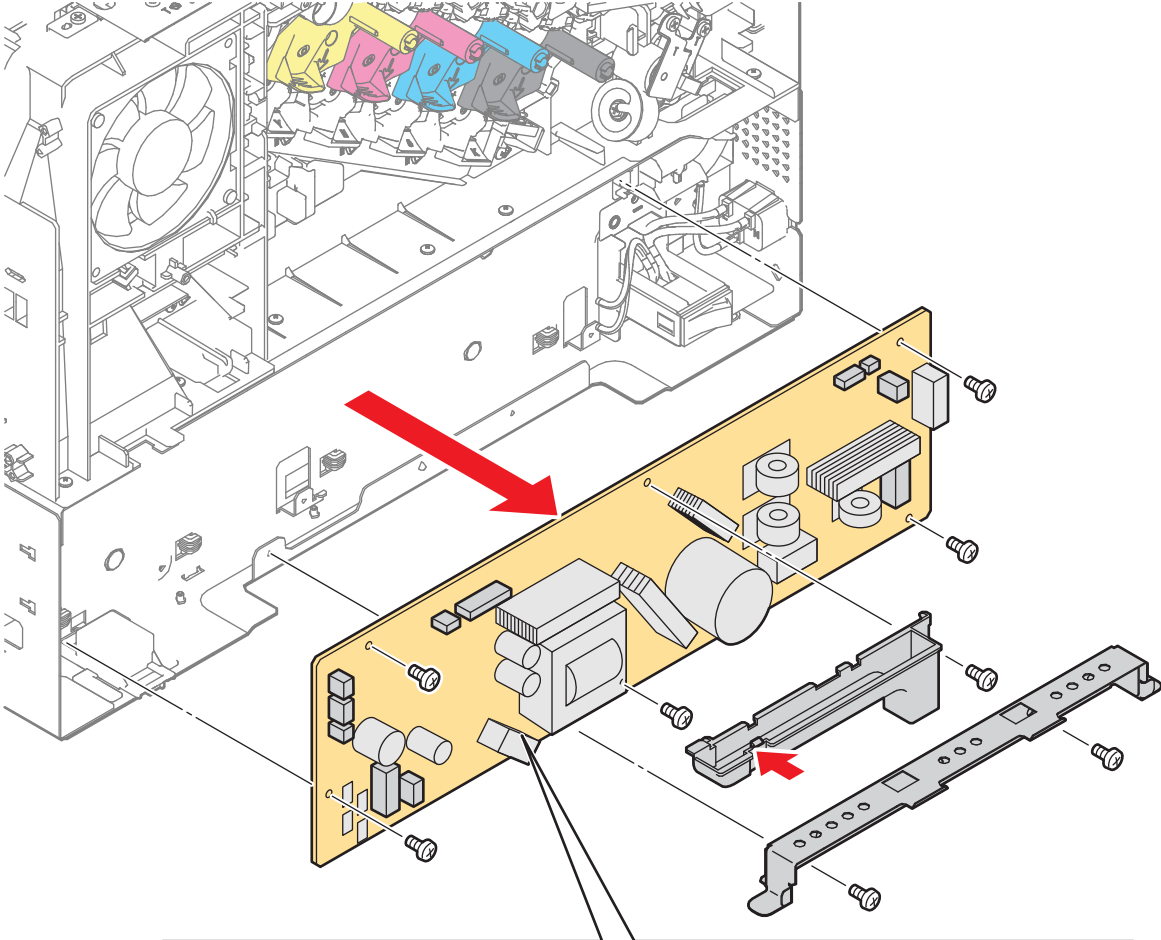
### PL18.1.34



**WARNING:** The Fuser is very hot. Take added care when handling the fuser to avoid being burned.

1. Remove the Fuser Assembly. (page 4-46)
2. Remove the Waste Cartridge. (page 4-50)
3. Remove the Waste Cartridge Lock. (page 4-39)
4. Remove the Front Door Assembly. (page 4-128)
5. Remove the Right Cover Assembly. (page 4-131)
6. Disengage the all connectors on the LVPS.
7. Remove the screw (silver, 6mm) that attaches the Upper LVPS Duct and remove the duct while unlocking it by pressing the base of the hook.
8. Remove the two screws (silver, 6mm) that attach the R Frame Handle to the printer and remove the handle.
9. Remove the five screws (silver, 6mm) that attach the LVPS to the printer and remove the LVPS.



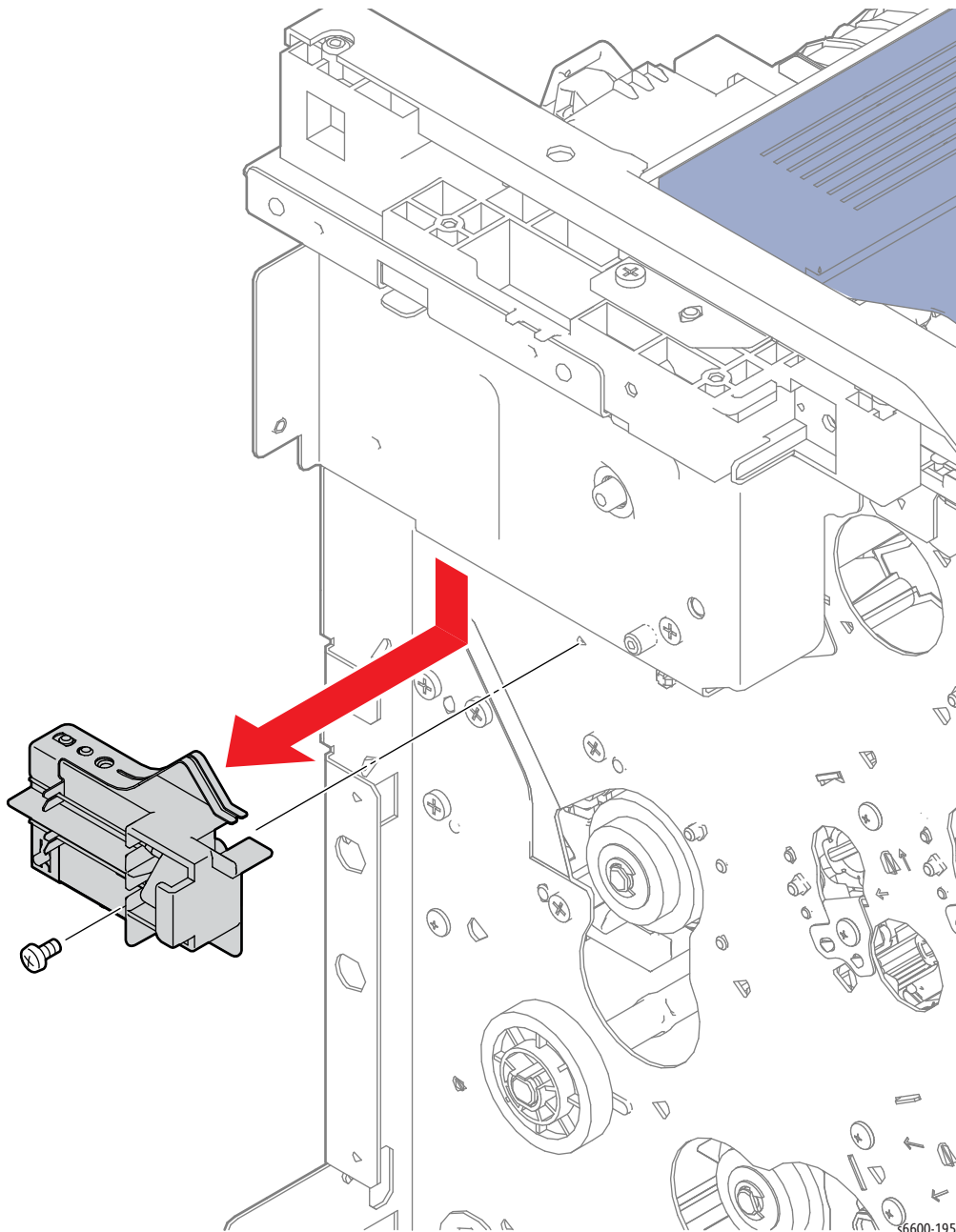


s6600-194

## Varistor Assembly

### PL18.1.99


1. Remove the Front Door Assembly. (page 4-128)
2. Remove the Left Cover Assembly. (SFP page 4-134; MFP page 4-136)
3. Remove the Development HVPS Board. (page 4-99)
4. Remove the IP Board. (SFP page 4-102; MFP page 4-104)
5. Remove the Drive Assembly. (SFP page 4-11; MFP page 4-16)
6. Remove the screw (silver, 6mm) that attaches the Varistor Assembly to the printer and remove the assembly.



# Covers

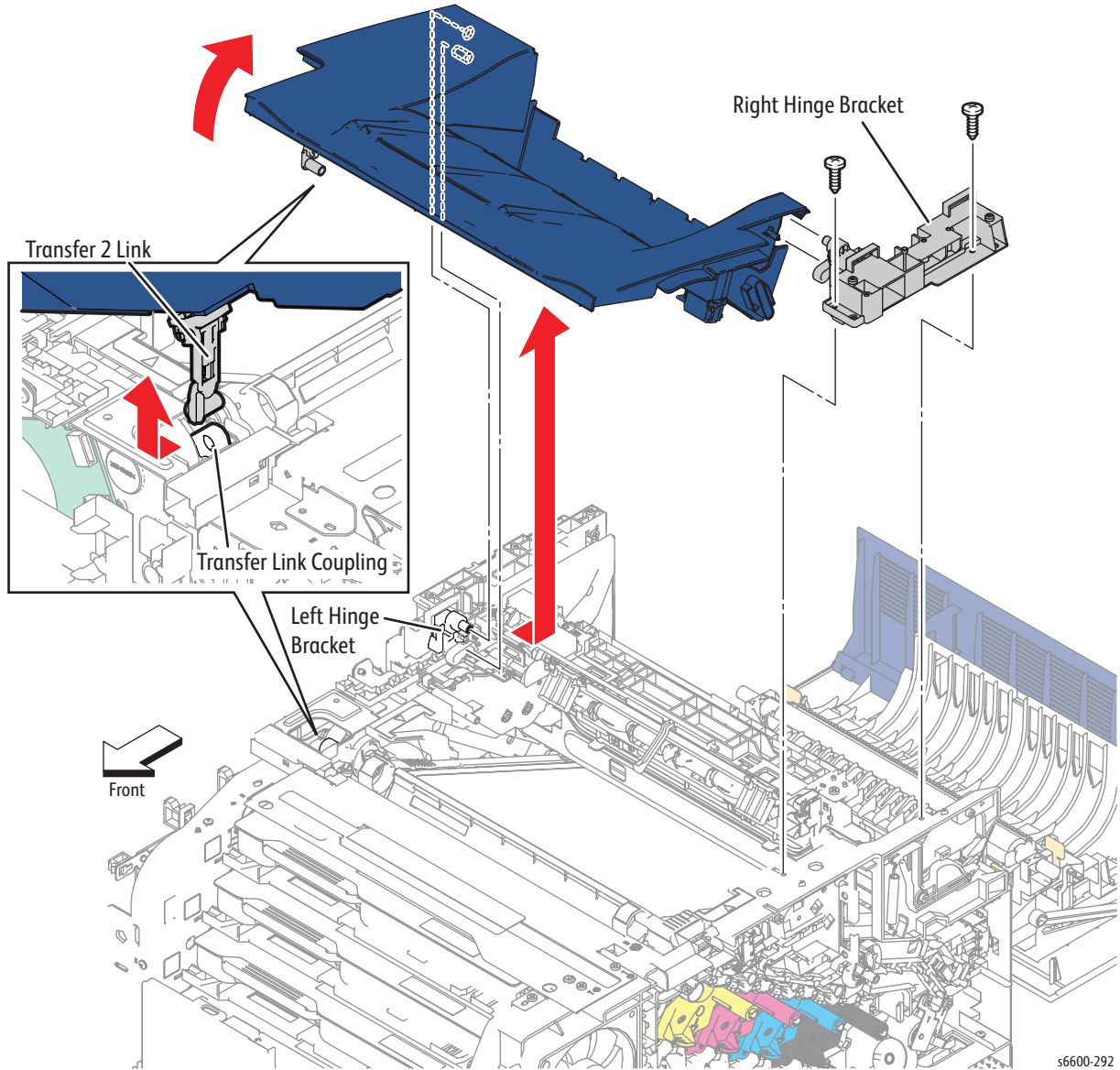
## SFP Top Cover Assembly

### PL19.1.1

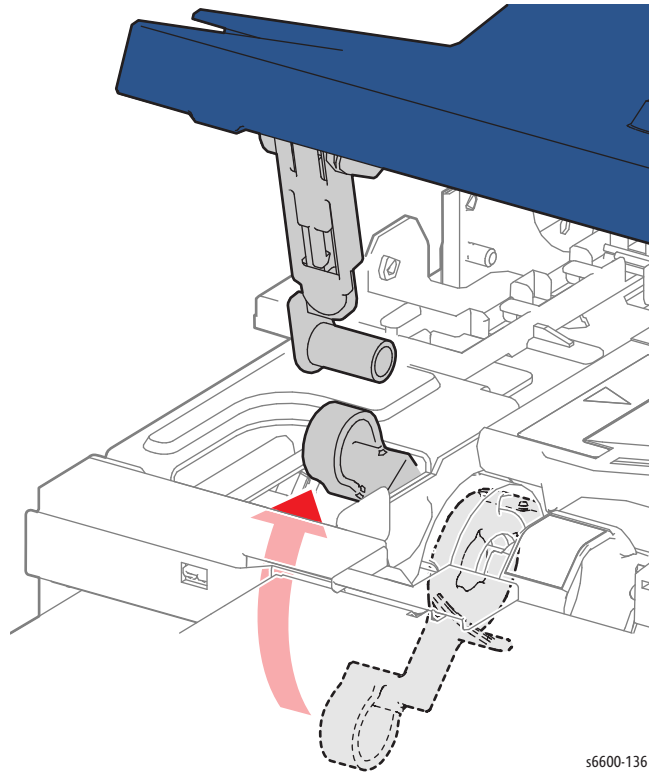
 **WARNING:** The Fuser is very hot. Take added care when handling the fuser to avoid being burned.

1. Remove the Right Cover Assembly. (page 4-131)
2. Remove the Left Cover Assembly. (page 4-134)
3. Remove the Left Sub-top Cover. (page 4-126)
4. Remove the Exit Cover. (page 4-125)
5. Open the Top Cover Assembly.
6. Remove the Transfer 2 Link (PL19.1.4) from the Transfer Link Coupling.
7. Remove the two screws (silver, tapping, 8mm) that attach the Right Hinge Bracket (PL19.1.20) to the printer and remove the bracket.
8. Shift the Top Cover Assembly to the right to release the cover from the Left Hinge Bracket (PL19.1.15), then lift up to remove the cover from the printer.

Service Parts Disassembly



**Note:** When the installation hole on the Transfer Link Coupling for the Transfer 2 Link is retracted, raise it by accessing the Transfer Link Coupling from inside the frame.

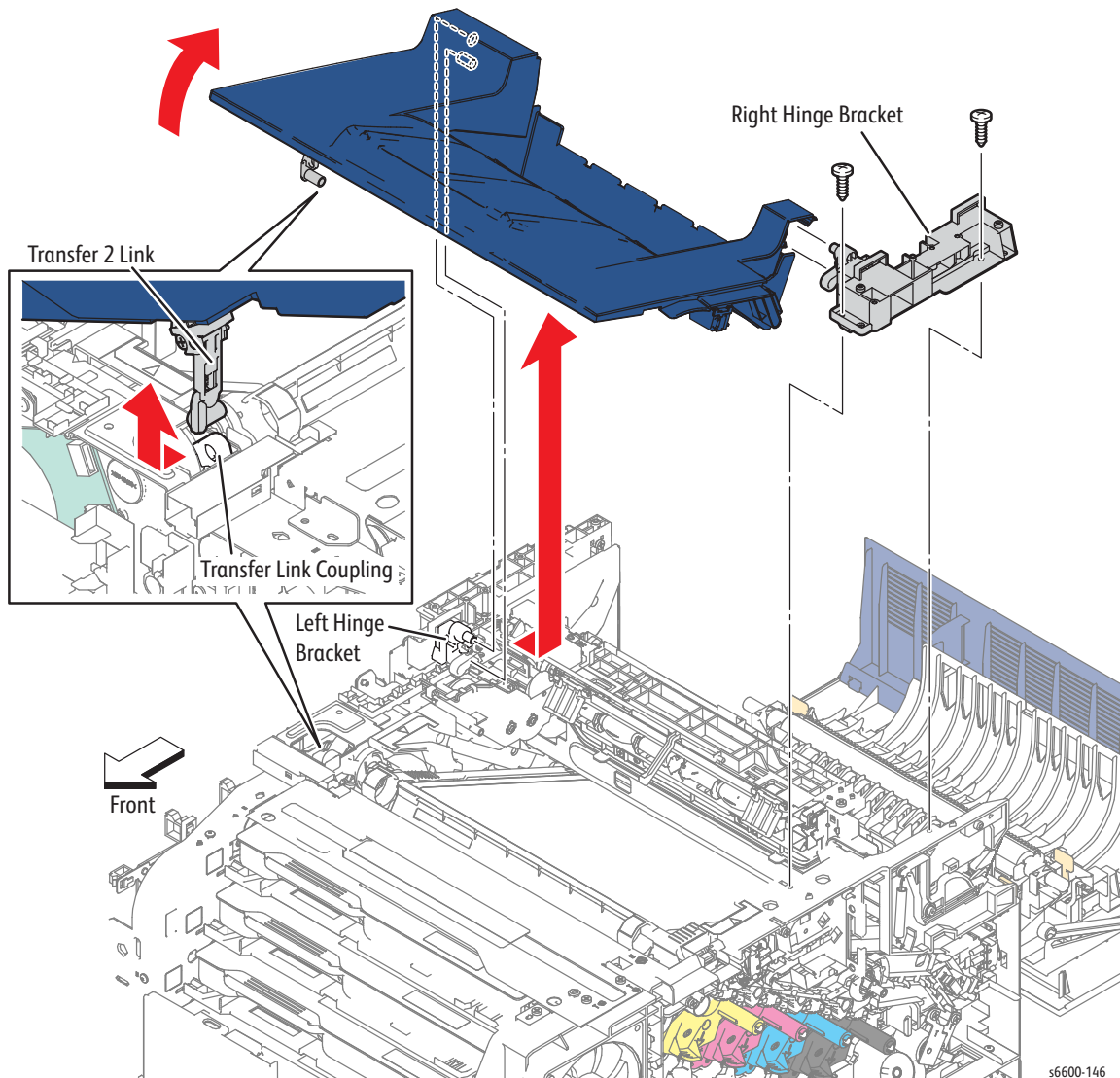


## MFP Top Cover Assembly

### PL19.1.1

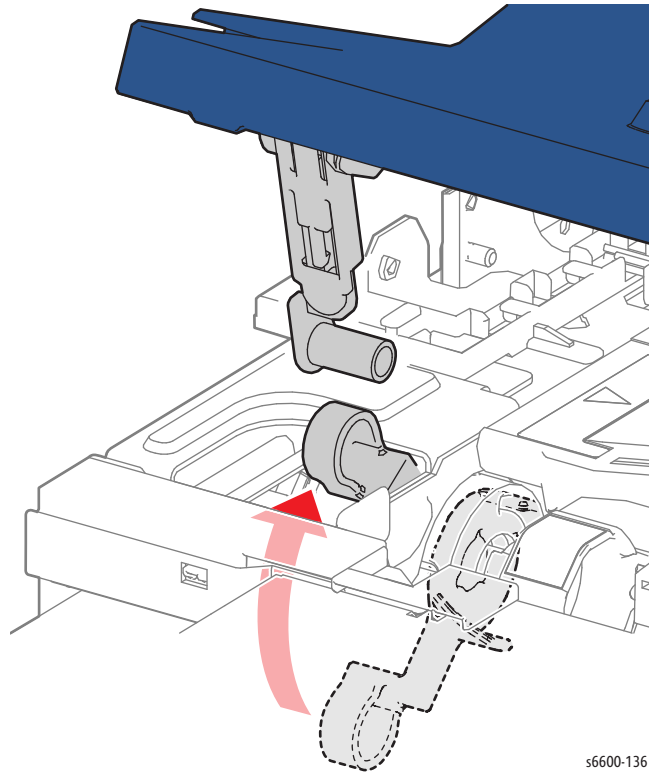
**!** **WARNING:** The Fuser is very hot. Take added care when handling the fuser to avoid being burned.

1. Remove the Right Hand Inner Pole Cover. (page 4-123)
2. Remove the Left Hand Inner Pole Cover. (page 4-120)
3. Remove the Exit Cover. (page 4-125)
4. Open the Top Cover Assembly.
5. Remove the Transfer 2 Link (PL19.1.4) from the Transfer Coupling Link.
6. Remove the two screws (silver, tapping, 8mm) that attach the Right Hinge Bracket (PL19.1.29) to the printer and remove the bracket.
7. Shift the Top Cover Assembly to the right to release the cover from the Left Hinge Bracket (PL19.1.15), then lift up to remove the cover from the printer.



s6600-146

**Note:** If the installation hole on the Transfer Link Coupling for the Transfer 2 Link is retracted, raise it by accessing the Transfer Link Coupling from inside the frame.

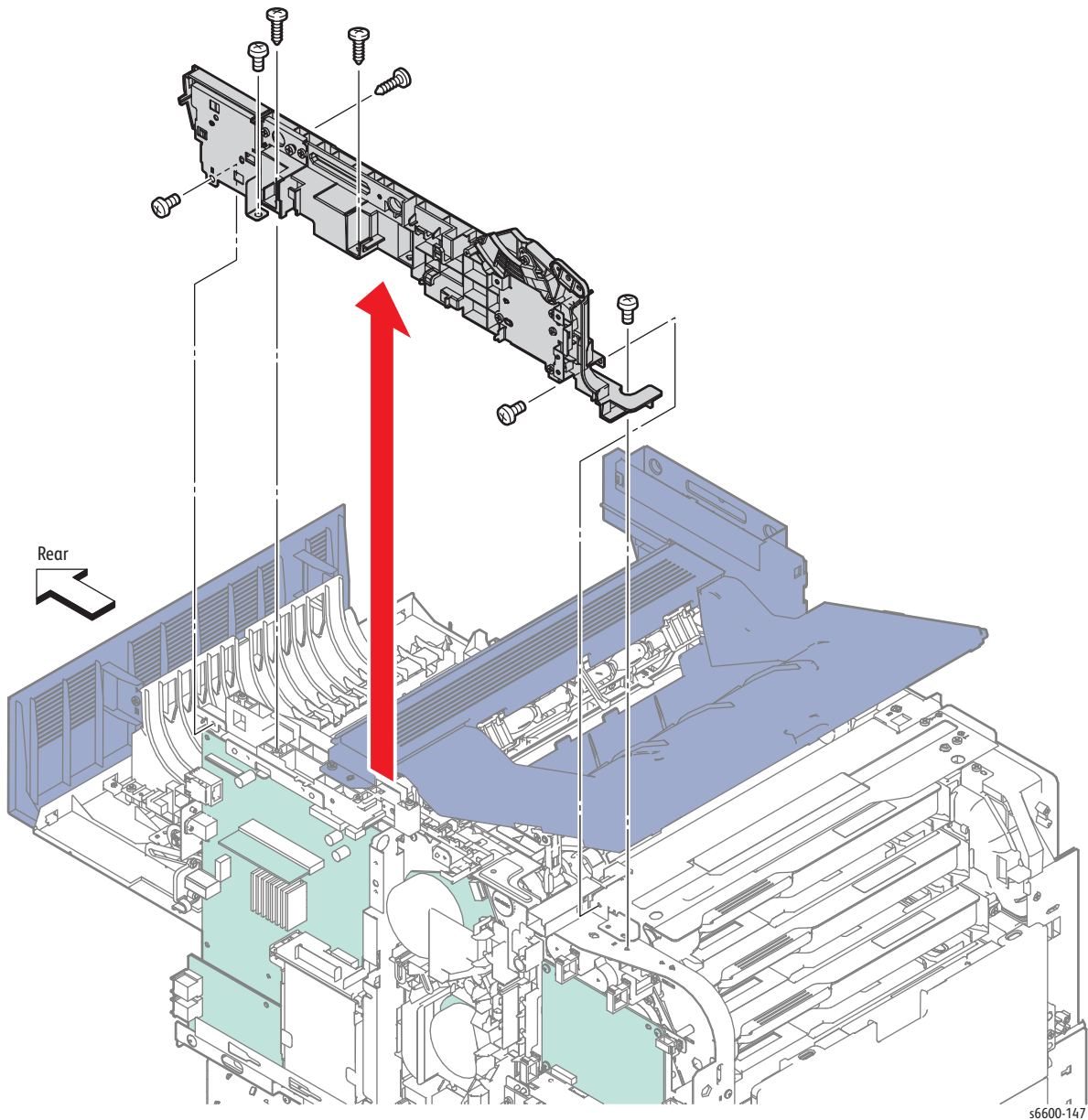


## MFP Left Hand Inner Pole Cover

### PL19.1.14

**!** **WARNING:** The Fuser is very hot. Take added care when handling the fuser to avoid being burned.

1. Remove the USB Hub Board. (page 4-121)
2. Remove the Scanner Assembly. (page 4-138)
3. Remove seven screws (three silver, tapping, 8mm; four silver, 6mm) that attach the MFP Left Hand Inner Pole Cover to the printer and remove the cover.



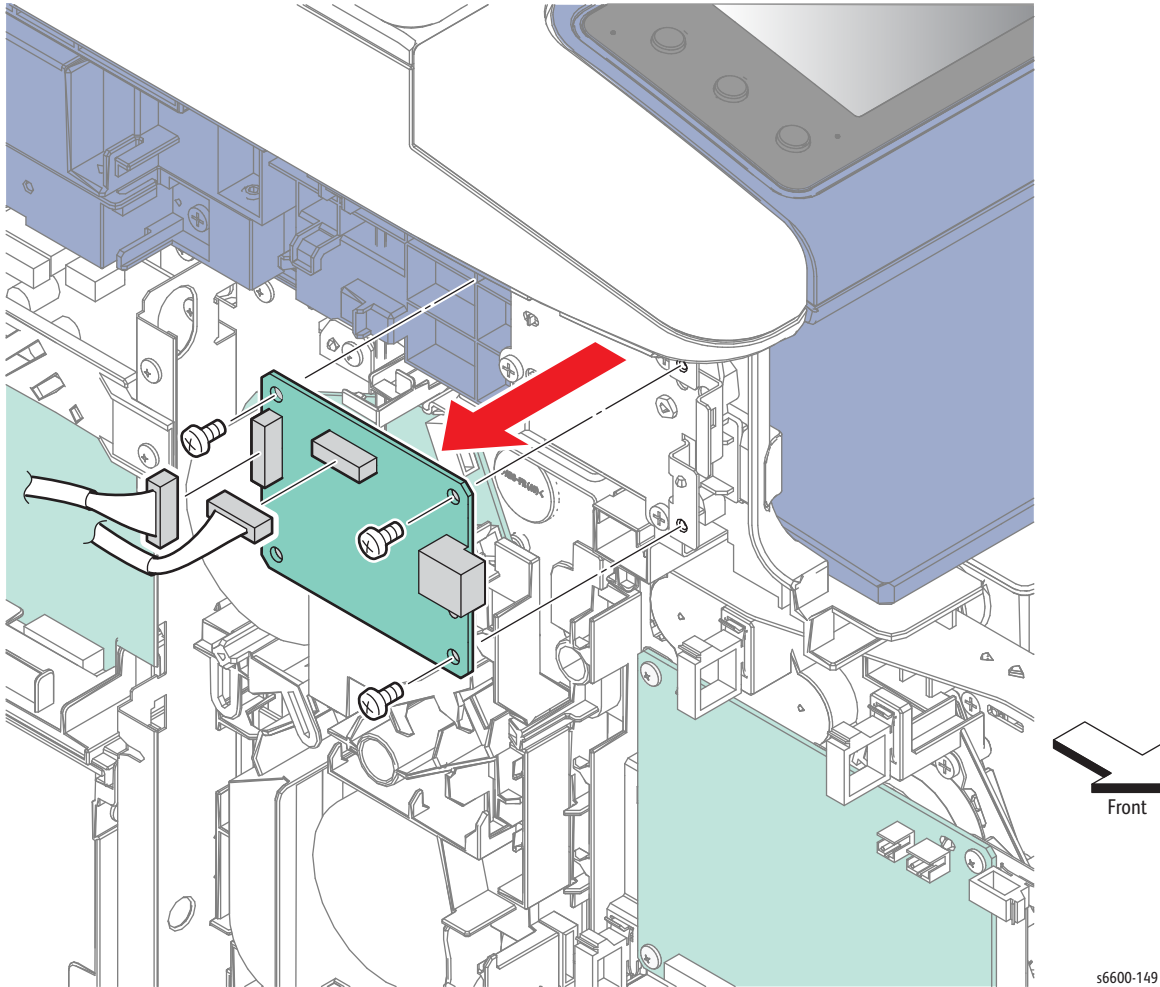


## USB Hub Board

### PL19.1.15

**Note:** This procedure applies only to the MFP. The USB Hub Board is not present in the SFP.

1. Remove the Left Cover Assembly. (page 4-136)
2. Unplug the two connectors from the USB Hub Board .
3. Remove the three screws (silver, 6mm) that attach the USB Hub Board to the printer and remove the board.

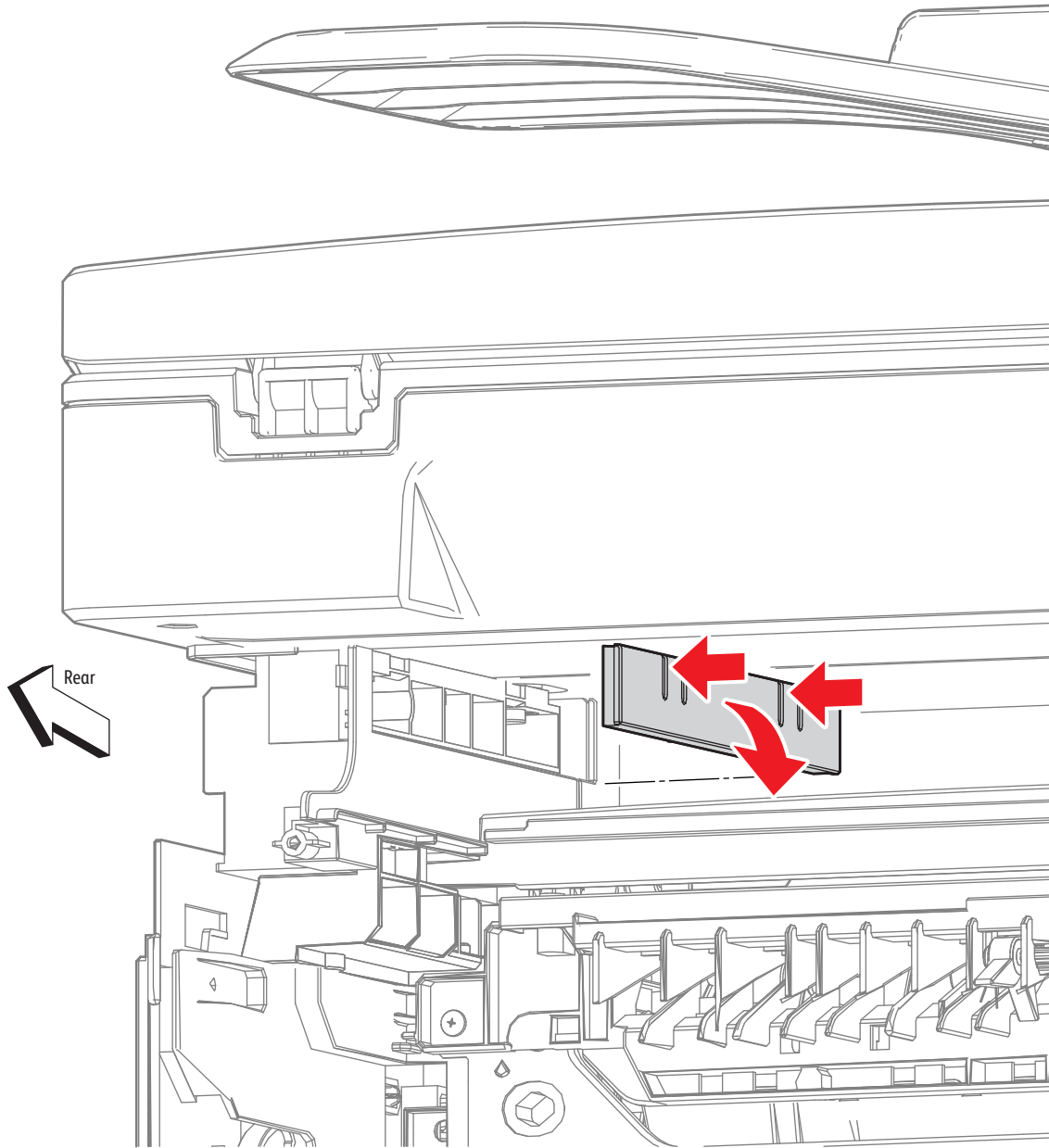


## MFP Upper Right Hand Pole Cover

### PL19.1.19

**!** **WARNING:** The Fuser is very hot. Take added care when handling the fuser to avoid being burned.

1. Remove the Fuser Assembly. (page 4-46)
2. Carefully pry out the Upper Right Hand Pole Cover with a small flat-blade screwdriver or similar tool.



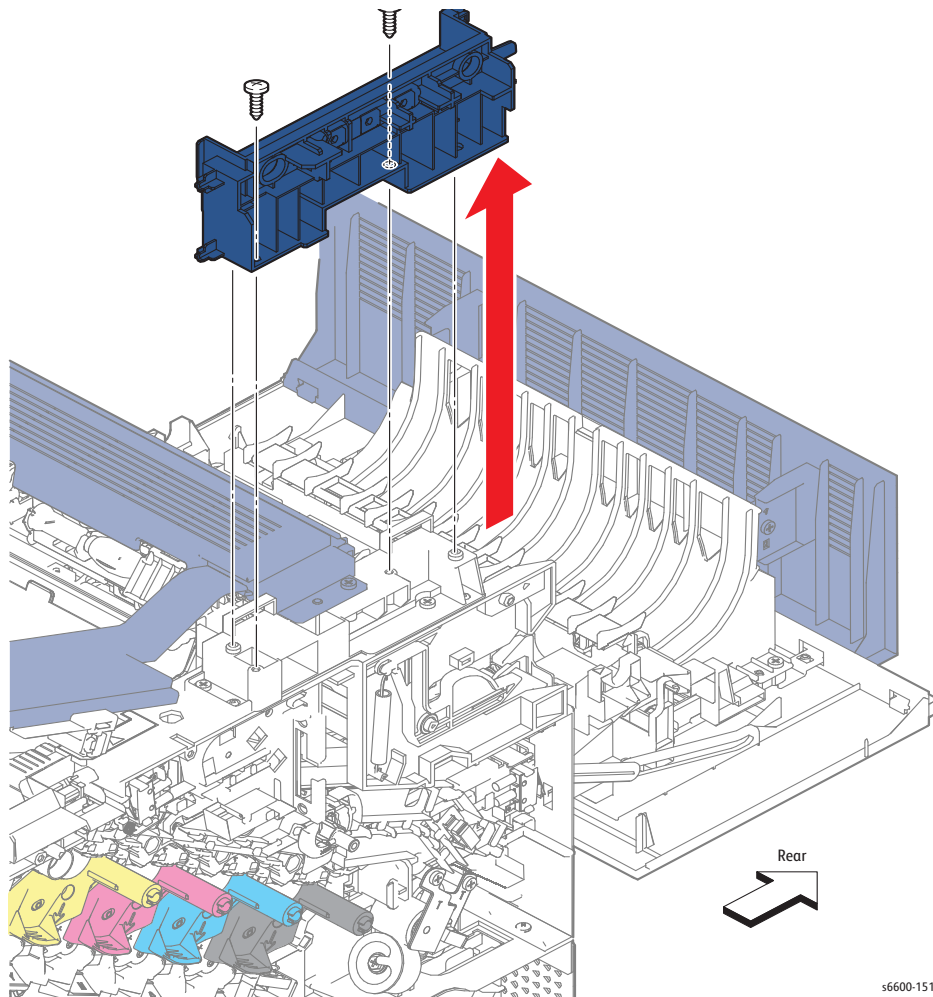
s6600-150

## MFP Right Hand Inner Pole Cover

### PL19.1.20

**!** **WARNING:** The Fuser is very hot. Take added care when handling the fuser to avoid being burned.

1. Remove the Scanner Assembly. (page 4-138)
2. Remove the two screws (silver, tapping, 8mm) that attach the Right Hand Inner Pole Cover to the printer and remove the cover.



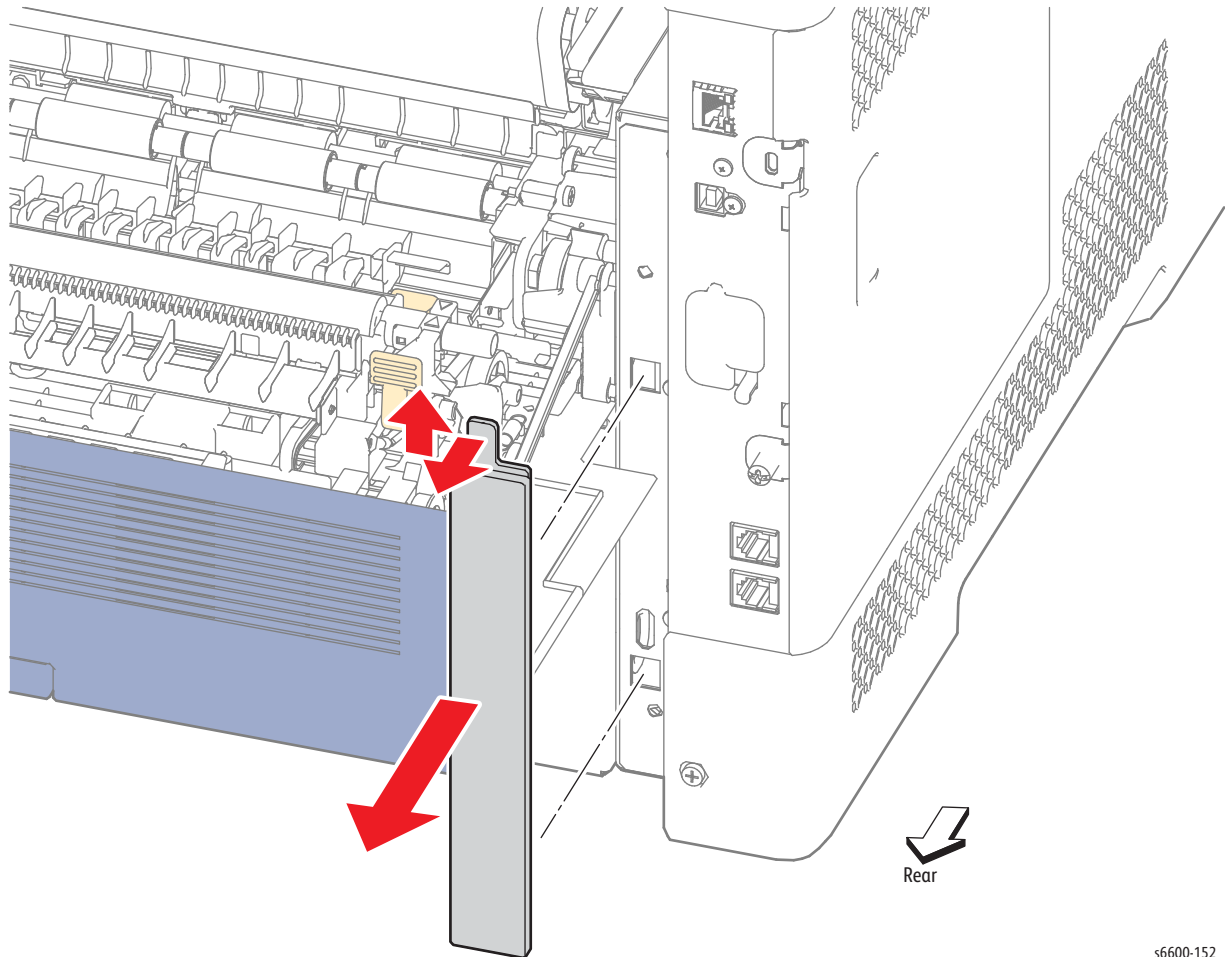
s6600-151

## MFP Lower Left Hand Rear Cover

### PL19.1.23

**!** **WARNING:** The Fuser is very hot. Take added care when handling the fuser to avoid being burned.

1. Open the Rear Door Assembly (PL19.1.95).
2. Release the boss that holds the Lower Left Hand Rear Cover and remove it by sliding it upward until the two hooks are released.



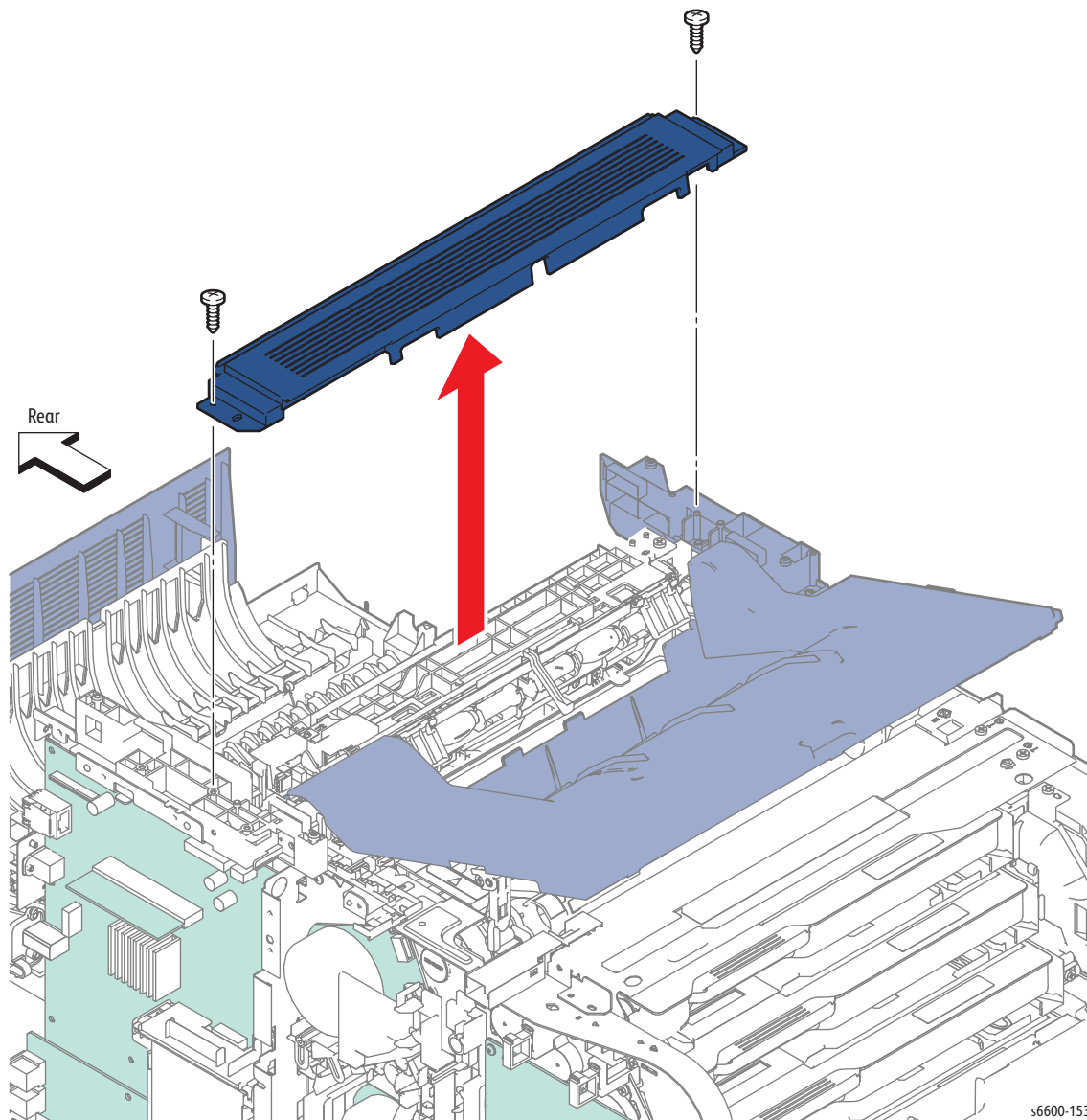
s6600-152

## Exit Cover

### PL19.1.11

**!** **WARNING:** The Fuser is very hot. Take added care when handling the fuser to avoid being burned.

1. Remove the Left Cover Assembly. (SFP page 4-134; MFP page 4-136)
2. SFP Only: Remove the Left Sub-top Cover. (page 4-126)
3. MFP Only: Remove the Scanner Assembly. (page 4-138)
4. Remove the two screws (silver, tapping, 8mm) that attach the Exit Cover to the printer and remove the cover.



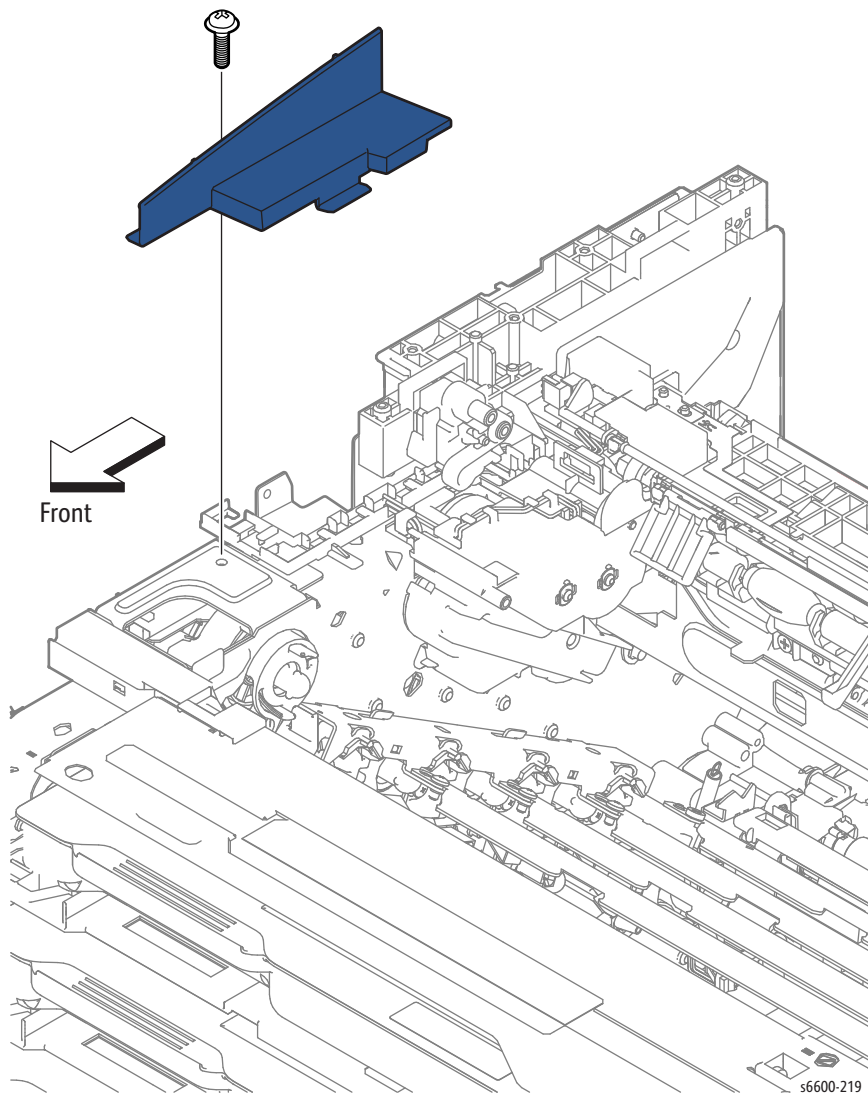
s6600-153

## SFP Left Sub-top Cover

### PL19.1.10

**!** **WARNING:** The Fuser is very hot. Take added care when handling the fuser to avoid being burned.

1. Remove the Right Cover Assembly. (page 4-131)
2. Remove the Left Cover Assembly. (page 4-134)
3. Remove the screw (6mm, silver) that attaches th]e Left Sub-Top Cover to the printer and remove the cover.

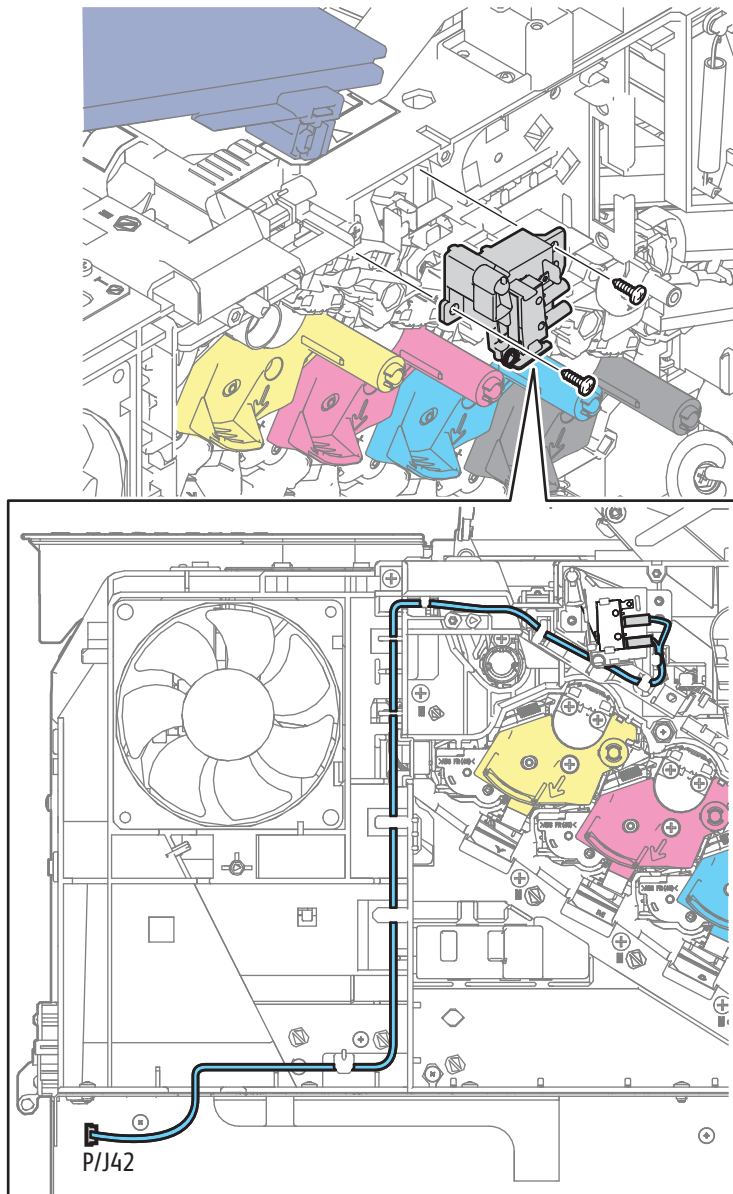


## Right Interlock Switch Assembly

### PL19.1.21

**!** **WARNING:** The Fuser is very hot. Take added care when handling the fuser to avoid being burned.

1. Remove the Right Cover Assembly. (page 4-131)
2. Unplug connector P/J42 from the LVPS (PL18.1.34), and release the harness from the guides.
3. Open the Top Cover.
4. Remove the two screws (silver, tapping, 8mm) that attach the Right Side Interlock Bracket (PL19.1.22) to the printer and remove the Right Interlock Switch Assembly.

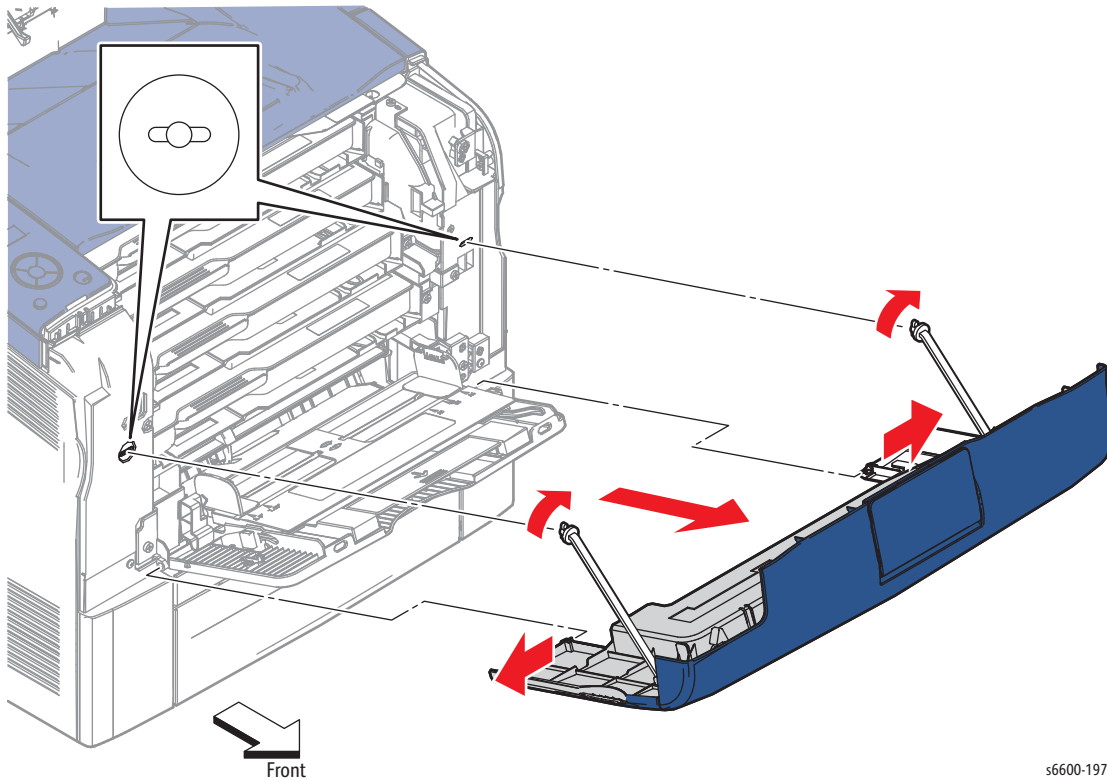


56600-196

## Front Door Assembly

(SFP PL19.1.34 / MFP PL19.1.42)

1. Remove the Bypass Tray Assembly (page 4-71) to simplify the Front Door removal.
2. Open the Front Door Assembly.
3. Rotate the ends of the left and right Front Straps (SFP PL19.1.31; MFP 19.1.39) 90 degrees to release them from the slots on printer.
4. Push the hinge on either the left or right side enough to release the hinge from the boss. Then slide the door in the other direction to free the other hinge boss and remove the door.



s6600-197



## Rear Door Assembly

### PL19.1.95

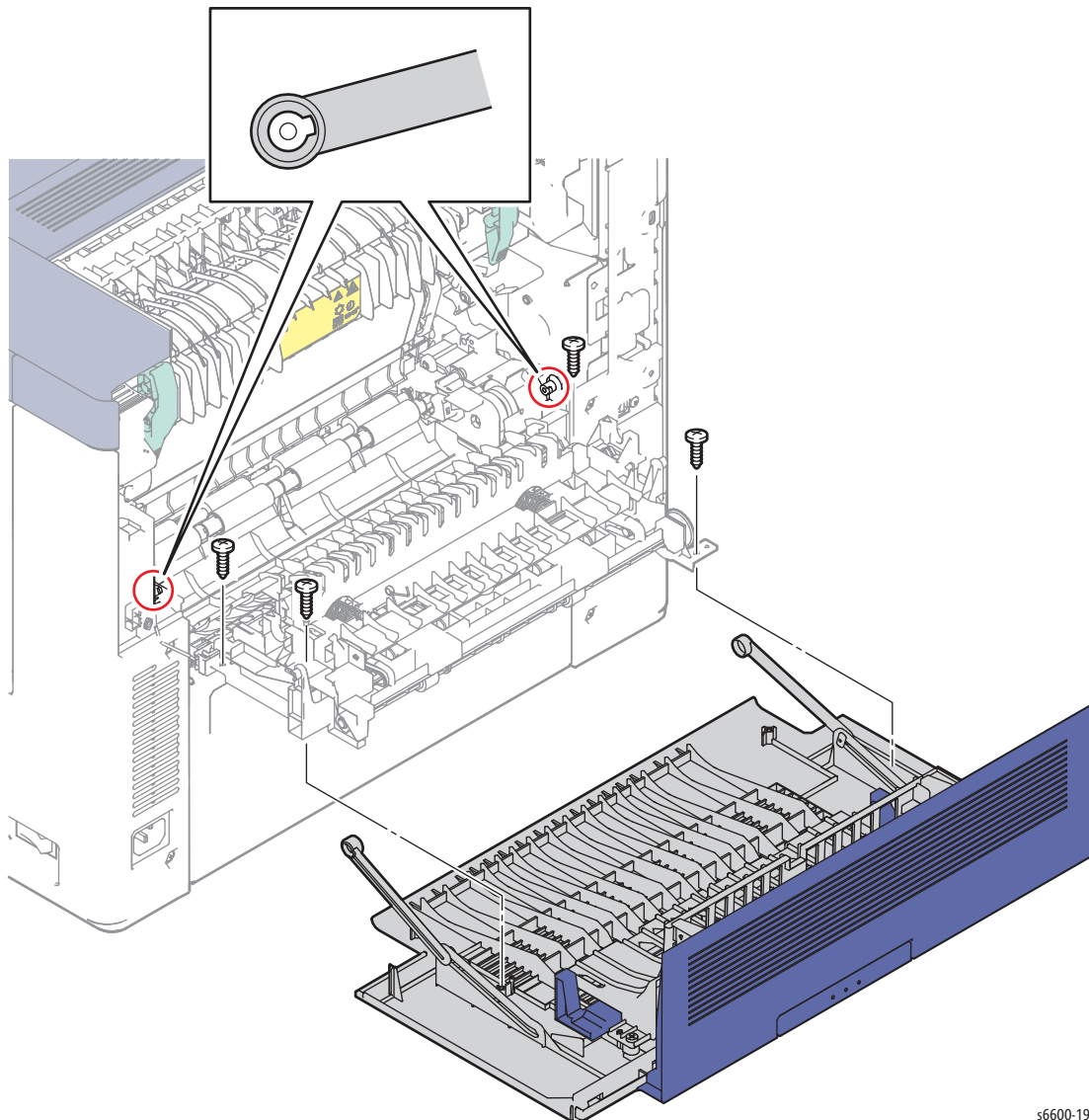
1. Open the Rear Door Assembly .
2. Remove the Transfer Roller. (page 4-79)

**!** **CAUTION:** To prevent the door from falling off as you remove the screws, support the door from underneath.

3. Remove the four screws (silver, tapping, 8mm) that attach the Rear Door Assembly to the printer and remove the cover.

**Note:** The removal procedure for Rear Cover Link is the same on both the right and left sides.

4. Remove the Rear Cover Links (PL19.1.14) by raising the Rear Cover slightly so that the hole on each Rear Cover Link can be released from the boss holding it to the printer.



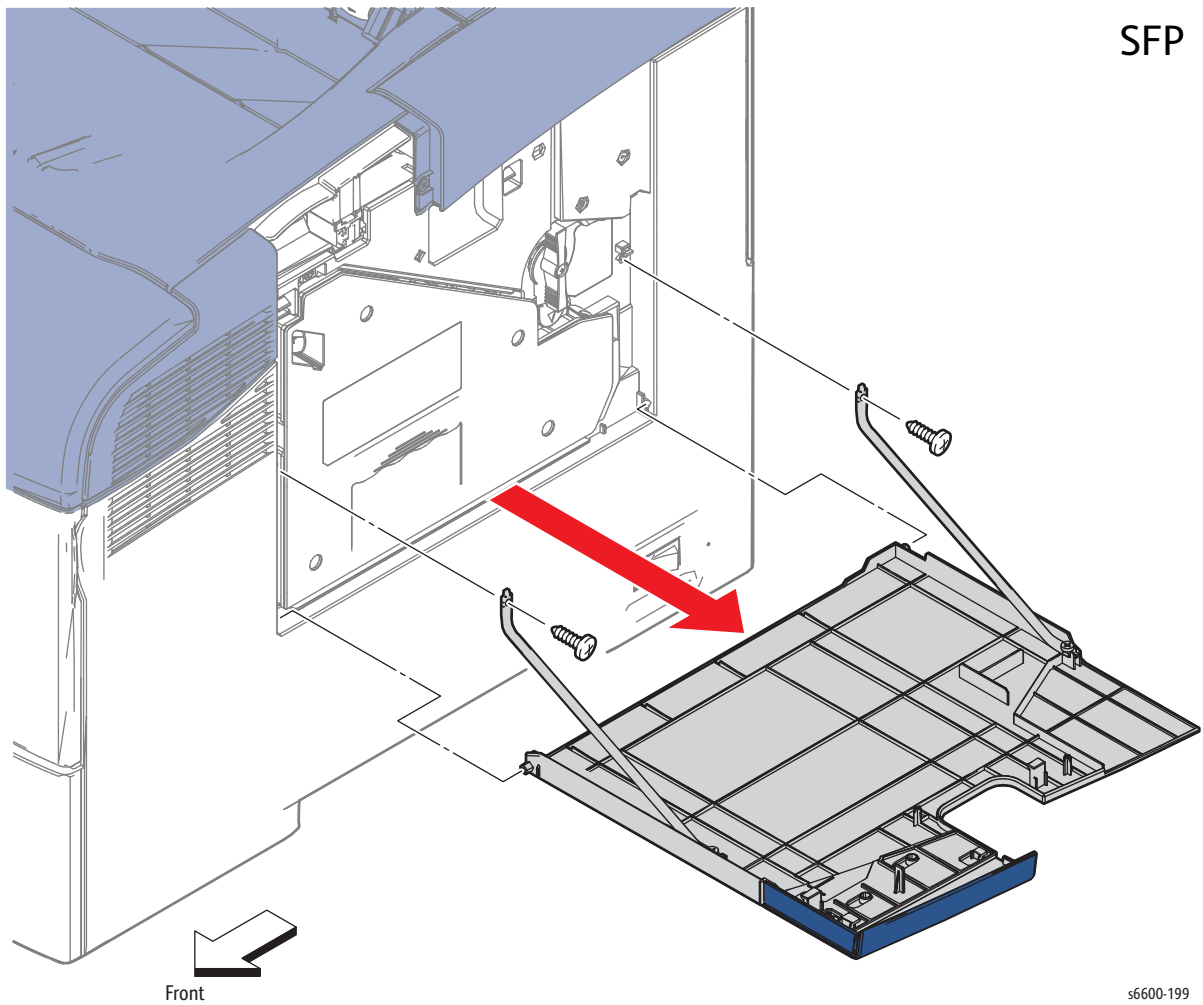
s6600-198

## Right Side Door Assembly

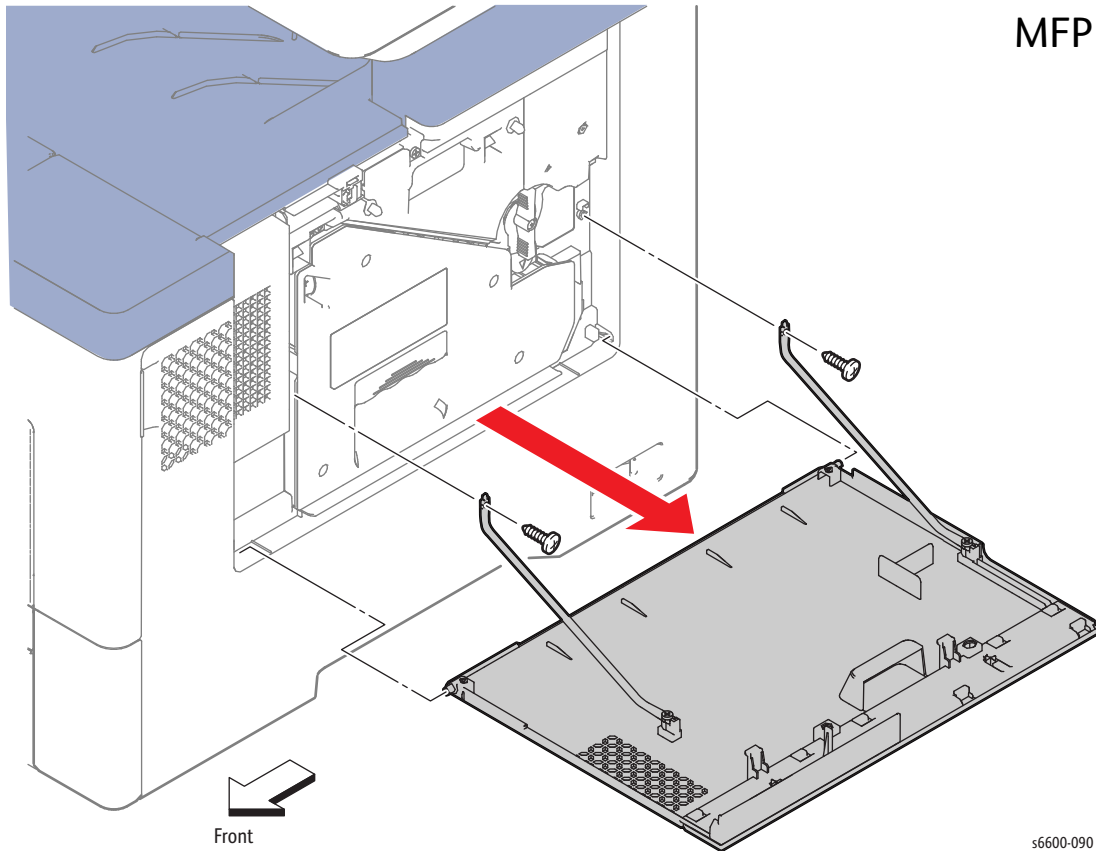
### PL19.1.96

1. Open the Right Side Door Assembly.
2. Remove the two screws (silver, tapping, 8mm) that attach each of the Right Side Door Straps (SFP PL19.1.29; MFP PL 19.1.37) to the Right Cover Assembly (PL19.1.97).
3. Remove the Right Side Door Assembly while flexing it to release the bosses one by one from the holes.

**Tip:** When removing the Right Side Door, lift it to the almost-closed position to allow it to flex easily.



MFP



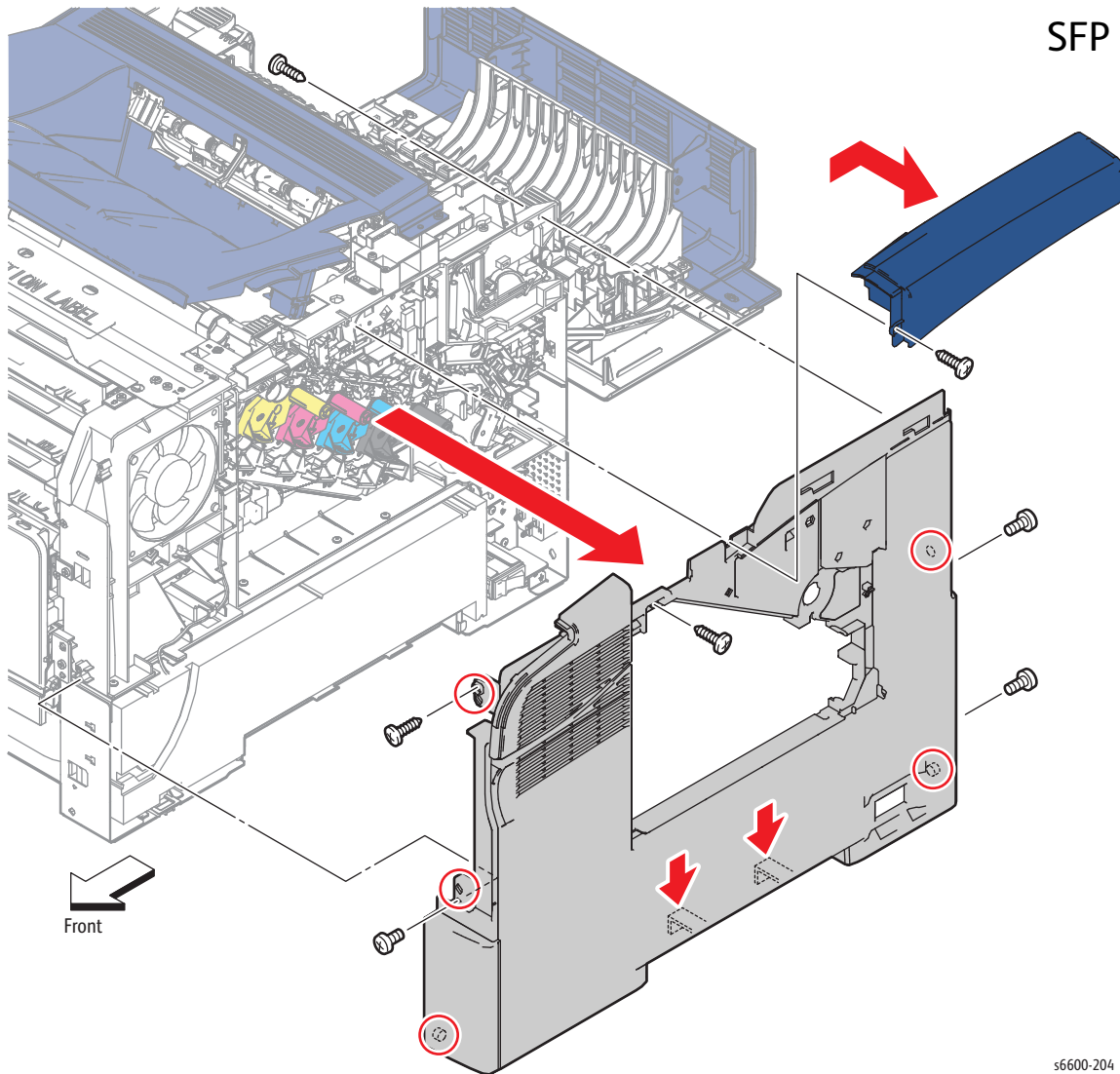
## Right Cover Assembly

### PL19.1.97

**!** **WARNING:** The Fuser is very hot. Take added care when handling the fuser to avoid being burned.

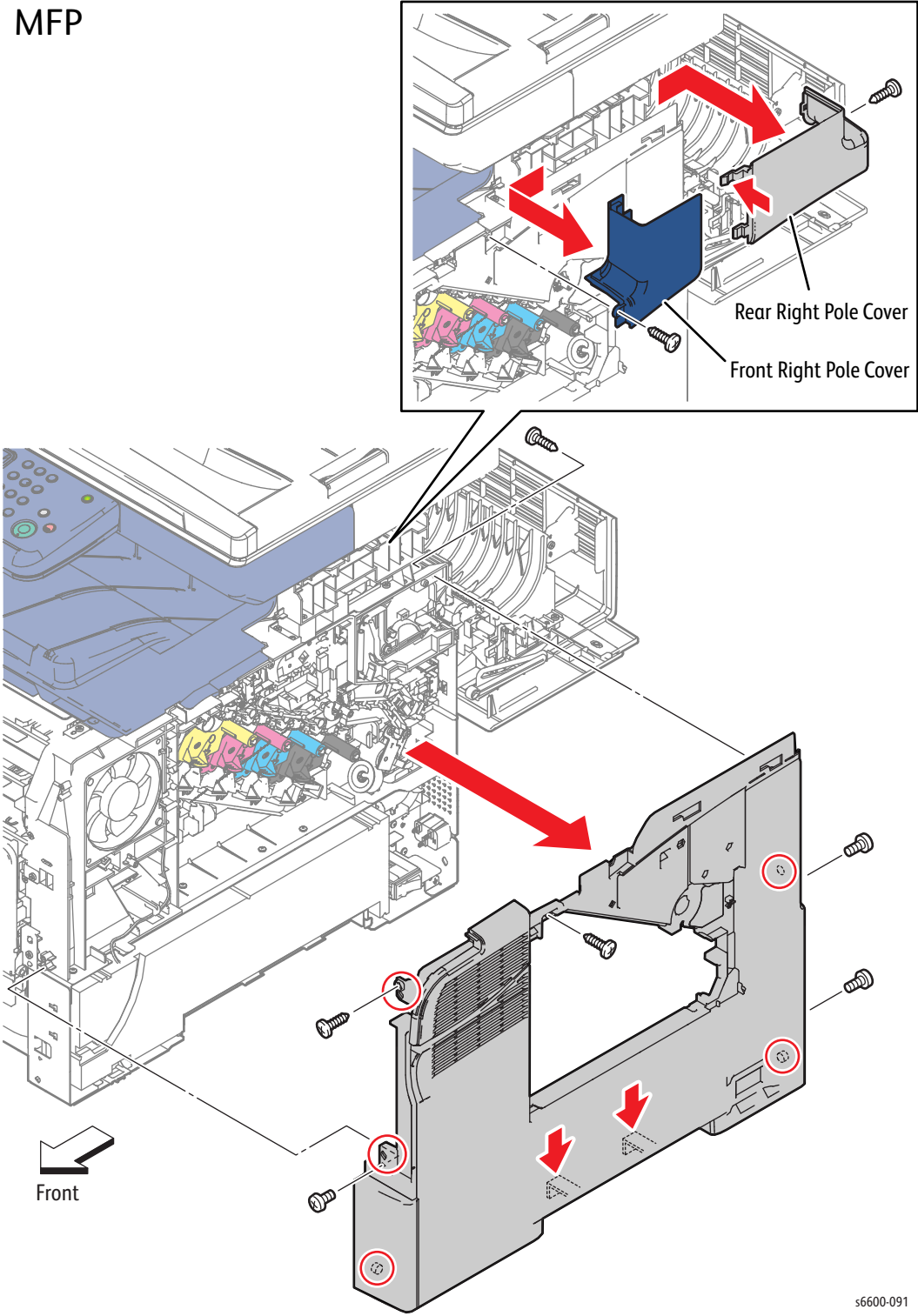
1. Remove the Fuser Assembly. (page 4-46)
2. Remove the Waste Cartridge. (page 4-50)
3. Remove the Waste Cartridge Lock. (page 4-39)
4. Remove the Right Side Door Assembly. (page 4-130)
5. Remove the Front Door Assembly. (page 4-128)
6. **SFP only:** Remove the screw (silver, tapping, 8mm) that attaches the Right Top Cover to the frame.  
**Note:** For the next two steps, refer to the inset in the illustration on page 4-133.
7. **MFP only:** Remove the screw (silver, tapping, 8mm) that attaches the Rear Right Pole Cover (PL 19.1.35), then release the hook and remove the cover.
8. **MFP only:** Remove the screw (silver, tapping, 8mm) that attaches the Front Right Pole Cover (PL 19.1.61) and remove the cover.
9. Remove the two screws (silver, 6mm) at the rear and the screw (silver, tapping, 8mm) inside the rear that attach the rear of the Right Cover Assembly.

10. Remove the two (SFP) or one (MFP) screw(s) (silver, tapping, 8mm) that attach the side of the Right Cover Assembly. Refer to the figures.
11. Remove the two screws (silver, tapping, 8mm) and the one screw (silver, 6mm) that attach the front of the Right Cover Assembly.
12. Release the three bosses on the front of the Right Cover Assembly, release the two hooks below the recessed grip using a flatblade screwdriver (or something similar) while flexing the front end slightly outward, and then release the two bosses on the rear end.
13. Remove the Right Cover Assembly.



s6600-204

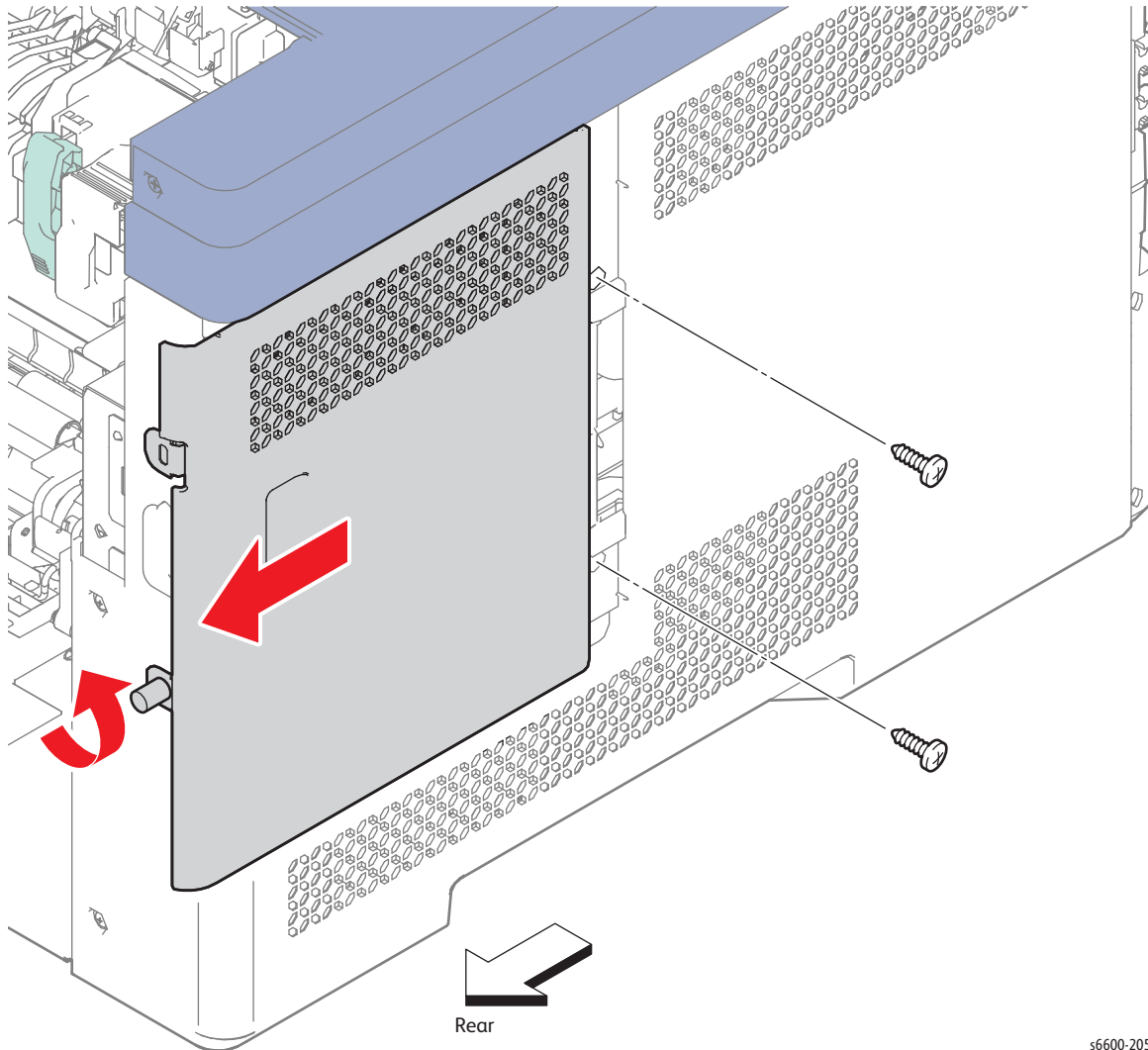
MFP



## SFP Left Cover Assembly

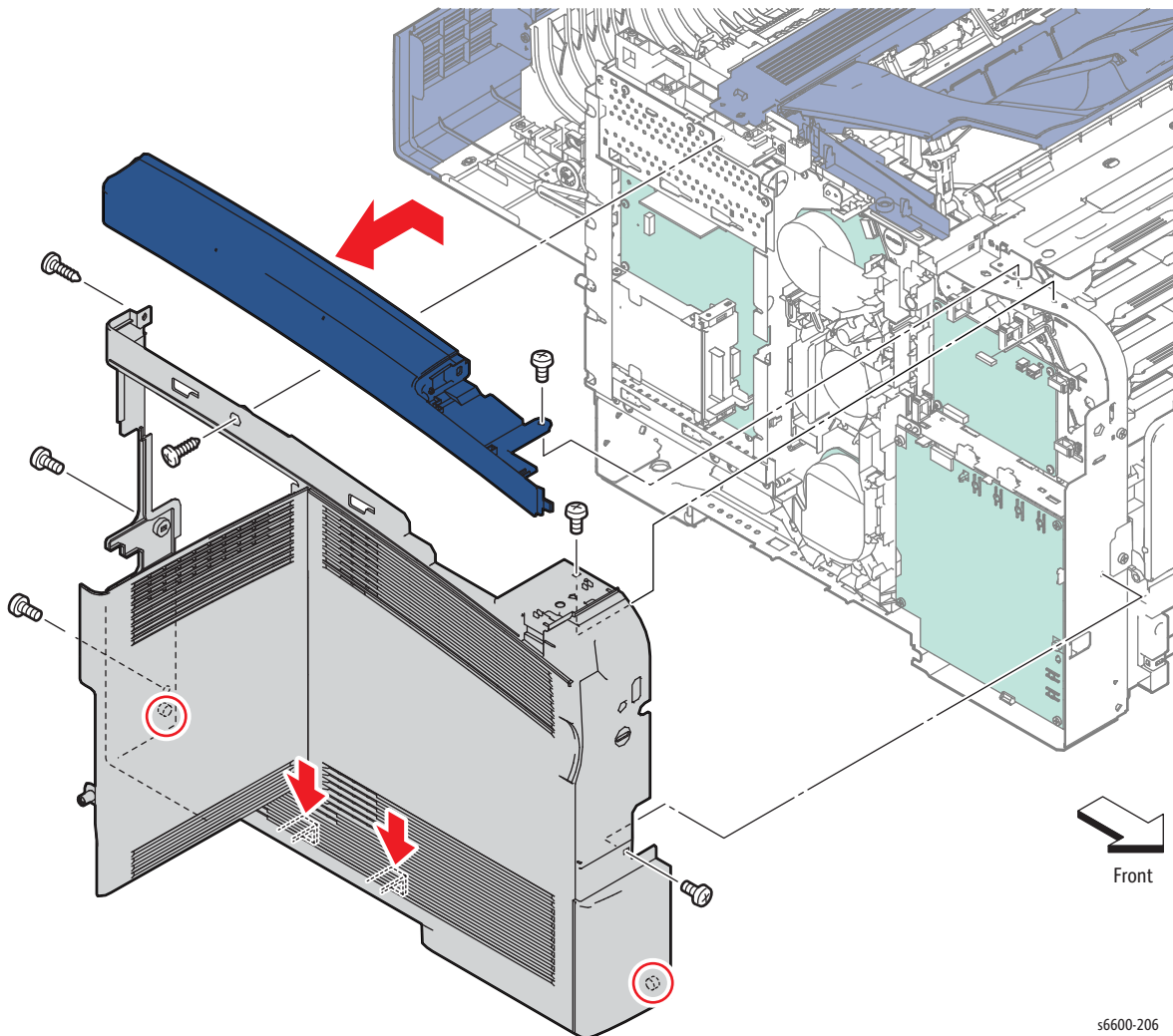
### PL19.1.98

1. Remove the Control Panel Assembly. (page 4-7)
2. Remove the Front Door Assembly. (page 4-128)
3. Loosen the knurled screw that secures the IP Board Cover (PL19.1.44), slide the cover rearward and remove the two screws (silver, tapping, 8mm).



s6600-205

4. Remove the screw (silver, 6mm) that attaches the Top Left Cover to the printer, and slide the cover to the rear and out to remove it. Allow the harness for the Control Panel to feed through the hole in the cover.
5. Remove the two screws (silver, 6mm) and the one screw (silver, tapping, 8mm) that attach the Left Cover Assembly at the rear.
6. Remove the screw (silver, tapping, 8mm) that attaches the Left Cover Assembly at the top on the side above the IP Board Cover.
7. Remove the screw (silver, 6mm) that attaches the Left Cover Assembly at the top near the front.
8. Remove the screw (silver, 6mm) that attaches the front of the Left Cover Assembly.
9. Release the boss on the bottom front of the Left Cover Assembly, release the two hooks below the recessed grip using a flatblade screwdriver or the like while flexing the front end slightly outward, and then release the boss on the rear end.

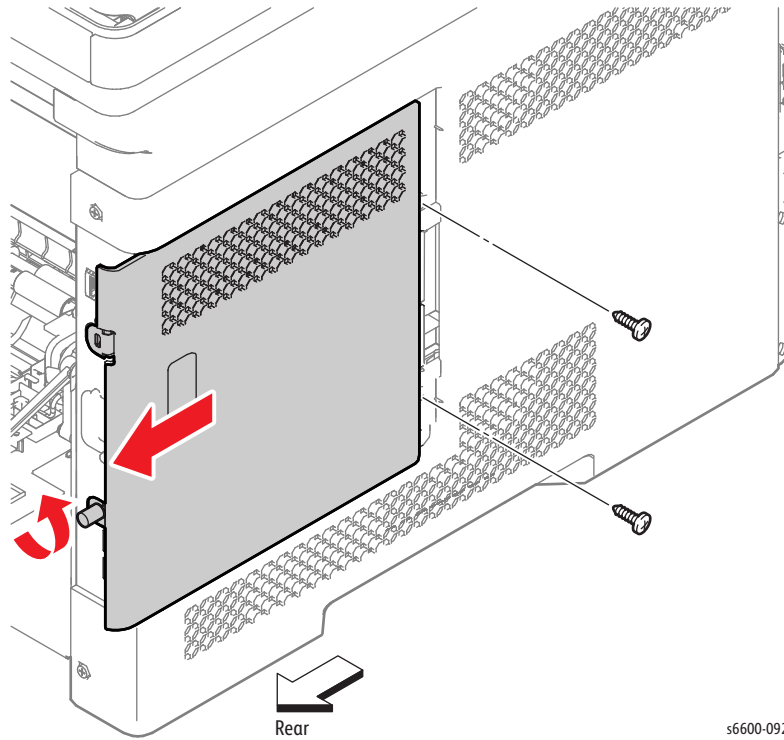


s6600-206

## MFP Left Cover Assembly

### PL19.1.98

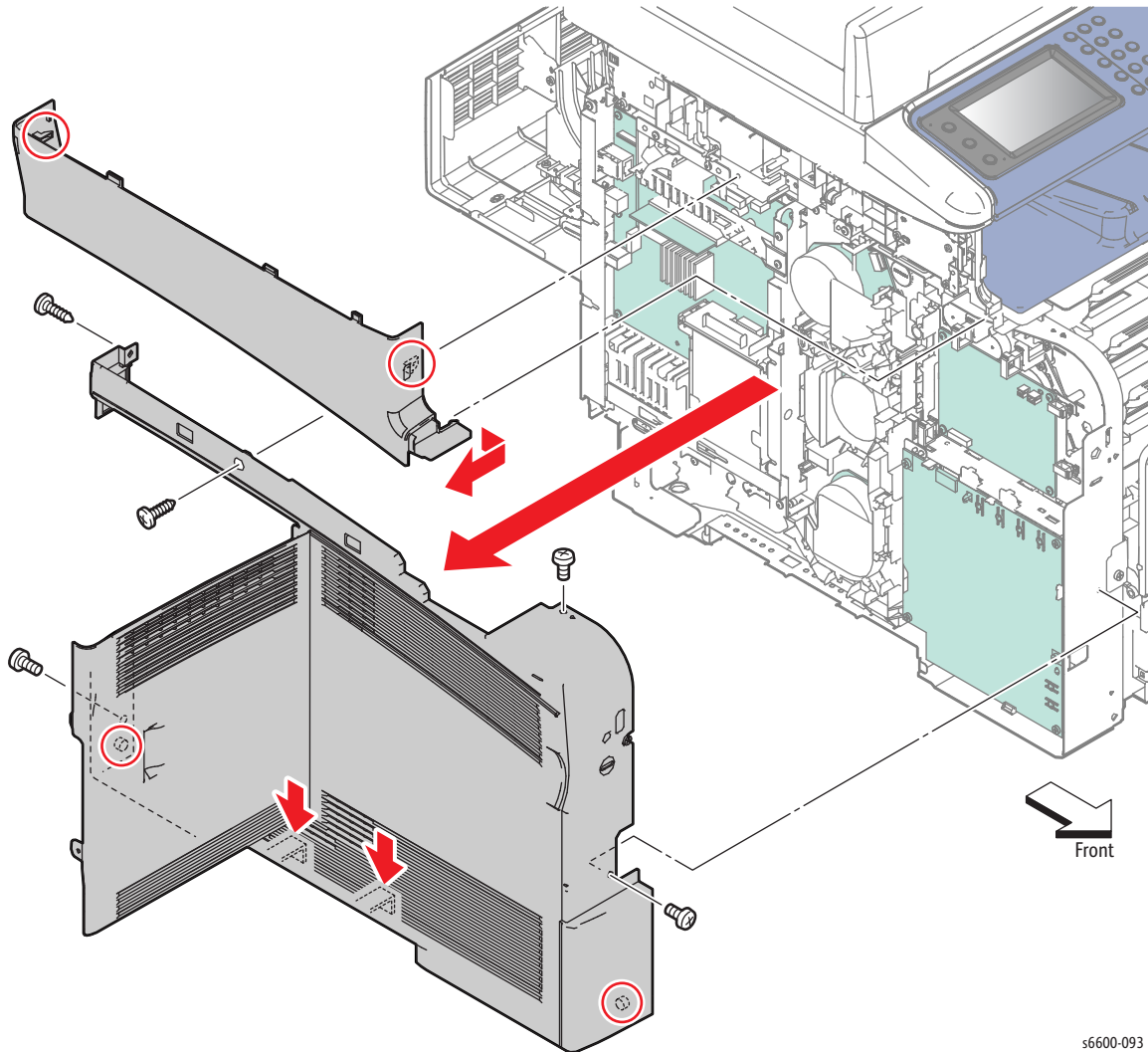
1. Remove the Front Door Assembly. (page 4-128)
2. Loosen the knurled screw that attaches the IP Board Cover (PL19.1.44), slide the cover rearward, and remove the two screws (silver, tapping, 8mm).



s6600-092



3. Swing up the Control Panel Assembly.
4. Release the front and rear hooks holding the Outer Left Pole Cover (PL19.1.64) using a flatblade screwdriver or similar tool, and remove the cover.
5. Remove the two screws (silver, 6mm) that attach the rear of the Left Cover Assembly.
6. Remove the screw (silver, 6mm) that attaches the Left Cover Assembly at the top near the front.
7. Remove the screw (silver, 6mm) that attaches the front of the Left Cover Assembly.
8. Release the boss on the bottom front of the Left Cover Assembly, release the two hooks below the recessed grip using a flatblade screwdriver or the like while flexing the front end slightly outward, and then release the boss on the rear end.




s6600-093

# Scanner

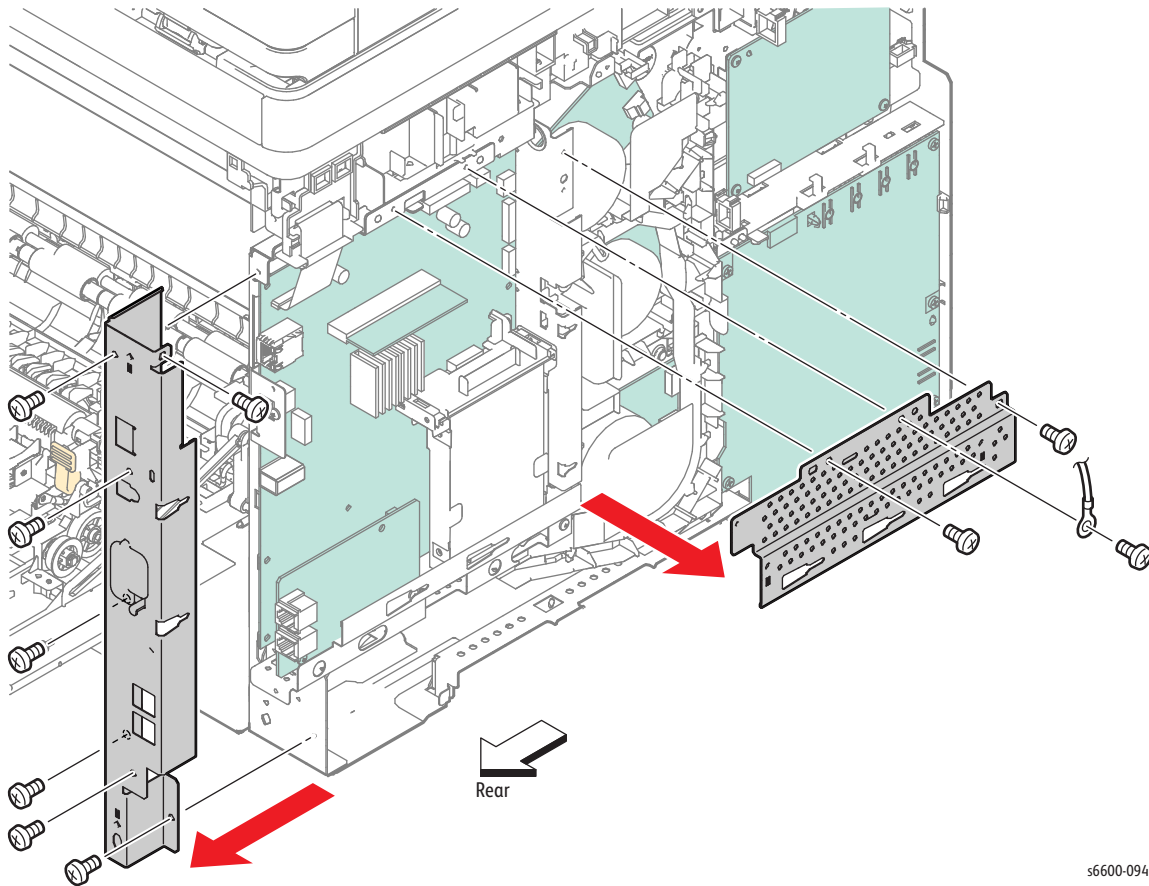
## Scanner Assembly

### PL51.1.1

 **WARNING:** The Fuser is very hot. Take added care when handling the fuser to avoid being burned.

1. Remove the Fuser Assembly. (page 4-46)
2. Remove the Waste Cartridge. (page 4-50)
3. Remove the Waste Cartridge Lock. (page 4-39)
4. Remove the Front Door Assembly. (page 4-128)
5. Remove the Right Cover Assembly. (page 4-131)
6. Remove the Left Cover Assembly. (page 4-136)
7. Remove the Lower Left Hand Rear Cover. (page 4-124)
8. Remove the Upper Right Hand Pole Cover. (page 4-122)
9. Remove the Control Panel Assembly. (page 4-8)

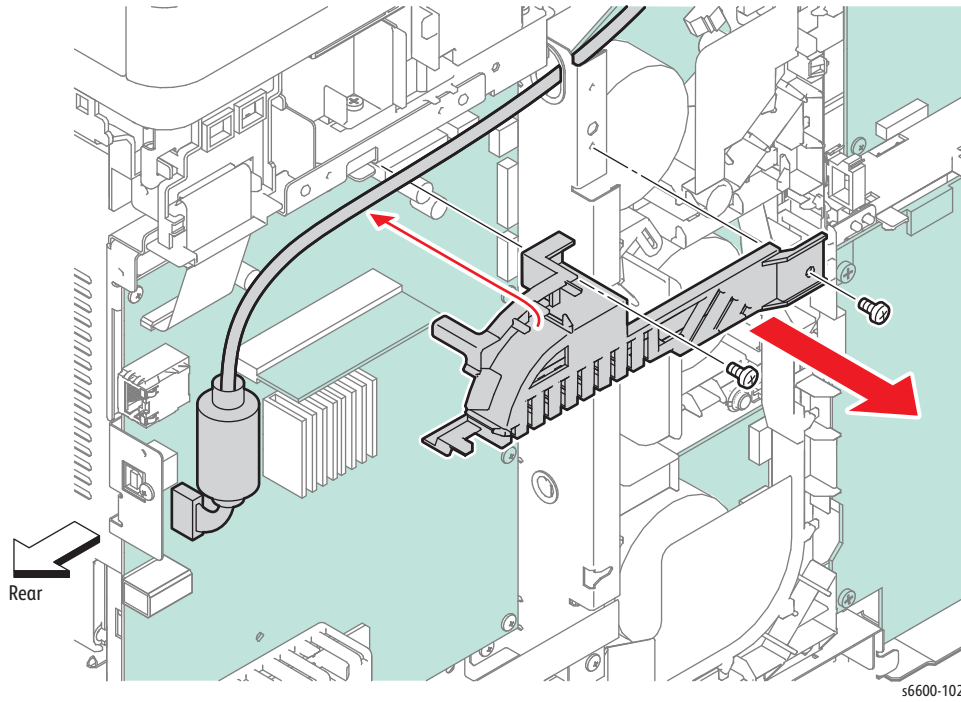
10. Remove the seven screws (silver, 6mm) that attach the MFP Rear IP Board Plate (PL18.1.24) to the printer and remove the MFP Rear IP Board Plate.
11. Remove the three screws (silver, 6mm) that attach the MFP Top IP Board Plate (PL18.1.19) and remove the MFP Top IP Board Plate by removing the grounding wire.



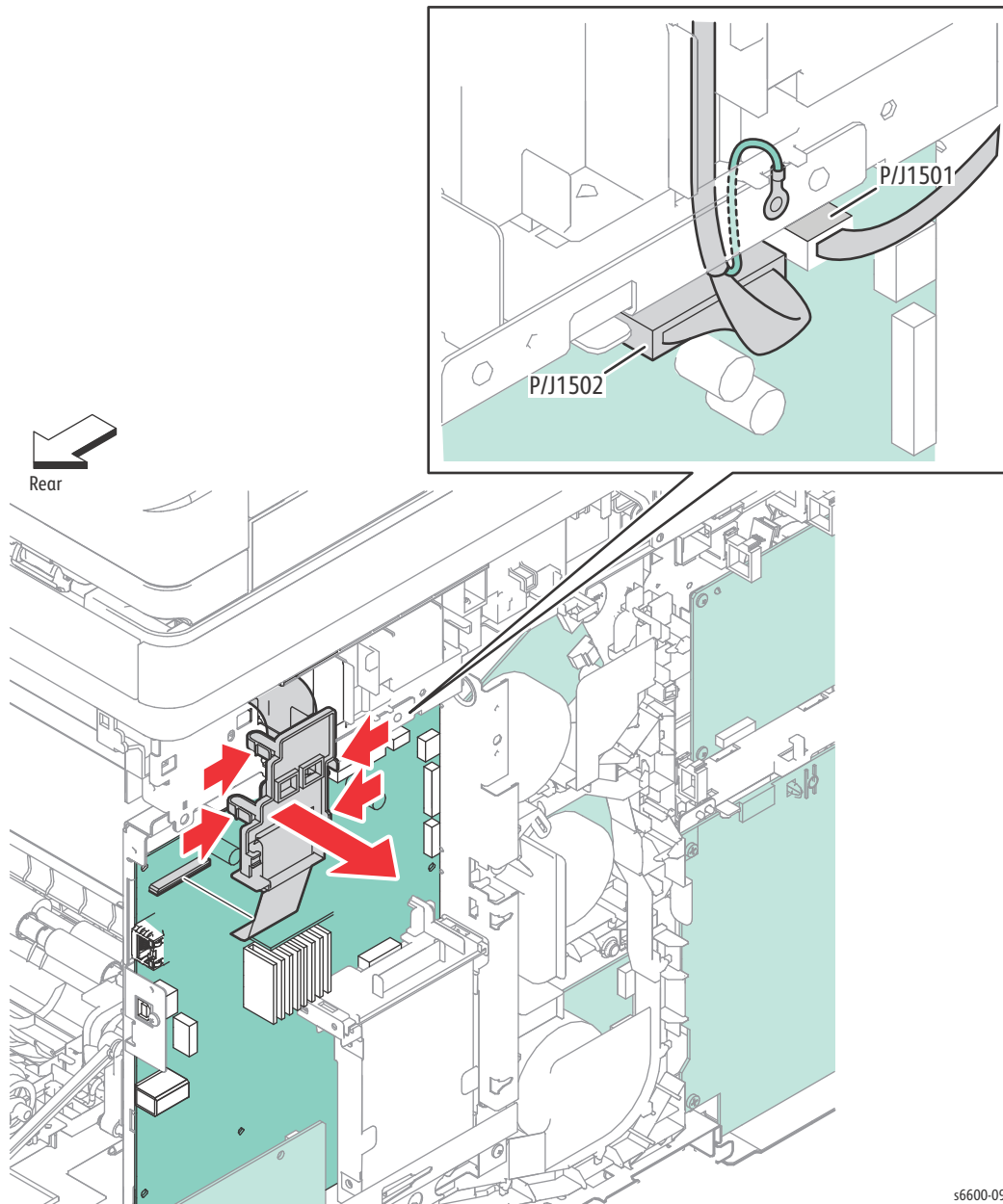
s6600-094

## Service Parts Disassembly

12. Release the harness from the cable guides in the IP Board Top Guard (PL18.1.48).
13. Remove the two screws (silver, 6mm) that attach the IP Board Top Guard and remove it.



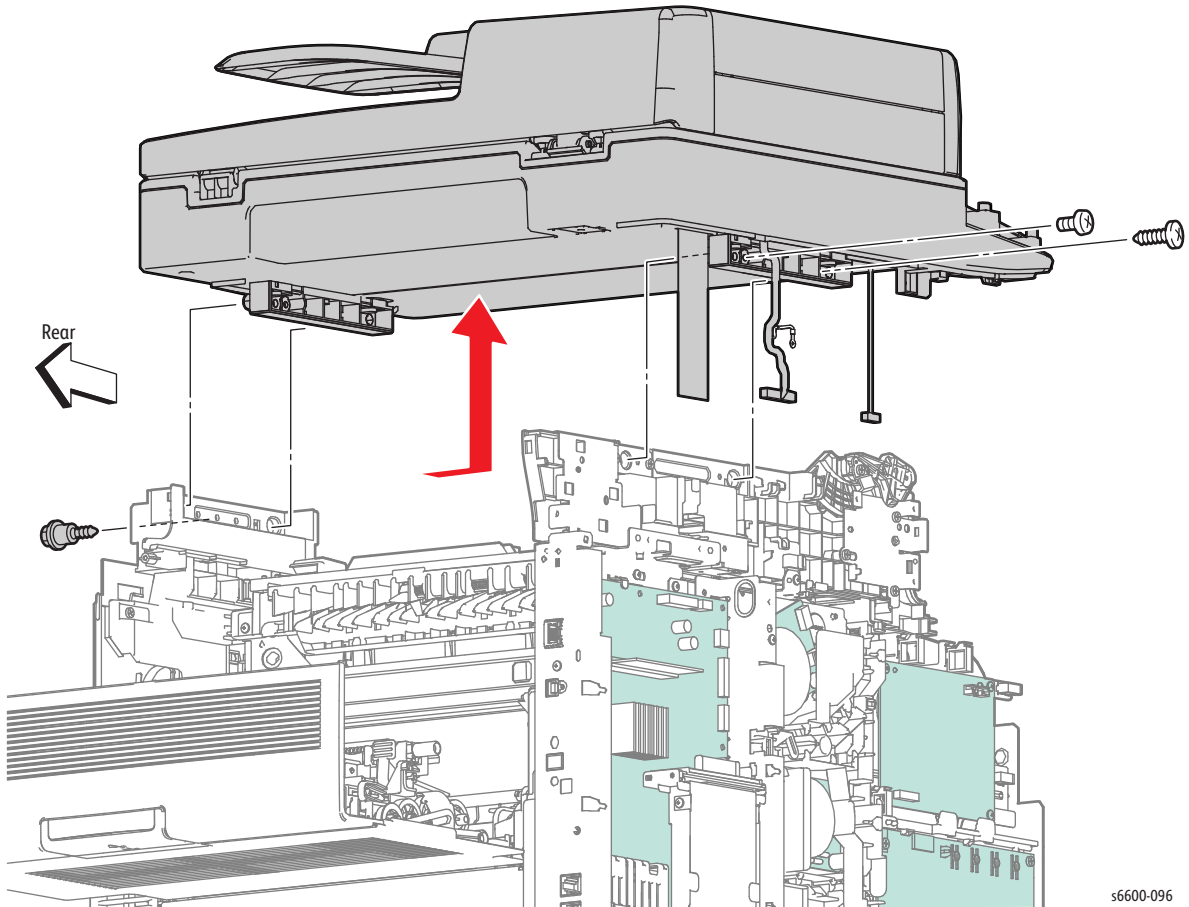
14. Unplug the two connectors (P/J1502 and P/J1501) from the IP Board (PL18.1.22), and then release the harness from the harness guide.
15. Unplug the flat cable connected to the IP Board and remove the FFC Core Holder (PL19.1.12) while releasing the four hooks holding it.



s6600-095

## Service Parts Disassembly

16. Remove the screws (one silver, 6mm; and one silver, tapping, 8mm) that attach the left side of the Scanner Assembly.
17. Remove the special screw (silver, tapping, 8mm) that attaches the right side of the Scanner Assembly.
18. Slide the Scanner Assembly to the left until the four bosses are released and lift it off the printer.



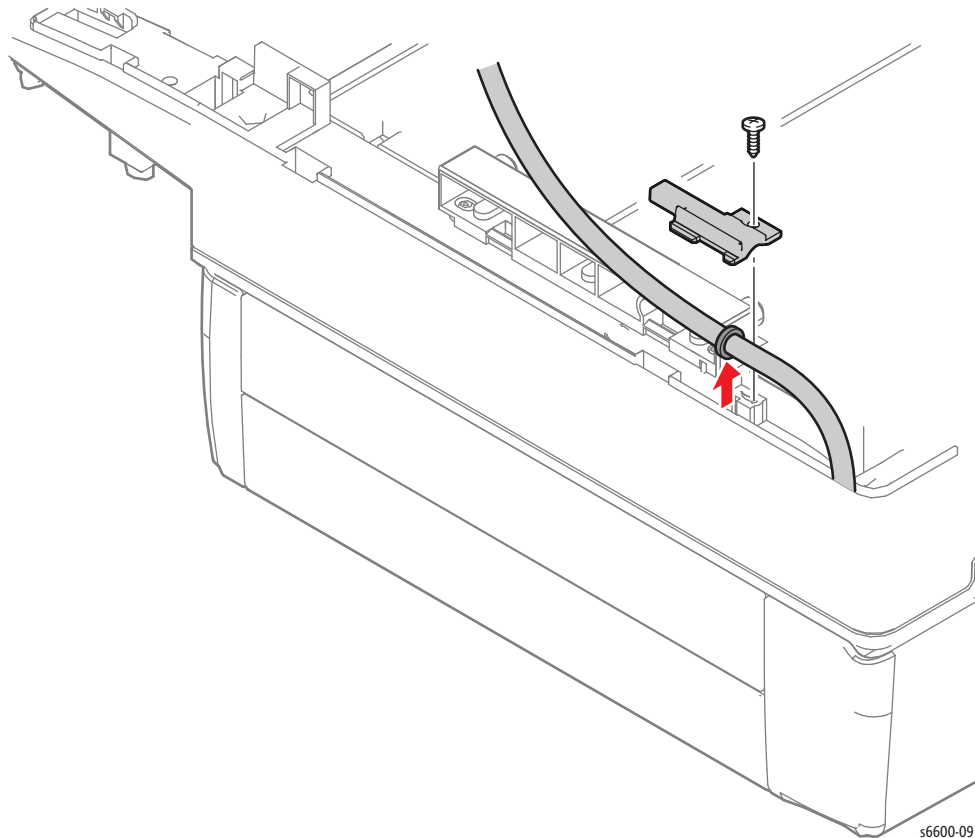
s6600-096

## DADF Assembly / IIT Assembly

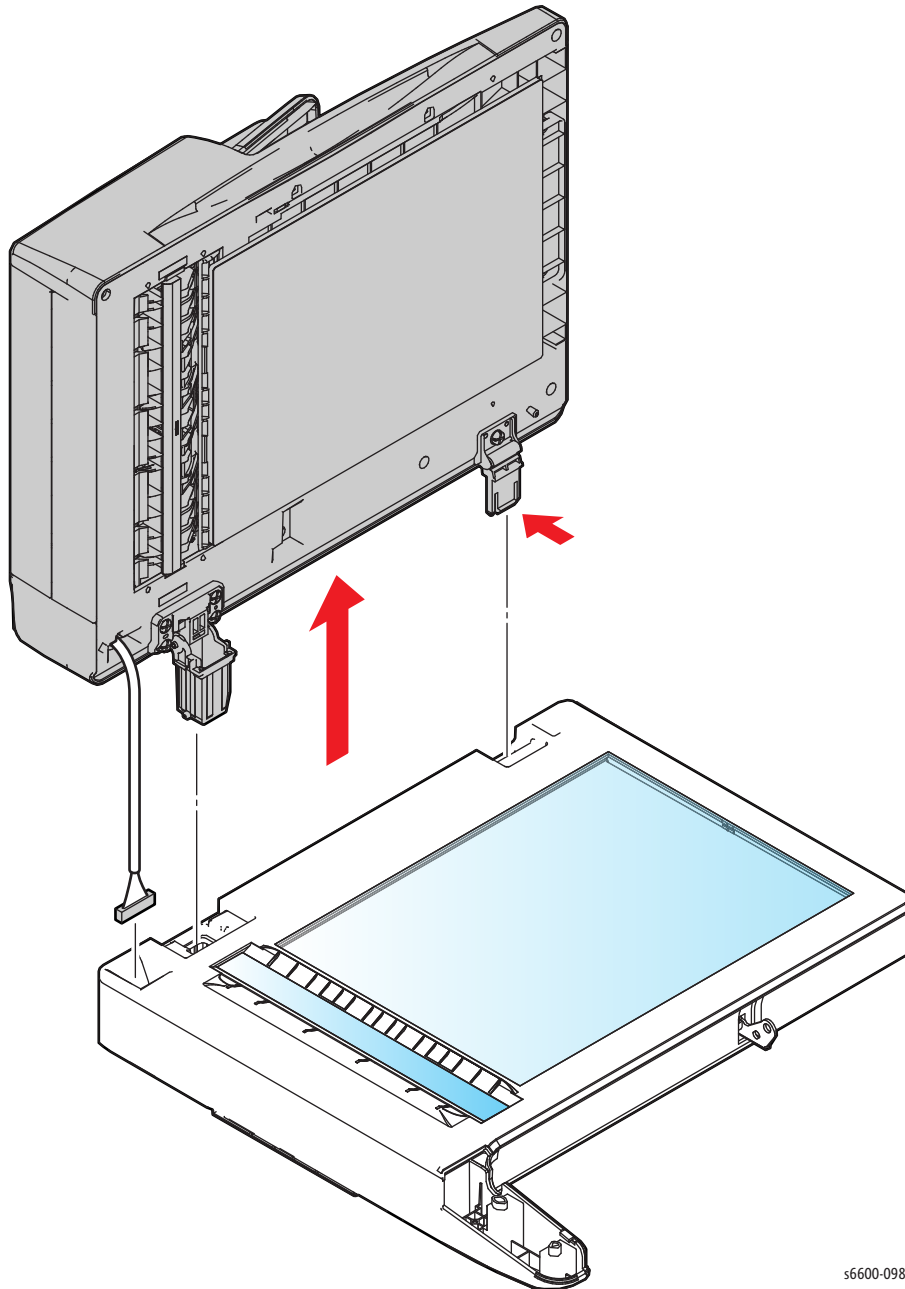
### PL51.1.2 / PL51.1.3

**!** **WARNING:** The Fuser is very hot. Take added care when handling the fuser to avoid being burned.

1. Remove the Fuser Assembly. (page 4-46)
2. Remove the Waste Cartridge. (page 4-50)
3. Remove the Waste Cartridge Lock. (page 4-39)
4. Remove the Front Door Assembly. (page 4-128)
5. Remove the Right Cover Assembly. (page 4-131)
6. Remove the Left Cover Assembly. (page 4-136)
7. Remove the Lower Left Hand Rear Cover. (page 4-124)
8. Remove the Upper Right Hand Pole Cover. (page 4-122)
9. Remove the Control Panel Assembly. (page 4-8)
10. Remove the Scanner Assembly. (page 4-138)
11. Turn the Scanner Assembly over.
12. Remove the screw (silver, tapping, 8mm) that attaches the Harness Cover to the IIT Assembly and remove the cover. Save the cover for re-use during reassembly.
13. Release the IIT Assembly harness from the groove on the underside of the IIT Assembly.



14. Turn the Scanner Assembly over.
15. Open the DADF Assembly, release the hook on the R Hinge (PL51.1.8) using a flatblade screwdriver or the like, and separate the DADF Assembly from the IIT Assembly while pulling the harness out through the hole on the IIT Assembly.



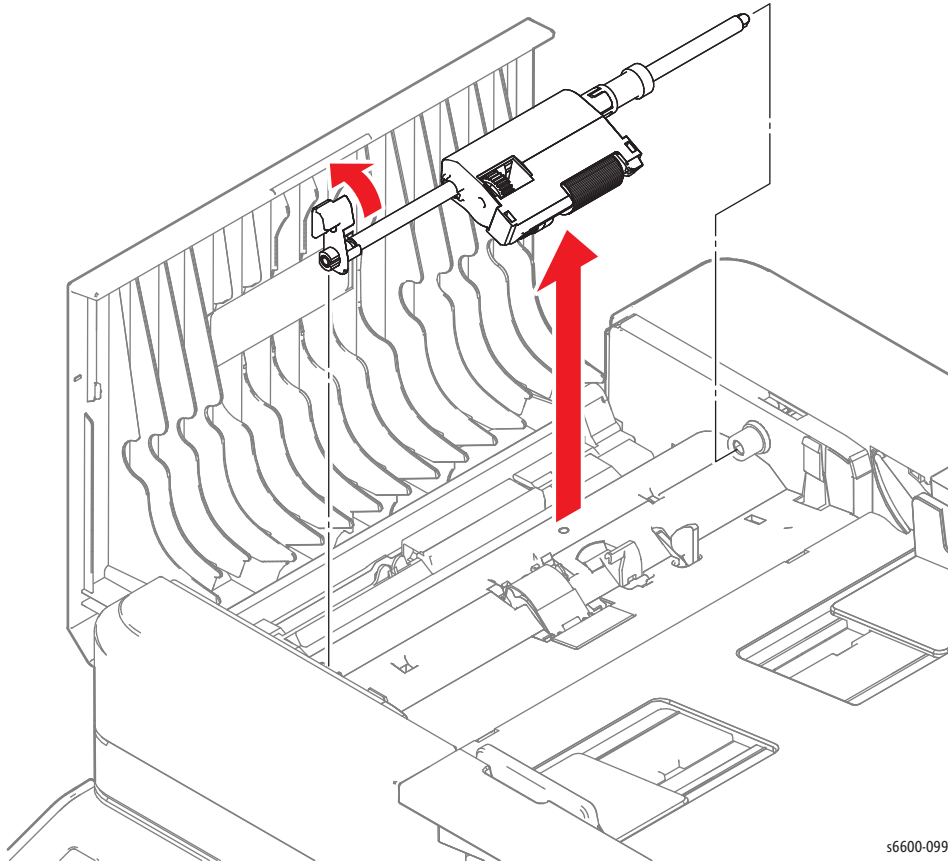
s6600-098



## IIT Pick-up Module

### PL51.1.4

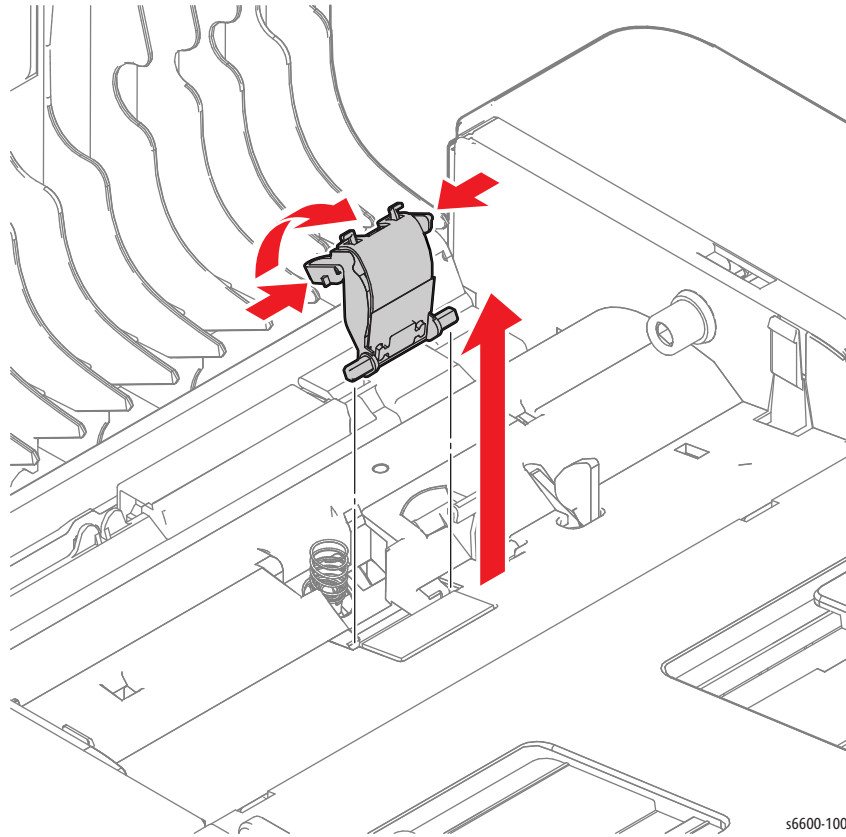
1. Open the DADF Top Cover.
2. Swing up the tab securing the IIT Pick-up until it is released and remove the IIT Pick-up.



s6600-099

Service Parts Disassembly

3. Release the two hooks holding the IIT Separation Pad and remove it by swinging it up.

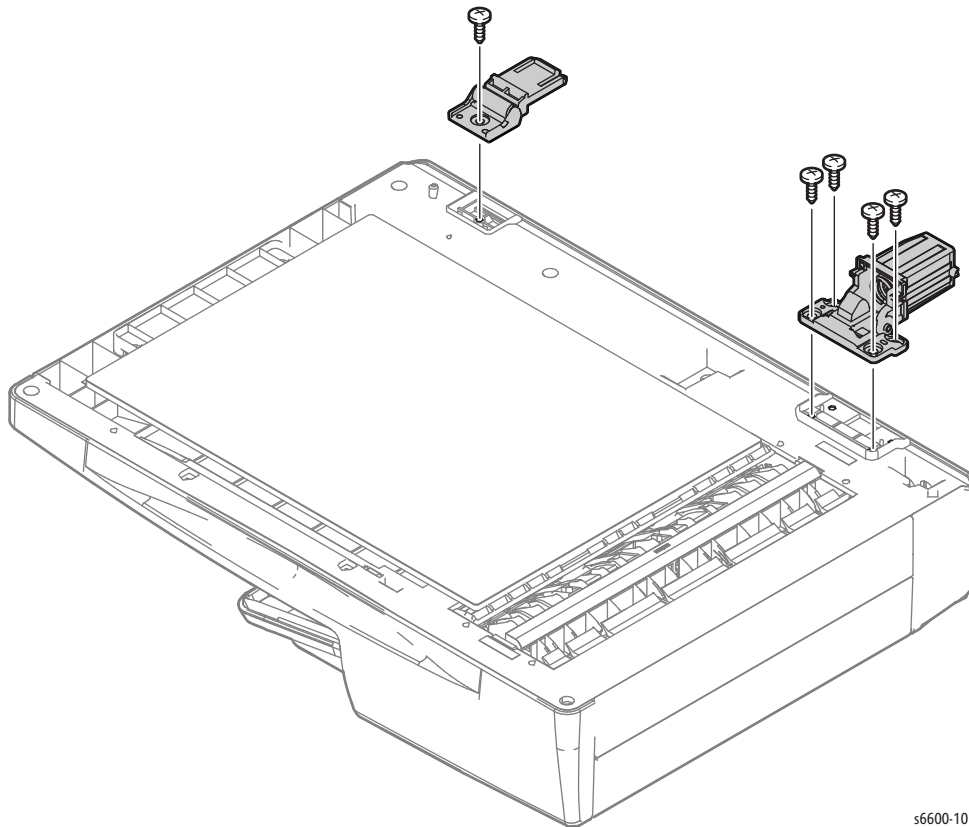


## L Hinge/ R Hinge

### PL51.1.7 / PL51.1.8

**!** **WARNING:** The Fuser is very hot. Take added care when handling the fuser to avoid being burned.

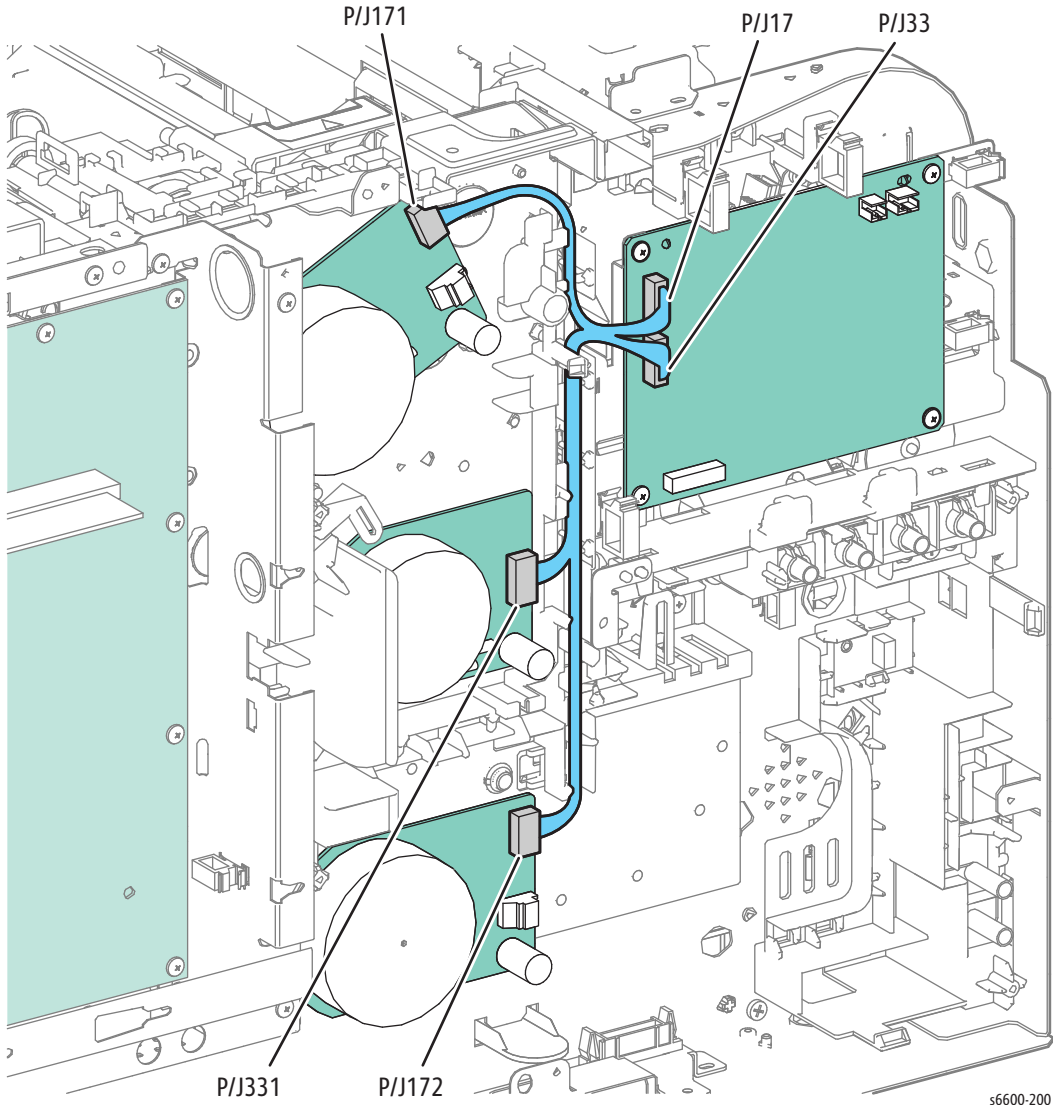
1. Remove the DADF Assembly / IIT Assembly. (page 4-143)
2. Remove the four screws (silver, tapping, 6mm) that attach the L Hinge (PL51.1.7) to the printer and remove the hinge.
3. Remove the screw (silver, tapping, 6mm) that attaches the R Hinge (PL51.1.8) to the printer and remove the hinge.



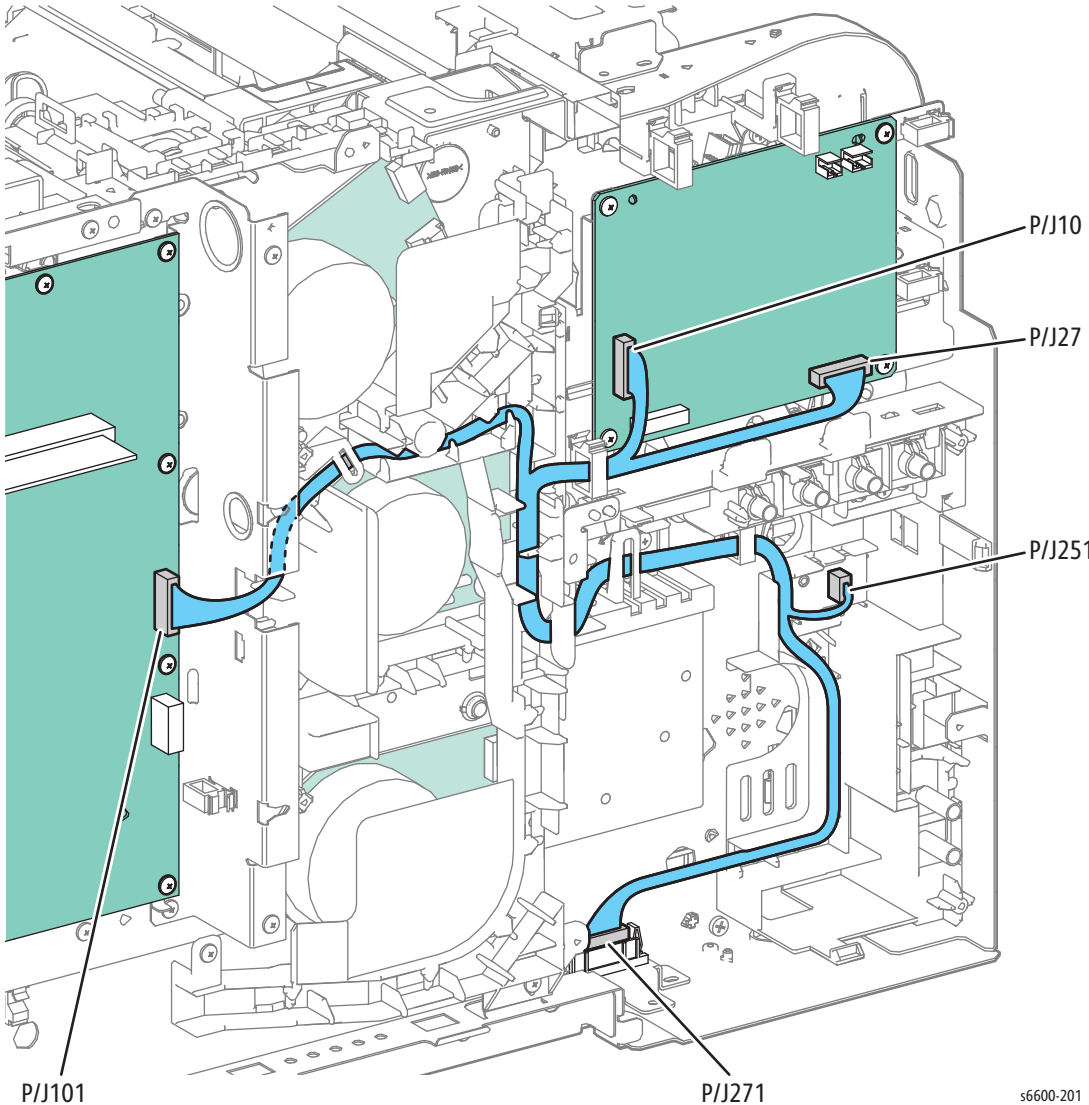
s6600-101

# Harness

## Drive Harness Assembly

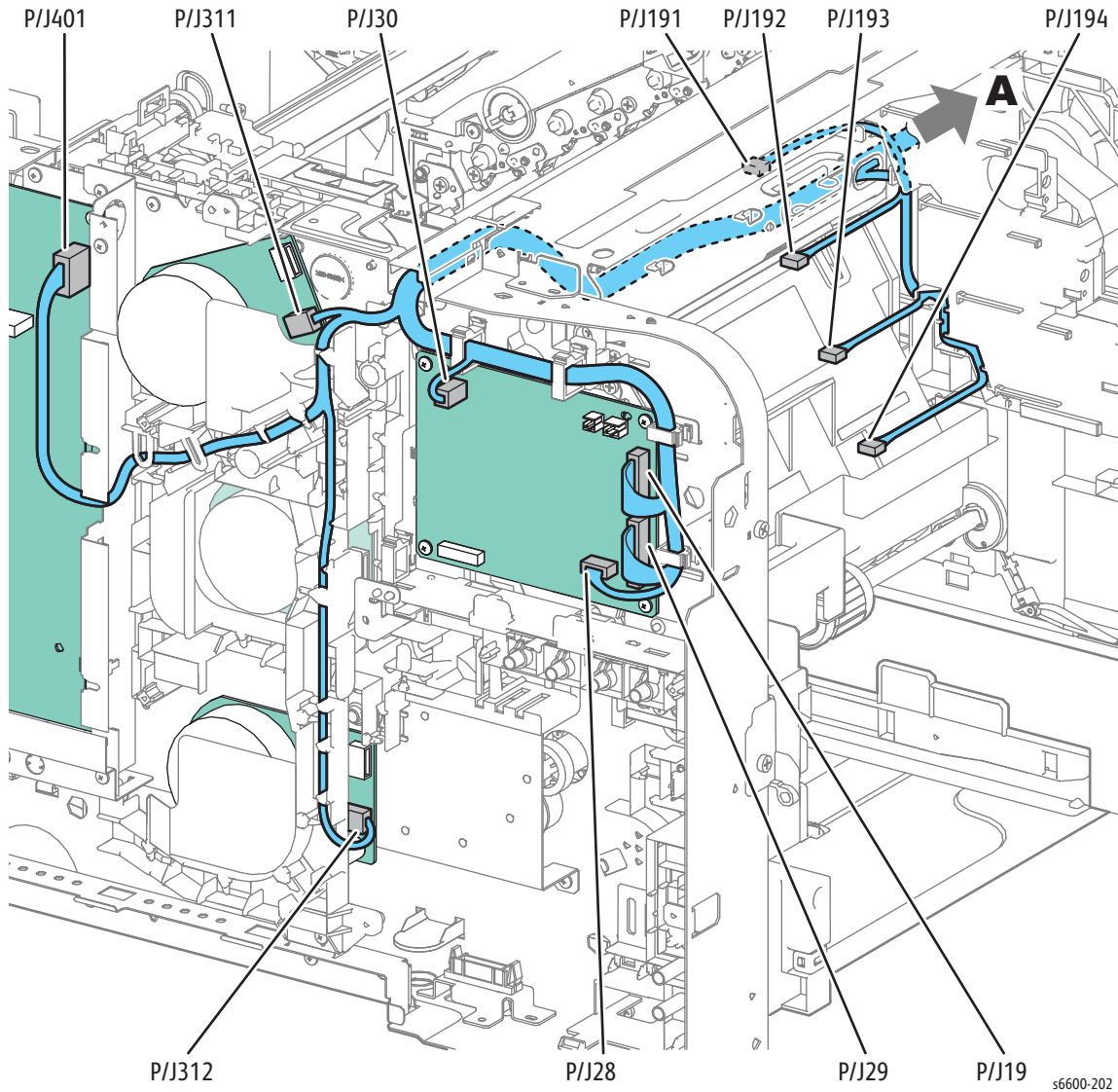


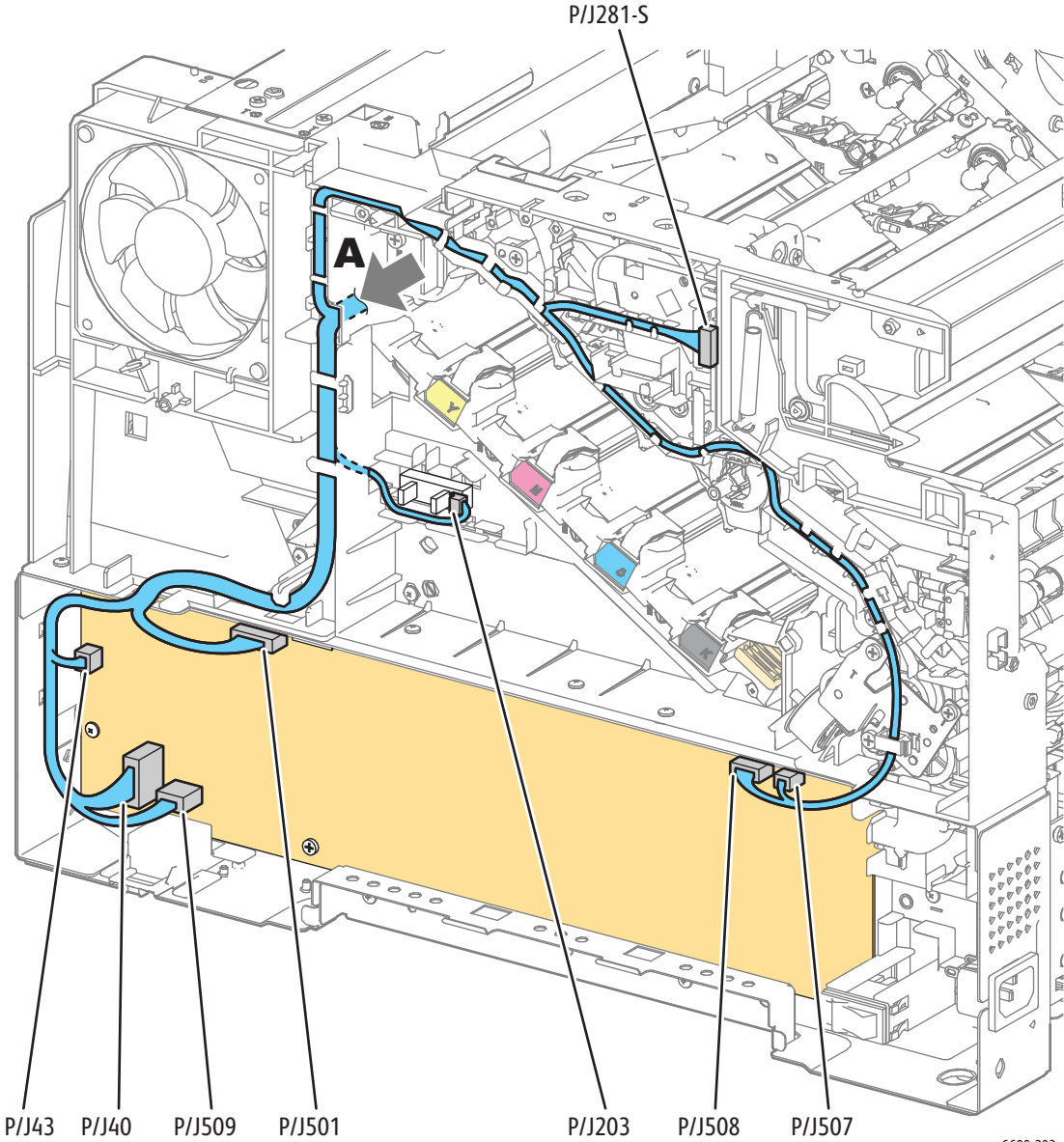
# Main Harness Assembly



s6600-201

## SFP Top Harness Assembly





s6600-203





# Parts Lists

# 5

## In this chapter...

- Serial Number Location and Range
- Using the Parts List
- Parts Navigation: Phaser 6600
- Parts Navigation: WorkCentre 6605
- Parts Lists
- Xerox Supplies and Accessories

## Serial Number Location and Range

Changes to Xerox products are made to accommodate improved components. When ordering parts include this information:

- Component's part number
- Product type or model number
- Serial Number of the printer

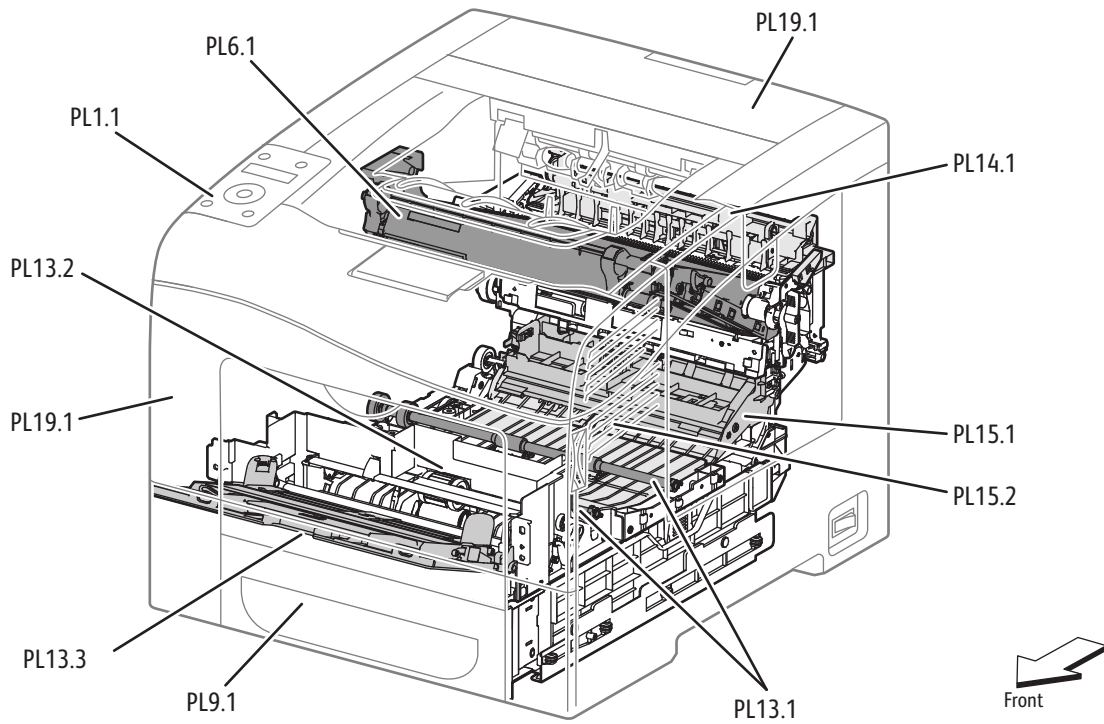
The serial number label is located on the rear of the printer as shown.



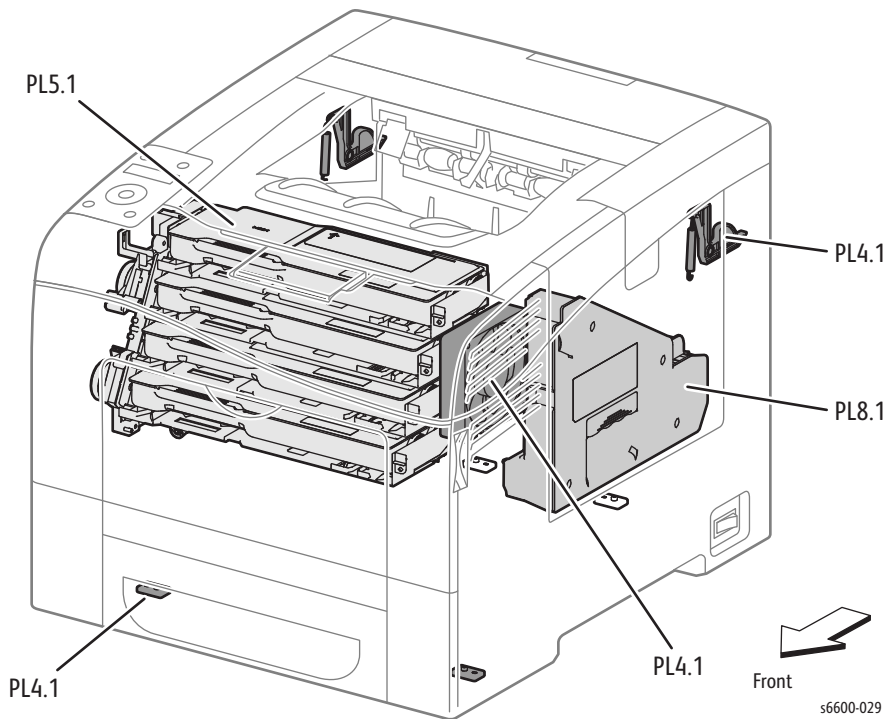
## Using the Parts List

- Most of the parts lists for the MFP and SFP are common. The lists that are not common include the product name in the title. For example, Parts List 1.1 for the SFP is titled *Phaser 6600 UI (Control Panel)*; Parts List 1.1 for the MFP is titled *WorkCentre 6605 UI (Control Panel)*.
- **ID No.:** The callout number from the exploded part diagram.
- **Name/Description:** The name of the part to be ordered and the number of parts supplied per order.
- **Part Number:** The material part number used to order that specific part.
- Parts identified throughout this manual are referenced **PL#.#.#**; For example, PL3.1.10 means the part is item 10 of Parts List 3.1.
- A Black triangle preceding a number followed by a parenthetical statement in an illustrated parts list means the item is a parent assembly, made up of the individual parts called out in parentheses.
- The notation “**with X~Y**” following a part name indicates an assembly that is made up of components X through Y. For example, “1 (with 2~4)” means part 1 consists of part 2, part 3, and part 4.
- The notation “**J1<>J2 and P2**” is attached to a wire harness. It indicates that connector Jack 1 is attached to one end of the wire harness and connector J2 is attached to the other end that is plugged into P2.
- Only parts with part numbers are available for ordering. Parts without part numbers are available on the parent assembly.

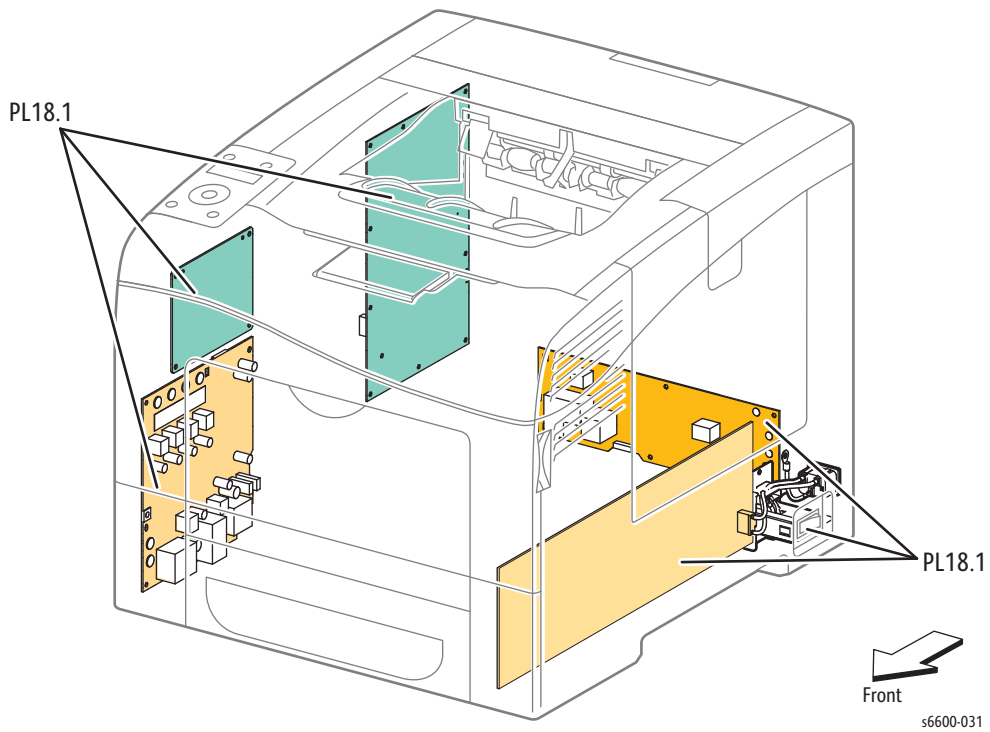
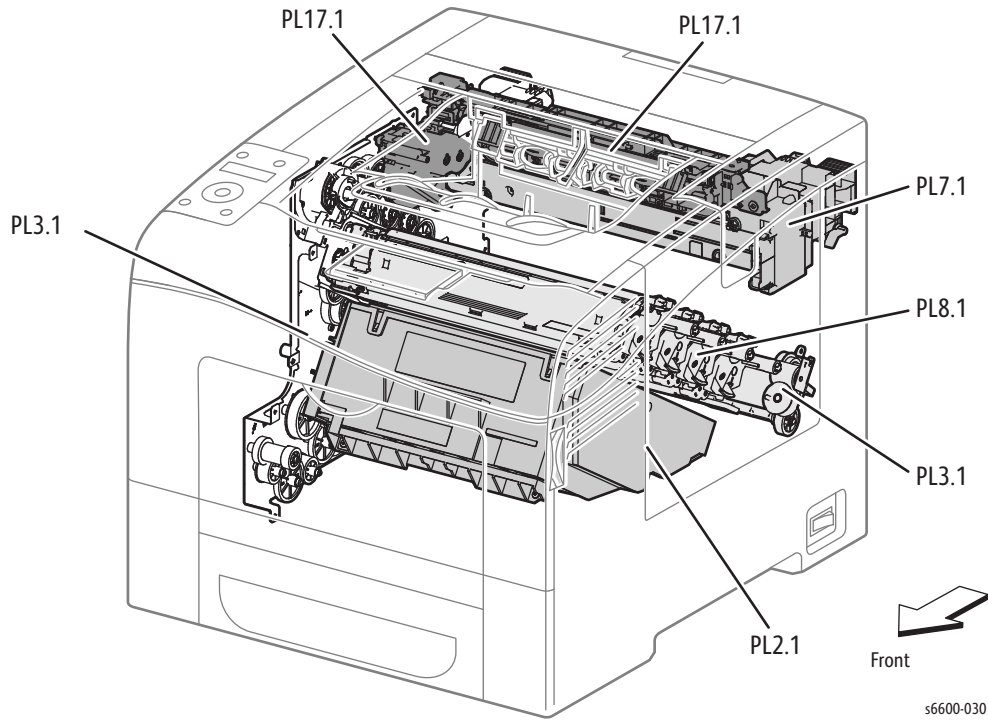
# Parts Navigation: Phaser 6600



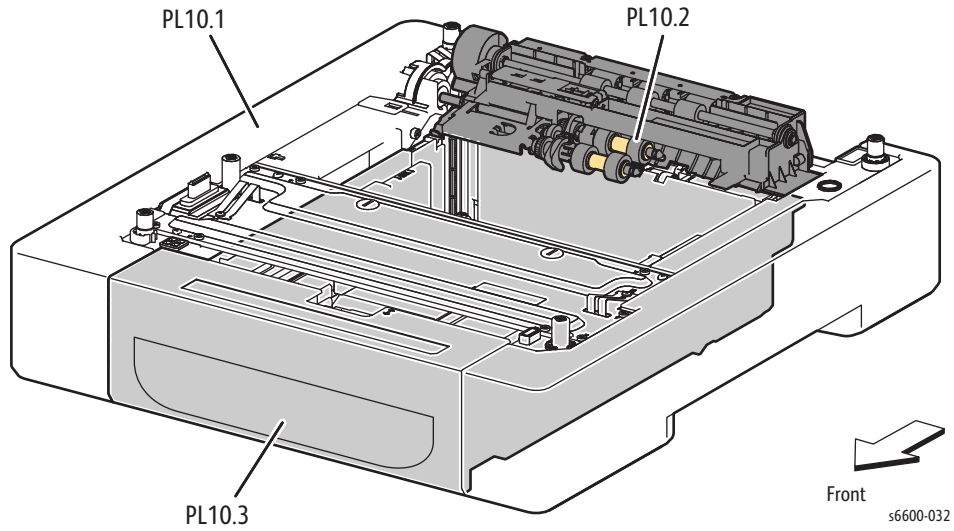
s6600-028



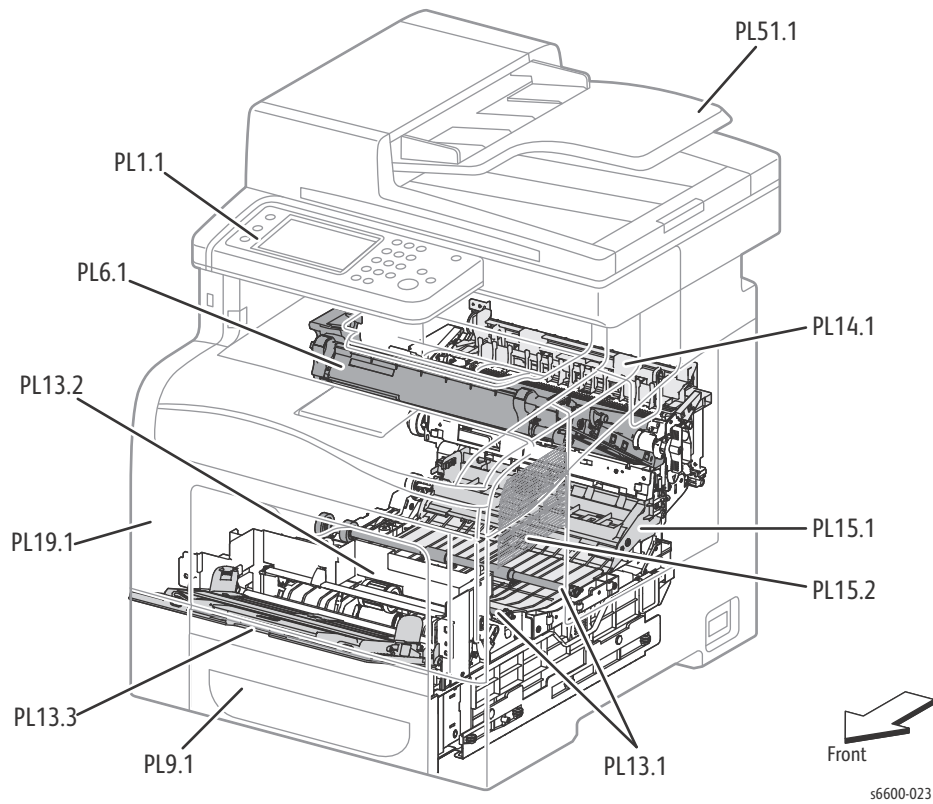
s6600-029

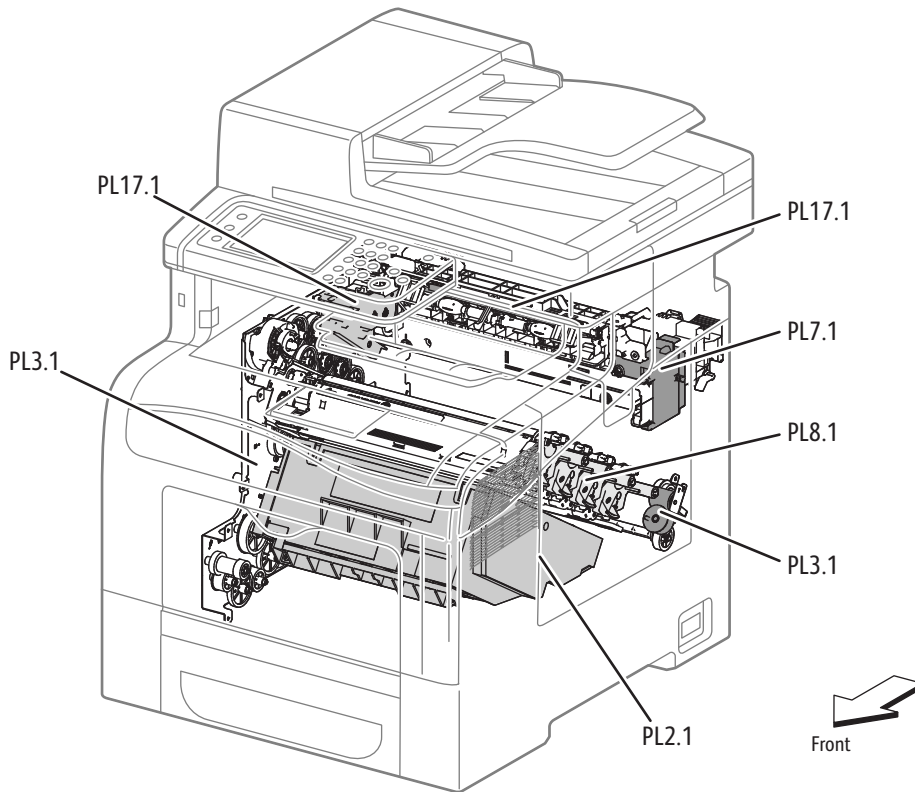
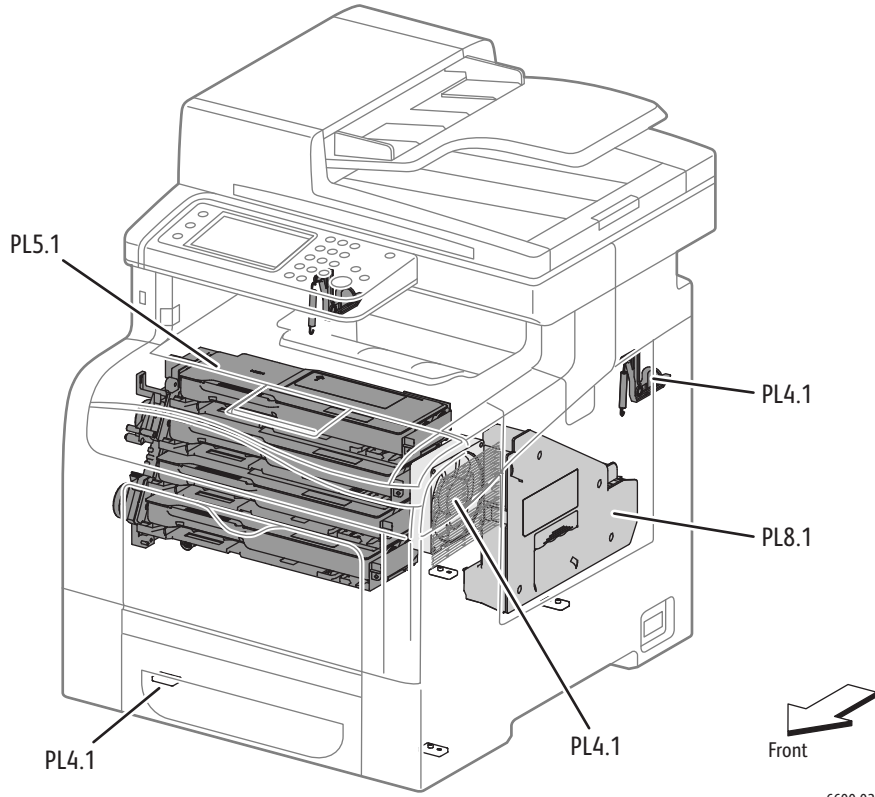


Parts Lists

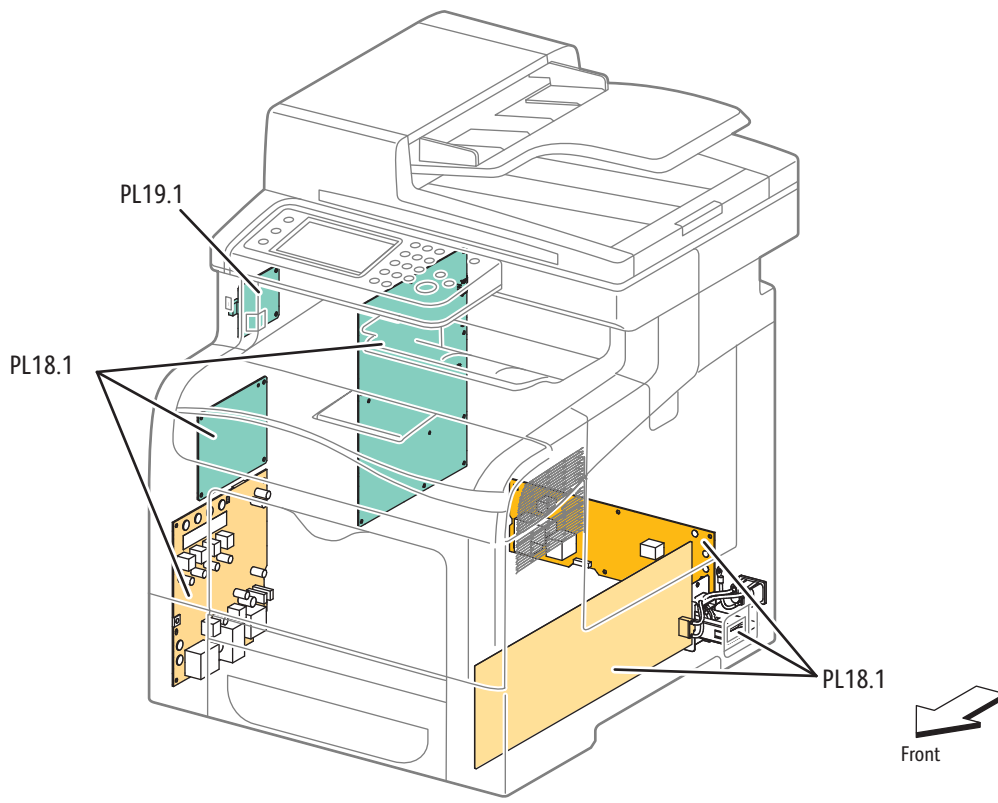


# Parts Navigation: WorkCentre 6605









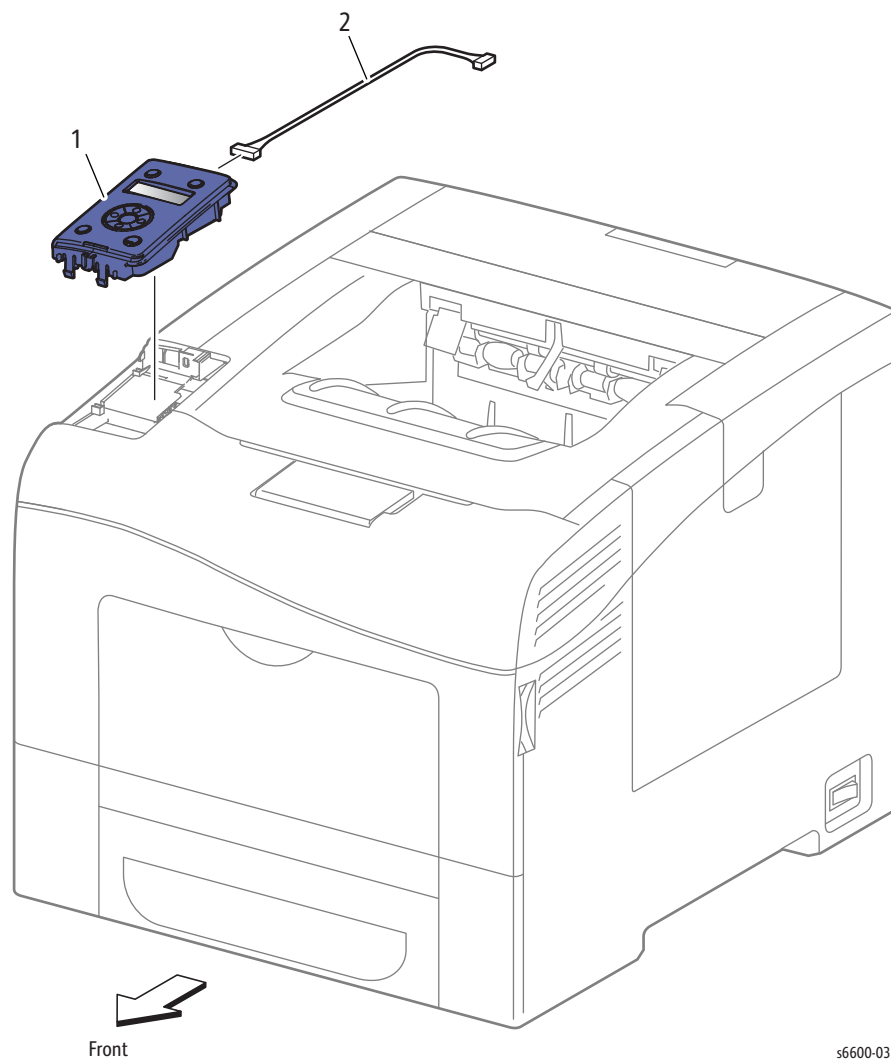
s6600-026

# Parts Lists

The following list names each parts list and gives its page number:

<b>Parts List 1.1 Phaser 6600 UI (Control Panel)</b> .....	5-11
<b>Parts List 1.1 WorkCentre 6605 UI (Control Panel)</b> .....	5-12
<b>Parts List 2.1 Laser Unit</b> .....	5-13
<b>Parts List 3.1 Drive</b> .....	5-14
<b>Parts List 4.1 NOHAD</b> .....	5-15
<b>Parts List 5.1 Dispenser</b> .....	5-17
<b>Parts List 6.1 Transfer</b> .....	5-19
<b>Parts List 7.1 Fuser</b> .....	5-21
<b>Parts List 8.1 Xerographic</b> .....	5-22
<b>Parts List 9.1 Tray</b> .....	5-24
<b>Parts List 10.1 Option Feeder</b> .....	5-27
<b>Parts List 10.2 Option Feeder</b> .....	5-29
<b>Parts List 10.3 Option Feeder</b> .....	5-30
<b>Parts List 13.1 Bypass Tray (MSI)</b> .....	5-32
<b>Parts List 13.2 Bypass Tray (MSI)</b> .....	5-34
<b>Parts List 13.3 Bypass Tray (MSI)</b> .....	5-36
<b>Parts List 14.1 Duplex</b> .....	5-38
<b>Parts List 15.1 Registration / Feeder</b> .....	5-39
<b>Parts List 15.2 Registration / Feeder</b> .....	5-41
<b>Parts List 17.1 Exit</b> .....	5-43
<b>Parts List 18.1 Phaser 6600 Electrical (1/2)</b> .....	5-45
<b>Parts List 18.1 WorkCentre 6605 Electrical (2/2)</b> .....	5-48
<b>Parts List 18.2 Electrical (2/2)</b> .....	5-51
<b>Parts List 19.1 Phaser 6600 Covers</b> .....	5-53
<b>Parts List 19.1 WorkCentre 6605 Covers</b> .....	5-56
<b>Parts List 51.1 WorkCentre 6605 Scanner</b> .....	5-60

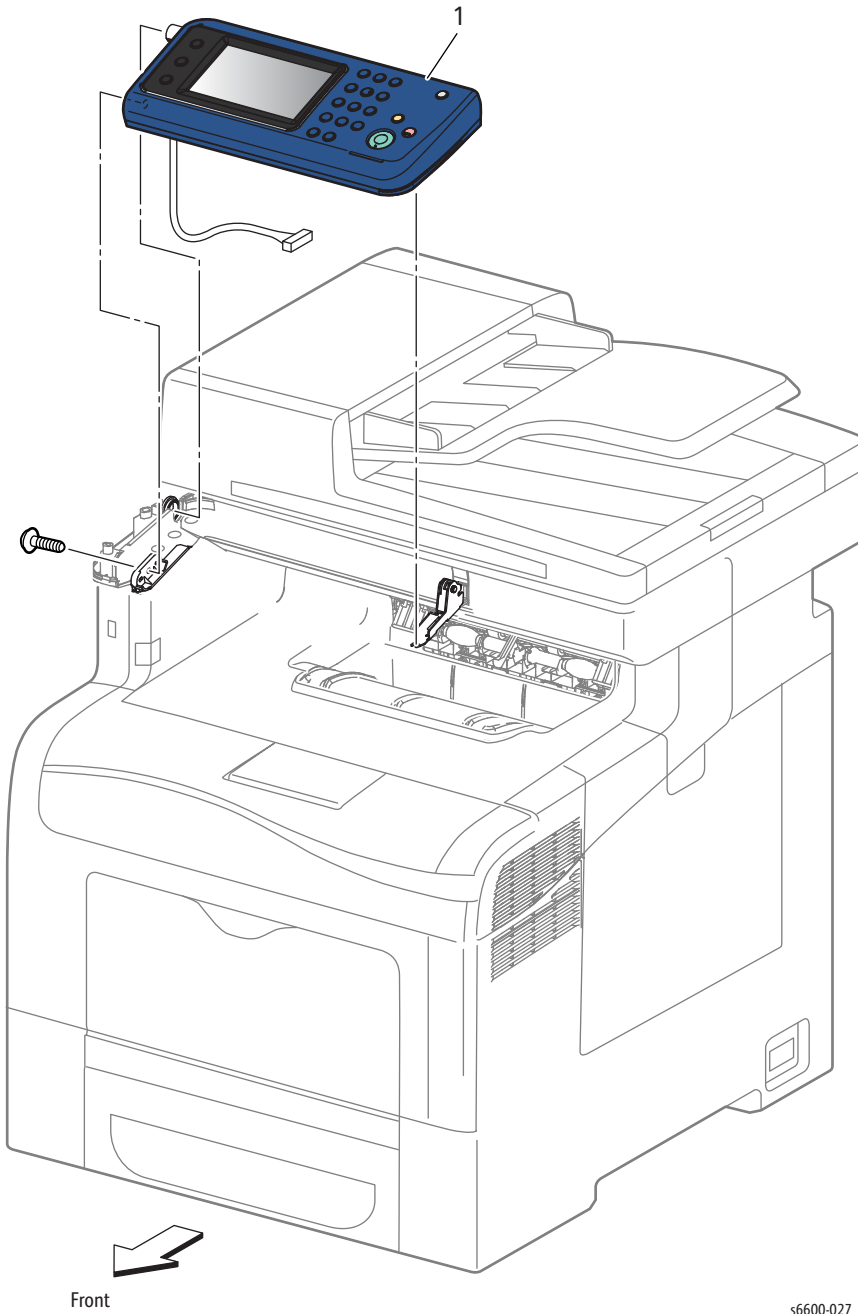
## Parts List 1.1 Phaser 6600 UI (Control Panel)



### Parts List 1.1 Phaser 6600 UI (Control Panel)

Item	Name	Part Number
1	Panel Assy UI 110V (Control Panel)	848K58080
2	Harness Assy UI (Control Panel Harness)	952K03260

## Parts List 1.1 WorkCentre 6605 UI (Control Panel)

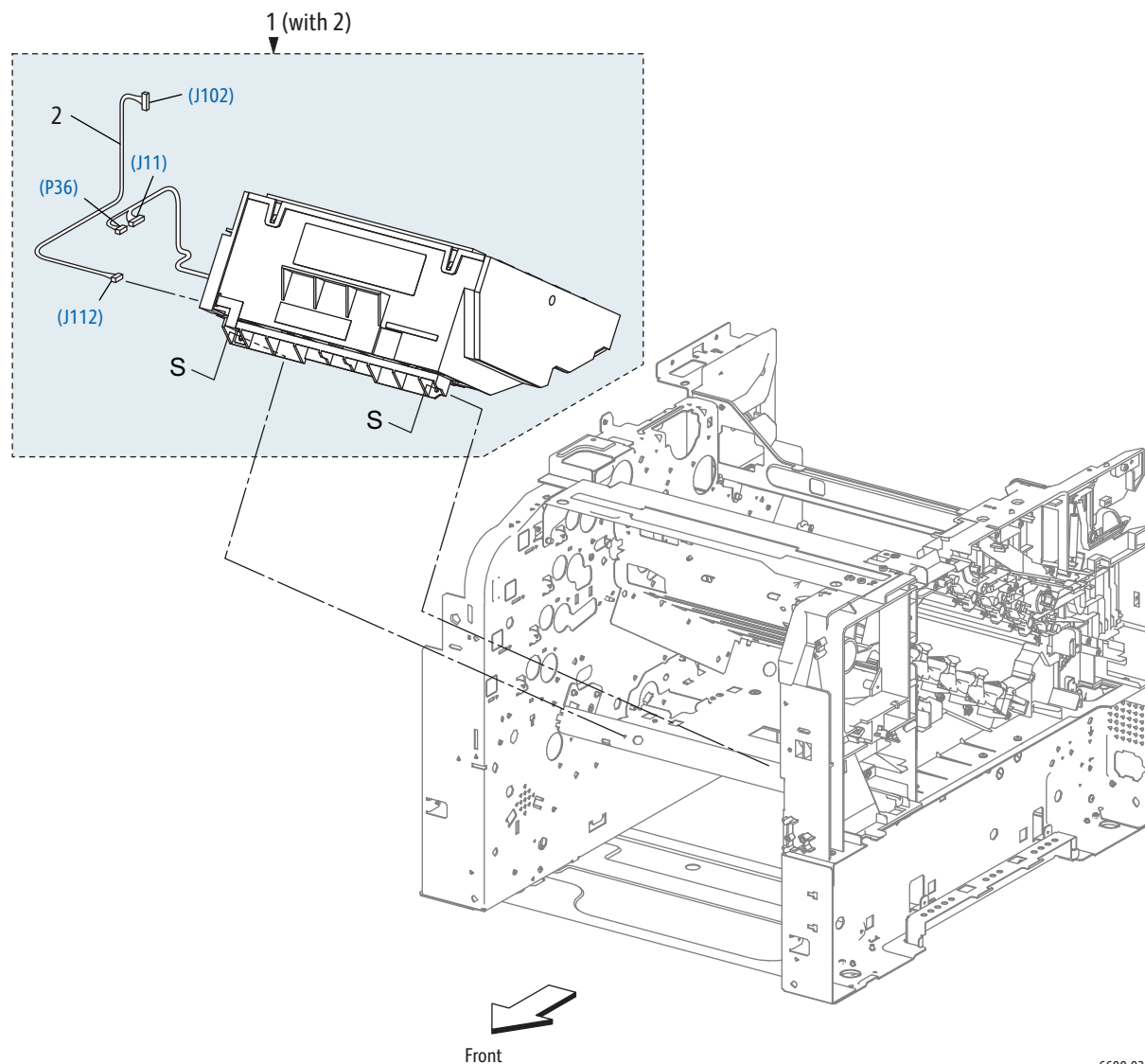


### PL 1.1 WorkCentre 6605 UI (Control Panel)

Item	Name	Part Number
1A	Console Assy UI AIO (Control Panel Assembly) 110 V	<b>See attached bulletin</b>
1B	Console Assy UI AIO (Control Panel Assembly) 220 V	



## Parts List 2.1 Laser Unit

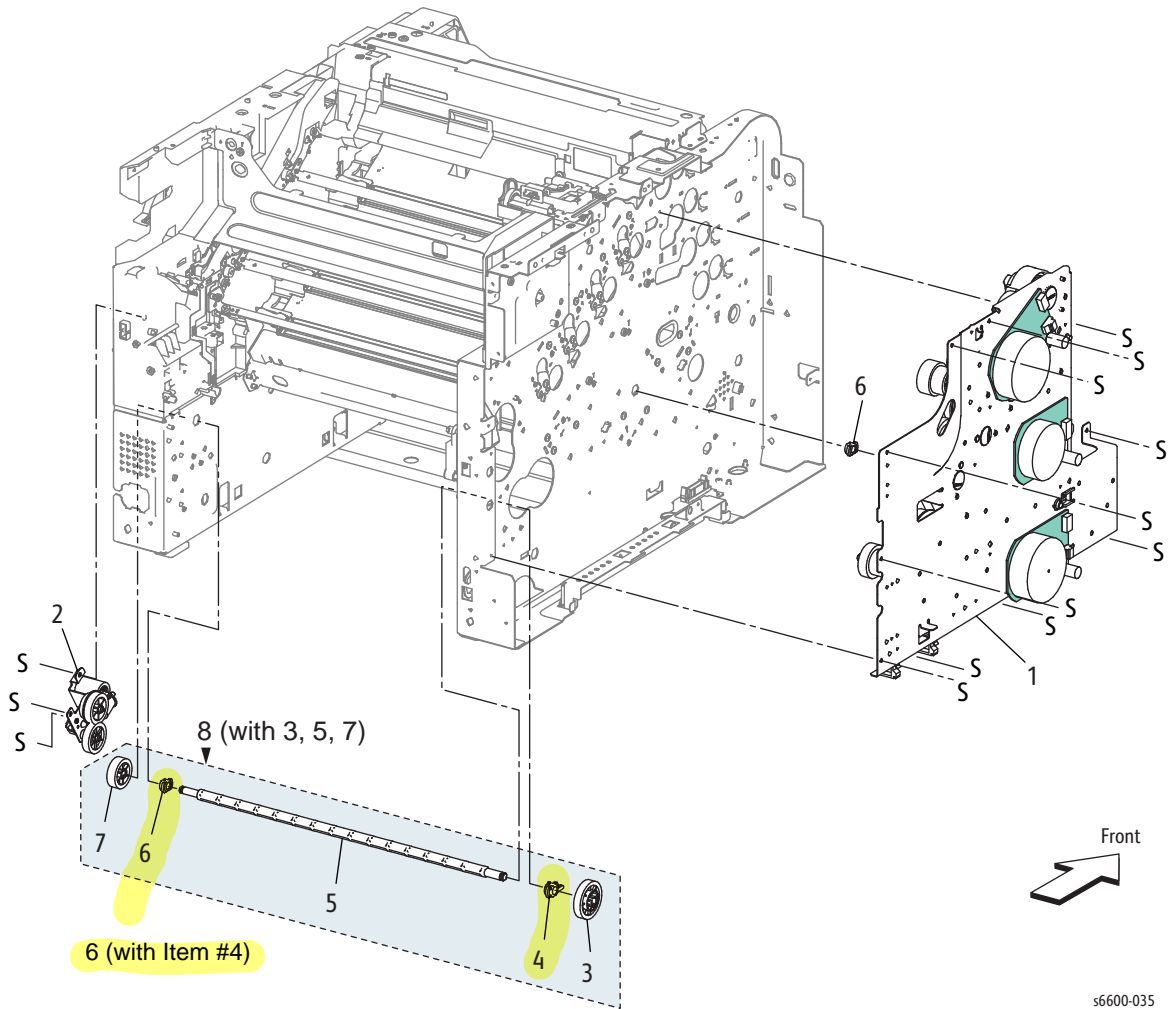


s6600-034

### Parts List 2.1 Laser Unit

Item	Name	Part Number
1	ROS Assy (with 2) (Laser Unit)	062K24630
2	Harness Assy ROS Video (Laser Unit Video Harness Assembly)	—

Parts List 3.1 Drive

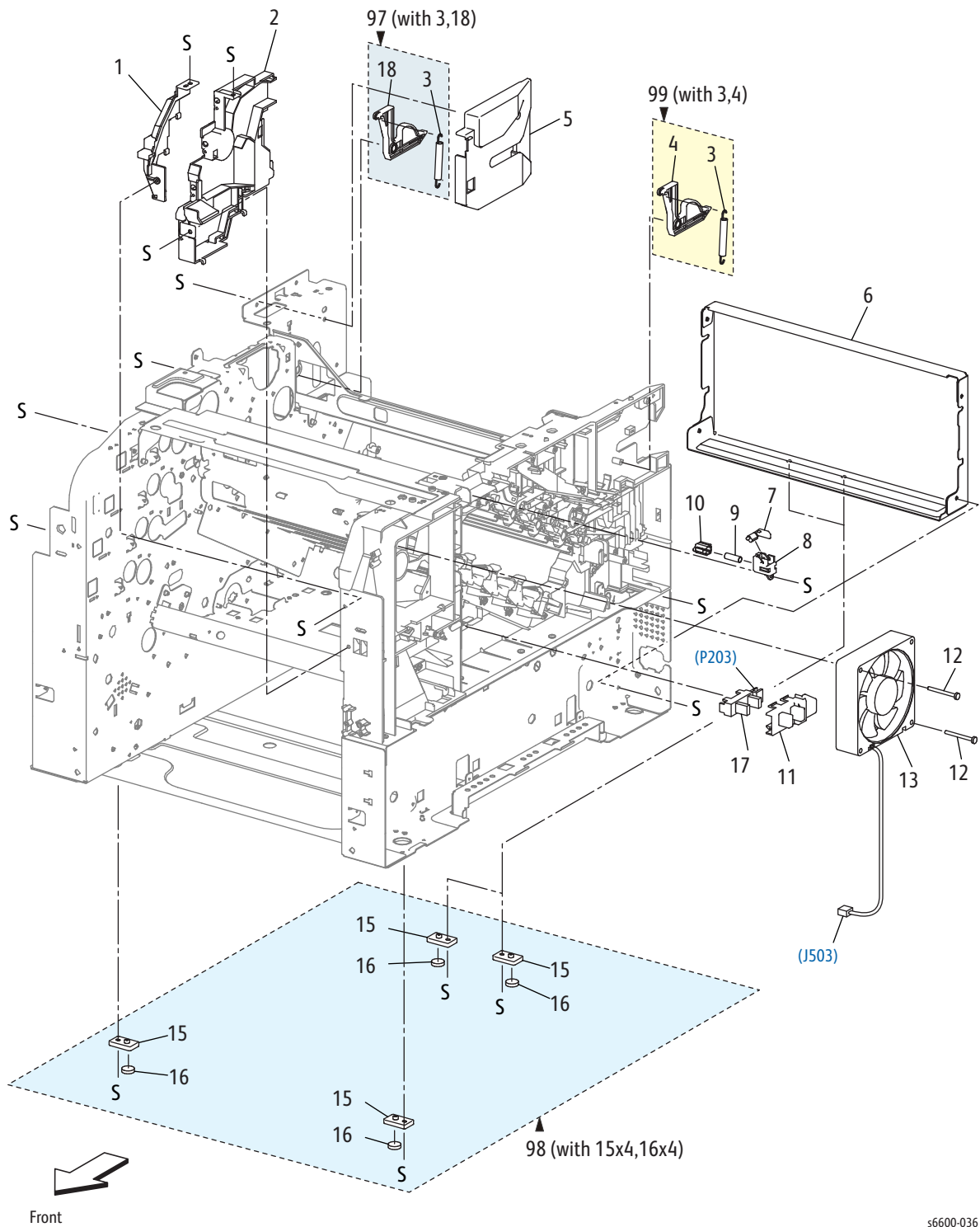


s6600-035

Parts List 3.1 Drive

Item	Name	Part Number
1	Drive Assy Seg3 (Drive Assembly)	007K17954
2	Drive Assy Waste (Waste Drive Assembly)	007K17960
3	Gear Waste 2 (Waste Gear 2)	—
4	Bearing Waste 1(Waste Bearing 1; part of item 6)	—
5	Shaft Idler Waste (Waste Idler Shaft)	—
6	Bearing Waste 2 (Waste Bearing 2, includes item 4)	604K90781
7	Gear Waste 3 (Waste Gear 3)	—
8	Drive Shaft Assembly Kit (with 3, 5, 7)	007K17971

Parts List 4.1 NOHAD



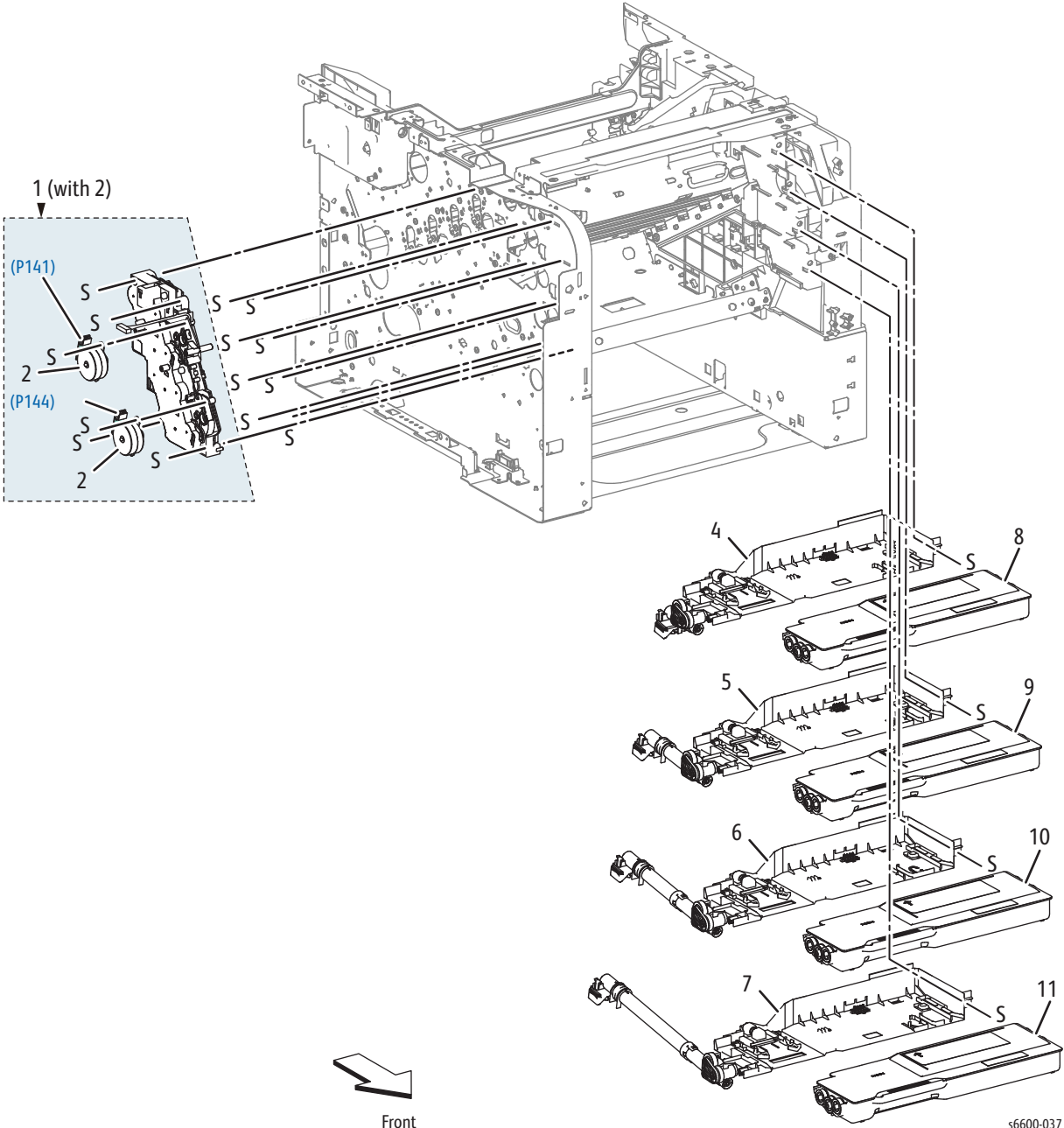
s6600-036

## Parts List 4.1 NOHAD

Item	Name	Part Number
1	Duct_frame_seg3 (Frame Duct)	—
2	Duct_base_seg3 (Base Duct)	—
3	Spring Latch (Latch Spring)	—
4	Latch Rear R (Right Rear Latch)	—
5	Bracket Latch L (Left Latch Bracket)	—
6	Frame Rear S3	—
7	Actuator-Belt IL RT	—
8	Holder-Belt IL	—
9	Spring-Belt IL	—
10	Actuator-Belt IL LN	—
11	Cover-Sensor Waste (Waste Sensor Cover)	—
12	Screw Fan	—
13	Fan Main (Main Fan)	127E86480
14	—	—
15	Foot Base Front (Front Base Foot)	—
16	Foot	—
17	Sensor Toner Full (Toner Full Sensor)	930W00511
18	Latch Rear L (Left Rear Latch)	—
97	Kit Latch L (with3,18) (Left Latch Kit)	604K73980
98	Kit Foot Assy (with15x4,16x4) (Foot Assembly Kit)	604K76341
99	Kit Latch R (with3,4) (Right Latch Kit)	604K76350



# Parts List 5.1 Dispenser

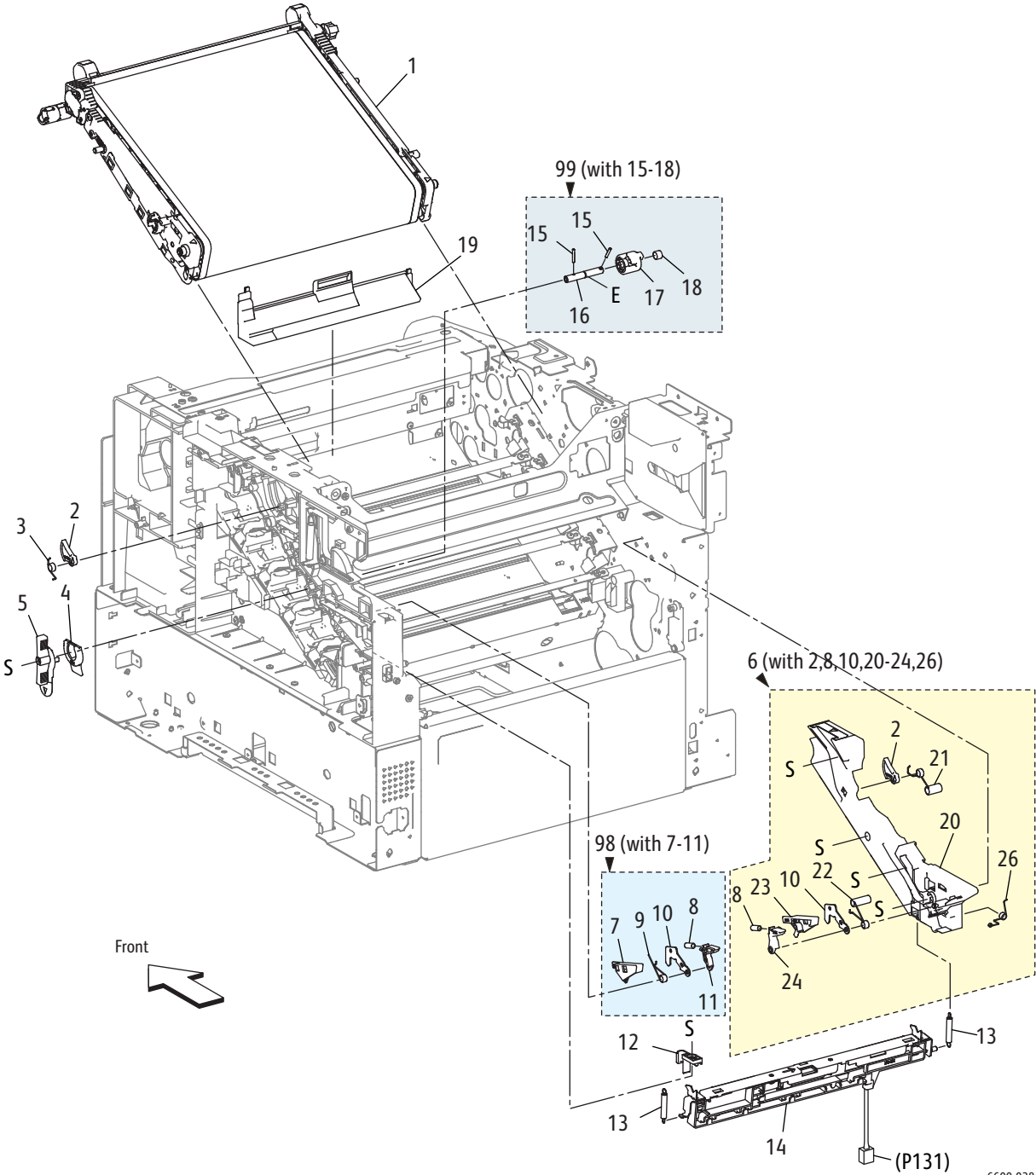


s6600-037

**Parts List 5.1 Dispenser**

<b>Item</b>	<b>Name</b>	<b>Part Number</b>
1	Motor High Assy Disp (Upper Dispenser Motor Assembly) (with 2)	127K64252
2	Motor Assy Disp (Dispenser Motor)	127K64260
3	—	—
4	Disp Assy- Y (Dispenser Assembly - Y)	094K93432
5	Disp Assy- M (Dispenser Assembly - M)	094K93422
6	Disp Assy- C (Dispenser Assembly - C)	094K93412
7	Disp Assy- K (Dispenser Assembly - K)	094K93402
8	Toner Cartridge Y	—
9	Toner Cartridge M	—
10	Toner Cartridge C	—
11	Toner Cartridge K	—

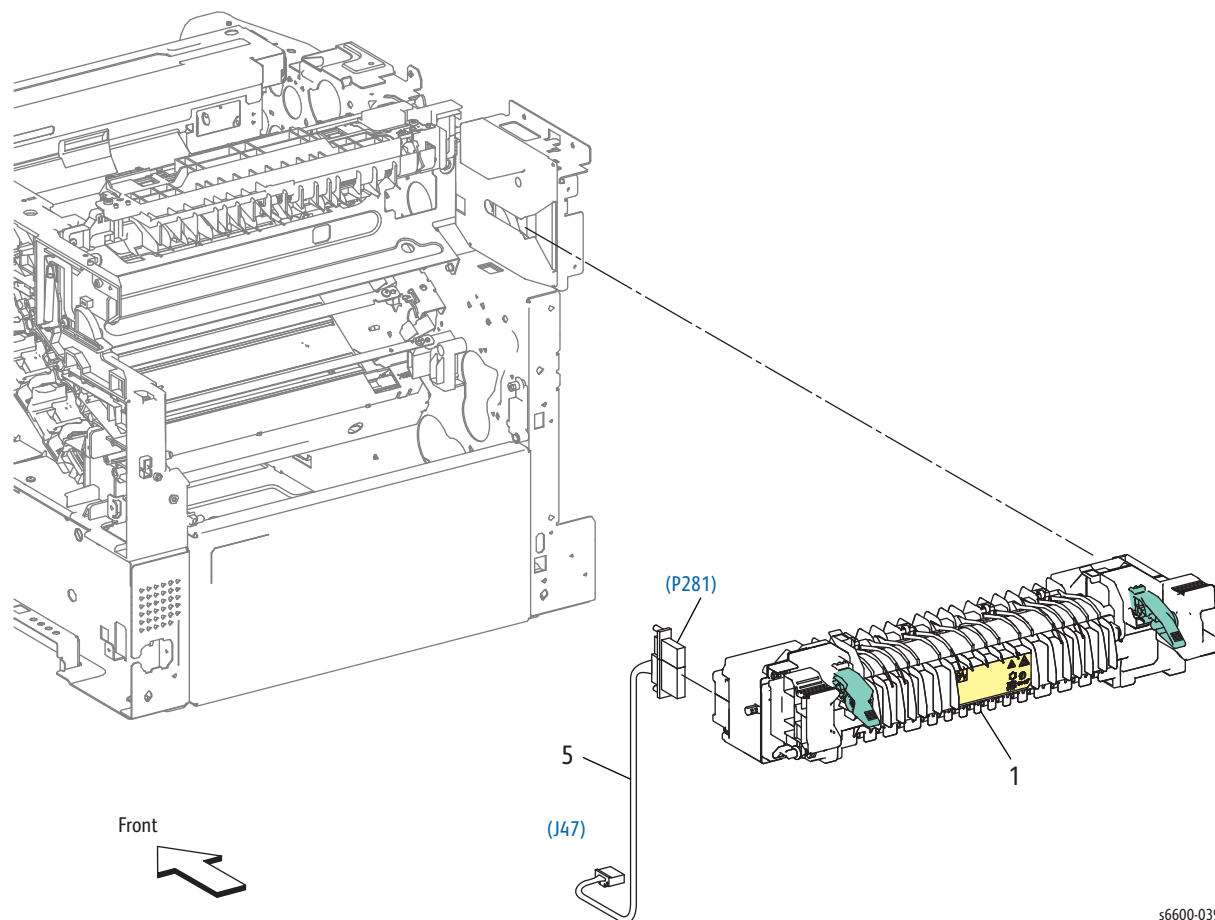
Parts List 6.1 Transfer



## Parts List 6.1 Transfer

Item	Name	Part Number
1	Belt Assy-IBT, Unit (Transfer Belt Assembly)	See Item #97
2	Latch-IBT Front (Front Transfer Belt Latch)	—
3	Spring-IBT Front R (Right Front Transfer Belt Spring)	—
4	Actuator-Coupling (Coupling Actuator)	—
5	Handle-IBT (Waste Cartridge Lock)	803E15100
6	Guide Assy-IBT L (with 2, 8, 10, 20-24, 26) (Left Transfer Belt Guide Assembly)	032K07420
7	Housing-Latch IBT R (Transfer Belt Right Latch Housing)	—
8	Spring-Latch IBT (Transfer Belt Latch Spring)	—
9	Spring-IBT Rear R (Transfer Belt Right Rear Spring)	—
10	Plate-Latch IBT (Transfer Belt Latch Plate)	—
11	Arm-Latch IBT R (Transfer Belt Right Latch Arm)	—
12	Guide-CTD R (Right CTD Guide)	—
13	Spring-CTD (CTD Spring)	809E96300
14	Sensor Assy CTD (CTD Sensor Assembly)	130K77830
15	Pin-Dowel (Dowel Pin)	—
16	Shaft-Coupling (Coupling Shaft)	—
17	Coupling-Retract IBT (Transfer Belt Retract Coupling)	—
18	Spring-Coupling (Coupling Spring)	—
19	Cover-Harness IBT(Transfer Belt Harness Cover)	—
20	Guide-Belt L (Left Belt Guide)	—
21	Spring-IBT Front L (Left Front Transfer Belt Spring)	—
22	Spring-IBT Rear L (Left Rear Transfer Belt Spring)	—
23	Housing-Latch IBT L (Left Transfer Belt Latch Housing)	—
24	Arm-Latch IBT L (Left Transfer Belt Latch Arm)	—
25	—	—
26	Spring-Gnd ADC	—
97	Kit Belt Assy-IBT, Unit (with1) (Transfer Belt Assembly Kit)	604K77530
98	Kit Latch R (with7-11) (Transfer Belt Right Latch Kit)	604K76280
99	Kit Coupling (with15-18) (Coupling Kit)	604K76290

## Parts List 7.1 Fuser

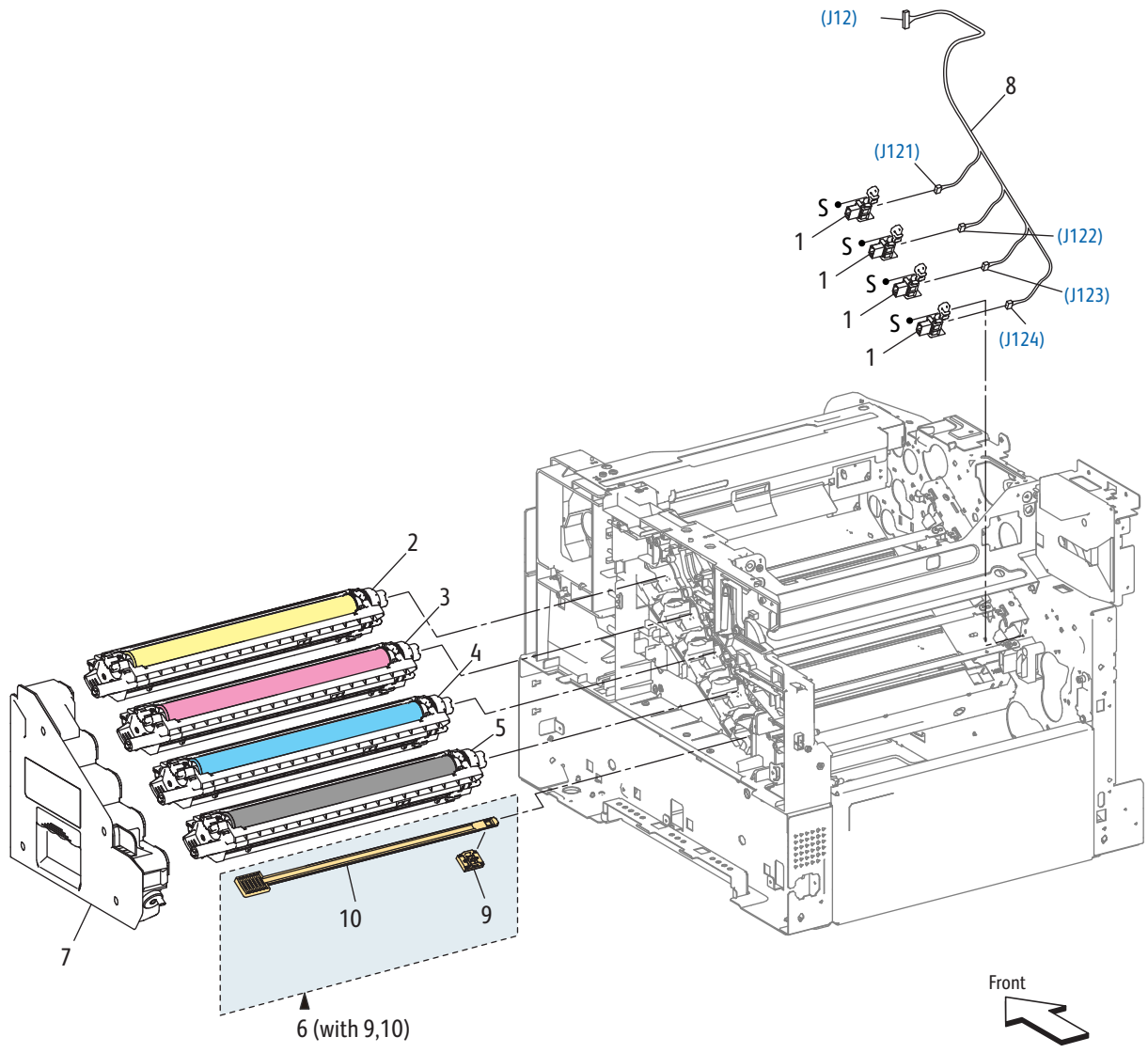


s6600-039

### Parts List 7.1 Fuser

Item	Name	Part Number
1A	Fusing Assy 110V (Fuser Assembly)	115R00076
1B	Fusing Assy 220V (Fuser Assembly)	115R00077
2	—	—
3	—	—
4	—	—
5A	Harness Assy Htr 100V (Heater Harness Assembly)	—
5B	Harness Assy Htr 200V (Heater Harness Assembly)	—

# Parts List 8.1 Xerographic



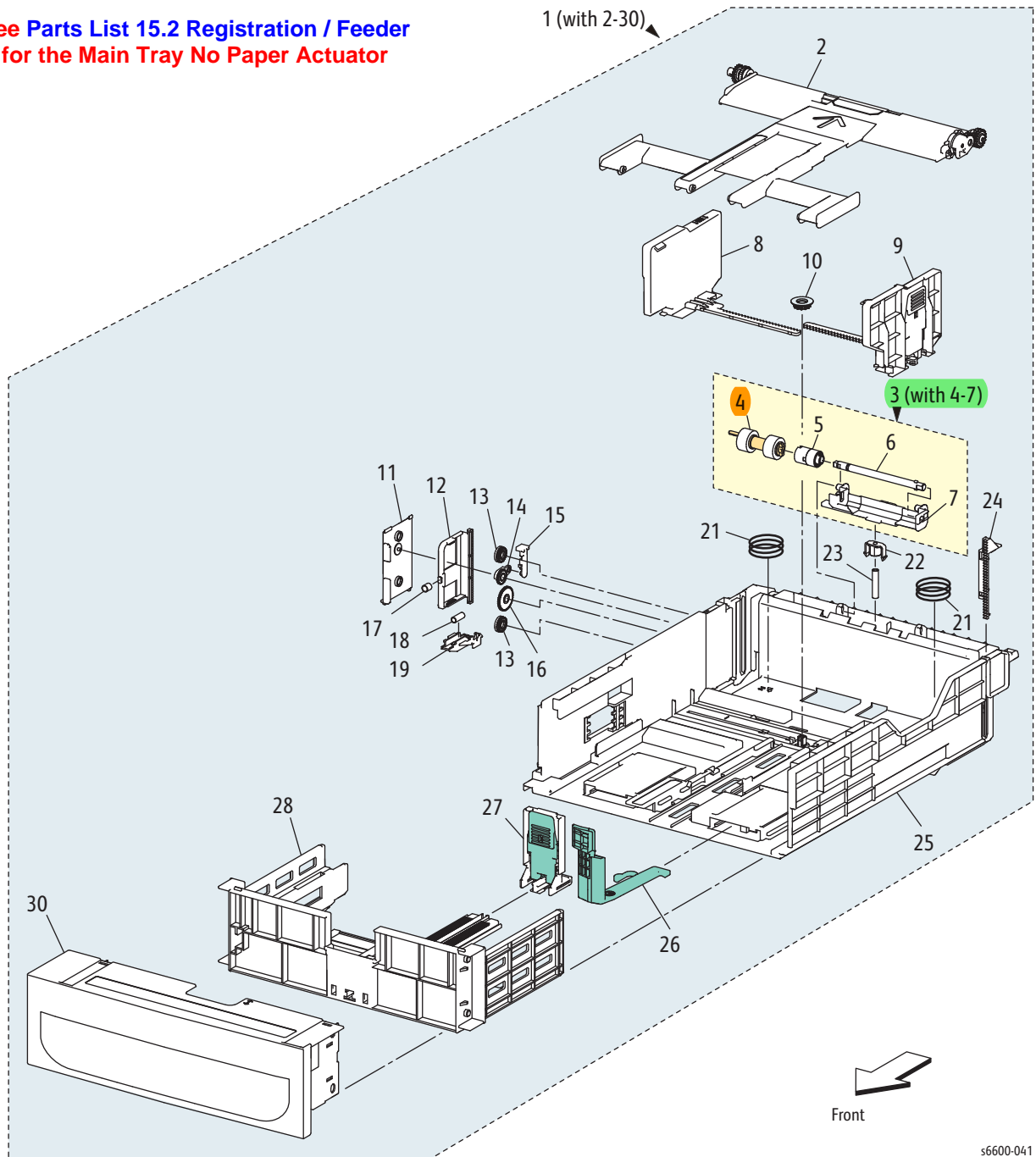
56600-040

**Part List 8.1 Xerographic**

<b>Item</b>	<b>Name</b>	<b>Part Number</b>
1	CRUM Connector Assembly	019K12700
2	Xero Deve CRU Assy (Imaging Unit)-Y	—
3	Xero Deve CRU Assy (Imaging Unit)-M	—
4	Xero Deve CRU Assy (Imaging Unit)-C	—
5	Xero Deve CRU Assy (Imaging Unit)-K	—
6	Cleaner Assembly (with9,10)	—
7	Box Assy-Waste (Waste Cartridge)	—
8	Connector Assy-Crum Trans (Transfer CRUM Connector Assembly)	—
9	Cleaner Assembly Base	—
10	Rod Cleaner	—
95	Kit Xero Deve CRU Assy (Imaging Unit)-Y (with2)	604K77581
96	Kit Xero Deve CRU Assy (Imaging Unit)-M (with3)	604K77571
97	Kit Xero Deve CRU Assy (Imaging Unit)-C (with4)	604K77561
98	Kit Xero Deve CRU Assy (Imaging Unit)-K (with5)	604K77551

# Parts List 9.1 Option Tray

**See Parts List 15.2 Registration / Feeder  
for the Main Tray No Paper Actuator**



s6600-041

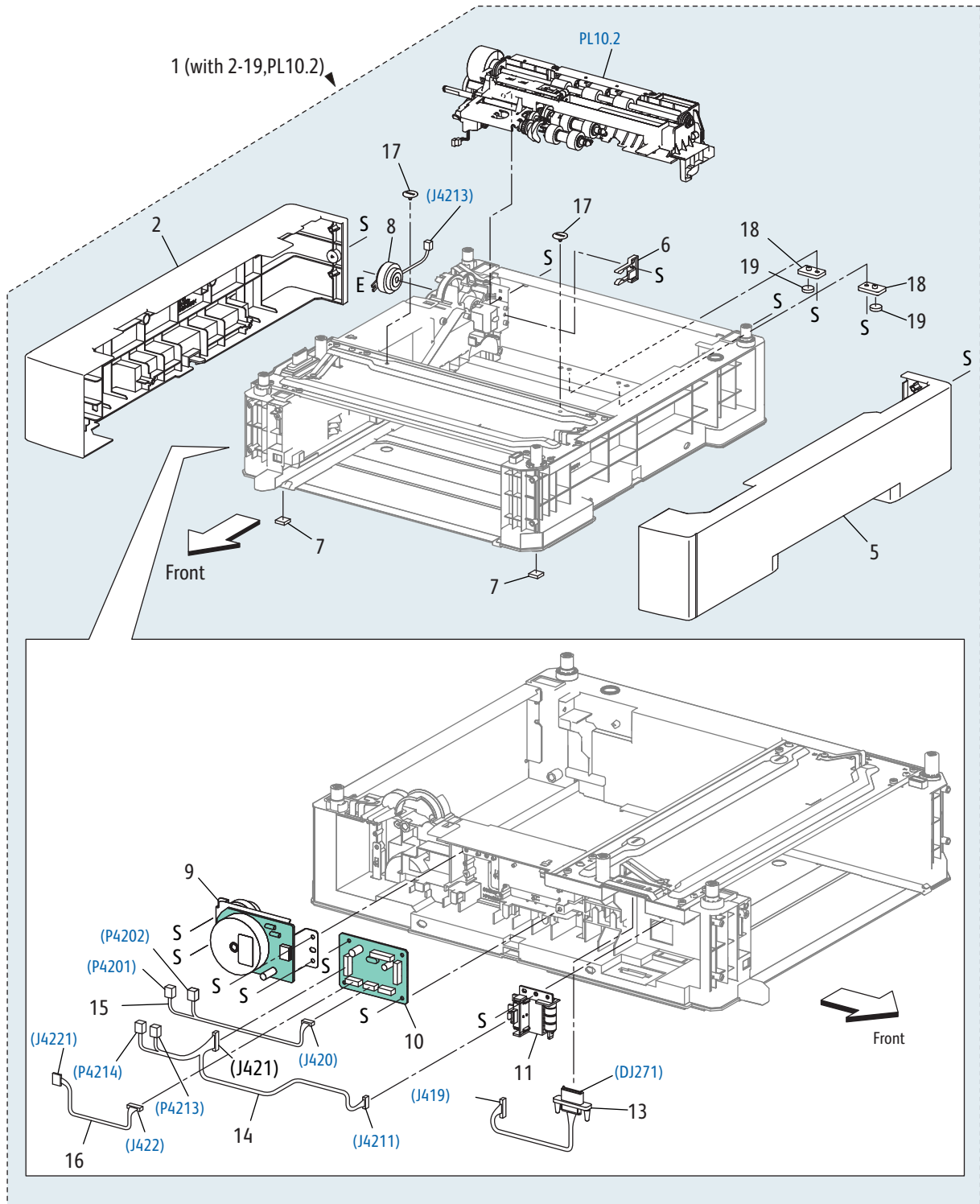


## Parts List 9.1 Main Tray

Item	Name	Part Number
1	Cassette Assy 550 IOT (with 2-30) (550-sheet Main Tray)	050K66496
2	Plate Assy Bottom (Bottom Plate Assembly)	—
3	Holder Assy Retard CST (with 4-7) (Tray Retard Holder Assembly)	604K77660
4	Roll Assy Feed (Feed Roller Kit, with 2 Feed Rolls)	675K47673
5	Clutch Friction RTD Z	—
6	Shaft Retard CST (Tray Retard Shaft)	—
7	Holder Retard CST	—
8	Guide Assy Side L 550 (Left Side Guide Assembly)	—
9	Guide Assy Side R 550 (Right Side Guide Assembly)	—
10	Gear Pinion	—
11	Cover BTM Lock 550	—
12	Rack BTM Lock 550	—
13	Gear BTM Lock Pinion	—
14	Gear Lever BTM Lock	—
15	Lever BTM Lock	—
16	Gear 40 BTM Lock	—
17	Spring BTM Lock	—
18	Spring Lock PB	—
19	Actuator Lock PB L	—
20	—	—
21	Spring BTM UP 550 A4	—
22	Holder Spring Retard MSI (Bypass Tray Retard Spring Holder)	—
23	Spring Retard CST	—
24	Rack Lift UP PB 550	—
25	Housing Base 550	—
26	Lever Ext End 550	—
27	Guide Assy End 550 Opt (550 Option End Guide Assembly)	—
28	Housing End 550	—
29	—	—
30	Handle CST 550	—

This page intentionally left blank

# Parts List 10.1 Option Feeder

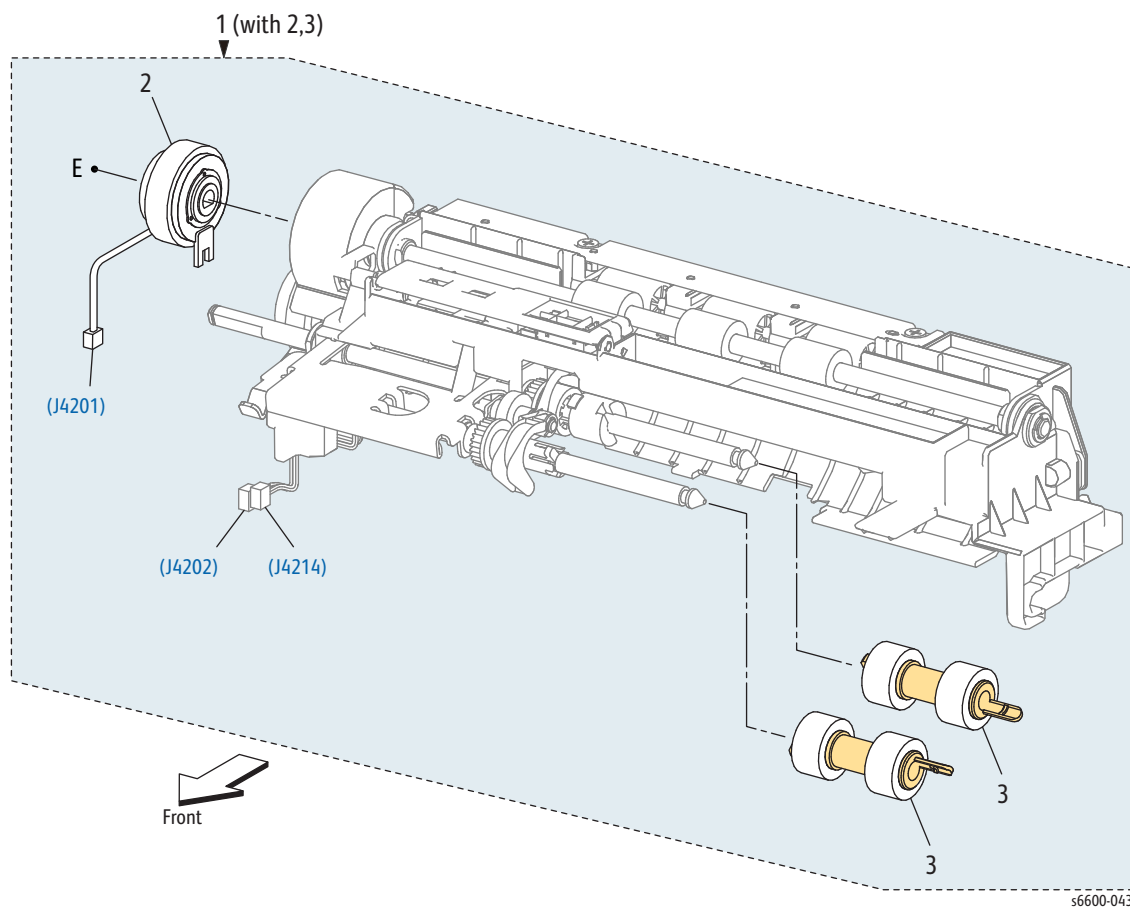


s6600-042

**Parts List 10.1 Option Feeder**

Item	Name	Part Number
1	Feeder Assy Opt 550 (with2-19,PL10.2) (Optional 550-Sheet Feeder)	604K77500
2	Cover Side L 550 Opt (550 Option Left-Side Cover)	—
3	—	—
4	—	—
5	Cover Side R 550 Opt (550 Option Right Side Cover)	—
6	Stopper CST (Cassette Stopper)	803E10840
7	Foot Assembly	—
8	Clutch Assy Opt Feed (550 Option Feed Clutch Assembly)	005K83210
9	Drive Assy Opt 550 (550 Option Drive Assembly)	007K18020
10	PWBA Feed-H (550 Option Feeder Board)	960K62140
11	Switch Assy Size 550 (550 Size Switch Assembly)	110K16610
12	—	—
13	Harness Assy Fdr Drawer1 (Drawer 1 Feeder Harness Assembly)	—
14	Harness Assy C2 Size (C2 Size Harness Assembly)	—
15	Harness Assy C2 Turn (C2 Turn Harness Assembly)	—
16	Harness Assy Fdr Mot (Feeder Motor Harness Assembly)	—
17	Screw Joint (Joint Screw)	—
18	Foot Base Front	—
19	Foot	—

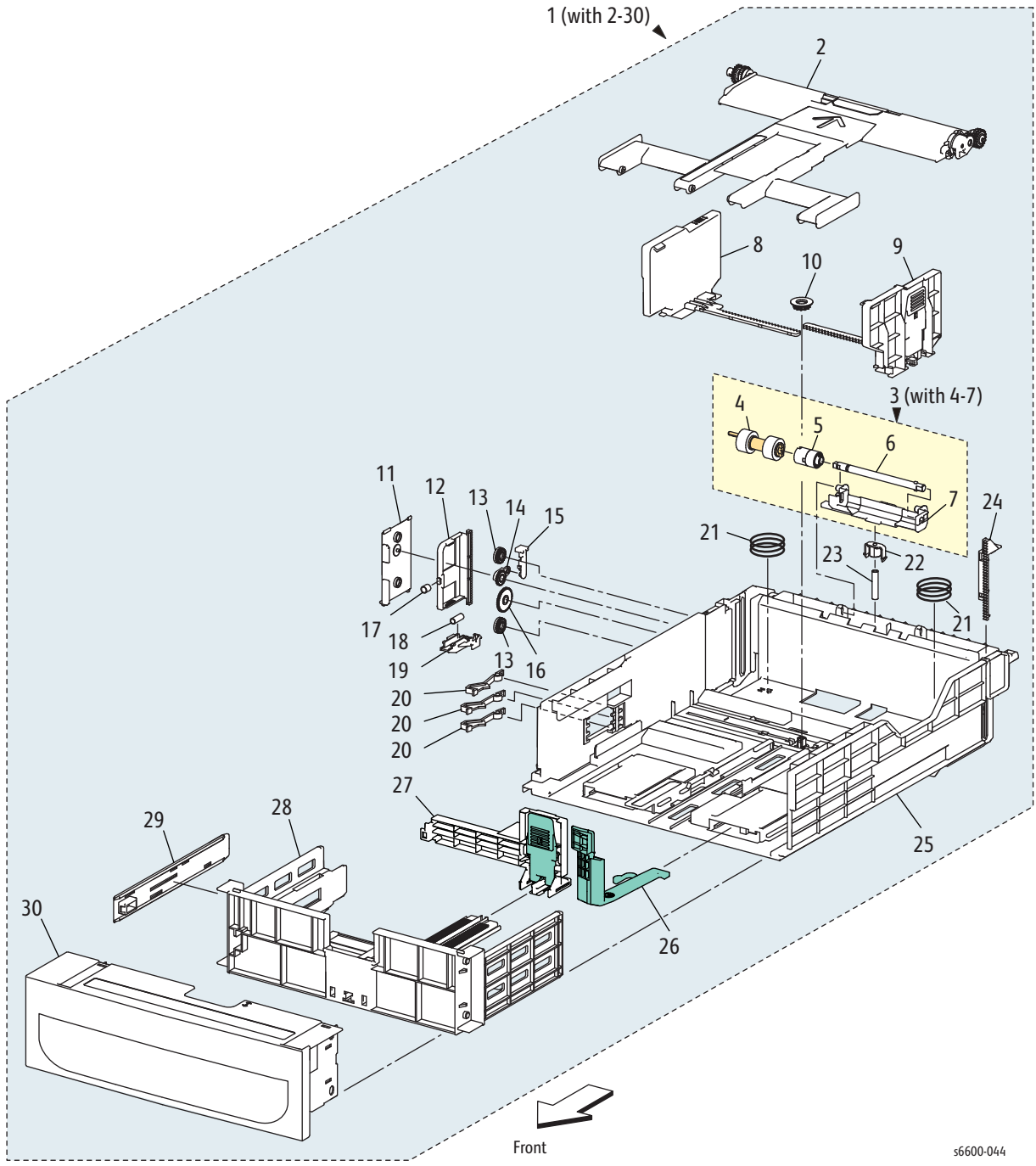
## Parts List 10.2 Option Feeder



## Parts List 10.2 Option Feeder

Item	Name	Part Number
1	Feed Assy Opt 550 Main (with2,3) (550 Option Main Feed Assembly)	059K71760
2	Clutch Assy Regi (550 Option Regi Clutch Assembly)	—
3	Roll Assy Feed (Feed Roller Kit, with 2 Feed Rolls)	675K47673
4	Gear Opt Feeder (550 Option Feeder Gear)	—
5	Bracket Spring Nudger	—
6	Feed Sub Assy	—

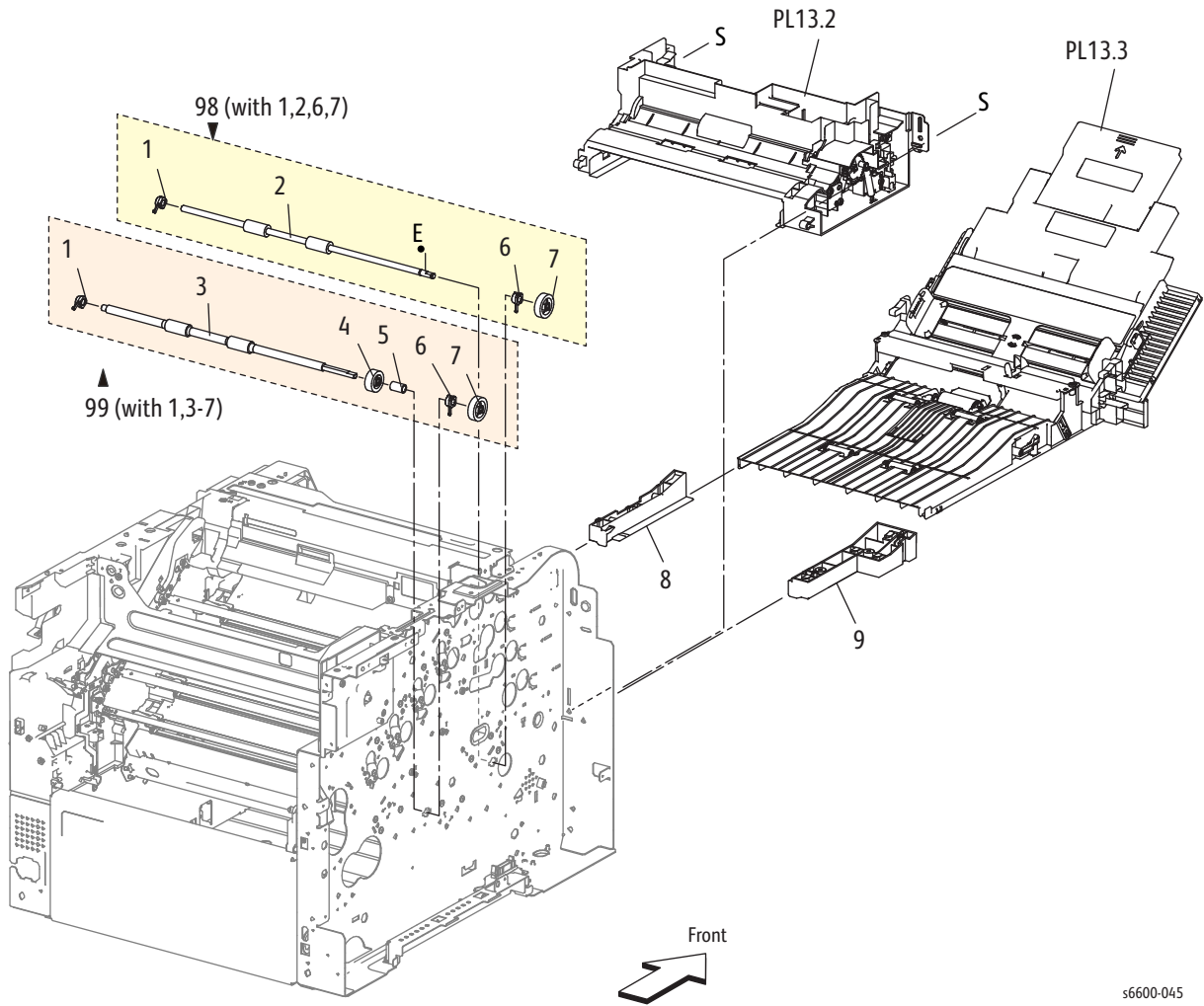
# Parts List 10.3 Option Tray



**Parts List 10.3 Option Tray**

Item	Name	Part Number
1	Cassette Assy 550 Opt (with2-30) (550 Option Cassette Tray)	050K66516
2	Plate Assy Bottom	—
3	Holder Assy Retard Cst (with4-7)	—
4	Roll Assy Feed (Feed Roller Kit, with 2 Feed Rolls)	675K47673
5	Clutch Friction Rtd Z	—
6	Shaft Retard Cst	—
7	Holder Retard Cst	—
8	Guide Assy Side L 550 (Left Side Guide Assembly)	—
9	Guide Assy Side R 550 (Right Side Guide Assembly)	—
10	Gear Pinion	—
11	Cover Btm Lock 550	—
12	Rack Btm Lock 550	—
13	Gear Btm Lock Pinion	—
14	Gear Lever Btm Lock	—
15	Lever Btm Lock	—
16	Gear 40 Btm Lock	—
17	Spring Btm Lock	—
18	Spring Lock PB	—
19	Actuator Lock PB L	—
20	Actuator Size	—
21	Spring Btm Up 550 A4	—
22	Holder Spring Retard MSI (Bypass Tray Retard Spring Holder)	—
23	Spring Retard Cst	—
24	Rack Lift Up PB 550	—
25	Housing Base 550	—
26	Lever Ext End 550	—
27	Guide Assy End 550 Opt (550 Option End Guide Assembly)	—
28	Housing End 550	—
29	Plate Slot Size	—
30	Handle Cst 550 Opt (550 Option Cassette Handle)	—

# Parts List 13.1 Bypass Tray (MSI)



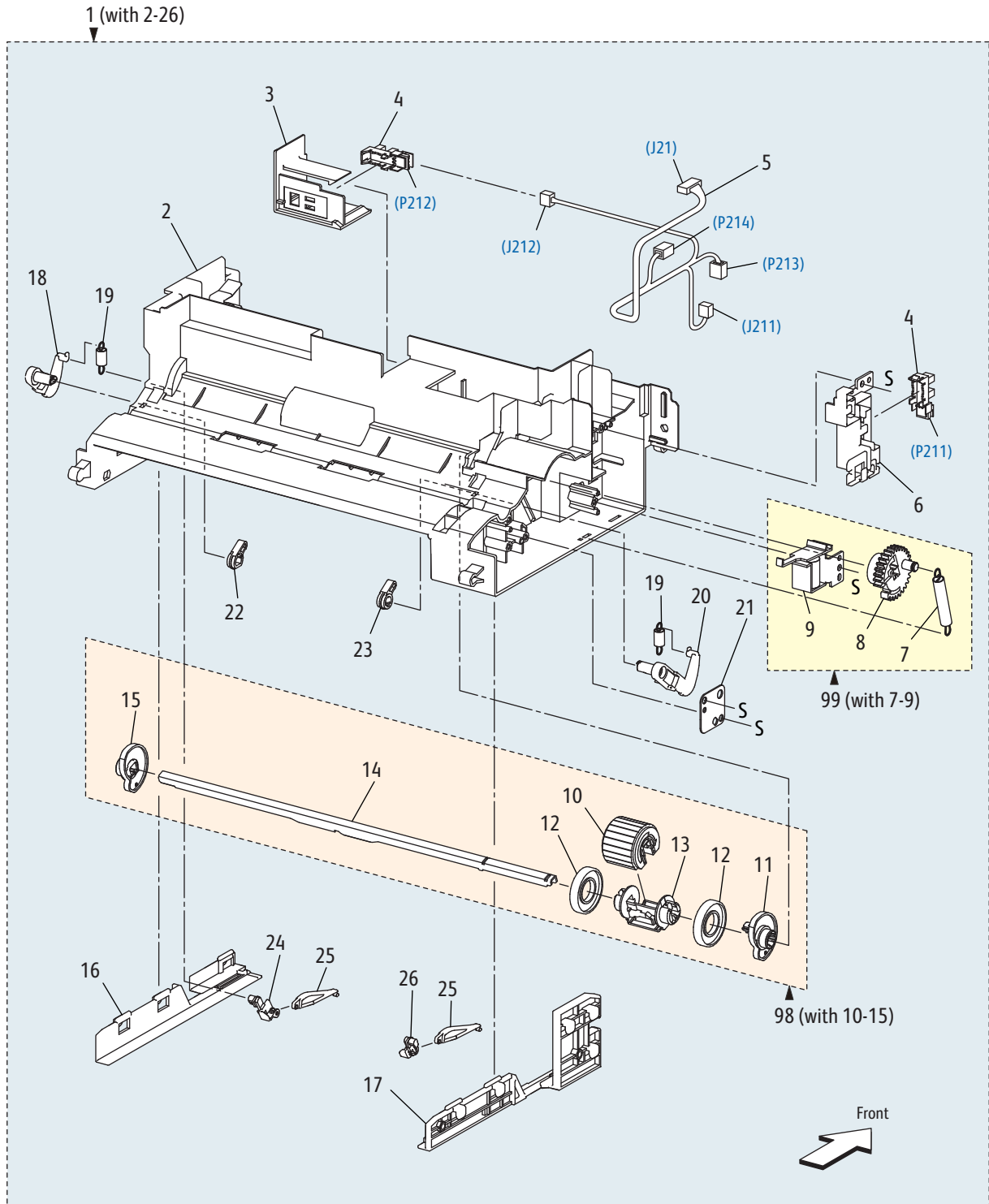
s6600-045



**Parts List 13.1 Bypass Tray**

<b>Item</b>	<b>Name</b>	<b>Part Number</b>
1	Bearing Dup (Duplex Bearing)	—
2	Roll Assy TA1 (TA1 Roller Assembly)	—
3	Roll Assy TA2 (TA2 Roller Assembly)	—
4	Gear TA 1	—
5	Spacer TA2	—
6	Bearing TA	—
7	Gear Turn	—
8	Guide MSI R (Right Bypass Tray Guide)	—
9	Guide MSI L (Left Bypass Tray Guide)	—
98	Kit Roll Assy 1 (with1,2,6,7) (Roller Assembly Kit 1)	604K73890
99	Kit Roll Assy 2 (with1,3-7) (Roller Assembly Kit 2)	604K73900

Parts List 13.2 Bypass Tray (MSI)

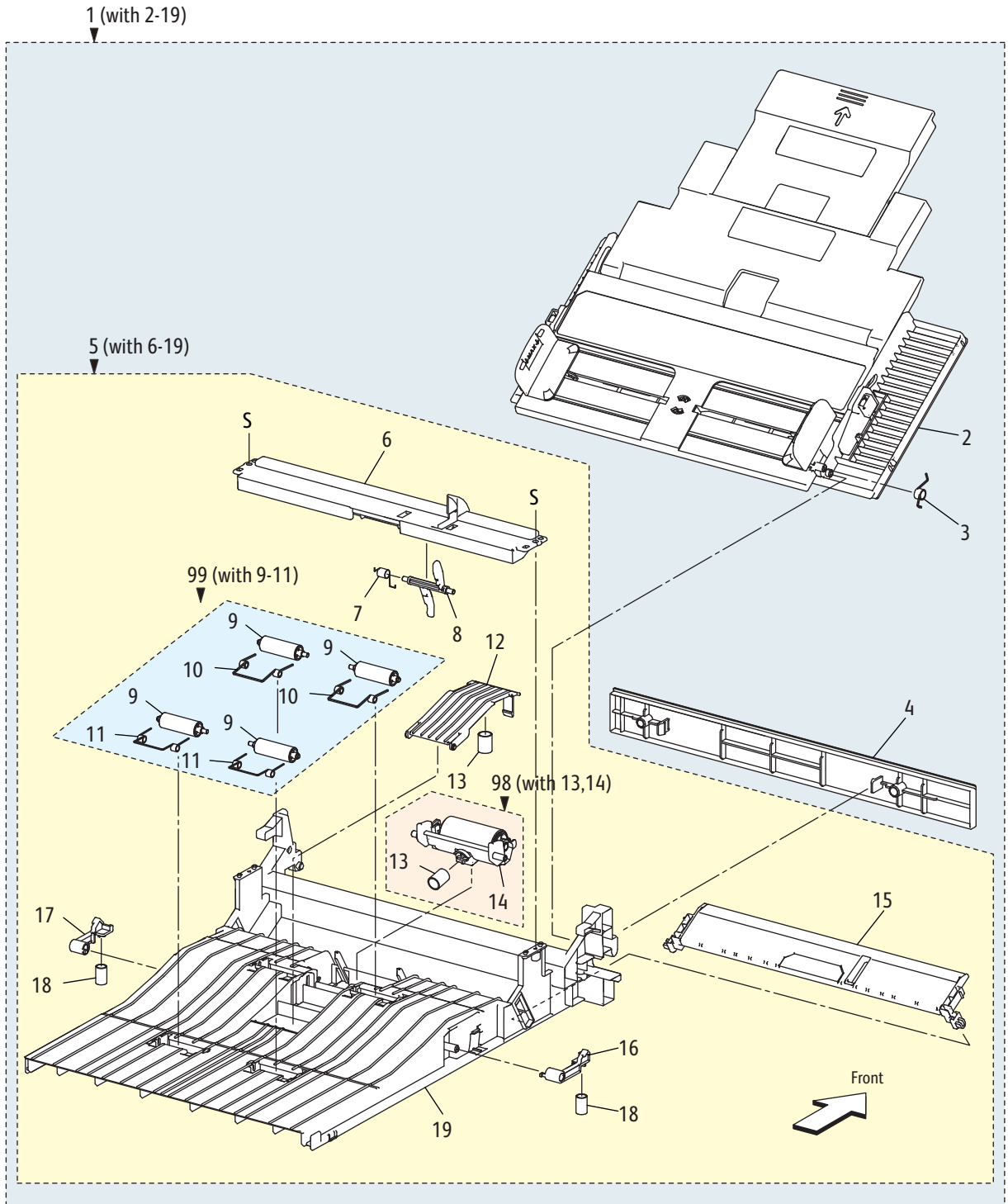


56600-046

## Parts List 13.2 Bypass Tray

Item	Name	Part Number
1	Frame Assy MSI (with2-26) (Bypass Tray Frame Assembly)	801K47622
2	Frame MSI (Bypass Tray Frame)	—
3	Bracket No Paper MSI (Bypass Tray No Paper Bracket)	—
4	MSI Detect Sensor (Bypass Tray No Paper Sensor)	930W00123
5	Harness Assy MSI (Bypass Tray Harness Assembly)	—
6	Guide Harness MSI (Bypass Tray Harness Guide)	—
7	Spring Feed	—
8	Gear Feed MSI (Bypass Tray Feed Gear)	—
9	Solenoid Feed MSI (Bypass Tray Feed Solenoid)	—
10	Roll Assy Feed (Feed Roller Assembly)	059K78701
11	Cam MSI L (Left Bypass Tray Cam)	—
12	Roll Core	—
13	Holder Feed	—
14	Shaft Feed MSI (Bypass Tray Feed Shaft)	—
15	Cam MSI R (Right Bypass Tray Cam)	—
16	Guide Support R (Right Support Guide)	—
17	Guide Support L (Left Support Guide)	—
18	Arm R (Right Arm)	—
19	Spring NF (NF Spring)	—
20	Arm L (Left Arm)	—
21	Bracket Gear (Gear Bracket)	—
22	Follower R (Right Follower)	—
23	Follower L (Left Follower)	—
24	Guide Bottom R (Right Bottom Guide)	—
25	Slide Bottom (Bottom Slide)	—
26	Guide Bottom L (Left Bottom Guide)	—
98	Kit Roll Assy (with10-15) (Roller Kit Assembly)	604K73910
99	Kit Solenoid Assy (with7-9) (Solenoid Kit Assembly)	604K73921

# Parts List 13.3 Bypass Tray (MSI)

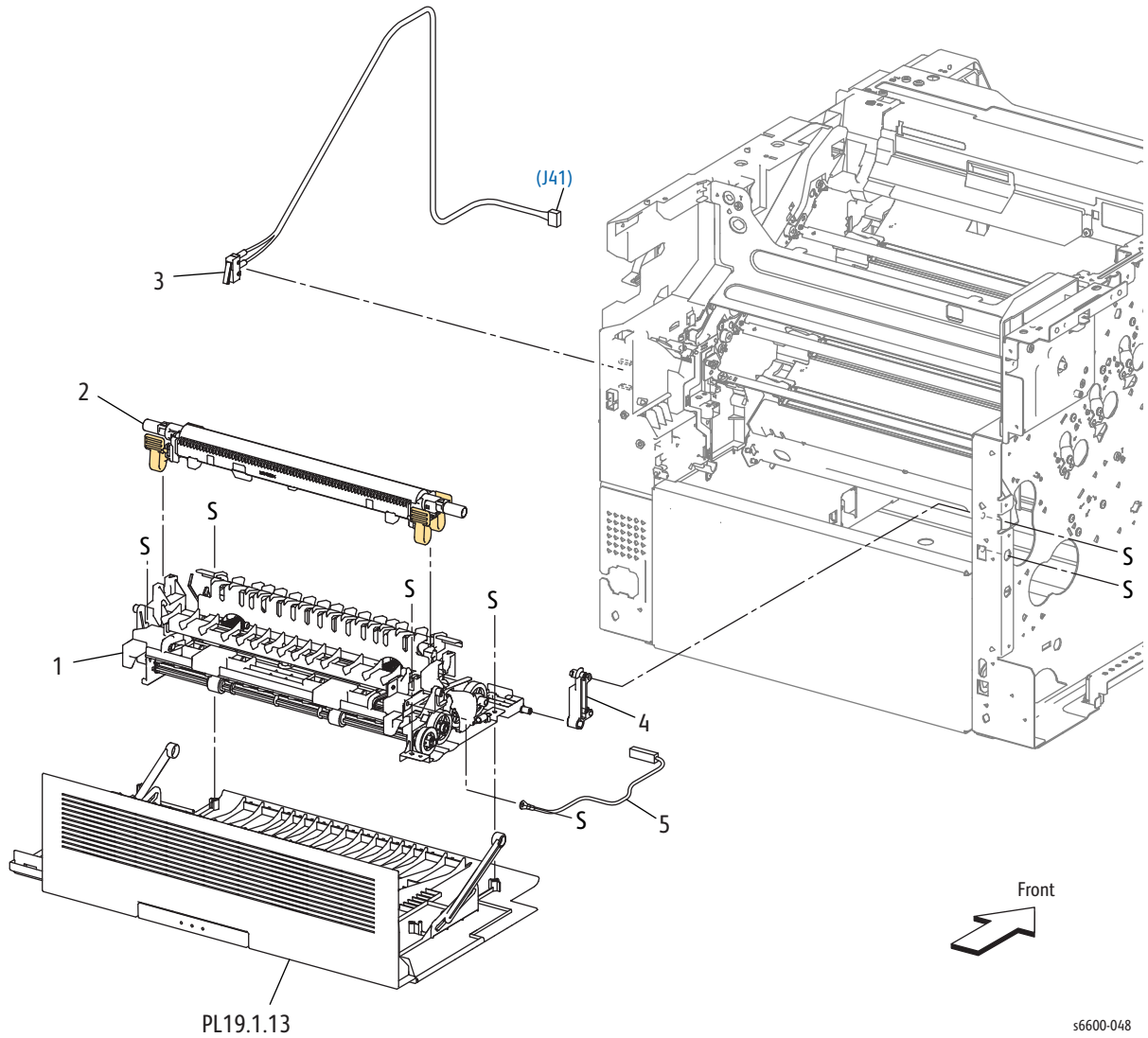


s6600-047

## Parts List 13.3 MSI

Item	Name	Part Number
1	Tray Assy MSI Main (with2-19) (Bypass Tray Assembly)	050K66572
2	Cover Assy MSI (Bypass Tray Cover Assembly)	848K51102
3	Spring Damper (Damper Spring)	—
4	Cover MSI Under (Bypass Tray Lower Cover)	—
5	Chute Assy MSI (with6-19) (Bypass Tray Chute Assembly)	054K46612
6	Bar MSI Front (Bypass Tray Front Bar)	—
7	Spring No Paper (No Paper Spring)	—
8	Actuator No Paper (No Paper Actuator)	—
9	Roll Pinch MSI (Bypass Tray Pinch Roller)	—
10	Spring Pinch TA1 (TA1 Pinch Spring)	—
11	Spring Pinch TA2 (TA2 Pinch Spring)	—
12	Chute Retard (Retard Chute)	—
13	Spring Retard MSI (Bypass Tray Retard Spring)	—
14	Holder Assy Retard (Retard Holder Assembly)	—
15	Plate Assy Bottom (Bottom Plate Assembly)	—
16	Latch MSI L (Left Bypass Tray Latch)	—
17	Latch MSI R (Right Bypass Tray Latch)	—
18	Spring Latch MSI (Bypass Tray Latch Spring)	—
19	Chute MSI (Bypass Tray Chute)	—
98	Kit Roll Assy Separater (with13,14) (Separator Roller Assembly Kit)	604K74440
99	Kit Roll Pinch (with9-11) (Pinch Roller Kit)	604K73940

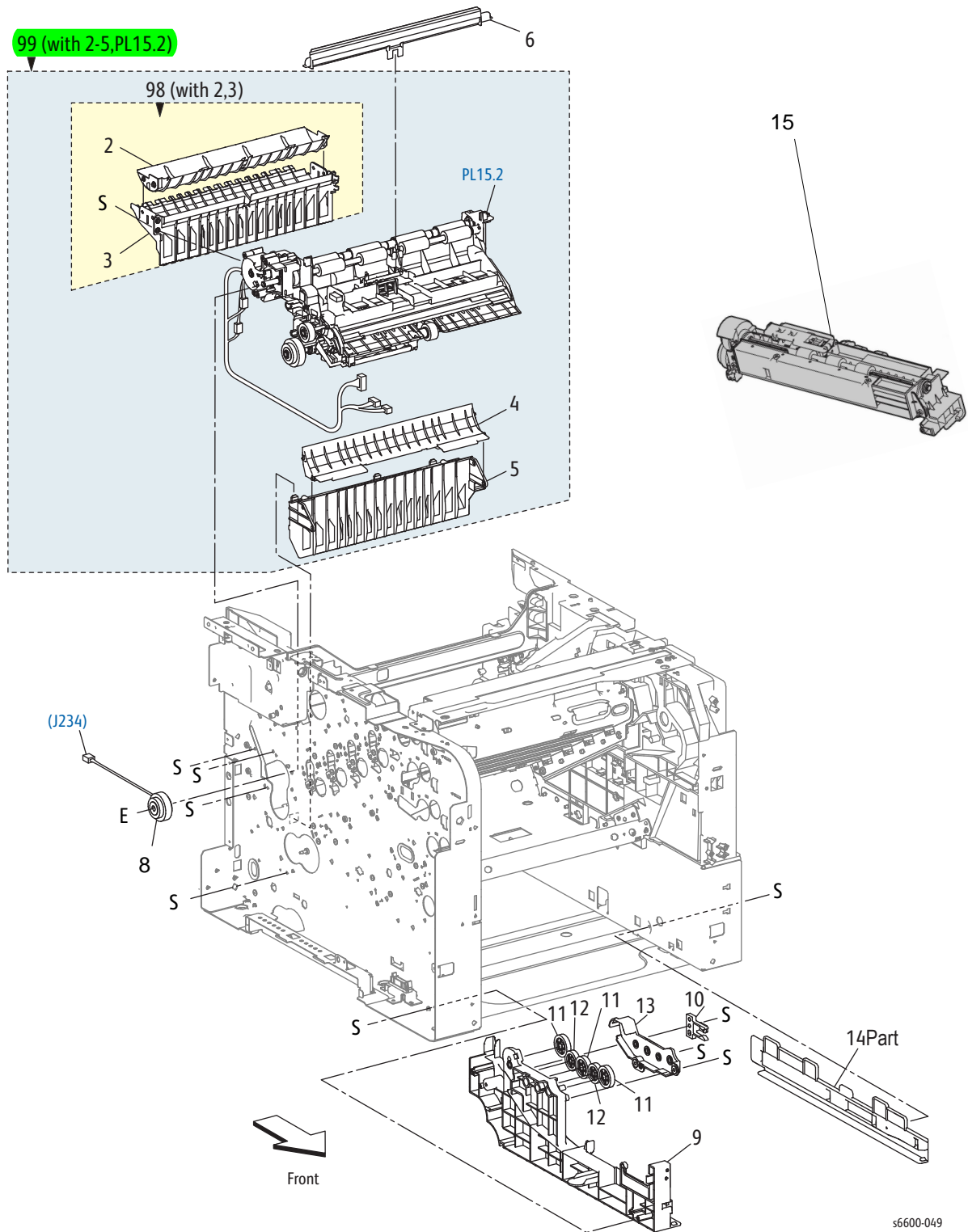
Parts List 14.1 Duplex



Parts List 14.1 Duplex

Item	Name	Part Number
1	Kit Duplex Assembly	054K46661
2	Roll Assy-2ND CRU (Transfer Roller)	—
3	Harness Assy Rear SW(Rear Interlock Switch)	—
4	Bracket Hinge Rear	868E68951
5	Harness Assembly	110K16891
99	Kit Roll Assy-2ND CRU (with2) (Transfer Roller)	604K77540

# Parts List 15.1 Registration / Feeder

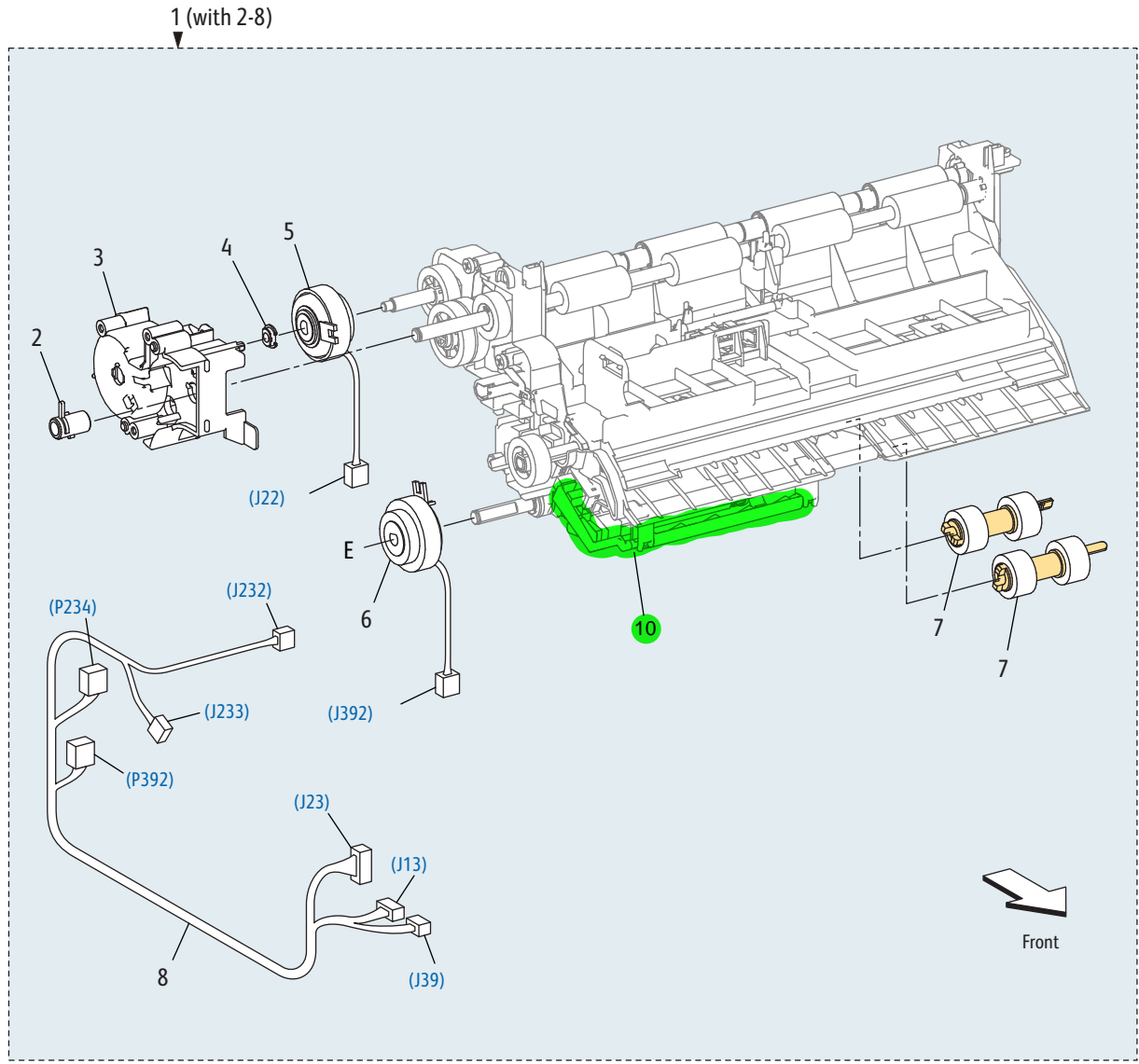


## Parts List 15.1 Registration / Feeder

Item	Name	Part Number
1	—	—
2	Chute Dup Upper (Upper Duplex Chute)	—
3	Chute Assy Dup Regi (Regi Duplex Chute Assembly)	—
4	Chute Regi Lower	—
5	Chute Regi Opt 550	—
6	Chute Assy Upper IBT (Upper Transfer Belt Chute Assembly)	054K46650
7	—	—
8	Registration Clutch (part of Item #15)	—
9	Guide Tray L (Left Tray Guide)	—
10	Stopper CST (Cassette Stopper)	—
11	Gear Idle 28	—
12	Gear Idle 25	—
13	Cover Gear MSI	—
14	Guide Tray R (Right Tray Guide)	—
15	Feed Assy with Registration Clutch	059K71760
98	Kit Chute Dup Assy (with 2,3) (Duplex Chute Assembly Kit)	054K46640
99A	Kit Chute Regi High Assy <b>DN</b> (with 2-5, PL15.2) (Upper Regi Chute Assembly Kit) <b>DN = Duplex/Network</b>	<b>604K77750</b>
99B	Kit Chute Regi High Assy <b>N</b> (with 2-5, PL15.2) (Upper Regi Chute Assembly Kit) <b>N = Network</b>	<b>604K77760</b>



# Parts List 15.2 Registration / Feeder

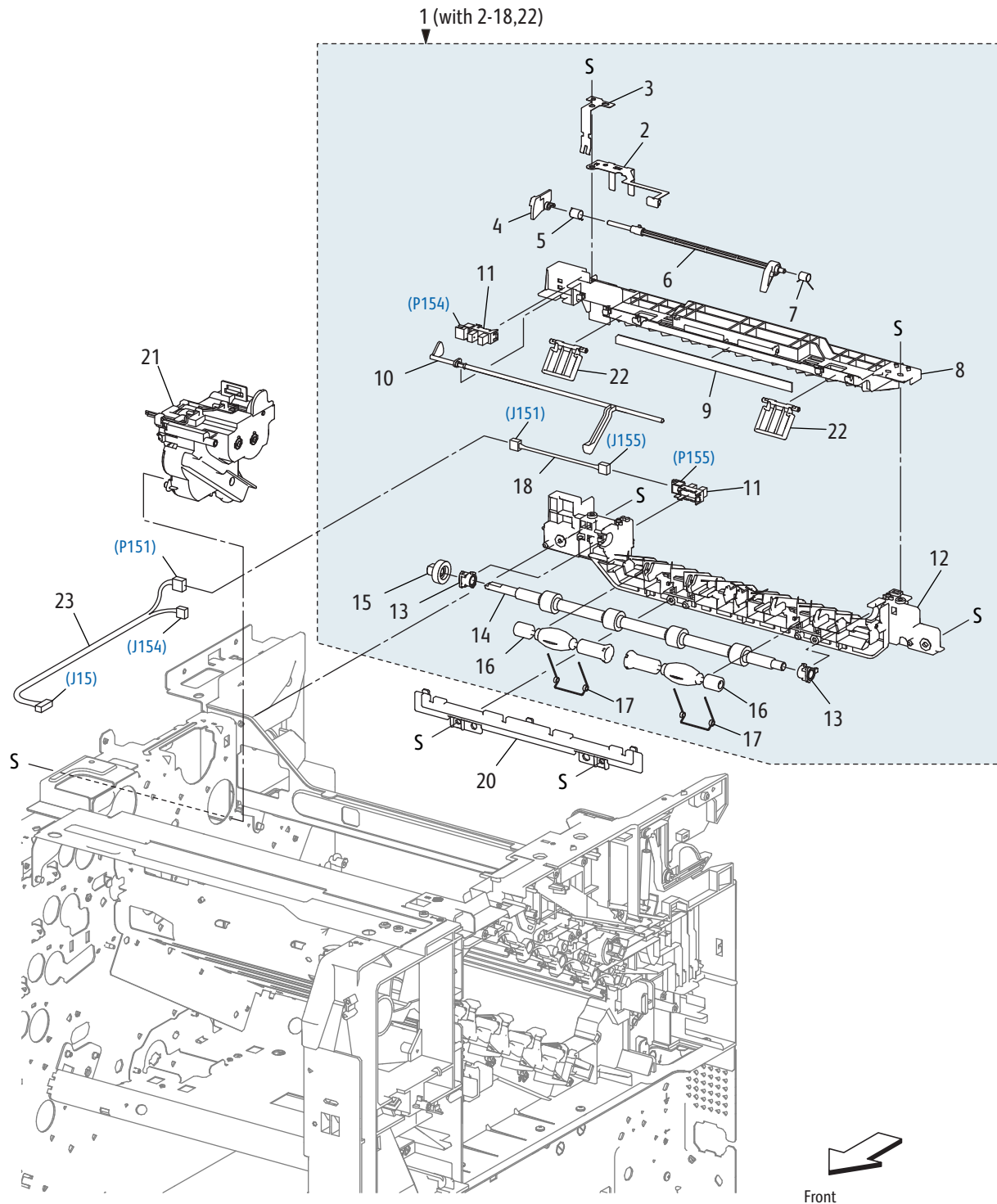


s6600-050

## Parts List 15.2 Registration / Feeder

Item	Name	Part Number
1	Simplex-only Registration Chute Assembly	054K47990
2	Bearing Regi R (Right Regi Bearing)	—
3	Cover Dup Gear (Duplex Gear Cover)	—
4	Bearing CLH AD	—
5	Clutch Assy Dup (Duplex Clutch Assembly)	121K48680
6	Clutch Assy Opt Feed (Feed Clutch Assembly)	—
7	Roll Assy Feed (Feed Roller Kit, with 2 Rolls)	675K47673
8	Harness Assy Regi (Regi Harness Assembly)	—
9	Chute Sub Assy Regi (Regi Chute Sub-Assembly)	—
10	No Paper Actuator	120E33761

Parts List 17.1 Exit

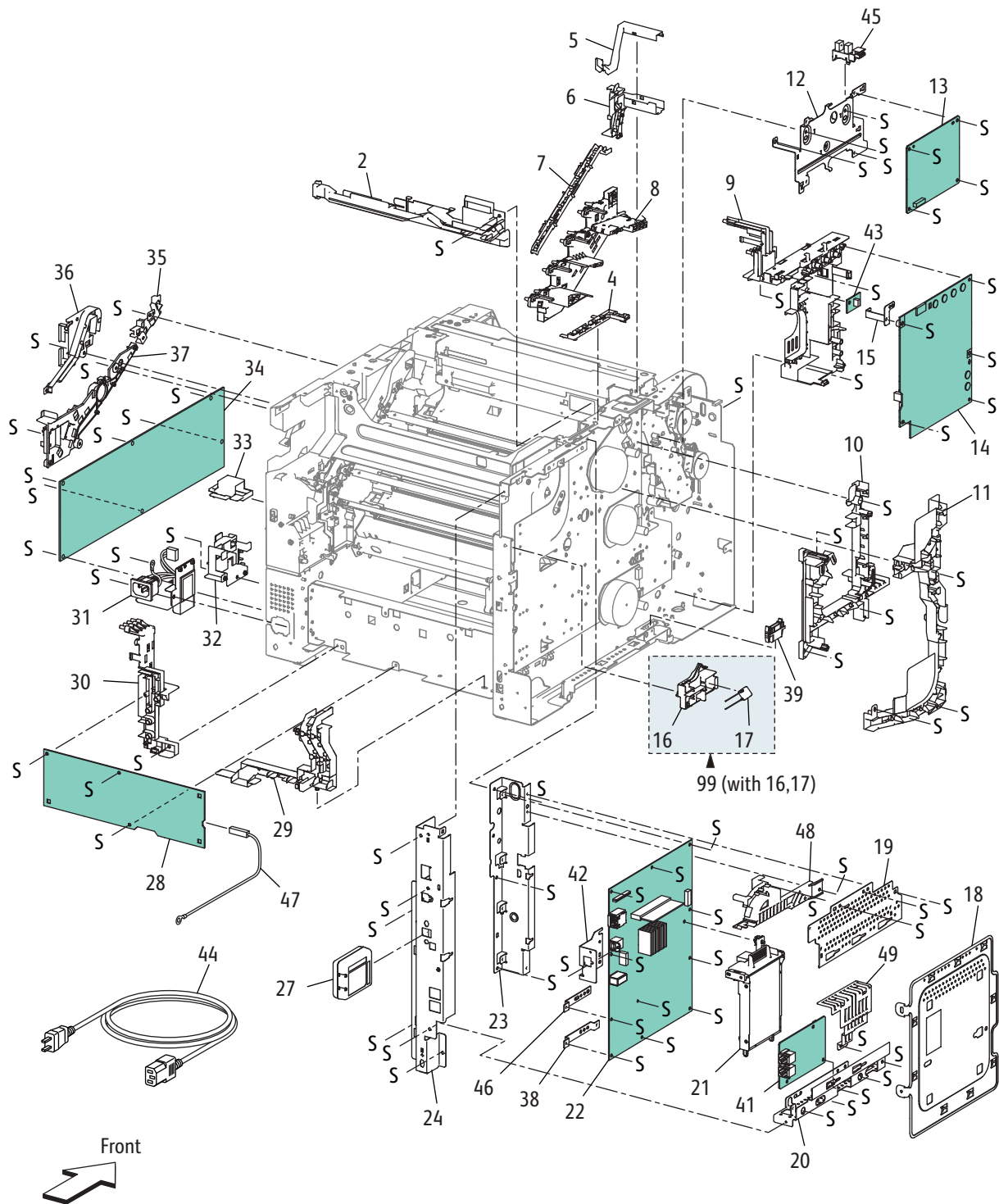


s6600-051

**Parts List 17.1 Exit**

Item	Name	Part Number
1	Kit Assy Exit (with 2-18,22) (Exit Kit Assembly)	054K49180 (alt 054K49231)
2	Plate Earth Exit B	—
3	Plate Earth Exit A	—
4	Actuator Exit B	—
5	Spring Actuator B	—
6	Actuator Exit A	—
7	Spring Actuator A	—
8	Chute Exit Upper S3	—
9	Eliminator Exit	—
10	Actuator Full Stack	—
11	Sensor-Photo Int (Interlock Photo Sensor)	930W00123
12	Chute Exit Lower S3	—
13	Bearing-Exit	—
14	Roll Assy Exit (Exit Roller Assembly)	—
15	Gear Exit	—
16	Roll-Pinch	—
17	Spring-Pinch	—
18	Harness Assy Exit Snr (Exit Sensor Harness Assembly)	—
19	—	—
20	Cover Exit Tray (Exit Tray Cover)	—
21A	Drive Assy Exit DN (Exit Drive Assy with Duplex)	007K18762
21B	Drive Assy Exit N (Exit Drive Assy w/o Duplex)	007K18772
22	Flapper Exit	—
23	Harness Assy Snr (Sensor Harness Assembly)	—

Parts List 18.1 Phaser 6600 Electrical (1/3)



S6600-052

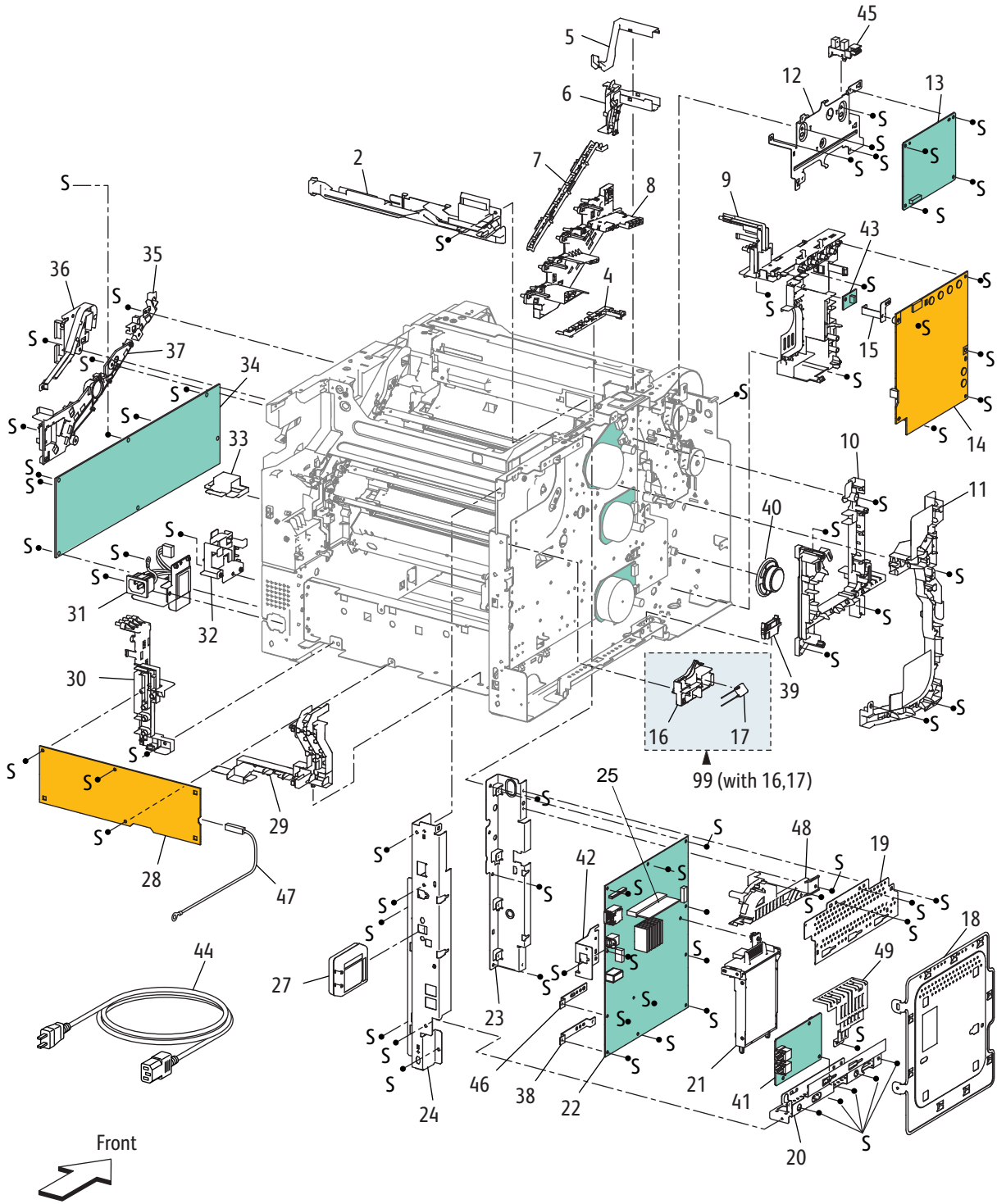
**Parts List 18.1 Phaser 6600 Electrical (1/3)**

Item	Name	Part Number
1	—	—
2	Guide_ Harness_ Top	—
3	—	—
4	Guide_ Harness_ Exit	—
5	Cover Harness Top	—
6	Guide Harness Top L (Left Top Harness Guide)	—
7	Guide_ Harness_ Erase_ CRM	—
8	Housing _ Assy_ Charge_ Deve (Developer Charge Housing Assembly)	—
9	Housing_ Assy_ Charge_ Deve_ Out (Outer Developer Charge Housing Assembly)	—
10	Guide Harness Video (Video Harness Guide)	—
11	Guide Harness L (Left Harness Guide)	—
12	Plate MCU (MCU Plate)	—
13	PWBA MCU (MCU Board)	960K67961
14	PWBA HVPS XD (Development HVPS Board)	105K26092
15	Plate Earth HV (HV Ground Plate)	—
16	Housing Assy Gnd Fusing (Fuser Ground Housing Assembly)	—
17	Varistor, NVD10UCD1100	—
18	Plate Window	—
19	Plate ESS Top	—
20	Plate_ ESS_ Bottom	—
21	160 GB HDD Productivity Kit	604K84810
22	PWBA ESS (IP Board)	960K60494
23	Plate ESS Front (Front IP Board Plate)	—
24	Plate ESS Rear (Rear IP Board Plate)	—
25	—	—
26	—	—
27	Wireless Kit (Drop-Ship only; not a service part)	016E21300
28	PWBA HVPS TR (Transfer HVPS Board)	105K26102
29	Guide_ Harness_ PH	—
30	Housing_ Assy_ Wire_ TR_IN (Inner Transfer Wire Housing Assembly)	—

**Parts List 18.1 Phaser 6600 Electrical (1/3)**

Item	Name	Part Number
31	AC In (AC Inlet)	604K76361
32	Guide Harness LV AC	—
33	Cap LV Bottom	—
34A	LVPS 110V	105K30560
34B	LVPS 220V	105K30570
35	Guide Harness R (Right Harness Guide)	—
36	Holder Drower	—
37	Housing Assy Wire TR Out	—
38	Bracket ESS SFP (IP Board Bracket)	—
39	Fdr Drawer1	913W12104
40	—	—
41	—	—
42	—	—
43	PWBA EEPROM XPRO (EEPROM Board)	—
44A	Power Cord US 110V	675K43778
44B	Power Cord TAA 220V Euro	—
44C	Power Cord TAA 220V UK	—
45	Sensor-Photo INT (Interlock Photo Sensor)	930W00123
46	—	—
47	Harness Assy BTR	—
99	Varistor Assy (with16,17)	848K69221

# Parts List 18.1 WorkCentre 6605 Electrical (2/3)



s6600-001



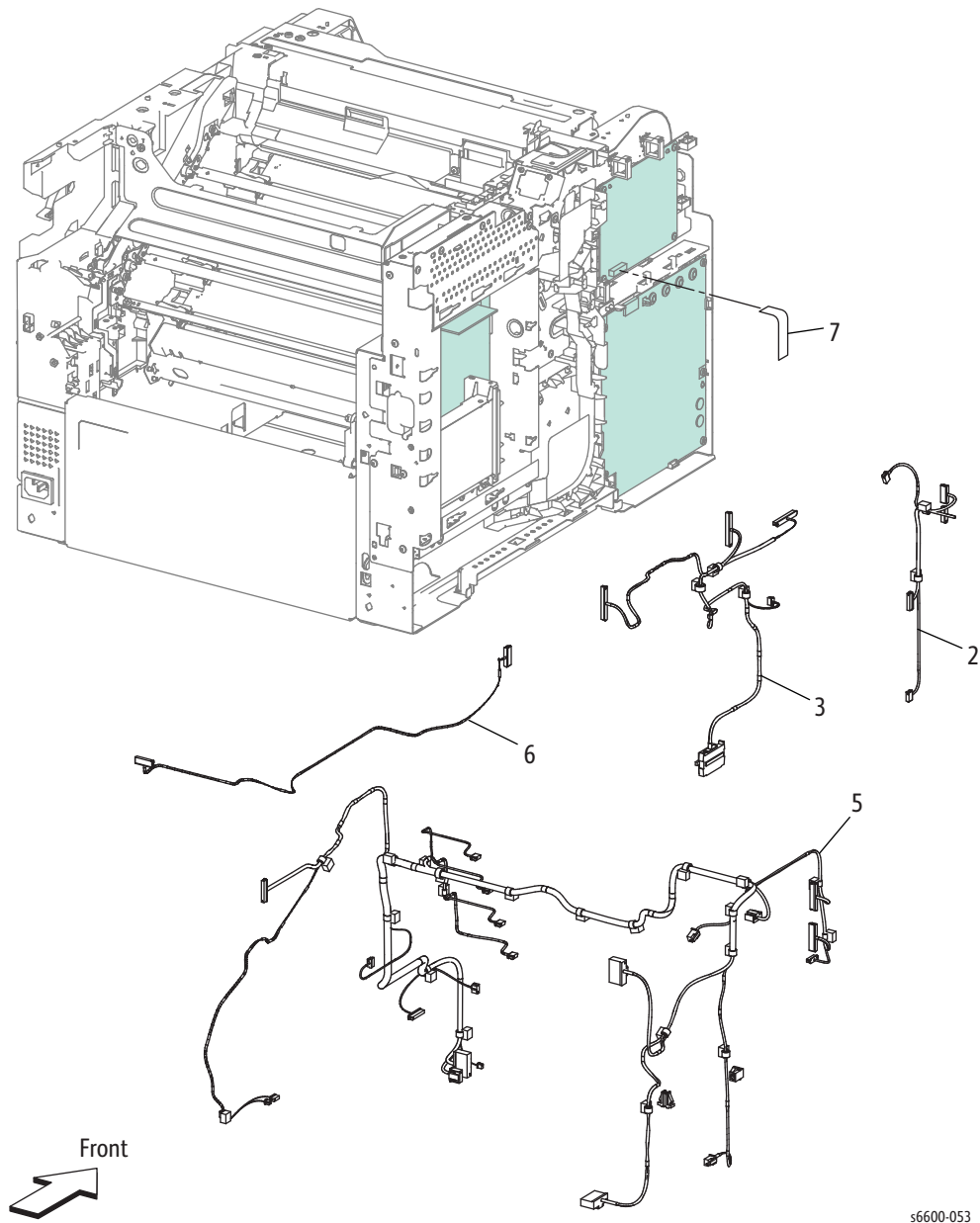
**Parts List 18.1 WorkCentre 6605 Electrical (2/3)**

Item	Name	Part Number
1	—	—
2	Guide Harness Top (Top Harness Guide)	—
3	—	—
4	Guide Harness Exit (Exit Harness Guide)	—
5	Cover Harness Top (Top Harness Cover)	—
6	Guide Harness Top L (Top Left Harness Guide)	—
7	Guide Harness Erase CRM (CRM Erase Harness Guide)	—
8	Housing Assy Charge Deve (Developer Charge Housing Assembly)	—
9	Housing Assy Charge Deve Out (Outer Developer Charge Housing Assembly)	—
10	Guide Harness Video (Video Harness Guide)	—
11	Guide Harness L (Left Harness Guide)	—
12	Plate MCU (MCU Plate)	—
13	PWBA MCU (MCU Board)	960K67961
14	PWBA HVPS XD (Development HVPS Board)	105K26092
15	Plate Earth HV (HV Ground Plate)	—
16	Housing Assy Gnd Fusing (Fuser Ground Housing Assembly)	—
17	Varistor, NVD10UCD1100	—
18	Plate Window AIO	—
19	Plate ESS Top AIO (MFP Top IP Board Plate)	—
20	Plate ESS Bottom AIO (MFP Bottom IP Board Plate)	—
21	160 GB HDD Productivity Kit	604K84810
22	PWBA ESS AIO (IP Board)	960K69200
23	Plate ESS Front AIO (MFP Front IP Board Plate)	—
24	Plate ESS Rear AIO (MFP Rear IP Board Plate)	—
25	Optional 512MB RAM (Productivity Kit)	237E25990
26	—	—
27	Wireless Kit (Drop-Ship only; not a service part)	016E21300
28	TR HVPS Board	105K26102
29	Guide_ Harness_ PH	—
30	Housing_ Assy_ Wire_ TR_IN	—

**Parts List 18.1 WorkCentre 6605 Electrical (2/3)**

Item	Name	Part Number
31	AC In (AC Inlet)	604K76361
32	Guide_ Harness_ LV_AC	—
33	Cap LV Bottom	—
34A	LVPS 110V	105K30560
34B	LVPS 220V	105K30570
35	Guide Harness R (Right Harness Guide)	—
36	Holder_ Drawer	—
37	Housing_ Assy_ Wire_ TR_ Out	—
38	Bracket ESS SFP (IP Board Bracket)	—
39	Fdr Drawer1	913W12104
40	Speaker Assembly AIO	—
41	PWBA FAX	960K53602
42	Bracket USB (USB BrackeMCUt)	—
43	PWBA EEPROM XPRO (EEPROM Board)	—
44	Power Cord US 110V	675K43778
44B	Power Cord TAA 220V Euro	—
44C	Power Cord TAA 220V UK	—
45	Sensor-Photo INT (Interlock Photo Sensor)	930W00123
46	Bracket ESS AIO (MFP IP Board Bracket)	674E04131
47	Harness Assy BTR	—
48	Guard ESS Top AIO (Guide Harness Bypass Tray) (Top IP Board Guard (Bypass Tray Harness Guide))	—
49	Guard ESS Bottom AIO (Bottom IP Board Guard)	—
		—
99	Varistor Assy (with16,17)	848K69221

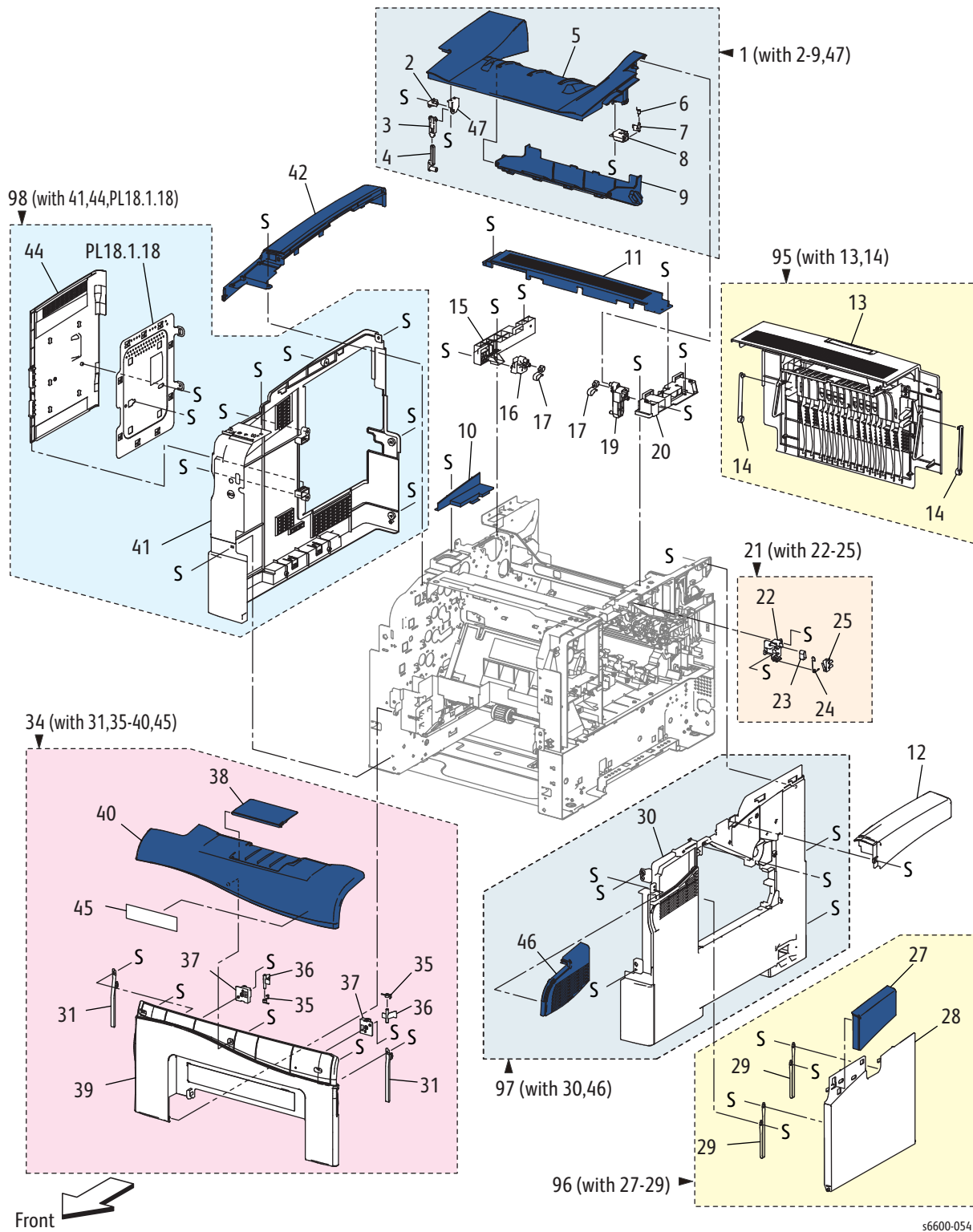
### Parts List 18.2 Electrical (3/3)



**Parts List 18.2 Electrical (3/3)**

Item		Part Number
1	—	—
2	Harness Assy Drive (Drive Harness Assembly)	—
3	Harness Assy Main (Main Harness Assembly)	—
4	—	—
5	Harness Assy Top SFP (Top Harness Assembly)	—
6	Harness Assy HVPS (HVPS Harness Assembly)	—
7	FFC MCU-HVPS (MCU-HVPS Flat Flex Cable)	—

# Parts List 19.1 Phaser 6600 Covers



s6600-054

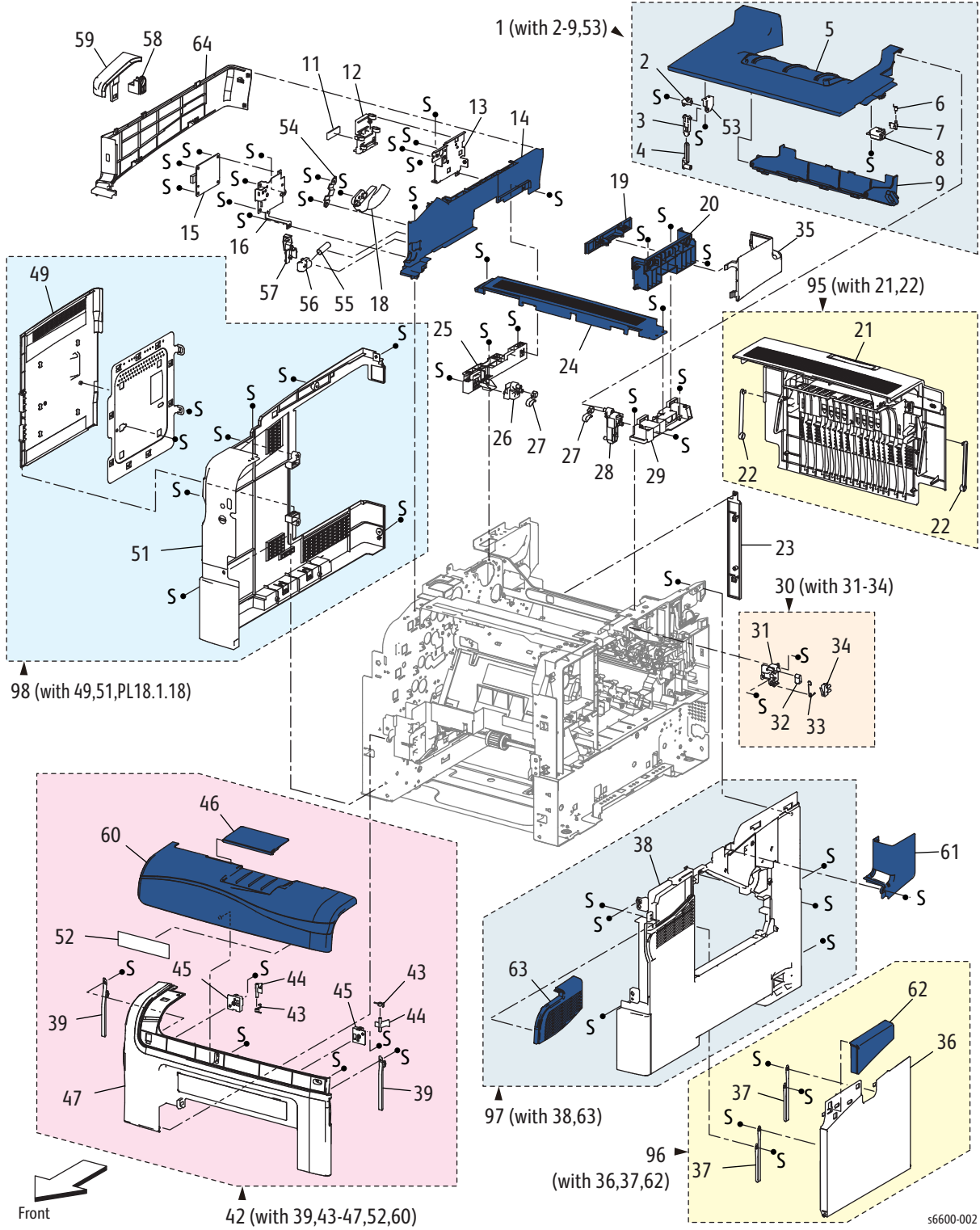
**Parts List 19.1 Phaser 6600 Covers**

<b>Item</b>		<b>Part Number</b>
1	Cover Assy Top SFP (with2-9,47) (Top Cover Assembly)	848K59082
2	Holder Link Trans	—
3	Link Trans 1	—
4	Link Trans 2	—
5	Cover Top SFP	—
6	Spring Actuator Intlk	—
7	Actuator Turn Intlk	—
8	Holder Actuator Intlk	—
9	Cover Tray Bottom (Bottom Tray Cover)	—
10	Cover Top Under L (Left Sub-top Cover)	—
11	Cover Exit (Exit Cover)	848E69601
12	Cover Top R (Right Top Cover)	—
13	Cover Assy Rear (Rear Cover Assembly)	—
14	Link Rear Cover	—
15	Bracket Hinge L (Left Hinge Bracket)	—
16	Hinge Top L (Left Top Hinge)	—
17	Stopper Cover Top (Top Cover Stopper)	—
18	—	—
19	Hinge Top R (Right Top Hinge)	—
20	Bracket Hinge R (Right Hinge Bracket)	—
21	Switch Assy Interlock R (with22-25) (Right Interlock Switch Assembly)	110K16891
22	Bracket Intlk Side R (Right Side Interlock Bracket)	—
23	Actuator Swing Intlk	—
24	Spring WC IL	—
25	Harness Assy Door I/L	—
26	—	—
27	Cover Side R Door Upper SFP (Right-Side Door Upper Cover)	—
28	Cover Side R Door SFP (Right Side Door Cover)	—
29	Strap Cover Side R (Right Side Cover Strap)	—
30	Cover Side R (Right Side Cover)	—

## Parts List 19.1 Phaser 6600 Covers

Item		Part Number
31	Strap Front (Front Strap)	—
32	—	—
33	—	—
34	Cover Assy Front SFP (with31,35-40,45) (SFP Front Cover Assembly)	848K73070
35	Spring Latch Front (Front Latch Spring)	—
36	Latch Front	—
37	Bracket Latch	—
38	Cover Front Ext	—
39	Cover Front SFP	—
40	Cover Front Band SFP	—
41	Cover Side L SFP (SFP Left Side Cover)	—
42	Cover Top L (Top Left Cover)	—
43	—	—
44	Cover ESS SFP	—
45	Plate Logo	—
46	Cover Side R Front SFP (Front Right Side Cover)	—
47	Holder Link Trans Support	—
		—
95	Kit Cover Assy Rear(with13,14) (Rear Door Assembly)	604K77700
96	Cover Assy Waste Door(with27-29) (Right Side Door)	848K73742
97A	Kit Cover Assy Right DN (with30,46) (Right Cover Assembly - DN)	604K80431
97B	Kit Cover Assy Right N (with30,46) (Right Cover Assembly - N)	848K73722
98	Left Cover Assy(with41,44,PL18.1.18) (Left Cover Assembly)	848K73050
99	Kit Plate Logo x100P (with 45 x 100)	604K77710

Parts List 19.1 WorkCentre 6605 Covers



s6600-002



## Parts List 19.1 WorkCentre 6605 Covers

Item		Part Number
1	Cover Assy Top AIO (with2-9,53) (Top Cover Assembly)	848K59102
2	Holder Link Trans	—
3	Link Trans 1	—
4	Link Trans 2	—
5	Cover Top AIO	—
6	Spring Actuator Intlk	—
7	Actuator Turn Intlk	—
8	Holder Actuator Intlk	—
9	Cover Tray Bottom	—
10	—	—
11	Core FFC	—
12	Holder FFC Core	—
13	Bracket Guide FFC (FFC Guide Bracket)	—
14	Cover-Pole in LH AIO (MFP Left Hand Inner Pole Cover)	—
15	PWBA USB Hub (USB Hub Board)	960K57396
16	Bracket USB (USB Bracket)	—
17	—	—
18	—	—
19	Cover Pole in RH Upper AIO (Upper Right Hand Inner Pole Cover)	—
20	Cover Pole in RH AIO (Right Hand Inner Pole Cover)	—
21	Cover Assy Rear (Rear Cover Assembly)	848K51190
22	Link Rear Cover	—
23	Cover-Rear Lower LH (Lower Left Hand Rear Cover)	—
24	Cover Exit (Exit Cover)	—
25	Bracket Hinge L (Left Hinge Bracket)	—
26	Hinge Top L (Left Top Hinge)	—
27	Stopper Cover Top (Top Cover Stopper)	—
28	Hinge Top R (Right Top Hinge)	—
29	Bracket Hinge R (Right Hinge Bracket)	—
30	Switch Assy Interlock R (with31-34) (Right Interlock Switch Assembly)	110K16891

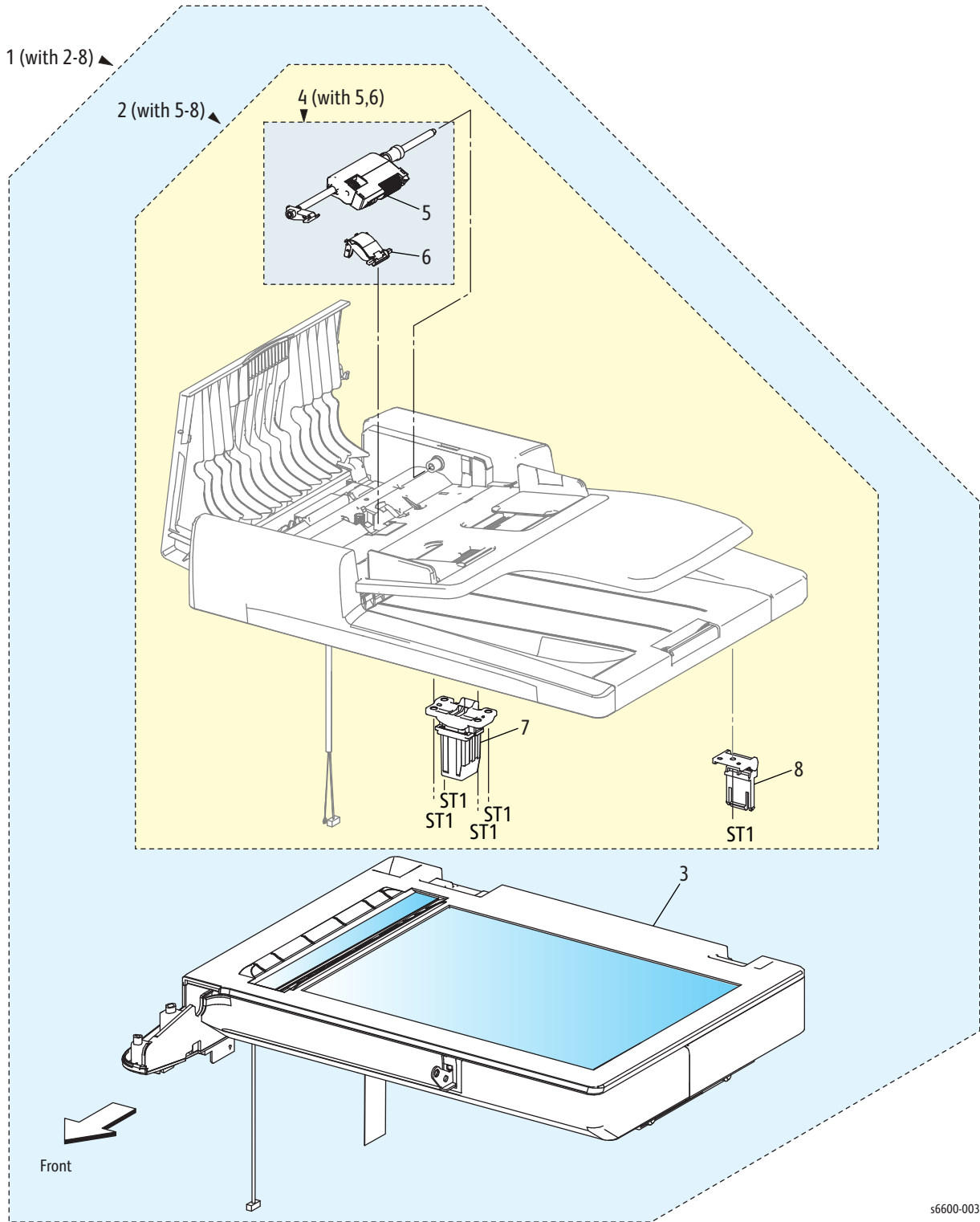
**Parts List 19.1 WorkCentre 6605 Covers**

Item		Part Number
31	Actuator Swing Intlk	—
32	Bracket Intlk Side R (Right Side Interlock Bracket)	—
33	Spring WC IL	—
34	Harness Assy Door I/L	—
35	Strap Cover Side R (Rear Right Pole Cover)	—
36	Cover Side R Door SFP (Right-Side Door Cover)	—
37	Strap Cover Side R (Right Side Door Strap)	—
38	Cover-Side R (Right Side Cover)	—
39	Strap Front (Front Strap)	—
40	—	—
41	—	—
42	Cover Assy Front AIO (with39,43-47,52,60) (MFP Front Door Assembly)	848K73110
43	Spring Latch Front (Front Latch Spring)	—
44	Latch Front	—
45	Bracket Latch	—
46	Cover Front Ext	—
47	Cover-Front AIO	—
48	—	—
49	Cover ESS AIO (IP Board Cover)	—
50	—	—
51	Cover-Side L AIO (Left Side Cover)	—
52	Plate Logo	—
53	Holder Link Trans Support	—
54	Holder Dumper UI (Control Panel Damper Holder)	—
55	Spring Tilt Button	—
56	Lever Lock UI	—
57	Link Stopper UI	—
58	Holder UI Pivot (Control Panel Pivot Holder)	—
59	Cover Hinge UI (Control Panel Hinge Cover)	—
60	Cover Front Top AIO	—

**Parts List 19.1 WorkCentre 6605 Covers**

Item		Part Number
61	Cover Base Front (Front Right Pole Cover)	—
62	Cover Side Door Upr AIO	—
63	Cover Side R Front Top AIO (Top Front Right Side Cover)	—
64	Cover Base L Out IIT (Outer Left Pole Cover)	—
		—
95	Kit Cover Assy Rear (with 21,22) (Rear Door Assembly)	604K77700
96	Cover Assy Waste Door (with 36,37,62) (Right Side Door)	848K73752
97A	Kit Cover Assy Right DN (with 38,63) (Right Cover Assembly - DN)	604K80441
97B	Kit Cover Assy Right N (with 38,63) (Right Cover Assembly - N)	848K73732
98	Left Cover Assembly(with 49,51,PL18.1.18)	848K73090

## Parts List 51.1 WorkCentre 6605 Scanner



**Parts List 51.1 WorkCentre 6605 Scanner**

<b>Item</b>	<b>Name</b>	<b>Part Number</b>
1	Scanner Assembly (With2-8)	—
2	DADF Assembly (with5-8)	059K74113
3	IIT Assembly	062K24012
4	IIT Pick-up Module Kit (With5,6)	604K77980
5	IIT Pick-up	—
6	IIT Separation pad	—
7	Hinge L (Left Hinge)	003K89090
8	Hinge R (Right Hinge)	003K89100

# Xerox Supplies and Accessories

## Hardware Kit

Description	Part Number
Hardware Kit	604K60070
Screw For Plastic, Tapping - ST1	—
Screw For Plastic, Tapping - ST4	—
Screw For Plastic, Tapping W/flange ST-10	—
Screw For Metal Sheet SM2	—

## Consumables

Description	Part Number
Toner Cartridge Yellow Magenta Cyan Black	Go to <a href="http://www.xerox.com/office/6600supplies">www.xerox.com/office/6600supplies</a>
Waste Cartridge	108R01124
Imaging Unit Kit(Y, M, C, K, and Cleaner Assembly)	108R01121
Yellow	604K77581
Magenta	604K77571
Cyan	604K77561
Black	604K77551
Long Life Maintenance Kit (Transfer Unit)	108R01122

## Routine Maintenance Items

Description	Part Number
Fuser	
110V	115R00076
220V	115R00077
Maintenance Kit (Transfer Belt, Transfer Roller, Cassette Retard Roller)	676K20770
IIT Pick-up Module Kit	604K77980
Feed Roller Assembly Kit (3 pcs.)	675K47673
Cassette Retard Roller Kit	604K77660





# Maintenance

# 6

## In this chapter...

- Service Maintenance Procedure
- Cleaning
- Moving the Printer
- Adjustments and Maintenance Procedures

### **825-701 FAX\_SET UI FAX SPEED** **On-Panel Fax Communication Speed**

0 = 2400 baud  
1 = 4800 baud  
2 = 9600 baud  
3 = 14400 baud  
4 = 33600 baud

## Service Maintenance Procedure

Perform the following procedures whenever you check, service, or repair a printer. Cleaning the printer, as outlined in the following steps, assures proper operation of the printer and reduces the probability of having to service the printer in the future.


The frequency of use, the type of media printed on, and operating environment are factors in determining how critical cleaning the machine is and how often it is necessary.

### Recommended Tools

- Toner vacuum cleaner
- Clean water
- Clean, dry, lint-free cloth

# Cleaning

## General Precautions

 **CAUTION:** When cleaning your printer do not use organic or strong chemical solvents or aerosol cleaners. Do not pour fluids directly into any area. Use supplies and cleaning materials only as directed in this documentation.

 **WARNINGS:**

- Keep all cleaning materials out of the reach of children.
- Do not use pressurized spray cleaning aids on or in the printer. Some pressurized sprays contain explosive mixtures and are not suitable for use in electrical applications. Use of such cleaners increase the risk of fire and explosion.
- Do not remove the covers or guards that are fastened with screws. You cannot maintain or service any parts that are behind these covers and guards. Do not attempt any maintenance procedure that is not described in the documentation supplied with your printer.
- Internal parts of the printer can be hot. Use caution when doors and covers are open.
- Do not place anything on top of the printer.
- Do not leave the covers and doors open for any length of time, especially in well-lit places. Light exposure can damage the imaging units.
- Do not open covers and doors during printing.
- Do not tilt the printer while it is in use.
- Do not touch the electrical contacts or gears. Doing so could damage the printer and cause the print quality to deteriorate.
- Ensure any parts removed during cleaning are replaced before you plug in the printer.


## Recommended Tools

- Toner vacuum cleaner
- Clean water
- Clean, dry, lint-free cloth

## Cleaning the Exterior

Clean the exterior of the printer once a month.

- Wipe the paper tray, output tray, control panel, and other parts with a damp, soft cloth.
- After cleaning, wipe with a dry, soft cloth.
- For stubborn stains, apply a small amount of mild detergent to the cloth and gently wipe the stain off.

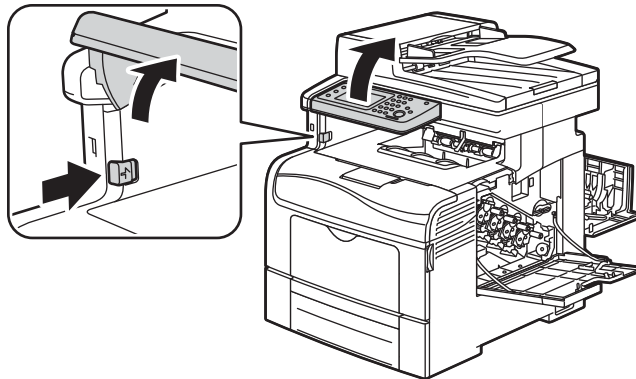
 **CAUTION:** Do not spray detergent directly on the printer. Liquid detergent could enter the printer through a gap and cause problems. Never use cleaning agents other than water or mild detergent.

## Cleaning the Scanner (MFP Only)

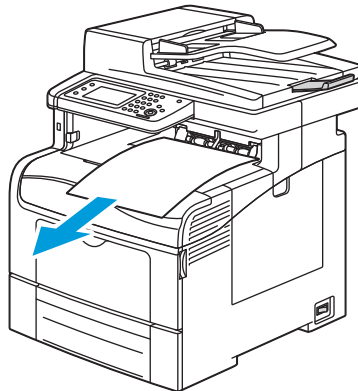
Clean the scanner as a standard part of service when anything is spilled on it, or when debris or dust collect on any of the surfaces. Keep the feed rollers clean to ensure the best possible copies and scans.

### Cleaning Procedure

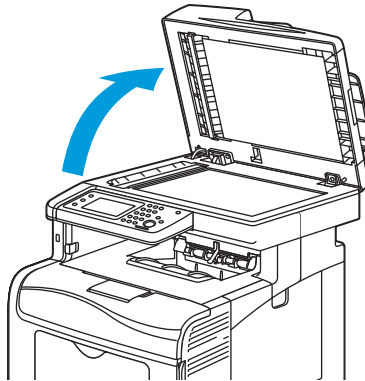
1. Slightly dampen a soft, lint-free cloth with water.
2. To gain better access to the output tray, push the Control Panel Latch Release, then lift the control panel up.



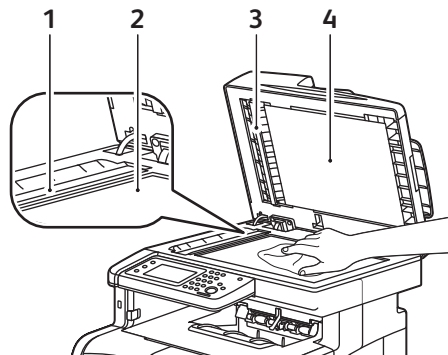
3. Remove any paper or other media from the output tray.



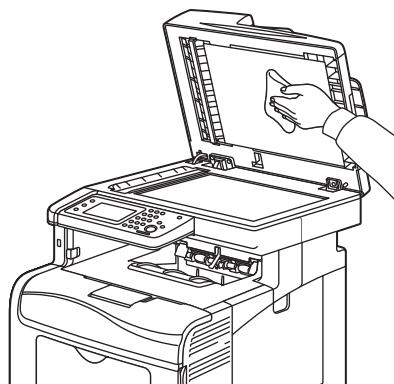
4. Wipe the area under the scanner until it is clean.
5. Open the document cover.



6. Wipe the surface of the document glass until it is clean and dry.  
**Note:** For best results, use Xerox® Glass Cleaner to remove marks and streaks.



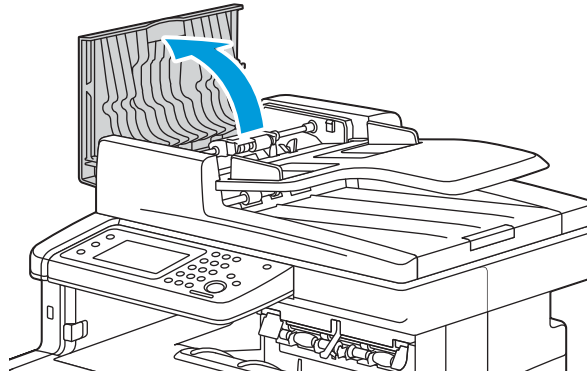
7. Wipe the white underside of the document cover until it is clean and dry.



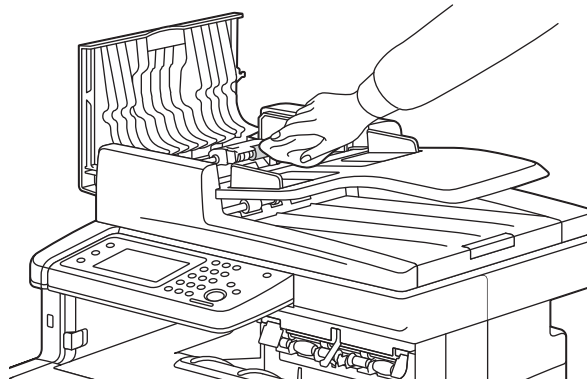
8. Close the document cover.

## Cleaning the Feed Rollers on the DADF

1. Open the DADF Cover.



2. With a dry, soft lint-free cloth or paper towel, wipe the DADF feed roller until it is clean.



**Note:** If the DADF rollers get stained with toner or debris, they can cause stains on the documents. To remove the stains, use a soft lint-free cloth dampened with a neutral detergent or water.

3. Close the DADF.

## Cleaning the Interior

Clean the interior of the printer regularly to prevent stains inside the printer that can deteriorate printing quality. Clean the printer interior whenever you replace an imaging unit.

After clearing paper jams or replacing a toner cartridge, inspect the inside of the printer before closing the printer covers.

- Remove any remaining pieces of paper or debris. For details, see [Clearing Paper Jams](#) on page 224.
- Remove any dust or stains with a dry, clean cloth.

**!** **WARNING:** Never touch a labeled area on or near the heat roller in the fuser. You can get burned. If a sheet of paper is wrapped around the heat roller, do not try to remove it immediately. Switch off the printer immediately and wait 40 minutes for the fuser to cool. Try to remove the jam after the printer has cooled.

## Cleaning the Laser Lenses

If prints have voids or light streaks through one or more color, use the following instructions to clean the laser lenses.

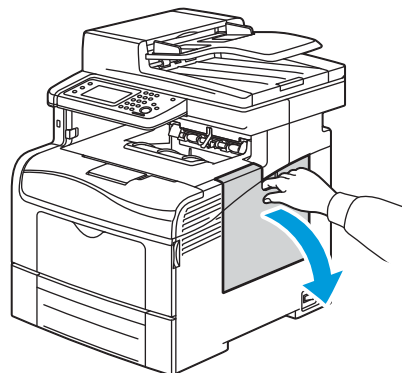
**Note:** The figures depict the MFP, but the procedure is applicable to the SFP.

**!** **WARNING:** If you accidentally get toner on your clothes, lightly dust them off as best as you can. If some toner remains on your clothes, use cool water, not hot, to rinse off the toner. If toner gets on your skin, wash it off with cool water and a mild soap. If you get toner in your eyes, wash it out immediately with cool water and consult a doctor.

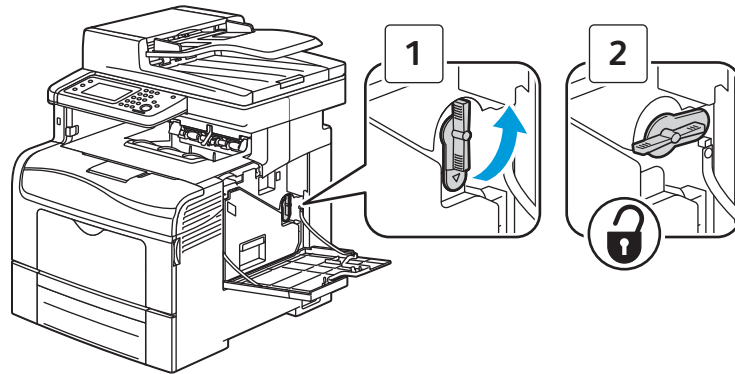
1. Turn off the printer.

**!** **CAUTION:** If the optional Productivity Kit (HD) is not installed, ensure that the Ready LED is off before you turn off the printer. The data in the memory is cleared when the printer is turned off.

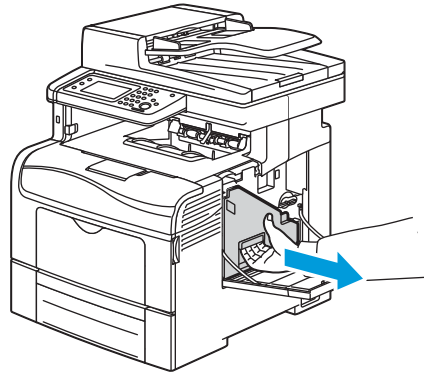
2. Open the right side door.



3. To unlock the waste cartridge, turn the waste cartridge lever 90-degrees counterclockwise.

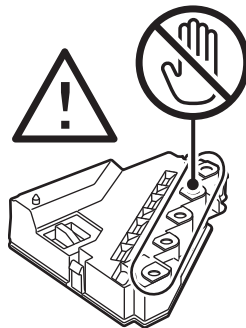


4. Grasp the handle of the waste cartridge, then pull it out. To prevent toner spills, keep the openings facing up.



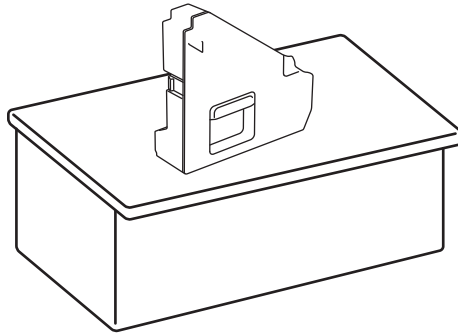
Notes:

- Be careful not to spill toner when handling the waste cartridge.
- After removing the waste cartridge, do not touch the area shown in the illustration.

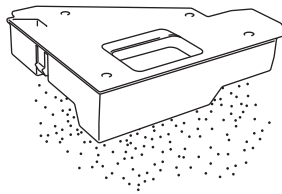




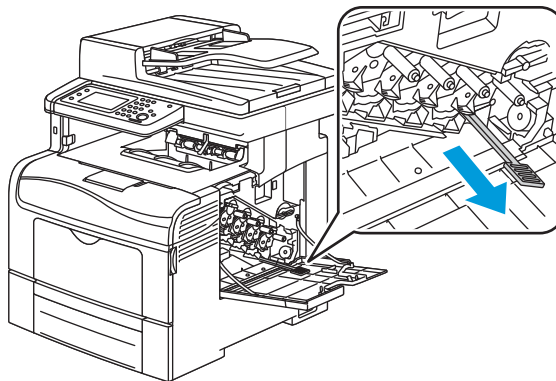
5. Place the removed waste cartridge on a level surface.



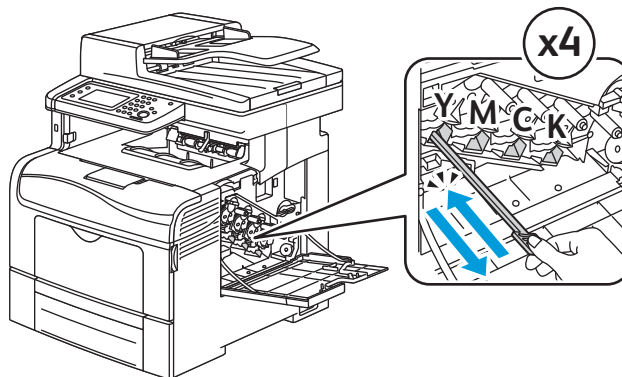
- !** **CAUTION:** To avoid toner spills or malfunction, do not lay the waste cartridge on its side.



6. Remove the cleaning rod from inside the printer.

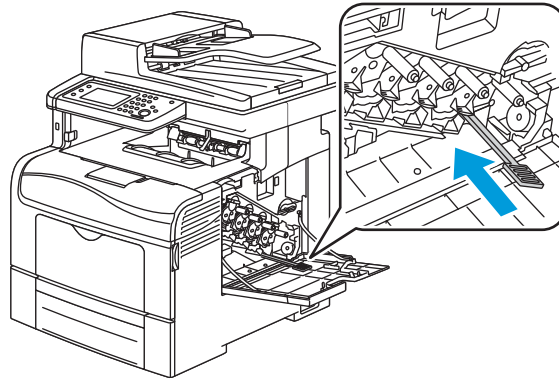


7. Insert the cleaning rod into one of the four cleaning holes until it clicks, then pull it out. Repeat this two more times. Repeat this step for the other three colors.

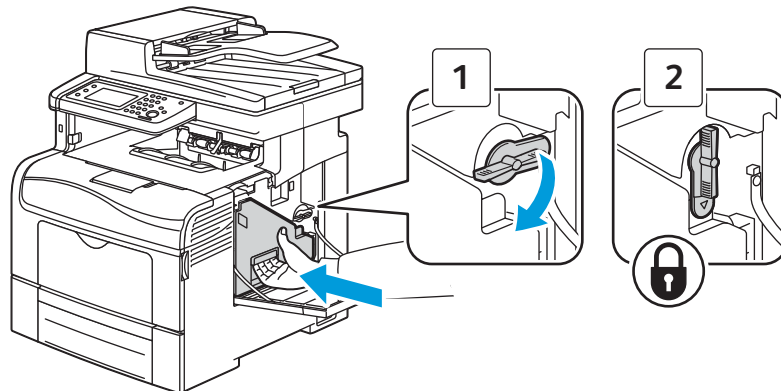


Maintenance

8. Repeat the procedure for the holes in the other three slots.
9. Return the cleaning rod to its original location.

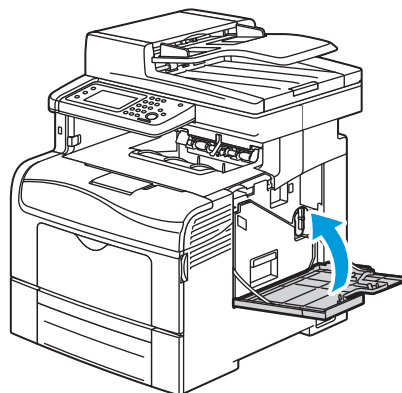


10. Reinsert the waste cartridge, and turn the waste cartridge lock lever 90-degrees clockwise.



**Note:** If the waste cartridge does not fit into place properly, ensure that the Transfer Belt is inserted fully.

11. Close the side door.

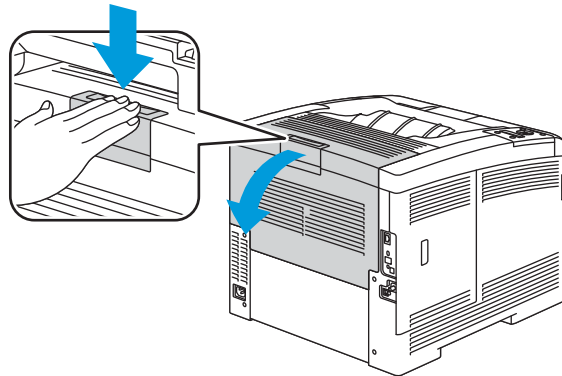


## Cleaning the Color Toner Density Sensors

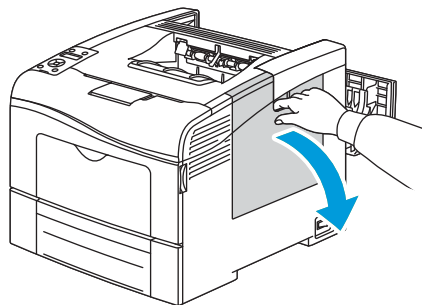
1. Turn off the printer.

**! CAUTION:** If the optional Productivity Kit (HD) is not installed, ensure that the Ready LED is off before you turn off the printer. The data in the memory is cleared when the printer is turned off.

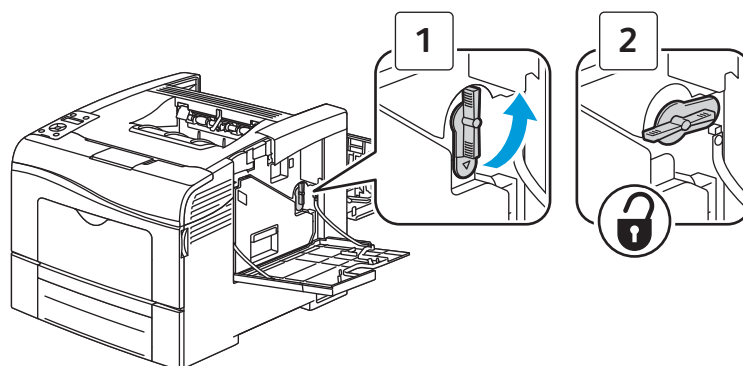
2. Push down on the rear door release and pull open the door.



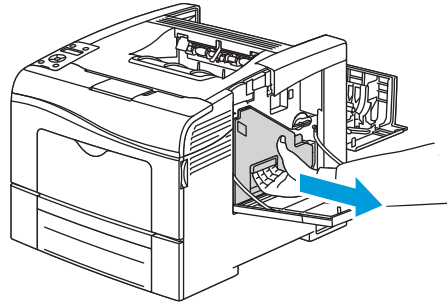
3. Open the side door.



4. To unlock the waste cartridge, turn the waste cartridge lever 90-degrees counterclockwise.



5. Grasp the handle of the waste cartridge, then pull it out. To prevent toner spills, keep the openings facing up.

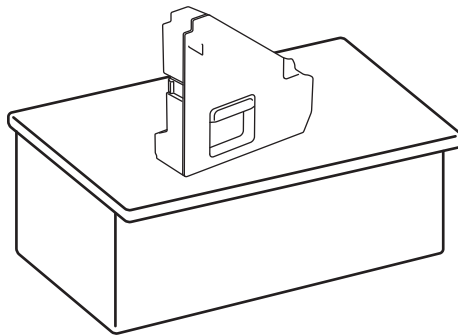


Notes:

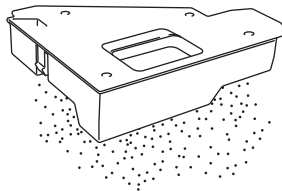
- Be careful not to spill toner when handling the waste cartridge.
- After removing the waste cartridge, do not touch the area shown in the illustration.



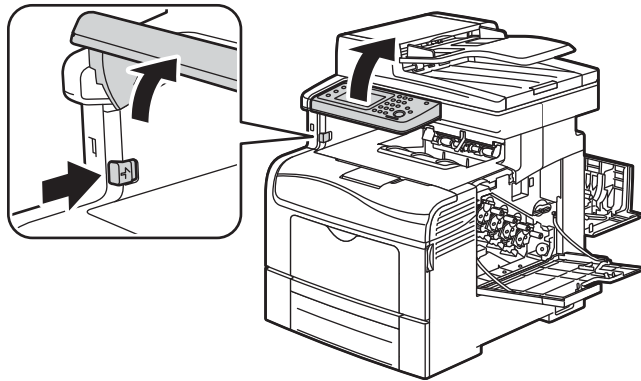
6. Place the removed waste cartridge on a level surface.



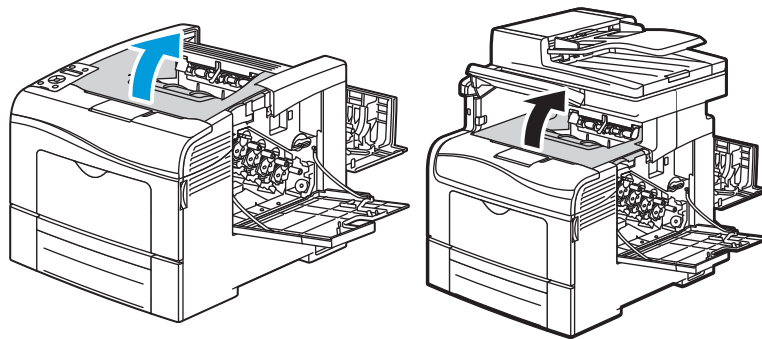
**!** **CAUTION:** To avoid toner spills or malfunction, do not lay the waste cartridge on its side.



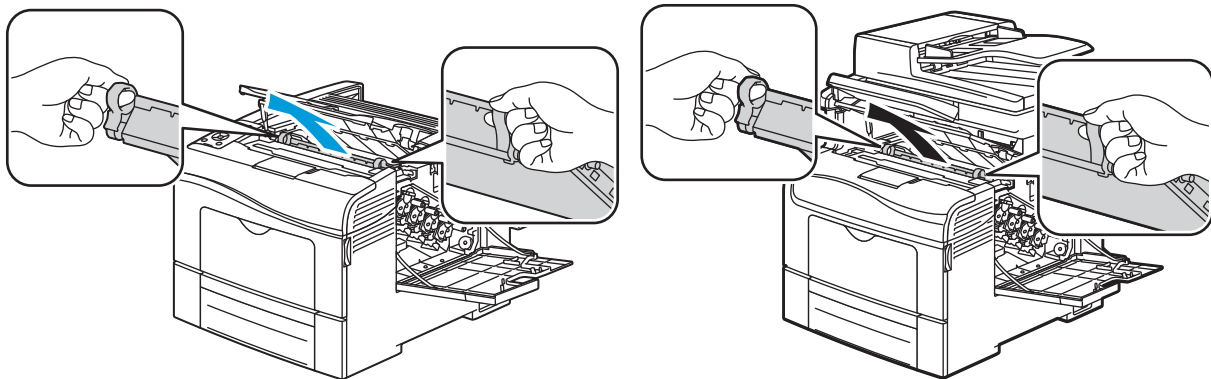
7. **MFP only:** Push the release, then raise the front of the control panel.



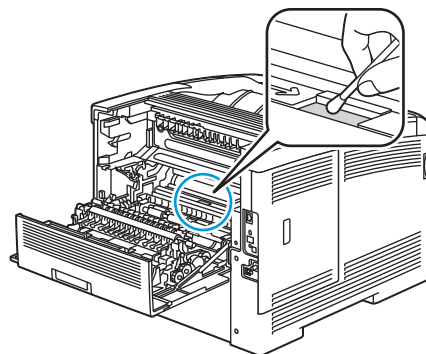
8. Open the top cover.



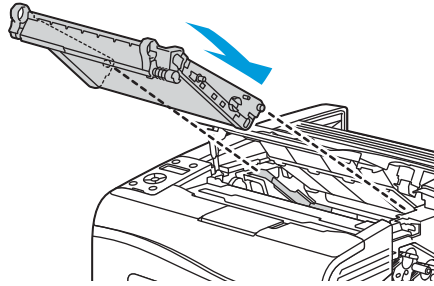
9. Pull out the Transfer Belt.



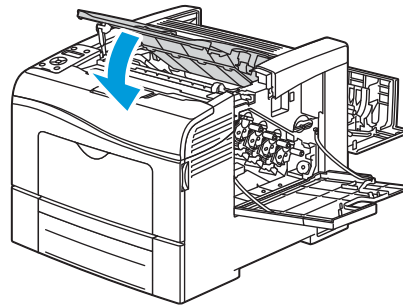
10. Use a dry cotton swab to clean the color toner density sensors.



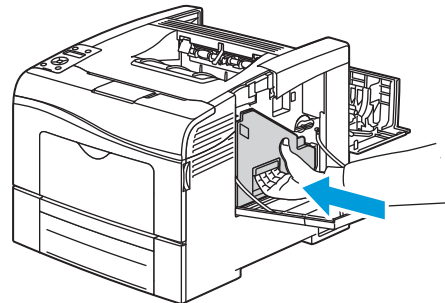
11. Reinsert the belt unit into the printer.



12. Close the top cover.

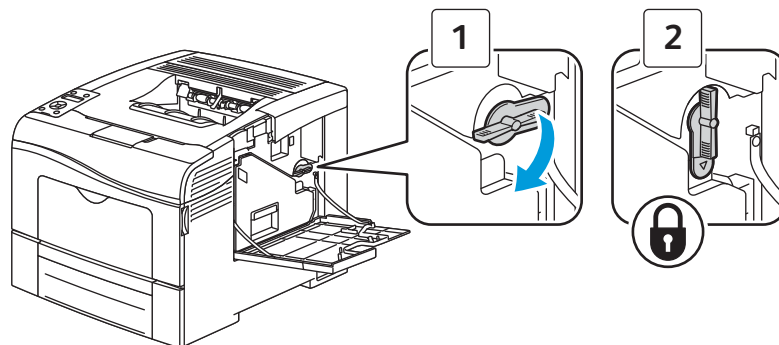


13. Reinsert the waste cartridge.

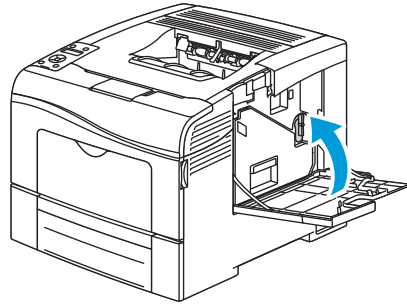


**Note:** If the waste cartridge does not fit into place properly, ensure that the belt is inserted fully.

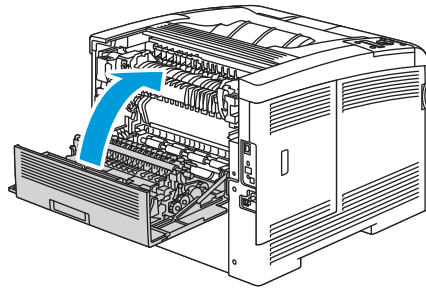
14. To lock the waste cartridge, turn the waste cartridge lock lever 90-degrees clockwise.



15. Close the side door.



16. Close the rear door.



## Moving the Printer

**! WARNINGS:**

- Always use at least two people to lift the printer.
- To prevent you from dropping the printer or injury, lift the printer firmly by gripping the recessed areas on both sides of the printer. Never lift the printer by gripping any other areas.
- If the optional 550-sheet feeder has been installed, uninstall it before moving the printer. If the optional 550-sheet feeder is not fixed securely to the printer, it could fall to the ground and cause injuries.

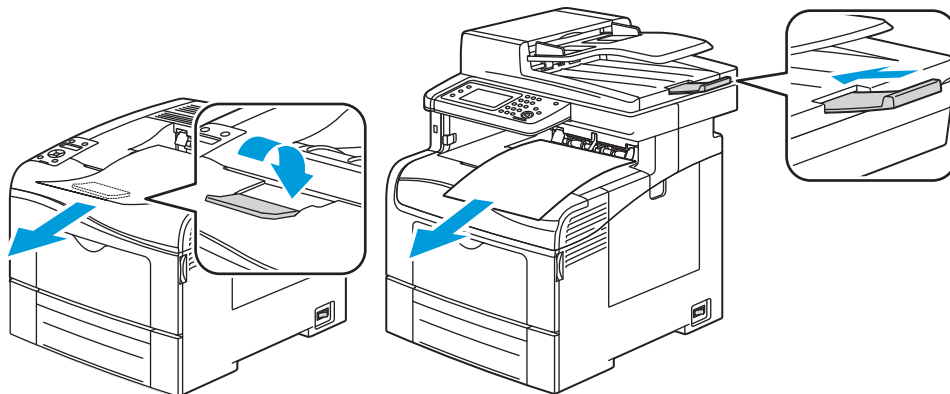
Follow these instructions when moving the printer:

1. Turn off the printer and disconnect the power cord and other cables from the back of the printer.

**! CAUTION:** If the optional Productivity Kit (HD) is not installed, ensure that the Ready LED is off before you turn off the printer. The data in the memory is cleared when the printer is turned off.

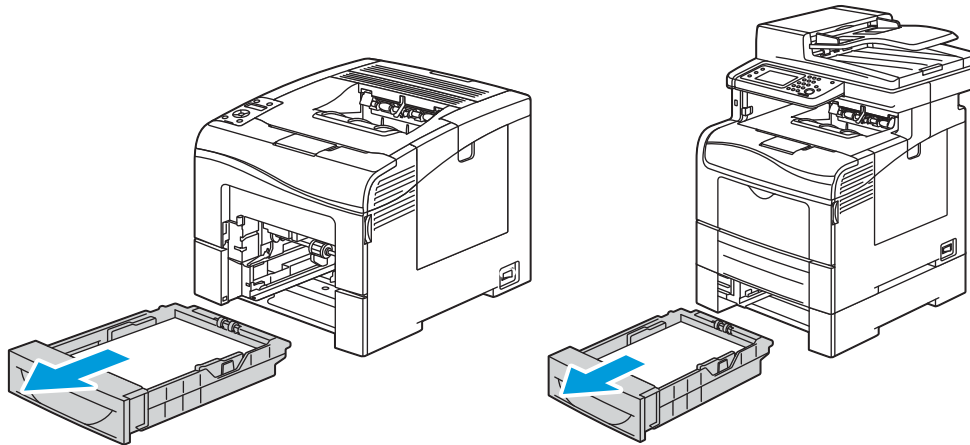
**! WARNING:** To prevent electric shock, never touch the power plug with wet hands. When removing the power cord, ensure that you pull the plug and not the cord. Pulling the cord can damage it, which can lead to fire or electric shock.

2. Remove any paper or other media from the output tray. If the output tray extension is extended, close it.





- Remove the paper from the paper tray.  
Keep the paper wrapped and away from humidity and dirt.



- Lift and carry the printer as shown in the illustration.



#### Notes:

- When moving the printer, do not tilt it more than 10 degrees to the front, back, left, or right. Tilting the printer more than 10 degrees can cause toner spillage.
- When moving the printer over a long distance, remove the imaging units and toner cartridges to prevent toner from spilling. Pack the printer inside a box. For a repacking kit and instructions, go to [www.xerox.com/office/WC6605support](http://www.xerox.com/office/WC6605support).

**!** **CAUTION:** Failure to repackage the printer properly for shipment can result in damage not covered by the Xerox® Warranty, Service Agreement, or Total Satisfaction Guarantee. The Xerox® Warranty, Service Agreement, or Total Satisfaction Guarantee do not cover damage to the printer caused by improper moving.

After moving the printer:

- Reinstall any parts you removed.
- Reconnect the printer to the cables and power cord.
- Plug in and turn on the printer.

# Adjustments and Maintenance Procedures

## Color Registration

The printer automatically adjusts the color registration when automatic adjustment is turned on. You can also adjust color registration manually any time the printer is idle. You must adjust the color registration any time the printer is moved. If you are having printing problems, adjust the color registration.

### Setting Automatic Color Registration

1. At the control panel, press the **Menu** button (SFP) or **Machine Status** button (MFP).
2. **SFP:** Navigate to **Admin Settings**, then press **OK**.  
**MFP:** Touch **Tools**, then touch **Admin Settings**.
3. **SFP:** Navigate to **Service Tools**, then press **OK**.  
**MFP:** Touch **Service Tools**.
4. **SFP:** Select **Auto Regi Adjust**, then press **OK**.  
**MFP:** Touch **Auto Registration**, then touch **ON**.
5. **SFP:** Select **On**, then press **OK**.  
**MFP:** Touch **OK**.

### Performing an Automatic Color Registration Adjustment

Automatic color registration adjustment occurs every time a new toner cartridge is installed. You can run this adjustment at other times as needed.

To perform an automatic color registration adjustment:

#### SFP Procedure

1. At the printer control panel, press the **Menu** button.
2. Navigate to **Admin Settings**, then press **OK**.
3. Navigate to **Service Tools**, then press **OK**.
4. Select **Adjust Color Regi**, then press **OK**.
5. At **Auto Adjust**, press **OK**.
6. At the **Are you sure?** prompt, press the **Up** or **Down** arrows to select **Yes**, then press **OK**.
7. To begin the calibration, press **OK**.

#### MFP Procedure

1. At the printer control panel, press the **Machine Status** button.
2. Touch **Tools**, then touch **Admin Settings**.
3. Touch **Service Tools**.
4. Touch **Color Registration > Auto Registration > On**.

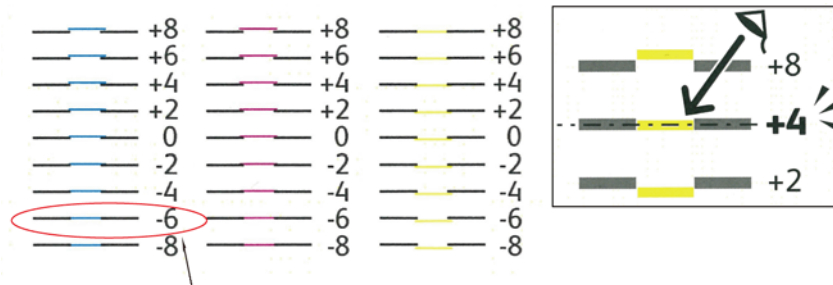
The printer runs while it performs the Auto Registration routine.

## Performing a Manual Color Registration Adjustment

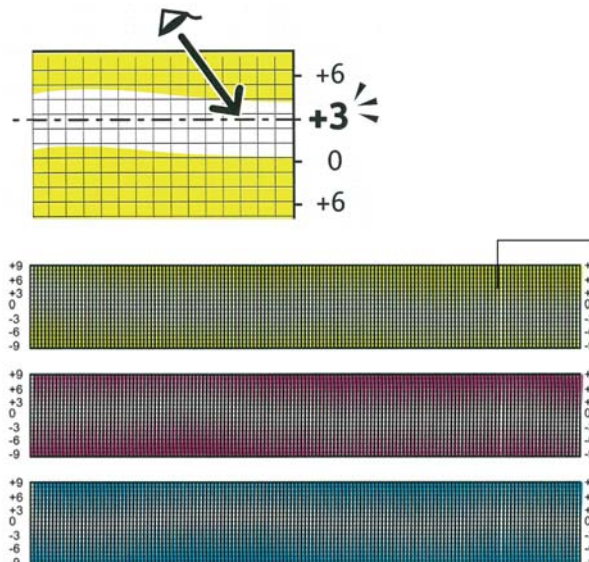
Color Registration adjusts the printer to make corrections to blurry or hazy prints, or prints with color halos.

To perform a color registration adjustment:

1. At the control panel, press the **Menu** button (SFP) or **Machine Status** button (MFP).
2. **SFP:** Navigate to **Admin Settings**, then press **OK**.  
**MFP:** Touch **Tools**, then touch **Admin Settings**.
3. **SFP:** Navigate to **Service Tools**, then press **OK**.  
**MFP:** Touch **Service Tools**.
4. **MFP:** Touch **Color Registration** > **Print Registration Chart**.
5. Starting with the left side calibration lines, circle the line in each group where the color bar aligns with the adjacent black bars.



6. Repeat the process for the right side calibration lines, RY, RM, and RC.
7. Align a straight edge through the middle of the white zone in each of the PY, PM, and PC charts. Circle the number at the end of each chart that represents the middle of the white zone.



8. **SFP:** Navigate to **Enter Number**.  
**MFP:** Touch **Enter Registration Value**.
9. To enter values for each LY, LM, and LC fields,  
**SFP:** use the **Up** and **Down** arrow buttons. Adjust the value to what you circled for each field, then press **OK**.  
**MFP:** use - and + to adjust the value to what you circled in step 5.
10. **SFP:** Repeat step 9 to enter values for each RY, RM, and RC field, and each PY, PM, and PC fields.  
**MFP:** Touch **Next**.
11. **MFP only:** To enter values for each RY, RM, and RC fields, use - and + to adjust the value to what you circled in step 6.
12. **MFP only:** Touch **Next**.
13. **MFP only:** To enter values for each PY, PM, and PC fields, use - and + to adjust the value to what you circled in step 7.
14. **MFP only:** Touch **OK**.
15. **SFP & MFP:** Print another Registration Chart, then repeat the process until you complete the color registration corrections.
16. **MFP only:** Touch the **Back** arrow to return to the next menu level, or press the **Services Home** button to return to Service Home.

## Adjusting the Transfer Roller Bias

The bias voltage applied to the Transfer Roller (BTR2) controls how the toner transfers from the Transfer Belt to the paper. If the bias voltage is too low, the toner does not transfer properly, producing light colors and white spots. If the bias voltage is too high, mottling of the image can occur.

Adjusting the Transfer Roller bias requires entering Service Mode and editing NVM using a specific Chain-Link code. Refer to “NVM Read and Write (Edit NVM)” on page 2-28 for detailed instructions on editing NVM values. Refer to the table below for the Chain-Link codes associated with 11 different paper types.

To adjust the Transfer Roller bias:

1. Identify the paper type that is producing symptoms of mis-adjusted bias.
2. Enter Service Mode and navigate to **Printer Diag > Engine Diag > NVM Settings > Edit NVM**.
3. Enter the Chain-Link code for the paper identified in step 1. Refer to the table for the appropriate Chain-Link code.

Parameter	Paper Type	Range	Initial	Chain Link
Plain Paper-L	Hole-Punched or Colored	1~16	6	746-500
Plain Paper-H	Plain	1~16	6	746-501
Recycled	Recycled	1~16	6	746-503
Heavier Paper-L	Special or Heavyweight Cardstock	1~16	6	746-504
Heavier Paper-H	Special or Heavyweight Cardstock	1~16	6	746-505
Coated Paper-M	Lightweight Glossy Cardstock	1~16	6	746-512
Coated Paper-H	Heavyweight Glossy Cardstock	1~16	6	746-513
Envelope	Envelope	1~16	6	746-509
Label-H	Labels	1~16	6	746-507



**CAUTION:** In the following step, do not use values higher than 16.

4. Adjust the value up or down as necessary to a value with the range 1-16. The default setting is 6.

## Adjusting the Transfer Belt Offsets

The Transfer Belt Offset only needs adjustment in cases where the Transfer Roller Bias adjustment has reached its limit without resolving the problem.

Adjusting the Transfer Belt Offset for black (K) or color (YMC) requires entering Service Mode and editing NVM using a specific Chain-Link code. Refer to “NVM Read and Write (Edit NVM)” on page 2-28 for detailed instructions on editing NVM values. Refer to the table below for the Chain-Link codes associated with each offset adjustment.

To adjust the Transfer Belt Offset:

1. Enter Service Mode and navigate to **Printer Diag > Engine Diag > NVM Settings > Edit NVM**.
2. Enter the Chain-Link code (see the table) for either K or YMC Offset.

Parameter	Range	Initial	Chain Link
K Offset	1~11	6	746-516
YMC Offset	1~11	6	746-517



**CAUTION:** In the following step, do not use values higher than 11.

3. Adjust the value up or down as necessary to a value with the range 1-11. The default setting is 6.

## Adjusting Altitude

Print quality varies with barometric pressure. Since the barometric pressure decreases as the altitude increases, altitude can affect the print quality. To optimize print quality for your location, select an altitude setting to match the your location.

Adjusting for altitude requires entering Service Mode and editing NVM using a specific Chain-Link code. Refer to “NVM Read and Write (Edit NVM)” on page 2-28 for detailed instructions on editing NVM values.

To adjust altitude:

1. Enter Service Mode and navigate to **Printer Diag > Engine Diag > NVM Settings > Edit NVM**.
2. Enter Chain-Link code 746-515.
3. Set the value to 1000, 2000, or 3000, whichever is closest to your altitude in meters. The default setting is 0. Use *only* the NVM values listed in the following table.

Altitude	NVM value
0 m	0 (default)
1000 m	2
2000 m	4
3000 m	6

## Adjusting the Fuser

The Fuser uses heat and pressure to bond the toner image to the paper. For optimal print quality, the printer automatically adjusts the temperature of the Fuser when you change the paper type. Because of differences in paper construction and thickness, the adjustment made by the printer is not enough or is too much for all paper types. If the Fuser temperature is too low, the toner will not properly bond to the paper. If the Fuser is too hot, the paper can curl.

Changing the Fuser temperature for a particular paper type requires entering Service Mode and editing NVM using a specific Chain-Link code. Refer to “NVM Read and Write (Edit NVM)” on page 2-28 for detailed instructions on editing NVM values.

To adjust the Fuser:

1. Identify the paper type for which you need to adjust the fuser temperature.
2. Enter Service Mode and navigate to **Printer Diag > Engine Diag > NVM Settings > Edit NVM**.
3. Enter the Chain-Link code for the paper identified in step 1. Refer to the table for the appropriate Chain-Link code.
4. Adjust the value up or down as necessary, using one of the following settings:  
-9, -6, -3, 0 (default), +3, +6, +9.

The value of the setting raises (if positive) or lowers (if negative) the Fuser temperature by that many degrees celsius above or below the default temperature for the specified paper type and printer speed. For example, entering +3 will raise the temperature by 3° C.

Media Name	Media Mode	Chain-Link	Default
Plain	Plain-H	744 016	0
Special	Heavier - L	744 017	0
Hole Punched	Plain-L	744 018	0
Colored	Plain-L	744 019	0
Lightweight Cardstock	Heavier-L	744 036	0
Heavyweight Cardstock	Heavier-H	744 037	0
Labels	Label-H	744 039	0
Envelope	Envelope	744 041	0
Lightweight Glossy Cardstock	Coated-M	744 044	0
Heavyweight Glossy Cardstock	Coated-H	744 045	0

## Updating Firmware

Although the firmware update process is designed to be performed by users, you might be called upon in the course of a service call to update the firmware on a printer. The *Xerox Support & Drivers* web site provides a Windows utility called *xeroxfwup* to install updates. A tool will also be available for Mac OS X systems.

In addition to the utility and firmware, downloads include update instructions. Running the utility updates the firmware and reboots the printer. The entire process takes less than 10 minutes.

Updates apply to three types of firmware within the printer and MFP:

1. MCU (print engine)
2. Boot
3. Main (controller)

Depending on the issues a customer needs to resolve, they may need to update one, two, or all three types.

When updating two or more types, the order of installation is not critical, but Xerox Engineers recommend installing them in the order shown above.

Before installing the firmware updates, print the Configuration Page. It provides the current firmware versions along with the printer settings.

1. Before launching the *xeroxfwup* utility, use CentreWare IS to enable software downloads.
  - a. Select the *Properties* tab.
  - b. Expand the Security settings.
  - c. Select *Secure Settings*.
  - d. Scroll to locate *Software Download*.
  - e. Check the box and click **Save Changes**.
2. Launch the *xeroxfwup* utility.
3. Choose the connection type - Network or USB. Verify the selected connection type matches the computer connection to the printer. If you select Network, the utility lists the detected network printers by IP Address; if you select USB, the utility lists the connected printer.
4. Select the checkbox for the printer to be upgraded in the displayed list. If the utility fails to detect the correct printer, select the Add button to search for the printer by IP Address.

After completing the update process, print another Configuration Page.

Use this page to verify the new version number indicating the update loaded successfully. Look for updates to the following versions:

- Firmware Version (Main)
- Boot Version
- Engine Version



# Wiring

# 7

## In this chapter...

### Printer Plug/Jack Designations

- Phaser 6600 Plug/Jack Designators
- Phaser 6600 Plug/Jack Locations
- WorkCentre 6605 Plug/Jack Designators
- WorkCentre 6605 Plug/Jack Locations

### System Wiring

- Notations Used in the Wiring Diagrams
- Connection Details
- Phaser 6600 General Wiring Diagram
- WorkCentre 6605 General Wiring Diagram
- AC Power
- Fuser
- Drive
- Bypass Tray (MSI)
- Laser Unit
- SFP Controller
- MFP Controller
- Paper Transport
- HVPS
- Xerographic
- Developer
- Exit
- 550 Feeder
- Scanner

## Printer Plug/Jack Designations

This chapter contains the plug/jack designators, locator diagrams, and wiring diagrams. The Plug/Jack Locator diagrams show the P/J locations within the printer. Use these illustrations to locate connections called out in the troubleshooting procedures.

1. Locate the P/J connector designator in the first column of the table.
2. Use the coordinates to locate the correct map and the connection indicated on the map by its P/J designation number. Notice that the Y-coordinate numbers are sequential from one map to the next, starting at 101 in the first map (SFP or MFP) and ending at 190 in the last map for the 550-Sheet Feeder.
3. The Remarks column provides a brief description of each connection.

### Phaser 6600 Plug/Jack Designators

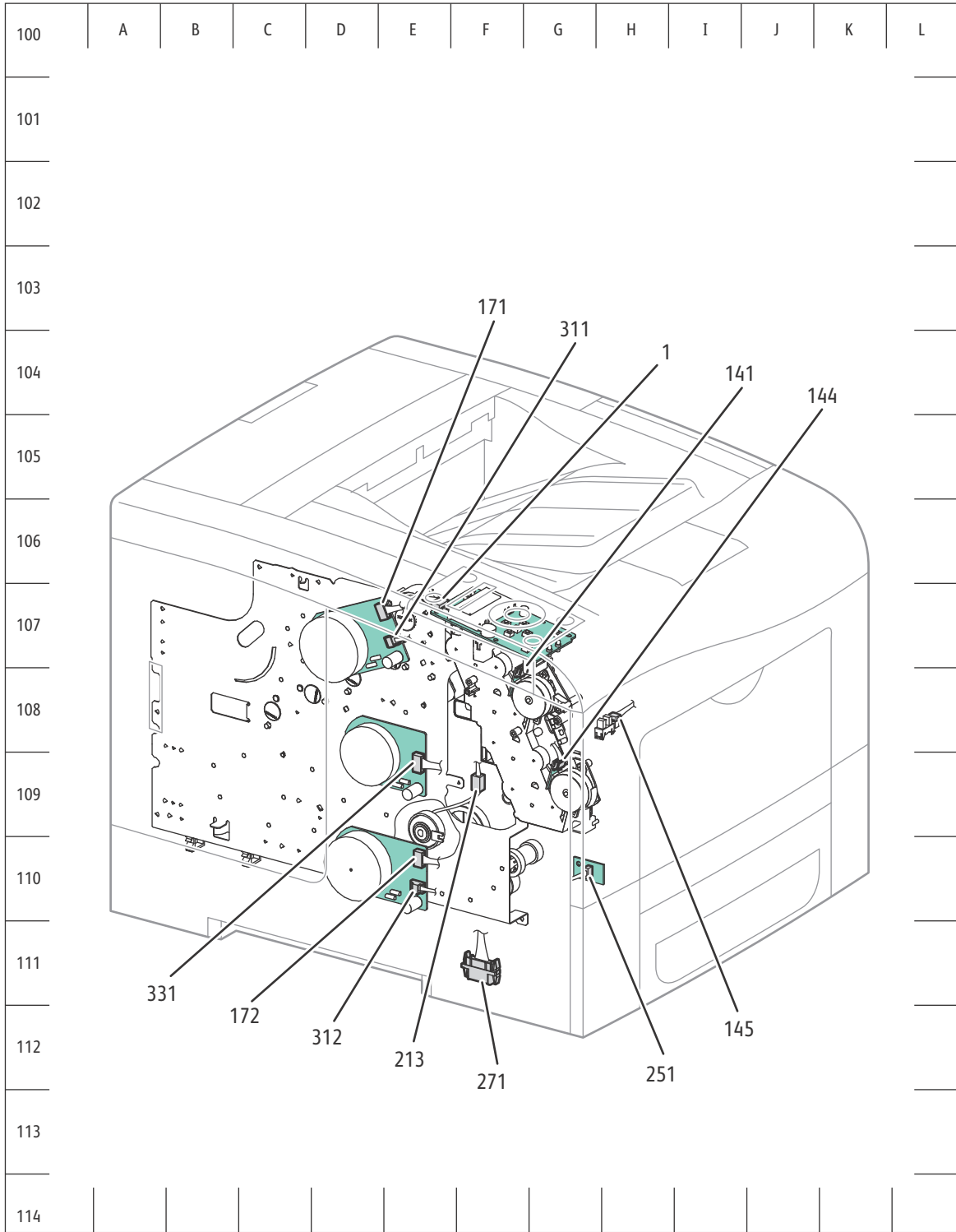
P/J	Coordinates	Remarks
1	G-183	No Connection
10	H-164	Connects MCU Board and Main Harness Assembly
11	I-165	Connects MCU Board and Laser Unit
12	J-163	Connects MCU Board and X CRUM Harness Assembly
12	D-165	Connects IP Board and Control Panel Harness
13	I-164	Connects MCU Board and Regi Harness Assembly
14	H-163	Connects MCU Board and Upper Dispenser Motor Assembly
15	I-163	Connects MCU Board and Sensor Harness Assembly
17	H-163	Connects MCU Board and Drive Harness Assembly
18	H-165	Connects MCU Board and MCU-HVPS Flat Flex Connector (FFC)
19	J-163	Connects MCU Board and Top Harness Assembly
21	H-164	Connects MCU Board and Bypass Tray Harness Assembly
22	H-164	Connects MCU Board and Duplex Clutch
23	H-164	Connects MCU Board and Regi Harness Assembly
27	J-165	Connects MCU Board and Main Harness Assembly
28	J-164	Connects MCU Board and Fuser Harness Assembly
29	J-164	Connects MCU Board and Top Harness Assembly
30	H-163	Connects MCU Board and Top Harness Assembly
33	H-164	Connects MCU Board and Drive Harness Assembly
36	I-165	Connects MCU Board and Laser Unit

P/J	Coordinates	Remarks
38	J-163	Connects MCU Board and Exit Clutch2 (Exit Drive Assembly)
39	J-164	Connects MCU Board and Regi Harness Assembly
40	B-158	Connects LVPS and Top Harness Assembly
40	J-163	Connects MCU Board and Exit Clutch1 [Exit Drive Assembly]
41	B-157	Connects LVPS and Rear Interlock Switch
42	B-157	Connects LVPS and Front Interlock Switch
43	B-158	Connects LVPS and Top Harness Assembly
47	H-157	Connects LVPS and Heater Harness Assembly
48	H-158	Connects LVPS and SW Harness Assembly
101	D-164	Connects IP Board and Main Harness Assembly
111	D-165	Connects IP Board and Laser Unit Video Harness Assembly
112	H-139	Connects Laser Unit and Laser Unit Video Harness Assembly
121	G-138	Connects Imaging Unit CRUM Y and X CRUM Harness Assembly
122	F-139	Connects Imaging Unit CRUM M and X CRUM Harness Assembly
123	F-139	Connects Imaging Unit CRUM C and X CRUM Harness Assembly
124	E-140	Connects Imaging Unit CRUM K and X CRUM Harness Assembly
131	I-152	Connects CTD Sensor Assembly and Regi Harness Assembly
132	G-152	Connects inside CTD Sensor Assembly
141	F-108	Connects Dispenser Motor (YM) and Upper Dispenser Motor Assembly
144	G-109	Connects Dispenser Motor (CK) Motor and Upper Dispenser Motor Assembly
145	H-109	Connects Front Cover Sensor and Upper Dispenser Motor Assembly
151	F-122	Connects Sensor Harness Assembly and Sensor Harness Assembly
154	F-122	Connects Full Stack Sensor and Exit Sensor Harness Assembly
155	E-122	Connects Exit Sensor and Exit Sensor 2 Harness Assembly
171	E-108	Connects Main Motor and Drive Harness Assembly
172	E-110	Connects Paper Transport Motor and Drive Harness Assembly
181	I-171	Connects Development HVPS Board and MCU-HVPS Flat Flex Connector (FFC)
182	H-173	Connects Development HVPS Board and HVPS Harness Assembly
191	F-136	Connects Toner CRUM Y and Top Harness Assembly
192	F-137	Connects Toner CRUM M and Top Harness Assembly
193	G-137	Connects Toner CRUM C and Top Harness Assembly

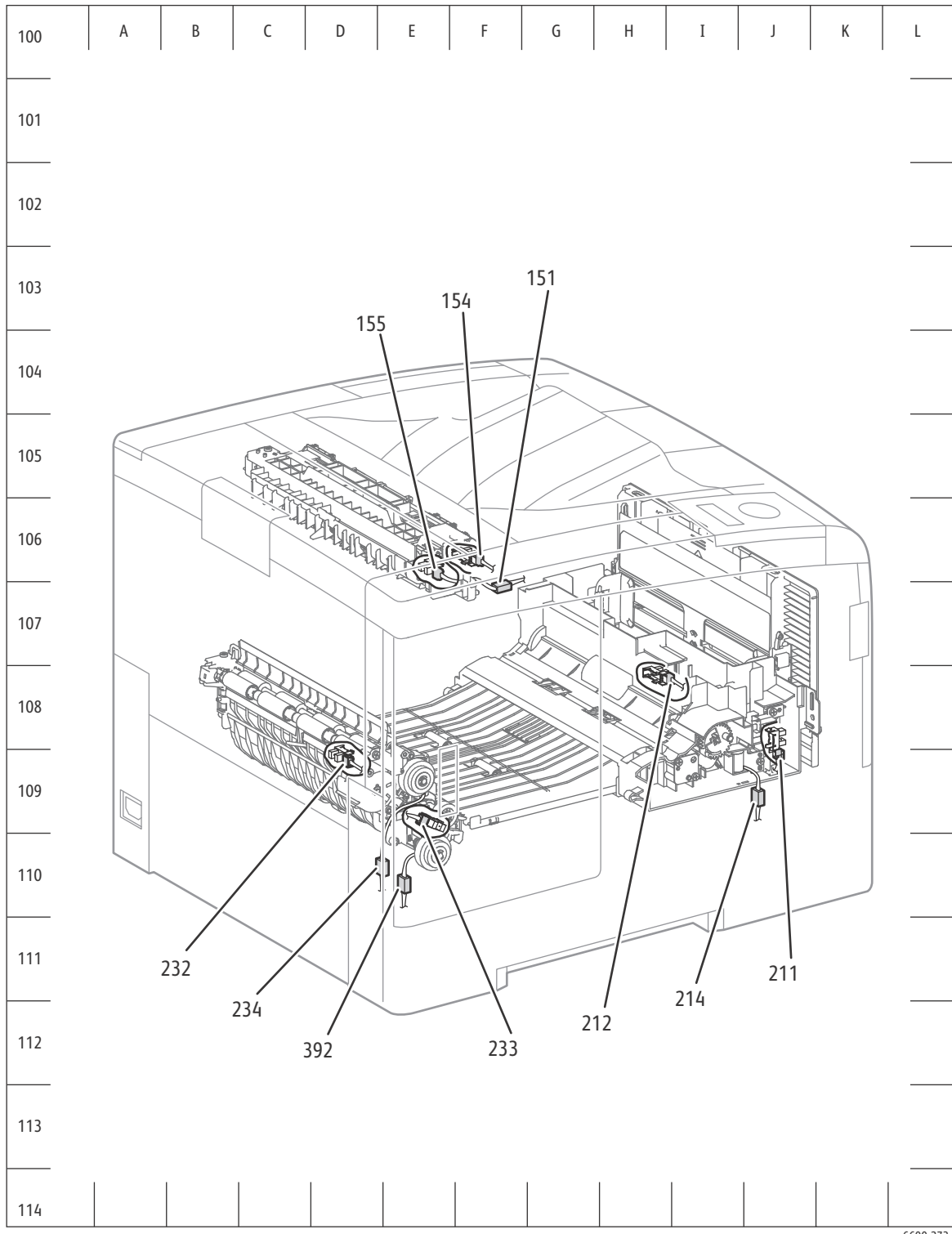
P/J	Coordinates	Remarks
194	G-138	Connects Toner CRUM K and Top Harness Assembly
203	G-153	Connects Toner Full Sensor and Top Harness Assembly
211	J-124	Connects Bypass Tray Sensor and Bypass Tray Harness Assembly
212	H-123	Connects Bypass Tray No Paper Sensor and Bypass Tray Harness Assembly
213	F-110	Connects Take Away Clutch 2 and Bypass Tray Harness Assembly
214	I-125	Connects Bypass Tray Feed Solenoid and Bypass Tray Harness Assembly
232	D-124	Connects Regi Sensor and Regi Harness Assembly
233	E-125	Connects CST No Paper Sensor and Regi Harness Assembly
234	D-126	Connects Regi Clutch and Regi Harness Assembly
251	G-111	Connects EEPROM XPRO PWB and Main Harness Assembly
271	F-112/I-182	Connects Feeder Drawer 1 Harness Assembly and Main Harness Assembly
271	I-182	Connects Feeder Drawer 1 Harness Assembly and Main Harness Assembly
281	E-152	Connects Fuser and Heater Harness Assembly
311	E-108	Connects Main Motor and Top Harness Assembly
312	E-111	Connects Paper Transport Motor and Top Harness Assembly
331	E-109	Connects Deve Motor and Drive Harness Assembly
392	E-126	Connects CST Feed Clutch and Regi Harness Assembly
402	C-166	Connects IP Board and Top Harness Assembly
403	C-166	Connects IP Board and Top Harness Assembly
419	G-183	Connects 550 Option Feeder Board and Feeder Drawer 1 Harness Assembly
420	G-183	Connects 550 Option Feeder Board and C2 Turn Harness Assembly
421	F-183	Connects 550 Option Feeder Board and C2 Size Harness Assembly
422	F-183	Connects 550 Option Feeder Board and Feeder Motor Harness Assembly
423	G-183	Connects 550 Option Feeder Board and Feeder Drawer 2 Harness Assembly
431	H-140	Connects Laser Unit and Top Harness Assembly
501	C-157	Connects LVPS and Top Harness Assembly
503	C-157	Connects LVPS and Main Fan
504*	B-158	Connects LVPS and Top Harness Assembly
505*	B-159	Connects LVPS and Top Harness Assembly
507	H-157	Connects LVPS and Top Harness Assembly
508	H-157	Connects LVPS and Top Harness Assembly

<b>P/J</b>	<b>Coordinates</b>	<b>Remarks</b>
509	B-158	Connects LVPS and Top Harness Assembly
1821	C-173	Connects Transfer HVPS and HVPS Harness Assembly
4201	E-184	Connects C2 Turn Clutch and C2 Turn Harness Assembly
4202	E-184	Connects No Paper Harness Assembly and C2 Turn Harness Assembly
4203	D-182	Connects C2 No Paper Sensor and No Paper Harness Assembly
4211	I-183	Connects CST Size Switch and C2 Size Harness Assembly
4212	D-182	Connects C2 Regi Sensor and Prereg Sensor Harness Assembly
4213	E-184	Connects C2 Feed Clutch and C2 Size Harness Assembly
4214	E-184	Connects Prereg Sensor Harness Assembly and C2 Size Harness Assembly
4221	F-183	Connects Option Feeder Motor and Feeder Motor Harness Assembly
281-S	E-152	Connects Fuser and Fuser Harness Assembly
CN1	F-108	Connects Control Panel Assembly and Control Panel Harness

## Phaser 6600 Plug/Jack Locations

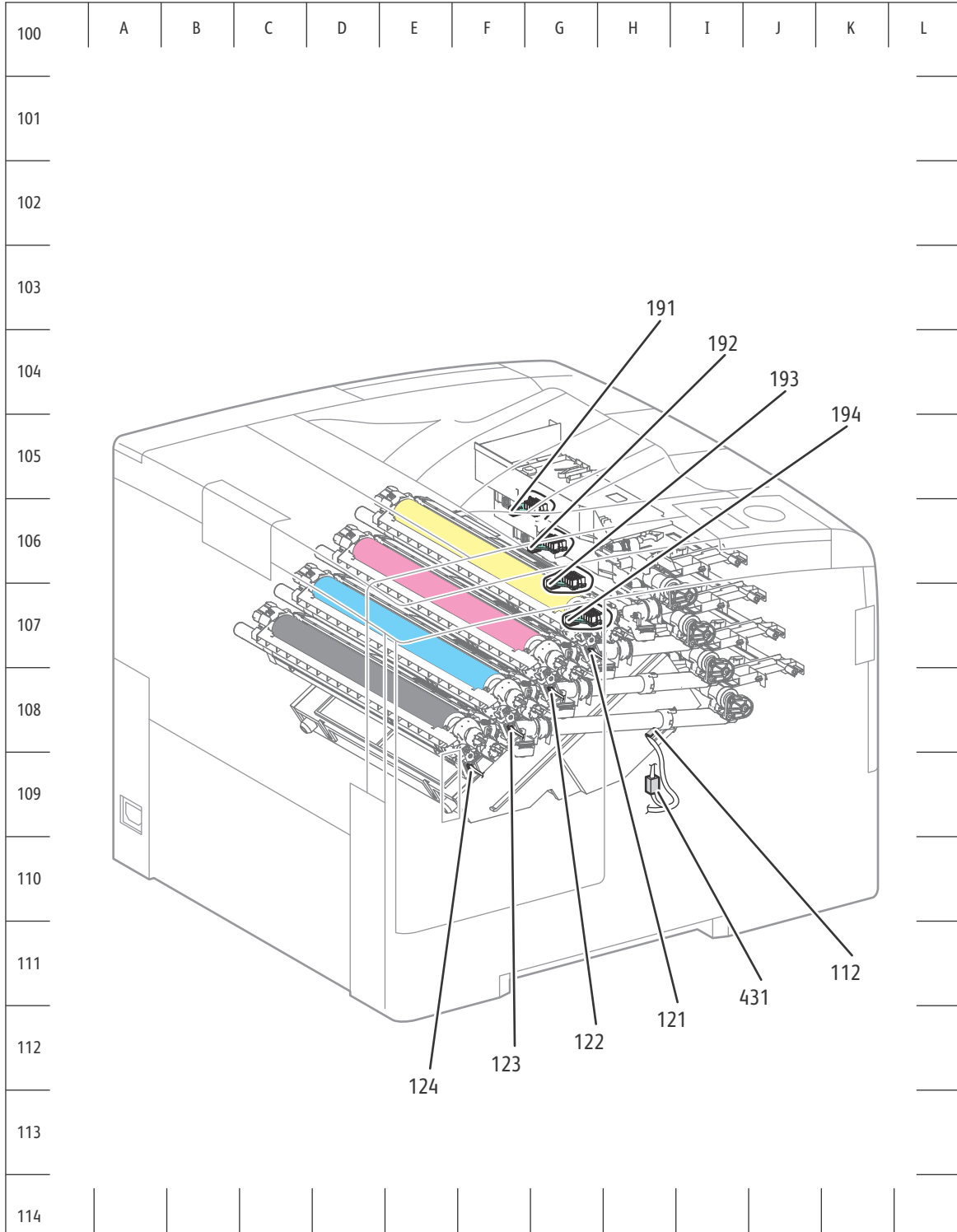


s6600-272



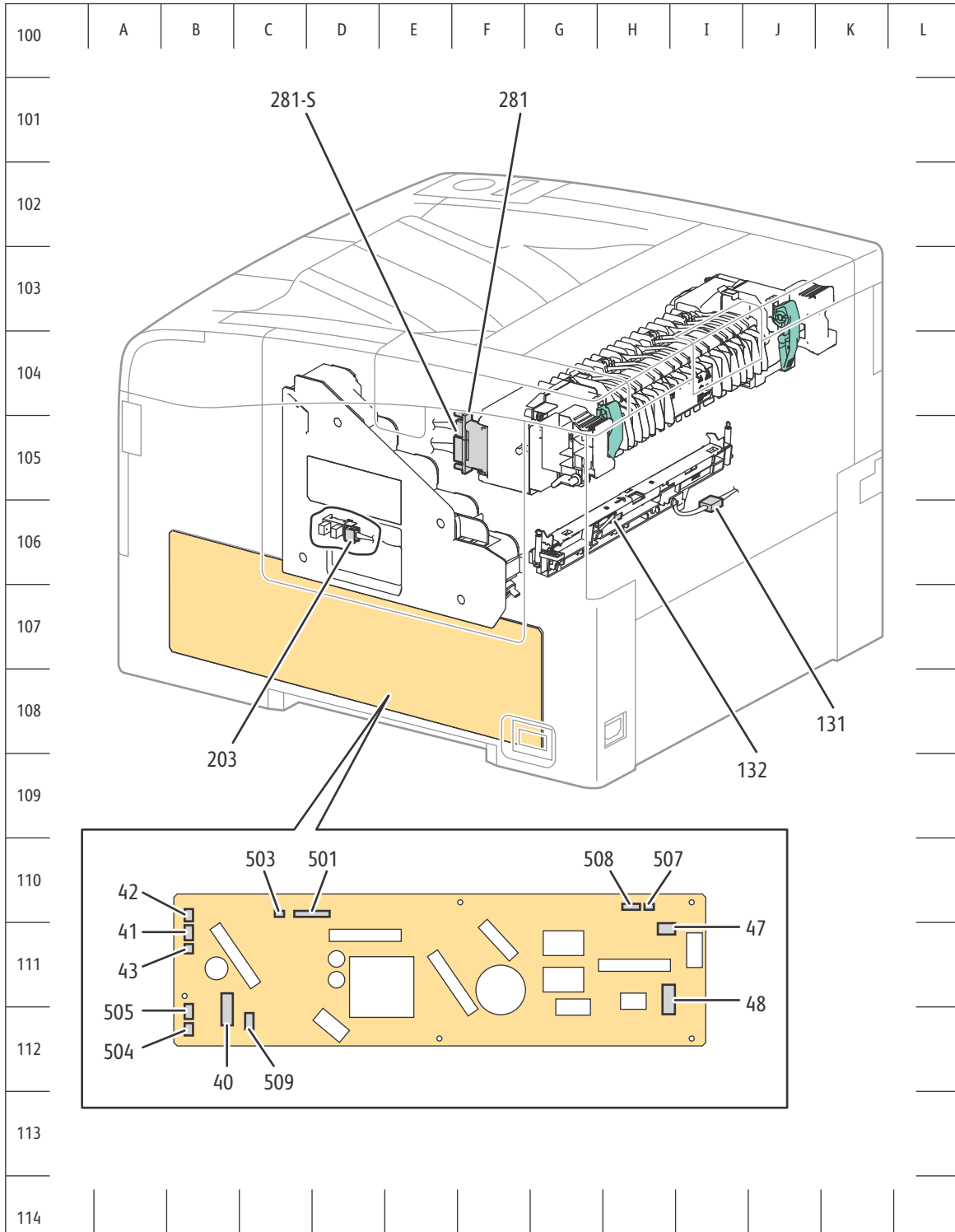
s6600-273

# Wiring



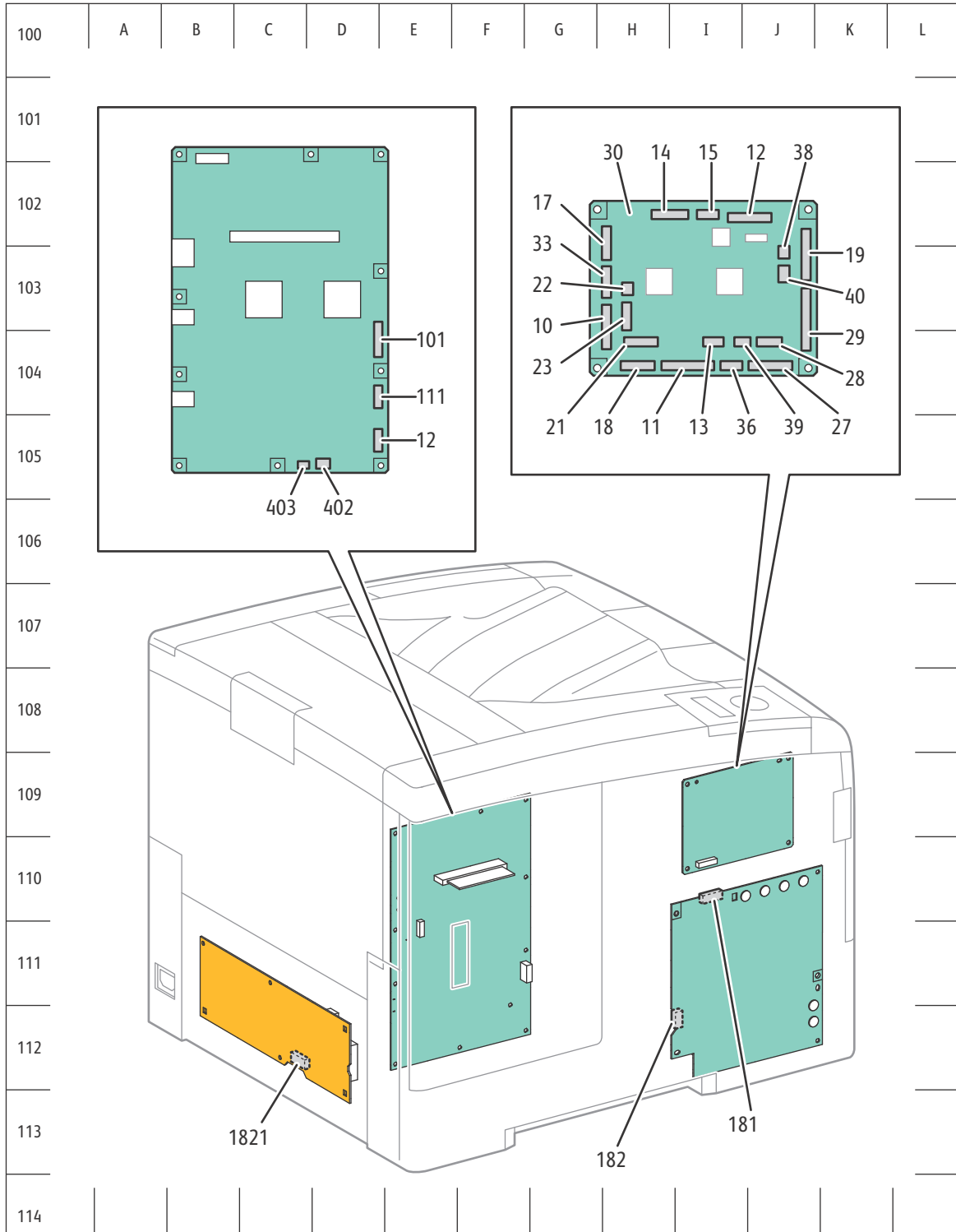
s6600-274





s6600-275

# Wiring



KJS07005XA

## WorkCentre 6605 Plug/Jack Designators

P/J	Coordinates	Remarks
1	G-183	Not Connects
10	H-164	Connects MCU Board and Main Harness Assembly
11	I-165	Connects MCU Board and Laser Unit
12	J-163	Connects MCU Board and X CRUM Harness Assembly
13	I-164	Connects MCU Board and Regi Harness Assembly
14	H-163	Connects MCU Board and Upper Dispenser Motor Assembly
15	I-163	Connects MCU Board and Sensor Harness Assembly
17	H-163	Connects MCU Board and Drive Harness Assembly
18	H-165	Connects MCU Board and MCU-HVPS Flat Flex Connector (FFC)
19	J-163	Connects MCU Board and Top Harness Assembly
21	H-164	Connects MCU Board and Bypass Tray Harness Assembly
22	H-164	Connects MCU Board and Duplex Clutch
23	H-164	Connects MCU Board and Regi Harness Assembly
27	J-165	Connects MCU Board and Main Harness Assembly
28	J-164	Connects MCU Board and Fuser Harness Assembly
29	J-164	Connects MCU Board and Top Harness Assembly
30	H-163	Connects MCU Board and Top Harness Assembly
33	H-164	Connects MCU Board and Drive Harness Assembly
36	I-165	Connects MCU Board and Laser Unit
38	J-163	Connects MCU Board and Exit Clutch2 [Exit Drive Assembly]
39	J-164	Connects MCU Board and Regi Harness Assembly
40	B-158	Connects LVPS and Top Harness Assembly
40	J-163	Connects MCU Board and Exit Clutch1 [Exit Drive Assembly]
41	B-157	Connects LVPS and Rear Interlock Switch
42	B-157	Connects LVPS and Front Interlock Switch
43	B-158	Connects LVPS and Top Harness Assembly
47	H-157	Connects LVPS and Heater Harness Assembly
48	H-158	Connects LVPS and SW Harness Assembly
101	D-163	Connects IP Board and Main Harness Assembly

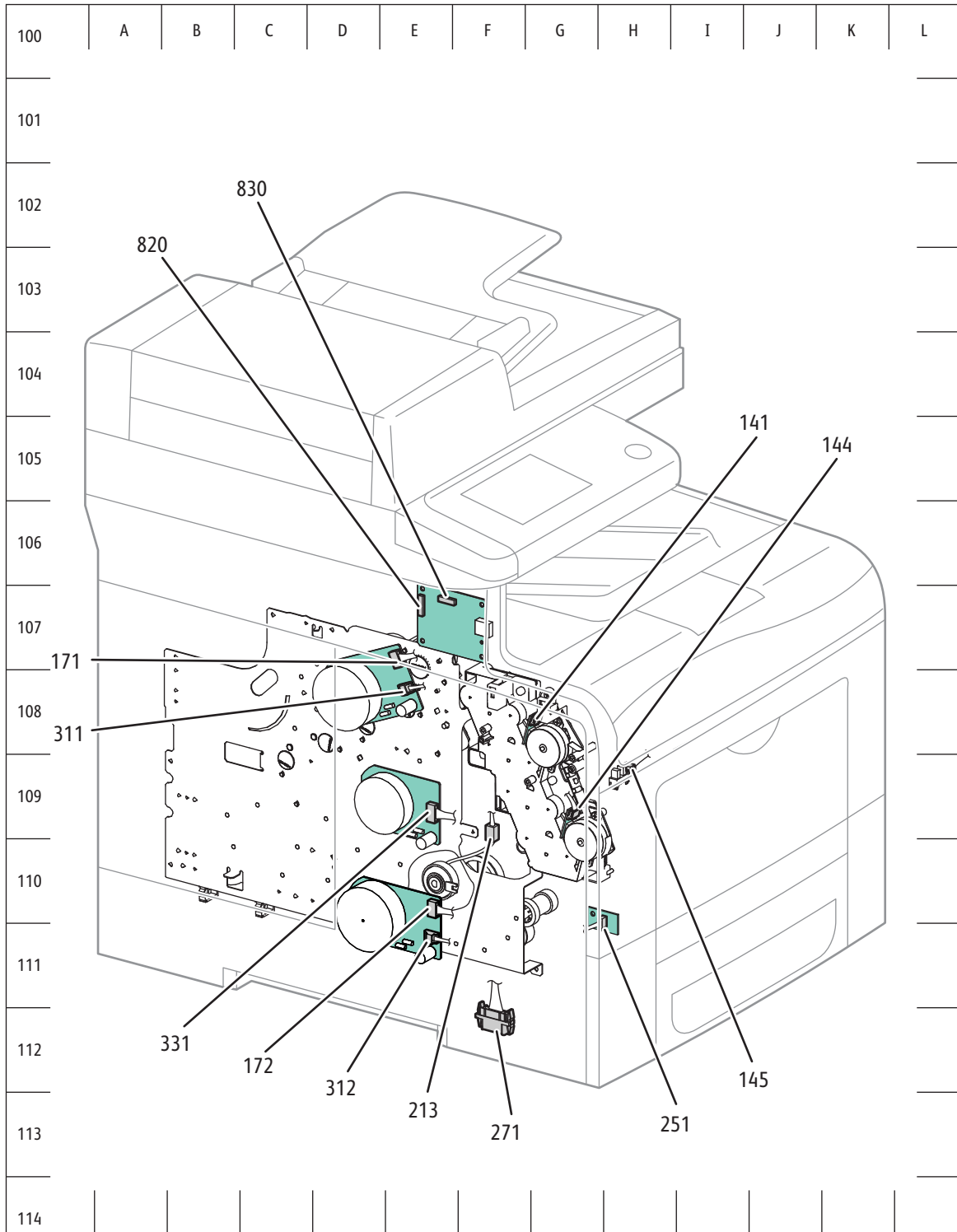
P/J	Coordinates	Remarks
102	D-163	Connects IP Board and Laser Unit Video Harness Assembly
112	H-139	Connects Laser Unit and Laser Unit Video Harness Assembly
121	G-138	Connects Imaging Unit CRUM Y and X CRUM Harness Assembly
122	F-139	Connects Imaging Unit CRUM M and X CRUM Harness Assembly
123	F-139	Connects Imaging Unit CRUM C and X CRUM Harness Assembly
124	E-140	Connects Imaging Unit CRUM K and X CRUM Harness Assembly
131	I-152	Connects CTD Sensor Assembly and Regi Harness Assembly
132	G-152	Connects inside CTD Sensor Assembly
141	F-108	Connects Dispenser Motor (YM) and Upper Dispenser Motor Assembly
144	G-109	Connects Dispenser Motor (CK) Motor and Upper Dispenser Motor Assembly
145	H-109	Connects Front Cover Sensor and Upper Dispenser Motor Assembly
151	F-122	Connects Sensor Harness Assembly and Sensor Harness Assembly
154	F-122	Connects Full Stack Sensor and Exit Sensor Harness Assembly
155	E-122	Connects Exit Sensor and Exit Sensor 2 Harness Assembly
171	E-108	Connects Main Motor and Drive Harness Assembly
172	E-110	Connects Paper Transport Motor and Drive Harness Assembly
181	I-171	Connects Development HVPS Board and MCU-HVPS Flat Flex Connector (FFC)
182	H-173	Connects Development HVPS Board and Hvps Harness Assembly
191	F-136	Connects Toner CRUM Y and Top Harness Assembly
192	F-137	Connects Toner CRUM M and Top Harness Assembly
193	G-137	Connects Toner CRUM C and Top Harness Assembly
194	G-138	Connects Toner CRUM K and Top Harness Assembly
203	G-153	Connects Toner Full Sensor and Top Harness Assembly
211	J-124	Connects Bypass Tray Sensor and Bypass Tray Harness Assembly
212	H-123	Connects Bypass Tray No Paper Sensor and Bypass Tray Harness Assembly
213	F-110	Connects Take Away Clutch 2 and Bypass Tray Harness Assembly
214	I-125	Connects Bypass Tray Feed Solenoid and Bypass Tray Harness Assembly
232	D-124	Connects Regi Sensor and Regi Harness Assembly
233	E-125	Connects CST No Paper Sensor and Regi Harness Assembly
234	D-126	Connects Regi Clutch and Regi Harness Assembly
251	G-111	Connects EEPROM XPRO Board and Main Harness Assembly

P/J	Coordinates	Remarks
271	F-112/I-182	Connects Feeder Drawer 1 Harness Assembly and Main Harness Assembly
271	I-182	Connects Feeder Drawer 1 Harness Assembly and Main Harness Assembly
281	E-152	Connects Fuser and Heater Harness Assembly
311	E-108	Connects Main Motor and Top Harness Assembly
312	E-111	Connects Paper Transport Motor and Top Harness Assembly
331	E-109	Connects Deve Motor and Drive Harness Assembly
392	E-126	Connects CST Feed Clutch and Regi Harness Assembly
401	D-162	Connects IP Board and Top Harness Assembly
419	G-183	Connects IP Board and Top Harness Assembly
420	G-183	Connects 550 Option Feeder Board and Feeder Drawer 1 Harness Assembly
421	F-183	Connects 550 Option Feeder Board and C2 Turn Harness Assembly
422	F-183	Connects 550 Option Feeder Board and C2 Size Harness Assembly
423	G-183	Connects 550 Option Feeder Board and Feeder Motor Harness Assembly
431	H-140	Connects Laser Unit and Top Harness Assembly
501	C-157	Connects LVPS and Top Harness Assembly
503	C-157	Connects LVPS and Main Fan
507	H-157	Connects LVPS and Top Harness Assembly
508	H-157	Connects LVPS and Top Harness Assembly
509	B-158	Connects LVPS and Top Harness Assembly
810	A-164	Connects IP Board and USB Hub Board
820	E-107	Connects USB Hub Board and IP Board
830	E-107	Connects USB Hub Board and Control Panel Assembly
902	C-166	Connects IP Board and FAX Board
1302	D-165	Connects IP Board and Speaker
1401	A-162	Connects IP Board and Scanner Assembly
1501	D-162	Connects IP Board and Scanner Assembly
1502	C-162	Connects IP Board and Scanner Assembly
1821	C-173	Connects Transfer HVPS and HVPS Harness Assembly
4201	E-184	Connects C2 Turn Clutch and C2 Turn Harness Assembly
4202	E-184	Connects No Paper Harness Assembly and C2 Turn Harness Assembly
4203	D-182	Connects C2 No Paper Sensor and No Paper Harness Assembly

## Wiring

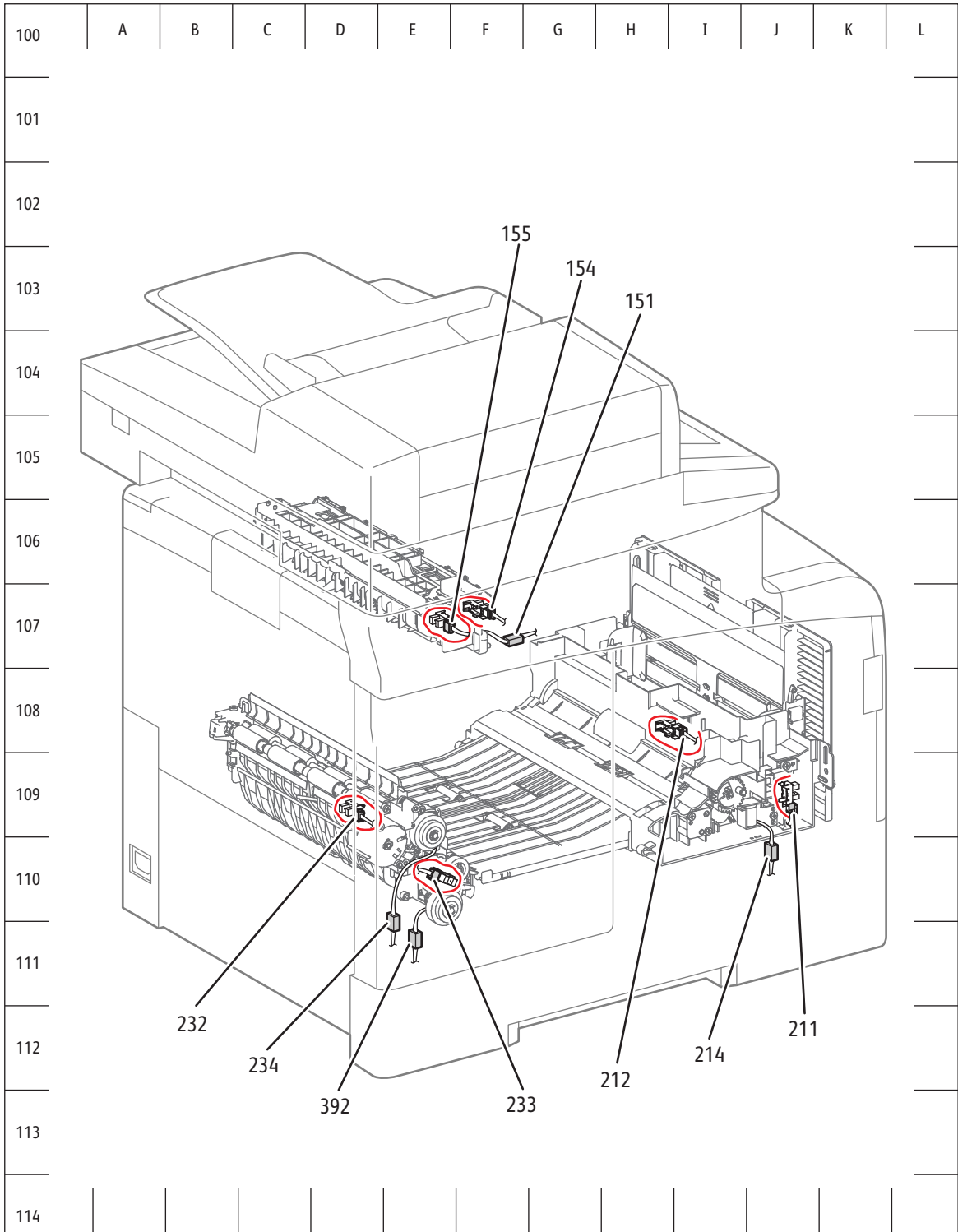
<b>P/J</b>	<b>Coordinates</b>	<b>Remarks</b>
4211	I-183	Connects CST Size Switch and C2 Size Harness Assembly
4212	D-182	Connects C2 Regi Sensor and Prereg Sensor Harness Assembly
4213	E-184	Connects C2 Feed Clutch and C2 Size Harness Assembly
4214	E-184	Connects Prereg Sensor Harness Assembly and C2 Size Harness Assembly
4221	F-183	Connects Option Feeder Motor and Feeder Motor Harness Assembly
281-S	E-152	Connects Fuser and Fuser Harness Assembly

## WorkCentre 6605 Plug/Jack Locations



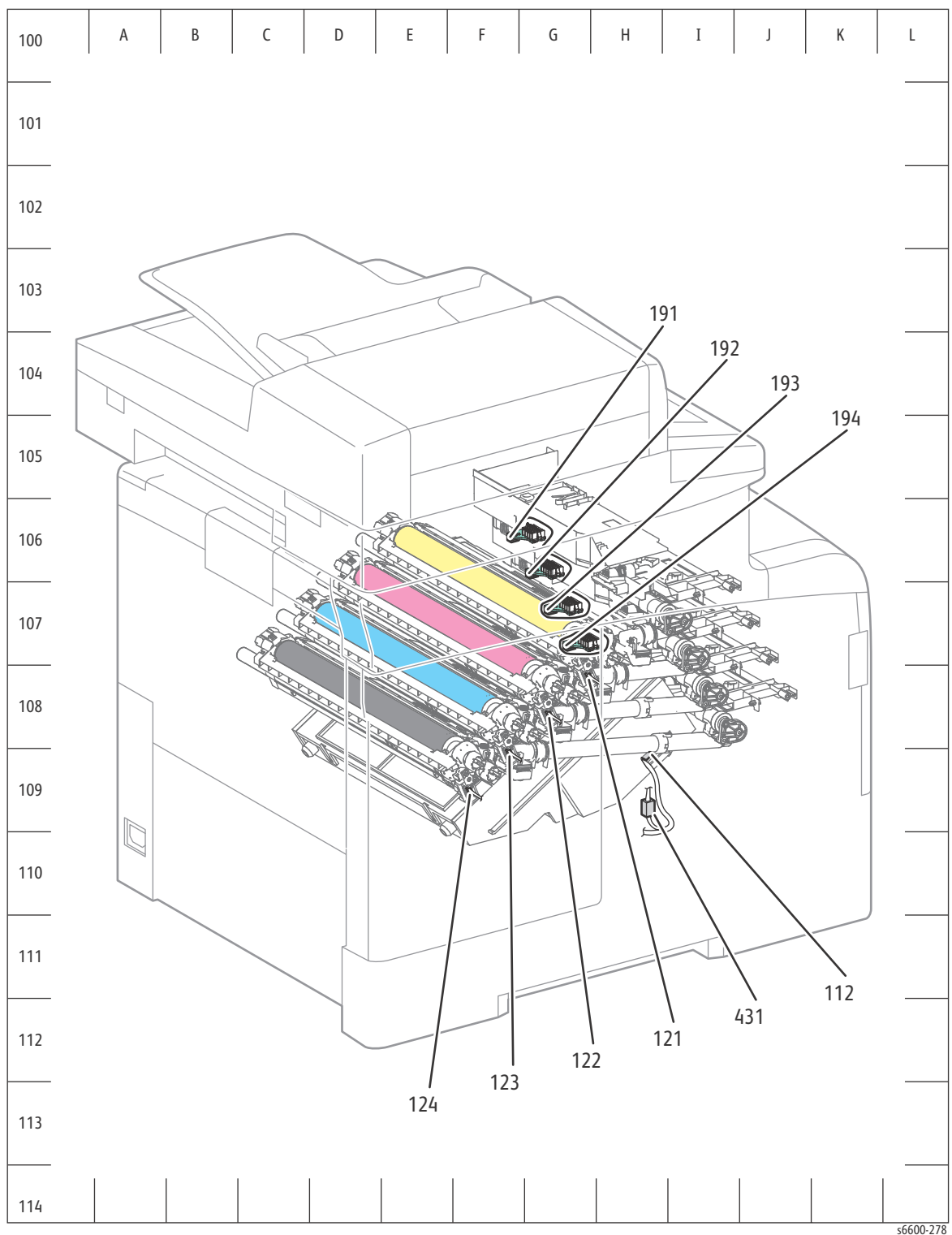
s6600-215

# Wiring

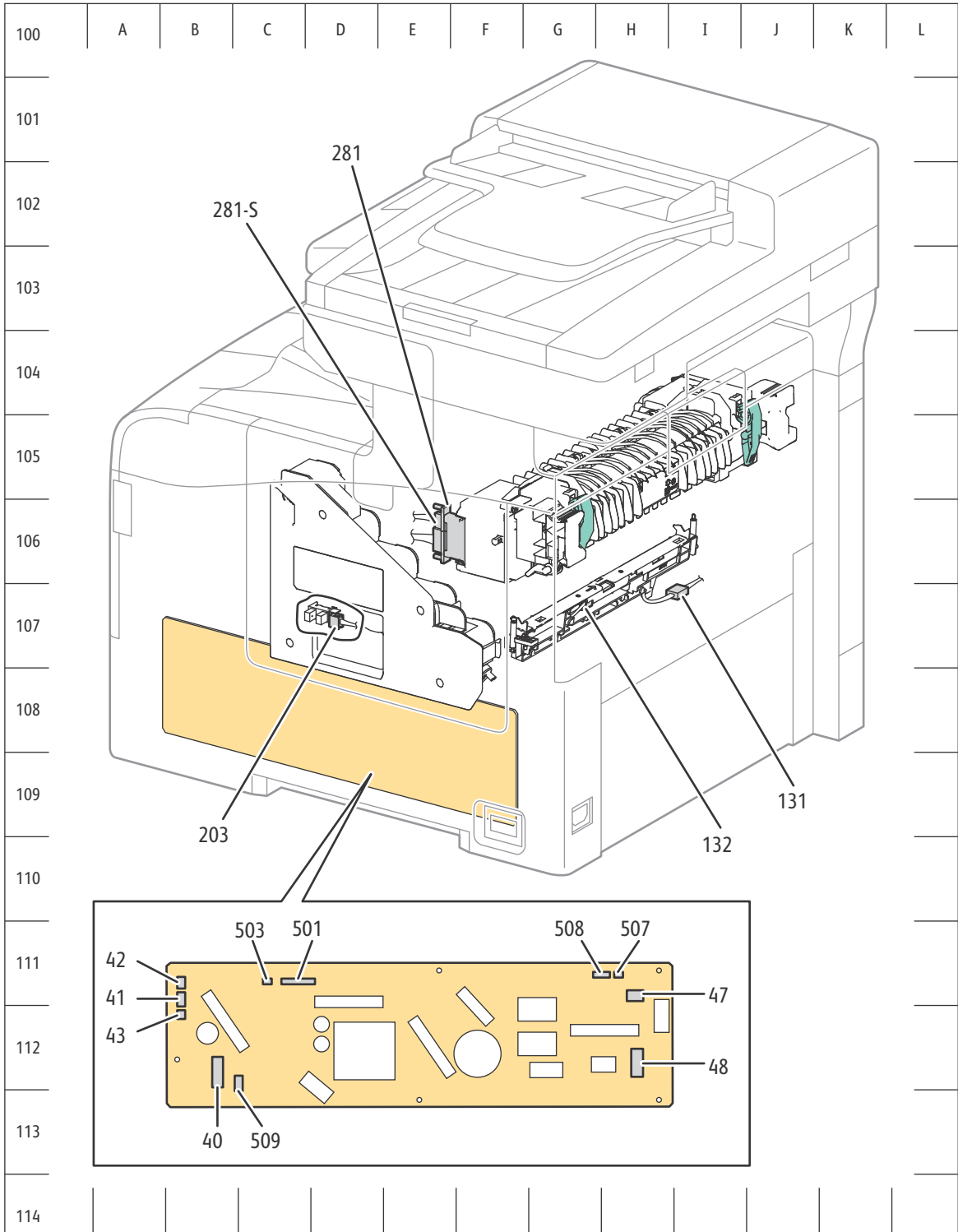


s6600-217

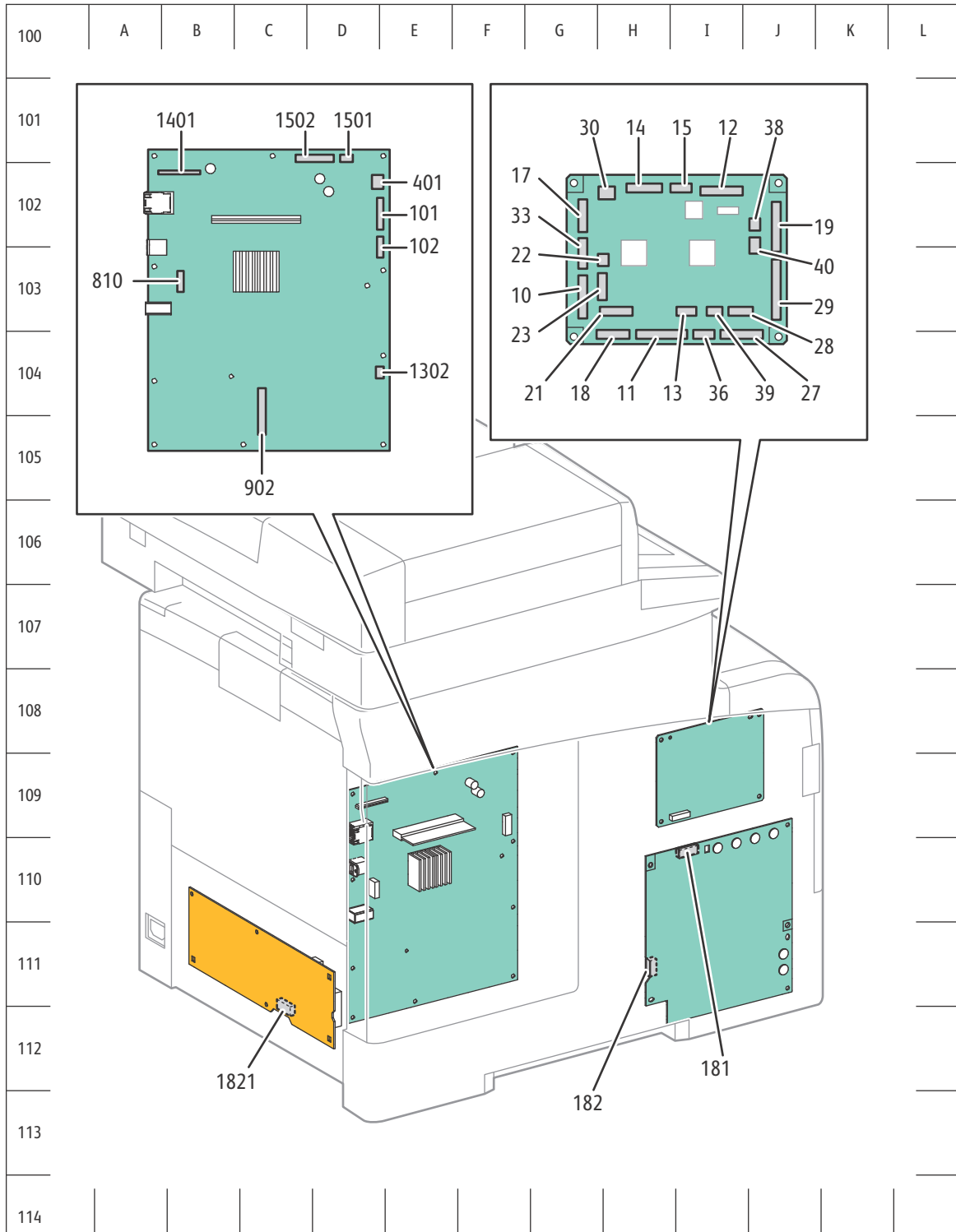




# Wiring

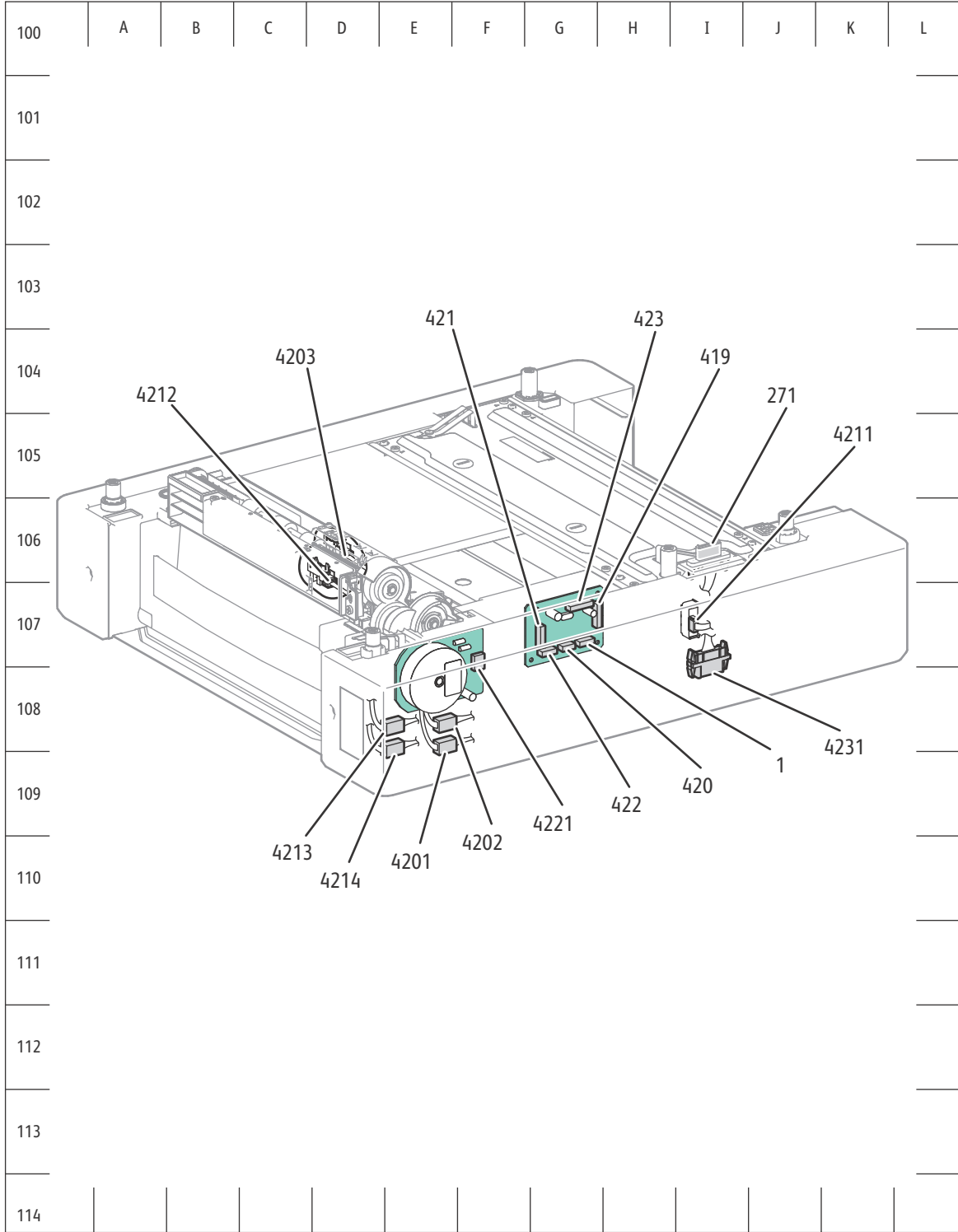


KJA07004XA



s6600-280

# Wiring











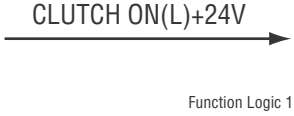


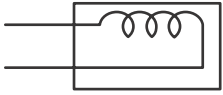
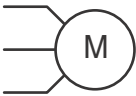

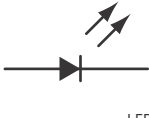
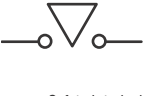
s6600-277

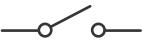


# System Wiring

## Notations Used in the Wiring Diagrams

The following table lists the symbols used in the wiring diagrams.

Symbol	Description
 <p>Plug</p>	Denotes a Plug.
 <p>Jack</p>	Denotes a Jack.
<p>P/Jxx</p>  <p>Plug and Jack</p>	Denotes Pin yy and Jack yy of the connector Pxx and Jxx.
<p>JPxxx</p>  <p>Jumper</p>	Denotes a Jumper Point (JPxxx/xxx). Each end of the Jumper connection has a numeric designation.
 <p>Subassembly 1</p>	Denotes the parts. PL X.Y.Z implies the item "Z" of plate (PL) "X.Y" in Parts List.
 <p>Subassembly 2</p>	Denotes functional parts attached with functional parts name.
 <p>Subassembly 3</p>	Denotes the control and its outline in the Board.

Symbol	Description
	<p>Denotes a connection between parts with harness or wires, attached with signal name/contents.</p>
	<p>Denotes function, and logic value of the signal to operate the function (Low: L, High: H). The given voltage is for signal in high status. The arrow indicates the direction of signal.</p>
	<p>Denotes function, and logic value of the signal when the function operated (Low: L, High: H). The given voltage is for signal in high status. The arrow indicates the direction of signal.</p>
	<p>Denotes a connection between wires.</p>
	<p>Denotes a Clutch or Solenoid.</p>
	<p>Denotes a Motor.</p>
	<p>Denotes a Photo Sensor.</p>
	<p>Denotes an LED.</p>
	<p>Denotes a Safety Interlock Switch.</p>

Symbol	Description
 <p>On Off Switch</p>	Denotes an On-Off Switch (single-pole, single-throw switch).
 <p>Temperature Switch</p>	Denotes an On-Off Switch (Temperature - normally close).
	Denotes an NPN Photo-transistor.
I/L +24 VDC	Denotes DC voltage when the Interlock Switch in MCU Board turns On.
+5 VDC +3.3 VDC	Denotes DC voltage.
SG	Denotes signal ground.
AG	Denotes analog ground.
RTN	Denotes return.

## Connection Details

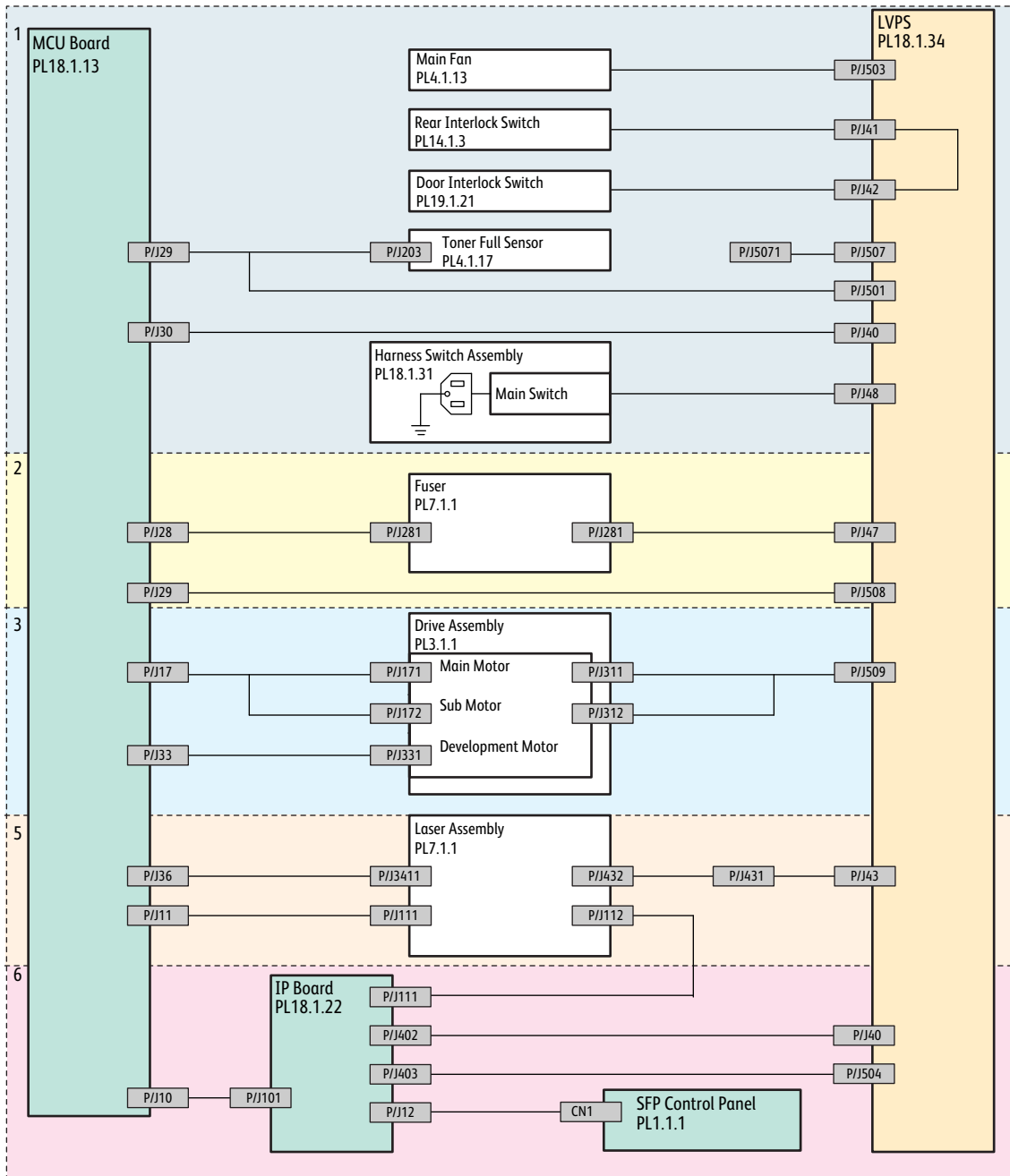
This table lists the thirteen wiring diagrams and the details of the connections shown in each diagram. Except for the Controllers, diagrams 1-12 are the same for the MFP and SFP; diagram 13 covers the Scanner and applies only to the MFP.

Diagram	Connection Details
1 AC Power	Connections of LVPS with MCU Board. Connections of AC IN Assembly with LVPS. Connections of Main Fan with LVPS. Connections of Rear Interlock Switch with LVPS. Connections of Door Interlock Switch with LVPS. Connections of MCU Board with Toner Full Sensor.
2 Fuser	Connections of FUSING Assembly with LVPS. Connections of FUSING Assembly with MCU Board. Connections of LVPS with MCU Board.
3 Drive	Connections of DRIVE Assembly with MCU Board. Connections of DRIVE Assembly with LVPS.
4 Bypass Tray (MSI)	Connections of Bypass Tray Sensor with MCU Board. Connections of Bypass Tray No Paper Sensor with MCU Board. Connections of DRIVE Assembly with MCU Board. Connections of Bypass Tray Feed Solenoid with MCU Board.
5 Laser Unit	Connections of Laser Unit with MCU Board. Connections of Laser Unit with PWBA LVPS.
6 SFP Controller	Connections of IP Board with MCU Board. Connections of IP Board with LVPS. Connections of IP Board with Laser Unit. Connections of IP Board with Control Panel. Connections of IP Board with USB Bracket Assembly.
6 MFP Controller	Connections of IP Board with MCU Board. Connections of IP Board with LVPS. Connections of IP Board with Laser Unit. Connections of IP Board with FAX Board. Connections of IP Board with USB Hub Board. Connections of USB Hub Board with Control Panel Assembly .
7 Paper Transport	Connections of Regi Clutch with MCU Board. Connections of Regi Chute Assembly with MCU Board. Connections of Feed Clutch with MCU Board. Connections of Duplex Clutch with MCU Board.
8 HVPS	Connections of HVPS XERO DEVE with HVPS TR. Connections of HVPS XERO DEVE with MCU Board.

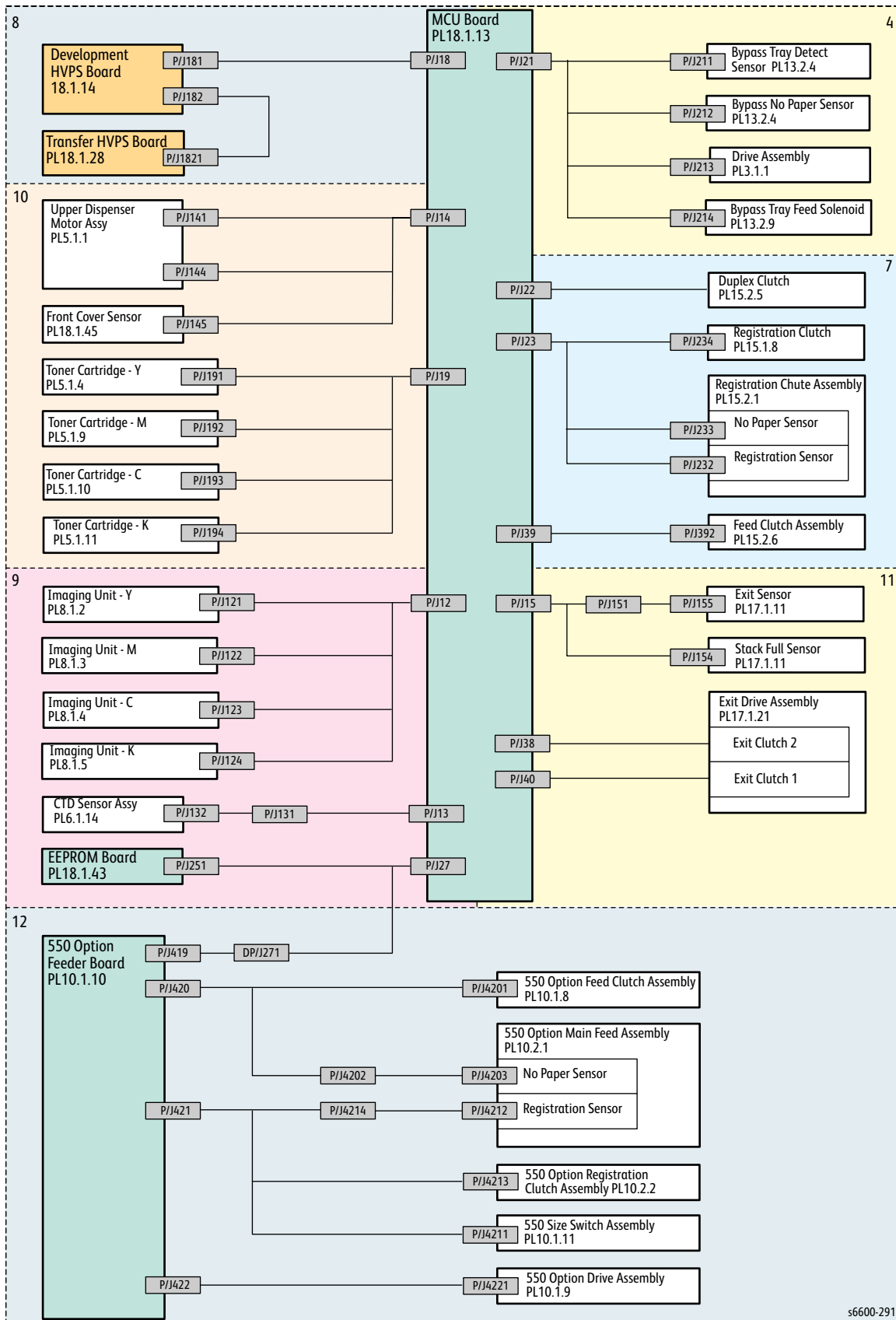


Diagram	Connection Details
9 Xerographic	Connections of XERO DEVE CRU Assembly Y with MCU Board. Connections of XERO DEVE CRU Assembly M with MCU Board. Connections of XERO DEVE CRU Assembly C with MCU Board. Connections of XERO DEVE CRU Assembly K with MCU Board. Connections of CTD Sensor with MCU Board. Connections of PWBA EEPROM with MCU Board.
10 Developer	Connections of TONER CARTRIDGE Y with MCU Board. Connections of TONER CARTRIDGE M with MCU Board. Connections of TONER CARTRIDGE C with MCU Board. Connections of TONER CARTRIDGE K with MCU Board. Connections of Toner Dispense Motor(Y,M) with MCU Board. Connections of Toner Dispense Motor(C,K) with MCU Board. Connections of Front Cover Sensor with MCU Board.
11 Exit	Connections of Exit Sensor with MCU Board. Connections of Full Stack Sensor with MCU Board. Connections of Exit Clutch 1 with MCU Board. Connections of Exit Clutch 2 with MCU Board.
12 550 Feeder	Connections of 550 Option Feeder Board with MCU Board. Connections of Turn Roll Clutch with 550 Option Feeder Board. Connections of CHUTE Assembly PINCH 550 with 550 Option Feeder Board. Connections of Feed Clutch with 550 Option Feeder Board. Connections of 550 Size Switch Assembly with 550 Option Feeder Board. Connections of DRIVE Assembly OPT 550 with 550 Option Feeder Board.
13 Scanner	Connections of Scanner Assembly with IP Board. Connections of Scanner Assembly with Control Panel Assembly.

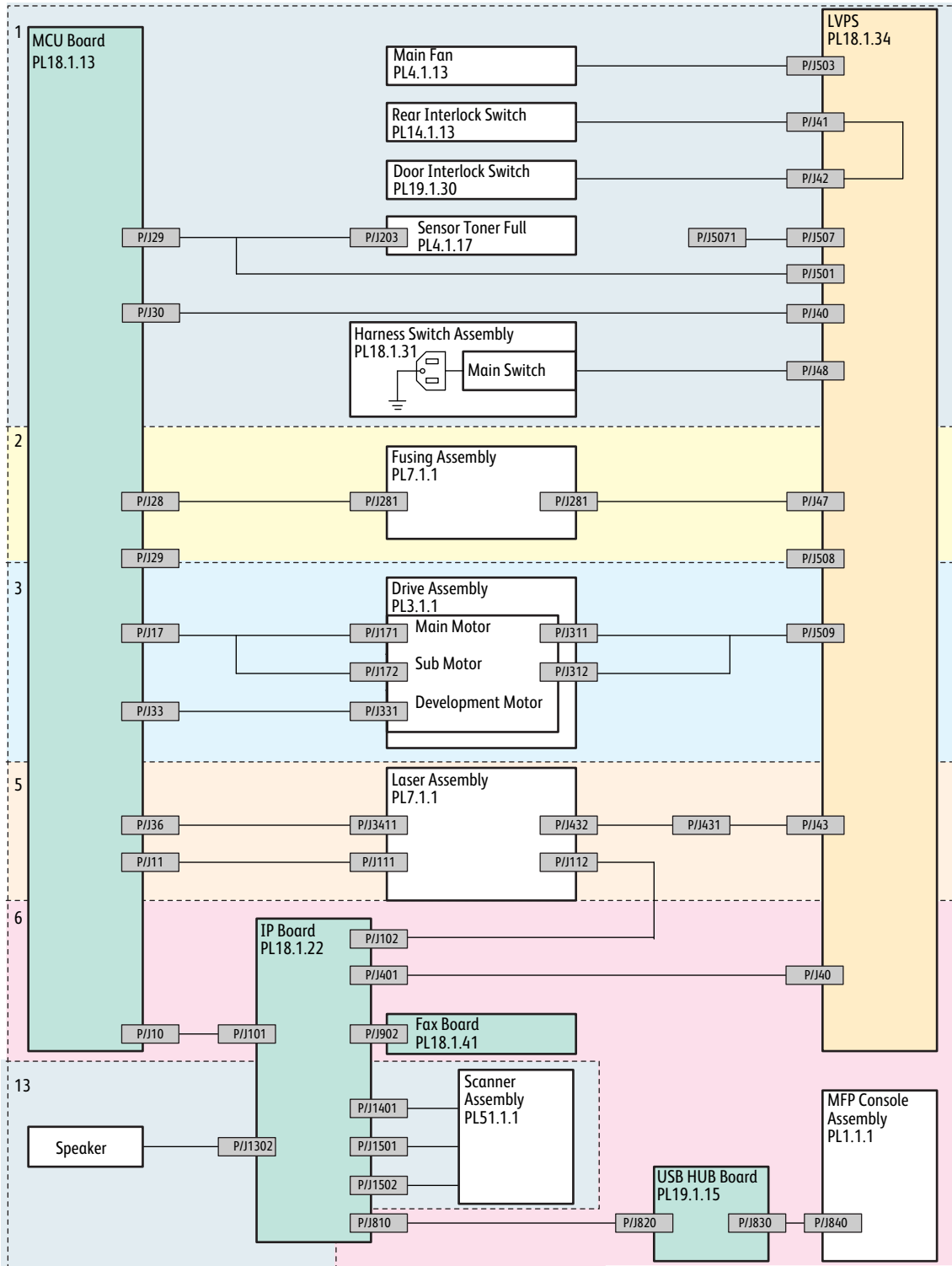
## Phaser 6600 General Wiring Diagram



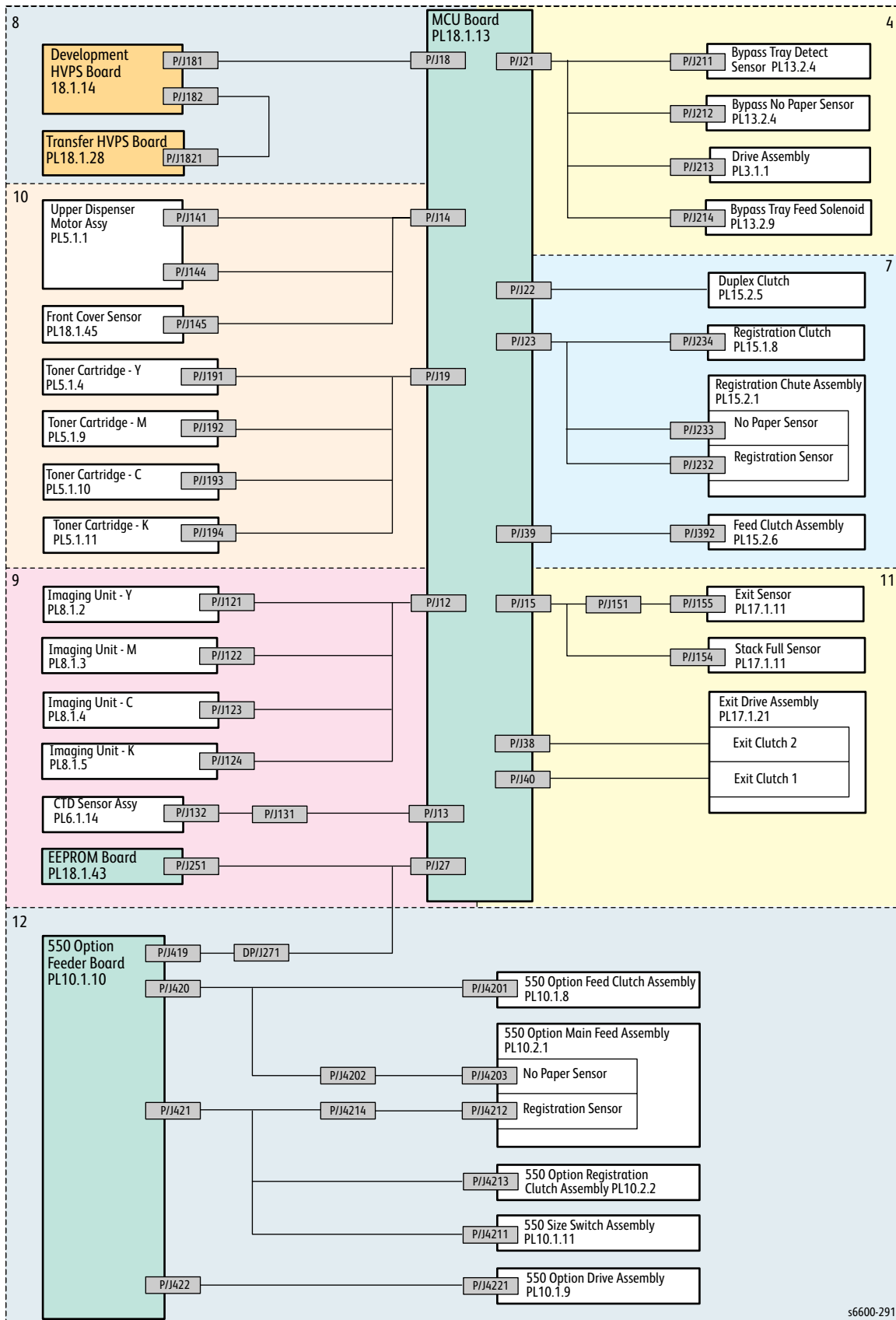
s6600-293



# WorkCentre 6605 General Wiring Diagram

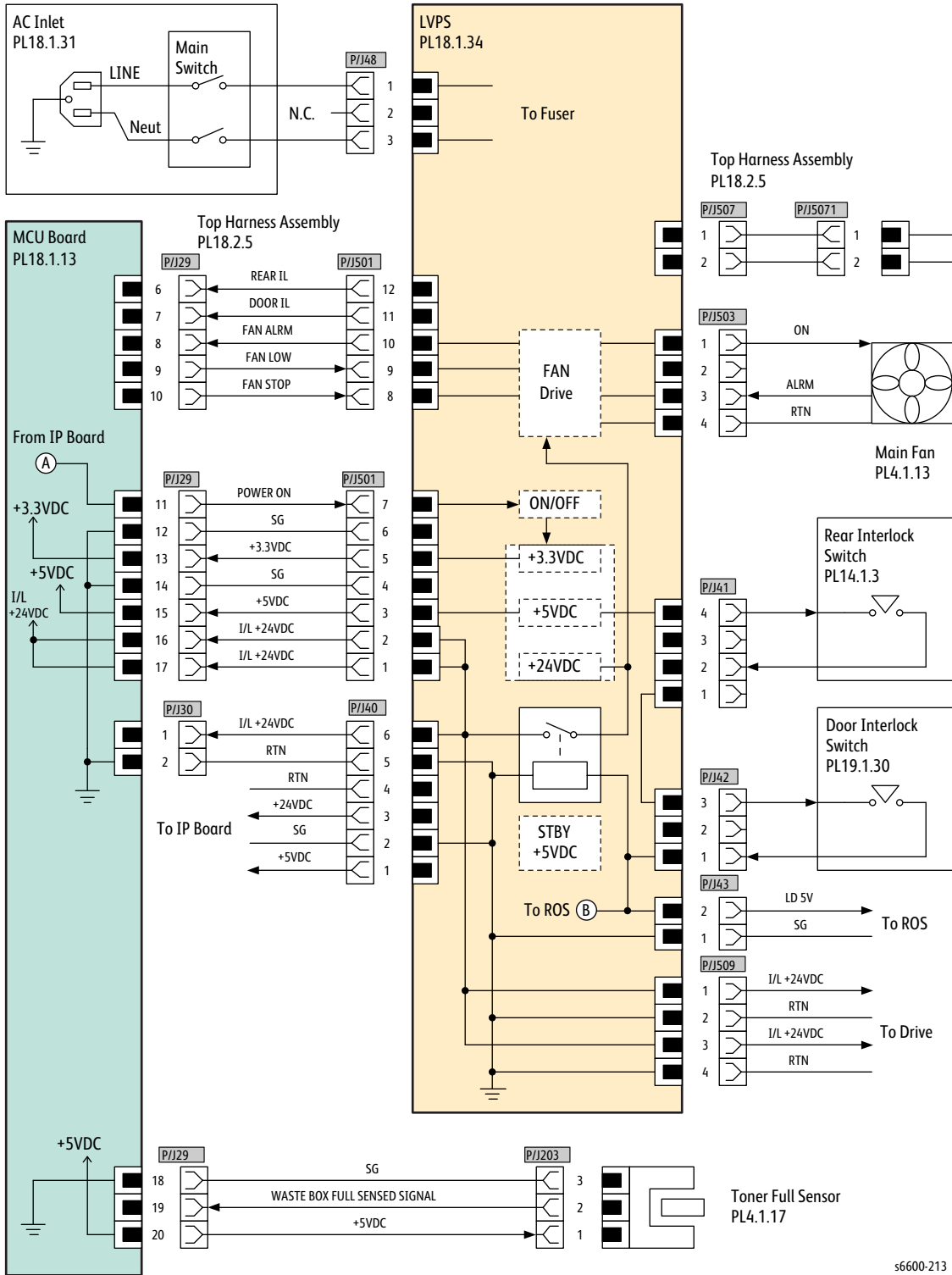


s6600-234



s6600-291

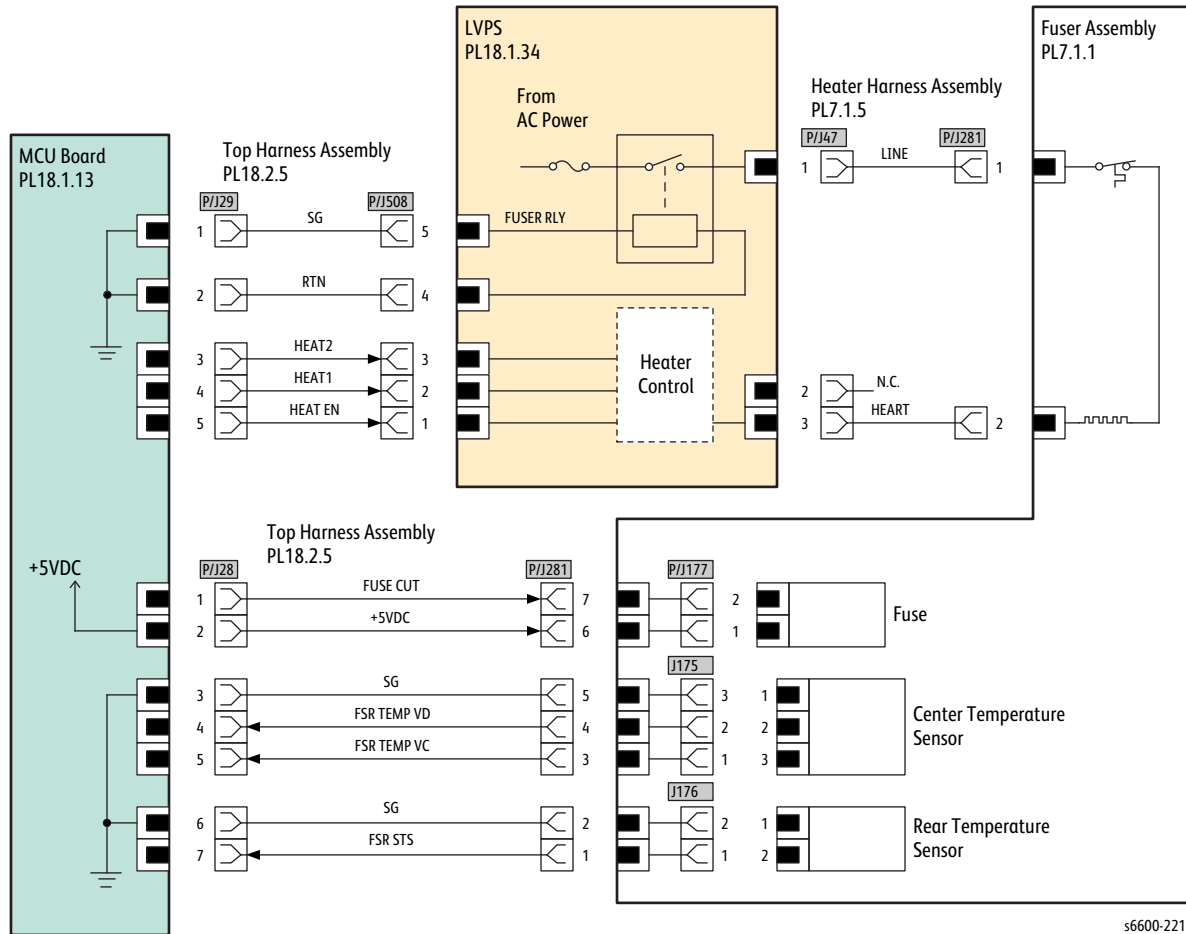
AC Power



s6600-213

Signal line name	Description
REAR IL	ON/OFF detect signal of the Rear Interlock Switch
DOOR IL	ON/OFF detect signal of the Door Interlock Switch
FAN ALRM FAN LOW FAN STOP	Drive control signal of the Main Fan
WASTE BOX FULL SENSED SIGNAL	Full detect signal of the Waste Cartridge by the Toner Full Sensor

Fuser

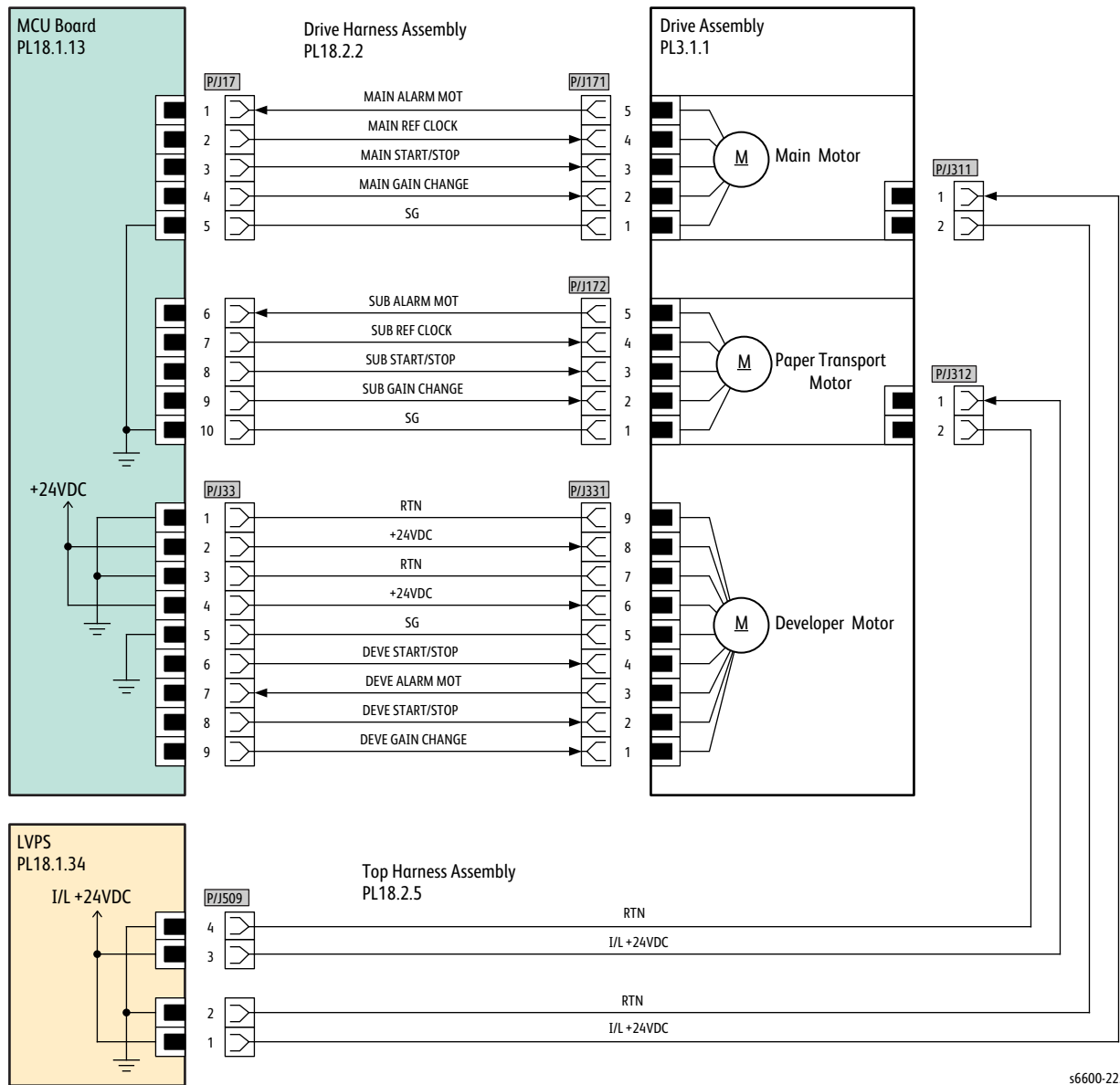


s6600-221

Signal line name	Description
HEAT2 HEAT1 HEAT EN	Temperature control signal of the Fusing Assembly
FUSE CUT	Control signal of the Fuse
FSR TEMP VD FSR TEMP VC	Temperature data measured by the Center Temp. Sensor
FSR STS	Temperature data measured by the Rear Temp. Sensor



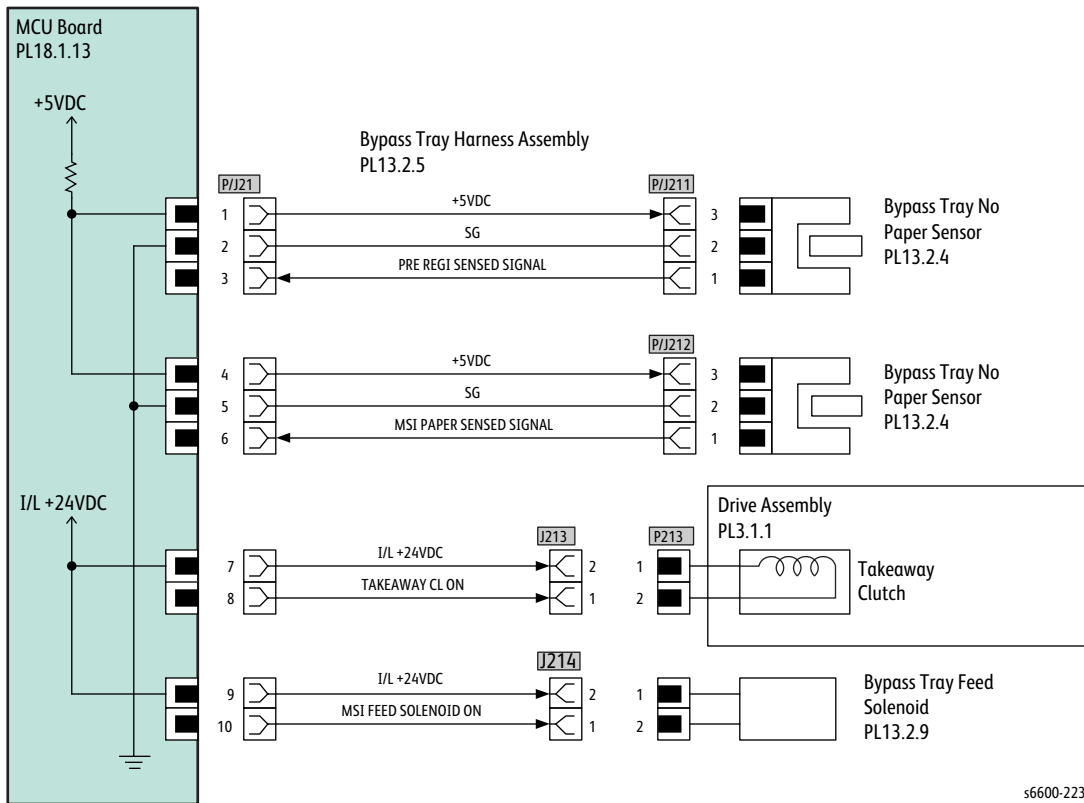
Drive



s6600-222

Signal line name	Description
MAIN ALARM MOT MAIN REF CLOCK MAIN START/STOP MAIN GAIN CHANGE	Drive control signal of the Main Motor
SUB ALARM MOT SUB REF CLOCK SUB START/STOP SUB GAIN CHANGE	Drive control signal of the Paper Transport Motor
DEVE START/STOP DEVE ALARM MOT DEVE START/STOP DEVE GAIN CHANGE	Drive control signal of the Deve Motor

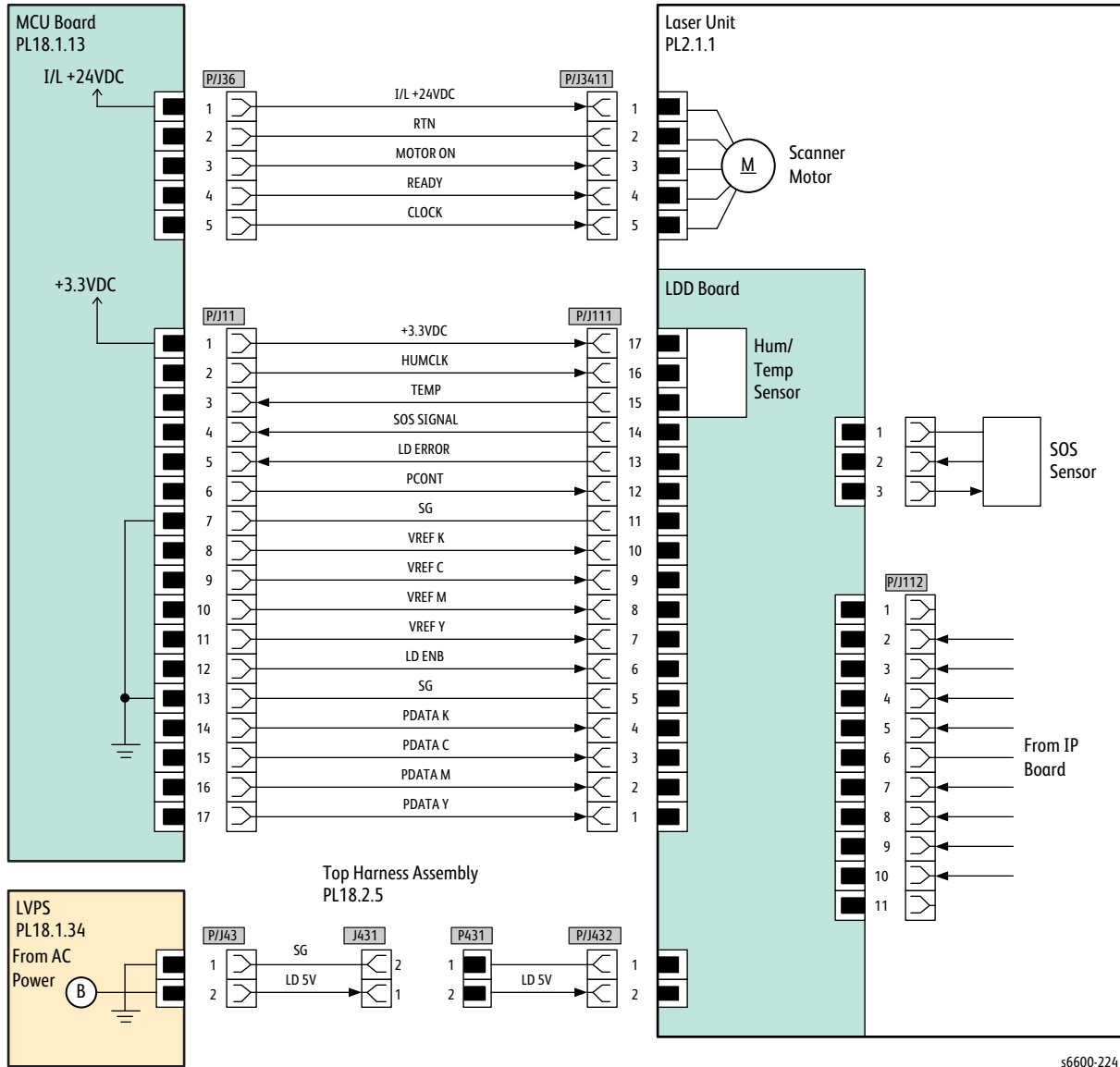
## Bypass Tray (MSI)



s6600-223

Signal line name	Description
PRE REGI SENSED SIGNAL	Detect signal of paper in the Pre Registration section by the MSI Sensor
MSI PAPER SENSED SIGNAL	Detect signal of paper in the MSI section by the MSI No Paper Sensor
TAKEAWAY CL ON	ON/OFF signal of the Takeaway Clutch
MSI FEED SOLENOID ON	ON/OFF signal of the MSI Feed Sorenoid

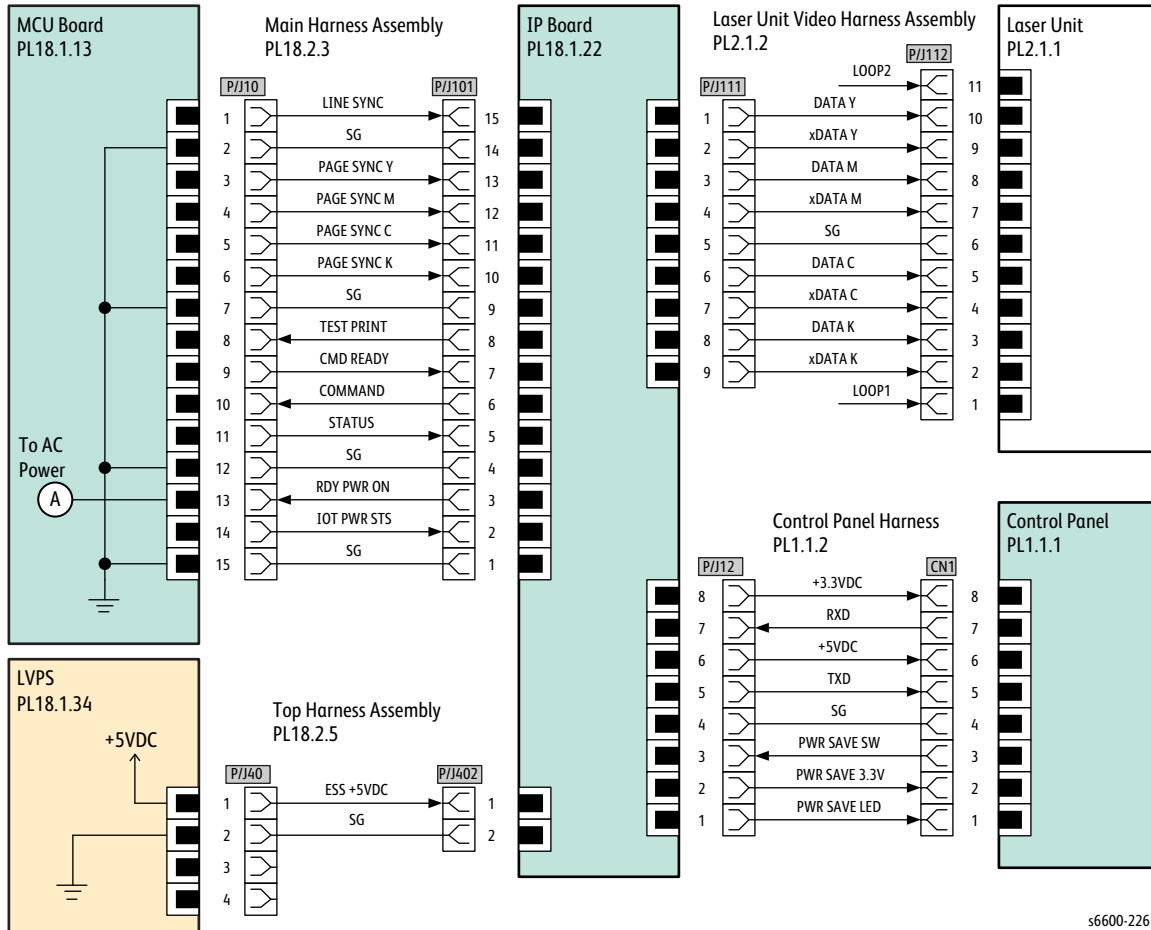
## Laser Unit



s6600-224

Signal line name	Description
MOTOR ON READY CLOCK	Drive control signal of the Scanner Motor in the Laser Unit
HUMCLK TEMP SOS SIGNAL LD ERROR PCONT VREF K VREF C VREF M VREF Y LD ENB PDATA K PDATA C PDATA M PDATA Y	Control signal of the LD light intensity in the Laser Unit

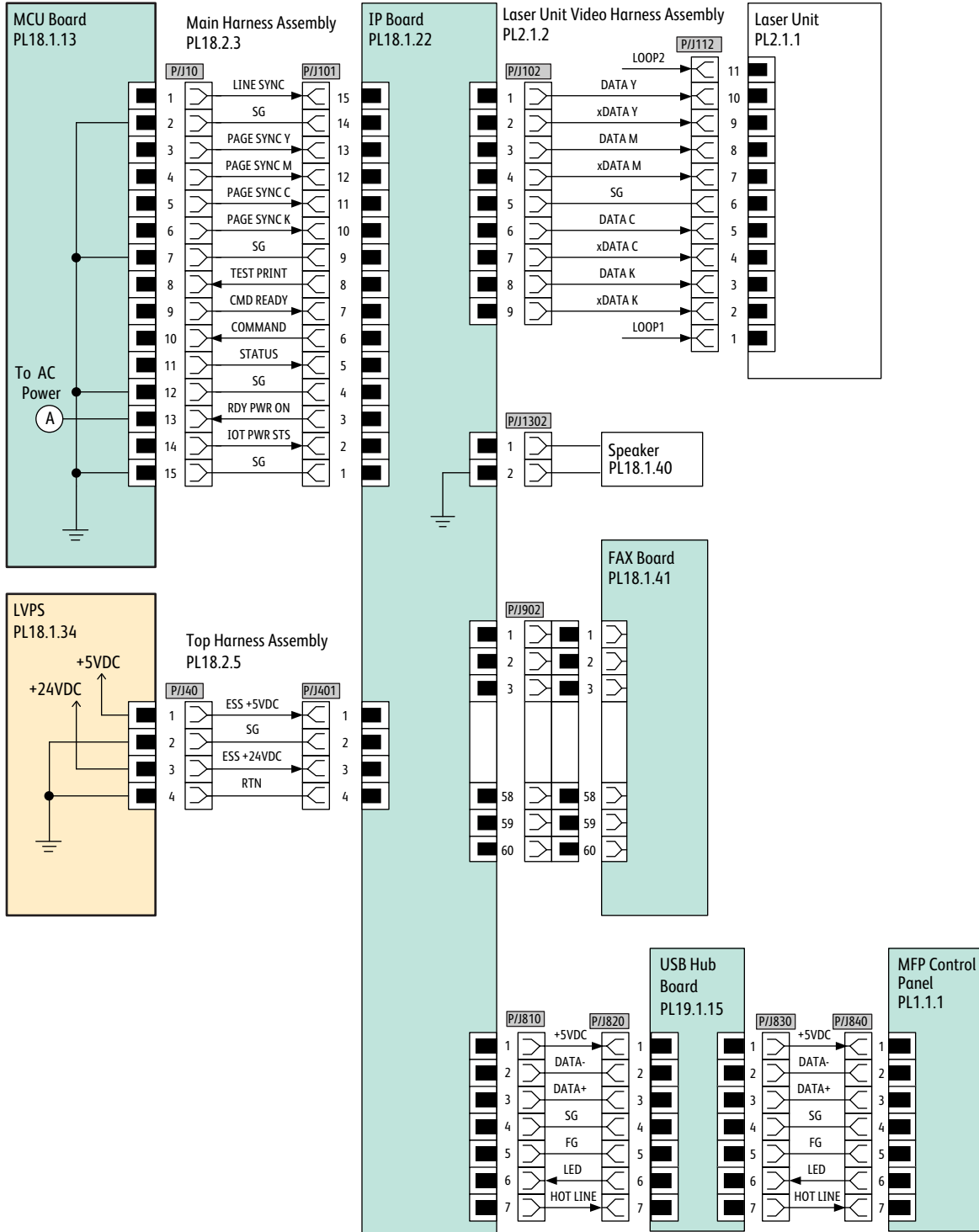
# SFP Controller



s6600-226

Signal line name	Description
LINE SYNC PAGE SYNC Y PAGE SYNC M PAGE SYNC C PAGE SYNC K TEST PRINT CMD READY COMMAND STATUS RDY PWR ON IOT PWR STS	Control signal of the IP Board
DATA Y xDATA Y DATA M xDATA M DATA C xDATA C DATA K xDATA K	Image data of each color (Y/M/C/K)
RXD TXD PWRSAVESW PWRSVE3.3V PWRSVELED	Control signal of the Control Panel Assembly

# MFP Controller

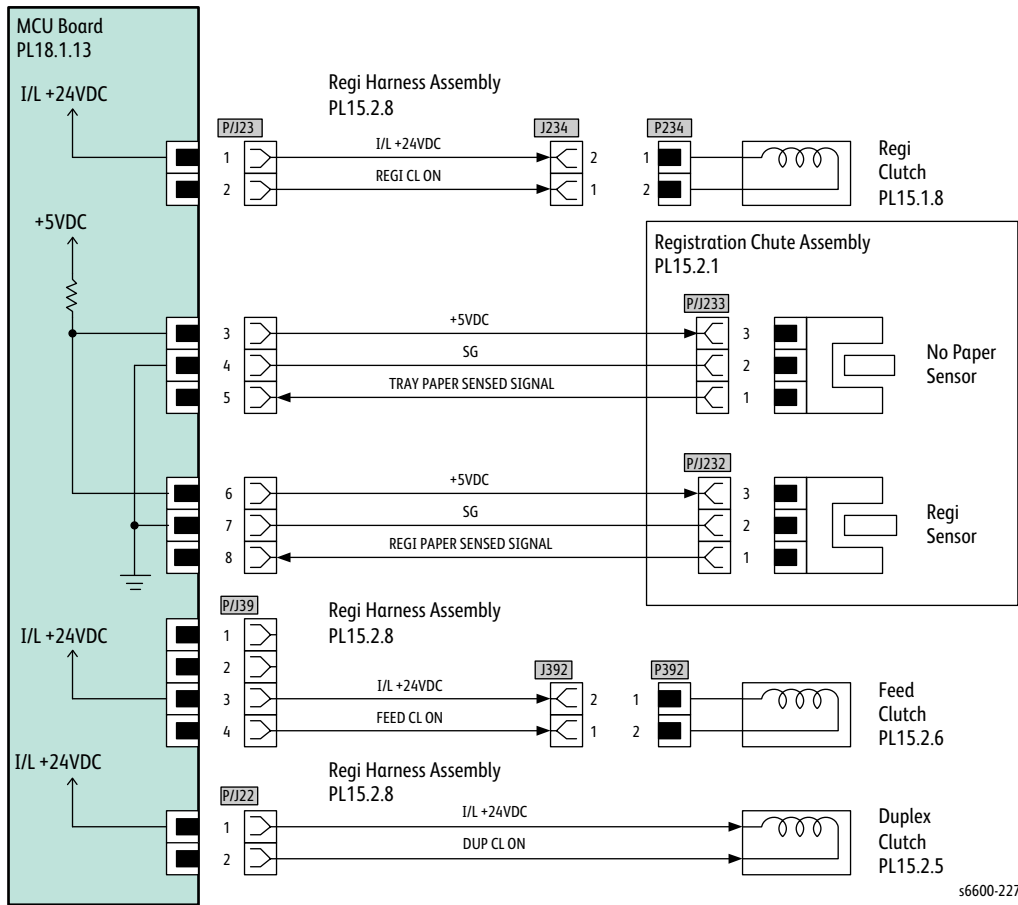


s6600-225



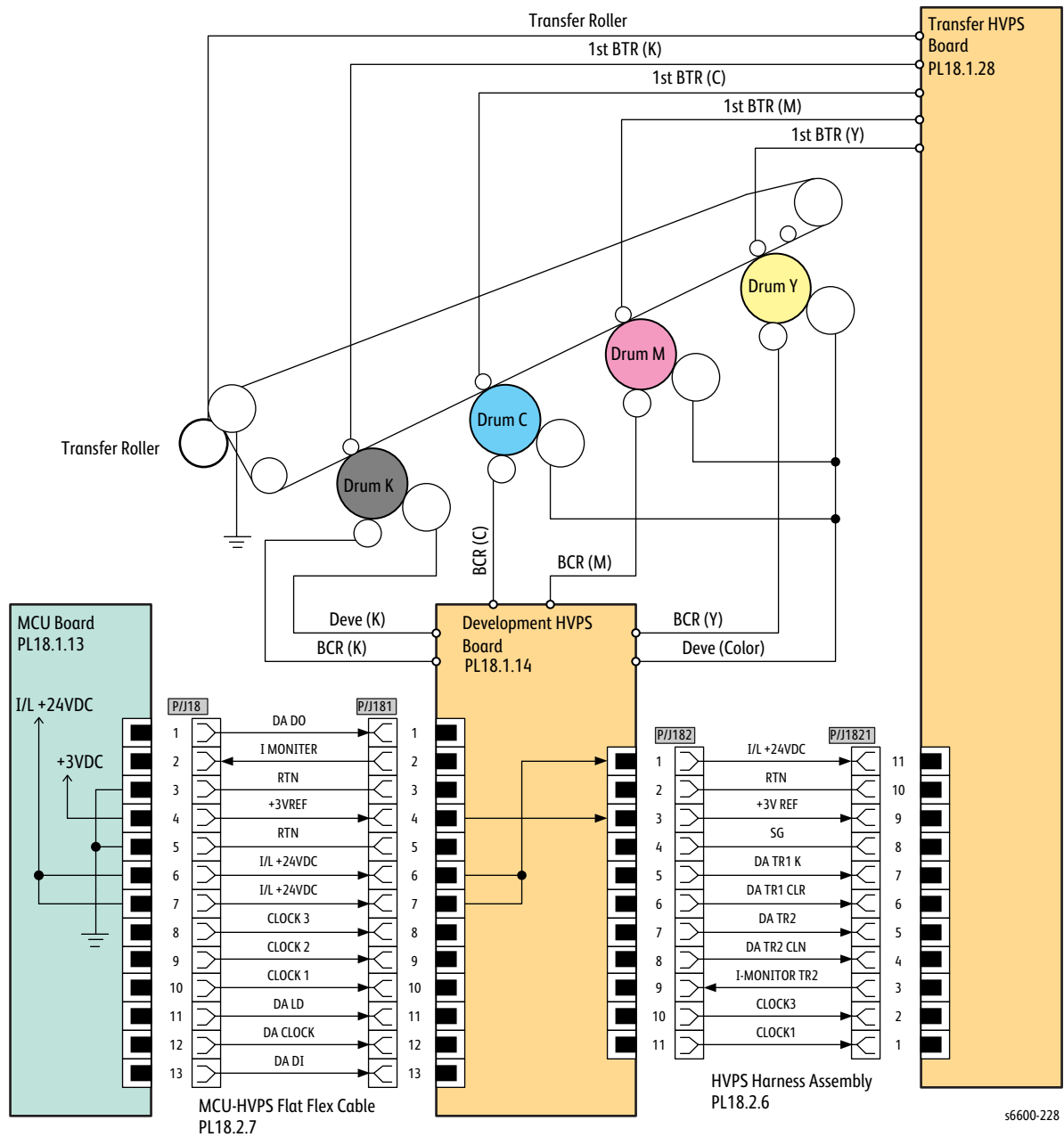
Signal line name	Description
LINE SYNC PAGE SYNC Y PAGE SYNC M PAGE SYNC C PAGE SYNC K TEST PRINT CMD READY COMMAND STATUS RDY PWR ON IOT PWR STS	Control signal of the PWBA ESS
DATA Y xDATA Y DATA M xDATA M DATA C xDATA C DATA K xDATA K	Image data of each color (Y/M/C/K)
RXD TXD	Control signal of the PANEL Assembly UI

## Paper Transport



Signal line name	Description
REGI CL ON	ON/OFF signal for the Regi Clutch
TRAY PAPER SENSED SIGNAL	Media detected in the tray by the No Paper Sensor
REGI PAPER SENSED SIGNAL	Media detected in the Pre Registration section by the Regi Sensor
FEED CL ON	ON/OFF signal for the Feed Clutch
DUP CL ON	ON/OFF signal for the Duplex Clutch

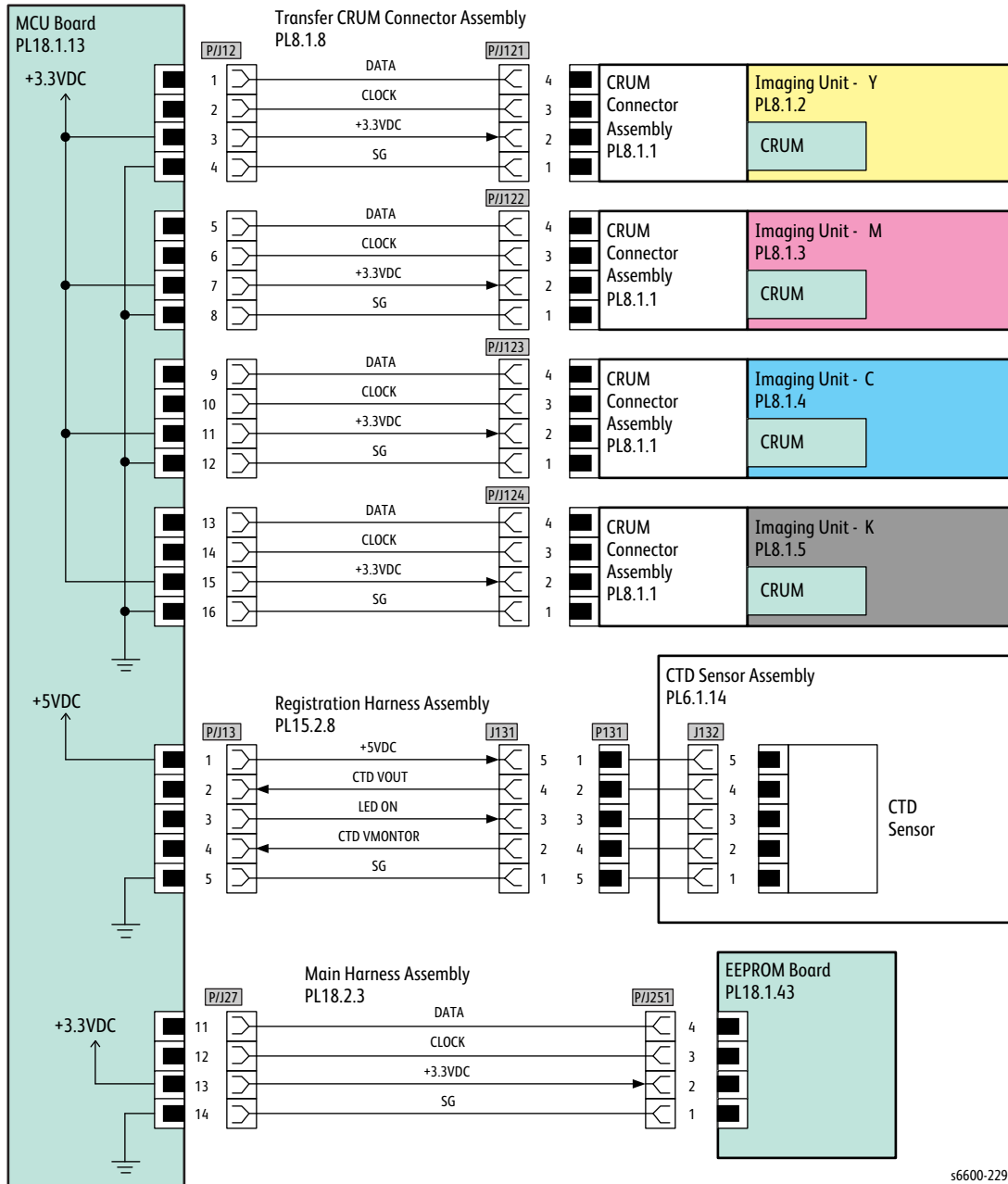
HVPS



## Wiring

Signal line name	Description
DA DO	Control signal of the HVPS
I MONITER	
+3VREF	
I/L +24VDC	
CLOCK 3	
CLOCK 2	
CLOCK 1	
DA LD	
DA CLOCK	
DA DI	
DA TR1 K	
DA TR1 CLR	
DA TR2	
DA TR2 CLN	
I-MONITOR TR2	

Xerographic

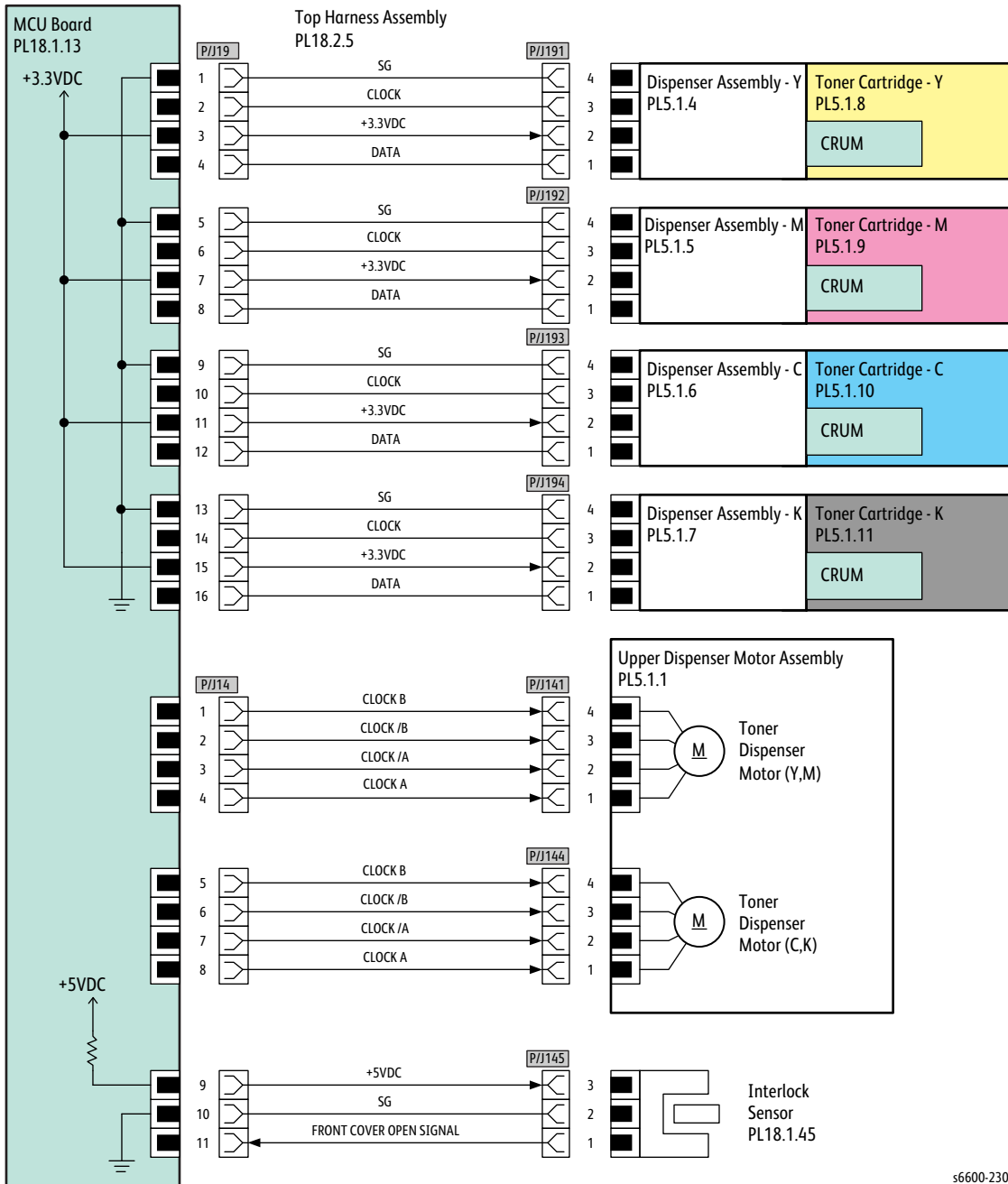


s6600-229

## Wiring

Signal line name	Description
DATA CLOCK	Control signal of the XERO DEVE CRU Assembly Y/M/C/K and the PWBA EEPROM
CTD VOUT	Toner patch density data measured by the CTD Sensor
LED ON	LED lighting signal of the CTD Sensor
CTD VMONTOR	Voltage monitor signal of the CTD Sensor

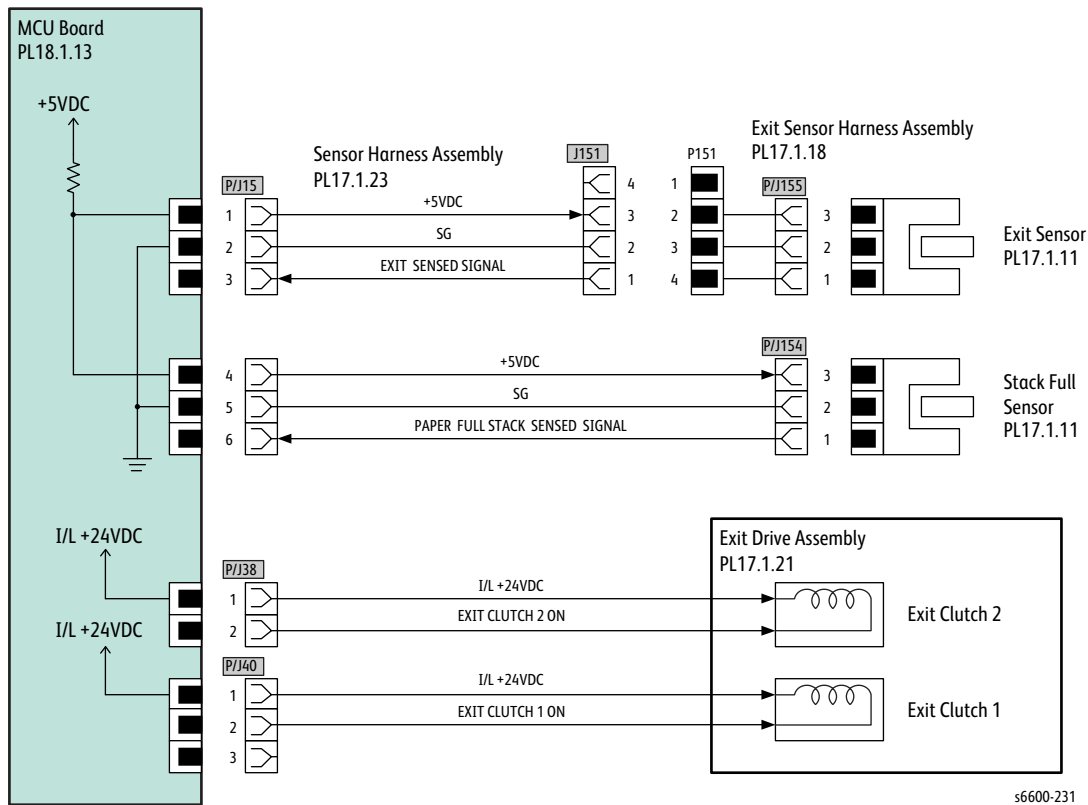
Developer



s6600-230

Signal line name	Description
CLOCK DATA	Control signal of the Toner Cartridge Y/M/C/K
CLOCK B CLOCK /B CLOCK /A CLOCK A	Drive control signal of the Toner Dispense Motor (Y,M) / (C,K)
FRONT COVER OPEN SIGNAL	FRONT COVER opening/closing detect signal by the Front Cover Sensor

## Exit

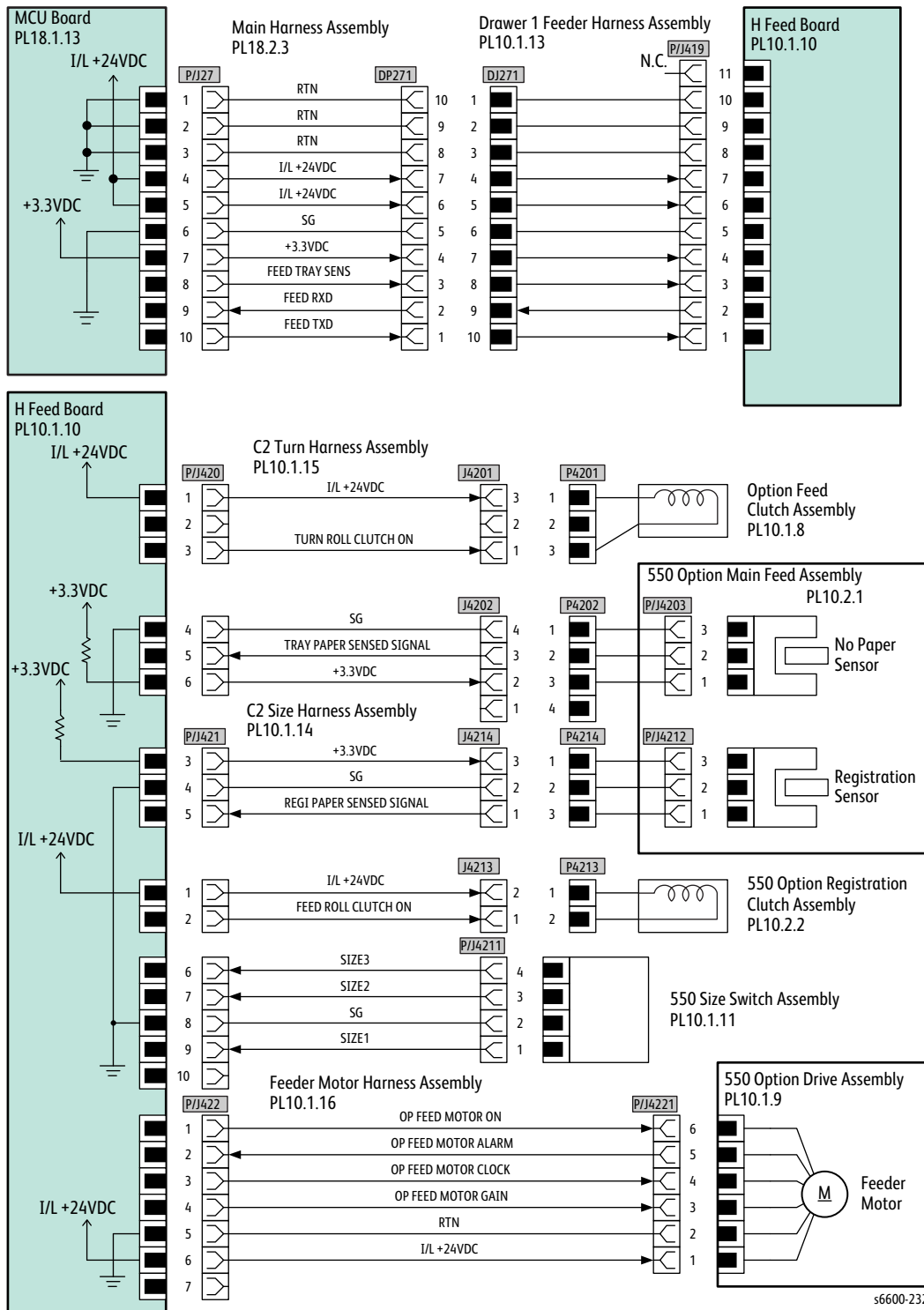


s6600-231

Signal line name	Description
EXIT SENSED SIGNAL	Detect signal of paper in the Exit section by the Exit Sensor
PAPER FULL STACK SENSED SIGNAL	Paper full detect signal of the output tray by the Full Stack Sensor
EXIT CLUTCH 2 ON	ON/OFF signal of the EXIT CLUTCH 2
EXIT CLUTCH 1 ON	ON/OFF signal of the EXIT CLUTCH 1



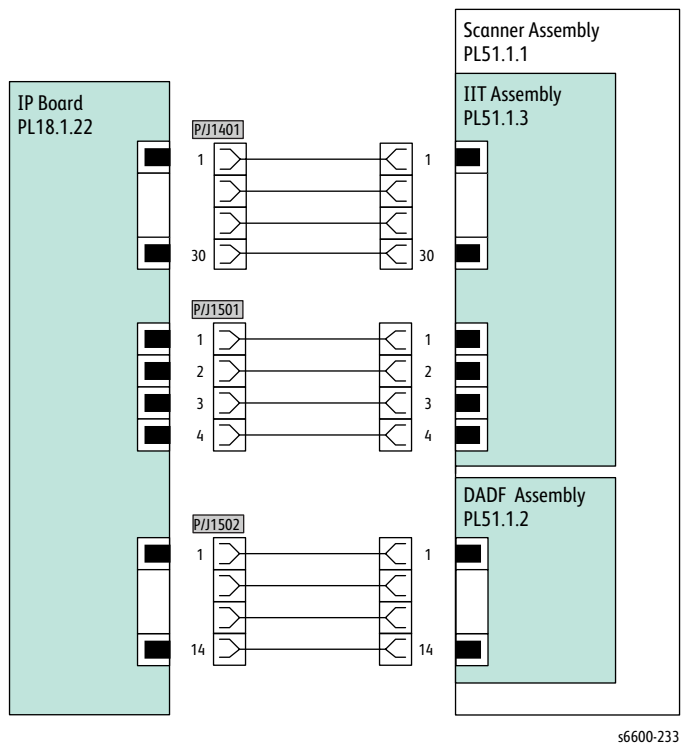
# 550 Feeder



s6600-232

Signal line name	Description
FEED TRAY SENS FEED RXD FEED TXD	Control signal of the 550 Option Feeder Board
TURN ROLL CLUTCH ON	ON/OFF signal of the Turn Roll Clutch
TRAY PAPER SENSED SIGNAL	Detect signal of paper inside the optional tray by the C2 No Paper Sensor
REGI PAPER SENSED SIGNAL	Detect signal of paper in the Registration section of the optional tray by the C2 Regi Sensor
FEED ROLL CLUTCH ON	ON/OFF signal of the C2 Feed Clutch
SIZE3 SIZE2 SIZE1	Detect signal of a paper size inside the optional tray by the 550 Size Switch Assembly
OP FEED MOTOR ON OP FEED MOTOR ALARM OP FEED MOTOR CLOCK OP FEED MOTOR GAIN	Drive control signal of the Option Feeder Motor

# Scanner





# Reference

## In this chapter...

- Acronyms and Abbreviations
- Phaser 6600 Menu Map
- E, H, & S Incident Report Form

# Acronyms and Abbreviations

Acronym	Description
A3	Paper size 297 millimeters (11.69 inches) x 420 millimeters (16.54 inches).
A4	Paper size 210 millimeters (8.27 inches) x 297 millimeters (11.69 inches).
A5	Paper size 148 millimeters (5.82 inches) x 210 millimeters (2.10 inches).
AC	Alternating Current is type of current available at power source for the printer.
ADC	Automatic Density Control
AMPV	Average Monthly Print Volume
APC	Auto Power Control
ASSY	Assembly
ATM	Adobe Type Manager
BCR	Bias Charge Roller
BOOTP	Boot Parameter Protocol
BTR	Bias Transfer Roller
CCD	Charge Coupled Device (Photoelectric Converter)
CCW	Counter-Clock Wise
CMYK	Toner colors for the printer: Y=yellow, C=cyan, M=magenta, K=black
CRU	Customer Replaceable Unit
CRUM	Customer Replaceable Unit Meter/Memory
CST	Cassette
dB	Decibel
DC	Direct Current
DDNS	Dynamic Domain Name System
DDR2 DIMM	Double Data Rate Dual In-Line Memory Module
DEV	Developer
DHCP	Dynamic Host Configuration Protocol
DPI	Dots Per Inch

Acronym	Description
DRV	Drive
DUP	Duplex
Duplex	2-sided printing
EA	Emulsion Aggregation (Toner)
EEPROM	Electrically Erasable Programmable Read-Only Memory
ESD	Electrostatic Discharge. A transfer of charge between bodies at different electrostatic potential.
ESS	Image process controller
FCC	Federal Communications Commission
FDR	Feeder
FPOT	First Print Output Time
FRU	Field Replaceable Unit
GB	Giga Byte
GDI	Graphics Device Interface
GND	Ground
HARN	Harness
HCF	High-Capacity Feeder
HDD	Hard Disk Drive
HUM	Humidity
HV	High Voltage
HVPS	High-Voltage Power Supply
Hz	Hertz (cycles per second)
IDT	Intermediate Drum Transfer
IEC	International Electrotechnical Commission
I/F	Interface
IIT	Image Input Terminal - DADF, Scanner
IOT	Image Output Terminal - the printer
IP	Image Processor
KB	Kilo Byte
LAN	Local Area Network
LCD	Liquid Crystal Display

Acronym	Description
LD	Laser Diode
LED	Light Emitting Diode
LEF	Long-Edge Feed
LPD	Line Printer Daemon
LPR	Line Printer Remote
LTR	Letter Size Paper (8.5 x 11 inches)
LVPS	Low-Voltage Power Supply
MB	Mega Byte
MCU	Machine Control Unit (Engine Control Board)
MHz	Mega Hertz
MIB	Management Information Base
MM	Millimeters
MOT	Motor
MPT	Multi-Purpose Tray
NCS	Non-Contact Sensor
NVM	Non-Volatile Memory
NVRAM	Non-Volatile Random Access Memory
OHP	Overhead Paper (Transparency)
OPT	Optional
OS	Operating System
PCB	Printed Circuit Board
PCL	Printer Command Language
PDL	Page Description Language
P/J	Plug Jack (electrical connections)
PJL	Printer Job Language
PL	Parts List
POP3	Post Office Protocol version 3
PPD	PostScript Printer Description
PPM	Pages Per Minute
PWBA	Printed Wiring Board Assembly
RAM	Random Access Memory

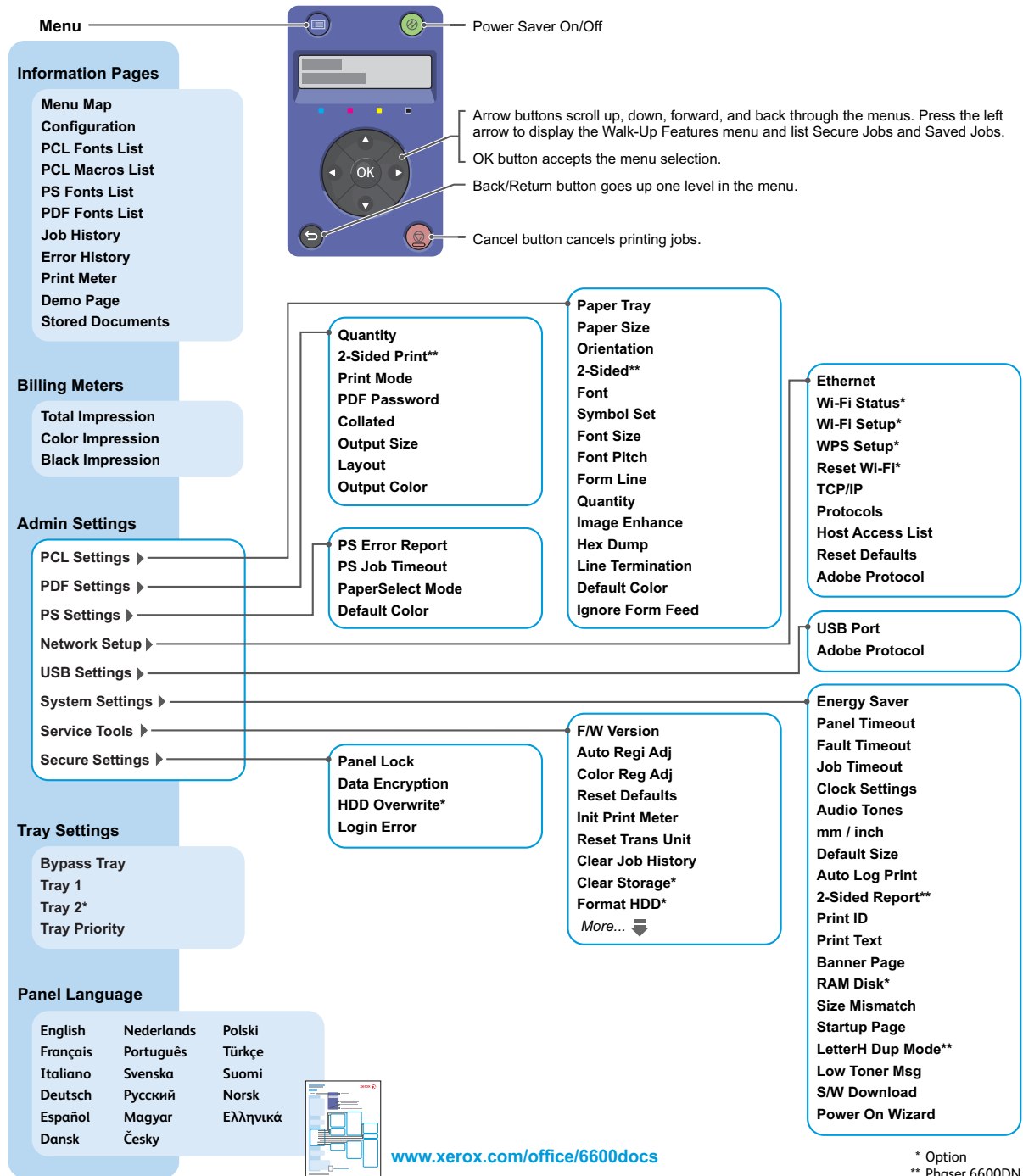


Acronym	Description
RH	Relative Humidity
RMS	Root Mean Square Voltage
ROM	Read-Only Memory
ROS	Raster Output Scanner - Laser Unit
SEF	Short-Edge Feed
SMB	Server Message Block
SNMP	Simple Network Management Protocol
SNR	Sensor
SOL	Solenoid
SOS	Start of Scan
TDC	Toner Density Control
TNR	Toner
UI	User Interface
USB	Universal Serial Bus
WINS	Wireless Integrated Network Sensor

# Phaser 6600 Menu Map

Xerox® Phaser® 6600  
Color Printer

## Menus



© 2012 Xerox Corporation. All rights reserved. XEROX® and XEROX and Design® are trademarks of Xerox Corporation in the United States and/or other countries.

# E, H, & S Incident Report Form

The form on the following pages is the form that is current *at the time* of this manual's publication. For the most current version of the form, download from Xerox Global Service Net at <https://www.xrxgsn.com/secure/main.pl?CatId=1789>.

**CONFIDENTIAL**  
(when filled in)



## EHS 700 - Health & Safety Incident Report Form for Incidents Involving a Xerox Product

For incidents in Canada: PIPEDA consent given <input type="checkbox"/> YES <input type="checkbox"/> NO	EH&S Office Use ONLY EH&S Incident Reference Number:
PIPEDA is the Canadian "Personal Information Protection and Electronic Documents Act."	

*Date Of Incident (mm / dd / yy):	
<b>Product Description</b>	
*Model No. or Product Name:	
Product Serial Number:	Serial Number(s) of Accessory (ies):
Installation Date:	Total Copy Meter:
Date of last service maintenance:	
List damaged and affected part(s) of the machine by description and part number:	
<u>*Description</u>	<u>Part Number</u>
*Location of product and affected part(s):	
<b>Customer Identification</b>	
*Customer Name:	*Name of Customer Contact Person:
*Address:	E-mail:
	*Telephone:
	Fax:
<b>Customer Service Engineer Identification</b>	
*Name (required for Xerox serviced equipment):	Employee:
	E-mail:
Location:	*Phone (required for Xerox serviced equipment):
<b>Individual Providing Notification</b>	
*Name:	*Title:
	*Telephone Number:
*Organization:	E-Mail:
Mailing Address:	*Date Report Submitted:

\* Required information is preceded by asterisk, title shown in red, turquoise wash background

Details of Incident	
<b>*Description Of Incident:</b> (Check all that apply)	
<input type="checkbox"/> Smoke	<b>Describe quantity and duration of smoke:</b>
<input type="checkbox"/> Fire with open flames seen	
<input type="checkbox"/> Electric shock to operator or service representative	
<input type="checkbox"/> Physical injury/illness to operator or service representative	<b>Describe:</b>
<input type="checkbox"/> Other, <b>Describe:</b>	
<b>MANDATORY DESCRIPTION</b> (above): Provide a detailed description of all valid factors that may have contributed to the incident. Hardware involved in the incident should be preserved and retained for further investigation should investigation be deemed necessary by EH&S.	
LIST INCIDENT DESCRIPTIONS AND SUPPORT DIAGRAMS/DATA INCLUDED OR ATTACHED:	
<b>*Any damage to customer property?</b> No <input type="checkbox"/> Yes <input type="checkbox"/> Describe:	
<b>*Did external emergency response provider(s) such as fire department, ambulance, etc. respond?</b> No <input type="checkbox"/> Yes <input type="checkbox"/> Identify: (i.e., source, names of individuals)	
Apparent cause of incident (identify part that is suspect to be responsible for the incident)	
<b>*Preliminary actions taken to mitigate incident:</b>	

<b>Instructions:</b> E-mail or fax both pages of this completed form to EH&S: <ul style="list-style-type: none"><li>For incidents in <b>Xerox Europe</b> and <b>Developing Markets East</b> (Middle East, Africa, India, China, and Hong Kong) Submit to Elaine Grange e-mail: <a href="mailto:ehs-europe@xerox.com">ehs-europe@xerox.com</a> or fax: +44 (0) 1707 35 3914 [Intelnet 8*668 3914]</li><li>For incidents in <b>North America</b> and <b>Developing Markets West</b> (Brazil, Mexico, Latin America North and Latin America South, Submit form to Doris Bush e-mail: <a href="mailto:usa.xerox.ehs@xerox.com">usa.xerox.ehs@xerox.com</a> or fax 585-216-8817 [ Intelnet 8*219-8817 ]</li></ul>
--

\* Required information is preceded by asterisk, title shown in red, turquoise wash background



# Index

## A

- acronyms described, A-2
- adjustments
  - altitude, 6-22
  - color registration, 6-18, 6-19
  - Fuser, 6-23
  - Transfer Belt offsets, 6-22
  - Transfer Roller bias, 6-21

## B

- Buttons, Control Panel
  - MFP functions, 1-25
  - SFP functions, 1-24
- Bypass Tray, 1-45
  - Feed Roller removal, 4-68
  - removal, 4-71

## C

- caution labels, 1-8 to 1-13
- CCD Image Sensor, 1-50
- CE mark, 1-16
- cleaning
  - DADF Feed Rollers, 6-6
  - exterior, 6-4
  - laser lenses, 6-7
  - Scanner, 6-4
  - toner density sensors, 6-11
- color registration adjustment
  - automatic, 6-18
  - manual, 6-19
- configuration report, 2-33
- configurations, 1-57 to 1-59
- consumables
  - dimensions, 1-62
  - life, 1-54
  - part numbers, 5-62
- Control Panel, 1-24
  - MFP buttons, 1-25
  - removal, MFP, 4-8
  - SFP buttons, 1-24
- CRUM
  - Imaging Unit, 1-54
  - Toner Cartridge, 1-54

- CTD Sensor Assembly
  - description, 1-41
  - part number, 5-20
  - removal, 4-41
  - sensor error, 2-183

## D

- DADF Assembly
  - cover open error, 2-209
  - description, 1-51
  - document stopper, 1-52
  - duplex paper path, 1-34
  - jam error, 2-208
  - Pick-up Module removal, 4-145
  - pinch roller, 1-53
  - removal, 4-143
  - sensors, 1-51
  - simplex paper path, 1-33
  - specifications, 1-80
- diagnostic tests, 2-19 to 2-88
- dimensions
  - consumables, 1-62
  - paper tray, 1-62
  - printer, 1-61
- disassembly procedures, 4-1 to 4-151
  - Bypass Tray, 4-63 to 4-76
  - cautions, 4-3
  - Control Panel, 4-7 to 4-9
  - Covers, 4-115 to 4-137
  - Dispenser, 4-27 to 4-37
  - Drive, 4-11 to 4-22
  - Duplexer, 4-77 to 4-79
  - Electrical, 4-97 to 4-114
  - Exit, 4-93 to 4-95
  - Fuser, 4-46
  - Laser Unit, 4-10
  - NOHAD, 4-23 to 4-26
  - Optional Feeder, 4-53 to 4-62
  - Registration/Feeder, 4-80 to 4-92
  - Scanner, 4-138 to 4-147
  - transfer, 4-38 to 4-45
  - Tray, 4-51 to 4-52
  - Xerographic, 4-47 to 4-50
- Drive Assembly
  - exit, 1-46
  - main, 1-37
- Duplex Assembly
  - operation, 1-32
  - removal, 4-77

## E

- electrical components, 1-47
- electrical properties, 1-60
- Electrostatic discharge (ESD), 1-6
- error code
  - fault isolation procedures, 2-177 to 2-229
  - Phaser 6600 list, 2-91 to 2-112
  - WC6605 list, 2-112 to 2-177
- error history report, 2-90
- error messages, 2-89 to 2-177
- Exit Assembly
  - removal, 4-93
- Exit Drive Assembly, 1-46
  - removal, 4-95
- Exit Sensor, 1-46

## F

- fault isolation procedures
  - level 1, 2-177 to 2-209
  - level 2, 2-210 to 2-224
  - other, 2-225 to 2-229
- FAX
  - Board removal, 4-97
  - fault isolation procedure, 2-227
  - specifications, 1-80
- Feed Roller Assembly
  - removal, 4-92
- First Print Output Time, 1-68
- Full Stack Sensor, 1-46
- Fuser, 1-43
  - removal, 4-46
  - temperature adjustment, 6-23
- fusing operation, 1-31

## H

- hard disk
  - erase, 2-15
  - removal, 4-100
  - test, 2-21
- Hardware Kit, 5-62
- harness routing
  - Drive Harness Assembly, 4-148
  - Main Harness Assembly, 4-149
  - SFP Top Harness Assembly, 4-150
- Health and Safety Incident Reporting, 1-14, A-7

## I

- IIT Assembly, 1-50
- image quality
  - specification, 1-71
  - troubleshooting, 3-1 to 3-25
  - troubleshooting chart, 3-3
- image transfer, 1-31
- Imaging Unit
  - CRUM, 1-54
  - life rating, 1-54
- IP Board
  - removal, MFP, 4-104
  - removal, SFP, 4-102

## K

- Keys, Control Panel
  - functions, MFP, 1-25
  - functions, SFP, 1-24

## L

- labels, caution & warning, 1-8 to 1-13
- Laser Unit
  - description, 1-36
  - removal, 4-10

## M

- Main Drive Assembly, 1-37
- maintenance items
  - life, 1-54
- MCU Board
  - removal, 4-98
- mechanical properties, 1-61
- menu map
  - Phaser 6600 user, A-6
  - service mode, 2-11
  - service mode, Phaser 6600, 2-11
  - WC6605 Fax/Scanner diag, 2-13
  - WC6605 printer diag, 2-12



- mode
  - color track, 1-76
  - energy saver (sleep), 1-67
  - FAX, 1-66
  - FAX/scanner diag, 2-10
  - G3 (FAX), 1-82
  - non-genuine toner, 1-79
  - operation, 1-66
  - print, 1-66
  - printer diag, 2-10
  - scan, 1-66
  - service, 2-8
- motor
  - 550 Option drive, 1-48
  - assembly, upper dispenser, 1-39
  - DADF, 1-33, 1-34, 1-51
  - developer, 1-31, 1-37
  - laser scan, 1-36
  - main, 1-31, 1-32, 1-37, 1-46
  - paper transport, 1-26, 1-28, 1-29, 1-30, 1-32, 1-37, 1-44, 1-45
  - scanner carriage, 1-50
  - toner dispense, 1-39
- motor failure
  - developer, 2-182
  - fan, 2-177
  - main, 2-180
  - paper transport, 2-181
- moving the printer, 6-16
  
- N**
- Non-Genuine Mode, 1-79
  
- O**
- Optional Feeder
  - Feed Roller removal, 4-62
  - removal, 4-53
- options, 1-71
- output properties, 1-68
  
- P**
- paper feed
  - bypass tray, 1-28
  - cassette, 1-26
  - registration, 1-29
- paper path
  - DADF, 1-33
  - print engine, 1-26
- paper specifications, 1-69
- paper transport, 1-44
- parts lists, 5-10 to 5-62
  - Bypass Tray, 5-32 to 5-36
  - consumables, 5-62
  - Covers, 5-53 to 5-59
  - Dispenser, 5-17
  - Drive, 5-14
  - Duplex, 5-38
  - Electrical, 5-45 to 5-51
  - Exit, 5-43
  - Fuser, 5-21
  - Hardware Kit, 5-62
  - Laser Unit, 5-13
  - NOHAD, 5-15
  - Option Feeder, 5-27 to 5-30
  - Registration/Feeder, 5-39 to 5-41
  - routine maintenance items, 5-63
  - Scanner, 5-60
  - Transfer, 5-19
  - Tray, 5-24
  - UI (Control Panel), 5-11 to 5-12
  - Xerographic, 5-22
- parts navigation
  - MFP, 5-7
  - SFP, 5-4
- Phaser 6600 Menu Map, A-6
- plug/jack
  - designators, MFP, 7-11
  - designators, SFP, 7-2
  - locations, MFP, 7-15 to 7-20
  - locations, SFP, 7-6 to 7-10
- power consumption spec, 1-60
- print function test, 2-40
- print resolution, 1-19
- print settings report, 2-34
- printer
  - configuration, 1-19
  - dimensions, 1-61
  - serial number, 5-2
- product symbols, 1-4
- Product terms, 1-4

## R

## registration

- adjustment, 6-18 to 6-19
- auto, scanner, 2-62
- feed, 1-29
- out of alignment, 3-24
- parameter settings, 2-52
- parts lists, 5-39
- scanner parameter, 2-62
- skew correction, 1-30

## regulations

- Canada, 1-16
- FCC, 1-16
- United States, 1-16

## report

- configuration, 2-33
- E, H, & S Incident Report Form, A-7
- error history, 2-90
- health & safety incident, 1-14
- printer settings, 2-34

## resolution, 1-19

## routine maintenance items

- description, 1-55
- part numbers, 5-63

## rush current spec, 1-60

## S

## safety

- incident reporting, 1-14

## Safety Precautions

- Power, 1-5

## Safety Summary, 1-7

## Scanner

- cleaning, 6-4
- maintenance, 2-61
- parts list, 5-60
- removal, 4-138
- specifications, 1-79
- wiring diagram, 7-51

## sensor

- bypass tray, 1-45
- bypass tray no paper, 1-45
- bypass tray no paper removal, 4-66
- bypass tray, removal, 4-67
- CCD image, 1-50
- CTD, 1-41
- CTD removal, 4-41
- CTD, cleaning, 6-11
- DADF cover open, 1-51

DADF document, 1-51

DADF duplex, 1-51

DADF scan, 1-51

exit, 1-31, 1-46

full stack, 1-46

fuser temp center, 1-43

fuser temp rear, 1-43

humidity/temperature, 1-36

no paper, 1-44

no paper, 550 Option, 1-48

regi, 1-44

regi, 550 Option, 1-48

scanner home position, 1-50

start of scan, 1-36

test, 2-23

waste toner full, 1-38

waste toner full removal, 4-23

## serial number

format, 5-2

location, 5-2

## service mode

diagnostic tests, 2-19 to 2-88

functions overview, 2-14 to 2-16

how to enter, 2-8

how to exit, 2-10

menu maps, 2-11

using diagnostics, 2-10

## specifications, 1-57 to 1-83

DADF, 1-80

electrical, 1-60

environment, 1-70

FAX, 1-80

FPOT, 1-68

IIT (Scanner), 1-79

input capacities, 1-68

mechanical, 1-61

MFP clearance requirements, 1-65

operating modes, 1-66

output, 1-68

paper, 1-69

print image quality, 1-71

print resolution, 1-19

resolution, 1-66

running mode, 1-66

SFP clearance requirements, 1-64

warm-up time, 1-68

- standard orientation
  - MFP, 4-6
  - SFP, 4-5
- symbols
  - product, 1-4
  - wiring diagram, 7-21

## T

- Technical support, 1-18
- test prints, 2-40 to 2-51
- Toner Cartridge
  - CRUM, 1-54
  - life rating, 1-54
  - removal, 4-37
- Transfer Belt Assembly, 1-41
  - removal, 4-38
- Transfer Roller
  - removal, 4-79
- Transfer Roller Assembly, 1-41
- tray capacities, input, 1-68
- troubleshooting
  - exit jams, 2-6
  - FAX, 2-227
  - image quality, 3-2 to 3-25
  - initial actions, 2-2 to 2-6

## U

- user-installed options, 1-71

## W

- warm-up time, 1-68
- warning labels, 1-8 to 1-13
- Waste Cartridge
  - description, 1-38
  - removal, 4-50
- Wireless Kit
  - removal, 4-107
- wiring diagrams, 7-26 to 7-51
  - 550 Feeder, 7-49
  - AC Power, 7-30
  - Bypass Tray (MSI), 7-35
  - Developer, 7-47
  - Drive, 7-33
  - Exit, 7-48
  - Fuser, 7-32
  - general, Phaser 6600, 7-26
  - general, WorkCentre 6605, 7-28
  - HVPS, 7-43
  - Laser Unit, 7-36
  - MFP Controller, 7-40
  - Paper Transport, 7-42
  - Scanner, 7-51
  - SFP Controller, 7-38
  - Xerographic, 7-45





COPYRIGHT © 2012, XEROX CORPORATION.  
ALL RIGHTS RESERVED. UNPUBLISHED  
RIGHTS RESERVED UNDER THE COPYRIGHT  
LAWS OF THE UNITED STATES.

PART#: 702P00566

