

Transmittal Page

Product Xerox ColorQube 9303 Family	Title Service Manual	Part Number 708P89812
Launch		Date March 2011

Please note the following:

This output is created from an electronic documentation (EDOC) database and is *not* optimised for hard copy. Please be aware of the following:

- Text may not appear to be in the logical order when flowing around figures.
- Text may continue on a following page without indication.
- Figures may not appear on the page containing the figure reference.
- EDOC hot link references can over write text.

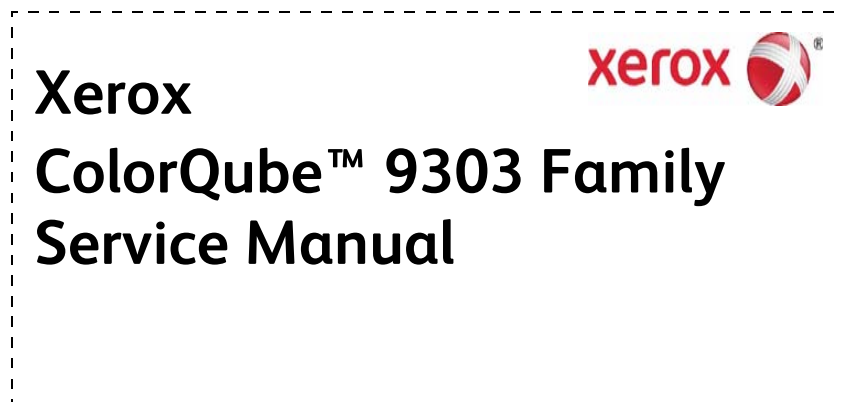

Front pocket insert

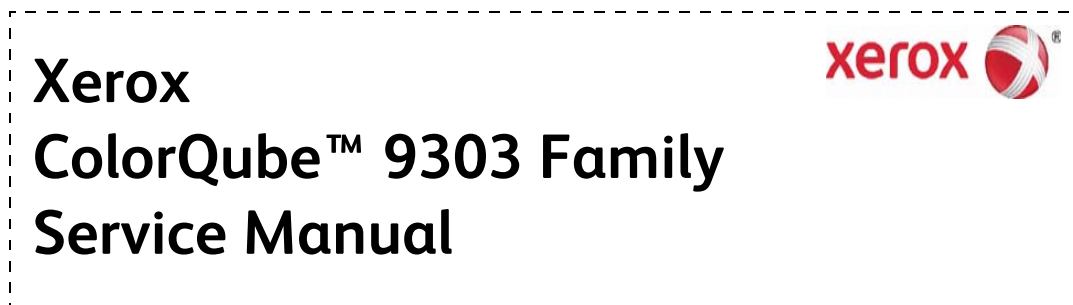

Spine insert

Revision Control List

Product: Xerox ColorQube 9303™	Title: Service Manual	Part Number: 708P89812	Revision: March 2011
--	---------------------------------	----------------------------------	--------------------------------

Documentation compatible with this revision.

EDOC (Compact Disc) 708P89811
EDOC Supplement (hard copy wiring diagrams) 708P89813

All pages in this manual are dated March 2011.

708P89812
March 2011



Xerox ColorQube™ 9303 Family Service Manual

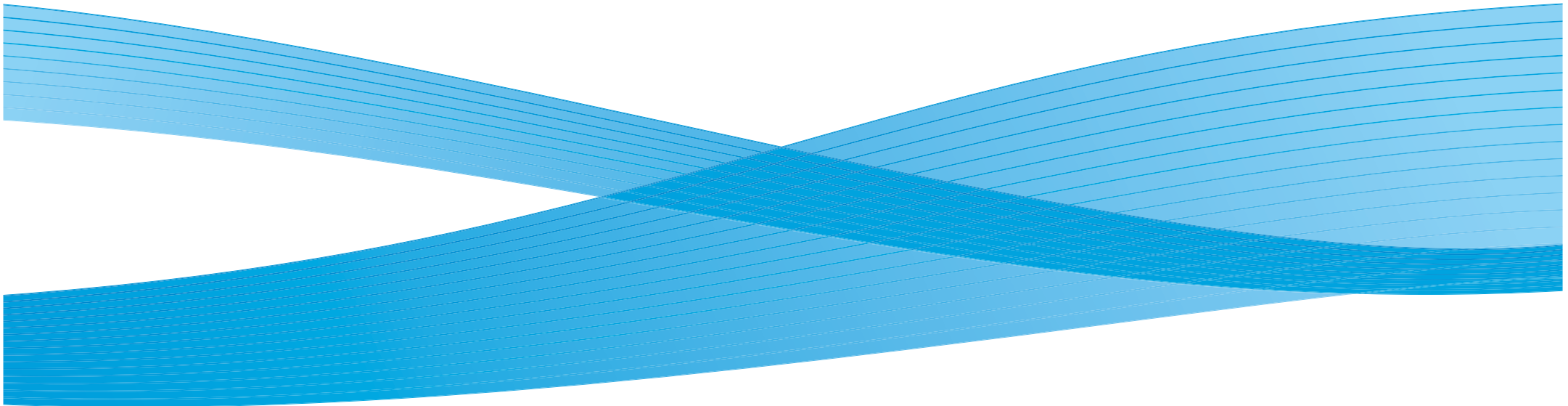

Prepared by:
Creative and Technical Communications - Europe & Asia
Xerox Global Services
Bessemer Road,
Welwyn Garden City
Hertfordshire
AL7 1BU
United Kingdom

© 2009- 2011 Xerox Corporation. All Rights Reserved. XEROX® and XEROX and Design® are trademarks of Xerox Corporation in the United States and/or other countries.

Other company trademarks are also acknowledged.

While every care has been taken in the preparation of this manual, no liability will be accepted by Xerox Europe arising out of any inaccuracies or omissions.

All service documentation is supplied to Xerox external customers for informational purposes only. Xerox service documentation is intended for use by certified, product trained service personnel only. Xerox does not warrant or represent that it will notify or provide to such customer any future change to this documentation. Customer performed service of equipment, or modules, components or parts of such equipment may affect whether Xerox is responsible to fix machine defects under the warranty offered by Xerox with respect to such equipment. You should consult the applicable warranty for its terms regarding customer or third-party provided service.

About This Manual	iii
How To Use This Manual.....	iv
Documentation Symbol.....	iv
Mod/Tag Identification.....	v
Voltages Resistances and Tolerances.....	v
Safety Information.....	vii
Health and Safety Incident Reporting	viii
Translated Warnings.....	ix

About This Manual

This manual is part of a multinational service documentation system that is structured in the standard Xerox service manual format.

Organization

The service manual is the document used as the primary information source for repairing and maintaining this family of products and is available as EDOC on a CDROM, or as a PDF on CDROM. The information within the manual is divided into an introduction and eight other sections.

Section 1 Service Call Procedures

This section is used to start and complete a service call. The procedures in this section will either direct you to a Repair Analysis Procedure (RAP), or identify a faulty component or sub-assembly.

Section 2 Status Indicator Repair Analysis Procedures

This section contains the Repair Analysis Procedures (RAPs) and checkouts necessary to diagnose, isolate and repair faults other than image quality faults.

- The fault codes on the machine user interface are preceded with the number **3**. For example a fault in the scanner might display **362-485-00** on the user interface.
- This manual describes the procedure for the fault under the heading **62-485-00 Supply 12 Volts Error RAP**.

Section 3 Image Quality

This section contains the Image Quality Repair Analysis Procedures (IQ RAPs), checkouts and setup procedures necessary to diagnose, isolate and repair image quality faults.

Section 4 Repairs / Adjustments

This section contains all the repair and adjustment procedures.

Repairs

Repairs include procedures for the removal and installing of parts which have the following special conditions:

- When there is a personnel or machine safety issue.
- When removal or installation cannot be determined from the exploded view of the parts list.
- When there is a cleaning or a lubricating activity associated with the procedure.
- When the part requires an adjustment after a part is installed.
- When a special tool is required for removal or installing a part.

Adjustments

Adjustments include procedures for the adjusting of the parts that must be within specification for the correct operation of the system.

Section 5 Parts List

This section contains the detailed and illustrated spare parts list. Any part that is spared or that must be removed to access a spared part is illustrated.

Section 6 General Procedures / Information

This section contains all other procedures, product specifications and general information. It also contains Mod/Tag information. The abbreviations used in this Manual are in [GP 40](#) Glossary of Terms, Acronyms and Abbreviations.

Section 7 Wiring Data

This section contains PWB layout, lists of plug / jack locations and wiring diagrams of the power distribution and wire networks in the machine.

Section 8 Principles of Operation

This section contains the Principles of Operation.

Publication Comments Sheet

A Publication Comment Sheet is provided at the rear of the PDF version of the manual.

How To Use This Manual

Always start with the Service Call Procedures, Section 1. Perform **SCP 1** Initial Actions and verify the problem, then follow the directions given.

How to Differentiate Between Machine Variants

The machine will be identified in this manual by the identifier ColorQube 9301 / 9302 / 9303.

When a procedure, parts list description or other reference is unique amongst different speeds of machine, the appropriate speed range will be quoted. For example, 38ppm, 45ppm 55ppm. Any artwork will also be specific.

NOTE: *This manual services all configurations of the machine. Ignore references to options not installed on the machine.*

Warnings, Cautions And Notes

WARNING

A warning is used whenever an operating or maintenance procedure, practice, condition or statement, if not strictly observed, could result in personal injury.

A translated version of all warnings is in **Translated Warnings**.

CAUTION

A caution is used whenever an operation or maintenance procedure, practice, condition or statement, if not strictly observed, could result in damage to the equipment.

NOTE: *A note is used where it is essential to highlight a procedure, practice, condition or statement.*

Documentation Symbol

This symbol is displayed in the service documentation:

ESD Caution Symbol



CAUTION

Certain components in this product are susceptible to damage from electrostatic discharge. Observe all ESD procedures to avoid component damage.

Mod/Tag Identification

Figure 1, shows the Mod/Tag identification symbols.

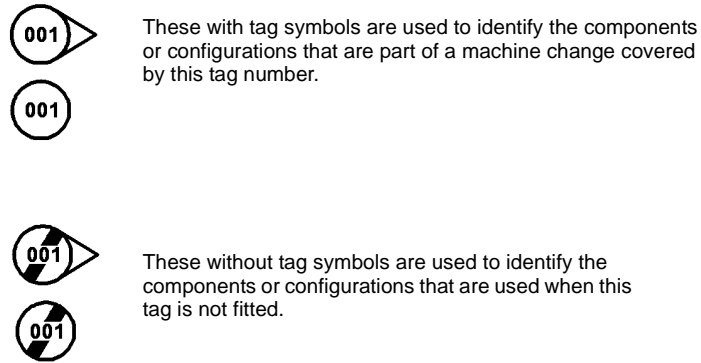

U-1-0001-A

Figure 1 Mod/Tag identification symbols

Voltages Resistances and Tolerances

For AC power specifications, refer to GP 22 Electrical Power Requirements.

DC Voltage Levels and Tolerances

DC Voltages should be measured between an available test point and a machine ground.

Table 1 shows the range of the common voltages.

Table 1 DC Voltage Levels

Nominal voltage	Voltage tolerance range	RAP reference
0 volts	0.00 to 0.10V	01L 0V Distribution RAP
+3.3V ESTAR	+/- 2.5%	01B +3.3V ESTAR Distribution RAP
+3.3V	+/- 2.5%	01C +3.3V Distribution RAP
+5.V	5.1V +/- 5%	01D +5V Distribution RAP
+12V	+/- 5%	01E +12V Distribution RAP
-12V	+/- 5%	01F -12V Distribution RAP
+17V	See Note	01G +17V Distribution RAP
+24V	+/- 5%	01H +24V Distribution RAP
+50V	47V to 49V	01J +50V Distribution RAP
-50V	-47V to -49V	01K -50V Distribution RAP

Non-standard voltage levels will be quoted on the relevant circuit diagram. All other voltage levels are plus or minus 10%.

NOTE: During power self test and when in sleep mode, this supply is 17V unregulated and is approximately +17V. When the machine is in active mode, this supply raises to +24V +/- 5%

Resistance Tolerances

All resistance measurement tolerances are plus or minus 10%, unless otherwise stated in the procedure.

DC Signal Nomenclature

Figure 1 shows the signal nomenclature used in this manual.

NOTE: This links to the parts list. If installation of the new component is simple, the parts list artwork is sufficient to show how the component is assembled in the machine. If installation of the new component is not simple, the parts listing will contain cross references to repair procedures and adjustments, as necessary.

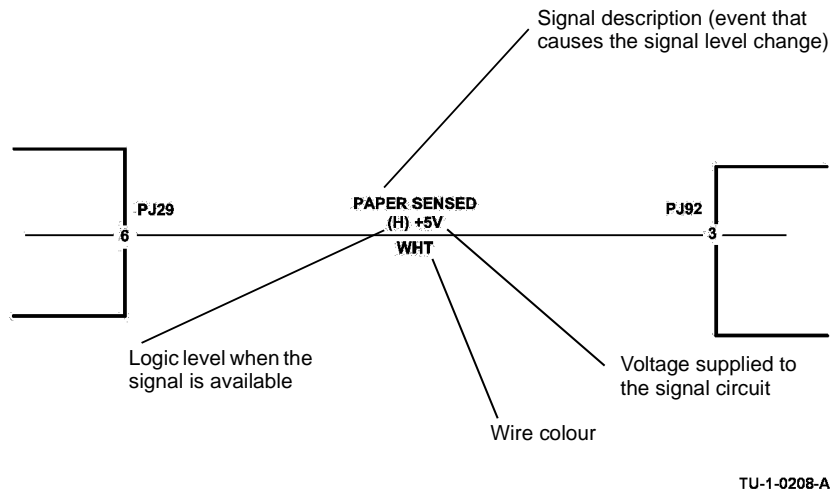

Figure 1 Signal Nomenclature

Table 2 shows the signal tolerances.

Table 2 Signal tolerances

Signal voltage	(H) logic level	(L) logic level
+5V	+3.85V or greater	At or near 0.8V
+3.3V	+2V or greater	At or near 0.8V

Non standard signal tolerances will be quoted on the relevant wiring diagram.

NOTE: The logic level shown with the signal name will be the actual signal as measured with a service meter. This will not necessarily be the same as the logic state shown on the diagnostic screen.

Samples of RAP Reference Text

Throughout the manual there are linked references that extend the diagnostic procedure or add more information:

- [GP 11](#) How to Check a Sensor.

NOTE: This links to a General Procedure.

- [WD 1.5](#)

NOTE: This links to a relevant wiring diagram.

Install new components as necessary:

- Tray 1 feed sensor, [PL 81.25](#) Item 19.

Safety Information

The warning that follows is for general guidance when live working.

WARNING

Do not work in a confined space. 1m (39 inches) space is needed for safe working.

Safety Icons

The safety icons that follow are displayed on the machine:

Hot Surface Symbol

This symbol indicates hot surfaces. Take care when servicing the machine.



Lethal Voltage Symbol

This symbol indicates potentially lethal voltages. Take care when servicing the machine when the power cord is connected.



Fuses

WARNING

Do not install a fuse of a different type or rating. Installing the wrong type or rating of fuse can cause overheating and a risk of fire.

Part Replacement

Only use genuine Xerox approved spare parts or components to maintain compliance with legislation and safety certification.

Disassembly Precautions

Do not leave the machine with any covers removed at a customer location.

Re-assembly Precautions

Use extreme care during re-assembly. Check all harnesses to ensure they do not contact moving parts and do not get trapped between components.

General Procedures

Observe all warnings displayed on the machine and written in the service procedures. Do not attempt to perform any task that is not specified in the service procedures.

Health and Safety Incident Reporting

I. Summary

This section defines requirements for notification of health and safety incidents involving Xerox products (equipment and materials) at customer locations.

II. Scope

Xerox Corporation and subsidiaries worldwide.

III. Objective

To enable prompt resolution of health and safety incidents involving Xerox products and to ensure Xerox regulatory compliance.

IV. Definitions

Incident:

An event or condition occurring in a customer account that has resulted in injury, illness or property damage. Examples of incidents include machine fires, smoke generation, physical injury to an operator or service representative. Alleged events and product conditions are included in this definition.

V. Requirements

Initial Report:

1. Xerox organizations shall establish a process for individuals to report product incidents to Xerox Environment Health & Safety within 24 hours of becoming aware of the event.
2. The information to be provided at the time of reporting is contained in Appendix A (Health and Safety Incident Report involving a Xerox product).
3. The initial notification may be made by any of the methods that follow:
 - For incidents in North America and Developing Markets West (Brazil, Mexico, Latin American North and Latin American South):
 - Phone* Xerox EH&S at: +1-800-828-6571.
 - Electronic mail Xerox EH&S at: usa.xerox.ehs@xerox.com.
 - Fax Xerox EH&S at: +1-585-216-8817 [internet 8-219-8817].
 - For incidents in Europe and Developing Markets East (Middle East, Africa, India, China and Hong Kong):
 - Phone* Xerox EH&S at: +44 (0) 1707 353434.
 - Electronic mail Xerox EH&S at: ehs-europe@xerox.com.
 - Fax Xerox EH&S at: +44 (0) 1707 353914 [internet 8 668 3914].

*Initial notification made by phone must be followed within 24 hours by a completed incident report and sent to the indicated electronic mail address or fax number.

NOTE: *If sending a fax, please also send the original via internal mail.*

Responsibilities for resolution:

1. Business Groups / Product Design Teams responsible for the product involved in the incident shall:
 - a. Manage field bulletins, customer correspondence, product recalls, safety retrofits.
 - b. Fund all field retrofits.

2. Field Service Operations shall:
 - a. Preserve the Xerox product involved and the scene of the incident inclusive of any associated equipment located in the vicinity of the incident.
 - b. Return any affected equipment/part(s) to the location designated by Xerox EH&S and/or the Business Division.
 - c. Implement all safety retrofits.
3. Xerox EH&S shall:
 - a. Manage and report all incident investigation activities.
 - b. Review and approve proposed product corrective actions and retrofits, if necessary.
 - c. Manage all communications and correspondence with government agencies.
 - d. Define actions to correct confirmed incidents.

VI. Appendices

The Health and Safety Incident Report involving a Xerox Product (Form # EH&S-700) is available in the locations that follow:

- On electronic documentation (EDOC), located in the folder \safety.
- In the hardcopy, located at the end of the manual.

Translated Warnings

Cleaning Warnings

WARNING

Do not attempt to mop up the spilt oil with conventional mops and water. This will spread the contamination and will extend the slip hazard.

DANGER: Ne pas essuyer avec une éponge ou une serpillère et de l'eau si de l'huile est renversée. Cela étalerait l'huile et augmenterait la zone représentant un risque de chute.

AVVERTENZA: non tentare di pulire una fuoriuscita di olio utilizzando uno spazzolone e acqua per evitare di estendere l'area contaminata e aumentare il rischio di scivolare.

VORSICHT: Nicht versuchen, ausgetretenes Öl mit einem herkömmlichen Wischlappen und Wasser zu beseitigen. Dadurch wird das Öl verteilt und es besteht eine noch größere Rutschgefahr.

AVISO: Absténgase de limpiar el aceite derramado a la manera convencional con una fregona y agua, ya que ello sólo provocaría la extensión de la contaminación y aumentaría el peligro de deslizamiento.

WARNING

Do not clean the stripper blade. The stripper blade is very sharp and can cause injury. If the stripper blade is dirty a new blade must be installed.

DANGER: Effectuez cette procédure avec précaution. La lame du doigt décolleur est très tranchante et peut être source de blessures.

AVVERTENZA: Fare attenzione durante questa procedura. La lama del separatore è molto tagliente e può causare lesioni personali.

VORSICHT: Bei diesem Vorgang vorsichtig vorgehen. Die Abstreifklinge ist sehr scharf und es besteht Verletzungsgefahr.

AVISO: Tenga cuidado durante este procedimiento. El conjunto de dedos de despegue es muy filudo y puede producir lesiones.

WARNING

Immediately clean an oil spill. Spilt oil is a slip hazard. Do not walk in the contaminated area. Walking in the contaminated area will spread the contamination and contaminate footwear. Contaminated footwear is a slip hazard.

DANGER: Dans le cas où de l'huile est renversée, nettoyez immédiatement pour éviter tout risque de chute. Évitez de marcher dans la zone où de l'huile a été renversée pour ne pas l'étaler sur le sol et prévenir tout risque de chute.

AVVERTENZA: Pulire immediatamente una fuoriuscita di olio per evitare il rischio di scivolare. Non camminare nell'area contaminata per evitare di diffondere l'area contaminata e di contaminare le calzature. Con le calzature contaminate si corre il rischio di scivolare.

VORSICHT: Ölflecke unverzüglich entfernen. Bei verschüttetem Öl besteht Rutschgefahr. Ölverschmutzten Bereich nicht betreten. Durch Treten in eine Öllache breitet sich die Verschmutzung aus und die Schuhe werden verunreinigt. Mit öligen Schuhsohlen besteht Rutschgefahr.

AVISO: Limpie de inmediato el aceite derramado. El aceite derramado puede ocasionar resbalones. No camine en la zona donde ocurrió el derrame. Si camina en ella, se untará de aceite los zapatos y esparcirá el aceite a otras zonas. Los zapatos con aceite pueden ocasionar resbalones

WARNING

Wear protective gloves when using solvents and cleaning agents, [PL 26.10 Item 5](#)

DANGER: Porter des gants de protection lors de l'utilisation de solvants et de produits de nettoyage, [PL 26.10 Item 5](#).

AVVERTENZA: utilizzare guanti protettivi durante l'impiego di solventi e soluzioni per pulizia [PL 26.10 Item 5](#).

VORSICHT: Beim Einsatz von Lösungs- und Reinigungsmitteln Handschuhe tragen [PL 26.10 Item 5](#).

AVISO: Póngase guantes de protección cuando utilice disolventes y productos de limpieza [PL 26.10 Item 5](#).

WARNING

Wear the protective gloves included in the silicon oil removal kit when using the syringe to remove the oil.

DANGER: Il est indispensable de porter les gants de protection inclus dans le kit silicone de nettoyage de l'huile lors de l'utilisation de la seringue de pour nettoyer l'huile.

AVVERTENZA: Quando si usa la siringa per rimuovere l'olio, indossare i guanti protettivi inclusi nel kit di rimozione dell'olio di silicone.

VORSICHT: Beim Entfernen von Öl mit der Ölabsaugpumpe die im Reinigungsset für die Silikonölbeseitigung enthaltenen Schutzhandschuhe tragen.

AVISO: Póngase los guantes protectores incluidos en el kit de extracción del aceite de silicona cuando utilice la jeringa para extraer el aceite.

Electrical Warnings

WARNING

Do not attempt any repairs to the power cord or safety ground harness/conductor.

DANGER: Ne pas tenter de réparer le faisceau/conducteur de mise à la masse ou du cordon d'alimentation.

AVVERTENZA: non eseguire riparazioni sul cavo dell'alimentazione o sul conduttore di terra di sicurezza.

VORSICHT: Keine Reparaturen am Netzkabel oder am Schutzleiter vornehmen.

AVISO: No intente reparar el cable de alimentación ni el conductor/mazo de tierra de protección.

WARNING

Do not install a fuse of a different type or rating. Installing the wrong type or rating of fuse can cause overheating and a risk of fire.

DANGER: Ne pas installer de fusible de type ou de calibre différent. Il existe un risque de surchauffe voire d'incendie.

AVVERTENZA: per evitare rischi di surriscaldamento o d'incendio, non installare un fusibile di tipo o carica diversi da quelli esistenti.

VORSICHT: Keine Sicherungen anderer Art oder anderer Leistung auf dem IOT-PWB installieren - Überhitzungs- und Brandgefahr.

AVISO: No instale un fusible de potencia o tipo distinto. Un fusible de potencia o tipo distinto puede producir sobrecalentamiento y el riesgo de incendio.

WARNING

Do not switch on the electricity to the machine while a ground circuit is disconnected. Ground circuits ensure that the machine remains safe during a fault condition.

DANGER: Ne pas mettre la machine sous tension si un circuit de mise à la masse est déconnecté. Les circuits de mise à la masse permettent de garantir la sécurité de la machine lors d'un incident.

AVVERTENZA: Non accendere la macchina se uno dei conduttori di terra non è connesso. In caso di guasti elettrici, tali conduttori garantiscono la sicurezza del sistema.

VORSICHT: Stromzufuhr zum Gerät nicht einschalten, wenn keine Erdung gegeben ist.

AVISO: No encienda la máquina mientras esté desconectado algún circuito de tierra. Los circuitos de tierra mantienen la seguridad de la máquina en las situaciones de averías o errores.

WARNING

Do not touch the ink loader melt plates while the machine is switched on. Dangerous voltages may be present that could cause death or injury.

DANGER: Ne pas toucher les plaques de fusion du chargeur d'encre tant que la machine est sous tension. Elles représentent un risque de chocs électriques qui sont un danger de mort ou peuvent entraîner des blessures graves.

AVVERTENZA: non toccare le piastre di fusione del caricatore di inchiostro mentre la macchina è accesa. La presenza di voltaggi pericolosi comporta il rischio di morte o lesioni personali.

VORSICHT: Die Schmelzplatten des Tintenfüllbereichs nicht berühren, solange das Gerät eingeschaltet ist. An den Platten liegt eine Spannung an; es besteht Stromschlag- bzw. Lebensgefahr!

AVISO: No toque las planchas fundidas del cargador de tinta mientras la máquina esté encendida, ya que podría haber tensiones peligrosas que podrían provocar lesiones o incluso la muerte.

WARNING

Do not use the on/off switch as a safety disconnect device. The on/off switch is not a disconnect device. Disconnect the power cord from the supply to isolate the equipment.

DANGER: Ne pas utiliser l'interrupteur comme système d'arrêt d'urgence. Déconnecter le cordon d'alimentation de la prise pour isoler l'équipement.

AVVERTENZA: Non usare l'interruttore di accensione/spengimento come dispositivo di sicurezza per il disinserimento dell'elettricità, in quanto l'interruttore non è stato designato per questa funzione. Per isolare la macchina dalla corrente elettrica, scollegare il cavo dell'alimentazione dalla presa a muro.

VORSICHT: Der Netzschalter reicht zur Trennung von der Netzspannung NICHT aus. Um das Gerät von der Netzspannung zu trennen, den Netzstecker abziehen.

AVISO: No utilice el interruptor de encendido/apagado como dispositivo de desconexión seguro. El interruptor de encendido/apagado no es un dispositivo de desconexión. Para aislar el equipo totalmente, desconecte el cable de alimentación de la toma de corriente.

WARNING

Ensure that the electricity to the machine is switched off while performing tasks that do not need electricity. Refer to **GP 14**. Disconnect the power cord. Electricity can cause death or injury. Moving parts can cause injury.

DANGER: Assurez-vous que la machine est hors tension lorsque vous effectuez des

tâches ne nécessitant pas d'alimentation électrique. Reportez-vous à **GP 14**. Débranchez le câble d'alimentation pour prévenir tout risque d'électrocution. Les chocs électriques peuvent présenter un danger de mort ou entraîner des blessures graves. De plus, certaines pièces, lorsqu'elles sont en mouvement, peuvent être source de blessures graves.

AVVERTENZA: Accertarsi di isolare la macchina dall'alimentazione elettrica quando si eseguono attività che non richiedono elettricità. Vedere **GP 14**. Scollegare il cavo di alimentazione. L'elettricità può causare morte o lesioni personali. Le parti in movimento possono causare lesioni personali.

VORSICHT: Sicherstellen, dass die Stromversorgung des Geräts bei Arbeiten, die keinen Strom erfordern, ausgeschaltet ist. Siehe auch **GP 14**. Den Netzstecker ziehen. Andernfalls besteht Stromschlaggefahr und Verletzungsgefahr durch bewegliche Teile.

AVISO: Asegúrese de mantener la máquina aislada de la energía eléctrica mientras realiza tareas que no necesitan electricidad. Consulte **GP 14**. Desconecte el cable de alimentación. La energía eléctrica puede producir lesiones o incluso la muerte. Las piezas sueltas pueden producir lesiones.

WARNING

Switch off the electricity to the machine. Refer to **GP 14**. Disconnect the power cord from the customer supply while performing tasks that do not need electricity. Electricity can cause death or injury. Moving parts can cause injury.

DANGER: Mettez la machine hors tension. Reportez-vous à **GP 14**. Déconnectez le cordon d'alimentation de l'alimentation du client lorsque vous réalisez des tâches qui ne nécessitent pas d'électricité. L'électricité peut être à l'origine de blessures, voire d'un accident mortel. Les pièces amovibles peuvent être à l'origine de blessures.

AVVERTENZA: Spegnere la macchina. Vedere **GP 14**. Scollegare il cavo di alimentazione dall'alimentatore quando si eseguono attività che non richiedono elettricità. L'elettricità può causare morte o lesioni personali. Le parti in movimento possono causare lesioni personali.

VORSICHT: Schalten Sie die Stromversorgung der Maschine ab. Siehe auch **GP 14**. Ziehen Sie das Stromkabel ab, wenn Sie Aufgaben ausführen, für die keine Stromversorgung benötigt wird. Stromschläge können Todesfällen oder Verletzungen verursachen. Bewegliche Teile können zu Verletzungen führen.

AVISO: Apague la electricidad de la máquina. Consulte el **GP 14**. Desconecte el cable de alimentación eléctrica de la toma de pared mientras esté realizando tareas que no necesiten corriente. La electricidad puede causar daños o la muerte. Las partes móviles pueden causar daños.

WARNING

Take care when measuring AC mains (line) voltage. Electricity can cause death or injury.

DANGER: Prendre des précautions lors du relevé de la tension de la prise de courant alternatif. L'électricité peut entraîner des blessures graves voire mortelles.

AVVERTENZA: Procedere con cautela durante la misurazione della tensione CA della rete. L'elettricità può causare infortuni o morte.

VORSICHT: Bei der Netzspannungsprüfung stets vorsichtig vorgehen

AVISO: Tenga cuidado al medir la tensión de la línea de alimentación de corriente alterna. La electricidad puede causar lesiones e incluso la muerte.

General Warnings

WARNING

A warning is used whenever an operating or maintenance procedure, practice, condition or statement, if not strictly observed, could result in personal injury.

DANGER: Une note Danger est utilisée chaque fois qu'une procédure d'utilisation ou de maintenance peut être cause de blessure si elle n'est pas strictement respectée.

AVVERTENZA: Un segnale di avvertenza è utilizzato ogni volta che una procedura operativa o di manutenzione, una pratica, una condizione o un'istruzione, se non strettamente osservata, potrebbe causare lesioni personali.

VORSICHT: Weist darauf hin, dass ein Abweichen von den angeführten Arbeits- und Wartungsanweisungen gesundheitliche Schäden, möglicherweise sogar schwere Verletzungen zur Folge haben kann.

AVISO: Un aviso se utiliza siempre que un procedimiento de operación o mantenimiento, práctica o condición puede causar daños personales si no se respetan estrictamente.

WARNING

Do not leave an old stripper blade at the customer's site.

DANGER: Ne pas laisser les lames usagées du doigt décolleur sur le site client.

AVVERTENZA: non lasciare mai una vecchia lama di separazione presso la sede del cliente.

VORSICHT: Alte Abstreifklingen nicht am Kundenstandort zurücklassen, sondern entsorgen.

AVISO: No deje un conjunto de dedos de despegue antiguo en las instalaciones del cliente.

WARNING

Do not undock the HVF BM from the machine. The HVF BM is unstable when undocked from the machine. Do not show the customer how to undock the HVF BM.

DANGER: Ne déconnectez pas le module HVF BM de la machine. Le module HCSS BM devient instable lorsqu'il est déconnecté de la machine. Ne démontrez pas au client comment déconnecter le module HCSS BM.

AVVERTENZA: Non sganciare il modulo HVF BM dalla macchina. Questo modulo non è stabile quando è sganciato dalla macchina. Non mostrare al cliente come sganciare il modulo HCSS BM.

VORSICHT: Docken Sie nicht den HVF BM von der Maschine ab. Der HCSS BM ist instabil, wenn er von der Maschine abgedockt ist. Zeigen Sie dem Kunden nicht, wie der HCSS BM abgedockt wird.

AVISO: No desacople el apilador o grapadora de alta capacidad HVF BM de la máquina. Ésta no es estable cuando se desacopla de la máquina. No muestre al cliente cómo desacoplar el apilador/grapadora de alta capacidad HCSS BM.

WARNING

Do not work in a confined space. 1 m (39 inches) space is needed for safe working.

DANGER: Ne pas travailler dans un espace restreint. 1 mètre d'espace est nécessaire pour un dépannage en toute sécurité.

AVVERTENZA: Non lavorare in uno spazio limitato; è necessario uno spazio di almeno un metro attorno alla macchina per la sicurezza dell'operatore.

VORSICHT: Nur mit ausreichendem Bewegungsspielraum (1 m) arbeiten.

AVISO: No trabaje en un espacio reducido. Se necesita 1 metro de espacio para trabajar

con seguridad.

WARNING

Mandatory safety warning. This procedure must be performed by 2 people. The module is heavy.

DANGER: Avertissement obligatoire. Cette procédure doit être effectuée par 2 personnes. Le module est très lourd.

AVVERTENZA: Avviso di sicurezza obbligatorio. A causa della pesantezza del modulo, questa procedura deve essere eseguita da due persone.

VORSICHT: Verbindliche Sicherheitsvorschrift - dieser Vorgang muss von zwei Personen ausgeführt werden, da das Modul sehr schwer ist.

AVISO: Aviso de seguridad obligatorio. Este procedimiento debe ejecutarse entre dos personas. El módulo pesa mucho.

WARNING

Take care not to topple the LCSS. The LCSS is unstable when undocked from the machine. Do not show the customer how to undock the LCSS.

DANGER: Attention à ne pas faire tomber la trieuse/agrafeuse petite capacité. Elle n'est pas stable lorsqu'elle est détachée de la machine. Ne pas montrer au client comment détacher la trieuse/agrafeuse.

AVVERTENZA: fare attenzione a non destabilizzare il modulo della pinzatrice/impilatore da 2000 fogli. Quando è sganciato dalla macchina, il modulo è instabile: non mostrare al cliente come sganciarlo

VORSICHT: Stapler nicht umstoßen. Nach Trennung des Staplers vom Document Centre ist dieser sehr instabil

AVISO: Tenga cuidado de que no se caiga el apilador/grapadora de baja capacidad. Cuando no está acoplada a la máquina es inestable. No le muestre al cliente como desacoplar el apilador/grapadora de baja capacidad.

WARNING

Take care not to topple Tray 5. Tray 5 is unstable when undocked from the machine. Do not show the customer how to undock Tray 5.

DANGER: Attention à ne pas faire tomber le magasin 5. Le magasin 5 n'est pas stable lorsqu'il est détaché de la machine. Ne pas montrer au client comment détacher le magasin 5.

AVVERTENZA: Fare attenzione a non destabilizzare il vassoio 5. Quando è sganciato dalla macchina, questo vassoio è instabile: non mostrare al cliente come sganciarlo.

VORSICHT: Behälter 5 nicht umstoßen. Der Behälter ist nach der Trennung vom Gerät sehr instabil. Benutzer nicht im Trennen des Behälters vom Gerät einweisen.

AVISO: Tenga cuidado de que no se caiga la bandeja 5. Cuando no está acoplada a la máquina, la bandeja 5 es inestable. No le muestre al cliente como desacoplar la bandeja 5.

WARNING

USA and Canada. Do not install this machine in a hallway or exit route that does not have 1.12 m (44 inches) of space additional to the normal space requirements in front of the machine. To conform with fire regulations this additional 1.12 m (44 inches) of space is needed in front of the machine in hallway and exit routes.

DANGER: États-Unis et Canada. Si cette machine est installée dans un couloir ou une voie de sortie, 1,12 m (44 pouces) d'espace supplémentaire à l'espace normal doit être disponible devant la machine conformément aux normes de sécurité d'incendie.

AVVERTENZA: N/A

VORSICHT: N/A

AVISO: Estados Unidos y Canadá. No instale esta máquina en un corredor o ruta de salida que no tenga 1.12 m (44 pulgadas) de ancho delante de la máquina, sin incluir el espacio que ocupe la máquina. Este espacio adicional de 1.12 m (44 pulgadas) delante de la máquina en corredores y rutas de salida es necesario para cumplir los requisitos de las normas sobre incendios.

WARNING

Use safe handling procedures when removing the module, **GP 16**. The module is heavy.

DANGER: Conformez-vous aux procédures de manipulation de sécurité pour le retrait du module. Reportez-vous à **GP 16**. Le module est lourd.

AVVERTENZA: Utilizzare procedure di gestione sicure durante la rimozione del modulo. Vedere **GP 16**. Il modulo è pesante.

VORSICHT: Verwenden Sie sichere Vorgehensweisen zum Entfernen des Moduls. Siehe auch **GP 16**. Das Modul ist sehr schwer.

AVISO: Utilice los procedimientos de seguridad cuando elimine el módulo. Consulte el **GP 16**. El módulo es pesado.

Heat Warnings

WARNING

Do not touch the ink reservoir while it is hot.

DANGER: Ne pas toucher au réservoir d'encre tant qu'il est chaud.

AVVERTENZA: non toccare il serbatoio di inchiostro quando è caldo.

VORSICHT: Den Tintenbehälter erst anfassen, wenn er abgekühlt ist.

AVISO: No toque el depósito de tinta mientras éste esté caliente.

WARNING

Take care during this procedure. Motors will become hot during normal operation.

DANGER: Exécuter cette procédure avec précaution. Les moteurs peuvent devenir très chauds en fonctionnement normal.

AVVERTENZA: procedere con cautela durante questa procedura. I motori si riscaldano molto durante il funzionamento.

VORSICHT: Bei diesem Vorgang vorsichtig vorgehen, da Motoren im Normalbetrieb heiß werden können.

AVISO: Tenga cuidado al efectuar este procedimiento. Los motores alcanzan altas temperaturas durante su funcionamiento normal.

WARNING

Take care during this procedure. The drum will become hot during normal operation.

DANGER: Faites attention pendant cette procédure. Dans des conditions normales de fonctionnement, le tambour devient chaud.

AVVERTENZA: Prestare attenzione durante questa procedura. Il tamburo diventa caldo durante il normale funzionamento.

VORSICHT: Die Trommel wird im Normalbetrieb heiß.

AVISO: Tome precauciones durante el procedimiento. El cilindro tendrá una temperatura elevada durante el funcionamiento normal.

WARNING

Take care during this procedure. The registration/preheat assembly will become hot

during normal operation.

DANGER: Exécuter cette procédure avec précaution. Le module de cadrage/préchauffage peut devenir très chaud en fonctionnement normal.

AVVERTENZA: procedere con cautela durante questa procedura. Il complessivo di registrazione/preriscaldamento raggiunge alte temperature durante il funzionamento.

VORSICHT: Bei diesem Vorgang vorsichtig vorgehen, da das Ausrichtungsmodul/Vorheizaggregat im Normalbetrieb heiß wird.

AVISO: Tenga cuidado al realizar este procedimiento, ya que el conjunto de registro/precalentamiento alcanza una elevada temperatura durante su funcionamiento normal.

Mechanical Warnings

WARNING

Do not remove the DADH while the DADH is lowered. In the lowered position the counterbalance springs are compressed and can cause injury when released.

DANGER: Ne pas retirer le CAD alors qu'il est en position basse. Dans cette position, les ressorts compensateurs sont comprimés et peuvent entraîner des blessures s'ils se relâchent.

AVVERTENZA: non rimuovere l'alimentatore automatico documenti quando è abbassato. In questa posizione, le molle del contrappeso sono compresse e possono causare lesioni al rilascio.

VORSICHT: Vorlageneinzug nicht in abgesenkter Position entfernen. Bei abgesenktem Vorlageneinzug sind die Ausgleichsfedern zusammengedrückt und können bei Freigabe Verletzungen verursachen.

AVISO: No quite el alimentador de documentos automático si está bajado. Cuando está bajado, los resortes de contrapeso están comprimidos y pueden causar lesiones al soltarse.

WARNING

Keep away from the crease blade mechanism when working in close proximity to the booklet maker while the machine is powered on. The crease blade mechanism activates quickly and with great force.

DANGER: Ne pas s'approcher du mécanisme de la lame de pliage lors d'une activité à proximité de la plieuse/brocheuse pendant que la machine est sous tension. Ce mécanisme s'active rapidement et avec force.

AVVERTENZA: Quando la macchina è accesa, tenersi a debita distanza dalla lama di piegatura mentre si opera in prossimità della stazione libretto. Il meccanismo della lama di piegatura si attiva con velocità e forza notevoli.

VORSICHT: Wenn bei eingeschaltetem Gerät nahe am Booklet Maker gearbeitet wird, von der Schneidevorrichtung fernhalten. Die Schneidevorrichtung wird schnell und mit viel Druck ausgelöst.

AVISO: Manténgase apartado del mecanismo de la cuchilla hendedora cuando trabaje junto al realizador de folletos si la máquina está encendida. Dicho mecanismo se activa de forma rápida y con mucha fuerza.

WARNING

Take care during this procedure. Sharp edges may be present that can cause injury.

DANGER: Exécuter cette procédure avec précaution. La présence de bords tranchants peut entraîner des blessures.

AVVERTENZA: procedere con cautela durante questa procedura. Possono essere presenti oggetti con bordi taglienti pericolosi.

VORSICHT: Bei diesem Vorgang vorsichtig vorgehen, damit keine Verletzungen durch die scharfen Kanten entstehen.

AVISO: Tenga cuidado al efectuar este procedimiento. Puede haber bordes afilados que podrían producir lesiones.

WARNING

Take care during this procedure. The stripper blade is very sharp and can cause injury.

DANGER: Effectuez cette procédure avec précaution. La lame du doigt décolleur est très tranchante et peut être source de blessures.

AVVERTENZA: Fare attenzione durante questa procedura. La lama del separatore è molto tagliente e può causare lesioni personali.

VORSICHT: Bei diesem Vorgang vorsichtig vorgehen. Die Abstreifklinge ist sehr scharf und es besteht Verletzungsgefahr.

AVISO: Tenga cuidado durante este procedimiento. El conjunto de dedos de despegue es muy filudo y puede producir lesiones.

1 Service Call Procedures

SCP 1 Initial Actions.....	1-3
SCP 2 Call Actions.....	1-3
SCP 3 Fault Analysis	1-4
SCP 4 Subsystem Maintenance	1-6
SCP 5 Final Actions	1-7

SCP 1 Initial Actions

Use Service Call Procedures to find a problem with the machine.

Always use SCP 1 Initial Actions to collect information on the machine performance. Do not skip Initial Actions.

Also refer to [GP 33](#) Machine Features.

Procedure

WARNING

Do not work in a confined space. 1m (39 inches) space is needed for safe working.

1. If the reason for the call is an oil spill from the machine, go to [GP 27](#) Cleaning Procedure.
2. Ask the operator to describe or demonstrate the problem.

NOTE: *If the machine is password protected, login into Service Copy Mode, refer to [GP 1](#) Service Mode.*

3. If the problem is the result of an incorrect action by the operator, refer the operator to the user documentation.
4. Check the steps that follow:
 - a. The power lead is connected to the wall outlet and to the machine.
 - b. Documents are not loaded in the DADH or on the document glass.
 - c. The paper is loaded correctly.
If the paper in the trays does not match the paper specified on the UI, change the paper or the specification to match.
 - d. All paper trays are closed.
 - e. All covers are closed or installed.
 - f. If a telephone line is installed, make sure that the line is connected between the machine and the wall jack.
 - g. If a telephone line is installed, make sure that the customer telephone line is functioning.
 - h. That there is sufficient supply of ink sticks.
 - i. If the problem is media related. Check the relevant area of paper path for scraps of media or sheets not easily visible to a customer
5. Check the machine service log book for previous actions that relate to this call.
6. Go to [SCP 2](#) Call Actions.

SCP 2 Call Actions

Use SCP 2 Call Actions during a service call.

Procedure

1. If this is the first service call to this machine perform the following actions:
 - a. Check the machine configuration with the customer.
Refer to [dC131](#) Read / Write to check the following:
 - Machine speed, refer to NVM ID 616-003. If incorrect a pre-serialized SIM is required, obtain through normal channels.
 - Product identifier, refer to NVM ID 616-052. If necessary, correct within the NVM location.
 - Service plan, refer to NVM ID 606-269. If necessary, correct in [dC136](#) or [dC103](#).
 - b. Check that all the required hardware and software is installed and enabled.
 - c. Check that the machine tray settings are correct.
 - d. Mark off the hardware options, software options or Tags installed on the Tag matrix cards.
 - e. Enter the machine information and the customer information in the service log book.
2. Check and record the total print count.
3. Review any copy, print and fax samples.
4. Make sure the user access settings are correct. If necessary, refer to the user documentation.
5. To prevent the deletion of the soft machine settings, perform an NVM save from service mode on the UI using [dC361](#) NVM Save and Restore in the maintenance routines.
6. If necessary perform [GP 17](#) Network Clone Procedure.
NOTE: *The clone file must be taken whenever the customer changes the network controller setting or the system software is changed. Advise the administrator to perform this procedure at a regular interval.*
7. Before switching off the machine or clearing the memory, check for a customer job in the memory.
8. Go to [SCP 3](#) Fault Analysis.

SCP 3 Fault Analysis

Use SCP 3 Fault Analysis to identify a fault.

Procedure

If an error message or fault code appears, go to the relevant RAP. If necessary refer to [OF 4 Status Codes and Messages RAP](#).

Check the fault history. Refer to [GP 2 Fault Codes and History Files](#). If necessary, go to the relevant RAP.

Check if a Service Code is displayed on the Machine Information tab on the user interface, refer to [OF 12 Service Codes RAP](#). If necessary, perform [OF 12 Service Codes RAP](#).

To check for Power on Self Test (POST) errors. Refer to [OF 16 Post Error RAP](#).

If a fault code is not displayed use the machine in all modes until the fault is found. Use the list that follows to find the correct procedure for the machine fault. When the fault is cleared, go to [SCP 4 Subsystem Maintenance](#), then [SCP 5 Final Actions](#).

- [Power Up Problems](#)
- [Sleep Mode Problems](#)
- [User Interface Problems](#)
- [Messages](#)
- [Image Quality Problems](#)
- [DADH Problems](#)
- [Paper Supply and Paper Feed Problems](#)
- [OCT Problems](#)
- [LCSS Problems](#)
- [HVF, HVF BM, Inserter and Tri-Folder Problems](#)
- [Fax Problems](#)
- [Other Problems](#)
- [Additional Information](#)

Power Up Problems

- Go to the [OF 3 Unresponsive Machine RAP](#) if the machine has any of the faults that follow:
 - The machine will not power up.
 - There is no information on the user interface.
 - There is no LED illumination on the user interface.
 - All the panel lights are on, the UI touch screen is illuminated and the machine then powers off.
 - The UI touch screen repeatedly cycles back to the install wizard screen.
- If the UI display stops on the splash screen, [Figure 1](#), go to [OF 16 POST Error RAP](#).



U-1-1568-A

Figure 1 Splash screen

- If the UI displays 'The machine is not available' or the machine does not come to a 'Ready to scan your job' state. Go to the [OF 5 Boot Up Failure RAP](#).

Sleep Mode Problems

- If the machine fails to enter or exit sleep mode, go to the [OF 7 Sleep Mode RAP](#).

User Interface Problems

- Go to the [OF 3 Unresponsive Machine RAP](#) if the machine has the faults that follow:
 - The machine is silent.
 - There is no information on the user interface.
 - There is no LED illumination on the user interface.
- If the user interface is not illuminated or fails to respond correctly, go to [OF 2 UI Touch Screen Failure RAP](#).
- If the user interface is illuminated, but there is no information, go to the [02-321-00 XEIP Browser Dead RAP](#).
- If the UI is offset, corrupted or has a problem selecting features, refer to [GP 32 User Interface Panel Diagnostics](#), check panel calibration and the UI functions.

Messages

- If a message is displayed, but not a fault code, go to [OF 4 Status Code and Message RAP](#).

Image Quality Problems

- Go to the [IQ 1 Image Quality Entry RAP](#).

DADH Problems

- If the DADH does not detect the documents in the DADH input tray, go to [05B DADH Document Sensor Failure RAP](#).
- If the DADH has a fault, but not a fault code, go to the [05A DADH Other Faults RAP](#).
- If the DADH has detected a document of the wrong size. Perform the procedures that follow:
 - [62A Scanning Document Size RAP](#).
 - [05-257-00 Unknown Document Size RAP](#).

Paper Supply and Paper Feed Problems

- For the paper supply faults that do not have a fault code, perform the relevant procedures that follow:
 - [71A Tray 1 Empty RAP](#).

- 71B Tray 1 Wrong Size Paper RAP.
- 72A Tray 2 Empty RAP.
- 72B Tray 2 Wrong Size Paper RAP.
- 73A Tray 3 Out Of Paper RAP.
- 74A Bypass Tray RAP.
- 75B Tray 5 Empty RAP
- If the machine produces a multifeed, go to the [OF 8](#) Multifeed RAP.

OCT Problems

- If the prints adhere to each other in the OCT, check the static brush at the exit rolls [PL 10.15](#) Item 5.

LCSS Problems

- If the machine has an LCSS fault, but not a fault code, perform the relevant procedures that follow:
 - [12A-110](#) Pause to Unload (PTU) Fault RAP.
 - [12B-110](#) Bin 1 Overload RAP.
 - [12C-110](#) LCSS Initialization Failure RAP.
 - [12D-110](#) LCSS Power Distribution RAP.
 - [12E-110](#) LCSS Paper Entry RAP.
 - [12F-110](#) LCSS PWB DIP Switch Settings RAP.
 - [12G-110](#) LCSS PWB Damage RAP.
 - [12H-110](#) Copy Damage in the LCSS RAP.
 - [12J-110](#) Mis-Registration in Stapled Sets and Non-Stapled Sets RAP.
 - [12K-110](#) LCSS Poor Stacking RAP.
 - [12L-110](#) Stapling Prime Failure RAP.
 - [12M-110](#) Staple Head Operation Failure RAP.
 - [12N-110](#) Chad Bin Present and Bin Full RAP.
- If the punched holes are out of position, perform [ADJ 12.3-110](#) Hole Punch Position.
- If the machine has the problems that follow, go to the [12F-110](#) LCSS PWB DIP Switch Settings RAP:
 - False jam clearance messages.
 - Communication errors between the LCSS and the machine.
- If the staples of a stapled set are not correct, go to the [12L-110](#) Stapling Prime Failure RAP.

HVF, HVF BM, Inserter and Tri-Folder Problems

- If the machine has a fault in the HVF or HVF BM, but with no fault code, perform the relevant procedures that follow:
 - [12A-171](#) HVF BM Power Distribution RAP.
 - [12B-171](#) HVF BM to Machine Communication Interface and BM Present RAP.
 - [12C-171](#) HVF BM Bin 2 Failure RAP.
 - [12D-171](#) Booklet Quality RAP.
 - [12E-171](#) Copy Damage in the HVF BM RAP.
 - [12F-171](#) Mis-Registration in Stapled and Unstapled Sets RAP.
 - [12G-171](#) HVF BM Poor Stacking RAP.
 - [12H-171](#) Pause To Unload (PTU) RAP.

- [12J-171](#) Inserter Paper Sensing and +5V Supply RAP.
- [12K-171](#) HVF Initialization Failure RAP.
- [12L-171](#) Tri-Folder Not Detected RAP.
- [12N-171](#) Chad Bin Present and Bin Full RAP.
- [12M-171](#) Buffer Clamp RAP.
- If a booklet is not stapled or folded correctly go to:
 - [ADJ 12.6-171](#) Booklet Compiling Position.
 - [ADJ 12.7-171](#) Booklet Crease Position.
 - [ADJ 12.8-171](#) Booklet Staple Position.
- If the tri-folder paper fold is not in the correct position, perform [ADJ 12.2-171](#) Tri-Folder Paper Settings.

Fax Problems

- For Fax problems with no fault code, perform the relevant procedures that follow:
 - [20A](#) Fax Entry RAP.
 - [20B](#) Unable To Send A Fax RAP.
 - [20C](#) Unable To Send A Fax To Some Machines RAP.
 - [20D](#) Unable To Receive A Fax RAP.
 - [20E](#) Fax Will Not Print RAP.
 - [20F](#) Fax Tab Not Available RAP.
 - [20G](#) Fax Module Checkout RAP.
 - [20H](#) Fax Problems on Digital Networks RAP.

Other Problems

- Ink leak. Go to the [93B](#) Ink Leak Checkout RAP.
- The ink level gauges on the UI do not correlate with the number of ink sticks in the ink loader. Go to the [OF 9](#) Ink Stick Count Mismatch.
- The key plate is in the incorrect position and preventing the loading of the ink sticks. Go to the [OF 11](#) Unable to Load Ink Sticks.
- Intermittent failure. Go to the [OF 10](#) Intermittent Failure RAP.
- Machine noise. Go to the [OF 1](#) Unusual Noise RAP.
- Hot machine. Go to the [OF 6](#) Fans and Air Systems RAP.
- Convenience stapler faults. Go to the [OF 13](#) Convenience Stapler RAP.
- Machine odour. Go to the [OF 6](#) Fans and Air Systems RAP.
- Check the fault history, [GP 2](#) Fault Codes and History Files.
- Xerox extensible interface platform faults. Go to the [OF 14](#) Xerox Extensible Interface Platform RAP.
- Xerox secure access faults. Go to the [OF 15](#) Xerox Secure Access RAP.
- Network problems, go to the [16A](#) Network Error Entry RAP.
- If the foreign device is not detected, go to the [03A](#) Foreign Device PWB Fault RAP.

Additional Information

If necessary, refer to the following general procedures and information:

- [GP 1](#) Service Mode
- [GP 2](#) Fault Codes and History Files
- [GP 3](#) Service Information
- [GP 4](#) Machine Software

- [GP 5](#) Customer Administration Tools
- [GP 6](#) Marking Unit Maintenance Positions
- [GP 7](#) System Grounding Verification
- [GP 8](#) Special Tools and Consumables
- [GP 9](#) User Interface Service Menu Map
- [GP 10](#) How to Check a Motor
- [GP 11](#) How to Check a Sensor
- [GP 12](#) How to Check a Solenoid or Clutch
- [GP 13](#) How to Check a Switch
- [GP 14](#) How to Switch Off the Machine or Switch On the Machine
- [GP 15](#) Location and Function of PWB LEDs
- [GP 16](#) How to Safely Lift or Move Heavy Modules
- [GP 17](#) Network Clone Procedure
- [GP 18](#) Machine Lubrication
- [GP 19](#) Machine SIM Card Matrix
- [GP 20](#) Paper and Media Size Specifications
- [GP 21](#) Installation Space Requirements
- [GP 22](#) Electrical Power Requirements
- [GP 23](#) Environmental Data
- [GP 24](#) Hardware Kit Contents
- [GP 25](#) First Copy / Print Out Time and Power On / Off Time
- [GP 26](#) Restriction of Hazardous Substances (RoHS)
- [GP 27](#) Cleaning Procedure
- [GP 28](#) Marking Unit Assembly Wiring Harnesses
- [GP 29](#) Component Locations
- [GP 30](#) How to Mask Jets / Jet Substitution
- [GP 31](#) How to Open and Close the Stripper Gate
- [GP 32](#) User Interface Panel Diagnostics
- [GP 33](#) Machine Features
- [GP 34](#) Service Plan
- [GP 35](#) Copy and Print Speeds
- [GP 36](#) How to Unlock the Cleaning Unit
- [GP 37](#) Post Part Replacement Routines
- [GP 38](#) How to Set the Date and Time
- [GP 39](#) How to Enable HTTP
- [GP 40](#) Glossary of Terms, Acronyms and Abbreviations

SCP 4 Subsystem Maintenance

Use SCP 4 Subsystem Maintenance to maintain the machine.

Procedure

WARNING

Ensure that the electricity to the machine is switched off while performing tasks that do not need electricity. Refer to [GP 14](#). Disconnect the power cord. Electricity can cause death or injury. Moving parts can cause injury.

Go to the correct procedure:

- [HFSI](#)
- [Lubrication](#)
- [How to Clean the Machine](#)

HFSI

The High Frequency Service Items are shown in [Table 1](#) HFSI replacement and [Table 2](#) HFSI cleaning. To change HFSI settings, refer to [dC135](#) CRU / HFSI Status.

Table 1 HFSI replacement

Item	Component	Description	The recommended life for new component installation	Parts list reference
Tray 1 feed	Feed rolls	All sheets fed from tray 1 after last HFSI reset	600k feeds	PL 81.25 Item 6 PL 81.25 Item 9 PL 81.25 Item 11
Tray 2 feed	Feed rolls	All sheets fed from tray 2 after last HFSI reset	600k feeds	PL 81.26 Item 6 PL 81.26 Item 9 PL 81.26 Item 11
Tray 3 feed	Feed rolls	All sheets fed from tray 3 after last HFSI reset	600k feeds	PL 81.30 Item 6 PL 81.30 Item 9 PL 81.30 Item 11
Bypass tray 4 feeds	Bypass tray feed rolls	The total bypass tray 4 feeds after the last HFSI reset	600k feeds	PL 74.10 Item 7 PL 74.10 Item 13 PL 74.10 Item 14
Tray 5 feeds	Tray 5 feed rolls	All sheets fed from tray 5 after last HFSI reset	600k feeds	PL 81.45 Item 2
Insert tray 6	Insert tray feed rolls	Total Insert tray feeds	80k feeds	PL 12.310 Item 1
Transfix strip-per	Transfix strip-per assembly	All sheets fed after last HFSI reset	460k feeds	PL 10.20 Item 14

Table 2 HFSI cleaning

Item	Component	Description	The recommended cleaning frequency	Parts list reference
Drum fan shroud	Drum fan shroud	All sheets fed after last HFSI reset	500k feeds	PL 94.20 Item 5
Upper JL baffle	Upper baffle	All sheets fed after last HFSI reset	400k feeds	PL 10.10 Item 9

Lubrication

To lubricate the machine, refer to [ADJ 4.1](#) Machine Lubrication.

How to Clean the Machine

To clean the machine, refer to [GP 27](#) Cleaning Procedure.

SCP 5 Final Actions

Use SCP 5 Final Actions to complete the service call.

Procedure

Perform the steps that follow:

1. If necessary, perform an NVM Restore from service mode on the UI using [dC361](#) NVM Save and Restore.
2. If necessary, perform [GP 17](#) Network Clone Procedure.

NOTE: The clone file will need to be taken whenever the customer changes the network controller setting or after the system software is changed.

3. If necessary, go to [SCP 4](#) Subsystem Maintenance.
4. Clear all fault counters, go to [GP 1](#).
5. Check that the Service Code on the Machine Information tab displays 0. If any number other than 0 is displayed go to the [OF 12](#) Service Codes RAP.
6. Empty waste tray and reset waste tray count in the Call Closeout window in service mode.
7. Operate the machine in all modes.
8. Make copies and / or prints from all trays and check the registration and copy quality.
9. Make a proof copy or print of a customer document.
10. If some of the customers selections were changed, return the selections to the customer settings.
11. Mark off the hardware options, software options or Tags installed on the Tag matrix cards.
12. Perform an NVM Save from service mode on the UI using [dC361](#) NVM Save and Restore in the maintenance routines.
13. If some changes were made to the configuration or options were added, print the configuration report. Store the configuration report with the machine log book. Discard the previous version of the configuration report.
14. Make sure the machine and service area are clean. Refer to [GP 27](#) Cleaning Procedures.
15. If necessary, provide the customer with training.
16. At the completion of the service call, report the value of the usage counters.

2 Status Indicator RAPs

Chain 1 - Standby Power

01-505-00 Mid Left Door Open RAP	2-9
01-506-00 Upper Left Door Open RAP	2-9
01-510-00 Front Door Open RAP	2-10
01-525-00 +24V, +/-12V, +5V Short Circuit and Overload RAP	2-10
01-530-00 +/- 50V Short Circuit and Overload RAP	2-12
01-535-00 Power Interlock Failed: No Heater Requests RAP	2-13
01-540-00, 01-544-00 +24V, +/-12V, +5V Failure RAP	2-14
01-542-00, 01-546-00 50V Failure RAP	2-15
01A AC Power Distribution RAP	2-16
01B +3.3V ESTAR Distribution RAP	2-20
01C +3.3V Distribution RAP	2-22
01D +5V Distribution RAP	2-23
01E +12V Distribution RAP	2-26
01F -12V Distribution RAP	2-28
01G +17V Distribution RAP	2-29
01H +24V Distribution RAP	2-30
01J +50V Distribution RAP	2-34
01K -50V Distribution RAP	2-35
01L 0V Distribution RAP	2-37

Chain 2 - User Interface

02-302-00, 02-306-00, 02-308-00 Flash Failure RAP	2-39
02-315-00 Service Registry Bad Data RAP	2-39
02-316-00, 02-317-00 SRS Error RAP	2-40
02-320-00 Data Time Out Error RAP	2-40
02-321-00 XEIP Browser Dead RAP	2-41
02-380-00, 02-381-00 UI Communication Fault RAP	2-41
02-390-00 Configurable Services RAP	2-42

Chain 3 - Machine Run Control

03-316-00 CCM Cannot Communicate with IOT RAP	2-43
03-325-00 System Detects the Machine Clock Failed to Increment During Power On RAP	2-43
03-331-00, 03-332-00 Main Controller and Network Controller on the SBC PWB Cannot Communicate RAP	2-44
03-338-00 The Main Controller on the SBC Has Reset RAP	2-44
03-346-00 Unable To Communicate With UI RAP	2-45
03-347-00 Main Controller PWB Cannot Communicate with UI PWB RAP	2-45
03-355-00 CCM POST Failure Detected RAP	2-46
03-362-00 CCS Power Fault RAP	2-46
03-397-00 System Configuration Recovery Attempt RAP	2-47
03-398-00, 03-399-00 SIM Card Fault RAP	2-47
03-401-00, 03-403-00 Fax Not Detected RAP	2-48
03-417-00 Incompatible Fax Software RAP	2-48
03-777-00 Power Loss Detected RAP	2-49
03-788-00 CCS Runtime Could Not Enter Power Saver Mode S3 RAP	2-49
03-790-00 Timezone Cannot Be Set RAP	2-50
03A Foreign Device PWB Fault RAP	2-50

Chain 5 - DADH

05-250-00, 05-251-00 DADH Checksum Error RAP	2-51
05-252-00 DADH Stepper Controller Communications Error	2-51
05-253-00, 05-254-00 DADH Communications Error RAP	2-52
05-255-00 Late Pre Scan Message RAP	2-52
05-256-00 Eject Count Error RAP	2-53
05-257-00 Unknown Document Size RAP	2-53
05-258-00, 05-307-00 DADH Cover Interlock Open RAP	2-55
05-259-00, 05-260-00 DADH Active Line or Standby Error RAP	2-56
05-300-00 DADH Open RAP	2-56
05-310-00 Document Too Short RAP	2-57
05-330-00, 05-331-00 DADH Feed Sensor Failure RAP	2-57
05-335-00 DADH TAR Sensor Failure RAP	2-59
05-340-00 DADH Pre Registration Sensor Failure RAP	2-60
05-345-00, 05-346-00 DADH Exit Sensor Failure RAP	2-61
05-350-00, 05-352-00 DADH CVT Sensor Failure RAP	2-63
05A DADH Other Faults RAP	2-64
05B DADH Document Sensor Failure RAP	2-64
05C DADH Motor Failure RAP	2-65
05D DADH Feed Clutch Failure RAP	2-65
05E Damaged Documents RAP	2-66
05F Platen Down Failure RAP	2-67

Chain 10 - Transfix and Copy/Print Transportation

10-110-00 to 10-113-00, 10-125-00 to 10-128-00, 10-147-00, 10-148-00	
Post Transfix Jam RAP	2-69
10-140-00 to 10-146-00, 10-149-00 to 10-151-00 Exit Jam RAP	2-71
10-500-00 to 10-540-00 Transfix Error RAP	2-72
10-545-00 Drum Position Error for Transfix RAP	2-74
10-550-00 Drum Stall During Transfix RAP	2-75
10-555-00 Post Transfix Motor (M4) Over Current RAP	2-75
10-560-00, 10-565-00 Transfix Motor Over Current RAP	2-76
10-570-00 Stripper Solenoid Over Current RAP	2-77
10-571-00, 10-572-00 Stripper Latch Sensor Error RAP	2-78

Chain 12-65 - Offset Catch Tray

12-701-00-65 Offset Catch Tray Failure RAP	2-79
--	------

Chain 12-110 - LCSS

12-024-00-110, 12-025-00-110 Paddle Roll Failure RAP	2-81
12-043-00-110, 12-046-00-110 Hole Punch Operation Failure RAP	2-82
12-127-00-110 Sheet Late to Hole Punch RAP	2-83
12-151-00-110, 12-152-00-110 Sheet Late to Bin 1 RAP	2-83
12-171-00-110, 12-172-00-110 Paper Exiting to Bin 0 RAP	2-85
12-199-00-110 Unexpected Sheet at Finisher Entry RAP	2-86
12-310-00-110, 12-312-00-110, 12-313-00-110 Interlocks RAP	2-87
12-340-00-110, 12-341-00-110, 12-342-00-110 Ejector Movement Failure RAP	2-88
12-371-00-110, 12-372-00-110, 12-378-00-110 Staple Head Unit Movement Failure RAP	2-89

12-392-00-110, 12-393-00-110, 12-394-00-110 Front Tamper Move Failure RAP	2-90	12-396-00-171 to 12-399-00-171 HVF Rear Tamper Fault RAP	2-143
12-396-00-110, 12-397-00-110, 12-398-00-110, Rear Tamper Move Failure RAP	2-91	12-403-00-171, 12-413-00-171, 12-414-00-171 HVF BM Staple Head 2 and Stapler Module RAP	2-144
12-462-00-110 Bin 1 Movement Failure RAP	2-93	12-415-00-171 HVF BM Crease Roll Gate Home RAP	2-145
12-492-00-110 to 12-494-00-110 IME to Finisher Failure RAP	2-94	12-417-00-171, 12-418-00-171 HVF BM Flapper RAP	2-146
12-762-00-110, 12-764-00-110, 12-765-00-110 IME to Finisher Communication Failure RAP	2-95	12-450-00-171, 12-456-00-171 to 12-459-00-171 HVF Ejector Module RAP	2-147
12-950-00 IME Delivers Sheet Too Early RAP	2-95	12-451-00-171 to 12-455-00-171 HVF Ejector Roll and Lower Paddle Fault RAP	2-148
12A-110 Pause To Unload (PTU) Fault RAP	2-96	12-460-00-171 to 12-462-00-171 HVF Bin 1 Position RAP	2-151
12B-110 Bin 1 Overload RAP	2-96	12-463-00-171, 12-464-00-171 HVF BM +24V Failure RAP	2-153
12C-110 LCSS Initialization Failure RAP	2-97	12-465-00-171 to 12-468-00-171 Paddle Unit Position RAP	2-154
12D-110 LCSS Power Distribution RAP	2-98	12-473-00-171 to 12-478-00-171 Support Finger Position RAP	2-155
12E-110 LCSS Paper Entry RAP	2-99	12-479-00-171 Inserter Paper Length Fault RAP	2-157
12F-110 LCSS PWB DIP Switch Settings RAP	2-100	12-492-00-171 to 12-494-00-171 IME To Finisher Failure RAP	2-159
12G-110 LCSS PWB Damage RAP	2-100	12-762-00-171, 12-764-00-171, 12-765-00-171 IME To Finisher Communication Failure RAP	2-159
12H-110 Copy Damage in the LCSS RAP	2-102	12A-171 HVF Power Distribution RAP	2-160
12J-110 Mis-Registration in Stapled Sets and Non-Stapled Sets RAP	2-102	12B-171 HVF BM to Machine Communications Interface and BM Present RAP	2-162
12K-110 LCSS Poor Stacking RAP	2-103	12C-171 HVF BM Bin 2 Failure RAP	2-163
12L-110 Stapling Prime Failure RAP	2-103	12D-171 Booklet Quality RAP	2-164
12M-110 Staple Head Operation Failure RAP	2-105	12E-171 Copy Damage in the HVF BM RAP	2-167
12N-110 Chad Bin Present and Bin Full RAP	2-106	12F-171 Mis-Registration in Stapled and Unstapled Sets RAP	2-168
Chain 12-171 - HVF		12G-171 HVF BM Poor Stacking RAP	2-168
12-024-00-171, 12-025-00-171 HVF Paddle Roller Position RAP	2-107	12H-171 Pause to Unload (PTU) RAP	2-169
12-044-00-171 to 12-047-00-171 HVF Punch Head Position RAP	2-108	12J-171 Inserter Paper Sensing and +5V Supply RAP	2-169
12-056-00-171, 12-057-00-171 Inserter Bottom Plate RAP	2-109	12K-171 HVF Initialization Failure RAP	2-171
12-061-00-171, 12-416-00-171 HVF BM Crease Blade Fault RAP	2-109	12L-171 Tri-Folder Not Detected RAP	2-172
12-062-00-171 HVF BM Crease Roll Motor Failure RAP	2-110	12M-171 Buffer Path Clamp Problems RAP	2-173
12-063-00-171, 12-411-00-171 HVF BM Staple Unit 1 Failure RAP	2-111	12N-171 Chad Bin Present and Bin Full RAP	2-174
12-065-00-171, 12-383-00-171 HVF BM Backstop Motor Fault RAP	2-112		
12-066-00-171, 12-384-00-171, 12-419-00-171, 12-420-00-171 HVF BM Tamper Fault RAP	2-113	Chain 16 - Network Controller	
12-083-00-171, 12-440-00-171 to 12-444-00-171 HVF Paper Pusher Fault RAP	2-113	16-000-00 to 16-000-26 Cannot Create RPC With ENS RAP	2-175
12-113-00-171, 12-114-00-171, 12-190-00-171, 12-192-00-171 HVF BM Entry RAP	2-114	16-001-09 to 16-001-90 Unable to Synchronize Startup RAP	2-175
12-125-00-171, 12-126-00-171 HVF Entry Sensor RAP	2-116	16-002-09 to 16-002-19 Unable to Register as RPC RAP	2-176
12-141-00-171, 12-142-00-171 HVF Buffer Path Sensor RAP	2-117	16-003-09 to 16-003-90 Too Many IPC Handles RAP	2-176
12-151-171, 12-152-171 HVF Compiler Exit Sensor RAP	2-118	16-004-14 to 16-005-92 RPC Failure to Register RAP	2-177
12-157-00-171, 12-158-00-171 HVF Buffer Position Sensor RAP	2-119	16-006-09, 16-006-19 Cannot Register for Events RAP	2-177
12-166-00-171 HVF BM Compiler Exit Jam RAP	2-120	16-007-92 to 16-010-99 Invalid IPC / RPC Data RAP	2-178
12-171-00-171, 12-172-00-171 HVF Top Tray Exit Sensor Fault RAP	2-121	16-013-14, 16-014-14 Copier Synchronization Error RAP	2-178
12-181-00-171, 12-182-00-171 HVF BM Exit Jam RAP	2-122	16-015-14, 16-015-19 Data Store Variable Not Set RAP	2-179
12-183-00-171, 12-184-00-171 HVF BM Paper Jam RAP	2-125	16-016-14, 16-016-19 Data Store Initialization Failed RAP	2-179
12-185-00-171 to 12-187-00-171 Tri-Folder Exit Sensor and Assist Sensor RAP	2-127	16-017-19 to 16-021-26 Send Event Failure / Could Not Get Host Name RAP	2-180
12-191-00-171, 12-193-00-171, 12-194-00-171, 12-196-00-171 Inserter Paper Jam RAP	2-130	16-021-46 Unable to Get Host Name RAP	2-180
12-198-00-171, 12-199-00-171 HVF Paper Jam RAP	2-132	16-023-09, 16-023-26 RPC Call Failure RAP	2-181
12-288-00-171, 12-289-00-171 HVF Nip Split RAP	2-133	16-026-09 to 16-026-92 Memory Allocation Error RAP	2-181
12-310-00-171, 12-312-00-171, 12-313-00-171 HVF Docking and Interlocks RAP	2-134	16-027-90 Unable to Obtain Queue ID RAP	2-182
12-316-00-171, 12-319-00-171 Inserter Interlocks RAP	2-135	16-028-09, 16-028-90 Unable to Complete RPC Call / Invalid Range RAP	2-182
12-317-00-171, 12-318-00-171 Tri-folder Interlocks RAP	2-136	16-030-19 Unable to Obtain Client RAP	2-183
12-367-00-171, 12-368-00-171, 12-380-00-171 HVF Punch Unit Paper Edge Detect RAP	2-137	16-031-09 Invalid Event Notification RAP	2-183
12-369-00-171 to 12-377-00-171 HVF Stapler Position and Priming RAP	2-139	16-032-19, 16-039-00 NVM Connection Failure / Pthread Create Error RAP	2-184
12-392-00-171 to 12-395-00-171 HVF Front Tamper Fault RAP	2-142	16-040-92 Semaphore Fault RAP	2-184
		16-048-09 Unable to Set Binding RAP	2-185
		16-048-14, 16-048-90 Cannot Set ESS Client Binding RAP	2-185

16-048-99 Unable to Set Client Binding RAP	2-186	16-609-19, 16-609-105 Too Many IPC Handlers / Invalid RPC Data RAP	2-212
16-150-09 Cannot Send Registration Event RAP	2-186	16-609-26 Fault Service Encountered Error RAP	2-212
16-150-14 Unable to Obtain RPC Transport RAP	2-187	16-609-46 to 16-609-92 Invalid IPC Data Received RAP	2-213
16-150-19 Unable to Sync Peer RAP	2-187	16-610-00, 16-610-07 IPC Send Failure RAP	2-213
16-150-26 Fault Service Failed to Write Log RAP	2-188	16-610-09 Cannot Send IPC Message RAP	2-214
16-150-90 Invalid IPC Request Destination RAP	2-188	16-610-11 to 16-610-90 Unable to Send IPC Message RAP	2-214
16-150-92 Consumer Interface Fault RAP	2-189	16-610-92 Failure to Send Queue Status RAP	2-215
16-151-09 to 16-151-19 Invalid IPC Command / SNMP Reg Failure RAP	2-189	16-610-99 Unable to Send IPC Message RAP	2-215
16-151-26 Fault Service Failed to Get a Log RAP	2-190	16-611-07, 16-611-38 Client Removal Failed RAP	2-216
16-151-90 Environment Variable Failure RAP	2-190	16-611-19 to 16-611-47 Unable to Remove RPC Connection RAP	2-216
16-152-09 Internal IPC Failure RAP	2-191	16-611-66 to 16-611-99 Unable to Remove RPC Connection RAP	2-217
16-152-14 Empty Internal Event Failure RAP	2-191	16-612-09 to 16-612-68 Unable to Do Shutdown Sync RAP	2-217
16-152-19 Unable to Send Request to SESS RAP	2-192	16-613-09 to 16-614-19 DC Sync / Comms Error RAP	2-218
16-152-26 Unable to Send Request to SESS RAP	2-192	16-614-47 Invalid Software Upgrade RAP	2-218
16-153-09 Unable to Obtain IPC Queue RAP	2-193	16-615-35, 16-615-46 Data Store Variable Not Set RAP	2-219
16-153-14 Unable to Initialize Event List RAP	2-193	16-615-47 Multiple Software Upgrade File RAP	2-219
16-153-19 NVM Save Failure RAP	2-194	16-615-66 Data Store Variable Not Set RAP	2-220
16-154-09 ESS Registration Configuration Error RAP	2-194	16-615-67, 16-615-90, 16-616-38, 16-616-46	
16-154-14 Cannot Create Internal Event Queue RAP	2-195	SESS Data Store Environmental Variable RAP	2-220
16-154-19 NVM Read Failure RAP	2-195	16-616-47 IPC Message Failure RAP	2-221
16-155-19 ESS Failed to Boot from Alternate Disk RAP	2-196	16-616-67 Submission Of E-mail OR IFax Job Failed RAP	2-221
16-156-19 Service Run Loop Failed RAP	2-196	16-617-19 RPC Information Corrupt RAP	2-222
16-160-09 ESS Reg Service Process Death RAP	2-197	16-617-47 TAR Extraction Failure RAP	2-222
16-161-09, 16-164-09 Cannot Send Reg Event / List Access Failure RAP	2-197	16-618-47 DLM SPI Extraction Failure RAP	2-223
16-162-09 to 16-163-09 Cannot Send Reg Event / ESS Services Failure RAP	2-198	16-619-14 to 16-619-93 Cannot Unregister From Registration Service RAP	2-223
16-429-00, 16-431-00 Unable to Write to Data Store / Get System Time RAP	2-198	16-620-07 to 16-620-90 Registration Service Failed RAP	2-224
16-432-00 Unknown Scheduler Received RAP	2-199	16-620-92, 16-620-93, 16-620-99 Unable to Register With Network Controller Registration	
16-433-00 RPC Call Failed RAP	2-199	Service RAP	2-224
16-434-00 Unable to Change Scheduler RAP	2-200	16-621-00, 16-621-07, 16-621-11, 16-621-28, 16-621-35, 16-621-38, 16-621-47, 16-621-66,	
16-600-07 to 16-600-67 Cannot Create RPC Connection RAP	2-200	16-621-67, 16-621-93, 16-621-99 Unable to Obtain Host Name RAP	2-225
16-601-26 to 16-601-46 Queue Setup / System Control Failed / Invalid UI Info RAP	2-201	16-622-07, 16-622-09, 16-622-11, 16-622-14, 16-622-19, 16-622-26, 16-622-28, 16-622-35,	
16-601-47 Diagnostics Service Failed IPC Queue Setup RAP	2-201	16-622-38, 16-622-46, 16-622-47 Corrupt RPC Table RAP	2-225
16-601-66, 16-601-67 Unable to Do Start Up Sync RAP	2-202	16-622-66, 16-622-67, 16-622-68 Unable to Register RPC Service RAP	2-226
16-601-68 Unable to Start Up and Sync RAP	2-202	16-623-35, 16-623-47, 16-624-46 ENS Service Failed to Respond In Time RAP	2-226
16-601-105 Unable Synchronize At Start Up RAP	2-203	16-625-35, 16-625-46, 16-625-66, 16-625-67, 16-625-90 Invalid IPC Type RAP	2-227
16-602-07 to 16-602-105 RPC Service Registration Failure RAP	2-203	16-626-00, 16-626-11, 16-626-38, 16-626-47, 16-626-67 Memory Leak RAP	2-227
16-603-11, 16-603-28 Replace Handler Call Failed RAP	2-204	16-628-07, 16-628-35, 16-628-46, 16-628-66, 16-628-67	
16-603-46 to 16-603-67 Too Many IPC Handlers RAP	2-204	Range Environment Variable RAP	2-228
16-603-68, 16-604-105 Replace Handler Call Failed / Data Store Variable Not Set RAP	2-205	16-628-09, 16-629-11, 16-629-26, 16-629-46, 16-629-67, 16-629-68, 16-629-92, 16-629-93	
16-603-105, 16-604-14 RPC Call Failure to NC Reg Service RAP	2-205	No Acknowledgment For RPC Message RAP	2-228
16-604-38 to 16-605-07 Could Not Register With Reg Service RAP	2-206	16-630-09, 16-630-26, 16-630-35, 16-630-38, 16-630-46, 16-630-47, 16-630-66, 16-630-67,	
16-605-14, 16-605-105 Unable to Unregister As RPC Service / RPC Call Failure RAP	2-206	16-630-68, 16-630-99 Corrupt RPC RAP	2-229
16-605-26 Fault Service Timed Out Registering RAP	2-207	16-631-19, 16-631-46, 16-631-19, 16-633-19, 16-634-46, 16-635-07, 16-635-35, 16-635-46,	
16-605-35 to 16-605-67 RPC Call Failure to ESS RAP	2-207	16-635-99-16-636-35, 16-636-99 XDR Data Error RAP	2-229
16-606-07 Cannot Register For Events RAP	2-208	16-637-11, 16-637-26, 16-637-38, 16-637-47, 16-637-66, 16-637-67, 16-637-93, 16-637-95	
16-606-35 to 16-606-99 Cannot Register For Events RAP	2-208	File Error RAP	2-230
16-606-105 OS Problem RAP	2-209	16-638-66, 16-638-67, 16-639-38, 16-639-46, 16-640-28, 16-640-35, 16-640-46, 16-641-00,	
16-607-19 to 16-608-14 Invalid RPC Data / Unable to Free Resources RAP	2-209	16-641-26, 16-641-46 O/S Failure RAP	2-230
16-608-26 Fault Service Failed to Unbind RAP	2-210	16-642-46, 16-642-47, 16-643-19, 16-643-26, 16-643-47, 16-644-11	
16-608-28 to 16-608-67 Unable to Free IPC Resources RAP	2-210	Unable To Close File RAP	2-231
16-608-105 Unable Build UI SVC Obtain Client Failed RAP	2-211	16-644-11, 16-644-26, 16-644-46, 16-644-47, 16-644-66, 16-644-67, 16-645-11, 16-645-26,	
16-609-07 Unknown Message Received RAP	2-211	16-645-46, 16-645-47, 16-645-66, 16-645-67 Unable To Read From File RAP	2-231

16-646-26, 16-647-19, 16-647-26, 16-649-35, 16-650-35, 16-650-99 Invalid Service Attribute RAP	2-232
16-651-19, 16-651-35, 16-651-99, 16-652-38, 16-652-99, 16-653-38, 16-654-38, 16-654-99, 16-655-38, 16-656-38 Register Failure RAP	2-232
16-658-07, 16-659-11, 16-659-28, 16-659-93, 16-659-95, 16-660-95, 16-660-99, 16-661-95 Parser Utility Open Failure RAP	2-233
16-662-11, 16-662-28, 16-662-93, 16-662-95, 16-663-28, 16-663-93, 16-663-95 Parser Utility Template Failed To Parse RAP	2-233
16-664-11, 16-664-28, 16-664-93, 16-664-95, 16-665-95 Parser Utility Closing Failure RAP	2-234
16-666-11, 16-666-28, 16-666-93, 16-666-95 Parser Utility Invocation Failed RAP	2-234
16-667-11, 16-667-28, 16-667-95, 16-668-47 Parser Utility Set Status Failure RAP	2-235
16-668-93, 16-668-95 Unable To Determine Local File Statistics RAP	2-235
16-669-28, 16-669-93, 16-669-95, 16-670-00 Unable To Write Job Template RAP	2-236
16-670-11, 16-670-28, 16-670-47, 16-670-93, 16-671-00, 16-671-47 Unable To Decode Template File RAP	2-236
16-617-93, 16-671-95, 16-672-09, 16-672-95, 16-673-95, 16-674-00, 16-674-09, 16-675-00, 16-6700-00, 16-700-35 File Error RAP	2-237
16-674-09, 16-675-00, 16-700-00, 16-701-00, 16-701-99, 16-702-00, 16-702-95, 16-707-00, 16-709-00 XSA Database Failure RAP	2-237
16-710-00, 16-710-35, 16-716-00, 16-728-00, 16-730-00, 16-730-28, 16-730-35, 16-730-66, 16-740-19, 16-750-07, 16-750-09, 16-750-11 Unable To Create Client Handle RAP	2-238
16-742-19 Hard Disk ODIO Failure RAP	2-238
16-750-14, 16-750-19, 16-750-26, 16-750-35, 16-750-38, 16-750-46, 16-750-47, 16-750-66, 16-750-67, 16-750-90 Invalid Request RAP	2-239
16-750-92, 16-750-93, 16-750-95, 16-751-00, 16-751-07, 16-751-09, 16-751-11, 16-751-14, 16-751-19, 16-751-26 Database Error RAP	2-239
16-751-28, 16-751-35, 16-751-38, 16-751-46, 16-751-66, 16-751-67, 16-751-92, 16-751-93 Unknown Attribute RAP	2-240
16-752-00, 16-753-00 File Cabinet Application Registration Error RAP	2-240
16-752-07, 16-752-09, 16-752-14, 16-752-19, 16-752-26, 16-752-28, 16-752-35, 16-752-46, 16-752-47 Invalid File Details RAP	2-241
16-752-66, 16-752-67, 16-752-92, 16-752-93, 16-752-95, 16-753-09, 16-753-14, 16-753-19, 16-753-26, 16-753-28 Scan to FAX Registration Error RAP	2-241
16-753-35, 16-753-46, 16-753-47, 16-753-66, 16-753-67, 16-753-90, 16-753-92, 16-753-93, 16-753-95, 16-753-09 Data Store Read Failure RAP	2-242
16-754-14, 16-754-19, 16-754-26, 16-754-28, 16-754-35, 16-754-46, 16-754-47, 16-754-66, 16-754-67, 16-754-68 OS Error RAP	2-242
16-754-90, 16-754-92, 16-754-92, 16-754-93, 16-754-95, 16-755-00, 16-755-09, 16-755-14, 16-755-19, 16-755-26, 16-755-28 Fault Service Error RAP	2-243
16-755-35, 16-755-46, 16-755-47, 16-755-67, 16-755-90, 16-755-93, 16-755-99, 16-756-09, 16-756-14 Request Error RAP	2-243
16-756-35, 16-756-46, 16-756-47, 16-756-66, 16-756-67, 16-756-93, 16-757-09, 16-757-14, 16-757-19, 16-757-26 NVM Corrupt RAP	2-244
16-757-35, 16-757-46, 16-757-47, 16-757-66, 16-757-67, 16-757-93, 16-758-09, 16-758-14, 16-758-19, 16-758-26 Unable to Write NVM Value RAP	2-244
16-758-35, 16-758-46, 16-758-47, 16-758-66, 16-758-67, 16-758-93, 16-759-09, 16-759-14, 16-759-19, 16-759-26 Service Run Loop Failed RAP	2-245
16-759-46, 16-759-47, 16-759-66, 16-759-67, 16-759-93, 16-760-09, 16-760-14, 16-760-19, 16-760-26, 16-760-46 Fail to Enable Process RAP	2-245
16-760-47, 16-760-67, 16-760-68, 16-760-93, 16-760-99, 16-761-09, 16-761-14, 16-761-19, 16-761-26, 16-761-46 File Error RAP	2-246

16-761-47 to 16-769-95 Other Network Faults 1 RAP	2-246
16-770-09 to 16-779-95 Other Network Faults 2 RAP	2-248
16-780-00 to 16-789-47 Other Network Faults 3 RAP	2-249
16-790-09 to 16-799-47 Other Network Faults 4 RAP	2-250
16-800-09 to 16-809-47 Other Network Faults 5 RAP	2-251
16-810-00 to 16-16-819-47 Other Network Faults 6 RAP	2-252
16-820-47 to 16-829-47 Other Network Faults 7 RAP	2-253
16-830-47 to 16-839-47 Other Network Faults 8 RAP	2-253
16-840-47 to 16-849-47 Other Network Faults 9 RAP	2-254
16-850-47 to 16-859-47 Other Network Faults 10 RAP	2-254
16-860-47 to 16-869-47 Other Network Faults 11 RAP	2-255
16-870-47 to 16-879-47 Other Network Faults 12 RAP	2-255
16-880-47 to 16-890-47 Other Network Faults 13 RAP	2-256
16-891-00, 16-892-00 Edge Server Auto Registration Failed RAP	2-256
16-900-19 to 16-909-19 Other Network Faults 14 RAP	2-257
16-910-19 to 16-919-19 Other Network Faults 15 RAP	2-257
16-920-19 to 16-929-19 Other Network Faults 16 RAP	2-258
16-930-19 to 16-939-19 Other Network Faults 17 RAP	2-258
16-940-19 to 16-949-19 Other Network Faults 18 RAP	2-259
16-950-19 to 16-959-19 Other Network Faults 19 RAP	2-259
16-960-19 to 16-969-19 Other Network Faults 20 RAP	2-260
16-975-19 to 16-979-35 Other Network Faults 21 RAP	2-260
16-980-00 to 16-989-35 Other Network Faults 22 RAP	2-261
16-985-19, 16-986-19 Network Scanning Application Registration Error RAP	2-262
16-987-19, 16-988-19 Server Fax Application Registration Error RAP	2-262
16-989-19 Disk Encryption Operation Failed RAP	2-263
16-990-00 to 16-999-35 Other Network Faults 23 RAP	2-263
16A Network Error Entry RAP	2-264
16B FTP or SMB Unable to Connect to Remote Server RAP	2-264
16C Remote Directory Lock Failed RAP	2-266

Chain 19 - Image Processing

19-300-00 to 19-310-00 Image Disk (HDD) Failure RAP	2-267
19-401-00, 19-402-00 Stress Out of Memory RAP	2-267
19-403-00 EPC Out of Memory RAP	2-268
19-409-00 Job Integrity Failure RAP	2-268
19-410-00 to 19-410-13 Image Structure Failure RAP	2-269
19-750-00 EPC Memory Change Detected RAP	2-269
19-752-00 Image Rotation Detected RAP	2-270
19-754-00 Image Disk Change RAP	2-270

Chain 20 - Fax

20-302-00, 20-303-00 Fax Reset Failure RAP	2-271
20-305-00 Fax System Low Memory Unrecoverable RAP	2-271
20-320-00 Fax Fault Not Cleared by Reset RAP	2-272
20-322-00 Non-Volatile Device not Installed RAP	2-272
20-323-00, 20-324-00 Fax System Memory Low RAP	2-273
20-331-00, 20-338-00, 20-339-00, 20-341-00, 20-345-00 Fax Network Line 1 Fault RAP	2-273
20-332-00, 20-340-00 Fax Network Line 2 Fault RAP	2-274
20-342-00 Fax File Integrity Fault RAP	2-274
20-701-00 Fax Phone Book Download Failed RAP	2-275
20-710-00, 20-711-00 Image Overwrite Error RAP	2-275

20A Fax Entry RAP	2-276	62-486-00 +24V Supply Error RAP	2-300
20B Unable To Send A Fax RAP	2-276	62-487-00 System Phase Lock Loop (PLL) Error RAP	2-301
20C Unable To Send A Fax To Some Machines RAP	2-277	62A Scanning Document Size RAP	2-301
20D Unable To Receive A Fax RAP	2-278	62B LED Exposure Lamp Failure RAP	2-302
20E Fax Will Not Print RAP	2-279		
20F Fax Tab Not Available RAP	2-279	Chain 70 to 75 - Paper Supply	
20G Fax Module Checkout	2-280	70-312-00 Tray 1 to Tray 3 Communication Failure RAP	2-303
20H Fax Problems on Digital Networks RAP	2-280	70-305-00, 70-325-00 Lower Left Door Open RAP	2-303
		71-101-00 to 71-155-00 Tray 1 Mis-Feed Jam RAP	2-304
Chain 22 - System Errors		71-215-00 Tray 1 Elevate Up Failure RAP	2-305
22-300-05 to 22-309-04 Other Network Faults 24 RAP	2-281	71-320-00 Tray 1 Open In Run RAP	2-306
22-310-04 to 22-318-04 Other Network Faults 25 RAP	2-281	71A Tray 1 Empty RAP	2-306
22-315-04 One or More Modules Did Not Respond RAP	2-282	71B Tray 1 Wrong Size Paper RAP	2-307
22-319-04 IOT Integrity Problem While Printing a Job RAP	2-282	72-101-00 to 72-155-00 Tray 2 Mis-Feed Jam RAP	2-308
22-321-00 SM Failed to Remove Scan to File RAP	2-283	72-215-00 Tray 2 Elevate Up Failure RAP	2-309
22-321-04 Proposal Response Time Out Error RAP	2-283	72-320-00 Tray 2 Open in Run RAP	2-310
22-325-01 Cleaning Unit Extended Life Mode Entered RAP	2-284	72A Tray 2 Empty RAP	2-310
22-328-00 Incomplete System Information RAP	2-284	72B Tray 2 Wrong Size Paper RAP	2-311
22-330-00 Page Pack PIN Entry Locked RAP	2-285	73-101-00 to 73-155-00 Tray 3 Mis-Feed Jam RAP	2-312
22-330-01 List Jobs Request Timed Out Between UI and Copy Controller RAP	2-285	73-212-00 Tray 3 Elevate Encoder Failure RAP	2-313
22-330-02 List Jobs Request Timed Out Between Copy Controller and ESS Print Service RAP	2-286	73-215-00 Tray 3 Hoist Failure RAP	2-314
22-330-03 List Jobs Request Timed Out Between Copy Controller and Scan to File Service RAP	2-286	73-320-00 Tray 3 Open in Run RAP	2-315
22-330-04 List Jobs Request Timed Out Between Copy Controller and Scan to Fax Service RAP	2-287	73-325-00 Feeder HT Drawer Open in Run RAP	2-315
22-330-05 List Jobs Request Timed Out Between Queue Utility and DC Job Service RAP	2-287	73A Tray 3 Out of Paper RAP	2-316
22-330-06 ESS Scan to Distribution Service not Responding to List Jobs RPC Call RAP	2-288	74-101-00 Bypass Tray 4 Mis-Feed RAP	2-316
22-350-01, 22-350-02 Software Detects Non-Valid Xerox SOK RAP	2-288	74-120-00 Bypass Tray 4 Guides Move in Run RAP	2-317
22-351-01 to 22-351-03 SOK Write Failure RAP	2-289	74-214-00 Bypass Tray 4 Nudger Failure RAP	2-317
22-352-00 Serial Number Missing RAP	2-289	74A Bypass Tray 4 Size Sensing Problems RAP	2-318
22-371-00, 22-372-00 Fax Application Registration Error RAP	2-290	75-101-00 Tray 5 Mis-Feed RAP	2-319
22-701-04 Module Completion Message Received RAP	2-290	75-212-00, 75-215-00 Tray 5 Elevate Up Failure RAP	2-320
22-720-00 Service Registry Bad Data/Corrupted RAP	2-291	75-213-00, 75-216-00 Tray 5 Elevate Down Failure RAP	2-321
22-721-00 No Response From The Service Registry RAP	2-291	75-312-00 IME to Tray 5 Communication Failure RAP	2-322
22-750-04 to 22-755-17 Configuration Mismatch RAP	2-292	75-320-00 Tray 5 Opened In Run RAP	2-323
		75-325-00 Tray 5 Undocked In Run RAP	2-323
		75A Tray 5 Door Open During Run RAP	2-324
		75B Tray 5 Empty RAP	2-324
Chain 42 - Fans and Cooling		Chain 82 to 89 - Paper Transport	
42-504-00 Enclosure Fan Over Current RAP	2-293	82-110-00 to 82-114-00, 82-152-00, 82-157-00 to 82-159-00, 82-164-00 to 82-166-00 Media Path Sensor (5) RAP	2-325
42-505-00 Abatement Fan Over Current RAP	2-293	82-125-00 to 82-133-00, 82-153-00, 82-160-00, 82-162-00, 82-163-00 Confirm Sensor (16) RAP	2-326
Chain 62 - Scanner		82-132-00, 82-155-00 Media Path Sensor 16 Duplex Mode RAP	2-327
62-277-00 Scanner to DADH Communication Fail Entry RAP	2-295	82-133-00 Media Path Sensor 16 Time out from Tray 5 RAP	2-328
62-310-00 Scanner to Single Board Controller Communication Fail RAP	2-295	82-140-00, 82-142-00 Media Path Sheet Too Wide or Narrow RAP	2-329
62-450-00 to 62-472-00 Calibration Failure RAP	2-296	82-141-00, 82-147-00, 82-148-00, 82-154-00 Media Path Sensor 14 RAP	2-330
62-473-00 UART RX Wrap Error RAP	2-297	82-145-00, 82-146-00, 82-150-00, 82-151-00, 82-156-00 Media Path Sensor 14 Time Out in Duplex Mode RAP	2-332
62-474-00, 62-475-00 Stepper Speed/Reset Error RAP	2-297	82-161-00 Early Confirm Timeout RAP	2-334
62-476-00 Scan Carriage Home Sensor RAP	2-298	82-500-00, 82-501-00 Vertical Transport Motor M2 Failure RAP	2-335
62-477-00 to 62-481-00 Timing Errors RAP	2-299	82-502-00, 82-503-00 Horizontal Transport Motor M6 Failure RAP	2-336
62-484-00 Apps Code Not Present RAP	2-299	82-507-00, 82-508-00 Nip C and Nip D Release Solenoid Over Current RAP	2-337
62-485-00 +12V Supply Error RAP	2-300		

82-510-00 Trailer Slowdown Calculation Fail RAP	2-337	91-610-00 to 91-613-00 Printhead Wave Amp Calibration Error RAP	2-378
83-110-00, 83-111-00, 83-113-00, 83-114-00, 83-118-00 Media Path Sensor 13 Duplex Mode RAP	2-338	91-614-00 to 91-617-00 Printhead Data Error RAP	2-379
83-112-00, 83-115-00, 83-116-00, 83-117-00, 83-119-00 Media Path Sensor 13 Invert Mode RAP	2-340	91-630-00 IOD Scan Process Failure RAP	2-379
83-120-00 to 83-125-00 Media Path Sensor 17 RAP	2-342	91-631-00 IOD Dark Adjust Failure RAP	2-380
83-500-00 Output Transport Motor M5 Failure RAP	2-343	91-636-00 IOD in Degraded Mode RAP	2-381
83-504-00 HPP Diverter Solenoid Failure RAP	2-344	91-637-00 Drum Runout Calibration Needed RAP	2-383
83-506-00 Nip D Release Solenoid Failure RAP	2-344	91-638-00 IOD Detects Chronic Jet Error RAP	2-384
88-500-00 to 88-502-00, 88-512-00 Preheat Thermal Error RAP	2-345	91-660-00 to 91-663-00, 91-820-00 to 91-823-00 Printhead Link Error RAP	2-385
88-508-00 Registration / Preheat Air Pump Incorrect Current RAP	2-346	91-669-00 Excessive Skew RAP	2-386
89-110-00 to 89-113-00, 89-129-00 Media Path Sensor 10 Failure RAP	2-347	91-670-00 Scanned Image Out of Sequence RAP	2-386
89-125-00 to 89-128-00, 89-130-00, 89-131-00 Media Path Sensor 20 Failure RAP	2-348	91-671-00 Fiducials Not Found RAP	2-387
89-500-00, 89-502-00 Registration Motor Over Current RAP	2-349	91-672-00 Missing Jets RAP	2-387
89-504-00 Registration Sensor Over Current RAP	2-350	91-673-00 Floating Point Error RAP	2-388
89-520-00 Home Sensor Timeout RAP	2-351	91-674-00 to 91-677-00, 91-812-00 to 91-815-00 Printhead Adjustment Error RAP	2-388
89-531-00 to 89-545-00 Registration Process Error RAP	2-353	91-678-00 to 91-681-00, 91-816-00 to 91-819-00, 91-961-00 to 91-964-00, Printhead Convergence Adjustment Error RAP	2-389
89-550-00, 89-551-00 Media Registration Error RAP	2-353	91-682-00 Ambient Thermistor Error RAP	2-390
89-555-00 Media Registration Out of Range RAP	2-354	91-698-00, 91-699-00, 91-706-00, 91-712-00, 91-718-00, 91-720-00, 91-729-00, 91-730-00, 91-732-00 IOD Excessive Head Misalignment RAP	2-391
89-561-00 Media Registration Parameters Reset RAP	2-354	91-721-00, 91-722-00, 91-735-00, 91-736-00 IOD Contamination Error RAP	2-393
89-562-00 Incorrect Media RAP	2-355	91-725-00 to 91-728-00, 91-945-00 to 91-948-00, IOD Bad Target Scan RAP	2-394
89-564-00 Calibration Image Error RAP	2-355	91-824-00 PQM Insufficient Ink RAP	2-395
89-565-00, 89-566-00 Scan Measurement Was Out Of Range RAP	2-356	91-825-00 PQM Insufficient Paper RAP	2-395
89-567-00 Calibration Scan Detected Floating Point Exception RAP	2-356	91-826-00 PQM Insufficient Jets RAP	2-396
		91-827-00 PQM Align Needed RAP	2-396
Chain 91 - Marking Unit		91-828-00 PQM Y-Dot Position Needed RAP	2-397
91-500-00, 91-600-00 Initial Position Error RAP	2-357	91-829-00 PQM Drum Runout Needed RAP	2-397
91-501-00 to 91-502-00 Image Timing Error RAP	2-357	91-830-00 PQM Uniformity Needed RAP	2-398
91-503-00 Print Image Data Did Not Arrive From the Controller in Time RAP	2-358	91-831-00 PQM Uniformity Reset Needed RAP	2-398
91-504-00, 91-505-00 Printhead Stitch Motor Over Current RAP	2-358	91-832-00 PQM Empty Waste Tray RAP	2-399
91-506-00 to 91-509-00 Roll Motor Over Current RAP	2-359	91-833-00 PQM Cleaning Pages Needed RAP	2-399
91-510-00, 91-511-00 X Axis Motor Over Current RAP	2-360	91-834-00 PQM Tool Not Usable RAP	2-400
91-512-00, 91-605-00 Marking Unit Motor Short RAP	2-361	91-835-00 PQM Tool Manually Disabled RAP	2-400
91-513-00, 91-514-00, 91-581-00, 91-583-00 IOD Drive Error RAP	2-362	91-836-00 PQM System Busy RAP	2-401
91-515-00 Vertical Wiper Motor Over Current RAP	2-363	91-837-00 PQM Align Calibration Needed RAP	2-401
91-516-00 Low Pressure Assist Over Current RAP	2-364	91-838-00 PQM: CLD Baseline Needed RAP	2-402
91-517-00 Marking Unit Air Pump Over Current RAP	2-364	91-842-00 to 91-845-00 Printhead Nvram Read or Decode Error RAP	2-402
91-519-00 to 91-522-00, 91-655-00 to 91-658-00, 91-683-00 to 91-690-00, 91-807 to 91-811-00 Printhead NVM Read or Write Error RAP	2-365	91-848-00 to 91-851-00 IOD Align Calibration Error RAP	2-403
91-523-00 to 91-558-00, 91-664-00 to 91-667-00, 91-800-00 to 91-803-00, 91-856-00 to 91-859-00 Printhead Thermal Error RAP	2-366	91-852-00 to 91-854-00 Y Dot Position SVD Calculation RAP	2-403
91-559-00 Marking Unit Components Out of Position RAP	2-367	91-855-00 Thermal Safety Circuit Failure Undetected RAP	2-404
91-560-00 Carriage Selection Time Out RAP	2-369	91-929-00 to 91-940-00 IOD Jet Position Noise RAP	2-404
91-562-00, 91-563-00 Upper Carriage Error RAP	2-370	91-941-00 to 91-944-00 PQM Too Many Purges RAP	2-405
91-565-00, 91-566-00 Upper Printhead Restraint Error RAP	2-371	91-949-00 to 91-952-00 Closed Loop Drift Baseline RAP	2-406
91-567-00 to 91-568-00 Lower Carriage Error RAP	2-372	91-953-00 to 91-960-00, 91-965-00 to 91-968-00 Closed Loop Drift Measurement RAP	2-407
91-570-00, 91-571-00 Lower Printhead Restraint Error RAP	2-373	91-970-00 to 91-981-00 Printhead Reservoir and Jet Stack Heater Unstable RAP	2-408
91-572-00, 91-573-00, 91-575-00 Wiper Vertical Error RAP	2-374	91A Printhead Communications RAP	2-409
91-574-00, 91-576-00, 91-598-00 Wiper Horizontal Error RAP	2-375		
91-586-00 Quad Wave Amplifier Short RAP	2-376	Chain 92 - IOT Process Control	
91-587-00, 91-588-00 Quad Wave Amplifier Thermal Error RAP	2-377	92-501-00 to 92-504-00, 92-519-00 Serial Link Safety Transient RAP	2-411
91-607-00, 91-608-00 Printhead to Drum Error RAP	2-377	92-505-00, 92-506-00 Marking Unit Communications Error RAP	2-411
		92-510-00, 92-511-00 Marking Unit Ink Delivery Communications Error RAP	2-412
		92-515-00, 92-516-00 Drum Driver Communications Error RAP	2-412

92-520-00 Power Supply Communications Error RAP	2-413	Reservoir Fill Error RAP	2-441
92-525-00, 92-526-00 Media Path Communications Error RAP	2-413	93-565-00 to 93-599-00 and 93-800-00 to 93-812-00	
92-530-00 3TM Serial Link Error RAP	2-414	Printheads 1, 2, 3 & 4 Ink Level Sense Error RAP	2-443
92-531-00 Paper Tray Module Communications Error RAP	2-414	93-813-00 to 93-820-00 Ink Melt Reservoir Level Sense Failure RAP	2-444
92-535-00, 92-536-00 Tray 5 Communications Error RAP	2-415	93-825-00, 93-892-00 Ink Key Plate Motor Over Current RAP	2-445
92-541-00 ADC Interrupt Storm Fault RAP	2-415	93-871-00 to 93-874-00 Ink Level Sense Error RAP	2-445
92-542-00 PS Interrupt Storm Fault RAP	2-416	93-890-00 Marking Unit Air Solenoid Over Current RAP	2-446
92-543-00, 92-544-00 MU Interrupt Storm Faults RAP	2-416	93-891-00 Ink Transport Over Current RAP	2-446
92-545-00 DD Interrupt Storm Fault RAP	2-417	93-901-00 to 93-904-00 Ink Melt Reservoir Fill Failure RAP	2-447
92-546-00, 92-547-00 MP Interrupt Storm Faults RAP	2-417	93-909-00 to 93-924-00 Printhead Reservoir Level Failure RAP	2-447
92-548-00 TTM Interrupt Storm Fault RAP	2-418	93-933-00 to 93-936-00 Head Purge Failure RAP	2-448
92-549-00 PFP Interrupt Storm Fault RAP	2-418	93-937-00 to 93-940-00 Ink Melt Reservoir Leak Error RAP	2-448
92-551-00 CIS Interrupt Storm Fault RAP	2-419	93A Ink Melt Reservoir Check RAP	2-449
92-550-00, 92-555-00 System Timer Error RAP	2-419	93B Ink Leak Checkout RAP	2-450
92-552-00 SBC Interrupt Storm Fault RAP	2-420		
92-554-00 AC Line Failed RAP	2-420		
92-556-00, 92-557-00, 92-558-00, 92-559-00 ECM Failure RAP	2-421	Chain 94 - Ink Transfer	
92-560-00, 92-561-00 Marking Unit Firmware Version Mismatch RAP	2-421	94-504-00 Cleaning Unit Reservoir Pressure Low RAP	2-451
92-562-00 Drum Driver Firmware Version Mismatch RAP	2-422	94-505-00 Cleaning Unit Reservoir Pressure High RAP	2-451
92-563-00 Power Supply Firmware Version Mismatch RAP	2-422	94-510-00, 94-512-00 Drum Image Initial Position Error RAP	2-452
92-564-00 Media Path Firmware Version Mismatch RAP	2-423	94-514-00, 94-518-00 Drum Imaging Error RAP	2-453
92-565-00 3TM Firmware Version Mismatch RAP	2-423	94-519-00 Drum Imaging Error RAP	2-453
92-566-00 Tray 5 Firmware Version Mismatch RAP	2-424	94-520-00 Cleaning Unit Drive Error RAP	2-454
92-567-00 ECM FPGA Version Mismatch RAP	2-424	94-522-00 Cleaning Unit Motor Stall RAP	2-454
92-568-00 ECM Initialization Error RAP	2-425	94-524-00 Drum Drive Motor Over Current RAP	2-456
92-569-00 Image FPGA Version Mismatch RAP	2-425	94-526-00 Drum Drive Stall RAP	2-456
92-570-00 Interrupt Storm Fault RAP	2-426	94-527-00, 94-531-00 Cleaning Unit Early Life Over Current RAP	2-458
92-571-00 Software Error RAP	2-426	94-528-00, 94-532-00, 94-533-00 Cleaning Unit Over Current RAP	2-458
92-575-00 ADC Out of Range RAP	2-427	94-534-00 Drum Drive Belt Slip RAP	2-459
92-579-00 CDI Submit Sheet Error RAP	2-427	94-535-00 Drum Driver Command Current Error RAP	2-460
92-581-00 Image Transfer Error RAP	2-428	94-536-00, 94-538-00, 94-540-00, 94-542-00, 94-544-00, 94-546-00, 94-632-00, 94-633-00	
92-583-00 Cold Temperature Boot Time-out RAP	2-428	Drum Heat Error RAP	2-461
92-585-00 LVDS Contone Terminal Error During Image Transfer RAP	2-429	94-545-00 Drum Runout Calibration Error RAP	2-462
92-586-00 Print Engine Speed Fault RAP	2-429	94-547-00, 94-555-00 Y-Axis Belt Ratio Error RAP	2-462
92-598-00, 92-599-00, 92-600-00, 92-610-000 to 92-614-00, IME NVRAM Error RAP	2-430	94-548-00 Y-Axis Position Error RAP	2-463
92-803-00, 92-804-00 DSP2 Overlay Error RAP	2-430	94-549-00 Drum Runout Calibration Error RAP	2-463
92-805-00 Fuse A Blown RAP	2-431	94-551-00, 94-552-00, 94-553-00 Drum Y-Axis Error RAP	2-464
92-806-00 Fuse B Blown RAP	2-432	94-558-00, 94-560-00, 94-562-00, 94-564-00, 94-566-00	
92-807-00 Diagnostic Routine Not Implemented RAP	2-432	Cleaning Unit Position Error RAP	2-464
		94-568-00, 94-570-00, 94-572-00, 94-573-00 Cleaning Unit Data Error RAP	2-465
Chain 93 - Ink Delivery		94-574-00 Cleaning Unit Sync Error RAP	2-465
93-501-00 to 93-516-00 Ink Loader Is Jammed RAP	2-433	94-610-00, 94-612-00 Cleaning Unit Error RAP	2-466
93-520-00, 93-521-00, 93-522-00 Ink Melt Reservoir Thermal Error RAP	2-433	94-611-00 Cleaning Unit Removal Pump Test Fail RAP	2-466
93-523-00 to 93-526-00, 93-527-00 to 93-530-00, 93-532-00, 93-533-00, 93-957-00		94-615-00 Non Xerox Cleaning Unit Detected RAP	2-467
Ink Melt Error RAP	2-434	94-616-00 Cleaning Unit Low Oil Detected RAP	2-467
93-525-00, 93-528-00, 93-531-00, 93-534-00 Ink Melt Thermistor Error RAP	2-435	94-617-00, 94-618-00 Oil Pump Error RAP	2-468
93-535-00 to 93-537-00, 93-958-00 Upper Umbilical Thermal Error RAP	2-436	94-619 Cleaning Unit Delivery Line Blocked RAP	2-468
93-538-00 to 93-540-00, 93-959-00 Lower Umbilical Thermal Error RAP	2-437	94-620-00 Drum Fan Stall RAP	2-469
93-545-00 to 93-548-00 Ink Melt Reservoir Level Sense Error RAP	2-438	94-621-00 Abatement Fan Stall RAP	2-469
93-549-00 to 93-552-00 and 93-557-00 to 93-560-00 Printheads 1 and 3 Printhead		94-622-00 Cleaning Unit Unusable RAP	2-470
Reservoir Fill Error RAP	2-438	94-629-00 Extreme Customer Usage RAP	2-471
93-553-00 to 93-556-00 and 93-561-00 to 93-564-00 Printheads 2 and 4 Printhead		94-631-00 Cleaning Unit Connectivity Failure RAP	2-471
		94-634-00, 94-635-00 DMU Thermistor Failure RAP	2-472

94A Enclosure Fan Error RAP	2-472
94B Drum Drive Control Test Actions RAP	2-473

Chain 99 - PEST

99-000-00 to 99-067-00 PEST Error 1 RAP	2-475
99-081-00 to 99-112-00 PEST Error 2 RAP	2-476
99-120-00 to 99-140-00 PEST Error 3 RAP	2-477
99-143-00 to 99-150-00 PEST Error 4 RAP	2-477
99-180-00 to 99-217-00 PEST Error 5 RAP	2-478
99-221-00 to 99-244-00 PEST Error 6 RAP	2-479
99-250-00 to 99-271-00 PEST Error 7 RAP	2-480
99-272-00 to 99-292-00 PEST Error 8 RAP	2-481
99-293-00 to 99-312-00 PEST Error 9 RAP	2-482
99-313-00 to 99-329-00 PEST Error 10 RAP	2-483
99-330-00 to 99-349-00 PEST Error 11 RAP	2-484
99-360-00 to 99-382-00 PEST Error 12 RAP	2-485
99-394-00 to 99-413-00 PEST Error 13 RAP	2-486
99-414-00 to 99-428-00 PEST Error 14 RAP	2-487
99-429-00 to 99-443-00 PEST Error 15 RAP	2-488
99-444-00 to 99-460-00 PEST Error 16 RAP	2-489
99-461-00 to 99-477-00 PEST Error 17 RAP	2-491
99-480-00 to 99-497-00 PEST Error 18 RAP	2-492
99-500-00 to 99-515-00 PEST Error 19 RAP	2-493
99-516-00 to 99-533-00 PEST Error 20 RAP	2-494
99-534-00 to 99-548-00 PEST Error 21 RAP	2-495
99-549-00 to 99-563-00 PEST Error 22 RAP	2-497
99-564-00 to 99-565-00 PEST Error 23 RAP	2-498
99-600-00 to 99-605-00 PEST Error 24 RAP	2-498
99-606-00 to 99-610-00 PEST Error 25 RAP	2-499
99-611-00 to 99-625-00 PEST Error 26 RAP	2-499
99-626-00 to 99-640-00 PEST Error 27 RAP	2-500
99-641-00 to 99-655-00 PEST Error 28 RAP	2-501
99-656-00 to 99-670-00 PEST Error 29 RAP	2-502
99-671-00 to 99-685-00 PEST Error 30 RAP	2-503
99-686-00 to 99-700-00 PEST Error 31 RAP	2-504
99-701-00 to 99-721-00 PEST Error 32 RAP	2-505
99-730-00 to 99-742-00 PEST Error 33 RAP	2-505
99-743-00 to 99-766-00 PEST Error 34 RAP	2-506
99-767-00 to 99-782-00 PEST Error 35 RAP	2-507
99-785-00 to 99-802-00 PEST Error 36 RAP	2-508
99-805-00 to 99-823-00 PEST Error 37 RAP	2-508
99-824-00 to 99-838-00 PEST Error 38 RAP	2-510
99-839-00 to 99-871-00 PEST Error 39 RAP	2-511
99-872-00 to 99-887-00 PEST Error 40 RAP	2-513
99-890-00 to 99-904-00 PEST Error 41 RAP	2-514
99-905-00 to 99-921-00 PEST Error 42 RAP	2-516
99-922-00 to 99-938-00 PEST Error 43 RAP	2-518
99-939-00 to 99-954-00 PEST Error 44 RAP	2-519
99-955-00 to 99-962-00 PEST Error 45 RAP	2-521
99-992-00 PEST Error 46 RAP	2-522
99-996-00 to 99-999-00 PEST Error 47 RAP	2-522

OF - Other Faults

OF 1 Unusual Noise RAP	2-523
OF 2 UI Touch Screen Failure RAP	2-528
OF 3 Unresponsive Machine RAP	2-529
OF 4 Status Codes and Messages RAP	2-532
OF 4a Status Codes in Numerical Order	2-532
OF 4b Status Messages in Alphabetical Order	2-570
OF 5 Boot Up Failure RAP	2-601
OF 6 Fans and Air Systems RAP	2-604
OF 7 Sleep Mode RAP	2-604
OF 8 Multi-feed RAP	2-605
OF 9 Ink Stick Count Mismatch	2-606
OF 10 Intermittent Failure RAP	2-607
OF 11 Unable to Load Ink Sticks	2-609
OF 12 Service Code RAP	2-610
OF 13 Convenience Stapler RAP	2-613
OF 14 Extensible Interface Platform RAP	2-614
OF 15 Xerox Secure Access RAP	2-614
OF 16 POST Error RAP	2-616

01-505-00 Mid Left Door Open RAP

01-505-00 The mid door interlock switch detects that the mid left door is open.

Initial Actions

WARNING

Ensure that the electricity to the machine is switched off while performing tasks that do not need electricity. Refer to **GP 14**. Disconnect the power cord. Electricity can cause death or injury. Moving parts can cause injury.

- Check the actuator on the mid left door assembly, **PL 70.30 Item 16**. If the actuator is damaged, install a new mid left door assembly, **PL 70.30 Item 16**.
- Make sure the latch springs on the mid left door are installed correctly. Make sure that the mid left door closes correctly. If necessary, install a new mid left door assembly, **PL 70.30 Item 16**.

Procedure

Enter **dC330** code 01-101 to check the mid door interlock switch, S01-101, **PL 82.10 Item 10**. Actuate S01-101. **The display changes.**

Y N

Go to **WD 8.1**. Check S01-101.

References:

- **GP 13** How to Check a Switch.
- PJ104, **Media Path Driver PWB**.
- **01C** +3.3V Distribution RAP.
- **01L** 0V Distribution RAP

Install new components as necessary:

- Mid door interlock switch, **PL 82.10 Item 10**.
- Media path driver PWB, **PL 1.15 Item 5**.

Check that S01-101 is installed correctly.

01-506-00 Upper Left Door Open RAP

01-506-00 The upper door interlock switch detects that the upper left door is open.

Initial Actions

WARNING

Ensure that the electricity to the machine is switched off while performing tasks that do not need electricity. Refer to **GP 14**. Disconnect the power cord. Electricity can cause death or injury. Moving parts can cause injury.

- Check the actuator on the upper left door assembly, **PL 70.30 Item 18**. If the actuator is damaged, install a new upper left door assembly, **PL 70.30 Item 18**.
- Make sure the latch springs, **PL 70.30 Item 20** on the upper left door are installed correctly. Make sure that the middle left door closes correctly. If necessary, install a new upper left door assembly, **PL 70.30 Item 18**.

Procedure

Enter **dC330** code 01-100 to check the upper door interlock switch, S01-100, **PL 82.10 Item 10**. Actuate S01-100. **The display changes.**

Y N

Go to **WD 8.1**. Check S01-100.

References:

- **GP 13** How to Check a Switch.
- PJ104, **Media Path Driver PWB**.
- **01C** +3.3V Distribution RAP.
- **01L** 0V Distribution RAP

Install new components as necessary:

- Upper door interlock switch, **PL 82.10 Item 10**.
- Media path driver PWB, **PL 1.15 Item 5**.

Check that S01-100 is installed correctly.

01-510-00 Front Door Open RAP

01-510-00 The front door interlock switch detects that the front door is open.

Initial Actions

WARNING

Ensure that the electricity to the machine is switched off while performing tasks that do not need electricity. Refer to **GP 14**. Disconnect the power cord. Electricity can cause death or injury. Moving parts can cause injury.

- Check the actuator on the front door moulding, **PL 81.11 Item 7**. If the actuator is damaged, install a new front door assembly, **PL 81.11 Item 11**.
- Make sure the access magnetic catch, **PL 81.11 Item 8** is not missing. Make sure that the front door closes correctly. If necessary, install a new front door assembly, **PL 81.11 Item 11**.

Procedure

Enter **dC330** code 01-103 to check the front door interlock switch, S01-103, **PL 1.15 Item 7**. Actuate S01-103. **The display changes.**

Y N

Go to **WD 9.3**. Check S01-103.

References:

- **GP 13** How to Check a Switch.
- **PJ801**, **Drum Driver PWB**.
- **01B** +3.3V ESTAR Distribution RAP.
- **01L** 0V Distribution RAP

Install new components as necessary:

- Front door interlock switch, **PL 1.15 Item 7**.
- Drum driver PWB, **PL 1.15 Item 4**.

Check that S01-103 is installed correctly.

01-525-00 +24V, +/-12V, +5V Short Circuit and Overload RAP

01-525-00 An over current condition has been detected with the +24V, +12V, -12V or +5V supply.

Procedure

WARNING

Ensure that the electricity to the machine is switched off while performing tasks that do not need electricity. Refer to **GP 14**. Disconnect the power cord. Electricity can cause death or injury. Moving parts can cause injury.

Switch off the machine, then switch on the machine, **GP 14**. Check the PEST fault history, **dC123**. **There are hard PEST faults shown.**

Y N

The yellow LED, **Figure 1**, illuminates within one minute.

Y N

Perform the short circuit checks that follow:

- **+24V Short Circuit Check**
- **+12V Short Circuit Check**
- **-12V Short Circuit Check**
- **+5V Short Circuit Check**

If no short circuit is found and the supply is still not available, install a new power supply unit, **PL 1.15 Item 2**.

Refer to **WD 1.4** and **WD 9.4**. **The voltage on PJ902 pin 31 on the Drum driver PWB is less than +1.5V.**

Y N

Install a new power supply unit, **PL 1.15 Item 2**.

Install a new drum driver PWB, **PL 1.15 Item 4**.

Perform the RAP(s) given by the hard PEST fault code(s).

+24V Short Circuit Check

Procedure

Switch off the machine, **GP 14**.

Refer to **WD 1.4**. Disconnect PJDC1 from the power supply unit and check for a short circuit between pin 11 of the disconnected PJ and the chassis. **The circuit is good.**

Y N

Go to **01H** and follow the procedure for the **IME controller PWB**.

Go to **01H** and follow the procedure for the **Quad wave amp PWB**.

Refer to **WD 1.5**. Disconnect PJDC3 from the power supply unit and check for a short circuit between pin 15 of the disconnected PJ and the chassis. **The circuit is good.**

Y N

Go to **01H** and follow the procedure for the **drum driver PWB**.

With PJDC3 still disconnected from the power supply unit, check for a short circuit between pin 24 of the disconnected PJ and the chassis. **The circuit is good.**

Y N

Go to 01H and follow the procedure for the [media path driver PWB](#).

Refer to [WD 1.5](#). Disconnect PJDC4 from the [power supply unit](#) and check for a short circuit between pins 17 to chassis and from pin 18 to the chassis with the PJDC4 disconnected. **The circuit is good.**

Y N

Go to 01H and follow the procedure for the [power distribution PWB](#).

No short has been found in the +24V circuits, refer to the fault history for an insight into the fault area, then go to 01H and check that area.

+12V Short Circuit Check

Procedure

Switch off the machine, [GP 14](#).

Refer to [WD 1.4](#). Disconnect PJDC1 from the [power supply unit](#) and check for a short circuit between pin 13 of the disconnected PJ and the chassis. **The circuit is good.**

Y N

Go to 01E and follow the procedure for the [IME controller PWB](#).

Go to 01E and follow the procedure for the [Quad wave amp PWB](#).

Refer to [WD 1.5](#). Disconnect PJDC3 from the [power supply unit](#) and check for a short circuit between pin 17 of the disconnected PJ and the chassis. **The circuit is good.**

Y N

Go to 01E and follow the procedure for the [drum driver PWB](#).

With PJDC3 still disconnected from the [power supply unit](#), check for a short circuit between pin 22 of the disconnected PJ and the chassis. **The circuit is good.**

Y N

Go to 01E and follow the procedure for the [media path driver PWB](#).

Refer to [WD 1.5](#). Disconnect PJDC4 from the [power supply unit](#) and check for a short circuit between pin 14 of the disconnected PJ and the chassis. **The circuit is good.**

Y N

Go to 01E and follow the procedure for the [power distribution PWB](#).

With PJDC4 still disconnected from the [power supply unit](#), check for a short circuit between pin 15 of the disconnected PJ and the chassis. **The circuit is good.**

Y N

Go to 01E and follow the procedure for the HDD.

No short has been found in the +12V circuits, refer to the fault history for an insight into the fault area, then go to 01E and check that area.

-12V Short Circuit Check

Procedure

Switch off the machine, [GP 14](#).

Refer to [WD 1.4](#). Disconnect PJDC1 from the [power supply unit](#) and check for a short circuit between pin 12 of the disconnected PJ and the chassis. **The circuit is good.**

Y N

Go to 01F and follow the procedure for the [IME controller PWB](#).

Go to 01F and follow the procedure for the [Quad wave amp PWB](#).

Refer to [WD 1.5](#). Disconnect PJDC3 from the [power supply unit](#) and check for a short circuit between pin 16 of the disconnected PJ and the chassis. **The circuit is good.**

Y N

Go to 01F and follow the procedure for the [drum driver PWB](#).

With PJDC3 still disconnected from the [power supply unit](#), check for a short circuit between pin 23 of the disconnected PJ and the chassis. **The circuit is good.**

Y N

Go to 01F and follow the procedure for the [media path driver PWB](#).

No short has been found in the -12V circuits, refer to the fault history for an insight into the fault area, then go to 01F and check that area.

+5V Short Circuit Check

Procedure

Switch off the machine, [GP 14](#).

Refer to [WD 1.4](#). Disconnect PJDC1 from the [power supply unit](#) and check for a short circuit between pin 17 of the disconnected PJ and the chassis. **The circuit is good.**

Y N

Go to 01D and follow the procedure for the [IME controller PWB](#).

Go to 01D and follow the procedure for the [Quad wave amp PWB](#).

Refer to [WD 1.5](#). Disconnect PJDC3 from the [power supply unit](#) and check for a short circuit between pin 19 of the disconnected PJ and the chassis. **The circuit is good.**

Y N

Go to 01D and follow the procedure for the [drum driver PWB](#).

With PJDC3 still disconnected from the [power supply unit](#), check for a short circuit between pin 20 of the disconnected PJ and the chassis. **The circuit is good.**

Y N

Go to 01D and follow the procedure for the [media path driver PWB](#).

Refer to [WD 1.5](#). Disconnect PJDC4 from the [power supply unit](#) and check for a short circuit between pin 13 of the disconnected PJ and the chassis. **The circuit is good.**

Y N

Go to 01D and follow the procedure for the [power distribution PWB](#).

With PJDC4 still disconnected from the [power supply unit](#), check for a short circuit between pin 11 of the disconnected PJ and the chassis. **The circuit is good.**

Y N

Go to 01E and follow the procedure for the HDD.

The fault is still active.

Y N

Perform [SCP 5](#) Final Actions.

A

A
Install a new power supply unit, [PL 1.15 Item 2](#).

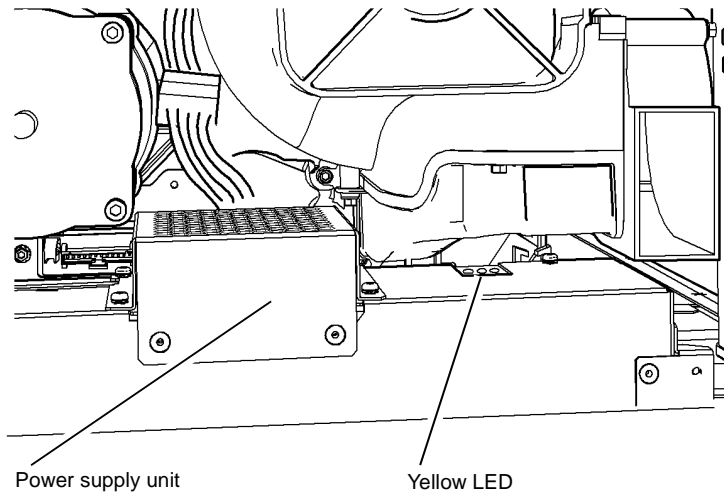

Figure 1 Component location

U-1-1491-A

01-530-00 +/- 50V Short Circuit and Overload RAP

01-530-00 An over current condition has been detected with the +50V or -50V supply.

Procedure

WARNING

Ensure that the electricity to the machine is switched off while performing tasks that do not need electricity. Refer to [GP 14](#). Disconnect the power cord. Electricity can cause death or injury. Moving parts can cause injury.

Switch off the machine, then switch on the machine, [GP 14](#). Check the PEST fault history, [dC123](#). There are hard PEST faults shown.

Y N
The red LED, [Figure 1](#), is illuminated.

Y N
Perform the short circuit checks that follow:

- [+50V Short Circuit Check](#)
- [-50V Short Circuit Check](#)

If no short circuit is found and the supply is still not available, install a new power supply unit, [PL 1.15 Item 2](#).

Refer to [WD 1.4](#) and [WD 9.4](#). The voltage on PJ902 pin 29 on the [drum driver PWB](#) is less than +1.5V.

Y N
Install a new power supply unit, [PL 1.15 Item 2](#).

Install a new drum driver PWB, [PL 1.15 Item 4](#).

Perform the RAP(s) given by the hard PEST fault code(s).

+50V Short Circuit Check

Procedure

Switch off the machine, [GP 14](#).

Refer to [WD 1.4](#). Disconnect PJDC1 from the [power supply unit](#) and check for a short circuit between pin 10 of the disconnected PJ and the chassis. **The circuit is good.**

Y N
Go to [01J](#) and follow the procedure for the [IME controller PWB](#).
Go to [01J](#) and follow the procedure for the [Quad wave amp PWB](#).

Refer to [WD 1.5](#). Disconnect PJDC3 from the [power supply unit](#) and check for a short circuit between pin 12 of the disconnected PJ and the chassis. **The circuit is good.**

Y N
Go to [01J](#) and follow the procedure for the [media path driver PWB](#).

With PJDC3 still disconnected from the [power supply unit](#), check for a short circuit between pins 13 and 14 of the disconnected PJ and the chassis. **the circuit is good.**

Y N
Go to [01J](#) and follow the procedure for the [drum driver PWB](#).

No short has been found in the +50V circuits, refer to the fault history for an insight into the fault area, then go to [01J](#) and check that area.

-50V Short Circuit Check

Procedure

Switch off the machine, [GP 14](#).

Refer to [WD 1.4](#). Disconnect PJDC1 from the [power supply unit](#) and check for a short circuit between pin 18 of the disconnected PJ and the chassis. **The circuit is good.**

Y N

Go to [01K](#) and follow the procedure for the [IME controller PWB](#).

Go to [01K](#) and follow the procedure for the [Quad wave amp PWB](#).

The fault is still active.

Y N

Perform [SCP 5](#) Final Actions.

Install a new power supply unit, [PL 1.15 Item 2](#).

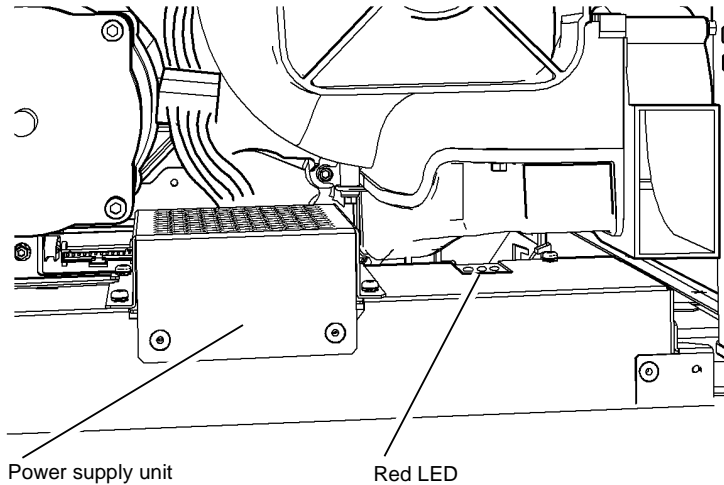

Figure 1 Component location

01-535-00 Power Interlock Failed: No Heater Requests RAP

01-535-00 The IME power interlock has failed because the AC power manager heater requests are not being updated.

Procedure

WARNING

Ensure that the electricity to the machine is switched off while performing tasks that do not need electricity. Refer to [GP 14](#). Disconnect the power cord. Electricity can cause death or injury. Moving parts can cause injury.

Switch off the machine, then switch on the machine, [GP 14](#).

Go to [WD 9.3](#) and check the front door interlock switch (S01-103) and PJ801. **The voltage at PJ801 pin 4 on the drum driver PWB changes when the front door interlock switch is actuated/deactuated.**

Y N

Refer to [GP 13](#), How to Check a Switch. Check the wiring between the interlock switch and PJ801 and repair the wiring as necessary, refer to [REP 1.1](#). If necessary, install new components:

- Front door interlock switch, (S01-103), [PL 1.15 Item 7](#).
- Drum driver PWB, [PL 1.15 Item 4](#).

Go to [01A](#), AC Power Distribution RAP and check for the correct AC supply. If necessary, install a new power supply unit, [PL 1.15 Item 2](#).

01-540-00, 01-544-00 +24V, +/-12V, +5V Failure RAP

01-540-00 The +24V, +12V, -12V and +5V supplies have shut down unexpectedly.

01-544-00 The IME +24V, +12V, -12V and +5V supplies have failed to switch on.

Procedure

WARNING

Ensure that the electricity to the machine is switched off while performing tasks that do not need electricity. Refer to GP 14. Disconnect the power cord. Electricity can cause death or injury. Moving parts can cause injury.

Switch off the machine, then switch on the machine, GP 14.

Check that the three LEDs on the top of the power supply unit illuminate within one minute of switch-on, Figure 1. The LEDs illuminate.

Y N
Either the power supply unit is faulty or there is a short circuit. Refer to WD 9.4 and WD 1.4. Measure the voltage at pin 27 of PJ902 on the drum driver PWB. The voltage should be greater than +2.5V, indicating the drum driver PWB is enabling the +24V, +12V, -12V and +5V supplies in the power supply unit. The voltage is greater than +2.5V.

Y N
Check the condition of the drum driver power supply interface cable between PJDC2 on the power supply unit and PJ902 on the drum driver PWB. It should be correctly and securely connected at each end, and should be undamaged. This cable carries power control signals from and to the power supply unit. The cable is good.

Y N
Correct the cable connection or install a new drum driver power supply interface cable, PL 1.15 Item 10, as necessary.

Switch off the machine, GP 14. Check pin 27 of PJ902 on the drum driver PWB. Pin 27 is short circuit to ground.

Y N
Install a new drum driver PWB, PL 1.15 Item 4.

Repair the wiring, REP 1.1.

Either the power supply unit is faulty or there is a short circuit. Go to 01-525-00 +24V, +/-12V, +5V Short Circuit and Overload RAP.

Refer to WD 9.4 and WD 1.4. Measure the voltage at pin 24 of PJ902 on the drum driver PWB. This can be measured on the top of the connector, while it is connected to the drum driver PWB. The voltage should be greater than +2.5V, indicating that the power supply is enabled. The yellow LED on the power supply unit should also be lit, Figure 1. The voltage is greater than +2.5V.

Y N
Check the condition of the drum driver power supply interface cable between PJDC2 on the power supply unit and PJ902 on the drum driver PWB. It should be correctly and securely connected at each end, and should be undamaged. This cable carries power control signals from and to the power supply unit. The cable is good.

Y N
Correct the cable connection or install a new drum driver power supply interface cable, PL 1.15 Item 10, as necessary.

A B
Switch off the machine, GP 14. Check pin 24 of PJ902 on the drum driver PWB. Pin 24 is short circuit to ground.
Y N
Install a new power supply unit, PL 1.15 Item 2.
Repair the wiring, REP 1.1.

Install a new drum driver PWB, PL 1.15 Item 4. The fault is still active.

Y N
Perform SCP 5 Final Actions.

Go to 01H +24V Distribution RAP.

Other voltage supplies are inter-dependent. Also refer to the RAP's that follow:

- 01D +5V Distribution RAP.
- 01E +12V Distribution RAP.
- 01F -12V Distribution RAP.
- 01L 0V Distribution RAP.

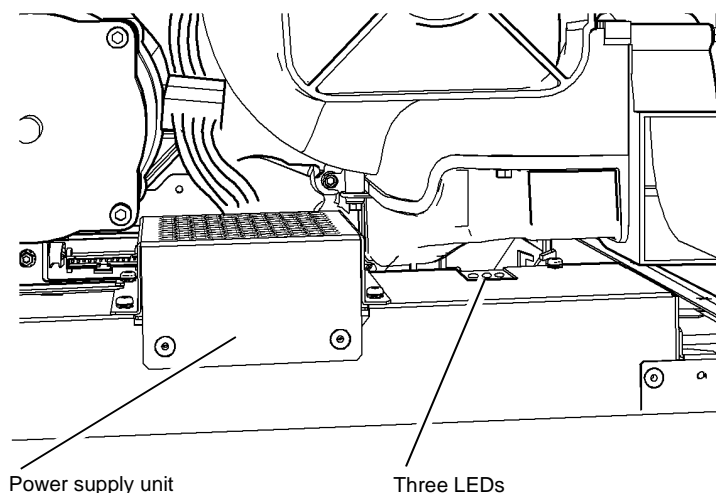

Figure 1 Component location

U-1-1493-A

01-542-00, 01-546-00 50V Failure RAP

01-542-00 The IME +50V or -50V supply has shutdown unexpectedly.

01-546-00 The IME +50V or -50V supply has failed to switch on.

Initial Actions

If possible, repair all the current listed faults, before performing this procedure, refer to dC123.

Procedure

WARNING

Ensure that the electricity to the machine is switched off while performing tasks that do not need electricity. Refer to GP 14. Disconnect the power cord. Electricity can cause death or injury. Moving parts can cause injury.

Switch off the machine GP 14. Refer to WD 1.4 and WD 9.4. Check the condition of the drum driver power supply interface cable between PJDC2 on the power supply unit and PJ902 on the drum driver PWB. It should be correctly and securely connected at each end, and should be undamaged, PL 1.15 Item 10. **The ribbon cable is secure and in good condition.**

Y N
Correct the cable connection or install a new drum driver power supply interface cable, PL 1.15 Item 10, as necessary.

Switch on the machine GP 14. **The fault code is still present.**

Y N
Perform SCP 5 Final Actions.

Check the 3 LEDs on the power supply are illuminated, Figure 1. **The 3 LEDs are on and remain illuminated after 60 seconds.**

Y N
Either the power supply unit is not enabled or is faulty or there is a short circuit on the +50V or -50V output circuits.

NOTE: The voltage on PJ902 at pin 28 must be greater than +2.5V to enable +/-50V outputs.

Switch on the machine GP 14. Go to WD 1.4 and WD 9.4. Check the voltage on PJ902 pin 28 on the drum driver PWB. **The voltage is greater than +2.5V.**

Y N
Refer to WD 1.4 and WD 9.4. Check the drum driver power supply interface cable for short circuits on PJ902 at pin 28 and pin 29. **The cable is good.**

Y N
Repair the drum driver power supply interface cable as necessary, REP 1.1. If necessary, install a new drum driver power supply interface cable, PL 1.15 Item 10.

Install a new drum driver PWB, PL 1.15 Item 4.

The control voltages are correct. If the +50V or -50V supplies are still not present, either there is a power supply unit fault or there is a short circuit. Go to 01-530-00 +/-50V Short Circuit and Overload RAP.

A
Refer to WD 1.4 and WD 9.4. Check the red LED, Figure 1, is illuminated and the voltage on PJ902 pin 26 on the Drum driver PWB is greater than +2.5V. **The LED is illuminated and the voltage is greater than 2.5V.**

Y N
Switch off the machine GP 14. Check PJ902 pin 26 on the drum driver PWB. **Pin 26 is shorted to ground.**

Y N
Install a new power supply unit, PL 1.15 Item 2.

Repair the wiring, REP 1.1.

Install a new drum driver PWB, PL 1.15 Item 4.

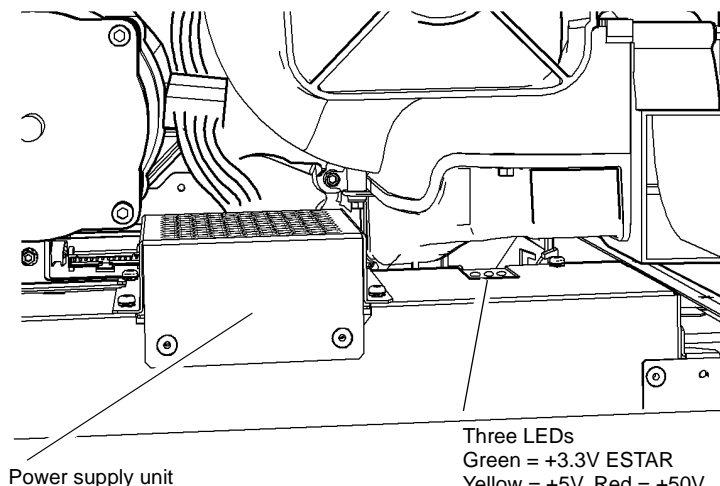

Figure 1 Component location

A

01A AC Power Distribution RAP

Use this RAP to diagnose faults with the AC power distribution throughout the machine.

Initial Actions

WARNING

Ensure that the electricity to the machine is switched off while performing tasks that do not need electricity. Refer to [GP 14](#). Disconnect the power cord. Electricity can cause death or injury. Moving parts can cause injury.

Switch off the machine, then switch on the machine, [GP 14](#). Check for PEST errors, go to [dC123](#) PEST Fault History. If a fault is given, perform the appropriate RAP. If the machine is unresponsive, go to [OF 3](#).

Procedure

AC Power is distributed widely throughout this machine. Either work through this RAP or if the faulty area of the machine is known, select the required check from the list that follows:

NOTE: If multiple heater failures are noted, the fault is likely to exist in one of the following:

- [Marking unit heater PWB supply, WD 9.8.](#)
- [Head thermistors safety circuit, refer to the 99-394-00 to 99-413-00 PEST Error 13 RAP](#)
- [WD 1.4, WD 9.2, WD 9.4 and WD 9.6](#) for IME common heater relay. The line signal must be greater than +2.5V to close the relays
- Check the power supply output for the items that follow:
 - Ink melt, refer to [Ink Reservoir Heaters Check](#). If there is no voltage output, install a new power supply unit, [PL 1.15 Item 2](#)
 - Registration pre-heater, refer to [Registration / Pre-Heaters Check](#). If there is no voltage output, install a new power supply unit, [PL 1.15 Item 2](#)
 - Drum heaters, refer to [Drum Heaters Check](#). If there is no voltage output, install a new power supply unit, [PL 1.15 Item 2](#)
 - [Marking unit heater PWB supply, refer to Marking Unit Heater PWB Supply Check](#). If there is no voltage output, install a new power supply unit, [PL 1.15 Item 2](#)

- [Power to the Power Supply Unit Check](#)
- [Main Power Rocker Switch Check](#)
- [Ink Reservoir Heaters Check](#)
- [Ink Melt Heaters Check](#)
- [Drum Heaters Check](#)
- [Registration / Pre-Heaters Check](#)
- [Thermal Cutout Check](#)
- [Finisher Supply Check](#)
- [Marking Unit Heater PWB Supply Check](#)
- [Lower Umbilical Heater Check](#)
- [Head 1 Reservoir and Jetstack Heaters Check](#)
- [Head 3 Reservoir and Jetstack Heaters Check](#)
- [Upper Umbilical Heater Check](#)
- [Head 2 Reservoir and Jetstack Heaters Check](#)
- [Head 4 Reservoir and Jetstack Heaters Check](#)

Power to the Power Supply Unit Check

Procedure

Check the green LED on top of the power supply, [Figure 1](#). The green LED is lit.

Y N
Check the customer AC supply. The AC supply is good.

Y N
Inform the customer to resolve the power supply fault.

Check the power cord, [PL 1.15 Item 1](#).

The ink reservoir, [PL 93.10 Item 10](#), is warm.

Y N
Go to:

- [Main Power Rocker Switch Check](#)
- [Ink Reservoir Heaters Check](#)

AC power is present and the power interlocks are operating.

Main Power Rocker Switch Check

Procedure

Switch off the machine, [GP 14](#), disconnect the power cord. Refer to [WD 1.1](#). Disconnect PJ8AC on the [power supply unit](#) and measure the continuity between pins 1 and 2 of the cable, **Continuity is measured when the main power rocker switch is in the on position and open circuit is measured when the main power rocker switch is in the off position.**

Y N
Check the wiring between PJ8AC on the [power supply unit](#) and the main power rocker switch and repair as necessary, refer to [REP 1.1](#). If necessary, install new a main power rocker switch, [PL 1.15 Item 3](#).

Continuity is measured when the main power rocker switch is in off position.

Y N
There is a short circuit or the switch has failed. Check the wiring between PJ8AC on the [power supply unit](#) and the main power switch and repair as necessary, refer to [REP 1.1](#). If necessary, install new a main power rocker switch, [PL 1.15 Item 3](#).

Install a new power supply unit, [PL 1.15 Item 2](#).

Ink Reservoir Heaters Check

Procedure

Switch off the electricity to the machine, [GP 14](#), and disconnect the power cord. Refer to [WD 9.8](#). Disconnect PJ201 from the [marking unit heater PWB](#). Check the electrical resistance of the ink reservoir heaters, by measuring the resistance across the pins of the PJ201 harness as follows:

- Ink reservoir heater 1, pin 1 to pin 3. Expect a cold resistance of approximately 45-55 ohms.
- Ink reservoir heater 2, pin 2 to pin 4. Expect a cold resistance of approximately 45-55 ohms.

The measured resistances are correct.

Y N
Go to [WD 9.8](#). Check the wiring between PJ201 on the [marking unit heater PWB](#) and the ink reservoir heaters. Repair the wiring as necessary, [REP 1.1](#). If necessary, install a new reservoir assembly, [PL 93.10 Item 26](#).

A

A

The ink reservoir heaters are good. If necessary, install a new Marking unit heater PWB, [PL 92.10 Item 5](#). Perform [SCP 5 Final Actions](#).

Ink Melt Heaters Check

Procedure

Switch off the electricity to the machine, [GP 14](#), and disconnect the power cord. Refer to [WD 1.2](#). Disconnect PJ5AC from the [power supply unit](#). Check the electrical resistance of the four ink melt heaters by measuring the resistance across the pins of the PJ5AC harness as follows:

- Black ink melt heater, pin 6 to pin 12. Expect a cold resistance of approximately 70-80 ohms.
- Yellow ink melt heater, pin 6 to pin 13. Expect a cold resistance of approximately 70-80 ohms.
- Cyan ink melt heater, pin 7 to pin 1. Expect a cold resistance of approximately 70-80 ohms.
- Magenta ink melt heater, pin 7 to pin 11. Expect a cold resistance of approximately 70-80 ohms.
- Check that pin 7 to chassis is open circuit.
- Check that pin 6 to the chassis is open circuit.

The measured resistances are correct.

Y N

Go to [WD 1.2](#). Check the wiring between PJ5AC and PJX to the ink melt heaters. Repair the wiring as necessary, refer to [REP 1.1](#). If necessary, install a new ink loader melt plate assembly, [PL 93.10 Item 3](#).

The ink melt heaters are good. If necessary, install a new power supply unit, [PL 1.15 Item 2](#).

Drum Heaters Check

Procedure

Switch off the electricity to the machine, [GP 14](#), and disconnect the power cord. Refer to [WD 1.2](#). Disconnect PJ5AC from the [power supply unit](#). Check the electrical resistance of the two drum heaters by measuring the resistance across the pins of the PJ5AC harness as follows:

- Drum heater 1 first section, pin 15 to pin 16. Expect a cold resistance of approximately 40-50 ohms.
- Drum heater 1 second section, pin 15 to pin 17. Expect a cold resistance of approximately 40-50 ohms.
- Drum heater 2 first section, pin 10 to pin 19. Expect a cold resistance of approximately 40-50 ohms.
- Drum heater 2 second section, pin 10 to pin 20. Expect a cold resistance of approximately 40-50 ohms.
- Check that pin 15 to the chassis is open circuit.
- Check that pin 10 to the chassis is open circuit.

The measured resistances are correct.

Y N

Go to [WD 1.2](#). Check the wiring between PJ5AC on the [power supply unit](#), and PJX to the drum heaters. Repair the wiring as necessary, refer to [REP 1.1](#). As necessary, install a new drum, [PL 94.20 Item 1](#).

Go to [Thermal Cutout Check](#)

Registration / Pre-Heaters Check

Procedure

Switch off the electricity to the machine, [GP 14](#), and disconnect the power cord. Refer to [WD 1.2](#). Disconnect PJ5AC from the [power supply unit](#). Check the electrical resistance of the registration/pre-heaters by measuring the resistance across the pins of the PJ5AC harness as follows:

- Registration pre-heater 1, pin 3 to pin 9. Expect a cold resistance of approximately 50-60 ohms.
- Registration pre-heater 2, pin 2 to pin 8. Expect a cold resistance of approximately 50-60 ohms.
- Check that pin 8 to the chassis is open circuit.
- Check that pin 9 to the chassis is open circuit.

The measured resistances are correct.

Y N

Go to [WD 1.2](#). Check the wiring between PJ5AC on the [power supply unit](#), and PJ140 to the registration preheat assembly. Repair the wiring as necessary, refer to [REP 1.1](#). As necessary, install a new registration preheat assembly [PL 88.10 Item 1](#).

The registration/pre-heaters are good. If necessary, install a new power supply unit, [PL 1.15 Item 2](#).

Thermal Cutout Check

Procedure

Switch off the electricity to the machine, [GP 14](#), and disconnect the power cord. Refer to [WD 1.2](#). Disconnect PJ5AC harness on the [power supply unit](#). Check the continuity of the thermal cutouts on the thermal cutout PWB, by measuring the resistance across the pins of the PJ5AC harness as follows:

- cutout for drum heater 1, pin 4 to pin 14. Expect a short circuit.
- cutout for drum heater 2, pin 5 to pin 18. Expect a short circuit.
- Check that pin 4 and 5 to the chassis is open circuit.

The measured resistances are correct.

Y N

Go to [WD 1.2](#). Check the wiring between PJ5AC on the [power supply unit](#) and PJ140 to the thermal cutout PWB, [PL 88.10 Item 11](#). Repair as necessary, refer to [REP 1.1](#). As necessary, install a new thermal cutout PWB, [PL 94.20 Item 11](#).

The thermal cutouts are good. Refer to [WD 9.4](#). Switch on the electricity to the machine, [GP 14](#), and check the voltage on PJ902 pin 1 or pin 2 on the [drum driver PWB](#) is greater than +2.5V. Check the voltage on PJ902 pin 33 on the [drum driver PWB](#) is greater than +2.5V. **The voltages are good.**

Y N

Install a new drum driver PWB, [PL 1.15 Item 4](#).

Check the condition of harness between PJDC2 of the [power supply unit](#) and PJ 902 of the [drum driver PWB](#). **The harness is good.**

Y N

Repair the harness, [REP 1.1](#).

Install a new power supply unit, [PL 1.15 Item 2](#).

Finisher Supply Check

Procedure

Verify that the machine is configured for a finisher and that the machine is ready to print. Refer to [WD 1.4](#) and [WD 9.4](#). Check the Finisher On signal from PJDC2, pin 3 on the [power supply unit](#) to PJ902, pin 3 on the [drum driver PWB](#). **The signal is good.**

Y N

Switch off the electricity to the machine, [GP 14](#), and disconnect the power cord. Repair the wiring as necessary, [REP 1.1](#) or install new wiring, [PL 1.15 Item 10](#). If necessary, install new components:

- Cord bracket assembly, [PL 12.75 Item 4](#).
- Power supply unit, [PL 1.15 Item 2](#).
- Drum driver PWB, [PL 1.15 Item 4](#).
- Drum driver power supply interface cable (PJ902), [PL 1.15 Item 10](#).

An HVF is installed.

Y N

Switch off the electricity to the machine, [GP 14](#), and disconnect the power cord. Refer to [WD 1.1](#) and [WD 12.1](#). Check the wiring between PJ3AC on the [power supply unit](#) and CN1 on the LCSS power supply module, [PL 12.75 Item 2](#). As necessary, repair the wiring, [REP 1.1](#). If necessary, install new components:

- Cord bracket assembly, [PL 12.75 Item 4](#).
- LCSS power supply unit, [PL 12.75 Item 2](#).
- Power supply unit, [PL 1.15 Item 2](#).

NOTE: Verify that no short circuits exist between the line, neutral and ground on the harness to the finisher, before a new [power supply unit](#) is installed.

Switch off the electricity to the machine, [GP 14](#), and disconnect the power cord. Refer to [WD 1.1](#) and [WD 12.6](#). Check the wiring between PJ3AC on the [power supply unit](#) and CN1 on the HVF power supply unit, [PL 12.140 Item 1](#). As necessary, repair the wiring, [REP 1.1](#). If necessary, install new components:

- Power cord, [PL 12.140 Item 4](#).
- HVF power supply unit, [PL 12.140 Item 1](#).
- Power supply unit, [PL 1.15 Item 2](#).

NOTE: Verify that no short circuits exist between the line, neutral and ground on the harness to the finisher, before a new [power supply unit](#) is installed.

Marking Unit Heater PWB Supply Check

Procedure

Refer to [WD 1.1](#) and [WD 9.8](#), check the wiring between PJ4AC on the [power supply unit](#) and PJ101 on the [marking unit heater PWB](#). If necessary, repair the wiring, [REP 1.1](#).

Lower Umbilical Heater Check

Procedure

Switch off the electricity to the machine, [GP 14](#), and disconnect the power cord. Refer to [WD 9.8](#). Disconnect PJ701 from the [marking unit heater PWB](#). Check the electrical resistance of the lower umbilical heater, by measuring the resistance across pin 1 to pin 8 of the PJ701 harness, expect a cold resistance of approximately 85-95 ohms. **The measured resistance is correct.**

Y N

Go to [WD 9.8](#). Check the wiring between PJ701 on the [marking unit heater PWB](#) and the lower umbilical heater. Repair the wiring as necessary, refer to [REP 1.1](#). If necessary, install new components:

- Umbilical, [PL 91.25 Item 10](#).
- Marking unit heater PWB, [PL 92.10 Item 5](#).
- Power supply unit, [PL 1.15 Item 2](#).

The lower umbilical heater is good. If necessary, install a new power supply unit, [PL 1.15 Item 2](#).

Head 1 Reservoir and Jetstack Heaters Check

Procedure

Switch off the electricity to the machine, [GP 14](#), and disconnect the power cord. Refer to [WD 9.8](#). Disconnect PJ701 from the [marking unit heater PWB](#). Check the electrical resistance of the head 1 reservoir and jetstack heaters, by measuring the resistance across the pins of the PJ701 harness as follows:

- Head 1 reservoir heater, pin 2 to pin 3. Expect a cold resistance of approximately 95-105 ohms.
- Head 1 first half jetstack heater, pin 5 to pin 4. Expect a cold resistance of approximately 495-505 ohms.
- Head 1 second half jetstack heater, pin 5 to pin 6. Expect a cold resistance of approximately 495-505 ohms.
- Check that pin 2 to ground and pin 5 to ground are open circuit.

The measured resistances are correct.

Y N

Go to [WD 9.8](#). Check the wiring between PJ701 on the [marking unit heater PWB](#) and the head 1 reservoir and jet stack heater. Repair the wiring as necessary, refer to [REP 1.1](#). If necessary, install a new printhead 1, [PL 91.25 Item 2](#).

The head 1 heaters are good. If necessary, install a new marking unit heater PWB, [PL 92.10 Item 5](#).

Head 3 Reservoir and Jetstack Heaters Check

Procedure

Switch off the electricity to the machine, [GP 14](#), and disconnect the power cord. Refer to [WD 9.8](#). Disconnect PJ701 from the [marking unit heater PWB](#). Check the electrical resistance of the head 3 reservoir and jetstack heaters, by measuring the resistance across the pins of the PJ701 harness as follows:

- Head 3 reservoir heater, pin 9 to pin 10. Expect a cold resistance of approximately 95-105 ohms.
- Head 3 first half jetstack heater, pin 12 to pin 11. Expect a cold resistance of approximately 495-505 ohms.

- Head 3 second half jetstack heater, pin 12 to pin 13. Expect a cold resistance of approximately 495-505 ohms.
- Check that pin 9 and pin 12 to the chassis is open circuit.

The measured resistances are correct.

Y N

Go to [WD 9.8](#). Check the wiring between PJ701 on the [marking unit heater PWB](#) and the head 3 reservoir and jet stack heater. Repair the wiring as necessary, refer to [REP 1.1](#). If necessary, install a new printhead 3, [PL 91.25 Item 2](#).

The head 3 heaters are good. If necessary, install a new marking unit heater PWB, [PL 92.10 Item 5](#). Re-connect PJ701.

Upper Umbilical Heater Check

Procedure

Switch off the electricity to the machine, [GP 14](#), and disconnect the power cord. Refer to [WD 9.8](#). Disconnect PJ401 from the [marking unit heater PWB](#). Check the electrical resistance of the upper umbilical heater, by measuring the resistance across the pins of the PJ401 harness as follows:

- Upper umbilical heater, pin 1 to pin 7. Expect a cold resistance of approximately 85-95 ohms.
- Check that pin 1 and pin 7 to the chassis is open circuit.

The measured resistances are correct.

Y N

Go to [WD 9.8](#). Check the wiring between PJ401 on the [marking unit heater PWB](#) and the upper umbilical heater. Repair the wiring as necessary, refer to [REP 1.1](#). If necessary, install a new umbilical, [PL 91.20 Item 10](#).

The upper umbilical heater is good. If necessary, install a new power supply unit, [PL 1.15 Item 2](#).

Head 2 Reservoir and Jetstack Heaters Check

Procedure

Switch off the electricity to the machine, [GP 14](#), and disconnect the power cord. Disconnect PJ401 from the [marking unit heater PWB](#). Check the electrical resistance of the head 2 reservoir and jetstack heaters, by measuring the resistance across the pins of the PJ401 harness as follows:

- Head 2 reservoir heater, pin 2 to pin 3. Expect a cold resistance of approximately 95-105 ohms.
- Head 2 first half jetstack heater, pin 5 to pin 4. Expect a cold resistance of approximately 495-505 ohms.
- Head 2 second half jetstack heater, pin 5 to pin 6. Expect a cold resistance of approximately 495-505 ohms.
- Check that pin 2 and pin 5 to the chassis is open circuit.

The measured resistances are correct.

Y N

Go to [WD 9.8](#). Check the wiring between PJ401 on the [marking unit heater PWB](#) and the head 2 reservoir and jet stack heater. Repair the wiring as necessary, refer to [REP 1.1](#). If necessary, install a new printhead 2, [PL 91.20 Item 2](#).

B

B

The head 2 heaters are good. If necessary, install a new marking unit heater PWB, [PL 92.10 Item 5](#).

Head 4 Reservoir and Jetstack Heaters Check

Procedure

Switch off the electricity to the machine, [GP 14](#), and disconnect the power cord. Refer to [WD 9.8](#). Disconnect PJ401 from the [marking unit heater PWB](#). Check the electrical resistance of the head 4 reservoir and jetstack heaters, by measuring the resistance across the pins of the PJ401 harness as follows:

- Head 4 reservoir heater, pin 8 to pin 9. Expect a cold resistance of approximately 95-105 ohms.
- Head 4 first half jetstack heater, pin 11 to pin 10. Expect a cold resistance of approximately 495-505 ohms.
- Head 4 second half jetstack heater, pin 11 to pin 12. Expect a cold resistance of approximately 495-505 ohms.
- Check that pin 8 and pin 11 to the chassis is open circuit.

The measured resistances are correct.

Y N

Go to [WD 9.8](#). Check the wiring between PJ401 on the [marking unit heater PWB](#) and the head 4 reservoir and jet stack heater. Repair the wiring as necessary, refer to [REP 1.1](#). If necessary, install a new printhead 4, [PL 91.20 Item 2](#).

The head 4 heaters are good. Re-connect PJ401. If necessary, install a new marking unit heater PWB, [PL 92.10 Item 5](#).

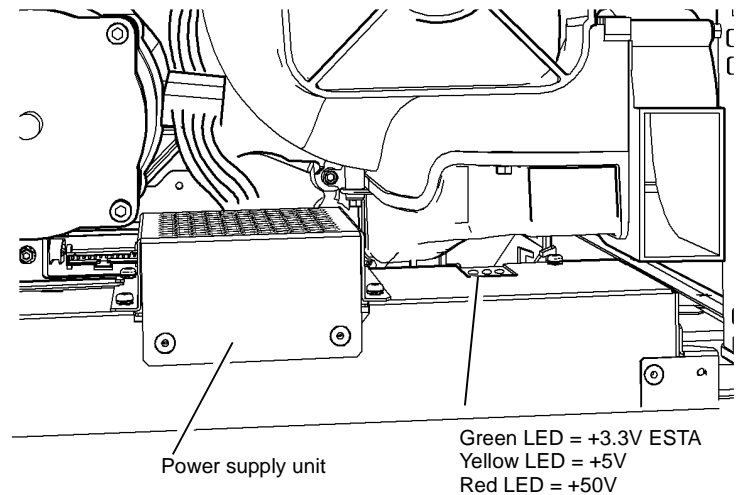

U-1-1298-A

Figure 1 Component location

01B +3.3V ESTAR Distribution RAP

Use this RAP to diagnose +3.3V ESTAR supply and distribution faults in the machine. This supply is used to power the IME logic circuits. This supply is not to be confused with the +3.3V supply, which is generated on the [power distribution PWB](#). To diagnose +3.3V faults go to [01C](#).

Procedure

WARNING

Ensure that the electricity to the machine is switched off while performing tasks that do not need electricity. Refer to [GP 14](#). Disconnect the power cord. Electricity can cause death or injury. Moving parts can cause injury.

Check the green LED, [Figure 1](#), on top of the [power supply unit](#). This is lit to indicate that the +3.3V ESTAR supply is available in the [power supply unit](#). **The green LED is lit.**

Y N
The AC supply is good.
Y N
Go to [01A AC Power Distribution RAP](#).
Go to the [01A AC Power Distribution RAP](#). Perform the Main Power Rocker Switch Check.

Switch off, then switch on the machine, [GP 14](#). Check the PEST fault history, [dC123](#). **There are hard PEST faults shown.**

Y N
Check that the +3.3V is within tolerance, +3.3V +/- 2.5% at JDC1 between pin 9 and pin 14 refer to [WD 1.4](#).

NOTE: To view the +3.3V ESTAR supply generation, refer to [WD 1.3](#). +3.3V ESTAR is only distributed on PJDC1 and PJDC3 on the [power supply unit](#). A short circuit on this output also disables the +17V output.

The +3.3V supply is within tolerance.

Y N
Install a new power supply unit, [PL 1.15 Item 2](#).

Determine which PWB has the distribution fault, go to [PWB Checks](#).

Perform the RAP(s) given by the hard PEST fault code(s), then return to this RAP.

PWB Checks

Check the PWB's below to determine which PWB has the distribution fault. Follow the distribution back to the supply. Repair the wiring, [REP 1.1](#) or install a new PWB or power supply unit, [PL 1.15 Item 2](#) as necessary. Refer to [GP 15](#) for the location and function of the LED's on the PWB's.

NOTE: Many of the PWB's have distribution fuses.

Select the required PWB:

- [IME Controller PWB](#)
- [Media Path Driver PWB](#)
- [Marking Unit Heater PWB](#)
- [Marking Unit Driver PWB](#)

- [Drum Driver PWB](#)
- [Quad Wave Amp PWB](#)
- [Ink Load Entry PWB](#)
- [Printhead 1 to 4](#)
- [3 Tray Module PWB](#)

IME Controller PWB

- To view the +3.3V ESTAR distribution from the [power supply unit](#) to the [IME controller PWB](#), refer to [WD 1.4](#).
- For +3.3V ESTAR faults on the [IME controller PWB](#), refer to:
 - [WD 9.5](#)
 - [WD 9.6](#)
 - [WD 9.7](#)
- The components that follow are driven from +3.3V ESTAR from the [IME controller PWB](#)
 - Printheads, [PL 91.20 Item 2](#) or [PL 91.25 Item 2](#)
 - Quad wave amp PWB, [PL 92.10 Item 3](#)
 - Marking unit driver PWB, [PL 92.10 Item 4](#)
- If necessary, install a new IME controller PWB, [PL 92.10 Item 1](#), or one of the components in the list above.

Media Path Driver PWB

- To view the +3.3V ESTAR distribution from the [power supply unit](#) to the [media path driver PWB](#), refer to [WD 1.5](#).
- For +3.3V ESTAR faults on the [media path driver PWB](#) refer to:
 - [WD 8.1](#)
 - [WD 8.2](#)
 - [WD 8.3](#)
 - [WD 8.4](#)
 - [WD 8.5](#)
- Repair the wiring as necessary, [REP 1.1](#).
- The components that follow are driven from +3.3V ESTAR from the [media path driver PWB](#):
 - Upper door interlink [PL 82.10 Item 10](#)
 - Vertical transport sensor [PL 82.10 Item 7](#)
 - 3 tray module [PL 73.16](#)
 - Ink loader door switch [PL 93.10 Item 19](#)
 - Bypass width sensor [PL 74.11 Item 6](#)
 - Potentiometer [PL 74.11 Item 10](#)
 - Ink load entry PWB [PL 93.10 Item 8](#)
 - Tray 5 control PWB [PL 75.68 Item 8](#)
- If necessary, install a new media path driver PWB, [PL 1.15 Item 5](#), or one of the components in the list above.

Marking Unit Heater PWB

- To view the +3.3V ESTAR distribution from the [marking unit heater PWB](#), refer to [WD 9.8](#).
- For +3.3V ESTAR faults on the [marking unit heater PWB](#), refer to [WD 9.8](#)
- If necessary, install a new marking unit heater PWB, [PL 92.10 Item 5](#).

Marking Unit Driver PWB

- To view the +3.3V ESTAR distribution from the [IME controller PWB](#), refer to [WD 9.7](#).
- For +3.3V ESTAR faults on the [marking unit driver PWB](#), refer to:
 - [WD 9.10](#)
 - [WD 9.11](#)
 - [WD 9.12](#)
- If necessary, install a new marking unit driver PWB, [PL 92.10 Item 4](#).

Drum Driver PWB

- The +3.3V ESTAR LED on the [drum driver PWB](#) is shown in [WD 9.2](#).
- To view the +3.3V ESTAR distribution from the [power supply unit](#), to the [drum driver PWB](#), refer to [WD 1.5](#).
- For +3.3V ESTAR faults on the [drum driver PWB](#), refer to:
 - [WD 9.2](#)
 - [WD 9.3](#)
 - [WD 9.4](#)
- The +3.3V ESTAR LED on this PWB is shown in [WD 9.2](#).
- The components that follow are driven from +3.3V ESTAR from the [drum driver PWB](#):
 - Front door interlock switch [PL 1.15 Item 7](#)
 - Waste tray sensor [PL 91.05 Item 4](#)
- If necessary, install a new [drum driver PWB](#), [PL 1.15 Item 4](#), or one of the components in the list above.

Quad Wave Amp PWB

- To view the +3.3V ESTAR distribution from the [IME controller PWB](#) to the quad wave amp PWB, refer to [WD 9.5](#).
- For +3.3V ESTAR faults on the quad wave amplifier PWB, refer to [WD 9.13](#).
- If necessary, install a new quad wave amp PWB, [PL 92.10 Item 3](#).

Ink Load Entry PWB

- To view the +3.3V ESTAR distribution from the [marking unit driver PWB](#) to the [ink load entry PWB](#), refer to [WD 8.4](#).
- For +3.3V ESTAR faults on the [ink load entry PWB](#), refer to:
 - [WD 9.17](#)
 - [WD 9.18](#)
- If necessary, install a new ink load entry PWB, [PL 93.10 Item 8](#).

Printhead 1 to 4

- To view the +3.3V ESTAR distribution from the [IME controller PWB](#) to the printhead PWB's, refer to:
 - [WD 9.5](#)
 - [WD 9.6](#)
- For +3.3V ESTAR faults on the printheads, refer to:
 - [WD 9.20](#)
 - [WD 9.21](#)
- The +3.3V ESTAR LEDs on these printheads are shown in:
 - [WD 9.20](#)
 - [WD 9.21](#)

- If necessary, install a new printhead 1 or printhead 3 [PL 91.25 Item 2](#) or install a new printhead 2 or printhead 4 [PL 91.20 Item 2](#).

3 Tray Module PWB

- To view the +3.3V ESTAR distribution from the [media path driver PWB](#), refer to [WD 8.2](#)
- For +3.3V ESTAR faults on the [3 tray module PWB](#), refer to:
 - [WD 7.3](#)
 - [WD 7.4](#)
- If necessary, install a new 3 tray module PWB, [PL 73.16 Item 4](#).

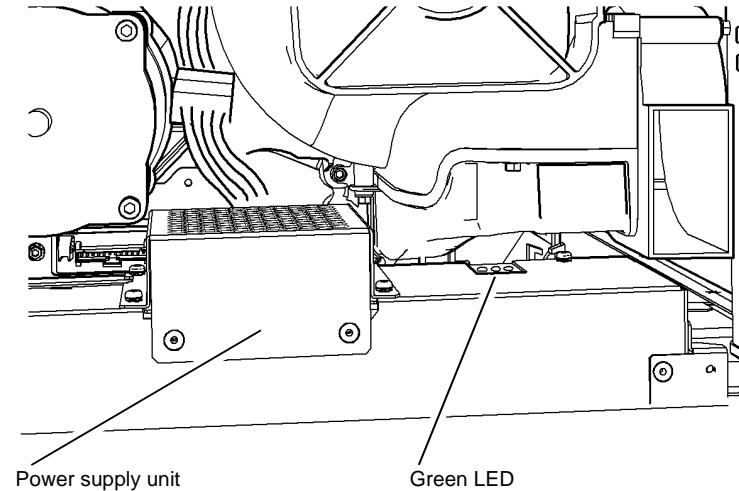

U-1-1494-A

Figure 1 Component location

01C +3.3V Distribution RAP

Use this RAP to diagnose +3.3V supply and distribution faults. This supply is not to be confused with the +3.3 ESTAR supply, which is generated in the [power supply unit](#). Go to [01B](#) to diagnose +3.3V ESTAR faults.

Procedure

WARNING

Ensure that the electricity to the machine is switched off while performing tasks that do not need electricity. Refer to [GP 14](#). Disconnect the power cord. Electricity can cause death or injury. Moving parts can cause injury.

The green LED is lit on the power supply, [Figure 1](#).

Y N
Go to [01B](#) +3.3V ESTAR Distribution RAP.

Check the PWB's below to determine which PWB has the distribution fault. Follow the distribution back to the supply. Repair the wiring, [REP 1.1](#) or install a new PWB or power supply unit, [PL 1.15 Item 2](#) as necessary. Refer to [GP 15](#) for the location and function of the LED's on the PWB's.

To view the +3.3V supply generation, refer to [WD 1.6](#).

Power Distribution PWB

- For +3.3V faults on the [power distribution PWB](#), refer to [WD 1.6](#).
- If necessary repair the wiring, [REP 1.1](#).
- If necessary, install a new power distribution PWB, [PL 3.11 Item 1](#).
- If necessary, install a new power supply unit, [PL 1.15 Item 2](#)

Single Board Controller PWB

- To view the +3.3V distribution from the [power distribution PWB](#), refer to [WD 1.6](#).
- For +3.3V faults on the [single board controller PWB](#), refer to:
 - [WD 3.1](#)
 - [WD 3.2](#)
- If necessary repair the wiring, [REP 1.1](#).
- If necessary, install a new single board controller PWB, [PL 3.11 Item 13](#).

Scanner PWB

- To view the +3.3V distribution from the [power distribution PWB](#), refer to [WD 1.7](#).
- For +3.3 faults on the [scanner PWB](#), refer to:
 - [WD 6.1](#)
 - [WD 6.2](#)
 - [WD 6.3](#)
- If necessary repair the wiring, [REP 1.1](#).
- If necessary, install a new scanner PWB, [PL 62.16 Item 8](#).

Full Width Array

- To view the +3.3V distribution from the [scanner PWB](#), refer to [WD 6.3](#).
- For +3.3 faults on the full width array, refer to [WD 6.3](#).
- If necessary, install a new scan carriage assembly, [PL 62.15 Item 1](#).

DADH PWB

- To view the +3.3V distribution from the [DADH PWB](#), refer to [WD 5.1](#).
- For +3.3 faults on the DADH PWB, refer to:

- [WD 5.1](#).
- [WD 5.2](#).
- If necessary repair the wiring, [REP 1.1](#).
- If necessary, install a new DADH PWB, [PL 5.10 Item 5](#).

UI PWB

- To view the +3.3V distribution from the [single board controller PWB](#), refer to [WD 3.2](#).
- For +3.3 faults on the [UI PWB](#), refer to [WD 3.2](#).
- If necessary repair the wiring, [REP 1.1](#).
- If necessary, install a new user interface control PWB, [PL 2.10 Item 2](#) or user interface status PWB, [PL 2.10 Item 4](#).

Registration / Pre-heat Interface PWB

- +3.3V is generated within this PWB from the +5V supply. Refer to [WD 8.6](#).
- If necessary, install a new registration/pre-heat interface PWB, [PL 88.10 Item 10](#).

IOD Pre-amplifier PWB

- +3.3V is generated within this PWB from the +5V supply. Refer to [WD 9.22](#).
- If necessary, install a new IOD pre-amplifier PWB, [PL 94.15 Item 4](#).

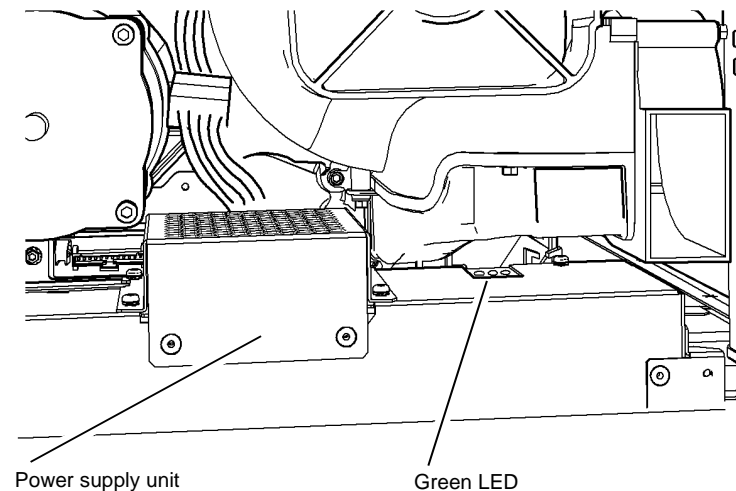

Figure 1 Component location

U-1-1499-A

01D +5V Distribution RAP

Use this RAP to diagnose +5V supply and distribution faults.

NOTE: Refer to RAP 12A-171 to diagnose +5V supply and distribution faults on the HVF. Refer to RAP 12D-110 to diagnose +5V supply and distribution faults on the LCSS.

Procedure

WARNING

Ensure that the electricity to the machine is switched off while performing tasks that do not need electricity. Refer to GP 14. Disconnect the power cord. Electricity can cause death or injury. Moving parts can cause injury.

NOTE: To view the +5V supply generation, refer to WD 1.3.

The yellow LED on top of the power supply unit, Figure 1, indicates that the +5V supply is available in the power supply unit. The green LED is lit but the yellow led is extinguished.

Y N
Go to the 01C 3.3V Distribution RAP.

Switch off, then switch on the machine, GP 14. Check the PEST fault history, dC123. There are hard PEST faults shown.

Y N
Check that the +5V is within tolerance, +5V +/- 2% at JDC1 pin 17. Refer to WD 1.4. The +5V is good.

Y N
Install a new power supply unit, PL 1.15 Item 2.

CAUTION

Do not disconnect or connect PJ's while the machine has power on, to avoid equipment damage.

Check for short circuits. Refer to 01-525-00 +24V, +/-12V, +5V Short Circuit and Overload RAP, +5V short circuit check. The circuit is good.

Y N
Switch off the machine, GP 14. Disconnect connectors on the power supply to isolate the PWB's that follow:

- PJDC1 to isolate the IME controller PWB.
- PJDC3 to isolate drum driver PWB and media path driver PWB.
- PJDC4 to isolate the power distribution PWB and HDD.

Repair the short circuit. Refer to REP 1.1. Install new parts as necessary.

Determine which PWB has the distribution fault, go to PWB Checks.

Perform the RAP(s) given by the hard PEST fault code(s), then return to this RAP.

PWB Checks

Check the PWB's below to determine which PWB has the distribution fault. Follow the distribution back to the supply. Repair the wiring, REP 1.1 or install a new PWB or power supply unit, PL 1.15 Item 2 as necessary. Refer to GP 15 for the location and function of the LED's on the PWB's.

NOTE: Many PWB's have distribution fuses.

Select the required PWB:

- IME Controller PWB
- Drum Driver PWB
- Media Path Driver PWB
- Power Distribution PWB
- 3 Tray Module PWB
- Registration / Pre-heat Interface PWB
- Marking Unit Driver PWB
- Tray 5 Control PWB
- Single Board Controller PWB
- Scanner PWB
- DADH PWB
- HDD
- Cleaning Unit PWB
- LCSS PWB
- HVF PWB
- BM PWB (Booklet Maker)
- Tri-folder PWB
- Inserter PWB
- OCT PWB

IME Controller PWB

- To view the +5V distribution from the power supply unit, refer to WD 1.4.
- For +5V faults on the IME controller PWB, refer to:
 - WD 9.6
 - WD 9.7
- The marking unit driver PWB PL 92.10 Item 4, is driven from +5V from the IME controller PWB
- Repair the wiring as necessary, REP 1.1
- If necessary, install a new IME controller PWB, PL 92.10 Item 1, or a new marking unit driver PWB, PL 92.10 Item 4

Drum Driver PWB

- To view the +5V distribution from the power supply unit, refer to WD 1.5
- For +5V faults on the drum driver PWB, refer to:
 - WD 9.1
 - WD 9.2
 - WD 9.3
- The components that follow are driven from +5V from the drum driver PWB:
 - IOD assembly PL 94.15 Item 1
 - Front transfix motor encoder, part of the front transfix motor, PL 10.20 Item 11
 - Rear transfix motor encoder, part of the rear transfix motor, PL 10.20 Item 11
 - Front and rear transfix flexure encoder PL 10.20 Item 5
 - Drum position encoder assembly PL 94.20 Item 8
 - Registration/Pre-heat interface PWB PL 88.10 Item 10
 - Stripper latch sensor, PL 10.10 Item 17
 - Pre exit sensor, PL 10.10 Item 6.
 - Cleaning unit motor assembly, PL 94.10 Item 19

- Cleaning unit home sensor, [PL 94.10 Item 17](#)
- Post transfix sensor, [PL 10.10 Item 6](#)
- Repair the wiring as necessary, [REP 1.1](#).
- If necessary, install a new drum driver PWB, [PL 1.15 Item 4](#), or one of the components in the list above

Media Path Driver PWB

- To view the +5V distribution from the [power supply unit](#), refer to [WD 1.5](#)
- For +5V faults on the [media path driver PWB](#), refer to:
 - [WD 8.1](#)
 - [WD 8.2](#)
 - [WD 8.3](#)
 - [WD 8.4](#)
 - [WD 8.5](#)
 - [WD 8.6](#)
- The +5V LED on this PWB is shown in [WD 8.5](#)
- The components that follow are driven from the [media path driver PWB](#):
 - Registration/Pre-heat interface PWB, [PL 88.10 Item 10](#) see below for components driven by this PWB
 - Vertical transport sensor, [PL 82.10 Item 7](#)
 - Confirm sensor, [PL 82.10 Item 7](#)
 - Vertical transport motor encoder, part of the vertical transport motor, [PL 82.10 Item 12](#)
 - 3 Tray module, [PL 73.16](#) and components, see below for components driven by this PWB
 - Bypass empty sensor, [PL 74.10 Item 18](#)
 - Bypass feed sensor, [PL 74.10 Item 19](#)
 - Bypass nudger home sensor, [PL 74.10 Item 18](#)
 - Tray 5 control PWB, [PL 75.68 Item 8](#) see below for components driven by this PWB
 - OCT [PL 12.00 Item 1](#)
 - LCSS PWB, [PL 12.75 Item 1](#), see below for components driven by this PWB
 - HVF PWB [PL 12.140 Item 2](#), see below for components driven by this PWB
 - Duplex start sensor [PL 10.15 Item 3](#)
 - Exit sensor [PL 10.15 Item 3](#)
 - Duplex sensor [PL 82.15 Item 3](#)
 - Horizontal transport motor encoder, part of the horizontal transport motor, [PL 82.15 Item 9](#)
 - Duplex end sensor [PL 82.15 Item 3](#)
- Repair the wiring as necessary, [REP 1.1](#)
- If necessary, install a new media path driver PWB, [PL 1.15 Item 5](#), or one of the components in the list above.

Power Distribution PWB

- To view the +5V distribution from the [power supply unit](#), refer to [WD 1.5](#).
- For +5V faults on the [power distribution PWB](#), refer to:
 - [WD 1.6](#)
 - [WD 1.7](#)
- Repair the wiring as necessary, [REP 1.1](#).
- If necessary, install a new power distribution PWB, [PL 3.11 Item 1](#).

3 Tray Module PWB

- To view the +5V distribution from the [media path driver PWB](#), refer to [WD 8.2](#).
- For +5V faults on the [3 tray module PWB](#), refer to:
 - [WD 7.3](#).
 - [WD 7.4](#).
 - [WD 7.5](#)
- The +5V LED on this PWB is shown in [WD 7.3](#).
- Repair the wiring as necessary, [REP 1.1](#).
- If necessary, install a new 3 tray module PWB, [PL 73.16 Item 4](#).

Registration / Pre-heat Interface PWB

- To view the +5V distribution from the [drum driver PWB](#), refer to [WD 9.2](#).
- To view +5V distribution from the [media path driver PWB](#), refer to [WD 8.1](#).
- For +5V faults on the [registration/preheat interface PWB](#), refer to [WD 8.6](#).
- The components that follow are driven from +5V from the reg/preheat interface PWB:
 - Reg/preheat home sensor, part of [PL 88.10 Item 10](#).
 - Pre transfix sensor Q89-006. [PL 88.10 Item 12](#).
- Repair the wiring as necessary, [REP 1.1](#).
- If necessary, install a new Registration/Pre-heat interface PWB, [PL 88.10 Item 10](#), or one of the components in the list above.

Marking Unit Driver PWB

- To view the +5V distribution from the [IME controller PWB](#), refer to [WD 9.7](#)
- For +5V faults on the [marking unit driver PWB](#), refer to [WD 9.10](#)
- Repair the wiring as necessary, [REP 1.1](#).
- If necessary install a new marking unit driver PWB, [PL 92.10 Item 4](#)

Tray 5 Control PWB

- To view the +5V distribution from the [media path driver PWB](#), refer to [WD 8.4](#).
- For +5V faults on the [tray 5 control PWB](#), refer to:
 - [WD 7.1](#).
 - [WD 7.2](#).
- Repair the wiring as necessary, [REP 1.1](#).
- If necessary, install a new tray 5 control PWB, [PL 75.68 Item 8](#).

Single Board Controller PWB

- To view the +5V distribution from the [power distribution PWB](#), refer to [WD 1.6](#).
- For +5V faults on the [single board controller PWB](#), refer to:
 - [WD 3.1](#).
 - [WD 3.2](#).
- If necessary repair the wiring, [REP 1.1](#).
- If necessary, install a new single board controller PWB, [PL 3.11 Item 13](#).

Scanner PWB

- To view the +5V distribution from the [power distribution PWB](#), refer to [WD 1.7](#).
- For +5V faults on the [scanner PWB](#), refer to:
 - [WD 6.1](#).
 - [WD 6.2](#).
 - [WD 6.3](#).
- Repair the wiring as necessary, [REP 1.1](#).
- If necessary, install a new scanner PWB, [PL 62.16 Item 8](#).

DADH PWB

- **Note:** This PWB does not have an external +5V supply. +5V is generated on-board from the +3.3V supply, as shown in [WD 5.2](#).
- For +5V faults on the [DADH PWB](#), refer to:
 - [WD 5.1](#).
 - [WD 5.2](#).
- Repair the wiring as necessary, [REP 1.1](#).
- If necessary, install a new DADH PWB, [PL 5.10 Item 5](#).

HDD

- To view the +5V distribution from the [power supply unit](#), refer to [WD 1.5](#).
- For +5V faults on HDD, refer to [WD 1.5](#).
- If necessary, install a new hard disk drive, [PL 3.11 Item 2](#).

Cleaning Unit PWB

- For +5V faults on the cleaning unit PWB, refer to [WD 9.19](#).

NOTE: The +5V supply is generated internally on the cleaning unit PWB, refer to [WD 9.19](#).

- The reed switch assembly (level sensing), part of [PL 94.10 Item 21](#), is driven from +5V from the cleaning unit PWB:

NOTE: The cleaning unit PWB and reed switch are not spared individually, the next highest assembly is the cleaning unit.

- Repair the wiring as necessary, [REP 1.1](#).
- If necessary, install a new cleaning unit, [PL 94.10 Item 21](#).

LCSS PWB

- To view the +5V distribution from the LCSS power supply module, refer to [WD 12.1](#).
- For +5V faults on the LCSS, refer to:
 - [WD 12.1](#)
 - [WD 12.2](#)
 - [WD 12.3](#)
 - [WD 12.4](#)
 - [WD 12.5](#)
- Repair the wiring as necessary, [REP 1.1](#).
- If necessary, install a new LCSS PWB, [PL 12.75 Item 1](#).

HVF PWB

- To view the +5V distribution from the HVF power supply module, refer to [WD 12.6](#).
- For +5V faults on the HVF, refer to:
 - [WD 12.6](#)
 - [WD 12.7](#)
 - [WD 12.8](#)
 - [WD 12.9](#)
 - [WD 12.10](#)
 - [WD 12.11](#)
 - [WD 12.12](#)
 - [WD 12.13](#)
 - [WD 12.14](#)
 - [WD 12.15](#)
- Repair the wiring as necessary, [REP 1.1](#).

- If necessary, install a new HVF PWB, [PL 12.140 Item 2](#).

BM PWB (Booklet Maker)

- To view the +5V distribution from the [HVF PWB](#), refer to [WD 12.6](#).
- For +5V faults on the BM, refer to:
 - [WD 12.16](#)
 - [WD 12.17](#)
 - [WD 12.18](#)
 - [WD 12.19](#)
- Repair the wiring as necessary, [REP 1.1](#).
- If necessary, install a new BM PWB, [PL 12.175 Item 10](#).

Tri-folder PWB

- To view the +5V distribution from the [BM PWB](#), refer to [WD 12.6](#).
- For +5V faults on the tri-folder PWB, refer to [WD 12.20](#).
- Repair the wiring as necessary, [REP 1.1](#).
- If necessary, install a new tri-folder PWB, [PL 12.205 Item 16](#).

Inserter PWB

- To view the +5V distribution from the [HVF PWB](#), refer to [WD 12.14](#).
- For +5V faults on the [inserter PWB](#), refer to:
 - [WD 12.21](#)
 - [WD 12.22](#)
- Repair the wiring as necessary, [REP 1.1](#).
- If necessary, install a new inserter PWB, [PL 12.310 Item 9](#).

OCT PWB

- To view the +5V distribution from the [media path driver PWB](#), refer to [WD 8.5](#).
- For +5V faults on the OCT, refer to [WD 12.23](#).
- Repair the wiring as necessary, [REP 1.1](#).
- If necessary, install a new OCT, [PL 12.00 Item 1](#).

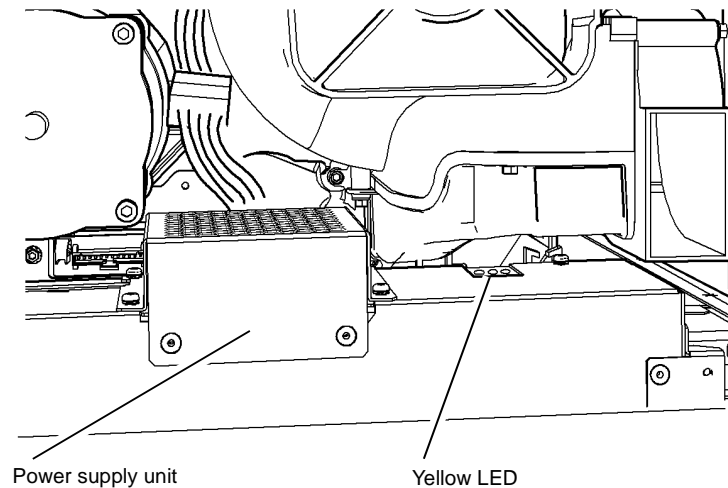

U-1-1495-A

Figure 1 Component location

01E +12V Distribution RAP

Use this RAP to diagnose +12V supply and distribution faults.

Procedure

WARNING

Ensure that the electricity to the machine is switched off while performing tasks that do not need electricity. Refer to [GP 14](#). Disconnect the power cord. Electricity can cause death or injury. Moving parts can cause injury.

NOTE: To view the +12V supply generation, refer to [WD 1.3](#).

The yellow LED on top of the [power supply unit](#), [Figure 1](#), indicates that the +5V supply is available in the [power supply unit](#). The +5V and +12V supplies are generated from the -12V/+24V supply in the [power supply unit](#). **The yellow LED is lit.**

Y N

Install a new power supply unit, [PL 1.15 Item 2](#).

Check that the +12V is within tolerance, +12V +/- 5% at JDC1 pin 13. **The +12V is good.**

Y N

Install a new power supply unit, [PL 1.15 Item 2](#).

CAUTION

To avoid equipment damage, do not disconnect or connect PJ's while the machine is switched on.

Check for short circuits. Refer to the [01-525-00 +24V, +/-12V, +5V Short Circuit and Overload RAP](#), +5V short circuit check. **The circuit is good.**

Y N

Switch off the machine, [GP 14](#). Disconnect connectors on the power supply to isolate the PWB's that follow:

- PJDC1 to isolate the [IME controller PWB](#).
- PJDC3 to isolate [drum driver PWB](#) and [media path driver PWB](#).

Repair the short circuit. Refer to [REP 1.1](#). Install new parts as necessary.

Check the PWB's below to determine which PWB has the distribution fault. Follow the distribution back to the supply. Repair the wiring, [REP 1.1](#) or install a new PWB or power supply unit, [PL 1.15 Item 2](#) as necessary. Refer to [GP 15](#) for the location and function of the LED's on the PWB's.

NOTE: Many PWB's have distribution fuses.

PWB Checks

- [IME Controller PWB](#)
- [Marking Unit Driver PWB](#)
- [Solenoid Patch PWB](#)
- [Drum Driver PWB](#)
- [Cleaning Unit](#)
- [Media Path Driver PWB](#)
- [Registration/Pre-heat Interface PWB](#)
- [Power Distribution PWB](#)

- [Single Board Controller PWB](#)
- [Scanner PWB](#)
- [Full Width Array](#)
- [UI PWB](#)
- [HDD](#)
- [Quad Wave Amp PWB](#)
- [Printheads 1 to 4](#)

IME Controller PWB

- To view the +12V distribution from the [power supply unit](#), refer to [WD 1.4](#).
- For +12V faults on the [IME controller PWB](#), refer to:
 - [WD 9.5](#)
 - [WD 9.6](#)
 - [WD 9.7](#)
- The items that follow are driven from +12V from the [IME controller PWB](#):
 - Print heads, [PL 91.25 Item 2](#), [PL 91.25 Item 2](#).
 - Marking unit driver PWB [PL 92.10 Item 4](#).
- Repair the wiring as necessary, [REP 1.1](#).
- If necessary, install a new IME controller PWB, [PL 92.10 Item 1](#), or one of the items in the list above.

Marking Unit Driver PWB

- To view the +12V distribution from the [IME controller PWB](#), refer to [WD 9.7](#).
- For +12V faults on the [marking unit driver PWB](#), refer to:
 - [WD 9.10](#)
 - [WD 9.12](#)
- The [solenoid patch PWB](#), [PL 93.10 Item 9](#) is driven from +12V from the [marking unit driver PWB](#)
- Repair the wiring as necessary, [REP 1.1](#).
- If necessary, install a new marking unit driver PWB, [PL 92.10 Item 4](#).

Solenoid Patch PWB

- To view the +12V distribution from the [marking unit driver PWB](#), refer to [WD 9.12](#).
- For +12V faults on the [solenoid patch PWB](#), refer to [WD 9.14](#).
- The components that follow are driven from +12V from the [solenoid patch PWB](#):
 - Reservoir pump [PL 93.10 Item 11](#).
 - LPA valve solenoid [PL 93.10 Item 15](#).
- Repair the wiring as necessary, [REP 1.1](#).
- If necessary, install a new solenoid patch PWB, [PL 93.10 Item 9](#), or one of the items in the list above.

Drum Driver PWB

- To view the +12V distribution from the [power supply unit](#), refer to [WD 1.5](#).
- For +12V faults on the [drum driver PWB](#), refer to:
 - [WD 9.2](#)
 - [WD 9.3](#)
 - [WD 9.4](#)
- The +12V LED on this PWB is shown in [WD 9.2](#).

- The components that follow are driven from +12V from the [drum driver PWB](#):
 - Enclosure Fan, [PL 1.15 Item 6](#).
 - Marking unit cooling fan, [PL 1.15 Item 23](#).
 - Abatement fan assembly, [PL 94.20 Item 11](#).
 - Cleaning unit, [PL 94.10 Item 21](#).
 - Stripper Jam Clearance LED assembly, [PL 10.10 Item 10](#)
 - Registration/preheat Interface PWB, [PL 88.10 Item 10](#)
- Repair the wiring as necessary, [REP 1.1](#).
- If necessary, install a new drum driver PWB, [PL 1.15 Item 4](#), or one of the items in the list above.

Cleaning Unit

- To view the +12V distribution from the [drum driver PWB](#), refer to [WD 9.4](#).
- For +12V faults on the cleaning unit PWB, refer to [WD 9.19](#).
- Repair the wiring as necessary, [REP 1.1](#).
- If necessary, install a new cleaning unit, [PL 94.10 Item 21](#).

NOTE: The cleaning unit PWB is not spared individually, the next highest assembly is the cleaning unit.

Media Path Driver PWB

- To view the +12V distribution from the [power supply unit](#), refer to [WD 1.5](#).
- For +12V faults on the [media path driver PWB](#), refer to:
 - [WD 8.1](#)
 - [WD 8.5](#)
- The components that follow are driven from +12V from the [media path driver PWB](#):
 - Exit illuminator, [PL 10.15 Item 16](#).
 - Horizontal illuminator, [PL 82.15 Item 11](#).
 - Registration/preheat illuminator PWB, [PL 82.15 Item 17](#).
 - Registration/preheat interface PWB, [PL 88.10 Item 10](#).
- Repair the wiring as necessary, [REP 1.1](#).
- If necessary, install a new media path driver PWB, [PL 1.15 Item 5](#), or one of the items in the list above.

Registration/Pre-heat Interface PWB

- To view the +12V distribution from the [drum driver PWB](#), refer to [WD 9.2](#).
- To view +12 V distribution from [media path driver PWB](#), refer to [WD 8.1](#).
- For +12V faults on the registration/pre-heat interface PWB, refer to [WD 8.6](#).
- The components that follow are driven from +12V from the reg/preheat interface PWB:
 - Registration scan bar Q89-005, [PL 88.10 Item 2](#).
 - Registration/preheat air pumps MOT88-008, [PL 88.10 Item 5](#).
- Repair the wiring as necessary, [REP 1.1](#).
- If necessary, install a new registration/pre-heat interface PWB, [PL 88.10 Item 10](#), or one of the items in the list above

Power Distribution PWB

- To view the +12V distribution from the [power supply unit](#), refer to [WD 1.5](#).
- For +12V faults on the [power distribution PWB](#), refer to:

- [WD 1.6](#)
- [WD 1.7](#)

- Check for +12V on both sides of fuse F2 on the [power distribution PWB](#). If +12V is not present, check the wiring between PJ8 pin 11 on the [power distribution PWB](#) and PJ920 pin 5 on the [scanner PWB](#).
- Repair the wiring as necessary, [REP 1.1](#).
- If necessary, install a new power distribution PWB, [PL 3.11 Item 1](#).

Single Board Controller PWB

- To view the +3.3V distribution from the [power distribution PWB](#), refer to [WD 1.6](#).
- For +3.3V faults on the [single board controller PWB](#), refer to:
 - [WD 3.1](#)
 - [WD 3.2](#)
- If necessary repair the wiring, [REP 1.1](#) or install a new DADH/IIT power comms harness, [PL 62.16 Item 7](#).
- If necessary, install a new single board controller PWB, [PL 3.11 Item 13](#).

Scanner PWB

- To view the +12V distribution from the [power distribution PWB](#), refer to [WD 1.7](#).
- For +12V faults on the [scanner PWB](#), refer to:
 - [WD 6.1](#)
 - [WD 6.3](#)
- The scan carriage, [PL 62.15 Item 6](#) is driven from +12V from the [scanner PWB](#):
- Repair the wiring as necessary, [REP 1.1](#).
- If necessary, install a new scanner PWB, [PL 62.16 Item 8](#).

Full Width Array

- To view the +12V distribution from the [scanner PWB](#), refer to [WD 6.3](#).
- For +12V faults on the full width array, refer to [WD 6.3](#).
- Repair the wiring as necessary, [REP 1.1](#).
- If necessary, install a new scan carriage assembly, [PL 62.15 Item 1](#).

UI PWB

- To view the +12V distribution from the [single board controller PWB](#), refer to [WD 3.2](#)
- For +12V faults on the [UI PWB](#), refer to [WD 3.2](#).
- If necessary repair the wiring, [REP 1.1](#).
- If necessary, install a new user interface control PWB, [PL 2.10 Item 2](#) or user interface status PWB, [PL 2.10 Item 4](#).

HDD

- To view the +12V distribution from the [power supply unit](#), refer to [WD 1.5](#).
- For +12V faults on HDD, refer to [WD 3.3](#).
- If necessary, install a new hard disk drive, [PL 3.11 Item 2](#).

Quad Wave Amp PWB

- To view the +12V distribution from the [IME controller PWB](#), refer to [WD 9.5](#).
- For +12V faults on [quad wave amp PWB](#), refer to [WD 9.13](#).
- Repair the wiring as necessary, [REP 1.1](#).
- If necessary, install a new quad wave amp PWB, [PL 92.10 Item 3](#).

Printheads 1 to 4

- To view the +12 V distribution from the [IME controller PWB](#), refer to [WD 9.5](#) and [WD 9.6](#).
- For +12V faults on the printhead, refer to [WD 9.20](#) and [WD 9.21](#).
- If necessary, install a new printhead [PL 91.20 Item 2](#) or [PL 91.25 Item 2](#).

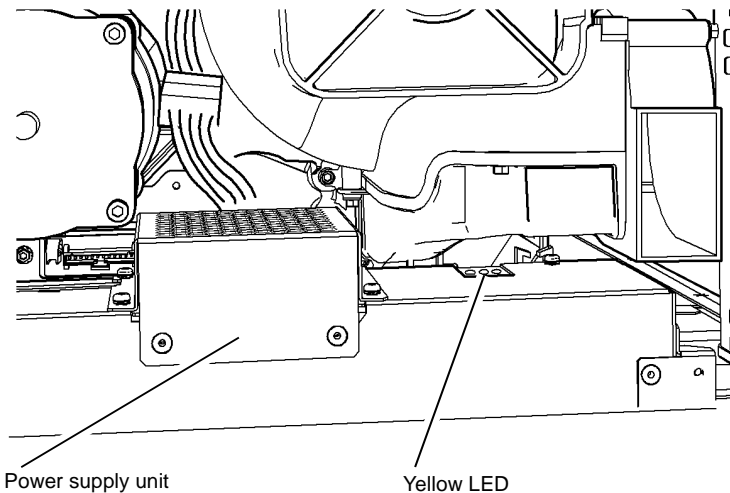

Figure 1 Component location

01F -12V Distribution RAP

Use this RAP to diagnose -12V supply and distribution faults.

NOTE: Refer to [RAP 12A-171](#) to diagnose -12V supply and distribution faults on the HVF. Refer to [RAP 12D-110](#) to diagnose -12V supply and distribution faults on the LCSS.

Procedure

WARNING

Ensure that the electricity to the machine is switched off while performing tasks that do not need electricity. Refer to [GP 14](#). Disconnect the power cord. Electricity can cause death or injury. Moving parts can cause injury.

CAUTION

To avoid equipment damage, do not disconnect or connect PJ's while the machine is switched on.

NOTE: To view the -12V supply generation, refer to [WD 1.3](#).

The yellow LED on top of the [power supply unit](#), [Figure 1](#), indicates that the +5V supply is available in the [power supply unit](#). The +5V and +12V supplies are generated from the -12V/+24V supply in the [power supply unit](#). The yellow LED is lit.

Y N
Go to the [01-540-00](#), [01-544-00](#) +24V, +/-12V, +5V Failure RAP.

Check that the -12V is within tolerance, -12V +/- 5% at JDC1 pin 12. The -12V is good.

Y N
Check for short circuits. Refer to the [01-525-00](#) +24V, +/-12V, +5V Short Circuit and Overload RAP, -12V short circuit check.

NOTE: The -12V supply is protected via a foldback circuit. A short circuit will result in 0V output, but the power supply will not switch off. Removing the short will restore -12V output from the power supply.

If a short circuit is found, disconnect connectors on the [power supply unit](#) to isolate the PWB's that follow:

- PJDC1 to isolate the [IME controller PWB](#).
- PJDC3 to isolate [drum driver PWB](#) and [media path driver PWB](#).

Check the PWB's below to determine which PWB has the distribution fault. Follow the distribution back to the supply. Repair the wiring, [REP 1.1](#) or install a new PWB or power supply unit, [PL 1.15 Item 2](#) as necessary. Refer to [GP 15](#) for the location and function of the LED's on the PWB's.

IME Controller PWB

- To view the -12V distribution from the [power supply unit](#), refer to [WD 1.4](#).
- For -12V faults on the [IME controller PWB](#), refer to:
 - [WD 9.5](#)
 - [WD 9.6](#)
 - [WD 9.7](#)
- The components that follow are driven from -12V from the [IME controller PWB](#).
 - Print heads, [PL 91.25 Item 2](#), [PL 91.25 Item 2](#).
 - Quad wave amp PWB [PL 92.10 Item 3](#).
- Repair the wiring as necessary, [REP 1.1](#).
- If necessary, install a new IME controller PWB, [PL 92.10 Item 1](#), or one of the items in the list above.

Drum Driver PWB

- To view the -12V distribution from the [power supply unit](#), refer to [WD 1.5](#).
- For -12V faults on the [drum driver PWB](#), refer to [WD 9.2](#).
- Repair the wiring as necessary, [REP 1.1](#).
- If necessary, install a new drum driver PWB, [PL 1.15 Item 4](#).

Marking Unit Driver PWB

- To view the -12V distribution from the [IME controller PWB](#), refer to [WD 9.7](#).
- For -12V faults on the [marking unit driver PWB](#), refer to [WD 9.10](#).
- Repair the wiring as necessary, [REP 1.1](#).
- If necessary, install a new marking unit driver PWB, [PL 92.10 Item 4](#).

Quad Wave Amp PWB

- To view the -12V distribution from the [IME controller PWB](#), refer to [WD 9.5](#).
- For -12V faults on [quad wave amp PWB](#), refer to [WD 9.13](#).
- Repair the wiring as necessary, [REP 1.1](#).
- If necessary, install a new quad wave amp PWB, [PL 92.10 Item 3](#).

Printheads 1 to 4

- To view the -12 V distribution from the [IME controller PWB](#), refer to [WD 9.5](#), [WD 9.6](#) and [WD 9.7](#)
- For -12V faults on the printhead, refer to [WD 9.20](#) and [WD 9.21](#).
- If necessary, install a new printhead [PL 91.20 Item 2](#) or [PL 91.25 Item 2](#).

Media Path Driver PWB

NOTE: The [media path driver PWB](#) receives -12V from the harness but it is not connected.

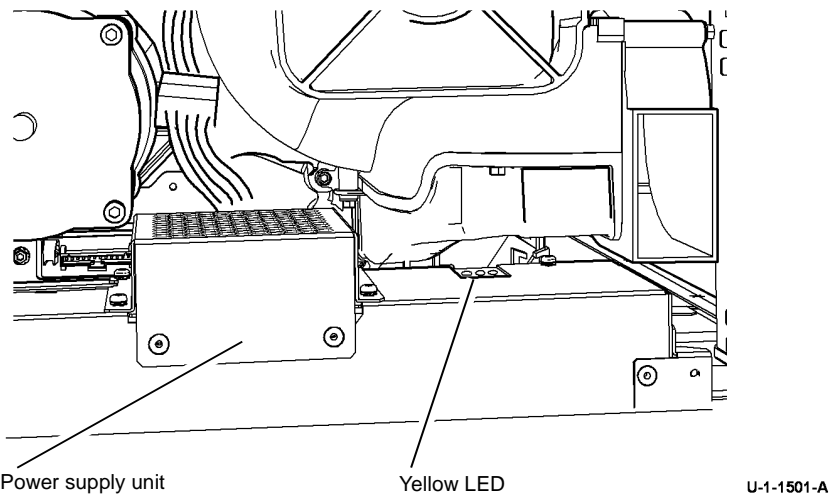

Figure 1 Component location

01G +17V Distribution RAP

Use this RAP to diagnose +17V supply and distribution faults.

Procedure

WARNING

Ensure that the electricity to the machine is switched off while performing tasks that do not need electricity. Refer to [GP 14](#). Disconnect the power cord. Electricity can cause death or injury. Moving parts can cause injury.

Check the power distribution PWB. Follow the distribution back to the supply. Repair the wiring, [REP 1.1](#) or install a new PWB or power supply unit, [PL 1.15 Item 2](#) as necessary.

NOTE: To view the +17V supply generation, refer to [WD 1.5](#).

NOTE: The voltage of this supply varies. At start up, the output is +17V unregulated and an average of about +17V can be measured. During the normal run mode, the output of this supply rises to +24V. The supply then drops back to +17V unregulated during the sleep mode. If the yellow LED is lit on the power supply, the output should be about +24V.

Power distribution PWB

- To view the +17V distribution from the [power supply unit](#), refer to [WD 1.5](#).

NOTE: A short circuit on this output also disables the +3.3V ESTAR output.

NOTE: A short circuit on the +3.3V may result in the +17V output being disabled from overload.

NOTE: A missing or invalid power normal signal (refer to [WD 8.2](#) on PJ402 pin 10) may result in an overload on the +17V output, causing the supply to be disabled.

- For +17V faults on the [power distribution PWB](#), refer to:
 - [WD 1.5](#)
 - [WD 1.6](#)
- If necessary, install a new power distribution PWB, [PL 3.11 Item 1](#).

01H +24V Distribution RAP

Use this RAP to diagnose +24V supply and distribution faults.

NOTE: This supply is not to be confused with the +17V supply, which is shown in [WD 1.5](#).

NOTE: Refer to [RAP 12A-171](#) to diagnose +24V supply and distribution faults on the HVF. Refer to [RAP 12D-110](#) to diagnose +24V supply and distribution faults on the LCSS.

Procedure

WARNING

Ensure that the electricity to the machine is switched off while performing tasks that do not need electricity. Refer to [GP 14](#). Disconnect the power cord. Electricity can cause death or injury. Moving parts can cause injury.

CAUTION

To avoid equipment damage, do not disconnect or connect PJ's while the machine is switched on.

NOTE: To view the +24V supply generation, refer to [WD 1.3](#).

Check the PEST fault history, [dC123](#). There are hard PEST faults shown.

Y N
Check the LEDs on top of the [power supply unit](#), [Figure 1](#). The yellow LED is lit.

Y N
The green LED is lit.

Y N
Go to the [01C 3.3V Distribution RAP](#)

Check for short circuits. Refer to the [01-525-00 +24V, +/-12V, +5V Short Circuit and Overload RAP](#), +24V short circuit check.

Switch off the machine, [GP 14](#). Disconnect the following connectors on the [power supply unit](#) to isolate the PWB's that follow:

- PJDC1 to isolate the [IME controller PWB](#).
- PJDC3 to isolate the [drum driver PWB](#) and [media path driver PWB](#).
- PJDC4 to isolate the [power distribution PWB](#) and HDD.

A short circuit exists.

Y N
Either the [power supply unit](#) is faulty or there is a short circuit. Refer to [WD 9.4](#) and [WD 1.4](#). Measure the voltage at pin 27 of PJ902 on the [drum driver PWB](#). The voltage should be greater than +2.5V, indicating the [drum driver PWB](#) is enabling the +24V, +12V, -12V and +5V supplies in the [power supply unit](#). The voltage is greater than +2.5V.

Y N
Check the condition of the drum driver power supply interface cable between PJDC2 on the [power supply unit](#) and PJ902 on the [drum driver PWB](#). It should be correctly and securely connected at each end, and should be undamaged. This cable carries power control signals from and to the [power supply unit](#). The cable is good.

Y N
Install a new drum driver power supply interface cable, [PL 1.15 Item 10](#), as necessary.

A B C D E
Switch off the machine, [GP 14](#). Check pin 27 of PJ902 on the [drum driver PWB](#). Pin 27 is short circuit to ground.
Y N
Install a new drum driver PWB, [PL 1.15 Item 4](#).
Repair the wiring, [REP 1.1](#).
Install a new power supply unit, [PL 1.15 Item 2](#).
Repair the wiring, [REP 1.1](#). Install new components as necessary.
Check that the +24V is within tolerance, +24.5V +/- 5%, (+23.275V to +25.725V), at JDC1 pin 11. Refer to [WD 1.4](#). The +24V is good.
Y N
Install a new power supply unit, [PL 1.15 Item 2](#).
Determine which PWB has the supply fault, go to [PWB Checks](#).

Perform the RAP(s) given by the hard PEST fault code(s), then return to this RAP.

PWB Checks

Check the PWB's below to determine which PWB has the distribution fault. Follow the distribution back to the supply. Repair the wiring, [REP 1.1](#) or install a new PWB or power supply unit, [PL 1.15 Item 2](#) as necessary. Refer to [GP 15](#) for the location and function of the LED's on the PWB's.

NOTE: Many PWB's have distribution fuses.

- [IME Controller PWB](#)
- [Marking Unit Driver PWB](#)
- [Solenoid Patch PWB](#)
- [Power Distribution PWB](#)
- [Scanner PWB](#)
- [DADH PWB](#)
- [Media Path Driver PWB](#)
- [3 Tray Module PWB](#)
- [Drum Driver PWB](#)
- [Tray 5 Control PWB](#)
- [LCSS PWB](#)
- [HVF PWB](#)
- [BM PWB \(Booklet Maker\)](#)
- [Tri-folder PWB](#)
- [Inserter PWB](#)
- [OCT PWB](#)
- [Cleaning Unit](#)

IME Controller PWB

- To view the +24V distribution from the [power supply unit](#), refer to [WD 1.4](#).
- For +24V faults on the [IME controller PWB](#), refer to:
 - [WD 9.6](#)
 - [WD 9.7](#)

- The marking unit driver PWB, [PL 92.10 Item 4](#), is driven from +24V from the [IME controller PWB](#)
- Repair the wiring as necessary, [REP 1.1](#)
- If necessary, install a new IME controller PWB, [PL 92.10 Item 1](#).

Marking Unit Driver PWB

- To view the +24V distribution from the [IME controller PWB](#), refer to [WD 9.7](#).
- For +24V faults on the [marking unit driver PWB](#), refer to:
 - [WD 9.10](#)
 - [WD 9.12](#)
- The [solenoid patch PWB](#), [PL 93.10 Item 9](#) is driven from +24V from the [marking unit driver PWB](#):
- Repair the wiring as necessary, [REP 1.1](#).
- If necessary, install a new marking unit driver PWB, [PL 92.10 Item 4](#).

Solenoid Patch PWB

- To view the +24V distribution from the [marking unit driver PWB](#), refer to [WD 9.12](#).
- For +24V faults on the [solenoid patch PWB](#), refer to:
 - [WD 9.14](#)
 - [WD 9.15](#)
- The components that follow are driven from +24V from the [solenoid patch PWB](#):
 - Purge solenoid valves 1 to 4 SOL93-059, 060, 061, 062, part of [PL 93.10 Item 10](#).
 - Black ink solenoid valves 5 to 8 SOL063,064, 065, 066, part of [PL 93.10 Item 10](#)
 - Yellow ink solenoid valves 9 to 12,SOL067, 068, 069, 070, part of [PL 93.10 Item 10](#)
 - Cyan ink solenoid valves 13 to 16 SOL071, 072, 073, 074, part of [PL 93.10 Item 10](#)
 - Magenta ink solenoid valves 17 to 20 SOL075, 076, 077, 078, part of [PL 93.10 Item 10](#)
- Repair the wiring as necessary, [REP 1.1](#).
- If necessary, install a new solenoid patch PWB, [PL 93.10 Item 9](#).

Power Distribution PWB

- To view the +24V distribution from the [power supply unit](#), refer to [WD 1.5](#)
- For +24V faults on the [power distribution PWB](#), refer to:
 - [WD 1.6](#)
 - [WD 1.7](#)
- Check for +24V on both sides of fuse F8 on the [power distribution PWB](#). If +24V is not present, check the following wiring:
 - Between PJ8 pins 7 and 9 on the [power distribution PWB](#) and PJ920 pins 1 and 3 on the [scanner PWB](#).
 - Between PJ8 pins 1, 3 and 5 on the [power distribution PWB](#) and PJ188 pins 1, 2 and 3 on the [DADH PWB](#).
- Repair the wiring as necessary, [REP 1.1](#).
- If necessary, install a new power distribution PWB, [PL 3.11 Item 1](#).

Scanner PWB

- To view the +24V distribution from the [power distribution PWB](#), refer to [WD 1.7](#)
- For +24V faults on the [scanner PWB](#), refer to:
 - [WD 6.1](#)

- [WD 6.2](#)

- The components that follow are driven from +24V from the [scanner PWB](#):
 - LED exposure lamp(s), [PL 62.15 Item 2](#).
- Repair the wiring as necessary, [REP 1.1](#)
- If necessary, install a new scanner PWB, [PL 62.16 Item 8](#)

DADH PWB

- To view the +24V distribution from the [power distribution PWB](#), refer to [WD 1.7](#).
- For +24V faults on the [DADH PWB](#), refer to:
 - [WD 5.1](#)
 - [WD 5.2](#)
- The components that follow are driven from +24V from the [DADH PWB](#):
 - DADH CVT motor MOT05-099, [PL 5.25 Item 9](#).
 - DADH feed motor MOT05-074, [PL 5.15 Item 16](#).
 - DADH duplex solenoid SOL05-100, [PL 5.30 Item 3](#).
 - Nudger motor MOT05-098, [PL 5.15 Item 5](#).
 - DADH feed clutch CL05-062, [PL 5.15 Item 9](#).
 - DADH cover interlock switch S05-212, [PL 5.15 Item 11](#).
- Repair the wiring as necessary, [REP 1.1](#)
- If necessary, install a new DADH PWB, [PL 5.10 Item 5](#).

Media Path Driver PWB

- To view the +24V distribution from the [power supply unit](#), refer to [WD 1.5](#)
- For +24V faults on the [media path driver PWB](#), refer to:
 - [WD 8.2](#)
 - [WD 8.3](#)
 - [WD 8.4](#)
 - [WD 8.5](#)
- The components that follow are driven from +24V from the [media path driver PWB](#):
 - Bypass feed motor (M7) MOT74-420, [PL 74.10 Item 2](#).
 - 3 tray module PWB, [PL 73.16 Item 4](#).
 - Tray 5 control PWB, [PL 75.68 Item 8](#).
 - OCT, [PL 12.00 Item 1](#).
 - LCSS PWB, [PL 12.75 Item 1](#).
 - HVF PWB, [PL 12.140 Item 2](#).
- Repair the wiring as necessary, [REP 1.1](#).
- If necessary, install a new media path driver PWB, [PL 1.15 Item 5](#)

3 Tray Module PWB

- To view the +24 distribution from the [media path driver PWB](#), refer to [WD 8.2](#)
- For +24V faults on the three trays module PWB, refer to:
 - [WD 7.3](#)
 - [WD 7.4](#)
 - [WD 7.5](#)
- The +24V LED on this PWB is shown in [WD 7.3](#)
- The components that follow are driven from +24V from the [3 tray module PWB](#):

- T1 feed / elevator motor MOT71-002, [PL 81.25 Item 22](#).
- T2 feed / elevator motor MOT72-001, [PL 81.26 Item 22](#).
- T3 feed motor MOT73-001, [PL 81.30 Item 22](#).
- 3 tray transport motor MOT70.025, [PL 73.16 Item 3](#).
- Tray up limit switch, S73-384, [PL 81.30 Item 25](#).
- Tray 3 elevate motor, MOT73-002, [PL 73.16 Item 2](#).
- Repair the wiring as necessary, [REP 1.1](#)
- If necessary, install a new 3 tray module PWB, [PL 73.16 Item 4](#)

Drum Driver PWB

- To view the +24V distribution from the [power supply unit](#), refer to [WD 1.5](#)
- For +24V faults on the [drum driver PWB](#), refer to:
 - [WD 9.1](#)
 - [WD 9.2](#)
- The components that follow are driven from +24V from the [drum driver PWB](#):
 - Drum fan MOT42-064, [PL 94.20 Item 4](#).
 - Cleaning unit delivery pump, part of [PL 94.10 Item 21](#).
 - Cleaning unit return reservoir pump, part of [PL 94.10 Item 21](#).
 - Cleaning unit PWB, part of [PL 94.10 Item 21](#).
- Repair the wiring as necessary, [REP 1.1](#).
- If necessary, install a new drum driver PWB, [PL 1.15 Item 4](#).

Tray 5 Control PWB

- To view the +24V distribution from the [media path driver PWB](#), refer to [WD 8.4](#).
- For +24V faults on the [tray 5 control PWB](#), refer to:
 - [WD 7.1](#).
 - [WD 7.2](#).
- The components that follow are driven from +24V from the [tray 5 control PWB](#):
 - Tray 5 transport motor MOT75.018, [PL 81.40 Item 2](#).
 - Elevator motor MOT75-019, [PL 75.68 Item 4](#).
 - Upper limit switch S75-412, [PL 75.68 Item 12](#).
 - Tray down limit switch S75-415, [PL 75.70 Item 2](#).
 - Feed motor MOT75-117, [PL 81.40 Item 3](#).
- Repair the wiring as necessary, [REP 1.1](#).
- If necessary, install a new tray 5 control PWB, [PL 75.68 Item 8](#).

LCSS PWB

- To view the +24V distribution from the LCSS power supply module, refer to [WD 12.1](#).
- For +24V faults on the LCSS, refer to:
 - [WD 12.1](#)
 - [WD 12.3](#)
 - [WD 12.4](#)
 - [WD 12.5](#)
- The components that follow are driven from +24V from the [LCSS PWB](#):
 - Docking interlock switch S12-177, [PL 12.15 Item 2](#).
 - Front door interlock switch S12-303, [PL 12.75 Item 5](#).

- Transport motor 1 MOT12-223, [PL 12.40 Item 2](#).
- SH1 motor MOT12-247, part of [PL 12.55 Item 5](#).
- SU1 motor MOT12-249, part of [PL 12.55 Item 5](#).
- Transport motor 2 MOT12-224, [PL 12.60 Item 5](#).
- Paddle roll motor MOT12-237, [PL 12.25 Item 10](#).
- Punch head motor MOT12-243, [PL 12.20 Item 2](#).
- Front tamper motor MOT12-226, part of [PL 12.45 Item 1](#).
- Rear tamper motor MOT12-227, part of [PL 12.45 Item 1](#).
- Bin 1 upper limit switch S12-190, [PL 12.30 Item 3](#).
- Top cover interlock switch S12-197, [PL 12.75 Item 6](#).
- Bin 1 lower limit switch S12-191, [PL 12.35 Item 1](#).
- Bin 1 elevator motor MOT12.-241, [PL 12.30 Item 8](#).
- Repair the wiring as necessary, [REP 1.1](#).
- If necessary, install a new LCSS PWB, [PL 12.75 Item 1](#).

HVF PWB

- To view the +24V distribution from the HVF power supply module, refer to [WD 12.6](#).
- For +24V faults on the HVF, refer to:
 - [WD 12.6](#)
 - [WD 12.7](#)
 - [WD 12.8](#)
 - [WD 12.9](#)
 - [WD 12.10](#)
 - [WD 12.13](#)
 - [WD 12.14](#)
 - [WD 12.15](#)
- The components that follow are driven from +24V from the [HVF PWB](#):
 - Transport motor 1 MOT12-223, [PL 12.120 Item 2](#).
 - Buffer motor MOT12-262, [PL 12.120 Item 1](#).
 - Nip split motor MOT12-164, [PL 12.125 Item 15](#).
 - Transport motor 2 MOT12-224, [PL 12.120 Item 1](#).
 - BM diverter solenoid SOL12-258, [PL 12.120 Item 4](#).
 - Exit diverter solenoid SOL12-225, [PL 12.120 Item 4](#).
 - Bypass feed motor MOT12-263, [PL 12.120 Item 2](#).
 - Set clamp solenoid SOL12-056, [PL 12.120 Item 4](#).
 - Docking interlock switch S12-177, [PL 12.100 Item 16](#).
 - Front door interlock switch S12-303, [PL 12.115 Item 28](#).
 - Top cover interlock switch S12-197, [PL 12.115 Item 24](#).
 - Paddle unit motor MOT12-239, [PL 12.120 Item 6](#).
 - Paddle roll motor MOT12-238, part of [PL 12.115 Item 2](#).
 - Paper pusher motor MOT12-265, [PL 12.115 Item 13](#).
 - Bin 1 elevator motor MOT12-241, [PL 12.105 Item 10](#).
 - Stapler gate safety switch S12-319, [PL 12.115 Item 17](#).
 - Rear tamper motor MOT12-227, [PL 12.110 Item 19](#).

- Staple head 1 motor MOT12-247, part of [PL 12.110 Item 12](#).
- Stapler unit 1 motor MOT12-249, [PL 12.110 Item 27](#).
- Ejector motor MOT12-236, part of [PL 12.110 Item 2](#).
- Ejector roll motor MOT12-233, part of [PL 12.110 Item 2](#).
- Pressing & support motor MOT12-323, [PL 12.110 Item 9](#).
- Front tamper motor MOT12-226, [PL 12.125 Item 6](#).
- Punch unit motor MOT12-245, part of [PL 12.125 Item 19](#).
- Punch head motor MOT12-244, part of [PL 12.125 Item 19](#).
- Repair the wiring as necessary, [REP 1.1](#).
- If necessary, install a new HVF PWB, [PL 12.140 Item 2](#).

BM PWB (Booklet Maker)

- To view the +24V distribution from the [HVF PWB](#), refer to [WD 12.6](#).
- For +24V faults on the BM, refer to:
 - [WD 12.17](#)
 - [WD 12.19](#)
- The components that follow are driven from +24V from the [BM PWB](#):
 - BM SH1 motor MOT12-254, part of [PL 12.185 Item 7](#).
 - BM SH2 motor MOT12-275, part of [PL 12.185 Item 7](#).
 - BM compiler motor MOT 12-251, [PL 12.175 Item 1](#).
 - BM backstop motor MOT 12-255, [PL 12.160 Item 4](#).
 - BM tamper 1 motor MOT12-256, [PL 12.155 Item 3](#).
 - BM stack hold solenoid SOL12-259 (1 of 2), [PL 12.165 Item 17](#).
 - BM stack hold solenoid SOL12-259 (2 of 2), [PL 12.165 Item 17](#).
 - BM conveyor drive motor MOT12-274, [PL 12.190 Item 4](#).
 - BM crease roll gate motor MOT12-273, [PL 12.175 Item 8](#).
 - BM crease roll motor MOT12-253, [PL 12.175 Item 12](#).
 - BM crease blade motor MOT12-252, [PL 12.170 Item 3](#).
 - BM flapper motor MOT12-271, [PL 12.175 Item 1](#).
- Repair the wiring as necessary, [REP 1.1](#).
- If necessary, install a new BM PWB, [PL 12.175 Item 10](#).

Tri-folder PWB

- To view the +24V distribution from the [BM PWB](#), refer to [WD 12.6](#).
- For +24V faults on the tri-folder PWB, refer to [WD 12.20](#).
- The components that follow are driven from +24V from the [tri folder PWB](#):
 - Tri folder top cover interlock switch S12-210, [PL 12.215 Item 3](#).
 - Tri folder front door interlock switch S12-209, [PL 12.215 Item 2](#).
 - Tri folder diverter solenoid SOL12-267, [PL 12.215 Item 16](#).
 - Tri folder assist gate solenoid SOL12-268, [PL 12.215 Item 8](#).
 - Tri folder drive clutch CL12-269, [PL 12.205 Item 9](#).
- Repair the wiring as necessary, [REP 1.1](#).
- If necessary, install a new tri-folder PWB, [PL 12.205 Item 16](#).

Inserter PWB

- To view the +24V distribution from the [HVF PWB](#), refer to [WD 12.14](#).
- For +24V faults on the [inserter PWB](#), refer to:
 - [WD 12.21](#)
 - [WD 12.22](#)

- The components that follow are driven from +24V from the [inserter PWB](#):
 - Inserter top cover interlock switch S12-178, [PL 12.305 Item 8](#).
 - Inserter jam cover interlock switch S12-179, [PL 12.300 Item 18](#).
 - Inserter clutch CL12-260, [PL 12.310 Item 3](#).
 - Inserter motor MOT12-261, [PL 12.315 Item 1](#).
- Repair the wiring as necessary, [REP 1.1](#).
- If necessary, install a new inserter PWB, [PL 12.310 Item 9](#).

OCT PWB

- To view the +24V distribution from the [media path driver PWB](#), refer to [WD 8.5](#).
- For +24V faults on the OCT PWB, refer to [WD 12.23](#).
- The OCT offset motor MOT12-300, part of [PL 12.00 Item 1](#), is driven from +24V from the [inserter PWB](#)
- Repair the wiring as necessary, [REP 1.1](#).
- If necessary, install a new OCT, [PL 12.00 Item 1](#).

Cleaning Unit

- To view the +24V distribution from the [drum driver PWB](#), refer to [WD 9.2](#)
- For +24V faults on the cleaning unit PWB, refer to [WD 9.19](#)
- The cleaning unit solenoid valve, part of [PL 94.10 Item 21](#), is driven from +24V from the cleaning unit PWB:
- Repair the wiring as necessary, [REP 1.1](#).
- If necessary, install a new cleaning unit, [PL 94.10 Item 21](#).

NOTE: The cleaning unit PWB is not spared individually, the next highest assembly is the cleaning unit.

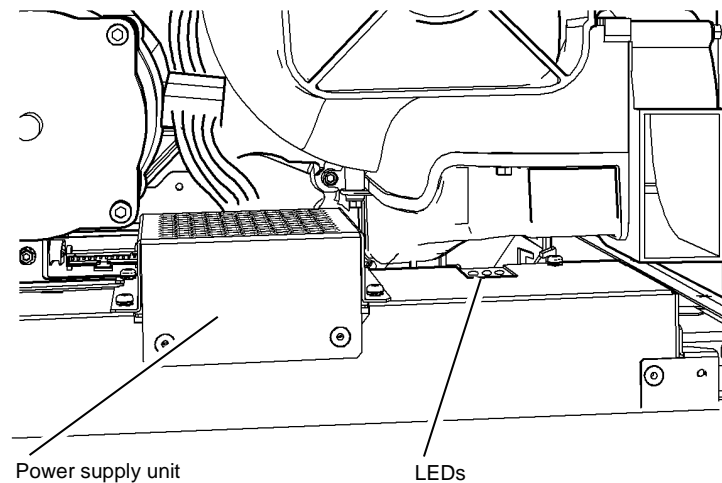

U-1-1531-A

Figure 1 Component location

01J +50V Distribution RAP

Use this RAP to diagnose +50V supply and distribution faults.

Procedure

WARNING

Ensure that the electricity to the machine is switched off while performing tasks that do not need electricity. Refer to [GP 14](#). Disconnect the power cord. Electricity can cause death or injury. Moving parts can cause injury.

To view the +50V generation, refer to [WD 1.3](#).

Check the red LED on top of the [power supply unit](#), [Figure 1](#), that indicates that the +50V supply is available in the [power supply unit](#). The red LED is lit and the AC supply is good.

Y N
Install a new power supply unit, [PL 1.15 Item 2](#).

Check the PEST fault history, [dC123](#). There are hard PEST faults shown.

Y N
Check that the +50V is within tolerance, +50V +/- 2% at JDC1 pin 10. Refer to [WD 1.4](#).
The +50V is good.

Y N
Install a new power supply unit, [PL 1.15 Item 2](#).

Determine which PWB has the supply fault. Go to [PWB Checks](#).

Perform the RAP(s) given by the hard PEST fault code(s), then return to this RAP.

PWB Checks

Check the PWB's below to determine which PWB has the distribution fault. Follow the distribution back to the supply. Repair the wiring, [REP 1.1](#) or install a new PWB or power supply unit, [PL 1.15 Item 2](#) as necessary. Refer to [GP 15](#) for the location and function of the LED's on the PWB's.

NOTE: Many PWB's have distribution fuses.

IME Controller PWB

- To view the +50V distribution from the [power supply unit](#), refer to [WD 1.4](#).
- For +50V faults on the [IME controller PWB](#), refer to:
 - [WD 9.5](#)
 - [WD 9.6](#)
 - [WD 9.7](#)
- The components that follow are driven from +50V from the [IME controller PWB](#):
 - Marking unit driver PWB [PL 92.10 Item 4](#).
 - Quad wave amp PWB [PL 92.10 Item 3](#).
- Repair the wiring as necessary, [REP 1.1](#).
- If necessary, install a new IME controller PWB, [PL 92.10 Item 1](#).

Media Path Driver PWB

- To view the +50V distribution from the [power supply unit](#), refer to [WD 1.5](#).
- For +50V faults on the [media path driver PWB](#), refer to:
 - [WD 8.1](#)

- [WD 8.3](#)
- [WD 8.5](#)
- The +50V LED on this PWB is shown in [WD 8.5](#).
- The components that follow are driven from +50V from the [media path driver PWB](#):
 - Nip C release solenoid SOL82-007, [PL 82.15 Item 4](#).
 - HPP diverter solenoid SOL83-004, [PL 82.15 Item 5](#).
 - Exit/duplex diverter solenoid SOL83-006, [PL 10.15 Item 14](#).
 - Nip D release solenoid SOL82-008, [PL 70.30 Item 13](#).
- Repair the wiring as necessary, [REP 1.1](#).
- If necessary, install a new media path driver PWB, [PL 1.15 Item 5](#).

Drum Driver PWB

- To view the +50V distribution from the [power supply unit](#), refer to [WD 1.5](#).
- For +50V faults on the [drum driver PWB](#), refer to [WD 9.2](#).
- The +50V LED on this PWB is shown in [WD 9.2](#).
- The stripper solenoid SOL10-021, [PL 10.10 Item 3](#), is driven from +50V from the [drum driver PWB](#):
- Repair the wiring as necessary, [REP 1.1](#).
- If necessary, install a new drum driver PWB, [PL 1.15 Item 4](#).

Quad Wave Amp PWB

- To view the +50V distribution from the [IME controller PWB](#), refer to [WD 9.5](#).
- For +50V faults on [quad wave amp PWB](#), refer to [WD 9.13](#).
- Repair the wiring as necessary, [REP 1.1](#).
- If necessary, install a new quad wave amp PWB, [PL 92.10 Item 3](#).

Marking Unit Driver PWB

- To view the +50V distribution from the [IME controller PWB](#), refer to [WD 9.7](#).
- For +50V faults on the [marking unit driver PWB](#), refer to:
 - [WD 9.10](#)
 - [WD 9.11](#)
- The Waste tray lock solenoid SOL91-044, [PL 91.10 Item 17](#), is driven from +50V from the [marking unit driver PWB](#):
- Repair the wiring as necessary, [REP 1.1](#).
- If necessary, install a new marking unit driver PWB, [PL 92.10 Item 4](#).

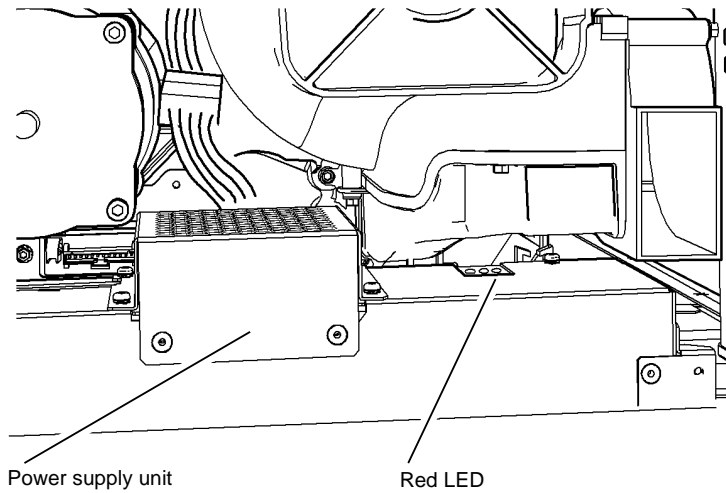

Figure 1 Component location

U-1-1496-A

01K -50V Distribution RAP

Use this RAP to diagnose -50V supply and distribution faults.

Procedure

WARNING

Ensure that the electricity to the machine is switched off while performing tasks that do not need electricity. Refer to [GP 14](#). Disconnect the power cord. Electricity can cause death or injury. Moving parts can cause injury.

To view the -50V generation, refer to [WD 1.3](#).

Check the condition of the drum driver power supply interface cable between PJDC2 on the power supply unit and PJ902 on the drum driver PWB. It should be correctly and securely connected at each end, and should be undamaged. This cable carries power control signals from and to the power supply unit. **The cable is good.**

Y N

Install a new drum driver power supply interface cable, [PL 1.15 Item 10](#).

Check the red LED on top of the power supply unit, [Figure 1](#) that indicates that the +50V supply is available in the power supply unit. **The red LED is lit.**

Y N

The red LED is extinguished and the AC supply is good. Check the PEST fault history, [dC123](#). **There are hard PEST faults shown.**

Y N

Perform the [01-542-00](#), [01-546-00](#), 50V Failure RAP.

Perform the RAP(s) given by the hard PEST fault code(s), then return to this RAP.

Check that the -50V is within tolerance, -50V +/- 2% at JDC1 pin 18. Refer to [WD 1.4](#). **The -50V is good.**

Y N

Install a new power supply unit, [PL 1.15 Item 2](#).

Go to [PWB Checks](#).

PWB Checks

Check the PWB's below to determine which PWB has the distribution fault. Follow the distribution back to the supply. Repair the wiring, [REP 1.1](#) or install a new PWB or power supply unit, [PL 1.15 Item 2](#) as necessary. Refer to [GP 15](#) for the location and function of the LED's on the PWB's.

IME Controller PWB

- To view the -50V distribution from the power supply unit, refer to [WD 1.4](#).
- For -50V faults on the IME controller PWB, refer to:
 - [WD 9.5](#)
 - [WD 9.6](#)
- The quad wave amp PWB, [PL 92.10 Item 3](#) is driven from -50V from the IME controller PWB.
- Repair the wiring as necessary, [REP 1.1](#).
- If necessary, install a new IME controller PWB, [PL 92.10 Item 1](#).

Quad Wave Amp PWB

- To view the -50V distribution from the [IME controller PWB](#), refer to [WD 9.5](#).
- For -50V faults on [quad wave amp PWB](#), refer to [WD 9.13](#).
- Repair the wiring as necessary, [REP 1.1](#).
- If necessary, install a new quad wave amp PWB, [PL 92.10 Item 3](#).

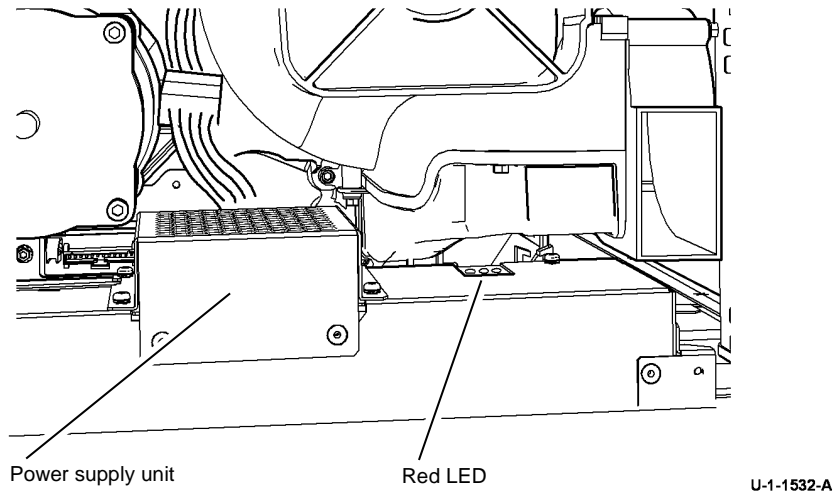

Figure 1 Component location

01L 0V Distribution RAP

Use this RAP to diagnose 0V faults.

Procedure

WARNING

Ensure that the electricity to the machine is switched off while performing tasks that do not need electricity. Refer to [GP 14](#). Disconnect the power cord. Electricity can cause death or injury. Moving parts can cause injury.

Important: 0V return lines are connected together and to the chassis, both inside the power supply units and at the PWB's.

- To measure the continuity of a 0V line between the [power supply unit](#) and a PWB, isolate the line concerned by disconnecting the PJs at both ends. In this way there will be no misleading parallel paths. As necessary, repair the wiring, [REP 1.1](#) or install a new harness. The same applies between the [power distribution PWB](#) and other PWB's.
- To check the connection of a 0V line to chassis via the [power supply unit](#), connect the PJ at the [power supply unit](#) only, disconnect from the PWB, and measure the continuity to the chassis. As necessary, repair the wiring, [REP 1.1](#) or install a new power supply unit, [PL 1.15 Item 2](#).
- To check the connection of a 0V line to chassis via the PWB, connect the power PJ at the PWB only, disconnect from the [power supply unit](#), and measure the continuity to the chassis. If necessary repair the wiring or install a new PWB.
- To check the 0V line between a PWB and a component, (sensor, motor, etc.), disconnect the PWB PJ, then check the wiring for condition, short circuits, open circuits etc. As necessary, repair the wiring, [REP 1.1](#), install a new harness, component or PWB.

This procedure lists the wiring diagrams that show the occurrence of 0V lines. Select the suspect area from the list below, check the wiring for condition, short circuits and open circuits. Repair the wiring as necessary, [REP 1.1](#) or install a new harness or faulty component.

- [Power Supply Unit](#)
- [Power Distribution PWB](#)
- [Single Board Controller PWB](#)
- [UI Control PWB, Touch Screen and UI Status PWB](#)
- [Foreign Device Interface PWB](#)
- [DADH PWB](#)
- [Scanner PWB](#)
- [Tray 5 Control PWB](#)
- [3 Tray Module PWB](#)
- [Media Path Driver PWB](#)
- [Drum Driver PWB](#)
- [IME Controller PWB](#)
- [Marking Unit Heater PWB](#)
- [Marking Unit Driver PWB](#)
- [Quad Wave Amp PWB](#)
- [Solenoid Patch PWB](#)
- [Ink Load Entry PWB](#)
- [Cleaning Unit PWB](#)
- [Printheads 1, 2, 3 and 4 PWB's](#)
- [IOD Pre-amplifier PWB](#)

- [LCSS PWB](#)
- [HVF Control PWB](#)
- [BM PWB \(Booklet maker\)](#)
- [Tri-folder PWB](#)
- [Inserter PWB](#)
- [OCT PWB](#)

Power Supply Unit

- Refer to [WD 1.3](#), [WD 1.4](#) and [WD 1.5](#).
- Repair the wiring as necessary, [REP 1.1](#).
- If necessary install a new power supply unit, [PL 1.15 Item 2](#).

Power Distribution PWB

- Refer to [WD 1.6](#) and [WD 1.7](#).
- Repair the wiring as necessary, [REP 1.1](#).
- If necessary install a new power supply unit, [PL 1.15 Item 2](#).

Single Board Controller PWB

- Refer to [WD 3.1](#), [WD 3.2](#) and [WD 3.3](#).
- Repair the wiring as necessary, [REP 1.1](#).
- If necessary, install a new single board controller PWB, [PL 3.11 Item 13](#) or associated components.

UI Control PWB, Touch Screen and UI Status PWB

- Refer to [WD 3.1](#). If necessary, install new components from the list that follows:
 - UI control PWB, [PL 2.10 Item 2](#).
 - Touch screen, [PL 2.10 Item 3](#).
 - UI status PWB, [PL 2.10 Item 4](#).
 - LCD to PWB harness, [PL 2.10 Item 11](#).
 - UI control to UI status harness, [PL 2.10 Item 9](#).
- Repair the wiring as necessary, [REP 1.1](#).
- If necessary, install a new user interface control PWB.
- If necessary, install a new touch screen, [PL 2.10 Item 3](#).
- If necessary, install a new user interface status PWB, [PL 2.10 Item 4](#).

Foreign Device Interface PWB

- Refer to [WD 3.3](#).
- Repair the wiring as necessary, [REP 1.1](#).
- If necessary, install a new foreign device interface PWB, [PL 3.11 Item 23](#), or associated components.

DADH PWB

- Refer to [WD 5.1](#) and [WD 5.2](#)
- Repair the wiring as necessary, [REP 1.1](#)
- If necessary, install a new DADH PWB, [PL 5.10 Item 5](#), or associated components.

Scanner PWB

- Refer to [WD 6.1](#), [WD 6.2](#) and [WD 6.3](#)
- Repair the wiring as necessary, [REP 1.1](#)
- If necessary, install a new scanner PWB, [PL 62.16 Item 8](#), or associated components.

Tray 5 Control PWB

- Refer to [WD 7.1](#) and [WD 7.2](#)

- Repair the wiring as necessary, [REP 1.1](#).
- If necessary, install a new tray 5 control PWB [PL 75.68 Item 8](#), or associated components.

3 Tray Module PWB

- Refer to [WD 7.3](#), [WD 7.4](#) and [WD 7.5](#)
- Repair the wiring as necessary, [REP 1.1](#).
- If necessary, install a new 3 tray module PWB, [PL 73.16 Item 4](#), or associated components

Media Path Driver PWB

- Refer to [WD 8.1](#), [WD 8.2](#), [WD 8.3](#), [WD 8.4](#) and [WD 8.5](#).
- Repair the wiring as necessary, [REP 1.1](#).
- If necessary, install a new media path driver PWB, [PL 1.15 Item 5](#) or associated components.

Drum Driver PWB

- Refer to [WD 9.1](#), [WD 9.2](#), [WD 9.3](#) and [WD 9.4](#).
- Repair the wiring as necessary, [REP 1.1](#)
- If necessary, install a new drum driver PWB, [PL 1.15 Item 4](#), or associated components

IME Controller PWB

- Refer to [WD 1.1](#), [WD 9.5](#), [WD 9.6](#) and [WD 9.7](#)
- Repair the wiring as necessary, [REP 1.1](#)
- If necessary, install a new IME controller PWB, [PL 92.10 Item 1](#), or associated components.

Marking Unit Heater PWB

- Refer to [WD 9.8](#)
- Repair the wiring as necessary, [REP 1.1](#)
- If necessary, install a new marking unit heater PWB, [PL 92.10 Item 5](#), or associated components.

Marking Unit Driver PWB

- Refer to [WD 9.9](#), [WD 9.10](#), [WD 9.11](#) and [WD 9.12](#)
- Repair the wiring as necessary, [REP 1.1](#)
- If necessary, install a new marking unit driver PWB, [PL 92.10 Item 4](#), or associated components.

Quad Wave Amp PWB

- Refer to [WD 9.13](#)
- Repair the wiring as necessary, [REP 1.1](#)
- If necessary, install a new quad wave amp PWB, [PL 92.10 Item 3](#), or associated components.

Solenoid Patch PWB

- Refer to [WD 9.14](#), [WD 9.15](#) and [WD 9.16](#)
- Repair the wiring as necessary, [REP 1.1](#)
- If necessary, install a new reservoir, [PL 93.10 Item 10](#), or associated components.

Ink Load Entry PWB

- Refer to [WD 9.17](#) and [WD 9.18](#)
- Repair the wiring as necessary, [REP 1.1](#)
- If necessary, install a new ink load entry PWB, [PL 93.10 Item 8](#), or associated components.

Cleaning Unit PWB

- Refer to [WD 9.19](#)
- Repair the wiring as necessary, [REP 1.1](#).
- If necessary, install a new cleaning unit PWB, [PL 94.10 Item 21](#), or associated components.

Printheads 1, 2, 3 and 4 PWB's

- Refer to [WD 9.20](#) and [WD 9.21](#)
- Repair the wiring as necessary, [REP 1.1](#)
- If necessary, install a new printhead 1, 2, 3 or 4 PWB, [PL 91.20 Item 3](#) and [PL 91.25 Item 3](#).

IOD Pre-amplifier PWB

- Refer to [WD 9.22](#)
- Repair the wiring as necessary, [REP 1.1](#).
- If necessary, install a new IOD assembly, [PL 94.15 Item 1](#), or associated components.

LCSS PWB

- The LCSS low voltage power comes from its own power supply module as shown in [WD 12.1](#). Refer to [WD 12.1](#), [WD 12.2](#), [WD 12.3](#), [WD 12.4](#) and [WD 12.5](#)
- Repair the wiring as necessary, [REP 1.1](#).
- If necessary, install a new LCSS power supply module, [PL 12.75 Item 2](#), LCSS PWB, [PL 12.75 Item 1](#), or associated components.

HVF Control PWB

- The HVF low voltage power comes from its own power supply module as shown in [WD 12.6](#). Refer to [WD 12.6](#), [WD 12.7](#), [WD 12.8](#), [WD 12.9](#), [WD 12.10](#), [WD 12.11](#), [WD 12.12](#), [WD 12.13](#), [WD 12.14](#) and [WD 12.15](#)
- Repair the wiring as necessary, [REP 1.1](#)
- If necessary, install a new HVF PWB, [PL 12.140 Item 2](#), or associated components.

BM PWB (Booklet maker)

- The BM low voltage power comes from the HVF power supply module as shown in [WD 12.6](#). Refer to [WD 12.6](#), [WD 12.16](#), [WD 12.17](#), [WD 12.18](#) and [WD 12.19](#).
- Repair the wiring as necessary, [REP 1.1](#).
- If necessary, install a new BM PWB, [PL 12.175 Item 10](#), or associated components.

Tri-folder PWB

- The tri-folder low voltage power comes from the HVF power supply module as shown in [WD 12.6](#). Refer to [WD 12.6](#) and [WD 12.20](#)
- Repair the wiring as necessary, [REP 1.1](#).
- If necessary, install a new tri-folder PWB, [PL 12.205 Item 16](#), or associated components.

Insertor PWB

- The insertor low voltage power comes from the HVF power supply module as shown in [WD 12.14](#). Refer to [WD 12.14](#), [WD 12.21](#) and [WD 12.22](#)
- Repair the wiring as necessary, [REP 1.1](#).
- If necessary, install a new insertor PWB, [PL 12.310 Item 9](#), or associated components.

OCT PWB

- The OCT low voltage power comes from the [media path driver PWB](#), as shown in [WD 8.5](#). Refer to [WD 8.5](#) and [WD 12.23](#).
- Repair the wiring as necessary, [REP 1.1](#).
- If necessary, install a new OCT, [PL 12.00 Item 1](#), or media path driver PWB, [PL 1.15 Item 5](#).

02-302-00, 02-306-00, 02-308-00 Flash Failure RAP

02-302-00 Flash rewrite failure.

02-306-00 Flash erase failure.

02-308-00 Flash download failure.

Procedure

WARNING

Ensure that the electricity to the machine is switched off while performing tasks that do not need electricity. Refer to GP 14. Disconnect the power cord. Electricity can cause death or injury. Moving parts can cause injury.

1. Switch the machine off, then switch on the machine, GP 14.

02-315-00 Service Registry Bad Data RAP

02-315-00 Service registry bad or corrupted data

Procedure

WARNING

Ensure that the electricity to the machine is switched off while performing tasks that do not need electricity. Refer to GP 14. Disconnect the power cord. Electricity can cause death or injury. Moving parts can cause injury.

1. Switch the machine off, then switch on the machine, GP 14.

02-316-00, 02-317-00 SRS Error RAP

02-316-00 SRS returns to LUI invalid fields, invalid data or missing data.

02-317-00 LUI gets no response from SRS.

Procedure

WARNING

Ensure that the electricity to the machine is switched off while performing tasks that do not need electricity. Refer to GP 14. Disconnect the power cord. Electricity can cause death or injury. Moving parts can cause injury.

1. Switch the machine off, then switch on the machine, GP 14.

02-320-00 Data Time Out Error RAP

02-320-00 UI does not receive requested data from the CCM within the specified time out window.

Procedure

WARNING

Ensure that the electricity to the machine is switched off while performing tasks that do not need electricity. Refer to GP 14. Disconnect the power cord. Electricity can cause death or injury. Moving parts can cause injury.

1. Switch the machine off, then switch on the machine, GP 14.

02-321-00 XEIP Browser Dead RAP

02-321-00 The user interface has detected that the EIP (Extensible Interface Platform) browser does not respond, or is known to be not working.

Procedure

WARNING

Ensure that the electricity to the machine is switched off while performing tasks that do not need electricity. Refer to [GP 14](#). Disconnect the power cord. Electricity can cause death or injury. Moving parts can cause injury.

CAUTION

Before a new user interface assembly is installed, identify the machine software level ([GP 4](#)). Check the compatibility of the software on the new user interface assembly. Install the software to meet the customer machine requirements. Use the Customer Administration Tool (CAT), [GP 5](#).

Perform the following steps:

1. Switch off the machine, then switch on the machine, [GP 14](#).

NOTE: If the UI is unavailable, the power down request cannot be confirmed. The machine will power down automatically after 60 seconds.

2. Ensure the Custom Services button is enabled on the user interface, as detailed in the System Administrator's Guide. If necessary, re-load the software set, [GP 4](#) Machine Software.
3. Check that the machine is communicating with the network, for example by sending a print job. If necessary, check the network cable and check with the customer that their network and web browser are running correctly.
4. Refer to [WD 3.1](#). Check the communications cable between PJ905 on the [UI PWB](#) and PJ19 on the [single board controller PWB](#). If necessary, repair the wiring, [REP 1.1](#), or install a new user interface harness, [PL 2.10 Item 7](#). If necessary, install new components:
 - Single board controller PWB, [PL 3.11 Item 13](#).
 - User interface control PWB, [PL 2.10 Item 2](#).

02-380-00, 02-381-00 UI Communication Fault RAP

02-380-00 Communication via H-H USB net path connection between SBC and UI panel is not working

02-381-00 Communication via USB connection between SBC and UI panel is not working.

Procedure

WARNING

Ensure that the electricity to the machine is switched off while performing tasks that do not need electricity. Refer to [GP 14](#). Disconnect the power cord. Electricity can cause death or injury. Moving parts can cause injury.

CAUTION

Before a new user interface assembly is installed, identify the machine software level ([GP 4](#)). Check the compatibility of the software on the new user interface assembly. Install the software to meet the customer machine requirements. Use the Customer Administration Tool (CAT), [GP 5](#).

Perform the following steps:

1. Switch off the machine, then switch on the machine, [GP 14](#).

NOTE: If the UI is unavailable, the power down request cannot be confirmed. The machine will power down automatically after 60 seconds.

2. Refer to [WD 3.1](#). Check the communications cable between PJ905 on the [UI PWB](#) to PJ19 on the [single board controller PWB](#). If necessary, repair the wiring, [REP 1.1](#), or install a new user interface harness, [PL 2.10 Item 7](#). If necessary, install new components:
 - Single board controller PWB, [PL 3.11 Item 13](#).
 - User interface control PWB, [PL 2.10 Item 2](#).

02-390-00 Configurable Services RAP

02-390-00 During power up all configurable services have not achieved a stable state after 5 minutes from power up.

Procedure

WARNING

Ensure that the electricity to the machine is switched off while performing tasks that do not need electricity. Refer to GP 14. Disconnect the power cord. Electricity can cause death or injury. Moving parts can cause injury.

1. Switch the machine off, then switch on the machine, GP 14.
2. Reload the software set, GP 4 Machine Software.

03-316-00 CCM Cannot Communicate with IOT RAP

03-316-00 The communications between the single board controller PWB through the media path PWB and to the IME controller PWB have failed.

Initial Actions

WARNING

Ensure that the electricity to the machine is switched off while performing tasks that do not need electricity. Refer to [GP 14](#). Disconnect the power cord. Electricity can cause death or injury. Moving parts can cause injury.

- If the fault occurs during a software upgrade, wait 15 minutes for the software programming operation to complete, before performing the next action.
- Switch off the machine, then switch on the machine, [GP 14](#).
- Check the fault history file for other 03-xxx fault codes. If the 03-xxx fault codes occur randomly, the cause may be due to electrical noise. Go to [OF 10](#) Intermittent Failure RAP.

Procedure

1. Switch off the machine, [GP 14](#). Ensure all the connectors on the single board controller PWB, [PL 3.11 Item 13](#), media path driver PWB, [PL 1.15 Item 5](#) and the IME controller PWB, [PL 92.10 Item 1](#) are correctly and securely seated. Switch on the machine, [GP 14](#).
2. If the fault was detected during a software upgrade. Re-load the software set, [GP 4](#) Machine Software.
3. Refer to [WD 3.3](#), [WD 8.2](#), [WD 8.4](#) and [WD 9.5](#). Check the wiring between PJ20 on the [single board controller PWB](#) and PJ402 on the [media path driver PWB](#). Check the wiring between PJ408 on the [media path driver PWB](#) and PJ402 on the [IME controller PWB](#). Repair the wiring as necessary, [REP 1.1](#).
4. Install new components as necessary:
 - SBC drawer service loop harness, [PL 3.11 Item 16](#).
 - Single board controller PWB, [PL 3.11 Item 13](#).
 - Media path driver PWB, [PL 1.15 Item 5](#).
 - IME controller PWB, [PL 92.10 Item 1](#).

03-325-00 System Detects the Machine Clock Failed to Increment During Power On RAP

03-325-00 The software has detected that the machine clock has failed to increment within 1.5 seconds during the power on self test operation.

Initial Actions

WARNING

Ensure that the electricity to the machine is switched off while performing tasks that do not need electricity. Refer to [GP 14](#). Disconnect the power cord. Electricity can cause death or injury. Moving parts can cause injury.

Check the fault history file for other 03-xxx fault codes. If the 03-xxx fault codes occur randomly, the cause may be due to electrical noise. Go to [OF 10](#) Intermittent Failure RAP.

Procedure

NOTE: The machine may continue to boot with this fault, but printing may be disabled. The status code, 03-505 is raised with this fault code.

1. Switch off the machine, then switch on the machine, [GP 14](#).
2. Re-load the software set, [GP 4](#).
3. Check the battery on the NVM module PWB, [GP 45](#).
4. Install new components as necessary:
 - Single board controller PWB, [PL 3.11 Item 13](#).
 - Battery, [PL 3.11 Item 18](#).
 - NVM module PWB, [PL 3.11 Item 17](#).

03-331-00, 03-332-00 Main Controller and Network Controller on the SBC PWB Cannot Communicate RAP

03-331-00 Integral network communication error on the single board controller PWB.

03-332-00 The main controller and network controller (integral components of the single board controller PWB) were unable to communicate within a 12 minutes time span.

Initial Actions

WARNING

Ensure that the electricity to the machine is switched off while performing tasks that do not need electricity. Refer to [GP 14](#). Disconnect the power cord. Electricity can cause death or injury. Moving parts can cause injury.

Check the fault history file for other 03-xxx fault codes. If the 03-xxx fault codes occur randomly, the cause may be due to electrical noise. Go to the [OF 10](#) Intermittent Failure RAP.

Procedure

1. Switch off the machine, then switch on the machine, [GP 14](#).
2. Check the network connection to the [single board controller PWB](#) PJ14 is correctly inserted.
3. Re-load the software set, [GP 4](#) Machine Software.
4. Install new components as necessary:
 - Single board controller PWB, [PL 3.11 Item 13](#).

03-338-00 The Main Controller on the SBC Has Reset RAP

03-338-00 System detects that the software in the single board controller PWB has been reset. This was due either to the watch dog timing out or the software writing to an illegal address.

Initial Actions

WARNING

Ensure that the electricity to the machine is switched off while performing tasks that do not need electricity. Refer to [GP 14](#). Disconnect the power cord. Electricity can cause death or injury. Moving parts can cause injury.

Check the fault history file for other 03-xxx fault codes. If the 03-xxx fault codes occur randomly, the cause may be due to electrical noise. Go to the [OF 10](#) Intermittent Failure RAP.

Procedure

1. Switch off the machine, then switch on the machine, [GP 14](#).
2. Re-load the software set, [GP 4](#) Machine Software.
3. If the fault remains, install a new single board controller PWB, [PL 3.11 Item 13](#).

03-346-00 Unable To Communicate With UI RAP

03-346-00 Unable to re-establish communication with the UI after 30 seconds.

Procedure

WARNING

Ensure that the electricity to the machine is switched off while performing tasks that do not need electricity. Refer to [GP 14](#). Disconnect the power cord. Electricity can cause death or injury. Moving parts can cause injury.

1. Switch off the machine, then switch on the machine, [GP 14](#).
2. Reload the software set, [GP 4](#) Machine Software.

03-347-00 Main Controller PWB Cannot Communicate with UI PWB RAP

03-347-00 The single board controller PWB to UI control PWB communications have failed.

Initial Actions

WARNING

Ensure that the electricity to the machine is switched off while performing tasks that do not need electricity. Refer to [GP 14](#). Disconnect the power cord. Electricity can cause death or injury. Moving parts can cause injury.

- Switch off the machine, then switch on the machine, [GP 14](#).
- Check the fault history file for other 03-xxx fault codes. If the 03-xxx fault codes occur randomly, the cause may be due to electrical noise. Go to [OF 10](#) Intermittent Failure RAP.

Procedure

1. Switch off the machine, [GP 14](#). Ensure all the connectors on the single board controller, [PL 3.11 Item 13](#) and the UI control PWB, [PL 2.10 Item 2](#) are correctly and securely seated. Switch on the machine, [GP 14](#).
2. Re-load the software set, [GP 4](#) Machine Software.
3. Refer to [WD 3.2](#). Check the wiring between PJ19 on the [single board controller PWB](#) and PJ900, PJ901 and PJ905 on the [User Interface control PWB](#). Repair the wiring as necessary, [REP 1.1](#). If necessary, install a new user interface harness, [PL 2.10 Item 7](#).
4. Install new components as necessary:
 - User interface control PWB, [PL 2.10 Item 2](#).
 - Single board controller PWB, [PL 3.11 Item 13](#).

03-355-00 CCM POST Failure Detected RAP

03-355-00 The software has detected a CCM POST failure during the NVM integrity test/NVM battery failure.

Initial Actions

WARNING

Ensure that the electricity to the machine is switched off while performing tasks that do not need electricity. Refer to [GP 14](#). Disconnect the power cord. Electricity can cause death or injury. Moving parts can cause injury.

- Check the fault history file for other 03-xxx fault codes. If the 03-xxx fault codes occur randomly, the cause may be due to electrical noise. Go to [OF 10](#) Intermittent Failure RAP.
- Check that the battery on the NVM module PWB is located correctly and in good condition, [GP 45](#).
- Reseat the NVM module PWB, [PL 3.11 Item 17](#).

Procedure

NOTE: The machine may continue to boot with this fault, but printing may be disabled. The status code, 03-505 is raised with this fault code.

1. Switch off the machine, then switch on the machine, [GP 14](#).
2. Re-load the software set, [GP 4](#).
3. Install new components as necessary:
 - Battery, [PL 3.11 Item 18](#).
 - NVM module PWB, [PL 3.11 Item 17](#).
 - Single board controller PWB, [PL 3.11 Item 13](#).

03-362-00 CCS Power Fault RAP

03-362-00 The single board controller software has failed to exit from a timer loop and has detected that this is caused by an abnormal power condition.

Initial Actions

WARNING

Ensure that the electricity to the machine is switched off while performing tasks that do not need electricity. Refer to [GP 14](#). Disconnect the power cord. Electricity can cause death or injury. Moving parts can cause injury.

- Switch off the machine, then switch on the machine, [GP 14](#).
- Check the fault history file for other 03-xxx fault codes. If the 03-xxx fault codes occur randomly, the cause may be due to electrical noise. Go to [OF 10](#) Intermittent Failure RAP.

Procedure

1. Switch off the machine, then switch on the machine, [GP 14](#).
2. Check the wiring and connections between the power supply unit, [PL 1.15 Item 2](#), the power distribution PWB, [PL 3.11 Item 1](#) and the single board controller PWB, [PL 3.11 Item 13](#). Repair the wiring as necessary, [REP 1.1](#).
3. Go to the following RAPs and check the low voltage supplies to the single board controller PWB:
 - [01C](#) +3.3V Distribution RAP.
 - [01D](#) +5V Distribution RAP.
 - [01E](#) +12V Distribution RAP.
 - [01G](#) +17V Distribution RAP.
 - [01H](#) +24V Distribution RAP.
 - [01L](#) 0V Distribution RAP

As necessary, repair the wiring, [REP 1.1](#), or install new components as necessary:

- Power distribution PWB, [PL 3.11 Item 1](#).
- Single board controller PWB, [PL 3.11 Item 13](#).
- PDB to SBC Harness (PJ17), [PL 3.11 Item 10](#).
- Power supply unit, [PL 1.15 Item 2](#).

03-397-00 System Configuration Recovery Attempt RAP

03-397-00 System configuration is lost and an attempted recovery made (from SIM).

Initial Actions

WARNING

Ensure that the electricity to the machine is switched off while performing tasks that do not need electricity. Refer to GP 14. Disconnect the power cord. Electricity can cause death or injury. Moving parts can cause injury.

- Switch off the machine, then switch on the machine, GP 14.
- Check the fault history file for other 03-xxx fault codes. If the 03-xxx fault codes occur randomly, the cause may be due to electrical noise. Go to OF 10 Intermittent Failure RAP.

Procedure

1. Switch off the machine, then switch on the machine, GP 14.
2. Check that the SIM card is installed.
NOTE: The SIM card is also referred to as the product enablement key.
3. Check for damage to the SIM card:
 - Enter dC131.
 - Select CCS NVM ID 616-3 Product Configuration.
 - Check that the value is set to 112 or 113 or 114. If the value is set to 49, the SIM card is missing or damaged. Obtain a SIM card that is compatible with this machine.
4. Check that the SIM card is a valid option for this machine, GP 19. If there is a mismatch between the SIM card and the machine then the two are not compatible. Obtain a SIM card that is compatible with this machine.
5. Check that the battery on the NVM module PWB is located correctly and in good condition, GP 45.
6. Install new components as necessary:
 - Battery, PL 3.11 Item 18.
 - NVM module PWB, PL 3.11 Item 17.
 - Product enablement key, PL 3.11 Item 22.
 - Single board controller PWB, PL 3.11 Item 13.
7. Perform an NVM restore, refer to NVM Save and Restore, dC361.
8. If an NVM restore cannot be completed perform the following:
 - Set the market region. Enter dC134, set value to appropriate market region.
 - Enter Service Admin.
 - a. Press and hold the # key, * key and the Stop key.
 - b. Enter the passcode 2732. Touch the Enter button on the UI.
 - c. Select machine status / Paper Management / Tray Contents
 - d. Set the tray 3 contents as appropriate to the machine location A4 or 8.5 x 11 inch.
9. Rest all counters and exit diagnostics.

03-398-00, 03-399-00 SIM Card Fault RAP

03-398-00 SIM card serial number mismatch between the option and the machine

03-399-00 SIM card data cannot be processed by the machine.

Procedure

WARNING

Ensure that the electricity to the machine is switched off while performing tasks that do not need electricity. Refer to GP 14. Disconnect the power cord. Electricity can cause death or injury. Moving parts can cause injury.

1. Switch off the machine, then switch on the machine, GP 14.
2. Check that the machine serial number is correct, refer to dC132.
3. Check that the SIM card is a valid option for this machine, GP 19. There is a mismatch between the SIM card and the machine and the two are not compatible. Obtain a SIM card that is compatible with this machine.

NOTE: A pre-serialized SIM card will be required. Escalate the request through normal channels.

NOTE: The SIM card is also referred to as the product enablement key.

4. Install new components as necessary:
 - Product enablement key, PL 3.11 Item 22.
 - Single board controller PWB, PL 3.11 Item 13.

03-401-00, 03-403-00 Fax Not Detected RAP

03-401-00 The basic fax module has not been detected or confirmed.

03-403-00 Extended fax PWB has not been confirmed or detected. This is for information only. The machine does not have an extended fax PWB.

Procedure

WARNING

Ensure that the electricity to the machine is switched off while performing tasks that do not need electricity. Refer to **GP 14**. Disconnect the power cord. Electricity can cause death or injury. Moving parts can cause injury.

1. Switch off the machine, then switch on the machine, **GP 14**.
2. Check that the Fax module, **PL 20.05 Item 1**, has been installed.
3. Perform the Initial Actions in **20A Fax Entry RAP**.
4. Perform the **20G Fax Module Checkout RAP**.
5. If necessary, install a new Fax module, **PL 20.05 Item 1**.
6. If necessary, re-load the software set, **GP 4 Machine Software**.
7. Install new components as necessary:
 - Single board controller PWB, **PL 3.11 Item 13**.

03-417-00 Incompatible Fax Software RAP

03-417 The fax software version supplied at power up is not compatible with the image processing software.

Procedure

WARNING

Ensure that the electricity to the machine is switched off while performing tasks that do not need electricity. Refer to **GP 14**. Disconnect the power cord. Electricity can cause death or injury. Moving parts can cause injury.

Switch off the machine, then switch on the machine, **GP 14**.

Perform the following:

- Reload the software set, **GP 4, Machine Software**.
- If necessary, install a new Fax module, **PL 20.05 Item 1**.

03-777-00 Power Loss Detected RAP

03-777-00 This fault code in the fault history file indicates that the system has previously detected a power input loss.

Procedure

WARNING

Ensure that the electricity to the machine is switched off while performing tasks that do not need electricity. Refer to [GP 14](#). Disconnect the power cord. Electricity can cause death or injury. Moving parts can cause injury.

1. Check with the customer that the AC mains (line) input power supply is not experiencing interruptions.
2. Check with the customer that the machine does not share a power supply with any other equipment. Sharing a power supply may cause the safety over current device to switch off the electrical supply to the machine. This would cause a 03-777-00 fault. If possible, ensure the machine is connected to a dedicated power supply.
3. Check the fault history file for other 03-xxx fault codes. If the 03-xxx fault codes occur randomly, the cause may be due to electrical noise. Go to the [OF 10](#) Intermittent Failure RAP.
4. Go to [01A](#) AC Power Distribution RAP and check the power input circuit and its connectors.

03-788-00 CCS Runtime Could Not Enter Power Saver Mode S3 RAP

03-788 The copy control software could not enter power save mode. The copy control software was unable to update its parameters from the UI, when the machine previously came out of sleep mode. It was then unable to re-enter the sleep mode, S3.

Procedure

WARNING

Ensure that the electricity to the machine is switched off while performing tasks that do not need electricity. Refer to [GP 14](#). Disconnect the power cord. Electricity can cause death or injury. Moving parts can cause injury.

1. Check the fault history file for other 03-xxx fault codes. If the 03-xxx fault codes occur randomly, the cause may be due to electrical noise. Go to the [OF 10](#) Intermittent Failure RAP.
2. Switch off the machine, then switch on the machine, [GP 14](#).
3. Refer to [WD 3.1](#). Check the wiring between PJ19 on the [single board controller PWB](#) and PJ900, PJ901 and PJ905 on the [UI Control PWB](#). Repair the wiring as necessary, [REP 1.1](#).
4. Install new components as necessary:
 - User interface control PWB, [PL 2.10 Item 2](#).
 - Single board controller PWB, [PL 3.11 Item 13](#).

03-790-00 Timezone Cannot Be Set RAP

03-790-00 At power up the Timezone is not valid due to NVM corruption, or OS file system problem. Timezone overridden to GMT: DST disabled.

Procedure

WARNING

Ensure that the electricity to the machine is switched off while performing tasks that do not need electricity. Refer to [GP 14](#). Disconnect the power cord. Electricity can cause death or injury. Moving parts can cause injury.

Reset the time zone in customer domain tools, refer to [GP 5](#).

03A Foreign Device PWB Fault RAP

Use this RAP when the foreign interface device is not detected.

Initial Actions

WARNING

Ensure that the electricity to the machine is switched off while performing tasks that do not need electricity. Refer to [GP 14](#). Disconnect the power cord. Electricity can cause death or injury. Moving parts can cause injury.

CAUTION

Do not show the customer how to install a temporary shorting link. Do not leave a shorting link installed.

- Switch off the machine, then switch on the machine, [GP 14](#).
- Ensure the foreign device interface PWB, [PL 3.11 Item 14](#) is securely connected to the single board controller PWB, [PL 3.11 Item 13](#).

Procedure

If available check the operation of the foreign interface device with a foreign interface test tool, [PL 26.10 Item 14](#), in conjunction with the 7655/65/75 indicator/instruction chart.

To check a foreign interface device if the test tool is not available/suitable, perform the procedure that follows:

Refer to [WD 3.3](#). Check the foreign device interface harness, [PL 3.11 Item 23](#). **The harness is good.**

Y N

Perform the following as necessary:

- Repair the harness, [REP 1.1](#).
- Install a new foreign device interface harness, [PL 3.11 Item 23](#).

NOTE: Do not attempt to repair the harness from the bulkhead connector to the foreign device.

Check the +3.3V supply to PJ25 at pins 1, 5, 9, 16 and 22 on the [single board controller PWB](#). **The +3.3V supply is good.**

Y N

Check the +3.3V distribution. Refer to:

- [01C](#) +3.3V Distribution RAP.
- [01L](#) 0V Distribution RAP.

Disconnect the foreign device. Install a temporary shorting link between pins 2 and 3 on the foreign device interface harness bulkhead connector. Check the voltage at pin 2. **0V is measured.**

Y N

Install a new foreign device interface PWB, [PL 3.11 Item 14](#).

Install a temporary shorting link between pins 1 and 3 on the foreign device interface harness bulkhead connector. Check the display. **The machine is enabled.**

Y N

Install new components as necessary:

- Install a new foreign device interface PWB, [PL 3.11 Item 14](#).
- Single board controller PWB, [PL 3.11 Item 13](#).

The enable circuits are working correctly.

NOTE: Currently the signals used for billing, e.g. machine function, premium tray, etc. cannot be adequately measured with a standard meter.

05-250-00, 05-251-00 DADH Checksum Error RAP

05-250-00 The DADH flash memory is corrupted. A kernel checksum error has been detected.

05-251-00 The DADH flash memory is corrupted. An application checksum error has been detected.

Initial Actions

WARNING

Ensure that the electricity to the machine is switched off while performing tasks that do not need electricity. Refer to [GP 14](#). Disconnect the power cord. Electricity can cause death or injury. Moving parts can cause injury.

Switch off, then switch on the machine, [GP 14](#).

Procedure

1. Re-load the software set, [GP 4 Machine Software](#).
2. If necessary, install a new DADH PWB, [PL 5.10 Item 5](#).

05-252-00 DADH Stepper Controller Communications Error

05-252-00 DADH PWB to stepper motors communications have failed.

Initial Actions

WARNING

Ensure that the electricity to the machine is switched off while performing tasks that do not need electricity. Refer to [GP 14](#). Disconnect the power cord. Electricity can cause death or injury. Moving parts can cause injury.

Switch off, then switch on the machine, [GP 14](#).

Procedure

1. Switch off the machine, [GP 14](#). Ensure all the connectors on the DADH PWB, [PL 5.10 Item 5](#), are correctly and securely seated. Switch on the machine, [GP 14](#).
2. Refer to [WD 5.1](#). Check the wiring between PJ181 on the [DADH PWB](#) and the feed motor, [PL 5.15 Item 16](#) and the CVT motor, [PL 5.25 Item 9](#). Repair the wiring as necessary, [REP 1.1](#).
3. Install new components as necessary:
 - DADH feed motor, [PL 5.15 Item 16](#).
 - DADH CVT motor, [PL 5.25 Item 9](#).
 - DADH PWB, [PL 5.10 Item 5](#).

05-253-00, 05-254-00 DADH Communications Error RAP

05-253-00 The DADH PWB to single board controller PWB communications have failed.

05-254-00 The DADH PWB to single board controller PWB communications are out of sequence.

Initial Actions

WARNING

Ensure that the electricity to the machine is switched off while performing tasks that do not need electricity. Refer to [GP 14](#). Disconnect the power cord. Electricity can cause death or injury. Moving parts can cause injury.

- Switch off the machine, then switch on the machine, [GP 14](#).

Procedure

1. Switch off the machine, [GP 14](#). Ensure all the connectors on the DADH PWB, [PL 5.10 Item 5](#), scanner PWB, [PL 62.16 Item 8](#) and the single board controller PWB, [PL 3.11 Item 13](#) are correctly and securely seated. Switch on the machine, [GP 14](#).
2. If the fault was detected during a software upgrade. Re-load the software set, [GP 4 Machine Software](#).
3. Refer to [WD 3.1](#), [WD 5.2](#) and [WD 6.1](#). Check the wiring between PJ188 on the [DADH PWB](#) and PJ921 on the [scanner PWB](#). Check the wiring between PJ922 on the [scanner PWB](#) and PJ15 on the [single board controller PWB](#). Repair the wiring as necessary, [REP 1.1](#).
4. Install new components as necessary:
 - DADH communication/power cable, [PL 5.10 Item 6](#).
 - DADH/IIT power comms harness, [PL 62.16 Item 7](#).
 - DADH PWB, [PL 5.10 Item 5](#).
 - Scanner PWB, [PL 62.16 Item 8](#).
 - Single board controller PWB, [PL 3.11 Item 13](#).

05-255-00 Late Pre Scan Message RAP

05-255-00 The DADH pre scan status message was not received in time.

Procedure

WARNING

Ensure that the electricity to the machine is switched off while performing tasks that do not need electricity. Refer to [GP 14](#). Disconnect the power cord. Electricity can cause death or injury. Moving parts can cause injury.

1. Switch off, then switch on the machine, [GP 14](#).

05-256-00 Eject Count Error RAP

05-256-00 The number of ejections from the DADH did not match the number of feeds.

Procedure

WARNING

Ensure that the electricity to the machine is switched off while performing tasks that do not need electricity. Refer to [GP 14](#). Disconnect the power cord. Electricity can cause death or injury. Moving parts can cause injury.

1. Switch off, then switch on the machine, [GP 14](#).

05-257-00 Unknown Document Size RAP

05-257-00 The DADH has failed to detect the document size during pre-feed.

Initial Actions

WARNING

Ensure that the electricity to the machine is switched off while performing tasks that do not need electricity. Refer to [GP 14](#). Disconnect the power cord. Electricity can cause death or injury. Moving parts can cause injury.

- Make sure that a bright light is not above the DADH input tray. Refer to [TAG D-007](#) and check size sensor 1 and size sensor 2. If necessary, adjust the position of the machine.
- Remove all documents from the DADH and input tray.
- Make sure that the sensors and the area around the sensors are clean.

Procedure

NOTE: The DADH width sensor is a potentiometer. The arm on the potentiometer is attached to the width guides. This gives a variable voltage to indicate the paper width setting.

Enter [dC330](#) code 05-221 to check the DADH tray size sensor 1 Q05-221, [PL 5.35 Item 8](#). Actuate Q05-221. **The display changes.**

Y N

Refer to [WD 5.2](#). Check Q05-221.

References:

- [GP 11](#) How to Check a Sensor.
- P/J190, [DADH PWB](#).
- [01D](#) +5V Distribution RAP.
- [01L](#) 0V Distribution RAP.

Install new components as necessary:

- DADH tray size sensor 1, [PL 5.35 Item 8](#).
- DADH PWB, [PL 5.10 Item 5](#).

Enter [dC330](#) code 05-222 to check the DADH tray size sensor 2 Q05-222, [PL 5.35 Item 8](#). Actuate Q05-222. **The display changes.**

Y N

Refer to [WD 5.2](#). Check Q05-222.

References:

- [GP 11](#) How to Check a Sensor.
- P/J190, [DADH PWB](#).
- [01D](#) +5V Distribution RAP.
- [01L](#) 0V Distribution RAP.

Install new components as necessary:

- DADH tray size sensor 2, [PL 5.35 Item 8](#).
- DADH PWB, [PL 5.10 Item 5](#).

Open the DADH top cover. Enter [dC330](#) code 05-204 to check the DADH feed sensor, Q05-204, [PL 5.15 Item 2](#). Actuate Q05-204. **The display changes.**

Y N

Refer to [WD 5.1](#). Check Q05-204.

References:

- [GP 11](#) How to Check a Sensor.
- P/J184, [DADH PWB](#).
- [01D](#) +5V Distribution RAP.
- [01L](#) 0V Distribution RAP.

Install new components as necessary:

- DADH feed sensor, [PL 5.15 Item 2](#).
- DADH PWB, [PL 5.10 Item 5](#).

Enter [dC330](#) code 05-206 to check the DADH pre-reg sensor, Q05-206, [PL 5.25 Item 1](#). Actuate Q05-206. **The display changes.**

Y N

Refer to [WD 5.1](#). Check Q05-206.

References:

- [GP 11](#) How to Check a Sensor.
- P/J184, [DADH PWB](#).
- [01C](#) +3.3V Distribution RAP.
- [01L](#) 0V Distribution RAP.

Install new components as necessary:

- DADH pre-reg sensor, [PL 5.25 Item 1](#).
- DADH PWB, [PL 5.10 Item 5](#).

Completely open the DADH width guides. Refer to [WD 5.2](#). Measure the voltage at P/J190 pin 8. Completely close the DADH width guides. **The voltage changes from approximately 3.3V to approximately 0V.**

Y N

Remove the DADH input tray assembly, [PL 5.35 Item 1](#). Make sure the arm of the DADH width sensor is installed correctly, [Figure 1](#). Check the mechanical operation of the width guides. Install new components as necessary:

- DADH width sensor, [PL 5.35 Item 11](#).
- DADH input tray assembly, [PL 5.35 Item 1](#).

Go to [dC131](#). Check that the IIT DADH NVM parameters for the detection of the size of paper are correct. Install new components as necessary:

- DADH PWB, [PL 5.10 Item 5](#).
- DADH input tray assembly, [PL 5.35 Item 1](#).

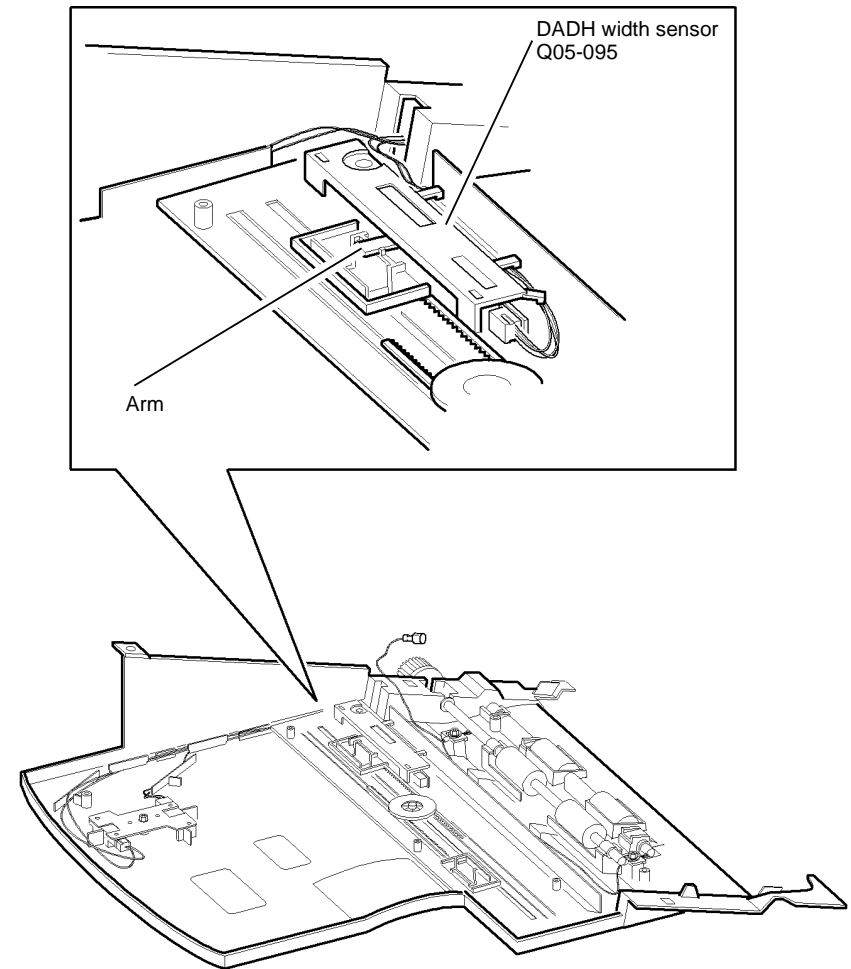

U-1-0052-A

Figure 1 Component location

05-258-00, 05-307-00 DADH Cover Interlock Open RAP

05-258-00 The DADH cover interlock switch detects that the top cover is open during initialization.

05-307-00 The DADH cover interlock switch detects that the top cover is open.

Initial Actions

WARNING

Ensure that the electricity to the machine is switched off while performing tasks that do not need electricity. Refer to [GP 14](#). Disconnect the power cord. Electricity can cause death or injury. Moving parts can cause injury.

- Remove all documents from the DADH.
- Check the switch actuator on the DADH cover, [Figure 1](#). If the actuator is damaged, install a new DADH top cover, [PL 5.20 Item 15](#).
- Make sure the latch springs, [PL 5.20 Item 7](#) are installed correctly. Make sure that the top cover closes correctly. If necessary, install a new top access cover assembly, [PL 5.20 Item 17](#).
- Check that the EPC memory PWB, [PL 3.11 Item 21](#), is correctly seated.

Procedure

Enter [dC330](#) code 05-212 to check the DADH cover interlock switch, [Figure 1](#), S05-212. Actuate S05-212. **The display changes.**

Y N

Refer to [WD 5.1](#). Check S05-212.

References:

- [GP 13](#) How to Check a Switch.
- [P/J187](#), [DADH PWB](#).
- [01H](#) +24V Distribution RAP.
- [01L](#) 0V Distribution RAP.

Install new components as necessary:

- DADH cover interlock switch, [PL 5.15 Item 11](#).
- DADH PWB, [PL 5.10 Item 5](#).

Check that S05-212 is installed correctly.

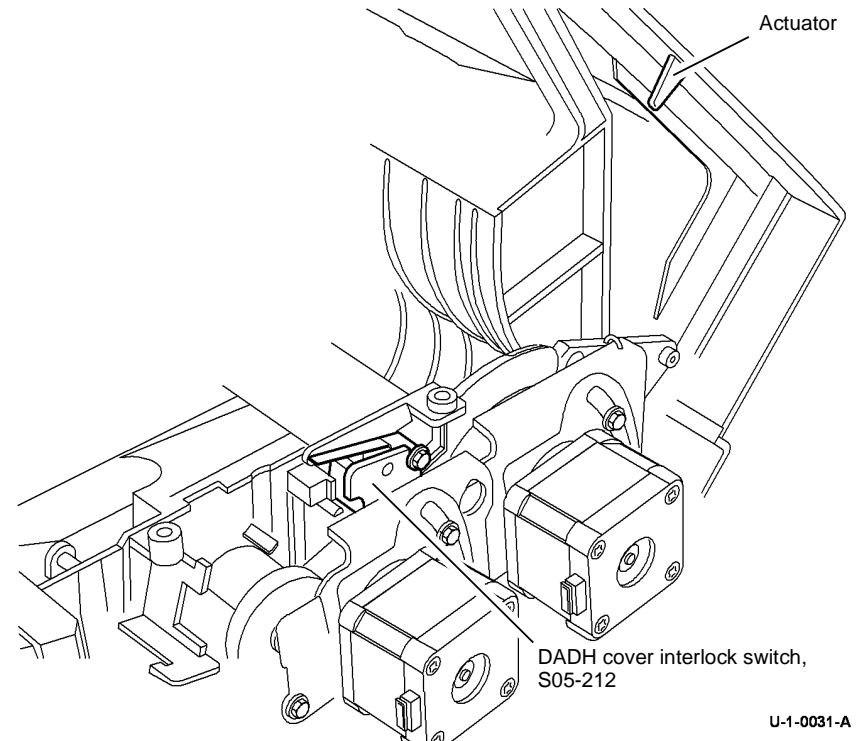

U-1-0031-A

Figure 1 Component location

05-259-00, 05-260-00 DADH Active Line or Standby Error RAP

05-259-00 The DADH active line is in the wrong state during the scan

05-260-00 The DADH is not in standby at the start of the job.

Initial Actions

WARNING

Ensure that the electricity to the machine is switched off while performing tasks that do not need electricity. Refer to [GP 14](#). Disconnect the power cord. Electricity can cause death or injury. Moving parts can cause injury.

Switch off, then switch on the machine, [GP 14](#).

Procedure

1. Refer to [WD 5.2](#) and [WD 6.1](#). Check the wiring between PJ188 on the [DADH PWB](#) and PJ921 on the [scanner PWB](#). Repair the wiring as necessary, [REP 1.1](#).
2. If necessary, install a new DADH PWB, [PL 5.10 Item 5](#).

05-300-00 DADH Open RAP

05-300-00 The platen down sensor detects that the DADH is open during run.

Initial Actions

WARNING

Ensure that the electricity to the machine is switched off while performing tasks that do not need electricity. Refer to [GP 14](#). Disconnect the power cord. Electricity can cause death or injury. Moving parts can cause injury.

Check that the DADH platen down sensor magnet, [PL 5.10 Item 10](#) is installed and aligned correctly to the platen down sensor.

NOTE: The DADH has two magnets, the magnet on the left front corner of the DADH actuates the platen down sensor, refer to [PL 5.10 Item 10](#).

Procedure

Enter [dC330](#) code 62-019 to check the platen down sensor, Q62-019, [PL 62.16 Item 5](#). Open and close the DADH. **The display changes.**

Y N

Refer to [WD 6.2](#). Check Q62-019.

References:

- [GP 13](#) How to Check a Switch.
- PJ927, [Scanner PWB](#).
- [01C](#) +3.3V Distribution RAP.
- [01L](#) 0V Distribution RAP.

Install new components as necessary:

- Platen down sensor, [PL 62.16 Item 5](#).
- Scanner PWB, [PL 62.16 Item 8](#).

Perform the steps that follow. Install new components as necessary:

- Check that Q62-019 is installed correctly.
- Check the DADH frame for distortion, go to [ADJ 5.2](#). If the DADH frame is distorted, install a new DADH, [PL 5.10 Item 9](#).

05-310-00 Document Too Short RAP

05-310-00 The DADH detects a document that is shorter than 110mm.

Initial Actions

WARNING

Ensure that the electricity to the machine is switched off while performing tasks that do not need electricity. Refer to [GP 14](#). Disconnect the power cord. Electricity can cause death or injury. Moving parts can cause injury.

- Remove all documents from the DADH.
- Make sure that the documents are longer than 110 mm (4.3 inches).
- Check for toner contamination on and in the locality of the DADH feed sensor Q05-204, [PL 5.15 Item 2](#).

Procedure

If the documents are longer than 110mm, go to the procedures that follow:

- [05-330-00](#), [05-331-00](#) CVT - DADH Feed Sensor Failure RAP.
- [05-335-00](#) DADH TAR Sensor Failure RAP.
- [05-350-00](#), [05-352-00](#) DADH CVT Sensor Failure RAP.
- [05-340-00](#) CVT-DADH Pre-Reg Sensor Failure RAP.

05-330-00, 05-331-00 DADH Feed Sensor Failure RAP

05-330-00 The DADH feed sensor does not detect the lead edge of the document within the correct time after the feed motor runs.

05-331-00 The DADH feed sensor does not detect the trail edge of the document within the correct time.

Initial Actions

WARNING

Ensure that the electricity to the machine is switched off while performing tasks that do not need electricity. Refer to [GP 14](#). Disconnect the power cord. Electricity can cause death or injury. Moving parts can cause injury.

- Remove all documents from the DADH.
- Make sure that the customer is not using damaged documents. If the DADH damages the documents, go to the [05E Damaged Documents RAP](#).
- Clean the DADH feed sensor, [PL 5.15 Item 2](#), and the area around the sensor, [Figure 2](#).
- Check that the feed roll assembly is installed correctly, refer to [REP 5.14](#).
- Check that the CVT roll is installed correctly, refer to [REP 5.15](#).
- Make sure that the feed rolls are clean and rotate freely, refer to [ADJ 5.4](#). If necessary, install a new feed roll assembly, [PL 5.15 Item 1](#) or feed roll assembly cover, [PL 5.15 Item 21](#).
- Go to [dC135 CRU/HFSI Status](#). Check the count of the document feeder feed roller. If the count is near end of life, install a new feed roll assembly, [PL 5.15 Item 1](#).
- Check the operation of the feed yoke, [Figure 1](#). Make sure that the feed yoke shaft is under the moulded clip of the feed housing. Make sure that the feed yoke spring, [PL 5.15 Item 7](#) is connected to the feed housing and to the feed yoke.
- Make sure that the front feed gate, [PL 5.15 Item 12](#) and the rear feed gate, [PL 5.15 Item 13](#) are locked in the down position.
- Check the DADH CVT sensor and actuator for damage, [PL 5.20 Item 12](#).

Procedure

Open the DADH top cover. Remove the DADH rear cover, [PL 5.10 Item 1](#). Hold the DADH cover interlock switch closed, [PL 5.15 Item 11](#). Enter [dC330](#) code 05-204 to check the DADH feed sensor, Q05-204. Actuate Q05-204. **The display changes.**

Y N

Refer to [WD 5.1](#). Check Q05-204.

References:

- [GP 11](#) How to Check a Sensor.
- P/J184, [DADH PWB](#).
- [01D +5V](#) Distribution RAP.
- [01L 0V](#) Distribution RAP.

Install new components as necessary:

- DADH feed sensor, [PL 5.15 Item 2](#).
- DADH PWB, [PL 5.10 Item 5](#).

Enter [dC330](#) code 05-074 to run the DADH feed motor, MOT05-074. **MOT05-074 runs.**

Y N

Go to the [05C DADH Motor Failure RAP](#).

While MOT 05-074 runs, stack the code 05-062 to energize the DADH feed clutch, CL05-062.

NOTE: The feed clutch disengages after 30 seconds. The feed motor stops after 3 minutes.

CL05-062 energizes, the nudger rolls and the feed rolls rotate.

Y N

Perform the steps that follow:

- Go to the [05D DADH Feed Clutch Failure RAP](#) and check CL05-062.
- [ADJ 5.1 DADH Drive Belt Adjustment](#).

Enter [dC330](#) code 05-098, to run the DADH nudger motor. **The feed roll assembly lowers, then raises after 10 seconds.**

Y N

Refer to [WD 5.1](#). Check the nudger motor.

References:

- [GP 10](#) How to Check a motor.
- P/J183, [DADH PWB](#) and P/J201.
- [01H](#) +24V Distribution RAP.
- [01L](#) 0V Distribution RAP.

Install new components as necessary:

- DADH nudger motor, [PL 5.15 Item 5](#).
- DADH feed assembly, [PL 5.15 Item 18](#).
- DADH PWB, [PL 5.10 Item 5](#).

Perform the steps that follow:

- Check that the DADH feed sensor, Q05-204 is installed correctly, [Figure 2](#). If necessary, install a new feed roll assembly, [PL 5.15 Item 1](#).
- Ensure the feed motor drive belt and DADH CVT motor belt are tensioned correctly, [ADJ 5.1](#).
- When large documents are fed (A3 or 11x17 inch), check the items that follow:
 - Check that the DADH CVT motor rotates freely, refer to the [05C DADH Motor Failure RAP](#).
 - Check the CVT motor drive belt, refer to [ADJ 5.1 DADH Drive Belt Adjustment](#).
 - Check that the CVT roll is clean and rotates freely, refer to [ADJ 5.4](#).
 - If necessary install a new DADH feed motor, [PL 5.25 Item 9](#).
- Go to the [05D DADH Feed Clutch Failure RAP](#) and check CL05-062.
- Make sure that the size of the documents are sensed correctly. Refer to the [05-257-00 Document Size Sensor Failure RAP](#).

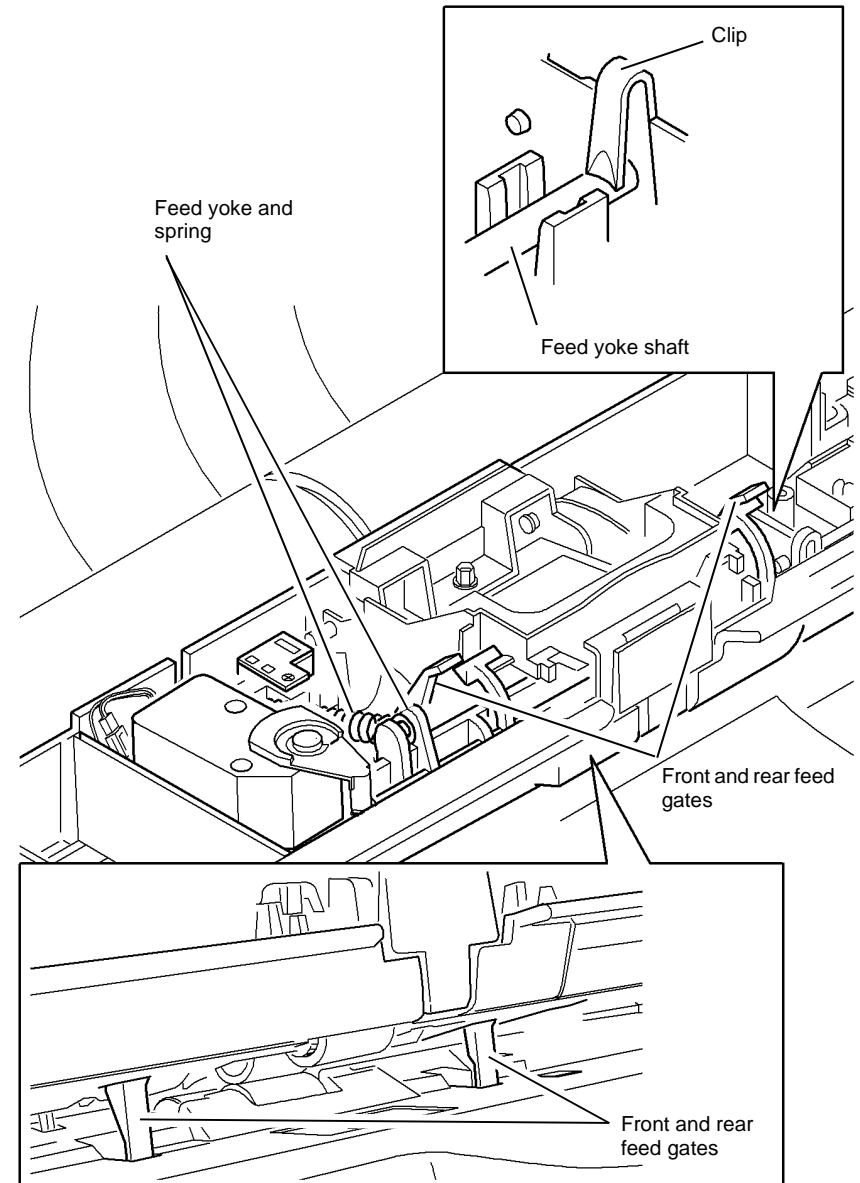

U-1-0035-A

Figure 1 Component location

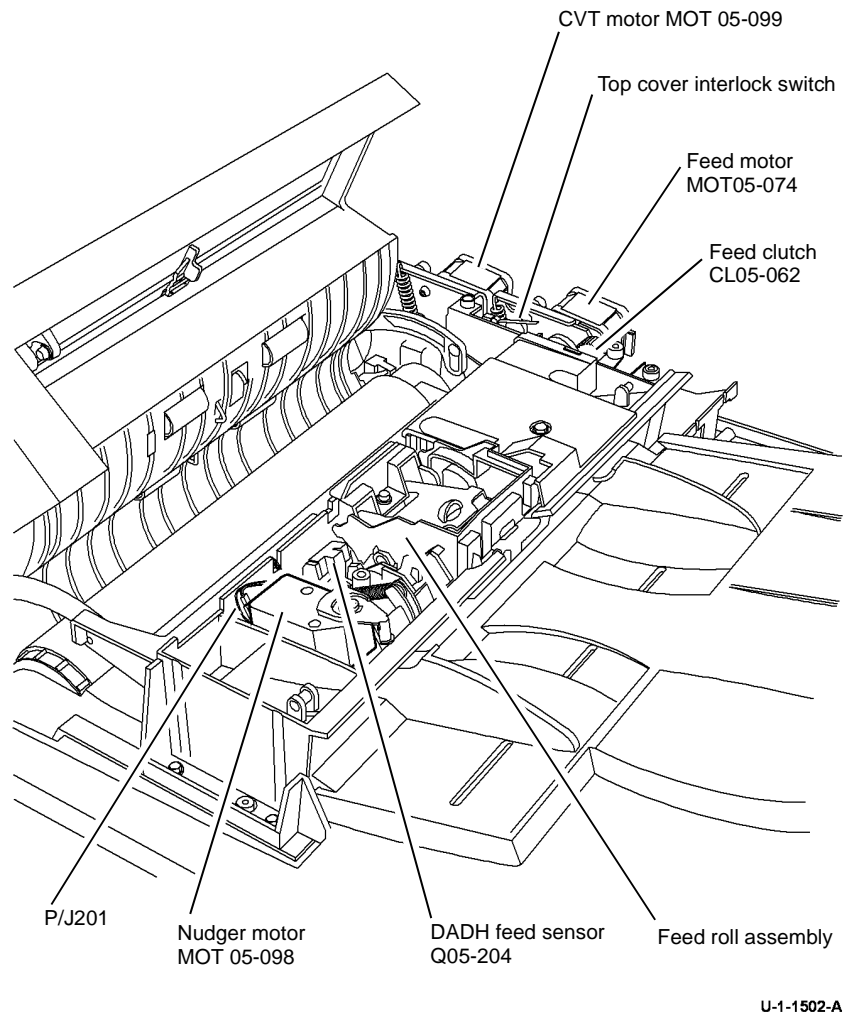

Figure 2 Component location

05-335-00 DADH TAR Sensor Failure RAP

05-335-00 The DADH TAR sensor does not detect the lead edge of the document within the correct time.

Initial Actions

WARNING

Ensure that the electricity to the machine is switched off while performing tasks that do not need electricity. Refer to [GP 14](#). Disconnect the power cord. Electricity can cause death or injury. Moving parts can cause injury.

- Remove all documents from the DADH.
- Clean the feed rolls, refer to [ADJ 5.4](#). If necessary, install a new feed roll assembly, [PL 5.15 Item 1](#).

Procedure

NOTE: To get access to the DADH TAR sensor, remove the DADH top cover, [PL 5.20 Item 15](#).

Open the DADH top cover. Enter [dC330](#) code 05-096 to check the DADH TAR sensor, Q05-096, [PL 5.20 Item 11](#). Actuate Q05-096. **The display changes.**

Y N

Refer to [WD 5.1](#). Check Q05-096.

References:

- [GP 11](#) How to Check a Sensor.
- P/J186, [DADH PWB](#) and P/J191.
- [01C](#) +3.3V Distribution PWB.
- [01L](#) 0V Distribution RAP.

Install new components as necessary:

- DADH TAR sensor, [PL 5.20 Item 11](#).
- DADH PWB, [PL 5.10 Item 5](#).

Remove the DADH rear cover, [PL 5.10 Item 1](#). Hold the DADH cover interlock switch closed, [PL 5.15 Item 11](#). Enter [dC330](#) code 05-074 to run the DADH feed motor, MOT05-074, [PL 5.15 Item 16](#). **MOT05-074 runs.**

Y N

Go to the [05C](#) DADH Motor Failure RAP.

The takeaway roll rotates.

Y N

Perform the steps follow:

- Check the feed motor drive belt, [PL 5.35 Item 5](#).
- [ADJ 5.1](#) Feed Motor Drive Belt Adjustment.
- Check the takeaway roll and pulley, [PL 5.35 Item 6](#) and [PL 5.35 Item 15](#), refer to [GP 7](#).

Perform the steps that follow:

- Check that the DADH TAR sensor, Q05-096 is installed correctly.
- Go to the [05D](#) DADH Feed Clutch Failure RAP and check the DADH feed clutch.
- Make sure that the takeaway roll is clean and rotates freely, refer to [ADJ 5.4](#).

- Make sure that the takeaway roll idlers are clean and rotate freely, refer to [ADJ 5.4](#).
- Check the takeaway roll static eliminator and ground harness, [PL 5.35 Item 7](#).
- Make sure that the DADH ground harness is connected correctly, [PL 5.10 Item 11](#).
- [ADJ 5.1](#) Feed Motor Drive Belt Adjustment.

Install new components as necessary:

- DADH takeaway roll, [PL 5.35 Item 6](#).
- DADH input tray assembly, [PL 5.35 Item 1](#).
- DADH top access cover assembly, [PL 5.20 Item 17](#).
- DADH feed assembly, [PL 5.15 Item 18](#).

If the fault continues, make sure that documents correctly continue past the previous sensor in the document path. Refer to the [05-330-00](#), [05-331-00](#) DADH Feed Sensor Failure RAP.

05-340-00 DADH Pre Registration Sensor Failure RAP

05-340-00 The DADH pre registration sensor does not detect the lead edge of the document within the correct time.

Initial Actions

WARNING

Ensure that the electricity to the machine is switched off while performing tasks that do not need electricity. Refer to [GP 14](#). Disconnect the power cord. Electricity can cause death or injury. Moving parts can cause injury.

- Remove all documents from the DADH.
- Remove the DADH top cover assembly, [PL 5.20 Item 16](#). Make sure the harnesses are routed correctly and away from the document path, [Figure 1](#).

Procedure

NOTE: To access the DADH pre registration sensor, remove the DADH top cover, [PL 5.20 Item 15](#).

Open the top access cover assembly. Enter [dC330](#) code 05-206 to check the DADH pre registration sensor, Q05-206, [PL 5.25 Item 1](#). Actuate Q05-206. **The display changes.**

Y N

Refer to [WD 5.1](#). Check Q05-206.

References:

- [GP 11](#) How to Check a Sensor.
- P/J186, [DADH PWB](#).
- [01C](#) +3.3V Distribution PWB.
- [01L](#) 0V Distribution RAP.

Install new components as necessary:

- DADH pre registration sensor, [PL 5.25 Item 1](#).
- DADH PWB, [PL 5.10 Item 5](#).

Remove the DADH rear cover, [PL 5.10 Item 1](#). Hold the DADH cover interlock switch closed, [PL 5.15 Item 11](#). Enter [dC330](#) code 05-099 to check the DADH CVT motor, MOT05-099, [PL 5.25 Item 9](#). **MOT05-099 runs.**

Y N

Go to the [05C](#) DADH Motor Failure RAP.

The CVT roll rotates.

Y N

Perform the steps that follow:

- Check the DADH CVT motor drive belt, [PL 5.25 Item 11](#).
- Check the DADH CVT motor tension spring. Make sure that the DADH CVT motor drive belt tension is correct, [ADJ 5.1](#).
- Check the CVT roll pulley, [PL 5.25 Item 17](#).

If necessary, install a new DADH CVT roll, [PL 5.25 Item 5](#).

The fault only occurs in duplex mode.

Y N
Go to the [Final Checkout](#).

This fault can be caused by the DADH feed motor running too slowly in reverse. Refer to the [05C DADH Motor Failure RAP](#). If the fault continues, go to [Final Checkout](#).

Final Checkout

Perform the steps that follow:

- Check that Q05-206 is installed correctly, [PL 5.25 Item 1](#).
- Make sure that the CVT idler rolls are clean and rotate freely, refer to [ADJ 5.4](#).
- Make sure that the CVT roll is clean, refer to [ADJ 5.4](#).
- Make sure the feed motor drive belt and the DADH CVT motor drive belt are tensioned correctly, [ADJ 5.1](#).

Install new components as necessary:

- DADH CVT roll, [PL 5.25 Item 5](#).
- DADH top access cover assembly, [PL 5.20 Item 17](#).

If the fault continues, make sure that documents correctly exit the previous sensor in the document path. Refer to the [05-350-00](#), [05-352-00](#) DADH CVT Sensor Failure RAP.

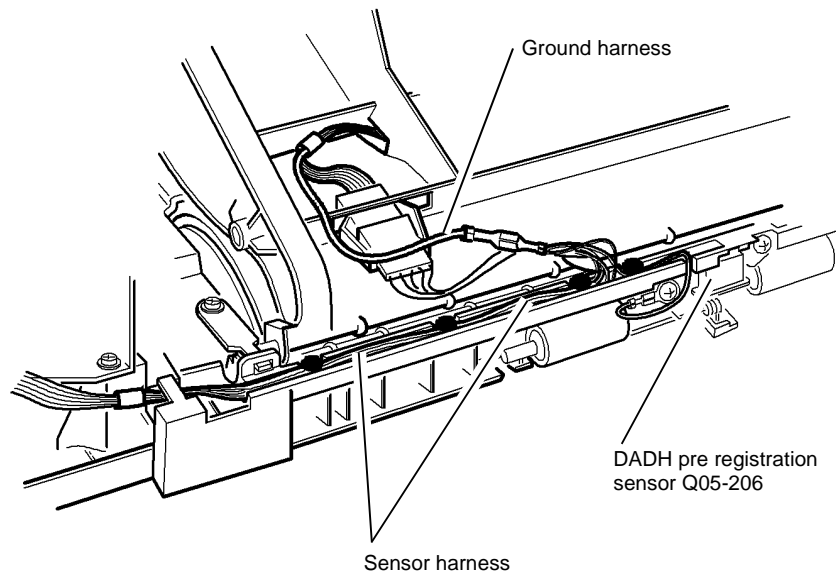

U-1-0037-A

Figure 1 Component location

05-345-00, 05-346-00 DADH Exit Sensor Failure RAP

05-345-00 The DADH exit sensor does not detect the lead edge of the document within the correct time in the forward mode.

05-346-00 The DADH exit sensor does not detect the trail edge of the document within the correct time in the forward mode.

Initial Actions

WARNING

Ensure that the electricity to the machine is switched off while performing tasks that do not need electricity. Refer to [GP 14](#). Disconnect the power cord. Electricity can cause death or injury. Moving parts can cause injury.

- Remove all documents from the DADH exit tray. Raise the DADH, remove all documents that are wound around the CVT roll.
- Make sure that the customer has set the document width guides correctly.

Procedure

NOTE: The DADH exit sensor is a reflective type sensor.

Enter [dC330](#) code 05-209 to check the DADH exit sensor, Q05-209, [PL 5.30 Item 13](#). Raise the DADH. Actuate Q05-209. **The display changes.**

Y N
Refer to [WD 5.2](#). Check Q05-209.
References:

- [GP 11](#) How to Check a Sensor.
- P/J189, [DADH PWB](#).
- [01D +5V](#) Distribution RAP.
- [01L 0V](#) Distribution RAP.

Install new components as necessary:

- DADH exit sensor, [PL 5.30 Item 13](#).
- DADH PWB, [PL 5.10 Item 5](#).

Close the DADH. Open the DADH top cover. Remove the DADH rear cover, [PL 5.10 Item 1](#). Hold the DADH cover interlock switch closed. Enter [dC330](#) code 05-099 to run the DADH CVT motor, MOT05-099, [PL 5.25 Item 9](#). **MOT05-099 runs.**

Y N
Go to the [05C DADH Motor Failure RAP](#).

The CVT roll rotates.

Y N
Perform the steps that follow:

- Check the DADH CVT motor DADH CVT motor drive belt, [PL 5.25 Item 11](#).
- Check the DADH CVT motor tension spring, [PL 5.25 Item 10](#). Make sure the DADH CVT motor drive belt tension is correct, [ADJ 5.1](#).
- Check the CVT roll pulley, [PL 5.25 Item 17](#).

If necessary, install a new DADH CVT roll, [PL 5.25 Item 5](#).

A

NOTE: The exit roll idlers remain lowered for 30 seconds.

Enter **dC330** code 05-100 to energize the DADH duplex solenoid, SOL05-100, **PL 5.30 Item 3**, to lower the exit roll idlers **PL 5.30 Item 6**. **The exit roll idlers lower.**

Y N

Perform the steps that follow:

- Refer to **WD 5.1**. Check SOL05-100.

References:

- **GP 12** How to Check a Solenoid or Clutch.
- P/J181, **DADH PWB** and P/J205.
- **01H** +24V Distribution RAP.
- **01L** 0V Distribution RAP.

- Check the baffle assembly link arm, **PL 5.30 Item 11**. Make sure that the link arm is connected correctly to the DADH duplex solenoid, refer to **REP 5.5**.

Install new components as necessary:

- DADH duplex solenoid, **PL 5.30 Item 3**.
- DADH PWB, **PL 5.10 Item 5**.
- Lower baffle assembly, **PL 5.30 Item 14**.

Enter **dC330** code 05-074 to run the DADH feed motor, MOT05-074, **PL 5.15 Item 16**. **MOT05-074 runs.**

Y N

Go to the **05C** DADH Motor Failure RAP.

The exit roll rotates.

Y N

Perform the steps that follow:

- Check the feed motor drive belt, **PL 5.35 Item 5**.
- Check the feed motor tension spring, **PL 5.15 Item 17**. Check the feed motor drive belt tension, **ADJ 5.1**.
- Check the exit roll and pulley, **PL 5.35 Item 6** and **PL 5.35 Item 15**.

If necessary, install a new DADH input tray assembly, **PL 5.35 Item 1**.

The fault only occurs in duplex mode.

Y N

Go to the **Final Checkout**.

NOTE: During normal operation, the exit roll idlers remain raised (closed) in simplex mode. In duplex mode, the exit roll idlers remain raised unless the document is longer than 280 mm (11 inches). The exit roll idlers raise and lower while feeding longer documents in duplex mode.

Exit diagnostics mode. Close the DADH top cover. Make two copies in duplex mode. Check that the second document is held in the feed rolls, **PL 5.15 Item 1**, until the first document is fed into the output tray. **The feed rolls held the second document.**

Y N

Go to the **05D** DADH Feed Clutch Failure RAP.

Go to the **Final Checkout**.

Final Checkout

Perform the steps that follow:

- For 05-345-00 and 05-346-00 faults:
 - Check that the pre-scan idlers are clean and rotate freely, refer to **ADJ 5.4**.
 - Check that the post-scan idlers are clean and rotate freely, refer to **ADJ 5.4**.
 - Check the CVT ramp assembly for damage and rough edges, **PL 62.10 Item 5**.
 - Check the duplex gate for damage and rough edges, **PL 5.25 Item 12**.
 - Check that the DADH exit sensor, Q05-209 is installed correctly, **PL 5.30 Item 13**.
 - Make sure that the DADH ground harness is connected correctly, **PL 5.10 Item 11**.
 - Make sure the DADH feed motor drive belt and DADH CVT motor drive belt are tensioned correctly, **ADJ 5.1**.

Install new components as necessary:

- Top access cover assembly, **PL 5.20 Item 17**.
 - Lower baffle assembly, **PL 5.30 Item 14**.
 - For 05-346-00 faults:
 - Make sure that the exit rolls are clean and rotate freely, refer to **ADJ 5.4**.
 - Make sure that the exit roll idlers are clean and rotate freely, refer to **ADJ 5.4**.
 - Make sure the tension springs on the exit roll shaft are in the correct position, refer to **REP 5.5**.
 - Check the exit roll static eliminator and ground harness, **PL 5.35 Item 7**.
 - Check the restack arm for damage or rough edges, **PL 5.35 Item 3**.
- Install new components as necessary:
- DADH exit roll, **PL 5.35 Item 6**.
 - DADH input tray assembly, **PL 5.35 Item 1**.

If the fault continues, make sure that all documents correctly exit the previous sensor in the document path. Refer to the **05-340-00** DADH Pre-Reg Sensor Failure RAP.

05-350-00, 05-352-00 DADH CVT Sensor Failure RAP

05-350-00 The DADH CVT sensor does not detect the lead edge of the document within the correct time in the forward mode.

05-352-00 The DADH CVT sensor does not detect the lead edge of the document within the correct time in the reverse mode.

Initial Actions

WARNING

Ensure that the electricity to the machine is switched off while performing tasks that do not need electricity. Refer to [GP 14](#). Disconnect the power cord. Electricity can cause death or injury. Moving parts can cause injury.

Remove all documents from the DADH.

Procedure

NOTE: To get access to the DADH CVT sensor, remove the DADH top cover, [PL 5.20 Item 15](#).

Enter [dC330](#) code 05-097 to check the DADH CVT sensor Q05-097, [PL 5.20 Item 12](#). Actuate Q05-097. **The display changes.**

Y N

Refer to [WD 5.1](#). Check Q05-097.

References:

- [GP 11](#) How to Check a Sensor.
- P/J186 and P/J191, [DADH PWB](#).
- [01C](#) +3.3V Distribution RAP.
- [01L](#) 0V Distribution RAP.

Install new components as necessary:

- DADH CVT sensor, [PL 5.20 Item 12](#).
- DADH PWB, [PL 5.10 Item 5](#).

Remove the DADH rear cover, [PL 5.10 Item 1](#). Hold the DADH cover interlock switch closed, [PL 5.15 Item 11](#). Enter [dC330](#) code 05-099 to check the DADH CVT motor, MOT05-099, [PL 5.25 Item 9](#). **MOT05-099 runs.**

Y N

Go to the [05C](#) DADH Motor Failure RAP.

The CVT roll rotates.

Y N

Perform the steps that follow:

- Check the DADH CVT motor drive belt, [PL 5.25 Item 11](#).
- Check the DADH CVT motor tension spring. Make sure that the DADH CVT motor drive belt tension is correct, [ADJ 5.1](#).
- Check the CVT roll pulley, [PL 5.25 Item 17](#).

If necessary, install a new DADH CVT roll, [PL 5.25 Item 5](#).

The fault only occurs in duplex mode (fault code 05-352-00).

Y N

Go to the [Final Checkout](#).

NOTE: The exit roll idlers remain lowered for 30 seconds.

Enter [dC330](#) code 05-100 to check the DADH duplex solenoid, SOL05-100. Energize SOL05-100 to lower the exit roll idlers, [PL 5.35 Item 6](#). **The exit roll idlers lower.**

Y N

Refer to [WD 5.1](#). Check SOL05-100.

References:

- [GP 12](#) How to Check a Solenoid or Clutch.
- P/J181, [DADH PWB](#).
- [01H](#) +24V Distribution RAP.
- [01L](#) 0V Distribution RAP.

Install new components as necessary:

- DADH duplex solenoid, [PL 5.30 Item 3](#).
- DADH PWB, [PL 5.10 Item 5](#).
- Lower baffle assembly, [PL 5.30 Item 14](#).

NOTE: During normal operation, the exit roll idlers remain raised (closed) in simplex mode. In duplex mode, the exit roll idlers remain raised unless the document is longer than 280 mm (11 inches). The exit roll idlers raise and lower while feeding longer documents in duplex mode.

Exit the diagnostics mode. Close the DADH top cover. Make two copies in duplex mode. Check that the second document is held in the feed rolls until the first document is fed into the output tray. **The feed rolls held the second document.**

Y N

Go to the [05D](#) DADH Feed Clutch Failure RAP.

The fault is caused if the DADH feed motor runs too slowly in reverse, refer to the [05C](#) DADH Motor Failure RAP. If the fault continues, go to the [Final Checkout](#).

Final Checkout

Perform the steps that follow. Install new components as necessary:

- Check that the CVT roll is clean and rotates freely, refer to [ADJ 5.4](#).
- Check the DADH CVT sensor, [PL 5.20 Item 12](#) is installed correctly.
- Check the takeaway roll static eliminator and ground harness, [PL 5.35 Item 7](#).
- Make sure that the DADH ground harness is connected correctly, [PL 5.10 Item 11](#).
- Make sure the feed motor drive belt tension is correct, [ADJ 5.1](#).
- DADH feed assembly, [PL 5.15 Item 18](#).

If the fault continues, make sure that documents correctly exit the previous sensor in the document path. Refer to the [05-335-00](#) DADH TAR Sensor Failure RAP.

05A DADH Other Faults RAP

This RAP gives the additional information on common DADH problems. Perform the RAP for all current fault codes before this RAP is performed.

Procedure

Go to the correct RAP:

- [05B](#) DADH Document Sensor Failure RAP.
- [05C](#) DADH Motor Failure RAP.
- [05D](#) DADH Feed Clutch Failure RAP.
- [05E](#) Damaged Documents RAP.
- [05F](#) Platen Down Failure RAP.

05B DADH Document Sensor Failure RAP

Initial Actions

- Remove all documents from the DADH.
- Clean the DADH document sensor, [PL 5.35 Item 19](#) and the area around the sensor.
- The DADH document sensor can fail to detect the last document in a document set if static electricity is on the input tray. If necessary, clean the input tray with antistatic fluid, refer to [ADJ 5.4](#).

Procedure

WARNING

Ensure that the electricity to the machine is switched off while performing tasks that do not need electricity. Refer to [GP 14](#). Disconnect the power cord. Electricity can cause death or injury. Moving parts can cause injury.

Enter [dC330](#) code 05-102 to check the DADH document sensor, Q05-102, [PL 5.35 Item 19](#).

The display changes.

Y N

Refer to [WD 5.1](#). Check Q05-102.

References:

- [GP 11](#) How to Check a Sensor.
- P/J184, [DADH PWB](#).
- [01D](#) +5V Distribution RAP.
- [01L](#) 0V Distribution RAP.

Install new components as necessary:

- DADH document sensor, [PL 5.35 Item 19](#).
- DADH PWB, [PL 5.10 Item 5](#).

If the problem continues, install new components as necessary:

- DADH document sensor, [PL 5.35 Item 19](#).
- DADH PWB, [PL 5.10 Item 5](#).

05C DADH Motor Failure RAP

Procedure

WARNING

Ensure that the electricity to the machine is switched off while performing tasks that do not need electricity. Refer to [GP 14](#). Disconnect the power cord. Electricity can cause death or injury. Moving parts can cause injury.

Go to the correct procedure:

- [DADH Feed Motor Failure](#)
- [DADH CVT Motor Failure](#)

DADH Feed Motor Failure

NOTE: In duplex mode, the DADH feed motor runs in the forward and reverse direction. The duplex mode component control code is provided to reverse the drive of the feed motor.

NOTE: When referring to [WD 5.1](#), the Motor on (pulses) +24V indicated on PJ204, will read +12V on a digital meter.

Refer to [WD 5.1](#). Check the DADH feed motor, MOT05-074, [PL 5.15 Item 16](#).

References:

- [GP 10](#) How to Check a Motor.
- P/J181, [DADH PWB](#) and P/J204.
- [01H](#) +24V Distribution RAP.
- [01L](#) 0V Distribution RAP.

Install new components as necessary:

- DADH feed motor, [PL 5.15 Item 16](#).
- DADH PWB, [PL 5.10 Item 5](#).

DADH CVT Motor Failure

Refer to [WD 5.1](#). Check the DADH CVT motor, MOT05-099, [PL 5.25 Item 9](#).

NOTE: When referring to [WD 5.1](#), the Motor on (pulses) +24V indicated on PJ203, will read +12V on a digital meter.

References:

- [GP 10](#) How to Check a Motor.
- P/J181, [DADH PWB](#) and P/J203.
- [01H](#) +24V Distribution RAP.
- [01L](#) 0V Distribution RAP.

Install new components as necessary:

- DADH CVT motor, [PL 5.25 Item 9](#).
- DADH PWB, [PL 5.10 Item 5](#).

05D DADH Feed Clutch Failure RAP

Use this RAP when the DADH feed clutch does not operate correctly.

Also use this RAP if the feed clutch energizes at the wrong time in duplex mode, which causes:

- Mis-feeds.
- The feed rolls to reverse and eject the original documents into the DADH input tray.

Procedure

WARNING

Ensure that the electricity to the machine is switched off while performing tasks that do not need electricity. Refer to [GP 14](#). Disconnect the power cord. Electricity can cause death or injury. Moving parts can cause injury.

Refer to [WD 5.1](#). Check the DADH feed clutch, CL05-062, [PL 5.15 Item 9](#).

References:

- [GP 12](#) How to Check a Solenoid or Clutch.
- P/J183, [DADH PWB](#) and P/J202.
- [01H](#) +24V Distribution RAP.
- [01L](#) 0V Distribution RAP.

Install new components as necessary:

- DADH feed clutch, [PL 5.15 Item 9](#), or the alternative DADH feed clutch and spacer kit *W/TAG D-005*, [PL 5.15 Item 28](#).
- DADH PWB, [PL 5.10 Item 5](#).
- DADH feed assembly, [PL 5.15 Item 18](#).

05E Damaged Documents RAP

Use this RAP if the documents get damaged by the DADH.

Procedure

WARNING

Ensure that the electricity to the machine is switched off while performing tasks that do not need electricity. Refer to GP 14. Disconnect the power cord. Electricity can cause death or injury. Moving parts can cause injury.

Perform the steps that follow:

1. If the DADH damages the underside of the documents mid-way along the lead edge, install a new feed roll assembly, PL 5.15 Item 1.
2. ADJ 5.2 DADH height adjustment.
3. Check the input tray for damage, PL 5.35 Item 1.
 - Make sure that the document width guides move freely.
 - Check that the takeaway roll assembly, PL 5.35 Item 17 and exit roll assembly, PL 5.35 Item 6 for damage and contamination, refer to ADJ 5.4.
 - Check the restack arm for damage, PL 5.35 Item 3.
4. Open the DADH top access cover assembly, PL 5.20 Item 17.
 - Check the document path for damage.
 - Check the takeaway roll idlers and CVT roll idlers, PL 5.20 Item 3 for damage. Make sure the idlers are clean and rotate freely, refer to ADJ 5.4.
5. Raise the DADH. Lower the baffle assembly, Figure 1.
 - Remove any pieces of paper.
 - Check the duplex gate, PL 5.25 Item 12 for damage. Make sure the duplex gate moves freely.
 - Check the CVT roll, PL 5.25 Item 5 for damage. If necessary, clean the CVT roll, ADJ 5.4.
 - Check the pre-scan idlers, PL 5.25 Item 6 and post scan idlers, PL 5.30 Item 4 for damage. Make sure the idlers are clean and rotate freely, refer to ADJ 5.4.
 - Check the document path for damage.
 - Check the baffle assembly, PL 5.30 Item 14 for damage.
 - Check the exit roll idlers for damage, PL 5.30 Item 6. Make sure the idlers are clean and rotate freely, ADJ 5.4.
6. Check the CVT ramp assembly, PL 62.10 Item 5 for damage.
7. Make sure that the customers documents are within the specification, refer to GP 20.

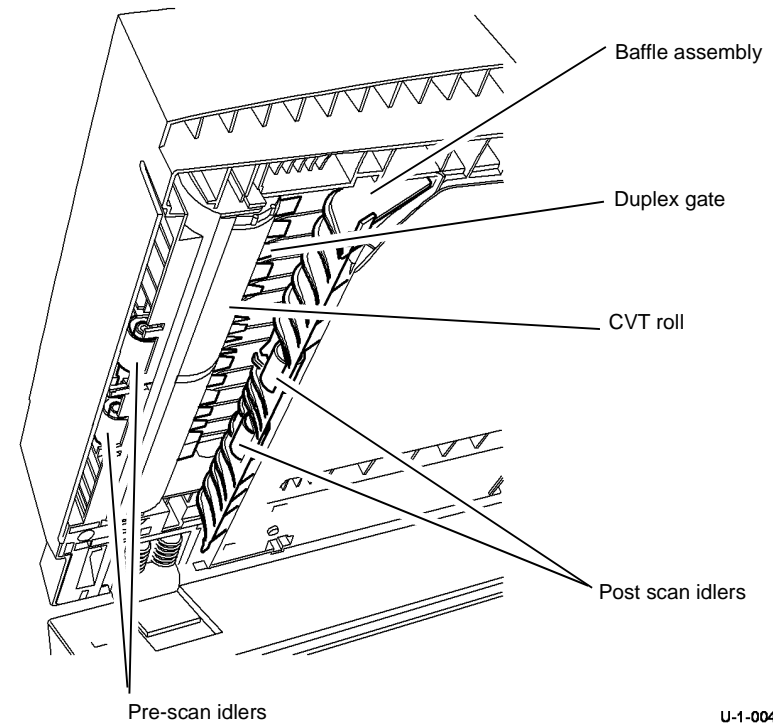

U-1-0046-A

Figure 1 Component location

05F Platen Down Failure RAP

Use this RAP when the platen down sensor does not respond to opening and closing the DADH.

Procedure

Go to [05-300-00](#) DADH Open RAP.

10-110-00 to 10-113-00, 10-125-00 to 10-128-00, 10-147-00, 10-148-00 Post Transfix Jam RAP

10-110-00 Timing sensor 11 detects that the sheet is too long.

10-111-00 Timing sensor 11 detects that the sheet is too short.

10-112-00 The lead edge is late to timing sensor 11.

10-113-00 The trail edge is late from timing sensor 11.

10-125-00 Timing sensor 12 detects that the sheet is too long.

10-126-00 Timing sensor 12 detects that the sheet is too short.

10-127-00 The lead edge was late to timing sensor 12.

10-128-00 The trail edge was late from timing sensor 12.

10-147-00 The lead edge is early to timing sensor 11.

10-148-00 The lead edge is early to timing sensor 12.

Initial Actions

WARNING

Ensure that the electricity to the machine is switched off while performing tasks that do not need electricity. Refer to [GP 14](#). Disconnect the power cord. Electricity can cause death or injury. Moving parts can cause injury.

WARNING

Do not clean the stripper blade. The stripper blade is very sharp and can cause injury. If the stripper blade is dirty a new blade must be installed.

WARNING

Take care during this procedure. Sharp edges may be present that can cause injury.

- Check that the media loaded into the trays matches the UI display.
- Check for obstructions in the paper path.
- Check the jam clearance guide 3b is latched correctly, [PL 10.12 Item 1](#).
- Ensure that the springs for both the front and rear latch forks, [PL 10.10 Item 14](#), are not broken or fallen off.
- Ensure that the springs are orientated the correct way. The longer end hook of the spring should be hooked from under the stripper cam, [PL 10.10 Item 18](#).
- If the displayed fault code is 10-112-00, check the transfix stripper blade, [PL 10.20 Item 14](#) for damage. Refer to [REP 10.6](#) Transfix Blade. Install new components as required.
- Go to [dC135](#) CRU/HFSI Status. Check the count of the transfix stripper. If the count is near end of life, install a new transfix stripper blade, [PL 10.20 Item 14](#).
- If the displayed fault code is 10-112-00, check the drum stripper blade assembly, [PL 10.12 Item 3](#) for damage or contamination. Refer to [REP 10.21](#) Stripper Blade, Gate and Baffle. Install new components as required.
- Check for multifeeds. If there are multifeeds, refer to the [OF 8](#) Multifeed RAP.

- If glossy media is used, instruct the customer to feed the media from the bypass tray and select glossy for the media type.

Procedure

Refer to [Figure 1](#). Lower the drum stripper gate and baffle assembly, [GP 31](#). Check that the stripper blade shaft is installed correctly. Slide the shaft forwards and backwards and feel for the shaft to engage on the detent. Raise the stripper blade into the operating position. Check that the stripper blade shaft lock is engaging correctly at the front and rear. **The stripper blade latch mechanism is good.**

Y N

Install new stripper components as necessary, [PL 10.10](#), [PL 10.12](#).

Check the drum stripper blade timing. Print three copies of [TP 14](#) Drum Stripper Blade Test Page. **Stripper blade timing is good.**

Y N

Check the stripper solenoid SOL10-021 [PL 10.10 Item 3](#). Refer to [10-570-00](#) Stripper Solenoid Over Current RAP.

Cheat the front door interlock. Enter [dC330](#) code 10-018 to run the post transfix motor (M4), [PL 10.10 Item 5](#). **The motor runs.**

Y N

Refer to [WD 8.2](#). Check the post transfix motor (M4). Refer to:

- [GP 10](#) How to Check a Motor.
- PJ303, [Media path driver PWB](#).
- [01J](#) +50V Distribution RAP.
- [01L](#) 0V Distribution RAP.

Install new components as necessary:

- Post transfix motor (M4), [PL 10.10 Item 5](#).
- Media path driver PWB, [PL 1.15 Item 5](#).

Observe roller drive J, [PL 10.10 Item 1](#) and roller drive L, [PL 10.10 Item 2](#). **The rollers rotate.**

Y N

Check the gear drive, drive gears and roller drives, [PL 10.10](#).

If necessary, install new components:

- Drive gears, [PL 10.10 Item 13](#).
- Gear drive, [PL 10.10 Item 4](#).
- Roller drive J, [PL 10.10 Item 1](#).
- Roller drive L, [PL 10.10 Item 2](#).

Unlatch the stripper gate, [GP 31](#). Enter [dC330](#) code 10-015, post transfix sensor (11), Q10-015, [PL 10.10 Item 6](#). Manually actuate Q10-015. **The display changes.**

Y N

Refer to [WD 9.3](#). Check the post transfix sensor (11), Q10-015. Refer to:

- [GP 11](#) How to Check a Sensor.
- PJ802, [Drum driver PWB](#).
- [01D](#) +5V Distribution RAP.
- [01L](#) 0V Distribution RAP.

A

A

Install new components as necessary:

- Post transfix sensor (11), [PL 10.10 Item 6](#).
- Drum driver PWB, [PL 1.15 Item 4](#).

Enter [dC330](#) code 10-016 pre exit sensor (12), Q10-016, [PL 10.10 Item 6](#). Manually actuate Q10-016. **The display changes.**

Y N

Refer to [WD 9.3](#). Check the pre exit sensor (12), Q10-016. Refer to:

- [GP 11](#) How to Check a Sensor.
- PJ801, [Drum driver PWB](#).
- [01D](#) +5V Distribution RAP.
- [01L](#) 0V Distribution RAP.

Install new components as necessary:

- Pre exit sensor (12), [PL 10.10 Item 6](#).
- Drum driver PWB, [PL 1.15 Item 4](#).

Enter [dC330](#) code 82-007 to energize the nip C release solenoid, SOL82-007, [PL 82.15 Item 4](#). **SOL82-007 energizes.**

Y N

Refer to [WD 8.1](#). Check the nip C release solenoid, SOL82-007. Refer to:

- [GP 12](#) How to Check a Solenoid or Clutch.
- PJ303, [Media path driver PWB](#).
- [01J](#) +50V Distribution RAP.
- [01L](#) 0V Distribution RAP.

Install new components as necessary:

- Nip C release solenoid, [PL 82.15 Item 4](#).
- Media path driver PWB, [PL 1.15 Item 5](#).

Enter [dC330](#) code 82-008 to energize the nip D release solenoid, SOL82-008, [PL 70.30 Item 13](#), **SOL82-008 energizes.**

Y N

Refer to [WD 8.3](#). Check the nip D release solenoid, SOL82-008. Refer to:

- [GP 12](#) How to Check a Solenoid or Clutch.
- PJ405, [Media path driver PWB](#).
- [01J](#) +50V Distribution RAP.
- [01L](#) 0V Distribution RAP.

Install new components as necessary:

- Nip D release solenoid, [PL 70.30 Item 13](#).
- Media path driver PWB, [PL 1.15 Item 5](#).

Re-enter the [dC330](#) codes 82-007 and 82-008. Check that nip C and nip D open fully and close fully when the solenoids energize and de-energize. **The nips operate correctly.**

Y N

Check for obstructions. Install new components as necessary:

- Horizontal paper path components, [PL 82.15](#).
- Left hand upper door components, [PL 70.30](#).

B

Status Indicator RAPs

10-110-00 to 10-113-00, 10-125-00 to 10-128-00, 10-

B

Run [dC625](#) Registration / Preheat Calibration. If the fault persists, check the following:

- Roller drive J, [PL 10.10 Item 1](#).
- Roller drive L, [PL 10.10 Item 2](#).
- Gear drive, [PL 10.10 Item 4](#).

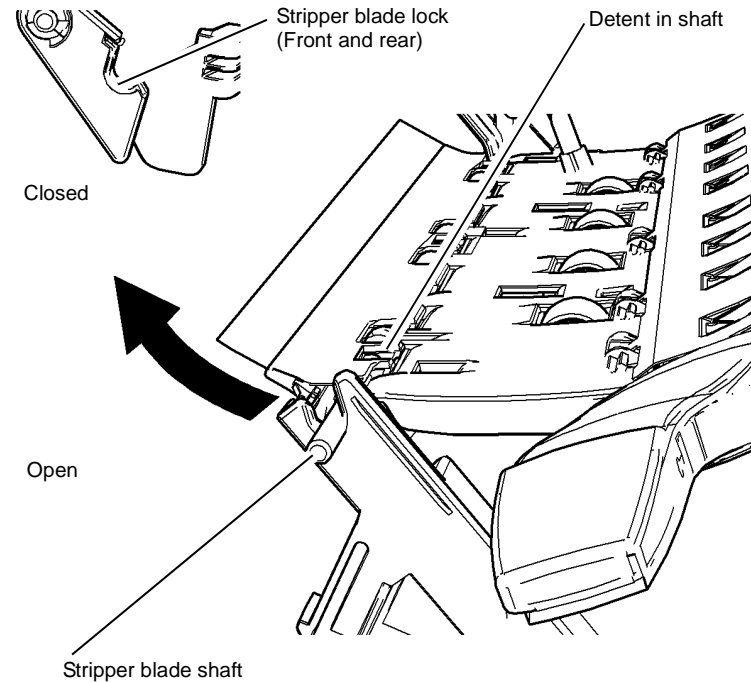

U-1-0977-A

Figure 1 Component Location

10-140-00 to 10-146-00, 10-149-00 to 10-151-00 Exit Jam RAP

10-140-00 Timing sensor 15 detects that the sheet is too long.

10-141-00 Timing sensor 15 detects that the sheet is too short.

10-142-00 Timing sensor 15 detects that the sheet is too long after invert.

10-143-00 Timing sensor 15 detects that the sheet is too short after invert.

10-144-00 The lead edge is late to timing sensor 15.

10-145-00 The trail edge is late from timing sensor 15.

10-146-00 The lead edge is late to timing sensor 15 after invert.

10-149-00 The lead edge is early to timing sensor 15.

10-150-00 The lead edge is early to timing sensor 15 after invert.

10-151-00 The trail edge is late from timing sensor 15 after invert.

Initial Actions

WARNING

Ensure that the electricity to the machine is switched off while performing tasks that do not need electricity. Refer to [GP 14](#). Disconnect the power cord. Electricity can cause death or injury. Moving parts can cause injury.

- Check that the media loaded into the trays matches the UI display.
- Check for obstructions in the paper path.
- Check the jam clearance guide 3b and 4a are latched correctly
- Check for multifeeds. If there are multifeeds, refer to the [OF 8](#) Multifeed Rap.
- If glossy media is used, instruct the customer to feed the media from the bypass tray and select glossy for the media type.

Procedure

Cheat the front door interlock. Enter [dC330](#) code 10-017 exit sensor (15), Q10-017, [PL 10.15 Item 3](#). Raise and lower handle 4a to actuate Q10-017. **The display changes.**

- Y N**
- Refer to [WD 8.5](#). Check Q10-017. Refer to:
- [GP 11](#) How to Check a Sensor.
 - PJ905, [Media path driver PWB](#).
 - [01D](#) +5V Distribution RAP.
 - [01L](#) 0V Distribution RAP.
- Install new components as necessary:
- Exit sensor (15), [PL 10.15 Item 3](#).
 - Media path driver PWB, [PL 1.15 Item 5](#).

A

Enter [dC330](#) code 83-006 exit duplex diverter solenoid, SOL83-006, [PL 10.15 Item 14](#). Press Start. **SOL83-006 energizes.**

- Y N**
- Refer to [WD 8.1](#). Check SOL83-006. Refer to:
- [GP 12](#) How to Check a Solenoid or Clutch.
 - PJ303, [Media path driver PWB](#).
 - [01J](#) +50V Distribution RAP.
 - [01L](#) 0V Distribution RAP.
- Install new components as necessary:
- Exit / duplex diverter solenoid, [PL 10.15 Item 14](#).
 - Media path driver PWB, [PL 1.15 Item 5](#).

The diverter gate moves and retracts freely within one second.

- Y N**
- Check the operation and condition of the diverter gate. If necessary install new diverter gate components, [PL 10.15](#), or install a new exit paper path assembly, [PL 10.15 Item 19](#), as necessary.

Enter [dC330](#) code 10-018 Post transfix motor (M4) MOT10-018. **MOT10-018 runs.**

- Y N**
- Refer to [WD 8.2](#). Check MOT10-018. Refer to:
- [GP 10](#) How to Check a Motor.
 - PJ303, [Media path driver PWB](#).
 - [01J](#) +50V Distribution RAP.
 - [01L](#) 0V Distribution RAP.
- Install new components as necessary:
- Post transfix motor (M4), [PL 10.10 Item 5](#).
 - Media path driver PWB, [PL 1.15 Item 5](#).

Enter [dC330](#) code 83-001 exit motor (M5), MOT83-001. **MOT83-001 runs.**

- Y N**
- Refer to [WD 8.2](#). Check MOT83-001. Refer to:
- [GP 10](#) How to Check a Motor.
 - PJ303, [Media path driver PWB](#).
 - [01J](#) +50V Distribution RAP.
 - [01L](#) 0V Distribution RAP.
- Install new components as necessary:
- Exit motor (M5), [PL 10.15 Item 11](#).
 - Media path driver PWB, [PL 1.15 Item 5](#).

The exit paper path rolls rotate.

- Y N**
- Check the drive belt, pulleys and drive gears on the exit paper path assembly, [PL 10.15](#). If necessary, install new components:
- Roller nip N, [PL 10.15 Item 1](#).
 - Roller nip P, [PL 10.15 Item 6](#).
 - Pulley 3 mm driven, [PL 10.15 Item 7](#).

A

B

B

- Belt 3 mm (112T), [PL 10.15 Item 8](#).
- Belt 3 mm (92T), [PL 10.15 Item 9](#).
- Pulley 3 mm (21T one way), [PL 10.15 Item 10](#).
- Drive gear, [PL 10.15 Item 12](#).

Check the following:

- The bearings, shafts and rolls on the exit paper path assembly, [PL 10.15](#).
- Roller nip N, [PL 10.15 Item 1](#).
- Roller drive L, [PL 10.10 Item 2](#).
- Roller nip P, [PL 10.15 Item 6](#).

10-500-00 to 10-540-00 Transfix Error RAP

10-500-00 Insufficient force is detected by the front transfix flexure encoder.

10-505-00 Insufficient force is detected by the rear transfix flexure encoder.

10-511-00 The transfix load timing error.

10-512-00 Transfix unloading is not detected in time.

10-516-00 Transfix flexure encoder reading does not change during transfix homing (for possible future use).

10-517-00 Transfix out of position during unload (for possible future use).

10-521-00 Transfix load front position error.

10-522-00 Transfix load rear position error.

10-523-00 Transfix unload front position error.

10-524-00 Transfix unload rear position error.

10-525-00 Transfix motor failure.

10-530-00 Transfix gap set failure.

10-535-00 The transfix load gain/offset calibration is inconsistent with expected value.

10-536-00 Transfix calibration NVM reset error.

10-537-00 The front transfix flexure encoder did not reach home position on time.

10-538-00 The rear transfix flexure encoder did not reach home position on time.

10-540-00 The transfix task was late.

Initial Actions

WARNING

Ensure that the electricity to the machine is switched off while performing tasks that do not need electricity. Refer to GP 14. Disconnect the power cord. Electricity can cause death or injury. Moving parts can cause injury.

Ensure that the ground wire is connected at the front of the transfix roller.

Procedure

Enter [dC978](#) Transfix Calibration Values. Check the calibration values against the label on the front of the drum frame, [Figure 1](#). **The calibration values match.**

Y N

Enter the correct transfix load values in NVM. Run test prints to verify that the problem is corrected. Perform [SCP 5](#) Final Actions.

A

A

Switch off the machine, [GP 14](#). Use a screwdriver to manually rotate the transfix gear, [Figure 2](#). This action will move the transfix roller. Move the transfix roller onto, then off the drum. Perform the action at the front and rear.

- Check that the transfix mechanisms operate smoothly. Watch for the transfix roller or encoder moving up and down. Check that the effort to move the front and rear transfix mechanisms is similar.

NOTE: The transfix motors will give some resistance to movement. If the transfix mechanisms move without any resistance, this indicates a problem.

- While the transfix roller is away from the drum, spin the roller. Check that the roller spins freely without binding or generating unusual noise.
- Check that the gear train and the transfix bearings are good. Check for excessive movement between the linkage arm and the pin. This is caused by missing or worn bushing inside the front or rear transfix linkage assembly, [PL 10.20 Item 8](#) and [PL 10.20 Item 10](#).

The transfix components are good.

Y N

Install new transfix components as necessary, [PL 10.20](#).

Switch on the machine, [GP 14](#). Check [dC123](#) PEST Fault History if a fault is displayed. Enter [dC140](#) Analog Monitor. Use a screwdriver to manually rotate the front and rear transfix gears. Monitor all encoders:

- 10-010 Rear transfix flexure encoder.
- 10-011 Rear transfix motor encoder.
- 10-012 Front transfix flexure encoder.
- 10-013 Front transfix motor encoder.
- Manually move the front and rear flexure encoder harness wires. A good encoder is indicated by a value between 5 and 100 ticks.

If more than 100 ticks, check for loose encoder or intermittent short.

If less than 5 ticks, check for open or missing code strip.

Repair the harness as required, [REP 1.1](#).

The display changes for all encoders.

Y N

Refer to [WD 9.1](#) and [WD 9.3](#). Check and the wiring between the drum driver PWB and the relevant transfix flexure motor encoder. Repair as necessary. [REP 1.1](#). Refer to:

- PJ 401, PJ 501, PJ 801, [Drum Driver PWB](#).
- [01D](#) +5V Distribution RAP
- [01L](#) 0V Distribution RAP

If the wiring is good, install new components as necessary:

- Transfix flexure encoder, [PL 10.20 Item 5](#).
- Transfix motor, [PL 10.20 Item 11](#).
- Drum driver PWB, [PL 1.15 Item 4](#).

Enter [dC330](#) codes 10-019 and 10-020 to run the front and rear transfix motors. When the motors run the transfix drive arms will move up and down approximately 10 times. **The motors run.**

Y N

Refer to [WD 9.1](#). Check the relevant motor. Refer to:

- [GP 10](#) How to Check a Motor.

B

B

- PJ401, [Drum driver PWB](#).
- [01J](#) +50V Distribution RAP.
- [01L](#) 0V Distribution RAP.

Install new components as necessary:

- Transfix motor, [PL 10.20 Item 11](#).
- Drum driver PWB, [PL 1.15 Item 4](#).

Enter [dC962](#) Transfix Load Test and run the test. **The transfix load test passed.**

Y N

If errors are indicated, check out the fault description displayed.

If the fault still occurs, perform the following:

1. For fault codes 10-500 or 10-505, make sure that the relevant transfix encoder screws are tight and the relevant transfix encoder is secured to the frame.
2. Recheck the fault code description, use it to aid in identifying which link assembly is at fault. Inspect for worn or damaged gears and check for a cracked linkage. Install new components as necessary:
 - Front compound gear, [PL 10.20 Item 7](#).
 - Front transfix linkage assembly, [PL 10.20 Item 8](#).
 - Rear compound gear, [PL 10.20 Item 9](#).
 - Rear transfix linkage assembly, [PL 10.20 Item 10](#).
3. Check the transfix roll ground wire, refer [GP 7](#) System Grounding Verification.

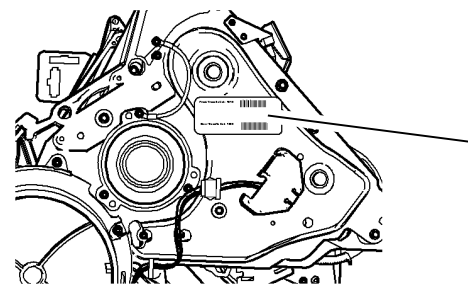

Calibration label for front and rear transfix values

Figure 1 Calibration label

U-1-1294-A

10-545-00 Drum Position Error for Transfix RAP

10-545-00 The drum was not at the correct position to start the transfix operation.

Initial Actions

WARNING

Ensure that the electricity to the machine is switched off while performing tasks that do not need electricity. Refer to [GP 14](#). Disconnect the power cord. Electricity can cause death or injury. Moving parts can cause injury.

CAUTION

Use care when working near the drum. The drum can be damaged easily, which will cause print quality defects.

- Switch off, then switch on the machine, [GP 14](#).
- Check for damage or debris that restricts drum or drum encoder movement.

Procedure

Install a new IME Controller PWB, [PL 92.10 Item 1](#).

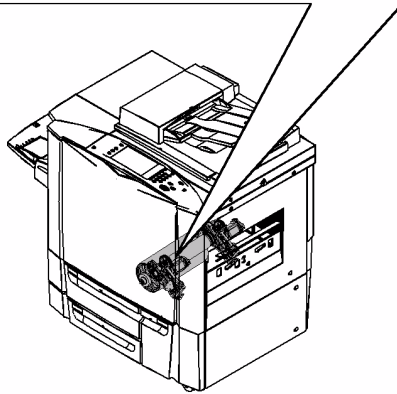
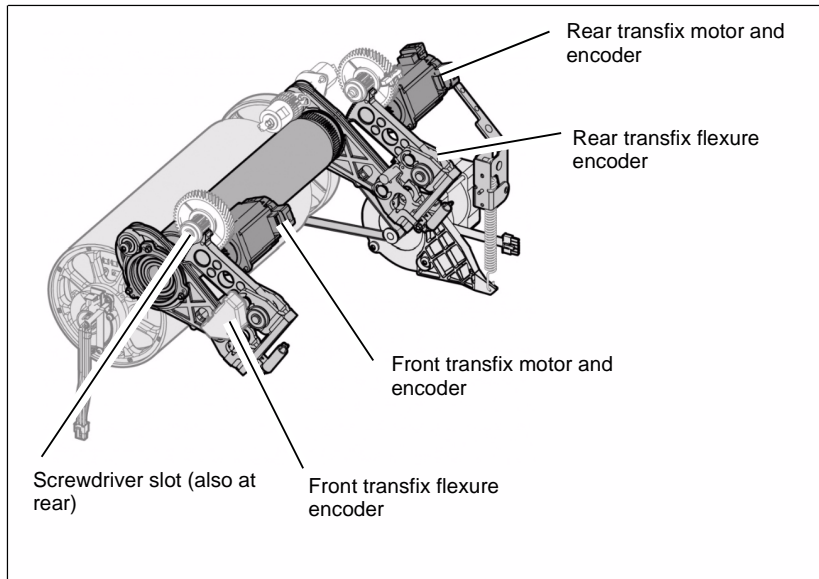

U-1-0978-A

Figure 2 Transfix component locations

10-550-00 Drum Stall During Transfix RAP

10-550-00 The drum stalled during transfix.

Initial Actions

Check that the print media loaded into all of the trays matches the UI display for each tray. If necessary correct the settings or load the correct media.

NOTE: Media that is too thick will cause drive errors if the machine is not expecting thick media. For media specification refer to [GP 20](#)

Procedure

Perform the following:

1. [GP 7](#) System Ground Check.
2. [dC625](#) Registration / Preheat Calibration.
3. If the fault remains, go to the [94-534-0094-526-00](#) Drum Drive Belt Slip RAP.

10-555-00 Post Transfix Motor (M4) Over Current RAP

10-555-00 The post transfix motor M4 is taking too much current.

Procedure

WARNING

Ensure that the electricity to the machine is switched off while performing tasks that do not need electricity. Refer to [GP 14](#). Disconnect the power cord. Electricity can cause death or injury. Moving parts can cause injury.

Manually rotate roller drives J and L, [Figure 1](#). Check that the rollers rotate freely and are free of defects or debris. **The rollers are good.**

Y N

Clean the rollers, [GP 27](#) or install new rollers [PL 10.10 Item 1](#) and [PL 10.10 Item 2](#).

Enter [dC330](#) 10-018 to run the post transfix motor (M4), (MOT10-018), [PL 10.10 Item 5](#). **The motor runs.**

Y N

Refer to [WD 8.2](#). Check the post transfix motor (M4). Refer to:

- [GP 10](#) How to Check a Motor.
- PJ303, [Media path driver PWB](#).
- [01J](#) +50V Distribution RAP.
- [01L](#) 0V Distribution RAP.

Install new components as necessary:

- Post transfix motor (M4), [PL 10.10 Item 5](#)
- Media path driver PWB, [PL 1.15 Item 5](#).

If the error persists, install new components as necessary.

- Post transfix motor (M4), [PL 10.10 Item 5](#)
- Roller drive J, [PL 10.10 Item 1](#).
- Roller drive L, [PL 10.10 Item 2](#).

10-560-00, 10-565-00 Transfix Motor Over Current RAP

10-560-00 Front transfix motor over current.

10-565-00 Rear transfix motor over current.

Procedure

Refer to the [10-500-00 to 10-540-00](#) Transfix Error RAP.

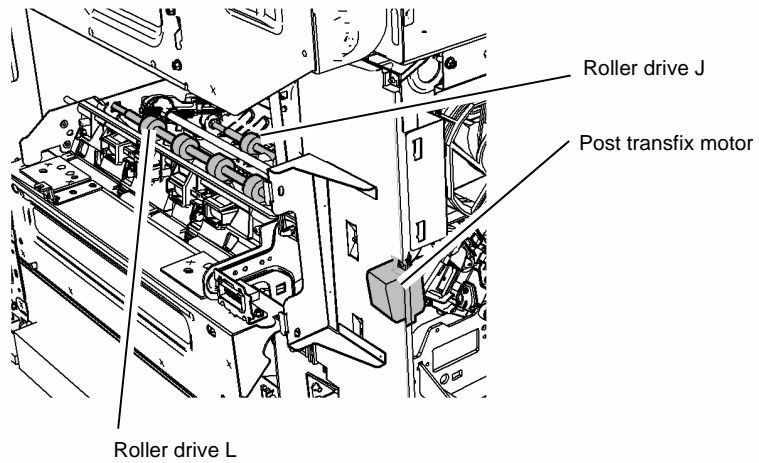

U-1-0980-A

Figure 1 Component location

10-570-00 Stripper Solenoid Over Current RAP

10-570-00 Stripper solenoid over current.

Initial Actions

WARNING

Ensure that the electricity to the machine is switched off while performing tasks that do not need electricity. Refer to [GP 14](#). Disconnect the power cord. Electricity can cause death or injury. Moving parts can cause injury.

WARNING

Take care during this procedure. The stripper blade is very sharp and can cause injury.

WARNING

Do not clean the stripper blade. The stripper blade is very sharp and can cause injury. If the stripper blade is dirty a new blade must be installed.

- Check the harness leading to the stripper solenoid, [PL 10.10 Item 3](#).

Procedure

Refer to [Figure 1](#). Lower the stripper gate and baffle assembly, [GP 31](#). Check that the stripper blade shaft is installed correctly. Slide the shaft forwards and backwards and feel for the shaft to engage on the detent. Raise the stripper blade into the operating position. Check that the stripper blade shaft lock is engaging correctly at the front and rear. **The stripper blade latch mechanism is good.**

Y N

Install new stripper components as necessary, [PL 10.10](#), [PL 10.12](#).

Enter [dC330](#) code 10-021 to energize the stripper solenoid, SOL10-021, [PL 10.10 Item 3](#).

The solenoid energizes.

Y N

Refer to [WD 9.2](#). Check the stripper solenoid. Refer to:

- [GP 12](#), How to Check a Solenoid.
- [P/J601](#), [Drum driver PWB](#).
- [01J](#) +50V Distribution RAP.
- [01L](#) 0V Distribution RAP.

Install new components as necessary:

- Stripper solenoid assembly, [PL 10.10 Item 3](#).
- Drum driver PWB, [PL 1.15 Item 4](#).

Check for obstructions that could prevent the stripper solenoid from engaging the stripper blade. Install new components as necessary, [PL 10.10](#), [PL 10.12](#).

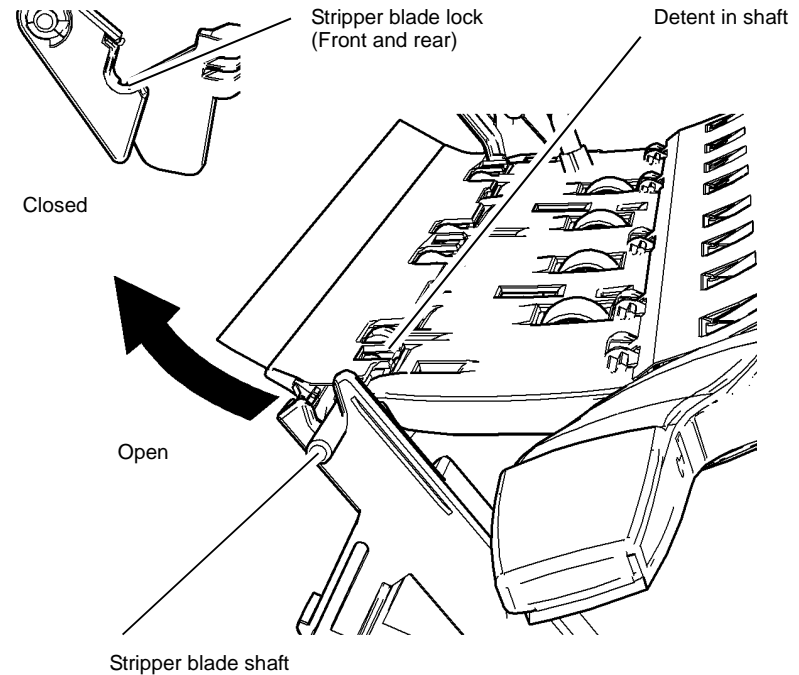

U-1-1644-A

Figure 1 Component location

10-571-00, 10-572-00 Stripper Latch Sensor Error RAP

10-571-00 Stripper latch sensor time out.

10-572-00 Stripper latch bad sensor state.

Initial Actions

WARNING

Ensure that the electricity to the machine is switched off while performing tasks that do not need electricity. Refer to [GP 14](#). Disconnect the power cord. Electricity can cause death or injury. Moving parts can cause injury.

WARNING

Take care during this procedure. The stripper blade is very sharp and can cause injury.

WARNING

Do not clean the stripper blade. The stripper blade is very sharp and can cause injury. If the stripper blade is dirty a new blade must be installed.

- Unlatch, then fully latch the stripper blade, [GP 31](#).

Procedure

Enter the [dC330](#) code 10-014 to monitor the stripper latch sensor, [PL 10.10 Item 17](#). Stack [dC330](#) code 10-023 to run the post transfix motor (M4), [PL MOT10-018](#), [PL 10.10 Item 5](#) in reverse to latch the stripper gate. **MOT10-018 runs.**

Y N

Refer to [WD 8.2](#). Check MOT10-018. Refer to:

- [GP 10](#), How to Check a Motor.
- P/J303, [Media Path Driver PWB](#).
- [01J](#) +50V Distribution RAP.
- [01L](#) 0V Distribution RAP.

Install new components as necessary:

- Post transfix motor (M4), [PL 10.10 Item 5](#).
- Media path driver PWB, [PL 1.15 Item 5](#).

Stack the code 10-025 to run the post transfix motor (M4) to unlatch the stripper gate. **The sensor display changes.**

Y N

Remove the post transfix motor (M4) and the gear drive, refer to [REP 10.8](#). Check for damage. **The gear drive is good.**

Y N

Install new components as necessary, [PL 10.10](#).

Refer to [WD 9.3](#). Check the stripper latch sensor, Q10-014. Refer to:

- [GP 11](#), How to Check a Sensor
- P/J801 [Drum driver PWB](#).
- [01B](#) +3.3V ESTAR Distribution RAP.
- [01L](#) 0V Distribution RAP.

Install new components as necessary:

- Stripper latch sensor, [PL 10.10 Item 17](#).

A

- Drum driver PWB, [PL 1.15 Item 4](#).

Check all components in the stripper system for damage, [PL 10.10](#). Pay special attention to:

- Front latchfork, [PL 10.10 Item 11](#)
 - Back latchfork, [PL 10.10 Item 12](#).
 - Return spring, [PL 10.10 Item 14](#).
 - Stripper latch cam, [PL 10.10 Item 15](#).
- Install new components as necessary, [PL 10.10](#).

12-701-00-65 Offset Catch Tray Failure RAP

12-701 The offset catch tray (OCT) fails to offset the paper stack.

Initial Actions

WARNING

Ensure that the electricity to the machine is switched off while performing tasks that do not need electricity. Refer to GP 14. Disconnect the power cord. Electricity can cause death or injury. Moving parts can cause injury.

- Check that the offset catch tray is correctly installed and there is no obstruction to prevent movement between offset positions. If the tray is damaged, install a new OCT PL 12.00 Item 1.

Procedure

1. Go to WD 12.23, check the OCT wiring.
2. Repair the wiring or install a new OCT, PL 12.00 Item 1.
3. Switch off the machine, then switch on the machine, GP 14.
4. Check the OCT feed offset motor, Figure 1.
5. Check the gears and rack for damage, rotational failure and foreign material.
6. Check the OCT index sensor, Figure 1.
7. Check the OCT tray 90% full sensor, Figure 1.
8. Check the communication link between the OCT and the media path driver board PWB, WD 8.5 and WD 12.23.
9. Check the sensor actuator.

If necessary, install new components:

- OCT module, PL 12.00 Item 1
- Media path driver PWB, PL 1.15 Item 5.

Perform SCP 5 Final Actions.

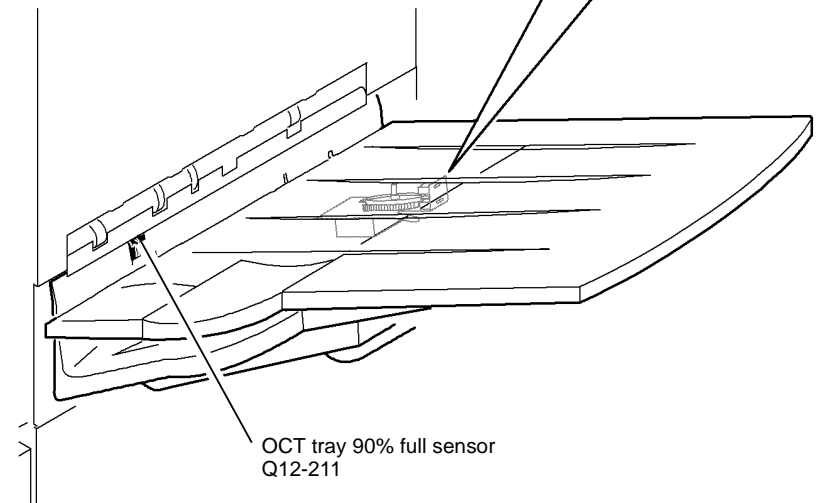
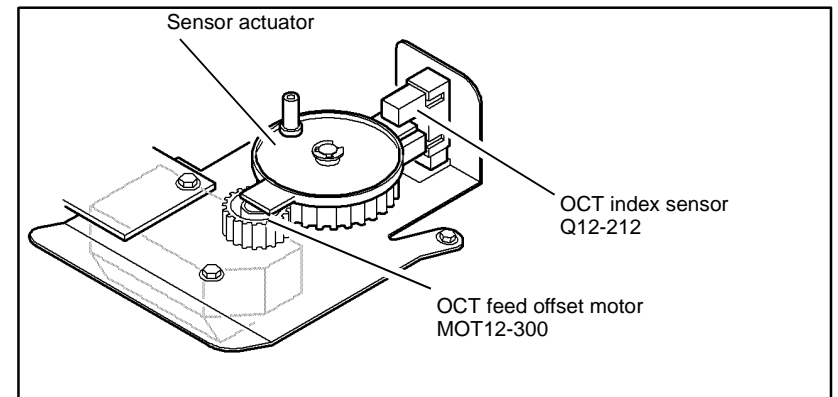

U-1-0187-A

Figure 1 Component location

12-024-00-110, 12-025-00-110 Paddle Roll Failure RAP

12-024-00-110 The paddle is not at the home position.

12-025-00-110 The paddle fails to rotate.

NOTE: The paddle is in the home position when the sensor flag is located between the sensor jaws. If a jam occurs in the compiler, bin 1 will not be available.

NOTE: With reference to [WD 12.3](#) component control codes;

Code 12-237 drives the paddle roll motor until the paddle wheel shaft assembly is at the home position.

Code 12-238 runs the paddle roll motor.

Initial Actions

WARNING

Ensure that the electricity to the machine is switched off while performing tasks that do not need electricity. Refer to [GP 14](#). Disconnect the power cord. Electricity can cause death or injury. Moving parts can cause injury.

WARNING

Take care not to topple the LCSS. The LCSS is unstable when undocked from the machine. Do not show the customer how to undock the LCSS.

Check the following:

- That there is no paper or other obstructions in the vicinity of the paddle.
- The paddle roll position sensor bracket is holding the sensor in the correct position, i.e. the flag is in the middle of the sensor gap and the sensor does not touch any moving components.
- Check that the paper type is set correctly. If heavyweight paper is used but not set in the UI, the compiler capacity can be exceeded. Refer to [12J-110](#) Mis-Registration in Stapled Sets and Non-stapled Sets RAP.
- Check the position of the paddles. With the paddle roll in the home position both sets of paddles must be within the output cover, if they are not, refer to [REP 12.12-110](#) Paddle Wheel Shaft Assembly. If any of the paddles are out of alignment to other paddles, install a new paddle wheel shaft assembly, [PL 12.25 Item 4](#) or a new paddle, [PL 31.10 Item 4](#).
- LCSS PWB DIP switch settings, refer to [12F-110](#) LCSS PWB DIP Switch Settings RAP.

Procedure

NOTE: All LCSS interlocks must be made to supply +24V to the motors.

NOTE: In diagnostics, actuating any LCSS sensor or switch can change the displayed state on the UI. Make sure that the correct sensor or switch is tested.

Run the paddle roll motor MOT 12-238, [PL 12.25 Item 10](#). Enter [dC330](#) codes 12-237 paddle roll motor home position and 12-238 paddle roll motor run. **The paddle rotates correctly.**

Y N

Go to [WD 12.3](#). Check the paddle roll motor MOT12-238.

Refer to:

- [12G-110](#) LCSS PWB Damage RAP.
- [GP 10](#), How to Check a Motor.

A

- [P/J310](#), [LCSS PWB](#).
- [12D-110](#) LCSS Power Distribution RAP
- [01L 0V](#) Distribution RAP

Install new components as necessary:

- Paddle roll motor, [PL 12.25 Item 10](#).
- LCSS PWB, [PL 12.75 Item 1](#).

Enter [dC330](#) code 12-238 and stack the code 12-186, to actuate the paddle roll motor home sensor Q12-186. **The display cycles high/low.**

Y N

Go to [WD 12.4](#). Check Q12-186.

Refer to:

- [12G-110](#) LCSS PWB Damage RAP.
- [GP 11](#), How to Check a Sensor.
- [P/J314](#), [LCSS PWB](#).
- [12D-110](#) LCSS Power Distribution RAP
- [01L 0V](#) Distribution RAP

Install new components as necessary:

- Paddle roll motor home sensor, [PL 12.25 Item 11](#).
- LCSS PWB, [PL 12.75 Item 1](#).

Perform [SCP 5](#) Final Actions.

A

12-043-00-110, 12-046-00-110 Hole Punch Operation Failure RAP

12-043-00-110 The hole punch fails to perform a punch cycle.

12-046-00-110 The hole punch is not at the home position.

Initial Actions

WARNING

Ensure that the electricity to the machine is switched off while performing tasks that do not need electricity. Refer to [GP 14](#). Disconnect the power cord. Electricity can cause death or injury. Moving parts can cause injury.

WARNING

Take care not to topple the LCSS. The LCSS is unstable when undocked from the machine. Do not show the customer how to undock the LCSS.

- Check the LCSS PWB DIP switch settings, refer to [12F-110](#) LCSS PWB DIP Switch Settings RAP.
- Check that the hole punch is present and correctly installed.
- Check that the punch has not jammed in the down position. This can occur with transparencies and labels.

NOTE: The home position of the punch unit is when the cut-out in the actuator is between the punch head home sensor jaws.

NOTE: With reference to [WD 12.3](#) component control codes;

Code 12-243 moves the hole punch to the home position.

Code 12-244 cycles the hole punch until time-out.

Procedure

Go to [WD 12.2](#). Check the link between P/J307 pins 10 and 11, [LCSS PWB](#). The link is good.

Y N

Repair the wiring or connector.

Enter [dC330](#) code 12-195 to actuate the punch head present sensor Q12-195, [PL 12.20 Item 1](#). The display changes.

Y N

Go to [WD 12.2](#). Check Q12-195.

Refer to:

- [12G-110](#) LCSS PWB Damage RAP.
- [GP 11](#) How to Check a Sensor.
- P/J307, [LCSS PWB](#).
- [12D-110](#) LCSS Power Distribution RAP.
- [01L](#) 0V Distribution RAP

Install new components as necessary:

- Punch head present sensor, [PL 12.20 Item 1](#).
- LCSS PWB, [PL 12.75 Item 1](#).

A

Enter [dC330](#) code 12-194 to actuate the punch head home sensor Q12-194, [PL 12.20 Item 1](#).

The display changes.

Y N

Go to [WD 12.2](#), check Q12-194.

Refer to:

- [12G-110](#) LCSS PWB Damage RAP.
- [GP 11](#) How to Check a Sensor.
- P/J307, [LCSS PWB](#).
- [12D-110](#) LCSS Power Distribution RAP.
- [01L](#) 0V Distribution RAP

Install new components as necessary:

- Punch head home sensor, [PL 12.20 Item 1](#).
- LCSS PWB, [PL 12.75 Item 1](#).

Enter [dC330](#) code 12-244. The punch cycles.

Y N

Go to [WD 12.3](#), check the hole punch motor MOT12-243, [PL 12.20 Item 2](#).

Refer to:

- [12G-110](#) LCSS PWB Damage RAP.
- [GP 10](#), How to Check a Motor.
- P/J311, [LCSS PWB](#).
- [12D-110](#) LCSS Power Distribution RAP.
- [01L](#) 0V Distribution RAP

Install new components as necessary:

- Punch head motor assembly, [PL 12.20 Item 2](#).
- LCSS PWB, [PL 12.75 Item 1](#).

NOTE: The chad bin collects the pieces of paper cut out by the hole punch. The chad bin level sensor will not operate if the tray is incorrectly installed. Ensure the chad bin is fully inserted and the lever engages in the slot.

Enter [dC330](#) code 12-193. Actuate the chad bin level sensor Q12-193, using a strip of paper,

[PL 12.20 Item 7](#). The display changes.

Y N

Go to [WD 12.2](#). Check Q12-193.

Refer to:

- [12G-110](#) LCSS PWB Damage RAP.
- [GP 11](#) How to Check a Sensor.
- P/J307, [LCSS PWB](#).
- [12D-110](#) LCSS Power Distribution RAP.
- [01L](#) 0V Distribution RAP

Install new components as necessary:

- Chad bin level sensor, [PL 12.20 Item 7](#).
- LCSS PWB, [PL 12.75 Item 1](#).

Perform [SCP 5](#) Final Actions.

A

12-127-00-110 Sheet Late to Hole Punch RAP

12-127-00-110 Sheet late at the punch sensor.

Initial Actions

WARNING

Ensure that the electricity to the machine is switched off while performing tasks that do not need electricity. Refer to [GP 14](#). Disconnect the power cord. Electricity can cause death or injury. Moving parts can cause injury.

WARNING

Take care not to topple the LCSS. The LCSS is unstable when undocked from the machine. Do not show the customer how to undock the LCSS.

Check the following:

- The LCSS PWB DIP switch settings, refer to [12F-110 LCSS PWB DIP Switch Settings RAP](#).
- Ensure the paper tray guides are set to the correct position for the size of paper in the tray.
- For a paper jam at the entrance to the LCSS. Check that there is no obstruction that would prevent a sheet from arriving in position for punching, refer to the [12H-110 Copy Damage in the LCSS RAP](#).
- The punch sensor 1, Q12-078 for chad debris, [PL 12.20 Item 7](#).

Procedure

NOTE: In diagnostics, actuating any LCSS sensor or switch can change the displayed state on the UI. Make sure that the correct sensor or switch is tested.

Enter [dC330](#) code 12-078 to actuate the punch sensor Q12-078. **The display changes.**

Y N

Go to [WD 12.2](#). Check Q12-078.

Refer to:

- [12G-110 LCSS PWB Damage RAP](#).
- [GP 11](#), How to Check a Sensor.
- [P/J307](#), [LCSS PWB](#).
- [12D-110 LCSS Power Distribution RAP](#).
- [01L 0V Distribution RAP](#).

Install new components as necessary:

- Punch sensor, [PL 12.20 Item 7](#).
- LCSS PWB, [PL 12.75 Item 1](#).

Perform [SCP 5](#) Final Actions.

12-151-00-110, 12-152-00-110 Sheet Late to Bin 1 RAP

12-151-00-110 The trailing edge of the sheet is late to the compile exit sensor, Q12-106.

12-152-00-110 The leading edge of the sheet is late to the compile exit sensor, Q12-106.

Initial Actions

WARNING

Ensure that the electricity to the machine is switched off while performing tasks that do not need electricity. Refer to [GP 14](#). Disconnect the power cord. Electricity can cause death or injury. Moving parts can cause injury.

WARNING

Take care not to topple the LCSS. The LCSS is unstable when undocked from the machine. Do not show the customer how to undock the LCSS.

NOTE: Paper is diverted to bin 0 when the diverter gate solenoid is energized.

Paper is fed to bin 1 when the diverter gate solenoid is de-energized.

Check the following:

- LCSS PWB DIP switch settings, refer to [12F-110 LCSS PWB DIP Switch Settings RAP](#).
- Ensure the paper tray guides are set to the correct position for the size of paper in all trays.
- The tensioner on the intermediate paper drive belt. Check that the tensioner is free to move and that the tensioner pulley is free to rotate. If necessary re-lubricate the tensioner and tensioner pulley, [REP 12.3-110](#). Refer to [GP 18](#) Machine Lubrication.

NOTE: The tensioner arm and the tensioner pulley require different lubricants, refer to [REP 12.3-110](#) for details

- That the drive pulleys on both transport motor 1 and 2 are secure and do not slip on the motor shaft.
- All the transport drive belts are correctly fitted and are in a good condition.
- All the transport rolls and idler pulleys are free to rotate.
- The diverter gate and linkage for free movement.
- A paper jam in the path to bin 1, to the compiler, and for poor stacking on bin 1.
- Ensure that the LCSS is fully latched to the machine, refer to [REP 12.13-110](#).
- Torn paper fragments from a previous jam clearance action.

Refer to the [12H-110 Copy Damage in the LCSS RAP](#) and the [12J-110 Mis-Registration in Stapled Sets and Non-Stapled Sets RAP](#).

Procedure

NOTE: All LCSS interlocks must be made to supply +24V to the motors.

Figure 1. Enter [dC330](#) code 12-224 to run the transport motor 2 MOT12-224. **The motor runs.**

Y N

Go to [WD 12.3](#). Check MOT12-224.

Refer to:

- [12G-110 LCSS PWB Damage RAP](#).

A

A

- GP 10, How to check a motor.
- P/J309, LCSS PWB.
- 12D-110 LCSS Power Distribution RAP.
- 01L 0V Distribution RAP.

Install new components as necessary:

- Transport motor 2, PL 12.60 Item 5.
- LCSS PWB, PL 12.75 Item 1.

Figure 1. Enter dC330 code 12-225 to the exit diverter solenoid S12-225. The diverter solenoid energizes.

Y N

Go to WD 12.2. Check SOL12-225.

Refer to:

- 12G-110 LCSS PWB Damage RAP.
- GP 12, How to Check a Solenoid or Clutch.
- P/J306, LCSS PWB.
- 12D-110 LCSS Power Distribution RAP.
- 01L 0V Distribution RAP.

Install new components as necessary:

- Exit diverter solenoid, PL 12.60 Item 12.
- LCSS PWB, PL 12.75 Item 1.

Figure 1. Enter dC330 code 12-106 to actuate the compile exit sensor Q12-106. The display changes.

Y N

Go to WD 12.4. Check Q12-106.

Refer to:

- 12G-110 LCSS PWB Damage RAP.
- GP 11, How to Check a sensor.
- P/J313, LCSS PWB.
- 12D-110 LCSS Power Distribution RAP.
- 01L 0V Distribution RAP.

Install new components as necessary:

- Compiler exit sensor, PL 12.65 Item 4.
- LCSS PWB, PL 12.75 Item 1.

Figure 1. Enter dC330, code 12-223 to run the transport motor 1, MOT12-223. The motor runs.

Y N

Go to WD 12.1. Check MOT12-223.

Refer to:

- 12G-110 LCSS PWB Damage RAP.
- GP 10, How to Check a Motor.
- P/J305, LCSS PWB.
- 12D-110 LCSS Power Distribution RAP.
- 01L 0V Distribution RAP.

B

B

Install new components as necessary:

- Transport motor 1, PL 12.40 Item 2.
- LCSS PWB, PL 12.75 Item 1.

If the fault is still present, perform 12-396-00-110, 12-397-00-110, 12-398-00-110, Rear Tamper Move Failure RAP.

NOTE: A software problem can cause the machine to incorrectly display the fault code 12-152-00-110.

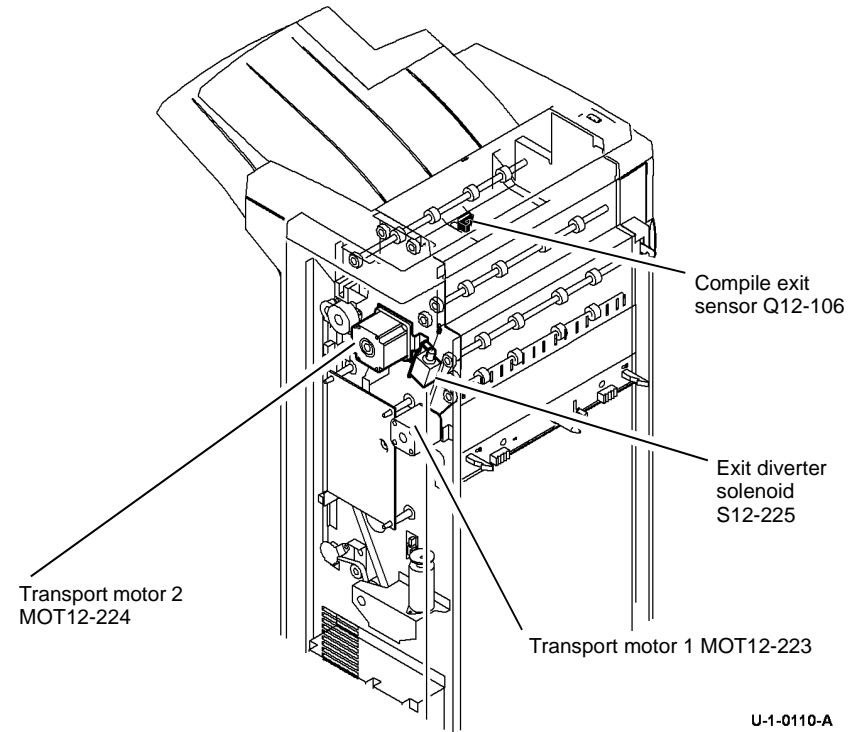

U-1-0110-A

Figure 1 Component location

12-171-00-110, 12-172-00-110 Paper Exiting to Bin 0 RAP

12-171-00-110 The leading edge of the sheet is late to the top exit sensor.

12-172-00-110 The trailing edge of the sheet is late from the top exit sensor.

Initial Actions

WARNING

Ensure that the electricity to the machine is switched off while performing tasks that do not need electricity. Refer to [GP 14](#). Disconnect the power cord. Electricity can cause death or injury. Moving parts can cause injury.

WARNING

Take care not to topple the LCSS. The LCSS is unstable when undocked from the machine. Do not show the customer how to undock the LCSS.

Check the following:

- LCSS PWB DIP switch settings, refer to [12F-110](#) LCSS PWB DIP Switch Settings RAP.
- Ensure the paper tray guides are set to the correct position for the size of paper in the tray.
- The tensioner on the intermediate paper drive belt. Check that the tensioner is free to move and that the tensioner pulley is free to rotate. If necessary lubricate the tensioner and tensioner pulley, [REP 12.3-110](#). Refer to [GP 18](#) Machine Lubrication.

NOTE: The tensioner arm and the tensioner pulley require different lubricants, refer to [REP 12.3-110](#).

- The drive pulleys on both transport motor 1 and 2 are secure and do not slip on the motor shaft.
- All the transport drive belts are correctly fitted and are in a good condition.
- All the transport rolls and idler pulleys are free to rotate.
- The diverter gate and linkage for free movement.
- A paper jam in the path to bin 0.
- Torn paper fragments from a previous jam clearance action.
- A paper jam in the path to the top tray. If the jams occur shortly after install. Check the gap between the entry guide cover, [PL 12.70 Item 5](#) and the paper guide [PL 12.60 Item 10](#). If the gap is less than 1mm, adjust or install a new entry guide cover. Refer to the replacement procedure in [REP 12.15-110](#).

Refer to the [12H-110](#) Copy Damage in the LCSS RAP and the [12J-110](#) Mis-Registration in Stapled Sets and Non-Stapled Sets RAP.

NOTE: Paper is diverted to bin 0 when the diverter gate solenoid is energized.

Paper is fed to bin 1 when the diverter gate solenoid is de-energized.

Procedure

NOTE: All LCSS interlocks must be made to supply +24V to the motors.

Enter [dC330](#) code 12-224 to run transport motor 2 MOT12-224, [Figure 1](#). The motor runs.

Y N
Go to [WD 12.3](#). Check MOT12-224.

Refer to:

- [12G-110](#) LCSS PWB Damage RAP.
- [GP 10](#), How to Check a Motor.
- P/J309, [LCSS PWB](#).
- [12D-110](#) LCSS Power Distribution RAP.
- [01L 0V](#) Distribution RAP.

Install new components as necessary:

- Transport motor 2, [PL 12.60 Item 5](#).
- LCSS PWB, [PL 12.75 Item 1](#).

Enter [dC330](#) code 12-225 to energize the exit diverter solenoid S12-225, [Figure 1](#). The diverter gate solenoid energizes.

Y N
Go to [WD 12.2](#). Check SOL12-225.
Refer to:

- [12G-110](#) LCSS PWB Damage RAP.
- [GP 12](#), How to Check a Solenoid.
- P/J306, [LCSS PWB](#).
- [12D-110](#) LCSS Power Distribution RAP.
- [01L 0V](#) Distribution RAP.

Install new components as necessary:

- Exit diverter solenoid, [PL 12.60 Item 12](#).
- LCSS PWB, [PL 12.75 Item 1](#).

Enter [dC330](#) code 12-107 to actuate the top tray exit sensor Q12-107, [Figure 1](#). The display changes.

Y N
Go to [WD 12.4](#). Check Q12-107.
Refer to:

- [12G-110](#) LCSS PWB Damage RAP.
- [GP 11](#), How to Check a Sensor.
- P/J313, [LCSS PWB](#).
- [12D-110](#) LCSS Power Distribution RAP.
- [01L 0V](#) Distribution RAP.

Install new components as necessary:

- Top tray exit sensor, [PL 12.60 Item 11](#).
- LCSS PWB, [PL 12.75 Item 1](#).

Enter [dC330](#) code 12-223 to run the transport motor 1, MOT12-223, [Figure 1](#). The motor runs.

Y N
Go to [WD 12.1](#). Check MOT12-223.
Refer to:

- [12G-110](#) LCSS PWB Damage RAP.
- [GP 10](#), How to Check a Motor.
- P/J305, [LCSS PWB](#).

A

B

B

- 12D-110 LCSS Power Distribution RAP.
 - 01L 0V Distribution RAP.
- Install new components as necessary:
- Transport motor 1, PL 12.40 Item 2.
 - LCSS PWB, PL 12.75 Item 1.

Perform SCP 5 Final Actions.

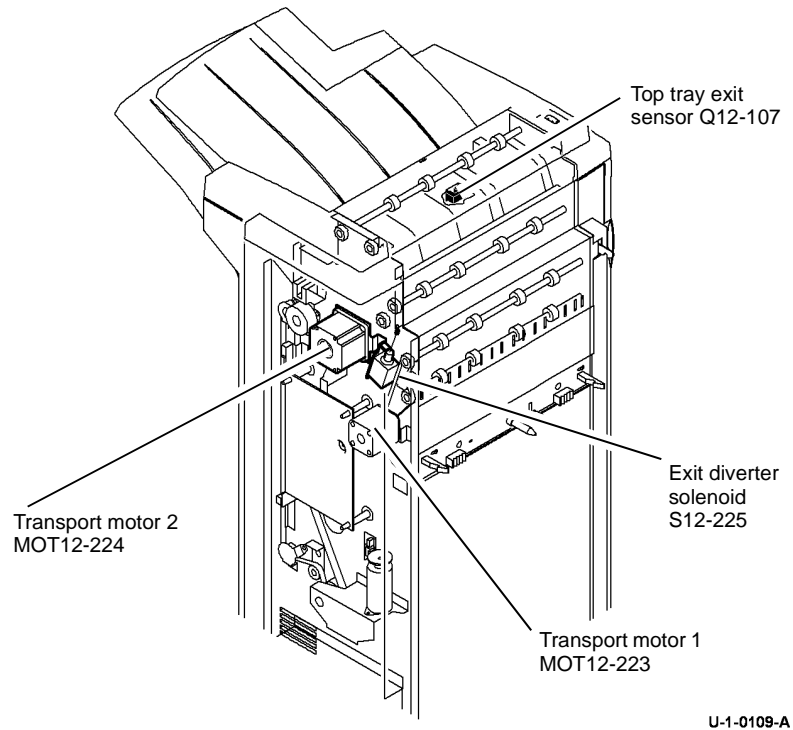

Figure 1 Component location

12-199-00-110 Unexpected Sheet at Finisher Entry RAP

12-199-00-110 The leading edge of the sheet detected at finisher entry, without first receiving a paper at IOT exit sensor command.

Initial Actions

WARNING

Ensure that the electricity to the machine is switched off while performing tasks that do not need electricity. Refer to GP 14. Disconnect the power cord. Electricity can cause death or injury. Moving parts can cause injury.

WARNING

Take care not to topple the LCSS. The LCSS is unstable when undocked from the machine. Do not show the customer how to undock the LCSS.

CAUTION

Do not connect the output device power cord directly to the AC wall outlet. The output device cannot operate without the machine. The machine controls the distribution of electricity to the output device for correct power on and power off sequencing.

Check the following:

- LCSS PWB DIP switch settings, refer to 12F-110 LCSS PWB DIP Switch Settings RAP.
- Check the fault history file for related fault codes.
- Check that the communication harness from the finisher to the IME is secure.
- Check the size of paper in the paper trays is correct.

Procedure

1. Switch off the machine, the switch on the machine, GP 14.
2. Check the communication harness. Repair the wiring as necessary, REP 1.1.
3. Un-dock the LCSS, REP 12.13-110, Check the paper path for obstructions and damage. Cheat the docking interlock switch.
4. Check the entry sensor GP 11. Enter dC330 code 12-077 to actuate the entry sensor Q12-077, PL 12.70 Item 3.
5. Go to WD 12.1. Check the wiring and PJ connections between the entry sensor and PJ304 on the LCSS PWB.

If necessary install new components:

- Entry sensor, PL 12.70 Item 3.
- LCSS PWB, PL 12.75 Item 1.

12-310-00-110, 12-312-00-110, 12-313-00-110 Interlocks RAP

12-310-00-110 The docking interlock is open during run mode.

12-312-00-110 The top cover interlock is open during run mode.

12-313-00-110 The front door interlock is open during run mode.

Initial Actions

WARNING

Ensure that the electricity to the machine is switched off while performing tasks that do not need electricity. Refer to [GP 14](#). Disconnect the power cord. Electricity can cause death or injury. Moving parts can cause injury.

WARNING

Take care not to topple the LCSS. The LCSS is unstable when undocked from the machine. Do not show the customer how to undock the LCSS.

- Check the LCSS PWB DIP switch settings, refer to [12F-110 LCSS PWB DIP Switch Settings RAP](#).
- Check the following:
 - The LCSS is docked to the machine.
 - The LCSS front door is closed.
 - The LCSS top cover is closed.

Procedure

Go to [WD 12.1](#). Check for +24V on P/J 302 pin 1. If the voltage is not present, refer to [12D-110 LCSS Power Distribution RAP](#) and [01L 0V Distribution RAP](#).

Go to the appropriate RAP:

- [12-310-00-110 Docking Interlock RAP](#)
- [12-312-00-110 Top Cover Interlock RAP](#)
- [12-313-00-110 Front Door Interlock RAP](#)

12-310-00-110 Docking Interlock RAP

Un-dock the LCSS [REP 12.13-110](#). Check the docking interlock S12-177, [PL 12.15 Item 2](#), as follows:

- Check the interlock actuator on the machine is not damaged or missing.

NOTE: The wiring harness passes underneath the docking interlock switch housing. If this harness is not correctly positioned, the switch can be mis-located, giving intermittent docking interlock problems.
- Enter [dC330](#) code 12-177, actuate the docking interlock. If the display does not change, refer to:
 - [GP 13](#), How to Check a Switch.
 - P/J302, [LCSS PWB](#).
- Go to [WD 12.1](#). Check the wiring between P/J 302 and the docking interlock switch.
- If necessary, install a new docking interlock switch, [PL 12.15 Item 2](#).

12-312-00-110 Top Cover Interlock RAP

Check the top cover interlock switch S12-197, [PL 12.75 Item 6](#), as follows:

- Check the switch actuator.
- Enter [dC330](#) code 12-197, actuate the top cover interlock switch. If the display does not change, refer to:
 - [GP 13](#), How to Check a switch.
 - P/J315, [LCSS PWB](#).
- Go to [WD 12.4](#). Check the wiring between P/J315 and the top cover interlock switch.
- If necessary install a new top cover interlock switch, [PL 12.75 Item 6](#).

12-313-00-110 Front Door Interlock RAP

Check the front door interlock switch S12-303, [PL 12.75 Item 5](#), as follows:

- Check the switch actuator.
- Enter [dC330](#) code 12-303, actuate the front door interlock switch. If the display does not change, refer to:
 - [GP 13](#), How to Check a switch.
 - P/J302, [LCSS PWB](#).
- Go to [WD 12.1](#). Check the wiring between P/J302 and the front door interlock switch.
- If necessary install a new front door interlock switch, [PL 12.75 Item 5](#).

Perform [SCP 5](#) Final Actions.

12-340-00-110, 12-341-00-110, 12-342-00-110 Ejector Movement Failure RAP

12-340-00-110 The ejector is not at the home position.

12-341-00-110 The ejector is not at the out position.

12-342-00-110 The ejector fails to perform a cycle of operation.

NOTE: A cycle of operation for the ejector is to cycle from the home position to the out position and back to the home position.

Initial Actions

WARNING

Ensure that the electricity to the machine is switched off while performing tasks that do not need electricity. Refer to [GP 14](#). Disconnect the power cord. Electricity can cause death or injury. Moving parts can cause injury.

WARNING

Take care not to topple the LCSS. The LCSS is unstable when undocked from the machine. Do not show the customer how to undock the LCSS.

- Check the LCSS PWB DIP switch settings, refer to [12F-110 LCSS PWB DIP Switch Settings RAP](#).
- Un-dock the LCSS, [REP 12.13-110](#), Check for any obstructions that would prevent the ejector from moving. Cheat the docking interlock switch.

Procedure

NOTE: All LCSS interlocks must be made to supply +24V to the motors.

NOTE: With reference to [WD 12.1](#) component control codes;
Code 12-234 moves the ejector assembly to the home position.
Code 12-235 moves the ejector assembly to the out position.
Code 12-236 cycles the ejector until time-out.

Enter [dC330](#) code 12-185, actuate the ejector out sensor Q12-185, [PL 12.50 Item 3](#). The display changes.

Y N

Go to [WD 12.1](#). Check Q12-185.

Refer to:

- [12G-110 LCSS PWB Damage RAP](#).
- [GP 11](#) How to Check a Sensor.
- P/J304, [LCSS PWB](#).
- [12D-110 LCSS Power Distribution RAP](#).
- [01L 0V Distribution RAP](#).

Install new components as necessary:

- Ejector out sensor, [PL 12.50 Item 3](#).
- LCSS PWB, [PL 12.75 Item 1](#).

Enter [dC330](#) code 12-184, actuate the ejector home sensor Q12-184, [PL 12.50 Item 3](#). The display changes.

Y N

Go to [WD 12.1](#). Check Q12-184.

A

Refer to:

- [12G-110 LCSS PWB Damage RAP](#).
- [GP 11](#) How to Check a Sensor.
- P/J304, [LCSS PWB](#).
- [12D-110 LCSS Power Distribution RAP](#).
- [01L 0V Distribution RAP](#).

Install new components as necessary:

- Ejector home sensor, [PL 12.50 Item 3](#).
- LCSS PWB, [PL 12.75 Item 1](#).

Enter [dC330](#) code 12-236 to check the movement of the ejector, [PL 12.50 Item 1](#). The ejector motor cycles.

Y N

Check that the large tie-wrap around the motor of the ejector assembly has not cut through the motor wires and caused a short circuit to the case of the motor. If necessary cut the tie-wrap, then tape and isolate the wires. The ejector motor cycles.

Y N

Go to [WD 12.1](#). Check the ejector motor home MOT12-234.

Refer to:

- [12G-110 LCSS PWB Damage RAP](#).
- [GP 10](#), How to Check a Motor.
- P/J303, [LCSS PWB](#).
- [12D-110 LCSS Power Distribution RAP](#).
- [01L 0V Distribution RAP](#).

Install new components as necessary:

- Ejector assembly, [PL 12.50 Item 1](#).
- LCSS PWB, [PL 12.75 Item 1](#).

The ejector cycles noisily, colliding with the end stops.

Y N

Check the stapler to ensure the staples are correctly formed. Mis-formed staples can cause the set to hang in the stapler causing ejector movement failures. The staples are correctly formed.

Y N

Clear the staple head of any mis-formed staples, then check the operation of the stapler. If necessary, install a new staple head unit, [PL 12.55 Item 5](#).

If the ejector is still not moving, install a new ejector assembly, [PL 12.50 Item 1](#). Perform [SCP 5](#) Final Actions.

Go to [WD 12.1](#). +5v is available at P/J 304 between pins 7 and 8.

Y N

Go to the [12D-110 LCSS Power Distribution RAP](#) and [01L 0V Distribution RAP](#).

Connect a service meter at P/J 304 between pins 8 and 9. Slowly rotate the ejector motor encoder. The voltage changes between +5V and 0V.

Y N

Go to [WD 12.1](#). Check the wiring and connectors between the ejector motor encoder sensor and the LCSS PWB. If necessary repair the wiring, [REP 1.1](#). If the wiring is good, install a new ejector motor encoder sensor, [PL 12.50 Item 3](#).

Perform the [12G-110 LCSS PWB Damage RAP](#). If necessary install a new LCSS PWB, [PL 12.75 Item 1](#).

12-371-00-110, 12-372-00-110, 12-378-00-110 Staple Head Unit Movement Failure RAP

12-371-00-110 The staple head unit fails to move.

12-372-00-110 The staple head unit is not at the home position.

12-378-00-110 The staple head unit is not indexed correctly.

NOTE: The home position is when the staple head unit is at the corner stapling position (fully to the front of the LCSS and rotated through 45 degrees).

Initial Actions

WARNING

Ensure that the electricity to the machine is switched off while performing tasks that do not need electricity. Refer to [GP 14](#). Disconnect the power cord. Electricity can cause death or injury. Moving parts can cause injury.

WARNING

Take care not to topple the LCSS. The LCSS is unstable when undocked from the machine. Do not show the customer how to undock the LCSS.

- Check the LCSS PWB DIP switch settings, refer to [12F-110 LCSS PWB DIP Switch Settings RAP](#).
- Un-dock the LCSS from the machine, [REP 12.13-110](#), move the ejector assembly fully to the right, manually move the stapler unit along the full length of the track using the green thumb-wheel. Check the home sensor flag and the two dual position flags for damage, see NOTE. Check for damage or obstructions that would prevent the stapling unit from moving. If necessary, install a new staple head unit, [PL 12.55 Item 5](#) or a new stapler traverse assembly, [PL 12.55 Item 1](#).

NOTE: For dual position stapling, the SU1 front index sensor uses two flags.

- Dock the LCSS to the machine.

Procedure

NOTE: All LCSS interlocks must be made to supply +24V to the motors.

NOTE: With reference to [WD 12.3](#), component control codes;

Code 12-249 increments the stapling unit motor in the forward direction.

Code 12-045 increments the stapling unit motor in the reverse direction.

Code 12-250 cycles the stapling unit between home, first and second stapling positions.

Enter [dC330](#) code 12-235 to move the ejector assembly fully to the right, [PL 12.50 Item 1](#).

Enter code 12-250. **The stapling unit cycles back and forth along the track.**

- Y N**
- Go to [WD 12.3](#). Check the SU1 motor, MOT12-249.
- Refer to:
- [12G-110 LCSS PWB Damage RAP](#).
 - [GP 10](#), How to Check a Motor.
 - P/J308, [LCSS PWB](#).

- A**
- [Figure 1](#), Component location.
 - [12D-110 LCSS Power Distribution RAP](#).
 - [01L 0V Distribution RAP](#)

Install new components as necessary:

- Stapler traverse assembly, [PL 12.55 Item 1](#).
- LCSS PWB, [PL 12.75 Item 1](#).

Enter [dC330](#) code 12-135. Actuate the stapler home sensor Q12-135 by moving the stapler unit to and from the home position, using the green thumb-wheel. **The display changes.**

Y N

Go to [WD 12.3](#). Check Q12-135.

Refer to:

- [12G-110 LCSS PWB Damage RAP](#).
- [GP 11](#). How to check a sensor.
- [Figure 1](#).
- P/J308, [LCSS PWB](#).
- [12D-110 LCSS Power Distribution RAP](#).
- [01L 0V Distribution RAP](#)

Install new components as necessary:

- Stapler home sensor, [PL 12.55 Item 3](#).
- LCSS PWB, [PL 12.75 Item 1](#).

Enter [dC330](#) code 12-235 to move the ejector assembly fully to the right. Enter code 12-168. Actuate the stapler index sensor Q12-168 by moving the stapler unit to and from the flag position (approximately 115 mm (4.5 inches) from the front of the track), using the green thumb-wheel. **The display changes.**

Y N

Go to [WD 12.2](#). Check Q12-201.

Refer to:

- [12G-110 LCSS PWB Damage RAP](#).
- [GP 11](#) How to Check a Sensor.
- P/J308, [LCSS PWB](#).
- [12D-110 LCSS Power Distribution RAP](#).
- [01L 0V Distribution RAP](#)

Install new components as necessary:

- Stapler index sensor, [PL 12.55 Item 3](#).
- LCSS PWB, [PL 12.75 Item 1](#).

Perform [SCP 5](#) Final Actions.

A

12-392-00-110, 12-393-00-110, 12-394-00-110 Front Tamper Move Failure RAP

12-392-00-110 Front tamper fails to move from the home position.

12-393-00-110 Front tamper fails to return to the home position.

12-394-00-110 Front tamper does not return to the away home position.

Initial Actions

WARNING

Ensure that the electricity to the machine is switched off while performing tasks that do not need electricity. Refer to [GP 14](#). Disconnect the power cord. Electricity can cause death or injury. Moving parts can cause injury.

WARNING

Take care not to topple the LCSS. The LCSS is unstable when undocked from the machine. Do not show the customer how to undock the LCSS.

- Check for damage or obstructions that would prevent the tamper assembly from operating correctly. If necessary, install a new tamper assembly, [PL 12.45 Item 1](#).
- Jams can be caused by removing prints from bin 1 before the machine has finished printing. If the tampers are touched while they are moving, they may stall and cause the machine to shutdown. The resulting shutdown can cause un-clearable jams in the finisher and the tray 3 and tray 4 to paper path interface.
- Jams can also be caused if the tray settings do not match the paper in the trays. Make sure the tray settings are correct.
- Check the condition and the tension of the front tamper drive belt. Tensioning is achieved by a spring on the motor, the motor should be free to move.
- If there is a large jam of paper above bin 1 that has obstructed the tampers, this has probably been caused by poorly stacked sets failing to actuate the bin 1 upper level sensor. Perform the following:
 - Check the paper for defects that could degrade the tamping operation e.g. curl, paper condition, buckling or paper type. Refer to [IQ 1 Image Quality Entry RAP](#).
 - Check the operation of the paddle roll, refer to [12-024-00-110, 12-025-00-110 Paddle Roll Failure RAP](#).
 - Check the operation of the bin 1 upper level sensor, refer to [12-462-00-110 Bin 1 Movement Failure RAP](#).
 - Refer to the [12J-110 Mis-Registration in Stapled Sets and Non-Stapled Sets RAP](#).
 - Check the LCSS PWB DIP switch settings, refer to [12F-110 LCSS PWB DIP Switch Settings RAP](#).

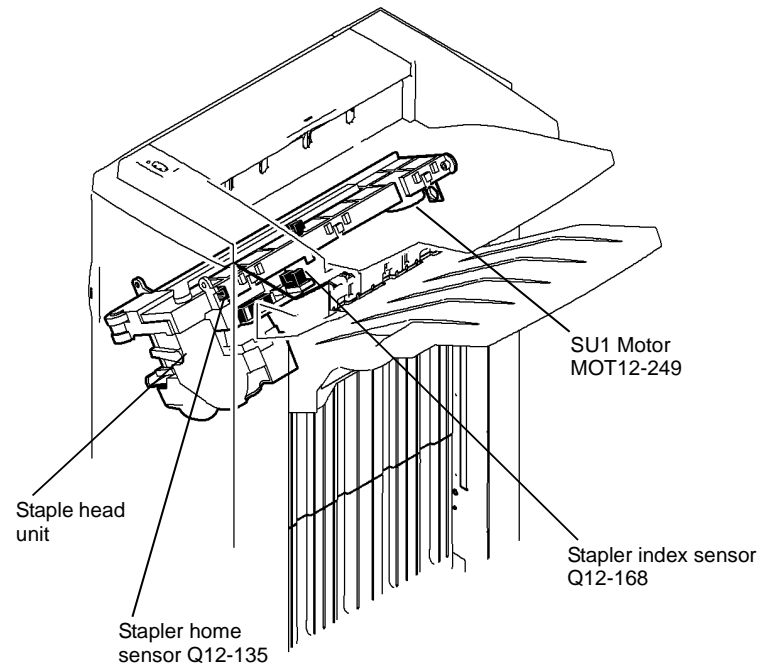

U-1-0106-A

Figure 1 Component location

Enter dC330 codes 12-226 and 12-228 alternately. The front tamper moves between the home and inboard positions.

Y N

Go to [WD 12.3](#). Check the front tamper motor, MOT12-226, [PL 12.45 Item 1](#).

Refer to:

- [12G-110](#) LCSS PWB Damage RAP.
- [GP 10](#) How to Check a Motor.
- P/J312, [LCSS PWB](#).
- [12D-110](#) LCSS Power Distribution RAP.
- [01L](#) 0V Distribution RAP

Install new components as necessary:

- Tamper assembly, [PL 12.45 Item 1](#).
- LCSS PWB, [PL 12.75 Item 1](#).

Enter dC330 code 12-180, actuate the front tamper home sensor, Q12-180, [PL 12.45 Item 3](#).

The display changes.

Y N

Go to [WD 12.3](#). Check Q12-180.

Refer to:

- [12G-110](#) LCSS PWB Damage RAP.
- [GP 11](#) How to Check a Sensor.
- P/J312, [LCSS PWB](#).
- [12D-110](#) LCSS Power Distribution RAP.
- [01L](#) 0V Distribution RAP

Install new components as necessary:

- Tamper assembly, [PL 12.45 Item 1](#).
- LCSS PWB, [PL 12.75 Item 1](#).

NOTE: The front tamper home sensor is bonded onto the tamper unit and is not replaceable. Therefore, failure of this sensor will require the replacement of the tamper assembly.

Enter dC330 code 12-182, actuate the front tamper away sensor, Q12-182, [PL 12.45 Item 3](#).

The display changes.

Y N

Go to [WD 12.4](#). Check Q12-182.

Refer to:

- [12G-110](#) LCSS PWB Damage RAP.
- [GP 11](#), How to Check a Sensor.
- P/J312, [LCSS PWB](#).
- [12D-110](#) LCSS Power Distribution RAP.
- [01L](#) 0V Distribution RAP

Install new components as necessary:

- Front tamper away sensor, [PL 12.45 Item 3](#).
- LCSS PWB, [PL 12.75 Item 1](#).

Perform [SCP 5](#) Final Actions.

12-396-00-110, 12-397-00-110, 12-398-00-110, Rear Tamper Move Failure RAP

12-396-00-110 Rear tamper fails to move from the home position.

12-397-00-110 Rear tamper fails to return to the home position.

12-398-00-110 Rear tamper fails to move from the away home position.

Initial Actions

WARNING

Ensure that the electricity to the machine is switched off while performing tasks that do not need electricity. Refer to [GP 14](#). Disconnect the power cord. Electricity can cause death or injury. Moving parts can cause injury.

WARNING

Take care not to topple the LCSS. The LCSS is unstable when undocked from the machine. Do not show the customer how to undock the LCSS.

- Check for damage or obstructions that would prevent the tamper assembly from operating correctly. If necessary, install a new tamper assembly, [PL 12.45 Item 1](#).
- Jams can be caused by removing prints from bin 1 before the machine has finished printing. If the tampers are touched while they are moving, they may stall and cause the machine to shutdown. The resulting shutdown can cause un-clearable jams in the finisher and the tray 3 and tray 4 to paper path interface.
- Jams can also be caused if the tray settings do not match the paper in the trays. Make sure the tray settings are correct.
- Check the condition of the rear tamper drive belt and that it is correctly tensioned. Tensioning is achieved by a spring on the motor, the motor should be free to move.
- If there is a large jam of paper above bin 1 that has obstructed the tampers, this has probably been caused by poorly stacked sets failing to actuate the bin 1 upper level sensor. Perform the following:
 - Check the paper for defects that could degrade the tamping operation e.g. curl, paper condition, buckling or paper type. Refer to [IQ 1](#) Image Quality Entry RAP.
 - Check the operation of the paddle roll, refer to [12-024-00-110](#), [12-025-00-110](#) Paddle Roll Failure RAP.
 - Check the operation of the bin 1 upper level sensor, refer to [12-462-00-110](#) Bin 1 Movement Failure RAP.
 - Refer to the [12J-110](#) Mis-Registration in Stapled Sets and Non-Stapled Sets RAP.
 - Check the LCSS PWB DIP switch settings, refer to [12F-110](#) LCSS PWB DIP Switch Settings RAP.

Procedure

NOTE: All LCSS interlocks must be made to supply +24V to the motors.

NOTE: With reference to [WD 12.3](#) component control codes;

Code 12-227 moves the rear tamper to the home position.

Code 12-229 moves the rear tamper inboard (away from home).

Code 12-230 moves both tampers to the A4 LEF position.

Code 12-231 moves both tampers to the 8.5 x 11 LEF position.

Code 12-232 Cycles the tampers in and out until time-out.

Enter [dC330](#) codes 12-227 and 12-229 alternately. **The rear tamper moves between the home and inboard positions.**

Y N

Go to [WD 12.3](#). Check the rear tamper motor, MOT12-227, [PL 12.45 Item 1](#).

Refer to:

- [12G-110](#) LCSS PWB Damage RAP.
- [GP 10](#), How to Check a Motor.
- P/J312, [LCSS PWB](#).
- [12D-110](#) LCSS Power Distribution RAP.
- [01L](#) 0V Distribution RAP

Install new components as necessary:

- Tamper assembly, [PL 12.45 Item 1](#).
- LCSS PWB, [PL 12.75 Item 1](#).

Enter [dC330](#) code 12-181, actuate the rear tamper home sensor, Q12-181, [PL 12.45 Item 3](#).

The display changes.

Y N

Go to [WD 12.3](#). Check Q12-181.

Refer to:

- [12G-110](#) LCSS PWB Damage RAP.
- [GP 11](#), How to Check a Sensor.
- P/J312, [LCSS PWB](#).
- [12D-110](#) LCSS Power Distribution RAP.
- [01L](#) 0V Distribution RAP

Install new components as necessary:

- Tamper assembly, [PL 12.45 Item 1](#).
- LCSS PWB, [PL 12.75 Item 1](#).

NOTE: The rear tamper home sensor is bonded onto the tamper unit and is not replaceable. Therefore, failure of this sensor will require the replacement of the tamper assembly.

Enter [dC330](#) code 12-183, actuate the rear tamper away sensor, Q12-183, [PL 12.45 Item 3](#).

The display changes.

Y N

Go to [WD 12.4](#). Check Q12-183.

Refer to:

- [12G-110](#) LCSS PWB Damage RAP.

A

- [GP 11](#), How to Check a Sensor.
- P/J312, [LCSS PWB](#).
- [12D-110](#) LCSS Power Distribution RAP.
- [01L](#) 0V Distribution RAP

Install new components as necessary:

- Rear tamper away sensor, [PL 12.45 Item 3](#).
- LCSS PWB, [PL 12.75 Item 1](#).

Perform [SCP 5](#) Final Actions.

12-462-00-110 Bin 1 Movement Failure RAP

12-462-00-110 Bin 1 failed to leave the bin 1 upper level sensor during stacking or failed to initialise correctly.

NOTE: The home position of bin 1 is when the bin is just lower than the stack level sensor. See the final actions at the end of the procedure.

Two sensors and two switches monitor the level of paper in bin 1 and the position of the tray:

- The bin 1 upper level sensor, detects the top of the paper stack in bin 1, or the empty bin 1, [PL 12.35 Item 3](#).
- The bin 1 90% full sensor, detects when the tray has descended to a position where the tray is 90% full, [PL 12.30 Item 5](#).
- Bin 1 upper limit switch, prevents over travel, S12-190, [PL 12.30 Item 3](#).
- Bin 1 lower limit switch, prevents over travel, S12-191, [PL 12.35 Item 1](#).

NOTE: With reference to [WD 12.5](#) component control codes;

Code 12-241 elevates bin 1 to the home position.

Code 12-059 elevates bin 1 incrementally up.

Code 12-060 elevates bin 1 incrementally down.

Code 12-242 cycles bin 1 up and down until time-out.

Initial Actions

WARNING

Ensure that the electricity to the machine is switched off while performing tasks that do not need electricity. Refer to [GP 14](#). Disconnect the power cord. Electricity can cause death or injury. Moving parts can cause injury.

WARNING

Take care not to topple the LCSS. The LCSS is unstable when undocked from the machine. Do not show the customer how to undock the LCSS.

Perform the following:

- Check for a physical obstruction that would prevent bin 1 from moving, such as an item of furniture.
- Check that bin 1 is level front to back, if necessary perform [ADJ 12.1-110](#) LCSS Bin 1 Level.
- Check the LCSS PWB DIP switch settings, refer to [12F-110](#) LCSS PWB DIP Switch Settings RAP.
- Refer to the [12J-110](#) Mis-Registration in Stapled Sets and Non-Stapled Sets RAP.
- If there is a large jam of paper above bin 1, this has probably been caused by poorly stacked sets failing to actuate the bin 1 upper level sensor.

Perform the relevant check:

- If paper is overflowing the tray when it is at the lower limit, check the tray 90% full sensor.
- If paper cannot be fed to bin 1 when it is at the highest position, check the bin 1 upper level sensor.

Check the front and rear bin 1 drive belts. If necessary install new components, [PL 12.30 Item 1](#).

Procedure

NOTE: All LCSS interlocks must be made to supply +24V to the motors.

NOTE: In diagnostics, actuating any LCSS sensor or switch can change the displayed state on the UI. Make sure that the correct sensor or switch is tested.

Remove the LCSS rear cover. Enter [dC330](#) code 12-192, bin 1 motor encoder sensor Q12-192 [PL 12.30 Item 11](#), then slowly rotate the encoder disk by hand. **The display changes.**

Y N

Go to [WD 12.1](#). Check Q12-192.

Refer to:

- [12G-110](#) LCSS PWB Damage RAP.
- [GP 11](#) How to Check a Sensor.
- P/J304, [LCSS PWB](#).
- [12D-110](#) LCSS Power Distribution RAP.
- [01L](#) OV Distribution RAP

Install new components as necessary:

- Bin 1 motor encoder sensor Q12-192, [PL 12.30 Item 11](#).
- LCSS PWB, [PL 12.75 Item 1](#).

Enter [dC330](#) code 12-242. **Bin 1 cycles down and up.**

Y N

Go to [WD 12.5](#). Check the bin 1 elevator motor, MOT12-241, [PL 12.30 Item 8](#).

Refer to:

- [12G-110](#) LCSS PWB Damage RAP.
- [GP 10](#) How to Check a Motor.
- P/J318, [LCSS PWB](#).
- [12D-110](#) LCSS Power Distribution RAP.
- [01L](#) OV Distribution RAP

Install new components as necessary:

- Bin 1 elevator motor, [PL 12.30 Item 8](#).
- LCSS PWB, [PL 12.75 Item 1](#).

Enter [dC330](#) code 12-188, actuate the bin 1 upper level sensor Q12-188, [PL 12.35 Item 3](#). **The display changes.**

Y N

Go to [WD 12.4](#). Check Q12-188.

Refer to:

- [12G-110](#) LCSS PWB Damage RAP.
- [GP 11](#) How to Check a Sensor.
- P/J314, [LCSS PWB](#).
- [12D-110](#) LCSS Power Distribution RAP.
- [REP 12.13-110](#) LCSS Un-docking.
- [01L](#) OV Distribution RAP

Install new components as necessary:

- Bin 1 upper level sensor, [PL 12.35 Item 3](#).
- LCSS PWB, [PL 12.75 Item 1](#).

Enter [dC330](#) code 12-190, actuate the bin 1 upper limit switch S12-190, [PL 12.30 Item 3](#). **The display changes.**

Y N

Go to [WD 12.4](#). Check S12-190.

Refer to:

- [12G-110](#) LCSS PWB Damage RAP.

A

A

- [GP 13](#) How to Check a Switch.
- P/J315, [LCSS PWB](#).
- [12D-110](#) LCSS Power Distribution RAP.
- [01L](#) 0V Distribution RAP

Install new components as necessary:

- Bin 1 upper limit switch, [PL 12.30 Item 3](#).
- LCSS PWB, [PL 12.75 Item 1](#).

Enter [dC330](#) code 12-191, actuate the bin 1 lower limit switch S12-191, [PL 12.35 Item 1](#). The display changes.

Y N

Go to [WD 12.5](#). Check S12-191.

Refer to:

- [12G-110](#) LCSS PWB Damage RAP.
- [GP 13](#) How to Check a Switch.
- P/J317, [LCSS PWB](#).
- [12D-110](#) LCSS Power Generation RAP.
- [REP 12.13-110](#) LCSS Un-docking.

Install new components as necessary:

- Bin 1 lower limit switch, [PL 12.35 Item 1](#).
- LCSS PWB, [PL 12.75 Item 1](#).

Enter [dC330](#) code 12-187, actuate the bin 1 90% full sensor Q12-187, [PL 12.30 Item 5](#). The display changes.

Y N

Go to [WD 12.5](#). Check Q12-187.

Refer to:

- [12G-110](#) LCSS PWB Damage RAP.
- [GP 11](#) How to Check a Sensor.
- P/J316, [LCSS PWB](#).
- [12D-110](#), LCSS Power Distribution RAP.
- [01L](#) 0V Distribution RAP

Install new components as necessary:

- Bin 1 90% full sensor, [PL 12.30 Item 5](#).
- LCSS PWB, [PL 12.75 Item 1](#).

As final actions, check the following sequence of operation:

- Paper is delivered to the tray until the bin 1 upper level sensor, Q12-188 is actuated.
- The bin 1 elevator motor MOT12-241 lowers the tray until the bin 1 upper level sensor, Q12-188 is de-actuated.
- The Bin 1 elevator motor raises the tray until the paper stack height actuates the Bin 1 upper level sensor, then the Bin 1 elevator motor lowers the tray to continue the cycle.
- When the tray is emptied, the tray returns to the home position. The tray is elevated until the bin 1 upper level sensor, Q12-188 is made. The tray is then lowered until the bin 1 upper level sensor, Q12-188 is just cleared. In the home position the bin 1 upper limit switch, S12-190 is actuated.

12-492-00-110 to 12-494-00-110 IME to Finisher Failure RAP

12-492-00-110 CDI Communications failure with the finisher.

12-493-00-110 The finisher failed to cycle up.

12-494-00-110 The finisher failed to return a prep time to the IME within 1 second.

Initial Actions

WARNING

Ensure that the electricity to the machine is switched off while performing tasks that do not need electricity. Refer to [GP 14](#). Disconnect the power cord. Electricity can cause death or injury. Moving parts can cause injury.

WARNING

Take care not to topple the LCSS. The LCSS is unstable when undocked from the machine. Do not show the customer how to undock the LCSS.

- Switch off the machine, then switch on the machine
- Check that the communication harness from the finisher is plugged in to the IME.

Procedure

Refer to in line connector [PJ904](#) and to [WD 8.5](#). Switch the machine off, [GP 14](#) and disconnect PJ904 on the back of the image processing module. Reconnect PJ904 and switch the machine on, [GP 14](#). If the fault is still present check for damaged pins on PJ904 and on the media path driver PWB. Install new components as required.

12-762-00-110, 12-764-00-110, 12-765-00-110 IME to Finisher Communication Failure RAP

12-762-00-110 Communications failure between the IME and the finisher.

12-764-00-110 The IME cannot detect a finisher plugged in.

12-765-00-110 The IME has detected an incompatible / unknown finisher.

Initial Actions

WARNING

Ensure that the electricity to the machine is switched off while performing tasks that do not need electricity. Refer to GP 14. Disconnect the power cord. Electricity can cause death or injury. Moving parts can cause injury.

WARNING

Take care not to topple the LCSS. The LCSS is unstable when undocked from the machine. Do not show the customer how to undock the LCSS.

- Check that the communication harness from the finisher is plugged in to the IME.
- Check that the actuator, PL 12.15 Item 7 is attached to the right hand machine frame and is making the docking interlock.
- Check that the LCSS has initialized correctly, refer to 12C-110 LCSS Initialization Failure RAP.

Procedure

Refer to in line connector PJ904 and to WD 8.5. Switch the machine off, GP 14 and disconnect PJ904 on the back of the image processing module. Reconnect PJ904 and switch the machine on, GP 14. If the fault is still present check for damaged pins on PJ904 and on the media path driver PWB. Install new components as required.

12-950-00 IME Delivers Sheet Too Early RAP

12-950-00 IME delivers sheet to finisher before the finisher preparation time has expired.

Procedure

WARNING

Ensure that the electricity to the machine is switched off while performing tasks that do not need electricity. Refer to GP 14. Disconnect the power cord. Electricity can cause death or injury. Moving parts can cause injury.

1. For a single occurrence of this fault, take no action.
2. For multiple occurrences of this fault, switch off the machine, then switch on the machine, GP 14. If the fault remains, reinstall software, GP 4.

12A-110 Pause To Unload (PTU) Fault RAP

Use this RAP when the pause to unload (PTU) feature fails to operate.

Initial Actions

WARNING

Ensure that the electricity to the machine is switched off while performing tasks that do not need electricity. Refer to [GP 14](#). Disconnect the power cord. Electricity can cause death or injury. Moving parts can cause injury.

WARNING

Take care not to topple the LCSS. The LCSS is unstable when undocked from the machine. Do not show the customer how to undock the LCSS.

Switch off the machine, then switch on the machine, [GP 14](#).

Check the following:

- The LCSS PWB DIP switch settings, refer to [12F-110 LCSS PWB DIP Switch Settings RAP](#).

Procedure

NOTE: In diagnostics, actuating any LCSS sensor or switch can change the displayed state on the UI. Make sure that the correct sensor or switch is tested.

Enter [dC330](#) code 12-324 to illuminate the pause to unload LED [PL 12.75 Item 3](#). The LED illuminates.

Y N
Go to [WD 12.4](#). Disconnect PJ312. +2V is available at PJ312 between pins B10 and B12 when the code is entered.

Y N
Perform the [12G-110 LCSS PWB Damage RAP](#). If necessary install a new LCSS PWB, [PL 12.75 Item 1](#).

Check the wiring between the LCSS PWB and the pause to unload PWB. The wiring is good.

Y N
Repair the wiring.

Install a new pause to unload PWB, [PL 12.75 Item 3](#).

Enter [dC330](#) code 12-208 to actuate the pause to unload switch S12-208. The display changes.

Y N
Go to [WD 12.4](#). Check the wiring between the LCSS PWB and the pause to unload PWB. The wiring is good.

Y N
Repair the wiring.

Refer to the [12G-110 LCSS PWB Damage RAP](#). Install new components as necessary:

- Pause to unload PWB, [PL 12.75 Item 3](#).
- LCSS PWB, [PL 12.75 Item 1](#).

Perform [SCP 5](#) Final Actions.

12B-110 Bin 1 Overload RAP

Use this RAP to resolve a fault on the bin 1 90% full sensor.

Procedure

WARNING

Ensure that the electricity to the machine is switched off while performing tasks that do not need electricity. Refer to [GP 14](#). Disconnect the power cord. Electricity can cause death or injury. Moving parts can cause injury.

WARNING

Take care not to topple the LCSS. The LCSS is unstable when undocked from the machine. Do not show the customer how to undock the LCSS.

Enter [dC330](#) code 12-187, actuate the bin 1 90% full sensor Q12-187, [PL 12.30 Item 5](#). The display changes.

Y N
Go to [WD 12.5](#). Check Q12-187.
Refer to:

- [12G-110 LCSS PWB Damage RAP](#).
- [GP 11](#), How to Check a sensor.
- P/J316, [LCSS PWB](#).
- [12D-110 LCSS Power Generation RAP](#).

Install new components as necessary:

- Bin 1 90% full sensor, [PL 12.30 Item 5](#).
- LCSS PWB, [PL 12.75 Item 1](#).

Perform [SCP 5](#) Final Actions.

12C-110 LCSS Initialization Failure RAP

When an initialization command is received from the machine, the units are initialized in two stages:

- The following units are initialized sequentially:
 1. If the staple head is not at the home position, it is driven to the home position
 2. If the stapling unit is not at the home position, it is driven to the home position
 3. If the ejector is not at the home position, it is driven to the home position
- The following units are then initialized simultaneously:
 1. If the front tamper is not at the home position, it is driven to the home position
 2. If the rear tamper is not at the home position, it is driven to the home position
 3. If the hole punch is not at the home position, it is driven to the home position
 4. If the paddle is not at the home position, it is driven to the home position
 5. If the stacker is not at the home position, it is driven to the home position

NOTE: The staple cartridge must be fully pushed home.

Initial Actions

WARNING

Ensure that the electricity to the machine is switched off while performing tasks that do not need electricity. Refer to GP 14. Disconnect the power cord. Electricity can cause death or injury. Moving parts can cause injury.

WARNING

Take care not to topple the LCSS. The LCSS is unstable when undocked from the machine. Do not show the customer how to undock the LCSS.

CAUTION

Do not install a new LCSS PWB until the cause of the damage to the old LCSS PWB has been determined, go to 12G-110 LCSS PWB Damage RAP.

Check the fuse on the LCSS PWB, If the fuse (F1) is good, continue at the procedure. If the fuse not good, install a new LCSS PWB, PL 12.75 Item 1.

Check the LCSS PWB DIP switch settings, refer to 12F-110 LCSS PWB DIP Switch Settings RAP.

Remove the LCSS covers, REP 12.1-110, so that the units can be viewed. Cheat the front door interlock switch and the top cover interlock switch. Check that LED 2 is illuminated, this shows that all interlocks are made. If the LED fails to illuminate, go to 12-310-00-110, 12-312-00-110, 12-313-00-110 Interlocks RAP.

Procedure

Figure 1. Check that the software heartbeat is present on LED 1. The LED should flash twice per second if the LCSS software is running. If necessary re-load the LCSS software, refer to GP 4 Machine Software.

If the initialization sequence fails to place any unit at the home position, refer to the appropriate RAPs:

- Front tamper not at home, refer to 12-392-00-110, 12-393-00-110, 12-394-00-110 Front Tamper Move Failure RAP

- Rear tamper not at home, refer to 12-396-00-110, 12-397-00-110, 12-398-00-110, Rear Tamper Move Failure RAP.
- Paddle not at home, refer to 12-024-00-110, 12-025-00-110 Paddle Roll Failure RAP.
- Bin 1 not at home, refer to 12-462-00-110 Bin 1 Movement Failures RAP.
- Punch not at home, refer to 12-043-00-110, 12-046-00-110 Hole Punch Operation Failure RAP
- Staple head not at home, refer to 12M-110 Staple Head Operation Failure RAP.
- Stapling unit not at home, refer to 12-371-00-110, 12-372-00-110, 12-378-00-110 Staple Head Unit Movement Failure RAP.
- Ejector not at home, refer to 12-340-00-110, 12-341-00-110, 12-342-00-110 Ejector Movement Failure RAP.

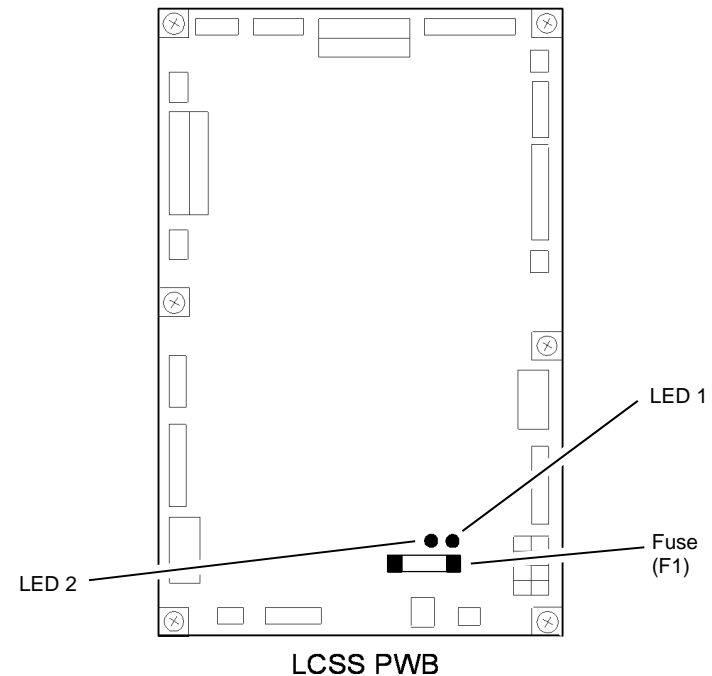

Figure 1 LED location

U-1-0119-A

12D-110 LCSS Power Distribution RAP

The LCSS has an integral power supply providing +24V and +5V supplies to the LCSS PWB. The AC power for the LCSS power supply comes from the LVPS and base module of the machine.

Procedure

WARNING

Ensure that the electricity to the machine is switched off while performing tasks that do not need electricity. Refer to [GP 14](#). Disconnect the power cord. Electricity can cause death or injury. Moving parts can cause injury.

WARNING

Take care when measuring AC mains (line) voltage. Electricity can cause death or injury.

WARNING

Take care not to topple the LCSS. The LCSS is unstable when undocked from the machine. Do not show the customer how to undock the LCSS.

CAUTION

Do not connect the finisher power cord directly to the AC wall outlet. The finisher cannot operate without the machine. The machine controls the distribution of electricity to the finisher for correct power on and power off sequencing.

Close or cheat all the LCSS interlocks. Refer to [GP 15](#) for the location and function of the LED's on the PWB's. The LED's on the LCSS PWB are illuminated, [PL 12.75 Item 1](#).

Y N

+24V is available at Fuse (F1) on the LCSS PWB.

Y N

Go to [WD 12.1](#). +24V is available at P/J300 between pins 1 and 2, also between pins 5 and 3.

Y N

Disconnect P/J 300. +24V is available at P/J300 between pins 1 and 2, also between pins 5 and 3 on the end of the harness.

Y N

Loosen the 4 screws and lift the power supply module away from the LCSS frame, [PL 12.75 Item 2](#). Go to [WD 12.1](#). ACL is available at CN1 between pins 1 and 3.

Y N

Go to the [01A AC Power RAP](#) and check the AC output voltages.

Check the wiring between CN2 and P/J 300. The wiring is good.

Y N

Repair the wiring.

Install a new power supply module, [PL 12.75 Item 2](#).

Check for a short circuit or an overload in the wiring or components connected to the +24V on the LCSS PWB. Repair the wiring as necessary, [REP 1.1](#).

Go to [WD 12.4](#) +24V is available at PJ315 pin 5 on the LCSS PWB.

Y N

Go to the [12-310-00-110](#), [12-312-00-110](#), [12-313-00-110](#) Interlocks RAP.

A B C

WARNING

Do not install a fuse of a different type or rating. Installing the wrong type or rating of fuse can cause overheating and a risk of fire.

Perform the following:

- Switch off the machine, [GP 14](#).
- Go to [WD 12.1](#). Disconnect the +24V harness to the docking interlock switch, S12-177.
- Go to [WD 12.1](#). Disconnect the +24V harness to the front door interlock switch, S12-303.
- Go to [WD 12.4](#). Disconnect the +24V harness to the top cover interlock switch, S12-197.
- Go to [WD 12.1](#). Disconnect the +24V harness to the transport motor 1, MOT12-223.
- Go to [WD 12.3](#). Disconnect the +24V harness to the transport motor 2, MOT12-224.
- Go to [WD 12.3](#). Disconnect the +24V harness to the SU1 motor SU1 motor, MOT12-249.
- Go to [WD 12.3](#). Disconnect the +24V harness to the paddle roll motor, MOT12-238.
- Go to [WD 12.4](#). Disconnect the +24V harness to the bin 1 lower limit switch, S12-191.
- Go to [WD 12.3](#). Disconnect the +24V harness to the front tamper motor MOT12-226.
- Go to [WD 12.3](#). Disconnect the +24V harness to the rear tamper motor MOT12-227.
- Go to [WD 12.5](#). Disconnect the +24V harness to the bin 1 elevator motor MOT12-241.
- Go to [WD 12.5](#). Disconnect the +24V harness to the bin 1 lower limit switch, S12-191.
- Go to [WD 12.3](#) Disconnect the +24V harness to the hole punch motor, MOT12-243.
- Go to [WD 12.2](#) Disconnect the +24V harness to the staple head 1 motor, MOT12-247.
- Check each harness for short circuits and overheating, [GP 7](#).
- Install new components as necessary.
- Install a new fuse F1 on the LCSS PWB, switch on the machine, [GP 14](#).
- Monitor the voltage at the left end of the fuse and re-connect the circuits one at a time. Energize the re-connected components using [dC330](#) control codes.
- If the voltage drops below +22V, switch off the machine, [GP 14](#). Re-check the component and harness for overheating or short circuits. Install new components as necessary.

Perform the [12G-110 LCSS PWB Damage RAP](#), if necessary install a new LCSS PWB, [PL 12.75 Item 2](#).

Go to [WD 12.1](#). +5V is available at P/J300 between pins 4 and 6, also between pins 7 and 8.

A B C

Y N
Disconnect P/J300. **+5V is available at P/J300 between pins 4 and 6, also between pins 7 and 8 on the end of the harness.**

Y N
Loosen the 4 screws and lift the power supply module away from the LCSS frame.
Go to [WD 12.1](#). **ACL is available at CN1 between pins 1 and 3.**

Y N
Go to the [01A](#) AC Power RAP and check the AC output voltages.

Check the wiring between CN2 and P/J300. **The wiring is good.**

Y N
Repair the wiring.

Install a new power supply module, [PL 12.75 Item 2](#).

Check for a short circuit or overload in the wiring or components connected to +5V on the LCSS PWB. Repair the wiring as necessary, [REP 1.1](#).

Perform the [12G-110](#) LCSS PWB Damage RAP. If necessary install a new LCSS PWB, [PL 12.75 Item 1](#).

12E-110 LCSS Paper Entry RAP

The leading edge of the sheet is late to the entry sensor Q12-077, [PL 12.70 Item 3](#).

Initial Actions

WARNING

Ensure that the electricity to the machine is switched off while performing tasks that do not need electricity. Refer to [GP 14](#). Disconnect the power cord. Electricity can cause death or injury. Moving parts can cause injury.

WARNING

Take care not to topple the LCSS. The LCSS is unstable when undocked from the machine. Do not show the customer how to undock the LCSS.

Refer to the [12H-110](#) Copy Damage in the LCSS RAP.

Check the following:

- LCSS PWB DIP switch settings, refer to [12F-110](#) LCSS PWB DIP Switch Settings RAP.
- Ensure the paper tray guides are set to the correct position for the size of paper in the tray.
- Check the input guide for damage or wear that could cause paper to jam.
- Paper jam in the machine to LCSS paper path, [ADJ 12.2-110](#) Machine to LCSS Alignment.
- IOT exit path and feed rolls.
- Feeding performance from a paper tray loaded with a new ream of paper.

Procedure

NOTE: In diagnostics, actuating any LCSS sensor or switch can change the displayed state on the UI. Make sure that the correct sensor or switch is tested.

Lower the paper entry guide assembly, [PL 12.40 Item 8](#), to access the entry sensor. Enter [dC330](#) code 12-077, actuate the entry sensor Q12-077. **The display changes.**

Y N
Go to [WD 12.1](#). Check Q12-077.

Refer to:

- [12G-110](#) LCSS PWB Damage RAP.
- [GP 11](#), How to Check a Sensor.
- P/J304, [LCSS PWB](#).
- [12D-110](#) LCSS Power Distribution RAP.
- [01L](#) 0V Distribution RAP

Install new components as necessary:

- Entry sensor, [PL 12.70 Item 3](#).
- LCSS PWB, [PL 12.75 Item 1](#).

Make sure that the paper correctly continues past the previous sensor in the paper path. Refer to the [10-140-00 to 10-146-00](#), [10-149-00 to 10-151-00](#) Exit Jam RAP.

12F-110 LCSS PWB DIP Switch Settings RAP

To show the correct settings for the DIP switches on the LCSS PWB.

Procedure

WARNING

Ensure that the electricity to the machine is switched off while performing tasks that do not need electricity. Refer to [GP 14](#). Disconnect the power cord. Electricity can cause death or injury. Moving parts can cause injury.

WARNING

Take care not to topple the LCSS. The LCSS is unstable when undocked from the machine. Do not show the customer how to undock the LCSS.

Problems that can result from incorrect DIP switch settings are:

- False jam clearance instructions for the LCSS and/or the machine exit area.
- Communication errors between the LCSS and machine.
- Erratic behavior of the LCSS.

Check the DIP switch settings, [Figure 1](#). If necessary, switch off the machine, [GP 14](#). Correct the DIP switch setting, then switch on the machine, [GP 14](#).

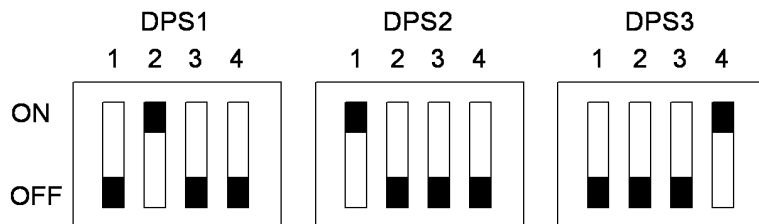

U-1-0121-A

Figure 1 DIP switch settings

12G-110 LCSS PWB Damage RAP

Use this RAP to determine the cause of damage to the LCSS PWB, so that the cause can be repaired before a new LCSS PWB is installed.

Initial Actions

WARNING

Ensure that the electricity to the machine is switched off while performing tasks that do not need electricity. Refer to [GP 14](#). Disconnect the power cord. Electricity can cause death or injury. Moving parts can cause injury.

WARNING

Take care not to topple the LCSS. The LCSS is unstable when undocked from the machine. Do not show the customer how to undock the LCSS.

Check the fuse on the LCSS PWB. If the fuse is good, continue at the procedure. If the fuse not good, install a new LCSS PWB, [PL 12.75 Item 1](#).

Procedure

The LCSS PWB can be damaged by a component connected to it going short-circuit. If a new LCSS PWB is installed and power applied to the machine, the new LCSS PWB will be damaged in the same way. The cause of the damage must be found by following this procedure.

Remove the LCSS PWB and inspect the components shown in [Figure 1](#) for damage. The damage to the component may be in the form of a crack, a small crater or a burnt patch. Refer to [Table 1](#) to locate the component causing the damage to the LCSS PWB.

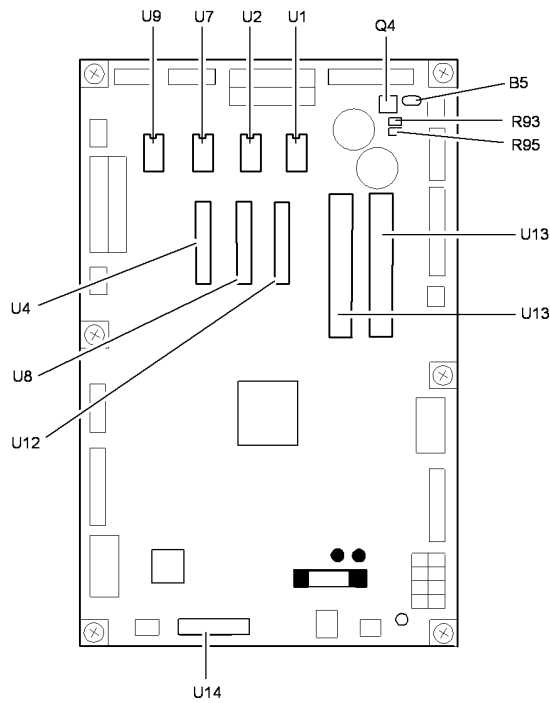

U-1-0122-A

Figure 1 LCSS PWB components

Table 1 LCSS PWB Drive Components

LCSS PWB component	Driven component	Normal resistance measurement +/- 10%	Spared part and references
U9	Rear tamper motor	PJ312 pin A1 to A3 = 29 ohms. PJ312 pin A1 to A4 = 29 ohms. PJ312 pin A2 to A5 = 29 ohms. PJ312 pin A2 to A6 = 29 ohms.	Tamper assembly, PL 12.45 Item 1. 12-396-00-110, 12-397-00-110, 12-398-00-110, RAP
U8	Staple head motor	PJ308 pin A8 to A10 = 20 ohms. PJ308 pin A9 to A11 = 20 ohms	Staple head unit, PL 12.55 Item 5. 12M-110 RAP
U7	Front tamper motor	PJ312 pin A7 to A9 = 29 ohms. PJ312 pin A7 to A10 = 29 ohms. PJ312 pin A8 to A11 = 29 ohms. PJ312 pin A8 to A12 = 29 ohms.	Tamper assembly, PL 12.45 Item 1. 12-392-00-110, 12-393-00-110, 12-394-00-110 RAP

Table 1 LCSS PWB Drive Components

LCSS PWB component	Driven component	Normal resistance measurement +/- 10%	Spared part and references
U13	Transport motor 1	PJ305 pin 1 to 4 = 4 ohms. PJ305 pin 1 to 5 = 4 ohms. PJ305 pin 2 to 6 = 4 ohms. PJ305 pin 2 to 3 = 4 ohms.	Transport motor 1, PL 12.40 Item 2. 12-171-00-110, 12-172-00-110 RAP
U15	Transport motor 2	PJ309 pin 1 to 4 = 1.3 ohms. PJ309 pin 1 to 5 = 1.3 ohms. PJ309 pin 2 to 6 = 1.3 ohms. PJ309 pin 2 to 7 = 1.3 ohms.	Transport motor 2, PL 12.60 Item 5. 12-171-00-110, 12-172-00-110 RAP
U4	Hole punch motor	PJ311 pin 1 to 2 = 6 ohms	Hole punch motor, PL 12.20 Item 2. 12-043-00-110, 12-046-00-110 RAP
U2	Paddle motor	PJ310 pin 1 to 3 = 29 ohms. PJ310 pin 1 to 4 = 29 ohms. PJ310 pin 2 to 5 = 29 ohms. PJ310 pin 2 to 6 = 29 ohms.	Paddle motor assembly, PL 12.25 Item 10. 12-024-00-110, 12-025-00-110 RAP
U1	SU1 motor (stapler indexing)	PJ308 pin B9 to B11 = 20 ohms. PJ308 pin B9 to B12 = 20 ohms. PJ308 pin B10 to B13 = 20 ohms. PJ308 pin B10 to B14 = 20 ohms.	Stapler traverse assembly, PL 12.55 Item 1. 12-371-00-110, 12-372-00-110, 12-378-00-110 RAP
U12	Ejector motor	PJ303 pin 1 to 2 = 8 ohms	Ejector assembly, PL 12.50 Item 1. 12-340-00-110, 12-341-00-110, 12-342-00-110 RAP
Q4, B5, R93, R95	Diverter gate solenoid	PJ306 pin 1 to pin 2 = 74 ohms	Diverter gate solenoid, PL 12.60 Item 12. 12-171-00-110, 12-172-00-110 RAP
U14	Bin 1 elevator motor	PJ318 pin 1 to 2 = 7.7 ohms	Bin 1 elevator motor, PL 12.30 Item 8. 12-462-00-110 RAP

NOTE: If difficulty is found in connecting the service meter probes to the connector headers on the LCSS PWB, refer to the RAP quoted in Table 1 and make the measurement at another point in the harness to the driven component.

If the defective driven component is found using the table checks, disconnect the connector closest to the driven component, then check the driven component again to identify any short circuit in the wiring to the driven component. Repair the wiring or install new parts as necessary.

If the defective driven component can not be found using the table checks, refer to GP 7, check each driven component to ensure that it is not seized. Motors should rotate reasonably easily. Solenoid armatures should slide easily in the coil. Also check the drive components to ensure that they rotate easily, if necessary install new parts.

When the a new driven component has been installed or the defective drive components have been repaired, install a new LCSS PWB, PL 12.75 Item 1.

12H-110 Copy Damage in the LCSS RAP

Use this RAP to identify and correct the causes of copy damage in the LCSS.

Procedure

WARNING

Ensure that the electricity to the machine is switched off while performing tasks that do not need electricity. Refer to [GP 14](#). Disconnect the power cord. Electricity can cause death or injury. Moving parts can cause injury.

WARNING

Take care not to topple the LCSS. The LCSS is unstable when undocked from the machine. Do not show the customer how to undock the LCSS.

Check the following:

- Look for torn paper in the LCSS paper path. Torn fragments can pass through the IOT and LCSS paper path without causing a problem until they finally wedge themselves at some point. A likely place for a piece of paper to be wedged is at the hole punch assembly, where the top and bottom guides form the narrowest part of the paper path.
- Ensure that the shaft diverter assembly, [PL 12.60 Item 13](#), operates correctly and has full movement.
- Ensure that the hole punches park at the fully open position. If they protrude even slightly, a jam will occur in the narrow paper path of the hole punch.
- Ensure that the jam clearance guide, [PL 12.70 Item 6](#), closes and latches correctly. Check that the magnet at the rear is located and functions correctly. Check the clip at the front is positioned correctly, [PL 12.70 Item 7](#).
- Ensure that all idler rolls in the LCSS paper path are free to rotate, particularly those on the jam clearance guide, where the paper turns through 90 degrees.
- Ensure that the paper path ribs of the jam clearance guide, [PL 12.70 Item 6](#), and the entry guide cover, [PL 12.70 Item 5](#), are free of scores and nicks. Check also for contamination and glue from label stock.

12J-110 Mis-Registration in Stapled Sets and Non-Stapled Sets RAP

Use this RAP to identify and correct the causes of mis-registration in stapled sets, resulting in staples missing some sheets in the set, or poorly registered non-stapled sets.

Procedure

WARNING

Ensure that the electricity to the machine is switched off while performing tasks that do not need electricity. Refer to [GP 14](#). Disconnect the power cord. Electricity can cause death or injury. Moving parts can cause injury.

WARNING

Take care not to topple the LCSS. The LCSS is unstable when undocked from the machine. Do not show the customer how to undock the LCSS.

The most likely cause of mis-registration is paper condition and/or damage such as curl, wrinkle, creases, dog ears, etc.

Curl, wrinkle and creases are probably caused in the IOT, go to [IQ 1](#) Image Quality Entry RAP.

For other copy/print damage and dog ears, go to the [12H-110](#) Copy Damage in the LCSS RAP.

Check the following:

- Check that bin 1 is seated correctly and the bin 1 alignment clip is in position, [PL 12.10 Item 13](#).
- Turn over the paper stack in the tray in use.
- Use a new ream of paper in the tray in use.
- Paper type, especially recycled paper, can lead to registration problems. Try changing to a different brand or type of paper.
- Ensure that the guides in the paper trays are correctly set and reported on the UI for the paper size loaded.
- Check that paper type is set correctly. If heavyweight paper is used but not set in the UI, the compiler capacity can be exceeded.
- Check for obstructions in the compiler.
- Ensure that the paddle roll operates correctly and that the paddles are not damaged. The paddles should park completely inside the top section of the compiler, with the shorter paddle in a vertical position. If all of the paddles are out of position, check the paddle roll position sensor, [PL 12.25 Item 11](#), the flag, [PL 12.25 Item 7](#) and the paddle motor assembly, [PL 12.25 Item 10](#). If only one paddle is mis-aligned with the others, it can be re-positioned by hand (they are not bonded to the shaft).
- Ensure that the tampers operate correctly, i.e. are not stalling or losing position during the job. Inspect the tampers for damage, if necessary install new parts. [PL 12.45](#).
- Inspect the bin 1 entry nips for roll damage. The idlers should be held against the rubber driving rolls and they should be free to rotate within their support springs. If necessary, install new parts, [PL 12.65](#).
- Inspect the four spring loaded guides on the output cover, [PL 12.10 Item 7](#). Ensure that they are correctly located and are free to move up and down.

12K-110 LCSS Poor Stacking RAP

Use this RAP to find the cause of poor stacking in the LCSS.

Procedure

WARNING

Ensure that the electricity to the machine is switched off while performing tasks that do not need electricity. Refer to [GP 14](#). Disconnect the power cord. Electricity can cause death or injury. Moving parts can cause injury.

Check the following:

- Look for sets that are not dropping back fully in bin 1 and therefore not operating the bin 1 level sensor:
 - Large paper sizes should not be stacked on top of small paper sizes.
 - Ensure that the paper stack in each paper tray has been fanned.
 - Turn over the paper stack in each paper tray.
 - Ensure that all paper or other copy stock being used is within the size and weight specifications. Refer to [GP 20](#) Paper and Media Size Specifications.
 - Try using a fresh ream of paper.
 - Ensure that the edge guides of all paper trays are adjusted correctly for the paper size and that the trays are fully closed.
 - Check that bin 1 is seated correctly and the bin 1 alignment clip is in position, [PL 12.10 Item 13](#).
- Labels must not be fed to bin 1, feed all labels bin 0 only.
- It is recommended that transparencies are fed to bin 0 whenever possible.
- Check that bin 1 is level front to back. If necessary perform [ADJ 12.1-110](#) LCSS Bin 1 Level.
- Check that the bin 1 upper level sensor Q12-188 is working correctly. Refer to the [12-462-00-110](#) Bin 1 Movement Failure RAP.
- Check the operation of the front and rear tampers. Refer to [12-392-00-110](#), [12-393-00-110](#), [12-394-00-110](#) Front Tamper Move Failure RAP and [12-396-00-110](#), [12-397-00-110](#), [12-398-00-110](#), Rear Tamper Move Failure RAP.
- Check that the output device is not near an air conditioning or ventilation output duct. Air flow across the output bins can cause poor stacking.

12L-110 Stapling Prime Failure RAP

Use this RAP when the staples in the stapling head are not primed.

Initial Actions

WARNING

Ensure that the electricity to the machine is switched off while performing tasks that do not need electricity. Refer to [GP 14](#). Disconnect the power cord. Electricity can cause death or injury. Moving parts can cause injury.

WARNING

Take care not to topple the LCSS. The LCSS is unstable when undocked from the machine. Do not show the customer how to undock the LCSS.

- Switch off the machine, then switch on the machine, [GP 14](#).
- Check the LCSS PWB DIP switch settings, refer to [12F-110](#) LCSS PWB DIP Switch Settings RAP.
- Check the following:
 - The staple cartridge has staples in it and is correctly installed,
 - The leading staples in the staple head have been primed, [Figure 3](#).
 - Check that the sheets of staples in the cartridge are feeding one at a time. If staple sheets overlap, they will jam in the cartridge. If necessary, install a new staple cartridge, [PL 26.10 Item 16](#).

NOTE: The term “priming” refers to 2 staples at the front of the cartridge, that have been pre-formed automatically by the action of the stapler, refer to [Figure 3](#).

NOTE: The SH 1 low staples sensor, SH 1 cartridge sensor, SH 1 home sensor and the SH 1 priming sensor are all integral to the staple head unit. These sensors can be checked using component control codes but they cannot be exchanged as components.

Procedure

Figure 1. Enter [dC330](#) code 12-196, actuate the SH1 paper sensor Q12-196. The display changes.

Y N

Go to [WD 12.2](#). Check Q12-196.

Refer to:

- [12G-110](#) LCSS PWB Damage RAP.
- [GP 11](#), How to Check a Sensor.
- PJ308, [LCSS PWB](#).
- [12D-110](#) LCSS Power Distribution RAP.
- [01L 0V](#) Distribution RAP

Install new components as necessary:

- SH1 paper sensor, [PL 12.55 Item 4](#).
- LCSS PWB, [PL 12.75 Item 1](#).

A

A

NOTE: If the SH1 priming sensor does not see staples in the primed position, the staple head cycles a number of times to prime the staple head. This occurs when the LCSS interlocks are made.

Follow the customer instruction label inside the LCSS front door to remove the staple cartridge, slide out the top sheet of staples from the cartridge, to expose a fresh sheet of staples on the top of the stack. Ensure the forming plate is fully closed, **Figure 2**. Install the staple cartridge and close the door. The stapler will now cycle a few times to feed and prime the new sheet of staples. Open the door and remove the staple cartridge. Examine the sheet of staples that have been fed to the staple forming part of the stapler, by opening the forming plate, **Figure 3**. **The first two staples have been partially formed.**

Y N

Install a new staple cartridge, **PL 26.10 Item 16** and repeat the check. If the first two staples are not partially formed install a new staple head unit, **PL 12.55 Item 5**. Perform **SCP 5 Final Actions**

Install a new staple head unit, **PL 12.55 Item 5**. Perform **SCP 5 Final Actions**.

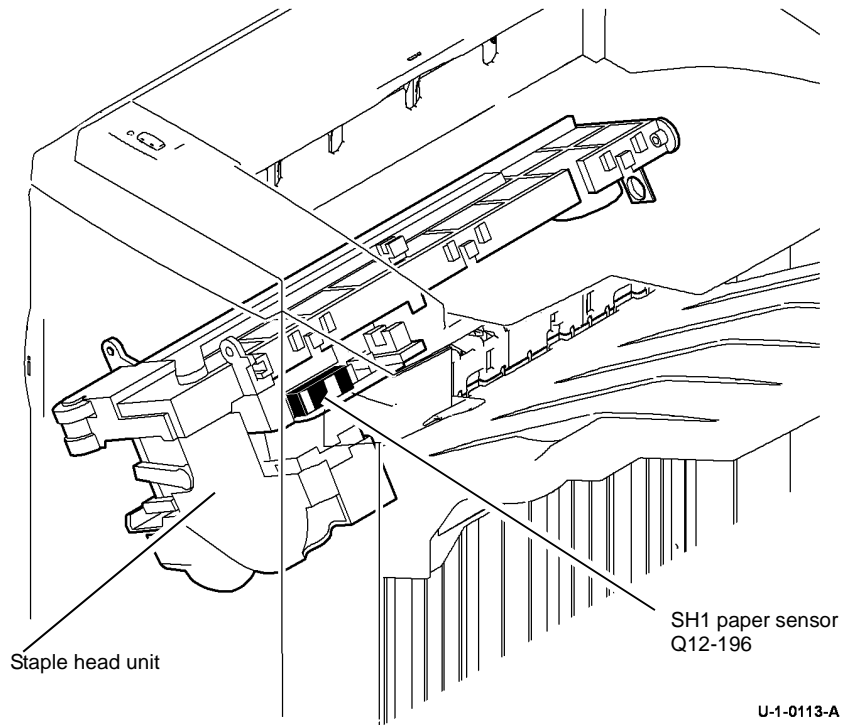
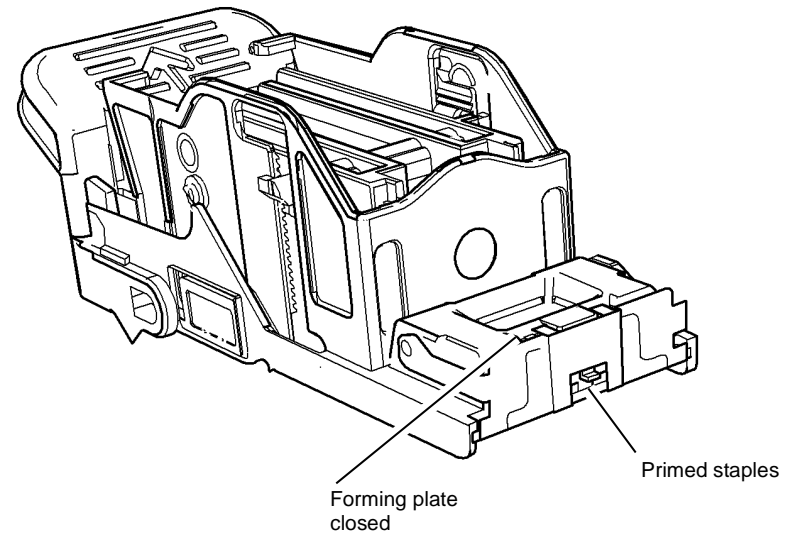

Figure 1 Component location



U-1-0115-A

Figure 2 Staple cartridge closed

12M-110 Staple Head Operation Failure RAP

Use this RAP when the staple head fails to cycle or the staple head is not at the home position.

NOTE: The home position is with the jaws of the staple head fully open.

Initial Actions

WARNING

Ensure that the electricity to the machine is switched off while performing tasks that do not need electricity. Refer to [GP 14](#). Disconnect the power cord. Electricity can cause death or injury. Moving parts can cause injury.

WARNING

Take care not to topple the LCSS. The LCSS is unstable when undocked from the machine. Do not show the customer how to undock the LCSS.

CAUTION

Do not run code 12-247 without 2 sheets of paper in the stapler jaws. Running this code without the paper in position can cause damage to the machine.

Switch off the machine, then switch on the machine, [GP 14](#).

Check the following:

- The LCSS PWB DIP switch settings, refer to [12F-110 LCSS PWB DIP Switch Settings RAP](#).
- The staple head unit is correctly installed [PL 12.55 Item 5](#).

NOTE: With reference to [WD 12.2](#), component control codes;

Code 12-247 cycles the staple head 1 motor.

Code 12-248 reverses the staple head 1 motor to the home position.

Procedure

NOTE: After repairing the fault using this RAP, switch off the machine, then switch on the machine, [GP 14](#), to enable operation of the staple head.

NOTE: All LCSS interlocks must be made to supply +24V to the motors.

Place two sheet of paper in the stapler jaws then enter [dC330](#) code 12-247 to cycle the staple head once. Enter code 12-248 to reverse the staple head to the home position. **The staple head operates as expected.**

Y N

Go to [WD 12.2](#). Check the wiring and connectors between the LCSS PWB and the staple head. **The wiring is good.**

Y N

Repair the wiring.

Refer to:

- [12G-110 LCSS PWB Damage RAP](#).
- [GP 13](#), How to Check a Switch.
- P/J 308, [LCSS PWB](#)
- [12D-110 LCSS Power Distribution RAP](#).
- [01L 0V Distribution RAP](#)

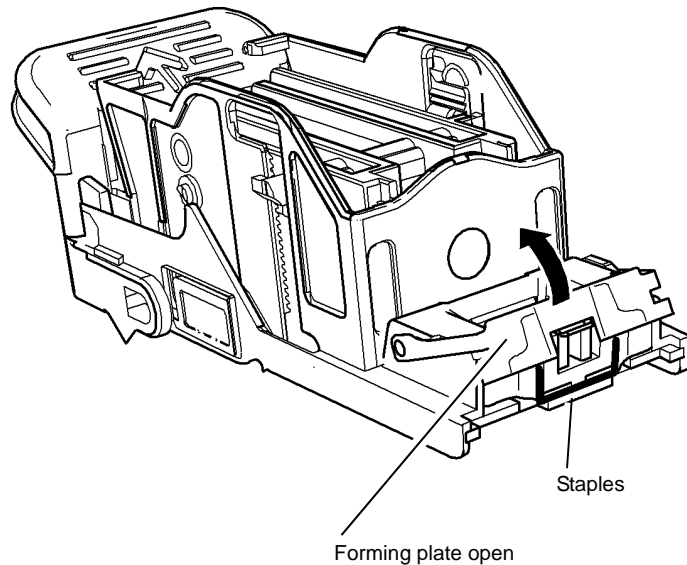

U-1-0114-A

Figure 3 Staple cartridge open

A

Install new components as necessary:

- Staple head unit, [PL 12.55 Item 5](#).
- LCSS PWB, [PL 12.75 Item 1](#).

Perform [SCP 5](#) Final Actions.

12N-110 Chad Bin Present and Bin Full RAP

Use this RAP when there is a false indication of a missing or full chad bin.

Initial Actions

WARNING

Ensure that the electricity to the machine is switched off while performing tasks that do not need electricity. Refer to [GP 14](#). Disconnect the power cord. Electricity can cause death or injury. Moving parts can cause injury.

- Check that the chad bin is fully inserted.
- Check that the actuator for the chad bin level sensor engages in the slot of the chad bin.
- Check that the sensor hole in the side of the chad bin is clear of obstructions.

Procedure

Enter [dC330](#) code 12-193. Actuate the chad bin level sensor Q12-193, using a strip of paper, [PL 12.20 Item 7](#). The display changes.

Y N

Go to [WD 12.2](#). Check the chad bin level sensor Q12-193.

Refer to:

- [12G-110](#) LCSS PWB Damage RAP.
- [GP 11](#) How to Check a Sensor.
- [P/J307](#), [LCSS PWB](#).
- [12D-110](#) LCSS Power Distribution RAP.
- [01L 0V](#) Distribution RAP

Install new components as necessary:

- Chad bin level sensor, [PL 12.20 Item 7](#).
- LCSS PWB, [PL 12.75 Item 1](#).

Perform [SCP 5](#) Final Actions.

12-024-00-171, 12-025-00-171 HVF Paddle Roller Position RAP

12-024-00-171 The paddle roller has failed to return to the home position.

12-025-00-171 The paddle roller has failed to move from the home position.

Initial Actions

WARNING

Ensure that the electricity to the machine is switched off while performing tasks that do not need electricity. Refer to GP 14. Disconnect the power cord. Electricity can cause death or injury. Moving parts can cause injury.

Check for damage or any obstruction that would prevent paddle movement. If necessary, install new components.

Procedure

Enter dC330, code 12-186. Manually actuate the paddle roll home sensor, Q12-186, Figure 1. The display changes.

- Y N
- Go to WD 12.9. Check the wiring and repair as necessary, REP 1.1. Check the paddle roller home sensor, Q12-186. Refer to:
- GP 11 How to Check a Sensor.
 - 12A-171 HVF Power Distribution RAP.
 - 01L 0V Distribution RAP
- Install new components as necessary:
- Paddle unit, PL 12.115 Item 2.
 - HVF PWB, PL 12.140 Item 2.

Enter dC330, code 12-238 Paddle Roll Motor Run, to check the movement of the paddle, Figure 1. The paddle turns.

- Y N
- Go to WD 12.10. Check the wiring and repair as necessary, REP 1.1. Check the paddle roller motor, MOT12-238. Refer to:
- GP 10 How to Check a Motor.
 - 12A-171 HVF Power Distribution RAP.
 - 01L 0V Distribution RAP
- Install new components as necessary:
- Paddle unit, PL 12.115 Item 2.
 - HVF PWB, PL 12.140 Item 2.

Perform SCP 5 Final Actions.

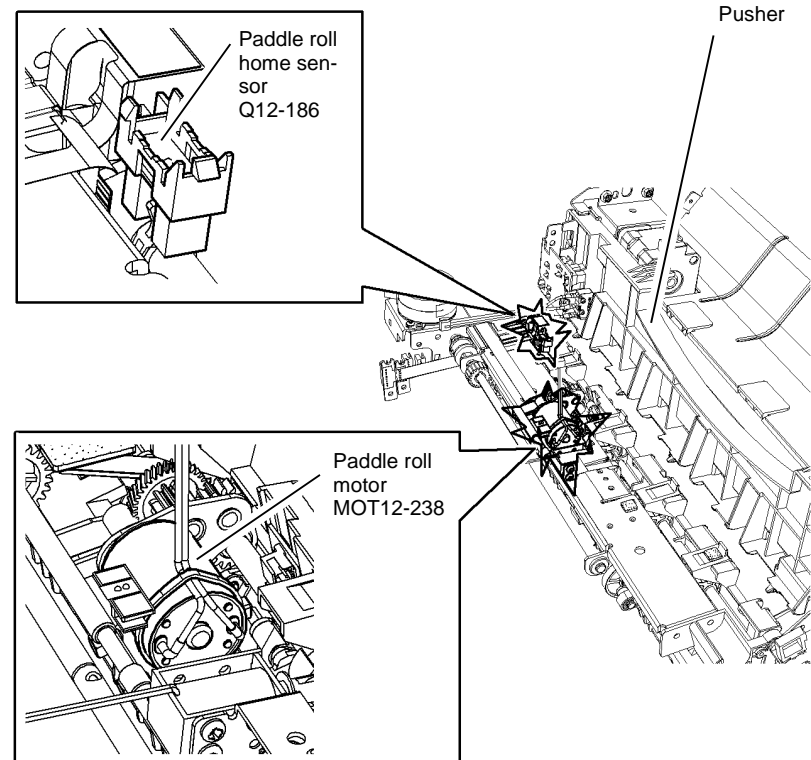

Figure 1 Components

U-1-0124-A

12-044-00-171 to 12-047-00-171 HVF Punch Head Position RAP

12-044-00-171 The punch head has failed to return to the home position within the required time.

12-045-00-171 The punch head has failed to move from the home position within the required time.

12-046-00-171 The punch unit has failed to return to the home position within the required time.

12-047-00-171 The punch unit has failed to move from the home position within the required time.

Initial Actions

WARNING

Ensure that the electricity to the machine is switched off while performing tasks that do not need electricity. Refer to **GP 14**. Disconnect the power cord. Electricity can cause death or injury. Moving parts can cause injury.

Check the punch head area for any obstruction or damage that could prevent the free movement of the head or the unit. If necessary, install new components.

Procedure

Enter **dC330**, code 12-244 for the punch head motor, MOT12-244, **Figure 1**. The control code 12-243, punch head move home, can also be used. **The motor runs.**

Y N

Go to **WD 12.24**. Check the wiring from the motor to the PWB. Repair as necessary, **REP 1.1**. Check the punch head motor, MOT12-244. Refer to:

- **GP 10** How to Check a Motor.
- **12A-171** HVF Power Distribution RAP.
- **01L 0V** Distribution RAP

Install new components as necessary:

- Hole punch module, **PL 12.125 Item 19**.
- HVF PWB, **PL 12.140 Item 2**.

Enter **dC330**, code 12-194 for the punch head home sensor and stack the code 12-244 for the punch head motor. Observe the condition of the sensor on the UI. **The display changes.**

Y N

Go to **WD 12.12**. Check the wiring from the sensor to the PWB. Repair as necessary, **REP 1.1**. Check the punch head home sensor, Q12-194. Refer to:

- **GP 11** How to Check a Sensor.
- **12A-171** HVF Power Distribution RAP.
- **01L 0V** Distribution RAP

Install new components as necessary:

- Hole punch module, **PL 12.125 Item 19**.
- HVF PWB, **PL 12.140 Item 2**.

Enter **dC330**, code 12-245 for the punch unit motor to travel in the forward direction, or enter the code 12-246 for the punch unit motor to travel in the reverse direction. **The motor runs.**

Y N

Go to **WD 12.24**. Check the wiring from the motor to the PWB. Repair as necessary, **REP 1.1**. Check MOT12-245. Refer to:

- **GP 10** How to Check a Motor.
 - **12A-171** HVF Power Distribution RAP.
 - **01L 0V** Distribution RAP
- Install new components as necessary:
- Hole punch module, **PL 12.125 Item 19**.
 - HVF PWB, **PL 12.140 Item 2**.

Enter **dC330**, code 12-114 for the punch unit home sensor and stack the code 12-245 or 12-246 to take the punch unit motor to home, then away from home. Observe the condition of the sensor on the UI. **The display changes.**

Y N

Go to **WD 12.12**. Check the wiring from the sensor to the PWB. Repair as necessary, **REP 1.1**. Check the punch unit home sensor, Q12-114. Refer to:

- **GP 11** How to Check a Sensor.
- **12A-171** HVF Power Distribution RAP.
- **01L 0V** Distribution RAP

Install new components as necessary:

- Hole punch module, **PL 12.125 Item 19**.
- HVF PWB, **PL 12.140 Item 2**.

Perform **SCP 5** Final Actions.

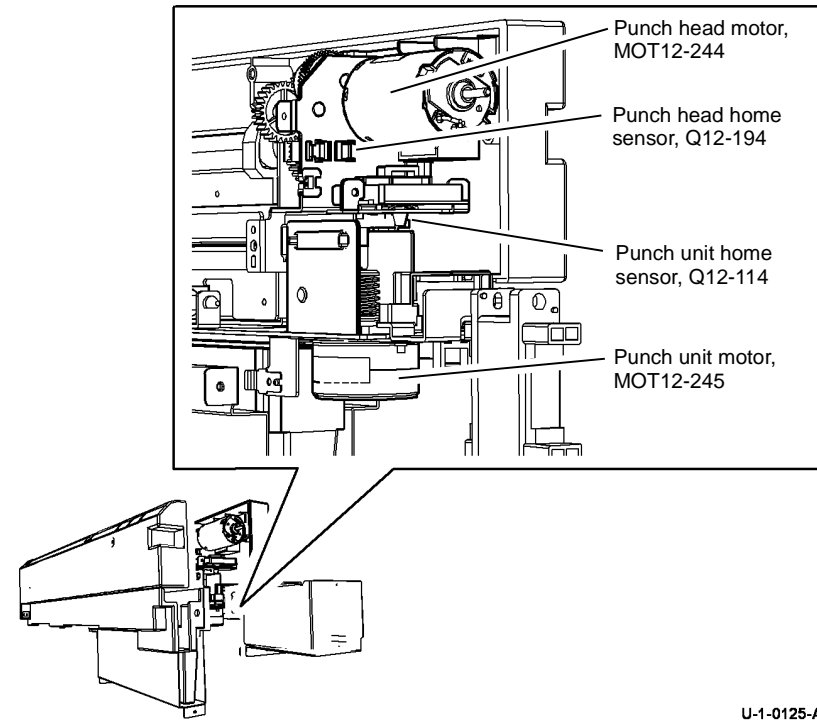

Figure 1 Component location

U-1-0125-A

12-056-00-171, 12-057-00-171 Inserter Bottom Plate RAP

12-056-00-171 The inserter bottom plate has failed to return to the home position.

12-057-00-171 The inserter bottom plate has failed to lift.

Initial Actions

WARNING

Ensure that the electricity to the machine is switched off while performing tasks that do not need electricity. Refer to **GP 14**. Disconnect the power cord. Electricity can cause death or injury. Moving parts can cause injury.

Check that the bottom plate area is clear and that there is no damage or obstructions. Install new components as necessary.

Procedure

Enter **dC330**, code 12-261 for the inserter motor MOT12-261. **The motor runs.**

- Y N**
- Go to **WD 12.14** and **WD 12.22**. Check the wiring from the inserter motor **PL 12.315 Item 1** to the HVF PWB **PL 12.140 Item 2**. Repair as necessary, **REP 1.1**. Check the inserter motor, MOT12-261. Refer to:
- **GP 10** How to Check a Motor.
 - **12A-171** HVF Power Distribution RAP.
 - **01L 0V** Distribution RAP
- Install new components as necessary:
- Inserter Motor, **PL 12.315 Item 1**.
 - HVF PWB, **PL 12.140 Item 2**.

Enter **dC330**, code 12-085 for the inserter bottom plate sensor, then actuate the inserter bottom plate sensor Q12-085. **The display changes.**

- Y N**
- Go **WD 12.13** and **WD 12.21**. Check the wiring from the inserter bottom plate sensor **PL 12.300 Item 16** to the HVF PWB **PL 12.140 Item 2**. Repair as necessary, **REP 1.1**. Check the inserter bottom plate sensor, Q12-085. Refer to:
- **GP 11** How to Check a Sensor.
 - **12A-171** HVF Power Distribution RAP.
 - **01L 0V** Distribution RAP
- Install new components as necessary:
- Inserter bottom plate sensor, **PL 12.300 Item 16**.
 - HVF PWB, **PL 12.140 Item 2**.

Enter **dC330**, code 12-315 for the inserter pickup sensor, then actuate the inserter pick sensor Q12-315 **PL 12.310 Item 10**. **The display changes.**

- Y N**
- Go to **WD 12.14**, **WD 12.21** and **WD 12.22**. Check the wiring from the inserter pickup sensor **PL 12.310 Item 10** to the HVF PWB. Check the inserter pickup sensor. Refer to:
- **GP 11** How to Check a Sensor.
- Install new components as necessary:
- Inserter pickup sensor, **PL 12.310 Item 10**.
 - HVF PWB, **PL 12.140 Item 2**.

Perform **SCP 5** Final Actions.

12-061-00-171, 12-416-00-171 HVF BM Crease Blade Fault RAP

12-061-00-171 The crease blade has failed to clear the crease blade home sensor.

12-416-00-171 The crease blade has failed to return to the home position.

Initial Actions

- Turn the crease blade knob (6d) **PL 12.150 Item 4** to ensure that the crease blade mechanism is free to move. If necessary, clear any paper jam in the area of the blade.
- Ensure that the crease blade assembly is level front to back and is installed correctly, refer to **REP 12.36-171**.
- Check the following parts for damage:
 - Crease blade assembly, **PL 12.170 Item 13**.
 - Drive gear, **PL 12.170 Item 6**.
 - Connecting rods, **PL 12.170 Item 9**.
 - Crank, **PL 12.170 Item 8**.

Procedure

WARNING

Keep away from the crease blade mechanism when working in close proximity to the booklet maker while the machine is powered on. The crease blade mechanism activates quickly and with great force.

WARNING

Ensure that the electricity to the machine is switched off while performing tasks that do not need electricity. Refer to **GP 14**. Disconnect the power cord. Electricity can cause death or injury. Moving parts can cause injury.

Enter **dC330** code 12-214. Actuate the BM crease blade home sensor Q12-214, **PL 12.170 Item 1**, by rotating the crease blade knob **PL 12.150 Item 4**, so that the actuator moves into and out of the BM crease blade home sensor. **The display changes.**

- Y N**
- Go to **WD 12.16**. Check Q12-214.
- Refer to:
- **GP 11** How to Check a Sensor.
 - **12A-171** HVF Power Distribution RAP.
 - **01L 0V** Distribution RAP
- Install new components as necessary:
- BM PWB, **PL 12.175 Item 10**.
 - BM crease blade home sensor, **PL 12.170 Item 1**.

Enter **dC330** code 12-215. Actuate the BM crease blade motor encoder sensor Q12-215, **PL 12.170 Item 1** by slowly rotating the crease blade knob **PL 12.150 Item 4**. **The display changes.**

- Y N**
- Go to **WD 12.16**. Check the BM crease blade motor encoder, Q12-215.
- Refer to:
- **GP 11** How to Check a Sensor.

A

- 12A-171 HVF Power Distribution RAP.
- 01L 0V Distribution RAP

Install new components as necessary:

- BM PWB, PL 12.175 Item 10.
- BM crease blade motor encoder sensor, PL 12.170 Item 1.

Enter dC330, code 12-252 to run the BM crease blade motor, MOT12-252, PL 12.170 Item 3.

The motor runs.

Y N

Go to WD 12.18. Check MOT 12-252.

Refer to:

- GP 10 How to Check a Motor.
- 12A-171 HVF Power Distribution RAP.
- 01L 0V Distribution RAP

Install new components as necessary:

- BM crease blade motor assembly, PL 12.170 Item 3.
- BM PWB, PL 12.175 Item 10.

The fault may be intermittent, check for damaged wiring or bad connectors, REP 1.1. If necessary install new components.

12-062-00-171 HVF BM Crease Roll Motor Failure RAP

12-062-00-171 The HVF BM crease roll motor has failed to run.

Initial Actions

Clear any paper jam in the area of the crease rolls.

Procedure

WARNING

Keep away from the crease blade mechanism when working in close proximity to the booklet maker while the machine is powered on. The crease blade mechanism activates quickly and with great force.

WARNING

Ensure that the electricity to the machine is switched off while performing tasks that do not need electricity. Refer to GP 14. Disconnect the power cord. Electricity can cause death or injury. Moving parts can cause injury.

Release the crease roll nip pressure by moving the crease roll handle (6c), PL 12.150 Item 5, fully counter clockwise. Remove the BM right hand cover, PL 12.185 Item 15, to access the crease rolls. Enter dC330 code 12-216. Actuate the BM crease roll motor encoder sensor by rotating the crease rolls slowly by hand. **The display changes.**

Y N

Go to WD 12.17. Check the BM crease roll motor encoder sensor, Q12-216, PL 12.175 Item 9.

Refer to:

- GP 11 How to Check a Sensor.
- 12A-171 HVF Power Distribution RAP.
- 01L 0V Distribution RAP

Install new components as necessary:

- BM PWB, PL 12.175 Item 10.
- BM crease roll motor encoder sensor, PL 12.175 Item 9.

Enter dC330, code 12-253 to run the BM crease roll motor, MOT12-253, PL 12.175 Item 12.

The motor runs.

Y N

Go to WD 12.18. Check the BM crease roll motor, MOT12-253.

Refer to:

- GP 10 How to Check a Motor.
- 12A-171 HVF Power Distribution RAP.
- 01L 0V Distribution RAP

Install new components as necessary:

- BM crease roll motor, PL 12.175 Item 12.
- BM PWB, PL 12.175 Item 10.

The fault may be intermittent, check for damaged wiring or bad connectors, REP 1.1. If necessary install new components:

- BM crease roll motor encoder sensor, PL 12.175 Item 9.
- BM crease roll motor, PL 12.175 Item 12.
- BM PWB, PL 12.175 Item 10

12-063-00-171, 12-411-00-171 HVF BM Staple Unit 1 Failure RAP

12-063-00-171 The HVF BM staple unit 1 has failed to leave the home position.

12-411-00-171 The HVF BM staple unit 1 has failed to return to the home position.

Initial Actions

WARNING

Ensure that the electricity to the machine is switched off while performing tasks that do not need electricity. Refer to [GP 14](#). Disconnect the power cord. Electricity can cause death or injury. Moving parts can cause injury.

- Check that there is no damage or obstruction that would prevent the stapling unit from cycling.
- Check that the sheets of staples in the cartridge are feeding one at a time. If staple sheets overlap, they will jam in the cartridge. If necessary, install a new staple cartridge, [PL 12.185 Item 8](#).
- Check for jammed staples in the stapler head.
- Ensure that the customer job does not exceed the capacity of the booklet maker. Refer to [12D-171 Booklet Quality RAP](#) for booklet maker quality specifications.

Procedure

Enter [dC330](#), code 12-217 to check the BM staple head (SH) carrier closed sensor, Q12-217, [PL 12.185 Item 18](#). Open and close the staple head carrier. **The display changes.**

- Y** **N**
- Go to [WD 12.16](#). Check the BM SH carrier closed sensor, Q12-217.
Refer to:
- [GP 11](#) How to Check a Sensor.
 - [12A-171](#) HVF Power Distribution RAP.
 - [01L](#) 0V Distribution RAP
- Install new components as necessary:
- BM Stapler head carrier closed sensor, [PL 12.185 Item 18](#).
 - BM PWB, [PL 12.175 Item 10](#).

Remove the HVF front door, refer to [REP 12.1-171](#) HVF Covers. Pull out the BM module. Remove the staple head 1 cover, [PL 12.185 Item 14](#). Enter [dC330](#), code 12-218 to check the BM SH1 home switch. Manually rotate the staple head to actuate the BM SH1 home switch.

The display changes.

- Y** **N**
- Go to [WD 12.16](#). Check the BM SH 1 home switch, S12-218.
Refer to:
- [GP 13](#), How to Check a Switch.
 - [12A-171](#) HVF Power Distribution RAP.
 - [01L](#) 0V Distribution RAP
- Install new components as necessary:
- BM staple head 1, [PL 12.185 Item 7](#).
 - BM PWB, [PL 12.175 Item 10](#).

A
Enter [dC330](#), code 12-254 to run the BM SH1 motor. **The staple head cycled.**

- Y** **N**
- Go to [WD 12.16](#) and [WD 12.19](#). Check the wiring and connectors.
The wiring and connectors are good.
- Y** **N**
- Repair the wiring or connectors, [REP 1.1](#).
- Install a new BM staple head 1, [PL 12.185 Item 7](#).

The fault may be intermittent, check for damaged wiring or bad connectors, [REP 1.1](#). If necessary install new components:

- BM staple head 1, [PL 12.185 Item 7](#).
- BM PWB, [PL 12.175 Item 10](#).

A

12-065-00-171, 12-383-00-171 HVF BM Backstop Motor Fault RAP

12-065-00-171 The HVF BM backstop motor fails to move.

12-383-00-171 The HVF BM backstop is not at the home position.

Initial Actions

WARNING

Ensure that the electricity to the machine is switched off while performing tasks that do not need electricity. Refer to [GP 14](#). Disconnect the power cord. Electricity can cause death or injury. Moving parts can cause injury.

- Check for a jam or other obstruction that could prevent the backstop mechanism from moving.
- Check the following items:
 - Damaged BM back stop drive belt, [PL 12.160 Item 7](#).
 - Damaged BM back stop belt, [PL 12.165 Item 15](#).
 - Damaged pulley, [PL 12.160 Item 5](#).
 - Damaged pulley on the BM back stop drive shaft, [PL 12.165 Item 14](#).
 - Damaged pulley on the BM back stop idler shaft, [PL 12.160 Item 13](#).
 - The BM back stop drive belt is tensioned correctly. Refer to [REP 12.20-171](#).
 - The BM back stop belt is tensioned correctly. Refer to [REP 12.26-171](#).

NOTE: With reference to [WD 12.17](#) component control codes;

Code 12-255 runs the BM backstop motor to the A4 position.

Procedure

Enter [dC330](#) code 12-204. Actuate the BM guide home sensor, Q12-204, [PL 12.160 Item 18](#).

The display changes.

Y N

Go to [WD 12.18](#). Check Q12-204.

Refer to:

- [GP 11](#) How to Check a Sensor.
- [12A-171](#) HVF Power Distribution RAP.
- [01L](#) 0V Distribution RAP

Install new components as necessary:

- BM guide home sensor, [PL 12.160 Item 18](#).
- BM PWB, [PL 12.175 Item 10](#).

Enter [dC330](#), code 12-255 to run the BM backstop motor, MOT12-255, [PL 12.160 Item 4](#). The motor runs.

Y N

Go to [WD 12.17](#). Check MOT12-255

Refer to:

- [GP 10](#) How to Check a Motor.
- [12A-171](#) HVF Power Distribution RAP.
- [01L](#) 0V Distribution RAP

A

Install new components as necessary:

- BM backstop motor, [PL 12.160 Item 4](#).
- BM PWB, [PL 12.175 Item 10](#).

Enter [dC330](#) code 12-259 to energize the BM stack hold solenoid, SOL12-259, [PL 12.165 Item 17](#). The solenoid energizes.

Y N

Go to [WD 12.17](#). Check the BM stack hold solenoid, SOL12-259.

Refer to:

- [GP 12](#) How to Check a Solenoid or Clutch.
- [12A-171](#) HVF Power Distribution RAP.
- [01L](#) 0V Distribution RAP

Install new components as necessary:

- BM PWB, [PL 12.175 Item 10](#).
- Back stop assembly, [PL 12.165 Item 18](#).

The fault may be intermittent, check for damaged wiring or bad connectors, [REP 1.1](#). If necessary install new components:

- BM guide home sensor, [PL 12.160 Item 18](#).
- BM backstop motor, [PL 12.160 Item 4](#).
- BM PWB, [PL 12.175 Item 10](#).

A

12-066-00-171, 12-384-00-171, 12-419-00-171, 12-420-00-171 HVF BM Tamper Fault RAP

12-066-00-171 The HVF BM tamper has failed to clear the home sensor.

12-384-00-171 The HVF BM tamper is not at the home sensor.

12-419-00-171 The HVF BM tamper home fault.

12-420-00-171 The HVF BM tamper move fault.

Initial Actions

WARNING

Ensure that the electricity to the machine is switched off while performing tasks that do not need electricity. Refer to [GP 14](#). Disconnect the power cord. Electricity can cause death or injury. Moving parts can cause injury.

- Check for a jam or other obstruction that could prevent the tamper mechanism from moving.
- Check for damaged tamper components, [PL 12.155](#).

Procedure

Enter [dC330](#) code 12-205. Actuate the BM tamper 1 home sensor, Q12-205, [PL 12.155](#) [Item 1](#). The display changes.

Y N
Go to [WD 12.18](#). Check Q12-205
Refer to:

- [GP 11](#) How to Check a Sensor.
- [12A-171](#) HVF Power Distribution RAP.
- [01L 0V](#) Distribution RAP

Install new components as necessary:

- BM PWB, [PL 12.175](#) [Item 10](#).
- BM tamper 1 home sensor, [PL 12.155](#) [Item 1](#).

Enter [dC330](#), code 12-256, to run the BM tamper 1 motor, MOT12-256, [PL 12.155](#) [Item 3](#).

The motor runs.

Y N
Go to [WD 12.17](#). Check MOT12-256.
Refer to:

- [GP 10](#) How to Check a Motor.
- [12A-171](#) HVF Power Distribution RAP.
- [01L 0V](#) Distribution RAP

Install new components as necessary:

- BM PWB, [PL 12.175](#) [Item 10](#).
- BM tamper 1 motor, [PL 12.155](#) [Item 3](#).

The fault may be intermittent, check for damaged wiring or bad connectors, [REP 1.1](#). If necessary install new components:

- BM tamper 1 home sensor, [PL 12.155](#) [Item 1](#).
- BM tamper 1 motor, [PL 12.155](#) [Item 3](#).
- BM PWB, [PL 12.175](#) [Item 10](#).

12-083-00-171, 12-440-00-171 to 12-444-00-171 HVF Paper Pusher Fault RAP

12-083-00-171 The paper pusher motor has stalled.

12-440-00-171 The paper pusher has failed to return to the home, (upper) position.

12-441-00-171 The paper pusher has failed to move from the home, (upper) position.

12-442-00-171 The paper pusher has failed to return to the away, (lower) position.

12-443-00-171 The paper pusher has failed to move from the away, (lower) position.

12-444-00-171 The stapler gate safety switch has failed.

Initial Actions

WARNING

Ensure that the electricity to the machine is switched off while performing tasks that do not need electricity. Refer to [GP 14](#). Disconnect the power cord. Electricity can cause death or injury. Moving parts can cause injury.

- Check for a jam or other obstruction that could prevent the paper pusher from moving.
- Check for damaged paper pusher components.

Procedure

Enter [dC330](#), code 12-265 to run the paper pusher motor, MOT12-265, [PL 12.115](#) [Item 13](#). The motor runs.

Y N
Go to [WD 12.10](#). Check MOT12-265
Refer to:

- [GP 10](#) How to Check a Motor.
- [12A-171](#) HVF Power Distribution RAP
- [01L 0V](#) Distribution RAP

Install new components as necessary:

- Paper pusher motor, [PL 12.115](#) [Item 13](#).
- HVF PWB, [PL 12.140](#) [Item 2](#).

Go to [WD 12.11](#). Check the stapler gate safety switch S12-319.

Refer to:

- [GP 13](#) How to check a switch.
- P/J304, [HVF PWB](#), [PL 12.140](#) [Item 2](#).
- [12A-171](#) HVF Power Distribution RAP
- [01L 0V](#) Distribution RAP

The switch is good.

Y N
Install new components as necessary.

- Sensor assembly, [PL 12.115](#) [Item 22](#).
- HVF PWB [PL 12.140](#) [Item 2](#).

A

A

Enter **dC330**, code 12-092. Manually actuate the paper pusher upper sensor, Q12-092, **PL 12.115 Item 16**. **The display changes.**

Y N

Go to **WD 12.9**. Check Q12-092.

Refer to:

- **GP 11** How to Check a Sensor.
- **12A-171** HVF Power Distribution RAP
- **01L 0V** Distribution RAP

Install new components as necessary:

- Paper pusher upper sensor, **PL 12.115 Item 16**.
- HVF PWB **PL 12.140 Item 2**.

Enter **dC330**, code 12-094. Manually actuate the paper pusher lower sensor, Q12-094, **PL 12.115 Item 16**. **The display changes.**

Y N

Refer to:

- **GP 11** How to Check a Sensor.
- **12A-171** HVF Power Distribution RAP
- **01L 0V** Distribution RAP

Install new components as necessary:

- Paper pusher lower sensor, **PL 12.115 Item 16**.
- HVF PWB **PL 12.140 Item 2**.

The fault may be intermittent, check for damaged wiring or bad connectors, **REP 1.1**. If necessary install new components:

- Paper pusher upper / lower sensor, **PL 12.115 Item 16**.
- Paper pusher motor assembly, **PL 12.115 Item 13**.
- Sensor assembly, **PL 12.115 Item 22**.
- HVF PWB, **PL 12.140 Item 2**.

12-113-00-171, 12-114-00-171, 12-190-00-171, 12-192-00-171 HVF BM Entry RAP

12-113-00-171 The paper leading edge is late arriving at the booklet maker exit sensor.

12-114-00-171 The paper trailing edge is late leaving the booklet maker exit sensor.

12-125-00-171 The entry sensor is not turned on within a specified time.

12-190-00-171 The paper leading edge is late arriving at the booklet maker entry sensor.

12-192-00-171 The paper trailing edge is late leaving the booklet maker entry sensor.

Initial Actions

WARNING

Switch off the electricity to the machine. Refer to **GP 14. Disconnect the power cord from the customer supply while performing tasks that do not need electricity. Electricity can cause death or injury. Moving parts can cause injury.**

- Check for a jam or other obstruction in the bypass transport.
- Check for a jam or other obstruction in the BM paper entry guide.

Procedure

Enter **dC330**, code 12-087. Manually actuate the HVF booklet exit sensor, Q12-087, **Figure 1**. **The display changes.**

Y N

Go to **WD 12.7**. Check Q12-087.

Refer to:

- **GP 11** How to Check a Sensor.
- **12A-171** HVF Power Distribution RAP
- **01L 0V** Distribution RAP

Install new components as necessary:

- HVF booklet exit sensor, **PL 12.135 Item 3**.
- HVF PWB, **PL 12.140 Item 2**.

Enter **dC330**, code 12-258. Energize the BM diverter solenoid SOL12-258, **Figure 1**. **The solenoid energizes.**

Y N

Go to **WD 12.8**. Check SOL12-258.

Refer to:

- **GP 12** How to Check a Solenoid or Clutch.
- **12A-171** HVF Power Distribution RAP.
- **01L 0V** Distribution RAP

Install new components as necessary:

- BM diverter solenoid, **PL 12.120 Item 4**.
- HVF PWB, **PL 12.140 Item 2**.

A

A

Enter **dC330**, code 12-263 to run the bypass feed motor, MOT12-263, **Figure 1**. The motor runs.

Y N

Go to **WD 12.8**. Check the bypass feed motor, MOT 12-263.

Refer to:

- **GP 10** How to Check a Motor.
- **12A-171** HVF Power Distribution RAP
- **01L 0V** Distribution RAP

Install new components as necessary:

- Bypass Feed motor, **PL 12.120** Item 2.
- HVF PWB, **PL 12.140** Item 2.

Check the drive belt on the motor. **The drive belt is good.**

Y N

Install a new drive belt, **PL 12.120** Item 8.

Enter **dC330**, code 12-089. Manually actuate the BM entry sensor, Q12-089, **Figure 2**. The display changes.

Y N

Go to **WD 12.16**. Check Q12-089.

Refer to:

- **GP 11** How to Check a Sensor.
- **12A-171** HVF Power Distribution RAP
- **01L 0V** Distribution RAP

Install new components as necessary:

- BM entry sensor, **PL 12.150** Item 16.
- HVF PWB, **PL 12.140** Item 2.

Enter **dC330**, code 12-251 to run the BM compiler motor, MOT12-251, **Figure 2**. The motor runs.

Y N

Go to **WD 12.17**. Check MOT12-251.

Refer to:

- **GP 10** How to Check a Motor.
- **12A-171** HVF Power Distribution RAP
- **01L 0V** Distribution RAP

Install new components as necessary:

- BM compiler motor, **PL 12.175** Item 1.
- HVF PWB, **PL 12.140** Item 2.

Lower the stapler bracket assembly, **Figure 2**. Enter **dC330** code 12-170 BM paper present sensor, Q12-170. Actuate Q12-170. **The display changes.**

Y N

Go to **WD 12.18**. Check Q12-170.

Refer to:

- **GP 11** How to Check a Sensor.
- **12A-171** HVF Power Distribution RAP.

B

B

- **01L 0V** Distribution RAP

Install new components as necessary:

- BM paper present sensor, **PL 12.185** Item 5.
- BM PWB, **PL 12.175** Item 10.

Check the drive belt on the motor. **The drive belt is good.**

Y N

Install a new drive belt, **PL 12.175** Item 15.

The fault may be intermittent, check for damaged wiring or bad connectors, **REP 1.1**. If necessary install new components:

- HVF booklet exit sensor, **PL 12.135** Item 3.
- BM diverter solenoid, **PL 12.120** Item 4.
- BM diverter gate, **PL 12.125** Item 9.
- BM compiler motor, **PL 12.175** Item 1.
- Bypass Feed motor, **PL 12.120** Item 2.
- HVF PWB, **PL 12.140** Item 2.

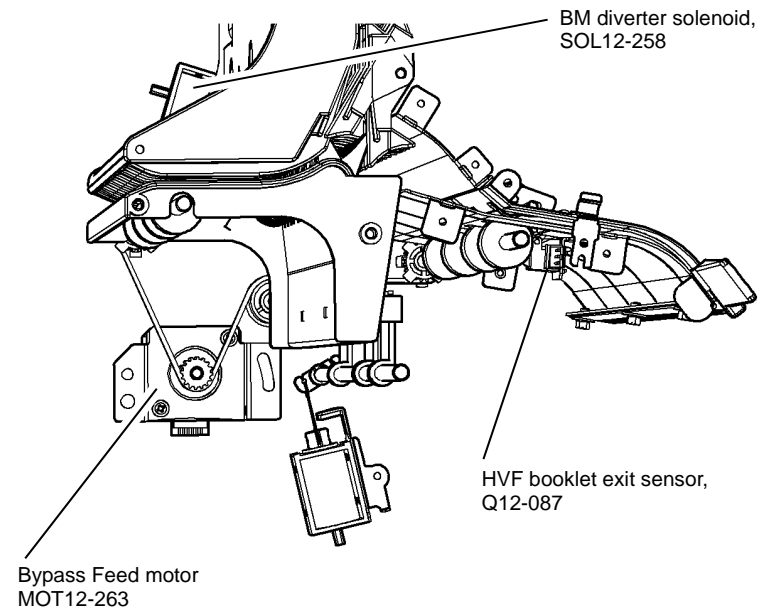

Figure 1 Component location

U-1-0137-A

12-125-00-171, 12-126-00-171 HVF Entry Sensor RAP

12-125-00-171 The entry sensor is not turned on within a specified time.

12-126-00-171 The paper trailing edge is late leaving the entry sensor.

Initial Actions

WARNING

Ensure that the electricity to the machine is switched off while performing tasks that do not need electricity. Refer to [GP 14](#). Disconnect the power cord. Electricity can cause death or injury. Moving parts can cause injury.

- Check for a jam or other obstruction in the entrance guide.
- Check the entrance guide for damage.

Procedure

Enter [dC330](#), code 12-077. Manually actuate the entry sensor, Q12-077, [PL 12.135 Item 2](#).

The display changes.

Y N

Go to [WD 12.7](#). Check Q12-077.

Refer to:

- [GP 11](#) How to Check a Sensor.
- [12A-171](#) HVF Power Distribution RAP
- [01L 0V](#) Distribution RAP

Install new components as necessary:

- Entry sensor, [PL 12.135 Item 2](#).
- HVF PWB, [PL 12.140 Item 2](#).

Enter [dC330](#), code 12-263 to run the bypass feed motor, MOT12-263, [PL 12.120 Item 2](#). The motor runs.

Y N

Go to [WD 12.8](#). Check MOT 12-263

Refer to:

- [GP 10](#) How to Check a Motor.
- [12A-171](#) HVF Power Distribution RAP
- [01L 0V](#) Distribution RAP

Install new components as necessary:

- Bypass feed motor, [PL 12.120 Item 2](#).
- HVF PWB, [PL 12.140 Item 2](#).

Check the transport motor 1 belt. **The belt is good.**

Y N

Install a new transport motor 1 belt, [PL 12.120 Item 7](#).

The fault may be intermittent, check for damaged wiring or bad connectors, [REP 1.1](#). If necessary install new components:

- Entry sensor, [PL 12.135 Item 2](#)
- Transport motor 1, [PL 12.120 Item 2](#).
- HVF PWB, [PL 12.140 Item 2](#).

If the fault remains, make sure that the paper correctly continues past the previous sensor in the paper path. Refer to the [10-140-00 to 10-146-00](#), [10-149-00 to 10-151-00](#) Exit Jam RAP.

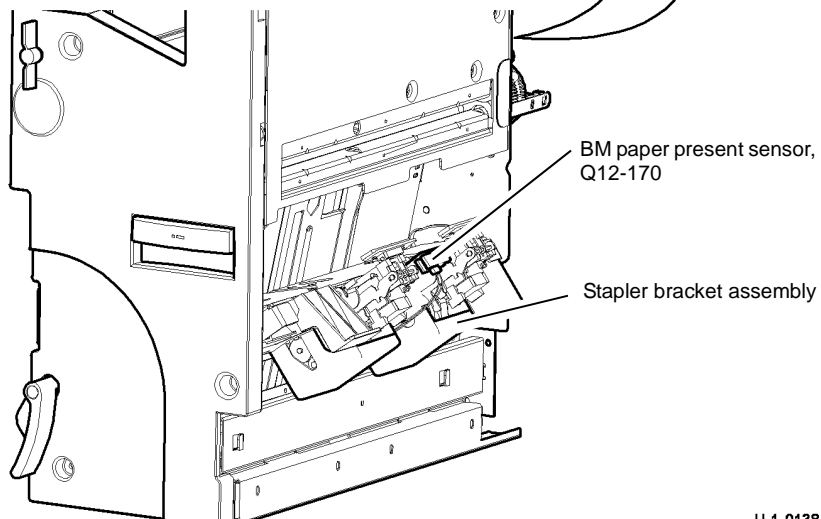
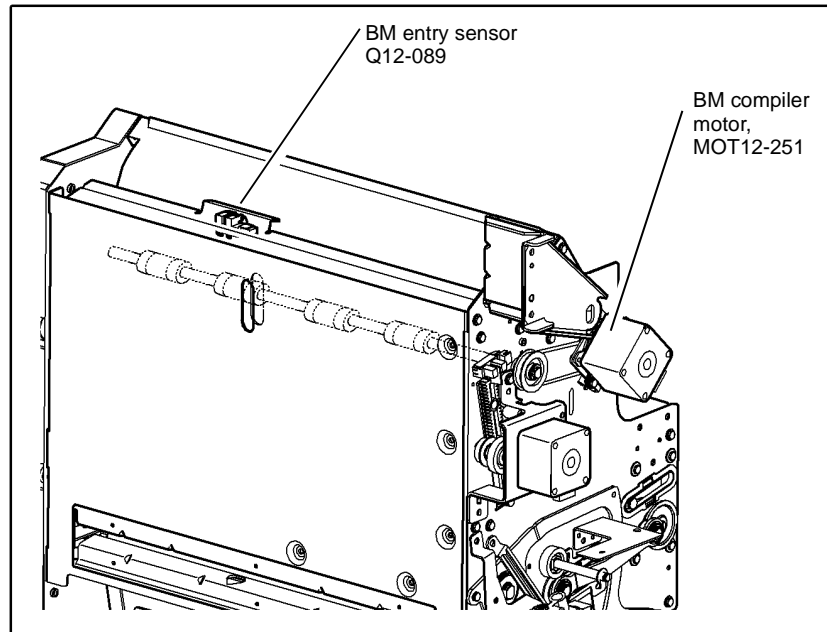

U-1-0138-A

Figure 2 Component location

12-141-00-171, 12-142-00-171 HVF Buffer Path Sensor RAP

12-141-00-171 The paper trailing edge is late leaving the buffer path sensor.

12-142-00-171 The paper leading edge is late arriving at the buffer path sensor.

Initial Actions

WARNING

Ensure that the electricity to the machine is switched off while performing tasks that do not need electricity. Refer to [GP 14](#). Disconnect the power cord. Electricity can cause death or injury. Moving parts can cause injury.

- Check for a jam or other obstruction in buffer path transport.
- Check the paper guide for damage.

Procedure

Enter [dC330](#), code 12-321. Manually actuate the buffer path sensor, Q12-321, [PL 12.135 Item 2](#).

2. The display changes.

Y N

Go to [WD 12.7](#). Check Q12-321.

Refer to:

- [GP 11](#) How to Check a Sensor.
- [12A-171](#) HVF Power Distribution RAP
- [01L](#) 0V Distribution RAP

Install new components as necessary:

- Buffer path sensor, [PL 12.135 Item 2](#).
- HVF PWB, [PL 12.140 Item 2](#).

Enter [dC330](#), code 12-258. Energize the BM diverter solenoid SOL12-258, [PL 12.120 Item 4](#).

The solenoid energizes.

Y N

Go to [WD 12.8](#). Check SOL12-258.

Refer to:

- [GP 12](#) How to Check a Solenoid or Clutch.
- [12A-171](#) HVF Power Distribution RAP.
- [01L](#) 0V Distribution RAP

Install new components as necessary:

- BM diverter solenoid, [PL 12.120 Item 4](#).
- HVF PWB, [PL 12.140 Item 2](#).

Enter [dC330](#), code 12-262 to run the buffer motor, MOT12-262, [PL 12.120 Item 1](#). The motor runs.

Y N

Go to [WD 12.7](#). Check MOT12-262.

Refer to:

- [GP 10](#) How to Check a Motor.
- [12A-171](#) HVF Power Distribution RAP
- [01L](#) 0V Distribution RAP

A

Install new components as necessary:

- Buffer motor, [PL 12.120 Item 1](#).
- HVF PWB, [PL 12.140 Item 2](#).

Check the buffer feed motor belt, [PL 12.120 Item 9](#). The drive belt is good.

Y N

Install a new buffer feed motor belt, [PL 12.120 Item 9](#).

The fault may be intermittent, check for damaged wiring or bad connectors, [REP 1.1](#). If necessary install new components:

- Buffer path sensor, [PL 12.135 Item 2](#).
- Buffer motor, [PL 12.120 Item 1](#).
- HVF PWB, [PL 12.140 Item 2](#).

A

12-151-171, 12-152-171 HVF Compiler Exit Sensor RAP

12-151-00-171 The paper trailing edge is late leaving the compiler exit sensor.

12-152-00-171 The paper leading edge is late arriving at the compiler exit sensor.

Initial Actions

WARNING

Ensure that the electricity to the machine is switched off while performing tasks that do not need electricity. Refer to GP 14. Disconnect the power cord. Electricity can cause death or injury. Moving parts can cause injury.

- Check for a jam or other obstruction in the paper guide.
- Check the paper guide for damage.

Procedure

Enter dC330, code 12-106. Manually actuate the compiler exit sensor, Q12-106, Figure 1.

The display changes.

Y N
Go to WD 12.7. Check the sensor, Q12-106.
Refer to:

- GP 11 How to Check a Sensor.
- 12A-171 HVF Power Distribution RAP
- 01L 0V Distribution RAP

Install new components as necessary:

- Compiler exit sensor, PL 12.135 Item 2.
- HVF PWB, PL 12.140 Item 2.

Enter dC330, code 12-225. Energize the exit diverter solenoid SOL12-225, Figure 1. The solenoid energizes.

Y N
Go to WD 12.8. Check SOL12-225.
Refer to:

- GP 12 How to Check a Solenoid or Clutch.
- 12A-171 HVF Power Distribution RAP.
- 01L 0V Distribution RAP

Install new components as necessary:

- Exit diverter solenoid, PL 12.120 Item 4.
- HVF PWB, PL 12.140 Item 2.

Enter dC330, code 12-224 to run the transport motor 2, MOT 12-224, Figure 1. The motor runs.

Y N
Go to WD 12.8. Check the transport motor 2, MOT 12-224.
Refer to:

- GP 10 How to Check a Motor.
- 12A-171 HVF Power Distribution RAP
- 01L 0V Distribution RAP

A
Install new components as necessary:

- Transport motor 2, PL 12.120 Item 1.
- HVF PWB, PL 12.140 Item 2.

Check the transport motor 2 drive belt. The drive belt is good.

Y N
Install a new transport motor 2 drive belt, PL 12.120 Item 10.

The fault may be intermittent, check for damaged wiring or bad connectors, REP 1.1. If necessary install new components:

- Compiler exit sensor, PL 12.135 Item 2.
- Exit diverter solenoid, PL 12.120 Item 4.
- Diverter gate, PL 12.125 Item 7.
- HVF PWB, PL 12.140 Item 2.

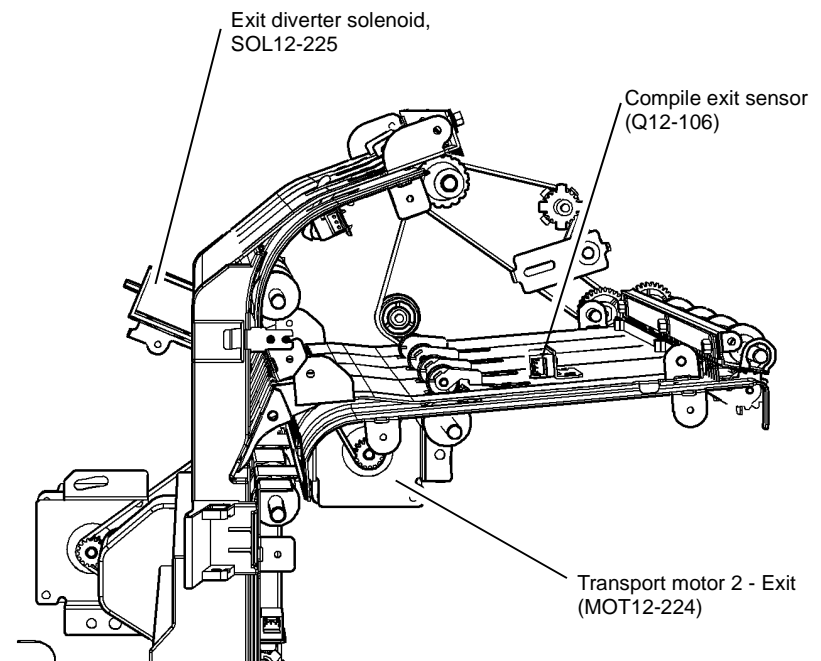

Figure 1 Component location

U-1-0135-A

12-157-00-171, 12-158-00-171 HVF Buffer Position Sensor RAP

12-157-00-171 The paper leading edge is late arriving at the buffer position sensor.

12-158-00-171 The paper trailing edge is late leaving the buffer position sensor.

Initial Actions

WARNING

Ensure that the electricity to the machine is switched off while performing tasks that do not need electricity. Refer to [GP 14](#). Disconnect the power cord. Electricity can cause death or injury. Moving parts can cause injury.

- Check for a jam or other obstruction in inserter transport.
- Check the paper guide for damage.

Procedure

Enter [dC330](#), code 12-086. Manually actuate the buffer position sensor, Q12-086, [PL 12.135 Item 2](#). The display changes.

Y N

Go to [WD 12.7](#). Check Q12-086.

Refer to:

- [GP 11](#) How to Check a Sensor.
- [12A-171](#) HVF Power Distribution RAP
- [01L](#) 0V Distribution RAP

Install new components as necessary:

- Buffer position sensor, [PL 12.135 Item 2](#).
- HVF PWB, [PL 12.140 Item 2](#).

Enter [dC330](#), code 12-223 to run the transport motor 1, MOT 12-223, [PL 12.120 Item 2](#). The motor runs.

Y N

Go to [WD 12.7](#). Check the wiring and repair as necessary, [REP 1.1](#). Check MOT12-223.

Refer to:

- [GP 10](#) How to Check a Motor.
- [12A-171](#) HVF Power Distribution RAP.
- [01L](#) 0V Distribution RAP

Install new components as necessary:

- Transport motor 1, [PL 12.120 Item 2](#).
- HVF PWB, [PL 12.140 Item 2](#).

Check the transport motor 1 drive belt, [PL 12.120 Item 7](#). The drive belt is good.

Y N

Install a new transport motor 1 drive belt, [PL 12.120 Item 7](#).

Enter [dC330](#), code 12-263 to run the bypass feed motor, MOT12-263, [PL 12.120 Item 2](#). The motor runs.

Y N

Go to [WD 12.8](#). Check MOT12-263.

Refer to:

- [GP 10](#) How to Check a Motor.
- [12A-171](#) HVF Power Distribution RAP
- [01L](#) 0V Distribution RAP

Install new components as necessary:

- Bypass feed motor, [PL 12.120 Item 2](#).
- HVF PWB, [PL 12.140 Item 2](#).

Check the bypass feed motor drive belt, [PL 12.120 Item 8](#). The drive belt is good.

Y N

Install a new bypass feed motor drive belt, [PL 12.120 Item 8](#).

The fault may be intermittent, check for damaged wiring or bad connectors, [REP 1.1](#). If necessary install new components:

- Buffer position sensor, [PL 12.135 Item 2](#).
- Transport motor 1, [PL 12.120 Item 2](#).
- HVF PWB, [PL 12.140 Item 2](#).

12-166-00-171 HVF BM Compiler Exit Jam RAP

12-166-00-171 The trail edge is late leaving the BM compiler exit sensor.

Initial Actions

WARNING

Ensure that the electricity to the machine is switched off while performing tasks that do not need electricity. Refer to [GP 14](#). Disconnect the power cord. Electricity can cause death or injury. Moving parts can cause injury.

- If necessary, remove any paper from the booklet maker.
- Check that there is no damage or obstruction in the booklet compiling area or the paper path to the booklet compiling area.
- Check that the stapler bracket assembly, [PL 12.185 Item 10](#), is correctly latched.
- Check the operation of the BM tampers, refer to the [12-066-00-171](#), [12-384-00-171](#), [12-419-00-171](#), [12-420-00-171](#) HVF BM Tamper Failure RAP. If the tampers are operating correctly, go to [ADJ 12.5-171](#) Booklet Tamping and check the tampers are correctly adjusted.

Procedure

Lower the stapler bracket assembly, [Figure 1](#). Enter [dC330](#) code 12-170 BM paper present sensor, Q12-170. Actuate Q12-170. **The display changes.**

Y N

Go to [WD 12.18](#). Check Q12-170.

Refer to:

- [GP 11](#) How to Check a Sensor.
- [12A-171](#) HVF Power Distribution RAP.
- [01L](#) 0V Distribution RAP

Install new components as necessary:

- BM paper present sensor, [PL 12.185 Item 5](#).
- BM PWB, [PL 12.175 Item 10](#).

Go to [WD 12.18](#). Check the connectors and harness between PJ568 and PJ556. Refer to [REP 1.1](#). **The wiring and connectors are good.**

Y N

Repair the wiring, [REP 1.1](#) or install new components as necessary.

Enter [dC330](#) code 12-251 BM compiler motor, MOT12-251. **MOT12-251 runs.**

Y N

Go to [WD 12.17](#). Check MOT12-251.

Refer to:

- [GP 10](#) How to Check a Motor.
- [12A-171](#) HVF Power Distribution RAP.
- [01L](#) 0V Distribution RAP

Install new components as necessary

- BM compiler motor, [PL 12.175 Item 1](#).
- BM PWB, [PL 12.175 Item 10](#).

A

Unlatch the entrance baffle assembly, [PL 12.150 Item 22](#). Run again MOT12-251. **The BM entry roll rotates.**

Y N

Check the following components:

- BM compiler motor belt, [PL 12.175 Item 15](#).
- BM entry roll pulley, [PL 12.150 Item 14](#).
- BM entry roll, [PL 12.150 Item 15](#).

Install new components as necessary.

Make a 60 page booklet (15 sheets of paper). Check that the top sheet of paper has not been torn from the booklet. **The booklet is good.**

Y N

Check that the components in the lower crease roll gear and clutch assembly are correctly installed. Refer to the replacement procedure in [REP 12.52-171](#) BM Crease Rolls, Gears and Bearings.

Perform [SCP 5](#) Final Actions.

12-171-00-171, 12-172-00-171 HVF Top Tray Exit Sensor Fault RAP

12-171-00-171 The paper leading edge is late arriving at the top exit sensor.

12-172-00-171 The paper trailing edge is late leaving the top exit sensor.

Initial Actions

WARNING

Ensure that the electricity to the machine is switched off while performing tasks that do not need electricity. Refer to [GP 14](#). Disconnect the power cord. Electricity can cause death or injury. Moving parts can cause injury.

- Check for a jam or other obstruction in the paper guide.
- Check the paper guide for damage.

Procedure

Enter [dC330](#), code 12-107. Manually actuate the top tray exit sensor, [Q12-107](#), [PL 12.135 Item 3](#). The display changes.

Y N

Go to [WD 12.7](#). Check [Q12-107](#).

Refer to:

- [GP 11](#) How to Check a Sensor.
- [12A-171](#) HVF Power Distribution RAP
- [01L 0V](#) Distribution RAP

Install new components as necessary:

- Top tray exit sensor, [PL 12.135 Item 3](#).
- HVF PWB, [PL 12.140 Item 2](#)

Enter [dC330](#), code 12-225. Energize the exit diverter solenoid [SOL12-225](#), [PL 12.120 Item 4](#). The solenoid energizes.

Y N

Go to [WD 12.8](#). Check [SOL12-225](#).

Refer to:

- [GP 12](#) How to Check a Solenoid or Clutch.
- [12A-171](#) HVF Power Distribution RAP.
- [01L 0V](#) Distribution RAP

Install new components as necessary:

- Exit diverter solenoid, [PL 12.120 Item 4](#).
- HVF PWB, [PL 12.140 Item 2](#)

Enter [dC330](#), code 12-224 to run the transport motor 2, [MOT12-224](#), [PL 12.120 Item 1](#). The motor runs.

Y N

Go to [WD 12.8](#). Check [MOT12-224](#).

Refer to:

- [GP 10](#) How to Check a Motor.
- [12A-171](#) HVF Power Distribution RAP

A

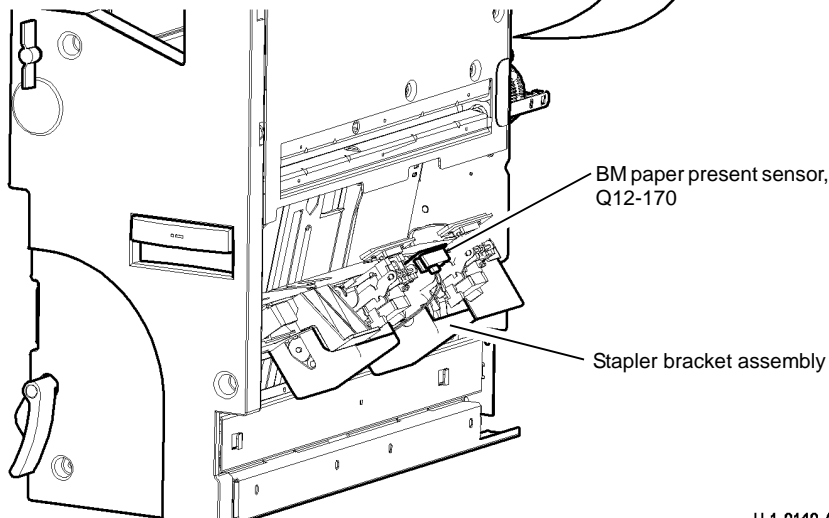
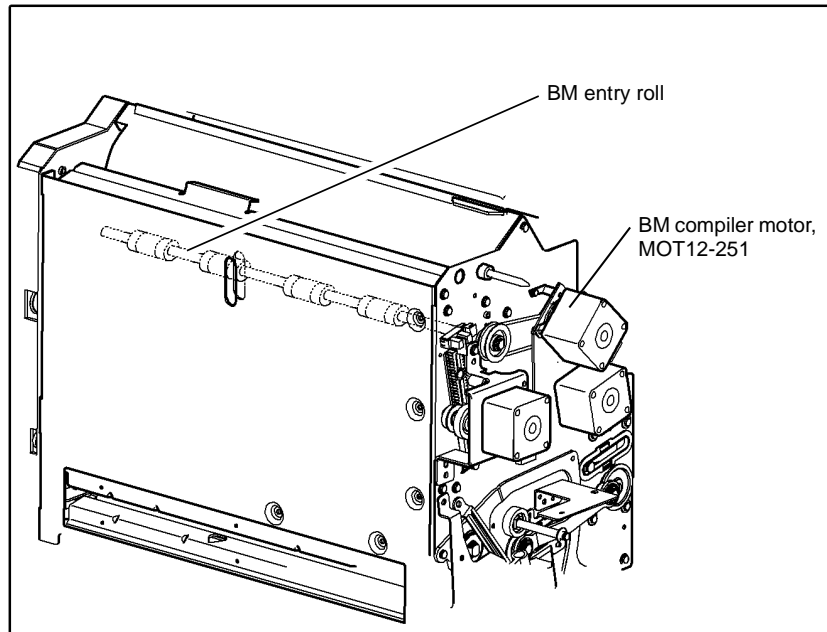

U-1-0140-A

Figure 1 Component location

A

- 01L 0V Distribution RAP
- Install new components as necessary:
- Transport motor 2, [PL 12.120 Item 1](#).
 - HVF PWB, [PL 12.140 Item 2](#).

Check the transport motor 2 drive belts (A) & (B). **The drive belts are good.**

Y N

Install a new transport motor 2 drive belt (A) [PL 12.120 Item 10](#) and/or transport motor drive belt (B), [PL 12.120 Item 11](#).

The fault may be intermittent, check for damaged wiring or bad connectors, [REP 1.1](#). If necessary install new components:

- Top exit sensor, [PL 12.135 Item 3](#).
- Exit diverter solenoid, [PL 12.120 Item 4](#).
- Diverter exit gate, [PL 12.125 Item 7](#).
- Transport motor 2, [PL 12.120 Item 1](#).
- HVF PWB, [PL 12.140 Item 2](#).

12-181-00-171, 12-182-00-171 HVF BM Exit Jam RAP

12-181-00-171 The lead edge is late arriving at the BM exit sensor.

12-182-00-171 The trail edge is late leaving the BM exit sensor.

Initial Actions

WARNING

Ensure that the electricity to the machine is switched off while performing tasks that do not need electricity. Refer to [GP 14](#). Disconnect the power cord. Electricity can cause death or injury. Moving parts can cause injury.

WARNING

Keep away from the crease blade mechanism when working in close proximity to the booklet maker while the machine is powered on. The crease blade mechanism activates quickly and with great force.

- Turn the crease blade knob (6d) to ensure that the crease blade mechanism is free to move. If necessary, clear any paper jam in the exit area.
- For 12-182-00 faults. Remove and re-seat the BM staple cartridge. Check for miss-formed staple which may cause the sheet to snag and skew.

Procedure

Enter [dC330](#) code 12-215. Actuate the BM crease blade motor encoder sensor, Q12-215, [Figure 1](#) by rotating the crease blade knob (6d). **The display changes.**

Y N

Go to [WD 12.16](#). Check Q12-215.

Refer to:

- [GP 11](#) How to Check a Sensor.
- [12A-171](#) HVF Power Distribution RAP.
- [01L 0V](#) Distribution RAP

Install new components as necessary:

- BM PWB, [PL 12.175 Item 10](#).
- BM crease blade motor encoder sensor, [PL 12.170 Item 1](#).

Release the crease roll nip pressure by moving the crease roll handle fully counter clockwise. Remove the BM right hand cover, [PL 12.185 Item 15](#) to access the crease rolls. Enter [dC330](#) code 12-216. Actuate the BM crease roll motor encoder sensor by rotating the crease rolls slowly by hand. **The display changes.**

Y N

Go to [WD 12.17](#). Check Q12-216.

Refer to:

- [GP 11](#) How to Check a Sensor.
- [12A-171](#) HVF Power Distribution RAP.
- [01L 0V](#) Distribution RAP

Install new components as necessary:

- BM PWB, [PL 12.175 Item 10](#).
- BM crease roll motor encoder sensor, [PL 12.175 Item 9](#).

A

A
Enter **dC330** code 12-213. Actuate the BM exit sensor, Q12-213, **Figure 2. The display changes.**

Y N
Go to **WD 12.18**. Check Q12-213.
Refer to:

- **GP 11** How to Check a Sensor.
- **12A-171** HVF Power Distribution RAP.
- **01L 0V** Distribution RAP

Install new components as necessary:

- BM PWB, **PL 12.175 Item 10**.
- BM exit sensor, **PL 12.185 Item 17**.

Enter **dC330**, code 12-253 to run the BM crease roll motor, MOT12-253. **The motor runs.**

Y N
Go to **WD 12.18**. Check MOT12-253.
Refer to:

- **GP 10** How to Check a Motor.
- **12A-171** HVF Power Distribution RAP.
- **01L 0V** Distribution RAP

Install new components as necessary:

- BM crease roll motor, **PL 12.175 Item 12**.
- BM PWB, **PL 12.175 Item 10**.

Enter **dC330**, code 12-253 to run the BM crease roll motor, MOT12-253. **The motor drives the gears.**

Y N
Install new components as necessary:

- Crease roll drive train gears, **PL 12.180**.

Enter **dC330**, code 12-252 to run the BM crease blade motor, MOT12-252. **The motor runs.**

Y N
Go to **WD 12.18**. Check MOT12-252.
Refer to:

- **GP 10** How to Check a Motor.
- **12A-171** HVF Power Distribution RAP.
- **01L 0V** Distribution RAP

Install new components as necessary:

- BM crease blade motor, **PL 12.170 Item 3**.
- BM PWB, **PL 12.175 Item 10**

NOTE: The BM crease roll gate motor has two component control codes:

12-273 cycles the crease roll gate.

12-276 opens the crease roll gate.

Enter **dC330**, code 12-273 to cycle the BM crease roll gate motor, MOT12-273. **The motor runs.**

Y N
Go to **WD 12.18**. Check MOT12-273.

B

B

Refer to:

- **GP 10** How to Check a Motor.
- **12A-171** HVF Power Distribution RAP.
- **01L 0V** Distribution RAP

Install new components as necessary:

- BM crease roll gate motor, **PL 12.175 Item 8**.
- BM PWB, **PL 12.175 Item 10**.

The BM module has a tri-folder module installed.

Y N
The fault may be intermittent, check for damaged wiring or bad connectors, **REP 1.1**. If necessary install a new BM PWB, **PL 12.175 Item 10**.

Check the drive coupler, **PL 12.205 Item 17** is engaged with the BM crease roll motor encoder disc, **PL 12.175 Item 13**. **The coupler and encoder are correctly engaged.**

Y N
Align the drive coupler, refer to **REP 12.68-171** Tri-folder Drive Install Kit.

Check the drive assembly for wear, damage, contamination and misalignment, **PL 12.205 Item 12**. **The condition of the drive assembly is good.**

Y N
Install a new drive assembly, **PL 12.205 Item 12**.

Check the condition of the drive belt, **PL 12.205 Item 11**. **The drive belt is good.**

Y N
Install a new tri-folder install kit, **PL 12.205 Item 14**.

The fault may be intermittent, check for damaged wiring or bad connectors, **REP 1.1**. If necessary install a new BM PWB, **PL 12.175 Item 10**.

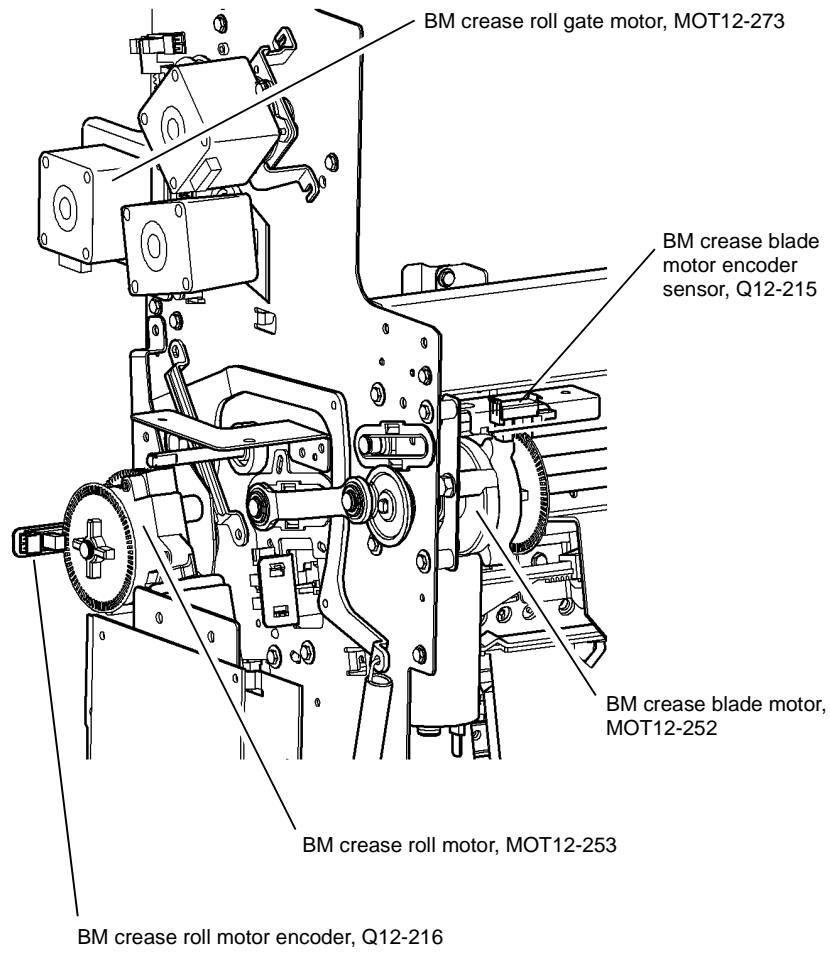

Figure 1 Component location

U-1-0142-A

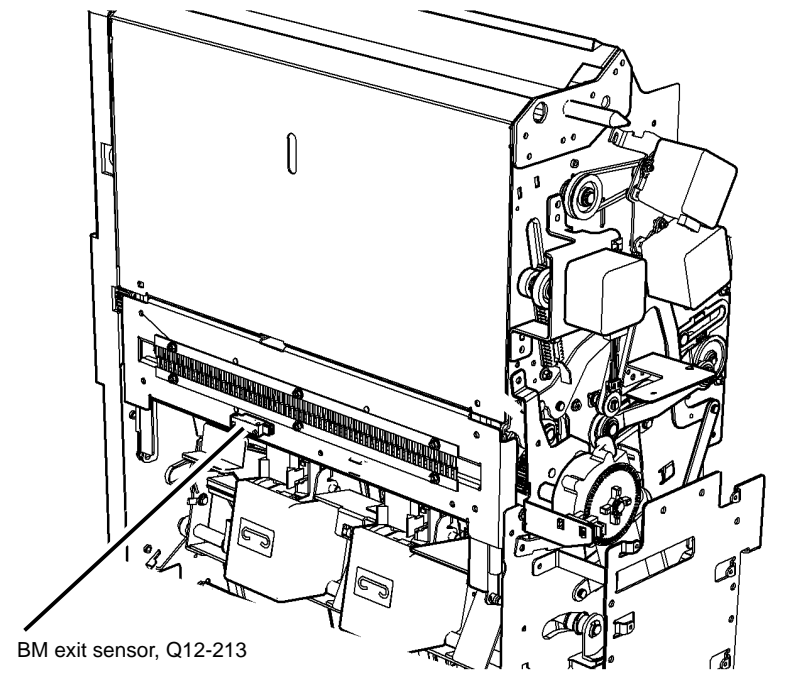

Figure 2 Component location

U-1-0143-A

12-183-00-171, 12-184-00-171 HVF BM Paper Jam RAP

12-183-00-171 The BM PWB has detected an unexpected sheet in the booklet maker paper path.

12-184-00-171 The BM PWB has detected a stray sheet in the booklet maker paper path after jam clearance.

Initial Actions

WARNING

Ensure that the electricity to the machine is switched off while performing tasks that do not need electricity. Refer to [GP 14](#). Disconnect the power cord. Electricity can cause death or injury. Moving parts can cause injury.

- Check for a jam or other obstruction in the booklet maker paper path.
- Check the paper path for damage.

Procedure

Enter [dC330](#) code 12-170. Manually actuate the BM paper present sensor, Q12-170, [Figure 1](#).

The display changes.

Y N

Go to [WD 12.18](#). Check Q12-170.

Refer to:

- [GP 11](#) How to Check a Sensor.
- [12A-171](#) HVF Power Distribution RAP.
- [01L](#) 0V Distribution RAP

Install new components as necessary:

- BM PWB, [PL 12.175](#) Item 10.
- BM paper present sensor, [PL 12.185](#) Item 5.

Enter [dC330](#) code 12-213. Manually actuate the BM exit sensor, [Figure 2](#). The display changes.

Y N

Go to [WD 12.18](#). Check Q12-213.

Refer to:

- [GP 11](#) How to Check a Sensor.
- [12A-171](#) HVF Power Distribution RAP.
- [01L](#) 0V Distribution RAP

Install new components as necessary:

- BM PWB, [PL 12.175](#) Item 10.
- BM exit sensor, [PL 12.185](#) Item 17.

Enter [dC330](#) code 12-089. Manually actuate the BM entry sensor, Q12-089, [Figure 1](#). The display changes.

Y N

Go to [WD 12.16](#). Check Q12-089.

Refer to:

- [GP 11](#) How to Check a Sensor.

A

- [12A-171](#) HVF Power Distribution RAP.
- [01L](#) 0V Distribution RAP

Install new components as necessary:

- BM PWB, [PL 12.175](#) Item 10.
- BM entry sensor, [PL 12.150](#) Item 16.

The HVF has a tri-folder.

Y N

The fault may be intermittent, check the wiring, [REP 1.1](#). If necessary install a new BM PWB, [PL 12.175](#) Item 10.

Enter [dC330](#) code 12-164. Manually actuate the tri-folder entry sensor, Q12-164, [Figure 3](#).

The display changes.

Y N

Go to [WD 12.19](#) and [WD 12.20](#). Check Q12-164. Check the wiring between PJ602 pin 10 on the tri-folder control PWB and PJ563 pin 1 on the BM PWB.

Refer to:

- [GP 11](#) How to Check a Sensor.
- [12A-171](#) HVF Power Distribution RAP.
- [01L](#) 0V Distribution RAP

Install new components as necessary:

- Tri-folder entry sensor, [PL 12.215](#) Item 11.
- Tri-folder control PWB, [PL 12.205](#) Item 16.
- BM PWB, [PL 12.175](#) Item 10.

The fault may be intermittent, check the wiring, [REP 1.1](#). If necessary install a new BM PWB, [PL 12.175](#) Item 10.

A

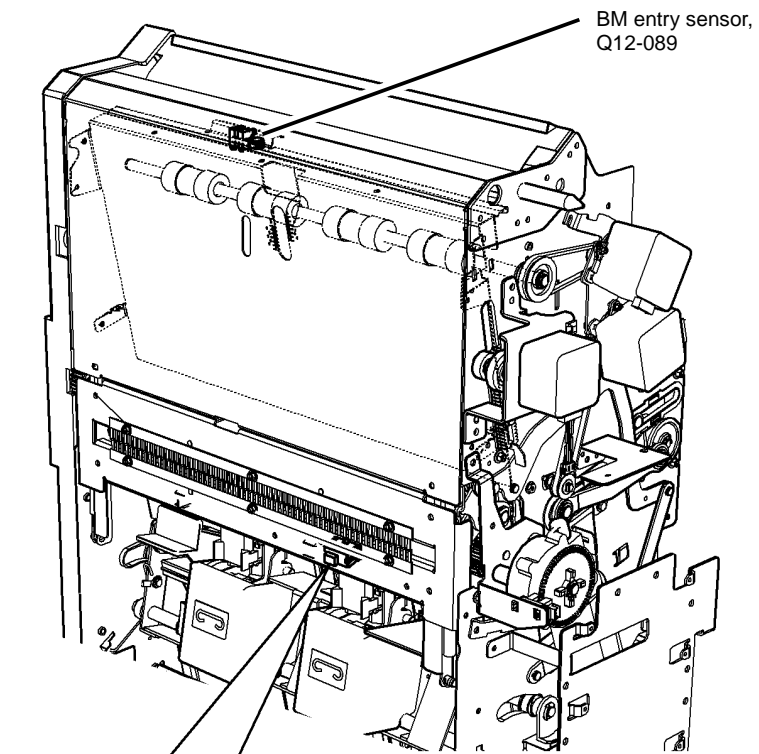

BM entry sensor,
Q12-089

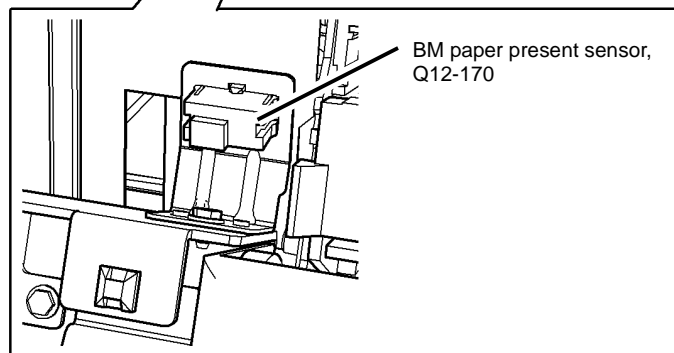

BM paper present sensor,
Q12-170

Figure 1 Component location

U-1-0144-A

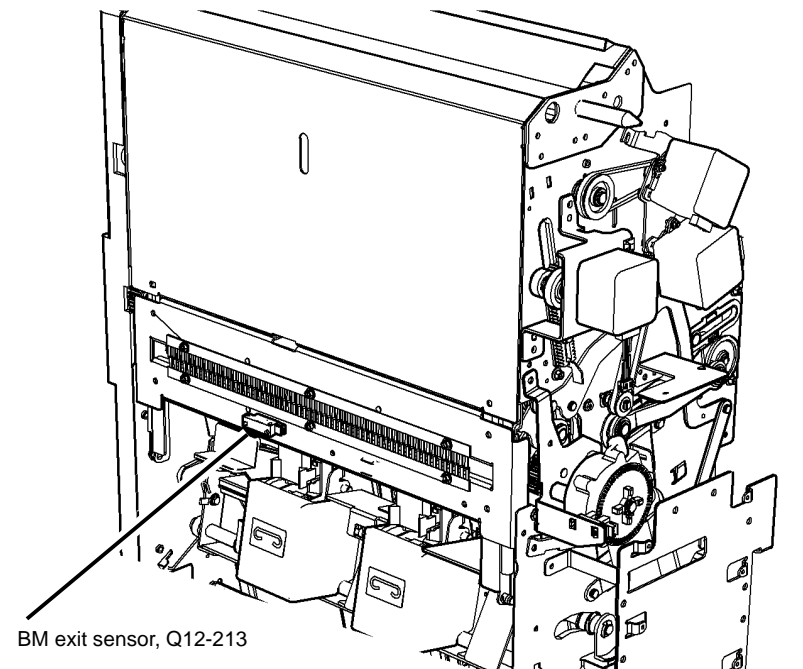

BM exit sensor, Q12-213

Figure 2 Component location

U-1-0145-A

12-185-00-171 to 12-187-00-171 Tri-Folder Exit Sensor and Assist Sensor RAP

12-185-00-171 The lead edge is late arriving at the tri-folder exit sensor.

12-186-00-171 The trail edge is late leaving the tri-folder exit sensor.

12-187-00-171 The lead edge is late arriving at the tri-folder assist gate sensor.

Initial Actions

WARNING

Ensure that the electricity to the machine is switched off while performing tasks that do not need electricity. Refer to GP 14. Disconnect the power cord. Electricity can cause death or injury. Moving parts can cause injury.

- Check for a jam or other obstruction in the tri-folder.
- Check the tri-folder for damage.

Procedure

Enter dC330 code 12-165. Manually actuate the tri-folder assist gate sensor, Q12-165, Figure 1. The display changes.

Y N

Go to WD 12.19 and WD 12.20. Check Q12-165.

Refer to:

- GP 11 How to Check a Sensor.
- 12A-171 HVF Power Distribution RAP.
- 01L 0V Distribution RAP

Install new components as necessary:

- Tri-folder assist gate sensor, PL 12.215 Item 6.
- Tri-folder control PWB, PL 12.205 Item 16.
- BM PWB, PL 12.175 Item 10.

Enter dC330 code 12-166. Manually actuate the tri-folder exit sensor, Q12-166, Figure 2. The display changes.

Y N

Go to WD 12.19 and WD 12.20. Check Q12-166.

Refer to:

- GP 11 How to Check a Sensor.
- 12A-171 HVF Power Distribution RAP.
- 01L 0V Distribution RAP

Install new components as necessary:

- Tri-folder exit sensor, PL 12.215 Item 12.
- Tri-folder control PWB, PL 12.205 Item 16.
- BM PWB, PL 12.175 Item 10.

Enter dC330 code 12-267 to energize the tri-folder diverter solenoid, SOL12-267. The solenoid energizes.

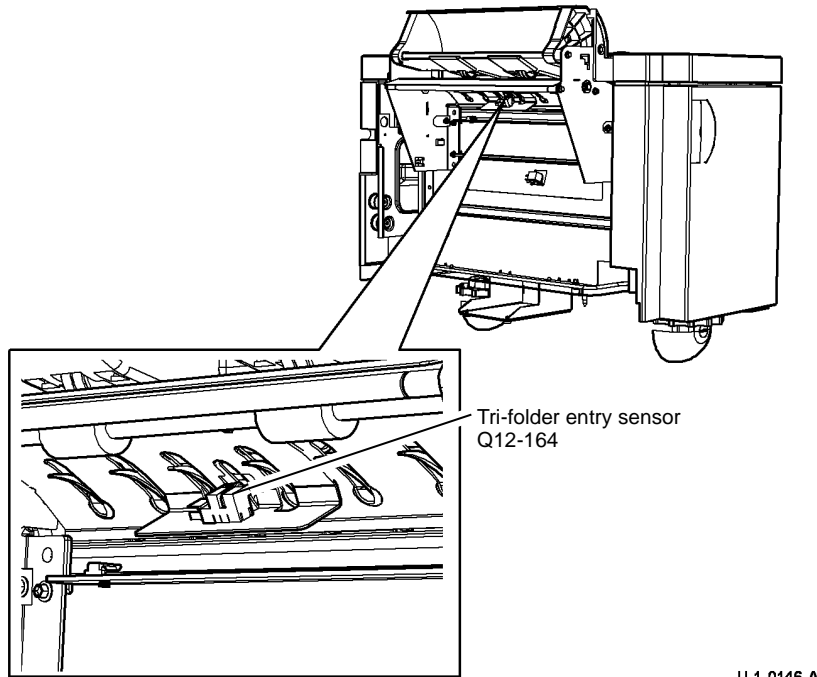

Figure 3 Component location

U-1-0146-A

Y N
 Go to [WD 12.19](#) and [WD 12.20](#). Check SOL12-267.
 Refer to:

- [GP 12](#) How to Check a Solenoid or Clutch.
- [12A-171](#) HVF Power Distribution RAP.
- [01L](#) 0V Distribution RAP

Install new components as necessary:

- Tri-folder diverter solenoid, [PL 12.215 Item 16](#).
- Tri-folder control PWB, [PL 12.205 Item 16](#).
- BM PWB, [PL 12.175 Item 10](#).

Enter [dC330](#) code 12-268 to energize the tri-folder assist gate solenoid, SOL12-268, [Figure 1](#).
The solenoid energizes.

Y N
 Go to [WD 12.19](#) and [WD 12.20](#). Check SOL12-268.
 Refer to:

- [GP 12](#) How to Check a Solenoid or Clutch.
- [12A-171](#) HVF Power Distribution RAP.
- [01L](#) 0V Distribution RAP

Install new components as necessary:

- Tri-folder assist gate solenoid, [PL 12.215 Item 8](#).
- Tri-folder control PWB, [PL 12.205 Item 16](#).
- BM PWB, [PL 12.175 Item 10](#).

Enter [dC330](#) code 12-269 to energize the tri-folder crease roll clutch, CL12-269, [Figure 1](#).
The clutch energizes.

Y N
 Go to [WD 12.19](#) and [WD 12.20](#). Check CL12-269.
 Refer to:

- [GP 12](#) How to Check a Solenoid or Clutch.
- [12A-171](#) HVF Power Distribution RAP.
- [01L](#) 0V Distribution RAP

Install new components as necessary:

- Tri-folder crease roll clutch, [PL 12.205 Item 9](#).
- Tri-folder control PWB, [PL 12.205 Item 16](#).
- BM PWB, [PL 12.175 Item 10](#).

Enter [dC330](#), code 12-273 to run the BM crease roll motor, MOT12-253, [Figure 3](#). **The motor runs.**

Y N
 Go to [WD 12.18](#). Check MOT12-253.
 Refer to:

- [GP 10](#) How to Check a Motor.
- [12A-171](#) HVF Power Distribution RAP.
- [01L](#) 0V Distribution RAP

A
 Install new components as necessary:

- BM crease roll motor, [PL 12.175 Item 12](#).
- BM PWB, [PL 12.175 Item 10](#).

Perform [SCP 5](#) Final Actions

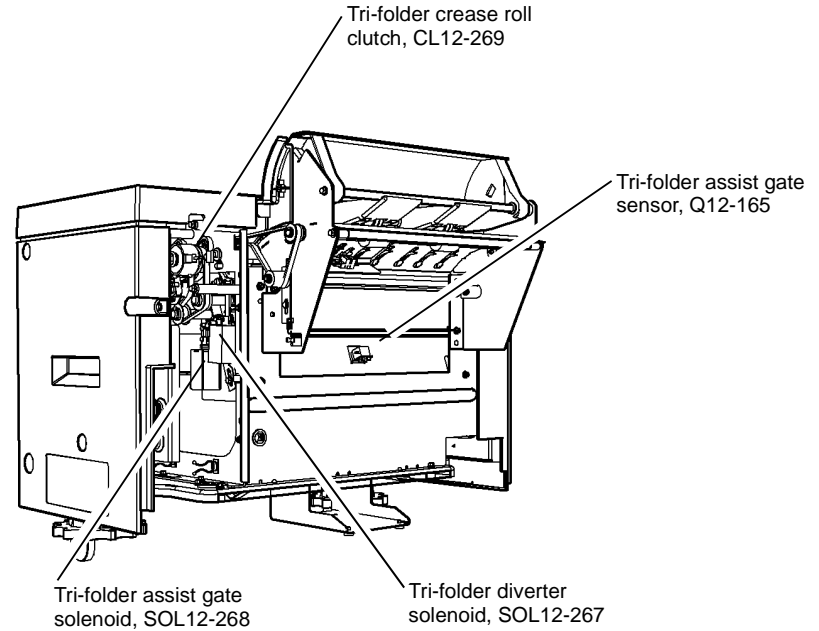

Figure 1 Component location

U-1-0147-A

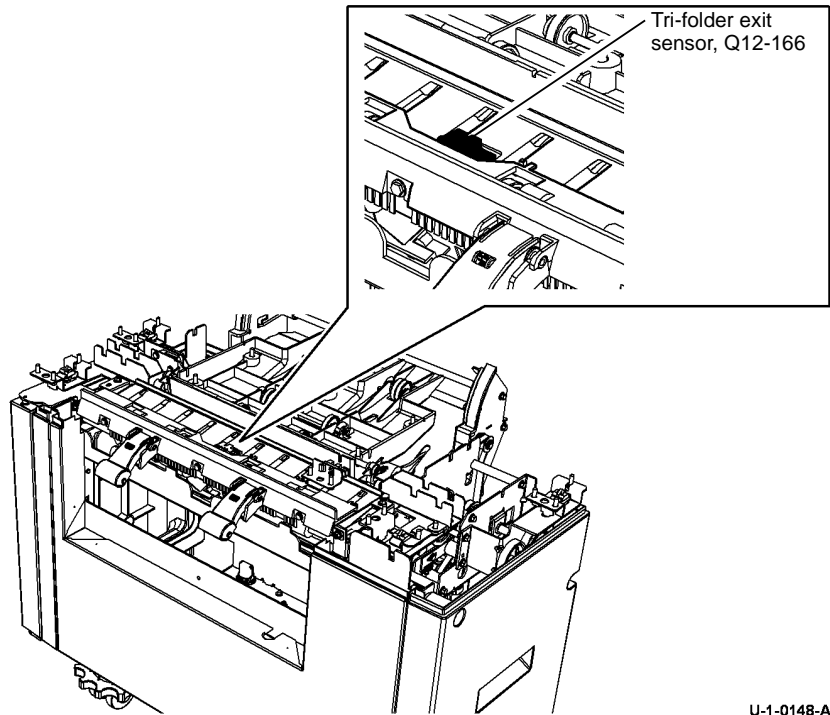
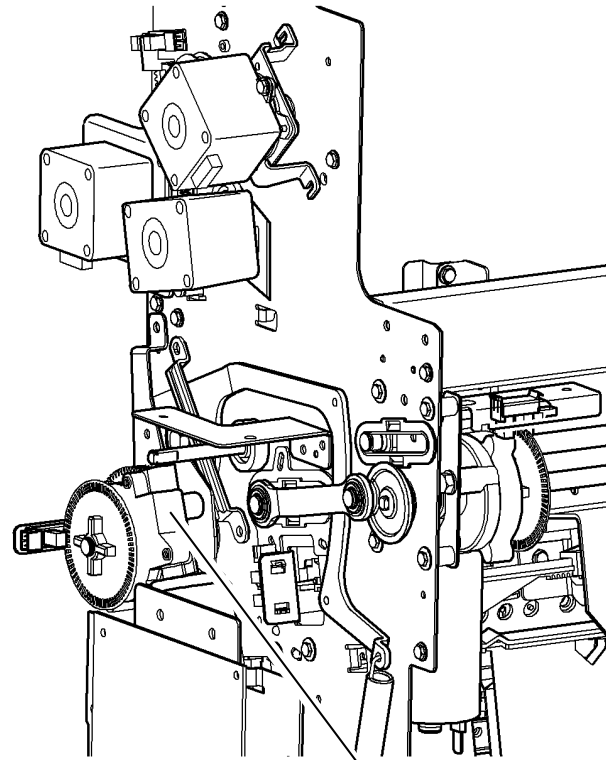

Figure 2 Component location

U-1-0148-A



BM crease roll motor,
MOT12-253

U-1-0149-A

Figure 3 Component location

12-191-00-171, 12-193-00-171, 12-194-00-171, 12-196-00-171 Inserter Paper Jam RAP

12-191-00-171 The leading edge is late arriving at the inserter standby sensor.

12-193-00-171 The trailing edge is late leaving the inserter standby sensor.

12-194-00-171 The leading edge is late arriving at the inserter pickup sensor.

12-196-00-171 The trailing edge is late leaving the inserter pickup sensor.

Fault code 12-191-00 may also be generated where a fault in the inserter causes jamming in the IME.

Initial Actions

WARNING

Ensure that the electricity to the machine is switched off while performing tasks that do not need electricity. Refer to [GP 14](#). Disconnect the power cord. Electricity can cause death or injury. Moving parts can cause injury.

- Check for a jam or other obstruction in the inserter.
- Check the inserter for damage.
- Check the condition of the inserter feed rolls. Use a cloth dampened with water to clean the rolls. If necessary, install a new inserter pickup assembly, [PL 12.310 Item 1](#).
- Go to [dC135](#) CRU/HFSI Status. Check the count of the inserter feed roller set. If the count is near end of life, install a new inserter pickup assembly, [PL 12.310 Item 1](#).

Procedure

Enter [dC330](#) code 12-315. Manually actuate the inserter pickup sensor, Q12-315, [Figure 1](#). **The display changes.**

Y N
Go to [WD 12.14](#), [WD 12.21](#) and [WD 12.22](#) Check Q12-315.
Refer to:

- [GP 11](#) How to Check a Sensor.
- [12A-171](#) HVF Power Distribution RAP.
- [01L 0V](#) Distribution RAP

Install new components as necessary:

- Inserter pickup sensor, [PL 12.310 Item 10](#).
- Inserter PWB, [PL 12.310 Item 9](#).
- HVF PWB, [PL 12.140 Item 2](#).

Enter [dC330](#) code 12-084. Manually actuate the inserter TE sensor, Q12-084, [Figure 1](#). **The display changes.**

Y N
Go to [WD 12.13](#) and [WD 12.21](#). Check Q12-084.
Refer to:

- [GP 11](#) How to Check a Sensor.
- [12A-171](#) HVF Power Distribution RAP.

- [01L 0V](#) Distribution RAP
- Install new components as necessary:
- Inserter TE sensor, [PL 12.310 Item 11](#).
 - Inserter PWB, [PL 12.310 Item 9](#).
 - HVF PWB, [PL 12.140 Item 2](#).

Enter [dC330](#) code 12-083. Manually actuate the inserter LE sensor, Q12-083, [Figure 1](#). **The display changes.**

Y N
Go to [WD 12.13](#) and [WD 12.21](#). Check Q12-083.
Refer to:

- [GP 11](#) How to Check a Sensor.
- [12A-171](#) HVF Power Distribution RAP.
- [01L 0V](#) Distribution RAP

Install new components as necessary:

- Inserter LE sensor, [PL 12.310 Item 11](#).
- Inserter PWB, [PL 12.310 Item 9](#).
- HVF PWB, [PL 12.140 Item 2](#).

Enter [dC330](#) code 12-316. Manually actuate the inserter acceleration sensor Q12-316, [Figure 1](#). **The display changes.**

Y N
Go to [WD 12.13](#), [WD 12.21](#) and [WD 12.22](#). Check the sensor.
Refer to:

- [GP 11](#) How to Check a Sensor.
- [12A-171](#) HVF Power Distribution RAP.
- [01L 0V](#) Distribution RAP

Install new components as necessary:

- Inserter acceleration sensor, [PL 12.300 Item 10](#).
- Inserter PWB, [PL 12.310 Item 9](#).
- HVF PWB, [PL 12.140 Item 2](#).

Enter [dC330](#) code 12-320. Manually actuate the inserter standby sensor Q12-320. **The voltage changes.**

Y N
Go to [WD 12.14](#). Check the sensor.
Refer to:

- [GP 11](#) How to Check a Sensor.
- [12A-171](#) HVF Power Distribution RAP.
- [01L 0V](#) Distribution RAP

Install new components as necessary:

- Inserter standby sensor, [PL 12.135 Item 2](#).
- HVF PWB, [PL 12.140 Item 2](#).

Enter [dC330](#) code 12-260 to energize the inserter clutch CL12-260. **The clutch energizes.**

Y N
Go to [WD 12.14](#), [WD 12.21](#) and [WD 12.22](#). Check CL 12-260.

B

Refer to:

- GP 12 How to Check a Solenoid or Clutch.
- 12A-171 HVF Power Distribution RAP.
- 01L 0V Distribution RAP

Install new components as necessary:

- Inserter clutch, PL 12.310 Item 3.
- Inserter PWB, PL 12.310 Item 9.
- HVF PWB, PL 12.140 Item 2.

Enter dC330, code 12-261 to run the inserter motor, MOT12-261. **The motor runs.**

Y N

Go to WD 12.14 and WD 12.22. Check MOT12-261.

Refer to:

- GP 10 How to Check a Motor.
- 12A-171 HVF Power Distribution RAP.
- 01L 0V Distribution RAP

Install new components as necessary:

- Inserter motor, PL 12.315 Item 1.
- Inserter PWB, PL 12.310 Item 9.
- HVF PWB, PL 12.140 Item 2

Perform SCP 5 Final Actions

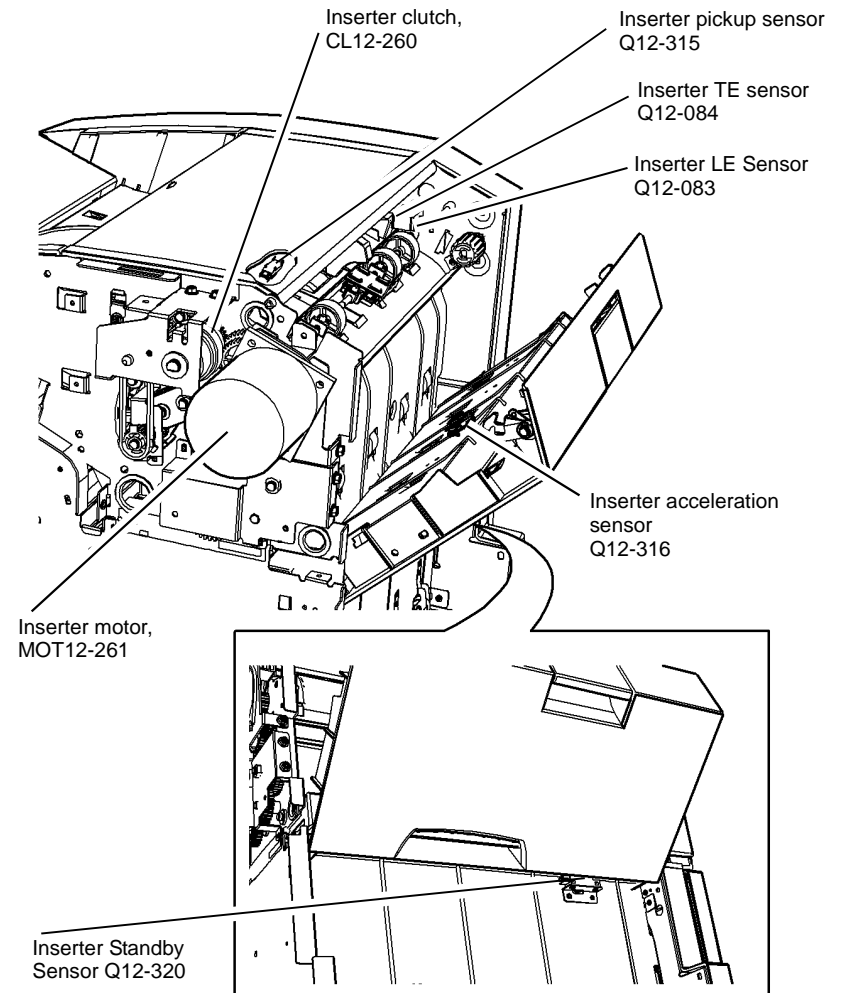

U-1-0151-A

Figure 1 Component location

12-198-00-171, 12-199-00-171 HVF Paper Jam RAP

12-198-00-171 A stray sheet was detected in the finisher, after a jam clearance.

12-199-00-171 An unexpected sheet has been detected in the finisher.

Initial Actions

WARNING

Ensure that the electricity to the machine is switched off while performing tasks that do not need electricity. Refer to [GP 14](#). Disconnect the power cord. Electricity can cause death or injury. Moving parts can cause injury.

- Check for a jam or other obstruction in the HVF paper path.
- Check the paper path for damage.

Procedure

Enter [dC330](#), code 12-077. Manually actuate the entry sensor, Q12-077, [Figure 1](#). The display changes.

- Y N**
- Go to [WD 12.7](#). Check Q12-077.
- Refer to:
- [GP 11](#) How to Check a Sensor.
 - [12A-171](#) HVF Power Distribution RAP
 - [01L](#) 0V Distribution RAP
- Install new components as necessary:
- Entry sensor, [PL 12.135 Item 2](#).
 - HVF PWB, [PL 12.140 Item 2](#).

Enter [dC330](#), code 12-086. Manually actuate the buffer position sensor, Q12-086, [Figure 1](#). The display changes.

- Y N**
- Go to [WD 12.7](#). Check Q12-086.
- Refer to:
- [GP 11](#) How to Check a Sensor.
 - [12A-171](#) HVF Power Distribution RAP
 - [01L](#) 0V Distribution RAP
- Install new components as necessary:
- Buffer position sensor, [PL 12.135 Item 2](#).
 - HVF PWB, [PL 12.140 Item 2](#).

Enter [dC330](#), code 12-321. Manually actuate the buffer path sensor, Q12-321, [Figure 1](#). The display changes.

- Y N**
- Go to [WD 12.7](#). Check Q12-321.
- Refer to:
- [GP 11](#) How to Check a Sensor.
 - [12A-171](#) HVF Power Distribution RAP
 - [01L](#) 0V Distribution RAP

Install new components as necessary:

- Buffer path sensor, [PL 12.135 Item 2](#).
- HVF PWB, [PL 12.140 Item 2](#).

Enter [dC330](#), code 12-106. Manually actuate the compile exit sensor, Q12-106, [Figure 1](#). The display changes.

- Y N**
- Go to [WD 12.7](#). Check Q12-106.
- Refer to:
- [GP 11](#) How to Check a Sensor.
 - [12A-171](#) HVF Power Distribution RAP
 - [01L](#) 0V Distribution RAP
- Install new components as necessary:
- Compiler exit sensor, [PL 12.135 Item 2](#).
 - HVF PWB, [PL 12.140 Item 2](#).

Enter [dC330](#), code 12-107. Manually actuate the top tray exit sensor, Q12-107, [Figure 1](#). The display changes.

- Y N**
- Go to [WD 12.7](#). Check Q12-107.
- Refer to:
- [GP 11](#) How to Check a Sensor.
 - [12A-171](#) HVF Power Distribution RAP
 - [01L](#) 0V Distribution RAP
- Install new components as necessary:
- Top tray exit sensor, [PL 12.135 Item 3](#).
 - HVF PWB, [PL 12.140 Item 2](#).

HVF BM machines only, enter [dC330](#), code 12-087. Manually actuate the HVF booklet exit sensor, Q12-087, [Figure 1](#). The display changes.

- Y N**
- Go to [WD 12.7](#). Check Q12-087.
- Refer to:
- [GP 11](#) How to Check a Sensor.
 - [12A-171](#) HVF Power Distribution RAP
 - [01L](#) 0V Distribution RAP
- Install new components as necessary:
- HVF booklet exit sensor, [PL 12.135 Item 3](#).
 - HVF PWB [PL 12.140 Item 2](#).

The fault may be intermittent, check for damaged wiring or bad connectors, [REP 1.1](#). If necessary install new components.

12-288-00-171, 12-289-00-171 HVF Nip Split RAP

12-288-00-171 The nip split has failed to operate.

12-289-00-171 The nip split has failed to return to the home position.

Initial Actions

WARNING

Ensure that the electricity to the machine is switched off while performing tasks that do not need electricity. Refer to [GP 14](#). Disconnect the power cord. Electricity can cause death or injury. Moving parts can cause injury.

- Check for a jam or other obstruction in the nip split.
- Check the nip split for damage.

Procedure

Enter [dC330](#), code 12-264 to run the nip split motor, MOT12-264, [Figure 1](#). The **nip-split mechanism can be heard.**

Y N

Go to [WD 12.8](#). Check MOT12-264.

Refer to:

- [GP 10](#) How to Check a Motor.
- [12A-171](#) HVF Power Distribution RAP.
- [01L 0V](#) Distribution RAP

Install new components as necessary:

- Nip split motor, [PL 12.125](#) Item 15.
- HVF PWB, [PL 12.140](#) Item 2.

Enter [dC330](#) code 12-088. Manually actuate the nip home sensor, Q12-088, [Figure 1](#). The **display changes.**

Y N

Go to [WD 12.7](#). Check Q12-088.

Refer to:

- [GP 11](#) How to Check a Sensor.
- [12A-171](#) HVF Power Distribution RAP.
- [01L 0V](#) Distribution RAP

Install new components as necessary:

- Nip home sensor, [PL 12.135](#) Item 1.
- HVF PWB, [PL 12.140](#) Item 2.

Enter [dC330](#) code 12-091. Manually actuate the nip split sensor, Q12-091. The **display changes.**

Y N

Go to [WD 12.7](#). Check Q12-091.

Refer to:

- [GP 11](#) How to Check a Sensor.
- [12A-171](#) HVF Power Distribution RAP.
- [01L 0V](#) Distribution RAP

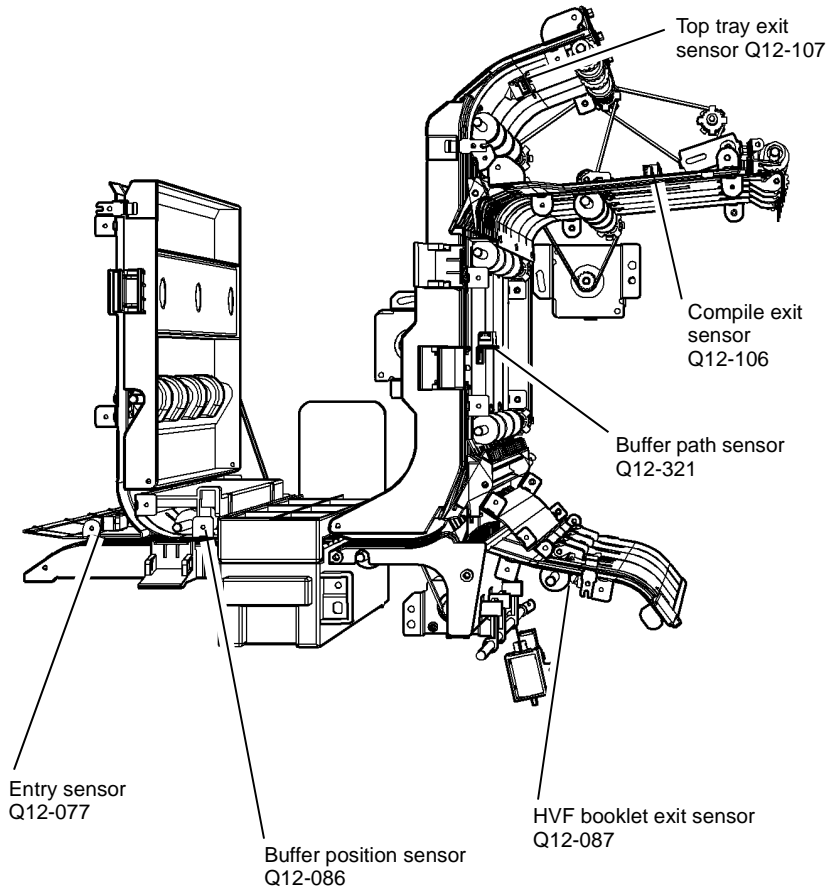

Figure 1 Component location

A

Install new components as necessary:

- Nip split sensor, [PL 12.135 Item 1](#).
- HVF PWB, [PL 12.140 Item 2](#).

Perform [SCP 5 Final Actions](#).

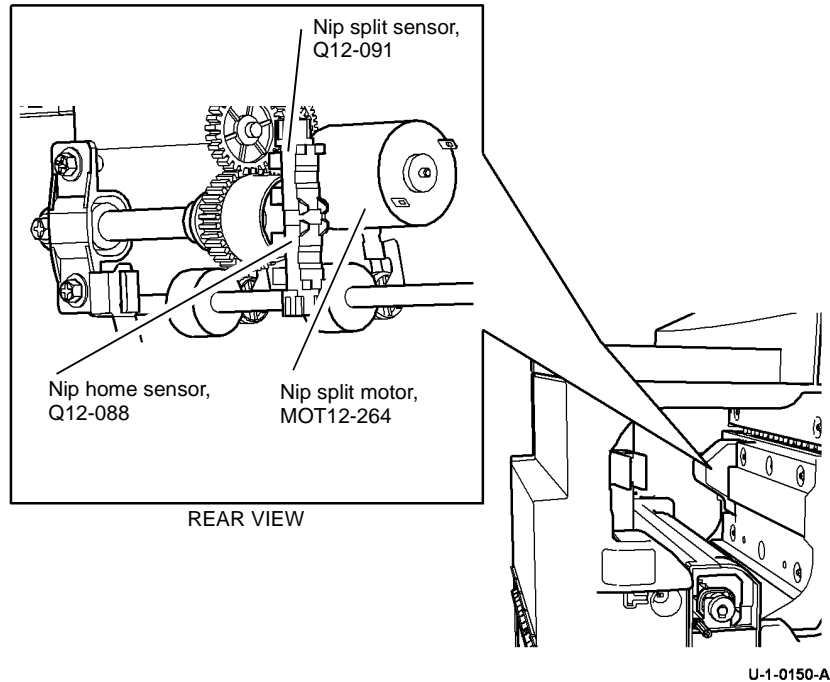

Figure 1 Component location

12-310-00-171, 12-312-00-171, 12-313-00-171 HVF Docking and Interlocks RAP

12-310-00-171 The finisher was detected to be undocked in the run mode.

12-312-00-171 The top cover interlock was detected open during a run.

12-313-00-171 The finisher front door interlock was detected open during a run.

Initial Actions

WARNING

Ensure that the electricity to the machine is switched off while performing tasks that do not need electricity. Refer to [GP 14](#). Disconnect the power cord. Electricity can cause death or injury. Moving parts can cause injury.

- Ensure the HVF is correctly docked to the machine and all interlocks are closed.
- Check the interlock actuator for damage.

Procedure

Go to the relevant procedure:

- [12-177-00-171 Docking Interlock](#)
- [12-197-00-171 Top Cover Interlock](#)
- [12-303-00-171 Front Door Interlock](#)

12-177-00-171 Docking Interlock

Check the docking interlock switch, S12-177, [Figure 1](#).

- Check the switch actuator mounted on the machine is correctly installed and un-broken.
- Enter [dC330](#), code 12-177, actuate the switch and check the display.

Refer to:

- [GP 13](#) How to Check a Switch.
- [WD 12.8](#).

- Check the wiring.
- If necessary, install a new docking interlock switch, [PL 12.100 Item 16](#).

12-197-00-171 Top Cover Interlock

Check the top cover interlock switch, S12-197, [Figure 1](#).

- Check the switch actuator is not damaged.
- Enter [dC330](#), code 12-197, actuate the switch and check the display.

Refer to:

- [GP 13](#) How to Check a Switch.
- [WD 12.8](#).

- Check the wiring, [REP 1.1](#).
- If necessary, install a new top cover interlock switch, [PL 12.115 Item 24](#).

12-303-00-171 Front Door Interlock

Check the front door interlock switch, S12-303, [Figure 1](#).

- Check the switch actuator on the inside of the front door is not damaged.
- Enter [dC330](#), code 12-303 actuate the switch and check the display.

Refer to:

- [GP 13](#) How to Check a Switch.
- [WD 12.8](#).

- Check the wiring, [REP 1.1](#).

- If necessary, install a new front door interlock switch, [PL 12.115 Item 28](#).

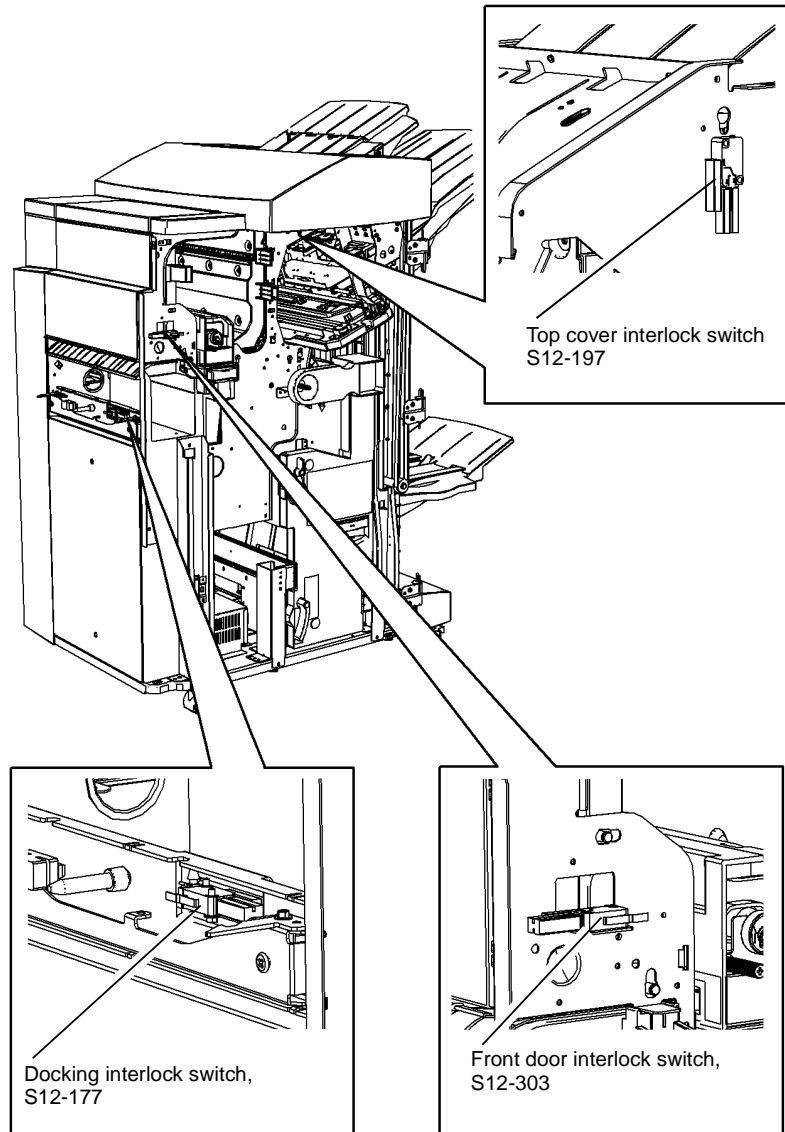

U-1-0153-A

Figure 1 Component location

12-316-00-171, 12-319-00-171 Inserter Interlocks RAP

12-316-00-171 The inserter top cover interlock was detected open in the run mode.

12-319-00-171 The inserter left hand door was detected open in the run mode.

Initial Actions

WARNING

Ensure that the electricity to the machine is switched off while performing tasks that do not need electricity. Refer to [GP 14](#). Disconnect the power cord. Electricity can cause death or injury. Moving parts can cause injury.

Check that the inserter top cover and left hand door can be fully closed and that the interlocks are actuated. Remove any obstruction as necessary.

Procedure

Go to the relevant procedure:

- [12-316-00-171 Inserter Top Cover Interlock](#)
- [12-319-00-171 Inserter Jam Cover Interlock](#)

12-316-00-171 Inserter Top Cover Interlock

Check the inserter top cover interlock switch, S12-178, [Figure 1](#).

- Check the switch actuator mounted on the machine is correctly installed and un-broken.
- Enter [dC330](#), code 12-178, actuate the switch and check the display.

Refer to:

- [GP 13](#) How to Check a Switch.
- [WD 12.14](#) and [WD 12.21](#).

- Check the wiring, [REP 1.1](#).
- If necessary, install a new inserter top cover interlock switch, [PL 12.305 Item 8](#).

12-319-00-171 Inserter Jam Cover Interlock

Check the inserter jam cover interlock switch, S12-179, [Figure 1](#).

- Check the switch actuator is not damaged.
- Enter [dC330](#), code 12-179 actuate the switch and check the display.

Refer to:

- [GP 13](#) How to Check a Switch.
- [WD 12.14](#) and [WD 12.21](#).

- Check the wiring, [REP 1.1](#).
- If necessary, install a new inserter jam cover interlock switch, [PL 12.300 Item 18](#).

12-317-00-171, 12-318-00-171 Tri-folder Interlocks RAP

12-317-00-171 The tri-folder top cover interlock was detected open during a run.

12-318-00-171 The tri-folder front door interlock was detected open during a run.

Initial Actions

WARNING

Ensure that the electricity to the machine is switched off while performing tasks that do not need electricity. Refer to [GP 14](#). Disconnect the power cord. Electricity can cause death or injury. Moving parts can cause injury.

Check that the tri-folder top cover and front door can be fully closed and that the interlocks are actuated. Remove any obstruction as necessary.

Procedure

Figure 1. The two yellow, +24V interlock LED's on the BM PWB will extinguish if a tri-folder interlock is open.

Check that the yellow, +24V interlock LED on the BM control PWB is lit. **The LED is lit.**

Y N

Go to [WD 12.9](#), [WD 12.17](#), [WD 12.19](#), [WD 12.20](#). Check the wiring and repair as necessary, [REP 1.1](#). Check the tri-folder top cover interlock switch and the tri-folder front door interlock switch, S12-209. Refer to:

- [GP 13](#) How to Check a Switch.
- [12A-171](#) HVF Power Distribution RAP.
- [01L](#) 0V Distribution RAP

Install new components as necessary:

- Tri-folder top cover interlock switch, [PL 12.215 Item 3](#).
- Tri-folder front door interlock switch, [PL 12.215 Item 2](#).
- Tri-folder PWB, [PL 12.205 Item 16](#).
- BM PWB, [PL 12.175 Item 10](#).
- HVF PWB, [PL 12.140 Item 2](#).

Enter [dC330](#), code 12-209 tri-folder front door interlock switch, S12-209. Open the tri-folder front door. **The display changes.**

Y N

Go to [WD 12.19](#) and [WD 12.20](#). Check the wiring and repair as necessary, [REP 1.1](#). Check the tri-folder front door interlock, S12-209. Refer to:

- [GP 13](#) How to Check a Switch.
- [12A-171](#) HVF Power Distribution RAP.
- [01L](#) 0V Distribution RAP

Install new components as necessary:

- Tri-folder front door interlock switch, [PL 12.215 Item 2](#).
- Tri-folder PWB, [PL 12.205 Item 16](#).
- BM PWB, [PL 12.175 Item 10](#).

Enter [dC330](#), code 12-210 tri-folder top cover interlock sensor, Q12-210. Open the tri-folder top cover. **The display changes.**

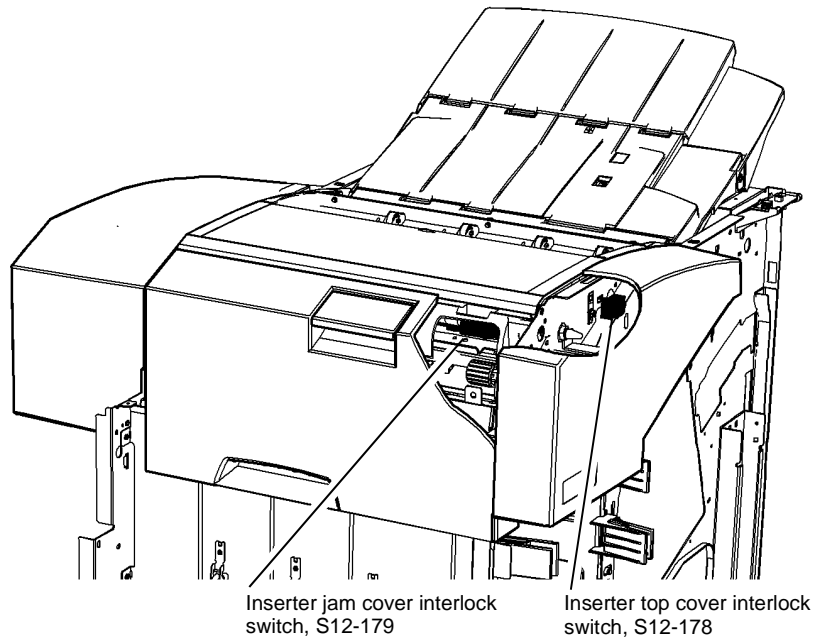

U-1-0154-A

Figure 1 Component location

- Y N
- Go to [WD 12.19](#) and [WD 12.20](#). Check the wiring and repair as necessary, [REP 1.1](#). Check the tri-folder top cover interlock sensor, Q12-210. Refer to:
- [GP 11](#) How to Check a Sensor.
 - [12A-171](#) HVF Power Distribution RAP.
 - [01L](#) 0V Distribution RAP
- Install new components as necessary:
- Tri-folder top cover interlock sensor, [PL 12.200](#) Item 10.
 - Tri-folder PWB, [PL 12.205](#) Item 16.
 - BM PWB, [PL 12.175](#) Item 10.

Perform [SCP 5](#) Final Actions.

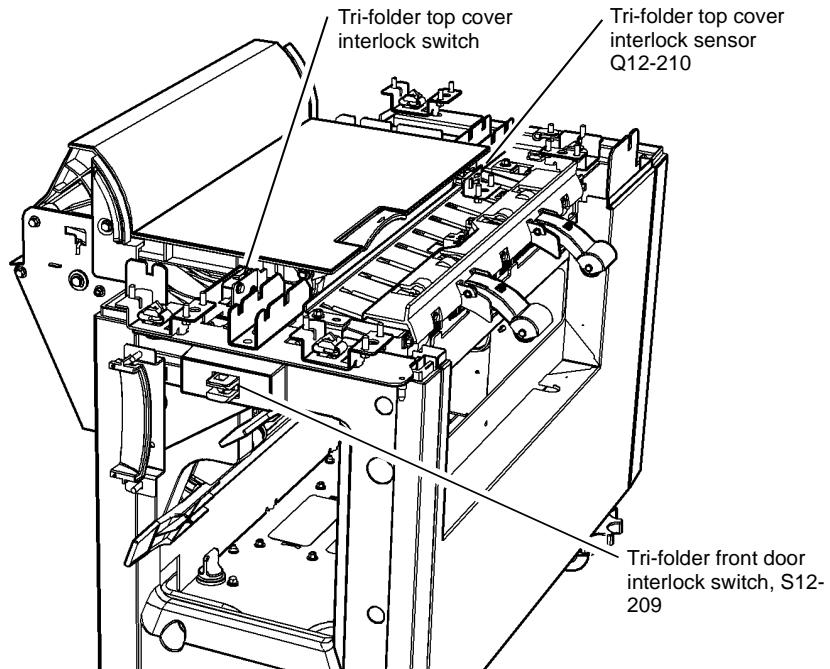

U-1-0155-A

Figure 1 Component location

12-367-00-171, 12-368-00-171, 12-380-00-171 HVF Punch Unit Paper Edge Detect RAP

12-367-00-171 The punch unit failed to detect the edge of the A4 LE feed paper.

12-368-00-171 The punch unit failed to detect the edge of the 8.5"x 11" SE feed paper.

12-380-00-171 The punch unit failed to detect the edge of the 8.5"x11" LE feed paper.

Initial Actions

WARNING

Ensure that the electricity to the machine is switched off while performing tasks that do not need electricity. Refer to [GP 14](#). Disconnect the power cord. Electricity can cause death or injury. Moving parts can cause injury.

- Check that the paper path through the punch is clear, [Figure 1](#).
- Check the punch module is seated at the rear of the machine.
- Check that a ColorQube punch unit is installed. A ColorQube unit has 3 sensors on the unit, [Figure 1](#).

Procedure

[Figure 1](#). Punch sensor 1, Q12-078 detects 8.5"x11" LE feed paper. Punch sensor 2, Q12-075 detects 8.5"x11" SE feed paper. Punch sensor 3, Q12-076 detects A4 LE feed paper.

Enter [dC330](#), enter the relevant code then actuate and check each of the three punch sensors.

- code 12-078 for punch sensor 1.
- code 12-075 for punch sensor 2.
- code 12-076 for punch sensor 3.

The display changes.

Y N

Go to [WD 12.12](#) for punch sensor 1 and [WD 12.24](#) for punch sensors 2 & 3. Check the wiring and repair as necessary, [REP 1.1](#). Refer to:

- [GP 11](#) How to Check a Sensor.
- [12A-171](#) HVF Power Distribution RAP.
- [01L](#) 0V Distribution RAP

Install new components as necessary:

- Punch sensor 1, [PL 12.125](#) Item 17.
- Punch sensor 2, [PL 12.125](#) Item 17.
- Punch sensor 3, [PL 12.125](#) Item 17.
- HVF PWB, [PL 12.140](#) Item 2.

Enter [dC330](#), code 12-223 transport motor 1, to check that the motor runs. **The motor runs.**

Y N

Go to [WD 12.7](#). Check the wiring and repair as necessary, [REP 1.1](#). Check MOT12-223. Refer to:

- [GP 10](#) How to Check a Motor.
- [12A-171](#) HVF Power Distribution RAP.
- [01L](#) 0V Distribution RAP

A

A

Install new components as necessary:

- Transport motor 1, [PL 12.120 Item 2](#).
- HVF PWB, [PL 12.140 Item 2](#).

Check the transport motor 1 drive belt, [PL 12.120 Item 7](#). **The drive belt is good.**

Y N

Install a new transport motor 1 drive belt, [PL 12.120 Item 7](#).

Enter [dC330](#), code 12-245 punch unit motor, to check that the motor runs. **The motor runs.**

Y N

Go to [WD 12.24](#). Check the wiring and repair as necessary, [REP 1.1](#). Check MOT12-245.

Refer to:

- [GP 10](#) How to Check a Motor.
- [12A-171](#) HVF Power Distribution RAP.
- [01L](#) 0V Distribution RAP

Install new components as necessary:

- Hole punch module, [PL 12.125 Item 19](#).
- HVF PWB, [PL 12.140 Item 2](#).

Perform [SCP 5](#) Final Actions.

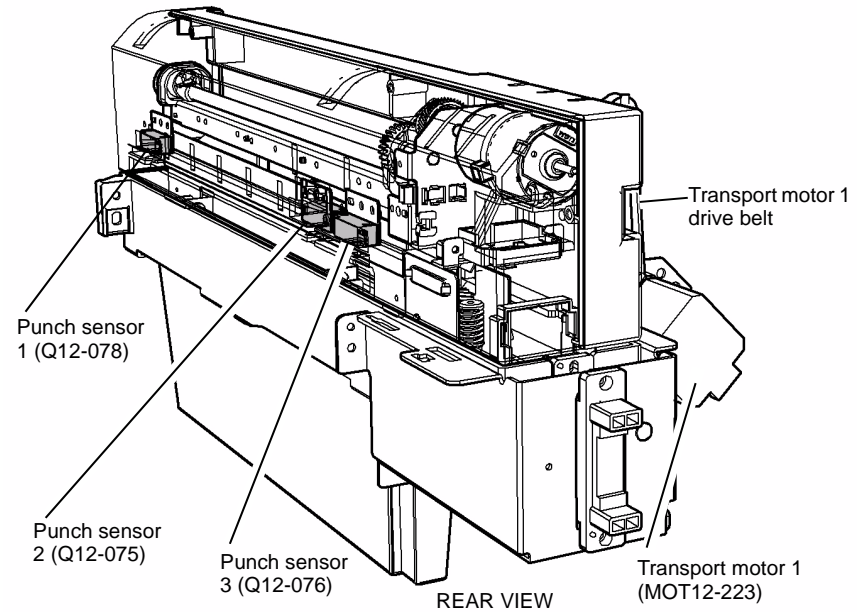

U-1-0158-A

Figure 1 Component location

12-369-00-171 to 12-377-00-171 HVF Stapler Position and Priming RAP

12-369-00-171 The stapler return end home failure.

12-370-00-171 The stapler end home failure.

12-371-00-171 The stapler did not move from the home position within the required time.

12-372-00-171 The stapler did not return to the home position within the required time.

12-373-00-171 The stapler did not enter the mid home position.

12-374-00-171 The stapler did not leave the mid home position.

12-375-00-171 The stapler jaw did not enter the home position.

12-376-00-171 The stapler jaw did not leave the home position.

12-377-00-171 A stapler priming failure was detected.

Initial Actions

WARNING

Ensure that the electricity to the machine is switched off while performing tasks that do not need electricity. Refer to [GP 14](#). Disconnect the power cord. Electricity can cause death or injury. Moving parts can cause injury.

CAUTION

Do not run code 12-247 without 2 sheets of paper in the stapler jaws. Running this code without the paper in position can cause damage to the machine.

If stapling has failed, perform the following:

- Check that the staple head unit is correctly installed.
- Check that the staple cartridge has staples in it and is correctly installed in the staple head.
- Check that the leading staples in the staple head have been primed.
- Check that the sheets of staples in the cartridge are feeding one at a time. If staple sheets overlap, they will jam in the cartridge. If necessary, install a new cartridge.

Procedure

NOTE: Sensors Q12-133, Q12-134, Q12-317 and Q12-318 are integral to the staple head unit and although they can be checked they are not spared separately.

[Figure 1](#) and [Figure 2](#) show the locations of the components.

Enter [dC330](#), code 12-249 to run the stapler unit 1 motor, MOT12-249 and send it to the inboard end of the machine. **The motor runs.**

Y N
Go to [WD 12.15](#). Check MOT12-249.
Refer to:

- [GP 10](#) How to Check a Motor.

- A**
- [12A-171](#) HVF Power Distribution RAP.
 - [01L 0V](#) Distribution RAP
- Install new components as necessary:
- Stapler assembly, [PL 12.110 Item 14](#).
 - HVF PWB, [PL 12.140 Item 2](#).

With the stapler unit still at the inboard end, enter [dC330](#), code 12-135. Manually actuate the stapler unit home sensor, Q12-135 [Figure 2](#). **The display changes.**

Y N
Go to [WD 12.10](#). Check Q12-135.
Refer to:

- [GP 11](#) How to Check a Sensor.
- [12A-171](#) HVF Power Distribution RAP.
- [01L 0V](#) Distribution RAP

Install new components as necessary:

- Stapler unit home sensor, [PL 12.110 Item 15](#).
- HVF PWB, [PL 12.140 Item 2](#).

Enter [dC330](#), code 12-045 to send the stapler unit to the outboard end of the machine. Enter code 12-176, stapler unit mid home sensor. Manually actuate the stapler unit mid home sensor, Q12-176, [Figure 2](#). **The display changes.**

Y N
Go to [WD 12.11](#). Check Q12-176.
Refer to:

- [GP 11](#) How to Check a Sensor.
- [12A-171](#) HVF Power Distribution RAP
- [01L 0V](#) Distribution RAP

Install new components as necessary:

- Stapler unit mid home sensor, [PL 12.110 Item 15](#).
- HVF PWB, [PL 12.140 Item 2](#).

Place two sheets of paper in the stapler jaws. Raise the finisher top cover. [Figure 1](#), fully lower the paper pusher, then lower the top cover. Enter [dC330](#), code 12-247 to run the staple head 1 motor, MOT12-247. **The motor runs.**

Y N
Enter [dC330](#), code 12-319, stapler gate safety switch. Manually actuate the stapler gate safety switch. **The display changes.**

Y N
Go to [WD 12.11](#). Check S12-319.
Refer to:

- [GP 13](#) How to Check a Switch.
- [12A-171](#) HVF Power Distribution RAP.
- [01L 0V](#) Distribution RAP

Install new components as necessary:

- Stapler gate safety switch, [PL 12.115 Item 17](#).
- HVF PWB, [PL 12.140 Item 2](#).

A

B

C

B **C**
Go to [WD 12.14](#). Check MOT12-247.
Refer to:

- [GP 10](#) How to Check a Motor.
- [12A-171](#) HVF Power Distribution RAP.
- [01L 0V](#) Distribution RAP

Install new components as necessary:

- Stapler assembly, [PL 12.110 Item 14](#).
- HVF PWB, [PL 12.140 Item 2](#).

Remove the stapled paper and raise the paper pusher fully upwards. Go to [WD 12.10](#). **+5V is available at T502 between pins 1 and 4, also between pin 1 and 7 on the staple head.**

Y **N**
Check the wiring between T502 and PJ301. **The wiring is good.**
Y **N**
Repair the wiring, [REP 1.1](#).
Install a new HVF PWB, [PL 12.140 Item 2](#).

Enter [dC330](#), code 12-134 actuate the stapler priming sensor, Q12-134, by removing and installing the staple cartridge. **The display changes.**

Y **N**
Go to [WD 12.10](#). Check for a change in signal level at PJ301 pin 9 when Q12-134 is being actuated. **The signal level changes.**
Y **N**
Check the wiring between PJ301 pin 9 and the stapler unit. **The wiring is good.**
Y **N**
Repair the wiring, [REP 1.1](#).
Install a new stapler assembly, [PL 12.110 Item 14](#).
Install a new HVF PWB, [PL 12.140 Item 2](#).

Enter [dC330](#), code 12-317 actuate the stapler cartridge sensor, Q12-317, by removing and installing the staple cartridge. **The display changes.**

Y **N**
Go to [WD 12.10](#). Check for a change in signal level at PJ301 pin 10 when Q12-317 is being actuated. **The signal level changes.**
Y **N**
Check the wiring between PJ301 pin 10 and the stapler unit. **The wiring is good.**
Y **N**
Repair the wiring, [REP 1.1](#).
Install a new stapler assembly [PL 12.110 Item 14](#).
Install a new HVF PWB, [PL 12.140 Item 2](#).

With the 2 sheets of paper still in place enter [dC330](#) code 12-318 to monitor the staple jaw home sensor Q12-318, stack the code 12-247 to cycle the staple head. **The display changes.**

Y **N**
Go to [WD 12.10](#), check for a change in signal level at PJ301 pin 12, while code 12-247 is running. **The signal level changes.**

Y **N**
Check the wiring between PJ301 pin 12 and the stapler unit. **The wiring is good.**
Y **N**
Repair the wiring, [REP 1.1](#).
Install a new stapler assembly, [PL 12.110 Item 14](#).

Install a new HVF PWB, [PL 12.140 Item 2](#).

Enter [dC330](#), code 12-133, actuate the low staples sensor, Q12-133, by removing and installing the staple cartridge. **The display changes.**

Y **N**
Go to [WD 12.10](#), check for a change in signal level at PJ301 pin 13 when Q12-133 is being actuated. **The signal level changes.**
Y **N**
Check the wiring between PJ391 pin 13 and the staple head unit. **The wiring is good.**
Y **N**
Repair the wiring [REP 1.1](#).
Install a new stapler assembly, [PL 12.110 Item 14](#).
Install a new HVF PWB, [PL 12.140 Item 2](#).

The fault may be intermittent, check for damaged wiring or bad connectors, [REP 1.1](#). If necessary install new components.

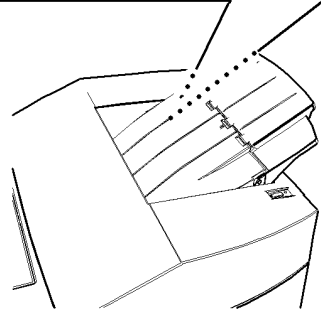
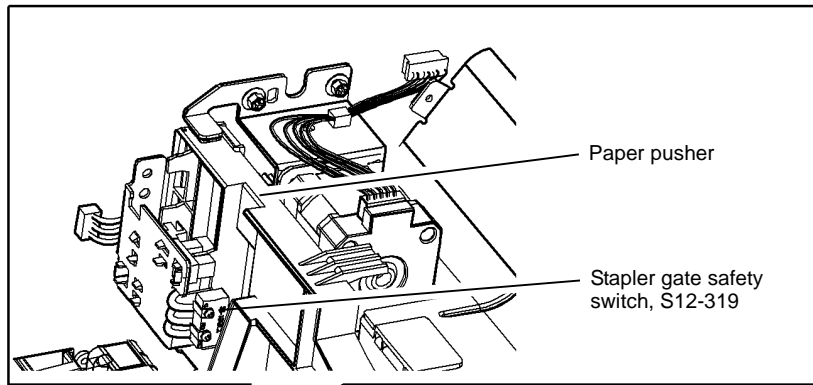

Figure 1 Component location

U-1-0156-A

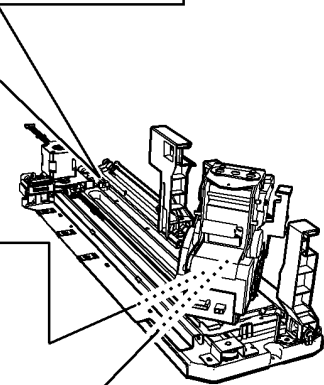
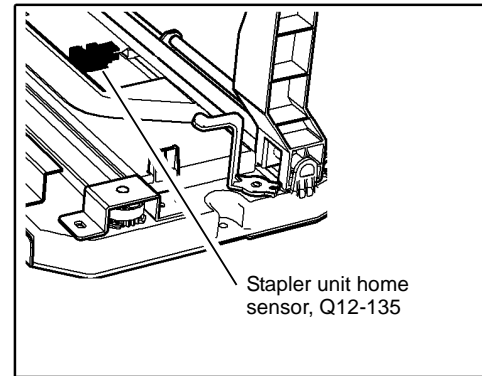
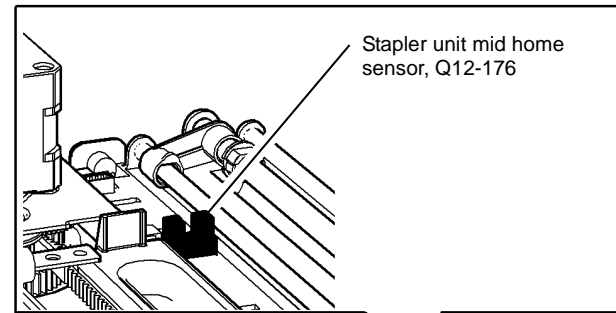

Figure 2 Component location

U-1-0157-A

12-392-00-171 to 12-395-00-171 HVF Front Tamper Fault RAP

12-392-00-171 The front tamper did not move from the home position.

12-393-00-171 The front tamper did not return to the home position.

12-394-00-171 The front tamper did not enter the away position.

12-395-00-171 The front tamper did not move from the away position.

Initial Actions

WARNING

Ensure that the electricity to the machine is switched off while performing tasks that do not need electricity. Refer to GP 14. Disconnect the power cord. Electricity can cause death or injury. Moving parts can cause injury.

- Check for damage or obstructions that would prevent the front tamper from operating correctly.
- Jams can be caused if the tray settings do not match the paper in the trays. Make sure the tray settings are correct.

Procedure

Figure 1 shows the location of the components.

Enter dC330, code 12-228 to move the tamper inboard, then enter 12-226 to move the tamper outboard. **The tamper moves.**

- Y N**
- Go to **WD 12.15**. Check the wiring and repair as necessary, **REP 1.1**. Check the front tamper motor home, MOT12-226. Refer to:
- **GP 10** How to Check a Motor.
 - **12A-171** HVF Power Distribution RAP.
 - **01L** 0V Distribution RAP
- Install new components as necessary:
- Front tamper motor, **PL 12.125** Item 6.
 - HVF PWB, **PL 12.140** Item 2.

Stack the dC330 code 12-180, front tamper home sensor, Q12-180. Move the tamper using the control codes 12-226 and 12-228. **The display changes.**

- Y N**
- Go to **WD 12.15**. Check the wiring and repair as necessary, **REP 1.1**. Check Q12-180. Refer to:
- **GP 11** How to Check a Sensor.
 - **12A-171** HVF Power Distribution RAP.
 - **01L** 0V Distribution RAP
- Install new components as necessary:
- Tamper front home sensor, **PL 12.135** Item 1.
 - HVF PWB, **PL 12.140** Item 2.

A

Stack the dC330 code 12-182, tamper front away sensor, Q12-182. Move the tamper using the control codes 12-226 and 12-228. **The display changes.**

- Y N**
- Go to **WD 12.15**. Check the wiring and repair as necessary, **REP 1.1**. Check Q12-182. Refer to:
- **GP 11** How to Check a Sensor.
 - **12A-171** HVF Power Distribution RAP.
 - **01L** 0V Distribution RAP
- Install new components as necessary:
- Tamper front away sensor, **PL 12.135** Item 1.
 - HVF PWB, **PL 12.140** Item 2.

Perform **SCP 5** Final Actions.

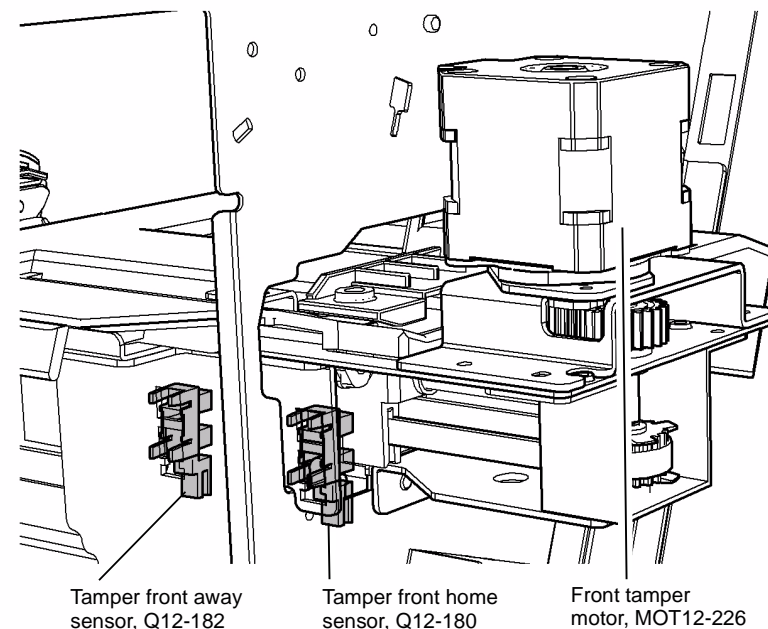

Figure 1 Component location

U-1-0159-A

12-396-00-171 to 12-399-00-171 HVF Rear Tamper Fault RAP

12-396-00-171 The rear tamper tray did not move from the home position.

12-397-00-171 The rear tamper tray did not return to the home position.

12-398-00-171 The rear tamper tray did not move from the away position.

12-399-00-171 The rear tamper tray did not return to the away position.

Initial Actions

WARNING

Ensure that the electricity to the machine is switched off while performing tasks that do not need electricity. Refer to [GP 14](#). Disconnect the power cord. Electricity can cause death or injury. Moving parts can cause injury.

- Check for damage or obstructions that would prevent the rear tamper from operating correctly.
- Check that the drive belt is securely in position, [Figure 1](#).
- Jams can be caused if the tray settings do not match the paper in the trays. Make sure the tray settings are correct.

Procedure

Enter the [dC330](#) code, 12-229 to move the rear tamper inboard. (The code 12-227 can be used to move the rear tamper outboard.) **The tamper moves.**

Y N

Go to [WD 12.14](#). Check the wiring and repair as necessary, [REP 1.1](#). Check the rear tamper motor, MOT12-227. Refer to:

- [GP 10](#) How to Check a Motor.
- [12A-171](#) HVF Power Distribution RAP.
- [01L](#) 0V Distribution RAP

Install new components as necessary:

- Rear tamper motor, [PL 12.110](#) Item 19.
- HVF PWB, [PL 12.140](#) Item 2.

Stack the [dC330](#) code, 12-181, rear tamper home sensor, Q12-181. Move the rear tamper motor using the code 12-229. **The display changes.**

Y N

Go to [WD 12.11](#). Check the wiring and repair as necessary, [REP 1.1](#). Check Q12-181. Refer to:

- [GP 11](#) How to Check a Sensor.
- [12A-171](#) HVF Power Distribution RAP.
- [01L](#) 0V Distribution RAP

Install new components as necessary:

- Rear tamper home sensor, [PL 12.110](#) Item 15.
- HVF PWB, [PL 12.140](#) Item 2.

Enter the [dC330](#) code, 12-183, rear tamper away sensor. Use a piece of paper inserted from the rear of the machine to actuate the rear tamper away sensor, Q12-183. **The display changes.**

Y N

Go to [WD 12.11](#). Check the wiring and repair as necessary, [REP 1.1](#). Check Q12-183.

Refer to:

- [GP 11](#) How to Check a Sensor.
- [12A-171](#) HVF Power Distribution RAP.
- [01L](#) 0V Distribution RAP

Install new components as necessary:

- Rear tamper away sensor, [PL 12.110](#) Item 15.
- HVF PWB, [PL 12.140](#) Item 2.

Perform [SCP 5](#) Final Actions.

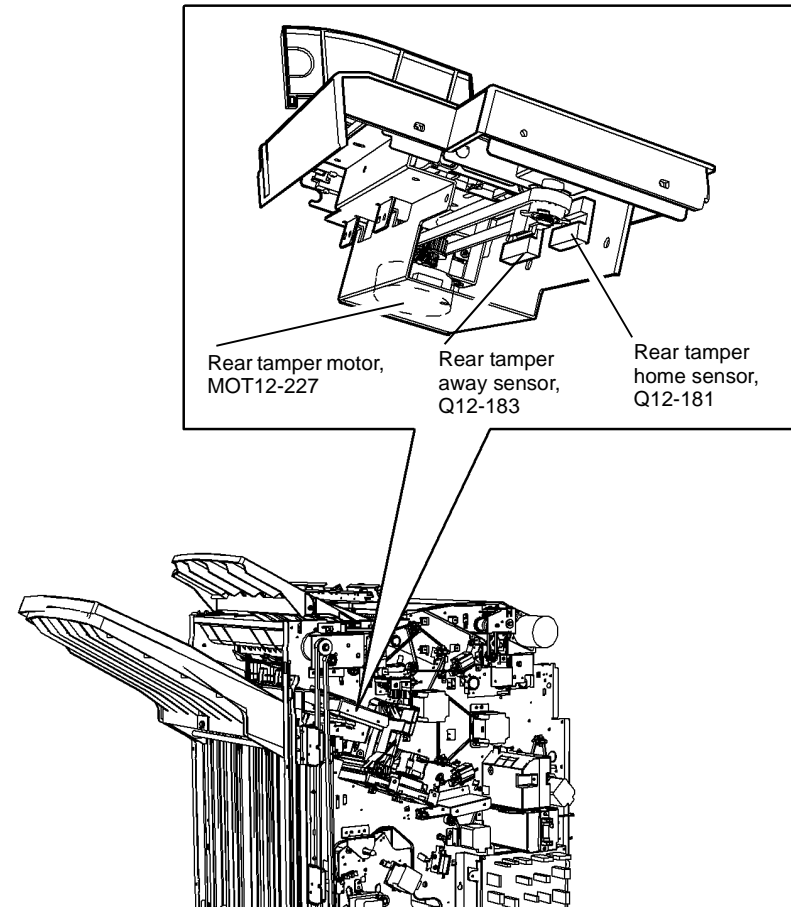

U-1-0160-A

Figure 1 Component location

12-403-00-171, 12-413-00-171, 12-414-00-171 HVF BM Staple Head 2 and Stapler Module RAP

12-403-00-171 The booklet maker staple head 2 motor has failed to move.

12-413-00-171 The booklet maker staple head 2 is not detected in the home position.

12-414-00-171 The booklet maker stapler module is not detected in the home (staple head closed) position during hard / soft initialize, or at set boundary.

Initial Actions

WARNING

Ensure that the electricity to the machine is switched off while performing tasks that do not need electricity. Refer to GP 14. Disconnect the power cord. Electricity can cause death or injury. Moving parts can cause injury.

- Check that there is no damage or obstruction that would prevent the stapling unit from cycling.
- Check that the sheets of staples in the cartridge are feeding one at a time. If staple sheets overlap, they will jam in the cartridge. If necessary, install a new staple cartridge, PL 12.185 Item 8.
- Ensure that the customer job does not exceed the capacity of the booklet maker. Refer to 12D-171 Booklet Quality RAP for booklet maker quality specifications.

Procedure

Enter dC330, code 12-217 to check the BM staple head carrier closed sensor, Q12-217, Figure 1. Open and close the staple head carrier. The display changes.

- Y N
- Go to WD 12.16. Check Q12-217.
Refer to:
- GP 11 How to Check a Sensor.
 - 12A-171 HVF Power Distribution RAP.
 - 01L 0V Distribution RAP
- Install new components as necessary:
- BM staple head carrier closed sensor, PL 12.185 Item 18.
 - BM PWB, PL 12.175 Item 10.

Remove the HVF front door, refer to REP 12.1-171 HVF Covers. Pull out the BM module. Remove the staple head 2 cover, PL 12.185 Item 14. Enter dC330, code 12-220 to check the BM SH2 home switch. Manually rotate the staple head to actuate the BM SH2 home switch.

The display changes.

- Y N
- Go to WD 12.16. Check the BM SH 2 home switch, S12-220.
Refer to:
- GP 13, How to Check a Switch.
 - 12A-171 HVF Power Distribution RAP.
 - 01L 0V Distribution RAP

- Install new components as necessary:
- BM staple head 2, PL 12.185 Item 7.
 - BM PWB, PL 12.175 Item 10.

Enter dC330, code 12-275 to run the BM SH2 motor. The staple head cycled.

Y N
Go to WD 12.16 and WD 12.19. Check the wiring and connectors.
The wiring and connectors are good.

Y N
Repair the wiring or connectors, REP 1.1.

Install a new BM staple head 2, PL 12.185 Item 7.

The fault may be intermittent, check for damaged wiring or bad connectors, REP 1.1. If necessary install new components:

- BM staple head carrier closed sensor, PL 12.185 Item 18.
- BM staple head 2 assembly, PL 12.185 Item 7.
- BM PWB, PL 12.175 Item 10.

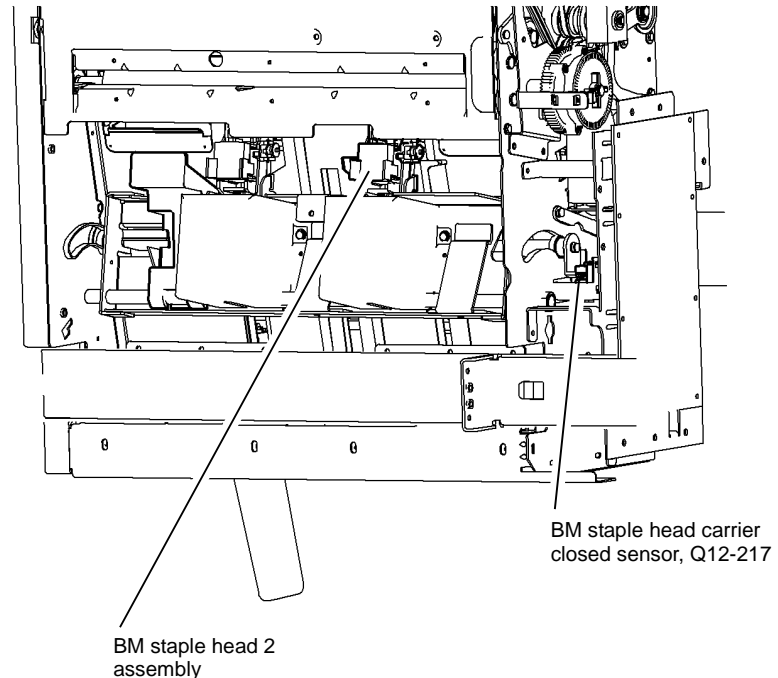

Figure 1 Component location

U-1-0161-A

12-415-00-171 HVF BM Crease Roll Gate Home RAP

12-415-00-171 The crease roll gate is not at the home position.

Initial Actions

WARNING

Ensure that the electricity to the machine is switched off while performing tasks that do not need electricity. Refer to [GP 14](#). Disconnect the power cord. Electricity can cause death or injury. Moving parts can cause injury.

- Check for a jam or other obstruction that can prevent the crease roll gate mechanism from moving.
- Check the following parts for damage:
 - Crease roll gate rack gears, [PL 12.180 Item 8](#).
 - Crease roll gate racks, [PL 12.180 Item 14](#).

Procedure

Enter [dC330](#) code 12-222. Actuate the BM crease roll gate home sensor, Q12-222, [Figure 1](#). The display changes.

Y N

Go to [WD 12.16](#). Check Q12-222.
Refer to:

- [GP 11](#) How to Check a Sensor.
- [12A-171](#) HVF Power Distribution RAP.
- [01L](#) 0V Distribution RAP

Install new components as necessary:

- BM PWB, [PL 12.175 Item 10](#).
- BM crease roll gate home sensor, [PL 12.175 Item 9](#).

NOTE: The BM crease roll gate motor has two component control codes:

12-273 cycles the crease roll gate.

12-276 opens the crease roll gate.

Enter [dC330](#), code 12-273 to cycle the BM crease roll gate motor, MOT12-273. The motor runs.

Y N

Go to [WD 12.18](#). Check MOT12-273.
Refer to:

- [GP 10](#) How to Check a Motor.
- [12A-171](#) HVF Power Distribution RAP.
- [01L](#) 0V Distribution RAP

Install new components as necessary:

- BM PWB, [PL 12.175 Item 10](#).
- BM crease roll gate motor, [PL 12.175 Item 8](#).

The fault may be intermittent, check for damaged wiring or bad connectors, [REP 1.1](#). If necessary install a new BM PWB, [PL 12.175 Item 10](#).

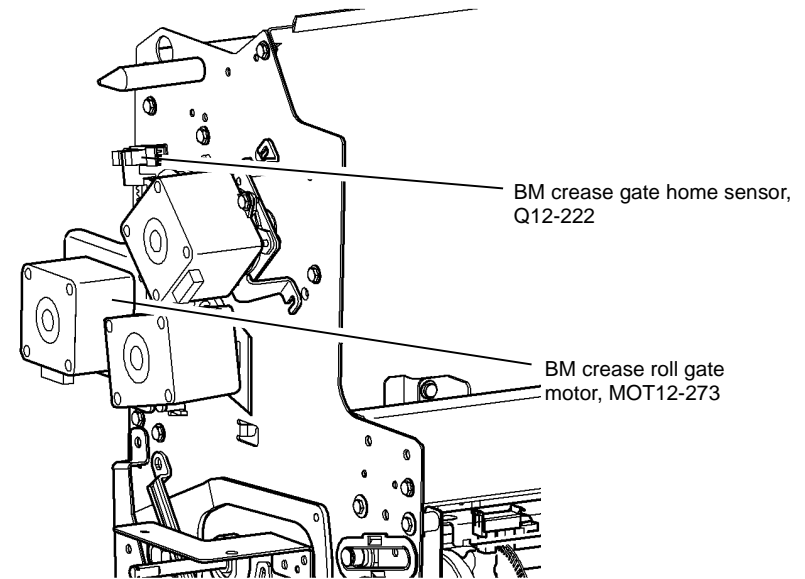

Figure 1 Component location

U-1-0162-A

12-417-00-171, 12-418-00-171 HVF BM Flapper RAP

12-417-00-171 The booklet maker flapper did not return to the home position.

12-418-00-171 The booklet maker flapper did not move from the home position.

Initial Actions

WARNING

Ensure that the electricity to the machine is switched off while performing tasks that do not need electricity. Refer to GP 14. Disconnect the power cord. Electricity can cause death or injury. Moving parts can cause injury.

Check for damage or obstructions that would prevent the BM flapper from rotating.

Procedure

NOTE: All HVF BM interlocks must be made to supply +24V to the motors.

Enter dC330, code 12-271 to check the BM flapper motor, MOT12-271, **Figure 1. The flapper rotates.**

Y N

Go to WD 12.19. Check MOT12-271.

Refer to:

- GP 10 How to Check a Motor.
- 12A-171, HVF Power Distribution RAP.
- 01L 0V Distribution RAP

Install new components as necessary:

- BM flapper motor, PL 12.175 Item 1.
- BM PWB, PL 12.175 Item 10.
- BM flapper, PL 12.150 Item 23.

Enter dC330, code 12-207. Actuate the flapper home sensor, Q12-207. **The changes.**

Y N

Go to WD 12.16. Check Q12-207.

Refer to:

- GP 11 How to Check a Sensor.
- 12A-171, HVF Power Distribution RAP.
- 01L 0V Distribution RAP

Install new components as necessary:

- Flapper home sensor, PL 12.150 Item 12.
- BM PWB, PL 12.175 Item 10.

Perform SCP 5 Final Actions.

BM

display

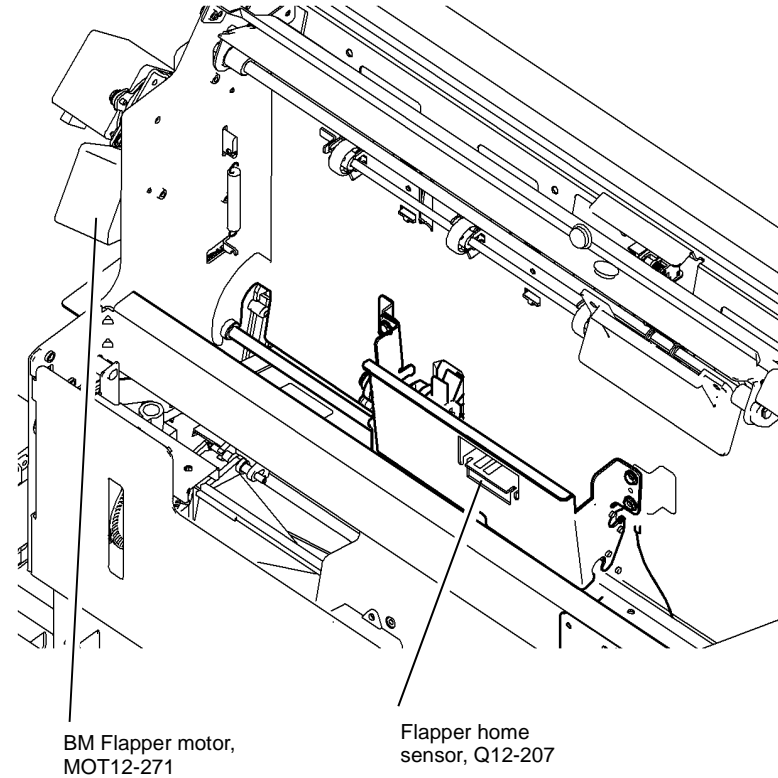

U-1-0163-A

Figure 1 Component location

12-450-00-171, 12-456-00-171 to 12-459-00-171 HVF Ejector Module RAP

12-450-00-171 The ejector module motor has stalled

12-456-00-171 The ejector module did not return to the home position.

12-457-00-171 The ejector module did not move from the home position.

12-458-00-171 The ejector module did not return to the out position.

12-459-00-171 The ejector module did not move from the out position.

Initial Actions

WARNING

Ensure that the electricity to the machine is switched off while performing tasks that do not need electricity. Refer to **GP 14**. Disconnect the power cord. Electricity can cause death or injury. Moving parts can cause injury.

- Check for damage or obstructions that would prevent the ejector module from operating correctly.
- Check the ribbon cable on the ejector for kinks and potential breaks in the conductors.
- Go to **12K-171** HVF Initialization Failure RAP to determine when the fault occurs.
- Check the harness to the ejector unit and the connectors under the unit.

Procedure

Figure 1 shows the location of the components.

Enter the **dC330** code 12-184, ejector home sensor, Q12-184. Stack the **dC330** code 12-249 to move the stapler unit inboard. This action moves the stapler unit inboard, and moves the ejector module to the out position. **The display changes.**

Y N
The ejector module moved to the out position.

Y N

Go to **WD 12.15**. Check the wiring and repair as necessary, **REP 1.1**. Check the ejector motor, MOT12-236. Refer to:

- **GP 10** How to Check a Motor.
- **12A-171**, HVF Power Distribution RAP.
- **01L 0V** Distribution RAP

Install new components as necessary:

- Ejector assembly, **PL 12.110 Item 2**.
- HVF PWB, **PL 12.140 Item 2**.

Go to **WD 12.11**. Check the wiring and repair as necessary, **REP 1.1**. Check the ejector home sensor, Q12-184. Refer to:

- **GP 11** How to Check a Sensor.
- **12A-171**, HVF Power Distribution RAP.
- **01L 0V** Distribution RAP

Install new components as necessary:

- Ejector assembly, **PL 12.110 Item 2**.

- A**
- HVF PWB, **PL 12.140 Item 2**.

Exit diagnostics mode, selecting the re-boot option. This returns the ejector module to the home position. Enter the **dC330** code, 12-185, ejector out sensor, Q12-185. Stack the **dC330** code, 12-249 to move the stapler unit inboard. **The display changes.**

Y N

Go to **WD 12.11**. Check the wiring and repair as necessary, **REP 1.1**. Check the ejector out sensor, Q12-185. Refer to:

- **GP 11** How to Check a Sensor.
- **12A-171**, HVF Power Distribution RAP.
- **01L 0V** Distribution RAP

Install new components as necessary:

- Ejector assembly, **PL 12.110 Item 2**.
- HVF PWB, **PL 12.140 Item 2**.

Exit the diagnostics mode, selecting the re-boot option. This returns the ejector module to the home position. Enter the **dC330** code 12-096, ejector motor encoder sensor, Q12-096. Stack the **dC330** code, 12-249 to move the stapler unit inboard. **The display changes condition for a few seconds.**

Y N

Go to **WD 12.11**. Check the wiring and repair as necessary, **REP 1.1**. Check Q12-096. Refer to:

- **GP 10** How to Check a Motor.
- **12A-171**, HVF Power Distribution RAP.
- **01L 0V** Distribution RAP

Install new components as necessary:

- Ejector assembly, **PL 12.110 Item 2**.
- HVF PWB, **PL 12.140 Item 2**.

Perform **SCP 5** Final Actions.

A

12-451-00-171 to 12-455-00-171 HVF Ejector Roll and Lower Paddle Fault RAP

12-451-00-171 The ejector roll motor has stalled.

12-452-00-171 The ejector roll did not return to the home position.

12-453-00-171 The ejector roll did not move from the home position.

12-454-00-171 The lower paddle has failed to return to the home position.

12-455-00-171 The lower paddle has failed to move from the home position.

Initial Actions

WARNING

Ensure that the electricity to the machine is switched off while performing tasks that do not need electricity. Refer to **GP 14**. Disconnect the power cord. Electricity can cause death or injury. Moving parts can cause injury.

- Check for any damage or obstructions that would prevent the ejector roll and lower paddle from operating correctly.

Procedure

Figure 1, Figure 2 and Figure 3 show the component locations.

Enter **dC330** code, 12-242 to lower the bin 1 stacker tray. Enter **dC330** code 12-249, staple unit 1 forward. This moves the ejector module to the out position. Enter **dC330** code 12-098, ejector plate home sensor, Q12-098. Manually turn the ejector belts a few centimeters. **The display changes.**

Y N

Go to **WD 12.11**. Check the wiring and repair as necessary, **REP 1.1**. Check Q12-098.

Refer to:

- **GP 11** How to Check a Sensor.
- **12A-171**, HVF Power Distribution RAP.
- **01L 0V** Distribution RAP

Install new components as necessary:

- Ejector assembly, **PL 12.110 Item 2**.
- HVF PWB, **PL 12.140 Item 2**.

Enter the **dC330** code 12-097, ejector roll motor encoder sensor, Q12-097. Enter the code, 12-233 to rotate the ejector roll motor one cycle of the ejector plates in the forward direction. **The display changes.**

Y N

The ejector roll motor turned.

Y N

Go to **WD 12.15**. Check the wiring and repair as necessary, **REP 1.1**. Check MOT12-233. Refer to:

- **GP 10** How to Check a Motor.
- **12A-171** HVF Power Distribution RAP.
- **01L 0V** Distribution RAP

A B

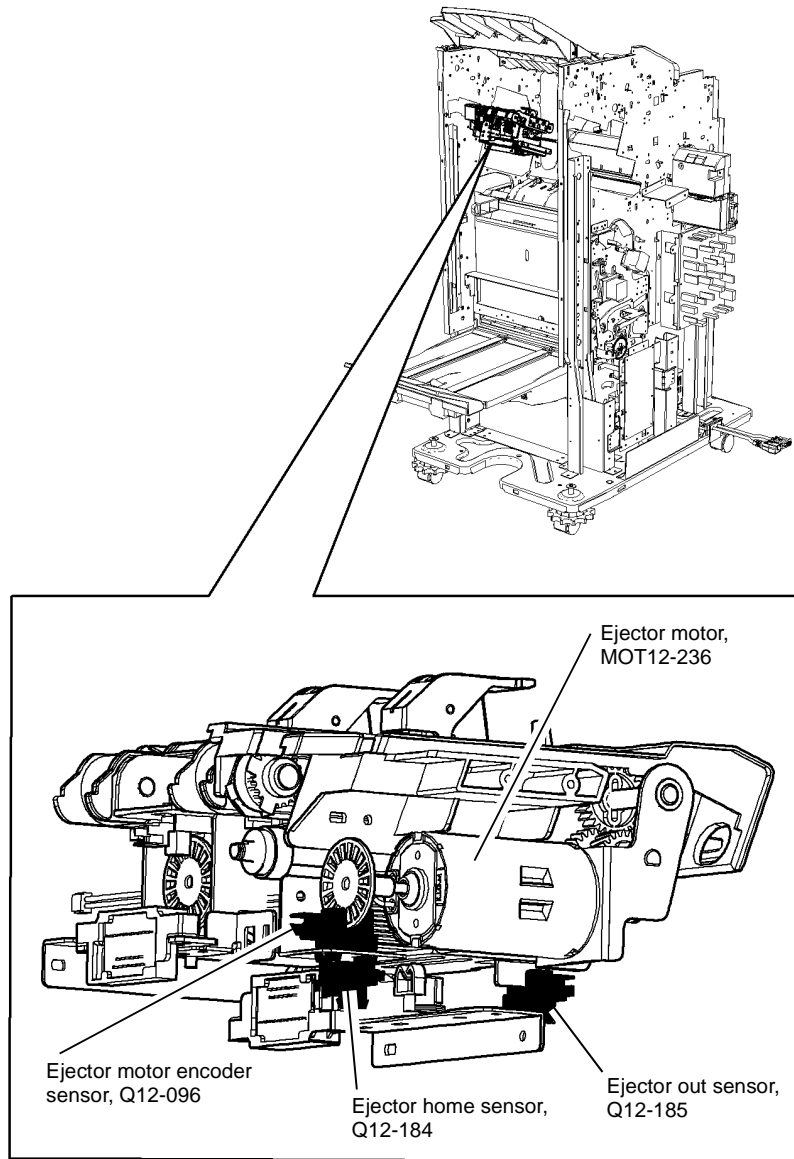

U-1-0164-A

Figure 1 Component location

A B

Install new components as necessary:

- Ejector assembly, [PL 12.110 Item 2](#).
- HVF PWB, [PL 12.140 Item 2](#).

Go to [WD 12.11](#). Check the wiring and repair as necessary, [REP 1.1](#). Check the ejector roll motor encoder sensor, Q12-097. Refer to:

- [GP 11](#) How to Check a Sensor.
- [12A-171](#) HVF Power Distribution RAP.
- [01L](#) 0V Distribution RAP

Install new components as necessary:

- Ejector assembly, [PL 12.110 Item 2](#).
- HVF PWB, [PL 12.140 Item 2](#).

Enter [dC330](#) code 12-099, ejector lower paddle home sensor. Rotate the lower paddle upwards and inwards for one full rotation, [Figure 3](#). **The voltage changes from a logic high to a low, and then back to high.**

Y N

Go to [WD 12.11](#). Check the wiring and repair as necessary, [REP 1.1](#). Check the ejector lower paddle home sensor, S12-099. Refer to:

- [GP 13](#) How to Check a Switch.
- [12A-171](#), HVF Power Distribution RAP.
- [01L](#) 0V Distribution RAP

Install new components as necessary:

- Ejector assembly, [PL 12.110 Item 2](#).
- HVF PWB, [PL 12.140 Item 2](#).

Enter [dC330](#) code 12-202, Ejector paper present sensor, Q12-202. Actuate the ejector paper present sensor by placing a sheet of paper on the ejector module. **The display changes.**

Y N

Go to [WD 12.12](#). Check the wiring and repair as necessary, [REP 1.1](#). Check the ejector paper present sensor, Q12-202. Refer to:

- [GP 11](#) How to Check a Sensor.
- [12A-171](#), HVF Power Distribution RAP.
- [01L](#) 0V Distribution RAP

Install new components as necessary:

- Ejector assembly, [PL 12.110 Item 2](#).
- HVF PWB, [PL 12.140 Item 2](#).

Perform [SCP 5](#) Final Actions.

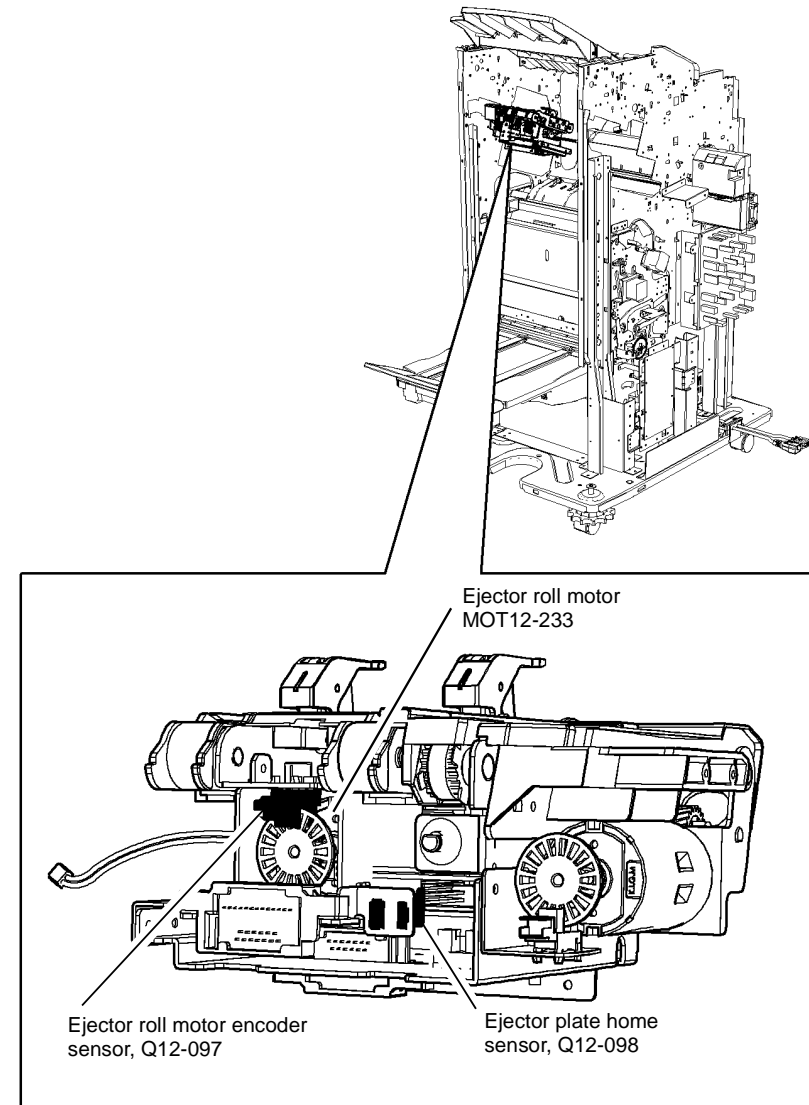

U-1-0165-A

Figure 1 Component location

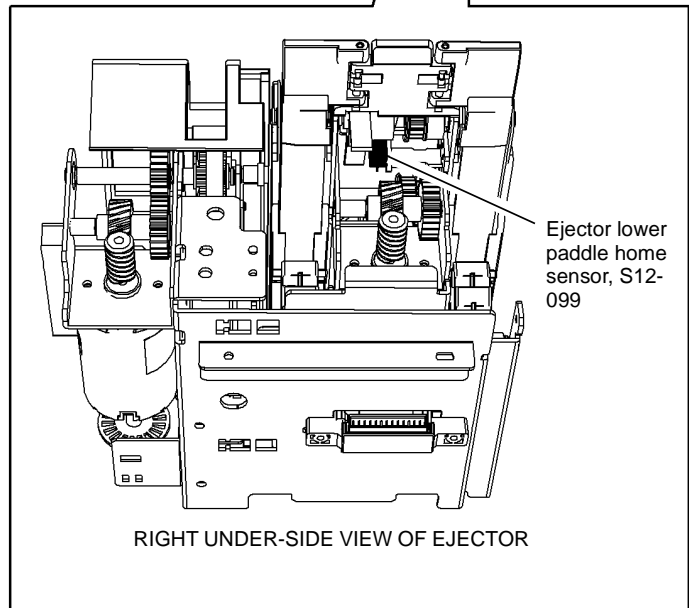
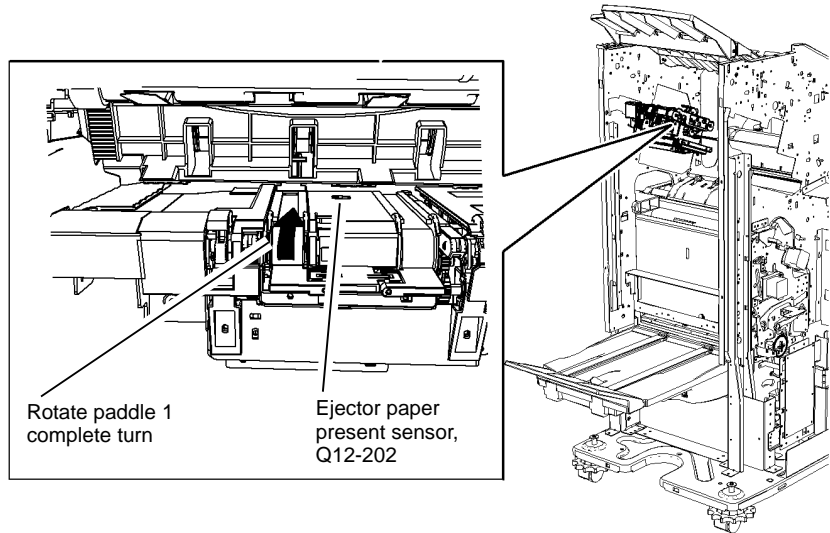
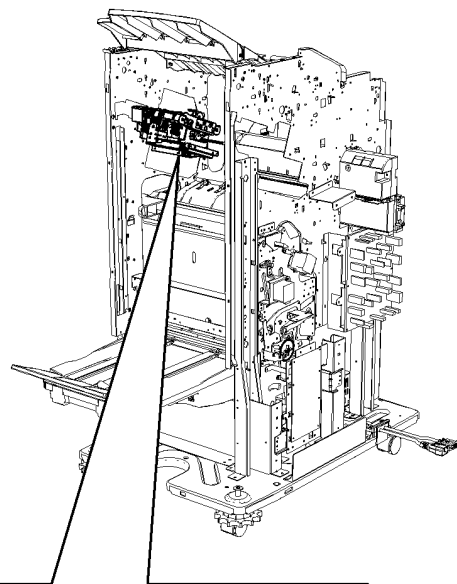

RIGHT UNDER-SIDE VIEW OF EJECTOR

Ejector lower
paddle home
sensor, S12-
099

U-1-0166-A

Figure 2 Component location

Figure 3 Component location

U-1-0167-A

12-460-00-171 to 12-462-00-171 HVF Bin 1 Position RAP

12-460-00-171 Bin 1 motor has stalled.

12-461-00-171 Bin 1 did not actuate the bin 1 upper level sensor during stacking.

12-462-00-171 Bin 1 did not leave the bin 1 upper level sensor during stacking or the stacker failed to initialize correctly.

Initial Actions

WARNING

Ensure that the electricity to the machine is switched off while performing tasks that do not need electricity. Refer to GP 14. Disconnect the power cord. Electricity can cause death or injury. Moving parts can cause injury.

- Check that bin 1 is not damaged and there are no obstructions that would prevent bin 1 from moving.
- Press the pause to unload button (PTU) to lower bin 1. Press again the pause to unload button to raise bin 1.

Procedure

NOTE: The bin 1 90% full sensor and the bin 1 lower limit switch are mounted on the same bracket. This bracket can be in either of two positions. It is in the upper position, only when a tri-folder module is installed.

NOTE: The bin 1 upper level sensor controls the height of the tray during normal use. The sensor is in two parts: the receiver at the rear of the tray and the transmitter at the front of the tray. Only the LED of the front sensor is used and only the light sensitive transistor of the rear sensor is used. Refer to WD 12.13.

Figure 1 shows the location of the components.

NOTE: If required, the following component control codes can be used to move bin 1 tray:

12-059, elevator motor up.

12-060, elevator motor down.

12-241, elevator home.

12-242, elevator cycle.

Place a 1 cm (0.4 inch) stack of paper on the bin 1 tray. Switch off the machine, then switch on the machine. **The bin 1 tray moves during initialization.**

Y N

If the tray is not at the upper limit, enter the dC330 code 12-190, bin 1 upper limit switch. Manually actuate the switch, Figure 1. **The display changes.**

Y N

Go to WD 12.13. Check the wiring and repair as necessary, REP 1.1. Check S12-190. Refer to:

- GP 13 How to Check a Switch.
- 12A-171, HVF Power Distribution RAP.
- 01L 0V Distribution RAP

Install new components as necessary:

- Bin 1 upper limit switch, PL 12.105 Item 7.

A B

A B

- HVF PWB, PL 12.140 Item 2.

If the tray is not at the lower limit, enter the dC330 code 12-191, bin 1 lower limit switch. Manually actuate the switch, Figure 1. **The display changes.**

Y N

Go to WD 12.13. Check the wiring and repair as necessary, REP 1.1. Check S12-191. Refer to:

- GP 13 How to Check a Switch.
- 12A-171, HVF Power Distribution RAP.
- 01L 0V Distribution RAP

Install new components as necessary:

- Bin 1 lower limit switch, PL 12.105 Item 7.
- HVF PWB, PL 12.140 Item 2.

Go to WD 12.10. Check the wiring and repair as necessary, REP 1.1. Check the bin 1 elevator motor, MOT12-241. Refer to:

- GP 10 How to Check a Motor.
- 12A-171, HVF Power Distribution RAP.
- 01L 0V Distribution RAP

Install new components as necessary:

- Bin 1 elevator motor, PL 12.105 Item 10.
- HVF PWB, PL 12.140 Item 2.

Enter the dC330 code, 12-163, bin 1 motor encoder sensor. Turn the encoder wheel. **The display changes.**

Y N

Go to WD 12.13. Check the wiring and repair as necessary. Check Q12-163. Refer to:

- GP 11 How to Check a Sensor.
- 12A-171, HVF Power Distribution RAP.
- 01L 0V Distribution RAP

Install new components as necessary:

- Bin 1 motor encoder sensor, PL 12.105 Item 3.
- HVF PWB, PL 12.140 Item 2.

Enter the dC330 code 12-188, bin 1 upper level sensor. Remove the paper from the tray. Actuate the sensor by breaking the light beam from the rear sensor to the front sensor. **The display changes.**

Y N

Go to WD 12.13 and WD 12.15. Check the wiring and repair as necessary. Check the two parts of the bin 1 upper level sensor, Q12-188. Refer to:

- GP 11 How to Check a Sensor.
- 12A-171, HVF Power Distribution RAP.

Install new components as necessary:

- Bin 1 upper level sensor (receiver), PL 12.110 Item 16.
- Bin 1 upper level sensor (transmitter), PL 12.110 Item 20.
- HVF PWB, PL 12.140 Item 2.

C

C

Enter the dC330 code 12-187, bin 1 90% full sensor. Actuate the sensor using a piece of paper. **The display changes.**

Y

N

Go to [WD 12.13](#). Check the wiring and repair as necessary. Check Q12-187. Refer to:

- [GP 11](#) How to Check a Sensor.
- [12A-171](#), HVF Power Distribution RAP.
- [01L](#) 0V Distribution RAP

Install new components as necessary:

- Bin1 90% full sensor, [PL 12.105 Item 3](#).
- HVF PWB, [PL 12.140 Item 2](#).

Lower the bin 1 tray by pressing the PTU switch. Enter the dC330 code 12-322, paper pressing sensor Q12-322. Actuate the paper pressing sensor using a sheet of paper. **The display changes.**

Y

N

Go to [WD 12.12](#). Check the wiring and repair as necessary, [REP 1.1](#). Check the paper pressing sensor, Q12-322. Refer to:

- [GP 11](#) How to Check a Sensor.
- [12A-171](#), HVF Power Distribution RAP.
- [01L](#) 0V Distribution RAP

Install new components as necessary:

- Paper pressing sensor, [PL 12.110 Item 17](#).
- HVF PWB, [PL 12.140 Item 2](#).

Perform [SCP 5](#) Final Actions.

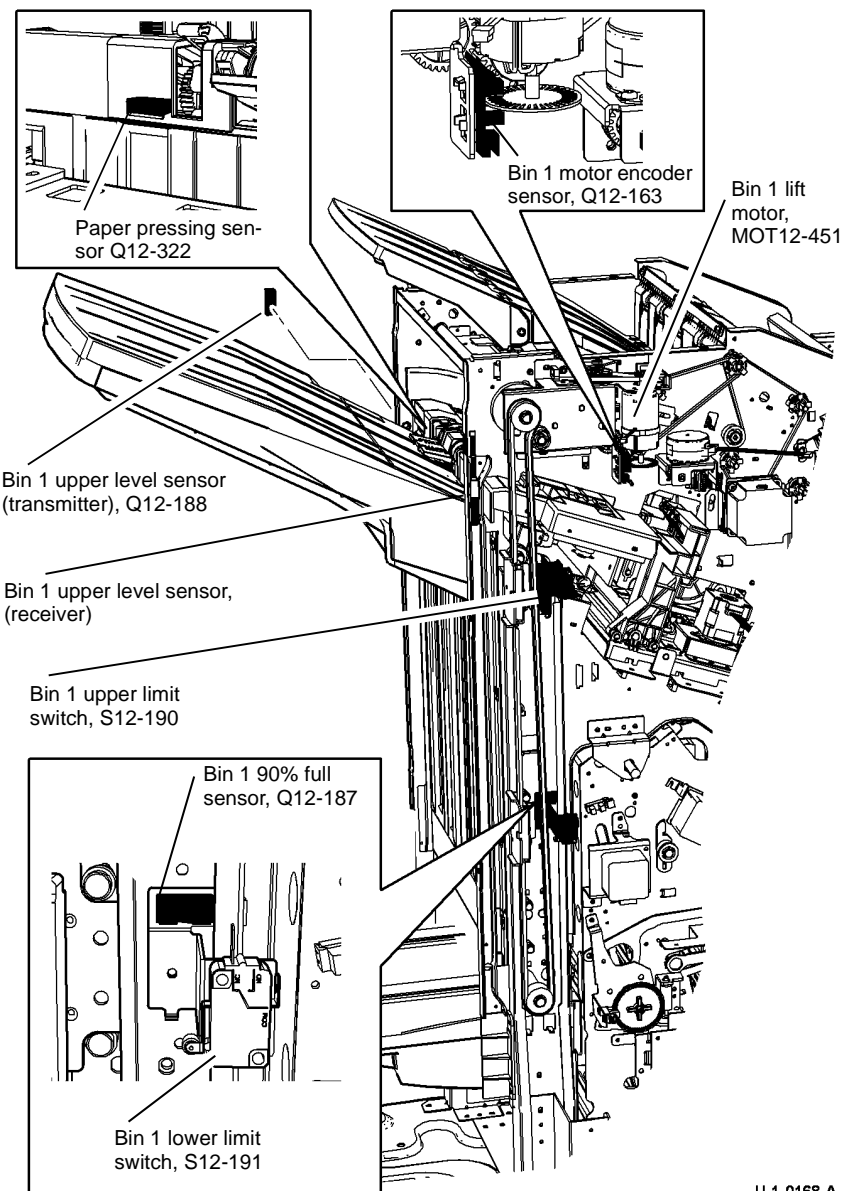

U-1-0168-A

Figure 1 Component location

12-463-00-171, 12-464-00-171 HVF BM +24V Failure RAP

12-463-00-171 The booklet maker control PWB has failed to detect +24V at the input from the HVF.

12-464-00-171 The booklet maker control PWB has detected an internal +24V failure, such as over current, short circuit or under voltage.

Initial Actions

WARNING

Ensure that the electricity to the machine is switched off while performing tasks that do not need electricity. Refer to **GP 14**. Disconnect the power cord. Electricity can cause death or injury. Moving parts can cause injury.

WARNING

Take care when measuring AC mains (line) voltage. Electricity can cause death or injury.

- Ensure the HVF BM is correctly docked to the machine and all interlocks are closed.
- Check the interlock actuator for damage.

Procedure

Refer to **Figure 1**. Close or cheat all the HVF BM interlocks. The HVF BM performs a mechanical reset.

Y N
Go to **WD 1.1**. ACL is available at PJ3AC on the LVPS and base module between pins 1 and 2.

Y N
Go to the **01A** AC Power RAP and check the AC output voltages.

Go to **WD 12.6**. +24V is available at PJ111 between pins 1 and 4.

Y N
Figure 1. +24V is available at T001 on the HVF power supply between pins 1 and 5.

Y N
Install a new HVF power supply module, **PL 12.140** Item 1.

Check the connectors and harness between T001 and PJ111. Repair the harness as necessary, **REP 1.1**.

Go to **WD 12.6**. +24V is available at PJ111 between pins 1 and 4 and between pins 3 and 6.

Y N
Go to the **12-310-00-171, 12-312-00-171, 12-313-00-171** Interlocks RAP.

Go to **WD 12.6**. +24V is available at PJ559 between pins 1 and 2.

Y N
+24V is available at PJ131 between pins 1 and 2.

Y N
Install a new HVF PWB, **PL 12.140** Item 2.

Check the connectors and harness between PJ559 and PJ131. Repair the harness as necessary, **REP 1.1**.

A B
If a inserter is installed, go to PJ703. +24V is available between PJ703 pin 1 and PJ111 pin 1.

Y N
Go to **12-316-00-171, 12-319-00-171** HVF Inserter Interlock RAP

Go to **WD 12.6**. +24V is available at PJ601 between pins 1 and pin 4.

Y N
Install a new BM PWB, **PL 12.175** Item 10.

Go to **WD 12.6**. +24V is available at PJ601 between pins 4 and 6.

Y N
Go to the **12-310-00-171, 12-312-00-171, 12-313-00-171** Docking and Interlocks RAP.

The +24V supply is good. Go to **SCP 5** Final actions.

The +24V supply is good. Go to **SCP 5** Final actions.

A B

12-465-00-171 to 12-468-00-171 Paddle Unit Position RAP

12-465-00-171 The paddle unit has failed to return to the upper position.

12-466-00-171 The paddle unit has failed to move from the upper position.

12-467-00-171 The paddle unit has failed to return to the lower position.

12-468-00-171 The paddle unit has failed to move from the lower position.

Initial Actions

WARNING

Ensure that the electricity to the machine is switched off while performing tasks that do not need electricity. Refer to [GP 14](#). Disconnect the power cord. Electricity can cause death or injury. Moving parts can cause injury.

Check for damage or obstructions that would prevent the paddle unit from operating correctly.

Procedure

NOTE: All HVF BM interlocks must be made to supply +24V to the motors.

Enter [dC330](#), code 12-239 to run the paddle unit motor, MOT12-239, [Figure 1](#). The motor runs.

Y N

Go to [WD 12.10](#). Check the paddle unit motor, MOT12-239.

Refer to:

- [GP 10](#) How to Check a Motor.
- [12A-171](#), HVF Power Distribution RAP.
- [01L 0V](#) Distribution RAP

Install new components as necessary:

- Paddle unit motor, [PL 12.120](#) Item 6.
- HVF PWB, [PL 12.140](#) Item 2.

The paddle unit moves.

Y N

Check the drive gears on the paddle unit. Install new components as necessary, [PL 12.115](#) Item 2.

Enter [dC330](#), code 12-174 paddle unit upper sensor, Q12-174. Select code 12-240 to run the paddle unit motor. The sensor status changes.

Y N

Go to [WD 12.9](#). Check Q12-174.

Refer to:

- [GP 11](#) How to Check a Sensor.
- [12A-171](#), HVF Power Distribution RAP.
- [01L 0V](#) Distribution RAP

Install new components as necessary:

- Paddle unit, [PL 12.115](#) Item 2.
- HVF PWB, [PL 12.140](#) Item 2.

Enter [dC330](#), code 12-175 paddle unit lower sensor, Q12-175. Select code 12-239 to run the paddle unit motor. The sensor status changes.

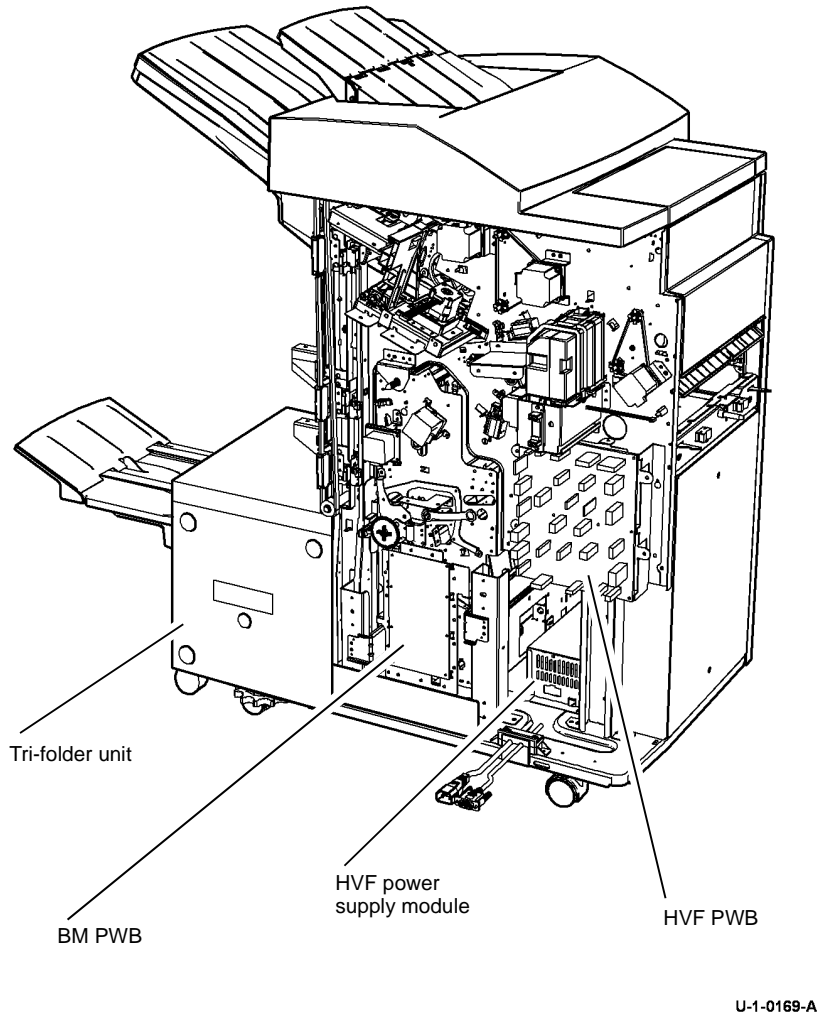

Figure 1 Component location

Y N
Go to [WD 12.9](#). Check Q12-175.

Refer to:

- [GP 11](#) How to Check a Sensor.
- [12A-171](#), HVF Power Distribution RAP.
- [01L 0V](#) Distribution RAP

Install new components as necessary:

- Paddle unit, [PL 12.115 Item 2](#).
- HVF PWB, [PL 12.140 Item 2](#).

Perform [SCP 5](#) Final Actions.

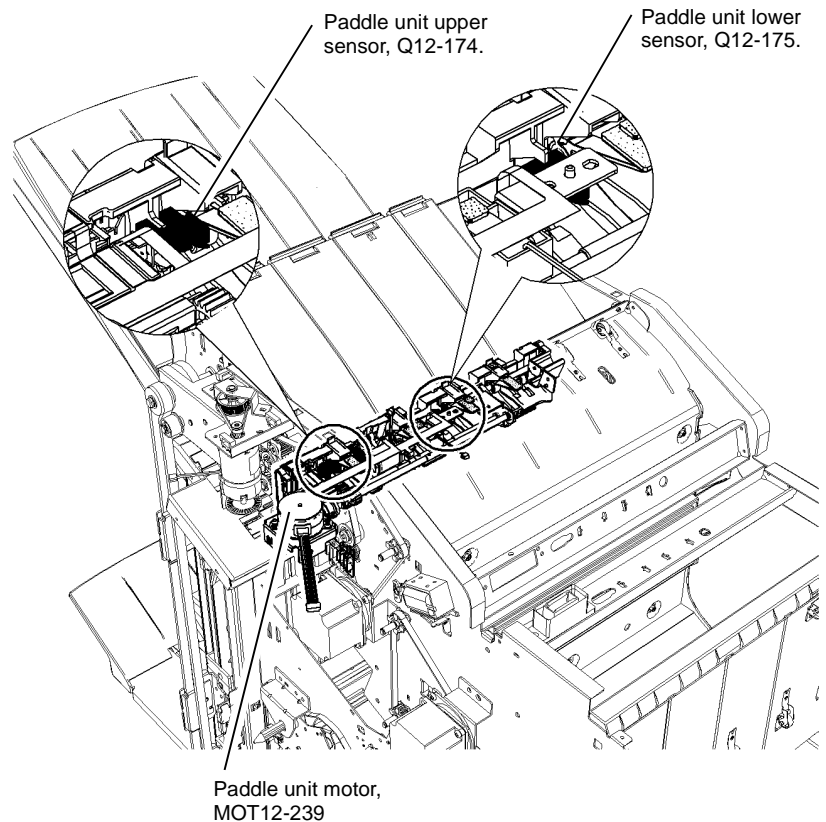

Figure 1 Component location

12-473-00-171 to 12-478-00-171 Support Finger Position RAP

12-473-00-171 The pressing and support motor does not return to initial position within the required time.

12-474-00-171 The pressing and support motor does not move out to initial position within the required time.

12-475-00-171 The pressing and support motor does not return to home position within the required time.

12-476-00-171 The pressing and support motor does not move out of home position within the required time.

12-477-00-171 The pressing and support motor does not return to out position within the required time.

12-478-00-171 The pressing and support motor does not move out of out position within the required time.

Procedure

WARNING

Ensure that the electricity to the machine is switched off while performing tasks that do not need electricity. Refer to [GP 14](#). Disconnect the power cord. Electricity can cause death or injury. Moving parts can cause injury.

NOTE: When manually extending the fingers to check the sensors, the pressing and support A sensor operates first, followed by the pressing and support B sensor. The pressing and support C sensor operates when the fingers are fully extended. All three sensors are spared as part of the rear tamper assembly.

[Figure 2](#) shows the component locations.

Remove the HVF front door and front cover [REP 12.1-171](#). Cheat the front door interlock. Enter [dC330](#) code 12-249 SU1 Motor Forward, to move staple head to the rear of the HVF. Disconnect then reconnect the pressing and support A sensor, [Figure 2](#).

Enter [dC330](#) code 12-172, pressing and support A sensor, Q12-172. Note the position of the support fingers at rest. Turn the gear wheel shown in [Figure 1](#), downwards. The support fingers extend to the right as the gear is turned. Extend the support fingers approximately 6 mm (0.25 inch). **The display changes.**

Y N

Go to [WD 12.12](#). Check Q12-172. Refer to:

- [GP 11](#) How to Check a Sensor.
- [12A-171](#), HVF Power Distribution RAP.
- [01L 0V](#) Distribution RAP

Install new components as necessary:

- Rear tamper assembly, [PL 12.110 Item 29](#).
- HVF PWB, [PL 12.140 Item 2](#).

Enter the [dC330](#) code 12-171 pressing and support B sensor, Q12-171. Turn the gear wheel to extend the support fingers approximately 25 mm (1 inch). **The display changes.**

Y N

Go to [WD 12.12](#). Check Q12-171. Refer to:

- [GP 11](#) How to Check a Sensor.
- [12A-171](#), HVF Power Distribution RAP.
- [01L 0V](#) Distribution RAP

Install new components as necessary:

- Rear tamper assembly, [PL 12.110 Item 29](#).
- HVF PWB, [PL 12.140 Item 2](#).

Enter the [dC330](#) code 12-173, pressing and support C sensor, Q12-173. Turn the gear wheel to extend the support fingers approximately 105 mm (4.1 inch). **The display changes.**

Y N

Go to [WD 12.12](#). Check Q12-173. Refer to:

- [GP 11](#) How to Check a Sensor.
- [12A-171](#), HVF Power Distribution RAP.
- [01L 0V](#) Distribution RAP

Install new components as necessary:

- Rear tamper assembly, [PL 12.110 Item 29](#).
- HVF PWB, [PL 12.140 Item 2](#).

Make several small sets of prints. Check that the support fingers extend between each set. **The support fingers extended.**

Y N

Remove the HVF top cover and rear cover, [REP 12.1-171](#). Enter the [dC330](#) code 12-093, pressing and support encoder sensor, Q12-093. Manually turn the support motor encoder disc. **The display changes.**

Y N

Go to [WD 12.12](#). Check Q12-093. Refer to:

- [GP 11](#) How to Check a Sensor.
- [12A-171](#), HVF Power Distribution RAP.
- [01L 0V](#) Distribution RAP

Install new components as necessary:

- Pressing and support encoder sensor, [PL 12.110 Item 15](#).
- HVF PWB, [PL 12.140 Item 2](#).

Go to [WD 12.15](#) and check the wiring and repair as necessary, [REP 1.1](#). Install new components as necessary:

- Motor encoder assembly, [PL 12.110 Item 18](#).
- HVF PWB, [PL 12.140 Item 2](#).

Perform [SCP 5](#) Final Actions.

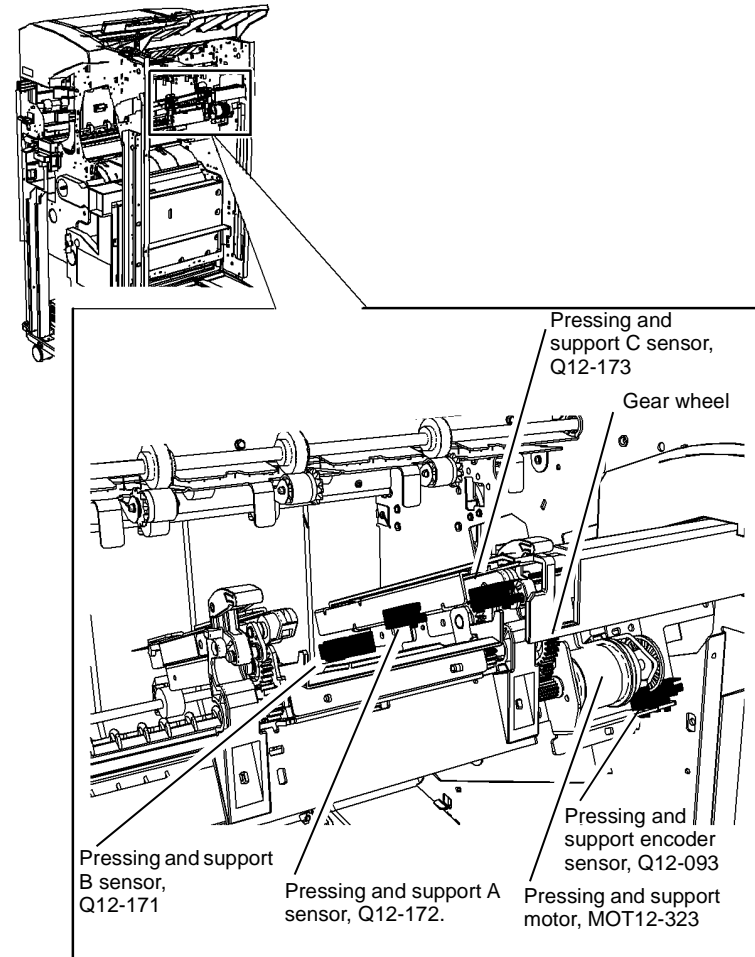

U-1-0171-A

Figure 1 Component location

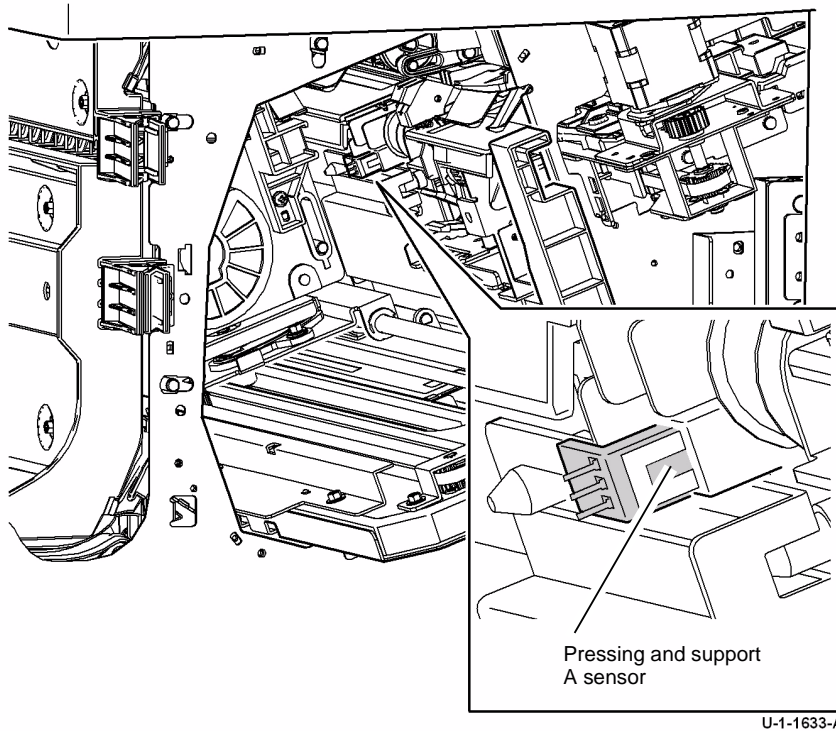

U-1-1633-A

Figure 2 Component location

12-479-00-171 Inserter Paper Length Fault RAP

12-479-00-171 A shorter than expected sheet has been fed from the inserter.

Initial Actions

WARNING

Ensure that the electricity to the machine is switched off while performing tasks that do not need electricity. Refer to **GP 14**. Disconnect the power cord. Electricity can cause death or injury. Moving parts can cause injury.

Check that the inserter paper path is clear of obstructions and the sensors are clean.

Procedure

Figure 1 shows the component locations.

Enter the **dC330** code 12-079, inserter paper length sensor 1, Q12-079. Actuate the sensor.

The display changes.

Y N

Go to **WD 12.13**, **WD 12.21** and **WD 12.22**. Check the inserter paper length sensor 1, Q12-079. Refer to:

- **GP 11** How to Check a Sensor.
- **12A-171**, HVF Power Distribution RAP.
- **01L 0V** Distribution RAP

Install new components as necessary:

- Inserter paper length sensor 1, **PL 12.300** Item 12.
- Inserter PWB, **PL 12.310** Item 9.
- HVF PWB, **PL 12.140** Item 2.

Enter the **dC330** code 12-080, inserter paper length sensor 2, Q12-080. Actuate the sensor.

The display changes.

Y N

Go to **WD 12.13**, **WD 12.21** and **WD 12.22**. Check the inserter paper length sensor 2, Q12-080. Refer to:

- **GP 11** How to Check a Sensor.
- **12A-171**, HVF Power Distribution RAP.
- **01L 0V** Distribution RAP

Install new components as necessary:

- Inserter paper length sensor 2, **PL 12.300** Item 12.
- Inserter PWB, **PL 12.310** Item 9.
- HVF PWB, **PL 12.140** Item 2.

Enter the **dC330** code 12-090, inserter paper length sensor 3, Q12-090. Actuate the sensor.

The display changes.

Y N

Go to **WD 12.14** and **WD 12.22**. Check the inserter paper length sensor 3, Q12-090. Refer to:

- **GP 11** How to Check a Sensor.
- **12A-171**, HVF Power Distribution RAP.
- **01L 0V** Distribution RAP

A

A

Install new components as necessary:

- Inserter paper length sensor 3, [PL 12.300 Item 12](#).
- Inserter PWB, [PL 12.310 Item 9](#).
- HVF PWB, [PL 12.140 Item 2](#).

Enter the **dC330** code 12-084, inserter TE sensor, Q12-084. Actuate the sensor. **The display changes.**

Y N

Go to [WD 12.13](#) and [WD 12.21](#). Check the inserter TE sensor, Q12-084. Refer to:

- [GP 11](#) How to Check a Sensor.
- [12A-171](#), HVF Power Distribution RAP.
- [01L 0V](#) Distribution RAP

Install new components as necessary:

- Inserter TE sensor, [PL 12.310 Item 11](#).
- Inserter PWB, [PL 12.310 Item 9](#).
- HVF PWB, [PL 12.140 Item 2](#).

Enter the **dC330** code 12-083, inserter LE sensor, Q12-083. Actuate the sensor. **The display changes.**

Y N

Go to [WD 12.13](#) and [WD 12.21](#). Check the inserter LE sensor, Q12-083. Refer to:

- [GP 11](#) How to Check a Sensor.
- [12A-171](#), HVF Power Distribution RAP.
- [01L 0V](#) Distribution RAP

Install new components as necessary:

- Inserter LE sensor, [PL 12.310 Item 11](#).
- Inserter PWB, [PL 12.310 Item 9](#).
- HVF PWB, [PL 12.140 Item 2](#).

Enter the **dC330** code 12-260, to energize the inserter clutch, CL12-260. **The inserter clutch energizes.**

Y N

Go to [WD 12.14](#), [WD 12.21](#) and [WD 12.22](#). Check the inserter clutch, CL12-260. Refer to:

- [GP 12](#) How to Check a Solenoid or Clutch.
- [12A-171](#), HVF Power Distribution RAP.
- [01L 0V](#) Distribution RAP

Install new components as necessary:

- Inserter clutch, [PL 12.310 Item 3](#).
- Inserter PWB, [PL 12.310 Item 9](#).
- HVF PWB, [PL 12.140 Item 2](#).

Enter the **dC330** code 12-261, to run the inserter motor, MOT12-261. **The motor runs.**

Y N

Go to [WD 12.14](#) and [WD 12.22](#). Check MOT12-261. Refer to:

- [GP 10](#) How to Check a Motor.
- [12A-171](#), HVF Power Distribution RAP.
- [01L 0V](#) Distribution RAP

B

B

Install new components as necessary:

- Inserter unit motor, [PL 12.315 Item 1](#).
- Inserter PWB, [PL 12.310 Item 9](#).
- HVF PWB, [PL 12.140 Item 2](#).

Perform **SCP 5** Final Actions.

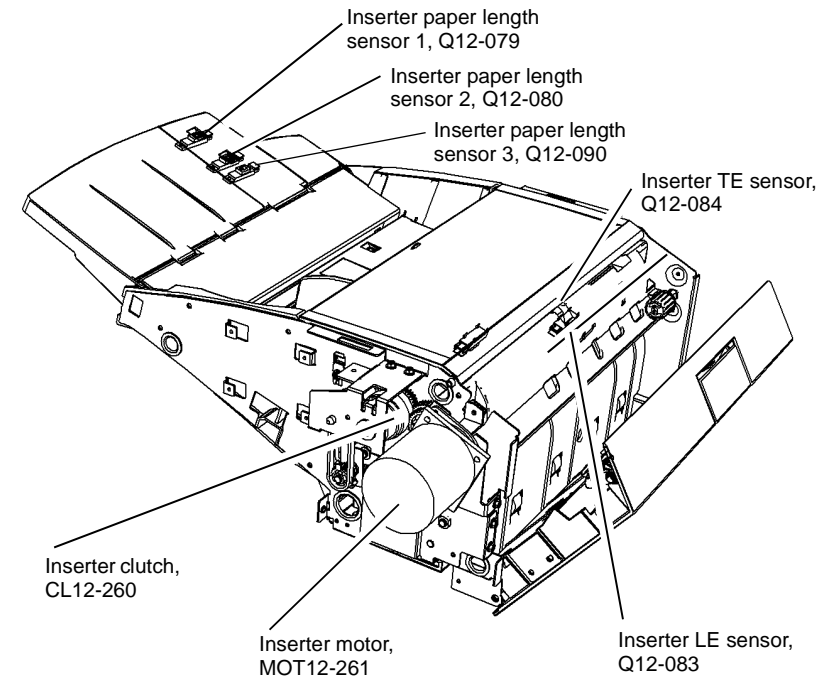

U-1-0172-A

Figure 1 Component location

12-492-00-171 to 12-494-00-171 IME To Finisher Failure RAP

12-492-00-171 CDI Communications failure with the finisher.

12-493-00-171 The finisher failed to cycle up.

12-494-00-171 The finisher failed to return a prep time to the IME within 1 second.

Initial Actions

WARNING

Ensure that the electricity to the machine is switched off while performing tasks that do not need electricity. Refer to [GP 14](#). Disconnect the power cord. Electricity can cause death or injury. Moving parts can cause injury.

- Switch off the machine, then switch on the machine, [GP 14](#).
- Check the finisher power cord is plugged into the IME.
- Check that the communication harness from the finisher is plugged in to the IME.

Procedure

Refer to in line connector [PJ904](#) and to [WD 8.5](#). Switch the machine off, [GP 14](#) and disconnect [PJ904](#) on the back of the image processing module. Reconnect [PJ904](#) and switch the machine on, [GP 14](#). If the fault is still present check for damaged pins on [PJ904](#) and on the [Media Path Driver PWB](#).

Install new components as necessary:

- Media path driver PWB, [PL 1.15 Item 5](#).
- Power communications cable, [PL 12.140 Item 7](#).
- Power cord, [PL 12.140 Item 4](#).

12-762-00-171, 12-764-00-171, 12-765-00-171 IME To Finisher Communication Failure RAP

12-762-00-171 Communications failure between the IME and the finisher

12-764-00-171 The IME cannot detect a finisher plugged in.

12-765-00-171 The IME has detected an incompatible / unknown finisher.

Initial Actions

WARNING

Ensure that the electricity to the machine is switched off while performing tasks that do not need electricity. Refer to [GP 14](#). Disconnect the power cord. Electricity can cause death or injury. Moving parts can cause injury.

- Check that the finisher is not incompatible for fault 12-762-00 and 12-765-00.
- Check that the communication harness from the finisher is plugged in to the IME.
- Check that the actuator, [PL 12.100 Item 17](#) is attached to the right hand machine frame and is making the docking interlock.
- Go to [12K-171](#) HVF Initialization Failure RAP to determine when the fault occurs.

Procedure

Refer to in line connector [PJ904](#) and to [WD 8.5](#). Switch the machine off, [GP 14](#) and disconnect [PJ904](#) on the back of the image processing module. Reconnect [PJ904](#) and switch the machine on, [GP 14](#). If the fault is still present check for damaged pins on [PJ904](#) and on the [Media Path Driver PWB](#).

Install new components as necessary:

- Media path driver PWB, [PL 1.15 Item 5](#).
- Power communications cable, [PL 12.140 Item 7](#).

12A-171 HVF Power Distribution RAP

The HVF has an integral power supply providing +24V and +5V supplies to the HVF PWB and HVF BM PWB. The AC power for the HVF power supply comes from the LVPS and base module of the machine. Refer to [Figure 3](#) for component location.

Initial Actions

WARNING

Ensure that the electricity to the machine is switched off while performing tasks that do not need electricity. Refer to [GP 14](#). Disconnect the power cord. Electricity can cause death or injury. Moving parts can cause injury.

WARNING

Take care when measuring AC mains (line) voltage. Electricity can cause death or injury.

CAUTION

Do not connect the HVF power cord directly to the AC wall outlet. The HVF cannot operate without the machine. The machine controls the distribution of electricity to the HVF/HVF BM for correct power on and power off sequencing.

- Ensure the HVF/HVF BM is correctly docked to the machine and all interlocks are closed.
- Check the interlock actuator for damage.
- Refer to [HVF PWB and BM PWB LEDs](#) to identify the status of the PWB's.

Procedure

[Figure 1](#) shows the component locations.

Close or cheat all the HVF BM interlocks. The HVF BM performs a mechanical reset.

Y N
Go to [WD 12.6](#). +5V is available at PJ113 between pins 1 and 2.

Y N
+5V is available at T001 on the HVF power supply module between pins 4 and 8.

Y N
Go to [WD 1.1](#). ACL is available at PJ3AC on the LVPS and base module between pins 1 and 2.

Y N
Go to the 01A AC Power RAP and check the AC output voltages.
Install a new HVF power supply module, [PL 12.140 Item 1](#).

Go to [WD 12.6](#). Disconnect PJ113. +5V is available at the harness end of PJ113 between pins 1 and 2.

Y N
Check the connectors and harness between T001 and PJ113. Repair the harness as necessary, [REP 1.1](#).

Install a new HVF PWB, [PL 12.140 Item 2](#).

Go to [WD 12.6](#). +24V is available at PJ111 between pins 1 and 4.

Y N
+24V is available at T001 between pins 5 and 3.

A

B

Y N
Install a new HVF power supply module, [PL 12.140 Item 1](#).

Check the in-line fuse, F1 (10A), and as necessary install a new fuse, [PL 12.140 Item 5](#). Check the connectors and harness between T001 and PJ111. Repair the harness as necessary, [REP 1.1](#).

Go to [WD 12.6](#) and [WD 12.8](#). Close the front door and top cover and ensure the HVF is docked to the machine. +24V is available at PJ111 pin 1 and PJ112 pins 8.

Y N
Go to the [12-310-00-171](#), [12-312-00-171](#), [12-313-00-171](#) Docking and Interlocks RAP.

Go to [WD 12.6](#). +5V is available at PJ559 between pins 4 and 5.

Y N
+5V is available at PJ132 between pins 1 and 2.

Y N
Install a new HVF PWB, [PL 12.140 Item 2](#)

Check the connectors and harness between PJ132 and PJ559. Repair the harness as necessary.

Go to [WD 12.6](#). +24V is available at PJ559 between pins 1 and 2.

Y N
+24V is available at PJ131 between pins 1 and 2.

Y N
Install a new HVF PWB, [PL 12.140 Item 2](#).

Check the connectors and harness between PJ559 and PJ131. Repair the harness as necessary, [REP 1.1](#).

If an inserter is installed, go to PJ703. +24V is available between PJ703 pin 1 and PJ111 pin 1.

Y N
Go to [12-316-00-171](#), [12-319-00-171](#) HVF Inserter Interlock RAP

Go to [WD 12.6](#). +5V is available at PJ601 between pins 3 and 4.

Y N
+5V is available at PJ553 between pins 3 and 4.

Y N
Install a new HVF PWB, [PL 12.140 Item 2](#).

Check the connectors and harness between PJ553 and PJ601. Repair the harness as necessary, [REP 1.1](#).

Go to [WD 12.6](#). +24V is available at PJ601 between pins 1 and 4.

Y N
+24V is available at PJ553 between pins 1 and 4.

Y N
Install a new BM PWB, [PL 12.175 Item 10](#).

A B

A C D

A C D

Check the connectors and harness between PJ553 and PJ601. Repair the harness as necessary, REP 1.1.

The +24V and +5V supplies are good. Go to SCP 5 Final actions.

Go to WD 12.6. +24V is available at PJ601 between pins 4 and 6.

Y N

Go to the 12-310-00-171, 12-312-00-171, 12-313-00-171 Docking and Interlocks RAP.

The +24V and +5V supplies are good. Go to SCP 5 Final actions.

HVF PWB and BM PWB LEDs

Figure 1 shows the LED's on the HVF PWB.

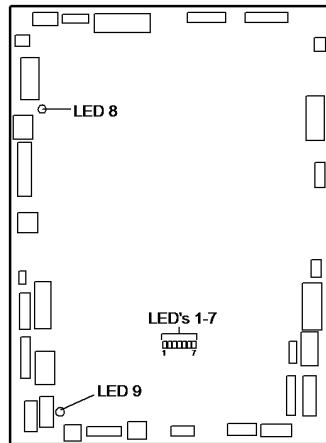

U-1-0726-A

Figure 1 LEDs on the HVF PWB

The LEDs are:

- LED 1 - red. Not used.
- LED 2 - red. Not used.
- LED 3 - red, flashing. This indicates the functioning of the CPU. When flashing at 2Hz, (every 1/2 second), the software is running normally. When flashing at about 1/4Hz, (every 4 seconds), this indicates that the software is encountering a code problem and a possible software upgrade is needed. If this LED is OFF, the CPU does not function and a new HVF PWB is needed.
- LED 4 - red. Not used.
- LED 5 - red. Not used.
- LED 6 - red. Not used.
- LED 7 - red. Not used.

- LED 8 - red, steady. This indicates that the HVF top cover, front door and docking interlocks are all closed and +24V is available at the HVF module.
- LED 9 - red, steady. This indicates that the +5V supply is present in the HVF module.

Figure 2 shows the LED's on the BM PWB.

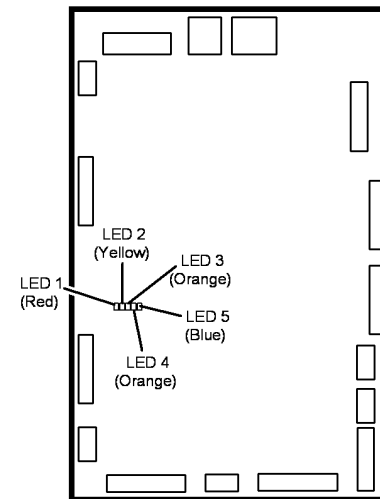

U-1-0727-A

Figure 2 LEDs on the BM control PWB

The LEDs are:

- LED 1 - red, steady. This indicates a fault or other abnormal status.
- LED 2 - yellow, flashing at about 1Hz. This indicates that the software is operating in normal mode. In other modes, e.g., software downloading, the flashing rate is higher.
- LED 3 - orange, steady. This indicates either:
 - that the tri-folder front door and top cover interlocks are closed, and +24V is available to the BM module or, if the tri-folder is not installed;
 - that the interlock cheater is present in PJ553 on the BM control PWB the logic cheater is present in PL563 on the BM control PWB.
- LED 4 - orange, steady. This indicates that the +24V supply is within voltage and current limits, and that the power limiting circuit has not been active for over a set time limit.
- LED 5 - blue, steady. This indicates that the +5V supply is present in the BM module.

12B-171 HVF BM to Machine Communications Interface and BM Present RAP

A communication fault exists between the HVF BM and the machine.

Procedure

WARNING

Ensure that the electricity to the machine is switched off while performing tasks that do not need electricity. Refer to [GP 14](#). Disconnect the power cord. Electricity can cause death or injury. Moving parts can cause injury.

[WD 12.9](#) and [WD 12.19](#) show the communications between the booklet maker and the HVF PWB. For communications between the HVF PWB and the machine go to [WD 12.9](#).

The pulses on the connections between PJ133 and PJ562 cannot be measured, but may be detected using a meter that can record maximum and minimum voltage levels, or by using an AC voltage range. Check the wiring and repair as necessary, [REP 1.1](#).

If necessary, install new components:

- Booklet maker PWB, [PL 12.175 Item 10](#).
- HVF PWB, [PL 12.140 Item 2](#).

If the machine indicates that the booklet maker is not present, check that PJ133, pin 6 is held at 0V. If necessary, repair the wiring, [REP 1.1](#) or install a new HVF PWB, [PL 12.140 Item 2](#).

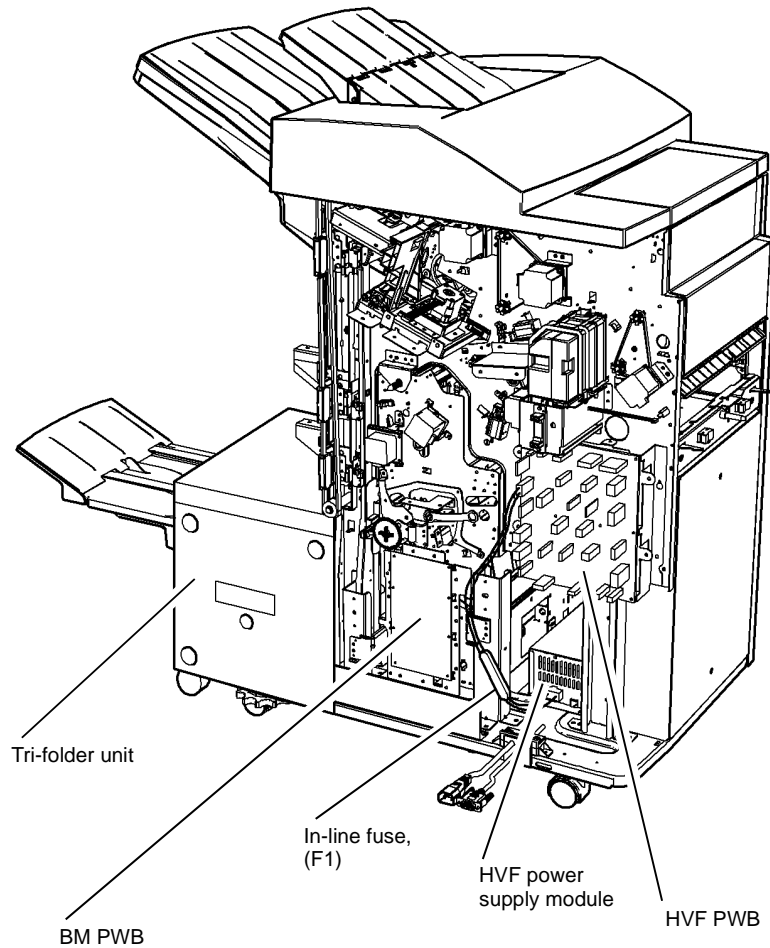

U-1-0173-A

Figure 3 Component location

12C-171 HVF BM Bin 2 Failure RAP

Bin 2 fails to remove the finished booklets from the exit area of the booklet maker.

Initial Actions

WARNING

Ensure that the electricity to the machine is switched off while performing tasks that do not need electricity. Refer to [GP 14](#). Disconnect the power cord. Electricity can cause death or injury. Moving parts can cause injury.

Check for a jam or any other obstruction that could prevent the conveyor belt mechanism from moving.

Procedure

Enter [dC330](#) code 12-206. Actuate the BM bin 2 path transport full sensor, Q12-206, [Figure 1](#). The display changes.

Y N

If a tri-folder is installed, go to [WD 12.18](#). Check the connection at PJ583 on the tri-folder. The connection are good.

Y N

Check the connectors and harness at the tri-folder. Repair the harness as necessary, [REP 1.1](#).

Go to [WD 12.18](#). Check Q12-206.

Refer to:

- [GP 11](#) How to Check a Sensor.
- [12A-171 HVF Power Distribution RAP](#).
- [01L 0V Distribution RAP](#)

Install new components as necessary:

- BM PWB, [PL 12.175 Item 10](#).
- BM bin 2 90% full sensor [PL 12.190 Item 5](#).

NOTE: The BM conveyor belts drive motor stops after 10 seconds.

Enter [dC330](#), code 12-274 to run the BM conveyor drive motor, MOT12-274. The motor runs.

Y N

If a tri-folder is installed, go to [WD 12.17](#). Check the connection at PJ583 on the tri-folder. The connection are good.

Y N

Check the connectors and harness at the tri-folder. Repair the harness as necessary, [REP 1.1](#).

Go to [WD 12.17](#). Check MOT12-274.

Refer to:

- [GP 10](#) How to Check a Motor.
- [12A-171 HVF Power Distribution RAP](#).
- [01L 0V Distribution RAP](#)

Install new components as necessary:

- BM conveyor belts drive motor, [PL 12.190 Item 4](#).

- BM PWB, [PL 12.175 Item 10](#).

The fault may be intermittent, check for damaged wiring or bad connectors, [REP 1.1](#). If necessary install new conveyor belts, [PL 12.190 Item 1](#).

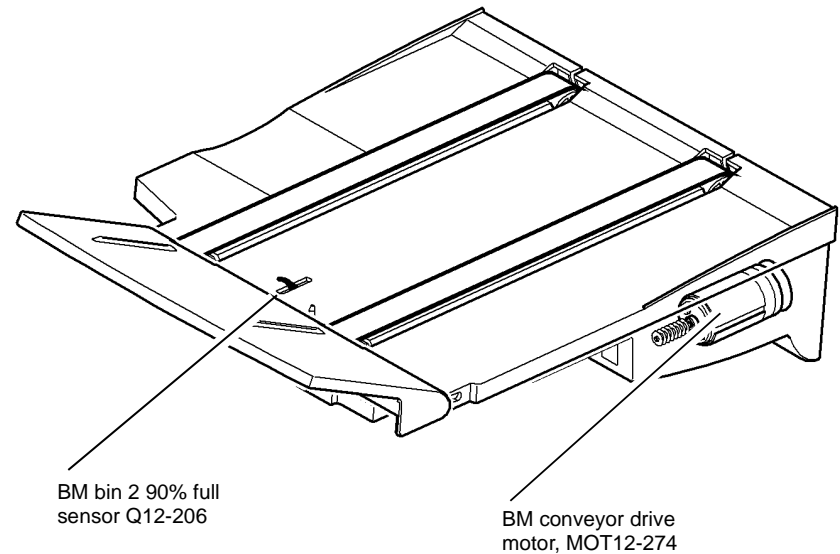

U-1-0174-A

Figure 1 Component location

A

12D-171 Booklet Quality RAP

Use this RAP to identify and correct the causes of poor booklet quality in the HVF BM.

The following booklet quality problems are covered in this RAP:

- The alignment of the top and bottom edges of the booklet are not within specification.
- The alignment of the open side edges of the booklet are not within specification.
- The booklet staples are badly formed.
- The booklet compiling is not correct (page order is wrong).
- The booklet crease is skewed greater than the specification.
- The booklet crease is off-centre, greater than the specification.
- The booklet staple position is not within the specification.
- The booklet is not sufficiently creased.

Initial Actions

WARNING

Ensure that the electricity to the machine is switched off while performing tasks that do not need electricity. Refer to GP 14. Disconnect the power cord. Electricity can cause death or injury. Moving parts can cause injury.

- Check that the paper loaded in the paper trays matches the paper size displayed on the UI.
- Ensure that the paper being fed to the BM conforms to the specification, GP 20 Paper and Media Size Specification.
- Ensure that the booklets being produced do not exceed the maximum contents given in Table 1.

Table 1 Booklet contents

Media	Paper weight	Maximum number of sheets	Maximum number of booklet pages	Maximum number of unstapled sheets
Plain paper	60 to 80gsm (16 to 21lb bond)	15	60	5
Heavyweight	90gsm (24lb bond)	13	52	-
Heavyweight	120gsm (32lb bond)	10	40	-
Heavyweight	160gsm (43lb bond)	7	28	-
Heavyweight	216gsm (58lb bond)	5	20	-
Plain paper with heavy-weight cover	60 to 80 gsm (16 to 21lb bond) with 160 gsm (43lb bond) cover	14 including 1 cover	56	-

- Check the machine and HVF BM paper paths for any obstruction that could cause misalignment of the paper fed to the BM compiling area.

Procedure

Produce three 4 sheet / 16 page booklets, using 80gsm (20lb) paper. Paper size and weight must conform the specification in GP 20 Paper and Media Size Specification.

Examine the booklets for defects. Refer to the following:

- Top and Bottom Edge Alignment.
- Open Side Edge Alignment.
- Badly Formed Booklet Staples
- Booklet Compiler is Not Correct
- Skewed Booklet Crease.
- Booklet Crease is Off Centre.
- Booklet Staple Position is Not On The Fold.
- The Booklet is Not Sufficiently Creased.

Top and Bottom Edge Alignment

Figure 1, open out the booklet at the centre page and press it onto a flat surface. Measure the mis-alignment of the top and bottom edges of the booklet.

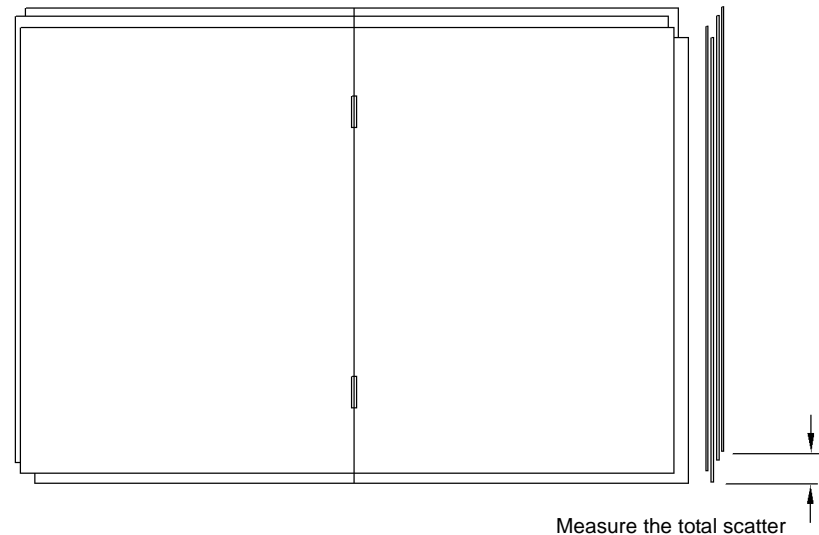

U-1-0175-A

Figure 1 Top and bottom alignment

Table 2 Top and bottom edge alignment

Paper weight	95% of booklets	99.7% of booklets
80gsm (20lb)	1mm	2mm
All other BM approved weights in GP 20	2mm	3mm

If the top and bottom edge alignment does not conform to the specification in [Table 2](#), check the operation of the BM tampers, refer to the [12-066-00-171](#), [12-384-00-171](#), [12-419-00-171](#), [12-420-00-171](#) HVF BM Tamber Failure RAP. If the tampers are operating correctly, go to [ADJ 12.5-171](#) Booklet Tamping and check the tampers are correctly adjusted.

If the booklet skew does not conform to the specification in [Table 4](#). Perform the following:

- Check the operation of the BM stack hold solenoids, refer to [12-065-00-171](#), [12-383-00-171](#) HVF Booklet Back Stop failure RAP.
- If the stack hold solenoids are operating correctly, check for contamination or debris in the compiling area of the BM that could cause the mis-alignment.

Open Side Edge Alignment

[Figure 2](#), open out the booklet at the centre page and press it onto a flat surface. Measure the mis-alignment of the open side edges of the booklet.

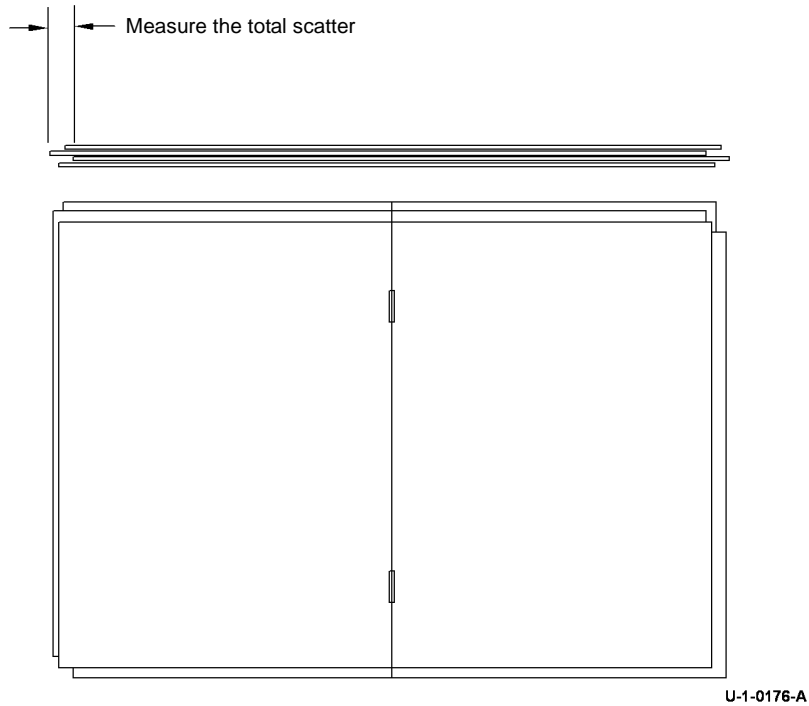

Figure 2 Open side edge alignment

Table 3 Open side edge alignment

Paper weight	95% of booklets	99.7% of booklets
80gsm (20lb)	1mm	2mm
All other BM approved weights in GP 20	2mm	3mm

If the open side edge alignment does not conform to the specification in [Table 3](#), check the operation of the BM stack hold solenoids, refer to the [12-065-00-171](#), [12-383-00-171](#) HVF Booklet Back Stop Failure RAP. If the stack hold solenoids are operating correctly, check carefully for any contamination or debris in the compiling area of the BM, that could cause the mis-alignment.

Badly Formed Booklet Staples

If the booklet staples are not formed correctly, perform [ADJ 12.3-171](#) Staple Anvil Alignment.

Booklet Compiler is Not Correct

If the page order of the booklets is not correct, perform [ADJ 12.6-171](#) Booklet Compiling Position.

Skewed Booklet Crease

[Figure 3](#), open out the booklet at the centre page and press it onto a flat surface. Measure the amount of booklet skew.

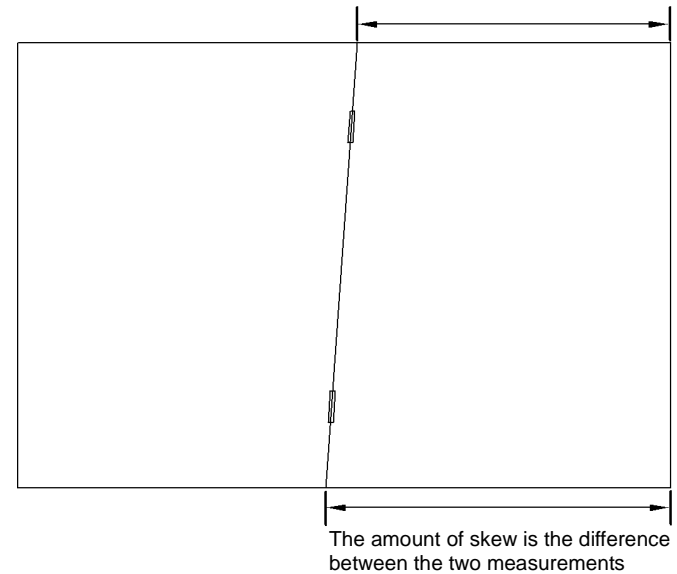

Figure 3 Booklet skew

Table 4 Skew tolerance

Paper weight	Paper size A4, 8.5x11in, 8.5x13in or 8.5x14in	Paper size A4, 8.5x11in, 8.5x13in or 8.5x14in	Paper size A3 or 11x17in	Paper size A3 or 11x17in
-	95% of booklets	99.7% of booklets	95% of booklets	99.7% of booklets
80gsm (20lb)	Less than 1.0mm	Less than 2.5mm	Less than 1.4mm	Less than 3.1mm
All other booklet maker approved weights in GP 20	Less than 1.5mm	Less than 3.0mm	Less than 2.1mm	Less than 3.6mm

If the booklet skew does not conform to the specification in Table 4, check the operation of the BM stack hold solenoids, refer to the 12-065-00-171, 12-383-00-171 HVF Booklet Back Stop Failure RAP. If the stack hold solenoids are operating correctly, check for any contamination or debris in the compiling area of the BM, that could cause the mis-alignment.

Booklet Crease is Off Centre

Figure 4, open out the booklet at the centre page and press it onto a flat surface. Measure the position of the booklet crease.

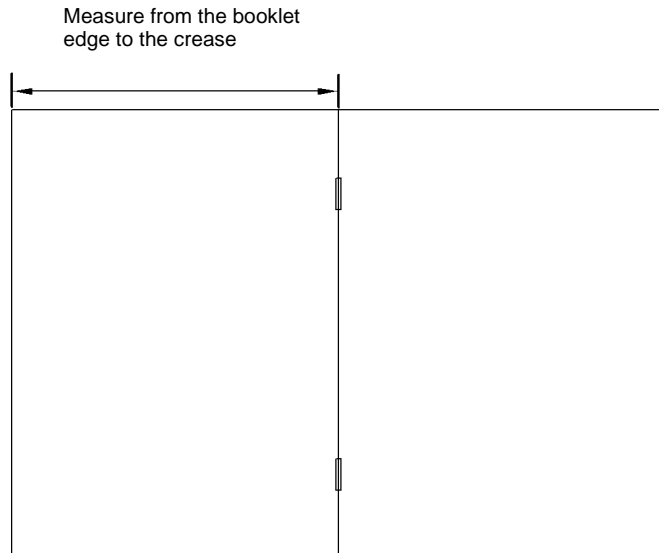

U-1-0178-A

Figure 4 Booklet crease position

Table 5 Crease position and tolerance

Paper size	Edge to crease measurement
A4	148.5 +/- 1.5mm
A3	210 +/- 1.5mm
8.5x11 inch	139.5 +/- 1.5mm
8.5x13 inch	165.1 +/- 1.5mm
8.5x14 inch	178.0 +/- 1.5mm
11x17 inch	216.0 +/- 1.5mm

If the booklet crease position does not conform to the specification in Table 5, perform ADJ 12.7-171 Booklet Crease Position.

Booklet Staple Position is Not On The Fold

Figure 5, open out the booklet at the centre page and press it onto a flat surface. Measure the position of the booklet staple from the crease line.

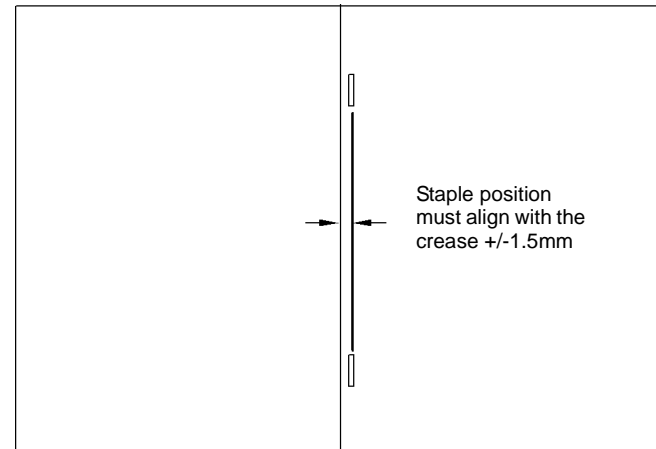

U-1-0179-A

Figure 5 Booklet staple position

If the booklet staple position does not conform to the specification in [Figure 5](#), perform [ADJ 12.8-171](#) Booklet Staple Position.

The Booklet is Not Sufficiently Creased

[Figure 6](#), Measure the open dimension of the booklets.

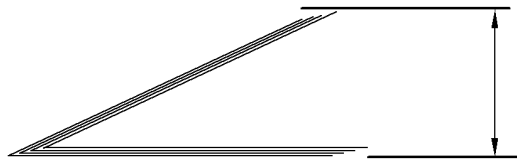

U-1-0180-A

Figure 6 Booklet creasing

Table 6 Creasing tolerance

Paper weight	Paper size A4, 8.5x11in, 8.5x13in or 8.5x14in	Paper size A4, 8.5x11in, 8.5x13in or 8.5x14in	Paper size A3 or 11x17in	Paper size A3 or 11x17in
-	95% of booklets	99.7% of booklets	95% of booklets	99.7% of booklets
80gsm (20lb)	Less than 30mm	Less than 35mm	Less than 22mm	Less than 25mm

If the open dimension of the booklets does not conform to the specification in [Table 6](#), install new crease nip springs, [PL 12.170](#) [Item 12](#).

12E-171 Copy Damage in the HVF BM RAP

Use this RAP to identify and correct the causes of copy damage in the HVF BM.

Procedure

WARNING

Ensure that the electricity to the machine is switched off while performing tasks that do not need electricity. Refer to [GP 14](#). Disconnect the power cord. Electricity can cause death or injury. Moving parts can cause injury.

Check the following:

- Check the alignment between the IME and the HVF BM, [ADJ 12.1-171](#).
- Look for paper fragments in the HVF BM paper path. Paper fragments can move through the IME and HVF BM paper path without causing a problem until they finally wedge themselves at some point. A likely place for a fragment of paper to be wedged is at the hole punch assembly, where the top and bottom guides form the narrowest part of the paper path.
- Ensure that the exit diverter solenoid SOL12-225, [PL 12.120](#) [Item 4](#), energizes correctly and has full movement.
- Ensure that the hole punches park at the fully open position. If they protrude, even slightly, a jam will occur in the narrow paper path of the hole punch. Refer to the [12-044-00-171](#) to [12-047-00-171](#) Punch Head Position RAP.
- Check that all the idler rolls in the HVF BM paper path are free to rotate, particularly those on the jam clearance guides. Refer to [ADJ 4.1](#) Machine Lubrication.
- Make sure that the jam clearance guides 5a, 5b and 5c close and latch correctly.
- Check that the paper path ribs of the BM paper guide 6e, [PL 12.150](#) [Item 7](#) and the upper exit guide [PL 12.125](#) [Item 8](#) are free of scores and nicks. Check also for contamination and glue from label stock.
- Make sure that the compiler carriage tampers move to the correct paper size.
- Check that the paper size reported on the user interface corresponds to the actual paper size loaded in the trays, refer to the [71B](#) Tray 1 and 2 Wrong Size Paper RAP.
- Make sure that the BM tampers move to the correct paper size, refer to the [12-066-00-171](#), [12-384-00-171](#), [12-419-00-171](#), [12-420-00-171](#) HVF BM Tamber Failure RAP.
- Ensure that the BM paper guide, [PL 12.150](#) [Item 7](#), closes and latches correctly.
- If heavy-weight paper is used, the paper can stop in the vertical transport and cause a fault. The fault is caused when the vertical transport motor is over loaded. Check the position of the jam clearance guides 5a, 5b and 5c. Check the vertical transport rolls and bearings for contamination. If necessary remove and clean the drive shaft and the bearings. If the problem continues then install a new transport motor.

12F-171 Mis-Registration in Stapled and Unstapled Sets RAP

Use this RAP to identify and correct the causes of mis-registration in stapled sets, resulting in staples missing some sheets in the set, or poorly registered non-stapled sets.

Procedure

WARNING

Ensure that the electricity to the machine is switched off while performing tasks that do not need electricity. Refer to [GP 14](#). Disconnect the power cord. Electricity can cause death or injury. Moving parts can cause injury.

A probable cause of mis-stapled or mis-compiled sheets is a defective paddle unit or ejector assembly.

- If output prints 2 to 100 in the compile area are not fully pulled back against the HVF backstops inspect the paddles of the paddle unit for physical signs of wear, [PL 12.115 Item 25](#).
- If output print 1 in the compile area is not fully pulled back against the HVF backstops inspect the ejector paddle assembly for physical signs of wear, [PL 12.110 Item 22](#).

A probable cause of mis-registration is the condition of the paper and/or damage such as, curl, wrinkle, creases, dog ears, etc.

- Curl, wrinkle and creases are probably caused in the IME, go to the [IQ 1 Image Quality Entry RAP](#).
- For other copy / print damage and dog ears, go to the [12E-171 Copy Damage](#) in the HVF BM RAP.

Check the following:

- Check the alignment between the IME and the HVF BM, [ADJ 12.1-171](#).
- Turn over the paper stack in the tray in use.
- Use a new ream of paper in the tray in use.
- Paper type, especially recycled paper, can lead to registration problems. Try changing to a different brand or type of paper.
- Ensure that the guides in the paper trays are correctly set and reported on the UI for the paper size loaded, refer to the [71B Tray 1 and 2 Wrong Size Paper RAP](#).
- Check that paper type is set correctly. If heavyweight paper is used but not set in the UI, the compiler capacity can be exceeded.
- Check for obstructions in the compiler.
- Ensure the paddle roll mechanism in the eject housing operating correctly, refer to the [12-024-00-171, 12-025-00-171 Paddle Roll Position RAP](#).
- Make sure that the compiler carriage tampers move to the correct paper size.
- Make sure that the BM tampers move to the correct paper size, refer to [12-066-00-171, 12-384-00-171, 12-419-00-171, 12-420-00-171 HVF BM Tamper Failure RAP](#).

12G-171 HVF BM Poor Stacking RAP

Use this RAP to find the cause of poor stacking in the HVF BM.

Procedure

WARNING

Ensure that the electricity to the machine is switched off while performing tasks that do not need electricity. Refer to [GP 14](#). Disconnect the power cord. Electricity can cause death or injury. Moving parts can cause injury.

Check the following:

- Look for sets that are not dropping back fully in the bin 1 tray and therefore not being detected by the kicker fingers and sensors:
 - Large paper sizes should not be stacked on top of small paper sizes.
 - Ensure that the paper stack in each paper tray has been fanned.
 - Turn over the paper stack in each paper tray.
 - Ensure that all paper or other copy stock being used is within the size and weight specifications. Refer to [GP 20 Paper and Media Size Specifications](#).
 - Try using a fresh ream of paper.
 - Ensure that the edge guides of all paper trays are adjusted correctly for the paper size and that the trays are fully closed.
- Labels must not be fed to bin1, but to bin 0 only.
- It is recommended that transparencies are fed to bin 0 whenever possible.
- Check that the bin 1 upper limit switch, S12-190 and the bin 1 lower limit switch, S12-191 are working correctly. Refer to the [12-460-00-171 to 12-462-00-171 Bin 1 Position RAP](#).
- Make sure that the compiler carriage tampers move to the correct paper size.
- Check that the HVF BM is not positioned near an air conditioning or ventilation output duct. Air flow across the output bins can cause poor stacking.

12H-171 Pause to Unload (PTU) RAP

Use this RAP to diagnose pause to unload problems.

Procedure

WARNING

Ensure that the electricity to the machine is switched off while performing tasks that do not need electricity. Refer to [GP 14](#). Disconnect the power cord. Electricity can cause death or injury. Moving parts can cause injury.

Figure 1 shows the component locations. Go to [WD 12.15](#). Check the wiring and the voltages. Refer to [PJ903](#). Repair the wiring as necessary, [REP 1.1](#). Install new components as necessary:

- PTU PWB, [PL 12.140 Item 3](#).
- HVF PWB, [PL 12.140 Item 2](#).

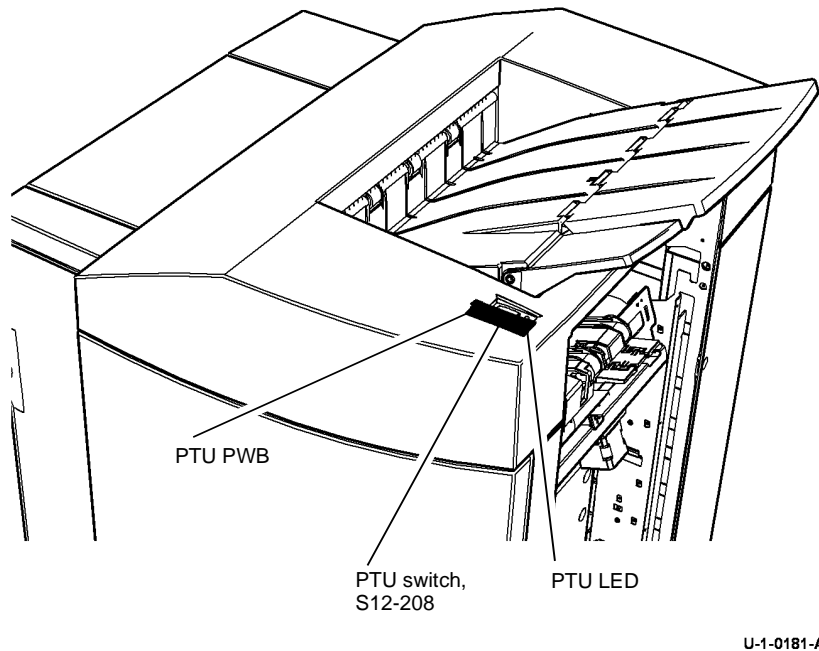

Figure 1 Component location

12J-171 Inserter Paper Sensing and +5V Supply RAP

Use this RAP to find the cause of inserter empty, inserter paper width and +5v supply problems.

Procedure

WARNING

Ensure that the electricity to the machine is switched off while performing tasks that do not need electricity. Refer to [GP 14](#). Disconnect the power cord. Electricity can cause death or injury. Moving parts can cause injury.

Figure 1 and Figure 2 show the component locations.

If a +5V supply problem is suspected, perform the following:

Go to the [12A-171](#) HVF Power Distribution RAP. Check the 0V and +5V supply from the HVF PWB to the inserter PWB. Repair the wiring as necessary, [REP 1.1](#).

Install new components as necessary:

- Inserter PWB, [PL 12.310 Item 9](#).
- HVF PWB, [PL 12.140 Item 2](#).

To diagnose inserter paper sensing and paper width problems, perform the following:

Enter the [dC330](#) code 12-082 inserter unit empty sensor, Q12-082. Actuate the sensor. The display changes.

Y N

Go to [WD 12.13](#) and [WD 12.21](#). Check Q12-082. Refer to:

- [GP 11](#) How to Check a Sensor.
- PJ8 and PJ4 on the [Inserter PWB](#).
- [12A-171](#) HVF Power Distribution RAP
- [01L](#) 0V Distribution RAP

Install new component as necessary:

- Inserter unit empty sensor, [PL 12.300 Item 11](#).
- Inserter PWB, [PL 12.310 Item 9](#).
- HVF PWB, [PL 12.140 Item 2](#).

Enter [dC330](#) code 12-081, inserter paper width sensor 1, Q12-081. Actuate the sensor. The display changes.

Y N

Go to [WD 12.13](#) and [WD 12.21](#). Check Q12-081. Refer to:

- [GP 11](#) How to Check a Sensor.
- PJ8 and PJ4 on the [Inserter PWB](#).
- [12A-171](#) HVF Power Distribution RAP.
- [01L](#) 0V Distribution RAP

Install new components as necessary:

- Inserter paper width sensor 1, [PL 12.300 Item 13](#).
- Inserter PWB, [PL 12.310 Item 9](#).
- HVF PWB, [PL 12.140 Item 2](#).

Enter [dC330](#) code 169, inserter paper width sensor 2, Q12-169. Actuate the sensor. The display changes.

Y N

Go to [WD 12.13](#), [WD 12.21](#) and [WD 12.22](#) and check the inserter paper width sensor 2.

Refer to:

- [GP 11](#) How to Check a Sensor.
- PJ8 and PJ4 on the [Inserter PWB](#).
- [12A-171](#) HVF Power Distribution RAP.
- [01L](#) 0V Distribution RAP

Install new components as necessary:

- Inserter paper width sensor 2, [PL 12.300](#) Item 13.
- Inserter PWB, [PL 12.310](#) Item 9.
- HVF PWB, [PL 12.140](#) Item 2.

Go to [WD 12.13](#) and [WD 12.22](#). Measure the voltage from the inserter acceleration sensor (Q12-316), while actuating the sensor with paper. **The voltage changes.**

Y N

Check the inserter acceleration sensor (Q12-316). Refer To:

- [GP 11](#) How to check a Sensor.
- PJ11 and PJ4 on the [Inserter PWB](#).
- [12A-171](#) HVF Power Distribution RAP.
- [01L](#) 0V Distribution RAP

Install new components as necessary:

- Inserter acceleration sensor, [PL 12.300](#) Item 10.
- Inserter PWB, [PL 12.310](#) Item 9.
- HVF PWB, [PL 12.140](#) Item 2.

Go to [WD 12.14](#) and [WD 12.22](#). Measure the voltage from the inserter pickup sensor (Q12-315) while actuating the sensor with paper. **The voltage changes.**

Y N

Check the inserter pickup sensor (Q12-315). Refer to:

- [GP 11](#) How to check a Sensor.
- PJ7 and PJ4 on the [Inserter PWB](#).
- [12A-171](#) HVF Power Distribution RAP.
- [01L](#) 0V Distribution RAP

Install new components as necessary:

- Inserter pickup sensor [PL 12.310](#) Item 10.
- Inserter PWB, [PL 12.310](#) Item 9.
- HVF PWB, [PL 12.140](#) Item 2.

Perform [SCP 5](#) final actions.

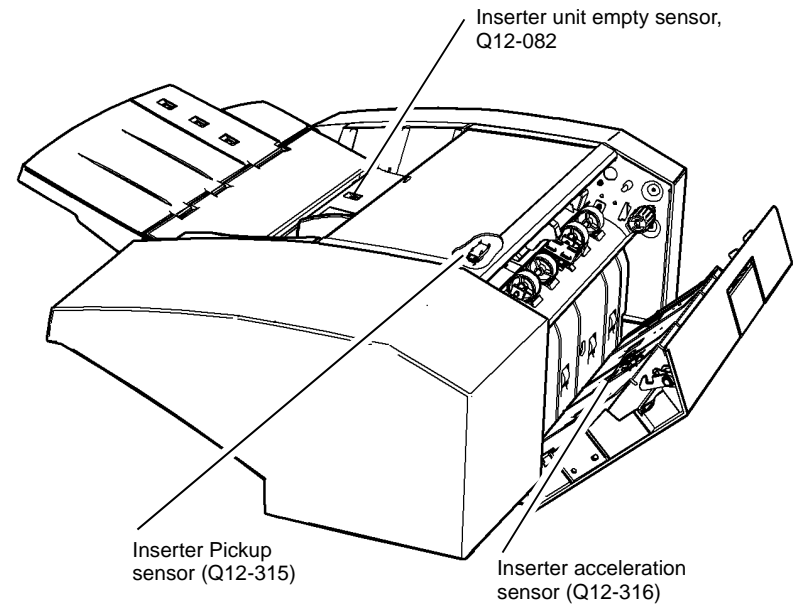

Figure 1 Component location

U-1-0182-A

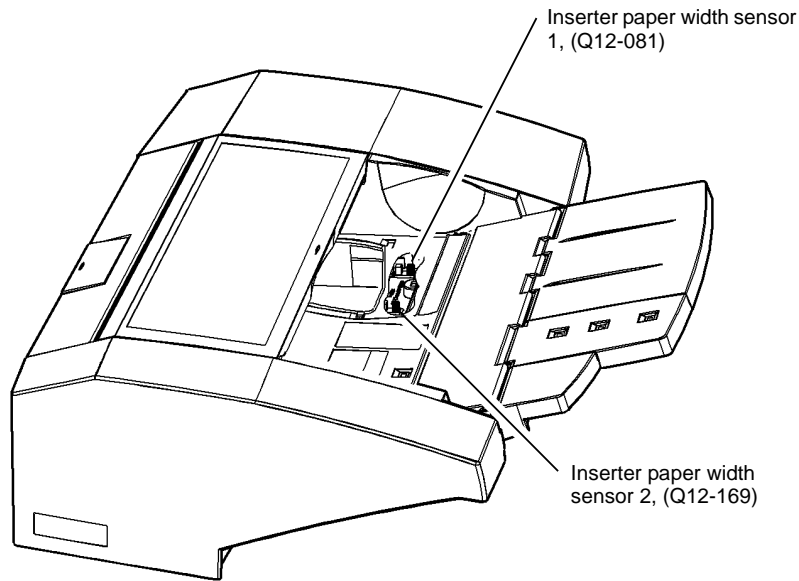

Figure 2 Component location

U-1-0183-A

12K-171 HVF Initialization Failure RAP

When an initialization command is received from the machine, the HVF is initialized with the following actions:

1. The stacker tray moves down and then up.
2. The lower paddle rotates to home position.
3. The paddle unit moves up.
4. The paper pusher comes down
5. The ejector moves out.
6. The staple head moves to the rear.
7. The staple head moves back home, front.
8. The pusher moves up to home position
9. The ejector moves back into home position.
10. The pressing and support fingers come out and then move in.
11. The paddle unit moves down.
12. The paddles in the paddle unit rotate twice.
13. The HVF should now be ready to run if all these checks completed successfully.

NOTE: The HVF initialization procedure can be triggered by opening and closing the HVF front door, or by raising and lowering the top tray. When this is done the tray will not lower completely, but will adjust its position.

The booklet maker is initialized as follows:

1. The BM tampers are driven to their home position, unless already home.
2. The BM backstop is driven to the home position, unless already home.
3. The BM crease roll gate is driven to the home position, unless already home.
4. The BM crease blade is driven to the home position, unless already home.
5. The BM staple heads are driven to their home position, unless already home.

Initial Actions

WARNING

Ensure that the electricity to the machine is switched off while performing tasks that do not need electricity. Refer to GP 14. Disconnect the power cord. Electricity can cause death or injury. Moving parts can cause injury.

Open the HVF front door. Cheat the front door interlock switch. Fully pull out the BM module

Procedure

If the initialization sequence fails to place any unit at the home position, refer to the appropriate RAPs:

- Front tamper not at home, refer to [12-392-00-171](#) to [12-395-00-171](#) HVF Front tamper Tray RAP
- Rear tamper not at home, refer to [12-396-00-171](#) to [12-399-00-171](#) HVF Rear Tamper Tray RAP.
- Paddle not at home, refer to [12-024-00-171](#), [12-025-00-171](#) Paddle Roll Position RAP.
- Bin 1 not at home, refer to [12-460-00-171](#) to [12-462-00-171](#) HVF Bin 1 Position RAP.
- Punch not at home, refer to [12-044-00-171](#) to [12-047-00-171](#) Punch head Position RAP

- Staple head not at home, refer to [12-369-00-171](#) to [12-377-00-171](#) HVF stapler Position and Priming RAP.
- Ejector not at home, refer to [12-450-00-171](#), [12-456-00-171](#) to [12-459-00-171](#) HVF Ejector Module RAP.
- The buffer motor fails to start, refer to [12-141-00-171](#), [12-142-00-171](#) HVF Buffer Path RAP.
- Entry feed motor 1 fails to start, refer to [12-125-00-171](#), [12-126-00-171](#) HVF Entry Sensor RAP.
- Transport motor 2 fails to start, refer to [12-171-00-171](#), [12-172-00-171](#) HVF Top Exit Sensor RAP.
- The booklet maker diverter solenoid fails to energizes, refer to [12-113-00-171](#), [12-114-00-171](#), [12-190-00-171](#), [12-192-00-171](#) HVF BM Entry RAP.
- The exit diverter solenoid fails to energies, refer to [12-171-00-171](#), [12-172-00-171](#) HVF Top Exit Sensor RAP.
- Either of the BM staple heads are not at the home position, refer to [12-063-00-171](#), [12-411-00-171](#) HVF BM Stapler Unit 1 Failure RAP or [12-403-00-171](#), [12-413-00-171](#), [12-414-00-171](#) HVF BM Stapler Head 2 and Stapler Module RAP.
- The BM tampers are not at the home position, refer to [12-066-00-171](#), [12-384-00-171](#), [12-419-00-171](#), [12-420-00-171](#) HVF BM Tamper Failure RAP.
- The BM backstop is not at the home position, refer to [12-065-00-171](#), [12-383-00-171](#) HVF BM Backstop Failure RAP.
- The BM crease roll gate is not at the home position, refer to [12-415-00-171](#) HVF BM Crease Roll Gate Home RAP.
- The BM crease blade is not at the home position, refer to [12-061-00-171](#), [12-416-00-171](#) HVF BM Creasing RAP.

12L-171 Tri-Folder Not Detected RAP

Use this RAP when the machine fails to detect the tri-folder module.

Initial Actions

WARNING

Ensure that the electricity to the machine is switched off while performing tasks that do not need electricity. Refer to GP 14. Disconnect the power cord. Electricity can cause death or injury. Moving parts can cause injury.

Check for damage or obstructions that would prevent the tri-folder from operating correctly.

Procedure

Go to [WD 12.19](#). Check the wiring of the tri-folder present link, and repair as necessary, [REP 1.1](#). Check for 0V at PJ563, pin 7. Refer to:

- [12A-171](#) HVF Power Distribution RAP.
- [01L](#) 0V Distribution RAP.

12M-171 Buffer Path Clamp Problems RAP

Use this RAP when having problems with the buffer path clamp on the HVF. Problems in this area result in paper jams at the exit and poor compiling.

Initial Actions

WARNING

Ensure that the electricity to the machine is switched off while performing tasks that do not need electricity. Refer to [GP 14](#). Disconnect the power cord. Electricity can cause death or injury. Moving parts can cause injury.

Check that the solenoid and the clamp can move freely without obstruction.

Procedure

[Figure 1](#) shows the location of the components.

Enter the [dC330](#) code 12-056, set clamp solenoid. **The solenoid actuates.**

Y N

Go to [WD 12.8](#) and check the wiring. Repair as necessary, [REP 1.1](#). Check SOL12-056.

Refer to:

- [GP 12](#) How to Check a Solenoid or Clutch.
- [12A-171](#) HVF Power Distribution RAP.
- [01L 0V](#) Distribution RAP

Install new components as necessary:

- Set clamp solenoid, [PL 12.120](#) Item 4.
- HVF PWB, [PL 12.140](#) Item 2.

Perform [SCP 5](#) Final Actions.

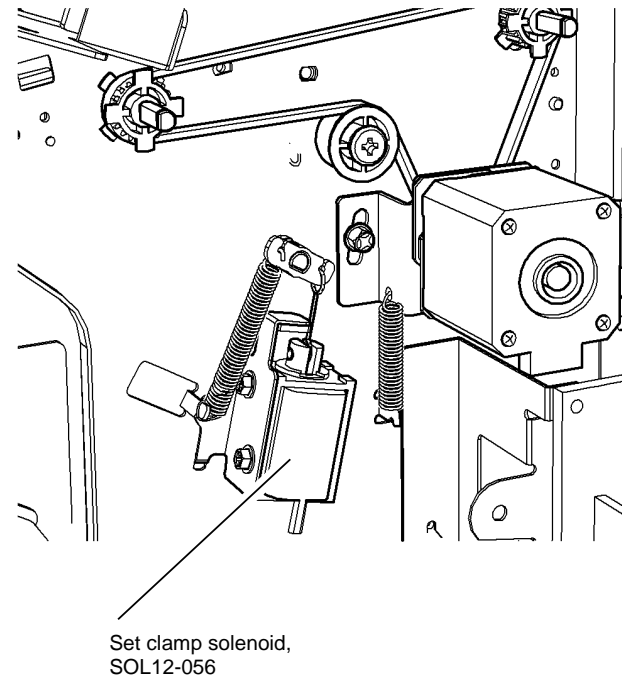

REAR VIEW

Figure 1 Component location

U-1-0186-A

12N-171 Chad Bin Present and Bin Full RAP

Use this RAP when there is a false indication of a missing or full chad bin.

Initial Actions

WARNING

Ensure that the electricity to the machine is switched off while performing tasks that do not need electricity. Refer to [GP 14](#). Disconnect the power cord. Electricity can cause death or injury. Moving parts can cause injury.

Check that the chad sensor hole in the side of the bin is clear of obstruction. Check that the bin is fully inserted and is empty.

Procedure

[Figure 1](#) shows the location of the components.

Enter [dC330](#) code 12-118, chad bin present sensor, Q12-118. Remove the chad bin and actuate the sensor manually. **The display changes.**

Y N

Go to [WD 12.12](#) and check the wiring. Repair as necessary, [REP 1.1](#). Check the chad bin present sensor, Q12-118. Refer to:

- [GP 11](#) How to Check a Sensor.
- [12A-171](#) HVF Power Distribution RAP.
- [01L](#) 0V Distribution RAP

As necessary, install new components:

- Chad bin present sensor, [PL 12.125](#) [Item 18](#).
- HVF PWB, [PL 12.140](#) [Item 2](#).

Enter the [dC330](#) code, 12-193, chad bin level sensor, Q12-193. Remove the chad bin and actuate the sensor with paper. **The display changes.**

Y N

Go to [WD 12.12](#) and check the wiring. Repair as necessary, [REP 1.1](#). Check Q12-193. Refer to:

- [GP 11](#) How to Check a Sensor.
- [12A-171](#) HVF Power Distribution RAP.
- [01L](#) 0V Distribution RAP

Install new components as necessary:

- Chad bin level sensor, [PL 12.125](#) [Item 17](#).
- HVF PWB, [PL 12.140](#) [Item 2](#).

Perform [SCP 5](#) Final Actions.

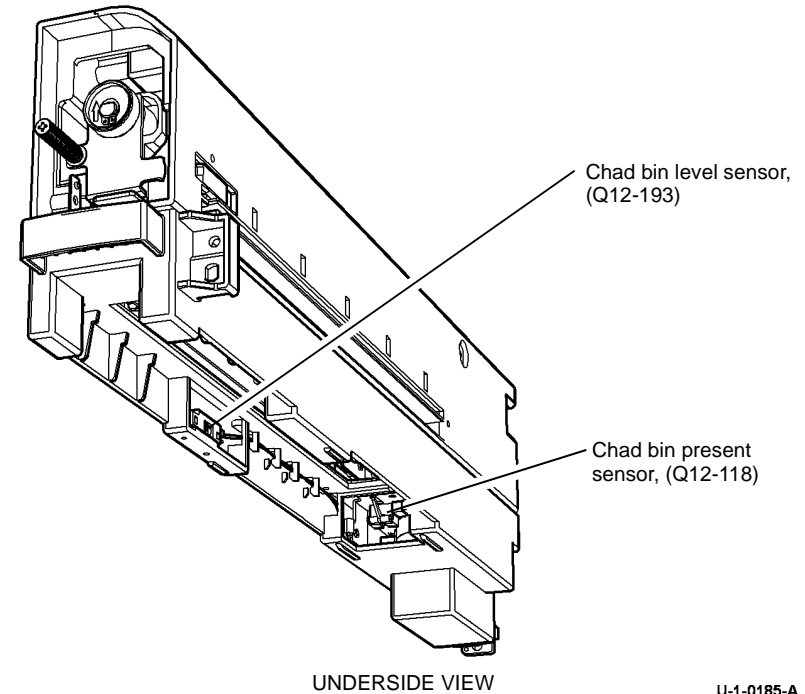

UNDERSIDE VIEW

U-1-0185-A

Figure 1 Component location

16-000-00 to 16-000-26 Cannot Create RPC With ENS RAP

16-000-00 Format services non shutdown ESS faults

16-000-01 ENS service non shutdown ESS faults

16-000-09 Cannot create RPC connection with ENS

16-000-14 Cannot create RPC connection with ENS

16-000-19 Cannot create RPC connection with ENS

16-000-26 Cannot create RPC connection with ENS

Procedure

WARNING

Ensure that the electricity to the machine is switched off while performing tasks that do not need electricity. Refer to GP 14. Disconnect the power cord. Electricity can cause death or injury. Moving parts can cause injury.

1. If a single occurrence, the network controller (ESS) will automatically re-boot.
2. For multiple occurrences, reinstall software, GP 4.

16-001-09 to 16-001-90 Unable to Synchronize Startup RAP

16-001-09 Unable to do startup synchronization

16-001-14 Unable to do startup synchronization

16-001-19 Unable to do startup synchronization

16-001-26 Unable to Start up and synchronize with SC

16-001-47 Unable to do startup synchronization

16-001-90 Unable to do startup synchronization

Procedure

WARNING

Ensure that the electricity to the machine is switched off while performing tasks that do not need electricity. Refer to GP 14. Disconnect the power cord. Electricity can cause death or injury. Moving parts can cause injury.

1. If a single occurrence, take no action.
2. For multiple occurrences switch off the machine, then switch on the machine, GP 14.
3. If the fault remains, reinstall software, GP 4.

16-002-09 to 16-002-19 Unable to Register as RPC RAP

16-002-09 Unable to Register as an RPC server

16-002-14 Unable to Register as an RPC server

16-002-19 Unable to Register as an RPC server

16-002-26 Unable to Register as an RPC server

16-002-46 Unable to Register as an RPC server

Procedure

WARNING

Ensure that the electricity to the machine is switched off while performing tasks that do not need electricity. Refer to GP 14. Disconnect the power cord. Electricity can cause death or injury. Moving parts can cause injury.

1. If a single occurrence, take no action.
2. For multiple occurrences, switch off the machine, then switch on the machine, GP 14.
3. If the fault remains, reinstall software, GP 4.

16-003-09 to 16-003-90 Too Many IPC Handles RAP

16-003-09 Too many IPC handles

16-003-14 Too many IPC handles

16-003-19 Too many IPC handlers

16-003-90 Utility insert handler failure

Procedure

WARNING

Ensure that the electricity to the machine is switched off while performing tasks that do not need electricity. Refer to GP 14. Disconnect the power cord. Electricity can cause death or injury. Moving parts can cause injury.

1. If a single occurrence, take no action.
2. For multiple occurrences, switch off the machine, then switch on the machine, GP 14.
3. If the fault remains, reinstall software, GP 4.

16-004-14 to 16-005-92 RPC Failure to Register RAP

16-004-14 RPC call failure to ESS registration service

16-004-19 RPC connect failure to ESS registration service

16-004-26 RPC connect failure to ESS registration service

16-004-46 RPC connect failure to ESS registration service (to register with)

16-005-14 RPC call failure to ESS registration service

16-005-19 RPC call failure to ESS registration service

16-005-26 RPC call failure to ESS registration service

16-005-46 RPC call failure to ESS registration service (to register with)

16-005-68 RPC call failure to ESS registration service (to register with)

16-005-90 RPC call failure to ESS registration failed

16-005-92 RPC call failure to ESS registration service (to register with)

Procedure

WARNING

Ensure that the electricity to the machine is switched off while performing tasks that do not need electricity. Refer to GP 14. Disconnect the power cord. Electricity can cause death or injury. Moving parts can cause injury.

1. If a single occurrence, take no action.
2. For multiple occurrences, switch off the machine, then switch on the machine, GP 14.
3. If the fault remains, reinstall software, GP 4.

16-006-09, 16-006-19 Cannot Register for Events RAP

16-006-09 Cannot register for events

16-006-19 Cannot register for events

Procedure

WARNING

Ensure that the electricity to the machine is switched off while performing tasks that do not need electricity. Refer to GP 14. Disconnect the power cord. Electricity can cause death or injury. Moving parts can cause injury.

1. Switch off the machine, then switch on the machine, GP 14.
2. If the fault remains, reinstall software, GP 4.

16-007-92 to 16-010-99 Invalid IPC / RPC Data RAP

16-007-92 Invalid RPC data received

16-009-09 Invalid IPC data received

16-010-14 Unable to send IPC

16-010-99 IPC open, create, signal queue failed

Procedure

WARNING

Ensure that the electricity to the machine is switched off while performing tasks that do not need electricity. Refer to GP 14. Disconnect the power cord. Electricity can cause death or injury. Moving parts can cause injury.

1. If a single occurrence, take no action.
2. For multiple occurrences, switch off the machine, then switch on the machine, GP 14.
3. If the fault remains, reinstall software, GP 4.

16-013-14, 16-014-14 Copier Synchronization Error RAP

16-013-14 Digital copier ENS synchronization error

16-014-14 Digital copier ENS synchronization error

Procedure

WARNING

Ensure that the electricity to the machine is switched off while performing tasks that do not need electricity. Refer to GP 14. Disconnect the power cord. Electricity can cause death or injury. Moving parts can cause injury.

1. Switch off the machine, then switch on the machine, GP 14.
2. If the fault remains, reinstall software, GP 4.

16-015-14, 16-015-19 Data Store Variable Not Set RAP

16-015-14 SESS data store environmental variable not set

16-015-19 SESS data store environmental variable not set

Procedure

WARNING

Ensure that the electricity to the machine is switched off while performing tasks that do not need electricity. Refer to GP 14. Disconnect the power cord. Electricity can cause death or injury. Moving parts can cause injury.

1. If a single occurrence, switch off the machine, then switch on the machine, GP 14.
2. For multiple occurrences, reinstall the software, GP 4.

16-016-14, 16-016-19 Data Store Initialization Failed RAP

16-016-14 Data store initialization failed

16-016-19 Data store initialization failed

Procedure

WARNING

Ensure that the electricity to the machine is switched off while performing tasks that do not need electricity. Refer to GP 14. Disconnect the power cord. Electricity can cause death or injury. Moving parts can cause injury.

1. If a single occurrence, the network controller (ESS) will automatically re-boot.
2. For multiple occurrences, reinstall the software, GP 4.

16-017-19 to 16-021-26 Send Event Failure / Could Not Get Host Name RAP

16-017-19 Send event failure. Unable to send event to ESS ENS

16-021-19 ESS PM registration connect error

16-021-26 Service could not get Host name

Procedure

WARNING

Ensure that the electricity to the machine is switched off while performing tasks that do not need electricity. Refer to GP 14. Disconnect the power cord. Electricity can cause death or injury. Moving parts can cause injury.

1. If a single occurrence, take no action.
2. For multiple occurrences, switch off the machine, then switch on the machine, GP 14.
3. If the fault remains, reinstall software, GP 4.

16-021-46 Unable to Get Host Name RAP

16-021-46 Unable to get Host Name

Procedure

WARNING

Ensure that the electricity to the machine is switched off while performing tasks that do not need electricity. Refer to GP 14. Disconnect the power cord. Electricity can cause death or injury. Moving parts can cause injury.

1. If a single occurrence, switch off the machine, then switch on the machine, GP 14.
2. For multiple occurrences, reinstall the software, GP 4.

16-023-09, 16-023-26 RPC Call Failure RAP

16-023-09 RPC call failure to ENS

16-023-26 RPC call failure to ENS

Procedure

WARNING

Ensure that the electricity to the machine is switched off while performing tasks that do not need electricity. Refer to GP 14. Disconnect the power cord. Electricity can cause death or injury. Moving parts can cause injury.

1. If a single occurrence, take no action.
2. For multiple occurrences switch off the machine, then switch on the machine, GP 14.
3. If the fault remains, reinstall software, GP 4.

16-026-09 to 16-026-92 Memory Allocation Error RAP

16-026-09 Memory allocation failure

16-026-14 Malloc error

16-026-46 Memory allocation failure

16-026-90 Malloc error

16-026-92 Memory allocation failure

Procedure

WARNING

Ensure that the electricity to the machine is switched off while performing tasks that do not need electricity. Refer to GP 14. Disconnect the power cord. Electricity can cause death or injury. Moving parts can cause injury.

1. If a single occurrence, take no action.
2. For multiple occurrences, switch off the machine, then switch on the machine, GP 14
3. If the fault remains, reinstall software, GP 4.

16-027-90 Unable to Obtain Queue ID RAP

16-027-90 Unable to obtain well known queue ID

Procedure

WARNING

Ensure that the electricity to the machine is switched off while performing tasks that do not need electricity. Refer to GP 14. Disconnect the power cord. Electricity can cause death or injury. Moving parts can cause injury.

1. If a single occurrence, take no action.
2. For multiple occurrences, reinstall the software, GP 4.

16-028-09, 16-028-90 Unable to Complete RPC Call / Invalid Range RAP

16-028-09 Unable to complete RPC call

16-028-90 Invalid range string

Procedure

WARNING

Ensure that the electricity to the machine is switched off while performing tasks that do not need electricity. Refer to GP 14. Disconnect the power cord. Electricity can cause death or injury. Moving parts can cause injury.

1. If a single occurrence, take no action.
2. For multiple occurrences, switch off the machine, then switch on the machine, GP 14
3. If the fault remains, reinstall software, GP 4.

16-030-19 Unable to Obtain Client RAP

16-030-19 Unable to obtain client RPC handle to EJS

Procedure

WARNING

Ensure that the electricity to the machine is switched off while performing tasks that do not need electricity. Refer to GP 14. Disconnect the power cord. Electricity can cause death or injury. Moving parts can cause injury.

1. If a single occurrence, take no action.
2. For multiple occurrences switch off the machine, then switch on the machine, GP 14.
3. If the fault remains, reinstall software, GP 4.

16-031-09 Invalid Event Notification RAP

16-031-09 Invalid event notification received

Procedure

WARNING

Ensure that the electricity to the machine is switched off while performing tasks that do not need electricity. Refer to GP 14. Disconnect the power cord. Electricity can cause death or injury. Moving parts can cause injury.

1. If a single occurrence, take no action.
2. For multiple occurrences, switch off the machine, then switch on the machine, GP 14.
3. If the fault remains, reinstall software, GP 4.

16-032-19, 16-039-00 NVM Connection Failure / Pthread Create Error RAP

16-032-19 NVM connection failure

16-039-00 Pthread create error

Procedure

WARNING

Ensure that the electricity to the machine is switched off while performing tasks that do not need electricity. Refer to GP 14. Disconnect the power cord. Electricity can cause death or injury. Moving parts can cause injury.

1. If a single occurrence, take no action.
2. For multiple occurrences, reinstall the software, GP 4.

16-040-92 Semaphore Fault RAP

16-040-92 Semaphore fault

Procedure

WARNING

Ensure that the electricity to the machine is switched off while performing tasks that do not need electricity. Refer to GP 14. Disconnect the power cord. Electricity can cause death or injury. Moving parts can cause injury.

1. If a single occurrence, switch off the machine, then switch on the machine, GP 14.
2. For multiple occurrences, reinstall software, GP 4.

16-048-09 Unable to Set Binding RAP

16-048-09 Unable to set binding

Procedure

WARNING

Ensure that the electricity to the machine is switched off while performing tasks that do not need electricity. Refer to GP 14. Disconnect the power cord. Electricity can cause death or injury. Moving parts can cause injury.

1. If a single occurrence, take no action.
2. For multiple occurrences, switch off the machine, then switch on the machine, GP 14.
3. If the fault remains, reinstall software, GP 4.

16-048-14, 16-048-90 Cannot Set ESS Client Binding RAP

16-048-14 Cannot set ESS client binding

16-048-90 Cannot set ESS client binding

Procedure

WARNING

Ensure that the electricity to the machine is switched off while performing tasks that do not need electricity. Refer to GP 14. Disconnect the power cord. Electricity can cause death or injury. Moving parts can cause injury.

1. Switch off the machine, then switch on the machine, GP 14
2. If the fault remains, reinstall software, GP 4.

16-048-99 Unable to Set Client Binding RAP

16-048-99 Unable to set client binding

Procedure

WARNING

Ensure that the electricity to the machine is switched off while performing tasks that do not need electricity. Refer to GP 14. Disconnect the power cord. Electricity can cause death or injury. Moving parts can cause injury.

1. If a single occurrence, take no action.
2. For multiple occurrences switch off the machine, then switch on the machine, GP 14.
3. If the fault remains, reinstall software, GP 4.

16-150-09 Cannot Send Registration Event RAP

16-150-09 Cannot send Registration Event

Procedure

WARNING

Ensure that the electricity to the machine is switched off while performing tasks that do not need electricity. Refer to GP 14. Disconnect the power cord. Electricity can cause death or injury. Moving parts can cause injury.

1. Switch off the machine, then switch on the machine, GP 14.
2. If the fault remains, reinstall software, GP 4.

16-150-14 Unable to Obtain RPC Transport RAP

16-150-14 Unable to obtain RPC transport

Procedure

WARNING

Ensure that the electricity to the machine is switched off while performing tasks that do not need electricity. Refer to GP 14. Disconnect the power cord. Electricity can cause death or injury. Moving parts can cause injury.

1. If a single occurrence, take no action.
2. For multiple occurrences, switch off the machine, then switch on the machine, GP 14.
3. If the fault remains, reinstall software, GP 4.

16-150-19 Unable to Sync Peer RAP

16-150-19 Unable to sync peer (within ESS) infrastructure services

Procedure

WARNING

Ensure that the electricity to the machine is switched off while performing tasks that do not need electricity. Refer to GP 14. Disconnect the power cord. Electricity can cause death or injury. Moving parts can cause injury.

1. Switch off the machine, then switch on the machine, GP 14.
2. If the fault remains, reinstall software, GP 4.

16-150-26 Fault Service Failed to Write Log RAP

16-150-26 Fault Service Failed to write log

Procedure

WARNING

Ensure that the electricity to the machine is switched off while performing tasks that do not need electricity. Refer to GP 14. Disconnect the power cord. Electricity can cause death or injury. Moving parts can cause injury.

1. Switch off the machine, then switch on the machine, GP 14.
2. If the fault remains, reinstall software, GP 4.

16-150-90 Invalid IPC Request Destination RAP

16-150-90 Invalid IPC request destination

Procedure

WARNING

Ensure that the electricity to the machine is switched off while performing tasks that do not need electricity. Refer to GP 14. Disconnect the power cord. Electricity can cause death or injury. Moving parts can cause injury.

1. If a single occurrence, take no action.
2. For multiple occurrences, switch off the machine, then switch on the machine, GP 14.
3. If the fault remains, reinstall software, GP 4.

16-150-92 Consumer Interface Fault RAP

16-150-92 Consumer interface fault

Procedure

WARNING

Ensure that the electricity to the machine is switched off while performing tasks that do not need electricity. Refer to GP 14. Disconnect the power cord. Electricity can cause death or injury. Moving parts can cause injury.

1. Switch off the machine, then switch on the machine, GP 14
2. If the fault remains, reinstall software, GP 4.

16-151-09 to 16-151-19 Invalid IPC Command / SNMP Reg Failure RAP

16-151-09 Invalid IPC command

16-151-14 SNMP event registration failed

16-151-19 Invalid IPC command

Procedure

WARNING

Ensure that the electricity to the machine is switched off while performing tasks that do not need electricity. Refer to GP 14. Disconnect the power cord. Electricity can cause death or injury. Moving parts can cause injury.

1. If a single occurrence, take no action.
2. For multiple occurrences, switch off the machine, then switch on the machine, GP 14
3. If the fault remains, reinstall software, GP 4.

16-151-26 Fault Service Failed to Get a Log RAP

16-151-26 Fault service failed to get a log handle

Procedure

WARNING

Ensure that the electricity to the machine is switched off while performing tasks that do not need electricity. Refer to GP 14. Disconnect the power cord. Electricity can cause death or injury. Moving parts can cause injury.

1. Switch off the machine, then switch on the machine, GP 14.
2. If the fault remains, reinstall software, GP 4.

16-151-90 Environment Variable Failure RAP

16-151-90 Put environment variable failure

Procedure

WARNING

Ensure that the electricity to the machine is switched off while performing tasks that do not need electricity. Refer to GP 14. Disconnect the power cord. Electricity can cause death or injury. Moving parts can cause injury.

1. If a single occurrence, take no action.
2. For multiple occurrences, reinstall software, GP 4.

16-152-09 Internal IPC Failure RAP

16-152-09 Internal IPC failure

Procedure

WARNING

Ensure that the electricity to the machine is switched off while performing tasks that do not need electricity. Refer to GP 14. Disconnect the power cord. Electricity can cause death or injury. Moving parts can cause injury.

1. If a single occurrence, take no action.
2. For multiple occurrences, switch off the machine, then switch on the machine, GP 14.
3. If the fault remains, reinstall software, GP 4.

16-152-14 Empty Internal Event Failure RAP

16-152-14 Empty internal event received by ENS

Procedure

WARNING

Ensure that the electricity to the machine is switched off while performing tasks that do not need electricity. Refer to GP 14. Disconnect the power cord. Electricity can cause death or injury. Moving parts can cause injury.

1. If a single occurrence, take no action.
2. For multiple occurrences, switch off the machine, then switch on the machine, GP 14.
3. If the fault remains, reinstall software, GP 4.

16-152-19 Unable to Send Request to SESS RAP

16-152-19 Unable to send request to SESS

Procedure

WARNING

Ensure that the electricity to the machine is switched off while performing tasks that do not need electricity. Refer to [GP 14](#). Disconnect the power cord. Electricity can cause death or injury. Moving parts can cause injury.

1. If a single occurrence, take no action.
2. For multiple occurrences, switch off the machine, then switch on the machine, [GP 14](#).
3. If the fault remains, reinstall software, [GP 4](#).

16-152-26 Unable to Send Request to SESS RAP

16-152-26 Unable to send request to SESS

Procedure

WARNING

Ensure that the electricity to the machine is switched off while performing tasks that do not need electricity. Refer to [GP 14](#). Disconnect the power cord. Electricity can cause death or injury. Moving parts can cause injury.

1. If a single occurrence, reinstall software, [GP 4](#).
2. For multiple occurrences, first check the harness connections then if problem persists install a new HDD, [PL 3.11 Item 2](#).

16-153-09 Unable to Obtain IPC Queue RAP

16-153-09 Unable to obtain IPC queue

Procedure

WARNING

Ensure that the electricity to the machine is switched off while performing tasks that do not need electricity. Refer to GP 14. Disconnect the power cord. Electricity can cause death or injury. Moving parts can cause injury.

1. If a single occurrence, take no action.
2. For multiple occurrences, switch off the machine, then switch on the machine, GP 14.
3. If the fault remains, reinstall software, GP 4.

16-153-14 Unable to Initialize Event List RAP

16-153-14 Can not initialize internal event list

Procedure

WARNING

Ensure that the electricity to the machine is switched off while performing tasks that do not need electricity. Refer to GP 14. Disconnect the power cord. Electricity can cause death or injury. Moving parts can cause injury.

1. If a single occurrence, take no action.
2. For multiple occurrences, switch off the machine, then switch on the machine, GP 14.
3. If the fault remains, reinstall software, GP 4.

16-153-19 NVM Save Failure RAP

16-153-19 NVM save failure

Procedure

WARNING

Ensure that the electricity to the machine is switched off while performing tasks that do not need electricity. Refer to GP 14. Disconnect the power cord. Electricity can cause death or injury. Moving parts can cause injury.

1. If a single occurrence, take no action.
2. For multiple occurrences, reinstall software, GP 4.

16-154-09 ESS Registration Configuration Error RAP

16-154-09 ESS Registration service configuration error

Procedure

WARNING

Ensure that the electricity to the machine is switched off while performing tasks that do not need electricity. Refer to GP 14. Disconnect the power cord. Electricity can cause death or injury. Moving parts can cause injury.

1. If a single occurrence, reinstall software, GP 4.
2. If problem persists there could be a bad software release. Install new software, GP 4.

16-154-14 Cannot Create Internal Event Queue RAP

16-154-14 Cannot create internal event

Procedure

WARNING

Ensure that the electricity to the machine is switched off while performing tasks that do not need electricity. Refer to GP 14. Disconnect the power cord. Electricity can cause death or injury. Moving parts can cause injury.

1. Switch off the machine, then switch on the machine, GP 14.
2. If the fault remains, reinstall software, GP 4.

16-154-19 NVM Read Failure RAP

16-154-19 NVM read failure

Procedure

WARNING

Ensure that the electricity to the machine is switched off while performing tasks that do not need electricity. Refer to GP 14. Disconnect the power cord. Electricity can cause death or injury. Moving parts can cause injury.

1. If a single occurrence, take no action.
2. For multiple occurrences, reinstall software, GP 4.

16-155-19 ESS Failed to Boot from Alternate Disk RAP

16-155-19 ESS failed to boot from alternate disk partition

Procedure

WARNING

Ensure that the electricity to the machine is switched off while performing tasks that do not need electricity. Refer to GP 14. Disconnect the power cord. Electricity can cause death or injury. Moving parts can cause injury.

1. If a single occurrence, take no action.
2. For multiple occurrences, reinstall software, GP 4.

16-156-19 Service Run Loop Failed RAP

16-156-19 Service run loop failed

Procedure

WARNING

Ensure that the electricity to the machine is switched off while performing tasks that do not need electricity. Refer to GP 14. Disconnect the power cord. Electricity can cause death or injury. Moving parts can cause injury.

1. If a single occurrence, switch off the machine, then switch on the machine, GP 14.
2. For multiple occurrences, reinstall software, GP 4.

16-160-09 ESS Reg Service Process Death RAP

16-160-09 ESS Registration Service Process Death

Procedure

WARNING

Ensure that the electricity to the machine is switched off while performing tasks that do not need electricity. Refer to GP 14. Disconnect the power cord. Electricity can cause death or injury. Moving parts can cause injury.

1. If a single occurrence, take no action.
2. For multiple occurrences, switch off the machine, then switch on the machine, GP 14.
3. If the fault remains, reinstall software, GP 4.

16-161-09, 16-164-09 Cannot Send Reg Event / List Access Failure RAP

16-161-09 Cannot send registration event

16-164-09 List access failure (create, add, find, delete)

Procedure

WARNING

Ensure that the electricity to the machine is switched off while performing tasks that do not need electricity. Refer to GP 14. Disconnect the power cord. Electricity can cause death or injury. Moving parts can cause injury.

1. Switch off the machine, then switch on the machine, GP 14.
2. If the fault remains, reinstall software, GP 4.

16-162-09 to 16-163-09 Cannot Send Reg Event / ESS Services Failure RAP

16-162-09 ESS platform manager services process death

16-163-09 ESS DM agent services process death

Procedure

WARNING

Ensure that the electricity to the machine is switched off while performing tasks that do not need electricity. Refer to GP 14. Disconnect the power cord. Electricity can cause death or injury. Moving parts can cause injury.

1. Switch off the machine, then switch on the machine, GP 14.
2. If the fault remains, reinstall software, GP 4.

16-429-00, 16-431-00 Unable to Write to Data Store / Get System Time RAP

16-429-00 Unable to write to data store

16-431-00 Unable to get system time

Procedure

WARNING

Ensure that the electricity to the machine is switched off while performing tasks that do not need electricity. Refer to GP 14. Disconnect the power cord. Electricity can cause death or injury. Moving parts can cause injury.

1. Switch off the machine, then switch on the machine, GP 14.
2. If the fault remains, reinstall software, GP 4.

16-432-00 Unknown Scheduler Received RAP

16-432-00 Unknown scheduler received

Procedure

WARNING

Ensure that the electricity to the machine is switched off while performing tasks that do not need electricity. Refer to GP 14. Disconnect the power cord. Electricity can cause death or injury. Moving parts can cause injury.

1. Switch off the machine, then switch on the machine, GP 14.
2. If the fault remains, reinstall software, GP 4.

16-433-00 RPC Call Failed RAP

16-433-00 RPC call failed

Procedure

WARNING

Ensure that the electricity to the machine is switched off while performing tasks that do not need electricity. Refer to GP 14. Disconnect the power cord. Electricity can cause death or injury. Moving parts can cause injury.

1. If a single occurrence, take no action.
2. For multiple occurrences, switch off the machine, then switch on the machine, GP 14.
3. If the fault remains, reinstall software, GP 4.

16-434-00 Unable to Change Scheduler RAP

16-434-00 Unable to change scheduler received

Procedure

WARNING

Ensure that the electricity to the machine is switched off while performing tasks that do not need electricity. Refer to GP 14. Disconnect the power cord. Electricity can cause death or injury. Moving parts can cause injury.

1. Switch off the machine, then switch on the machine, GP 14.
2. If the fault remains, reinstall software, GP 4.

16-600-07 to 16-600-67 Cannot Create RPC Connection RAP

16-600-07 Cannot create RPC connection to ENS

16-600-35 Cannot create RPC connection to ENS

16-600-46 Cannot create RPC connection to ENS

16-600-66 Unable to create RPC connection to ENS

16-600-67 Unable to create RPC connection to ENS

Procedure

WARNING

Ensure that the electricity to the machine is switched off while performing tasks that do not need electricity. Refer to GP 14. Disconnect the power cord. Electricity can cause death or injury. Moving parts can cause injury.

1. If a single occurrence, the network controller (ESS) will automatically re-boot.
2. For multiple occurrences, reinstall the software, GP 4.

16-601-26 to 16-601-46 Queue Setup / System Control Failed / Invalid UI Info RAP

16-601-26 Fault Service Failed IPC Queue Setup

16-601-35 System control initialization Failed

16-601-46 Invalid UI information (RPC data) returned

Procedure

WARNING

Ensure that the electricity to the machine is switched off while performing tasks that do not need electricity. Refer to GP 14. Disconnect the power cord. Electricity can cause death or injury. Moving parts can cause injury.

1. If a single occurrence, take no action.
2. For multiple occurrences, switch off the machine, then switch on the machine, GP 14.
3. If the fault remains, reinstall software, GP 4.

16-601-47 Diagnostics Service Failed IPC Queue Setup RAP

16-601-47 Diagnostics service failed IPC queue setup

Procedure

WARNING

Ensure that the electricity to the machine is switched off while performing tasks that do not need electricity. Refer to GP 14. Disconnect the power cord. Electricity can cause death or injury. Moving parts can cause injury.

1. Switch off the machine, then switch on the machine, GP 14.
2. If the fault remains, reinstall software, GP 4.

16-601-66, 16-601-67 Unable to Do Start Up Sync RAP

16-601-66 Unable to do start up synchronization

16-601-67 Unable to do start up synchronization

Procedure

WARNING

Ensure that the electricity to the machine is switched off while performing tasks that do not need electricity. Refer to GP 14. Disconnect the power cord. Electricity can cause death or injury. Moving parts can cause injury.

1. If a single occurrence switch off the machine, then switch on the machine, GP 14.
2. For multiple occurrences, reinstall software, GP 4.

16-601-68 Unable to Start Up and Sync RAP

16-601-68 Unable to start up & synchronize with SC

Procedure

WARNING

Ensure that the electricity to the machine is switched off while performing tasks that do not need electricity. Refer to GP 14. Disconnect the power cord. Electricity can cause death or injury. Moving parts can cause injury.

1. Switch off the machine, then switch on the machine, GP 14.
2. If the fault remains, reinstall software, GP 4.

16-601-105 Unable Synchronize At Start Up RAP

16-601-105 Unable to do start up synchronization

Procedure

WARNING

Ensure that the electricity to the machine is switched off while performing tasks that do not need electricity. Refer to GP 14. Disconnect the power cord. Electricity can cause death or injury. Moving parts can cause injury.

1. If a single occurrence, switch off the machine, then switch on the machine, GP 14.
2. For multiple occurrences, reinstall software, GP 4.

16-602-07 to 16-602-105 RPC Service Registration Failure RAP

16-602-07 RPC service registration failure

16-602-09 Unable to unregistered as RPC service during shutdown

16-602-11 RPC server register failed

16-602-28 RPC server registration failed

16-602-35 RPC server registration failed

16-602-38 RPC server registration failed

16-602-66 Unable to register as an RPC server

16-602-67 Unable to register as an RPC server

16-602-68 Unable to register as an RPC server

16-602-105 Unable to register as an RPC server

Procedure

WARNING

Ensure that the electricity to the machine is switched off while performing tasks that do not need electricity. Refer to GP 14. Disconnect the power cord. Electricity can cause death or injury. Moving parts can cause injury.

1. If a single occurrence, take no action.
2. For multiple occurrences, switch off the machine, then switch on the machine, GP 14.
3. If the fault remains, reinstall software, GP 4.

16-603-11, 16-603-28 Replace Handler Call Failed RAP

16-603-11 Replace handler call failed

16-603-28 Replace handler call failed

Procedure

WARNING

Ensure that the electricity to the machine is switched off while performing tasks that do not need electricity. Refer to GP 14. Disconnect the power cord. Electricity can cause death or injury. Moving parts can cause injury.

1. If a single occurrence, switch off the machine, then switch on the machine, GP 14.
2. For multiple occurrences, reinstall software, GP 4.

16-603-46 to 16-603-67 Too Many IPC Handlers RAP

16-603-46 Too many IPC handlers

16-603-66 Too many IPC handlers

16-603-67 Too many IPC handlers

Procedure

WARNING

Ensure that the electricity to the machine is switched off while performing tasks that do not need electricity. Refer to GP 14. Disconnect the power cord. Electricity can cause death or injury. Moving parts can cause injury.

1. If a single occurrence, take no action.
2. For multiple occurrences, switch off the machine, then switch on the machine, GP 14.
3. If the fault remains, reinstall software, GP 4.

16-603-68, 16-604-105 Replace Handler Call Failed / Data Store Variable Not Set RAP

16-603-68 Replace handler call failed

16-604-105 SESS data store environmental variable not set

Procedure

WARNING

Ensure that the electricity to the machine is switched off while performing tasks that do not need electricity. Refer to GP 14. Disconnect the power cord. Electricity can cause death or injury. Moving parts can cause injury.

1. If a single occurrence, switch off the machine, then switch on the machine, GP 14.
2. For multiple occurrences, reinstall software, GP 4.

16-603-105, 16-604-14 RPC Call Failure to NC Reg Service RAP

16-603-105 RPC call failure to network controller registration service.

16-604-14 Unable to unregister as RPC service during shutdown. Registration failed.

Procedure

WARNING

Ensure that the electricity to the machine is switched off while performing tasks that do not need electricity. Refer to GP 14. Disconnect the power cord. Electricity can cause death or injury. Moving parts can cause injury.

1. If a single occurrence, take no action.
2. For multiple occurrences, switch off the machine, then switch on the machine, GP 14.
3. If the fault remains, reinstall software, GP 4.

16-604-38 to 16-605-07 Could Not Register With Reg Service RAP

16-604-38 Could not register with registration service

16-604-99 Could not register with registration service

16-605-07 Unable to register with registration service

Procedure

WARNING

Ensure that the electricity to the machine is switched off while performing tasks that do not need electricity. Refer to GP 14. Disconnect the power cord. Electricity can cause death or injury. Moving parts can cause injury.

1. Switch off the machine, then switch on the machine, GP 14.
2. If the fault remains, reinstall software, GP 4.

16-605-14, 16-605-105 Unable to Unregister As RPC Service / RPC Call Failure RAP

16-605-14 RPC call failure to ESS registration service

16-605-105 Unable to unregister as RPC service during shutdown

Procedure

WARNING

Ensure that the electricity to the machine is switched off while performing tasks that do not need electricity. Refer to GP 14. Disconnect the power cord. Electricity can cause death or injury. Moving parts can cause injury.

1. If a single occurrence, take no action.
2. For multiple occurrences, switch off the machine, then switch on the machine, GP 14.
3. If the fault remains, reinstall software, GP 4.

16-605-26 Fault Service Timed Out Registering RAP

16-605-26 Fault service timed out registering with registration service

Procedure

WARNING

Ensure that the electricity to the machine is switched off while performing tasks that do not need electricity. Refer to GP 14. Disconnect the power cord. Electricity can cause death or injury. Moving parts can cause injury.

1. Switch off the machine, then switch on the machine, GP 14.
2. If the fault remains, reinstall software, GP 4.

16-605-35 to 16-605-67 RPC Call Failure to ESS RAP

16-605-35 RPC call failure to ESS registration service

16-605-47 RPC call failure to ESS registration service (to register with)

16-605-66 RPC call failure to ESS registration service

16-605-67 RPC call failure to ESS registration service

Procedure

WARNING

Ensure that the electricity to the machine is switched off while performing tasks that do not need electricity. Refer to GP 14. Disconnect the power cord. Electricity can cause death or injury. Moving parts can cause injury.

1. If a single occurrence, take no action.
2. For multiple occurrences, switch off the machine, then switch on the machine, GP 14.
3. If the fault remains, reinstall software, GP 4.

16-606-07 Cannot Register For Events RAP

16-606-07 Cannot register for events

Procedure

WARNING

Ensure that the electricity to the machine is switched off while performing tasks that do not need electricity. Refer to GP 14. Disconnect the power cord. Electricity can cause death or injury. Moving parts can cause injury.

1. Switch off the machine, then switch on the machine, GP 14.
2. If the fault remains, reinstall software, GP 4.

16-606-35 to 16-606-99 Cannot Register For Events RAP

16-606-35 Cannot register for events

16-606-46 Cannot register for events

16-606-99 Cannot register for events

Procedure

WARNING

Ensure that the electricity to the machine is switched off while performing tasks that do not need electricity. Refer to GP 14. Disconnect the power cord. Electricity can cause death or injury. Moving parts can cause injury.

1. Switch off the machine, then switch on the machine, GP 14.
2. If the fault remains, reinstall software, GP 4.

16-606-105 OS Problem RAP

16-606-105 OS problem

Procedure

WARNING

Ensure that the electricity to the machine is switched off while performing tasks that do not need electricity. Refer to GP 14. Disconnect the power cord. Electricity can cause death or injury. Moving parts can cause injury.

1. If a single occurrence, switch off the machine, then switch on the machine, GP 14.
2. For multiple occurrences, reinstall software, GP 4.

16-607-19 to 16-608-14 Invalid RPC Data / Unable to Free Resources RAP

16-607-19 Invalid RPC data received

16-607-46 Invalid RPC data received

16-607-47 Invalid RPC disk diagnostic data received

16-607-92 Invalid RPC data received

16-607-105 Service run loop failed

16-608-09 Unable to free IPC resources

16-608-11 IPC unregister failed

16-608-14 Unable to free IPC resources

Procedure

WARNING

Ensure that the electricity to the machine is switched off while performing tasks that do not need electricity. Refer to GP 14. Disconnect the power cord. Electricity can cause death or injury. Moving parts can cause injury.

1. If a single occurrence, take no action.
2. For multiple occurrences, switch off the machine, then switch on the machine, GP 14.
3. If the fault remains, reinstall software, GP 4.

16-608-26 Fault Service Failed to Unbind RAP

16-608-26 Fault service failed to unbind with SC

Procedure

WARNING

Ensure that the electricity to the machine is switched off while performing tasks that do not need electricity. Refer to GP 14. Disconnect the power cord. Electricity can cause death or injury. Moving parts can cause injury.

1. If a single occurrence, reinstall software, GP 4.
2. For multiple occurrences, first check the harness connections then if problem persists install a new HDD, PL 3.11 Item 2.

16-608-28 to 16-608-67 Unable to Free IPC Resources RAP

16-608-28 IPC unregister fail

16-608-35 Unable to free IPC resources

16-608-38 Unable to unregister as IPC server

16-608-46 Unable to free IPC resources

16-608-66 Unable to free IPC resources

16-608-67 Unable to free IPC resources

Procedure

WARNING

Ensure that the electricity to the machine is switched off while performing tasks that do not need electricity. Refer to GP 14. Disconnect the power cord. Electricity can cause death or injury. Moving parts can cause injury.

1. If a single occurrence, take no action.
2. For multiple occurrences, switch off the machine, then switch on the machine, GP 14.
3. If the fault remains, reinstall software, GP 4.

16-608-105 Unable Build UI SVC Obtain Client Failed RAP

16-608-105 Unable build UI SVC obtain client failed

Procedure

WARNING

Ensure that the electricity to the machine is switched off while performing tasks that do not need electricity. Refer to [GP 14](#). Disconnect the power cord. Electricity can cause death or injury. Moving parts can cause injury.

1. If a single occurrence, take no action.
2. For multiple occurrences, switch off the machine, then switch on the machine, [GP 14](#).
3. If the fault remains, reinstall software, [GP 4](#).

16-609-07 Unknown Message Received RAP

16-609-07 Unknown message received from DM agent

Procedure

WARNING

Ensure that the electricity to the machine is switched off while performing tasks that do not need electricity. Refer to [GP 14](#). Disconnect the power cord. Electricity can cause death or injury. Moving parts can cause injury.

1. If a single occurrence, reinstall software, [GP 4](#).
2. For multiple occurrences, first check the harness connections then if problem persists install a new HDD, [PL 3.11 Item 2](#).

16-609-19, 16-609-105 Too Many IPC Handlers / Invalid RPC Data RAP

16-609-19 Invalid RPC data received

16-609-105 Too many IPC handlers

Procedure

WARNING

Ensure that the electricity to the machine is switched off while performing tasks that do not need electricity. Refer to GP 14. Disconnect the power cord. Electricity can cause death or injury. Moving parts can cause injury.

1. If a single occurrence, take no action.
2. For multiple occurrences, switch off the machine, then switch on the machine, GP 14.
3. If the fault remains, reinstall software, GP 4.

16-609-26 Fault Service Encountered Error RAP

16-609-26 Fault service encountered error trying to get IPC message

Procedure

WARNING

Ensure that the electricity to the machine is switched off while performing tasks that do not need electricity. Refer to GP 14. Disconnect the power cord. Electricity can cause death or injury. Moving parts can cause injury.

1. If a single occurrence, reinstall software, GP 4.
2. For multiple occurrences, first check the harness connections then if problem persists install a new HDD, PL 3.11 Item 2.

16-609-46 to 16-609-92 Invalid IPC Data Received RAP

16-609-46 Invalid IPC data received

16-609-47 Invalid IPC data received. Get SC diagnostics handle failed;

16-609-92 Invalid IPC data received

Procedure

WARNING

Ensure that the electricity to the machine is switched off while performing tasks that do not need electricity. Refer to GP 14. Disconnect the power cord. Electricity can cause death or injury. Moving parts can cause injury.

1. If a single occurrence, take no action.
2. For multiple occurrences, switch off the machine, then switch on the machine, GP 14.
3. If the fault remains, reinstall software, GP 4.

16-610-00, 16-610-07 IPC Send Failure RAP

16-610-00 IPC send failure to ESS triple A service for queue command authorization

16-610-07 IPC send failure to DM agent

Procedure

WARNING

Ensure that the electricity to the machine is switched off while performing tasks that do not need electricity. Refer to GP 14. Disconnect the power cord. Electricity can cause death or injury. Moving parts can cause injury.

1. If a single occurrence, take no action.
2. For multiple occurrences, switch off the machine, then switch on the machine, GP 14.
3. If the fault remains, reinstall software, GP 4.

16-610-09 Cannot Send IPC Message RAP

16-610-09 Cannot send IPC message to ESS platform manage

Procedure

WARNING

Ensure that the electricity to the machine is switched off while performing tasks that do not need electricity. Refer to GP 14. Disconnect the power cord. Electricity can cause death or injury. Moving parts can cause injury.

1. Switch off the machine, then switch on the machine, GP 14.
2. If the fault remains, reinstall software, GP 4.

16-610-11 to 16-610-90 Unable to Send IPC Message RAP

16-610-11 IPC communication failed

16-610-19 Unable to send IPC message

16-610-26 Unable to send IPC message

16-610-28 IPC communication failed

16-610-35 Unable to send IPC message

16-610-46 Unable to send IPC message

16-610-90 IPC send response error

Procedure

WARNING

Ensure that the electricity to the machine is switched off while performing tasks that do not need electricity. Refer to GP 14. Disconnect the power cord. Electricity can cause death or injury. Moving parts can cause injury.

1. If a single occurrence, take no action.
2. For multiple occurrences, switch off the machine, then switch on the machine, GP 14.
3. If the fault remains, reinstall software, GP 4.

16-610-92 Failure to Send Queue Status RAP

16-610-92 Failure to send queue status

Procedure

WARNING

Ensure that the electricity to the machine is switched off while performing tasks that do not need electricity. Refer to **GP 14**. Disconnect the power cord. Electricity can cause death or injury. Moving parts can cause injury.

1. Switch off the machine, then switch on the machine, **GP 14**.
2. If the fault remains, reinstall software, **GP 4**.

16-610-99 Unable to Send IPC Message RAP

16-610-99 Unable to send IPC message

Procedure

WARNING

Ensure that the electricity to the machine is switched off while performing tasks that do not need electricity. Refer to **GP 14**. Disconnect the power cord. Electricity can cause death or injury. Moving parts can cause injury.

1. If a single occurrence, take no action.
2. For multiple occurrences, switch off the machine, then switch on the machine, **GP 14**.
3. If the fault remains, reinstall software, **GP 4**.

16-611-07, 16-611-38 Client Removal Failed RAP

16-611-07 Client removal failure

16-611-38 Client removal failure

Procedure

WARNING

Ensure that the electricity to the machine is switched off while performing tasks that do not need electricity. Refer to GP 14. Disconnect the power cord. Electricity can cause death or injury. Moving parts can cause injury.

1. If a single occurrence, take no action.
2. For multiple occurrences, switch off the machine, then switch on the machine, GP 14.
3. If the fault remains, reinstall software, GP 4.

16-611-19 to 16-611-47 Unable to Remove RPC Connection RAP

16-611-09 Unable to remove RPC connection

16-611-14 Unable to remove RPC connection

16-611-19 Unable to remove RPC connection

16-611-26 Unable to remove RPC connection

16-611-46 Unable to remove RPC connection

16-611-47 Unable to remove RPC connection

Procedure

WARNING

Ensure that the electricity to the machine is switched off while performing tasks that do not need electricity. Refer to GP 14. Disconnect the power cord. Electricity can cause death or injury. Moving parts can cause injury.

1. If a single occurrence, take no action.
2. For multiple occurrences, switch off the machine, then switch on the machine, GP 14.
3. If the fault remains, reinstall software, GP 4.

16-611-66 to 16-611-99 Unable to Remove RPC Connection RAP

16-611-66 Unable to remove RPC connection

16-611-67 Unable to remove RPC connection

16-611-99 Unable to remove RPC connection

Procedure

WARNING

Ensure that the electricity to the machine is switched off while performing tasks that do not need electricity. Refer to GP 14. Disconnect the power cord. Electricity can cause death or injury. Moving parts can cause injury.

1. If a single occurrence, take no action.
2. For multiple occurrences, switch off the machine, then switch on the machine, GP 14.
3. If the fault remains, reinstall software, GP 4.

16-612-09 to 16-612-68 Unable to Do Shutdown Sync RAP

16-612-09 Unable to do shutdown synchronization

16-612-14 Unable to do shutdown synchronization

16-612-35 Unable to do shutdown synchronization

16-612-46 Unable to do shutdown synchronization

16-612-47 Downgrade not permitted

16-612-68 Unable to do shutdown synchronization

Procedure

WARNING

Ensure that the electricity to the machine is switched off while performing tasks that do not need electricity. Refer to GP 14. Disconnect the power cord. Electricity can cause death or injury. Moving parts can cause injury.

1. If a single occurrence, take no action.
2. For multiple occurrences, switch off the machine, then switch on the machine, GP 14.
3. If the fault remains, reinstall software, GP 4.

16-613-09 to 16-614-19 DC Sync / Comms Error RAP

16-613-09 DC registration synchronization error

16-613-14 DC ENS synchronization error

16-613-19 DC sys mgr sync error

16-614-09 DC registration communications error

16-614-14 Digital copier ENS registration error

16-614-19 DC sys mgr communications error

Procedure

WARNING

Ensure that the electricity to the machine is switched off while performing tasks that do not need electricity. Refer to GP 14. Disconnect the power cord. Electricity can cause death or injury. Moving parts can cause injury.

1. Switch off the machine, then switch on the machine, GP 14.
2. If the fault remains, reinstall software, GP 4.

16-614-47 Invalid Software Upgrade RAP

16-614-47 Invalid SW upgrade file

Procedure

WARNING

Ensure that the electricity to the machine is switched off while performing tasks that do not need electricity. Refer to GP 14. Disconnect the power cord. Electricity can cause death or injury. Moving parts can cause injury.

1. Verify that the correct software file is being used, refer to GP 4.

16-615-35, 16-615-46 Data Store Variable Not Set RAP

16-615-35 SESS data store environmental variable not set

16-615-46 SESS data store environmental variable not set

Procedure

WARNING

Ensure that the electricity to the machine is switched off while performing tasks that do not need electricity. Refer to GP 14. Disconnect the power cord. Electricity can cause death or injury. Moving parts can cause injury.

1. If a single occurrence, switch off the machine, then switch on the machine, GP 14.
2. For multiple occurrences, reinstall software, GP 4.

16-615-47 Multiple Software Upgrade File RAP

16-615-47 Multiple SW upgrade files in directory

Procedure

WARNING

Ensure that the electricity to the machine is switched off while performing tasks that do not need electricity. Refer to GP 14. Disconnect the power cord. Electricity can cause death or injury. Moving parts can cause injury.

1. Ensure that there is only one software upgrade file in the directory, refer to GP 4.

16-615-66 Data Store Variable Not Set RAP

16-615-66 SESS data store environmental variable not set

Procedure

WARNING

Ensure that the electricity to the machine is switched off while performing tasks that do not need electricity. Refer to GP 14. Disconnect the power cord. Electricity can cause death or injury. Moving parts can cause injury.

1. If a single occurrence, switch off the machine, then switch on the machine, GP 14.
2. For multiple occurrences, reinstall software, GP 4.

16-615-67, 16-615-90, 16-616-38, 16-616-46 SESS Data Store Environmental Variable RAP

16-615-67 SESS data store environmental variable not set.

16-615-90 Corrupt environment variable, configuration script error.

16-616-35 SESS Faults 206 or 207. Data store not created. Corrupt environment.

16-616-38 Shared memory fault when initializing with the data store.

16-616-46 SESS Faults 206 or 207, data store not created, corrupt environment variable.

Procedure

WARNING

Ensure that the electricity to the machine is switched off while performing tasks that do not need electricity. Refer to GP 14. Disconnect the power cord. Electricity can cause death or injury. Moving parts can cause injury.

1. For a single occurrence, take no action.
2. For multiple occurrences switch off the machine, then switch on the machine, GP 14.
3. If the fault remains, reinstall the software, GP 4.

16-616-47 IPC Message Failure RAP

16-616-47 IPC message failure.

Procedure

WARNING

Ensure that the electricity to the machine is switched off while performing tasks that do not need electricity. Refer to GP 14. Disconnect the power cord. Electricity can cause death or injury. Moving parts can cause injury.

1. For a single occurrence, take no action.
2. For multiple occurrences switch off the machine, then switch on the machine, GP 14.
3. If the fault remains, reinstall the software, GP 4.

16-616-67 Submission Of E-mail OR IFax Job Failed RAP

16-616-67 Submission of e-mail or IFax job failed.

Procedure

WARNING

Ensure that the electricity to the machine is switched off while performing tasks that do not need electricity. Refer to GP 14. Disconnect the power cord. Electricity can cause death or injury. Moving parts can cause injury.

1. For a single occurrence, take no action.
2. For multiple occurrences switch off the machine, then switch on the machine, GP 14.
3. If the fault remains, reinstall the software, GP 4.

16-617-19 RPC Information Corrupt RAP

16-617-19 Invalid event information or data. ENS failure, system RPC information corrupt.

Procedure

WARNING

Ensure that the electricity to the machine is switched off while performing tasks that do not need electricity. Refer to GP 14. Disconnect the power cord. Electricity can cause death or injury. Moving parts can cause injury.

1. For a single occurrence, switch off the machine, then switch on the machine, GP 14.
2. For multiple occurrences, reinstall software, GP 4.

16-617-47 TAR Extraction Failure RAP

16-617-47 TAR extraction failure

Procedure

WARNING

Ensure that the electricity to the machine is switched off while performing tasks that do not need electricity. Refer to GP 14. Disconnect the power cord. Electricity can cause death or injury. Moving parts can cause injury.

1. For a single occurrence, switch off the machine, then switch on the machine, GP 14.
2. For multiple occurrences, reinstall software, GP 4.

16-618-47 DLM SPI Extraction Failure RAP

16-618-47 DLM SPI Extraction failure

Procedure

WARNING

Ensure that the electricity to the machine is switched off while performing tasks that do not need electricity. Refer to GP 14. Disconnect the power cord. Electricity can cause death or injury. Moving parts can cause injury.

1. For a single occurrence, switch off the machine, then switch on the machine, GP 14.
2. For a multiple occurrence, reinstall software, GP 4.

16-619-14 to 16-619-93 Cannot Unregister From Registration Service RAP

16-619-14 Registration service failed to respond in time.

16-619-19 Registration service failed to respond in time.

16-619-26 Could not register with Registration Service. Communication failure, software error.

16-619-46 Unable to unregister with Network Controller Registration Service. Registration Service was too slow to respond.

16-619-47 DMPR Failure at web.

16-619-68 Unable to unregister with Network Controller Registration Service. Registration Service was too slow to respond.

16-619-93 Unable to unregister with Network Controller Registration Service. Registration Service was too slow to respond.

Procedure

WARNING

Ensure that the electricity to the machine is switched off while performing tasks that do not need electricity. Refer to GP 14. Disconnect the power cord. Electricity can cause death or injury. Moving parts can cause injury.

1. For a single occurrence, switch off the machine, then switch on the machine, GP 14.
2. For a multiple occurrence, reinstall software, GP 4.

16-620-07 to 16-620-90 Registration Service Failed RAP

16-620-07 Registration Service failed.

16-620-14 Registration Service failed.

16-620-19 Registration Service failed.

16-620-35 Registration Service failed.

16-620-38 Registration Service failed.

16-620-46 Registration Service failed.

16-620-47 Upgrade request rejected.

16-620-90 Registration Service failed.

Procedure

WARNING

Ensure that the electricity to the machine is switched off while performing tasks that do not need electricity. Refer to GP 14. Disconnect the power cord. Electricity can cause death or injury. Moving parts can cause injury.

1. For a single occurrence, switch off the machine, then switch on the machine, GP 14.
2. For a multiple occurrence, reinstall software, GP 4.

16-620-92, 16-620-93, 16-620-99 Unable to Register With Network Controller Registration Service RAP

16-620-92 Unable to unregister with network controller registration service due to registration service failure.

16-620-93 Unable to unregister with network controller registration service due to registration service failure.

16-620-99 Registration Service failed.

Procedure

WARNING

Ensure that the electricity to the machine is switched off while performing tasks that do not need electricity. Refer to GP 14. Disconnect the power cord. Electricity can cause death or injury. Moving parts can cause injury.

1. For a single occurrence, switch off the machine, then switch on the machine, GP 14.
2. For a multiple occurrence, reinstall software, GP 4.

16-621-00, 16-621-07, 16-621-11, 16-621-28, 16-621-35, 16-621-38, 16-621-47, 16-621-66, 16-621-67, 16-621-93, 16-621-99 Unable to Obtain Host Name RAP

16-621-00 Unable to get host name. Configuration error.

16-621-07 Unable to get host name. Configuration error.

16-621-11 Unable to get host name. Configuration error.

16-621-28 Unable to get host name. Configuration error.

16-621-35 Failed to get host name using GetHostName call.

16-621-38 Failed to get host name using GetHostName call.

16-621-47 Failed to get host name using GetHostName call.

16-621-66 Unable to get host name.

16-621-67 Unable to get host name.

16-621-93 Failed to get host name using GetHostName call.

16-621-99 Failed to get host name using GetHostName call.

Procedure

WARNING

Ensure that the electricity to the machine is switched off while performing tasks that do not need electricity. Refer to GP 14. Disconnect the power cord. Electricity can cause death or injury. Moving parts can cause injury.

1. For single occurrence, switch on the machine, then switch off the machine, GP 14.
2. For multiple occurrence, reinstall software, GP 4.

16-622-07, 16-622-09, 16-622-11, 16-622-14, 16-622-19, 16-622-26, 16-622-28, 16-622-35, 16-622-38, 16-622-46, 16-622-47 Corrupt RPC Table RAP

16-622-07 Corrupt O/S RPC table.

16-622-09 Corrupt O/S table.

16-622-11 Corruptly O/S table.

16-622-14 Corruptly O/S table.

16-622-19 Corruptly O/S table.

16-622-26 Corruptly O/S table.

16-622-28 Corruptly O/S table.

16-622-35 Corruptly O/S table.

16-622-38 Corruptly O/S table.

16-622-46 Corruptly O/S table.

16-622-47 Software upgrade file failure.

Procedure

WARNING

Ensure that the electricity to the machine is switched off while performing tasks that do not need electricity. Refer to GP 14. Disconnect the power cord. Electricity can cause death or injury. Moving parts can cause injury.

1. For single occurrence, switch on the machine, then off the machine, GP 14.
2. For multiple occurrence, reinstall software, GP 4.

16-622-66, 16-622-67, 16-622-68 Unable to Register RPC Service RAP

16-622-66 Unable to unregister as RPC service during shutdown.

16-622-67 Unable to register as RPC service during shutdown.

16-622-68 Unable to register as RPC service during shutdown.

Procedure

WARNING

Ensure that the electricity to the machine is switched off while performing tasks that do not need electricity. Refer to GP 14. Disconnect the power cord. Electricity can cause death or injury. Moving parts can cause injury.

1. For a single occurrence, switch off the machine, then switch on the machine, GP 14.
2. For multiple occurrences, reinstall software, GP 4.

16-623-35, 16-623-47, 16-624-46 ENS Service Failed to Respond In Time RAP

16-623-35 ENS Service failed to respond in time.

16-623-47 ENS service failed to respond in time.

16-624-46 RPC corrupted o/s failure.

Procedure

WARNING

Ensure that the electricity to the machine is switched off while performing tasks that do not need electricity. Refer to GP 14. Disconnect the power cord. Electricity can cause death or injury. Moving parts can cause injury.

1. For a single occurrences, switch off the machine, then switch on the machine, GP 14.
2. For multiple occurrences, reinstall software, GP 4.

16-625-35, 16-625-46, 16-625-66, 16-625-67, 16-625-90 Invalid IPC Type RAP

16-625-35 Unknown message received. Software version mismatch.

16-625-46 Software version mismatch.

16-625-66 Invalid IPC message type.

16-625-67 Invalid IPC message type.

16-625-90 Known service sends message that does not make sense.

Procedure

WARNING

Ensure that the electricity to the machine is switched off while performing tasks that do not need electricity. Refer to GP 14. Disconnect the power cord. Electricity can cause death or injury. Moving parts can cause injury.

1. For a single occurrence, switch off the machine, then switch on the machine, GP 14.
2. For multiple occurrences, reinstall software, GP 4.

16-626-00, 16-626-11, 16-626-38, 16-626-47, 16-626-67 Memory Leak RAP

16-626-00 Memory leak, software bug memory corrupt. Virtual memory exhausted. Process size exceeding system limits.

16-626-11 Memory leak, software bug memory corrupt. Virtual memory exhausted. Process size exceeding system limits.

16-626-38 Memory leak, software bug memory corrupt. Virtual memory exhausted. Process size exceeding system limits.

16-626-47 Memory leak, software bug memory corrupt. Virtual memory exhausted. Process size exceeding system limits.

16-626-67 Memory allocation failed.

Procedure

WARNING

Ensure that the electricity to the machine is switched off while performing tasks that do not need electricity. Refer to GP 14. Disconnect the power cord. Electricity can cause death or injury. Moving parts can cause injury.

1. For a single occurrence, switch off the machine, then switch on the machine, GP 14.
2. For multiple occurrences, reinstall software, GP 4.

16-628-07, 16-628-35, 16-628-46, 16-628-66, 16-628-67 Range Environment Variable RAP

16-628-07 Range environment variable not set. Set to invalid numeric string.

16-628-35 Range environment variable not set. Set to invalid numeric string.

16-628-46 Range environment variable not set. Set to invalid numeric string.

16-628-66 Range environment variable not set. Set to invalid numeric string.

16-628-67 Range environment variable not set. Set to invalid numeric string.

Procedure

WARNING

Ensure that the electricity to the machine is switched off while performing tasks that do not need electricity. Refer to GP 14. Disconnect the power cord. Electricity can cause death or injury. Moving parts can cause injury.

1. For a single occurrence, switch off the machine, then switch on the machine, GP 14.
2. For multiple occurrences, reinstall software, GP 4.

16-628-09, 16-629-11, 16-629-26, 16-629-46, 16-629-67, 16-629-68, 16-629-92, 16-629-93 No Acknowledgment For RPC Message RAP

16-628-09 Unable to complete RPC call.

16-629-11 Fault service call to PSW callback failed.

16-629-26 Fault service call to PSW callback failed.

16-629-46 No acknowledgment for RPC message.

16-629-67 No acknowledgment for RPC message.

16-629-68 No acknowledgment for RPC message.

16-629-92 No acknowledgment for RPC message. RPC time out calling program received void response due to corrupt RPC.

16-629-93 No acknowledgment for RPC message. RPC time out calling program received void response due to corrupt RPC.

Procedure

WARNING

Ensure that the electricity to the machine is switched off while performing tasks that do not need electricity. Refer to GP 14. Disconnect the power cord. Electricity can cause death or injury. Moving parts can cause injury.

1. For a single occurrence, switch off the machine, then switch on the machine, GP 14.
2. For multiple occurrences, reinstall software, GP 4.

16-630-09, 16-630-26, 16-630-35, 16-630-38, 16-630-46, 16-630-47, 16-630-66, 16-630-67, 16-630-68, 16-630-99 Corrupt RPC RAP

16-630-09 Corrupt O/S RPC table.

16-630-26 Corrupt system configuration.

16-630-35 Unable to get RPC client handle. Corrupt system configuration.

16-630-38 Null pointer returned when obtain client attempted.

16-630-46 Corrupt system configuration.

16-630-47 Corrupt system configuration.

16-630-66 Unable to get RPC client handle.

16-630-67 Unable to get RPC client handle.

16-630-68 Unable to get RPC client handle.

16-630-99 Corrupt system configuration.

Procedure

WARNING

Ensure that the electricity to the machine is switched off while performing tasks that do not need electricity. Refer to GP 14. Disconnect the power cord. Electricity can cause death or injury. Moving parts can cause injury.

1. For a single occurrence, switch off the machine, then switch on the machine, GP 14.
2. For multiple occurrences, reinstall software, GP 4.

16-631-19, 16-631-46, 16-631-19, 16-633-19, 16-634-46, 16-635-07, 16-635-35, 16-635-46, 16-635-99-16-636-35, 16-636-99 XDR Data Error RAP

16-631-19 Software error in the ENS service or in the service generating the fault.

16-631-46 Software error in the ENS or in the service generating the fault.

16-633-19 Invalid system configuration. NVM corrupted.

16-634-46 Unable to specify shutdown routine during initialization.

16-635-07 Cannot free XDR data.

16-635-35 Cannot free XDR data.

16-635-46 Unable to free XDR data.

16-635-99 Unable to convert serialized data to internal data structure.

16-636-35 Unable to convert serialized data to internal data structure. Unable to free XDR data.

16-636-99 Unable to convert serialized data to internal structure. Unable to free XDR data.

Procedure

WARNING

Ensure that the electricity to the machine is switched off while performing tasks that do not need electricity. Refer to GP 14. Disconnect the power cord. Electricity can cause death or injury. Moving parts can cause injury.

1. For a single occurrence, switch off the machine, then switch on the machine, GP 14.
2. For multiple occurrences, reinstall software, GP 4.

16-637-11, 16-637-26, 16-637-38, 16-637-47, 16-637-66, 16-637-67, 16-637-93, 16-637-95 File Error RAP

16-637-11 Failed to open system jobs file.

16-637-26 Failed to open system jobs file.

16-637-38 Disk write error.

16-637-47 Failed to open a file. Bad disk.

16-637-66 File I/O error.

16-637-67 File I/O error.

16-637-93 File I/O error.

16-637-95 File I/O error.

Procedure

WARNING

Ensure that the electricity to the machine is switched off while performing tasks that do not need electricity. Refer to GP 14. Disconnect the power cord. Electricity can cause death or injury. Moving parts can cause injury.

1. For a single occurrence, switch off the machine, then switch on the machine, GP 14.
2. For multiple occurrences, reinstall software, GP 4.

16-638-66, 16-638-67, 16-639-38, 16-639-46, 16-640-28, 16-640-35, 16-640-46, 16-641-00, 16-641-26, 16-641-46 O/S Failure RAP

16-638-66 Unable to initialize with queue library.

16-638-67 Unable to initialize with queue library.

16-639-38 O/S failure memory.

16-639-46 O/S failure memory.

16-640-28 Calling program received void.

16-640-35 RPC send corrupt.

16-640-46 O/S failure.

16-641-00 Cannot log fault to network controller fault log. Either registration or network controller fault service is not available.

16-641-26 Unable to log a fault on the network controller.

16-641-46 Cannot log fault to network controller fault service.

Procedure

WARNING

Ensure that the electricity to the machine is switched off while performing tasks that do not need electricity. Refer to GP 14. Disconnect the power cord. Electricity can cause death or injury. Moving parts can cause injury.

1. For a single occurrence, switch off the machine, then switch on the machine, GP 14.
2. For multiple occurrences, reinstall software, GP 4.

16-642-46, 16-642-47, 16-643-19, 16-643-26, 16-643-47, 16-644-11 Unable To Close File RAP

16-642-46 Software error.

16-642-47 Software error.

16-643-19 Disk write error.

16-643-26 Failed to close system jobs file.

16-643-47 Failed to close a file.

Procedure

WARNING

Ensure that the electricity to the machine is switched off while performing tasks that do not need electricity. Refer to GP 14. Disconnect the power cord. Electricity can cause death or injury. Moving parts can cause injury.

1. For a single occurrence, switch off the machine, then switch on the machine, GP 14.
2. For multiple occurrences, reinstall software, GP 4.

16-644-11, 16-644-26, 16-644-46, 16-644-47, 16-644-66, 16-644-67, 16-645-11, 16-645-26, 16-645-46, 16-645-47, 16-645-66, 16-645-67 Unable To Read From File RAP

16-644-11 Common logging utility failed to get log size.

16-644-26 Common logging utility failed to get log size.

16-644-47 Failed while trying to get data for next process to be verified.

16-644-66 File I/O error.

16-644-67 File I/O error.

16-645-11 Failed write to system jobs file.

16-645-26 Failed write to system jobs file.

16-645-46 Failed to write to a file.

16-645-47 Failed to write to a file.

16-645-66 File I/O error.

16-645-67 File I/O error.

Procedure

WARNING

Ensure that the electricity to the machine is switched off while performing tasks that do not need electricity. Refer to GP 14. Disconnect the power cord. Electricity can cause death or injury. Moving parts can cause injury.

1. For a single occurrence, switch off the machine, then switch on the machine, GP 14.
2. For multiple occurrences, reinstall software GP 4.

16-646-26, 16-647-19, 16-647-26, 16-649-35, 16-650-35, 16-650-99 Invalid Service Attribute RAP

16-646-26 Failed to delete system jobs file.

16-647-19 Lynx OS not responding

16-647-26 Diagnostic failure, O/S failure.

16-649-35 Software error.

16-650-35 Service making invalid attribute request.

16-650-99 Service making invalid attribute request.

Procedure

WARNING

Ensure that the electricity to the machine is switched off while performing tasks that do not need electricity. Refer to GP 14. Disconnect the power cord. Electricity can cause death or injury. Moving parts can cause injury.

1. For a single occurrence, switch off the machine, then switch on the machine, GP 14.
2. For multiple occurrences, reinstall software, GP 4.

16-651-19, 16-651-35, 16-651-99, 16-652-38, 16-652-99, 16-653-38, 16-654-38, 16-654-99, 16-655-38, 16-656-38 Register Failure RAP

16-651-19 IPC, OS, SESS or SC operation.

16-651-35 IPC and OS failure. SESS not responding.

16-651-99 IPC and OS failure. SESS not responding.

16-652-38 SPI enroll failed. Unable to enroll SPI callbacks.

16-652-98 SPI enroll failed. Unable to enroll SPI callbacks.

16-652-99 SPI enroll failed. Unable to enroll SPI callbacks.

16-653-38 When DM passes completed job logged an invalid job.

16-654-38 DM returned from SPI register function because of error.

16-654-99 DM returned from log function because of error.

16-655-38 DM returned to SPI register function because of error.

16-656-38 RPC processing fault.

Procedure

WARNING

Ensure that the electricity to the machine is switched off while performing tasks that do not need electricity. Refer to GP 14. Disconnect the power cord. Electricity can cause death or injury. Moving parts can cause injury.

1. For a single occurrence, switch off the machine, then switch on the machine, GP 14.
2. For multiple occurrences, reinstall software, GP 4.

16-658-07, 16-659-11, 16-659-28, 16-659-93, 16-659-95, 16-660-95, 16-660-99, 16-661-95 Parser Utility Open Failure RAP

16-658-07 Unable to get host name. Configuration error.

16-659-11 Parser utility open failure.

16-659-28 Parser utility open failure.

16-659-93 Parser utility open failure.

16-659-95 Parser utility open failure.

16-660-95 Cannot read local directory entries.

16-660-99 Service initialization failed.

16-661-95 Cannot create spool directory.

Procedure

WARNING

Ensure that the electricity to the machine is switched off while performing tasks that do not need electricity. Refer to GP 14. Disconnect the power cord. Electricity can cause death or injury. Moving parts can cause injury.

1. For a single occurrence, switch off the machine, then switch on the machine, GP 14.
2. For multiple occurrences, reinstall software, GP 4.

16-662-11, 16-662-28, 16-662-93, 16-662-95, 16-663-28, 16-663-93, 16-663-95 Parser Utility Template Failed To Parse RAP

16-662-11 Parser utility template failed to parse.

16-662-28 Parser utility template failed to parse.

16-662-93 Parser utility template failed to parse.

16-662-95 Parser utility template failed to parse.

16-663-11 Parser utility template failed to parse.

16-663-28 Parser utility template failed to parse.

16-663-93 Parser utility template failed to parse.

16-663-95 Parser utility template failed to parse.

Procedure

WARNING

Ensure that the electricity to the machine is switched off while performing tasks that do not need electricity. Refer to GP 14. Disconnect the power cord. Electricity can cause death or injury. Moving parts can cause injury.

1. For a single occurrence, switch off the machine, then switch on the machine, GP 14.
2. For multiple occurrences, reinstall software, GP 4.

16-664-11, 16-664-28, 16-664-93, 16-664-95, 16-665-95 Parser Utility Closing Failure RAP

16-664-11 Parser utility parser closing failed.

16-664-28 Parser utility parser closing failed.

16-664-93 Parser utility parser closing failed.

16-664-95 Parser utility parser closing failed.

16-665-95 Unable to detach from child thread.

Procedure

WARNING

Ensure that the electricity to the machine is switched off while performing tasks that do not need electricity. Refer to GP 14. Disconnect the power cord. Electricity can cause death or injury. Moving parts can cause injury.

1. For a single occurrence, switch off the machine, then switch on the machine, GP 14.
2. For multiple occurrences, reinstall software, GP 4.

16-666-11, 16-666-28, 16-666-93, 16-666-95 Parser Utility Invocation Failed RAP

16-666-11 Parser utility invocation failed.

16-666-28 Parser utility invocation failed.

16-666-93 Parser utility invocation failed.

16-666-95 Parser utility invocation failed.

Procedure

WARNING

Ensure that the electricity to the machine is switched off while performing tasks that do not need electricity. Refer to GP 14. Disconnect the power cord. Electricity can cause death or injury. Moving parts can cause injury.

1. For a single occurrence, switch off the machine, then switch on the machine, GP 14.
2. For multiple occurrences, reinstall software, GP 4.

16-667-11, 16-667-28, 16-667-95, 16-668-47 Parser Utility Set Status Failure RAP

16-667-11 Parser utility set status failed.

16-667-28 Parser utility set status failed.

16-667-95 Parser utility set status failed.

16-668-47 Failed to write NVM.

Procedure

WARNING

Ensure that the electricity to the machine is switched off while performing tasks that do not need electricity. Refer to GP 14. Disconnect the power cord. Electricity can cause death or injury. Moving parts can cause injury.

1. For a single occurrence, switch off the machine, then switch on the machine, GP 14.
2. For multiple occurrences, reinstall software, GP 4.

16-668-93, 16-668-95 Unable To Determine Local File Statistics RAP

16-668-93 Unable to determine local file statistics.

16-668-95 Unable to determine local file statistics.

Procedure

WARNING

Ensure that the electricity to the machine is switched off while performing tasks that do not need electricity. Refer to GP 14. Disconnect the power cord. Electricity can cause death or injury. Moving parts can cause injury.

1. For a single occurrence, switch off the machine, then switch on the machine, GP 14.
2. For multiple occurrences, reinstall software, GP 4.

16-669-28, 16-669-93, 16-669-95, 16-670-00 Unable To Write Job Template RAP

16-669-28 Unable to write job template to network controller disk.

16-669-93 Unable to write job template to network controller disk.

16-669-95 Unable to write job template to network controller disk.

16-670-00 Unable to lock/unlock data store.

Procedure

WARNING

Ensure that the electricity to the machine is switched off while performing tasks that do not need electricity. Refer to GP 14. Disconnect the power cord. Electricity can cause death or injury. Moving parts can cause injury.

1. For a single occurrence, switch off the machine, then switch on the machine, GP 14.
2. For multiple occurrences, reinstall software, GP 4.

16-670-11, 16-670-28, 16-670-47, 16-670-93, 16-671-00, 16-671-47 Unable To Decode Template File RAP

16-670-11 Unable to decode template file.

16-670-28 Unable to decode template file.

16-670-47 Failed to save NVM.

16-670-93 Unable to decode template file.

16-671-00 Sort jobs failed.

16-671-47 Failed to initialize NVM.

Procedure

WARNING

Ensure that the electricity to the machine is switched off while performing tasks that do not need electricity. Refer to GP 14. Disconnect the power cord. Electricity can cause death or injury. Moving parts can cause injury.

1. For a single occurrence, switch off the machine, then switch on the machine GP 14.
2. For multiple occurrences, reinstall software, GP 4.

16-617-93, 16-671-95, 16-672-09, 16-672-95, 16-673-95, 16-674-00, 16-674-09, 16-675-00, 16-6700-00, 16-700-35 File Error RAP

16-671-93 Unable to encode template file.

16-671-95 Unable to encode template file.

16-672-09 Software error. File system corruption.

16-672-95 Software error. File system corruption.

16-673-95 Software error. File system corruption.

16-674-00 RPC server not responding.

Procedure

WARNING

Ensure that the electricity to the machine is switched off while performing tasks that do not need electricity. Refer to GP 14. Disconnect the power cord. Electricity can cause death or injury. Moving parts can cause injury.

1. For a single occurrence, switch off the machine, then switch on the machine, GP 14.
2. For multiple occurrences, reinstall software, GP 4.

16-674-09, 16-675-00, 16-700-00, 16-701-00, 16-701-99, 16-702-00, 16-702-95, 16-707-00, 16-709-00 XSA Database Failure RAP

16-674-09 RPC server not responding.

16-675-00 Database server not responding.

16-700-00 In a list job request, an unknown attribute was requested.

16-700-35 Unknown attribute requested passes into a function.

16-701-00 LOA failure. Unable to communicate with XSA database.

16-701-99 LOA failure. Unable to communicate with XSA database.

16-702-00 LOA failure. Unable to communicate with XSA database.

16-702-95 LOA failure. Unable to communicate with XSA database.

16-707-00 Unknown queue request received.

16-709-00 Unknown modify request received.

Procedure

WARNING

Ensure that the electricity to the machine is switched off while performing tasks that do not need electricity. Refer to GP 14. Disconnect the power cord. Electricity can cause death or injury. Moving parts can cause injury.

1. For a single occurrence, switch off the machine, then switch on the machine, GP 14.
2. For multiple occurrences, reinstall software, GP 4.

16-710-00, 16-710-35, 16-716-00, 16-728-00, 16-730-00, 16-730-28, 16-730-35, 16-730-66, 16-740-19, 16-750-07, 16-750-09, 16-750-11 Unable To Create Client Handle RAP

16-710-00 Service being communicated to is dead. System resource corrupted.

16-710-35 Service trying to communicate to is dead. System resources corrupted.

16-716-00 Data store not created. Corrupt environment variable.

16-728-00 Range environment variable set to invalid numeric string.

16-730-00 Unable to create client handle.

16-730-28 Unable to create client handle.

16-730-35 Unable to create client handle.

16-730-66 Unable to create client handle.

16-740-19 Immediate image overwrite failed on network controller hard disk.

16-750-07 Message received from DM not processed correctly.

16-750-09 Service tried to register and service is already registered.

16-750-11 Template cache file is missing.

Procedure

WARNING

Ensure that the electricity to the machine is switched off while performing tasks that do not need electricity. Refer to GP 14. Disconnect the power cord. Electricity can cause death or injury. Moving parts can cause injury.

1. For a single occurrence, switch off the machine, then switch on the machine, GP 14.
2. For multiple occurrences, reinstall software, GP 4.

16-742-19 Hard Disk ODIO Failure RAP

16-742-19 Hard disk ODIO failure

Procedure

WARNING

Ensure that the electricity to the machine is switched off while performing tasks that do not need electricity. Refer to GP 14. Disconnect the power cord. Electricity can cause death or injury. Moving parts can cause injury.

1. For a single occurrence, switch off the machine, then switch on the machine, GP 14.
2. For multiple occurrences, reinstall software, GP 4.

16-750-14, 16-750-19, 16-750-26, 16-750-35, 16-750-38, 16-750-46, 16-750-47, 16-750-66, 16-750-67, 16-750-90 Invalid Request RAP

16-750-14 Too many messages sent to SESS system control.

16-750-19 Invalid request data from calling service.

16-750-26 Invalid number of faults requested.

16-750-35 Data store failure.

16-750-38 Initialization of SPI and job tracking table failed in SVC initialize service.

16-750-46 Client requested an unknown object or invalid object type.

16-750-47 Bad parameter returned.

16-750-66 Failure to set service state.

16-750-67 Failure to set service state.

16-750-90 Unexpected service sends this message.

Procedure

WARNING

Ensure that the electricity to the machine is switched off while performing tasks that do not need electricity. Refer to GP 14. Disconnect the power cord. Electricity can cause death or injury. Moving parts can cause injury.

1. For a single occurrence, switch off the machine, then switch on the machine, GP 14.
2. For multiple occurrences, reinstall software, GP 4.

16-750-92, 16-750-93, 16-750-95, 16-751-00, 16-751-07, 16-751-09, 16-751-11, 16-751-14, 16-751-19, 16-751-26 Database Error RAP

16-750-92 Unable to open bit map captured to disk. bad or full disk.

16-750-93 IFS error when requesting memory.

16-750-95 Local spool area does not exist.

16-751-00 Database err known by service registry or registry not available.

16-751-07 Message received from network controller AAA not processed correctly.

16-751-09 Registration receives unrequested ENS notification.

16-751-11 Initialization procedure fails.

16-751-14 SC not responding.

16-751-19 Invalid permission to change date.

16-751-26 Unrecognized code. Service raises code that the fault service doesn't know how to handle.

Procedure

WARNING

Ensure that the electricity to the machine is switched off while performing tasks that do not need electricity. Refer to GP 14. Disconnect the power cord. Electricity can cause death or injury. Moving parts can cause injury.

1. For a single occurrence, switch off the machine, then switch on the machine, GP 14.
2. For multiple occurrences, reinstall software, GP 4.

16-751-28, 16-751-35, 16-751-38, 16-751-46, 16-751-66, 16-751-67, 16-751-92, 16-751-93 Unknown Attribute RAP

16-751-28 Templates attributes are invalid, or syntax error.

16-751-35 Invalid queue ID.

16-751-38 Unknown attribute returned for completed job list.

16-751-46 Client requested an unknown object or invalid object type.

16-751-47 Failed to replace the current directory with directory from alt. partition.

16-751-66 Unable to send event to network controller ENS.

16-751-67 Unable to send event to network controller ENS.

16-751-92 Cannot set job to complete.

16-751-93 Invalid template attribute.

Procedure

WARNING

Ensure that the electricity to the machine is switched off while performing tasks that do not need electricity. Refer to GP 14. Disconnect the power cord. Electricity can cause death or injury. Moving parts can cause injury.

1. For a single occurrence, switch off the machine, then switch on the machine, GP 14.
2. For multiple occurrences, reinstall software, GP 4.

16-752-00, 16-753-00 File Cabinet Application Registration Error RAP

16-752-00 File cabinet application registration error

16-753-00 File cabinet application un-registration error

Procedure

WARNING

Ensure that the electricity to the machine is switched off while performing tasks that do not need electricity. Refer to GP 14. Disconnect the power cord. Electricity can cause death or injury. Moving parts can cause injury.

1. If a single occurrence, switch off the machine, then switch on the machine, GP 14.
2. For multiple occurrences, reinstall software, GP 4.

16-752-07, 16-752-09, 16-752-14, 16-752-19, 16-752-26, 16-752-28, 16-752-35, 16-752-46, 16-752-47 Invalid File Details RAP

16-752-07 Data store error.

16-752-09 Configuration control problem.

16-752-14 SC not responding. SC IPC queue does not exist.

16-752-19 RPC failure.

16-752-26 Unrecognized SESS error code.

16-752-28 Template cache file is missing.

16-752-35 Invalid queue ID.

16-752-46 Invalid row of table object.

16-752-47 Invalid test pattern source.

Procedure

WARNING

Ensure that the electricity to the machine is switched off while performing tasks that do not need electricity. Refer to GP 14. Disconnect the power cord. Electricity can cause death or injury. Moving parts can cause injury.

1. For a single occurrence, switch off the machine, then switch on the machine, GP 14.
2. For multiple occurrences, reinstall software, GP 4.

16-752-66, 16-752-67, 16-752-92, 16-752-93, 16-752-95, 16-753-09, 16-753-14, 16-753-19, 16-753-26, 16-753-28 Scan to FAX Registration Error RAP

16-752-66 Scan to FAX services registration error.

16-752-67 Scan to FAX services registration error.

16-752-92 Configuration problem.

16-752-93 Error accessing jobs in job list.

16-752-95 File transfer failure.

16-753-09 Software bug.

16-753-14 Calling service used an invalid event number.

16-753-19 Invalid event information or data. ENS failure. System RPC information corrupt.

16-753-26 PSW failure. O/S failure. CCM failure.

16-753-28 Cannot communicate with UI for template list request.

Procedure

WARNING

Ensure that the electricity to the machine is switched off while performing tasks that do not need electricity. Refer to GP 14. Disconnect the power cord. Electricity can cause death or injury. Moving parts can cause injury.

1. For a single occurrence, switch off the machine, then switch on the machine, GP 14.
2. For multiple occurrences, reinstall software, GP 4.

16-753-35, 16-753-46, 16-753-47, 16-753-66, 16-753-67, 16-753-90, 16-753-92, 16-753-93, 16-753-95, 16-753-09 Data Store Read Failure RAP

16-753-35 Unable to change EJS status to offline.

16-753-46 Invalid table row.

16-753-47 Failed to close a directory during verification check. Corrupt disk.

16-753-66 Data store read failure.

16-753-67 Data store read failure.

16-753-90 Software error.

16-753-92 Configuration problem.

16-753-93 Error adding jobs in job list.

16-753-95 Requested transfer protocol not supported.

16-754-09 Still registered services after time out.

Procedure

WARNING

Ensure that the electricity to the machine is switched off while performing tasks that do not need electricity. Refer to GP 14. Disconnect the power cord. Electricity can cause death or injury. Moving parts can cause injury.

1. For a single occurrence, switch off the machine, then switch on the machine, GP 14.
2. For multiple occurrences, reinstall software, GP 4.

16-754-14, 16-754-19, 16-754-26, 16-754-28, 16-754-35, 16-754-46, 16-754-47, 16-754-66, 16-754-67, 16-754-68 OS Error RAP

16-754-14 Receipt is not there. Failure on ENS side.

16-754-19 Shutdown request reason unknown.

16-754-26 Fault service encountered error reading fault log. File system corrupted.

16-754-28 Initialization procedure fails.

16-754-35 OS corrupt.

16-754-46 Attempted to write a read only object. Software configuration error.

16-754-47 Failed to replace a file that was missing with file from alt. partition.

16-754-66 OS problem.

16-754-67 OS problem.

16-754-68 Initialize procedure fails.

Procedure

WARNING

Ensure that the electricity to the machine is switched off while performing tasks that do not need electricity. Refer to GP 14. Disconnect the power cord. Electricity can cause death or injury. Moving parts can cause injury.

1. For a single occurrence, switch off the machine, then switch on the machine, GP 14.
2. For multiple occurrences, reinstall software, GP 4.

16-754-90, 16-754-92, 16-754-92, 16-754-93, 16-754-95, 16-755-00, 16-755-09, 16-755-14, 16-755-19, 16-755-26, 16-755-28 Fault Service Error RAP

16-754-90 Software bug.

16-754-92 Data store failure.

16-754-93 Error deleting jobs from job list.

16-754-95 Unable to remove advisory lock on network server.

16-755-00 Service registry cannot initialize database.

16-755-09 Cannot register new service due to too many entries in SRV table.

16-755-14 Message buffer full. Full queue.

16-755-19 SESS system control broken or too many IPC messages.

16-755-26 Disk write error. Software error.

16-755-28 Cancel request failed.

Procedure

WARNING

Ensure that the electricity to the machine is switched off while performing tasks that do not need electricity. Refer to GP 14. Disconnect the power cord. Electricity can cause death or injury. Moving parts can cause injury.

1. For a single occurrence, switch off the machine, then switch on the machine, GP 14.
2. For multiple occurrences, reinstall software, GP 4.

16-755-35, 16-755-46, 16-755-47, 16-755-67, 16-755-90, 16-755-93, 16-755-99, 16-756-09, 16-756-14 Request Error RAP

16-755-35 OS corrupt. Software corrupt. Data store corrupt.

16-755-46 Mismatched data type during object write. Software configuration error or request mishandled configuration index data.

16-755-47 Failed to repair the permission of the current file being checked.

16-755-67 Cancel request failed.

16-755-90 Software limit reached.

16-755-93 Unable to initialize with IFS.

16-755-99 Unable to abort job fault.

16-756-09 Service not registered.

16-756-14 Client provided wrong binding information. Client not required as RPC server.

16-756-26 Software error.

Procedure

WARNING

Ensure that the electricity to the machine is switched off while performing tasks that do not need electricity. Refer to GP 14. Disconnect the power cord. Electricity can cause death or injury. Moving parts can cause injury.

1. For a single occurrence, switch off the machine, then switch on the machine, GP 14.
2. For multiple occurrences, reinstall software, GP 4.

16-756-35, 16-756-46, 16-756-47, 16-756-66, 16-756-67, 16-756-93, 16-757-09, 16-757-14, 16-757-19, 16-757-26 NVM Corrupt RAP

16-756-35 OS corrupt. Software error. NVM error.

16-756-46 Poll select failed.

16-756-47 Executable missing or corrupt. Invalid test parameters.

16-756-66 Unable to read NVM value.

16-756-67 Unable to read NVM value.

16-756-93 IPA operation failed.

16-757-09 System RPC corrupt.

16-757-14 Programming bug. Attempted to shorten time out.

16-757-19 System manager died or communications link failed.

16-757-26 Software error. Bad disk.

Procedure

WARNING

Ensure that the electricity to the machine is switched off while performing tasks that do not need electricity. Refer to GP 14. Disconnect the power cord. Electricity can cause death or injury. Moving parts can cause injury.

1. For a single occurrence, switch off the machine, then switch on the machine, [GP 14](#).
2. For multiple occurrences, reinstall software, [GP 4](#).

16-757-35, 16-757-46, 16-757-47, 16-757-66, 16-757-67, 16-757-93, 16-758-09, 16-758-14, 16-758-19, 16-758-26 Unable to Write NVM Value RAP

16-757-35 OS corrupt. Software error. NVM corrupt.

16-757-46 O/S failure.

16-757-47 Failed while trying to replace the file with a file from alt. partition. Configuration error.

16-757-66 Unable to write NVM.

16-757-67 Unable to write NVM.

16-757-93 Unable to set ICS document state.

16-758-09 Invalid service failure reported.

16-758-14 RPC communications error to client.

16-758-19 Unable to unregister registration service.

16-758-26 Fault service encountered error trying to access its own queue ID.

Procedure

WARNING

Ensure that the electricity to the machine is switched off while performing tasks that do not need electricity. Refer to GP 14. Disconnect the power cord. Electricity can cause death or injury. Moving parts can cause injury.

1. For a single occurrence, switch off the machine, then switch on the machine, [GP 14](#).
2. For multiple occurrences, reinstall software, [GP 4](#).

16-758-35, 16-758-46, 16-758-47, 16-758-66, 16-758-67, 16-758-93, 16-759-09, 16-759-14, 16-759-19, 16-759-26 Service Run Loop Failed RAP

16-758-35 Unable to change EJS state to offline.

16-758-46 Failed setting up monitor routine with registration service.

16-758-47 Error searching for job ID during print job submission. Print submission tool failed.

16-758-66 Service run loop failed.

16-758-67 Service loop failed.

16-758-93 Unable to obtain data store object handle.

16-759-09 Software error.

16-759-14 Request for wildcard from non-NC

16-759-19 Network controller failed cold reset 3 times in a row.

16-759-26 Service requesting information of fault service. Software error.

Procedure

WARNING

Ensure that the electricity to the machine is switched off while performing tasks that do not need electricity. Refer to GP 14. Disconnect the power cord. Electricity can cause death or injury. Moving parts can cause injury.

1. For a single occurrence, switch off the machine, then switch on the machine, GP 14.
2. For multiple occurrences, reinstall software, GP 4.

16-759-46, 16-759-47, 16-759-66, 16-759-67, 16-759-93, 16-760-09, 16-760-14, 16-760-19, 16-760-26, 16-760-46 Fail to Enable Process RAP

16-759-46 Process no in correct state, O/S failure.

16-759-47 Failed to abort the requested process.

16-759-66 OA event register failed.

16-759-67 OA event register failed.

16-759-93 Unable to create.dat file.

16-760-09 Software error. Check fault log for more specific reasons.

16-760-14 Software error. Calling service not registered.

16-760-19 Any network controller start up.

16-760-26 Software failure.

16-760-46 Software failure.

Procedure

WARNING

Ensure that the electricity to the machine is switched off while performing tasks that do not need electricity. Refer to GP 14. Disconnect the power cord. Electricity can cause death or injury. Moving parts can cause injury.

1. For a single occurrence, switch off the machine, then switch on the machine, GP 14.
2. For multiple occurrences, reinstall software, GP 4.

16-760-47, 16-760-67, 16-760-68, 16-760-93, 16-760-99, 16-761-09, 16-761-14, 16-761-19, 16-761-26, 16-761-46 File Error RAP

16-760-47 Found incorrect checksum partition 1 during software verify check. Bad disk and bad software.

16-760-67 Create list failed.

16-760-68 SRS returns to login service. Invalid fields, invalid data or missing data.

16-760-93 Job report failure from CCM.

16-760-99 RPC failure. CCM not responding.

16-761-09 Software error. Check fault log for more specific reasons.

16-761-14 Invalid RPC data.

16-761-19 Any network controller shut down.

16-761-26 Unable to become client of UI.

16-761-46 Hardware failure.

Procedure

WARNING

Ensure that the electricity to the machine is switched off while performing tasks that do not need electricity. Refer to GP 14. Disconnect the power cord. Electricity can cause death or injury. Moving parts can cause injury.

1. For a single occurrence, switch off the machine, then switch on the machine, [GP 14](#).
2. For multiple occurrences, reinstall software, [GP 4](#).

16-761-47 to 16-769-95 Other Network Faults 1 RAP

16-761-47 Failed to initialize. Files needed for software verify.

16-761-67 Failed to retrieve public list.

16-761-68 Login gets no response from SRS.

16-761-93 Image conversion to TIFF failed.

16-761-95 Unable to read template pool configuration information.

16-762-09 Netware process failed. Software error. Check fault log for more specific reasons.

16-762-14 Invalid internal table type.

16-762-19 DC platform mgr communication error.

16-762-26 Unable to become client of SCS diagnostic service.

16-762-46 Hardware failure.

16-762-47 Missing file found during software verify check. Disk access problem. Configuration problem.

16-762-67 Invalid index for recipient list.

16-762-68 Service registry bad data corrupted.

16-762-93 IFS Image done call failed.

16-762-95 Unable to read document repository configuration information.

16-763-09 Software error. Check fault log for more specific reasons.

16-763-14 Reached internal limit for events.

16-763-19 System manager died, its platform crashed or RPC comm corrupt.

16-763-26 No acknowledgment to RPC message. RPC time-out.

16-763-46 Hardware failure.

16-763-47 Invalid permission found during software verify check.

16-763-67 Failed to retrieve LDAP list.

16-763-93 Document image count not found.

16-763-95 Internal destination error.

16-764-09 Apple talk process failure. Software error. Check fault log for more specific reasons.

16-764-14 Internal logic error.

16-764-19 System call to signal failed.

16-764-46 Hardware failure.

16-764-47 Found incorrect checksum during software verify check. Bad disk and bad software.

16-764-67 Create list failed.

16-765-09 Software error. Check fault log for more specific reasons.

16-765-19 Set status failed.

16-765-46 Software failure.

16-765-47 Novell daemon not running.

16-765-67 Failed to retrieve recipient list.

16-765-93 Unable to access data store.

16-766-09 Adobe process failure. Check faults log for more specific reasons.

16-766-19 DM admin error.

16-766-46 Software failure.

16-766-47 No servers responded.

16-766-67 Failed to bind to LDAP server.

16-766-93 TIFF handle has become null.

16-766-95 Cannot create image file name.

16-767-09 Software error. Check fault log for more specific reasons.

16-767-19 Request to cancel spooling job error. Job map library unable to cancel job.

16-767-46 Software failure.

16-767-47 Server name in configuration list is not up.

16-767-67 Error performing LDAP search.

16-767-93 Get document image count failed.

16-767-95 Cannot determine filing policy for transfer.

16-768-09 Software error. Check fault log for more specific reasons.

16-768-19 Job map library unable to hold or release jobs.

16-768-46 Software failure.

16-768-47 Network controller not attached to server.

16-768-67 Error performing public search.

16-768-93 Increment image count failed.

16-768-95 Cannot get network advisory lock file name.

16-769-09 Software error. Check fault log for more specific reasons.

16-769-19 Novell network failed to respond to request.

16-769-46 Software failure.

16-769-47 Network controller not attached to the print queue.

16-769-67 Failed to cancel search request.

16-769-93 IFS de-register call failed.

16-769-95 Cannot determine appropriate lock name and address.

Procedure

WARNING

Ensure that the electricity to the machine is switched off while performing tasks that do not need electricity. Refer to GP 14. Disconnect the power cord. Electricity can cause death or injury. Moving parts can cause injury.

1. For a single occurrence, switch off the machine, then switch on the machine, GP 14.
2. For multiple occurrences, reinstall software, GP 4.

16-770-09 to 16-779-95 Other Network Faults 2 RAP

16-770-09 Software error. Check fault log for more specific reasons.

16-770-19 SESS/DM job command not processed.

16-770-46 Software failure.

16-770-47 Network controller attached to both queue and server.

16-770-67 Required attribute missing.

16-771-09 Software error. Check fault log for more specific reasons.

16-771-19 UI/PSW/RDT/ RPC corrupt.

16-771-46 Software failure.

16-771-47 Failed to configure novell network.

16-772-09 Software error. Check fault log for more specific reasons.

16-772-19 Software error.

16-772-46 TCPIP address already being used.

16-772-47 Failed doing registration or RPC call.

16-772-95 Invalid transfer request.

16-773-09 Software error. Check fault log for more specific reasons.

16-773-19 Software error.

16-773-46 Failed requesting platform reset.

16-774-09 Check fault log for more specific reasons.

16-774-19 Client provided wrong binding info. Client not registered as RPC server. System RPC info is corrupt.

16-774-46 BOOTP status file error.

16-775-19 Data store not configured. Software error.

16-775-46 TCPIP missing configuration data.

16-775-95 Cannot create temporary file name.

16-776-09 Software error. Check fault log for more specific reasons.

16-776-19 Software error.

16-776-46 TCPIP invalid interface.

16-776-95 Cannot clean up after job completion.

16-777-09 Software error. Check fault log for more specific reasons.

16-777-19 Software error. Data store corrupt, missing configuration.

16-777-46 TCPIP invalid addressing.

16-777-95 Cannot log requested network server.

16-778-09 Software error. Check fault log for more specific reasons.

16-778-19 Software error.

16-778-46 TCPIP socket failure.

16-778-95 Cannot generate confirmation sheet.

16-779-00 System manager power saver complete callback failed. System manager failed or communications link failed.

16-779-09 Software error. Check fault log for more specific reasons.

16-779-19 System manager callback SM power save completed failed.

16-779-46 TCPIP interface attach.

16-779-47 SESS diagnostic failure.

16-779-95 Cannot create the template/job log name.

Procedure

WARNING

Ensure that the electricity to the machine is switched off while performing tasks that do not need electricity. Refer to GP 14. Disconnect the power cord. Electricity can cause death or injury. Moving parts can cause injury.

1. For a single occurrence, switch off the machine, then switch on the machine, GP 14.
2. For multiple occurrences, reinstall software, GP 4.

16-780-00 to 16-789-47 Other Network Faults 3 RAP

16-780-00 Power save request time out.

16-780-09 Software error. Check fault log for more specific reasons.

16-780-19 Power saver request time out.

16-780-46 TCPIP enable interface.

16-780-47 SESS diagnostic failure.

16-780-95 Cannot determine the remote directory.

16-781-09 Software error. Check fault log for more specific reasons.

16-781-19 Customer software upgrade file is corrupted on transfer.

16-781-46 TCPIP NVRAM failure.

16-781-47 SESS diagnostic failure.

16-782-09 Network controller configuration synchronization process failure. Software error. check fault log for more specific reasons.

16-782-19 Software upgrade manifest file does not match software upgrade files.

16-782-46 TCPIP gateway failure.

16-782-47 SESS diagnostic failure.

16-783-09 Software error. IPC failure. SC not processing IPC.

16-783-19 Network controller does not enter upgrade mode. Network controller does not respond to upgrade prep command.

16-783-46 TCPIP host file failure.

16-783-47 SESS diagnostic failure.

16-784-09 Software error. Registration service out of date.

16-784-19 Software upgrade aborted, IOT failed to enter upgrade mode. IOT does not respond to upgrade prep command.

16-784-46 TCPIP resolve file failure.

16-784-47 SESS diagnostic failure.

16-785-09 Network controller agent process failure. Software error. Check fault log for more specific reasons.

16-785-19 UI does not respond to upgrade prep command.

16-785-46 TCPIP resolve file failure.

16-785-47 SESS diagnostic failure.

16-786-09 Software error. Check alt log for more specific reasons.

16-786-19 Network controller ntar of upgrade file fails.

16-786-46 TCPIP ELT file failure.

16-786-47 SESS diagnostic failure.

16-787-09 Software error. Check fault log more specific reasons.

16-787-19 Network controller times out. Cannot communicate with IOT.

16-787-46 TCPIP IPC failure.

16-787-47 SESS diagnostic failure.

16-788-09 Software error. Check fault log for more specific reasons.

16-788-19 Option load failure software.

16-788-46 Failed performing dynamic DNS update.

16-788-47 SESS diagnostic failure.

16-789-09 Software error. Check fault log for more specific reasons.

16-789-19 Option load failure software.

16-789-46 Failed performing autonet IP process.

16-789-47 SESS diagnostic failure.

Procedure

WARNING

Ensure that the electricity to the machine is switched off while performing tasks that do not need electricity. Refer to GP 14. Disconnect the power cord. Electricity can cause death or injury. Moving parts can cause injury.

1. For a single occurrence, switch off the machine, then switch on the machine, GP 14.
2. For multiple occurrences, reinstall software, GP 4.

16-790-09 to 16-799-47 Other Network Faults 4 RAP

16-790-09 Software error. Check fault log for more specific reasons.

16-790-19 Option load failure software.

16-790-47 SESS diagnostic failure.

16-791-09 Software error. Check fault log for more specific reasons.

16-791-19 Scan to file DLM is not defined.

16-791-46 DHCP V6 failure

16-791-47 SESS diagnostic failure.

16-792-09 Software error. Check fault log for more specific reasons.

16-792-19 Lan fax DLM is not defined.

16-792-47 SESS diagnostic failure.

16-793-09 Software error. Check fault log for more specific reasons.

16-793-19 Job based accounting DLM is not defined.

16-793-47 SESS diagnostic failure.

16-794-09 Cross platform synchronization error.

16-794-19 Install password mismatch.

16-794-47 SESS diagnostic failure.

16-795-09 Software error. Check fault log for more specific reasons.

16-795-19 Option load failure software.

16-795-47 SESS diagnostic failure.

16-796-09 Software error. Check fault log for more specific reasons.

16-796-19 Option load failure software.

16-796-47 SESS diagnostic failure.

16-797-09 Software error. Check fault log for more specific reasons.

16-797-19 Option load failure software.

16-797-47 SESS diagnostic failure.

16-798-09 Software error. Check fault log for more specific reasons.

16-798-19 Option already enabled.

16-798-47 SESS diagnostic failure.

16-799-09 Software error. Check fault log for more specific reasons.

16-799-19 Option already enabled.

16-799-47 SESS diagnostic failure.

Procedure

WARNING

Ensure that the electricity to the machine is switched off while performing tasks that do not need electricity. Refer to GP 14. Disconnect the power cord. Electricity can cause death or injury. Moving parts can cause injury.

1. For a single occurrence, switch off the machine, then switch on the machine, GP 14.
2. For multiple occurrences, reinstall software, GP 4.

16-800-09 to 16-809-47 Other Network Faults 5 RAP

16-800-09 List access failure (create, add, find, delete.)

16-800-19 Option not supported.

16-800-46 Unable to connect to device when setting up IP over Ethernet.

16-800-47 SESS diagnostic failure.

16-801-09 Invalid SESS event/IPC error.

16-801-19 Serial mismatch.

16-801-46 Unable to connect to device when setting up IP over token ring.

16-801-47 SESS diagnostic failure.

16-802-09 Web service edge client process death.

16-802-19 Counters do not match.

16-802-46 Error occurred when attempting to get the IP data from the DHCP server.

16-802-47 SESS diagnostic failure.

16-803-09 Web service edge client process death.

16-803-46 Unable to get the IP address from the RARP server.

16-803-47 SESS diagnostic failure.

16-804-09 Web service edge client process death.

16-804-47 SESS diagnostic failure.

16-805-09 Web service edge client process death.

16-805-19 Accounting install failed.

16-805-47 SESS diagnostic failure.

16-806-00 CPI death error.

16-806-09 CPI service unavailable.

16-806-19 Counters did not increment.

16-806-47 SESS diagnostic failure.

16-807-00 Job log service death error.

16-807-09 Job log service unavailable.

16-807-19 State change failed.

16-807-47 SESS diagnostic failure.

16-808-00 Job tracker death error.

16-808-09 Job tracker service unavailable.

16-808-47 SESS diagnostic failure.

16-809-00 Kerberos death error.

16-809-09 Kerberos service unavailable.

16-809-47 SESS diagnostic failure.

Procedure

WARNING

Ensure that the electricity to the machine is switched off while performing tasks that do not need electricity. Refer to GP 14. Disconnect the power cord. Electricity can cause death or injury. Moving parts can cause injury.

1. For a single occurrence, switch off the machine, then switch on the machine, GP 14.
2. For multiple occurrences, reinstall software, GP 4.

16-810-00 to 16-16-819-47 Other Network Faults 6 RAP

16-810-00 Scan to distribution death error.

16-810-09 Scan service available.

16-810-19 Failed to remove accounting.

16-810-47 SESS diagnostic failure.

16-811-00 SMB death error.

16-811-09 SMB service unavailable.

16-811-19 Failed to initiate operation.

16-811-47 SESS diagnostic failure.

16-812-00 TCP/IP death error.

16-812-09 TCPIP service unavailable.

16-812-19 Failed to change the enable upgrade flag.

16-812-47 SESS diagnostic failure.

16-813-00 WS scan temp death error.

16-813-09 Scan service unavailable

16-813-47 SESS diagnostic failure.

16-814-00 Scan compressor death error.

16-814-09 Scan compressor service unavailable.

16-814-47 SESS diagnostic failure.

16-815-09 Service registry process death.

16-815-47 SESS diagnostic failure.

16-816-09 EIP service not responding.

16-816-47 SESS diagnostic failure.

16-817-47 SESS diagnostic failure.

16-818-47 SESS diagnostic failure.

16-819-47 SESS diagnostic failure.

Procedure

WARNING

Ensure that the electricity to the machine is switched off while performing tasks that do not need electricity. Refer to GP 14. Disconnect the power cord. Electricity can cause death or injury. Moving parts can cause injury.

1. For a single occurrence, switch off the machine, then switch on the machine, GP 14.
2. For multiple occurrences, reinstall software, GP 4.

16-820-47 to 16-829-47 Other Network Faults 7 RAP

16-820-47 SESS diagnostics failure.

16-821-47 SESS diagnostics failure.

16-822-47 SESS diagnostics failure.

16-823-47 SESS diagnostics failure.

16-824-47 SESS diagnostics failure.

16-825-47 SESS diagnostics failure.

16-826-47 SESS diagnostics failure.

16-827-47 SESS diagnostics failure.

16-828-47 SESS diagnostics failure.

16-829-47 SESS diagnostics failure.

Procedure

WARNING

Ensure that the electricity to the machine is switched off while performing tasks that do not need electricity. Refer to [GP 14](#). Disconnect the power cord. Electricity can cause death or injury. Moving parts can cause injury.

1. For a single occurrence, switch off the machine, then switch on the machine, [GP 14](#).
2. For multiple occurrences, reinstall software, [GP 4](#).

16-830-47 to 16-839-47 Other Network Faults 8 RAP

16-830-47 Unable to get the default router for the device.

16-831-47 Unable to get the subnet mask for the device.

16-832-47 Failure while getting local IP devices on the network.

16-833-47 Failure while performing ARP command.

16-834-47 Failed to get a default file server from the config. utility.

16-835-47 Failed to the novell frame type from the config. utility.

16-836-47 Failed SESS call to initialize netware.

16-837-47 Diagnostic name returned from SESS not found in list.

16-838-47 Failed to setup catching alarm signals for repair time outs.

16-839-47 Failure to repair a file of file length 0. Corrupt disk.

Procedure

WARNING

Ensure that the electricity to the machine is switched off while performing tasks that do not need electricity. Refer to [GP 14](#). Disconnect the power cord. Electricity can cause death or injury. Moving parts can cause injury.

1. For a single occurrence, switch off the machine, then switch on the machine, [GP 14](#).
2. For multiple occurrences, reinstall software, [GP 4](#).

16-840-47 to 16-849-47 Other Network Faults 9 RAP

16-840-47 Corrupt OS, software error.

16-841-47 Corrupt file system.

16-842-47 Machine out of configuration. Software error.

16-843-47 Corrupt OS machine in bad running state. Software error.

16-844-47 Corrupt OS machine in bad running state. Software error.

16-845-47 Corrupt OS machine in bad running state. Software error.

16-846-47 Corrupt OS machine in bad running state. Software error.

16-847-47 Corrupt OS machine in bad running state. Software error.

16-848-47 Error reading the fault file from fault service.

16-849-47 Error creating command array from stream editor.

Procedure

WARNING

Ensure that the electricity to the machine is switched off while performing tasks that do not need electricity. Refer to GP 14. Disconnect the power cord. Electricity can cause death or injury. Moving parts can cause injury.

1. For a single occurrence, switch off the machine, then switch on the machine, GP 14.
2. For multiple occurrences, reinstall software, GP 4.

16-850-47 to 16-859-47 Other Network Faults 10 RAP

16-850-47 Failed adding stream to stream editor array.

16-851-47 Failed on call to stream editor.

16-852-47 Unable to read a fault for the error report.

16-853-47 Failed getting the last reset time for the error report.

16-854-47 Failed calling fault service for the error report.

16-855-47 Failed sending event for diagnostic test.

16-856-47 Failed doing a unix c system call.

16-857-47 Abort request, unable to find process.

16-858-47 Failed to dump the fault logs.

16-859-47 Software verify test returned error.

Procedure

WARNING

Ensure that the electricity to the machine is switched off while performing tasks that do not need electricity. Refer to GP 14. Disconnect the power cord. Electricity can cause death or injury. Moving parts can cause injury.

1. For a single occurrence, switch off the machine, then switch on the machine, GP 14.
2. For multiple occurrences, reinstall software, GP 4.

16-860-47 to 16-869-47 Other Network Faults 11 RAP

16-860-47 No machines responded to an ICMP echo request.

16-861-47 Failed setting up monitor routine with registration service.

16-862-47 Command not valid to cancel.

16-863-47 Illegal buffer length.

16-864-47 Illegal local session number.

16-865-47 SESS NETBIOS test session closed.

16-866-47 SESS NETBIOS test command cancelled.

16-867-47 SESS NETBIOS test name de-registered. Name de-registered, session active.

16-868-47 SESS NETBIOS test local session table full. Local session table full.

16-869-47 SESS NETBIOS test no listen in remote computer.

Procedure

WARNING

Ensure that the electricity to the machine is switched off while performing tasks that do not need electricity. Refer to GP 14. Disconnect the power cord. Electricity can cause death or injury. Moving parts can cause injury.

1. For a single occurrence, switch off the machine, then switch on the machine, GP 14.
2. For multiple occurrences, reinstall software, GP 4.

16-870-47 to 16-879-47 Other Network Faults 12 RAP

16-870-47 SESS NETBIOS test illegal name number.

16-871-47 SESS NETBIOS test cannot find name or no answer.

16-872-47 SESS NETBIOS test name in use.

16-873-47 SESS NETBIOS test name deleted.

16-874-47 SESS NETBIOS test session abnormal end.

16-875-47 SESS NETBIOS test name conflict. Name conflict on network.

16-876-47 Software verify setup SIGTERM failed.

16-877-47 SESS PCI test unknown error.

16-878-47 SESS PCI test failed to open driver.

16-879-47 SESS PCI test failed flushing stream buffer.

Procedure

WARNING

Ensure that the electricity to the machine is switched off while performing tasks that do not need electricity. Refer to GP 14. Disconnect the power cord. Electricity can cause death or injury. Moving parts can cause injury.

1. For a single occurrence, switch off the machine, then switch on the machine, GP 14.
2. For multiple occurrences, reinstall software, GP 4.

16-880-47 to 16-890-47 Other Network Faults 13 RAP

16-880-47 SESS PCI test failed on put message call.

16-881-47 SESS PCI test invalid argument.

16-882-47 SESS PCI test failed on put message call.

16-883-47 SESS PCI test failed on ioctl call.

16-884-47 SESS PCI test control flag area too small.

16-885-47 SESS PCI test driver not initialized.

16-886-47 SESS PCI test info request failed.

16-887-47 SESS PCI test driver failed to register.

16-888-47 SESS PCI test driver failed to unregister.

16-889-47 Software verify get data failed.

16-890-47 Software verify get next proc failed.

Procedure

WARNING

Ensure that the electricity to the machine is switched off while performing tasks that do not need electricity. Refer to GP 14. Disconnect the power cord. Electricity can cause death or injury. Moving parts can cause injury.

1. For a single occurrence, switch off the machine, then switch on the machine, GP 14.
2. For multiple occurrences, reinstall software, GP 4.

16-891-00, 16-892-00 Edge Server Auto Registration Failed RAP

16-891-00 Edge server auto registration failed

16-892-00 Edge server communication failed

Procedure

WARNING

Ensure that the electricity to the machine is switched off while performing tasks that do not need electricity. Refer to GP 14. Disconnect the power cord. Electricity can cause death or injury. Moving parts can cause injury.

1. If a single occurrence, switch off the machine, then switch on the machine, GP 14.
2. For multiple occurrences, reinstall software, GP 4.

16-900-19 to 16-909-19 Other Network Faults 14 RAP

16-900-19 Failed to open SMC driver.

16-901-19 Failed to make ioctl call using SMC driver.

16-902-19 Address specified is invalid.

16-903-19 Result from ioctl does not match FD.

16-904-19 Invalid ioctl request.

16-905-19 Unknown ioctl failure.

16-906-19 Malloc failed for net upgrade.

16-908-19 Error opening file.

16-909-19 Error transfer data to CCM.

Procedure

WARNING

Ensure that the electricity to the machine is switched off while performing tasks that do not need electricity. Refer to GP 14. Disconnect the power cord. Electricity can cause death or injury. Moving parts can cause injury.

1. For a single occurrence, switch off the machine, then switch on the machine, GP 14.
2. For multiple occurrences, reinstall software, GP 4.

16-910-19 to 16-919-19 Other Network Faults 15 RAP

16-910-19 Failed untar file.

16-911-19 Error changing directory.

16-912-19 Install script did not execute.

16-913-19 Write failure to file.

16-914-19 Shared memory was corrupted.

16-915-19 Open failed.

16-916-19 CRC failed.

16-917-19 Failed to close on checksum.

16-918-19 CRC comparison failed.

16-919-19 Restart request failed.

Procedure

WARNING

Ensure that the electricity to the machine is switched off while performing tasks that do not need electricity. Refer to GP 14. Disconnect the power cord. Electricity can cause death or injury. Moving parts can cause injury.

1. For a single occurrence, switch off the machine, then switch on the machine, GP 14.
2. For multiple occurrences, reinstall software, GP 4.

16-920-19 to 16-929-19 Other Network Faults 16 RAP

16-920-19 ELT daemon start failed.

16-922-19 NVM store failed.

16-923-19 Failed saving persistent data.

16-924-19 Failed in restoring persistent data.

16-925-19 Failed saving web config data.

16-926-19 Failed to save data store values.

16-927-19 Failed to restore web config data.

16-928-19 Failed to install files.

16-929-19 Failed to restore data store values.

Procedure

WARNING

Ensure that the electricity to the machine is switched off while performing tasks that do not need electricity. Refer to GP 14. Disconnect the power cord. Electricity can cause death or injury. Moving parts can cause injury.

1. For a single occurrence, switch off the machine, then switch on the machine, GP 14.
2. For multiple occurrences, reinstall software, GP 4.

16-930-19 to 16-939-19 Other Network Faults 17 RAP

16-930-19 Failed to remove jobs.

16-931-19 Failed to close on SMC driver.

16-932-19 NVM write failure.

16-933-19 Failed to remove file.

16-934-19 Job based accounting not enough dc memory.

16-935-19 Auto-upgrade failed. Cannot read/write attributes to machine.

16-936-19 Auto-upgrade failed. Cannot connect to remote server.

16-937-19 Auto-upgrade failed. Cannot access directory on remote server.

16-938-19 Auto-upgrade failed. Cannot access directory remote server.

16-939-19 Auto-upgrade failed. Multiple upgrade files found on remote server.

Procedure

WARNING

Ensure that the electricity to the machine is switched off while performing tasks that do not need electricity. Refer to GP 14. Disconnect the power cord. Electricity can cause death or injury. Moving parts can cause injury.

1. For a single occurrence, switch off the machine, then switch on the machine, GP 14.
2. For multiple occurrences, reinstall software, GP 4.

16-940-19 to 16-949-19 Other Network Faults 18 RAP

16-940-19 Auto-upgrade failed. Machine in diagnostics mode.

16-941-19 Auto-upgrade failed. Network controller cannot communicate with main controller.

16-942-19 Auto-upgrade failed upgrade is invalid. Incompatible with main controller.

16-943-19 Auto-upgrade failed. Upgrade file invalid. Installed software is more recent.

16-944-19 Auto-upgrade failed. Upgrade file is invalid. File corruption detected.

16-945-19 Auto-upgrade failed. Upgrade file is invalid. File not appropriate for current machine software.

16-946-19 Failed install scan to email.

16-947-19 Failed to install internet fax.

16-948-19 Remove of scan to email option failed.

16-949-19 Remove of internet fax option failed.

Procedure

WARNING

Ensure that the electricity to the machine is switched off while performing tasks that do not need electricity. Refer to GP 14. Disconnect the power cord. Electricity can cause death or injury. Moving parts can cause injury.

1. For a single occurrence, switch off the machine, then switch on the machine, GP 14.
2. Verify that the correct software file is being used, refer to GP 4.
3. For multiple occurrences, reinstall software, GP 4.

16-950-19 to 16-959-19 Other Network Faults 19 RAP

16-950-19 Scan to email image processing hardware not available.

16-951-19 Internet fax image processing hardware not available.

16-952-19 Scan to email memory size error.

16-953-19 Internet fax memory size error.

16-954-19 Set by internet fax service when it gets no response from service registry when trying to register.

16-955-19 Internet Fax application un-registration error

16-956-19 E-mail application registration error

16-957-19 E-mail application un-registration error

16-958-19 Failed to install kerberos.

16-959-19 Failed to install SMB.

Procedure

WARNING

Ensure that the electricity to the machine is switched off while performing tasks that do not need electricity. Refer to GP 14. Disconnect the power cord. Electricity can cause death or injury. Moving parts can cause injury.

1. For a single occurrence, switch off the machine, then switch on the machine, GP 14.
2. For multiple occurrences, reinstall software, GP 4.

16-960-19 to 16-969-19 Other Network Faults 20 RAP

16-960-19 Failed to install SMTP.

16-961-19 Failed to remove kerberos.

16-962-19 Failed to remove SMB.

16-963-19 Failed to remove SMTP.

16-964-19 Failed to cancel operation.

16-965-19 Failed to send platform unavailable.

16-966-19 Failed to install job tracker.

16-967-19 Failed to remove job tracker.

16-968-19 Failed to install POP3.

16-969-19 Failed to remove POP3.

Procedure

WARNING

Ensure that the electricity to the machine is switched off while performing tasks that do not need electricity. Refer to GP 14. Disconnect the power cord. Electricity can cause death or injury. Moving parts can cause injury.

1. For a single occurrence, switch off the machine, then switch on the machine, GP 14.
2. For multiple occurrences, reinstall software, GP 4.

16-975-19 to 16-979-35 Other Network Faults 21 RAP

16-975-19 Failed to install immediate image overwrite.

16-976-19 Failed to install immediate image overwrite.

16-977-00 Queue list jobs failure. Request to SESS's document manager failed for list jobs. Corrupt data sent to DM communication problem Dm failed.

16-977-19 Network controller PM failed to remove disk overwrite. Option load failure software.

16-977-35 Queue list jobs failure. Request to SESS's document manager failed for list jobs. Corrupt data sent to DM. Communication problem DM failed.

16-978-00 Unable to get copy jobs. Invalid data communication problem.

16-978-19 Network controller PM failed to remove job overwrite. Option load failure software.

16-978-35 Unable to get copy jobs. Invalid data communication problem.

16-979-00 Unknown attribute returned. Invalid data returned data store corrupt

16-979-19 Network controller PM failed to remove embedded fax. Option load failure software.

16-979-35 Unknown attribute returned. Invalid data returned data store corrupt.

Procedure

WARNING

Ensure that the electricity to the machine is switched off while performing tasks that do not need electricity. Refer to GP 14. Disconnect the power cord. Electricity can cause death or injury. Moving parts can cause injury.

1. For a single occurrence, switch off the machine, then switch on the machine, GP 14.
2. For multiple occurrences, reinstall software, GP 4.

16-980-00 to 16-989-35 Other Network Faults 22 RAP

16-980-00 DM request handle NULL. Null data received from DM.

16-980-19 Network controller PM failed to install G4. Option load failure software.

16-980-35 DM request handle NULL. Null data received from DM.

16-981-00 Object handler corrupted. Null handle returned. Data store corrupt.

16-981-35 Unable to obtain job handle which is used to fetch data store attributes.

16-982-00 Unknown finishing value returned. Unable to map attribute or invalid data.

16-982-19 Failed to remove embedded fax.

16-982-35 Unknown finishing value returned. Unable to map attribute or invalid data.

16-983-00 Unknown offset value returned. Unable to map attribute or invalid data.

16-983-19 Failed to remove G4.

16-983-35 Unknown offset value returned. Unable to map attribute or invalid data.

16-984-00 Unknown job state reason value returned. Unable to map attribute or invalid data.

16-984-35 Unknown job state reason value returned. Unable to map attribute or invalid data.

16-985-00 Unknown medium type value returned. Unable to map attribute or invalid data.

16-985-35 Unknown medium type value returned. Unable to map attribute or invalid data.

16-986-00 Unknown collection value returned. Unable to map attribute or invalid data.

16-986-35 Unknown collection value returned. Unable to map attribute or invalid data.

16-987-00 Unknown tray value returned. Unable to map attribute or invalid data.

16-987-35 Unknown tray value returned. Unable to map attribute or invalid data.

16-988-00 Unknown signature value returned. Unable to map attribute or invalid data.

16-988-35 Unknown signature value returned. Unable to map attribute or invalid data.

16-989-00 Unknown plex value returned. Unable to map attribute. Invalid information received

2.

16-989-35 Unknown plex value returned. Unable to map attribute. Invalid information received

3.

Procedure

WARNING

Ensure that the electricity to the machine is switched off while performing tasks that do not need electricity. Refer to GP 14. Disconnect the power cord. Electricity can cause death or injury. Moving parts can cause injury.

1. For a single occurrence, switch off the machine, then switch on the machine, GP 14.
2. For multiple occurrences, reinstall software, GP 4.

16-985-19, 16-986-19 Network Scanning Application Registration Error RAP

16-985-19 Network scanning application registration error

16-986-19 Network scanning application un-registration error

Procedure

WARNING

Ensure that the electricity to the machine is switched off while performing tasks that do not need electricity. Refer to GP 14. Disconnect the power cord. Electricity can cause death or injury. Moving parts can cause injury.

1. If a single occurrence, switch off the machine, then switch on the machine, GP 14.
2. For multiple occurrences, reinstall software, GP 4.

16-987-19, 16-988-19 Server Fax Application Registration Error RAP

16-987-19 Server Fax application registration error

16-988-19 Server Fax application un-registration error

Procedure

WARNING

Ensure that the electricity to the machine is switched off while performing tasks that do not need electricity. Refer to GP 14. Disconnect the power cord. Electricity can cause death or injury. Moving parts can cause injury.

1. If a single occurrence, switch off the machine, then switch on the machine, GP 14.
2. For multiple occurrences, reinstall software, GP 4.

16-989-19 Disk Encryption Operation Failed RAP

16-989-19 Disk encryption operation failed

Procedure

WARNING

Ensure that the electricity to the machine is switched off while performing tasks that do not need electricity. Refer to GP 14. Disconnect the power cord. Electricity can cause death or injury. Moving parts can cause injury.

1. If a single occurrence, switch off the machine, then switch on the machine, GP 14.
2. For multiple occurrences, reinstall software, GP 4.

16-990-00 to 16-999-35 Other Network Faults 23 RAP

16-990-00 Promote response from DM received with errors. Software error.

16-990-35 Promote response from DM received with errors. Software error.

16-991-00 Request to DM to promote job failed. Failure status returned on call to request library to promote job. Data store problem.

16-991-35 Request to DM to promote job failed. Failure status returned on call to request library to promote job. Data store problem.

16-992-00 Unable to build SESS job identifier for promote routing that converts the job ID returned. Null memory allocation error.

16-992-35 Unable to build SESS job identifier for promote routine that converts the job ID returned. Null memory allocation error.

16-993-00 Unable to get admin name from data store for promote. Request library call failed.

16-993-35 Unable to get admin name from data store for promote. Request library call failed.

16-994-00 Cancel response from DM received with errors. Software error.

16-994-35 Cancel response with errors. A job could not be cancelled.

16-995-00 Request to DM to cancel job failed.

16-995-35 Request to DM to cancel job failed.

16-996-00 Routine that converts the job ID returned. Null memory allocation error.

16-996-35 Routine that converts the job ID returned. Null memory allocation error.

16-997-00 Request library call failed.

16-997-35 Request library call failed.

16-998-00 Job not found in held table.

16-998-35 Job not set to released state. Job not found in held table.

16-999-00 Could not obtain job PIN for authorization.

16-999-35 Could not obtain job PIN for authorization.

Procedure

WARNING

Ensure that the electricity to the machine is switched off while performing tasks that do not need electricity. Refer to GP 14. Disconnect the power cord. Electricity can cause death or injury. Moving parts can cause injury.

1. For a single occurrence, switch off the machine, then switch on the machine, GP 14.
2. For multiple occurrences, reinstall software, GP 4.

16A Network Error Entry RAP

Use this RAP when the customer reports network failures. e.g. Cannot connect to the scan server when using the FPT or SMB protocols, or when a folder on the scan server cannot be opened.

NOTE: The fault message will be printed on the confirmation report. The report may take several minutes to print after scanning the document.

Initial Actions

Consult your manager before troubleshooting the customer's network, as the policy varies according to region.

Procedure

NOTE: If it is possible to log into the web UI by entering the IP address of the machine, then the network controller on the single board controller PWB is good.

Perform the following:

1. Check that the machines date and time are correctly set, refer to [GP 38](#).
2. Print a configuration report.
3. Check with customer that the printing of the confirmation report is enabled. If necessary, ask the customer to enable printing of the confirmation report.
4. Ensure that the machine is configured for scan to file:
 - a. Check the back of the configuration report under the heading Workflow Scanning.
 - b. If a IP address or name is not listed next to Alt1 Repository Protocol, ask the customer to configure the machine before continuing.
5. Go to the relevant procedure:
 - [16B](#) FTP or SMB Unable to Connect to Remote Server RAP.
 - [16C](#) Remote Directory Lock Failed RAP.

16B FTP or SMB Unable to Connect to Remote Server RAP

Either the machine cannot connect, find or login to the scan server.

Procedure

NOTE: The FTP/SMB protocol will be followed by a colon and port number, :21 is for FTP and :139 is for SMB.

Scan the document using the default template and one other template. **The fault is present on both templates.**

Y N

The template that failed is incorrectly configured. Ask the customer or system administrator to verify the settings of the web template that failed, including the login password.

Ask the customer to open the machines CWIS page. **The machines CWIS page can be opened.**

Y N

Look at the front of the configuration report. Make sure that HTTP is enabled and set to port 80. **The settings are correct.**

Y N

Enable HTTP, [GP 39](#) and set the port to 80 on the UI. Restart this RAP from the beginning. If this path has been followed previously, escalate the fault to the system Administrator. If the customer does not have a System Administrator, they should contact the Customer Support Centre or request a Xerox analyst troubleshoot their network which will be subject to a charge.

Disconnect the network cable from the machine. Make sure the PWS network adaptor settings are set to Auto. Use a crossover cable, [PL 26.10 Item 2](#) to connect the PWS to the machine. **Either the two LEDs on the SBC PWB or the PWS are lit, indicating a connection.**

Y N

Perform the following:

1. Change the network speed setting of the machine, [GP 43](#).
2. If either the two LEDs on the SBC PWB or the PWS are not lit, repeat the steps in [GP 43](#).
3. If the LEDs light, use the new network speed setting. Inform the customer that the network speed has been changed then follow the Yes path from this step.
4. If the LEDs do not light, install a new single board controller PWB, [PL 3.11 Item 13](#).

Correctly configure the IP address of the PWS, [GP 42](#). Make sure the firewall of the PWS is disabled, [GP 44](#). Ping the machine from the PWS, [GP 41](#).

NOTE: Re-enable the PWS firewall after completion of this procedure.

The machine responds to the ping request.

Y N

Perform an Altboot, [GP 4](#).

The machine software is up to date.

Y N

Upgrade the software, [GP 4](#). **The fault persists.**

A B

A B

Y N
Perform SCP 5 Final Actions.

Perform the **Customers Settings Check. Changes were made to the customers settings.**

Y N
Escalate the fault to the system Administrator. If the customer does not have a System Administrator, they should contact the Customer Support Centre or request a Xerox analyst troubleshoot their network which will be subject to a charge.

Retry the job. **The job was successful.**

Y N
Escalate the fault to the system Administrator. If the customer does not have a System Administrator, they should contact the Customer Support Centre or request a Xerox analyst troubleshoot their network which will be subject to a charge.

Perform SCP 5 Final Actions.

Perform the **Customers Settings Check. Changes were made to the customers settings.**

Y N
Escalate the fault to the system Administrator. If the customer does not have a System Administrator, they should contact the Customer Support Centre or request a Xerox analyst troubleshoot their network which will be subject to a charge.

Retry the job. **The job was successful.**

Y N
Escalate the fault to the system Administrator. If the customer does not have a System Administrator, they should contact the Customer Support Centre or request a Xerox analyst troubleshoot their network which will be subject to a charge.

Perform SCP 5 Final Actions.

Ask the customer to ping the scan servers IP address or name.

NOTE: The scan server is the computer that the job is being sent. The scan servers IP address or name is displayed on the confirmation report.

The customer can ping the scan server.

Y N
Check the configuration report for default gateway IP address listed under TCP/IPv6 Settings. **A default gateway IP address is listed.**

Y N
Perform the **Customers Settings Check. Changes were made to the customers settings.**

Y N
Escalate the fault to the system Administrator. If the customer does not have a System Administrator, they should contact the Customer Support Centre or request a Xerox analyst troubleshoot their network which will be subject to a charge.

C D E

Retry the job. **The job was successful.**

Y N
Escalate the fault to the system Administrator. If the customer does not have a System Administrator, they should contact the Customer Support Centre or request a Xerox analyst troubleshoot their network which will be subject to a charge.

Perform SCP 5 Final Actions.

The customer can ping the default gateway IP address.

Y N
Escalate the fault to the system Administrator. If the customer does not have a System Administrator, they should contact the Customer Support Centre or request a Xerox analyst troubleshoot their network which will be subject to a charge.

Perform the **Customers Settings Check. Changes were made to the customers settings.**

Y N
Escalate the fault to the system Administrator. If the customer does not have a System Administrator, they should contact the Customer Support Centre or request a Xerox analyst troubleshoot their network which will be subject to a charge.

Retry the job. **The job was successful.**

Y N
Escalate the fault to the system Administrator. If the customer does not have a System Administrator, they should contact the Customer Support Centre or request a Xerox analyst troubleshoot their network which will be subject to a charge.

Perform SCP 5 Final Actions.

Perform the **Customers Settings Check. Changes were made to the customers settings.**

Y N
Escalate the fault to the system Administrator. If the customer does not have a System Administrator, they should contact the Customer Support Centre or request a Xerox analyst troubleshoot their network which will be subject to a charge.

Retry the job. **The job was successful.**

Y N
Escalate the fault to the system Administrator. If the customer does not have a System Administrator, they should contact the Customer Support Centre or request a Xerox analyst troubleshoot their network which will be subject to a charge.

Perform SCP 5 Final Actions.

Customers Settings Check

NOTE: Both the configuration and confirmation reports are required to check the customers settings. Corrections must be made through the machines CWIS page.

Check the following with the customer, ask the customer to correct any errors:

1. That the scan server is switched on and online.

NOTE: The scan server is the computer that the job is being sent.

C D E

2. That the scan servers IP address or name is correct.
3. That the path and user name are correct.
4. **(SMB protocol only)** That the Share name is correct, referred too as the Volume on the configuration report.
5. Check with System Administrator that the correct password has been entered on the machines CWIS page.

NOTE: *The password is not printed on the configuration or confirmation reports.*

16C Remote Directory Lock Failed RAP

Use this RAP when the customer reports that the machine has logged onto the scan server, but cannot create a folder inside of the scan directory. The creation of the scan folder is necessary for the machine to successfully complete the can to file job.

NOTE: *The scan server is the computer that the job is being sent.*

Procedure

The machines login name that it is using to log onto the scan server, for this file repository, does not have sufficient rights. Ask the customer to verify the rights for this user at the scan server, or escalate the problem to their System Administrator. If the customer does not have a System Administrator, they should contact the Customer Support Centre or request a Xerox analyst troubleshoot their network which will be subject to a charge.

19-300-00 to 19-310-00 Image Disk (HDD) Failure RAP

19-300-00 Unable to read or write data from the image disk.

19-301-00 Unable to write data to the image disk.

19-302-00 Bad data received from the disk (i.e. disk returns data other than a read or write operation in response to a read or write request from).

19-303-00 Unable to format the image disk.

19-310-00 Disk system does not return capacity information during power up.

Procedure

WARNING

Ensure that the electricity to the machine is switched off while performing tasks that do not need electricity. Refer to GP 14. Disconnect the power cord. Electricity can cause death or injury. Moving parts can cause injury.

Refer to [WD 3.3](#). Check that the SATA cable from PJ222 on the [single board controller PWB](#) to PJ210 on the hard disk drive is correctly connected and not damaged. If necessary, install a new cable, [PL 3.11 Item 3](#).

Refer to [WD 1.5](#) and [WD 3.3](#). Check the power harness from PJDC4 on the [power supply unit](#) to PJ211 on the hard disk drive. **The wiring is good.**

Y N

Repair the harness, [REP 1.1](#) or install a new harness, [PL 3.11 Item 12](#), as necessary.

Refer to [WD 3.3](#). Measure +5V between pins 3 and 2 on PJ211 at the hard disk drive. **+5V was measured.**

Y N

Go to [01D](#) +5V Distribution RAP.

Measure +12V between pins 5 and 4 on PJ211 at the hard disk drive. **+12V was measured.**

Y N

Go to [01E](#) +12V Distribution RAP.

If necessary, perform a software upgrade, [GP 4](#).

Install new components as necessary:

- Hard disk drive, [PL 3.11 Item 2](#).
- Single board controller PWB, [PL 3.11 Item 13](#).

19-401-00, 19-402-00 Stress Out of Memory RAP

19-401-00 Out of memory caused by a stress document.

19-402-00 Out of memory caused by a stress job.

Procedure

WARNING

Ensure that the electricity to the machine is switched off while performing tasks that do not need electricity. Refer to GP 14. Disconnect the power cord. Electricity can cause death or injury. Moving parts can cause injury.

If this fault remains for more than five minutes, switch off the machine, then switch on the machine, [GP 14](#). **The fault has cleared.**

Y N

Perform a software upgrade, [GP 4](#).

Go to [SCP 5](#) Final Actions.

19-403-00 EPC Out of Memory RAP

19-403-00 Out of memory with greater than one job in EPC.

Procedure

WARNING

Ensure that the electricity to the machine is switched off while performing tasks that do not need electricity. Refer to **GP 14**. Disconnect the power cord. Electricity can cause death or injury. Moving parts can cause injury.

No service action is required. Re-scan the job.

19-409-00 Job Integrity Failure RAP

19-409-00 Video determines that it cannot guarantee the integrity of the job being processed.

Procedure

WARNING

Ensure that the electricity to the machine is switched off while performing tasks that do not need electricity. Refer to **GP 14**. Disconnect the power cord. Electricity can cause death or injury. Moving parts can cause injury.

Perform the following:

1. Switch the off machine, then switch on the machine, **GP 14**.
2. Re-run all the uncompleted jobs.

19-410-00 to 19-410-13 Image Structure Failure RAP

19-410-00 The system has detected a mark output time-out.

19-410-01 The system has detected a mark output time-out.

19-410-02 The system has detected a compress image time-out.

19-410-03 The system has detected a decompress image time-out.

19-410-04 The system has detected a merge image time-out.

19-410-05 The system has detected a rotate image time-out.

19-410-06 The system has detected a network Input failure.

19-410-07 The system has detected an e-fax send/receive failure.

19-410-08 The system has detected a scan input failure.

19-410-09 The system has detected a byte counter error.

19-410-10 The system has detected the image set up was too late.

19-410-11 The system has detected a DMA master abort.

19-410-12 The system has detected a Huffman error, (image encoding error).

19-410-13 The system has detected an EOR error.

Procedure

WARNING

Ensure that the electricity to the machine is switched off while performing tasks that do not need electricity. Refer to GP 14. Disconnect the power cord. Electricity can cause death or injury. Moving parts can cause injury.

If this fault remains for more than five minutes, switch off the machine, then switch on the machine, GP 14. Re-run the job. **The fault has cleared.**

Y N

Perform a software re-load, GP 4.

Go to SCP 5 Final Actions.

19-750-00 EPC Memory Change Detected RAP

19-750-00 The system detects that the EPC memory size configuration has changed during the power on sequence.

Procedure

WARNING

Ensure that the electricity to the machine is switched off while performing tasks that do not need electricity. Refer to GP 14. Disconnect the power cord. Electricity can cause death or injury. Moving parts can cause injury.

No service action required. Re-run the job.

19-752-00 Image Rotation Detected RAP

19-752-00 The system detects that the image rotation configuration has changed during the Power On sequence.

Procedure

WARNING

Ensure that the electricity to the machine is switched off while performing tasks that do not need electricity. Refer to [GP 14](#). Disconnect the power cord. Electricity can cause death or injury. Moving parts can cause injury.

Switch off the machine, then switch on the machine, [GP 14](#). Re-run the job.

19-754-00 Image Disk Change RAP

19-754-00 The system detects that the Image disk configuration (present vs. not present) has changed during the power on sequence.

Procedure

WARNING

Ensure that the electricity to the machine is switched off while performing tasks that do not need electricity. Refer to [GP 14](#). Disconnect the power cord. Electricity can cause death or injury. Moving parts can cause injury.

Switch off the machine, then switch on the machine, [GP 14](#). Re-run the job. **The fault has cleared.**

Y N

Go to [19-300-00 to 19-310-00](#) Image Disk (HDD) Failure RAP.

Go to [SCP 5](#) Final Actions.

20-302-00, 20-303-00 Fax Reset Failure RAP

The fax card will automatically reset itself.

20-302-00 Unexpected reset fault due to fax card hardware or software error.

20-303-00 Unrecoverable fault due to fax card hardware or software error.

Initial Actions

WARNING

Ensure that the electricity to the machine is switched off while performing tasks that do not need electricity. Refer to GP 14. Disconnect the power cord. Electricity can cause death or injury. Moving parts can cause injury.

- Make a backup of the phone book and the customer settings, refer to dC361 Save and Restore.

Procedure

Switch off the machine, then switch on the machine, GP 14. **The fault still occurs.**

Y N
| Go to SCP 5 and complete the final actions.

Clear the fax card NVM. Go to dC301 NVM Initialization, select Embedded Fax NVM initialization and perform the routine, All Data. **The fault is cleared.**

Y N
| Reload the software, GP 4. **The fault is cleared.**

Y N
| Go to RAP 20G Fax Module Checkout.

Go to SCP 5 and complete the final actions.

Go to SCP 5 and complete the final actions.

20-305-00 Fax System Low Memory Unrecoverable RAP

The fax card will automatically reset itself.

20-305-00 Unrecoverable fax system low memory due to fax card hardware or software error

Initial Actions

WARNING

Ensure that the electricity to the machine is switched off while performing tasks that do not need electricity. Refer to GP 14. Disconnect the power cord. Electricity can cause death or injury. Moving parts can cause injury.

- Make a backup of the phone book and the customer settings, refer to dC361 NVM Save and Restore.

Procedure

Switch off the machine, then switch on the machine, GP 14. **The fault still occurs.**

Y N
| Go to SCP 5 and complete the final actions.

Clear the images from the fax card. Go to dC301 NVM Initialization. Select Embedded Fax NVM Initialization. Perform the routine, All Data. **The fault is cleared.**

Y N
| Reload the software, GP 4.

Go to SCP 5 and complete the final actions.

20-320-00 Fax Fault Not Cleared by Reset RAP

20-320-00 After five instances of an unrecoverable fax fault and has not been cleared by a card reset.

Initial Actions

WARNING

Ensure that the electricity to the machine is switched off while performing tasks that do not need electricity. Refer to **GP 14**. Disconnect the power cord. Electricity can cause death or injury. Moving parts can cause injury.

- Make a backup of the phone book and the customer settings, refer to **dC361** NVM Save and Restore.

Procedure

Switch off the machine, then switch on the machine, **GP 14**. **The fault still occurs.**

Y N
Go to **SCP 5** and complete the final actions.

Clear the fax card NVM. Go to **dC301** NVM Initialization. Select Embedded Fax NVM initialization. Perform the routine, All data. **The fault is cleared.**

Y N
Reload the software, **GP 4**.

Go to **SCP 5** and complete the final actions.

20-322-00 Non-Volatile Device not Installed RAP

20-322-00 The non-volatile device has not been installed on the embedded fax card.

Initial Actions

WARNING

Ensure that the electricity to the machine is switched off while performing tasks that do not need electricity. Refer to **GP 14**. Disconnect the power cord. Electricity can cause death or injury. Moving parts can cause injury.

- Make a backup of the phone book and the customer settings, refer to **dC361** NVM Save and Restore.

Procedure

Switch off the machine, then switch on the machine, **GP 14**. **The fault still occurs.**

Y N
Go to **SCP 5** and complete the final actions.

Clear the fax card NVM. Go to **dC301** NVM Initialization. Select Embedded Fax NVM initialization. Perform the routine, All data. **The fault still occurs.**

Y N
Go to **SCP 5** and complete the final actions.

Install new parts as necessary:

- Fax module, **PL 20.05 Item 1**.

20-323-00, 20-324-00 Fax System Memory Low RAP

20-323-00 The fax system memory is low, less than 6Mb.

20-324-00 There is not enough memory to use the fax service.

Initial Actions

WARNING

Ensure that the electricity to the machine is switched off while performing tasks that do not need electricity. Refer to GP 14. Disconnect the power cord. Electricity can cause death or injury. Moving parts can cause injury.

- Make a backup of the phone book and the customer settings, refer to dC361 NVM Save and Restore.

Procedure

Switch off the machine, then switch on the machine, GP 14. **The fault still occurs.**

Y N
Go to SCP 5 and complete the final actions.

Clear the fax card NVM. Go to dC301 NVM Initialization. Select Embedded Fax NVM initialization. Perform the routine, All data. **The fault is cleared.**

Y N
Install new components as necessary:

- Fax module, PL 20.05 Item 1.

Go to SCP 5 and complete the final actions.

20-331-00, 20-338-00, 20-339-00, 20-341-00, 20-345-00 Fax Network Line 1 Fault RAP

20-331-00 No communication via the PSTN 1 port.

20-338-00 Fax Communication Error at power up or reboot.

20-339-00 Internal fax card fault.

20-341-00 Miscellaneous basic card problems.

20-345-00 Fax port 1 modem failure.

Initial Actions

WARNING

Ensure that the electricity to the machine is switched off while performing tasks that do not need electricity. Refer to GP 14. Disconnect the power cord. Electricity can cause death or injury. Moving parts can cause injury.

- Make a backup of the phone book and the customer settings, refer to dC361 NVM Save and Restore.

Procedure

Switch off the machine, then switch on the machine, GP 14. **The fault still occurs.**

Y N
Go to SCP 5 and complete the final actions.

Check the connection between the fax module, PL 20.05 Item 1 and the fax connector PWB, PL 20.05 Item 2. **The connections are good.**

Y N
Install new parts as necessary:

- Fax connector PWB, PL 20.05 Item 2.
- Fax module, PPL 20.05 Item 1.

Check that the customer line is operational, plug a phone into the line and check for a dial tone. If a phone is not available then use a line test tool, PL 26.11 Item 16. **The phone line connection is good.**

Y N
The telephone line has a fault, inform the customer to have the line checked by the telephone company.

Install new parts in the following order:

- Telephone cable, PL 20.05 Item 3.
- Fax module, PL 20.05 Item 1.
- Fax connector PWB, PL 20.05 Item 2.
- Single board controller PWB, PL 3.11 Item 13.

20-332-00, 20-340-00 Fax Network Line 2 Fault RAP

20-332-00 No communication via the PSTN 2 port.

20-340-00 Fax port 2 modem failure.

Initial Actions

WARNING

Ensure that the electricity to the machine is switched off while performing tasks that do not need electricity. Refer to GP 14. Disconnect the power cord. Electricity can cause death or injury. Moving parts can cause injury.

- Make a backup of the phone book and the customer settings, refer to dC361 NVM Save and Restore.

Procedure

Switch off the machine, then switch on the machine, GP 14. **The fault still occurs.**

Y N
Go to SCP 5 and complete the final actions.

Check that the customer line is operational, plug a phone into the line and check for a dial tone. If a phone is not available then use a line test tool, PL 26.11 Item 16. **The phone line connection is good.**

Y N
The telephone line has a fault, advise the customer to have the line checked by the telephone company.

Install new parts in the following order:

- Telephone cable, PL 20.05 Item 3.
- Fax module, PL 20.05 Item 1.

20-342-00 Fax File Integrity Fault RAP

20-342-00 An error has occur when accessing the file on a non-volatile device.

Initial Actions

WARNING

Ensure that the electricity to the machine is switched off while performing tasks that do not need electricity. Refer to GP 14. Disconnect the power cord. Electricity can cause death or injury. Moving parts can cause injury.

- Make a backup of the phone book and the customer settings, refer to dC361 NVM Save and Restore.

Procedure

Switch off the machine, then switch on the machine, GP 14. **The fault still occurs.**

Y N
Go to SCP 5 and complete the final actions.

Clear the fax card NVM. Go to dC301 NVM Initialization. Select Embedded Fax NVM initialization. Perform the routine, All data. **The fault is cleared.**

Y N
Reload the software, GP 4.

Go to SCP 5 and complete the final actions.

20-701-00 Fax Phone Book Download Failed RAP

20-701-00 The fax phone book download failed.

Initial Actions

WARNING

Ensure that the electricity to the machine is switched off while performing tasks that do not need electricity. Refer to GP 14. Disconnect the power cord. Electricity can cause death or injury. Moving parts can cause injury.

- Check that the Fax module is correctly grounded.

Procedure

1. Reload the machine software, GP 4.
2. Install a new single board controller, PL 3.11 Item 13.

20-710-00, 20-711-00 Image Overwrite Error RAP

20-710 Immediate image overwrite error has occurred on the fax card when overwriting the job.

20-711 On demand image overwrite error has occurred on the fax card when overwriting the memory.

Initial Actions

WARNING

Ensure that the electricity to the machine is switched off while performing tasks that do not need electricity. Refer to GP 14. Disconnect the power cord. Electricity can cause death or injury. Moving parts can cause injury.

- Make a backup of the phone book and the customer settings, refer to dC361 NVM Save and Restore.

Procedure

WARNING

Ensure that the electricity to the machine is switched off while performing tasks that do not need electricity. Refer to GP 14. Disconnect the power cord. Electricity can cause death or injury. Moving parts can cause injury.

Switch off the machine, then switch on the machine, GP 14. **The fault still occurs.**

Y N

Go to SCP 5 Final Actions.

Clear the fax card NVM. Go to dC301 NVM Initialization. Select Embedded Fax NVM initialization. Perform the routine, All data. **The fault is cleared.**

Y N

Perform an Altboot, GP 4. **The fault is cleared.**

Y N

Install new components as necessary:

- Fax module, PL 20.05 Item 1.
- Install a new single board controller PWB, PL 3.11 Item 13.

Go to SCP 5 Final Actions.

Go to SCP 5 Final Actions.

20A Fax Entry RAP

Use this RAP to isolate components which contribute to Fax communications failure.

Initial Actions

WARNING

Ensure that the electricity to the machine is switched off while performing tasks that do not need electricity. Refer to [GP 14](#). Disconnect the power cord. Electricity can cause death or injury. Moving parts can cause injury.

- Check that the telephone line cables are properly connected. Fax Line 1 from the telephone line outlet connects to line 1 socket on the machine. Fax line 2 (if installed) from the telephone line outlet connects to line 2 socket on the machine.
- Use a hand set to dial remote number and listen to dial type, (tone / pulse)
- Check the ground connection on the fax module
- Check the Fault History. If the fault codes are [20-331-00](#), [20-338-00](#), [20-339-00](#), [20-341-00](#), [20-345-00](#) or [20-332-00](#), [20-340-00](#), then go to the appropriate RAP.
- Check the Fax setup for any active feature that would inhibit the sending of a Fax, such as: Delayed start time, Local name and ID are set, Dialing type or junk Fax prevention. Enter Admin / Tools / Service Settings / Embedded Fax Setting and check the following:
 - Fax Country setting
 - Line Setup
 - Options
 - Dial type setting, tone / pulse.
- Enter Admin / Tools / Service Settings / Embedded Fax Settings / Print Fax Reports. Print a Activity Report and check for error codes.

Procedure

The Fax tab is available

Y N
Go to [20F](#) Fax Tab Not Available RAP.

The machine will send a Fax to all machines.

Y N
The machine will send a fax to some machines.
Y N
Go to [20B](#) Unable To Send A Fax RAP.

Go to [20C](#) Unable To Send A Fax To Some Machines RAP.

The machine will receive a fax from the remote machine.

Y N
Go to [20D](#) Unable To Receive A Fax RAP.

The Fax prints out.

Y N
Go to [20E](#) Fax Will Not Print RAP.

The fault is cleared.

Y N
Go to [20G](#) Fax module Checkout RAP.

The Fax is working correctly. Send a three page test Fax to a known good Fax machine. Print a Protocol Report and check for errors.

20B Unable To Send A Fax RAP

Use this RAP to isolate components which contribute to a send failure.

Initial Actions

WARNING

Ensure that the electricity to the machine is switched off while performing tasks that do not need electricity. Refer to [GP 14](#). Disconnect the power cord. Electricity can cause death or injury. Moving parts can cause injury.

- Refer to the [20A](#) Fax Entry RAP and complete all of the initial actions.

Procedure

Verify with the customer that PSTN / PABX (Public Switched Telephone Network / Private Automatic Branch Exchange) line is operational. Connect a telephone handset into line outlet and listen for a dial tone. Use a known good telephone handset. **The dial tone is present.**

Y N
Use the line test tool, [PL 26.11 Item 16](#) to check the telephone line. **The green normal indicator light is on.**

Y N
Ask the customer to request a line check by the telephone company.

Use a telephone handset to dial a known good number. **The ring back is heard.**

Y N
Ask the customer to request a line check by the telephone company.

Enable audio line monitor (Enter Admin / Tools / Service Settings / Embedded Fax Setting / Transmission Defaults / Audio Line Monitor) and set to Enable and High volume.

Dial the Fax number and listen for a dial tone or dialing and answer tones. **A Fax tone is present.**

Y N
Enter [dC131](#) NVM Read / Write. Reset the value at the following location:
NVM ID 200-415 Line1CurrentDetect = 0
NVM ID 200-416 Line2CurrentDetect = 0 **A Fax tone is present.**

Y N
Go to the [20G](#) Fax Module Checkout.
Install new components as necessary:

- Fax module, [PL 20.05 Item 1](#).
- Telephone cable, [PL 20.05 Item 3](#).

The Fax is working correctly. Send a three page test Fax to a known good Fax machine. Enter Admin / Tools / Service Settings / Embedded Fax Setting / Print Fax Reports. Print a Protocol Report and check for errors.

The dial tone - dialling answer tones are present.

Y N
The exchange is receiving the digits too quickly or is not processing the digits correctly. Ask the customer if the exchange is DTMF (Dual Tone Multiple Frequency) or pulse dialing.

Perform the following:

- Ensure that the machine is set for the correct dialing tone. Enter [dC131](#) NVM Read / Write. Reset the values at NVM ID 200-201 FaxLine1DialTypeDef and at NVM ID 200-202 FaxLine2DialTypeDef set to 0 = Tone or 1 = Pulse.
- Insert a pause (,) between the first and second digit of the dial string. In the Dialling Options select Dialling Characters / Pause / Add Character / Save.

A B

A B
The Fax only dials once and hangs up or the busy tone has unusual timing, frequency or level. **The busy tones are recognized.**

Y N
Check the number for a voice or tone answer.

The Fax is working correctly. Send a three page test Fax to a known good Fax machine. Enter Admin / Tools / Service Settings / Embedded Fax Setting / Print Fax Reports. Print a Protocol Report and check for errors. Re-enter the details from the fax options

Check that the customer is dialing the correct number. **The number is correct.**

Y N
Ask the customer to dial the number using the appropriate access codes.

Enable audio line monitor (Enter Admin / Tools / Service Settings / Embedded Fax Setting / Transmission Defaults / Audio Line Monitor) and set to Enable. Select High volume and max time.

Dial the Fax number and listen for a dial tone or dialing and answer tones. **A Fax tone is present.**

Y N
Enter **dC131** NVM Read / Write. Reset the value at the following location:
NVM ID 200-415 Line1CurrentDetect = 0
NVM ID 200-416 Line2CurrentDetect = 0 **A Fax tone is present.**

Y N
Go to the **20G** Fax Module Checkout.
Install new components as necessary:

- Fax module, **PL 20.05 Item 1.**
- Telephone cable, **PL 20.05 Item 3.**

The Fax is working correctly. Send a three page test Fax to a known good Fax machine. Enter Admin / Tools / Service Settings / Embedded Fax Setting / Print Fax Reports. Print a Protocol Report and check for errors.

The dial tone - dialling answer tones are present.

Y N
The exchange is receiving the digits too quickly or is not processing the digits correctly. Ask the customer if the exchange is DTMF (Dual Tone Multiple Frequency) or pulse dialing.
Perform the following:

- Ensure that the machine is set for the correct dialing tone.
Enter **dC131** NVM Read / Write. Reset the values at NVM ID 200-201 FaxLine1DialTypeDef and at NVM ID 200-202 FaxLine2DialTypeDef set to 0 = Tone or 1 = Pulse.
- Insert a pause (,) between the first and second digit of the dial string. In the Dialling Options select Dialling Characters / Pause / Add Character / Save.
- Enter **dC131** NVM Read / Write. Set NVM ID 200-397 FaxTimeBeforeDial to 13.

The Fax only dials once and hangs up or the busy tone has unusual timing, frequency or level. **Are the busy tones recognized.**

Y N

- Check the number for a voice or tone answer.
- Check that the values at NVM ID 200-237 to 200-241 are set to the correct defaults to match the appropriate country setting.

The fax is working correctly. Send a three page test Fax to a known good Fax machine. Enter Admin / Tools / Service Settings / Embedded Fax Setting / Print Fax Reports. Print a Protocol Report and check for errors. Re-enter the details from the fax options

20C Unable To Send A Fax To Some Machines RAP

Use this RAP to isolate components which contribute to a failure to send a Fax to some machines.

Initial Actions

WARNING

Ensure that the electricity to the machine is switched off while performing tasks that do not need electricity. Refer to GP 14. Disconnect the power cord. Electricity can cause death or injury. Moving parts can cause injury.

- Refer to the **20A** Fax Entry RAP and complete all of the initial actions.

Procedure

The correct number is being dialled to make the connection. **The connection is made.**

Y N
The exchange is not processing the digits correctly, the machine needs longer pause between digits.

- Insert a pause (,) between the first and second digit of the dial string. In the Dialling Options select Dialling Characters / Pause / Add Character / Save.
- Enter **dC131** NVM Read / Write. Change setting at NVM ID 200-410 FaxDTMFInter-digitTime to 100.

Call the fax number from a known good telephone and listen for the answer fax tone. **The Fax tone is heard.**

Y N
Fax on remote end is not picking up or no Fax is connected. Advise customer to check the machine at the remote end.

Enter Admin / Tools / Service Settings / Embedded Fax Setting / Print Fax Reports. Print a Protocol Report. The Protocol Report shows RNR (Receive Not Ready) is received from the remote Fax repeatedly until time out and DCN (Disconnect). Check communication failure after V34-PH2 / V34-PH3 or DCS / TCF. **The remote Fax receives and prints the Fax.**

Y N
Compatibility problem with remote Fax.

- Print a Protocol Report and check for communication errors.
- Line quality too poor for Super G3 to function correctly. Possible mains interference on line.
- Disable V34 (Super G3). Enter **dC131** NVM Read / Write. Reset the value at the following locations:
 - NVM ID 200-087 T30MaxSpeedL1Tx = 11 (14400).
 - NVM ID 200-088 T30MaxSpeed2Tx = 11 (14400).If mains noise, try installing and using line 2 instead of line 1.
- When sending to a PC fax or fax server that has an ISDN card, there is a need to customize the CEQ values. Enter **dC131** NVM Read / Write. Set the value at NVM ID 203-031 to 0.

The Protocol Report shows MCF (Message Confirmation) is not sent by the remote Fax (last page), only DCN (Disconnect). **The failure report printed out, but the remote fax prints multiple copies of the job or failed page.**

Y N
The Fax is working correctly. Send a three page test Fax to a known good Fax machine. Print a Protocol Report and check for errors.

The machine will resend up to 10 times before printing the failure report. Enter Admin / Tools / Service Settings/ Embedded Fax Setting / Transmission Defaults / Automatic Resend. Set number of resend to 1 or 2.

20D Unable To Receive A Fax RAP

Use this RAP to isolate components which contribute to the fax not received from the machine.

Initial Actions

WARNING

Ensure that the electricity to the machine is switched off while performing tasks that do not need electricity. Refer to [GP 14](#). Disconnect the power cord. Electricity can cause death or injury. Moving parts can cause injury.

WARNING

Do not touch the test pads on the embedded fax PWB while the fax cable is connected to the machine. Dangerous voltages may be present that could cause death or injury.

- Refer to the [20A](#) Fax Entry RAP and complete all of the initial actions.

Procedure

Verify with the customer that PSTN / PABX (public switched telephone network / private automatic branch exchange) line is operational. Use a known good telephone handset or use the line test tool, [PL 26.11 Item 16](#) to check the telephone line. **The dial tone is present.**

Y N

Ask the customer to request a line check by the telephone company.
Ensure Fax service is enabled and supported on that line by a PBX administrator.

Call the handset from another telephone. **The phone rings.**

Y N

Ask the customer to request a line check by the telephone company.
Ensure Fax service is enabled and supported on that line by a PBX administrator.

Enable audio line monitor (Enter Admin / Tools / Service Setting / Embedded Fax Setting / Transmission Defaults / Audio Line Monitor) and set to Enable and High volume.

Dial the Fax number and listen for a dial tone or dialing and answer tones. **A Fax tone is present.**

Y N

Go to [20G](#) Embedded Fax Checkout
Install new components as necessary:

- Fax module, [PL 20.05 Item 1](#).
- Telephone cable, [PL 20.05 Item 3](#).

Reconnect the fax and call the fax number from a independent telephone line and listen for a Fax tone. **The machine answers and a fax tone is heard.**

Y N

Enter Admin / Tools / Service Settings / Embedded Fax Setting / Print Fax Reports. Print Activity Report. Check for receive calls on the Activity Report. Machine probably does not beep to indicate incoming call.

Check that the NVM values at NVM ID 200-203, NVM ID 200-423 and 200-426 are set to the correct defaults to match the appropriate country setting. **The machine answers and a Fax tone is heard.**

Y N

Go to [20G](#) Fax Module Checkout

A B

A B

Install new components as necessary:

- Fax module, [PL 20.05 Item 1](#).

The Fax is working correctly. Send a three page test Fax to a known good Fax machine. Print a Protocol Report and check for errors.

Receive a three page test Fax from the original Fax machine. Print a Protocol Report and check for errors. **The Protocol Report shows communication failure after CSI / DIS (Called Subscriber Identified / Digital Identification Signal) or DCS / TCF (Digital Command Signal / Training Check) or after V34-PH2 / V34-PH3 or EQM (Eye Quality Monitor) value greater than 5000.**

Y N

The problem may be intermittent, inform the operator of the remote machine, they should report the problem to the telephone company.

Perform the following:

- Confirm line is standard PSTN / PBX analogue line
- Line quality too poor for Super G3 or G3 to function correctly. Possible mains interference on line. Possible DSL line, not properly filtered.
- Ask customer to request Fax capable service from telephone company.
- If mains noise, install a new fax module, [PL 20.05 Item 1](#). Use line 1.
- Enter [dC131](#) NVM Read / Write. Set the value at the following locations:
 - NVM ID 200-085 T30 Maximum resolution Line 1 Rx = 7
 - NVM ID 200-086 T30 Maximum resolution Line 2 Rx = 7This sets the receive resolution capabilities for line 1 and line 2 to 400 x 400 max, this will shorten the DIS.
- The DIS field is too long to enable successful communication.
Enter [dC131](#) NVM Read / Write. Change NVM ID 200-141 USSTOCKSUPPORTRAX to 0 (disable).
- Disable V34 (Super G3). Enter [dC131](#) NVM Read / Write and reset the value at the following locations:
 - NVM ID 200-089 T30MaxSpeedL1Rx = 11 (14400)
 - NVM ID 200-090 T30MaxSpeedL2Rx = 11 (14400)If the problem still exists try a lower line receive (Rx) speed: 12 = 12000, 13 = 9600, 14 = 7200, 15 = 4800, 16 = 2400
- Send a three page test Fax from a known good fax machine.

20E Fax Will Not Print RAP

Use this RAP to solve fax printing problems.

Initial Actions

WARNING

Ensure that the electricity to the machine is switched off while performing tasks that do not need electricity. Refer to [GP 14](#). Disconnect the power cord. Electricity can cause death or injury. Moving parts can cause injury.

- Check the condition of the paper in all trays.
- Check that the paper trays are loaded with the appropriate paper sizes for printing the Fax. Refer to [GP 20](#).

Procedure

- If the received fax has mixed size documents (example, the first prints are 8.5 x 11 and then followed by 8.5 x 14 prints). Check in the 'All Incomplete Jobs' queue, the job will print 8.5 x 11 pages without printing 8.5 x 14 pages and then the job will be deleted.

Perform the following:

In Tools menu, go to Fax setup and select:

- Receive Defaults.
- Receive Printing mode and change to Manual.
- In paper sizes, select correct page for each size to match the paper in the tray.
- Save and then change back to Auto. Save and Exit.

- If the User Interface is asking for a size paper that is not loaded in trays.

Perform the following:

In Tools menu, go to Fax setup and select:

- Receive Defaults.
- Receive Printing mode.
- Select manual, change small paper setting to None and Save.

NOTE: For small, long and large paper sizes select NONE if the corresponding paper is not loaded in the paper trays.

- Change setting to Auto and Save.

20F Fax Tab Not Available RAP

Use this RAP to isolate the problem when the Fax tab is not available or greyed out.

Initial Actions

WARNING

Ensure that the electricity to the machine is switched off while performing tasks that do not need electricity. Refer to [GP 14](#). Disconnect the power cord. Electricity can cause death or injury. Moving parts can cause injury.

- Switch off the machine, then switch on the machine, [GP 14](#).
- Check for the correct installation of the fax option. Refer to the system administration guide CD1, for the install instruction. Follow the screen prompts.

Procedure

The Fax tab is displayed on the user interface screen.

Y N

The fax installation was not completed.

Go to Admin / Tools / Service Setting / Embedded Fax Setting / Fax Setup. Select Enable and Save. Switch off the machine and switch on the machine, [GP 14](#). This will initiate the 'Fax Install Wizard' and follow the prompts on the screen to complete the install of the Fax.

The Fax tab is displayed after installation.

Y N

Check that the fax module is installed correctly, [PL 20.05](#).

Perform the following:

1. Switch off the machine, [GP 14](#).
2. Check the connection between the fax module and the fax connector PWB, [PL 20.05](#).
Check the fax connector PWB ribbon cable, [PL 3.11 Item 7](#) connection between the single board controller PWB, [PL 3.11 Item 13](#) and the fax connector PWB, [PL 20.05 Item 2](#).
3. Switch on the machine, [GP 14](#).

The super fine tab is displayed.

Y N

The Server Fax may be enabled.

Go to Admin / Tools / Service Setting / Embedded Fax Setting / Fax Setup and press Disable and Save. This will disable the Server Fax.

After installing Fax Module. The Fax selection tab is greyed out and requesting a pass code to enable the Fax (Scan to E-mail installed).

Y N

The fax is installed correctly. Send a three page test fax to a known good fax machine. Enter Admin / Tools / Service Settings / Embedded Fax Setting / Print Fax Reports. Print a Protocol Report and check for errors.

Perform an AltBoot, [GP 4](#).

NOTE: Software should only be loaded on a working machine. Loading or reloading software onto a machine (or fax card) that has a fault will not work.

20G Fax Module Checkout

Use this RAP to check for problems with the fax module.

Initial Actions

WARNING

Ensure that the electricity to the machine is switched off while performing tasks that do not need electricity. Refer to [GP 14](#). Disconnect the power cord. Electricity can cause death or injury. Moving parts can cause injury.

- Switch off the machine, then switch on the machine, [GP 14](#).
- Check that the embedded fax PWB, [PL 20.05 Item 4](#) is located correctly.
- Check that the fax module is correctly grounded.
- For copy quality defects, go to [IQ 27](#) Unacceptable Received Fax Image Quality RAP.

Procedure

Go to [WD 3.2](#) and [WD 3.1](#). Check the +3.3V, +5V and +12V voltages. The voltages are good.

Y N

Refer to the following:

- [01C](#) +3.3V Distribution RAP
- [01D](#) +5V Distribution RAP
- [01E](#) +12V Distribution RAP
- [01L](#) 0V Distribution RAP

Install a new components as required.

Switch off the machine [GP 14](#). Disconnect the following:

- The Fax module from the fax connector PWB, [PL 20.05](#).
- The Fax connector PWB ribbon cable from the single board controller PWB, [PL 3.11](#).

Check that the connectors are clean and not damaged. If the connectors are damaged then install new components as necessary:

- Fax connector PWB, [PL 20.05 Item 2](#).
- Fax module, [PL 20.05 Item 1](#).
- Fax connector PWB ribbon cable, [PL 3.11 Item 7](#)
- Single board controller PWB, [PL 3.11 Item 13](#).

Reconnect the following:

- The Fax connector PWB ribbon cable to the single board controller PWB.
- The fax module to the fax connector PWB.

Switch on the machine, [GP 14](#). The fault is cleared.

Y N

Return to the original fault code RAP and perform the remaining actions in the procedure.

Go to [SCP 5](#) and perform the final actions.

20H Fax Problems on Digital Networks RAP

Use this RAP to isolate the problem when using digital networks.

The Fax option was designed as an analogue Group 3 device. This will have the best performance when connected to a dedicated analog phone PSTN (Public Switched Telephone Network) line or POTS (Plain Old Telephone system).

- The Fax option will function on the following technologies:
 - ADSL - Asymmetric Digital Subscriber Line
 - DSL - Digital Subscriber Line
 - VOIP - Voice Over Internet Protocol
 - FOIP - Fax Over Internet Protocol, (T.38 protocol).
 - T1 Trunk / E1 Trunk (Europe).

NOTE: Due to the compression used on the technologies. The level of performance will be lower than on a PSTN or POTS.

- The Fax option will not function on the following technology:
 - ISDN - Integrated Services Digital Network

Initial Actions

WARNING

Ensure that the electricity to the machine is switched off while performing tasks that do not need electricity. Refer to [GP 14](#). Disconnect the power cord. Electricity can cause death or injury. Moving parts can cause injury.

- Switch off the machine, then switch on the machine, [GP 14](#).
- Check with the customer or IT person on what network the Fax service is being used and what is the quality of service.
- Check that an analogue adapter or a connection for analogue terminals are available.
- Ask the customer to check with service provider that an analogue port for Fax service has been provided and enabled.

Procedure

Perform the steps that follow:

- Go to [20A](#) Fax Entry RAP.
- Request the latest SPAR release.
- Disable V34.

Enter [dC131](#) NVM Read / Write and reset the value at the following locations:

- NVM ID 200-087 T30MaxSpeedL1Tx = 11 (14400)
 - NVM ID 200-088 T30MaxSpeedL2Tx = 11 (14400)
 - NVM ID 200-089 T30MaxSpeedL1Rx = 11 (14400)
 - NVM ID 200-090 T30MaxSpeedL2Rx = 11 (14400)
 - NVM ID 203-105 V34toV21FallbackTime = 20
- If problems are still not resolved after these actions, then escalate the problem using the normal escalation process

22-300-05 to 22-309-04 Other Network Faults 24 RAP

22-300-05 Image complete not received from video.

22-300-10 Failed to transfer image due to decoding error.

22-300-16 When machine determines that it needs to do a reset in order to avoid an impending real time clock overflow.

22-301-05 Scan resources not available.

22-309-04 Consecutive no accepts received from a module exceeds threshold value (currently 20). Five consecutive 22-309-04 will cause 22-319-04.

Procedure

WARNING

Ensure that the electricity to the machine is switched off while performing tasks that do not need electricity. Refer to GP 14. Disconnect the power cord. Electricity can cause death or injury. Moving parts can cause injury.

Switch off the machine, then switch on the machine, GP 14.

22-310-04 to 22-318-04 Other Network Faults 25 RAP

22-310-04 Pages received from extended job service out of sequence.

22-314-04 Module registration error.

22-316-04 Job requires paper tray that does not exist.

22-317-04 Job requires finishing capability that does not exist.

22-318-04 Job requires an IOT capability that does not exist.

Procedure

WARNING

Ensure that the electricity to the machine is switched off while performing tasks that do not need electricity. Refer to GP 14. Disconnect the power cord. Electricity can cause death or injury. Moving parts can cause injury.

Switch off the machine, then switch on the machine, GP 14.

22-315-04 One or More Modules Did Not Respond RAP

22-315-04 One or more modules did not respond with completion message.

Procedure

WARNING

Ensure that the electricity to the machine is switched off while performing tasks that do not need electricity. Refer to GP 14. Disconnect the power cord. Electricity can cause death or injury. Moving parts can cause injury.

Switch off the machine, then switch on the machine, GP 14.

22-319-04 IOT Integrity Problem While Printing a Job RAP

22-319-04 Integrity problem while printing a job. The IOT cycles down and up 10 times without printing a page within the same job causing the fault. The system automatically executes a reset.

Procedure

WARNING

Ensure that the electricity to the machine is switched off while performing tasks that do not need electricity. Refer to GP 14. Disconnect the power cord. Electricity can cause death or injury. Moving parts can cause injury.

Perform the following:

1. Switch off the machine, then switch on the machine, GP 14.
2. Delete the original job, then rerun the job.

22-321-00 SM Failed to Remove Scan to File RAP

22-321-00 SM failed to remove the scan to file.

Procedure

WARNING

Ensure that the electricity to the machine is switched off while performing tasks that do not need electricity. Refer to **GP 14**. Disconnect the power cord. Electricity can cause death or injury. Moving parts can cause injury.

Switch off the machine, then switch on the machine, **GP 14**.

22-321-04 Proposal Response Time Out Error RAP

22-321-04 Proposal response time out error - RS422 configuration mismatch.

Procedure

WARNING

Ensure that the electricity to the machine is switched off while performing tasks that do not need electricity. Refer to **GP 14**. Disconnect the power cord. Electricity can cause death or injury. Moving parts can cause injury.

Perform the following:

1. Switch off the machine, then switch on the machine, **GP 14**.
2. Check machine configuration.

22-325-01 Cleaning Unit Extended Life Mode Entered RAP

22-325-01 Cleaning unit extended life mode entered (CU snooze mode).

Procedure

WARNING

Ensure that the electricity to the machine is switched off while performing tasks that do not need electricity. Refer to **GP 14**. Disconnect the power cord. Electricity can cause death or injury. Moving parts can cause injury.

Switch off the machine, then switch on the machine, **GP 14**.

22-328-00 Incomplete System Information RAP

22-328-00 Incomplete system information. The accounting service data has been corrupted.

Procedure

WARNING

Ensure that the electricity to the machine is switched off while performing tasks that do not need electricity. Refer to **GP 14**. Disconnect the power cord. Electricity can cause death or injury. Moving parts can cause injury.

Switch off the machine, then switch on the machine, **GP 14**.

22-330-00 Page Pack PIN Entry Locked RAP

22-330-00 An incorrect page pack PIN has been entered more than 3 times and entry is now locked for 24 hours. Only one retry is now possible every 24 hours.

Procedure

WARNING

Ensure that the electricity to the machine is switched off while performing tasks that do not need electricity. Refer to GP 14. Disconnect the power cord. Electricity can cause death or injury. Moving parts can cause injury.

Perform the following:

1. Switch off the machine, then switch on the machine, GP 14.
2. Obtain a new PIN and try again.

22-330-01 List Jobs Request Timed Out Between UI and Copy Controller RAP

22-330-01 List jobs request timed out between UI and copy controller.

Procedure

WARNING

Ensure that the electricity to the machine is switched off while performing tasks that do not need electricity. Refer to GP 14. Disconnect the power cord. Electricity can cause death or injury. Moving parts can cause injury.

Switch off the machine, then switch on the machine, GP 14.

22-330-02 List Jobs Request Timed Out Between Copy Controller and ESS Print Service RAP

22-330-02 List jobs request timed out between copy controller and ESS print service.

Procedure

WARNING

Ensure that the electricity to the machine is switched off while performing tasks that do not need electricity. Refer to GP 14. Disconnect the power cord. Electricity can cause death or injury. Moving parts can cause injury.

Switch off the machine, then switch on the machine, GP 14.

22-330-03 List Jobs Request Timed Out Between Copy Controller and Scan to File Service RAP

22-330-03 List jobs request timed out between copy controller and scan to file service.

Procedure

WARNING

Ensure that the electricity to the machine is switched off while performing tasks that do not need electricity. Refer to GP 14. Disconnect the power cord. Electricity can cause death or injury. Moving parts can cause injury.

Switch off the machine, then switch on the machine, GP 14.

22-330-04 List Jobs Request Timed Out Between Copy Controller and Scan to Fax Service RAP

22-330-04 List jobs request timed out between copy controller and scan to Fax service.

Procedure

WARNING

Ensure that the electricity to the machine is switched off while performing tasks that do not need electricity. Refer to GP 14. Disconnect the power cord. Electricity can cause death or injury. Moving parts can cause injury.

Switch off the machine, then switch on the machine, GP 14.

22-330-05 List Jobs Request Timed Out Between Queue Utility and DC Job Service RAP

22-330-05 List jobs request timed out between queue utility and DC job service.

Procedure

WARNING

Ensure that the electricity to the machine is switched off while performing tasks that do not need electricity. Refer to GP 14. Disconnect the power cord. Electricity can cause death or injury. Moving parts can cause injury.

Switch off the machine, then switch on the machine, GP 14.

22-330-06 ESS Scan to Distribution Service not Responding to List Jobs RPC Call RAP

22-330-06 ESS scan to distribution service not responding to list RPC call.

Procedure

WARNING

Ensure that the electricity to the machine is switched off while performing tasks that do not need electricity. Refer to GP 14. Disconnect the power cord. Electricity can cause death or injury. Moving parts can cause injury.

Switch off the machine, then switch on the machine, GP 14.

22-350-01, 22-350-02 Software Detects Non-Valid Xerox SOK RAP

22-350-01 Software detected non-valid Xerox SOK 1.

22-350-02 Software detected non-valid Xerox SOK 2 or 3.

Procedure

WARNING

Ensure that the electricity to the machine is switched off while performing tasks that do not need electricity. Refer to GP 14. Disconnect the power cord. Electricity can cause death or injury. Moving parts can cause injury.

Perform the following:

1. Switch off the machine, then switch on the machine, GP 14.
2. Ignore all requested options from the software option key (SOK).

22-351-01 to 22-351-03 SOK Write Failure RAP

22-351-01 SOK 1 write failure.

22-351-02 SOK 2 write failure.

22-351-03 SOK 3 write failure.

Procedure

WARNING

Ensure that the electricity to the machine is switched off while performing tasks that do not need electricity. Refer to [GP 14](#). Disconnect the power cord. Electricity can cause death or injury. Moving parts can cause injury.

Perform the following:

1. Switch off the machine, then switch on the machine, [GP 14](#).
2. Ignore all requested options from the software option key (SOK).

22-352-00 Serial Number Missing RAP

22-352-00 Serial number has been lost.

Initial Actions

WARNING

Ensure that the electricity to the machine is switched off while performing tasks that do not need electricity. Refer to [GP 14](#). Disconnect the power cord. Electricity can cause death or injury. Moving parts can cause injury.

- Switch off the machine, then switch on the machine, [GP 14](#).
- Check the fault history file for 03-xxx fault codes. Go to the appropriate RAP.

Procedure

1. Check that the machine serial number is correct on the UI or the option to install the correct value is available, refer to [dC132](#).
2. Check that the SIM card is present in the SIM slot in the image processing module, [PL 3.11 Item 22](#).

NOTE: The SIM card is also referred to as the product enablement key.

3. Switch off the machine, then switch on the machine, [GP 14](#).
4. Enter [dC131](#). Select CCS NVM ID 616-003 Product Configuration. Perform the following:
 - a. Check that the values are set to 112 = 9301, 113 = 9302 or 114 = 9303 as appropriate to what speed the machine should be. No further action should be required as the machine has recovered its configuration from the SIM card.
 - b. If the value is 0 the machine has never been installed. A blank SIM card of the appropriate speed, billing plan and service plan can be installed. This should have been supplied with the machine so a replacement would need to be obtained through normal process to complete a missing part not delivered at install.
 - c. If the value is 49, this is the default at manufacture. Any other number is likely caused by a memory corruption. For all these instances a pre-serialized SIM card/SW module will be required. Escalate the request through normal channels to obtain one.

22-371-00, 22-372-00 Fax Application Registration Error RAP

22-371-00 Set by the fax service when it gets no response from the service registry when trying to register.

22-372-00 Set by the fax service when it gets no response from the service registry when trying to un-register.

Procedure

WARNING

Ensure that the electricity to the machine is switched off while performing tasks that do not need electricity. Refer to GP 14. Disconnect the power cord. Electricity can cause death or injury. Moving parts can cause injury.

Perform the following:

1. Switch off the machine, then switch on the machine, GP 14.
2. Check the fax connections.
3. Reload the software, GP 4.

22-701-04 Module Completion Message Received RAP

22-701-04 Module completion message received after IOT returned to standby.

Procedure

WARNING

Ensure that the electricity to the machine is switched off while performing tasks that do not need electricity. Refer to GP 14. Disconnect the power cord. Electricity can cause death or injury. Moving parts can cause injury.

Switch off the machine, then switch on the machine, GP 14.

22-720-00 Service Registry Bad Data/Corrupted RAP

22-720-00 Service bad data/corrupted.

Procedure

WARNING

Ensure that the electricity to the machine is switched off while performing tasks that do not need electricity. Refer to **GP 14**. Disconnect the power cord. Electricity can cause death or injury. Moving parts can cause injury.

Switch off the machine, then switch on the machine, **GP 14**.

22-721-00 No Response From The Service Registry RAP

22-721-00 Triple A gets no response from the service registry service.

Procedure

WARNING

Ensure that the electricity to the machine is switched off while performing tasks that do not need electricity. Refer to **GP 14**. Disconnect the power cord. Electricity can cause death or injury. Moving parts can cause injury.

Switch off the machine, then switch on the machine, **GP 14**.

22-750-04 to 22-755-17 Configuration Mismatch RAP

22-750-04 Output device configuration mismatch.

22-750-17 When the system detects that the accessory card configuration mismatch has changed during the power on sequence.

22-751-04 Paper tray configuration mismatch.

22-754-17 When the system detects the UI configuration has changed during the power on sequence.

22-755-17 After the 2nd user confirmation of configuration mismatch if the system detects that the RDT configuration has changed during the power on sequence.

Procedure

WARNING

Ensure that the electricity to the machine is switched off while performing tasks that do not need electricity. Refer to GP 14. Disconnect the power cord. Electricity can cause death or injury. Moving parts can cause injury.

Switch off the machine, then switch on the machine, GP 14.

42-504-00 Enclosure Fan Over Current RAP

42-504-00 The enclosure fan current demand is inconsistent with expected value.

Procedure

Go to [OF 6 Fans and Air Systems RAP](#).

42-505-00 Abatement Fan Over Current RAP

42-505-00 The abatement fan current demand is inconsistent with expected value.

Procedure

Go to [OF 6 Fans and Air Systems RAP](#).

62-277-00 Scanner to DADH Communication Fail Entry RAP

62-277-00 A communication failure between scanner PWB and DADH PWB has been detected.

Initial Actions

WARNING

Ensure that the electricity to the machine is switched off while performing tasks that do not need electricity. Refer to [GP 14](#). Disconnect the power cord. Electricity can cause death or injury. Moving parts can cause injury.

- Switch off, then switch on the machine, [GP 14](#).

Procedure

Remove the DADH rear cover, [PL 5.10 Item 1](#). Remove the scanner PWB cover, refer to [REP 62.12](#). Refer to [WD 5.2](#) and [WD 6.1](#). Check the wiring between PJ188 on the [DADH PWB](#) and PJ921 on the [scanner PWB](#). **The wiring is good.**

Y N

Re-seat loose connectors or install new components as necessary:

- DADH Communication/power cable, [PL 5.10 Item 6](#).
- DADH PWB, [PL 5.10 Item 5](#).
- Scanner PWB, [PL 62.16 Item 8](#).

Perform [SCP 5](#) Final Actions.

62-310-00 Scanner to Single Board Controller Communication Fail RAP

62-310-00 A communication failure between the scanner PWB and the single board controller PWB has been detected.

Initial Actions

WARNING

Ensure that the electricity to the machine is switched off while performing tasks that do not need electricity. Refer to [GP 14](#). Disconnect the power cord. Electricity can cause death or injury. Moving parts can cause injury.

- Switch off, then switch on the machine, [GP 14](#).

Procedure

Remove the scanner PWB cover, refer to [REP 62.12](#). Refer to [WD 6.1](#) and [WD 3.1](#). Check the wiring between PJ922 on the [scanner PWB](#) and PJ15 on the [single board controller PWB](#). **The wiring is good.**

Y N

Re-seat loose connectors or install new components as necessary:

- IIT video/SBC PWB harness, [PL 62.10 Item 13](#).
- Scanner PWB, [PL 62.16 Item 8](#).
- Single board controller PWB, [PL 3.11 Item 13](#).

Refer to [WD 3.2](#) and [WD 6.1](#). Check the wiring between PJ920 on the [scanner PWB](#) and PJ18 on the [single board controller PWB](#). **The wiring is good.**

Y N

Re-seat loose connectors or install new components as necessary:

- DADH/IIT power comms harness, [PL 62.16 Item 7](#).
- Scanner PWB, [PL 62.16 Item 8](#).
- Single board controller PWB, [PL 3.11 Item 13](#).

Refer to [WD 1.7](#) and [WD 6.1](#). Check the wiring and voltages between PJ920 on the [scanner PWB](#) and PJ8 on the [power distribution PWB](#). **Wiring and voltages are good.**

Y N

Re-seat loose connectors or install new components as necessary:

- SBC drawer service loop harness, [PL 3.11 Item 16](#).
- Power distribution PWB, [PL 3.11 Item 1](#).
- Scanner PWB, [PL 62.16 Item 8](#).

Refer to [WD 1.5](#) and [WD 1.6](#). Check the wiring between PJ1 on the [power distribution PWB](#) and PJDC4 on the [power supply unit](#). Check for the correct voltages from the power supply at PJDC4 and at PJ1 on the [power distribution PWB](#). **Wiring and voltages are good.**

Y N

Re-seat loose connectors or install new components as necessary:

- Power supply unit, [PL 1.15 Item 2](#).
- Power distribution PWB, [PL 3.11 Item 1](#).

Perform [SCP 5](#) Final Actions.

62-450-00 to 62-472-00 Calibration Failure RAP

- 62-450-00 Calibration dark range not clear.
- 62-451-00 Calibration dark range not done.
- 62-452-00 Calibration Pixel offset not clear.
- 62-453-00 Calibration Pixel offset not done.
- 62-454-00 Calibration gain range not clear.
- 62-455-00 Calibration gain range not done.
- 62-456-00 Calibration Pixel gain not clear.
- 62-457-00 Calibration Pixel gain not done.
- 62-458-00 Calibration dark range errors.
- 62-459-00 Calibration pixel offset hi errors.
- 62-460-00 Calibration pixel offset lo errors.
- 62-461-00 Calibration gain range errors.
- 62-462-00 Calibration pixel gain hi errors.
- 62-463-00 Calibration pixel gain lo errors.
- 62-464-00 Scan controller busy error.
- 62-465-00 Dark loop settle error.
- 62-466-00 Dark range rail error.
- 62-467-00 Gain range rail error.
- 62-468-00 Colour state error.
- 62-469-00 FPGA Comms error.
- 62-470-00 FPGA Read error.
- 62-471-00 FPGA write wrap error.
- 62-472-00 FPGA Bus time out error.

Initial Actions

WARNING

Ensure that the electricity to the machine is switched off while performing tasks that do not need electricity. Refer to [GP 14](#). Disconnect the power cord. Electricity can cause death or injury. Moving parts can cause injury.

- Switch off, then switch on the machine, [GP 14](#).

Procedure

Enter [dC330](#) code 62-002 to activate the exposure lamps. **Exposure lamps illuminate.**

Y N

Go to [62B](#) Exposure Lamp Failure RAP.

Remove the scanner PWB cover, refer to [REP 62.12](#). Refer to [WD 6.3](#). Check the wiring between PJ928 on the [scanner PWB](#) and the scan carriage assembly. **The wiring is good.**

Y N

Re-seat loose connectors or install new components as necessary:

- Scan carriage assembly, [PL 62.15 Item 1](#).
- Scanner PWB, [PL 62.16 Item 8](#).
- Scan carriage ribbon cable, [PL 62.15 Item 4](#).

Refer to [WD 3.1](#), [WD 3.2](#) and [WD 6.1](#). Check the wiring between:

- PJ922 on the [scanner PWB](#) and PJ15 on the [single board controller PWB](#).
- PJ920 on the [scanner PWB](#) and PJ18 on the [single board controller PWB](#).

The wiring is good.

Y N

Re-seat loose connectors or install new components as necessary:

- IIT video/SBC PWB harness, [PL 62.10 Item 13](#).
- DADH/IIT power comms harness, [PL 62.16 Item 7](#).
- Scanner PWB, [PL 62.16 Item 8](#).
- Single board controller PWB, [PL 3.11 Item 13](#).

Go to [IQ 29](#), refer to the CVT and Document Glass Checkout. Check the white calibration strip on the front undersides of the document and CVT glass. **Calibration strip is clean.**

Y N

Clean with film remover, [PL 26.11 Item 14](#).

Perform [SCP 5](#) Final Actions.

62-473-00 UART RX Wrap Error RAP

62-473-00 UART RX wrap error.

Initial Actions

WARNING

Ensure that the electricity to the machine is switched off while performing tasks that do not need electricity. Refer to [GP 14](#). Disconnect the power cord. Electricity can cause death or injury. Moving parts can cause injury.

- Switch off, then switch on the machine, [GP 14](#).

Procedure

Refer to [WD 3.2](#) and [WD 6.1](#). Check the wiring between PJ18 on the [single board controller PWB](#) and PJ920 on the [scanner PWB](#). The wiring is good.

Y N

Re-seat loose connectors or install a new DADH/IIT power comms harness, [PL 62.16 Item 7](#).

Install new components as necessary:

- Scanner PWB, [PL 62.16 Item 8](#).
- Single board controller PWB, [PL 3.11 Item 13](#).

62-474-00, 62-475-00 Stepper Speed/Reset Error RAP

62-474-00 Stepper speed error.

62-475-00 Move before reset error.

Procedure

WARNING

Ensure that the electricity to the machine is switched off while performing tasks that do not need electricity. Refer to [GP 14](#). Disconnect the power cord. Electricity can cause death or injury. Moving parts can cause injury.

Go to [62-473-00](#) UART RX Wrap Error RAP.

62-476-00 Scan Carriage Home Sensor RAP

62-476-00 Carriage home sensor is not cleared or made in time.

Initial Actions

WARNING

Ensure that the electricity to the machine is switched off while performing tasks that do not need electricity. Refer to GP 14. Disconnect the power cord. Electricity can cause death or injury. Moving parts can cause injury.

- Switch off, then switch on the machine, GP 14.

Procedure

Visually check the scanner carriage alignment through the document glass. **Carriage alignment is good.**

Y N

Perform ADJ 62.2 Scan Carriage Assembly.

Refer to WD 1.7, WD 3.1, WD 3.2 and WD 6.1. Check the wiring between:

- PJ8 on the power distribution PWB and PJ920 on the scanner PWB.
- PJ15 on the single board controller PWB and PJ922 on the scanner PWB.
- PJ18 on the single board controller PWB and PJ920 on the scanner PWB.

The wiring is good.

Y N

Re-seat loose connectors, repair the wiring or install new components as necessary:

- DADH/IIT power comms harness, PL 62.16 Item 7.
- IIT video SBC PWB harness, PL 62.10 Item 13.
- Scanner PWB, PL 62.16 Item 8.
- Power distribution PWB, PL 3.11 Item 1.
- Single board controller PWB, PL 3.11 Item 13.

Enter dC330 code 62-023 carriage motor, MOT62-063. The scan carriage returns to the home position.

Y N

Check the condition and adjustment of the scan drive belt, refer to ADJ 62.3 Carriage Motor and Scanner Drive Belt. **The scan drive belt is good.**

Y N

Install a new scan drive belt, PL 62.16 Item 12.

Refer to WD 6.2. Check MOT62-023. Refer to:

- GP 10, How to Check a Motor.
- PJ929, Scanner PWB.
- 01H +24V Distribution RAP.
- 01L 0V Distribution RAP.

Install new components as necessary:

- Carriage motor and bracket assembly PL 62.16 Item 15.
- Scanner PWB, PL 62.16 Item 8.

A

Enter dC330 code 62-018 carriage home sensor, Q62-018. Stack codes 62-023 and 62-024 to move the carriage home, then away from home. **The display changes.**

Y N

Refer to WD 6.2. Check Q62-018:

- GP 11, How to Check a Sensor.
- PJ923, Scanner PWB.
- 01D +5V Distribution RAP.
- 01C +3.3V Distribution RAP.
- 01L 0V Distribution RAP.

Install new components as necessary:

- Carriage home sensor PL 62.15 Item 7.
- Scanner PWB, PL 62.16 Item 8.

Perform SCP 5 Final Actions.

A

62-477-00 to 62-481-00 Timing Errors RAP

62-477-00 Stepper busy error.

62-478-00 Real time error.

62-479-00 Page synchronization error.

62-480-00 Initialize time error.

62-481-00 DADH client time out.

Procedure

WARNING

Ensure that the electricity to the machine is switched off while performing tasks that do not need electricity. Refer to GP 14. Disconnect the power cord. Electricity can cause death or injury. Moving parts can cause injury.

Go to 62-473-00 UART RX Wrap Error RAP.

62-484-00 Apps Code Not Present RAP

62-484-00 Apps code not present.

Procedure

WARNING

Ensure that the electricity to the machine is switched off while performing tasks that do not need electricity. Refer to GP 14. Disconnect the power cord. Electricity can cause death or injury. Moving parts can cause injury.

Go to 62-473-00 UART RX Wrap Error RAP.

62-485-00 +12V Supply Error RAP

62-485-00 +12V supply error.

Initial Actions

WARNING

Ensure that the electricity to the machine is switched off while performing tasks that do not need electricity. Refer to [GP 14](#). Disconnect the power cord. Electricity can cause death or injury. Moving parts can cause injury.

- Switch off, then switch on the machine, [GP 14](#).

Procedure

Enter [dC330](#) code 62-021 12V Detect. **The 12V supply is detected.**

Y N

Check the +12V power supply, refer to:

- [01E](#) +12V distribution RAP.
- [01L](#) 0V distribution RAP.

Refer to [WD 1.7](#) and [WD 6.1](#). Check the wiring between PJ8 on the [power distribution PWB](#) and PJ920 on the [scanner PWB](#). **The wiring is good.**

Y N

Re-seat loose connectors or install new components as necessary:

- DADH/IIT power comms harness, [PL 62.16 Item 7](#).
- Scanner PWB, [PL 62.16 Item 8](#).
- Power distribution PWB, [PL 3.11 Item 1](#).

Refer to [WD 1.5](#) and [WD 1.6](#). Check the wiring between PJ1 on the [power distribution PWB](#) and PJDC4 on the [power supply unit](#). **The wiring is good.**

Y N

Re-seat loose connectors or install new components as necessary:

- Power supply unit, [PL 1.15 Item 2](#).
- Power distribution PWB, [PL 3.11 Item 1](#).
- Single board controller PWB, [PL 3.11 Item 13](#).

Perform [SCP 5](#) Final Actions.

62-486-00 +24V Supply Error RAP

62-486-00 +24V supply error.

Initial Actions

WARNING

Ensure that the electricity to the machine is switched off while performing tasks that do not need electricity. Refer to [GP 14](#). Disconnect the power cord. Electricity can cause death or injury. Moving parts can cause injury.

- Switch off, then switch on the machine, [GP 14](#).

Procedure

Enter [dC330](#) code 62-020 24V Detect. **The +24V supply is detected.**

Y N

Check the +24V power supply, refer to:

- [01H](#) +24V distribution RAP.
- [01L](#) 0V distribution RAP.

Refer to [WD 1.7](#) and [WD 6.1](#). Check the wiring between PJ8 on the [power distribution PWB](#) and PJ920 on the [scanner PWB](#). **The wiring is good.**

Y N

Re-seat loose connectors or install new components as necessary:

- DADH/IIT power comms harness, [PL 62.16 Item 7](#).
- Scanner PWB, [PL 62.16 Item 8](#).
- Power distribution PWB, [PL 3.11 Item 1](#).

Refer to [WD 1.5](#) and [WD 1.6](#). Check the wiring between PJ1 on the [power distribution PWB](#) and PJDC4 on the [power supply unit](#). **The wiring is good.**

Y N

Re-seat loose connectors or install new components as necessary:

- Power supply unit, [PL 1.15 Item 2](#).
- Power distribution PWB, [PL 3.11 Item 1](#).
- Single board controller PWB, [PL 3.11 Item 13](#).

Perform [SCP 5](#) Final Actions.

62-487-00 System Phase Lock Loop (PLL) Error RAP

62-487-00 System phase lock loop (PLL) error.

Procedure

WARNING

Ensure that the electricity to the machine is switched off while performing tasks that do not need electricity. Refer to [GP 14](#). Disconnect the power cord. Electricity can cause death or injury. Moving parts can cause injury.

Go to [62-473-00](#) UART RX Wrap Error RAP.

62A Scanning Document Size RAP

The scanner has encountered a document that is larger than expected.

The scanner has encountered a document of unknown size. The document size sensors have incorrectly determined the size of the original.

Procedure

WARNING

Ensure that the electricity to the machine is switched off while performing tasks that do not need electricity. Refer to [GP 14](#). Disconnect the power cord. Electricity can cause death or injury. Moving parts can cause injury.

NOTE: If necessary, temporarily install the document glass when checking the document size sensors to ensure that the document is the correct distance from the sensor.

Check that the input module angle sensor actuator is not damaged. If necessary install a new input module angle sensor actuator [PL 62.15 Item 10](#). Enter [dC330](#) code 62-301 angle sensor, Q62-301. Actuate Q62-301. **The display changes.**

Y N

Refer to [WD 6.2](#). Check Q62-301, [PL 62.15 Item 7](#).

- [GP 11](#), How to Check a Sensor.
- PJ923, [Scanner PWB](#).
- [01D](#) +5V Distribution RAP.
- [01C](#) +3.3V Distribution RAP.
- [01L](#) 0V Distribution RAP.

Install new components as necessary:

- Angle sensor, [PL 62.15 Item 7](#).
- Scanner PWB, [PL 62.16 Item 8](#).

Raise the DADH. Enter [dC330](#) code 62-251 document size sensor 1, Q62-251. Actuate Q62-25 by placing a piece of paper on the document glass above the sensor. Repeat the test for Q62-252 document size sensor 2, Q62-252. **The display changes.**

Y N

Refer to [WD 6.2](#). Check Q62-251 and Q62-252.

- [GP 11](#), How to Check a Sensor
- PJ923, [Scanner PWB](#).
- [01D](#) +5V Distribution RAP.
- [01C](#) +3.3V Distribution RAP.
- [01L](#) 0V Distribution RAP

Install new components as necessary:

- Document size sensor 1 or 2, [PL 62.16 Item 10](#).
- Scanner PWB, [PL 62.16 Item 8](#).

Refer to [WD 1.7](#), [WD 3.1](#), [WD 3.2](#) and [WD 6.1](#). Check the wiring between:

- PJ8 on the [power distribution PWB](#) and PJ920 on the [scanner PWB](#).
- PJ15 on the [single board controller PWB](#) and PJ922 on the [scanner PWB](#).
- PJ18 on the [single board controller PWB](#) and PJ920 on the [scanner PWB](#).

The wiring is good.

Y N

Re-seat loose connectors, repair the wiring or install new components as necessary:

- DADH/IIT power comms harness, [PL 62.16 Item 7](#).
- IIT video SBC PWB harness, [PL 62.10 Item 13](#).
- Scanner PWB, [PL 62.16 Item 8](#).
- Power distribution PWB, [PL 3.11 Item 1](#).
- Single board controller PWB, [PL 3.11 Item 13](#).

Perform [SCP 5](#) Final Actions.

62B LED Exposure Lamp Failure RAP

The LED lamp(s) do not illuminate.

Procedure

WARNING

Ensure that the electricity to the machine is switched off while performing tasks that do not need electricity. Refer to [GP 14](#). Disconnect the power cord. Electricity can cause death or injury. Moving parts can cause injury.

Enter [dC330](#), input code 62-002 to activate the exposure lamps. **The exposure lamps illuminate.**

Y N

Remove the scanner PWB cover, refer to [REP 62.12](#). Refer to [WD 1.7](#), [WD 3.1](#), [WD 3.2](#) and [WD 6.1](#). Check the wiring between:

- PJ8 on the [power distribution PWB](#) and PJ920 on the [scanner PWB](#).
- PJ15 on the [single board controller PWB](#) and PJ922 on the [scanner PWB](#).
- PJ18 on the [single board controller PWB](#) and PJ920 on the [scanner PWB](#).

The wiring is good.

Y N

Re-seat loose connectors, repair the wiring or install new components as necessary:

- DADH/IIT power comms harness, [PL 62.16 Item 7](#).
- IIT video SBC PWB harness, [PL 62.10 Item 13](#).
- Scanner PWB, [PL 62.16 Item 8](#).
- Power distribution PWB, [PL 3.11 Item 1](#).
- Single board controller PWB, [PL 3.11 Item 13](#).

Refer to [WD 6.2](#). Check the wiring between PJ926 on the [scanner PWB](#) and the LED Exposure lamps, [PL 62.15 Item 2](#). **The wiring is good.**

Y N

Re-seat loose connectors or install new components as necessary:

- Scanner PWB, [PL 62.16 Item 8](#).
- LED exposure lamps, [PL 62.15 Item 2](#).

Refer to [WD 6.2](#). Check the in line ribbon harness [PL 62.15 Item 3](#) between CN1 and CN2. **The harness is good.**

Y N

Re-seat loose connectors or install new components as necessary:

- LED exposure lamps, [PL 62.15 Item 2](#).
- In line ribbon harness, [PL 62.15 Item 3](#).

Perform [SCP 5](#) Final Actions.

Perform [SCP 5](#) Final Actions.

70-312-00 Tray 1 to Tray 3 Communication Failure RAP

70-312-00 IME to tray 1, tray 2 and tray 3 communications failure.

Procedure

WARNING

Ensure that the electricity to the machine is switched off while performing tasks that do not need electricity. Refer to [GP 14](#). Disconnect the power cord. Electricity can cause death or injury. Moving parts can cause injury.

Refer to [WD 7.3](#) and [WD 8.2](#). Perform the following:

1. Switch off the machine, then switch on the machine, [GP 14](#).
2. Check the harness between PJ950 on the [3 tray module PWB](#) and PJ 401 on the [media path driver PWB](#).
3. Check the PJ connections and wiring. Repair the wiring as necessary, [REP 1.1](#).

If necessary, install new components:

- 3 Tray module PWB, [PL 73.16 Item 4](#).
- Media path driver PWB, [PL 1.15 Item 5](#).
- Media path driver PWB to 3 tray module PWB harness (PJ950 to PJ401), [PL 1.15 Item 21](#).

70-305-00, 70-325-00 Lower Left Door Open RAP

70-305-00 Lower left door open.

70-325-00 Lower left door open during run.

Initial Actions

- Ensure the lower left door assembly, [PL 70.25 Item 5](#) is closed.
- Check the door hinge and latch for damage, [PL 70.25](#).

Procedure

WARNING

Ensure that the electricity to the machine is switched off while performing tasks that do not need electricity. Refer to [GP 14](#). Disconnect the power cord. Electricity can cause death or injury. Moving parts can cause injury.

Enter [dC330](#) code 01-302 lower door interlock, Q01-301, [PL 70.10 Item 18](#). Press Start. Manually actuate the sensor. **The display changes.**

Y N

Refer to [WD 7.4](#). Check the lower door interlock. Refer to:

- [GP 11](#) How to Check a Sensor.
- PJ953, [3 tray module PWB](#).
- [01D](#) +5V Distribution RAP.
- [01L](#) 0V Distribution RAP.

Install new components as necessary:

- Lower door interlock sensor, [PL 70.10 Item 18](#).
- 3 tray module PWB, [PL 73.16 Item 4](#).
- Media path driver PWB, [PL 1.15 Item 5](#).

Perform the following:

- Check that the sensor is correctly located.
- Check that the actuator on the lower left door assembly is not damaged or missing.
- If necessary, install a new lower left door assembly, [PL 70.25 Item 5](#).

71-101-00 to 71-155-00 Tray 1 Mis-Feed Jam RAP

71-101-00 Tray 1 misfeed jam

71-106-00 LE late to TAR1 sensor from tray 1.

71-130-00 TTM1 TE late at TAR.

71-132-00 TTM1 LE too early at TAR.

71-150-00 TTM1 too long at TAR.

71-151-00 TTM1 too short at TAR.

71-152-00 TTM1 too long at TAR no auto purge.

71-153-00 TTM1 too short at TAR no auto purge.

71-154-00 TTM1 mismatch long at TAR.

71-155-00 TTM1 mismatch short at TAR.

Initial Actions

WARNING

Ensure that the electricity to the machine is switched off while performing tasks that do not need electricity. Refer to [GP 14](#). Disconnect the power cord. Electricity can cause death or injury. Moving parts can cause injury.

- Check the condition of the paper in tray 1. Refer to [IQ 1](#) and [GP 20](#).
- Check that the paper guides are set correctly.
- Check that the lower left door, [PL 70.25 Item 5](#) is latched correctly.
- Check the condition of the tray 1 feed, nudger and retard rolls. Use a cloth dampened with water to clean the rolls, [GP 27](#). If necessary, install a new tray 1 feed roll kit, [PL 81.25 Item 28](#).
- Go to [dC135](#) CRU/HFSI Status. Check the count of the tray 1 feed roll set. If the count is near end of life, install a new tray 1 feed roll kit, [PL 81.25 Item 28](#).

Procedure

Enter [dC330](#) code 71-101 tray 1 feed sensor, Q71-101, [PL 81.25 Item 19](#). Press Start. Remove tray 1 and tray 2. Manually actuate the sensor. **The display changes.**

Y N

Refer to [WD 7.3](#). Check tray 1 feed sensor, Q71-101. Refer to:

- [GP 11](#) How to Check a Sensor.
- PJ951, [3 tray module PWB](#).
- [01D](#) +5V Distribution RAP.
- [01L](#) 0V Distribution RAP.

Install new components as necessary:

- Tray 1 feed sensor, [PL 81.25 Item 19](#).
- 3 tray module PWB, [PL 73.16 Item 4](#).

A

Status Indicator RAPs

71-101-00 to 71-155-00

A

- Media path driver PWB, [PL 1.15 Item 5](#).

Enter [dC330](#) code 71-395 TAR 1 sensor, Q71-395, [PL 73.16 Item 11](#). Press Start. Open the left door and manually actuate the sensor. **The display changes.**

Y N

Refer to [WD 7.4](#). Check takeaway roll sensor 1, Q71-395. Refer to:

- [GP 11](#) How to Check a Sensor.
- PJ955, [3 tray module PWB](#).
- [01D](#) +5V Distribution RAP.
- [01L](#) 0V Distribution RAP.

Install new components as necessary:

- TAR 1 Sensor, [PL 73.16 Item 11](#).
- 3 tray module PWB, [PL 73.16 Item 4](#).
- Media path driver PWB, [PL 1.15 Item 5](#).

Check that the nudger spring is installed correctly, [PL 81.25 Item 10](#). Check that the spring is not damaged. **The spring is good.**

Y N

Install a new spring, [PL 81.25 Item 10](#).

Enter [dC330](#) code 70-025 3 tray transport motor, MOT70-025, [PL 73.16 Item 3](#). Press Start. **The motor runs.**

Y N

Refer to [WD 7.5](#). Check MOT70-025. Refer to:

- [GP 10](#) How to Check a Motor.
- PJ956, [3 tray module PWB](#).
- [01H](#) +24V Distribution RAP.
- [01L](#) 0V Distribution RAP.

Install new components as necessary:

- 3 tray transport motor, [PL 73.16 Item 3](#)
- 3 Tray Module PWB, [PL 73.16 Item 4](#).
- Media path driver PWB, [PL 1.15 Item 5](#).

Observe the takeaway rolls, [PL 73.16](#). **The takeaway rolls rotate.**

Y N

Check the drive belt and gears, [PL 73.16 Item 7](#).

Check the condition of the takeaway rolls, [PL 73.16](#). **The takeaway rolls are good.**

Y N

Clean or install new takeaway rolls, [PL 73.16 Item 9](#).

CAUTION

To prevent damage to the feed mechanism, the paper tray must be pulled out before MOT 71-002 is run in diagnostics.

Enter [dC330](#) code 71-002 tray 1 feed / elevate motor, MOT71-002, [PL 81.25 Item 22](#). Press start. **The feed rolls rotate.**

Y N

Remove the tray feed assembly, REP 81.1. Manually rotate the feed roll shaft. **The drive gears rotate.**

Y N

Check the gears for damage. If necessary, install new components, PL 81.25.

Install the tray 1 feed assembly.

Refer to WD 7.3. Check MOT71-002. Refer to:

- GP 10 How to Check a Motor.
- PJ951, 3 tray module PWB.
- 01H +24V Distribution RAP.
- 01L 0V Distribution RAP.

Install new Components as necessary:

- Tray 1 feed / elevate motor, PL 81.25 Item 22.
- 3 tray module PWB, PL 73.16 Item 4.
- Media path driver PWB, PL 1.15 Item 5.

The nudger roll rotates.

Y N

Check the nudger roll drive belt and drive coupling for damage. If necessary, install new components, PL 81.25.

With the paper tray removed. Manually move the retard nip split mechanism. **The retard roll moves against the feed roll.**

Y N

Check the retard roll drive coupling and mechanism for damage. If necessary, install new components, PL 81.25.

Perform the following:

- Check the feed roll assembly, PL 81.25 Item 11.
- Check the feed assembly, PL 81.25 Item 1.

71-215-00 Tray 1 Elevate Up Failure RAP

71-215-00 Tray 1 stack height sensor did not actuate within the correct time after the feed / elevator motor turned on.

Initial Actions

WARNING

Ensure that the electricity to the machine is switched off while performing tasks that do not need electricity. Refer to GP 14. Disconnect the power cord. Electricity can cause death or injury. Moving parts can cause injury.

- Check for paper or obstructions behind the tray.
- Check that the tray 1 stack height sensor, PL 81.25 Item 17 is clean and located correctly.
- Ensure that the tray is pushed fully home.
- Check the stack height mechanism actuator in the feeder, PL 81.25.
- Check the drive gears and coupling on the tray, PL 70.10.
- Check the elevator drive coupling on the feeder assembly, PL 81.25.
- Check for the lift plate is not bowed under the elevate plate assembly.

Procedure

Enter dC330 code 71-336 tray 1 stack height sensor, Q71-336, PL 81.25 Item 17. Press Start. Pull out tray 1. Manually actuate the sensor. **The display changes**

Y N

Refer to WD 7.3. Check tray 1 stack height sensor, Q71-336. Refer to:

- GP 11 How to Check a Sensor.
- PJ951, 3 tray module PWB.
- 01D +5V Distribution RAP.
- 01L 0V Distribution RAP.

Install new components as necessary:

- Tray 1 stack height sensor, PL 81.25 Item 17.
- 3 tray module PWB, PL 73.16 Item 4.
- Media path driver PWB, PL 1.15 Item 5.

CAUTION

To prevent damage to the elevator and paper feed mechanism, the paper tray must be pulled out before MOT71-002 is run in diagnostics.

Enter dC330 code 71-002 tray 1 feed / elevator motor, MOT71-002, PL 81.25 Item 22. Pull out tray 1. Press Start. **The motor runs**

Y N

Refer to WD 7.3. Check tray 1 feed / elevator motor, MOT71-002. Refer to:

- GP 10 How to Check a Motor.
- PJ951, 3 tray module PWB.
- 01H +24V Distribution RAP.
- 01L 0V Distribution RAP.

Install new components as necessary:

- Tray 1 feed / elevator motor, PL 81.25 Item 22.
- 3 tray module PWB, PL 73.16 Item 4.
- Media path driver PWB, PL 1.15 Item 5.

Perform the following:

- Check the feeder / elevator motor drive gears, PL 81.25.
- Check the tray 1 stack height mechanism on the feeder assembly,

If the fault still occurs, go to 71A Tray 1 Empty RAP.

71-320-00 Tray 1 Open In Run RAP

71-320-00 Tray 1 was opened during run when the paper is fed from tray 1.

Initial Actions

WARNING

Ensure that the electricity to the machine is switched off while performing tasks that do not need electricity. Refer to [GP 14](#). Disconnect the power cord. Electricity can cause death or injury. Moving parts can cause injury.

- Check for obstructions behind the tray.
- Ensure the tray is pushed fully home.
- Check the tray 1 location catch for damage, [PL 70.10 Item 17](#).

Procedure

Tray 1 and tray 2 do not have a dedicated home sensor. The 5 size sensing switches on the 3 tray module PWB, [PL 73.16 Item 4](#), are used. When at least one switch is actuated the tray is closed. When no switches are actuated, the tray is open.

Enter [dC330](#) codes 71-311, 71-312, 71-313, 71-314 and 71-315. Press Start. Remove the tray and manually actuate each switch. **The display changes for each switch.**

Y N

Refer to [WD 7.5](#). Check tray 1 size switches. Refer to:

- [GP 13](#) How to Check a Switch.
- [01D](#) +5V Distribution RAP.
- [01L](#) 0V Distribution RAP.

Install new components as necessary:

- 3 tray module PWB, [PL 73.16 Item 4](#).
- Media path driver PWB, [PL 1.15 Item 5](#).

Perform the following:

- Check the length and width sensing bracket on the paper tray, [PL 70.10 Item 12](#), [PL 70.10 Item 13](#).
- If the fault persists, install new components as necessary:
 - 3 tray module PWB, [PL 73.16 Item 4](#).
 - Media path driver PWB, [PL 1.15 Item 5](#).

71A Tray 1 Empty RAP

Use this RAP when the copier display instructs the operator to add paper to the tray that is not empty.

Procedure

WARNING

Switch off the electricity to the machine. Refer to [GP 14](#). Disconnect the power cord from the customer supply while performing tasks that do not need electricity. Electricity can cause death or injury. Moving parts can cause injury.

Enter [dC330](#) code 71-201. Press Start. Manually actuate the tray empty sensor Q71-201, [PL 81.25 Item 19](#). **The display changes.**

Y N

Refer to [WD 7.3](#). Check tray 1 empty sensor, Q71-201.

Refer to:

- [GP 11](#) How to Check a Sensor.
- [PJ951](#), [3 tray module PWB](#)
- [01D](#) +5V Distribution RAP.
- [01L](#) 0V Distribution RAP.

Install new components as necessary.

- Tray 1 empty sensor, [PL 81.25 Item 19](#).
- 3 tray module PWB, [PL 73.16 Item 4](#).
- Media path driver PWB, [PL 1.15 Item 5](#).

Perform the following:

- Check that the sensor is free of paper dust and is located correctly.
- Check the paper feed mechanism and feedhead, [PL 81.25 Item 1](#).

71B Tray 1 Wrong Size Paper RAP

Use this RAP when the paper fed from the tray does not match the paper size indicated by the tray paper size switch. Tray 1 and tray 2 feed mechanisms are identical.

Initial Actions

WARNING

Ensure that the electricity to the machine is switched off while performing tasks that do not need electricity. Refer to [GP 14](#). Disconnect the power cord. Electricity can cause death or injury. Moving parts can cause injury.

- Check that the tray paper guides are set up to the edges of the paper.
- Check for paper down the back of the tray.
- Make sure the guides are located in the tray base slots if a standard paper size is used.
- Check the length and width bracket on the rear of the tray, [PL 70.10 Item 12](#) and [PL 70.10 Item 13](#).

Procedure

Refer to [Table 1](#). Compare the paper size in the tray to the size switches actuated. Enter [dC330](#) and relevant component control code as shown in the table. Press Start. Manually actuate the paper size switch on the 3 tray module PWB, [PL 73.16 Item 4](#). The display changes.

Y N

Refer to [WD 7.5](#). Check the tray 1 size switch 1, 2, 3, 4 and 5 at the switch on the 3 tray module PWB. Check the voltage on the centre pin of the relevant switch on the rear of the PWB. Refer to:

- [GP 13](#) How to Check a Switch.
- [01B](#) +3.3V ESTAR Distribution RAP
- [01L](#) 0V Distribution RAP

Install new components as necessary:

- 3 tray module PWB, [PL 73.16 Item 4](#).
- Media path driver PWB, [PL 1.15 Item 5](#).

Set the paper tray paper guides to a standard size of paper. Push in the tray. Refer to [Table 1](#) to identify the switches that should be actuated.

Enter [dC330](#) and relevant component control code to operate the size switch as shown in the table. Press Start. Open and close the tray and observe the change of state of the size switch.

Set the paper guides to various other paper sizes, to actuate all 5 size switches **The size switches change to the correct state for the paper size selected.**

Y N

Check the length and width sensing bracket on the paper tray, [PL 70.10 Item 12](#), [PL 70.10 Item 13](#). Install new parts as required.

If the problem is random, check the paper tray for worn or damaged parts. If necessary install a new tray assembly, [PL 70.10 Item 1](#).

Table 1 Tray 1 paper size table

Paper	Size switch 1 (S71-311)	Size switch 2 (S71-312)	Size switch 3 (S71-313)	Size switch 4 (S71-314)	Size switch 5 (S71-315)
A5 SEF 5.5 x 8.5 inch SEF	0V	+3.3V	0V	0V	+3.3V
A4 LEF	+3.3V	0V	0V	0V	+3.3V
A4 SEF	0V	+3.3V	+3.3V	0V	0V
A3 SEF	+3.3V	0V	+3.3V	+3.3V	+3.3V
A5 SEF B5 SEF and JIS B5 5.5 x 8.5 inch SEF	0V	+3.3V	0V	+3.3V	+3.3V
EXEC 184 x 267 mm B5 SEF and JIS B5	0V	+3.3V	0V	+3.3V	0V
8.5 x 11 LEF (Letter)	0V	0V	0V	+3.3V	+3.3V
8.5 x 11 SEF (Letter)	0V	+3.3V	+3.3V	+3.3V	0V
8.5 x 13 SEF (Folio) 216 x 330 mm	0V	+3.3V	+3.3V	0V	+3.3V
8.5 x 14 SEF (Legal) B4 SEF and JIS B4	0V	+3.3V	+3.3V	+3.3V	+3.3V
11 x 17 SEF (Tabloid)	0V	0V	+3.3V	+3.3V	+3.3V

72-101-00 to 72-155-00 Tray 2 Mis-Feed Jam RAP

72-101-00 Tray 2 misfeed jam.

72-106-00 LE late to TAR 2 sensor.

72-110-00 LE late to TAR 1 sensor from tray 2.

72-130-00 TTM2 TE late at TAR.

72-131-00 TTM2 LE late at TAR.

72-132-00 TTM2 LE too early at TAR.

72-133-00 TTM2 LE too early at TAR1.

72-150-00 TTM2 too long at TAR.

72-151-00 TTM2 too short at TAR.

72-152-00 TTM2 too long at TAR no auto purge.

72-153-00 TTM2 too short at TAR no auto purge.

72-154-00 TTM2 mismatch long at TAR.

72-155-00 TTM2 mismatch short at TAR.

Initial Actions

WARNING

Ensure that the electricity to the machine is switched off while performing tasks that do not need electricity. Refer to [GP 14](#). Disconnect the power cord. Electricity can cause death or injury. Moving parts can cause injury.

- Check the condition of the paper in tray 2. Refer to [IQ 1](#) and [GP 20](#).
- Check that the paper guides are set correctly.
- Check that the left hand door is latched correctly.
- Check the condition of the tray 2 feed, nudge and retard rolls. Use a cloth dampened with water to clean the rolls, [GP 27](#). If necessary, install a new tray 2 feed roll kit, [PL 81.26 Item 28](#).
- Go to [dC135](#) CRU / HFSI Status. Check the count of the tray 2 feed roll set. If the count is near end of life, install a new tray 2 feed roll kit, [PL 81.26 Item 28](#).

Procedure

Enter [dC330](#) code 72-102 tray 2 feed sensor, Q72-102, [PL 81.26 Item 19](#). Press Start. Remove tray 1 and tray 2 then manually actuate the sensor. **The display changes.**

Y N

Refer to [WD 7.3](#). Check tray 2 feed sensor, Q72-102. Refer to:

- [GP 11](#) How to Check a Sensor.
- PJ952, [3 tray module PWB](#).

A

A

- [01D](#) +5V Distribution RAP.
- [01L](#) 0V Distribution RAP.

Install new components as necessary:

- Tray 2 feed sensor, [PL 81.26 Item 19](#).
- 3 tray module PWB, [PL 73.16 Item 4](#).
- Media path driver PWB, [PL 1.15 Item 5](#).

Enter [dC330](#) code 72-396 TAR 2 sensor, Q72-396, [PL 73.16 Item 11](#). Press Start. Open the left hand door and manually actuate the sensor. **The display changes.**

Y N

Refer to [WD 7.4](#). Check TAR 2 sensor, Q72-396. Refer to:

- [GP 11](#) How to Check a Sensor.
- PJ955, [3 tray module PWB](#).
- [01D](#) +5V Distribution RAP.
- [01L](#) 0V Distribution RAP.

Install new components as necessary:

- TAR sensor 2, [PL 73.16 Item 11](#).
- 3 tray module PWB, [PL 73.16 Item 4](#).
- Media path driver PWB, [PL 1.15 Item 5](#).

Check that the nudge spring is installed correctly, [PL 81.26 Item 10](#). Check that the spring is not damaged. **The spring is good.**

Y N

Install a new spring, [PL 81.26 Item 10](#).

Enter [dC330](#) code 71-395 TAR 1 sensor, Q71-395, [PL 73.16 Item 11](#). Press Start. Open the left hand door and manually actuate the sensor. **The display changes.**

Y N

Refer to [WD 7.4](#). Check TAR 1 sensor, Q71-395. Refer to:

- [GP 11](#) How to Check a Sensor.
- PJ955, [3 tray module PWB](#).
- [01D](#) +5V Distribution RAP.
- [01L](#) 0V Distribution RAP.

Install new components as necessary:

- TAR 1 sensor, [PL 73.16 Item 11](#).
- 3 tray module PWB, [PL 73.16 Item 4](#).
- Media path driver PWB, [PL 1.15 Item 5](#).

Enter [dC330](#) code 70-025 3 tray module transport motor, MOT70-025, [PL 73.16 Item 3](#). Press Start. **The motor runs.**

Y N

Refer to [WD 7.5](#). Check 3 tray module transport motor, MOT81-025. Refer to:

- [GP 10](#) How to Check a Motor.
- PJ956 on [3 tray module PWB](#).
- [01H](#) +24V Distribution RAP.
- [01L](#) 0V Distribution RAP.

B

B

Install new components as necessary:

- 3 tray module transport motor, [PL 73.16 Item 3](#).
- 3 tray module PWB, [PL 73.16 Item 4](#).
- Media path driver PWB, [PL 1.15 Item 5](#).

Observe the takeaway rolls. **The transport rolls rotate.**

Y N

Check the drive belt and gears, [PL 73.16 Item 7](#).

Check the condition of the takeaway rolls, [PL 73.16](#). **The takeaway rolls are good.**

Y N

Clean or Install new takeaway rolls, [PL 73.16 Item 9](#).

CAUTION

To prevent damage to the feed mechanism, the paper tray must be pulled out before MOT 72-001 is run in diagnostics.

Enter [dC330](#) code 72-001 tray 2 feed / elevator motor, MOT72-001, [PL 81.26 Item 22](#). Press Start. **The motor runs.**

Y N

Refer to [WD 7.3](#). Check tray 2 feed / elevator motor, MOT72-001. Refer to:

- [GP 10](#) How to Check a Motor.
- PJ952, [3 tray module PWB](#).
- [01H](#) +24V Distribution RAP.
- [01L](#) 0V Distribution RAP.

Install new components as necessary:

- Tray 2 feed / elevator motor, [PL 81.26 Item 22](#).
- 3 tray module PWB, [PL 73.16 Item 4](#).
- Media path driver PWB, [PL 1.15 Item 5](#).

The nudger roll rotates.

Y N

Check the nudger roll drive belt and drive coupling for damage. If necessary, install a new components, [PL 81.26 Item 12](#).

With the paper tray removed. Manually move the retard nip split mechanism, [PL 81.26](#). **The retard roll moves against the feed roll.**

Y N

Check the retard roll drive coupling and mechanism for damage. If necessary, install new components, [PL 81.26](#).

Perform the following:

- Check the feed roll assembly, [PL 81.26 Item 11](#).
- Check the feed assembly, [PL 81.26 Item 1](#).

72-215-00 Tray 2 Elevate Up Failure RAP

72-215-00 Tray 2 hoist failure

Initial Actions

WARNING

Ensure that the electricity to the machine is switched off while performing tasks that do not need electricity. Refer to [GP 14](#). Disconnect the power cord. Electricity can cause death or injury. Moving parts can cause injury.

- Check that the tray 2 stack height sensor, [PL 81.26 Item 17](#) is clean and located correctly.
- Check for obstructions behind the tray.
- Ensure that the tray is pushed fully home.
- Check the stack height mechanism actuator on the back of the tray, [PL 81.26](#).
- Check the drive gears and coupling on the tray, [PL 70.10](#).
- Check the elevator drive coupling on the feeder assembly, [PL 81.26](#).
- Check for the lift plate is not bowed under the elevate plate assembly.

Procedure

Enter [dC330](#) code 72-337 tray 2 stack height sensor, Q72-337, [PL 81.26 Item 17](#). Press Start. Pull out tray 1. Manually actuate the sensor. **The display changes**

Y N

Refer to [WD 7.3](#). Check tray 2 stack height sensor, Q72-337. Refer to:

- [GP 11](#) How to Check a Sensor.
- PJ952, [3 tray module PWB](#).
- [01D](#) +5V Distribution RAP.
- [01L](#) 0V Distribution RAP.

Install new components as necessary:

- Tray 2 stack height sensor, [PL 81.26 Item 17](#).
- 3 tray module PWB, [PL 73.16 Item 4](#).
- Media path driver PWB, [PL 1.15 Item 5](#).

CAUTION

To prevent damage to the elevator and paper feed mechanism, the paper tray must be pulled out before MOT72-001 is run in diagnostics.

Enter [dC330](#) code 72-001 tray 2 feed / elevate motor, MOT72-001, [PL 81.26 Item 22](#). Pull out tray 2. Press Start. **The motor runs**

Y N

Refer to [WD 7.3](#). Check tray 2 feed / elevate motor, MOT72-001. Refer to:

- [GP 10](#) How to Check a Motor.
- PJ952, [3 tray module PWB](#).
- [01H](#) +24V Distribution RAP.
- [01L](#) 0V Distribution RAP.

Install new components as necessary:

- Tray 2 feed / elevator motor, [PL 81.26 Item 22](#).
- 3 tray module PWB, [PL 73.16 Item 4](#).
- Media path driver PWB, [PL 1.15 Item 5](#).

Perform the following:

- Check the feeder / elevator motor drive gears, [PL 81.26](#).
- Check the tray 2 stack height mechanism on the feeder assembly,

If the fault still occurs then go to [72A](#) Tray 2 Empty RAP.

72-320-00 Tray 2 Open in Run RAP

72-320-00 Tray 2 was opened during run.

Initial Actions

WARNING

Ensure that the electricity to the machine is switched off while performing tasks that do not need electricity. Refer to [GP 14](#). Disconnect the power cord. Electricity can cause death or injury. Moving parts can cause injury.

- Check for obstructions behind the tray.
- Ensure that the tray is pushed fully home.
- Check the tray 2 location catch for damage, [PL 70.10 Item 17](#).

Procedure

Tray 1 and tray 2 do not have a dedicated home sensor. The 5 size switches on the 3 tray module PWB, [PL 73.16 Item 4](#), are used. When at least one switch is actuated, the tray is closed. When all switches are not actuated, the tray is open.

Enter [dC330](#) and enter code 72-321, 72-322, 72-323, 72-324 and 72-325 one at a time. Press Start. Remove the tray and manually actuate each switch. **The display changes for each switch.**

Y N

Refer to [WD 7.5](#). Check tray 2 size switches. Refer to:

- [GP 13](#) How to Check a Switch.
- [01D](#) +5V Distribution RAP.
- [01L](#) 0V Distribution RAP.

Install new components as necessary:

- 3 tray module PWB, [PL 73.16 Item 4](#).
- Media path driver PWB, [PL 1.15 Item 5](#).

Perform the following:

- Check the size switches on the 3 tray module PWB, [PL 73.16 Item 4](#).
- Check the length and width sensing bracket on the paper tray, [PL 70.10 Item 12](#), [PL 70.10 Item 13](#)
- If the fault persists, install new components as necessary:
 - 3 tray module PWB, [PL 73.16 Item 4](#).
 - Media path driver PWB, [PL 1.15 Item 5](#).

72A Tray 2 Empty RAP

Use this RAP when the copier display instructs the operator to add paper to the tray that is not empty.

Procedure

WARNING

Ensure that the electricity to the machine is switched off while performing tasks that do not need electricity. Refer to [GP 14](#). Disconnect the power cord. Electricity can cause death or injury. Moving parts can cause injury.

Tray 2 empty sensor, Q72-201. Enter [dC330](#) code 72-201, [PL 81.26 Item 19](#). Press Start. Manually actuate the tray empty sensor. **The display changes.**

Y N

Refer to [WD 7.3](#). Check tray 2 empty sensor, Q72-201.

Refer to:

- [GP 11](#) How to Check a Sensor.
- [PJ952](#), [3 tray module PWB](#).
- [01D](#) +5V Distribution RAP.
- [01L](#) 0V Distribution RAP.

Install new components as necessary.

- Tray 2 empty sensor, [PL 81.26 Item 19](#).
- 3 tray module PWB, [PL 73.16 Item 4](#).
- Media path driver PWB, [PL 1.15 Item 5](#).

Perform the following:

- Check that the sensor is free of paper dust.
- Check the paper feed mechanism, [PL 81.26 Item 1](#).

72B Tray 2 Wrong Size Paper RAP

Use this RAP when the paper fed from the tray does not match the paper size indicated by the tray paper size switch. Tray 1 and tray 2 feed mechanisms are identical.

Initial Actions

WARNING

Ensure that the electricity to the machine is switched off while performing tasks that do not need electricity. Refer to [GP 14](#). Disconnect the power cord. Electricity can cause death or injury. Moving parts can cause injury.

- Check that the tray paper guides are set up to the edges of the paper.
- Check for paper down the back of the tray.
- Make sure the guides are located in the tray base slots if a standard paper size is used.
- Check the length sensing bracket, [PL 70.10 Item 12](#) and width sensing bracket, [PL 70.10 Item 13](#) on the rear of the tray.

Procedure

Refer to [Table 1](#). Compare the paper size in the tray to the size switches actuated.

Enter [dC330](#) and relevant component control code as shown in the table. Press Start. Manually actuate the paper size switch on the 3 tray module PWB, [PL 73.16 Item 4](#). The display changes.

Y N

Refer to [WD 7.5](#). Check tray 2 size switch 1, 2, 3, 4 and 5 at the switch on the 3 tray module PWB. Check the voltage on the centre pin of the relevant switch on the rear of the PWB. Refer to:

- [GP 13](#) How to Check a Switch.
- [01B](#) +3.3V ESTAR Distribution RAP.
- [01L](#) 0V Distribution RAP.

Install new components as necessary:

- 3 tray module PWB, [PL 73.16 Item 4](#).
- Media path driver PWB, [PL 1.15 Item 5](#).

Set the paper tray paper guides to a standard size of paper. Push in the tray. Refer to [Table 1](#) to identify the switches that should be actuated.

Enter [dC330](#) and relevant component control code to operate the size switch as shown in the table. Press Start. Open and close the tray and observe the change of state of the size switch.

Set the paper guides to other paper sizes, to actuate all 5 size switches **The size switches change to the correct state for the paper size selected.**

Y N

Check the length and width sensing bracket on the paper tray, [PL 70.10 Item 12](#), [PL 70.10 Item 13](#). Install new parts as necessary.

If the problem is random, check the paper tray for worn or damaged parts. If necessary install a new tray assembly, [PL 70.10 Item 1](#).

NOTE: Standard sizes will be offered as indicated, as well a custom sizes limited to the range supported.

Table 1 Tray 2 paper size table

Paper	Size switch 1 (S72-321)	Size switch 2 (S72-322)	Size switch 3 (S72-323)	Size switch 4 (S72-324)	Size switch 5 (S72-325)
A5 SEF 5.5 x 8.5 inch SEF	0V	+3.3V	0V	0V	+3.3V
A4 LEF	+3.3V	0V	0V	0V	+3.3V
A4 SEF	0V	+3.3V	+3.3V	0V	0V
A3 SEF	+3.3V	0V	+3.3V	+3.3V	+3.3V
A5 SEF B5 SEF and JIS B5 5.5 x 8.5 inch SEF	0V	+3.3V	0V	+3.3V	+3.3V
EXEC 184 x 267 mm B5 SEF and JIS B5	0V	+3.3V	0V	+3.3V	0V
8.5 x 11 LEF (Letter)	0V	0V	0V	+3.3V	+3.3V
8.5 x 11 SEF (Letter)	0V	+3.3V	+3.3V	+3.3V	0V
8.5 x 13 SEF (Folio) 216 x 330 mm	0V	+3.3V	+3.3V	0V	+3.3V
8.5 x 14 SEF (Legal) B4 SEF and JIS B4	0V	+3.3V	+3.3V	+3.3V	+3.3V
11 x 17 SEF (Tabloid)	0V	0V	+3.3V	+3.3V	+3.3V

73-101-00 to 73-155-00 Tray 3 Mis-Feed Jam RAP

73-101-00 Tray 3 misfeed jam.

73-106-00 LE late to TAR 3 sensor.

73-110-00 LE late to TAR 2 sensor.

73-130-00 TTM3 TE late at TAR.

73-132-00 TTM3 LE too early at TAR.

73-140-00 TTM3 TE late at HZ XP

73-141-00 TTM3 LE too early HZ XP

73-150-00 TTM3 too long at TAR.

73-151-00 TTM3 too short at TAR.

73-152-00 TTM3 too long at TAR no auto purge.

73-153-00 TTM3 too short at TAR no auto purge.

73-154-00 TTM3 mismatch long at TAR.

73-155-00 TTM3 mismatch short at TAR.

Initial Actions

WARNING

Ensure that the electricity to the machine is switched off while performing tasks that do not need electricity. Refer to [GP 14](#). Disconnect the power cord. Electricity can cause death or injury. Moving parts can cause injury.

- Check the condition of the paper in tray 3. Refer to [GP 20](#).
- Ensure that the tray is pushed fully home.
- Ensure that the tray 3 paper tray guides are set correctly, [ADJ 73.1](#).
- Check that the EPC memory PWB is installed and seated correctly, [PL 3.11 Item 21](#).
- Check the condition of the tray 3 feed, nudge and retard rolls. Use a cloth dampened with water to clean the rolls, [GP 27](#). If necessary, install a new tray 3 feed roll kit, [PL 81.30 Item 26](#).
- Go to [dC135](#) CRU/HFSI Status. Check the count of the tray 3 feed roll set. If the count is near end of life, install a new tray 3 feed roll kit, [PL 81.30 Item 26](#).

Procedure

Enter [dC330](#) code 73-103 tray 3 feed sensor, Q73-103, [PL 81.30 Item 19](#). Open tray 3. Press Start. Manually actuate the sensor. **The display changes.**

Y N

Refer to [WD 7.4](#). Check tray 3 feed sensor, Q73-103. Refer to:

- [GP 11](#) How to Check a Sensor.

A

A

- PJ953, [3 tray module PWB](#).
- [01D](#) +5V Distribution RAP.
- [01L](#) 0V Distribution RAP.

Install new components as necessary:

- Tray 3 feed sensor, [PL 81.30 Item 19](#).
- 3 tray module PWB, [PL 73.16 Item 4](#).
- Media path driver PWB, [PL 1.15 Item 5](#).

Enter [dC330](#) code 73-397 TAR 3 sensor, Q73-397, [PL 81.35 Item 18](#). Press Start. Pull out the horizontal transport assembly, [PL 81.35 Item 1](#). Manually actuate the sensor by placing a piece of paper over the sensor but not in the nip rolls. Push in the horizontal transport. **The display changes.**

Y N

Refer to [WD 7.4](#). Check TAR 3 sensor, Q73-397. Refer to:

- [GP 11](#) How to Check a Sensor.
- PJ954, [3 tray module PWB](#).
- [01D](#) +5V Distribution RAP.
- [01L](#) 0V Distribution RAP.

Install new components as necessary:

- TAR 3 sensor, [PL 81.35 Item 18](#).
- 3 tray module PWB, [PL 73.16 Item 4](#).
- Media path driver PWB, [PL 1.15 Item 5](#).

Remove the right side cover, [PL 70.25 Item 4](#). Check that the nudge spring is installed correctly, [PL 81.30 Item 10](#). Check that the spring is not damaged. **The spring is good.**

Y N

Install a new spring, [PL 81.30 Item 10](#).

Enter [dC330](#) code 70-398 tray 3 transport sensor (2), Q70-398, [PL 81.35 Item 18](#). Press Start. Pull out the horizontal transport assembly, [PL 81.35 Item 1](#). Manually actuate the sensor by placing a piece of paper over the sensor but not in the nip rolls. Push in the horizontal transport. **The display changes.**

Y N

Refer to [WD 7.4](#). Check tray 3 transport sensor (2), Q70-398. Refer to:

- [GP 11](#) How to Check a Sensor.
- PJ954, [3 tray module PWB](#).
- [01D](#) +5V Distribution RAP.
- [01L](#) 0V Distribution RAP.

Install new components as necessary:

- Tray 3 transport sensor (2), [PL 81.35 Item 18](#).
- 3 tray module PWB, [PL 73.16 Item 4](#).
- Media path driver PWB, [PL 1.15 Item 5](#).

Enter [dC330](#) code 70-025 3 tray transport motor, MOT70-025, [PL 73.16 Item 3](#). Press Start. **The motor runs.**

Y N

Refer to [WD 7.5](#). Check 3 tray transport motor, MOT70-025. Refer to:

- [GP 10](#) How to Check a Motor.
- PJ953, [3 tray module PWB](#)
- [01H](#) +24V Distribution RAP
- [01L](#) 0V Distribution RAP

Install new components as necessary:

- 3 tray module transport motor, [PL 73.16 Item 3](#).
- 3 tray module PWB, [PL 73.16 Item 4](#).
- Media path driver PWB, [PL 1.15 Item 5](#).

The transport rolls rotate.

Y N

Check the gears and drive belt, [PL 73.16](#).

CAUTION

To prevent damage to the feed mechanism, the paper tray must be pulled out before MOT 73-001 is run in diagnostics.

Enter [dC330](#) code 73-001 tray 3 feed motor, MOT73-001, [PL 81.30 Item 22](#). Press Start. **The motor runs.**

Y N

Refer to [WD 7.4](#). Check tray 3 feed motor, MOT73-001. Refer to:

- [GP 10](#) How to Check a Motor.
- PJ953, [3 tray module PWB](#).
- [01H](#) +24V Distribution RAP.
- [01L](#) 0V Distribution RAP.

Install new components as necessary:

- Tray 3 feed motor, [PL 81.30 Item 22](#).
- 3 tray module PWB, [PL 73.16 Item 4](#).
- Media path driver PWB, [PL 1.15 Item 5](#).

Perform the following:

- Check the feed roll assembly, [PL 81.30 Item 11](#).
- Check the tray 3 feed assembly, [PL 81.30 Item 1](#). Refer to [REP 81.2](#) and check the feed head housing location.
- Check the tray is level. Perform the following:
 1. Remove the tray front cover.
 2. Elevate the tray to the stack height position.
 3. Hold the elevator drive gear and pull out the tray. Check that the tray is level.
 4. If the tray is not level then install new elevator cables, [PL 73.15 Item 18](#).
- If the fault still occurs, check the following:
 - The takeaway roll 3, [PL 81.35 Item 16](#).
 - The transport roll 2, [PL 81.35 Item 15](#).
 - The transport roll 1, [PL 81.35 Item 14](#).

73-212-00 Tray 3 Elevate Encoder Failure RAP

73-212-00 Tray 3 encoder failure on hoist.

Initial Actions

WARNING

Ensure that the electricity to the machine is switched off while performing tasks that do not need electricity. Refer to [GP 14](#). Disconnect the power cord. Electricity can cause death or injury. Moving parts can cause injury.

- Check that the encoder is located correctly, [PL 73.16 Item 2](#).
- Check that the encoder sensor and wheel are clean.

Procedure

Pull out the relevant tray and allow it to move fully down. Close the tray. **The tray moves up.**

Y N

Go to [73-215-00](#) Tray 3 Hoist Failure RAP.

Enter [dC140](#) Analog Monitor select code 073-003 3TM elevator encoder. Perform the routine for the encoder. **The encoder routine is good.**

Y N

Refer to [WD 7.5](#). Check the 3TM elevator encoder sensor, Q73-003. Refer to:

- [GP 11](#) How to Check a Sensor.

NOTE: In this check place a piece of paper in the sensor. The check is difficult due to the problem in moving the timing disc.

- PJ954, [3 tray module PWB](#).
- [01D](#) +5V Distribution RAP.
- [01L](#) 0V Distribution RAP.

Install new components as necessary.

- Tray 3 elevator motor, [PL 73.16 Item 2](#).
- 3 tray module PWB, [PL 73.16 Item 4](#).
- Media path driver PWB, [PL 1.15 Item 5](#).

Check the encoder wheel for damage and that it is located on the motor correctly. If necessary install new components, [PL 73.16](#).

73-215-00 Tray 3 Hoist Failure RAP

73-215-00 Tray 3 hoist failure.

Initial Actions

WARNING

Ensure that the electricity to the machine is switched off while performing tasks that do not need electricity. Refer to [GP 14](#). Disconnect the power cord. Electricity can cause death or injury. Moving parts can cause injury.

- Check for obstructions behind the tray.
- Ensure that the tray is pushed fully home.
- Check that the tray elevator cables and mechanisms are located correctly. Refer to [REP 73.3](#).
- If the tray only elevates up by 25 mm (1 inch) and stops. Go to [73A](#) RAP and check the tray empty actuator.

Procedure

Enter [dC330](#) code 73-303 tray 3 home sensor, Q73-303, [PL 73.16 Item 8](#). Press Start. Pull out the tray. **The display changes.**

Y N

Refer to [WD 7.4](#). Check tray 3 home sensor, Q73-303. Refer to:

- [GP 11](#) How to Check a Sensor.
- [PJ954](#), [3 tray module PWB](#).
- [01D](#) +5V Distribution RAP.
- [01L](#) 0V Distribution RAP.

Install new components as necessary:

- Tray 3 home sensor, [PL 73.16 Item 8](#).
- 3 tray module PWB, [PL 73.16 Item 4](#).
- Media path driver PWB, [PL 1.15 Item 5](#).

Enter [dC330](#) code 73-383 tray 3 stack height sensor, Q73-383, [PL 81.30 Item 17](#). Press Start. Pull out tray 3. Manually actuate the stack height sensor. **The display changes.**

Y N

Refer to [WD 7.4](#). Check tray 3 stack height sensor, Q73-383. Refer to:

- [GP 11](#) How to Check a Sensor.
- [PJ953](#), [3 tray module PWB](#).
- [01D](#) +5V Distribution RAP.
- [01L](#) 0V Distribution RAP.

Install new components as necessary:

- Tray 3 stack height sensor, [PL 81.30 Item 17](#).
- 3 tray module PWB, [PL 73.16 Item 4](#).
- Media path driver PWB, [PL 1.15 Item 5](#).

Enter [dC330](#) code 73-002 tray 3 elevator motor, MOT73-002, [PL 73.16 Item 2](#). Pull out tray 3. Press Start. **The motor runs.**

Y N

Refer to [WD 7.5](#). Check that the tray 3 limit switch, [PL 81.30 Item 25](#), is not actuated. While not actuated, check for +24V at both contacts on the switch. Refer to:

- [GP 13](#) How to Check a Switch.
- [PJ957](#), [3 tray module PWB](#).
- [01H](#) +24V Distribution RAP.
- [01L](#) 0V Distribution RAP.

Install new components as necessary:

- Tray 3 limit switch, [PL 81.30 Item 25](#).
- 3 tray module PWB, [PL 73.16 Item 4](#).

Refer to [WD 7.5](#). Check tray 3 elevator motor, MOT73-002. Refer to:

- [GP 10](#) How to Check a Motor.
- [PJ957](#), [3 tray module PWB](#).
- [01H](#) +24V Distribution RAP.
- [01L](#) 0V Distribution RAP.

Install new components as necessary:

- Tray 3 elevator motor, [PL 73.16 Item 2](#).
- 3 tray module PWB, [PL 73.16 Item 4](#).
- Media path driver PWB, [PL 1.15 Item 5](#).

Perform the following:

- Check elevator cables, [PL 73.15](#).
- Check elevator motor drive coupling, [PL 73.16 Item 2](#).
- Check tray elevator drive gears and drive coupling, [PL 73.15 Item 11](#).

If the fault still occurs, then go to [73A](#) Tray 3 Out of Paper RAP.

73-320-00 Tray 3 Open in Run RAP

73-320-00 Tray 3 open during run when the paper is fed from tray 3.

Initial Actions

WARNING

Ensure that the electricity to the machine is switched off while performing tasks that do not need electricity. Refer to [GP 14](#). Disconnect the power cord. Electricity can cause death or injury. Moving parts can cause injury.

- Check for obstructions behind the tray.
- Ensure that the tray is pushed fully home.
- Check the tray 3 home sensor, [PL 73.16 Item 8](#) actuator on the tray.
- Check the tray 3 latch parts (on the tray and on the machine base), [PL 73.16 Item 1](#).

Procedure

Enter [dC330](#) code 73-303 tray 3 home sensor, Q73-303, [PL 73.16 Item 8](#). Press Start. Open and fully close the tray. **The display changes.**

Y N

Refer to [WD 7.4](#). Check tray 3 home sensor, Q73-303. Refer to:

- [GP 11](#) How to Check a Sensor.
- PJ954, [3 tray module PWB](#).
- [01D](#) +5V Distribution RAP.
- [01L](#) 0V Distribution RAP.

Install new components as necessary:

- Tray 3 home sensor, [PL 73.16 Item 8](#).
- 3 tray module control PWB, [PL 73.16 Item 4](#).
- Media path driver PWB, [PL 1.15 Item 5](#).

Check the tray 3 home sensor is secure and correctly positioned.

If the problem continues, install new components as necessary:

- Tray 3 home sensor, [PL 73.16 Item 8](#).
- 3 tray module PWB, [PL 73.16 Item 4](#).
- Media path driver PWB, [PL 1.15 Item 5](#).

73-325-00 Feeder HT Drawer Open in Run RAP

73-325-00 Tray 3 horizontal transport drawer open in run.

Initial Actions

WARNING

Ensure that the electricity to the machine is switched off while performing tasks that do not need electricity. Refer to [GP 14](#). Disconnect the power cord. Electricity can cause death or injury. Moving parts can cause injury.

- Check for obstructions behind the transport.
- Ensure that the transport is pushed fully home.
- Check the switch actuator on the back of the drawer, part of the horizontal transport, [PL 73.16 Item 18](#).
- Check the latch on the rear of the horizontal transport, [PL 81.35](#) above the connector for damage

Procedure

Enter [dC330](#) code 70-100 horizontal transport home switch, Q70-100, on the 3 tray module PWB, [PL 73.16 Item 4](#). Press Start. Open and fully close the horizontal transport. **The display changes.**

Y N

Refer to [WD 7.5](#). Check horizontal transport home switch, Q70-100. The home switch is located on the 3 tray module PWB. Check the voltage on the centre pin of the switch on the rear of the PWB. Refer to:

- [GP 13](#) How to Check a Switch.
- [01B](#) +3.3V ESTAR Distribution RAP
- [01L](#) 0V Distribution RAP.

Install new components as necessary:

- 3 tray module PWB, [PL 73.16 Item 4](#).
- Media path driver PWB, [PL 1.15 Item 5](#).

Check the alignment of the actuator to the sensor on the horizontal transport., [PL 81.35 Item 1](#). If the problem continues, install new components as necessary:

- HT and main harness latch, [PL 73.16 Item 18](#).
- Horizontal transport assembly, [PL 81.35 Item 1](#).
- 3 tray module PWB, [PL 73.16 Item 4](#).
- Media path driver PWB, [PL 1.15 Item 5](#).

73A Tray 3 Out of Paper RAP

Use this RAP when the copier display instructs the operator to add paper to tray 3 when the tray is not empty.

Initial Actions

WARNING

Ensure that the electricity to the machine is switched off while performing tasks that do not need electricity. Refer to [GP 14](#). Disconnect the power cord. Electricity can cause death or injury. Moving parts can cause injury.

- Check the position of the tray empty sensor, [PL 81.30 Item 19](#).
- Clean the tray empty sensor.

Procedure

Enter [dC330](#) code 73-201 tray 3 empty sensor, [PL 81.30 Item 19](#). Press Start.

Use a piece of paper to manually actuate the tray empty sensor with a piece of paper. **The display changes.**

Y N

Refer to [WD 7.4](#). Check tray 3 empty sensor, Q73-201. Refer to:

- [GP 11](#) How to Check a Sensor.
- PJ953, [3 tray module PWB](#).
- [01D](#) +5V Distribution RAP.
- [01L](#) 0V Distribution RAP.

Install new components as necessary:

- Tray 3 empty sensor, [PL 81.30 Item 19](#).
- 3 tray module PWB, [PL 73.16 Item 4](#).
- Media path driver PWB, [PL 1.15 Item 5](#).

Enter [dC330](#) code 73-383 tray 3 stack height sensor, Q73-383, [PL 81.30 Item 17](#). Press Start.

Pull out tray 3. Manually actuate the stack height sensor. **The display changes**

Y N

Refer to [WD 7.4](#). Check tray 3 stack height sensor, Q73-383. Refer to:

- [GP 11](#) How to Check a Sensor.
- PJ953, [3 tray module PWB](#).
- [01D](#) +5V Distribution RAP.
- [01L](#) 0V Distribution RAP.

Install new components as necessary:

- Tray 3 stack height sensor, [PL 81.30 Item 17](#).
- 3 tray module PWB, [PL 73.16 Item 4](#).
- Media path driver PWB, [PL 1.15 Item 5](#).

The fault may be intermittent. Perform the following:

- Check that the base plate in tray 3 is located correctly.
- Check that PJ958 harness is connected correctly and not damaged. Refer to [REP 81.2](#) Tray 3 Paper Feed Assembly. Repair the wiring as necessary, [REP 1.1](#).

74-101-00 Bypass Tray 4 Mis-Feed RAP

74-101-00 Tray 4 misfeed jam. The feed sensor did not actuate in the correct time after paper feed from the bypass tray

Initial Actions

WARNING

Ensure that the electricity to the machine is switched off while performing tasks that do not need electricity. Refer to [GP 14](#). Disconnect the power cord. Electricity can cause death or injury. Moving parts can cause injury.

- Check the condition of the paper in tray. Refer to [GP 20](#).
- Check the paper guides are set correctly.
- Check the condition of the bypass tray 4 feed, nudger and retard rolls. Use a cloth dampened with water to clean the rolls, [GP 27](#). If necessary, install a new tray 4 feed roll kit, [PL 31.11 Item 26](#).
- Go to [dC135](#) CRU/HFSI Status. Check the count of the tray 4 bypass feed roll set. If the count is near end of life, install a new tray 4 feed roll kit, [PL 31.11 Item 26](#).

Procedure

Enter [dC330](#) code 74-406 bypass feed sensor, Q74-406, [PL 74.10 Item 19](#). Press Start. Manually actuate the bypass feed sensor. **The display changes.**

Y N

Refer to [WD 8.3](#). Check bypass feed sensor, Q74-406. Refer to:

- [GP 11](#) How to Check a Sensor.
- PJ405, [Media path driver PWB](#).
- [01C](#) +3.3V Distribution RAP.
- [01L](#) 0V Distribution RAP.

Install new components as necessary:

- Bypass feed sensor, [PL 74.10 Item 19](#).
- Media path driver PWB, [PL 1.15 Item 5](#).

Enter [dC330](#) code 74-420 bypass feed motor (M7), MOT74-420, [PL 74.10 Item 2](#). Support the nudger assembly. Press Start. **The motor runs.**

Y N

Refer to [WD 8.3](#). Check bypass feed motor (M7), MOT74-420. Refer to:

- [GP 10](#) How to Check a Motor.
- PJ405, [Media path driver PWB](#).
- [01H](#) +24V Distribution RAP.
- [01L](#) 0V Distribution RAP.

Install new components as necessary:

- Bypass module, [PL 74.10 Item 1](#).
- Media path driver PWB, [PL 1.15 Item 5](#).

Perform the following:

- Check the feed roll assembly, [PL 74.10 Item 14](#).
- Check the takeaway nip rolls, [PL 70.30 Item 12](#).

Install new components as necessary.

74-120-00 Bypass Tray 4 Guides Move in Run RAP

74-120-00 Bypass tray 4 paper guides moved during run.

Procedure

WARNING

Ensure that the electricity to the machine is switched off while performing tasks that do not need electricity. Refer to [GP 14](#). Disconnect the power cord. Electricity can cause death or injury. Moving parts can cause injury.

Perform the following:

1. Check that the paper guides are in the correct position.
2. Check the paper guides for damage.
3. Check the operation of the paper guides and the function of the width sensor, Q74-415. Refer to [dC140](#) Analog Monitor and check the voltage on the potentiometer, refer to [WD 8.3](#).

If necessary, install new components:

- Bypass module, [PL 74.10 Item 1](#).

74-214-00 Bypass Tray 4 Nudger Failure RAP

74-214-00 Bypass tray 4 nudger failed to operate.

Initial Actions

WARNING

Ensure that the electricity to the machine is switched off while performing tasks that do not need electricity. Refer to [GP 14](#). Disconnect the power cord. Electricity can cause death or injury. Moving parts can cause injury.

- Check the feeder assembly, [PL 74.10](#) for damage.
- Check that the nudger home sensor, [PL 74.10 Item 18](#) is positioned correctly.

Procedure

Enter [dC330](#) code 74-413 bypass nudger home sensor, Q74-413, [PL 74.10 Item 18](#). Press Start. Manually actuate the sensor. **The display changes.**

Y N

Refer to [WD 8.3](#). Check Q74-413. Refer to:

- [GP 11](#) How to Check a Sensor.
- PJ405, [Media path driver PWB](#).
- [01C](#) +3.3V Distribution RAP.
- [01L](#) 0V Distribution RAP.

Install new components as necessary:

- Bypass nudger home sensor, [PL 74.10 Item 18](#).
- Media path driver PWB, [PL 1.15 Item 5](#).

Enter [dC330](#) code 74-420 Bypass feed motor, MOT74-420, [PL 74.10 Item 2](#). Press Start. **The motor runs.**

Y N

Refer to [WD 8.3](#). Check bypass feed motor, MOT74-420. Refer to:

- [GP 10](#) How to Check a Motor.
- PJ405, [Media path driver PWB](#).
- [01H](#) +24V Distribution RAP.
- [01L](#) 0V Distribution RAP.

Install new components as necessary:

- Bypass module, [PL 74.10 Item 1](#).
- Media path driver PWB, [PL 1.15 Item 5](#).

Check the cam mechanism for the nudger home sensor. Manually rotate the cam and check for damage. Install new parts as required, [PL 74.10](#).

If necessary, install a new bypass module, [PL 74.10 Item 1](#).

74A Bypass Tray 4 Size Sensing Problems RAP

Use this RAP to troubleshoot problems when the bypass tray 4 fails to indicate the correct paper size.

Initial Actions

WARNING

Ensure that the electricity to the machine is switched off while performing tasks that do not need electricity. Refer to [GP 14](#). Disconnect the power cord. Electricity can cause death or injury. Moving parts can cause injury.

- Check the condition of the media used in the bypass tray. Refer to [IQ 1](#) and [GP 20](#).
- Check that the width sensor guide is up to the edge of the paper.
- If there is a width sensing problem, then check that the bypass tray width sensing potentiometer, [PL 74.11 Item 10](#) is not damaged.

Procedure

Enter [dC330](#) code 74-335 bypass empty sensor, Q74-335, [PL 74.10 Item 18](#). Press Start. Manually actuate the sensor. **The display changes.**

Y N

Refer to [WD 8.3](#). Check the bypass empty sensor, Q74-335. Refer to:

- [GP 11](#) How to Check a Sensor.
- PJ405, [Media path driver PWB](#).
- [01C](#) +3.3V Distribution RAP.
- [01L](#) 0V Distribution RAP.

Install new components as necessary.

- Bypass empty sensor, [PL 74.10 Item 18](#).
- Media path driver PWB, [PL 1.15 Item 5](#).

Enter [dC330](#) code 74-350 bypass width sensor Q74-350, [PL 74.11 Item 6](#). Press Start. Move the width guides to actuate the sensor. **The display changes.**

Y N

Refer to [WD 8.3](#). Check bypass width sensor, Q74-350. Refer to:

- [GP 11](#) How to Check a Sensor.
- PJ405, [Media path driver PWB](#).
- [01C](#) +3.3V Distribution RAP.
- [01L](#) 0V Distribution RAP.

Install new components as necessary.

- Bypass width sensor, [PL 74.11 Item 6](#).
- Media path driver PWB, [PL 1.15 Item 5](#).

Enter [dC140](#) code 74-415 Bypass width potentiometer, Q74-415, [PL 74.11 Item 10](#). Press Start. Move the width guides to actuate the sensor. **The display changes.**

Y N

NOTE: The width sensor is a potentiometer. The arm on the potentiometer is attached to the bypass tray side guide. This gives a variable voltage to indicate the paper width setting.

Refer to [WD 8.3](#). Check bypass width potentiometer, Q74-415. Refer to:

- PJ405, [Media path driver PWB](#).
- [01C](#) +3.3V Distribution RAP.
- [01L](#) 0V Distribution RAP.

Install new components as necessary.

- Bypass module, [PL 74.10 Item 1](#).
- Media path driver PWB, [PL 1.15 Item 5](#).

Perform the following:

- Ensure that the customer is not filling the tray above the max fill line.
- Clean the feed, retard and nudger roll with a cloth dampened with water, [GP 27](#).
- If necessary, install new components as required, [PL 74.10](#).

75-101-00 Tray 5 Mis-Feed RAP

75-101-00 Tray 5 feed sensor did not actuate in the correct time after paper feed from tray 5.

Initial Actions

WARNING

Ensure that the electricity to the machine is switched off while performing tasks that do not need electricity. Refer to [GP 14](#). Disconnect the power cord. Electricity can cause death or injury. Moving parts can cause injury.

- Check the condition of the paper in tray 5. Refer to [GP 20](#).
- Check that the middle left side door, [PL 70.30 Item 16](#) is correctly latched.
- Check that the paper tray is set to the correct paper size.
- Check the condition of the tray 5 feed, nudger and retard rolls. Use a cloth dampened with water to clean the rolls, [GP 27](#). If necessary, install a new tray 5 feed roll kit, [PL 81.45 Item 20](#).
- Go to [dC135 CRU/HFSI Status](#). Check the count of the tray 5 feed roll set. If the count is near end of life, install a new tray 5 feed roll kit, [PL 81.45 Item 20](#).

Procedure

Enter [dC330](#) code 75-105 tray 5 feed sensor, Q75-105 [PL 81.45 Item 6](#). Press Start. Manually actuate the sensor. **The display changes.**

Y N

Refer to [WD 7.1](#). Check tray 5 feed sensor, Q75-105. Refer to:

- [GP 11](#) How to Check a Sensor.
- [PJ504](#), [tray 5 control PWB](#).
- [01D](#) +5V Distribution RAP.
- [01L](#) 0V Distribution RAP.

Install new components as necessary:

- Tray 5 feed sensor, [PL 81.45 Item 6](#).
- Tray 5 control PWB, [PL 75.68 Item 8](#).

Enter [dC330](#) code 75-117 tray 5 feed motor, MOT75-117, [PL 81.40 Item 3](#). Open the door. Press Start. **The motor runs.**

Y N

Refer to [WD 7.2](#). Check tray 5 feed motor, MOT75-117. Refer to:

- [GP 10](#) How to Check a motor.
- [PJ511](#), [tray 5 control PWB](#).
- [01H](#) +24V Distribution RAP.
- [01L](#) 0V Distribution RAP.

Install new components as necessary:

- Tray 5 feed motor, [PL 81.40 Item 3](#).
- Tray 5 control PWB, [PL 75.68 Item 8](#).

The feed shaft rotates.

Y N

Check the drive gears between the motor and the feed shaft. Install new components as necessary:

- Motor drive gear, [PL 81.40 Item 5](#).
- Gear 30T bearing, [PL 81.40 Item 18](#).
- Gear 29T, [PL 81.45 Item 11](#).

The feed roll rotates.

Y N

Check the one way coupling between the feed roller and the clutch. Install new components as necessary:

- One way coupling, [PL 81.45 Item 4](#).
- Clutch, [PL 81.45 Item 10](#).
- Feed roller, [PL 81.45 Item 2](#).

The nudger roll rotates.

Y N

Check the nudger pulley and nudger roller. Check the roller belt between the feed roller and the nudger roller. Install new components as necessary:

- Nudger pulley, [PL 81.45 Item 3](#).
- Roller belt, [PL 81.45 Item 15](#).
- Nudger roller, [PL 81.45 Item 8](#).

The retard roll rotates.

Y N

Check the coupling between the retard roller, retard clutch and clutch. Install new components as necessary:

- Retard clutch, [PL 81.46 Item 3](#).
- Clutch, [PL 81.46 Item 7](#).
- Retard roller, [PL 81.46 Item 2](#).

Enter [dC330](#) code 75-011 tray 5 transport motor, MOT75-018 [PL 81.40 Item 2](#). Press Start.

The motor runs.

Y N

Refer to [WD 7.1](#). Check tray 5 transport motor, MOT75-018. Refer to:

- [GP 10](#) How to Check a Motor.
- [PJ503](#), [tray 5 control PWB](#).
- [01H](#) +24V Distribution RAP.
- [01L](#) 0V Distribution RAP.

Install new components as necessary:

- Tray 5 transport motor, [PL 81.40 Item 2](#).
- Tray 5 control PWB, [PL 75.68 Item 8](#).

The take away roller rotates.

Y N

Check the drive belt and the one way pulley clutch for damage, [GP 7](#). Check the belt tensioner. Install new components as necessary:

- Drive belt, [PL 81.40 Item 7](#).
- One way pulley clutch, [PL 81.46 Item 4](#).
- Take away roller, [PL 81.46 Item 5](#).

A

B

B

Enter **dC330** code 82-125 confirm sensor (16), Q82-125, **PL 82.10 Item 7**. Press Start. Open the left hand door and manually actuate the sensor. **The display changes.**

Y N

Refer to **WD 8.1**. Check confirm sensor (16), Q82-125. Refer to:

- **GP 11** How to Check a Sensor.
- PJ104, **Media path driver PWB**.
- **01D** +5V Distribution RAP.
- **01L** 0V Distribution RAP.

Install new components as necessary:

- Confirm sensor (16), **PL 82.10 Item 7**.
- Media path control PWB, **PL 1.15 Item 5**.

Perform **SCP 5** Final Actions.

75-212-00, 75-215-00 Tray 5 Elevate Up Failure RAP

75-212-00 A signal was not detected by the encoder when the elevator motor was driving up.

75-215-00 The tray 5 stack height sensor did not actuate in expected time during hoist.

Initial Actions

WARNING

Ensure that the electricity to the machine is switched off while performing tasks that do not need electricity. Refer to GP 14. Disconnect the power cord. Electricity can cause death or injury. Moving parts can cause injury.

- Check for obstructions in the tray.
- Check that the door latches correctly.
- Open and close the tray 5 door. If the tray moves up check for intermittent failures. Refer to **WD 7.1** and **WD 7.2**.

Procedure

Enter **dC330** code 75-010 tray 5 door switch, S75-010, **PL 75.60 Item 6**. Press Start. Manually toggle the door interlock switch. **The display changes.**

Y N

Check the wiring to the switch, **REP 1.1**.

Refer to **WD 7.2**. Check tray 5 switch, S75-010. Refer to:

- **GP 13** How to Check a Switch.
- PJ507, **tray 5 control PWB**.
- **01D** +5V Distribution RAP.
- **01L** 0V Distribution RAP.

Install new components as necessary:

- Tray 5 door interlock switch, **PL 75.60 Item 6**.
- Tray 5 control PWB, **PL 75.68 Item 8**

Enter **dC330** code 75-011 tray 5 stack height sensor, Q75-011, **PL 81.45 Item 7**. Press Start. Manually actuate the stack height sensor on the paper feed assembly. **The display changes.**

Y N

Refer to **WD 7.2**. Check tray 5 stack height sensor, Q75-402. Refer to:

- **GP 11** How to Check a Sensor.
- PJ505, **tray 5 control PWB**.
- **01D** +5V Distribution RAP.
- **01L** 0V Distribution RAP.

Install new components as necessary:

- Tray 5 stack height sensor, **PL 81.45 Item 7**.
- Tray 5 control PWB, **PL 75.68 Item 8**.

Check the voltage on PJ504 pin 4 on the tray 5 control PWB. Manually actuate the tray upper limit switch (S75-412), **PL 75.68 Item 12**, on the paper feed assembly. **The voltage changes.**

Y N

Refer to **WD 7.1**. Check tray 5 upper limit switch, S75-412. Refer to:

- **GP 13** How to Check a Switch.

A

A

- PJ504, [tray 5 control PWB](#).
- [01H](#) +24V Distribution RAP.
- [01L](#) 0V Distribution RAP.

Install new components as necessary:

- Tray 5 stack upper limit switch, [PL 75.68 Item 12](#).
- Tray 5 control PWB, [PL 75.68 Item 8](#).

Enter [dC140](#) code 75-015 tray 5 elevator encoder sensor, Q75-015, [PL 75.68 Item 5](#). Press Start. Manually lift the motor to actuate the sensor. **The display changes.**

Y N

Refer to [WD 7.2](#). Check tray 5 elevator encoder, Q75-015. Refer to:

- [GP 11](#) How to Check a Sensor.
- PJ506, [tray 5 control PWB](#).
- [01D](#) +5V Distribution RAP.
- [01L](#) 0V Distribution RAP.

Install new components as necessary:

- Elevator encoder sensor, [PL 75.68 Item 5](#).
- Tray 5 control PWB, [PL 75.68 Item 8](#).

Enter [dC330](#) code 75-019 tray 5 elevator motor (up), MOT75-019, [PL 75.68 Item 4](#). Press Start. **The motor runs.**

Y N

Refer to [WD 7.1](#). Check tray 5 elevator motor, MOT75-019. Refer to:

- [GP 10](#) How to Check a Motor.
- PJ504, [tray 5 control PWB](#).
- [01H](#) +24V Distribution RAP.
- [01L](#) 0V Distribution RAP.

Install new components as necessary:

- Tray 5 elevator motor, [PL 75.68 Item 4](#).
- Tray 5 control PWB, [PL 75.68 Item 8](#).
- Media path driver PWB, [PL 1.15 Item 5](#).

The tray 5 elevator motor is operating correctly. Perform [SCP 5](#) Final Actions.

75-213-00, 75-216-00 Tray 5 Elevate Down Failure RAP

75-213-00 Tray 5 encoder failure on lower. A signal was not detected by the encoder when the elevator motor was driving down.

75-216-00 Tray 5 lower failure. The tray 5 stack down sensor did not actuate in expected time during lower.

Initial Actions

WARNING

Ensure that the electricity to the machine is switched off while performing tasks that do not need electricity. Refer to [GP 14](#). Disconnect the power cord. Electricity can cause death or injury. Moving parts can cause injury.

- Check for obstructions in the tray.
- Check that the door latches correctly.
- Open and close the tray 5 door. If the tray moves down, check for intermittent failures. Refer to [WD 7.1](#) and [WD 7.2](#).

Procedure

Enter [dC330](#) code 75-010 tray 5 door switch, S75-010, [PL 75.60 Item 6](#). Press Start. Manually toggle the door interlock switch. **The display changes.**

Y N

Refer to [WD 7.2](#). Check tray 5 door interlock switch, S75-010. Refer to:

- [GP 13](#) How to Check a Switch.
- PJ507, [tray 5 control PWB](#).
- [01D](#) +5V Distribution RAP.
- [01L](#) 0V Distribution RAP.

Install new components as necessary:

- Tray 5 door interlock switch, [PL 75.60 Item 6](#).
- Tray 5 control PWB, [PL 75.68 Item 8](#).

Enter [dC330](#) code 75-012 tray 5 down sensor, Q75-012, [PL 75.68 Item 9](#). Press Start. Manually actuate the stack down sensor actuator. **The display changes.**

Y N

Refer to [WD 7.2](#). Check tray 5 down sensor, Q75-012. Refer to:

- [GP 11](#) How to Check a Sensor.
- PJ505, [tray 5 control PWB](#).
- [01D](#) +5V Distribution RAP.
- [01L](#) 0V Distribution RAP.

Install new components as necessary:

- Tray 5 down sensor, [PL 75.68 Item 9](#).
- Tray 5 control PWB, [PL 75.68 Item 8](#).

Check the voltage on PJ504 pin 6 on the [tray 5 control PWB](#), [WD 7.1](#). Manually actuate the tray 5 down limit switch (S75-415), [PL 75.70 Item 2](#), on the paper tray. **The voltage changes.**

Y N

Refer to [WD 7.1](#). Check tray 5 down limit switch, S75-415. Refer to:

NOTE: Tray down limit switch S75-415 is located in the paper tray. Press the plate under the paper tray to actuate the switch.

- [GP 13](#) How to Check a Switch.
- PJ504, [tray 5 control PWB](#).
- [01H](#) +24V Distribution RAP.
- [01L](#) 0V Distribution RAP.

Install new components as necessary:

- Tray 5 down limit switch, [PL 75.70 Item 2](#).
- Tray 5 control PWB, [PL 75.68 Item 8](#).

Enter [dC140](#) code 75-015 tray 5 elevator motor encoder sensor, Q75-015, [PL 75.68 Item 5](#). Press Start. Manually lift the motor to actuate the sensor. **The display changes.**

Y N

Refer to [WD 7.2](#). Check tray 5 elevator motor encoder, Q75-015. Refer to:

- [GP 11](#) How to Check a Sensor.
- PJ506, [tray 5 control PWB](#).
- [01D](#) +5V Distribution RAP.
- [01L](#) 0V Distribution RAP.

Install new components as necessary:

- Elevator motor encoder sensor, [PL 75.68 Item 5](#).
- Tray 5 control PWB, [PL 75.68 Item 8](#).

Enter [dC330](#) code 75-373 tray 5 elevator motor (down), MOT75-019, [PL 75.68 Item 4](#). Press Start. **The motor runs.**

Y N

Refer to [WD 7.1](#). Check tray 5 elevator motor (down), MOT75-019. Refer to:

- [GP 10](#) How to Check a Motor.
- PJ504, [tray 5 control PWB](#).
- [01H](#) +24V Distribution RAP.
- [01L](#) 0V Distribution RAP.

Install new components as necessary:

- Tray 5 elevator motor, [PL 75.68 Item 4](#).
- Tray 5 control PWB, [PL 75.68 Item 8](#).
- Media path driver PWB, [PL 1.15 Item 5](#).

The tray 5 elevator motor is operating correctly. Perform [SCP 5](#) Final Actions.

75-312-00 IME to Tray 5 Communication Failure RAP

75-312-00 Image marking engine to tray 5 communications failure.

Procedure

WARNING

Ensure that the electricity to the machine is switched off while performing tasks that do not need electricity. Refer to [GP 14](#). Disconnect the power cord. Electricity can cause death or injury. Moving parts can cause injury.

Refer to [WD 7.1](#) and [WD 8.4](#). Perform the following:

1. Switch off the machine, then switch on the machine, [GP 14](#).
2. Check the communications link between the [tray 5 control PWB](#) and PJ704 on the [media path driver PWB](#).

If necessary, install new components:

- Communication harness, [PL 75.68 Item 26](#).
- Tray 5 control PWB, [PL 75.68 Item 8](#).
- Media path driver PWB, [PL 1.15 Item 5](#).

75-320-00 Tray 5 Opened In Run RAP

75-320-00 Tray 5 was opened during run when the paper is fed from tray 5.

Initial Actions

WARNING

Ensure that the electricity to the machine is switched off while performing tasks that do not need electricity. Refer to [GP 14](#). Disconnect the power cord. Electricity can cause death or injury. Moving parts can cause injury.

- Ensure that the door is pushed fully home.
- Check the switch actuator on the door.

Procedure

Enter [dC330](#) code 75-010 tray 5 door switch, S75-010, [PL 75.60 Item 6](#). Press Start. Open and fully close the door **The display changes.**

Y N

Refer to [WD 7.2](#). Check tray 5 door switch, S75-010. Refer to:

- [GP 13](#) How to Check a Switch.
- PJ507, [tray 5 control PWB](#).
- [01D](#) +5V Distribution RAP.
- [01L](#) 0V Distribution RAP.

Install new components as necessary:

- Tray 5 door switch, [PL 75.60 Item 6](#).
- Tray 5 control PWB, [PL 75.68 Item 8](#).

Check that the door opens and closes and latches correctly. If necessary install new front door assembly, [PL 75.60 Item 1](#).

75-325-00 Tray 5 Undocked In Run RAP

75-325-00 Tray 5 was undocked during run when the paper is fed from tray 5.

Initial Actions

WARNING

Ensure that the electricity to the machine is switched off while performing tasks that do not need electricity. Refer to [GP 14](#). Disconnect the power cord. Electricity can cause death or injury. Moving parts can cause injury.

- Ensure the tray base is located correctly.
- Check for obstructions between the tray 5 module and the machine.

Procedure

Enter [dC330](#) code 75-017 tray 5 docking switch, S75-017, [PL 75.64 Item 1](#). Press Start. Undock and dock tray 5, refer to [REP 75.7](#). **The display changes.**

Y N

Refer to [WD 7.2](#). Check tray 5 docking switch, S75-017. Refer to:

- [GP 13](#) How to Check a Switch.
- PJ507, [tray 5 control PWB](#).
- [01D](#) +5V Distribution RAP.
- [01L](#) 0V Distribution RAP.

Install new components as necessary:

- Tray 5 docking switch, [PL 75.64 Item 1](#).
- Tray 5 control PWB, [PL 75.68 Item 8](#).

Perform the following:

- Check the docking latch, [PL 75.62 Item 6](#) on tray 5 is latched onto the machine.
- Check the slide assembly, [PL 75.62 Item 12](#).

75A Tray 5 Door Open During Run RAP

Use this RAP when the tray 5 door is open during run when the paper is fed from tray 5.

Initial Actions

WARNING

Ensure that the electricity to the machine is switched off while performing tasks that do not need electricity. Refer to [GP 14](#). Disconnect the power cord. Electricity can cause death or injury. Moving parts can cause injury.

- Ensure that the door is pushed fully home.
- Check the switch actuator on the door.

Procedure

Enter [dC330](#) code 75-010 tray 5 door switch, S75-010, [PL 75.60 Item 6](#). Press Start. Open and fully close the door **The display changes.**

Y N

Refer to [WD 7.2](#). Check tray 5 door switch, S75-010. Refer to:

- [GP 13](#) How to Check a Switch.
- PJ507, [tray 5 control PWB](#).
- [01D](#) +5V Distribution RAP.
- [01L](#) 0V Distribution RAP.

Install new components as necessary:

- Tray 5 door switch, [PL 75.60 Item 6](#).
- Tray 5 control PWB, [PL 75.68 Item 8](#).

If the problem continues, install new components as necessary:

- Tray 5 door switch, [PL 75.60 Item 6](#).
- Tray 5 control PWB, [PL 75.68 Item 8](#).

75B Tray 5 Empty RAP

Use this RAP to solve problems associated with the tray 5 empty sensor.

Initial Actions

WARNING

Ensure that the electricity to the machine is switched off while performing tasks that do not need electricity. Refer to [GP 14](#). Disconnect the power cord. Electricity can cause death or injury. Moving parts can cause injury.

- Check that the hole in the tray, directly under the sensor is clear and not obstructed.
- Check the sensor for contamination.

Procedure

Enter [dC330](#) code 75-016 tray 5 empty sensor, Q75-016, [PL 81.45 Item 6](#). Press Start. Manually actuate the tray empty sensor. **The display changes.**

Y N

Refer to [WD 7.1](#). Check tray 5 empty sensor, Q75-016. Refer to:

- [GP 11](#) How to Check a Sensor.
- PJ505, [tray 5 control PWB](#).
- [01D](#) +5V Distribution RAP.
- [01L](#) 0V Distribution RAP.

Install new components as necessary:

- Tray 5 empty sensor, [PL 81.45 Item 6](#).
- Tray 5 control PWB, [PL 75.68 Item 8](#).

The fault may be intermittent. Perform the steps that follow:

- Check the wiring harness for damaged wire. If necessary repair the harness, [REP 1.1](#).
- Check that tray 5 empty sensor is located correctly.

82-110-00 to 82-114-00, 82-152-00, 82-157-00 to 82-159-00, 82-164-00 to 82-166-00 Media Path Sensor (5) RAP

82-110-00 The sheet has arrived at the media path sensor (5) too early.

82-111-00 The media path sensor (5) has detected a sheet mismatch, the sheet was too long.

82-112-00 The media path sensor (5) has detected a sheet mismatch, the sheet was too short.

82-113-00 Media path sensor (5) lead edge timeout.

82-114-00 Media path sensor (5) trail edge timeout.

82-152-00 The sheet has arrived at the media path sensor (5) too early.

82-157-00 The media path sensor (5) has detected the sheet was too long. The machine will auto purge the media path.

82-158-00 The media path sensor (5) has detected the sheet was too short. The machine will auto purge the media path.

82-159-00 MP MP2 stall bridged sheet zone 1A.

82-164-00 The media path sensor (5) has detected the sheet was too long. The machine will not auto purge the media path.

82-165-00 The media path sensor (5) has detected the sheet was too short. The machine will not auto purge the media path.

82-166-00 TTM horizontal transport bridge sheet in zone 1A.

Initial Actions

WARNING

Ensure that the electricity to the machine is switched off while performing tasks that do not need electricity. Refer to GP 14. Disconnect the power cord. Electricity can cause death or injury. Moving parts can cause injury.

- Check the paper stack in the tray.
- Check that the tray guides are against the edges of the paper.
- Check for paper down the back of the tray.
- Check that the tray is pushed fully home.
- Check for obstructions in the paper path.
- Check that the upper and mid left side doors are latched.
- If glossy media is used then instruct the customer to feed the media from the bypass tray and select glossy for the media type.

Procedure

Enter **dC330** code 82-110 vertical transport sensor (5), Q82-110. Press Start. Open the mid left door then manually actuate the sensor. **The display changes.**

Y N

Go to **WD 8.1**. Check the vertical transport sensor (5), Q82-110. Refer to:

- **GP 11** How to Check a Sensor.
- PJ104, **Media Path Driver PWB**.
- **01D** +5V Distribution RAP.

A

- **01L** 0V Distribution RAP.
- Install new components as necessary:
- Vertical transport sensor (5), **PL 82.10 Item 7**.
 - Media path driver PWB, **PL 1.15 Item 5**.

Enter **dC330** code 82-001 vertical transport motor (M2), MOT82-001. Press Start. **The motor runs.**

Y N

Go to **WD 8.1**. Check the vertical transport motor (M2), MOT82-001. Refer to:

- **GP 10** How to Check a Motor.
- PJ104, **Media path driver PWB**.
- **01D** +5V Distribution RAP.
- **01J** +50V Distribution RAP.
- **01L** 0V Distribution RAP.

Install new components as necessary:

- Vertical transport motor (M2), **PL 82.10 Item 12**.
- Media path driver PWB, **PL 1.15 Item 5**.

The vertical transport rolls, PL 82.10 rotate.

Y N

Check the drive belt and gears on the vertical transport, **PL 82.10**.

If necessary, install new components:

- Transport rolls, **PL 82.10**.
- Drive belts, **PL 82.10**.
- Drive gears, **PL 82.10**.

Enter **dC140** Analog Monitor. Select 82-100 vertical transport motor encoder (M2). Press Start. The number of ticks (i.e. 36 ticks) will flash on the display and then return to show 0 ticks. Repeat by selecting stop and then start on the popup menu, the number only remains for a few seconds. **The number of ticks is displayed.**

Y N

Go to **WD 8.1**. Check the vertical transport motor (M2), MOT82-001 and the encoder wire harness. Refer to:

- **GP 10** How to Check a Motor.
- PJ104, **Media path driver PWB**.
- **01D** +5V Distribution RAP.
- **01J** +50V Distribution RAP.
- **01L** 0V Distribution RAP.

Install new components as necessary:

- Vertical transport motor (M2), **PL 82.10 Item 12**.
- Media path driver PWB, **PL 1.15 Item 5**.

Check the following:

- The bearing, shaft and rolls on the transport roll assembly, **PL 82.10**.
- The idler rolls in the middle left door assembly, **PL 70.30 Item 16**.
- The transport rolls for wear, **PL 82.10**.

Install new components as necessary.

A

82-125-00 to 82-133-00, 82-153-00, 82-160-00, 82-162-00, 82-163-00 Confirm Sensor (16) RAP

82-125-00 The sheet has arrived at the confirm sensor (16) too early.

82-126-00 The confirm sensor (16) has detected the sheet was too long. The machine will auto purge the media path.

82-127-00 The confirm sensor (16) has detected the sheet was too short. The machine will auto purge the media path.

82-128-00 The confirm sensor (16) has detected a sheet mismatch, the sheet was too long.

82-129-00 The confirm sensor (16) has detected a sheet mismatch, the sheet was too short.

82-130-00 Lead edge late to the confirm sensor (16) from the tree tray module.

82-131-00 Trail edge late at the confirm sensor (16).

82-153-00 The sheet has arrived at the confirm sensor (16) too early.

82-160-00 MP MP2 stall bridged sheet zone 2

82-162-00 The confirm sensor (16) has detected the sheet was too long. The machine will not auto purge the media path.

82-163-00 The confirm sensor (16) has detected the sheet was too short. The machine will not auto purge the media path.

Initial Actions

WARNING

Ensure that the electricity to the machine is switched off while performing tasks that do not need electricity. Refer to GP 14. Disconnect the power cord. Electricity can cause death or injury. Moving parts can cause injury.

- Check the paper stack in the tray.
- Check that the tray guides are against the edges of the paper.
- Check that the tray is pushed fully home.
- Check for obstructions in the paper path.
- Check that the upper and mid left doors are fully latched.
- If a 82-130-00 fault occurs when feeding from the bypass tray. Check the bypass feed roll assembly, [PL 74.10 Item 14](#).

Procedure

Enter [dC330](#) code 82-125 confirm sensor (16), Q82-125. Press Start. Open the upper left door then manually actuate the sensor. **The display changes.**

Y N

Go to [WD 8.1](#). Check the confirm sensor (16), Q82-125. Refer to:

- [GP 11](#) How to Check a Sensor.
- PJ104, [Media path driver PWB](#).
- [01D](#) +5V Distribution RAP.
- [01L](#) 0V Distribution RAP.

A

Install new components as necessary:

- Confirm sensor (16), [PL 82.10 Item 7](#).
- Media path driver PWB, [PL 1.15 Item 5](#).

Enter [dC330](#) code 82-001 vertical transport motor (M2), MOT82-001. Press Start. **The motor runs.**

Y N

Go to [WD 8.1](#). Check the vertical transport motor (M2), MOT82-001. Refer to:

- [GP 10](#) How to Check a Motor.
- PJ104, [Media path driver PWB](#).
- [01D](#) +5V Distribution RAP.
- [01J](#) +50V Distribution RAP.
- [01L](#) 0V Distribution RAP.

Install new components as necessary:

- Vertical transport motor (M2), [PL 82.10 Item 12](#).
- Media path driver PWB, [PL 1.15 Item 5](#).

The vertical transport rolls rotate.

Y N

Check the drive belt and drive gears on the vertical transport, [PL 82.10](#).

If necessary, install new components:

- Transport rolls, [PL 82.10](#).
- Drive belts, [PL 82.10](#).
- Drive gears, [PL 82.10](#).

Enter [dC140](#) Analog Monitor. Select 82-100 vertical transport motor encoder (M2). Press Start. The number of ticks (i.e. 36 ticks) will flash on the display and then return to show 0 ticks. Repeat by selecting stop and then start on the popup menu, the number only remains for a few seconds. **The number of ticks is displayed.**

Y N

Go to [WD 8.1](#). Check the vertical transport motor (M2), MOT82-001. Refer to:

- [GP 10](#) How to Check a Motor.
- PJ104, [Media path driver PWB](#).
- [01D](#) +5V Distribution RAP.
- [01J](#) +50V Distribution RAP.
- [01L](#) 0V Distribution RAP.

Install new components as necessary:

- Vertical transport motor (M2), [PL 82.10 Item 12](#).
- Media path driver PWB, [PL 1.15 Item 5](#).

Check the following:

- Check the wiring for damage and correct harness routing to the vertical paper path.
- The bearing, shaft and rolls on the transport roll assembly, [PL 82.10](#),
- The idler rolls in the upper left side door, [PL 70.30 Item 4](#).
- The transport rolls for wear, [PL 82.10 Item 1](#), [PL 82.10 Item 2](#).

Install new components as necessary.

A

82-132-00, 82-155-00 Media Path Sensor 16 Duplex Mode RAP

82-132-00 Lead edge timed out, sheet late at the media path sensor 16 in duplex mode.

82-155-00 Lead edge too early at the media path sensor 16 in duplex mode.

Initial Actions

WARNING

Ensure that the electricity to the machine is switched off while performing tasks that do not need electricity. Refer to [GP 14](#). Disconnect the power cord. Electricity can cause death or injury. Moving parts can cause injury.

- Check for obstructions in the paper path.
- Check the vertical and horizontal transport rolls for contamination or wear.
- Check that the upper and middle left side doors are fully latched.

Procedure

Enter [dC330](#) code 82-125 confirm sensor (16), Q82-125. Press Start. Open the left hand door and manually actuate the sensor. **The display changes.**

Y N

Go to [WD 8.1](#). Check confirm sensor (16), Q82-125. Refer to:

- [GP 11](#) How to Check a Sensor.
- PJ104, [Media path driver PWB](#).
- [01D](#) +5V Distribution RAP.
- [01L](#) 0V Distribution RAP.

Install new components as necessary:

- Confirm sensor 16, [PL 82.10](#) Item 7.
- Media path driver PWB, [PL 1.15](#) Item 5.

Enter [dC330](#) code 82-002 vertical transport motor (M2) (reverse), MOT82-001. Press Start.

The motor runs.

Y N

Go to [WD 8.1](#). Check vertical transport motor (M2), MOT82-001. Refer to:

- [GP 10](#) How to Check a Motor.
- PJ104, [Media path driver PWB](#).
- [01D](#) +5V Distribution RAP.
- [01J](#) +50V Distribution RAP.
- [01L](#) 0V Distribution RAP.

Install new components as necessary:

- Vertical Transport motor 2, [PL 82.10](#) Item 12.
- Media path driver PWB, [PL 1.15](#) Item 5.

The vertical transport rolls rotate.

Y N

Check the drive belt and drive gears on the vertical transport, [PL 82.10](#).

If necessary, install new components:

- Transport rolls, [PL 82.10](#).
- Drive belts, [PL 82.10](#).
- Drive gears, [PL 82.10](#).

Enter [dC140](#) Analog Monitor. Select 82-100 vertical transport motor encoder (M2). Press Start. The number of ticks (i.e. 36 ticks) will flash on the display and then return to show 0 ticks. Repeat by selecting stop and then start on the popup menu, the number only remains for a few seconds. **The number of ticks is displayed.**

Y N

Go to [WD 8.1](#). Check vertical transport motor (M2), MOT82-001 and the encoder wire harness. Refer to:

- [GP 10](#) How to Check a Motor.
- PJ104, [Media path driver PWB](#).
- [01D](#) +5V Distribution RAP.
- [01J](#) +50V Distribution RAP.
- [01L](#) 0V Distribution RAP.

Install new components as necessary:

- Vertical transport motor (M2), [PL 82.10](#) Item 12.
- Media path driver PWB, [PL 1.15](#) Item 5.

Enter [dC330](#) code 82-004 Horizontal transport motor (M6) (reverse), MOT82-003. Press Start.

The motor runs.

Y N

Go to [WD 8.5](#). Check horizontal transport motor (M6), MOT82-003. Refer to:

- [GP 10](#) How to Check a Motor.
- PJ905, [Media path driver PWB](#).
- [01D](#) +5V Distribution RAP.
- [01J](#) +50V Distribution RAP.
- [01L](#) 0V Distribution RAP.

Install new components as necessary:

- Horizontal transport motor (M6), [PL 82.15](#) Item 9.
- Media path driver PWB, [PL 1.15](#) Item 5.

The horizontal transport rolls rotate.

Y N

Check the drive belt and drive gears on the horizontal transport, [PL 82.10](#) / [PL 82.15](#).

If necessary, install new components:

- Transport rolls, [PL 82.15](#).
- Drive belts, [PL 82.15](#).
- Drive gears, [PL 82.15](#).

Enter [dC140](#) Analog Monitor. Select 82-102 horizontal transport motor encoder (M6). Press Start. The number of ticks (i.e. 36 ticks) will flash on the display and then return to show 0 ticks. Repeat by selecting stop and then start on the popup menu, the number only remains for a few seconds. **The number of ticks is displayed.**

A

Y N

Go to [WD 8.5](#). Check horizontal transport motor (M6), MOT82-003 and the encoder wire harness. Refer to:

- [GP 10](#) How to Check a Motor.
- PJ905, [Media path driver PWB](#).
- [01D](#) +5V Distribution RAP.
- [01J](#) +50V Distribution RAP.
- [01L](#) 0V Distribution RAP.

Install new components as necessary:

- Horizontal transport motor (M6), [PL 82.15 Item 9](#).
- Media path driver PWB, [PL 1.15 Item 5](#).

Check the following:

- The bearing, shaft and rolls on the horizontal and vertical transport assembly.
- The idler rolls in the upper left side door, [PL 70.30 Item 4](#).
- The transport rolls for wear, [PL 82.10 Item 1](#), [PL 82.10 Item 2](#).

Install new components as necessary.

NOTE: Calibration of the registration / preheat assembly, [dC625](#), is only required when:

- The registration / preheat assembly is removed or replaced.
- The horizontal transport assembly is removed or replaced.

Calibration of the registration / preheat assembly is NOT required when:

- A printhead is replaced.
- The IOD assembly is removed or replaced.

82-133-00 Media Path Sensor 16 Time out from Tray 5 RAP

82-133-00 Lead edge late to the media path sensor 16 when feeding from tray 5.

Initial Actions

WARNING

Ensure that the electricity to the machine is switched off while performing tasks that do not need electricity. Refer to [GP 14](#). Disconnect the power cord. Electricity can cause death or injury. Moving parts can cause injury.

- Check the paper in tray 5.
- Check that the paper guides are set the correct paper size.
- Check tray 5 feed assembly, [PL 81.45 Item 2](#).
- Check for obstructions in the paper path.
- Check that the upper and middle left side doors are fully latched, [PL 70.30 Item 14](#), [PL 70.30 Item 16](#).

Procedure

Enter [dC330](#) code 82-125 confirm sensor (16), Q82-125. Press Start. Open the left hand door and manually actuate the sensor. **The display changes.**

Y N

Go to [WD 8.1](#). Check confirm sensor (16), Q82-125. Refer to:

- [GP 11](#) How to Check a Sensor.
- PJ104, [Media path driver PWB](#).
- [01D](#), +5V Distribution RAP.
- [01L](#) 0V Distribution RAP.

Install new components as necessary:

- Confirm sensor (16), [PL 82.10 Item 7](#).
- Media path driver PWB, [PL 1.15 Item 5](#).

Enter [dC330](#) code 82-001 vertical transport motor (M2), MOT82-001. Press Start. **The motor runs.**

Y N

Go to [WD 8.1](#). Check vertical transport motor (M2), MOT82-001. Refer to:

- [GP 10](#) How to Check a Motor.
- PJ104, [Media path driver PWB](#).
- [01D](#) +5V Distribution RAP.
- [01J](#) +50V Distribution RAP.
- [01L](#) 0V Distribution RAP.

Install new components as necessary:

- Vertical transport motor (M2), [PL 82.10 Item 12](#).
- Media path driver PWB, [PL 1.15 Item 5](#).

The vertical transport rolls rotate.

Y N

Check the drive belt and drive gears on the vertical transport, [PL 82.10](#).

A

A

If necessary, install new components:

- Transport rolls, [PL 82.10](#).
- Drive belts, [PL 82.10](#).
- Drive gears, [PL 82.10](#).

Enter [dC140](#) Analog Monitor. Select 82-100 vertical transport motor encoder (M2). Press Start. The number of ticks (i.e. 36 ticks) will flash on the display and then return to show 0 ticks. Repeat by selecting stop and then start on the popup menu, the number only remains for a few seconds. **The number of ticks is displayed.**

Y N

Go to [WD 8.1](#). Check vertical transport motor (M2), MOT82-001 and the encoder wire harness. Refer to:

- [GP 10](#) How to Check a Motor.
- PJ104, [Media path driver PWB](#).
- [01D](#) +5V Distribution RAP.
- [01J](#) +50V Distribution RAP.
- [01L](#) 0V Distribution RAP.

Install new components as necessary:

- Vertical transport motor (M2), [PL 82.10 Item 12](#).
- Media path driver PWB, [PL 1.15 Item 5](#).

Check the following:

- The bearing, shaft and rolls on the transport roll assembly, [PL 82.10](#).
- The idler rolls in the upper left side door, [PL 70.30 Item 4](#).
- The transport rolls for wear, [PL 82.10 Item 1](#), [PL 82.10 Item 2](#).
- Check tray 5 feed assembly, [PL 81.45 Item 2](#).

Install new components as necessary.

82-140-00, 82-142-00 Media Path Sheet Too Wide or Narrow RAP

82-140-00 Media path sheet too wide.

82-142-00 Media path sheet too narrow.

Initial Actions

WARNING

Ensure that the electricity to the machine is switched off while performing tasks that do not need electricity. Refer to [GP 14](#). Disconnect the power cord. Electricity can cause death or injury. Moving parts can cause injury.

- Check the paper guides are set correctly in the paper tray.
- Check for the correct size of paper in the tray.
- The paper size shown on the UI screen indicates the same paper size that is in the paper tray. If different, then reset the paper guides in the tray so that the two match.

Procedure

This dimension is measured by the registration scan bar (10) Q89-005 on the registration / pre-heat assembly.

- Refer to [WD 8.6](#). Check the connection of the ribbon cable between the registration scan bar and PJ1 on the registration / preheat interface PWB.
- Remove the registration / preheat assembly, [REP 89.1](#).

Perform the following:

- Check and clean the registration scan bar sensor, [PL 88.10 Item 2](#).
- Remove and clean the scan bar baffle and the scan bar with lint free cloth, [PL 26.10 Item 6](#).

If the fault is still present then install new components as necessary:

1. Registration / preheat assembly, [PL 88.10 Item 1](#).
2. Media Path Driver PWB, [PL 1.15 Item 5](#).

82-141-00, 82-147-00, 82-148-00, 82-154-00 Media Path Sensor 14 RAP

82-141-00 or 82-154-00 The sheet has arrived too early at media path sensor 14.

82-147-00 Lead edge time out, sheet late at the media path sensor 14 at pre-registration.

82-148-00 Trail edge time out, sheet late clearing at the media path sensor 14 at pre-registration.

Initial Actions

WARNING

Ensure that the electricity to the machine is switched off while performing tasks that do not need electricity. Refer to [GP 14](#). Disconnect the power cord. Electricity can cause death or injury. Moving parts can cause injury.

- Check for obstructions in the paper path.
- Check the vertical and horizontal transport rolls for contamination or wear.
- Check that the upper left side door is latched correctly.

Procedure

Enter [dC330](#) code 83-125 duplex end sensor (14), Q83-125, [PL 82.15 Item 3](#). Press Start. Open the front door and manually actuate the sensor. **The display changes.**

Y N

Go to [WD 8.5](#). Check duplex end sensor (14), Q83-125. Refer to:

- [GP 11](#) How to Check a Sensor.
- PJ905, [Media path driver PWB](#).
- [01D](#) +5V Distribution RAP.
- [01J](#) +50V Distribution RAP.
- [01L](#) 0V Distribution RAP.

Install new components as necessary:

- Duplex end sensor (14), [PL 82.15 Item 3](#).
- Media path driver PWB, [PL 1.15 Item 5](#).

Enter [dC330](#) code 82-001 vertical transport motor (M2), MOT82-001. Press Start. **The motor runs.**

Y N

Go to [WD 8.1](#). Check vertical transport motor, MOT82-001. Refer to:

- [GP 10](#) How to Check a Motor.
- PJ104, [Media path driver PWB](#).
- [01D](#) +5V Distribution RAP.
- [01J](#) +50V Distribution RAP.
- [01L](#) 0V Distribution RAP.

Install new components as necessary:

- Vertical Transport motor (M2), [PL 82.10 Item 12](#).
- Media path driver PWB, [PL 1.15 Item 5](#).

The vertical transport rolls rotate.

Y N

Check the drive belt and drive gears on the vertical transport, [PL 82.10](#)

If necessary, install new components:

- Transport rolls, [PL 82.10](#).
- Drive belts, [PL 82.10](#).
- Drive gears, [PL 82.10](#).

Enter [dC140](#) Analog Monitor. Select 82-100 vertical transport motor encoder (M2). Press Start. The number of ticks (i.e. 36 ticks) will flash on the display and then return to show 0 ticks. Repeat by selecting stop and then start on the popup menu, the number only remains for a few seconds. **The number of ticks is displayed.**

Y N

Go to [WD 8.1](#). Check vertical transport motor (M2), MOT82-001 and check the encoder wire harness. Refer to:

- [GP 10](#) How to Check a Motor.
- PJ104, [Media path driver PWB](#).
- [01D](#) +5V Distribution RAP.
- [01J](#) +50V Distribution RAP.
- [01L](#) 0V Distribution RAP.

Install new components as necessary:

- Vertical transport motor (M2), [PL 82.10 Item 12](#).
- Media path driver PWB, [PL 1.15 Item 5](#).

Enter [dC330](#) code 82-003 Horizontal transport motor (M6) (forward), MOT82-003. Press Start. **The motor runs.**

Y N

Go to [WD 8.5](#). Check horizontal transport motor (M6), MOT82-003. Refer to:

- [GP 10](#) How to Check a Motor.
- PJ905, [Media path driver PWB](#).
- [01D](#) +5V Distribution RAP.
- [01J](#) +50V Distribution RAP.
- [01L](#) 0V Distribution RAP.

Install new components as necessary:

- Horizontal transport motor (M6), [PL 82.15 Item 9](#).
- Media path driver PWB, [PL 1.15 Item 5](#).

The horizontal transport rolls rotate.

Y N

Check the drive belt and drive gears on the horizontal transport, [PL 82.15](#).

If necessary, install new components:

- Transport rolls, [PL 82.15 Item 10](#).
- Drive belts, [PL 82.15 Item 7](#).
- Drive gears, [PL 82.15](#).

NOTE: Under powered stepper motors can still operate in component control. Check [dC123](#) PEST fault history and check for under powered motors.

Enter [dC140](#) Analog Monitor. Select 82-102 horizontal transport motor encoder (M6). Press Start. The number of ticks (i.e. 36 ticks) will flash on the display and then return to show 0 ticks. Repeat by selecting stop and then start on the popup menu, the number only remains for a few seconds. **The number of ticks is displayed.**

Y N
Go to [WD 8.5](#). Check horizontal transport motor (M6), MOT82-003 and the encoder wire harness. Refer to:

- [GP 10](#) How to Check a Motor.
- PJ905, [Media path driver PWB](#).
- [01D](#) +5V Distribution RAP.
- [01J](#) +50V Distribution RAP.
- [01L](#) 0V Distribution RAP.

Install new components as necessary:

- Horizontal transport motor (M6), [PL 82.15 Item 9](#).
- Media path driver PWB, [PL 1.15 Item 5](#).

Enter [dC330](#) code 89-007 registration motor A1 (M3), MOT89-007. Press Start. **The motor runs.**

Y N
Go to [WD 8.1](#). Check registration motor A1 (M3), MOT89-007. Refer to:

- [GP 10](#) How to Check a Motor.
- PJ202, [Media path driver PWB](#).
- [01J](#) +50V Distribution RAP.
- [01L](#) 0V Distribution RAP.

Install new components as necessary:

- Registration / preheat assembly, [PL 88.10 Item 1](#)
- Media path driver PWB, [PL 1.15 Item 5](#)

Enter [dC330](#) code 89-008 registration motor A2 (M3), MOT89-008. Press Start. **The motor runs.**

Y N
Go to [WD 8.1](#). Check registration motor A2 (M3), MOT89-008. Refer to:

- [GP 10](#) How to Check a Motor.
- PJ202, [Media path driver PWB](#).
- [01J](#) +50V Distribution RAP.
- [01L](#) 0V Distribution RAP.

Install new components as necessary:

- Registration / preheat IF PWB, [PL 88.10 Item 10](#)
- Registration / preheat assembly, [PL 88.10 Item 1](#)
- Media path driver PWB, [PL 1.15 Item 5](#)

Enter [dC330](#) code 89-016 Registration / preheat hatch open. Press Start. **The hatch opens.**

Y N
Check the hatch lift mechanism for damage.
Install new components as necessary:

- Registration / preheat assembly, [PL 88.10 Item 1](#)
- Media path driver PWB, [PL 1.15 Item 5](#)

Enter [dC330](#) code 82-007 Nip C release solenoid, SOL82-007. Press Start. **The solenoid energizes.**

Y N
Go to [WD 8.1](#). Check SOL82-007. Refer to:

- [GP 12](#) How to Check a Solenoid or Clutch.
- PJ303, [Media path driver PWB](#).
- [01J](#) +50V Distribution RAP.
- [01L](#) 0V Distribution RAP.

Install new components as necessary:

- Nip C release solenoid, [PL 82.15 Item 4](#).
- Media path driver PWB, [PL 1.15 Item 5](#).

Enter [dC330](#) code 82-008 Nip D release solenoid, SOL82-008, [PL 70.30 Item 13](#). Press Start. **SOL82-008 energizes.**

Y N
Go to [WD 8.3](#). Check SOL82-008. Refer to:

- [GP 12](#) How to Check a Solenoid or Clutch.
- PJ405, [Media path driver PWB](#).
- [01J](#) +50V Distribution RAP.
- [01L](#) 0V Distribution RAP.

Install new components as necessary:

- Nip D release solenoid, [PL 70.30 Item 13](#).
- Media path driver PWB, [PL 1.15 Item 5](#).

Enter [dC330](#) code 83-004 HPP diverter solenoid, SOL83-004. Press Start. Check that the diverter gate moves correctly when activating the solenoid **The solenoid energizes.**

Y N
Go to [WD 8.1](#). Check SOL83-004. Refer to:

- [GP 12](#) How to Check a Solenoid or Clutch.
- PJ303, [Media path driver PWB](#).
- [01J](#) +50V Distribution RAP.
- [01L](#) 0V Distribution RAP.

Install new components as necessary:

- HPP diverter solenoid, [PL 82.15 Item 5](#).
- Media path driver PWB, [PL 1.15 Item 5](#).

Check the following:

- The bearing, shaft and rolls on the horizontal and vertical transport assembly, [PL 82.10 / PL 82.15](#).
- The idler rolls in the upper left side door, [PL 74.10 Item 4](#).
- The transport rolls for wear, [PL 82.10 Item 1](#), [PL 82.10 Item 2](#).
- Check the grounding of the horizontal paper path, [GP 7](#).

Install new components as necessary.

NOTE: Calibration of the registration / preheat assembly, [dC625](#), is only required when:

- The registration / preheat assembly is removed or replaced.
- The horizontal transport assembly is removed or replaced.

Calibration of the registration / preheat assembly is NOT required when:

- A printhead is replaced.
- The IOD assembly is removed or replaced.

82-145-00, 82-146-00, 82-150-00, 82-151-00, 82-156-00 Media Path Sensor 14 Time Out in Duplex Mode RAP

82-145-00 The sheet was too long to clear sensor 14 in duplex mode.

82-146-00 The sheet was too short to clear the media path sensor 14 in duplex mode.

82-150-00 Lead edge late too the media path sensor 14 in duplex mode.

82-151-00 Trail edge late too clear the media path sensor 14 in duplex mode.

82-156-00 Lead edge of sheet too early at the media path sensor 14 in duplex mode.

Initial Actions

WARNING

Ensure that the electricity to the machine is switched off while performing tasks that do not need electricity. Refer to [GP 14](#). Disconnect the power cord. Electricity can cause death or injury. Moving parts can cause injury.

- Check for obstructions in the paper path.
- Check the vertical and horizontal transport rolls for contamination or wear.

Procedure

Enter [dC330](#) code 83-125 duplex end sensor (14), Q83-125. Press Start. Open the front door and manually actuate the sensor. **The display changes.**

Y N

Go to [WD 8.5](#). Check duplex end sensor (14), Q83-125. Refer to:

- [GP 11](#) How to Check a Sensor.
- PJ905, [Media path driver PWB](#).
- [01D](#) +5V Distribution RAP.
- [01L](#) 0V Distribution RAP.

Install new components as necessary:

- Duplex end sensor 14, [PL 82.15 Item 3](#).
- Media path driver PWB, [PL 1.15 Item 5](#).

Enter [dC330](#) code 82-001 vertical transport motor (M2), MOT82-001. Press Start. **The motor runs.**

Y N

Go to [WD 8.1](#). Check vertical transport motor (M2), MOT82-001. Refer to:

- [GP 10](#) How to Check a Motor.
- PJ104, [Media path driver PWB](#).
- [01D](#) +5V Distribution RAP.
- [01J](#) +50V Distribution RAP.
- [01L](#) 0V Distribution RAP.

Install new components as necessary:

- Vertical Transport motor (M2), [PL 82.10 Item 12](#).
- Media path driver PWB, [PL 1.15 Item 5](#).

A

Status Indicator RAPs

82-145-00, 82-146-00, 82-150-00, 82-151-00, 82-156-00

A

The vertical transport rolls rotate.

Y N

Check the drive belt and drive gears on the vertical transport, [PL 82.10](#). If necessary, install new components:

- Transport rolls, [PL 82.10 Item 1](#), [PL 82.10 Item 2](#).
- Drive belts, [PL 82.10](#).
- Drive gears, [PL 82.10](#).

Enter [dC140](#) Analog Monitor. Select 82-100 vertical transport motor encoder (M2). Press Start. The number of ticks (i.e. 36 ticks) will flash on the display and then return to show 0 ticks. Repeat by selecting stop and then start on the popup menu, the number only remains for a few seconds. **The number of ticks is displayed.**

Y N

Go to [WD 8.1](#). Check vertical transport motor (M2), MOT82-001 and the encoder wire harness. Refer to:

- [GP 10](#) How to Check a Motor.
- PJ104, [Media path driver PWB](#).
- [01D](#) +5V Distribution RAP.
- [01J](#) +50V Distribution RAP.
- [01L](#) 0V Distribution RAP.

Install new components as necessary:

- Vertical transport motor (M2), [PL 82.10 Item 12](#).
- Media path driver PWB, [PL 1.15 Item 5](#).

Enter [dC330](#) code 82-008 nip D release solenoid, SOL82-008. Press Start. **The solenoid energize.**

Y N

Go to [WD 8.3](#). Check nip D release solenoid, SOL82-008. Refer to:

- [GP 12](#) How to Check a Solenoid or Clutch.
- PJ405, [Media path driver PWB](#).
- [01J](#) +50V Distribution RAP.
- [01L](#) 0V Distribution RAP.

Install new components as necessary:

- Nip D release solenoid, [PL 70.30 Item 13](#).
- Media path driver PWB, [PL 1.15 Item 5](#).

Enter [dC330](#) code 82-007 Nip C release solenoid, SOL82-007. Press Start. **The solenoid energizes.**

Y N

Go to [WD 8.1](#). Check SOL82-007. Refer to:

- [GP 12](#) How to Check a Solenoid or Clutch.
- PJ303, [Media path driver PWB](#).
- [01J](#) +50V Distribution RAP.
- [01L](#) 0V Distribution RAP.

Install new components as necessary:

- Nip C release solenoid, [PL 82.15 Item 4](#).
- Media path driver PWB, [PL 1.15 Item 5](#).

B

B

Enter **dC330** code 83-004 HPP diverter solenoid, SOL83-004. Press Start. Check that the diverter gate moves correctly when activating the solenoid **The solenoid energizes.**

Y N

Go to **WD 8.1**. Check SOL83-004. Refer to:

- **GP 12** How to Check a Solenoid or Clutch.
- PJ303, **Media path driver PWB**.
- **01J** +50V Distribution RAP.
- **01L** 0V Distribution RAP.

Install new components as necessary:

- HPP diverter solenoid, **PL 82.15 Item 5**.
- Media path driver PWB, **PL 1.15 Item 5**.

Enter **dC330** code 82-003 Horizontal transport motor (M6), MOT82-003. Press Start. **The motor runs.**

Y N

Go to **WD 8.5**. Check horizontal transport motor (M6), MOT82-003. Refer to:

- **GP 10** How to Check a Motor.
- PJ905, **Media path driver PWB**.
- **01D** +5V Distribution RAP.
- **01J** +50V Distribution RAP.
- **01L** 0V Distribution RAP.

Install new components as necessary:

- Horizontal transport motor (M6), **PL 82.15 Item 9**.
- Media path driver PWB, **PL 1.15 Item 5**.

The horizontal transport rolls rotate.

Y N

Check the drive belt and drive gears on the horizontal transport, **PL 82.15**.

If necessary, install new components:

- Transport rolls, **PL 82.15 Item 10**.
- Drive belts, **PL 82.15 Item 7**.
- Drive gears, **PL 82.15**

Enter **dC140** Analog Monitor. Select 82-102 horizontal transport motor encoder (M6). Press Start. The number of ticks (i.e. 36 ticks) will flash on the display and then return to show 0 ticks. Repeat by selecting stop and then start on the popup menu, the number only remains for a few seconds. **The number of ticks is displayed.**

Y N

Go to **WD 8.5**. Check horizontal transport motor (M6), MOT82-003 and encoder wire harness. Refer to:

- **GP 10** How to Check a Motor.
- PJ905, **Media path driver PWB**.
- **01D** +5V Distribution RAP.
- **01J** +50V Distribution RAP.
- **01L** 0V Distribution RAP.

Install new components as necessary:

- Horizontal transport motor (M6), **PL 82.15 Item 9**.

C

C

- Media path driver PWB, **PL 1.15 Item 5**.

Enter **dC330** code 89-007 registration motor A1 (M3), MOT89-007. Press Start. **The motor runs.**

Y N

Go to **WD 8.1**. Check registration motor A1 (M3), MOT89-007. Refer to:

- **GP 10** How to Check a Motor.
- PJ202, **Media path driver PWB**.
- **01J** +50V Distribution RAP.
- **01L** 0V Distribution RAP.

Install new components as necessary:

- Registration / preheat assembly, **PL 88.10 Item 1**
- Media path driver PWB, **PL 1.15 Item 5**

Enter **dC330** code 89-008 registration motor A2 (M3), MOT89-008. Press Start. **The motor runs.**

Y N

Go to **WD 8.1**. Check registration motor A2 (M3), MOT89-008. Refer to:

- **GP 10** How to Check a Motor.
- PJ202, **Media path driver PWB**.
- **01J** +50V Distribution RAP.
- **01L** 0V Distribution RAP.

Install new components as necessary:

- Registration / preheat IF PWB, **PL 88.10 Item 10**
- Registration / preheat assembly, **PL 88.10 Item 1**
- Media path driver PWB, **PL 1.15 Item 5**

Check the following:

- The bearing, shaft and rolls on the horizontal and vertical transport assembly,
- The idler rolls in the upper left side door, **PL 70.30 Item 4**.
- The transport rolls for wear, **PL 82.10 Item 1, PL 82.10 Item 2**.
- Check the grounding of the horizontal paper path, **GP 7**.

Install new components as necessary.

82-161-00 Early Confirm Timeout RAP

82-161-00 Early confirm timeout.

Initial Actions

WARNING

Ensure that the electricity to the machine is switched off while performing tasks that do not need electricity. Refer to [GP 14](#). Disconnect the power cord. Electricity can cause death or injury. Moving parts can cause injury.

- Check for obstructions in the tray 3 horizontal transport paper path.
- Check the tray 3 horizontal transport rolls.

Procedure

Enter [dC330](#) code 73-397 TAR 3 Sensor, Q73-397, [PL 81.35 Item 18](#). Press Start. Pull out the horizontal transport. Manually actuate the sensor by placing a piece of paper over the sensor but not in the nip rolls. Push in the horizontal transport.

NOTE: Sensors Q73-397 and Q70-398 in the horizontal transport, have the same item number. Ensure you check the correct sensor.

The display changes.

Y N

Go to [WD 7.4](#). Check TAR 3 Sensor, Q73-397. Refer to:

- [GP 11](#) How to Check a Sensor.
- PJ954, [3 tray module PWB](#)
- [01D](#) +5V Distribution RAP.
- [01L](#) 0V Distribution RAP.

Install new components as necessary:

- TAR 3 sensor, [PL 81.35 Item 18](#).
- 3 Tray Module PWB, [PL 73.16 Item 4](#).

Enter [dC330](#) code 70-398 tray 3 transport sensor, Q70-398, [PL 81.35 Item 18](#). Press Start. Pull out the horizontal transport. Manually actuate the sensor by placing a piece of paper over the sensor but not in the nip rolls. Push in the horizontal transport.

NOTE: Sensors Q73-397 and Q70-398 in the horizontal transport, have the same item number. Ensure you check the correct sensor.

The display changes.

Y N

Go to [WD 7.4](#). Check tray 3 transport sensor, Q70-398. Refer to:

- [GP 11](#) How to Check a Sensor.
- PJ954, [3 tray module PWB](#).
- [01D](#) +5V Distribution RAP.
- [01L](#) 0V Distribution RAP.

Install new components as necessary:

- Tray 3 transport sensor, [PL 81.35 Item 18](#).
- 3 Tray Module PWB, [PL 73.16 Item 4](#).

A

Enter [dC330](#) code 70-025 3 tray transport motor, MOT70-025. Press Start. **The motor runs.**

Y N

Go to [WD 7.5](#). Check 3 tray transport motor, MOT70-025. Refer to:

- [GP 10](#) How to Check a Motor.
- PJ953, [3 tray module PWB](#).
- [01H](#) +24V Distribution RAP.
- [01L](#) 0V Distribution RAP.

Install new components as necessary:

- 3 tray module transport motor, [PL 73.16 Item 3](#).
- 3 tray module PWB, [PL 73.16 Item 4](#).

The transport rolls rotate.

Y N

Check the gears and drive belt, [PL 73.16](#).

Perform the following:

- If the fault still occurs, check the grounding of the following, [GP 7](#):
 - The takeaway roll assembly, [PL 81.35 Item 16](#).
 - The transport roll 2 assembly, [PL 81.35 Item 15](#).
 - The transport roll 1 assembly, [PL 81.35 Item 14](#).

A

82-500-00, 82-501-00 Vertical Transport Motor M2 Failure RAP

82-500-00 Transport motor M2 over current fault.

82-501-00 Transport motor M2 stalled.

Initial Actions

WARNING

Ensure that the electricity to the machine is switched off while performing tasks that do not need electricity. Refer to [GP 14](#). Disconnect the power cord. Electricity can cause death or injury. Moving parts can cause injury.

- Check for obstructions in the paper path.
- Check the vertical transport rolls, gears and drive belts for contamination or wear.

Procedure

Enter [dC330](#) code 82-001 vertical transport motor (M2), MOT82-001. Press Start. **The motor runs.**

Y N

Go to [WD 8.1](#). Check vertical transport motor (M2), MOT82-001. Refer to:

- [GP 10](#) How to Check a Motor.
- PJ104, [Media path driver PWB](#).
- [01D](#) +5V Distribution RAP.
- [01J](#) +50V Distribution RAP.
- [01L](#) 0V Distribution RAP.

Install new components as necessary:

- Vertical transport motor (M2), [PL 82.10 Item 12](#).
- Media path driver PWB, [PL 1.15 Item 5](#).

Enter [dC140](#) Analog Monitor. Select 82-100 vertical transport motor encoder (M2). Press Start. The number of ticks (i.e. 36 ticks) will flash on the display and then return to show 0 ticks. Repeat by selecting stop and then start on the popup menu, the number only remains for a few seconds. **The number of ticks is displayed.**

Y N

Go to [WD 8.1](#). Check vertical transport motor (M2), MOT82-001. Refer to:

- [GP 10](#) How to Check a Motor.
- PJ104, [Media path driver PWB](#).
- [01D](#) +5V Distribution RAP.
- [01J](#) +50V Distribution RAP.
- [01L](#) 0V Distribution RAP.

Install new components as necessary:

- Vertical transport motor (M2), [PL 82.10 Item 12](#).
- Media path driver PWB, [PL 1.15 Item 5](#).

Check the following:

- Check the wiring for damage and correct harness routing to the vertical paper path.

- The bearing, shaft and rolls on the transport roll assembly,
- Check the drive belt and drive gears on the vertical transport, [PL 82.10](#).

If necessary, install new components:

- Transport rolls, [PL 82.10 Item 1](#), [PL 82.10 Item 2](#).
- Drive belts, [PL 82.10](#).
- Drive gears, [PL 82.10](#).

82-502-00, 82-503-00 Horizontal Transport Motor M6 Failure RAP

82-502-00 Transport motor M6 over current fault.

82-503-00 Transport motor M6 stalled.

Initial Actions

WARNING

Ensure that the electricity to the machine is switched off while performing tasks that do not need electricity. Refer to [GP 14](#). Disconnect the power cord. Electricity can cause death or injury. Moving parts can cause injury.

- Check for obstructions in the horizontal paper path.
- Check the nip rolls on the horizontal paper path, [PL 82.15 Item 10](#).

Procedure

Enter [dC330](#) code 82-003 horizontal transport motor (M6), MOT82-003. Press Start. **The motor runs.**

Y N

Go to [WD 8.5](#). Check horizontal transport motor (M6), MOT82-003. Refer to:

- [GP 10](#) How to Check a Motor.
- PJ905, [Media path driver PWB](#).
- [01D](#) +5V Distribution RAP.
- [01J](#) +50V Distribution RAP.
- [01L](#) 0V Distribution RAP.

Install new components as necessary:

- Horizontal transport motor (M6), [PL 82.15 Item 9](#).
- Media path driver PWB, [PL 1.15 Item 5](#).

Enter [dC140](#) Analog Monitor. Select 82-102 horizontal transport motor encoder (M6). Press Start. The number of ticks (i.e. 36 ticks) will flash on the display and then return to show 0 ticks. Repeat by selecting stop and then start on the popup menu, the number only remains for a few seconds. **The number of ticks is displayed.**

Y N

Go to [WD 8.5](#). Check horizontal transport motor (M6), MOT82-003 and the encoder wire harness. Refer to:

- [GP 10](#) How to Check a Motor.
- PJ905, [Media path driver PWB](#).
- [01D](#) +5V Distribution RAP.
- [01J](#) +50V Distribution RAP.
- [01L](#) 0V Distribution RAP.

Install new components as necessary:

- Horizontal transport motor (M6), [PL 82.15 Item 9](#).
- Media path driver PWB, [PL 1.15 Item 5](#).

Check the following:

- Check the wiring for damage, [REP 1.1](#).

- The bearing, shaft and rolls on the horizontal paper path, [PL 82.15 Item 14](#).
- Check the drive belt and drive gears on the horizontal paper path, [PL 82.15](#).

If necessary, install new components:

- Transport rolls, [PL 82.15 Item 10](#).
- Transport drive belts, [PL 82.15 Item 7](#).
- Drive belt, [PL 82.15 Item 8](#).
- Drive gears, [PL 82.15](#).

82-507-00, 82-508-00 Nip C and Nip D Release Solenoid Over Current RAP

82-507-00 An over current condition was detected with nip C release solenoid.

82-508-00 An over current condition was detected with nip D release solenoid.

Procedure

WARNING

Ensure that the electricity to the machine is switched off while performing tasks that do not need electricity. Refer to **GP 14**. Disconnect the power cord. Electricity can cause death or injury. Moving parts can cause injury.

Refer to **WD 8.1** and **WD 8.3**. Perform the following:

- Check the wiring for damage.
- Check the nip C release solenoid mechanism, **PL 82.15 Item 4**.
- Check the nip D release solenoid mechanism, **PL 70.30 Item 13**.
- Check the nip C release solenoid, refer to **WD 8.1**, and **GP 12** How to Check a Solenoid or Clutch.
- Check the nip D release solenoid, refer to **WD 8.3**, and **GP 12** How to Check a Solenoid or Clutch.
- Go to **WD 1.5** and **WD 8.5**. Check the harness and voltages between PJ 803 on the **media path driver PWB** and PJDC3 on the **power supply unit**. Install new components or repair harness as necessary, **REP 1.1**.

If necessary, install new components:

- Nip C release solenoid, **PL 82.15 Item 4**.
- Nip D release solenoid, **PL 70.30 Item 13**.
- Media Path Driver PWB, **PL 1.15 Item 5**.
- Power Supply Unit, **PL 1.15 Item 2**.

82-510-00 Trailer Slowdown Calculation Fail RAP

82-510-00 System timing error.

Procedure

WARNING

Ensure that the electricity to the machine is switched off while performing tasks that do not need electricity. Refer to **GP 14**. Disconnect the power cord. Electricity can cause death or injury. Moving parts can cause injury.

Refer to **WD 8.1**, **WD 8.2**, **WD 8.3**, **WD 8.4** and **WD 8.5**. Perform the following:

- Switch off the machine, then switch on the machine, **GP 14**.
- Check the PJ connections on the media path driver PWB.

If necessary, install new components:

- Media path driver PWB, **PL 1.15 Item 5**.

83-110-00, 83-111-00, 83-113-00, 83-114-00, 83-118-00 Media Path Sensor 13 Duplex Mode RAP

83-110-00 The sheet too long over media path sensor 13 at duplex start.

83-111-00 The sheet too short over media path sensor 13 at duplex start.

83-113-00 Media path invert sensor 13 too short at duplex start.

83-114-00 Duplex start sensor 13 LE timeout

83-118-00 Sheet arrived too early at the media path sensor 13.

Initial Actions

WARNING

Ensure that the electricity to the machine is switched off while performing tasks that do not need electricity. Refer to [GP 14](#). Disconnect the power cord. Electricity can cause death or injury. Moving parts can cause injury.

- Check for obstructions in the paper path.
- Check the exit paper path and transport rolls for contamination or wear, [PL 10.15](#).
- If the fault was caused while running glossy media. Instruct the customer to feed the media from the bypass tray and select glossy for the media type on the UI.

Procedure

Enter [dC330](#) code 83-110 duplex start sensor (13), Q83-110. Press Start. Open the front door and manually actuate the sensor. **The display changes.**

Y N

Go to [WD 8.5](#). Check duplex start sensor (13), Q83-110. Refer to:

- [GP 11](#) How to Check a Sensor.
- PJ905, [Media path driver PWB](#).
- [01D](#) +5V Distribution RAP.
- [01L](#) 0V Distribution RAP.

Install new components as necessary:

- Duplex start sensor (13), [PL 10.15 Item 3](#).
- Media path driver PWB, [PL 1.15 Item 5](#).

Enter [dC330](#) code 83-006 exit duplex diverter solenoid, SOL83-006. Press Start. **The solenoid energize.**

Y N

Go to [WD 8.1](#). Check exit duplex diverter, SOL83-006. Refer to:

- [GP 12](#) How to Check a Solenoid or Clutch.
- PJ303, [Media path driver PWB](#).
- [01J](#) +50V Distribution RAP.
- [01L](#) 0V Distribution RAP.

Install new components as necessary:

- Exit / duplex diverter solenoid, [PL 10.15 Item 14](#).
- Media path driver PWB, [PL 1.15 Item 5](#).

A

The diverter gate moves freely.

Y N

Check the operation and condition of the diverter gate. If necessary install a new exit paper path assembly, [PL 10.15 Item 19](#).

Enter [dC330](#) code 83-001 exit motor (M5), MOT83-001. Press Start. **The motor runs.**

Y N

Go to [WD 8.2](#). Check exit motor (M5), MOT83-001. Refer to:

- [GP 10](#) How to Check a Motor.
- PJ303, [Media path driver PWB](#).
- [01J](#) +50V Distribution RAP.
- [01L](#) 0V Distribution RAP.

Install new components as necessary:

- Exit motor (M5), [PL 10.15 Item 11](#).
- Media path driver PWB, [PL 1.15 Item 5](#).

The exit paper path rolls rotate.

Y N

Check the drive belt and drive gears on the exit paper path, [PL 10.15](#).

If necessary, install new components:

- N and P nip rolls, [PL 10.15 Item 1](#).
- Drive belts, [PL 10.15 Item 9](#).
- Drive gears, [PL 10.15](#).

Enter [dC330](#) code 82-003 Horizontal transport motor (M6) (forward), MOT82-003. Press Start.

The motor runs.

Y N

Go to [WD 8.5](#). Check horizontal transport motor (M6), MOT82-003. Refer to:

- [GP 10](#) How to Check a Motor.
- PJ905, [Media path driver PWB](#).
- [01D](#) +5V Distribution RAP.
- [01J](#) +50V Distribution RAP.
- [01L](#) 0V Distribution RAP.

Install new components as necessary:

- Horizontal transport motor (M6), [PL 82.15 Item 9](#).
- Media path driver PWB, [PL 1.15 Item 5](#).

The horizontal paper path rolls rotate.

Y N

Check the drive belt and drive gears on the exit paper path, [PL 82.15](#).

If necessary, install new components:

- Nip and takeaway rolls, [PL 82.15 Item 10](#).
- Drive belts, [PL 82.15 Item 7](#).
- Drive gears, [PL 82.15](#).

A

Status Indicator RAPs

83-110-00, 83-111-00, 83-113-00, 83-114-00, 83-118-00

B

March 2011
2-338

ColorQube™ 9303 Family

B

Enter **dC140** Analog Monitor. Select 82-102 horizontal transport motor encoder (M6). Press Start. The number of ticks (i.e. 36 ticks) will flash on the display and then return to show 0 ticks. Repeat by selecting stop and then start on the popup menu, the number only remains for a few seconds. **The number of ticks is displayed.**

Y N

Go to **WD 8.5**. Check horizontal transport motor (M6), MOT82-003 and the encoder wire harness. Refer to:

- **GP 10** How to Check a Motor.
- PJ905, **Media path driver PWB**.
- **01D** +5V Distribution RAP.
- **01J** +50V Distribution RAP.
- **01L** 0V Distribution RAP.

Install new components as necessary:

- Horizontal transport motor (M6), **PL 82.15 Item 9**.
- Media path driver PWB, **PL 1.15 Item 5**.

Enter **dC330** code 82-007 nip C release solenoid, SOL 82-007, press start. **The solenoid energizes.**

Y N

Go to **WD 8.1**, check SOL 82-007, refer to:

- **GP 12** How to Check a Solenoid or Clutch
- PJ405 **Media Path Driver PWB**.
- **01J** +50V Distribution RAP.
- **01L** 0V Distribution RAP.

Install new components as necessary:

- Nip C release solenoid, **PL 82.15 Item 4**.
- Media path driver PWB, **PL 1.15 Item 5**.

Enter **dC330** code 82-008 nip D release solenoid, SOL 82-008, press start. **The solenoid energizes.**

Y N

Go to **WD 8.3**, check SOL 82-008, refer to:

- **GP 12** How to Check a Solenoid or Clutch
- PJ405 **Media Path Driver PWB**.
- **01J** +50V Distribution RAP.
- **01L** 0V Distribution RAP.

Install new components as necessary:

- Nip D release solenoid, **PL 70.30 Item 13**.
- Media path driver PWB, **PL 1.15 Item 5**.

Enter **dC330** code 83-004 HPP diverter solenoid, SOL 83-004, press start. Ensure that the HPP diverter gate moves fully when the solenoid is energized and returns fully when the solenoid is generalized. **The solenoid energizes and the diverter gate moves correctly.**

Y N

Go to **WD 8.1**, check SOL 83004. Refer to:

- **GP 12** How to Check a Solenoid or Clutch
- PJ303 **Media Path Driver PWB**.

C

C

- **01J** +50V Distribution RAP.
- **01L** 0V Distribution RAP.

Install new components as necessary:

- HPP diverter solenoid, **PL 82.15 Item 5**
- Horizontal paper path assembly, **PL 82.15 Item 1**.
- Media path driver PWB, **PL 1.15 Item 5**.

Check the bearings, drive shaft's and nip rolls on the exit paper path, **PL 10.15**. Install new components as necessary.

83-112-00, 83-115-00, 83-116-00, 83-117-00, 83-119-00 Media Path Sensor 13 Invert Mode RAP

83-112-00 The sheet too long over media path sensor 13 at invert.

83-115-00 The trailing edge times out over media path sensor 13 at invert

83-116-00 The leading edge was late too media path sensor 13at invert

83-117-00 The trailing edge was late over media path sensor 13 at invert.

83-119-00 Lead edge of sheet arrive too early at media path sensor 13 when inverting to output

Initial Actions

WARNING

Ensure that the electricity to the machine is switched off while performing tasks that do not need electricity. Refer to [GP 14](#). Disconnect the power cord. Electricity can cause death or injury. Moving parts can cause injury.

- Check for obstructions in the paper path.
- Check the exit paper path rolls.
- If tabbed sheets are used, inform the customer to ensure that the sheets are fed with tab trailing.
- If pre-drilled paper is used, check that the pre-drilled pages are fed with the holes trailing.

Procedure

Enter [dC330](#) code 83-110 duplex start sensor (13), Q83-110. Press Start. Open the front door and manually actuate the sensor. **The display changes.**

Y N

Go to [WD 8.5](#). Check duplex start sensor (13), Q83-110. Refer to:

- [GP 11](#) How to Check a Sensor.
- PJ905, [Media path driver PWB](#).
- [01D](#) +5V Distribution RAP.
- [01L](#) 0V Distribution RAP.

Install new components as necessary:

- Duplex start sensor (13), [PL 10.15 Item 3](#).
- Media path driver PWB, [PL 1.15 Item 5](#).

Enter [dC330](#) code 83-006 exit / duplex diverter solenoid, SOL83-006. Press Start. **The solenoid energize.**

Y N

Go to [WD 8.1](#). Check exit / duplex diverter solenoid, SOL83-006. Refer to:

- [GP 12](#) How to Check a Solenoid or Clutch.
- PJ303, [Media path driver PWB](#).
- [01J](#) +50V Distribution RAP.
- [01L](#) 0V Distribution RAP.

Install new components as necessary:

- Exit / duplex diverter solenoid, [PL 10.15 Item 14](#).
- Media path driver PWB, [PL 1.15 Item 5](#).

The diverter gate moves freely.

Y N

Check the operation and condition of the diverter gate. If necessary install a new diverter gate, [PL 10.15 Item 17](#).

Enter [dC330](#) code 83-001 exit motor (M5), MOT83-001. Press Start. **The motor runs.**

Y N

Go to [WD 8.2](#). Check exit motor (M5), MOT83-001. Refer to:

- [GP 10](#) How to Check a Motor.
- PJ303, [Media path driver PWB](#).
- [01J](#) +50V Distribution RAP.
- [01L](#) 0V Distribution RAP.

Install new components as necessary:

- Exit motor (M5), [PL 10.15 Item 11](#).
- Media path driver PWB, [PL 1.15 Item 5](#).

The Exit paper path rolls rotate.

Y N

Check the drive belt and drive gears on the exit paper path, [PL 10.15](#).

If necessary, install new components:

- N and P nip rolls, [PL 10.15](#).
- Drive belts, [PL 10.15](#).
- Drive gears, [PL 10.15](#).

Enter [dC330](#) code 82-003 Horizontal transport motor (M6) (forward), MOT82-003. Press Start.

The motor runs.

Y N

Go to [WD 8.5](#). Check horizontal transport motor (M6), MOT82-003. Refer to:

- [GP 10](#) How to Check a Motor.
- PJ905, [Media path driver PWB](#).
- [01D](#) +5V Distribution RAP.
- [01J](#) +50V Distribution RAP.
- [01L](#) 0V Distribution RAP.

Install new components as necessary:

- Horizontal transport motor (M6), [PL 82.15 Item 9](#).
- Media path driver PWB, [PL 1.15 Item 5](#).

The horizontal paper path rolls rotate.

Y N

Check the drive belt and drive gears on the exit paper path, [PL 82.15](#).

If necessary, install new components:

- Nip and takeaway rolls, [PL 82.15 Item 10](#).
- Drive belts, [PL 82.15 Item 7](#).

B

- Drive gears, [PL 82.15](#).

Enter [dC140](#) Analog Monitor. Select 82-102 horizontal transport motor encoder (M6). Press Start. The number of ticks (i.e. 36 ticks) will flash on the display and then return to show 0 ticks. Repeat by selecting stop and then start on the popup menu, the number only remains for a few seconds. **The number of ticks is displayed.**

Y N

Go to [WD 8.5](#). Check horizontal transport motor (M6), MOT82-003 and the encoder wire harness. Refer to:

- [GP 10](#) How to Check a Motor.
- PJ905, [Media path driver PWB](#).
- [01D](#) +5V Distribution RAP.
- [01J](#) +50V Distribution RAP.
- [01L](#) 0V Distribution RAP.

Install new components as necessary:

- Horizontal transport motor (M6), [PL 82.15 Item 9](#).
- Media path driver PWB, [PL 1.15 Item 5](#).

Enter [dC330](#) code 82-007 nip C release solenoid, SOL 82-007, press start. **The solenoid energizes.**

Y N

Go to [WD 8.1](#), check SOL 82-007, refer to:

- [GP 12](#) How to Check a Solenoid or Clutch
- PJ405 [Media Path Driver PWB](#).
- [01J](#) +50V Distribution RAP.
- [01L](#) 0V Distribution RAP.

Install new components as necessary:

- Nip C release solenoid, [PL 82.15 Item 4](#).
- Media path driver PWB, [PL 1.15 Item 5](#).

Enter [dC330](#) code 82-008 nip D release solenoid, SOL 82-008, press start. **The solenoid energizes.**

Y N

Go to [WD 8.3](#), check SOL 82-008, refer to:

- [GP 12](#) How to Check a Solenoid or Clutch
- PJ405 [Media Path Driver PWB](#)
- [01J](#) +50V Distribution RAP.
- [01L](#) 0V Distribution RAP.

Install new components as necessary:

- Nip D release solenoid, [PL 70.30 Item 13](#).
- Media path driver PWB, [PL 1.15 Item 5](#).

Enter [dC330](#) code 83-004 HPP diverter solenoid, SOL 83-004, press start. Ensure that the HPP diverter gate moves fully when the solenoid is energized and returns fully when the solenoid is generalized. **The solenoid energizes and the diverter gate moves correctly.**

Y N

Go to [WD 8.1](#), check SOL 83004. Refer to:

- [GP 12](#) How to Check a Solenoid or Clutch
- PJ303 [Media Path Driver PWB](#).
- [01J](#) +50V Distribution RAP.
- [01L](#) 0V Distribution RAP.

Install new components as necessary:

- HPP diverter solenoid, [PL 82.15 Item 5](#).
- Horizontal paper path assembly, [PL 82.15 Item 1](#).
- Media path driver PWB, [PL 1.15 Item 5](#).

Check the bearings, drive shaft's and nip rolls on the exit paper path, [PL 10.15](#).
Install new components as necessary.

83-120-00 to 83-125-00 Media Path Sensor 17 RAP

83-120-00 Detected a sheet length too long over media path sensor 17.

83-121-00 Detected a sheet length too short over media path sensor 17.

83-122-00 Lead edge of sheet to late at media path sensor 17.

83-123-00 The trailing edge was late to clear media path sensor 17.

83-124-00 Trail edge of sheet failed to clear media path sensor 17 in time when inverting to output

83-125-00 Lead edge of sheet arrives too early at media path sensor 17.

Initial Actions

WARNING

Ensure that the electricity to the machine is switched off while performing tasks that do not need electricity. Refer to GP 14. Disconnect the power cord. Electricity can cause death or injury. Moving parts can cause injury.

- Check for obstructions in the paper path.
- Check the vertical and horizontal transport rolls.
- If tabbed sheets are used, inform the customer to ensure that the sheets are fed with tab trailing.
- If pre-drilled paper is used, check that the pre-drilled pages are fed with the holes trailing.

Procedure

Enter **dC330** code 83-010 duplex sensor (17), Q83-010. Press Start. Open the front door and manually actuate the sensor. **The display changes.**

Y N

Go to **WD 8.5**. Check duplex sensor (17), Q83-010. Refer to:

- **GP 11** How to Check a Sensor.
- PJ905, **Media path driver PWB**.
- **01D** +5V Distribution RAP.
- **01L** 0V Distribution RAP.

Install new components as necessary:

- Duplex sensor 17, **PL 82.15 Item 3**.
- Media path driver PWB, **PL 1.15 Item 5**.

Enter **dC330** code 82-003 Horizontal transport motor (M6), MOT82-003. Press Start. Then enter the code 82-004 to run the motor in reverse. **The motor runs in both forward and reverse directions.**

Y N

Go to **WD 8.5**. Check Horizontal transport motor (M6), MOT82-003. Refer to:

- **GP 10** How to Check a Motor.
- PJ905, **Media path driver PWB**.
- **01D** +5V Distribution RAP.
- **01J** +50V Distribution RAP.

- **01L** 0V Distribution RAP.

Install new components as necessary:

- Horizontal transport motor (M6), **PL 82.15 Item 9**.
- Media path driver PWB, **PL 1.15 Item 5**.

The horizontal transport rolls rotate.

Y N

Check the drive belts and drive gears on the horizontal transport, **PL 82.15**.

If necessary, install new components:

- Transport rolls, **PL 82.15 Item 10**.
- Drive belts, **PL 82.15 Item 7** and **PL 82.15 Item 8**.
- Drive gears, **PL 82.15 Item 6**, **PL 82.15 Item 13** and **PL 82.15 Item 16**.

Enter **dC140** Analog Monitor. Select 82-102 horizontal transport motor encoder (M6). Press Start. The number of ticks (i.e. 36 ticks) will flash on the display and then return to show 0 ticks. Repeat by selecting stop and then start on the popup menu, the number only remains for a few seconds. **The number of ticks is displayed.**

Y N

Go to **WD 8.5**. Check horizontal transport motor (M6), MOT82-003. Refer to:

- **GP 10** How to Check a Motor.
- PJ905, **Media path driver PWB**.
- **01D** +5V Distribution RAP.
- **01J** +50V Distribution RAP.
- **01L** 0V Distribution RAP.

Install new components as necessary:

- Horizontal transport motor (M6), **PL 82.15 Item 9**.
- Media path driver PWB, **PL 1.15 Item 5**.

Enter **dC330** code 83-004 HPP diverter solenoid, SOL 83-004, press start. Ensure that the HPP diverter gate moves fully when the solenoid is energized and returns fully when the solenoid is generalized. **The solenoid energizes and the diverter gate moves correctly.**

Y N

Go to **WD 8.1**, check SOL 83004. Refer to:

- **GP 12** How to Check a Solenoid or Clutch
- PJ303 **Media Path Driver PWB**.
- **01J** +50V Distribution RAP.
- **01L** 0V Distribution RAP.

Install new components as necessary:

- HPP diverter solenoid, **PL 82.15 Item 5**.
- Horizontal paper path assembly, **PL 82.15 Item 1**.
- Media path driver PWB, **PL 1.15 Item 5**.

Enter **dC330** code 82-008 nip D release solenoid, SOL 82-008, press start. **The solenoid energizes.**

Y N

Go to **WD 8.3**, check SOL 82-008, refer to:

- **GP 12** How to Check a Solenoid or Clutch.

B

- PJ405 [Media Path Driver PWB](#).
- [01J +50V Distribution RAP](#).
- [01L 0V Distribution RAP](#).

Install new components as necessary:

- Nip D release solenoid, [PL 70.30 Item 13](#).
- Media path driver PWB, [PL 1.15 Item 5](#).

Enter [dC330](#) code 82-007 nip C release solenoid, SOL 82-007, press start. **The solenoid energizes.**

Y N

Go to [WD 8.1](#), check SOL 82-007, refer to:

- [GP 12](#) How to Check a Solenoid or Clutch
- PJ405 [Media Path Driver PWB](#)
- [01J +50V Distribution RAP](#).
- [01L 0V Distribution RAP](#).

Install new components as necessary:

- Nip C release solenoid, [PL 82.15 Item 4](#).
- Media path driver PWB, [PL 1.15 Item 5](#).

The components are all working correctly, check the paper path for any foreign object that would hinder paper transport.

Check the items that follow, if necessary install new components:

- The bearing, shaft and rolls on the horizontal transport assembly, [PL 82.15](#).
- The idler rolls in the middle left door assembly, [PL 70.30 Item 16](#).
- The transport rolls for wear, [PL 82.10 Item 1](#) and [PL 82.10 Item 2](#).

83-500-00 Output Transport Motor M5 Failure RAP

83-500-00 Transport motor M5 over current fault.

Initial Actions

WARNING

Ensure that the electricity to the machine is switched off while performing tasks that do not need electricity. Refer to [GP 14](#). Disconnect the power cord. Electricity can cause death or injury. Moving parts can cause injury.

- Check for obstructions in the exit paper path.

Procedure

Enter [dC330](#) code 83-001 exit motor (M5), MOT83-001. Press Start. **The motor runs.**

Y N

Go to [WD 8.2](#). Check exit motor (M5), MOT82-003. Refer to:

- [GP 10](#) How to Check a Motor.
- PJ303, [Media path driver PWB](#).
- [01J +50V Distribution RAP](#).
- [01L 0V Distribution RAP](#).

Install new components as necessary:

- Exit motor (M5), [PL 10.15 Item 11](#).
- Media path driver PWB, [PL 1.15 Item 5](#).

Check the following:

- The bearing, shaft and nip rolls on the nip roller 'N', [PL 10.15 Item 1](#).
- Check the drive belt and drive gears on the exit paper path, [PL 10.15](#).
- Check the wiring for damage.

If necessary, install new components:

- Nip rolls, [PL 10.15 Item 1](#) and [PL 10.15 Item 6](#).
- Drive belts, [PL 10.15 Item 8](#) and [PL 10.15 Item 9](#).
- Drive gears, [PL 10.15 Item 12](#).

83-504-00 HPP Diverter Solenoid Failure RAP

83-504-00 HPP diverter solenoid over current fault.

Initial Actions

WARNING

Ensure that the electricity to the machine is switched off while performing tasks that do not need electricity. Refer to [GP 14](#). Disconnect the power cord. Electricity can cause death or injury. Moving parts can cause injury.

- Check for obstructions in the paper path.

Procedure

Enter [dC330](#) code 83-004 HPP diverter solenoid, SOL83-004. Press Start. The solenoid energizes.

Y N

Go to [WD 8.1](#). Check SOL83-004. Refer to:

- [GP 12](#) How to Check a Solenoid or Clutch.
- PJ303, [Media path driver PWB](#).
- [01J](#) +50V Distribution RAP.
- [01L](#) 0V Distribution RAP.

Install new components as necessary:

- HPP diverter solenoid, [PL 82.15 Item 5](#).
- Media path driver PWB, [PL 1.15 Item 5](#).

Check the operation and condition of the diverter gate. Ensure that the energized solenoid moves the diverter gate fully. If necessary install a new horizontal paper path assembly, [PL 82.15 Item 1](#).

83-506-00 Nip D Release Solenoid Failure RAP

83-506-00 Nip D release solenoid over current fault.

Initial Actions

WARNING

Ensure that the electricity to the machine is switched off while performing tasks that do not need electricity. Refer to [GP 14](#). Disconnect the power cord. Electricity can cause death or injury. Moving parts can cause injury.

- Check for obstructions in the paper path.

Procedure

Enter [dC330](#) code 82-008 Nip D release solenoid, SOL82-008, [PL 70.30 Item 13](#). Press Start. SOL82-008 energizes.

Y N

Go to [WD 8.3](#). Check SOL82-008. Refer to:

- [GP 12](#) How to Check a Solenoid or Clutch.
- PJ405, [Media path driver PWB](#).
- [01J](#) +50V Distribution RAP.
- [01L](#) 0V Distribution RAP.

Install new components as necessary:

- Nip D release solenoid, [PL 70.30 Item 13](#).
- Media path driver PWB, [PL 1.15 Item 5](#).

Check the operation of the nip release link arm, [PL 70.30 Item 10](#). If necessary, install a new upper left door, [PL 70.30 Item 18](#).

88-500-00 to 88-502-00, 88-512-00 Preheat Thermal Error RAP

88-500-00 The registration / preheat assembly is too hot.

88-501-00 The registration / preheat assembly is too slow to warm up.

88-502-00 The registration / preheat assembly thermistor has failed.

88-512-00 The preheat heater went unstable while printing.

Initial Actions

WARNING

Ensure that the electricity to the machine is switched off while performing tasks that do not need electricity. Refer to [GP 14](#). Disconnect the power cord. Electricity can cause death or injury. Moving parts can cause injury.

- If the fault code is 88-500-00 then install a new power supply unit, [PL 1.15 Item 2](#).
- Check the 2 wiring harnesses leading to the registration / preheat assembly interface PWB, [Figure 1](#).
- Check the 2 wiring harnesses leading to the chassis bulkhead from the registration / preheat assembly.

Procedure

Enter [dC335](#) and test the registration / preheat thermistor. Select RaLPH in the component list.

NOTE: The registration / preheat thermistor is mounted on the underside of the heater plate.

The temperature read out changes as the RaLPH warms up, cools down and is approximately correct.

Y N

Install a new registration / preheat assembly, [PL 88.10 Item 1](#). Calibrate the new assembly, [dC625](#).

Check the resistance at [media path driver PWB, WD 8.1](#) from PJ104 pin 16 to 17. Resistance should measure approximately 240K ohms cold or 42K ohms hot. **The resistance is within specification.**

Y N

Check connections at [media path driver PWB, WD 8.1](#) PJ104 pin 16 to [registration / preheat interface PWB, WD 8.6](#) PJ4 pin 3 and [media path driver PWB, WD 8.1](#) from PJ104 pin 17 to [registration / preheat interface PWB, WD 8.6](#) PJ4 pin 2. Repair or install new components as necessary.

Check the preheater resistance at [power supply unit, WD 1.2](#) PJ5AC as follows:

1. Preheater 1, pin 3 to pin 9.
2. Preheater 2, pin 2 to pin 8.

Preheater resistance is 50 ohms +/- 10%. **The resistance is within specification.**

Y N

Check the wiring between PJ5AC, [WD 1.2](#) on the [power supply unit](#) and PJ140 on the Registration / preheat assembly. Repair damaged wiring or install a new registration / preheat assembly [PL 88.10 Item 1](#).

A

Install a new power supply, [PL 1.15 Item 2](#).

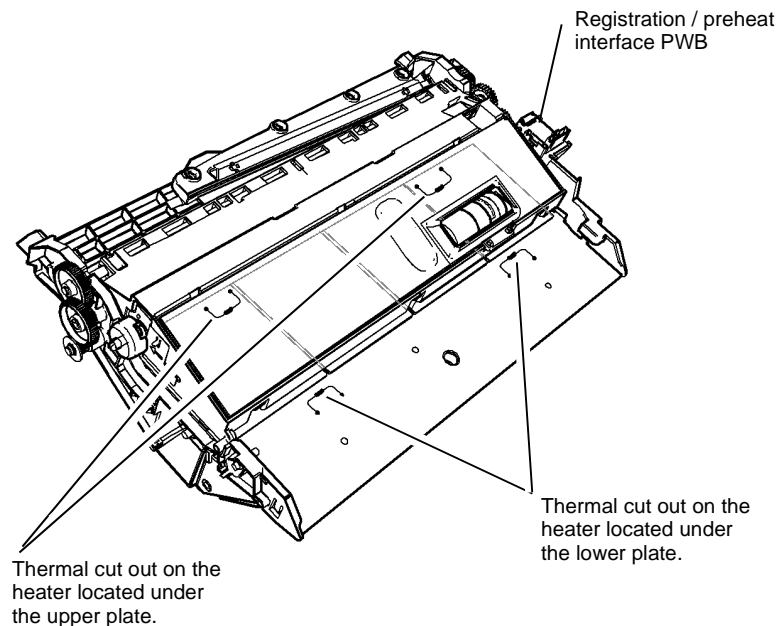

Figure 1 Component location

U-1-1138-A

NOTE: Calibration of the registration/preheat assembly, [dC625](#) is only required when:

- The registration / preheat assembly is removed or replaced,
- The horizontal transport assembly is removed or replaced.

Calibration of the registration / preheat assembly is NOT required when:

- A printhead is replaced.
- The IOD assembly is removed or replaced.

A

88-508-00 Registration / Preheat Air Pump Incorrect Current RAP

88-508-00 The registration / preheat air pumps are drawing incorrect current.

Procedure

WARNING

Ensure that the electricity to the machine is switched off while performing tasks that do not need electricity. Refer to [GP 14](#). Disconnect the power cord. Electricity can cause death or injury. Moving parts can cause injury.

NOTE: Air pump motors vibrate slightly when running, feeling the motor as it starts, stops and runs is the best way to determine if the motor is operating. Use [dc330](#) to test.

Enter [dC330](#) and test the registration / preheat air pumps MOT88-008, [Figure 1](#). Refer to [GP 10](#), How to Check a Motor. **The pumps run.**

Y N
Refer to [WD 8.6](#). Check connections at PJ5 of the [registration / preheat interface PWB](#) and at each pump. **The connections are secure.**

Y N
Reseat all connections to the pump motors and registration / preheat interface PWB.

Refer to [WD 8.1](#). Check for +12V at PJ104 pin 21 on the [media path driver PWB](#). **+12V is present.**

Y N
Check the +12V distribution, go to the [01E +12V Distribution RAP](#). If necessary, install a new media driver path PWB, [PL 1.15 Item 5](#).

Refer to [WD 8.1](#). Check the wiring between PJ104 on the [media path driver PWB](#) and PJ4 on the registration / preheat interface PWB. If the wiring is good, install new air pumps [PL 88.10 Item 3](#), [PL 88.10 Item 5](#). If the error persists, install a new registration / preheat assembly [PL 88.10 Item 1](#).

The fault may be intermittent, if the error persists, install new air pumps [PL 88.10 Item 3](#), [PL 88.10 Item 5](#).

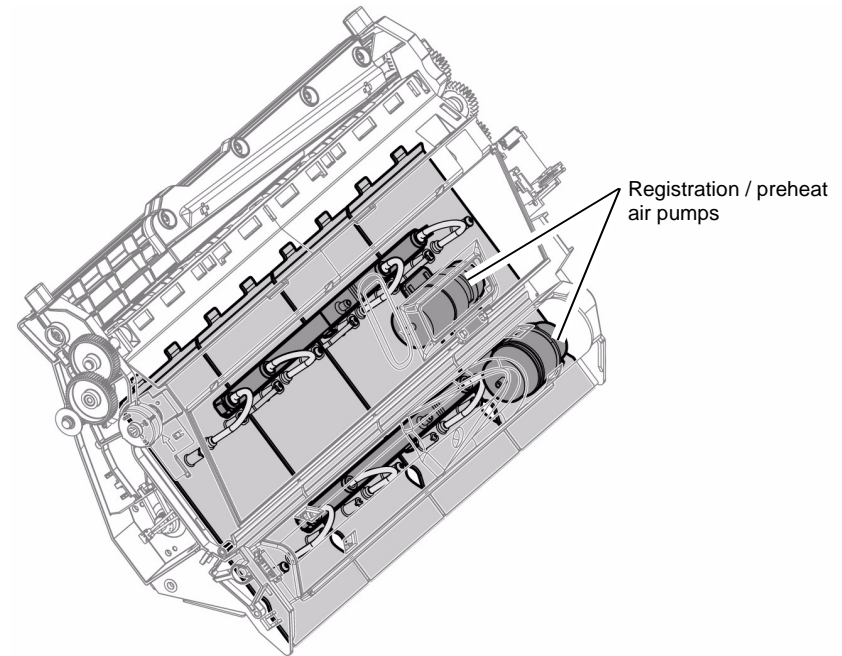

U-1-1139-A

Figure 1 Component location

NOTE: Calibration of the registration / preheat assembly, [dC625](#) is only required when:

- The registration/preheat assembly is removed or replaced,
- The horizontal transport assembly is removed or replaced.

Calibration of the registration / preheat assembly is NOT required when:

- A printhead is replaced.
- The IOD assembly is removed or replaced.

89-110-00 to 89-113-00, 89-129-00 Media Path Sensor 10 Failure RAP

89-110-00 The sheet is too long at registration.

89-111-00 The sheet is too short over media path sensor 10 at registration.

89-112-00 The leading edge was late to the media path sensor 10 at registration.

89-113-00 The trailing edge was late over media path sensor 10 at registration.

89-129-00 The sheet arrives late at nip rolls A.

Initial Actions

WARNING

Ensure that the electricity to the machine is switched off while performing tasks that do not need electricity. Refer to [GP 14](#). Disconnect the power cord. Electricity can cause death or injury. Moving parts can cause injury

If the registration / preheat assembly was recently removed and reinstalled or installed a new prior to this fault occurring. Check that the ribbon cable to the registration / preheat interface PWB is seated correctly. Go to [REP 89.1](#) and refer to figure 2 location of ribbon cable.

Procedure

Open the registration / preheat assembly cover assembly and heat shield. Refer to [REP 10.7](#) to release the cover assembly. Insert a sheet of paper into the registration / preheat assembly and cover the registration scan bar, [PL 88.10 Item 2](#), Q89-005. Close the front door assembly.

The UI reports a paper jam in area 3a.

Y N
Check the connection of the ribbon cable at the scan bar (sensor 10) and at the [registration / preheat interface PWB, WD 8.6](#).
Reseat all connections to the registration / preheat interface PWB.
Install a new registration / preheat assembly, [PL 88.10 Item 1](#).

Enter [dC330](#) code 89-007 registration motor A1 (M3), MOT89-007. Press Start. The motor runs.

Y N
Go to [WD 8.1](#). Check registration motor A1 (M3), MOT89-007. Refer to:

- [GP 10](#) How to Check a Motor.
- PJ202, [Media path driver PWB](#).
- [01J](#) +50V Distribution RAP.
- [01L](#) 0V Distribution RAP.

Install new components as necessary:

- Registration / preheat assembly, [PL 88.10 Item 1](#).
- Media path driver PWB, [PL 1.15 Item 5](#).

Enter [dC330](#) code 89-008 registration motor A2 (M3), MOT89-008. Press Start. The motor runs.

Y N
Go to [WD 8.1](#). Check registration motor A2 (M3), MOT89-008. Refer to:

- [GP 10](#) How to Check a Motor.
- PJ202, [Media path driver PWB](#).
- [01J](#) +50V Distribution RAP.
- [01L](#) 0V Distribution RAP.

Install new components as necessary:

- Registration / preheat assembly, [PL 88.10 Item 1](#).
- Media path driver PWB, [PL 1.15 Item 5](#).

Enter [dC330](#) code 82-007 Nip C release solenoid, SOL82-007. Press Start. The solenoid energizes.

Y N
Go to [WD 8.1](#). Check SOL82-007. Refer to:

- [GP 12](#) How to Check a Solenoid or Clutch.
- PJ303, [Media path driver PWB](#).
- [01J](#) +50V Distribution RAP.
- [01L](#) 0V Distribution RAP.

Install new components as necessary:

- Nip C release solenoid, [PL 82.15 Item 4](#).
- Media path driver PWB, [PL 1.15 Item 5](#).

Enter [dC330](#) code 82-008 Nip D release solenoid, SOL82-008. Press Start. The solenoid energizes.

Y N
Go to [WD 8.3](#). Check SOL82-008. Refer to:

- [GP 12](#) How to Check a Solenoid or Clutch.
- PJ405, [Media path driver PWB](#).
- [01J](#) +50V Distribution RAP.
- [01L](#) 0V Distribution RAP.

Install new components as necessary:

- Nip D release solenoid, [PL 70.30 Item 13](#).
- Media path driver PWB, [PL 1.15 Item 5](#).

Enter [dC330](#) code 83-004 HPP diverter solenoid, SOL83-004. Press Start. Check that the diverter gate moves correctly when activating the solenoid. The solenoid energizes.

Y N
Go to [WD 8.1](#). Check SOL83-004. Refer to:

- [GP 12](#) How to Check a Solenoid or Clutch.
- PJ303, [Media path driver PWB](#).
- [01J](#) +50V Distribution RAP.
- [01L](#) 0V Distribution RAP.

Install new components as necessary:

- HPP diverter solenoid, [PL 82.15 Item 5](#).
- Media path driver PWB, [PL 1.15 Item 5](#).

A

A

Enter **dC330** code 82-003 Horizontal transport motor (M6) (forward), MOT82-003. Press Start.

The motor runs.

Y N

Go to **WD 8.5**. Check horizontal transport motor (M6), MOT82-003. Refer to:

- **GP 10** How to Check a Motor.
- PJ905, **Media path driver PWB**.
- **01D** +5V Distribution RAP.
- **01J** +50V Distribution RAP.
- **01L** 0V Distribution RAP.

Install new components as necessary:

- Horizontal transport motor (M6), **PL 82.15 Item 9**.
- Media path driver PWB, **PL 1.15 Item 5**.

The horizontal transport rolls rotate.

Y N

Check the drive belt and drive gears on the horizontal transport, **PL 82.10 / PL 82.15**.

If necessary, install new components:

- Transport rolls, **PL 82.15**.
- Drive belts, **PL 82.15**.
- Drive gears, **PL 82.15**.

Enter **dC140** Analog Monitor. Select 82-102 horizontal transport motor encoder (M6). Press Start. Manually rotate the drive gears forward and backward. The display changes.

Y N

Go to **WD 8.5**. Check horizontal transport motor (M6), MOT82-003. Refer to:

- **GP 10** How to Check a Motor.
- PJ905, **Media path driver PWB**.
- **01D** +5V Distribution RAP.
- **01J** +50V Distribution RAP.
- **01L** 0V Distribution RAP

Install new components as necessary:

- Horizontal transport motor (M6), **PL 82.15 Item 9**.
- Media path driver PWB, **PL 1.15 Item 5**.

Check the horizontal transport rolls and nip rolls. **PL 82.15 Item 10**.

NOTE: Calibration of the registration / preheat assembly, **dC625**, is only required when:

- The registration / preheat assembly is removed or replaced.
- The horizontal transport assembly is removed or replaced.

Calibration of the registration / preheat assembly is NOT required when:

- A printhead is replaced.
- The IOD assembly is removed or replaced.

89-125-00 to 89-128-00, 89-130-00, 89-131-00 Media Path Sensor 20 Failure RAP

89-125-00 The sheet is too long over media path sensor 20 at pre-transfix.

89-126-00 The sheet is too short over media path sensor 20 at pre-transfix.

89-127-00 The leading edge was late at media path sensor 20 at pre-transfix.

89-128-00 The trailing edge was late at media path sensor 20 at pre-transfix.

89-130-00 The lead edge of the sheet was too early at media path sensor 20.

89-131-00 The media path sensor 20 static jam, sensor may be dusty.

Initial Actions

WARNING

Ensure that the electricity to the machine is switched off while performing tasks that do not need electricity. Refer to **GP 14**. Disconnect the power cord. Electricity can cause death or injury. Moving parts can cause injury

- Check the registration transport for contamination or paper debris.
- Check for shingled or multi-feed sheets. Go to **OF 8** Multi-feed RAP and check the appropriate tray.

Procedure

Clean the pre transfix sensor 20, **PL 88.10 Item 12** and refer to **GP 27**. The fault remains.

Y N

Perform **SCP 5** Final Actions.

Enter **dC330** code 89-006 pre transfix sensor (20), Q89-006. Press Start. Manually actuate the sensor. The display changes.

Y N

Go to **WD 8.6**. Check pre transfix sensor 20, Q89-006. Refer to:

- **REP 89.1** Registration / preheat Assembly and Lower Platelet Assembly
- **GP 11** How to Check a Sensor.
- PJ5, **Registration / preheat IF PWB**.
- **01D** +5V Distribution RAP.
- **01L** 0V Distribution RAP.

Install new components as necessary:

- Pre transfix sensor (20), **PL 88.10 Item 12**.
- Registration / preheat IF PWB, **PL 88.10 Item 10**.
- Media path PWB, **PL 1.15 Item 5**.

Enter **dC330** code 88-008 registration / preheat air pumps, MOT88-008. Press Start. The air pumps run.

Y N

Go to **WD 8.6**. Check registration / preheat air pumps, MOT88-008. Refer to:

- **GP 10** How to Check a Motor.

A

A

- PJ5, [Registration / preheat IF PWB](#).
- [01E](#) +12V Distribution RAP.
- [01L](#) 0V Distribution RAP.

Install new components as necessary:

- Registration / preheat air pumps, [PL 88.10 Item 5](#).
- Registration / preheat IF PWB, [PL 88.10 Item 10](#).

Check the registration transport for obstructions.

89-500-00, 89-502-00 Registration Motor Over Current RAP

89-500-00 Motor M3_A1 current demand is inconsistent with expected value.

89-502-00 Motor M3_A2 current demand is inconsistent with expected value.

Initial Actions

WARNING

Ensure that the electricity to the machine is switched off while performing tasks that do not need electricity. Refer to GP 14. Disconnect the power cord. Electricity can cause death or injury. Moving parts can cause injury

Check and clear the media path.

Procedure

Refer to [Figure 1](#). Enter [dC330](#) and test the registration motors (MOT89-007 and MOT89-008).

Refer to [GP 10](#) How to check a motor. **The motors run.**

Y N

Refer to [WD 8.1](#). Check connections at PJ202 on the [media path driver PWB](#). **The connections are good.**

Y N

Reseat connections to the registration motors and [registration / preheat interface PWB](#). Check the bulkhead connector. Reseat the [in-line connector](#) to the chassis bulkhead.

Check operation of the registration rollers when the motors are run. **The rollers rotate.**

Y N

Check registration roller drive belts and drive gears for damage or debris.

If the fault persists, install a new registration / preheat assembly [PL 88.10 Item 1](#).

The fault may be intermittent, if the fault persists, install new components as necessary:

- Registration / preheat assembly [PL 88.10 Item 1](#).
- Media path driver PWB, [PL 1.15 Item 5](#).

89-504-00 Registration Sensor Over Current RAP

89-504-00 The registration sensor 10 current demand is inconsistent with expected value.

Procedure

WARNING

Ensure that the electricity to the machine is switched off while performing tasks that do not need electricity. Refer to [GP 14](#). Disconnect the power cord. Electricity can cause death or injury. Moving parts can cause injury

Perform [dC969](#) Clean Ink Smears. The pages exit the registration.

Y N

Open the registration / preheat assembly cover assembly and heat shield. Refer to [REP 10.7](#) to release the cover assembly. Insert a sheet of paper into the registration / preheat assembly and cover the registration scan bar, Q89-005, [Figure 1](#). Close the front door assembly. The UI reports a paper jam in area 3a.

Y N

Go to [WD 8.6](#). Check Q89-005. Refer to:

- PJ 1, [Registration / preheat Interface PWB](#).
- [01C](#) +3.3V Power Distribution RAP.
- [01L](#) 0V Distribution RAP.

Install new components as necessary:

- Registration / preheat assembly, [PL 88.10 Item 1](#).

The fault may be intermittent, if the error persists, install a new registration / preheat assembly [PL 88.10 Item 1](#).

The fault may be intermittent, if the error persists, install a new registration / preheat assembly [PL 88.10 Item 1](#).

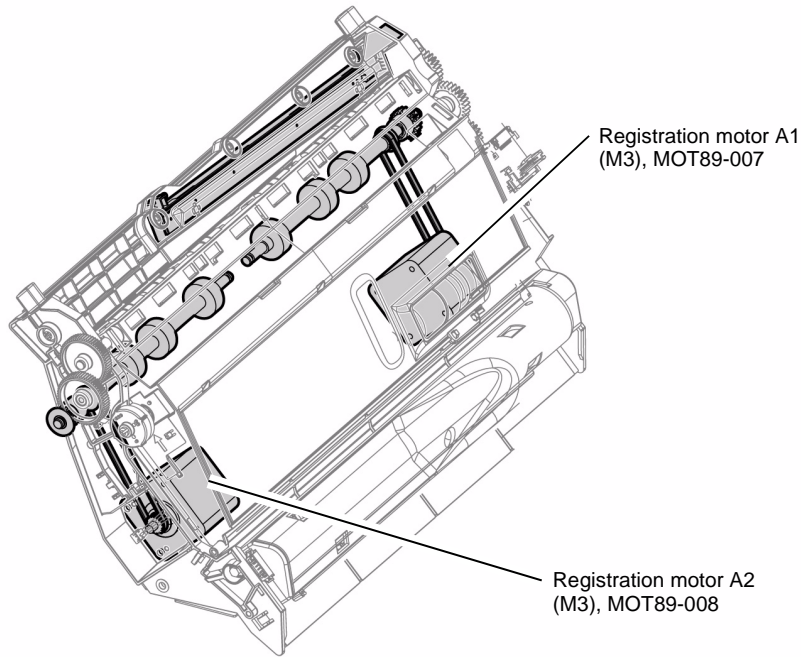

U-1-1140-A

Figure 1 Component location

NOTE: Calibration of the registration / preheat assembly, [dC625](#) is only required when:

- The registration / preheat assembly is removed or replaced,
- The horizontal transport assembly is removed or replaced.

Calibration of the registration / preheat assembly is NOT required when:

- A printhead is replaced.
- The IOD assembly is removed or replaced.

89-520-00 Home Sensor Timeout RAP

89-520-00 Stance sensor timeout.

The home sensor, mounted on the registration / preheat interface PWB, reports a value inconsistent with expected value.

Procedure

WARNING

Ensure that the electricity to the machine is switched off while performing tasks that do not need electricity. Refer to [GP 14](#). Disconnect the power cord. Electricity can cause death or injury. Moving parts can cause injury

Enter [dC330](#) code 89-004 to check the registration / preheat home sensor Q89-004, [Figure 1](#). Manually rotate the drive shaft to actuate the sensor, [Figure 2](#). The display changes.

Y N

Check that the flag on the drive gear for damage, [Figure 1](#).
Go to [WD 8.6](#). Check the registration / preheat home sensor, Q89-004.
Refer to:

- [GP 11](#) How to Check a Sensor.
- PJ4, [Registration / preheat interface PWB](#).
- [01D](#) +5V Power Distribution RAP.
- [01L](#) 0V Distribution RAP.

Install new components as necessary:

- Registration / preheat assembly, [PL 88.10 Item 1](#).

Enter [dC330](#) code 89-007 registration motor A1 (M3), MOT89-007. Press Start. The motor runs.

Y N

Go to [WD 8.1](#). Check registration motor A1 (M3), MOT89-007. Refer to:

- [GP 10](#) How to Check a Motor.
- PJ202, [Media path driver PWB](#).
- [01J](#) +50V Distribution RAP.
- [01L](#) 0V Distribution RAP.

Install new components as necessary:

- Registration / preheat assembly, [PL 88.10 Item 1](#).
- Media path driver PWB, [PL 1.15 Item 5](#).

Enter [dC330](#) code 89-008 registration motor A2 (M3), MOT89-008. Press Start. The motor runs.

Y N

Go to [WD 8.1](#). Check registration motor A2 (M3), MOT89-008. Refer to:

- [GP 10](#) How to Check a Motor.
- PJ202, [Media path driver PWB](#).
- [01J](#) +50V Distribution RAP.
- [01L](#) 0V Distribution RAP.

Install new components as necessary:

- Registration / preheat IF PWB, [PL 88.10 Item 10](#).

A

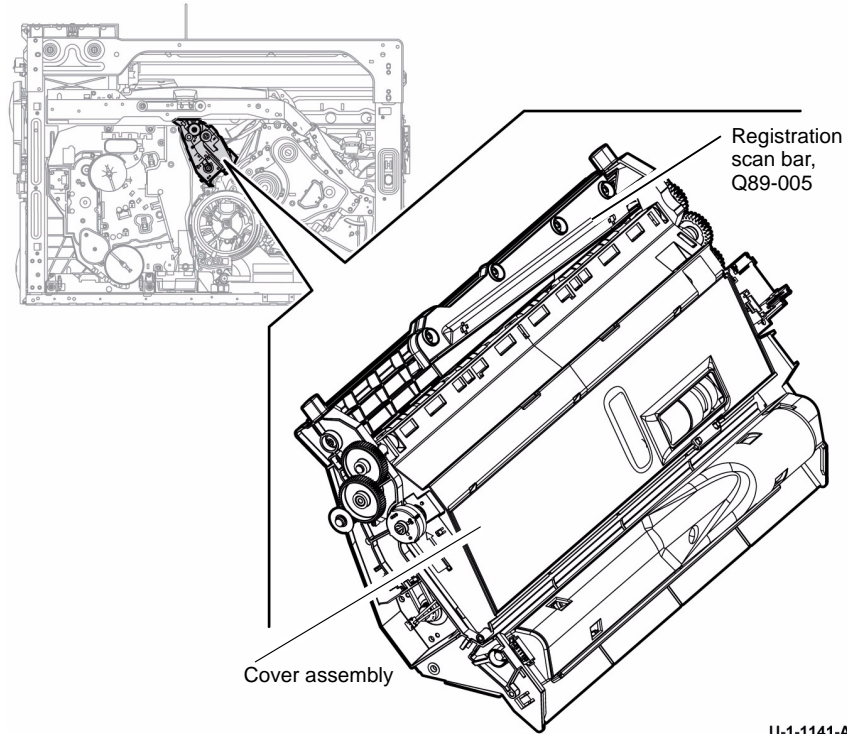

U-1-1141-A

Figure 1 Registration/preheat assembly.

NOTE: Calibration of the registration / preheat assembly, [dC625](#) is only required when:

- The registration / preheat assembly is removed or replaced,
- The horizontal transport assembly is removed or replaced.

Calibration of the registration / preheat assembly is NOT required when:

- A printhead is replaced.
- The IOD assembly is removed or replaced.

A

- Registration / preheat assembly, [PL 88.10 Item 1](#).
- Media path driver PWB, [PL 1.15 Item 5](#).

Perform the following actions:

- Check for wiring damage or obstructions preventing jam clearance hatch movement. Refer to [REP 89.1](#).
- If the error persists, install a new registration / preheat assembly [PL 88.10 Item 1](#).

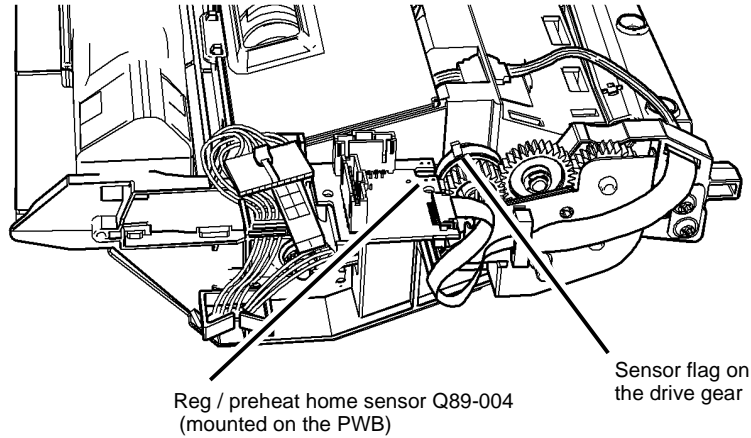

U-1-1299-A

Figure 1 Component location

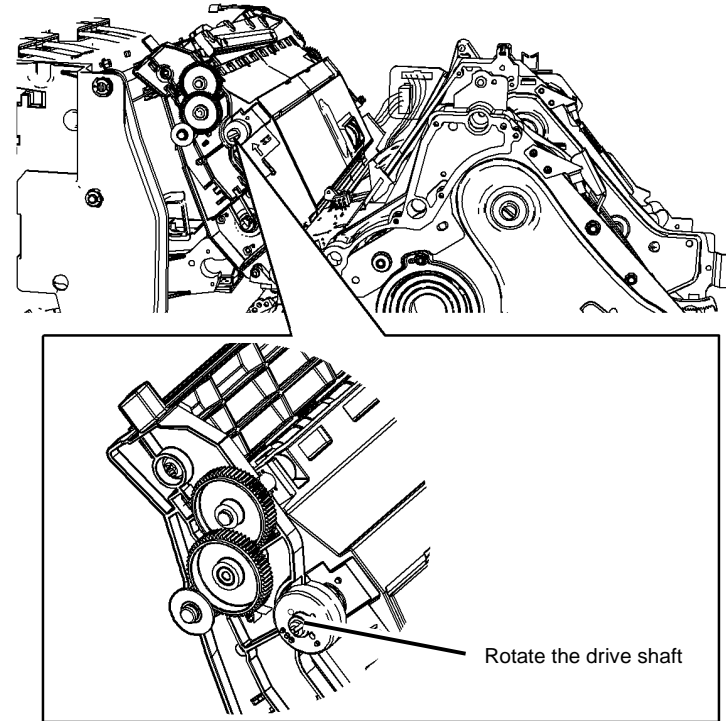

U-1-1406-A

Figure 2 Component location

89-531-00 to 89-545-00 Registration Process Error RAP

89-531-00 The registration sensor (10) failed to detect the leading edge.

89-532-00 The registration sensor (10) timed out or failed to complete normally.

89-533-00 The registration sensor (10) generated a floating point exception.

89-534-00 The registration sensor (10) scan failed.

89-540-00 Sensor 10 post registration processing failure.

89-541-00 Sensor 10 post processing leading edge not detected.

89-542-00 Sensor 10 post processing lateral edge not detected.

89-543-00 Sensor 10 post processing leading edge error.

89-544-00 Sensor 10 post processing lateral edge error.

89-545-00 Sensor 10 post processing leading edge crossing too small.

Initial Actions

WARNING

Ensure that the electricity to the machine is switched off while performing tasks that do not need electricity. Refer to [GP 14](#). Disconnect the power cord. Electricity can cause death or injury. Moving parts can cause injury

- Check for damage or debris that restricts movement of the assembly.
- Check for dust or media debris around the registration scan bar.

Procedure

Enter [dC715](#) Active registration control and disable registration control. Enter [dC969](#) Clean Ink Smears and run the routine. **The pages exit the registration / preheat assembly.**

Y N
Go to the [89-110-00 to 89-113-00](#), [89-129-00](#) Media Path Sensor 10 Failure RAP.

Install a new registration / preheat assembly, [PL 88.10 Item 1](#)

NOTE: Calibration of the registration / preheat assembly, [dC625](#), is only required when:

- The registration / preheat assembly is removed or replaced.
- The horizontal transport assembly is removed or replaced.

Calibration of the registration / preheat assembly is NOT required when:

- A printhead is replaced.
- The IOD assembly is removed or replaced.

89-550-00, 89-551-00 Media Registration Error RAP

89-550-00 The registration sensor detected excessive skew on the incoming media.

89-551-00 The registration sensor detected excessive offset on the incoming media.

Initial Actions

- Ensure that the tray 3 paper tray guides are set correctly, [ADJ 73.1](#).
- Check and clean the vertical and horizontal transport nip rolls up to the registration / preheat assembly.
- Perform [dC625](#) Registration / preheat Calibration routine.

Procedure

Run the job from a different tray. **The fault still occurs.**

Y N
Check the tray from which the fault occurs and install new components as necessary.

Enter [dC330](#) code 82-007 Nip C release solenoid, SOL83-007. Press Start. **The solenoid energizes.**

Y N
Go to [WD 8.1](#). Check SOL83-007. Refer to:

- [GP 12](#) How to Check a Solenoid or Clutch.
- PJ303, [Media path driver PWB](#).
- [01J](#) +50V Distribution RAP.
- [01L](#) 0V Distribution RAP.

Install new components as necessary:

- Nip C release solenoid, [PL 82.15 Item 4](#).
- Media path driver PWB, [PL 1.15 Item 5](#).

Enter [dC330](#) code 82-008 Nip D release solenoid, SOL83-008. Press Start. **The solenoid energizes.**

Y N
Go to [WD 8.3](#). Check SOL83-008. Refer to:

- [GP 12](#) How to Check a Solenoid or Clutch.
- PJ405, [Media path driver PWB](#).
- [01J](#) +50V Distribution RAP.
- [01L](#) 0V Distribution RAP.

Install new components as necessary:

- Nip D release solenoid, [PL 70.30 Item 13](#).
- Media path driver PWB, [PL 1.15 Item 5](#).

Check the vertical and horizontal transport rolls and drive belts. Install new parts as necessary. Refer to [PL 82.10](#) for the vertical transport and [PL 82.15](#) for the horizontal transport.

If the error persists, install a new registration / preheat assembly [PL 88.10 Item 1](#).

NOTE: Calibration of the registration / preheat assembly, [dC625](#) is only required when:

- The registration / preheat assembly is removed or replaced.
- The horizontal transport assembly is removed or replaced.

Calibration of the registration / preheat assembly is NOT required when:

- A printhead is replaced.
- The IOD assembly is removed or replaced.

89-555-00 Media Registration Out of Range RAP

89-555-00 The stored registration correction values are out of range.

Initial Actions

WARNING

Ensure that the electricity to the machine is switched off while performing tasks that do not need electricity. Refer to [GP 14](#). Disconnect the power cord. Electricity can cause death or injury. Moving parts can cause injury

- Calibrate the assembly using [dC625](#) registration calibration routine.
- If the fault 89-555-00 occurs and the media has severe skew or offset, go to [89-550-00](#), [89-551-00](#) Media Registration Error RAP.

Procedure

Switch off, then switch on the machine, [GP 14](#). Perform [dC969](#) to print chase sheets to determine if NVM is restored. **Chase sheets print without error.**

Y N

Open the registration / preheat assembly cover assembly and heat shield. Refer to [REP 10.7](#) to release the cover assembly. Insert a sheet of paper into the registration / preheat assembly and cover the registration scan bar, [PL 88.10 Item 2](#), Q89-005. Close the front door assembly. **The UI reports a paper jam in area 3a.**

Y N

Go to [WD 8.6](#). Check Q89-005. Refer to:

- PJ 1, [Registration / preheat Interface PWB](#).
- [01C](#) +3.3V Power Distribution RAP.
- [01L](#) 0V Distribution RAP.

Install new components as necessary:

- Registration / preheat assembly, [PL 88.10 Item 1](#)

Check system grounding, go to [GP 7](#). **The system grounding is good.**

Y N

Correct any system grounding issues, then retest.

Check and clear the registration / preheat assembly.

If the error persists, install a new registration / preheat assembly [PL 88.10 Item 1](#).

NOTE: Calibration of the registration / preheat assembly, [dC625](#) is only required when:

- The registration / preheat assembly is removed or replaced,
- The horizontal transport assembly is removed or replaced.

Calibration of the registration / preheat assembly is NOT required when:

- A printhead is replaced.
- The IOD assembly is removed or replaced.

89-561-00 Media Registration Parameters Reset RAP

89-561-00 Registration / preheat assembly calibration failed.

Initial Actions

WARNING

Ensure that the electricity to the machine is switched off while performing tasks that do not need electricity. Refer to [GP 14](#). Disconnect the power cord. Electricity can cause death or injury. Moving parts can cause injury

- Check for debris or obstructions in the media path.

Procedure

Enter [dC625](#) and run the registration calibration routine. **Calibration is successful.**

Y N

Go to [WD 8.6](#). Check all connections.

Refer to:

- PJ 1 [Registration / preheat interface PWB](#).
- PJ 2 to PJ 701 on the [Drum driver PWB](#).
- PJ 4 to PJ 104 on the [Media path driver PWB](#).

Reseat any loose connections.

Check system grounding, go to [GP 7](#). **The system grounding is good.**

Y N

Correct any system grounding issues, then retest.

Install new components as necessary

- Registration / preheat assembly [PL 88.10 Item 1](#).

Install a new registration / preheat assembly [PL 88.10 Item 1](#).

NOTE: Calibration of the registration / preheat assembly, [dC625](#), is only required when:

- The registration / preheat assembly is removed or replaced.
- The horizontal transport assembly is removed or replaced.

Calibration of the registration / preheat assembly is NOT required when:

- A printhead is replaced.
- The IOD assembly is removed or replaced.

89-562-00 Incorrect Media RAP

89-562-00 No media of the specified size is available.

Initial Actions

WARNING

Ensure that the electricity to the machine is switched off while performing tasks that do not need electricity. Refer to [GP 14](#). Disconnect the power cord. Electricity can cause death or injury. Moving parts can cause injury

- Check that the machines settings match the media loaded in all trays.
- If the fault occurs when [dC625](#) Registration / preheat Calibration is run. Then ensure that there is a minimum of 30 sheets loaded in the tray of A4 or 8.5 x 11inch media in long edge feed orientation.

Procedure

Check that the correct media in the appropriate paper tray. If necessary load the correct media and / or adjust the paper guides.

If the correct media is loaded, trouble shoot the relevant tray:

- [71B](#) Tray 1 Wrong Size Paper RAP.
- [72B](#) Tray 2 Wrong Size Paper RAP.
- [74A](#) Bypass Tray Size Sensing Problems RAP.

For tray 3, check the settings in the UI match what is loaded.

Tray 5 is fixed so this fault will not be seen.

89-564-00 Calibration Image Error RAP

89-564-00 The machine failed to create a calibration image or sheet.

Initial Actions

WARNING

Ensure that the electricity to the machine is switched off while performing tasks that do not need electricity. Refer to [GP 14](#). Disconnect the power cord. Electricity can cause death or injury. Moving parts can cause injury

- Switch off the machine, then switch on the machine, [GP 14](#).

Procedure

This fault is caused by a hardware memory failure within the IME.

Remove and reseal the NVRAM, [PL 92.10 Item 11](#) on the IME Controller PWB, [PL 92.10 Item](#)

1. The fault is cleared.

Y N

Install the RAM from a new IME Controller PWB, [PL 92.10 Item 1](#).

Perform [SCP 5](#) Final Actions.

89-565-00, 89-566-00 Scan Measurement Was Out Of Range RAP

89-565-00 The intermediate registration value is not valid.

89-566-00 The computed calibration parameter is out of range.

Initial Actions

WARNING

Ensure that the electricity to the machine is switched off while performing tasks that do not need electricity. Refer to **GP 14**. Disconnect the power cord. Electricity can cause death or injury. Moving parts can cause injury

- Calibrate the assembly using **dC625** registration calibration routine.
- If the media has severe skew or offset, go to **89-550-00, 89-551-00** Media Registration Error RAP.
- Check for a Service code to indicate the machine is running in degraded mode, refer to **OF 12** Service Code RAP.

Procedure

An error with either IOD alignment or Y runout needs to be resolved before running the **dC625** Registration / preheat Calibration. Refer to **91-637-00** Drum Runout Calibration Needed RAP.

89-567-00 Calibration Scan Detected Floating Point Exception RAP

89-567-00 Calibration scan detected floating point exception. This occurs because the scan did not detect the registration calibration image correctly.

Initial Actions

WARNING

Ensure that the electricity to the machine is switched off while performing tasks that do not need electricity. Refer to **GP 14**. Disconnect the power cord. Electricity can cause death or injury. Moving parts can cause injury

- Calibrate the assembly using **dC625** registration calibration routine.
- If the media has severe skew or offset, go to **89-550-00, 89-551-00** Media Registration Error RAP.
- Check for a Service code to indicate the machine is running in degraded mode, refer to **OF 12** Service Code RAP.

Procedure

WARNING

Ensure that the electricity to the machine is switched off while performing tasks that do not need electricity. Refer to **GP 14**. Disconnect the power cord. Electricity can cause death or injury. Moving parts can cause injury.

Check connections between the registration / preheat interface **PWB** at PJ2 and drum driver **PWB** at PJ701. Refer to **WD 8.6** and **WD 9.2**. Repair harness as necessary, **REP 1.1**.

If the fault continues install new components in order:

1. Drum driver **PWB**, **PL 1.15 Item 5**.
2. Registration / preheat assembly, **PL 88.10 Item 1**.

NOTE: Calibration of the registration / preheat assembly, **dC625**, is only required when:

- The registration / preheat assembly is removed or replaced.
- The horizontal transport assembly is removed or replaced.

Calibration of the registration / preheat assembly is **NOT** required when:

- A printhead is replaced.
- The IOD assembly is removed or replaced.

91-500-00, 91-600-00 Initial Position Error RAP

91-500-00 The staggered full width array (SFWA) was not left at the correct position to start the imaging process.

91-600-00 The staggered full width array (SFWA) stitch or roll motor un-initialized failure.

Procedure

WARNING

Ensure that the electricity to the machine is switched off while performing tasks that do not need electricity. Refer to GP 14. Disconnect the power cord. Electricity can cause death or injury. Moving parts can cause injury.

The SWFA was not in the correct position to start the imaging process. The mechanisms were or may have been moved manually instead of under the software control. This fault will not occur under normal operation.

Perform the following:

1. Switch off the machine, GP 14.
2. Manually move the upper and lower carriages to the parked position, refer to GP 6.
3. Switch on the machine, GP 14.
4. If the fault is still present then re-load the software, GP 4.

91-501-00 to 91-502-00 Image Timing Error RAP

91-501-00 Printhead image timing error.

91-502-00 Marking sequence timing error.

Initial Actions

WARNING

Ensure that the electricity to the machine is switched off while performing tasks that do not need electricity. Refer to GP 14. Disconnect the power cord. Electricity can cause death or injury. Moving parts can cause injury.

CAUTION

Use care when opening the marking unit drawer when hot. Ink can spill from the ink reservoir located at the back of the drawer if opened with too much force. Ink cross-color contamination could also occur.

CAUTION

Do not touch the exposed face of the printheads. Surface contamination or minor damage can destroy the printhead. Printheads must only be cleaned by a purge cycle.

NOTE: The LED on the upper (master) printhead circuit board indicates the presence of +3.3 V.

- Retry the affected job. Print samples may help to identify the cause of the fault.
- Check the error history for similar or related events.
- Check the service loop for abrasions, PL 92.10 Item 9.

Procedure

Check system grounding, refer to GP 7. **The system grounding is good.**

Y N

Correct any system grounding faults, refer to GP 7. Pay particular attention to the exit, transfix roller, and drum ground connections.

Make a copy from the DADH. **The fault remains.**

Y N

Go to SCP 5 Final Actions.

Install a new IME controller PWB, PL 92.10 Item 1.

91-503-00 Print Image Data Did Not Arrive From the Controller in Time RAP

91-503-00 The image did not reach the IME controller PWB.

Procedure

WARNING

Ensure that the electricity to the machine is switched off while performing tasks that do not need electricity. Refer to [GP 14](#). Disconnect the power cord. Electricity can cause death or injury. Moving parts can cause injury.

Go to [92-581-00](#) Image Transfer Error RAP.

91-504-00, 91-505-00 Printhead Stitch Motor Over Current RAP

91-504-00 The printhead stitch adjust motor 1 current demand exceeds expected value.

91-505-00 The printhead stitch adjust motor 2 current demand exceeds expected value.

Initial Actions

WARNING

Ensure that the electricity to the machine is switched off while performing tasks that do not need electricity. Refer to [GP 14](#). Disconnect the power cord. Electricity can cause death or injury. Moving parts can cause injury.

CAUTION

Use care when opening the marking unit drawer when hot. Ink can spill from the ink reservoir located at the back of the drawer if opened with too much force. Ink cross-color contamination could also occur.

CAUTION

Do not touch the exposed face of the printheads. Surface contamination or minor damage can destroy the printhead. Printheads must only be cleaned by a purge cycle.

NOTE: Override the front door interlock to provide voltage to the motor under test.

- Ensure that the harnesses leading to the motors and surrounding components are routed correctly and secured by the harness clamps, refer to [GP 28](#). Focus on areas above and behind the umbilicals.
- Check for damage or debris that restricts printhead movement.

Procedure

Open the marking unit drawer, [GP 6](#) to observe the motors, [Figure 1](#). Enter dC330 code 91-029 or 91-030 to run the relevant printhead stitch adjust motor, MOT91-029 (1) or MOT91-030 (2).

NOTE: Movement of the motors is small. If necessary, mark the lead screw of the motor to see the movement.

The motor runs.

Y N

Go to [WD 9.9](#) and [WD 9.10](#). Check MOT91-029 or MOT91-030.

Refer to:

- [GP 10](#) How to Check a Motor.

NOTE: The motor will not turn freely due to the gear reduction.

- PJ303 (motor 1) or PJ102 (motor 2), [Marking Unit Driver PWB](#).
- [01H](#) +24V Power Distribution RAP.
- [01L](#) 0V Distribution RAP

Install new components as necessary:

- Printhead stitch adjust motor 1, [PL 91.25](#) Item 4.
- Printhead stitch adjust motor 2, [PL 91.20](#) Item 4.
- Marking unit driver PWB, [PL 92.10](#) Item 4

A

A

Perform [dC971](#) Head to Head Alignment Adjustment, then check the image quality, refer to [IQ 1](#).

Check for obstructions or debris blocking motor or printhead movement. **The printhead area is free of obstructions.**

Y N

Clean the area and retest.

Check the wire routing along the carriage for abrasions. Install a new wire harness or repair the harness, [REP 1.1](#) as necessary. If the error persists, install a new printhead stitch adjust motor, [PL 91.20 Item 4](#).

Perform [dC971](#) Head to Head Alignment Adjustment, then check the image quality, refer to [IQ 1](#).

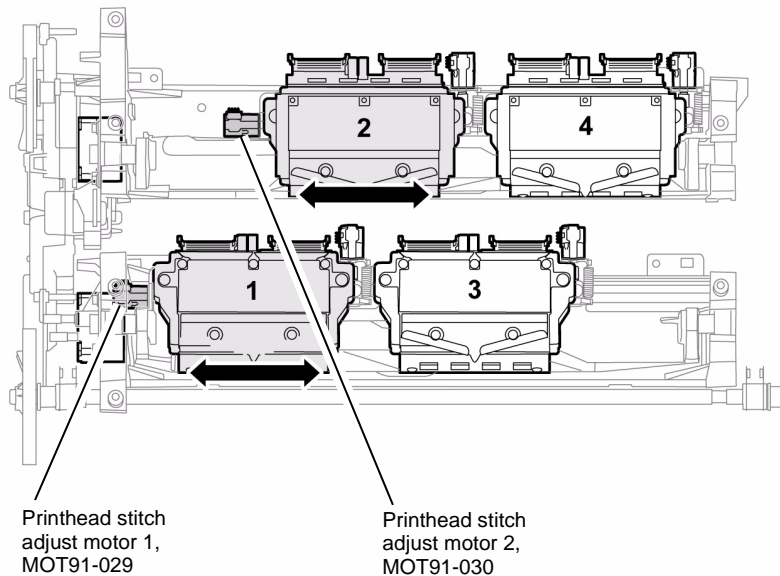

Figure 1 Component location

U-1-1022-A

91-506-00 to 91-509-00 Roll Motor Over Current RAP

91-506-00 The printhead roll adjust motor 1 current demand exceeds expected value.

91-507-00 The printhead roll adjust motor 2 current demand exceeds expected value.

91-508-00 The printhead roll adjust motor 3 current demand exceeds expected value.

91-509-00 The printhead roll adjust motor 4 current demand exceeds expected value.

Initial Actions

WARNING

Ensure that the electricity to the machine is switched off while performing tasks that do not need electricity. Refer to [GP 14](#). Disconnect the power cord. Electricity can cause death or injury. Moving parts can cause injury.

CAUTION

Use care when opening the marking unit drawer when hot. Ink can spill from the ink reservoir located at the back of the drawer if opened with too much force. Ink cross-color contamination could also occur.

CAUTION

Do not touch the exposed face of the printheads. Surface contamination or minor damage can destroy the printhead. Printheads must only be cleaned by a purge cycle.

NOTE: Override the front door interlock to provide voltage to the motor under test.

- Ensure that the harnesses leading to the printhead and surrounding component are routed correctly and secured by the harness clamps, refer to [GP 28](#). Focus on areas above and behind the umbilicals.
- Check for damage or debris that restricts printhead movement.

Procedure

Open the marking unit drawer, [GP 6](#) to observe the motors. Enter [dC330](#) code to run the relevant printhead roll adjust motor, MOT91-024 (1), MOT91-026 (2), MOT91-027 (3), MOT91-028 (4), [Figure 1](#).

NOTE: Movement of the motors is small. If necessary, mark the lead screw of the motor to see the movement.

The motor runs.

Y N

Go to [WD 9.9](#) or [WD 9.10](#). Check the relevant motor.

Refer to:

- [GP 10](#) How to Check a Motor.

NOTE: The motor will not turn freely due to the gear reduction.

- PJ303 (motor 1 and 3) PJ102 (motor 2 and 4), [Marking Unit Driver PWB](#).
- [01H](#) +24V Power Distribution RAP.
- [01L](#) 0V Distribution RAP

Install new components as necessary:

- Printhead roll adjust motor, [PL 91.20 Item 4](#) or [PL 91.25 Item 4](#).

A

A

- Marking unit driver PWB, [PL 92.10 Item 4](#).

Perform [dC971](#) Head to Head Alignment Adjustment, then check the image quality, refer to [IQ 1](#).

Check for obstructions or debris blocking motor or printhead movement. **The printhead is free of obstructions.**

Y N

Clean the area and retest.

Check the wire routing along the carriage for abrasions. Install a new wire harness or repair the harness, [REP 1.1](#) as necessary. If the error persists, install a new printhead roll adjust motor, [PL 91.20 Item 4](#).

Perform [dC971](#) Head to Head Alignment Adjustment, then check the image quality, refer to [IQ 1](#).

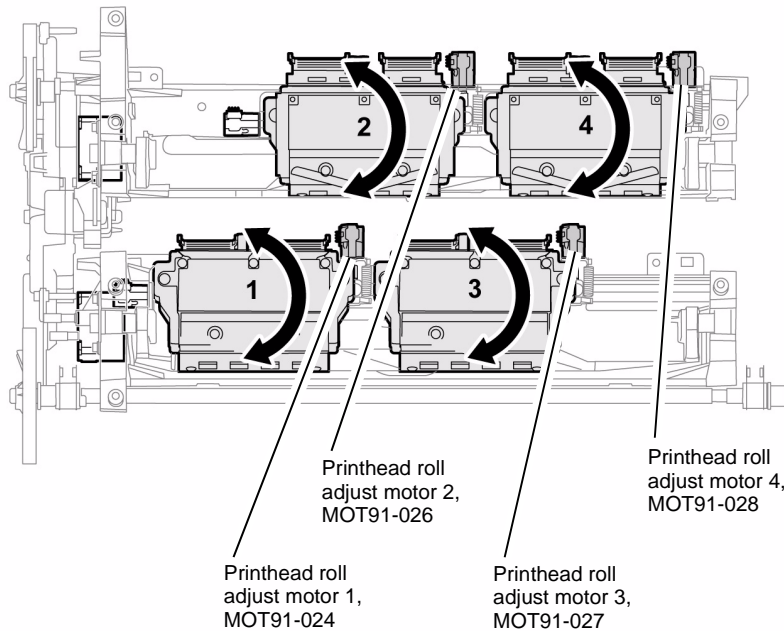

Figure 1 Component location

U-1-1023-A

91-510-00, 91-511-00 X Axis Motor Over Current RAP

91-510-00 The upper X axis motor current demands exceed expected value.

91-511-00 The lower X axis motor current demands exceed expected value.

Initial Actions

WARNING

Ensure that the electricity to the machine is switched off while performing tasks that do not need electricity. Refer to [GP 14](#). Disconnect the power cord. Electricity can cause death or injury. Moving parts can cause injury.

CAUTION

Use care when opening the marking unit drawer when hot. Ink can spill from the ink reservoir located at the back of the drawer if opened with too much force. Ink cross-color contamination could also occur.

CAUTION

Do not touch the exposed face of the printheads. Surface contamination or minor damage can destroy the printhead. Printheads must only be cleaned by a purge cycle.

NOTE: Override the front door interlock to provide voltage to the motor under test.

- Check the harness leading to the carriage and surrounding components, refer to [GP 28](#). Focus on areas above and behind the umbilicals.
- Check for damage to the harness and possible shorts.

Procedure

Open the marking unit drawer, [GP 6](#) to observe the motors. Enter [dC330](#) codes 91-033 and 91-034 to run the upper X axis drive motor, MOT91-033 and the lower X axis drive motor, MOT91-034, [Figure 1](#). **MOT91-033 and MOT91-034 run.**

Y N

Go to [WD 9.9](#) and [WD 9.11](#). Check MOT91-033 or MOT91-034.

Refer to:

- [GP 10](#) How to Check a Motor.
- PJ303 (lower) PJ102 (upper), [Marking Unit Driver PWB](#).
- [01H](#) +24V Power Distribution RAP.
- [01L](#) 0V Distribution RAP

Install new components as necessary:

- Upper axis drive motor, [PL 91.20 Item 5](#).
- Lower axis drive motor, [PL 91.25 Item 5](#).
- Marking unit driver PWB, [PL 92.10 Item 4](#).

Check for obstructions or debris blocking motor or printhead movement. **The printhead is free of obstructions.**

Y N

Clean the area and retest.

Check the wire routing along the carriage for abrasions. Install a new wire harness or repair the harness, [REP 1.1](#) as necessary. If the error persists, install new components as necessary:

- Upper axis drive motor, [PL 91.20 Item 5](#).

- Lower axis drive motor, [PL 91.25 Item 5](#).
- Marking unit driver PWB, [PL 92.10 Item 4](#).

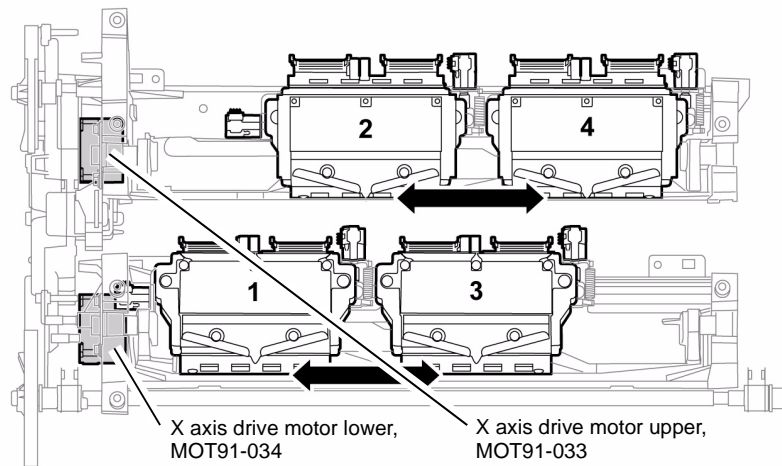

U-1-1024-A

Figure 1 Component location

91-512-00, 91-605-00 Marking Unit Motor Short RAP

91-512-00 The carriage docking motor current demand exceeds expected value.

91-605-00 One of several marking unit motors, driven by the marking unit driver PWB, is drawing more current than expected.

Initial Actions

WARNING

Ensure that the electricity to the machine is switched off while performing tasks that do not need electricity. Refer to [GP 14](#). Disconnect the power cord. Electricity can cause death or injury. Moving parts can cause injury.

CAUTION

Use care when opening the marking unit drawer when hot. Ink can spill from the ink reservoir located at the back of the drawer if opened with too much force. Ink cross-color contamination could also occur.

CAUTION

Do not touch the exposed face of the printheads. Surface contamination or minor damage can destroy the printhead. Printheads must only be cleaned by a purge cycle.

- Ensure that the harnesses leading to the marking unit motors are secured by the harness clamps, refer to [GP 28](#).
- Check for damage or debris restricting motor movement.

Procedure

Enter [dC330](#). Run the following motors:

- Code 91-021 Carriage drive select motor, MOT91-021, part of the carriage drive train, [PL 91.10 Item 1](#). Refer to [WD 9.11](#).
- Code 91-023 HM vertical motion motor, MOT91-023, [PL 91.15 Item 12](#). Refer to [WD 9.11](#).
- Code 91-024 Printhead roll adjust motor 1, MOT91-024, [PL 91.25 Item 4](#). Refer to [WD 9.10](#).
- Code 91-025 HM horizontal motion motor, MOT91-025, part of the HM horizontal drive gearbox, [PL 91.15 Item 15](#). Refer to [WD 9.11](#).
- Code 91-026 Printhead roll adjust motor 2, MOT91-026, [PL 91.20 Item 4](#). Refer to [WD 9.9](#).
- Code 91-027 Printhead roll adjust motor 3, MOT91-027, [PL 91.25 Item 4](#). Refer to [WD 9.10](#).
- Code 91-028 Printhead roll adjust motor 4, MOT91-028, [PL 91.20 Item 4](#). Refer to [WD 9.9](#).
- Code 91-029 Printhead stitch adjust motor 1, MOT91-029, [PL 91.25 Item 4](#). Refer to [WD 9.10](#).
- Code 91-030 Printhead stitch adjust motor 2, MOT91-030, [PL 91.20 Item 4](#). Refer to [WD 9.9](#).
- Code 91-031 Carriage drive motor, MOT91-031, [PL 91.10 Item 16](#). Refer to [WD 9.11](#).
- Code 91-033 X axis drive motor upper, MOT91-033, [PL 91.20 Item 5](#). Refer to [WD 9.9](#).
- Code 91-034 X axis drive motor lower, MOT91-034, [PL 91.25 Item 5](#). Refer to [WD 9.11](#).

The motors run.

Y N

Go to the relevant wiring diagram. Check the relevant motor.

Refer to:

- [GP 10](#) How to Check a Motor.
- PJ102, PJ303, PJ304, PJ401, PJ605, PJ607, [Marking Unit Driver PWB](#).
- [01H](#) +24V Power Distribution RAP.
- [01J](#) +50V Power Distribution RAP.
- [01L](#) 0V Distribution RAP

Install new components as necessary:

- Marking unit driver PWB, [PL 92.10](#) Item 4

Check the wiring harnesses connecting motors to the marking unit driver PWB. Pay particular attention to wiring routed near the carriages. **The wiring is good.**

Y N

Install new wiring or repair as necessary, [REP 1.1](#).

Perform [SCP 5](#) Final Actions.

91-513-00, 91-514-00, 91-581-00, 91-583-00 IOD Drive Error RAP

91-513-00 The IOD shuttle motor current is inconsistent with the expected value.

91-514-00 IOD drive stall.

91-581-00 IOD Home time-out.

91-583-00 IOD stall recovery failed.

Initial Actions

WARNING

Ensure that the electricity to the machine is switched off while performing tasks that do not need electricity. Refer to [GP 14](#). Disconnect the power cord. Electricity can cause death or injury. Moving parts can cause injury.

WARNING

Take care during this procedure. The drum will become hot during normal operation.

CAUTION

Do not disconnect and reconnect the flex cables at the IOD PWB. The flex cables are easily damaged. The cable must only be handled in the area of the blue backer.

CAUTION

Use care when working near the drum. The drum can be damaged easily, which will cause print quality defects.

NOTE: Override the front door interlock to provide voltage to the motor under test.

- Check the IOD to drum driver PWB cable, [PL 94.15](#) Item 5.
- Check for damage or debris that restricts IOD movement.

Procedure

Go to [dC914](#) Head to Head Alignment Test. Select test option 1 Move IOD Scan Bar. Follow instructions on the screen and observe the IOD movement. Select Position and run in the order:

1. Select Home (moves slowly to the front until a stall is encountered) and return to park position.
2. Select Rear (moves to the rear) and return to park position.

If the initial fault was 91-581-00 and a ticking noise is heard during the test then install a new IOD assembly, [PL 94.15](#) Item 1.

NOTE: Always end in the Park position (centre) to protect the IOD sensor from debris.

The IOD sensor runs to all positions without unusual noises.

Y N

Perform the following:

1. Check for obstructions or debris blocking motor movement.
2. Go to [WD 9.22](#). Check the IOD shuttle motor, MOT91-043, [Figure 1](#).

Refer to:

- [GP 10](#) How to Check a Motor.
- PJ660, [IOD pre amplifier PWB](#).
- [01H](#) +24V Power Distribution RAP

A

A

- 01L 0V Distribution RAP
- If necessary, install a new IOD assembly, [PL 94.15 Item 1](#).

Enter diagnostics select Diagnostic Routines and select [dC914](#) Head to Head Alignment Test. Select test option 10 to [dC971](#) Head to Head Alignment Adjustment then follow Measure Head Alignment. Follow the instructions on the screen. **The procedure ran without declaring a fault.**

Y N
Refer to the appropriate RAP for the new fault code.

If the fault is intermittent. Check the wire routing to the IOD for abrasions. Repair the harness, [REP 1.1](#) as necessary. If the error persists, install a new Drum Driver PWB, [PL 1.15 Item 4](#).

NOTE: Calibration of the registration / preheat assembly is only required when:

- The registration / preheat assembly is removed or replaced,
- The horizontal transport assembly is removed or replaced.

Calibration of the registration / preheat assembly is NOT required when:

- A printhead is replaced.
- The IOD assembly is removed or replaced.

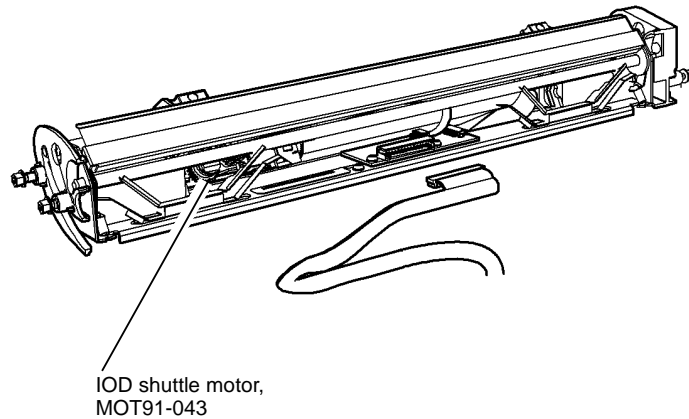

U-1-1001-A

Figure 1 Component location

91-515-00 Vertical Wiper Motor Over Current RAP

91-515-00 The HM vertical motion motor current demand exceeds expected value.

Initial Actions

WARNING

Ensure that the electricity to the machine is switched off while performing tasks that do not need electricity. Refer to [GP 14](#). Disconnect the power cord. Electricity can cause death or injury. Moving parts can cause injury.

NOTE: Override the front door interlock to provide voltage to the device under test.

- Check belts, gears, pulleys and wiper alignment, [PL 91.15](#).
- Check for damage or debris that restricts wiper movement.
- Check the harness leading to the motor and surrounding components. Refer to [GP 28](#).

Procedure

Enter [dC330](#) code 91-023 to run the HM vertical motion motor, MOT91-023, [PL 91.15 Item 12](#). **MOT91-023 runs.**

Y N
Go to [WD 9.11](#). Check MOT91-023.
Refer to:

- [GP 10](#) How to Check a Motor.
- PJ401, [Marking Unit Driver PWB](#).
- [01H](#) +24V Power Distribution RAP
- [01L](#) 0V Distribution RAP

Install new components as necessary:

- HM vertical motion motor, [PL 91.15 Item 12](#).
- Marking unit driver PWB, [PL 92.10 Item 4](#).

Check for obstructions or debris blocking motor, gearbox, or belt movement. **The wiper moves up and down smoothly.**

Y N
Clean the wiper drive components and retest.

Check the wiring harness. Repair the harness, [REP 1.1](#) as necessary. If the error persists, install a new HM vertical motion motor, [PL 91.15 Item 12](#).

91-516-00 Low Pressure Assist Over Current RAP

91-516-00 The low pressure assist solenoid valve current demand exceeds expected value.

Initial Actions

WARNING

Ensure that the electricity to the machine is switched off while performing tasks that do not need electricity. Refer to [GP 14](#). Disconnect the power cord. Electricity can cause death or injury. Moving parts can cause injury.

Check the harnesses leading to the ink reservoir and sensing components.

Procedure

Perform the following:

1. Go to [WD 9.14](#). Check the low pressure assist (LPA) valve solenoid, SOL91-045, [PL 93.10 Item 15](#).
Refer to:
 - [GP 12](#) How to Check a Solenoid or Clutch.
 - PJ130, [Solenoid Patch PWB](#).
 - [01E](#) +12V Power Distribution RAP
 - [01D](#) +5V Distribution RAP
 - [01L](#) 0V Distribution RAP
2. Check the solenoid valve harness. Repair the harness, [REP 1.1](#) as necessary.
If the error persists, install new components as necessary:
 - Ink reservoir, [PL 93.10 Item 10](#).
 - Marking unit driver PWB, [PL 92.10 Item 4](#).

91-517-00 Marking Unit Air Pump Over Current RAP

91-517-00 The marking unit ink load air pump current demand exceeds expected value.

Initial Actions

WARNING

Ensure that the electricity to the machine is switched off while performing tasks that do not need electricity. Refer to [GP 14](#). Disconnect the power cord. Electricity can cause death or injury. Moving parts can cause injury.

Check the harness leading to the pump and surrounding components.

Procedure

Perform the following:

1. Go to [WD 9.14](#). Check the reservoir pump, MOT93-050, [PL 93.10 Item 11](#).
Refer to:
 - [GP 11](#) How to Check a Motor.
 - PJ130, [Solenoid Patch PWB](#).
 - [01E](#) +12V Power Distribution RAP
 - [01D](#) +5V Distribution RAP
 - [01L](#) 0V Distribution RAP
2. Check the reservoir pump harness. Repair the harness, [REP 1.1](#) as necessary.
If the error persists, install a new components as necessary:
 - Ink reservoir, [PL 93.10 Item 10](#).
 - Marking unit driver PWB, [PL 92.10 Item 4](#).

91-519-00 to 91-522-00, 91-655-00 to 91-658-00, 91-683-00 to 91-690-00, 91-807 to 91-811-00 Printhead NVM Read or Write Error RAP

- 91-519-00 Printhead 1 NVM error detected. HCD read failure.
- 91-520-00 Printhead 2 NVM error detected. HCD read failure.
- 91-521-00 Printhead 3 NVM error detected. HCD read failure.
- 91-522-00 Printhead 4 NVM error detected. HCD read failure.
- 91-655-00 Printhead 1 field corrections corrupt. HFC read or write failure.
- 91-656-00 Printhead 2 field corrections corrupt. HFC read or write failure.
- 91-657-00 Printhead 3 field corrections corrupt. HFC read or write failure.
- 91-658-00 Printhead 4 field corrections corrupt. HFC read or write failure.
- 91-683-00 Printhead 1 TRC read failed.
- 91-684-00 Printhead 2 TRC read failed.
- 91-685-00 Printhead 3 TRC read failed.
- 91-686-00 Printhead 4 TRC read failed.
- 91-687-00 Printhead 1 TRC write failed.
- 91-688-00 Printhead 2 TRC write failed.
- 91-689-00 Printhead 3 TRC write failed.
- 91-690-00 Printhead 4 TRC write failed.
- 91-807-00 Attempt to read or write printhead 1 NVM HAY or HAU sections failed.
- 91-808-00 Attempt to read or write printhead 2 NVM HAY or HAU sections failed.
- 91-809-00 Attempt to read or write printhead 3 NVM HAY or HAU sections failed.
- 91-810-00 Attempt to read or write printhead 4 NVM HAY or HAU sections failed.
- 91-811-00 Machine has timed out waiting for the adjustment load task to complete reading printhead NVM.

Procedure

WARNING

Ensure that the electricity to the machine is switched off while performing tasks that do not need electricity. Refer to GP 14. Disconnect the power cord. Electricity can cause death or injury. Moving parts can cause injury.

CAUTION

Use care when opening the marking unit drawer when hot. Ink can spill from the ink reservoir located at the back of the drawer if opened with too much force. Ink cross-color contamination could also occur.

CAUTION

Do not touch the exposed face of the printheads. Surface contamination or minor damage can destroy the printhead. Printheads must only be cleaned by a purge cycle.

Check that the ribbon cables connecting the relevant printhead to the IME controller PWB are correctly and securely connected, and not damaged. Re-seat the ribbon cable as necessary.

The wiring is good.

Y N
Install new ribbon cables as necessary, PL 92.10.

Go to GP 7 to check the system grounding. The system grounding is good.

Y N
Repair any grounding issues found, GP 7.

Switch off, then switch on the machine, GP 14. The fault is still present.

Y N
The fault is an NVM write error generated when dC972 is performed. Re-try the relevant routine:

- Faults 91-655-00 to 91-658-00, 91-949-00 to 91-952-00, dC972 option 3 Head to Head Uniformity.
- Faults 91-687-00 to 91-690-00, dC972 option 4 TRC Generation.
- Faults 91-807-00 to 91-810-00, dC972 option 3, Head to Head Uniformity, then option 5, Y Dot Position Correction.

The fault is still present.

Y N
Complete the remaining routines in dC972, up to and including option 5.

Perform Final Actions.

The fault is a NVM read error generated during machine initialization. The fault is generated by a newly installed printhead.

Y N
Switch off, then switch on the machine, GP 14. The fault is still present.

Y N
Perform SCP 5 Final Actions.

Perform Final Actions.

Perform dC972 option 1. Select manual and all 4 printheads. Switch off, then switch on the machine, GP 14. The fault remains.

Y N
Perform SCP 5 Final Actions.

Perform Final Actions.

Final Actions

Perform the following:

1. Go to WD 9.5, WD 9.6, WD 9.7, WD 9.20 and WD 9.21. Check all connections:
 - PJ101, Printhead PWB.
 - PJ201, PJ301, PJ902, PJ904, IME Controller PWB.
2. Install new components as necessary:
 - Printhead, PL 91.20 Item 2.
 - IME controller PWB, PL 92.10 Item 1.

NOTE: Calibration of the registration / preheat assembly, dC625 is only required when:

- The registration / preheat assembly is removed or replaced,
- The horizontal transport assembly is removed or replaced.

Calibration of the registration / preheat assembly is NOT required when:

- A printhead is replaced.
- The IOD assembly is removed or replaced.

91-523-00 to 91-558-00, 91-664-00 to 91-667-00, 91-800-00 to 91-803-00, 91-856-00 to 91-859-00 Printhead Thermal Error RAP

91-523-00 Printhead 1 Left Jet Heater is Too Hot
91-524-00 Printhead 2 Left Jet Heater is Too Hot
91-525-00 Printhead 3 Left Jet Heater is Too Hot
91-526-00 Printhead 4 Left Jet Heater is Too Hot
91-527-00 Printhead 1 Left Jet Heater is Too Slow
91-528-00 Printhead 2 Left Jet Heater is Too Slow
91-529-00 Printhead 3 Left Jet Heater is Too Slow
91-530-00 Printhead 4 Left Jet Heater is Too Slow
91-531-00 Printhead 1 Left Jet Thermistor value inconsistent with expected value.
91-532-00 Printhead 2 Left Jet Thermistor value inconsistent with expected value.
91-533-00 Printhead 3 Left Jet Thermistor value inconsistent with expected value.
91-534-00 Printhead 4 Left Jet Thermistor value inconsistent with expected value.
91-535-00 Printhead 1 Right Jet Heater is Too Hot
91-536-00 Printhead 2 Right Jet Heater is Too Hot
91-537-00 Printhead 3 Right Jet Heater is Too Hot
91-538-00 Printhead 4 Right Jet Heater is Too Hot
91-539-00 Printhead 1 Right Jet Heater is Too Slow
91-540-00 Printhead 2 Right Jet Heater is Too Slow
91-541-00 Printhead 3 Right Jet Heater is Too Slow
91-542-00 Printhead 4 Right Jet Heater is Too Slow
91-543-00 Printhead 1 Right Jet Thermistor value inconsistent with expected value.
91-544-00 Printhead 2 Right Jet Thermistor value inconsistent with expected value.
91-545-00 Printhead 3 Right Jet Thermistor value inconsistent with expected value.
91-546-00 Printhead 4 Right Jet Thermistor value inconsistent with expected value.
91-547-00 Printhead 1 Reservoir Heater Too Hot
91-548-00 Printhead 2 Reservoir Heater Too Hot
91-549-00 Printhead 3 Reservoir Heater Too Hot
91-550-00 Printhead 4 Reservoir Heater Too Hot
91-551-00 Printhead 1 Reservoir Heater Too Slow
91-552-00 Printhead 2 Reservoir Heater Too Slow
91-553-00 Printhead 3 Reservoir Heater Too Slow
91-554-00 Printhead 4 Reservoir Heater Too Slow

91-555-00 Printhead 1 Reservoir Thermistor value inconsistent with expected value.
91-556-00 Printhead 2 Reservoir Thermistor value inconsistent with expected value.
91-557-00 Printhead 3 Reservoir Thermistor value inconsistent with expected value.
91-558-00 Printhead 4 Reservoir Thermistor value inconsistent with expected value.
91-664-00 Printhead 1 thermal failure.
91-665-00 Printhead 2 thermal failure.
91-666-00 Printhead 3 thermal failure.
91-667-00 Printhead 4 thermal failure.
91-800-00 Head 1 thermal glitch.
91-801-00 Head 2 thermal glitch.
91-802-00 Head 3 thermal glitch.
91-803-00 Head 4 thermal glitch.
91-856-00 Head 1 thermal persistent glitch.
91-857-00 Head 2 thermal persistent glitch.
91-858-00 Head 3 thermal persistent glitch.
91-859-00 Head 4 thermal persistent glitch.

Initial Actions

WARNING

Ensure that the electricity to the machine is switched off while performing tasks that do not need electricity. Refer to GP 14. Disconnect the power cord. Electricity can cause death or injury. Moving parts can cause injury.

CAUTION

Do not touch the exposed face of the printheads. Surface contamination or minor damage can destroy the printhead. Printheads must only be cleaned by a purge cycle.

CAUTION

Use care when opening the marking unit drawer when hot. Ink can spill from the ink reservoir located at the back of the drawer if opened with too much force. Ink cross-color contamination could also occur.

CAUTION

The video cable (striped and labeled A, PL 92.10 Item 7) and the wave amp cable (white and labeled B, PL 92.10 Item 8) should not be interchanged at the printhead connectors. Damage to the printhead and IME controller PWB will occur if the cables are installed incorrectly

- Check all 3 wiring harness leading to the indicated printhead. Focus on areas above and behind the umbilicals. Ensure each harness is securely and correctly seated, refer to GP 28.

Procedure

Check for damage to the cables connecting each printhead. **The wiring is good.**

Y N
|
Install new cables as necessary, PL 92.10.

A

A
Perform the printhead thermal tests, [dC335](#). **The tests complete successfully.**

Y N
Check the PEST fault history, [dC123](#) for marking unit heater faults (umbilicals, printheads and ink melt reservoir). **All marking unit heaters have failed.**

Y N
Go to [WD 9.8](#), [WD 9.13](#) and [WD 9.20](#), [WD 9.21](#). Check the connections and wiring:

- PJ101 and PJ301, [Printhead PWB](#).
- Disconnect the 8 pin AC printhead connector. Inspect the pins at both ends for damage.
- PJ401, PJ701, [Marking Unit Heater PWB](#).

Install new components as necessary:

- Marking unit heater PWB, [PL 92.10 Item 5](#).
- Printhead, [PL 91.20 Item 2](#).
- Power supply unit, [PL 1.15 Item 2](#).

Refer to [WD 1.1](#) and [WD 9.8](#), check the wiring between PJ4AC on the [Power Supply Unit](#) and PJ101 on the [Marking Unit Heater PWB](#). **The wiring is good.**

Y N
Repair the wiring, [REP 1.1](#).

Check the +3.3V ESTAR distribution to the marking unit heater PWB, refer to the [01B +3.3V ESTAR Distribution RAP](#). If the fault is still present, install new components as necessary:

- Marking unit heater PWB cable, [PL 92.10 Item 12](#).
- Marking unit heater PWB, [PL 92.10 Item 5](#).
- Marking unit driver PWB, [PL 92.10 Item 4](#).
- Power supply unit, [PL 1.15 Item 2](#).

The error is intermittent. Refer to [GP 7](#) and check system grounding. Repair any ground issues found.

NOTE: Calibration of the registration / preheat assembly, [dC625](#) is only required when:

- The registration / preheat assembly is removed or replaced,
- The horizontal transport assembly is removed or replaced.

Calibration of the registration / preheat assembly is NOT required when:

- A printhead is replaced.
- The IOD assembly is removed or replaced.

91-559-00 Marking Unit Components Out of Position RAP

The home position sensors are monitored as wiper or carriage motion is performed. This fault occurs when carriage or wiper motion is requested and the sensors are not in the expected state.

91-559-00 The carriage or wiper components are out of position for a requested action.

Initial Actions

WARNING

Ensure that the electricity to the machine is switched off while performing tasks that do not need electricity. Refer to [GP 14](#). Disconnect the power cord. Electricity can cause death or injury. Moving parts can cause injury.

CAUTION

Do not handle or attempt to clean the wiper blade. Wiper blade contamination can damage the printheads.

CAUTION

Do not touch the exposed face of the printheads. Surface contamination or minor damage can destroy the printhead. Printheads must only be cleaned by a purge cycle.

CAUTION

Use care when opening the marking unit drawer when hot. Ink can spill from the ink reservoir located at the back of the drawer if opened with too much force. Ink cross-color contamination could also occur.

- Check for damage or debris that restricts movement of the wiper.
- Check the harness leading to the vertical and horizontal wiper drives and home sensor. Refer to [GP 28](#).

Procedure

Check the position of the carriages. **The carriages are docked to the drum.**

Y N
Perform [dC967](#) Head to Drum Spacing Check. **dC967 runs successfully.**
Y N
Perform [ADJ 91.1](#) Printhead Attachment Check.
Perform [SCP 5](#) Final Actions.

Enter [dC330](#). Run the following motors:

- Code 91-023 HM vertical motion motor, MOT91-023, [PL 91.15 Item 12](#).
- Code 91-033 X axis drive motor upper, MOT91-033, [PL 91.20 Item 5](#).
- Code 91-034 X axis drive motor lower, MOT91-034, [PL 91.25 Item 5](#).
- Code 91-031 carriage docking motor, MOT91-031, [PL 91.10 Item 16](#).

The motors run.

Y N
Go to [WD 9.9](#) and [WD 9.11](#). Check MOT91-023, MOT91-033 and MOT91-034.
Refer to:

- [GP 10](#) How to Check a Motor.
- PJ303 (lower), PJ102 (upper) and PJ401, [Marking Unit Driver PWB](#).
- [01J +50V Distribution RAP](#)

A

- 01H +24V Power Distribution RAP.
- 01L 0V Distribution RAP.

Install new components as necessary:

- HM vertical motion motor, [PL 91.15 Item 12](#).
- X axis drive motor upper, [PL 91.20 Item 5](#).
- X axis drive motor lower, [PL 91.25 Item 5](#).
- Carriage drive train, [PL 91.10 Item 1](#).
- Marking unit driver PWB, [PL 92.10 Item 4](#).

Enter [dC330](#) codes 91-011 and 91-012 to check the lower carriage home sensor, Q91-011 and the upper carriage home sensor, Q91-012, [Figure 1](#). Actuate each sensor. **The display changes.**

Y N

Go to [WD 9.11](#). Check Q91-011 and Q91-012.

Refer to:

- [GP 11](#) How to Check a Sensor.
- PJ304, [Marking Unit Driver PWB](#).
- 01B +3.3V ESTAR Power Distribution RAP.
- 01L 0V Distribution RAP

Install new components as necessary:

- Lower carriage home sensor, [PL 91.10 Item 8](#).
- Upper carriage home sensor, [PL 91.10 Item 8](#).
- Marking unit driver PWB, [PL 92.10 Item 4](#).

Check the condition of the wiper assembly including wiper motors, gearbox, and belts:

- Ensure that the wiper, [PL 91.15 Item 13](#) is aligned horizontally.
- Check the HM belt, [PL 91.15 Item 2](#) and the horizontal drive cable, [PL 91.15 Item 16](#). Check that they are positioned and tensioned correctly. Install new components as necessary, [PL 91.15](#).

Enter [dC965](#). Run the printhead maintenance cycle test. Observe the wiper assembly motion. Check that the wiper moves up and down smoothly. Check also that the paddle correctly positions the wiper. **The wiper operation is good.**

Y N

Clean the wiper drive components and retest. Check the wiring harness. Repair the harness, [REP 1.1](#) as necessary. Install new components as necessary:

- Vertical belts, [PL 91.15 Item 2](#).
- Horizontal drive cable, [PL 91.15 Item 16](#).

Check the area surrounding the carriage, wiper assembly, and umbilicals for wiring damage or obstructions that prevent carriage or wiper movement. **The wiring is good.**

Y N

Go to [WD 9.11](#). Install new wiring or repair as necessary, [REP 1.1](#).

Go to [WD 9.9](#) and [WD 9.11](#). Check all connections:

- PJ303 (lower), PJ102 (upper) and PJ401, [Marking Unit Driver PWB](#).
- PJ304, [Marking Unit Driver PWB](#).

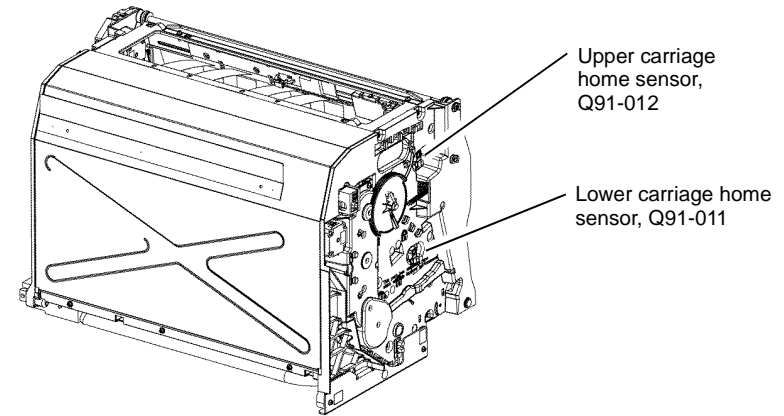

U-1-0993-A

Figure 1 Component location

91-560-00 Carriage Selection Time Out RAP

91-560-00 The carriage drive select motor timed out moving to stop.

Initial Actions

WARNING

Ensure that the electricity to the machine is switched off while performing tasks that do not need electricity. Refer to [GP 14](#). Disconnect the power cord. Electricity can cause death or injury. Moving parts can cause injury.

CAUTION

Do not touch the exposed face of the printheads. Surface contamination or minor damage can destroy the printhead. Printheads must only be cleaned by a purge cycle.

CAUTION

Use care when opening the marking unit drawer when hot. Ink can spill from the ink reservoir located at the back of the drawer if opened with too much force. Ink cross-color contamination could also occur.

NOTE: Override the front door interlock to provide voltage to the device under test.

NOTE: The carriage drive select motor (MOT91-021) is not spared individually, it is only supplied as part of the carriage drive train assembly.

- Check the wire harness leading to the carriage drive select motor and carriage home sensors, [Figure 1](#).
- Check the service loop for abrasions, [PL 92.10 Item 9](#).

Procedure

Enter [dC330](#) code 91-021 carriage drive select motor, MOT91-021. [Figure 1](#). **MOT91-021** runs.

- Y N
- Go to [WD 9.11](#). Check MOT91-021.
Refer to:
- [GP 10](#) How to Check a Motor.
 - PJ607, [Marking Unit Driver PWB](#).
 - [01H](#) +24V Power Distribution RAP
 - [01L](#) 0V Distribution RAP
- Install new components as necessary;
- Carriage drive train, [PL 91.10 Item 1](#).
 - Marking unit driver PWB, [PL 92.10 Item 4](#).

Check for obstructions or damage inside the carriage drive train. Observe the gearbox operation and that the selector moves up and down. **The drives are good.**

- Y N
- Install new components as necessary;
- Upper or lower carriage drive gear, [PL 91.10 Item 9](#) and [PL 91.10 Item 10](#).

If the error persists, install a new carriage drive train, [PL 91.10 Item 1](#).

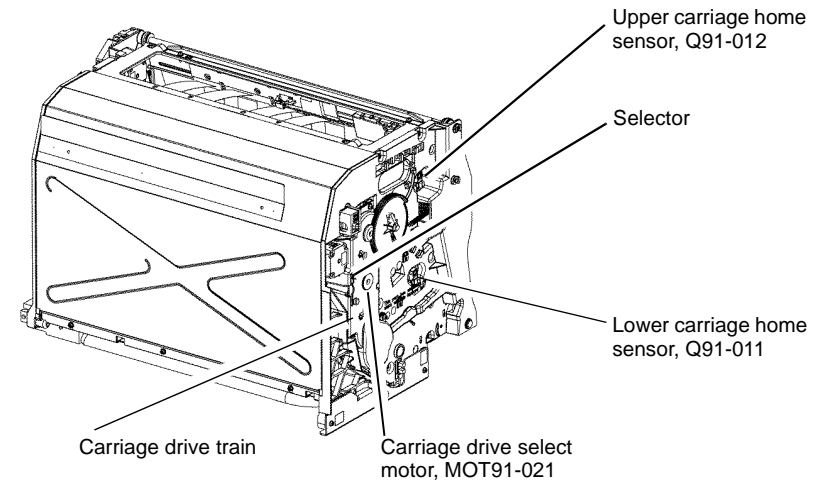

U-1-0994-A

Figure 1 Component location

91-562-00, 91-563-00 Upper Carriage Error RAP

91-562-00 Print Head Carriage no edge found.

91-563-00 Upper Print Head Carriage unexpected event.

Initial Actions

WARNING

Ensure that the electricity to the machine is switched off while performing tasks that do not need electricity. Refer to [GP 14](#). Disconnect the power cord. Electricity can cause death or injury. Moving parts can cause injury.

CAUTION

Do not touch the exposed face of the printheads. Surface contamination or minor damage can destroy the printhead. Printheads must only be cleaned by a purge cycle.

CAUTION

Use care when opening the marking unit drawer when hot. Ink can spill from the ink reservoir located at the back of the drawer if opened with too much force. Ink cross-color contamination could also occur.

- Check for obstructions, damage or debris that restricts carriage movement.
- Check the service loop for abrasions, [PL 92.10 Item 9](#).
- Check the harness leading to the carriage drive and their related sensors. Refer to [GP 28](#).

Procedure

Move the marking unit into the service position, [GP 6](#).

Check the area surrounding the carriage and umbilicals for wiring damage or obstructions that prevent carriage movement. **The wiring is good.**

Y N
Install new wiring or repair as necessary, [REP 1.1](#).

Enter [dC330](#) code 91-031 to run the carriage docking motor, MOT91-031, part of the carriage drive train, [Figure 1](#). **MOT91-031 runs.**

Y N
Go to [WD 9.11](#). Check MOT91-031.
Refer to:

- [GP 10](#) How to Check a Motor.
- PJ605, [Marking Unit Driver PWB](#).
- [01H](#) +24V Power Distribution RAP.
- [01L](#) 0V Distribution RAP

Install new components as necessary:

- Carriage drive train, [PL 91.10 Item 1](#).
- Marking unit driver PWB, [PL 92.10 Item 4](#).

Observe the motor and gearbox operation, the selector moves up and down. Enter [dC330](#) code 91-021 carriage drive select motor, MOT91-021, part of the carriage drive train, [Figure 1](#). **MOT91-021 runs.**

Y N
Go to [WD 9.11](#). Check MOT91-021.
Refer to:

- [GP 10](#) How to Check a Motor.
- PJ607, [Marking Unit Driver PWB](#).
- [01H](#) +24V Power Distribution RAP
- [01L](#) 0V Distribution RAP

Install new components as necessary:

- Carriage drive train, [PL 91.10 Item 1](#).
- Upper or lower carriage drive gear, [PL 91.10 Item 9](#) and [PL 91.10 Item 10](#).
- Marking unit driver PWB, [PL 92.10 Item 4](#).

Enter [dC330](#) code 91-012 to test the upper carriage home sensor, Q91-012. Actuate Q91-012.

The display changes.

Y N
Go to [WD 9.11](#). Check Q91-012.
Refer to:

- [GP 11](#) How to Check a Sensor.
- PJ304, [Marking Unit Driver PWB](#).
- [01B](#) +3.3V ESTAR Power Distribution RAP.
- [01L](#) 0V Distribution RAP

Install new components as necessary:

- Upper carriage home sensor, [PL 91.10 Item 8](#).
- Carriage drive train, [PL 91.10 Item 1](#).
- Marking unit driver PWB, [PL 92.10 Item 4](#).

Enter [dC330](#) code 91-011 to test the lower carriage home sensor, Q91-011. Actuate Q91-011.

The display changes.

Y N
Go to [WD 9.11](#). Check Q91-011.
Refer to:

- [GP 11](#) How to Check a Sensor.
- PJ304, [Marking Unit Driver PWB](#).
- [01B](#) +3.3V ESTAR Power Distribution RAP.
- [01L](#) 0V Distribution RAP

Install new components as necessary:

- Lower carriage home sensor, [PL 91.10 Item 8](#).
- Carriage drive train, [PL 91.10 Item 1](#).
- Marking unit driver PWB, [PL 92.10 Item 4](#).

Check for obstructions or damage inside carriage drive train. **The drives are good.**

Y N
Install a new carriage drives train, [PL 91.10 Item 1](#).

Perform [dC967](#) Head to Drum Spacing Check. **dC967 runs successfully.**

Y N
Perform [ADJ 91.1](#) Printhead Attachment Check.

Go to [WD 9.9](#) and [WD 9.11](#). Check all connections:

- PJ605, PJ 607, PJ304, [Marking Unit Driver PWB](#).

91-565-00, 91-566-00 Upper Printhead Restraint Error RAP

91-565-00 Upper printhead carriage time-out moving restraint

91-566-00 Upper printhead carriage restraint stalled.

Procedure

These fault codes are shown for information only. The machine does not have carriage restraint motors.

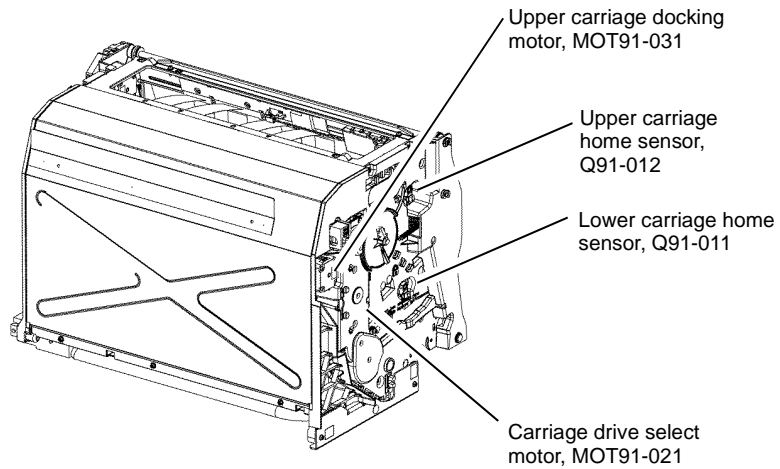

U-1-0995-A

Figure 1 Component location

91-567-00 to 91-568-00 Lower Carriage Error RAP

91-567-00 Lower Print Head Carriage no edge found.

91-568-00 Lower Print Head Carriage unexpected event.

Initial Actions

WARNING

Ensure that the electricity to the machine is switched off while performing tasks that do not need electricity. Refer to [GP 14](#). Disconnect the power cord. Electricity can cause death or injury. Moving parts can cause injury.

CAUTION

Do not touch the exposed face of the printheads. Surface contamination or minor damage can destroy the printhead. Printheads must only be cleaned by a purge cycle.

CAUTION

Use care when opening the marking unit drawer when hot. Ink can spill from the ink reservoir located at the back of the drawer if opened with too much force. Ink cross-color contamination could also occur.

- Check the harness leading to carriage drive and related sensors. Refer to [GP 28](#).
- Check for damage or debris that restricts carriage movement.
- Check the service loop for abrasions, [PL 92.10 Item 9](#).

Procedure

Move the marking unit into the service position, [GP 6](#).

Check the area surrounding the carriage and umbilicals for wiring damage or obstructions that prevent carriage movement. **The wiring is good and correctly secured in the cable clamps.**

Y N

Correctly secure the wiring. Install new wiring or repair as necessary, [REP 1.1](#).

Enter [dC330](#) code 91-032 to run the carriage docking motor, MOT91-031, part of the carriage drive train, [Figure 1](#). **MOT91-031 runs.**

Y N

Go to [WD 9.11](#). Check MOT91-031.

Refer to:

- [GP 10](#) How to Check a Motor
- PJ605, [Marking Unit Driver PWB](#)
- [01H](#) +24V Power Distribution RAP
- [01L](#) 0V Distribution RAP

Install new components as necessary:

- Carriage drives train, [PL 91.10 Item 1](#).
- Marking unit driver PWB, [PL 92.10 Item 4](#).

Observe the motor and gearbox operation, the selector moves up and down. Enter [dC330](#) code 91-021 carriage drive select motor, MOT91-021, part of the carriage drive train, [Figure 1](#). **MOT91-021 runs.**

Y N

Go to [WD 9.11](#). Check MOT91-021.

A

Refer to:

- [GP 10](#) How to Check a Motor.
- PJ607, [Marking Unit Driver PWB](#).
- [01H](#) +24V Power Distribution RAP
- [01L](#) 0V Distribution RAP

Install new components as necessary:

- Carriage drive train, [PL 91.10 Item 1](#).
- Upper or lower carriage drive gear, [PL 91.10 Item 9](#) and [PL 91.10 Item 10](#).
- Marking unit driver PWB, [PL 92.10 Item 4](#).

Enter [dC330](#) code 91-011 to test the lower carriage home sensor, Q91-011. Actuate Q91-011.

The display changes.

Y N

Go to [WD 9.11](#). Check Q91-011.

Refer to:

- [GP 11](#) How to Check a Sensor.
- PJ304, [Marking Unit Driver PWB](#).
- [01B](#) +3.3V ESTAR Power Distribution RAP.
- [01L](#) 0V Distribution RAP

Install new components as necessary:

- Lower carriage home sensor, [PL 91.10 Item 8](#).
- Marking unit driver PWB, [PL 92.10 Item 4](#).

Enter [dC330](#) code 91-012 to test the upper carriage home sensor, Q91-012. Actuate Q91-012.

The display changes.

Y N

Go to [WD 9.11](#). Check Q91-012.

Refer to:

- [GP 11](#) How to Check a Sensor.
- PJ304, [Marking Unit Driver PWB](#).
- [01B](#) +3.3V ESTAR Power Distribution RAP.
- [01L](#) 0V Distribution RAP

Install new components as necessary:

- Upper carriage home sensor, [PL 91.10 Item 11](#).
- Marking unit driver PWB, [PL 92.10 Item 4](#).

Check for obstructions or damage inside carriage drive train. **The drives are good.**

Y N

Install a new carriage drives train, [PL 91.10 Item 1](#).

Perform [dC967](#) Head to Drum Spacing Check. **dC967 runs successfully.**

Y N

Perform [ADJ 91.1](#) Printhead Attachment Check.

Go to [WD 9.11](#). Check all connections:

- PJ607, PJ304, [Marking Unit Driver PWB](#).

91-570-00, 91-571-00 Lower Printhead Restraint Error RAP

91-570-00 Lower printhead carriage timeout moving restraint.

91-571-00 Lower printhead carriage restraint stalled.

Procedure

These fault codes are shown for information only. The machine does not have carriage restraint motors.

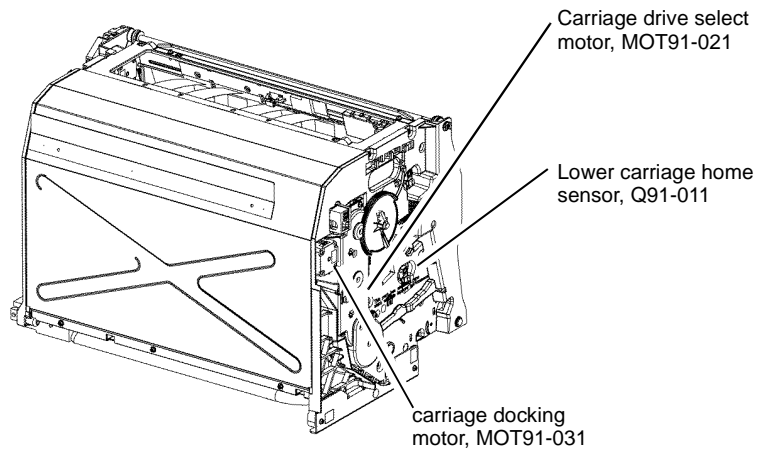

U-1-0996-A

Figure 1 Component location

91-572-00, 91-573-00, 91-575-00 Wiper Vertical Error RAP

91-572-00 Printhead wiper vertical motion edge not found.

91-573-00 The wiper encountered an unexpected event while in vertical motion.

91-575-00 The vertical wiper could not complete the requested motion.

NOTE: Invalid move errors are typically the result of mechanisms being moved manually instead of under machine control.

Initial Actions

WARNING

Ensure that the electricity to the machine is switched off while performing tasks that do not need electricity. Refer to [GP 14](#). Disconnect the power cord. Electricity can cause death or injury. Moving parts can cause injury.

CAUTION

Do not handle or attempt to clean the wiper blade. Wiper blade contamination can damage the printheads.

CAUTION

Do not touch the exposed face of the printheads. Surface contamination or minor damage can destroy the printhead. Printheads must only be cleaned by a purge cycle.

CAUTION

Use care when opening the marking unit drawer when hot. Ink can spill from the ink reservoir located at the back of the drawer if opened with too much force. Ink cross-color contamination could also occur.

- Check the HM tension spring is connected, [Figure 1](#). If necessary install a new spring, [PL 91.15 Item 14](#).
- Check that the wiper is level. Refer to the Replacement procedure in [REP 91.3](#).
- Check HM wiper, [PL 91.15 Item 13](#) for full travel.
- Check for damage or debris that restricts wiper movement.

Procedure

Cheat the front door interlock. Open the marking unit drawer, [GP 6](#) to observe wiper motion. Enter [dC330](#) code 91-023 to run the HM vertical motion motor, [MOT91-023](#), [Figure 1](#).

NOTE: The HM vertical motion motor will run a complete cycle.

MOT91-023 runs.

Y N

Go to [WD 9.11](#). Check [MOT91-023](#).

Refer to:

- [GP 10](#) How to Check a Motor.
- [PJ401](#), [Marking Unit Driver PWB](#).
- [01H](#) +24V Power Distribution RAP.
- [01L](#) 0V Distribution RAP.

Install new components as necessary:

- HM vertical motion motor, [PL 91.15 Item 12](#).
- Marking unit driver PWB, [PL 92.10 Item 4](#).

A

Enter [dC330](#) code 91-014 to test the HM position sensor, [Q91-014](#). Actuate [Q91-014](#). The display changes.

Y N

Go to [WD 9.11](#). Check [S91-014](#).

Refer to:

- [GP 13](#) How to Check a Switch.
- [PJ304](#), [Marking Unit Driver PWB](#).
- [01B](#) +3.3V ESTAR Power Distribution RAP.
- [01L](#) 0V Distribution RAP

Install new components as necessary:

- HM position sensor, [PL 91.15 Item 17](#).
- Marking unit driver PWB, [PL 92.10 Item 4](#).

Check the area surrounding the carriage, wiper assembly, and umbilicals for wiring damage or obstructions that prevent carriage or wiper movement. **The wiring is good.**

Y N

Install new wiring or repair, [REP 1.1](#) as necessary.

Go to [WD 9.11](#). Check all connections:

- [PJ401](#), [PJ304](#), [Marking Unit Driver PWB](#).

If necessary, install a new marking unit driver PWB, [PL 92.10 Item 4](#).

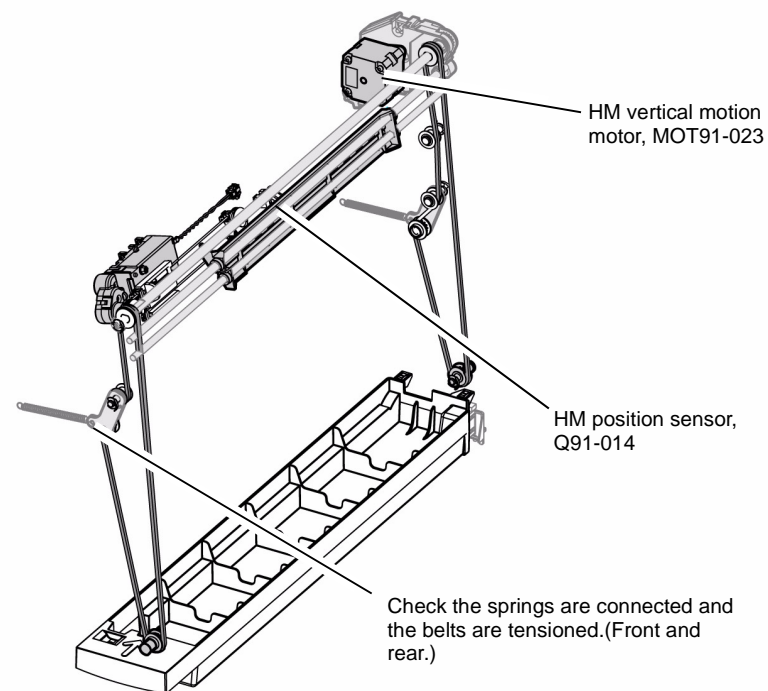

U-1-0997-A

Figure 1 Component location

91-574-00, 91-576-00, 91-598-00 Wiper Horizontal Error RAP

91-574-00 The head maintenance (HM) wiper did not reach position on time.

91-576-00 The head maintenance (HM) wiper was not in the expected vertical position.

91-598-00 The head maintenance (HM) horizontal motion motor stalled.

NOTE: Invalid move errors are typically the result of mechanisms being moved manually instead of under machine control.

Initial Actions

WARNING

Ensure that the electricity to the machine is switched off while performing tasks that do not need electricity. Refer to **GP 14**. Disconnect the power cord. Electricity can cause death or injury. Moving parts can cause injury.

CAUTION

Do not handle or attempt to clean the wiper blade. Wiper blade contamination can damage the printheads.

CAUTION

Do not touch the exposed face of the printheads. Surface contamination or minor damage can destroy the printhead. Printheads must only be cleaned by a purge cycle.

CAUTION

Use care when opening the marking unit drawer when hot. Ink can spill from the ink reservoir located at the back of the drawer if opened with too much force. Ink cross-color contamination could also occur.

- Check the harness leading to the horizontal wiper motor.
- Check for damage or debris that restricts horizontal motion.
- Switch off, then switch on the machine.

Procedure

Cheat the front door interlock. Move the marking unit into the maintenance position, **GP 6** to observe wiper motion. Enter **dC330** code 91-025 to run the HM horizontal motion motor, MOT91-025, **Figure 1**. **MOT91-025 runs.**

Y N

Go to **WD 9.11**. Check MOT91-025.

Refer to:

- **GP 10** How to Check a Motor.
- PJ304, **Marking Unit Driver PWB**.
- **01H** +24V Power Distribution RAP.
- **01L** 0V Distribution RAP

Install new components as necessary:

- HM horizontal motion motor, **PL 91.15 Item 15**.
- Horizontal drive cable, **PL 91.15 Item 16**.
- Marking unit driver PWB, **PL 92.10 Item 4**.

A

Check the alignment of the HM wiper **PL 91.15 Item 13**. Refer to **REP 91.3**. **HM wiper alignment is good**

Y N

Install a new HM wiper, **PL 91.15 Item 13**.

Check the position and tension of the horizontal drive cable, **PL 91.15 Item 16** and HM belt, **PL 91.15 Item 2**. **Position and tension are good.**

Y N

Install new components as necessary:

- Horizontal drive cable, **PL 91.15 Item 16**
- HM belt, **PL 91.15 Item 2**

Check the HM drive pulley, **PL 91.15 Item 18** and HM idler pulley, **PL 91.15 Item 19**. **Drive and idler pulleys are good.**

Y N

Install new components as necessary:

- HM drive pulley, **PL 91.15 Item 18**
- HM idler pulley, **PL 91.15 Item 19**

Check the horizontal drive paddle, **PL 91.15 Item 5**, for proper travel. **Paddle travel is good.**

Y N

Install new horizontal drive paddle, **PL 91.15 Item 5**.

Enter **dC965** Printhead Maintenance Cycle Test. Test horizontal motion. Observe HM Wiper motion. **The HM Wiper moves smoothly.**

Y N

Clean the wiper drive components and retest.

Install new components as necessary:

- HM wiper, **PL 91.15 Item 13**.
- HM horizontal motion motor, **PL 91.15 Item 15**.
- Horizontal drive cable, **PL 91.15 Item 16**.

Check the area surrounding the wiper assembly and umbilicals for wiring damage or obstructions that prevent HM Wiper movement. **The wiring is good.**

Y N

Install new wiring or repair as necessary, **REP 1.1**.

Go to **WD 9.11**. Check all connections:

- PJ304, **Marking Unit Driver PWB**.

If necessary, install a new marking unit driver PWB, **PL 92.10 Item 4**.

A

91-586-00 Quad Wave Amplifier Short RAP

91-586-00 the quad wave amplifier current demand is inconsistent with the expected value.

Procedure

WARNING

Ensure that the electricity to the machine is switched off while performing tasks that do not need electricity. Refer to [GP 14](#). Disconnect the power cord. Electricity can cause death or injury. Moving parts can cause injury.

CAUTION

Use care when opening the marking unit drawer when hot. Ink can spill from the ink reservoir located at the back of the drawer if opened with too much force. Ink cross-color contamination could also occur.

CAUTION

Do not touch the exposed face of the printheads. Surface contamination or minor damage can destroy the printhead. Printheads must only be cleaned by a purge cycle.

Check the ribbon cables connecting the quad wave amp PWB and printheads for abrasions or possible electrical arc points, [PL 92.10](#). **The cables and connectors are good.**

Y N

Install new components as necessary, [PL 92.10](#).

Check that the marking unit cooling fan, [PL 1.15 Item 23](#) runs. **The fan runs.**

Y N

Go to [WD 9.4](#). Check the marking unit cooling fan.

Refer to:

- [GP 10](#) How to Check a Motor.
- PJ901, [Drum Driver PWB](#).
- [01E](#) +12V Power Distribution RAP.
- [01L](#) 0V Distribution RAP

Install new components as necessary:

- Marking unit cooling fan, [PL 1.15 Item 23](#).
- Quad wave amp PWB, [PL 92.10 Item 3](#).
- Drum driver PWB, [PL 1.15 Item 4](#).

Install a new quad wave amp PWB, [PL 92.10 Item 3](#).

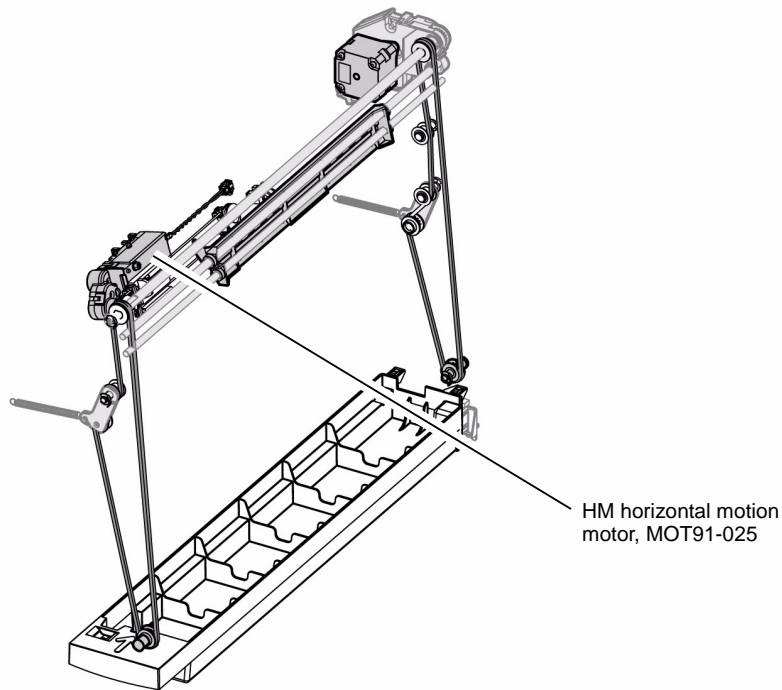

Figure 1 Component location

U-1-0998-A

91-587-00, 91-588-00 Quad Wave Amplifier Thermal Error RAP

91-587-00 The quad wave amp PWB is too hot.

91-588-00 The quad wave amp PWB thermistor reading is invalid.

Initial Actions

WARNING

Ensure that the electricity to the machine is switched off while performing tasks that do not need electricity. Refer to [GP 14](#). Disconnect the power cord. Electricity can cause death or injury. Moving parts can cause injury.

CAUTION

Use care when opening the marking unit drawer when hot. Ink can spill from the ink reservoir located at the back of the drawer if opened with too much force. Ink cross-color contamination could also occur.

CAUTION

Do not touch the exposed face of the printheads. Surface contamination or minor damage can destroy the printhead. Printheads must only be cleaned by a purge cycle.

NOTE: The eight thermistors are located on the quad wave amp PWB, one for each amplifier. If any one amplifier overheats, this fault is generated.

Check the wiring harness leading to the marking unit fan and the quad wave amp PWB.

Procedure

Check that the marking unit cooling fan, [PL 1.15 Item 23](#) runs. **The fan runs.**

Y N

Go to [WD 9.4](#). Check the marking unit cooling fan.
Refer to:

- [GP 10](#) How to Check a Motor.
- [PJ901](#), [Drum Driver PWB](#).
- [01E](#) +12V Power Distribution RAP.
- [01L](#) 0V Distribution RAP

Install new components as necessary:

- Marking unit cooling fan, [PL 1.15 Item 23](#).
- Drum driver PWB, [PL 1.15 Item 4](#).

Go to [WD 9.13](#). Check the ribbon cable connecting PJ590 on the quad wave amp PWB to PJ101 on the IME controller PWB. Check the ribbon cable for damage, and that it is connected correctly. Check for continuity through the ribbon cable. **The cable and connector are good.**

Y N

Correctly connect the ribbon cable. If necessary, install a new Quad wave amp / IME controller PWB cable, [PL 92.10 Item 13](#).

Install new components as necessary:

- Quad wave amp PWB, [PL 92.10 Item 3](#).
- IME controller PWB, [PL 92.10 Item 1](#).

91-607-00, 91-608-00 Printhead to Drum Error RAP

91-607-00 Head to drum contact. Following printhead replacement, thermal data indicates the printhead is in contact with the drum. System should reboot into diagnostics mode when this fault is detected.

91-608-00 Head to drum measurement is outside tolerance.

NOTE: The machine runs a proximity check when a new printhead is detected.

Procedure

WARNING

Ensure that the electricity to the machine is switched off while performing tasks that do not need electricity. Refer to [GP 14](#). Disconnect the power cord. Electricity can cause death or injury. Moving parts can cause injury.

CAUTION

Use care when opening the marking unit drawer when hot. Ink can spill from the ink reservoir located at the back of the drawer if opened with too much force. Ink cross-color contamination could also occur.

CAUTION

Do not touch the exposed face of the printheads. Surface contamination or minor damage can destroy the printhead. Printheads must only be cleaned by a purge cycle.

Check installation of the printhead. Check the following:

- The AC wiring to the printhead.
- The interface ribbon harness to the printhead, refer to [REP 91.21](#).
- The two securing screws for the printhead are tight and seated correctly, refer to [REP 91.21](#).

The printhead is installed correctly.

Y N

Remove the printhead. Check for debris or damage that would prevent the correct printhead installation.

Check the following:

- The umbilical is seated in the ball plate, refer to [REP 91.31](#).
- The nozzles on the umbilicals are clean.
- Ink or debris on the ball plate, refer to [REP 91.31](#).
- Ink or debris on the back of the printhead.
- The cables are correctly routed on the umbilical, refer to [REP 91.31](#).

Re-install the printhead. Starting with the left screw, alternately tighten each screw 2 or 3 turns until each screw is completely tight. Do not overtighten. Switch on the machine directly into service mode, [GP 1](#). Run [dC967](#) Head to Drum Spacing Check.

NOTE: When a printhead is re-installed into the same location from where it was removed, the head to drum spacing check will not run automatically.

Check all connections leading to the printhead. If the error persists, install a new printhead [PL 91.20 Item 2](#).

NOTE: Calibration of the registration / preheat assembly, [dC625](#) is only required when:

- The registration / preheat assembly is removed or replaced,
- The horizontal transport assembly is removed or replaced.

Calibration of the registration / preheat assembly is NOT required when:

- A printhead is replaced.
- The IOD assembly is removed or replaced.

91-610-00 to 91-613-00 Printhead Wave Amp Calibration Error RAP

91-610-00 Printhead 1 wave amp calibration error.

91-611-00 Printhead 2 wave amp calibration error.

91-612-00 Printhead 3 wave amp calibration error.

91-613-00 Printhead 4 wave amp calibration error.

Procedure

WARNING

Ensure that the electricity to the machine is switched off while performing tasks that do not need electricity. Refer to **GP 14**. Disconnect the power cord. Electricity can cause death or injury. Moving parts can cause injury.

CAUTION

Do not touch the exposed face of the printheads. Surface contamination or minor damage can destroy the printhead. Printheads must only be cleaned by a purge cycle.

CAUTION

Use care when opening the marking unit drawer when hot. Ink can spill from the ink reservoir located at the back of the drawer if opened with too much force. Ink cross-color contamination could also occur.

CAUTION

The video cable (striped and labeled A, **PL 92.10 Item 7**) and the wave amp cable (white and labeled B, **PL 92.10 Item 8**) should not be interchanged at the printhead connectors. Damage to the printhead and IME controller PWB will occur if the cables are installed incorrectly.

All 4 fault codes are recorded in the fault history, **dC122**.

Y N

Go to **WD 9.13**, **WD 9.20**, **WD 9.21**.

Check for damage to the video cable (striped and labeled A) and the wave amp cable (white and labeled B) connecting each printhead to the quad wave amp PWB.

Reset the video cable and the wave amp cable on the printhead connectors PJ101 and PJ301. **The wiring is good.**

Y N

Install new cables as necessary:

- Video cable, **PL 92.10 Item 7**.
- Wave amp cable, **PL 92.10 Item 8**.

Go to **WD 9.13**, **WD 9.20** and **WD 9.21**.

Check and reset all connections on the IME controller PWB and quad wave amp PWB

- PJ201 and PJ301, PJ902 and PJ904, **IME Controller PWB**.
- PJ110, PJ150, PJ930 and PJ970, **Quad wave amp PWB**.

The cables are good.

Y N

Install new cables as necessary:

- Video cable, **PL 92.10 Item 7**.
- Wave amp cable, **PL 92.10 Item 8**.

A B

Perform the following check:

Disconnect the video cable and the wave amp cable from the suspect printhead.

Refer to **Figure 1**.

- The resistance between GND and VPP should be 5K ohms or greater
- Perform the same check between GND and VSS.
- If the resistance is 4 ohms or less, then the printhead is shorted.

The printhead resistances are good.

Y N

Install a new printhead, **PL 91.20 Item 2**.

Check the cable between the IME controller PWB and quad wave amp PWB for damage.

Install new cable as necessary, **PL 92.10 Item 13**.

Install new components as necessary:

- Quad wave amp PWB, **PL 92.10 Item 3**.
- IME controller PWB, **PL 92.10 Item 1**.
- Printhead, **PL 91.20 Item 2**.

Install new components as necessary:

- Quad wave amp PWB, **PL 92.10 Item 3**.
- IME controller PWB, **PL 92.10 Item 1**.

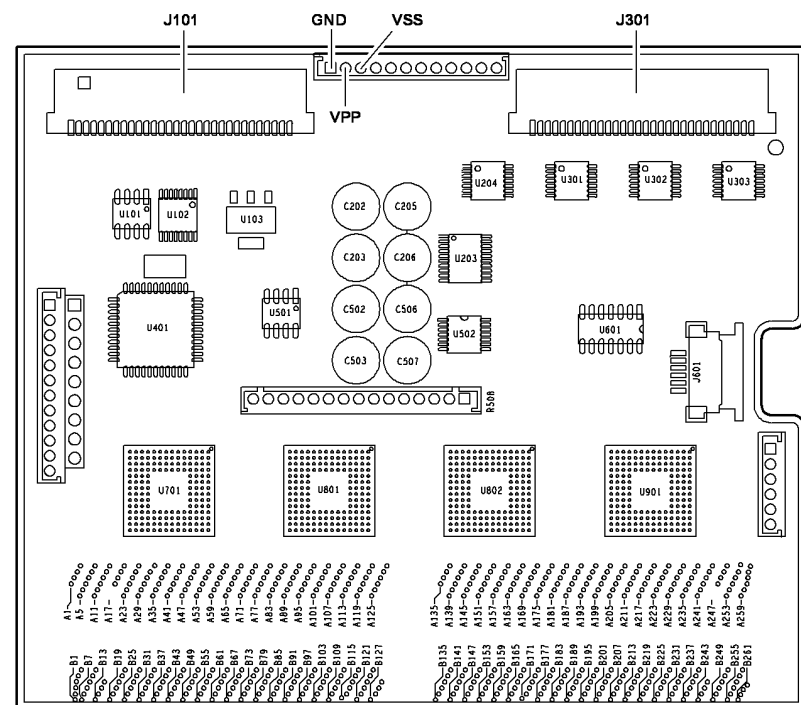

U-1-1627-A

Figure 1 Printhead PWB

A B

91-614-00 to 91-617-00 Printhead Data Error RAP

91-614-00 Printhead 1 field data corrupt.

91-615-00 Printhead 2 field data corrupt.

91-616-00 Printhead 3 field data corrupt.

91-617-00 Printhead 4 field data corrupt.

Initial Actions

WARNING

Ensure that the electricity to the machine is switched off while performing tasks that do not need electricity. Refer to [GP 14](#). Disconnect the power cord. Electricity can cause death or injury. Moving parts can cause injury.

CAUTION

Use care when opening the marking unit drawer when hot. Ink can spill from the ink reservoir located at the back of the drawer if opened with too much force. Ink cross-color contamination could also occur.

CAUTION

Do not touch the exposed face of the printheads. Surface contamination or minor damage can destroy the printhead. Printheads must only be cleaned by a purge cycle.

- Check the harness leading to the indicated printhead.
- Check for damage to surrounding harnesses.

Procedure

All 4 fault codes are recorded in the fault history, [dC122](#).

Y **N**
Enter [dC972](#) and run the Printhead Uniformity test. **The test completes successfully.**

Y **N**
Go to [WD 9.5](#), [WD 9.6](#), [WD 9.7](#), [WD 9.20](#) and [WD 9.21](#). Check all connections:

- PJ101, [Printhead PWB](#).
- PJ201, PJ301, PJ902, PJ904, [IME Controller PWB](#).

Install new components as necessary:

- Printhead, [PL 91.20 Item 2](#).
- IME controller PWB, [PL 92.10 Item 1](#).

Check the system grounding, refer to [GP 7](#). **The system grounding is good.**

Y **N**
Correct any system grounding issues, [GP 7](#), then retest.

Check the ribbon cables from the IME controller PWB for abrasions. Install a new ribbon cable, [PL 92.10](#) as necessary. If the error persists, install a new printhead, [PL 91.20 Item 2](#).

NOTE: Calibration of the registration / preheat assembly, [dC625](#) is only required when:

- The registration / preheat assembly is removed or replaced,
- The horizontal transport assembly is removed or replaced.

Calibration of the registration / preheat assembly is NOT required when:

- A printhead is replaced.
- The IOD assembly is removed or replaced.

Install a new IME controller PWB, [PL 92.10 Item 1](#).

91-630-00 IOD Scan Process Failure RAP

91-630-00 The IOD scan process has failed.

The IOD scans a target on the drum to optimize print quality and to check for missing jets. During this scanning process, the drum with the target on it moves over the stationary scan bar of the IOD. The image is scanned multiple times. Each scan is initiated by a signal from the drum encoder. If a lower than expected number of scans is encountered, this fault is raised.

Initial Actions

WARNING

Ensure that the electricity to the machine is switched off while performing tasks that do not need electricity. Refer to [GP 14](#). Disconnect the power cord. Electricity can cause death or injury. Moving parts can cause injury.

WARNING

Take care during this procedure. The drum will become hot during normal operation.

Check the harness and the plug connections to the drum drive motor and the drum position encoder.

Procedure

Go to [dC122](#) Fault History and [dC123](#) PEST Fault History. Check for drum drive faults occurring at the same time as the current 91-630 fault. **A drum drive related fault was declared.**

Y **N**
Refer to [WD 1.1](#) and [WD 9.1](#). Check the drum drive motor and the drum position encoder. Install the following components in the listed order. After the installation of each component perform the [dC971](#) routine, then check for the 91-630-00 fault. Continue with component installation until the 91-630-00 fault is cleared, then go to [SCP 5](#) Final actions.

1. Install a new drum position encoder assembly, [PL 94.20 Item 8](#).
2. Install a new drum belt, [PL 94.20 Item 2](#). Clean the drum drive pulley with IPA.
3. Install a new drum driver PWB, [PL 1.15 Item 4](#).
4. Install a new drum drive motor, [PL 94.20 Item 6](#).

If the fault is still present then install a new IME controller PWB, [PL 92.10 Item 1](#).

The fault may be intermittent, check for damaged wiring or loose connectors. Repair the wiring as necessary, [REP 1.1](#).

When all faults are cleared, go to [SCP 5](#) Final actions.

Refer to the appropriate RAP and follow the procedure to rectify any other fault. After completing the RAP perform [dC971](#) Head to Head Alignment adjust. Follow the on screen instructions and run the routine. If a 91-630-00 fault occurs then return to the start of this procedure. If the fault is cleared then go to [SCP 5](#) Final actions.

91-631-00 IOD Dark Adjust Failure RAP

91-631-00 The IOD dark adjust failed.

Initial Actions

WARNING

Ensure that the electricity to the machine is switched off while performing tasks that do not need electricity. Refer to [GP 14](#). Disconnect the power cord. Electricity can cause death or injury. Moving parts can cause injury.

WARNING

Take care during this procedure. The drum will become hot during normal operation.

CAUTION

Do not connect the harness to the IOD PWB with the machine powered on. Damage to the IOD sensor may result.

Check for damage or debris that restricts IOD movement.

Procedure

CAUTION

Do not disconnect and reconnect the flex cables at the IOD PWB. The flex cables are easily damaged. The cable must only be handled in the area of the blue backer.

CAUTION

Use care when working near the drum. The drum can be damaged easily, which will cause print quality defects.

Perform [dC971](#) Head to Head Alignment Adjustment. Go to [dC122](#) Fault History. Check for another occurrence of fault 91-631. **The fault reoccurred.**

Y N

The fault may be intermittent, check for damaged wiring or loose connectors. Repair the wiring as necessary, [REP 1.1](#). Install new components as necessary:

- IOD assembly, [PL 94.15 Item 1](#).
- Drum driver PWB, [PL 1.15 Item 4](#).

Go to [WD 9.1](#) and [WD 9.22](#). Check the cable between PJ101 on the [Drum Driver PWB](#) and PJ1 on the [IOD Pre Amplifier PWB](#). **The connections and cable are good.**

Y N

Correct the cable and connections. Install new components as necessary:

- IOD to drum driver PWB cable, [PL 94.15 Item 5](#).
- IOD assembly, [PL 94.15 Item 1](#).
- Drum driver PWB, [PL 1.15 Item 4](#).

Remove the IOD assembly, [PL 94.15 Item 1](#). Check that the 12 pin flex cable is connected at the sensor, [Figure 1](#). Handle the flex cable only in the area of the blue backer and hold the fold closed. If the connections are good then install a new IOD assembly, [PL 94.15 Item 1](#). **The fault is cleared.**

Y N

Install a new drum driver PWB, [PL 1.15 Item 4](#).

Perform [SCP 5](#) Final actions

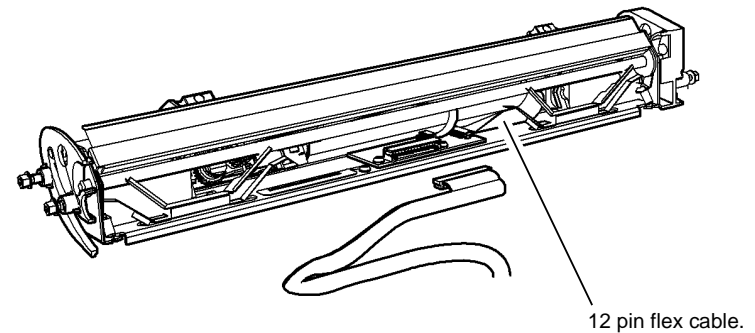

U-1-1227-A

Figure 1 Component location

91-636-00 IOD in Degraded Mode RAP

91-636-00 The machines print quality maintenance software periodically runs corrective procedures to maintain output quality. This error indicates that these procedures are suspended due to unrecoverable errors.

This procedure describes how to return a machine to normal operation from fault tolerant mode, also known as IOD degraded mode. Fault tolerant mode is indicated by the fault code 91-636-00 or by the service code displayed on the UI, refer to the [OF 12 Service Code RAP](#).

Initial Actions

- Check the PEST error log ([dC123](#)) for component failures.
- Check service code displayed on the machine information UI, refer to [OF 12](#).
- Check the fault history ([dC122](#)) to verify fault tolerant mode.
- Check that the EPC memory PWB is installed and seated correctly, [PL 3.11 Item 21](#).

Procedure

WARNING

Ensure that the electricity to the machine is switched off while performing tasks that do not need electricity. Refer to [GP 14](#). Disconnect the power cord. Electricity can cause death or injury. Moving parts can cause injury.

If the IOD sensor detects an imaging problem, one or more attempts are made to correct the error. If the machine is unable to self-correct specific imaging errors, it suspends operation of one or more of these normal print-quality adjustment routines. Refer to [Table 1](#).

1. Enter [dC131](#) NVM Read/Write and check the status of each routine by entering the NVM chain-link listed in [Table 1](#).
2. Check if the routine is in degraded state by checking the status value in [dC131](#) NVM Read/Write with the value in [Table 2](#).

3. If the routine is found to be in degraded mode. Refer to [Table 2](#) and perform the actions as required.
4. Check and clear all related faults listed in [dC122](#) by using the appropriate RAP to return the status to optimal.

NOTE: The optimal value for all settings is 0.

5. When the routine is returned to optimal, recheck the current status values of the other routines.
6. Repeat this procedure (1 through to 5) until all the routines report a NVM status value of 0.

Table 1 Print Quality Management Status Check

Adjustment Routine	NVM Chain	NVM Link	NVM Settings	Manual Procedure	Comment
Head to Head Alignment Adjustment	490	019	0 - 4	dC971	Manual and Automatic Refer to dC131 for NVM settings
Drum Runout Calibration	492	069	0 or 1	dC977	Refer to dC131 for NVM settings
Printhead Uniformity	490	008	0 - 4	dC972 Option 3	Manual and Automatic Refer to dC131 for NVM settings
TRC Generation	490	011	0 - 4	dC972 Option 4	Refer to dC131 for NVM settings
Y-dot position	490	005	0 - 4	dC972 Option 5	Manual and Automatic Refer to dC131 for NVM settings

Table 2 Routine Status Value and Description

Adjustment Routines	NVM Status Value	NVM Description	IOD Degraded	Actions	Do not manually write status value to NVM
dC971 Head to Head Alignment	0	Optimal	No	No	Do not write
dC971 Head to Head Alignment	1	Non-Optimal	no	Run the routine	Do not write
dC971 Head to Head Alignment	2	Auto Disabled	Yes	Run the routine	Do not write
dC971 Head to Head Alignment	3	Manually Disabled	Yes	Set status to 4 to Manually Enabled and run the routine	-
dC971 Head to Head Alignment	4	Manually Enabled	No	Run the routine	-
dC977 Drum Runout	0	Optimal	No	No	Do not write
dC977 Drum Runout	1	Non-Optimal	Yes	Run the routine	Do not write

Table 2 Routine Status Value and Description

Adjustment Routines	NVM Status Value	NVM Description	IOD Degraded	Actions	Do not manually write status value to NVM
dC972 Printhead Uniformity	0	Optimal	No	No	Do not write
dC972 Printhead Uniformity	1	Non-Optimal	No	No	Do not write
dC972 Printhead Uniformity	2	Auto Disabled	Yes	Run the dC972 in automatic mode to calibrate the printer uniformity. Fix issues that prevent successful completion. If the print quality is unacceptable, then run the following: 1. Run option 3 in Manual 2. Run option 4 in Manual 3. Run option 5 for high quality calibration.	Do not write
dC972 Printhead Uniformity	3	Manually Disabled	Yes	Set status to 4 to Manually Enabled Run the dC972 in automatic mode to calibrate the printer uniformity. Fix issues that prevent successful completion. If the print quality is unacceptable, then run the following: 1. Run option 3 in Manual 2. Run option 4 in Manual 3. Run option 5 for high quality calibration.	-
dC972 Printhead Uniformity	4	Manually Enabled	Yes	Run the dC972 in automatic mode to calibrate the printer uniformity. Fix issues that prevent successful completion. If the print quality is unacceptable, then run the following: 1. Run option 3 in Manual 2. Run option 4 in Manual 3. Run option 5 for high quality calibrate.	-
TRC Generation	0	Optimal	No	No	Do not write
TRC Generation	1	Non-Optimal	Yes	Run dC972 option 4.	Do not write
TRC Generation	2	Auto Disabled	Yes	Run dC972 option 4.	Do not write
TRC Generation	3	Manually Disabled	Yes	Set status to 4 to Manually Enable and run dC972 option 4.	-
TRC Generation	4	Manually Enabled	Yes	Run dC972 option 4.	-
Y-dot Position Correction	0	Optmal	No	No	Do not write
Y-dot Position Correction	1	Non-Optimal	Yes	Run dC972 option 5.	Do not write
Y-dot Position Correction	2	Auto Disabled	Yes	Run dC972 option 5.	Do not write
Y-dot Position Correction	3	Manually Disabled	Yes	Set status to 4 to Manually Enabled and run dC972 option 5.	-
Y-dot Position Correction	4	Manually Enabled	Yes	Run dC972 option 5.	-

The NVM descriptions are explained below.

- Optimal means that the calibration firmware has successfully optimized the Print Quality related to the routine executed.
- Non-Optimal state indicates that the calibration firmware has not yet had a chance to execute the related Print Quality routine. Non-Optimal state also indicates that the routine could have run with failures, but not reached Auto disabled state. Execute the routine manually and check dC122 for associated fault reports.
- Auto Disabled state refers to when the routine was executed and failed more than a specified number of retries. See Table 3 for maximum number of retries for each routine before it is automatically disabled.
- If manually disabled, both automatic and manual executions are blocked. To clear manually disabled, set the manually enabled flag by using the NVM value of 4 (use the specified tool's NVM chain and link). When manually enabled, the tool will transition to non-optimal state and the memories of all failure counters associated with the tool are cleared.

Only Manually Enabled and Manually Disabled NVM Status values (3 and 4) are to be written to NVM. DO NOT write any other Status value (0, 1 or 2) to NVM.

Table 3 Consecutive Failures

Adjustment Routine	NVM Chain	NVM Link	Maximum number of retries before disabling	Comment
Head to Head Alignment Adjust	-	-	2	Maximum of 2 retries before disable. Not in NVM. Reset at reboot
Drum Runout	-	-	0	Not in the NVM. Routine can only be executed manually.
Head to Head Uniformity	490	004	3	Maximum number of 3 retries before disable.
TRC Generation			0	Routine can only be executed manually.
Y-dot position Correction	490	010	3	Maximum of 3 retries before disable.

91-637-00 Drum Runout Calibration Needed RAP

91-637-00 The drum runout table in NVM dC301 was reset. This fault clears when the drum runout (also known as Y runout) diagnostic routine is manually run, and the values are properly set in NVM. This fault can be caused by corruption of the NVM, a calibration error during the drum runout routine or encoder problems.

Initial Actions

Check the fault history and service codes (refer to [OF 12](#)) for fault codes 94-534-00, 94-547-00 and 94-555-00. If the fault codes are present then go to the appropriate RAP before proceeding with this RAP.

Procedure

WARNING

Ensure that the electricity to the machine is switched off while performing tasks that do not need electricity. Refer to [GP 14](#). Disconnect the power cord. Electricity can cause death or injury. Moving parts can cause injury.

CAUTION

Use care when working near the drum. The drum can be damaged easily, which will cause print quality defects.

Run dC971 to perform a complete alignment of all the printheads. From dC612, run the [TP 16](#) Stitch Identification Test Pages. Examine the horizontal lines print, also used to evaluate Y stitch, to determine if runout correction is incorrect. **Drum runout calibration is needed.**

Y N

Perform [SCP 5](#) Final actions.

Enter dC977 to re-calibrate the drum runout values. **The drum runout completes without error.**

Y N

1. Perform the RAP associated with the error code received during the drum runout calibration.
2. Go to [WD 9.1](#) and [WD 9.22](#). Check the IOD sensor, part of the IOD assembly, [PL 94.15 Item 1](#). Refer to:
 - PJ1, IOD Pre Amplifier PWB.
 - PJ101, [Drum Driver PWB](#).
 - [01D](#) +5V Power Distribution RAP

Enter dC612 and make Y runout prints and examine. **The prints are good (no runout).**

Y N

- Install new components as necessary:
- Drum position encoder assembly, [PL 94.20 Item 8](#).
 - IOD assembly, [PL 94.15 Item 1](#).

CAUTION

Do not connect the harness to the IOD PWB J1 with the machine powered on. Damage to the IOD Sensor may result.

Switch off the machine, then switch on the machine, [GP 14](#).

CAUTION

Do not disconnect and reconnect the flex cables at the IOD PWB. The flex cables are easily damaged. The cable must only be handled in the area of the blue backer.

Observe the IOD sensor, wait for the IOD sensor to be initialized. **The IOD sensor runs to all positions without unusual noise.**

Y N

Perform the actions that follow:

- Switch off the machine, [GP 14](#).
- Inspect the harness connection PJ101 on the drum driver PWB. Ensure the harness is correctly connected and there are no broken wires. Repair the wiring as necessary, [REP 1.1](#). Install new components as necessary.
- Inspect the harness connection to PJ1 [IOD Pre-Amplifier PWB](#). Ensure the harness is correctly connected and there are no broken wires. Repair the wiring as necessary, [REP 1.1](#). Install new components as necessary:
- Go to [WD 9.22](#). Check MOT91-043, refer to:
 - [GP 10](#) How to Check A Motor
 - [01H](#) +24V Power Distribution RAP
 - [01L](#) 0V Distribution RAP
- Remove the IOD assembly, [REP 91.22](#). Inspect the IOD assembly for debris. Remove any debris that may be in the gear train, then re-install the IOD assembly. If no obvious problems are found by inspection, install a new IOD assembly, [PL 94.15](#) [Item 1](#).

Switch on the machine, [GP 14](#). **The fault still exists.**

Y N

Perform [SCP 5](#) Final actions.

Install a new drum driver PWB, [PL 1.15](#) [Item 4](#).

Perform [SCP 5](#) Final actions.

91-638-00 IOD Detects Chronic Jet Error RAP

91-638-00 The IOD has detected chronic jets.

Also use this RAP to recover weak, sputtering or missing jets not detected by the IOD.

Initial Actions

WARNING

Ensure that the electricity to the machine is switched off while performing tasks that do not need electricity. Refer to [GP 14](#). Disconnect the power cord. Electricity can cause death or injury. Moving parts can cause injury.

Enter the customer administration tools, [GP 5](#). On the Tools tab select Troubleshooting then Automatic Light Lines Fix. Set Quick Fix to On. Set Full Fix to Eco Fix.

NOTE: Ensure that the customer's Automatic Light Lines and Full Fix settings are restored to the original settings when the fault has been corrected.

NOTE: By setting Quick Fix to On, except for service jet test pages (executed via [dC968](#)) all images will use jet substitution.

Procedure

NOTE: Before printing [TP 20](#) or [TP 21](#), ensure that A4 or 8.5 x 11 inch plain paper is loaded long edge feed into tray 4. Use the best quality media available. Do not use hole punched paper.

Fault code 91-638 is displayed in the fault history, [dC122](#).

Y N

Print the service Jet Test Pages, [TP 21](#). **There are more than 21 chronic or masked jets.**

Y N

A chronic jet is less than 10 jets from another chronic or masked jet.

Y N

Mask the chronic jet, [GP 30](#) How to Mask Jets / Jet Substitution.

Go to [Procedure A](#).

Go to [Procedure A](#).

Go to [Procedure A](#).

Procedure A

Procedure

Print five copies of [TP 11](#) Colour Bands and Dithers Test Pages. **The missing jet is visible on both solids and dithers.**

Y N

Go to [IQ 9](#) Line Deletions in the Process Direction RAP. Perform the Missing Jet Check-out.

Empty the waste tray. Perform [dC968](#) Head Purge and [dC971](#) Head to Head Alignment Adjustment on the faulty heads up to three times. After each purge / alignment cycle, print five copies of [TP 11](#) Colour Bands and Dithers Test pages. **The test pages are good.**

Y N

Remove the waste tray and check that ink is present. **Ink is present.**

A

A

Y N

An empty waste tray can indicate a problem with the purge system. Refer to [93-549-00 to 93-552-00](#) and [93-557-00 to 93-560-00](#) Printheads 1 and 3 Printhead Reservoir Fill Error RAP or [93-553-00 to 93-556-00](#) and [93-561-00 to 93-564-00](#) Printheads 2 and 4 Printhead Reservoir Fill Error RAP.

Print print five copies at A3 (11x17) or 10 copies at A4 (8.5x11) of TP 10 Solid Fill Test Pages (refer to [TP 2 to TP 10](#)). Print five copies of [TP 11](#) Colour Bands and Dithers Test Pages. Perform [dC968](#) Head Purge. Print [TP 21](#) Service Jet Test Pages. **There are more than 21 chronic or masked jets.**

Y N

A chronic jet is less than 10 jets from another chronic or masked jet.

Y N

Mask the chronic jet, [GP 30](#) How to Mask Jets / Jet Substitution.

Perform [Procedure B](#).

Perform [Procedure B](#).

Perform [SCP 5](#) Final Actions.

Procedure B

Procedure

Perform [dC959](#) Cleaning Unit Exerciser Self Test. **The self test was successful.**

Y N

Install a new cleaning unit, [PL 94.10](#) Item 21.

Print [TP 20](#) Oil Bar Chase and Metering Blade Timing Test Pages. Evaluate the oil bar chase page only. **Test page is good.**

Y N

Go to the [IQ 21](#) Oil on Output RAP.

Perform [dC965](#) Printhead Maintenance Cycle test. Observe wiper motion during the test. Look for erratic wiper motion that may indicate wiper chatter or a motor failure. **The wiper moves smoothly across the printhead.**

Y N

Check the printhead maintenance wiper assembly. Refer to:

- [91-572-00, 91-573-00, 91-575-00](#) Wiper Vertical Error RAP.
- [91-574-00, 91-576-00, 91-598-00](#) Wiper Horizontal Error RAP.

Print five copies of [TP 11](#) Colour Bands and Dithers Test Pages. **The test pages are good.**

Y N

Perform [dC972](#) Printhead Uniformity, option 6 Reset Head Uniformity Data. Select the faulty printheads. Print five copies of [TP 11](#) Colour Bands and Dithers Test Pages. **The test pages are good.**

Y N

Install new printheads as necessary, [PL 91.20](#) Item 2 or [PL 91.25](#) Item 2.

Perform [dC972](#) Printhead Uniformity, option 1 Printhead Uniformity. Select all printheads.

Perform [SCP 5](#) Final Actions.

91-660-00 to 91-663-00, 91-820-00 to 91-823-00 Printhead Link Error RAP

91-660-00 Printhead 1 link broken.

91-661-00 Printhead 2 link broken.

91-662-00 Printhead 3 link broken.

91-663-00 Printhead 4 link broken.

91-820-00 Printhead 1 link error.

91-821-00 Printhead 2 link error.

91-822-00 Printhead 3 link error.

91-823-00 Printhead 4 link error.

Procedure

WARNING

Ensure that the electricity to the machine is switched off while performing tasks that do not need electricity. Refer to [GP 14](#). Disconnect the power cord. Electricity can cause death or injury. Moving parts can cause injury.

Go to the [91-519-00 to 91-522-00, 91-655-00 to 91-658-00, 91-683-00 to 91-690-00, 91-807 to 91-811-00](#) Printhead NVM Read or Write Error RAP.

91-669-00 Excessive Skew RAP

91-669-00 The scanned image has too much skew to process.

Initial Actions

WARNING

Ensure that the electricity to the machine is switched off while performing tasks that do not need electricity. Refer to **GP 14**. Disconnect the power cord. Electricity can cause death or injury. Moving parts can cause injury.

- Check the CVT glass for contamination, if necessary clean the glass. Refer to **ADJ 62.1** Optics Cleaning Procedure.
- Check the DADH operation.
- Check the media path for debris or wear.
- Check the media and the media settings.

Procedure

Remove the documents from the DADH. Perform **dC608** DADH Registration and **dC609** Document Glass Registration.

Check the document guides on the DADH. Make sure that they are correctly adjusted to the document size. Re-scan the test patterns. **The fault remains.**

Y N

Perform **dC972** Print Head Uniformity.

Go to **IQ 10** Margin, Mis-registration or Skew RAP.

91-670-00 Scanned Image Out of Sequence RAP

91-670-00 The expected image did not match the scanned image.

Procedure

WARNING

Ensure that the electricity to the machine is switched off while performing tasks that do not need electricity. Refer to **GP 14**. Disconnect the power cord. Electricity can cause death or injury. Moving parts can cause injury.

Load the test patterns correctly in the DADH, refer to **dC972** Print Head Uniformity. Refer to the illustrations in Option 3 Manual and Option 4 Manual.

91-671-00 Fiducials Not Found RAP

91-671-00 The test pattern fiducials (on/off line pattern) for jet alignment could not be found.

Procedure

WARNING

Ensure that the electricity to the machine is switched off while performing tasks that do not need electricity. Refer to [GP 14](#). Disconnect the power cord. Electricity can cause death or injury. Moving parts can cause injury.

Perform the following:

1. Check the CVT glass for contamination, if necessary clean the glass. Refer to [ADJ 62.1](#) Optics Cleaning Procedure.
2. Remove the documents from the DADH. Perform [dC608](#) DADH Registration and [dC609](#) Document Glass Registration
3. Load the test patterns correctly in the DADH, refer to [dC972](#) Print Head Uniformity. Refer to the illustrations in Option 3 Manual and Option 4 Manual.
4. Check the contrast and print quality of the fiducials and the horizontal line above the fiducials, [Figure 1](#). If the print quality is poor, go to [IQ 1](#) Image Quality Entry RAP. Perform the procedure for 'Deletions in the process direction'.

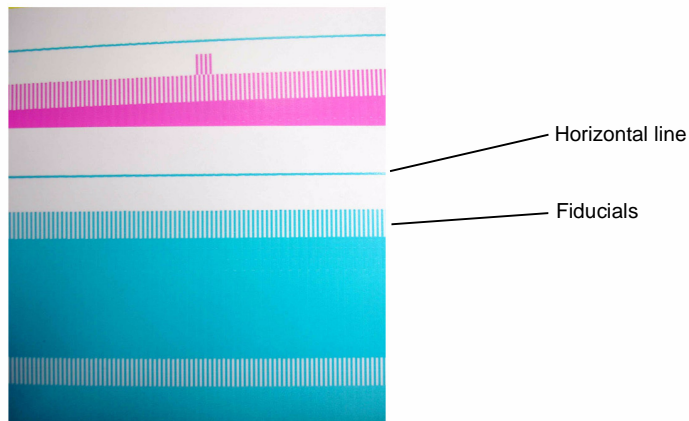

Figure 1 Fiducials

U-1-1230-A

91-672-00 Missing Jets RAP

91-672-00 Too many missing jets were detected to perform the operation.

Procedure

WARNING

Ensure that the electricity to the machine is switched off while performing tasks that do not need electricity. Refer to [GP 14](#). Disconnect the power cord. Electricity can cause death or injury. Moving parts can cause injury.

This fault is only raised when running a head calibration service diagnostics routine. The fault indicates that there are too many missing jets. Go to [91-638-00](#) IOD Detects Chronic Jet Error RAP.

91-673-00 Floating Point Error RAP

91-673-00 The machine has detected a floating point calculation error.

Procedure

WARNING

Ensure that the electricity to the machine is switched off while performing tasks that do not need electricity. Refer to GP 14. Disconnect the power cord. Electricity can cause death or injury. Moving parts can cause injury.

1. Clean the DADH, ADJ 5.4.
2. Clean the optics ADJ 62.1.
3. Perform dC608 Document Feeder Registration.
4. Perform the 91-669-00 Excessive Skew RAP.
5. Perform the 91-671-00 Fiducials Not Found RAP.

91-674-00 to 91-677-00, 91-812-00 to 91-815-00 Printhead Adjustment Error RAP

91-674-00 The required voltage or normal adjustment exceeds the maximum on printhead 1.

91-675-00 The required voltage or normal adjustment exceeds the maximum on printhead 2.

91-676-00 The required voltage or normal adjustment exceeds the maximum on printhead 3.

91-677-00 The required voltage or normal adjustment exceeds the maximum on printhead 4.

NOTE: Faults 91-674-00 to 91-677-00 are raised when a manual dC972 option 3 Head to Head Uniformity is performed and an unusually large adjustment is calculated. The routine will abort without saving changes.

91-812-00 The required voltage adjustment exceeds the maximum on printhead 1.

91-813-00 The required voltage adjustment exceeds the maximum on printhead 2.

91-814-00 The required voltage adjustment exceeds the maximum on printhead 3.

91-815-00 The required voltage adjustment exceeds the maximum on printhead 4.

NOTE: Faults 91-812-00 to 91-815-00 are raised when an automatic dC972 option 3 Head to Head Uniformity is performed and errors are detected. The routine will abort without saving changes.

Procedure

WARNING

Ensure that the electricity to the machine is switched off while performing tasks that do not need electricity. Refer to GP 14. Disconnect the power cord. Electricity can cause death or injury. Moving parts can cause injury.

Check the test pattern (TP 1) that was printed for evidence of colour mixing or wrong colours. If necessary, the test pattern can be printed from dC972, option 3 Head to Head Uniformity. **Colour mixing or wrong colours are evident.**

Y N

The best quality, bright white plain paper available must be used for the manual uniformity calibration, go to dC972 Printhead Uniformity and refer to Media Requirements.

NOTE: Automatic uniformity has no specific media requirements.

The correct media is used.

Y N

Load the correct media, then perform the following dC972 routines:

1. Option 3 Head to Head Uniformity - manual.
2. Option 4 TRC Generation - manual.
3. Option 5 Y Dot Position Correction, select all heads.

Perform the following dC972 routines:

1. Option 6 Reset Head Uniformity Data.
2. Option 3 Head to Head Uniformity - manual.

A

A

The fault remains.

Y N

Perform the following dC972 routines:

1. Option 4 TRC Generation - manual.
2. Option 5 Y Dot Position Correction, select all heads.

Install a new printhead, PL 91.20 Item 2 or PL 91.25 Item 2.

Perform the relevant procedure:

- IQ 14 Some Colours Uneven RAP.
- IQ 15 Wrong Colour RAP.

When the image quality fault is corrected, perform the following dC972 routines:

1. Option 3 Head to Head Uniformity - manual.
2. Option 4 TRC Generation - manual.
3. Option 5 Y Dot Position Correction, select all heads.

91-678-00 to 91-681-00, 91-816-00 to 91-819-00, 91-961-00 to 91-964-00, Printhead Convergence Adjustment Error RAP

91-678-00 Voltage and/or norm adjustment can not bring printhead 1 into tolerance.

91-679-00 Voltage and/or norm adjustment can not bring printhead 2 into tolerance.

91-680-00 Voltage and/or norm adjustment can not bring printhead 3 into tolerance.

91-681-00 Voltage and/or norm adjustment can not bring printhead 4 into tolerance.

NOTE: Faults 91-678-00 to 91-681-00 are raised when a manual dC972 option 3 Head to Head Uniformity is performed and errors are detected. The machine will complete the routine but may have an image quality defect.

91-816-00 Voltage adjustment can not bring printhead 1 into tolerance.

91-817-00 Voltage adjustment can not bring printhead 2 into tolerance.

91-818-00 Voltage adjustment can not bring printhead 3 into tolerance.

91-819-00 Voltage adjustment can not bring printhead 4 into tolerance.

91-961-00 IOD CLD Adjust measurement did not converge for head 1.

91-962-00 IOD CLD Adjust measurement did not converge for head 2.

91-963-00 IOD CLD Adjust measurement did not converge for head 3.

91-964-00 IOD CLD Adjust measurement did not converge for head 4.

NOTE: Faults 91-816-00 to 91-819-00 and 91-961-00 to 91-964-00 are raised when an automatic dC972 option 3 Head to Head Uniformity is performed and errors are detected. The routine will abort without saving changes.

Procedure

WARNING

Ensure that the electricity to the machine is switched off while performing tasks that do not need electricity. Refer to GP 14. Disconnect the power cord. Electricity can cause death or injury. Moving parts can cause injury.

Check the test pattern (TP 1) that was printed for evidence of colour mixing or wrong colours. If necessary, the test pattern can be printed from dC972, option 3 Head to Head Uniformity. Image quality is good.

Y N

Colour mixing or wrong colours are evident.

Y N

The best quality, bright white plain paper available must be used for the manual uniformity calibration, go to dC972 Printhead Uniformity and refer to Media Requirements.

A B

NOTE: Automatic uniformity has no specific media requirements.

The correct media is used.

Y N

Load the correct media, then perform the following **dC972** routines:

1. Option 3 Head to Head Uniformity - manual.
2. Option 4 TRC Generation - manual.
3. Option 5 Y Dot Position Correction, select all heads.

Perform the following **dC972** routines:

1. Option 6 Reset Head Uniformity Data.
2. Option 3 Head to Head Uniformity - manual.

The fault remains.

Y N

Perform the following **dC972** routines:

1. Option 4 TRC Generation - manual.
2. Option 5 Y Dot Position Correction, select all heads.

Perform the **Final Checkout**.

Perform the relevant procedure:

- **IQ 14** Some Colours Uneven RAP.
- **IQ 15** Wrong Colour RAP.

When the image quality fault is corrected, perform the following **dC972** routines:

1. Option 3 Head to Head Uniformity - manual.
2. Option 4 TRC Generation - manual.
3. Option 5 Y Dot Position Correction, select all heads.

If the fault remains, perform the **Final Checkout**.

Perform the following **dC972** routines:

1. Option 4 TRC Generation - manual.
2. Option 5 Y Dot Position Correction, select all heads.

If the fault remains, perform the **Final Checkout**.

Final Checkout

Go to **WD 6.2**. Check the wiring between the LED exposure lamps and PJ926 on the **Scanner PWB**. Install new components as necessary:

- LED exposure lamp, **PL 62.15 Item 2**.
- Scanner PWB, **PL 62.16 Item 8**.
- Printhead, **PL 91.20 Item 2** or **PL 91.25 Item 2**.

91-682-00 Ambient Thermistor Error RAP

91-682-00 The ambient thermistor reading is invalid.

This fault is raised if the ADC reading for the ambient thermistor is not within the range of a valid temperature reading. The fault is not a fatal error and the operation of the printer will continue if this fault is reported.

The ambient thermistor is used to determine the marking unit fan speed that is needed to effectively cool the wave amps. If the ambient thermistor is not operational the wave amp will still be cooled by the fan but possibly not as efficiently.

Procedure

WARNING

Ensure that the electricity to the machine is switched off while performing tasks that do not need electricity. Refer to GP 14. Disconnect the power cord. Electricity can cause death or injury. Moving parts can cause injury.

The ambient thermistor is mounted on the Marking Unit Driver PWB and if this thermistor goes open or short circuit it would be necessary to replace the PWB.

If this fault occurs, install a new Marking Unit Driver PWB, **PL 92.10 Item 4**.

91-698-00, 91-699-00, 91-706-00, 91-712-00, 91-718-00, 91-720-00, 91-729-00, 91-730-00, 91-732-00 IOD Excessive Head Misalignment RAP

91-698-00 IOD excessive stitch or roll misalignment.

91-699-00 IOD stitch / roll motors not zeroed.

91-706-00 The IOD detects printhead 1 Y axis is at the limit of travel.

91-712-00 The IOD detects printhead 2 Y-axis is at the limit of travel.

91-718-00 The IOD detects printhead 4 X-axis is at the limit of travel.

91-720-00 The IOD detects printhead 4 Y axis is at the limit of travel.

91-729-00 The IOD target Y-position out of range.

91-730-00 The IOD target Y-position out of far range.

91-732-00 The IOD detects printhead 3 Y axis is at the limit of travel.

Initial Actions

WARNING

Ensure that the electricity to the machine is switched off while performing tasks that do not need electricity. Refer to [GP 14](#). Disconnect the power cord. Electricity can cause death or injury. Moving parts can cause injury.

CAUTION

Use care when opening the marking unit drawer when hot. Ink can spill from the ink reservoir located at the back of the drawer if opened with too much force. Ink cross-color contamination could also occur.

CAUTION

Do not tilt the printhead excessively while warm. If possible, allow adequate time for the ink to solidify before removing the printhead. Once removed, rest the printhead on the screws that secure the lower (slave) circuit board.

CAUTION

The video cable (striped and labeled A, [PL 92.10 Item 7](#)) and the wave amp cable (white and labeled B, [PL 92.10 Item 8](#)) should not be interchanged at the printhead connectors. Damage to the printhead and IME controller PWB will occur if the cables are installed incorrectly.

CAUTION

Do not touch the exposed face of the printheads. Surface contamination or minor damage can destroy the printhead. Printheads must only be cleaned by a purge cycle.

- Check the wiring harnesses leading to carriage drive and sensing components. Focus on areas above and behind the umbilicals.
- Check for damage or debris that restricts carriage movement.

Procedure

NOTE: The LED on upper (master) printhead PWB indicates the presence of +3.3V.

Perform [dC971](#) Head to Head Alignment Adjustment. The adjustment completed successfully.

Y N

Check the fault history, [dC122](#). A new fault code is listed.

Y N

Enter diagnostics tab and select [dC914](#) Head to Head Alignment Test. Follow the instructions to run the following motors:

- Upper stitch motor (printhead stitch adjust motor 2, [PL 91.20 Item 4](#), MOT91-030)
- Lower stitch motor (printhead stitch adjust motor 1, [PL 91.25 Item 4](#), MOT91-029)

CAUTION

Do not repeatedly operate a roll motor. Repeated operation of a roll motor can overheat and damage the motor.

- Printhead 2 roll motor (printhead roll adjust motor 2, [PL 91.20 Item 4](#), MOT91-026)
- Printhead 4 roll motor (printhead roll adjust motor 4, [PL 91.20 Item 4](#), MOT91-028)
- Printhead 1 roll motor (printhead roll adjust motor 1, [PL 91.25 Item 4](#), MOT91-024)
- Printhead 3 roll motor (printhead roll adjust motor 3, [PL 91.25 Item 4](#), MOT91-027)
- Upper carriage motor (X-axis drive motor upper, [PL 91.20 Item 5](#), MOT91-033)
- Lower carriage motor (X-axis drive motor lower, [PL 91.25 Item 5](#), MOT91-034)

The upper stitch motor runs.

Y N

Refer to [WD 9.9](#), check the upper stitch motor (printhead stitch adjust motor 2, MOT91-030).

Check the wiring between PJ102 on the [marking unit driver PWB](#) and printhead stitch adjust motor 2.

Refer to:

- [GP 10](#) How to Check a Motor.
- [01H](#) +24V Power Distribution RAP.
- [01J](#) +50V Power Distribution RAP.
- [01L](#) 0V Distribution RAP.

Install new components as necessary.

- Printhead stitch adjust motor 2, [PL 91.20 Item 4](#).
- Marking unit driver PWB, [PL 92.10 Item 4](#).

The lower stitch motor runs.

Y N

Refer to [WD 9.10](#), check the lower stitch motor (printhead stitch adjust motor 1, MOT91-029).

Check the wiring between PJ303 on the [marking unit driver PWB](#) and printhead stitch adjust motor 1.

A B C

A B C

Refer to:

- GP 10 How to Check a Motor.
- 01H +24V Power Distribution RAP.
- 01J +50V Power Distribution RAP.
- 01L 0V Distribution RAP.

Install new components as necessary.

- Printhead stitch adjust motor 1, PL 91.25 Item 4.
- Marking unit driver PWB, PL 92.10 Item 4.

Printhead 2 roll motor runs.

Y N

Refer to WD 9.9 check printhead 2 roll motor (printhead roll adjust motor 2, MOT91-026).

Check the wiring between PJ102 on the marking unit driver PWB and printhead 2 roll motor.

Refer to:

- GP 10 How to Check a Motor.
- 01H +24V Power Distribution RAP.
- 01J +50V Power Distribution RAP.
- 01L 0V Distribution RAP.

Install new components as necessary.

- Printhead roll adjust motor 2, PL 91.20 Item 4.
- Marking unit driver PWB, PL 92.10 Item 4.

Printhead 4 roll motor runs.

Y N

Refer to WD 9.9, check printhead 4 roll motor (printhead roll adjust motor 4, MOT91-028).

Check the wiring between PJ102 on the marking unit driver PWB and printhead 4 roll motor.

Refer to:

- GP 10 How to Check a Motor.
- 01H +24V Power Distribution RAP.
- 01J +50V Power Distribution RAP.
- 01L 0V Distribution RAP.

Install new components as necessary.

- Printhead roll adjust motor 4, PL 91.20 Item 4.
- Marking unit driver PWB, PL 92.10 Item 4.

Printhead 1 roll motor runs.

Y N

Refer to WD 9.10, check printhead 1 roll motor (printhead roll adjust motor 1, MOT91-024).

Check the wiring between PJ303 on the marking unit driver PWB and printhead 1 roll motor.

Refer to:

- GP 10 How to Check a Motor.
- 01H +24V Power Distribution RAP.

A B D

A B D

- 01J +50V Power Distribution RAP.
- 01L 0V Distribution RAP.

Install new components as necessary.

- Printhead roll adjust motor 1, PL 91.25 Item 4.
- Marking unit driver PWB, PL 92.10 Item 4.

Printhead 3 roll motor runs.

Y N

Refer to WD 9.10, check printhead 3 roll motor (printhead roll adjust motor 3, MOT91-027).

Check the wiring between PJ303 on the marking unit driver PWB and printhead 3 roll motor.

Refer to:

- GP 10 How to Check a Motor.
- 01H +24V Power Distribution RAP.
- 01J +50V Power Distribution RAP.
- 01L 0V Distribution RAP.

Install new components as necessary.

- Printhead roll adjust motor 3, PL 91.25 Item 4.
- Marking unit driver PWB, PL 92.10 Item 4.

The upper carriage motor runs.

Y N

Refer to WD 9.9, check the upper carriage motor (X-axis drive motor upper, MOT91-033).

Check the wiring between PJ102 on the marking unit driver PWB and the upper carriage motor.

Refer to:

- GP 10 How to Check a Motor.
- 01H +24V Power Distribution RAP.
- 01J +50V Power Distribution RAP.
- 01L 0V Distribution RAP.

Install new components as necessary.

- X-axis drive motor upper, PL 91.20 Item 5.
- Marking unit driver PWB, PL 92.10 Item 4.

The lower carriage motor runs.

Y N

Refer to WD 9.11, check the lower carriage motor (X-axis drive motor lower, MOT91-034).

Check the wiring between PJ303 on the marking unit driver PWB and the lower carriage motor.

Refer to:

- GP 10 How to Check a Motor.
- 01H +24V Power Distribution RAP.
- 01J +50V Power Distribution RAP.
- 01L 0V Distribution RAP.

A B E

A B E

Install new components as necessary.

- X-axis drive motor lower, [PL 91.25 Item 5](#).
- Marking unit driver PWB, [PL 92.10 Item 4](#).

Perform the following:

1. Inspect the docking pins and docking surfaces for debris that could prevent the carriage from fully docking. Clean the docking pins and surfaces as necessary, [GP 27](#).
2. Move the marking unit back into the operational position, refer to [GP 6](#).
3. Observe the carriage as it moves into the docked position.
To do this enter the Diagnostic tab and select [dC612](#) Print Test Patterns. Select [TP 16](#), Stitch Identification Test Pages. The carriage will move into the docked position to enable printing.

The carriage docks correctly against the drum.

Y N

Inspect the marking unit drive system for broken or bound linkages. Install new components necessary. [PL 91.10](#).

Check the fault history, [dC122](#).

If fault codes 91-712-00 and 91-720-00 are listed install a new upper carriage assembly, [PL 91.20 Item 1](#).

If fault codes 91-706-00 and 91-732-00 are listed install a new lower carriage assembly, [PL 91.25 Item 1](#).

If the fault is intermittent. Check the area surrounding the carriage and umbilicals for wiring damage or obstructions. Repair the harness, [REP 1.1](#) as necessary.

Go to the appropriate RAP.

Enter [dC612](#) and print TP 16, Stitch Identification Test Pages and check that the print quality is good.

Perform [SCP 5](#) Final Actions

91-721-00, 91-722-00, 91-735-00, 91-736-00 IOD Contamination Error RAP

91-721-00 IOD calibration.

91-722-00 IOD calibration 2D.

91-735-00 IOD non-static scanbar artifact.

91-736-00 IOD static scanbar artifact.

Procedure

WARNING

Ensure that the electricity to the machine is switched off while performing tasks that do not need electricity. Refer to [GP 14](#). Disconnect the power cord. Electricity can cause death or injury. Moving parts can cause injury.

WARNING

Take care during this procedure. The drum will become hot during normal operation.

CAUTION

Do not connect the harness to the IOD PWB with the machine powered on. This may damage the IOD sensor.

CAUTION

Use care when working near the drum. The drum can be damaged easily, which will cause print quality defects.

CAUTION

Do not disconnect and reconnect the flex cables at the IOD PWB. the flex cables are easily damaged. The cable must only be handled in the area of the blue backer.

Perform [dC969](#) Cleaning Ink Smears. Check the prints. **The prints are clean.**

Y N

Repeat [dC969](#) until the prints are clean.

Perform [dC971](#) Head to Head Alignment. **The routine completes successfully.**

Y N

Enter [dC330](#) and select 94-009 Drum Drive Slew Speed. Select start and inspect the drum for contamination as it rotates. **The drum is clean.**

Y N

Clean the drum, [GP 27](#).

Clean the IOD, [GP 27](#).

Check the wire routing under the IOD for abrasions. Repair the harness, [REP 1.1](#) as necessary. If the fault remains, install new components as necessary:

- IOD assembly, [PL 94.15 Item 1](#).
- Drum driver PWB, [PL 1.15 Item 4](#).

91-725-00 to 91-728-00, 91-945-00 to 91-948-00, IOD Bad Target Scan RAP

91-725-00 IOD target.

91-726-00 IOD target missing.

91-727-00 IOD target corrupted.

91-728-00 IOD target missing or corrupted.

91-945-00 IOD Invalid CLD row measurement avg on head 1.

91-946-00 IOD Invalid CLD row measurement avg on head 2.

91-947-00 IOD Invalid CLD row measurement avg on head 3.

91-948-00 IOD Invalid CLD row measurement avg on head 4.

Initial Actions

WARNING

Ensure that the electricity to the machine is switched off while performing tasks that do not need electricity. Refer to GP 14. Disconnect the power cord. Electricity can cause death or injury. Moving parts can cause injury.

WARNING

Take care during this procedure. The drum will become hot during normal operation.

WARNING

Do not clean the stripper blade. The stripper blade is very sharp and can cause injury. If the stripper blade is dirty a new blade must be installed.

CAUTION

Do not connect the harness to the IOD PWB with the machine powered on. This may damage the IOD sensor.

CAUTION

Use care when working near the drum. The drum can be damaged easily, which will cause print quality defects.

CAUTION

Do not disconnect and reconnect the flex cables at the IOD PWB. The flex cables are easily damaged. The cable must only be handled in the area of the blue backer.

Procedure

NOTE: Before printing the jet test page, ensure that A4 or 8.5 x11 inch plain paper is loaded LEF into tray 4. Use the best quality media available. Do not use hole punched paper.

Select dC968 Head Purge. Select Print Jet Test Pages. Check the prints for missing jets, refer to IQ 1. **The prints are good.**

Y N
Perform dC968 Head Purge.

A

If the head purge does not correct the missing jets, go to 91-638-00 IOD Detects Chronic Jet Error RAP.

Perform dC969 Clean Ink Smears. Check the prints. **The prints are clean.**

Y N
Repeat dC969 until the prints are clean.

Perform dC971 Head to Head Alignment. **The routine completes successfully.**

Y N

- Clean the IOD, GP 27.
- Open the stripper blade, GP 31 and check for contamination. If the blade is contaminated, install a new stripper blade, PL 10.12 Item 3
- Check for components that could be rubbing on the drum. Correct as required.

Enter dC330 code 94-009 Drum Drive Slew speed. Select start and inspect the drum for contamination as it rotates. **The drum is clean.**

Y N
Clean the drum, GP 27.

Perform SCP 5 Final Actions

If the fault is intermittent. Check the harness under the IOD for abrasions. Repair the harness, REP 1.1 as necessary.

91-824-00 PQM Insufficient Ink RAP

91-824-00 The machine has insufficient ink to perform the print quality maintenance routine.

Procedure

WARNING

Ensure that the electricity to the machine is switched off while performing tasks that do not need electricity. Refer to GP 14. Disconnect the power cord. Electricity can cause death or injury. Moving parts can cause injury.

Perform the following:

1. Load additional ink.
2. If the fault remains, go to the 93-871-00 to 93-874-00 Ink Level Sense Error RAP.

91-825-00 PQM Insufficient Paper RAP

91-825-00 The machine has insufficient paper to perform the print quality maintenance routine.

Procedure

WARNING

Ensure that the electricity to the machine is switched off while performing tasks that do not need electricity. Refer to GP 14. Disconnect the power cord. Electricity can cause death or injury. Moving parts can cause injury.

Perform the following:

1. Load additional media into the relevant tray.
2. If the fault remains, go to the 73A Tray 3 Out of Paper RAP.

91-826-00 PQM Insufficient Jets RAP

91-826-00 Insufficient jets are available to perform the print quality maintenance routine.

Procedure

WARNING

Ensure that the electricity to the machine is switched off while performing tasks that do not need electricity. Refer to GP 14. Disconnect the power cord. Electricity can cause death or injury. Moving parts can cause injury.

Go to the 91-638-00 IOD Detects Chronic Jet Error RAP.

91-827-00 PQM Align Needed RAP

91-827-00 A head to head alignment is required before the print quality maintenance routine can be performed.

Procedure

WARNING

Ensure that the electricity to the machine is switched off while performing tasks that do not need electricity. Refer to GP 14. Disconnect the power cord. Electricity can cause death or injury. Moving parts can cause injury.

The dC971 Head to Head Alignment Adjustment is a prerequisite for the calibration that was manually requested. The previous attempt may have aborted.

Perform the following:

1. Perform dC971 Head to Head Alignment Adjustment - manual.
2. Enter dC122 Fault History. Check for device faults that prevent completion of the routine. Go to the appropriate RAP.

91-828-00 PQM Y-Dot Position Needed RAP

91-828-00 A Y dot position correction is required before the print quality maintenance routine can be performed.

Procedure

WARNING

Ensure that the electricity to the machine is switched off while performing tasks that do not need electricity. Refer to GP 14. Disconnect the power cord. Electricity can cause death or injury. Moving parts can cause injury.

The **dC972** Printhead Uniformity, option 5 Y Dot Position Correction is a prerequisite for the calibration that was manually requested. The previous attempt may have aborted.

Perform the following:

1. **dC972** Printhead Uniformity, option 5 Y Dot Position Correction. Select all printheads.
2. Enter **dC122** Fault History. Check for device faults that prevent completion of the routine. Go to the appropriate RAP.

91-829-00 PQM Drum Runout Needed RAP

91-829-00 A drum runout calibration is required before the print quality maintenance routine can be performed.

Procedure

WARNING

Ensure that the electricity to the machine is switched off while performing tasks that do not need electricity. Refer to GP 14. Disconnect the power cord. Electricity can cause death or injury. Moving parts can cause injury.

Go to the **91-637-00** Drum Runout Calibration Needed RAP.

91-830-00 PQM Uniformity Needed RAP

91-830-00 Printhead uniformity is required before the print quality maintenance routine can be performed.

Procedure

WARNING

Ensure that the electricity to the machine is switched off while performing tasks that do not need electricity. Refer to **GP 14**. Disconnect the power cord. Electricity can cause death or injury. Moving parts can cause injury.

The **dC972** Printhead Uniformity, option 3 Head to Head Uniformity is a prerequisite for the calibration that was manually requested. The previous attempt may have aborted.

Perform the following:

1. Perform **dC972** Printhead Uniformity, option 3 Head to Head Uniformity.
2. Enter **dC122** Fault History. Check for device faults that prevent completion of the routine. Go to the appropriate RAP.

91-831-00 PQM Uniformity Reset Needed RAP

91-831-00 A printhead uniformity reset is required before the print quality maintenance routine can be performed.

Procedure

WARNING

Ensure that the electricity to the machine is switched off while performing tasks that do not need electricity. Refer to **GP 14**. Disconnect the power cord. Electricity can cause death or injury. Moving parts can cause injury.

The **dC972** Printhead Uniformity, option 6 Reset Head Uniformity Data is a prerequisite for the calibration that was manually requested. The previous attempt may have aborted.

Perform the following:

1. **dC972** Printhead Uniformity, option 6 Reset Head Uniformity Data. Select all printheads.
2. **dC972** Printhead Uniformity, option 1 Printhead Uniformity - manual and select all printheads.

91-832-00 PQM Empty Waste Tray RAP

91-832-00 The waste tray must be emptied before the print quality maintenance routine can be performed.

Procedure

WARNING

Ensure that the electricity to the machine is switched off while performing tasks that do not need electricity. Refer to [GP 14](#). Disconnect the power cord. Electricity can cause death or injury. Moving parts can cause injury.

Perform the following:

1. Empty the ink waste tray and reset the waste counter.
2. Check that the machine has sufficient ink and A4 or letter size paper loaded.

If the message to empty the waste tray or the message Waste Tray not detected (missing). Insert the Waste Tray, will not clear. Perform the following steps:

1. Enter Service mode, [GP 1](#). Select Call Closeout and select Reset Waste Counter.
2. Check that the magnet is still located on the bottom of the waste tray. If necessary install a new waste tray, [PL 91.10 Item 15](#).
3. Refer to [WD 9.4](#) and check the waste tray sensor and the wiring harness. Install new components as necessary:
 - Waste tray sensor, [PL 91.05 Item 4](#).
 - Drum driver PWB, [PL 1.15 Item 4](#).

91-833-00 PQM Cleaning Pages Needed RAP

91-833-00 The cleaning pages requested by the print quality maintenance routine can not be printed.

Procedure

WARNING

Ensure that the electricity to the machine is switched off while performing tasks that do not need electricity. Refer to [GP 14](#). Disconnect the power cord. Electricity can cause death or injury. Moving parts can cause injury.

Perform the following:

1. Check that the machine has sufficient ink and A4 or letter size paper loaded.
2. Empty the ink waste tray and reset the waste counter.
3. Check that the machine is in a ready to copy state. If necessary, go to the [OF 5](#) Boot Up Failure RAP.
4. If the cleaning pages still fail to print, go to [dC968](#) Head Purge and reprint the cleaning pages.

91-834-00 PQM Tool Not Usable RAP

91-834-00 The requested print quality maintenance routine is not usable.

Procedure

WARNING

Ensure that the electricity to the machine is switched off while performing tasks that do not need electricity. Refer to GP 14. Disconnect the power cord. Electricity can cause death or injury. Moving parts can cause injury.

Perform the following:

1. Check that the machine has sufficient ink and A4 or letter size paper loaded.
2. Empty the ink waste tray.
3. Check that the machine is in a ready to copy state. If necessary, go to the OF 5 Boot Up Failure RAP.
4. Enter dC122 Fault History. Check for a new fault code. Go to the appropriate RAP.
5. Re-run the diagnostic routine that failed.

91-835-00 PQM Tool Manually Disabled RAP

91-835-00 A print quality maintenance routine has been manually disabled.

Procedure

WARNING

Ensure that the electricity to the machine is switched off while performing tasks that do not need electricity. Refer to GP 14. Disconnect the power cord. Electricity can cause death or injury. Moving parts can cause injury.

Go to the 91-636-00 IOD in Degraded Mode RAP.

91-836-00 PQM System Busy RAP

91-836-00 The print quality maintenance system is busy.

Procedure

WARNING

Ensure that the electricity to the machine is switched off while performing tasks that do not need electricity. Refer to GP 14. Disconnect the power cord. Electricity can cause death or injury. Moving parts can cause injury.

The system is currently performing a previously requested dC971 Head to Head Alignment or dC968 Head Purge. Wait for the system busy message (on the status lines) to clear and retry the aborted calibration.

91-837-00 PQM Align Calibration Needed RAP

91-837-00 PQM align stitch offset out of calibration. A head to head alignment is required before the print quality maintenance routine can be performed.

Procedure

WARNING

Ensure that the electricity to the machine is switched off while performing tasks that do not need electricity. Refer to GP 14. Disconnect the power cord. Electricity can cause death or injury. Moving parts can cause injury.

The dC971 Head to Head Alignment Adjustment is a prerequisite after heads are changed or if NVRAM reset (Reset All).

Perform the following:

1. Perform dC971 Head to Head Alignment Adjustment - manual.
2. Enter dC122 Fault History. Check for device faults that prevent completion of the routine. Go to the appropriate RAP.

91-838-00 PQM: CLD Baseline Needed RAP

91-838-00 PQM: CLD Baseline Needed. The Closed Loop Drift (CLD) baseline has not been run after installation of new printheads.

Procedure

WARNING

Ensure that the electricity to the machine is switched off while performing tasks that do not need electricity. Refer to [GP 14](#). Disconnect the power cord. Electricity can cause death or injury. Moving parts can cause injury.

CAUTION

Use care when opening the marking unit drawer when hot. Ink can spill from the ink reservoir located at the back of the drawer if opened with too much force. Ink cross-color contamination could also occur.

CAUTION

Do not touch the exposed face of the printheads. Surface contamination or minor damage can destroy the printhead. Printheads must only be cleaned by a purge cycle.

Check that the ribbon cables connecting the relevant printhead to the IME controller PWB are correctly and securely connected, and not damaged. Re-seat the ribbon cable as necessary.

The wiring is good.

Y N
Install new ribbon cables as necessary, [PL 92.10](#).

Go to [GP 7](#) to check the system grounding. The system grounding is good.

Y N
Repair any grounding faults found, [GP 7](#).

Switch off, then switch on the machine, [GP 14](#). The fault is still present.

Y N
Perform [SCP 5](#) Final Actions.

Perform [dC972](#) Head to Head Uniformity - manual. Switch off, then switch on the machine, [GP 14](#). The fault remains.

Y N
Perform [SCP 5](#) Final Actions.

Go to [WD 9.5](#), [WD 9.6](#), [WD 9.7](#), [WD 9.20](#) and [WD 9.21](#). Check all connections:

- PJ101, [Printhead PWB](#).
- PJ902, PJ904, PJ201, PJ301, [IME Controller PWB](#).

Install new components as necessary:

- Printhead, [PL 91.20](#) Item 2 or [PL 91.25](#) Item 2.
- IME controller PWB, [PL 92.10](#) Item 1

NOTE: CLD Baseline is automatically and transparently run as part of the Head to Head Uniformity routine. This will only occur once after the installation of a printhead.

91-842-00 to 91-845-00 Printhead Nvram Read or Decode Error RAP

91-842-00 Printhead 1 Nvram jet mask section read or decode error.

91-843-00 Printhead 2 Nvram jet mask section read or decode error.

91-844-00 Printhead 3 Nvram jet mask section read or decode error.

91-845-00 Printhead 4 Nvram jet mask section read or decode error.

Procedure

WARNING

Ensure that the electricity to the machine is switched off while performing tasks that do not need electricity. Refer to [GP 14](#). Disconnect the power cord. Electricity can cause death or injury. Moving parts can cause injury.

This RAP is for information only, no service action is necessary. These fault codes will be automatically cleared by the machine.

91-848-00 to 91-851-00 IOD Align Calibration Error RAP

91-848-00 IOD align calibration: X stitch measurement limit excessive X stitch was measured and the align calibration process cannot complete.

91-849-00 IOD align calibration: Y stitch measurement limit excessive Y stitch was measured and the align calibration process cannot complete.

91-850-00 IOD align calibration: X offset correction limit align calibration resulted in an X stitch correction value that is too large.

91-851-00 IOD align calibration: Y offset correction limit align calibration resulted in an Y stitch correction value that is too large.

Procedure

WARNING

Ensure that the electricity to the machine is switched off while performing tasks that do not need electricity. Refer to GP 14. Disconnect the power cord. Electricity can cause death or injury. Moving parts can cause injury.

Enter **dC612** and print TP 16. Check the stitch identification test pages. **A stitch defect is present**

Y N
Perform **SCP 5** Final Actions

Manually disable the IOD align calibration:

1. Enter **dC131** NVM read/write NVM ID 490-41 and change value to 3.
2. Enter **dC971** and start the routine.
3. Enter **dC612** and print TP 16 and check the identification test pages.

A stitch defect is present

Y N
Perform **SCP 5** Final Actions

Manually re-enable the IOD align calibration:

1. Enter **dC131** NVM read/write NVM ID 490-41 and change value to 4.
2. Enter **dC971** and start the routine.
3. Enter **dC612** and print TP 16 and check the identification test pages.

A stitch defect is present

Y N
Perform **SCP 5** Final Actions

Go to **91-698-00, 91-699-00, 91-706-00, 91-712-00, 91-718-00, 91-720-00, 91-729-00, 91-730-00, 91-732-00** IOD Excessive Head Misalignment RAP.

Enter **dC612** and print TP 16 Stitch Identification and check that the print quality is good.

If the stitch defect is still present, swap the print heads around to move the artifact to the outside of the page.

91-852-00 to 91-854-00 Y Dot Position SVD Calculation RAP

91-852-00 PQM: TRC Wait for Ypos SVD Complete.

91-853-00 PQM: Unif Wait for Ypos SVD Complete.

91-854-00 PQM: Ydp Wait for Ypos SVD Complete.

NOTE: The above codes were designed for tracking background software calibrations that run during the boot-up of the machine. No service action is required.

Procedure

WARNING

Ensure that the electricity to the machine is switched off while performing tasks that do not need electricity. Refer to GP 14. Disconnect the power cord. Electricity can cause death or injury. Moving parts can cause injury.

The above fault codes may initiate if machine activities are requested manually or automatically during the calculation process. If the faults are persistent perform the following:

1. Enter **dC122** Fault History. If necessary perform the relevant RAP.
2. Switch off, then switch on the machine, **GP 14**.
3. If the fault is still present then re-load the software, **GP 4**.

91-855-00 Thermal Safety Circuit Failure Undetected RAP

91-855-00 Thermal Safety Circuit Fail.

Procedure

WARNING

Ensure that the electricity to the machine is switched off while performing tasks that do not need electricity. Refer to GP 14. Disconnect the power cord. Electricity can cause death or injury. Moving parts can cause injury.

CAUTION

Use care when opening the marking unit drawer when hot. Ink can spill from the ink reservoir located at the back of the drawer if opened with too much force. Ink cross-color contamination could also occur.

CAUTION

Do not touch the exposed face of the printheads. Surface contamination or minor damage can destroy the printhead. Printheads must only be cleaned by a purge cycle.

The above code will initiate if there was a individual printhead thermal safety circuit failure that was unidentifiable by the IME controller PWB.

Go to the 91A Printhead Communications RAP.

91-929-00 to 91-940-00 IOD Jet Position Noise RAP

91-929-00 IOD excessive Head 1 X position noise.

91-930-00 IOD excessive Head 2 X position noise.

91-931-00 IOD excessive Head 3 X position noise.

91-932-00 IOD excessive Head 4 X position noise.

91-933-00 IOD excessive Head 1 Y position noise.

91-934-00 IOD excessive Head 2 Y position noise.

91-935-00 IOD excessive Head 3 Y position noise.

91-936-00 IOD excessive Head 4 Y position noise.

91-937-00 IOD excessive Head 1 roll position noise.

91-938-00 IOD excessive Head 2 roll position noise.

91-939-00 IOD excessive Head 3 roll position noise.

91-940-00 IOD excessive Head 4 roll position noise.

Position measurement errors (position noise) are caused by one or more pixels landing on the drum surface at a distance that is far from the expected position. This position noise causes the head to exceed the limits set for the jet position noise.

Initial Actions

WARNING

Ensure that the electricity to the machine is switched off while performing tasks that do not need electricity. Refer to GP 14. Disconnect the power cord. Electricity can cause death or injury. Moving parts can cause injury.

CAUTION

Use care when opening the marking unit drawer when hot. Ink can spill from the ink reservoir located at the back of the drawer if opened with too much force. Ink cross-color contamination could also occur.

CAUTION

Do not tilt the printhead excessively while warm. If possible, allow adequate time for the ink to solidify before removing the printhead. Once removed, rest the printhead on the screws that secure the lower (slave) circuit board.

CAUTION

The video cable (striped and labeled A, PL 92.10 Item 7) and the wave amp cable (white and labeled B, PL 92.10 Item 8) should not be interchanged at the printhead connectors. Damage to the printhead and IME controller PWB will occur if the cables are installed incorrectly

CAUTION

Do not touch the exposed face of the printheads. Surface contamination or minor damage can destroy the printhead. Printheads must only be cleaned by a purge cycle.

NOTE: The LED on upper (master) printhead circuit board indicates the presence of +3.3V.

- Check in dC122 Fault History and note the last fault code.

Procedure

Enter **dC971** Head to Head Alignment Adjustment.

Enter **dC122** Fault History and observe the last fault shown. **The fault is cleared.**

Y N

Perform **dC968** Head Purge on all 4 Heads.

Enter **dC122** Fault History and observe the last fault shown. **The fault is cleared.**

Y N

Perform **dC972** Print Head uniformity and run option 5, Y-Dot Position Correction.

Enter **dC122** Fault History and observe the last fault shown. **The fault is cleared.**

Y N

Install a new printhead as required:

- Printhead upper carriage, **PL 91.20 Item 2.**
- Printhead lower carriage, **PL 91.25 Item 2.**

Enter **dC612** Print Test Patterns. Select and print TP 16 Stitch Identification and check that print quality is good. Go to **SCP 5** Final Actions.

Enter **dC612** Print Test Patterns. Select and print TP 16 Stitch Identification and check that the print quality is good. Go to **SCP 5** Final Actions.

Enter **dC612** Print Test Patterns. Select and print TP 16 Stitch Identification and check that print quality is good. Go to **SCP 5** Final Actions.

91-941-00 to 91-944-00 PQM Too Many Purges RAP

91-941-00 PQM too many purges head1.

91-942-00 PQM too many purges head2.

91-943-00 PQM too many purges head3.

91-944-00 PQM too many purges head4.

Initial Actions

- If the customer has complained that the printing speed of the machine is slow, refer to service bulletin T7536 Troubleshooting Productivity Issues.
- If the Fault History **dC122** shows the fault code 91-638-00 perform the IOD Detects Chronic Jet Error RAP.

Procedure

WARNING

Ensure that the electricity to the machine is switched off while performing tasks that do not need electricity. Refer to GP 14. Disconnect the power cord. Electricity can cause death or injury. Moving parts can cause injury.

Go to the eCenterware page for the machine, then download the service log file from the Maintenance Assistant tab. This file will list the last 5 power on dates and print counts. **The last five power on dates occurred in the previous two weeks.**

Y N

Print the jet test pages from **dC968**. **All jets are present.**

Y N

Keep the jet test pages. Go to **IQ 9** Deletion in the process Direction RAP.

On each of the jet test pages there is a listing of the jet fix status. Refer to **Table 1** for details of the jet conditions that will result in automatic purges. **There are more than 2 jets of 3 or more colours (a total of at least 6 jets) on the same printhead, listed as either missing or chronic.**

Y N

Replace all printheads with listed bad jets, **REP 91.29**. If no jets are marked as bad, the machine has recovered, perform **SCP 5** Final Actions.

Install a new printhead as required:

- Upper printhead, **PL 91.20 Item 2.**
- Lower printhead, **PL 91.25 Item 2.**

Remove the inner cover, **PL 81.11 Item 2**. Enter **dC968**, then purge the printhead with multiple missing jets. Observe the purge routine. Print the jet test pages. **The purge sequence cleaned the printheads.**

Y N

Perform **93-933-00 to 93-936-00** Head Purge Failure RAP.

There are more than 2 jets of 3 or more colours (a total of at least 6 jets) on the same head listed as either missing or chronic.

Y N

The machine has recovered, perform **SCP 5** Final Actions.

A B

- A B
 Remove the IOD assembly, [REP 91.22](#). Inspect the IOD for contamination or malfunction.
 If necessary install a new IOD assembly [PL 94.15 Item 1](#).

Each power cycle can result in a cold purge, which will cause the waste tray to fill up at a faster rate than is customary. Confirm if the customer is turning the machine off on a regular basis. Instruct the customer that it is not necessary to turn the machine off frequently, discuss the power save option *intelligent ready* with the customer, refer to [GP 5](#) & [GP 14](#).

Table 1 Automatic purges based on printer model

Number of missing jets that trigger a proactive purge (includes chronic or masked jets for total count).				
Model Number	Colour Total	Mono Total	Mono/Colour Consecutive	Logic Operand
9301	Never	3	2	OR
9302	6	3	2	OR
9303	2	3	2	OR

91-949-00 to 91-952-00 Closed Loop Drift Baseline RAP

91-949-00 IOD CLD Baseline measurement out of range on head 1.

91-950-00 IOD CLD Baseline measurement out of range on head 2.

91-951-00 IOD CLD Baseline measurement out of range on head 3.

91-952-00 IOD CLD Baseline measurement out of range on head 4.

NOTE: The above faults are raised when the routine dC 972 option 3 Head to Head Uniformity - manual is performed and a unusually large or small measurement is obtained for the CLD baseline. The Head to Head Uniformity may be actable but the CLD baseline may abort.

Procedure

WARNING

Ensure that the electricity to the machine is switched off while performing tasks that do not need electricity. Refer to [GP 14](#). Disconnect the power cord. Electricity can cause death or injury. Moving parts can cause injury.

Check the test pattern ([TP 1](#)) that was printed for evidence of colour mixing or wrong colours. If necessary, the test pattern can be printed from [dC972](#), option 3 Head to Head Uniformity. **Colour mixing or wrong colours are evident.**

Y N

Perform in listed order the following procedures;

1. Enter [dC612](#) then print TP 12 chase pages to clean ink from the drum.
2. Enter [dC968](#) then perform the Jet test pages routine. Check for a large number of missing jets, refer to [TP 21](#).
3. dC 972 option 3 Head to Head Uniformity - manual.

The fault remains.

Y N

Perform in listed order the following [dC972](#) procedures;

1. Option 4 TRC Generation.
2. Option 5 Y Dot Position Correction, select all heads.

Check the fault history for chain 91 faults in the link code range 500-999 that have IOD in the fault name, refer to [GP 2](#) Fault Codes and History Files. As necessary perform any associated RAPs, and then clean the drum [GP 27](#).

Perform the relevant procedures;

- [IQ 14](#) Some Colours Uneven RAP.
- [IQ 15](#) Wrong Colour RAP.

91-953-00 to 91-960-00, 91-965-00 to 91-968-00 Closed Loop Drift Measurement RAP

- 91-953-00 IOD CLD Adjust measurement out of range on head 1.
- 91-954-00 IOD CLD Adjust measurement out of range on head 2.
- 91-955-00 IOD CLD Adjust measurement out of range on head 3.
- 91-956-00 IOD CLD Adjust measurement out of range on head 4.
- 91-957-00 IOD CLD Fiducial search error for head 1.
- 91-958-00 IOD CLD Fiducial search error for head 2.
- 91-959-00 IOD CLD Fiducial search error for head 3.
- 91-960-00 IOD CLD Fiducial search error for head 4.
- 91-965-00 IOD CLD Sensitivity error for head 1.
- 91-966-00 IOD CLD Sensitivity error for head 2.
- 91-967-00 IOD CLD Sensitivity error for head 3.
- 91-968-00 IOD CLD Sensitivity error for head 4.

NOTE: The above faults are raised when the routine dC 972 option 3 Head to Head Uniformity manual or automatic is performed, and a unusually large or small measurement is obtained or the image on the drum is partially missing. The routine will abort without saving changes.

Procedure

WARNING

Ensure that the electricity to the machine is switched off while performing tasks that do not need electricity. Refer to GP 14. Disconnect the power cord. Electricity can cause death or injury. Moving parts can cause injury.

Check the test pattern (TP 1) that was printed for evidence of colour mixing or wrong colours. If necessary, the test pattern can be printed from dC972, option 3 Head to Head Uniformity.

Colour mixing or wrong colours are evident.

Y N
Enter dC612 then print TP 12 chase pages to clean ink from the drum, then run dC972 option 3 Head to Head Uniformity - automatic. **The fault remains.**

Y N
Print new test patterns from dC972, option 3. **The quality of the prints is good.**

- Y N
Perform in listed order the following dC972 routines;
1. Option 6 Reset Head Uniformity Data.
 2. Option 3 Head to Head Uniformity - Manual.
 3. Option 4 TRC Generation.
 4. Option 5 Y Dot Position Correction - select all heads.

A B C

A B C

Print new test patterns from dC972, option 3. **The print quality is good.**

Y N
Install a new printhead, PL 91.20 Item 2, PL 91.25 Item 2.

Go to SCP 5 Final Actions

Go to SCP 5 Final Actions

Enter dC968 then perform the Jet test pages routine. Check for a large number of missing jets, refer to TP 21.

Check the fault history for chain 91 faults in the link code range 500-999 that have IOD in the fault name, refer to GP 2 Fault Codes and History Files. As necessary perform any associated RAPs, and then clean the drum GP 27.

Perform the relevant procedures;

- IQ 14 Some Colours Uneven RAP
- IQ 15 Wrong Colour RAP

91-970-00 to 91-981-00 Printhead Reservoir and Jet Stack Heater Unstable RAP

91-970-00 Head 1 right jet stack heater went unstable while printing.

91-971-00 Head 2 right jet stack heater went unstable while printing.

91-972-00 Head 3 right jet stack heater went unstable while printing.

91-973-00 Head 4 right jet stack heater went unstable while printing.

91-974-00 Head 1 left jet stack heater went unstable while printing.

91-975-00 Head 2 left jet stack heater went unstable while printing.

91-976-00 Head 3 left jet stack heater went unstable while printing.

91-977-00 Head 4 left jet stack heater went unstable while printing.

91-978-00 Head 1 reservoir heater went unstable while printing.

91-979-00 Head 2 reservoir heater went unstable while printing.

91-980-00 Head 3 reservoir heater went unstable while printing.

91-981-00 Head 4 reservoir heater went unstable while printing.

Procedure

WARNING

Ensure that the electricity to the machine is switched off while performing tasks that do not need electricity. Refer to [GP 14](#). Disconnect the power cord. Electricity can cause death or injury. Moving parts can cause injury.

Go to [WD 9.4](#). Check that the marking unit cooling fan is running, [Figure 1](#). The fan is running.

Y N

Go to [WD 9.4](#). Check the marking unit cooling fan.

Refer to:

- [OF 6](#) Fans and Air Systems RAP
- [GP 10](#), How to Check a Motor.
- PJ901, [Drum Driver PWB](#).
- [01E](#) +12V Distribution RAP.
- [01L](#) 0V Distribution RAP

Install new components as necessary:

- Marking unit fan, [PL 1.15 Item 23](#).
- Drum driver PWB, [PL 1.15 Item 4](#).

Enter [dC335](#) Heater Monitor and Exerciser, then run the relevant Test. The test is good.

Y N

Check the PEST fault history, [dC123](#) for marking unit heater faults (umbilicals, printheads and ink melt reservoir). All marking unit heaters have failed.

Y N

Refer to:

- [01A](#) AC Power Distribution RAP, Head 1 to 4 Reservoir and Jet stack Heater Checks.

A B

- [01B](#) +3.3V ESTAR Distribution RAP.
- [01L](#) 0V Distribution RAP.

Install new components as necessary:

- Lower carriage harness, [PL 91.25 Item 12](#) or upper carriage harness, [PL 91.20 Item 12](#).
- Marking unit heater PWB, [PL 92.10 Item 5](#).

Refer to [WD 1.1](#) and [WD 9.8](#), check the wiring between PJ4AC on the [Power Supply Unit](#) and PJ101 on the [Marking Unit Heater PWB](#). The wiring is good.

Y N

Repair the wiring, [REP 1.1](#).

Check the +3.3V ESTAR distribution to the marking unit heater PWB, refer to the [01B](#) +3.3V ESTAR Distribution RAP. If the fault is still present, install new components as necessary:

- Marking unit heater PWB cable, [PL 92.10 Item 12](#).
- Marking unit heater PWB, [PL 92.10 Item 5](#).
- Power supply unit, [PL 1.15 Item 2](#).

The fault may be intermittent. Go to [WD 9.8](#). Check for loose connections between:

- The marker unit driver PWB and the relevant printhead.

Refer to:

- PJ701, [Marking unit heater PWB](#)

If the fault persists, install new components as necessary:

- Lower carriage harness, [PL 91.25 Item 12](#) or Upper carriage harness, [PL 91.20 Item 12](#).
- Printhead upper, [PL 91.20 Item 2](#) or Printhead lower, [PL 91.25 Item 2](#).
- Marking unit heater PWB, [PL 92.10 Item 5](#)

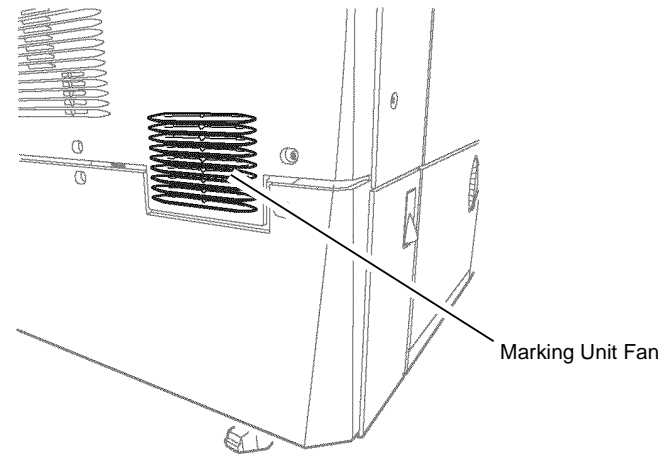

Figure 1 Component Location

U-1-1649-A

91A Printhead Communications RAP

This RAP gives additional information on printhead communication problems. Perform the RAP for all current fault codes before this RAP is performed.

Initial Actions

WARNING

Ensure that the electricity to the machine is switched off while performing tasks that do not need electricity. Refer to [GP 14](#). Disconnect the power cord. Electricity can cause death or injury. Moving parts can cause injury.

CAUTION

Use care when opening the marking unit drawer when hot. Ink can spill from the ink reservoir located at the back of the drawer if opened with too much force. Ink cross-color contamination could also occur.

CAUTION

Do not touch the exposed face of the printheads. Surface contamination or minor damage can destroy the printhead. Printheads must only be cleaned by a purge cycle.

- Check the harness leading to the indicated printhead.
- Check for damage to surrounding harnesses.

Procedure

Check that the ribbon cables connecting the printheads to the wave amp PWB and IME controller PWB are securely connected and not damaged. Re-seat the ribbon cables as necessary. **The wiring is securely connected and undamaged.**

Y N

Repair or replace the damaged cables as necessary, [REP 1.1](#).

Check and note the voltages at the test points on the IME controller PWB, [Figure 1](#). **All 4 test points read +3.2V.**

Y N

- If any test point reads +2.1V install a new video cable, [PL 92.10 Item 7](#), for the indicated printhead.
- If any test point reads 0V check the PEST error log for error 99-395-00. If error 99-395-00 is found switch off the machine, [GP 14](#), then disconnect the heater harness to the affected printhead, [Figure 2](#). Switch on the machine and check the test point for the affected printhead. If the voltage is still 0V then install a new printhead, [PL 91.20 Item 2](#), [PL 91.25 Item 2](#).

NOTE: Ignore any error messages associated with the disconnected heater harness.

- If any test point reads +0.3V go to [dC335](#) and check all set point mode temperatures for the suspect printhead. Look for non responsive heaters, irregular temperature fluctuations or other symptoms that would indicate a thermistor error on the printhead. If necessary compare the results of the suspect printhead with temperatures reported from a known good printhead. If thermistor errors are detected install a new printhead, [PL 91.20 Item 2](#), [PL 91.25 Item 2](#).

Check the system grounding, [GP 7](#). **The grounding is good.**

Y N

Repair any grounding issues found, [GP 7](#).

Install new components as necessary:

- Printhead, [PL 91.20 Item 2](#) or [PL 91.25 Item 2](#).
- IME controller PWB, [PL 92.10 Item 1](#).
- Quad wave amp PWB, [PL 92.10 Item 3](#).

NOTE: Calibration of the registration / preheat assembly, [dC625](#) is only required when:

- The registration / preheat assembly is removed or replaced,
- The horizontal transport assembly is removed or replaced.

Calibration of the registration / preheat assembly is **NOT** required when:

- A printhead is replaced.
- The IOD assembly is removed or replaced.

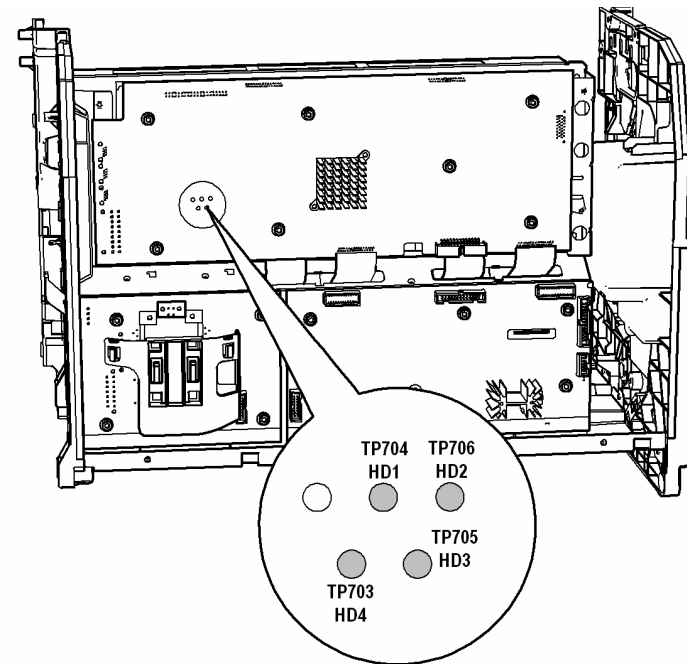

U-1-1548-A

Figure 1 IME controller PWB test points

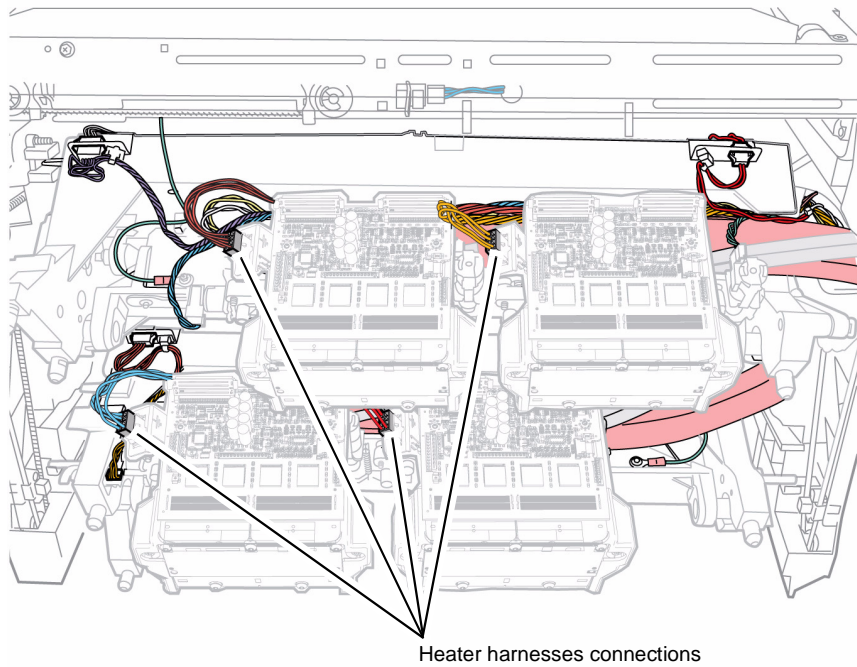

U-1-1549-A

Figure 2 Heater harness connections to printheads

92-501-00 to 92-504-00, 92-519-00 Serial Link Safety Transient RAP

92-501-00 MpSerialLinkSafetyTransient.

92-502-00 MuSerialLinkSafetyTransient.

92-503-00 MuidSerialLinkSafetyTransient.

92-504-00 DDSerialLinkSafetyTransient.

92-519-00 PsSerialLinkDownTransient.

Procedure

WARNING

Ensure that the electricity to the machine is switched off while performing tasks that do not need electricity. Refer to [GP 14](#). Disconnect the power cord. Electricity can cause death or injury. Moving parts can cause injury.

Perform the following:

1. Switch off then switch on the machine, [GP 14](#).

92-505-00, 92-506-00 Marking Unit Communications Error RAP

92-505-00 Marker unit communications failure

92-506-00 Marker unit communications failure

Initial Actions

WARNING

Ensure that the electricity to the machine is switched off while performing tasks that do not need electricity. Refer to [GP 14](#). Disconnect the power cord. Electricity can cause death or injury. Moving parts can cause injury.

- If the fault 92-505-00 is accompanied by 92-510-00 and 92-575-00. Check for a loss of connection on the cable between the IME controller and the marking unit driver PWB.

Procedure

Go to [WD 9.7](#) and [WD 9.10](#). Check for loose connections between:

- The IME controller PWB and the marking unit driver PWB.

Refer to:

- PJ903, [IME controller PWB](#).
- PJ203, [Marking unit driver PWB](#).

If the fault persists, install new components as necessary:

- Marking unit driver PWB cable (PJ203), [PL 92.10 Item 14](#).
- IME controller PWB, [PL 92.10 Item 1](#).
- Marking unit driver PWB, [PL 92.10 Item 4](#).

92-510-00, 92-511-00 Marking Unit Ink Delivery Communications Error RAP

92-510-00 Ink delivery communications failure on marking unit driver PWB.

92-511-00 Ink delivery communications failure on marking unit driver PWB.

Initial Actions

WARNING

Ensure that the electricity to the machine is switched off while performing tasks that do not need electricity. Refer to [GP 14](#). Disconnect the power cord. Electricity can cause death or injury. Moving parts can cause injury.

- If the fault 92-510-00 is accompanied by 92-505-00 and 92-575-00. Check for a loss of connection on the cable between the IME controller and the marking unit driver PWB. Go to [92-505-00](#), [92-506-00](#) Marking Unit Communications Error RAP.

Procedure

Check for loose connections on the marking unit driver PWB. If the fault persists, install new components as necessary:

- Marking unit driver PWB, [PL 92.10 Item 4](#).

92-515-00, 92-516-00 Drum Driver Communications Error RAP

92-515-00 Drum driver communications failure

92-516-00 Drum driver communications error

Procedure

WARNING

Ensure that the electricity to the machine is switched off while performing tasks that do not need electricity. Refer to [GP 14](#). Disconnect the power cord. Electricity can cause death or injury. Moving parts can cause injury.

Go to [WD 9.2](#) and [WD 9.6](#). Check for loose connections between the drum driver PWB and the IME controller PWB, refer to:

- PJ403, [IME controller PWB](#).
- PJ603, [Drum driver PWB](#).

If the fault persists, install new components as necessary:

- IME controller PWB, [PL 92.10 Item 1](#).
- Drum driver PWB, [PL 1.15 Item 4](#).

92-520-00 Power Supply Communications Error RAP

92-520-00 Power supply communications error

Procedure

WARNING

Ensure that the electricity to the machine is switched off while performing tasks that do not need electricity. Refer to [GP 14](#). Disconnect the power cord. Electricity can cause death or injury. Moving parts can cause injury.

Go to [WD 9.4](#) and [WD 1.4](#). Check the connections between the PJ902 on the [drum driver PWB](#) and PJDC2 on the [power supply Unit](#).

If the fault persists, install new components as necessary:

- Drum driver power supply interface cable, [PL 1.15 Item 10](#).
- Drum driver PWB, [PL 1.15 Item 4](#).
- Power supply unit, [PL 1.15 Item 2](#).

92-525-00, 92-526-00 Media Path Communications Error RAP

92-525-00 Media path communications failure

92-526-00 Media path communications error

Initial Actions

WARNING

Ensure that the electricity to the machine is switched off while performing tasks that do not need electricity. Refer to [GP 14](#). Disconnect the power cord. Electricity can cause death or injury. Moving parts can cause injury.

- Check the MU Drawer service loop harness for damage, [PL 92.10 Item 9](#).

Procedure

Go to [WD 8.4](#) and [WD 9.5](#). Check for bad wiring between PJ402, on the [IME controller PWB](#) and PJ408 on the [Media path driver PWB](#).

If the fault persists, install new components as necessary:

- Media path driver PWB, [PL 1.15 Item 5](#).
- IME controller PWB, [PL 92.10 Item 1](#).

92-530-00 3TM Serial Link Error RAP

92-530-00 Three trays module serial link error.

Procedure

WARNING

Ensure that the electricity to the machine is switched off while performing tasks that do not need electricity. Refer to [GP 14](#). Disconnect the power cord. Electricity can cause death or injury. Moving parts can cause injury.

Go to [WD 8.2](#) and [WD 7.3](#). Check the wiring between:

- The media path driver PWB and the 3 tray module (3TM) PWB.

Refer to:

- PJ950, [3TM PWB](#).
- PJ401, [Media path driver PWB](#).

If the fault persists, install new components as necessary:

- 3 Tray module PWB, [PL 73.16 Item 4](#).
- Media path driver PWB, [PL 1.15 Item 5](#).

92-531-00 Paper Tray Module Communications Error RAP

92-531-00 Paper tray module (3TM) communication error.

Procedure

WARNING

Ensure that the electricity to the machine is switched off while performing tasks that do not need electricity. Refer to [GP 14](#). Disconnect the power cord. Electricity can cause death or injury. Moving parts can cause injury.

Go to [92-530-00](#) 3TM Serial Link Error RAP.

92-535-00, 92-536-00 Tray 5 Communications Error RAP

92-535-00 Tray 5 control PWB serial communications error.

92-536-00 Tray 5 communications error.

Procedure

WARNING

Ensure that the electricity to the machine is switched off while performing tasks that do not need electricity. Refer to [GP 14](#). Disconnect the power cord. Electricity can cause death or injury. Moving parts can cause injury.

Go to [WD 7.1](#). and [WD 8.4](#). Check for loose connections between:

- The tray 5 control PWB and the media path driver PWB.

Refer to:

- PJ502, PJ513, [Media path driver PWB](#).
- PJ704, [Marking unit driver PWB](#).

If the fault persists, install new components as necessary:

- Tray 5 control PWB, [PL 75.68 Item 8](#).
- Media path driver PWB, [PL 1.15 Item 5](#).

92-541-00 ADC Interrupt Storm Fault RAP

92-541-00 ADC interrupt storm.

Initial Actions

WARNING

Ensure that the electricity to the machine is switched off while performing tasks that do not need electricity. Refer to [GP 14](#). Disconnect the power cord. Electricity can cause death or injury. Moving parts can cause injury.

- Switch off the machine, then switch on the machine, [GP 14](#).

Procedure

Perform the steps that follow before installing a new IME controller PWB, [PL 92.10 Item 1](#).

Remove and reinsert the following communication connectors. There should be a click when the connector is correctly seated.

- Move the marking unit to the maintenance position, [GP 6](#). Four connectors on the [IME controller PWB](#) PJ201, PJ301, PJ401, PJ402, [WD 9.5](#).

If the problem continues then reseal the print head data cables (marked with letter A). If this is a hard failure then try reseating or install new print head data cables, one at a time. Look for faults 91-519-00 to 91-522-00, 91-660-00 to 91-667 and 91-523-00 to 91-546-00 may help to isolate which head cable has a problem. Install new components as necessary, [PL 92.10](#).

92-542-00 PS Interrupt Storm Fault RAP

92-542-00 PS interrupt storm.

Initial Actions

WARNING

Ensure that the electricity to the machine is switched off while performing tasks that do not need electricity. Refer to GP 14. Disconnect the power cord. Electricity can cause death or injury. Moving parts can cause injury.

- Switch off the machine, then switch on the machine, GP 14.

Procedure

Perform the following:

1. Install a new power supply unit, PL 1.15 Item 2.
2. If the fault persists, install a new IME controller PWB, PL 92.10 Item 1.

92-543-00, 92-544-00 MU Interrupt Storm Faults RAP

92-543-00 MU interrupt storm.

92-544-00 MUID interrupt storm.

Initial Actions

WARNING

Ensure that the electricity to the machine is switched off while performing tasks that do not need electricity. Refer to GP 14. Disconnect the power cord. Electricity can cause death or injury. Moving parts can cause injury.

- Switch off the machine, then switch on the machine, GP 14.

Procedure

Install a new marking unit driver PWB, PL 92.10 Item 4.

92-545-00 DD Interrupt Storm Fault RAP

92-545-00 DD interrupt storm.

Initial Actions

WARNING

Ensure that the electricity to the machine is switched off while performing tasks that do not need electricity. Refer to GP 14. Disconnect the power cord. Electricity can cause death or injury. Moving parts can cause injury.

- Switch off the machine, then switch on the machine, GP 14.

Procedure

Install a new drum driver PWB, PL 1.15 Item 4.

92-546-00, 92-547-00 MP Interrupt Storm Faults RAP

92-546-00 MP interrupt storm.

92-547-00 IMD interrupt storm.

Initial Actions

WARNING

Ensure that the electricity to the machine is switched off while performing tasks that do not need electricity. Refer to GP 14. Disconnect the power cord. Electricity can cause death or injury. Moving parts can cause injury.

- Switch off the machine, then switch on the machine, GP 14.

Procedure

Install a new media path PWB, PL 1.15 Item 5.

92-548-00 TTM Interrupt Storm Fault RAP

92-548-00 TTM interrupt storm.

Initial Actions

WARNING

Ensure that the electricity to the machine is switched off while performing tasks that do not need electricity. Refer to [GP 14](#). Disconnect the power cord. Electricity can cause death or injury. Moving parts can cause injury.

- Switch off the machine, then switch on the machine, [GP 14](#).

Procedure

Perform the following:

1. Refer to [WD 7.3](#) and [WD 8.2](#). Check the wiring between PJ401 on [media path driver PWB](#) and PJ950 on [3 tray module PWB](#). Ensure the connectors are seated correctly. Repair the wiring as necessary, [REP 1.1](#).
2. Install new components as necessary:
 - Media path driver PWB to tray 3 module harness, [PL 1.15 Item 21](#).
 - Media path driver PWB, [PL 1.15 Item 5](#).

92-549-00 PFP Interrupt Storm Fault RAP

92-549-00 PFP (Tray 5) interrupt storm.

Initial Actions

WARNING

Ensure that the electricity to the machine is switched off while performing tasks that do not need electricity. Refer to [GP 14](#). Disconnect the power cord. Electricity can cause death or injury. Moving parts can cause injury.

- Switch off the machine, then switch on the machine, [GP 14](#).

Procedure

Perform the following:

1. Refer to [WD 7.1](#) and [WD 8.4](#). Check the wiring between PJ704 on [media path driver PWB](#) and PJ502 on the [tray 5 control PWB](#). Ensure the connectors are seated correctly. Repair the wiring as necessary, [REP 1.1](#).
2. If necessary, install a new media path driver PWB, [PL 1.15 Item 5](#).

92-551-00 CIS Interrupt Storm Fault RAP

92-551-00 CIS interrupt storm.

Initial Actions

WARNING

Ensure that the electricity to the machine is switched off while performing tasks that do not need electricity. Refer to **GP 14**. Disconnect the power cord. Electricity can cause death or injury. Moving parts can cause injury.

- Switch off the machine, then switch on the machine, **GP 14**.

Procedure

Perform the following:

1. Check the following wiring. Ensure the connectors are seated correctly. Repair the wiring as necessary, **REP 1.1**.
 - a. Refer to **WD 8.6** and **WD 9.2**. Between PJ2 on the **registration / preheat Interface PWB** and PJ701 on the **drum driver PWB**. Between PJ1 on the **registration / preheat interface PWB** and the registration scan bar, **PL 88.10 Item 2**. If necessary, install a new drum driver MR sensor harness, **PL 1.15 Item 9**.
 - b. Refer to **WD 9.1** and **WD 9.22**. Between PJ101 on the **drum driver PWB** and PJ1 on the **IOD pre amp PWB**. Between PJ2 on the **IOD pre amp PWB** and the IOD scan bar, **PL 94.15**. If necessary, install a new IOD to drum driver PWB cable, **PL 94.15 Item 5**.
2. If necessary, install a new drum driver PWB, **PL 1.15 Item 4**.

92-550-00, 92-555-00 System Timer Error RAP

92-550-00 Safety timer time out.

92-555-00 System timer skipped.

Initial Actions

WARNING

Ensure that the electricity to the machine is switched off while performing tasks that do not need electricity. Refer to **GP 14**. Disconnect the power cord. Electricity can cause death or injury. Moving parts can cause injury.

- Switch off the machine, then switch on the machine, **GP 14**.

Procedure

Re-install the machine software, **GP 4**. **The fault remains.**

Y **N**
| Perform **SCP 5** Final Actions.

Install a new IME control PWB, **PL 92.10 Item 1**.

92-552-00 SBC Interrupt Storm Fault RAP

92-552-00 SBC interrupt storm.

Initial Actions

WARNING

Ensure that the electricity to the machine is switched off while performing tasks that do not need electricity. Refer to [GP 14](#). Disconnect the power cord. Electricity can cause death or injury. Moving parts can cause injury.

- Switch off the machine, then switch on the machine, [GP 14](#).

Procedure

Perform the following:

1. Refer to [WD 3.3](#) and [WD 8.2](#). Check the ribbon cable between PJ402 on the [media path driver PWB](#) and PJ20 on the [single board controller PWB](#). Ensure the connectors are seated correctly.
2. If necessary, install a new media path driver PWB, [PL 1.15 Item 5](#).

92-554-00 AC Line Failed RAP

92-554-00 The AC power cord has been disconnected or the AC supply has failed.

Initial Actions

WARNING

Ensure that the electricity to the machine is switched off while performing tasks that do not need electricity. Refer to [GP 14](#). Disconnect the power cord. Electricity can cause death or injury. Moving parts can cause injury.

- Check that the AC power cord is correctly connected.

Procedure

Go to the [01A AC Power Distribution RAP](#).

92-556-00, 92-557-00, 92-558-00, 92-559-00 ECM Failure RAP

92-556-00 ECM PCI access failure.

92-557-00 ECM ADC failed.

92-558-00 ECM PS line cross failed.

92-559-00 ECM FPGA access error.

Initial Actions

Switch Off the machine then switch On the Machine, [GP 14](#).

Procedure

WARNING

Ensure that the electricity to the machine is switched off while performing tasks that do not need electricity. Refer to [GP 14](#). Disconnect the power cord. Electricity can cause death or injury. Moving parts can cause injury.

Check the wiring and connectors to the IME control PWB. The wiring and connectors are good.

Y N

Repair the wiring, Go to [REP 1.1](#).

Install a new IME control PWB, [PL 92.10 Item 1](#).

92-560-00, 92-561-00 Marking Unit Firmware Version Mismatch RAP

92-560-00 Marking unit firmware version mismatch.

92-561-00 Marking unit firmware version mismatch.

Procedure

WARNING

Ensure that the electricity to the machine is switched off while performing tasks that do not need electricity. Refer to [GP 14](#). Disconnect the power cord. Electricity can cause death or injury. Moving parts can cause injury.

Install a new marking unit driver PWB, [PL 92.10 Item 4](#).

92-562-00 Drum Driver Firmware Version Mismatch RAP

92-562-00 Drum driver firmware version mismatch.

Procedure

WARNING

Ensure that the electricity to the machine is switched off while performing tasks that do not need electricity. Refer to **GP 14**. Disconnect the power cord. Electricity can cause death or injury. Moving parts can cause injury.

Install a new drum driver PWB, **PL 1.15** Item 4.

92-563-00 Power Supply Firmware Version Mismatch RAP

92-563-00 IME power supply firmware version mismatch.

Procedure

WARNING

Ensure that the electricity to the machine is switched off while performing tasks that do not need electricity. Refer to **GP 14**. Disconnect the power cord. Electricity can cause death or injury. Moving parts can cause injury.

Install a new power supply unit, **PL 1.15** Item 2.

92-564-00 Media Path Firmware Version Mismatch RAP

92-564-00 Media path firmware version mismatch.

Procedure

WARNING

Ensure that the electricity to the machine is switched off while performing tasks that do not need electricity. Refer to **GP 14**. Disconnect the power cord. Electricity can cause death or injury. Moving parts can cause injury.

Install a new media path driver PWB, **PL 1.15 Item 5**.

92-565-00 3TM Firmware Version Mismatch RAP

92-565-00 3 trays module firmware version mismatch.

Procedure

WARNING

Ensure that the electricity to the machine is switched off while performing tasks that do not need electricity. Refer to **GP 14**. Disconnect the power cord. Electricity can cause death or injury. Moving parts can cause injury.

Install a new 3 tray module PWB, **PL 73.16 Item 4**.

92-566-00 Tray 5 Firmware Version Mismatch RAP

92-566-00 Paper feeder platform firmware version mismatch.

Procedure

WARNING

Ensure that the electricity to the machine is switched off while performing tasks that do not need electricity. Refer to **GP 14**. Disconnect the power cord. Electricity can cause death or injury. Moving parts can cause injury.

Install a new tray 5 control PWB, **PL 75.68 Item 8**.

92-567-00 ECM FPGA Version Mismatch RAP

92-567-00 ECM FPGA Version Mismatch. The IME and CCS software is incompatible.

Procedure

WARNING

Ensure that the electricity to the machine is switched off while performing tasks that do not need electricity. Refer to **GP 14**. Disconnect the power cord. Electricity can cause death or injury. Moving parts can cause injury.

A software upgrade must be performed, **GP 4** Machine Software.

92-568-00 ECM Initialization Error RAP

92-568-00 IME controls did not initialize correctly.

Initial Actions

WARNING

Ensure that the electricity to the machine is switched off while performing tasks that do not need electricity. Refer to GP 14. Disconnect the power cord. Electricity can cause death or injury. Moving parts can cause injury.

- Switch off the machine, then switch on the machine, GP 14.

Procedure

Install a new IME controller PWB, PL 92.10 Item 1.

92-569-00 Image FPGA Version Mismatch RAP

92-569-00 Image FPGA version mismatch.

Initial Actions

WARNING

Ensure that the electricity to the machine is switched off while performing tasks that do not need electricity. Refer to GP 14. Disconnect the power cord. Electricity can cause death or injury. Moving parts can cause injury.

- Switch off the machine, then switch on the machine, GP 14.
- The fault will occur if the IME controller PWB was replaced with an incompatible version of software on it.

Procedure

Re-install the machine software, GP 4. **The fault remains.**

Y N
| Perform SCP 5 Final Actions.

Install a new IME controller PWB, PL 92.10 Item 1.

92-570-00 Interrupt Storm Fault RAP

92-570-00 Interrupt storm fault.

Initial Actions

WARNING

Ensure that the electricity to the machine is switched off while performing tasks that do not need electricity. Refer to [GP 14](#). Disconnect the power cord. Electricity can cause death or injury. Moving parts can cause injury.

- Switch off the machine, then switch on the machine, [GP 14](#).

Procedure

Perform the steps that follow before installing a new IME controller PWB, [PL 92.10 Item 1](#).

Remove and reinsert the following communication connectors. There should be a click when the connector is correctly seated.

- PJ16 on the [single board controller PWB](#), [WD 3.2](#).
- The RJ45 type in line connector (part of the service loop), [WD 9.5](#) located behind the lower rear cover to the right of the power supply unit.

If the problem continues then install a new service loop, [PL 92.10 Item 9](#).

92-571-00 Software Error RAP

92-571-00 Software error.

Initial Actions

WARNING

Ensure that the electricity to the machine is switched off while performing tasks that do not need electricity. Refer to [GP 14](#). Disconnect the power cord. Electricity can cause death or injury. Moving parts can cause injury.

- Switch off the machine, then switch on the machine, [GP 14](#).

Procedure

If the fault is still present, install a new IME controller PWB, [PL 92.10 Item 1](#).

92-575-00 ADC Out of Range RAP

92-575-00 Analog to digital conversion of thermistor readings inconsistent with expected value.

Initial Actions

WARNING

Ensure that the electricity to the machine is switched off while performing tasks that do not need electricity. Refer to GP 14. Disconnect the power cord. Electricity can cause death or injury. Moving parts can cause injury.

- Check the PEST log history dC123 to determine which thermistor is at fault.
- If the fault 92-575-00 is accompanied by 92-505-00 and 92-510-00. Check for a loss of connection on the cable between the IME controller and the marking unit driver PWB. Go to 92-505-00, 92-506-00 Marking Unit Communications Error RAP.

Procedure

If a PEST code is available then go the appropriate RAP. Install new components as required.

92-579-00 CDI Submit Sheet Error RAP

92-579-00 A CDI submit sheet error has been detected.

Initial Actions

WARNING

Ensure that the electricity to the machine is switched off while performing tasks that do not need electricity. Refer to GP 14. Disconnect the power cord. Electricity can cause death or injury. Moving parts can cause injury.

- Switch off the machine, then switch on the machine, GP 14.

Procedure

Re-install the machine software, GP 4.

92-581-00 Image Transfer Error RAP

92-581-00 Image transfer failure from Single board controller PWB to IME controller PWB.

Procedure

WARNING

Ensure that the electricity to the machine is switched off while performing tasks that do not need electricity. Refer to [GP 14](#). Disconnect the power cord. Electricity can cause death or injury. Moving parts can cause injury.

- Go to [WD 9.5](#) and [WD 3.1](#). Check for loose connections between the IME controller PWB and the single board controller PWB. Refer to:
 - PJ401, [IME controller PWB](#).
 - PJ5, [Single board controller PWB](#).
- Check the following components for damage:
 - Service loop, [PL 92.10 Item 9](#).
 - Check the RJ45 type in-line connector between PJ401 on [IME controller PWB](#) and PJ5 on [single board controller PWB](#). The connector is behind the rear cover [PL 70.25 Item 8](#) on the 3 tray module to the right of the marking unit cooling fan, [PL 1.15 Item 23](#).
 - Check all ground connections in this area, refer to [GP 7](#).
- Re-install the machine software, [GP 4](#).
- If the fault persists, install new components as necessary:
 - Service loop, [PL 92.10 Item 9](#).
 - Single board controller PWB, [PL 3.11 Item 13](#).
 - IME controller PWB, [PL 92.10 Item 1](#).

92-583-00 Cold Temperature Boot Time-out RAP

92-583-00 Cold temperature boot time-out.

Initial Actions

WARNING

Ensure that the electricity to the machine is switched off while performing tasks that do not need electricity. Refer to [GP 14](#). Disconnect the power cord. Electricity can cause death or injury. Moving parts can cause injury.

- Switch off the machine, then switch on the machine, [GP 14](#).

Procedure

Ensure the ambient temperature in the room is above 6 degrees C.

If the machine temperature is above 5 degrees C and the 92-583 fault occurs, it would indicate that the reservoir thermistor is at fault. Refer to [WD 9.16](#). Install new components as required:

- Solenoid Patch PWB, [PL 93.10 Item 9](#).
- Reservoir, [PL 93.10 Item 10](#).

92-585-00 LVDS Contone Terminal Error During Image Transfer RAP

92-585-00 LVDS contone terminal error during image transfer.

Initial Actions

WARNING

Ensure that the electricity to the machine is switched off while performing tasks that do not need electricity. Refer to [GP 14](#). Disconnect the power cord. Electricity can cause death or injury. Moving parts can cause injury.

- Check the MU Drawer service loop, [PL 92.10 Item 9](#) for damage.
- Check all ground connections in this area, refer to [GP 7](#).

Procedure

1. Go to [WD 9.5](#) and [WD 3.1](#). Check for loose connections between the IME controller PWB and the single board controller PWB. Refer to:
 - PJ401, [IME controller PWB](#).
 - PJ5, [Single board controller PWB](#).
2. Reseat the printhead ribbon cables, refer to [REP 91.29](#).
3. If the fault persists, install new components as necessary:
 - IME controller PWB, [PL 92.10 Item 1](#).
 - Single board controller PWB, [PL 3.11 Item 13](#).

92-586-00 Print Engine Speed Fault RAP

92-586-00 The print engine is running at default speed.

Procedure

WARNING

Ensure that the electricity to the machine is switched off while performing tasks that do not need electricity. Refer to [GP 14](#). Disconnect the power cord. Electricity can cause death or injury. Moving parts can cause injury.

- Switch off the machine, then switch on the machine, [GP 14](#).

92-598-00, 92-599-00, 92-600-00, 92-610-000 to 92-614-00, IME NVRAM Error RAP

Critical system settings have been reset to their default values. The system can continue operating, but requires manual configuration to custom settings.

92-598-00 NVM dynamic data corrupted.

92-599-00 NVM system constants corrupted.

92-600-00 NVM critical settings corrupted.

92-598-00 to 92-600-00 faults are raised during initialization if the CRC values for the described section of the IME NVRAM are invalid. When this occurs, the IME sets defaults values.

92-610-00 EngNvNewMagic Invalid - NVM magic number detected by IME.

92-611-00 EngNvNewFormat - Invalid NVM format number detected by IME

92-610-00 and 92-611-00 faults are raised during initialization if the data ID for the magic number or format number is not the expected value. When this occurs, the IME sets defaults values.

92-612-00 EngNvCDIFactoryReset - IOT CDI NVM factory init has been performed.

92-613-00 EngNvCDISystemReset - IOT CDI NVM system init has been performed.

92-614-00 EngNvCDIUserReset - IOT CDI NVM user init has been performed.

92-612-00 to 92-614-00 faults are raised when a **dC301** is sent to the IME for a factory, system or user initialization. When this occurs, the IME sets defaults values.

Procedure

WARNING

Ensure that the electricity to the machine is switched off while performing tasks that do not need electricity. Refer to GP 14. Disconnect the power cord. Electricity can cause death or injury. Moving parts can cause injury.

These faults are for information only. If a service action is required, a separate fault code will be raised.

92-803-00, 92-804-00 DSP2 Overlay Error RAP

92-803-00 DSP2 overlay setup time-out.

92-804-00 DSP2 overlay cleanup time-out.

These faults are raised when a DSP2 motor is enabled during IOD calibration.

NOTE: The DSP2 motors are:

- Tray 1 feed/elevator motor.
- Tray 2 feed/elevator motor.
- Tray 3 feed motor.
- Tray 5 feed motor.
- Tray 5 transport motor.
- Cleaning unit motor.
- Front transfix motor.
- Rear transfix motor.

Procedure

WARNING

Ensure that the electricity to the machine is switched off while performing tasks that do not need electricity. Refer to GP 14. Disconnect the power cord. Electricity can cause death or injury. Moving parts can cause injury.

Switch off the machine, then switch on the machine, **GP 14**.

92-805-00 Fuse A Blown RAP

92-805-00 Fuse A on the drum driver PWB has blown.

Procedure

WARNING

Ensure that the electricity to the machine is switched off while performing tasks that do not need electricity. Refer to [GP 14](#). Disconnect the power cord. Electricity can cause death or injury. Moving parts can cause injury.

Check fuse A for continuity.

NOTE: The fuse is located below PJ601 on the *drum driver PWB* and is marked F602. The fuse is non-reparable.

Fuse A is blown.

Y N
Go to [WD 9.2](#). +24V is available PJ602, pin 12.
Y N
Go to [WD 1.5](#). +24V is available at PJDC3, pin 15.
Y N
Go to [01-525-00](#) +24V, +/-12V, +5V Short Circuit and Overload RAP and check for a short circuit.
Check the wiring between the power supply unit, [PL 1.15 Item 2](#), and the drum driver PWB, [PL 1.15 Item 4](#), for an open circuit. **The wiring is good.**
Y N
Repair the wiring as necessary, [REP 1.1](#).
Install a new power supply unit, [PL 1.15 Item 2](#).
Go to [WD 9.2](#) and [WD 9.6](#). Check the wiring between PJ603 on the *drum driver PWB* and PJ403 on the *IME controller PWB*. **The wiring is good.**
Y N
Repair the wiring as necessary, [REP 1.1](#).
Install new components as necessary:

- Drum driver PWB, [PL 1.15 Item 4](#).
- IME controller PWB, [PL 92.10 Item 1](#).

Go to [WD 9.2](#). Check the wiring between the cleaning unit connector, [PL 94.10 Item 6](#) and PJ601 on the *drum driver PWB*.

NOTE: If necessary, remove the drum drive motor to gain access to the cleaning unit connector, refer to [REP 91.33](#).

The wiring is good.

Y N
Repair the wiring as necessary, [REP 1.1](#). Install a new drum driver PWB, [PL 1.15 Item 4](#).

Go to [WD 9.1](#) and [WD 9.22](#). Check the wiring between the IOD shuttle motor and PJ101 on the *drum driver PWB*. **The wiring is good.**

Y N
Repair the wiring as necessary, [REP 1.1](#). Install a new drum driver PWB, [PL 1.15 Item 4](#).
Install a new drum driver PWB, [PL 1.15 Item 4](#). **The fault remains.**
Y N
Perform [SCP 5](#) Final Actions.
Install a new cleaning unit, [PL 94.10 Item 21](#). **The fault remains.**
Y N
Install a new drum driver PWB, [PL 1.15 Item 4](#).
Install a new IOD assembly, [PL 94.15 Item 1](#). Install a new drum driver PWB, [PL 1.15 Item 4](#).

92-806-00 Fuse B Blown RAP

92-806-00 Fuse B on the drum driver PWB has blown.

Procedure

WARNING

Ensure that the electricity to the machine is switched off while performing tasks that do not need electricity. Refer to [GP 14](#). Disconnect the power cord. Electricity can cause death or injury. Moving parts can cause injury.

NOTE: Fuse B is non-reparable.

Go to [WD 9.2](#). +24V is available PJ602, pin 12.

Y N

Go to [WD 1.5](#). +24V is available at PJDC3, pin 15.

Y N

Go to [01-525-00](#) +24V, +/-12V, +5V Short Circuit and Overload RAP and check for a short circuit.

Check the wiring between the power supply unit, [PL 1.15 Item 2](#), and the drum driver PWB, [PL 1.15 Item 4](#), for an open circuit. **The wiring is good.**

Y N

Repair the wiring as necessary, [REP 1.1](#).

Install a new power supply unit, [PL 1.15 Item 2](#).

Go to [WD 9.2](#). Check the wiring between the cleaning unit connector, [PL 94.10 Item 6](#) and PJ601 on the [drum driver PWB](#).

NOTE: If necessary, remove the drum drive motor to gain access to the cleaning unit connector, refer to [REP 91.33](#).

The wiring is good.

Y N

Repair the wiring as necessary, [REP 1.1](#). Install a new drum driver PWB, [PL 1.15 Item 4](#).

Go to [WD 9.4](#). Check the wiring between the abatement fan and PJ901 on the [drum driver PWB](#). **The wiring is good.**

Y N

Repair the wiring as necessary, [REP 1.1](#). Install a new drum driver PWB, [PL 1.15 Item 4](#).

Install a new drum driver PWB, [PL 1.15 Item 4](#). **The fault remains.**

Y N

Perform [SCP 5](#) Final Actions.

Install a new cleaning unit, [PL 94.10 Item 21](#). **The fault remains.**

Y N

Install a new drum driver PWB, [PL 1.15 Item 4](#).

Install a new abatement fan assembly, [PL 94.20 Item 11](#). Install a new drum driver PWB, [PL 1.15 Item 4](#).

92-807-00 Diagnostic Routine Not Implemented RAP

92-807-00 In dC972 automatic TRC generation is not implemented.

Procedure

WARNING

Ensure that the electricity to the machine is switched off while performing tasks that do not need electricity. Refer to [GP 14](#). Disconnect the power cord. Electricity can cause death or injury. Moving parts can cause injury.

Go to [dC972](#) Printhead Uniformity. Perform a manual TRC generation.

93-501-00 to 93-516-00 Ink Loader Is Jammed RAP

93-501-00 Black ink loader is jammed.

93-506-00 Magenta ink loader is jammed.

93-511-00 Cyan ink loader is jammed.

93-516-00 Yellow ink loader is jammed.

Initial Actions

WARNING

Ensure that the electricity to the machine is switched off while performing tasks that do not need electricity. Refer to [GP 14](#). Disconnect the power cord. Electricity can cause death or injury. Moving parts can cause injury.

WARNING

Do not touch the ink loader melt plates while the machine is switched on. Dangerous voltages may be present that could cause death or injury.

Perform the following:

- Check for jammed ink sticks.
- Check for non Xerox ink sticks and report as appropriate.
- Check for wrong colour ink sticks loaded.

Procedure

Go to [93-891-00](#) Ink Transport Over Current RAP.

93-520-00, 93-521-00, 93-522-00 Ink Melt Reservoir Thermal Error RAP

93-520-00 Ink melt reservoir heater is too hot

93-521-00 Ink melt reservoir is heating too slowly

93-522-00 Ink melt reservoir thermistor fault

Initial Actions

WARNING

Ensure that the electricity to the machine is switched off while performing tasks that do not need electricity. Refer to [GP 14](#). Disconnect the power cord. Electricity can cause death or injury. Moving parts can cause injury.

WARNING

Do not touch the ink loader melt plates while the machine is switched on. Dangerous voltages may be present that could cause death or injury.

- Check that the machine is installed to allow adequate airflow. Refer to [GP 21](#) Installation Space Requirements.

Procedure

Check that the marking unit cooling fan is running, [Figure 1](#). **The fan is running.**

Y N

Go to [WD 9.4](#). Check the marking unit cooling fan.

Refer to:

- [OF 6](#) Fans and Air Systems RAP
- [GP 10](#), How to Check a Motor.
- [PJ901](#), [Drum Driver PWB](#).
- [01E](#) +12V Distribution RAP.
- [01L](#) 0V Distribution RAP.

Install new components as necessary:

- Marking unit cooling fan, [PL 1.15 Item 23](#).
- Drum driver PWB, [PL 1.15 Item 4](#).

Check the PEST fault history, [dC123](#) for marking unit heater faults (umbilicals, printheads and ink melt reservoir). **All marking unit heaters have failed.**

Y N

Go to [WD 9.8](#). Check the resistance and continuity of the reservoir heaters and wiring. The resistance should be approximately 45-55 ohms between pins 1 and 3 and between pins 2 and 4 on [PJ201](#) on the [Marking Unit Heater PWB](#). **The resistance is correct.**

Y N

Install a new ink reservoir, [PL 93.10 Item 10](#).

Check the wiring between the marking unit driver PWB, the solenoid patch PWB and the ink melt reservoir thermistor. Check that the ink reservoir thermistor is not open or shorted. Refer to:

- [WD 9.9](#), [WD 9.12](#) and [WD 9.16](#).

A

A

- PJ101, PJ801, [Marking Unit Driver PWB](#).
- PJ760, PJ910, PJ630 [Solenoid patch PWB](#).

The wiring and thermistor is good.

Y N

Install a new ink reservoir, [PL 93.10 Item 10](#).

Install new components as necessary.

- Marking unit heater PWB, [PL 92.10 Item 5](#).
- Marking unit driver PWB, [PL 92.10 Item 4](#).

Refer to [WD 1.1](#) and [WD 9.8](#), check the wiring between PJ4AC on the [Power Supply Unit](#) and PJ101 on the [Marking Unit Heater PWB](#). The wiring is good.

Y N

Repair the wiring, [REP 1.1](#).

Check the +3.3V ESTAR distribution to the marking unit heater PWB, refer to the [01B +3.3V ESTAR Distribution RAP](#). If the fault is still present, install new components as necessary:

- Marking unit heater PWB cable, [PL 92.10 Item 12](#).
- Marking unit heater PWB, [PL 92.10 Item 5](#).
- Marking unit driver PWB, [PL 92.10 Item 4](#).
- Power supply unit, [PL 1.15 Item 2](#).

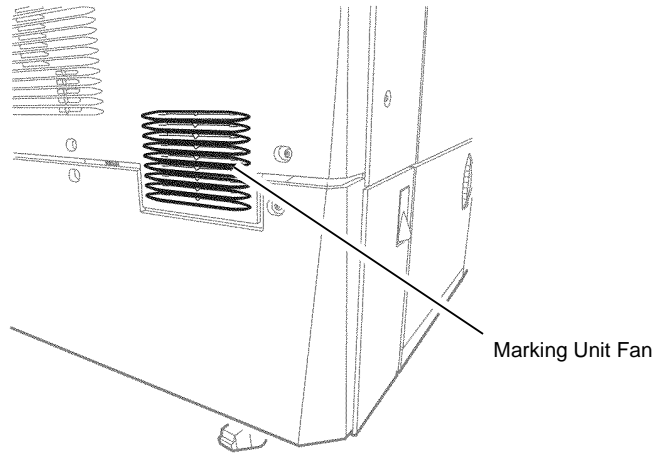

Figure 1 Component Location

U-1-1134-A

93-523-00 to 93-526-00, 93-527-00 to 93-530-00, 93-532-00, 93-533-00, 93-957-00 Ink Melt Error RAP

93-523-00 Cyan ink melter is too hot

93-524-00 Cyan ink melter is heating too slowly

93-526-00 Magenta ink melter is too hot

93-527-00 Magenta ink melter is heating too slowly

93-529-00 Yellow ink melter is too hot

93-530-00 Yellow ink melter is heating too slowly

93-532-00 Black ink melter is too hot

93-533-00 Black ink melter is heating too slowly

93-957-00 Melt reservoir heater went unstable while printing

Initial Actions

WARNING

Ensure that the electricity to the machine is switched off while performing tasks that do not need electricity. Refer to [GP 14](#). Disconnect the power cord. Electricity can cause death or injury. Moving parts can cause injury.

WARNING

Do not touch the ink loader melt plates while the machine is switched on. Dangerous voltages may be present that could cause death or injury.

- Check that the machine is installed to allow adequate airflow. Refer to [GP 21](#) Installation Space Requirements.
- Check that the ink sticks are not jammed in the ink stick transport and at the melt plate assembly, below the ink low sensors.
- Check that the ink sticks are in contact with the melt plate.

Procedure

Check that the marking unit fan is running, [Figure 1](#). The fan is running.

Y N

Go to [WD 9.4](#). Check the marking unit cooling fan.

Refer to:

- [OF 6](#) Fans and Air Systems RAP
- [GP 10](#), How to Check a Motor.
- P/J901, [Drum driver PWB](#).
- [01E](#) +12V Distribution RAP.
- [01L](#) 0V Distribution RAP

Install new components as necessary:

- Marking unit cooling fan, [PL 1.15 Item 23](#).
- Drum driver PWB, [PL 1.15 Item 4](#).

A

A

Go to [WD 1.2](#), [WD 8.4](#) and [WD 9.17](#). Check the wiring between:

- The power supply unit and the ink melt heaters. Ensure that the ink melt heaters are correctly connected to PJ5AC on the [Power supply unit](#).

NOTE: The 4 heater harnesses are colour coded to the corresponding letter on the ink melt plate assembly. Refer to [REP 91.16](#).

- The media path driver PWB, the ink load entry PWB and the ink thermistors.

Refer to:

- P/J5AC [Power supply unit](#)
- P/J406 [Media path driver PWB](#)
- P/J301 [Ink load entry PWB](#)
- [01A](#) AC Power Distribution RAP.
- [01B](#) +3.3V ESTAR Distribution RAP.
- [01L](#) 0V Distribution RAP

The wiring is good.

Y N

Repair the wiring as necessary, [REP 1.1](#).

Remove the ink loader melt plate assembly, [PL 93.10 Item 3](#). Remove any debris on the ink side of the ink melt heaters.

Install new components as necessary.

- Power supply unit, [PL 1.15 Item 2](#).
- Ink loader melt plate assembly, [PL 93.10 Item 3](#)
- Ink load sensor assembly, [PL 93.10 Item 7](#).
- Media path driver PWB, [PL 1.15 Item 5](#).

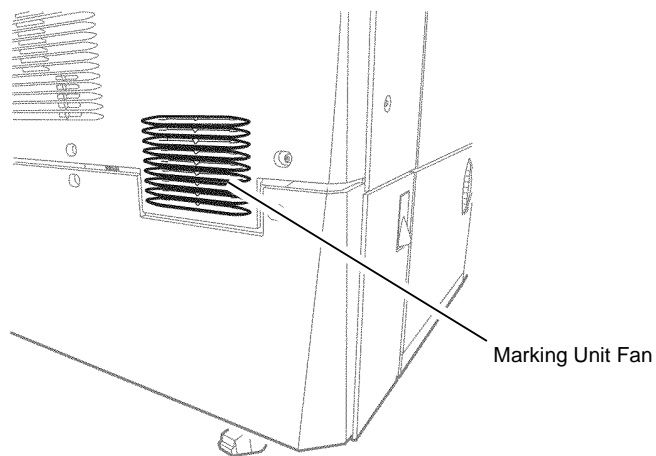

U-1-1135-A

Figure 1 Component Location

93-525-00, 93-528-00, 93-531-00, 93-534-00 Ink Melt Thermistor Error RAP

93-525-00 Cyan ink melter thermistor fault

93-528-00 Magenta ink melter thermistor fault

93-531-00 Yellow ink melter thermistor fault

93-534-00 Black ink melter thermistor fault

Initial Actions

WARNING

Ensure that the electricity to the machine is switched off while performing tasks that do not need electricity. Refer to [GP 14](#). Disconnect the power cord. Electricity can cause death or injury. Moving parts can cause injury.

WARNING

Do not touch the ink loader melt plates while the machine is switched on. Dangerous voltages may be present that could cause death or injury.

- Check that the ink melt thermistors are connected.

Procedure

Go to [WD 9.17](#) and [WD 8.4](#). Check the following wiring:

- Between the ink melt thermistors and PJ301 on the [Ink Load Entry PWB](#).
- Between PJ901 on the [Ink Load Entry PWB](#) and PJ406 on the [Media Path Driver PWB](#).

The wiring is good.

Y N

Repair the wiring as necessary, [REP 1.1](#).

Install new components as necessary:

- Ink loader melt plate assembly, [PL 93.10 Item 3](#).
- Ink load sensor assembly, [PL 93.10 Item 7](#).
- Media path driver PWB, [PL 1.15 Item 5](#).

93-535-00 to 93-537-00, 93-958-00 Upper Umbilical Thermal Error RAP

93-535-00 Upper umbilical heater is too hot

93-536-00 Upper umbilical is heating too slowly

93-537-00 Upper umbilical thermistor fault

93-958-00 Upper Umbilical heater went unstable while printing

Initial Actions

WARNING

Ensure that the electricity to the machine is switched off while performing tasks that do not need electricity. Refer to [GP 14](#). Disconnect the power cord. Electricity can cause death or injury. Moving parts can cause injury.

Check that the machine is installed to allow adequate airflow. Refer to [GP 21](#) Installation Space Requirements.

Procedure

Check that the marking unit fan is running, [Figure 1](#). The fan is running.

Y N

Go to [WD 9.4](#). Check the marking unit fan.

Refer to:

- [OF 6](#) Fans and Air Systems RAP
- [GP 10](#), How to Check a Motor.
- PJ901, [Drum Driver PWB](#).
- [01E](#) +12V Distribution RAP.
- [01L](#) 0V Distribution RAP

Install new components as necessary:

- Marking unit fan, [PL 1.15 Item 23](#).
- Drum driver PWB, [PL 1.15 Item 4](#).

Enter [dC335](#) Heater Monitor and Exerciser. Select Graph to run the Upper Umbilical Test. The test is good (the heater reaches and remains at the set point).

Y N

Check the PEST fault history, [dC123](#) for marking unit heater faults (umbilicals, printheads and ink melt reservoir). All marking unit heaters have failed.

Y N

Go to [WD 9.8](#) and [WD 9.9](#). Check the following wiring:

- Between PJ102 on the [Marking Unit Driver PWB](#) and the upper umbilical thermistor. Measure the resistance between PJ102 pins B9 and B10. The resistance is widely variable, but must not be an open circuit.
- Between PJ401 on the [Marking Unit Heater PWB](#) and the upper umbilical heater. Measure the resistance between PJ401 pins 1 and 7. The resistance should be approximately 80-100 ohms.

Refer to:

- [01A](#) AC Power Distribution RAP.
- [01B](#) +3.3V ESTAR Distribution RAP.
- [01L](#) 0V Distribution RAP

Install new components as necessary.

- Upper umbilical, [PL 91.20 Item 10](#).

A B

- Marking unit driver PWB, [PL 92.10 Item 4](#)
- Marking unit heater PWB, [PL 92.10 Item 5](#)

Refer to [WD 1.1](#) and [WD 9.8](#), check the wiring between PJ4AC on the [Power Supply Unit](#) and PJ101 on the [Marking Unit Heater PWB](#). The wiring is good.

Y N

Repair the wiring, [REP 1.1](#).

Check the +3.3V ESTAR distribution to the marking unit heater PWB, refer to the [01B](#) +3.3V ESTAR Distribution RAP. If the fault is still present, install new components as necessary:

- Power supply unit, [PL 1.15 Item 2](#).
- Marking unit heater PWB cable, [PL 92.10 Item 12](#).
- Marking unit heater PWB, [PL 92.10 Item 5](#).
- Marking unit driver PWB, [PL 92.10 Item 4](#).

The fault may be intermittent. Go to [WD 9.8](#) and [WD 9.9](#). Check for loose connections between:

- The marker unit driver PWB and the upper umbilical thermistor.
- The marking unit heater PWB and the upper umbilical heater.

Refer to:

- PJ401, [Marking Unit Heater PWB](#).
- PJ102, [Marking Unit Driver PWB](#).

If the fault persists, install new components as necessary.

- Power supply unit, [PL 1.15 Item 2](#).
- Upper umbilical, [PL 91.20 Item 10](#).
- Marking unit driver PWB, [PL 92.10 Item 4](#).
- Marking unit heater PWB, [PL 92.10 Item 5](#).

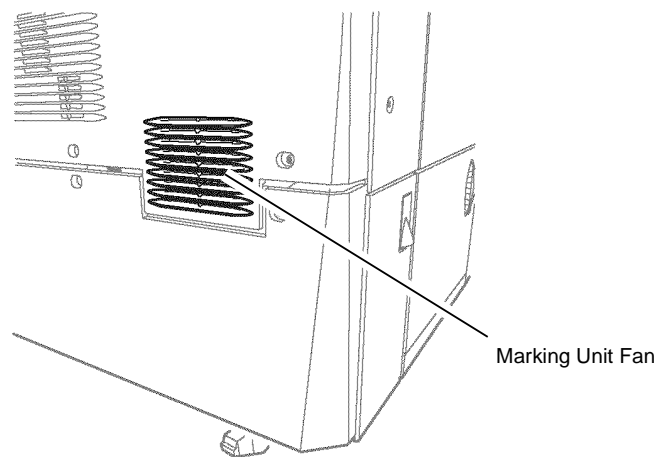

Figure 1 Component Location

U-1-1136-A

A B

Status Indicator RAPs

93-535-00 to 93-537-00, 93-958-00

March 2011
2-436

ColorQube™ 9303 Family

93-538-00 to 93-540-00, 93-959-00 Lower Umbilical Thermal Error RAP

93-538-00 Lower umbilical heater is too hot

93-539-00 Lower umbilical is heating too slowly

93-540-00 Lower umbilical thermistor is faulty

93-959-00 Lower Umbilical heater went unstable while printing

Procedure

WARNING

Ensure that the electricity to the machine is switched off while performing tasks that do not need electricity. Refer to [GP 14](#). Disconnect the power cord. Electricity can cause death or injury. Moving parts can cause injury.

Check that the marking unit fan is running, [Figure 1](#). The fan is running.

Y N

Go to [WD 9.4](#). Check the marking unit fan.

Refer to:

- [OF 6](#) Fans and Air Systems RAP
- [GP 10](#), How to Check a Motor.
- PJ901, [Drum Driver PWB](#).
- [01E](#) +12V Distribution RAP.
- [01L](#) 0V Distribution RAP

Install new components as necessary:

- Marking unit fan, [PL 1.15 Item 23](#).
- Drum driver PWB, [PL 1.15 Item 4](#).

Enter [dC335](#) Heater Monitor and Exerciser. Select Graph to run the Lower Umbilical Test.

The test is good.

Y N

Check the PEST fault history, [dC123](#) for marking unit heater faults (umbilicals, printheads and ink melt reservoir). All marking unit heaters have failed.

Y N

Go to [WD 9.8](#) and [WD 9.10](#). Check the following wiring:

- Between PJ303 on the [Marking Unit Driver PWB](#) and the lower umbilical thermistor. Measure the resistance between PJ303 pins B4 and B5. The resistance is widely variable, but must not be an open circuit.
- Between PJ701 on the [Marking Unit Heater PWB](#) and the lower umbilical heater. Measure the resistance between PJ701 pins 1 and 8. The resistance should be approximately 80-100 ohms.

Refer to:

- [01A](#) AC Power Distribution RAP.
- [01B](#) +3.3V ESTAR Distribution RAP.
- [01L](#) 0V Distribution RAP

Install new components as necessary.

- Lower umbilical, [PL 91.25 Item 10](#).
- Marking unit driver PWB, [PL 92.10 Item 4](#).

A B

- Marking unit heater PWB, [PL 92.10 Item 5](#).

Refer to [WD 1.1](#) and [WD 9.8](#), check the wiring between PJ4AC on the [Power Supply Unit](#) and PJ101 on the [Marking Unit Heater PWB](#). The wiring is good.

Y N

Repair the wiring, [REP 1.1](#).

Check the +3.3V ESTAR distribution to the marking unit heater PWB, refer to the [01B](#) +3.3V ESTAR Distribution RAP. If the fault is still present, install new components as necessary:

- Power supply unit, [PL 1.15 Item 2](#).
- Marking unit heater PWB cable, [PL 92.10 Item 12](#).
- Marking unit heater PWB, [PL 92.10 Item 5](#).
- Marking unit driver PWB, [PL 92.10 Item 4](#).

The fault may be intermittent. Go to [WD 9.8](#) and [WD 9.10](#). Check for loose connections between:

- The marker unit driver PWB and the lower umbilical thermistor.
- The marking unit heater PWB and the lower umbilical heater.

Refer to:

- PJ303, [Marking unit driver PWB](#)
- PJ701, [Marking unit heater PWB](#)

If the fault persists, install new components as necessary.

- Power supply unit, [PL 1.15 Item 2](#).
- Lower umbilical, [PL 91.25 Item 10](#).
- Marking unit driver PWB, [PL 92.10 Item 4](#)
- Marking unit heater PWB, [PL 92.10 Item 5](#)

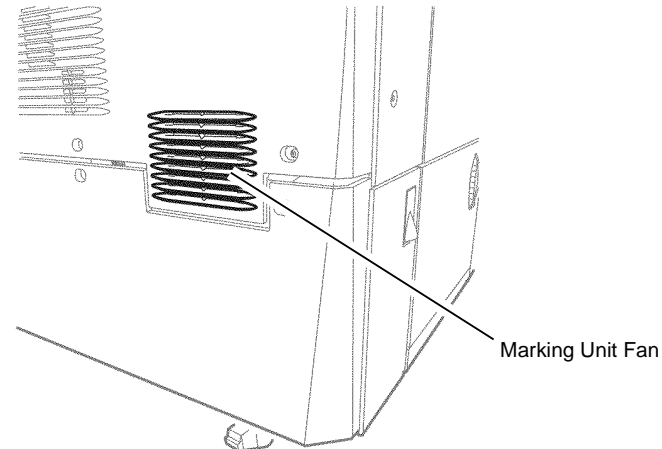

U-1-1137-A

Figure 1 Component Location

A B

93-545-00 to 93-548-00 Ink Melt Reservoir Level Sense Error RAP

93-545-00 The black melt reservoir ink conductivity is out of usable range.

93-546-00 The magenta melt reservoir ink conductivity is out of usable range.

93-547-00 The cyan melt reservoir ink conductivity is out of usable range.

93-548-00 The yellow melt reservoir conductivity is out of usable range.

Initial Actions

- Check for ink stick jams.
- Check for non Xerox ink sticks and report as appropriate.
- Check for wrong colour ink sticks loaded.
- Check that the ink sticks are in contact with the melt plate.
- Check that the tips of the melt plates are the correct colour.
- Check for reservoir contamination from ink shards getting into the incorrect colour reservoir.
- Check the ink melt plate for damage may cause melt ink to enter the incorrect colour reservoir.

Procedure

WARNING

Ensure that the electricity to the machine is switched off while performing tasks that do not need electricity. Refer to **GP 14**. Disconnect the power cord. Electricity can cause death or injury. Moving parts can cause injury.

Check that the ink reservoir, **PL 93.10 Item 10** is in good condition with no ink overflow. Check for damage that may cause the reservoir to leak. **The reservoir is good.**

Y N
Check that the umbilical clamp fasteners are tight, refer to **REP 91.31**. If the fasteners are loose, clean the area, then firmly tighten the fasteners. If necessary, install a new ink reservoir, **PL 93.10 Item 10**.

Go to **WD 9.9** and **WD 9.16**. Check the wiring between the ink level sensors, the solenoid patch PWB and the marking unit driver PWB.

Refer to:

- P/J101, **Marking Unit Driver PWB**.
- P/J380, P/J 760, P/J780 **Solenoid Patch PWB**.
- **01B** +3.3V ESTAR Distribution RAP.
- **01L** 0V Distribution RAP

Install new components as necessary.

- Ink reservoir, **PL 93.10 Item 10**.
- Ink level sensor cable (Ribbon cable), **PL 93.10 Item 18**.
- Marking unit driver PWB, **PL 92.10 Item 4**.

93-549-00 to 93-552-00 and 93-557-00 to 93-560-00 Printheads 1 and 3 Printhead Reservoir Fill Error RAP

93-549-00 Head 1 black reservoir did not fill within the correct time.

93-550-00 Head 1 magenta reservoir did not fill within the correct time.

93-551-00 Head 1 cyan reservoir did not fill within the correct time.

93-552-00 Head 1 yellow reservoir did not fill within the correct time.

93-557-00 Head 3 black reservoir did not fill within the correct time.

93-558-00 Head 3 magenta reservoir did not fill within the correct time.

93-559-00 Head 3 cyan reservoir did not fill within the correct time.

93-560-00 Head 3 yellow reservoir did not fill within the correct time.

Procedure

WARNING

Ensure that the electricity to the machine is switched off while performing tasks that do not need electricity. Refer to **GP 14**. Disconnect the power cord. Electricity can cause death or injury. Moving parts can cause injury.

CAUTION

Do not remove the solenoid patch PWB, **PL 93.10 Item 9**.

NOTE: If the printhead reservoirs do not fill, it can cause massive jet loss. If necessary, refer to the **IQ 9 Deletions in the Process Direction RAP**.

Move the marking unit into the service position, **GP 6**. Check that the air channels from ink reservoir solenoids 5, 7, 11, 12, 15, 16, 17, and 19 is free of ink, **Figure 1**.

If the ink has blocked the air channels then install a new umbilical and ink reservoir at the same time. Failure to replace both units will cause another ink reservoir failure.

NOTE: Some ink discoloration of the air channels is normal.

The channels are free of ink.

Y N
Install a new lower umbilical, **PL 91.25 Item 10** and new ink reservoir, **PL 93.10 Item 10**.

Check that the print heads, drum and waste tray are clean, without excessive ink contamination.

NOTE: Excessive ink contamination will be obvious.

The print heads, drum and waste tray are clean.

Y N
The print area is contaminated with excessive ink. The purge line is blocked. Perform the steps that follow:

- **GP 27** Cleaning Procedure.
- Install a new purge line filter, **PL 91.25 Item 9**.

A

A

- Install a new purge line, [PL 91.25 Item 11](#).
- If the ink contamination has reached the ink reservoir through the purge line, install a new ink reservoir, [PL 93.10 Item 10](#).

Go to [WD 9.6](#), [WD 9.7](#), [WD 9.20](#), [WD 9.21](#). Check the ribbon cables between the printheads and the IME Controller PWB. Refer to:

- P/J101, P/J301, [Printhead PWB](#)
- P/J902, P/J904 [IME controller PWB](#)

The ribbon cables are good.

Y N

Re-seat the ribbon cables or install new cables, [PL 92.10](#).

Check that the level sense connection at PJ601 on the [Printhead PWB](#) is in good condition and is properly and securely connected. **The connection is good.**

Y N

As necessary, install new components:

- Print head, [PL 91.20 Item 2](#), [PL 91.25 Item 2](#).

Disconnect the air hose between the lower and upper purge hoses on the ink reservoir, [Figure 2](#).

Enter [dC330](#) and stack the code 93-050 to run the reservoir pump MOT93-050, [PL 93.10 Item 11](#) and code 91-045 low pressure assist valve SOL 91.045, [PL 93.10 Item 15](#). The pump will run for approximately 10 seconds. If the pump runs, then the air pressure from the disconnected air hose is sufficient to feel on the skin, or partially inflate a rubber glove. **The pump runs**

Y N

Go to [WD 9.14](#). Check the connection from the solenoid patch PWB to the reservoir pump motor (MOT93-050) at PJ130.

Go to [WD 9.14](#) and [WD 9.12](#). Check the ink reservoir pump motor.

Refer to:

- [GP 10](#), How to Check a Motor.
- P/J130, [Solenoid patch PWB](#).
- P/J801, [Marking unit driver PWB](#)
- [01E](#) +12V Distribution RAP.
- [01L](#) 0V Distribution RAP

Install new components as necessary:

- Marking unit driver PWB, [PL 92.10 Item 4](#).
- Ink Reservoir, [PL 93.10 Item 10](#).

Reconnect the air hose from the pump to the ink reservoir, [Figure 2](#).

Enter the correct [dC330](#) output code to check the ink reservoir solenoids associated with the fault code:

- Purge solenoid valve 3, SOL93-061.
- Purge solenoid valve 4, SOL93-062.
- Black ink solenoid valve 5, SOL93-063.
- Black ink solenoid valve 7, SOL93-065.
- Yellow ink solenoid valve 11, SOL93-069.
- Yellow ink solenoid valve 12, SOL93-070.

- Cyan ink solenoid valve 15, SOL93-073.
- Cyan ink solenoid valve 16, SOL93-074.
- Magenta ink solenoid valve 17, SOL93-075.
- Magenta ink solenoid valve 19, SOL93-077.

All solenoids energize

Y N

Go to [WD 9.14](#), [WD 9.15](#) and [WD 9.12](#). Check the ink reservoir solenoids.

Refer to:

- [GP 12](#), How to Check a Solenoid.
- P/J430, P/J110, P/J410, P/J610, P/J810 [Solenoid patch PWB](#).
- P/J801, [Marking unit driver PWB](#)
- [01H](#) +24V Distribution RAP.
- [01L](#) 0V Distribution RAP

Install new components as necessary:

- Ink Reservoir, [PL 93.10 Item 10](#).
- Marking unit driver PWB, [PL 92.10 Item 4](#).

Switch off the machine then switch on the machine [GP 14](#). Allow the printheads to try and recover. **The fault is cleared**

Y N

Install a new ink reservoir [PL 93.10 Item 10](#).

Before installing a new ink reservoir. Check that the 4 screws securing the solenoid patch PWB are not loose. If necessary tighten but do not overtighten the screws. Check that the check valves on the umbilicals are securely fixed to the umbilicals, [PL 91.25 Item 19](#). If the clips are damaged, install a new umbilical, [PL 91.25 Item 20](#). **The fault is still present.**

Y N

Perform [dC972](#) Printhead Uniformity.

Install new components;

1. Install the relevant new printhead [PL 91.25 Item 2](#).
2. Install a new IME controller PWB, [PL 92.10 Item 1](#).

Perform [SCP 5](#) Final Actions.

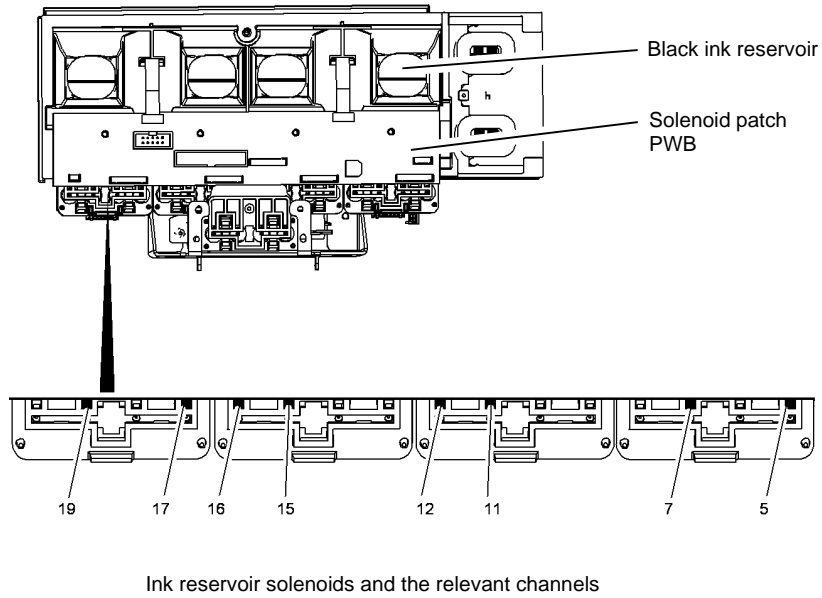

Figure 1 Component location

U-1-1541-A

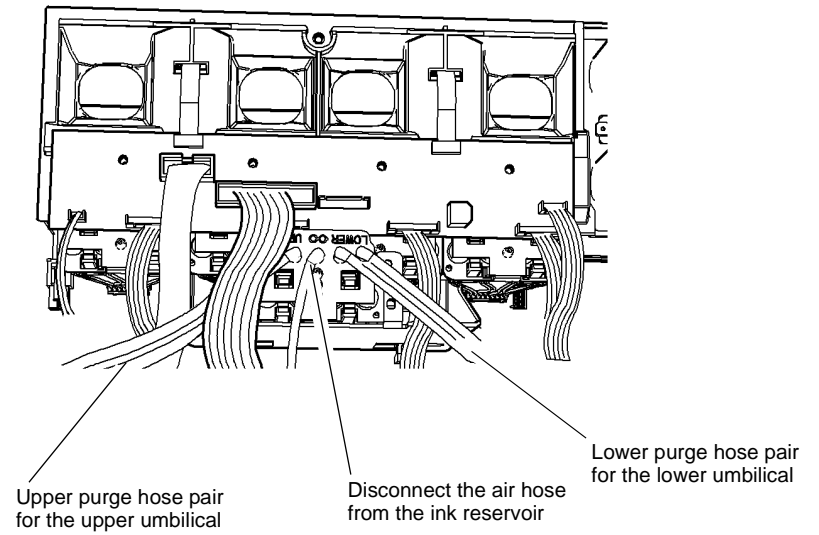

Figure 2 Reservoir pump air hose

U-1-1640-A

93-553-00 to 93-556-00 and 93-561-00 to 93-564-00 Printheads 2 and 4 Printhead Reservoir Fill Error RAP

93-553-00 Head 2 black reservoir did not fill within the correct time.

93-554-00 Head 2 magenta reservoir did not fill within the correct time.

93-555-00 Head 2 cyan reservoir did not fill within the correct time.

93-556-00 Head 2 yellow reservoir did not fill within the correct time.

93-561-00 Head 4 black reservoir did not fill within the correct time.

93-562-00 Head 4 magenta reservoir did not fill within the correct time.

93-563-00 Head 4 cyan reservoir did not fill within the correct time.

93-564-00 Head 4 yellow reservoir did not fill within the correct time.

Procedure

WARNING

Ensure that the electricity to the machine is switched off while performing tasks that do not need electricity. Refer to [GP 14](#). Disconnect the power cord. Electricity can cause death or injury. Moving parts can cause injury.

CAUTION

Do not remove the solenoid patch PWB, [PL 93.10 Item 9](#).

NOTE: If the printhead reservoirs do not fill, it can cause massive jet loss. If necessary, refer to the [IQ 9 Deletions in the Process Direction RAP](#).

Move the marking unit into the service position, [GP 6](#). Check that the air channels from ink reservoir solenoids 6, 8, 9, 10, 13, 14, 18 and 20 is free of ink, [Figure 1](#).

If the ink has blocked the air channels then install a new umbilical and ink reservoir at the same time. Failure to replace both units will cause another ink reservoir failure.

NOTE: Some ink discoloration of the air channels is normal.

The channels are free of ink.

Y N

Install a new upper umbilical, [PL 91.20 Item 10](#) and a new ink reservoir, [PL 93.10 Item 10](#).

Check that the print area is clean, without excessive ink contamination.

NOTE: Excessive ink contamination will be obvious.

The print area is clean.

Y N

The print area is contaminated with excessive ink. The purge line may be blocked. Perform the steps that follow:

- [GP 27](#) Cleaning Procedure.
- Install a new purge line filter [PL 91.20 Item 9](#).

A

- If the ink contamination has reached the melt reservoir through the purge line, install a new ink reservoir, [PL 93.10 Item 10](#).

Move the marking unit to the service position, [GP 6](#). Go to [WD 9.5](#), [WD 9.20](#), [WD 9.21](#). Check the ribbon cables between the printheads and the IME Controller PWB. Refer to:

- P/J101, P/J301, [Printhead PWB](#)
- P/J201, P/J301 [IME controller PWB](#)

The ribbon cables are good.

Y N

Re-seat the ribbon cables or install new cables, [PL 92.10](#).

Check that the level sense connection at PJ601 on the [Printhead PWB](#) is in good condition and is properly and securely connected. The connection is good.

Y N

As necessary, install new components:

- Print head, [PL 91.20 Item 2](#), [PL 91.25 Item 2](#).

Disconnect the air hose between the lower and upper purge hoses on the ink reservoir, [Figure 2](#).

Enter [dC330](#) and stack the code 93-050 to run the reservoir pump MOT93-050, [PL 93.10 Item 11](#) and code 91-045 low pressure assist valve SOL 91.045, [PL 93.10 Item 15](#). The pump will run for approximately 10 seconds. If the pump runs, then the air pressure from the disconnected air hose is sufficient to feel on the skin, or partially inflate a rubber glove. The pump runs

Y N

Go to [WD 9.14](#). Check the connection from the solenoid patch PWB to the reservoir pump motor MOT93-050 at PJ130.

Go to [WD 9.14](#) and [WD 9.12](#). Check the ink reservoir pump motor.

Refer to:

- [GP 10](#), How to Check a Motor.
- P/J130, [Solenoid patch PWB](#).
- P/J801, [Marking unit driver PWB](#)
- [01E](#) +12V Distribution RAP.
- [01L](#) 0V Distribution RAP

Install new components as necessary:

- Marking unit driver PWB, [PL 92.10 Item 4](#).
- ink reservoir, [PL 93.10 Item 10](#).

Reconnect the air hose from the pump to the ink reservoir, [Figure 2](#).

Enter the correct [dC330](#) output code to check the ink reservoir solenoids associated with the fault code:

- Purge solenoid valve 1, SOL93-059.
- Purge solenoid valve 2, SOL93-060.
- Black ink solenoid valve 6, SOL93-064.
- Black ink solenoid valve 8, SOL93-066.
- Yellow ink solenoid valve 9, SOL93-067.
- Yellow ink solenoid valve 10, SOL93-068.
- Cyan ink solenoid valve 13, SOL93-071.

A

- Cyan ink solenoid valve 14, SOL93-072.
- Magenta ink solenoid valve 18, SOL93-076.
- Magenta ink solenoid valve 20, SOL93-078.

All solenoids energise

Y N
Go to [WD 9.12](#), [WD 9.14](#) and [WD 9.15](#). Check the ink reservoir solenoids.
Refer to:

- [GP 12](#), How to Check a Solenoid.
- P/J430, P/J110, P/J410, P/J610, P/J810 [Solenoid patch PWB](#).
- P/J801, [Marking unit driver PWB](#)
- [01H](#) +24V Distribution RAP.
- [01L](#) 0V Distribution RAP

Install new components as necessary:

- Ink Reservoir, [PL 93.10 Item 10](#).
- Marking unit driver PWB, [PL 92.10 Item 4](#).

Switch off, then switch on the machine [GP 14](#), to try and allow the printheads to recover. **The fault is cleared**

Y N
Install a new ink reservoir [PL 93.10 Item 10](#).
Before installing a new ink reservoir. Check that the 4 screws securing the solenoid patch PWB are not loose. If necessary tighten but do not overtighten the screws. Check that the check valves on the umbilicals are securely fixed to the umbilicals, [PL 91.25 Item 19](#). If the clips are damaged, install a new umbilical, [PL 91.25 Item 20](#). **The fault is still present.**

Y N
Perform [dC972](#) Printhead Uniformity.

Install new components as necessary:

- Install the relevant printhead [PL 91.20 Item 2](#).
- IME controller PWB, [PL 92.10 Item 1](#).

Perform [SCP 5](#) Final Actions.

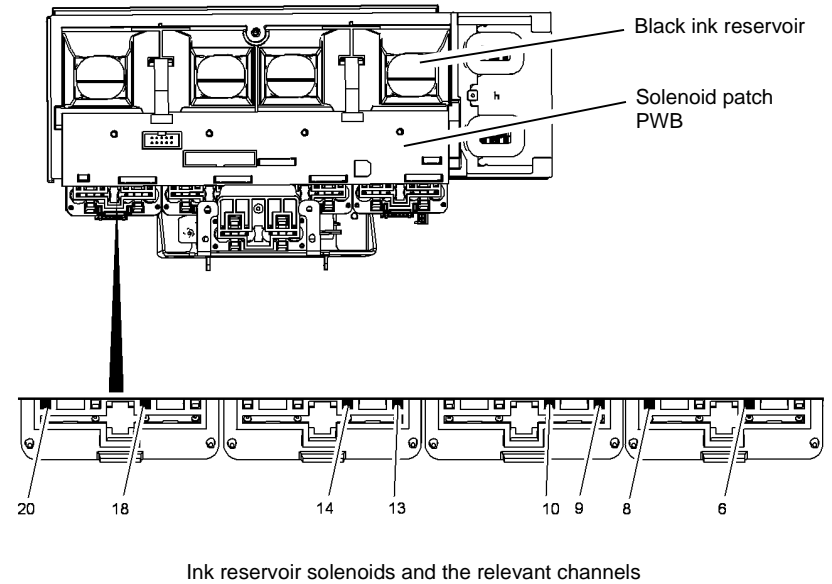

Ink reservoir solenoids and the relevant channels

Figure 1 Component location

U-1-1542-A

93-565-00 to 93-599-00 and 93-800-00 to 93-812-00 Printheads 1, 2, 3 & 4 Ink Level Sense Error RAP

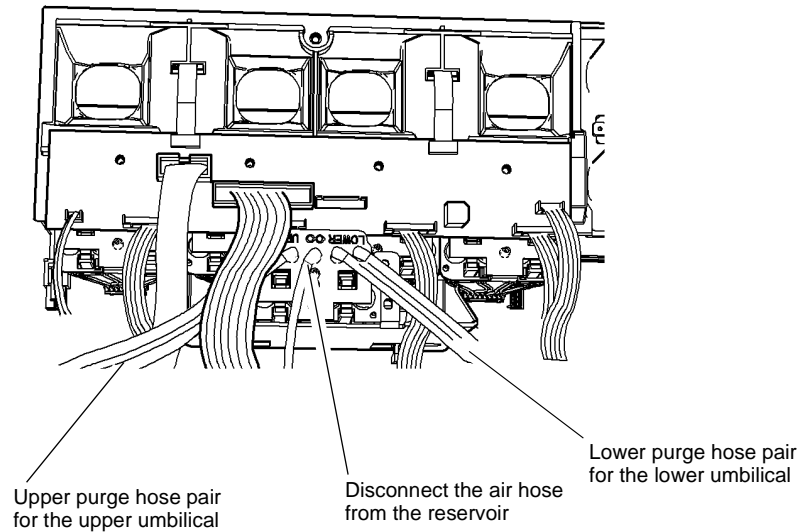

Figure 2 Reservoir pump air hose

U-1-1639-A

93-565-00 Head 1 black reservoir level sense failure

93-566-00 Head 1 magenta reservoir level sense failure

93-567-00 Head 1 cyan reservoir level sense failure

93-568-00 Head 1 yellow reservoir level sense failure

93-569-00 Head 2 black reservoir level sense failure

93-570-00 Head 2 magenta reservoir level sense failure

93-571-00 Head 2 cyan reservoir level sense failure

93-572-00 Head 2 yellow reservoir level sense failure

93-573-00 Head 3 black reservoir level sense failure

93-574-00 Head 3 magenta reservoir level sense failure

93-575-00 Head 3 cyan reservoir level sense failure

93-576-00 Head 3 yellow reservoir level sense failure

93-577-00 Head 4 black reservoir level sense failure

93-578-00 Head 4 magenta reservoir level sense failure

93-579-00 Head 4 cyan reservoir level sense failure

93-580-00 Head 4 yellow reservoir level sense failure

93-581-00 Head 1 black reservoir level sense open circuit

93-582-00 Head 1 magenta reservoir level sense open circuit

93-583-00 Head 1 cyan reservoir level sense open circuit

93-584-00 Head 1 yellow reservoir level sense open circuit

93-585-00 Head 2 black reservoir level sense open circuit

93-586-00 Head 2 magenta reservoir level sense open circuit

93-587-00 Head 2 cyan reservoir level sense open circuit

93-588-00 Head 2 yellow reservoir level sense open circuit

93-589-00 Head 3 black reservoir level sense open circuit

93-590-00 Head 3 magenta reservoir level sense open circuit

93-591-00 Head 3 cyan reservoir level sense open circuit

93-592-00 Head 3 yellow reservoir level sense open circuit
93-593-00 Head 4 black reservoir level sense open circuit
93-594-00 Head 4 magenta reservoir level sense open circuit
93-595-00 Head 4 cyan reservoir level sense open circuit
93-596-00 Head 4 yellow reservoir level sense open circuit
93-597-00 Head 1 black reservoir level sense short circuit
93-598-00 Head 1 magenta reservoir level sense short circuit
93-599-00 Head 1 cyan reservoir level sense short circuit
93-800-00 Head 1 yellow reservoir level sense short circuit
93-801-00 Head 2 black reservoir level sense short circuit
93-802-00 Head 2 magenta reservoir level sense short circuit
93-803-00 Head 2 cyan reservoir level sense short circuit
93-804-00 Head 2 yellow reservoir level sense short circuit
93-805-00 Head 3 black reservoir level sense short circuit
93-806-00 Head 3 magenta reservoir level sense short circuit
93-807-00 Head 3 cyan reservoir level sense short circuit
93-808-00 Head 3 yellow reservoir level sense short circuit
93-809-00 Head 4 black reservoir level sense short circuit
93-810-00 Head 4 magenta reservoir level sense short circuit
93-811-00 Head 4 cyan reservoir level sense short circuit
93-812-00 Head 4 yellow reservoir level sense short circuit

Procedure

WARNING

Ensure that the electricity to the machine is switched off while performing tasks that do not need electricity. Refer to GP 14. Disconnect the power cord. Electricity can cause death or injury. Moving parts can cause injury.

Verify the fault code. Go to the relevant RAP:

- Head 1 and head 3 faults.
 - 93-549-00 to 93-552-00 and 93-557-00 to 93-560-00 Printheads 1 and 3 Printhead Reservoir Fill Error RAP
- Head 2 and head 4 faults.
 - 93-553-00 to 93-556-00 and 93-561-00 to 93-564-00 Printheads 2 and 4 Printhead Reservoir Fill Error RAP

93-813-00 to 93-820-00 Ink Melt Reservoir Level Sense Failure RAP

93-813-00 Black melt reservoir level sense open circuit
93-814-00 Magenta melt reservoir level sense open circuit
93-815-00 Cyan melt reservoir level sense open circuit
93-816-00 Yellow melt reservoir level sense open circuit
93-817-00 Black melt reservoir level sense short circuit
93-818-00 Magenta melt reservoir level sense short circuit
93-819-00 Cyan melt reservoir level sense short circuit
93-820-00 Yellow melt reservoir level sense short circuit

Procedure

WARNING

Ensure that the electricity to the machine is switched off while performing tasks that do not need electricity. Refer to GP 14. Disconnect the power cord. Electricity can cause death or injury. Moving parts can cause injury.

1. If the ink sticks are not in contact with the melt plate correct the ink stick jam. Install new components as necessary PL 93.10.
2. Go to WD 9.9 and WD 9.16. Check the wiring between the ink level sensors, the solenoid patch PWB and the marking unit driver PWB.
Refer to:
 - P/J101, Marking unit driver PWB
 - P/J380, P/J760, P/J780 Solenoid patch PWB.
 - 01B +3.3V ESTAR Distribution RAP.
 - 01L 0V Distribution RAP
3. If the sensor continues to report a fault, install a new ink melt reservoir, PL 93.10 Item 10.
4. Install new components as necessary:
 - Ink reservoir, PL 93.10 Item 10.
 - Marking unit driver PWB, PL 92.10 Item 4.

93-825-00, 93-892-00 Ink Key Plate Motor Over Current RAP

93-825-00 The ink key plate motor is over current.

93-892-00 Indicates an over current interrupt from the motor driver chip.

Initial Actions

WARNING

Ensure that the electricity to the machine is switched off while performing tasks that do not need electricity. Refer to [GP 14](#). Disconnect the power cord. Electricity can cause death or injury. Moving parts can cause injury.

- Clean the ink loading area to ensure that the ink key plate moves smoothly.

Procedure

CAUTION

The ink key motor can overheat if run repeatedly. Allow 2 minutes between each run of the ink key motor.

Enter [dC330](#) code 93-051 or 052 or 053, to run the ink key plate motor, MOT93-051, [PL 93.10 Item 14](#). **MOT93-051 runs.**

Y N

Go to [WD 8.4](#). Check MOT93-051.

Refer to:

- [GP 10](#) How to Check a Motor.
- P/J406, [Media path driver PWB](#).
- [01H](#) +24V Distribution RAP.
- [01L](#) 0V Distribution RAP

Install new components as necessary:

- Ink key plate motor, [PL 93.10 Item 14](#).
- Ink loader upper assembly, [PL 93.10 Item 1](#).
- Media path driver PWB, [PL 1.15 Item 5](#).

The key plate moves when the motor runs.

Y N

Clean the ink loading area to ensure that the ink key plate moves smoothly. If necessary, install a new ink loader upper assembly, [PL 93.10 Item 1](#).

The fault may be intermittent, check the wiring to the ink key plate motor. If necessary, install a new ink loader upper assembly, [PL 93.10 Item 1](#).

93-871-00 to 93-874-00 Ink Level Sense Error RAP

93-871-00 Black melt reservoir level sense failure.

93-872-00 Magenta melt reservoir level sense failure

93-873-00 Cyan melt reservoir level sense failure

93-874-00 Yellow melt reservoir level sense failure

Procedure

WARNING

Ensure that the electricity to the machine is switched off while performing tasks that do not need electricity. Refer to [GP 14](#). Disconnect the power cord. Electricity can cause death or injury. Moving parts can cause injury.

Go to [WD 9.9](#) and [WD 9.16](#). Check the wiring between the ink level sensors, the solenoid patch PWB and the marking unit driver PWB.

Refer to:

- P/J101, [Marking Unit Driver PWB](#)
- P/J380, P/J760, P/J780 [Solenoid Patch PWB](#).
- [01B](#) +3.3V ESTAR Distribution RAP.
- [01L](#) 0V Distribution RAP

Install new components as necessary.

- Ink reservoir, [PL 93.10 Item 10](#).
- Marking unit driver PWB, [PL 92.10 Item 4](#).

NOTE: Ink level sense errors can be caused by ink cross contamination. If the machine was recently moved, cross contamination may have occurred. If the cross contamination is severe, it may be necessary to install a new ink reservoir, [PL 93.10 Item 10](#).

93-890-00 Marking Unit Air Solenoid Over Current RAP

93-890-00 The marking unit air solenoid is taking too much current.

Procedure

WARNING

Ensure that the electricity to the machine is switched off while performing tasks that do not need electricity. Refer to [GP 14](#). Disconnect the power cord. Electricity can cause death or injury. Moving parts can cause injury.

Go to the [91-516-00](#) Low Pressure Assist Over Current RAP.

93-891-00 Ink Transport Over Current RAP

93-891-00 The ink transport motor is taking too much current.

Initial Actions

WARNING

Ensure that the electricity to the machine is switched off while performing tasks that do not need electricity. Refer to [GP 14](#). Disconnect the power cord. Electricity can cause death or injury. Moving parts can cause injury.

- Check the ink loader assembly for debris blocking the transport belts.
- Check the ink loader for damage close to the transport motor.

Procedure

Enter [dC330](#) codes 93-048 and 93-049 to run the ink transport motor [PL 93.10 Item 5](#), forward and in reverse. **The motor runs.**

Y N

Go to [WD 8.4](#). Check the ink transport motor.

Refer to:

- [GP 10](#), How to Check a Motor.
- P/J406, [Media path driver PWB](#).
- [01H](#) +24V Distribution RAP
- [01L](#) 0V Distribution RAP

Install new components as necessary:

- Ink transport motor, [PL 93.10 Item 5](#).
- Media path driver PWB, [PL 1.15 Item 5](#).

The ink stick transport belts move.

Y N

Install new components as necessary:

- Ink transport drive gear, [PL 93.10 Item 6](#).
- Ink loader upper assembly, [PL 93.10 Item 1](#).

- Check for obstructions and debris that may cause the transport belts to jam intermittently.
- Check for damage to the ink loader upper assembly, [PL 93.10 Item 1](#).

93-901-00 to 93-904-00 Ink Melt Reservoir Fill Failure RAP

93-901-00 Black melt reservoir over fill failure

93-902-00 Magenta melt reservoir over fill failure

93-903-00 Cyan melt reservoir over fill failure

93-904-00 Yellow melt reservoir over fill failure

Procedure

WARNING

Ensure that the electricity to the machine is switched off while performing tasks that do not need electricity. Refer to [GP 14](#). Disconnect the power cord. Electricity can cause death or injury. Moving parts can cause injury.

WARNING

Do not touch the ink loader melt plates while the machine is switched on. Dangerous voltages may be present that could cause death or injury.

Ensure that the melt plates on the ink loader are operating correctly. Check the last 40 faults for the following codes:

- 93-523 to 534

The last 40 faults is clear of ink melt plate faults

Y N

Perform the relevant RAP:

- [93-523-00 to 93-526-00](#), [93-527-00 to 93-530-00](#), [93-532-00](#), [93-533-00](#), [93-957-00](#) Ink Melt Error RAP
- [93-525-00](#), [93-528-00](#), [93-531-00](#), [93-534-00](#) Ink Melt Thermistor Error RAP

Perform [dC612](#) Print Test Pattern. Run 100 solid fills of the affected colour. Check the ink melt reservoir for overfill. **The ink reservoir is good.**

Y N

Go back to the beginning of this RAP.

Perform [SCP 5](#) Final Actions

Go to [WD 9.9](#) and [WD 9.16](#). Check the wiring between the ink level sensors, the solenoid patch PWB and the marking unit driver PWB. Refer to:

- P/J101, [Marking unit driver PWB](#)
- P/J380, P/J760, P/J780 [Solenoid patch PWB](#).
- [01B](#) +3.3V ESTAR Distribution RAP.
- [01L](#) 0V Distribution RAP

The wiring is good.

Y N

Repair the wiring [REP 1.1](#).

Install new components as necessary.

- Ink reservoir, [PL 93.10 Item 10](#).
- Marking unit driver PWB, [PL 92.10 Item 4](#).

93-909-00 to 93-924-00 Printhead Reservoir Level Failure RAP

93-909-00 Head 1 black reservoir level sense failure

93-910-00 Head 1 magenta reservoir level sense failure

93-911-00 Head 1 cyan reservoir level sense failure

93-912-00 Head 1 yellow reservoir level sense failure

93-913-00 Head 2 black reservoir level sense failure

93-914-00 Head 2 magenta reservoir level sense failure

93-915-00 Head 2 cyan reservoir level sense failure

93-916-00 Head 2 yellow reservoir level sense failure

93-917-00 Head 3 black reservoir level sense failure

93-918-00 Head 3 magenta reservoir level sense failure

93-919-00 Head 3 cyan reservoir level sense failure

93-920-00 Head 3 yellow reservoir level sense failure

93-921-00 Head 4 black reservoir level sense failure

93-922-00 Head 4 magenta reservoir level sense failure

93-923-00 Head 4 cyan reservoir level sense failure

93-924-00 Head 4 yellow reservoir level sense failure

Procedure

WARNING

Ensure that the electricity to the machine is switched off while performing tasks that do not need electricity. Refer to [GP 14](#). Disconnect the power cord. Electricity can cause death or injury. Moving parts can cause injury.

Clear the fault code by:

- Switch the machine off and then switch the machine on, [GP 14](#).

93-933-00 to 93-936-00 Head Purge Failure RAP

93-933-00 Head 1 purge failure

93-934-00 Head 2 purge failure

93-935-00 Head 3 purge failure

93-936-00 Head 4 purge failure

Initial Actions

WARNING

Ensure that the electricity to the machine is switched off while performing tasks that do not need electricity. Refer to [GP 14](#). Disconnect the power cord. Electricity can cause death or injury. Moving parts can cause injury.

Check that all purge lines are connected. Re-install all purge lines as necessary.

Procedure

Check the purge line components for damage. Ensure that the purge lines are clean and not contaminated. Ensure that the purge line is connected to the ink melt reservoir. **The purge line are clean and undamaged**

Y N

Install new components as necessary:

- Purge line, [PL 91.20 Item 11](#).
- Purge line filter, [PL 91.20 Item 9](#).
- Ink reservoir assembly, [PL 93.10 Item 26](#).
- Printhead, [PL 91.20 Item 2](#)

Perform [93A](#) Ink melt reservoir check.

93-937-00 to 93-940-00 Ink Melt Reservoir Leak Error RAP

93-937-00 A leak has been detected in the black melt reservoir

93-938-00 A leak has been detected in the magenta melt reservoir

93-939-00 A leak has been detected in the cyan melt reservoir

93-940-00 A leak has been detected in the yellow melt reservoir

Initial Actions

WARNING

Ensure that the electricity to the machine is switched off while performing tasks that do not need electricity. Refer to [GP 14](#). Disconnect the power cord. Electricity can cause death or injury. Moving parts can cause injury.

WARNING

Do not touch the ink loader melt plates while the machine is switched on. Dangerous voltages may be present that could cause death or injury.

Clean ink leakages as necessary, refer to [GP 27](#).

Procedure

Check the following:

- That the ink reservoir, [PL 93.10 Item 10](#) is installed correctly and not damaged.
- That the upper umbilical, [PL 91.20 Item 10](#) is installed correctly and not damaged. Also check the connection between the upper umbilical to ink melt reservoir. Ensure the gasket is installed correctly. Refer to [REP 91.31](#).
- That the lower umbilical, [PL 91.25 Item 10](#) is installed correctly and not damaged. Also check the connection between the lower umbilical to ink melt reservoir. Ensure the gasket is installed correctly. Refer to [REP 91.31](#).

The components are good

Y N

Install new components as necessary:

- Ink reservoir, [PL 93.10 Item 10](#)
- Upper umbilical, [PL 91.20 Item 10](#).
- Lower umbilical, [PL 91.25 Item 10](#).

Go to [WD 9.9](#) and [WD 9.16](#). Check the wiring and connectors between PJ101 on the [Marking Unit Driver PWB](#) and PJ760 on the [Solenoid patch PWB](#). Repair the wiring as necessary, [REP 1.1](#). If necessary install new components:

- Ink reservoir, [PL 93.10 Item 10](#).
- Marking unit driver PWB, [PL 92.10 Item 4](#).

93A Ink Melt Reservoir Check RAP

Procedure

WARNING

Ensure that the electricity to the machine is switched off while performing tasks that do not need electricity. Refer to [GP 14](#). Disconnect the power cord. Electricity can cause death or injury. Moving parts can cause injury.

WARNING

Do not touch the ink loader melt plates while the machine is switched on. Dangerous voltages may be present that could cause death or injury.

Check the following:

- That the ink melt reservoir, [PL 93.10 Item 10](#) is installed correctly and not damaged.
- That the upper umbilical, [PL 91.20 Item 10](#) is installed correctly and not damaged. Also check for leaks at the connection between the upper umbilical to ink melt reservoir. Refer to [REP 91.31](#).
- That the lower umbilical, [PL 91.25 Item 10](#) is installed correctly and not damaged. Also check for leaks at the connection between the lower umbilical to ink melt reservoir. Refer to [REP 91.31](#).
- That the air tubes, part of the ink reservoir, [PL 93.10 Item 10](#) are installed correctly and not damaged.

The components are good

Y N

Install new components as necessary:

- Ink reservoir, [PL 93.10 Item 10](#)
- Upper umbilical, [PL 91.20 Item 10](#).
- Lower umbilical, [PL 91.25 Item 10](#).

Move the marking unit to the service position, [GP 6](#).

Disconnect the air hose between the lower and upper purge hoses on the ink reservoir, [Figure 1](#).

Enter [dC330](#) and stack the code 93-050 to run the ink reservoir pump MOT93-050, [PL 93.10 Item 11](#) and code 91-045 low pressure assist valve SOL 91.045, [PL 93.10 Item 15](#). The pump will run for approximately 10 seconds. If the pump runs, then the air pressure from the disconnected air hose is sufficient to feel on the skin, or partially inflate a rubber glove. **The pump runs**

Y N

Go to [WD 9.14](#) and [WD 9.12](#). Check the ink reservoir pump.
Refer to:

- [GP 10](#), How to Check a Motor.
- P/J130, [Solenoid patch PWB](#).
- P/J801, [Marking unit driver PWB](#)
- [01E](#) +12V Distribution RAP.
- [01L](#) 0V Distribution RAP

Install new components as necessary:

- Marking unit driver PWB, [PL 92.10 Item 4](#).
- Ink reservoir, [PL 93.10 Item 10](#).

A

Reconnect the air hose from the pump to the ink reservoir, [Figure 1](#).

Enter the correct [dC330](#) code to check the ink reservoir solenoids:

- Purge solenoid valve 1, SOL93-059.
- Purge solenoid valve 2, SOL93-060.
- Purge solenoid valve 3, SOL93-061.
- Purge solenoid valve 4, SOL93-062.
- Black ink solenoid valve 5, SOL93-063.
- Black ink solenoid valve 6, SOL93-064.
- Black ink solenoid valve 7, SOL93-065.
- Black ink solenoid valve 8, SOL93-066.
- Yellow ink solenoid valve 9, SOL93-067.
- Yellow ink solenoid valve 10, SOL93-068.
- Yellow ink solenoid valve 11, SOL93-069.
- Yellow ink solenoid valve 12, SOL93-070.
- Cyan ink solenoid valve 13, SOL93-071.
- Cyan ink solenoid valve 14, SOL93-072.
- Cyan ink solenoid valve 15, SOL93-073.
- Cyan ink solenoid valve 16, SOL93-074.
- Magenta ink solenoid valve 17, SOL93-075.
- Magenta ink solenoid valve 18, SOL93-076.
- Magenta ink solenoid valve 19, SOL93-077.
- Magenta ink solenoid valve 20, SOL93-078.

All solenoids energise

Y N

Go to [WD 9.14](#), [WD 9.15](#) and [WD 9.12](#). Check the ink reservoir solenoids.

Refer to:

- [GP 12](#), How to Check a Solenoid.
- P/J430, P/J110, P/J410, P/J610, P/J810 [Solenoid patch PWB](#).
- P/J801, [Marking unit driver PWB](#)
- [01H](#) +24V Distribution RAP.
- [01L](#) 0V Distribution RAP

Install new components as necessary:

- Ink Reservoir, [PL 93.10 Item 10](#).
- Marking unit driver PWB, [PL 92.10 Item 4](#).

Turn the machine off, then on, [GP 14](#). Check the PEST log for the following codes:

- For 99-150-00, go to the [99-143-00 to 99-150-00](#) PEST Error 4 RAP.
- For 99-292-00 to 99-312-00, go to the [99-293-00 to 99-312-00](#) PEST Error 9 RAP.
- For 99-460-00, go to the [99-444-00 to 99-460-00](#) PEST Error 16 RAP.
- For 99-461-00 to 99-467-00 or 99-470-00 to 99-477-00, go to the [99-461-00 to 99-477-00](#) PEST Error 17 RAP.
- For 99-480-00 to 99-496-00, go to the [99-480-00 to 99-497-00](#) PEST Error 18 RAP.
- For 99-497-00 to 99-507-00, go to the [99-500-00 to 99-515-00](#) PEST Error 19 RAP.
- For 99-530-00 to 99-533-00, go to the [99-516-00 to 99-533-00](#) PEST Error 20 RAP.

A

- For 99-564-00, 99-565-00 or 99-568-00 to 99-580-00, go to the [99-564-00 to 99-565-00](#) PEST Error 23 RAP.
- For 99-682-00, 99-684-00, 99-685-00, go to the [99-671-00 to 99-685-00](#) PEST Error 30 RAP.
- For 99-686-00 to 99-700-00, go to the [99-686-00 to 99-700-00](#) PEST Error 31 RAP.
- For 99-701-00 to 99-706-00, go to the [99-701-00 to 99-721-00](#) PEST Error 32 RAP.

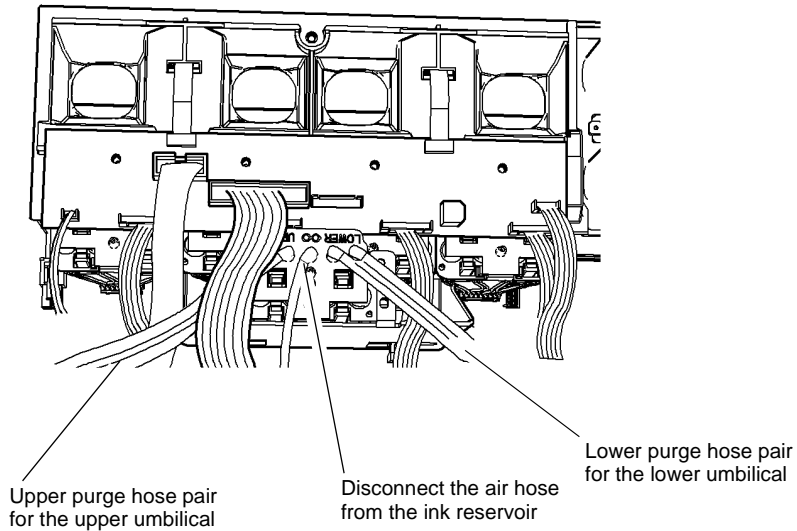

Figure 1 Reservoir pump air hose

U-1-1641-A

93B Ink Leak Checkout RAP

This RAP is to be used when an ink leak is present in the machine.

Procedure

WARNING

Ensure that the electricity to the machine is switched off while performing tasks that do not need electricity. Refer to [GP 14](#). Disconnect the power cord. Electricity can cause death or injury. Moving parts can cause injury.

CAUTION

Wait for the ink and other components to cool before attempting the removal procedures.

Check the following areas for leaking ink:

- Umbilical / Ink reservoir connection. If present perform the following:
 1. Remove the umbilicals, refer to [REP 91.31](#).
 2. Check the upper check valve unit, [PL 91.20 Item 19](#) and reservoir gasket [PL 91.20 Item 18](#). Clean as necessary, refer to [GP 27](#).
 3. Check the lower check valve unit, [PL 91.25 Item 19](#) and reservoir gasket [PL 91.25 Item 18](#). Clean as necessary, refer to [GP 27](#).
 4. Reassemble the components.
- Umbilical / printhead connection, If present perform the following:
 1. Check the purge line filter assemblies, install a new assembly if necessary:
 - Upper purge line filter assembly, [PL 91.20 Item 17](#).
 - Lower purge line filter assembly, [PL 91.25 Item 17](#).
 2. Remove the printhead, refer to [REP 91.29](#).
 3. Check the connection and gasket. Clean as necessary, refer to [GP 27](#).
 4. Reassemble the components.
- Ink reservoir or umbilical leaking elsewhere, If present perform the following:
 1. Install new components as necessary:
 - Upper umbilical kit, [PL 91.20 Item 20](#).
 - Lower umbilical kit, [PL 91.25 Item 20](#).
 - Ink reservoir assembly, [PL 93.10 Item 26](#).
 2. Clean ink leakages as necessary, refer to [GP 27](#).
- Printheads leaking elsewhere, if present perform the following:
 1. Install new components as necessary:
 - Upper printhead, [PL 91.20 Item 2](#).
 - Lower printhead, [PL 91.25 Item 2](#).
 2. Clean ink leakages as necessary, refer to [GP 27](#).
- Check melt plates and melt plate housing for debris that can cause incorrect delivery of ink from loader to ink reservoir.
- Check for correct ink loader installation.

94-504-00 Cleaning Unit Reservoir Pressure Low RAP

94-504-00 Cleaning unit reservoir pressure is too low.

Procedure

WARNING

Ensure that the electricity to the machine is switched off while performing tasks that do not need electricity. Refer to [GP 14](#). Disconnect the power cord. Electricity can cause death or injury. Moving parts can cause injury.

CAUTION

Use care when working near the drum. The drum can be damaged easily, which will cause print quality defects.

Install a new cleaning unit, [PL 94.10 Item 21](#) and continue with the procedure.

NOTE: Ensure the new cleaning unit is above 6 degrees Celsius or 43 degrees Fahrenheit. Do not install a very cold cleaning unit.

Check the fault history, [GP 2](#). **Multiple occurrences of fault 94-504-00 are listed.**

Y N
Perform [SCP 5](#) Final Actions.

Go to [WD 9.2](#), [WD 9.4](#) and [WD 9.19](#). Check the wiring between the cleaning unit and the drum driver PWB. **The wiring is good.**

Y N
Repair the wiring as necessary, [REP 1.1](#) or install a new cleaning unit interface harness, [PL 1.15 Item 17](#).

Check for grounding faults, [GP 7](#) System Grounding Verification. If the fault remains, install a new drum driver PWB, [PL 1.15 Item 4](#).

94-505-00 Cleaning Unit Reservoir Pressure High RAP

94-505-00 Cleaning unit reservoir pressure is too high.

Procedure

WARNING

Ensure that the electricity to the machine is switched off while performing tasks that do not need electricity. Refer to [GP 14](#). Disconnect the power cord. Electricity can cause death or injury. Moving parts can cause injury.

CAUTION

Use care when working near the drum. The drum can be damaged easily, which will cause print quality defects.

Cheat the front door interlock. Listen at the front of the cleaning unit. **The cleaning unit can be heard running.**

Y N
Switch off, then switch on the machine, [GP 14](#). **The fault is still present.**

Y N
Perform [SCP 5](#) Final Actions.

Install a new cleaning unit, [PL 94.10 Item 21](#). **The fault is still present.**

Y N
Perform [SCP 5](#) Final Actions.

Remove the new cleaning unit. Remove the drum drive motor and belt, refer to [REP 91.24](#). Check that the 12 pin connector on the rear of the machine is connected correctly and not damaged. **The 12 pin connector is good.**

Y N
Install a new 12 pin connector, [PL 94.10 Item 6](#).

Go to [WD 9.2](#), [WD 9.4](#) and [WD 9.19](#). Check the wiring between the cleaning unit and the drum driver PWB. Repair the wiring as necessary, [REP 1.1](#) or install a new harness, [PL 1.15 Item 17](#). Reinstall the original cleaning unit. **The fault is still present.**

Y N
Perform [SCP 5](#) Final Actions.

Remove the cleaning unit. Install a new drum driver PWB, [PL 1.15 Item 4](#). Reinstall the original cleaning unit. **The fault is still present.**

Y N
Perform [SCP 5](#) Final Actions.

Check for grounding faults, [GP 7](#) System Grounding Verification.

Remove the front door interlock cheat. Install a new cleaning unit, [PL 94.10 Item 21](#). Cheat the front door interlock. Listen at the front of the cleaning unit. **The cleaning unit can be heard running.**

Y N
Perform [SCP 5](#) Final Actions.

Remove the cleaning unit. Remove the drum drive motor and belt, refer to [REP 91.24](#). Check that the 12 pin connector on the rear of the machine is connected correctly and not damaged. **The 12 pin connector is good.**

Y N

Install a new 12 pin connector, [PL 94.10 Item 6](#).

Go to [WD 9.2](#), [WD 9.4](#) and [WD 9.19](#). Check the wiring between the cleaning unit and the drum driver PWB. Repair the wiring as necessary, [REP 1.1](#) or install a new harness, [PL 1.15 Item 17](#). Reinstall the cleaning unit. Cheat the front door interlock. Listen at the front of the cleaning unit. **The cleaning unit can be heard running.**

Y N

Perform [SCP 5](#) Final Actions.

Remove the cleaning unit. Install a new drum drive motor PWB, [PL 1.15 Item 4](#). unit. Cheat the front door interlock. Listen at the front of the cleaning unit. **The cleaning unit can be heard running.**

Y N

Perform [SCP 5](#) Final Actions.

Check for grounding faults, [GP 7](#) System Grounding Verification.

94-510-00, 94-512-00 Drum Image Initial Position Error RAP

94-510-00 The imaging software detected the drum at the wrong position.

94-512-00 The drum has stalled during imaging.

Procedure

WARNING

Ensure that the electricity to the machine is switched off while performing tasks that do not need electricity. Refer to [GP 14](#). Disconnect the power cord. Electricity can cause death or injury. Moving parts can cause injury.

1. Perform the [94-534-00](#) Drum Drive Belt Slip RAP.
2. If the fault remains, reload the software, [GP 4](#) Machine Software.

94-514-00, 94-518-00 Drum Imaging Error RAP

94-514-00 Image data not ready when needed during drum revolution

94-518-00 Software timing error during imaging

Procedure

WARNING

Ensure that the electricity to the machine is switched off while performing tasks that do not need electricity. Refer to GP 14. Disconnect the power cord. Electricity can cause death or injury. Moving parts can cause injury.

1. Reload the software, GP 4 Machine Software.
2. If the fault remains, install a new IME controller PWB, PL 92.10 Item 1.

94-519-00 Drum Imaging Error RAP

94-519-00 Drum Imaging Failure

Procedure

WARNING

Ensure that the electricity to the machine is switched off while performing tasks that do not need electricity. Refer to GP 14. Disconnect the power cord. Electricity can cause death or injury. Moving parts can cause injury.

1. Perform the dC977 Drum Runout Calibration.
 2. Perform the dC914 Head to Head Alignment Test.
- If the fault remains, install new components as necessary:
- IME controller PWB, PL 92.10 Item 1.
 - Drum position encoder assembly, PL 94.20 Item 8.

94-520-00 Cleaning Unit Drive Error RAP

94-520-00 Cleaning unit motor is taking too much current.

Procedure

WARNING

Ensure that the electricity to the machine is switched off while performing tasks that do not need electricity. Refer to [GP 14](#). Disconnect the power cord. Electricity can cause death or injury. Moving parts can cause injury.

Go to [dC123](#) Pest Fault History and check for faults related to the drum, drum drive or drum control components.

Go to [dC959](#) Cleaning Unit Exerciser. Perform a full speed exercise. **The fault remains.**

Y N
Perform [SCP 5](#) Final Actions.

Go to [dC959](#) Cleaning Unit Exerciser. Perform a slow speed exercise. **The fault remains.**

Y N
Perform [SCP 5](#) Final Actions.

Remove the drum drive motor and belt, refer to [REP 91.24](#). Check the 12 pin connector, [PL 94.10 Item 12](#). Check the cleaning unit motor, [PL 94.10 Item 24](#) for damage. Go to [WD 9.2](#). Check the wiring between the cleaning unit and the drum driver PWB. Repair the wiring as necessary, [REP 1.1](#) or install a new harness, [PL 1.15 Item 17](#).

Install new components as necessary:

- 12 pin connector, [PL 94.10 Item 12](#).
- Cleaning unit motor assembly, [PL 94.10 Item 19](#).
- Drum driver PWB, [PL 1.15 Item 4](#).

94-522-00 Cleaning Unit Motor Stall RAP

94-522-00 Cleaning unit motor stall.

Procedure

WARNING

Ensure that the electricity to the machine is switched off while performing tasks that do not need electricity. Refer to [GP 14](#). Disconnect the power cord. Electricity can cause death or injury. Moving parts can cause injury.

Go to [dC123](#) Pest Fault History and check for faults related to the drum, drum drive or drum control components.

Go to [dC959](#) Cleaning Unit Exerciser. Perform a full speed exercise. **The fault remains.**

Y N
Perform [SCP 5](#) Final Actions.

Print [TP 20](#) Oil Bar Chase and Metering Blade Timing Test Pages. Evaluate the metering blade timing test page only. **The metering blade engages and disengages with the drum correctly.**

Y N
Remove the cleaning unit, refer to [REP 94.1](#). Ensure the cleaning unit camshaft is unlocked, refer to [REP 91.32](#), Figure 4. If necessary, use a screwdriver to manually rotate the cam shaft, [Figure 1](#). Go to [dC959](#) Cleaning Unit Exerciser. Perform a full speed exercise. **The fault remains.**

Y N
Install a new cleaning unit, [PL 94.10 Item 21](#). Go to [dC959](#) Cleaning Unit Exerciser. Perform a full speed exercise. **The fault remains.**

Y N
Perform [SCP 5](#) Final Actions.

Reinstall the original cleaning unit.

Enter [dC140](#) code 94-103 to monitor the cleaning unit motor encoder, [PL 94.10 Item 20](#). Use a screwdriver to manually rotate the cam shaft. **The display changes.**

Y N
Go to [WD 9.2](#) and [WD 9.3](#). Check the cleaning unit motor and encoder. Refer to:

- [GP 10](#), How to Check a Motor.
- P/J601, P/J802 [Drum driver PWB](#).

- [01D+5V](#) Distribution RAP.
- [01J +50V](#) Distribution RAP.
- [01L 0V](#) Distribution RAP

Reinstall the original cleaning unit. Install new components as necessary:

- Cleaning unit motor assembly, [PL 94.10 Item 19](#).
- Drum driver PWB, [PL 1.15 Item 4](#).

Enter [dC330](#) code 94-105 to monitor the cleaning unit home sensor, [PL 94.10 Item 17](#). Use a screwdriver to manually rotate the camshaft. Ensure that cam rotates through the whole of allowable travel. **The display changes.**

A

A

Y N

Go to [WD 9.3](#). Check the cleaning unit motor and encoder.

Refer to:

- [GP 11](#), How to Check a Sensor
- P/J802 [Drum driver PWB](#).
- [01D](#) +5V Distribution RAP.
- [01L](#) 0V Distribution RAP

Reinstall the original cleaning unit. Install new components as necessary:

- Cleaning unit home sensor, [PL 94.10 Item 17](#).
- Cleaning unit motor assembly, [PL 94.10 Item 19](#).
- Drum driver PWB, [PL 1.15 Item 4](#).

Check that the camshaft rotates freely. **The camshaft rotates freely.**

Y N

Perform the following:

1. Inspect the camshaft for obstructions that would prevent it from moving freely.
2. Remove the camshaft assembly, [PL 94.10 Item 4](#), [REP 91.32](#). Check the bushings, [PL 94.10 Item 8](#) and [PL 94.10 Item 14](#) for wear or damage. Install new components as necessary:
 - Camshaft assembly, [PL 94.10 Item 4](#).
 - Cleaning unit motor assembly, [PL 94.10 Item 19](#).

Remove the drum drive motor and belt, refer to [REP 91.24](#). Check the 12 pin connector, [PL 94.10 Item 12](#). Go to [WD 9.2](#). Check the wiring between the cleaning unit and the drum driver PWB. Repair the wiring as necessary, [REP 1.1](#) or install a new harness, [PL 1.15 Item 17](#).

Reinstall the original cleaning unit. Install new components as necessary:

- 12 pin connector, [PL 94.10 Item 12](#).
- Drum driver PWB, [PL 1.15 Item 4](#).

Perform [SCP 5](#) Final Actions.

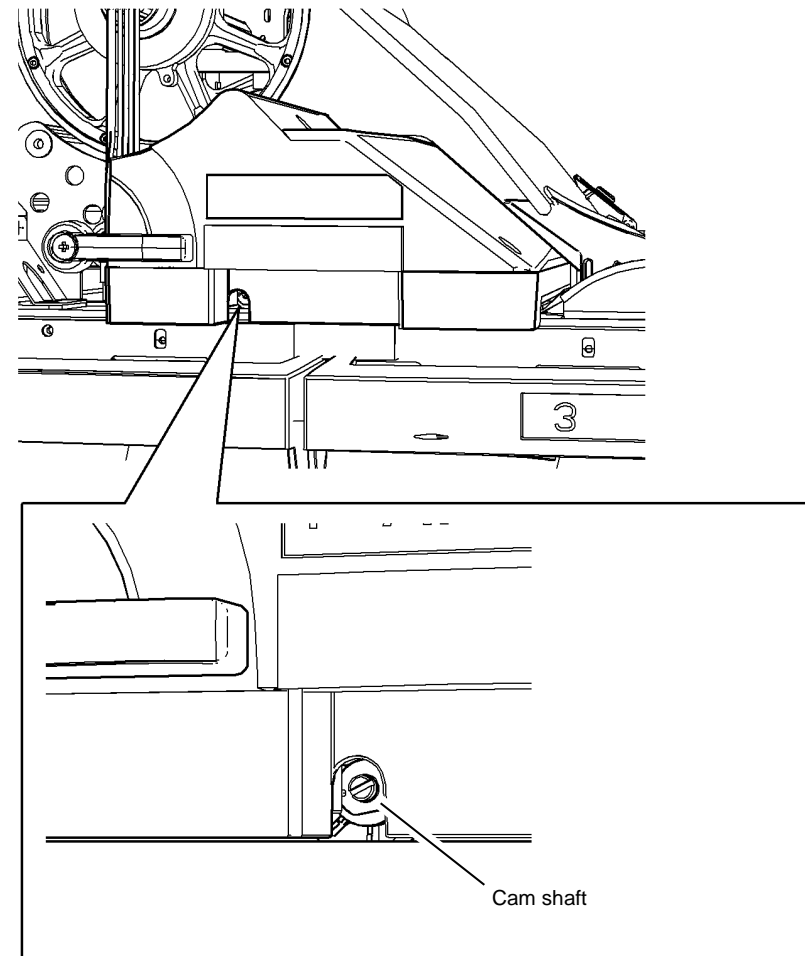

U-1-0976-A

Figure 1 Component location

94-524-00 Drum Drive Motor Over Current RAP

94-524-00 Drum drive motor is taking too much current.

Initial Actions

WARNING

Ensure that the electricity to the machine is switched off while performing tasks that do not need electricity. Refer to [GP 14](#). Disconnect the power cord. Electricity can cause death or injury. Moving parts can cause injury.

CAUTION

Use care when working near the drum. The drum can be damaged easily, which will cause print quality defects.

- Check that the print media loaded into all of the trays matches the UI display for each tray. If necessary correct the settings or load the correct media. Media that is too thick for the machine settings will cause drive errors.
- Check the trays for mixed media weights and correct if necessary.
- Check for evidence of multi-feeds. Multiple sheets of media may cause drum drive errors. If multi-feeds are indicated go to [OF 8](#) Multi-feed RAP.

Procedure

Go to [dC123](#) Pest Fault History and check for faults related to the drum, drum drive or drum control components.

1. Check the wiring between PJ6AC on the power supply unit and CN1 on the drum drive motor.
Refer to [WD 1.1](#). Repair as necessary, [REP 1.1](#).
2. Go to [WD 1.1](#), [WD 9.1](#) and [WD 9.3](#). Check the wiring between the drum drive motor encoder and the [Drum driver PWB](#), PJ802. Repair the wiring as necessary, [REP 1.1](#). If necessary install a new harness:
 - Drum driver to front components harness (PJ501), [PL 1.15 Item 14](#).
 - Cleaning unit interface harness (PJ601, PJ802), [PL 1.15 Item 17](#).
3. Remove the drum drive motor, [REP 91.24](#). Perform the following:
 - Check that the motor shaft rotates freely.
 - Check for a resistance of 510 to 1800 ohms across pins 1 and 6 of the drum drive motor encoder.
 - Check the resistance of the winding on the drum drive motor. The resistance should be in the range 9 to 12 ohms. Check across pin 1 and pin 2, pin 2 and pin 3 and pin 1 and pin 3, all three values should be the same. If the resistance is outside of this range, install a new drum drive motor.
4. Check system grounds, refer to [GP 7](#). Pay particular attention to the media path baffles, transfix roller, and drum ground connections.
5. Install new components as necessary:
 - Drum drive motor, [PL 94.20 Item 6](#).
 - Power supply unit, [PL 1.15 Item 2](#).
 - Drum driver PWB, [PL 1.15 Item 4](#).

94-526-00 Drum Drive Stall RAP

94-526-00 Drum has stalled.

Initial Actions

WARNING

Ensure that the electricity to the machine is switched off while performing tasks that do not need electricity. Refer to [GP 14](#). Disconnect the power cord. Electricity can cause death or injury. Moving parts can cause injury.

CAUTION

Use care when working near the drum. The drum can be damaged easily, which will cause print quality defects.

- Check that the print media loaded into all of the trays matches the UI display for each tray. If necessary correct the settings or load the correct media. Media that is too thick for the machine settings will cause drive errors.
- Check the trays for mixed media weights and correct if necessary.
- Check for evidence of multi-feeds. Multiple sheets of media may cause drum drive errors. If multi-feeds are indicated go to [OF 8](#) Multi-feed RAP.
- Check the fault history for Mis-Feed Jam fault codes 71-101-00 to 71-155-00, 72-101-00 to 72-155-00, 73-101-00 to 73-155-00, 74-101-00 and 75-101-00. If the fault codes are present, perform the appropriate RAP before proceeding with this RAP.
- Check the fault history, [dC122](#) for 10-500-00 to 10-540-00 or 10-550 fault codes. If the fault codes are present, perform the appropriate RAP before proceeding with this RAP.
- Enter [dC978](#) Transfix Calibration Values. Check the calibration values against the label on the front of the drum frame. If necessary, enter the correct transfix load values.

NOTE: The calibration values are found on a label on the drum frame behind the inner cover, [PL 81.11 Item 2](#).

Procedure

Go to [dC123](#) Pest Fault History and check for faults related to the drum, drum drive or drum control components.

Refer to [Figure 1](#). Perform the following:

1. While the transfix roller is not loaded, spin the roller. Check that the roller spins freely without binding or generating unusual noise. Check the surface of the transfix roller for contamination or damage. Install new components as necessary, [PL 10.20](#).
2. Remove the drum and abatement fan assembly, refer to [REP 91.24](#). Release the drum belt tension. With the drum drive and transfix roller disengaged from the drum, manually rotate the drum. If the drum does not rotate freely, install new components as necessary, [PL 94.20](#) and [PL 31.11](#).
3. Remove the drum drive motor, refer to [REP 91.24](#). Check that the motor shaft rotates freely. If necessary, install a new drum drive motor, [PL 94.20 Item 6](#).
4. If 10-536 is in the fault history, [dC122](#), check the transfix calibration values, [dC978](#). If the transfix values have been reset, re-enter the correct transfix values.

NOTE: The calibration values are found on a label on the drum frame behind the inner cover, [PL 81.11 Item 2](#).

5. Switch off the machine, then switch on the machine, [GP 14](#). Check for, power supply, drum motor thermal protection circuit and drum motor current feedback PEST faults then perform the relevant RAP.
6. Check the fault history, [dC122](#) for 94-550 or 94-551 faults. If either fault is present, perform the relevant RAP.
7. Check system grounds, refer to [GP 7](#). Pay particular attention to the media path baffles, transfix roller, and drum ground connections.
8. Install new components as necessary:
 - Drum drive belt, [PL 94.20 Item 2](#).
 - Drum position encoder assembly, [PL 94.20 Item 8](#).
 - Power supply unit, [PL 1.15 Item 2](#).
 - Drum driver PWB, [PL 1.15 Item 4](#).
 - Drum drive motor, [PL 94.20 Item 6](#).
 - IME controller PWB, [PL 92.10 Item 1](#).

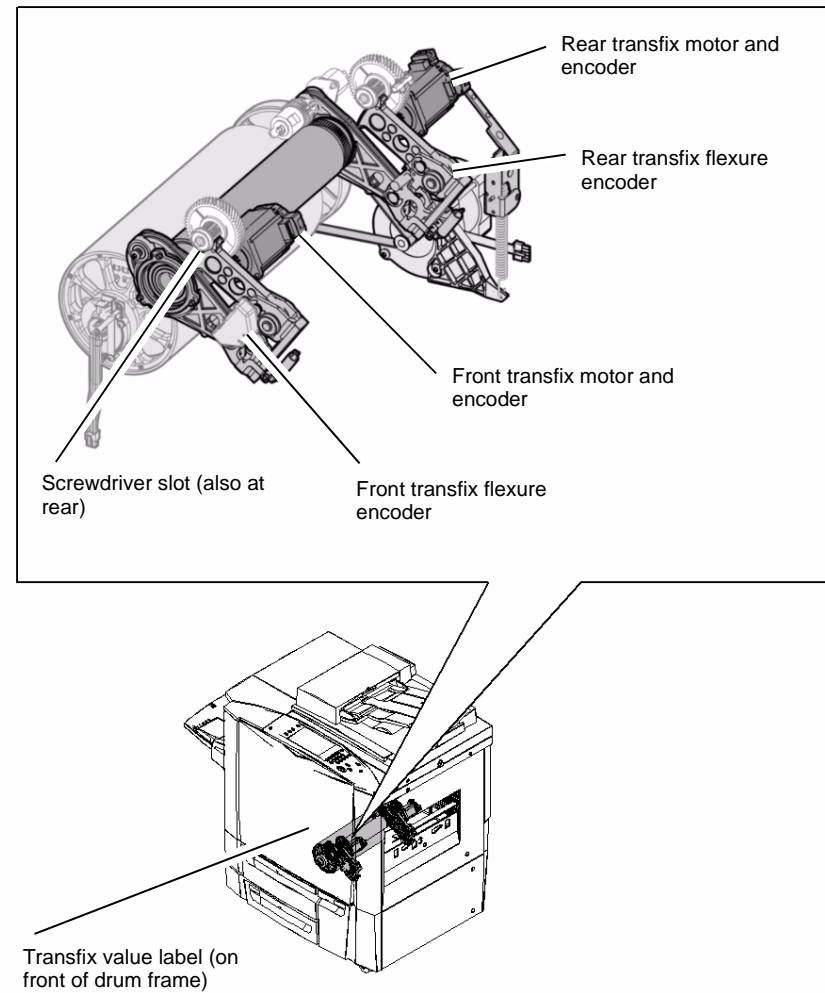

U-1-0979-A

Figure 1 Transfix component locations

94-527-00, 94-531-00 Cleaning Unit Early Life Over Current RAP

94-527-00 Oil delivery pump (early life) is taking too much current.

94-531-00 Oil delivery pump (early life) is taking too much current.

Procedure

WARNING

Ensure that the electricity to the machine is switched off while performing tasks that do not need electricity. Refer to [GP 14](#). Disconnect the power cord. Electricity can cause death or injury. Moving parts can cause injury.

These faults are shown for information only. No corrective actions are necessary. If the fault becomes more serious, faults 94-528-00, 94-532-00 or 94-533-00 will be raised.

94-528-00, 94-532-00, 94-533-00 Cleaning Unit Over Current RAP

94-528-00 Drum driver oil pump 1 is taking too much current.

94-532-00 Drum driver oil pump 2 is taking too much current.

94-533-00 Drum driver oil valve is taking too much current.

Procedure

WARNING

Ensure that the electricity to the machine is switched off while performing tasks that do not need electricity. Refer to [GP 14](#). Disconnect the power cord. Electricity can cause death or injury. Moving parts can cause injury.

CAUTION

Use care when working near the drum. The drum can be damaged easily, which will cause print quality defects.

Install a new cleaning unit, [PL 94.10 Item 21](#). Make 20 copies. Wait 1 minute. **The fault is still present with the new cleaning unit.**

Y N

Perform [SCP 5](#) Final Actions.

Remove the new cleaning unit, refer to [REP 94.1](#). Remove the drum drive motor and belt, refer to [REP 91.24](#). Check the 12 pin connector, [PL 94.10 Item 6](#). Go to [WD 9.2](#). Check the wiring between the cleaning unit and the drum driver PWB. Repair the wiring as necessary, [REP 1.1](#) or install a new harness, [PL 1.15 Item 17](#). Reinstall the original cleaning unit.

Install new components as necessary:

- 12 pin connector, [PL 94.10 Item 6](#).
- Drum driver PWB, [PL 1.15 Item 4](#).

94-534-00 Drum Drive Belt Slip RAP

94-534-00 Excessive slipping of the drum belt.

Initial Actions

WARNING

Ensure that the electricity to the machine is switched off while performing tasks that do not need electricity. Refer to [GP 14](#). Disconnect the power cord. Electricity can cause death or injury. Moving parts can cause injury.

CAUTION

Use care when working near the drum. The drum can be damaged easily, which will cause print quality defects.

- Check that the print media loaded into all of the trays matches the UI display for each tray. If necessary correct the settings or load the correct media. Media that is too thick for the machine settings will cause drive errors.
- Check the trays for mixed media weights and correct if necessary.
- Check for evidence of multi-feeds. Multiple sheets of media may cause drum drive errors. If multi-feeds are indicated go to [OF 8](#) Multi-feed RAP.
- Check the fault history for Mis-Feed Jam fault codes 71-101-00 to 71-155-00, 72-101-00 to 72-155-00, 73-101-00 to 73-155-00, 74-101-00 and 75-101-00. If the fault codes are present then perform the appropriate RAP before proceeding with this RAP.
- Check the fault history, [dC122](#) for 10-500-00 to 10-540-00 or 10-550 fault codes. If the fault codes are present, perform the appropriate RAP before proceeding with this RAP.
- Enter [dC978](#) Transfix Calibration Values. Check the calibration values against the label on the front of the drum frame. If necessary, enter the correct transfix load values.

NOTE: The calibration values are found on a label on the drum frame behind the inner cover, [PL 81.11 Item 2](#).

Procedure

Go to [dC123](#) Pest Fault History and check for faults related to the drum, drum drive or drum control components.

Refer to [Figure 1](#). Perform the following:

1. While the transfix roller is not loaded, spin the roller. Check that the roller spins freely without binding or generating unusual noise. Check the surface of the transfix roller for contamination or damage. Install new components as necessary, [PL 10.20](#).
2. If 10-536 is in the fault history, [dC122](#), check the transfix calibration values, [dC978](#). If the transfix values have been reset, re-enter the correct transfix values.

NOTE: The calibration values are found on a label on the drum frame behind the inner cover, [PL 81.11 Item 2](#).

3. Switch off the machine, then switch on the machine, [GP 14](#). Check for, power supply, drum motor thermal protection circuit and drum motor current feedback PEST faults then perform the relevant RAP.
4. Check the fault history, [dC122](#) for 94-550 or 94-551 faults. If either fault is present, perform the relevant RAP.

5. Remove the drum and abatement fan assembly, refer to [REP 91.24](#). Manually rotate the drum and observe the drum motor. Abrupt rotations of the drum motor about its tensioning pivot indicates problems with the drum belt, such as voids or contamination in the grooves.
6. Check the drum belt tensioner mechanism. Make sure that the tensioner is latched correctly and applying tension to the motor bracket. Inspect the motor bracket for free rotation around its pivot, allowing tension to be transmitted to the drum belt.
7. Release the drum belt tension. Make sure that the drum drive motor pivots freely.
8. With the drum drive and transfix roller disengaged from the drum, manually rotate the drum. If the drum does not rotate freely, install new components as necessary:
 - Drum, [PL 94.20 Item 1](#).
 - Drum pulley, [PL 94.20 Item 3](#).
9. Remove the drum drive motor and drum belt, [REP 91.24](#). Perform the following:
Perform the necessary actions:
 - Clean the drum pulley, [GP 27](#).
 - Clean the drum belt, [GP 27](#).
 - Clean the drum drive motor pulley, [GP 27](#).
 - If necessary install a new belt, [PL 94.20 Item 2](#).
10. Check system grounds, refer to [GP 7](#). Pay particular attention to the media path baffles, transfix roller, and drum ground connections.
11. Refer to [WD 1.1](#) and [WD 9.3](#). Perform the following:
 - a. Check the wiring between PJ6AC and the drum drive motor. Repair as necessary, [REP 1.1](#).
 - b. Check the drum driver power supply interface cable, [PL 1.15 Item 10](#). If necessary, install a new drum driver power supply interface cable, [PL 1.15 Item 10](#).
 - c. Check the wiring between the drum drive motor encoder and the [Drum driver PWB](#), PJ802. Repair the wiring as necessary, [REP 1.1](#). If necessary install a new cleaning unit interface harness (PJ601, PJ802), [PL 1.15 Item 17](#).
12. Install new components as necessary:
 - Drum drive belt, [PL 94.20 Item 2](#).
 - Drum position encoder assembly, [PL 94.20 Item 8](#).
 - Power supply unit, [PL 1.15 Item 2](#).
 - Drum driver PWB, [PL 1.15 Item 4](#).
 - Drum drive motor, [PL 94.20 Item 6](#).
 - IME controller PWB, [PL 92.10 Item 1](#).

94-535-00 Drum Driver Command Current Error RAP

94-535-00 The drum driver PWB fails to monitor the drum drive current.

Procedure

WARNING

Ensure that the electricity to the machine is switched off while performing tasks that do not need electricity. Refer to [GP 14](#). Disconnect the power cord. Electricity can cause death or injury. Moving parts can cause injury.

Refer to:

- P/JDC2, [Power supply unit](#).
- P/J603, [Drum driver PWB](#).

Perform the following:

1. Switch off the machine, then switch on the machine, [GP 14](#). Check for PEST faults then perform the relevant RAP.
2. Go to [WD 9.2](#). Check the ribbon cable, [PL 1.15 Item 10](#) between the power supply unit and the drum driver PWB.
3. Install new components as necessary:
 - Drum driver power supply interface cable, [PL 1.15 Item 10](#).
 - Drum driver PWB, [PL 1.15 Item 4](#).
 - Drum drive motor, [PL 94.20 Item 6](#).
 - Power supply unit, [PL 1.15 Item 1](#).

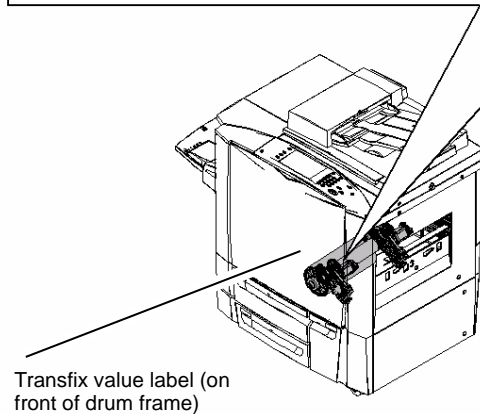
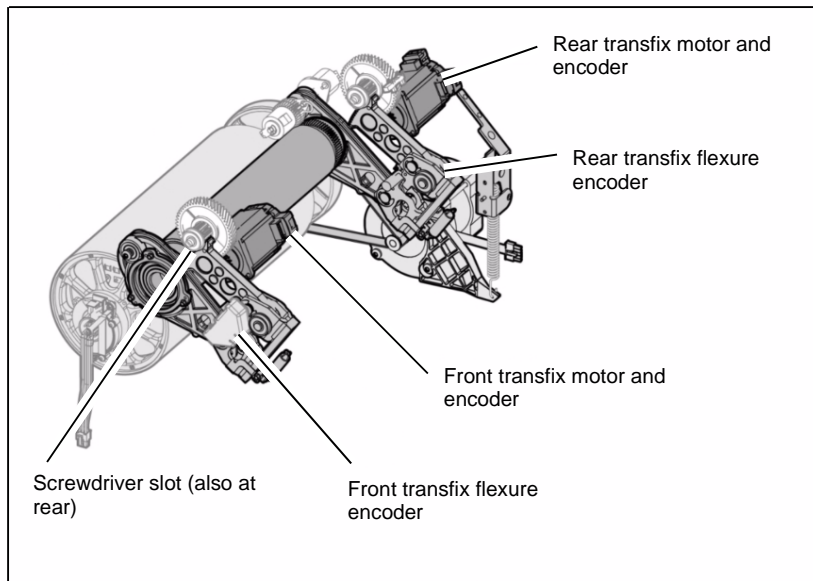

U-1-1683-A

Figure 1 Transfix component locations

94-536-00, 94-538-00, 94-540-00, 94-542-00, 94-544-00, 94-546-00, 94-632-00, 94-633-00 Drum Heat Error RAP

94-536-00 Drum front heater is too hot

94-538-00 Drum front heater is heating too slowly

94-540-00 Drum front thermistor is faulty

94-542-00 Drum rear heater is too hot

94-544-00 Drum rear heater is heating too slowly

94-546-00 Drum rear thermistor is faulty

94-632-00 Drum front heater went unstable while printing

94-633-00 Drum rear heater went unstable while printing

Initial Actions

Check that the machine is installed to allow adequate airflow. Refer to [GP 21](#) Installation Space Requirements.

Procedure

WARNING

Ensure that the electricity to the machine is switched off while performing tasks that do not need electricity. Refer to [GP 14](#). Disconnect the power cord. Electricity can cause death or injury. Moving parts can cause injury.

Enter [dC330](#) code 42-064 to run the drum fan, [PL 94.20 Item 4](#). The fan runs.

Y N

Go to [WD 9.1](#). Check the drum fan.

Refer to:

- [OF 6](#) Fans and Air Systems RAP
- [GP 10](#), How to Check a Motor.
- [P/J501](#) Drum driver PWB.
- [01H](#) +24V Distribution RAP.
- [01L](#) 0V Distribution RAP

Install new components as necessary:

- Drum fan, [PL 94.20 Item 4](#).
- Drum driver PWB, [PL 1.15 Item 4](#).

Enter [dC335](#) Heater Monitor and Exerciser. Select the front drum heater. Set the Setpoint Mode to Ready. Select Graph to run the test. Check that the temperature is correct and stable. Repeat the test for the rear drum heater.

NOTE: If the drum heater test fails to work correctly. Switch the machine off and then on, [GP 14](#). Enter [dC335](#) and rerun the drum heater test.

The tests were good.

Y N

Go to [WD 1.2](#), [WD 9.1](#) and [WD 9.3](#). Check the wiring between:

- The power supply unit and the drum heaters.
- The power supply unit and the thermal cutout PWB.
- The drum driver PWB and the front and rear thermistors.

Refer to:

- [P/J5AC](#), [Power supply unit](#).
- [P/J501](#), [P/J801](#) Drum Driver PWB
- [01A](#) AC Power Distribution RAP.
- [01B](#) +3.3V ESTAR Distribution RAP.
- [01L](#) 0V Distribution RAP

Install new components as necessary.

- Front drum thermistor, [PL 94.20 Item 9](#)
- Rear drum thermistor, [PL 94.20 Item 10](#).
- Drum, [PL 94.20 Item 1](#).
- Drum driver PWB, [PL 1.15 Item 4](#).
- Power supply unit, [PL 1.15 Item 2](#).
- Thermal cutout PWB, [PL 88.10 Item 11](#).

The fault may be intermittent. Go to [WD 1.2](#), [WD 9.1](#) and [WD 9.3](#). Check for loose connections between:

- The power supply unit and the drum heaters.
- The power supply unit and the thermal cutout PWB.
- The drum driver PWB and the front and rear thermistors.

Refer to:

- [P/J5AC](#) Power supply unit.
- [P/J501](#), [P/J801](#) Drum driver PWB
- [01A](#), AC Power Distribution RAP.
- [01B](#), +3.3V ESTAR Distribution RAP.
- [01L](#) 0V Distribution RAP

If the fault persists, install new components as necessary.

- Front drum thermistor, [PL 94.20 Item 9](#).
- Rear drum thermistor, [PL 94.20 Item 10](#).
- Drum, [PL 94.20 Item 1](#).
- Drum driver PWB, [PL 1.15 Item 4](#).
- Power supply unit, [PL 1.15 Item 2](#).
- Thermal cutout PWB, [PL 88.10 Item 11](#).

94-545-00 Drum Runout Calibration Error RAP

94-545-00 Drum runout calibration error - drum motor encoder.

Procedure

WARNING

Ensure that the electricity to the machine is switched off while performing tasks that do not need electricity. Refer to [GP 14](#). Disconnect the power cord. Electricity can cause death or injury. Moving parts can cause injury.

Go to [dC123](#) Pest Fault History and check for faults related to the drum, drum drive or drum control components.

Enter [dC140](#) code 94-101 to monitor the drum drive motor encoder. Manually rotate the drum.

The display changes

Y N

Go to [WD 1.1](#) and [WD 9.3](#). Check the wiring between the drum drive motor encoder and the drum driver PWB.

Refer to:

- [P/J802](#), [Drum driver PWB](#).
- [01D](#) +5V Distribution RAP.
- [01L](#) 0V Distribution RAP.

The wiring is good.

Y N

Repair the wiring as necessary, [REP 1.1](#).

Install new components as necessary:

- Drum drive motor, [PL 94.20 Item 6](#).
- Drum driver PWB, [PL 1.15 Item 4](#).

Install a new drum drive motor, [PL 94.20 Item 6](#).

94-547-00, 94-555-00 Y-Axis Belt Ratio Error RAP

94-547-00 Y-axis belt ratio error.

94-555-00 Y-axis belt ratio hard error.

Procedure

WARNING

Ensure that the electricity to the machine is switched off while performing tasks that do not need electricity. Refer to [GP 14](#). Disconnect the power cord. Electricity can cause death or injury. Moving parts can cause injury.

1. Check the drum belt tensioner. Make sure that the tensioner is latched correctly and applying tension to the drum belt. Release the drum belt tension. Make sure that the drum drive motor pivots freely.
2. Remove the drum belt, [PL 94.20 Item 2](#). Check the drum belt for contamination or damage. Clean the drum belt as necessary, [GP 27](#).
3. For fault 94-547-00. Check the drum drive motor pulley for contamination, clean as necessary, [GP 27](#).
4. Install a new drum belt, [PL 94.20 Item 2](#).

94-548-00 Y-Axis Position Error RAP

94-548-00 The drum position was incorrect after repositioning.

Procedure

WARNING

Ensure that the electricity to the machine is switched off while performing tasks that do not need electricity. Refer to **GP 14**. Disconnect the power cord. Electricity can cause death or injury. Moving parts can cause injury.

1. Perform the **94-534-00** Drum Drive Belt Slip RAP.
2. If the fault remains, reload the software, **GP 4** Machine Software.

94-549-00 Drum Runout Calibration Error RAP

94-549-00 Drum runout calibration - drum encoder.

Procedure

WARNING

Ensure that the electricity to the machine is switched off while performing tasks that do not need electricity. Refer to **GP 14**. Disconnect the power cord. Electricity can cause death or injury. Moving parts can cause injury.

Go to **dC123** Pest Fault History and check for faults related to the drum, drum drive or drum control components.

Enter **dC140** code 94-102 to monitor the drum position encoder. Manually rotate the drum.

The display changes

Y N

Go to **WD 9.1**. Check the wiring between the drum position encoder and the drum driver PWB.

Refer to:

- P/J501, **Drum driver PWB**.
- **01D** +5V Distribution RAP.
- **01L** 0V Distribution RAP

The wiring is good.

Y N

Repair the wiring as necessary, **REP 1.1**.

Install new components as necessary:

- Drum position encoder assembly, **PL 94.20** Item 8.
- Drum driver PWB, **PL 1.15** Item 4.

Remove the drum drive motor, **PL 94.20** Item 6. Check that the motor shaft rotates freely. If necessary, install a new drum drive motor, **PL 94.20** Item 6. With the drum drive motor removed, check that the drum rotates freely, install new components as necessary, **PL 94.20**.

The motor shaft rotates freely.

Y N

Install a new drum drive motor, **PL 94.20** Item 6.

With the drum drive motor removed, check rotation of the drum. **The drum rotates freely.**

Y N

Install new components as necessary, **PL 94.20**.

Go to **WD 9.1**. Check the wiring between the drum position encoder and the drum driver PWB.

Refer to:

- P/J501, **Drum driver PWB**.
- **01D** +5V Distribution RAP.
- **01L** 0V Distribution RAP

The wiring is good.

Y N

Repair the wiring as necessary, **REP 1.1**.

Install new components as necessary:

- Drum position encoder assembly, **PL 94.20** Item 8.
- Drum driver PWB, **PL 1.15** Item 4.

94-551-00, 94-552-00, 94-553-00 Drum Y-Axis Error RAP

94-551-00 Drum Y-axis home calculation error.

94-552-00 Drum Y-axis Initialization error.

94-553-00 Drum Y-axis home data error.

Procedure

WARNING

Ensure that the electricity to the machine is switched off while performing tasks that do not need electricity. Refer to GP 14. Disconnect the power cord. Electricity can cause death or injury. Moving parts can cause injury.

1. Perform the 94-534-00 Drum Drive Belt Slip RAP.
2. If the fault remains, reload the software, GP 4 Machine Software.

94-558-00, 94-560-00, 94-562-00, 94-564-00, 94-566-00 Cleaning Unit Position Error RAP

94-558-00 Cleaning unit timing error

94-560-00 Cleaning unit position error

94-562-00 Cleaning unit fast forward home time-out

94-564-00 Cleaning unit slow forward home time-out

94-566-00 Cleaning unit reverse home time-out

Procedure

WARNING

Ensure that the electricity to the machine is switched off while performing tasks that do not need electricity. Refer to GP 14. Disconnect the power cord. Electricity can cause death or injury. Moving parts can cause injury.

Go to the 94-522-00 Cleaning Unit Motor Stall RAP.

94-568-00, 94-570-00, 94-572-00, 94-573-00 Cleaning Unit Data Error RAP

94-568-00 Cleaning unit usage data read error

94-570-00 Cleaning unit usage data write error

94-572-00 Cleaning unit usage data detect error

94-573-00 Cleaning unit usage data version error

Procedure

WARNING

Ensure that the electricity to the machine is switched off while performing tasks that do not need electricity. Refer to [GP 14](#). Disconnect the power cord. Electricity can cause death or injury. Moving parts can cause injury.

CAUTION

Use care when working near the drum. The drum can be damaged easily, which will cause print quality defects.

Install a new cleaning unit, [PL 94.10 Item 21](#). The fault is still present.

Y N
Perform [SCP 5](#) Final Actions.

Reinstall the original cleaning unit. Remove the drum drive motor and belt, refer to [REP 91.24](#). Check the 12 pin connector, [PL 94.10 Item 6](#). Go to [WD 9.2](#) and [WD 9.4](#). Check the wiring between the cleaning unit and the drum driver PWB. Repair the wiring as necessary, [REP 1.1](#) or install a new harness, [PL 1.15 Item 17](#).

Install new components as necessary:

- 12 pin connector, [PL 94.10 Item 6](#).
- Drum driver PWB, [PL 1.15 Item 4](#).

94-574-00 Cleaning Unit Sync Error RAP

94-574-00 Cleaning unit NVM sync access error

Procedure

WARNING

Ensure that the electricity to the machine is switched off while performing tasks that do not need electricity. Refer to [GP 14](#). Disconnect the power cord. Electricity can cause death or injury. Moving parts can cause injury.

Switch off, then switch on the machine, [GP 14](#). The fault remains.

Y N
Perform [SCP 5](#) Final Actions.

Install a new IME controller PWB, [PL 92.10 Item 1](#).

94-610-00, 94-612-00 Cleaning Unit Error RAP

94-610-00 Cleaning unit delivery pump test fail

94-612-00 Cleaning unit valve test fail

Procedure

WARNING

Ensure that the electricity to the machine is switched off while performing tasks that do not need electricity. Refer to [GP 14](#). Disconnect the power cord. Electricity can cause death or injury. Moving parts can cause injury.

Check the fault history, [GP 2](#). Multiple occurrences of fault 94-610-00 are listed.

Y N
Go to [dC959](#) Cleaning Unit Exerciser. Perform a cleaning unit self test. The fault remains.
Y N
Switch off, then switch on the machine, [GP 14](#) to clear the fault. Perform [SCP 5](#) Final Actions.
Install a new cleaning unit, [PL 94.10 Item 21](#).

Go to [WD 9.2](#), [WD 9.4](#) and [WD 9.19](#). Check the wiring between the cleaning unit and the drum driver PWB. The wiring is good.

Y N
Repair the wiring as necessary, [REP 1.1](#) or install a new cleaning unit interface harness, [PL 1.15 Item 17](#).

Check for grounding faults, [GP 7](#) System Grounding Verification. If the fault remains, install a new drum driver PWB, [PL 1.15 Item 4](#).

94-611-00 Cleaning Unit Removal Pump Test Fail RAP

94-611-00 Cleaning unit removal pump test fail

Procedure

WARNING

Ensure that the electricity to the machine is switched off while performing tasks that do not need electricity. Refer to [GP 14](#). Disconnect the power cord. Electricity can cause death or injury. Moving parts can cause injury.

Go to the [94-504-00](#) Cleaning Unit Reservoir Pressure Low RAP.

94-615-00 Non Xerox Cleaning Unit Detected RAP

94-615-00 A non Xerox cleaning unit has been detected.

Procedure

WARNING

Ensure that the electricity to the machine is switched off while performing tasks that do not need electricity. Refer to [GP 14](#). Disconnect the power cord. Electricity can cause death or injury. Moving parts can cause injury.

NOTE: This procedure is only to be performed when the machine does not reorganize a genuine Xerox cleaning unit.

Perform the following:

1. Verify that the cleaning unit is a Xerox item. Remove, then reinstall the cleaning unit.
2. If the fault remains, install a new cleaning unit, [PL 94.10 Item 21](#).

94-616-00 Cleaning Unit Low Oil Detected RAP

94-616-00 Low oil is detected in the cleaning unit, before the scheduled end of life.

Procedure

WARNING

Ensure that the electricity to the machine is switched off while performing tasks that do not need electricity. Refer to [GP 14](#). Disconnect the power cord. Electricity can cause death or injury. Moving parts can cause injury.

CAUTION

Use care when working near the drum. The drum can be damaged easily, which will cause print quality defects.

Install a new cleaning unit, [PL 94.10 Item 21](#). Switch off, then switch on the machine [GP 14](#). Cheat the front door interlock. Listen at the front of the cleaning unit. **The cleaning unit can be heard running.**

Y N

The fault is still present.

Y N

Perform [SCP 5](#) Final Actions.

Go to [WD 9.2](#), [WD 9.4](#) and [WD 9.19](#). Check the wiring between the cleaning unit and the drum driver PWB. **The wiring is good.**

Y N

Repair the wiring as necessary, [REP 1.1](#) or install a new harness, [PL 1.15 Item 17](#).

Install a new drum driver PWB, [PL 1.15 Item 4](#). **The fault is still present.**

Y N

Perform [SCP 5](#) Final Actions.

Check for grounding faults, [GP 7](#) System Grounding Verification.

Remove the front door interlock cheat. Remove the new cleaning unit. Go to [WD 9.2](#), [WD 9.4](#) and [WD 9.19](#). Check the wiring between the cleaning unit and the drum driver PWB. **The wiring is good.**

Y N

Repair the wiring as necessary, [REP 1.1](#) or install a new harness, [PL 1.15 Item 17](#).

Install a new drum driver PWB, [PL 1.15 Item 4](#). Reinstall the new cleaning unit. Cheat the front door interlock. Listen at the front of the cleaning unit. **The cleaning unit can be heard running.**

Y N

Perform [SCP 5](#) Final Actions.

Check for grounding faults, go to [GP 7](#) System Grounding Verification.

94-617-00, 94-618-00 Oil Pump Error RAP

94-617-00 Oil delivery pump stalled

94-618-00 Oil removal pump stalled

Procedure

WARNING

Ensure that the electricity to the machine is switched off while performing tasks that do not need electricity. Refer to [GP 14](#). Disconnect the power cord. Electricity can cause death or injury. Moving parts can cause injury.

Check the fault history, [GP 2](#). Multiple occurrences of faults 94-617-00 or 94-618-00 are listed.

Y N

Install a new cleaning unit, [PL 94.10 Item 21](#).

Go to [WD 9.2](#), [WD 9.4](#) and [WD 9.19](#). Check the wiring between the cleaning unit and the drum driver PWB. **The wiring is good.**

Y N

Repair the wiring as necessary, [REP 1.1](#) or install a new harness, [PL 1.15 Item 17](#).

Install a new drum driver PWB, [PL 1.15 Item 4](#). Reinstall the new cleaning unit. Check the front door interlock. Listen at the front of the cleaning unit. **The cleaning unit can be heard running.**

Y N

Perform [SCP 5](#) Final Actions.

Check for grounding faults, go to [GP 7](#) System Grounding Verification.

94-619 Cleaning Unit Delivery Line Blocked RAP

94-619-00 Oil delivery line blocked.

Procedure

WARNING

Ensure that the electricity to the machine is switched off while performing tasks that do not need electricity. Refer to [GP 14](#). Disconnect the power cord. Electricity can cause death or injury. Moving parts can cause injury.

Install a new cleaning unit, [PL 94.10 Item 21](#).

94-620-00 Drum Fan Stall RAP

94-620-00 The drum fan has stalled.

Initial Actions

WARNING

Ensure that the electricity to the machine is switched off while performing tasks that do not need electricity. Refer to [GP 14](#). Disconnect the power cord. Electricity can cause death or injury. Moving parts can cause injury.

- Check the harness leading to the fan.
- Check for damage or debris that restricts movement of the fan.

Procedure

Enter [dC330](#) code 42-064 to run the drum fan, [PL 94.20 Item 4](#). **The drum fan runs.**

- Y N
- Go to [WD 9.1](#). Check the drum fan.
- Refer to:
- [OF 6](#) Fans and Air Systems RAP
 - [GP 10](#) How to Check a Motor.
 - PJ501, [Drum Driver PWB](#).
 - [01H](#) +24V Power Distribution RAP.
 - [01L](#) 0V Distribution RAP
- Install new components as necessary
- Drum fan, [PL 94.20 Item 4](#).
 - Drum driver PWB, [PL 1.15 Item 4](#).

Check for obstructions or debris blocking fan rotation. **The fan is clean.**

- Y N
- Clean ducts and filters as necessary, [GP 27](#).

The fault may be intermittent, check for damaged wiring or loose connectors. Repair the wiring as necessary, [REP 1.1](#). If necessary install a new drum fan [PL 94.20 Item 4](#).

94-621-00 Abatement Fan Stall RAP

94-621-00 The abatement fan has stalled.

Initial Actions

WARNING

Ensure that the electricity to the machine is switched off while performing tasks that do not need electricity. Refer to [GP 14](#). Disconnect the power cord. Electricity can cause death or injury. Moving parts can cause injury.

- Check the harness leading to the fan.
- Check for damage or debris that restricts movement of the fan.

Procedure

Enter [dC330](#) code 42-062 to run the abatement fan, [Figure 1](#). **The abatement fan runs.**

- Y N
- Go to [WD 9.4](#). Check the abatement fan.
- Refer to:
- [OF 6](#) Fans and Air Systems RAP
 - [GP 10](#) How to Check a Motor.
 - PJ901, [Drum Driver PWB](#).
 - [01E](#) +12V Power Distribution RAP.
 - [01L](#) 0V Distribution RAP
- Install new components as necessary
- Abatement fan assembly, [PL 94.20 Item 11](#).
 - Drum driver PWB, [PL 1.15 Item 4](#).

Check for obstructions or debris blocking fan rotation. **The fan is clean.**

- Y N
- Clean ducts and filters as necessary, [GP 27](#).

The fault may be intermittent, check for damaged wiring or loose connectors. Repair the wiring as necessary, [REP 1.1](#). If necessary install a new abatement fan, [PL 94.20 Item 11](#).

94-622-00 Cleaning Unit Unusable RAP

94-622-00 Cleaning unit previously marked unusable.

Procedure

WARNING

Ensure that the electricity to the machine is switched off while performing tasks that do not need electricity. Refer to **GP 14**. Disconnect the power cord. Electricity can cause death or injury. Moving parts can cause injury.

CAUTION

Do not reuse a cleaning unit that has oil contamination.

Install a new cleaning unit, **PL 94.10 Item 21**.

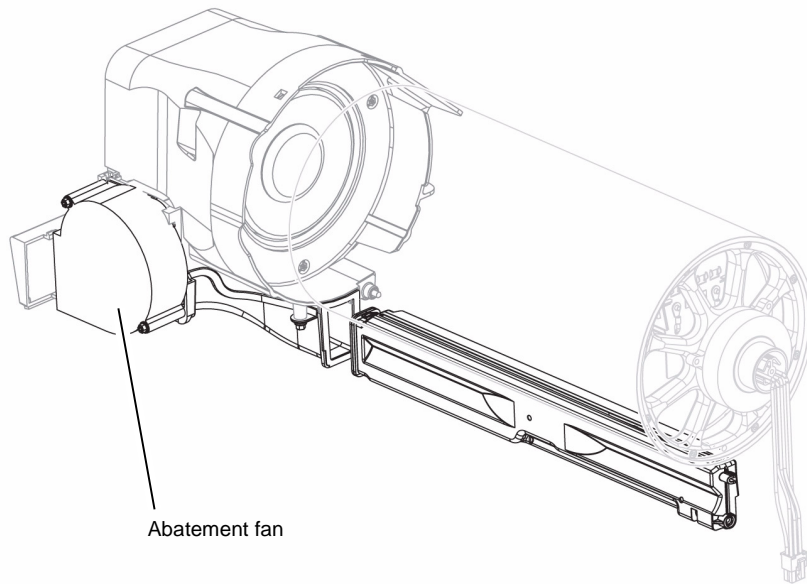

Abatement fan

U-1-1025-A

Figure 1 Component location

94-629-00 Extreme Customer Usage RAP

94-629-00 DM Gel countdown enabled.

Procedure

WARNING

Ensure that the electricity to the machine is switched off while performing tasks that do not need electricity. Refer to **GP 14**. Disconnect the power cord. Electricity can cause death or injury. Moving parts can cause injury.

This fault is shown for information only. No corrective actions are necessary.

94-631-00 Cleaning Unit Connectivity Failure RAP

94-631-00 Persistent cleaning unit connectivity failure.

Procedure

WARNING

Ensure that the electricity to the machine is switched off while performing tasks that do not need electricity. Refer to **GP 14**. Disconnect the power cord. Electricity can cause death or injury. Moving parts can cause injury.

Install a new cleaning unit, **PL 94.10 Item 21**.

94-634-00, 94-635-00 DMU Thermistor Failure RAP

94-634-00 DMU Thermistor Fail. The IME timed out waiting for the cleaning unit to warm-up. The IME has assumed that the cleaning unit thermistor has failed, although the cleaning unit is at operational temperature.

94-635-00 DMU thermistor sensor fail. Anomalous data received when using pressure sensor to determine CU oil level. The IME will revert to open loop oil consumption algorithm.

Procedure

These faults are shown for information only. No corrective actions are necessary.

94A Enclosure Fan Error RAP

Use this RAP to troubleshoot problems with the drum driver enclosure fan, MOT 42-063.

Procedure

WARNING

Ensure that the electricity to the machine is switched off while performing tasks that do not need electricity. Refer to GP 14. Disconnect the power cord. Electricity can cause death or injury. Moving parts can cause injury.

Referring to [WD 9.4](#) and [PL 1.15](#), check the enclosure fan is running. Check the wiring to the drum driver PWB. Install new components as necessary:

- Enclosure fan, MOT42-063, [PL 1.15 Item 6](#).
- Drum driver PWB, [PL 1.15 Item 4](#).

94B Drum Drive Control Test Actions RAP

Use this RAP to resolve problems identified by [dC708](#) Drum Drive Control Test.

Procedure

NOTE: On issue of the service manual (March 2011), [dC708](#) was considered to be unreliable. Therefore, it is advisable to go to [dC122](#) Fault History and [dC123](#) PEST Fault History then check for drum drive related faults.

Run [dC708](#) Drum Drive Control Test. Observe the results of the test and perform the relevant actions. On completion repeat the [dC708](#) Drum Drive Control Test, and check for additional actions, then return to the originating RAP.

0 Drum drive test normal

Passed test successfully

1 Low power slew test failed

Check the following for damage:

1. The wiring between PJ6AC on the power supply unit and the drum drive motor.
Refer to [WD 1.1](#). Repair as necessary, [REP 1.1](#).
2. The drum driver power supply interface cable, [PL 1.15 Item 10](#), install a new cable if necessary.
3. The cleaning unit interface harness, [PL 1.15 Item 17](#). Check between the drum drive motor and the drum driver PWB. Repair the harness if necessary, [REP 1.1](#). Refer to [WD 1.1](#) and [WD 9.3](#), PJ 802.
4. If the no obvious damage is found replace the drum drive motor then the drum drive PWB.

2 Hall analog signal out of range

Referring to [WD 9.3](#) check for +0.8V between PJ802 pin 12 and ground.

- If +0.7V to +0.9V is found install a new drum drive motor, [PL 94.20 Item 6](#).
- If no voltage is found install a new drum drive PWB, [PL 1.15 Item 4](#).

3 Analog sine or cosine drum encode signals out of range

1. Install a new drum encoder, [PL 94.20 Item 8](#).
2. If the fault persists install a new drum drive PWB, [PL 1.15 Item 4](#).

4 Drum home failed on index calibration

Clean the drum encoder or replace if necessary, [PL 94.20 Item 8](#).

5 Drum calibrate failed on hall signal

- Go to [WD 1.1](#) and [WD 9.1](#). Check the wiring between the drum motor and the drum driver PWB
Refer to:
 - P/J501, [Drum driver PWB](#).
 - [01D](#) +5V Distribution RAP.
 - [01L](#) 0V Distribution RAP

Install new components as necessary:

- Drum encoder, [PL 94.20 Item 8](#).
- Drum driver PWB, [PL 1.15 Item 4](#).
- Install a new drum drive motor, [PL 94.20 Item 6](#).
- Install a new drum driver PWB, [PL 1.15 Item 4](#).

6 Drum calibrate failed on encoder signal

- Go to [WD 9.1](#). Check the wiring between the drum encoder and the drum driver PWB
Refer to:
 - P/J501, [Drum driver PWB](#).
 - [01D](#) +5V Distribution RAP.
 - [01L](#) 0V Distribution RAP

Install new components as necessary:

- Drum encoder, [PL 94.20 Item 8](#).
- Drum driver PWB, [PL 1.15 Item 4](#).
- Install a new drum drive motor, [PL 94.20 Item 6](#).
- Install a new drum driver PWB, [PL 1.15 Item 4](#).

7 Drum following error higher than normal

1. Remove the drum fan shroud, [PL 94.20 Item 5](#) and manually rotate the drum.
 - If the drum rotates freely install a new drum drive motor, [PL 94.20 Item 6](#).
 - If the drum does not rotate freely remove the drum drive belt, [PL 94.20 Item 2](#).
 - Manually rotate the drum. If the drum spins freely install a new drum drive motor.
 - If the drum does not spin freely inspect the drum for obstructions and correct as necessary.

8 Belt slip test failed

Inspect, clean or replace the drum belt as required, [PL 94.20 Item 2](#).

9 Slew under load test failed: excessive motor torque with transfix loaded

- Check the transfix roller, [PL 10.20 Item 1](#), for free rotation.
- If the transfix roller does not rotate freely check for obstructions and repair as necessary or install a new transfix roller.

99-000-00 to 99-067-00 PEST Error 1 RAP

99-000-00 PEST test started.

99-052-00 Board link, MUD link broken.

99-053-00 Board link, PS link broken.

99-055-00 Cable video, printhead 1.

99-056-00 Cable video, printhead 2.

99-057-00 Cable video, printhead 3.

99-058-00 Cable video, printhead 4.

99-059-00 Cable video, printhead 1.

99-060-00 Cable video, printhead 2.

99-061-00 Cable video, printhead 3.

99-062-00 Cable video, printhead 4.

99-066-00 Board link, 3TM link broken.

99-067-00 Board link, PFP ink broken.

Procedure

WARNING

Ensure that the electricity to the machine is switched off while performing tasks that do not need electricity. Refer to GP 14. Disconnect the power cord. Electricity can cause death or injury. Moving parts can cause injury.

Refer to Table 1. Perform the relevant action. For an explanation of PEST codes refer to dC123.

Table 1 PEST Hard and Soft Fault Codes

Code	Hard/Soft	Action
99-057	Hard	Go to the 91A Printhead Communications RAP. Check pins 7 to 11 on the video cable from the IME controller PWB to the printhead 3 PWB.
99-058	Hard	Go to the 91A Printhead Communications RAP. Check pins 7 to 11 on the video cable from the IME controller to the printhead 4 PWB.
99-059	Hard	Go to the 91A Printhead Communications RAP. Check pins 14 to 27 on the video cable from the IME controller PWB to the printhead 1 PWB.
99-060	Hard	Go to the 91A Printhead Communications RAP. Check pins 14 to 27 on the video cable from the IME controller to the printhead 2 PWB.
99-061	Hard	Go to the 91A Printhead Communications RAP. Check pins 14 to 27 on the video cable from the IME controller PWB to the printhead 3 PWB.
99-062	Hard	Go to the 91A Printhead Communications RAP. Check pins 14 to 27 on the video cable from the IME controller to the printhead 4 PWB.
99-066	Hard	Go to the 92-530-00 RAP. Check the 3 tray module harness for damage.
99-067	Hard	Go to the 92-535-00, 92-536-00 RAP. Check for loose connections.

Table 1 PEST Hard and Soft Fault Codes

Code	Hard/Soft	Action
99-000	Soft	For information only. Indicates the start of the PEST procedure.
99-052	Hard	Refer to WD 9.7 and WD 9.10. Check the wiring between the marking unit driver PWB and the IME controller PWB. If the wiring harness is good, then install new marking unit driver PWB, PL 92.10 Item 4 or IME controller PWB, PL 92.10 Item 1.
99-053	Hard	Go to the 92-520-00 RAP. Check for loose or damaged connections.
99-055	Hard	Go to the 91A Printhead Communications RAP. Check pins 7 to 11 on the video cable from the IME controller PWB, PL 92.10 Item 1 to the printhead 1 PWB, PL 91.25 Item 2.
99-056	Hard	Go to the 91A Printhead Communications RAP. Check pins 7 to 11 on the video cable from the IME controller PWB to the printhead 2 PWB.

99-081-00 to 99-112-00 PEST Error 2 RAP

99-081-00 Wave amp cable, VPP or VSS head 1 open.

99-082-00 Wave amp cable, VPP or VSS head 2 open.

99-083-00 Wave amp cable, VPP or VSS head 3 open.

99-084-00 Wave amp cable, VPP or VSS head 4 open.

99-085-00 Wave amp cable, VPP or VSS head 1 short.

99-086-00 Wave amp cable, VPP or VSS head 2 short.

99-087-00 Wave amp cable, VPP or VSS head 3 short.

99-088-00 Wave amp cable, VPP or VSS head 4 short.

99-100-00 Board link, DDB safe mode.

99-110-00 Solenoid, DMU valve over current.

99-111-00 Stripper solenoid over current.

99-112-00 Pump, DMU delivery over current.

Initial Actions

WARNING

Ensure that the electricity to the machine is switched off while performing tasks that do not need electricity. Refer to GP 14. Disconnect the power cord. Electricity can cause death or injury. Moving parts can cause injury.

Procedure

Refer to Table 1. Perform the relevant action. For an explanation of PEST codes refer to dC123.

Table 1 PEST Hard and Soft Fault Codes

Code	Hard/Soft	Action
99-081	Hard	Install new wave amp cable for printhead 1, PL 92.10 Item 8.
99-082	Hard	Install new wave amp cable for printhead 2, PL 92.10 Item 8.
99-083	Hard	Install new wave amp cable for printhead 3, PL 92.10 Item 8.
99-084	Hard	Install new wave amp cable for printhead 4, PL 92.10 Item 8.
99-085	Hard	Go to 91-610-00 to 91-613-00. Check the video and wave amp cables to printhead 1. The fault indicates a failure of the wave amp power signals between the quad wave amp PWB and the IME controller PWB.

Table 1 PEST Hard and Soft Fault Codes

Code	Hard/Soft	Action
99-086	Hard	Go to 91-610-00 to 91-613-00. Check the video and wave amp cables to printhead 2. The fault indicates a failure of the wave amp power signals between the wave amp PWB and the IME controller PWB.
99-087	Hard	Go to 91-610-00 to 91-613-00. Check the video and wave amp cables to printhead 3. The fault indicates a failure of the wave amp power signals between the quad wave amp PWB and the IME controller PWB.
99-088	Hard	Go to 91-610-00 to 91-613-00. Check the video and wave amp cables to printhead 4. The fault indicates a failure of the wave amp power signals between the wave amp PWB and the IME controller PWB.
99-100	Hard	Safe mode indicates a firm ware mismatch. Check code version and upgrade or revert as appropriate. If problem continues install a new drum driver PWB, PL 1.15 Item 4.
99-110	Hard	Go to 94-505-00 RAP.
99-111	Hard	Install a new drum driver PWB, PL 1.15 Item 4.
99-112	Hard	Go to 94-505-00 RAP. Check the wiring between the cleaning unit and the drum driver PWB.

99-120-00 to 99-140-00 PEST Error 3 RAP

99-120-00 Media path driver PWB safe mode.

99-121-00 Motor, H bridge enable MPD open.

99-130-00 Solenoid, nip C over current.

99-131-00 Solenoid, nip D over current.

99-133-00 Solenoid, duplex over current.

99-134-00 Solenoid, CAR diverter over current.

99-140-00 Board link, MUD safe mode.

Initial Actions

WARNING

Ensure that the electricity to the machine is switched off while performing tasks that do not need electricity. Refer to GP 14. Disconnect the power cord. Electricity can cause death or injury. Moving parts can cause injury.

Procedure

Refer to Table 1. Perform the relevant action. For an explanation of PEST codes refer to dC123.

Table 1 PEST Hard and Soft Fault Codes

Code	Hard/Soft	Action
99-120	Hard	Safe mode indicates a firm ware mismatch. Check code version and upgrade or revert as appropriate. If problem continues install a new media path driver PWB, PL 1.15 Item 5.
99-121	Hard	Go to 82-132-00, 82-155-00 RAP. Check the horizontal transport motor.
99-130	Hard	Install a new media path driver PWB, PL 1.15 Item 5.
99-131	Hard	Install a new media path driver PWB, PL 1.15 Item 5.
99-133	Hard	Install a new media path driver PWB, PL 1.15 Item 5.
99-134	Hard	Install a new media path driver PWB, PL 1.15 Item 5.
99-140	Hard	Safe mode indicates a firm ware mismatch. Check code version and upgrade or revert as appropriate. If problem continues install a new marking unit driver PWB, PL 92.10 Item 4.

99-143-00 to 99-150-00 PEST Error 4 RAP

99-143-00 Thermistor, MU ambient open.

99-144-00 Thermistor, MU ambient short.

99-150-00 Solenoid, ink delivery valves over current.

Initial Actions

WARNING

Ensure that the electricity to the machine is switched off while performing tasks that do not need electricity. Refer to GP 14. Disconnect the power cord. Electricity can cause death or injury. Moving parts can cause injury.

Procedure

Refer to Table 1. Perform the relevant action. For an explanation of PEST codes refer to dC123.

Table 1 PEST Hard and Soft Fault Codes

Code	Hard/Soft	Action
99-143	Soft	Go to the 91-682-00 RAP. Check that the temperature reading is within range.
99-144	Soft	Go to the 91-682-00 RAP. Check that the temperature reading is within range.
99-150	Hard	Install a new marking unit driver PWB, PL 92.10 Item 4.

99-180-00 to 99-217-00 PEST Error 5 RAP

99-180-00 Board link 3TM safe mode.

99-185-00 Board link PFP safe mode.

99-210-00 Power, drum driver board ADC ref to 3.3V / out of range.

99-211-00 Power DDB ADC ref to 24V out of range.

99-212-00 Power 24V base above max.

99-213-00 Power 24V base below min.

99-214-00 Power 24V base not stable.

99-215-00 Power DDB ADC 50V APG out of range.

99-216-00 Power 50V base above max.

99-217-00 Power 50V base below min.

Initial Actions

WARNING

Ensure that the electricity to the machine is switched off while performing tasks that do not need electricity. Refer to GP 14. Disconnect the power cord. Electricity can cause death or injury. Moving parts can cause injury.

Procedure

Refer to Table 1. Perform the relevant action. For an explanation of PEST codes refer to dC123.

Table 1 PEST Hard and Soft Fault Codes

Code	Hard/Soft	Action
99-180	Hard	Safe mode indicates a firm ware mismatch. Check IME code version vs. 3TM PLD version and upgrade or revert as appropriate. If problem continues install a new 3 Trays module PWB, PL 73.16 Item 4.
99-185	Hard	Safe mode indicates a firm ware mismatch. Check IME code version vs. tray 5 PLD version and upgrade or revert as appropriate. If problem continues install a new tray 5 control PWB, PL 75.68 Item 8.
99-210	Soft	Go to the 01B RAP.
99-211	Soft	Go to the 01H RAP.

Table 1 PEST Hard and Soft Fault Codes

Code	Hard/Soft	Action
99-212	Soft	<p>Switch off the machine, GP 14. Check all 24V devices for heat or noise and the harnesses for damage or short circuits (i.e. chaffing). If a 24V component has been replaced then check that harness first.</p> <p>To isolate 5 major areas:</p> <ol style="list-style-type: none"> Unplug all drum driver PWB connectors except PJ602, PJ603 and PJ 902. If the fault 99-212 is removed but other 99-xxx errors occur, Then check all 24V components and harnesses to the drum driver PWB. Unplug all media path driver PWB connectors except PJ803, PJ408 and PJ 402. If the fault 99-212 is removed but other 99-xxx errors occur, Then check all 24V components and harnesses to the media path driver PWB. Unplug all marking unit driver PWB connectors except PJ203. If the fault 99-212 is removed but other 99-xxx errors occur, Then check all 24V components and harnesses to the marking unit driver PWB. Remove power to the quad wave amp PWB, by disconnecting PJ101 on the IME controller PWB. If the fault 99-212 is removed and no 99 errors occur, but a 91-610 error occurs. Then check all 24V components and harnesses to the quad wave amp PWB. Remove power to the CBC tray by disconnecting PJ1 on the power distribution PWB. If the fault 99-212 is removed and replaced by a soft error 99-213. Then check all 24V components and harnesses. <p>If none of those solve the problem, then try disconnecting the printhead connectors from the IME controller PWB. This will also raise head link errors so check for both. The error could be internal to one of the PWB's, refer to the 01H RAP.</p>
99-213	Soft	Go to the 01H RAP.
99-214	Soft	Go to the 01H RAP.
99-215	Soft	Go to the 01J RAP and the 01K RAP.

Table 1 PEST Hard and Soft Fault Codes

Code	Hard/Soft	Action
99-216	Soft	<p>Switch off the machine, GP 14. Check all 50V devices for heat or noise and the harnesses for damage or short circuits (i.e. chaffing). If a 50V component has been replaced then check that harness first.</p> <p>To isolate 4 major areas:</p> <ol style="list-style-type: none"> 1. Unplug all drum driver PWB connectors except PJ602, PJ603 and PJ 902. If the fault 99-216 is removed but other 99-xxx errors occur, Then check all 50V components and harnesses to the drum driver PWB. 2. Unplug all media path driver PWB connectors except PJ803, PJ408 and PJ 402. If the fault 99-216 is removed but other 99-xxx errors occur, Then check all 50V components and harnesses to the media path driver PWB. 3. Unplug all marking unit driver PWB connectors except PJ203. If the fault 99-216 is removed but other 99-xxx errors occur, Then check all 50V components and harnesses to the marking unit driver PWB. 4. Remove power to the quad wave amp PWB, by disconnecting PJ101 on the IME controller PWB. If the fault 99-216 is removed and no 99 errors occur, but a 91-610 error occurs. Then check all 50V components and harnesses to the quad wave amp PWB. <p>The error could be internal to one of the PWB's, refer to the 01J RAP and the 01K RAP.</p>
99-217	Soft	Go to the 01J RAP and the 01K RAP.

99-221-00 to 99-244-00 PEST Error 6 RAP

99-221-00 Main board 1.225V out of range.

99-230-00 Power AC voltage below min.

99-231-00 Power AC voltage middle error.

99-232-00 Power AC voltage above max.

99-235-00 Power AC base below min.

99-236-00 Power AC base above max.

99-237-00 AC power gauge is not stable.

99-240-00 Power DDB ADC 5V off missing.

99-241-00 Power DDB ADC +12V off missing.

99-242-00 Power DDB ADC -12V off missing.

99-243-00 Power DDB ADC +50V off missing.

99-244-00 Power IMEC ADC -50V off missing.

Initial Actions

WARNING

Ensure that the electricity to the machine is switched off while performing tasks that do not need electricity. Refer to **GP 14. Disconnect the power cord. Electricity can cause death or injury. Moving parts can cause injury.**

Procedure

Refer to **Table 1**. Perform the relevant action. For an explanation of PEST codes refer to **dC123**.

Table 1 PEST Hard and Soft Fault Codes

Code	Hard/Soft	Action
99-221	Soft	Go to the 01B RAP.
99-230	Soft	Go to the 01A RAP.
99-231	Soft	Go to the 01A RAP.
99-232	Soft	Go to the 01A RAP.
99-235	Soft	Go to the 01A RAP.
99-236	Soft	Go to the 01A RAP.
99-237	Soft	Go to the 01A RAP.

Table 1 PEST Hard and Soft Fault Codes

Code	Hard/Soft	Action
99-240	Hard	The power supply is good and believes the voltage is OK. But check for a wiring harness failure between the power supply and the drum driver PWB or an internal failure of the drum driver PWB. Check and repair the drum driver / media path power harness, PL 1.15 Item 15 . Install a new Drum driver PWB, PL 1.15 Item 4 . Refer to the 01D +5V Distribution RAP.
99-241	Hard	The power supply is good and believes the voltage is OK. But check for a wiring harness failure between the power supply and the drum driver PWB or an internal failure of the drum driver PWB. Check and repair the drum driver / media path power harness, PL 1.15 Item 15 . Install a new Drum driver PWB, PL 1.15 Item 4 . Refer to the 01E +12V Distribution RAP.
99-242	Hard	The power supply is good and believes the voltage is OK. But check for a wiring harness failure between the power supply and the drum driver PWB or an internal failure of the drum driver PWB. Check and repair the drum driver / media path power harness, PL 1.15 Item 15 . Install a new Drum driver PWB, PL 1.15 Item 4 . Refer to the 01F -12V Distribution RAP.
99-243	Hard	The power supply is good and believes the voltage is OK. But check for a wiring harness failure between the power supply and the drum driver PWB or an internal failure of the drum driver PWB. Check and repair the drum driver / media path power harness, PL 1.15 Item 15 . Install a new Drum driver PWB, PL 1.15 Item 4 . Refer to the 01J +50V Distribution RAP.
99-244	Hard	The power supply is good and believes the voltage is OK. But check for a wiring harness failure between the power supply at PJDC1 and the IME controller PWB at PJ701 or an internal failure of the IME controller PWB. Check and repair the harness, REP 1.1 . Install a new IME controller PWB, PL 92.10 Item 1 . Refer to the 01K -50V Distribution RAP.

99-250-00 to 99-271-00 PEST Error 7 RAP

- 99-250-00 Power IMEC ADC 1.1V out of range.
- 99-251-00 Power 1.2V out of range.
- 99-252-00 Power IMEC ADC 1.8V out of range.
- 99-253-00 Power IMEC ADC 2.5V out of range.
- 99-254-00 Power IMEC ADC 3.3V out of range.
- 99-255-00 Power IMEC ADC -50V out of range.
- 99-256-00 Power DDB ADC 5.0V out of range.
- 99-257-00 Power DDB ADC +12V out of range.
- 99-258-00 Power DDB ADC -12V out of range.
- 99-259-00 Power DDB ADC +24V out of range.
- 99-260-00 Power DDB ADC +50V out of range.
- 99-270-00 Fuse DDB 5V open.
- 99-271-00 Fuse DDB 12V open.

Initial Actions

WARNING

Ensure that the electricity to the machine is switched off while performing tasks that do not need electricity. Refer to [GP 14](#). Disconnect the power cord. Electricity can cause death or injury. Moving parts can cause injury.

Procedure

Refer to [Table 1](#). Perform the relevant action. For an explanation of PEST codes refer to [dC123](#).

Table 1 PEST Hard and Soft Fault Codes

Code	Hard/Soft	Action
99-250	Soft	Go to the 01B RAP.
99-251	Soft	Go to the 01B RAP.
99-252	Soft	Go to the 01B RAP.
99-253	Soft	Go to the 01B RAP.
99-254	Soft	Go to the 01B RAP.
99-255	Soft	Go to the 01K RAP.
99-256	Soft	Go to the 01D RAP.
99-257	Soft	Go to the 01E RAP.
99-258	Soft	Go to the 01F RAP.
99-259	Soft	Go to the 01H RAP.
99-260	Soft	Go to the 01J RAP.
99-270	Soft	Go to the 01D RAP. Check downstream devices for short circuits and bad wiring harnesses.
99-271	Soft	Go to the 01E RAP. Check downstream devices for short circuits and bad wiring harnesses.

99-272-00 to 99-292-00 PEST Error 8 RAP

99-272-00 Drum driver PWB, 24V fuse A open.

99-273-00 Drum driver PWB, 24V fuse B open.

99-274-00 Drum driver PWB, 50V fuse open.

99-280-00 Media path driver PWB, 3.3V over current detected.

99-281-00 Media path driver PWB, 5V fuse open.

99-282-00 Media path driver PWB, 12V fuse open.

99-283-00 Media path driver PWB, 24V fuse A open.

99-284-00 Media path driver PWB, 24V fuse B open.

99-285-00 Media path driver PWB, 24V fuse C open.

99-286-00 Media path driver PWB, 50V fuse A open.

99-287-00 Media path driver PWB, 50V fuse B open.

99-290-00 Marking unit driver PWB, 12V fuse 3.3V open.

99-291-00 Marking unit driver PWB, 12V fuse open.

99-292-00 Marking unit driver PWB, 24V fuse open.

Initial Actions

WARNING

Ensure that the electricity to the machine is switched off while performing tasks that do not need electricity. Refer to GP 14. Disconnect the power cord. Electricity can cause death or injury. Moving parts can cause injury.

Procedure

Refer to Table 1. Perform the relevant action. For an explanation of PEST codes refer to dC123.

Table 1 PEST Hard and Soft Fault Codes

Code	Hard/Soft	Action
99-272	Soft	Go to the 01H RAP. Check downstream devices for short circuits and bad wiring harnesses. Refer to the 01-525-00 +24V, +/-12V, +5V Short Circuit and Overload RAP.
99-273	Soft	Go to the 01H RAP. Check downstream devices for short circuits and bad wiring harnesses. Refer to the 01-525-00 +24V, +/-12V, +5V Short Circuit and Overload RAP.

Table 1 PEST Hard and Soft Fault Codes

Code	Hard/Soft	Action
99-274	Soft	Go to the 01D RAP. Check downstream devices for short circuits and bad wiring harnesses. Refer to the 01-525-00 +24V, +/-12V, +5V Short Circuit and Overload RAP.
99-280	Hard	Go to the 01B RAP. Check downstream for short circuits and bad wiring harnesses.
99-281	Hard	Go to the 01D RAP. Check down stream for short circuits and bad wiring harnesses. Refer the 01-525-00 +24V, +/-12V, +5V Short Circuit and Overload RAP.
99-282	Hard	Go to the 01E RAP. Check downstream for short circuits and bad wiring harnesses. Refer to the 01-525-00 +24V, +/-12V, +5V Short Circuit and Overload RAP.
99-283	Hard	Go to the 01H RAP. Check downstream devices for short circuits and bad wiring harnesses. Refer to the 01-525-00 +24V, +/-12V, +5V Short Circuit and Overload RAP.
99-284	Hard	Go to the 01H RAP. Check down stream devices for short circuits and bad wiring harnesses. Refer to the 01-525-00 +24V, +/-12V, +5V Short Circuit and Overload RAP.
99-285	Hard	Go to the 01H RAP. Check downstream devices for short circuits and bad wiring harnesses. Refer to the 01-525-00 +24V, +/-12V, +5V Short Circuit and Overload RAP. Check for +12V at the media path driver PWB, PJ803, WD 8.5. If the voltage is good go to the 01H RAP. If the voltage is not good, go to the 01E +12v Distribution RAP.
99-286	Hard	Go to the 01D RAP. Check downstream devices for short circuits and bad wiring harnesses. Refer to the 01-525-00 +24V, +/-12V, +5V Short Circuit and Overload RAP.
99-287	Hard	Go to the 01D RAP. Check downstream devices for short circuits and bad wiring harnesses. Refer to the 01-525-00 +24V, +/-12V, +5V Short Circuit and Overload RAP.
99-290	Hard	Go to the 01B RAP. Check downstream devices for short circuits and bad wiring harnesses.
99-291	Hard	Go to the 01E RAP. Check downstream devices for short circuits and bad wiring harnesses. Refer to the 01-525-00 +24V, +/-12V, +5V Short Circuit and Overload RAP.
99-292	Hard	Go to the 01H RAP. Check downstream devices for short circuits and bad wiring harnesses. Refer to the 01-525-00 +24V, +/-12V, +5V Short Circuit and Overload RAP.

99-293-00 to 99-312-00 PEST Error 9 RAP

99-293-00 Fuse MUD 50V open.

99-301-00 Connector, marking unit driver PWB.

99-302-00 Connector, marking unit driver PWB.

99-303-00 Connector, marking unit driver PWB.

99-304-00 Connector, marking unit driver PWB.

99-305-00 Connector, marking unit driver PWB.

99-306-00 Connector, marking unit driver PWB.

99-307-00 Connector, marking unit driver PWB.

99-308-00 Connector, marking unit driver PWB.

99-309-00 Connector, marking unit driver PWB.

99-310-00 Connector, MU solenoid patch PWB.

99-311-00 Connector, MU solenoid patch PWB.

99-312-00 Connector, MU solenoid patch PWB.

Initial Actions

WARNING

Ensure that the electricity to the machine is switched off while performing tasks that do not need electricity. Refer to [GP 14](#). Disconnect the power cord. Electricity can cause death or injury. Moving parts can cause injury.

Procedure

Refer to [Table 1](#). Perform the relevant action. For an explanation of PEST codes refer to [dC123](#).

Table 1 PEST Hard and Soft Fault Codes

Code	Hard/Soft	Action
99-304	Hard	Check that PJ801 on the marking unit driver PWB is securely connected. Check the wiring for an open circuit, repair as necessary, REP 1.1 . Refer to WD 9.12 .
99-305	Hard	Check that PJ101 on the marking unit driver PWB is securely connected. Check the wiring for an open circuit, repair as necessary, REP 1.1 . Refer to WD 9.9 and WD 9.16 .
99-306	Hard	Check that PJ901 on the marking unit heater PWB is securely connected. Check the wiring for an open circuit, repair as necessary, REP 1.1 . Refer to WD 9.8 and WD 9.12 .
99-307	Hard	Check that PJ701 on the marking unit heater PWB is securely connected. Check the wiring for an open circuit, repair as necessary, REP 1.1 . Refer to WD 9.8 .
99-308	Hard	Check that PJ401 on the marking unit heater PWB is securely connected. Check the wiring for an open circuit, repair as necessary, REP 1.1 . Refer to WD 9.8 .
99-309	Hard	Check that PJ201 on the marking unit heater PWB is securely connected. Check the wiring for an open circuit, repair as necessary, REP 1.1 . Refer to WD 9.8 .
99-310	Hard	Check that PJ430 on the solenoid patch PWB is securely connected. Check the wiring for an open circuit, repair as necessary, REP 1.1 . Refer to WD 9.14 .
99-311	Hard	Check that PJ110 on the solenoid patch PWB is securely connected. Check the wiring for an open circuit, repair as necessary, REP 1.1 . Refer to WD 9.14 .
99-312	Hard	Check that PJ410 on the solenoid patch PWB is securely connected. Check the wiring for an open circuit, repair as necessary, REP 1.1 . Refer to WD 9.15 .

Table 1 PEST Hard and Soft Fault Codes

Code	Hard/Soft	Action
99-293	Hard	Go to the 01D RAP.
99-301	Hard	Check PJ303 on the marking unit driver PWB and its wiring. Refer to WD 9.10 .
99-302	Hard	Check PJ102 on the marking unit driver PWB and its wiring. Refer to WD 9.9 .
99-303	Hard	Check that PJ304 on the marking unit driver PWB is securely connected. Check the wiring for an open circuit, repair as necessary, REP 1.1 . Refer to WD 9.11 .

99-313-00 to 99-329-00 PEST Error 10 RAP

99-313-00 Connector, MU solenoid patch PWB.

99-314-00 Connector, MU solenoid patch PWB.

99-315-00 Connector, MU solenoid patch PWB.

99-316-00 Connector, MU solenoid patch PWB.

99-317-00 Connector, MU solenoid patch PWB.

99-320-00 Connector IME other open.

99-321-00 Connector, drum driver PWB.

99-322-00 Connector, drum driver PWB.

99-323-00 Connector, drum driver PWB.

99-324-00 Connector, drum driver PWB.

99-325-00 Connector, drum driver PWB.

99-326-00 Connector, drum driver PWB.

99-327-00 Connector, drum driver PWB.

99-328-00 Connector, drum driver PWB.

99-329-00 Connector, drum driver PWB.

Initial Actions

WARNING

Ensure that the electricity to the machine is switched off while performing tasks that do not need electricity. Refer to [GP 14](#). Disconnect the power cord. Electricity can cause death or injury. Moving parts can cause injury.

Procedure

Refer to [Table 1](#). Perform the relevant action. For an explanation of PEST codes refer to [dC123](#).

Table 1 PEST Hard and Soft Fault Codes

Code	Hard/Soft	Action
99-313	Hard	Check that PJ610 on the solenoid patch PWB is securely connected. Check the wiring for an open circuit, repair as necessary, REP 1.1 . Refer to WD 9.15 .

Table 1 PEST Hard and Soft Fault Codes

Code	Hard/Soft	Action
99-314	Hard	Check that PJ810 on the solenoid patch PWB is securely connected. Check the wiring for an open circuit, repair as necessary, REP 1.1 . Refer to WD 9.15 .
99-315	Hard	Check that PJ130 on the solenoid patch PWB is securely connected. Check the wiring for an open circuit, repair as necessary, REP 1.1 . Refer to WD 9.14 .
99-316	Hard	Check that PJ380 on the solenoid patch PWB is securely connected. Check the wiring for an open circuit, repair as necessary, REP 1.1 . Refer to WD 9.16 .
99-317	Hard	Check that PJ780 on the solenoid patch PWB is securely connected. Check the wiring for an open circuit, repair as necessary, REP 1.1 . Refer to WD 9.16 .
99-320	Hard	This fault code is for future use and is included for reference only.
99-321	Hard	Check that PJ902 on the drum driver PWB is securely connected. Check the wiring for an open circuit, repair as necessary, REP 1.1 . Refer to WD 1.4 and WD 9.4 .
99-322	Hard	Check that PJ802 on the drum driver PWB is securely connected. Check the wiring for an open circuit, repair as necessary, REP 1.1 . Refer to WD 9.4 and WD 9.19 .
99-323	Hard	Check that PJ601 on the drum driver PWB is securely connected. Check the wiring for an open circuit, repair as necessary, REP 1.1 . Refer to WD 9.2 , WD 9.3 and WD 9.19 .
99-324	Hard	Check that PJ701 on the drum driver PWB is securely connected. Check the wiring for an open circuit, repair as necessary, REP 1.1 . Refer to WD 9.2 , and WD 8.6 .
99-325	Hard	Check that PJ401 on the drum driver PWB is securely connected. Check the wiring for an open circuit, repair as necessary, REP 1.1 . Refer to WD 9.1 .
99-326	Hard	Check that PJ801 on the drum driver PWB is securely connected. Check the wiring for an open circuit, repair as necessary, REP 1.1 . Refer to WD 9.3 and WD 9.1 .
99-327	Hard	Check that PJ901 on the drum driver PWB is securely connected. Check the wiring for an open circuit, repair as necessary, REP 1.1 . Refer to WD 9.4 .
99-328	Hard	Check that PJ501 on the drum driver PWB is securely connected. Check the wiring for an open circuit, repair as necessary, REP 1.1 . Refer to WD 9.1 and WD 1.1 .
99-329	Hard	Check that PJ101 on the drum driver PWB is securely connected. Check the wiring for an open circuit, repair as necessary, REP 1.1 . Refer to WD 9.1 and WD 9.22 .

99-330-00 to 99-349-00 PEST Error 11 RAP

99-330-00 Connector, IOD pre-amplifier PWB.

99-331-00 Connector DMU hot plug open.

99-332-00 Connector, registration / preheat interface PWB.

99-333-00 Connector, registration / preheat interface PWB.

99-334-00 Connector, registration / preheat interface PWB.

99-340-00 Connector, media path driver PWB.

99-341-00 Connector, media path driver PWB.

99-342-00 Connector, media path driver PWB.

99-343-00 Connector, media path driver PWB.

99-344-00 Connector, media path driver PWB.

99-345-00 Connector, media path driver PWB.

99-346-00 Connector, MPD harness M3

99-347-00 Connector, MPD harness M2

99-348-00 Connector, MPD harness M5

99-349-00 Connector, MPD harness M6

Initial Actions

WARNING

Ensure that the electricity to the machine is switched off while performing tasks that do not need electricity. Refer to [GP 14](#). Disconnect the power cord. Electricity can cause death or injury. Moving parts can cause injury.

Procedure

Refer to [Table 1](#). Perform the relevant action. For an explanation of PEST codes refer to [dC123](#).

Table 1 PEST Hard and Soft Fault Codes

Code	Hard/Soft	Action
99-330	Hard	Check that PJ2 to the IOD pre-amp PWB, refer to WD 9.22 and WD 9.1 and PJ1 on the registration / pre-heat interface PWB, refer to WD 8.6 are securely connected. Check the wiring for an open circuit, repair as necessary, REP 1.1 .
99-331	Hard	This fault code is for future use and is included for reference only.

Table 1 PEST Hard and Soft Fault Codes

Code	Hard/Soft	Action
99-332	Hard	Check that PJ4 on the registration / preheat interface is securely connected. Check the wiring for an open circuit, repair as necessary, REP 1.1 . Refer to WD 8.6 .
99-333	Hard	Check that PJ5 on the registration / preheat interface is securely connected. Check the wiring for an open circuit, repair as necessary, REP 1.1 . Refer to WD 8.6 .
99-334	Hard	Check that PJ1 on the registration / preheat interface is securely connected. Check the wiring for an open circuit, repair as necessary, REP 1.1 . Refer to WD 8.6 .
99-340	Hard	Check that PJ202 on the media path driver PWB is securely connected. Check the wiring for an open circuit, repair as necessary, REP 1.1 . Refer to WD 8.1 .
99-341	Hard	Check that PJ104 on the media path driver PWB is securely connected. Check the wiring for an open circuit, repair as necessary, REP 1.1 . Refer to WD 8.1 and WD 8.6 .
99-342	Hard	Check that PJ303 on the media path driver PWB is securely connected. Check the wiring for an open circuit, repair as necessary, REP 1.1 . Refer to WD 8.1 and WD 8.5 .
99-343	Hard	Check that PJ905 on the media path driver PWB is securely connected. Check the wiring for an open circuit, repair as necessary, REP 1.1 . Refer to WD 8.5 .
99-344	Hard	Check that PJ406 on the media path driver PWB is securely connected. Check the wiring for an open circuit, repair as necessary, REP 1.1 . Refer to WD 8.4 , WD 9.17 and WD 9.18 .
99-345	Hard	Check that PJ405 on the media path driver PWB is securely connected. Check the wiring for an open circuit, repair as necessary, REP 1.1 . Refer to WD 8.3 .
99-346	Hard	Check that PJ202 on the media path driver PWB harness to registration motor (M3) is securely connected. Check the wiring for an open circuit, repair as necessary, REP 1.1 . Refer to WD 8.1 .
99-347	Hard	Check that PJ104 on the media path driver PWB harness to vertical transport motor (M2) is securely connected. Check the wiring for an open circuit, repair as necessary, REP 1.1 . Refer to WD 8.1 .
99-348	Hard	Check that PJ303 on the media path driver PWB harness to exit motor (M5) is securely connected. Check the wiring for an open circuit, repair as necessary, REP 1.1 . Refer to WD 8.2 .
99-349	Hard	Check that PJ905 on the media path driver PWB harness to horizontal transport motor (M6) is securely connected. Check the wiring for an open circuit, repair as necessary, REP 1.1 . Refer to WD 8.5 .

99-360-00 to 99-382-00 PEST Error 12 RAP

99-360-00 Connectors TTM 1 open.

99-361-00 Connector TTM 2 open.

99-362-00 Connector TTM 3 open.

99-365-00 Power supply unit.

99-366-00 Connector, media path driver PWB.

99-370-00 Connector, PS J4AC marking unit.

99-371-00 Connector, PS J5AC.

99-372-00 Connector AC PS heater 3 open.

99-373-00 Connector AC PS fuse 1 open.

99-374-00 Connector AC PS fuse 2 open.

99-375-00 Connector AC PS fuse 3 open.

99-380-00 Fan power supply short.

99-381-00 Fan power supply open.

99-382-00 Fan power supply stalled.

Initial Actions

WARNING

Ensure that the electricity to the machine is switched off while performing tasks that do not need electricity. Refer to GP 14. Disconnect the power cord. Electricity can cause death or injury. Moving parts can cause injury.

Procedure

Refer to Table 1. Perform the relevant action. For an explanation of PEST codes refer to dC123.

Table 1 PEST Hard and Soft Fault Codes

Code	Hard/Soft	Action
99-366	Hard	LCSS: Go to the 12-199-00-110 Unexpected Sheet at Finisher Entry RAP. OCT: Go to the 12-701-00-65 Offset Catch Tray Failure RAP. HVF: Go to the 12-762-00-171, 12-764-00-171, 12-765-00-171 IME to Finisher Communication Failure RAP. Check the communication harness between the finisher and PJ904 on the media path driver PWB.
99-370	Hard	Check that PJ4AC on the power supply is securely connected. Check the wiring for an open circuit, repair as necessary, REP 1.1. Refer to WD 1.1.
99-371	Hard	Check that PJ5AC on the power supply is securely connected. Check the wiring for an open circuit, repair as necessary, REP 1.1. Refer to WD 1.2.
99-372	Hard	This fault code is for future use and is included for reference only.
99-373	Hard	This fault code is for future use and is included for reference only.
99-374	Hard	This fault code is for future use and is included for reference only.
99-375	Hard	This fault code is for future use and is included for reference only.
99-380	Hard	Install a new power supply, PL 1.15 Item 2.
99-381	Hard	Install a new power supply, PL 1.15 Item 2.
99-382	Soft	Install a new power supply, PL 1.15 Item 2.

Table 1 PEST Hard and Soft Fault Codes

Code	Hard/Soft	Action
99-360	Hard	This fault code is for future use and is included for reference only.
99-361	Hard	This fault code is for future use and is included for reference only.
99-362	Hard	This fault code is for future use and is included for reference only.
99-365	Hard	Go to the 01A RAP. Check that the finisher power cord is securely connected to the IME.

99-394-00 to 99-413-00 PEST Error 13 RAP

99-394-00 Power triacs PS short triac.

99-395-00 Power, triacs MUH short triac.

99-405-00 Power, head thermistors safety circuit error.

99-410-00 Heater, head reservoir 1 open.

99-411-00 Heater, head reservoir 2 open.

99-412-00 Heater, head reservoir 3 open.

99-413-00 Heater, head reservoir 4 open.

Initial Actions

WARNING

Ensure that the electricity to the machine is switched off while performing tasks that do not need electricity. Refer to **GP 14**. Disconnect the power cord. Electricity can cause death or injury. Moving parts can cause injury.

Procedure

Refer to [Table 1](#). Perform the relevant action. For an explanation of PEST codes refer to [dC123](#).

Table 1 PEST Hard and Soft Fault Codes

Code	Hard/Soft	Action
99-394	Hard	Check the PEST fault history, dC123 for marking unit heater faults (umbilicals, printheads and ink melt reservoir). Identify which heater is open and install new components as necessary. Then install a new power supply, PL 1.15 Item 2 .
99-395	Hard	Check the PEST fault history, dC123 for marking unit heater faults (umbilicals, printheads and ink melt reservoir). Identify which heater is open and install new components as necessary. Then install a new marking unit heater PWB, PL 92.10 Item 5 .

Table 1 PEST Hard and Soft Fault Codes

Code	Hard/Soft	Action
99-405	Hard	Refer to IME Controller test points TP703-706 (Lower Left corner of the board, with labels HD1-HD4 to indicate which head) Check at each test point. <ul style="list-style-type: none"> If the voltage is ~3.2V, then that head is good. If the voltage is ~2.1V then the data cable has an open contact. Install a new video cable, PL 92.10 Item 7, for the indicated printhead. If the voltage is ~0.02V, then it has a thermistor / temperature error, check the PEST fault history, dC123 for shorted triac. Unplug AC heaters to that head, if still bad, install a new printhead. If the voltage is ~0.3V then check the cable on that head and look for a thermistor error on another head. <p>If all 4 voltages are OK, it may be intermittent, try POPO to catch the fault again and measure immediately. Refer to the 91A Printhead Communications RAP.</p>
99-410	Hard	Go to the 91-523-00 to 91-558-00 , 91-664-00 to 91-667-00 , 91-800-00 to 91-803-00 , 91-856-00 to 91-859-00 Printhead Thermal Error RAP. Check the AC / heater cabling to printhead 1. If it is open or short, install a new a cable. If necessary, install a new printhead.
99-411	Hard	Go to the 91-523-00 to 91-558-00 , 91-664-00 to 91-667-00 , 91-800-00 to 91-803-00 , 91-856-00 to 91-859-00 Printhead Thermal Error RAP. Check the AC / heater cabling to printhead 2. If it is open or short, install a new a cable. If necessary, install a new printhead.
99-412	Hard	Go to the 91-523-00 to 91-558-00 , 91-664-00 to 91-667-00 , 91-800-00 to 91-803-00 , 91-856-00 to 91-859-00 Printhead Thermal Error RAP. Check the AC / heater cabling to printhead 3. If it is open or short, install a new a cable. If necessary, install a new printhead.
99-413	Hard	Go to the 91-523-00 to 91-558-00 , 91-664-00 to 91-667-00 , 91-800-00 to 91-803-00 , 91-856-00 to 91-859-00 Printhead Thermal Error RAP. Check the AC / heater cabling to printhead 4. If it is open or short, install a new a cable. If necessary, install a new printhead.

99-414-00 to 99-428-00 PEST Error 14 RAP

99-414-00 Heater, head reservoir 1 short.

99-415-00 Heater, head reservoir 2 short.

99-416-00 Heater, head reservoir 3 short.

99-417-00 Heater, head reservoir 4 short.

99-418-00 Heater, head reservoir 1 below min.

99-419-00 Heater, head reservoir 2 below min.

99-420-00 Heater, head reservoir 3 below min.

99-421-00 Heater, head reservoir 4 below min.

99-422-00 Heater, head reservoir 1 above max.

99-423-00 Heater, head reservoir 2 above max.

99-424-00 Heater, head reservoir 3 above max.

99-425-00 Heater, head reservoir 4 above max.

99-426-00 Heater, jet stack H1 left open.

99-427-00 Heater, jet stack H1 right open.

99-428-00 Heater, jet stack H2 left open.

Initial Actions

WARNING

Ensure that the electricity to the machine is switched off while performing tasks that do not need electricity. Refer to GP 14. Disconnect the power cord. Electricity can cause death or injury. Moving parts can cause injury.

Procedure

Refer to Table 1. Perform the relevant action. For an explanation of PEST codes refer to dC123.

Table 1 PEST Hard and Soft Fault Codes

Code	Hard/Soft	Action
99-414	Hard	Go to the 91-523-00 to 91-558-00, 91-664-00 to 91-667-00, 91-800-00 to 91-803-00, 91-856-00 to 91-859-00 Printhead Thermal Error RAP. Check the AC / heater cabling to printhead 1. If it is open or short, install a new a cable. If necessary, install a new printhead.

Table 1 PEST Hard and Soft Fault Codes

Code	Hard/Soft	Action
99-415	Hard	Go to the 91-523-00 to 91-558-00, 91-664-00 to 91-667-00, 91-800-00 to 91-803-00, 91-856-00 to 91-859-00 Printhead Thermal Error RAP. Check the AC / heater cabling to printhead 2. If it is open or short, install a new a cable. If necessary, install a new printhead.
99-416	Hard	Go to the 91-523-00 to 91-558-00, 91-664-00 to 91-667-00, 91-800-00 to 91-803-00, 91-856-00 to 91-859-00 Printhead Thermal Error RAP. Check the AC / heater cabling to printhead 3. If it is open or short, install a new a cable. If necessary, install a new printhead.
99-417	Hard	Go to the 91-523-00 to 91-558-00, 91-664-00 to 91-667-00, 91-800-00 to 91-803-00, 91-856-00 to 91-859-00 Printhead Thermal Error RAP. Check the AC / heater cabling to printhead 4. If it is open or short, install a new a cable. If necessary, install a new printhead.
99-418	Soft	Go to the 91-523-00 to 91-558-00, 91-664-00 to 91-667-00, 91-800-00 to 91-803-00, 91-856-00 to 91-859-00 Printhead Thermal Error RAP. Check the AC / heater cabling to printhead 1. If it is open or short, install a new a cable. If necessary, install a new printhead.
99-419	Soft	Go to the 91-523-00 to 91-558-00, 91-664-00 to 91-667-00, 91-800-00 to 91-803-00, 91-856-00 to 91-859-00 Printhead Thermal Error RAP. Check the AC / heater cabling to printhead 2. If it is open or short, install a new a cable. If necessary, install a new printhead.
99-420	Soft	Go to the 91-523-00 to 91-558-00, 91-664-00 to 91-667-00, 91-800-00 to 91-803-00, 91-856-00 to 91-859-00 Printhead Thermal Error RAP. Check the AC / heater cabling to printhead 3. If it is open or short, install a new a cable. If necessary, install a new printhead.
99-421	Soft	Go to the 91-523-00 to 91-558-00, 91-664-00 to 91-667-00, 91-800-00 to 91-803-00, 91-856-00 to 91-859-00 Printhead Thermal Error RAP. Check the AC / heater cabling to printhead 4. If it is open or short, install a new a cable. If necessary, install a new printhead.
99-422	Soft	Go to the 91-523-00 to 91-558-00, 91-664-00 to 91-667-00, 91-800-00 to 91-803-00, 91-856-00 to 91-859-00 Printhead Thermal Error RAP. Check the AC / heater cabling to printhead 1. If it is open or short, install a new a cable. If necessary, install a new printhead.
99-423	Soft	Go to the 91-523-00 to 91-558-00, 91-664-00 to 91-667-00, 91-800-00 to 91-803-00, 91-856-00 to 91-859-00 Printhead Thermal Error RAP. Check the AC / heater cabling to printhead 2. If it is open or short, install a new a cable. If necessary, install a new printhead.
99-424	Soft	Go to the 91-523-00 to 91-558-00, 91-664-00 to 91-667-00, 91-800-00 to 91-803-00, 91-856-00 to 91-859-00 Printhead Thermal Error RAP. Check the AC / heater cabling to printhead 3. If it is open or short, install a new a cable. If necessary, install a new printhead.
99-425	Soft	Go to the 91-523-00 to 91-558-00, 91-664-00 to 91-667-00, 91-800-00 to 91-803-00, 91-856-00 to 91-859-00 Printhead Thermal Error RAP. Check the AC / heater cabling to printhead 4. If it is open or short, install a new a cable. If necessary, install a new printhead.

Table 1 PEST Hard and Soft Fault Codes

Code	Hard/Soft	Action
99-426	Hard	Go to the 01A AC Power Distribution RAP. Check the AC / heater cabling to printhead 1. If it is open or short, install a new a cable. If necessary, install a new printhead.
99-427	Hard	Go to the 01A AC Power Distribution RAP. Check the AC / heater cabling to printhead 1. If it is open or short, install a new a cable. If necessary, install a new printhead.
99-428	Hard	Go to the 01A AC Power Distribution RAP. Check the AC / heater cabling to printhead 2. If it is open or short, install a new a cable. If necessary, install a new printhead.

99-429-00 to 99-443-00 PEST Error 15 RAP

- 99-429-00 Heater, jet stack H2 right open.
- 99-430-00 Heater, jet stack H3 left open.
- 99-431-00 Heater, jet stack H3 right open.
- 99-432-00 Heater, jet stack H4 left open.
- 99-433-00 Heater, jet stack H4 right open.
- 99-434-00 Heater, jet stack H1 left short.
- 99-435-00 Heater, jet stack H1 right short.
- 99-436-00 Heater, jet stack H2 left short.
- 99-437-00 Heater, jet stack H2 right short.
- 99-438-00 Heater, jet stack H3 left short.
- 99-439-00 Heater, jet stack H3 right short.
- 99-440-00 Heater, jet stack H4 left short.
- 99-441-00 Heater, jet stack H4 right short.
- 99-442-00 Heater, jet stack H1 left below min.
- 99-443-00 Heater, jet stack H1 right below min.

Initial Actions

WARNING

Ensure that the electricity to the machine is switched off while performing tasks that do not need electricity. Refer to GP 14. Disconnect the power cord. Electricity can cause death or injury. Moving parts can cause injury.

Procedure

Refer to Table 1. Perform the relevant action. For an explanation of PEST codes refer to dC123.

Table 1 PEST Hard and Soft Fault Codes

Code	Hard/Soft	Action
99-429	Hard	Go to the 01A AC Power Distribution RAP. Select the Head 2 Reservoir and Jetstack Heaters Check. Install new components as required.

Table 1 PEST Hard and Soft Fault Codes

Code	Hard/Soft	Action
99-430	Hard	Go to the 01A AC Power Distribution RAP. Select the Head 3 Reservoir and Jetstack Heaters Check. Install new components as required.
99-431	Hard	Go to the 01A AC Power Distribution RAP. Select the Head 3 Reservoir and Jetstack Heaters Check. Install new components as required.
99-432	Hard	Go to the 01A AC Power Distribution RAP. Select the Head 4 Reservoir and Jetstack Heaters Check. Install new components as required.
99-433	Hard	Go to the 01A AC Power Distribution RAP. Select the Head 4 Reservoir and Jetstack Heaters Check. Install new components as required.
99-434	Hard	Go to the 01A AC Power Distribution RAP. Select the Head 1 Reservoir and Jetstack Heaters Check. Install new components as required.
99-435	Hard	Go to the 01A AC Power Distribution RAP. Select the Head 1 Reservoir and Jetstack Heaters Check. Install new components as required.
99-436	Hard	Go to the 01A AC Power Distribution RAP. Select the Head 2 Reservoir and Jetstack Heaters Check. Install new components as required.
99-437	Hard	Go to the 01A AC Power Distribution RAP. Select the Head 2 Reservoir and Jetstack Heaters Check. Install new components as required.
99-438	Hard	Go to the 01A AC Power Distribution RAP. Select the Head 3 Reservoir and Jetstack Heaters Check. Install new components as required.
99-439	Hard	Go to the 01A AC Power Distribution RAP. Select the Head 3 Reservoir and Jetstack Heaters Check. Install new components as required.
99-440	Hard	Go to the 01A AC Power Distribution RAP. Select the Head 4 Reservoir and Jetstack Heaters Check. Install new components as required.
99-441	Hard	Go to the 01A AC Power Distribution RAP. Select the Head 4 Reservoir and Jetstack Heaters Check. Install new components as required.
99-442	Soft	Go to the 01A AC Power Distribution RAP. Select the Head 1 Reservoir and Jetstack Heaters Check. Install new components as required.
99-443	Soft	Go to the 01A AC Power Distribution RAP. Select the Head 1 Reservoir and Jetstack Heaters Check. Install new components as required.

99-444-00 to 99-460-00 PEST Error 16 RAP

99-444-00 Heater, jet stack H2 left below min.

99-445-00 Heater, jet stack H2 right below min.

99-446-00 Heater, jet stack H3 left below min.

99-447-00 Heater, jet stack H3 right below min.

99-448-00 Heater, jet stack H4 left below min.

99-449-00 Heater, jet stack H4 right below min.

99-450-00 Heater, jet stack H1 left above max.

99-451-00 Heater, jet stack H1 right above max.

99-452-00 Heater, jet stack H2 left above max.

99-453-00 Heater, jet stack H2 right above max.

99-454-00 Heater, jet stack H3 left above max.

99-455-00 Heater, jet stack H3 right above max.

99-456-00 Heater, jet stack H4 left above max.

99-457-00 Heater, jet stack H4 right above max.

99-460-00 Heater, umbilical upper open.

Initial Actions

WARNING

Ensure that the electricity to the machine is switched off while performing tasks that do not need electricity. Refer to GP 14. Disconnect the power cord. Electricity can cause death or injury. Moving parts can cause injury.

Procedure

Refer to Table 1. Perform the relevant action. For an explanation of PEST codes refer to dC123.

Table 1 PEST Hard and Soft Fault Codes

Code	Hard/Soft	Action
99-444	Soft	Go to the 01A AC Power Distribution RAP. Select the Head 2 Reservoir and Jetstack Heaters Check. Install new components as required.
99-445	Soft	Go to the 01A AC Power Distribution RAP. Select the Head 2 Reservoir and Jetstack Heaters Check. Install new components as required.

Table 1 PEST Hard and Soft Fault Codes

Code	Hard/Soft	Action
99-446	Soft	Go to the 01A AC Power Distribution RAP. Select the Head 3 Reservoir and Jetstack Heaters Check. Install new components as required.
99-447	Soft	Go to the 01A AC Power Distribution RAP. Select the Head 3 Reservoir and Jetstack Heaters Check. Install new components as required.
99-448	Soft	Go to the 01A AC Power Distribution RAP. Select the Head 4 Reservoir and Jetstack Heaters Check. Install new components as required.
99-449	Soft	Go to the 01A AC Power Distribution RAP. Select the Head 4 Reservoir and Jetstack Heaters Check. Install new components as required.
99-450	Soft	Go to the 01A AC Power Distribution RAP. Select the Head 1 Reservoir and Jetstack Heaters Check. Install new components as required.
99-451	Soft	Go to the 01A AC Power Distribution RAP. Select the Head 1 Reservoir and Jetstack Heaters Check. Install new components as required.
99-452	Soft	Go to the 01A AC Power Distribution RAP. Select the Head 2 Reservoir and Jetstack Heaters Check. Install new components as required.
99-453	Soft	Go to the 01A AC Power Distribution RAP. Select the Head 2 Reservoir and Jetstack Heaters Check. Install new components as required.
99-454	Soft	Go to the 01A AC Power Distribution RAP. Select the Head 3 Reservoir and Jetstack Heaters Check. Install new components as required.
99-455	Soft	Go to the 01A AC Power Distribution RAP. Select the Head 3 Reservoir and Jetstack Heaters Check. Install new components as required.
99-456	Soft	Go to the 01A AC Power Distribution RAP. Select the Head 4 Reservoir and Jetstack Heaters Check. Install new components as required.
99-457	Soft	Go to the 01A AC Power Distribution RAP. Select the Head 4 Reservoir and Jetstack Heaters Check. Install new components as required.

Table 1 PEST Hard and Soft Fault Codes

Code	Hard/Soft	Action
99-460	Hard	<p>Check the dC123 PEST log for addition heater faults.</p> <p>If there are multiple heater open faults for the marking unit (12 head heaters, 2 umbilical heaters and 2 melt reservoir heaters).</p> <ul style="list-style-type: none"> • Check the cable between marking unit driver PWB at PJ701 and marking unit heater PWB at PJ901. • Enter dC330 component control to attempt to activate one heater (this will enable the AC relays) check that AC voltage is at the marking Unit heater PWB at PJ101. • If voltages are not present, check the AC cable between the marking unit PWB at PJ101 and the power supply at PJ4AC. If the cable is OK. Check the power supply unit fuses. These fuses are inside the power supply unit and not replaceable. If a fuse is blown, isolate and repair the cause of the blown fuse and then install a new power supply unit, PL 1.15 Item 2. • If voltages are present at the marking unit heater PWB. Check the fuses on the PWB. If a fuse is blown, isolate and repair the cause of the blown fuse and then install a new marking unit heater PWB, PL 92.10 Item 5. • If there is only this one heater fault, check the AC / heater cabling to the umbilical. If it is open or short replace the cable, otherwise install a new umbilical. <p>Refer to the 93-535-00 to 93-537-00, 93-958-00 Upper Umbilical Thermal Error RAP. Run the upper umbilical test.</p>

99-461-00 to 99-477-00 PEST Error 17 RAP

99-461-00 Heater, umbilical lower open.

99-462-00 Heater, umbilical upper short.

99-463-00 Heater, umbilical lower short.

99-464-00 Heater, umbilical upper below min.

99-465-00 Heater, umbilical lower below min.

99-466-00 Heater, umbilical upper above max.

99-467-00 Heater, umbilical lower above max.

99-470-00 Heater, melt reservoir 1 open.

99-471-00 Heater, melt reservoir 2 open.

99-472-00 Heater, melt reservoir 1 short.

99-473-00 Heater, melt reservoir 2 short.

99-474-00 Heater, melt reservoir 1 below min.

99-475-00 Heater, melt reservoir 2 below min.

99-476-00 Heater, melt reservoir 1 above max.

99-477-00 Heater, melt reservoir 2 above max.

Initial Actions

WARNING

Ensure that the electricity to the machine is switched off while performing tasks that do not need electricity. Refer to GP 14. Disconnect the power cord. Electricity can cause death or injury. Moving parts can cause injury.

- PEST fault 99-471 can be raised as a hard or a soft fault. Enter dC123 PEST Fault History. A hard fault will appear before the 99-999 separator and a soft fault will appear after the 99-999 separator.

Procedure

Refer to Table 1. Perform the relevant action. For an explanation of PEST codes refer to dC123.

Table 1 PEST Hard and Soft Fault Codes

Code	Hard/Soft	Action
99-461	Hard	Go to the 93-538-00 to 93-540-00, 93-959-00 Lower Umbilical Thermal Error RAP. Check the AC / heater cabling umbilical. If it is open or short install a new cable. If necessary, install a new umbilical.
99-462	Hard	Go to 93-535-00 to 93-537-00, 93-958-00 Upper Umbilical Thermal Error RAP. Check the AC / heater cabling umbilical. If it is open or short replace cable, otherwise replace the umbilical.

Table 1 PEST Hard and Soft Fault Codes

Code	Hard/Soft	Action
99-463	Hard	Go to the 93-538-00 to 93-540-00, 93-959-00 Lower Umbilical Thermal Error RAP. Check the AC / heater cabling umbilical. If it is open or short install a new cable. If necessary, install a new umbilical.
99-464	Soft	Go to 93-535-00 to 93-537-00, 93-958-00 Upper Umbilical Thermal Error RAP. Check the AC / heater cabling umbilical. If it is open or short replace cable, otherwise replace the umbilical.
99-465	Soft	Go to the 93-538-00 to 93-540-00, 93-959-00 Lower Umbilical Thermal Error RAP. Check the AC / heater cabling umbilical. If it is open or short install a new cable. If necessary, install a new umbilical.
99-466	Soft	Go to 93-535-00 to 93-537-00, 93-958-00 Upper Umbilical Thermal Error RAP. Check the AC / heater cabling umbilical. If it is open or short replace cable, otherwise replace the umbilical.
99-467	Soft	Go to the 93-538-00 to 93-540-00, 93-959-00 Lower Umbilical Thermal Error RAP. Check the AC / heater cabling umbilical. If it is open or short install a new cable. If necessary, install a new umbilical.
99-470	Soft	Go to the 93-520-00, 93-521-00, 93-522-00 Ink Melt Reservoir Thermal Error RAP. Check the AC / heater cabling umbilical. If it is open or short, install a new cable. If necessary, install a new reservoir.
99-471	Soft	Go to the 93-520-00, 93-521-00, 93-522-00 Ink Melt Reservoir Thermal Error RAP. Check the AC / heater cabling umbilical. If it is open or short, install a new cable. If necessary, install a new reservoir. This soft fault is raised only if reservoir 2 heater is open.
99-471	Hard	Go to the 93-520-00, 93-521-00, 93-522-00 Ink Melt Reservoir Thermal Error RAP. Check the AC / heater cabling umbilical. If it is open or short, install a new cable. If necessary, install a new reservoir. This hard fault is raised if both reservoir 1 and 2 heaters are open.
99-472	Hard	Go to the 93-520-00, 93-521-00, 93-522-00 Ink Melt Reservoir Thermal Error RAP. Check the AC / heater cabling umbilical. If it is open or short, install a new cable. If necessary, install a new reservoir.
99-473	Hard	Go to the 93-520-00, 93-521-00, 93-522-00 Ink Melt Reservoir Thermal Error RAP. Check the AC / heater cabling umbilical. If it is open or short, install a new cable. If necessary, install a new reservoir.
99-474	Soft	Go to the 93-520-00, 93-521-00, 93-522-00 Ink Melt Reservoir Thermal Error RAP. Check the AC / heater cabling umbilical. If it is open or short, install a new cable. If necessary, install a new reservoir.
99-475	Soft	Go to the 93-520-00, 93-521-00, 93-522-00 Ink Melt Reservoir Thermal Error RAP. Check the AC / heater cabling umbilical. If it is open or short, install a new cable. If necessary, install a new reservoir.
99-476	Soft	Go to the 93-520-00, 93-521-00, 93-522-00 Ink Melt Reservoir Thermal Error RAP. Check the AC / heater cabling umbilical. If it is open or short, install a new cable. If necessary, install a new reservoir.
99-477	Soft	Go to the 93-520-00, 93-521-00, 93-522-00 Ink Melt Reservoir Thermal Error RAP. Check the AC / heater cabling umbilical. If it is open or short, install a new cable. If necessary, install a new reservoir.

99-480-00 to 99-497-00 PEST Error 18 RAP

99-480-00 Heater, ink melter cyan open.

99-481-00 Heater, ink melter magenta open.

99-482-00 Heater, ink melter yellow open.

99-483-00 Heater, ink melter black open.

99-484-00 Heater, ink melter cyan short.

99-485-00 Heater, ink melter magenta short.

99-486-00 Heater, ink melter yellow short.

99-487-00 Heater, ink melter black short.

99-490-00 Heater, ink melter cyan below min.

99-491-00 Heater, ink melter magenta below min.

99-492-00 Heater, ink melter yellow below min.

99-493-00 Heater, ink melter black below min.

99-494-00 Heater, ink melter cyan above max.

99-495-00 Heater, ink melter magenta above max.

99-496-00 Heater, ink melter yellow above max.

99-497-00 Heater, ink melter black above max.

Initial Actions

WARNING

Ensure that the electricity to the machine is switched off while performing tasks that do not need electricity. Refer to GP 14. Disconnect the power cord. Electricity can cause death or injury. Moving parts can cause injury.

Procedure

Refer to Table 1. Perform the relevant action. For an explanation of PEST codes refer to dC123.

Table 1 PEST codes and action

Code	Hard/Soft	Action
99-480	Hard	Go to the 93-523-00 to 93-526-00, 93-527-00 to 93-530-00, 93-532-00, 93-533-00, 93-957-00 Ink Melt Error RAP. Check the AC / heater cabling umbilical. If it is open or short, install a new cable. If necessary, install a new ink melt plate assembly.

Table 1 PEST codes and action

Code	Hard/Soft	Action
99-481	Hard	Go to the 93-523-00 to 93-526-00, 93-527-00 to 93-530-00, 93-532-00, 93-533-00, 93-957-00 Ink Melt Error RAP. Check the AC / heater cabling umbilical. If it is open or short, install a new cable. If necessary, install a new ink melt plate assembly.
99-482	Hard	Go to the 93-523-00 to 93-526-00, 93-527-00 to 93-530-00, 93-532-00, 93-533-00, 93-957-00 Ink Melt Error RAP. Check the AC / heater cabling umbilical. If it is open or short, install a new cable. If necessary, install a new ink melt plate assembly.
99-483	Hard	Go to the 93-523-00 to 93-526-00, 93-527-00 to 93-530-00, 93-532-00, 93-533-00, 93-957-00 Ink Melt Error RAP. Check the AC / heater cabling umbilical. If it is open or short, install a new cable. If necessary, install a new ink melt plate assembly.
99-484	Hard	Go to the 93-523-00 to 93-526-00, 93-527-00 to 93-530-00, 93-532-00, 93-533-00, 93-957-00 Ink Melt Error RAP. Check the AC / heater cabling umbilical. If it is open or short, install a new cable. If necessary, install a new ink melt plate assembly.
99-485	Hard	Go to the 93-523-00 to 93-526-00, 93-527-00 to 93-530-00, 93-532-00, 93-533-00, 93-957-00 Ink Melt Error RAP. Check the AC / heater cabling umbilical. If it is open or short, install a new cable. If necessary, install a new ink melt plate assembly.
99-486	Hard	Go to the 93-523-00 to 93-526-00, 93-527-00 to 93-530-00, 93-532-00, 93-533-00, 93-957-00 Ink Melt Error RAP. Check the AC / heater cabling umbilical. If it is open or short, install a new cable. If necessary, install a new ink melt plate assembly.
99-487	Hard	Go to the 93-523-00 to 93-526-00, 93-527-00 to 93-530-00, 93-532-00, 93-533-00, 93-957-00 Ink Melt Error RAP. Check the AC / heater cabling umbilical. If it is open or short, install a new cable. If necessary, install a new ink melt plate assembly.
99-490	Soft	Go to the 93-523-00 to 93-526-00, 93-527-00 to 93-530-00, 93-532-00, 93-533-00, 93-957-00 Ink Melt Error RAP. Check the AC / heater cabling umbilical. If it is open or short, install a new cable. If necessary, install a new ink melt plate assembly.
99-491	Soft	Go to the 93-523-00 to 93-526-00, 93-527-00 to 93-530-00, 93-532-00, 93-533-00, 93-957-00 Ink Melt Error RAP. Check the AC / heater cabling umbilical. If it is open or short, install a new cable. If necessary, install a new ink melt plate assembly.
99-492	Soft	Go to the 93-523-00 to 93-526-00, 93-527-00 to 93-530-00, 93-532-00, 93-533-00, 93-957-00 Ink Melt Error RAP. Check the AC / heater cabling umbilical. If it is open or short, install a new cable. If necessary, install a new ink melt plate assembly.
99-493	Soft	Go to the 93-523-00 to 93-526-00, 93-527-00 to 93-530-00, 93-532-00, 93-533-00, 93-957-00 Ink Melt Error RAP. Check the AC / heater cabling umbilical. If it is open or short, install a new cable. If necessary, install a new ink melt plate assembly.

Table 1 PEST codes and action

Code	Hard/Soft	Action
99-494	Soft	Go to the 93-523-00 to 93-526-00, 93-527-00 to 93-530-00, 93-532-00, 93-533-00, 93-957-00 Ink Melt Error RAP. Check the AC / heater cabling umbilical. If it is open or short, install a new cable. If necessary, install a new ink melt plate assembly.
99-495	Soft	Go to the 93-523-00 to 93-526-00, 93-527-00 to 93-530-00, 93-532-00, 93-533-00, 93-957-00 Ink Melt Error RAP. Check the AC / heater cabling umbilical. If it is open or short, install a new cable. If necessary, install a new ink melt plate assembly.
99-496	Soft	Go to the 93-523-00 to 93-526-00, 93-527-00 to 93-530-00, 93-532-00, 93-533-00, 93-957-00 Ink Melt Error RAP. Check the AC / heater cabling umbilical. If it is open or short, install a new cable. If necessary, install a new ink melt plate assembly.
99-497	Soft	Go to the 93-523-00 to 93-526-00, 93-527-00 to 93-530-00, 93-532-00, 93-533-00, 93-957-00 Ink Melt Error RAP. Check the AC / heater cabling umbilical. If it is open or short, install a new cable. If necessary, install a new ink melt plate assembly.

99-500-00 to 99-515-00 PEST Error 19 RAP

- 99-500-00 Thermistor, ink melter cyan open.
- 99-501-00 Thermistor, ink melter magenta open.
- 99-502-00 Thermistor, ink melter yellow open.
- 99-503-00 Thermistor, ink melter black open.
- 99-504-00 Thermistor, ink melter cyan short.
- 99-505-00 Thermistor, ink melter magenta short.
- 99-506-00 Thermistor, ink melter yellow short.
- 99-507-00 Thermistor, ink melter black short.
- 99-510-00 Heater, drum front open.
- 99-511-00 Heater, drum rear open.
- 99-512-00 Heater, drum front short.
- 99-513-00 Heater, drum rear short.
- 99-514-00 Heater, drum front below min temp.
- 99-515-00 Heater, drum rear below min temp.

Initial Actions

WARNING

Ensure that the electricity to the machine is switched off while performing tasks that do not need electricity. Refer to GP 14. Disconnect the power cord. Electricity can cause death or injury. Moving parts can cause injury.

Procedure

Refer to Table 1. Perform the relevant action. For an explanation of PEST codes refer to dC123.

Table 1 PEST codes and action

Code	Hard/Soft	Action
99-500	Hard	Go to the 93-525-00, 93-528-00, 93-531-00, 93-534-00 Ink Melt Thermistor Error RAP. Check the AC / heater cabling umbilical. If it is open or short, install a new cable. If necessary, install a new ink melt plate assembly.
99-501	Hard	Go to the 93-525-00, 93-528-00, 93-531-00, 93-534-00 Ink Melt Thermistor Error RAP. Check the AC / heater cabling umbilical. If it is open or short, install a new cable. If necessary, install a new ink melt plate assembly.

Table 1 PEST codes and action

Code	Hard/Soft	Action
99-502	Hard	Go to the 93-525-00 , 93-528-00 , 93-531-00 , 93-534-00 Ink Melt Thermistor Error RAP. Check the AC / heater cabling umbilical. If it is open or short, install a new cable. If necessary, install a new ink melt plate assembly.
99-503	Hard	Go to the 93-525-00 , 93-528-00 , 93-531-00 , 93-534-00 Ink Melt Thermistor Error RAP. Check the AC / heater cabling umbilical. If it is open or short, install a new cable. If necessary, install a new ink melt plate assembly.
99-504	Hard	Go to the 93-525-00 , 93-528-00 , 93-531-00 , 93-534-00 Ink Melt Thermistor Error RAP. Check the AC / heater cabling umbilical. If it is open or short, install a new cable. If necessary, install a new ink melt plate assembly.
99-505	Hard	Go to the 93-525-00 , 93-528-00 , 93-531-00 , 93-534-00 Ink Melt Thermistor Error RAP. Check the AC / heater cabling umbilical. If it is open or short, install a new cable. If necessary, install a new ink melt plate assembly.
99-506	Hard	Go to the 93-525-00 , 93-528-00 , 93-531-00 , 93-534-00 Ink Melt Thermistor Error RAP. Check the AC / heater cabling umbilical. If it is open or short, install a new cable. If necessary, install a new ink melt plate assembly.
99-507	Hard	Go to the 93-525-00 , 93-528-00 , 93-531-00 , 93-534-00 Ink Melt Thermistor Error RAP. Check the AC / heater cabling umbilical. If it is open or short, install a new cable. If necessary, install a new ink melt plate assembly.
99-510	Hard	Go to 94-536-00 , 94-538-00 , 94-540-00 , 94-542-00 , 94-544-00 , 94-546-00 , 94-632-00 , 94-633-00 RAP.
99-511	Hard	Go to the 94-536-00 , 94-538-00 , 94-540-00 , 94-542-00 , 94-544-00 , 94-546-00 , 94-632-00 , 94-633-00 Drum Heat Error RAP.
99-512	Hard	Go to the 94-536-00 , 94-538-00 , 94-540-00 , 94-542-00 , 94-544-00 , 94-546-00 , 94-632-00 , 94-633-00 Drum Heat Error RAP. Check the AC / heater cabling to the drum heater. If it is open, check the drum thermal cutout PWB, PL 88.10 Item 11 .
99-513	Hard	Go to the 94-536-00 , 94-538-00 , 94-540-00 , 94-542-00 , 94-544-00 , 94-546-00 , 94-632-00 , 94-633-00 Drum Heat Error RAP. Check the AC / heater cabling to the drum heater. If it is open, check the drum thermal cutout PWB, PL 88.10 Item 11 .
99-514	Soft	Go to the 94-536-00 , 94-538-00 , 94-540-00 , 94-542-00 , 94-544-00 , 94-546-00 , 94-632-00 , 94-633-00 Drum Heat Error RAP. Check the AC / heater cabling to the drum heater. If it is open, check the drum thermal cutout PWB, PL 88.10 Item 11 .
99-515	Soft	Go to the 94-536-00 , 94-538-00 , 94-540-00 , 94-542-00 , 94-544-00 , 94-546-00 , 94-632-00 , 94-633-00 Drum Heat Error RAP. Check the AC / heater cabling to the drum heater. If it is open, check the drum thermal cutout PWB, PL 88.10 Item 11 .

99-516-00 to 99-533-00 PEST Error 20 RAP

99-516-00 Heater, drum front above max.

99-517-00 Heater, drum rear above max.

99-520-00 Heater, media preheat 1 open.

99-521-00 Heater, media preheat 2 open.

99-522-00 Heater, media preheat 1 and 2 open.

99-523-00 Heater, media preheat 1 short.

99-524-00 Heater, media preheat 2 short.

99-525-00 Heater, media preheat 1 below min.

99-526-00 Heater, media preheat 2 below min.

99-527-00 Heater, media preheat 1 above max.

99-528-00 Heater, media preheat 2 above max.

99-530-00 Thermistor, umbilical upper open.

99-531-00 Thermistor, umbilical lower open.

99-532-00 Thermistor, umbilical upper short.

99-533-00 Thermistor, umbilical lower short.

Initial Actions

WARNING

Ensure that the electricity to the machine is switched off while performing tasks that do not need electricity. Refer to GP 14. Disconnect the power cord. Electricity can cause death or injury. Moving parts can cause injury.

Procedure

Refer to [Table 1](#). Perform the relevant action. For an explanation of PEST codes refer to [dC123](#).

Table 1 PEST codes and action

Code	Hard/Soft	Action
99-516	Soft	Go to the 94-536-00 , 94-538-00 , 94-540-00 , 94-542-00 , 94-544-00 , 94-546-00 , 94-632-00 , 94-633-00 Drum Heat Error RAP. Check the AC / heater cabling to the drum heater. If it is open, check the drum thermal cutout PWB, PL 88.10 Item 11 .
99-517	Soft	Go to the 94-536-00 , 94-538-00 , 94-540-00 , 94-542-00 , 94-544-00 , 94-546-00 , 94-632-00 , 94-633-00 Drum Heat Error RAP. Check the AC / heater cabling to the drum heater. If it is open, check the drum thermal cutout PWB, PL 88.10 Item 11 .

Table 1 PEST codes and action

Code	Hard/Soft	Action
99-520	Soft	Go to the 88-500-00 to 88-502-00, 88-512-00 Preheat Thermal Error RAP. Check the registration / preheat thermistor.
99-521	Soft	Go to the 88-500-00 to 88-502-00, 88-512-00 RAP. Check the registration / preheat sensor.
99-522	Soft	Go to the 88-500-00 to 88-502-00, 88-512-00 Preheat Thermal Error RAP. Check the AC / heater cabling to registration / preheat sensor. If it is open or short, install a new cable. If necessary, install a new registration / preheat sensor.
99-523	Hard	Go to the 88-500-00 to 88-502-00, 88-512-00 Preheat Thermal Error RAP. Check the AC / heater cabling to registration / preheat sensor. If it is open or short, install a new cable. If necessary, install a new registration / preheat sensor.
99-524	Hard	Go to the 88-500-00 to 88-502-00, 88-512-00 Preheat Thermal Error RAP. Check the AC / heater cabling to registration / preheat sensor. If it is open or short, install a new cable. If necessary, install a new registration / preheat sensor.
99-525	Soft	Go to the 88-500-00 to 88-502-00, 88-512-00 Preheat Thermal Error RAP. Check the AC / heater cabling to registration / preheat sensor. If it is open or short, install a new cable. If necessary, install a new registration / preheat sensor.
99-526	Soft	Go to the 88-500-00 to 88-502-00, 88-512-00 Preheat Thermal Error RAP. Check the AC / heater cabling to registration / preheat sensor. If it is open or short, install a new cable. If necessary, install a new registration / preheat sensor.
99-527	Soft	Go to the 88-500-00 to 88-502-00, 88-512-00 Preheat Thermal Error RAP. Check the AC / heater cabling to registration / preheat sensor. If it is open or short, install a new cable. If necessary, install a new registration / preheat sensor.
99-528	Soft	Go to the 88-500-00 to 88-502-00, 88-512-00 Preheat Thermal Error RAP. Check the AC / heater cabling to registration / preheat sensor. If it is open or short, install a new cable. If necessary, install a new registration / preheat sensor.
99-530	Hard	Go to the 93-535-00 to 93-537-00, 93-958-00 Upper Umbilical Thermal Error RAP. Check the DC cabling to the umbilical. If it is open or short, install a new cable. If necessary, install a new umbilical.
99-531	Hard	Go to the 93-538-00 to 93-540-00, 93-959-00 Lower Umbilical Thermal Error RAP. Check the DC cabling to the umbilical. If it is open or short, install a new cable. If necessary, install a new umbilical.
99-532	Hard	Go to the 93-535-00 to 93-537-00, 93-958-00 Upper Umbilical Thermal Error RAP. Check the DC cabling to the umbilical. If it is open or short, install a new cable. If necessary, install a new umbilical.
99-533	Hard	Go to the 93-538-00 to 93-540-00, 93-959-00 Lower Umbilical Thermal Error RAP. Check the DC cabling to the umbilical. If it is open or short, install a new cable. If necessary, install a new umbilical.

99-534-00 to 99-548-00 PEST Error 21 RAP

99-534-00 Front drum thermistor, open circuit.

99-535-00 Front drum thermistor, short circuit.

99-536-00 Rear drum thermistor, short circuit.

99-537-00 Rear drum thermistor, open circuit.

99-538-00 Wave amp thermistor, open circuit.

99-539-00 Wave amp thermistor, short circuit.

99-540-00 Thermistor, jet stack H1 right open circuit.

99-541-00 Thermistor, jet stack H1 left open circuit.

99-542-00 Thermistor, jet stack H2 right open circuit.

99-543-00 Thermistor, jet stack H2 left open circuit.

99-544-00 Thermistor, jet stack H3 right open circuit.

99-545-00 Thermistor, jet stack H3 left open circuit.

99-546-00 Thermistor, jet stack H4 right open circuit.

99-547-00 Thermistor, jet stack H4 left open circuit.

99-548-00 Thermistor, jet stack H1 right short circuit.

Initial Actions

WARNING

Ensure that the electricity to the machine is switched off while performing tasks that do not need electricity. Refer to GP 14. Disconnect the power cord. Electricity can cause death or injury. Moving parts can cause injury.

Procedure

Refer to Table 1. Perform the relevant action. For an explanation of PEST codes refer to dC123.

Table 1 PEST codes and action

Code	Hard/Soft	Action
99-534	Hard	Go to the 94-536-00, 94-538-00, 94-540-00, 94-542-00, 94-544-00, 94-546-00, 94-632-00, 94-633-00 Drum Heat Error RAP. Check the DC cabling to the drum heater. If it is open or short, install a new cable. If necessary, install a new drum.

Table 1 PEST codes and action

Code	Hard/Soft	Action
99-535	Hard	Go to the 94-536-00, 94-538-00, 94-540-00, 94-542-00, 94-544-00, 94-546-00, 94-632-00, 94-633-00 Drum Heat Error RAP. Check the DC cabling to the drum heater. If it is open or short, install a new cable. If necessary, install a new drum.
99-536	Hard	Go to the 94-536-00, 94-538-00, 94-540-00, 94-542-00, 94-544-00, 94-546-00, 94-632-00, 94-633-00 Drum Heat Error RAP. Check the DC cabling to the drum heater. If it is open or short, install a new cable. If necessary, install a new drum.
99-537	Hard	Go to the 94-536-00, 94-538-00, 94-540-00, 94-542-00, 94-544-00, 94-546-00, 94-632-00, 94-633-00 Drum Heat Error RAP. Check the DC cabling to the drum heater. If it is open or short, install a new cable. If necessary, install a new drum.
99-538	Hard	Go to the 91-587-00, 91-588-00 Quad Wave Amplifier Thermal Error RAP. Check the quad wave amp / IME controller PWB cable, PL 92.10 Item 13. Go to 01E +12V Distribution RAP. Go to 01F -12V Distribution RAP. If an open circuit or a short circuit is found, install a new quad wave amp / IME controller PWB cable. If the circuit is good, install a new quad wave amp PWB, PL 92.10 Item 3.
99-539	Hard	Go to the 91-587-00, 91-588-00 Quad Wave Amplifier Thermal Error RAP. Check the quad wave amp / IME controller PWB cable, PL 92.10 Item 13. Go to 01E +12V Distribution RAP. Go to 01F -12V Distribution RAP. If an open circuit or a short circuit is found install a new quad wave amp / IME controller PWB cable. If the circuit is good install a new quad wave amp PWB, PL 92.10 Item 3.
99-540	Hard	Go to the 91-523-00 to 91-558-00, 91-664-00 to 91-667-00, 91-800-00 to 91-803-00, 91-856-00 to 91-859-00 Printhead Thermal Error RAP. Make sure the small ribbon cable on the right side of the printhead 1 is securely seated. If necessary, install a new printhead.
99-541	Hard	Go to the 91-523-00 to 91-558-00, 91-664-00 to 91-667-00, 91-800-00 to 91-803-00, 91-856-00 to 91-859-00 Printhead Thermal Error RAP. Make sure the small ribbon cable on the right side of the printhead 1 is securely seated. If necessary, install a new printhead.
99-542	Hard	Go to the 91-523-00 to 91-558-00, 91-664-00 to 91-667-00, 91-800-00 to 91-803-00, 91-856-00 to 91-859-00 Printhead Thermal Error RAP. Make sure the small ribbon cable on the right side of the printhead 2 is securely seated. If necessary, install a new printhead.
99-543	Hard	Go to the 91-523-00 to 91-558-00, 91-664-00 to 91-667-00, 91-800-00 to 91-803-00, 91-856-00 to 91-859-00 Printhead Thermal Error RAP. Make sure the small ribbon cable on the right side of the printhead 2 is securely seated. If necessary, install a new printhead.

Table 1 PEST codes and action

Code	Hard/Soft	Action
99-544	Hard	Go to the 91-523-00 to 91-558-00, 91-664-00 to 91-667-00, 91-800-00 to 91-803-00, 91-856-00 to 91-859-00 Printhead Thermal Error RAP. Make sure the small ribbon cable on the right side of the printhead 3 is securely seated. If necessary, install a new printhead.
99-545	Hard	Go to the 91-523-00 to 91-558-00, 91-664-00 to 91-667-00, 91-800-00 to 91-803-00, 91-856-00 to 91-859-00 Printhead Thermal Error RAP. Make sure the small ribbon cable on the right side of the printhead 3 is securely seated. If necessary, install a new printhead.
99-546	Hard	Go to the 91-523-00 to 91-558-00, 91-664-00 to 91-667-00, 91-800-00 to 91-803-00, 91-856-00 to 91-859-00 Printhead Thermal Error RAP. Make sure the small ribbon cable on the right side of the printhead 4 is securely seated. If necessary, install a new printhead.
99-547	Hard	Go to the 91-523-00 to 91-558-00, 91-664-00 to 91-667-00, 91-800-00 to 91-803-00, 91-856-00 to 91-859-00 Printhead Thermal Error RAP. Make sure the small ribbon cable on the right side of the printhead 4 is securely seated. If necessary, install a new printhead.
99-548	Hard	Go to the 91-523-00 to 91-558-00, 91-664-00 to 91-667-00, 91-800-00 to 91-803-00, 91-856-00 to 91-859-00 Printhead Thermal Error RAP. Make sure the small ribbon cable on the right side of the printhead 1 is securely seated. If necessary, install a new printhead.

99-549-00 to 99-563-00 PEST Error 22 RAP

99-549-00 Thermistor, jet stack H1 left short.

99-550-00 Thermistor, jet stack H2 right short.

99-551-00 Thermistor, jet stack H2 left short.

99-552-00 Thermistor, jet stack H3 right short.

99-553-00 Thermistor, jet stack H3 left short.

99-554-00 Thermistor, jet stack H4 right short.

99-555-00 Thermistor, jet stack H4 left short.

99-556-00 Thermistor, head reservoir H1 open.

99-557-00 Thermistor, head reservoir H2 open.

99-558-00 Thermistor, head reservoir H3 open.

99-559-00 Thermistor, head reservoir H4 open.

99-560-00 Thermistor, head reservoir H1 short.

99-561-00 Thermistor, head reservoir H2 short.

99-562-00 Thermistor, head reservoir H3 short.

99-563-00 Thermistor, head reservoir H4 short.

Initial Actions

WARNING

Ensure that the electricity to the machine is switched off while performing tasks that do not need electricity. Refer to GP 14. Disconnect the power cord. Electricity can cause death or injury. Moving parts can cause injury.

Procedure

Refer to Table 1. Perform the relevant action. For an explanation of PEST codes refer to dC123.

Table 1 PEST codes and action

Code	Hard/Soft	Action
99-549	Hard	Go to the 91-523-00 to 91-558-00, 91-664-00 to 91-667-00, 91-800-00 to 91-803-00, 91-856-00 to 91-859-00 Printhead Thermal Error RAP. Make sure the small ribbon cable on the right side of the printhead 1 is securely seated. If necessary, install a new printhead.
99-550	Hard	Go to the 91-523-00 to 91-558-00, 91-664-00 to 91-667-00, 91-800-00 to 91-803-00, 91-856-00 to 91-859-00 Printhead Thermal Error RAP. Make sure the small ribbon cable on the right side of the printhead 2 is securely seated. If necessary, install a new printhead.
99-551	Hard	Go to the 91-523-00 to 91-558-00, 91-664-00 to 91-667-00, 91-800-00 to 91-803-00, 91-856-00 to 91-859-00 Printhead Thermal Error RAP. Make sure the small ribbon cable on the right side of the printhead 2 is securely seated. If necessary, install a new printhead.

Table 1 PEST codes and action

Code	Hard/Soft	Action
99-552	Hard	Go to the 91-523-00 to 91-558-00, 91-664-00 to 91-667-00, 91-800-00 to 91-803-00, 91-856-00 to 91-859-00 Printhead Thermal Error RAP. Make sure the small ribbon cable on the right side of the printhead 3 is securely seated. If necessary, install a new printhead.
99-553	Hard	Go to the 91-523-00 to 91-558-00, 91-664-00 to 91-667-00, 91-800-00 to 91-803-00, 91-856-00 to 91-859-00 Printhead Thermal Error RAP. Make sure the small ribbon cable on the right side of the printhead 3 is securely seated. If necessary, install a new printhead.
99-554	Hard	Go to the 91-523-00 to 91-558-00, 91-664-00 to 91-667-00, 91-800-00 to 91-803-00, 91-856-00 to 91-859-00 Printhead Thermal Error RAP. Make sure the small ribbon cable on the right side of the printhead 4 is securely seated. If necessary, install a new printhead.
99-555	Hard	Go to the 91-523-00 to 91-558-00, 91-664-00 to 91-667-00, 91-800-00 to 91-803-00, 91-856-00 to 91-859-00 Printhead Thermal Error RAP. Make sure the small ribbon cable on the right side of the printhead 4 is securely seated. If necessary, install a new printhead.
99-556	Hard	Go to the 91-523-00 to 91-558-00, 91-664-00 to 91-667-00, 91-800-00 to 91-803-00, 91-856-00 to 91-859-00 Printhead Thermal Error RAP. Make sure the small ribbon cable on the right side of the printhead 1 is securely seated. If necessary, install a new printhead.
99-557	Hard	Go to the 91-523-00 to 91-558-00, 91-664-00 to 91-667-00, 91-800-00 to 91-803-00, 91-856-00 to 91-859-00 Printhead Thermal Error RAP. Make sure the small ribbon cable on the right side of the printhead 2 is securely seated. If necessary, install a new printhead.
99-558	Hard	Go to the 91-523-00 to 91-558-00, 91-664-00 to 91-667-00, 91-800-00 to 91-803-00, 91-856-00 to 91-859-00 Printhead Thermal Error RAP. Make sure the small ribbon cable on the right side of the printhead 3 is securely seated. If necessary, install a new printhead.
99-559	Hard	Go to the 91-523-00 to 91-558-00, 91-664-00 to 91-667-00, 91-800-00 to 91-803-00, 91-856-00 to 91-859-00 Printhead Thermal Error RAP. Make sure the small ribbon cable on the right side of the printhead 4 is securely seated. If necessary, install a new printhead.
99-560	Hard	Go to the 91-523-00 to 91-558-00, 91-664-00 to 91-667-00, 91-800-00 to 91-803-00, 91-856-00 to 91-859-00 Printhead Thermal Error RAP. Make sure the small ribbon cable on the right side of the printhead 1 is securely seated. If necessary, install a new printhead.
99-561	Hard	Go to the 91-523-00 to 91-558-00, 91-664-00 to 91-667-00, 91-800-00 to 91-803-00, 91-856-00 to 91-859-00 Printhead Thermal Error RAP. Make sure the small ribbon cable on the right side of the printhead 2 is securely seated. If necessary, install a new printhead.
99-562	Hard	Go to the 91-523-00 to 91-558-00, 91-664-00 to 91-667-00, 91-800-00 to 91-803-00, 91-856-00 to 91-859-00 Printhead Thermal Error RAP. Make sure the small ribbon cable on the right side of the printhead 3 is securely seated. If necessary, install a new printhead.
99-563	Hard	Go to the 91-523-00 to 91-558-00, 91-664-00 to 91-667-00, 91-800-00 to 91-803-00, 91-856-00 to 91-859-00 Printhead Thermal Error RAP. Make sure the small ribbon cable on the right side of the printhead 4 is securely seated. If necessary, install a new printhead.

99-564-00 to 99-565-00 PEST Error 23 RAP

99-564-00 Thermistor, melt reservoir open.

99-565-00 Thermistor, melt reservoir short.

Initial Actions

WARNING

Ensure that the electricity to the machine is switched off while performing tasks that do not need electricity. Refer to GP 14. Disconnect the power cord. Electricity can cause death or injury. Moving parts can cause injury.

Procedure

Refer to Table 1. Perform the relevant action. For an explanation of PEST codes refer to dC123.

Table 1 PEST codes and action

Code	Hard/Soft	Action
99-564	Hard	Go to the 93-520-00, 93-521-00, 93-522-00 Ink Melt Reservoir Thermal Error RAP. Check the DC cabling to the reservoir. If it is open or short, install a new cable.
99-565	Hard	Go to the 93-520-00, 93-521-00, 93-522-00 Ink Melt Reservoir Thermal Error RAP. Check the DC cabling to the reservoir. If it is open or short, install a new cable.

99-600-00 to 99-605-00 PEST Error 24 RAP

99-600-00 Purge solenoid valve head 1.

99-601-00 Solenoid, ink purge valve H2 open.

99-602-00 Solenoid, ink purge valve H3 open.

99-603-00 Solenoid, ink purge valve H4 open.

99-604-00 Solenoid, ink dose valve H1 yellow open.

99-605-00 Solenoid, ink dose valve H1 cyan open.

Initial Actions

WARNING

Ensure that the electricity to the machine is switched off while performing tasks that do not need electricity. Refer to GP 14. Disconnect the power cord. Electricity can cause death or injury. Moving parts can cause injury.

Procedure

Refer to Table 1. Perform the relevant action. For an explanation of PEST codes refer to dC123.

Table 1 PEST codes and action

Code	Hard/Soft	Action
99-600	Hard	Go to the 93A Ink Melt Reservoir Check RAP. Check the DC cabling to the reservoir. If it is open or short replace, install a new cable. If necessary, install a new ink reservoir.
99-601	Hard	Go to the 93A Ink Melt Reservoir Check RAP. Check the DC cabling to the reservoir. If it is open or short replace, install a new cable. If necessary, install a new ink reservoir.
99-602	Hard	Go to the 93A Ink Melt Reservoir Check RAP. Check the DC cabling to the reservoir. If it is open or short replace, install a new cable. If necessary, install a new ink reservoir.
99-603	Hard	Go to the 93A Ink Melt Reservoir Check RAP. Check the DC cabling to the reservoir. If it is open or short replace, install a new cable. If necessary, install a new ink reservoir.
99-604	Hard	Go to the 93A Ink Melt Reservoir Check RAP. Check the DC cabling to the reservoir. If it is open or short replace, install a new cable. If necessary, install a new ink reservoir.
99-605	Hard	Go to the 93A Ink Melt Reservoir Check RAP. Check the DC cabling to the reservoir. If it is open or short replace, install a new cable. If necessary, install a new ink reservoir.

99-606-00 to 99-610-00 PEST Error 25 RAP

99-606-00 Solenoid, ink dose valve H1 magenta open.

99-607-00 Solenoid, ink dose valve H1 black open.

99-608-00 Solenoid, ink dose valve H2 cyan yellow open.

99-609-00 Solenoid, ink dose valve H2 cyan open.

99-610-00 Solenoid, ink dose valve H2 magenta open.

Initial Actions

WARNING

Ensure that the electricity to the machine is switched off while performing tasks that do not need electricity. Refer to **GP 14**. Disconnect the power cord. Electricity can cause death or injury. Moving parts can cause injury.

Procedure

Refer to **Table 1**. Perform the relevant action. For an explanation of PEST codes refer to **dC123**.

Table 1 PEST codes and action

Code	Hard/Soft	Action
99-606	Hard	Go to the 93A Ink Melt Reservoir Check RAP. Check the DC cabling to the reservoir. If it is open or short, install a new cable. If necessary, install a new ink reservoir.
99-607	Hard	Go to the 93A Ink Melt Reservoir Check RAP. Check the DC cabling to the reservoir. If it is open or short, install a new cable. If necessary, install a new ink reservoir.
99-608	Hard	Go to the 93A Ink Melt Reservoir Check RAP. Check the DC cabling to the reservoir. If it is open or short, install a new cable. If necessary, install a new ink reservoir.
99-609	Hard	Go to the 93A Ink Melt Reservoir Check RAP. Check the DC cabling to the reservoir. If it is open or short, install a new cable. If necessary, install a new ink reservoir.
99-610	Hard	Go to the 93A Ink Melt Reservoir Check RAP. Check the DC cabling to the reservoir. If it is open or short, install a new cable. If necessary, install a new ink reservoir.

99-611-00 to 99-625-00 PEST Error 26 RAP

99-611-00 Solenoid, ink dose valve H2 black open.

99-612-00 Solenoid, ink dose valve H3 yellow open.

99-613-00 Solenoid, ink dose valve H3 cyan open.

99-614-00 Solenoid, ink dose valve H3 magenta open.

99-615-00 Solenoid, ink dose valve H3 black open.

99-616-00 Solenoid, ink dose valve H4 yellow open.

99-617-00 Solenoid, ink dose valve H4 cyan open.

99-618-00 Solenoid, ink dose valve H4 magenta open.

99-619-00 Solenoid, ink dose valve H4 black open.

99-620-00 Solenoid, ink purge valve H1 short.

99-621-00 Solenoid, ink purge valve H2 short.

99-622-00 Solenoid, ink purge valve H3 short.

99-623-00 Solenoid, ink purge valve H4 short.

99-624-00 Solenoid, ink dose valve H1 cyan short.

99-625-00 Solenoid, ink dose valve H1 magenta short.

Initial Actions

WARNING

Ensure that the electricity to the machine is switched off while performing tasks that do not need electricity. Refer to **GP 14**. Disconnect the power cord. Electricity can cause death or injury. Moving parts can cause injury.

Procedure

Refer to **Table 1**. Perform the relevant action. For an explanation of PEST codes refer to **dC123**.

Table 1 PEST codes and action

Code	Hard/Soft	Action
99-611	Hard	Go to the 93A Ink Melt Reservoir Check RAP. Check the DC cabling to the reservoir. If it is open or short, install a new cable. If necessary, install a new ink reservoir.

Table 1 PEST codes and action

Code	Hard/Soft	Action
99-612	Hard	Go to the 93A Ink Melt Reservoir Check RAP. Check the DC cabling to the reservoir. If it is open or short, install a new cable. If necessary, install a new ink reservoir.
99-613	Hard	Go to the 93A Ink Melt Reservoir Check RAP. Check the DC cabling to the reservoir. If it is open or short, install a new cable. If necessary, install a new ink reservoir.
99-614	Hard	Go to the 93A Ink Melt Reservoir Check RAP. Check the DC cabling to the reservoir. If it is open or short, install a new cable. If necessary, install a new ink reservoir.
99-615	Hard	Go to the 93A Ink Melt Reservoir Check RAP. Check the DC cabling to the reservoir. If it is open or short, install a new cable. If necessary, install a new ink reservoir.
99-616	Hard	Go to the 93A Ink Melt Reservoir Check RAP. Check the DC cabling to the reservoir. If it is open or short, install a new cable. If necessary, install a new ink reservoir.
99-617	Hard	Go to the 93A Ink Melt Reservoir Check RAP. Check the DC cabling to the reservoir. If it is open or short, install a new cable. If necessary, install a new ink reservoir.
99-618	Hard	Go to the 93A Ink Melt Reservoir Check RAP. Check the DC cabling to the reservoir. If it is open or short, install a new cable. If necessary, install a new ink reservoir.
99-619	Hard	Go to the 93A Ink Melt Reservoir Check RAP. Check the DC cabling to the reservoir. If it is open or short, install a new cable. If necessary, install a new ink reservoir.
99-620	Hard	Go to the 93A Ink Melt Reservoir Check RAP. Check the DC cabling to the reservoir. If it is open or short, install a new cable. If necessary, install a new ink reservoir.
99-621	Hard	Go to the 93A Ink Melt Reservoir Check RAP. Check the DC cabling to the reservoir. If it is open or short, install a new cable. If necessary, install a new ink reservoir.
99-622	Hard	Go to the 93A Ink Melt Reservoir Check RAP. Check the DC cabling to the reservoir. If it is open or short, install a new cable. If necessary, install a new ink reservoir.
99-623	Hard	Go to the 93A Ink Melt Reservoir Check RAP. Check the DC cabling to the reservoir. If it is open or short, install a new cable. If necessary, install a new ink reservoir.
99-624	Hard	Go to the 93A Ink Melt Reservoir Check RAP. Check the DC cabling to the reservoir. If it is open or short, install a new cable. If necessary, install a new ink reservoir.
99-625	Hard	Go to the 93A Ink Melt Reservoir Check RAP. Check the DC cabling to the reservoir. If it is open or short, install a new cable. If necessary, install a new ink reservoir.

99-626-00 to 99-640-00 PEST Error 27 RAP

99-626-00 Solenoid, ink dose valve H1 yellow short.

99-627-00 Solenoid, ink dose valve H1 black short.

99-628-00 Solenoid, ink dose valve H2 cyan short.

99-629-00 Solenoid, ink dose valve H2 magenta short.

99-630-00 Solenoid, ink dose valve H2 yellow short.

99-631-00 Solenoid, ink dose valve H2 black short.

99-632-00 Solenoid, ink dose valve H3 cyan short.

99-633-00 Solenoid, ink dose valve H3 magenta short.

99-634-00 Solenoid, ink dose valve H3 yellow short.

99-635-00 Solenoid, ink dose valve H3 black short.

99-636-00 Solenoid, ink dose valve H4 cyan short.

99-637-00 Solenoid, ink dose valve H4 magenta short.

99-638-00 Solenoid, ink dose valve H4 yellow short.

99-639-00 Solenoid, ink dose valve H4 black short.

99-640-00 Solenoid, ink purge valve H1 below min.

Initial Actions

WARNING

Ensure that the electricity to the machine is switched off while performing tasks that do not need electricity. Refer to GP 14. Disconnect the power cord. Electricity can cause death or injury. Moving parts can cause injury.

Procedure

Refer to **Table 1**. Perform the relevant action. For an explanation of PEST codes refer to **dC123**.

Table 1 PEST codes and action

Code	Hard/Soft	Action
99-626	Hard	Go to the 93A Ink Melt Reservoir Check RAP. Check the DC cabling to the reservoir. If it is open or short, install a new cable. If necessary, install a new ink reservoir.

Table 1 PEST codes and action

Code	Hard/Soft	Action
99-627	Hard	Go to the 93A Ink Melt Reservoir Check RAP. Check the DC cabling to the reservoir. If it is open or short, install a new cable. If necessary, install a new ink reservoir.
99-628	Hard	Go to the 93A Ink Melt Reservoir Check RAP. Check the DC cabling to the reservoir. If it is open or short, install a new cable. If necessary, install a new ink reservoir.
99-629	Hard	Go to the 93A Ink Melt Reservoir Check RAP. Check the DC cabling to the reservoir. If it is open or short, install a new cable. If necessary, install a new ink reservoir.
99-630	Hard	Go to the 93A Ink Melt Reservoir Check RAP. Check the DC cabling to the reservoir. If it is open or short, install a new cable. If necessary, install a new ink reservoir.
99-631	Hard	Go to the 93A Ink Melt Reservoir Check RAP. Check the DC cabling to the reservoir. If it is open or short, install a new cable. If necessary, install a new ink reservoir.
99-632	Hard	Go to the 93A Ink Melt Reservoir Check RAP. Check the DC cabling to the reservoir. If it is open or short, install a new cable. If necessary, install a new ink reservoir.
99-633	Hard	Go to the 93A Ink Melt Reservoir Check RAP. Check the DC cabling to the reservoir. If it is open or short, install a new cable. If necessary, install a new ink reservoir.
99-634	Hard	Go to the 93A Ink Melt Reservoir Check RAP. Check the DC cabling to the reservoir. If it is open or short, install a new cable. If necessary, install a new ink reservoir.
99-635	Hard	Go to the 93A Ink Melt Reservoir Check RAP. Check the DC cabling to the reservoir. If it is open or short, install a new cable. If necessary, install a new ink reservoir.
99-636	Hard	Go to the 93A Ink Melt Reservoir Check RAP. Check the DC cabling to the reservoir. If it is open or short, install a new cable. If necessary, install a new ink reservoir.
99-637	Hard	Go to the 93A Ink Melt Reservoir Check RAP. Check the DC cabling to the reservoir. If it is open or short, install a new cable. If necessary, install a new ink reservoir.
99-638	Hard	Go to the 93A Ink Melt Reservoir Check RAP. Check the DC cabling to the reservoir. If it is open or short, install a new cable. If necessary, install a new ink reservoir.
99-639	Hard	Go to the 93A Ink Melt Reservoir Check RAP. Check the DC cabling to the reservoir. If it is open or short, install a new cable. If necessary, install a new ink reservoir.
99-640	Soft	Go to the 93A Ink Melt Reservoir Check RAP. Check the DC cabling to the reservoir. If it is open or short, install a new cable. If necessary, install a new ink reservoir.

99-641-00 to 99-655-00 PEST Error 28 RAP

99-641-00 Solenoid, ink purge valve H2 below min.

99-642-00 Solenoid, ink purge valve H3 below min.

99-643-00 Solenoid, ink purge valve H4 below min.

99-644-00 Solenoid, ink dose valve H1cyan below min.

99-645-00 Solenoid, ink dose valve H1 magenta below min.

99-646-00 Solenoid, ink dose valve H1 yellow below min.

99-647-00 Solenoid, ink dose valve H1 black below min.

99-648-00 Solenoid, ink dose valve H2 cyan below min.

99-649-00 Solenoid, ink dose valve H2 magenta below min.

99-650-00 Solenoid, ink dose valve H2 yellow below min.

99-651-00 Solenoid, ink dose valve H2 black below min.

99-652-00 Solenoid, ink dose valve H3 cyan below min.

99-653-00 Solenoid, ink dose valve H3 magenta below min.

99-654-00 Solenoid, ink dose valve H3 yellow below min.

99-655-00 Solenoid, ink dose valve H3 black below min.

Initial Actions

WARNING

Ensure that the electricity to the machine is switched off while performing tasks that do not need electricity. Refer to GP 14. Disconnect the power cord. Electricity can cause death or injury. Moving parts can cause injury.

Procedure

Refer to **Table 1**. Perform the relevant action. For an explanation of PEST codes refer to **dC123**.

Table 1 PEST codes and action

Code	Hard/Soft	Action
99-641	Soft	Go to the 93A Ink Melt Reservoir Check RAP. Check the DC cabling to the reservoir. If it is open or short, install a new cable. If necessary, install a new ink reservoir.

Table 1 PEST codes and action

Code	Hard/Soft	Action
99-642	Soft	Go to the 93A Ink Melt Reservoir Check RAP. Check the DC cabling to the reservoir. If it is open or short, install a new cable. If necessary, install a new ink reservoir.
99-643	Soft	Go to the 93A Ink Melt Reservoir Check RAP. Check the DC cabling to the reservoir. If it is open or short, install a new cable. If necessary, install a new ink reservoir.
99-644	Soft	Go to the 93A Ink Melt Reservoir Check RAP. Check the DC cabling to the reservoir. If it is open or short, install a new cable. If necessary, install a new ink reservoir.
99-645	Soft	Go to the 93A Ink Melt Reservoir Check RAP. Check the DC cabling to the reservoir. If it is open or short, install a new cable. If necessary, install a new ink reservoir.
99-646	Soft	Go to the 93A Ink Melt Reservoir Check RAP. Check the DC cabling to the reservoir. If it is open or short, install a new cable. If necessary, install a new ink reservoir.
99-647	Soft	Go to the 93A Ink Melt Reservoir Check RAP. Check the DC cabling to the reservoir. If it is open or short, install a new cable. If necessary, install a new ink reservoir.
99-648	Soft	Go to the 93A Ink Melt Reservoir Check RAP. Check the DC cabling to the reservoir. If it is open or short, install a new cable. If necessary, install a new ink reservoir.
99-649	Soft	Go to the 93A Ink Melt Reservoir Check RAP. Check the DC cabling to the reservoir. If it is open or short, install a new cable. If necessary, install a new ink reservoir.
99-650	Soft	Go to the 93A Ink Melt Reservoir Check RAP. Check the DC cabling to the reservoir. If it is open or short, install a new cable. If necessary, install a new ink reservoir.
99-651	Soft	Go to the 93A Ink Melt Reservoir Check RAP. Check the DC cabling to the reservoir. If it is open or short, install a new cable. If necessary, install a new ink reservoir.
99-652	Soft	Go to the 93A Ink Melt Reservoir Check RAP. Check the DC cabling to the reservoir. If it is open or short, install a new cable. If necessary, install a new ink reservoir.
99-653	Soft	Go to the 93A Ink Melt Reservoir Check RAP. Check the DC cabling to the reservoir. If it is open or short, install a new cable. If necessary, install a new ink reservoir.
99-654	Soft	Go to the 93A Ink Melt Reservoir Check RAP. Check the DC cabling to the reservoir. If it is open or short, install a new cable. If necessary, install a new ink reservoir.
99-655	Soft	Go to the 93A Ink Melt Reservoir Check RAP. Check the DC cabling to the reservoir. If it is open or short, install a new cable. If necessary, install a new ink reservoir.

99-656-00 to 99-670-00 PEST Error 29 RAP

99-656-00 Solenoid, ink dose valve H4 cyan below min.

99-657-00 Solenoid, ink dose valve H4 magenta below min.

99-658-00 Solenoid, ink dose valve H4 yellow below min.

99-659-00 Solenoid, ink dose valve H4 black below min.

99-660-00 Solenoid, ink purge valve H1 above max.

99-661-00 Solenoid, ink purge valve H2 above max.

99-662-00 Solenoid, ink purge valve H3 above max.

99-663-00 Solenoid, ink purge valve H4 above max.

99-664-00 Solenoid, ink dose valve H1cyan above max.

99-665-00 Solenoid, ink dose valve H1 magenta above max.

99-666-00 Solenoid, ink dose valve H1 yellow above max.

99-667-00 Solenoid, ink dose valve H1 black above max.

99-668-00 Solenoid, ink dose valve H2 cyan above max.

99-669-00 Solenoid, ink dose valve H2 magenta above max.

99-670-00 Solenoid, ink dose valve H2 yellow above max.

Initial Actions

WARNING

Ensure that the electricity to the machine is switched off while performing tasks that do not need electricity. Refer to GP 14. Disconnect the power cord. Electricity can cause death or injury. Moving parts can cause injury.

Procedure

Refer to **Table 1**. Perform the relevant action. For an explanation of PEST codes refer to **dC123**.

Table 1 PEST codes and action

Code	Hard/Soft	Action
99-656	Soft	Go to the 93A Ink Melt Reservoir Check RAP. Check the DC cabling to the reservoir. If it is open or short, install a new cable. If necessary, install a new ink reservoir.

Table 1 PEST codes and action

Code	Hard/Soft	Action
99-657	Soft	Go to the 93A Ink Melt Reservoir Check RAP. Check the DC cabling to the reservoir. If it is open or short, install a new cable. If necessary, install a new ink reservoir.
99-658	Soft	Go to the 93A Ink Melt Reservoir Check RAP. Check the DC cabling to the reservoir. If it is open or short, install a new cable. If necessary, install a new ink reservoir.
99-659	Soft	Go to the 93A Ink Melt Reservoir Check RAP. Check the DC cabling to the reservoir. If it is open or short, install a new cable. If necessary, install a new ink reservoir.
99-660	Soft	Go to the 93A Ink Melt Reservoir Check RAP. Check the DC cabling to the reservoir. If it is open or short, install a new cable. If necessary, install a new ink reservoir.
99-661	Soft	Go to the 93A Ink Melt Reservoir Check RAP. Check the DC cabling to the reservoir. If it is open or short, install a new cable. If necessary, install a new ink reservoir.
99-662	Soft	Go to the 93A Ink Melt Reservoir Check RAP. Check the DC cabling to the reservoir. If it is open or short, install a new cable. If necessary, install a new ink reservoir.
99-663	Soft	Go to the 93A Ink Melt Reservoir Check RAP. Check the DC cabling to the reservoir. If it is open or short, install a new cable. If necessary, install a new ink reservoir.
99-664	Soft	Go to the 93A Ink Melt Reservoir Check RAP. Check the DC cabling to the reservoir. If it is open or short, install a new cable. If necessary, install a new ink reservoir.
99-665	Soft	Go to the 93A Ink Melt Reservoir Check RAP. Check the DC cabling to the reservoir. If it is open or short, install a new cable. If necessary, install a new ink reservoir.
99-666	Soft	Go to the 93A Ink Melt Reservoir Check RAP. Check the DC cabling to the reservoir. If it is open or short, install a new cable. If necessary, install a new ink reservoir.
99-667	Soft	Go to the 93A Ink Melt Reservoir Check RAP. Check the DC cabling to the reservoir. If it is open or short, install a new cable. If necessary, install a new ink reservoir.
99-668	Soft	Go to the 93A Ink Melt Reservoir Check RAP. Check the DC cabling to the reservoir. If it is open or short, install a new cable. If necessary, install a new ink reservoir.
99-669	Soft	Go to the 93A Ink Melt Reservoir Check RAP. Check the DC cabling to the reservoir. If it is open or short, install a new cable. If necessary, install a new ink reservoir.
99-670	Soft	Go to the 93A Ink Melt Reservoir Check RAP. Check the DC cabling to the reservoir. If it is open or short, install a new cable. If necessary, install a new ink reservoir.

99-671-00 to 99-685-00 PEST Error 30 RAP

99-671-00 Solenoid, ink dose valve H2 black above max.

99-672-00 Solenoid, ink dose valve H3 cyan above max.

99-673-00 Solenoid, ink dose valve H3 magenta above max.

99-674-00 Solenoid, ink dose valve H3 yellow above max.

99-675-00 Solenoid, ink dose valve H3 black above max.

99-676-00 Solenoid, ink dose valve H4 cyan above max.

99-677-00 Solenoid, ink dose valve H4 magenta above max.

99-678-00 Solenoid, ink dose valve H4 yellow above max.

99-679-00 Solenoid, ink dose valve H4 black above max.

99-682-00 Solenoid, LPA valve below min.

99-684-00 Sensor, ADC ink level MeltResRef cyan open.

99-685-00 Sensor, ADC ink level MeltResRef magenta open.

Initial Actions

WARNING

Ensure that the electricity to the machine is switched off while performing tasks that do not need electricity. Refer to GP 14. Disconnect the power cord. Electricity can cause death or injury. Moving parts can cause injury.

Procedure

Refer to **Table 1**. Perform the relevant action. For an explanation of PEST codes refer to **dC123**.

Table 1 PEST codes and action

Code	Hard/Soft	Action
99-671	Soft	Go to the 93A Ink Melt Reservoir Check RAP. Check the DC cabling to the reservoir. If it is open or short, install a new cable. If necessary, install a new ink reservoir.
99-672	Soft	Go to the 93A Ink Melt Reservoir Check RAP. Check the DC cabling to the reservoir. If it is open or short, install a new cable. If necessary, install a new ink reservoir.
99-673	Soft	Go to the 93A Ink Melt Reservoir Check RAP. Check the DC cabling to the reservoir. If it is open or short, install a new cable. If necessary, install a new ink reservoir.

Table 1 PEST codes and action

Code	Hard/Soft	Action
99-674	Soft	Go to the 93A Ink Melt Reservoir Check RAP. Check the DC cabling to the reservoir. If it is open or short, install a new cable. If necessary, install a new ink reservoir.
99-675	Soft	Go to the 93A Ink Melt Reservoir Check RAP. Check the DC cabling to the reservoir. If it is open or short, install a new cable. If necessary, install a new ink reservoir.
99-676	Soft	Go to the 93A Ink Melt Reservoir Check RAP. Check the DC cabling to the reservoir. If it is open or short, install a new cable. If necessary, install a new ink reservoir.
99-677	Soft	Go to the 93A Ink Melt Reservoir Check RAP. Check the DC cabling to the reservoir. If it is open or short, install a new cable. If necessary, install a new ink reservoir.
99-678	Soft	Go to the 93A Ink Melt Reservoir Check RAP. Check the DC cabling to the reservoir. If it is open or short, install a new cable. If necessary, install a new ink reservoir.
99-679	Soft	Go to the 93A Ink Melt Reservoir Check RAP. Check the DC cabling to the reservoir. If it is open or short, install a new cable. If necessary, install a new ink reservoir.
99-682	Soft	Go to the 91-516-00 Low Pressure Assist Over Current RAP. Check the low pressure assist solenoid valve.
99-684	Hard	Go to the 93-545-00 to 93-548-00 Ink Melt Reservoir Level Sense Error RAP. Check the DC cabling to the reservoir. If it is open or short, install a new cable. If necessary, install a new ink reservoir.
99-685	Hard	Go to the 93-545-00 to 93-548-00 Ink Melt Reservoir Level Sense Error RAP. Check the DC cabling to the reservoir. If it is open or short, install a new cable. If necessary, install a new ink reservoir.

99-686-00 to 99-700-00 PEST Error 31 RAP

99-686-00 Sensor, ADC ink level MeltResRef yellow open.

99-687-00 Sensor, ADC ink level MeltResRef black open.

99-688-00 Sensor, ADC ink level MeltResFull cyan open.

99-689-00 Sensor, ADC ink level MeltResFull magenta open.

99-690-00 Sensor, ADC ink level MeltResFull yellow open.

99-691-00 Sensor, ADC ink level MeltResFull black open.

99-700-00 Pump, ink delivery air open.

Initial Actions

WARNING

Ensure that the electricity to the machine is switched off while performing tasks that do not need electricity. Refer to [GP 14](#). Disconnect the power cord. Electricity can cause death or injury. Moving parts can cause injury.

Procedure

Refer to [Table 1](#). Perform the relevant action. For an explanation of PEST codes refer to [dC123](#).

Table 1 PEST codes and action

Code	Hard/Soft	Action
99-686	Hard	Check the DC cabling to the reservoir. If it is open or short, install a new cable. If necessary, install a new ink reservoir. Go to the 93-545-00 to 93-548-00 RAP for related wiring diagrams.
99-687	Hard	Check the DC cabling to the reservoir. If it is open or short, install a new cable. If necessary, install a new ink reservoir. Go to the 93-545-00 to 93-548-00 RAP for related wiring diagrams.
99-688	Hard	Check the DC cabling to the reservoir. If it is open or short, install a new cable. If necessary, install a new ink reservoir. Go to the 93-545-00 to 93-548-00 RAP for related wiring diagrams.
99-689	Hard	Check the DC cabling to the reservoir. If it is open or short, install a new cable. If necessary, install a new ink reservoir. Go to the 93-545-00 to 93-548-00 RAP for related wiring diagrams.
99-690	Hard	Check the DC cabling to the reservoir. If it is open or short, install a new cable. If necessary, install a new ink reservoir. Go to the 93-545-00 to 93-548-00 RAP for related wiring diagrams.
99-691	Hard	Check the DC cabling to the reservoir. If it is open or short, install a new cable. If necessary, install a new ink reservoir. Go to the 93-545-00 to 93-548-00 RAP for related wiring diagrams.
99-700	Hard	Check the DC cabling to the reservoir. If it is open or short, install a new cable. If necessary, install a new ink reservoir. Go to the 91-517-00 Marking Unit Air Pump Over Current RAP for related wiring diagrams.

99-701-00 to 99-721-00 PEST Error 32 RAP

99-701-00 Pump, ink delivery air short.

99-702-00 Pump, ink delivery air stall.

99-710-00 Fan, rear closure open.

99-711-00 Fan, rear closure short.

99-712-00 Fan, rear closure stall.

99-715-00 Fan, marking drawer open.

99-716-00 Fan, marking drawer short.

99-717-00 Fan, marking drawer stall.

99-721-00 Fan, drum cooling short.

Initial Actions

WARNING

Ensure that the electricity to the machine is switched off while performing tasks that do not need electricity. Refer to GP 14. Disconnect the power cord. Electricity can cause death or injury. Moving parts can cause injury.

Procedure

Refer to Table 1. Perform the relevant action. For an explanation of PEST codes refer to dC123.

Table 1 PEST codes and action

Code	Hard/Soft	Action
99-701	Hard	Go to the 91-517-00 Marking Unit Air Pump Over Current RAP. Check the DC cabling to the reservoir. If it is open or short, install a new cable. If necessary, install a new ink reservoir.
99-702	Soft	Go to the 91-517-00 Marking Unit Air Pump Over Current RAP. Check the DC cabling to the reservoir. If it is open or short, install a new cable. If necessary, install a new ink reservoir.
99-710	Hard	Go to the 94A Enclosure Fan Error RAP. Check the cabling to the fan. If necessary, install a new enclosure fan.
99-711	Hard	Go to the 94A Enclosure Fan Error RAP. Check the cabling to the fan. If necessary, install a new enclosure fan.
99-712	Soft	Go to the 94A Enclosure Fan Error RAP. Check the cabling to the fan. If necessary, install a new enclosure fan.
99-715	Soft	Go to the 93-520-00, 93-521-00, 93-522-00 RAP. Check the cabling to the fan. If it is open or short replace the cable, otherwise replace the fan.
99-716	Hard	Go to the 93-520-00, 93-521-00, 93-522-00 Ink Melt Reservoir Thermal Error RAP. Check the marking unit cooling fan.
99-717	Soft	Go to the 93-520-00, 93-521-00, 93-522-00 Ink Melt Reservoir Thermal Error RAP. Check the marking unit cooling fan.
99-721	Hard	Go to the OF 6 Fans and Air Systems RAP. Check the cabling to the drum cooling fan. If necessary, install a new drum cooling fan.

99-730-00 to 99-742-00 PEST Error 33 RAP

99-730-00 Pump, ralph air pumps open.

99-731-00 Pump, ralph air pumps short.

99-732-00 Pump, ralph air pumps stall.

99-735-00 Thermistor, media preheat short.

99-736-00 Thermistor, media preheat open.

99-740-00 Solenoid, CAR diverter open.

99-741-00 Solenoid, CAR diverter short.

99-742-00 Solenoid, CAR diverter below min.

Initial Actions

WARNING

Ensure that the electricity to the machine is switched off while performing tasks that do not need electricity. Refer to GP 14. Disconnect the power cord. Electricity can cause death or injury. Moving parts can cause injury.

Procedure

Refer to Table 1. Perform the relevant action. For an explanation of PEST codes refer to dC123.

Table 1 PEST codes and action

Code	Hard/Soft	Action
99-730	Soft	Go to the 89-125-00 to 89-128-00, 89-130-00, 89-131-00 Media Path Sensor 20 Failure RAP. Check the cable to the pumps. If shorted, install a new registration / preheat assembly. If the problem persists, check the DC cabling to registration / preheat transport.
99-731	Hard	Go to the 89-125-00 to 89-128-00, 89-130-00, 89-131-00 Media Path Sensor 20 Failure RAP. Check the cable to the pumps. If shorted, install a new registration / preheat assembly. If the problem persists, check the DC cabling to registration / preheat transport.
99-732	Soft	Go to the 89-125-00 to 89-128-00, 89-130-00, 89-131-00 Media Path Sensor 20 Failure RAP. Check the cable to the pumps. If shorted, install a new registration / preheat assembly. If the problem persists, check the DC cabling to registration / preheat transport.
99-735	Hard	Go to the 88-500-00 to 88-502-00, 88-512-00 Preheat Thermal Error RAP. Check the DC cabling to the registration / preheat transport. If necessary, install a new registration / preheat assembly.
99-736	Hard	Go to the 88-500-00 to 88-502-00, 88-512-00 Preheat Thermal Error RAP. Check the DC cabling to the registration / preheat transport. If necessary, install a new registration / preheat assembly.

Table 1 PEST codes and action

Code	Hard/Soft	Action
99-740	Hard	Go to the 83-504-00 HPP Diverter Solenoid Failure RAP. Check the DC cabling to the solenoid. If necessary, install a new HPP diverter solenoid.
99-741	Hard	Go to the 83-504-00 HPP Diverter Solenoid Failure RAP. Check the DC cabling to the solenoid. If necessary, install a new HPP diverter solenoid.
99-742	Soft	Go to the 83-504-00 HPP Diverter Solenoid Failure RAP. Check the DC cabling to the solenoid. If necessary, install a new HPP diverter solenoid.

99-743-00 to 99-766-00 PEST Error 34 RAP

99-743-00 Solenoid, CAR diverter above max.

99-745-00 Solenoid, duplex open.

99-746-00 Solenoid, duplex short.

99-747-00 Solenoid, duplex below min.

99-748-00 Solenoid, duplex above max.

99-750-00 Solenoid, nip C open.

99-751-00 Solenoid, nip C short.

99-752-00 Solenoid, nip C below min.

99-753-00 Solenoid, nip C above max.

99-755-00 Solenoid, nip D open.

99-756-00 Solenoid, nip D short.

99-757-00 Solenoid, nip D below min.

99-758-00 Solenoid, nip D above max.

99-765-00 Solenoid, stripper open.

99-766-00 Solenoid, stripper short.

Initial Actions

WARNING

Ensure that the electricity to the machine is switched off while performing tasks that do not need electricity. Refer to [GP 14](#). Disconnect the power cord. Electricity can cause death or injury. Moving parts can cause injury.

Procedure

Refer to [Table 1](#). Perform the relevant action. For an explanation of PEST codes refer to [dC123](#).

Table 1 PEST codes and action

Code	Hard/Soft	Action
99-743	Soft	Go to the 83-504-00 HPP Diverter Solenoid Failure RAP. Check the DC cabling to the solenoid. If necessary, install a new HPP diverter solenoid.

Table 1 PEST codes and action

Code	Hard/Soft	Action
99-745	Hard	Go to the 83-110-00 , 83-111-00 , 83-113-00 , 83-114-00 , 83-118-00 Media Path Sensor 13 Duplex Mode RAP. Check the DC cabling to the exit duplex diverter solenoid. If necessary, install a new exit duplex diverter solenoid.
99-746	Hard	Go to the 83-110-00 , 83-111-00 , 83-113-00 , 83-114-00 , 83-118-00 Media Path Sensor 13 Duplex Mode RAP. Check the DC cabling to the exit duplex diverter solenoid. If necessary, install a new exit duplex diverter solenoid.
99-747	Soft	Go to the 83-110-00 , 83-111-00 , 83-113-00 , 83-114-00 , 83-118-00 Media Path Sensor 13 Duplex Mode RAP. Check the DC cabling to the exit duplex diverter solenoid. If necessary, install a new exit duplex diverter solenoid.
99-748	Soft	Go to the 83-110-00 , 83-111-00 , 83-113-00 , 83-114-00 , 83-118-00 Media Path Sensor 13 Duplex Mode RAP. Check the DC cabling to the exit duplex diverter solenoid. If necessary, install a new exit duplex diverter solenoid.
99-750	Hard	Go to the 89-550-00 , 89-551-00 Media Registration Error RAP. Check the DC cabling to the nip C release solenoid. If necessary, install a new nip C release solenoid.
99-751	Hard	Go to the 89-550-00 , 89-551-00 Media Registration Error RAP. Check the DC cabling to the nip C release solenoid. If necessary, install a new nip C release solenoid.
99-752	Soft	Go to the 89-550-00 , 89-551-00 Media Registration Error RAP. Check the DC cabling to the nip C release solenoid. If necessary, install a new nip C release solenoid.
99-753	Soft	Go to the 89-550-00 , 89-551-00 Media Registration Error RAP. Check the DC cabling to the nip C release solenoid. If necessary, install a new nip C release solenoid.
99-755	Hard	Go to the 83-506-00 Nip D Release Solenoid Failure RAP. Check the DC cabling to the nip D release solenoid. If necessary, install a new nip D release solenoid.
99-756	Hard	Go to the 83-506-00 Nip D Release Solenoid Failure RAP. Check the DC cabling to the nip D release solenoid. If necessary, install a new nip D release solenoid.
99-757	Soft	Go to the 83-506-00 Nip D Release Solenoid Failure RAP. Check the DC cabling to the nip D release solenoid. If necessary, install a new nip D release solenoid.
99-758	Soft	Go to the 83-506-00 Nip D Release Solenoid Failure RAP. Check the DC cabling to the nip D release solenoid. If necessary, install a new nip D release solenoid.
99-765	Hard	Go to the 10-570-00 Stripper Solenoid Over Current RAP. Check the DC cabling to the stripper solenoid. If necessary, install a new stripper solenoid.
99-766	Hard	Go to the 10-570-00 Stripper Solenoid Over Current RAP. Check the DC cabling to the stripper solenoid. If necessary, install a new stripper solenoid.

99-767-00 to 99-782-00 PEST Error 35 RAP

99-767-00 Solenoid, stripper below min.

99-768-00 Solenoid, stripper above max.

99-780-00 Pump, DMU delivery open.

99-781-00 Pump, DMU delivery short.

99-782-00 Pump, DMU delivery stall.

Initial Actions

WARNING

Ensure that the electricity to the machine is switched off while performing tasks that do not need electricity. Refer to GP 14. Disconnect the power cord. Electricity can cause death or injury. Moving parts can cause injury.

Procedure

Refer to [Table 1](#). Perform the relevant action. For an explanation of PEST codes refer to [dC123](#).

Table 1 PEST codes and action

Code	Hard/Soft	Action
99-767	Soft	Go to the 10-570-00 Stripper Solenoid Over Current RAP. Check the DC cabling to the stripper solenoid. If necessary, install a new stripper solenoid.
99-768	Soft	Go to the 10-570-00 Stripper Solenoid Over Current RAP. Check the DC cabling to the stripper solenoid. If necessary, install a new stripper solenoid.
99-780	Hard	Go to the 94-528-00 , 94-532-00 , 94-533-00 Cleaning Unit Over Current RAP. Check the DC cabling to the cleaning unit. If necessary, install a new cleaning unit.
99-781	Soft	Go to the 94-528-00 , 94-532-00 , 94-533-00 Cleaning Unit Over Current RAP. Check the DC cabling to the cleaning unit. If necessary, install a new cleaning unit.
99-782	Soft	Go to the 94-528-00 , 94-532-00 , 94-533-00 Cleaning Unit Over Current RAP. Check the DC cabling to the cleaning unit. If necessary, install a new cleaning unit.

99-785-00 to 99-802-00 PEST Error 36 RAP

99-785-00 Pump, DMU return open.

99-786-00 Pump, DMU return short.

99-801-00 Motor, drum maint open.

99-802-00 Motor, drum maint short.

Initial Actions

WARNING

Ensure that the electricity to the machine is switched off while performing tasks that do not need electricity. Refer to GP 14. Disconnect the power cord. Electricity can cause death or injury. Moving parts can cause injury.

Procedure

Refer to Table 1. Perform the relevant action. For an explanation of PEST codes refer to dC123.

Table 1 PEST codes and action

Code	Hard/Soft	Action
99-785	Hard	Go to the 94-528-00, 94-532-00, 94-533-00 Cleaning Unit Over Current RAP. Check the DC cabling to the cleaning unit. If necessary, install a new cleaning unit.
99-786	Soft	Go to the 94-528-00, 94-532-00, 94-533-00 Cleaning Unit Over Current RAP. Check the DC cabling to the cleaning unit. If necessary, install a new cleaning unit.
99-801	Hard	Refer to WD 9.2 and WD 9.3. Check the DC cabling to the cleaning unit motor. Measure the resistance between PJ601 pins 5 and 10 on the drum driver PWB for an open or short circuit and to the chassis for a short circuit. If a fault is found, repeat the measurement at the cleaning unit motor. If a short is measured, the drum driver PWB may be damaged and be reported as an 'open' error. If short error is reported, the cleaning unit motor is drawing excessive power. Install new components as necessary, cleaning unit motor assembly, PL 94.10 Item 19, Drum driver PWB, PL 1.15 Item 4.
99-802	Hard	Refer to WD 9.2 and WD 9.3. Check the DC cabling to the cleaning unit motor. Measure the resistance between PJ601 pins 5 and 10 on the drum driver PWB for an open or short circuit and to the chassis for a short circuit. If a fault is found, repeat the measurement at the cleaning unit motor. If a short is measured, the drum driver PWB may be damaged and be reported as an 'open' error. If short error is reported, the cleaning unit motor is drawing excessive power. Install new components as necessary, cleaning unit motor assembly, PL 94.10 Item 19, Drum driver PWB, PL 1.15 Item 4.

99-805-00 to 99-823-00 PEST Error 37 RAP

99-805-00 Motor, drum maint above max.

99-810-00 Motor, head roll 1 open.

99-811-00 Motor, head roll 1 short.

99-812-00 Motor, head roll 2 open.

99-813-00 Motor, head roll 2 short.

99-814-00 Motor, head roll 3 open.

99-815-00 Motor, head roll 3 short.

99-816-00 Motor, head roll 4 open.

99-817-00 Motor, head roll 4 short.

99-818-00 Motor, head roll 1-4 power fault.

99-819-00 Motor, head roll 1-4 power fault.

99-820-00 Motor, head stitch 1 open.

99-821-00 Motor, head stitch 1 short.

99-822-00 Motor, head stitch 2 open.

99-823-00 Motor, head stitch 2 short.

Initial Actions

WARNING

Ensure that the electricity to the machine is switched off while performing tasks that do not need electricity. Refer to GP 14. Disconnect the power cord. Electricity can cause death or injury. Moving parts can cause injury.

Procedure

Refer to Table 1. Perform the relevant action. For an explanation of PEST codes refer to dC123.

Table 1 PEST codes and action

Code	Hard/Soft	Action
99-805	Soft	Go to the 94-520-00 Cleaning Unit Drive Error RAP. Check the cleaning unit motor.
99-810	Soft	Go to the 91-506-00 to 91-509-00 Roll Motor Over Current RAP. Check printhead 1 roll adjust motor.

Table 1 PEST codes and action

Code	Hard/Soft	Action
99-811	Hard	Refer to WD 9.10 . Check the DC cabling to the printhead roll adjust motor 1. Measure the resistance at PJ303 on the marking unit driver PWB for an open or short circuit and to the chassis for a short circuit. If a fault is found, repeat the measurement at the printhead roll adjust motor 1. If a short is measured, the marking unit driver PWB may be damaged and be reported as an 'open' error. If short error is reported, the printhead roll adjust motor 1. is drawing excessive power. Install new components as necessary, printhead roll adjust motor 1, PL 91.25 Item 4 , marking unit driver PWB, PL 92.10 Item 4 . Refer to the 91-506-00 to 91-509-00 Roll Motor Over Current RAP.
99-812	Soft	Go to the 91-506-00 to 91-509-00 Roll Motor Over Current RAP. Check printhead 2 roll adjust motor.
99-813	Hard	Refer to WD 9.9 . Check the DC cabling to the printhead roll adjust motor 2. Measure the resistance at PJ102 on the marking unit driver PWB for an open or short circuit and to the chassis for a short circuit. If a fault is found, repeat the measurement at the printhead roll adjust motor 2. If a short is measured, the marking unit driver PWB may be damaged and be reported as an 'open' error. If short error is reported, the printhead roll adjust motor 2 is drawing excessive power. Install new components as necessary, printhead roll adjust motor 2, PL 91.20 Item 4 , marking unit driver PWB, PL 92.10 Item 4 . Refer to the 91-506-00 to 91-509-00 Roll Motor Over Current RAP.
99-814	Soft	Go to the 91-506-00 to 91-509-00 Roll Motor Over Current RAP. Check printhead 3 roll adjust motor.
99-815	Hard	Refer to WD 9.10 . Check the DC cabling to the printhead roll adjust motor 3. Measure the resistance at PJ303 on the marking unit driver PWB for an open or short circuit and to the chassis for a short circuit. If a fault is found, repeat the measurement at the printhead roll adjust motor 3. If a short is measured, the marking unit driver PWB may be damaged and be reported as an 'open' error. If short error is reported, the printhead roll adjust motor 3. is drawing excessive power. Install new components as necessary, printhead roll adjust motor 3, PL 91.25 Item 4 , marking unit driver PWB, PL 92.10 Item 4 . Refer to the 91-506-00 to 91-509-00 Roll Motor Over Current RAP.
99-816	Soft	Go to the 91-506-00 to 91-509-00 Roll Motor Over Current RAP. Check printhead 4 roll adjust motor.
99-817	Hard	Refer to WD 9.9 . Check the DC cabling to the printhead roll adjust motor 4. Measure the resistance at PJ102 on the marking unit driver PWB for an open or short circuit and to the chassis for a short circuit. If a fault is found, repeat the measurement at the printhead roll adjust motor 4. If a short is measured, the marking unit driver PWB may be damaged and be reported as an 'open' error. If short error is reported, the printhead roll adjust motor 4 is drawing excessive power. Install new components as necessary, printhead roll adjust motor 4, PL 91.20 Item 4 , marking unit driver PWB, PL 92.10 Item 4 . Refer to the 91-506-00 to 91-509-00 Roll Motor Over Current RAP. Check printhead 4 roll adjust motor.

Table 1 PEST codes and action

Code	Hard/Soft	Action
99-818	Soft	Go to the 91-506-00 to 91-509-00 Roll Motor Over Current RAP. Check printhead roll adjust motors.
99-819	Soft	Go to the 91-506-00 to 91-509-00 Roll Motor Over Current RAP. Check printhead roll adjust motors.
99-820	Soft	Go to the 91-504-00, 91-505-00 Printhead Stitch Motor Over Current RAP. Check printhead 1 stitch adjust motor.
99-821	Hard	Refer to WD 9.10 . Check the DC cabling to the printhead stitch adjust motor 1. Measure the resistance at PJ303 on the marking unit driver PWB for an open or short circuit and to the chassis for a short circuit. If a fault is found, repeat the measurement at the printhead stitch adjust motor 1. If a short is measured, the marking unit driver PWB may be damaged and be reported as an 'open' error. If short error is reported, the printhead stitch adjust motor 1. is drawing excessive power. Install new components as necessary, printhead stitch adjust motor 1, PL 91.25 Item 4 , marking unit driver PWB, PL 92.10 Item 4 . Refer to the 91-504-00, 91-505-00 Printhead Stitch Motor Over Current RAP. Check printhead 1 stitch adjust motor.
99-822	Soft	Go to the 91-504-00, 91-505-00 Printhead Stitch Motor Over Current RAP. Check printhead 2 stitch adjust motor.
99-823	Hard	Refer to WD 9.9 . Check the DC cabling to the printhead stitch adjust motor 2. Measure the resistance at PJ102 on the marking unit driver PWB for an open or short circuit and to the chassis for a short circuit. If a fault is found, repeat the measurement at the printhead stitch adjust motor 2. If a short is measured, the marking unit driver PWB may be damaged and be reported as an 'open' error. If short error is reported, the printhead roll adjust motor 2 is drawing excessive power. Install new components as necessary, printhead stitch adjust motor 2, PL 91.20 Item 4 , marking unit driver PWB, PL 92.10 Item 4 . Refer to the 91-504-00, 91-505-00 Printhead Stitch Motor Over Current RAP. Check printhead 2 stitch adjust motor.

99-824-00 to 99-838-00 PEST Error 38 RAP

99-824-00 Motor, head stitch 1-2 power fault.

99-829-00 Motor, carriage restraint upper/lower fault.

99-830-00 Motor, carriage select open.

99-831-00 Motor, carriage select short.

99-832-00 Motor, carriage drive open.

99-833-00 Motor, carriage drive short.

99-834-00 Motor, carriage drive power fault.

99-835-00 Motor, head maint vertical open.

99-836-00 Motor, head maint vertical short.

99-837-00 Motor, head maint horizontal open.

99-838-00 Motor, head maint horizontal short.

Initial Actions

WARNING

Ensure that the electricity to the machine is switched off while performing tasks that do not need electricity. Refer to GP 14. Disconnect the power cord. Electricity can cause death or injury. Moving parts can cause injury.

Procedure

Refer to Table 1. Perform the relevant action. For an explanation of PEST codes refer to dC123.

Table 1 PEST codes and action

Code	Hard/Soft	Action
99-824	Soft	Go to the 91-504-00, 91-505-00 Printhead Stitch Motor Over Current RAP. Check printhead 1 and 2 stitch adjust motor.
99-829	Soft	This fault code is shown for information only. The machine does not have carriage restraint motors.

Table 1 PEST codes and action

Code	Hard/Soft	Action
99-830	Hard	Refer to WD 9.11. Check the DC cabling to the carriage drive select motor. Measure the resistance at PJ607 on the marking unit driver PWB for an open or short circuit and to the chassis for a short circuit. If a fault is found, repeat the measurement at the carriage drive select motor. If a short is measured, the marking unit driver PWB may be damaged and be reported as an 'open' error. If short error is reported, the motor is drawing excessive power. Install new components as necessary, carriage drive chain, PL 91.10 Item 1, marking unit driver PWB, PL 92.10 Item 4. Refer to the 91-560-00 Carriage Selection Time Out RAP. Check the carriage drive select motor.
99-831	Hard	Refer to WD 9.11. Check the DC cabling to the carriage drive select motor. Measure the resistance at PJ607 on the marking unit driver PWB for an open or short circuit and to the chassis for a short circuit. If a fault is found, repeat the measurement at the carriage drive select motor. If a short is measured, the marking unit driver PWB may be damaged and be reported as an 'open' error. If short error is reported, the motor is drawing excessive power. Install new components as necessary, carriage drive chain, PL 91.10 Item 1, marking unit driver PWB, PL 92.10 Item 4. Refer to the 91-560-00 Carriage Selection Time Out RAP. Check the carriage drive select motor.
99-832	Hard	Refer to WD 9.11. Check the DC cabling to the carriage docking motor. Measure the resistance at PJ605 on the marking unit driver PWB for an open or short circuit and to the chassis for a short circuit. If a fault is found, repeat the measurement at the carriage docking motor. If a short is measured, the marking unit driver PWB may be damaged and be reported as an 'open' error. If short error is reported, the motor is drawing excessive power. Install new components as necessary, carriage docking motor, PL 91.10 Item 16, marking unit driver PWB, PL 92.10 Item 4. Refer to the 91-567-00 to 91-568-00 Lower Carriage Error RAP.
99-833	Hard	Refer to WD 9.11. Check the DC cabling to the carriage docking motor. Measure the resistance at PJ605 on the marking unit driver PWB for an open or short circuit and to the chassis for a short circuit. If a fault is found, repeat the measurement at the carriage docking motor. If a short is measured, the marking unit driver PWB may be damaged and be reported as an 'open' error. If short error is reported, the motor is drawing excessive power. Install new components as necessary, carriage docking motor, PL 91.10 Item 16, marking unit driver PWB, PL 92.10 Item 4. Refer to the 91-567-00 to 91-568-00 Lower Carriage Error RAP.
99-834	Soft	Go to the 91-567-00 to 91-568-00 Lower Carriage Error RAP. Check the carriage drive select motor.

Table 1 PEST codes and action

Code	Hard/Soft	Action
99-835	Hard	Refer to WD 9.11 . Check the DC cabling to the HM vertical motion motor. Measure the resistance at PJ401 on the marking unit driver PWB for an open or short circuit and to the chassis for a short circuit. If a fault is found, repeat the measurement at the HM vertical motion motor. If a short is measured, the marking unit driver PWB may be damaged and be reported as an 'open' error. If short error is reported, the motor is drawing excessive power. Install new components as necessary, HM vertical motion motor, PL 91.15 Item 12 , marking unit driver PWB, PL 92.10 Item 4 . Refer to the 91-559-00 Marking Unit Components Out of Position RAP. Check the HM vertical motion motor.
99-836	Hard	Refer to WD 9.11 . Check the DC cabling to the HM vertical motion motor. Measure the resistance at PJ401 on the marking unit driver PWB for an open or short circuit and to the chassis for a short circuit. If a fault is found, repeat the measurement at the HM vertical motion motor. If a short is measured, the marking unit driver PWB may be damaged and be reported as an 'open' error. If short error is reported, the motor is drawing excessive power. Install new components as necessary, HM vertical motion motor, PL 91.15 Item 12 , marking unit driver PWB, PL 92.10 Item 4 . Refer to the 91-559-00 Marking Unit Components Out of Position RAP. Check the HM vertical motion motor.
99-837	Hard	Refer to WD 9.11 . Check the DC cabling to the HM horizontal motion motor. Measure the resistance at PJ304 on the marking unit driver PWB for an open or short circuit and to the chassis for a short circuit. If a fault is found, repeat the measurement at the HM horizontal motion motor. If a short is measured, the marking unit driver PWB may be damaged and be reported as an 'open' error. If short error is reported, the motor is drawing excessive power. Install new components as necessary, HM horizontal motion motor, PL 91.15 Item 15 , marking unit driver PWB, PL 92.10 Item 4 . Refer to the 91-512-00 , 91-605-00 Marking Unit Motor Short RAP. Check the HM horizontal motion motor.
99-838	Hard	Refer to WD 9.11 . Check the DC cabling to the HM horizontal motion motor. Measure the resistance at PJ304 on the marking unit driver PWB for an open or short circuit and to the chassis for a short circuit. If a fault is found, repeat the measurement at the HM horizontal motion motor. If a short is measured, the marking unit driver PWB may be damaged and be reported as an 'open' error. If short error is reported, the motor is drawing excessive power. Install new components as necessary, HM horizontal motion motor, PL 91.15 Item 15 , marking unit driver PWB, PL 92.10 Item 4 . Refer to the 91-512-00 , 91-605-00 Marking Unit Motor Short RAP. Check the HM horizontal motion motor.

99-839-00 to 99-871-00 PEST Error 39 RAP

99-839-00 Motor, head maint vertical short.

99-840-00 Motor, X axis upper open.

99-841-00 Motor, X axis upper short.

99-842-00 Motor, X axis upper power low.

99-843-00 Motor, X axis upper power high.

99-845-00 Motor, X axis lower open.

99-846-00 Motor, X axis lower short.

99-847-00 Motor, X axis lower power low.

99-848-00 Motor, X axis lower power high.

99-860-00 Motor, IOD shuttle open.

99-861-00 Motor, IOD shuttle short.

99-863-00 Motor, IOD shuttle power low.

99-864-00 Motor, IOD shuttle power high.

99-870-00 Motor, ink keyplate open.

99-871-00 Motor, ink keyplate short.

Initial Actions

WARNING

Ensure that the electricity to the machine is switched off while performing tasks that do not need electricity. Refer to [GP 14](#). Disconnect the power cord. Electricity can cause death or injury. Moving parts can cause injury.

Procedure

Refer to [Table 1](#). Perform the relevant action. For an explanation of PEST codes refer to [dC123](#).

Table 1 PEST codes and action

Code	Hard/Soft	Action
99-839	Soft	Go to the 91-559-00 Marking Unit Components Out of Position RAP. Check the HM vertical motion motor.

Table 1 PEST codes and action

Code	Hard/Soft	Action
99-840	Hard	Refer to WD 9.9 . Check the DC cabling to the X axis drive motor upper. Measure the resistance at PJ102 on the marking unit driver PWB for an open or short circuit and to the chassis for a short circuit. If a fault is found, repeat the measurement at the X axis drive motor upper. If a short is measured, the marking unit driver PWB may be damaged and be reported as an 'open' error. If short error is reported, the motor is drawing excessive power. Install new components as necessary, X axis drive motor upper, PL 91.20 Item 5 , marking unit driver PWB, PL 92.10 Item 4 . Refer to the 91-510-00 , 91-511-00 X Axis Motor Over Current RAP. Check the upper X axis drive motor.
99-841	Hard	Refer to WD 9.9 . Check the DC cabling to the X axis drive motor upper. Measure the resistance at PJ102 on the marking unit driver PWB for an open or short circuit and to the chassis for a short circuit. If a fault is found, repeat the measurement at the X axis drive motor upper. If a short is measured, the marking unit driver PWB may be damaged and be reported as an 'open' error. If short error is reported, the motor is drawing excessive power. Install new components as necessary, X axis drive motor upper, PL 91.20 Item 5 , marking unit driver PWB, PL 92.10 Item 4 . Refer to the 91-510-00 , 91-511-00 X Axis Motor Over Current RAP. Check the upper X axis drive motor.
99-842	Soft	Go to the 91-510-00 , 91-511-00 X Axis Motor Over Current RAP. Check the upper X axis drive motor.
99-843	Soft	Go to the 91-510-00 , 91-511-00 X Axis Motor Over Current RAP. Check the upper X axis drive motor.
99-845	Hard	Refer to WD 9.11 . Check the DC cabling to the X axis drive motor lower. Measure the resistance at PJ303 on the marking unit driver PWB for an open or short circuit and to the chassis for a short circuit. If a fault is found, repeat the measurement at the X axis drive motor lower. If a short is measured, the marking unit driver PWB may be damaged and be reported as an 'open' error. If short error is reported, the motor is drawing excessive power. Install new components as necessary, X axis drive motor lower, PL 91.25 Item 5 , marking unit driver PWB, PL 92.10 Item 4 . Refer to the 91-510-00 , 91-511-00 X Axis Motor Over Current RAP. Check the lower X axis drive motor.
99-846	Hard	Refer to WD 9.11 . Check the DC cabling to the X axis drive motor lower. Measure the resistance at PJ303 on the marking unit driver PWB for an open or short circuit and to the chassis for a short circuit. If a fault is found, repeat the measurement at the X axis drive motor lower. If a short is measured, the marking unit driver PWB may be damaged and be reported as an 'open' error. If short error is reported, the motor is drawing excessive power. Install new components as necessary, X axis drive motor lower, PL 91.25 Item 5 , marking unit driver PWB, PL 92.10 Item 4 . Refer to the 91-510-00 , 91-511-00 X Axis Motor Over Current RAP. Check the lower X axis drive motor.

Table 1 PEST codes and action

Code	Hard/Soft	Action
99-847	Soft	Go to the 91-510-00 , 91-511-00 X Axis Motor Over Current RAP. Check the lower X axis drive motor.
99-848	Soft	Go to the 91-510-00 , 91-511-00 X Axis Motor Over Current RAP. Check the lower X axis drive motor.
99-860	Hard	Refer to WD 9.22 . Check the DC cabling to the IOD shuttle motor. Measure the resistance at PJ660 on the IOD pre-amplifier PWB for an open or short circuit and to the chassis for a short circuit. If a fault is found, repeat the measurement at the IOD shuttle motor. If a short is measured, the IOD pre-amplifier PWB may be damaged and be reported as an 'open' error. If short error is reported, the motor is drawing excessive power. Install new components as necessary, IOD assembly, PL 94.15 Item 1 . Refer to the 91-513-00 , 91-514-00 , 91-581-00 , 91-583-00 IOD Drive Error RAP. Check the IOD shuttle motor.
99-861	Hard	Refer to WD 9.22 . Check the DC cabling to the IOD shuttle motor. Measure the resistance at PJ660 on the IOD pre-amplifier PWB for an open or short circuit and to the chassis for a short circuit. If a fault is found, repeat the measurement at the IOD shuttle motor. If a short is measured, the IOD pre-amplifier PWB may be damaged and be reported as an 'open' error. If short error is reported, the motor is drawing excessive power. Install new components as necessary, IOD assembly, PL 94.15 Item 1 . Refer to the 91-513-00 , 91-514-00 , 91-581-00 , 91-583-00 IOD Drive Error RAP. Check the IOD shuttle motor.
99-863	Soft	Go to the 91-513-00 , 91-514-00 , 91-581-00 , 91-583-00 IOD Drive Error RAP. Check the IOD shuttle motor.
99-864	Soft	Go to the 91-513-00 , 91-514-00 , 91-581-00 , 91-583-00 IOD Drive Error RAP. Check the IOD shuttle motor.
99-870	Soft	Go to the 93-825-00 , 93-892-00 Ink Key Plate Motor Over Current RAP. Check the ink key plate motor.
99-871	Hard	Refer to WD 8.4 . Check the DC cabling to the ink key plate motor. Measure the resistance at PJ406 on the media path driver PWB for an open or short circuit and to the chassis for a short circuit. If a fault is found, repeat the measurement at the ink key plate motor. If a short is measured, the media path driver PWB may be damaged and be reported as an 'open' error. If short error is reported, the motor is drawing excessive power. Install new components as necessary, ink key plate motor, PL 93.10 Item 14 , media path driver PWB, PL 1.15 Item 5 . Refer to the 93-825-00 , 93-892-00 Ink Key Plate Motor Over Current RAP. Check the ink key plate motor.

99-872-00 to 99-887-00 PEST Error 40 RAP

99-872-00 Motor, ink SKU power low.

99-873-00 Motor, ink SKU power high.

99-875-00 Motor, ink load belt drive open.

99-876-00 Motor, ink load belt drive short.

99-877-00 Motor, ink load belt drive power low.

99-878-00 Motor, ink load belt drive power high.

99-880-00 Motor, drum drive open.

99-881-00 Motor, drum drive short.

99-882-00 Motor, drum drive power low.

99-883-00 Motor, drum drive power high.

99-886-00 Motor, drum drive current feedback.

99-887-00 Motor, drum drive thermal fuse.

Initial Actions

WARNING

Ensure that the electricity to the machine is switched off while performing tasks that do not need electricity. Refer to [GP 14](#). Disconnect the power cord. Electricity can cause death or injury. Moving parts can cause injury.

Procedure

Refer to [Table 1](#). Perform the relevant action. For an explanation of PEST codes refer to [dC123](#).

Table 1 PEST codes and action

Code	Hard/Soft	Action
99-872	Soft	Go to the 93-825-00 , 93-892-00 Ink Key Plate Motor Over Current RAP. Check the ink key plate motor.
99-873	Soft	Go to the 93-825-00 , 93-892-00 Ink Key Plate Motor Over Current RAP. Check the ink key plate motor.
99-875	Soft	Go to the 93-891-00 Ink Transport Over Current RAP. Check the ink transport motor.

Table 1 PEST codes and action

Code	Hard/Soft	Action
99-876	Hard	Refer to WD 8.4 . Check the DC cabling to the ink transport motor. Measure the resistance at PJ406 on the media path driver PWB for an open or short circuit and to the chassis for a short circuit. If a fault is found, repeat the measurement at the ink transport motor. If a short is measured, the media path driver PWB may be damaged and be reported as an 'open' error. If short error is reported, the motor is drawing excessive power. Install new components as necessary, ink transport motor, PL 93.10 Item 5 , media path driver PWB, PL 1.15 Item 5 . Refer to the 93-891-00 Ink Transport Over Current RAP. Check the ink transport motor.
99-877	Soft	Go to the 93-891-00 Ink Transport Over Current RAP. Check the ink transport motor.
99-878	Soft	Go to the 93-891-00 Ink Transport Over Current RAP. Check the ink transport motor.
99-880	Hard	Enter dC123 Pest fault history and check for PEST error 99-886 or 99-887, if present then follow those RAPs first. Refer to WD 1.1 . Then check the resistance at the drum motor leads (should be 10.5 ohms typical, valid range 9.0 to 12.0 ohms, between any 2 of the 3 leads, 3 measurements). Refer to WD 1.4 and WD 9.4 . Check the Interface harness and connectors for damage between the drum driver PWB at PJ902 and the power supply at PJDC2 (pins 11, 13, 15, 17). If above are OK, install a new power supply, PL 1.15 Item 2 . If fault still present, install a new drum driver PWB, PL 1.15 Item 4 . Note: This motor is disabled by front door interlock; soft error 99-992 will be given instead, the drum motor test will be skipped. This error will only be activated if door interlock is OK. Refer to the 94-524-00 RAP. Check the drum drive motor.
99-881	Hard	Refer to WD 1.1 . Then check the resistance at the drum motor leads (should be 10.5 ohms typical, valid range 9.0 to 12.0 ohms, between any 2 of the 3 leads, 3 measurements). Refer to WD 1.4 and WD 9.4 . Check the Interface harness and connectors for damage between the drum driver PWB at PJ902 and the power supply at PJDC2 (pins 11, 13, 15, 17). If above are OK, install a new power supply, PL 1.15 Item 2 . If fault is still present, install a new drum driver PWB, PL 1.15 Item 4 . Note: This motor is disabled by front door interlock; soft error 99-992 will be given instead, the drum motor test will be skipped. This error will only be activated if door interlock is OK. Refer to the 94-524-00 RAP. Check the drum drive motor.
99-882	Soft	Go to the 94-524-00 RAP. Check the drum drive motor.
99-883	Soft	Go to the 94-524-00 RAP. Check the drum drive motor.
99-886	Soft	Go to the 94-524-00 RAP. Check the drum drive motor.
99-887	Soft	If persistent, install a new drum motor, PL 94.20 Item 6 .

99-890-00 to 99-904-00 PEST Error 41 RAP

99-890-00 Motor, transfix front open.

99-891-00 Motor, transfix front short.

99-892-00 Motor, transfix front motor encoder.

99-893-00 Motor, transfix front below min.

99-894-00 Motor, transfix front above max.

99-895-00 Motor, transfix rear open.

99-896-00 Motor, transfix rear short.

99-897-00 Motor, transfix rear motor encoder.

99-898-00 Motor, transfix rear below min.

99-899-00 Motor, transfix rear above max.

99-901-00 Motor, MP2 open.

99-902-00 Motor, MP2 short.

99-904-00 Motor, MP2 power fault.

Initial Actions

WARNING

Ensure that the electricity to the machine is switched off while performing tasks that do not need electricity. Refer to **GP 14**. Disconnect the power cord. Electricity can cause death or injury. Moving parts can cause injury.

Procedure

Refer to **Table 1**. Perform the relevant action. For an explanation of PEST codes refer to **dC123**.

Table 1 PEST codes and action

Code	Hard/Soft	Action
99-890	Hard	Refer to WD 9.1 . Check the DC cabling to the front transfix motor. Measure the resistance at PJ401 on the drum driver PWB for an open or short circuit and to the chassis for a short circuit. If a fault is found, repeat the measurement at the front transfix motor. If a short is measured, the drum driver PWB may be damaged and be reported as an 'open' error. If short error is reported, the motor is drawing excessive power. Install new components as necessary, front transfix motor, PL 10.20 Item 11 , Drum driver PWB, PL 1.15 Item 4 . Refer to the 10-500-00 to 10-540-00 Transfix Error RAP. Check the front transfix motor.
99-891	Hard	Refer to WD 9.1 . Check the DC cabling to the front transfix motor. Measure the resistance at PJ401 on the drum driver PWB for an open or short circuit and to the chassis for a short circuit. If a fault is found, repeat the measurement at the front transfix motor. If a short is measured, the drum driver PWB may be damaged and be reported as an 'open' error. If short error is reported, the motor is drawing excessive power. Install new components as necessary, front transfix motor, PL 10.20 Item 11 , Drum driver PWB, PL 1.15 Item 4 . Refer to the 10-500-00 to 10-540-00 Transfix Error RAP. Check the front transfix motor.
99-892	Hard	Refer to WD 9.1 and WD 9.3 . Check the DC cabling to the front transfix flexure encoder. Measure the resistance at PJ801 on the drum driver PWB for an open or short circuit and to the chassis for a short circuit. If a fault is found, repeat the measurement at the front transfix flexure encoder. If a short is measured, the drum driver PWB may be damaged and be reported as an 'open' error. If short error is reported, the encoder is drawing excessive power. Install new components as necessary, front transfix encoder, PL 10.20 Item 5 , Drum driver PWB, PL 1.15 Item 4 . Refer to 10-500-00 to 10-540-00 Transfix Error RAP. Check the front transfix motor encoder. If the fault remains, install a new front transfix motor, PL 10.20 Item 11 .
99-983	Soft	Go to the 10-500-00 to 10-540-00 Transfix Error RAP. Check the front transfix motor.

Table 1 PEST codes and action

Code	Hard/Soft	Action
99-894	Soft	Go to the 10-500-00 to 10-540-00 Transfix Error RAP. Check the front transfix motor.
99-895	Hard	Refer to WD 9.1 . Check the DC cabling to the rear transfix motor. Measure the resistance at PJ401 on the drum driver PWB for an open or short circuit and to the chassis for a short circuit. If a fault is found, repeat the measurement at the rear transfix motor. If a short is measured, the drum driver PWB may be damaged and be reported as an 'open' error. If short error is reported, the motor is drawing excessive power. Install new components as necessary, rear transfix motor, PL 10.20 Item 11 , Drum driver PWB, PL 1.15 Item 4 . Go to the 10-500-00 to 10-540-00 Transfix Error RAP. Check the rear transfix motor.
99-896	Hard	Refer to WD 9.1 . Check the DC cabling to the rear transfix motor. Measure the resistance at PJ401 on the drum driver PWB for an open or short circuit and to the chassis for a short circuit. If a fault is found, repeat the measurement at the rear transfix motor. If a short is measured, the drum driver PWB may be damaged and be reported as an 'open' error. If short error is reported, the motor is drawing excessive power. Install new components as necessary, rear transfix motor, PL 10.20 Item 11 , Drum driver PWB, PL 1.15 Item 4 . Refer to the 10-500-00 to 10-540-00 Transfix Error RAP. Check the rear transfix motor.
99-897	Hard	Refer to WD 9.1 and WD 9.3 . Check the DC cabling to the rear transfix flexure encoder. Measure the resistance at PJ801 on the drum driver PWB for an open or short circuit and to the chassis for a short circuit. If a fault is found, repeat the measurement at the rear transfix flexure encoder. If a short is measured, the drum driver PWB may be damaged and be reported as an 'open' error. If short error is reported, the encoder is drawing excessive power. Install new components as necessary, rear transfix encoder, PL 10.20 Item 5 , Drum driver PWB, PL 1.15 Item 4 . Go to 10-500-00 to 10-540-00 Transfix Error RAP. Check the rear transfix motor. If the fault remains, install a new rear transfix motor, PL 10.20 Item 11 .
99-898	Soft	Go to the 10-500-00 to 10-540-00 Transfix Error RAP. Check the rear transfix motor.
99-899	Soft	Go to the 10-500-00 to 10-540-00 Transfix Error RAP. Check the rear transfix motor.

Table 1 PEST codes and action

Code	Hard/Soft	Action
99-901	Hard	Refer to WD 8.1 . Check the DC cabling to the vertical transport motor. Measure the resistance at PJ202 on the media path driver PWB for an open or short circuit and to the chassis for a short circuit. If a fault is found, repeat the measurement at the vertical transport motor. If a short is measured, the media path driver PWB may be damaged and be reported as an 'open' error. If short error is reported, the motor is drawing excessive power. Install new components as necessary, vertical transport motor, PL 82.10 Item 12 , media path driver PWB, PL 1.15 Item 5 . Refer to the 82-132-00, 82-155-00 Media Path Sensor 16 Duplex Mode RAP. Check the vertical transport motor.
99-902	Hard	Refer to WD 8.1 . Check the DC cabling to the vertical transport motor. Measure the resistance at PJ202 on the media path driver PWB for an open or short circuit and to the chassis for a short circuit. If a fault is found, repeat the measurement at the vertical transport motor. If a short is measured, the media path driver PWB may be damaged and be reported as an 'open' error. If short error is reported, the motor is drawing excessive power. Install new components as necessary, vertical transport motor, PL 82.10 Item 12 , media path driver PWB, PL 1.15 Item 5 . Refer to the 82-132-00, 82-155-00 Media Path Sensor 16 Duplex Mode RAP. Check the vertical transport motor.
99-904	Soft	Go to the 82-132-00, 82-155-00 Media Path Sensor 16 Duplex Mode RAP. Check the vertical transport motor.

99-905-00 to 99-921-00 PEST Error 42 RAP

99-905-00 Motor, MP6 open

99-906-00 Motor, MP6 short

99-909-00 Motor, MP6 power high

99-910-00 Motor, M3A1 open

99-911-00 Motor, M3A1 short

99-912-00 Motor, M3A1 power low

99-913-00 Motor, M3A1 power high

99-915-00 Motor, M3A2 open

99-916-00 Motor, M3A2 short

99-917-00 Motor, M3A2 power low

99-918-00 Motor, M3A2 power high

99-920-00 Motor, MP4 open

99-921-00 Motor, MP4 short

Initial Actions

WARNING

Ensure that the electricity to the machine is switched off while performing tasks that do not need electricity. Refer to **GP 14**. Disconnect the power cord. Electricity can cause death or injury. Moving parts can cause injury.

Procedure

Refer to **Table 1**. Perform the relevant action. For an explanation of PEST codes refer to **dC123**.

Table 1 PEST codes and action

Code	Hard/Soft	Action
99-905	Hard	Refer to WD 8.1 and WD 8.5 . Check the DC cabling to the horizontal transport motor. Measure the resistance at PJ303 on the media path driver PWB for an open or short circuit and to the chassis for a short circuit. If a fault is found, repeat the measurement at the horizontal transport motor. If a short is measured, the media path driver PWB may be damaged and be reported as an 'open' error. If short error is reported, the motor is drawing excessive power. Install new components as necessary, horizontal transport motor, PL 82.15 Item 9 , media path driver PWB, PL 1.15 Item 5 . Refer to the 82-132-00 , 82-155-00 Media Path Sensor 16 Duplex Mode RAP. Check the horizontal transport motor.
99-906	Hard	Refer to WD 8.1 and WD 8.5 . Check the DC cabling to the horizontal transport motor. Measure the resistance at PJ303 on the media path driver PWB for an open or short circuit and to the chassis for a short circuit. If a fault is found, repeat the measurement at the horizontal transport motor. If a short is measured, the media path driver PWB may be damaged and be reported as an 'open' error. If short error is reported, the motor is drawing excessive power. Install new components as necessary, horizontal transport motor, PL 82.15 Item 9 , media path driver PWB, PL 1.15 Item 5 . Go to the 82-132-00 , 82-155-00 Media Path Sensor 16 Duplex Mode RAP. Check the horizontal transport motor.
99-909	Soft	Go to the 82-132-00 , 82-155-00 Media Path Sensor 16 Duplex Mode RAP. Check the horizontal transport motor.
99-910	Hard	Refer to WD 8.1 . Check the DC cabling to the registration motor A1. Measure the resistance at PJ202 on the media path driver PWB for an open or short circuit and to the chassis for a short circuit. If a fault is found, repeat the measurement at the registration motor A1. If a short is measured, the media path driver PWB may be damaged and be reported as an 'open' error. If short error is reported, the motor is drawing excessive power. Install new components as necessary, registration / preheat assembly, PL 88.10 Item 1 , media path driver PWB, PL 1.15 Item 5 . Refer to the 89-110-00 to 89-113-00 , 89-129-00 Media Path Sensor 10 Failure RAP. Check the registration motor A1.

Table 1 PEST codes and action

Code	Hard/Soft	Action
99-911	Hard	Refer to WD 8.1 . Check the DC cabling to the registration motor A1. Measure the resistance at PJ202 on the media path driver PWB for an open or short circuit and to the chassis for a short circuit. If a fault is found, repeat the measurement at the registration motor A1. If a short is measured, the media path driver PWB may be damaged and be reported as an 'open' error. If short error is reported, the motor is drawing excessive power. Install new components as necessary, registration / preheat assembly, PL 88.10 Item 1 , media path driver PWB, PL 1.15 Item 5 . Refer to the 89-110-00 to 89-113-00 , 89-129-00 Media Path Sensor 10 Failure RAP. Check the registration motor A1.
99-912	Soft	Go to the 89-110-00 to 89-113-00 , 89-129-00 Media Path Sensor 10 Failure RAP. Check the registration motor A1.
99-913	Soft	Go to the 89-110-00 to 89-113-00 , 89-129-00 Media Path Sensor 10 Failure RAP. Check the registration motor A1.
99-915	Hard	Refer to WD 8.1 . Check the DC cabling to the registration motor A2. Measure the resistance at PJ202 on the media path driver PWB for an open or short circuit and to the chassis for a short circuit. If a fault is found, repeat the measurement at the registration motor A2. If a short is measured, the media path driver PWB may be damaged and be reported as an 'open' error. If short error is reported, the motor is drawing excessive power. Install new components as necessary, registration / preheat assembly, PL 88.10 Item 1 , media path driver PWB, PL 1.15 Item 5 . Refer to the 89-110-00 to 89-113-00 , 89-129-00 Media Path Sensor 10 Failure RAP. Check the registration motor A2.
99-916	Hard	Refer to WD 8.1 . Check the DC cabling to the registration motor A2. Measure the resistance at PJ202 on the media path driver PWB for an open or short circuit and to the chassis for a short circuit. If a fault is found, repeat the measurement at the registration motor A2. If a short is measured, the media path driver PWB may be damaged and be reported as an 'open' error. If short error is reported, the motor is drawing excessive power. Install new components as necessary, registration / preheat assembly, PL 88.10 Item 1 , media path driver PWB, PL 1.15 Item 5 . Refer to the 89-110-00 to 89-113-00 , 89-129-00 Media Path Sensor 10 Failure RAP. Check the registration motor A2.
99-917	Soft	Go to the 89-110-00 to 89-113-00 , 89-129-00 Media Path Sensor 10 Failure RAP. Check the registration motor A2.
99-918	Soft	Go to the 89-110-00 to 89-113-00 , 89-129-00 Media Path Sensor 10 Failure RAP. Check the registration motor A2.

Table 1 PEST codes and action

Code	Hard/Soft	Action
99-920	Hard	Refer to WD 8.2 . Check the DC cabling to the post transfix motor (M4). Measure the resistance at PJ303 on the media path driver PWB for an open or short circuit and to the chassis for a short circuit. If a fault is found, repeat the measurement at the post transfix motor (M4). If a short is measured, the media path driver PWB may be damaged and be reported as an 'open' error. If short error is reported, the motor is drawing excessive power. Install new components as necessary, post transfix motor (M4), PL 10.10 Item 5 , media path driver PWB, PL 1.15 Item 5 . Refer to the 10-110-00 to 10-113-00 , 10-125-00 to 10-128-00 , 10-147-00 , 10-148-00 Post Transfix Jam RAP. Check the post transfix motor.
99-921	Hard	Refer to WD 8.2 . Check the DC cabling to the post transfix motor (M4). Measure the resistance at PJ303 on the media path driver PWB for an open or short circuit and to the chassis for a short circuit. If a fault is found, repeat the measurement at the post transfix motor (M4). If a short is measured, the media path driver PWB may be damaged and be reported as an 'open' error. If short error is reported, the motor is drawing excessive power. Install new components as necessary, post transfix motor (M4), PL 10.10 Item 5 , media path driver PWB, PL 1.15 Item 5 . Refer to the 10-110-00 to 10-113-00 , 10-125-00 to 10-128-00 , 10-147-00 , 10-148-00 Post Transfix Jam RAP. Check the post transfix motor.

99-922-00 to 99-938-00 PEST Error 43 RAP

99-922-00 Motor, MP4 power low.

99-923-00 Motor, MP4 power high.

99-925-00 Motor, MP5 open.

99-926-00 Motor, MP5 short.

99-927-00 Motor, MP5 power low.

99-928-00 Motor, MP5 power high.

99-930-00 Motor (M7), MSI tray 4 feed open.

99-931-00 Motor (M7), MSI tray 4 feed short.

99-932-00 Motor (M7), MSI tray 4 feed power low.

99-933-00 Motor (M7), MSI tray 4 feed power high.

99-934-00 Motor, 3TM horizontal transport power low.

99-935-00 Motor, 3TM horizontal transport open.

99-936-00 Motor, 3TM horizontal transport short.

99-937-00 Motor, 3TM tray 3 elevator open.

99-938-00 Motor, 3TM tray 3 elevator short.

Initial Actions

WARNING

Ensure that the electricity to the machine is switched off while performing tasks that do not need electricity. Refer to [GP 14](#). Disconnect the power cord. Electricity can cause death or injury. Moving parts can cause injury.

- Check connections of the indicated component

Procedure

Refer to [Table 1](#). Perform the relevant action. For an explanation of PEST codes refer to [dC123](#).

Table 1 PEST codes and action

Code	Hard/Soft	Action
99-922	Soft	Go to the 10-110-00 to 10-113-00 , 10-125-00 to 10-128-00 , 10-147-00 , 10-148-00 Post Transfix Jam RAP. Check the post transfix motor.
99-923	Soft	Go to the 10-110-00 to 10-113-00 , 10-125-00 to 10-128-00 , 10-147-00 , 10-148-00 Post Transfix Jam RAP. Check the post transfix motor.

Table 1 PEST codes and action

Code	Hard/Soft	Action
99-925	Hard	Refer to WD 8.2 . Check the DC cabling to the exit motor (M5). Measure the resistance at PJ303 on the media path driver PWB for an open or short circuit and to the chassis for a short circuit. If a fault is found, repeat the measurement at the exit motor (M5). If a short is measured, the media path driver PWB may be damaged and be reported as an 'open' error. If short error is reported, the motor is drawing excessive power. Install new components as necessary, exit motor (M5), PL 10.15 Item 11 , media path driver PWB, PL 1.15 Item 5 . Refer to the 83-500-00 Output Transport Motor M5 Failure RAP. Check the exit motor.
99-926	Hard	Refer to WD 8.2 . Check the DC cabling to the exit motor (M5). Measure the resistance at PJ303 on the media path driver PWB for an open or short circuit and to the chassis for a short circuit. If a fault is found, repeat the measurement at the exit motor (M5). If a short is measured, the media path driver PWB may be damaged and be reported as an 'open' error. If short error is reported, the motor is drawing excessive power. Install new components as necessary, exit motor (M5), PL 10.15 Item 11 , media path driver PWB, PL 1.15 Item 5 . Refer to the 83-500-00 Output Transport Motor M5 Failure RAP. Check the exit motor.
99-927	Soft	Go to the 83-500-00 Output Transport Motor M5 Failure RAP. Check the exit motor.
99-928	Soft	Go to the 83-500-00 Output Transport Motor M5 Failure RAP. Check the exit motor.
99-930	Soft	Go to the 74-101-00 Bypass Tray 4 Mis-Feed RAP. Check the bypass feed motor.
99-931	Hard	Refer to WD 8.3 . Check the DC cabling to the bypass feed motor. Measure the resistance at PJ405 on the media path driver PWB for an open or short circuit and to the chassis for a short circuit. If a fault is found, repeat the measurement at the bypass feed motor. If a short is measured, the media path driver PWB may be damaged and be reported as an 'open' error. If short error is reported, the motor is drawing excessive power. Install new components as necessary, bypass module, PL 74.10 Item 1 , media path driver PWB, PL 1.15 Item 5 . Refer to the 74-101-00 Bypass Tray 4 Mis-Feed RAP. Check the bypass feed motor.
99-932	Soft	Go to the 74-101-00 Bypass Tray 4 Mis-Feed RAP. Check the bypass feed motor.
99-933	Soft	Go to the 74-101-00 Bypass Tray 4 Mis-Feed RAP. Check the bypass feed motor.
99-934	Soft	Go to the 71-101-00 to 71-155-00 RAP. Check the 3 tray transport motor.
99-935	Soft	Go to the 71-101-00 to 71-155-00 RAP. Check the 3 tray transport motor.

Table 1 PEST codes and action

Code	Hard/Soft	Action
99-936	Hard	Refer to WD 7.5 . Check the DC cabling to the 3 tray transport motor. Measure the resistance at PJ956 on the 3 tray module PWB for an open or short circuit and to the chassis for a short circuit. If a fault is found, repeat the measurement at the 3 tray transport motor. If a short is measured, the 3 tray module PWB may be damaged and be reported as an 'open' error. If short error is reported, the motor is drawing excessive power. Install new components as necessary, 3 tray transport motor, PL 73.16 Item 3 , 3 tray module PWB, PL 73.16 Item 4 . Refer to the 71-101-00 to 71-155-00 RAP. Check the 3 tray transport motor.
99-937	Soft	Go to the 73-215-00 Tray 3 Hoist Failure RAP. Check the tray 3 elevator motor.
99-938	Hard	Refer to WD 7.5 . Check the DC cabling to the tray 3 elevator motor. Measure the resistance at PJ957 on the 3 tray module PWB for an open or short circuit and to the chassis for a short circuit. If a fault is found, repeat the measurement at the tray 3 elevator motor. If a short is measured, the 3 tray module PWB may be damaged and be reported as an 'open' error. If short error is reported, the motor is drawing excessive power. Install new components as necessary, tray 3 elevator motor, PL 73.16 Item 2 , 3 tray module PWB, PL 73.16 Item 4 . Refer to the 73-215-00 Tray 3 Hoist Failure RAP. Check the tray 3 elevator motor.

99-939-00 to 99-954-00 PEST Error 44 RAP

99-939-00 Motor, 3TM tray 3 elevator power fault.

99-940-00 Motor, 3TM tray 1 feed open.

99-941-00 Motor, 3TM tray 1 feed short.

99-942-00 Motor, 3TM tray 1 feed power low.

99-943-00 Motor, 3TM tray 2 feed open.

99-944-00 Motor, 3TM tray 2 feed short.

99-945-00 Motor, 3TM tray 2 feed power low.

99-946-00 Motor, 3TM tray 3 feed open.

99-947-00 Motor, 3TM tray 3 feed short.

99-948-00 Motor, 3TM tray 3 feed power low.

99-950-00 Motor, PFP tray 5 transport open.

99-951-00 Motor, PFP tray 5 transport short.

99-952-00 Motor, PFP tray 5 transport power fault.

99-953-00 Motor, PFP tray 5 elevate open.

99-954-00 Motor, PFP tray 5 elevate short.

Initial Actions

WARNING

Ensure that the electricity to the machine is switched off while performing tasks that do not need electricity. Refer to [GP 14](#). Disconnect the power cord. Electricity can cause death or injury. Moving parts can cause injury.

Procedure

Refer to [Table 1](#). Perform the relevant action. For an explanation of PEST codes refer to [dC123](#).

Table 1 PEST codes and action

Code	Hard/Soft	Action
99-939	Soft	Go to the 73-215-00 Tray 3 Hoist Failure RAP. Check the tray 3 elevator motor.
99-940	Soft	Go to the 71-101-00 to 71-155-00 Tray 1 Mis-Feed Jam RAP. Check the tray 1 feed / elevate motor.

Table 1 PEST codes and action

Code	Hard/Soft	Action
99-941	Hard	Refer to WD 7.3 . Check the DC cabling to the tray 1 feed / elevate motor. Measure the resistance at PJ951 on the 3 tray module PWB for an open or short circuit and to the chassis for a short circuit. If a fault is found, repeat the measurement at the tray 1 feed / elevate motor. If a short is measured, the 3 tray module PWB may be damaged and be reported as an 'open' error. If short error is reported, the motor is drawing excessive power. Install new components as necessary, tray 1 feed / elevate motor, PL 81.25 Item 22 , 3 tray module PWB, PL 73.16 Item 4 . Refer to the 71-101-00 to 71-155-00 Tray 1 Mis-Feed Jam RAP. Check the tray 1 feed / elevate motor.
99-942	Soft	Go to the 71-101-00 to 71-155-00 Tray 1 Mis-Feed Jam RAP. Check the tray 1 feed / elevate motor.
99-943	Soft	Go to the 72-215-00 Tray 2 Elevate Up Failure RAP. Check the tray 2 feed / elevate motor.
99-944	Hard	Refer to WD 7.3 . Check the DC cabling to the tray 2 feed / elevate motor. Measure the resistance at PJ952 on the 3 tray module PWB for an open or short circuit and to the chassis for a short circuit. If a fault is found, repeat the measurement at the tray 2 feed / elevate motor. If a short is measured, the 3 tray module PWB may be damaged and be reported as an 'open' error. If short error is reported, the motor is drawing excessive power. Install new components as necessary, tray 2 feed / elevate motor, PL 81.26 Item 22 , 3 tray module PWB, PL 73.16 Item 4 . Refer to the 72-215-00 Tray 2 Elevate Up Failure RAP. Check the tray 2 feed / elevate motor.
99-945	Soft	Go to the 72-215-00 Tray 2 Elevate Up Failure RAP. Check the tray 2 feed / elevate motor.
99-946	Soft	Go to the 73-101-00 to 73-155-00 Tray 3 Mis-Feed Jam RAP. Check the tray 3 feed motor.
99-947	Hard	Refer to WD 7.4 . Check the DC cabling to the tray 3 feed motor. Measure the resistance at PJ953 on the 3 tray module PWB for an open or short circuit and to the chassis for a short circuit. If a fault is found, repeat the measurement at the tray 3 feed motor. If a short is measured, the 3 tray module PWB may be damaged and be reported as an 'open' error. If short error is reported, the motor is drawing excessive power. Install new components as necessary, tray 3 feed motor, PL 81.30 Item 22 , 3 tray module PWB, PL 73.16 Item 4 . Refer to the 73-101-00 to 73-155-00 Tray 3 Mis-Feed Jam RAP. Check the tray 3 feed motor.
99-948	Soft	Go to the 73-101-00 to 73-155-00 Tray 3 Mis-Feed Jam RAP. Check the tray 3 feed motor.
99-950	Soft	Go to the 75-101-00 Tray 5 Mis-Feed RAP. Check the tray 5 transport motor.

Table 1 PEST codes and action

Code	Hard/Soft	Action
99-951	Hard	Refer to WD 7.1 . Check the DC cabling to the tray 5 transport motor. Measure the resistance at PJ503 on the tray 5 control PWB for an open or short circuit and to the chassis for a short circuit. If a fault is found, repeat the measurement at the tray 5 transport motor. If a short is measured, the tray 5 control PWB may be damaged and be reported as an 'open' error. If short error is reported, the motor is drawing excessive power. Install new components as necessary, tray 5 transport motor, PL 81.40 Item 2 , tray 5 control PWB, PL 75.68 Item 8 . Go to the 75-101-00 Tray 5 Mis-Feed RAP. Check the tray 5 transport motor.
99-952	Soft	Go to the 75-101-00 Tray 5 Mis-Feed RAP. Check the tray 5 transport motor.
99-953	Soft	Go to the 75-212-00, 75-215-00 Tray 5 Elevate Up Failure RAP. Check the tray 5 elevator motor.
99-954	Hard	Refer to WD 7.1 . Check the DC cabling to the tray 5 elevator motor. Measure the resistance at PJ504 on the tray 5 control PWB for an open or short circuit and to the chassis for a short circuit. If a fault is found, repeat the measurement at the elevator motor. If a short is measured, the tray 5 control PWB may be damaged and be reported as an 'open' error. If short error is reported, the motor is drawing excessive power. Install new components as necessary, elevator motor, PL 75.68 Item 4 , tray 5 control PWB, PL 75.68 Item 8 . Refer to the 75-212-00, 75-215-00 Tray 5 Elevate Up Failure RAP. Check the tray 5 elevator motor.

99-955-00 to 99-962-00 PEST Error 45 RAP

99-955-00 Motor, PFP tray 5 elevate power fault.

99-956-00 Motor, PFP tray 5 feed open.

99-957-00 Motor, PFP tray 5 feed short.

99-958-00 Motor, PFP tray 5 feed power low.

99-960-00 Motor, OCT offset open.

99-961-00 Motor, OCT offset short.

99-962-00 Motor, OCT offset power low.

Initial Actions

WARNING

Ensure that the electricity to the machine is switched off while performing tasks that do not need electricity. Refer to [GP 14](#). Disconnect the power cord. Electricity can cause death or injury. Moving parts can cause injury.

Procedure

Refer to [Table 1](#). Perform the relevant action. For an explanation of PEST codes refer to [dC123](#).

Table 1 PEST codes and action

Code	Hard/Soft	Action
99-961	Hard	Refer to WD 12.23 . Check the DC cabling to the OCT offset motor. Measure the resistance at PJ495 on the OCT PWB for an open or short circuit and to the chassis for a short circuit. If a fault is found, repeat the measurement at the OCT offset motor. If a short is measured, the OCT PWB may be damaged and be reported as an 'open' error. If short error is reported, the motor is drawing excessive power. Install new components as necessary, OCT module, PL 12.00 Item 1 . Refer to the 12-701-00-65 Offset Catch Tray Failure RAP. Check the OCT feed offset motor.
99-962	Soft	Go to the 12-701-00-65 Offset Catch Tray Failure RAP. Check the OCT feed offset motor.

Table 1 PEST codes and action

Code	Hard/Soft	Action
99-955	Soft	Go to the 75-212-00 , 75-215-00 Tray 5 Elevate Up Failure RAP. Check the tray 5 elevator motor.
99-956	Soft	Go to the 75-101-00 Tray 5 Mis-Feed RAP. Check the tray 5 feed motor.
99-957	Hard	Refer to WD 7.2 . Check the DC cabling to the tray 5 feed motor. Measure the resistance at PJ511 on the tray 5 control PWB for an open or short circuit and to the chassis for a short circuit. If a fault is found, repeat the measurement at the tray 5 feed motor. If a short is measured, the tray 5 control PWB may be damaged and be reported as an 'open' error. If short error is reported, the motor is drawing excessive power. Install new components as necessary, tray 5 feed motor, PL 81.40 Item 3 , tray 5 control PWB, PL 75.68 Item 8 . Refer to the 75-101-00 Tray 5 Mis-Feed RAP. Check the tray 5 feed motor.
99-958	Soft	Go to the 75-101-00 Tray 5 Mis-Feed RAP. Check the tray 5 feed motor.
99-960	Soft	Go to the 12-701-00-65 Offset Catch Tray Failure RAP. Check the OCT feed offset motor.

99-992-00 PEST Error 46 RAP

99-992-00 Front door interlock open.

Initial Actions

WARNING

Ensure that the electricity to the machine is switched off while performing tasks that do not need electricity. Refer to GP 14. Disconnect the power cord. Electricity can cause death or injury. Moving parts can cause injury.

Procedure

Refer to Table 1. Perform the relevant action. For an explanation of PEST codes refer to dC123.

Table 1 PEST codes and action

Code	Hard/Soft	Action
99-992	Soft	Go to the 01-510-00 Front Door Open RAP. Check the front door interlock switch.

99-996-00 to 99-999-00 PEST Error 47 RAP

99-996-00 PEST failed to complete.

99-997-00 Misc.

99-999-00 Hard / soft fault separator.

Initial Actions

WARNING

Ensure that the electricity to the machine is switched off while performing tasks that do not need electricity. Refer to GP 14. Disconnect the power cord. Electricity can cause death or injury. Moving parts can cause injury.

Procedure

Refer to Table 1. Perform the relevant action. For an explanation of PEST codes refer to dC123.

Table 1 PEST codes and action

Code	Description	Hard/Soft	Action
99-996	PEST failed to complete	Hard	View the last indicated PEST faults, dC123, to find the failure area.
99-997	Misc	Hard	This fault code is for future use and is included for reference only.
99-999	Hard / soft fault separator	Soft	Information only: indicates change from a hard fault to a soft fault and vice versa in the PEST fault list, dC123.

OF 1 Unusual Noise RAP

Use this RAP to isolate unusual noises in the machine.

NOTE: Due to the intermittent nature of unusual noises, this RAP can only give guidance on how to isolate noises. This RAP will not find all possible causes. When machines become old and worn, unusual noises may arise that are not covered in this RAP.

Procedure

WARNING

Ensure that the electricity to the machine is switched off while performing tasks that do not need electricity. Refer to GP 14. Disconnect the power cord. Electricity can cause death or injury. Moving parts can cause injury.

1. Ask the customer if there are any specific machine functions that are noisy.
2. Ask the customer to demonstrate the function of the machine that generates the unusual noise.
3. Check the Fault and Error logs.
4. Switch off the machine, GP 14. Wait for two minutes, switch on the machine and allow the machine to perform a normal initialization and warm-up.
5. Run the machine in all modes. Also use the diagnostics to run individual components. Go to the relevant subsection:
 - DADH
 - Scanner
 - Tray 1 and 2 Assembly
 - Tray 3 Assembly
 - Bypass Tray 4 Assembly
 - Tray 5 Assembly
 - Vertical Paper Path
 - Horizontal Paper Path
 - Exit Paper Path
 - Registration / pre-heat Assembly
 - Nips / Diverters
 - Drum Drive motor / transfix motor / stripper assembly
 - Fans
 - Stripper Blade
 - LCSS
 - HVF / HVF BM

DADH

Run the following components:

- Enter dC330 code 05-099 DADH CVT motor to rotate the DADH CVT roll, PL 5.25 Item 5.
- Enter dC330 code 05-074 feed motor, to run the DADH takeaway rolls, PL 5.35 Item 6.
- Enter dC330 code 05-074 and add code 05-062 feed clutch, to energize the feed clutch and run the drive shaft, PL 5.15 Item 9.
- Enter dC330 code 05-074 and add code 05-098 nudger motor, to energize the nudger motor, PL 5.15 Item 5.

Possible causes and potential solutions are:

- **Grinding noise.**

Possible causes are:

- The intermediate feed bearing, PL 5.15 Item 22 can stick, preventing the feed roll from free wheeling as the document is transported by takeaway roll.
- Large flat spots, confined to one or two areas on the retard roll, which causes feed noise and an increase in 05-330, 05-331 and 05-335 jams.

Solution:

- Install a new the feed assembly, PL 5.15 Item 18.

- **Noise from the DADH input tray.**

Possible causes are:

- Document guides.

Solution:

- Clean the DADH input tray in the area below the input guides with antistatic fluid, PL 26.10 Item 11.

- **Squeaks from the DADH.**

Possible causes are:

- DADH exit roll assembly or takeaway roll assembly, PL 5.35 Item 6.

Solution:

- Remove and clean the shafts and plastic bushes with antistatic fluid, PL 26.10 Item 11.

- **Knocking noise.**

Possible causes are:

- The feed motor and CVT motor are not tensioned correctly, causing the drive belts to slip.

Solution:

- Adjust the DADH drive belts, ADJ 5.1.

- **Gear rattle.**

Possible causes are:

- A loose meshing of the clutch and motor gears PL 5.15 Item 9 and PL 5.15 Item 16.

Solution:

- Adjust the DADH drive belts, ADJ 5.1.

Scanner

Possible causes and potential solutions are:

- **Grinding.**

Possible causes are:

- The scan carriage is moving erratically and the scan motor is generating a grinding sound. The teeth of the scanner drive belt are not engaging with the capstan on the scan motor. PL 62.16 Item 12.

Solution:

- Perform ADJ 62.3 Scan Motor and Scanner Drive Belt adjustment.

Tray 1 and 2 Assembly

Remove tray 1 and tray 2 and run the following components:

- Enter code **dC330** code 71-002 T1 Feed / Elevate Motor, to run the tray 1 feed motor, **PL 81.25 Item 22**. The paper tray must be open when the motor is running.
- Enter code **dC330** code 72-001 T2 Feed / Elevate Motor, to run the tray 2 feed motor, **PL 81.26 Item 22**. The paper tray must be open when the motor is running.
- Open left hand door.
- Enter **dC330** code 70-025 3 tray transport motor, to run tray 1 and tray 2 transport rolls, **PL 73.16 Item 3**.

Possible causes and potential solutions are:

- **Squeaks.**

Possible causes are:

- Contamination of the drive shafts and bearings.
- Incorrectly adjusted or worn drive belts.
- Incorrectly aligned or damaged parts.

Solution:

- Remove and clean the drive shafts, bearings, **GP 27**.
- Check 3 tray transport drive belt. Install new parts as necessary, **PL 73.16 Item 7**.
- Check for parts that are damaged or out of position.
- Adjust or install new components as necessary.

Tray 3 Assembly

Run the following components:

- Enter **dC330** code 73-001 T3 Feed Motor, to operate the tray 3 feed motor, **PL 81.30 Item 22**. The paper tray must be open when motor is running.
- Pull out tray 3 and let the tray drop, then push the tray back in.
- Enter **dC330** code 73-002 T3 Elevate Motor, to elevate tray 3, **PL 73.16 Item 2**. The paper tray must be open when the motor is running.
- Enter **dC330** code 70-025 3 Tray Transport motor to run the 3 tray transport motor, **PL 73.16 Item 3**.

Possible causes and potential solutions are:

- **No drive or a knocking noise from the 3 tray transport motor.**

Possible causes are:

- The 3 tray transport motor, **PL 73.16 Item 3**.
- Worn or stretched elevator cables, **PL 73.15 Item 17**, **PL 73.15 Item 18**, **PL 73.15 Item 19**.

Solution:

- Check the drive belt and gears, **PL 73.16**.
- Check that the paper trays are correctly positioned and that the tray moves freely inside the tray assembly.
- Adjust or install new components as necessary.

Bypass Tray 4 Assembly

Run the following components:

- Enter **dC330** code 74-420 Bypass Feed Motor, to run the bypass feed motor, **PL 74.10 Item 2**.

Possible causes and potential solutions are:

- **No drive or a knocking noise from the bypass feed motor.**

Possible causes are:

- Incorrectly aligned or damaged parts.
- Contamination of the drive shafts and the bearings.

Solution:

- Check the bypass feed motor, rolls and bearings, **PL 73.16**.
- Adjust or install new components as necessary.

Tray 5 Assembly

Run the components as follows:

- Open the tray 5 door to lower the elevator.
- Close the door or actuate the interlock.
- Enter **dC330** code 75-019 Tray 5 Elevator Motor Up to drive the tray up, **PL 75.68 Item 4**.
- Enter **dC330** code 75-020 Tray 5 Elevator Motor Down to drive the tray down.
- Enter **dC330** code 75-018 Tray 5 Transport Motor to operate the tray 5 transport motor, **PL 81.40 Item 2**.
- Enter **dC330** code 75-117 Tray 5 Feed Motor to operate the tray 5 feed motor, **PL 81.40 Item 3**.

Possible causes are:

- Incorrectly aligned or damaged parts.
- Contamination of the drive shafts and the bearings.

Solution:

- Check the motor, rolls, bearings, **PL 73.16**. Clean as necessary, **GP 27**.
- Adjust or install new components as necessary.

Vertical Paper Path

NOTE: A door cheat for the main door is not required.

Run the components as follows:

- Enter **dC330** code 82-001 Vertical Trans Motor Fwd (M2) to run the vertical transport motor forward, **PL 82.10 Item 12**. To diagnose the source of the noise, run the motor with the upper left door and mid left door closed, then opened.
- Enter **dC330** code 82-002 Vertical Trans Motor Rev (M2) to run the vertical transport motor in reverse.

Possible causes are:

- Incorrectly aligned or damaged parts.
- Contamination of the drive shafts, idler rolls or bearings.

Solution:

- Check the motor, rolls, bearings, and drive belts, **PL 82.10**. Clean as necessary, **GP 27**.
- Check the idler rolls in the upper left door assembly, **PL 70.30**. Clean as necessary, **GP 27**.
- Check the bearings on the end of the transport roller drive 2, **PL 82.10 Item 1** and the transport roller TAR vertical, **PL 82.10 Item 2**. Clean as necessary, **GP 27**.
- Adjust or install new components as necessary.

Horizontal Paper Path

Run the following components:

- Enter **dC330** code 82-003 Horizontal Trans Motor Fwd (M6), to run the horizontal transport motor forward, [PL 82.15 Item 9](#). To diagnose the source of the noise, run the motor with the horizontal paper path (handle 4b) closed, then opened.
- Enter **dC330** code 82-004 Horizontal Trans Motor Rev (M6), to run the horizontal transport motor in reverse.

Possible causes are:

- Incorrectly aligned or damaged parts.
- Contamination of the drive shafts, idler rolls or bearings.

Solution:

- Check the motor, takeaway rolls, bearings, and drive belts, [PL 82.15](#). Clean as necessary, [GP 27](#).
- Check the idler rolls in the horizontal paper path assembly, [PL 82.15](#). Clean as necessary, [GP 27](#).
- Adjust or install new components as necessary.

Exit Paper Path

Run the following components:

- Enter **dC330** code 10-018 Post Transfix Motor (M4) to run the post-transfix motor forward, [PL 10.10 Item 5](#).
- Enter **dC330** code 83-001 Exit Motor Fwd (M5) to run the exit motor forward, [PL 10.15 Item 11](#).
- Enter **dC330** code 83-002 Exit Motor Rev (M5) to run the exit motor in reverse. Used for duplex and paper invert.

Possible causes:

- Post-transfix motor (M4), [PL 10.10 Item 5](#).
- Exit motor (M5), [PL 10.15 Item 11](#).
- Gear drive, [PL 10.10 Item 13](#).
- Idlers in stripper gate and baffle assembly, [PL 10.12 Item 1](#).

Solution:

- Enter **dC330** code 10-025 Strip Gate Unlatch and open the stripper gate and baffle assembly, [PL 10.12 Item 1](#).
- Stack the code 10-018 Post Transfix Motor (M4) to run the post-transfix motor forward, [PL 10.10 Item 5](#).
- If the noise repeats, the source is the M4 motor or gear assembly. Install new parts as necessary.
- If the noise does not repeat, the source is one of the idlers in the stripper gate and baffle assembly, [PL 10.12](#).
- Close stripper gate and baffle assembly.
- Enter **dC330** code 10-023 Strip Gate Latch.

If the noise repeats perform the following:

- Open horizontal paper path assembly, [PL 82.15 Item 1](#).
- If the noise repeats, the source is the M5 motor, idlers or gear assembly, [PL 10.15](#). Adjust or install new components as necessary.

- If the noise does not repeat, the source is the exit paper path, [PL 10.15 Item 19](#). Adjust or install new components as necessary.

Registration / pre-heat Assembly

NOTE: A door cheat for the main door is not required.

Run the following components:

- Enter **dC330** code 89-007 Registration Motor A1 to run registration motor A1, [PL 88.11 Item 8](#).
- Enter **dC330** code 89-008 Registration Motor A2 to run registration motor A2, [PL 88.11 Item 8](#).

Possible causes:

- Registration motor A1 and A2, [PL 88.11 Item 8](#).
- Incorrectly adjusted or worn drive belts, [PL 88.11 Item 4](#).

Solution:

- Clean contamination on the drive shafts and the bearings
- Adjust or install new components as necessary.

If the noise repeats perform the following:

- Enter **dC330** code 89-011 Nip A: Open to disengage all of the registration/ pre-heat Assembly idlers, [PL 88.10 Item 20](#).
- Enter **dC330** code 89-012 Nip A: Narrow to engage idlers 3 and 4, [PL 88.10 Item 20](#).
- Enter **dC330** code 89-013 Nip A: Medium to engage idlers 2 and 5, [PL 88.10 Item 20](#).
- Enter **dC330** code 89-014 Nip A: Wide to engage idlers 1 and 6, [PL 88.10 Item 20](#).

Possible causes:

- Incorrectly aligned or damaged registration/ pre-heat Assembly idlers, [PL 88.10 Item 20](#).

Solution:

- Adjust or install new components as necessary.

If the noise repeats perform the following:

- Enter **dC330** code 88-008 Reg/Preheat Air Pumps to switch on the registration/pre-heat air pump, [PL 88.10 Item 5](#).

Possible causes:

- Registration/pre-heat air pump.

Solution:

- Adjust or install new components as necessary.

Nips / Diverters

NOTE: A door cheat for the main door is not required.

Run the following components:

- Enter **dC330** code 82-008 Nip D Solenoid to open the nip 'D' release solenoid, [PL 70.30 Item 13](#). Used for short-edge feed and fast color mode.
- Enter **dC330** code 82-007 Nip C Release Solenoid to open the nip 'C' release solenoid, [PL 82.15 Item 4](#). Used for short-edge feed and fast color mode.
- Enter **dC330** code 83-004 HPP Diverter Solenoid to run the HPP diverter solenoid, [PL 82.15 Item 5](#). Used for duplex only.

- Enter **dC330** code 83-006 Exit Duplex Diverter Solenoid to run the exit/duplex diverter solenoid, [PL 10.15 Item 14](#). Used for duplex and paper invert.

Possible causes:

- Incorrectly aligned or damaged parts.

Solution:

- Adjust or install new components as necessary.

Drum Drive motor / transfix motor / stripper assembly

NOTE: A door cheat for the main door is required.

Run the following components:

- Enter **dC330** code 94-009 Drum Drive Motor Slew Speed to run the drum drive motor at slew speed, [PL 94.20 Item 6](#).
- Enter **dC330** code 94-017 Drum Drive Motor Transfix Speed to run the drum drive motor at transfix speed, [PL 94.20 Item 6](#).
- Enter **dC330** code 94-018 Drum Drive Motor Imaging Speed to run the Drum drive motor at print speed, [PL 94.20 Item 6](#).

Possible causes:

- Large vibrations that can shake the printer are only caused by contamination on the drum drive motor pulley. These vibrations are intermittent as the print cycle can temporarily clear the contamination.
- Watch the drum spin. If the noise is cyclic and repeats once per drum revolution, the noise is associated with the drum, [PL 94.20 Item 1](#) or drum heater, [PL 94.20 Item 28](#).
- If the noise repeats ~10x per drum revolution, the noise is associated with the drum motor, [PL 94.20 Item 6](#).

Solution:

- Remove the drum belt, [PL 94.20 Item 2](#) and repeat the noise evaluation to further isolate the noise source.
- Clean contamination on the drive shafts and the bearings
- Adjust or install new components as necessary.

If the noise repeats perform the following:

- Enter **dC330** code 10-024 Transfix Front and Back to operate the front and rear transfix motors, [PL 10.20 Item 11](#) and run a transfix cycle.
- Enter **dC330** code 10-021 Stripper Solenoid to engage the stripper system, [PL 10.10 Item 3](#).

Possible causes:

- Front and rear transfix motors, [PL 10.20 Item 11](#).
- Incorrectly aligned or damaged parts.

Solution:

- Adjust or install new components as necessary.

Fans

NOTE: A door cheat for the main door is not required.

Run the following components:

- Enter **dC330** code 42-062 Abatement Fan to run the abatement fan, [PL 94.20 Item 11](#).

- Enter **dC330** code 42-063 Enclosure Fan to run the enclosure fan, [PL 1.15 Item 6](#).
- Enter **dC330** code 42-064 Drum Fan to run the drum fan, [PL 94.20 Item 4](#).

Possible causes:

- Bearings in the cooling fans have worn or failed.
- Incorrectly aligned or damaged parts.

Solution:

- Check for parts that are damaged or out of position.
- Adjust or install new components as necessary.

Stripper Blade

- Scraping noise.

Possible causes are:

- The noise is caused by the stripper blade [PL 10.12 Item 3](#) pressing to heavily on the drum [PL 94.20 Item 1](#).

Solution:

- Ensure the stripper blade is correctly latched, refer to [GP 31](#).
- Adjust or install new components as necessary.

LCSS

Run the following components:

- Enter **dC330** code 12-223 Transport Motor 1, to run the entry transport rolls, [PL 12.40 Item 2](#).
- Enter **dC330** code 12-224 Transport Motor 2, to run the entry rolls, [PL 12.60 Item 5](#).
- Enter **dC330** code 12-238 Paddle Roll Motor run, rotates the paddle wheel, [PL 12.25 Item 10](#).
- Enter **dC330** code 12-232 Tamp Mot Cycle, cycles the front and rear tampers, [PL 12.45 Item 1](#).
- Enter **dC330** code 12-236 Eject Mot Cycle, cycles the eject assembly, [PL 12.50 Item 1](#).
- Enter **dC330** code 12-242 Bin 1 Elevator Motor Cycle, to move bin 1 up and down, [PL 12.30 Item 8](#).

NOTE: The bin will move down and then move up to the home position.

- Enter **dC330** code 12-244 Punch Head run, rotates the punch head, [PL 12.20 Item 2](#).
- Enter **dC330** code 12-250 SU1 Mot Cycle, cycles the stapler from the front to the rear, [PL 12.55 Item 5](#).

Possible causes and potential solutions are:

- **2 knocks for each stapled set.**

Solution:

- Go to the [12-340-00-110](#), [12-341-00-110](#), [12-342-00-110](#) Ejector Movement Failure RAP.

- **Noise from the right hand side of the machine.**

Possible causes are:

- The LCSS is not aligned correctly.

Solution:

- Check the machine to LCSS alignment, [ADJ 12.2-110](#).
- Adjust or install new components as necessary.

- **Clicking Noise from the LCSS**

Possible causes are:

- The staple head continually operating for approximately 15 seconds. This occurs every time the LCSS top cover or front door is opened then closed, because the stapler is attempting to prime the staple head, by indexing the staple stick forward and pre-forming two staples.

Solution:

- Check the staple cartridge for jammed staples and remove any that are found.
- Ensure the staple cartridge is fully seated.
- Ensure that the correct staple cartridge is installed.
- Perform [12L-110 Stapling Failure RAP](#).

HVF / HVF BM

Run the following components:

CAUTION

Ensure that the first tamper in the compiler carriage is returned to the home position before the second tamper is checked in diagnostics.

- Enter [dC330](#) code 12-223 Transport Motor 1, to run the input transport roll, [PL 12.120 Item 2](#).
- Enter [dC330](#) code 12-224 Transport Motor 2, to run the exit drive shafts to feed paper to the top tray or to the stacker tray, [PL 12.120 Item 1](#).
- Enter [dC330](#) code 12-226 Front Tamper Motor Home, to move the front tamper to the home position [PL 12.125 Item 6](#).
- Enter [dC330](#) code 12-227 Rear Tamper Motor Home, to move the rear tamper to the home position, [PL 12.125 Item 6](#).
- Enter [dC330](#) code 12-228 Front Tamper Motor Move, to move the front tamper to the centre of the compiler, [PL 12.125 Item 6](#)
- Enter [dC330](#) code 12-229 Rear Tamper Motor Move, to move the rear tamper to the centre of the compiler tray, [PL 12.125 Item 6](#).
- Enter [dC330](#) code 12-238 Paddle Roll Motor Run, to lift the paddle unit and rotate the paddle rolls, [PL 12.115 Item 2](#).
- Enter [dC330](#) code 12-237 Paddle Motor Home, to lift the paddle unit to the up position, [PL 12.115 Item 2](#).
- Enter [dC330](#) code 12-241 Bin 1 Elevator Motor Home, to move Bin 1 up to the home position, [PL 12.105 Item 10](#).
- Enter [dC330](#) code 12-242 Bin 1 Elevator Motor Cycle, to move Bin 1 up / down until time out or stop, [PL 12.105 Item 10](#).
- Enter [dC330](#) code 12-249 SU1 Motor Fwd, to move the stapler unit to the front, [PL 12.110 Item 12](#).
- Enter [dC330](#) code 12-248 SU1 Motor Rev Home, to move the stapler unit to the rear, [PL 12.110 Item 12](#).
- Enter [dC330](#) code 12-250 SU1 Motor Cycle, to run the stapler unit cycle routine, [PL 12.110 Item 12](#).
- Enter [dC330](#) code 12-251 BM Compiler Motor, runs the compiler BM entry roll, [PL 12.175 Item 1](#).

NOTE: *The tray moves down for 15 seconds and then stops.*

- Enter [dC330](#) code 12-252 BM Crease Blade Motor, to move crease blade assembly, [PL 12.175 Item 8](#).
- Enter [dC330](#) code 12-273 BM Crease Roll Gate Motor, to move the crease blade assembly, [PL 12.175 Item 8](#) and the crease roll gate, [PL 12.180 Item 19](#).
- Enter [dC330](#) code 12-253 BM Crease Roll Motor, to rotate the two crease rolls, [PL 12.175 Item 12](#).
- Enter [dC330](#) code 12-255 BM Back Stop Motor, to move the back stop assembly, [PL 12.160, PL 12.165](#).
- Enter [dC330](#) code 12-256 BM Tamper 1 Motor, to move the tamper rack and fingers, [PL 12.155 Item 3](#).
- Enter [dC330](#) code 12-274 BM Conveyor Drive motor, to run the output tray conveyor belts, [PL 12.190 Item 4](#).
- Enter [dC330](#) code 12-271 BM flapper Motor, to run the BM flapper, [PL 12.175 Item 1](#).
- Enter [dC330](#) code 12-273 BM Crease Roll Gate Motor, to move the crease roll gate up and down, [PL 12.180 Item 19](#).
- Enter [dC330](#) code 12-261 Inserter Motor, to run inserter main drives, [PL 12.315 Item 1](#).
- Enter [dC330](#) code 12-253 BM Crease Roll Motor, to run the tri-roller drives, [PL 12.175 Item 12](#).
- Enter [dC330](#) code 12-269 Clutch Drive, to engage the HVF clutch drive to drive tri-folding rolls, [PL 12.175 Item 12](#).

Possible causes and potential solutions are:

- **Noise from the right hand side of the machine.**

Possible causes are:

- The HVF BM is not aligned correctly.
- Bin 1 not aligned correctly on the main drive belts, [PL 12.105 Item 6](#).

Solution:

- Check the machine to HVF BM alignment, [ADJ 12.1-171](#).
- Check that the Bin 1 is level, refer to [REP 12.38-171 HVF Stacker Drive Belts](#).
- Adjust the components if appropriate.
- Install new parts as necessary.

- **Knocking.**

Possible causes are:

- Mis-adjusted or worn drive belts. [PL 12.120](#).
- The support fingers on the ejector hit bin1 each time they are moved out.

Solution:

- Adjust the belt tension as required.
- Pre-load bin 1 with 30 sheets of paper this acts as a damper and will stop the noise.
- Install new parts as necessary.

- **Squeak.**

Possible causes are:

- The transport drive shaft or bearings. [PL 12.130](#).
- Check that the paper guides are closed and located correctly.

Solution:

- Install new parts as necessary.

- **Clicking Noise from the HVF BM.**

Possible causes are:

- The noise is caused by the transport motor 2, [dC330](#) code 12-224, continually operating for approximately 15 seconds. This occurs every time the top tray, [PL 12.100 Item 9](#), or the front door, [PL 12.100 Item 3](#), is opened then closed.

Solution:

- Ensure the staple cartridge is fully seated and that the correct cartridge is installed.

NOTE: When a new staple cartridge is installed the stapler makes a repeating noise. This is normal it is the stapler performing a priming cycle.

- Perform [12-369-00-171](#) to [12-377-00-171](#) HVF Stapler Position and Priming RAP.

OF 2 UI Touch Screen Failure RAP

Use this RAP to solve user interface touch screen problems when the machine has power but either the display is missing, is too dark or the user interface touch screen responds incorrectly or does not refresh.

Initial Actions

WARNING

Ensure that the electricity to the machine is switched off while performing tasks that do not need electricity. Refer to [GP 14](#). Disconnect the power cord. Electricity can cause death or injury. Moving parts can cause injury.

- If the UI is blank. Check that the NVM module PWB, [PL 3.11 Item 17](#) is seated correctly.
- Refer to [GP 1](#) to access the user interface diagnostics.
- Press the Machine Status key. Select the Tools tab. Select Device Settings, then Display Brightness. Adjust the brightness level.
- Refer to [REP 2.1](#) to access the user interface assembly.
- Check and re-seat the PJ's on the user interface control PWB.
- If the UI fails to boot, observe the progress icon on the screen to determine the failure.
 - Yellow progress block = XUI code booting up.
 - Non moving green block = Code loaded but not communicating.
 - Moving green block = ESS is operational and XUI is trying to communicate with IME and CCS.
- If the problem occurs while entering or exiting sleep mode, go to the [OF 7](#) Sleep Mode RAP.

Procedure

Refer to [WD 3.2](#). Check the +3.3V from PJ223 on the [single board controller PWB](#) to PJ900 on the [user interface control PWB](#). **+3.3V is measured.**

Y N

Check the wiring and harness between the single board controller PWB and the user interface control PWB. Repair the wiring as necessary, [REP 1.2](#), or install a new harness, [PL 2.10 Item 7](#). If the wiring is good, go to [01C](#) +3.3V Distribution RAP.

Refer to [WD 3.2](#). Check the +12V from PJ223, pin 19 on the [single board controller PWB](#) to PJ901, pin 5 on the [user interface control PWB](#). **+12V is measured.**

Y N

Check the wiring and harness between the single board controller PWB and the user interface control PWB. Repair the wiring as necessary, [REP 1.2](#), or install a new user interface harness, [PL 2.10 Item 7](#). If the wiring is good, go to [01E](#) +12V Distribution RAP.

Reload the machine software, [GP 4](#). **The fault remains.**

Y N

Perform [SCP 5](#) Final Actions.

Check that the ribbon cables between the user interface control PWB and the touch screen are in good condition and are securely and correctly connected. Check the wiring and ribbon cables on the touch screen assembly. As necessary, install new components:

- LCD to PWB harness, (40-way ribbon cable), [PL 2.10 Item 11](#).
- User interface touch screen assembly, [PL 2.10 Item 3](#).
- User interface control PWB, [PL 2.10 Item 2](#).

OF 3 Unresponsive Machine RAP

Use the following procedure if the machine fails to reach an operational state when switched on. The UI screen display's: blank, energy saver, splash only, progress and Xerox, or repeatedly cycles back to the install wizard screen each time the machine is switched on.

Initial Actions

WARNING

Ensure that the electricity to the machine is switched off while performing tasks that do not need electricity. Refer to [GP 14](#). Disconnect the power cord. Electricity can cause death or injury. Moving parts can cause injury.

- Check the SBC PWB 7-Segment LED display unit, [Figure 3](#) and the IME POST LED's for a POST error code, [OF 16](#).
- If the problem occurs while entering or exiting sleep mode, go to [OF 7](#) Sleep Mode RAP.
- Open the image processing module, [PL 3.11](#).
 - Reseat the system memory PWB, [PL 3.11 Item 4](#).
 - Reseat the EPC memory PWB, [PL 3.11 Item 21](#).
 - Check the battery on the NVM module PWB is located correctly and in good condition, [GP 45](#).
 - Reseat the NVM module PWB, [PL 3.11 Item 17](#).
 - Reseat the connectors on the single board controller PWB, [PL 3.11 Item 13](#).
- Check with the customer that their power supply is good. If necessary, connect the machine to a known good AC supply. If the machine operates correctly at the new supply, inform the customer that the original supply must be at fault.
- If the problem occurs while entering or exiting sleep mode, go to [OF 7](#) Sleep Mode RAP.
- Check that the SIM card is inserted correctly in the back of the machine. Refer to [GP 19](#).
- Disconnect the output device then temporarily install a finisher bypass connector, [PL 26.10 Item 7](#).

Procedure

Switch on the machine, [GP 14](#). Observe the power light button on the UI. **The power button flashes.**

Y	N	Remove the rear cover, PL 81.10 Item 1 . Observe the green LED on the power supply unit, Figure 1 . The green LED on the power supply unit is lit.
Y	N	Disconnect PJDC4 on the Power Supply Unit . Toggle the power switch. The green LED is lit.
Y	N	Connect PJDC4. Disconnect PJDC3 on the Power Supply Unit . Toggle the power switch. The green LED is lit.
Y	N	Connect PJDC3 and disconnect PJDC1. Toggle the power switch. The green LED is lit.
Y	N	Go to 01A AC Power Distribution RAP and perform the Main Power Rocker Switch check. The switch is good

A B C D E

A

B

C

D

E

Y

N

Install a new main power rocker switch, [PL 1.15 Item 3](#).

Install a new power supply unit, [PL 1.15 Item 2](#).

The +3.3V ESTAR has a short circuit. Check for short circuits to chassis at PJDC1 pins 14,15 and 16 refer to [WD 1.4](#). Go to [01B](#) +3.3V ESTAR Distribution RAP. Check the supply to the IME controller PWB, [PL 92.10 Item 1](#).

There is a short or an over load in the marking unit on 3.3V ESTAR. Disconnect all PJ's from the [Media Path Driver PWB](#) and the [Drum Driver PWB](#) until the short is found. If necessary refer to the following RAPs:

- [01B](#) +3.3V ESTAR Distribution RAP, refer to Drum driver PWB and Media path driver PWB checkouts.

There is a short or an overload on the +17V or +3.3V supplies from the [Power Distribution PWB](#) or the power distribution PWB is faulty. Disconnect all PJ's until the fault is found. If necessary refer to the following RAPs:

- [01G](#) +17V Distribution RAP.
- [01C](#) +3.3V Distribution RAP.

Go to the [01B](#) 3.3V ESTAR Distribution RAP.

Remove the rear cover, [PL 81.10 Item 1](#). Check the LED's on the power supply unit, [Figure 1](#).

- Orange LED indicates +24V, +/-12V and +5V are good.
- Green LED indicates +3.3V ESTAR and +17V are good.
- Red LED indicates +/-50V are good.

All LED's are lit

Y N

Go to the relevant voltage distribution RAP:

- [01B](#) +3.3V ESTAR Distribution RAP.
- [01D](#) +5V Distribution RAP.
- [01E](#) +12V Distribution RAP.
- [01F](#) -12V Distribution RAP.
- [01G](#) +17V Distribution RAP
- [01H](#) +24V Distribution RAP.
- [01J](#) +50V Distribution RAP.
- [01K](#) -50V Distribution RAP.
- [01L](#) 0V Distribution RAP.
- Refer to [01-540-00](#), [01-544-00](#) RAP and [01-542-00](#), [01-546-00](#) RAP.

The green 'Xerox' screen is displayed.

Y N

Go to [OF 2](#) UI Touch Screen Failure RAP. **The UI is good**

Y N

Install new components as necessary.

F G

F G

Check the seven segment display on the single board controller PWB. **The seven segment display the decimal point is flashing heart beat.**

Y N

Go to the **01C** +3.3V Distribution RAP and check the +3.3V supply to the single board controller PWB. If the +3.3V supply to the PWB is good install a new single board controller PWB, **PL 3.11 Item 13.**

Check the connections to the hard disk drive, **PL 3.11 Item 2.** If the connections are good perform the actions that follow:

- Reload the software, **GP 4.**
- Install a new hard disk drive, **PL 3.11 Item 2.**

NOTE: If a new hard drive is installed then the software will need to be reloaded.

The green progress screen is displayed.

Y N

The display stays at the green 'Xerox' screen. Observe the LED's on the IME controller, **Figure 2.** Perform the relevant action:

- If the green LED is blinking, reload the software, **GP 4.**
- The single board controller is not booting or there is a communication problem between the single board controller PWB and the IME controller PWB.
 - Reboot in diagnostics state, **GP 1** and refer to How to enter directly into service mode. Enter **dC123** PEST Fault History and **dC122** Fault History. Review the fault history then go to the indicated RAP.
 - Check the power supplies to the power distribution PWB, single board controller PWB, HDD, scanner, DADH PWB, finisher, tray 5 and 3 tray module.

Go to the relevant voltage distribution RAP:

- 01D** +5V Distribution RAP.
- 01E** +12V Distribution RAP.
- 01G** +17V Distribution RAP
- 01H** +24V Distribution RAP.

Check the connections to the single board controller, hard disk drive and harness PJ 5, **PL 3.11 Item 2.** If the connections are good perform the actions that follow:

- Harness hard disk drive / Single board controller PWB, **PL 3.11 Item 3.**
- Reload the software, **GP 4.**
- Install a new hard disk drive, **PL 3.11 Item 2.**

NOTE: If a new hard drive is installed then the software will need to be reloaded.

Perform **SCP 5** Final Actions.

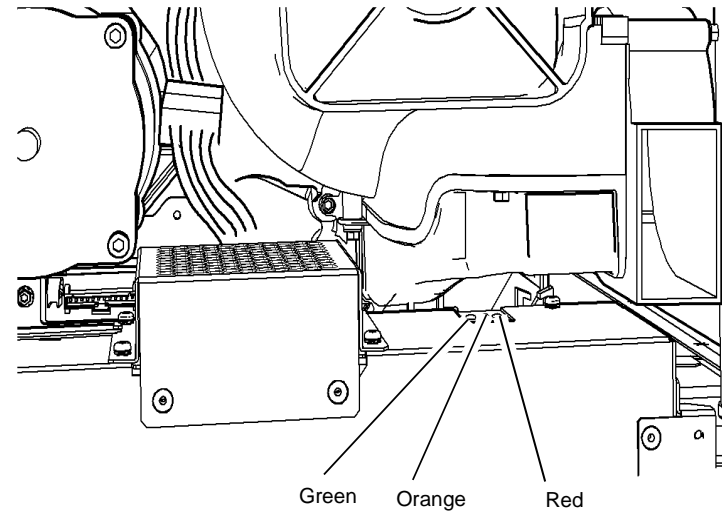
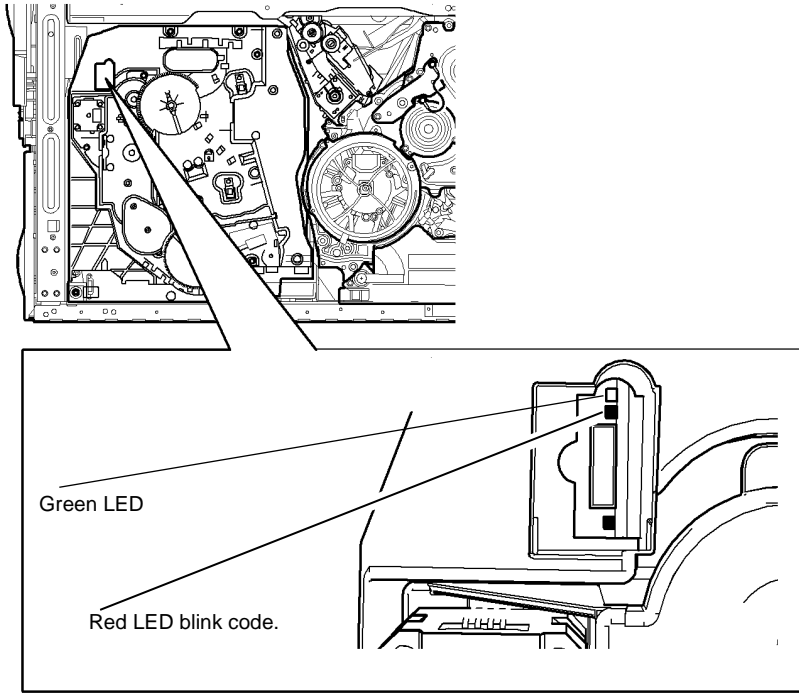

Figure 1 Power LEDs

U-1-1303-A



U-1-1444-A

Figure 2 IME Controller LEDs

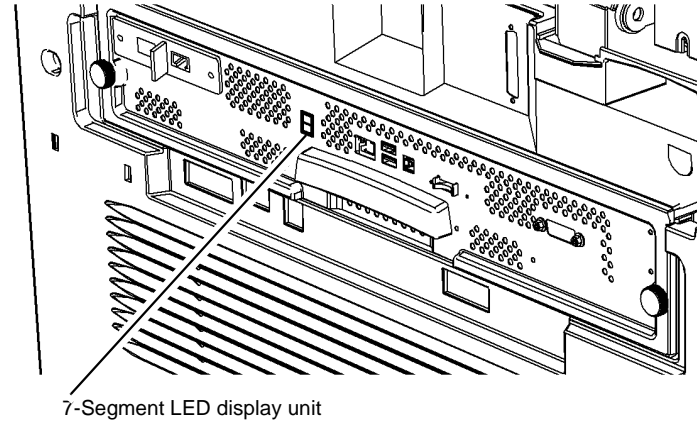

U-1-1651-A

Figure 3 7-Segment LED display unit

OF 4 Status Codes and Messages RAP

Use this RAP for faults and messages without fault codes.

The status code format is HCC-LLL-EE where HCC is the chain, LLL is the link and EE is the extension number. The hundreds digit H is not used and can be ignored. This digit is not shown on any status codes in this manual.

Example: Status code 01-510-00 Front door is open. Video displayed requesting the front door to be closed.

The fault code format is HCC-LLL-EE where HCC is the chain, LLL is the link and EE is the extension number. All faults are displayed with hundred digit 3 which can be ignored. This digit is not shown on any fault codes in this manual.

Example: Fault code 301-510-00 Front door is open when machine running.

Refer to [GP 2](#) Fault Codes and History Files.

Most recent fault and messages can be displayed on the UI without entering diagnostics, by pressing the Machine Status button on the keypad, touching the Fault tab on the UI, then select as appropriate:

- Current Faults.
- Current Messages.
- Fault History.

The tables in this procedure bring together the status codes, the relevant RAP or procedure references, and some of the UI messages.

NOTE: Not all status codes are shown in the active message window. Some status codes have no messages.

Procedure

WARNING

Ensure that the electricity to the machine is switched off while performing tasks that do not need electricity. Refer to [GP 14](#). Disconnect the power cord. Electricity can cause death or injury. Moving parts can cause injury.

Enter the Fault Codes and History Files, [GP 2](#) and identify and clear any active faults. Go to the following RAPs to identify a status code or message:

- [OF 4a](#) Status Codes in Numerical Order
- [OF 4b](#) Status Messages in Alphabetical Order

OF 4a Status Codes in Numerical Order

Status Code Tables

- [Table 1](#) Chain 01 Status codes
- [Table 2](#) Chain 02 Status codes
- [Table 3](#) Chain 03 Status codes
- [Table 4](#) Chain 04 Status codes
- [Table 5](#) Chain 05 Status codes
- [Table 6](#) Chain 10 Status codes
- [Table 7](#) Chain 12 Status codes
- [Table 8](#) Chain 14 Status codes
- [Table 9](#) Chain 16 Status codes
- [Table 10](#) Chain 17 Status codes
- [Table 11](#) Chain 19 Status codes
- [Table 12](#) Chain 20 Status codes
- [Table 13](#) Chain 22 Status codes
- [Table 14](#) Chain 70 to 78 Status codes
- [Table 15](#) Chain 82 to 89 Status codes
- [Table 16](#) Chain 91 to 94 Status codes

Table 1 Chain 01 Status codes

Status Code	UI Message	Reason for Message	Reference / Action
01-101-00	Paper jam in area 4b	IME jam at zone 4b (horizontal), open the front door	Clear the paper jam in area 4b. Print and copy services are disabled. Refer to 82-145-00 , 82-146-00 , 82-150-00 , 82-151-00 , 82-156-00 RAP, 82-141-00 , 82-147-00 , 82-148-00 , 82-154-00 RAP, 89-110-00 to 89-113-00 , 89-129-00 RAP
01-102-00	Paper jam in area 4a	IME jam at zone 4a (exit), open the front door	Clear the paper jam in area 4a. Print and copy services are disabled. Refer to 10-110-00 to 10-113-00 , 10-125-00 to 10-128-00 , 10-147-00 , 10-148-00 RAP, 10-140-00 to 10-146-00 , 10-149-00 to 10-151-00 RAP, 83-110-00 , 83-111-00 , 83-113-00 , 83-114-00 , 83-118-00 RAP, 83-112-00 , 83-115-00 , 83-116-00 , 83-117-00 , 83-119-00 RAP

Table 1 Chain 01 Status codes

Status Code	UI Message	Reason for Message	Reference / Action
01-103-00	Paper jam in areas 4a and 4b	IME jam at zone 4a (exit) and 4b (horizontal), open the front door	Clear the paper jam in area 4a and 4b. Print and copy services are disabled. Refer to 10-110-00 to 10-113-00, 10-125-00 to 10-128-00, 10-147-00, 10-148-00 RAP, 10-140-00 to 10-146-00, 10-149-00 to 10-151-00 RAP, 83-110-00, 83-111-00, 83-113-00, 83-114-00, 83-118-00 RAP, 83-112-00, 83-115-00, 83-116-00, 83-117-00, 83-119-00RAP
01-104-00	Paper jam in area 3b	IME jam at zone 3b (post transfix), open the front door	Clear the paper jam in area 3b. Print and copy services are disabled
01-105-00	Paper jam in area 3b and 4b	IME jam at zone 3b (post transfix) and 4b (horizontal), open the front door	Clear the paper jam in area 3b and 4b. Print and copy services are disabled
01-106-00	Paper jam in areas 3b and 4a	IME jam at zone 3b (post transfix) and 4a (exit), open the front door	Clear the paper jam in area 3b and 4a. Print and copy services are disabled. Refer to 10-110-00 to 10-113-00, 10-125-00 to 10-128-00, 10-147-00, 10-148-00 RAP, 10-140-00 to 10-146-00, 10-149-00 to 10-151-00 RAP, 83-110-00, 83-111-00, 83-113-00, 83-114-00, 83-118-00 RAP, 83-112-00, 83-115-00, 83-116-00, 83-117-00, 83-119-00 RAP
01-107-00	Paper jam in areas 3b, 4a and 4b	IME jam at zone 3b (post transfix), 4a (exit) and 4b (horizontal), open the front door	Clear the paper jam in area 3b, 4a and 4b. Print and copy services are disabled. Refer to 10-110-00 to 10-113-00, 10-125-00 to 10-128-00, 10-147-00, 10-148-00 RAP, 10-140-00 to 10-146-00, 10-149-00 to 10-151-00 RAP, 83-110-00, 83-111-00, 83-113-00, 83-114-00, 83-118-00 RAP, 83-112-00, 83-115-00, 83-116-00, 83-117-00, 83-119-00 RAP
01-108-00	Paper jam in area 3a	IME jam at zone 3a (registration / preheat), open the front door	Clear the paper jam in area 3a. Print and copy services are disabled. Refer to 89-110-00 to 89-113-00, 89-129-00 RAP, 89-125-00 to 89-128-00, 89-130-00, 89-131-00 RAP

Table 1 Chain 01 Status codes

Status Code	UI Message	Reason for Message	Reference / Action
01-109-00	Paper jam in areas 3a and 4b	IME jam at zone 3a (registration) and 4b (horizontal), open the front door	Clear the paper jam in area 3a and 4b. Print and copy services are disabled. Refer to 10-110-00 to 10-113-00, 10-125-00 to 10-128-00, 10-147-00, 10-148-00 RAP, 10-140-00 to 10-146-00, 10-149-00 to 10-151-00 RAP, 83-110-00, 83-111-00, 83-113-00, 83-114-00, 83-118-00 RAP, 83-112-00, 83-115-00, 83-116-00, 83-117-00, 83-119-00 RAP
01-110-00	Paper jam in area 3a and 4a	IME jam at zone 3a (registration) and 4a (exit), open the front door	Clear the paper jam in area 3a and 4a. Print and copy services are disabled. Refer to 89-110-00 to 89-113-00, 89-129-00 RAP, 89-125-00 to 89-128-00, 89-130-00, 89-131-00 RAP, 89-110-00 to 89-113-00, 89-129-00 RAP
01-111-00	Paper jam in areas 3a, 4a and 4b	IME jam at zone 3a (registration), 4a (exit) and 4b (horizontal), open the front door	Clear the paper jam in area 3a, 4a and 4b. Print and copy services are disabled. Refer to 10-110-00 to 10-113-00, 10-125-00 to 10-128-00, 10-147-00, 10-148-00 RAP, 10-140-00 to 10-146-00, 10-149-00 to 10-151-00 RAP, 83-110-00, 83-111-00, 83-113-00, 83-114-00, 83-118-00 RAP, 83-112-00, 83-115-00, 83-116-00, 83-117-00, 83-119-00 RAP
01-112-00	Paper jam in areas 3a and 3b	IME jam at zone 3a (registration) and 3b (post transfix), open the front door	Clear the paper jam in area 3a and 3b. Print and copy services are disabled. Refer to 10-110-00 to 10-113-00, 10-125-00 to 10-128-00, 10-147-00, 10-148-00 RAP, 10-140-00 to 10-146-00, 10-149-00 to 10-151-00 RAP, 83-110-00, 83-111-00, 83-113-00, 83-114-00, 83-118-00 RAP, 83-112-00, 83-115-00, 83-116-00, 83-117-00, 83-119-00 RAP

Table 1 Chain 01 Status codes

Status Code	UI Message	Reason for Message	Reference / Action
01-113-00	Paper jam in areas 3a, 3b and 4b	IME jam at zone 3a (registration), 3b (post transfix) and 4b (horizontal), open the front door	Clear the paper jam in area 3a, 3b and 4b. Print and copy services are disabled. Refer to 10-110-00 to 10-113-00, 10-125-00 to 10-128-00, 10-147-00, 10-148-00 RAP, 10-140-00 to 10-146-00, 10-149-00 to 10-151-00 RAP, 83-110-00, 83-111-00, 83-113-00, 83-114-00, 83-118-00 RAP, 83-112-00, 83-115-00, 83-116-00, 83-117-00, 83-119-00 RAP
01-114-00	Paper jam in areas 3a, 3b and 4a	IME jam at zone 3a (registration), 3b (post transfix) and 4a (exit), open the front door	Clear the paper jam in area 3a, 3b and 4a. Print and copy services are disabled. Refer to 10-110-00 to 10-113-00, 10-125-00 to 10-128-00, 10-147-00, 10-148-00 RAP, 10-140-00 to 10-146-00, 10-149-00 to 10-151-00 RAP, 83-110-00, 83-111-00, 83-113-00, 83-114-00, 83-118-00 RAP, 83-112-00, 83-115-00, 83-116-00, 83-117-00, 83-119-00 RAP
01-115-00	Paper jam in areas 3a, 3b, 4a and 4b	IME jam at zone 3a (registration), 4a (exit) and 4b (horizontal), open the front door	Clear the paper jam in area 3a, 4a and 4b. Print and copy services are disabled. Refer to 10-110-00 to 10-113-00, 10-125-00 to 10-128-00, 10-147-00, 10-148-00 RAP, 10-140-00 to 10-146-00, 10-149-00 to 10-151-00 RAP, 83-110-00, 83-111-00, 83-113-00, 83-114-00, 83-118-00 RAP, 83-112-00, 83-115-00, 83-116-00, 83-117-00, 83-119-00 RAP
01-500-00	Do not switch the power on again while powering down is in progress	The IME power switch is moved to the off position	Print jobs sent to the device will not print and may be lost
01-505-00	Middle left side door is open	The IME middle left door (below bypass tray) is open (without tray 5 installed)	Copying and printing are not available. Perform the 01-505-00 Middle Left Door Open RAP
01-506-00	Top left side door is open	The IME upper left door (bypass tray) is open	Copying and printing are not available. Perform the 01-506-00 Upper Left Door Open RAP

Table 1 Chain 01 Status codes

Status Code	UI Message	Reason for Message	Reference / Action
01-510-00	Front door is open	The front door is open.	Copying and printing are not available. Perform the 01-510-00 Front Door Open RAP
01-540-01	Check the settings for tray 1	Paper removed or added to tray 1	Confirm the tray 1 settings
01-540-02	Check the settings for tray 2	Paper removed or added to tray 2	Confirm the tray 2 settings
01-540-03	Check the settings for tray 3	Paper removed or added to tray 3	Confirm the tray 3 settings
01-540-04	Check the settings for tray 4	Paper removed or added to tray 4	Confirm the tray 4 settings
01-540-05	Check the settings for tray 5	Paper removed or added to tray 5	Confirm the tray 5 settings
01-540-06	Check the settings for tray 6	Paper removed or added to tray 6	Confirm the tray 6 settings
01-545-01	Tray 1 guides are not set properly	Dedicated tray 1 closed with media size other than what was set	Reload the required paper and correctly adjust the paper guides
01-545-02	Tray 2 guides are not set properly	Dedicated tray 2 closed with media size other than what was set	Reload the required paper and correctly adjust the paper guides
01-550-00	-	NC status code - system is in power save mode	Printing will start when a job is received or a user initiates a job at the machine
01-551-00	-	ESS status code - system is in sleep mode	Printing will start when a job is received or a user initiates a job at the machine

Table 2 Chain 02 Status codes

Status Code	UI Message	Reason for Message	Reference / Action
02-517-00	-	PagePack grace period active	-
02-518-00	-	PagePack grace period expired	-
02-520-00	The machine is not available	A software error has occurred.	Switch the machine off then on, GP 14
02-521-00	-	The XEIP browser is dead or not responding	Perform the 02-321-00 XEIP Browser Dead RAP

Table 2 Chain 02 Status codes

Status Code	UI Message	Reason for Message	Reference / Action
02-590-00	Machine power on failed. Power off then on and notify system administrator	Configurable services are not stable at power on	Switch the machine off then on, GP 14 . If the problem persists, perform the 02-390-00 Configurable Services RAP

Table 3 Chain 03 Status codes

Status Code	UI Message	Reason for Message	Reference / Action
03-504-00	The machine is offline	NC status code	Switch the machine off then on, GP 14
03-504-01	The machine is offline	NC status code	Switch the machine off then on, GP 14
03-505-00	System error. Power off then on and notify system administrator	The digital copier is not available	Perform 03-325-00 RAP and 03-355-00 RAP
03-518-00	Network controller not available. Power off then on and notify system administrator	The network controller is not available.	Switch the machine off then on, GP 14 . If the fault remains, reinstall software, GP 4 . If the problem persists, perform the 03-331-00 , 03-332-00 Main Controller and Network Controller on the SBC PWB Cannot Communicate RAP
03-521-00	No message	CCM to UI communication are lost	Switch the machine off then on, GP 14
03-535-00	No message	The machine is in non intrusive diagnostic mode	-
03-536-00	No message	The machine has entered intrusive diagnostic mode	-
03-538-00	Machine active registration disabled. Turn power off then on to enable	The machine active registration has been disabled via the dC715 Active Registration Control Routine	Re-enable the active registration mode in dC715
03-546-00	Incompatible Fax software detected (upgrade required)	Incompatible Fax software detected at power on	The embedded Fax software version is incompatible with the system. A software upgrade should be performed. Refer to 03-417-00 RAP

Table 3 Chain 03 Status codes

Status Code	UI Message	Reason for Message	Reference / Action
03-547-00	A Fax service error has occurred. Power off then on	Basic Fax not detected or confirmed	Switch the machine off then on, GP 14 . If the problem persists, perform the 20-331-00 , 20-338-00 , 20-339-00 , 20-341-00 , 20-345-00 Fax Network Line 1 Fault RAP
03-548-00	Fax line 2 is unavailable. Notify your system administrator.	Extended Fax not detected or confirmed	Check the Fax line connection
03-549-00	Fax memory error. Power off then on and notify system administrator	Fax POST failure status	Switch the machine off, then on GP 14
03-550-00	A Fax service error has occurred. Power off then on	Fax card is unavailable	Switch the machine off then on, GP 14 . If the problem persists, perform the 20-331-00 , 20-338-00 , 20-339-00 , 20-341-00 , 20-345-00 Fax Network Line 1 Fault RAP
03-551-00	A Fax service error has occurred. Power off then on	The Fax service is unavailable	Switch the machine off then on, GP 14 . If the problem persists, perform the 20-331-00 , 20-338-00 , 20-339-00 , 20-341-00 , 20-345-00 Fax Network Line 1 Fault RAP
03-555-00	Please wait... Maintenance in progress. Scan, copy and print services not available	The machine has entered intrusive customer tools mode.	Go to dC301 . Perform a copier NVM initialization and NVM data select all. After initialization perform the routines dC977 and dC978
03-556-00	Please wait... The scanner is initializing.	Power on while the IIT is being initialized	-
03-558-00	Please complete all steps required by the external accounting device to access this service	Not defined	-
03-558-01	Please insert card into the external accounting device to access this service	Not defined	-
03-558-02	Please enter access code into external accounting device to access this service	Not defined	-

Table 3 Chain 03 Status codes

Status Code	UI Message	Reason for Message	Reference / Action
03-558-03	Please insert money into the external accounting device to access this service	Not defined	-
03-558-04	Please insert key counter into the external accounting device to access this service	Not defined	-
03-559-00	Provide payment or the current job may be deleted.	Generic FDI. Unable to complete the current job.	The Job cannot be completed due to insufficient funds. Complete all steps required by the external accounting device to continue the job
03-559-01	Provide payment.	Walk Up FDI. Unable to complete the current job.	The Job cannot be completed due to insufficient funds. Complete all steps required by the external accounting device to continue the job
03-559-02	Enter your access code or the current job may be deleted.	Walk up code entered FDI. Not defined	The Job cannot be completed due to insufficient funds. Complete all steps required by the external accounting device to continue the job
03-559-03	Provide payment.	Walk up coin entered FDI. Not defined	The Job cannot be completed due to insufficient funds. Complete all steps required by the external accounting device to continue the job. To cancel this job, press the hard-panel Job Status button, select the job and then the Delete button
03-559-04	Provide payment or the current job may be deleted.	Walk up key entered FDI. Not defined	The Job cannot be completed due to insufficient funds. Complete all steps required by the external accounting device to continue the job
03-559-05	Provide payment or the current job may be deleted.	Walk up FDI. Unable to complete the current job - FDI inactivity timer enabled	The Job cannot be completed due to insufficient funds. Complete all steps required by the external accounting device to continue the job, select the Close button, then the Job Status button located on the control panel and then your job. If no action is taken, the job will be deleted

Table 3 Chain 03 Status codes

Status Code	UI Message	Reason for Message	Reference / Action
03-559-06	Provide payment or the current job may be deleted.	Walk up coin entered FDI. Not defined - FDI inactivity timer disabled	The Job cannot be completed due to insufficient funds. Complete all steps required by the external accounting device to continue the job. To immediately delete this job, select the Close button, then the Job Status button located on the control panel and then your job. If no action is taken, the job will be deleted
03-561-00	Please wait... the system is attempting to recover	The system is recovering	Wait until the system recovers
03-562-00	Some jobs may have been deleted	When some jobs may have been deleted	Removed upon user intervention
03-563-00	The network controller is initializing. Copy and print jobs may be delayed	Network service are being established	Please wait, the Network Controller is initializing. No user intervention is required. Printing is currently unavailable. If the problem persists, perform the 03-331-00 , 03-332-00 Main Controller and Network Controller on the SBC PWB Cannot Communicate RAP
03-564-00	Image rotation is not available. Power off then on and notify system administrator	Image rotation is not available	Switch the machine off then on, GP 14
03-565-00	System error. Power off then on and notify system administrator	System fault	Switch the machine off then on, GP 14
03-597-00	Communication error. Power off then on and notify system administrator	The document feeder is not available. Use the document glass	Perform 05-250-00 , 05-251-00 RAP
03-598-00	System error. Power off then on and notify system administrator	Unable to set ready mode. Printing and copying services are not available	Perform the 03-788-00 CCS Runtime Could Not Enter Power Saver Mode S3 RAP

Table 4 Chain 04 Status codes

Status Code	UI Message	Reason for Message	Reference / Action
04-565-00	System error. Power off then on and notify system administrator	IME controller communication failure	System fault. Switch the machine off then on, GP 14
04-568-00	The output tray is full. Empty the output tray	The OCT is full.	Empty the tray.
04-569-00	The output tray is almost full	The OCT detects that it is 90% full	The tray is almost full. The tray may be emptied now or when it is full. Printing and other machine services are unaffected

Table 5 Chain 05 Status codes

Status Code	UI Message	Reason for Message	Reference / Action
05-501-00	No message	The DADH is raised.	Close the DADH. If the fault remains, perform the 05-300-00 DADH Open RAP.
05-502-00	The document feeder top cover is open	The DADH top cover is open.	Close the DADH top cover. If the fault remains, perform the 05-258-00 , 05-307-00 DADH Cover Interlock Open RAP.
05-520-00	Paper jam in the document feeder	Post feed and takeaway roll jam	Remove the sheet. If the problem persists, perform the 05-330-00 , 05-331-00 Feed Sensor Failure RAP
05-522-00	Paper jam in the document feeder	A sheet is left over the DADH CVT sensor, the DADH post feed sensor or the TAR sensor after a jam.	Remove sheet. If the problem persists, perform the 05-350-00 , 05-352-00 RAP
05-525-00	No message	The Document feeder tray is empty	Perform the 05B DADH Document Sensor Failure RAP

Table 5 Chain 05 Status codes

Status Code	UI Message	Reason for Message	Reference / Action
05-526-00	Paper jam in the document feeder	A sheet is left over the DADH document present sensor after a jam. The 05-330 fault is raised	The fault is reset when DADH top cover closed after jam cleared. If the problem persists, perform the 05-330-00 , 05-331-00 RAP
05-527-00	Reload sheets in document feeder	Documents are in the DADH at power on or exit from power save	Remove the sheets from the original input tray
05-535-00	No message	Document feeder tray loaded	-
05-538-00	Communication error. Power off then on and notify system administrator	The DADH is not available.	A document feeder fault has occurred, copy jobs can only be made from the document glass. Printing can continue.
05-539-00	Document feeder - feed roller has been replaced	DADH feed head CRU replaced. Message automatically cleared half a second after setting	None
05-542-00	Communication error. Power off then on and notify system administrator	DADH document transport needs service	Perform 05A RAP
05-546-00	The document size was different than expected. The job has been deleted	On pre-feed the DADH fails to recognize the size of the document	Reload the originals or select the document size. If the problem persists, perform the 05-257-00 RAP
05-547-00	Re-order document feeder - feed roller but DO NOT replace until prompted	DADH feed roll assembly near end of life	Re-order a feed roll assembly PL 5.15 Item 1 .
05-560-00	Remove the document. It is too short to be fed by Document Feeder.	Upon fault 05-310 being raised	Remove the short document from DADH during jam clearance, If the problem persists, perform the 05-310-00 RAP
05-570-00	Scan and copy services not available. Print service is available	DADH jam	Remove, then re-load all document in the DADH

Table 5 Chain 05 Status codes

Status Code	UI Message	Reason for Message	Reference / Action
05-578-00	Re-order document feeder - feed roller but DO NOT replace until prompted	DADH roller feeds reaches near end of life limit.	Order new DADH feed roll assembly, PL 5.15 Item 1
05-579-00	Replace the document feed roller	DADH roller feeds reaches end of life	Install new DADH feed roll assembly, PL 5.15 Item 1 .
05-585-00	Select confirm if the document feeder - feed roller was replaced.	When status 05-579 is active and the DADH top cover is opened (status 05-502)	Select confirm if the document feeder - feed roller was replaced

Table 6 Chain 10 Status codes

Status Code	UI Message	Reason for Message	Reference / Action
10-536-00	No message	Transfix calibration NVRAM parameters are reset.	Refer to OF 12 Service Code RAP

Table 7 Chain 12 Status codes

Status Code	UI Message	Reason for Message	Reference / Action
12-410-00	No message	PTU selected whilst marking job is running	Pressing the Pause to Unload button will cancel this request
12-411-00	The current job exceeds the tray capacity, you will be prompted to empty the tray	Copy Job will exceed the output destination's capacity	Empty the tray
12-564-00	The finisher front door is open	The finisher front door is open (LCSS)	Close the finisher front door
12-564-01	The finisher front door is open	The finisher front door is open (HVF - all variants)	Close the finisher front door
12-564-02	The finisher front door is open	The finisher front door is open (HVF with tri-folder)	Close the finisher front door

Table 7 Chain 12 Status codes

Status Code	UI Message	Reason for Message	Reference / Action
12-579-00	Hole punching not available. Power off then on and notify system administrator	Hole punching is not available	Check that the hole punch unit is correctly installed. Switch the machine off then on, GP 14 . If the problem persists, perform the 12-043-00-110 , 12-046-00-110 RAP for LCSS, 12-044-00-171 to 12-047-00-171 RAP for HVF
12-600-00	Finisher is not docked. Re-dock finisher now	The finisher unit (LCSS) is not correctly docked. Printing has stopped	Dock the output module. If the problem persists, perform the 12-310-00-110 , 12-312-00-110 , 12-313-00-110 RAP
12-600-01	Finisher is not docked. Re-dock finisher now	The finisher unit (HVF without tri-folder) is not correctly docked. Printing has stopped	Dock the output module. If the problem persists, perform the 12-310-00-171 , 12-312-00-171 , 12-313-00-171 RAP
12-600-02	Finisher is not docked. Re-dock finisher now	The finisher unit (HVF with tri-folder) is not correctly docked. Printing has stopped	Dock the output module. If the problem persists, perform the 12-310-00-171 , 12-312-00-171 , 12-313-00-171 RAP
12-601-00	Close the finisher top tray	LCSS finisher top cover is open (cover over output tray)	Close the top cover
12-602-00	Close finisher top cover	The finisher top cover is open	Close the finisher top cover.
12-606-00	Close finisher top cover	The inserter top cover is open	Close the inserter top cover
12-607-00	Close the finisher folder top cover	The tri-folder top cover is open (HVF with tri-folder)	Close the tri-folder top cover
12-608-00	Close the finisher folder front door	The tri-folder unit front door is open (HVF with trifolder)	Close the tri-folder front door
12-609-00	Close finisher inserter left side door	The inserter left cover is open (HVF without Tri-folder)	Close the inserter left cover
12-610-00	Paper jam in the finisher	Paper is detected over the entry sensor (LCSS)	Clear the paper jam. If the problem persists, perform the 12-199-00-110 RAP

Table 7 Chain 12 Status codes

Status Code	UI Message	Reason for Message	Reference / Action
12-610-01	Paper jam in the finisher	Paper is detected over the entry sensor (HVF without tri-folder)	Clear the paper jam. If the problem persists, perform the 12-125-00-171, 12-126-00-171 RAP
12-611-00	Paper jam in the finisher	After receiving the paper at IOT exit sensor the entry sensor is not made within 1000 ms. (LCSS). Paper jam near the entry to the finisher unit.	Clear the paper jam. If the problem persists, perform the 12-199-00-110 RAP
12-611-01	Paper jam in the finisher	Paper jam near the entry to the finisher unit (HVF without tri-folder)	Clear the paper jam. If the problem persists, perform the 12-125-00-171, 12-126-00-171 RAP
12-612-00	Paper jam in the finisher	Paper is detected over the hole punch position sensor at power-up, interlock status change or after shutdown. (LCSS)	Clear the paper jam. If the problem persists, perform the 12-043-00-110, 12-046-00-110 RAP
12-617-00	Tray 6 (Inserter) is empty. Add paper	Tray 6 (Inserter) detects no paper present	Add paper to tray 6. If the problem persists, perform the 12J-171 RAP.
12-618-00	Paper jam in the finisher	Paper is detected over the top tray exit sensor at power-up, interlock status change or after shutdown (LCSS)	Clear the paper jam. If the problem persists, perform the 12-171-00-110, 12-172-00-110 RAP
12-618-01	Paper jam in the finisher	Paper is detected over the top tray exit sensor	Clear the paper jam. If the problem persists, perform the 12-125-00-171, 12-126-00-171 RAP
12-619-00	Paper jam in the finisher	Paper jam near the output to the top tray. (LCSS)	Clear the paper jam. If the problem persists, perform the 12-171-00-110, 12-172-00-110 RAP
12-619-01	Paper jam in the finisher	Paper jam near the output to the top tray. (HVF)	Clear the paper jam. If the problem persists, perform the 12-171-00-171, 12-172-00-171 RAP

Table 7 Chain 12 Status codes

Status Code	UI Message	Reason for Message	Reference / Action
12-620-00	Paper jam in the finisher	Paper is detected over the stacker exit sensor at power-up, interlock status change or after shutdown. (LCSS)	Clear the paper jam. If the problem persists, perform the 12-151-00-110, 12-152-00-110 RAP
12-620-01	Paper jam in the finisher	Paper jam near the output to the stacker tray. Sheet over 2nd top exit sensor	Clear the paper jam. If the problem persists, perform the 12-151-171, 12-152-171 RAP
12-621-00	Paper jam in the finisher	If entry sensor made to the stacker bin exit sensor made exceeds 1600 ms (A4 LEF 1st page/A3 SEF all pages) or 1100 ms (A4 LEF mid set page) or 900 ms (A4 LEF last page of set). (LCSS)	Clear the paper jam. If the problem persists, perform the 12-171-00-110, 12-172-00-110 RAP
12-621-01	Paper jam in the finisher	Paper jam near the output to the stacker tray. Sheet over 2nd top exit sensor	Clear the paper jam. If the problem persists, perform the 12-151-171, 12-152-171 RAP
12-624-00	Paper jam in the finisher	Sheet over the inserter pickup sensor	Clear the area or If the problem persists, perform the 12-479-00-171 RAP
12-625-00	Paper jam in the finisher	Sheet over the inserter tab standby sensor	Clear the area. If the problem persists, perform the 12-191-00-171, 12-193-00-171, 12-194-00-171, 12-196-00-171 RAP
12-626-00	Paper jam in the finisher	Sheet over the buffer position sensor	Clear the area. If the problem persists, perform the 12-198-00-171, 12-199-00-171 RAP
12-627-00	Paper jam in the finisher	Sheet over the HVF exit into BM sensor	Clear the area. If the problem persists, perform the 12-198-00-171, 12-199-00-171 RAP
12-627-01	Paper jam in the finisher	Page over the exit HVF into BM sensor (sensor in area 6a) cleared via area 6a	Clear the paper jam

Table 7 Chain 12 Status codes

Status Code	UI Message	Reason for Message	Reference / Action
12-627-02	Paper jam in the finisher	Page over the exit HVF into BM sensor (sensor in area 6a) cleared via area 6a	Clear the paper jam
12-628-00	Paper jam in the finisher	Sheet over the stacker bin exit sensor	Clear the area. If the problem persists, perform the 12-151-171 , 12-152-171
12-629-00	Paper jam in the finisher	Sheet over the tri-folder entry sensor	Clear the area. If the problem persists, perform the 12-183-00-171 , 12-184-00-171 RAP
12-630-01	Paper jam in the finisher	Sheet over the booklet maker entry sensor (without tri-folder)	Clear the area. If the problem persists, perform the 12-183-00-171 , 12-184-00-171 RAP
12-630-02	Paper jam in the finisher	Sheet over the booklet maker entry sensor (with tri-folder)	Clear the area. If the problem persists, perform the 12-183-00-171 , 12-184-00-171 RAP
12-636-01	Paper jam in the finisher	Sheet over the booklet maker exit sensor (without tri-folder)	Clear the jam from the output bin. If the problem persists, perform the 12-181-00-171 , 12-182-00-171 RAP
12-636-02	Paper jam in the finisher	Sheet over the booklet maker exit sensor (with tri-folder)	Clear the jam from the output bin. If the problem persists, perform the 12-181-00-171 , 12-182-00-171 RAP
12-640-00	Hole punch not detected (missing). Please insert the hole punch.	The finisher punch unit is missing or incorrectly installed.	Make sure that the punch unit is correctly installed. If the problem persists, perform the 12-043-00-110 , 12-046-00-110 RAP
12-641-00	The hole punch waste container is not detected. Please re-insert.	The chad bin has been removed from the finisher	Reinstall the chad bin. If the problem persists, perform the 12-043-00-110 , 12-046-00-110 RAP

Table 7 Chain 12 Status codes

Status Code	UI Message	Reason for Message	Reference / Action
12-642-00	Booklet maker staples low. Re-order booklet staple cartridge	The booklet maker staples are low	The booklet maker staple cartridge supplies are low. Re-order staple cartridge, PL 12.185 Item 8
12-643-00	Booklet maker staple cartridge is empty	The booklet maker staple cartridge is empty	The booklet maker staple cartridge is empty. Follow the instructions at the printer to load a new staple cartridge, PL 12.185 Item 8 . Printing can continue, but stapled booklet making is unavailable
12-643-01	Booklet maker staple cartridge is empty	The booklet maker staple cartridge is empty	Install a new booklet maker staple cartridge
12-644-00	Booklet maker staple cartridge is empty. Replace now	The booklet maker staple cartridge is empty and HVF finisher front door open	The booklet maker staple cartridge is empty. User intervention is required to install a new booklet maker staple cartridge, PL 12.185 Item 8 . Printing and copying can continue without stapled booklet making
12-649-00	The hole punch waste container is full. Empty hole punch waste container	The hole punch chad bin is full and needs emptying. (LCSS)	Hole punch waste container is full, jobs requesting hole punching will be held. Empty the chad bin
12-649-01	The hole punch waste container is full. Empty Hole Punch Waste Container	The hole punch chad bin is full and needs emptying. (HVF)	Hole punch waste container is full, jobs requesting hole punching will be held. Empty the chad bin
12-653-00	Stapling fault. Power off then on and notify system administrator	Stapling disabled, out of service. (LCSS)	Perform the 12-371-00-110 , 12-372-00-110 , 12-378-00-110 RAP

Table 7 Chain 12 Status codes

Status Code	UI Message	Reason for Message	Reference / Action
12-665-00	Finisher main tray is out of service. Power off then on and notify system administrator	Bin 1 out of service status (LCSS)	Perform the 12-151-00-110 , 12-152-00-110 RAP
12-692-00	Finisher top tray is full. Empty top tray.	The finisher top tray is full	Empty the top tray
12-701-00	Output tray offsetting is not available. Power off then on and notify system administrator	OCT offset failure occurred	Perform the 12-701-00-65 RAP
12-715-00	Staple cartridge is empty. Replace now	The finisher's main staple cartridge is empty. Follow the instructions at the printer to load a new staple cartridge. Non staple printing can continue. (LCSS)	Install new staple cartridge, PL 12.55 Item 7 .
12-715-01	Staple cartridge is empty. Replace now.	HVF staple cartridge is empty	Install a new staple cartridge. If the problem persists, perform the 12-369-00-171 to 12-377-00-171 RAP
12-716-00	Staple cartridge supplies are low.	LCSS and HVF staples are low	The finisher's main staple cartridge supplies are low. Re-order staple cartridge. Printing can continue. LCSS PL 12.55 Item 7 , HVF PL 12.110 Item 31 . HVFBM PL 12.185 Item 8 .
12-717-01	Paper jam in the finisher	Sheet over the HVF BM compiler paper present sensor (without tri-folder)	Clear the HVF BM paper present sensor area 6e. If the problem persists, perform the 12-166-00-171 RAP
12-717-02	Paper jam in the finisher	Sheet over the HVF BM compiler paper present sensor (with tri-folder)	Clear the HVF BM paper present sensor area 6e. If the problem persists, perform the 12-166-00-171 RAP

Table 7 Chain 12 Status codes

Status Code	UI Message	Reason for Message	Reference / Action
12-718-00	Paper jam in finisher folder unit	Sheet over the tri- folder assist sensor	Clear the paper jam. If the problem persists, perform the 12-185-00-171 to 12-187-00-171 RAP
12-719-00	Paper jam in finisher folder unit	Sheet over the tri- folder exit sensor	Clear the paper jam. If the problem persists, perform the 12-185-00-171 to 12-187-00-171 RAP
12-720-00	Booklet stapler not available. Power off then on and notify system administrator	Failure of any BM or TF function. The booklet maker and tri-folder are currently unavailable	Check for obstructions in the HVF BM and the tri-folder. Check that the HVF BM and tri-folder interlocks are made. Switch the machine off then on, GP 14 . Check the current fault codes list for HVF BM or tri-folder faults and perform the appropriate RAP
12-721-00	Stapling fault. Power off then on and notify system administrator	Stapler is not in position	The stapler module is open, close the stapler module
12-726-00	Booklet stapler not available. Power off then on and notify system administrator	Failure of the booklet maker stapling functions	Perform 12-063-00-171 , 12-411-00-171 RAP for staple unit 1, and 12-403-00-171 , 12-413-00-171 , 12-414-00-171 RAP for staple unit 2
12-727-00	The booklet maker tray in the finisher is nearly full.	The booklet maker output tray is nearly full	The booklet maker tray is near full. User intervention will be required soon to empty the tray to allow continued booklet making. Print and copy services can continue; other machine services are unaffected.

Table 7 Chain 12 Status codes

Status Code	UI Message	Reason for Message	Reference / Action
12-728-00	The booklet maker tray in the finisher is full. Empty the tray	The booklet maker output tray is full	Empty the tray. If necessary, If the problem persists, perform the 12C-171 RAP
12-729-00	Finisher top tray is nearly full	The finisher top output bin is nearly full	The top output bin is nearly full. This output bin may need to be unloaded soon. Printing can continue.
12-730-00	Finisher main tray is full	The stacker tray is full (LCSS and HVF)	The middle output bin is full. This output bin needs to be unloaded. Printing to this output bin is disabled. If the problem persists, perform the 12-462-00-110 RAP or 12-460-00-171 to 12-462-00-171 RAP
12-730-01	Finisher main tray is full	The stacker tray is full (HVF)	The middle output bin is full. This output bin needs to be unloaded. Printing to this output bin is disabled. If the problem persists, perform the 12-460-00-171 to 12-462-00-171 RAP
12-731-00	Tray 6 (inserter) is empty. Load more media for insertion	Post process inserter tray (tray 6) is empty. Jobs will be held if inserts are required	Load more media. If the problem persists, perform the 12J-171 RAP
12-732-00	Paper jam in the finisher	Sheet detected near the PPI pickup sensor	Clear the jam. If the problem persists, perform the 12-191-00-171, 12-193-00-171, 12-194-00-171, 12-196-00-171 RAP
12-733-00	Paper jam in the finisher	Sheet detected near the PPI tab standby sensor	Clear the jam. If the problem persists, perform the 12-191-00-171, 12-193-00-171, 12-194-00-171, 12-196-00-171 RAP
12-734-00	Finisher main tray is nearly full	Stacker tray bin is nearly full	No action necessary

Table 7 Chain 12 Status codes

Status Code	UI Message	Reason for Message	Reference / Action
12-735-00	Paper jam in the finisher	Sheet detected near the buffer sensor	Clear the sheet. If the problem persists, perform the 12-157-00-171, 12-158-00-171 RAP and 12-141-00-171, 12-142-00-171 RAP
12-736-01	Paper jam in the finisher	Sheet detected near the exit HVF to BM entry sensor. (without tri-folder)	Clear the sheet. If the problem persists, perform the 12-113-00-171, 12-114-00-171, 12-190-00-171, 12-192-00-171 RAP
12-736-02	Paper jam in the finisher	Sheet detected near exit HVF to BM entry sensor. (with tri-folder)	Clear the sheet. If the problem persists, perform the 12-113-00-171, 12-114-00-171, 12-190-00-171, 12-192-00-171 RAP
12-740-00	Tray is ready for unloading. Press the button on finisher to return tray to ready position	Finisher tray is ready for unloading	Follow the instructions to unload the tray.
12-741-00	Please wait... The output tray is lowering	The machine is paused for unloading. Need to press the button on the pop up screen	Follow the instructions. If the problem persists, perform the 12H-171
12-742-00	Output tray on-line	Pause to unload time-out warning	Finisher has gone back on-line
12-743-00	Booklet stapler not available. Power off then on and notify system administrator	Booklet making & tri-folding unavailable.	Booklet making and tri-folding is unavailable. Switch the machine off then on, GP 14. Check the current fault code list for HVF BM or tri-fold faults and go to appropriate RAP. Printing can continue to all available output trays

Table 7 Chain 12 Status codes

Status Code	UI Message	Reason for Message	Reference / Action
12-744-00	Tray 6 (Inserter) is unavailable. Check for obstructions. Power off then on	The inserter is unavailable	The post process inserter is not available. Switch the machine off then on, GP 14 . Check the current fault code list for inserter faults and go to appropriate RAP
12-745-00	Finisher top tray and main tray are not available	Top tray and stacker are unavailable (only the booklet maker tray is available)	Check for obstructions in the HVF BM and the tri-folder. Check that the HVF BM and tri-folder interlocks are made. Switch the machine off then on, GP 14 . Check the current fault codes list for HVF BM or tri-folder faults and perform the appropriate RAP.
12-746-00	Paper jam in the finisher	Sheet detected near the tri-fold entry sensor	Clear the sheet. If the problem persists, perform the 12-183-00-171 , 12-184-00-171 RAP
12-747-00	Paper jam in the finisher	Sheet detected near the tri-fold exit sensor	Clear the sheet. If the problem persists, perform the 12-185-00-171 to 12-187-00-171
12-748-00	Paper jam in the finisher	Sheet detected near the tri-fold assist sensor	Clear the sheet. If the problem persists, perform the 12-185-00-171 to 12-187-00-171 RAP
12-749-00	Insert sheet sent to a different tray to the rest of the job	An insert sheet has not arrived at its intended output destination	See the message text. If the problem persists, perform the 12-191-00-171 , 12-193-00-171 , 12-194-00-171 , 12-196-00-171 RAP and 12-125-00-171 , 12-126-00-171 RAP

Table 7 Chain 12 Status codes

Status Code	UI Message	Reason for Message	Reference / Action
12-750-00	Unexpected paper size or type detected from tray 6 (Inserter)	A shorter than expected sheet has been fed from the inserter	Follow the message text. Check the size of the paper in the inserter. Refer to 12J-171 RAP
12-752-00	Paper jam in the finisher	A page is over the buffer path sensor	Clear the area. If the problem persists, perform the 12-198-00-171 , 12-199-00-171 RAP
12-753-00	Paper jam in the finisher	A page is near the buffer path sensor	Clear the area. If the problem persists, perform the 12-198-00-171 , 12-199-00-171 RAP
12-755-00	No message	The finisher has detected a 50 sheet staple cartridge. A 100 sheet staple cartridge should be used	Install a 100 sheet staple cartridge
12-762-00	Finisher communication error. Check cabling. power off then on	Communication failure between IME and finisher	Switch the machine off then on, GP 14 . Check the finisher communication harness. If the problem persists, perform 12-762-00-110 , 12-764-00-110 , 12-765-00-110 RAP for LCSS. 12-762-00-171 , 12-764-00-171 , 12-765-00-171 RAP for HVF.
12-764-00	Finisher communication error. Check cabling. power off then on	The IME cannot detect a finisher plugged in (including catch tray)	Switch the machine off then on, GP 14 . Check the finisher communication harness. If the problem persists, perform 12-762-00-110 , 12-764-00-110 , 12-765-00-110 RAP for LCSS. 12-762-00-171 , 12-764-00-171 , 12-765-00-171 RAP for HVF.

Table 7 Chain 12 Status codes

Status Code	UI Message	Reason for Message	Reference / Action
12-765-00	Incompatible or unknown finisher detected. Check finisher compatibility	The IME interface indicates that the finisher is incompatible / unknown.	Switch the machine off then on, GP 14 . Check the finisher communication lead. If the problem persists, perform the 12-762-00-110 , 12-764-00-110 , 12-765-00-110 RAP for LCSS. 12-762-00-171 , 12-764-00-171 , 12-765-00-171 RAP for HVF
12-901-00	Unable to staple. Check for obstructions in the output trays	The finisher is in degraded mode, unable to staple	Switch the machine off then on, GP 14 . If the problem persists, perform 12F-171 RAP
12-902-00	Finisher main tray out of service. Check for obstructions in the main tray	The finisher is in degraded mode, stacker tray is out of service.	Switch the machine off then on, GP 14 . Check for obstructions in the tray
12-906-00	Finisher main tray out of service. Check for obstructions in the main tray	The finisher main tray is out of service, tray home fault	Switch the machine off then on, GP 14 . Check for obstructions in the tray
12-908-00	Hole punching is unavailable. Check for obstructions in the hole puncher	The finisher hole punch head motor has failed	Clear the paper jam. Switch the machine off then on, GP 14 . If the problem persists, perform the 12-043-00-110 , 12-046-00-110 RAP for LCSS
12-909-00	All output trays are unavailable. Check for obstructions in the finisher	Status raised based upon the report capabilities from the finisher	Clear any obstructions or paper jam. Switch the machine off then on, GP 14 . If the problem persists, perform the 12-462-00-110 RAP for LCSS
12-913-00	Booklet making is unavailable. Check for obstructions in the BM	Back stop motor fails to move or not home	Clear the paper jam. Switch the machine off then on, GP 14 . If the problem persists, perform the 12-065-00-171 , 12-383-00-171 HVF BM Back-stop Motor Fault RAP

Table 7 Chain 12 Status codes

Status Code	UI Message	Reason for Message	Reference / Action
12-921-00	Stapling not available. Call for assistance.	The stapler position sensor indicates the stapler module is not closed in initialization	Close the BM stapler module. If the problem persists, perform the 12-063-00-171 , 12-411-00-171 RAP for staple unit 1, and 12-403-00-171 , 12-413-00-171 , 12-414-00-171 RAP for staple unit 2
12-943-00	Booklet making and tri-folding are unavailable. Check for obstructions	Booklet making or tri-folding capability degraded	Check for obstructions in the HVF BM and the tri-folder. Check that the HVF BM and tri-folder interlocks are made. Switch the machine off then on, GP 14 . Check the current fault codes list for HVF BM or tri-folder faults and perform the appropriate RAP
12-944-00	Tray 6 (Inserter) is unavailable. Check for obstructions in the Inserter	Inserter capability degraded	Check for obstructions in the inserter. If the problem persists, perform the 12-191-00-171 , 12-193-00-171 , 12-194-00-171 , 12-196-00-171 RAP and 12J-171 RAP
12-945-00	All main stacker trays unavailable. Power off then on and notify system administrator	All trays have degraded capability, except booklet maker	Check for obstructions in the buffer, stacker and top tray areas. Switch the machine off then on, GP 14 . Check the current fault codes list for faults in the buffer, stacker and top tray areas and perform the appropriate RAP

Table 8 Chain 14 Status codes

Status Code	UI Message	Reason for Message	Reference / Action
14-517-00	Scanner fault. Power off then on and notify system administrator	Scanner fault.	Switch the machine off then on, GP 14 . Check the current fault codes list for faults in the scanner and perform the appropriate RAP.

Table 9 Chain 16 Status codes

Status Code	UI Message	Reason for Message	Reference / Action
16-501-00	Network services with job based accounting not available. Notify your system administrator	Job based accounting not enough DC memory. Some Network Controller services are not available	Not enough CCM memory to run the network accounting feature. Switch the machine off then on, GP 14 . If the problem persists, perform the 16-930-19 to 16-939-19 Other Network Faults 17 RAP
16-502-00	The network controller is about to be reset	Status active when ever the network controller detects that a platform reset is about to occur	Cleared when the network controller reset is initiated
16-503-00	System error. Power off then on and notify system administrator	Incomplete system information	Switch the machine off then on, GP 14 . All machine services are disabled
16-504-00	Some network services involving DDNS are not available. Notify your system administrator	DDNS error. Some network controller services are not available	The DDNS address resolution process has failed. Switch the machine off then on, GP 14 . If the problem persists check the DDNS server's network connections
16-505-00	Some network services involving scan to E-mail are not available. Notify system administrator	Insufficient memory for E-mail	Switch the machine off then on, GP 14 . If the problem persists check the network connections
16-506-00	Your administrator is reconfiguring the system. Services will not be available	Your administrator is reconfiguring the system	The system administrator is saving the machine configuration to a remote station.

Table 9 Chain 16 Status codes

Status Code	UI Message	Reason for Message	Reference / Action
16-507-00	Some network services involving SLP are not available. Notify your system administrator	SLP process stopped. Some network controller services are not available	Switch the machine off then on, GP 14 .
16-508-00	Autonet functions are not available. Notify your system administrator	Autonet is not available	Switch the machine off then on, GP 14 . Printing can continue if other network protocols are used
16-509-00	Some network services involving Internet Fax are not available. Notify system administrator	Insufficient memory for internet Fax	Switch the machine off then on, GP 14 . Printing can continue if other network protocols are used
16-510-00	Network services involving scan to E-mail are not available. Notify system administrator	Scan to E-mail process failed	Switch the machine off then on, GP 14 . If the problem persists check network connections
16-511-00	Network services related to Internet Fax are not available. Notify system administrator	Internet Fax process failed	Switch the machine off then on, GP 14 . If the problem persists check network connections
16-513-00	Some network services involving SSDP are not available. Notify your system administrator	Simple service discovery protocol (SSDP) failed	Switch the machine off then on, GP 14 .
16-514-00	Network services involving scan to E-mail are not available. Notify system administrator	Post office protocol (POP3) (for inbound IFAX messages) process failed	Switch the machine off then on, GP 14 .
16-517-00	Network services involving scan to E-mail are not available. Notify system administrator	SMTP process failed	Switch the machine off then on, GP 14 .
16-518-00	Network services using WS edge client are not available. Notify your system administrator	Web services edge client interface does not work	Switch the machine off then on, GP 14 . If the problem persists check network connections
16-519-00	Network services using WS edge client are not available. Notify your system administrator	Web services client controller does not work	Switch the machine off then on, GP 14 . If the problem persists check network connections
16-520-00	Network services using WS edge client are not available. Please notify the system administrator	Web services server controller interface does not work.	Switch the machine off then on, GP 14 . If the problem persists check network connections

Table 9 Chain 16 Status codes

Status Code	UI Message	Reason for Message	Reference / Action
16-521-00	Some network services involving CPI are not available. Notify your system administrator	The network controller's CPI service process has stopped	Machine services are temporarily disabled. The network controller connection is about to be reset
16-522-00	Some network services involving job log are not available. Notify system administrator	The network controller's job log service process has stopped	Some network services are not available. The network controller connection is about to be reset
16-523-00	Some network services with job tracker are not available. Notify your system administrator	The network controller's job tracker service process has stopped	Some network services are not available. The network controller connection is about to be reset
16-524-00	Some network services with Kerberos are not available. Notify your system administrator	The network controller's Kerberos service process has stopped	Some network services are not available. The Network Controller connection is about to be reset
16-525-00	Scan to distribution services are not available. Notify your system administrator	The network controller's scan to distribution service process has stopped	Some network services are not available. The network controller connection is about to be reset
16-526-00	Some network services involving SMB are not available. Notify your system administrator	The network controller's SMB service process has stopped.	Some network service are not available. The network controller connection is about to be reset
16-527-00	Some network services involving TCP/IP are not available. Notify your system administrator	The network controller's TCP/IP service process has stopped.	Some network service are not available. The network controller connection is about to be reset
16-528-00	Network services using WS scan temp are not available. Notify your system administrator	The network controller's WS scan temp service process has stopped.	Some network service are not available. The network controller connection is about to be reset
16-529-00	Network services with Scan compressor are not available. Notify your system administrator	The network controller's Scan compressor service process has stopped.	Some network service are not available. The network controller connection is about to be reset
16-533-00	Service limit exceeded. New services will not be available until some services are removed	Controller software service limit exceeded	Remove some existing services to enable new services to be added. Machine services are available but may be degraded
16-535-00	Immediate job overwrite failed. Perform an on demand overwrite immediately	Immediate job overwrite failed	Immediate job overwrite failed. Administrator intervention is required to perform an on demand overwrite immediately

Table 9 Chain 16 Status codes

Status Code	UI Message	Reason for Message	Reference / Action
16-536-00	Network controller error. Some network services not available. Notify system administrator.	The XSA service is unavailable. Network controller error	Switch the machine off then on, GP 14 .
16-544-00	Network cable unplugged	An Ethernet cable is unplugged	Ensure cables are properly connected
16-550-00	Machine entering SW upgrade mode. ALL jobs will be cancelled.	Machine entering SW upgrade mode - all jobs will be canceled.	The machine entered a software upgrade mode (all jobs will be deleted). No user intervention is required. Machine services are unavailable until the software upgrade process has completed.
16-551-00	Accounting out of memory. Notify your system administrator	Network controller - accounting log is full or a hard disk full state exists	Accounting administrator needs to retrieve accounting data log from the system
16-553-00	Additional memory is required to support scan to file. Notify your system administrator	Network controller - not enough physical memory is configured on the platform to support scan to file	Switch the machine off then on, GP 14 . Hardware must be added or replaced.
16-554-00	Workflow scanning hardware must be added or replaced. Notify your system administrator	Network controller - hardware must be added or replaced	Hardware must be added or replaced.
16-555-00	Insufficient memory for Fax job. Notify your system administrator.	Network controller - not enough physical memory is configured on the platform to support LAN Fax	Additional memory required to support Fax. The Fax service is not available
16-556-00	No message	There is an authentication problem between the 802.1x device and the 802.1x server	User intervention is required to check the settings on the 802.1x device to ensure they match the 802.1x server, then switch the machine off then on, GP 14 .
16-557-00	Network services using DC platform recovery not available. Notify system administrator	Network controller DC platform recovery failed	Switch the machine off then on, GP 14
16-558-00	Network services using DC platform recovery not available. Notify system administrator	Network controller DC communications failed	Switch the machine off then on, GP 14

Table 9 Chain 16 Status codes

Status Code	UI Message	Reason for Message	Reference / Action
16-559-00	Network services using BOOTP initialization not available. Notify system administrator	Network controller BOOTP initialization failure	Check the BOOTP Server and its network connection. Switch the machine off then on GP 14
16-560-00	Some network services are not available due to a process error. Notify system administrator.	Some processes on the network controller have failed	Switch the machine off then on, GP 14
16-561-00	Scan to file not available. Power off then on and notify system administrator	Network controller - scan to file processes have failed	Switch the machine off then on, GP 14
16-562-00	Some network services involving LPD are not available. Notify your system administrator	Network controller - the line printer daemon (LPD) process has failed	Switch the machine off then on, GP 14 . Printing can continue if other submission methods are used
16-563-00	Some network services involving Novell are not available. Notify your system administrator	Network controller - the Novell netware connectivity process has failed	Switch the machine off then on, GP 14 . Printing can continue if other submission methods are used
16-564-00	Some network services involving NetBios are not available. Notify system administrator	Network controller - the NetBIOS connectivity process has failed	Switch the machine off then on, GP 14 . Printing can continue if other submission methods are used
16-565-00	Network services involving Apple Talk are not available. Notify your system administrator	Apple Talk printing error. Printing can continue using other submission methods	Switch the machine off then on, GP 14 . Printing can continue if other submission methods are used
16-567-00	Some network services involving PostScript are not available. Notify your system administrator	Network controller - a PostScript interpreter error has occur, causing the process to fail	Switch the machine off then on, GP 14 . Printing can continue if other submission methods are used
16-568-00	Some network services involving PCL are not available. Notify your system administrator	Network controller - a PCL interpreter error has occurred, causing the process to fail	Switch the machine off then on, GP 14 , to enable PCL printing. Printing can continue if other job format methods are used
16-569-00	Network services involving a parallel port are not available. Notify system administrator	Network controller - parallel ports are not available	Switch the machine off then on, GP 14 . If the problem persists, perform the 16-761-47 to 16-769-95 Other Network Faults 1 RAP

Table 9 Chain 16 Status codes

Status Code	UI Message	Reason for Message	Reference / Action
16-570-00	Some network services involving HTTP are not available. Notify your system administrator	Network controller - an HTTP interpreter error has occurred, causing the process to fail	Switch the machine off then on, GP 14 . Printing can continue if other submission methods are used. If the problem persists, perform the 16-761-47 to 16-769-95 Other Network Faults 1 RAP
16-571-00	Network printing disabled. Notify your system administrator	Network controller - print service has failed	Switch the machine off then on, GP 14 . Printing cannot continue. If the problem persists, perform the 16-770-09 to 16-779-95 Other Network Faults 2 RAP
16-572-00	Network printing disabled. Notify your system administrator	Network controller - print service has failed	Switch the machine off then on, GP 14 . Printing cannot continue. If the problem persists, perform the 16-770-09 to 16-779-95 Other Network Faults 2 RAP
16-573-00	Network printing disabled. Notify your system administrator.	Network controller - ESS print service has failed	Switch the machine off then on, GP 14 . Printing cannot continue. If the problem persists, perform the 16-770-09 to 16-779-95 Other Network Faults 2 RAP
16-574-00	Job queue error. Power off then on and notify system administrator	ESS queue utility has failed. Only a partial list is available for display at this time	Switch the machine off then on, GP 14 . If the problem persists, perform the 16-770-09 to 16-779-95 Other Network Faults 2 RAP
16-575-00	The network controller connection is about to be reset	The network controller ESS registration service process has stopped	Automatic network controller reset. If the problem persists, perform the 16-160-09 ESS Reg Service Process Death RAP
16-576-00	Network controller connection is about to be reset	The network controller ESS event notification service process has stopped	Automatic network controller reset. Switch the machine off then on, GP 14 . If the problem persists, perform the 16-161-09, 16-164-09 Cannot Send Reg Event / List Access Failure RAP

Table 9 Chain 16 Status codes

Status Code	UI Message	Reason for Message	Reference / Action
16-577-00	Network controller connection is about to be reset	The network controller ESS platform manager service process has stopped	Automatic network controller reset. Machine is unavailable. If the problem persists, perform the 16-162-09 to 16-163-09 Cannot Send Reg Event / ESS Services Failure RAP
16-578-00	Incomplete system information. Power off then on and notify system administrator	The network controller ESS fault log service process has stopped	Switch the machine off then on, GP 14 . Printing and scanning can continue. If the problem persists, perform the 16-770-09 to 16-779-95 Other Network Faults 2 RAP
16-579-00	Job status not available. Power off then on and notify system administrator	The network controller ESS completed job log service has stopped	Switch the machine off then on, GP 14 . Printing and scanning can continue. If the problem persists, perform the 16-770-09 to 16-779-95 Other Network Faults 2 RAP
16-580-00	Incomplete system information. Power off then on and notify system administrator	The network controller ESS configuration utility process has stopped	Switch the machine off then on, GP 14 . Printing and scanning can continue. If the problem persists, perform the 16-780-00 to 16-789-47 Other Network Faults 3 RAP
16-581-00	Some network diagnostic services are not available. Notify your system administrator	The network controller ESS diagnostic service process has stopped	Switch the machine off then on, GP 14 . Printing and scanning can continue. If the problem persists, perform the 16-770-09 to 16-779-95 Other Network Faults 2 RAP and the 16-780-00 to 16-789-47 Other Network Faults 3 RAP
16-582-00	Some network authentication services unavailable. Notify your system administrator	The network controller ESS authentication SPI process has stopped	Switch the machine off then on, GP 14 . Print and other machine services are unaffected. If the problem persists, perform the 16-780-00 to 16-789-47 Other Network Faults 3 RAP
16-583-00	Incomplete system information. Power off then on and notify system administrator	The network controller ESS counters utility process has stopped	Switch the machine off then on, GP 14 . Printing and scanning can continue

Table 9 Chain 16 Status codes

Status Code	UI Message	Reason for Message	Reference / Action
16-584-00	Network controller connection is about to be reset	The network controller document manager agent process has stopped	Automatic network controller reset. Machine is unavailable
16-585-00	Incomplete system information. Power off then on and notify system administrator	The network controller ESS configuration synchronization process has stopped	Switch the machine off then on, GP 14 . Printing and scanning can continue. If the problem persists, perform the 16-780-00 to 16-789-47 Other Network Faults 3 RAP
16-586-00	Incomplete system information. Power off then on and notify system administrator	The network controller agent process has stopped	Switch the machine off then on, GP 14 . Print and other machine services are unaffected. If the problem persists, perform the 16-780-00 to 16-789-47 Other Network Faults 3 RAP
16-589-00	Network services involving a serial port are not available. Notify system administrator.	The network controller serial port connectivity has failed	Switch the machine off then on, GP 14 . Print and other machine services are unaffected. If the problem persists, perform the 16-780-00 to 16-789-47 Other Network Faults 3 RAP
16-590-00	Network connectivity configuration server not available. Notify your system administrator	The network controller CCS process has failed	Switch the machine off then on, GP 14 . Printing and scanning can continue. If the problem persists, perform the 16-800-09 to 16-809-47 Other Network Faults 5 RAP
16-591-00	Some network services involving Ethernet are not available. Notify system administrator.	Network controller Ethernet process has failed	Check Ethernet connection. Switch the machine off, then switch the machine on GP 14 . Local printing can continue. If the problem persists, perform the 16-800-09 to 16-809-47 Other Network Faults 5 RAP

Table 9 Chain 16 Status codes

Status Code	UI Message	Reason for Message	Reference / Action
16-593-00	Some network services involving DHCP are not available. Notify your system administrator.	Network controller - DHCP address resolution has failed	Check DHCP server network connection. Switch the machine off then on GP 14 . Copying and printing with local connections can continue. If the problem persists, perform the 16-800-09 to 16-809-47 Other Network Faults 5 RAP
16-594-00	Some network services involving RARP are not available. Notify your system administrator.	Network controller - RARP address resolution has failed	Check RARP server network connection. Switch the machine off then on GP 14 . Printing can continue with other submission methods. If the problem persists, perform the 16-800-09 to 16-809-47 Other Network Faults 5 RAP
16-595-00	LAN Fax service error. Power off then on and notify system administrator	The network controller LAN Fax service has failed	Switch the machine off then on, GP 14 . Print and other machine services are unaffected. If the problem persists, perform the 16-790-09 to 16-799-47 Other Network Faults 4 RAP
16-596-00	Some network accounting services are not available. Notify your system administrator.	Some network controller services are not available	Network accounting error. User intervention is required to switch the machine off then on, GP 14 . Print and other machine services are unaffected. If the problem persists, perform the 16-790-09 to 16-799-47 Other Network Faults 4 RAP
16-597-00	Some network services involving TIFF are not available. Notify your system administrator.	The network controller TIFF interpreter has failed	Switch the machine off then on, GP 14 . Printing can continue with other job formats. If the problem persists, perform the 16-790-09 to 16-799-47 Other Network Faults 4 RAP

Table 9 Chain 16 Status codes

Status Code	UI Message	Reason for Message	Reference / Action
16-598-00	Some network services involving TCP/IP are not available. Notify your system administrator.	Network controller - TCP/IP address is already in use on the network	Another IP address needs to be used. Switch the machine off then on, GP 14 . Copy and Fax services (if installed) can continue. If the problem persists, perform the 16-790-09 to 16-799-47 Other Network Faults 4 RAP
16-599-00	Network services with Port 9100 process are not available. Notify system administrator	Raw TCP/IP printing (port 9100) process has failed	Switch the machine off then on, GP 14 . Printing can continue with other submission methods. If the problem persists, perform the 16-790-09 to 16-799-47 Other Network Faults 4 RAP

Table 10 Chain 17 Status codes

Status Code	UI Message	Reason for Message	Reference / Action
17-510-00	Duplicate IPv6 address detected. Reconfigure with a unique address	Duplicate IPv6 address detected	Reconfigure with a unique address. Switch the machine off then on, GP 14 . Copy and Fax services (if installed) can continue
17-512-00	DHCPv6 services are not available. Notify your system administrator.	DHCPv6 Failure status	Switch the machine off then on, GP 14 . Printing can continue with other submission methods.
17-513-00	Duplicate IPv4 address detected. Reconfigure with a unique address	Duplicate IPv4 address detected.	Reconfigure with a unique address. Switch the machine off then on, GP 14 .
17-514-00	The machine is not available. Accounting communication failure	External accounting device communication failure	Administrator intervention required to check the connection to the external accounting device

Table 10 Chain 17 Status codes

Status Code	UI Message	Reason for Message	Reference / Action
17-551-00	Server Fax service cannot register. Power off then on and notify system administrator	Server Fax service cannot register	Switch the machine off then on, GP 14 . Server Fax is disabled, print and other machine services are unaffected. If the problem persists, perform the 16-987-19 , 16-988-19 Server Fax Application Registration Error RAP
17-553-00	Internet Fax service cannot register. Power off then on and notify system administrator	Internet Fax service cannot register	Switch the machine off then on, GP 14 . Internet Fax is disabled, print and other machine services are unaffected. If the problem persists, perform the 16-950-19 to 16-959-19 Other Network Faults 19 RAP
17-554-00	E-mail service cannot register. Power off then on and notify system administrator	Scan to E-mail service cannot register.	Switch the machine off then on, GP 14 . Scan to E-mail is disabled, print and other machine services are unaffected. If the problem persists, perform the 16-950-19 to 16-959-19 E-mail Application Registration Error RAP
17-556-00	The server Fax service cannot un-register. Notify your system administrator	Server Fax service cannot un-register	Switch the machine off then on, GP 14 . Server Fax is disabled, print and other machine services are unaffected. If the problem persists, perform the 16-987-19 , 16-988-19 Server Fax Application Registration Error RAP

Table 10 Chain 17 Status codes

Status Code	UI Message	Reason for Message	Reference / Action
17-557-00	The internet Fax service cannot un-register. Notify your system administrator	Internet Fax service cannot un-register	Switch the machine off then on, GP 14 . Internet Fax is disabled, print and other machine services are unaffected. If the problem persists, perform the 16-950-19 to 16-959-19 Other Network Faults 19 RAP
17-558-00	The E-mail service cannot un-register. Notify your system administrator	E-mail service cannot un-register	Switch the machine off then on, GP 14 . Scan to E-mail is disabled, print and other machine services are unaffected. If the problem persists, perform the 16-950-19 to 16-959-19 E-mail Application Registration Error RAP
17-559-00	Workflow scanning service cannot register. Power off then on and notify system administrator	Network scanning service cannot register.	Switch the machine off then on, GP 14 . Scan service is disabled, print and other machine services are unaffected. If the problem persists, perform the 16-985-19 , 16-986-19 Network Scanning Application Registration Error RAP
17-560-00	The workflow scanning service cannot un-register. Notify your system administrator	Network scanning service cannot un-register.	Switch the machine off then on, GP 14 . Scan service is disabled, print and other machine services are unaffected. If the problem persists, perform the 16-985-19 , 16-986-19 Network Scanning Application Registration Error RAP

Table 10 Chain 17 Status codes

Status Code	UI Message	Reason for Message	Reference / Action
17-561-00	The reprint saved jobs service cannot un-register. Notify your system administrator	Reprint saved jobs service cannot un-register.	Switch the machine off then on, GP 14 . Re-printing of saved jobs in disabled. If the problem persists, perform the 16-752-00 , 16-753-00 File Cabinet Application Registration Error RAP
17-562-00	No communications with Xerox SMart eSolutions server. Contact system administrator	Registration with edge server fails	User intervention is required to review SMart eSolutions settings. Machine services are unaffected. If the problem persists, perform the 16-891-00 , 16-892-00 Edge Server Auto Registration Failed RAP
17-563-00	No communications with Xerox SMart eSolutions server. Contact system administrator	Communication with edge server fails	User intervention is required to review SMart eSolutions settings. Machine services are unaffected. If the problem persists, perform the 16-891-00 , 16-892-00 Edge Server Auto Registration Failed RAP
17-565-00	Extensible services are not responding. Power machine off then on	EIP service not responding	Switch the machine off then on, GP 14 . Machine services are unaffected
17-570-00	No message	Communication with NNTP server failed	User intervention is required to verify network time protocol server settings, operability and machine time. Machine services are unaffected
17-580-00	Please wait... disk encryption operation in progress.	Disk encryption is in progress	No service action required, please wait for encryption to finish

Table 10 Chain 17 Status codes

Status Code	UI Message	Reason for Message	Reference / Action
17-590-00	Image overwrite is in progress... the machine is offline.	Image overwrite (ODIO) is in progress	No service action required, please wait for the overwrite to finish
17-507-00	On Demand Overwrite Failed. Perform an On Demand Overwrite immediately.	HDD or FAX On Demand Overwrite Failed.	On Demand Overwrite error. Administrator intervention is required to perform an On Demand Image Overwrite immediately. Printing can continue; other machine services are unaffected.

Table 11 Chain 19 Status codes

Status Code	UI Message	Reason for Message	Reference / Action
19-502-00	Please wait, freeing memory	Out of memory resources. The machine has run out of image processing memory for the current job	No user intervention required, please wait, printing will resume after memory is freed. Other machine services are unaffected. If the problem persists, perform the 19-401-00 , 19-402-00 Stress Out of Memory RAP
19-505-00	Some jobs may have been deleted	Compressor DVMA time-out. Current job has been deleted	Confirm that UI message has been seen. Re-scan the job. If the problem persists, perform the 19-403-00 EPC Out of Memory RAP
19-506-00	Immediate job overwrite failed. Perform an on demand overwrite immediately	Immediate job overwrite failed	Administrator intervention is required to perform an on demand image overwrite immediately. Printing can continue. Other machine services are unaffected
19-507-00	On Demand Overwrite Failed. Perform an On Demand Overwrite immediately.	HDD or FAX On Demand Overwrite Failed.	On Demand Overwrite error. Administrator intervention is required to perform an On Demand Image Overwrite immediately. Printing can continue; other machine services are unaffected.

Table 11 Chain 19 Status codes

Status Code	UI Message	Reason for Message	Reference / Action
19-510-00	Please wait.... the system is attempting to recover	System is attempting to recover. Image disk error	No service action required. Printing and other machine services are unaffected
19-511-00	Image disk is offline. Job(s) may take longer than normal. Notify system administrator	Image disk unavailable. Performance is degraded. Service is required	The system is unable to read from the image disk. Jobs may take longer than normal. Perform the 19-300-00 to 19-310-00 Image Disk (HDD) Failure RAP
19-512-00	Image disk offline. Power off then on and notify system administrator	The image disk cannot read or write and must be serviced. Power off/power on will temporarily alleviate the problem.	The system is unable to read from the image disk. Printing has stopped. Perform the 19-300-00 to 19-310-00 Image Disk (HDD) Failure RAP
19-513-00	Please wait... The image disk is full	The image disk is full	Print jobs may be delayed. No service action required. The system is attempting to recover. Printing and other machine services are available
19-514-00	All incomplete jobs have been deleted	Video job integrity fault detected	Video job integrity error; one or more jobs were deleted. No user intervention is required; the system has recovered. Printing and other machine services can continue. If the problem persists, perform the 19-409-00 Job Integrity Failure RAP
19-550-00	Configuration mismatch	The single board controller cannot access the EPC memory or the image disk	Switch the machine off then on, GP 14 . Install a new EPC memory module, PL 3.11 Item 21 . Install a new hard disk drive, PL 3.11 Item 2 . Install a new single board control PWB, PL 3.11 Item 13

Table 12 Chain 20 Status codes

Status Codes	UI Message	Reason for Message	Reference / Action
20-544-00	Please wait... The Fax service is initializing	The Fax service is initializing	The Fax service is re-starting. No user intervention is required. Printing and other machine services are available
20-545-00	Fax job could not be sent at this time, please try again	A Fax job could not be sent	Fax job could not be sent, re-try. Printing and other machine services are available
20-546-00	Fax memory is low. Contact your system administrator	Not enough memory to use Fax service	Switch the machine off then on, GP 14 . Fax and LAN Fax are disabled. Printing and other machine services are unaffected. If the problem persists, perform the 20-323-00, 20-324-00 Fax System Memory Low RAP
20-547-00	Fax memory is low. Contact your system administrator	Fax memory is low	User intervention is required to delete unnecessary mailbox files or Fax jobs stored for polling. FAX and LAN Fax services are disabled. Printing and other machine services are unaffected. If the problem persists, perform the 20-323-00, 20-324-00 Fax System Memory Low RAP
20-550-00	Fax line 2 is unavailable. Notify your system administrator	Extended Fax card failure detected	Switch the machine off then on, GP 14 . Fax service can continue from line 1. Printing and other machine services are available

Table 12 Chain 20 Status codes

Status Codes	UI Message	Reason for Message	Reference / Action
20-556-00	Fax memory error. Power off then on and notify system administrator	Fax service error. Reset Fax service	Fax and LAN Fax are disabled. Switch the machine off then on, GP 14 . Printing and other machine services are unaffected. If the problem persists, perform the 20-331-00 , 20-338-00 , 20-339-00 , 20-341-00 , 20-345-00 Fax Network Line 1 Fault RAP
20-558-00	Fax memory error. Power off then on and notify system administrator	Fax memory error	Fax and LAN Fax are disabled. Switch the machine off then on, GP 14 . Printing and other machine services are unaffected. If the problem persists, perform the 20-322-00 Non-Volatile Device not Installed RAP
20-559-00	Fax memory error. Power off then on and notify system administrator	Fax service error	Fax and LAN Fax are disabled. Switch the machine off then on, GP 14 . Printing and other machine services are unaffected. If the problem persists, perform the 20-320-00 Fax Fault Not Cleared by Reset RAP

Table 12 Chain 20 Status codes

Status Codes	UI Message	Reason for Message	Reference / Action
20-562-00	Fax line 1 is unavailable. Check line connection or notify your system administrator	No communication on Fax line 1	User intervention is required to check the external phone line connection. Fax and LAN Fax are disabled. Printing and other machine services are unaffected. If the problem persists, perform the 20-331-00 , 20-338-00 , 20-339-00 , 20-341-00 , 20-345-00 Fax Network Line 1 Fault RAP
20-563-00	Fax line 2 is unavailable. Check line connection or notify your system administrator	No communication on Fax line 2	User intervention is required to check the external phone line connection. Fax and LAN Fax are disabled. Printing and other machine services are unaffected. If the problem persists, perform the 20-332-00 , 20-340-00 Fax Network Line 2 Fault RAP
20-565-00	Fax job limit has been reached. Power off then on and notify system administrator	All jobs IDs allocated cannot create any more	Switch the machine off then on, GP 14 . Fax and LAN Fax are disabled
20-570-00	Fax memory error. Power off then on and notify system administrator	Fax service error	Switch the machine off then on, GP 14 . Fax and LAN Fax are disabled. Printing and other machine services are unaffected

Table 12 Chain 20 Status codes

Status Codes	UI Message	Reason for Message	Reference / Action
20-571-00	Fax memory error. Power off then on and notify system administrator	Fax service error	Fax line 1 is unavailable. Switch the machine off then on, GP 14 . Fax and LAN Fax are disabled. Printing and other machine services are unaffected. If the problem persists, perform the 20-331-00 , 20-338-00 , 20-339-00 , 20-341-00 , 20-345-00 Fax Network Line 1 Fault RAP
20-572-00	Fax line 2 is unavailable. Call for assistance	Fax service error. Fax line 2 is unavailable	Switch the machine off then on, GP 14 . Fax and LAN Fax are degraded. Printing and other machine services are unaffected. If the problem persists, perform the 20-332-00 , 20-340-00 Fax Network Line 2 Fault RAP
20-580-00	Fax service is unavailable. Turn machine off then on	NVM values supplied by the Fax are invalid. Fax NVM data error	No service action required. Fax and LAN Fax are disabled. Printing and other machine services are unaffected
20-595-00	Fax line 1 is unavailable. Call for assistance.	Fax service Error. Fax line 1 is unavailable	Fax line 1 is unavailable. Switch the machine off then on, GP 14 . Fax and LAN Fax are disabled. Printing and other machine services are unaffected. If the problem persists, perform the 20-331-00 , 20-338-00 , 20-339-00 , 20-341-00 , 20-345-00 Fax Network Line 1 Fault RAP

Table 13 Chain 22 Status codes

Status Codes	UI Message	Reason for Message	Reference / Action
22-502-04	Select the current messages button in the machine status for more information	An active message has been produced.	Go to the Status screen and select the Faults tab. Press the Active Messages button and perform the action appropriate to the message
22-503-04	All incomplete jobs have been deleted.	System error. Jobs have been lost and must be resubmitted	No user intervention is required. Machine is temporarily unavailable
22-503-05	The number of originals was less than the number originally scanned	Insufficient originals detected in the DADH.	Re-sort and reload all originals
22-504-04	No tray is configured with the required paper size	No paper tray is configured to run the stock size required for this job	Print and copy services are disabled, other machine services are unaffected Job must be deleted. Paper tray must be configured to match the job. If the problem persists, perform the 22-310-04 to 22-318-04 Other Network Faults 25 RAP
22-504-05	Invalid original size detected. It will be treated as the next largest standard size	Invalid mixed size original pair detected	Make sure the originals are not created or folded If the problem persists, perform the 05-257-00 RAP
22-504-16	Machine is in a non customer mode.	Non customer mode. Auto configuration is disabled. Wait for machine to exit Diagnostics mode. The machine is unavailable	Enter customer mode. Enter dC131 Read/ Write and check that NVM ID 425-001 = 0, 425-003 = 0 and 616-14 = 4

Table 13 Chain 22 Status codes

Status Codes	UI Message	Reason for Message	Reference / Action
22-505-00	Remove documents from the document feeder input tray or close the document feeder.	Documents sensed in the DADH tray during IIT standby and document handler cover is open.	To scan from the document glass, remove documents in the document feeder input tray. To use the document feeder to scan your documents, lower the document feeder.
22-505-02	Remove documents from the document feeder input tray or close the document feeder	Documents sensed in the DADH tray during IIT standby and document handler cover is open	To scan from the document glass, remove documents in the document feeder input tray. To use the document feeder to scan your documents, lower the document feeder
22-505-17	Machine is in a non-customer mode	Machine is in a non-customer mode	Enter customer mode Enter dC131 Read/Write and check that NVM ID 425-001 = 0, 425-003 = 0 and 616-14 = 4
22-506-17	Auto configuration is disabled	Machine is in a non-customer mode	Enter customer mode Enter dC131 Read/Write and check that NVM ID 425-001 = 0, 425-003 = 0 and 616-14 = 4
22-507-05	The document size was different than expected. The job has been deleted	Document is larger than expected	Try one of the following: Select mixed size originals and reload into the document feeder or make sure the originals are not creased or folded and retry from the document glass. If the problem persists, perform the 05-257-00 RAP

Table 13 Chain 22 Status codes

Status Codes	UI Message	Reason for Message	Reference / Action
22-508-04	Scanning will be delayed	Scan start up delayed whilst awaiting resources	No user intervention is required. Job will begin when system is ready. If the problem persists, perform the 22-330-06 ESS Scan to Distribution Service not Responding to List Jobs RPC Call RAP
22-511-04	Paper required for current job is not available	Media required for current marking job is not loaded	Load the correct paper to complete the held job or cancel the held job. Other machine services are unaffected
22-512-04	Auto paper select is not available	All trays direct select only	System administrator intervention is required to enable at least one tray for auto select. Printing and copying can continue without auto select, other machine services are unaffected
22-513-04	One or more queued jobs need resources	One or more queued jobs in the system are being held due to lack of resources	Add paper to the tray being used to clear queued job. Jobs will be held until resources become available. Other machine services are unaffected
22-557-00	Configuration parameter error.	Serial number sync failure, power on failed	Switch the machine off then on, GP 14 . Go to dC132 , check the serial number is correct. Enter dC131 NVM ID 616-003, check machine configuration. If the problem persists, perform the 22-350-01 , 22-350-02 RAP, 22-351-01 to 22-351-03 RAP, 22-352-00 RAP

Table 13 Chain 22 Status codes

Status Codes	UI Message	Reason for Message	Reference / Action
22-558-00	-	An HFSI item has reached or exceeded its threshold	Reset 'Actual' count to zero or reset the threshold
22-563-00	System error. Power off then on and notify system administrator	Incomplete system information	Switch the machine off then on, GP 14 . All machine services are disabled
22-566-00	The Fax service cannot register. Notify your system administrator	Fax service cannot register	Switch the machine off then on, GP 14 . Fax and LAN Fax are disabled. Other machine services are unaffected. If the problem persists, perform the 22-371-00 , 22-372-00 RAP
22-567-00	The Fax service cannot un-register. Notify your system administrator	Fax service cannot un-register	Switch the machine off then on, GP 14 . All machine services are disabled. If the problem persists, perform the 22-371-00 , 22-372-00 RAP
22-568-00	-	Status requiring POPO detected & auto-reset count less than 2.	The system will try to power off then on twice before asking for assistance
22-570-00	Cleaning unit needs to be replaced. Replace the cleaning unit now	DC1001 command to IME reports successful entry into snooze mode	Cleaning unit life extended. No user intervention is required. Print and copy services are available, but Image quality may be affected.

Table 14 Chain 70 to 78 Status codes

Status Code	UI Message	Reason for Message	Reference / Action
70-111-00	Ready to scan. Copying and printing not available. Jam in area 1b	Jam in lower feeder vertical transport (tray 5 not installed)	Clear the media jam. Copying and printing are not available. If the problem persists, perform the 71-101-00 to 71-155-00 RAP, 72-101-00 to 72-155-00 RAP
70-111-01	Ready to scan. Copying and printing not available. Jam in area 1b	Jam in lower feeder vertical transport (A4 tray 5 installed)	Clear the media jam. Copying and printing are not available. If the problem persists, perform the 71-101-00 to 71-155-00 RAP, 72-101-00 to 72-155-00 RAP
70-111-02	Ready to scan. Copying and printing not available. Jam in area 1b	Jam in lower feeder vertical transport (A3 tray 5 installed)	Clear the media jam. Copying and printing are not available. If the problem persists, perform the 71-101-00 to 71-155-00 RAP, 72-101-00 to 72-155-00 RAP
70-305-00	Ready to scan. Copying and printing not available. Bottom left side door is open	Feeder vertical transport lower left door is open	Copying and printing are not available. Close the door. If the problem persists, perform the 70-305-00 , 70-325-00 RAP
70-312-00	Trays 1 to 3 are not available. Notify your system administrator	Communications failure for trays 1 to 3	Switch the machine off then on, GP 14 . If the problem persists, perform the 70-312-00 RAP
70-314-00	Tray 1 is not available. Notify the system administrator	Trays 1 - 3 out of service (communications failure)	Copying and printing are not available. Perform the 70-312-00 Tray 1 to Tray 3 Communication Failure RAP.

Table 14 Chain 70 to 78 Status codes

Status Code	UI Message	Reason for Message	Reference / Action
71-102-00	Ready to scan. Copying and printing not available. Misfeed in tray 1	Misfeed in tray 1	Clear the media jam. Copying and printing are not available. If the problem persists, perform the 71-101-00 to 71-155-00 RAP
71-103-00	Unexpected paper size or type detected from tray 1	Media size mismatch in tray 1 (alternate method)	Open tray 1. Check paper size, orientation and type. If the problem persists, perform the 71B RAP.
71-300-00	-	Tray 1 is open	Close tray. Printing can continue from other trays
71-301-00	Tray 1 is open	Dedicated tray 1 is open	Check the paper and close the tray. Printing can continue from other trays. Refer to WD 7.5
71-302-00	Tray 1 is open	Adjustable tray 1 is open	Check the paper and close the tray. Printing can continue from other trays. Refer to WD 7.5
71-313-00	Tray 1 is not available. Notify your system administrator	Tray 1 mechanical failure	Copying and printing are not available. Switch the machine off then on, GP 14 . If the problem persists, perform the 71-215-00 Tray 1 Elevate Up Failure RAP
71-530-00	Tray 1 is empty. Add paper	Tray 1 is out of media	Add media. Copying and printing can continue from other trays. Refer to 71A RAP and WD 7.5
71-535-00	Tray 1 is nearly empty. Add paper	Tray 1 media low	Add media. Copying and printing can continue from other trays. Refer to 71A RAP and WD 7.5

Table 14 Chain 70 to 78 Status codes

Status Code	UI Message	Reason for Message	Reference / Action
71-536-00	Tray 1 lifting	Tray 1 lifting	No service action required. Print and copy services can continue from other trays if the correct media is available
72-102-00	Ready to scan. Copying and printing not available. Misfeed in tray 2	Misfeed in tray 2	Clear the media jam. Copying and printing are not available. Refer to 72-101-00 to 72-155-00 RAP
72-103-00	Unexpected paper size or type detected from tray 2	Media size mismatch in tray 2 (alternate method)	Open tray 2. Check paper size, orientation and type. Print and copy services can continue from other trays if the correct media is available
72-300-00	-	Tray 2 is open	Close tray. Printing can continue from other trays
72-301-00	Tray 2 is open. Check paper and close the tray	Dedicated tray 2 is open	Close tray. Print and copy services can continue from other trays if the correct media is available. Refer to 72-320-00 RAP and WD 7.5 .
72-302-00	Tray 2 is open. Check paper and close the tray	Adjustable tray 2 is open	Close tray. Print and copy services can continue from other trays if the correct media is available. Refer to 72-320-00 RAP and WD 7.5 .
72-313-00	Tray 2 is not available. Notify your system administrator	T2 out of service (mechanical failure)	Switch the machine off then on, GP 14 . Print and copy services can continue from other trays if the correct media is available. If the problem persists, perform the 72-215-00 Tray 2 Elevate Up Failure RAP.

Table 14 Chain 70 to 78 Status codes

Status Code	UI Message	Reason for Message	Reference / Action
72-530-00	Tray 2 is empty. Add paper	Tray 2 is out of media	Add media. Print and copy services can continue from other trays if the correct media is available. Refer to 72A RAP
72-535-00	Tray 2 is nearly empty. Add paper	Tray 2 media low	Add media. Print and copy services can continue from other trays if the correct media is available
72-536-00	Tray 2 lifting	Tray 2 lifting	No service action required. Print and copy services can continue from other trays if the correct media is available
73-102-00	Ready to scan. Copying and printing not available. Misfeed in tray 3	Misfeed in tray 3	Clear the media jam. Copying and printing are not available. Refer to 73-101-00 to 73-155-00 RAP
73-103-00	Unexpected paper size or type detected from Tray 3.	Media size mismatch in tray 3 (alternate method)	Open tray 3. Check paper size, orientation and type. Print and copy services can continue from other trays if the correct media is available
73-111-00	Ready to scan. Copying and printing not available. Jam in Paper Transport.	Jam in tray 3 horizontal transport	Clear the media jam. Copying and printing are not available. If the problem persists, perform the 73-101-00 to 73-155-00 Tray 3 Mis-Feed Jam RAP
73-300-00	Tray 3 is open. Check paper and close the tray	Tray 3 is open	Close Tray. Print and copy services can continue from other trays if the correct media is available
73-301-00	Tray 3 is open	Tray 3 is open	Close Tray. Printing can continue from other trays. If the problem persists, perform the 73-320-00 RAP

Table 14 Chain 70 to 78 Status codes

Status Code	UI Message	Reason for Message	Reference / Action
73-302-00	Tray 3 is open. Check paper and close the tray	Adjustable tray 3 is open	Close Tray. Print and copy services can continue from other trays if the correct media is available. If the problem persists, perform the 73-320-00 RAP
73-305-00	Ready to scan. Copying and printing not available. Paper transport is open.	Feeder horizontal transport drawer is open	Close the feeder horizontal transport. Copying and printing are not available. If the problem persists, perform the 73-325-00 Feeder HT Drawer Open in Run RAP
73-313-00	Tray 3 is not available. Notify your system administrator	T3 out of service (mechanical failure)	Switch the machine off then on, GP 14 . Print and copy services can continue from other trays if the correct media is available. If the problem persists, perform the 73-212-00 RAP, 73-215-00 RAP
73-530-00	Tray 3 is empty. Add paper	Tray 3 is out of media	Add media. Print and copy services can continue from other trays if the correct media is available. If the problem persists, perform the 73A RAP
73-535-00	Tray 3 is nearly empty. Add paper	Tray 3 media low	Add media. Print and copy services can continue from other trays if the correct media is available
73-536-00	Tray 3 lifting	Tray 3 lifting	Print and copy services can continue from other trays if the correct media is available
74-102-00	Misfeed in tray 4 (bypass).	Misfeed in tray 4	Clear the media jam. Copying and printing are not available. Refer to 74-101-00 RAP

Table 14 Chain 70 to 78 Status codes

Status Code	UI Message	Reason for Message	Reference / Action
74-103-00	Unexpected paper size or type detected from tray 4 (bypass).	Media size mismatch in tray 4 (alternate method)	Open tray 4, check paper size, orientation and type. Print and copy services can continue from other trays if the correct media is available. Refer to WD 8.3
74-120-00	-	Tray 4 guides move in run	Adjust the paper tray guides and confirm the paper tray settings. Print and copy services can continue from other trays if the correct media is available. If the problem persists, perform the 74-120-00 Bypass Tray Guides Move in Run RAP
74-313-00	Tray 4 (bypass) is not available. Notify your system administrator	Tray 4 mechanical failure	Switch the machine off then on, GP 14 . Print and copy services can continue from other trays if the correct media is available. Refer to the following, 74-101-00 Bypass Tray Mis-Feed RAP , 74-120-00 Bypass Tray Guides Move in Run RAP and 74-214-00 Bypass Tray Nudger Failure RAP .
74-530-00	-	Tray 4 is out of media	Add media. Print and copy services can continue from other trays if the correct media is available
75-102-00	Misfeed in tray 5	Misfeed in tray 5: A4 PFP	Clear the media jam. Copying and printing are not available. If the problem persists, perform the 75-101-00 RAP

Table 14 Chain 70 to 78 Status codes

Status Code	UI Message	Reason for Message	Reference / Action
75-102-01	Misfeed in Tray 5.	Misfeed in Tray 5: A3 PFP	Clear the media jam. Copying and printing are not available. If the problem persists, perform the 75-101-00 RAP
75-103-00	Unexpected paper size or type detected from tray 5	Media size mismatch in tray 5 (alternate method)	Lower Tray 5 using the button indicated. Check paper size, orientation and type. Print and copy services can continue from other trays if the correct media is available
75-103-01	Unexpected paper size or type detected from tray 5	Media size mismatch in tray 5 (alternate method)	Lower Tray 5 using the button indicated. Check paper size, orientation and type.
75-110-00	Jam in tray 5 docking area	Jam in tray 5 docking area	Clear the misfeed. Copying and printing are not available. Refer to 75-101-00 RAP .
75-110-01	Jam in tray 5 docking area	Jam in tray 5 docking area A3 PFP	Clear the misfeed. Copying and printing are not available. Refer to 75-101-00 RAP .
75-300-00	-	Tray 5 is open	Close Tray. Print and copy services can continue from other trays if the correct media is available. Refer to 75A RAP .
75-301-00	Tray 5 is open	Tray 5 is open	Close tray. Print and copy services can continue from other trays if the correct media is available. Refer to 75A RAP .
75-305-00	Tray 5 is undocked	Tray 5 is undocked	Re-dock tray 5 to the machine. Print and copy services can continue from other trays if the correct media is available. Refer to 75-325-00 RAP .

Table 14 Chain 70 to 78 Status codes

Status Code	UI Message	Reason for Message	Reference / Action
75-305-01	Tray 5 is undocked	Tray 5 is undocked	Re-dock tray 5 to the machine. Print and copy services can continue from other trays if the correct media is available. Refer to 75-325-00 RAP.
75-312-00	Tray 5 is not available. Notify your system administrator	Tray 5 communications failure	Switch the machine off, GP 14 . Check cabling connections. Switch the machine on, GP 14 . Print and copy services can continue from other trays if the correct media is available. Refer to 75-312-00 RAP.
75-313-00	Tray 5 is not available. Notify the system administrator	Tray 5 mechanical failure	Tray 5 is not available. Print and copy services can continue from other trays if the correct media is available. If the problem persists, perform the 75-212-00 , 75-215-00 Tray 5 Elevate Up Failure RAP
75-525-00	Tray 5 is overloaded. Remove some paper	Tray 5 is overloaded	Remove some media. Print and copy services can continue from other trays if the correct media is available. If the problem persists, perform the 75-212-00 , 75-215-00 RAP.
75-530-00	Tray 5 is empty. Add paper	Tray 5 is out of media	Add media. Print and copy services can continue from other trays if the correct media is available. If the problem persists, perform the 75B RAP

Table 14 Chain 70 to 78 Status codes

Status Code	UI Message	Reason for Message	Reference / Action
75-535-00	Tray 5 is nearly empty. Add paper	Tray 5 media low	Add media. Print and copy services can continue from other trays if the correct media is available. If the problem persists, perform the 75B RAP.
75-536-00	Tray 5 lifting	Tray 5 lifting	No action required. Print and copy services can continue from other trays if the correct media is available
75-537-00	Tray 5 lowering	Tray 5 lowering	No action required. Print and copy services can continue from other trays if the correct media is available
78-103-00	Unexpected paper size or type detected from tray 6 (inserter)	Media size mismatch in tray 6	Open tray 6. Check and confirm paper size, orientation and type.

Table 15 Chain 82 to 89 Status codes

Status Code	UI Message	Reason for Message	Reference / Action
82-100-00	Ready to scan. Copying and printing not available. Paper jam in area 1A	IME jam at zone 1A (middle vertical) (tray 5 not installed)	Open middle left door, clear the paper jam. If the problem persists, perform the 82-110-00 to 82-114-00 , 82-152-00 , 82-157-00 to 82-159-00 , 82-164-00 to 82-166-00 RAP and 82-133-00 RAP. Copying and printing are not available

Table 15 Chain 82 to 89 Status codes

Status Code	UI Message	Reason for Message	Reference / Action
82-100-01	Paper jam in area 1A	IME jam at zone 1A (middle vertical) (A4 PFP installed)	Slide tray 5 away from the machine, open the middle left door, clear the paper jam. If the problem persists, perform the 82-110-00 to 82-114-00 , 82-152-00, 82-157-00 to 82-159-00 , 82-164-00 to 82-166-00 RAP. Copying and printing are not available
82-100-02	Paper jam in area 1a.	Jam at zone 1A (middle vertical) (A3 PFP installed)	Slide tray 5 away from the machine, open the middle left door, clear the paper jam. If the problem persists, perform the 82-110-00 to 82-114-00 , 82-152-00, 82-157-00 to 82-159-00 , 82-164-00 to 82-166-00 RAP
82-101-00	Paper jam in area 2	IME jam at zone 2 (upper vertical)	Open upper left door, clear the paper jam. Refer to 82-125-00 to 82-133-00 , 82-153-00, 82-160-00, 82-162-00, 82-163-00 RAP, 82-132-00, 82-155-00 . Copying and printing are not available
82-103-00	The machine is not available. Paper jam in areas 2 and 1a	Sensor 16 LE time out that originated from the A4 PFP	Slide tray 5 away from the machine. Open the top and middle left side door to clear jam. If the problem persists, perform the 82-133-00 RAP.
82-103-01	The machine is not available	Sensor 16 LE time out that originated from the A3 PFP	Copying and printing not available. Slide tray 5 away from the machine. Open the top and middle left side door to clear jam. If the problem persists, perform the 82-133-00 RAP.

Table 15 Chain 82 to 89 Status codes

Status Code	UI Message	Reason for Message	Reference / Action
88-510-00	Please wait... Pre-heater cleaning in progress	IME preheater cleaning	Please wait until cleaning is completed. The printer is temporarily unavailable.
88-511-00	Please wait... Print engine cooling in progress	Media is exhausted during the cooling phase of clean for ink smears	No service action required. Please wait, cooling in progress...
89-525-00	-	IME clam shell open	-
89-560-00	Registration in progress	IME registration calibration	Please wait. The printer is temporarily unavailable
89-561-00	-	NVM entries for RALPH media registration calibration got corrupted or reset.	Refer to OF 12 Service Code RAP

Table 16 Chain 91 to 94 Status codes

Status Code	UI Message	Reason for Message	Reference / Action
91-584-00	Waste tray not detected (missing). Insert the waste tray	Waste ink tray is missing (not full and not present).	Install a waste ink tray, PL 91.10 Item 15 . Print and copy services are disabled. If the problem persists, refer to WD 9.4 . and 91-832-00 RAP
91-589-00	Waste tray locked while in use. Do not attempt to remove	IME waste ink tray is locked in place to allow it to cool	-
91-590-00	Waste tray is almost full and will need emptying soon	IME waste tray is almost full	The tray will need to be emptied soon. Printing and copying can continue
91-591-00	Waste tray is full. Please empty the waste tray	IME waste tray is full	Empty the tray. Copying and printing are not available. If necessary refer to WD 9.4 .
91-606-00	The machine is not available	Head to drum measurement is started.	Head to drum spacing check in progress. Please wait, this may take up to ten minutes to complete.

Table 16 Chain 91 to 94 Status codes

Status Code	UI Message	Reason for Message	Reference / Action
91-609-00	The machine is not available	Waste tray removal detected, when the waste tray is locked.	The waste tray is currently in use, please re-insert the waste tray. Copying and printing are not available
91-632-00	-	Print head 1 has changed since last boot	-
91-633-00	-	Print head 2 has changed since last boot	-
91-634-00	-	Print head 3 has changed since last boot	-
91-635-00	-	Print head 4 has changed since last boot	-
91-636-00	-	The IOD automatic image maintenance tool has tried repeatedly to run and has failed enough to exceed the disabled limitation, or has been manually disabled via diagnostics	If the problem persists, perform the 91-636-00 RAP
91-637-00	-	IOD Y run out NVRAM parameters are reset.	If the problem persists, perform the 91-637-00 RAP
91-638-00	-	IOD chronic jets detected.	Perform 91-638-00 RAP
91-639-00	-	Sent once per cold purge. Sent when the overall purge, which might request multiple heads to be purged, is requested. A cold purge is performed at power up. That is, the ink in the system is cold, it is warmed up, then a purge is performed	No service action required
91-640-00	-	Sent once per warm purge. Sent when the overall purge, which might request multiple heads to be purged, is requested. A warm purge is performed during the lifetime of a power on session. The ink is already up to temp, then the print heads are purged	No service action required

Table 16 Chain 91 to 94 Status codes

Status Code	UI Message	Reason for Message	Reference / Action
91-641-00	-	A freeze off means that 1, or more, print heads are allowed to cool down so that the ink is in a solid state. This would then be followed by a cold purge. The freeze off would be communicated by the freeze off DC status updates, and the cold purges that would follow would be communicated by the cold purge DC status updates	No service action required
91-642-00	-	Sent when a cold purge for head 1 has completed	No service action required
91-643-00	-	Sent when a cold purge for head 2 has completed	No service action required
91-644-00	-	Sent when a cold purge for head 3 has completed	No service action required
91-645-00	-	Sent when a cold purge for head 4 has completed	No service action required
91-646-00	-	Sent when a warm purge for head 1 has completed	No service action required
91-647-00	-	Sent when a warm purge for head 2 has completed	No service action required
91-648-00	-	Sent when a warm purge for head 3 has completed	No service action required
91-649-00	-	Sent when a warm purge for head 4 has completed	No service action required
91-650-00	-	Head 1 freeze off - has completed	No service action required
91-651-00	-	Head 2 freeze off - has completed	No service action required
91-652-00	-	Head 3 freeze off - has completed	No service action required
91-653-00	-	Head 4 freeze off - has completed	No service action required
91-654-00	Please wait... print engine maintenance - head purge in progress	Head purge in progress	No service action required.
91-659-00	Please wait... auto-mated print engine maintenance in progress	Auto maintenance routines in progress	No service action required.
91-668-00	Please wait... print quality maintenance in progress	IME print quality maintenance in progress	No service action required.

Table 16 Chain 91 to 94 Status codes

Status Code	UI Message	Reason for Message	Reference / Action
91-840-00	-	IME in jet substitution and single sided print mode. Increments the AIF counter by 1	No service action required.
91-841-00	-	IME in jet substitution and single sided print mode. Increments the AIF counter by 2	No service action required.
91-847-00	Waste tray is full. Please empty the waste tray	The waste tray is almost full and has also been removed	Empty the waste tray, then replace it in the machine
92-530-00	Paper tray communication fault. Please call for assistance	IME communications problem with paper tray. Paper trays 1 to 3 not available	Switch the machine off then on, GP 14 . Check connection on 3 trays module. If problem persists, perform the 70-312-00 Tray 1 to Tray 3 Communication Failure RAP. Copying and printing are not available.
92-531-00	Paper tray communication fault. Please call for assistance	3TM Communications problems (TtmSerialLinkSafety)	Switch the machine off then on, GP 14 . Check connection on 3 trays module. If problem persists, perform the 70-312-00 Tray 1 to Tray 3 Communication Failure RAP. Copying and printing are not available.
92-535-00	Paper feeder communication fault. Call for assistance	IME communications problem with paper feeder platform. High capacity paper tray not available	Switch the machine off then on, GP 14 . Check connection to printer. If problem persists, perform the 75-312-00 IME to Tray 5 Communication Failure RAP. Copying and printing are not available.
92-536-00	Tray 5 is unavailable. Please call for assistance	Tray 5 communications problems (tray 5 SerialLinkSafety)	Switch the machine off then on, GP 14 . Check connection to printer. If problem persists, perform the 92-535-00 , 92-536-00 RAP. Copying and printing are not available.

Table 16 Chain 91 to 94 Status codes

Status Code	UI Message	Reason for Message	Reference / Action
92-572-00	System fault. Call for assistance	IME. An unrecoverable fault has occurred	Switch the machine off then on, GP 14 . Copying and printing are not available.
92-573-00	Please wait... Printer is warming up	Warming Up	Print and copy services will resume shortly. Other machine services are unaffected
92-574-00	Please wait... adjustments are in progress	IME mechanical initialization	-
92-576-00	Please wait... adjustments are in progress	IME frame buffer borrow busy	Print engine adjustments in progress. Copying and printing are temporarily unavailable
92-577-00	Please wait... adjustments are in progress	Recovery in progress	-
92-578-00	Print engine in non-thermal mode.	IME in non-thermal mode. Print engine is operating in non-thermal manufacturing mode. Print and copy service disabled.	Enter diagnostics dC335 and select a heater routine. Run the routine and then exit diagnostics. The machine warms up. Enter dC131 Read/Write and check that NVM ID 425-003 = 0 Select exit and reboot.
92-582-00	Please wait... Warming up from extremely low ambient temperature.	IME cold boot timeout	Please wait. Printing and copying are not available until the machine temperature is within specification
92-587-00	Please wait... Printer is warming up	IME long term warming up	The printer is warming up. Print and copy services will resume shortly. Other machine services are unaffected
92-802-00	-	PEST soft faults are raised	Review dC123 PEST fault history log

Table 16 Chain 91 to 94 Status codes

Status Code	UI Message	Reason for Message	Reference / Action
93-500-00	Black Ink is empty. Load Xerox ColorQube Black Ink.	IME black ink is empty	Load more black solid ink. Copying and printing are not available. Check the ink low sensor and harness. Refer to WD 9.18 .
93-501-00	Black ink stick is jammed. Call for assistance	Ink stick loaded sensor actuated. Ink stick transport motor operated. Ink stick not detected by ink out sensor	Clear the ink loader jam. Copying and printing are not available
93-505-00	Magenta ink is empty. Load Xerox ColorQube Magenta Ink.	IME magenta ink is empty	Load more magenta solid ink. Copying and printing are not available. Check the ink low sensor and harness. Refer to WD 9.18
93-506-00	Magenta ink stick is jammed. Call for assistance	Ink stick loaded sensor actuated. Ink stick transport motor operated. Ink stick not detected by ink out sensor.	Clear the ink loader jam. Copying and printing are not available
93-510-00	Cyan ink is empty. Load Xerox ColorQube Cyan Ink.	IME cyan ink is empty	Load more cyan solid ink. Copying and printing are not available. Check the ink low sensor and harness. Refer to WD 9.18
93-511-00	Cyan ink stick is jammed. Call for assistance	Ink stick loaded sensor actuated. Ink stick transport motor operated. Ink stick not detected by ink out sensor.	Clear the ink loader jam. Copying and printing are not available
93-515-00	Yellow Ink is empty. Load Xerox ColorQube Yellow Ink.	IME yellow ink is empty	Load more yellow solid ink. Copying and printing are not available. Check the ink low sensor and harness. Refer to WD 9.18
93-516-00	Yellow ink stick is jammed. Call for assistance	Ink stick loaded sensor actuated. Ink stick transport motor operated. Ink stick not detected by ink out sensor.	Clear the ink loader jam. Copying and printing are not available
93-821-00	Re-order Xerox ColorQube Ink	Black ink reorder threshold has been reached	Load more black solid ink. Copying and printing can continue. If the ink stick cannot be loaded, go to OF 11 .

Table 16 Chain 91 to 94 Status codes

Status Code	UI Message	Reason for Message	Reference / Action
93-822-00	Re-order Xerox ColorQube Ink	Magenta ink reorder threshold has been reached	Load more magenta solid ink. Copying and printing can continue. If the ink stick cannot be loaded, go to OF 11
93-823-00	Re-order Xerox ColorQube Ink	Cyan ink reorder threshold has been reached	Load more cyan solid ink. Copying and printing can continue. If the ink stick cannot be loaded, go to OF 11 .
93-824-00	Re-order Xerox ColorQube Ink	Yellow ink reorder threshold has been reached	Load more yellow solid ink. Copying and printing can continue. If the ink stick cannot be loaded, go to OF 11 .
93-825-00	Ink levels are low. Load Xerox ColorQube Ink now	Black ink low threshold has been reached	Load more black solid ink sticks. Print and other machine services are unaffected. If the ink stick cannot be loaded, go to OF 11 .
93-826-00	Ink levels are low. Load Xerox ColorQube Ink now	Magenta ink low threshold has been reached	Load more magenta solid ink sticks. Print and other machine services are unaffected. If the ink stick cannot be loaded, go to OF 11 .
93-827-00	Ink levels are low. Load Xerox ColorQube Ink now	Cyan ink low threshold has been reached	Load more cyan solid ink sticks. Print and other machine services are unaffected. If the ink stick cannot be loaded, go to OF 11 .
93-828-00	Ink levels are low. Load Xerox ColorQube Ink now	Yellow ink low threshold has been reached	Load more yellow solid ink sticks. Print and other machine services are unaffected. If the ink stick cannot be loaded, go to OF 11 .
93-876-00	Ink loader main cover open	Ink loader door is open. Close the door. All machine services are available	Close the ink loader door. Refer to WD 8.2 . Check the ink loader switch (S93-025), PL 93.10 Item 19 .

Table 16 Chain 91 to 94 Status codes

Status Code	UI Message	Reason for Message	Reference / Action
93-877-00	-	This status is raised when the detected ink stick is different from the expected one (as per the billing type)	Incompatible black ink detected. Refer to GP 34. Notify the system administrator. All machine services are available.
93-878-00	-	This status is raised when the detected ink stick is different from the expected one (as per the billing type)	Incompatible magenta ink detected. Refer to GP 34. Notify the system administrator. All machine services are available.
93-879-00	-	This status is raised when the detected ink stick is different from the expected one (as per the billing type)	Incompatible cyan ink detected. Refer to GP 34. Notify the system administrator. All machine services are available.
93-880-00	-	This status is raised when the detected ink stick is different from the expected one (as per the billing type)	Incompatible yellow ink detected. Refer to GP 34. Notify the system administrator. All machine services are available.
93-881-00	-	This status is raised when the detected ink stick is different from the expected one (as per the billing type)	Incompatible black ink detected. Refer to GP 34. Notify the system administrator. All machine services are available.
93-882-00	Incompatible magenta ink stick detected, please contact the system administrator.	Magenta sold ink stick expected, metered was detected	Check that the machine is on the correct contract - Print a configuration page, General set up, service plan. Check the ink loaded is as per the customers contract GP 34. Check the ink load sensors dC330 - 93-026 to 93-041

Table 16 Chain 91 to 94 Status codes

Status Code	UI Message	Reason for Message	Reference / Action
93-883-00	Incompatible cyan ink stick detected, please contact the system administrator.	Cyan sold ink stick expected, metered was detected	Check that the machine is on the correct contract - Print a configuration page, General set up, service plan. Check the ink loaded is as per the customers contract GP 34. Check the ink load sensors dC330 - 93-026 to 93-041
93-884-00	Incompatible yellow ink stick detected, please contact the system administrator.	Yellow sold ink stick expected, metered was detected	Check that the machine is on the correct contract - Print a configuration page, General set up, service plan. Check the ink loaded is as per the customers contract GP 34. Check the ink load sensors dC330 - 93-026 to 93-041
93-885-00	Incompatible Black ink stick detected. Notify your system administrator.	Black sold ink stick expected, DMO was detected	Check that the machine is on the correct contract - Print a configuration page, General set up, service plan. Check the ink loaded is as per the customers contract GP 34. Check the ink load sensors dC330 - 93-026 to 93-041
93-886-00	Incompatible black ink stick detected. Notify your system administrator.	Black DMO ink stick expected, sold was detected	Check that the machine is on the correct contract - Print a configuration page, General set up, service plan. Check the ink loaded is as per the customers contract GP 34. Check the ink load sensors dC330 - 93-026 to 93-041

Table 16 Chain 91 to 94 Status codes

Status Code	UI Message	Reason for Message	Reference / Action
93-887-00	Incompatible black ink stick detected. Notify your system administrator.	Black metered ink stick expected, DMO was detected	Check that the machine is on the correct contract - Print a configuration page, General set up, service plan. Check the ink loaded is as per the customers contract GP 34. Check the ink load sensors dC330 - 93-026 to 93-041
93-888-00	Incompatible black ink stick detected. Notify your system administrator.	Black DMO ink stick expected, metered was detected	Check that the machine is on the correct contract - Print a configuration page, General set up, service plan. Check the ink loaded is as per the customers contract GP 34. Check the ink load sensors dC330 - 93-026 to 93-041
93-889-00	Close the ink loader main cover	In a recovery sequence or cold power start, when ink stick door is open	Close the ink loader main cover. Copying and printing are not available. Other machine services are unaffected
93-893-00	Please wait... Automated print engine maintenance in progress	This is raised while the IME is attempting to clear a potentially jammed black ink stick	No service action required. Print and copy services are temporarily disabled
93-894-00	Please wait... Automated print engine maintenance in progress	This is raised while the IME is attempting to clear a potentially jammed magenta ink stick	No service action required. Print and copy services are temporarily disabled
93-895-00	Please wait... Automated print engine maintenance in progress	This is raised while the IME is attempting to clear a potentially jammed cyan ink stick	No service action required. Print and copy services are temporarily disabled
93-896-00	Please wait... Automated print engine maintenance in progress	This is raised while the IME is attempting to clear a potentially jammed yellow ink stick	No service action required. Print and copy services are temporarily disabled

Table 16 Chain 91 to 94 Status codes

Status Code	UI Message	Reason for Message	Reference / Action
93-905-00	-	It is raised when the IME recognizes that the cyan ink stick is consumed. This means it went past the ink low flag (it's past the point it can be removed from the system and will be consumed). This is critical for supplies replenishment and is used to estimate the rate at which ink sticks are being used	No service action required. All services are available
93-906-00	-	It is raised when the IME recognizes that the magenta ink stick is consumed. This means it went past the ink low flag (it's past the point it can be removed from the system and will be consumed). This is critical for supplies replenishment and is used to estimate the rate at which ink sticks are being used	No service action required. All services are available
93-907-00	-	It is raised when the IME recognizes that the yellow ink stick is consumed. This means it went past the ink low flag (it's past the point it can be removed from the system and will be consumed). This is critical for supplies replenishment and is used to estimate the rate at which ink sticks are being used	No service action required. All services are available
93-908-00	-	It is raised when the IME recognizes that the black ink stick is consumed. This means it went past the ink low flag (it's past the point it can be removed from the system and will be consumed). This is critical for supplies replenishment and is used to estimate the rate at which ink sticks are being used	No service action required. All services are available

Table 16 Chain 91 to 94 Status codes

Status Code	UI Message	Reason for Message	Reference / Action
93-925-00	Black ink stick jam. Add black ink to aid jam recovery.	Black ink stick jam	Black ink stick jam detected. Load a black ink stick to aid jam recovery. Copying and printing not available.
93-926-00	Magenta ink stick jam. Add magenta ink to aid jam recovery.	Magenta ink stick jam	Magenta ink stick jam detected. Load a magenta ink stick to aid jam recovery. Copying and printing not available.
93-927-00	Cyan ink stick jam. Add cyan ink to aid jam recovery.	Cyan ink stick jam	Cyan ink stick jam detected. Load a cyan ink stick to aid jam recovery. Copying and printing not available.
93-928-00	Yellow ink stick jam. Add yellow ink to aid jam recovery.	Yellow ink stick jam	Yellow ink stick jam detected. Load a Yellow ink stick to aid jam recovery. Copying and printing not available.
93-941-00	-	Magenta sold ink stick expected, DMO was detected	Incompatible magenta ink detected. Refer to GP 34. Notify the system administrator. All machine services are available.
93-942-00	-	Cyan sold ink stick expected, DMO was detected	Incompatible cyan ink detected. Refer to GP 34. Notify the system administrator. All machine services are available.
93-943-00	-	Yellow sold ink stick expected, DMO was detected	Incompatible yellow ink detected. Refer to GP 34. Notify the system administrator. All machine services are available.
93-944-00	-	Magenta DMO ink stick expected, sold was detected	Incompatible magenta ink detected. Refer to GP 34. Notify the system administrator. All machine services are available.

Table 16 Chain 91 to 94 Status codes

Status Code	UI Message	Reason for Message	Reference / Action
93-945-00	-	Cyan DMO ink stick expected, sold was detected	Incompatible cyan ink detected. Refer to GP 34. Notify the system administrator. All machine services are available.
93-946-00	-	Yellow DMO ink stick expected, sold was detected	Incompatible yellow ink detected. Refer to GP 34. Notify the system administrator. All machine services are available.
93-947-00	-	Magenta DMO ink stick expected, metered was detected	Incompatible magenta ink detected. Refer to GP 34. Notify the system administrator. All machine services are available.
93-948-00	-	Cyan DMO ink stick expected, metered was detected	Incompatible cyan ink detected. Refer to GP 34. Notify the system administrator. All machine services are available.
93-949-00	-	Yellow DMO ink stick expected, metered was detected	Incompatible yellow ink detected. Refer to GP 34. Notify the system administrator. All machine services are available.
93-950-00	-	This status is raised when the detected ink stick is not a supported type	Incompatible black ink detected. Refer to GP 34. Notify the system administrator. All machine services are available.
93-951-00	-	This status is raised when the detected ink stick is not a supported type	Incompatible magenta ink detected. Refer to GP 34. Notify the system administrator. All machine services are available.

Table 16 Chain 91 to 94 Status codes

Status Code	UI Message	Reason for Message	Reference / Action
93-952-00	-	This status is raised when the detected ink stick is not a supported type	Incompatible cyan ink detected. Refer to GP 34 . Notify the system administrator. All machine services are available.
93-953-00	-	This status is raised when the detected ink stick is not a supported type	Incompatible yellow ink detected. Refer to GP 34 . Notify the system administrator. All machine services are available.
93-954-00	-	Magenta metered ink stick expected, DMO was detected	Incompatible magenta ink detected. Refer to GP 34 . Notify the system administrator. All machine services are available.
93-955-00	-	Cyan metered ink stick expected, DMO was detected	Incompatible cyan ink detected. Refer to GP 34 . Notify the system administrator. All machine services are available.
93-956-00	-	Yellow metered ink stick expected, DMO was detected	Incompatible yellow ink detected. Refer to GP 34 . Notify the system administrator. All machine services are available.
94-500-00	Cleaning unit will need replacing soon. Reorder now, DO NOT replace until requested	Drum maintenance unit - predicted re-order message	Re-order cleaning unit, PL 94.10 Item 21 , but do not install unit until requested. Copying and printing can continue
94-501-00	Cleaning unit needs to be replaced. Replace cleaning unit now	Cleaning unit is empty of oil and needs replacing	Install a new cleaning unit, PL 94.10 Item 21 . Copying and printing are not available

Table 16 Chain 91 to 94 Status codes

Status Code	UI Message	Reason for Message	Reference / Action
94-502-00	Cleaning unit is not detected. Please insert cleaning unit	Cleaning unit not present or not detected	Install cleaning unit PL 94.10 Item 21 . Refer to the 94-568-00 , 94-570-00 , 94-572-00 , 94-573-00 Cleaning Unit Data Error RAP. Copying and printing are not available
94-503-00	Cleaning Unit will need replacing soon. DO NOT replace until requested	This status is raised when the machine is in the last 3000 impressions	Re-order cleaning unit, PL 94.10 Item 21 , but do not install unit until requested. Copying and printing can continue
94-504-00	-	Cleaning unit predicted re-order message has been triggered, acknowledged and temporarily suppressed	No service action required. Machine services are unaffected
94-505-00	Cleaning unit fault. Call for assistance quoting error code 94-505	Cleaning unit failure. Replacing the cleaning unit may correct the fault	Install a new cleaning unit, PL 94.10 Item 21 . Copying and printing are not available. Other machine services are unaffected
94-528-00	Cleaning unit fault. Call for assistance quoting error code 94-528	Cleaning unit failure. Replacing the cleaning unit may correct the fault	Install a new cleaning unit, PL 94.10 Item 21 . Copying and printing are not available. Other machine services are unaffected
94-532-00	Cleaning unit fault. Call for assistance quoting error code 94-532	Cleaning unit failure. Replacing the cleaning unit may correct the fault	Install a new cleaning unit, PL 94.10 Item 21 . Copying and printing are not available. Other machine services are unaffected
94-533-00	Cleaning unit fault. Call for assistance quoting error code 94-533	Cleaning unit failure. Replacing the cleaning unit may correct the fault	Install a new cleaning unit, PL 94.10 Item 21 . Copying and printing are not available. Other machine services are unaffected
94-547-00	-	Y - axis belt ratio error. Imaging drum belt is worn	Install new drum belt, PL 94.20 Item 2 . Refer to OF 12 Service Code RAP

Table 16 Chain 91 to 94 Status codes

Status Code	UI Message	Reason for Message	Reference / Action
94-568-00	Cleaning unit fault. Call for assistance quoting error code 94-568	Cleaning unit failure. Replacing the cleaning unit may correct the fault	Install a new cleaning unit, PL 94.10 Item 21 . Copying and printing are not available. Other machine services are unaffected
94-570-00	Cleaning unit fault. Call for assistance quoting error code 94-570	Cleaning unit failure. Replacing the cleaning unit may correct the fault	Install a new cleaning unit, PL 94.10 Item 21 . Copying and printing are not available. Other machine services are unaffected
94-572-00	Cleaning unit fault. Call for assistance quoting error code 94-572	Cleaning unit failure. Replacing the cleaning unit may correct the fault	Install a new cleaning unit, PL 94.10 Item 21 . Copying and printing are not available. Other machine services are unaffected
94-573-00	Cleaning unit fault. Call for assistance quoting error code 94-573	Cleaning unit failure. Replacing the cleaning unit may correct the fault	Install a new cleaning unit, PL 94.10 Item 21 . Copying and printing are not available. Other machine services are unaffected
94-600-00	Load 8.5 x 11" paper in any tray to enable auto-drum cleaning	Letter/A4 chase media needed to clean drum	Load the required media. Refer to GP 20 . Copying and printing are not available
94-601-00	Load SRA3 (320 x 450 mm) paper in any tray to enable auto-drum cleaning	SRA3 paper needed to clean drum	Load the required media. Refer to GP 20 . Copying and printing are not available
94-602-00	Load 12 x 18" paper in any tray to enable auto-drum cleaning	12"x18" chase media needed to clean drum	Load the required media. Refer to GP 20 . Copying and printing are not available
94-603-00	Please wait... Printer cleaning in progress	Chase sheet being Fed	Ready to scan. Copying and printing not available.
94-604-00	Load A4 paper into any tray to enable auto-cleaning to proceed	A4 chase media needed to clean drum	Load any tray with A4 paper to enable auto-cleaning. Refer to GP 20 .

Table 16 Chain 91 to 94 Status codes

Status Code	UI Message	Reason for Message	Reference / Action
94-610-00	Cleaning Unit fault. Call for assistance quoting error code 94-610	Cleaning unit failure	A fault has occurred in the cleaning unit. Install a new cleaning unit PL 94.10 Item 21 .
94-611-00	Cleaning Unit fault. Call for assistance quoting error code 94-611	Cleaning unit failure	A fault has occurred in the cleaning unit. Install a new cleaning unit PL 94.10 Item 21 .
94-612-00	Cleaning Unit fault. Call for assistance quoting error code 94-612	Cleaning unit failure	A fault has occurred in the cleaning unit. Install a new cleaning unit PL 94.10 Item 21 .
94-613-00	Cleaning Unit fault. Call for assistance quoting error code 94-613	Cleaning unit failure	A fault has occurred in the cleaning unit. Install a new cleaning unit PL 94.10 Item 21 .
94-614-00	-	It is raised when the IME recognizes that the DMU has changed	No service action required
94-619-00	Cleaning Unit fault. Call for assistance quoting error code 94-619	Cleaning unit failure	A fault has occurred in the cleaning unit. Install a new cleaning unit PL 94.10 Item 21 .
94-622-00	Cleaning Unit fault. Call for assistance quoting error code 94-622	Cleaning unit failure	A fault has occurred in the cleaning unit. Install a new cleaning unit PL 94.10 Item 21 .
94-628-00	The installed cleaning unit is not compatible with this machine	IME has detected an incompatible cleaning unit fitted to the machine	Install a new cleaning unit PL 94.10 Item 21 . Copying and printing are not available.
94-630-00	Cleaning unit communication error. Remove and re-insert the cleaning unit	IME is unable to communicate with the cleaning unit	Remove and install the cleaning unit. Copying and printing are not available.

OF 4b Status Messages in Alphabetical Order

Status Message Tables

The status message tables contain all the messages to which a status code can be attributed.

- [Table 1](#) Status Messages - to F
- [Table 2](#) Status Messages G to N.
- [Table 3](#) Status Messages O to R.
- [Table 4](#) Status Messages S to Y.

Table 1 Status messages - to F

UI Message	Status Code	Reason for Message	Reference / Action
-	01-550-00	NC status code - system is in power save mode	Printing will start when a job is received or a user initiates a job at the machine
-	01-551-00	ESS status code - System is in sleep mode	Printing will start when a job is received or a user initiates a job at the machine
-	02-517-00	PagePack grace period active	No service action required
-	02-518-00	PagePack grace period expired	No service action required
-	02-521-00	XEIP Browser is dead or not responding	Perform the 02-321-00 XEIP Browser Dead RAP.
-	03-521-00	The CCM to UI communication is lost	Switch the machine off then on, GP 14 .
-	03-535-00	The machine has entered non-intrusive diagnostic mode	-
-	03-536-00	The machine has entered intrusive diagnostic mode	-
-	05-501-00	DADH is raised	Close the DADH. If the problem persists, perform the 05-300-00 DADH Open RAP.
-	05-525-00	Document feeder tray empty	Perform the 05B DADH Document Sensor Failure RAP.
-	05-535-00	The document feeder tray is loaded	No service action required
-	10-536-00	The transfix calibration NVRAM parameters are reset.	Refer to OF 12 Service Code RAP
-	12-410-00	PTU selected whilst marking job is running	Pressing the Pause to Unload button will cancel this request.
-	12-755-00	The finisher has detected a 50 sheet staple. A 100 sheet staple cartridge should be used	Install 100 sheet staple cartridge

Table 1 Status messages - to F

UI Message	Status Code	Reason for Message	Reference / Action
-	16-556-00	There is an authentication problem between the 802.1x device and the 802.1x server	User intervention is required to check the settings on the 802.1x device to ensure they match the 802.1x server, then switch the machine off then on, GP 14 .
-	17-570-00	Communication with NNTP server has failed	User intervention is required to verify network time protocol server settings, operability and machine time. Machine services are unaffected
-	22-502-00	An active message has been produced	Go to the Status screen and select the Faults tab. Press the Active Messages button and perform the action appropriate to the message
-	22-558-00	An HFSI item has reached or exceeded its threshold	Reset 'Actual' count to zero or reset the threshold
-	22-568-00	A status requiring POPO has been detected & auto-reset count less than 2	The system will try to power off then on twice before asking for assistance
-	71-300-00	Tray 1 is open	Close tray. Printing can continue from other trays
-	72-300-00	Tray 2 is open	Close tray. Printing can continue from other trays
-	74-120-00	Tray 4 guides have moved in run	Adjust the paper tray guides and confirm the paper tray settings. Print and copy services can continue from other trays if the correct media is available. If the problem persists, perform the 74-120-00 Bypass Tray Guides Move in Run RAP
-	74-530-00	Tray 4 is out of media	Add media. Print and copy services can continue from other trays if the correct media is available
-	75-300-00	Tray 5 is open	Close Tray. Print and copy services can continue from other trays if the correct media is available. Refer to 75A RAP.
-	89-525-00	IME clam shell is open	-

Table 1 Status messages - to F

UI Message	Status Code	Reason for Message	Reference / Action
-	89-561-00	NVM entries for RALPH media registration calibration got corrupted or reset	Refer to OF 12 Service Code RAP
-	91-632-00	Print head 1 has changed since last boot	-
-	91-633-00	Print head 2 has changed since last boot	-
-	91-634-00	Print head 3 has changed since last boot	-
-	91-635-00	Print head 4 has changed since last boot	-
-	91-636-00	The IOD automatic image maintenance tool has tried repeatedly to run and has failed enough to exceed the disabled limitation, or has been manually disabled via diagnostics	If the problem persists, perform the 91-636-00 RAP
-	91-637-00	IOD Y run out NVRAM parameters are reset	If the problem persists, perform the 91-637-00 RAP
-	91-638-00	IOD chronic jets are detected	Perform the 91-638-00 RAP
-	91-639-00	Sent once per cold purge. Sent when the overall purge, which might request multiple heads to be purged, is requested. A cold purge is performed at power up. That is, the ink in the system is cold, it is warmed up, then a purge is performed	No service action required
-	91-640-00	Sent once per warm purge. Sent when the overall purge, which might request multiple heads to be purge, is requested. A warm purge is performed during the lifetime of a power on session. The ink is already up to temp, then the print heads are purged	No service action required

Table 1 Status messages - to F

UI Message	Status Code	Reason for Message	Reference / Action
-	91-641-00	A freeze off means that one or more, print heads are allowed to cool down so that the ink is in a solid state. This would then be followed by a cold purge. The freeze off would be communicated by the freeze off DC status updates, and the cold purges that would follow would be communicated by the cold purge DC status updates	No service action required
-	91-642-00	Sent when a cold purge for head 1 has completed	No service action required
-	91-643-00	Sent when a cold purge for head 2 has completed	No service action required
-	91-644-00	Sent when a cold purge for head 3 has completed	No service action required
-	91-645-00	Sent when a cold purge for head 4 has completed	No service action required
-	91-646-00	Sent when a warm purge for head 1 has completed	No service action required
-	91-647-00	Sent when a warm purge for head 2 has completed	No service action required
-	91-648-00	Sent when a warm purge for head 3 has completed	No service action required
-	91-649-00	Sent when a warm purge for head 4 has completed	No service action required
-	91-650-00	Head 1 freeze off has completed	No service action required
-	91-651-00	Head 2 freeze off has completed	No service action required
-	91-652-00	Head 3 freeze off has completed	No service action required
-	91-653-00	Head 4 freeze off has completed	No service action required
-	91-840-00	IME in jet substitution and single sided print mode. Increments the AIF counter by 1	No service action required.

Table 1 Status messages - to F

UI Message	Status Code	Reason for Message	Reference / Action
-	91-841-00	IME in jet substitution and single sided print mode. Increments the AIF counter by 2	No service action required.
-	92-802-00	PEST soft faults are raised	Review dC123 PEST fault history log
-	92-820-00	PEST warnings exist	-
-	93-877-00	Magenta sold ink stick expected, DMO was detected	Incompatible black ink detected. Refer to GP 34. Notify the system administrator. All machine services are available
-	93-878-00	This status is raised when the detected ink stick is different from the expected one (as per the billing type)	Incompatible magenta ink detected. Refer to GP 34. Notify the system administrator. All machine services are available
-	93-879-00	This status is raised when the detected ink stick is different from the expected one (as per the billing type)	Incompatible cyan ink detected. Refer to GP 34. Notify the system administrator. All machine services are available
-	93-880-00	This status is raised when the detected ink stick is different from the expected one (as per the billing type)	Incompatible yellow ink detected. Refer to GP 34. Notify the system administrator. All machine services are available
-	93-881-00	This status is raised when the detected ink stick is different from the expected one (as per the billing type)	Incompatible black ink detected. Refer to GP 34. Notify the system administrator. All machine services are available.
-	93-905-00	It is raised when the IME recognizes that the cyan ink stick is consumed. This means it went past the ink low flag (it's past the point it can be removed from the system and will be consumed). This is critical for supplies replenishment and is used to estimate the rate at which ink sticks are being used	No service action required. All services are available

Table 1 Status messages - to F

UI Message	Status Code	Reason for Message	Reference / Action
-	93-906-00	It is raised when the IME recognizes that the magenta ink stick is consumed. This means it went past the ink low flag (it's past the point it can be removed from the system and will be consumed). This is critical for supplies replenishment and is used to estimate the rate at which ink sticks are being used	No service action required. All services are available
-	93-907-00	It is raised when the IME recognizes that the yellow ink stick is consumed. This means it went past the ink low flag (it's past the point it can be removed from the system and will be consumed). This is critical for supplies replenishment and is used to estimate the rate at which ink sticks are being used	No service action required. All services are available
-	93-908-00	It is raised when the IME recognizes that the black ink stick is consumed. This means it went past the ink low flag (it's past the point it can be removed from the system and will be consumed). This is critical for supplies replenishment and is used to estimate the rate at which ink sticks are being used	No service action required. All services are available
-	93-941-00	Magenta sold ink stick expected, DMO was detected	Incompatible magenta ink detected. Refer to GP 34. Notify the system administrator. All machine services are available

Table 1 Status messages - to F

UI Message	Status Code	Reason for Message	Reference / Action
-	93-942-00	Cyan sold ink stick expected, DMO was detected	Incompatible cyan ink detected. Refer to GP 34 . Notify the system administrator. All machine services are available
-	93-943-00	Yellow sold ink stick expected, DMO was detected	Incompatible yellow ink detected. Refer to GP 34 . Notify the system administrator. All machine services are available
-	93-944-00	Magenta DMO ink stick expected, sold was detected	Incompatible magenta ink detected. Refer to GP 34 . Notify the system administrator. All machine services are available
-	93-945-00	Cyan DMO ink stick expected, sold was detected	Incompatible cyan ink detected. Refer to GP 34 . Notify the system administrator. All machine services are available
-	93-946-00	Yellow DMO ink stick expected, sold was detected	Incompatible yellow ink detected. Refer to GP 34 . Notify the system administrator. All machine services are available
-	93-947-00	Magenta DMO ink stick expected, metered was detected	Incompatible magenta ink detected. Refer to GP 34 . Notify the system administrator. All machine services are available
-	93-948-00	This status is raised when the detected ink stick is different from the expected one (as per the billing type)	Incompatible Cyan Ink detected. Refer to GP 34 . Notify the System Administrator. All machine services are available
-	93-949-00	Yellow DMO ink stick expected, metered was detected	Incompatible yellow ink detected. Refer to GP 34 . Notify the system administrator. All machine services are available
-	93-950-00	This status is raised when the detected ink stick is not a supported type	Incompatible black ink detected. Refer to GP 34 . Notify the system administrator. All machine services are available

Table 1 Status messages - to F

UI Message	Status Code	Reason for Message	Reference / Action
-	93-951-00	This status is raised when the detected ink stick is not a supported type	Incompatible magenta ink detected. Refer to GP 34 . Notify the system administrator. All machine services are available
-	93-952-00	This status is raised when the detected ink stick is not a supported type	Incompatible cyan ink detected. Refer to GP 34 . Notify the system administrator. All machine services are available
-	93-953-00	This status is raised when the detected ink stick is not a supported type	Incompatible yellow ink detected. Refer to GP 34 . Notify the system administrator. All machine services are available
-	93-954-00	Magenta metered ink stick expected, DMO was detected	Incompatible magenta ink detected. Refer to GP 34 . Notify the system administrator. All machine services are available
-	93-955-00	Cyan metered ink stick expected, DMO was detected	Incompatible cyan ink detected. Refer to GP 34 . Notify the system administrator. All machine services are available
-	93-956-00	Yellow metered ink stick expected, DMO was detected	Incompatible yellow ink detected. Refer to GP 34 . Notify the system administrator. All machine services are available
-	94-504-00	Cleaning unit predicted reorder message has been triggered, acknowledged and temporarily suppressed	No service action required. Machine services are unaffected
-	94-547-00	Y - axis belt ratio error. Imaging drum belt is worn	Install new drum belt, PL 94.20 Item 2 . Refer to OF 12 Service Code RAP
-	94-614-00	It is raised when the IME recognizes that the DMU has changed	No service action required

Table 1 Status messages - to F

UI Message	Status Code	Reason for Message	Reference / Action
A Fax service error has occurred. Power off then on	03-550-00	Fax card is unavailable	Switch the machine off then on, GP 14 . If the problem persists, perform the 20-331-00 , 20-338-00 , 20-339-00 , 20-341-00 , 20-345-00 Fax Network Line 1 Fault RAP
A Fax service error has occurred. Power off then on	03-551-00	Fax service is unavailable	Switch the machine off then on, GP 14 . If the problem persists, perform the 20-331-00 , 20-338-00 , 20-339-00 , 20-341-00 , 20-345-00 Fax Network Line 1 Fault RAP
A Fax service error has occurred. Power off then on	03-547-00	Basic Fax card is not detected or confirmed	Switch the machine off then on, GP 14 . If the problem persists, perform the 20-331-00 , 20-338-00 , 20-339-00 , 20-341-00 , 20-345-00 Fax Network Line 1 Fault RAP
Accounting out of memory. Notify your system administrator	16-551-00	Network controller - accounting log is full or a hard disk full state exists	Accounting administrator needs to retrieve accounting data log from the system
Additional memory is required to support scan to file. Notify your system administrator	16-553-00	Network controller - not enough physical memory is configured on the platform to support scan to file	Switch the machine off then on, GP 14 . Hardware must be added or replaced
All incomplete jobs have been deleted	19-514-00	A video job integrity fault has been detected	Video job integrity error; one or more jobs were deleted. No user intervention is required; the system has recovered. Printing and other machine services can continue. If the problem persists, perform the 19-409-00 Job Integrity Failure RAP
All incomplete jobs have been deleted	22-503-04	System error. Jobs have been lost and must be re-submitted	No user intervention is required. Machine is temporarily unavailable
All main stacker trays unavailable. Power off then on and notify system administrator	12-945-00	All stacker trays have degraded capability, except the booklet maker tray	Check for obstructions in the buffer, stacker and top tray areas. Switch the machine off then on, GP 14 . Check the current fault codes list for faults in the buffer, stacker and top tray areas and perform the appropriate RAP.

Table 1 Status messages - to F

UI Message	Status Code	Reason for Message	Reference / Action
All output trays are unavailable. Check for obstructions in the finisher	12-909-00	This status is raised based upon the report capabilities from the finisher	Clear any obstructions or paper jam. Switch the machine off then on, GP 14 . If the problem persists, perform the 12-462-00-110 RAP for LCSS
Auto configuration is disabled	22-506-17	The machine is in a non customer mode.	Enter customer mode Enter dC131 Read/Write and check that NVM ID 425-001 = 0, 425-003 = 0 and 616-14 = 4
Auto paper select is not available	22-512-04	All trays are direct select only	System administrator intervention is required to enable at least one tray for auto select. Printing and copying can continue without auto select, other machine services are unaffected
Autonet functions are not available. Notify your System Administrator	16-508-00	Autonet is not available.	Switch the machine off then on, GP 14 . If the problem persists, perform the 16-780-00 to 16-789-47 Other Network Faults 3 RAP. Printing can continue if other network protocols are used
Black Ink is empty. Load Xerox ColorQube Black Ink	93-500-00	IME black ink is empty	Load more black solid ink. Copying and printing are not available. Check the ink low sensor and harness. Refer to WD 9.18
Black ink stick is jammed. Call for assistance	93-501-00	The ink stick loaded sensor is actuated. The ink stick transport motor has operated. The ink stick is not detected by the ink out sensor.	Clear the ink loader jam. Copying and printing are not available
Black ink stick jam. Add black ink to aid jam recovery	93-925-00	Black ink stick jam	Black ink stick jam detected. Load a black ink stick to aid jam recovery. Copying and printing are not available
Booklet maker staple cartridge is empty	12-643-00	Booklet maker staples are empty	The booklet maker staple cartridge is empty. Follow the instructions at the printer to load a new staple cartridge, PL 12.185 Item 8 . Printing can continue, but stapled booklet making is unavailable

Table 1 Status messages - to F

UI Message	Status Code	Reason for Message	Reference / Action
Booklet maker staple cartridge is empty	12-643-01	Booklet maker staples are empty	Install a new booklet maker staple cartridge
Booklet Maker Staple Cartridge is empty	12-644-00	Booklet maker staples are empty and the HVF finisher front door is open	The booklet maker staple cartridge is empty. User intervention is required to install a new booklet maker staple cartridge, PL 12.185 Item 8 . Printing and copying can continue without stapled booklet making.
Booklet Maker staples low. Re-order Booklet Staple Cartridge	12-642-00	Booklet maker staples are low	The booklet maker staple cartridge supplies are low. Re-order staple cartridge, PL 12.185 Item 8 .
Booklet Making and Tri-folding are unavailable. Check for obstructions	12-943-00	Booklet making or tri-folding capability is degraded	Check for obstructions in the HVF BM and the tri-folder. Check that the HVF BM and tri-folder interlocks are made. Switch the machine off then on, GP 14 . Check the current fault codes list for HVF BM or tri-folder faults and perform the appropriate RAP.
Booklet making is unavailable. Check for obstructions in the BM	12-913-00	The back stop motor fails to move or is not at the home position	Clear the paper jam. Switch the machine off then on, GP 14 . If the problem persists, perform the 12-065-00-171 , 12-383-00-171 HVF BM Backstop Motor Fault RAP
Booklet stapler not available. Power off then on and notify system administrator	12-720-00	Failure of any BM or TF function. The booklet maker and tri-folder are currently unavailable	Check for obstructions in the HVF BM and the tri-folder. Check that the HVF BM and tri-folder interlocks are made. Switch the machine off then on, GP 14 . Check the current fault codes list for HVF BM or tri-folder faults and perform the appropriate RAP.
Booklet Stapler not available. Power off then on and notify system administrator	12-726-00	Failure of the booklet maker stapling functions.	Perform 12-063-00-171 , 12-411-00-171 RAP for staple unit 1, and 12-403-00-171 , 12-413-00-171 , 12-414-00-171 RAP for staple unit 2

Table 1 Status messages - to F

UI Message	Status Code	Reason for Message	Reference / Action
Booklet Stapler not available. Power off then on and notify system administrator	12-743-00	Booklet making & tri-folding are unavailable.	Booklet Making and Tri-folding is unavailable. Switch the machine off then on, GP 14 . Check the current fault code list for HVF BM or tri-fold faults and go to appropriate RAP. Printing can continue to all available output trays
Check the settings for tray 1	01-540-01	Paper removed or added to tray 1	Confirm tray 1 settings.
Check the settings for tray 2	01-540-02	Paper removed or added to tray 2	Confirm tray 2 settings.
Check the settings for tray 3	01-540-03	Paper removed or added to tray 3	Confirm tray 3 settings.
Check the settings for tray 4	01-540-04	Paper removed or added to tray 4	Confirm tray 4 settings.
Check the settings for tray 5	01-540-05	Paper removed or added to tray 5	Confirm tray 5 settings.
Check the settings for tray 6	01-540-06	Paper removed or added to tray 6	Confirm tray 6 settings.
Cleaning unit communication error. Remove and re-insert the cleaning unit	94-630-00	IME is unable to communicate with the cleaning unit	Remove and install the cleaning unit. Copying and printing are not available.
Cleaning unit fault. Call for assistance quoting error code 94-505	94-505-00	Cleaning unit failure. Replacing the cleaning unit may correct the fault	Install a new cleaning unit, PL 94.10 Item 21 . Copying and printing are not available. Other machine services are unaffected
Cleaning unit fault. Call for assistance quoting error code 94-528	94-528-00	Cleaning unit failure. Replacing the cleaning unit may correct the fault	Install a new cleaning unit, PL 94.10 Item 21 . Copying and printing are not available. Other machine services are unaffected
Cleaning unit fault. Call for assistance quoting error code 94-532	94-532-00	Cleaning unit failure. Replacing the cleaning unit may correct the fault	Install a new cleaning unit, PL 94.10 Item 21 . Copying and printing are not available. Other machine services are unaffected
Cleaning unit fault. Call for assistance quoting error code 94-533	94-533-00	Cleaning unit failure. Replacing the cleaning unit may correct the fault	Install a new cleaning unit, PL 94.10 Item 21 . Copying and printing are not available. Other machine services are unaffected

Table 1 Status messages - to F

UI Message	Status Code	Reason for Message	Reference / Action
Cleaning unit fault. Call for assistance quoting error code 94-568	94-568-00	Cleaning unit failure. Replacing the cleaning unit may correct the fault	Install a new cleaning unit, PL 94.10 Item 21 . Copying and printing are not available. Other machine services are unaffected
Cleaning unit fault. Call for assistance quoting error code 94-570	94-570-00	Cleaning unit failure. Replacing the cleaning unit may correct the fault	Install a new cleaning unit, PL 94.10 Item 21 . Copying and printing are not available. Other machine services are unaffected
Cleaning unit fault. Call for assistance quoting error code 94-572	94-572-00	Cleaning unit failure. Replacing the cleaning unit may correct the fault	Install a new cleaning unit, PL 94.10 Item 21 . Copying and printing are not available. Other machine services are unaffected
Cleaning unit fault. Call for assistance quoting error code 94-573	94-573-00	Cleaning unit failure. Replacing the cleaning unit may correct the fault	Install a new cleaning unit, PL 94.10 Item 21 . Copying and printing are not available. Other machine services are unaffected
Cleaning Unit fault. Call for assistance quoting error code 94-610.	94-610-00	Cleaning unit failure	A fault has occurred in the cleaning unit. Install a new cleaning unit PL 94.10 Item 21
Cleaning Unit fault. Call for assistance quoting error code 94-611	94-611-00	Cleaning unit failure	A fault has occurred in the cleaning unit. Install a new cleaning unit PL 94.10 Item 21
Cleaning Unit fault. Call for assistance quoting error code 94-612	94-612-00	Cleaning unit failure	A fault has occurred in the cleaning unit, install new cleaning unit PL 94.10 Item 21
Cleaning Unit fault. Call for assistance quoting error code 94-613	94-613-00	Cleaning unit failure	A fault has occurred in the cleaning unit, install new cleaning unit PL 94.10 Item 21
Cleaning Unit fault. Call for assistance quoting error code 94-619	94-619-00	Cleaning unit failure	A fault has occurred in the cleaning unit, install new cleaning unit PL 94.10 Item 21
Cleaning Unit fault. Call for assistance quoting error code 94-622	94-622-00	Cleaning unit failure	A fault has occurred in the cleaning unit, install new cleaning unit PL 94.10 Item 21

Table 1 Status messages - to F

UI Message	Status Code	Reason for Message	Reference / Action
Cleaning unit is not detected. Please insert cleaning unit	94-502-00	Cleaning unit not present or not detected.	Install cleaning unit PL 94.10 Item 21 . Refer to the 94-568-00, 94-570-00, 94-572-00, 94-573-00 Cleaning Unit Data Error RAP. Copying and printing are not available
Cleaning unit needs to be replaced. Replace cleaning unit now	94-501-00	Cleaning unit is empty of oil and needs replacing.	Install a new cleaning unit, PL 94.10 Item 21 . Copying and printing are not available
Cleaning unit needs to be replaced. Replace the cleaning unit now	22-570-00	DC1001 command to IME reports successful entry into snooze mode	Cleaning Unit life extended. No user intervention is required. Print and Copy services are available, but Image quality may be affected
Cleaning unit will need replacing soon. Reorder now, DO NOT replace until requested	94-500-00	Drum maintenance unit - predicted re-order message	Re-order cleaning unit, PL 94.10 Item 21 , but do not install unit until requested. Copying and printing can continue
Cleaning Unit will need replacing soon. Re-order now. DO NOT replace until requested	94-503-00	This status is raised when the machine is in the last 3000 impressions.	Re-order cleaning unit, PL 94.10 Item 21 , but do not install unit until requested. Copying and printing can continue
Close Finisher Inserter Left Side Door	12-609-00	Inserter left cover open (HVF without tri-folder)	Close inserter left cover
Close Finisher Top Cover	12-602-00	LCSS finisher top cover open	Close the finisher top cover.
Close Finisher Top Cover.	12-606-00	Inserter top cover open	Close the inserter top cover
Close the Finisher Folder Front Door	12-608-00	The tri-folder unit front door is open (HVF with tri-folder)	Close the tri-folder front door
Close the Finisher Folder Top Cover	12-607-00	Tri-folder top cover open (HVF with tri-folder)	Close the tri-folder top cover
Close the Finisher Top Tray.	12-601-00	Finisher top cover open (cover over output tray)	Close the top cover
Close the ink loader main cover	93-889-00	In a recovery sequence or cold power start, when ink stick door is open.	Close the ink loader main cover. Copying and printing are not available. Other machine services are unaffected

Table 1 Status messages - to F

UI Message	Status Code	Reason for Message	Reference / Action
Communication error. Power off then on and notify system administrator	03-597-00	The document feeder is not available. Use the document glass	Perform the 05-250-00 , 05-251-00 RAP
Communication error. Power off then on and notify system administrator	05-538-00	DADH not available.	A document feeder fault has occurred, copy jobs can only be made from the document glass. Printing can continue.
Communication error. Power off then on and notify system administrator	05-542-00	DADH document transport needs service	Perform the 05A RAP
Configuration mismatch	19-550-00	The single board controller cannot access the EPC memory or the image disk.	Switch the machine off then on, GP 14 . Install a new EPC memory module, PL 3.11 Item 21 . Install a new hard disk drive, PL 3.11 Item 2 . Install a new single board control PWB, PL 3.11 Item 13
Configuration parameter error	22-557-00	Serial number sync failure, power on failed	Switch the machine off then on, GP 14 . Go to dC132 , check the serial number is correct. Enter dC131 NVM ID 616-003, check machine configuration. If the problem persists, perform the 22-350-01 , 22-350-02 RAP, 22-351-01 to 22-351-03 RAP, 22-352-00 RAP
Cyan Ink is empty. Load Xerox ColorQube Cyan Ink	93-510-00	IME cyan ink is empty	Load more cyan solid ink. Copying and printing are not available. Check the ink low sensor and harness. Refer to WD 9.18
Cyan ink stick is jammed. Call for assistance	93-511-00	Ink stick loaded sensor actuated. Ink stick transport motor operated. Ink stick not detected by ink out sensor.	Clear the ink loader jam. Copying and printing are not available
Cyan ink stick jam. Add cyan ink to aid jam recovery.	93-927-00	Cyan ink stick jam	Cyan ink stick jam detected. Load a cyan ink stick to aid jam recovery. Copying and printing not available

Table 1 Status messages - to F

UI Message	Status Code	Reason for Message	Reference / Action
DHCPv6 services are not available. Notify your system administrator.	17-512-00	DHCPv6 Failure status	Switch the machine off then on, GP 14 . Printing can continue with other submission methods
Do not switch the power on again while powering down is in progress	01-500-00	IME power switch is moved to the off position	Print jobs sent to the device will not print and may be lost
Document feeder - feed roller has been replaced.	05-539-00	DADH feed head CRU replaced. Message automatically cleared half a second after setting	None
Duplicate IPv4 address detected. Reconfigure with a unique address	17-513-00	Duplicate IPv4 address detected	Reconfigure with a unique address. Switch the machine off then on, GP 14 .
Duplicate IPv6 address detected. Reconfigure with a unique address	17-510-00	Duplicate IPv6 address detected	Reconfigure with a unique address. Switch the machine off then on, GP 14 . Copy and Fax services (if installed) can continue
E-mail service cannot register. Power off then on and notify system administrator	17-554-00	Scan to E-mail service cannot register.	Switch the machine off then on, GP 14 . Scan to E-mail is disabled, print and other machine services are unaffected. If the problem persists, perform the 16-950-19 to 16-959-19 E-mail Application Registration Error RAP
Empty chad bin	12-549-00	Hole punch chad bin is full and needs emptying	Empty chad bin
Enter your access code or the current job may be deleted.	03-559-02	Walk up code entered FDI. Not defined	The job cannot be completed due to insufficient funds. Enter the access code on the external accounting device to continue the job
Extensible services are not responding. Power machine off then on	17-565-00	EIP service not responding	Switch the machine off then on, GP 14 . Machine services are unaffected
Fax job could not be sent at this time, please try again	20-545-00	Fax job could not be sent	Fax job could not be sent, retry. Printing and other machine services are available

Table 1 Status messages - to F

UI Message	Status Code	Reason for Message	Reference / Action
Fax job limit has been reached. Power off then on and notify system administrator	20-565-00	All jobs IDs allocated cannot create any more	Switch the machine off then on, GP 14 . Fax and LAN Fax are disabled
Fax line 1 is unavailable. Call for assistance.	20-595-00	Fax service Error. Fax line 1 is unavailable	Fax line 1 is unavailable. Switch the machine off then on, GP 14 . Fax and LAN Fax are disabled. Printing and other machine services are unaffected. If the problem persists, perform the 20-331-00 , 20-338-00 , 20-339-00 , 20-341-00 , 20-345-00 Fax Network Line 1 Fault RAP
Fax line 1 is unavailable. Check line connection or notify your system administrator	20-562-00	No communication on Fax line 1	User intervention is required to check the external phone line connection. Fax and LAN Fax are disabled. Printing and other machine services are unaffected. If the problem persists, perform the 20-331-00 , 20-338-00 , 20-339-00 , 20-341-00 , 20-345-00 Fax Network Line 1 Fault RAP
Fax line 2 is unavailable. Check line connection or notify your system administrator	20-563-00	No communication on Fax line 2	User intervention is required to check the external phone line connection. Fax and LAN Fax are disabled. Printing and other machine services are unaffected. If the problem persists, perform the 20-332-00 , 20-340-00 Fax Network Line 2 Fault RAP
Fax line 2 is unavailable. Fax line 1 is still available.	20-572-00	Fax service error. Fax line 2 is unavailable	Switch the machine off then on, GP 14 . Fax and LAN Fax are degraded. Printing and other machine services are unaffected. If the problem persists, perform the 20-332-00 , 20-340-00 Fax Network Line 2 Fault RAP
Fax line 2 is unavailable. Notify your system administrator	03-548-00	Extended Fax not detected/confirmed	Check Fax line connection

Table 1 Status messages - to F

UI Message	Status Code	Reason for Message	Reference / Action
Fax line 2 is unavailable. Notify your system administrator	20-550-00	Extended Fax card failure detected	Switch the machine off then on, GP 14 . Fax service can continue from line 1. Printing and other machine services are available
Fax memory error. Power off then on and notify system administrator	03-549-00	Fax POST failure status.	Switch the machine off then on, GP 14 .
Fax memory error. Power off then on and notify system administrator	20-556-00	Fax service error. Reset Fax service	Fax and LAN Fax are disabled. Switch the machine off then on, GP 14 . Printing and other machine services are unaffected. If the problem persists, perform the 20-331-00 , 20-338-00 , 20-339-00 , 20-341-00 , 20-345-00 Fax Network Line 1 Fault RAP
Fax memory error. Power off then on and notify system administrator	20-558-00	Fax memory error	Fax and LAN Fax are disabled. Switch the machine off then on, GP 14 . Printing and other machine services are unaffected. If the problem persists, perform the 20-322-00 Non-Volatile Device not Installed RAP
Fax memory error. Power off then on and notify system administrator	20-559-00	Fax memory error	Fax and LAN Fax are disabled. Switch the machine off then on, GP 14 . Printing and other machine services are unaffected. If the problem persists, perform the 20-320-00 Fax Fault Not Cleared by Reset RAP
Fax memory error. Power off then on and notify system administrator	20-570-00	Fax service error	Switch the machine off then on, GP 14 . Fax and LAN Fax are disabled. Printing and other machine services are unaffected

Table 1 Status messages - to F

UI Message	Status Code	Reason for Message	Reference / Action
Fax memory is low. Contact your system administrator	20-546-00	Not enough memory to use Fax service	Switch the machine off then on, GP 14. Fax and LAN Fax are disabled. Printing and other machine services are unaffected. If the problem persists, perform the 20-323-00, 20-324-00 Fax System Memory Low RAP
Fax memory is low. Contact your system administrator	20-547-00	Fax memory is low	User intervention is required to delete unnecessary mailbox files or Fax jobs stored for polling. FAX and LAN Fax services are disabled. Printing and other machine services are unaffected. If the problem persists, perform the 20-323-00, 20-324-00 Fax System Memory Low RAP
Fax memory. Power off then on and notify system administrator	20-571-00	Fax service error	Fax line 1 is unavailable. Switch the machine off then on, GP 14. Fax and LAN Fax are disabled. Printing and other machine services are unaffected. If the problem persists, perform the 20-331-00, 20-338-00, 20-339-00, 20-341-00, 20-345-00 Fax Network Line 1 Fault RAP
Fax service is unavailable. Turn machine off then on	20-580-00	NVM values supplied by the Fax are invalid. Fax NVM data error	No service action required. Fax and LAN Fax are disabled. Printing and other machine services are unaffected
Finisher Communication Error. Check Cabling. Power Off then On	12-762-00	Communication failure between IME and finisher	Switch the machine off then on, GP 14. Check the finisher communication harness. If the problem persists, perform 12-762-00-110, 12-764-00-110, 12-765-00-110 RAP for LCSS. 12-762-00-171, 12-764-00-171, 12-765-00-171 RAP for HVF.

Table 1 Status messages - to F

UI Message	Status Code	Reason for Message	Reference / Action
Finisher Communication Error. Check Cabling. Power Off then On	12-764-00	The IME cannot detect a finisher plugged in (including catch tray)	Switch the machine off then on, GP 14. Check the finisher communication harness. If the problem persists, perform 12-762-00-110, 12-764-00-110, 12-765-00-110 RAP for LCSS. 12-762-00-171, 12-764-00-171, 12-765-00-171 RAP for HVF
Finisher Front Door Open	12-564-02	Finisher front door open (HVF with tri-folder)	Close the finisher front door
Finisher is not docked. Re-dock finisher now	12-600-00	The finisher unit (LCSS) is not correctly docked. Printing has stopped	Dock the output module. If the problem persists, perform the 12-310-00-110, 12-312-00-110, 12-313-00-110 RAP
Finisher is not docked. Re-dock finisher now	12-600-01	The finisher unit (HVF without tri-folder) is not correctly docked. Printing has stopped	Dock the output module. If the problem persists, perform the 12-310-00-171, 12-312-00-171, 12-313-00-171 RAP
Finisher is not docked. Re-dock finisher now	12-600-02	The finisher unit (HVF with tri-folder) is not correctly docked. Printing has stopped.	Dock the output module. If the problem persists, perform the 12-310-00-171, 12-312-00-171, 12-313-00-171 RAP
Finisher main tray is full	12-730-00	The stacker tray is full (LCSS and HVF)	The middle output bin is full. This output bin needs to be unloaded. Printing to this output bin is disabled. If the problem persists, perform the 12-462-00-110 RAP or 12-460-00-171 to 12-462-00-171 RAP
Finisher main tray is full	12-730-01	The stacker tray is full (HVF)	The middle output bin is full. This output bin needs to be unloaded. Printing to this output bin is disabled. If the problem persists, perform the 12-460-00-171 to 12-462-00-171 RAP
Finisher Main Tray is nearly full	12-734-00	Stacker tray bin nearly full	No action necessary
Finisher main tray is out of service. Power off then on and notify system administrator	12-665-00	Bin 1 out of service status (LCSS)	Perform 12-151-00-110, 12-152-00-110 RAP

Table 1 Status messages - to F

UI Message	Status Code	Reason for Message	Reference / Action
Finisher main tray out of service. Check for obstructions in the main tray	12-902-00	Finisher is in degraded mode, stacker tray is out of service.	Switch the machine off then on, GP 14 . Check for obstructions in the tray
Finisher main tray out of service. Check for obstructions in the main tray	12-906-00	Right center tray out of service, tray home fault	Switch the machine off then on, GP 14 . Check for obstructions in the tray
Finisher top tray and main tray are not available	12-745-00	Top tray and stacker unavailable (only booklet maker tray available)	Check for obstructions in the HVF BM and the tri-folder. Check that the HVF BM and tri-folder interlocks are made. Switch the machine off then on, GP 14 . Check the current fault codes list for HVF BM or tri-folder faults and perform the appropriate RAP
Finisher top tray is full. Empty top tray	12-692-00	Top tray is full	Empty top tray
Finisher top tray is nearly full	12-729-00	The top output bin is nearly full	The top output bin is nearly full. This output bin may need to be unloaded soon. Printing can continue
Front door is open	01-510-00	The front door is open	Copying and printing are not available. Perform the 01-510-00 Front Door Open RAP

Table 2 Status messages G to N

UI Message	Status Code	Reason for Message	Reference / Action
Hole punch not detected (missing). Please insert the hole punch.	12-640-00	Finisher punch unit is missing or incorrectly installed	Make sure that the punch unit is correctly installed. If the problem persists, perform the 12-043-00-110 , 12-046-00-110 RAP
Hole punching is unavailable. Check for obstructions in the hole puncher	12-908-00	Punch head motor fails	Clear the paper jam. Switch the machine off then on, GP 14 . GP 14 . If the problem persists, perform the 12-043-00-110 , 12-046-00-110 RAP for LCSS

Table 2 Status messages G to N

UI Message	Status Code	Reason for Message	Reference / Action
Hole punching not available. Power machine off then on and notify systems administrator	12-579-00	Hole punching is not available	Check that the hole punch unit is correctly installed. Switch the machine off then on, GP 14 . If the problem persists, perform the 12-043-00-110 , 12-046-00-110 RAP for LCSS, 12-044-00-171 to 12-047-00-171 RAP for HVF
Image disk is offline. Job(s) may take longer than normal. Notify system administrator	19-511-00	Image disk unavailable. Performance is degraded. Service is required	The system is unable to read from the image disk. Jobs may take longer than normal. Perform the 19-300-00 to 19-310-00 Image Disk (HDD) Failure RAP
Image disk offline. Power off then on and notify system administrator	19-512-00	The image disk cannot read or write and must be serviced. Power off/ power on will temporarily alleviate the problem	The system is unable to read from the image disk. Printing has stopped. Perform the 19-300-00 to 19-310-00 Image Disk (HDD) Failure RAP
Image overwrite is in progress... the machine is offline	17-590-00	Image overwrite (ODIO) is in progress	No service action required, please wait for the overwrite to finish
Image rotation is not available. Power off then on and notify system administrator	03-564-00	Image rotation is not available	Switch the machine off then on, GP 14
Immediate job overwrite failed. Perform an on demand overwrite immediately	19-506-00	Immediate job overwrite failed	Administrator intervention is required to perform an on demand image overwrite immediately. Printing can continue. Other machine services are unaffected
Immediate job overwrite failed. Perform and on demand overwrite immediately	16-535-00	Immediate job overwrite failed	Immediate job overwrite failed. Administrator intervention is required to perform an on demand overwrite immediately
Incompatible black ink stick detected. Notify your system administrator	93-887-00	Black metered ink stick expected, DMO was detected	Check that the machine is on the correct contract - Print a configuration page, General set up, service plan. Check the ink loaded is as per the customers contract GP 34 . Check the ink load sensors dC330 - 93-026 to 93-041

Table 2 Status messages G to N

UI Message	Status Code	Reason for Message	Reference / Action
Incompatible black ink stick detected. Notify your system administrator	93-888-00	Black DMO ink stick expected, metered was detected	Check that the machine is on the correct contract - Print a configuration page, General set up, service plan. Check the ink loaded is as per the customers contract GP 34 . Check the ink load sensors dC330 - 93-026 to 93-041
Incompatible black ink stick detected. Notify your system administrator.	93-885-00	Black sold ink stick expected, DMO was detected	Check that the machine is on the correct contract - Print a configuration page, General set up, service plan. Check the ink loaded is as per the customers contract GP 34 . Check the ink load sensors dC330 - 93-026 to 93-041
Incompatible black ink stick detected. Notify your system administrator.	93-886-00	Black DMO ink stick expected, sold was detected	Check that the machine is on the correct contract - Print a configuration page, General set up, service plan. Check the ink loaded is as per the customers contract GP 34 . Check the ink load sensors dC330 - 93-026 to 93-041
Incompatible Cyan ink stick detected, please contact the system administrator	93-883-00	Cyan sold ink stick expected, metered was detected	Check that the machine is on the correct contract - Print a configuration page, General set up, service plan. Check the ink loaded is as per the customers contract GP 34 . Check the ink load sensors dC330 - 93-026 to 93-041
Incompatible FAX software detected (upgrade required)	03-546-00	Incompatible Fax software detect at power on	The embedded Fax software version is incompatible with the system. A software upgrade should be performed Refer to 03-417-00 RAP
Incompatible Magenta ink stick detected, please contact the system administrator	93-882-00	Magenta sold ink stick expected, metered was detected	Check that the machine is on the correct contract - Print a configuration page, General set up, service plan. Check the ink loaded is as per the customers contract GP 34 . Check the ink load sensors dC330 - 93-026 to 93-041

Table 2 Status messages G to N

UI Message	Status Code	Reason for Message	Reference / Action
Incompatible or unknown finisher detected. Check Finisher compatibility	12-765-00	The IME interface indicates that the finisher is incompatible / unknown	Switch the machine off then on, GP 14 . Check the finisher communication lead. If the problem persists, perform 12-762-00-110 , 12-764-00-110 , 12-765-00-110 RAP for LCSS. 12-762-00-171 , 12-764-00-171 , 12-765-00-171 RAP for HVF
Incompatible yellow ink stick detected, please contact the system administrator	93-884-00	Yellow sold ink stick expected, metered was detected	Check that the machine is on the correct contract - Print a configuration page, General set up, service plan. Check the ink loaded is as per the customers contract GP 34 . Check the ink load sensors dC330 - 93-026 to 93-041
Incomplete system information. Power off then on and notify system administrator	16-583-00	The network controller ESS counters utility process has stopped	Switch the machine off then on, GP 14 . Printing and scanning can continue
Incomplete system information. Power off then on and notify system administrator	16-585-00	The network controller ESS configuration synchronization process has stopped	Switch the machine off then on, GP 14 . Printing and scanning can continue. If the problem persists, perform the 16-780-00 to 16-789-47 Other Network Faults 3 RAP
Incomplete system information. Power off then on and notify system administrator	16-586-00	The network controller agent process has stopped	Switch the machine off then on, GP 14 . Print and other machine services are unaffected. If the problem persists, perform the 16-780-00 to 16-789-47 Other Network Faults 3 RAP
Incomplete system information. Power off then on and notify system administrator	16-580-00	The network controller ESS configuration utility process has stopped	Switch the machine off then on, GP 14 . Printing and scanning can continue. If the problem persists, perform the 16-780-00 to 16-789-47 Other Network Faults 3 RAP
Incomplete system information. Switch the machine off then on, GP 14 and notify system administrator	16-578-00	The network controller ESS fault log service process has stopped	Switch the machine off then on, GP 14 . Printing and scanning can continue. If the problem persists, perform the 16-770-09 to 16-779-95 Other Network Faults 2 RAP

Table 2 Status messages G to N

UI Message	Status Code	Reason for Message	Reference / Action
Ink levels are low. Load Xerox ColorQube Ink now	93-825-00	The black ink low threshold has been reached	Load more black solid ink sticks. Print and other machine services are unaffected. If the ink stick cannot be loaded, go to OF 11
Ink levels are low. Load Xerox ColorQube Ink now	93-826-00	The magenta ink low threshold has been reached	Load more magenta solid ink sticks. Print and other machine services are unaffected. If the ink stick cannot be loaded, go to OF 11
Ink levels are low. Load Xerox ColorQube Ink now	93-827-00	The cyan ink low threshold has been reached	Load more cyan solid ink sticks. Print and other machine services are unaffected. If the ink stick cannot be loaded, go to OF 11
Ink levels are low. Load Xerox ColorQube Ink now	93-828-00	The yellow ink low threshold has been reached	Load more yellow solid ink sticks. Print and other machine services are unaffected. If the ink stick cannot be loaded, go to OF 11
Ink loader main cover open	93-876-00	The ink loader door is open. Close the door. All machine services are available	Close the ink loader door. Refer to WD 8.2 . Check ink loader door switch (S93-025), PL 93.10 Item 19
Insert sheet sent to a different tray to the rest of the job	12-749-00	An insert sheet has not arrived at its intended output destination	See the message text. If the problem persists, perform the 12-191-00-171 , 12-193-00-171 , 12-194-00-171 , 12-196-00-171 RAP and 12-125-00-171 , 12-126-00-171 RAP
Insufficient memory for Fax job. Notify your system administrator	16-555-00	Network controller - not enough physical memory is configured on the platform to support LAN Fax	Additional memory required to support Fax. The Fax service is not available
Internet Fax service cannot register. Power off then on and notify system administrator	17-553-00	The internet Fax service cannot register	Switch the machine off then on, GP 14 . Internet Fax is disabled, print and other machine services are unaffected. If the problem persists, perform the 16-950-19 to 16-959-19 Other Network Faults 19 RAP
Invalid original size detected. It will be treated as the next largest standard size	22-504-05	Invalid mixed size original pair is detected	Make sure the originals are not creased or folded If the problem persists, perform the 05-257-00 RAP

Table 2 Status messages G to N

UI Message	Status Code	Reason for Message	Reference / Action
Jam in tray 5 docking area	75-110-00	A Jam in tray 5 docking area	Clear the misfeed. Copying and printing are not available. Refer to 75-101-00 RAP
Jam in tray 5 docking area.	75-110-01	A Jam in tray 5 docking area A3 PFP	Clear the misfeed. Copying and printing are not available. Refer to 75-101-00 RAP
Job queue error. Switch the machine off then on, GP 14 and notify system administrator	16-574-00	The ESS queue utility has failed. Only a partial list is available for display at this time	Switch the machine off then on, GP 14 . If the problem persists, perform the 16-770-09 to 16-779-95 Other Network Faults 2 RAP
Job status information not available. Power off then on and notify system administrator	16-579-00	The network controller ESS completed job log service has stopped	Switch the machine off then on, GP 14 . Printing and scanning can continue. If the problem persists, perform the 16-770-09 to 16-779-95 Other Network Faults 2 RAP
Load 8.5 x 11" paper in any tray to enable auto-drum cleaning	94-600-00	Letter / A4 chase media is needed to clean the drum	Load the required media. Refer to GP 20 . Copying and printing are not available
Load 12 x 18" paper in any tray to enable auto-drum cleaning.	94-602-00	12"x18" chase media is needed to clean the drum	Load the required media. Refer to GP 20 . Copying and printing are not available
Load A4 paper into any tray to enable auto-cleaning to proceed	94-604-00	A4 chase media is needed to clean the drum	Load any tray with A4 paper to enable auto-cleaning. Refer to GP 20 .
Load SRA3 (320 x 450 mm) paper in any tray to enable auto-drum cleaning	94-601-00	SRA3 paper is needed to clean the drum	Load the required media. Refer to GP 20 . Copying and printing are not available
Machine Active Registration disabled. Turn power off then on to enable	03-538-00	The machine active registration has been disabled via the DC_715 diagnostic routine	Re-enable the active registration mode in dC715
Machine entering SW upgrade mode. ALL jobs will be cancelled.	16-550-00	Machine entering SW upgrade mode - all jobs will be canceled.	The machine entered a software upgrade mode (all jobs will be deleted). No user intervention is required. Machine services are unavailable until the software upgrade process has completed.

Table 2 Status messages G to N

UI Message	Status Code	Reason for Message	Reference / Action
Machine is in a non customer mode.	22-504-16	Non customer mode. Auto configuration is disabled. Wait for machine to exit Diagnostics mode. The machine is unavailable	Enter customer mode Enter dC131 Read/Write and check that NVM ID 425-001 = 0, 425-003 = 0 and 616-14 = 4
Machine is in a non-customer mode	22-505-17	The machine is in a non-customer mode	Enter customer mode Enter dC131 Read/Write and check that NVM ID 425-001 = 0, 425-003 = 0 and 616-14 = 4
Machine power on failed. Power off then on and notify system administrator	02-590-00	Configurable services are not stable at power on	Switch the machine off then on, GP 14 . If the problem persists, perform the 02-390-00 Configurable Services RAP
Magenta Ink is empty. Load Xerox ColorQube Magenta Ink.	93-505-00	IME magenta ink is empty	Load more magenta solid ink. Copying and printing are not available. Check the ink low sensor and harness. Refer to WD 9.18 .
Magenta ink stick is jammed. Call for assistance	93-506-00	The ink stick loaded sensor is actuated. The ink stick transport motor is operated. The ink stick is not detected by the ink out sensor	Clear the ink loader jam. Copying and printing are not available
Magenta ink stick jam. Add magenta ink to aid jam recovery.	93-926-00	Magenta ink stick jam	Magenta ink stick jam detected. Load a Magenta Ink stick to aid jam recovery. Switch the machine off then on, GP 14 .
Middle left side door is open	01-505-00	The IME middle left door (below bypass tray) is open (without tray 5 installed)	Copying and printing are not available. Perform the 01-505-00 Middle Left Door Open RAP.
Middle left side door is open	01-505-01	The IME middle left door (below bypass tray) is open (with tray 5 installed)	Copying and printing are not available. Perform the 01-505-00 Middle Left Door Open RAP.
Misfeed in tray 4 (bypass).	74-102-00	Misfeed in tray 4	Clear the media jam. Copying and printing are not available. Refer to 74-101-00 RAP
Misfeed in tray 5	75-102-00	Misfeed in tray 5 A4 PFP	Clear the media jam. Copying and printing are not available. If the problem persists, perform the 75-101-00 RAP

Table 2 Status messages G to N

UI Message	Status Code	Reason for Message	Reference / Action
Misfeed in tray 5.	75-102-01	Misfeed in tray 5: A3	Clear the media jam. Copying and printing are not available. If the problem persists, perform the 75-101-00 RAP
Network cable unplugged	16-544-00	An Ethernet cable is unplugged	Ensure cables are properly connected
Network connectivity configuration server not available. Notify your system administrator	16-590-00	The network controller CCS process has failed	Switch the machine off then on, GP 14 . Printing and scanning can continue. If the problem persists, perform the 16-780-00 to 16-789-47 Other Network Faults 3 RAP
Network controller connection is about to be reset	16-576-00	The network controller ESS event notification service process has stopped	Automatic network controller reset. Switch the machine off then on, GP 14 . If the problem persists, perform the 16-161-09 , 16-164-09 Cannot Send Reg Event / List Access Failure RAP
Network controller connection is about to be reset	16-577-00	The network controller ESS platform manager service process has stopped	Automatic network controller reset. Machine is unavailable. If the problem persists, perform the 16-162-09 to 16-163-09 Cannot Send Reg Event / ESS Services Failure RAP
Network controller connection is about to be reset	16-584-00	The network controller document manager agent process has stopped	Automatic network controller reset. Machine is unavailable
Network controller error. Some network services not available. Notify system administrator.	16-536-00	The XSA service is unavailable. Network controller error	Switch the machine off then on, GP 14
Network controller not available. Power off then on and notify system administrator	03-518-00	The network controller is not available.	Switch the machine off then on, GP 14 . If the fault remains, reinstall software, GP 4 . If the problem persists, perform the 03-331-00 , 03-332-00 Main Controller and Network Controller on the SBC PWB Cannot Communicate RAP

Table 2 Status messages G to N

UI Message	Status Code	Reason for Message	Reference / Action
Network printing disabled. Notify your system administrator	16-571-00	The network controller print service has failed	Switch the machine off then on, GP 14 . Printing cannot continue. If the problem persists, perform the 16-770-09 to 16-779-95 Other Network Faults 2 RAP
Network printing disabled. Notify your system administrator	16-572-00	The network controller print service has failed	Switch the machine off then on, GP 14 . Printing cannot continue. If the problem persists, perform the 16-770-09 to 16-779-95 Other Network Faults 2 RAP
Network printing disabled. Notify your system administrator.	16-573-00	The network controller ESS print service has failed	Switch the machine off then on, GP 14 . Printing cannot continue. If the problem persists, perform the 16-770-09 to 16-779-95 Other Network Faults 2 RAP
Network services involving a serial port are not available. Notify system administrator	16-589-00	The network controller serial port connectivity has failed	Switch the machine off then on, GP 14 . Print and other machine services are unaffected. If the problem persists, perform the 16-780-00 to 16-789-47 Other Network Faults 3 RAP
Network services involving Apple Talk are not available. Notify your system administrator	16-565-00	AppleTalk printing error. Printing can continue using other submission methods	Switch the machine off then on, GP 14 . Printing can continue if other submission methods are used
Network services involving parallel port are not available. Notify system administrator	16-569-00	The network controller parallel ports are not available	Switch the machine off then on, GP 14 . If the problem persists, perform the 16-761-47 to 16-769-95 Other Network Faults 1 RAP
Network services involving scan to E-mail are not available. Notify system administrator	16-510-00	The scan to E-mail process has failed	Switch the machine off then on, GP 14 . If the problem persists check network connections
Network services involving scan to E-mail are not available. Notify system administrator	16-514-00	The Post Office protocol (POP3) (for inbound IFAX messages) process has failed	Switch the machine off then on, GP 14

Table 2 Status messages G to N

UI Message	Status Code	Reason for Message	Reference / Action
Network services involving scan to E-mail are not available. Notify system administrator	16-517-00	SMTP process has failed	Switch the machine off then on, GP 14
Network services related to Internet Fax are not available. Notify system administrator	16-511-00	Internet Fax process failed	Switch the machine off then on, GP 14 . If the problem persists check network connections
Network services using BOOTP initialization not available. Notify system administrator	16-559-00	Network controller BOOTP initialization failure	Check the BOOTP server and its network connection. Switch the machine off then on, GP 14 .
Network services using DC platform recovery not available. Notify system administrator	16-557-00	Network controller DC platform recovery failed	Switch the machine off then on, GP 14
Network services using DC platform recovery not available. Notify system administrator	16-558-00	Network controller DC communications failed	Switch the machine off then on, GP 14
Network services using WS Edge Client are not available. Notify your system administrator	16-518-00	Web services edge client interface does not work	Switch the machine off then on, GP 14 . If the problem persists check network connections
Network services using WS Edge Client are not available. Notify your system administrator	16-520-00	Web services server controller interface does not work.	Switch the machine off then on, GP 14 . If the problem persists check network connections
Network services using WS Edge Client are not available. Notify your System Administrator	16-519-00	Web services client controller does not work	Switch the machine off then on, GP 14 . If the problem persists check network connections
Network services using WS Scan Temp are not available. Notify your system administrator	16-528-00	The network controller's WS scan temp service process has stopped.	Some network service are not available. The network controller connection is about to be reset

Table 2 Status messages G to N

UI Message	Status Code	Reason for Message	Reference / Action
Network services with Job Based Accounting not available. Notify your machine administrator	16-501-00	Job based accounting not enough DC memory. Some network controller services are not available	Not enough CCM memory to run the Network Accounting feature. Switch the machine off then on, GP 14 . If the problem persists, perform the 16-930-19 to 16-939-19 Other Network Faults 17 RAP
Network services with Port 9100 process are not available. Notify system administrator.	16-599-00	The Raw TCP/IP printing (port 9100) process has failed.	Switch the machine off then on, GP 14 . Printing can continue with other submission methods. If the problem persists, perform the 16-790-09 to 16-799-47 Other Network Faults 4 RAP
Network services with Scan Compressor are not available. Notify your system administrator	16-529-00	The network controller's scan compressor service process has stopped.	Some network service are not available. The network controller connection is about to be reset
No communications with Xerox SMart eSolutions server. Contact system administrator	17-562-00	Registration with edge server fails	User intervention is required to review SMart eSolutions settings. Machine services are unaffected. If the problem persists, perform the 16-891-00 , 16-892-00 Edge Server Auto Registration Failed RAP
No communications with Xerox SMart eSolutions server. Contact system administrator	17-563-00	Communication with edge server fails	User intervention is required to review SMart eSolutions settings. Machine services are unaffected. If the problem persists, perform the 16-891-00 , 16-892-00 Edge Server Auto Registration Failed RAP
No tray is configured with the required paper size	22-504-04	No paper tray is configured to run the stock size required for this job	Print and copy services are disabled, other machine services are unaffected Job must be deleted. Paper tray must be configured to run the stock size. If the problem persists, perform the 22-310-04 to 22-318-04 Other Network Faults 25 RAP

Table 3 Status messages O to R

UI Message	Status Code	Reason for Message	Reference / Action
On Demand Overwrite Failed. Perform an On Demand Overwrite immediately.	17-507-00	HDD or FAX On Demand Overwrite Failed.	On Demand Overwrite error. Administrator intervention is required to perform an On Demand Image Overwrite immediately. Printing can continue; other machine services are unaffected.
On Demand Overwrite Failed. Perform an On Demand Overwrite immediately.	19-507-00	HDD or FAX On Demand Overwrite Failed.	On Demand Overwrite error. Administrator intervention is required to perform an On Demand Image Overwrite immediately. Printing can continue; other machine services are unaffected.
One or more queued jobs needs resources	22-513-04	One or more queued job in the system is being held due to lack of resources	Add paper to the tray being used to clear queued job. Jobs will be held until resources become available. Other machine services are unaffected
Output tray offsetting is not available. Power off then on and notify system administrator	12-701-00	An OCT offset failure has occurred	Perform the 12-701-00-65 RAP
Output tray on-line	12-742-00	Pause to unload timeout warning	Finisher has gone back on-line
Paper feeder communication fault. Call for assistance.	92-535-00	IME communications problem with paper feeder platform. High capacity paper tray not available	Switch the machine off then on, GP 14 . Check connection to printer. If problem persists, perform the 75-312-00 IME to Tray 5 Communication Failure RAP. Copying and printing are not available
Paper jam in area 1A	82-100-00	IME jam at zone 1A (middle vertical) (tray 5 not installed)	Open middle left door, clear the paper jam. If the problem persists, perform the 82-110-00 to 82-114-00 , 82-152-00 , 82-157-00 to 82-159-00 , 82-164-00 to 82-166-00 RAP and 82-133-00 RAP. Copying and printing are not available

Table 3 Status messages O to R

UI Message	Status Code	Reason for Message	Reference / Action
Paper jam in area 1A	82-100-01	IME jam at zone 1A (middle vertical) (A 4 PFP installed)	Slide tray 5 away from the machine, open the middle left door, clear the paper jam. If the problem persists, perform the 82-110-00 to 82-114-00, 82-152-00, 82-157-00 to 82-159-00, 82-164-00 to 82-166-00 RAP. Copying and printing are not available
Paper jam in Area 1a	82-100-02	Jam at Zone 1A (middle vertical) (A4 PFP installed)	Slide Tray 5 away from the machine, open the middle left door, clear the paper jam. If the problem persists, perform the 82-110-00 to 82-114-00, 82-152-00, 82-157-00 to 82-159-00, 82-164-00 to 82-166-00 RAP
Paper jam in area 2	82-101-00	IME jam at zone 2 (upper vertical)	Open upper left door, clear the paper jam. Refer to 82-125-00 to 82-133-00, 82-153-00, 82-160-00, 82-162-00, 82-163-00 RAP, 82-132-00, 82-155-00. Copying and printing are not available
Paper jam in area 3a	01-108-00	IME jam at zone 3a (registration / pre-heat), open front door.	Clear the paper jam in area 3a. Print and copy services are disabled. Refer to 89-110-00 to 89-113-00, 89-129-00 RAP, 89-125-00 to 89-128-00, 89-130-00, 89-131-00 RAP
Paper jam in area 3a and 4a.	01-110-00	IME jam at zone 3a (registration) and 4a (exit), open front door	Clear the paper jam in area 3a and 4a. Print and copy services are disabled. Refer to 89-110-00 to 89-113-00, 89-129-00 RAP, 89-125-00 to 89-128-00, 89-130-00, 89-131-00 RAP, 89-110-00 to 89-113-00, 89-129-00 RAP
Paper jam in area 3b and 4b.	01-105-00	IME jam at zone 3b (post transfix) and 4b (horizontal), open front door.	Clear the paper jam in area 3b and 4b. Print and copy services are disabled.
Paper jam in area 3b.	01-104-00	IME jam at zone 3b (post transfix), open front door	Clear the paper jam in area 3b. Print and copy services are disabled.

Table 3 Status messages O to R

UI Message	Status Code	Reason for Message	Reference / Action
Paper jam in area 4a.	01-102-00	IME jam at zone 4a (exit), open front door.	Clear the paper jam in area 4a. Print and copy services are disabled. Refer to 10-110-00 to 10-113-00, 10-125-00 to 10-128-00, 10-147-00, 10-148-00 RAP, 10-140-00 to 10-146-00, 10-149-00 to 10-151-00 RAP, 83-110-00, 83-111-00, 83-113-00, 83-114-00, 83-118-00 RAP, 83-112-00, 83-115-00, 83-116-00, 83-117-00, 83-119-00 RAP
Paper jam in area 4b.	01-101-00	IME jam at zone 4b (horizontal), open front door.	Clear the paper jam in area 4b. Print and copy services are disabled. Refer to 82-145-00, 82-146-00, 82-150-00, 82-151-00, 82-156-00 RAP, 82-141-00, 82-147-00, 82-148-00, 82-154-00 RAP, 89-110-00 to 89-113-00, 89-129-00 RAP
Paper jam in areas 3a and 3b.	01-112-00	IME jam at zone 3a (registration) and 3b (post transfix), open front door.	Clear the paper jam in area 3a and 3b. Print and copy services are disabled. Refer to 10-110-00 to 10-113-00, 10-125-00 to 10-128-00, 10-147-00, 10-148-00 RAP, 10-140-00 to 10-146-00, 10-149-00 to 10-151-00 RAP, 83-110-00, 83-111-00, 83-113-00, 83-114-00, 83-118-00 RAP, 83-112-00, 83-115-00, 83-116-00, 83-117-00, 83-119-00 RAP
Paper jam in areas 3a and 4b.	01-109-00	IME jam at zone 3a (registration) and 4b (horizontal), open front door	Clear the paper jam in area 3a and 4b. Print and copy services are disabled. Refer to 10-110-00 to 10-113-00, 10-125-00 to 10-128-00, 10-147-00, 10-148-00 RAP, 10-140-00 to 10-146-00, 10-149-00 to 10-151-00 RAP, 83-110-00, 83-111-00, 83-113-00, 83-114-00, 83-118-00 RAP, 83-112-00, 83-115-00, 83-116-00, 83-117-00, 83-119-00 RAP

Table 3 Status messages O to R

UI Message	Status Code	Reason for Message	Reference / Action
Paper jam in areas 3a, 3b and 4a	01-114-00	IME jam at zone 3a (registration), 3b (post transfix) and 4a (exit), open front door	Clear the paper jam in area 3a, 3b and 4a. Print and copy services are disabled. Refer to 10-110-00 to 10-113-00, 10-125-00 to 10-128-00, 10-147-00, 10-148-00 RAP, 10-140-00 to 10-146-00, 10-149-00 to 10-151-00 RAP, 83-110-00, 83-111-00, 83-113-00, 83-114-00, 83-118-00 RAP, 83-112-00, 83-115-00, 83-116-00, 83-117-00, 83-119-00 RAP
Paper jam in areas 3a, 3b and 4b	01-113-00	IME jam at zone 3a (registration), 3b (post transfix) and 4b (horizontal), open front door	Clear the paper jam in area 3a, 3b and 4b. Print and copy services are disabled. Refer to 10-110-00 to 10-113-00, 10-125-00 to 10-128-00, 10-147-00, 10-148-00 RAP, 10-140-00 to 10-146-00, 10-149-00 to 10-151-00 RAP, 83-110-00, 83-111-00, 83-113-00, 83-114-00, 83-118-00 RAP, 83-112-00, 83-115-00, 83-116-00, 83-117-00, 83-119-00 RAP
Paper jam in areas 3a, 3b, 4a and 4b.	01-115-00	IME jam at zone 3a (registration), 3b (post transfix), 4a (exit) and 4b (horizontal), open front door	Clear the paper jam in area 3a, 3b, 4a and 4b. Print and copy services are disabled. Refer to 10-110-00 to 10-113-00, 10-125-00 to 10-128-00, 10-147-00, 10-148-00 RAP, 10-140-00 to 10-146-00, 10-149-00 to 10-151-00 RAP, 83-110-00, 83-111-00, 83-113-00, 83-114-00, 83-118-00 RAP, 83-112-00, 83-115-00, 83-116-00, 83-117-00, 83-119-00 RAP
Paper jam in areas 3a, 4a and 4b.	01-111-00	IME jam at zone 3a (registration), 4a (exit) and 4b (horizontal), open front door	Clear the paper jam in area 3a, 4a and 4b. Print and copy services are disabled. Refer to 10-110-00 to 10-113-00, 10-125-00 to 10-128-00, 10-147-00, 10-148-00 RAP, 10-140-00 to 10-146-00, 10-149-00 to 10-151-00 RAP, 83-110-00, 83-111-00, 83-113-00, 83-114-00, 83-118-00 RAP, 83-112-00, 83-115-00, 83-116-00, 83-117-00, 83-119-00 RAP

Table 3 Status messages O to R

UI Message	Status Code	Reason for Message	Reference / Action
Paper jam in areas 3b and 4a.	01-106-00	IME jam at zone 3b (post transfix) and 4a (exit), open front door.	Clear the paper jam in area 3b and 4a. Print and copy services are disabled. Refer to 10-110-00 to 10-113-00, 10-125-00 to 10-128-00, 10-147-00, 10-148-00 RAP, 10-140-00 to 10-146-00, 10-149-00 to 10-151-00 RAP, 83-110-00, 83-111-00, 83-113-00, 83-114-00, 83-118-00 RAP, 83-112-00, 83-115-00, 83-116-00, 83-117-00, 83-119-00 RAP
Paper jam in areas 3b, 4a and 4b.	01-107-00	IME jam at zone 3b (post transfix), 4a (exit) and 4b (horizontal), open front door.	Clear the paper jam in area 3b, 4a and 4b. Print and copy services are disabled. Refer to 10-110-00 to 10-113-00, 10-125-00 to 10-128-00, 10-147-00, 10-148-00 RAP, 10-140-00 to 10-146-00, 10-149-00 to 10-151-00 RAP, 83-110-00, 83-111-00, 83-113-00, 83-114-00, 83-118-00 RAP, 83-112-00, 83-115-00, 83-116-00, 83-117-00, 83-119-00 RAP
Paper jam in areas 4a and 4b.	01-103-00	IME jam at zone 4a (exit) and 4b (horizontal), open front door.	Clear the paper jam in area 4a and 4b. Print and copy services are disabled. Refer to 10-110-00 to 10-113-00, 10-125-00 to 10-128-00, 10-147-00, 10-148-00 RAP, 10-140-00 to 10-146-00, 10-149-00 to 10-151-00 RAP, 83-110-00, 83-111-00, 83-113-00, 83-114-00, 83-118-00 RAP, 83-112-00, 83-115-00, 83-116-00, 83-117-00, 83-119-00 RAP
Paper jam in finisher folder unit.	12-718-00	Sheet over tri-folder assist sensor	Clear the paper jam. If the problem persists, perform the 12-185-00-171 to 12-187-00-171 RAP
Paper jam in finisher folder unit.	12-719-00	Sheet over tri-folder exit sensor	Clear the paper jam. If the problem persists, perform the 12-185-00-171 to 12-187-00-171 RAP
Paper jam in the document feeder	05-520-00	Post feed and take-away roll jam	Remove the sheet. If the problem persists, perform the 05-330-00, 05-331-00 Feed Sensor Failure RAP

Table 3 Status messages O to R

UI Message	Status Code	Reason for Message	Reference / Action
Paper jam in the document feeder	05-522-00	Sheet left over DADH CVT sensor after jam. DADH post feed sensor or TAR sensor	Remove sheet. If the problem persists, perform the 05-350-00, 05-352-00 RAP
Paper jam in the document feeder	05-526-00	DADH - sheet left over DADH document present sensor after jam. 05-330 fault is raised	Reset when DADH top cover closed after jam cleared. If the problem persists, perform the 05-330-00, 05-331-00 RAP
Paper jam in the finisher	12-735-00	A sheet is detected near the buffer sensor	Clear the sheet. If necessary, perform the 12-157-00-171, 12-158-00-171 RAP and 12-141-00-171, 12-142-00-171 RAP
Paper jam in the finisher	12-736-01	A sheet is detected near the exit from the HVF to the BM entry sensor (without tri-folder)	Clear the sheet. If necessary, perform the 12-113-00-171, 12-114-00-171, 12-190-00-171, 12-192-00-171 RAP
Paper jam in the finisher	12-736-02	A sheet is detected near the exit from the HVF to the BM entry sensor (with tri-folder)	Clear the sheet. If necessary, perform the 12-113-00-171, 12-114-00-171, 12-190-00-171, 12-192-00-171 RAP
Paper jam in the finisher	12-752-00	A page is detected over the buffer path sensor	Clear the area. If the problem persists, perform the 12-198-00-171, 12-199-00-171 RAP
Paper jam in the finisher	12-753-00	A page is detected near buffer path sensor	Clear the area. If the problem persists, perform the 12-198-00-171, 12-199-00-171 RAP
Paper jam in the finisher	12-610-00	Paper is detected over the entry sensor (LCSS)	Clear the paper jam. If the problem persists, perform the 12-199-00-110 RAP
Paper jam in the finisher	12-610-01	Paper is detected over the entry sensor (HVF without tri-folder)	Clear the paper jam. If the problem persists, perform the 12-125-00-171, 12-126-00-171 RAP
Paper jam in the finisher	12-611-00	After receiving the paper at IOT exit sensor the entry sensor is not made within 1000 ms. (LCSS). Paper jam near the entry to the finisher unit	Clear the paper jam. If the problem persists, perform the 12-199-00-110 RAP
Paper jam in the finisher	12-611-01	Paper jam near the entry to the finisher unit (HVF without tri-folder)	Clear the paper jam. If the problem persists, perform the 12-125-00-171, 12-126-00-171 RAP

Table 3 Status messages O to R

UI Message	Status Code	Reason for Message	Reference / Action
Paper jam in the finisher	12-612-00	Paper is detected over the hole punch position sensor at power-up, interlock status change or after shutdown. (LCSS)	Clear the paper jam. If the problem persists, perform the 12-043-00-110, 12-046-00-110 RAP
Paper jam in the finisher	12-618-00	Paper is detected over the top tray exit sensor at power-up, interlock status change or after shutdown. (LCSS)	Clear the paper jam. If the problem persists, perform the 12-171-00-110, 12-172-00-110 RAP
Paper jam in the finisher	12-618-01	Paper is detected over the top tray exit sensor	Clear the paper jam. If the problem persists, perform the 12-125-00-171, 12-126-00-171 RAP
Paper jam in the finisher	12-619-00	Paper jam near the output to the top tray. (LCSS)	Clear the paper jam. If the problem persists, perform the 12-171-00-110, 12-172-00-110 RAP
Paper jam in the finisher	12-619-01	Paper jam near the output to the top tray. (HVF)	Clear the paper jam. If the problem persists, perform the 12-171-00-171, 12-172-00-171 RAP
Paper jam in the finisher	12-620-00	Paper is detected over the stacker exit sensor at power-up, interlock status change or after shutdown. (LCSS)	Clear the paper jam. If the problem persists, perform the 12-151-00-110, 12-152-00-110 RAP
Paper jam in the finisher	12-620-01	Paper jam near the output to the stacker tray. Sheet over 2nd top exit sensor	Clear the paper jam. If the problem persists, perform the 12-151-171, 12-152-171 RAP
Paper jam in the finisher	12-621-00	If entry sensor made to the stacker bin exit sensor made exceeds 1600 ms (A4 LEF 1st page/A3 SEF all pages) or 1100 ms (A4 LEF mid set page) or 900 ms (A4 LEF last page of set) (LCSS)	Clear the paper jam. If the problem persists, perform the 12-171-00-110, 12-172-00-110 RAP
Paper jam in the finisher	12-621-01	Paper jam near the output to the stacker tray. A sheet is over the 2nd top exit sensor	Clear the paper jam. If the problem persists, perform the 12-151-171, 12-152-171 RAP

Table 3 Status messages O to R

UI Message	Status Code	Reason for Message	Reference / Action
Paper jam in the finisher	12-624-00	A sheet is over the inserter pickup sensor	Clear the area. If the problem persists, perform the 12-479-00-171 RAP
Paper jam in the finisher	12-625-00	A sheet is over the inserter tab standby sensor	Clear the area. If the problem persists, perform the 12-191-00-171 , 12-193-00-171 , 12-194-00-171 , 12-196-00-171 RAP
Paper jam in the finisher	12-626-00	A sheet is over the buffer position sensor	Clear the area. If the problem persists, perform the 12-198-00-171 , 12-199-00-171 RAP
Paper jam in the finisher	12-627-00	A sheet is over the HVF exit into BM sensor	Clear the area. If the problem persists, perform the 12-198-00-171 , 12-199-00-171 RAP
Paper jam in the finisher	12-628-00	A sheet is over the stacker bin exit sensor	Clear the area. If the problem persists, perform the 12-151-171 , 12-152-171
Paper jam in the finisher	12-629-00	A sheet is over the tri-folder entry sensor	Clear the area. If the problem persists, perform the 12-183-00-171 , 12-184-00-171 RAP
Paper jam in the finisher	12-630-01	A sheet is over the booklet maker entry sensor (without tri-folder)	Clear the area. If the problem persists, perform the 12-183-00-171 , 12-184-00-171 RAP
Paper jam in the finisher	12-630-02	A sheet is over the booklet maker entry sensor (with tri-folder)	Clear the area. If the problem persists, perform the 12-183-00-171 , 12-184-00-171 RAP
Paper jam in the finisher	12-636-01	A sheet is over the booklet maker exit sensor. (without tri-folder)	Clear the jam from the output bin. If the problem persists, perform the 12-181-00-171 , 12-182-00-171 RAP
Paper jam in the finisher	12-636-02	A sheet is over the booklet maker exit sensor. (with tri-folder)	Clear the jam from the output bin. If the problem persists, perform the 12-181-00-171 , 12-182-00-171 RAP
Paper jam in the finisher.	12-732-00	A sheet is detected near the PPI pickup sensor	Clear the jam. If necessary, perform the 12-191-00-171 , 12-193-00-171 , 12-194-00-171 , 12-196-00-171 RAP
Paper jam in the finisher.	12-733-00	A sheet is detected near the PPI tab standby sensor	Clear the jam. If necessary, perform the 12-191-00-171 , 12-193-00-171 , 12-194-00-171 , 12-196-00-171 RAP
Paper jam in the finisher.	12-627-01	A page is over exit HVF into BM sensor (sensor in area 6a) cleared via area 6a	Clear the paper jam

Table 3 Status messages O to R

UI Message	Status Code	Reason for Message	Reference / Action
Paper jam in the finisher.	12-627-02	A page is over exit HVF into BM sensor (sensor in area 6a) Cleared via area 6a	Clear the paper jam
Paper jam in the finisher.	12-746-00	A sheet is detected near the tri-fold entry sensor	Clear the sheet. If the problem persists, perform the 12-183-00-171 , 12-184-00-171 RAP
Paper jam in the finisher.	12-747-00	A sheet is detected near the tri-fold exit sensor	Clear the sheet. If the problem persists, perform the 12-185-00-171 to 12-187-00-171
Paper jam in the finisher.	12-748-00	A sheet is detected near the tri-fold assist sensor	Clear the sheet. If the problem persists, perform the 12-185-00-171 to 12-187-00-171 RAP
Paper jam in the finisher.	12-717-01	A sheet is over HVF BM compiler paper present sensor (without tri-folder)	Clear the HFV BM paper present sensor area 6e. If the problem persists, perform the 12-166-00-171 RAP
Paper jam in the finisher.	12-717-02	A sheet is over HVF BM compiler paper present sensor (with tri-folder)	Clear the HFV BM paper present sensor area 6e. If the problem persists, perform the 12-166-00-171 RAP
Paper required for current job is not available	22-511-04	The media required for the current marking job is not loaded	Load the correct paper to complete the held job or cancel the held job. Other machine services are unaffected
Paper tray communication fault. Please call for assistance.	92-531-00	3TM Communications problems (Ttm-SerialLinkSafety)	Switch the machine off then on, GP 14 . Check connection on 3 trays module. If problem persists, perform the 70-312-00 Tray 1 to Tray 3 Communication Failure RAP. Copying and printing are not available.
Paper tray communication fault. Please call for assistance.	92-530-00	IME communications problem with paper tray. Paper trays 1 to 3 not available.	Switch the machine off then on, GP 14 . Check connection on 3 trays module. If problem persists, perform the 70-312-00 Tray 1 to Tray 3 Communication Failure RAP. Copying and printing are not available.
Please complete all steps required by the external accounting device to access this service	03-558-00	Not defined	-

Table 3 Status messages O to R

UI Message	Status Code	Reason for Message	Reference / Action
Please enter access code into external accounting device to access this service	03-558-02	Not defined	-
Please insert card into the external accounting device to access this service	03-558-01	Not defined	-
Please insert key counter into the external accounting device to access this service	03-558-04	Not defined	-
Please insert money into the external accounting device to access this service	03-558-03	Not defined	-
Please wait, freeing memory	19-502-00	Out of memory resources. The machine has run out of image processing memory for the current job.	No user intervention required, please wait, printing will resume after memory is freed. Other machine services are unaffected. If the problem persists, perform the 19-401-00 , 19-402-00 Stress Out of Memory RAP
Please wait... Adjustments are in progress	92-574-00	Mechanical initialization	-
Please wait... Adjustments are in progress	92-576-00	IME frame buffer borrow busy	Print engine adjustments in progress. Copying and printing are temporarily unavailable
Please wait... Adjustments are in progress	92-577-00	Recovery in progress	-
Please wait... Automated print engine maintenance in progress	93-893-00	This status is raised while the IME is attempting to clear a potentially jammed black ink stick.	No service action required. Print and copy services are temporarily disabled
Please wait... Automated print engine maintenance in progress	93-894-00	This status is raised while the IME is attempting to clear a potentially jammed magenta ink stick.	No service action required. Print and copy services are temporarily disabled

Table 3 Status messages O to R

UI Message	Status Code	Reason for Message	Reference / Action
Please wait... Automated print engine maintenance in progress	93-895-00	This status is raised while the IME is attempting to clear a potentially jammed cyan ink stick.	No service action required. Print and copy services are temporarily disabled
Please wait... Automated print engine maintenance in progress	93-896-00	This status is raised while the IME is attempting to clear a potentially jammed yellow ink stick.	No service action required. Print and copy services are temporarily disabled
Please wait... Automated print engine maintenance in progress.	91-659-00	Auto maintenance routines are in progress	No service action required.
Please wait... Maintenance in progress. Scan, copy and print services not available	03-555-00	Machine has entered intrusive customer tools mode.	Go to dC301 . Perform a Copier NVM Initialization and NVM data select All. After Initialization perform routines dC977 and dC978 .
Please wait... Preheater cleaning in progress.	88-510-00	IME preheater cleaning	Please wait until cleaning is completed. The printer is temporarily unavailable
Please wait... print engine maintenance - head purge in progress.	91-654-00	Head purge is in progress	No service action required
Please wait... print quality maintenance in progress.	91-668-00	IME print quality maintenance is in progress	No service action required
Please wait... Printer is warming up	92-573-00	The printer is warming up	Print and copy services will resume shortly. Other machine services are unaffected
Please wait... Printer is warming up	92-587-00	IME long term warming up	The printer is warming up. Print and copy services will resume shortly. Other machine services are unaffected
Please wait... The Fax service is initializing	20-544-00	The Fax service is initializing	The Fax service is re-starting. No user intervention is required. Printing and other machine services are available
Please wait... The image disk is full.	19-513-00	The image disk is full	Print jobs may be delayed. No service action required. The system is attempting to recover. Printing and other machine services are available

Table 3 Status messages O to R

UI Message	Status Code	Reason for Message	Reference / Action
Please wait... The output tray is lowering	12-741-00	The machine is paused for unloading. Press the button on the pop up screen	Follow the instructions. If the problem persists, perform the 12H-171 RAP
Please wait... the system is attempting to recover	03-561-00	The system is recovering	Wait until the system recovers
Please wait... The system is attempting to recover.	19-510-00	The system is attempting to recover. Image disk error	No service action required. Printing and other machine services are unaffected
Please wait... Warming up from extremely low ambient temperature.	92-582-00	IME cold boot timeout	Please wait. Printing and copying are not available until the machine temperature is within specification
Please wait...Printer cleaning in progress	94-603-00	Chase sheets are being fed	Ready to scan. Copying and printing not available
Please Wait... Disk encryption operation in progress.	17-580-00	Disk encryption is in progress	No service action required
Please wait... Print Engine cooling in progress.	88-511-00	Media is exhausted during the cooling phase of clean for ink smears.	No service action required. Please wait, cooling in progress
Please wait... The scanner is initializing.	03-556-00	Power on while the IIT is being initialized	No service action required
Print engine in non-thermal mode.	92-578-00	IME in non-thermal mode. Print engine is operating in non-thermal manufacturing mode. Print and copy service disabled.	Enter diagnostics dC335 and select a heater routine. Run the routine and then exit diagnostics. The machine warms up. Enter dC131 Read/Write and check that NVM ID 425-003 = 0
Print engine maintenance - head purge in progress....please wait.	91-564-00	Head purge in progress	No service action required.
Provide payment	03-559-01	Walk up FDI. Unable to complete the current job.	Your Job cannot be completed due to insufficient funds.Please complete all steps required by the external accounting device to continue your job

Table 3 Status messages O to R

UI Message	Status Code	Reason for Message	Reference / Action
Provide payment	03-559-03	Walk up coin entered FDI. Not defined	Your Job cannot be completed due to insufficient funds.Please insert money into the external accounting device to continue your job.To cancel this job, press the hard-panel Job Status button, select the job and then the Delete button
Provide payment or the current job may be deleted.	03-559-00	Generic FDI. Unable to complete the current job.	Your Job cannot be completed due to insufficient funds.Please complete all steps required by the external accounting device to continue your job
Provide payment or the current job may be deleted.	03-559-05	Walk Up FDI. Unable to complete the current job - FDI inactivity timer enabled	Your Job cannot be completed due to insufficient funds. Please insert card into the external accounting device to continue your job. To immediately delete this job, select the Close button, then the Job Status button located on the control panel and then your job.If no action is taken, the job will be deleted
Provide payment or the current job may be deleted.	03-559-06	Walk up coin entered FDI. Not Defined - FDI inactivity timer disabled	Your Job cannot be completed due to insufficient funds. Please insert money into the external accounting device to continue your job. To immediately delete this job, select the Close button, then the Job Status button located on the control panel and then your job. If no action is taken, the job will be deleted
Provide payment or the current job may be deleted.	03-559-04	Walk up key entered FDI. Not defined	Your Job cannot be completed due to insufficient funds.Please insert Key Counter into the external accounting device to continue your job.
Ready to scan. Copying and printing not available. Bottom left side door is open.	70-305-00	The feeder vertical transport lower left door is open	Copying and printing are not available. Close the door. If the problem persists, perform the 70-305-00, 70-325-00 RAP
Ready to scan. Copying and printing not available. Jam in area 1b.	70-111-00	Jam in the lower feeder vertical transport (tray 5 not installed)	Clear the media jam. Copying and printing are not available. If the problem persists, perform the 71-101-00 to 71-155-00 RAP, 72-101-00 to 72-155-00 RAP

Table 3 Status messages O to R

UI Message	Status Code	Reason for Message	Reference / Action
Ready to scan. Copying and printing not available. Jam in area 1b.	70-111-01	Jam in the lower feeder vertical transport (A4 tray 5 installed)	Clear the media jam. Copying and printing are not available. If the problem persists, perform the 71-101-00 to 71-155-00 RAP , 72-101-00 to 72-155-00 RAP
Ready to scan. Copying and printing not available. Jam in area 1b.	70-111-02	Jam in the lower feeder vertical transport (A3 tray 5 installed)	Clear the media jam. Copying and printing are not available. If the problem persists, perform the 71-101-00 to 71-155-00 RAP , 72-101-00 to 72-155-00 RAP
Ready to scan. Copying and printing not available. Jam in paper transport.	73-111-00	Jam in the tray 3 horizontal transport	Clear the media jam. Copying and printing are not available. If the problem persists, perform the 73-101-00 to 73-155-00 Tray 3 Mis-Feed Jam RAP
Ready to scan. Copying and printing not available. Misfeed in tray 1	71-102-00	Misfeed in tray 1	Clear the media jam. Copying and printing are not available. If the problem persists, perform the 71-101-00 to 71-155-00 RAP
Ready to scan. Copying and printing not available. Misfeed in tray 2	72-102-00	Misfeed in tray 2	Clear the media jam. Copying and printing are not available. Refer to 72-101-00 to 72-155-00 RAP
Ready to scan. Copying and printing not available. Misfeed in tray 3	73-102-00	Misfeed in tray 3	Clear the media jam. Copying and printing are not available. Refer to 73-101-00 to 73-155-00 RAP
Ready to scan. Copying and printing not available. Paper transport is open.	73-305-00	the feeder horizontal transport drawer is open	Close the feeder horizontal transport. Copying and printing are not available. If the problem persists, perform the 73-325-00 Feeder HT Drawer Open in Run RAP
Registration in progress	89-560-00	IME registration is being calibrated	Please wait. The printer is temporarily unavailable
Reload sheets in document feeder.	05-527-00	There is a document in the DADH at power on or exit from power save	Remove the sheets from the Original Input Tray.
Remove documents from the document feeder input tray or close the document feeder	22-505-00	Documents are sensed in the DADH tray during IIT standby and document handler cover is open	To scan from the document glass, remove documents in the document feeder input tray. To use the document feeder to scan your documents, lower the document feeder

Table 3 Status messages O to R

UI Message	Status Code	Reason for Message	Reference / Action
Remove documents from the document feeder input tray or close the document feeder	22-505-02	Documents are sensed in the DADH tray during IIT standby and document handler cover is open	To scan from the document glass, remove documents in the document feeder input tray. To use the document feeder to scan your documents, lower the document feeder
Remove the document. It is too short to be fed by Document Feeder	05-560-00	Upon fault 05-310 being raised	Remove document from DADH during jam clearance, If the problem persists, perform the 05-310-00 RAP
Re-order document feeder - feed roller but DO NOT replace until prompted	05-578-00	DADH roller feeds reaches near end of life	Order new DADH feed roll assembly, PL 5.15 Item 1 .
Re-order document feeder - feed roller but DO NOT replace until prompted	05-547-00	DADH feed roll assembly near end of life	Re-order feed roll assembly PL 5.15 Item 1 .
Re-order Xerox ColorQube Ink	93-821-00	Black ink reorder threshold has been reached	Load more black solid ink. Copying and printing can continue. If the ink stick cannot be loaded, go to OF 11
Re-order Xerox ColorQube Ink	93-822-00	Magenta ink reorder threshold has been reached	Load more magenta solid ink. Copying and printing can continue. If the ink stick cannot be loaded, go to OF 11
Re-order Xerox ColorQube Ink	93-823-00	Cyan ink reorder threshold has been reached	Load more cyan solid ink. Copying and printing can continue. If the ink stick cannot be loaded, go to OF 11
Re-order Xerox ColorQube Ink	93-824-00	Yellow ink reorder threshold has been reached	Load more yellow solid ink. Copying and printing can continue. If the ink stick cannot be loaded, go to OF 11
Replace the Document Feed Roller.	05-579-00	DADH roller feeds reaches end of life	Install new DADH feed roll assembly, PL 5.15 Item 1 .

Table 4 Status messages S to Y

UI Message	Status Code	Reason for Message	Reference / Action
Scan and copy services not available. Print service is available	05-570-00	DADH jam.	Remove, then re-load all document in the DADH.

Table 4 Status messages S to Y

UI Message	Status Code	Reason for Message	Reference / Action
Scan to Distribution Services are not available. Notify your system administrator	16-525-00	The network controller's scan to distribution service process has stopped	Some network service are not available. The network controller connection is about to be reset
Scan to file not available. Power off then on and notify system administrator	16-561-00	The network controller scan to file processes have failed	Switch the machine off then on, GP 14
Scanner fault. Power off then on and notify system administrator	14-517-00	Scanner fault.	Switch the machine off then on, GP 14 . Check the current fault codes list for faults in the scanner and perform the appropriate RAP.
Scanning will be delayed	22-508-04	Scan start up delayed whilst awaiting resources	No user intervention is required. Job will begin when system is ready. If the problem persists, perform the 22-330-06 ESS Scan to Distribution Service not Responding to List Jobs RPC Call RAP
Select confirm if the document feeder - feed roller was replaced	05-585-00	When Status 05-579 is active and the DADH top cover is opened (status 05-502)	Select confirm if the document feeder - feed roller was replaced
Select the current messages button in the machine status for more information	22-502-04	An active message has been produced	Go to the Status screen and select the Faults tab. Press the Active Messages button and perform the action appropriate to the message
Server Fax service cannot register. Power off then on and notify system administrator	17-551-00	Server Fax service cannot register	Switch the machine off then on, GP 14 . Server Fax is disabled, print and other machine services are unaffected. If the problem persists, perform the 16-987-19 , 16-988-19 Server Fax Application Registration Error RAP
Service limit exceeded. New services will not be available until some services are removed	16-533-00	Controller software service limit exceeded	Remove some existing services to enable new services to be added. Machine services are available but may be degraded
Some jobs may have been deleted	03-562-00	Status is raised when some jobs may have been deleted	Removed upon user intervention

Table 4 Status messages S to Y

UI Message	Status Code	Reason for Message	Reference / Action
Some jobs may have been deleted.	19-505-00	Compressor DVMA time-out. The current job has been deleted	Confirm that UI message has been seen. Re-scan the job. If the problem persists, perform the 19-403-00 EPC Out of Memory RAP
LAN Fax service error. Power off then on and notify system administrator	16-595-00	The network controller LAN-Fax service has failed	Switch the machine off then on, GP 14 . Print and other machine services are unaffected. If the problem persists, perform the 16-790-09 to 16-799-47 Other Network Faults 4 RAP
Some network accounting services are not available. Notify your system administrator.	16-596-00	Some network controller services are not available	Network accounting error. User intervention is required to power off/on the machine. Print and other machine services are unaffected. If the problem persists, perform the 16-790-09 to 16-799-47 Other Network Faults 4 RAP
Some network authentication services unavailable. Notify your system administrator	16-582-00	The network controller ESS authentication SPI process has stopped	Switch the machine off then on, GP 14 . Print and other machine services are unaffected. If the problem persists, perform the 16-780-00 to 16-789-47 Other Network Faults 3 RAP
Some network diagnostic services unavailable. Notify your system administrator	16-581-00	The network controller ESS diagnostic service process has stopped	Switch the machine off then on, GP 14 . Printing and scanning can continue. If the problem persists, perform the 16-770-09 to 16-779-95 Other Network Faults 2 RAP and the 16-780-00 to 16-789-47 Other Network Faults 3 RAP
Some network services are not available due to a process error. Notify system administrator.	16-560-00	Some processes on the network controller have failed	Switch the machine off then on, GP 14 .
Some network services involving CPI are not available. Notify your system administrator	16-521-00	The network controller's CPI service process has stopped	Machine services are temporarily disabled. The network controller connection is about to be reset

Table 4 Status messages S to Y

UI Message	Status Code	Reason for Message	Reference / Action
Some network services involving DDNS are not available. Notify your system administrator	16-504-00	DDNS error. Some network controller services are not available	The DDNS address resolution process has failed. Switch the machine off then on, GP 14 . If the problem persists check the DDNS server's network connections
Some network services involving DHCP are not available. Notify your system administrator	16-593-00	Network controller - DHCP address resolution has failed	Check DHCP server network connection. Switch the machine off then on, GP 14 . Copying and printing with local connection scan continue. If the problem persists, perform the 16-800-09 to 16-809-47 Other Network Faults 5 RAP
Some Network Services involving Ethernet are not available. Notify system administrator	16-591-00	Network controller Ethernet process has failed	Check Ethernet connection. Switch the machine off then on, GP 14 . Local printing can continue. If the problem persists, perform the 16-800-09 to 16-809-47 Other Network Faults 5 RAP
Some network services involving HTTP are not available. Notify your system administrator	16-570-00	Network controller - an HTTP interpreter error has occurred, causing the process to fail	Switch the machine off then on, GP 14 . Printing can continue if other submission methods are used. If the problem persists, perform the 16-761-47 to 16-769-95 Other Network Faults 1 RAP
Some network services involving Internet Fax are not available. Notify system administrator	16-509-00	There is insufficient memory for internet Fax	Switch the machine off then on, GP 14 . Printing can continue if other network protocols are used
Some network services involving Job Log are not available. Notify system administrator	16-522-00	The network controller's Job Log service process has stopped	Some network service are not available. The network controller connection is about to be reset
Some network services involving LPD are not available. Notify your system administrator	16-562-00	Network controller - the line printer daemon (LPD) process has failed	Switch the machine off then on, GP 14 . Printing can continue if other submission methods are used
Some network services involving NetBios are not available. Notify system administrator	16-564-00	Network controller - the NetBIOS connectivity process has failed	Switch the machine off then on, GP 14 . Printing can continue if other submission methods are used

Table 4 Status messages S to Y

UI Message	Status Code	Reason for Message	Reference / Action
Some network services involving Novell are not available. Notify the system administrator	16-563-00	Network controller - the Novell Netware connectivity process has failed	Switch the machine off then on, GP 14 . Printing can continue if other submission methods are used
Some network services involving PCL are not available. Notify system administrator	16-568-00	Network controller - a PCL interpreter error has occurred, causing the process to fail	Switch the machine off then on, GP 14 , to enable PCL printing. Printing can continue if other job format methods are used
Some network services involving PostScript are not available. Notify your system administrator	16-567-00	Network controller - a PostScript interpreter error has occur, causing the process to fail	Switch the machine off then on, GP 14 . Printing can continue if other submission methods are used
Some network services involving RARP are not available. Notify your system administrator.	16-594-00	Network controller - RARP address resolution has failed	Check RARP server network connection. Switch the machine off then on, GP 14 . Printing can continue with other submission methods. If the problem persists, perform the 16-800-09 to 16-809-47 Other Network Faults 5 RAP
Some network services involving Scan to E-mail are not available. Notify System Administrator	16-505-00	There is insufficient memory for E-mail	Switch the machine off then on, GP 14 . If the problem persists check the network connections
Some network services involving SLP are not available. Notify your system administrator	16-507-00	SLP process stopped. Some network controller services are not available	Switch the machine off then on, GP 14
Some network services involving SMB are not available. Notify your system administrator	16-526-00	The network controller's SMB service process has stopped.	Some network services are not available. The network controller connection is about to be reset
Some network services involving SSDP are not available. Notify your system administrator	16-513-00	Simple service discovery protocol (SSDP) failed	Switch the machine off then on, GP 14
Some network services involving TCP/IP are not available. Notify your system administrator	16-527-00	The network controller's TCP/IP service process has stopped.	Some network services are not available. The network controller connection is about to be reset

Table 4 Status messages S to Y

UI Message	Status Code	Reason for Message	Reference / Action
Some network services involving TCP/IP are not available. Notify your system administrator	16-598-00	Network controller - TCP/IP address is already in use on the network	Another IP address needs to be used. Switch the machine off then on, GP 14 . Copy and Fax services (if installed) can continue. If the problem persists, perform the 16-790-09 to 16-799-47 Other Network Faults 4 RAP
Some network services involving TIFF are not available. Notify your system administrator	16-597-00	The network controller TIFF interpreter has failed	Switch the machine off then on, GP 14 . Printing can continue with other job formats. If the problem persists, perform the 16-790-09 to 16-799-47 Other Network Faults 4 RAP
Some network services with Job Tracker are not available. Notify your system administrator	16-523-00	The network controller's job tracker service process has stopped	Some network services are not available. The network controller connection is about to be reset
Some network services with Kerberos are not available. Notify your system administrator	16-524-00	The network controller's Kerberos service process has stopped	Some network services are not available. The network controller connection is about to be reset
Staple cartridge is empty. Replace now	12-715-00	The finisher's main staple cartridge is empty. Follow the instructions at the printer to load a new staple cartridge. Non staple printing can continue. (LCSS)	Install new staple cartridge, PL 12.55 Item 7
Staple cartridge is empty. Replace now	12-715-01	The HVF staple cartridge is empty	Install a new staple cartridge. Perform 12-369-00-171 to 12-377-00-171 RAP
Staple cartridge supplies are low	12-716-00	The LCSS and HVF staples are low	The finisher's main staple cartridge supplies are low. Re-order staple cartridge. Printing can continue. LCSS PL 12.55 Item 7 , HVF PL 12.110 Item 31 . HVFBM PL 12.185 Item 8
Stapling fault. Power off then on and notify system administrator	12-653-00	Stapling is disabled, out of service (LCSS)	Perform 12-371-00-110, 12-372-00-110, 12-378-00-110 RAP
Stapling fault. Power off then on and notify system administrator	12-721-00	The stapler is not in position	The stapler module is open, close the stapler module

Table 4 Status messages S to Y

UI Message	Status Code	Reason for Message	Reference / Action
Stapling not available. Call for assistance	12-921-00	The stapler position sensor indicates the stapler module is not closed in initialisation	Close the BM stapler module. If necessary, perform the 12-063-00-171, 12-411-00-171 RAP for staple unit 1, and 12-403-00-171, 12-413-00-171, 12-414-00-171 RAP for staple unit 2
System error. Power off then on and notify system administrator	03-598-00	Unable to set ready mode. Printing and copying services are not available	Perform the 03-788-00 CCS Runtime Could Not Enter Power Saver Mode S3 RAP
System error. Power off then on and notify system administrator	03-565-00	System fault	Switch the machine off then on, GP 14
System error. Power off then on and notify system administrator	04-565-00	IME controller communication failure	System fault. Switch the machine off then on, GP 14
System error. Power off then on and notify system administrator	16-503-00	Incomplete system information	Switch the machine off then on, GP 14 . All machine services are disabled
System error. Power off then on and notify system administrator	22-563-00	Incomplete system information	Switch the machine off then on, GP 14 . All machine services are disabled
System Error. Power off then on and notify system administrator	03-505-00	The digital copier is not available	Perform 03-325-00 RAP and 03-355-00 RAP
System fault. Call for assistance	92-572-00	IME. An unrecoverable fault has occurred	Switch the machine off then on, GP 14 . Copying and printing are not available
The booklet maker tray in the Finisher is full. Empty the tray	12-728-00	The booklet maker output tray is full	Empty the tray. If necessary, perform the 12C-171 RAP
The booklet maker tray in the finisher is nearly full.	12-727-00	The booklet maker output tray is nearly full	The booklet maker tray is near full. User intervention will be required soon to empty the tray to allow continued booklet making. Print and Copy services can continue; other machine services are unaffected.
The booklet tray in the finisher is nearly full	12-727-00	The booklet maker output tray is nearly full	The booklet maker output tray is nearly full. Printing can continue, but this tray will need emptying soon.

Table 4 Status messages S to Y

UI Message	Status Code	Reason for Message	Reference / Action
The current job exceeds the tray capacity, you will be prompted to empty the tray.	12-411-00	Copy job will exceed the output destinations capacity	Empty the tray
The document feeder top cover is open	05-502-00	DADH top cover open.	Close the DADH top cover. If the problem persists, perform the 05-258-00 , 05-307-00 DADH Cover Interlock Open RAP.
The document size was different than expected. The job has been deleted.	05-546-00	On pre-feed the DADH fails to recognize the size of the document	Reload originals or select size. Perform 05-257-00 RAP
The document size was different than expected. The job has been deleted.	22-507-05	The document is larger than expected	Try one of the following: Select mixed size originals and reload into the document feeder or make sure the originals are not creased or folded and retry from the document glass. If the problem persists, perform the 05-257-00 RAP
The E-mail service cannot un-register. Notify your system administrator	17-558-00	Email service cannot un-register	Switch the machine off then on, GP 14 . Scan to E-mail is disabled, print and other machine services are unaffected. If the problem persists, perform the 16-950-19 to 16-959-19 E-mail Application Registration Error RAP
The Fax service cannot register. Notify your system administrator	22-566-00	Fax service cannot register	Switch the machine off then on, GP 14 . Fax and LAN Fax are disabled. Other machine services are unaffected. If the problem persists, perform the 22-371-00 , 22-372-00 RAP
The Fax service cannot un-register. Notify your system administrator	22-567-00	Fax service cannot un-register	Switch the machine off then on, GP 14 . All machine services are disabled. If the problem persists, perform the 22-371-00 , 22-372-00 RAP
The finisher front door is open	12-564-00	The finisher front door is open (LCSS)	Close the finisher front door
The finisher front door is open	12-564-01	The finisher front door is open (HVF - all variants)	Close the finisher front door

Table 4 Status messages S to Y

UI Message	Status Code	Reason for Message	Reference / Action
The hole punch waste container is full. Empty hole punch waste container.	12-649-00	The hole punch chad bin is full and needs emptying. (LCSS)	Hole punch waste container is full, jobs requesting hole punching will be held. Empty chad bin
The hole punch waste container is full. Empty hole punch waste container.	12-649-01	The hole punch chad bin is full and needs emptying. (HVF)	Hole punch waste container is full, jobs requesting hole punching will be held. Empty chad bin
The Hole Punch Waste Container is not detected. Please re-insert	12-641-00	The chad bin has been removed from the finisher	Reinstall the chad bin. If the problem persists, perform the 12-043-00-110 , 12-046-00-110 RAP
The installed cleaning unit is not compatible with this machine	94-628-00	IME detected an incompatible cleaning unit fitted to the machine	Install a new cleaning unit PL 94.10 Item 21 . Copying and printing are not available.
The internet Fax service cannot un-register. Notify your system administrator	17-557-00	Internet Fax service cannot un-register	Switch the machine off then on, GP 14 . Internet Fax is disabled, print and other machine services are unaffected. If the problem persists, perform the 16-950-19 to 16-959-19 Other Network Faults 19 RAP
The machine is not available	02-520-00	A software error has occurred.	Switch the machine off then on, GP 14
The machine is not available	82-103-01	Sensor 16 LE time out that originated from the A3 tray 5.	Copying and printing not available. Slide Tray 5 away from the machine. Open the top and middle left side door to clear jam. If the problem persists, perform the 82-133-00 RAP
The machine is not available	91-606-00	Head to drum measurement is started.	Head to Drum spacing check in Progress. Please wait, this may take up to ten minutes to complete
The machine is not available	91-609-00	Waste tray removal detected, when the waste tray is locked.	The waste tray is currently in use, please re-insert the waste tray. Copying and printing are not available
The machine is not available. Accounting communication failure	17-514-00	External accounting device communication failure	Administrator intervention required to check the connection to the external accounting device

Table 4 Status messages S to Y

UI Message	Status Code	Reason for Message	Reference / Action
The machine is not available. Paper jam in areas 2 and 1a	82-103-00	Sensor 16 LE time out that originated from the A4 PFP.	Slide Tray 5 away from the machine. Open the top and middle left side door to clear jam. If the problem persists, perform the 82-133-00 RAP.
The machine is offline	03-504-00	Network controller status code	Switch the machine off then on, GP 14
The machine is offline	03-504-01	Network controller status code	Switch the machine off then on, GP 14
The network controller connection is about to be reset	16-575-00	The network controller ESS registration service process has stopped	Automatic network controller reset. If the problem persists, perform the 16-160-09 ESS Reg Service Process Death RAP
The network controller is about to be reset	16-502-00	Status active when ever the network controller detects that a platform reset is about to occur	Cleared when the network controller reset is initiated
The network controller is initializing. Copy and print jobs may be delayed	03-563-00	Network service are being established	Please wait, the Network Controller is initializing. No user intervention is required. Printing is currently unavailable. If the problem persists, perform the 03-331-00 , 03-332-00 Main Controller and Network Controller on the SBC PWB Cannot Communicate RAP
The number of originals was less than the number originally scanned	22-503-05	Insufficient originals detected in the DADH.	Re-sort and reload all originals.
The output tray is almost full	04-569-00	The OCT detects that it is 90% full	The Tray is almost full. The tray may be emptied now or when it is full. Copy and print services available. Scan service is available.
The output tray is full. Empty the output tray	04-568-00	The OCT is full.	Empty the tray
The reprint saved jobs service cannot un-register. Notify your system administrator	17-561-00	Reprint saved jobs service cannot un-register.	Switch the machine off then on, GP 14 . Re-printing of saved jobs in disabled. If the problem persists, perform the 16-752-00 , 16-753-00 File Cabinet Application Registration Error RAP

Table 4 Status messages S to Y

UI Message	Status Code	Reason for Message	Reference / Action
The server Fax service cannot un-register. Notify your system administrator	17-556-00	Server Fax service cannot un-register	Switch the machine off then on, GP 14 . Server Fax is disabled, print and other machine services are unaffected. If the problem persists, perform the 16-987-19 , 16-988-19 Server Fax Application Registration Error RAP
The workflow scanning service cannot un-register. Notify your system administrator	17-560-00	Network scanning service cannot un-register.	Switch the machine off then on, GP 14 . Scan service is disabled, print and other machine services are unaffected. If the problem persists, perform the 16-985-19 , 16-986-19 Network Scanning Application Registration Error RAP
Top left side door is open	01-506-00	The IME upper left door (bypass tray) is open	Copying and printing are not available. If the problem persists, perform the 01-506-00 Upper Left Door Open RAP.
Tray 1 guides are not set properly	01-545-01	The dedicated tray 1 is closed with media size other than what was set	Reload required paper and correctly adjust the paper guides
Tray 1 is empty. Add paper	71-530-00	Tray 1 is out of media	Add media. Copying and printing can continue from other trays. Refer to 71A RAP and WD 7.5
Tray 1 is nearly empty. Add paper	71-535-00	Tray 1 media low	Add media. Copying and printing can continue from other trays. Refer to 71A RAP and WD 7.5
Tray 1 is not available. Notify the system administrator	70-314-00	Trays 1 - 3 out of service (communications failure)	Copying and printing are not available. If the problem persists, perform the 70-312-00 Tray 1 to Tray 3 Communication Failure RAP
Tray 1 is not available. Notify your system administrator	71-313-00	Tray 1 mechanical failure	Copying and printing are not available. Switch the machine off then on, GP 14 . If the problem persists, perform the 71-215-00 Tray 1 Elevate Up Failure RAP

Table 4 Status messages S to Y

UI Message	Status Code	Reason for Message	Reference / Action
Tray 1 is open	71-301-00	the dedicated tray 1 is open	Check the paper and close the tray. Printing can continue from other trays. Refer to WD 7.5
Tray 1 is open	71-302-00	the adjustable tray 1 is open	Check the paper and close the tray. Printing can continue from other trays. Refer to WD 7.5
Tray 1 lifting	71-536-00	Tray 1 lifting	No service action required. Print and copy services can continue from other trays if the correct media is available
Tray 2 guides are not set properly	01-545-02	The dedicated tray 2 is closed with media size other than what was set	Reload required paper and correctly adjust the paper guides
Tray 2 is empty. Add paper	72-530-00	Tray 2 is out of media	Add media. Print and copy services can continue from other trays if the correct media is available. Refer to 72A RAP
Tray 2 is nearly empty. Add paper	72-535-00	Tray 2 media low	Add media. Print and copy services can continue from other trays if the correct media is available
Tray 2 is not available. Notify your system administrator	72-313-00	Tray 2 out of service (mechanical failure)	Switch the machine off then on, GP 14 . Print and copy services can continue from other trays if the correct media is available. If the problem persists, perform the 72-215-00 Tray 2 Elevate Up Failure RAP
Tray 2 is open	72-302-00	The adjustable tray 2 is open	Close Tray. Print and copy services can continue from other trays if the correct media is available. Refer to 72-320-00 RAP and WD 7.5
Tray 2 is open. Check paper and close tray	72-301-00	The dedicated tray 2 is open	Close tray. Print and copy services can continue from other trays if the correct media is available. Refer to 72-320-00 RAP and WD 7.5

Table 4 Status messages S to Y

UI Message	Status Code	Reason for Message	Reference / Action
Tray 2 lifting	72-536-00	Tray 2 lifting	No service action required. Print and copy services can continue from other trays if the correct media is available
Tray 3 is empty. Add paper	73-530-00	Tray 3 is out of media	Add media. Print and copy services can continue from other trays if the correct media is available. If the problem persists, perform the 73A RAP
Tray 3 is lifting	73-536-00	Tray 3 lifting	Print and copy services can continue from other trays if the correct media is available
Tray 3 is nearly empty. Add paper	73-535-00	Tray 3 media low	Add media. Print and copy services can continue from other trays if the correct media is available
Tray 3 is not available. Notify your system administrator	73-313-00	Tray 3 out of service (mechanical failure)	Switch the machine off then on, GP 14 . Print and copy services can continue from other trays if the correct media is available. If the problem persists, perform the 73-212-00 RAP , 73-215-00 RAP
Tray 3 is open	73-301-00	Tray 3 is open	Close Tray. Printing can continue from other trays. If the problem persists, perform the 73-320-00 RAP
Tray 3 is open. Check paper and close the tray	73-300-00	The dedicated tray 3 is open	Close Tray. Print and copy services can continue from other trays if the correct media is available
Tray 3 is open. Check paper and close the tray	73-302-00	The adjustable tray 3 is open	Close Tray. Print and copy services can continue from other trays if the correct media is available. If the problem persists, perform the 73-320-00 RAP

Table 4 Status messages S to Y

UI Message	Status Code	Reason for Message	Reference / Action
Tray 4 (Bypass) is not available. Notify your System Administrator	74-313-00	Tray 4 mechanical failure	Switch the machine off then on, GP 14. Print and copy services can continue from other trays if the correct media is available. Refer to the following, 74-101-00 Bypass Tray Mis-Feed RAP, 74-120-00 Bypass Tray Guides Move in Run RAP and 74-214-00 Bypass Tray Nudger Failure RAP
Tray 5 is empty. Add paper	75-530-00	Tray 5 is out of media	Add media. Print and copy services can continue from other trays if the correct media is available. If the problem persists, perform the 75B RAP
Tray 5 is nearly empty. Add paper	75-535-00	Tray 5 media low	Add media. Print and copy services can continue from other trays if the correct media is available. If the problem persists, perform the 75B RAP
Tray 5 is not available. Notify the system administrator	75-313-00	Tray 5 mechanical failure	Tray 5 is not available. Print and copy services can continue from other trays if the correct media is available. If the problem persists, perform the 75-212-00, 75-215-00 Tray 5 Elevate Up Failure RAP
Tray 5 is not available. Notify your system administrator	75-312-00	Tray 5 communications failure	Switch the machine off, GP 14. Check cabling connections. Switch the machine on, GP 14. Print and copy services can continue from other trays if the correct media is available. Refer to 75-312-00 RAP
Tray 5 is open	75-301-00	Tray 5 is open	Close tray. Print and copy services can continue from other trays if the correct media is available. Refer to 75A RAP

Table 4 Status messages S to Y

UI Message	Status Code	Reason for Message	Reference / Action
Tray 5 is overloaded. Remove some paper	75-525-00	Tray 5 is overloaded	Remove some media. Print and copy services can continue from other trays if the correct media is available. Perform 75-212-00, 75-215-00 RAP
Tray 5 is unavailable. Please call for assistance.	92-536-00	Tray 5 communications problems (PfpSerialLink-Safety)	Switch the machine off then on, GP 14. Check connection to printer. If problem persists, perform the 92-535-00, 92-536-00 RAP. Copying and printing are not available
Tray 5 is un-docked	75-305-00	Tray 5 is undocked	Re-dock tray 5 to the machine. Print and copy services can continue from other trays if the correct media is available. Refer to 75-325-00 RAP
Tray 5 is undocked.	75-305-01	Tray 5 is undocked	Re-dock tray 5 to the machine. Print and copy services can continue from other trays if the correct media is available. Refer to 75-325-00 RAP
Tray 5 lifting	75-536-00	Tray 5 is lifting	No action required. Print and copy services can continue from other trays if the correct media is available
Tray 5 lowering	75-537-00	Tray 5 is lowering	No action required. Print and copy services can continue from other trays if the correct media is available
Tray 6 (inserter) is empty. Add paper	12-617-00	Tray 6 (Inserter) detects no paper present	Add paper to tray 6. If the problem persists, perform the 12J-171 RAP
Tray 6 (inserter) is empty. Load more media for insertion.	12-731-00	Post process inserter tray (tray 6) is empty. Jobs will be held if inserts are required.	Load more media. If the problem persists, perform the 12J-171 RAP
Tray 6 (inserter) is unavailable. Check for obstructions in the Inserter.	12-944-00	Inserter capability degraded	Check for obstructions in the inserter. If the problem persists, perform the 12-191-00-171, 12-193-00-171, 12-194-00-171, 12-196-00-171 RAP and 12J-171 RAP

Table 4 Status messages S to Y

UI Message	Status Code	Reason for Message	Reference / Action
Tray 6 (inserter) is unavailable. Check for obstructions. Power off then on.	12-744-00	Inserter unavailable	The Post Process Inserter is not available. Switch the machine off then on, GP 14 . Check the current fault code list for inserter faults and go to appropriate RAP
Tray is ready for unloading. Press the button on finisher to return tray to ready position	12-740-00	Tray is ready for unloading	Follow the instructions to unload the tray
Trays 1 to 3 are not available. Notify your system administrator.	70-312-00	Communications failure for trays 1 to 3	Switch the machine off then on, GP 14 . If the problem persists, perform the 70-312-00 RAP
Unable to staple. Check for obstructions in the output trays	12-901-00	The finisher is in degraded mode, unable to staple.	Switch the machine off then on, GP 14 . If the problem persists, perform the 12F-171 RAP
Unexpected paper size or type detected from tray 1	71-103-00	Media size mismatch in tray 1 (alternate method)	Open tray 1. Check paper size, orientation and type. If the problem persists, perform the 71B RAP
Unexpected paper size or type detected from tray 2	72-103-00	Media match in tray 2 (alternate method)	Open Tray 2. Check paper size, orientation and type. Print and copy services can continue from other trays if the correct media is available
Unexpected paper size or type detected from tray 3	73-103-00	Media size mismatch in tray 3 (alternate method)	Open Tray 3. Check paper size, orientation and type. Print and copy services can continue from other trays if the correct media is available
Unexpected paper size or type detected from tray 4 (bypass)	74-103-00	Media size mismatch in tray 4 (alternate method)	Open Tray 4, check paper size, orientation and type. Print and copy services can continue from other trays if the correct media is available Refer to WD 8.3
Unexpected paper size or type detected from tray 5	75-103-00	Media size mismatch in tray 5 (alternate method)	Lower Tray 5 using the button indicated. Check paper size, orientation and type. Print and copy services can continue from other trays if the correct media is available

Table 4 Status messages S to Y

UI Message	Status Code	Reason for Message	Reference / Action
Unexpected paper size or type detected from tray 5	75-103-01	Media size mismatch in tray 5 (alternate method)	Lower Tray 5 using the button indicated. Check paper size, orientation and type. Print and copy services can continue from other trays if the correct media is available
Unexpected paper size or type detected from tray 5	75-301-01	Media size mismatch in tray 5 (alternate method)	Lower Tray 5 using the button indicated. Check paper size, orientation and type
Unexpected paper size or type detected from tray 6 (Inserter)	12-750-00	A shorter than expected sheet has been fed from the inserter	Follow the message text. Check the size of the paper in the inserter. Refer to 12J-171 RAP
Unexpected paper size or type detected on tray 6 (inserter)	78-103-00	Media size mismatch in tray 6	Open Tray 6. Check and confirm paper size, orientation and type
Waste tray is almost full and will need emptying soon	91-590-00	IME waste tray is almost full	The tray will need to be emptied soon. Printing and copying can continue
Waste tray is full. Please empty the waste tray	91-847-00	The waste tray is almost full and has also been removed	Empty the waste tray, then replace it in the machine
Waste tray is full. Please empty the waste tray.	91-591-00	IME waste tray is full	Empty the tray. Copying and printing are not available. If necessary refer to WD 9.4
Waste tray locked while in use. Do not attempt to remove	91-589-00	IME waste ink tray is locked in place to allow it to cool	-
Waste tray not detected (Missing). Insert the Waste Tray.	91-584-00	Waste ink tray is missing (not full and not present)	Install a waste ink tray, PL 91.10 Item 15 . Print and copy services are disabled. If the problem persists, refer to WD 9.4 and 91-832-00 RAP
Workflow scanning hardware must be added or replaced. Notify your system administrator	16-554-00	Network controller - Hardware must be added or replaced	Hardware must be added or replaced
Workflow scanning service cannot register. Power off then on and notify system administrator	17-559-00	Network scanning service cannot register	Switch the machine off then on, GP 14 . Scan service is disabled, print and other machine services are unaffected. If the problem persists, perform the 16-985-19 , 16-986-19 Network Scanning Application Registration Error RAP

Table 4 Status messages S to Y

UI Message	Status Code	Reason for Message	Reference / Action
Yellow Ink is empty. Load Xerox ColorQube yellow ink.	93-515-00	IME yellow ink is empty	Load more yellow solid ink. Copying and printing are not available. Check the ink low sensor and harness. Refer to WD 9.18 .
Yellow ink stick is jammed. Call for assistance	93-516-00	Ink stick loaded sensor actuated. Ink stick transport motor operated. Ink stick not detected by ink out sensor	Clear the ink loader jam. Copying and printing are not available
Yellow ink stick jam. Add yellow ink to aid jam recovery.	93-928-00	Yellow ink stick jam	Yellow ink stick jam detected. Load a yellow Ink stick to aid jam recovery. Copying and printing not available
Your Administrator is reconfiguring the system. Services will not be available	16-506-00	The administrator is reconfigure the system	The system administrator is saving the machine configuration to a remote station

OF 5 Boot Up Failure RAP

Use this RAP if the UI displays 'The machine is not available' or 'Copying and printing not available' or the machine does not come to a 'Ready to scan your job' state. Also, use this RAP if the software loading procedure fails.

Initial Actions

WARNING

Ensure that the electricity to the machine is switched off while performing tasks that do not need electricity. Refer to GP 14. Disconnect the power cord. Electricity can cause death or injury. Moving parts can cause injury.

- Switch off the machine, then switch on the machine, [GP 14](#).
- Check the 7- Segment display unit on the SBC PWB, [Table 2](#).
- Pull out the image processing module, [OF 6](#). Check the chassis fan assembly, [PL 3.11 Item 5](#)
- If the boot up failure occurs after new components are installed, make sure the new components are compatible with the machine and all PJ's correctly seated. Check that no pins are damaged.
- Check that all the PJ's are seated correctly on the single board controller PWB.

Procedure

Perform the following:

1. Disconnect the DADH communication / power cable (PJ188 / PJ851), [PL 5.10 Item 6](#).
2. If an LCSS or HVF is installed, disconnect the communication cable and the power cord. Install a finisher bypass connector, [PL 26.10 Item 3](#).
3. If a fax is installed, remove the fax module, [PL 20.05 Item 1](#).
4. Switch on the machine, [GP 14](#).

The machine boots up.

Y N

Perform the following:

- Check the state of the LED's on the single board controller PWB, [Figure 1](#). Refer to [Table 1](#) which indicates the fault state and perform the relevant service actions.
NOTE: The non-fault state of the LED's is shown in [Figure 1](#).
- Re-install the original fax module. Connect the DADH communication / power cable. Connect the output device communication cable and power cord.

Connect the DADH communication / power cable (PJ188 / PJ851). Switch on the machine, [GP 14](#). **The machine boots up.**

Y N

Install new components as necessary:

- DADH PWB, [PL 5.10 Item 5](#).
- Scanner PWB, [PL 62.16 Item 8](#).

Connect the output device communication cable and power cord. Switch on the machine, [GP 14](#). **The machine boots up.**

Y N

The output device is a HVF with a booklet maker.

A

A

Y N

Install new components as necessary:

- OCT, [PL 12.00 Item 1](#).
- LCSS PWB, [PL 12.75 Item 1](#).
- HVF PWB, [PL 12.140 Item 2](#).

Disconnect the booklet maker PWB. **The machine boots up.**

Y N

Install a new HVF PWB, [PL 12.140 Item 2](#).Install a new BM PWB, [PL 12.175 Item 10](#).If necessary, reload the software. Refer to [GP 4 Machine Software](#).**Table 1 Single board controller PWB**

LED ID	LED colour	Fault State	Description
CR1	Green	Off	1.8V failure. Indicates a voltage supply or regulation fault. Install a new single board controller PWB, PL 3.11 Item 13 .
CR2	Green	On	Indicates a SIM error The SIM card is corrupt or does not contain the correct serial number. Install a new SIM card of the same type, PL 3.11 Item 22 , refer to GP 19 .
CR3	Green	Off	NOTE: This LED is normally on but flashes briefly when the SIM card is accessed. If the LED does not flash during SIM card access, this can indicate a fault. Check that the SIM card serial number and the machine chassis numbers match. Install a new SIM card of the same type, PL 3.11 Item 22 , refer to GP 19 . If the fault persists, install a new single board controller PWB, PL 3.11 Item 13 .
CR4	Green	Off	Indicates +3.3V failure. Check harnesses and install as necessary a new power distribution PWB, PL 3.11 Item 1 and a single board controller PWB, PL 3.11 Item 13 .
CR5	Green	Off	Indicates +3.3V failure. Check harnesses and install as necessary a new power distribution PWB, PL 3.11 Item 1 and a single board controller PWB, PL 3.11 Item 13 .
CR7	Green	A code appears	A alpha-numeric codes appear in the window, refer to OF 16 . The decimal point is the heartbeat and pulses.

Table 1 Single board controller PWB

LED ID	LED colour	Fault State	Description
CR8	Green	Off	+1.8V SLEEP failure Indicates a voltage supply or regulation fault. Install a new single board controller PWB, PL 3.11 Item 13 .
CR9	Green	Off	Image clock disabled
CR12	Green	Off	Indicates a voltage supply or regulation fault. Install a new single board controller PWB, PL 3.11 Item 13 . If CR4 or CR5 are also off, install a new power distribution PWB, PL 3.11 Item 1 .
CR14	Red	On	Indicates power failure
CR24	Green	On	Indicates that the FPGA is not programmed. Install a new single board controller PWB, PL 3.11 Item 13 .
CR10, CR11, CR13	-	-	Not used
Internet connector left side PJ14	Green / Yellow	Off	Check the ethernet cable. If necessary, install a new single board controller PWB, PL 3.11 Item 13 .
Internet connector right side PJ14	Green / Yellow	Off	NOTE: This LED should be on or flashing during data transfer. Check the ethernet cable.

Refer to [Figure 1](#) for the location and state of the LED's on the single board controller PWB in a non-fault condition.**Table 2 7-Segment LED display**

POST code name	Fault code	Decimal point status	Code Description	Service action
Display Test	8	On	Initial 7 segment display test	LED display or SBC PWB. Check that the NVM module PWB is fitted correctly, PL 3.11 Item 17 . Install a new SBC PWB, PL 3.11 Item 13
PWBA	1	Off	Failed explorer controller	Install a new SBC PWB, PL 3.11 Item 13 .
System memory	2	Flashing	Failed system memory	Install a new System memory PWB, PL 3.11 Item 4

Table 2 7-Segment LED display

POST code name	Fault code	Decimal point status	Code Description	Service action
EPC Memory	3	Flashing	Failed EPC memory	Install a new EPC memory PWB, PL 3.11 Item 21
NVM and RTC Module	4	Flashing	Failed NVM memory	Install a new NVM module PWB, PL 3.11 Item 17
Flash Module	5	Flashing	Failed flash memory	Flash module. Install a new SBC PWB, PL 3.11 Item 13 .
External Hard Drive	6	Flashing	Failed external hard drive	Install a new External hard drive, PL 3.11 Item 2
RTC module	7	Flashing	Failed RTC	RTC module. Install a new SBC PWB, PL 3.11 Item 13 .
Initial entry to kernel code	0	Flashing	Waiting for power normal	No action, no POST fault detected
U-boot complete	9	Flashing	U-boot hand over control to kernel	Kernel software
Kernel starting user space	U	Flashing	Kernel starting user space	Kernel / run time software
Machine in ready mode	Blank	Flashing	None, no fault detected	No action, no fault detected
UI platform available	A	Flashing	UI platform available	See NOTE:
IIT comms established	b	Flashing	IIT comms established	See NOTE:
NC platform available	C	Flashing	NC platform available	See NOTE:
Dc platform available	d	Flashing	Dc platform available	See NOTE:
IOT comms established	E	Flashing	IOT comms established	See NOTE:
Fax comms established	F	Flashing	Fax comms established Only if Fax installed	See NOTE:
Machine attempting sleep entry	L	Flashing	OS suspending drivers, entering sleep (Split power plane TBC)	None, for diagnostic information only
Machine in sleep state	r	Flashing	Resting in sleep	None, for diagnostic information only
Machine in semi-conscious state	t	Flashing	Running in semi-conscious mode	None, for diagnostic information only
Machine attempting sleep wake-up	H	Flashing	OS resuming drivers	None, for diagnostic information only

NOTE: On Application power up the 7-segment display cycles around displaying these codes until the relevant platform has fully synchronized with the system. Any code left displayed after power up indicates this event has not been detected in software and is a probable s/w issue

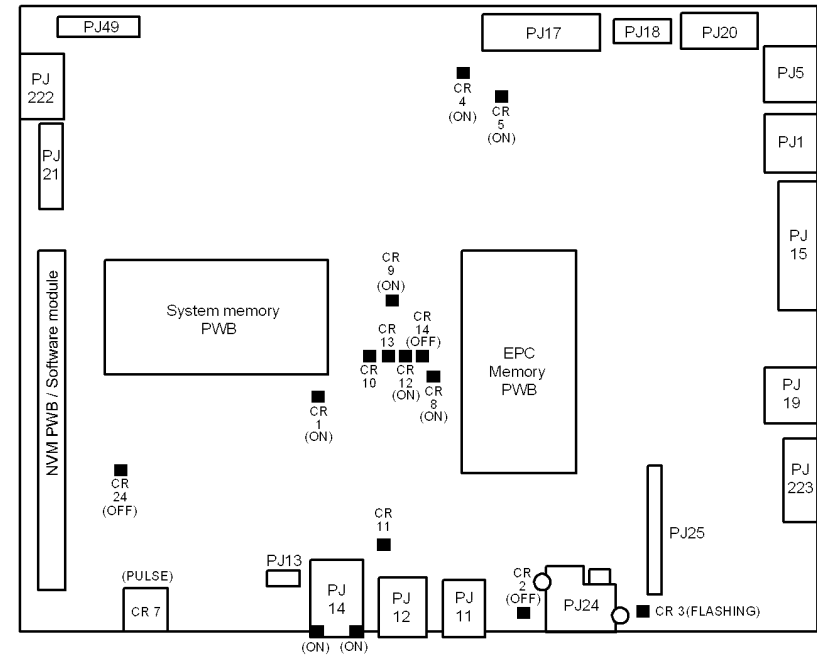

U-1-1653-A

Figure 1 Single board controller PWB

OF 6 Fans and Air Systems RAP

Use this RAP to diagnose faulty machine fans. Faulty fans can cause smells or overheating.

Procedure

WARNING

Ensure that the electricity to the machine is switched off while performing tasks that do not need electricity. Refer to [GP 14](#). Disconnect the power cord. Electricity can cause death or injury. Moving parts can cause injury.

NOTE: Bear in mind that not all fans operate all of the time that the machine is switched on.

Identify the suspect fan.

- Check the harness to the fan.
- Check for damage or debris that restricts the movement of the fan.
- From [Table 1](#), check that the fan operates and in the correct direction.

Refer to the following:

- The indicated PJ.
- The indicated PWB that supplies the fan.
- [GP 10](#) How to Check a Motor.

As necessary, install a new fan, or the assembly containing the fan, referring to the indicated parts list reference.

In [Table 1](#), The power supply fan blows air into the machine and the other fans blow air out towards the back of the machine.

Table 1 Fan information

Name	WD No.	PWB	PJ	Parts List Reference
Chassis fan	WD 1.7	Power distribution PWB	PJ7	PL 3.11 Item 5
Drum cooling fan	WD 9.1	Drum driver PWB	PJ501	PL 94.20 Item 4
Marking unit fan	WD 9.4	Drum driver PWB	PJ901	PL 1.15 Item 23
Abatement fan	WD 9.4	Drum driver PWB	PJ901	PL 94.20 Item 11
Enclosure fan	WD 9.4	Drum driver PWB	PJ901	PL 1.15 Item 6
Power supply fan	-	Power supply unit	-	PL 1.15 Item 2

OF 7 Sleep Mode RAP

Use this RAP when the machine has problems entering or leaving the sleep (energy saving) mode.

Initial Actions

WARNING

Ensure that the electricity to the machine is switched off while performing tasks that do not need electricity. Refer to [GP 14](#). Disconnect the power cord. Electricity can cause death or injury. Moving parts can cause injury.

In sleep mode, check that the machine is running very quietly and check that only the green LED on top of the power supply unit, [PL 1.15 Item 2](#) is lit. In this mode the sleep mode button at the right end of the UI keyboard, is illuminated with a green lamp. In run mode, all three power supply LED's are lit.

Procedure

The following signals are used to control and monitor the active state of the machine:

- **Active 24V.** Refer to [WD 1.4](#) and [WD 9.4](#).
 - Source - [Power Supply Unit](#), PJDC2, pin 24.
 - Destination - [Drum Driver PWB](#), PJ902, pin 24.
 - Action - This signal informs the drum driver PWB that the +24V supply is switched on. When this supply is on, it also enables the +5V, +12V and -12V supplies.
 - Active 24V signal level - This is +3.3V when the machine is in the normal mode and 0V in sleep mode.
- **Active 50V.** Refer to [WD 1.4](#) and [WD 9.4](#).
 - Source - [Power Supply Unit](#), PJDC2, pin 26.
 - Destination - [Drum Driver PWB](#), PJ902, pin 26.
 - Action - This signal informs the drum driver PWB that the +50V supply is switched on.
 - Active 50V signal level - This is +3.3V when the machine is in the normal mode and 0V in sleep mode.
- **Energy Star 24V.** Refer to [WD 9.4](#) and [WD 1.4](#).
 - Source - [Drum Driver PWB](#), PJ902, pin 27.
 - Destination - [Power Supply Unit](#), PJDC2, pin 27.
 - Action - This signal reports back to the power supply unit that the +24V supply was switched off when the machine entered sleep mode, and Energy Star became active. Switching this supply off, also switched off the +5V, +12V and -12V supplies.
 - Energy Star 24V signal level - This is +3.3V when the machine is in the normal mode and is 0V in sleep mode.
- **Energy Star 50V.** Refer to [WD 9.4](#) and [WD 1.4](#).
 - Refer to [WD 9.4](#) and [WD 1.4](#).
 - Source - [Drum Driver PWB](#), PJ902, pin 28.
 - Destination - [Power Supply Unit](#), PJDC2, pin 28.
 - Action - This signal reports back to the power supply unit that the +50V supply was switched off when the machine entered sleep mode, and Energy Star became active.
 - Energy Star 50V signal level - This is +3.3V when the machine is in the normal mode and is 0V in sleep mode.

- **Analogue Power Gauge 24V.** Refer to [WD 1.4](#) and [WD 9.4](#).
 - Source - [Power Supply Unit](#), PJDC2, pin 31.
 - Destination - [Drum Driver PWB](#), PJ902, pin 31.
 - Action - This signal informs the drum driver PWB that the +24V power used is within the expected range.
 - Analogue power gauge 24V signal level - This is an analogue signal between 0V and +3.3V. When this signal is below +2.11 volts, the power used is within the expected range.
- **Analogue Power Gauge 50V.** Refer to [WD 1.4](#) and [WD 9.4](#).
 - Source - [Power Supply Unit](#), PJDC2, pin 29.
 - Destination - [Drum Driver PWB](#), PJ902, pin 29.
 - Action - This signal informs the drum driver PWB that the +50V supply power used is within the expected range.
 - Analogue power gauge 50V signal level - This is an analogue signal between 0V and +3.3V. When this signal is below +2.11 volts, the power used is within the expected range.

The above signals are carried on a ribbon cable and are therefore difficult to measure. Check that the cable is in good condition and is securely and correctly connected. Install new components as required:

- Drum driver power supply interface cable, [PL 1.15 Item 10](#).
- Drum driver PWB, [PL 1.15 Item 4](#).
- Power supply unit, [PL 1.15 Item 2](#).

Check the power supplies during normal or sleep mode as follows:

- **+3.3V ESTAR.** Refer to [WD 1.3](#). This supply is switched on both in normal and sleep modes. If necessary, go to [01B +3.3V ESTAR Distribution RAP](#).
- **+3.3V.** Refer to [WD 1.6](#). This supply is switched on both in normal and sleep modes. If necessary, go to [01C +3.3V Distribution RAP](#).
- **+5V.** Refer to [WD 1.3](#). This supply is switched on during normal mode and is switched off during sleep mode. If necessary, go to [01D +5V Distribution RAP](#).
- **+12V.** Refer to [WD 1.3](#). This supply is switched on during normal mode and is switched off during sleep mode. If necessary, go to [01E +12V Distribution RAP](#).
- **-12V.** Refer to [WD 1.3](#). This supply is switched on during normal mode and is switched off during sleep mode. If necessary, go to [01F -12V Distribution RAP](#).
- **+17V.** Refer to [WD 1.5](#). This supply changes voltage according to the machine mode. When the machine is switched on, the machine enters Print Engine Self Test (PEST) and this supply is measured at about +17V. When the machine enters normal running mode, this supply rises to +24V. When the machine enters sleep mode, this supply returns to about +17V. It is used to generate the +3.3V for the IIT. If necessary, go to [01G +17V Distribution RAP](#).
- **+24V.** Refer to [WD 1.3](#). This supply is switched on during normal mode and is switched off during sleep mode. If necessary, go to [01H +24V Distribution RAP](#).
- **+50V.** Refer to [WD 1.3](#). This supply is switched on during normal mode and is switched off during sleep mode. If necessary, go to [01J +50V Distribution RAP](#).
- **-50V.** Refer to [WD 1.3](#). This supply is switched on during normal mode and is switched off during sleep mode. If necessary, go to [01K -50V Distribution RAP](#).

OF 8 Multi-feed RAP

To solve several sheet multi-feeds or extra blank sheet output problems.

Initial Actions

WARNING

Ensure that the electricity to the machine is switched off while performing tasks that do not need electricity. Refer to GP 14. Disconnect the power cord. Electricity can cause death or injury. Moving parts can cause injury.

- Check the condition of the paper. Do not use incorrectly cut paper, damp paper, paper with rough edges, badly drilled paper, paper with wrapper wax or glue contamination. Refer to [IQ 1 Image Quality Entry RAP](#).
- Check the paper specification, [GP 20](#).
- Multi-feed from the bypass tray, go to [74A By-pass Tray RAP](#)

Procedure

When checking for multi-feeds always use a new ream of paper. If a new ream can not be used, then perform the following:

1. Fan the paper.
2. Turn the paper round or turn the paper over.
3. Remove four or five sheets from the top of the stack.
4. When loading multi-reams of paper into tray 3. Remove the top and bottom sheet from each ream. This will prevent ream interface multi-feeds.

Tray 1 and Tray 2

Check the following:

1. Check that the paper tray side guides are set to the correct paper size.
2. The paper tray drops down when the tray is pulled out and the tray elevates up when pushed in.
 - a. Check the paper feed assembly, [REP 81.1](#).
 - b. Check the paper feed rolls, [REP 81.4](#).
 - c. Check that the clutch assembly, tray 1, [PL 81.25 Item 4](#) or tray 2, [PL 81.26 Item 4](#), has a torque resistance and does not rotate freely.
 - d. Install new components as necessary, Tray 1, [PL 81.25](#), Tray 2, [PL 81.26](#).
3. The paper trays for worn, broken or missing components.
 - a. Install new components as necessary, [PL 70.10 Item 1](#).

Tray 3

Check the following:

1. The tray moves down when the tray is pulled out, and moves up when the tray is closed.
 - a. Check tray 3 paper feed assembly, [REP 81.2](#).
 - b. Check that the clutch assembly, [PL 81.30 Item 4](#) has a torque resistance and does not rotate freely.
 - c. Install new components as necessary, [PL 81.30 Item 1](#).
2. The paper tray for worn, broken or missing components. Install new components as necessary, [PL 73.15](#).

Tray 5

Check the following:

1. The tray moves down when the door is opened, and moves up when the door is closed.
 - a. Check the tray 5 paper feed assembly, [REP 81.7](#).
 - b. Check the tray 5 paper feed rollers, [PL 81.45 Item 2](#).
 - c. Install new components as necessary, [PL 75.68](#), [PL 75.70](#).

Bypass Tray

Perform the following:

1. Ensure that the customer is not filling the tray above the max fill line.
2. Clean the feed roll and retard pad with a damp cloth with water.
3. Check that the clutch, [PL 74.10 Item 5](#) has a torque resistance and does not rotate freely.
4. Install a new clutch, feed roll, nudger and retard roll, [PL 74.10](#).

OF 9 Ink Stick Count Mismatch

Use this RAP when the number of ink sticks in the ink loader does not correspond with the percent values shown on the UI display.

The NVRAM value is read by the software and processed internally. It is actually the approximate number of micrograms of ink left in the ink loader and is not a percentage. The percentage is computed by the software and updated by the IME software to the UI.

Procedure

Only perform this procedure when:

- There is more than one ink stick difference between the number of ink sticks in the ink loader and the indicated value on the UI.
- If the NVM values have been corrupted.

Perform the following:

1. Remove the rear cover, [PL 81.10 Item 1](#).
2. Remove the ink loader access cover rear, [PL 81.10 Item 7](#).
3. Check the number of ink sticks in the loader.
4. Enter Service mode, [GP 1](#).
5. Select Adjustments.
6. Select [dC131](#) NVM Read / Write.
7. Enter the NVM ID from the list below:
 - Cyan NVM ID 420-001.
 - Magenta NVM ID 420-002.
 - Yellow NVM ID 420-003.
 - Black NVM ID 420-004.
8. Select Read. The NVM description and value will be displayed.
9. To calculate the new values which are nominal mass and measured in micrograms:
Black ink stick has a mass value = 204000000 micrograms.
Colour ink stick has a mass value = 189000000 micrograms
Count the number of complete ink sticks and estimate the size of the ink stick in the melt plate assembly. Make the calculation using the mass values for each ink colour. Enter the values in the NVM for each colour.
10. To modify the ink level value:
 - a. Select the NVM ID for the ink stick to be changed.
 - b. Select Read.
 - c. Select +/- in the Value of ink level box.
 - d. Enter the new value using the key pad. If the wrong value is entered, press C to back space.
 - e. Select Write to enter the new value in the NVM.
 - f. Select Call Closeout and Exit only.
11. Switch the machine off, then switch the machine on, [GP 14](#).
12. Check that the number of ink sticks in the ink loader correlates with the ink level indicator on the user interface.

OF 10 Intermittent Failure RAP

Use this RAP to locate failures when no specific cause can be found, i.e. if the machine resets to 'Ready to scan your job' or 'Please wait' during a print / copy run, or a fault code occurs which cannot easily be repeated.

Initial Actions

WARNING

Ensure that the electricity to the machine is switched off while performing tasks that do not need electricity. Refer to [GP 14](#). Disconnect the power cord. Electricity can cause death or injury. Moving parts can cause injury.

WARNING

Take care during this procedure. Sharp edges may be present that can cause injury.

Perform the following to gather additional information about the fault:

- Ask the customer if there are any specific print / copier functions that cause the fault to occur; e.g. using the input or output module, or making reduced images.
- Enter Machine Status and check the active messages and the event log. If a fault code is raised when the failure occurs, then go to the appropriate RAP.
- Make copies and observe where the paper stops and which components are switched ON or OFF when the failure occurs.
- Check if there is a repeating pattern to the failure.

Procedure

Go to the relevant checkout:

- [Customer Power Supply Checkout](#)
- [External Electrical Equipment Checkout](#)
- [Common Causes Checkout](#)
- [Connectors and Wiring Checkout](#)
- [Power Supply Checkout](#)
- [EPROMs Checkout](#)
- [Electric Motors Checkout](#)
- [Solenoids and Clutches Checkout](#)
- [Switches and Sensors Checkout](#)
- [Electrostatic Discharge Checkout](#)
- [Paper Trays 1 to 5 Checkout](#)
- [Output Device Checkout](#)

Customer Power Supply Checkout

WARNING

Take care when measuring AC mains (line) voltage. Electricity can cause death or injury.

CAUTION

If you suspect that the customer AC power is incorrect, DO NOT try to correct the customer power. DO NOT reconnect the printer. Inform the customer and your manager.

- Measure the customer power voltage at the power outlet and check that the customer power is within specification. Refer to [GP 22](#) Electrical Power Requirements.

- Check that the customer power does not drop below the specification when the copier is making copies; use a digital meter and select "Peak Hold". Refer to [GP 22](#) Electrical Power Requirements.

External Electrical Equipment Checkout

WARNING

Take care when measuring AC mains (line) voltage. Electricity can cause death or injury.

CAUTION

If you suspect that the customer power is incorrect, DO NOT try to correct the customer power. DO NOT reconnect the machine. Inform the customer and your manager.

Perform the following:

- Ask the customer if there is any electrical equipment, which uses a large amount of current, that is connected to the same supply circuit as the machine.
- With the customer's assistance, check if the failure occurs when electrical equipment near to the machine is switched ON or OFF.
- If possible, connect the machine to a different supply circuit from the equipment that is causing the problem.

Common Causes Checkout

Make the following checks of common causes of intermittent failures:

- Check for intermittent connections in the wiring to the LED exposure lamp.
- Check that the front door interlock switch is fully actuated by the front door interlock actuator. If the fault is eliminated when an interlock cheater is installed, check that the interlock actuator is not damaged. Install new parts as necessary.
- Check that the chassis fan, [PL 3.11 Item 5](#) is working correctly. Refer to [OF 6](#) Fans and Air Systems RAP.

Connectors and Wiring Checkout

Refer to [REP 1.1](#) for details of wiring harness repair.

Check the following:

- Visible signs of damage to the wiring and the ribbon cables. Especially check wiring to components that move.
- Check for pinched wires near moving parts.
- The DADH module harness for broken wiring and ensure that the earth terminals are secure.
- To check for wire breaks inside insulation, gently pull the relevant connector and wire while measuring continuity.
- Check that all the PWB and in-line connections are good; refer to [PJ Locations](#).
- Check the continuity of the ground connections to the input and output modules.
- Check that all the input and output module static eliminators are connected correctly and in good condition; refer to the relevant input or output module RAP.

Power Supply Checkout

Check the power cord for continuity.

EPROMs Checkout

Check that the NVM module PWB, EPC memory PWB and system memory PWB are installed correctly. If necessary, reseat or install new components, [PL 3.11](#).

Electric Motors Checkout

Refer to [GP 10](#) How to Check a Motor and perform the following:

- Disconnect each motor in turn to locate the motor that is causing the fault. When the faulty motor has been located, install a new motor.
- If the fault still exists, locate the PWB that drives the motor and install a new PWB.

Solenoids and Clutches Checkout

Refer to [GP 12](#) How to Check a Solenoid or Clutch and perform the following:

- Check that the components are installed correctly.
- Check that there is no mechanical binding, slipping or interference.
- Enter the relevant output codes and check that the energizing of the components is reliable. Check if the fault is caused when the components de-energize.
- If it is suspected that a clutch or solenoid is faulty, install a new component as necessary.
- If the fault still exists, locate the PWB that drives the component and install a new PWB.

Switches and Sensors Checkout

Refer to [GP 11](#) How to Check a Sensor and [GP 13](#) How to Check a Switch and perform the following:

- Check that the components are clean and installed correctly. Ensure that the wiring to the components is connected correctly.
- Enter the relevant input codes and check that the sensing of the components is reliable. Check if the fault is caused when the components are actuated.
- If it is suspected that a switch or sensor is faulty, install a new component as necessary.
- If the fault still exists, locate the PWB that controls the component and install a new PWB.

Electrostatic Discharge Checkout

Refer to [GP 7](#) System Grounding Verification and perform the following:

- If the fault only occurs when feeding from a specific paper tray, go to [Paper Trays 1 to 5 Checkout](#).
- Check that all EPROMs and the NVM module PWB are seated correctly and that the connectors are not damaged.

Paper Trays 1 to 5 Checkout

- Check that the paper tray size detection sensors match the size of paper in the trays. Check that the control panel indicators display the correct size of paper.
- Perform the [Electrostatic Discharge Checkout](#).
- Refer to the appropriate RAPs to check the operations of sensors, feed components and associated harnessing.
 - [71-101-00 to 71-155-00](#) Tray 1 Misfeed RAP
 - [72-101-00 to 72-155-00](#) Tray 2 Misfeed RAP
 - [73-101-00 to 73-155-00](#) Tray 3 Misfeed RAP
 - [75-101-00](#) Tray 5 Misfeed RAP
 - [74-101-00](#) Bypass Tray Misfeed RAP

Output Device Checkout

To run the machine without the output device connected, use a finisher bypass harness, [PL 26.10 Item 7](#). If the problem is cleared, then go to the appropriate output device.

- LCSS. Check the following:

- Ground connection on the power cord, [PL 12.75](#).
- Static eliminator on bin 0 entry, [PL 12.60 Item 7](#).
- Static eliminator on the tamper assembly, [PL 12.45 Item 5](#).
- Static eliminator on the bin 1 entry, [PL 12.65 Item 7](#).
- Check that all of the connectors on the LCSS PWB are pushed fully home. Ensure that all of the ground wires are connect to the frame.
- Check all the harnesses for damage and short circuit to ground.
- HVF. Check the following:
 - Ground connection to the power supply unit, [PL 12.140 Item 4](#).
 - Static eliminator on BM entry, [PL 12.150 Item 26](#).
 - Exit brush on HVF upper exit guide, [PL 12.125 Item 8](#).
 - Static eliminator on BM exit, [PL 12.185 Item 16](#).
 - Exit brush on the Tri folder right hand frame, [PL 12.215 Item 13](#).
 - Ground wire on the BM compiler motor, [PL 12.175 Item 1](#).
 - Ground wire on the BM back stop motor, [PL 12.160 Item 4](#).
 - Ground wires to HVF buffer motor and transport motor 2, [PL 12.120 Item 1](#).
 - Ground wires to HVF transport motor 1 and bypass feed motor, [PL 12.120 Item 2](#).
 - Ground wire between the BM flapper bracket, [PL 12.150 Item 24](#) and the crease blade assembly, [PL 12.170 Item 13](#).
 - Ground wire between the crease blade assembly, [PL 12.170 Item 13](#) and the BM tamper bracket, [PL 12.155 Item 12](#).
 - Ground wire between the base of the HVF and the BM.
 - Check that all of the connectors on the HVF PWB, and BM PWB are pushed fully home. Ensure that all of the ground wires are connected to the frame.
 - Where the Tri Folder PWB and the Inserter PWB options are installed check that the PWB connectors are pushed fully home. Ensure that all of the ground wires are connected to the frame
 - Ground wire on the Inserter PWB, [PL 12.310 Item 9](#).
 - Inserter docking PJ and connector.
 - Check all the harnesses for damage and short circuit to ground.

OF 11 Unable to Load Ink Sticks

When the machine powers off the key plate is moved to prevent the customer from loading ink sticks with the power off. This is to ensure that the ink sticks count will be correct.

Initial Actions

WARNING

Ensure that the electricity to the machine is switched off while performing tasks that do not need electricity. Refer to [GP 14](#). Disconnect the power cord. Electricity can cause death or injury. Moving parts can cause injury.

- Check that the machine is on the correct service plan, [GP 34](#).
- Check that the correct ink sticks are being used for the service plan, [GP 34](#).

Procedure

CAUTION

The ink key motor can overheat if run repeatedly. Allow 2 minutes between each run of the ink key motor.

To observe the operation of the key plate when in diagnostics. Open the ink loader access cover, [PL 81.10 Item 5](#). Use a magnet to cheat the ink loader cover switch, [PL 93.10 Item 19](#). Enter [dC330](#) code 93-051 or 052 or 053, to run the ink key plate motor, MOT93-051, [PL 93.10 Item 14](#). **MOT93-051 runs.**

Y N

Go to [WD 8.4](#). Check MOT93-051.

Refer to:

- [GP 10](#) How to Check a Motor.
- [P/J406](#), [Media path driver PWB](#).
- [01H](#) +24V Distribution RAP.
- [01L](#) 0V Distribution RAP

Install new components as necessary:

- Ink key plate motor, [PL 93.10 Item 14](#).
- Ink loader upper assembly, [PL 93.10 Item 1](#).
- Media path driver PWB, [PL 1.15 Item 5](#).

The key plate moves when the motor runs.

Y N

Perform a [dC361](#) NVM Save and Restore. Perform a [dC301](#) NVM Initialization to re-calibrate the machine. **The key plate moves to the correct position**

Y N

Perform a NVM restore the original NVM values. Perform a software load [GP 4](#).

If the problem is still present, install a new ink loader upper assembly, [PL 93.10 Item 1](#).

Refer to [dC301](#) and perform the actions required to re-calibrate the machine.

The fault may be intermittent, check the wiring to the ink key plate motor. Clean the ink loading area to ensure that the ink key plate moves smoothly. If necessary, install a new ink loader upper assembly, [PL 93.10 Item 1](#).

OF 12 Service Code RAP

Where a fault occurs on the machine but the machine is still able to run the status is displayed in the machine service code.

Procedure

To find out the service code status of the machine select the machine status key. The service code is displayed on the bottom left of the screen on the Machine Information tab, [Figure 1](#).

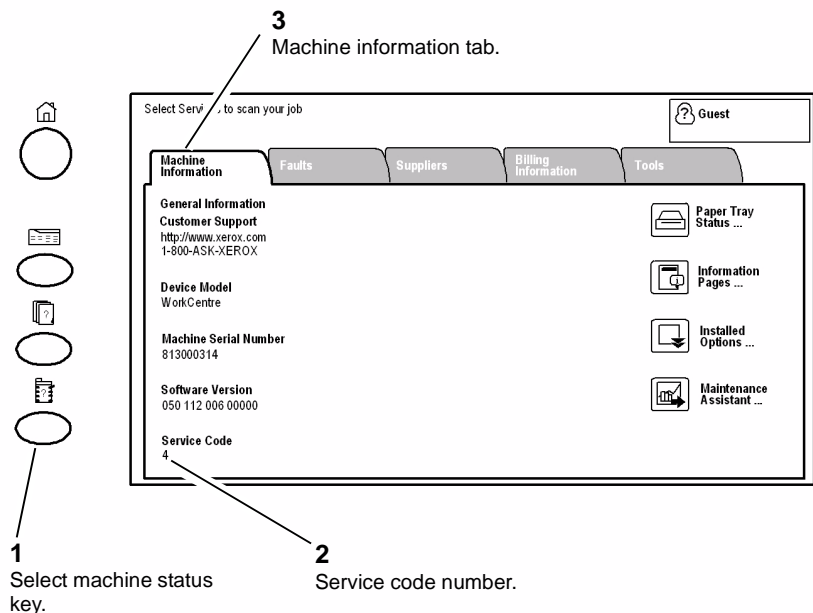

Figure 1 Service mode screen

- Identify the service code in the bottom left corner of the UI, [Figure 1](#).
 - The service codes are listed in [Table 1](#), the action needed is marked as 1.
 - The service actions required to correct the faults are listed in [Table 2](#).
- If there is more than one fault to the service code, ensure all actions are completed before moving onto the next stage.

Once the fault is fixed the service code on the UI will refresh to 0 when service mode is closed.

NOTE: A number other than 0 indicates a fault.

Table 1 Service code table

Service Code	Drum Drive Belt Error	PEST Warning Exist	IOD Chronic Jets Detected	IOD Y Run out NVRAM Reset	IOD in Degraded Mode	Reg / Preheat Calibrated Required	Transfix Calibration NVRAM Reset
0	0	0	0	0	0	0	0
1	0	0	0	0	0	0	1
2	0	0	0	0	0	1	0
3	0	0	0	0	0	1	1
4	0	0	0	0	1	0	0
5	0	0	0	0	1	0	1
6	0	0	0	0	1	1	0
7	0	0	0	0	1	1	1
8	0	0	0	1	0	0	0
9	0	0	0	1	0	0	1
10	0	0	0	1	0	1	0
11	0	0	0	1	0	1	1
12	0	0	0	1	1	0	0
13	0	0	0	1	1	0	1
14	0	0	0	1	1	1	0
15	0	0	0	1	1	1	1
16	0	0	1	0	0	0	0
17	0	0	1	0	0	0	1
18	0	0	1	0	0	1	0
19	0	0	1	0	0	1	1
20	0	0	1	0	1	0	0
21	0	0	1	0	1	0	1
22	0	0	1	0	1	1	0
23	0	0	1	0	1	1	1
24	0	0	1	1	0	0	0
25	0	0	1	1	0	0	1
26	0	0	1	1	0	1	0
27	0	0	1	1	0	1	1
28	0	0	1	1	1	0	0
29	0	0	1	1	1	0	1
30	0	0	1	1	1	1	0
31	0	0	1	1	1	1	1
32	0	1	0	0	0	0	0
33	0	1	0	0	0	0	1
34	0	1	0	0	0	1	0

Table 1 Service code table

Service Code	Drum Drive Belt Error	PEST Warning Exist	IOD Chronic Jets Detected	IOD Y Run out NVRAM Reset	IOD in Degraded Mode	Reg / Preheat Calibrated Required	Transfix Calibration NVRAM Reset
35	0	1	0	0	0	1	1
36	0	1	0	0	1	0	0
37	0	1	0	0	1	0	1
38	0	1	0	0	1	1	0
39	0	1	0	0	1	1	1
40	0	1	0	1	0	0	0
41	0	1	0	1	0	0	1
42	0	1	0	1	0	1	0
43	0	1	0	1	0	1	1
44	0	1	0	1	1	0	0
45	0	1	0	1	1	0	1
46	0	1	0	1	1	1	0
47	0	1	0	1	1	1	1
48	0	1	1	0	0	0	0
49	0	1	1	0	0	0	1
50	0	1	1	0	0	1	0
51	0	1	1	0	0	1	1
52	0	1	1	0	1	0	0
53	0	1	1	0	1	0	1
54	0	1	1	0	1	1	0
55	0	1	1	0	1	1	1
56	0	1	1	1	0	0	0
57	0	1	1	1	0	0	1
58	0	1	1	1	0	1	0
59	0	1	1	1	0	1	1
60	0	1	1	1	1	0	0
61	0	1	1	1	1	0	1
62	0	1	1	1	1	1	0
63	0	1	1	1	1	1	1
64	1	0	0	0	0	0	0
65	1	0	0	0	0	0	1
66	1	0	0	0	0	1	0
67	1	0	0	0	0	1	1
68	1	0	0	0	1	0	0
69	1	0	0	0	1	0	1
70	1	0	0	0	1	1	0
71	1	0	0	0	1	1	1
72	1	0	0	1	0	0	0

Table 1 Service code table

Service Code	Drum Drive Belt Error	PEST Warning Exist	IOD Chronic Jets Detected	IOD Y Run out NVRAM Reset	IOD in Degraded Mode	Reg / Preheat Calibrated Required	Transfix Calibration NVRAM Reset
73	1	0	0	1	0	0	1
74	1	0	0	1	0	1	0
75	1	0	0	1	0	1	1
76	1	0	0	1	1	0	0
77	1	0	0	1	1	0	1
78	1	0	0	1	1	1	0
79	1	0	0	1	1	1	1
80	1	0	1	0	0	0	0
81	1	0	1	0	0	0	1
82	1	0	1	0	0	1	0
83	1	0	1	0	0	1	1
84	1	0	1	0	1	0	0
85	1	0	1	0	1	0	1
86	1	0	1	0	1	1	0
87	1	0	1	0	1	1	1
88	1	0	1	1	0	0	0
89	1	0	1	1	0	0	1
90	1	0	1	1	0	1	0
91	1	0	1	1	0	1	1
92	1	0	1	1	1	0	0
93	1	0	1	1	1	0	1
94	1	0	1	1	1	1	0
95	1	0	1	1	1	1	1
96	1	1	0	0	0	0	0
97	1	1	0	0	0	0	1
98	1	1	0	0	0	1	0
99	1	1	0	0	0	1	1
100	1	1	0	0	1	0	0
101	1	1	0	0	1	0	1
102	1	1	0	0	1	1	0
103	1	1	0	0	1	1	1
104	1	1	0	1	0	0	0
105	1	1	0	1	0	0	1
106	1	1	0	1	0	1	0
107	1	1	0	1	0	1	1
108	1	1	0	1	1	0	0
109	1	1	0	1	1	0	1
110	1	1	0	1	1	1	0

Table 1 Service code table

Service Code	Drum Drive Belt Error	PEST Warning Exist	IOD Chronic Jets Detected	IOD Y Run out NVRAM Reset	IOD in Degraded Mode	Reg / Preheat Calibrated Required	Transfix Calibration NVRAM Reset
111	1	1	0	1	1	1	1
112	1	1	1	0	0	0	0
113	1	1	1	0	0	0	1
114	1	1	1	0	0	1	0
115	1	1	1	0	0	1	1
116	1	1	1	0	1	0	0
117	1	1	1	0	1	0	1
118	1	1	1	0	1	1	0
119	1	1	1	0	1	1	1
120	1	1	1	1	0	0	0
121	1	1	1	1	0	0	1
122	1	1	1	1	0	1	0
123	1	1	1	1	0	1	1
124	1	1	1	1	1	0	0
125	1	1	1	1	1	0	1
126	1	1	1	1	1	1	0
127	1	1	1	1	1	1	1

Table 2 Service Actions

Fault	Description	Actions Required
Registration / Pre-heat Calibration is required	The NVRAM has been corrupted and was reset to default or dC301 with Domain = Copier, NVM Data = System or All, was done resetting the NVRAM	Perform dC625 Registration / Pre-heat Calibration
Transfix Calibration NVRAM Reset	The NVRAM has been corrupted and was reset to default or dC301 with Domain = Copier, NVM Data = System or All, was done resetting the NVRAM	The transfix calibration values need to be entered from the labels on the engine frame. Enter dC978 Transfix Calibration Values.

Table 2 Service Actions

Fault	Description	Actions Required
Drum drive belt error	Drum drive belt is worn or damaged.	Go to 94-547-00, 94-555-00 Y-axis Belt Ratio Error RAP
PEST Warnings Exist	Check dC123 PEST Fault History for PEST chain link errors.	Go to the appropriate RAP
Chronic jets detected	Chronic jets are detected on one or more printheads.	Go to 91-638-00 IOD Detects Chronic Jet Error RAP
Y run out NVM reset	The NVRAM has been corrupted and was reset to default. or dC301 with Domain = Copier, NVM Data = System or All, was done resetting the NVRAM	Perform dC977 Drum Run out Calibration.
IOD in degraded mode	Print quality is suboptimal.	Go to 91-636-00 IOD in Degraded Mode RAP

OF 13 Convenience Stapler RAP

To identify problems with the convenience stapler.

Procedure

WARNING

Ensure that the electricity to the machine is switched off while performing tasks that do not need electricity. Refer to GP 14. Disconnect the power cord. Electricity can cause death or injury. Moving parts can cause injury.

WARNING

Take care when measuring AC mains (line) voltage. Electricity can cause death or injury.

CAUTION

Incorrect voltage may damage the convenience stapler. The convenience stapler must not be connected to the power outlet if the voltage is incorrect.

NOTE: There are no serviceable components in the convenience stapler.

Figure 1 shows the convenience stapler.

Check that the power lead is correctly connected to the convenience stapler PL 25.10 Item 1. Check the AC mains (line) voltage at the customer power outlet. **The voltage measured is within the power requirements, GP 22.**

Y N

If the voltages are incorrect or the wiring of the main supply is found to be defective, inform your technical manager and the customer. Do not attempt to repair or adjust the customer supply.

Install a new convenience stapler, PL 25.10 Item 1.

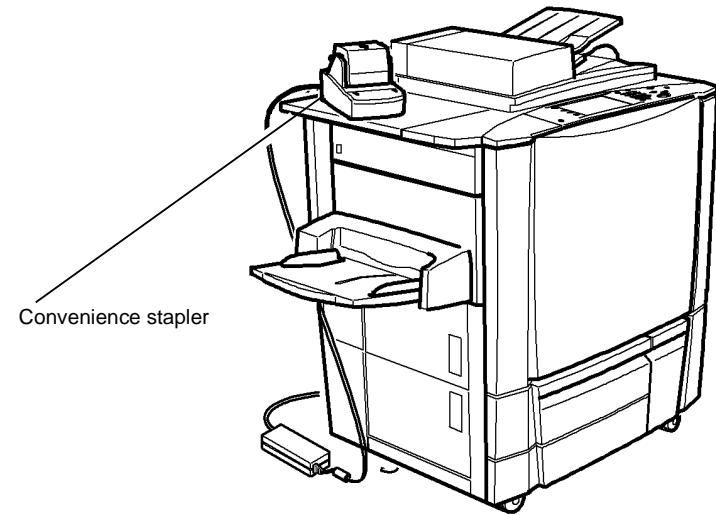

Figure 1 Component location

U-1-1196-A

OF 14 Extensible Interface Platform RAP

Use this RAP when experiencing faults with the Xerox Extensible Interface Platform.

Procedure

WARNING

Ensure that the electricity to the machine is switched off while performing tasks that do not need electricity. Refer to GP 14. Disconnect the power cord. Electricity can cause death or injury. Moving parts can cause injury.

1. Refer to WD 3.1. Check the communications cable between PJ905 on the UI PWB to PJ19 on the single board controller PWB. If necessary, repair the wiring, REP 1.1, or install a new harness, PL 2.10 Item 7.
If necessary, install new components:
 - Single board controller PWB, PL 3.11 Item 13.
 - UI PWB, PL 2.10 Item 2.
2. Go to 02-321-00 XEIP Browser Dead RAP.

OF 15 Xerox Secure Access RAP

Overview

Xerox Secure Access uses an external device, such as a card reader or biometric device, to authorize access to the machine. The reader then passes the information to the controller, which handles the authentication process, including which GUI screens are displayed, accepting GUI responses that defines their content and order. The controller can pass user identities and passwords directly to the machine after gathering the data from an external server. All communication is via a secure network link, Figure 1 Network Diagram.

Xerox Secure Access is controlled via the CentreWare Web GUI. The active status is displayed in tools within Access Control. If communications cannot be established with the Xerox Secure Access Server, the service may be temporarily disabled by touching the now enabled Off button within the Xerox Secure Access tools window. Once communication is re-established the stored Xerox Secure Access settings are restored.

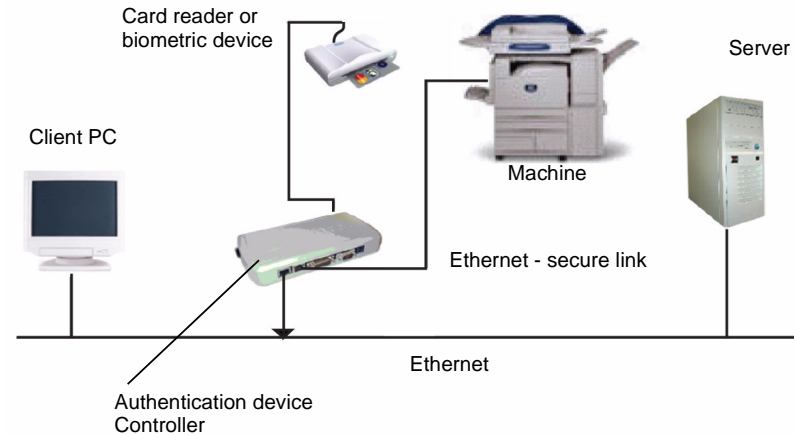

U-1-0192-A

Figure 1 Network Diagram

Initial Actions

WARNING

Ensure that the electricity to the machine is switched off while performing tasks that do not need electricity. Refer to GP 14. Disconnect the power cord. Electricity can cause death or injury. Moving parts can cause injury.

Before working on the Xerox Secure Access, test the machine in the service mode to ensure no faults are displayed and that the machine is functioning properly. If it is not, repair any problems before proceeding with diagnosing the Secure Access Accessory. Diagnostics can be entered to test copier functionality when Secure Access is installed.

Perform the steps that follow:

- Check the connection between the Card Reader and the Secure Access Authentication Device.
- Check which LED's are on or blinking on the Secure Access Authentication Device. If the LED's on the Secure Access Authentication Device are not operating, go to [Secure Access Authentication Device Failure](#).
- Check for the LED's are on or blinking on the Card Reader. If the LEDs on the Card Reader are not operating, go to Card Reader Failure.
- If customers have problems of install / setting up, or any other problems related to their Secure Access Administrator, they should refer to the Installation / Administration Guide or contact Xerox Technical Support.

Secure Access Authentication Device Failure

The primary failure modes are power problems or failed hardware components. The symptom of these failures can be detected by observing the LED's on the Secure Access Authentication Device, [Figure 2](#).

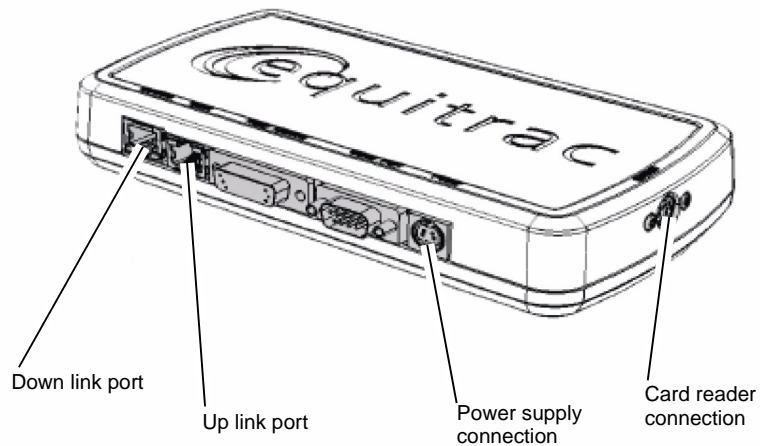

U-1-0193-A

Figure 2 Authentication device

Check the power to the Secure Access Authentication Device.

- Check the power supply at the wall socket. If there is no power at the wall socket, have the customer restore power and continue when confirmed.
- Disconnect the power cord from the wall socket and the power supply. Check the power cord for continuity and damage. If necessary install a new power cord.
Disconnect the power cord from the power supply and plug the power cord into the wall outlet. Using a multimeter, check for line voltage at the end of the power cord disconnected from the power supply. If there is power at the wall but not at the end of the power cord. Install a new power cord.

- Disconnect the small power cord from the Secure Access Authentication Device. Check there is +5V at the connector that plugs into the Secure Access Authentication Device. If there is no +5V, install a new the power supply.
- There is a 'Keyed' switch on the end of the Secure Access Authentication Device. Obtain the key from the customer. Insert the key into the 'keyed' switch and cycle the switch 1 quarter turn clockwise and then back to its start position. Observe the LEDs and listen for an audible tone.
- If the LEDs on the Secure Access Authentication Device "Uplink" and "Downlink" Ethernet ports do not cycle on and off as the controller goes through its boot-up process, or if the audible tone is not heard. Install a new Secure Access Authentication Device.

NOTE: A new device will require the Secure Access Administrator to reconfigure the server with the new MAC address of the new part. Be sure to inform the Secure Access Administrator of the MAC address of the device being removed and the MAC address of the new device

Card Reader Failure

The primary failure modes are power problems or failed hardware components. The symptom of these failures can be detected by observing the LED on the Card Reader. [Table 1](#).

- The Green LED on the Card Reader is On
- The Green LED on the Card Reader Flashes Rapidly
- The Red LED on the Card Reader is On
- The Red LED on Card Reader Flashes Slowly
- The Red LED on Card Reader Flashes Rapidly
- The Card Reader LED's are not On or Blinking

Table 1 LED identification

When the LED on the card reader is	Meaning
Red	The authentication device is in idle mode; there is no active session.
Green	The authentication device is in ready mode; a session is active.
Slow flashing red	The authentication device has no connection to the server.
Slow flashing green	The authentication device is communicating to the server.
Fast flashing red	Invalid card / password; access denied

The Green LED on the Card Reader is On

- This indicates an active Secure Access Session and the Card Read correctly corresponds to a valid Secure Access Account.
- If the UI on the machine is locked, check with the customer for a second PIN number for additional security. This PIN number will need to be entered via the soft keys on the UI.
- Ensure that the card corresponds to a valid Secure Access Account.

The Green LED on the Card Reader Flashes Rapidly

- This indicates a valid card swipe and in the process of authentication on the server.
- If the UI on the machine is locked, check with the customer for a second PIN number for additional security. This PIN number will need to be entered via the soft keys on the UI.

- If the UI on the machine is locked and no secondary PIN is required. Check that the Xerox Secure Access is installed correctly, and ask customer to check the configuration at the server.

The Red LED on the Card Reader is On

- This indicates the Card Reader is in an idle state. If the red LED remains on, and the UI remains locked after a card is swiped, re-orient the card and re-swipe.
- Try a known good card in the reader. If the other card is working on the problem Card Reader. Ask customer to make sure the card corresponds to a valid Secure Access Account.
- Try the card in a known good reader. If the card is working on a known good Card Reader, it may be a problem with the Secure Access Authentication Device. Check to see if the LEDs on the Secure Access Authentication Device are on.

The Red LED on Card Reader Flashes Slowly

- This indicates the reader is connected to the controller but the controller is not connected to the server. Check the Ethernet green LED on the Authentication Device.
- If the Ethernet green LED on the Authentication Device is off, make sure the connectors of the LAN connections are working properly. If the connections are working, this indicates the network may not work properly. Ask customer to check with Network Administrator.
- If the Ethernet green LED on the Authentication Device is either on or flashing, contact the Secure Access Administrator.

The Red LED on Card Reader Flashes Rapidly

- This indicates a valid card but does not correspond to a valid Secure Access Account at the server, test with a known valid user's card.
- If all cards react the same way, this indicates the Server Configuration may not be correct. Ask customer to check the Server Configuration.
- If all the card react this way, this indicates the cards are not valid. Ask customer to check the Server Configuration

The Card Reader LED's are not On or Blinking

- Check to see if the Secure Access is correctly installed.
- If there is still no LED on the Card Reader, install a new the Card Reader.

NOTE: *if there is another working Card Reader available, the readers can be changed over to confirm failure.*

- If the Card Reader is not functioning, the web page of the machine has a setting that will enable UI keypad access. If the users know their card access number, they can use the machine by manually entering their number. The process is as follows:
 1. Go to the machine web page under properties and then security and check the box that says "Allow local user interface initiation".
 2. Enable the keypad and test with valid credentials. This will validate the rest of the secure access function.
 3. Leave it in this mode until the new card reader can be installed.

OF 16 POST Error RAP

Power on Self Test (POST) occurs each time the machine is powered on. POST verifies the functionality of key subsystems before passing control to Print Engine Self Test (PEST).

- Use this RAP when the UI has stalled and shows the splash-logo screen, or the system appears to have power but the UI is blank.
- POST begins when power is switched on before higher level machine functions (such as the user interface) are operational.
- POST is performed by the IME controller PWB and the single board controller PWB.
- The IME POST results are displayed using the LED's on the front of the IME controller PWB, [Figure 1](#), and two LED's at the rear on the media path driver PWB, [Figure 2](#).
LED's on the front of the IME controller PWB, [Figure 1](#).
 - ENG OK (green, DS302) - Displays IME firmware status.
 - ENG error (red, DS301) - Displays IME firmware error blink codes, the first digit is 3 or 4.
 - Cable error (red, DS604) - Displays status of major cables in the IME and -12V needed for the printhead PWBs.
 - CPU error (red, DS605) - Displays IME operating system status and error blink codes, the first digit is 2.
- The 2 media path driver PWB LED's on the back of the machine display the same patterns codes as the 2 engine status LED's on the front IME. If there is a loss of communication with the media path drive PWB, at PJ 408, only the front LED's will blink.
LED's on the Media path driver PWB, [Figure 2](#).
 - IME OK (green, DS801) - Displays IME firmware status.
 - IME error (red, DS802) - Displays IME firmware error blink codes.
- The 7-Segment LED display unit on the rear of the machine attached to the SBC PWB, [Figure 3](#). This is to help diagnose common faults which prevent the machine from powering up correctly to the point where faults are displayed and diagnostics can be entered. The LED display should show just a pulsing decimal point when the machine boots correctly, The main codes are displayed for short periods of time during power up depending on how long each test takes, if any code is left displayed during power up and the machine appears not to have powered on correctly then this should point to the problem component. Refer to the [Table 3](#).

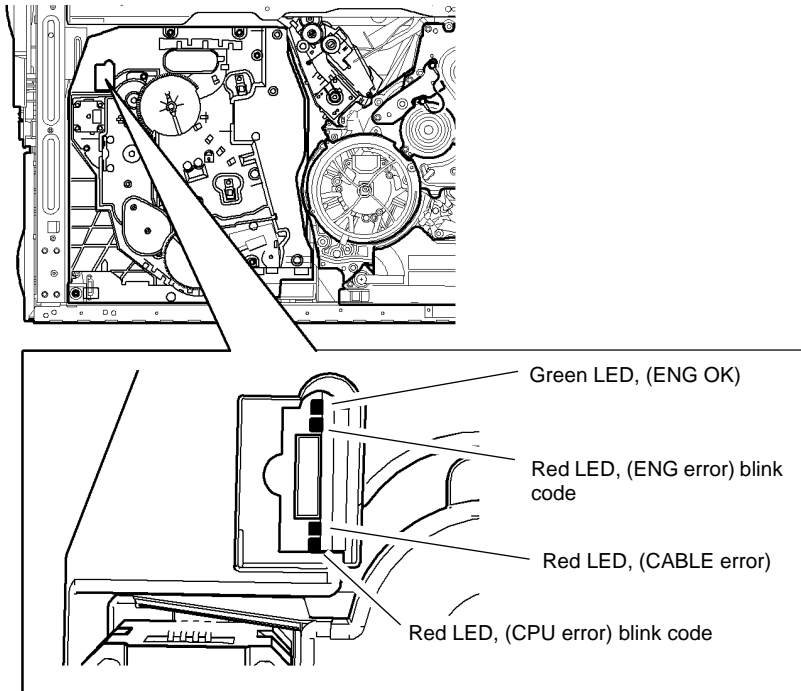

U-1-1308-A

Figure 1 POST LED front location

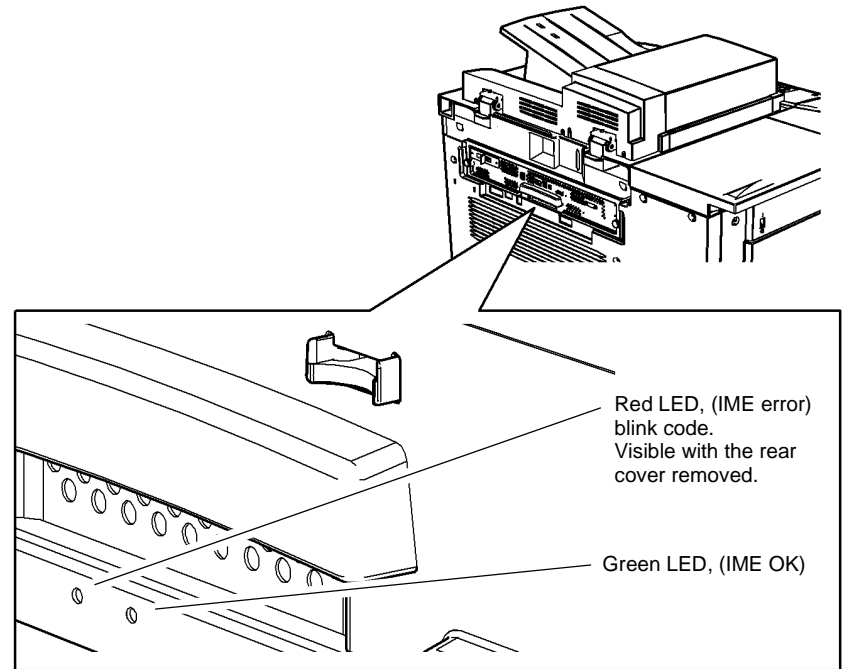

U-1-1336-A

Figure 2 POST LED rear location

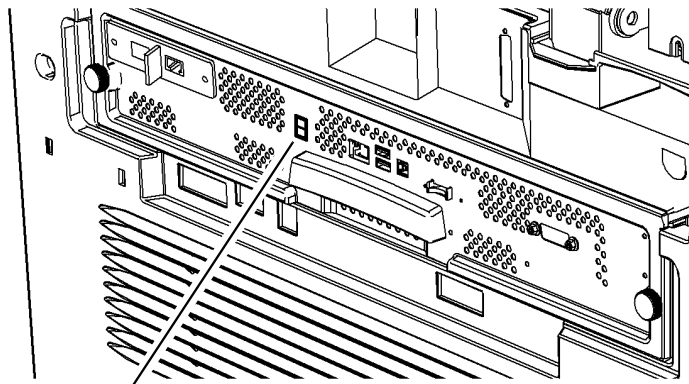

7-Segment LED display unit

U-1-1650-A

Figure 3 SBC LED display unit

Procedure

WARNING

Ensure that the electricity to the machine is switched off while performing tasks that do not need electricity. Refer to GP 14. Disconnect the power cord. Electricity can cause death or injury. Moving parts can cause injury.

The procedure has two elements. The first element is the system power up errors within the SBC PWB and the second element is the POST errors within the IME.

To check for the system power up error.

1. Switch off and then switch on the machine, GP 14.
2. If the system has powered up correctly then there will be a pulsing decimal point on the 7-segment display, Figure 3.
3. If the system power up sequence has failed then check the code on the LED display. Refer to Table 3 for the actions required for each code.

NOTE: In most cases the power up faults in the CCS tray are not related to any issues within the IME. But if the IME has a critical PEST fault that prevents the IME from bringing up the main power (Power Normal not raised) then the 7-segment display will show 0, which means the CCS OS kernel s/w will not start to bring up the rest of the system due to a loss of power.

To check for the IME POST error codes which consist of three digits, each digit may be a number from 1 to 9.

1. Watch the front red (ENG error) and red (CPU error) or the rear red (IME error) LEDs for a rapid flutter. This indicates that the next blinks will communicate POST error information.

- The sequence loops continuously so each set of blinks does not need to be read consecutively.
 2. After the flutter count the number of blinks to determine the hundreds digit. At the end of the first digit there will be a pause.
 3. After the pause count the number of blinks to determine the tens digit. At the end of the second digit there will be a second pause.
 4. After the second pause count the number of blinks to determine the ones digit.
 5. Refer to Table 1 for a list of POST blink codes and definitions.
 - IME POST Engine errors are blink codes 4XX.
 - IME POST Communication errors are blink codes 3XX.
 - IME POST CPU errors are blink codes 2XX.
 6. Check the wiring and all connectors on the relevant PWB as indicated by the error code. Perform the service actions shown in Table 1.
- NOTE:** After completing the service actions to clear the fault the print engine should boot up normally, but then display a fault code relating to the fault just cleared. Switch the machine off, then switch the machine on, GP 14 to clear the fault code.
7. If the fault remains or no blink codes are communicated, go to Additional LED Checks.

Table 1 POST Hard Fault Codes

Error	Code	Service action
POST_PROG_MACHINE_CHECK	212	Switch the machine off, then switch the machine on, GP 14. Install a new IME controller PWB, PL 92.10 Item 1.
POST_PROG_SYS_PANIC	213	Switch the machine off, then switch the machine on, GP 14. Install a new IME controller PWB, PL 92.10 Item 1.
POST_CPU_EXCEPTION_ERROR	214	Switch the machine off, then switch the machine on, GP 14. Install a new IME controller PWB, PL 92.10 Item 1.
POST_ECM FPGA_LOAD_FAILURE	215	Switch the machine off, then switch the machine on, GP 14. Install a new IME controller PWB, PL 92.10 Item 1.
POST_ECM FPGA_MAPPING_FAILURE	216	Switch the machine off, then switch the machine on, GP 14. Install a new IME controller PWB, PL 92.10 Item 1.
POST_ECM FPGA_ID_READ_FAILURE	217	Switch the machine off, then switch the machine on, GP 14. Install a new IME controller PWB, PL 92.10 Item 1.
POST_ECM FPGA_ID_MISMATCH	218	Switch the machine off, then switch the machine on, GP 14. Install a new IME controller PWB, PL 92.10 Item 1.
POST_FPGA_WRITE_MISMATCH	219	Switch the machine off, then switch the machine on, GP 14. Install a new IME controller PWB, PL 92.10 Item 1.
POST_Image FPGA_LOAD_FAILURE	223	Switch the machine off, then switch the machine on, GP 14. Install a new IME controller PWB, PL 92.10 Item 1.

Table 1 POST Hard Fault Codes

Error	Code	Service action
POST_Image FPGA_MAPPING_FAILURE	224	Switch the machine off, then switch the machine on, GP 14 . Install a new IME controller PWB, PL 92.10 Item 1 .
POST_Image FPGA_ID_READ_FAILURE	225	Switch the machine off, then switch the machine on, GP 14 . Install a new IME controller PWB, PL 92.10 Item 1 .
POST_Image FPGA_ID_MISMATCH	226	Switch the machine off, then switch the machine on, GP 14 . Install a new IME controller PWB, PL 92.10 Item 1 .
POST_Image FPGA_WRITE_MISMATCH	227	Switch the machine off, then switch the machine on, GP 14 . Install a new IME controller PWB, PL 92.10 Item 1 .
POST_NVRAM_ACCESS_FAILURE	231	Switch the machine off, then switch the machine on, GP 14 . Install a new IME controller PWB, PL 92.10 Item 1 .

Additional LED Checks

If the LED's remain on or dim then refer to [Table 2](#) for the possible patterns. Perform the relevant service actions. If the fault remains, go to the [OF 3 Unresponsive Machine RAP](#).

Table 2 LED status

UI Screen	CPU error Red LED	Cable error Red LED	Engine error Red LED	Engine OK Green	Service action
Dark	-	-	-	-	Go to OF 3 RAP
Splash	On dim	-	-	-	Perform IME Blink Condition A
Splash	Off	On Dim	On Dim	On Dim	Perform IME Blink Condition A
Splash	Off	-	On Bright	On Bright	Perform IME Blink Condition A
Splash	Off	-	Slow blink	Fast blink	Perform IME Blink Condition B
Splash	Slow blink	On Dim	On Dim	On Dim	Perform IME Blink Condition C
Splash	Off	On Bright	Off	Blink	Check all communication PJs on the IME controller PWB and the links to the printhead PWB.

Table 3 7-Segment LED display

POST code name	Fault code	Decimal point status	Code Description	Service action
Display Test	8	On	Initial 7 segment display test	LED display or SBC PWB. Check that the NVM module PWB is fitted correctly, PL 3.11 Item 17 . Install a new SBC PWB, PL 3.11 Item 13
PWBA	1	Off	Failed explorer controller	Install a new SBC PWB, PL 3.11 Item 13 .
System memory	2	Flashing	Failed system memory	Install a new System memory PWB, PL 3.11 Item 4
EPC Memory	3	Flashing	Failed EPC memory	Install a new EPC memory PWB, PL 3.11 Item 21
NVM and RTC Module	4	Flashing	Failed NVM memory	Install a new NVM module PWB, PL 3.11 Item 17
Flash Module	5	Flashing	Failed flash memory	Flash module. Install a new SBC PWB, PL 3.11 Item 13 .
Hard disk drive	6	Flashing	Failed hard drive	Install new components as necessary; Hard disk drive, PL 3.11 Item 2 . Hard disk drive/Single board controller PWB harness, PL 3.11 Item 3 . SBC PWB, PL 3.11 Item 13 .
RTC module	7	Flashing	Failed RTC	RTC module. Install a new SBC PWB, PL 3.11 Item 13 .
Initial entry to kernel code	0	Flashing	Waiting for power normal	No action, no POST fault detected
U-boot complete	9	Flashing	U-boot hand over control to kernel	Kernel software
Kernel starting user space	u	Flashing	Kernel starting user space	Kernel / run time software
Machine in ready mode	Blank	Flashing	None, no fault detected	No action, no fault detected
UI platform available	A	Flashing	UI platform available	See NOTE:
IIT comms established	b	Flashing	IIT comms established	See NOTE:

Table 3 7-Segment LED display

POST code name	Fault code	Decimal point status	Code Description	Service action
NC platform available	C	Flashing	NC platform available	See NOTE :
Dc platform available	d	Flashing	Dc platform available	See NOTE :
IOT comms established	E	Flashing	IOT comms established	See NOTE :
Fax comms established	F	Flashing	Fax comms established Only if Fax installed	See NOTE :
Machine attempting sleep entry	L	Flashing	OS suspending drivers, entering sleep (Split power plane TBC)	None, for diagnostic information only
Machine in sleep state	r	Flashing	Resting in sleep	None, for diagnostic information only
Machine in semi-conscious state	t	Flashing	Running in semi-conscious mode	None, for diagnostic information only
Machine attempting sleep wake-up	H	Flashing	OS resuming drivers	None, for diagnostic information only

NOTE: On Application power up the 7-segment display cycles around displaying these codes until the relevant platform has fully synchronized with the system. Any code left displayed after power up indicates this event has not been detected in software and is a probable s/w issue

IME Blink Condition A

This indicates a power failure or CPU fault.

1. Check 3.3V on the IME controller PWB at PJ701. Refer to [WD 9.6](#). If the voltage is not present, go to [01C +3.3V Distribution RAP](#).
2. Check memory module is seated correctly, [PL 92.10 Item 16](#).
3. Check that there is no link between the two pins on J805 (boot) and J806 (mode) on the IME controller PWB.
4. Install a new IME controller PWB, [PL 92.10 Item 1](#).

IME Blink Condition B

The operating system is OK but engine did not start.

1. Check that there is no link between the pins on J806 (mode) on IME controller PWB.
2. Install a new IME Controller PWB, [PL 92.10 Item 1](#).

IME Blink Condition C

A RAM error has been detected.

1. Check memory module is seated correctly, [PL 92.10 Item 16](#).
2. Check 3.3V on the IME controller PWB at J701. Refer to [WD 9.6](#). If the voltage is not present, go to [01C +3.3V Distribution RAP](#).
3. Install new memory module, [PL 92.10 Item 16](#).
4. Install a new IME controller PWB, [PL 92.10 Item 1](#).

3 Image Quality

Image Quality RAPs

IQ 1 Image Quality Entry RAP	3-3
IQ 2 Copy or Print Damage RAP	3-20
IQ 3 Blurred Image on Copies RAP	3-22
IQ 4 Wrong Copied Colours RAP	3-23
IQ 5 Jagged or Blurry Lines or Text RAP	3-24
IQ 6 Missing Ink or Grainy Output RAP	3-29
IQ 7 Metering Blade Timing RAP	3-31
IQ 8 Cross Process Ink Artifacts (Smudge) RAP	3-32
IQ 9 Deletions in the Process Direction RAP	3-34
IQ 10 Incorrect Margin, Misregistration or Skew RAP	3-41
IQ 11 Smudges, Debris, Smears in the Process Direction, or Paper Stack Marks RAP	3-43
IQ 12 Missing or Partial Image RAP	3-46
IQ 13 All Colours Uneven RAP	3-47
IQ 14 Some Colours Uneven RAP	3-54
IQ 15 Wrong Colour RAP	3-59
IQ 16 Scratches or Gloss Marks in the Process Direction RAP	3-63
IQ 17 Gloss Marks in the Cross-Process Direction RAP	3-64
IQ 18 Irregular Duplex Gloss Differences RAP	3-66
IQ 19 Image Ghosting RAP	3-67
IQ 20 Wavy or Stringy Lines RAP	3-69
IQ 21 Oil on Output RAP	3-70
IQ 22 Repeating Spot Deletions RAP	3-72
IQ 23 Residual Ink From Previous Print RAP	3-73
IQ 24 Wrinkling RAP	3-75
IQ 25 Random Spots RAP	3-77
IQ 26 Poor Ink Adhesion RAP	3-79
IQ 27 Unacceptable Received Fax Image Quality RAP	3-80
IQ 28 Show Through on Copies RAP	3-81
IQ 29 DADH, Document Glass and Scanner RAP	3-81
IQ 30 Blocking RAP	3-82

Image Quality Test Prints

TP 1 Initial Test Print Pages	3-83
TP 2 to TP 10 Solid Fill Test Pages	3-84
TP 11 Colour Bands and Dithers Test Pages	3-85
TP 12 Chase Page	3-86
TP 13 Text Test Pages	3-87
TP 14 Drum Stripper Blade Test Page	3-88
TP 15 Media Path Test Pages	3-89
TP 16 Stitch Identification Test Pages	3-91
TP 17 Service Usage Profile	3-92
TP 18 TRC Generation Test Pages	3-93
TP 19 Y-Dot Position Correction Test Page	3-94
TP 20 Oil Bar Chase and Metering Blade Timing Test Pages	3-95
TP 21 Jet Test Pages	3-97
TP 22 Cleaning Pages	3-101

TP 23 Drum Run Out and Y-Stitch Test Pages	3-102
TP 24 Registration Calibration Page	3-103
TP 25 IME Test Print	3-104
TP 26 Print Head Uniformity/Colour Bands Test Page	3-105

Image Quality Specifications

IQS 1 Registration and Skew	3-107
IQS 2 Image Area	3-108
IQS 3 Y-Dot Position	3-109
IQS 4 Y-Stitch	3-109
IQS 5 X-Stitch	3-110
IQS 6 Blurry Text	3-110
IQS 7 Curl	3-111
IQS 8 Uniformity in the Process Direction	3-111

IQ 1 Image Quality Entry RAP

Use this RAP to determine the source of an image quality problem.

Symptom descriptions use terminology listed in [Table 1](#). Refer to the example illustrations in each RAP for a representation of the symptom.

Test pages are listed in [Table 2](#).

Initial Actions

NOTE: To aid in troubleshooting image quality issues, use media from an unopened ream acclimatized to room temperature.

NOTE: Chase sheets are printed to the top tray during jam clearance. These must not be confused with blank or partial images.

- Check the error logs, [GP 2](#) and service code, [OF 12](#) for errors related to the imaging defect.
- Do not use cleaning pages ([TP 22](#)) to evaluate image quality.
- If possible, run a customer print job using default settings.
- Use approved media within specifications, [GP 20](#). Check media in the tray is clean and there are no loose particles which can cause ink blisters where ink adheres to the debris, not the media. If necessary, turn over the media in the tray.
- Check the operating environment is within specifications, [GP 23](#).
- Make sure the machine is positioned to allow adequate airflow at all vents. Refer to [GP 21](#) Installation Space Requirements.
- Make sure the interior of the machine is clean. Refer to [GP 27](#) Machine Cleaning Procedure.
- Check that the paper tray guides are set to the correct paper size.
- Check that the fixed paper tray guides are set to the correct paper size, [ADJ 73.1](#) Tray 3 Paper Tray Guide Setting, [ADJ 75.1](#) Tray 5 Paper Tray Guide Setting.
- Check the document guides on the DADH.
- Check that the image adjustment and print mode settings are correct for the image being printed/copied.
- Check the settings for the media size and type are correct for each tray.

NOTE: Always load A4 or 8.5 x 11 inch media as appropriate to your market region in Tray 4 before printing internal test prints. Failure to do this may result in the test prints printing the wrong size / location on the media and giving false results.

- If possible, check that the customer is not attempting to copy poor quality originals. If the original is too damaged to successfully feed through the DADH, suggest scanning directly from the document glass.

Procedure

NOTE: If possible, use the customer job to recreate the image quality defect.

Print [TP 1](#) Initial Test Print Pages. **The test pages are good.**

Y N

Check in the list below for any common defects that the test pages may have:

- The pages have light stripes or bands of a primary colour in the process direction with corresponding light lines in secondary colours, see [Figure 13](#) image 1 and [Figure 5](#) image 2. Perform the following as necessary:
 - Weak Jets with Y-dot Error Checkout in [IQ 5](#).
 - Missing or Weak Jet Checkout in [IQ 9](#).
- The pages have occasional light stripes or bands of a primary colour in the process direction with corresponding light lines in secondary colours, see [IQ 9](#) [Figure 6](#). Perform the following:
 - [91-638-00](#) IOD Detects Chronic Jet Error RAP.
- The pages have deletions of a single primary colour that run consistently in the process direction with corresponding light lines in secondary colours see [Figure 5](#) image 2. Perform the following as necessary:
 - Missing or Weak Jet Checkout in [IQ 9](#).
 - [91-638-00](#) IOD Detects Chronic Jet Error RAP.
- The pages have jagged or blurry lines or text in the 3 stitch regions (indicated by the chevrons), or lighter/darker stripes in the process direction in the stitch regions, see [Figure 12](#) images 1 and 2, [Figure 5](#) image 1. Perform the following as necessary:
 - Y-Stitch, Printhead Roll and Drum Runout Checkout in [IQ 5](#).
 - X-Stitch Defect Checkout in [IQ 9](#).
 - X-Stitch Checkout in [IQ 13](#).
- The pages have missing areas of ink in the process direction from one print head, see [IQ 9](#) [Figure 12](#). Perform the following:
 - Internally Leaking Printhead Checkout in [IQ 9](#).
- The pages have bands of missing ink and ink spots in the process direction, see [IQ 9](#) [Figure 7](#). Perform the following:
 - Scraping Checkout in [IQ 9](#).

If none of the descriptions match the image quality defect on the test pages, refer to [Table 1](#). Go to the relevant image quality RAP.

Check the test pages for damage. **The test pages are undamaged.**

Y N

Go to [IQ 2](#) Copy or Print Damage RAP.

Print a duplex copy of [TP 11](#) Colour Bands and Dithers Test Pages. **The test pages are good.**

Y N

Refer to [Table 1](#). Go to the relevant image quality RAP.

If a Fax is installed, send a test Fax to the machine. **The test Fax image quality is good.**

Y N

Compare the Fax print with the initial test pages. **The Fax print and initial test pages have the same defect.**

A

A

Y N

Go to [IQ 27](#) Unacceptable Received Fax Image Quality RAP.Refer to [Table 1](#). Go to the relevant image quality RAP.

Make 3 copies of the colour bands test page, [TP 26](#) from the document glass. **The copies are good.**

Y N

Check the image quality defect. **The defect on the copies is identical.**

Y N

Refer to [Table 1](#). Go to the relevant image quality RAP.Go to the [IQ 29](#) DADH, Document Glass and Scanner RAP.

B

B

Use the DADH to make copies of the initial test pages, [TP 1](#). **The copies are good.**

Y N

Go to [IQ 29](#) DADH, Document Glass and Scanner RAP.

If possible, use the customer document to make a copy from the document glass or DADH, at 100% magnification. Make another copy at a different magnification setting. Compare the copies. **The defect is on the same part of the image.**

Y N

Refer to [Table 1](#). Go to the relevant image quality RAP.Perform [ADJ 62.1](#) Optics Cleaning Procedure.

Image Quality Symptoms

Table 1 Image Quality Symptoms

Term	Description	IQ RAP	Test Pages
Adhesion	Ink flakes can easily be brushed off from the paper. Ink may have a raised spotty texture.	IQ 20 , IQ 26	TP 1
Background on copies	Undesirable ink dots on the copy. Uniform darkening across all the non-imaged (white) areas. The ink deposits are localized or may cover the entire copy. Depending on background density, background is referred to as low, medium, high, or very high. Background may occur in all colors, single colors, or any combination of single colors.	IQ 29	TP 9 (TP 2 to TP 10)
Banding in process direction	A light to dark relative variation in print density within a (near) uniform color across the print. May occur as a wide band or localized band in the process direction. <ul style="list-style-type: none"> If the defect matches any in Figure 1 or Figure 2, go to the IQ 13 All Colours Uneven RAP. If the defect matches any in Figure 3 or Figure 4, go to the IQ 14 Some Colours Uneven RAP. 	IQ 13 , IQ 14	TP 11
Black print	A print that is completely black or grey all over, but has no visible image of the original document. See digital defects.	-	TP 1
Blank print	See partial images/missing images.	-	-
Blocking	Blocking can occur where ink from one print is deposited on the back of another when prints are allowed to accumulate in a stack in the output tray. The combination of pressure from the weight of the media and ambient heat may cause partial transfer of the image to the next print in the stack. Blocking is aggravated by abrasion, vibration, or storage under a large stack of prints (compression). See also residual image.	IQ 30	-
Blurred image on copies	Image on copies is blurred.	IQ 3	TP 1
Blurred image on print	See jagged lines, jagged text or digital defects.		
Blurry lines	See jagged lines.	-	-
Blurry text	See jagged text.	-	-
Contamination	See debris.	-	-
Copy damage	Creases, curls, cuts, folds, wrinkles, or embossed marks on the print. Also see wrinkling.	IQ 2 , IQ 24	N/A
Debris	Ink or other fragments easily wiped from the print which are not adhered to the paper.	IQ 11	TP 9 (TP 2 to TP 10)
Deletions	Areas of the image missing from the print in the form of: <ul style="list-style-type: none"> Process direction deletions. If the defect matches any in Figure 5 or Figure 6, go to the IQ 9 Line Deletions in the Process Direction RAP. Spot deletions. If the defect matches Figure 7, go to the IQ 22 Repeating Spot Deletions RAP. White spots or a grainy appearance. If the defect matches Figure 8, go to the IQ 6 Missing Ink or Grainy Output RAP. White spots are areas of missing ink caused by poor ink adhesion, see adhesion. 	IQ 9 , IQ 22 , IQ 6	TP 1 , TP 9 (TP 2 to TP 10)
Digital defects	Image is stretched, geometrically relocated, progressively distorted, scrambled, precisely blurred, or colors are geometrically displaced or switched. Go to the 92-581-00 Image Transfer Error RAP.	N/A	N/A

Table 1 Image Quality Symptoms

Term	Description	IQ RAP	Test Pages
Displaced or Fragmented Image	Distorted images. Displaced images. See digital defects.	-	-
Dropout	Areas of missing ink pixels usually in mid-scale density areas. Image may look grainy.	IQ 6	TP 11 Duplex
Ghosting	Faint image which shows as a gloss differential from the previous print or previous area repeated onto a subsequent print.	IQ 19	TP 4 (TP 2 to TP 10)
Gloss bands (process or cross process direction)	Lines or bands of irregular gloss, most noticeable in solid areas, in process or cross process direction.	IQ 16, IQ 17	TP 5 (TP 2 to TP 10)
Gloss irregularities	Random changes in gloss level causing an irregular, uneven gloss or matted appearance, most noticeable in solid areas.	IQ 18	TP 5 (TP 2 to TP 10)
Grainy	Speckled or sand-like appearance in what is meant to be a smooth area.	IQ 6	TP 11
Ink discolouration	Color shift noted on the print relative to other prints of the same image. May be localized in process direction wide bands: <ul style="list-style-type: none"> If the defect is across some of the printheads and matches any in Figure 3, go to the IQ 14 Some Colours Uneven RAP. If the wrong colours are printed, Figure 9, go to the IQ 15 Wrong Colour RAP. If the defect is across all colours and matches any in Figure 1, go to the IQ 13 All Colours Uneven RAP. 	IQ 14, IQ 15, IQ 13	TP 10 (TP 2 to TP 10)
Ink transfer	See residual image.	-	-
Irregular line	See jagged lines.	-	-
Irregular process direction streak	See banding.	-	-
Irregular text	See jagged text.	-	-
Jagged line	Lines meant to be straight in the cross process direction are blurry, jagged or have relative misalignments. May be localized at the 3 boundaries between printheads. Pixel position may be slightly incorrect in the process direction.	IQ 5	TP 1
Jagged text	Text meant to be correctly formed in the cross process direction is blurry, jagged or has relative misalignments. May be localized at the 3 boundaries between printheads. Pixel position may be slightly incorrect in the process direction.	IQ 5	TP 1
Lead edge smear	See smudges, smears		-
Light image	The image is visible on the print, but with insufficient overall density: <ul style="list-style-type: none"> If the defect is across all colours, go to the IQ 13 All Colours Uneven RAP. If the defect is across some of the colours, go to the IQ 14 Some Colours Uneven RAP. 	IQ 13, IQ 14	TP 1
Light lines in the cross process direction	Image dependent increasingly faint localized bands in the cross process direction, Figure 10 .	IQ 13	TP 1
Lines	Lines of missing ink - see deletions.Lines of extra ink - see smudges, smears.	-	-
Marks	See spots of ink.See smudges, smears.	-	-
Missing colours	See deletions.	-	-
Missing images	See partial images.	-	-
Non uniformity	See banding.See dropout.See light Image.	-	-
Offsetting	See residual image.	-	-
Oil on output	Spots or splatter of oil on the output.	IQ 21	TP 1
Partial images	Either the complete or portions of the image are missing.	IQ 12	TP 1
Print damage	Creases, curls, cuts, folds, wrinkles, or embossed marks on the print. Also see wrinkling.	IQ 2	N/A
Repeat images	<ul style="list-style-type: none"> Gloss - see ghosting Ink/density - see residual images 	-	-
Residual image	Ink from a previous print is deposited onto subsequent print. See also blocking.	IQ 23	TP 10 (TP 2 to TP 10)

Table 1 Image Quality Symptoms

Term	Description	IQ RAP	Test Pages
Rotated image	The image on the printed document has turned 90 degrees to the image printed on the original document. Go to the 62A Scanning Document Size RAP.	N/A	N/A
Scratch	A very thin gloss band or area of removed ink from the image in the process direction caused by obstructions present in the paper path	IQ 16	TP 5 (TP 2 to TP 10)
Skew	A difference in angular alignment between printed image and the media edge	IQ 10	TP 1
Smudges, smears	Darker irregular streaks of ink in the process or cross process direction, in either the image or non-image areas: <ul style="list-style-type: none"> If the defect matches any in Figure 11, go to the IQ 11 Smudges, Smears in the Process Direction or Stack Marks RAP. If the image has extra ink in localized areas in the cross process direction, go to the IQ 8 Cross Process Ink Artifacts (Smudge) RAP. If the image has scratches or marks in the process direction, go to the IQ 16 Scratches or Gloss Marks in the Process Direction RAP. 	IQ 11, IQ 8, IQ 16	TP 1
Spots of ink	A deposit of ink in an undesired area on the print (usually circular in shape).	IQ 25	TP 1
Spots of missing ink	See deletions.	-	-
Stitch	Alignment is incorrect in either the process or cross process direction at the 3 printhead boundaries causing localized blurry or jagged appearance of the linear elements of the image. <ul style="list-style-type: none"> If the defect matches any in Figure 12 or Figure 13, go to the IQ 5 Jagged Lines or Text RAP. If the defect matches any in Figure 5 go to the IQ 9 Line Deletions in the Process Direction RAP. 	IQ 5, IQ 9	TP 1
Streaks	See banding.	-	-
Stretched or distorted Image	See digital defects.	-	-
Uneven density	See banding.	-	-
Wavy or stringy lines	Images have wavy or stringy lines of ink, or have a blistered appearance.	IQ 20	TP 1
Wrinkled image	Areas which have distinctive physical distortions in the paper.	IQ 24	TP 2 (TP 2 to TP 10)
Wrong copied colour	The colour of the copy does not match the colour of the original.	IQ 4	TP 1
Wrong printed colour	See ink discoloration. See banding.	-	-

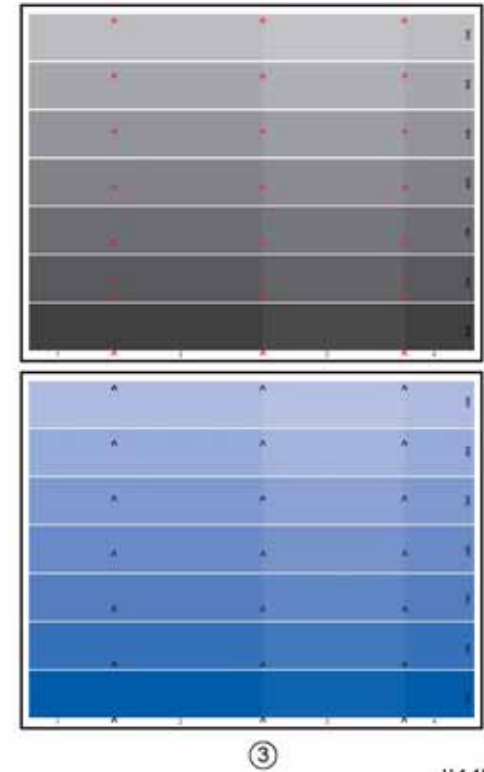
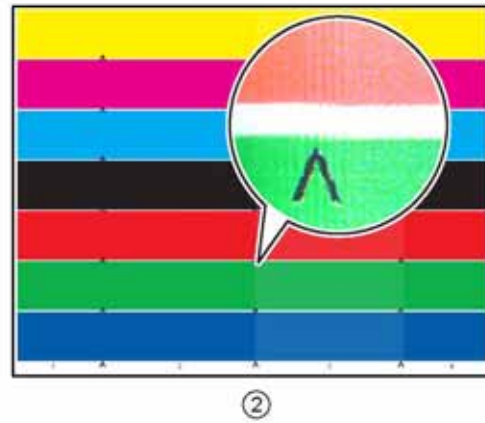
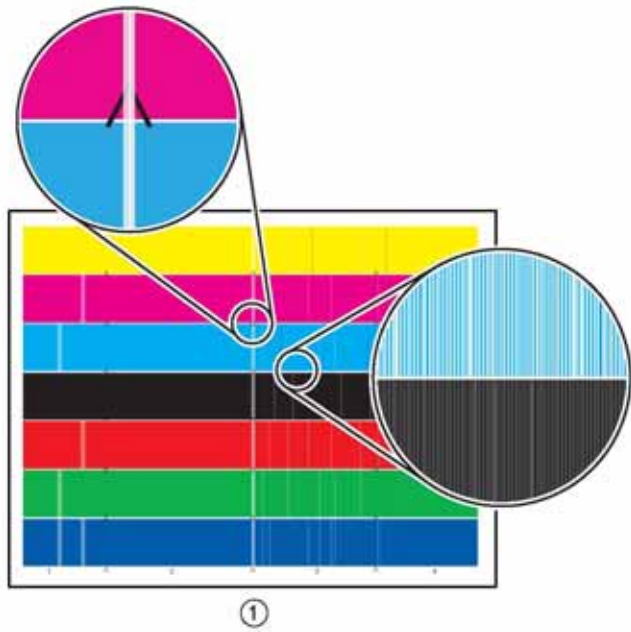

U-1-1514-A

Figure 1 IQ defects 1

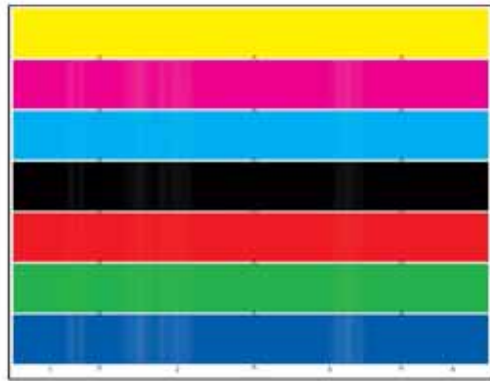

①

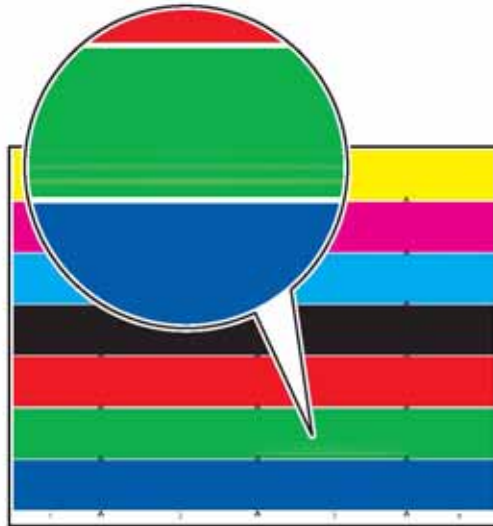

②

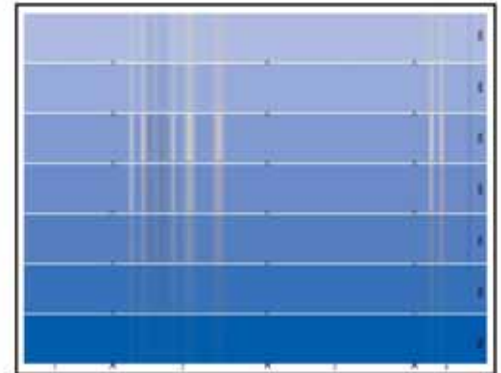
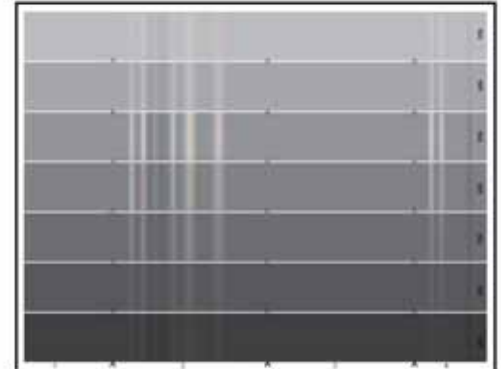

③

U-1-1515-A

Figure 2 IQ defects 2

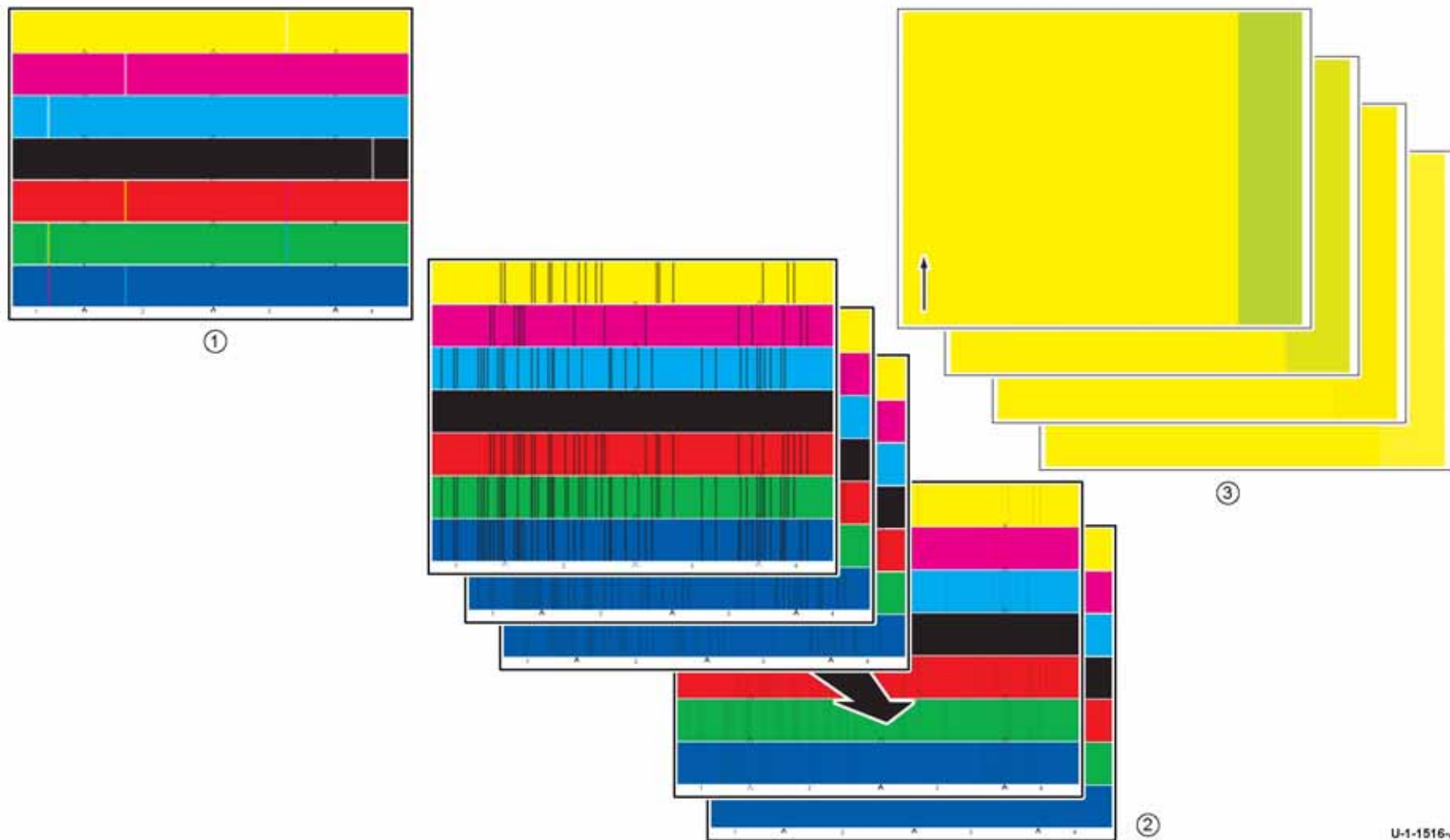
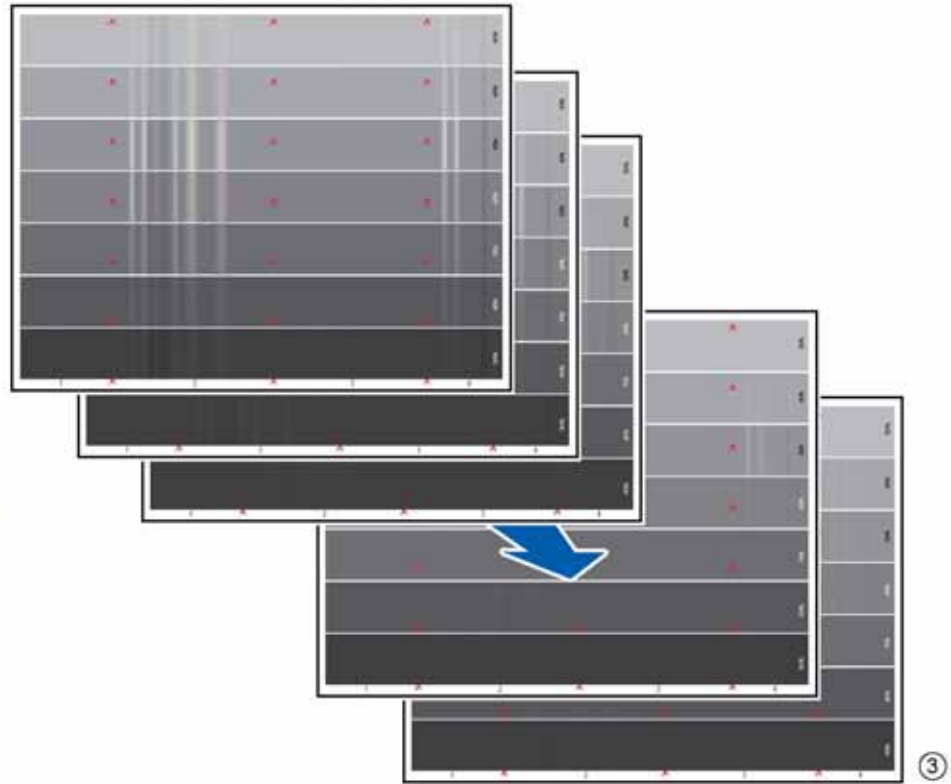
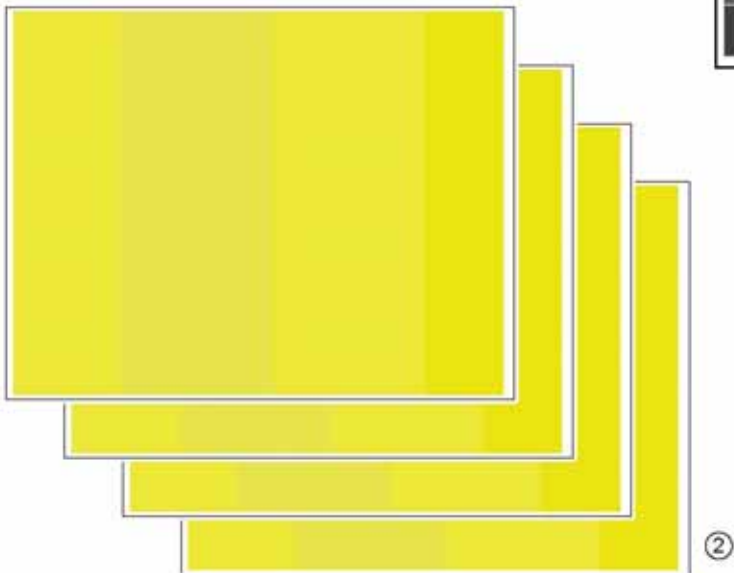
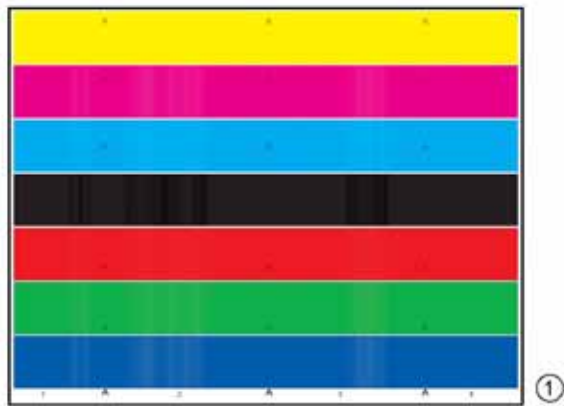

Figure 3 IQ defects 3

U-1-1516-A



U-1-1517-A

Figure 4 IQ defects 4

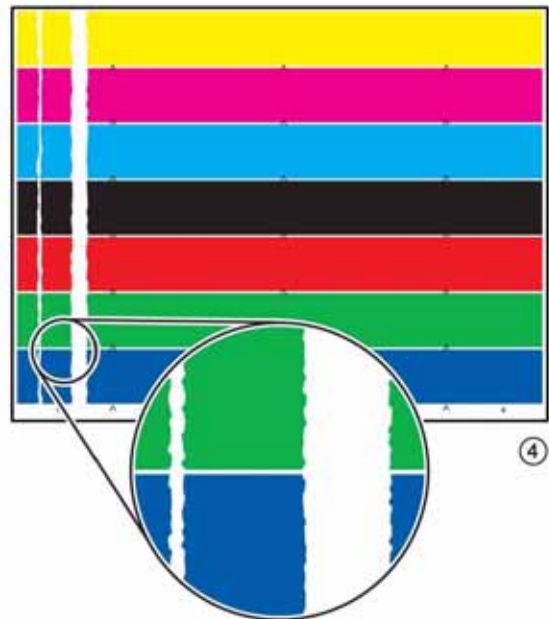
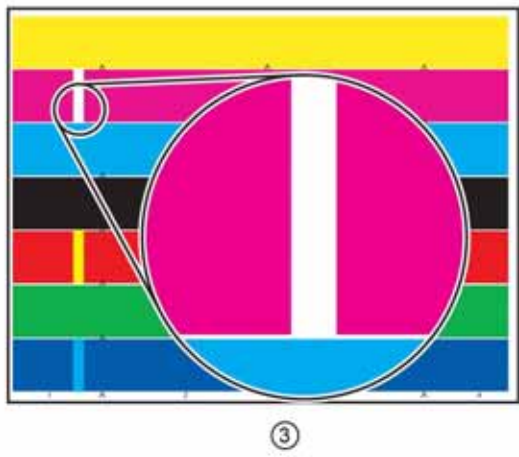
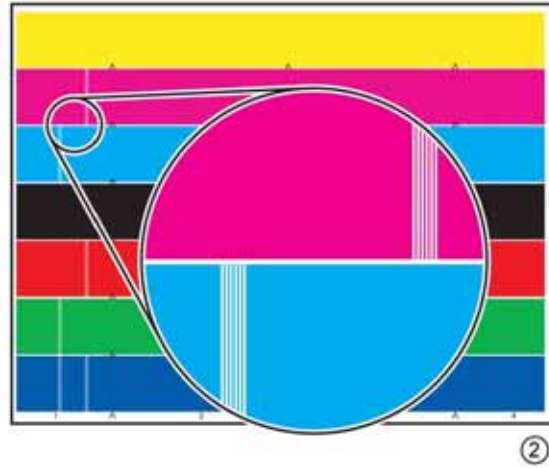
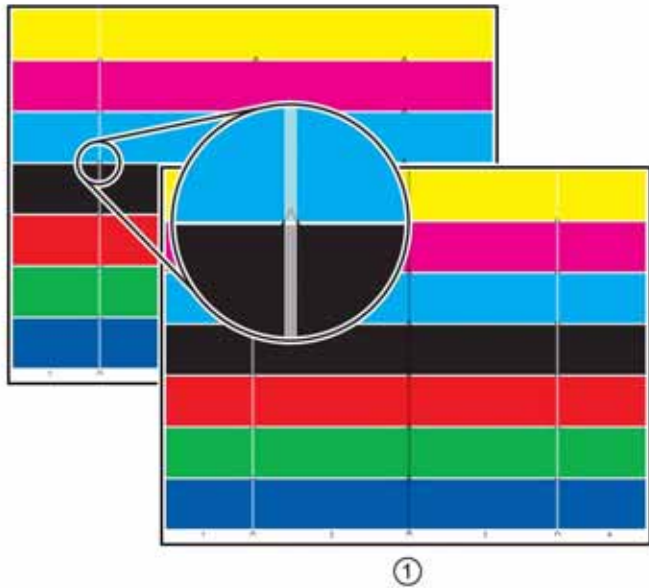

U-1-1518-A

Figure 5 IQ defects 5

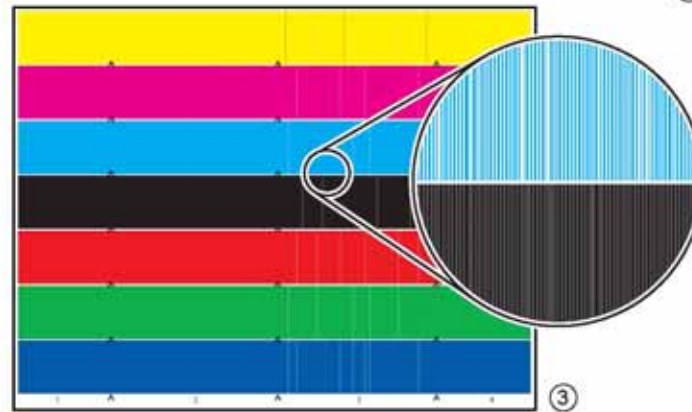
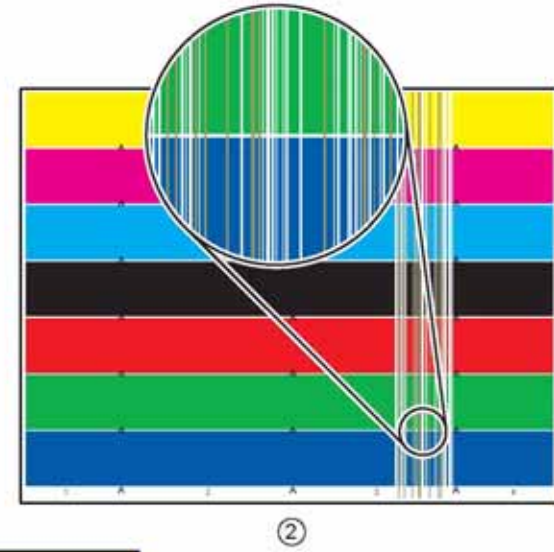
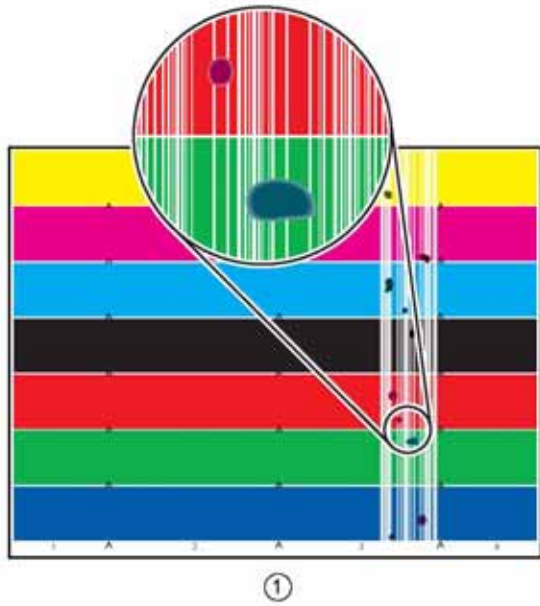

U-1-1519-A

Figure 6 IQ defects 6

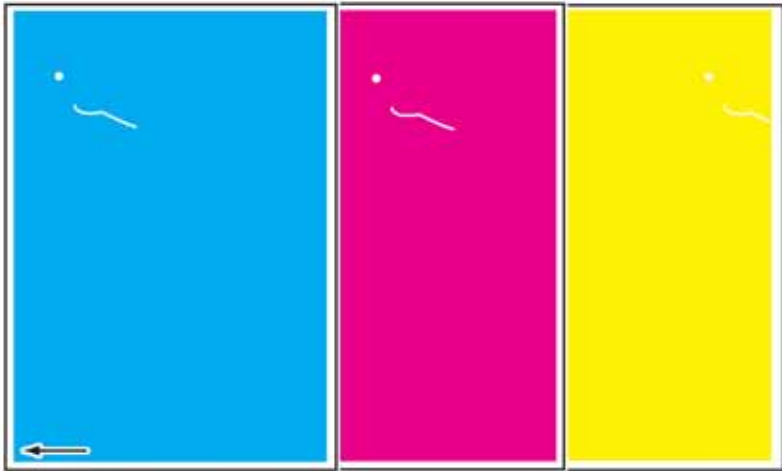

U-1-1520-A

Figure 7 IQ defects 7

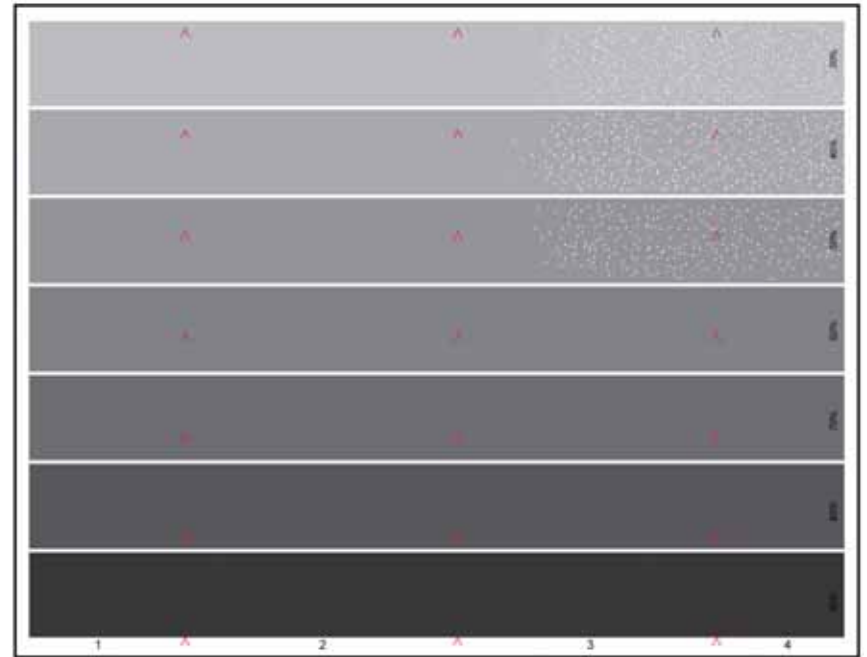

U-1-1553-A

Figure 8 IQ defects 8

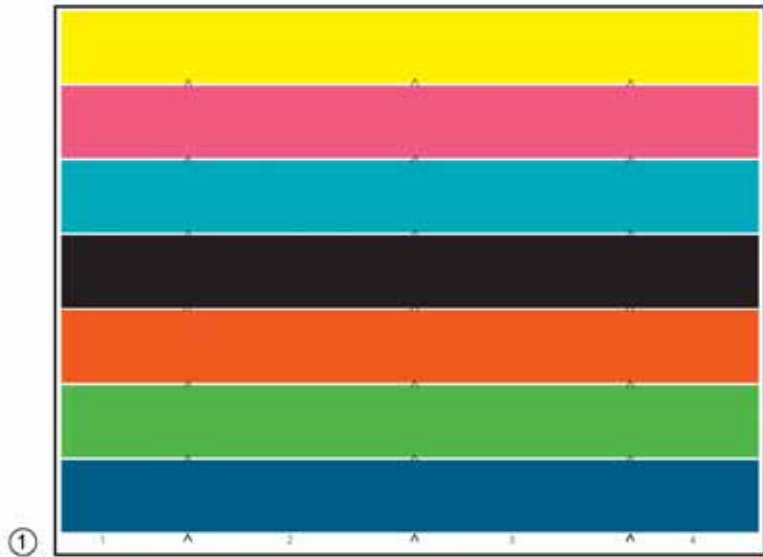

①

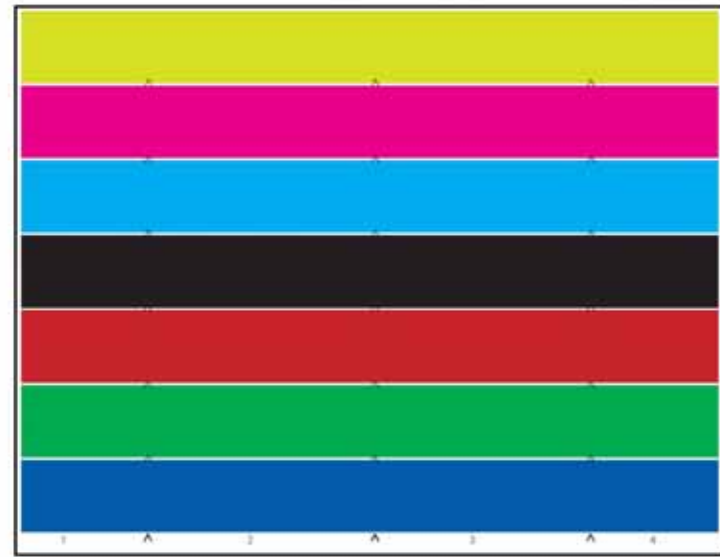

②

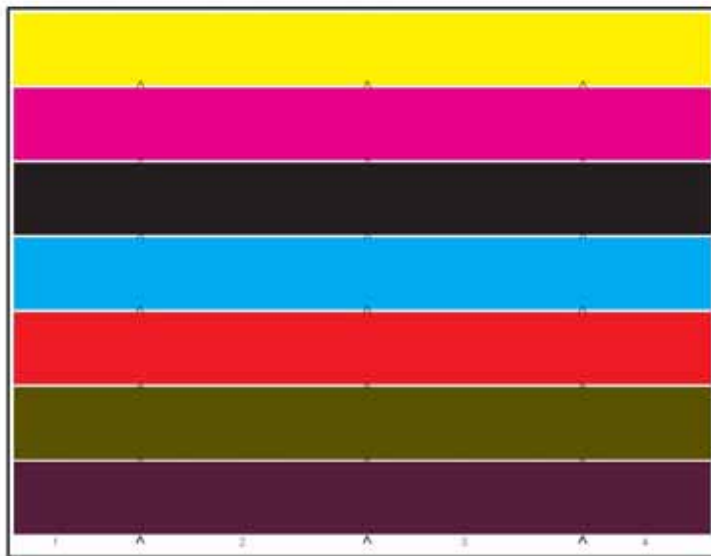

③

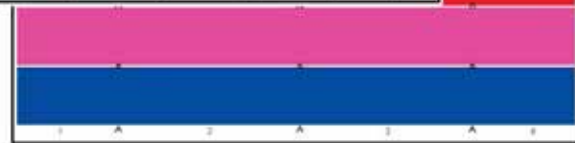
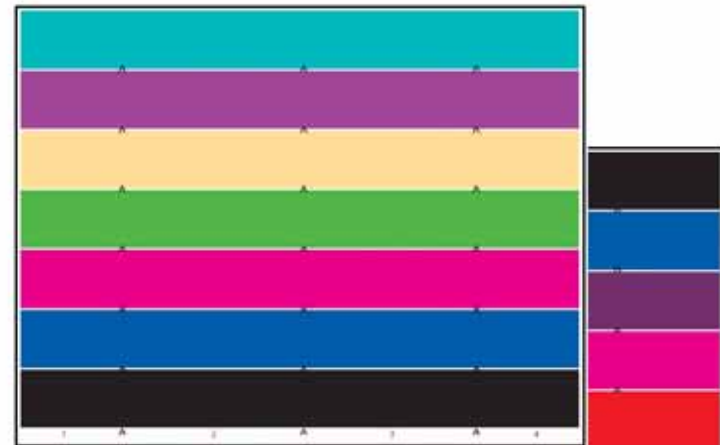

④

U-1-1522-A

Figure 9 IQ defects 9

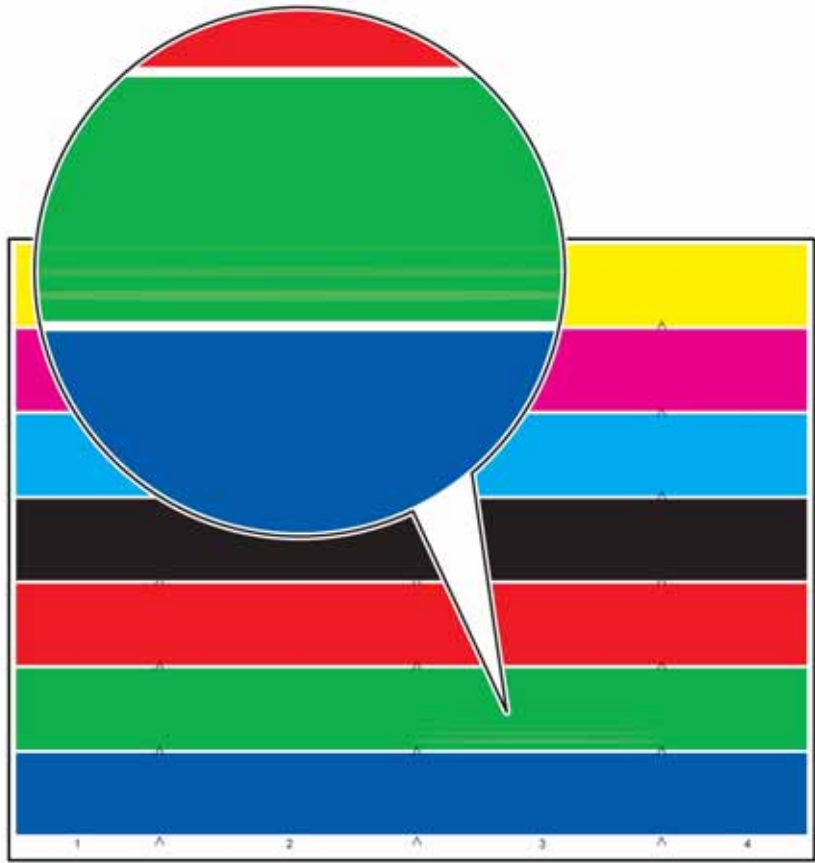

U-1-1523-A

Figure 10 IQ defects 10



①



②

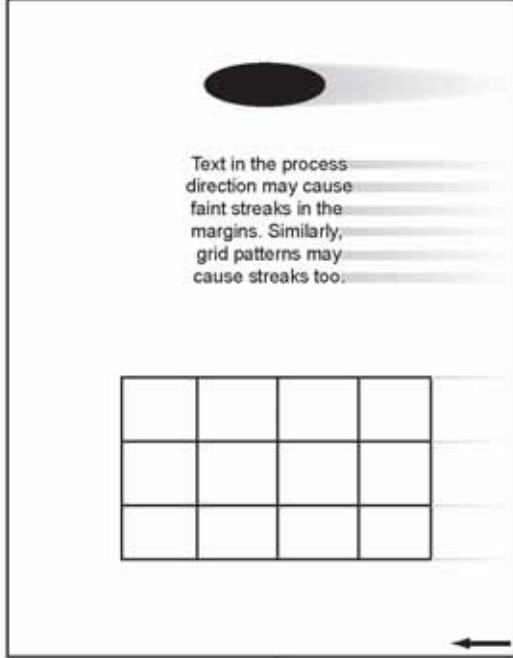

③

U-1-1524-A

Figure 11 IQ defects 11

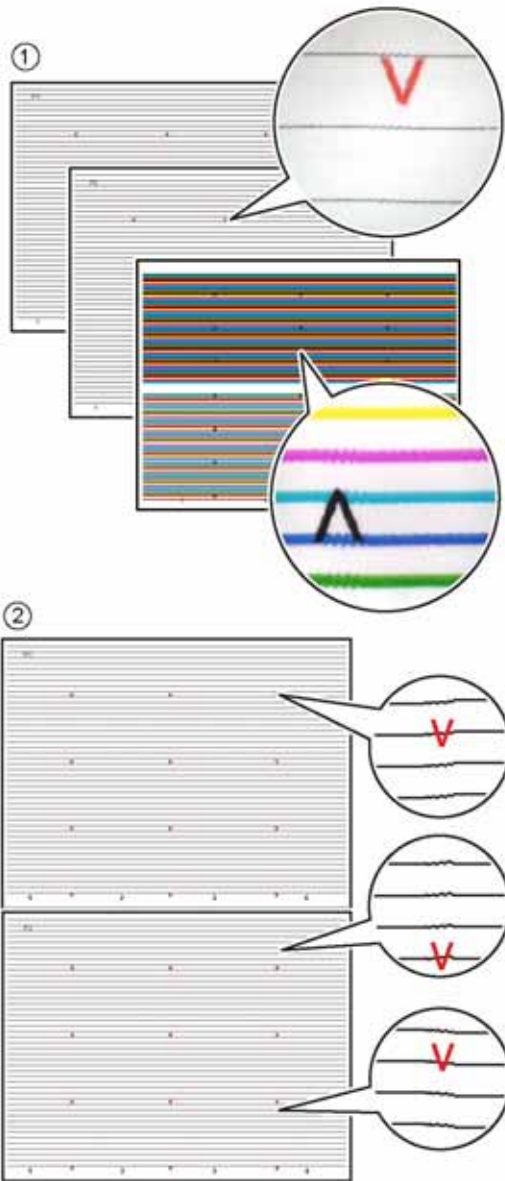

U-1-1525-A

Figure 12 IQ defects 12

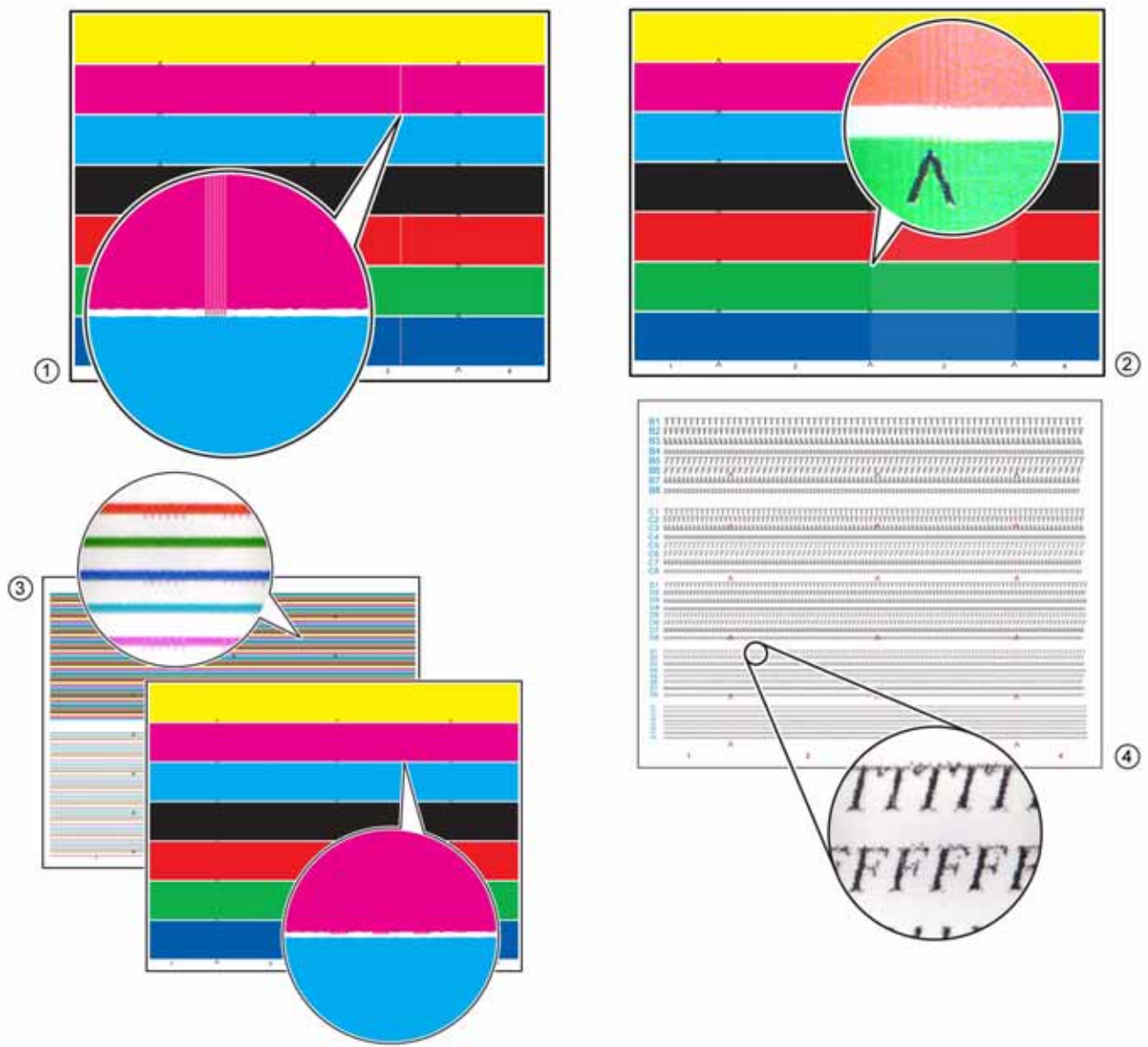

Figure 13 IQ defects 13

U-1-1526-A

Test Pages

Test pages aid in the identification of print quality problems. [Table 2](#) lists test pages available from diagnostics, provides a short description, and indicates where the pattern is accessed. Test pages are described in detail in the Test Pages section, select the appropriate link from [Table 2](#).

NOTE: These test pages are designed to enhance subtle defects. Defects revealed by these prints may not occur in the course of ordinary printing. In servicing the system, you should minimize the defects shown by the prints but not necessarily eliminate them. Refer to [IQS 1 Image Quality Specifications](#).

Table 2 Embedded Test Pages

Test Pages	Test Page Name	Description	Media size	Simplex or Duplex	Print From
TP 1	Initial test print pages	Multiple patterns on four sheets consisting of black text, cross process lines and colour bands	A4 (8.5 x 11) LEF	Simplex or duplex	dC612
TP 2 (TP 2 to TP 10)	Cyan solid fill test pages	Prints 2 cyan solid fills - 100% coverage within printable margins, primary only	A4 (8.5 x 11) LEF	Simplex or duplex	dC612
TP 3 (TP 2 to TP 10)	Magenta solid fill test pages	Prints 2 magenta solid fills - 100% coverage within printable margins, primary only	A4 (8.5 x 11) LEF	Simplex or duplex	dC612
TP 4 (TP 2 to TP 10)	Yellow solid fill test pages	Prints 2 yellow solid fills - 100% coverage within printable margins, primary only	A4 (8.5 x 11) LEF	Simplex or duplex	dC612
TP 5 (TP 2 to TP 10)	Black solid fill test pages	Prints 2 black solid fills - 100% coverage within printable margins, primary only	A4 (8.5 x 11) LEF	Simplex or duplex	dC612 and dC959
TP 6 (TP 2 to TP 10)	Red solid fill test pages	Prints 2 red solid fills - 100% coverage within printable margins	A4 (8.5 x 11) LEF	Simplex or duplex	dC612
TP 7 (TP 2 to TP 10)	Green solid fill test pages	Prints 2 green solid fills - 100% coverage within printable margins	A4 (8.5 x 11) LEF	Simplex or duplex	dC612
TP 8 (TP 2 to TP 10)	Blue solid fill test pages	Prints 2 blue solid fills - 100% coverage within printable margins	A4 (8.5 x 11) LEF	Simplex or duplex	dC612
TP 9 (TP 2 to TP 10)	White solid fill test pages	Prints 2 blank pages	A4 (8.5 x 11) LEF	Simplex or duplex	dC612
TP 10 (TP 2 to TP 10)	CMYKRGB solid fill test pages	Prints one set of all solid fill pages	A4 (8.5 x 11) LEF	Simplex or duplex	dC612
TP 11	Colour bands and dithers test pages	Prints a set of 6 pages of colour bands and dithers	A4 (8.5 x 11) LEF	Simplex	dC612
TP 12	Chase page	No ink on page. Does not exercise printheads or use imaging cycles. Used to clean ink from the drum	A4 (8.5 x 11) LEF	Simplex	dC612
TP 13	Text test pages	Prints 3 pages of portrait and landscape pages of text	A4 (8.5 x 11) LEF	Simplex	dC612
TP 14	Drum stripper blade test page	A set of prints used for verifying stripper blade actuation	A4 (8.5 x 11) LEF	Simplex	dC612
TP 15	Media path test pages	A map of the rollers and media path ribs. Used to identify the cause of scuffs and scratches	A4 (8.5 x 11) LEF	Simplex	dC612
TP 16	Stitch Identification test pages	Clearly identifies the region where printheads stitch the image together	A4 (8.5 x 11) LEF	Simplex	dC612
TP 17	Service usage profile	Machine usage and status information.	A4 (8.5 x 11)	Simplex or duplex	dC612
TP 18	TRC generation test pages	Dithers test pages for TRC calibration	A4 (8.5 x 11) LEF	Simplex	dC972 (option 4)
TP 19	Y-dot position correction test page	1 and 5 pixel cross-process lines	A4 (8.5 x 11) LEF	Simplex	dC972 (option 5)
TP 20	Oil bar chase and metering blade timing test pages	Prints 2 pages to enable a check of the cleaning unit functions	A4 (8.5 x 11) LEF	Simplex	dC959
TP 21	Jet test pages	Prints a sequence of 9 jet test pages	A4 (8.5 x 11) LEF	Simplex	dC968 and dC977
TP 22	Cleaning pages	Prints 2 head purge pages	A4 (8.5 x 11) LEF	Simplex	dC968
TP 23	Drum run out and Y-stitch test pages	Prints 2 pages of horizontal lines	A4 (8.5 x 11) LEF	Simplex	dC977
TP 24	Registration calibration page	Prints a registration target print	A4 (8.5 x 11) LEF	Simplex	dC625
TP 25	IME test print	Prints a simple page of primary colour bars from the IME in isolation	A4 (8.5 x 11)	Simplex	-
TP 26	Printhead uniformity/colour bands test page	Prints 7 solid fill bars of yellow, magenta, cyan, black, red, green and blue.	A4 (8.5 x 11) LEF	Simplex	dC972 (option 3)

IQ 2 Copy or Print Damage RAP

Use this RAP when the output copies or prints have nicks, tears, creases, folds, or curled edges.

Ensure [IQ 1](#) Image Quality Entry RAP is performed before starting this RAP.

Procedure

WARNING

Ensure that the electricity to the machine is switched off while performing tasks that do not need electricity. Refer to [GP 14](#). Disconnect the power cord. Electricity can cause death or injury. Moving parts can cause injury.

WARNING

Do not clean the stripper blade. The stripper blade is very sharp and can cause injury. If the stripper blade is dirty a new blade must be installed.

WARNING

Take care during this procedure. Sharp edges may be present that can cause injury.

WARNING

Take care not to topple the LCSS. The LCSS is unstable when un-docked from the machine. Do not show the customer how to un-dock the LCSS.

Check the paper trays for damaged paper. The paper in the tray is undamaged.

Y N
Load new paper in the trays.

Separate the finisher from the printer. Install a finisher bypass harness, [PL 26.10 Item 3](#). Make test prints. The prints are good.

Y N
Check the lead edge of the paper for damage. The damage is limited to the lead edge only.

Y N
Print chase pages, [TP 12](#) to identify where the prints are damaged. Check the paper path, [GP 29](#) Component Locations for the following:

- Obstructions.
- Damaged guides and rolls. Pay particular attention to the areas that align with the damaged on the prints. If necessary, print the Media Path Test Pages, [TP 15](#).
- The edges of the paper path for protruding objects.
- Ensure that the paper feed does not skew the paper, go to [OF 8](#) Multi-feed RAP.
- Check the prints for damaged or folded corners (dog ears).

If the damage or fold is upwards, then check the transfix stripper assembly, [PL 10.20 Item 14](#) and the exit path, [PL 10.15](#).

If the damage or fold is downward, then check the drum stripper blade assembly, [PL 10.10 Item 18](#) and [PL 10.10 Item 3](#).

Open the stripper gate, [GP 31](#). Carefully clear any paper debris from the area. Check the stripper blade for damage, [PL 10.12 Item 3](#). The stripper blade is damaged.

Y N
Press the machine status button on the keypad. Select the Faults tab on the UI, then Current Messages. If the message 'Cleaning unit life extended, image quality may be impacted' is displayed, install a new cleaning unit, [PL 94.10 Item 21](#). Or open the front door and remove the inner cover. Enter [dC959](#) and run the slow speed exerciser. While this is running, ensure the cleaning unit blade and roller is making contact with the drum. The cleaning unit blade and roller are making contact with the drum.

Y N
Check the cleaning unit components:

- Cam front, [PL 94.10 Item 9](#).
- Cam rear, [PL 94.10 Item 13](#).
- Drive gear, [PL 94.10 Item 23](#).
- Cleaning unit motor, [PL 94.10 Item 24](#).

Print [TP 14](#) Drum Striper Blade Test Print. The test page is good.

Y N
Refer to [Figure 1](#). The stripper blade releases from the drum before the MLE line is reached.

Y N
Refer to [Figure 2](#). The pattern shown is caused by the stripper blade bouncing on the drum. The stripper blade releases from the drum at the intersection of the MLE line.

Y N
Redefine the image quality defect. Refer to [IQ 1](#) Image Quality Entry RAP.

Install a new back latch fork, [PL 10.10 Item 12](#).

Install a new stripper solenoid assembly, [PL 10.10 Item 3](#).

Check that the stripper blade latches correctly at the front and at the rear. The stripper blade latches correctly.

Y N
Check the latch components. Install new components as necessary:

- Stripper guide latch cam shaft, [PL 10.10 Item 18](#).
- Stripper solenoid assembly, [PL 10.10 Item 3](#).

Check the transfix blade for damage, [PL 10.20 Item 14](#). The transfix blade is damaged.

Y N
Install a new stripper solenoid assembly, [PL 10.10 Item 3](#).

Install a new transfix stripper assembly, [PL 10.20 Item 14](#).

Install a new stripper blade [PL 10.12 Item 3](#).

Remove the finisher bypass connector and dock the finisher to the machine. An LCSS is installed

Y N

Check the alignment of the HVF/HVF BM to the machine, refer to [ADJ 12.1-171](#) Machine to HVF/HVF BM Alignment. **The alignment is good.**

Y N

Perform [ADJ 12.1-171](#) Machine to HVF/HVF BM Alignment.

Check the items that follow:

- Look for paper fragments in the HVF/HVF BM paper path. Paper fragments can move through the IOT and HVF/HVF BM paper path without causing a problem until they finally wedge themselves at some point. A likely place for a fragment of paper to be wedged is at the hole punch assembly, where the top and bottom guides form the narrowest part of the paper path.
- Ensure that the exit diverter solenoid, SOL 12-225, [PL 12.120 Item 4](#), operates correctly and has its full movement.
- Ensure that the hole punches park at the fully open position. If they protrude even slightly, a jam will occur in the narrow paper path of the hole punch. If the punch does not park correctly, refer to the [12-044-00-171](#) to [12-047-00-171](#) HVF Punch Head Position RAP.
- Check that all the idler rolls in the HVF/HVF BM paper path are free to rotate, particularly those on the jam clearance guides:
 - Top jam clearance guide, [PL 12.115 Item 26](#).
 - Buffer pocket jam clearance guide, [PL 12.125 Item 10](#).
 - Inserter jam clearance guide, [PL 12.125 Item 11](#).
 - Input jam clearance guide, [PL 12.125 Item 12](#).
- Make sure that the jam clearance guides 5a, 5b and 5d close and latch correctly.
- Check that the paper path ribs of the jam clearance guide 6e, [PL 12.150 Item 7](#) and the exit path [PL 12.185](#) are free of scores and nicks. Check also for contamination.
- Make sure that the compiler carriage tampers move to the correct paper size.
- Check that the paper size reported on the user interface corresponds to the actual paper size loaded in the trays, refer to the [71B](#) Tray 1 Wrong Size Paper RAP or [72B](#) Tray 2 Wrong Size Paper RAP.
- Make sure that the BM tampers move to the correct paper size, refer to the [12-066-00-171](#), [12-384-00-171](#), [12-419-00-171](#), [12-420-00-171](#) HVF BM Tamper Fault RAP.
- Ensure that the BM paper guide, [PL 12.150 Item 7](#), closes and latches correctly.
- If the top sheet of paper is being torn from booklets, check that the components in the lower crease roll gear and clutch assembly are correctly installed. Refer to [REP 12.52-171](#) BM Crease Rolls.
- If heavy-weight paper is used, the paper can stop in the vertical transport and cause a 10-126 fault. The fault is caused when the vertical transport motor is over loaded. Check the position of the jam clearance guide 5a, 6a and 5B. Check the vertical transport rolls and bearings for contamination. If necessary remove and clean the drive shaft and the bearings. If the problem continues then install a new transport motor.

Check the alignment of the LCSS to the machine, refer to [ADJ 12.2-110](#) Machine to LCSS Alignment. **The alignment is good.**

Y N

Perform [ADJ 12.2-110](#) Machine to LCSS Alignment.

B

B

Check the items that follow:

- Look for torn paper in the LCSS paper path. Torn fragments can pass through the IOT and LCSS paper path without causing a problem until they finally wedge themselves at some point. A likely place for a piece of paper to be wedged is at the hole punch assembly, where the top and bottom guides form the narrowest part of the paper path.
- Ensure that the shaft diverter assembly, [PL 12.60 Item 13](#), operates correctly and has full movement.
- Ensure that the hole punches park at the fully open position. If they protrude even slightly, a jam will occur in the narrow paper path of the hole punch. If the punch does not park correctly, refer to the [12-043-00-110](#), [12-046-00-110](#) Hole Punch Operation Failure RAP.
- Ensure that the jam clearance guide, [PL 12.70 Item 6](#), closes and latches correctly. Check that the magnet at the rear is located and functions correctly. Check the latch, [PL 12.70 Item 7](#) at the front is positioned correctly and that the guide engages fully with the latch.
- Ensure that all idler rolls in the LCSS paper path are free to rotate, particularly those on the jam clearance guide, [PL 12.70 Item 6](#), where the paper turns through 90 degrees.
- Ensure that the paper path ribs of the jam clearance guide, [PL 12.70 Item 6](#), and the entry guide outer cover, [PL 12.70 Item 5](#), are free of 'scores' and 'nicks'. Check also for contamination and glue from label stock. If necessary, install new parts.



Figure 1 TP 14 test print

U-1-1555-A



Figure 2 TP 14 test print

R-1-1554-A

IQ 3 Blurred Image on Copies RAP

Use this RAP when copied images are blurred. Refer to Figure 1.

Ensure IQ 1 Image Quality Entry RAP is performed before starting this RAP.

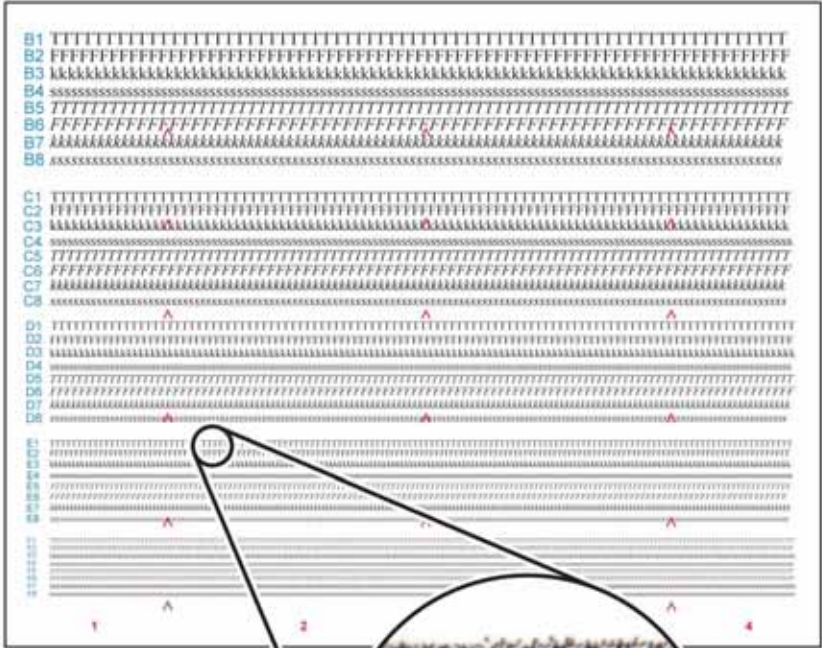

U-1-1079-A

Figure 1 Blurred copied image

Procedure

WARNING

Ensure that the electricity to the machine is switched off while performing tasks that do not need electricity. Refer to [GP 14](#). Disconnect the power cord. Electricity can cause death or injury. Moving parts can cause injury.

Check that the carriage is fully docked against the drum frame. **The carriage is fully docked.**

Y N
Remove any obstructions. Check the wiring that runs along the umbilicals.

Check that the print heads are securely attached to the carriage. **The printheads are securely attached.**

Y N
Perform [dC967](#) Head to Drum Spacing Check. **dC967 runs successfully.**
Y N
Perform [ADJ 91.1](#) Printhead Attachment Check.
Perform [SCP 5](#) Final Actions.

Make a copy of the text test pages ([TP 13](#)) from the document glass. **The copy quality is good.**

Y N
Perform the following

- Perform [ADJ 62.1](#) Optics Cleaning Procedure.
- [ADJ 62.3](#) Scan Motor and Scanner Drive Belt.

If the fault remains, install new components as necessary:

- Scan drive belt, [PL 62.16](#) Item 12.
- Carriage motor, [PL 62.16](#) Item 3.
- Scan carriage assembly, [PL 62.15](#) Item 1.
- Scanner module, [PL 62.10](#) Item 1.

Make a copy of the text test pages ([TP 13](#)) from the DADH. **The copy quality is good.**

Y N
Perform the following:

- [ADJ 5.2](#) DADH Height Adjustment.
- [ADJ 5.4](#) DADH Cleaning Procedure.

If the fault remains, install new components as necessary:

- Feed roll assembly, [PL 5.15](#) Item 1.
- CVT roll kit, [PL 5.25](#) Item 17.
- Top access cover assembly, [PL 5.20](#) Item 17.
- Lower baffle assembly, [PL 5.30](#) Item 14.

Re-define the image quality defect, refer to [IQ 1](#) Image Quality Entry RAP.

IQ 4 Wrong Copied Colours RAP

Use this RAP when the colour of the copy does not match the colour of the original.

NOTE: Due to the nature of solid ink printing, some difference in colour reproduction is normal.

Ensure [IQ 1](#) Image Quality Entry RAP is performed before starting this RAP.

Procedure

WARNING

Ensure that the electricity to the machine is switched off while performing tasks that do not need electricity. Refer to [GP 14](#). Disconnect the power cord. Electricity can cause death or injury. Moving parts can cause injury.

Make copies of the customers document with different original type settings and the auto background suppression switched on, then off. **The colours are reproduced accurately.**

Y N
Print the colour bands and dithers test pages, [TP 11](#). Make copies and evaluate the differences. **The colours are reproduced accurately.**

Y N
Perform the following:

1. Refer to [WD 3.1](#). Check that the connector is securely connected to PJ15 on the [single board controller PWB](#).
2. Check that the white AGC strip on the CVT glass is at the front and underside of the glass, refer to [REP 62.3](#).
3. Enter [dC131](#) NVM Read/Write. Make sure the following IIT DADH NVM settings are set to default:
 - 801-005.
 - 801-010.
 - 801-015.
 - 801-016.
 - 801-017.
 - 801-018.
 - 801-020.
 - 801-021.
 - 801-022.
 - 801-023.
 - 801-025.
 - 801-026.
4. If necessary, install a new [Scanner PWB](#):
 - [Scanner PWB](#), [PL 62.16](#) Item 8.

Refer to [WD 3.1](#), [WD 6.1](#) and [WD 9.5](#). Check the following wiring:

- Between PJ15 on the [single board controller PWB](#) and PJ922 on the [Scanner PWB](#).
- Between PJ5 on the [single board controller PWB](#) and PJ401 on the [IME Controller PWB](#).

Advise the customer which settings to use. Perform [SCP 5](#) Final Actions.

IQ 5 Jagged or Blurry Lines or Text RAP

Use this RAP to troubleshoot the following defects:

- Jagged lines in the cross process direction
- Jagged text in the cross process direction
- Blurry text
- Irregularly spaced text

Ensure **IQ 1** Image Quality Entry RAP is performed before starting this RAP.

Initial Actions

WARNING

Ensure that the electricity to the machine is switched off while performing tasks that do not need electricity. Refer to **GP 14**. Disconnect the power cord. Electricity can cause death or injury. Moving parts can cause injury.

WARNING

Take care during this procedure. The stripper blade is very sharp and can cause injury.

WARNING

Do not clean the stripper blade. The stripper blade is very sharp and can cause injury. If the stripper blade is dirty a new blade must be installed.

WARNING

Take care during this procedure. Sharp edges may be present that can cause injury.

CAUTION

Use care when moving the marking unit into the service position when hot. Ink can spill from the ink reservoir located at the back of the unit if opened with too much force. Cross-colour ink contamination could also occur.

CAUTION

Do not touch the exposed face of the printheads. Surface contamination or minor damage can easily make the printhead unusable.

- Check that the printheads are securely attached to the carriage. Run **dC967** Printhead to Drum Spacing. Perform **ADJ 91.1** Printhead Attachment Check.
- Check that the printhead carriages are fully docked against the drum frame. If not, check the wiring that runs along the umbilicals. Failure to properly route the upper or lower carriage wiring may lead to jagged or blurry lines or text.

Procedure

1. Print **TP 1** Initial Test Print Pages and **TP 16** Stitch Identification Test Pages. Check for the following defects:
 - Alignment errors, **Figure 1** and **Figure 2**. Dot placement errors spanning all colours in one or more of the printhead stitch zones. If observed, go to the **Y-Stitch, Printhead Roll and Drum Runout Checkout**.
 - Misdirected or weak jets, **Figure 3**. If observed, go to the **Weak Jets with Y-Dot Error Checkout**.

- Weak intensity and poor Y-dot placement in all colours and all jets of a single print-head, **Figure 4**. A pale band across the whole width of a head with misplacement in the process direction. If observed, go to the **Weak Intensity and Y-Dot Error in All Colours Across a Printhead**.
 - Y-dot placement defects in the process direction with acceptable jet intensity, **Figure 5**. A jagged edge in the process direction on lines and colour bands. If observed, go to the **Y-Dot Error Checkout**.
 - Jagged text, **Figure 6**. Pixel position may be incorrect in the process direction. If observed, go to the **Blurry / Jagged Text Defect Checkout**.
2. If the defect does not match any of the above, re-define the image quality defect. Refer to **IQ 1** Image Quality Entry RAP.

Y-Stitch, Printhead Roll and Drum Runout Checkout

Procedure

Evaluate **TP 16** Stitch Identification Test Page, **Figure 1** and **Figure 2**. The severity of the stitch defect varies in the process direction, **Figure 2**.

Y N

Perform **dC971** Head to Head Alignment Adjustment up to three times. Print **TP 16** Stitch Identification Test Pages. Refer to **IQS 3** Y-Dot Position. The severity of the alignment defect is within specification.

Y N

Perform **dC914** Head to Head Alignment Test and check for obstructions that block head alignment motion. The head alignment motion is free from obstructions.

Y N

Remove obstructions and check printhead stitch and roll motor operation, refer to:

- **91-504-00, 91-505-00** Printhead Stitch Motor Over Current RAP.
- **91-506-00 to 91-509-00** Roll Motor Over Current RAP.

Check that the printheads are securely attached to the carriage. The printheads are securely attached.

Y N

Perform **ADJ 91.1** Printhead Attachment Check.

Perform **dC971** Head to Head Alignment Adjustment. Print **TP 16** Stitch Identification Test Pages.

If the severity of the alignment defect exceeds specification, refer to **IQS 3** Y-Dot Position. Perform the following:

- Check for obstructions that block carriage and printhead motion.
- Clean the IOD, refer to **GP 27** Cleaning Procedure.
- Clean the drum, refer to **GP 27** Cleaning Procedure.

Perform **SCP 5** Final Actions.

NOTE: Before printing **TP 23**, ensure that A4 or 8.5 x 11 inch plain paper is loaded long edge feed into tray 4. Use the best quality media available. Do not use hole punched paper.

Perform **dC977** Drum Runout Calibration. Print **TP 23** Drum Runout and Y-stitch Test Pages. The test pages are good.

Y N
Go to 91-637-00 Drum Runout Calibration Needed RAP.
Perform SCP 5 Final Actions.

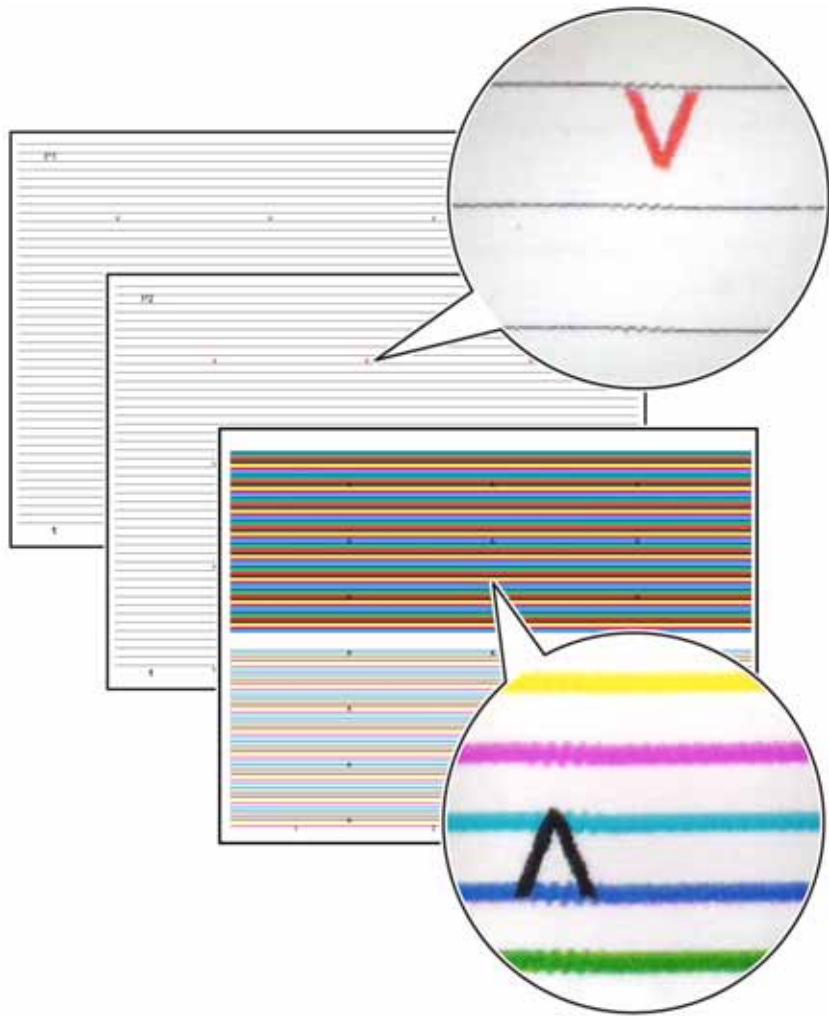

Figure 1 Y-stitch or printhead roll error

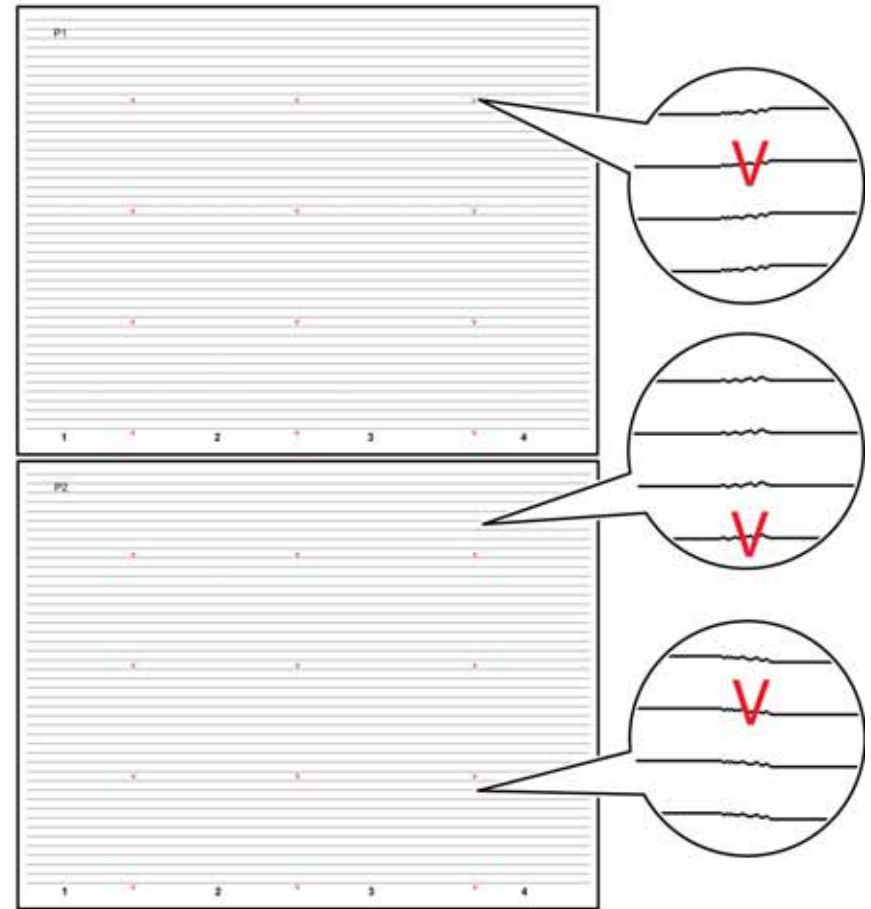
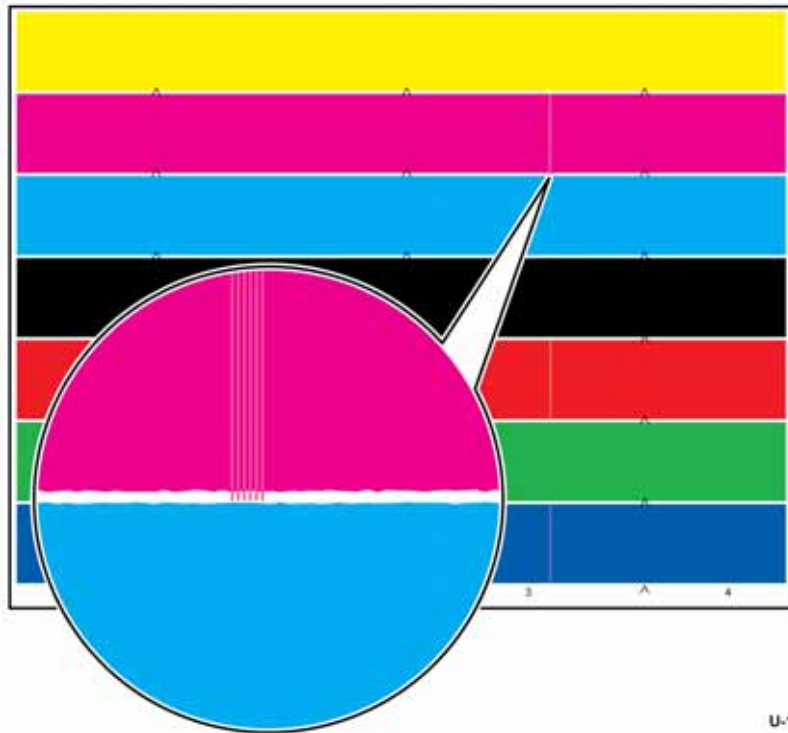

Figure 2 Drum run-out defect

U-1-1384-A

Weak Jets with Y-Dot Error Checkout

Refer to [Figure 3](#).



U-1-1429-A

Figure 3 Weak jets with Y-dot error

Go to [91-638-00](#) IOD Detects Chronic Jet Error RAP.

Weak Intensity and Y-Dot Error in All Colours Across a Printhead Checkout

Refer to [Figure 4](#).

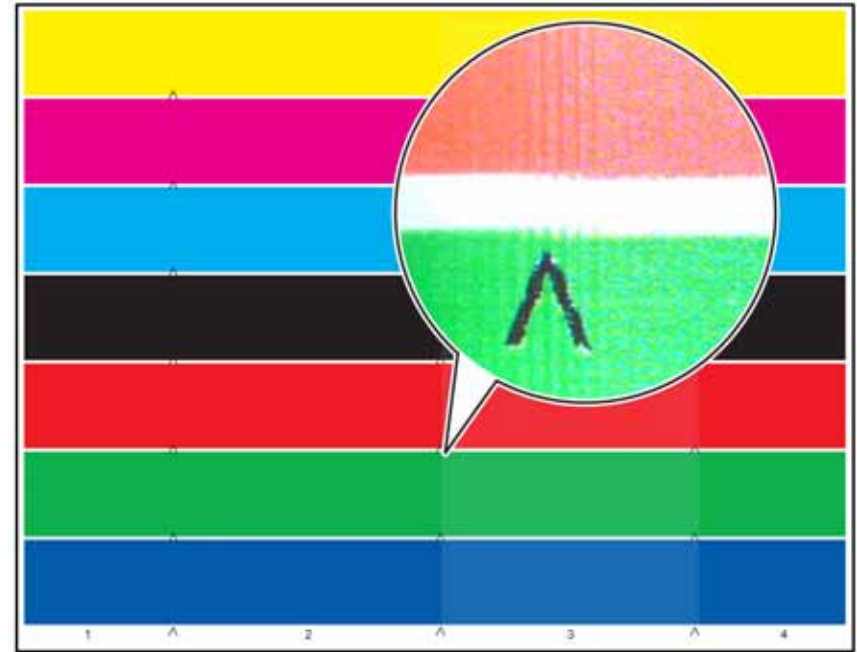

U-1-1088-A

Figure 4 Weak intensity and poor Y-dot position

Procedure

Print [TP 1](#) Initial Test Print Pages. **Test pages are good.**

Y N

Evaluate the colour bands test print. If the defect is similar to that shown in [Figure 4](#), Perform [dC972](#) Printhead Uniformity, option 1. Print [TP 1](#) Initial Test Print Pages. **The test pages are good.**

Y N

Evaluate the text print. Check the Y-dot position, refer to [IQS 3](#) Y-Dot Position. **The Y-dot position is acceptable.**

Y N

Install new printheads as necessary, [PL 91.20 Item 2](#) or [PL 91.25 Item 2](#).

Evaluate the text print, refer to [IQS 6](#) Blurry Text. **The blurry text is acceptable.**

A B

A B
 Y N
 Install new printheads as necessary, [PL 91.20 Item 2](#) or [PL 91.25 Item 2](#).
 Re-define the image quality defect, refer to [IQ 1 Image Quality Entry RAP](#).
 Perform [SCP 5 Final Actions](#).
 Perform [SCP 5 Final Actions](#).

Y-Dot Error Checkout

Refer to [Figure 5](#).

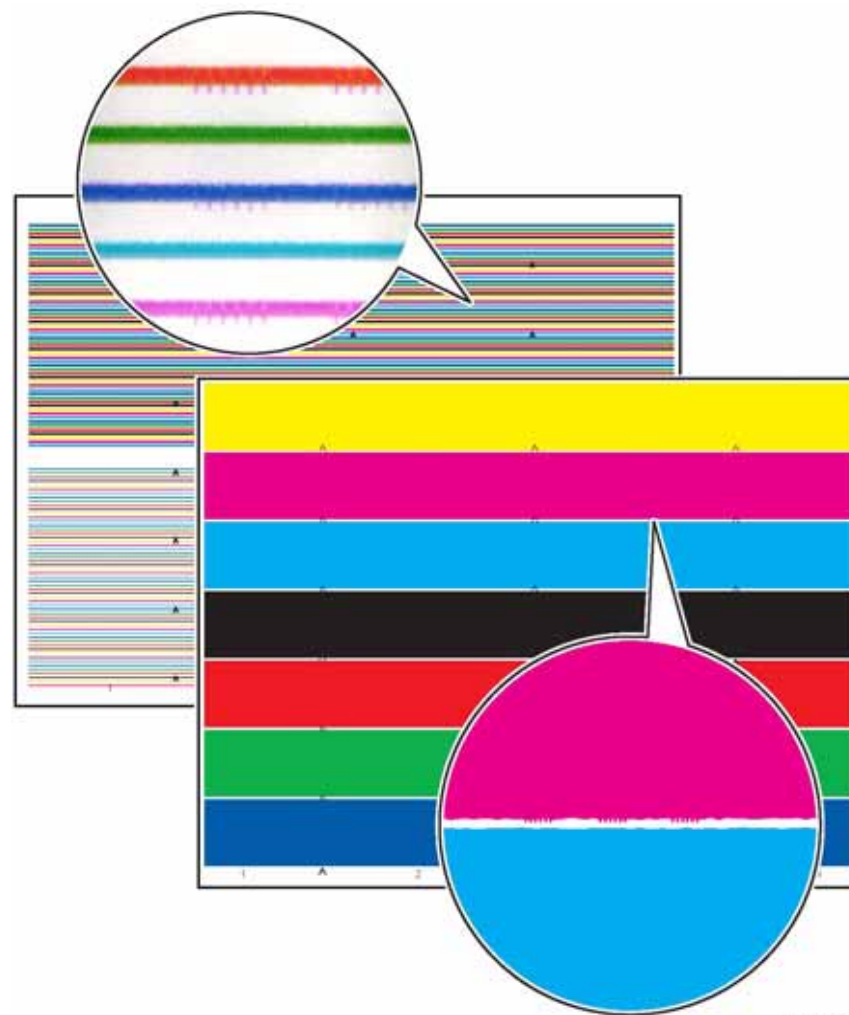

U-1-1122-A

Figure 5 Abnormal Y-dot position

Procedure

Perform [dC967](#) Head to Drum Spacing Check. The head to drum spacing check is successful.

Y N
Perform ADJ 91.1 Printhead Attachment Check.

Perform dC972 option 5, Y-dot position correction. Print TP 1 Initial Test Print Pages. Compare the test pages with IQS 3. **The test pages are good.**

Y N
Perform the following dC972 routines:
• Option 2 Head to Head Alignment Adjust.
• Option 3 Head to Head Uniformity.
• Option 4 TRC Generation.

Print TP 1 Initial Test Print Pages. Compare the test pages with IQS 3 and IQS 6. **The test pages are good.**

Y N
Perform dC972 option 5 Y Dot Position Correction. Print TP 1 Initial Test Print Pages. Compare the test pages with IQS 3 and IQS 6. **The test pages are good.**

Y N
Install new printheads as necessary, PL 91.20 Item 2 or PL 91.25 Item 2.

Perform SCP 5 Final Actions.

Perform SCP 5 Final Actions.

Perform SCP 5 Final Actions.

Blurry / Jagged Text Defect Checkout

Refer to Figure 6.

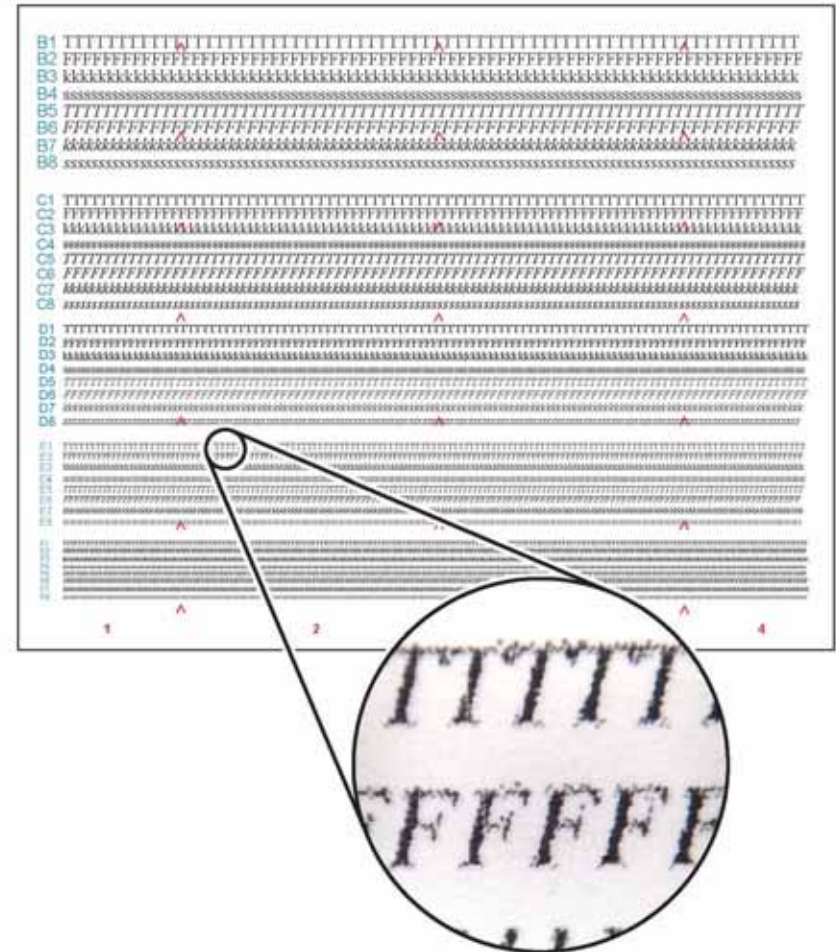

U-1-1416-A

Figure 6 Blurry / jagged text

Procedure

Check the position of the carriages. **The carriages are docked to the drum.**

Y N
Perform dC967 Head to Drum Spacing Check. **dC967 runs successfully.**

C

C

Y N

Perform ADJ 91.1 Printhead Attachment Check.

Perform SCP 5 Final Actions.

Perform dC972 option 5, Y-dot position correction. Print TP 1 Initial Test Print Pages. Evaluate the text page only and compare with IQS 6. **The text page is good.**

Y N

Perform dC972 option 1, Printhead Uniformity. Option 1 runs options 1 through 5, before proceeding to run option 5, Print TP 1 Initial Test Print Pages. Evaluate the text page only and compare with IQS 6. **The text pages are good.**

Y N

Perform dC972 option 5, Y-Dot Position Correction. Print TP 1 Initial Test Print Pages. Evaluate the text page only and compare with IQS 6. **The text pages are good.**

Y N

Install new printheads as necessary, PL 91.20 Item 2 or PL 91.25 Item 2.

Perform SCP 5 Final Actions.

Perform SCP 5 Final Actions.

Perform SCP 5 Final Actions.

IQ 6 Missing Ink or Grainy Output RAP

Use this RAP when the output has white spots or a grainy appearance, Figure 1.

A grainy appearance can be caused by:

- Image processing on certain postscript print files that contain transition areas between greys and near-greys.
- Inherent graininess in prints.
- Missing pixels (known as dropout). This is most visible in halftone regions and is most prevalent on duplex prints and / or rough / textured media.

NOTE: Media containing cotton, linen or parchments can exhibit dropout due to surface texture. Areas of missing ink on envelopes that outline the seams or flaps is normal.

NOTE: Opening the paper tray or switching from SEF to LEF prints can cause dropout on the next duplex print. Reprinting the job will normally resolve this issue.

Ensure IQ 1 Image Quality Entry RAP is performed before starting this RAP.

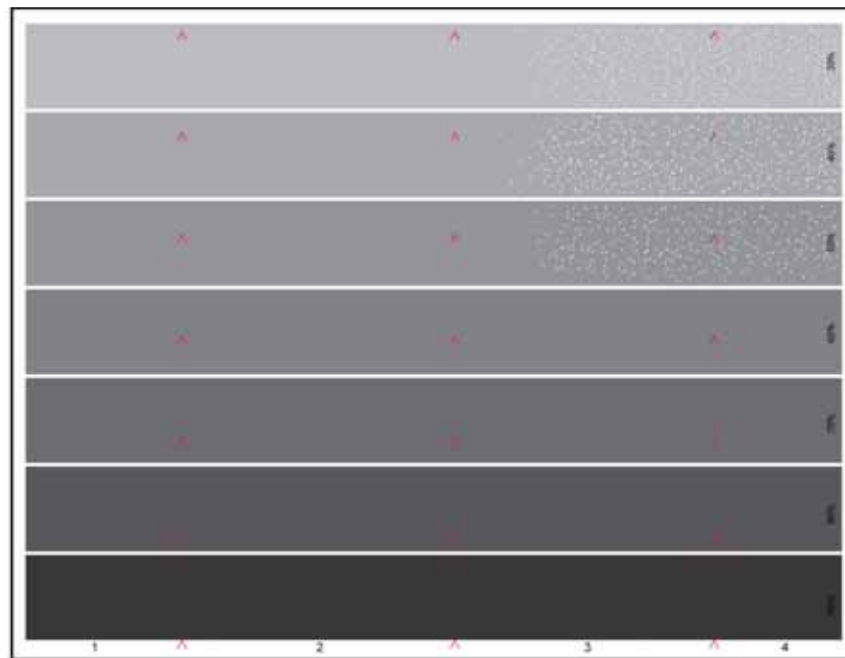

U-1-1645-A

Figure 1 Duplex dropout example

Initial Actions

WARNING

Ensure that the electricity to the machine is switched off while performing tasks that do not need electricity. Refer to [GP 14](#). Disconnect the power cord. Electricity can cause death or injury. Moving parts can cause injury.

WARNING

Take care during this procedure. The stripper blade is very sharp and can cause injury.

- If the customer is using banner pages, make sure they are printed in the same orientation as the job. Printing banner sheets in a different orientation to the job can cause dropout.
- Check that the defect occurs when making prints and is not related to copy quality. If the defect is present on copies only, Go to [IQ 29](#) DADH Document Glass and Scanner RAP.
- If the graininess only appears on postscript prints in transition areas between greys and near greys, print the job using composite black (selected from the print driver).

NOTE: This change can affect billing black / white / grey pages with greater than 1.5% coverage. It is therefore not recommended to save composite black as the default setting.

- Fast colour and standard print resolutions can cause more dropout. If graininess is observed at either of these resolutions, print the job at a higher resolution (enhanced or high resolution / photo).
- Turn the media over in the tray. Media quality can vary between sides.
- Print the job on smoother media. Inform the customer to use the smoothest, best quality media available.
- If the pattern of graininess is exactly the same on multiple copies of the same print, use a higher print resolution. This is an indication that the defect is inherent in the print file. No other service action is possible. Defect is within specification.
- Enlarging an image may result in a grainy appearance.
- Press the Machine Status button on the keypad, select the Fault tab on the UI, then Current Messages. If the message 'Cleaning unit life extended, image quality may be impacted' is displayed, install a new cleaning unit, [PL 94.10 Item 21](#).
- Check the drum page count in [dC131](#) NVM ID 492-070. If a drum has not been replaced on this machine, this page count will equal the meter total. If a new drum has been installed, the meter count will be higher than the drum page count (the offset will equal the page count that a new drum was installed on). If this NVM value has become corrupt or if the drum page count was not properly reset when a new drum was installed, images may have a more grainy appearance.

Procedure

Make a duplex print of [TP 11](#) Color Bands and Dithers Test Pages. Look at the last sheet only (black dither print). **The image level of graininess is the same on both sides.**

Y N

Check that the front and rear thermistors are not misaligned or bent and that they are making contact with the drum. Check that there is no paper or debris between the thermistors and the drum. **The thermistors are good.**

Y N

Install new components as necessary:

- Front drum thermistor, [PL 94.20 Item 9](#).
- Rear drum thermistor, [PL 94.20 Item 10](#).

A B

A B

Perform [dC335](#) Heater Monitor and Exerciser. Check the operating temperature of the drum and registration/preheat assemblies. **The temperatures are within the set point range.**

Y N

Check the fault history, [GP 2](#), for a corresponding fault code. Perform the relevant RAP.

Enter [dC978](#) Transfix Calibration Values. Check the transfix calibration values against those on the drum frame. **The calibration values match.**

Y N

Correct transfix calibration values in NVM, [dC131](#).

Enter [dC962](#) to test the transfix assembly. **The transfix assembly operates normally.**

Y N

Install new components as necessary:

- Transfix roller, [PL 10.20 Item 1](#).
- Flexure encoder, [PL 10.20 Item 5](#).
- Transfix motor, [PL 10.20 Item 11](#).

Open the front door and remove the inner cover. Enter [dC959](#), Cleaning Unit Exerciser, and run the slow speed exerciser. While this is running ensure the cleaning unit metering blade and roller are making contact with the drum. **The metering blade and roller are making contact with the drum.**

Y N

Check the cleaning unit front cam, [PL 94.10 Item 9](#), rear cam, [PL 94.10 Item 13](#), drive gear, [PL 94.10 Item 23](#) and cleaning unit motor, [PL 94.10 Item 24](#). Install new parts as necessary.

No other service action is possible. Defect is within specification.

Instruct the customer to run the job with extra heavy weight selected as the job media type regardless of the media type being used. Instruct the customer to change the paper type back to its original setting when finished. Extra heavy weight media selection affects stapling and hole punching finish options.

Go to [IQ 26](#) Poor Ink Adhesion.

IQ 7 Metering Blade Timing RAP

Use this RAP to diagnose faults with operation of the cleaning unit metering blade.

Ensure **IQ 1** Image Quality Entry RAP is performed before starting this RAP.

Procedure

WARNING

Ensure that the electricity to the machine is switched off while performing tasks that do not need electricity. Refer to GP 14. Disconnect the power cord. Electricity can cause death or injury. Moving parts can cause injury.

NOTE: Before printing TP 20, ensure that A4 or 8.5 x 11 inch plain paper is loaded long edge feed into tray 4. Use the best quality media available. Do not use hole punched paper.

1. Print **TP 20** Oil Bar Chase and Metering Blade Timing Test Pages.
2. Evaluate the metering blade timing test page only. If the metering blade engages and disengages within the tolerance zones, the cleaning unit and cleaning unit drive train are working correctly.
3. If the metering blade is engaging or disengaging outside the tolerance zones, **Figure 1** either the cleaning unit or the cleaning unit drive train is defective.
4. Refer to **94-520-00** Cleaning Unit Drive Train RAP to determine if the cleaning unit drive train is defective. If the drive train is operating correctly, install a new cleaning unit **PL 94.10** Item 21.

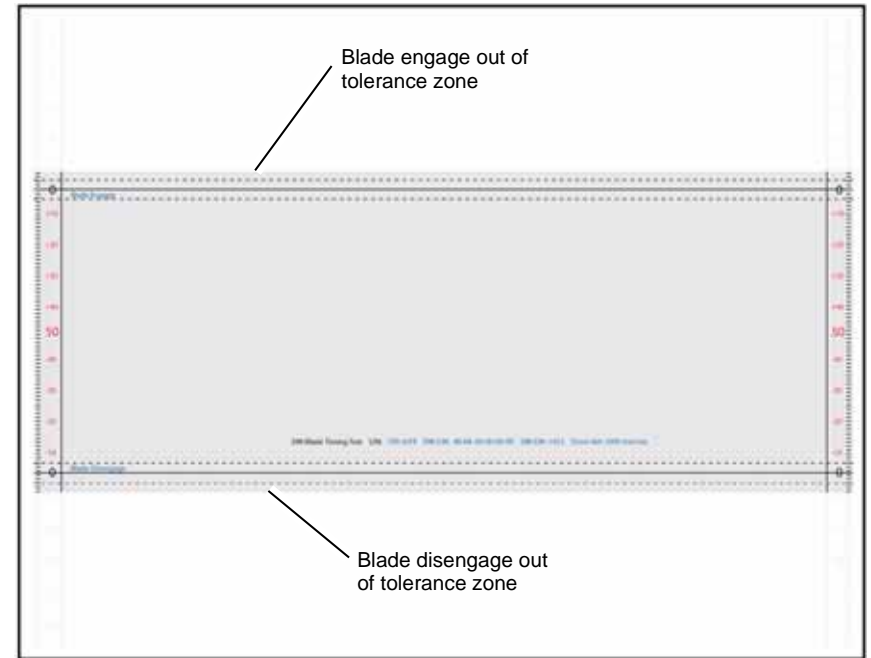

U-1-1379-A

Figure 1 Metering blade timing page (too long)

IQ 8 Cross Process Ink Artifacts (Smudge) RAP

Use this RAP when the output has extra ink in localized areas in the cross process direction, Figure 1.

Ensure IQ 1 Image Quality Entry RAP is performed before starting this RAP.

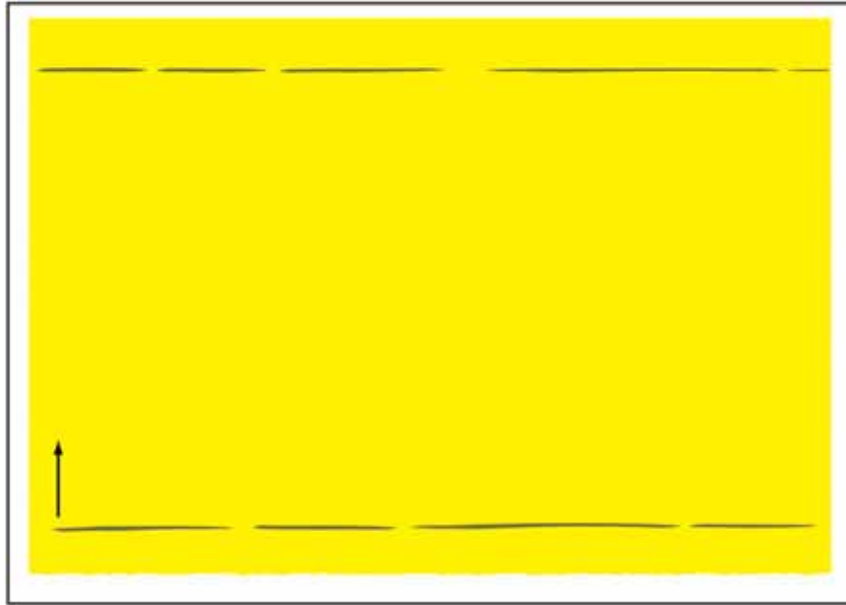

U-1-1126-A

Figure 1 Cross process ink artifacts

Procedure

WARNING

Ensure that the electricity to the machine is switched off while performing tasks that do not need electricity. Refer to GP 14. Disconnect the power cord. Electricity can cause death or injury. Moving parts can cause injury.

WARNING

Take care during this procedure. The stripper blade is very sharp and can cause injury.

WARNING

Do not clean the stripper blade. The stripper blade is very sharp and can cause injury. If the stripper blade is dirty a new blade must be installed.

WARNING

Take care during this procedure. Sharp edges may be present that can cause injury.

Open the stripper gate, GP 31. Inspect the drum stripper blade for ink accumulation.

NOTE: Occasionally, the combination of rough media, a high coverage image, and a long print job creates a condition where stripper blade ink accumulation is unavoidable. Advise the customer to consider changing to smoother media.

Print three copies of TP 4 Yellow Solid Fill Test Pages (TP 2 to TP 10). The test pages are good.

Y N

Press the Machine Status button select the Fault tab on the UI and enter Current Messages. Check if the message 'Cleaning unit life extended, image may be impacted' is displayed. **A different message is displayed.**

Y N

Install a new cleaning unit, PL 94.10 Item 21.

Open the front door and remove the inner cover. Enter dC959 and run the slow speed exerciser. While this is running, check that the cleaning unit blade and roller are making contact with the drum. **The cleaning unit blade and roller are making contact with the drum.**

Y N

Check the front cam, PL 94.10 Item 9, rear cam, PL 94.10 Item 13, drive gear, PL 94.10 Item 23 and the cleaning unit motor, PL 94.10 Item 24 **The components are good.**

Y N

Install new components as necessary.

Perform dC969 Clean Ink Smears. Print three copies of TP 4 Yellow Solid Fill Test Pages (TP 2 to TP 10). **The test pages are good.**

Y N

Install a new stripper blade assembly PL 10.12 Item 3.

Perform SCP 5 Final Actions.

Perform SCP 5 Final Actions.

Print TP 14 Drum Stripper Blade Test Print. **The stripper blade releases between the 35 mm and the 50 mm mark.**

Y N

Install a new stripper blade solenoid, PL 10.10 Item 3.

A B

A

B

Perform dC969 Clean Ink Smears. Print three copies of TP 4 Yellow Solid Fill Test pages (TP 2 to TP 10). **The test pages are good.**

Y N

Install a new stripper blade assembly, PL 10.12 Item 3.

Perform SCP 5 Final Actions.

Perform SCP 5 Final Actions.

Re-define the image quality defect, refer to IQ 1 Image Quality Entry RAP.

IQ 9 Deletions in the Process Direction RAP

Use this RAP to troubleshoot the following defects:

- Deletions in the process direction.
- Scraped ink in the process direction.
- Scratches in the process direction.
- X-stitch defects.
- Light lines in the process direction.
- Roving missing jets.

Ensure [IQ 1 Image Quality Entry RAP](#) is performed before starting this RAP.

Procedure

WARNING

Ensure that the electricity to the machine is switched off while performing tasks that do not need electricity. Refer to [GP 14](#). Disconnect the power cord. Electricity can cause death or injury. Moving parts can cause injury.

WARNING

Take care during this procedure. The stripper blade is very sharp and can cause injury.

WARNING

Do not clean the stripper blade. The stripper blade is very sharp and can cause injury. If the stripper blade is dirty a new blade must be installed.

WARNING

Take care during this procedure. Sharp edges may be present that can cause injury.

CAUTION

Use care when moving the marking unit into the service position when hot. Ink can spill from the ink reservoir located at the back of the unit if opened with too much force. Cross-colour ink contamination could also occur.

CAUTION

Do not touch the exposed face of the printheads. Surface contamination or minor damage can easily make the printhead unusable.

NOTE: Before printing test pages, ensure that A4 or 8.5 x 11 inch plain paper is loaded long edge feed into tray 4. Use the best quality media available. Do not use hole punched paper.

1. Evaluate the colour bands test page, [TP 26](#). Check for the following defects:

- X - Stitch - Defects along the X-stitch area indicated by the chevrons, [Figure 1](#). X-stitch generally appears as a set of white stripes in the stitch region. X-stitch can also appear as a darker, more dense strip indicating an overlap of ink. An X-stitch defect is seen in all colours but it may appear more severe in some colours (especially black). If observed, go to the [X-Stitch Defect Checkout](#).

NOTE: Chevrons on the test pages indicate the X-stitch region between each printhead. X-stitch defects occur along this narrow area of the print.

- Missing or weak jet - Deletions of a single primary colour that run consistently in the process direction, [Figure 2](#). If observed, go to the [Missing or Weak Jet Checkout](#).

- Scraped Ink - A line of missing ink in the process direction, [Figure 7](#). Edges of the defect are rough or jagged. Ink may appear in the margin or the trailing edge. Distinct from multiple missing jets by the irregular edges of the deletion. If observed, go to the [Scraping Checkout](#).
 - A broad line of missing ink of a single primary colour in the process direction with straight edges, [Figure 8](#). Distinct from scraping by the uniform edges of the deletion. If observed, go to the [Multiple Missing Jets Checkout](#).
 - Multiple deletions and blobs of ink on the print, [Figure 9](#). If observed, go to the [Purge Line Obstruction Checkout](#).
 - X-Axis defect - High-frequency bands in the process direction, [Figure 10](#). If observed, go to the [X-Axis Defect Checkout](#).
 - Missing or discoloured jets caused by a worn wiper blade forcing ink or debris into the printhead jetstack, [Figure 11](#). If observed, go to the [Printhead Maintenance Checkout](#).
 - Light lines in the process direction indicating missing jets, that clear after a head purge, followed by further missing jets on the same carriage. This is caused by a dirty wiper blade contaminating the printheads and is known as a roving jet. If this defect is observed, go to the [Printhead Maintenance Checkout](#).
 - Multiple missing lines of a primary colour in the process direction in a single printhead, [Figure 12](#). The missing lines will also show up in any secondary colours that are effected by the primary colour (i.e. missing lines in yellow will also show up in red and green). If this is observed go to the [Internally Leaking Printhead Checkout](#).
2. If the defect does not match any of the above re-define the image quality defect, refer to [IQ 1 Image Quality Entry RAP](#).

X-Stitch Defect Checkout

Refer to [Figure 1](#).

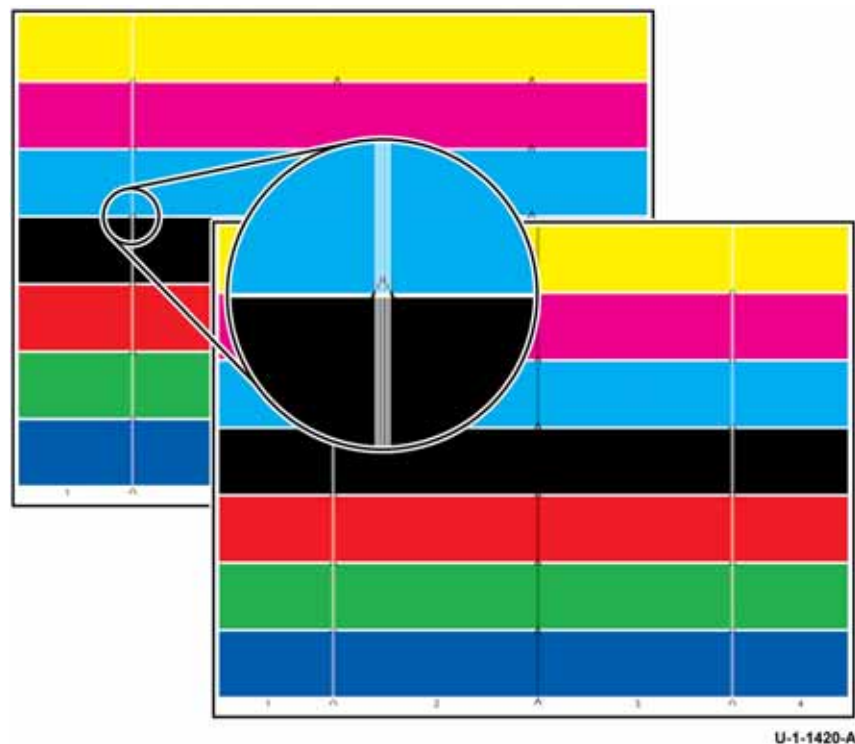

Figure 1 X-stitch defect

Procedure

Perform [dC971](#) Head to Head Alignment Adjustment up to 3 times. Print [TP 16](#) Stitch Identification Test Pages after each adjustment. **The test pages are good.**

Y N

Manually disable the IOD align calibration:

1. Enter [dC131](#) NVM read/write NVM ID 490-41 and change value to 3.
2. Enter [dC971](#) and start the routine.
3. Enter [dC612](#) and print [TP 16](#) and check the identification test pages.

The test pages are good.

Y N

Manually re-enable the IOD align calibration:

1. Enter [dC131](#) NVM read/write NVM ID 490-41 and change value to 4.
2. Enter [dC971](#) and start the routine.
3. Enter [dC612](#) and print [TP 16](#) and check the identification test pages.

A B

A B

The test pages are good.

Y N

Perform [dC914](#) Head to Head Alignment Test. Check the motion of the printhead stitch adjust motors, [PL 91.20 Item 4](#) and [PL 91.25 Item 4](#). **The stitch adjust motors run.**

Y N

Check the motion of the printhead X-axis drive motors, [PL 91.20 Item 5](#) and [PL 91.25 Item 5](#).

Go to the [91-504-00](#), [91-505-00](#) Printhead Stitch Motor Over Current RAP. **The X-axis drive motors run.**

Y N

Go to the [91-510-00](#), [91-511-00](#) X Axis Motor Over Current RAP.

Print [TP 16](#). Check the test pages for good alignment following motion testing. If the defect remains, perform the following:

1. Check for obstructions that block carriage and printhead motion.
2. Clean the IOD, refer to [GP 27](#) Cleaning Procedure.
3. Clean the drum, refer to [GP 27](#) Cleaning Procedure.

Perform [SCP 5](#) Final Actions.

Perform [SCP 5](#) Final Actions.

Print the colour bands test page, [TP 26](#). **The test page is good.**

Y N

Go to the [Printhead Maintenance Checkout](#).

If the stitch defect is still present, swap the print heads around to move the artifact to the outside of the page.

Perform [SCP 5](#) Final Actions.

Missing or Weak Jet Checkout

Refer to [Figure 2](#).

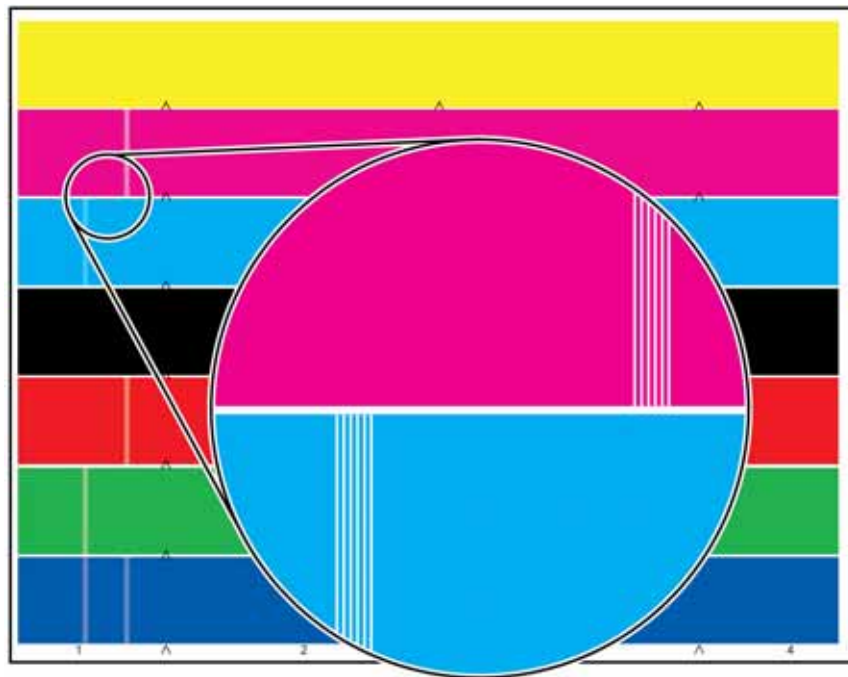

Figure 2 Missing jet

Procedure

Print [TP 21](#) Jet Test Pages and [TP 11](#) Colour Bands and Dithers Test Pages. Identify problem jets by referring to [Table 1](#) and [Figure 4](#), [Figure 5](#) and [Figure 6](#). The jet test pages are printed with no jet interlacing, so masked or missing jets will not generate colour bars. Consider the points that follow:

- If ink is missing from at least 4 numerically sequential and identically numbered jets in all 4 colours [Figure 11](#), go to the [Printhead Maintenance Checkout](#).
- All jets print their corresponding colour bar on the service jet test page.
- Masked (refer to [GP 30](#)) and chronic jets usually will not have a colour bar.
- Jets that begin to work after being masked (intermittent) will have a colour bar even though their label is green.
- Weak or missing jets that have a black jet number have not been detected by the IOD.
- If the IOD sensor has failed, it could report missing jets incorrectly, causing them to be mislabeled.

Table 1 Problem jet identification

Jet number colour label	Jet problem
Purple	Detected missing jets that have not been labelled as chronic
Red	Chronic jet
Green	Missing jet for which jet substitution is enabled manually
Black	Jetting issue not identified by IOD.

All jets are good.

Y N

There is a missing jet on dithers only, [Figure 3](#).

Y N

Go to the [91-638-00](#) IOD Detects Chronic Jet Error RAP.

Perform [dC972](#) Printhead Uniformity, option 4 TRC Generation. Print [TP 11](#) colour bands and dithers test pages. **The test pages are good.**

Y N

Perform [dC972](#) Printhead Uniformity, option 6 Reset Head Uniformity Data. Print [TP 21](#) jet test pages. **The test pages are good.**

Y N

Install new printheads as necessary, [PL 91.20 Item 2](#) or [PL 91.25 Item 2](#).

Perform [dC972](#) Printhead Uniformity, option 1 Printhead Uniformity.

Perform [SCP 5](#) Final Actions.

Print 2 copies of [TP 11](#) Colour Bands and Dithers Test Pages. **The test pages are good.**

Y N

Perform the following:

1. [dC959](#) Cleaning Unit Exerciser. If the test fails, install a new cleaning unit, [PL 94.10 Item 21](#).
2. Print [TP 20](#) oil bar chase and metering blade timing test pages. Evaluate the oil bar chase page only. If necessary, install a new cleaning unit, [PL 94.10 Item 21](#).

Print 2 copies of [TP 11](#) Colour Bands and Dithers Test Pages. **The test pages are good.**

Y N

Go to the [91-638-00](#) IOD Detects Chronic Jet Error RAP.

Perform [SCP 5](#) Final Actions.

Perform [SCP 5](#) Final Actions.

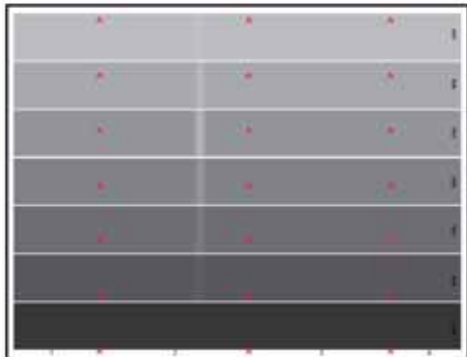

Figure 3 Missing jet on dithers only

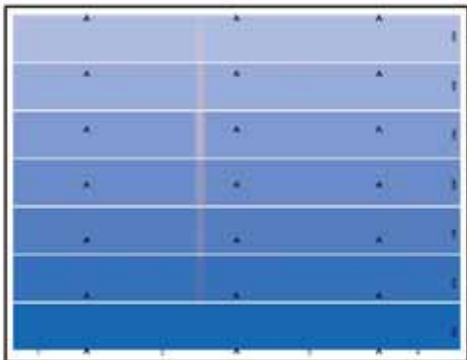

Figure 4 Missing jet 157

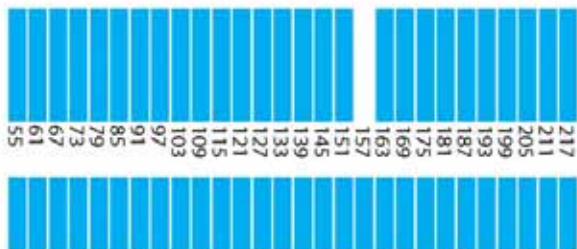

Figure 5 Weak jet 187



Figure 6 Sputtering jet 157



U-1-1552-A

U-1-1068-A

U-1-1071-A

U-1-1070-A

Scraping Checkout

Refer to [Figure 7](#).

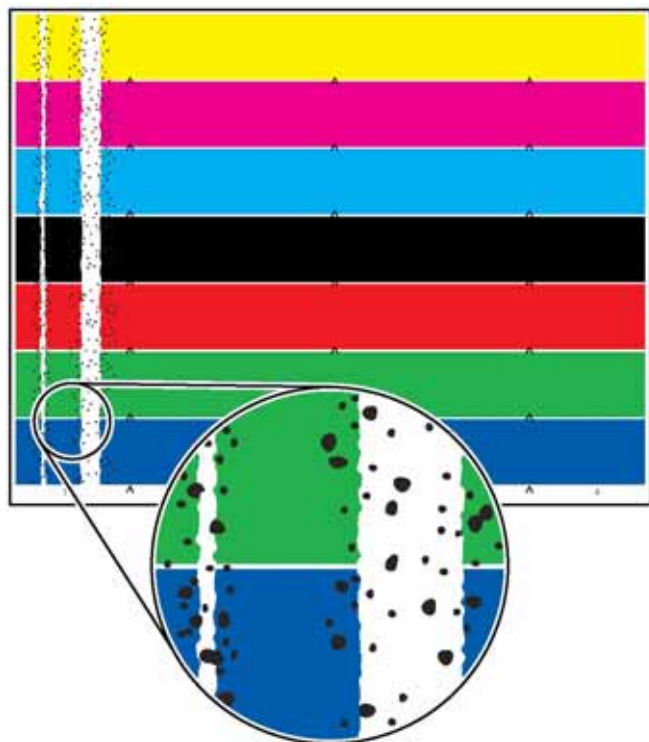

Figure 7 Scraping

Procedure

Check for accumulations of ink or media debris on components that could scrape the drum.
Perform the following:

1. Clean the following components, [GP 27](#) or install new components as necessary:
 - Abatement plenum, [PL 94.20 Item 12](#).
 - IOD shield and sensor, [PL 94.15](#).
2. If necessary, install a new stripper blade assembly, [PL 10.12 Item 3](#).
3. [IQ 7](#) Metering Blade Timing RAP.

Print the colour bands test page, [TP 26](#). **The test pages are good.**

Y N

Re-define the image quality defect, refer to [IQ 1](#) Image Quality Entry RAP.

Perform [SCP 5](#) Final Actions.

Multiple Missing Jets Checkout

Refer to [Figure 8](#). Shows multiple missing jets of a single primary colour.

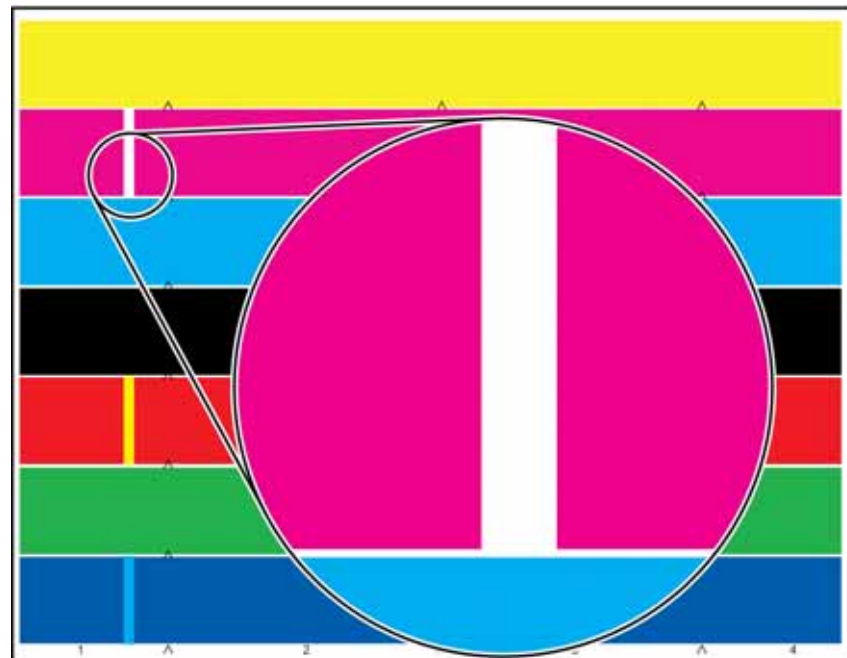

U-1-1425 -A

Figure 8 Multiple missing jets

Procedure

Perform the following:

1. Perform [dC968](#) Head Purge.
2. Print the jet test pages, [TP 21](#).

Analyse the jet test pages. **The jet test pages are good.**

Y N

Go to the [91-638-00](#) IOD Detects Chronic Jet Error RAP.

Perform [SCP 5](#) Final Actions.

Purge Line Obstruction Checkout

Refer to Figure 9.

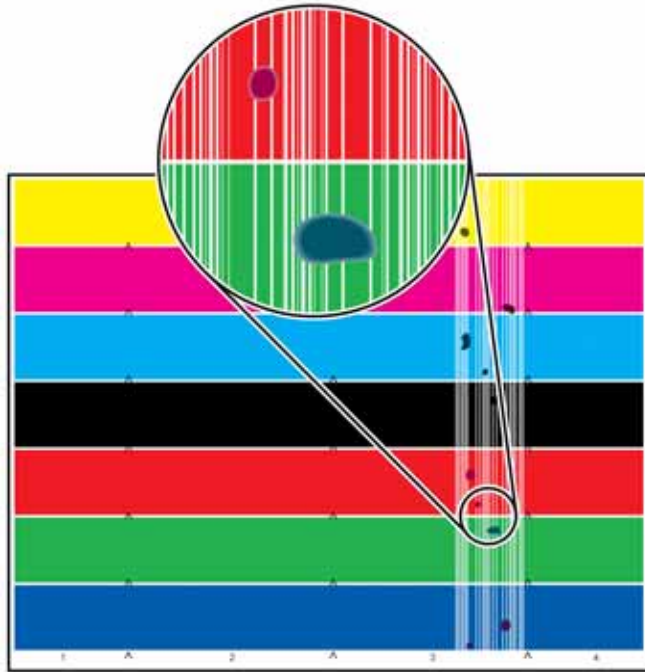

U-1-1116-A

Figure 9 Purge line obstruction

Procedure

Check for purge line issues, refer to the 93-549-00 to 93-552-00 and 93-557-00 to 93-560-00 Printheads 1 and 3 Printhead Reservoir Fill Error RAP or the 93-553-00 to 93-556-00 and 93-561-00 to 93-564-00 Printheads 2 and 4 Printhead Reservoir Fill Error RAP. **The purge line errors are found and corrected.**

Y N

Check the printheads for evidence of ink drooling from the printhead jetstack area. If necessary, install a new printhead, PL 91.20 Item 2 or PL 91.25 Item 2.

NOTE: Drool may occur after a purge is completed and the printhead will continue to 'ooze' small amounts of ink out of the printhead. Drool may also occur at initial warm up and effects all four printheads and does not continue after the purge cycle.

This may eventually lead to clogged jets and may stain the face plate.

Perform SCP 5 Final Actions.

X-Axis Defect Checkout

Refer to Figure 10.

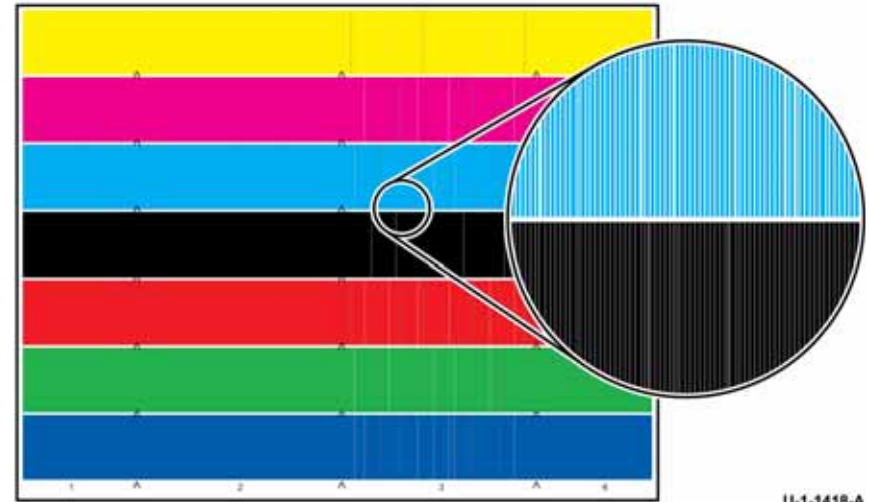

U-1-1418-A

Figure 10 X-axis defect

Procedure

Go to IQ 13 Uneven in All Colours RAP. Perform the X-Axis Checkout.

Printhead Maintenance Checkout

Refer to [Figure 11](#).

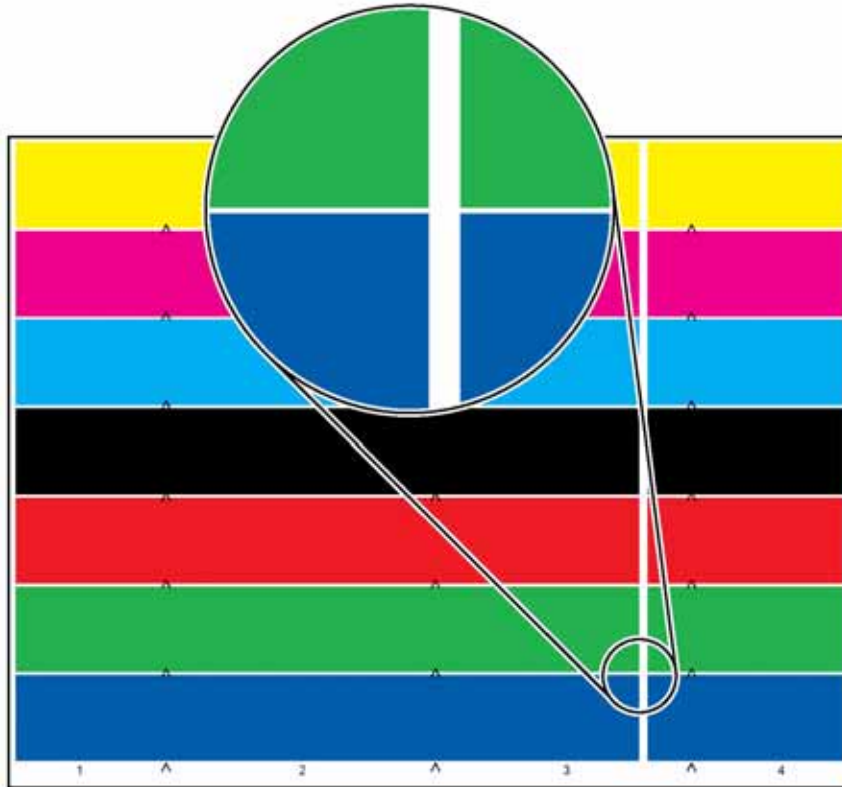

U-1-1342-A

Figure 11 Clogged or contaminated jets

Procedure

Print the jet test pages, [TP 21](#). Examine the jet test pages to determine the placement of the missing jets, [Figure 11](#). **The ink is missing from 4 numerically sequential and identically numbered jets in all 4 colours.**

Y N
Go to the [Missing or Weak Jet Checkout](#).

C

C

Perform [dC965](#) Printhead Maintenance Cycle Test. Observe wiper motion during the test. Look for erratic wiper motion that may indicate wiper chatter or motor failure. **The wiper moves smoothly across the printhead jetstack area.**

Y N

Perform the following:

1. Check the wiper mechanism, refer to the [91-572-00](#), [91-573-00](#), [91-575-00](#) Wiper Vertical Error RAP.
2. If necessary, install a new HM wiper, [PL 91.15 Item 13](#).

NOTE: Installation of a HM wiper, [PL 91.15 Item 13](#) is recommended if wiper chatter is observed.

3. [dC968](#) Head Purge.

Print the jet test pages, [TP 21](#). **The test pages are good.**

Y N

Go to the [91-638-00](#) IOD Detects Chronic Jet Error RAP.

Perform [SCP 5](#) Final Actions.

Go to the [Missing or Weak Jet Checkout](#).

Internally Leaking Printhead Checkout

Procedure

Evaluate the colour bands test page, TP 26. Check for the following defect:

NOTE: Since the printhead is leaking internally, no ink will be visible externally on the print head or on the printer.

If massive amounts of ink are missing in the process direction in one printhead similar to Figure 12, check for a leaky printhead. Note that the missing ink will generally affect a primary colour and its associated secondary colours. This issue most commonly shows up in black and yellow meaning the missing ink will also show up in the red and green bars. Purging the printhead to recover the missing jets will not resolve this issue. Often the missing ink will be noticed on the colour bands print on TP 26 but not on the jet tests pages printed from dC968. If this defect is observed then install a new printhead, PL 91.20 Item 2 and PL 91.25 Item 2.

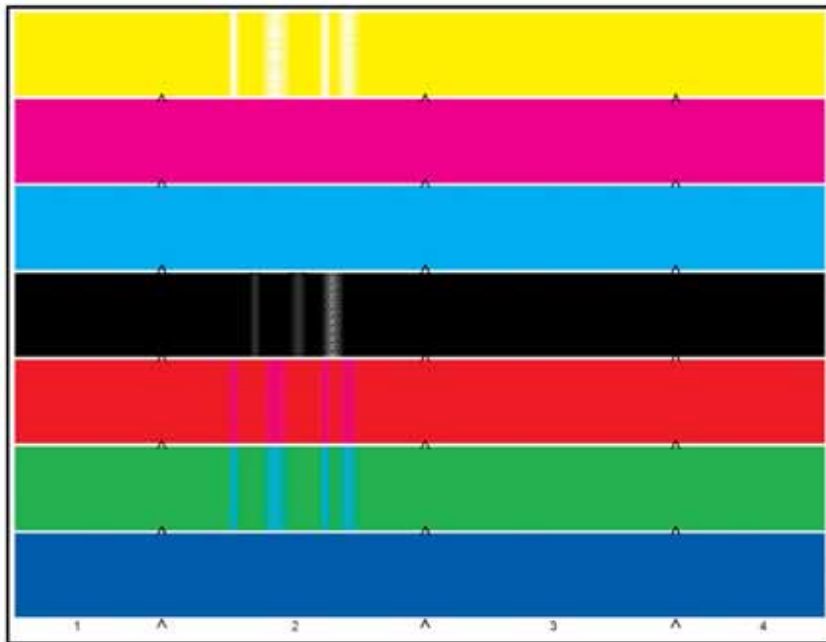

Figure 12 Printhead with internal leak

IQ 10 Incorrect Margin, Misregistration or Skew RAP

Use this RAP to determine the source of margin, misregistration or skew, Figure 1.

Ensure IQ 1 Image Quality Entry RAP is performed before starting this RAP.

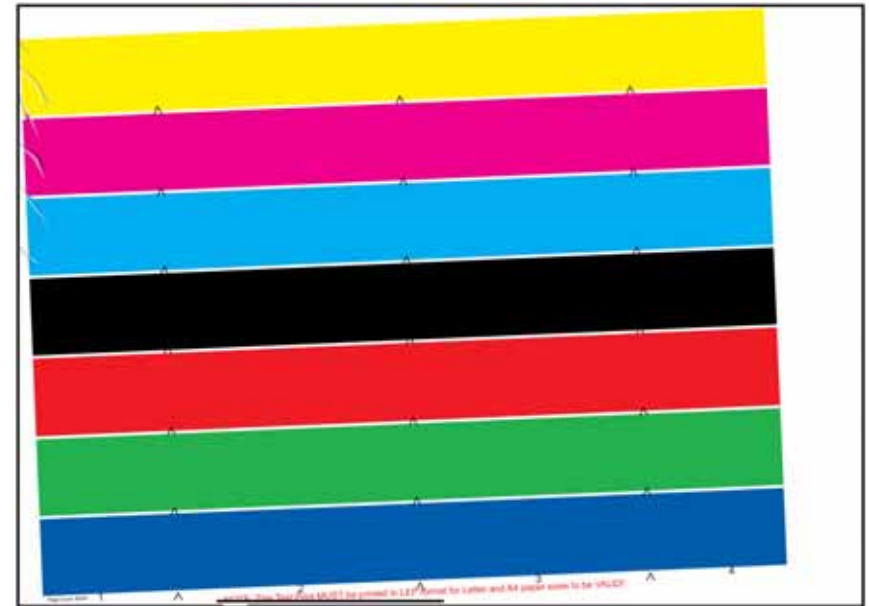

Figure 1 Image skew

Initial Actions

WARNING

Ensure that the electricity to the machine is switched off while performing tasks that do not need electricity. Refer to GP 14. Disconnect the power cord. Electricity can cause death or injury. Moving parts can cause injury.

- Perform dC608 Document Feeder Registration.
- Perform dC609 Document Glass Registration.

Procedure

Make 3 prints of TP 2, cyan solid fill test page (TP 2 to TP 10). Check the prints for skew, refer to IQS 1 Registration and Skew. **The prints are skewed.**

Y N
Make 3, duplex prints of TP 2, cyan solid fill test page (TP 2 to TP 10). Check the prints for skew, refer to [IQS 1](#) Registration and Skew. **The prints are skewed.**

Y N
Make 3 copies of TP 2 from the document glass. Check the copies for skew. **The copies are skewed.**

Y N
Make a copy of TP 2 from the DADH. Check the copies for skew. **The copies are skewed.**

Y N
No skew is present. Re-define the image quality defect. Refer to [IQ 1](#) Image Quality Entry RAP.

The skew is originating in the DADH. Go to [ADJ 5.3](#) DADH Skew Adjustment.

There is a skew problem originating in the scanner. Perform the following:

- Check that the scan carriage is parallel to edge of the document glass. If necessary, perform [ADJ 62.2](#) Scan Carriage Assembly.
- Check that the scan cables are wrapped around their drive pulleys, refer to [REP 62.7](#) Scan Cables.
- If necessary, install a new scanner, [PL 62.15](#) Item 1.

The skew occurs in the duplex paper path. Check the following nip and drive rolls, refer to [GP 29](#) Component Locations:

- Roller drive J - [PL 10.10](#) Item 1.
- Roller drive L - [PL 10.10](#) Item 2.
- Roller nip P - [PL 10.15](#) Item 6.
- Nip R, C and Q takeaway rolls, [PL 82.15](#) Item 10.
- Transport roller drive 2, D, F - [PL 82.10](#) Item 1.
- Transport roller TAR vertical, E - [PL 82.10](#) Item 2.

Clean the rolls, [GP 27](#) or install new components as necessary.

Perform [dC969](#) Clean Ink Smears. Print 3 copies of TP 2, cyan solid fill test page (TP 2 to TP 10). Check the prints for skew, refer to [IQS 1](#) Registration and Skew. **The prints are good.**

Y N
Perform [dC625](#) Registration/preheat Calibration. **The registration calibration is good.**

Y N
Enter [dC330](#) code 82-007, nip C release solenoid, [PL 82.15](#) Item 4 and 82-008, nip D release solenoid, [PL 70.30](#) Item 13. **The solenoids energize.**

Y N
Go to the [82-507-00](#), [82-508-00](#) Nip C and Nip D Release Solenoid Over Current RAP.

Check the operation of the air pumps, refer to [88-508-00](#) Registration/preheat Air Pump Incorrect Current RAP. If the air pumps are working, then install a new registration/preheat assembly, [PL 88.10](#) Item 1.

Make 3 prints of TP 2, cyan solid fill test page (TP 2 to TP 10). **The prints are good.**

Y N
Make five prints from each tray and the bypass tray to identify the source of skew. Perform the following:

- Check the tray feed rolls and guides for contamination.
- Check the tray feed rolls and transport rolls for wear. Install new components as necessary.
- Check that there is no variation in the size or weight of the sheets of paper in each tray.
- Check the paper path for obstructions. Refer to [IQ 2](#) Copy or Print Damage RAP.

Perform [SCP 5](#) Final Actions.

Perform [SCP 5](#) Final Actions.

IQ 11 Smudges, Debris, Smears in the Process Direction, or Paper Stack Marks RAP

Use this RAP to troubleshoot the following defects:

- Faint smudges or smears in the process direction at the edges of the print, [Figure 1](#) and [Figure 2](#).
- Faint smudges or smears in the process direction in line with text or printed horizontal lines, [Figure 3](#).

NOTE:

- Most roller and rib marks are inherent to the design and cannot be completely eliminated.
- Paper stack marks may only appear on the edge of the stack (but not on the surface of the print), they should be relatively faint. This type of marking is normal and no permanent solution is available. To clean, run chase pages, [TP 12](#) to the affected tray until the defect fades. The benefits of cleaning are temporary.

Ensure [IQ 1](#) Image Quality Entry RAP is performed before starting this RAP.

Initial Actions

WARNING

Ensure that the electricity to the machine is switched off while performing tasks that do not need electricity. Refer to [GP 14](#). Disconnect the power cord. Electricity can cause death or injury. Moving parts can cause injury.

WARNING

Take care during this procedure. The stripper blade is very sharp and can cause injury.

WARNING

Do not clean the stripper blade. The stripper blade is very sharp and can cause injury. If the stripper blade is dirty a new blade must be installed.

WARNING

Take care during this procedure. Sharp edges may be present that can cause injury.

CAUTION

If media is found between the drum and IOD sensor, remove the IOD sensor before removing the media. Pulling media out over the IOD can damage the IOD shield.

- Clear the media path. Check the area surrounding the drum, IOD, cleaning unit, abatement plenum, transfix roller, and drum stripper blade for ink debris or for full or partial sheets of media.
- Check the pre-heater for ink debris.

Procedure

The machine has a finisher fitted.

Y N
Go to [Machine Only](#).

Separate the finisher from the machine. Install a finisher bypass connector, [PL 26.10 Item 3](#). Print the initial test pages, [TP 1](#). The prints are good.

Y N
Go to [Machine Only](#).

A

A

The defect is in the finisher. Dock and connect the finisher. Compare the marks to [Figure 1](#). The marks are similar to [Figure 1](#), approximately 1 mm wide.

Y N
The machine has a HVF.

Y N
Print three copies of TP 4 Yellow Solid Fill Test Pages ([TP 2 to TP 10](#)) to different output trays to isolate where the marking is taking place. Inspect the media path of the LCSS. Look for trapped media debris or a build up of ink. Clean any contamination from the media path.

The marks are similar to [Figure 2](#).

Y N
Slight amounts of ink accumulation will show up as marks on the edge of the stack (on a large job). As the accumulation of ink increases, it can cause ink marks on the surface of the print from the ink transferring from the ribs onto the media. These marks are approximately 1 mm wide and correspond to the rib locations. Clean any contamination from the media path.

The booklet maker has additional paper path features which contact the image and create localized scuff marks. Clean the media path of the booklet maker.

The defect may occur when booklet making with paper above 120 gsm. The ink may transfer from one sheet to the other sheet it is being folded against. If this occurs then use paper of 120 gsm or below.

Print three copies of TP 4 Yellow Solid Fill Test Pages ([TP 2 to TP 10](#)) to different output trays to isolate where the marking is taking place. Inspect the media path of the finisher. Look for a build up of ink on ribs. Clean any contamination from the media path.

Machine Only Procedure

Check that the front drum thermistor, [PL 94.20 Item 9](#) and the rear drum thermistor, [PL 94.20 Item 10](#) are not bent or misaligned. Check for paper debris between the thermistors and the drum and ensure that the thermistors are making good contact with the drum. The thermistors are good.

Y N
Install new components as necessary

- Front drum thermistor, [PL 94.20 Item 9](#).
- Rear drum thermistor, [PL 94.20 Item 10](#).

Perform [dC335 Heater Monitor and Exerciser](#). Check the drum operating temperature. The drum temperature is good.

Y N
Go to [94-536-00, 94-538-00, 94-540-00, 94-542-00, 94-544-00, 94-546-00, 94-632-00, 94-633-00 Drum Heat Error RAP](#).

Perform [dC335 Heater Monitor and Exerciser](#). Check the preheat operating temperature. The preheat temperature is good.

Y N
Go to [88-500-00 to 88-502-00, 88-512-00 Preheat Thermal Error RAP](#).

B

B

Refer to [88-508-00](#) Registration/preheat Air Pump Incorrect Current RAP. **The Registration/preheat air pump is good.**

Y N

Install a new registration/preheat air pump, [PL 88.10 Item 5](#).

Press the Machine Status button select the fault tab on the UI and enter Current Messages. Check if the message 'Cleaning unit life extended, image may be impacted' is displayed. **A different message is displayed.**

Y N

Install a new cleaning unit, [PL 94.10 Item 21](#).

NOTE: *Installing a new cleaning unit may temporarily make smudging worse.*

Enter [dC969](#) and run Clean Print Smears. Print three copies of TP 4 Yellow Solid Fill Test Pages ([TP 2 to TP 10](#)). **The test prints are good.**

Y N

Open the stripper gate, [GP 31](#). Check the drum stripper blade for accumulations of ink or other debris. **The stripper blade is clean.**

Y N

Perform the following:

1. Check the stripper solenoid SOL10-021, [PL 10.10 Item 3](#). Refer to [10-570-00](#) Stripper Solenoid Over Current RAP. If necessary, install a new stripper solenoid assembly, [PL 10.10 Item 3](#).
2. Install a new cleaning unit, [PL 94.10 Item 21](#).

NOTE: *Installing a new cleaning unit may temporarily make smudging worse.*

3. Inspect the cleaning unit camshaft assembly, [PL 94.10 Item 4](#) for obstructions that would prevent it from moving freely. Remove the camshaft assembly. Check the bushings, [PL 94.10 Item 8](#) and [PL 94.10 Item 14](#) for wear or damage. If necessary, install a new camshaft assembly, [PL 94.10 Item 4](#).
4. If necessary, install a new drum stripper blade, [PL 10.12 Item 3](#).

Print [TP 15](#) Media Path Test Pages, to determine where in the paper path the marking is occurring. Refer to [GP 27](#) Cleaning Procedure to clean the media path.

If the problem persists, check the following areas for accumulation of ink or media debris.

Clean as necessary:

- Cleaning unit metering blade. Only remove paper debris. If the metering blade appears to have excessive ink build-up, refer to [IQ 21](#).
- Abatement plenum, [PL 94.20 Item 12](#).
- IOD shield and sensor, [PL 94.15 Item 1](#).
- Roller nip N, [PL 10.15 Item 1](#) and roller nip P, [PL 10.15 Item 6](#).
- Paper path ribs and guides.

Perform [SCP 5](#) Final Actions.

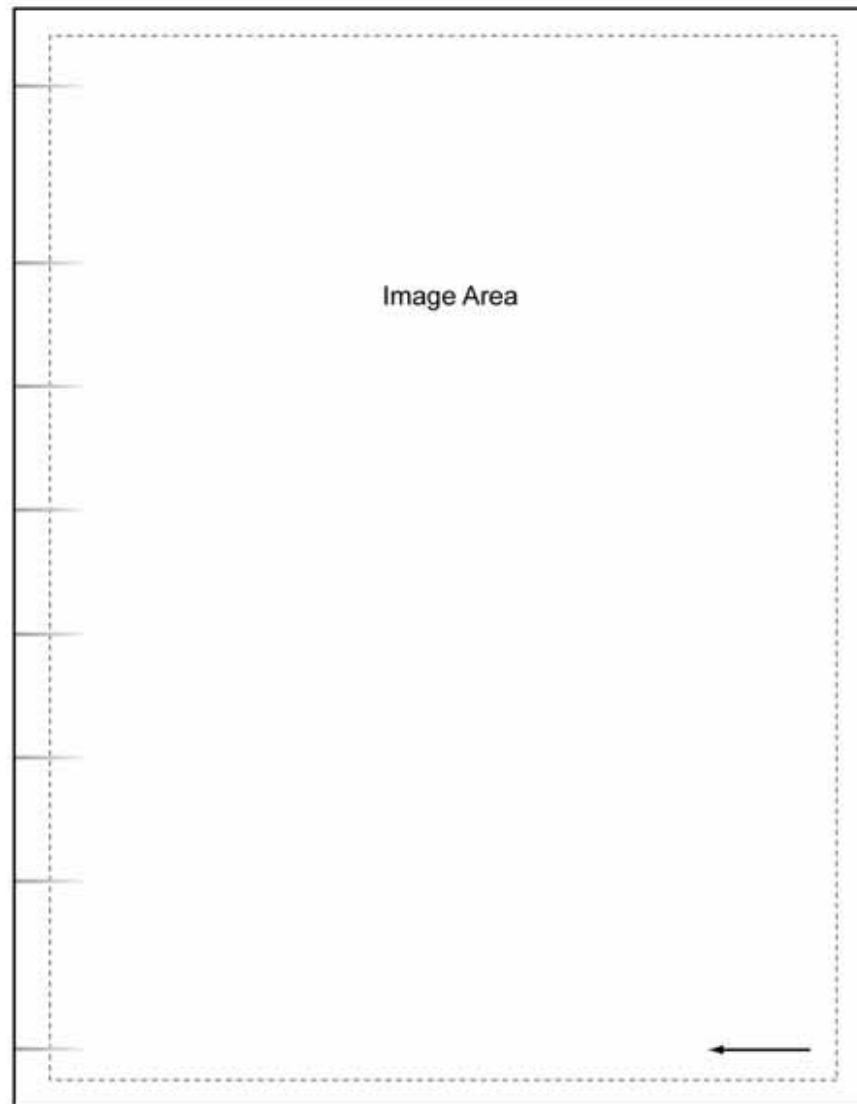

U-1-1344-A

Figure 1 Finisher rib marking example

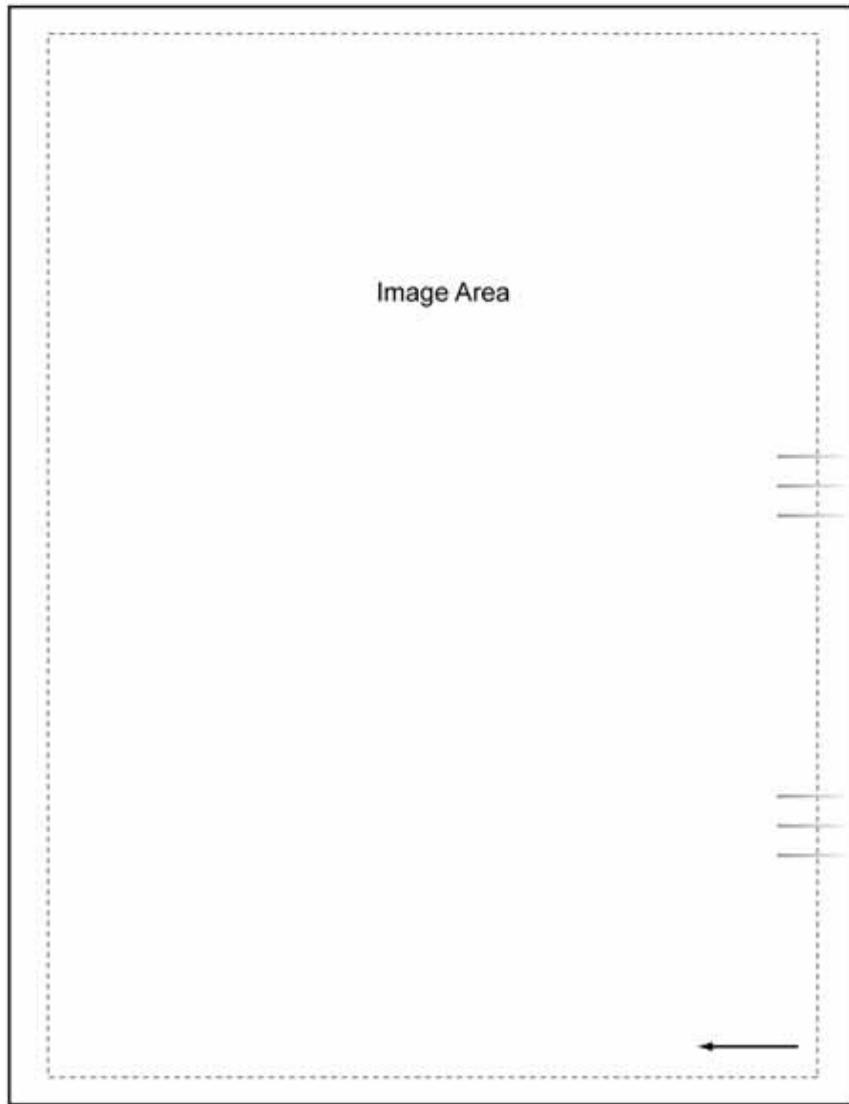

Figure 2 HVF BM ejector marking example

U-1-1346-A

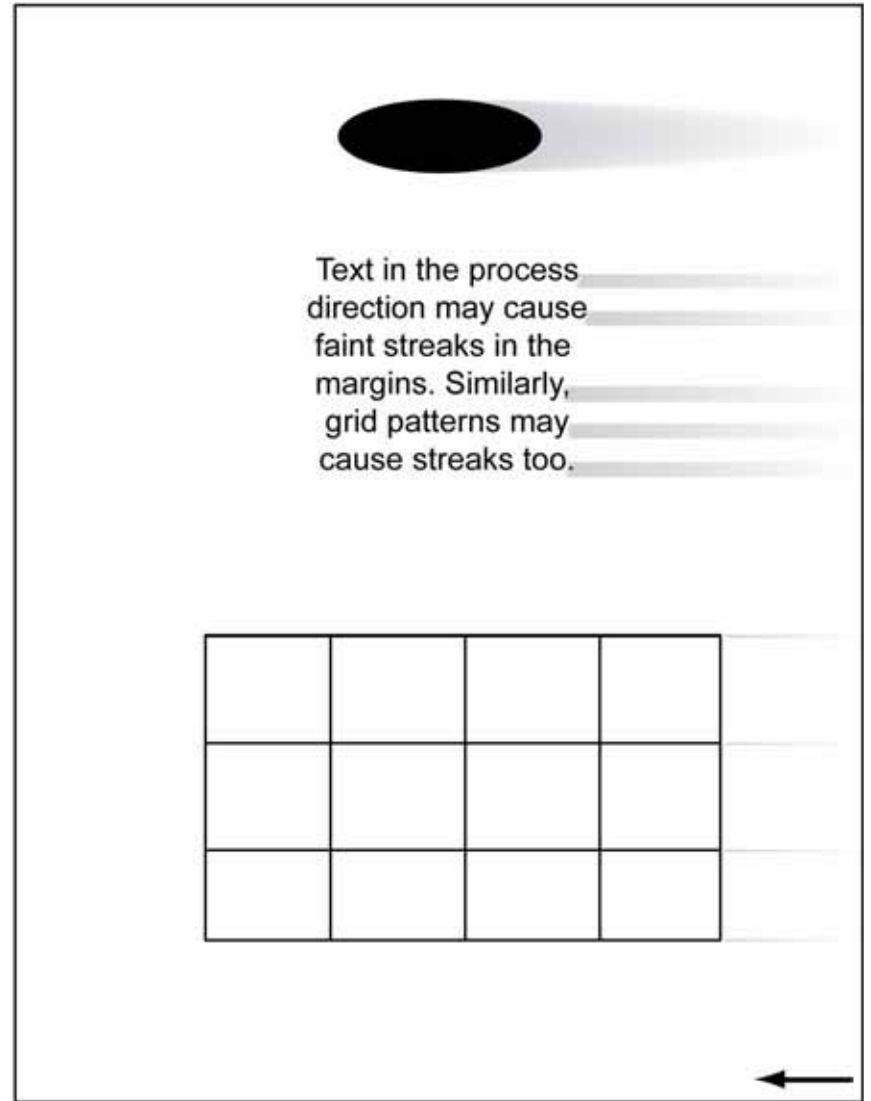

Figure 3 Streaking from IOT

U-1-1345-A

IQ 12 Missing or Partial Image RAP

Use this RAP to troubleshoot wide deletions in the process direction that affect a complete printhead or a when a single colour is missing from a single printhead.

The problem is usually caused by a communication or power error in the marking unit and causes the substantial or complete loss of a single printhead, [Figure 1](#) and may be seen in one or all colours. The problem may be an ink supply problem if only a part of the printhead is missing.

NOTE: Blank sheets accompanying multi-feeds or chase pages following a jam are normal.

Ensure [IQ 1](#) Image Quality Entry RAP is performed before starting this RAP.

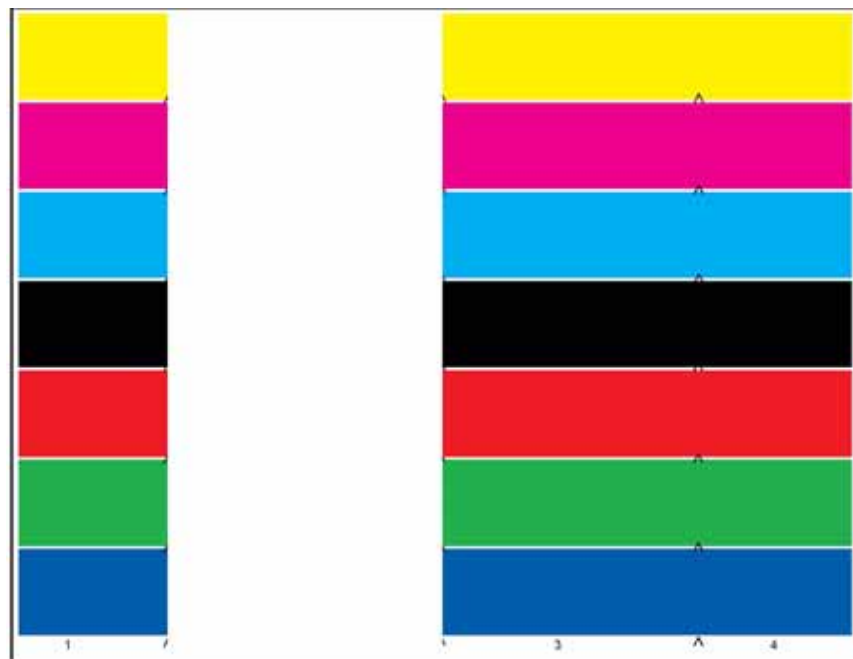

U-1-1347-A

Figure 1 Printhead 2 failure

Initial Actions

WARNING

Ensure that the electricity to the machine is switched off while performing tasks that do not need electricity. Refer to [GP 14](#). Disconnect the power cord. Electricity can cause death or injury. Moving parts can cause injury.

CAUTION

Use care when moving the marking unit into the service position when hot. Ink can spill from the ink reservoir located at the back of the unit if opened with too much force. Cross-colour ink contamination could also occur.

CAUTION

The video cable (striped and labeled A, [PL 92.10 Item 7](#)) and the wave amp cable (white and labeled B, [PL 92.10 Item 8](#)) should not be interchanged at the printhead connectors. Damage to the printhead and IME controller PWB will occur if the cables are installed incorrectly.

CAUTION

Do not touch the exposed face of the printheads. Surface contamination or minor damage can easily make the printhead unusable.

- Check for media or debris around the printhead and drum. Clean as necessary, refer to [GP 27](#) Cleaning Procedure.

Procedure

Switch off, then switch on the machine, [GP 14](#). Check the PEST fault history, [dC123](#). **New faults are listed in the PEST history.**

Y N
Print the initial test pages, [TP 1](#). **Test pages are good.**

Y N

NOTE: Before printing [TP 26](#), ensure that A4 or 8.5 x 11 inch plain paper is loaded long edge feed into tray 4. Use the best quality media available. Do not use hole punched paper.

Perform [dC968](#) Head Purge on the affected printhead. Print [TP 26](#) Printhead Uniformity / Colour Bands Test Page. **Test prints are good.**

Y N

Reseat the two ribbon cables, [PL 92.10 Item 7](#) and [PL 92.10 Item 8](#), attached to the affected printhead. Print the initial test pages, [TP 1](#). **The prints are good.**

Y N

Switch off the machine, [GP 14](#). Swap the two ribbon cables on the affected printhead with the two ribbon cables on the working printhead on the same carriage. Switch on the machine, [GP 14](#). Print the initial test pages, [TP 1](#). **The defect moves to a new location.**

Y N

Install a new quad wave amp PWB, [PL 92.10 Item 3](#). Print the initial test pages, [TP 1](#). **The test pages are good.**

Y N

Install a new IME controller PWB, [PL 92.10 Item 1](#). Print the initial test pages, [TP 1](#). **The test pages are good.**

Y N

Install a new printhead, [PL 91.20 Item 2](#) or [PL 91.25 Item 2](#).

A B C D E F G

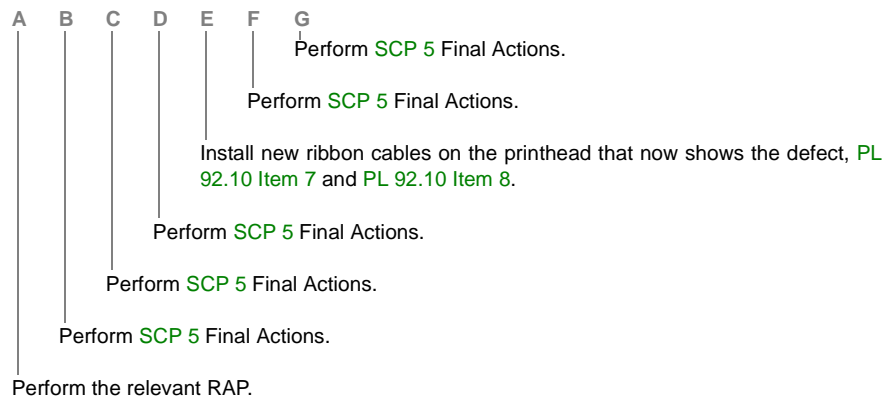

IQ 13 All Colours Uneven RAP

Use this RAP to troubleshoot uneven colours in all four primary colours (cyan, magenta, yellow and black).

Ensure **IQ 1** Image Quality Entry RAP is performed before starting this RAP.

Initial Actions

- Enter the customer administration tools, **GP 5**. On the Tools tab select Troubleshooting then Automatic Light Lines Fix. Set Quick Fix to On. Set Full Fix to Eco Fix.

NOTE: Ensure that the customer's Automatic Light Lines and Full Fix settings are restored to the original settings when the image quality defect has been corrected.

- Try running the customer's image in a higher print resolution.

Procedure

WARNING

Ensure that the electricity to the machine is switched off while performing tasks that do not need electricity. Refer to **GP 14**. Disconnect the power cord. Electricity can cause death or injury. Moving parts can cause injury.

CAUTION

Use care when moving the marking unit into the service position when hot. Ink can spill from the ink reservoir located at the back of the unit if opened with too much force. Cross-colour ink contamination could also occur.

CAUTION

Do not touch the exposed face of the printheads. Surface contamination or minor damage can easily make the printhead unusable.

Evaluate the colour bands test page, **TP 26**. Check for the following defects.

- X - stitch defects generally appear as a set of white stripes in the stitch region. X - stitch defects can also appear as a darker, more dense stripe indicating an overlap of ink. An X-stitch defect is seen in all colours but may appear more severe in black, **Figure 1**. The lines are in the stitch zone. If observed, go to **X-Stitch Checkout**.

NOTE: Chevrons on the print indicate the X-stitch region between each printhead. X-stitch defects occur along this narrow area of the print.

- High frequency lines of missing ink, dark lines or both, in the process direction, **Figure 2**. The lines are across the width of a printhead. If observed, go to **X-Axis Checkout**.
- Dark or light bands in the process direction, across the width of a printhead, **Figure 3**. The defect might be more noticeable in single colours, **Figure 4**. If observed, go to **Uniformity Checkout**.
- Faded lines in the process direction with indistinct edges, **Figure 5**. The defect is noticeable in all colours but may be more apparent in some, **Figure 6**. If observed, go to **Uniformity Checkout**.
- Faded lines in the cross process direction, **Figure 7**. Ringing seen between horizontal lines. If observed, go to **Ringing Checkout**.

- If the defect is not apparent in all four primary colours, go to the [IQ 14 Uneven in Some Colours RAP](#). If the colours are spatially uniform but incorrect, go to the [IQ 15 Wrong Colour RAP](#).

X-Stitch Checkout

Refer to [Figure 1](#).

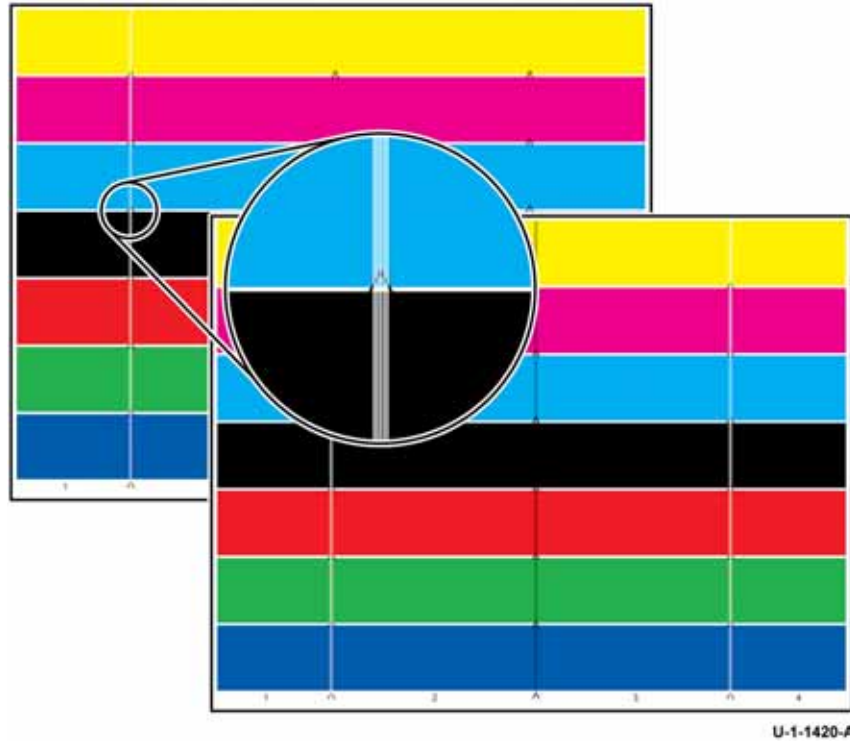

Figure 1 X-stitch error

Procedure

Perform [dC971 Head to Head Alignment Adjustment](#). **The printheads align without error.**

Y N

Perform [dC914 Head to Head Alignment Test](#). Check the motion of the printhead stitch adjust motor 1, [PL 91.25 Item 4](#) and the printhead stitch adjust motor 2, [PL 91.20 Item 4](#).

The print head stitch adjust motors run.

Y N

Install new components as necessary:

- Printhead stitch adjust motor 1, [PL 91.25 Item 4](#).
- Printhead stitch adjust motor 2, [PL 91.20 Item 4](#).

A B

A B

- Marking unit driver PWB, [PL 92.10 Item 4](#).
- IME controller PWB, [PL 92.10 Item 1](#).

NOTE: If a new printhead stitch adjust motor is installed, perform [dC971 Head to Head Alignment Adjust](#) to align the printheads.

Print the stitch identification test pages, [TP 16](#). Check printhead alignment. If the printheads fail to align, check for obstructions that block the carriage and printhead motion.

Perform [SCP 5 Final Actions](#).

X-Axis Checkout

Refer to [Figure 2](#).

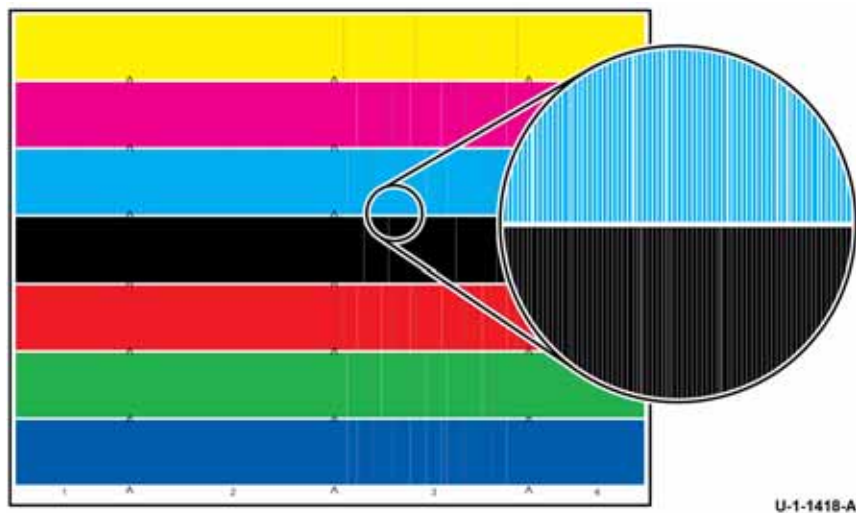

Figure 2 X-axis motion error

CAUTION

If carriage motion is obstructed to the point of producing stringy lines of ink, it is likely that strings of ink are scattered throughout the machine's interior. Check the printheads, abatement plenum, exit module, and transfix roller for ink residue, clean as necessary, [GP 27](#). Refer to [IQ 20](#) Wavy or Stringy Lines of Ink/Blistering RAP.

Procedure

Print the stitch identification test pages, [TP 16](#). **The prints are good.**

Y N

Perform the following:

1. Check for restrictions to printhead motion:
 - a. Wrong harness routing, refer to [GP 28](#) Marking Unit Assembly Wiring Harnesses.
 - b. Umbilical routing, [PL 91.20 Item 10](#) and [PL 91.25 Item 10](#). Check for obstructions or damage.
 - c. Contamination of the front and rear bearing shafts on the upper and lower SFWA frames.
 - d. Check that the orange shipping restraint clips are removed from the carriages.
2. Check the condition of the x-axis motors, [PL 91.20 Item 5](#) and [PL 91.25 Item 5](#):
 - Check for disconnected or damaged wiring harnesses. Repair as necessary, [REP 1.1](#).
 - Check the X-axis drive motor lead screw, and cone nut. Check that the anti-rotation stop is engaged. Refer to [REP 91.9](#) X Axis Drive Motor.

- C
3. Perform [dC914](#) Head to Head Alignment Test to check carriage motion. After correcting any obstructions, perform [dC971](#) Head to Head Alignment Adjust. Reprint the stitch identification test print, [TP 16](#).

The prints are good.

Y N

Install new components as necessary:

- X-axis motor, [PL 91.20 Item 5](#).
- Marking unit driver PWB, [PL 92.10 Item 4](#).
- IME controller PWB, [PL 92.10 Item 1](#).

Perform [dC971](#) Head to Head Alignment Adjust to align the printheads.

Perform [SCP 5](#) Final Actions.

Re-define the image quality defect, refer to [IQ 1](#) Image Quality Entry RAP.

C

Uniformity Checkout

Refer to Figure 3, Figure 4, Figure 5 and Figure 6.

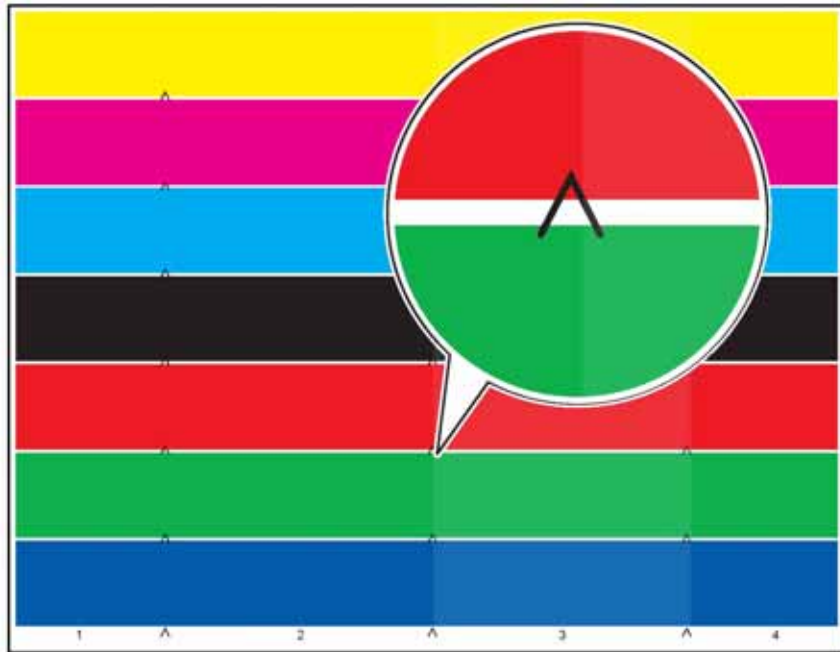

U-1-1488-A

Figure 3 Printhead wide non-uniformity

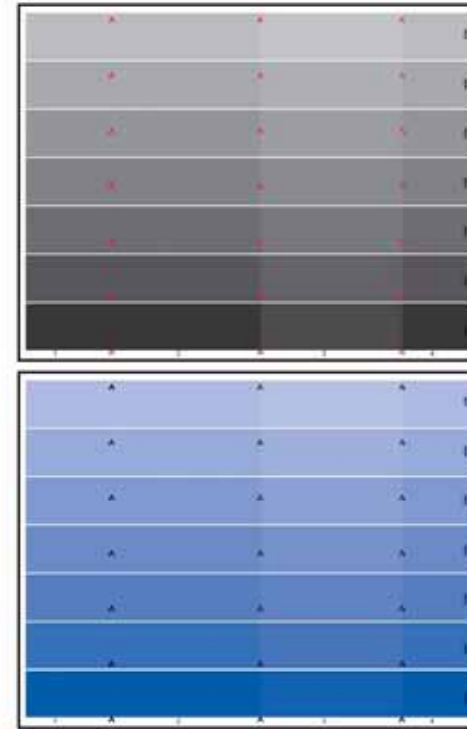

U-1-1349-A

Figure 4 Printhead non-uniformity on dithers

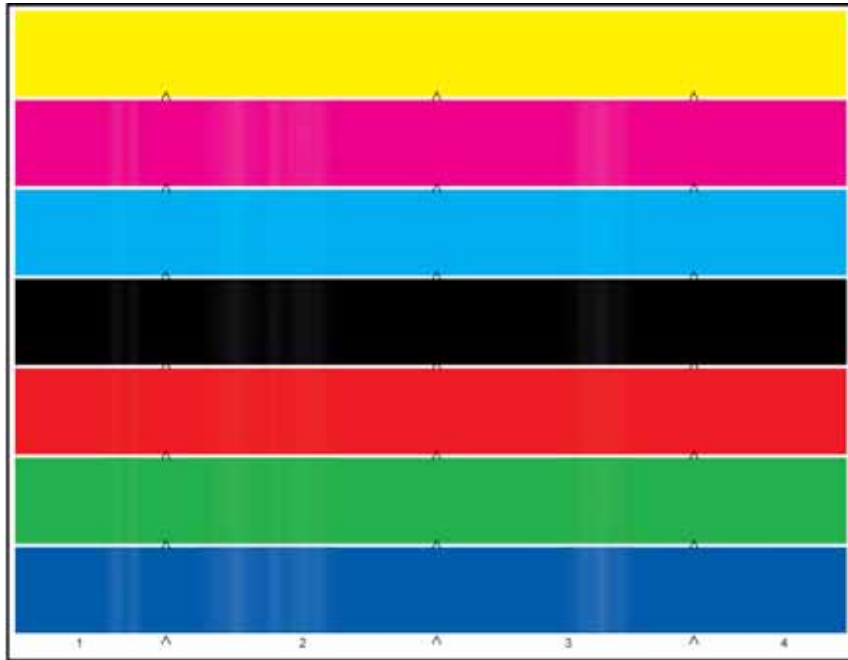

U-1-1077-A

Figure 5 Jet to jet non-uniformity



U-1-1558-A

Figure 6 Jet to jet non-uniformity on dithers

Procedure

NOTE: Before printing the test pages, ensure that A4 or 8.5 x 11 inch plain paper is loaded long edge feed into tray 4. Use the best quality media available. Do not use hole punched paper.

Evaluate the cyan / magenta test page and the red, blue and green bands in the colour bands print (TP 1). Check for distinctive non-uniform bands in the process direction. **The prints are good and are without non-uniform bands.**

Y N

Perform the following dC972 Print Head Uniformity routines:

1. Option 3 Head to head uniformity
2. Option 4 TRC Generation
3. Option 5 Y-dot position correction

Print TP 1. Evaluate the cyan / magenta test page and the red, blue and green bands on the colour bands test page for distinctive non-uniform bands in the process direction.

The prints are good and are without non-uniform bands.

Y N

Perform the following dC972 Print Head Uniformity routines:

D E

1. Option 6 Reset head uniformity data
2. Option 2 Head to head alignment adjust
3. Option 3 Head to head uniformity
4. Option 4 TRC Generation
5. Option 5 Y-dot position correction

Print **TP 1**. Evaluate the cyan / magenta test page and the red, blue and green bands on the colour bands test page for distinctive non-uniform bands in the process direction. **The prints are good and are without non-uniform bands.**

Y N

NOTE: The head to head uniformity uses one head as a reference to adjust the other printheads. Swapping the printheads then changes the reference print-head, which often results in better uniformity.

Swap printhead 1 with printhead 2 and printhead 3 with print head 4. On a 9301 machine make sure there are no chronic jets on print head 1 or printhead 4 before swapping the heads. If chronic jets are present, then install a new print-head to replace the print head that has a difference appearance than the other printheads. Perform **dC972**, Print **TP 1** and evaluate the cyan / magenta and the red, blue and green bands in the colour bands prints for distinctive non-uniform bands in the process direction. **The prints are good and are without non-uniform bands.**

Y N

Install new print heads as required, **PL 91.20 Item 2** or **PL 91.25 Item 2**.

NOTE: Certain colours (such as darker shades of blue, red and green) are more prone to show process direction banding. If banding is not seen on the test prints but the issue is with a particular shade of a colour as opposed to all or many shades of a colour, no other adjustments or repairs actions are possible.

Advise the customer to print the image in another print resolution or colour correction may result in a more satisfactory image. Changing the colour in the customers application may result in a more satisfactory image.

Perform **SCP 5** Final actions.

NOTE: Certain colours (such as darker shades of blue, red and green) are more prone to show process direction banding. If banding is not seen on the test prints but the issue is with a particular shade of a colour as opposed to all or many shades of a colour, no other adjustments or repairs actions are possible.

Advise the customer to print the image in another print resolution or colour correction may result in a more satisfactory image. Changing the colour in the customers application may result in a more satisfactory image.

Perform **SCP 5** Final actions.

NOTE: Certain colours (such as darker shades of blue, red and green) are more prone to show process direction banding. If banding is not seen on the test prints but the issue is with a particular shade of a colour as opposed to all or many shades of a colour, no other adjustments or repairs actions are possible.

Advise the customer to print the image in another print resolution or colour correction may result in a more satisfactory image. Changing the colour in the customers application may result in a more satisfactory image.

Perform **SCP 5** Final actions.

NOTE: Certain colours (such as darker shades of blue, red and green) are more prone to show process direction banding. If banding is not seen on the test prints but the issue is with a particular shade of a colour as opposed to all or many shades of a colour, no other adjustments or repairs actions are possible.

Advise the customer to print the image in another print resolution or colour correction may result in a more satisfactory image. Changing the colour in the customers application may result in a more satisfactory image.

Perform **SCP 5** Final actions.

Ringin^g Checkout

Refer to [Figure 7](#). This example is LEF in the process direction. Ringing is both pattern and image orientation dependent.

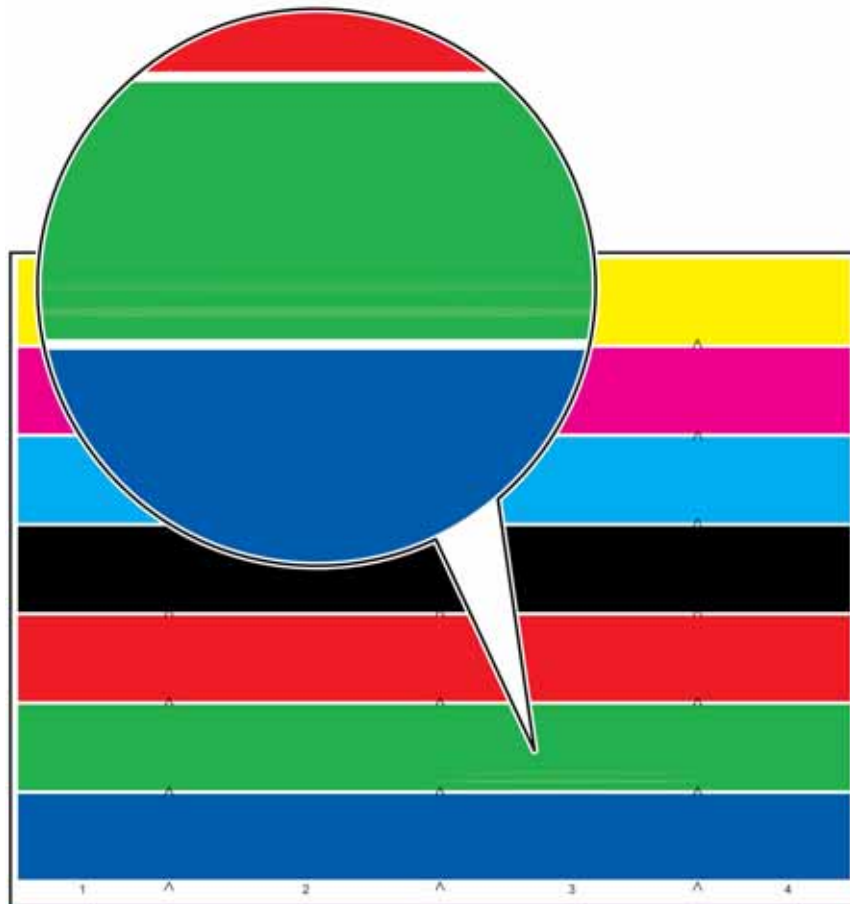

Figure 7 Ringing defect

Procedure

If printing on A4 or 8.5 x 11 inch paper, change the media orientation in the tray. Reprint the customer job. **The print is good.**

Y N
The printer may be printing within specification. **The defect is consistent printhead to printhead.**

Y N
Install a new printhead, [PL 91.20 Item 2](#) or [PL 91.25 Item 2](#).

No service action required. The defect is within specification.

Re-define the image quality defect, refer to [IQ 1](#) Image Quality Entry RAP.

IQ 14 Some Colours Uneven RAP

Use this RAP to troubleshoot the following defects:

- Light lines in the process direction
- Dark lines in the process direction
- Light discolouration in wide bands across a whole printhead in the process direction
- Dark discolouration in wide bands across a whole printhead in the process direction
- Discolouration in a single colour primary across the whole page
- Banding in the process direction

Ensure [IQ 1](#) Image Quality Entry RAP is performed before starting this RAP.

Initial Actions

- Enter the customer administration tools, [GP 5](#). On the Tools tab select Troubleshooting then Automatic Light Lines Fix. Set Quick Fix to On. Set Full Fix to Eco Fix.

NOTE: Ensure that the customer's Automatic Light Lines and Full Fix settings are restored to the original settings when the image quality defect has been corrected.

Procedure

WARNING

Ensure that the electricity to the machine is switched off while performing tasks that do not need electricity. Refer to [GP 14](#). Disconnect the power cord. Electricity can cause death or injury. Moving parts can cause injury.

CAUTION

Use care when moving the marking unit into the service position when hot. Ink can spill from the ink reservoir located at the back of the unit if opened with too much force. Cross-colour ink contamination could also occur.

CAUTION

Do not touch the exposed face of the printheads. Surface contamination or minor damage can easily make the printhead unusable.

Evaluate the colour bands test page, [TP 26](#). Check for the following defects:

- Light lines in the process direction in a primary colour with corresponding light lines in secondary colours, [Figure 1](#). Distinct parallel lines, often in groups of six lines, within a single primary colour and the corresponding secondary colours. If observed, go to the [Missing Jet Checkout](#).
- Dark lines in the process direction in a primary colour with corresponding dark lines in secondary colours, [Figure 3](#). Distinct parallel lines, often in groups of six lines, within a single primary colour and the corresponding secondary colours. If observed, go to the [Ink Mixing at the Printhead Faceplate Checkout](#).
- Dark discolouration in wide bands across a whole printhead in the process direction, [Figure 4](#). Uniform dark discolouration across a whole printhead. If observed, go to [Ink Mixing in the Printhead or in the Ink Melt Reservoir Checkout](#).
- Discolouration across the whole page, [Figure 5](#). Uniform discolouration in a single colour across the whole page. If observed, go to [Ink Mixing in the Printhead or in the Ink Melt Reservoir Checkout](#).

- Light discolouration in wide bands across a whole printhead in the process direction, [Figure 5](#). Uniform light discolouration across a whole printhead. If observed, go to [Ink Mixing in the Printhead or in the Ink Melt Reservoir Checkout](#).
- Banding in the process direction. Faded bands in the process direction across all colours, [Figure 6](#) or visible as coloured bands on single colour dithers, [Figure 7](#). If observed, go to the [Banding Checkout](#).
- If the defect is apparent in all four primary colours, go to the [IQ 13](#) Uneven in All Colours RAP. If the colours are spatially uniform but incorrect, go to the [IQ 15](#) Wrong Colour RAP.

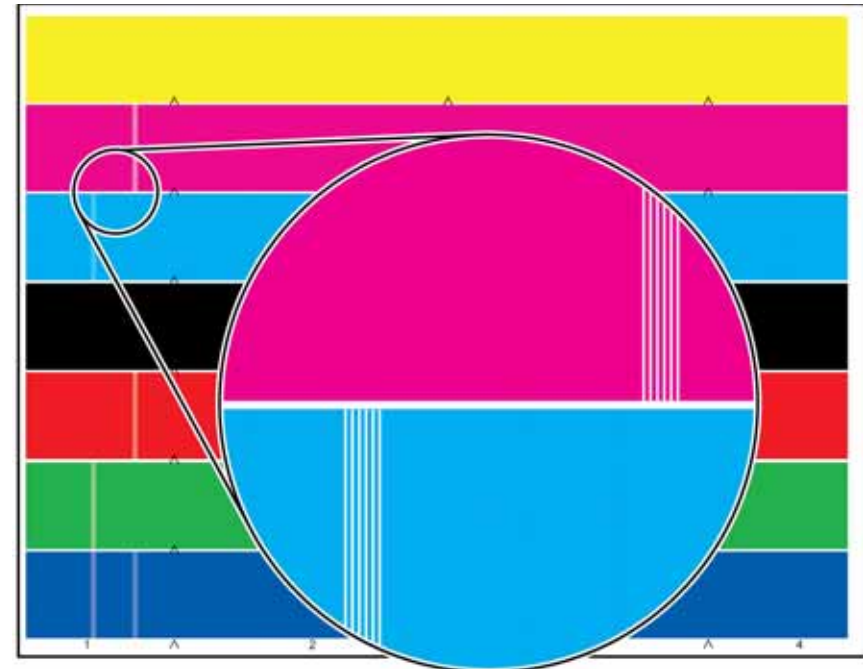

U-1-1630-A

Figure 1 Missing jet example

Missing Jet Checkout

Missing jets usually occur on a single printhead. Figure 2 shows examples of missing jets on multiple printheads to indicate various combinations of colours. The illustration shows a cyan missing jet on printhead 1, a magenta missing jet on printhead 2, a yellow missing jet on printhead 3, and a black missing jet on printhead 4. The defect is the width of a single jet. The defect could involve more than one jet of one or more colours.

NOTE:

- Missing cyan jets affect green and blue
- Missing magenta jets affect red and blue
- Missing yellow jets affect red and green
- Missing black jets affect dark shades of all colours

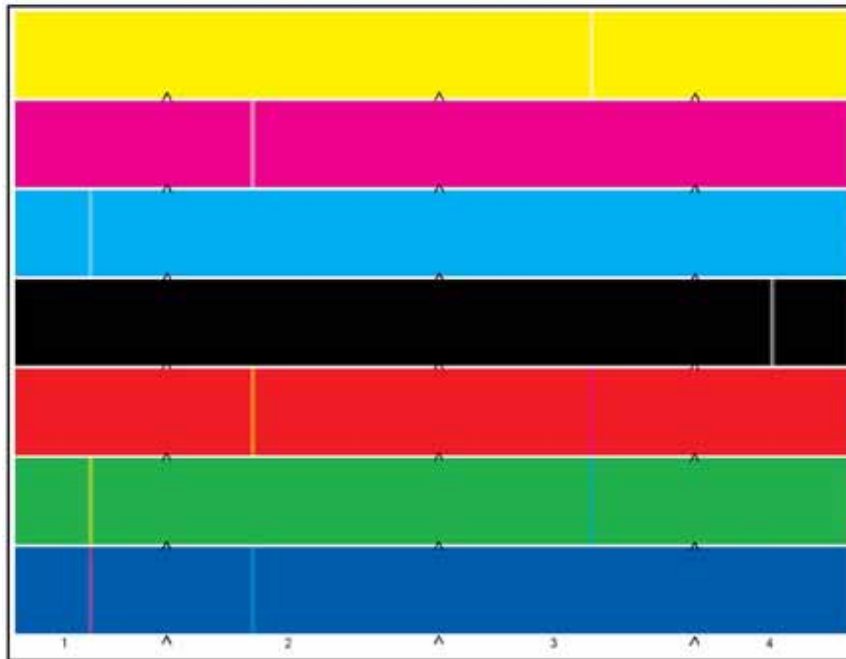

U-1-1130-A

Figure 2 Missing jets on multiple printheads

Procedure

Go to 91-638-00, IOD Detects Chronic Jet Error RAP.

Ink Mixing at the Printhead Faceplate Checkout

Figure 3 is an example of ink mixing at the surface of the printhead faceplate, showing the defect clearing up over a series of prints. This symptom appears as yellow ink looking black. To a lesser degree, cyan and magenta may look darker. Black is generally not affected.

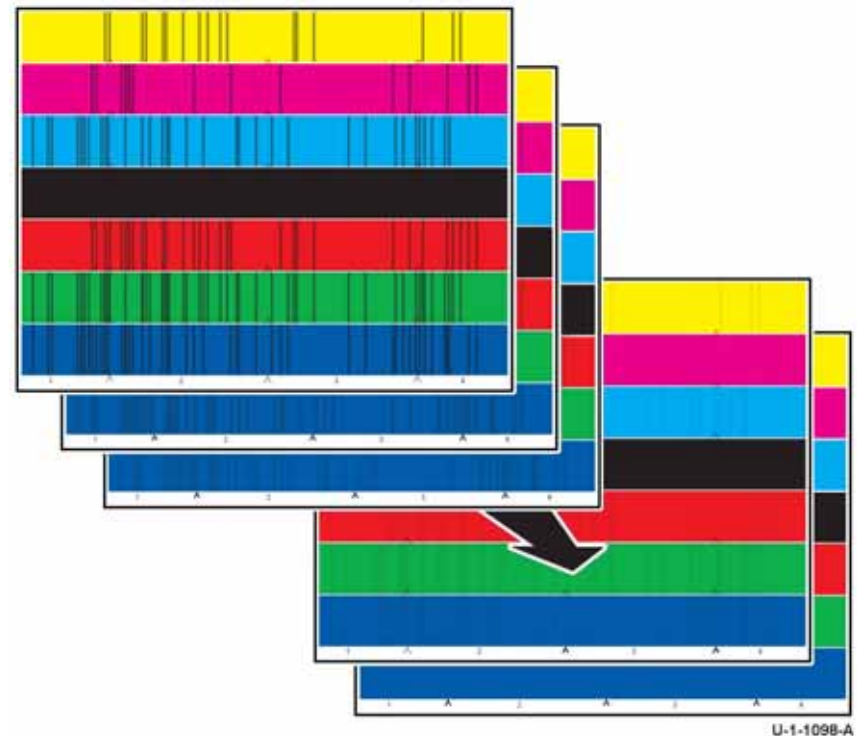

Figure 3 Ink mixing clearing with repeated prints

Procedure

Perform dC965 Printhead Maintenance Test. Check carriage and wiper motion. The wiper contacts and moves smoothly across the printhead faceplate area.

Y N

Wiper chatter is observed.

Y N

Go to the 91-572-00, 91-573-00, 91-575-00 Wiper Vertical Error RAP.

Install a new wiper blade, PL 91.15 Item 13.

Print 3 sets of cleaning pages, TP 22. Print the Initial Test Print Pages, TP 1. If ink mixing is still present, the defect is not caused by printhead faceplate mixing. Re-define the image quality defect, refer to IQ 1 Image Quality Entry RAP.

Ink Mixing in the Printhead or in the Ink Melt Reservoir Checkout

Ink mixing may occur in the printhead or in the ink melt reservoir. Ink mixing in the printhead appears as a band across the image, [Figure 4](#). Ink mixing in the ink melt reservoir appears as discoloration in all four printheads, [Figure 5](#).

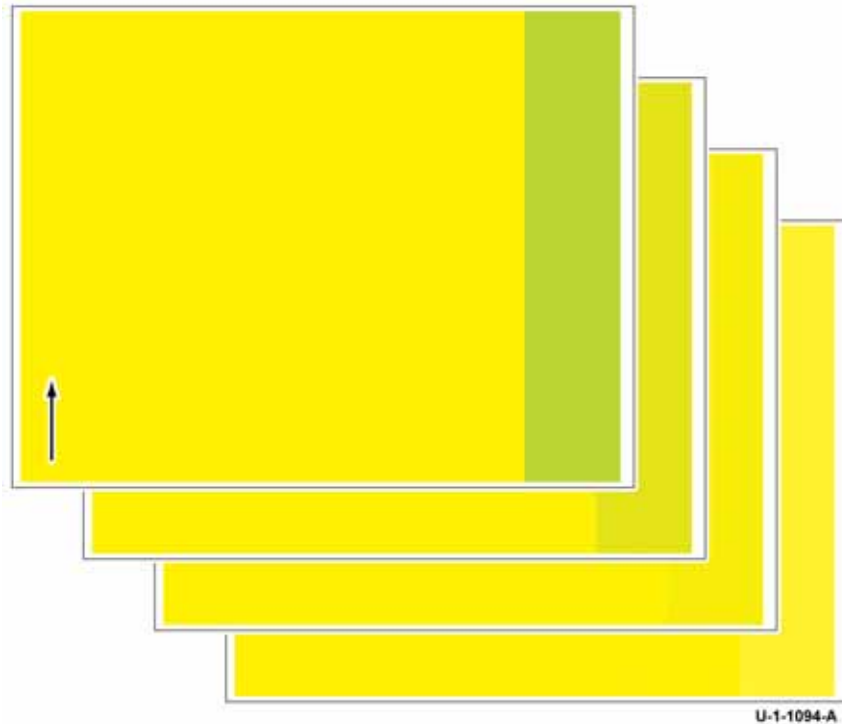

Figure 4 Ink mixing in printhead 4

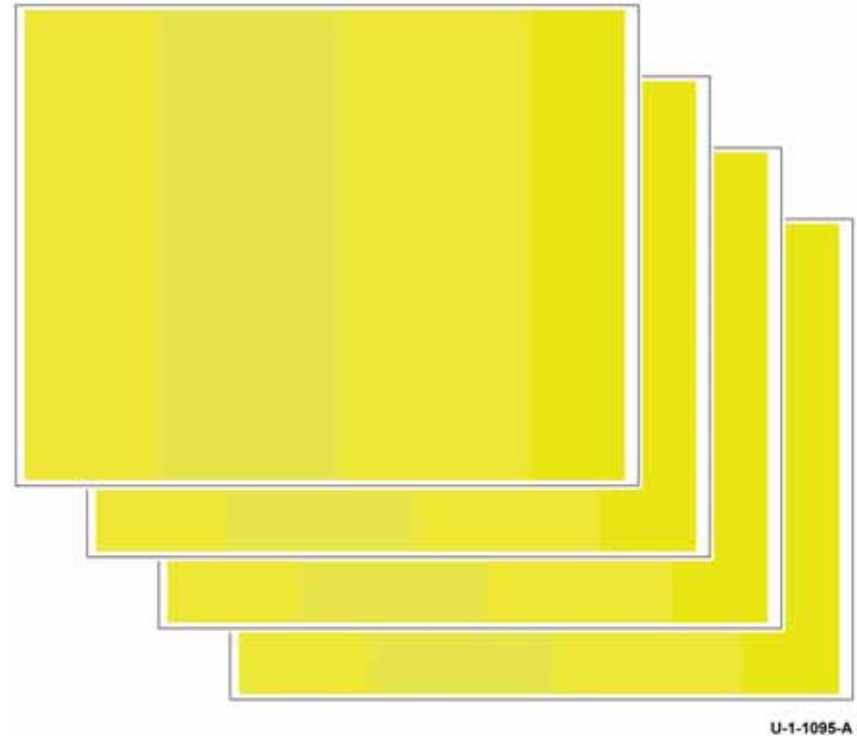

Figure 5 Ink mixing in the ink melt reservoir

Procedure

Check for evidence of overfilling of the reservoir, [PL 93.10 Item 10](#). **The reservoir is filled to the correct level.**

Y N

Go to [93-901-00 to 93-904-00 Ink Melt Reservoir Fill Failure RAP](#).

Check for evidence of cross contamination of the ink melt reservoir. **The reservoir is clear of cross contamination.**

Y N

Perform the following:

1. Install a new reservoir, [PL 93.10 Item 10](#).
2. [dC968 Head Purge](#) 3 times.

Check for leaks in the umbilical connections. **The umbilical connections are good.**

Y N

Go to [93-937-00 to 93-940-00 Ink Melt Reservoir Leak Error RAP](#).

A

A

NOTE: Before printing TP 26, ensure that A4 or 8.5 x 11 inch plain paper is loaded long edge feed into tray 4. Use the best quality media available. Do not use hole punched paper.

Print the colour bands test page, TP 26. Evaluate the test page. **All colours are good except cyan (cyan is mixed with green).**

Y N

Ink discolouration is across all 4 printheads.

Y N

Perform dC968 Head Purge 3 times. Purge all 4 printheads. **The discolouration has increased and affects all four heads.**

Y N

Check the service log for previous instances of ink mixing. **Ink mixing is a new fault.**

Y N

Install a new printhead, PL 91.20 Item 2 or PL 91.25 Item 2.

Perform dC968 Head Purge 3 times. Record which printhead had ink discolouration in the service log. Enter GP 5 Customer Administration Tools. Check if Intelligent Ready power save mode is on. If necessary, advise the customer that using Intelligent Ready power save mode may avoid future ink discolouration.

NOTE: Do not change the customer settings.

Install a new reservoir, PL 93.10 Item 10. Perform dC968 Head Purge 3 times.

Install a new reservoir, PL 93.10 Item 10. Perform dC968 Head Purge 3 times.

Perform dC968 Head Purge 3 times. Enter GP 5 Customer Administration Tools. Check if Intelligent Ready power save mode is on. If necessary, advise the customer that using Intelligent Ready power save mode may avoid future ink discolouration.

NOTE: Do not change the customer settings.

Banding Checkout

Refer to Figure 6 and Figure 7.

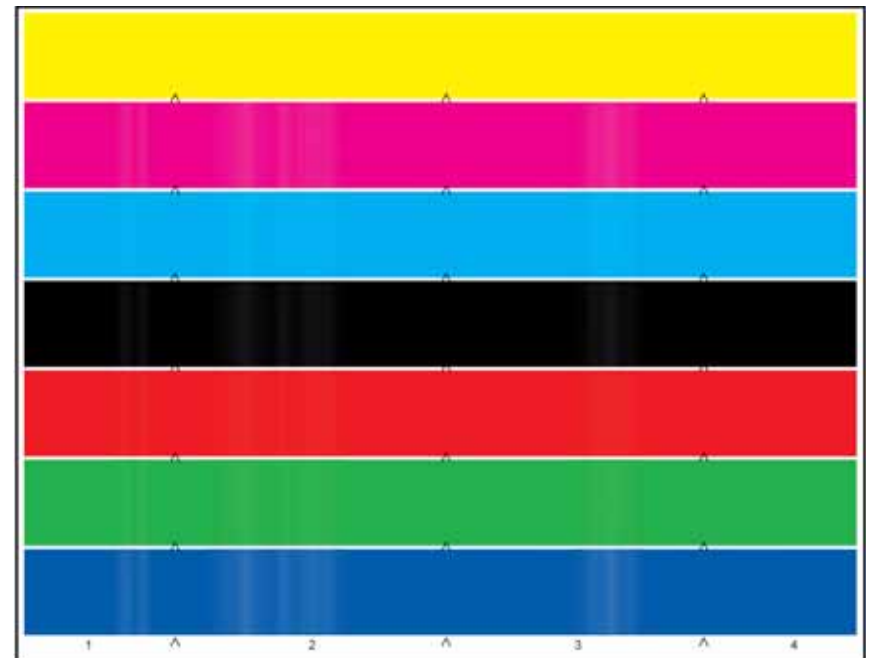

U-1-1077-A

Figure 6 Banding on colour bands



U-1-1637-A

Figure 7 Banding in dithers

Procedure

CAUTION

Ink mixing and ink discoloration must be corrected first. If not, printer calibration is performed with the wrong colour ink, and will require a future service call.

Try running the customers image in a higher print resolution.

NOTE: Before printing the test pages, ensure that A4 or 8.5 x 11 inch plain paper is loaded long edge feed into tray 4. Use the best quality media available. Do not use hole punched paper.

Evaluate the cyan / magenta test page and the red, blue and green bands in the colour bands print (TP 1). Check for non-uniform bands in the process direction. **The prints are good and are without non-uniform bands.**

Y N

Perform the following dC972 Print Head Uniformity routines:

1. Option 3 Head to head uniformity
2. Option 4 TRC Generation
3. Option 5 Y-dot position correction

B

B

Print TP 1. Evaluate the cyan / magenta test page and the red, blue and green bands on the colour bands test page for non-uniform bands in the process direction. **The prints are good and are without non-uniform bands.**

Y N

Perform the following dC972 Print Head Uniformity routines:

1. Option 6 Reset head uniformity data
2. Option 2 Head to head alignment adjust
3. Option 3 Head to head uniformity
4. Option 4 TRC Generation
5. Option 5 Y-dot position correction

Print TP 1. Evaluate the cyan / magenta test page and the red, blue and green bands on the colour bands test page for non-uniform bands in the process direction. **The prints are good and are without non-uniform bands.**

Y N

NOTE: The head to head uniformity uses one head as a reference to adjust the other printheads. Swapping the printheads then changes the reference printhead, which often results in better uniformity.

Swap printhead 1 with printhead 2 and printhead 3 with print head 4. On a 9301 machine make sure there are no chronic jets on printhead 1 or printhead 4 before swapping the heads. If chronic jets are present, then install a new printhead to replace the print head that has a difference appearance than the other printheads. Perform dC972, Print TP 1 and evaluate the cyan / magenta and the red, blue and green bands in the colour bands prints for a distinctive non-uniform bands in the process direction. **The prints are good and are without non-uniform bands.**

Y N

Install new printheads as required, PL 91.20 Item 2 or PL 91.25 Item 2.

Perform SCP 5 Final actions.

NOTE: Certain colours (such as darker shades of blue, red and green) are more prone to show process direction banding. If banding is not seen on the test prints but the issue is with a particular shade of a colour as opposed to all or many shades of a colour, no other adjustments or repairs actions are possible.

Advise the customer to print the image in another print resolution or colour correction may result in a more satisfactory image. Changing the colour in the customers application may result in a more satisfactory image.

Perform SCP 5 Final actions.

NOTE: Certain colours (such as darker shades of blue, red and green) are more prone to show process direction banding. If banding is not seen on the test prints but the issue is with a particular shade of a colour as opposed to all or many shades of a colour, no other adjustments or repairs actions are possible.

Advise the customer to print the image in another print resolution or colour correction may result in a more satisfactory image. Changing the colour in the customers application may result in a more satisfactory image.

Perform SCP 5 Final actions.

B

NOTE: Certain colours (such as darker shades of blue, red and green) are more prone to show process direction banding. If banding is not seen on the test prints but the issue is with a particular shade of a colour as opposed to all or many shades of a colour, no other adjustments or repairs actions are possible.

Advise the customer to print the image in another print resolution or colour correction may result in a more satisfactory image. Changing the colour in the customers application may result in a more satisfactory image.

Perform SCP 5 Final actions.

NOTE: Certain colours (such as darker shades of blue, red and green) are more prone to show process direction banding. If banding is not seen on the test prints but the issue is with a particular shade of a colour as opposed to all or many shades of a colour, no other adjustments or repairs actions are possible.

Advise the customer to print the image in another print resolution or colour correction may result in a more satisfactory image. Changing the colour in the customers application may result in a more satisfactory image.

IQ 15 Wrong Colour RAP

Use this RAP when the colours on the image are wrong. Refer to [Figure 1](#), [Figure 2](#), [Figure 3](#) and [Figure 4](#) to compare the defect to the colour band service test pattern, [Figure 5](#).

Ensure [IQ 1](#) Image Quality Entry RAP is performed before starting this RAP.

Initial Actions

WARNING

Ensure that the electricity to the machine is switched off while performing tasks that do not need electricity. Refer to [GP 14](#). Disconnect the power cord. Electricity can cause death or injury. Moving parts can cause injury.

WARNING

Do not touch the ink reservoir while it is hot.

CAUTION

Use care when moving the marking unit into the service position when hot. Ink can spill from the ink reservoir located at the back of the unit if opened with too much force. Cross-colour ink contamination could also occur.

- Enter [GP 5](#) Customer Administration Tools. Check if Intelligent Ready power save mode is on. If necessary, advise the customer that using Intelligent Ready power save mode may avoid future ink discolouration.

NOTE: Do not change the customer settings.

- Ensure that all inks are loaded in their correct channel in the ink loader. If necessary, rub the ink sticks on a clean sheet of white paper to determine the stick colour.

Procedure

The colour band service test pattern (XTP 798.000), [PL 26.11 Item 15](#) is used to determine if there are large differences in colour. No action should be taken to correct minor differences in colour that may occur between test pages and the service test pattern. Magenta is a colour that may look darker on the service test pattern, but this is normal.

NOTE: Before printing [TP 26](#), ensure that A4 or 8.5 x 11 inch plain paper is loaded long edge feed into tray 4. Use the best quality media available. Do not use hole punched paper.

Print the colour bands test page, [TP 26](#). Compare the print with [Figure 1](#), [Figure 2](#), [Figure 3](#) and [Figure 4](#). Wrong colours are seen across the entire print.

Y N

Go to the [IQ 14](#) Uneven in Some Colours RAP.

Check for ink leakage around the umbilical connections. The umbilical connections are good.

Y N

Go to the [93-937-00 to 93-940-00](#) Ink Melt Reservoir Leak Error RAP.

Print the colour bands and dithers test pages, [TP 11](#). The colours are correct compared to the service test pattern.

- Y N
 - Switch off, then switch on the machine, [GP 14](#), to clear any corrupt data. Print the colour bands and dithers test pages, [TP 11](#). **The colours are correct compared to the service test pattern.**
- Y N
 - Perform [dC968](#) Head Purge 3 times. Print 3 sets of cleaning pages, [TP 22](#). Print the colour bands and dithers test pages, [TP 11](#). **The colours are correct compared to the service test pattern.**
- Y N
 - Install a new ink reservoir [PL 93.10 Item 10](#). Perform [dC968](#) Head Purge 3 times to prime the ink delivery system. Print the colour bands and dithers test pages, [TP 11](#). **The colours are correct compared to the service test pattern.**
- Y N
 - Reseat all connections on the [IME Controller PWB](#). If necessary, install a new IME controller PWB, [PL 92.10 Item 1](#).
- Perform [SCP 5](#) Final Actions.
- Perform [SCP 5](#) Final Actions.
- Perform [SCP 5](#) Final Actions.

If [TP 11](#) is good but the customer's print jobs are incorrect, advise the customer to check the print driver settings.

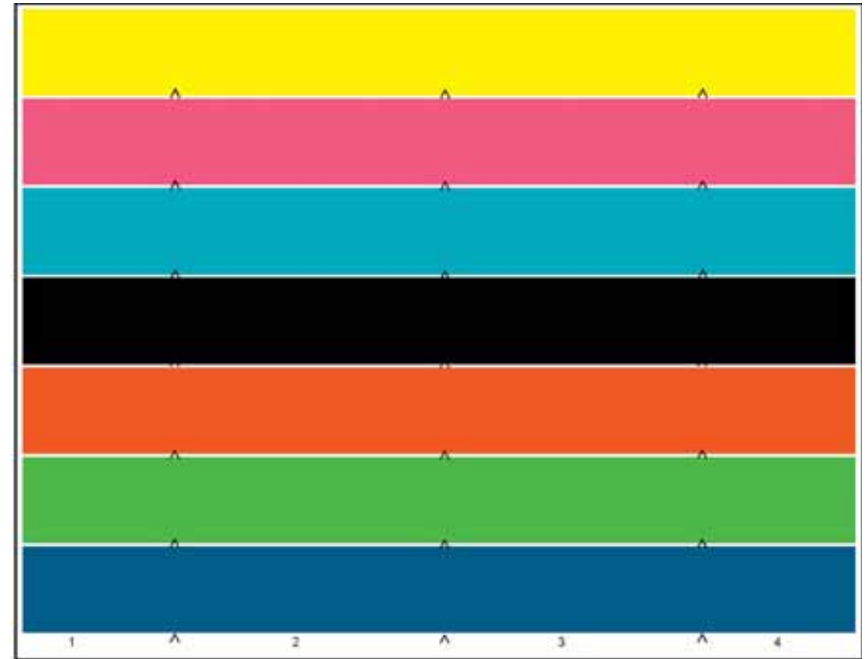

U-1-1354-A

Figure 1 Ink discolouration

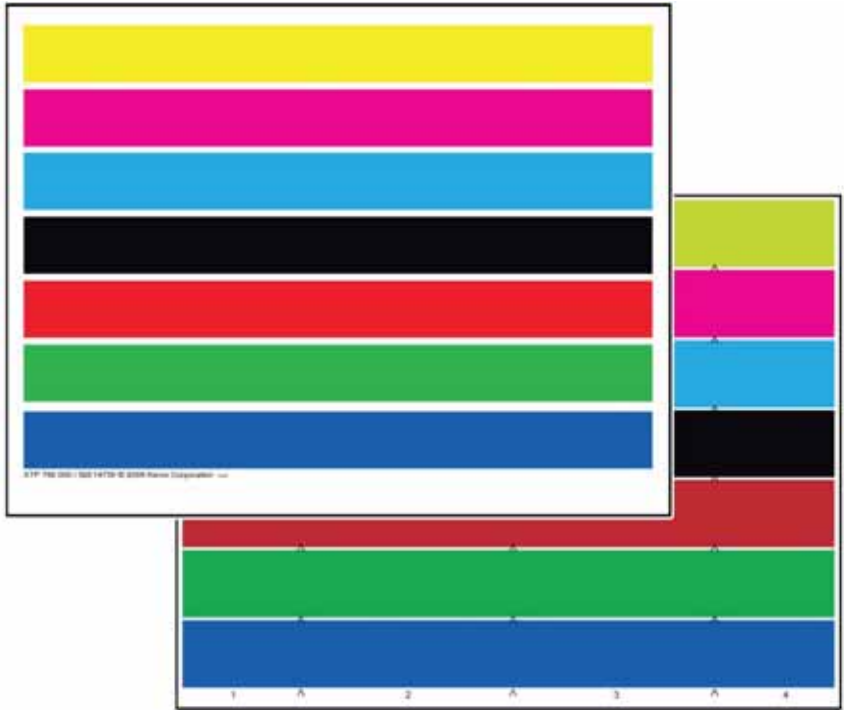

Figure 2 Ink mixing (cyan into yellow)

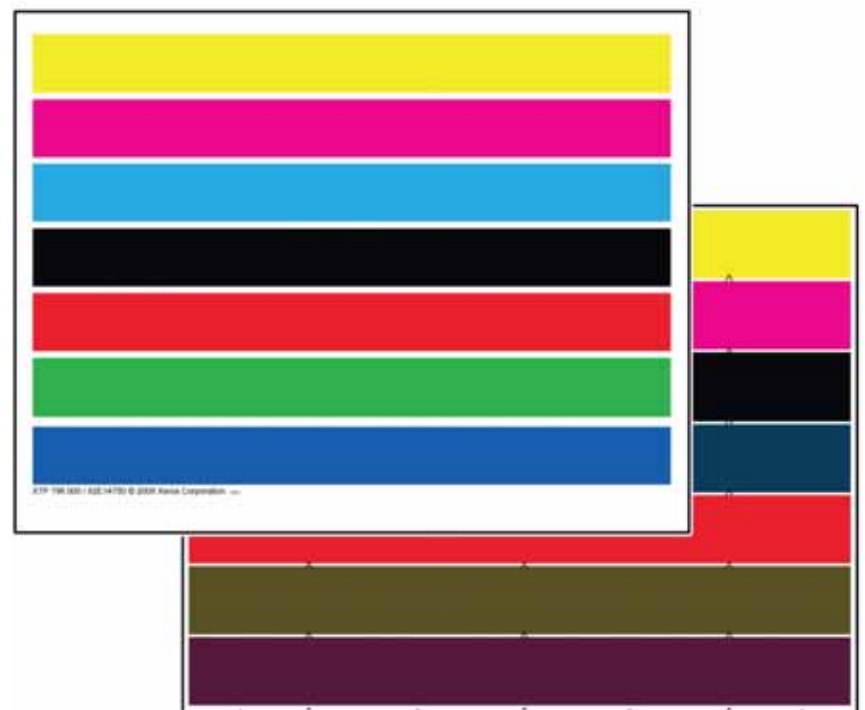

Figure 3 Incorrectly loaded ink black into cyan

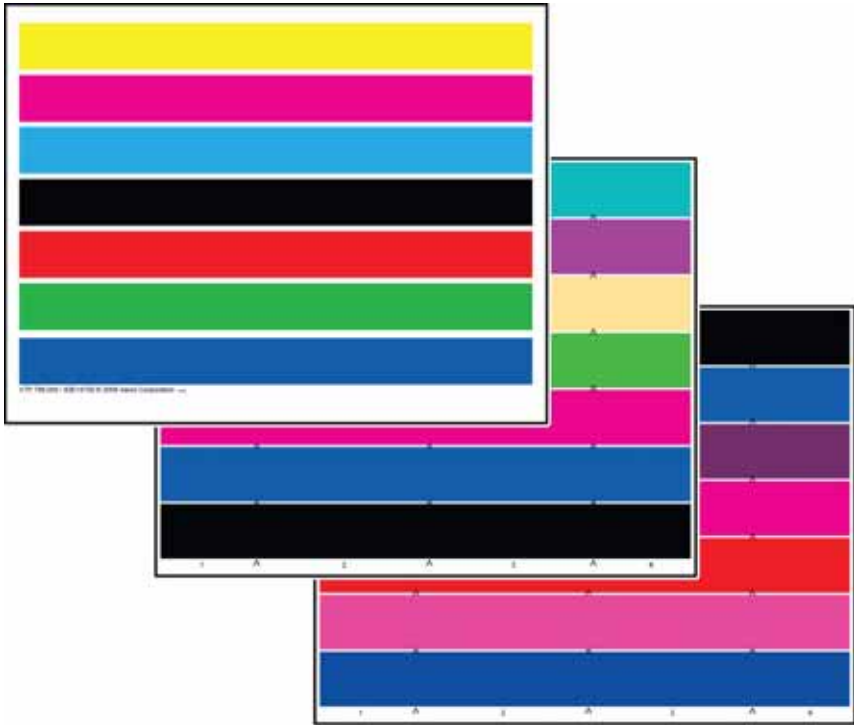

Figure 4 Corrupt image data

U-1-1357-A



Figure 5 Service test pattern

U-1-1556-A

IQ 16 Scratches or Gloss Marks in the Process Direction RAP

Use this RAP when the output displays scratches or gloss marks in the process direction.

Scratches or marks typically result from contact with transport components rollers and ribs or debris in the media path.

This defect may be accompanied with ink that is smudging in the non-imaged area of the media in line with the rollers or ribs. Roller marks usually have a well defined width of 10 to 15 mm, and run in the process direction, and are evenly spaced across the print. Rib marks are faint, narrow (up to 2 mm) burnish marks evenly spaced in the process direction. These typically come from the finishers. The HVF finisher and booklet maker have features which contact the image and can create localized scuff marks.

Ensure [IQ 1 Image Quality Entry RAP](#) is performed before starting this RAP.

Procedure

WARNING

Ensure that the electricity to the machine is switched off while performing tasks that do not need electricity. Refer to [GP 14](#). Disconnect the power cord. Electricity can cause death or injury. Moving parts can cause injury.

WARNING

Take care during this procedure. The stripper blade is very sharp and can cause injury.

WARNING

Do not clean the stripper blade. The stripper blade is very sharp and can cause injury. If the stripper blade is dirty a new blade must be installed.

WARNING

Take care during this procedure. Sharp edges may be present that can cause injury.

NOTE: There are usually no corrective actions for the defect. Some ribs can be cleaned, refer to [GP 27](#). Printing up to 50 [TP 12 Chase](#) pages can clean the ribs temporarily. Advise the customer that simplex jobs on light weight media cause fewer problems than duplex jobs on heavy weight media.

Check the cleaning unit metering blade for pieces of paper.

NOTE: Ink pixel build up on the metering blade is normal and should not be cleaned off.

The metering blade is good.

Y N
Clean the metering blade of paper debris.

Separate the finisher from the printer. Install a finisher bypass connector, [PL 26.10 Item 3](#). Print a duplex copy of [TP 6 Red Solid Fill Test Page \(TP 2 to TP 10\)](#). Evaluate both sides of the test page for process direction gloss streaks. **The test page is good.**

Y N
Open the stripper gate, [GP 31](#). Check the stripper blade for accumulations of ink or media debris. **The stripper blade is clean.**

Y N
Install a new stripper blade assembly, [PL 10.12 Item 3](#).

A B

A B

Print [TP 15 Media Path Test Pages](#) to isolate where the marking is taking place. Inspect, clean, or install new rollers as necessary.

If the problem persists perform the following:

- Check the following components for accumulations of ink or media debris.
 - Abatement plenum, [PL 94.20 Item 12](#).
 - IOD shield and sensor [PL 94.15](#).
- Inspect the drum for scratches, if necessary install a new drum, [PL 94.20 Item 1](#).
- Install a new cleaning unit, [PL 94.10 Item 21](#). Print 3 duplex copies of [TP 5 Black Solid Fill Test Pages \(TP 2 to TP 10\)](#) and evaluate the prints for scratches or gloss marks

Scratches or gloss marks are present.

Y N
Perform [SCP 5 Final Actions](#).

Re-install the original cleaning unit. The problem is not in the cleaning unit. Re-define the image quality defect, refer to [IQ 1 Image Quality Entry RAP](#).

The defect is located in the finisher. Dock and connect the finisher. Isolate the location where the marking is taking place by printing one copy of [TP 6 Red Solid Fills Test Page \(TP 2 to TP 10\)](#) to each output tray. Inspect the media path of the finisher. Look for a build up of ink on ribs and rollers. Clean any contamination from the media path. Check for dislodged rollers, install new components as necessary.

IQ 17 Gloss Marks in the Cross-Process Direction RAP

Use this RAP when the output has gloss marks in the cross process direction.

Typical defects include:

- Chatter, refer to [Figure 1](#). The cleaning unit metering blade is vibrating as it spreads oil onto the drum. Trace amounts of chatter on duplex is normal.
- Insufficient oil. Insufficient oil causes the inked sheet to appear glossier than normal and may also have cross-process cracking marks. This defect can also be caused by high drum temperature.
- Jagged streaks, refer to [Figure 1](#). The metering blade is leaving excess oil on the drum.
- When the registration/preheat assembly is too hot, on a duplex print, the side that is face up in the output tray can have significantly lower gloss than the side that is face down.
- Gloss band. Some print sequences may result in a gloss band, usually 2 to 3 inches wide, that may be visible under some lighting conditions. This is normal.
- Duplex gloss marks may appear for the first several duplex sheets following a simplex print job. Gloss marks will likely diminish after several prints. This is normal.

Ensure [IQ 1 Image Quality Entry RAP](#) is performed before starting this RAP.

Initial Actions

WARNING

Ensure that the electricity to the machine is switched off while performing tasks that do not need electricity. Refer to [GP 14](#). Disconnect the power cord. Electricity can cause death or injury. Moving parts can cause injury.

WARNING

Do not clean the stripper blade. The stripper blade is very sharp and can cause injury. If the stripper blade is dirty a new blade must be installed.

WARNING

Take care during this procedure. Sharp edges may be present that can cause injury.

Press the Machine Status button on the keypad, select the Fault tab on the UI, then Current Messages. If the message 'Cleaning unit life extended, image quality may be impacted' is displayed, install a new cleaning unit, [PL 94.10 Item 21](#).

Procedure

Print 3 simplex copies of TP 6 Red Solid Fill Test Pages ([TP 2 to TP 10](#)). Evaluate the final test page only for metering blade chatter, refer to [Figure 1](#). **The test pages are good.**

Y N

Install a new cleaning unit, [PL 94.10 Item 21](#). Print 3 simplex copies of TP 6 Red Solid Fill Test Pages ([TP 2 to TP 10](#)). Inspect the final test page only for metering blade chatter, refer to [Figure 1](#). **Chatter is present.**

Y N

Perform [SCP 5 Final Actions](#).

Re-install the original cleaning unit. The problem is not in the cleaning unit. Re-define the image quality defect, refer to [IQ 1 Image Quality Entry RAP](#).

A

Print 5 duplex copies of TP 6 Red Solid Fill Test Pages ([TP 2 to TP 10](#)). Inspect the final test page only for metering blade chatter, refer to [Figure 1](#). **The test pages are good.**

Y N

Install a new cleaning unit, [PL 94.10 Item 21](#). Print 5 duplex copies of TP 6 Red Solid Fill Test Pages ([TP 2 to TP 10](#)). Inspect the final test page only for metering blade chatter, refer to [Figure 1](#). **The test pages are good.**

Y N

Re-install the original cleaning unit. The problem is not in the cleaning unit. Re-define the image quality defect, refer to [IQ 1 Image Quality Entry RAP](#).

Check the cleaning unit metering blade for pieces of paper.

NOTE: Ink pixel build up on the metering blade is normal and should not be cleaned off.

The metering blade is good.

Y N

Clean the metering blade of paper debris.

Enter [dC959 Cleaning Unit Exerciser](#) and run the slow speed exerciser. **The slow speed exerciser completes successfully.**

Y N

Go to [94-520-00 Cleaning Unit Drive Error RAP](#).

Open the front door and remove the inner cover. Enter [dC959 Cleaning Unit Exerciser](#), and run the slow speed exerciser. While this is running ensure the cleaning unit metering blade and roller are making contact with the drum. **The metering blade and roller are making contact with the drum.**

Y N

Check the cleaning unit cams mechanism [PL 94.10 Item 9](#), [PL 94.10 Item 13](#) and the cleaning unit drive gear and motor [PL 94.10 Item 23](#), [PL 94.10 Item 24](#). Install new parts as necessary.

Check that the front drum thermistor, [PL 94.20 Item 9](#) and the rear drum thermistor, [PL 94.20 Item 10](#) are not bent or misaligned. Check for paper debris between the thermistors and the drum and ensure that the thermistors are making good contact with the drum. **The thermistors are good.**

Y N

Install new components as necessary

- Front drum thermistor, [PL 94.20 Item 9](#)
- Rear drum thermistor, [PL 94.20 Item 10](#)

Perform [dC335 Heater Monitor and Exerciser](#). Check the drum operating temperature.

The drum temperature is good.

Y N

Go to [94-536-00](#), [94-538-00](#), [94-540-00](#), [94-542-00](#), [94-544-00](#), [94-546-00](#), [94-632-00](#), [94-633-00 Drum Heat Error RAP](#).

The machine is operating within specification. Perform [SCP 5 Final Actions](#).

Re-define the image quality defect, refer to [IQ 1 Image Quality Entry RAP](#).

A

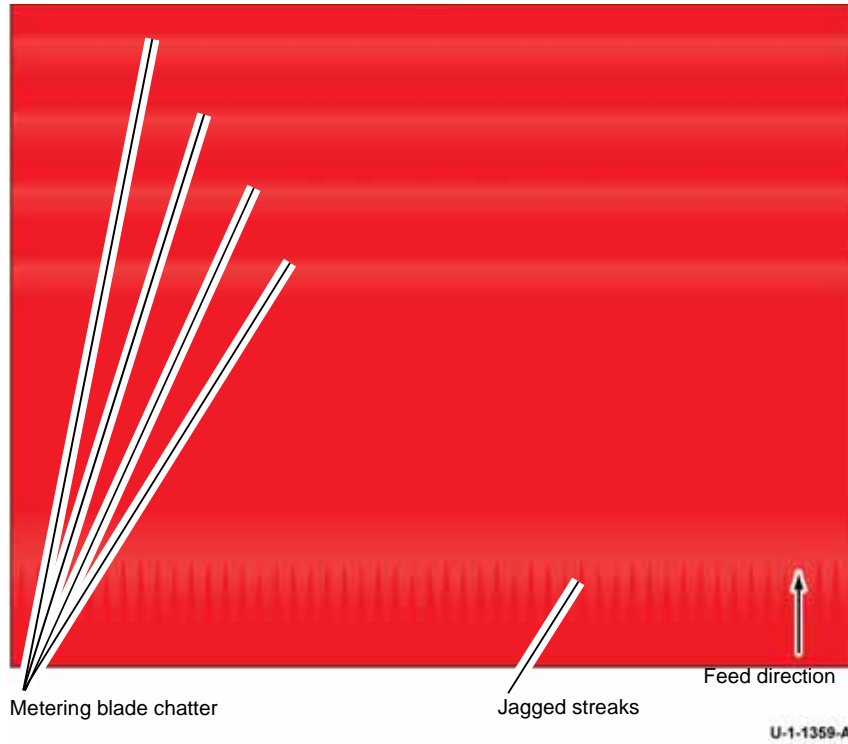

Figure 1 Cross-process gloss defects

IQ 18 Irregular Duplex Gloss Differences RAP

Use this RAP when the output displays gloss variations visible on large areas of high ink coverage.

Irregular gloss defects can be in any direction, [Figure 1](#).

Ensure [IQ 1](#) Image Quality Entry RAP is performed before starting this RAP.

Initial Actions

WARNING

Ensure that the electricity to the machine is switched off while performing tasks that do not need electricity. Refer to [GP 14](#). Disconnect the power cord. Electricity can cause death or injury. Moving parts can cause injury.

- Check the media type. Smoother media will provide a more uniform gloss finish.
- Check that the gloss defect is found only on the second printed side of a duplex print and has an irregular shape.

If the gloss defect is present on simplex prints and runs in either the process or cross process direction, go to:

- [IQ 16](#) Scratches or Gloss Marks in the Process Direction RAP
- [IQ 17](#) Gloss Marks in the Cross-Process Direction RAP
- [IQ 19](#) Image Ghosting RAP

Procedure

NOTE: When printing TP 5 from [dC959](#), ensure that A4 or 8.5 x 11 inch plain paper is loaded long edge feed into tray 4. Use the best quality media available. Do not use hole punched paper.

Print four duplex copies of TP 5 Black Solid Fill Test Pages ([TP 2](#) to [TP 10](#)). Evaluate the final prints for irregular gloss defects.

NOTE: It is normal for the second printed side (page 1) to be glossier than the first printed side (page 2).

Check that page 1 shows uniform gloss across the page and that no gloss defects are visible.

Page 1 is good.

Y N

Run [dC335](#) Heater Monitor and Exerciser Check the registration/preheat assembly temperature. Select RaLPH in the component list. **The registration/preheat temperature is good.**

Y N

Go to [88-500-00](#) to [88-502-00](#), [88-512-00](#) Preheat Thermal Error RAP.

Check the registration/preheat air pump, refer to [88-508-00](#) Registration/Preheat Air Pump Incorrect Current RAP. **The registration/preheat air pump is good.**

Y N

Install a new registration/preheat air pump, [PL 88.10](#) Item 5.

The printer is operating within specifications. Refer to [IQ 19](#) Image Ghosting RAP for additional fixes.

A
i
Perform [SCP 5](#) Final Actions.

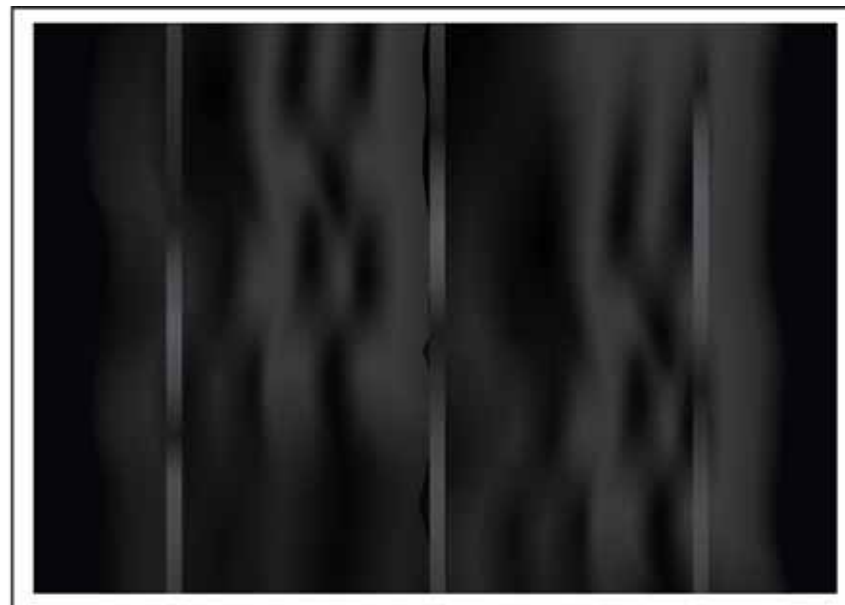

Figure 1 Irregular gloss print defect

U-1-1360-A

IQ 19 Image Ghosting RAP

Use this RAP to fix image ghosting problems. Two types of ghosting are possible, simplex and duplex. Examples of each type are shown in [Figure 1](#) and [Figure 2](#).

NOTE: *Blocking, where ink from one print is deposited on the back of another print, can occur when prints stack in the output tray. The combination of pressure from the weight of the media and ambient heat may cause partial transfer of the image to adjacent prints.*

Ensure [IQ 1](#) Image Quality Entry RAP is performed before starting this RAP.

Initial Actions

WARNING

Ensure that the electricity to the machine is switched off while performing tasks that do not need electricity. Refer to [GP 14](#). Disconnect the power cord. Electricity can cause death or injury. Moving parts can cause injury.

- Duplex ghosting may be caused by oil from the first side of the print transferring to the second side via the transfix roller. Some amount of transfix roller ghosting is normal. This type of ghosting is most pronounced on the first 2-sided print. Ghosting should fade on subsequent prints. When duplex ghosting is evident run multiple 2-sided prints to attempt to clear the defect and inform the customer.
- Attempt to repeat the customer's job using their print sequence and media.
- Press the Machine Status button on the keypad, select the Fault tab on the UI, then Current Messages. If the message 'Cleaning unit life extended, image quality may be impacted' is displayed, install a new cleaning unit, [PL 94.10 Item 21](#).

Procedure

NOTE: *Before printing TP 5 or TP 20, ensure that A4 or 8.5 x 11 inch plain paper is loaded long edge feed into tray 4. Use the best quality media available. Do not use hole punched paper.*

Print [TP 13](#), Text Test Pages, followed by four prints of TP 5 Black Solid Fill Test Pages ([TP 2](#) to [TP 10](#)). Evaluate the third and fourth prints for evidence of text in the black solid fills, visible as a gloss difference. **The prints are good.**

Y N
The defect is simplex ghosting. Enter [dC959](#) and run the Cleaning Unit Self Test. **The self test is successful.**

Y N
Install a new cleaning unit, [PL 94.10 Item 21](#).

Perform [dC959](#) Cleaning Unit Exerciser and run the slow speed exerciser. **The slow speed exerciser completes successfully.**

Y N
Go to [94-520-00](#) Cleaning Unit Drive Error RAP.

Print [TP 20](#) Oil Bar Chase and Metering Blade Timing Test Pages. Evaluate the metering blade timing test page only. **The test pages are good.**

Y N
Go to [IQ 7](#) Metering Blade Timing RAP.

A B
Check that the front drum thermistor, [PL 94.20 Item 9](#) and the rear drum thermistor, [PL 94.20 Item 10](#) are not bent or misaligned. Check for paper debris between the thermistors and the drum and ensure that the thermistors are making good contact with the drum. **The thermistors are good.**

Y N
Install new components as necessary

- Front drum thermistor, [PL 94.20 Item 9](#).
- Rear drum thermistor, [PL 94.20 Item 10](#).

Perform [dC335](#) Heater Monitor and Exerciser. Check the drum operating temperature. **The drum temperature is good.**

Y N
Go to [94-536-00](#), [94-538-00](#), [94-540-00](#), [94-542-00](#), [94-544-00](#), [94-546-00](#), [94-632-00](#), [94-633-00](#) Drum Heat Error RAP.

Install a new cleaning unit, [PL 94.10 Item 21](#). Print [TP 13](#), Text Test Pages, followed by four prints of TP 5 Black Solid Fill Test Pages ([TP 2](#) to [TP 10](#)). Evaluate the third and fourth prints for evidence of text in the black solid fills, visible as a gloss difference. **The prints are good**

Y N
Re-install the original cleaning unit. The problem is not in the cleaning unit. Re-define the image quality defect, refer to [IQ 1](#) Image Quality Entry RAP.

The defect is duplex ghosting which is inherent to the product. To reduce the defect, inform the customer to:

- Reprint the job.
- Print multiple, 2-sided sheets with heavy ink coverage (solid fill), then reprint the job.
- If possible, use different media.
- Print the jobs that exhibit this defect in simplex only.

The defect is duplex ghosting which is inherent to the product. To reduce the defect, inform the customer to:

- Reprint the job.
- Print multiple, 2-sided sheets with heavy ink coverage (solid fill), then reprint the job.
- If possible, use different media.
- Print the jobs that exhibit this defect in simplex only.

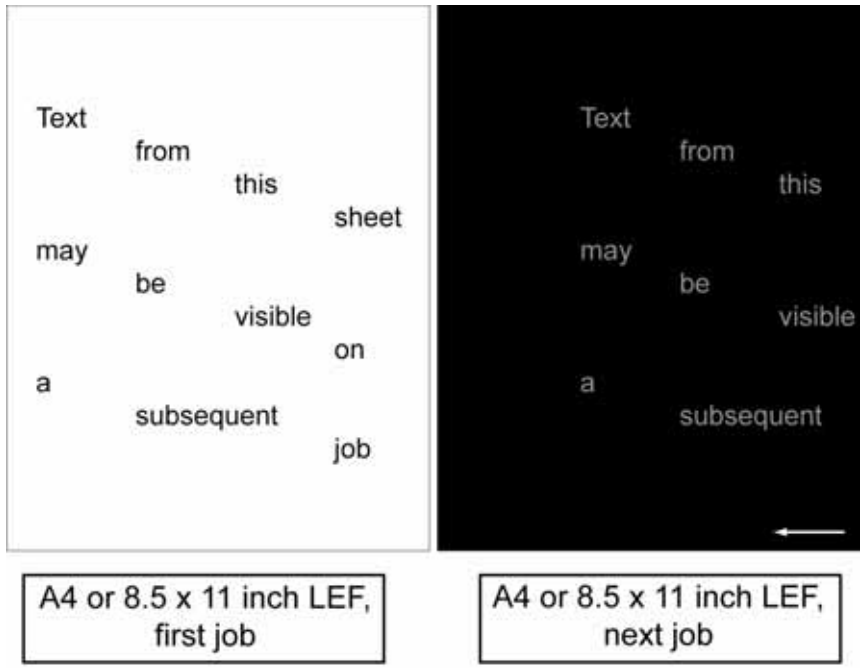

U-1-1362-A

Figure 1 Example of simplex ghosting

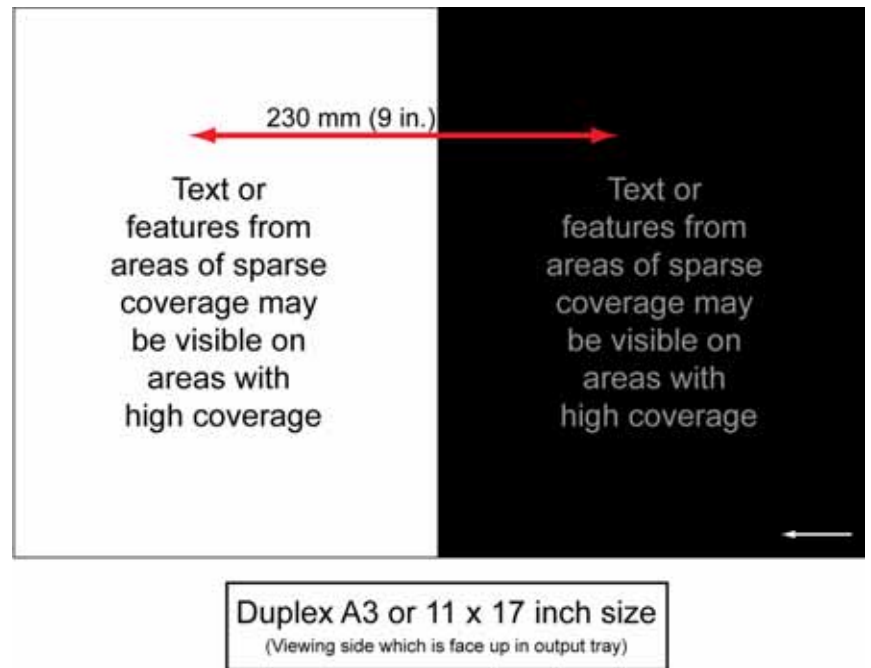

U-1-1361-A

Figure 2 Duplex transfix roller ghosting

IQ 20 Wavy or Stringy Lines RAP

Use this RAP to fix images that have wavy or stringy lines of ink, or have a blistered appearance.

- Obstruction of the carriage drive causes lines of ink to be deposited on the drum, [Figure 1](#). When this ink gets transixed onto the media, it will have an embossed texture and appears wavy. This defect is usually found on individual carriages.
- Excessive oil on the drum can result in a similar artifact with ink having a raised or blistered appearance where the ink can be rubbed off. Refer to [IQ 26](#).

NOTE: Another defect (not shown on the illustration) may occur on a single printhead where a ribbon cable has become unseated. This defect can look like a muddy strip with the stringy lines along one or both edges of the defect.

Ensure [IQ 1](#) Image Quality Entry RAP is performed before starting this RAP.

CAUTION

If carriage motion is obstructed to the point of producing stringy lines of ink, it is likely strings of ink are scattered throughout the machine's interior. Check the area surrounding the drum paying particular attention to the abatement plenum, IOD sensor, transfix roller, and exit module. Printhead jetting may also be affected.

Procedure

WARNING

Ensure that the electricity to the machine is switched off while performing tasks that do not need electricity. Refer to [GP 14](#). Disconnect the power cord. Electricity can cause death or injury. Moving parts can cause injury.

The defect is across the entire width (inboard to outboard) of the image.

Y N
Check that the printhead ribbon cables are correctly seated. **The ribbon cables are seated correctly.**

Y N
Reseat the ribbon cables.

Go to [IQ 13](#) All Colours Uneven RAP. Perform the X-Axis Checkout.

Remove the cleaning unit. Inspect the cleaning unit metering blade for pieces of paper.

NOTE: Ink pixel build up on the metering blade is normal and should not be cleaned off.

The metering blade is good.

Y N
Remove the paper pieces from the cleaning unit metering blade.

Go to [dC959](#) Cleaning Unit Exerciser. Print [TP 20](#) Oil Bar Chase and Metering Blade Timing Test Pages. Evaluate the metering blade timing test page only. If the metering blade engages and disengages within the tolerance zones, the cleaning unit and cleaning unit drive train are working correctly. **The metering blade engages and disengages inside of the tolerance zones.**

Y N
Go to [94-522-00](#) Cleaning Unit Motor Stall RAP.

A

A

Perform [dC959](#) Cleaning Unit Exerciser and run the slow speed exerciser. **The slow speed exerciser completes successfully.**

Y N
Go to [94-522-00](#) Cleaning Unit Motor Stall RAP.

Open the front door and remove the inner cover. Enter [dC959](#), Cleaning Unit Exerciser, and run the slow speed exerciser. While this is running ensure the cleaning unit metering blade and roller are making contact with the drum. **The metering blade and roller are making contact with the drum.**

Y N
Check the cleaning unit cams mechanism [PL 94.10 Item 9](#), [PL 94.10 Item 13](#) and the cleaning unit drive gear and motor [PL 94.10 Item 23](#), [PL 94.10 Item 24](#). Install new parts as necessary.

Re-define the image quality defect, refer to [IQ 1](#) Image Quality Entry RAP.

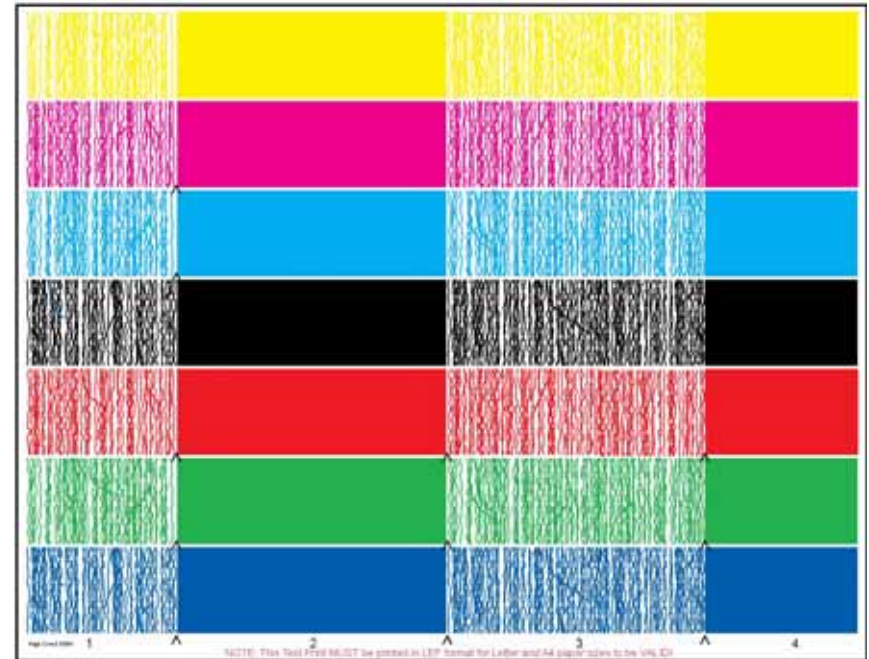

U-1-1560-A

Figure 1 Wavy or stringy lines defect

IQ 21 Oil on Output RAP

Use this RAP when prints are contaminated with cleaning unit oil.

Oil can transfer to prints in the form of spots, streaks, or cross-process lines from the metering blade or drum stripper blade. The oily stain may appear clear or have traces of colour when held up to light. Refer to [Figure 1](#).

Recycled, cotton, carbonless, parchment, linen or rough media are prone to poor ink transfer, causing gel to build up in the cleaning unit which may be transferred to the print.

Oil stains may appear at the leading corners following the printing of several sheets where the leading edge is narrower than the following job, for example short edge feed A4 or 8.5 x 11 inch followed by long edge feed A4 or 8.5 x 11 inch. This is expected behavior and will stop after a few prints.

Oil spots may appear after clearing paper jams. The oil spots should stop after several prints. This is expected behavior and will stop after a few prints.

Ensure [IQ 1](#) Image Quality Entry RAP is performed before starting this RAP.

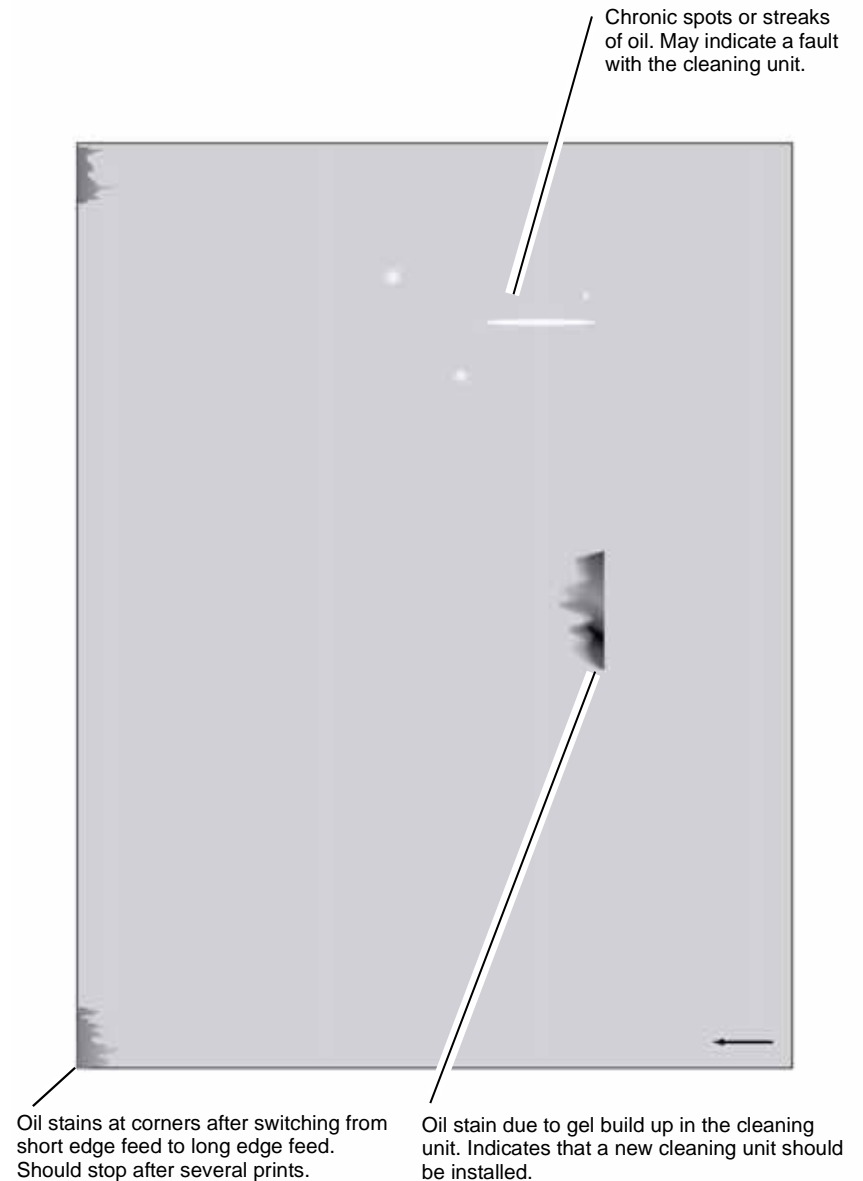

U-1-1053-A

Figure 1 Examples of oil contamination

Initial Actions

- Check that the media is free of defects. Media defects can resemble oil spots.
- Press the Machine Status button on the keypad, select the Fault tab on the UI, then Current Messages. If the message 'Cleaning unit life extended. Image quality may be impacted' is displayed, install a new cleaning unit, [PL 94.10 Item 21](#). Inspect the area around the drum for splattered oil. Clean as necessary, [GP 27](#).

Procedure

WARNING

Ensure that the electricity to the machine is switched off while performing tasks that do not need electricity. Refer to [GP 14](#). Disconnect the power cord. Electricity can cause death or injury. Moving parts can cause injury.

WARNING

Take care during this procedure. The stripper blade is very sharp and can cause injury.

WARNING

Do not clean the stripper blade. The stripper blade is very sharp and can cause injury. If the stripper blade is dirty a new blade must be installed.

WARNING

Take care during this procedure. Sharp edges may be present that can cause injury.

Check the machine for oil spillage and clean as necessary [GP 27](#). Machine oil spillage indicates that the cleaning unit has failed.

NOTE: A thin film of oil on the chassis pan below the cleaning unit is normal.

NOTE: Before printing [TP 20](#), ensure that A4 or 8.5 x 11 inch plain paper is loaded long edge feed into tray 4. Use the best quality media available. Do not use hole punched paper.

Oil spillage is indicated.

Y N

Remove the cleaning unit [PL 94.10 Item 21](#). Remove any pieces of paper from the metering blade and roller area. Do not wipe the metering blade. Ink pixel build up on the metering blade is normal. Print [TP 20](#) Oil Bar Chase and Metering Blade Timing test pages. Evaluate the oil bar chase page only.

NOTE: A thin line of oil approximately 35 mm below the horizontal line and no more than 1 mm wide is acceptable.

The test page is good.

Y N

The oil bar chase page has an oil spot similar to [Figure 2](#).

Y N

If the oil spots are randomly scattered on most prints, install a new cleaning unit, [PL 94.10 Item 21](#). Print [TP 20](#) oil bar chase and metering blade timing test pages. Evaluate the oil bar chase page only. **The random oil spots are still present.**

Y N

Inspect the area around the drum for splattered oil. Clean as necessary, [GP 27](#).

Evaluate the metering blade timing test page. **The test page is good.**

A B C

A B C

Y N

Re-install the original cleaning unit. Go to [IQ 7](#) Metering Blade Timing RAP.

Re-install the original cleaning unit. Perform the following:

1. Inspect the area around the drum for splattered oil. Clean as necessary, [GP 27](#).
2. Check the drum grounding, [GP 7](#) System Grounding Verification.

The drum grounding is good.

Y N

Go to [GP 7](#) System Grounding Verification and correct the drum grounding.

Re-define the image quality defect, refer to [IQ 1](#) Image Quality Entry RAP.

Install a new cleaning unit, [PL 94.10 Item 21](#). Print [TP 20](#) oil bar chase and metering blade timing test pages. Evaluate the oil bar chase page only. **The test page is good.**

Y N

Re-install the original cleaning unit. Go to [IQ 7](#) Metering Blade Timing RAP.

Perform [SCP 5](#) Final Actions.

Perform [SCP 5](#) Final Actions.

Install a new cleaning unit, [PL 94.10 Item 21](#).



U-1-1432-A

Figure 2 Oil spot

IQ 22 Repeating Spot Deletions RAP

Use this RAP when the output displays spot deletions, [Figure 1](#).

Ensure [IQ 1](#) Image Quality Entry RAP is performed before starting this RAP.

Initial Actions

WARNING

Ensure that the electricity to the machine is switched off while performing tasks that do not need electricity. Refer to [GP 14](#). Disconnect the power cord. Electricity can cause death or injury. Moving parts can cause injury.

CAUTION

Use care when moving the marking unit into the service position when hot. Ink can spill from the ink reservoir located at the back of the unit if opened with too much force. Cross-colour ink contamination could also occur.

CAUTION

Do not touch the exposed face of the printheads. Surface contamination or minor damage can render the printhead inoperative.

- Check the media path for dust or debris accumulations. Clean as necessary, refer to [GP 27](#) Cleaning Procedure.
- Inform the customer that using the best quality, smoothest media available will reduce the likelihood of encountering spot deletions.

NOTE: Media containing cotton, linen or parchments can exhibit deletions due to surface texture. Carbonless media, especially in large quantities, can also exhibit deletions. Areas of missing ink on envelopes that outline the seams and flaps is normal.

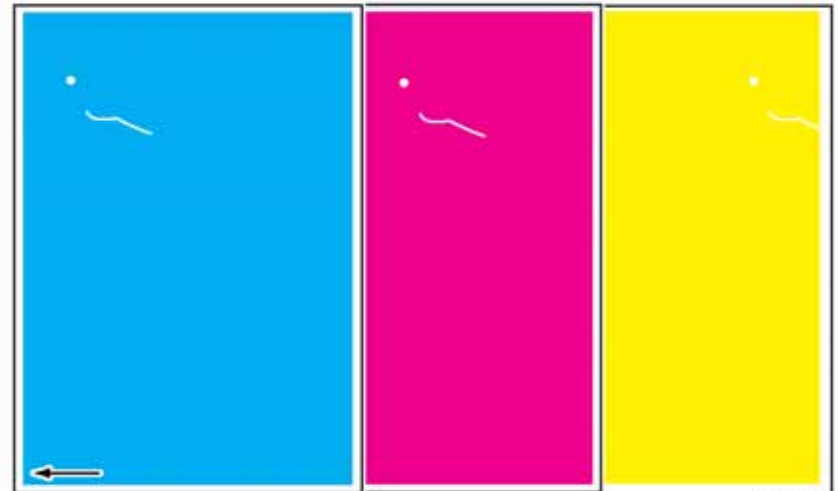

U-1-1364-A

Figure 1 Drum defect

Procedure

Check the stripper gate transport rollers J and L, [PL 10.10](#) for dirt or debris. **The rollers are clean.**

Y N

Clean the rollers, [GP 27](#) or install new components as necessary:

- Roller drive J, [PL 10.10 Item 1](#)
- Roller drive L, [PL 10.10 Item 2](#)

Print [TP 2](#) to [TP 10](#) Solid Fill Test Pages. Inspect all pages for scratches or marks caused by the drum or the transfix roller, refer to [Table 1](#).

Table 1 Repeating rotational defects

Component	Defect Spacing
Transfix Roller	A transfix roller defect appears approximately every 9 inches in the process direction and in the same location in the cross-process direction.
Drum	The drum's circumferential home position varies from print to print, so defect spacing changes in the process direction. The drum defect remains in the same location in the cross-process direction, Figure 1 .

Test pages are good.

Y N

Inspect the drum and transfix roller for ink, media debris, or cleaning unit residue. **The drum and transfix roller are clean.**

Y N

Clean the drum and transfix roller, refer to [GP 27](#) Cleaning Procedure.

Inspect the drum and transfix roller for damage. Install new components as necessary:

- Drum, [PL 94.20 Item 1](#)
- Transfix roller, [PL 10.20 Item 1](#)

Perform [SCP 5](#) Final Actions.

IQ 23 Residual Ink From Previous Print RAP

Use this RAP when the output has residual ink from a previous image. Refer to [Figure 1](#) and [Figure 2](#).

NOTE: Image transfer may also occur between media in the output tray. This effect, known as blocking, may have a similar appearance to residual images from previous prints. Refer to [IQ 30](#) Blocking RAP.

Initial Actions

- Ensure [IQ 1](#) Image Quality Entry RAP is performed before starting this RAP.
- The blocking defect may occur when booklet making with paper above 120 gsm. The ink may transfer from one sheet to the other sheet it is being folded against. If this occurs then use paper of 120 gsm or below.

Procedure

WARNING

Ensure that the electricity to the machine is switched off while performing tasks that do not need electricity. Refer to [GP 14](#). Disconnect the power cord. Electricity can cause death or injury. Moving parts can cause injury.

Print the solid colour test pages ([TP 2](#) to [TP 10](#)). Inspect the lead and trail edge of the test pages for ink that is not fully transfixed, [Figure 1](#) and for image skew, [Figure 2](#). **The test pages are good.**

Y N

Perform [dC625](#) Registration/preheat Calibration. **The calibration completes without error.**

Y N

Go to the [89-550-00](#), [89-551-00](#) Media Registration Error RAP.

Perform [SCP 5](#) Final Actions.

Go to the [IQ 6](#) Missing Ink or Grainy Output RAP.

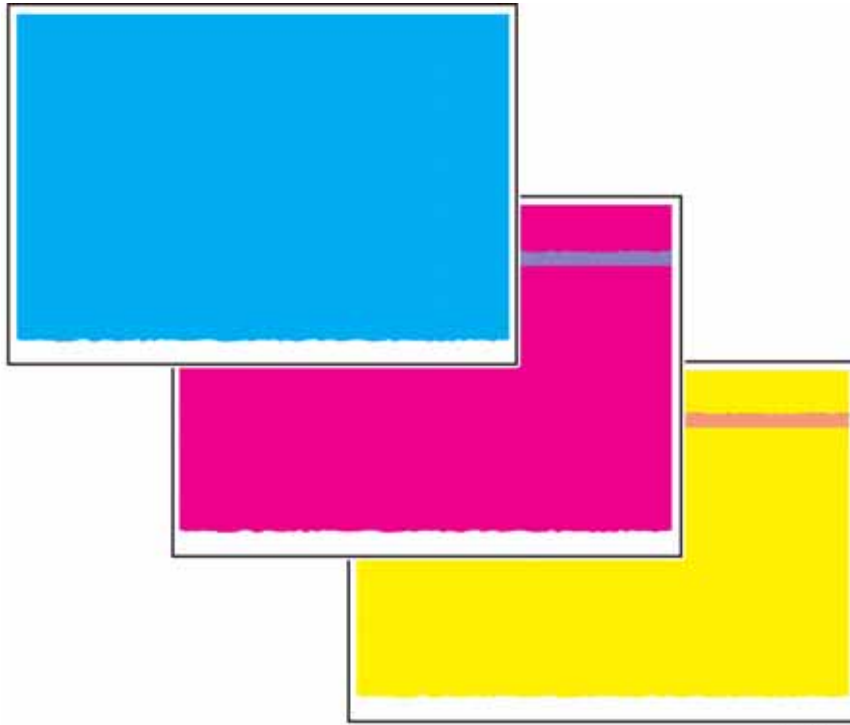

U-1-1365-A

Figure 1 Residual ink due to incomplete transfix

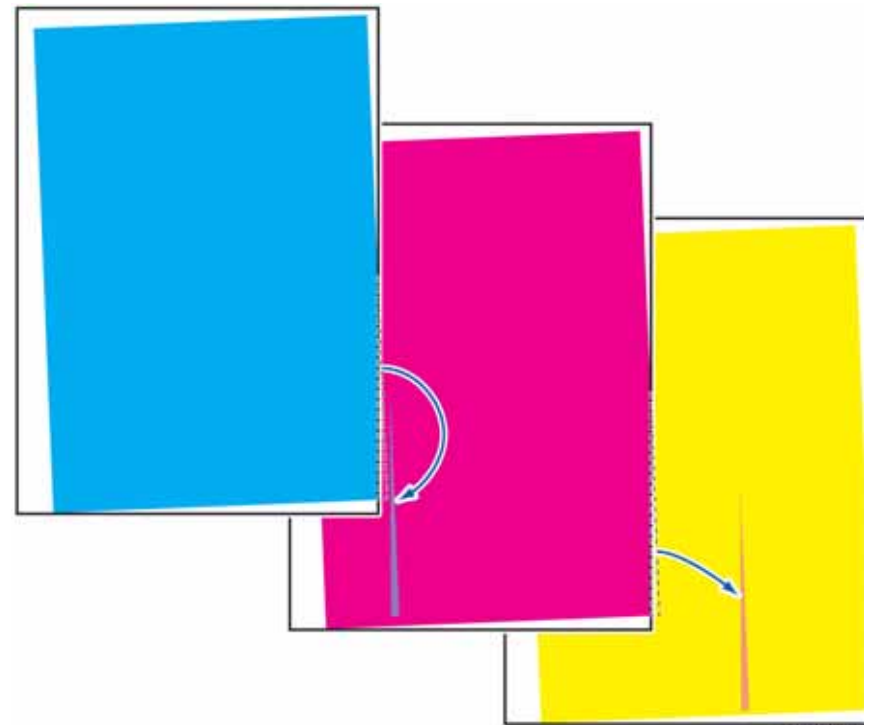

U-1-1366-A

Figure 2 Residual ink due to excessive skew

IQ 24 Wrinkling RAP

Use this RAP when the output is wrinkled. Refer to [Figure 1](#) and [Figure 2](#).

NOTE: Some wrinkling of envelope flaps is normal.

Ensure [IQ 1](#) Image Quality Entry RAP is performed before starting this RAP.



U-1-1367-A

Figure 1 Wrinkles, reduced margins or image skew

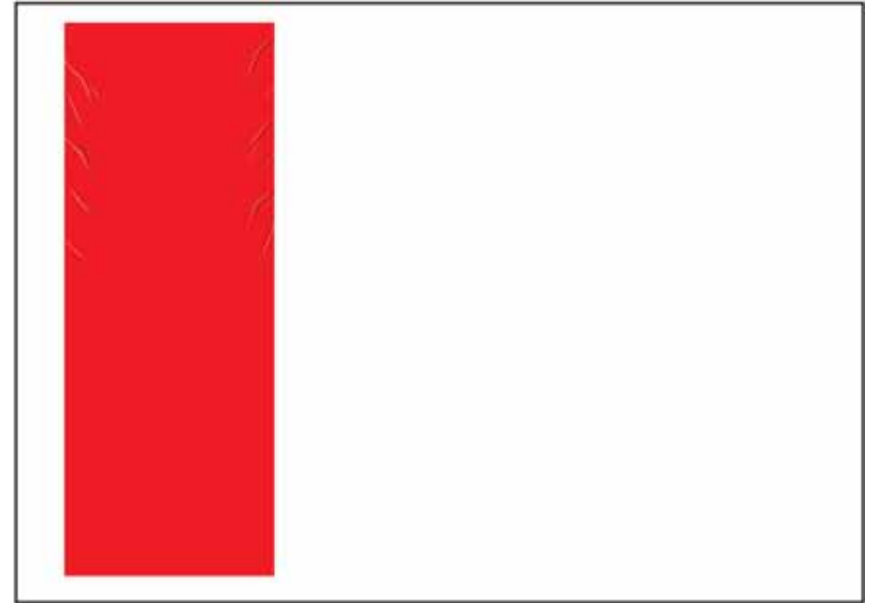

U-1-1368-A

Figure 2 Wrinkles related to uneven ink coverage

Procedure

WARNING

Ensure that the electricity to the machine is switched off while performing tasks that do not need electricity. Refer to [GP 14](#). Disconnect the power cord. Electricity can cause death or injury. Moving parts can cause injury.

WARNING

Take care during this procedure. The stripper blade is very sharp and can cause injury.

WARNING

Do not clean the stripper blade. The stripper blade is very sharp and can cause injury. If the stripper blade is dirty a new blade must be installed.

WARNING

Take care during this procedure. Sharp edges may be present that can cause injury.

NOTE: Wrinkling can be aggravated by extreme temperature and humidity environments. To reduce wrinkling, advise the customer to use a heavier weight media, change the feed orientation from LEF to SEF or increase the size of the image margins.

Print [TP 1](#) Initial Test Print Pages. Check the prints for skew, refer to [IQS 1](#) Registration and Skew. **The prints are skewed.**

Y N

Using a fresh ream of paper, print 4, duplex TP 2 cyan solid fill test pages ([TP 2 to TP 10](#)). **The prints are good.**

Y N

Perform [dC625](#) Registration/preheat Calibration. Print 4, duplex Cyan Solid Fill test pages ([TP 2 to TP 10](#)). **The prints are good.**

Y N

Perform [dC962](#) Transfix Load Test. **The transfix loading is within specification.**

Y N

Perform [dC978](#) Transfix Calibration Values. Check the stored transfix calibration values against those on the machine frame. If the stored values are different, correct the transfix values in NVM. If the values are the same, go to [10-500-00](#) to [10-540-00](#) Transfix Error RAP.

Open the stripper gate, [GP 31](#). Check the drum stripper blade for damage, debris or accumulation of ink. If necessary, install a new stripper blade, [PL 10.12 Item 3](#). Print 4, duplex Cyan Solid Fill test pages ([TP 2 to TP 10](#)) **The prints are good.**

Y N

Enter [dC330](#) code 82-007, nip C release solenoid, [PL 82.15 Item 4](#) and 82-008, nip D release solenoid, [PL 70.30 Item 13](#). **The solenoids energise.**

Y N

Go to the [82-507-00](#), [82-508-00](#) Nip C and Nip D Release Solenoid Over Current RAP.

If the defect persists, inform the customer to use heavier weight media, a different orientation or increase image margins.

Go to [SCP 5](#) Final Actions.

A

B

C

Go to [SCP 5](#) Final Actions.

Test the customers print job on the newly opened media.

- If the wrinkle defect is on a print job. Enter the Print Setup options / Properties / Advanced / Image Options and select Paper Compensation.

There is a slight increase in drop out and a small decrease in productivity when this option is used. Only use when the wrinkle defect is present.

- If the wrinkle defect is on a copy job. Select Image Quality and then Paper Compensation tab on the user interface.

There is a slight increase in drop out and a small decrease in productivity when this option is used. Only use when the wrinkle defect is present.

- If the defect persists, inform the customer to use heavier weight media, a different orientation or increase image margins.

Go to [IQ 10](#) Incorrect Margin, Misregistration or Skew RAP.

A B C

IQ 25 Random Spots RAP

Use this RAP when the output has random spots. Refer to [Figure 1](#).

Random spots are usually ink debris from the stripper blade, abatement plenum or printheads. Spots can appear on the image if the cleaning unit fails to thoroughly clean the drum. Large spots of primary colours can be caused by a faulty printhead.

Ensure [IQ 1](#) Image Quality Entry RAP is performed before starting this RAP.

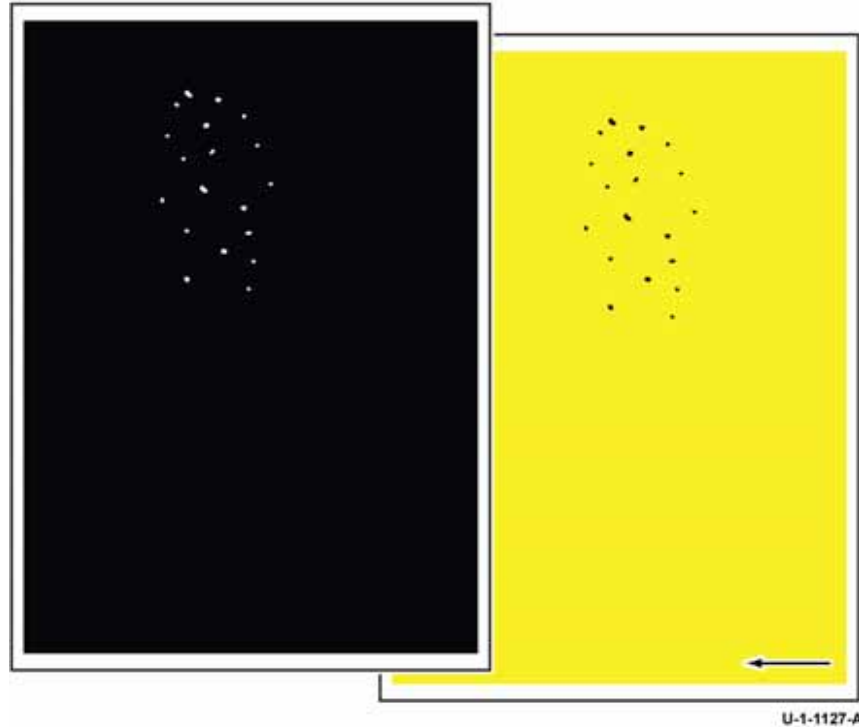

Figure 1 Random spots from incomplete drum cleaning

Initial Actions

WARNING

Ensure that the electricity to the machine is switched off while performing tasks that do not need electricity. Refer to [GP 14](#). Disconnect the power cord. Electricity can cause death or injury. Moving parts can cause injury.

WARNING

Take care during this procedure. The stripper blade is very sharp and can cause injury.

WARNING

Do not clean the stripper blade. The stripper blade is very sharp and can cause injury. If the stripper blade is dirty a new blade must be installed.

WARNING

Take care during this procedure. Sharp edges may be present that can cause injury.

CAUTION

Use care when moving the marking unit into the service position when hot. Ink can spill from the ink reservoir located at the back of the unit if opened with too much force. Cross-colour ink contamination could also occur.

CAUTION

Do not touch the exposed face of the printheads. Surface contamination or minor damage can easily make the printhead unusable.

- Press the Machine Status button on the keypad, select the Fault tab on the UI, then Current Messages. If the message 'Cleaning unit life extended. Image quality may be impacted' is displayed, install a new cleaning unit, [PL 94.10 Item 21](#).
- Check the media. If low grade or recycled media is found, suggest using a better grade of media. Defects in the media may appear as spots of ink, [Figure 2](#).

Procedure

Print [TP 14](#) Drum Stripper Blade Test Print. The stripper blade releases between the 35 mm and the 50 mm mark.

Y N

Install a new stripper blade solenoid, [PL 10.10 Item 3](#).

Perform [dC969](#) Clean Ink Smears. Print three copies of TP 4 Yellow Solid Fill Test pages ([TP 2 to TP 10](#)). The test pages are good.

Y N

Install a new stripper blade assembly, [PL 10.12 Item 3](#).

Perform [SCP 5](#) Final Actions.

Perform the self test routine in [dC959](#) Cleaning Unit Exerciser. The cleaning unit self test is successful.

Y N

Install a new cleaning unit, [PL 94.10 Item 21](#).

Remove the cleaning unit [PL 94.10 Item 21](#). Check the metering blade and roller area for paper debris. The metering blade and roller area are free of paper debris.

Y N

Remove the paper debris from the metering blade and roller area. Do not wipe the metering blade.

A

A

NOTE: Ink pixel build up on the metering blade is normal and should not be cleaned off

Perform the slow speed exerciser routine in dC959 Cleaning Unit Exerciser. **The test is successful.**

Y N

Go to the 94-520-00 Cleaning Unit Drive Error RAP.

Open the front door and remove the inner cover. Enter dC959 and run the slow speed exerciser. While this is running, check that the cleaning unit blade and roller are making contact with the drum. **The cleaning unit blade and roller are making contact with the drum.**

Y N

Check the front cam, PL 94.10 Item 9, rear cam, PL 94.10 Item 13, drive gear, PL 94.10 Item 23 and the cleaning unit motor, PL 94.10 Item 24
Install new components as necessary.

NOTE: Before printing TP 20, ensure that A4 or 8.5 x 11 inch plain paper is loaded long edge feed into tray 4. Use the best quality media available. Do not use hole punched paper.

Print TP 20 Oil Bar Chase and Metering Blade Timing Test Pages. Evaluate the metering blade timing page only. **The metering blade test page is good.**

Y N

Go to the IQ 7 Metering Blade Timing RAP.

Check the area surrounding the drum, transfix assembly, and exit module for ink residue or media debris. **The areas are clean.**

Y N

Clean the areas surrounding the drum, transfix assembly, and exit module, refer to GP 27 Cleaning Procedure. Print TP 11 Colour Bands and Dithers Test Pages. **The prints are good.**

Y N

Examine the test pages. **The spots are a primary colour, raised, round or oblong shaped, Figure 2.**

Y N

Perform dC969 Clean Ink Smears. Repeat cleaning until chase sheets are clean.

The machine has a jetting fault. Go to the IQ 9 Deletions RAP.

Perform SCP 5 Final Actions.

Go to the IQ 6 Missing Ink or Grainy Output RAP.

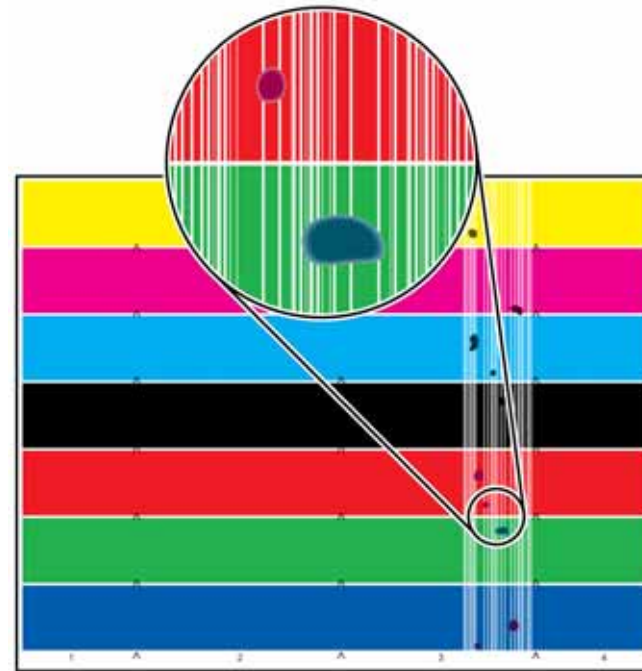

Figure 2 Ink spots

U-1-1563-A

IQ 26 Poor Ink Adhesion RAP

Use this RAP when the ink does not adhere to the media. Refer to [Figure 1](#).

Poor ink adhesion can be caused by overly glossy media coatings, improper oil application, or errors in drum or preheat temperature regulation.

NOTE: A similar defect, known as x-axis motion error, may be caused by obstruction of the carriage drive which causes lines of ink to be deposited on the drum. When this is transixed it has an embossed texture and appears wavy. Typically x-axis motion error affects individual carriages. Refer to [IQ 20 Wavy or Stringy Lines RAP](#).

Some customer actions will cause ink to be removed from the image such as scratch or abrading the surface of the image or applying / removing tape or sticky notes. This is expected behavior. No further service actions can correct this behavior.

Ensure [IQ 1 Image Quality Entry RAP](#) is performed before starting this RAP.

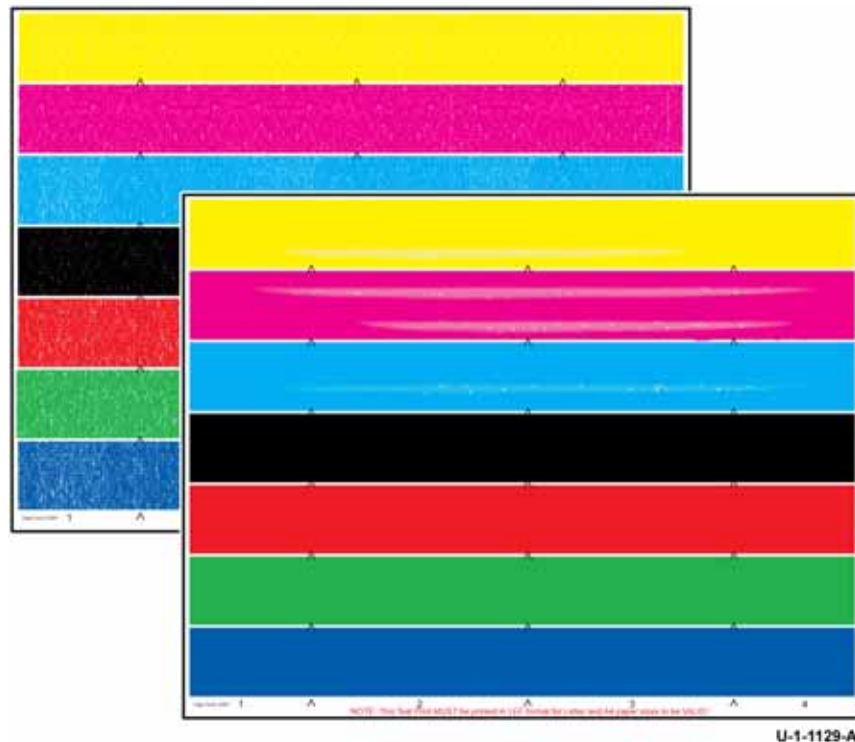

Figure 1 Poor ink adhesion

Initial Actions

WARNING

Ensure that the electricity to the machine is switched off while performing tasks that do not need electricity. Refer to [GP 14](#). Disconnect the power cord. Electricity can cause death or injury. Moving parts can cause injury.

- Press the Machine Status button on the keypad, select the Fault tab on the UI, then Current Messages. If the message 'Cleaning unit life extended, image quality may be impacted' is displayed, install a new cleaning unit, [PL 94.10 Item 21](#).
- If the customer is using glossy or heavyweight media, ensure the correct media type is selected in the user interface (UI).
- Ensure the customer is using supported media, refer to [GP 20 Paper and Media Size Specifications](#).

Procedure

WARNING

Ensure that the electricity to the machine is switched off while performing tasks that do not need electricity. Refer to [GP 14](#). Disconnect the power cord. Electricity can cause death or injury. Moving parts can cause injury.

NOTE: When printing TP 5 from [dC959](#), ensure that A4 or 8.5 x 11 inch plain paper is loaded long edge feed into tray 4. Use the best quality media available. Do not use hole punched paper.

Check the media type and finish, refer to [GP 20](#). If the media appears glossy, load new media. Print TP 5 Solid Black Fill test page ([TP 2 to TP 10](#)). **The image on the test page is good with no missing ink.**

Y N

Check that the front drum thermistor, [PL 94.20 Item 9](#) and the rear drum thermistor, [PL 94.20 Item 10](#) are not bent or misaligned. Check for paper debris between the thermistors and the drum and ensure that the thermistors are making good contact with the drum. **The thermistors are good.**

Y N

Install new components as necessary

- Front drum thermistor, [PL 94.20 Item 9](#)
- Rear drum thermistor, [PL 94.20 Item 10](#)

Perform [dC335 Heater Monitor and Exerciser](#). Check the drum operating temperature. **The drum temperature is good.**

Y N

Go to [94-536-00](#), [94-538-00](#), [94-540-00](#), [94-542-00](#), [94-544-00](#), [94-546-00](#), [94-632-00](#), [94-633-00](#) Drum Heat Error RAP.

Perform [dC335 Heater Monitor and Exerciser](#). Check the preheat temperature. **The preheat temperature is good.**

Y N

Go to [88-500-00](#) to [88-502-00](#), [88-512-00](#) Preheat Thermal Error RAP.

Enter [dC959 Cleaning Unit Exerciser](#). Run the cleaning unit self test. **The cleaning unit self test completes successfully.**

A

Y N

Install a new cleaning unit, [PL 94.10 Item 21](#).

Check the cleaning unit metering blade for pieces of paper.

NOTE: Ink pixel build up on the metering blade is normal and should not be cleaned off.

The metering blade is good.

Y N

Clean the metering blade of pieces of paper.

Enter [dC959](#) Cleaning Unit Exerciser and run the slow speed exerciser. **The slow speed exerciser completes successfully.**

Y N

Go to [94-522-00](#) Cleaning Unit Motor Stall RAP.

Open the front door and remove the inner cover. Enter [dC959](#), Cleaning Unit Exerciser, and run the slow speed exerciser. While this is running check if the cleaning unit metering blade and roller are making contact with the drum. **The metering blade and roller are making contact with the drum.**

Y N

Check the cleaning unit cams mechanism [PL 94.10 Item 9](#), [PL 94.10 Item 13](#) and the cleaning unit drive gear and motor [PL 94.10 Item 23](#), [PL 94.10 Item 24](#). Install new parts as necessary.

Enter [dC978](#) Transfix Calibration Values. Check the transfix calibration values against those on the drum frame. **The calibration values match.**

Y N

Correct the transfix calibration values in NVM, [dC131](#).

Enter [dC962](#) to test the transfix assembly. **The transfix assembly operates normally.**

Y N

Install new components as necessary:

- Transfix roller, [PL 10.20 Item 1](#).
- Flexure encoder, [PL 10.20 Item 5](#).
- Transfix motor, [PL 10.20 Item 11](#).

The machine is operating within specification. Perform [SCP 5](#) Final Actions.

Perform [SCP 5](#) Final Actions.

IQ 27 Unacceptable Received Fax Image Quality RAP

Use this RAP to identify the causes of poor reception.

Ensure [IQ 1](#) Image Quality Entry RAP is performed before starting this RAP.

Initial Actions

WARNING

Ensure that the electricity to the machine is switched off while performing tasks that do not need electricity. Refer to [GP 14](#). Disconnect the power cord. Electricity can cause death or injury. Moving parts can cause injury.

Verify the following:

- This problem occurs only when receiving transmissions.
- This problem occurs on all receiving transmissions.
- Check that the Fax country setting, NVM location 200-043, is correct. Refer to [Fax Document](#).

Procedure

The condition of the original transmission document is good.

Y N

Generate a new document from the original.

If possible, establish voice contact using the same telecommunication link as used to receive the document. **The line is free of interference sounds and the normal voice can be heard clearly.**

Y N

Go [20G](#) Fax Module Checkout.

Receive the document at a slower receive speed. Set the NVM location 200-089 Line 1 = 11 and location 200-090 Line 2 = 11. Refer to [Fax Document](#). **The image quality is acceptable.**

Y N

The telecommunication links and harnesses are connected properly and there is no visible damage.

Y N

Correct the connections. If necessary install a new line cable and connectors.

Verify the operation of the machine and the communication link by transmitting between machines over a known good link. **All received documents have an acceptable image quality.**

Y N

Install a new Fax module, [PL 20.05 Item 1](#).

Go [20G](#) Fax Module Checkout.

Inform the remote user of the required changes to the settings.

IQ 28 Show Through on Copies RAP

Use this RAP when copies have show through.

Show through can be caused by the exposure lamp shining through low weight paper picking up both sides of a duplex master. This can happen on duplex masters of 60 gsm or less.

Ensure [IQ 1](#) Image Quality Entry RAP is performed before starting this RAP.

Procedure

WARNING

Ensure that the electricity to the machine is switched off while performing tasks that do not need electricity. Refer to [GP 14](#). Disconnect the power cord. Electricity can cause death or injury. Moving parts can cause injury.

Ensure the master is scanned on the document glass with the DADH in the down position.

IQ 29 DADH, Document Glass and Scanner RAP

Use this RAP to identify defects caused by the DADH, document glass or scanner.

Ensure [IQ 1](#) Image Quality Entry RAP is performed before starting this RAP.

Procedure

Perform the following:

- [CVT and Document Glass Checkout](#)
- [DADH Checkout](#)
- [Scanner Checkout](#)

CVT and Document Glass Checkout

Perform the following:

1. Clean the top surface of the CVT glass and the document glass. Perform [ADJ 62.1](#) Optics Cleaning Procedure.
2. Check the position of the document pad, refer to [ADJ 5.6](#) DADH Document Pad.
3. Check that the white AGC strips on the document glass and the CVT glass are at the front and underside of the glass.
4. The AGC portion of the CVT glass should be clean and at the front bottom of the CVT glass, [PL 62.10 Item 3](#). If it is missing, dirty or the glass is not properly installed then this will cause faint, washed out, light copies from the DADH only.
5. [dC609](#) Document Glass Registration.

DADH Checkout

Perform the following:

1. Clean the underside of the DADH area around the CVT roll, [PL 5.25](#).
2. Clean the top surface of the CVT glass and the document glass. Perform [ADJ 62.1](#) Optics Cleaning Procedure.
3. If the documents are skewed. Check that the document input guides are correctly adjusted.
4. Check that the DADH is seated correctly, perform [ADJ 5.2](#) DADH Height Adjustment.
5. Make copies from the DADH. If the copies have a background problem, perform the following:
 - a. Check the DADH height, Refer to [ADJ 5.2](#) DADH Height Adjustment.
 - b. Check the mylar guide strip for damage, [PL 5.30 Item 12](#). If necessary install a new mylar guide strip, [PL 31.11 Item 14](#).
 - c. [dC608](#) Document Feeder Registration.
 - d. Copying thick documents can leave the DADH raised above the document glass. Raise and lower the DADH five times. If the DADH is still raised, install new counter-balances, [PL 5.10 Item 2](#) and [PL 5.10 Item 4](#).
6. Make copies from the DADH. If the copies are stretched or smudged, perform the following:
 - a. Lower the height of the DADH by half a turn of the setting screws, refer to [ADJ 5.2](#) DADH Height Adjustment. Make copies from the DADH after each adjustment. If the fault persists, re-adjust the height of the DADH as necessary.

- b. If the fault persists after the height of the DADH has been adjusted, install a new lower baffle assembly, [PL 5.30 Item 14](#). Re-adjust the height of the DADH to the default setting, refer to [ADJ 5.2 DADH Height Adjustment](#).

Scanner Checkout

Perform the following:

1. If the copy of the internal test page is fragmented and displaced, check the following:
 - a. Check the harness connections from the full width array to the [single board controller PWB, PL 62.15 Item 4](#).
 - b. Check the following:
 - Check the harness connections from the [Scanner PWB](#) to the [single board controller PWB, PL 62.16 Item 8](#) and [PL 3.11 Item 13](#).
 -
 - c. If fragmented and displaced images appear in a regular pattern across process direction, remove and re-seat all EPC memory PWBs, [PL 3.11 Item 21](#).
 - d. If necessary, go to the [62-310-00](#) Scanner to Single Board Controller Communication Fail Entry RAP.
2. Raise the DADH. Make a copy from the document glass. If the exposure lamp does not illuminate or partially illuminates, go to the [62-450-00](#) to [62-472-00](#) Calibration Failure RAP.
3. Perform [ADJ 62.1 Optics Cleaning Procedure](#).

IQ 30 Blocking RAP

Use this RAP when the output has ink transfer between images in the output tray stack.

NOTE: A residual image may also occur when ink has been retained on the drum. Ink from an earlier print then appears on the next sheet. Residual images may have a similar appearance to blocking. Refer to [IQ 23 Residual Ink From Previous Print RAP](#).

Ensure [IQ 1 Image Quality Entry RAP](#) is performed before starting this RAP.

Procedure

Advise the customer that this may be resolved by the use of lighter weight media. Alternatively emptying the output tray more frequently may help. No other service actions will correct this issue.

TP 1 Initial Test Print Pages

These A4 (8.5 x 11) pages are a set of diagnostic test prints used to initially diagnose image quality issues in IQ 1. TP 1 prints the five test pages shown in Figure 1.

Initial test print pages are printed from dC612.

NOTE: All test prints should be printed on A4 or 8.5 x 11 inch plain paper and long edge feed. Use the best quality media available. Do not use hole punched paper. Failure to do this will result in an error message being printed instead of the test page.

NOTE: Always load A4 or 8.5 x 11 inch media as appropriate to your market region in Tray 4 before printing internal test prints.

NOTE: When the paper selected for the test print pages is correct, the test pages will be printed with annotations on the bottom edge confirming the test print name, the LEF status and that double chevrons will be printed if the paper used is A4. The chevrons indicate the stitch position between print heads.

Purpose

These test pages are printed as part of an evaluation of image quality performance in IQ 1. Examine each print for the defect that follow:

- The colour bands print is useful for identifying:
 - Jetting defects, refer to IQ 5, IQ 20 and IQ 25.
 - Stitching defects, refer to IQ 5, IQ 9 and IQ 13.
 - Uniformity defects, refer to IQ 5, IQ 13 and IQ 14.
- The horizontal lines print is useful for identifying:
 - Y-dot position defects, refer to IQ 5.
 - Y-stitch defects, refer to IQ 5.
 - Print head alignment defects, refer to IQ 5, IQ 9, IQ 12, IQ 13 and IQ 14.
- The text print is useful for identifying:
 - Text defects, refer to IQ 5.
 - Resolution defects, refer to IQ 5.
- The cyan/magenta print is useful for identifying:
 - Uniformity defects, refer to IQ 14.

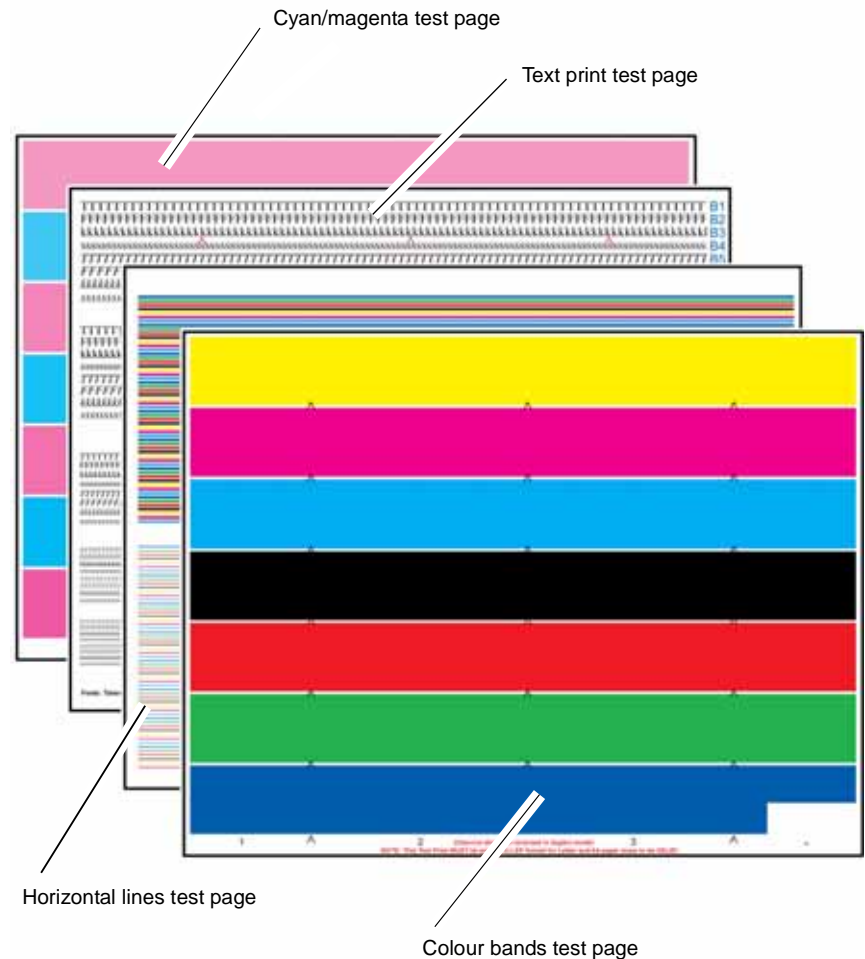

U-1-1369-A

Figure 1 Image quality analysis test pages

TP 2 to TP 10 Solid Fill Test Pages

Solid fills are used to purge the jets of contamination or to correct cross-colour contaminated jets. Solid fills are also used to examine media damage, cleaning unit function, skew, and margins.

Solid fill test pages are printed from [dC612](#). TP5 black solid fill can also be printed from [dC959](#).

NOTE: All test prints should be printed on A4 or 8.5 x 11 inch plain paper and long edge feed. Use the best quality media available. Do not use hole punched paper.

NOTE: When printing TP 5 from [dC959](#), ensure that the paper is loaded LEF into tray 4.

Purpose

Figure 1. These single-sided prints provide solid-fills in all eight colours:.

- Select TP 2 to print two cyan solid fills
- Select TP 3 to print two magenta solid fills
- Select TP 4 to print two yellow solid fills
- Select TP 5 to print two black solid fills
- Select TP 6 to print two red solid fills
- Select TP 7 to print two green solid fills
- Select TP 8 to print two blue solid fills
- Select TP 9 to print two white solid fills
- Select TP 10 to print a single set of all eight solid fills (cyan, magenta, yellow, black, red, green, blue and white).

To solve image quality problems associated with solid fills, refer to [IQ 5](#), [IQ 9](#), [IQ 10](#) and [IQ 24](#).

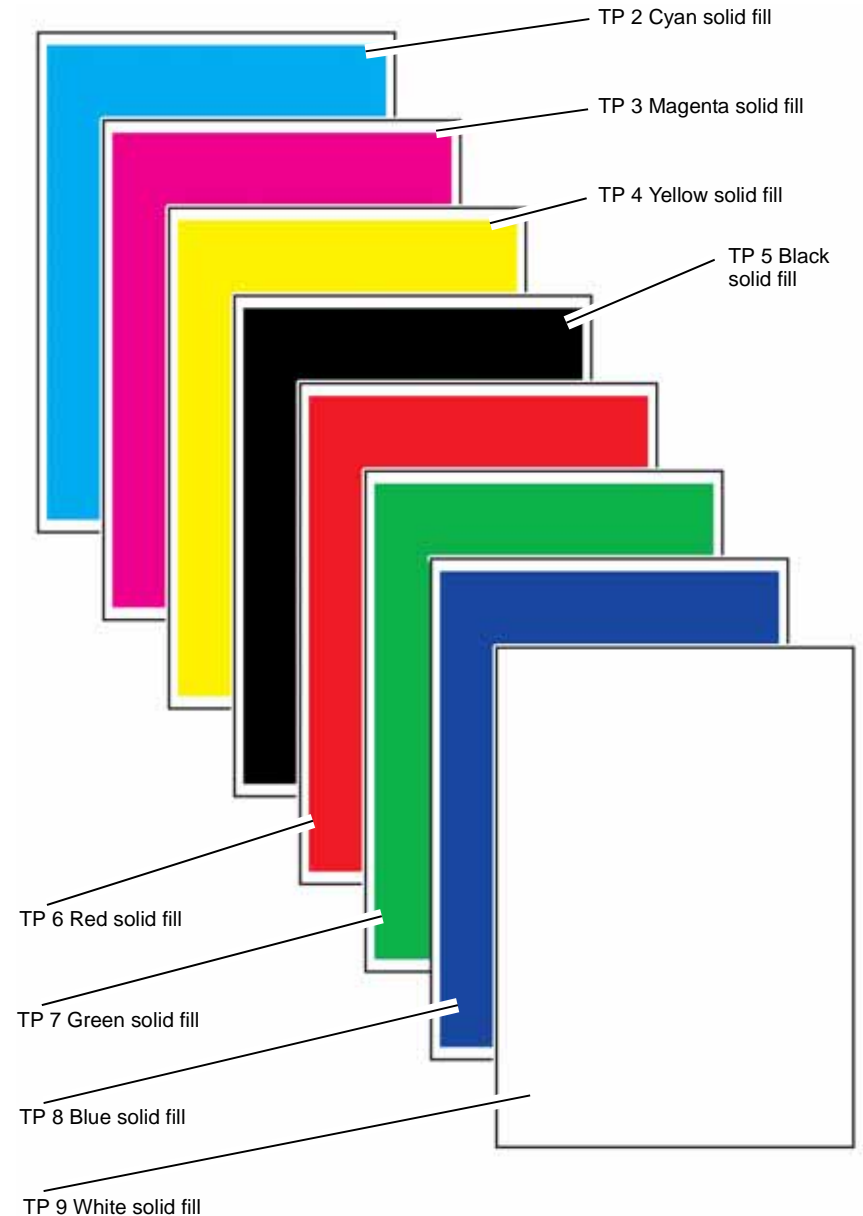

U-1-1054-A

Figure 1 Solid fill pages

TP 11 Colour Bands and Dithers Test Pages

These six A4 (8.5 x 11 inch) pages are a set of 6 diagnostic test prints used to diagnose image quality issues related to colour uniformity. [Figure 1](#) shows the test pages printed.

Colour bands and dithers test pages are printed from [dC612](#).

NOTE: All test prints should be printed on A4 or 8.5 x 11 inch plain paper and long edge feed. Use the best quality media available. Do not use hole punched paper. Failure to do this will result in an error message being printed instead of the test page.

NOTE: When the paper selected for the test print pages is correct, the test pages will be printed with annotations on the bottom edge confirming the test print name, LEF status and that double chevrons will be printed if the paper used is A4. The chevrons indicate the stitch position between print heads.

Purpose

These pages are used to evaluate print quality problems caused by drifting or mis-adjusted print heads.

To solve image quality problems associated with colour uniformity, refer to [IQ 13](#).

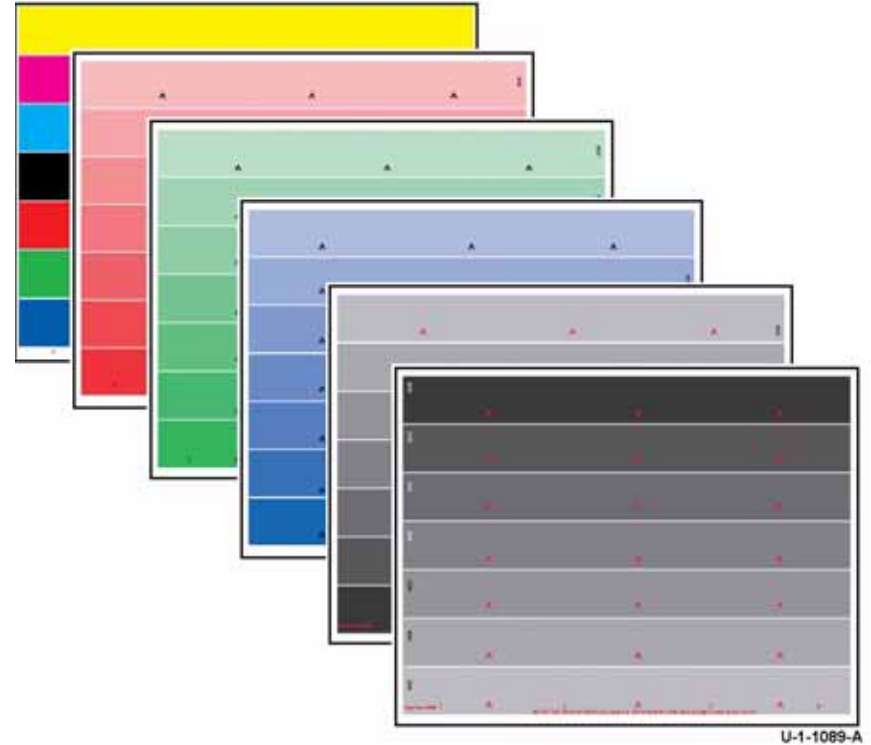

Figure 1 colour bands and dithers test pages

TP 12 Chase Page

Chase pages are picked from the selected tray and fed through the media path. No image is jetted onto the drum.

Chase pages are printed from dC612.

NOTE: All test prints should be printed on A4 or 8.5 x 11 inch plain paper and long edge feed. Use the best quality media available. Do not use hole punched paper.

Purpose

Chase pages are used to clear the drum of any residual image or possible contamination. Chase pages are also useful for examining jam conditions and media damage. Use chase pages to clear the media path, clean light contamination from the registration/preheat assembly, drum, or transfix roller.

TP 13 Text Test Pages

Figure 1 shows the three text test pages used to represent black, text-only printed documents.

Text test pages are printed from dC612.

NOTE: All test prints should be printed on A4 or 8.5 x 11 inch plain paper and long edge feed. Use the best quality media available. Do not use hole punched paper. Failure to do this will result in an error message being printed instead of the test page.

NOTE: When the paper selected for the test print pages is correct, the test pages will be printed with annotations on the bottom edge confirming the test print name, LEF status and that double chevrons will be printed if the paper used is A4. The chevrons indicate the stitch position between print heads.

Purpose

Text test pages are used to diagnose text quality defects. There are no known imaging problems that affect only text and allow all other printed objects, such as fills, dithers, lines, and pictures to be defect-free. Text quality is particularly sensitive to incorrectly placed dots; thus it is most dependent on proper print head operation, mechanical alignment, and motion. The third page of landscape text repeats the same characters over and over again across the page to aid in detecting spatial variations in dot placement. Look for relative differences between the quality of the characters across the print.

To solve image quality problems associated with text, refer to IQ 5 and IQ 19.

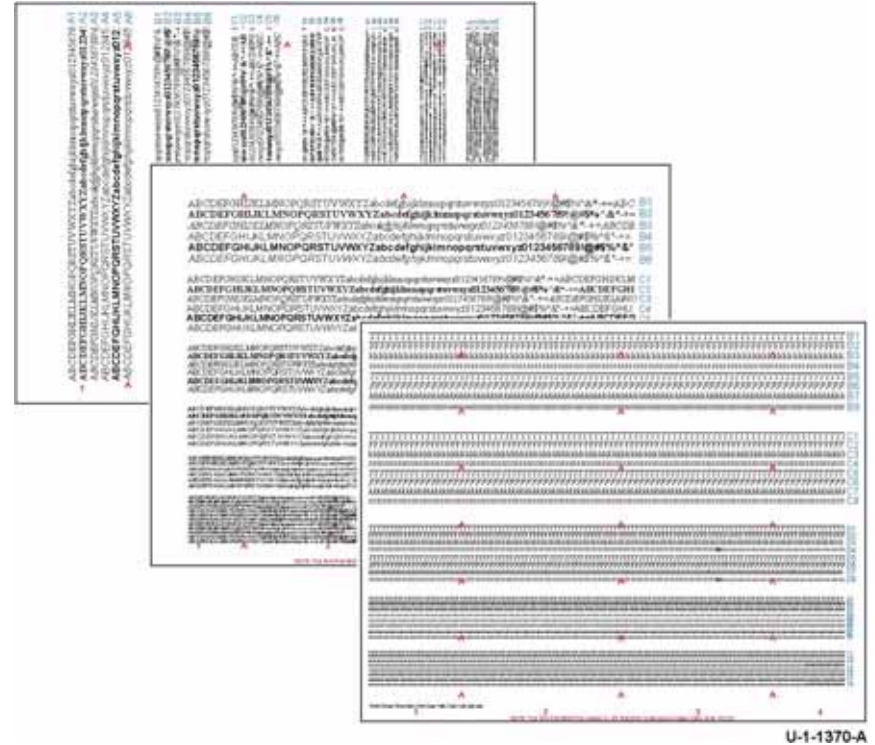

Figure 1 Text test pages

TP 14 Drum Stripper Blade Test Page

This page is a diagnostic test print used to diagnose errors related to the drum stripper blade and stripper drive. The drum stripper blade test page records stripper blade activity during two typical drum stripper activation sequences. In addition to blade timing, anomalies in the blade such as warping, bounce, or edge damage may be visible in the stripped area of the image.

The drum stripper blade test page is printed from dC612.

NOTE: All test prints should be printed on A4 or 8.5 x 11 inch plain paper and long edge feed. Use the best quality media available. Do not use hole punched paper. Failure to do this will result in an error message being printed instead of the test page.

NOTE: When the paper selected for the test print pages is correct, the test pages will be printed with annotations on the bottom edge confirming the test print name and the LEF status.

The test page is designed to print in a particular resolution in order for the scale to be representative of millimeters. First, the image is created on the drum. The drum stripper blade is activated to simulate the stripping of one sheet of media. The area where the stripper blade contacts the drum is visible on the print as the wiped off region. Figure 1 is an example of a normal drum stripper blade activation sequence. The test print is followed by two chase sheets to clean the drum.

Purpose

To record drum stripper blade action. Refer to Figure 1 showing test page details. Test page features include a background, a metric scale graduated in millimeters along each edge, a 'Start' line that corresponds to the point where the stripper drive solenoid is commanded to actuate, and a MLE line that corresponds to the point on the drum where the media leading edge would fall. During normal operation, the drum stripper blade makes contact in the 10 to 20 mm window (left side scale). The drum stripper blade releases from the drum in the 35 to 50 mm window (left side scale).

To solve image quality associated with the drum stripper blade, refer to IQ 8 Cross Process Ink Artifacts (Smudge) RAP.

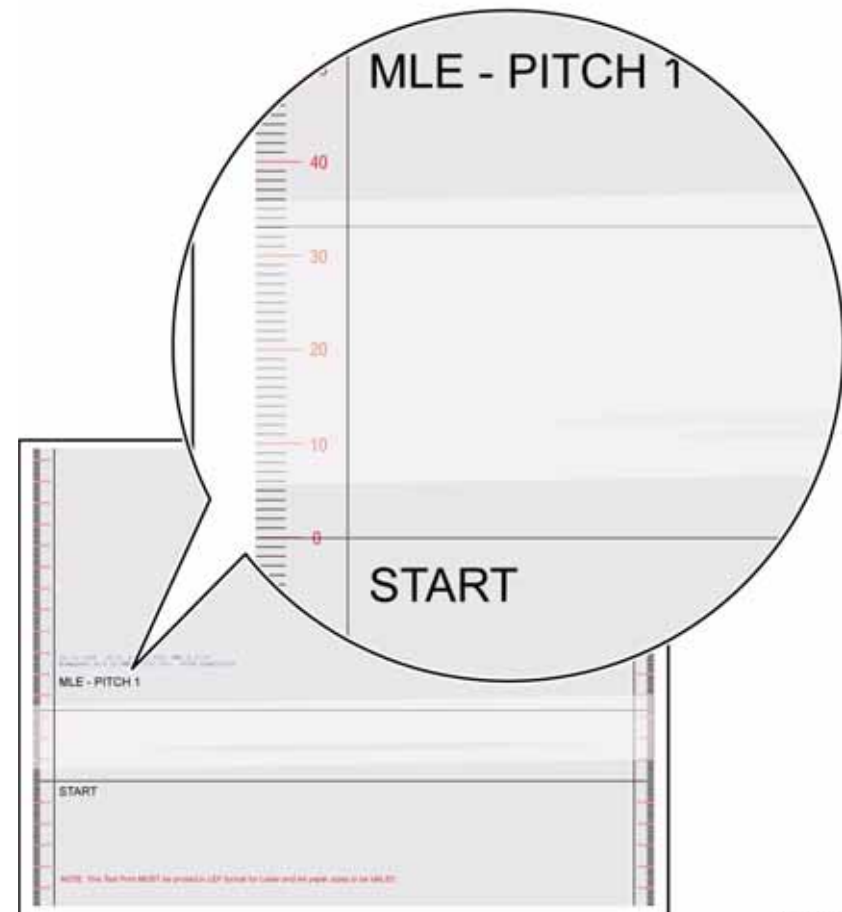

U-1-1371-A

Figure 1 Drum stripper blade test page

TP 15 Media Path Test Pages

Figure 2 shows the media path test page. Print the media path test page using the same size media as the affected print. Reconstruct the media path by aligning the test pages vertically. Jam zone 1a at the top to 4b at the bottom. Compare markings on the affected print to the features on the test print to determine the jam zone, nip, or ribs affecting the output. The test image is cropped according to the media size selected for printing. To see the complete image, use A3 (11 x 17 inch) media.

Media path test pages are printed from dC612.

NOTE: All test prints should be printed on A4 or 8.5 x 11 inch plain paper and long edge feed. Use the best quality media available. Do not use hole punched paper. Failure to do this will result in an error message being printed instead of the test page.

NOTE: When the paper selected for the test print pages is correct, the test pages will be printed with annotations on the bottom edge confirming the test print name and the LEF status.

Purpose

The media path test page is used to locate the source of scratches, marks, or gloss differences on the output due to transport components. The page is organized according to the media path layout shown in Figure 1. Each of the jam areas (1a to 4a) is segregated on the test print with a horizontal line. Rollers for each nip are identified by letter, and rib locations are indicated by rectangles or hash marks.

For example, jam zone 1a, located at the top of sheet 1, includes nips H and F and ribs to guide media up the vertical transport. The roller contact locations, both drive and idler, are shown along with contact points for the ribs.

To solve image quality associated with scratches, marks, or gloss differences, refer to IQ 16.

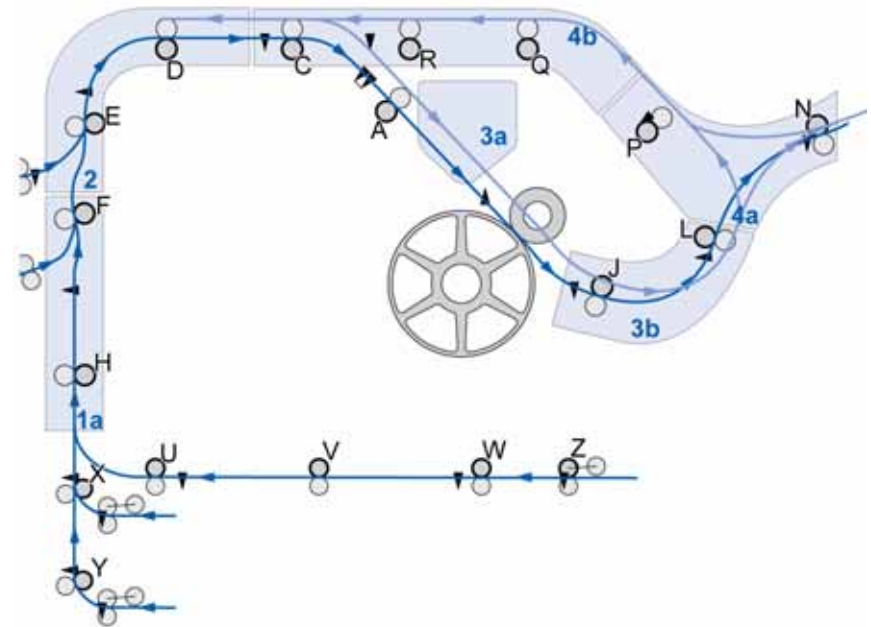

U-1-1372-A

Figure 1 Media path jam zone and nip layout

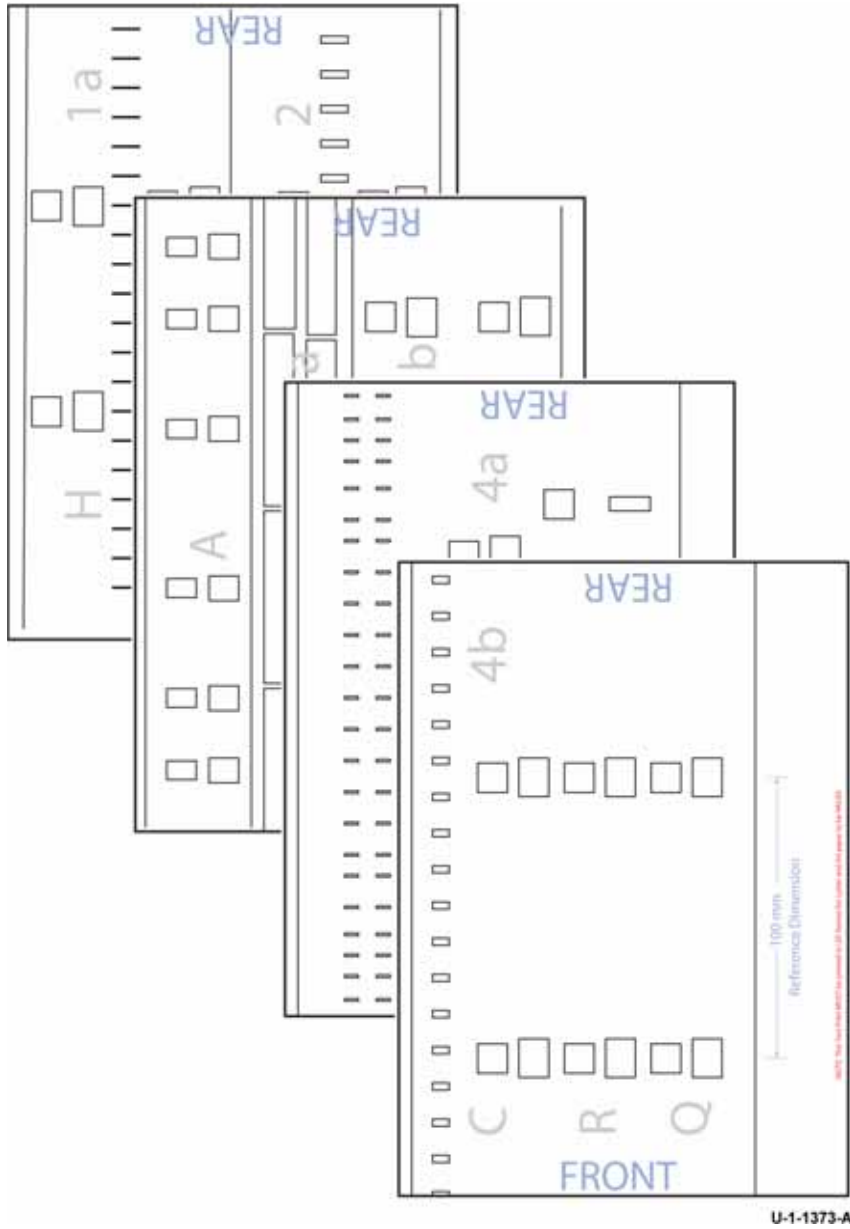

Figure 2 Media path test pages

TP 16 Stitch Identification Test Pages

The print heads work together to stitch the image together. The X-stitch and Y-stitch pages print when the stitch identification selection is made from [dC612](#).

Stitch identification test pages are printed from [dC612](#).

NOTE: All test prints should be printed on A4 or 8.5 x 11 inch plain paper and long edge feed. Use the best quality media available. Do not use hole punched paper. Failure to do this will result in an error message being printed instead of the test page.

NOTE: When the paper selected for the test print pages is correct, the test pages will be printed with annotations on the bottom edge confirming the test print name, the LEF status and that double chevrons will be printed if the paper used is A4. The chevrons indicate the stitch position between print heads.

Purpose

The X-stitch and Y-stitch pages indicate the accuracy of print head alignment. Refer to [Figure 1](#).

NOTE: The X-Stitch print is made up of an interference pattern. The degree of an x-stitch issue is highly exaggerated on this print. The actual x-stitch error will appear less pronounced on a customer image. If in doubt about the severity of an x-stitch issue print a customer image to determine if it is visible.

To solve image quality problems associated with stitch errors, refer to [IQ 5](#), [IQ 9](#) and [IQ 13](#).

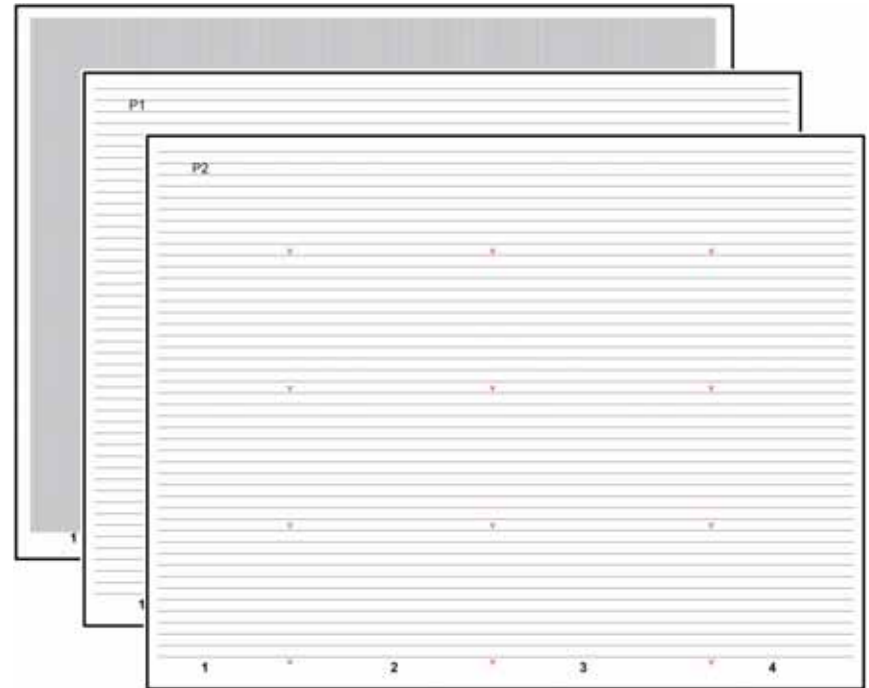

U-1-1114-A

Figure 1 Stitch identification test pages

TP 17 Service Usage Profile

This series of A4 (8.5 x 11 inch) prints list the information about the machine usage and printer status, [Figure 1](#).

Purpose

The service usage profile tracks printer activity, consumable usage and printer history. This data is stored in NVRAM. Service usage profile data includes error logs that retain detail on the type, date, location and frequency of engine and jam errors. While the service usage profile includes data on all aspects of the printer, this section focuses on accessing these error logs to review printer history.

The service usage profile list can be printed from [dC612](#).

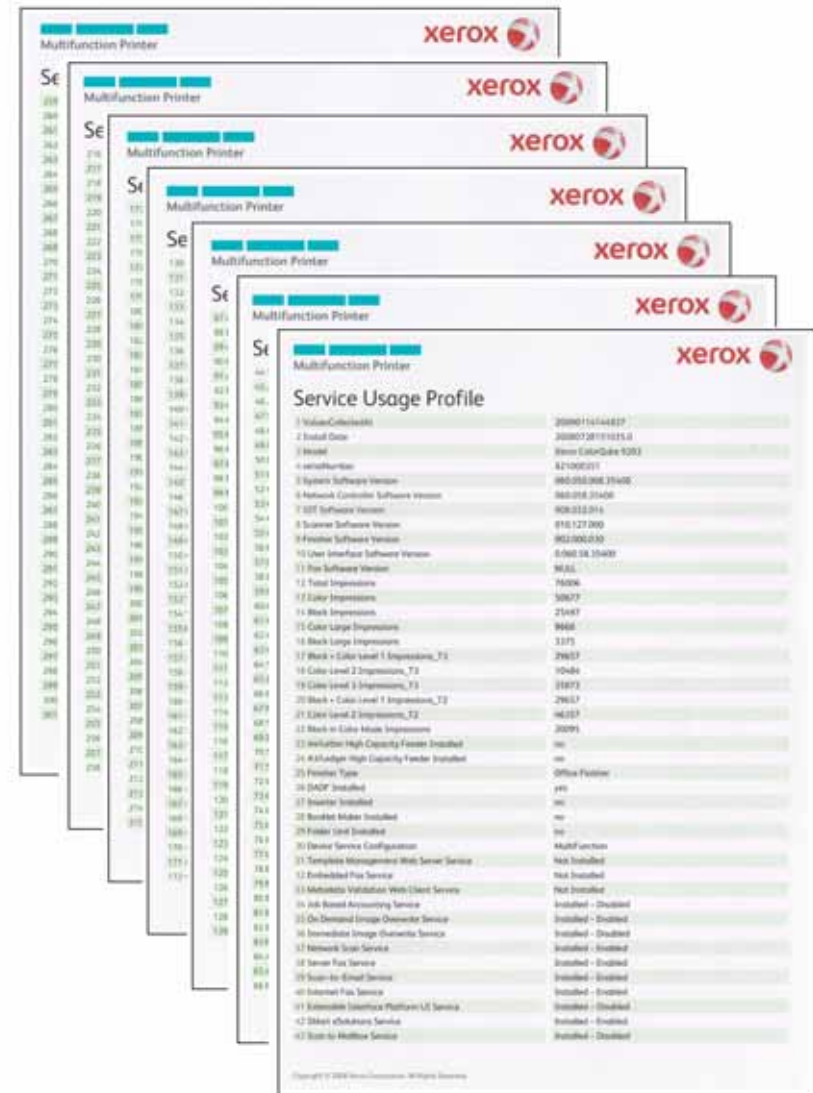

U-1-1503-A

Figure 1 Service usage profile

TP 18 TRC Generation Test Pages

These four A4 (8.5 x 11 inch) pages have red, green, blue, or black step dithers.

TRC generation test pages are printed from [dC972](#) option 4.

NOTE: Before printing this test page, ensure that A4 or 8.5 x 11 inch plain paper is loaded LEF into tray 4. Use the best quality media available. Do not use hole punched paper.

NOTE: When the paper selected for the test print pages is correct, the test pages will be printed with annotations on the bottom edge confirming that double chevrons will be printed if the paper used is A4. The chevrons indicate the stitch position between print heads.

Purpose

Figure 1. The TRC Generation Test Pages are a test print suite used to diagnose image quality issues related to colour uniformity in dithers. This page is part of the print head uniformity adjustment sequence used to correct print quality problems related to colour uniformity and dot position.

To solve image quality problems related to colour uniformity in dithers, refer to [IQ 13](#) and [IQ 14](#).

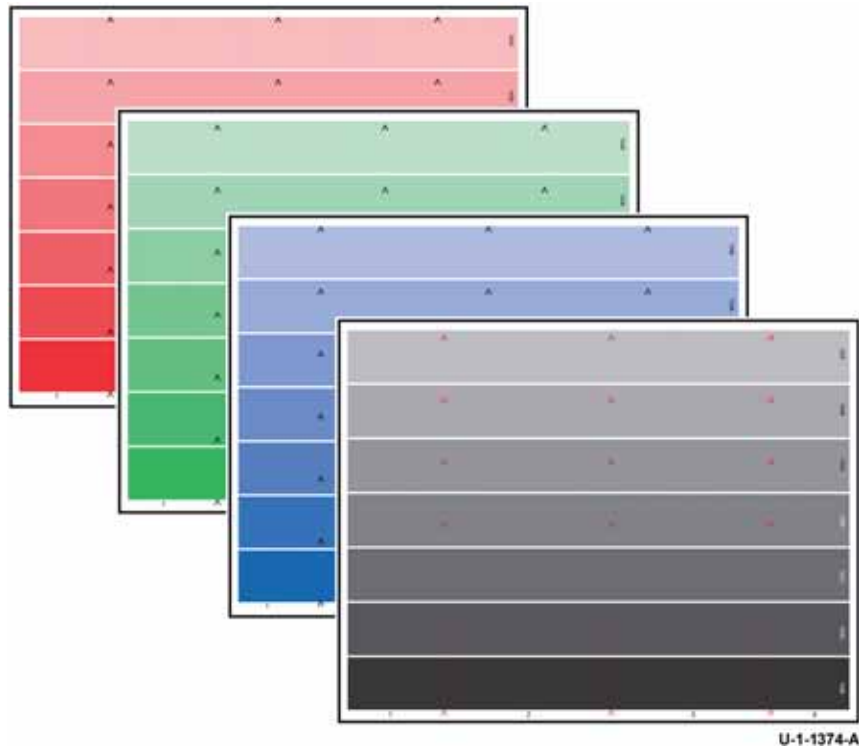

Figure 1 TRC generation dithers

TP 19 Y-Dot Position Correction Test Page

This A4 (8.5 x 11 inch) print consists of 1 and 5 pixel thick lines in the cross process direction. The colours of the lines are blue, green, red, black, yellow, magenta, and cyan.

The Y-dot position correction test page is printed from dC972 option 5.

NOTE: Before printing this test page, ensure that A4 or 8.5 x 11 inch plain paper is loaded LEF into tray 4. Use the best quality media available. Do not use hole punched paper.

NOTE: When the paper selected for the test print pages is correct, the test pages will be printed with annotations on the bottom edge confirming the test print name. Double chevrons will be printed if the paper used is A4. The chevrons indicate the stitch position between print heads.

Purpose

Figure 1. The Y-Dot Position Correction test page is a diagnostic test print used by service to diagnose image quality issues related to dot position errors in the process direction. This page is part of the print head uniformity adjustment sequence used to correct print quality problems related to colour uniformity and dot position.

To solve image quality problems associated with dot position in the process direction, refer to IQ 5.

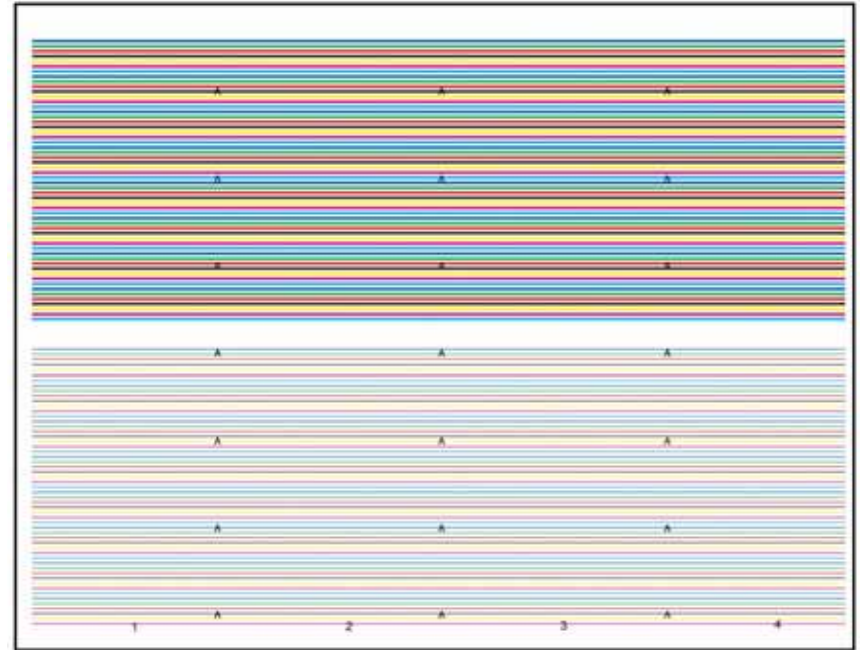

U-1-1090-A

Figure 1 Y-dot position pages

TP 20 Oil Bar Chase and Metering Blade Timing Test Pages

These test pages are used to check the operation of the cleaning unit.

The oil bar chase and metering blade timing test pages are printed from dC959 cleaning unit exerciser. Both pages are printed when the oil bar chase test page is selected.

NOTE: Before printing this test page, ensure that A4 or 8.5 x 11 inch plain paper is loaded long edge feed into tray 4. Use the best quality media available. Do not use hole punched paper.

NOTE: When the paper selected for the test print pages is correct, the test pages will be printed with annotations on the bottom edge of the visible image confirming the test print name.

Purpose

The oil bar chase test page is used to check that the metering blade leaves no more than a thin bar of oil on the drum when disengaging. The metering blade timing test page is used to ensure that the metering blade engages and disengages with the drum at the correct time.

1. Oil bar chase, A4 or 8.5 x 11 inch image, [Figure 1](#). A good oil bar chase page will have no oil contamination.

NOTE: A thin line of oil approximately 35 mm below the horizontal line and no more than 1 mm wide is acceptable.

Cleaning unit problems that may be indicated by this test page are described in [IQ 21](#) Oil on Output RAP.



U-1-1375-A

Figure 1 Oil bar chase page

2. Metering blade timing test, A4 or 8.5 x 11 inch image, [Figure 2](#). Cleaning unit problems that may be indicated by this test page are described in [IQ 7](#).

NOTE: The metering blade may not completely remove all pixels from the drum in the wiped area, this is normal behavior.

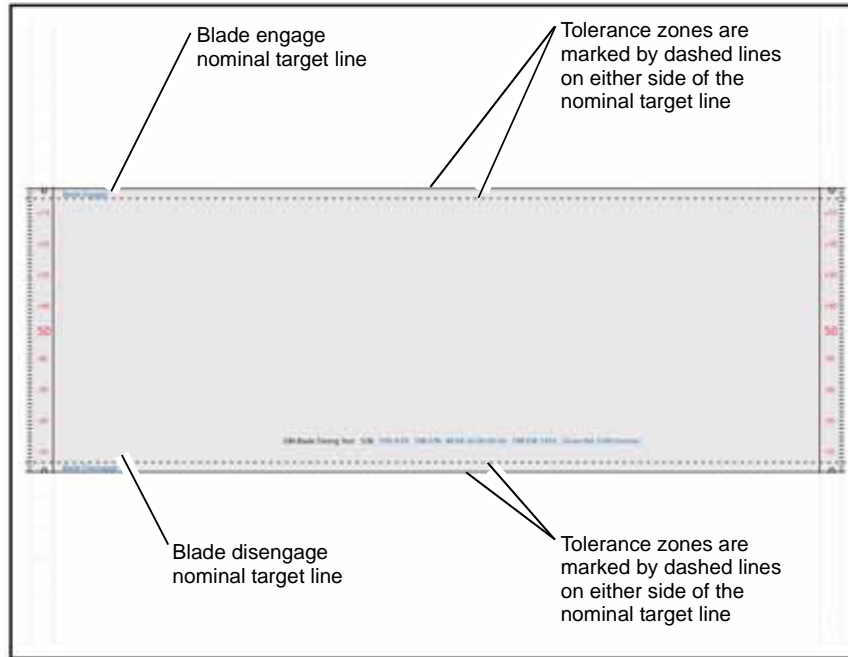

U-1-1378-A

Figure 2 Metering blade timing test page

TP 21 Jet Test Pages

These A4 (8.5 x 11 inch) pages are a set of diagnostic test prints used to check print head jet status. There are service jet test pages and customer jet test pages.

NOTE: Before printing this test page, ensure that A4 or 8.5 x 11 inch plain paper is loaded long edge feed into tray 4. Use the best quality media available. Do not use hole punched paper.

Printheads occasionally get clogged jets that require user intervention to restore jet function. When a clogged jet occurs, areas of solid colour may show signs of light stripes.

Jet test pages are used to check print head jet status. Two versions are available, service and customer. Jet test pages demonstrate effective print quality and provide visual feedback on the health of print head jet stack.

Service Jet Test Pages

Service jet test pages are printed from dC968 and dC977.

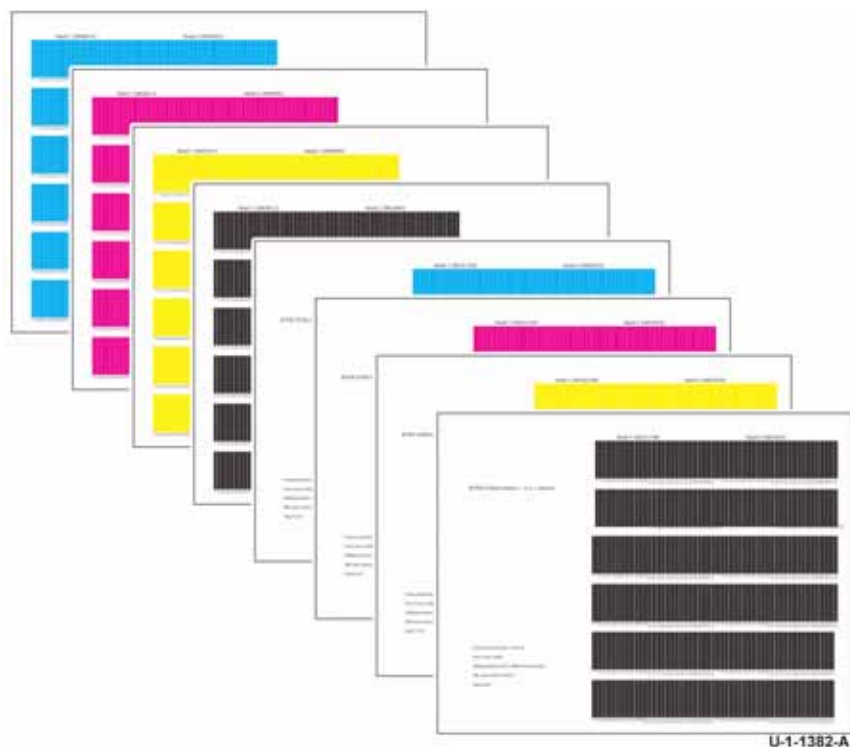

Figure 1 Jet test pages

The service jet test pages, shown in Figure 1, consists of eight test pattern pages. The first 4 pages show the conditions of print heads 1 and 2. The second 4 pages show the condition of print heads 3 and 4. After completing the jet test pages, a page containing a print quality management status check is produced, Figure 2. This table indicates the status of the each routine, refer to 91-636-00 IOD in Degraded Mode RAP for the corrective actions.

- The condition of each jet is shown in a bar of ink with the jet number directly beneath.
- The machine is able to detect the condition of jets in some conditions. Detected defective jets are indicated by a pointer beneath the number. The jet number and pointer for defective jets are colour coded according to the known condition of the jet.
- The total number of missing, chronic and masked jets per print head is shown to the side of the jet indicators.
- JSC[On,On]: indicates jet substitution is enabled (On) for both customer and machine settings. The machine may override the customer setting temporarily if the Quick Light Lines fix has been selected from the Tools/Fix Image Quality menu. After the next purge or machine reboot, the settings revert to customer settings. When jet sub is enabled, print speed slows down only when a jet is missing and is required for the current print.
- PC[On,On]: means the purge configuration is set to purge at night/when idle for both customer setting and machine setting. Same override rule applies. The purge here is jet fix purge that will only occur if the machine needs to auto recover an intermittent, weak, or missing jet.
- Beneath the data for print head jet status the test page lists the print head serial number, page count, current resolution, IME software version and page number.

To solve image quality problems related to weak, missing or sputtering jets, refer to IQ 9.

Print Quality Management Status Check						
Tool	NVM Chain	NVM Link	Status	Degraded	Consecutive Failures	DC number
Head to Head Alignment Adjust	490	19	2	Y	2	dc971
Alignment Calibration	490	41	0	N	0	dc971 Set Alignment Baseline
Drum Runout	492	69	1	N	0	dc977
Head to Head Uniformity	490	8	0	N	0	dc972 option3
CLD Baseline	490	61	1	Y	0	dc972 option 3 Manual
TRC Generation	490	11	0	N	0	dc972 option4
Y-dot Position Correction	490	5	1	N	0	dc972 option 5

U-1-1635-A

Figure 2 Print quality status

Definitions of Jet Conditions

NOTE: Service jet test pages are printed without jet substitution turned on and therefore will always show the true condition of each jet. The detected machine status may not always match the true condition of a jet at the time the jet pages are printed. Even if a jet number is purple, red or green you may see a colour bar over the jet number if the jet has managed to recover on its own.

There are 3 jet conditions indicated by the jet test pages:

- **Missing Jets**

Missing jets may be visible on the jet test pages as white space where the coloured bar for the jet should be. When a missing jet is detected by the machine, the jet number will be purple with a purple pointer indication beneath the jet number, [Figure 3](#).

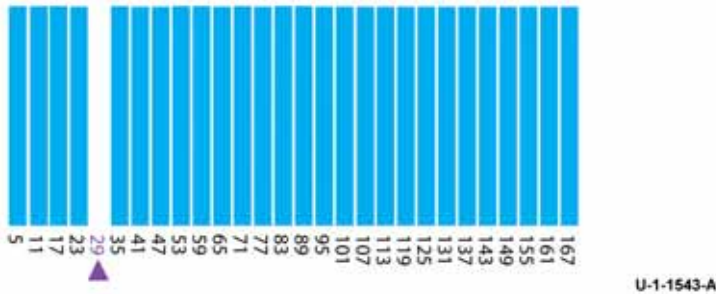

Figure 3 Missing jet number

- **Chronic Jets**

Chronic jets may be visible on the jet test pages as white space where the coloured bar for the jet should be. If the machine detects a missing jet but is unable to retrieve it with maintenance or corrective action the missing jet is designated as chronic. The jet number will be red with a red pointer indication beneath the jet number, [Figure 4](#).

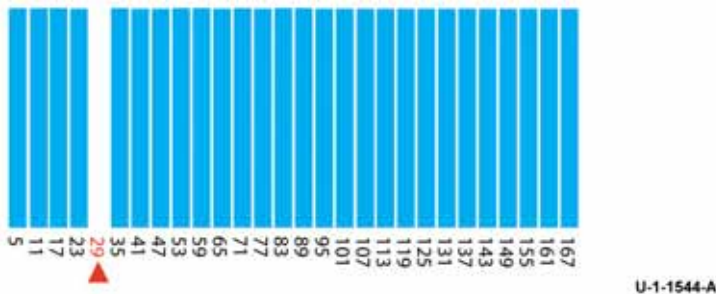

Figure 4 Chronic jet number

- **Masked Jets** ([GP 30](#) How to Mask Jets/Jet Substitution)

Masked jets may be visible on the jet test pages as white space where the coloured bar for the jet should be. Problem jets identified by the customer but not by the machine, which cannot be revived, can be masked manually. Once masked, the jet number will be green with a green pointer indication beneath the jet number, [Figure 5](#).

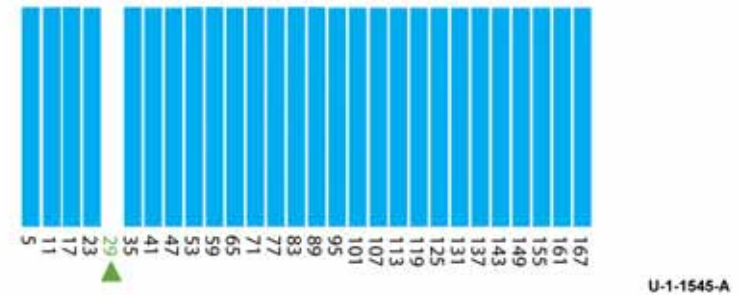
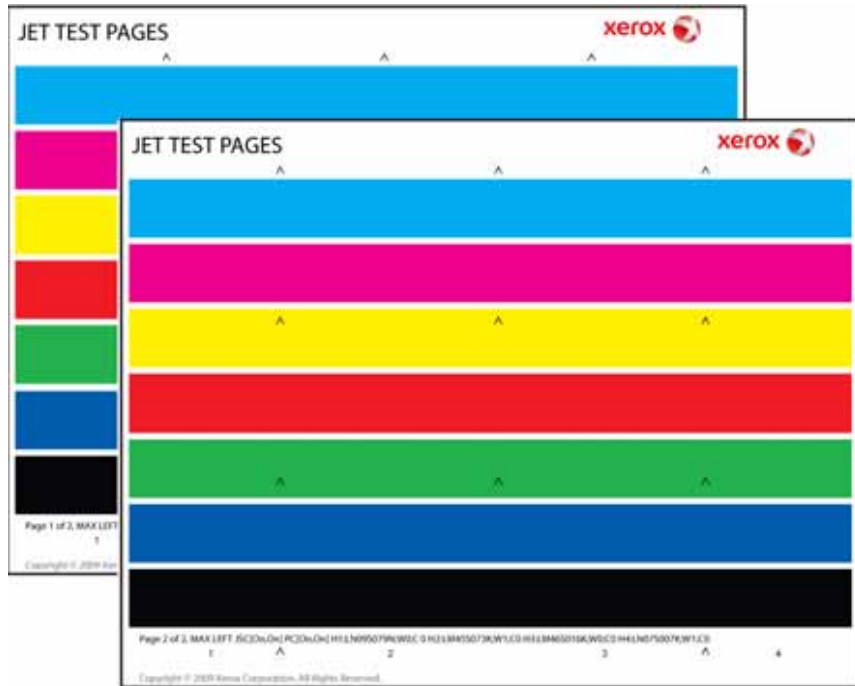

Figure 5 Masked jet number

Customer Jet Test Pages

NOTE: Information on the customer jet test pages is included here for completeness. Customer jet test pages are not used for fault isolation.

The customer jet test pages, shown in [Figure 6](#), are located in Fix Image Quality and available for customers to use when diagnosing print quality problems. [Figure 7](#) shows how the customer jet test pages includes jet status information for each print head and the current status of jet substitution. The customer jet test pages use jet substitution if enabled.



U-1-1096-A

Figure 6 Customer version of the jet test pages

Figure 7 shows the customer version of the jet test page. This version also prints long-edge feed with the default source being tray 3. The image portion of the print is intended to show the customer effective print quality with current jet substitution settings. The IOD can miss weak jets, that is why the customer needs this print to provide a tool when the machine has not self corrected. If the customer is not happy with these defects the light lines options in Fix Image Quality window provides tools to do both an align and a purge, which should fix the problems. This page helps customer service (or a customer) correct issues the machine cannot.

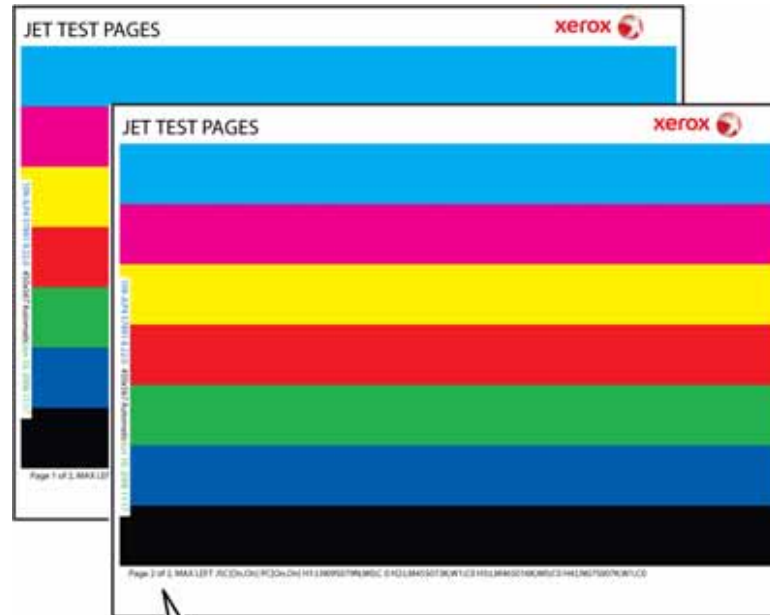

U-1-1087-A

Figure 7 Jet status information, customer page

The text at the bottom of the customer version, [Figure 7](#), provides the following:

- Max left/right: Indicates shift position in relation to the drum. Shifting involves all the jets in the imaging process.
- JSC[On,On]: indicates jet substitution is enabled (On) for both customer and machine settings. The machine may override the customer setting temporarily if the Quick Light Lines fix has been selected from the Tools/Fix Image Quality menu. After the next purge or machine reboot, the settings revert to customer settings. When jet sub is enabled, print speed slows down only when a jet is missing and is required for the current print.
- PC[On,On]: means the purge configuration is set to purge at night/when idle for both customer setting and machine setting. Same override rule applies. The purge here is jet fix purge that will only occur if the machine needs to auto recover an intermittent, weak, or missing jet.
- This info is followed by each print head serial number and the total number of IWMs (intermittently weak or missing jet) or CWMs (continuously weak or missing jet) for each print head as defined by the IOD information. Manually masked jets are identified after chronic jets.
 - W (weak) indicates the number of detected missing jets that have not been labelled as chronic.
 - C (chronic) indicates the number of missing jets that have been purged 3 times, including a cool down/melt cycle (to power the machine off and allow to cool down) for models 9302 and 9303.
 - M (masked) indicates the number of missing jets for which jet substitution is enabled either manually or by the machine.

For instance:

- H4:<serial number>; W2;C0;M1
describes
- Print head number 4:<serial number> has 2 weak jets, no chronic jets and one manually masked jet

TP 22 Cleaning Pages

The two-sheet cleaning page, [Figure 1](#), prints following a purge from [dC968](#) to clear the jets of any ink discoloration. The cleaning page must print long-edge feed on A4 or 8.5 x 11 inch media. Tray 3 is the default source.

Cleaning pages are printed from [dC968](#).

NOTE: All test prints should be printed on A4 or 8.5 x 11 inch plain paper and long edge feed. Use the best quality media available. Do not use hole punched paper.

NOTE: If the machine detects a paper jam when printing cleaning pages, the machine may automatically recover and purge the sheet. This will result in the cleaning page being printed on multiple sheets.

Purpose

The cleaning page flushes the jet nozzles of possible contamination or colour contaminated jets. The first sheet cleans print heads 2 and 4 on the upper carriage. The second sheet cleans print heads 1 and 3 on the lower carriage. Three sets of prints typically clear any ink mixing or discoloration associated with print head maintenance.

To solve image quality problems related to ink discoloration, refer to [IQ 14](#).

NOTE: Do not use the cleaning pages to evaluate image quality.

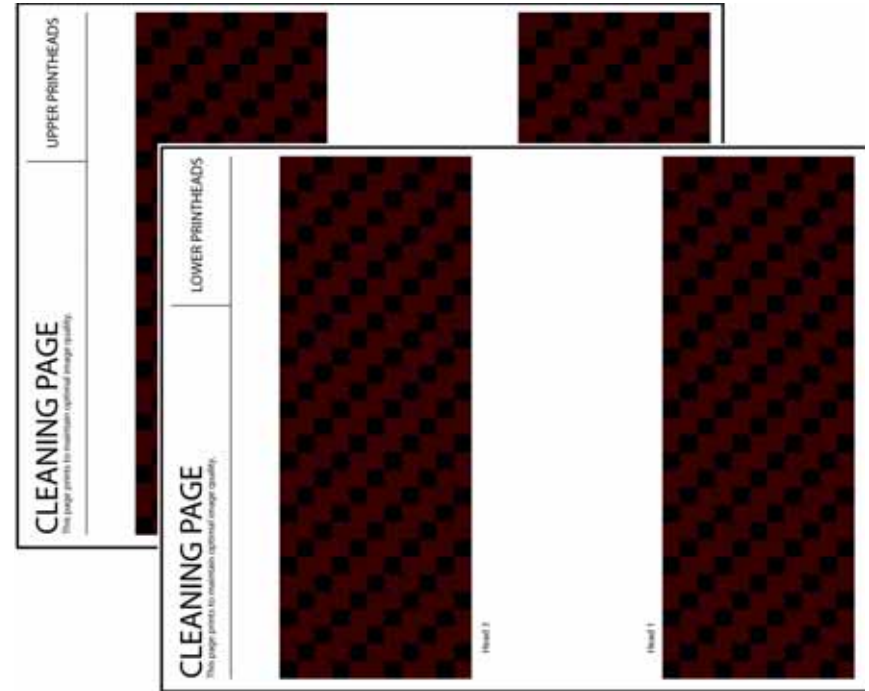

U-1-1383-A

Figure 1 Cleaning pages

TP 23 Drum Run Out and Y-Stitch Test Pages

Figure 1 shows the drum run out test pages without the defect on the horizontal lines. The two-page drum run out test print provides visual indication on the success or failure of drum run out and Y-stitch calibrations. Two pages of horizontal lines are printed to cover the entire drum. The print order is marked in the upper left corner (P1 and P2).

NOTE: Before printing this test page, ensure that A4 or 8.5 x 11 inch plain paper is loaded long edge feed into tray 4. Use the best quality media available. Do not use hole punched paper.

NOTE: When the paper selected for the test print pages is correct, the test pages will be printed with annotations on the bottom edge confirming the test print name. Double chevrons will be printed if the paper used is A4. The chevrons indicate the stitch position between print heads.

Drum run out and Y-stitch test pages are printed from dC977.

Purpose

To provide a visual indication of drum run out and Y-stitch accuracy.

To solve image quality problems related to drum run out and y-stitch errors, refer to IQ 5.



U-1-1112-A

Figure 1 Drum run out and Y-stitch pages

TP 24 Registration Calibration Page

This print is generated by **dC625** to calibrate the registration/preheat assembly. Calibration procedure requires A4 or 8.5 x 11 inch media.

NOTE: All test prints should be printed on A4 or 8.5 x 11 inch plain paper and long edge feed. Use the best quality media available. Do not use hole punched paper.

The registration calibration page is printed from **dC625**.

Purpose

Figure 1, serves as a target image for calibration of the registration/preheat assembly. Ten sheets are printed for each of the three stances of the registration/preheat assembly. The images are fed back through the duplex path and scanned by the registration sensor. Values for process, cross-process, and skew are calculated and stored in NVM.

To solve image quality problems related to registration calibration, refer to **IQ 8** Cross Process Ink Artifacts (Smudge) RAP and **IQ 10** Incorrect Margin, Misregistration or Skew RAP.



U-1-1048-A

Figure 1 Registration calibration page

TP 25 IME Test Print

This test print isolates the IME from other system issues. The image is a simple pattern of coloured bars as shown in Figure 1. The image includes primary colour bars printed by all four print heads. Image size is the width and length of the media less the 4.3 mm (0.017 inch) margins. The tray selection is from tray 1 or 2 and prints on A4 or 8.5 x 11 inch media only.



R-1-1119-A

Figure 1 IME Test Print

The print is produced simplex with a 600 x 600 resolution. Print orientation (LEF vs. SEF) is determined by how the selected tray is loaded. The tray is selected automatically based upon the same priority system used to select a chase source. An error is noted if none of the trays contain valid media. If a finisher is installed, the sheet is sent to the catch tray on the finisher.

Status Indication

- There is a set of LED's on the front of the IME controller PWB (front of machine), the red LED is the IME error LED, the green LED is the IME OK LED. Refer to OF 16 POST Error RAP.
- There is a set of LED's on the rear of the media path driver PWB (rear of machine), the red LED is the IME error LED, the green LED is the IME OK LED. Refer to OF 16 POST Error RAP.

- The front and rear LED's give the same information.
- There is a 7-segment LED display unit on the rear of the machine attached to the SBC PWB. The LED display should show just a pulsing decimal point when IME test print is being produced. Refer to OF 16 POST Error RAP.

Procedure

Check that either A4 or 8.5 x 11 inch size media is loaded in tray 1 or tray 2. Also check that ink and the other printing prerequisites are met. Print the IME test print using these steps:

NOTE: All test prints should be printed on A4 or 8.5 x 11 inch plain paper. Use the best quality media available. Do not use hole punched paper.

1. Turn the machine off, GP 14.
2. Open the mid left door, PL 70.30 Item 16.
3. Remove the waste tray.
4. Insert an interlock cheater in the front door interlock.
5. Turn the machine on, GP 14.

During power-up, the IME checks for the combination of waste tray and left side door sensors that activates the test print mode. PEST does not run in this mode.

The red IME error LED begins a repeating series of three blinks with a slight pause between (111, 111, 111). This sequence indicates IME test print mode is detected.

6. Close the left side door and install the waste tray. The red IME Error LED turns off and the green IME OK LED begins a sequence of three blinks. This indicates the IME is in test print mode. The IME generates the print as soon as the thermals come up to temperature and any errors are resolved.

NOTE: The red IME Error LEDs blink an error code if the IME determines it is unable to continue (e.g. out of media or ink). After printing the IME test page, the machine reboots to customer mode.

Errors and status are reported by blinking the status LED's (IME OK and IME Error LED).

- In the absence of a fault the green IME OK LED flashes in groups of three to indicate normal test print mode.
- During normal test print mode, the red IME error LED is turned Off.
- When an error is detected, the red IME error LED flashes an error code and the green IME OK LED remains Off.

For example, an error code of 124 is indicated on the red IME error LED by one flash followed by a brief pause, followed by two flashes and another brief pause, followed by four flashes followed by a longer pause. Between each sequence, the LED flutters to indicate the sequence is repeating.

Three results may occur:

- **111** indicates to close the door and replace the waste tray to proceed with the test print. The close cover result is flashed to indicate test print mode is detected. Replace the waste tray and close the left side door. When these actions are completed, the IME Error LED turns Off, and the IME OK LED flashes the three short flashes followed by a pause.

- **123** indicates a media resource error. Load the proper media or other needed items (ink, cleaning unit, etc.). This error can occur during warm-up if the drum is dirty. A resource error detected during warm-up may require larger than the A4 or 8.5 x 11 inch media in order to clean the drum. In this case, load A4 or 8.5 x 11 inch size media in tray 1 or 2 or the resource error will return when the printer checks for available media.
- **124** indicates a test print creation error. Install the waste tray, close the doors, and reboot to run PEST (Print Engine Self Test [dC123](#)). This error usually indicates insufficient memory and should not occur normally, but if detected, may indicate a hardware fault. PEST should indicate any IME issues preventing printing.

TP 26 Print Head Uniformity/Colour Bands Test Page

This A4 (8.5 x 11 inch) page has seven solid fill bars of colours, yellow, magenta, cyan, black, red, green and blue.

The print head uniformity/colour bands test page is printed from [dC972](#), option 3.

NOTE: Before printing this test page, ensure that A4 or 8.5 x 11 inch plain paper is loaded long edge feed into tray 4. Use the best quality media available. Do not use hole punched paper.

NOTE: When the paper selected for the test print pages is correct, the test pages will be printed with annotations on the bottom edge confirming the name of the test print. Double chevrons will be printed if the paper used is A4. The chevrons indicate the stitch position between print heads.

Purpose

The print head uniformity test page, [Figure 1](#) is used to diagnose image quality issues related to colour uniformity in solid fills.

To solve image quality problems associated with print head uniformity, refer to [IQ 13](#), [IQ 14](#) and [IQ 15](#).



U-1-1033-4

Figure 1 Print head uniformity/colour bands test page

IQS 1 Registration and Skew

Image Registration

Table 1 lists the registration specifications of the DADH, IIT and IOT.

Table 1 Registration Specifications

Registration	Document Glass	DADH	Print IOT	Document Glass Scan IIT	DADH Scan IIT
Process direction	± 2.1 mm	± 2.6 mm	± 2.0 mm	± 0.7 mm	± 1.7 mm
Cross-process	± 2.6 mm	± 4.1 mm	± 2.5 mm	± 0.7 mm	± 3.2 mm

Skew

To measure skew use this formula, Figure 1.

Skew (mrads) = Leading edge margin at rear corner (1) minus leading edge margin at front corner (2) divided by (media width - 8.6 mm) multiplied by 1000.

Refer to Table 2 for the skew specifications in mrads.

Table 2 Skew Specifications (mrads)

	Document Glass	DADH	Print IOT	Document Glass Scan IIT	DADH Scan IIT
Skew specification	± 6.2 mrad	± 9.0 mrad	± 5.4 mrad	± 3.1 mrad	± 7.2 mrad

- Skew for envelopes will exceed the limits stated.
- Skew for A5 / 8.5 x 5.5 shall be +/- 10 mrads.

Table 3 lists the skew specifications (mm) for the standard paper sizes.

Table 3 Skew Specifications (mm)

Media	Media Size (mm)	Document Glass	DADH	Print IOT	Document Glass Scan IIT	DADH Scan IIT
A4 long edge	297 mm	± 1.79 mm	± 2.6 mm	± 1.56 mm	± 0.89 mm	± 2.8 mm
A4 short edge	210 mm	± 1.25 mm	± 1.81 mm	± 1.09 mm	± 0.62 mm	± 1.45 mm
8.5 x 11 inch long edge	279 mm	± 1.68 mm	± 2.43 mm	± 1.46 mm	± 0.84 mm	± 1.95 mm
8.5 x 11 inch short edge	216 mm	± 1.29 mm	± 1.87 mm	± 1.12 mm	± 0.64mm	± 1.49 mm

NOTE: The measurement for skew and margin for Side 1 and Side 2 may not match

Margins

Refer to Figure 1. Process direction margin is measured on the leading edge at the center (3). Cross-process margin is measured on the rear edge near the leading edge corner (4).

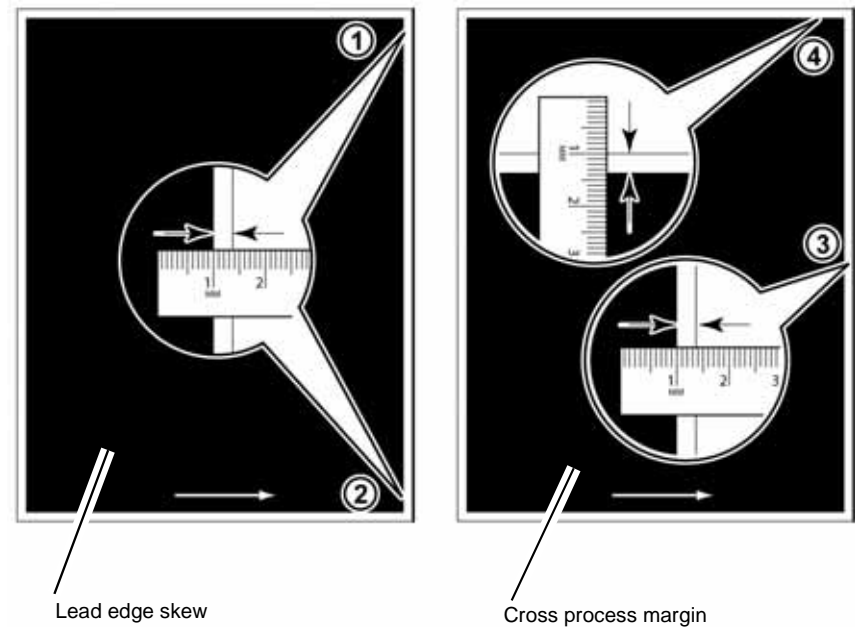

Figure 1 Skew and margin measurement

U-1-1385-A

IQS 2 Image Area

Image Area

Guaranteed image area is the maximum area over which IQ specifications are valid.

Refer to [Table 1](#) and [Figure 1](#).

Table 1 Image Area Specifications

Characteristic	Specification
Maximum image area	448.6 mm (17.6 inches) (process) x 300.3 mm (11.8 inches) (cross-process)
Minimum image area	210 mm (8.2 inches) (process) x 104 mm (4 inches) (cross-process)
Guaranteed image area	448.6 mm (17.6 inches) (process) x 298.648 mm (11.7 inches) (cross-process)
Resolution/gradation	Fast colour: 300 x 300 dpi Standard: 450 x 567 dpi Enhanced: 600 x 600 dpi (Image processing at 600 x 2400) Photo / Hi Res: 525 x 1200 dpi

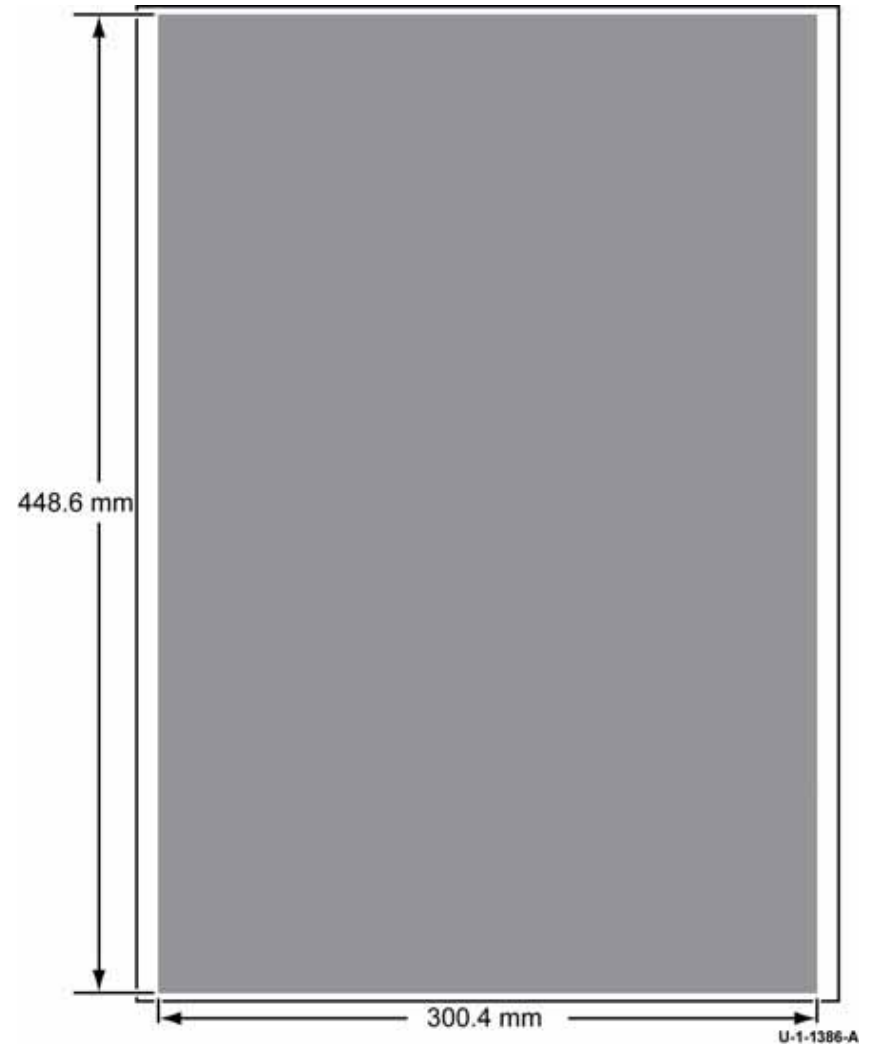

Figure 1 Maximum image area

IQS 3 Y-Dot Position

Specification

Figure 1, shows a level of position error that provides a basis for determining defect severity. If Y-dot position error exceeds Figure 1, corrective action is necessary. Refer to IQ 5.

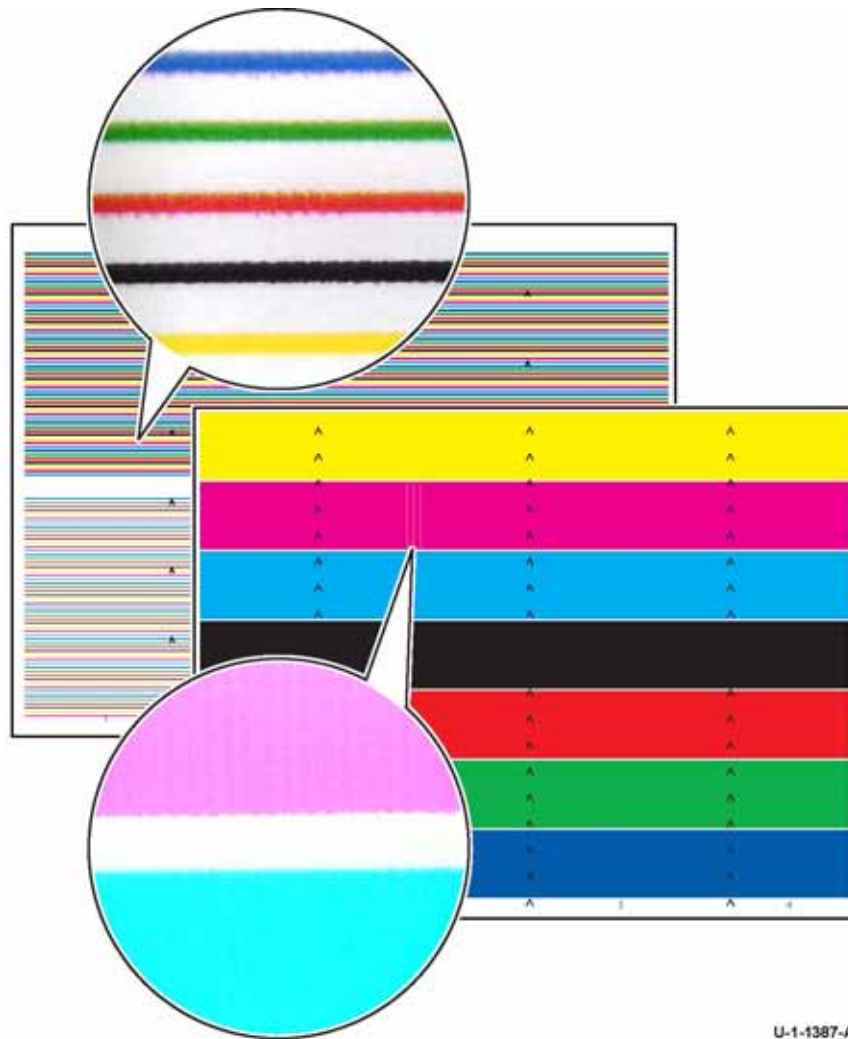

Figure 1 Maximum specified Y-dot misplacement

IQS 4 Y-Stitch

Specification

Figure 1 shows a level of y-stitch error that provides a basis for determining defect severity. If Y-stitch error exceeds Figure 1, corrective action is necessary.

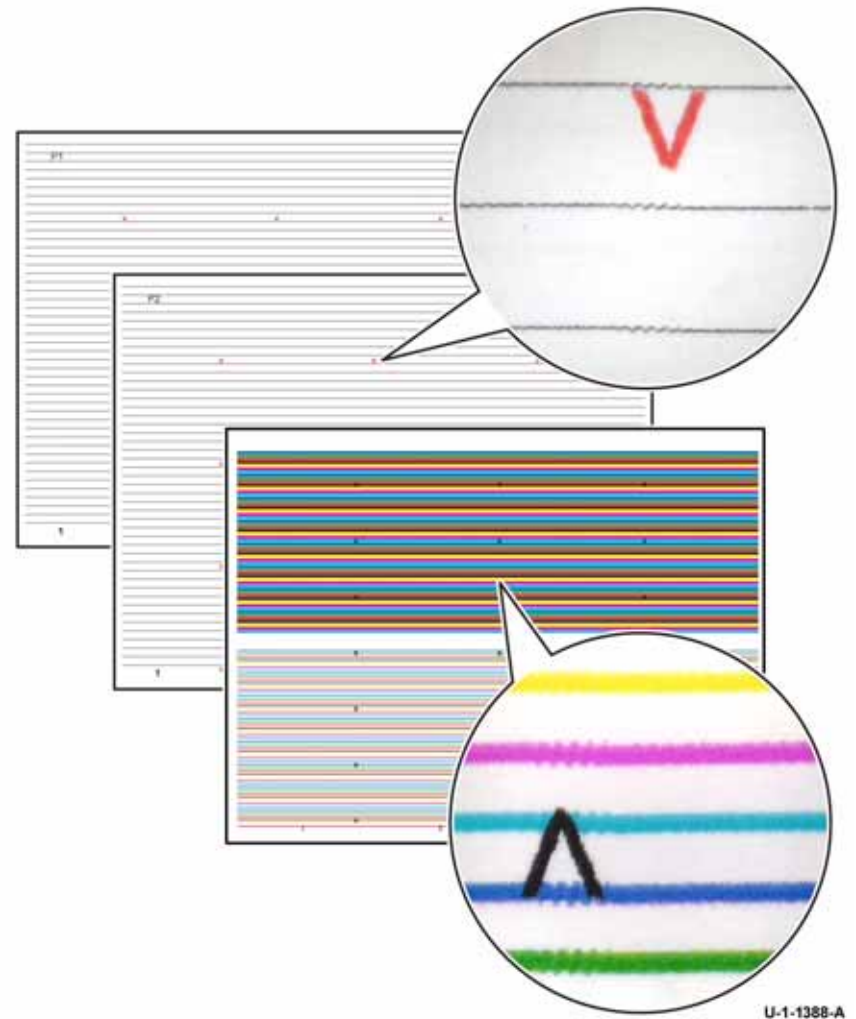

Figure 1 Maximum specified Y-stitch error

IQS 5 X-Stitch

Specification

Figure 1 shows a level of X-stitch error that provides a basis for determining defect severity. If X-stitch error exceeds Figure 1, corrective action is necessary.

NOTE: The x-stitch print is made up of an interference pattern. The degree of an x-stitch issue is highly exaggerated on this print. The actual x-stitch error will appear less pronounced on a customer image. If in doubt about the severity of an x-stitch issue print a customer image to determine if it is visible.

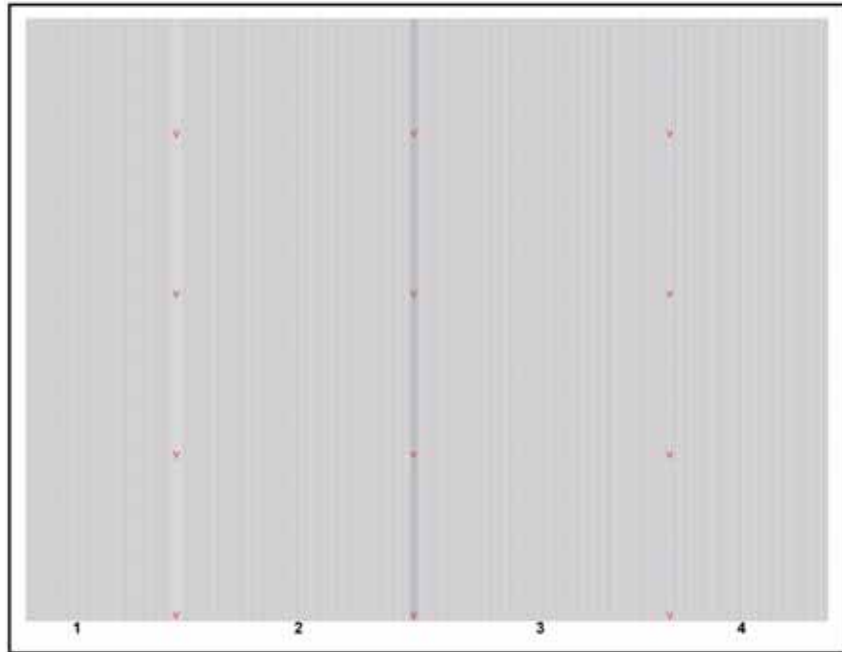

U-1-1389-A

Figure 1 Acceptable X-stitch example

IQS 6 Blurry Text

Specification

Figure 1 shows a level of blurry text error that provides a basis for determining defect severity. If the capital F in line D2 exceeds Figure 1, corrective action is necessary. Refer to IQ 5.

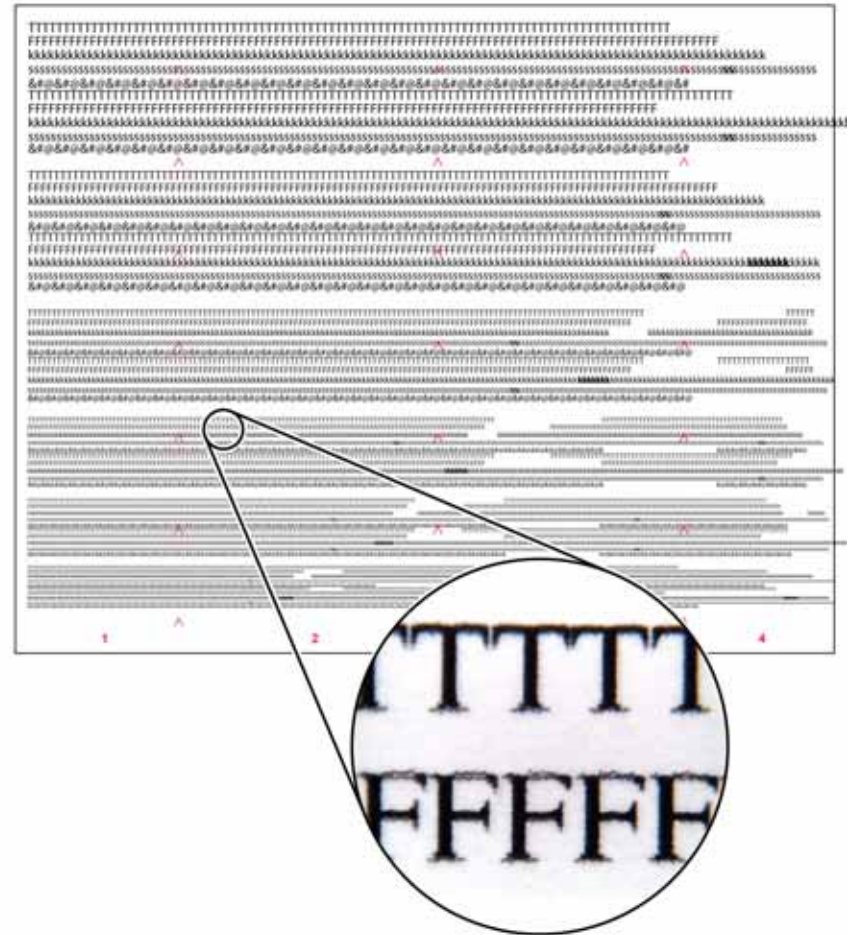

U-1-1121-A

Figure 1 Blurry text on TP 12

IQS 7 Curl

Media Curl

All modules shall handle flat curl of ± 12 mm in both process and cross process direction in input and output without degradation in performance. Degraded performance (e.g. increased jams, reduced tray capacity) can be expected for curl greater than ± 12 mm.

NOTE: Curl is expected to increase above 12 mm when printing very high area coverage (whole page), especially for duplex and paperweights below 80 gsm, or when using specific papers and / or paper batches with internal tension.

Curl is assessed as follows: Run 5 sheets of prints with less than 50% area coverage. Place the set on a flat surface so that the set curls upwards. Measure the height of each corner after minimum 15 seconds and maximum 1 minute from the output of the final sheet. No corner should exceed the 12 mm specification in 99.7% of the measurements.

IQS 8 Uniformity in the Process Direction

Specification

Figure 1 shows the cyan / magenta and the colour bands print that is printed out in TP 1. No distinct non-uniformity bands in the process direction should be observed on these prints. Refer to IQ 13 and IQ 14.

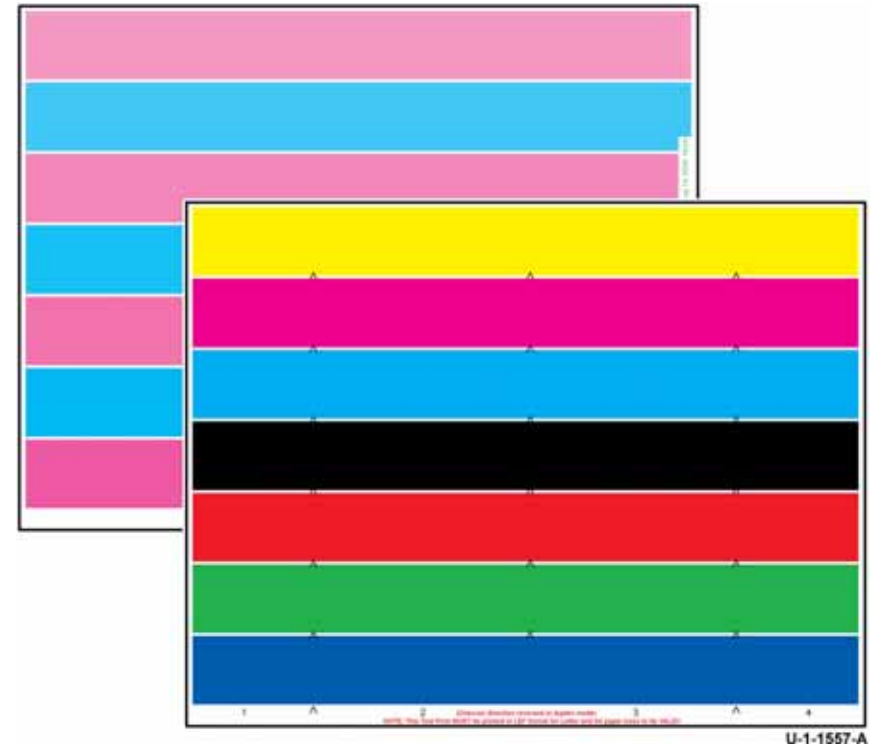

Figure 1 Uniformity test print

4 Repairs/Adjustments

REPs 1 - Standby Power

REP 1.1 Wiring Harness Repairs.....	4-5
REP 1.2 Molex SL Connectors	4-6
REP 1.3 Male Hirose DF1B Connectors	4-8
REP 1.4 AMP EI Connectors	4-10
REP 1.5 Hirose DF11 Connectors	4-12
REP 1.6 AMP CT Connectors.....	4-13
REP 1.7 Molex Mini-Fit Junior Connectors	4-14
REP 1.8 Front Door Interlock Switch	4-16
REP 1.9 Power Supply Unit	4-16

REPs 2 - User Interface

REP 2.1 User Interface Assembly.....	4-19
REP 2.2 User Interface Touch Screen.....	4-21
REP 2.3 User Interface PWB	4-22

REPs 3 - Machine Run Control

REP 3.1 IME Controller PWB.....	4-23
REP 3.2 Quad Wave Amp PWB	4-24
REP 3.3 Marking Unit Heater PWB.....	4-25
REP 3.4 Marking Unit Driver PWB.....	4-26
REP 3.5 Media Path Driver PWB	4-27
REP 3.6 Drum Driver PWB	4-28
REP 3.7 Single Board Controller PWB	4-29
REP 3.8 Hard Disk Drive.....	4-30
REP 3.9 NVM Module PWB and Battery	4-31

REPs 5 - DADH

REP 5.1 Top Cover Assembly	4-33
REP 5.2 Top Access Cover Assembly.....	4-34
REP 5.3 Feed Assembly	4-35
REP 5.4 Input Tray Assembly	4-36
REP 5.5 Baffle Assembly	4-37
REP 5.6 Takeaway Roll Assembly.....	4-39
REP 5.7 Duplex Solenoid.....	4-40
REP 5.8 Takeaway and CVT Sensor.....	4-42
REP 5.9 DADH Tray Size Sensors	4-43
REP 5.10 Registration Sensor	4-43
REP 5.11 Exit Sensor	4-44
REP 5.12 DADH Counterbalance	4-46
REP 5.13 Exit Roll Assembly	4-46
REP 5.14 Feed Roll Assembly.....	4-47
REP 5.15 Duplex Gate, CVT Roll and CVT Motor, Drive Belt	4-48
REP 5.16 Document Width Sensor.....	4-50
REP 5.17 Input Tray Static Eliminator.....	4-51
REP 5.18 Exit Roll Idler.....	4-52
REP 5.19 DADH Removal	4-53
REP 5.20 Mylar Guide Strip	4-54

REPs 10 - Transfix and Copy/Print Transportation

REP 10.1 Transfix Roller.....	4-55
REP 10.2 Front Transfix Linkage and Gear Kit.....	4-56
REP 10.3 Rear Transfix Linkage and Gear Kit.....	4-59
REP 10.4 Front Transfix Motor.....	4-63
REP 10.5 Rear Transfix Motor	4-63
REP 10.6 Transfix Blade.....	4-64
REP 10.7 Pre Transfix Sensor	4-65
REP 10.8 Post Transfix Motor (M4) and Gearbox.....	4-67
REP 10.9 Stripper Solenoid Assembly.....	4-68
REP 10.10 Roller Drive J	4-69
REP 10.11 Roller Drive L	4-71
REP 10.12 Exit / Duplex Solenoid.....	4-73
REP 10.13 Diverter Gate.....	4-75
REP 10.14 Exit Motor (M5)	4-77
REP 10.15 Duplex Start Sensor (13)	4-79
REP 10.16 Exit Sensor (15)	4-80
REP 10.17 Roller Nip P.....	4-83
REP 10.18 Roller Nip N.....	4-84
REP 10.19 Exit Illuminator PWB	4-85
REP 10.20 Exit Paper Path	4-86
REP 10.21 Stripper Blade, Gate and Baffle	4-88
REP 10.22 Upper Baffle.....	4-91
REP 10.23 Stripper Guide Latch Cam Shaft.....	4-92
REP 10.24 Front and Rear Flexure Encoder	4-94

REPs 12-110 - LCSS

REP 12.1-110 LCSS Covers.....	4-95
REP 12.2-110 Input Drive Belt and Paper Entry Transport Motor.....	4-96
REP 12.3-110 Intermediate Paper Drive Belt.....	4-97
REP 12.4-110 Paper Output Drive Belt and Transport Motor 2	4-98
REP 12.5-110 Bin 1 Drive Belts	4-99
REP 12.6-110 Tamper Assembly.....	4-102
REP 12.7-110 Hole Punch Unit, Motor and Sensors	4-103
REP 12.8-110 Stapler Traverse Assembly.....	4-105
REP 12.9-110 Staple Head Unit.....	4-106
REP 12.10-110 Ejector Assembly Sensors.....	4-107
REP 12.11-110 Bin 1 Upper Level Sensor	4-109
REP 12.12-110 Paddle Wheel Shaft Assembly	4-110
REP 12.13-110 LCSS Un-Docking.....	4-113
REP 12.14-110 LCSS PWB	4-114
REP 12.15-110 Entry Guide Cover	4-114
REP 12.16-110 Docking Latch Assembly	4-116
REP 12.17-110 Ejector Belt	4-117
REP 12.18-110 Paddles.....	4-118

REPs 12-171 - HVF

REP 12.1-171 HVF Covers	4-119
-------------------------------	-------

REP 12.2-171 HVF Stapler Assembly	4-122	REP 12.55-171 HVF PSU Assembly.....	4-189
REP 12.3-171 Top Tray	4-124	REP 12.56-171 BM Right Hand Cover.....	4-190
REP 12.4-171 Bin 1 Removal	4-125	REP 12.57-171 HVF Main PWB.....	4-191
REP 12.5-171 Right Side-Cover Removal	4-126	REP 12.58-171 Not Used.....	4-192
REP 12.6-171 HVF Ejector Assembly.....	4-127	REP 12.59-171 Crease Roll Gate Assembly.....	4-192
REP 12.7-171 Pressing Plate Fingers	4-129	REP 12.60-171 BM Paper Guide Assembly.....	4-195
REP 12.8-171 Front and Rear Support Fingers	4-129	REP 12.61-171 BM Module.....	4-198
REP 12.10-171 Stacker Idler Rolls	4-130	REP 12.62-171 BM Slide Assembly.....	4-203
REP 12.11-171 Front Tamper Motor Assembly	4-131	REP 12.63-171 Transport Motor 1	4-206
REP 12.12-171 Bin 1 Elevator Motor Assembly	4-132	REP 12.64-171 Bypass Feed Motor.....	4-206
REP 12.13-171 HVF/HVF BM Un-Docking	4-133	REP 12.65-171 Buffer Motor	4-207
REP 12.14-171 HVF Upper Exit Guide (5c).....	4-134	REP 12.66-171 Transport Motor 2	4-207
REP 12.15-171 HVF Rear Tamper Assembly.....	4-135	REP 12.67-171 Tri Folder Covers	4-208
REP 12.16-171 BM Flapper	4-137	REP 12.68-171 Tri-Folder Drive Assembly	4-209
REP 12.17-171 BM PWB.....	4-138	REP 12.69-171 Tri Folder Crease Roll Drive Assembly.....	4-212
REP 12.18-171 BM Crease Blade Motor	4-140	REP 12.70-171 Tri-Folder Feed Roller and Drive Belt.....	4-213
REP 12.19-171 BM Crease Roll Motor	4-142	REP 12.71-171 TF Assist Gate Solenoid.....	4-213
REP 12.20-171 BM Backstop Motor Assembly.....	4-144	REP 12.72-171 Tri Folder Crease Roll Springs	4-214
REP 12.21-171 BM Backstop Assembly.....	4-145	REP 12.73-171 Tri Folder Top Cover and Idler Assemblies	4-214
REP 12.22-171 BM Entry Roll.....	4-147	REP 12.74-171 Tri Folder Roller Assembly and Diverter Solenoid.....	4-215
REP 12.23-171 BM Entry Sensor	4-148	REP 12.75-171 Bin 1 Limit Switches.....	4-217
REP 12.24-171 BM Crease Roll Gate Motor	4-150	REP 12.76-171 Bin 1 Upper Level Sensor.....	4-218
REP 12.25-171 BM Compiler Motor and BM Flapper Motor.....	4-150	REP 12.77-171 Tri Folder Door Interlock Switches and Sensor	4-218
REP 12.26-171 Back Stop Drive Assembly	4-151	REP 12.78-171 Tri Folder Entry and Assist Gate Sensors	4-219
REP 12.27-171 BM Staple Heads.....	4-153	REP 12.79-171 Tri Folder Exit Sensor.....	4-219
REP 12.28-171 BM Stapler Bracket Assembly	4-155	REP 12.80-171 Tri Folder PWB	4-220
REP 12.29-171 BM Conveyor Belts.....	4-159	REP 12.81-171 Tri Folder Main and Bin 2 Tray Harnesses	4-221
REP 12.30-171 BM Tamper Assembly and Tamper 1 Motor.....	4-161	REP 12.82-171 Inserter Undocking.....	4-222
REP 12.31-171 HVF Buffer Guide Assembly.....	4-163	REP 12.83-171 Inserter Front and Rear Covers	4-223
REP 12.32-171 HVF Input Jam Clearance Guide.....	4-164	REP 12.84-171 Inserter Motor	4-223
REP 12.33-171 Buffer Pocket Jam Clearance Guide Assembly.....	4-165	REP 12.85-171 Inserter PWB	4-224
REP 12.34-171 Inserter Jam Clearance Guide Assembly	4-166	REP 12.86-171 Inserter Clutch	4-225
REP 12.35-171 Diverter Exit Gate	4-166	REP 12.87-171 Inserter Top Cover Interlock Switch.....	4-226
REP 12.36-171 Crease Blade Assembly	4-167	REP 12.88-171 Inserter Jam Cover Interlock Switch.....	4-226
REP 12.37-171 Stacker Driving Shaft Bearings.....	4-170	REP 12.89-171 Main Tray and Paper Length Sensors.....	4-227
REP 12.38-171 HVF Stacker Driving Belts	4-171	REP 12.90-171 Bottom Tray and Paper Sensors	4-228
REP 12.39-171 HVF BM Diverter Gate.....	4-172	REP 12.91-171 Inserter Top Cover and Inserter Pickup Sensor	4-229
REP 12.40-171 HVF Input Roll	4-173	REP 12.92-171 Lower Jam Cover and Acceleration Sensor	4-229
REP 12.41-171 HVF Inserter Guide Roll	4-174	REP 12.93-171 Inserter LE and TE Sensors	4-230
REP 12.42-171 HVF Buffer Pocket Roll.....	4-175	REP 12.94-171 Inserter Bottom Plate Sensor.....	4-231
REP 12.43-171 HVF Booklet Entrance Roll.....	4-176	REP 12.95-171 Inserter Pickup Assembly and Reverse Feed Roller	4-231
REP 12.44-171 HVF Buffer Lower Roll.....	4-177	REP 12.96-171 HVF Fixed and Adjustable Casters.....	4-232
REP 12.45-171 HVF Buffer Upper Roll.....	4-178	REP 12.97-171 Pause To Unload PWB Assembly	4-234
REP 12.46-171 HVF Stacker Exit Feed Roll.....	4-179	REP 12.98-171 Inserter Idle Roller Assembly.....	4-234
REP 12.47-171 HVF Top Exit Feed Roll.....	4-180	REP 12.99-171 Tri-Folder Removal	4-236
REP 12.48-171 Compiler Paddle Motor Assembly	4-182	REP 12.100-171 Ejector Paddle Assembly (W/TAG V-004).....	4-237
REP 12.49-171 Compiler Paddle Unit.....	4-183	REP 12.101-171 Paddle Wheel	4-238
REP 12.50-171 BM Exit Sensor.....	4-184		
REP 12.51-171 Compiler Paper Pusher Motor Assembly	4-185	REPs 62- Scanner	
REP 12.52-171 BM Crease Rolls.....	4-185	REP 62.1 Scanner Module.....	4-239
REP 12.53-171 Compiler Paper Pusher	4-188	REP 62.2 Top Cover	4-242
REP 12.54-171 Pusher Upper and Lower Sensors	4-189	REP 62.3 CVT Glass, CVT Ramp and Document Glass Assembly.....	4-242

REP 62.4 Scan Carriage Home Sensor	4-243	REP 82.4 Tray 3 Horizontal Transport Rolls	4-295
REP 62.5 Scan Carriage Assembly	4-244	REP 82.5 Tray 5 Transport motor	4-297
REP 62.6 Carriage Motor and Mounting	4-246	REP 82.6 Tray 5 Transport Drive Belt	4-298
REP 62.7 Scan Cables	4-247	REP 82.7 Tray 5 Takeaway Roller	4-299
REP 62.8 Scan Drive Belt	4-251	REP 82.8 Confirm Sensor	4-300
REP 62.9 Input Module Angle Sensor	4-252	REP 82.9 Vertical Transport	4-301
REP 62.10 LED Exposure Lamps	4-252	REP 83.1 Horizontal Paper Path	4-303
REP 62.11 Exposure Lamp Ribbon Harness	4-253	REP 83.2 Duplex End Sensor, Nip C Solenoid and HPP Diverter Solenoid	4-304
REP 62.12 Scanner PWB	4-255	REP 83.3 Duplex Sensor (17)	4-305
REP 62.13 Scan Carriage Ribbon Cable	4-256	REP 83.4 Horizontal Transport Motor	4-306
REP 62.14 Document Size Sensor 1 and Document Size Sensor 2	4-256	REP 83.5 Horizontal Transport Drive Belts And Takeaway Rolls	4-307
 REPs 70 to 75 - Paper Supply			
REP 70.1 3 Tray Module PWB	4-257	REP 89.1 Registration / Preheat Assembly and Lower Platelet Assembly	4-308
REP 70.2 Upper Left Hand Door Assembly	4-258	REP 89.2 Registration / Preheat Pumps	4-311
REP 71.1 Tray 1 and Tray 2 Removal	4-258	REP 89.3 Registration / Preheat Assembly Nip A Kit	4-311
REP 71.2 Tray 1 and Tray 2 Paper Guides	4-259	 REPs 91 - Marking Unit	
REP 71.3 Tray 1 and Tray 2 Lift Gear Assembly	4-260	REP 91.1 Carriage Drive Train	4-313
REP 73.1 Tray 3 Removal	4-261	REP 91.2 Vertical Gearbox and Motor	4-314
REP 73.2 Tray 3 Elevator Motor	4-263	REP 91.3 Head Maintenance Wiper	4-316
REP 73.3 Tray 3 Elevator Cables	4-263	REP 91.4 Front and Rear Tensioner Base	4-319
REP 73.4 Tray 3 Stack Height Sensor	4-265	REP 91.5 Head Maintenance Belts and Belt Retainer Clips	4-321
REP 73.5 Tray 3 Home Sensor	4-265	REP 91.6 Head Maintenance Horizontal Motion Motor	4-322
REP 73.6 Tray 3 Elevator Damper and Gears	4-266	REP 91.7 Marking Unit Upper Carriage	4-323
REP 75.1 Tray 5 Empty Sensor	4-267	REP 91.8 Upper Carriage Drive Shaft, Cranks, Upper Front and Rear Compliant Links	4-326
REP 75.2 Tray 5 Stack Height Sensor	4-268	REP 91.9 X Axis Drive Motor	4-327
REP 75.3 Tray 5 Down Sensor	4-269	REP 91.10 Lower Carriage Drive Shaft, Cranks, Lower Front and Rear Compliant Links	4-328
REP 75.4 Tray 5 Elevator Motor Assembly	4-270	REP 91.11 Service Loop	4-329
REP 75.5 Tray 5 Upper Limit Switch	4-271	REP 91.12 Purge Line Filter	4-331
REP 75.6 Tray 5 Down Limit Switch	4-272	REP 91.13 Stitch / Roll Motor	4-332
REP 75.7 Un-docking and Docking Tray 5	4-273	REP 91.14 Marking Unit Lower Carriage	4-333
REP 75.8 Tray 5 Covers	4-275	REP 91.15 Ink Loader Assembly	4-336
REP 75.9 Tray 5 Docking Latch	4-276	REP 91.16 Ink Loader Melt Plate Assembly	4-339
REP 75.10 Tray 5 Elevator Rack Assembly	4-278	REP 91.17 Ink Load Sensor Assembly	4-340
 REPs 81 to 89 - Paper Transport			
REP 81.1 Tray 1 and Tray 2 Paper Feed Assembly	4-281	REP 91.18 Ink Transport Motor and Drive Gear	4-341
REP 81.2 Tray 3 Paper Feed Assembly	4-282	REP 91.19 Ink Low Sensor Assembly	4-342
REP 81.3 Bypass Module	4-283	REP 91.20 Ink Reservoir Assembly	4-343
REP 81.4 Tray 1 and Tray 2 Feed Rolls	4-285	REP 91.21 Reservoir Pump	4-346
REP 81.5 Tray 3 Feed Rolls	4-287	REP 91.22 IOD Assembly	4-347
REP 81.6 Bypass Tray Feed Rolls	4-287	REP 91.23 Front and Rear Track Guide	4-349
REP 81.7 Tray 5 Feed Rollers	4-288	REP 91.24 Drum Drive Motor and Belt	4-351
REP 81.8 Tray 1 or Tray 2 Feed Sensor	4-289	REP 91.25 Drum and Front Drum Frame Assembly	4-353
REP 81.9 Tray 3 Feed Sensor	4-290	REP 91.26 Marking Unit Slide Assembly	4-357
REP 81.10 Bypass Tray Empty Sensor	4-291	REP 91.27 Cleaning Unit Motor Assembly and Home Sensor	4-358
REP 81.11 Tray 5 Feed Sensor	4-291	REP 91.28 Marking Unit Assembly	4-359
REP 81.12 Tray 5 Feed Motor	4-293	REP 91.29 Printhead	4-362
REP 81.13 Nip D Release Solenoid	4-293	REP 91.30 Drum Position Encoder Assembly	4-367
REP 82.1 3 Tray Module Transport Motor	4-294	REP 91.31 Umbilical Assembly	4-368
REP 82.2 3 Tray Module Transport Drive Belt	4-294	REP 91.32 Cleaning Unit Cam Shaft Assembly	4-371
REP 82.3 Tray 3 Horizontal Transport Assembly	4-295	REP 91.33 Cleaning Unit Plug Connector	4-373
		REP 91.34 Drum Pulley	4-374
		REP 91.35 Front and Rear Drum Thermistor	4-376
		REP 91.36 Abatement Plenum	4-377

REPs 94 - Ink Transfer	
REP 94.1 Cleaning Unit	4-379
ADJs 4 - Machine Lubrication	
ADJ 4.1 Machine Lubrication	4-381
ADJs 5 - DADH	
ADJ 5.1 DADH Drive Belt Adjustment.....	4-383
ADJ 5.2 DADH Height Adjustment.....	4-384
ADJ 5.3 DADH Skew Adjustment	4-386
ADJ 5.4 DADH Cleaning Procedure	4-387
ADJ 5.5 DADH Registration Adjustment	4-388
ADJ 5.6 DADH Document Pad	4-388
ADJs 12-110 - LCSS	
ADJ 12.1-110 LCSS Bin 1 Level.....	4-389
ADJ 12.2-110 Machine to LCSS Alignment	4-389
ADJ 12.3-110 Hole Punch Position	4-390
ADJ 12.4-110 Motor Drive Belt Tensioning.....	4-391
ADJs 12-171 - HVF	
ADJ 12.1-171 Machine to HVF / HVF BM, HVF BM to Tri-Folder Alignment.....	4-393
ADJ 12.2-171 Tri-Folder Paper Settings	4-394
ADJ 12.3-171 Stapler Anvil Alignment	4-395
ADJ 12.4-171 Crease Blade Position.....	4-398
ADJ 12.5-171 Booklet Tamping	4-398
ADJ 12.6-171 Booklet Compiling Position	4-400
ADJ 12.7-171 Booklet Crease Position	4-403
ADJ 12.8-171 Booklet Staple Position	4-404
ADJ 12.9-171 Booklet Maker Skew	4-405
ADJ 12.10-171 HVF Motor Drive Belt Tensioning.....	4-406
ADJ 12.11-171 HVF Idler Drive Belt Tensioning.....	4-407
ADJ 12.12-171 Tri-Folder Fold Adjustment.....	4-407
ADJs 62 - Scanner	
ADJ 62.1 Optics Cleaning Procedure	4-409
ADJ 62.2 Scan Carriage Assembly	4-410
ADJ 62.3 Carriage Motor and Scanner Drive Belt	4-411
ADJ 62.4 Document Glass Registration Adjustment.....	4-411
ADJs 73 to 75 - Paper Trays	
ADJ 73.1 Tray 3 Paper Tray Guide Setting.....	4-413
ADJ 75.1 Tray 5 Paper Tray Guide Setting.....	4-415
ADJ 75.2 Tray 5 Module to Machine Alignment.....	4-416
ADJ 75.3 Tray 5 Module Tray Alignment	4-416
ADJs 82 - Paper Transport	
ADJ 82.1 Media Registration Calibration	4-419
ADJs 91 - Marking Unit	
ADJ 91.1 Printhead Attachment Check.....	4-421

REP 1.1 Wiring Harness Repairs

Purpose

WARNING

Switch off the electricity to the machine. Refer to [GP 14](#). Disconnect the power cord from the customer supply while performing tasks that do not need electricity. Electricity can cause death or injury. Moving parts can cause injury.

WARNING

Do not attempt any repairs to the power cord or safety ground harness/conductor.

NOTE: Safety ground connections use green/yellow cables, or green cables with a yellow stripe or band.

The steps that follow identify the relevant procedures for repairing the various connectors contained within the copier.

1. If wiring is damaged, use connector splicing blocks to repair damaged wiring.
2. The following harness assemblies are not repairable; install new parts:
 - Any ribbon harness.
 - Bypass extension harness, [PL 1.15 Item 8](#).
 - Drum driver MR sensor harness, [PL 1.15 Item 9](#).
 - Chassis interlock harness, [PL 1.15 Item 11](#).
 - AC chassis heater harness, [PL 1.15 Item 13](#).
 - Drum driver to front components harness, [PL 1.15 Item 14](#).
 - Drum driver / media path power harness, [PL 1.15 Item 15](#).
 - Engine fan harness, [PL 1.15 Item 16](#).
 - Cleaning unit interface harness, [PL 1.15 Item 17](#).
 - Media path exit / horizontal harness, [PL 1.15 Item 19](#).
 - Transfix roller harness, [PL 1.15 Item 20](#).
 - Media path driver PWB to 3 tray module PWB harness, [PL 1.15 Item 21](#).
 - Mid rail front door switch harness, [PL 1.15 Item 22](#).
 - User interface harness, [PL 2.10 Item 7](#).
 - User interface control PWB to user interface status PWB harness, [PL 2.10 Item 9](#).
 - LCD to PWB harness, [PL 2.10 Item 11](#).
 - Hard disk drive / single board controller PWB harness, [PL 3.11 Item 3](#).
 - PDB to SBC harness (PJ17), [PL 3.11 Item 10](#).
 - Hard disk drive power harness, [PL 3.11 Item 12](#).
 - SBC drawer service loop harness, [PL 3.11 Item 16](#).
 - Foreign device interface harness, [PL 3.11 Item 23](#).
 - Communication/power cable, [PL 5.10 Item 6](#).
 - Power cord, [PL 12.140 Item 4](#).
 - Power communications cable, [PL 12.140 Item 7](#).
 - Bin 2 tray harness, [PL 12.205 Item 19](#).
 - BM PWB to tri-folder PWB harness, [PL 12.205 Item 20](#).
 - LED lamp ribbon harness, [PL 62.15 Item 5](#).
 - IIT video/SBC PWB harness, [PL 62.16 Item 6](#).

- DADH/IIT power comms harness, [PL 62.16 Item 7](#).
 - Media path driver PWB to Tray 5 PWB harness, [PL 75.68 Item 26](#).
 - Tray 5 elevator harness, [PL 75.70 Item 20](#).
 - Tray 5 elevator motor harness, [PL 81.40 Item 16](#).
 - Tray 5 centre reg interface harness, [PL 81.40 Item 17](#).
 - Upper carriage harness, [PL 91.20 Item 12](#).
 - Lower carriage harness, [PL 91.25 Item 12](#).
3. The following connectors can be repaired by removing the faulty terminals and installing new terminals:
 - Molex SL connectors - [REP 1.2](#).
 - Male Hirose DF 1B connectors - [REP 1.3](#).
 - AMP EI connectors - [REP 1.4](#).
 - Hirose DF11 Connectors - [REP 1.5](#).
 - AMP CT connectors - [REP 1.6](#).
 - Molex mini-fit junior connectors - [REP 1.7](#).

REP 1.2 Molex SL Connectors

Removal

WARNING

Switch off the electricity to the machine. Refer to GP 14. Disconnect the power cord from the customer supply while performing tasks that do not need electricity. Electricity can cause death or injury. Moving parts can cause injury.

NOTE: Molex connectors have small black housings in single and double row form with miniature square section pins and sockets.

1. If the damaged connector is in the centre of a double row housing beneath the latching clip, the latching prong will not be accessible to release the connector from the housing. Therefore it will be necessary to disassemble the housing as shown in Figure 1.

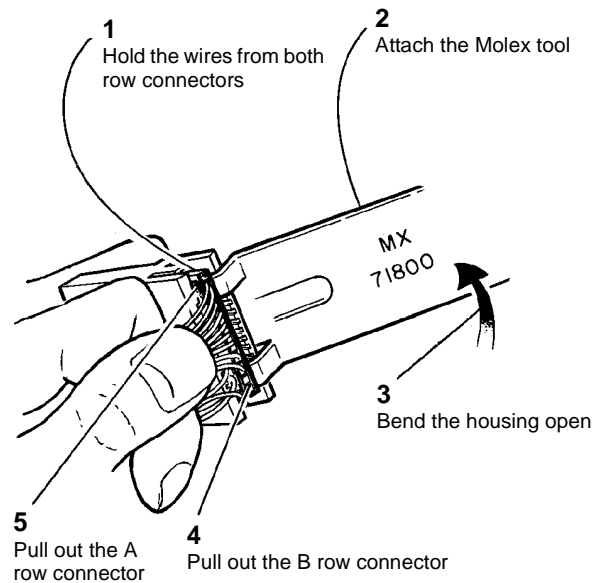

U-1-0659-A

Figure 1 Disassembling the connector.

2. Figure 2. Remove the terminal from the connector housing using the Molex extractor tool.

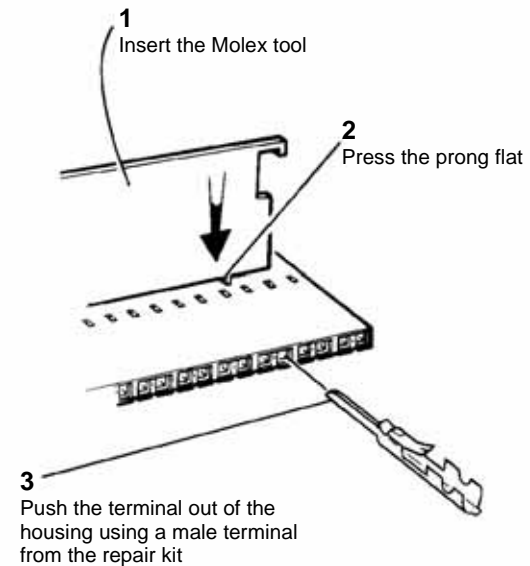

U-1-0194-A

Figure 2 Removing the terminal.

3. Cut off the damaged terminal, then strip 3 mm of insulation from the end of the wire.

Replacement

1. Select the correct replacement terminal, and identify the appropriate crimp positions for the terminal.
2. Figure 3. Insert a male or female terminal into the appropriate position of the crimp tool and close the tool just enough to hold the terminal.

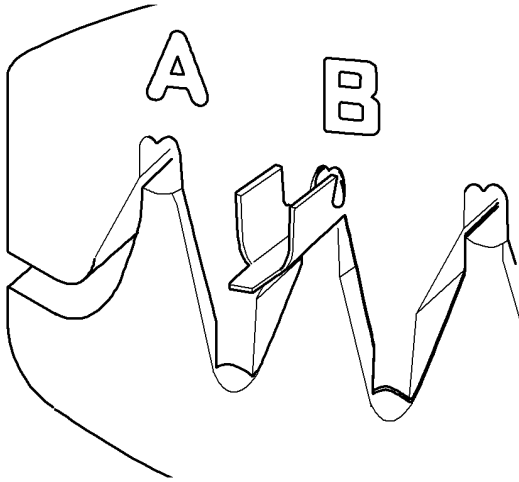

U-1-0195-A

Figure 3 Crimping the terminal.

3. Insert the wire fully into the terminal so that the stripped portion of the wire is within the inner grip of the terminal. Close the crimp tool fully to make the crimp.
4. **Figure 4.** Insert the crimped terminal into the appropriate position of the crimp tool and close the crimp tool, to fasten the insulation of the wire in the outer grip of the terminal.

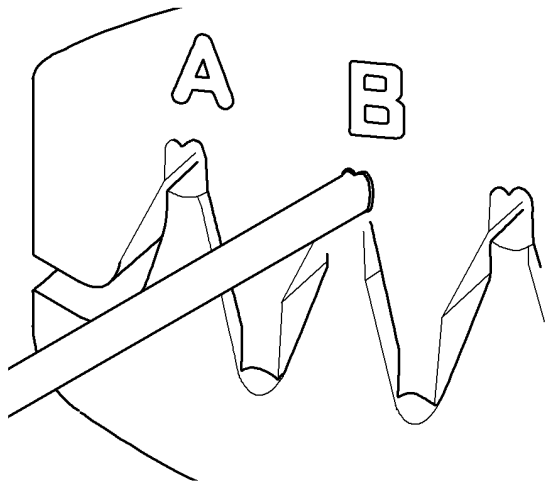

U-1-0196-A

Figure 4 Crimping the insulation grip.

5. **Figure 5.** Check that the crimp is correctly made.

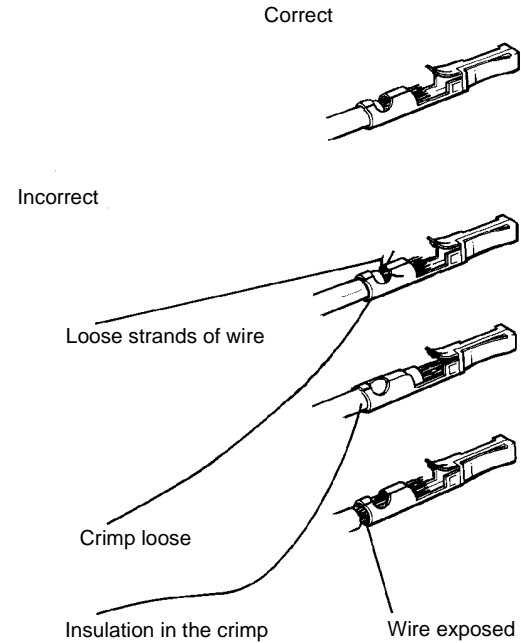

U-1-0197-A

Figure 5 Inspecting the finished crimp.

6. Insert the replacement terminal into the connector housing.
7. If the repair was carried out on a double row connector that was disassembled, push both connectors into the housing taking care that the "A" connector is fitted on the fastener side.

REP 1.3 Male Hirose DF1B Connectors

Removal

WARNING

Switch off the electricity to the machine. Refer to GP 14. Disconnect the power cord from the customer supply while performing tasks that do not need electricity. Electricity can cause death or injury. Moving parts can cause injury.

1. Figure 1. Remove the damaged terminal from the housing.

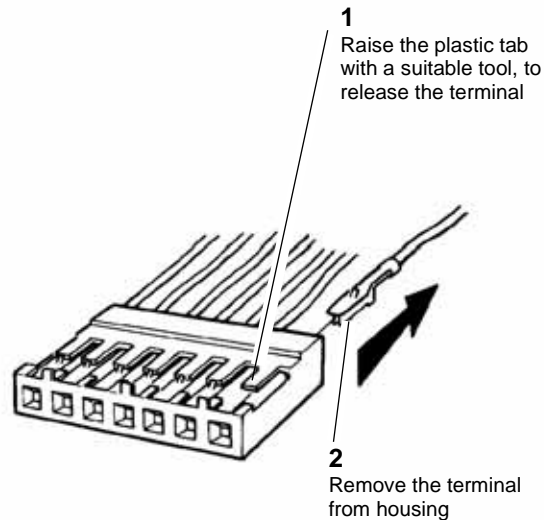

U-1-0198-A

Figure 1 Remove the terminal

2. Cut off the damaged terminal, then strip 3 mm of insulation from the end of the wire.

Replacement

CAUTION

There are different terminals for large gauge and small gauge wire. Ensure that the correct replacement terminal is used.

1. Select the correct replacement terminal and identify the appropriate crimp positions for the terminal.

NOTE: These connectors can be repaired using either crimp terminals or pre-crimped terminals with flying lead and butt connector, as required.

2. Figure 2. Insert the terminal into the appropriate position of the crimp tool and close the tool just enough to hold the terminal.

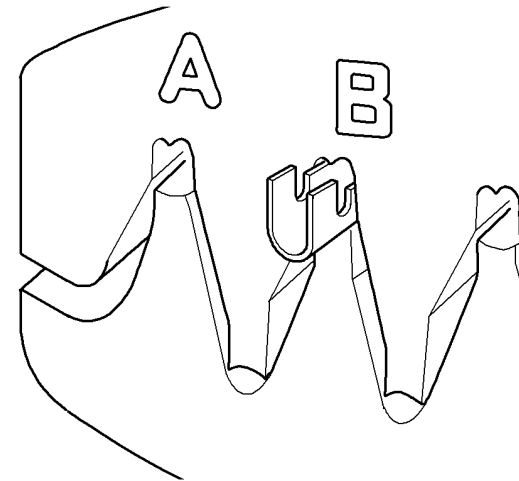

U-1-0199-A

Figure 2 Crimping the terminal.

3. Insert the wire fully into the terminal so that the stripped portion of the wire is within the longer grip of the terminal and the insulation of the wire is within the cable grip of the terminal. Close the crimp tool fully to make the crimp; check that the wire is firmly crimped in the terminal.

4. **Figure 3.** Insert the crimped terminal into the appropriate position of the crimp tool and close the crimp tool to firmly fasten the insulation of the wire in the cable grip of the terminal.

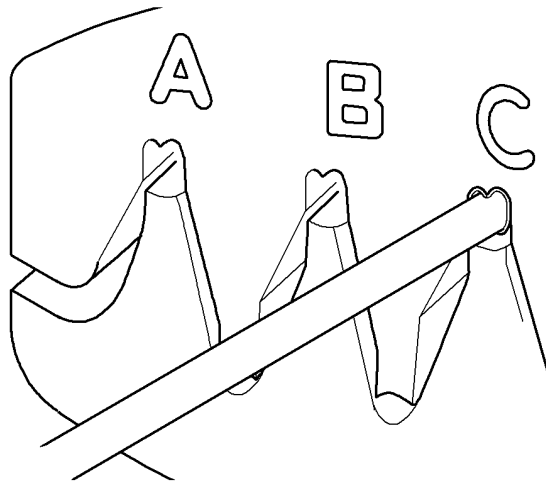

Figure 3 Crimping the insulation grip.

U-1-0200-A

5. **Figure 4.** Check that the crimp is correctly made.

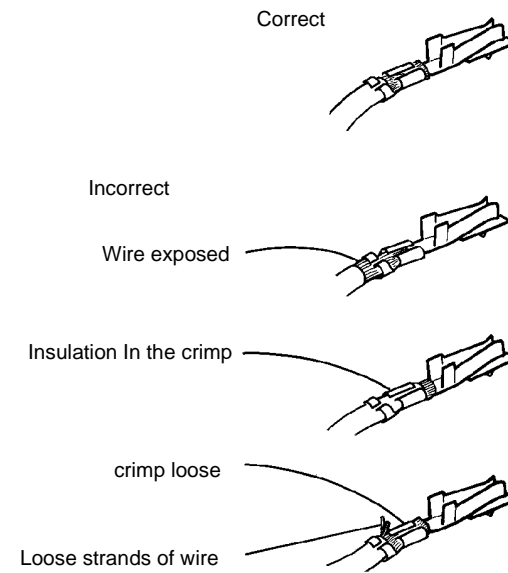

Figure 4 Inspecting the finished crimp.

U-1-0201-A

6. Insert the replacement terminal into the connector housing.

REP 1.4 AMP EI Connectors

Removal

WARNING

Switch off the electricity to the machine. Refer to GP 14. Disconnect the power cord from the customer supply while performing tasks that do not need electricity. Electricity can cause death or injury. Moving parts can cause injury.

NOTE: The male housings contain socket terminals, and the female housings contain pin terminals.

1. Use the extractor tool, to release the terminal from the housing. Refer to Figure 1 to identify the male housing and terminal type. Refer to Figure 2 to identify the female housing and the terminal type.

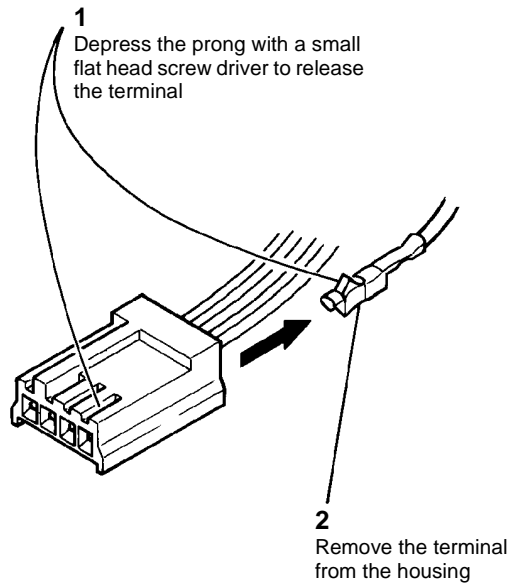

U-1-0202-A

Figure 1 Terminal removal; male housing.

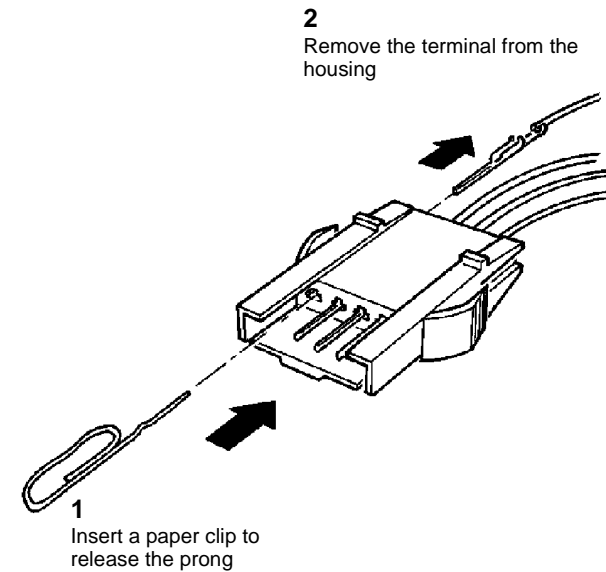

U-1-0203-A

Figure 2 Terminal removal; female housing.

2. Cut off the damaged terminal, then strip 3 mm of insulation from the end of the wire.

Replacement

1. Select the correct replacement terminal and identify the appropriate crimp positions for the terminal.
2. **Figure 3.** Insert the terminal into the appropriate position of the crimp tool and close the tool enough to hold the terminal.

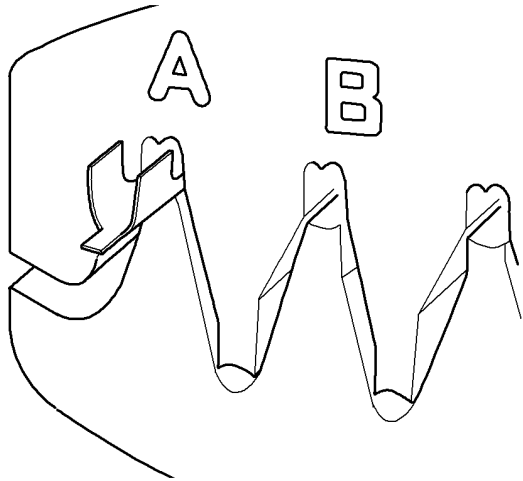

Figure 3 Crimping the terminal.

U-1-0204-A

3. Insert the wire completely into the terminal, so that the stripped portion of the wire is in the longer grip of the terminal. The insulation of the wire is within the cable grip of the terminal. Close the crimp tool completely to make the crimp. Check that the wire is crimped firmly in the terminal.

4. **Figure 4.** Insert the crimped terminal into the appropriate position of the crimp tool and close the crimp tool to firmly fasten the insulation of the wire in the cable grip of the terminal.

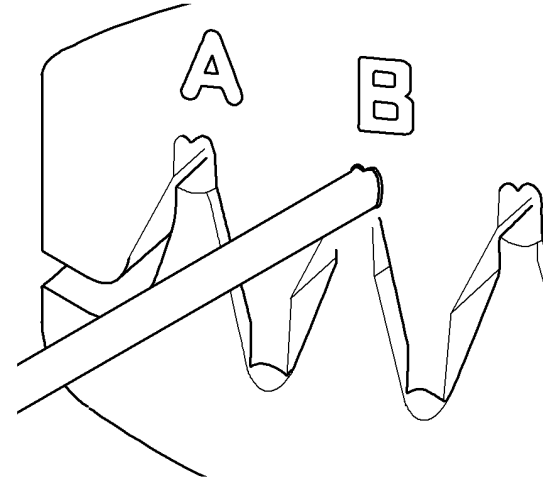

Figure 4 Crimping the insulated grip.

U-1-0205-A

5. **Figure 5.** Check that the crimp is correctly made.

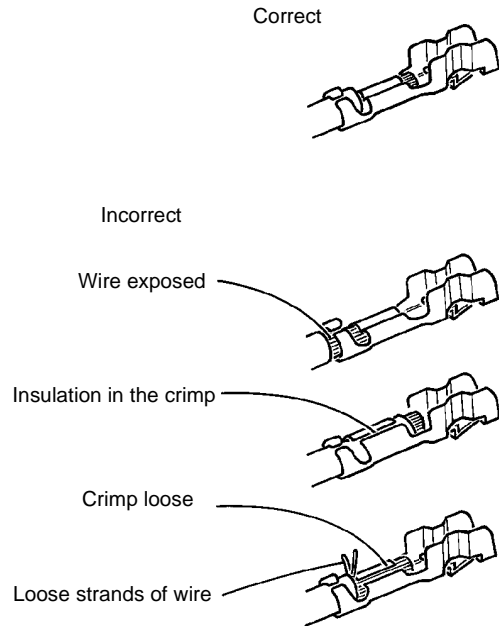

Figure 5 Inspect the finished crimp

6. Insert the replacement terminal into the connector housing.

U-1-0206-A

REP 1.5 Hirose DF11 Connectors

Removal

WARNING

Switch off the electricity to the machine. Refer to **GP 14**. Disconnect the power cord from the customer supply while performing tasks that do not need electricity. Electricity can cause death or injury. Moving parts can cause injury.

NOTE: The male housing contains female terminals that cannot be crimped in the field; if a terminal is damaged, install a new terminal with flying lead.

1. **Figure 1.** Remove the damaged terminal from the connector housing.

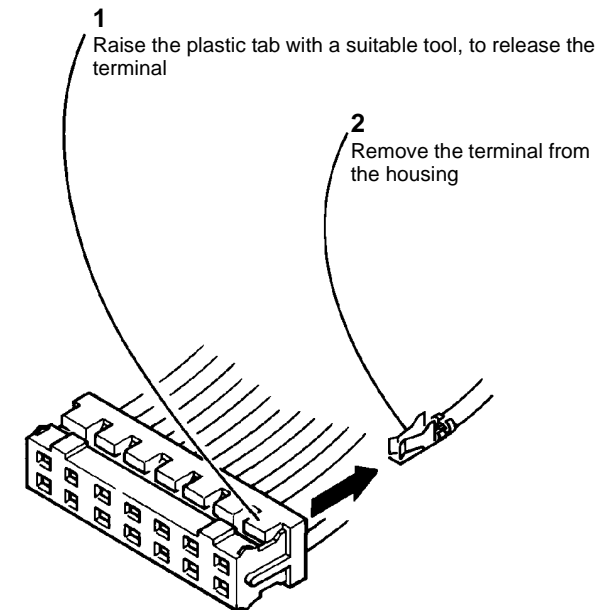

Figure 1 Terminal removal

U-1-0207-A

2. Cut the damaged terminal off the wire.

Replacement

1. Insert the replacement terminal with flying lead into the connector housing.
2. Use a butt connector to connect the flying lead to the original wire.

REP 1.6 AMP CT Connectors

Removal

WARNING

Switch off the electricity to the machine. Refer to GP 14. Disconnect the power cord from the customer supply while performing tasks that do not need electricity. Electricity can cause death or injury. Moving parts can cause injury.

CAUTION

Amp CT connectors use in-line adaptors to connect housings together. Ensure that the correct adaptor is used for each in-line connection. Do not attempt to disassemble or repair the in-line adaptors.

NOTE: There are two types of CT connector: insulation displacement connector (IDC) or crimp terminal. Repairing crimp terminal CT connectors is performed by installing individual replacement terminals with flying leads, connected to the existing wiring with connector splicing blocks (removal steps 2 and 3). Repairing IDC connectors is performed by installing a complete replacement housing with wires already fitted, connected to the existing wiring with connector splicing blocks (removal steps 4 and 5). The replacement procedure is only applicable to crimp terminal connectors.

1. Identify the terminal type. Go to step 2 for a housing containing crimp terminals, or go to step 4 for a housing containing insulation displacement (IDC) terminals.

2. **Figure 1.** Remove the damaged crimp terminal from the connector housing.

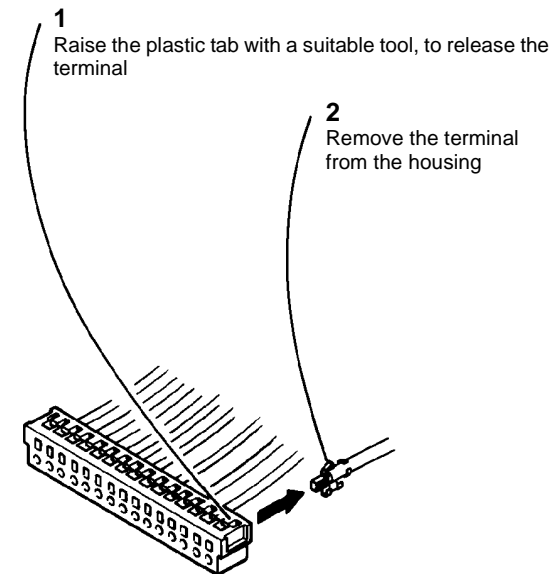

U-1-0208-A

Figure 1 Terminal removal.

3. Cut the damaged crimp terminal off of the wire.
4. IDC housings are repaired by installing a complete replacement housing with wires already fitted. These are connected with connector splicing blocks to the existing wiring. Select the correct replacement connector.
5. Cut one wire from the faulty connector and then reconnect the wire to the appropriate flying lead on the replacement connector. Repeat this process for each wire in turn, until the faulty connector has been fully disconnected and the replacement connector installed in its place.

Replacement

1. Insert the replacement crimp terminal with flying lead into the connector housing.
2. Use a connector splicing block to connect the flying lead to the original wire.

REP 1.7 Molex Mini-Fit Junior Connectors

Removal

WARNING

Switch off the electricity to the machine. Refer to GP 14. Disconnect the power cord from the customer supply while performing tasks that do not need electricity. Electricity can cause death or injury. Moving parts can cause injury.

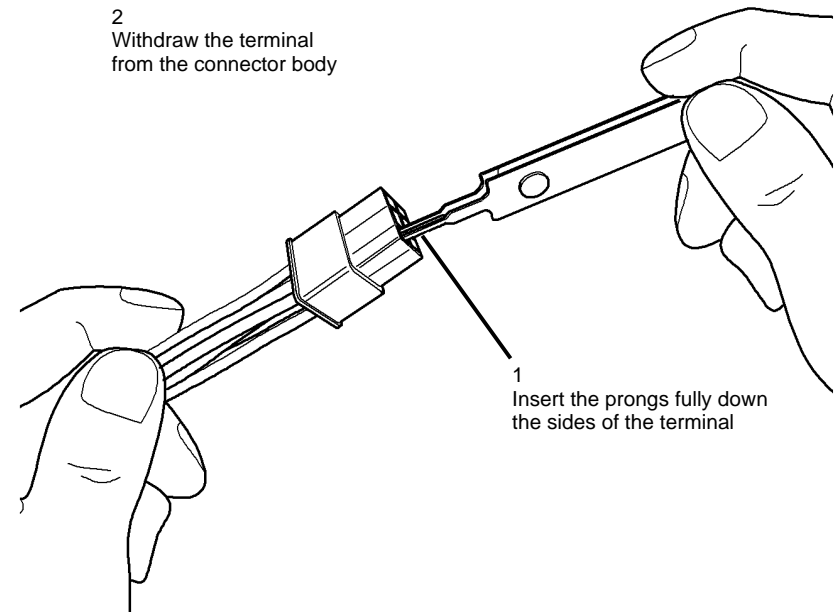

Figure 1 ESD Symbol

WARNING

Take care during this procedure. Sharp edges may be present that can cause injury.

1. **Figure 2.** Remove the terminal from the housing, using the Molex, Mini-Fit extractor tool.



U-1-0209-A

Figure 2 Removing the terminal

2. Cut off the damaged terminal, then strip 4 mm of insulation from the end of the wire.

Replacement

1. Select the correct terminal type.

2. **Figure 3.** Insert the terminal into the appropriate position of the crimp tool and close the tool just enough to hold the terminal.

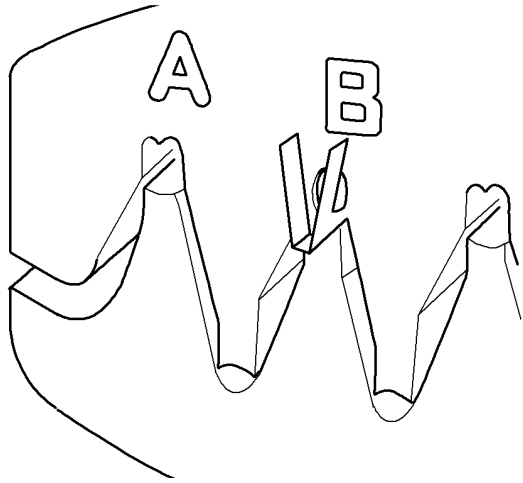

Figure 3 Crimping the terminal

U-1-0210-A

3. Insert the wire fully into the terminal so that the stripped portion is within the inner grip of the terminal. Close the crimp tool fully to make the crimp.
4. **Figure 4.** Insert the crimped terminal into the appropriate position of the crimp tool and close the crimp tool to fasten the wire insulation in the outer grip of the terminal.

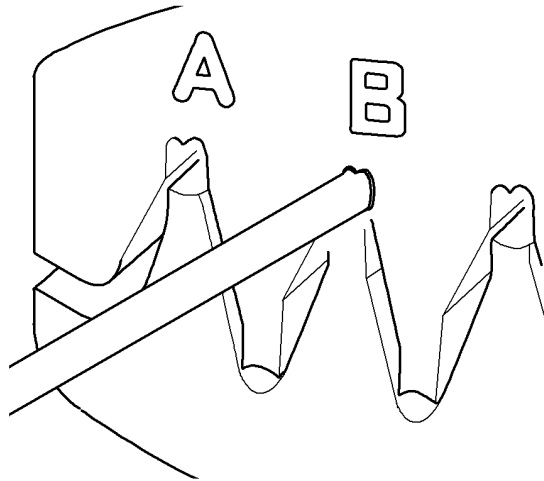
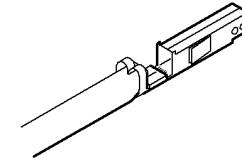

Figure 4 Crimping the insulation grip

U-1-0211-A

5. **Figure 5.** Check that the crimp is correctly made.

Correct



Incorrect:

Loose strands of wire

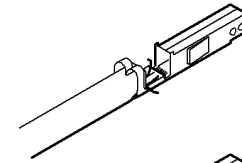

Insulation in the crimp

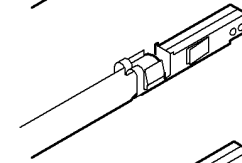

Wire exposed

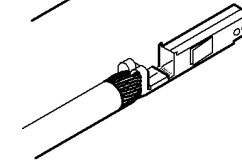

U-1-0212-A

Figure 5 Inspecting the finished crimp

6. Insert the replacement terminal into the connector housing.

REP 1.8 Front Door Interlock Switch

Parts List on [PL 1.15](#)

Removal

WARNING

Switch off the electricity to the machine. Refer to [GP 14](#). Disconnect the power cord from the customer supply while performing tasks that do not need electricity. Electricity can cause death or injury. Moving parts can cause injury.

WARNING

Take care during this procedure. Sharp edges may be present that can cause injury.

1. Open the front door.
2. Remove the front door interlock switch, [Figure 1](#).

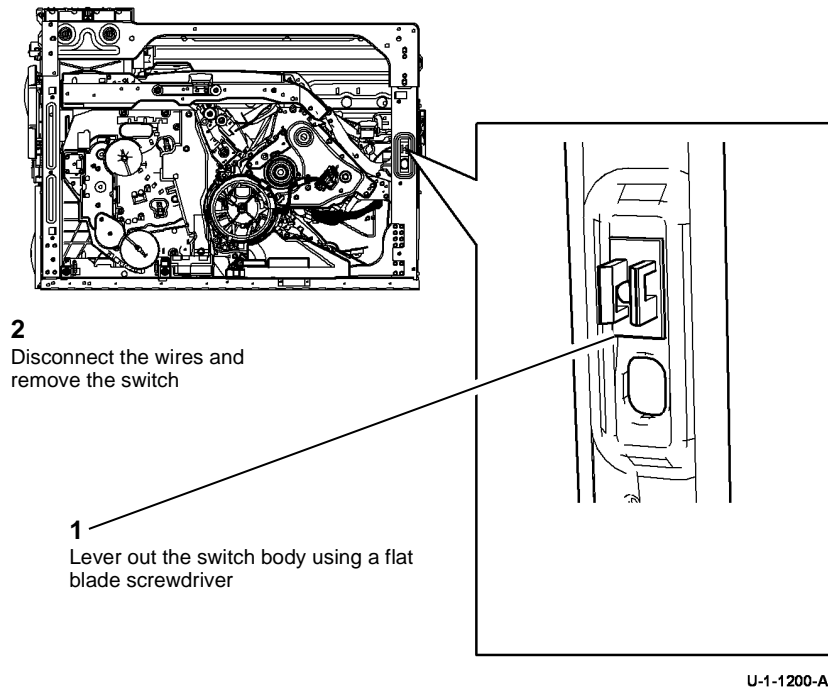

Figure 1 Front door interlock removal

Replacement

1. Replacement is the reverse of the removal process.

REP 1.9 Power Supply Unit

Parts List on [PL 1.15](#)

Removal

WARNING

Switch off the electricity to the machine. Refer to [GP 14](#). Disconnect the power cord from the customer supply while performing tasks that do not need electricity. Electricity can cause death or injury. Moving parts can cause injury.

WARNING

Take care during this procedure. Sharp edges may be present that can cause injury.

1. Remove the rear cover, [PL 81.10 Item 1](#).
2. Remove the main power cord, [PL 1.15 Item 1](#).
3. Disconnect the LCSS power cord, [PL 12.75 Item 8](#), if installed, or the HVF power cord. [PL 12.140 Item 4](#) if installed.
4. Remove the rear cover, [PL 70.25 Item 8](#)
5. Disconnect the harnesses, [Figure 1](#).

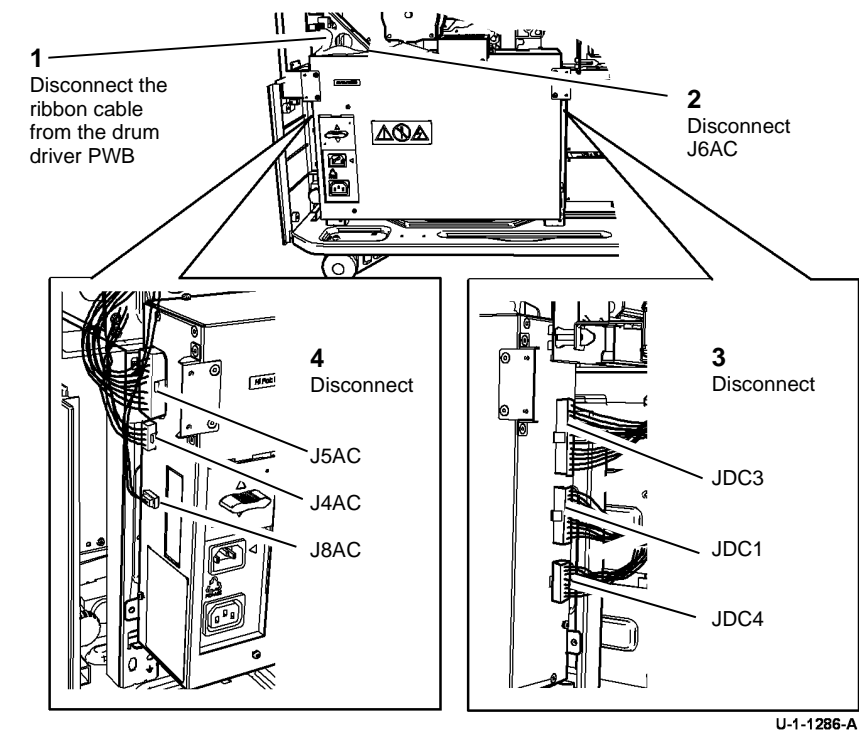

Figure 1 Disconnect harnesses

6. Remove the power supply unit, [Figure 2](#).

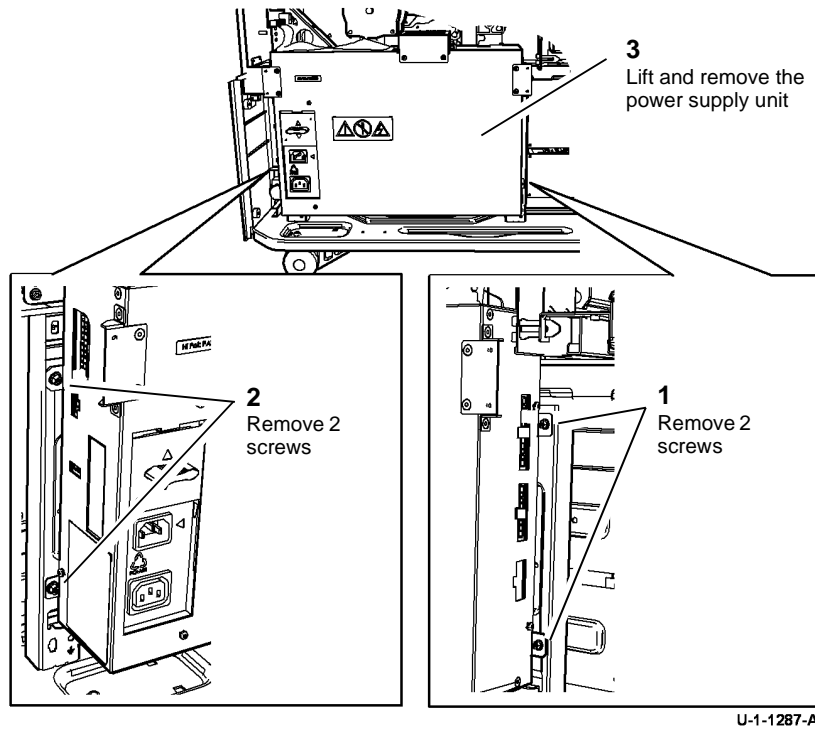

Figure 2 Remove the power supply unit

7. Remove the ribbon cable, [Figure 3](#).

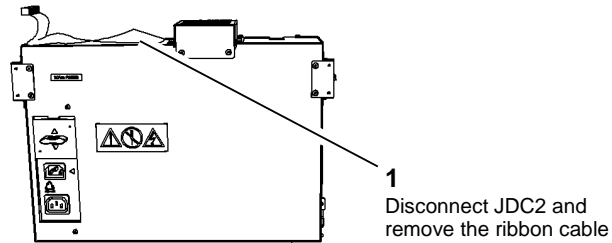

Figure 3 Remove the ribbon cable

Replacement

1. Replacement is the reverse of the removal process.
2. Install the ribbon cable JDC2 and note the location of the support lugs on the rear of the power supply unit, [Figure 4](#).

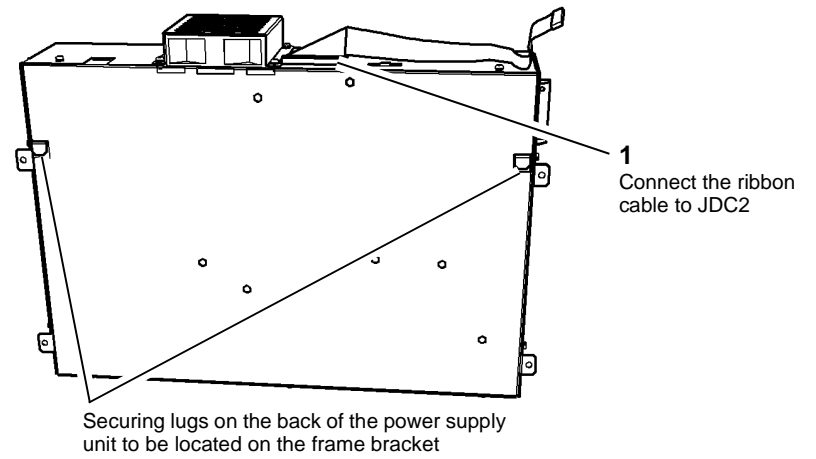
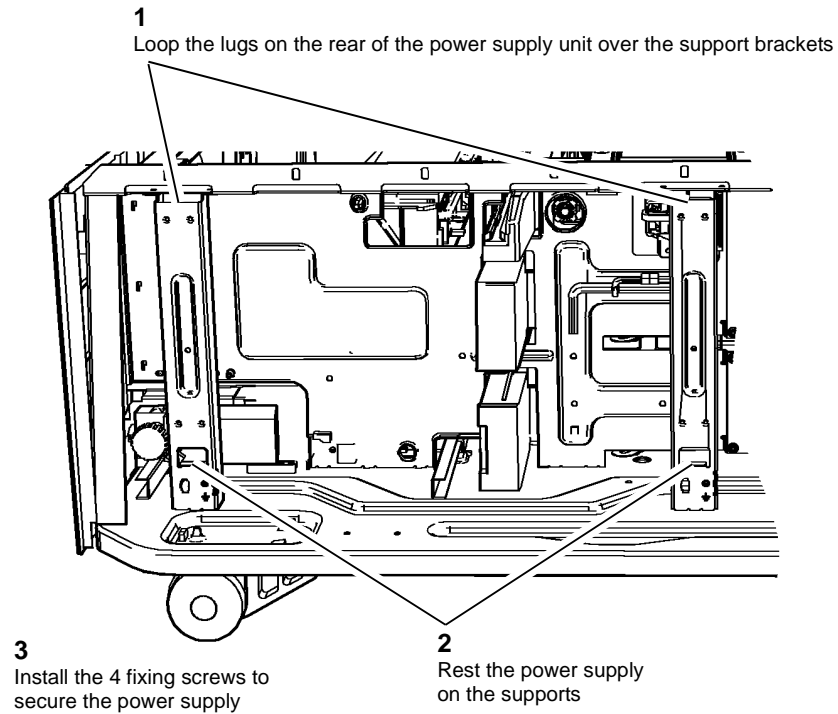

Figure 4 Install the ribbon cable

CAUTION

Ensure that wires are not pinched between the frame and the back of the power supply during installation

3. Install the power supply unit, [Figure 5](#).



U-1-1289-A

Figure 5 Install the power supply unit

4. Re-connect the connectors to the power supply unit and the ribbon cable to the drum driver PWB, [Figure 1](#).

REP 2.1 User Interface Assembly

Parts List on [PL 2.10](#)

Removal

WARNING

Switch off the electricity to the machine. Refer to [GP 14](#). Disconnect the power cord from the customer supply while performing tasks that do not need electricity. Electricity can cause death or injury. Moving parts can cause injury.



Figure 1 ESD Symbol

CAUTION

Ensure that ESD procedures are observed during the removal and installation of the user interface assembly.

NOTE: Detachment of the user interface (UI) control panel will enable the replacement of the user interface control PWBA, [PL 2.10 Item 2](#), user interface status PWBA, [PL 2.10 Item 4](#) and the user interface touch screen, [PL 2.10 Item 3](#). Only remove the complete user interface assembly when necessary, e.g. reinstallation onto a new scanner assembly.

1. Open the front door. If the complete UI assembly is to be removed, remove the scanner module, [REP 62.1](#).

2. Prepare to detach the UI control panel, [Figure 2](#).

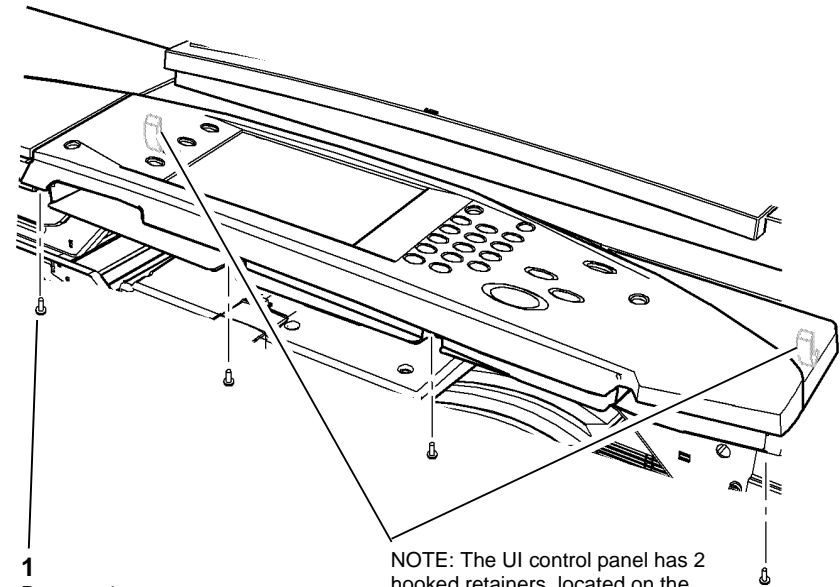

NOTE: The UI control panel has 2 hooked retainers, located on the underside at the left and right rear corners.

U-1-0772-A

Figure 2 Preparation

CAUTION

Ensure no strain is placed upon the UI harness.

3. Detach the UI control panel, [Figure 3](#).

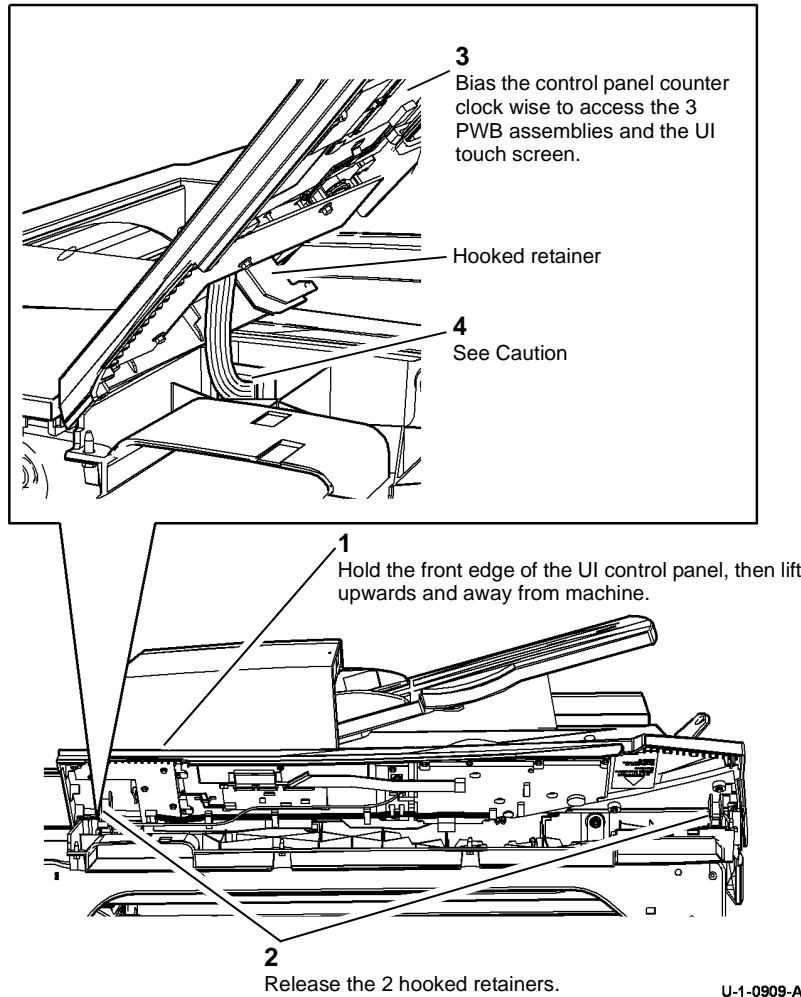

Figure 3 Detach the UI control panel

4. Remove the scanner rear cover, refer to [REP 62.2](#).
5. Remove the UI Harness cover, [PL 62.10 Item 16](#).
6. Release the UI Harness clamp, [PL 62.10 Item 9](#).
7. Remove the UI control panel with the UI harness, [PL 2.10 Item 7](#).
8. Remove the 4 nuts, [PL 62.10 Item 8](#) and the 4 washers.
9. Remove the UI base, [PL 62.10 Item 19](#) and the 4 grommets, [PL 62.10 Item 6](#).

Replacement

1. The replacement is the reverse of the removal procedure.
2. When installing the UI assembly hook the rear retainers into place. Lower the keyboard fully, then press down and push the UI assembly until it clicks into place. The 4 screws can then be installed.

REP 2.2 User Interface Touch Screen

Parts List on [PL 2.10](#)

Removal

WARNING

Switch off the electricity to the machine. Refer to [GP 14](#). Disconnect the power cord from the customer supply while performing tasks that do not need electricity. Electricity can cause death or injury. Moving parts can cause injury.



Figure 1 ESD Symbol

CAUTION

Ensure that ESD procedures are observed during the removal and installation of the user interface touch screen.

1. Detach the user interface control panel, [REP 2.1](#).
2. Place the user interface control panel on a flat surface.

3. Remove the user interface touch screen, [Figure 2](#).

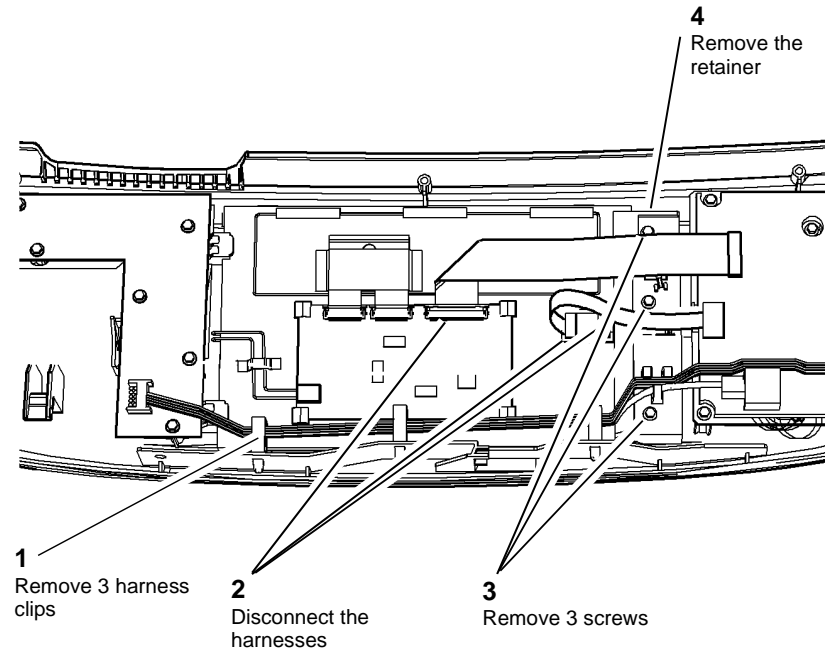

U-1-0773-A

Figure 2 Remove the user interface touch screen

Replacement

1. The replacement is the reverse of the removal procedure.
2. If a problem occurs with the display. Refer to [GP 32](#) User Interface Panel Diagnostics and check out the functions of the UI.

REP 2.3 User Interface PWB

Parts List on [PL 2.10](#)

Removal

WARNING

Switch off the electricity to the machine. Refer to [GP 14](#). Disconnect the power cord from the customer supply while performing tasks that do not need electricity. Electricity can cause death or injury. Moving parts can cause injury.



Figure 1 ESD Symbol

CAUTION

Ensure that ESD procedures are observed during the removal and installation of the user interface PWB.

1. Detach the user interface control panel, [REP 2.1](#)
2. Place the user interface control panel on a flat surface.

3. Remove the user interface PWB, [Figure 2](#).

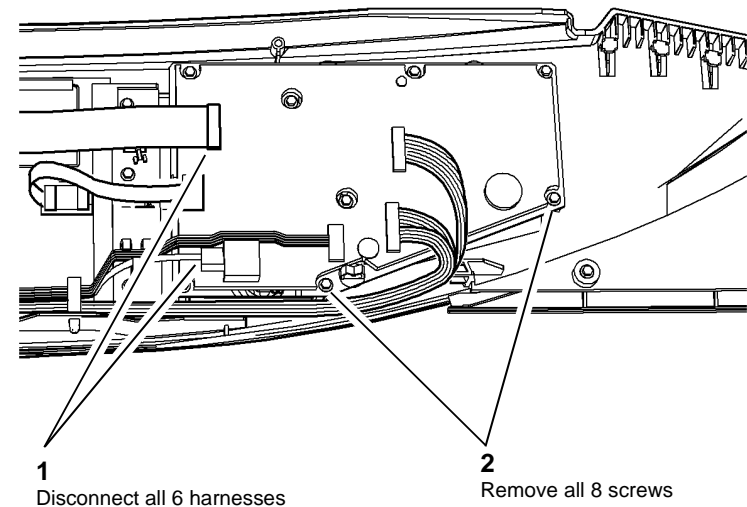

Figure 2 Remove the user interface PWB

U-1-0774-A

Replacement

The replacement is the reverse of the removal procedure.

REP 3.1 IME Controller PWB

Parts List on [PL 92.10](#)

Removal

WARNING

Switch off the electricity to the machine. Refer to [GP 14](#). Disconnect the power cord from the customer supply while performing tasks that do not need electricity. Electricity can cause death or injury. Moving parts can cause injury.



Figure 1 ESD Symbol

CAUTION

Ensure that ESD procedures are observed during the removal and installation of the IME controller PWB.

1. Open the front door
2. Remove the inner cover, [PL 81.11 Item 2](#).
3. Pull out the marking unit, [GP 6](#).
4. Remove the marking unit enclosure cover, [PL 91.10 Item 18](#).

5. Remove the IME controller PWB, [Figure 2](#).

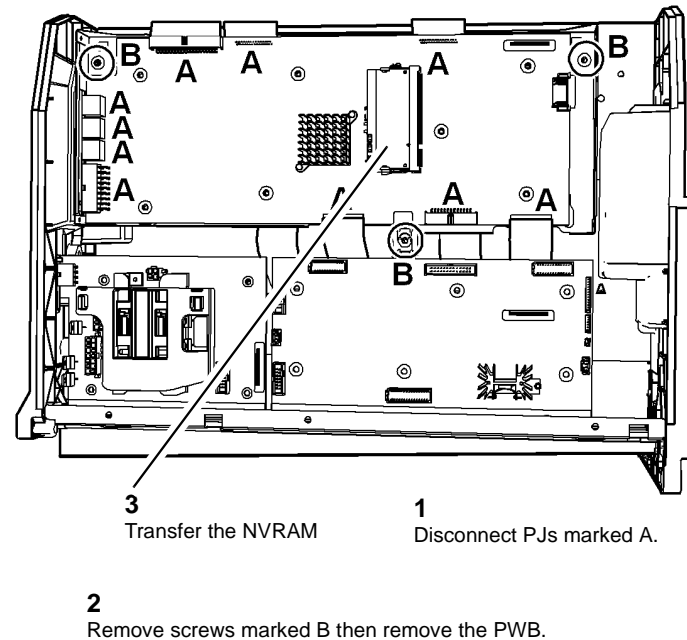

U-1-0981-A

Figure 2 IME controller PWB removal

Replacement

1. Replacement is the reversal of the removal process.
2. Transfer the NVRAM from the failed PWB and install onto the new PWB, [Figure 2](#).
3. Install the new NVRAM onto the failed IME Controller PWB to be returned.
If both IME controller PWB and IME NVRAM chip are replaced at the same time. Then perform the following:
 - a. [dC977](#) Drum Runout Calibration.
 - b. [dC625](#) Registration / Preheat Calibration.
 - c. The front and rear transfix calibration values need to be entered into [dC978](#). The values are located on the front of the drum frame.
 - d. Empty the waste tray, since the NVM tracking purge mass has been lost.
 - e. Enter [dC131](#) NVM Read / Write at location 492-70 Prints On This Drum and enter the page count of the machine.

REP 3.2 Quad Wave Amp PWB

Parts List on [PL 92.10](#)

Removal

WARNING

Switch off the electricity to the machine. Refer to [GP 14](#). Disconnect the power cord from the customer supply while performing tasks that do not need electricity. Electricity can cause death or injury. Moving parts can cause injury.



Figure 1 ESD Symbol

CAUTION

Ensure that ESD procedures are observed during the removal and installation of the quad wave amp PWB.

1. Remove the IME controller PWB, [REP 3.1](#).

2. Remove the quad wave amp PWB, [Figure 2](#).

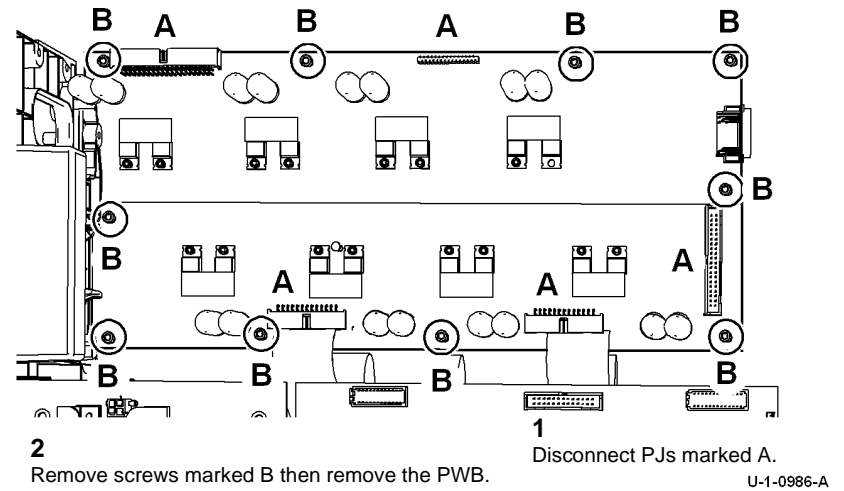

Figure 2 Quad wave amp PWB removal

Replacement

Replacement is the reverse of the removal procedure.

REP 3.3 Marking Unit Heater PWB

Parts List on [PL 92.10](#)

Removal

WARNING

Switch off the electricity to the machine. Refer to [GP 14](#). Disconnect the power cord from the customer supply while performing tasks that do not need electricity. Electricity can cause death or injury. Moving parts can cause injury.



Figure 1 ESD Symbol

CAUTION

Ensure that ESD procedures are observed during the removal and installation of the marking unit heater PWB.

1. Open the front door
2. Remove the inner cover, [PL 81.11 Item 2](#).
3. Pull out the marking unit, [REP 91.28](#).
4. Remove the marking unit enclosure cover, [PL 91.10 Item 18](#).
5. Remove the clamp, [PL 92.10 Item 6](#).

6. Remove the marking unit heater PWB, [Figure 2](#).

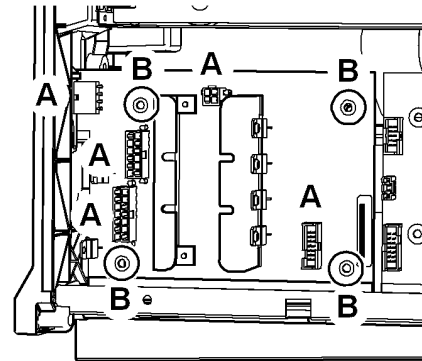

1. Disconnect PJs marked A.

2. Remove screws marked B then the PWB.

U-1-0989-A

Figure 2 Marking unit heater PWB removal

Replacement

Replacement is the reverse of the removal procedure.

REP 3.4 Marking Unit Driver PWB

Parts List on [PL 92.10](#)

Removal

WARNING

Switch off the electricity to the machine. Refer to [GP 14](#). Disconnect the power cord from the customer supply while performing tasks that do not need electricity. Electricity can cause death or injury. Moving parts can cause injury.



Figure 1 ESD Symbol

CAUTION

Ensure that ESD procedures are observed during the removal and installation of the marking unit driver PWB.

1. Open the front door
2. Remove the inner cover, [PL 81.11 Item 2](#).
3. Pull out the marking unit, [REP 91.28](#).
4. Remove the marking unit enclosure cover, [PL 91.10 Item 18](#).

5. Remove the marking unit driver PWB, [Figure 2](#).

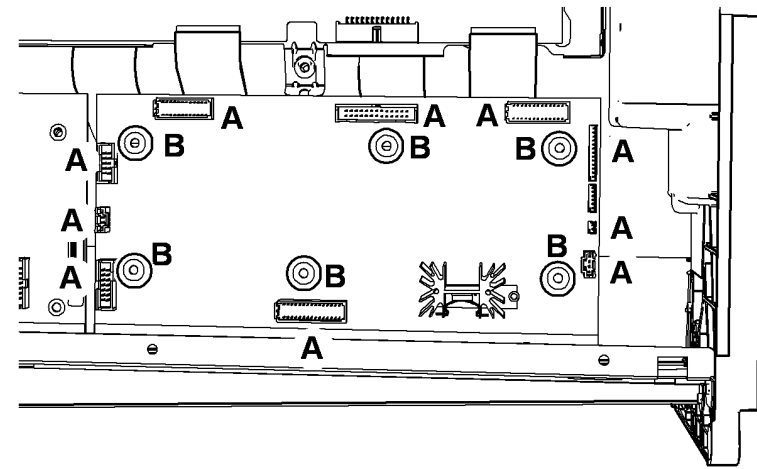

1
Disconnect PJs marked A.

2
Remove screws marked B then remove the PWB.

U-1-0987-A

Figure 2 Marking unit driver PWB removal

Replacement

Replacement is the reverse of the removal procedure.

REP 3.5 Media Path Driver PWB

Parts List on [PL 1.15](#)

Removal

WARNING

Switch off the electricity to the machine. Refer to [GP 14](#). Disconnect the power cord from the customer supply while performing tasks that do not need electricity. Electricity can cause death or injury. Moving parts can cause injury.

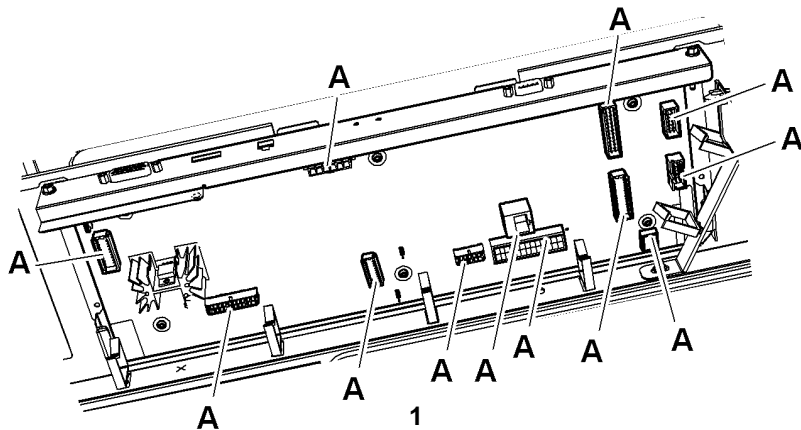

Figure 1 ESD Symbol

CAUTION

Ensure that ESD procedures are observed during the removal and installation of the media path driver PWB.

1. Remove the rear cover, [PL 81.10 Item 1](#).
2. Remove the enclosure fan, [PL 1.15 Item 6](#).
3. Disconnect the PJs, [Figure 2](#).



1
Disconnect PJs marked A.

U-1-0984-A

Figure 2 Disconnect PJs

4. Remove the media path driver PWB, [Figure 3](#).

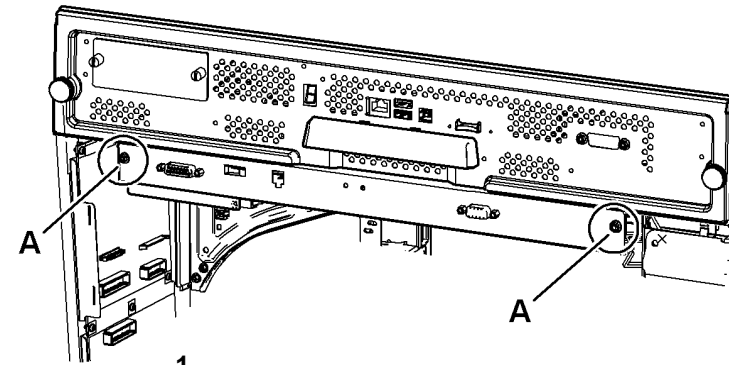

1
Remove the screws marked A then remove PWB assembly.

U-1-0985-A

Figure 3 Media path driver PWB removal

Replacement

Replacement is the reverse of the removal procedure.

REP 3.6 Drum Driver PWB

Parts List on [PL 1.15](#)

Removal

WARNING

Switch off the electricity to the machine. Refer to [GP 14](#). Disconnect the power cord from the customer supply while performing tasks that do not need electricity. Electricity can cause death or injury. Moving parts can cause injury.



Figure 1 ESD Symbol

CAUTION

Ensure that ESD procedures are observed during the removal and installation of the drum driver PWB.

1. Remove the rear cover, [PL 81.10 Item 1](#).
2. Remove the enclosure fan, [PL 1.15 Item 6](#).

3. Disconnect the PJs, [Figure 2](#).

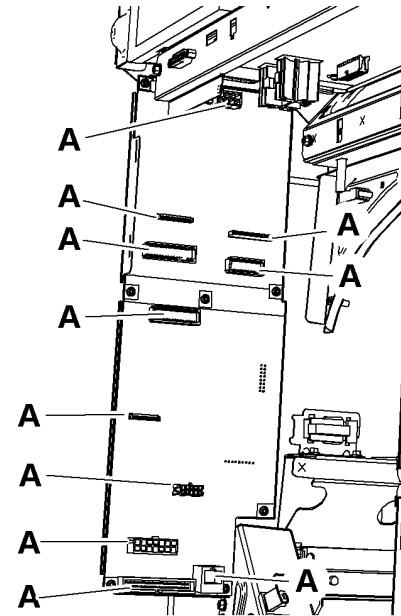

1. Disconnect PJs marked A.

Figure 2 Disconnect PJs

U-1-0982-A

4. Remove the drum driver PWB, [Figure 3](#).

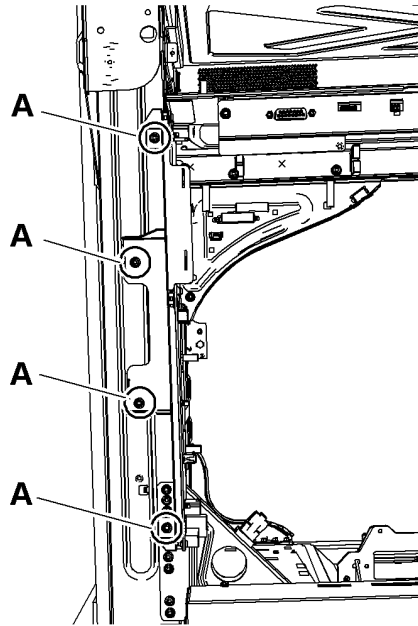

- 1
Remove screws marked A
then remove the PWB.

Figure 3 Drum driver PWB removal

Replacement

Replacement is the reverse of the removal procedure.

U-1-0983-A

REP 3.7 Single Board Controller PWB

Parts List on [PL 3.11](#)

Removal

WARNING

Switch off the electricity to the machine. Refer to [GP 14](#). Disconnect the power cord from the customer supply while performing tasks that do not need electricity. Electricity can cause death or injury. Moving parts can cause injury.



Figure 1 ESD Symbol

CAUTION

Ensure that ESD procedures are observed during the removal and installation of the single board controller PWB.

1. If installed, remove the following components:
 - Foreign device interface PWB, [PL 3.11 Item 14](#).
2. If a new single board controller PWB is to be installed, remove the following components:
 - System memory, [PL 3.11 Item 4](#).
 - NVM module PWB, [PL 3.11 Item 17](#).
 - EPC memory PWB, [PL 3.11 Item 21](#).
 - Product enablement key (SIM), [PL 3.11 Item 22](#).
3. Disconnect all connectors on the rear of the image processing module. Pull out the image processing module.
4. Remove the harness guide plate, [PL 3.11 Item 24](#).
5. Remove the SBC PWB cover, [PL 3.11 Item 11](#).
6. Disconnect all connectors on the single board controller PWB.

CAUTION

Lift the single board controller PWB. Do not slide the PWB in the image processing module. The PWB have components on the underside that can be easily damaged.

7. Remove the single board controller PWB, [Figure 2](#).

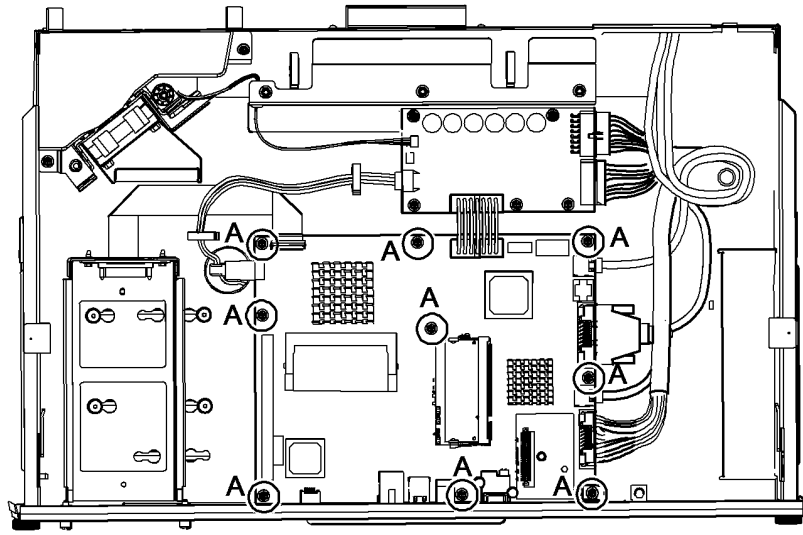

2
Remove the single board controller PWB.

1
Remove 9 screws marked A.

U-1-1609-A

Figure 2 Removal

Replacement

1. Replacement is the reverse of the removal procedure.

NOTE: Before installing the harness guide plate, ensure that the harnesses are correctly routed. Refer to [REP 62.1](#).

2. Perform an Altboot, refer to [GP 4](#) Machine Software.

REP 3.8 Hard Disk Drive

Parts List on [PL 3.11](#)

Removal

WARNING

Switch off the electricity to the machine. Refer to [GP 14](#). Disconnect the power cord from the customer supply while performing tasks that do not need electricity. Electricity can cause death or injury. Moving parts can cause injury.

WARNING

Take care during this procedure. Sharp edges may be present that can cause injury.

1. Pull out the image processing module.
2. Remove the Fax module if installed.
3. Remove the two harnesses from the hard disk drive, [Figure 1](#).

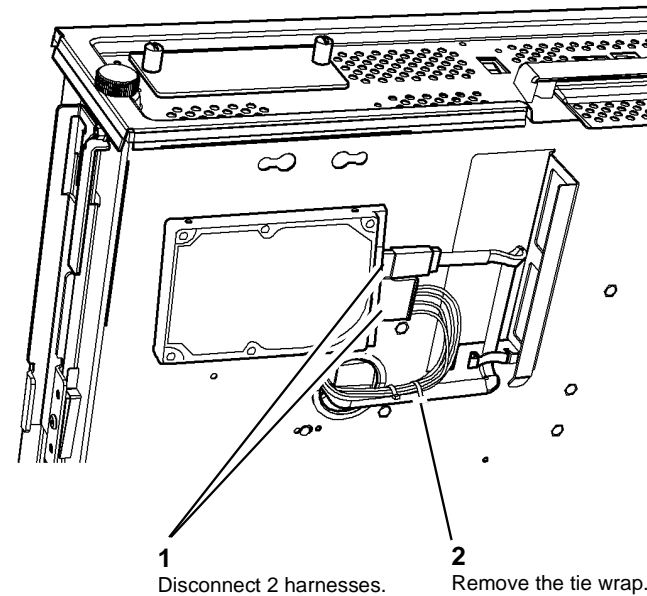

1
Disconnect 2 harnesses.

2
Remove the tie wrap.

U-1-1610-A

Figure 1 Hard Disk Drive harness

- Remove the hard disk drive, [Figure 2](#).

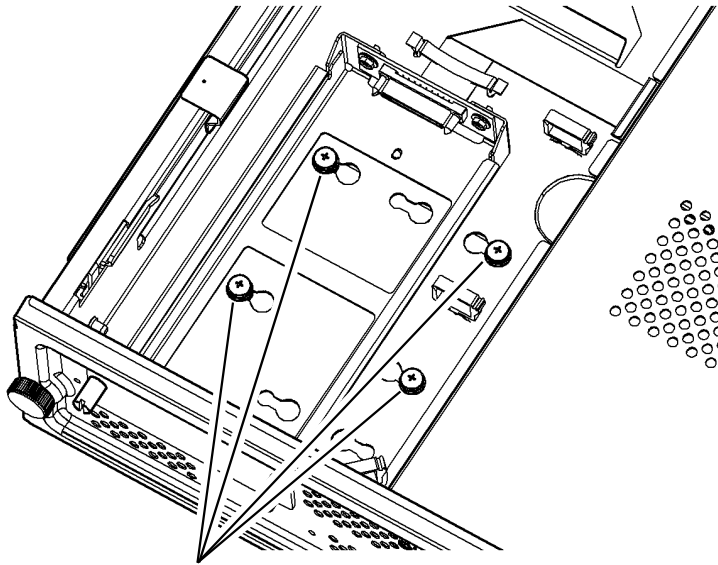

1
Remove 4 screws.

- Remove the hard disk drive.

Figure 2 Remove Hard Disk Drive

U-1-1652-A

Replacement

- Replacement is the reverse of the removal procedure.
- Ensure that the bracket locates into the slots on the drawer
- When the install is complete perform an AltBoot, [GP 4](#).

NOTE: If a new hard drive is installed then the software will need to be reloaded.

REP 3.9 NVM Module PWB and Battery

Parts List on [PL 3.11](#)

Removal

WARNING

Switch off the electricity to the machine. Refer to [GP 14](#). Disconnect the power cord from the customer supply while performing tasks that do not need electricity. Electricity can cause death or injury. Moving parts can cause injury.

WARNING

Take care during this procedure. Sharp edges may be present that can cause injury.



Figure 1 ESD Symbol

CAUTION

Ensure that ESD procedures are observed during the removal and installation of the NVM module PWB.

The NVM module PWB contains the local machine settings. These are retained using battery backed memory.

This module is extremely reliable and should only be changed as a last resort when all other possibilities have been ruled out.

Do not replace the module before the machine has completed the install wizard.

NOTE: All customer settings, machine configuration settings, customer copy count, usage and fault counters will be lost. Inform back office and follow the local process.

- To prevent the deletion of the soft machine settings, perform an NVM save from service mode on the UI using [dC361](#) NVM Save and Restore.
- Pull out the image processing module.
- Remove the harness guide plate, [PL 3.11 Item 24](#).
- Remove the SBC PWB Cover, [PL 3.11 Item 11](#).
- Remove the NVM module PWB, [PL 3.11 Item 17](#).
- If necessary, remove the battery, [PL 3.11 Item 18](#) from the NVM module PWB.

Replacement

CAUTION

Do not use a NVM module PWB that has previously been in another machine as it will transfer the machine serial number and speed to the new machine. Destroy used NVM modules.

1. If necessary, install the new battery onto the NVM module PWB. Check the battery is located correctly, [GP 45](#).
2. Install the NVM module PWB. Make sure the NVM module PWB is fully seated.
3. Install the SBC PWB Cover, [PL 3.11 Item 11](#).
4. Install the harness guide plate, [PL 3.11 Item 24](#).
5. At power up a 'configuration parameter' error will appear as the machine does not know what the serial number is. Enter the serial number from the machines frame serial number plate, [dC132](#). Type carefully and double check that the entered number is correct.

NOTE: *An incorrect entry can only be rectified with another new NVM module PWB.*

6. The machine will then retrieve the machine speed from the SIM. If the data cannot be retrieved from the SIM or the SIM is not present, the machine will default to 9301. Enter [dC131](#) NVM Read / Write location 616-003. Check that the machine speed is correct. If the setting is wrong, escalate through the normal channels to have a pre-serialized SIM sent to you.
7. Check with the customer that the billing plan and service plan are correct. If the customer has changed either since the machine was purchased these will not be reflected. Use [dC103](#) billing plan and [dC136](#) service plan to correct as necessary.
8. Open / Close all paper trays and confirm the media in each tray.
9. Enter Service Copy Mode ([GP 1](#)). Perform the following:
 - Select Machine Info / Tools / Device Settings / Paper Management / Paper Size Preferences. Set to inches or metric as necessary.
 - **(XE Only)** Check the tray 3 media setting. Select Machine Info / Tools / Device Setting / Paper Management / Tray contents. Set to A4 or 8.5 x 11 as necessary.
10. Set the correct market region, [dC134](#).
11. If a new NVM module PWB has been installed, perform an Altboot, [GP 4](#).

NOTE: *The Altboot is not required if only a new battery has been installed.*

12. Perform the following:
 - [dC608](#) Document Feeder Registration.
 - [dC609](#) Document Glass Registration.
 - NVM restore, [dC361](#) NVM Save and Restore.

NOTE: *Using [dC131](#) to make changes to the NVM settings will result in the values being overwritten during the next power cycle. Use only the diagnostics routines listed.*

REP 5.1 Top Cover Assembly

Parts List on [PL 5.20](#)

Removal

WARNING

Switch off the electricity to the machine. Refer to [GP 14](#). Disconnect the power cord from the customer supply while performing tasks that do not need electricity. Electricity can cause death or injury. Moving parts can cause injury.

1. Open the DADH top cover.
2. Remove the DADH top cover assembly, [Figure 1](#).

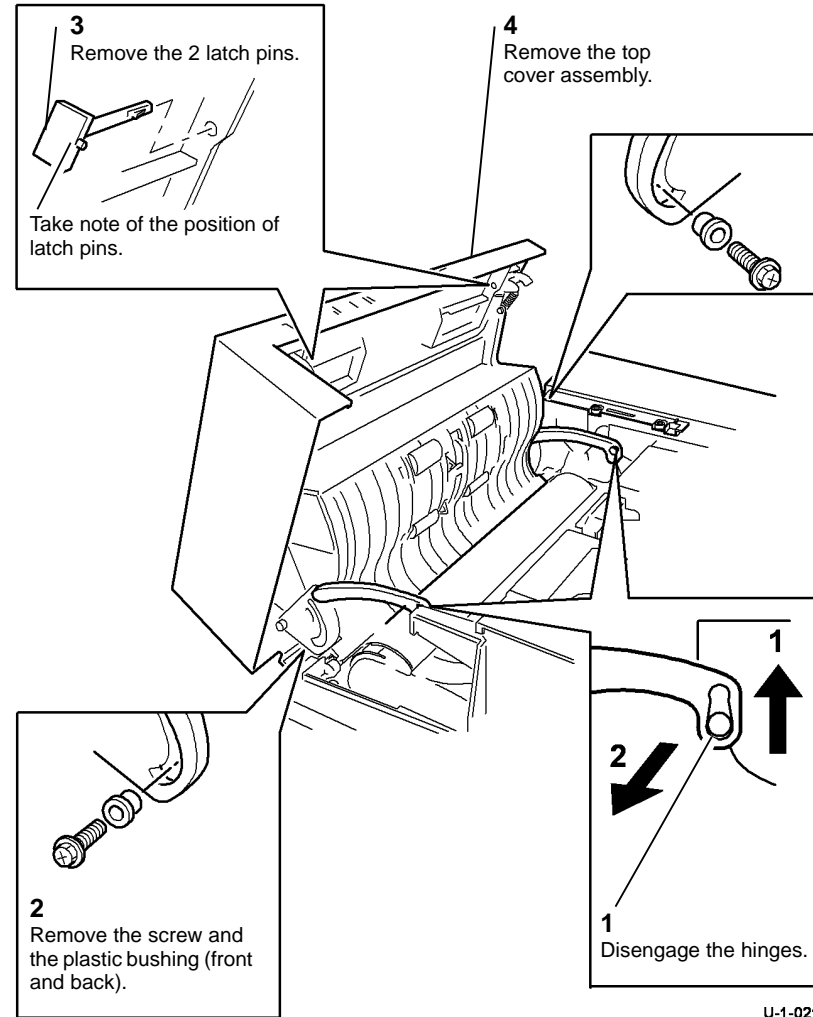

U-1-0213-A

Figure 1 Top cover

Replacement

The replacement is the reverse of the removal procedure. Make sure the latch pins are installed correctly, refer to [Figure 1](#).

REP 5.2 Top Access Cover Assembly

Parts List on [PL 5.20](#)

Removal

WARNING

Switch off the electricity to the machine. Refer to [GP 14](#). Disconnect the power cord from the customer supply while performing tasks that do not need electricity. Electricity can cause death or injury. Moving parts can cause injury.

1. Open the DADH top cover.
2. Remove the DADH rear cover, [PL 5.10 Item 1](#).
3. Remove the DADH top cover assembly, [REP 5.1](#).
4. Remove the DADH top access cover assembly, [Figure 1](#).

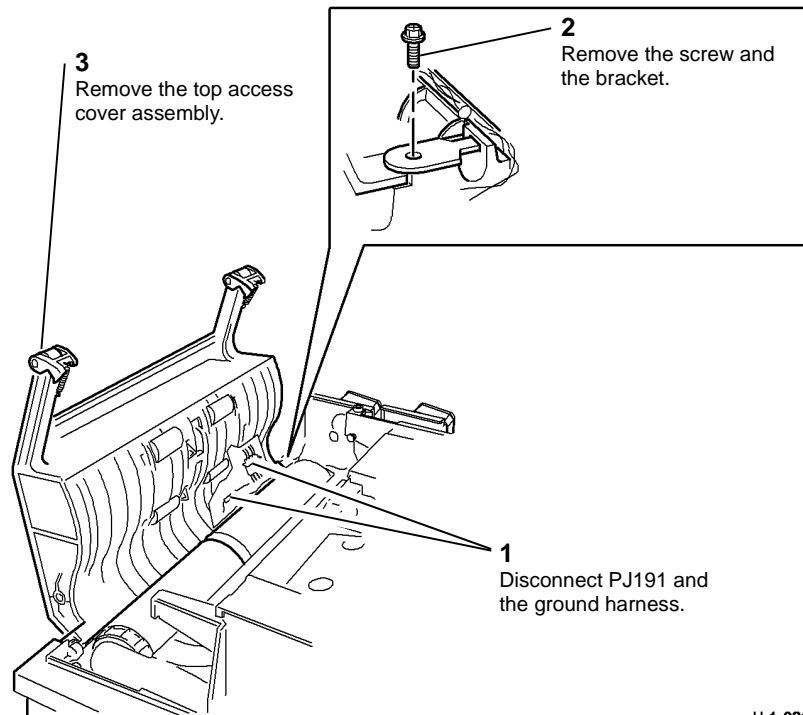

Figure 1 Top access cover assembly

Replacement

The replacement is the reverse of the removal procedure. Make sure that the 2 springs on the idler rolls are in the correct position, [Figure 2](#). Then install the top cover.

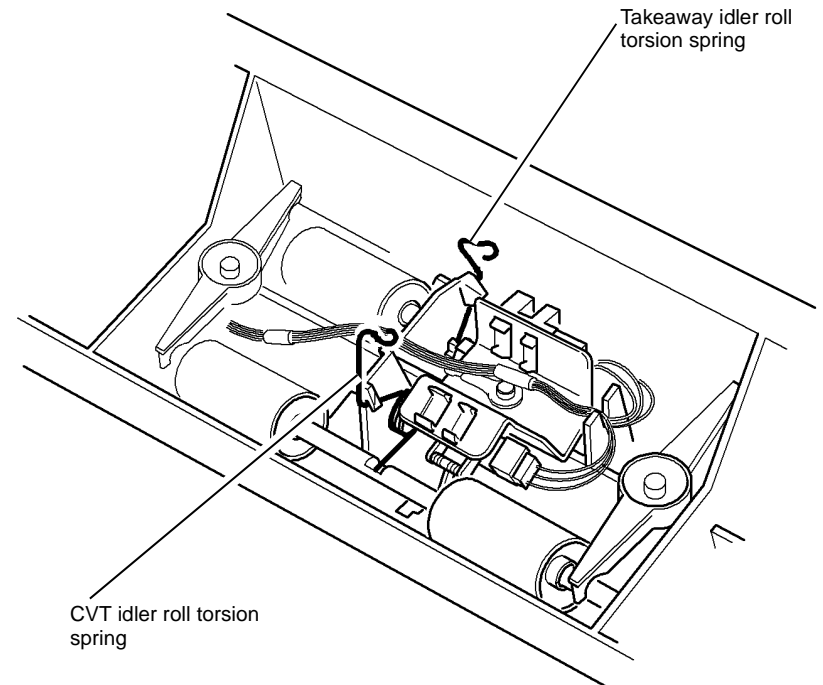

Figure 2 Torsion springs

REP 5.3 Feed Assembly

Parts List on [PL 5.15](#)

Removal

WARNING

Switch off the electricity to the machine. Refer to [GP 14](#). Disconnect the power cord from the customer supply while performing tasks that do not need electricity. Electricity can cause death or injury. Moving parts can cause injury.

WARNING

Take care during this procedure. Sharp edges may be present that can cause injury.

1. Open the DADH top cover.
2. Remove the DADH rear cover, [PL 5.10 Item 1](#).
3. Remove the feed roll assembly, [REP 5.14](#).

4. Remove the feed assembly, [Figure 1](#).

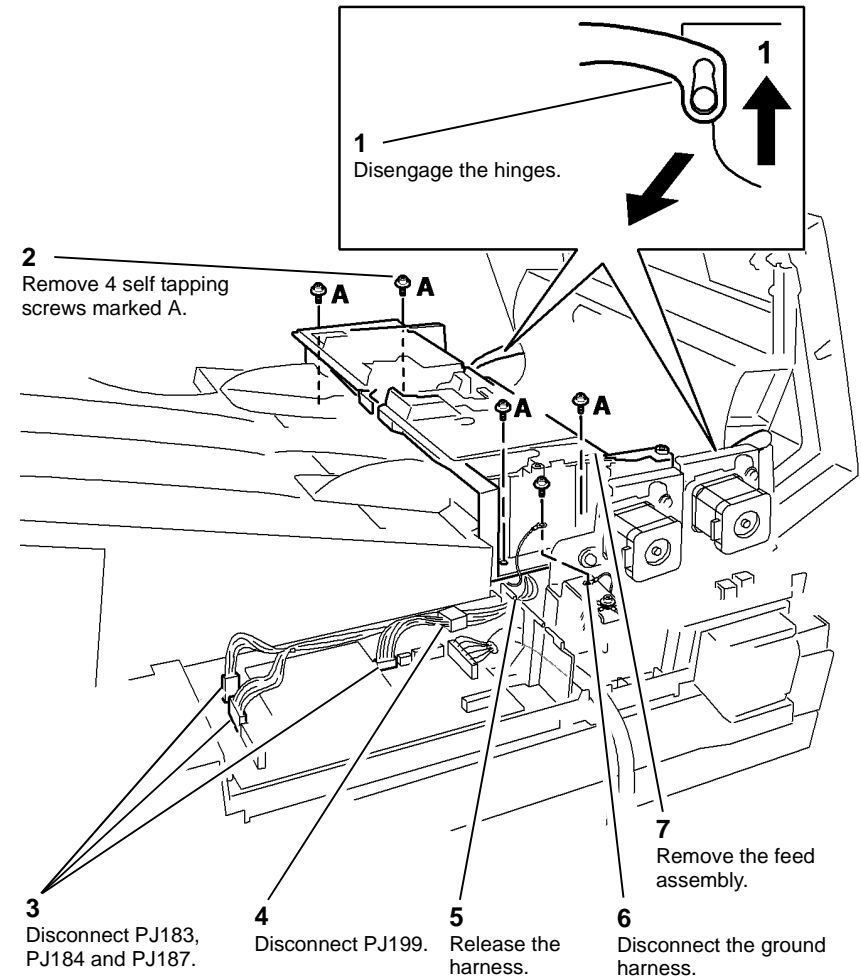

U-1-0216-A

Figure 1 Feed assembly

Replacement

The replacement is the reverse of the removal procedure.

REP 5.4 Input Tray Assembly

Parts List on [PL 5.35](#)

Removal

WARNING

Switch off the electricity to the machine. Refer to [GP 14](#). Disconnect the power cord from the customer supply while performing tasks that do not need electricity. Electricity can cause death or injury. Moving parts can cause injury.

WARNING

Take care during this procedure. Sharp edges may be present that can cause injury.

1. Remove the DADH, [REP 5.19](#).
2. Remove the feed assembly, [REP 5.3](#).

NOTE: To release the tension of the drive belts, refer to [ADJ 5.1](#).

3. Remove the input tray assembly, [Figure 1](#).

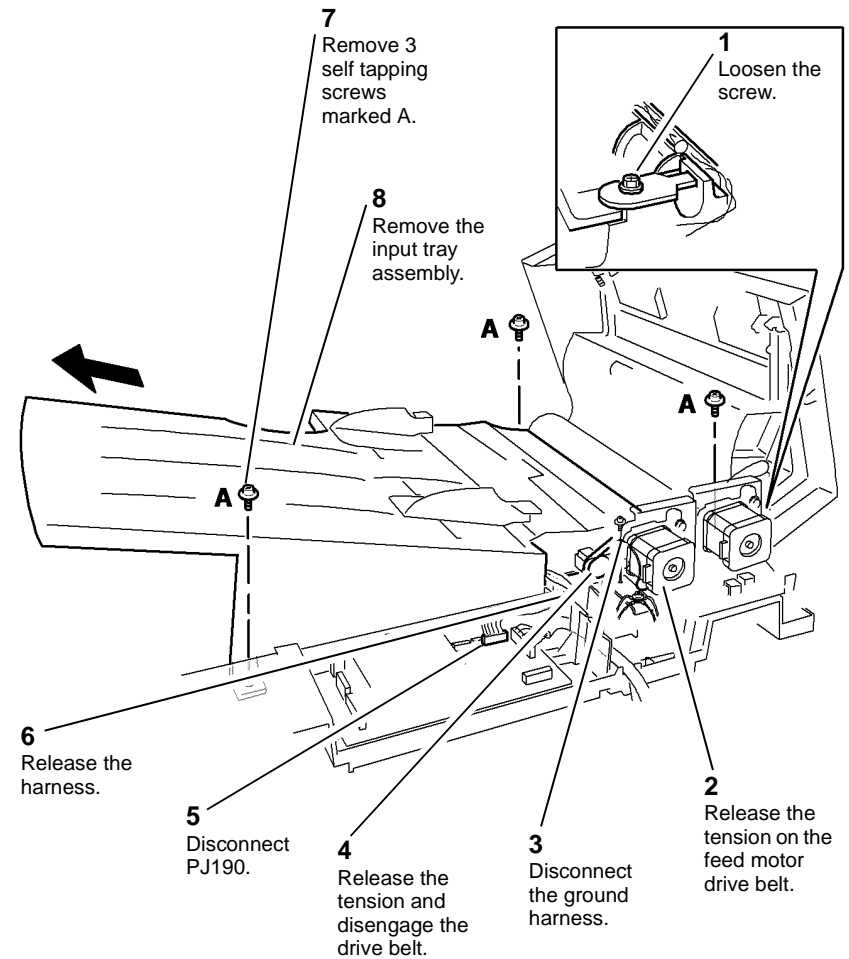

U-1-0217-A

Figure 1 Input tray assembly

Replacement

1. The replacement is the reverse of the removal procedure.
2. Perform [ADJ 5.1](#) DADH Drive Belt Adjustment.

REP 5.5 Baffle Assembly

Parts List on [PL 5.30](#)

Removal

WARNING

Switch off the electricity to the machine. Refer to [GP 14](#). Disconnect the power cord from the customer supply while performing tasks that do not need electricity. Electricity can cause death or injury. Moving parts can cause injury.

WARNING

Take care during this procedure. Sharp edges may be present that can cause injury.

1. Remove the DADH, [REP 5.19](#).
2. Remove the top access cover assembly, [REP 5.2](#).
3. Remove the feed assembly, [REP 5.3](#).
4. Remove the input tray assembly, [REP 5.4](#).
5. Remove the CVT roll, [REP 5.15](#).
6. Prepare to remove the baffle assembly, [Figure 1](#).

CAUTION

When the top access cover assembly, feed assembly, input tray assembly and CVT roll are removed the DADH structure is weak. Do not lower the DADH in this configuration.

7. Carefully install the DADH frame on the machine. Secure the DADH with the two thumb-screws.

CAUTION

Be careful to prevent damage to the document pad when the document pad is removed from the baffle assembly.

8. Move the baffle assembly lower cover to give access, [Figure 2](#).

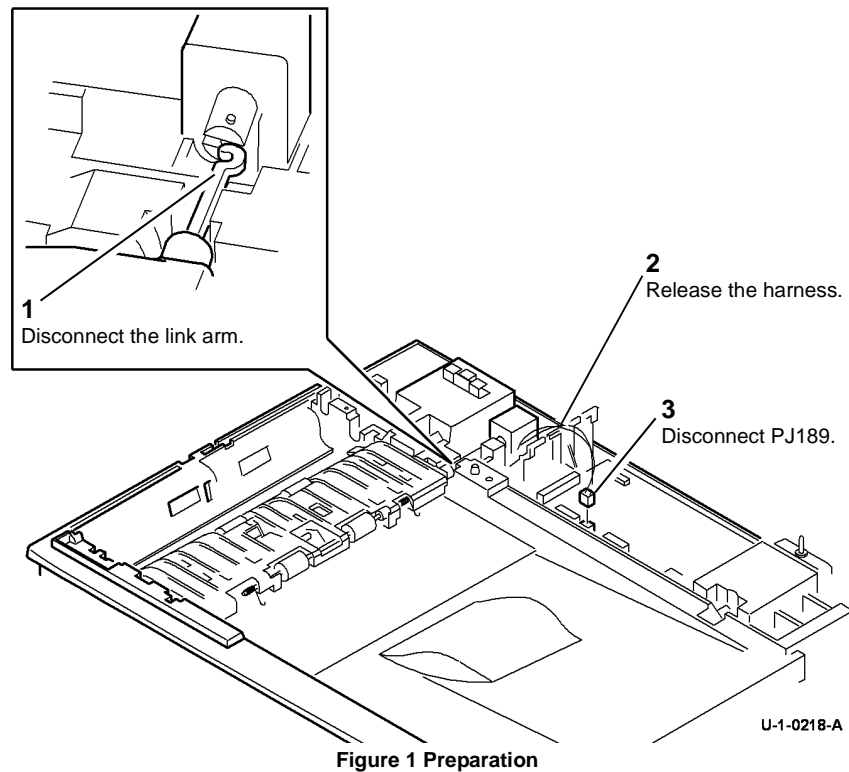

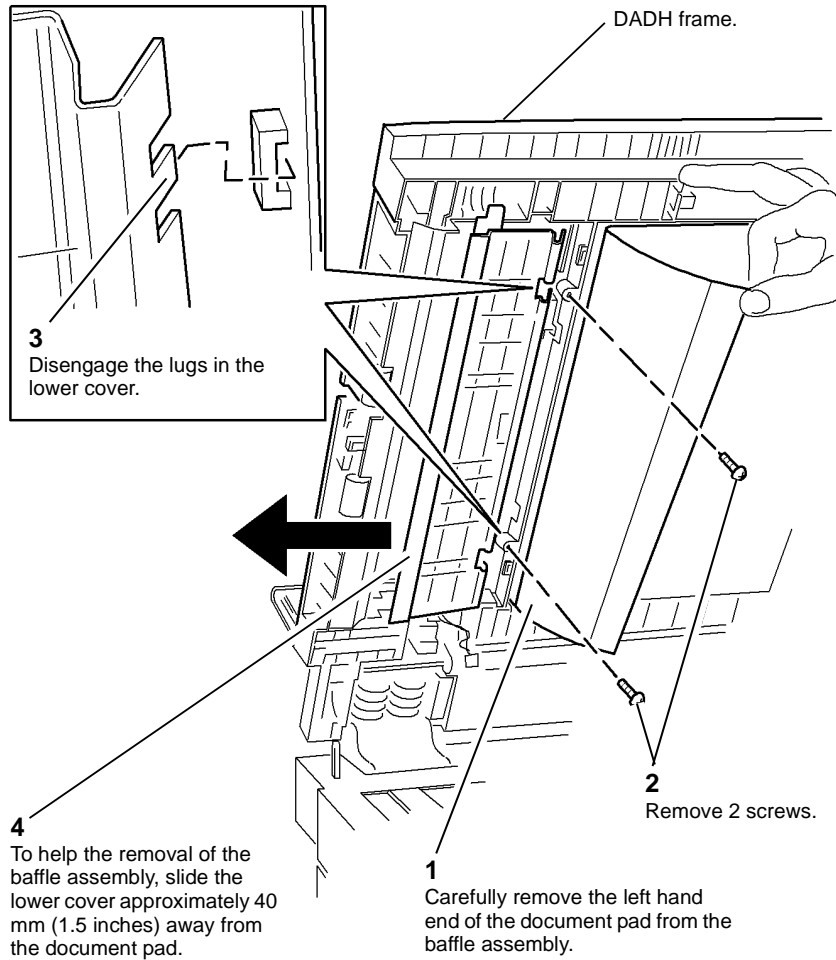

Figure 2 Lower cover movement

U-1-0219-A

10. Remove the baffle assembly, [Figure 3](#).

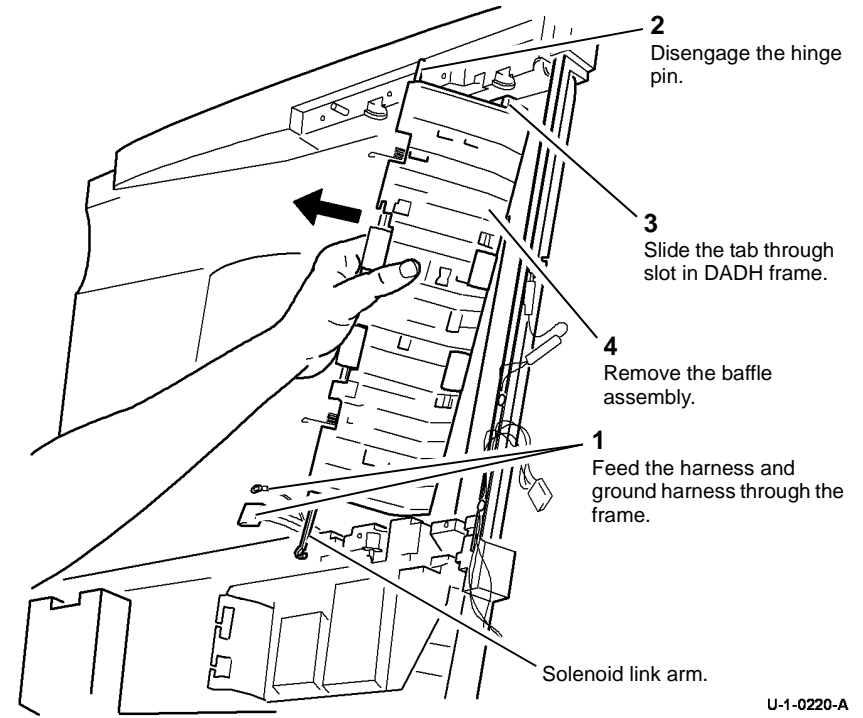

Figure 3 Baffle assembly

U-1-0220-A

9. Disconnect PJ196 from the exit sensor and remove the exit sensor, [REP 5.11](#).

CAUTION

Take care removing the baffle assembly, do not damage the solenoid link arm.

Replacement

The replacement is the reverse of the removal procedure. Make sure that the torsion springs and harness are in the correct position, [Figure 4](#).

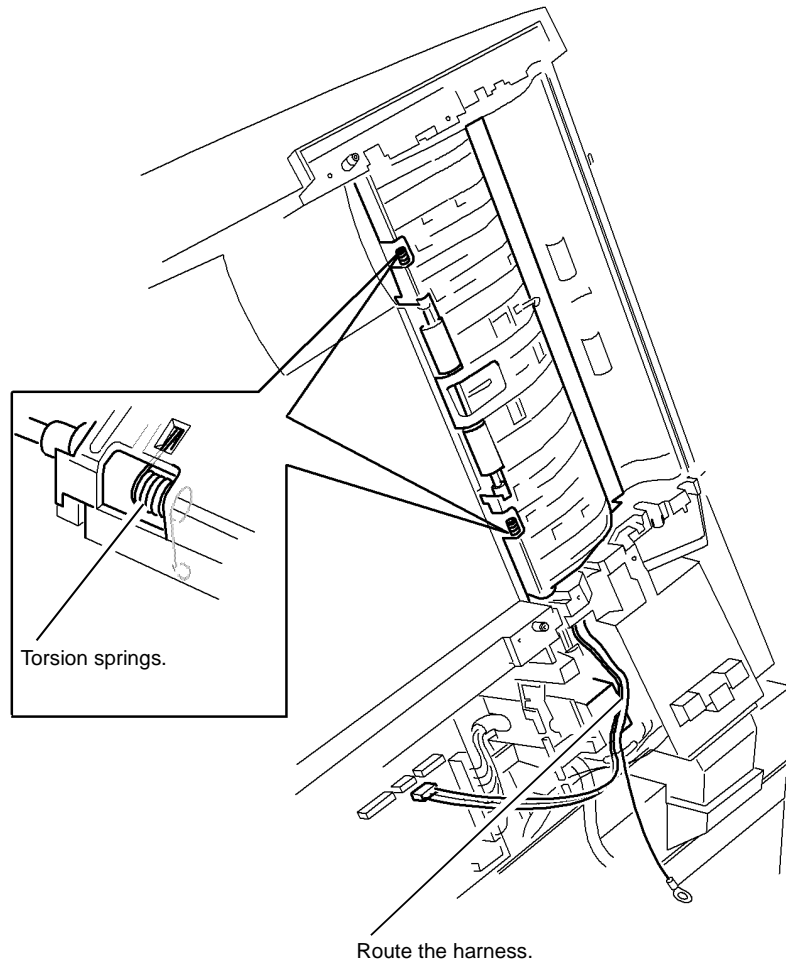

U-1-0221-A

Figure 4 Torsion springs and harness

REP 5.6 Takeaway Roll Assembly

Parts List on [PL 5.35](#)

Removal

WARNING

Switch off the electricity to the machine. Refer to [GP 14](#). Disconnect the power cord from the customer supply while performing tasks that do not need electricity. Electricity can cause death or injury. Moving parts can cause injury.

WARNING

Take care during this procedure. Sharp edges may be present that can cause injury.

1. Remove the feed assembly, [REP 5.3](#).

- Remove the takeaway roll assembly, [Figure 1](#).

NOTE: To release the tension of the drive belt on the feed motor, refer to [ADJ 5.1](#).

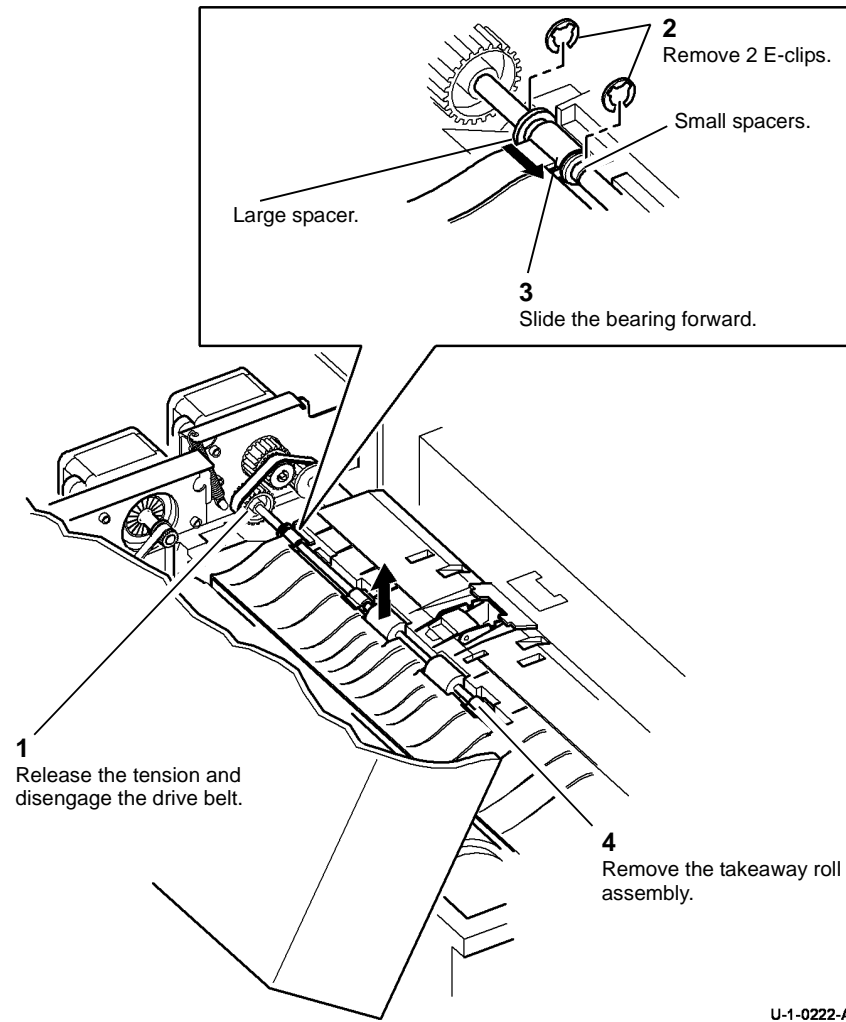

Figure 1 Takeaway roll assembly

U-1-0222-A

Replacement

The replacement is the reverse of the removal procedure. Make sure the spacers and E-clips are installed correctly, refer to [Figure 1](#).

REP 5.7 Duplex Solenoid

Parts List on [PL 5.30](#)

Removal

WARNING

Switch off the electricity to the machine. Refer to [GP 14](#). Disconnect the power cord from the customer supply while performing tasks that do not need electricity. Electricity can cause death or injury. Moving parts can cause injury.

WARNING

Take care during this procedure. Sharp edges may be present that can cause injury.

- Remove the DADH rear cover, [PL 5.10 Item 1](#).
- Prepare to remove the drive assembly, [Figure 1](#).

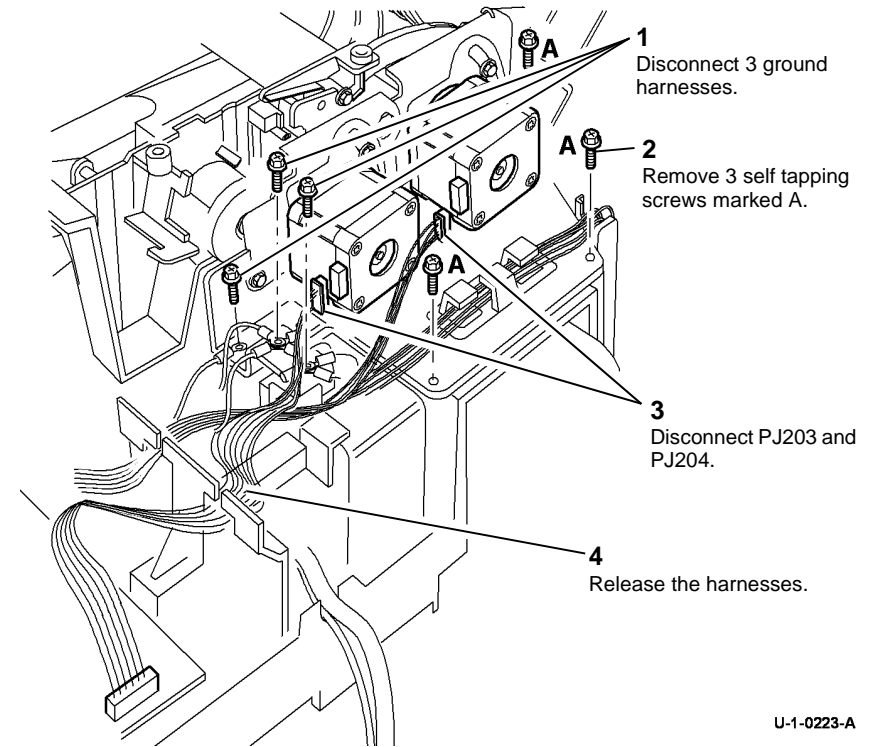
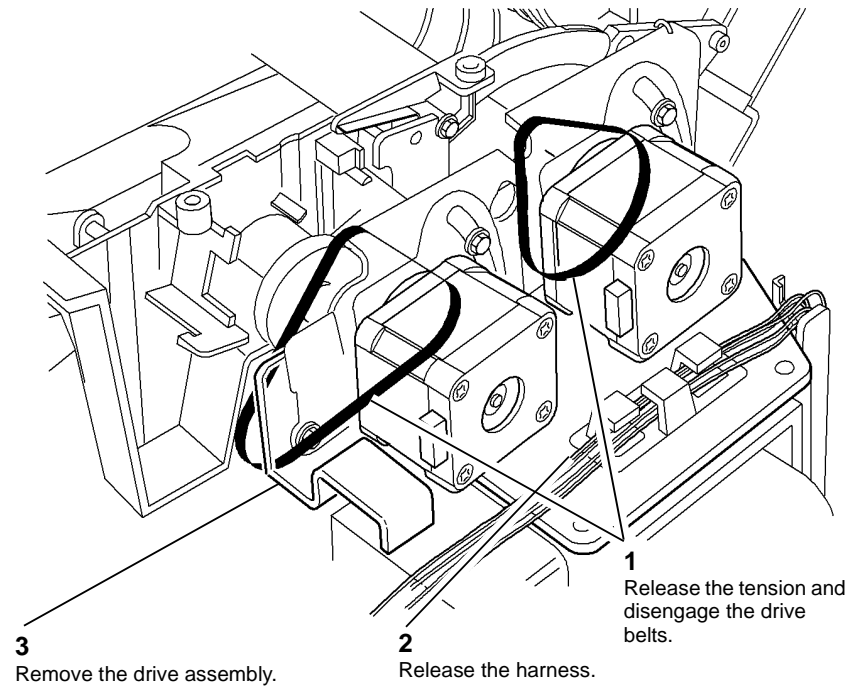

Figure 1 Drives assembly

U-1-0223-A

NOTE: To release the tension on the drive belts, refer to [ADJ 5.1](#).

3. Remove the drive assembly, [Figure 2](#).



U-1-0224-A

Figure 2 Drives assembly

4. Remove the duplex solenoid, [Figure 3](#).

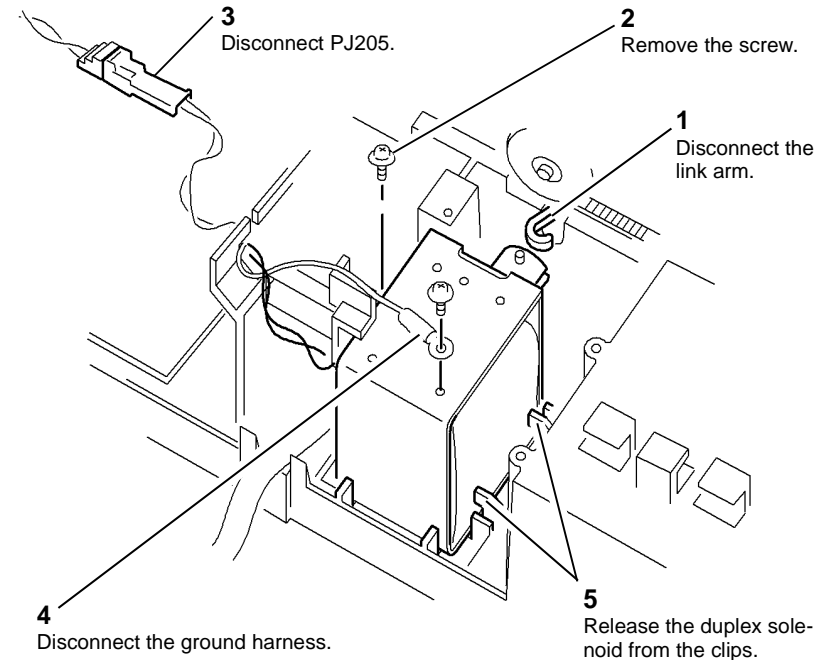

U-1-0225-A

Figure 3 Duplex solenoid

Replacement

CAUTION

The screw that attaches the ground harness to the duplex solenoid is shorter than the other screws. Do not use the incorrect screw.

1. The replacement is the reverse of the removal procedure. Make sure that the wiring is not caught below the drive assembly.
2. Perform the DADH motor adjustment, [ADJ 5.1](#).

REP 5.8 Takeaway and CVT Sensor

Parts List on [PL 5.20](#)

Removal

WARNING

Switch off the electricity to the machine. Refer to [GP 14](#). Disconnect the power cord from the customer supply while performing tasks that do not need electricity. Electricity can cause death or injury. Moving parts can cause injury.

WARNING

Take care during this procedure. Sharp edges may be present that can cause injury.

1. Remove the DADH top cover assembly, [REP 5.1](#).
2. Remove the takeaway or CVT sensor, [Figure 1](#).

2

Disconnect the correct PJ. Remove the correct sensor.

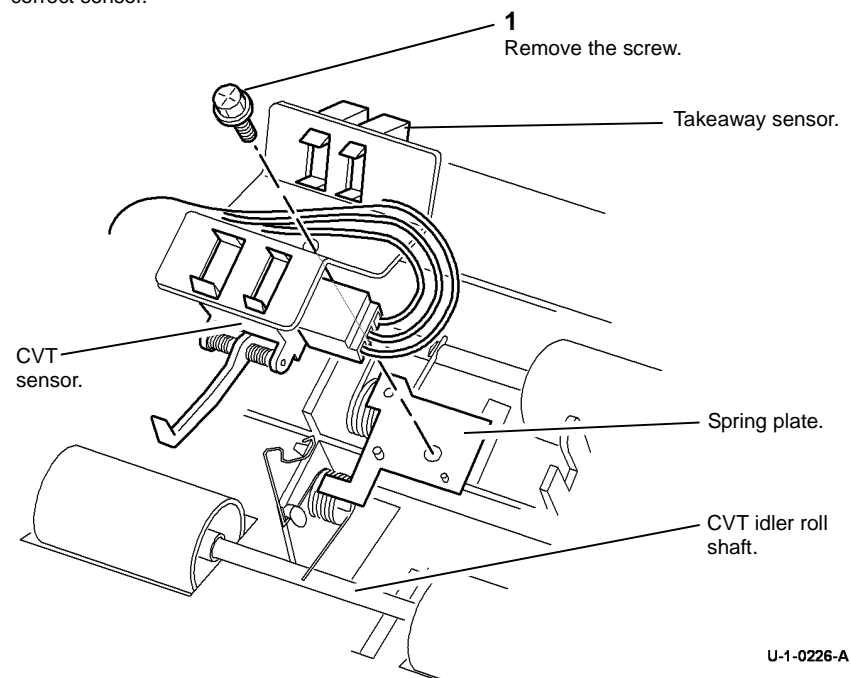

Figure 1 Takeaway and CVT sensors

Replacement

The replacement is the reverse of the removal procedure. Make sure the spring plate and idler roll torsion springs are in the correct position. Also make sure that the CVT sensor actuator is in the correct position below the CVT roll and the idler shaft. Refer to [Figure 1](#) and [Figure 2](#). Then install the top cover assembly,

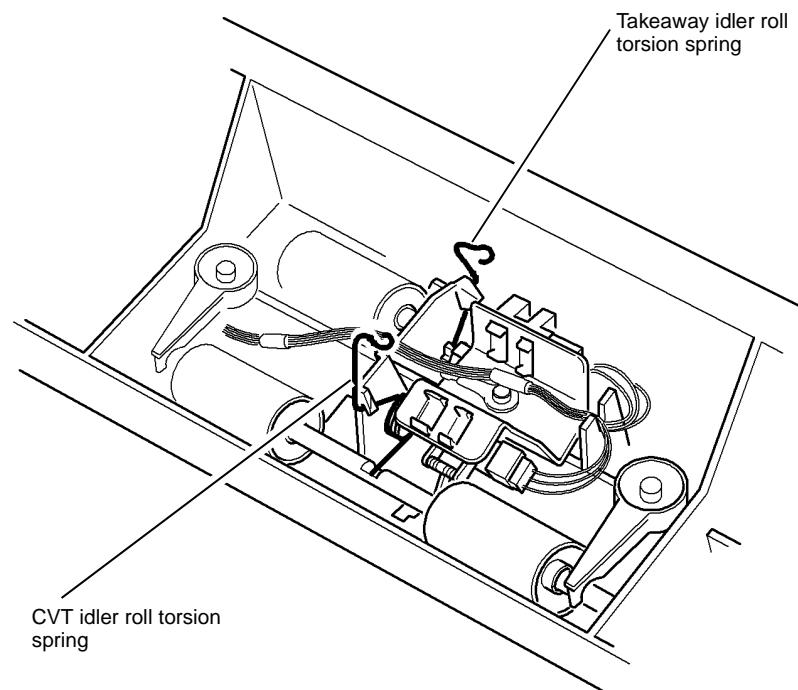

Figure 2 Torsion springs

REP 5.9 DADH Tray Size Sensors

Parts List on [PL 5.35](#)

Removal

WARNING

Switch off the electricity to the machine. Refer to [GP 14](#). Disconnect the power cord from the customer supply while performing tasks that do not need electricity. Electricity can cause death or injury. Moving parts can cause injury.

1. Remove the input tray assembly, [REP 5.4](#).

CAUTION

Disconnect the ground harness from the static eliminator before the input tray assembly lower cover is removed, refer to [Figure 1](#).

2. Turn the input tray assembly upside down, then remove the Lower cover right, [PL 5.35](#) Item 9.
3. Remove the relevant sensor, [Figure 1](#).

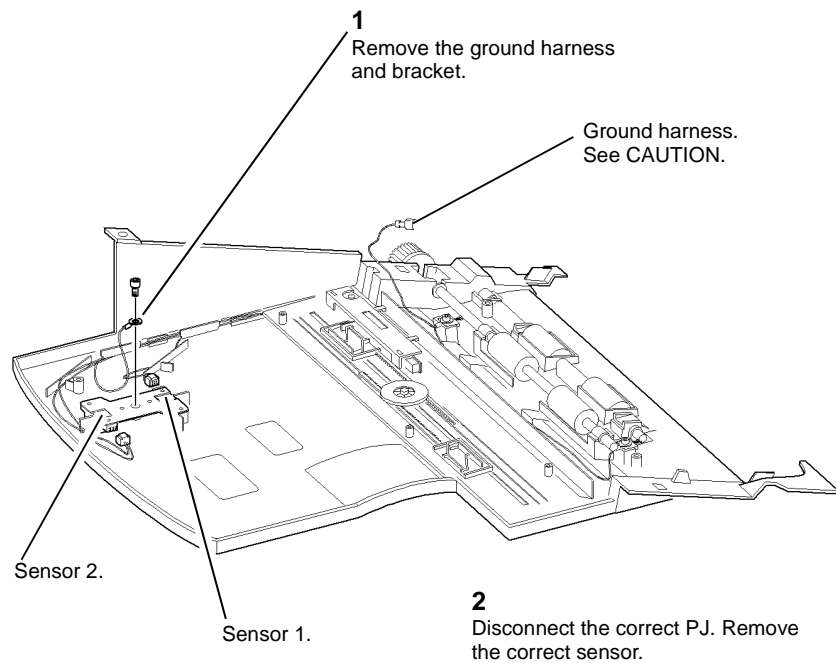

Figure 1 Tray size sensors

Replacement

The replacement is the reverse of the removal procedure.

REP 5.10 Registration Sensor

Parts List on [PL 5.25](#)

Removal

WARNING

Switch off the electricity to the machine. Refer to [GP 14](#). Disconnect the power cord from the customer supply while performing tasks that do not need electricity. Electricity can cause death or injury. Moving parts can cause injury.

1. Remove the DADH, top cover assembly, [REP 5.1](#).
2. Remove the registration sensor, [Figure 1](#).

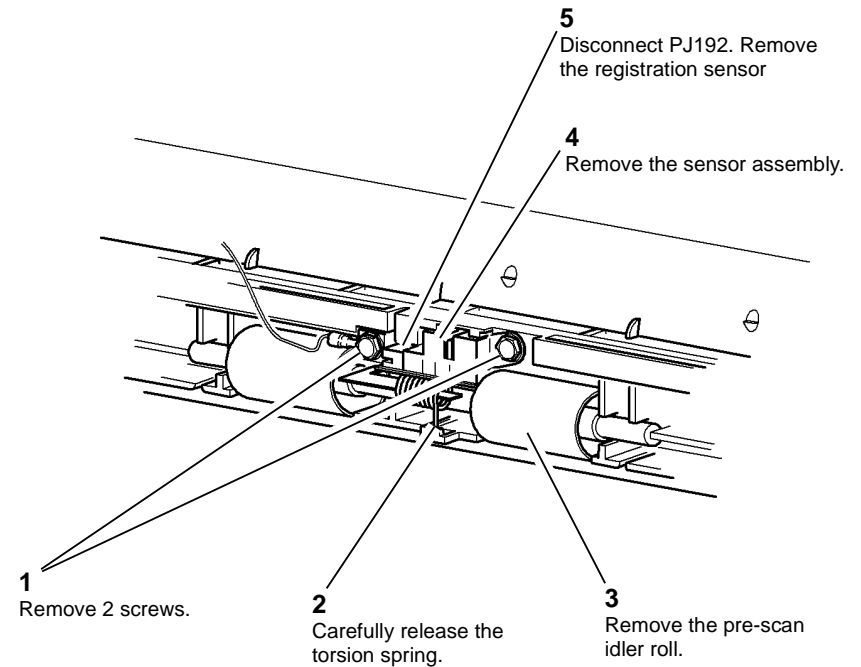

Figure 1 Registration sensor

Replacement

The replacement is the reverse of the removal procedure. Make sure that the torsion spring is installed correctly, [Figure 2](#).

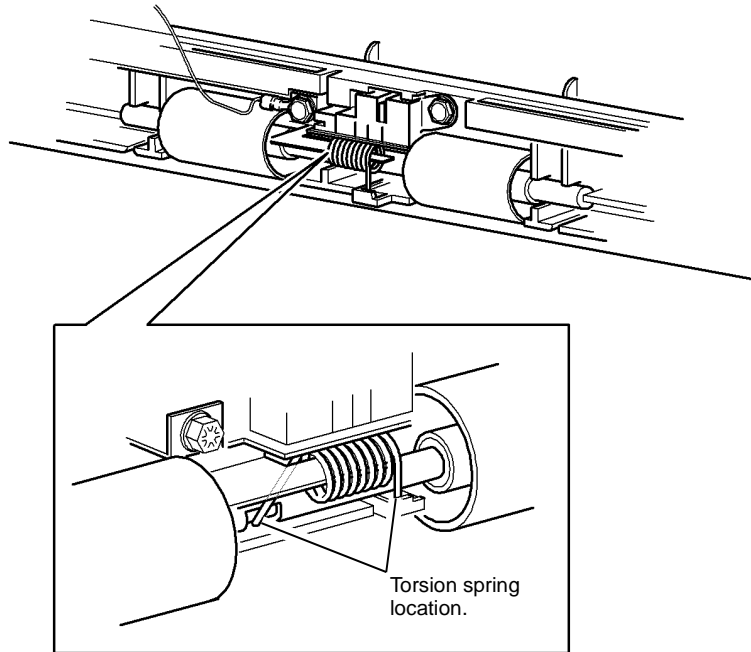

Figure 2 Torsion spring location

U-1-0230-A

REP 5.11 Exit Sensor

Parts List on [PL 5.30](#)

Removal

WARNING

Switch off the electricity to the machine. Refer to [GP 14](#). Disconnect the power cord from the customer supply while performing tasks that do not need electricity. Electricity can cause death or injury. Moving parts can cause injury.

1. Raise the DADH.

CAUTION

Be careful to prevent damage to the document pad when the document pad is removed from the baffle assembly.

2. Prepare to remove the exit sensor, **Figure 1**.

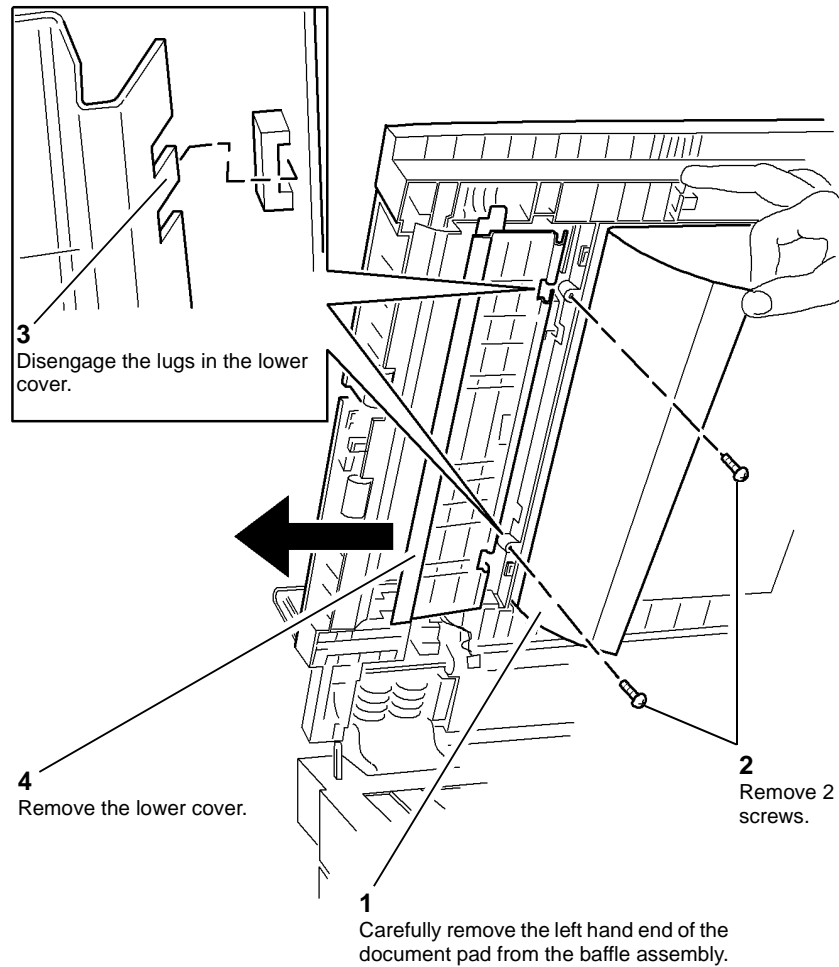

U-1-0231-A

Figure 1 Preparation

3. Remove the exit sensor, **Figure 2**.

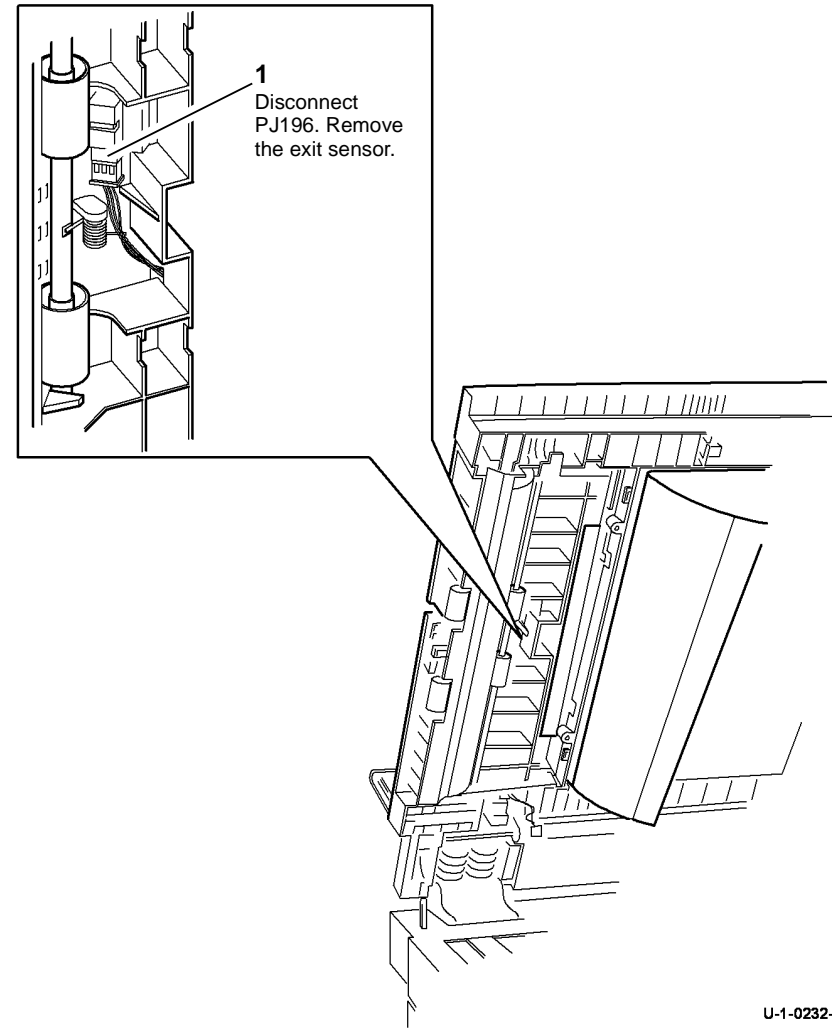

U-1-0232-A

Figure 2 Exit sensor removal

Replacement

The replacement is the reverse of the removal procedure.

REP 5.12 DADH Counterbalance

Parts List on [PL 5.10](#)

Removal

WARNING

Switch off the electricity to the machine. Refer to [GP 14](#). Disconnect the power cord from the customer supply while performing tasks that do not need electricity. Electricity can cause death or injury. Moving parts can cause injury.

WARNING

Do not remove the DADH while the DADH is lowered. In the lowered position the counterbalance springs are compressed and can cause injury when released.

WARNING

Take care during this procedure. Sharp edges may be present that can cause injury.

1. Remove the DADH, [REP 5.19](#).
2. Put the DADH upside down on a solid flat surface.

NOTE: The counterbalances are different. The removal procedure for the two counterbalances is same.

3. Remove the relevant counterbalance, right, [PL 5.10 Item 2](#) (4 screws) or left, [PL 5.10 Item 4](#) (4 screws).

Replacement

1. The replacement is the reverse of the removal procedure.
2. Perform the steps that follow:
 - DADH height adjustment, [ADJ 5.2](#).
 - DADH registration adjustment, [ADJ 5.5](#).
3. If a new right counterbalance has been installed, perform the DADH skew adjustment, [ADJ 5.3](#).

REP 5.13 Exit Roll Assembly

Parts List on [PL 5.35](#)

Removal

WARNING

Switch off the electricity to the machine. Refer to [GP 14](#). Disconnect the power cord from the customer supply while performing tasks that do not need electricity. Electricity can cause death or injury. Moving parts can cause injury.

1. Remove the feed assembly, [REP 5.3](#).
2. Remove the input tray assembly, [REP 5.4](#).

CAUTION

Disconnect the ground harness from the static eliminator before the input tray assembly lower cover left is removed, refer to [Figure 1](#).

3. Turn the input tray assembly upside down. Remove the Lower cover (right), [PL 5.35 Item 9](#) and Lower cover (left), [PL 5.35 Item 20](#).
4. Remove the exit roll assembly, [Figure 1](#).

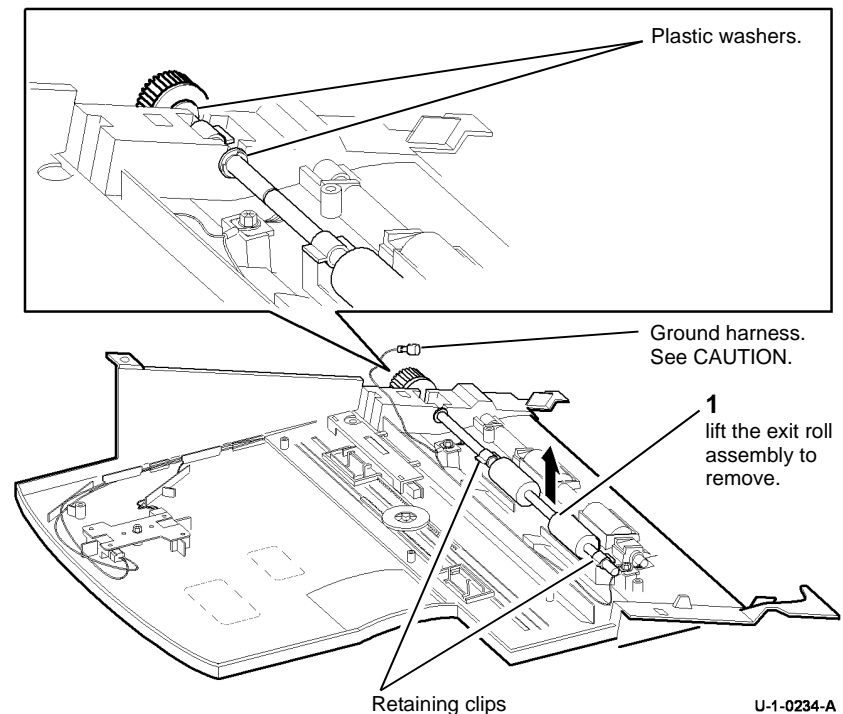

Figure 1 Exit roll assembly removal

Replacement

1. Place the exit roll assembly in position, ensure that the plastic washers are located on either side of the housing, refer to [Figure 1](#).
2. Press the retaining clips into their locating holes, refer to [Figure 1](#).
3. The remainder of the replacement procedure is the reverse of the removal procedure.

REP 5.14 Feed Roll Assembly

Parts List on [PL 5.15](#)

Removal

WARNING

Switch off the electricity to the machine. Refer to [GP 14](#). Disconnect the power cord from the customer supply while performing tasks that do not need electricity. Electricity can cause death or injury. Moving parts can cause injury.

1. Open the DADH top cover.

2. Remove the DADH feed roll assembly, [Figure 1](#).

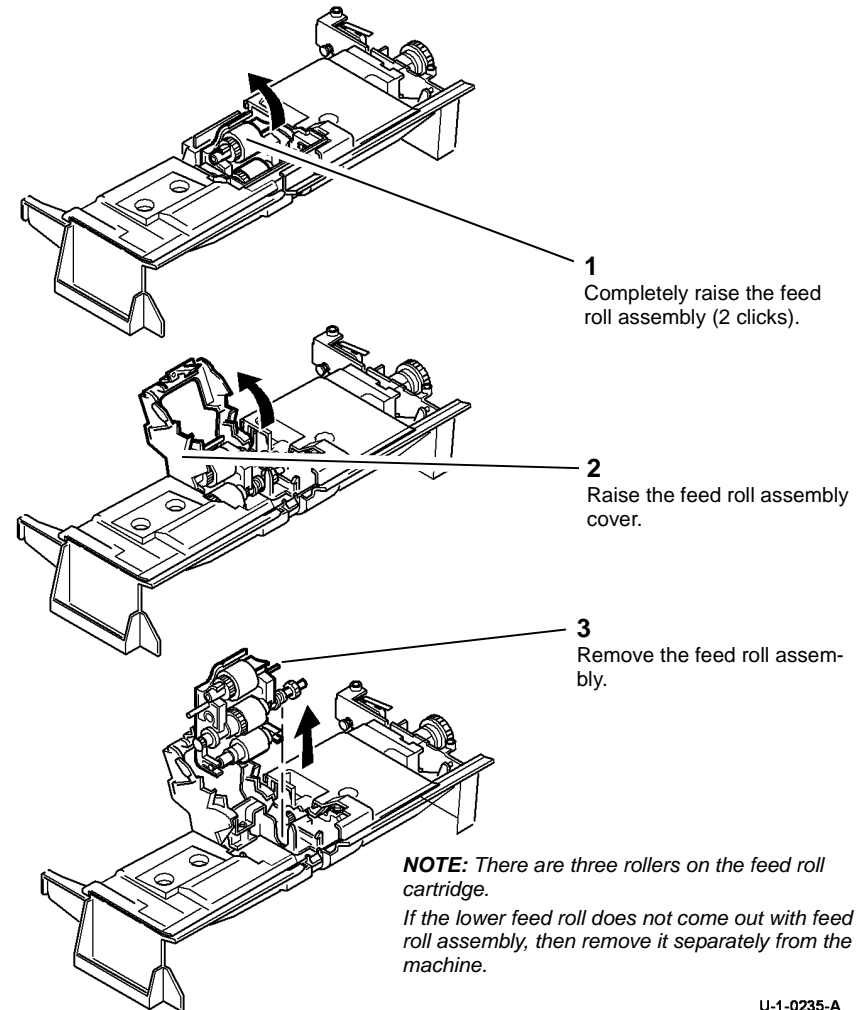

U-1-0235-A

Figure 1 Feed roll assembly

Replacement

1. The replacement is the reverse of the removal procedure. When the feed rolls are installed, make sure the lowest roll, (retard roll), is positioned as shown in [Figure 2](#).
2. If a new feed roll assembly is installed, reset the DADH feed count to zero. Refer to [dC135 CRU / HFSI Status](#).

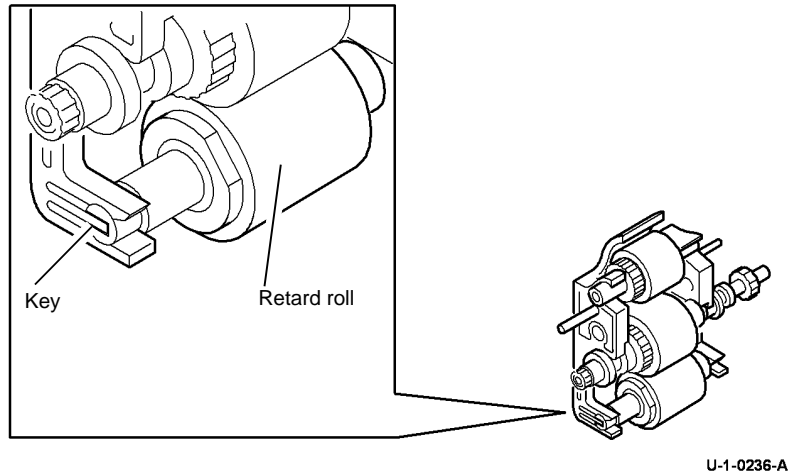

Figure 2 Retard roll position

U-1-0236-A

REP 5.15 Duplex Gate, CVT Roll and CVT Motor, Drive Belt

Parts List on [PL 5.25](#)

Removal

WARNING

Switch off the electricity to the machine. Refer to [GP 14](#). Disconnect the power cord from the customer supply while performing tasks that do not need electricity. Electricity can cause death or injury. Moving parts can cause injury.

1. Remove the feed assembly, [REP 5.3](#).
2. Remove the input tray assembly, [REP 5.4](#).
3. Remove the DADH drive assembly, refer to [REP 5.7](#).
4. Remove the duplex gate, [Figure 1](#).

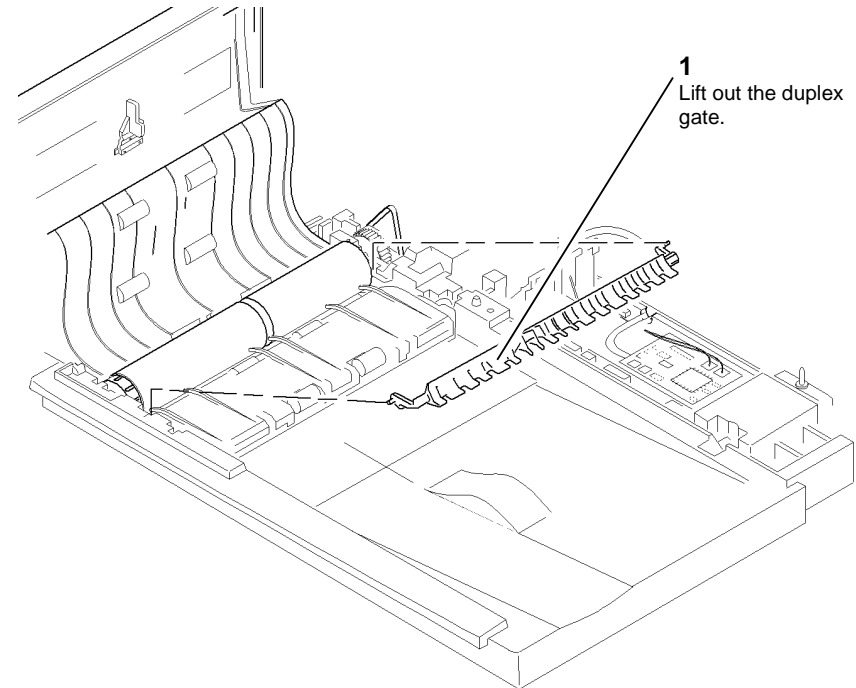

Figure 1 Duplex gate

U-1-0237-A

CAUTION

When the top access cover assembly, feed assembly, input tray assembly and CVT roll are removed the DADH structure is weak. Do not lower the DADH in this configuration

5. Carefully install the DADH frame on the machine. Secure the DADH with the 2 thumb-screws.

6. Disengage the back CVT roll bearing, [Figure 2](#).

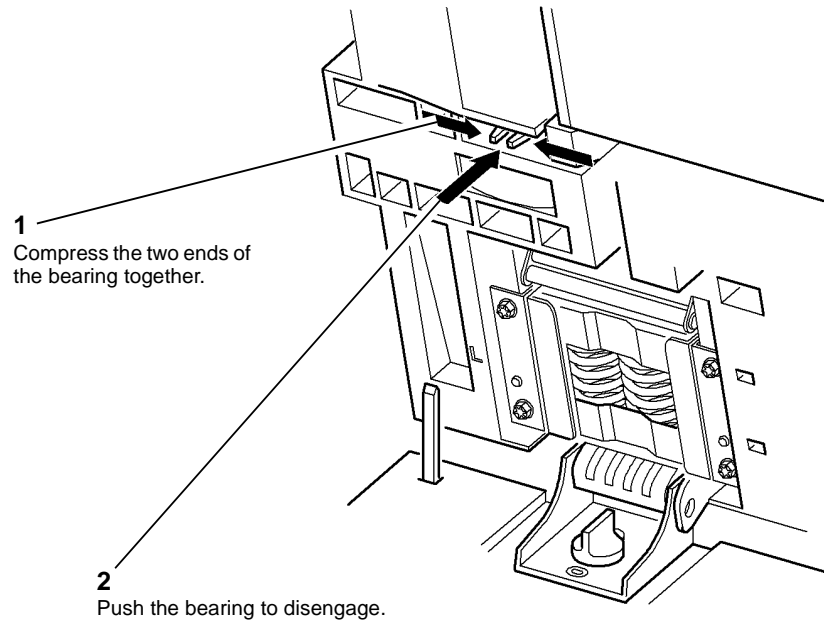

U-1-0238-A

Figure 2 Bearing

7. Release the front CVT roll bearing, [PL 5.25 Item 4](#). Remove the CVT roll and CVT motor, drive belt, [Figure 3](#).

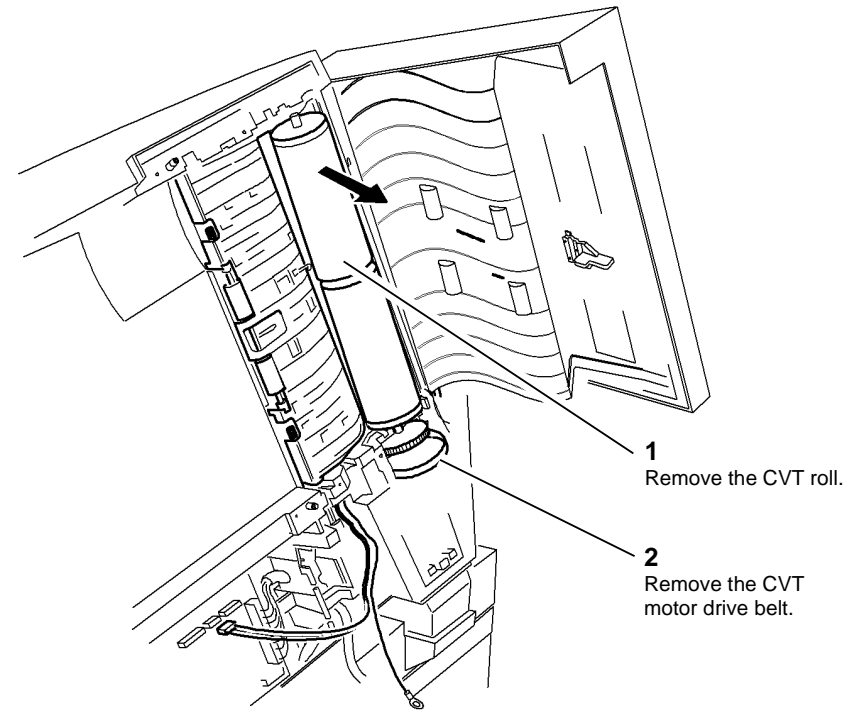

U-1-0239-A

Figure 3 CVT roll

Replacement

1. The replacement is the reverse of the removal procedure. Make sure the white washer is installed correctly, [Figure 4](#).
2. Perform the DADH CVT motor adjustment, refer to [ADJ 5.1](#).

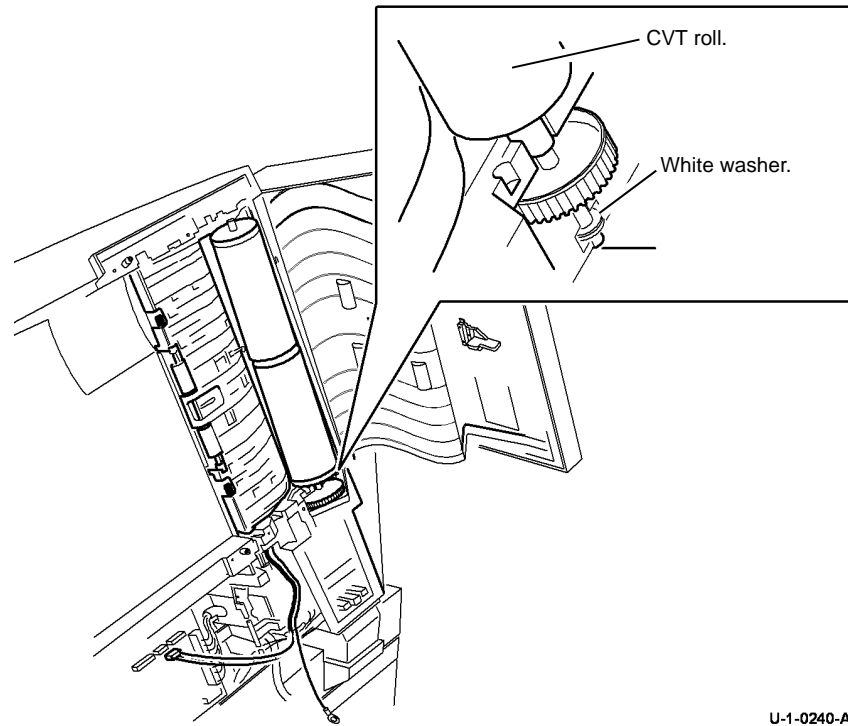

Figure 4 Replacement

REP 5.16 Document Width Sensor

Parts List on [PL 5.35](#)

Removal

WARNING

Switch off the electricity to the machine. Refer to [GP 14](#). Disconnect the power cord from the customer supply while performing tasks that do not need electricity. Electricity can cause death or injury. Moving parts can cause injury.

1. Remove the feed assembly, [REP 5.3](#).
2. Remove the input tray assembly, [REP 5.4](#).

CAUTION

Disconnect the ground harness from the static eliminator before the input tray assembly lower cover is removed, refer to [Figure 1](#).

3. Turn the input tray assembly upside down, then remove the Lower cover right, [PL 5.35 Item 9](#) and Lower cover left, [PL 5.35 Item 20](#)

- Remove the document width sensor, [Figure 1](#).

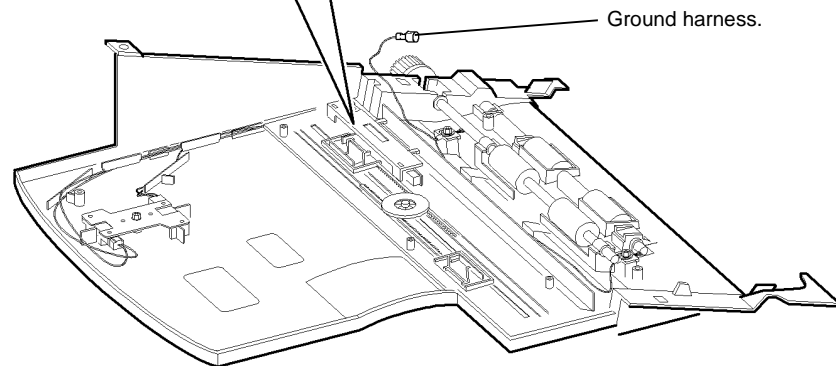
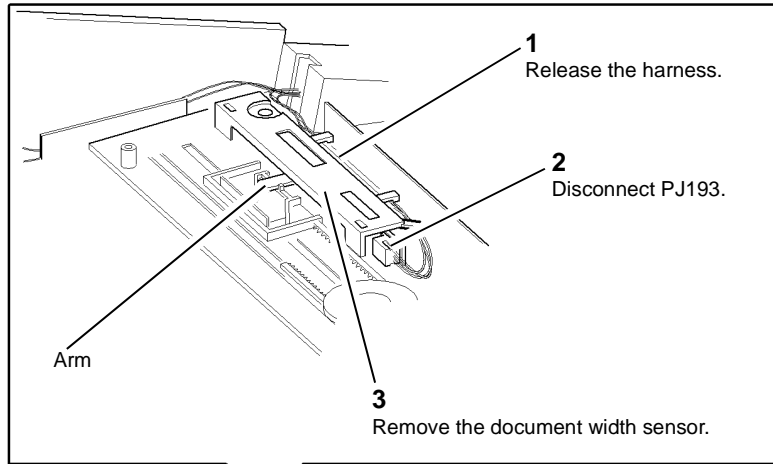

U-1-0241-A

Figure 1 Document width sensor

Replacement

The replacement is the reverse of the removal procedure. Make sure the document width sensor arm is attached correctly, refer to [Figure 1](#).

REP 5.17 Input Tray Static Eliminator

Parts List on [PL 5.35](#)

Removal

WARNING

Switch off the electricity to the machine. Refer to [GP 14](#). Disconnect the power cord from the customer supply while performing tasks that do not need electricity. Electricity can cause death or injury. Moving parts can cause injury.

- Remove the input tray assembly, [REP 5.4](#).

CAUTION

Disconnect the ground harness from the static eliminator before the input tray assembly lower cover is removed, refer to [Figure 1](#)

- Turn the input tray assembly upside down, then remove the Lower cover (right), [PL 5.35 Item 9](#) and Lower cover (left), [PL 5.35 Item 20](#).
- Remove the input tray static eliminators, [Figure 1](#).

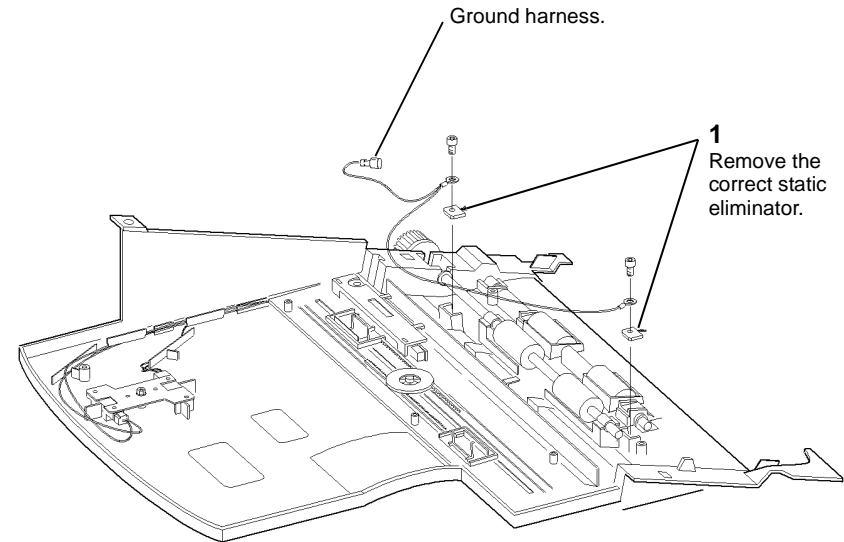

U-1-0242-A

Figure 1 Static eliminators

Replacement

The replacement is the reverse of the removal procedure.

REP 5.18 Exit Roll Idler

Parts List on **PL 5.30**

Removal

WARNING

Switch off the electricity to the machine. Refer to **GP 14**. Disconnect the power cord from the customer supply while performing tasks that do not need electricity. Electricity can cause death or injury. Moving parts can cause injury.

1. Remove the baffle assembly lower cover, **PL 5.30** Item 1.
2. Remove the baffle assembly, **REP 5.5**.
3. Prepare to remove the exit roll idlers, **Figure 1**.

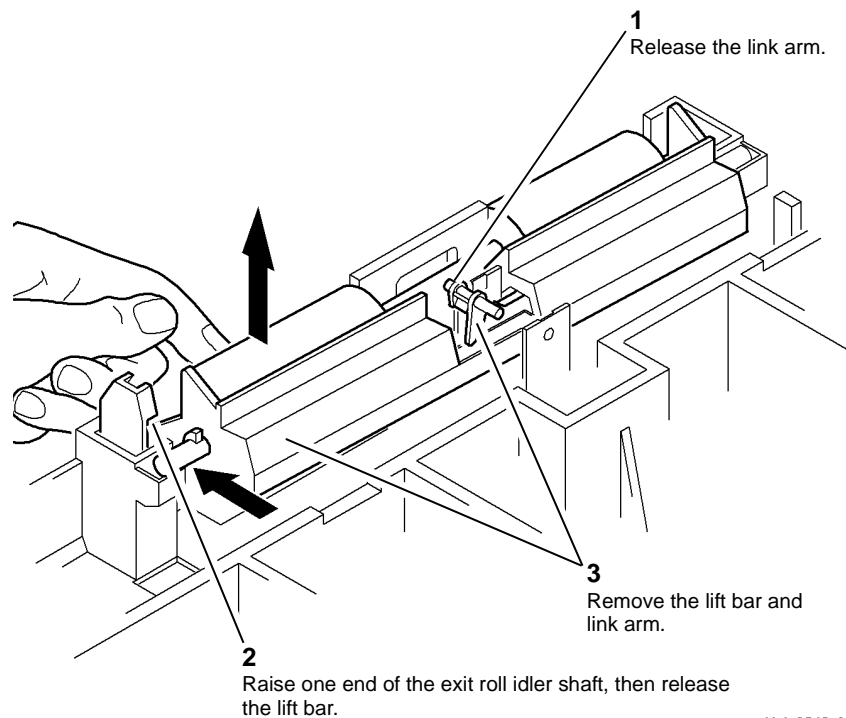

Figure 1 Preparation

4. Remove the exit roll idlers, **Figure 2**.

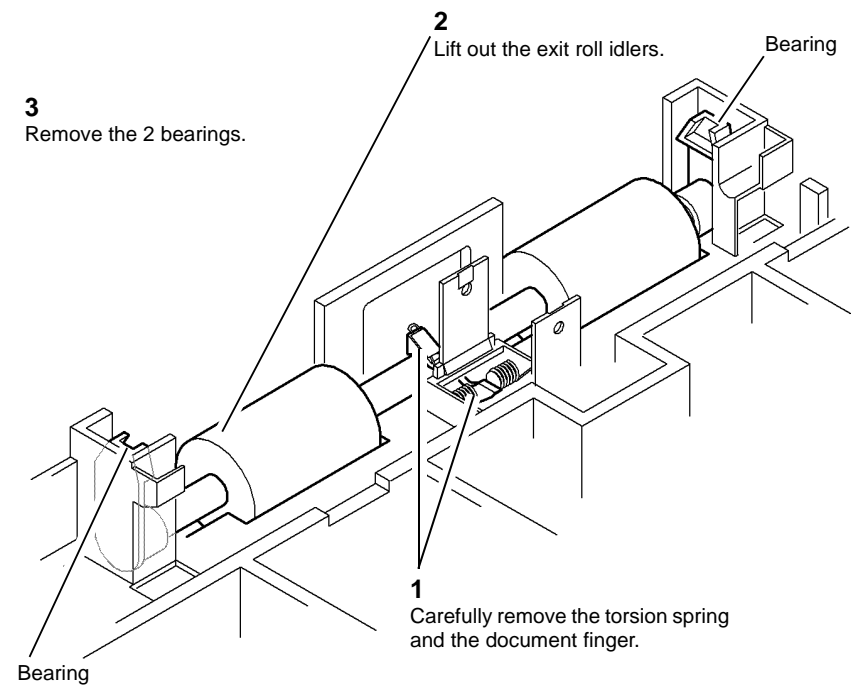
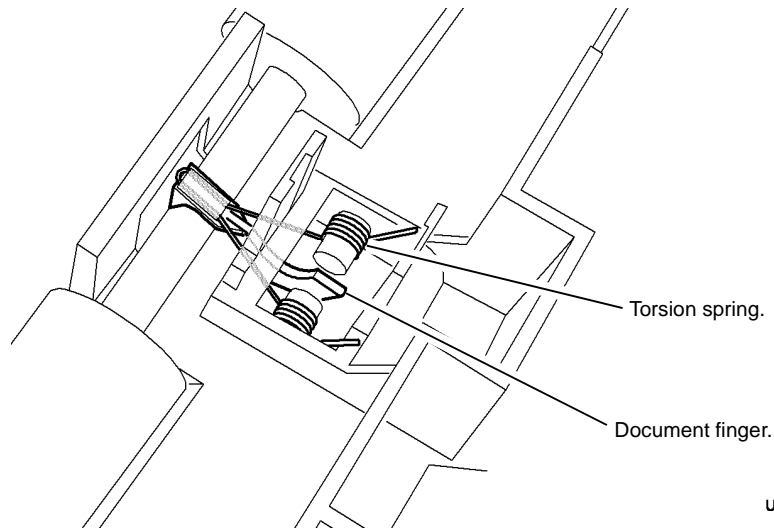

Figure 2 Exit roll idlers

U-1-0244-A

Replacement

The replacement is the reverse of the removal procedure. Make sure that the torsion spring and document finger are installed correctly, refer to [Figure 3](#).



U-1-0245-A

Figure 3 Torsion spring and document finger

REP 5.19 DADH Removal

Parts List on [PL 5.10](#)

Removal

WARNING

Switch off the electricity to the machine. Refer to [GP 14](#). Disconnect the power cord from the customer supply while performing tasks that do not need electricity. Electricity can cause death or injury. Moving parts can cause injury.

WARNING

Do not remove the DADH while the DADH is lowered. In the lowered position the counterbalance springs are compressed and can cause injury when released.

WARNING

Take care during this procedure. Sharp edges may be present that can cause injury.

1. Disconnect the communication/power cable, [PL 5.10 Item 6](#) and the DADH ground harness, [PL 5.10 Item 11](#).
2. Raise the DADH.

WARNING

Use safe handling procedures when removing the module, [GP 16](#). The module is heavy.

NOTE: The DADH weight is 13Kg (29lb.).

- Remove the DADH from the machine, [Figure 1](#).

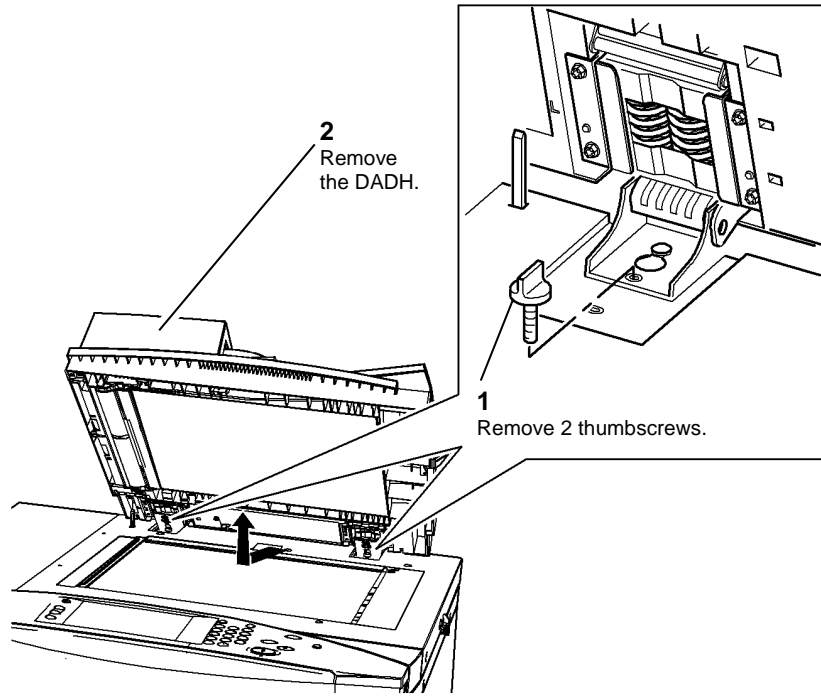

Figure 1 DADH removal

U-1-0246-A

Replacement

- The replacement is the reverse of the removal procedure.
- If a new DADH is installed, perform the steps that follow:
 - Attach the document pad, refer to [ADJ 5.6](#).
 - Reset the DADH feed count to zero. Refer to [dC135 CRU / HFSI Status](#).
 - DADH height adjustment, [ADJ 5.2](#).
 - DADH registration adjustment, [ADJ 5.5](#).
 - DADH skew adjustment, [ADJ 5.3](#).

REP 5.20 Mylar Guide Strip

Parts List on [PL 5.30](#)

Removal

WARNING

Switch off the electricity to the machine. Refer to [GP 14](#). Disconnect the power cord from the customer supply while performing tasks that do not need electricity. Electricity can cause death or injury. Moving parts can cause injury.

- Raise the DADH.
- Open the baffle assembly, [PL 5.30 Item 14](#).
- Remove the old mylar guide strip, [PL 5.30 Item 12](#).
- Use cleaning fluid to remove any contamination from the baffle assembly.

Replacement

- Remove the 3 backing strips from the pressure sensitive adhesive tape on the mylar guide.
- Adhere the mylar guide to the baffle assembly, [Figure 1](#).

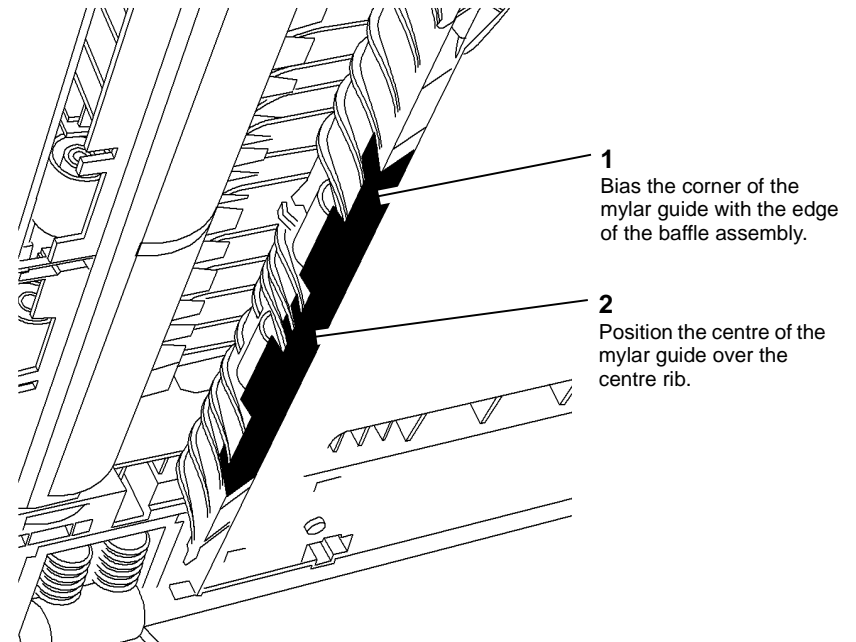

Figure 1 Mylar guide

U-1-0247-A

REP 10.1 Transfix Roller

Parts List on [PL 10.20](#)

Removal

WARNING

Switch off the electricity to the machine. Refer to [GP 14](#). Disconnect the power cord from the customer supply while performing tasks that do not need electricity. Electricity can cause death or injury. Moving parts can cause injury.

WARNING

Do not clean the stripper blade. The stripper blade is very sharp and can cause injury. If the stripper blade is dirty a new blade must be installed.

WARNING

Take care during this procedure. Sharp edges may be present that can cause injury.

CAUTION

Use care when working near the drum. The drum can be damaged easily, which will cause print quality defects.

1. Remove the exit paper path, [REP 10.20](#).
2. Remove the cleaning unit, refer to [REP 94.1](#).
3. Unlock the stripper gate, [GP 31](#) and fully lower/open the gate. This will lower and cover the stripper blade with its protective guard.
4. Remove the transfix blade, [REP 10.6](#).

5. Prepare to remove transfix roll, [Figure 1](#).

NOTE: It may be necessary to use a screwdriver to manually rotate the front and rear transfix motor shafts to move the transfix roller away from the drum.

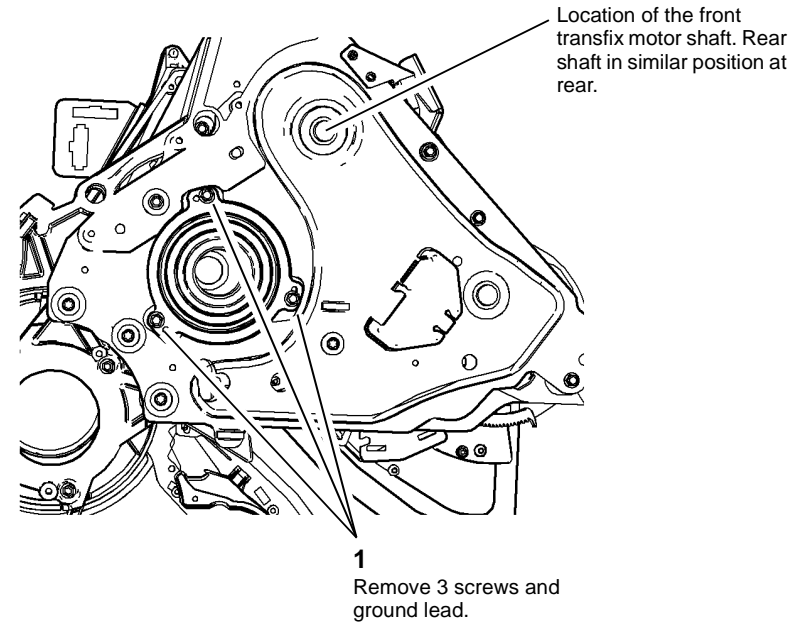

U-1-0866-A

Figure 1 Preparation

CAUTION

Support the weight at the rear of the transfix roll to avoid damage to the drum.

CAUTION

Make sure all three screws are moved to the adjacent threaded holes during removal. Leaving one screw in the original position, while attempting to remove the roller with the other two screws, can break a tab on the transfix roller. Move the screws back over to the larger, non-threaded holes for installation.

- Remove transfix roller, [Figure 2](#).

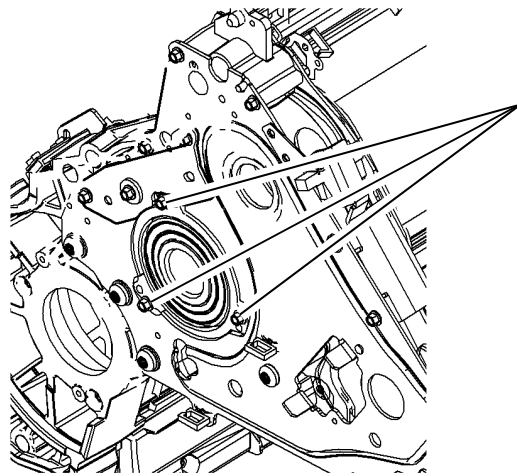

- Take note of the cautions above.
- Install the 3 screws into the adjacent threaded holes. Gradually tighten each screw in sequence to remove the bearing evenly.
- Remove the transfix roller from the front

U-1-0867-A

Figure 2 Transfix roll removal

Replacement

- Replacement is the reverse of the removal procedure.
- Clean the transfix roller and housing with a dry cloth. Remove all grease that is not necessary.

NOTE: High pressure bearing grease, [PL 26.11 Item 3](#), is used on the outside diameter of the transfix roller bearing holder. During normal removal and replacement the existing bearing grease used during manufacture will be sufficient. Only apply grease when both sides of any bearing surface are being replaced, or if the surfaces have been wiped clean. Apply the grease very sparingly.

- Ensure that the ground lead between the top transfix roller screw and the front drum frame is reconnected.

REP 10.2 Front Transfix Linkage and Gear Kit

Parts List on [PL 10.20](#)

Removal

WARNING

Switch off the electricity to the machine. Refer to [GP 14](#). Disconnect the power cord from the customer supply while performing tasks that do not need electricity. Electricity can cause death or injury. Moving parts can cause injury.

WARNING

Take care during this procedure. Sharp edges may be present that can cause injury.

CAUTION

Use care when working near the drum. The drum can be damaged easily, which will cause print quality defects.

- Remove the transfix roller, [REP 10.1](#).
- Remove the front drum shroud, [PL 94.20 Item 7](#).
- Prepare to remove the front plate, [Figure 1](#).

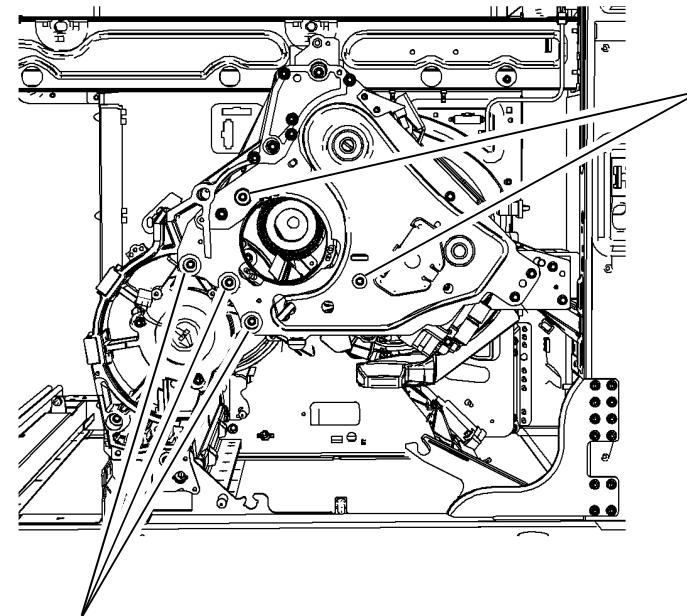

- Remove 3 T30 screws.

- Remove 2 long screws and washers.

U-1-0882-A

Figure 1 Preparation

4. Remove the front plate, [Figure 2](#).

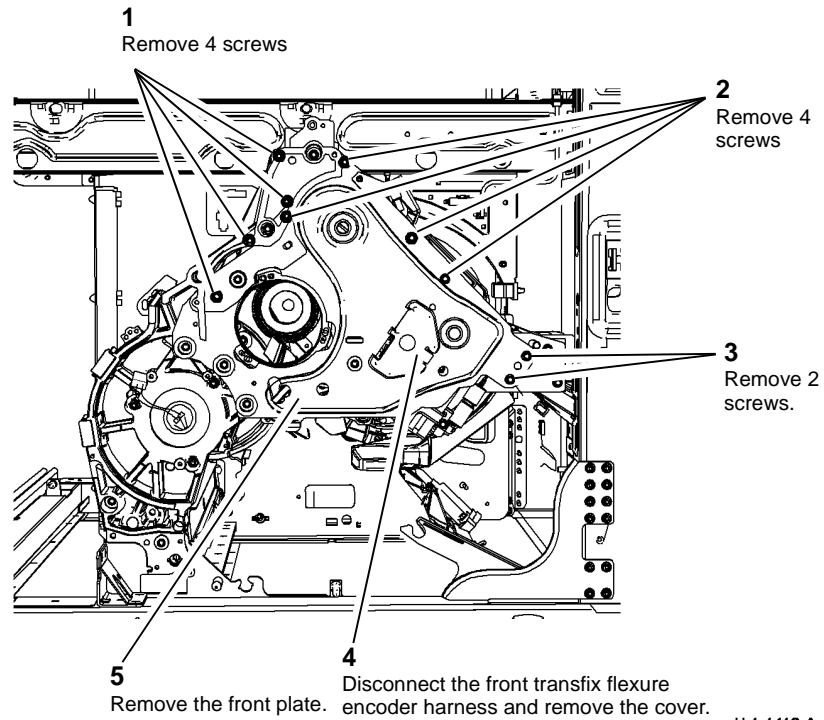

Figure 2 Front plate removal

5. Prepare to remove transfix linkage and gear, [Figure 3](#).

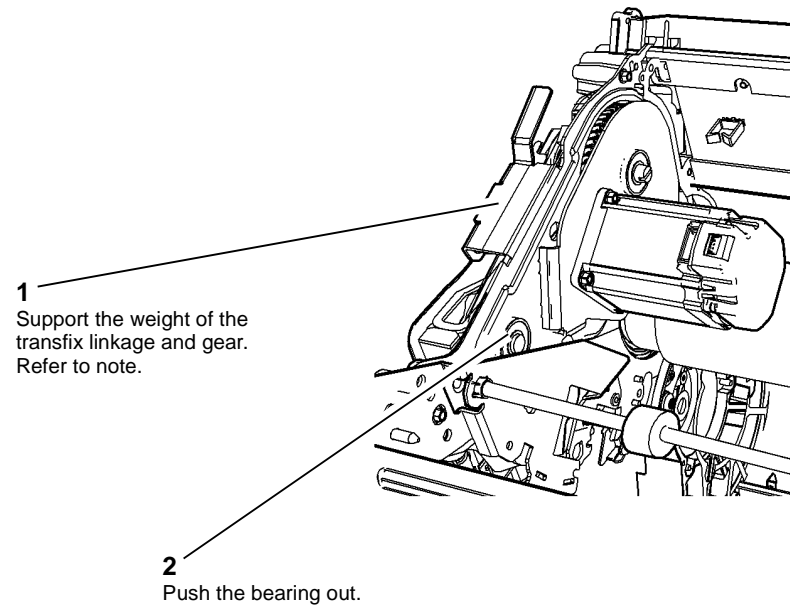

Figure 3 Preparation

NOTE: The transfix linkage and gear is shown in [Figure 5](#).

- Remove the transfix linkage and gear, [Figure 4](#).

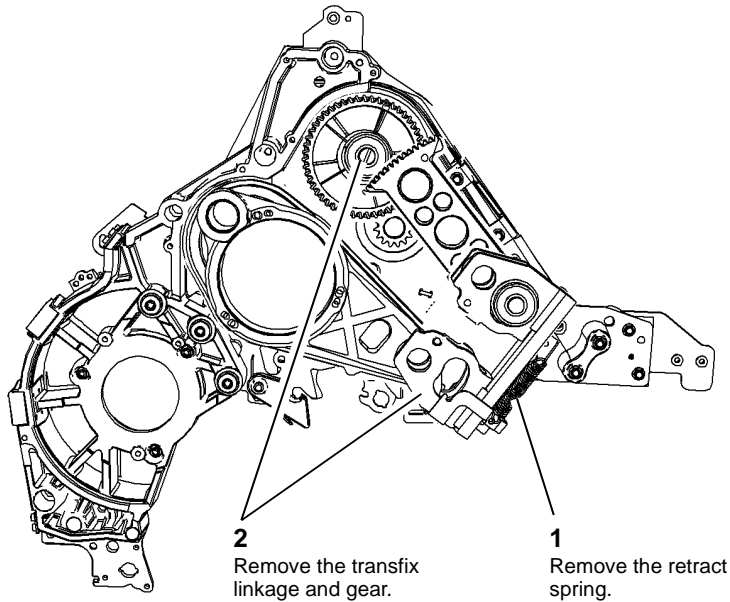

Figure 4 Transfix linkage removal

U-1-0884-A

- The removed transfix linkage is shown in [Figure 5](#).

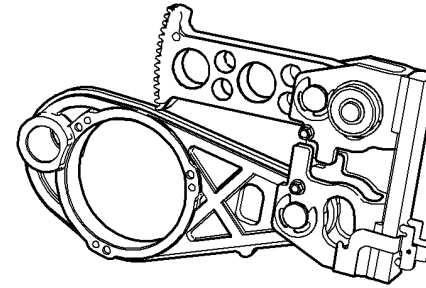

Figure 5 Transfix linkage

U-1-0885-A

Replacement

- Replacement is the reverse of the removal procedure.
- Before installing the new transfix linkage, use the transfix roller retaining screws to pre-tap the three transfix roller retaining holes in the linkage. This will prevent metal shavings from falling down into the machine during transfix roller installation.
- Ensure that the arm is in the correct position relative to the gear.
- Ensure that the spring is re-installed.
- Ensure that the ground lead between the top transfix roller screw and the front drum frame is reconnected.
- Cross out the old calibration value on the calibration label, [Figure 6](#).
- Write the new linkage calibration value on the calibration label, [Figure 6](#).

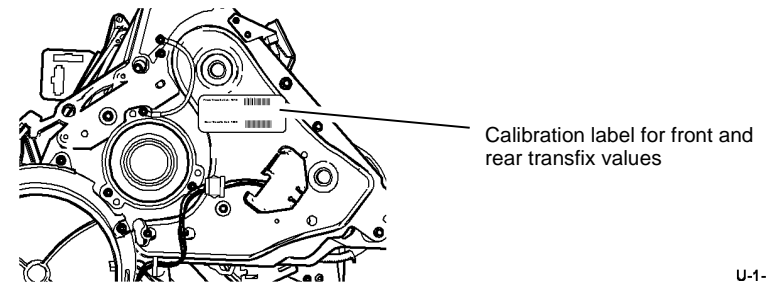

Figure 6 Calibration label

U-1-1292-A

- Perform [dC978](#) Transfix Calibration Values and load the correct values for the new linkage.

REP 10.3 Rear Transfix Linkage and Gear Kit

Parts List on [PL 10.20](#)

Removal

WARNING

Switch off the electricity to the machine. Refer to [GP 14](#). Disconnect the power cord from the customer supply while performing tasks that do not need electricity. Electricity can cause death or injury. Moving parts can cause injury.

WARNING

Take care during this procedure. Sharp edges may be present that can cause injury.

CAUTION

Use care when working near the drum. The drum can be damaged easily, which will cause print quality defects.

1. Remove the drum fan shroud, [PL 94.20](#) Item 5.
2. Remove the drum drive motor and belt, [REP 91.24](#).
3. Remove the post transfix motor (M4) and gearbox, [REP 10.8](#).
4. Remove the drum pulley, [REP 91.34](#).
5. Remove the fan assembly mount, [Figure 1](#).

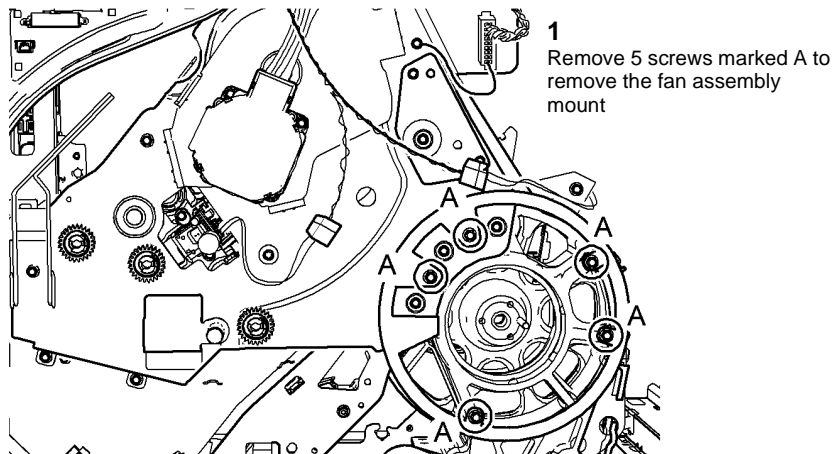

Figure 1 Fan mount removal

U-1-0886-A

6. Disconnect harnesses, [Figure 2](#).

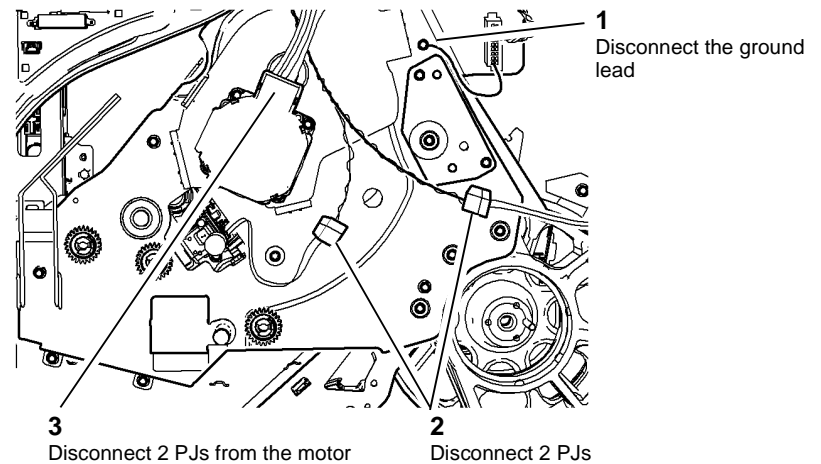
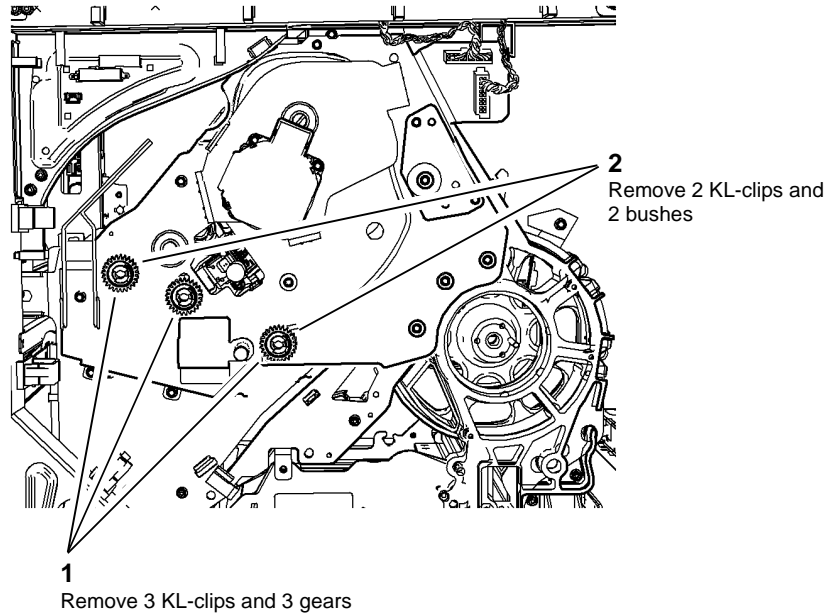

Figure 2 Disconnect harnesses

U-1-0887-A

7. Remove 3 gears, **Figure 3**.



U-1-1530-A

Figure 3 Gear removal

CAUTION

The bushes might remain in place after the screws are removed. Take care not to drop the bushes when the rear outer frame is removed.

8. Remove 2 screws and 2 bushes, **Figure 4**.

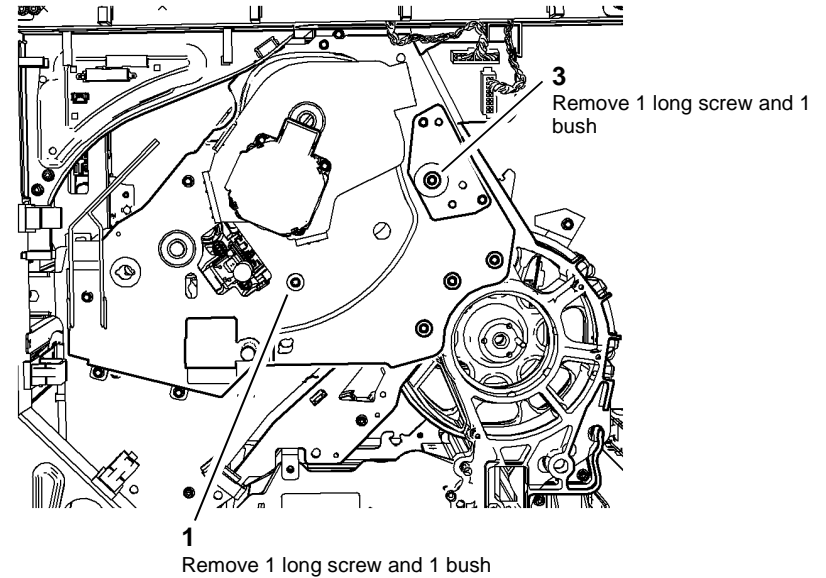

U-1-1529-A

Figure 4 Screw and bush removal

CAUTION

The rear compound gear can fall away from the rear plate when the rear outer frame is removed. Take care not to drop the rear compound gear.

9. Remove the rear outer frame, [Figure 5](#).

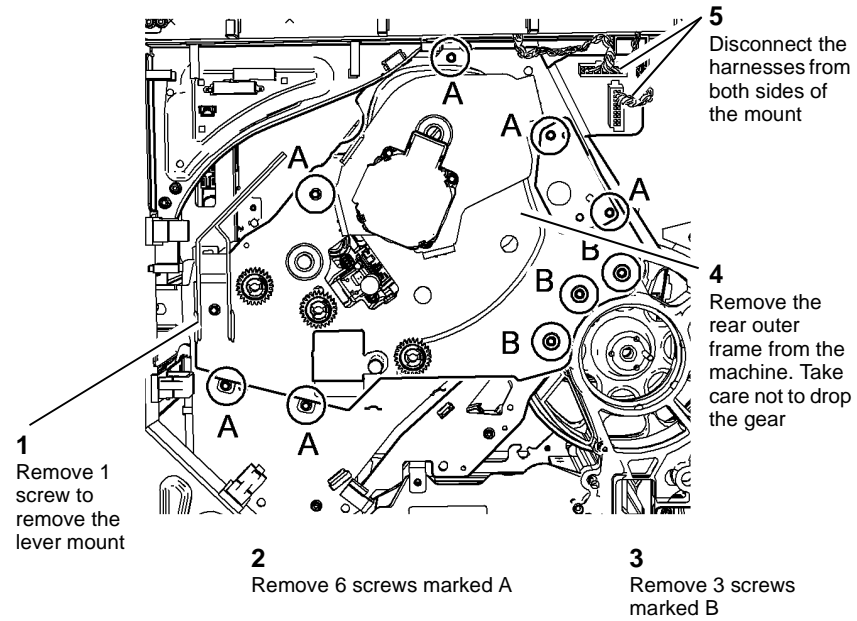

Figure 5 Rear outer frame removal

U-1-0889-A

10. Prepare to remove the rear transfix linkage and gear, [Figure 6](#).

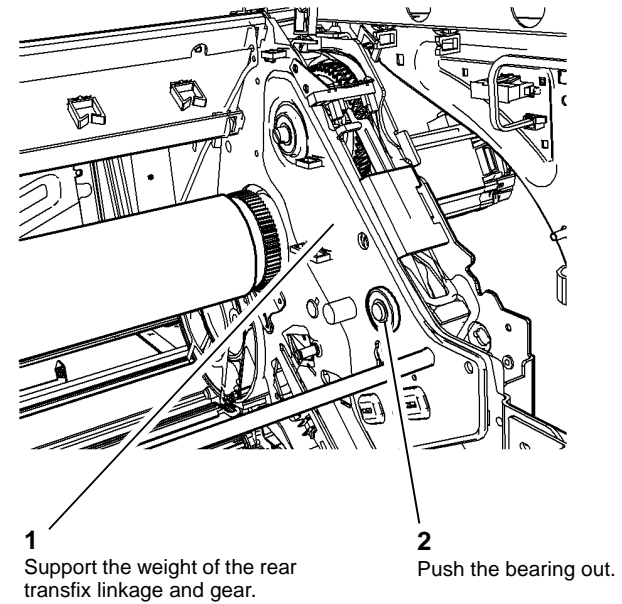

Figure 6 Preparation

U-1-0890-A

11. Remove the rear transfix linkage and gear, [Figure 7](#).

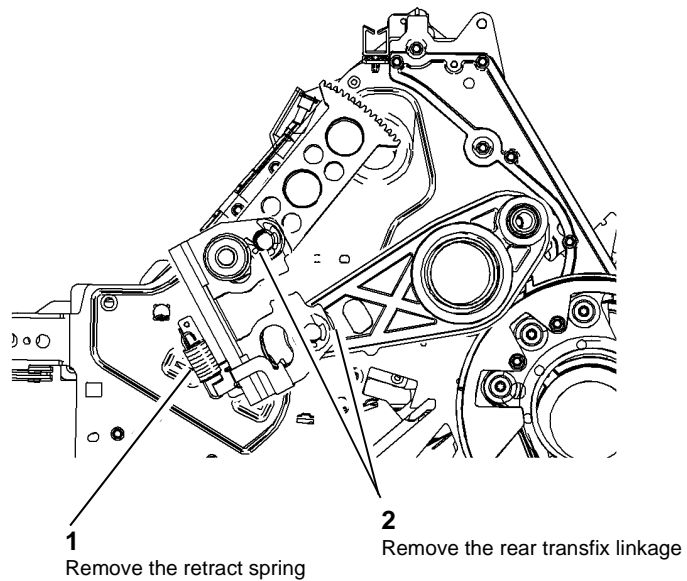

Figure 7 Rear transfix linkage removal

U-1-0891-A

Replacement

1. Replacement is the reverse of the removal procedure.

NOTE: Before tightening the screws, [Figure 5](#), it may be necessary to position the bushes removed in [Figure 4](#).

2. Ensure that the arm is in the correct position relative to the gear.
3. Ensure that the spring is re-installed.
4. Cross out the old calibration value from the calibration label on the front outer frame, [PL 10.20 Item 19, Figure 8](#).

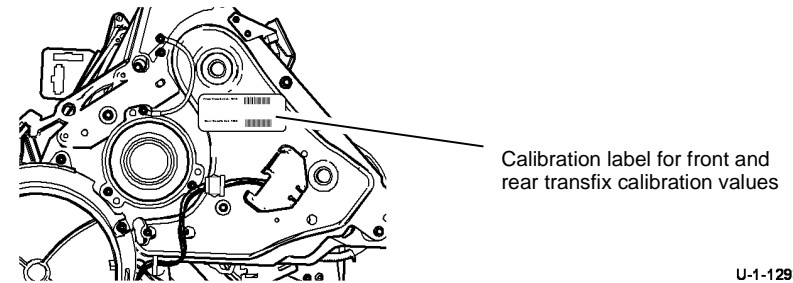

U-1-1293-A

Figure 8 Calibration label

5. Write the calibration values of the new linkage on the calibration label.
6. Perform [dC978 Transfix Calibration Values](#) and load the correct values for the new linkage.

REP 10.4 Front Transfix Motor

Parts List on [PL 10.20](#)

Removal

WARNING

Switch off the electricity to the machine. Refer to [GP 14](#). Disconnect the power cord from the customer supply while performing tasks that do not need electricity. Electricity can cause death or injury. Moving parts can cause injury.

WARNING

Take care during this procedure. Sharp edges may be present that can cause injury.

1. Remove the exit paper path, [REP 10.20](#).
2. Remove the front transfix motor, [Figure 1](#).

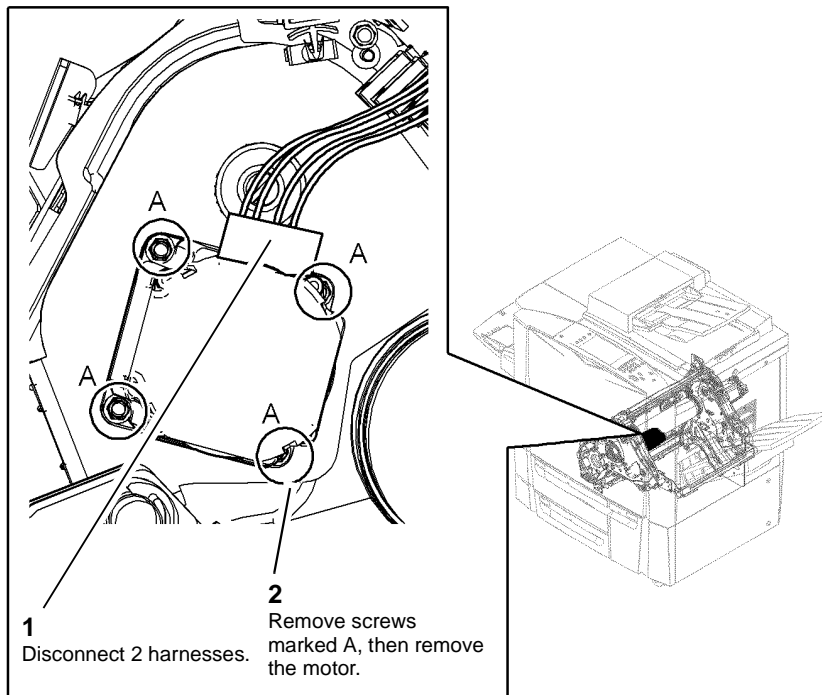

U-1-0913-A

Figure 1 Front transfix motor removal

Replacement

1. Replacement is the reverse of the removal procedure.

REP 10.5 Rear Transfix Motor

Parts List on [PL 10.20](#)

Removal

WARNING

Switch off the electricity to the machine. Refer to [GP 14](#). Disconnect the power cord from the customer supply while performing tasks that do not need electricity. Electricity can cause death or injury. Moving parts can cause injury.

WARNING

Take care during this procedure. Sharp edges may be present that can cause injury.

1. Remove the rear cover, [PL 81.10 Item 1](#).
2. Remove the rear transfix motor, [Figure 1](#).

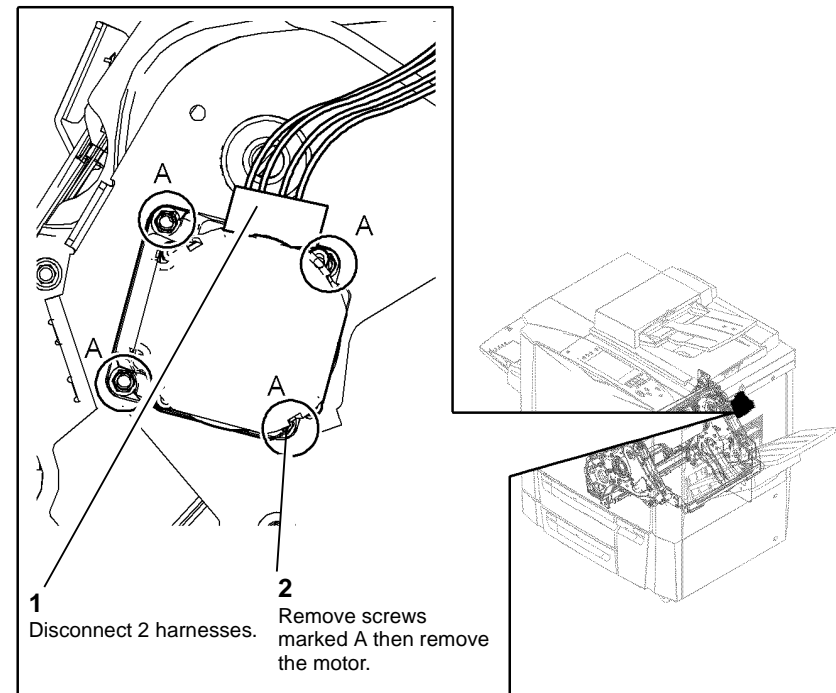

U-1-0914-A

Figure 1 Rear transfix motor removal

Replacement

1. Replacement is the reverse of the removal procedure.

REP 10.6 Transfix Blade

Parts List on [PL 10.20](#)

Removal

WARNING

Switch off the electricity to the machine. Refer to [GP 14](#). Disconnect the power cord from the customer supply while performing tasks that do not need electricity. Electricity can cause death or injury. Moving parts can cause injury.

WARNING

Take care during this procedure. Sharp edges may be present that can cause injury.

CAUTION

Do not hit the drum. Use care when you are working near the drum. The drum can be damaged easily, which will cause print quality defects.

1. Open the front door.
2. Remove the inner cover, [PL 81.11 Item 2](#).
3. Open the stripper gate, [GP 31](#).
4. Remove the transfix blade, [Figure 1](#).

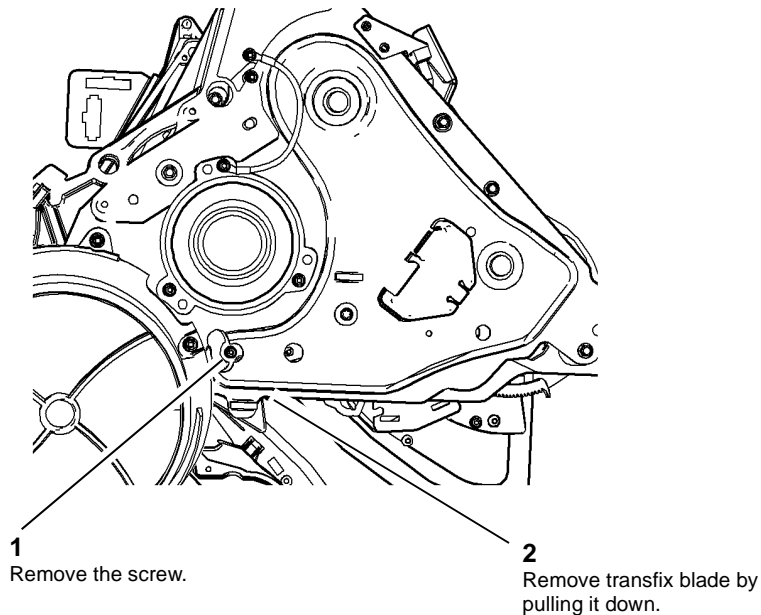

U-1-0868-A

Figure 1 Transfix blade removal

Replacement

1. Insert the transfix blade into the machine, [Figure 2](#).

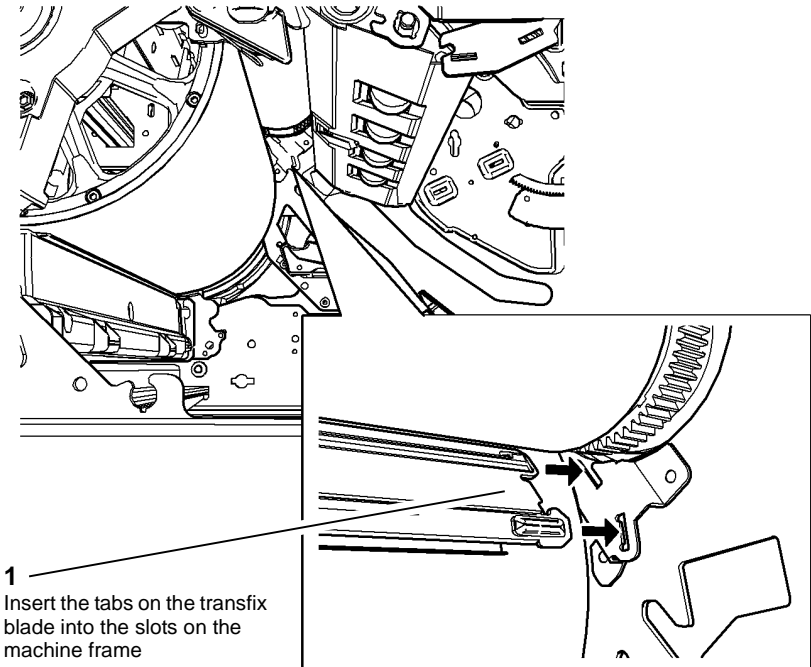

U-1-1231-A

Figure 2 Transfix blade replacement

2. Raise the front of the transfix blade until it interfaces with the pins in the front machine frame.

CAUTION

Be careful when the self tapping screw is installed into a plastic component. Do not over tighten.

3. Install the screw removed in [Figure 1](#).
4. Close the stripper gate, [GP 31](#).
5. If a new transfix stripper assembly is installed, reset the transfix stripper count to zero. Refer to [dC135 CRU / HFSI Status](#).

REP 10.7 Pre Transfix Sensor

Parts List on [PL 88.10](#)

Removal

WARNING

Switch off the electricity to the machine. Refer to [GP 14](#). Disconnect the power cord from the customer supply while performing tasks that do not need electricity. Electricity can cause death or injury. Moving parts can cause injury.

WARNING

Take care during this procedure. Sharp edges may be present that can cause injury.

CAUTION

Use care when working near the drum. The drum can be damaged easily, which will cause print quality defects.

1. Open the front door.
2. Remove the inner cover, [PL 81.11 Item 2](#).

3. Remove the lower platelet assembly, [Figure 1](#).

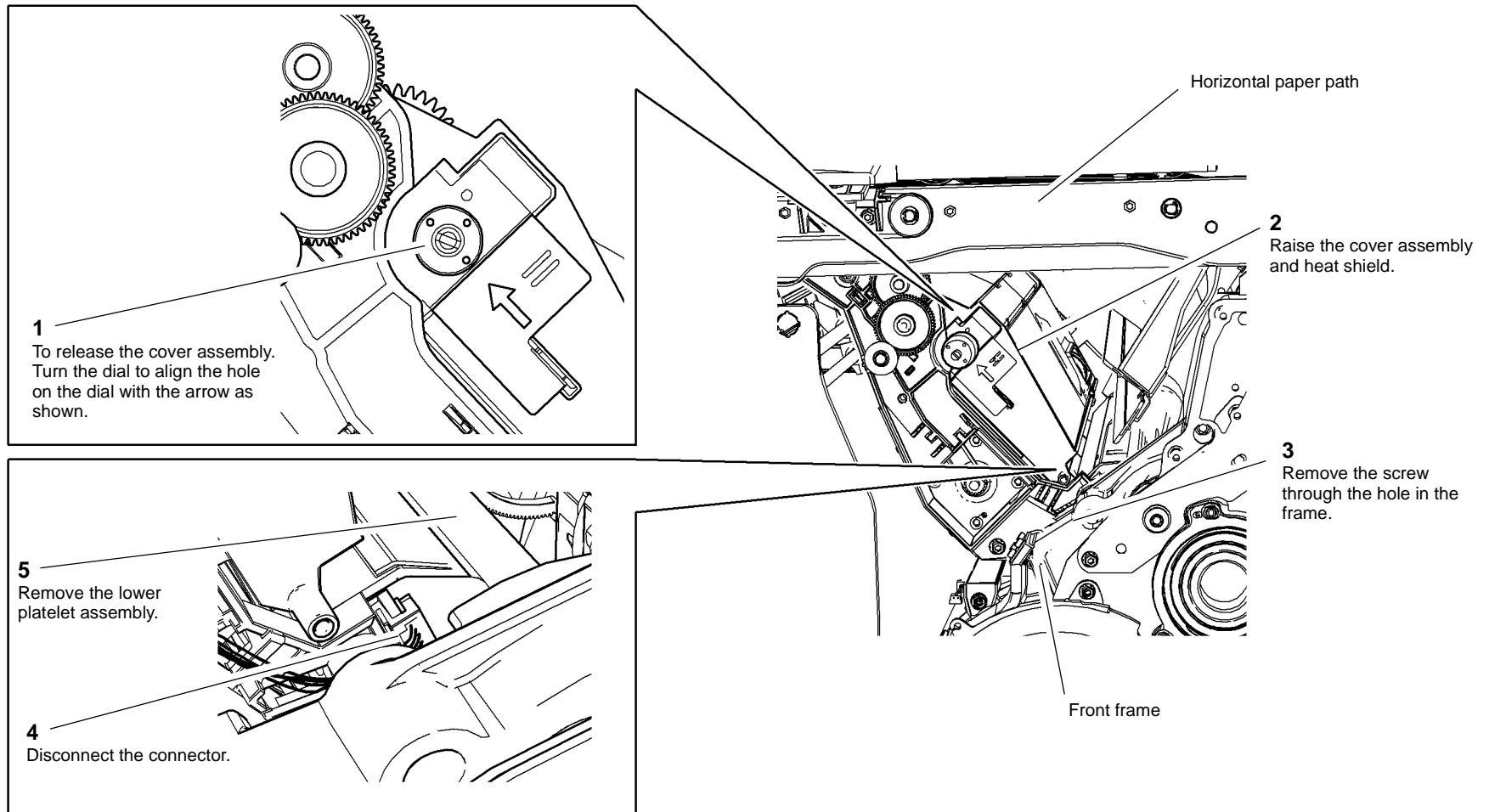

U-1-1490-A

Figure 1 Remove lower platelet assembly

- Remove the air pump cover, [Figure 2](#).

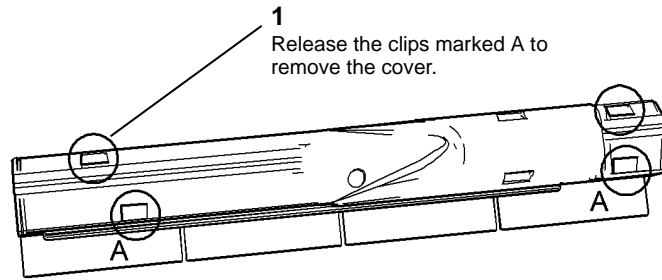

Figure 2 Air pump cover removal

U-1-0916-A

- Remove the pre transfix sensor, [Figure 3](#).

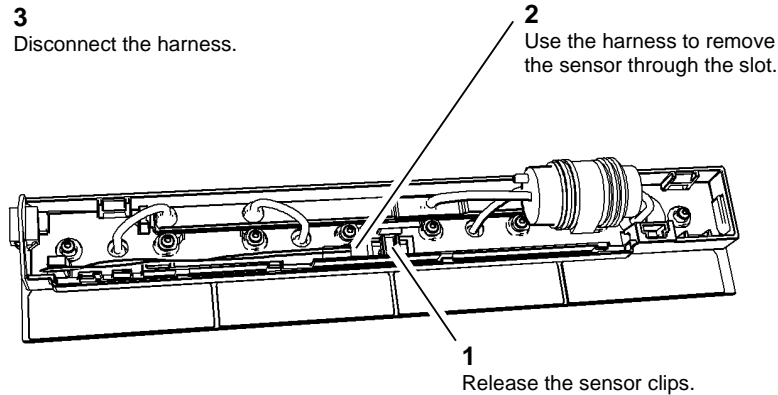

Figure 3 Sensor removal

U-1-0917-A

Replacement

- Replacement is the reverse of the removal procedure.
- If the registration / preheat assembly is removed. Perform the [dC625](#) Registration / Pre-heat Calibration.

REP 10.8 Post Transfix Motor (M4) and Gearbox

Parts List on [PL 10.10](#)

Removal

WARNING

Switch off the electricity to the machine. Refer to [GP 14](#). Disconnect the power cord from the customer supply while performing tasks that do not need electricity. Electricity can cause death or injury. Moving parts can cause injury.

WARNING

Take care during this procedure. Sharp edges may be present that can cause injury.

- Remove the rear cover, [PL 81.10](#) Item 1.
- Remove drum fan shroud, [PL 94.20](#) Item 5.
- Remove the drum motor and drive belt, [REP 91.24](#).
- Remove the post transfix motor (M4) ([PL 10.10](#) Item 5) and gearbox ([PL 10.10](#) Item 4), [Figure 1](#).

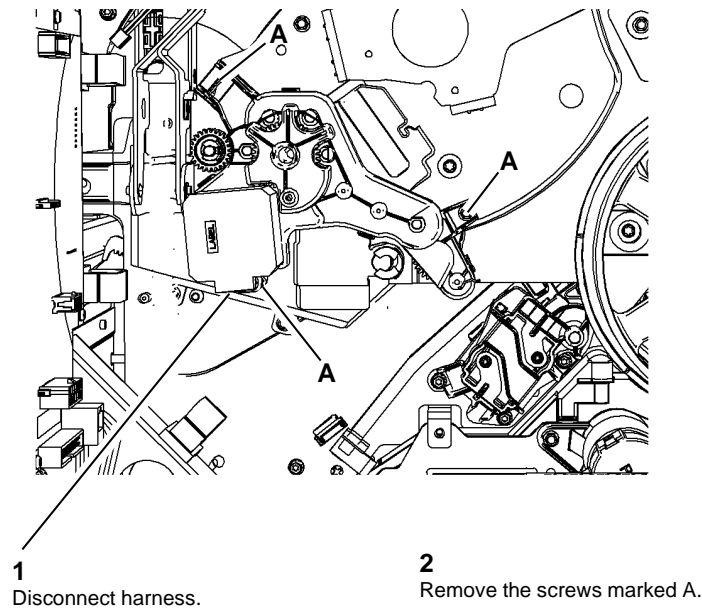

Figure 1 Drive motor (M4) and gearbox

U-1-0894-A

Replacement

Replacement is the reverse of the removal procedure.

REP 10.9 Stripper Solenoid Assembly

Parts List on [PL 10.10](#)

Removal

WARNING

Switch off the electricity to the machine. Refer to [GP 14](#). Disconnect the power cord from the customer supply while performing tasks that do not need electricity. Electricity can cause death or injury. Moving parts can cause injury.

WARNING

Take care during this procedure. Sharp edges may be present that can cause injury.

CAUTION

Use care when working near the drum. The drum can be damaged easily, which will cause print quality defects.

1. Manually unlock the stripper gate and baffle assembly, refer to [GP 31](#).
2. Open the stripper gate, [GP 31](#).
3. Remove the rear cover, [PL 81.10 Item 1](#).
4. Remove the drum drive motor and belt, [REP 91.24](#).
5. Remove stripper solenoid, [Figure 1](#).

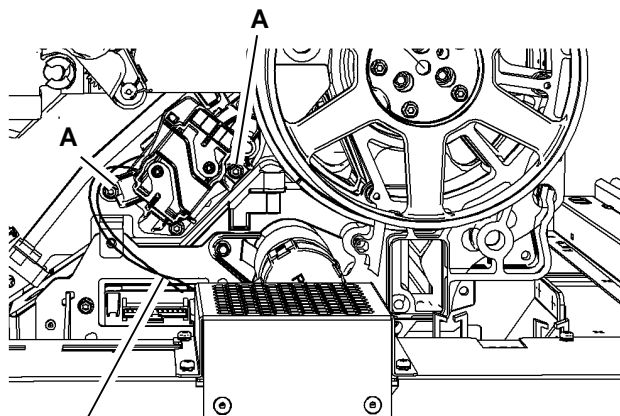

2
Disconnect the inline connector,
then remove the solenoid assembly.

1
Remove 2 screws marked A.

U-1-0895-A

Figure 1 Stripper solenoid removal

REP 10.10 Roller Drive J

Parts List on [PL 10.10](#)

Removal

WARNING

Switch off the electricity to the machine. Refer to [GP 14](#). Disconnect the power cord from the customer supply while performing tasks that do not need electricity. Electricity can cause death or injury. Moving parts can cause injury.

WARNING

Take care during this procedure. Sharp edges may be present that can cause injury.

CAUTION

Use care when working near the drum. The drum can be damaged easily, which will cause print quality defects.

1. Remove the exit paper path, [REP 10.20](#).
2. Unlock and fully open the stripper gate. [GP 31](#).
3. Remove the post transfix motor (M4) and gearbox, [REP 10.8](#).

4. Remove the 25T gear and bearing, [Figure 1](#).

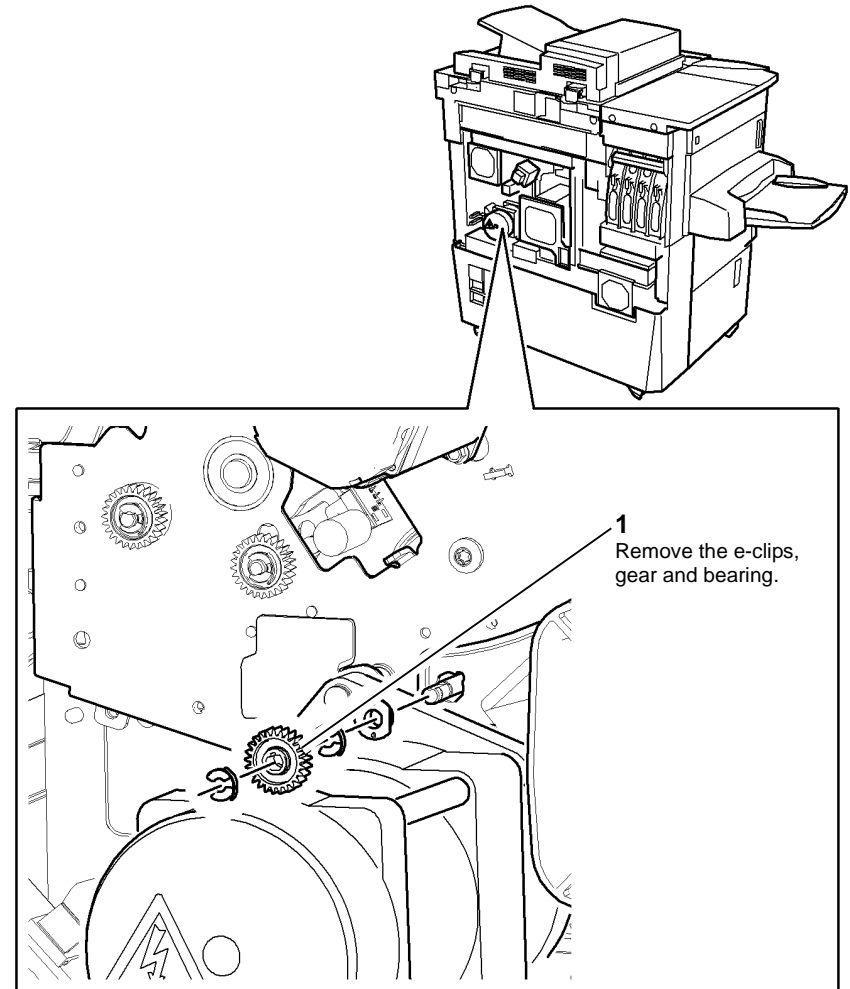

U-1-0918-A

Figure 1 Gear removal

5. Lower the upper baffle, [Figure 2](#).

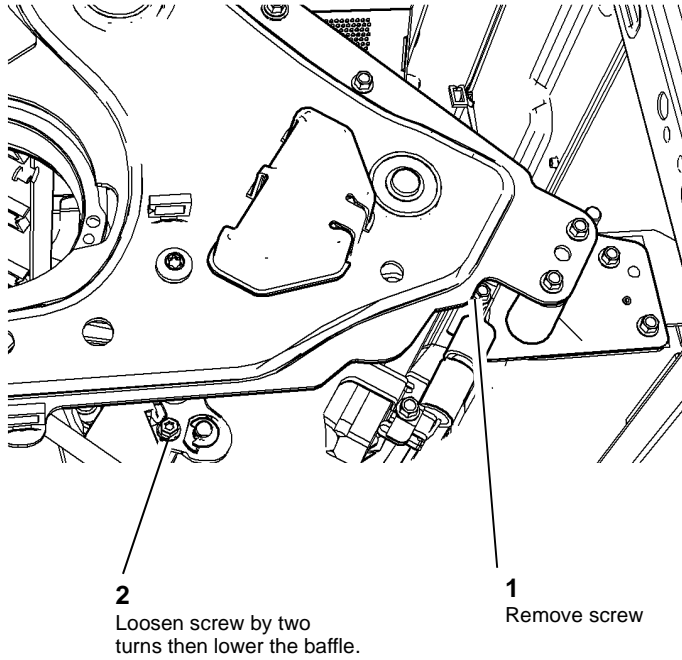

Figure 2 Lower the upper baffle

U-1-0958-A

6. Remove roller drive J, [Figure 3](#).

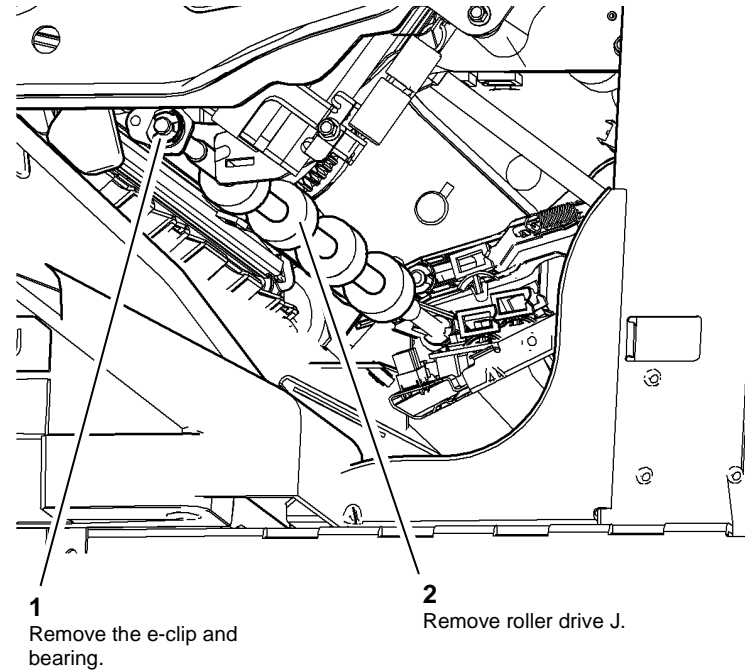

Figure 3 Roller removal

U-1-0921-A

Replacement

Replacement is the reverse of the removal procedure.

REP 10.11 Roller Drive L

Parts List on [PL 10.10](#)

Removal

WARNING

Switch off the electricity to the machine. Refer to [GP 14](#). Disconnect the power cord from the customer supply while performing tasks that do not need electricity. Electricity can cause death or injury. Moving parts can cause injury.

WARNING

Take care during this procedure. Sharp edges may be present that can cause injury.

1. Remove the exit paper path, [REP 10.20](#).
2. Unlock and fully open the stripper gate. [GP 31](#).
3. Remove the post transfix motor (M4) and gearbox, [REP 10.8](#).

4. Remove the 25T gear and rear bearing, [Figure 1](#).

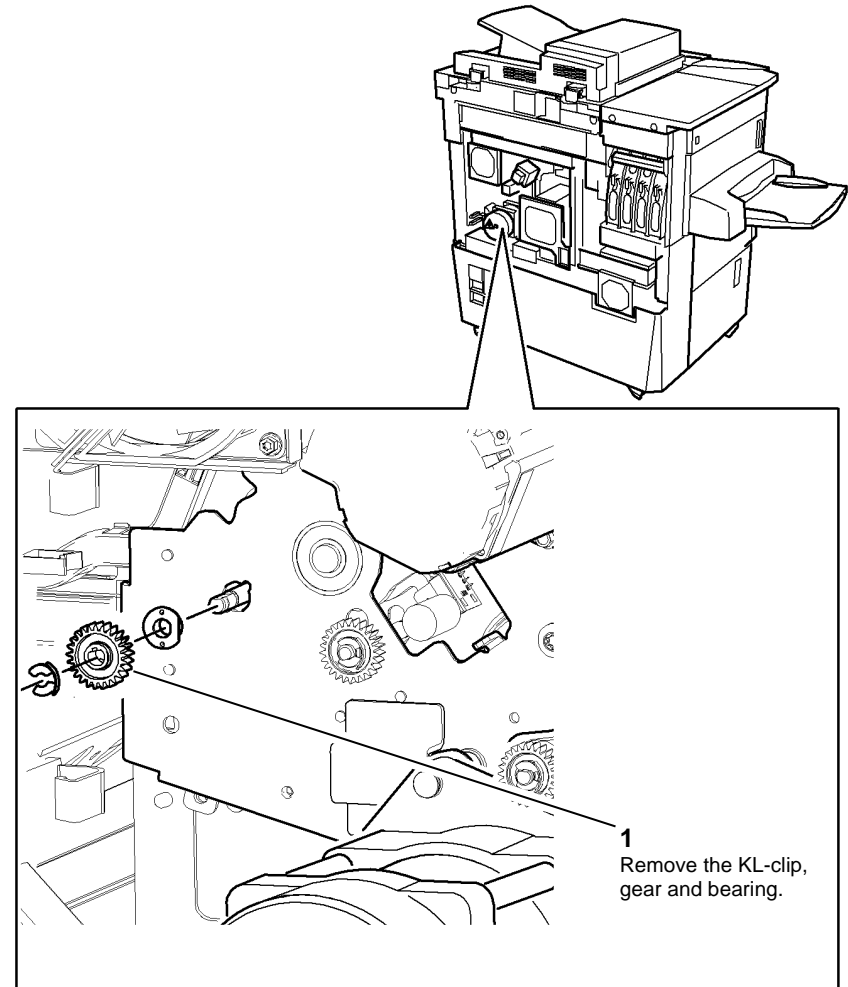

U-1-0940-A

Figure 1 Gear and bearing removal

5. Lower the upper baffle, [Figure 2](#).

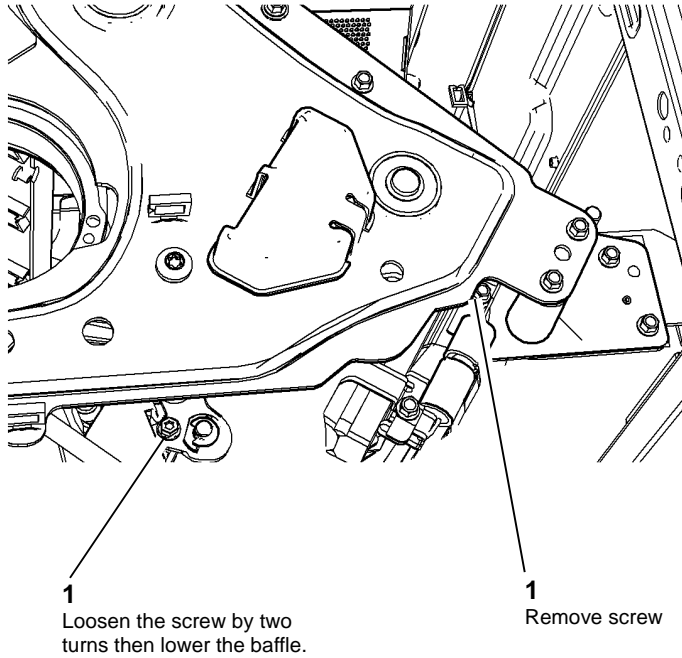

Figure 2 Lower the upper baffle

U-1-1646-A

6. Remove the roller drive L, [Figure 3](#).

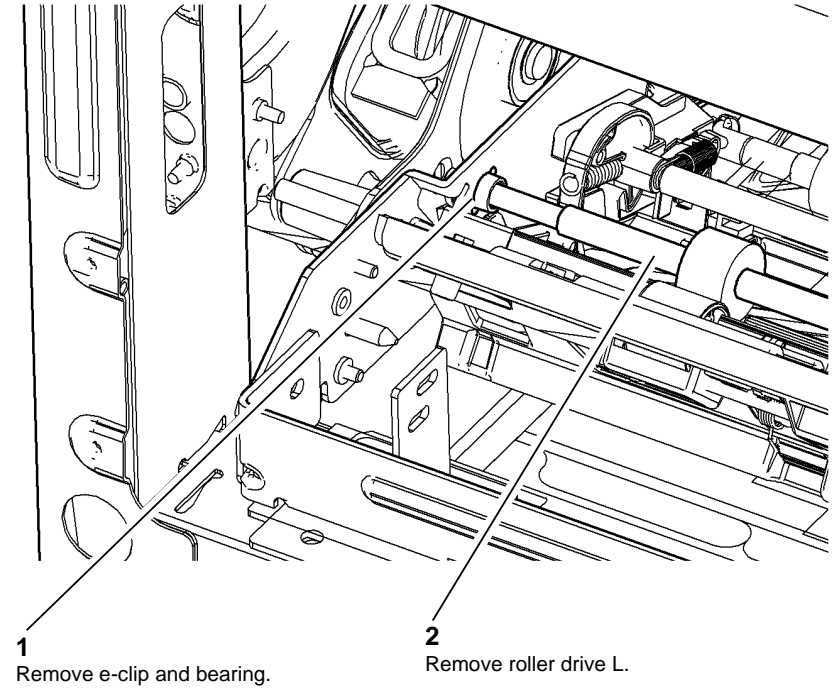

Figure 3 Roller removal

U-1-0923-A

Replacement

Replacement is the reverse of the removal procedure.

REP 10.12 Exit / Duplex Solenoid

Parts List on [PL 10.15](#)

Removal

WARNING

Switch off the electricity to the machine. Refer to [GP 14](#). Disconnect the power cord from the customer supply while performing tasks that do not need electricity. Electricity can cause death or injury. Moving parts can cause injury.

WARNING

Take care during this procedure. Sharp edges may be present that can cause injury.

1. Remove the exit paper path, [REP 10.20](#).

2. Open the exit transport jam clearance door, [Figure 1](#).

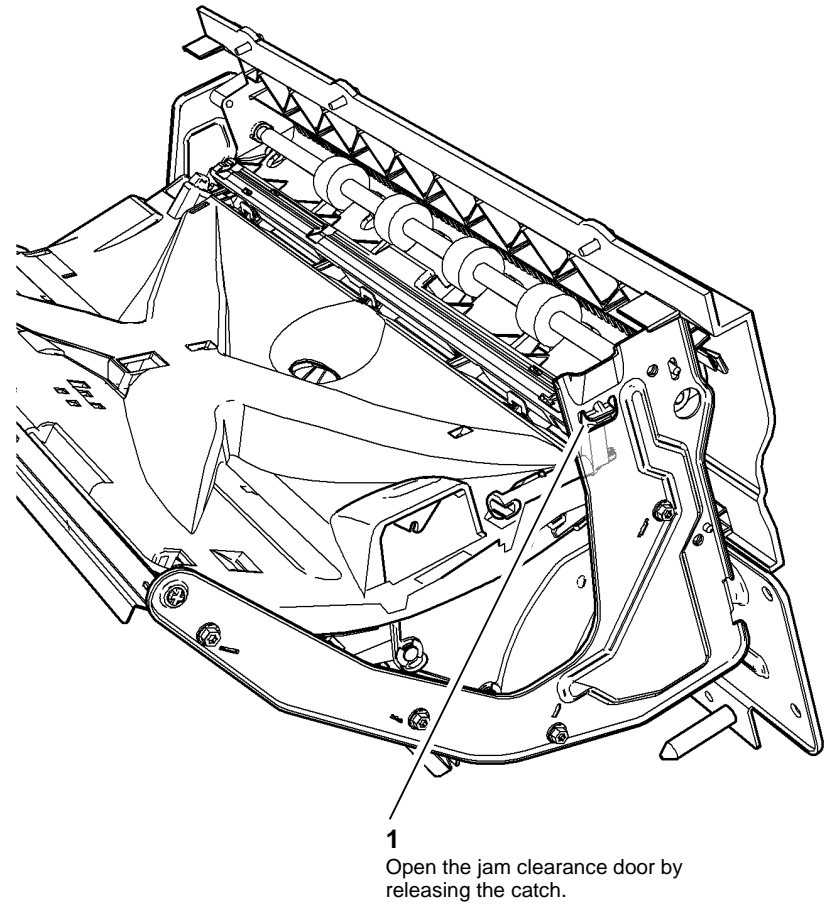

1
Open the jam clearance door by releasing the catch.

U-1-0922-A

Figure 1 Open jam clearance door

3. Remove diverter gate, [REP 10.13](#).

4. Remove the paper guide, [Figure 2](#).

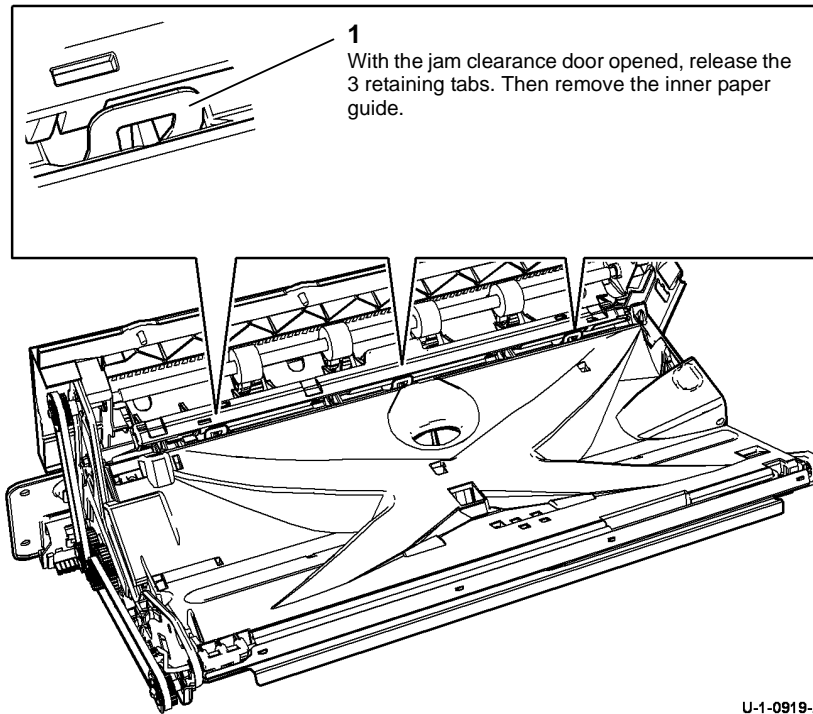

Figure 2 Paper guide removal

5. Remove the exit/duplex solenoid, [Figure 3](#).

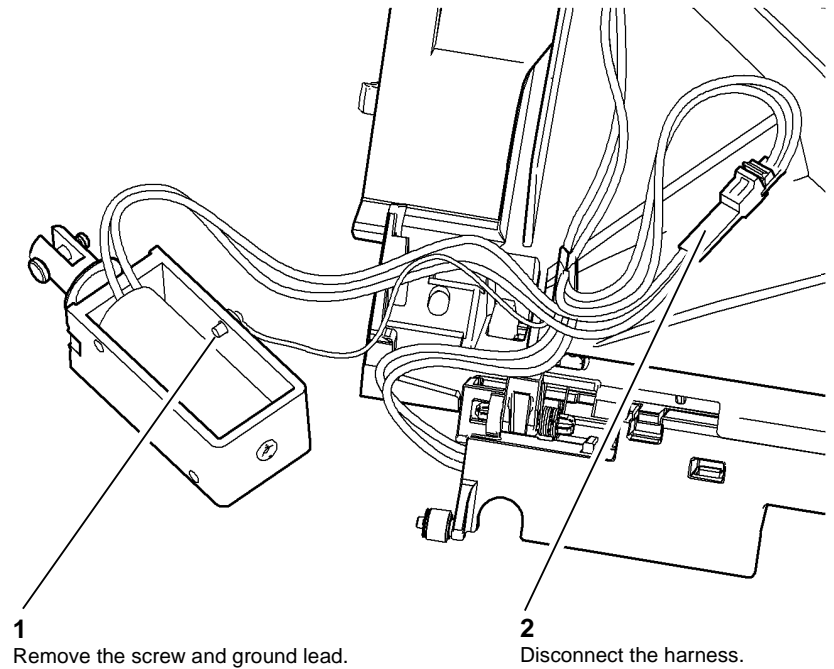

Figure 3 Solenoid removal

Replacement

Replacement is the reverse of the removal procedure.

REP 10.13 Diverter Gate

Parts List on [PL 10.15](#)

Removal

WARNING

Switch off the electricity to the machine. Refer to [GP 14](#). Disconnect the power cord from the customer supply while performing tasks that do not need electricity. Electricity can cause death or injury. Moving parts can cause injury.

WARNING

Take care during this procedure. Sharp edges may be present that can cause injury.

1. Remove the exit paper path, [REP 10.20](#).

2. Open the exit transport jam clearance door, [Figure 1](#).

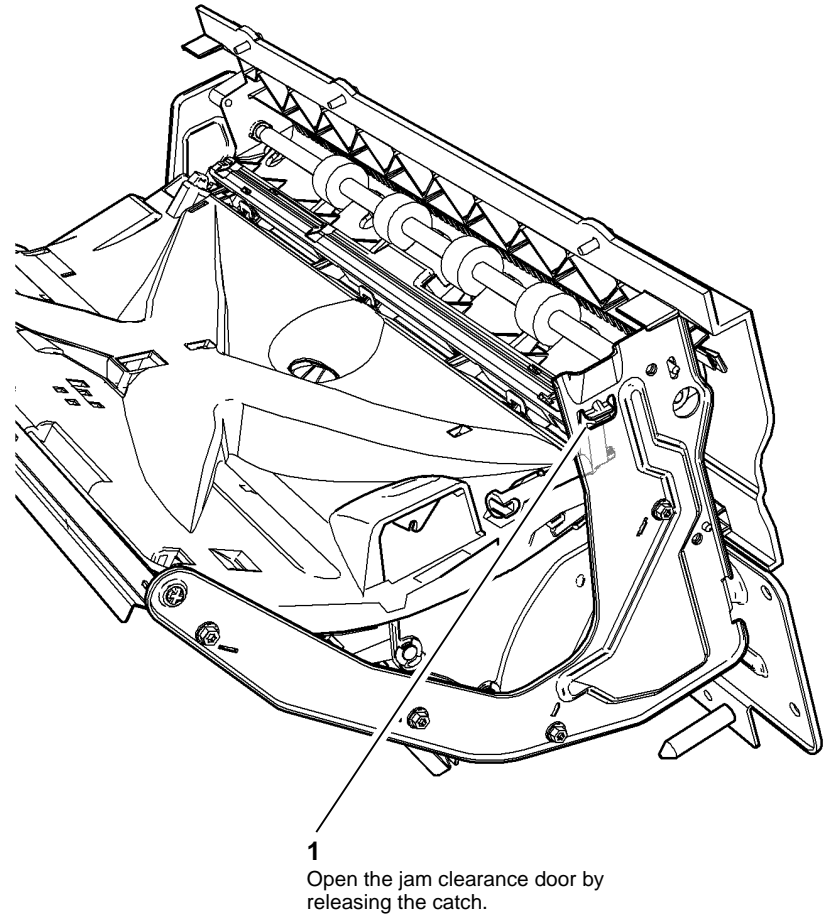

U-1-0941-A

Figure 1 Open jam clearance door

3. Remove the ground lead, [Figure 2](#).

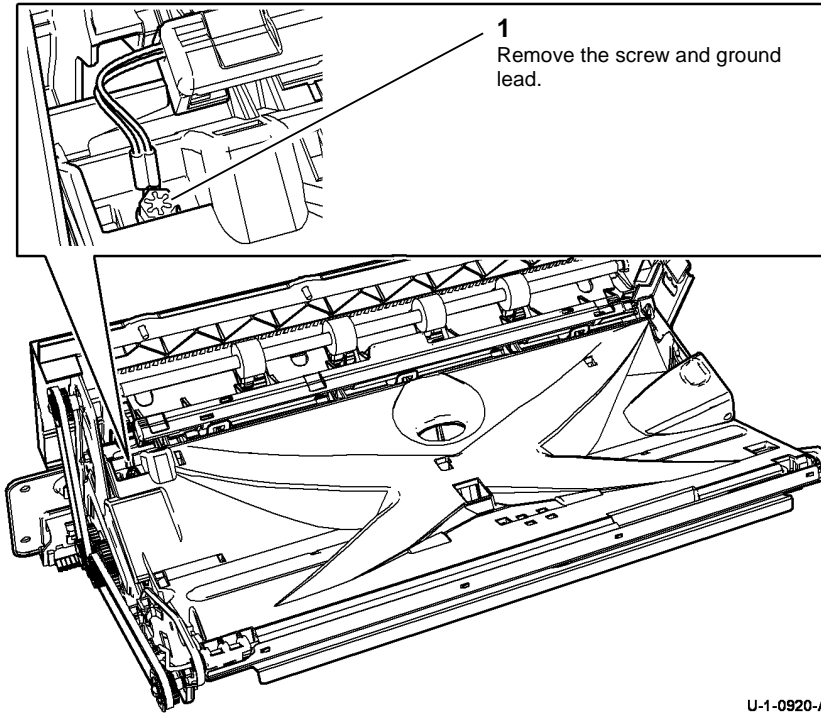

Figure 2 Ground screw removal

4. Remove the diverter gate from the top exit baffle, [Figure 3](#).

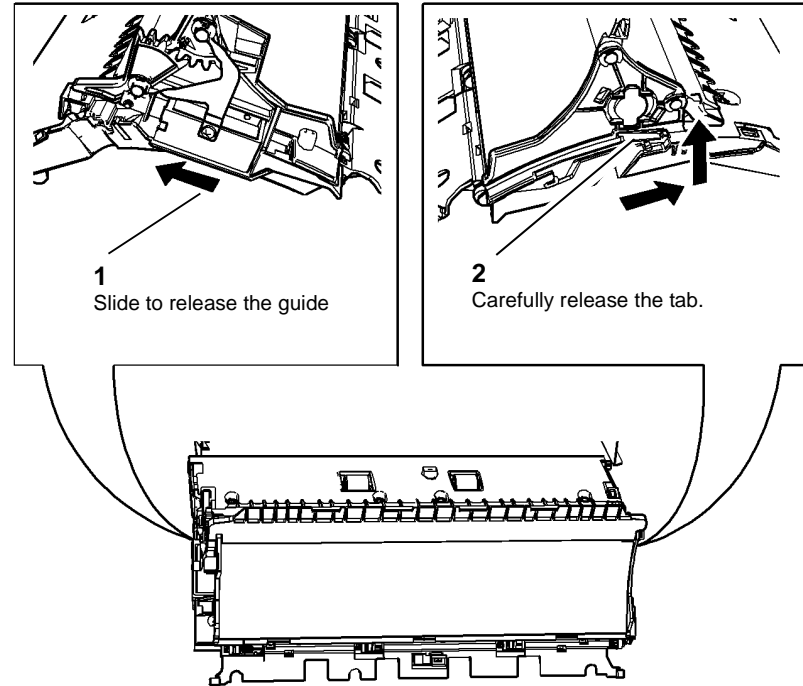
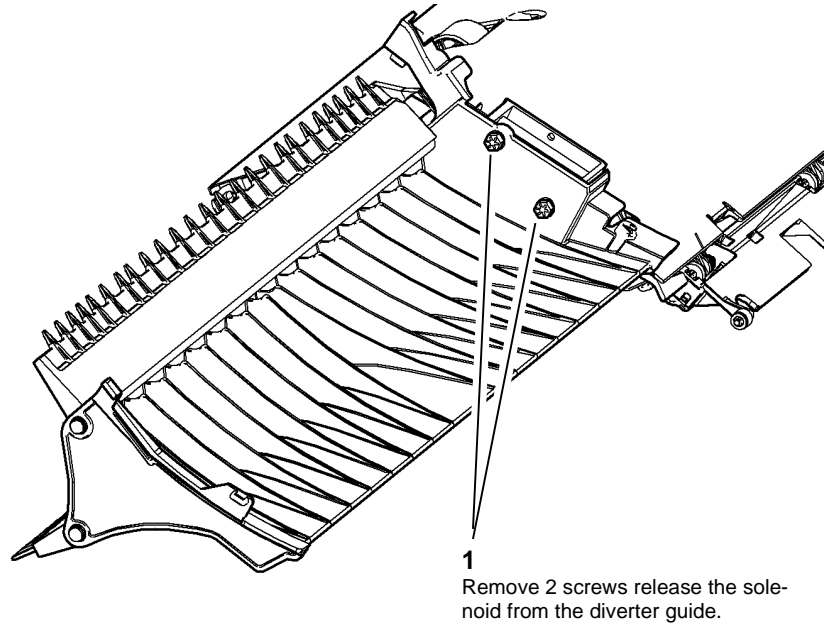

Figure 3 Release the diverter gate

5. Remove the exit / duplex solenoid from the diverter gate assembly, [Figure 4](#).



U-1-0925-A

Figure 4 Remove exit / duplex solenoid

Replacement

Replacement is the reverse of the removal procedure.

REP 10.14 Exit Motor (M5)

Parts List on [PL 10.15 Item 11](#)

Removal

WARNING

Switch off the electricity to the machine. Refer to [GP 14](#). Disconnect the power cord from the customer supply while performing tasks that do not need electricity. Electricity can cause death or injury. Moving parts can cause injury.

WARNING

Take care during this procedure. Sharp edges may be present that can cause injury.

1. Remove the exit paper path, [REP 10.20](#).
2. Remove the drive gears, [Figure 1](#).

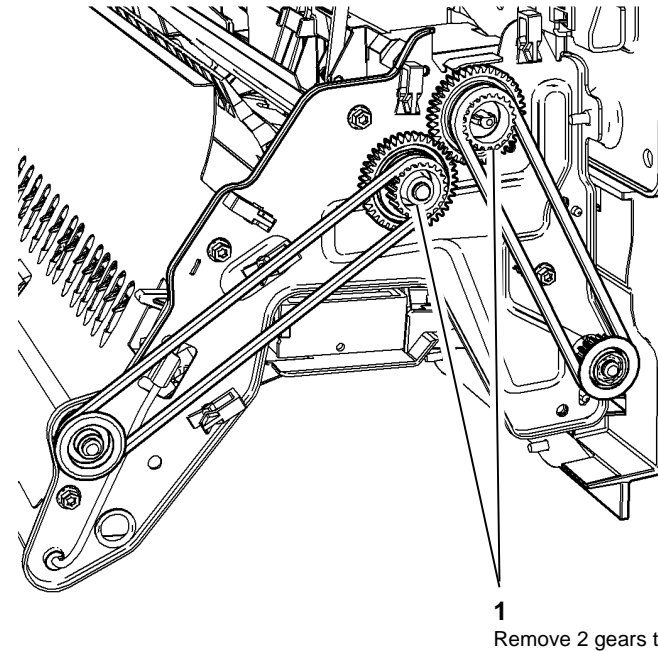

U-1-0924-A

Figure 1 Gear removal

3. Release the exit motor, [Figure 2](#).

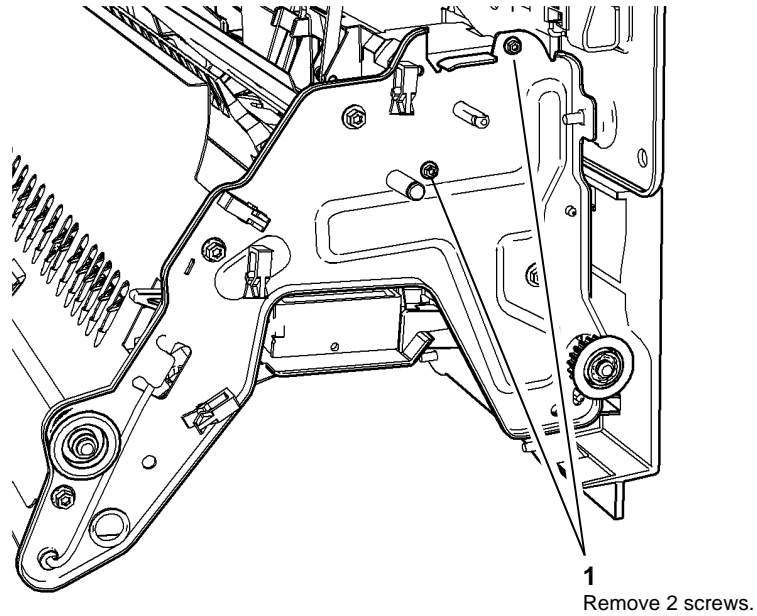

Figure 2 Motor release

U-1-0927-A

4. Remove the exit motor, [Figure 3](#).

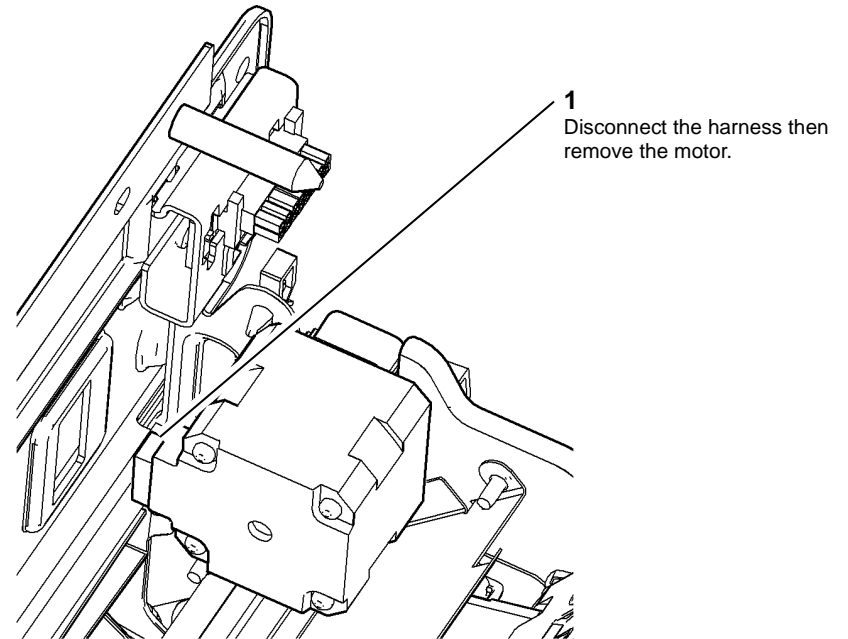

Figure 3 Motor removal

U-1-0928-A

Replacement

Replacement is the reverse of the removal procedure.

REP 10.15 Duplex Start Sensor (13)

Parts List on [PL 10.15](#)

Removal

WARNING

Switch off the electricity to the machine. Refer to [GP 14](#). Disconnect the power cord from the customer supply while performing tasks that do not need electricity. Electricity can cause death or injury. Moving parts can cause injury.

WARNING

Take care during this procedure. Sharp edges may be present that can cause injury.

1. Remove the exit paper path, [REP 10.20](#).
2. Remove the diverter gate, [REP 10.13](#).
3. Remove the paper guide, [Figure 1](#).

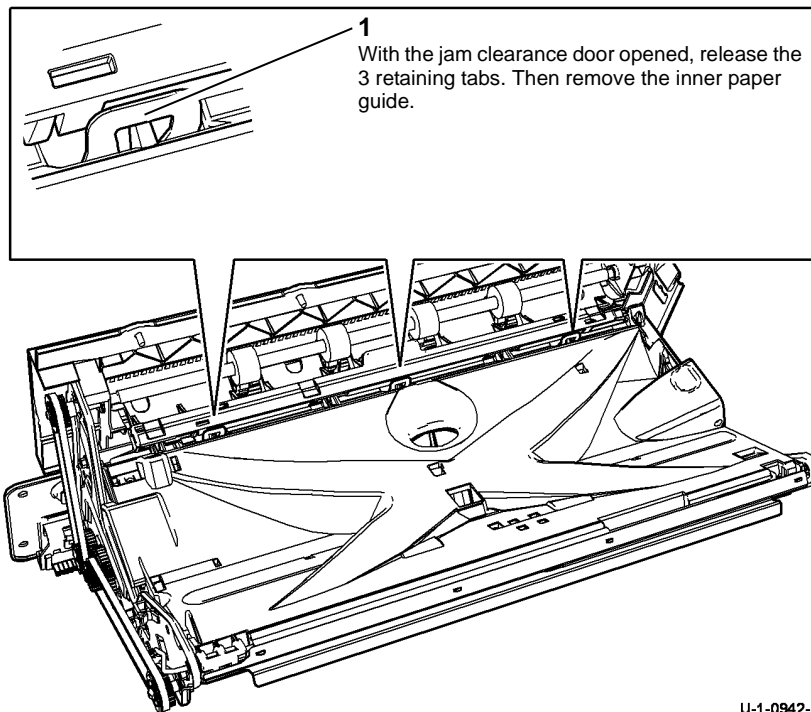

Figure 1 Paper guide removal

4. Remove the duplex sensor, [Figure 2](#).

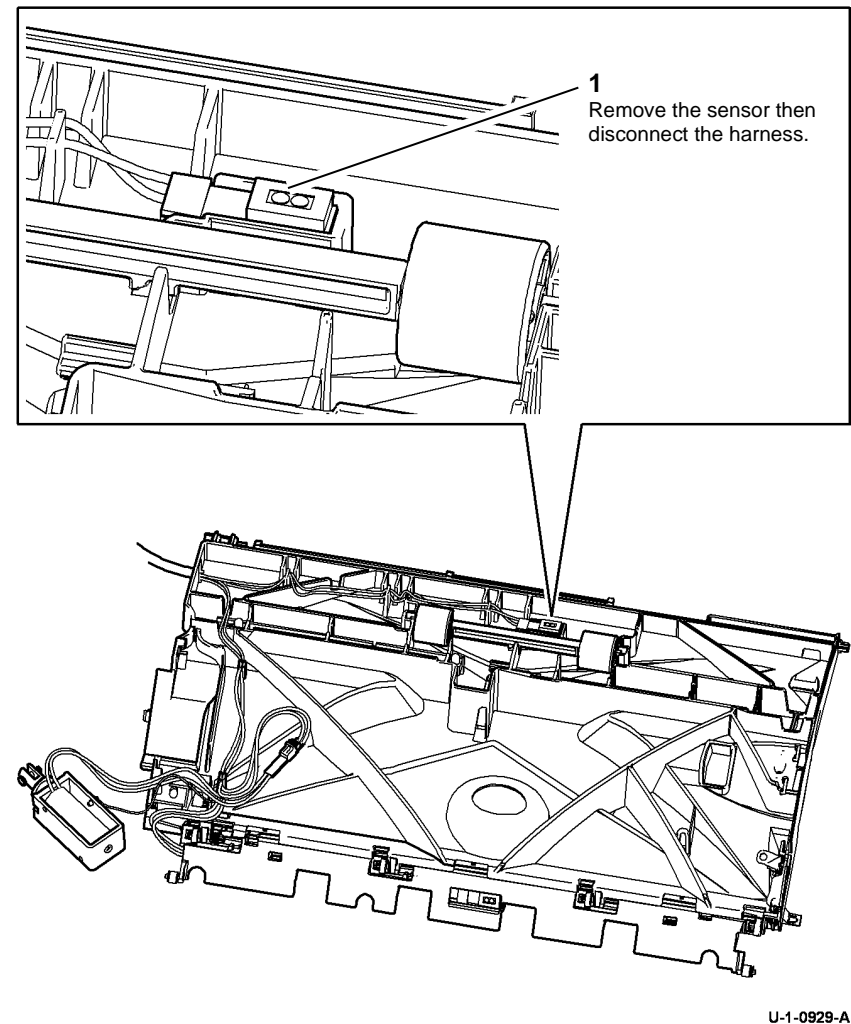
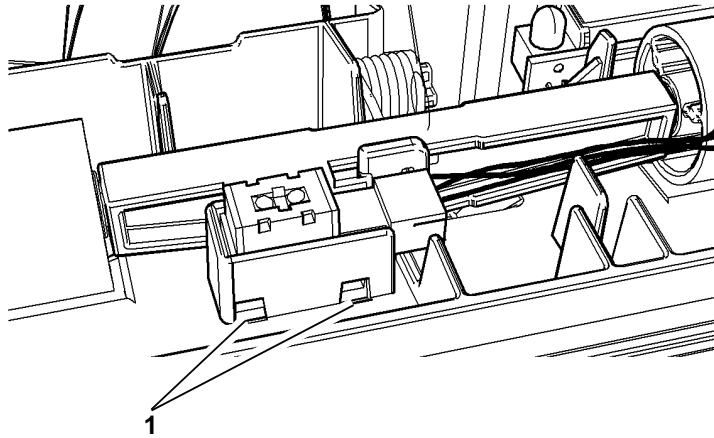

Figure 2 Sensor removal

Replacement

1. Replacement is the reverse of the removal procedure.
2. Ensure that the lugs on the sensor are located correctly in the sensor holder, [Figure 3](#).



1
Check the lugs secures the sensor in position

U-1-1151-A

Figure 3 Sensor location

REP 10.16 Exit Sensor (15)

Parts List on [PL 10.15](#)

Removal

WARNING

Switch off the electricity to the machine. Refer to [GP 14](#). Disconnect the power cord from the customer supply while performing tasks that do not need electricity. Electricity can cause death or injury. Moving parts can cause injury.

WARNING

Take care during this procedure. Sharp edges may be present that can cause injury.

1. Remove the exit paper path, [REP 10.20](#).

2. Open the exit transport jam clearance door, [Figure 1](#).

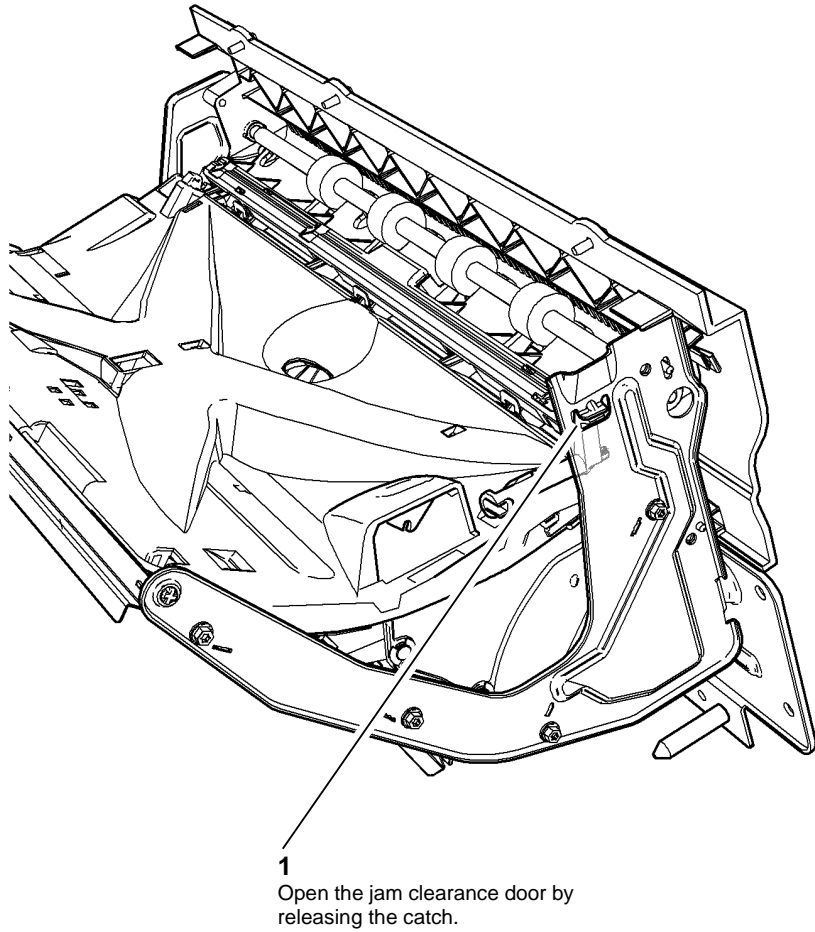

U-1-0943-A

Figure 1 Open jam clearance door

3. Remove the sensor cover, [Figure 2](#).

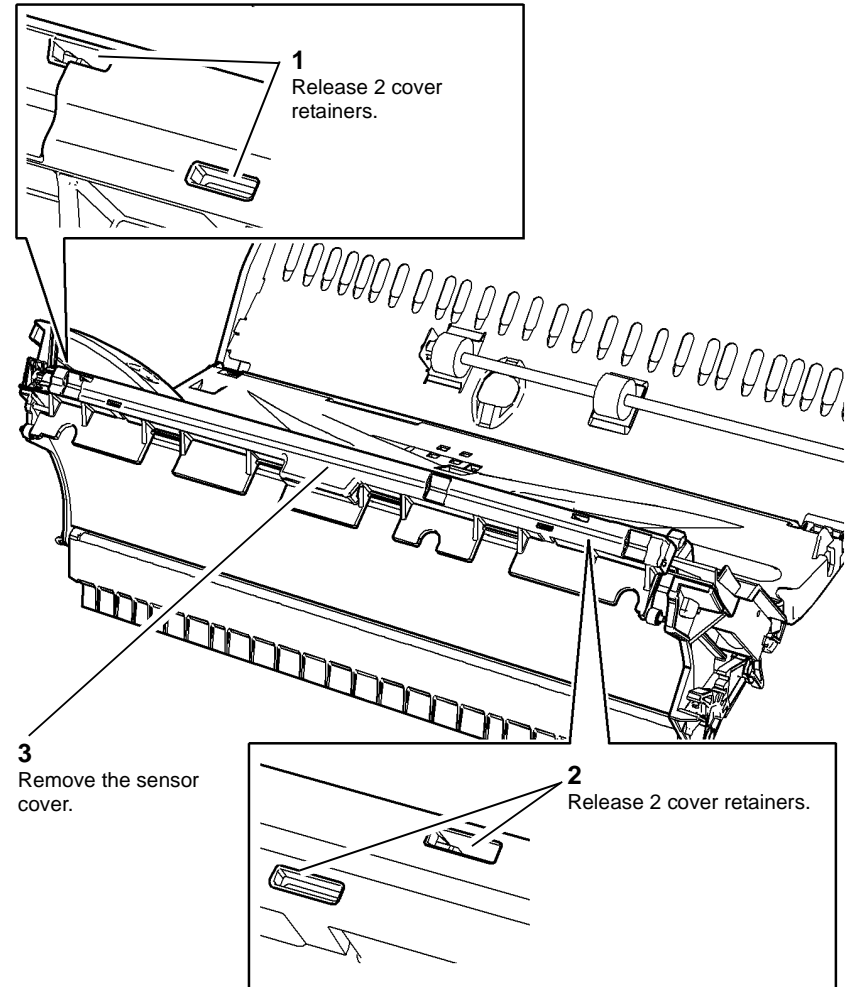

U-1-0930-A

Figure 2 Cover removal

4. Remove the exit sensor, [Figure 3](#).

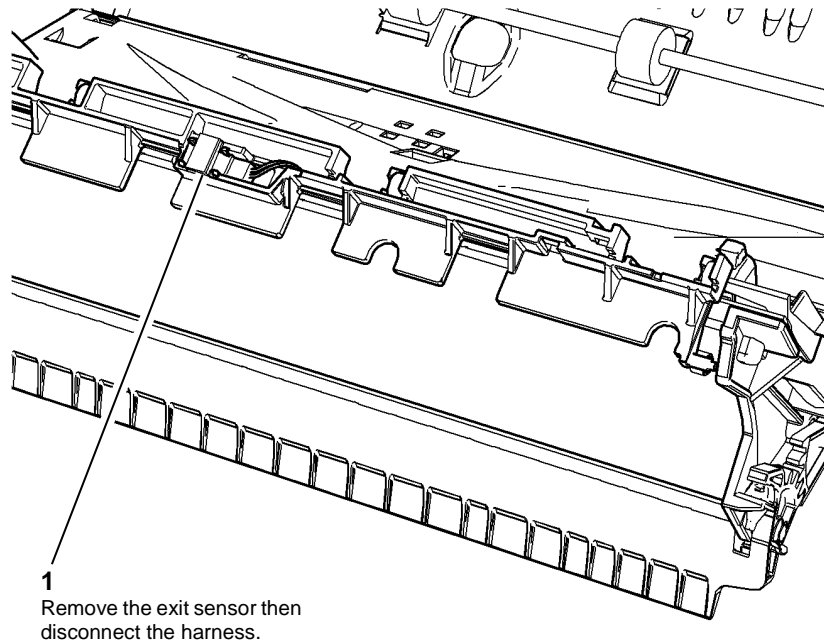

U-1-0931-A

Figure 3 Sensor removal

Replacement

1. Replacement is the reverse of the removal procedure.
2. Ensure that the lugs on the sensor are located correctly in the sensor holder, [Figure 4](#).

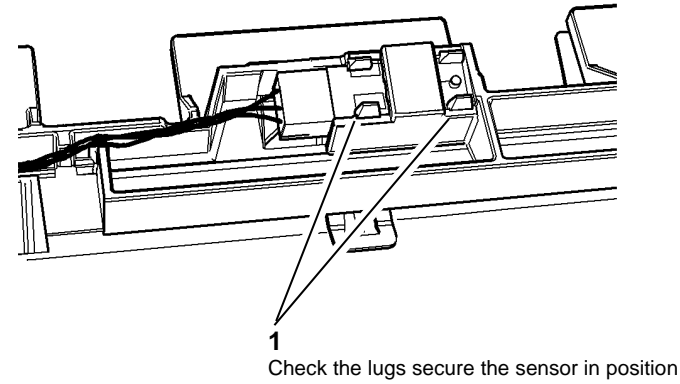

U-1-1152-A

Figure 4 Sensor location

REP 10.17 Roller Nip P

Parts List on [PL 10.15](#)

Removal

WARNING

Switch off the electricity to the machine. Refer to [GP 14](#). Disconnect the power cord from the customer supply while performing tasks that do not need electricity. Electricity can cause death or injury. Moving parts can cause injury.

WARNING

Take care during this procedure. Sharp edges may be present that can cause injury.

1. Remove the exit paper path, [REP 10.20](#).
2. Remove the belt and pulley, [Figure 1](#).

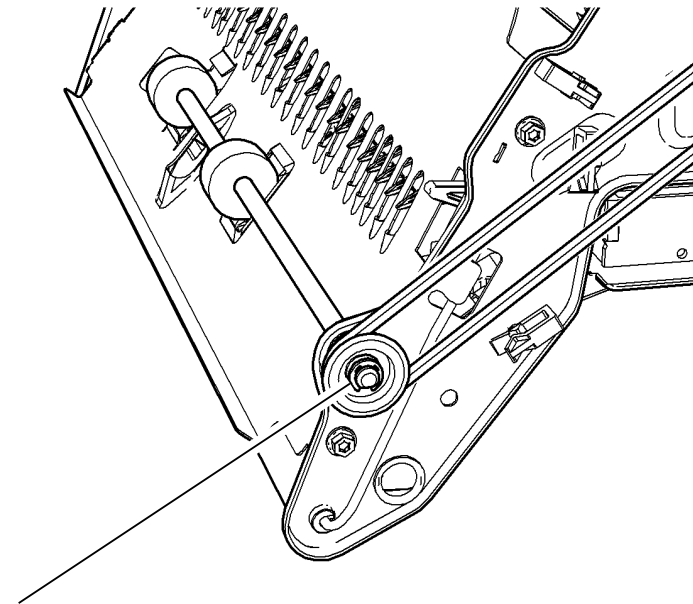

- 1 Remove the e-clip, gear and drive belt.

U-1-0932-A

Figure 1 Belt and pulley removal

3. Remove roller nip P, [Figure 2](#).

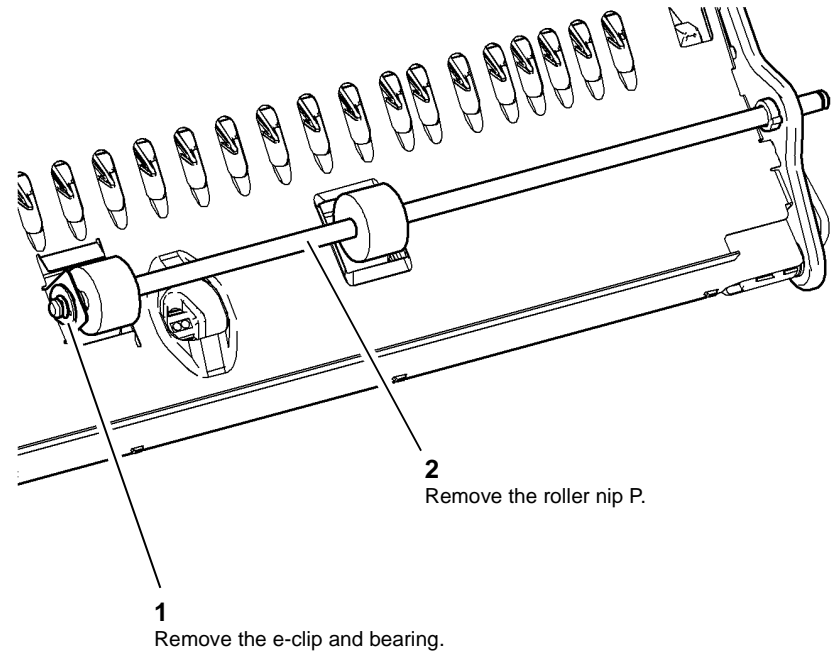

- 1 Remove the e-clip and bearing.

- 2 Remove the roller nip P.

U-1-0933-A

Figure 2 Roller nip removal

Replacement

Replacement is the reverse of the removal procedure.

REP 10.18 Roller Nip N

Parts List on [PL 10.15](#)

Removal

WARNING

Switch off the electricity to the machine. Refer to [GP 14](#). Disconnect the power cord from the customer supply while performing tasks that do not need electricity. Electricity can cause death or injury. Moving parts can cause injury.

WARNING

Take care during this procedure. Sharp edges may be present that can cause injury.

1. Remove the exit paper path, [REP 10.20](#).
2. Remove the mounting plate, [Figure 1](#).

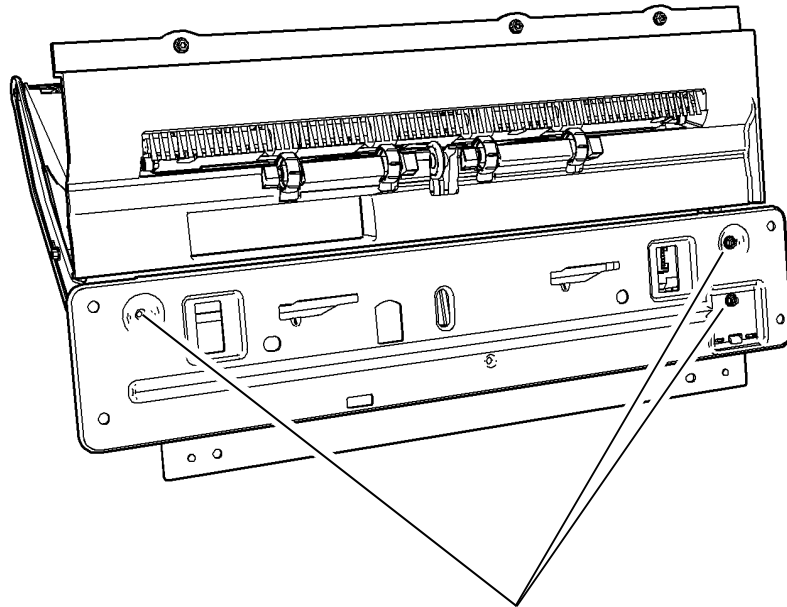

U-1-0934-A

Figure 1 Mounting plate removal

NOTE: Carefully remove the roller nip N housing from the exit paper path assembly. The springs and nip idlers will be ejected.

3. Prepare to remove the roller nip N, [Figure 2](#).

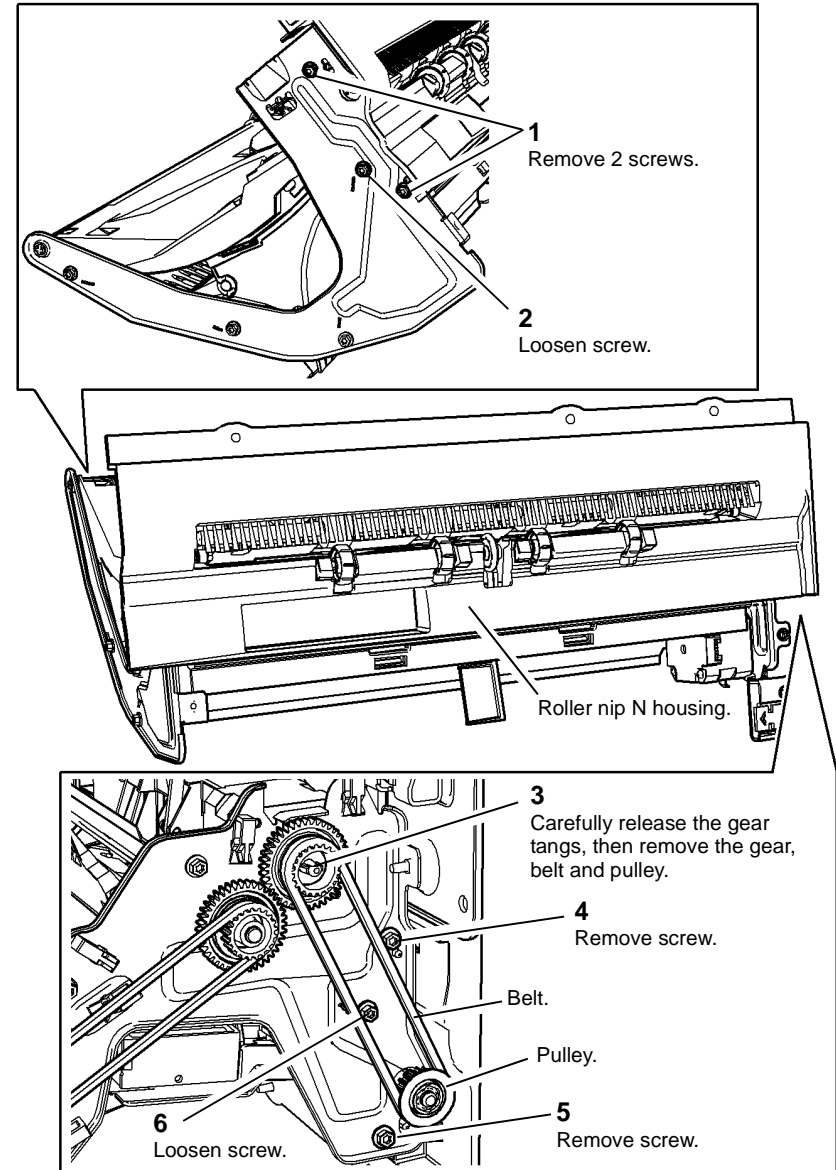

U-1-0935-A

Figure 2 Preparation

- Remove roller nip N, [Figure 3](#).

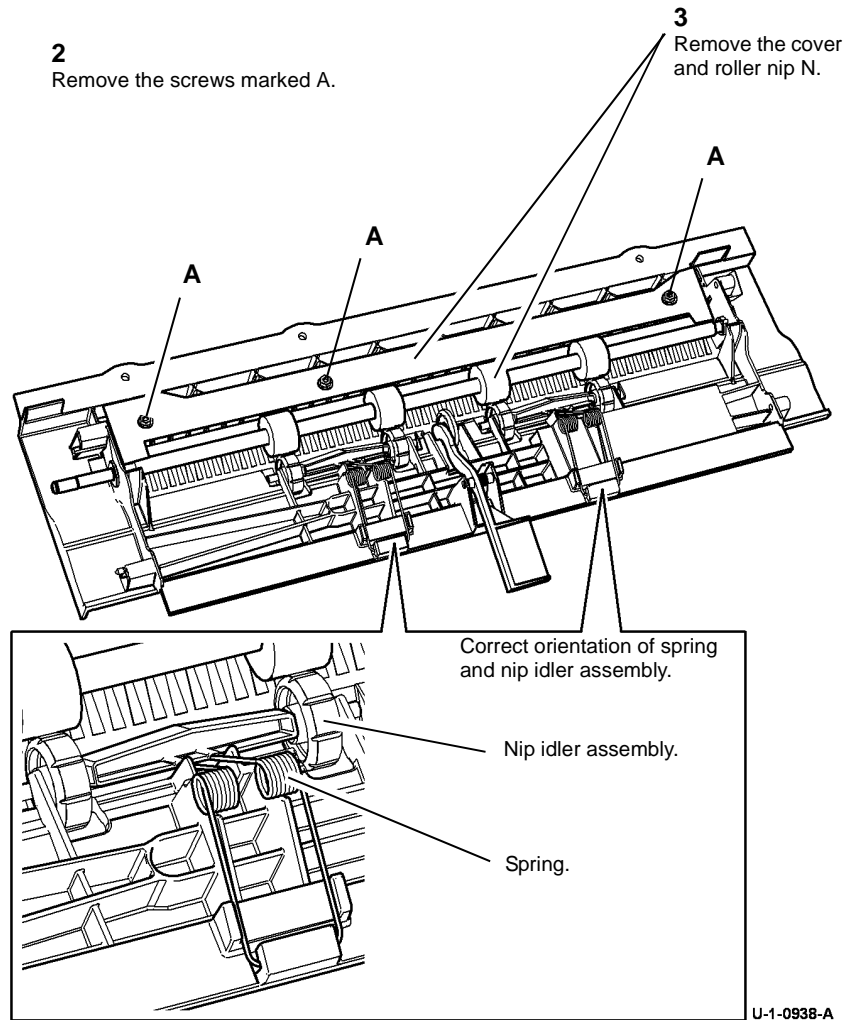

Figure 3 Roller nip N removal

Replacement

Replacement is the reverse of the removal procedure.

REP 10.19 Exit Illuminator PWB

Parts List on [PL 10.15](#)

Removal

WARNING

Switch off the electricity to the machine. Refer to [GP 14](#). Disconnect the power cord from the customer supply while performing tasks that do not need electricity. Electricity can cause death or injury. Moving parts can cause injury.

WARNING

Take care during this procedure. Sharp edges may be present that can cause injury.

- Remove the exit paper path, [REP 10.20](#).
- Remove diverter gate, [REP 10.13](#).
- Remove the paper guide, [Figure 1](#).

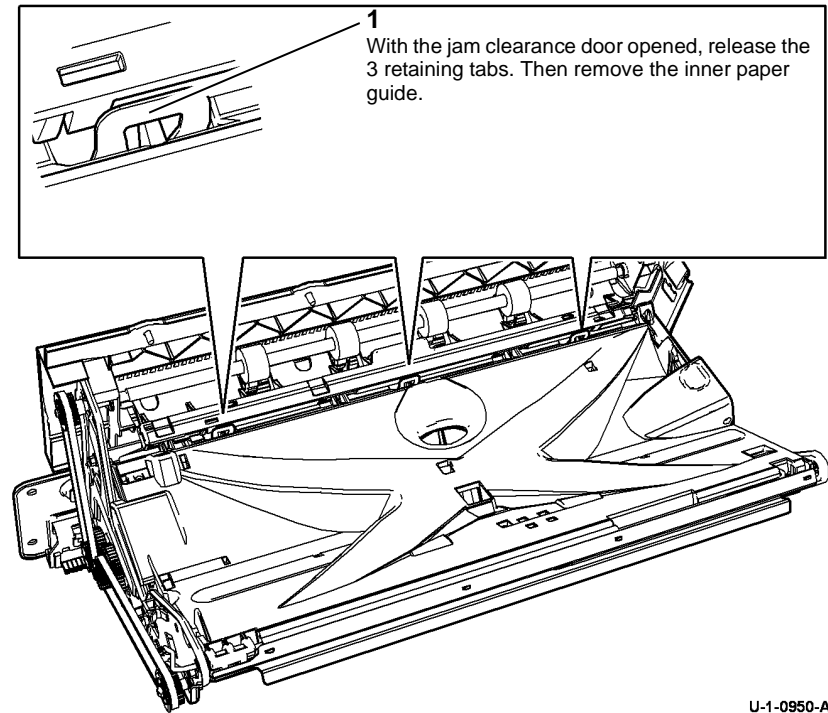
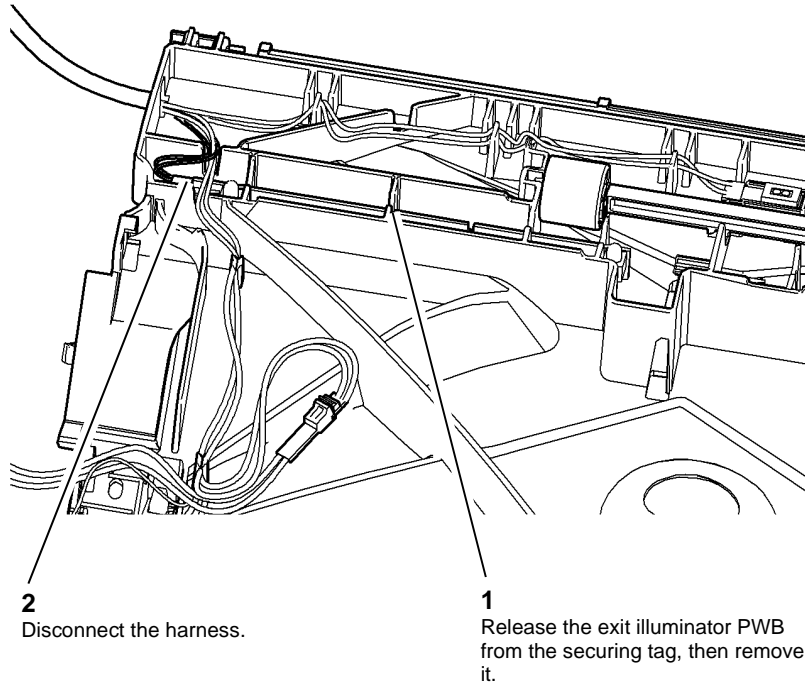

Figure 1 Paper guide removal

- Remove the exit illuminator PWB, [Figure 2](#).



2 Disconnect the harness.

1 Release the exit illuminator PWB from the securing tag, then remove it.

U-1-0939-A

Figure 2 LED PWB removal

Replacement

Replacement is the reverse of the removal procedure.

REP 10.20 Exit Paper Path

Parts List on [PL 10.15](#)

Removal

WARNING

Switch off the electricity to the machine. Refer to [GP 14](#). Disconnect the power cord from the customer supply while performing tasks that do not need electricity. Electricity can cause death or injury. Moving parts can cause injury.

WARNING

Take care during this procedure. Sharp edges may be present that can cause injury.

- Open the front door.
- Remove the inner cover, [PL 81.11 Item 2](#).
- Remove the finisher.
- Remove the right cover, [PL 81.10 Item 3](#).
- Remove handle 4a, [Figure 1](#).

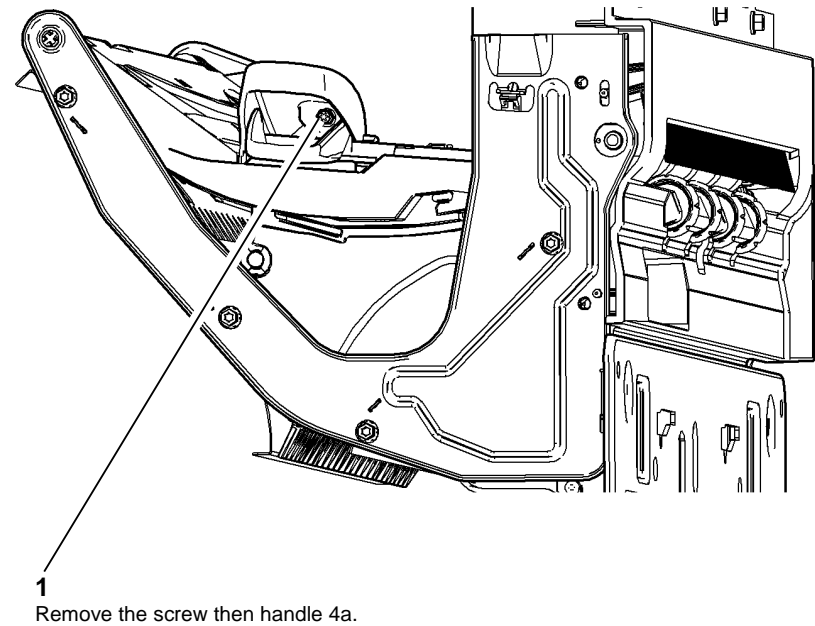

1 Remove the screw then handle 4a.

U-1-0948-A

Figure 1 Handle 4a removal

6. Remove the exit paper path, [Figure 2](#).

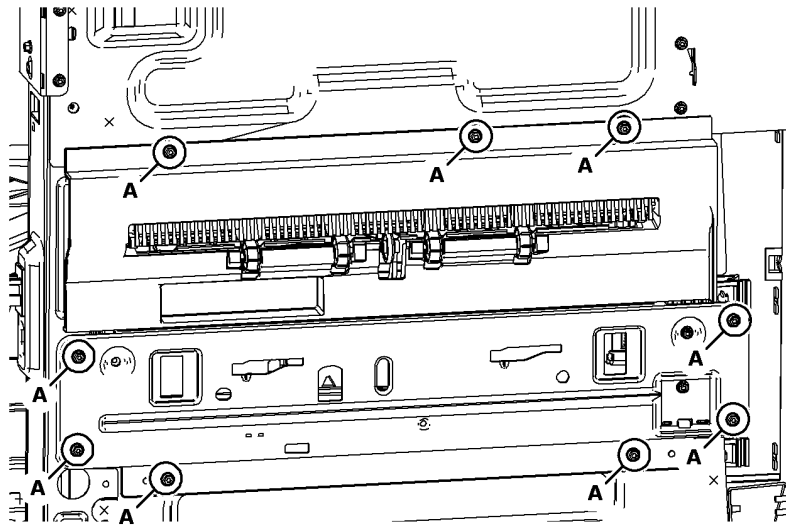

2
Remove the exit paper path

1
Remove the screws marked A.

U-1-0949-A

Figure 2 Exit paper path removal

Replacement

1. Replacement is the reverse of the removal procedure.
2. Ensure that the exit module counter balance spring is located in the keeper, [Figure 3](#).

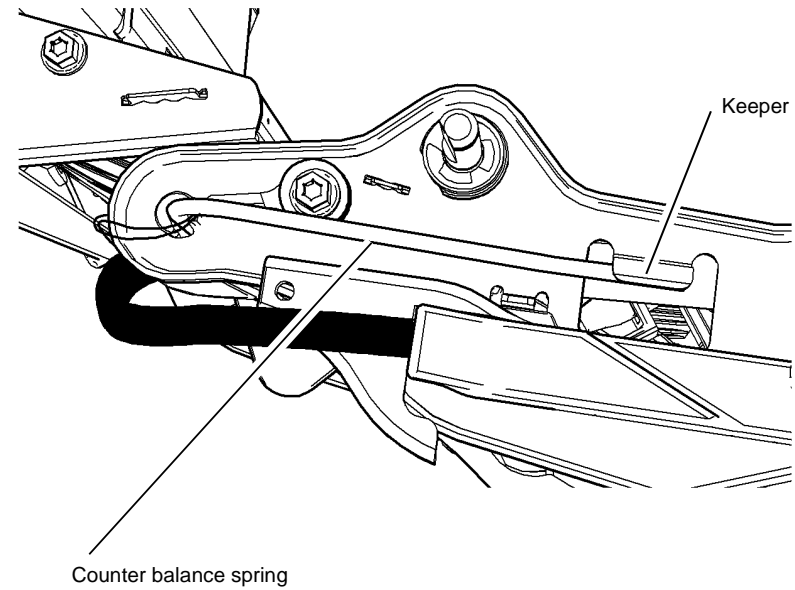

U-1-1010-A

Figure 3 Correct location (viewed at the rear)

3. Install the exit path, [Figure 4](#).

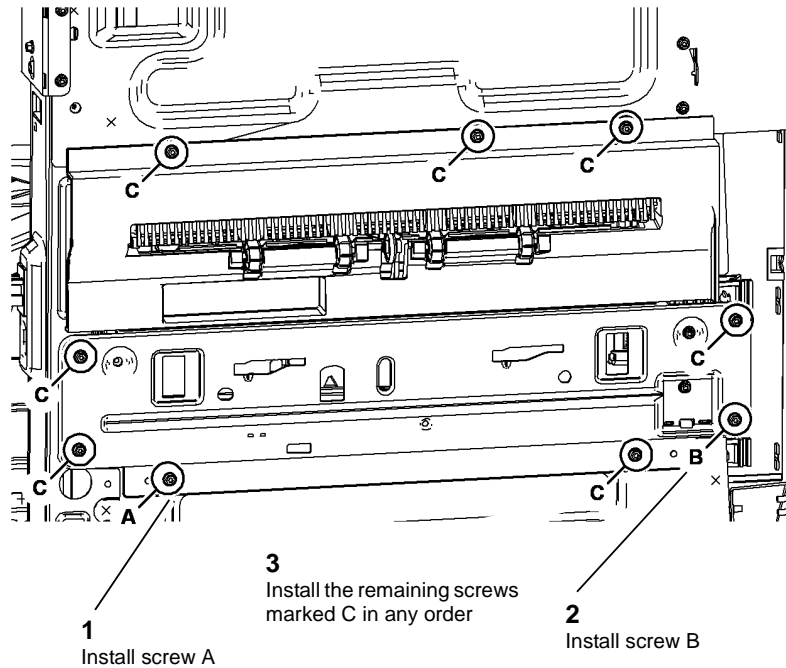

U-1-1302-A

Figure 4 Securing the exit path

4. Transfer the finisher docking actuator, [PL 12.100 Item 17](#), if present, from the old exit paper path assembly to the new exit paper path assembly.

REP 10.21 Stripper Blade, Gate and Baffle

Parts List on [PL 10.12](#)

Removal

WARNING

Switch off the electricity to the machine. Refer to [GP 14](#). Disconnect the power cord from the customer supply while performing tasks that do not need electricity. Electricity can cause death or injury. Moving parts can cause injury.

WARNING

Take care during this procedure. The stripper blade is very sharp and can cause injury.

WARNING

Do not clean the stripper blade. The stripper blade is very sharp and can cause injury. If the stripper blade is dirty a new blade must be installed.

CAUTION

Use care when working near the drum. The drum can be damaged easily, which will cause print quality defects.

1. Open the front door.
2. Remove the inner cover, [PL 81.11 Item 2](#).
3. Open the stripper gate, [GP 31](#).
4. Remove the stripper blade retaining tool from the base of the machine, refer to [Figure 4](#).
5. Use the stripper blade retaining tool to secure the stripper blade in the safe removal position, [Figure 1](#).

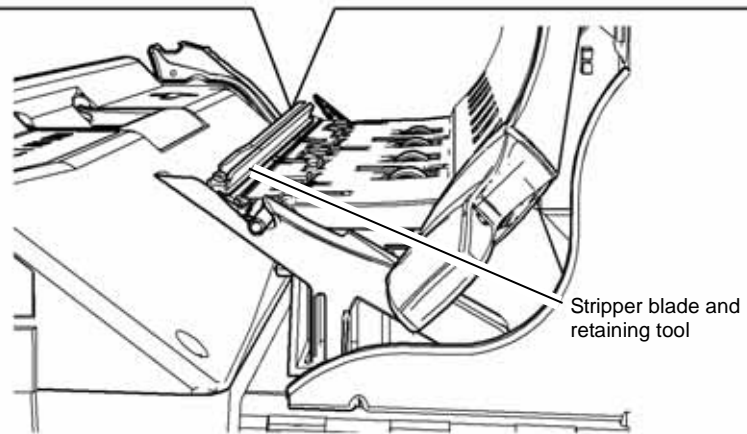
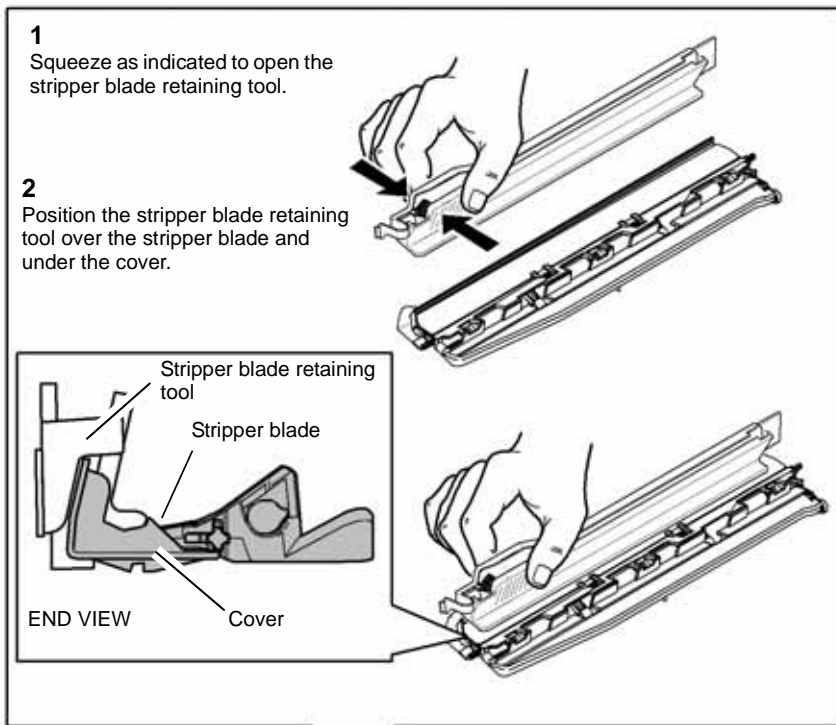
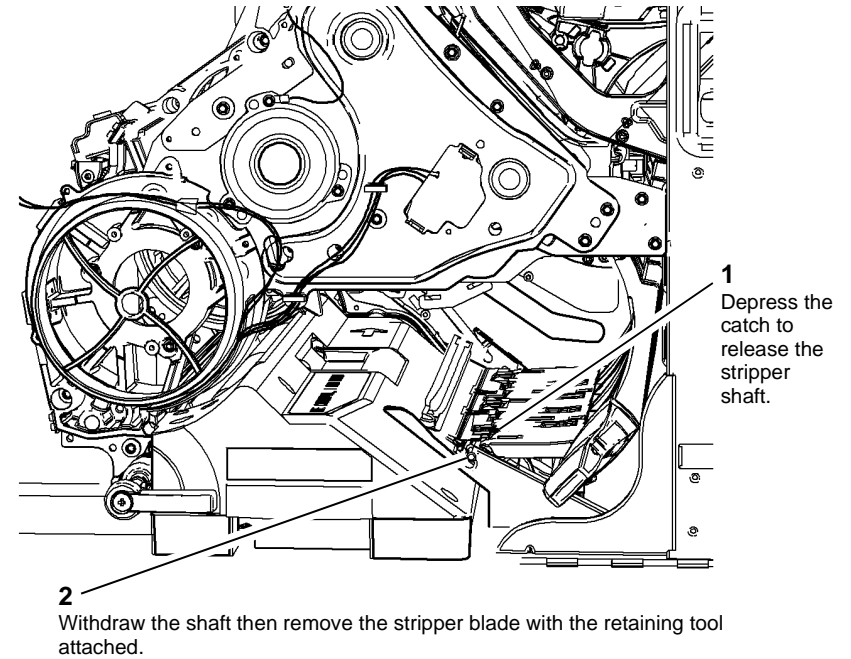

Figure 1 Secure the stripper blade

U-1-1575-A

6. Remove the stripper blade with the stripper blade retaining tool attached, [Figure 2](#).



U-1-0873-A

Figure 2 Stripper blade removal

- Remove the stripper gate and baffle, [Figure 3](#).

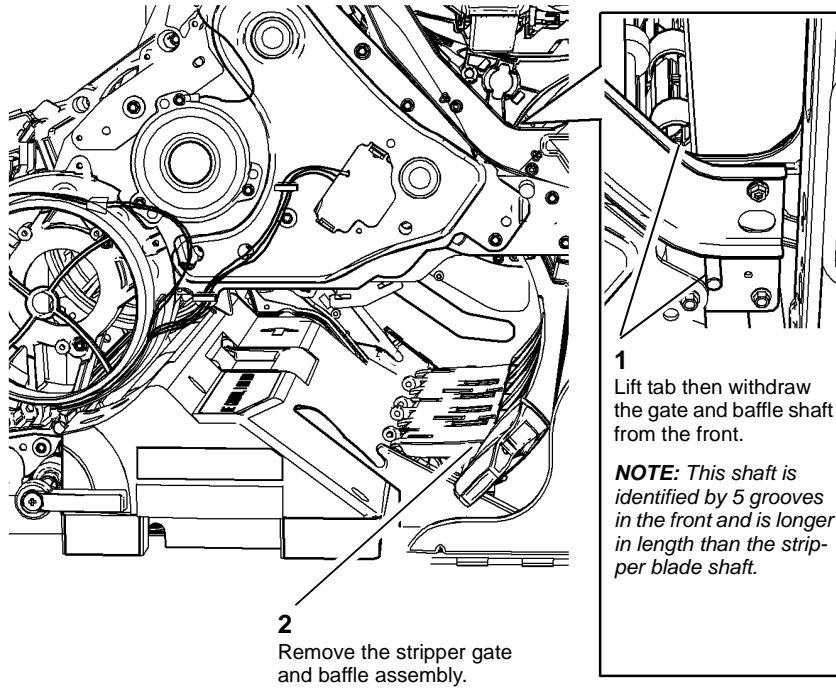

U-1-0874-A

Figure 3 Strip gate and baffle removal

Replacement

WARNING

Do not leave an old stripper blade at the customers site.

- Replacement is the reverse of the removal procedure.
- The new stripper blade will have a retaining tool already attached.

- After the stripper blade has been installed, remove the stripper blade retaining tool and store the tool in the base of the machine, [Figure 4](#).
- Open and close the stripper baffle several times. Check that the blade guard is correctly engaged and covering the blade when the baffle is open. If the blade is exposed then return to Step 4 in the removal process and rectify the problem.
- The old stripper blade must be returned with the retaining tool attached.
- Ensure that the old stripper blade is removed from the customers site for safe disposal.

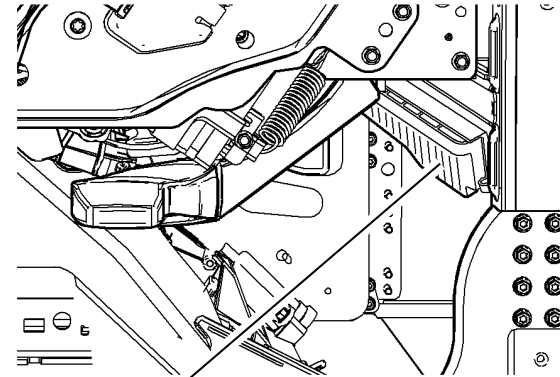

- Install the stripper blade retaining tool in the machine

U-1-1301-A

Figure 4 Stripper blade retaining tool

REP 10.22 Upper Baffle

Parts List on [PL 10.10](#)

Removal

WARNING

Switch off the electricity to the machine. Refer to [GP 14](#). Disconnect the power cord from the customer supply while performing tasks that do not need electricity. Electricity can cause death or injury. Moving parts can cause injury.

WARNING

Do not clean the stripper blade. The stripper blade is very sharp and can cause injury. If the stripper blade is dirty a new blade must be installed.

WARNING

Take care during this procedure. The stripper blade is very sharp and can cause injury.

CAUTION

Use care when working near the drum. The drum can be damaged easily, which will cause print quality defects.

1. Open the front door.
2. Remove the inner cover, [PL 81.11 Item 2](#).
3. Remove the exit paper path, [REP 10.20](#).

4. Prepare to remove the upper baffle, [Figure 1](#).

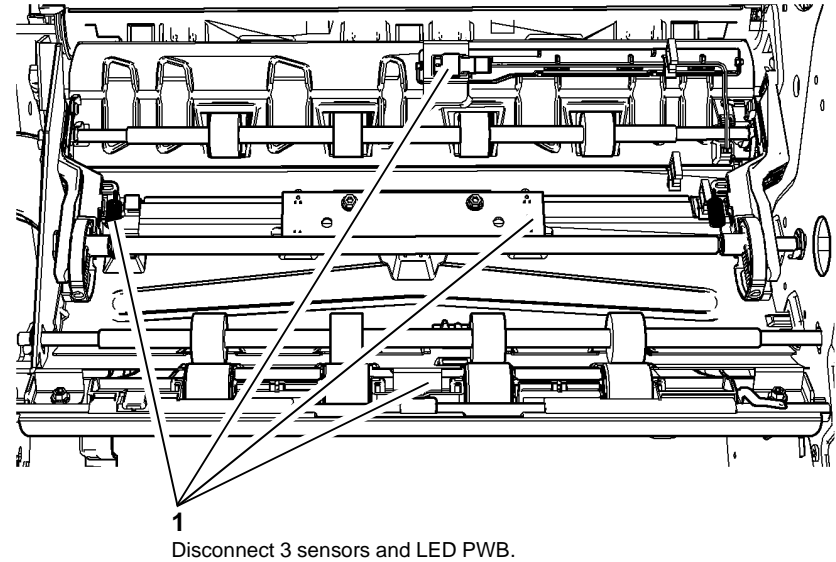

U-1-1026-A

Figure 1 Preparation

5. Unlock and fully open the stripper gate, [GP 31](#).

6. Remove the upper baffle, [Figure 2](#).

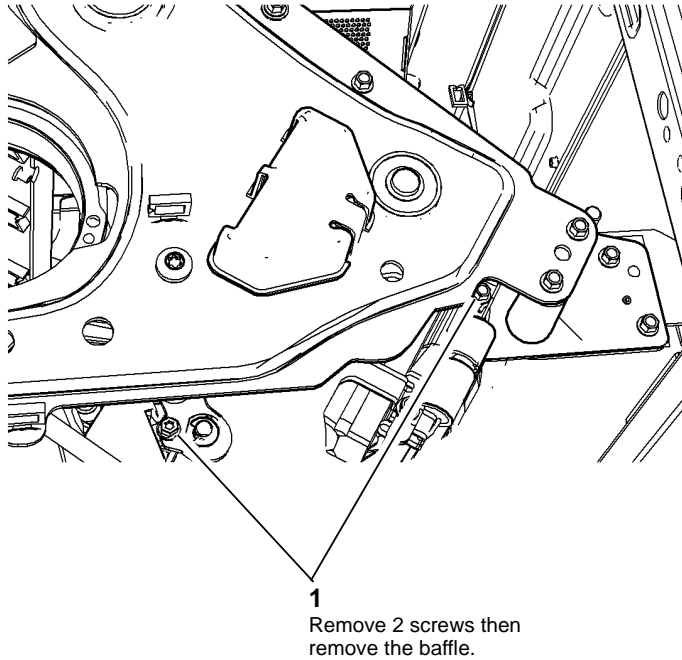

Figure 2 Remove upper baffle

U-1-1647-A

Replacement

1. Replacement is the reverse of the removal procedure.
2. If the upper baffle is cleaned, or a new upper baffle is installed, reset the upper JL baffle count to zero. Refer to [dC135 CRU / HFSI Status](#).

REP 10.23 Stripper Guide Latch Cam Shaft

Parts List on [PL 10.10](#)

Removal

WARNING

Switch off the electricity to the machine. Refer to [GP 14](#). Disconnect the power cord from the customer supply while performing tasks that do not need electricity. Electricity can cause death or injury. Moving parts can cause injury.

WARNING

Take care during this procedure. The stripper blade is very sharp and can cause injury.

1. Open the front door.
2. Remove the inner cover, [PL 81.11 Item 2](#).
3. Unlock and fully open the stripper gate, [GP 31](#).
4. Remove the exit paper path, [REP 10.20](#).
5. Remove the M4 motor and gearbox, [REP 10.8](#).

- Remove the centre 25T gear, [Figure 1](#).

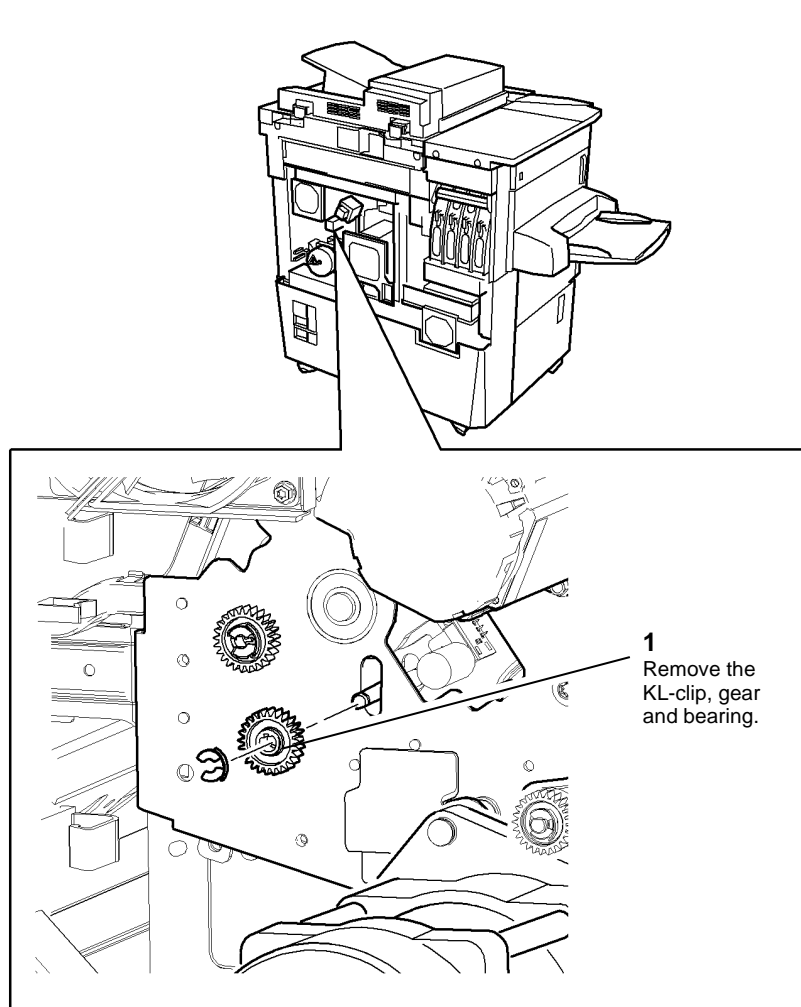

U-1-1029-A

Figure 1 Gear removal

- Remove the stripper guide latch cam shaft, [Figure 2](#).

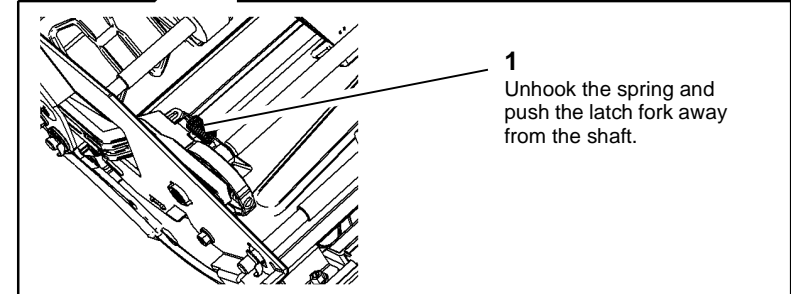
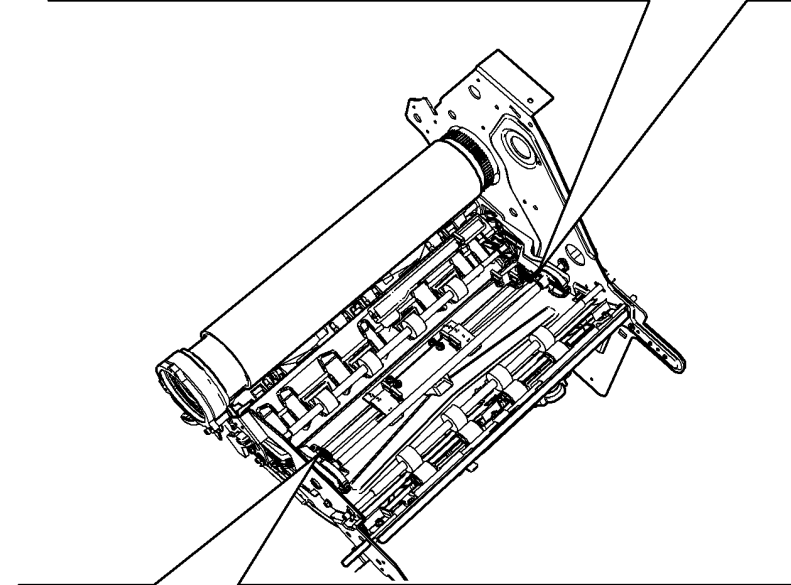
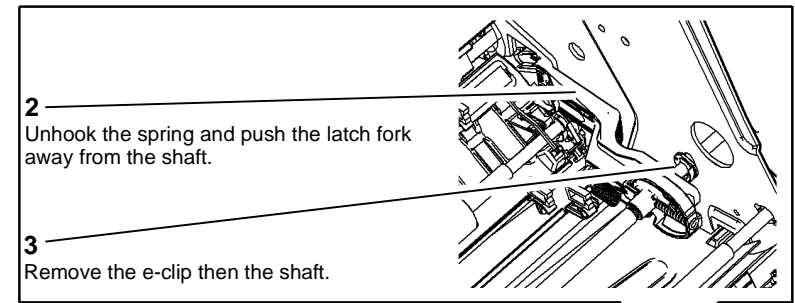

U-1-1131-A

Figure 2 Shaft removal

Replacement

- Replacement is the reverse of the removal procedure.

REP 10.24 Front and Rear Flexure Encoder

Parts List on [PL 10.20](#)

Removal

WARNING

Switch off the electricity to the machine. Refer to [GP 14](#). Disconnect the power cord from the customer supply while performing tasks that do not need electricity. Electricity can cause death or injury. Moving parts can cause injury.

WARNING

Take care during this procedure. The stripper blade is very sharp and can cause injury.

1. Open the front door.
2. Remove the inner cover, [PL 81.11 Item 2](#).
3. Remove the front cover and front flexure encoder, [Figure 1](#).

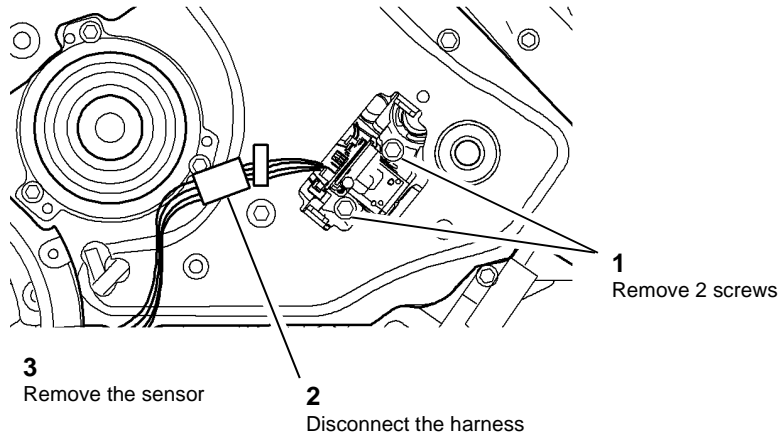

Figure 1 Front flexure encoder

U-1-1185-A

4. Remove the rear cover, [PL 81.10 Item 1](#).
5. Remove the post transfix motor (M4) and gearbox, [Figure 2](#).

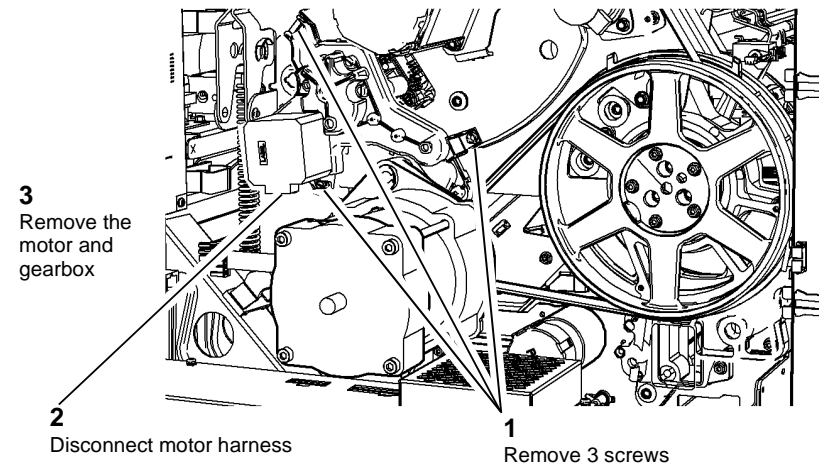

Figure 2 Post transfix motor and gearbox

U-1-1186-A

6. Remove the rear flexure encoder, [Figure 3](#).

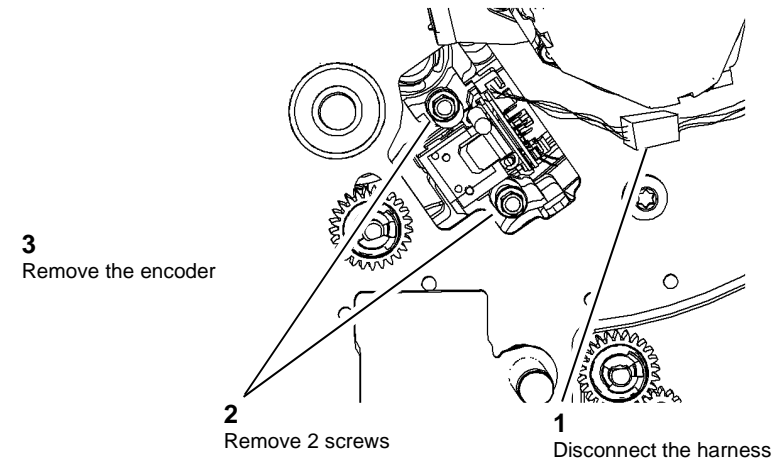

Figure 3 Rear flexure encoder

U-1-1187-A

Replacement

CAUTION

Take care not to damage or contaminate the flexure encoder.

1. Replacement is the reverse of the removal procedure.

REP 12.1-110 LCSS Covers

Parts List on [PL 12.10](#).

Removal

WARNING

Switch off the electricity to the machine. Refer to [GP 14](#). Disconnect the power cord from the customer supply while performing tasks that do not need electricity. Electricity can cause death or injury. Moving parts can cause injury.

WARNING

Take care during this procedure. Sharp edges may be present that can cause injury.

Remove the covers, [Figure 1](#).

NOTE: Removing the top cover first will allow easy removal of the front and rear covers.

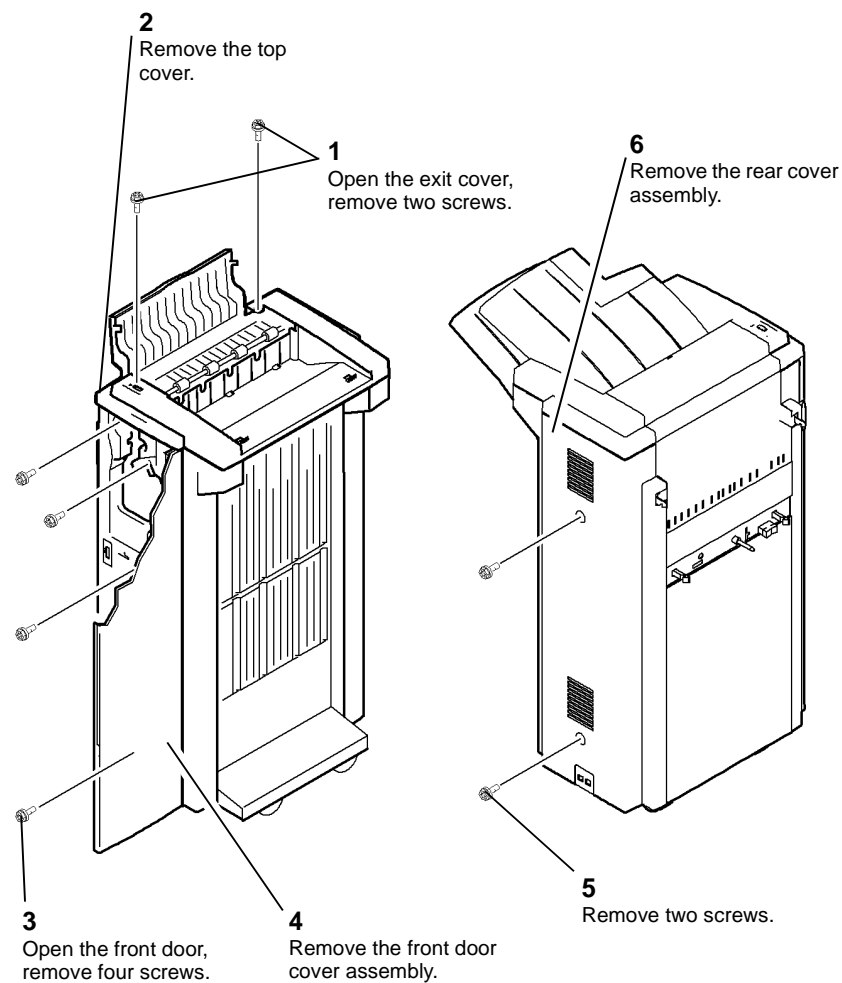

U-1-0374-A

Figure 1 Removing the covers

Replacement

Reverse the removal procedure to replace the covers.

REP 12.2-110 Input Drive Belt and Paper Entry Transport Motor

Parts List on [PL 12.40](#).

Removal

WARNING

Switch off the electricity to the machine. Refer to [GP 14](#). Disconnect the power cord from the customer supply while performing tasks that do not need electricity. Electricity can cause death or injury. Moving parts can cause injury.

WARNING

Take care during this procedure. Sharp edges may be present that can cause injury.

1. Remove the LCSS rear cover, [REP 12.1-110](#).
2. Remove the motor and drive belt, [Figure 1](#).

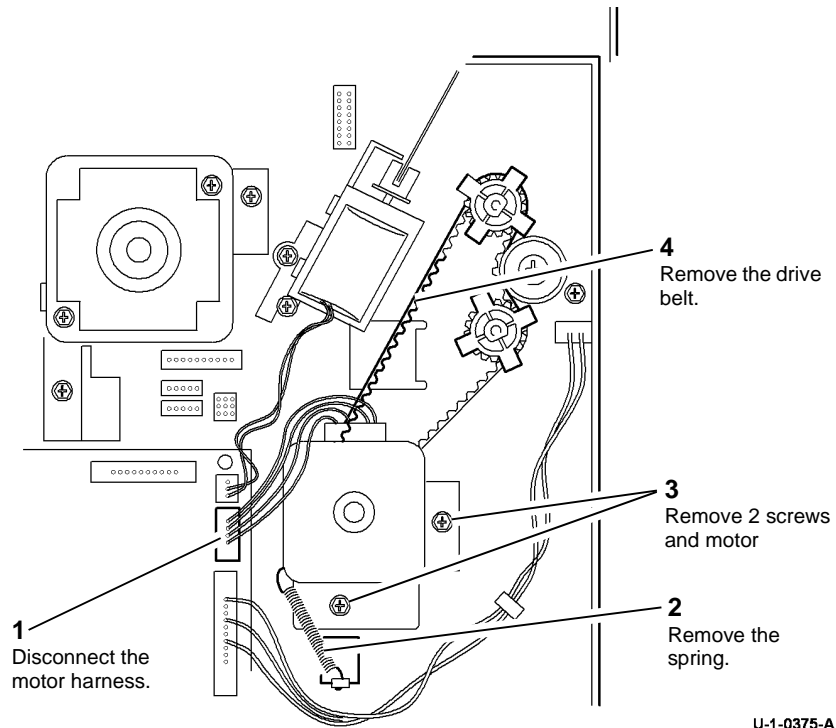

Figure 1 Removing the drive belt

Replacement

1. Place the belt around the pulleys.
2. Install the motor screws, but do not tighten.
3. Install the spring
4. Rotate the shaft by hand to ensure the belt runs smoothly over the pulleys and allow the spring to tension the belt, [ADJ 12.4-110](#).
5. Tighten the motor screws and re-connect the harness.
6. Install the LCSS rear cover, [REP 12.1-110](#).

REP 12.3-110 Intermediate Paper Drive Belt

Parts List on [PL 12.60](#).

Removal

WARNING

Switch off the electricity to the machine. Refer to [GP 14](#). Disconnect the power cord from the customer supply while performing tasks that do not need electricity. Electricity can cause death or injury. Moving parts can cause injury.

WARNING

Take care during this procedure. Sharp edges may be present that can cause injury.

1. Remove the LCSS rear cover [REP 12.1-110](#).
2. Remove the intermediate paper drive belt, [Figure 1](#).

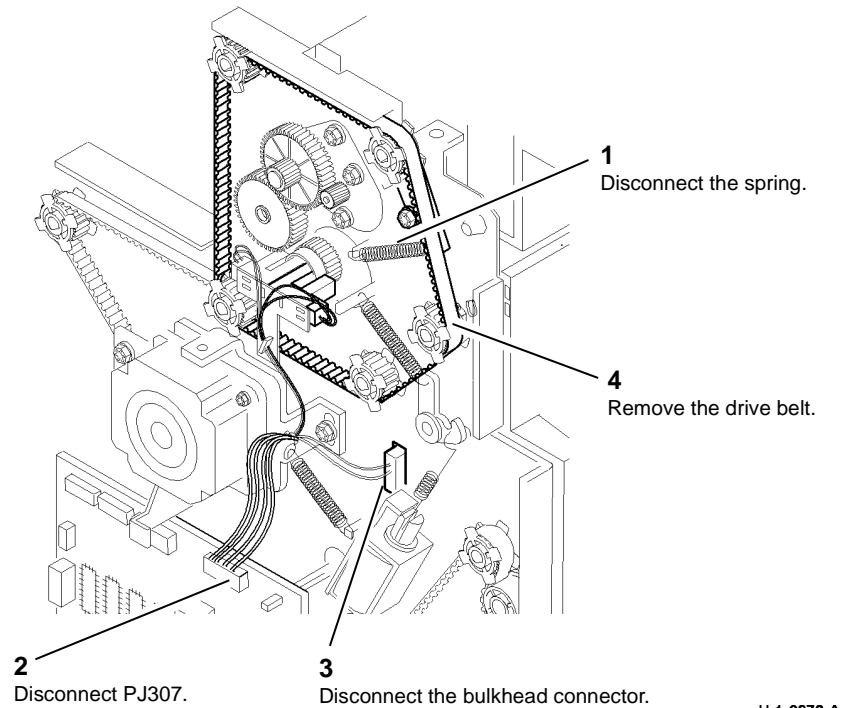

Figure 1 Removing the drive belt

Replacement

1. Lubricate the belt tensioner, refer to [ADJ 4.1](#).
2. Install the belt over the pulleys, ensuring that the belt is on all five pulleys.

NOTE: Two of the pulleys are free to slide along the shaft. Ensure the belt is correctly located on these pulleys.

3. Install the LCSS rear cover, [REP 12.1-110](#).

REP 12.4-110 Paper Output Drive Belt and Transport Motor

2

Parts List on [PL 12.60](#).

Removal

WARNING

Switch off the electricity to the machine. Refer to [GP 14](#). Disconnect the power cord from the customer supply while performing tasks that do not need electricity. Electricity can cause death or injury. Moving parts can cause injury.

WARNING

Take care during this procedure. Sharp edges may be present that can cause injury.

1. Remove the LCSS rear cover, [REP 12.1-110](#).
2. Remove the intermediate drive belt, [REP 12.3-110](#).
3. Remove the output drive belt and motor, [Figure 1](#).

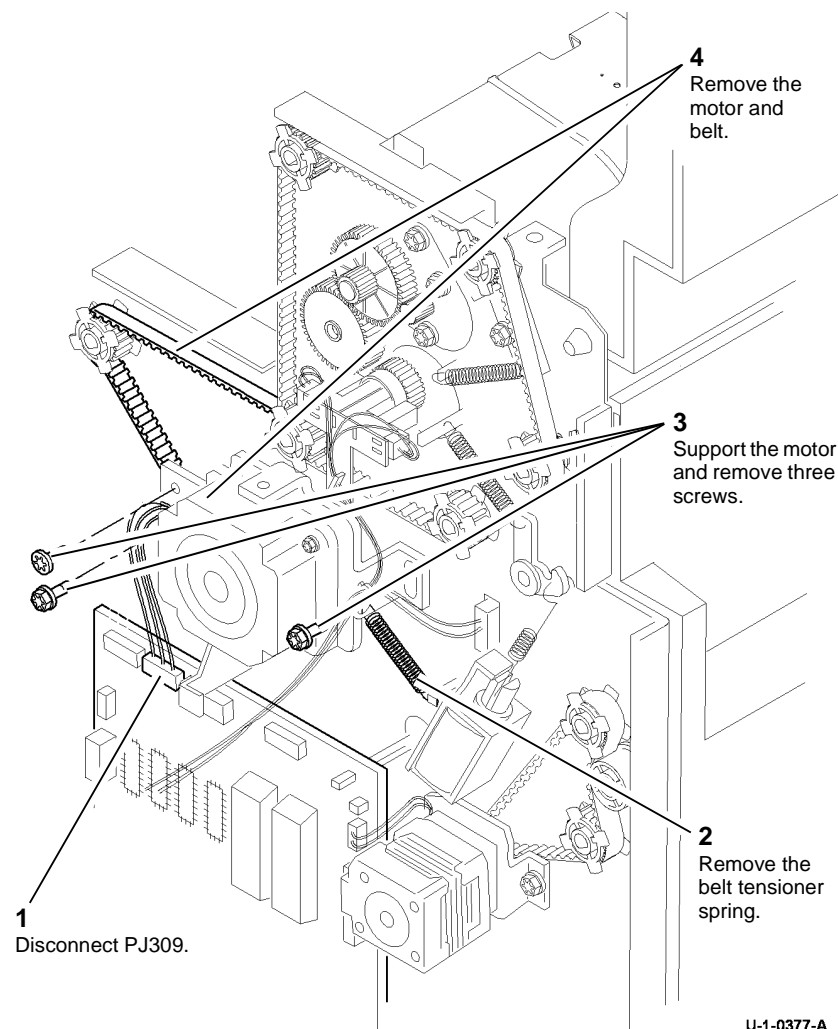

Figure 1 Removing the drive belt

Replacement

1. Install the belt over the pulleys.
2. Install the motor pivot shouldered screw and fully tighten.
3. Install the two motor mounting bracket securing screws but do not tighten them.
4. Install the belt tensioner spring.
5. Rotate the belt by hand to allow the spring to tension the belt, [ADJ 12.4-110](#). Tighten the screws.
6. Install the intermediate drive belt, [REP 12.3-110](#).
7. Install the LCSS rear cover, [REP 12.1-110](#).

REP 12.5-110 Bin 1 Drive Belts

Parts List on [PL 12.30](#).

Removal

WARNING

Switch off the electricity to the machine. Refer to [GP 14](#). Disconnect the power cord from the customer supply while performing tasks that do not need electricity. Electricity can cause death or injury. Moving parts can cause injury.

WARNING

Take care during this procedure. Sharp edges may be present that can cause injury.

1. Remove the LCSS front and rear covers, [REP 12.1-110](#).

2. Remove the bin 1 drive belt (rear) **Figure 1**.

NOTE: Keep all of the components removed as a set. The set of rear frame components are different from the front frame set.

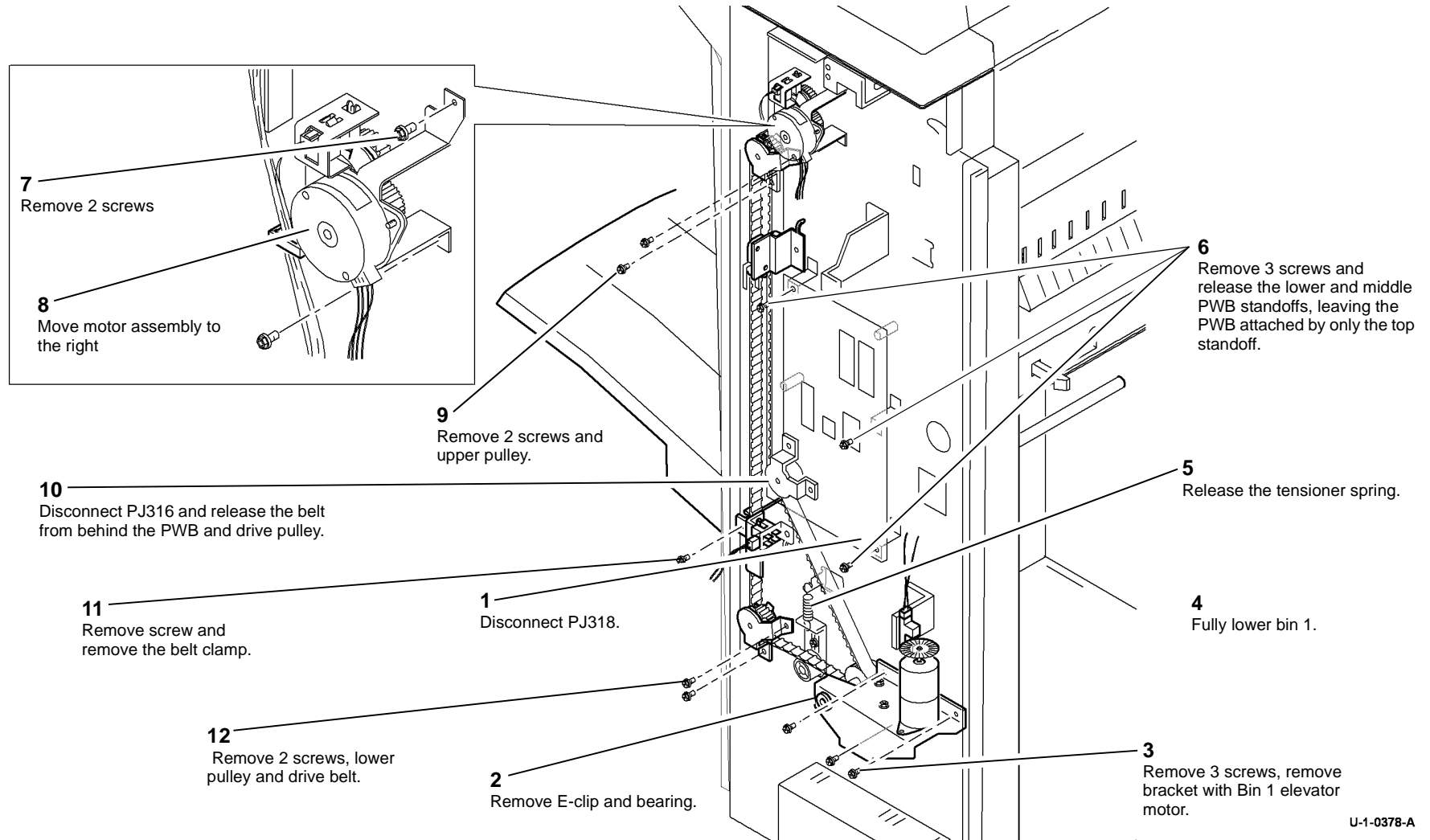
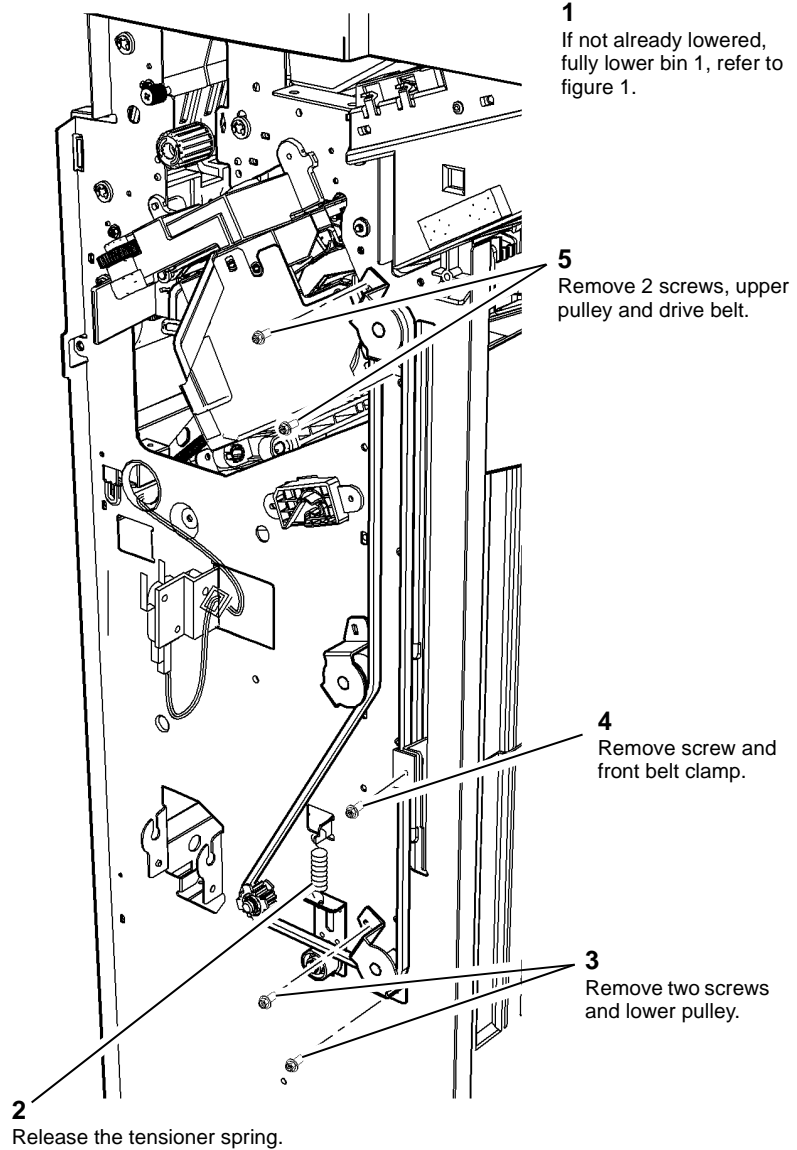

Figure 1 Bin 1 drive belt (rear)

U-1-0378-A

3. Remove the bin 1 drive belt (front) [Figure 2](#).



U-1-0379-A

Figure 2 Bin 1 drive belt (front)

Replacement

NOTE: Ensure the correct set of components are used for each side of the LCSS.

1. Reverse the removal procedure to replace the bin 1 drive belts.

NOTE: The bin 1 level can critically affect the overall stack registration. Refer to [ADJ 12.1-110](#) if adjustment is necessary.

2. Install the front and rear covers [REP 12.1-110](#).

REP 12.6-110 Tamper Assembly

Parts List on [PL 12.45](#).

Removal

WARNING

Switch off the electricity to the machine. Refer to [GP 14](#). Disconnect the power cord from the customer supply while performing tasks that do not need electricity. Electricity can cause death or injury. Moving parts can cause injury.

WARNING

Take care during this procedure. Sharp edges may be present that can cause injury.

1. Remove the LCSS covers [REP 12.1-110](#).
2. Prepare to remove the tamper assembly [Figure 1](#).

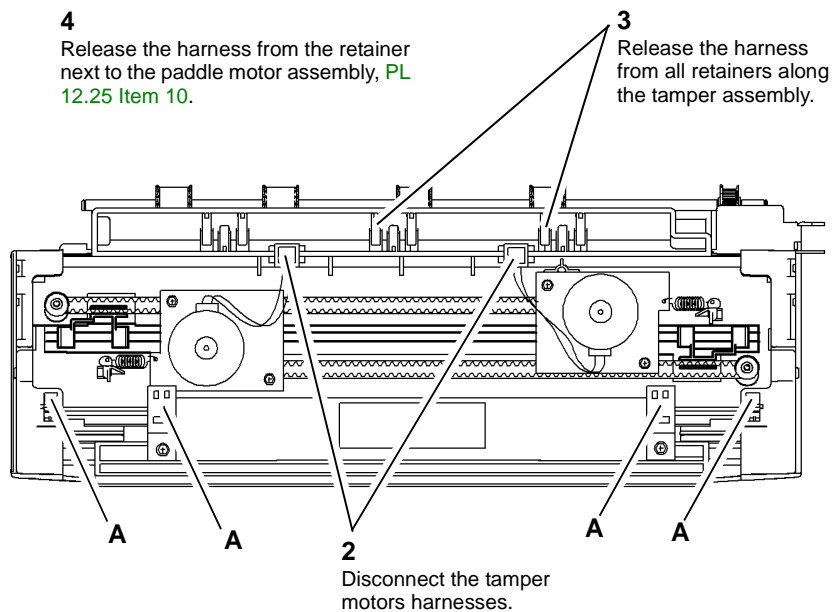

Figure 1 Preparing the tamper assembly

3. [Figure 2](#), remove the tamper assembly.

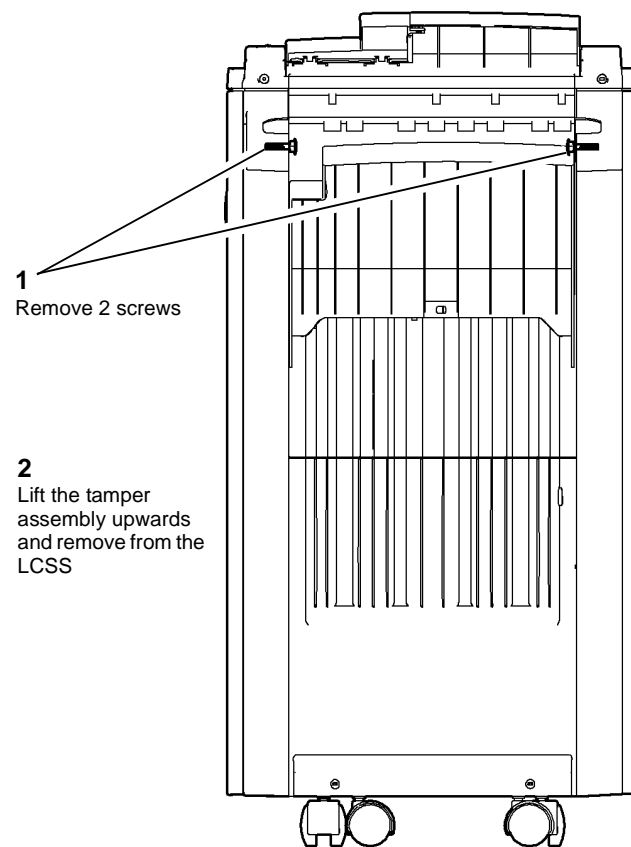

Figure 2 Removing the tamper assembly

U-1-0381-A

U-1-0380-A

Replacement

NOTE: Ensure that the slots in the tamper assembly locate correctly in the LCSS frame.

NOTE: Ensure that the sensors are correctly located in the tamper assembly, they are easily mis-located when being re-connected to the harnesses.

NOTE: Ensure that all connectors in the harness over the tamper assembly are securely connected.

Reverse the removal procedure to replace the tamper assembly.

REP 12.7-110 Hole Punch Unit, Motor and Sensors

Parts List on [PL 12.20](#).

Removal

WARNING

Switch off the electricity to the machine. Refer to [GP 14](#). Disconnect the power cord from the customer supply while performing tasks that do not need electricity. Electricity can cause death or injury. Moving parts can cause injury.

WARNING

Take care during this procedure. Sharp edges may be present that can cause injury.

1. Remove the LCSS covers, [REP 12.1-110](#).
2. Remove and empty the chad bin, [PL 12.20 Item 4](#).

3. Remove the hole punch unit, motor assembly and sensors, [Figure 1](#).

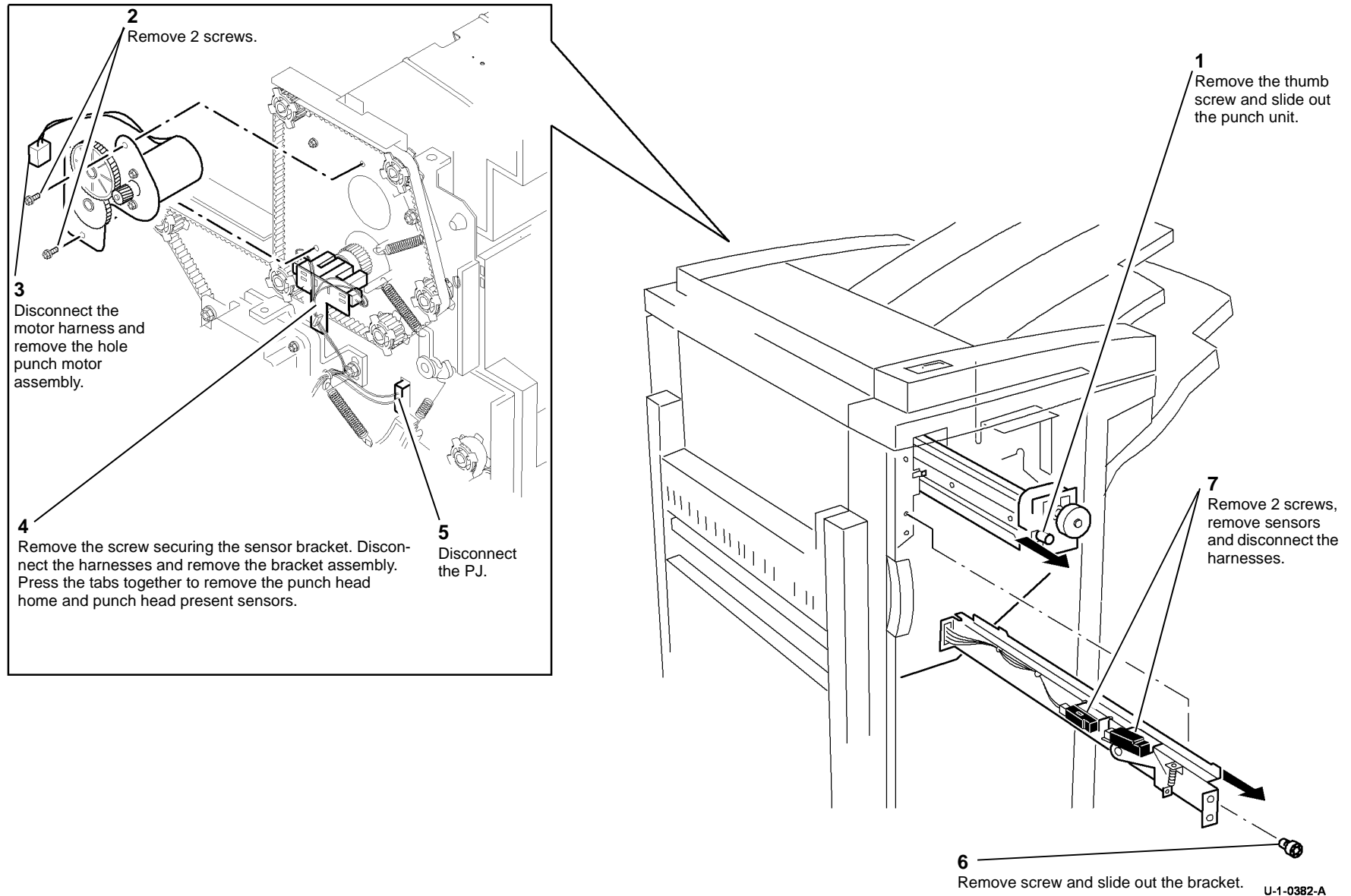

Figure 1 Hole punch unit, motor and sensors

Replacement

1. Reverse the removal procedure to replace the hole punch unit, motor assembly and sensors.
2. If necessary, perform [ADJ 12.3-110](#) Hole Punch Position.

NOTE: When installing the hole punch motor assembly, ensure that the belt tensioner arm does not get trapped behind the motor assembly plate.

REP 12.8-110 Stapler Traverse Assembly

Parts List on [PL 12.55](#).

Removal

WARNING

Switch off the electricity to the machine. Refer to [GP 14](#). Disconnect the power cord from the customer supply while performing tasks that do not need electricity. Electricity can cause death or injury. Moving parts can cause injury.

WARNING

Take care during this procedure. Sharp edges may be present that can cause injury.

WARNING

Take care not to topple the LCSS. The LCSS is unstable when un-docked from the machine. Do not show the customer how to un-dock the LCSS.

1. Un-dock the LCSS, [REP 12.13-110](#).
2. Remove the rear cover and front door cover assembly, [REP 12.1-110](#).
3. Manually move the ejector, [PL 12.50](#) Item 1 fully to the right.
4. [Figure 1](#), Disconnect the harness.

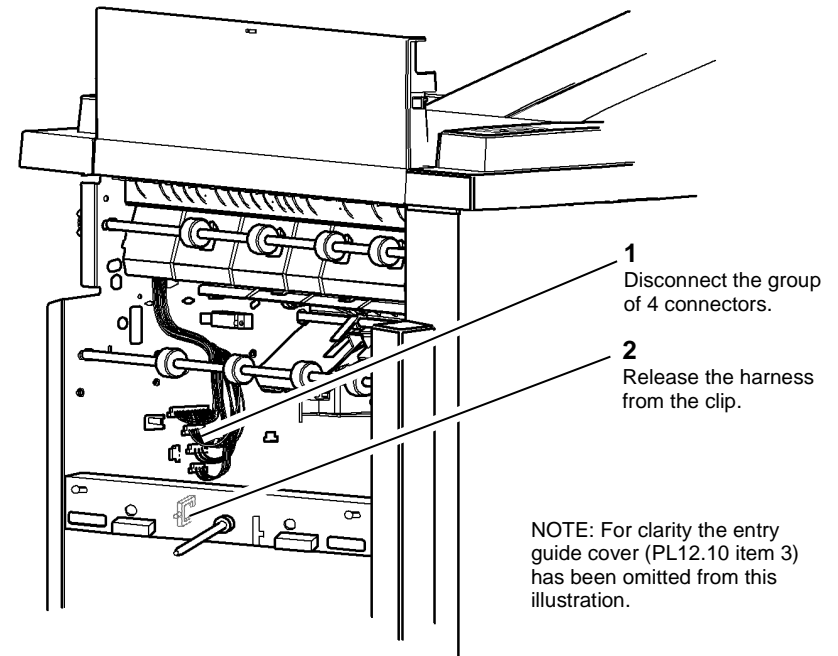

U-1-0383-A

Figure 1 Harness disconnection

CAUTION

When removing and replacing the stapler traverse assembly, support the weight of the assembly underneath the stapler and take care not to damage wiring.

5. Remove the stapler traverse assembly, [Figure 2](#).

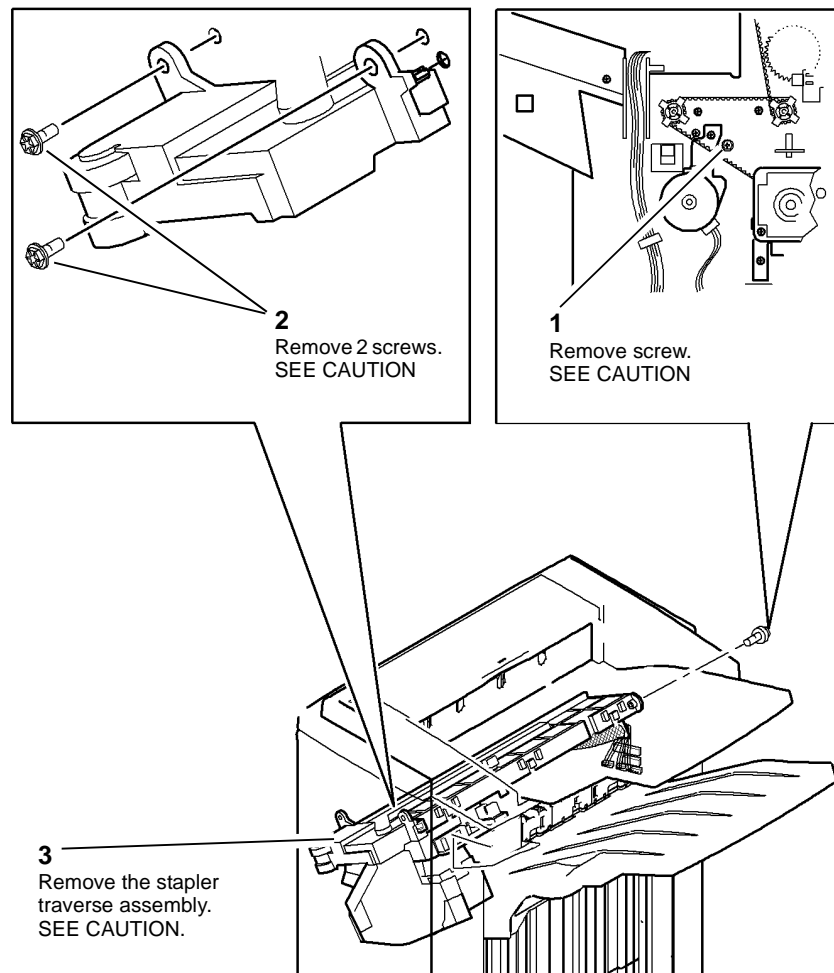

U-1-0384-A

Figure 2 Removing the stapler traverse assembly

Replacement

1. Ensure the stapling traverse assembly is engaged on the front and rear locating dowels.
2. Reverse the removal procedure to replace the stapling unit.

REP 12.9-110 Staple Head Unit

Parts List on [PL 12.55](#).

Removal

WARNING

Switch off the electricity to the machine. Refer to [GP 14](#). Disconnect the power cord from the customer supply while performing tasks that do not need electricity. Electricity can cause death or injury. Moving parts can cause injury.

WARNING

Take care during this procedure. Sharp edges may be present that can cause injury.

1. Remove the stapler traverse assembly, [REP 12.8-110](#).
2. Place the stapler traverse unit upside-down

3. Remove the staple head unit from the stapling unit [Figure 1](#).

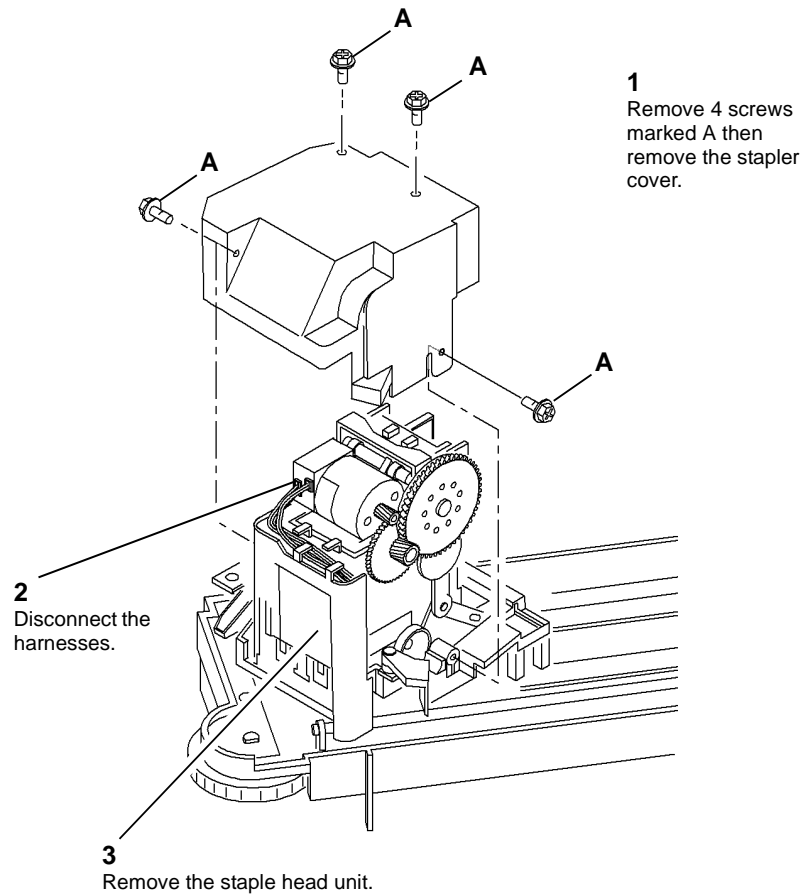

U-1-0385-A

Figure 1 Removing the staple head unit

Replacement

Reverse the removal procedure to replace the staple head unit.

REP 12.10-110 Ejector Assembly Sensors

Parts List on [PL 12.50](#).

Removal

WARNING

Switch off the electricity to the machine. Refer to [GP 14](#). Disconnect the power cord from the customer supply while performing tasks that do not need electricity. Electricity can cause death or injury. Moving parts can cause injury.

WARNING

Take care during this procedure. Sharp edges may be present that can cause injury.

WARNING

Take care not to topple the LCSS. The LCSS is unstable when un-docked from the machine. Do not show the customer how to un-dock the LCSS.

1. Disconnect the two harnesses between the LCSS and the machine.
2. Un-dock the LCSS, [REP 12.13-110](#) and move it away from the machine.
3. Ensure the stapling unit is at the home position.
4. If necessary, manually move the ejector to the left position.

5. Figure 1, remove the ejector assembly.

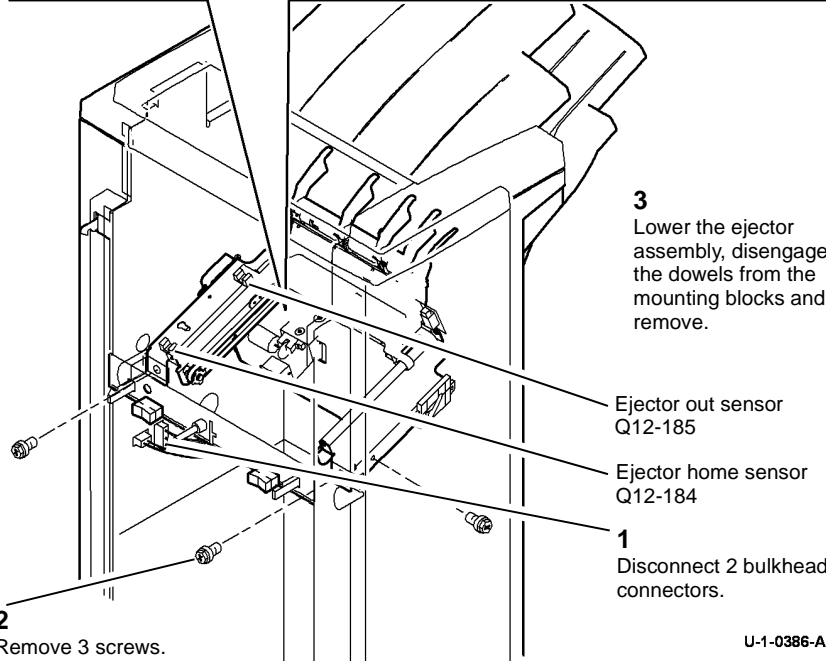
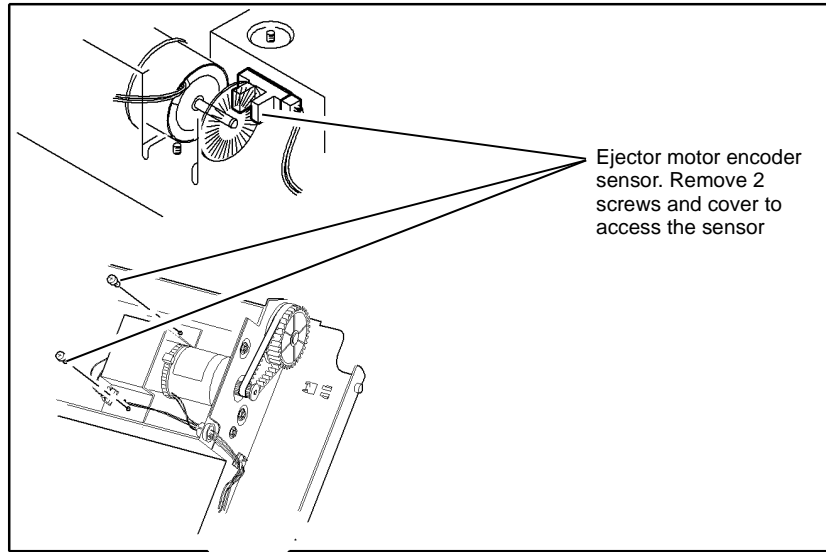

Figure 1 Removing the ejector assembly

6. Remove the appropriate sensor by releasing the sensor tabs and disconnecting the harness.

Replacement

CAUTION

When installing the ejector assembly onto the LCSS, ensure that the ejector fingers do not damage the wiring to the staple head unit.

Reverse the removal procedure to replace the eject assembly or sensors.

REP 12.11-110 Bin 1 Upper Level Sensor

Parts List on [PL 12.35](#).

Removal

WARNING

Switch off the electricity to the machine. Refer to [GP 14](#). Disconnect the power cord from the customer supply while performing tasks that do not need electricity. Electricity can cause death or injury. Moving parts can cause injury.

WARNING

Take care during this procedure. Sharp edges may be present that can cause injury.

1. Remove the ejector assembly, [REP 12.10-110](#).

2. Remove the bin 1 upper level sensor, [Figure 1](#).

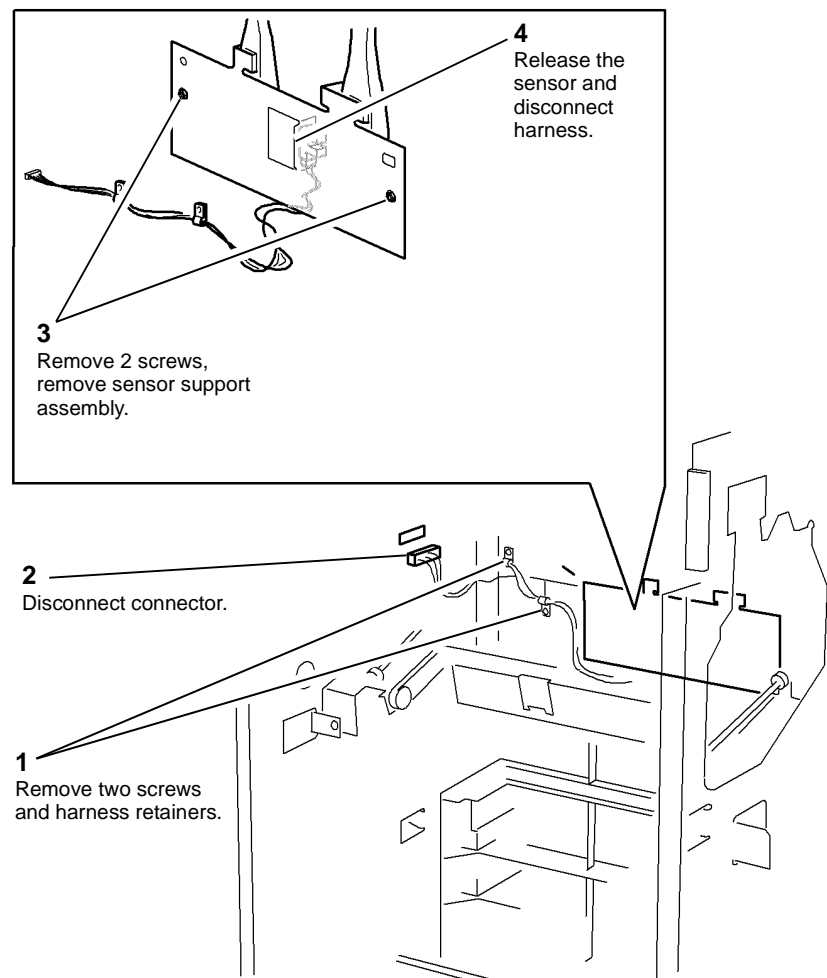

U-1-0387-A

Figure 1 Removal

Replacement

Reverse the removal procedures to replace the bin 1 level sensor.

REP 12.12-110 Paddle Wheel Shaft Assembly

Parts List on [PL 12.25](#).

Removal

WARNING

Switch off the electricity to the machine. Refer to [GP 14](#). Disconnect the power cord from the customer supply while performing tasks that do not need electricity. Electricity can cause death or injury. Moving parts can cause injury.

WARNING

Take care during this procedure. Sharp edges may be present that can cause injury.

1. Remove the stapler traverse assembly, [REP 12.8-110](#).
2. Remove the tamper assembly, [REP 12.6-110](#).
3. Remove bin 1, [PL 12.10 Item 10](#).

4. [Figure 1](#), remove the paddle motor assembly.

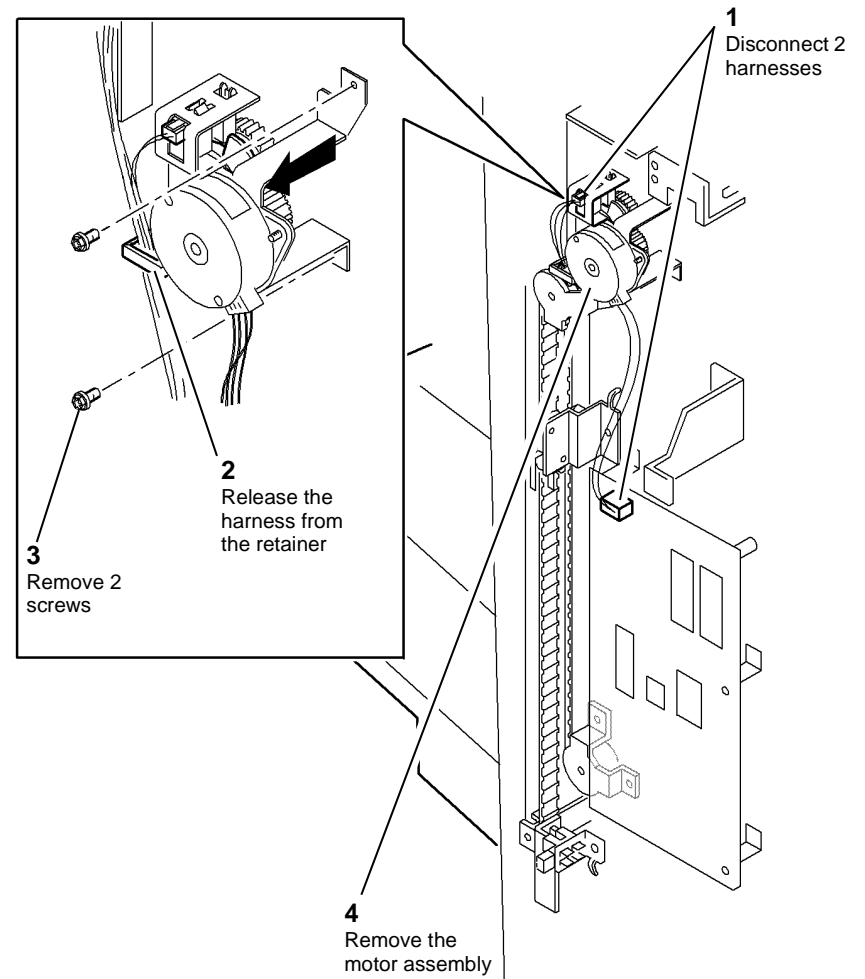

U-1-0388-A

Figure 1 Paddle motor assembly

5. **Figure 2**, prepare the rear components.

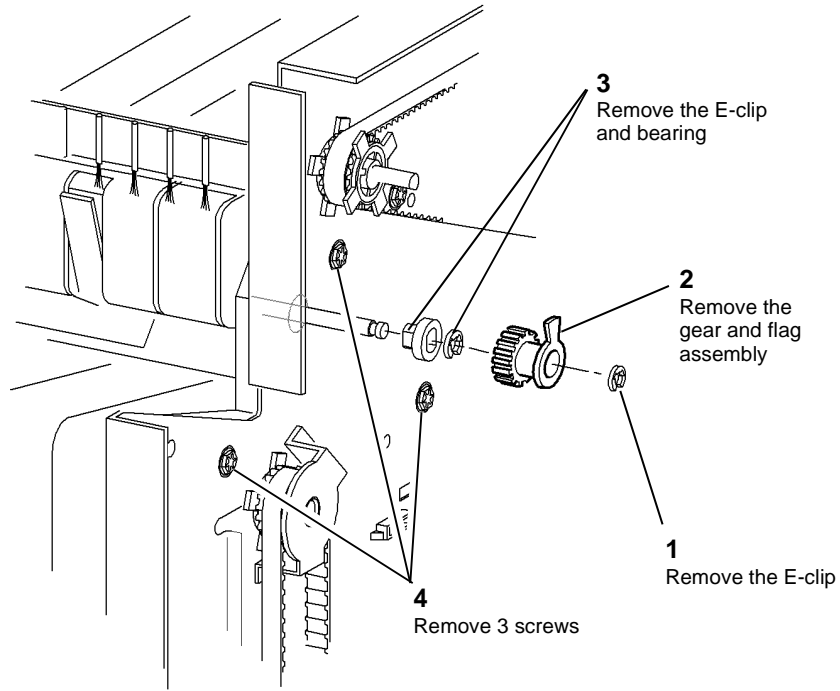

U-1-0389-A

Figure 2 Rear preparation

6. **Figure 3**, prepare the front components.

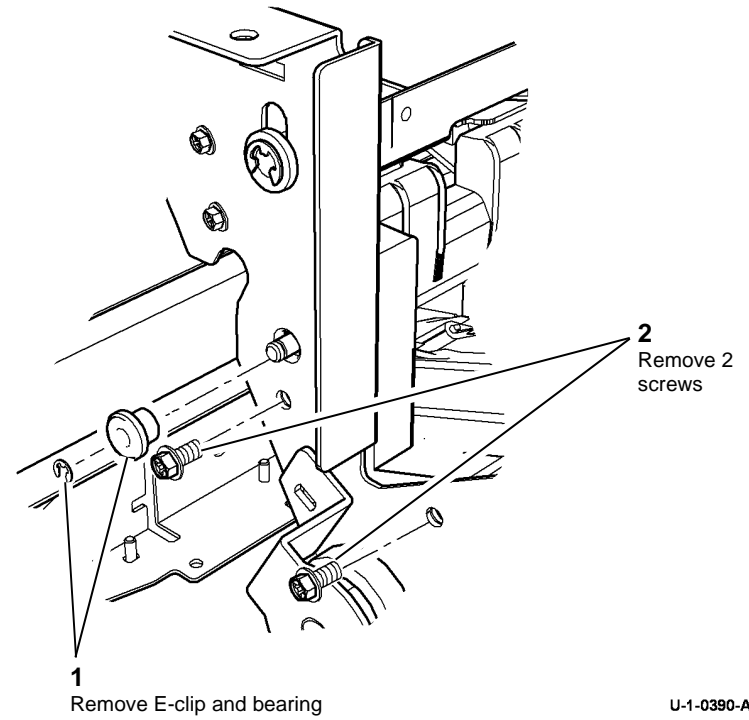

U-1-0390-A

Figure 3 Front preparation

7. Ensure that the compiler ejector is in the home position (fully to the left).

8. **Figure 4**, remove the paddle wheel shaft assembly.

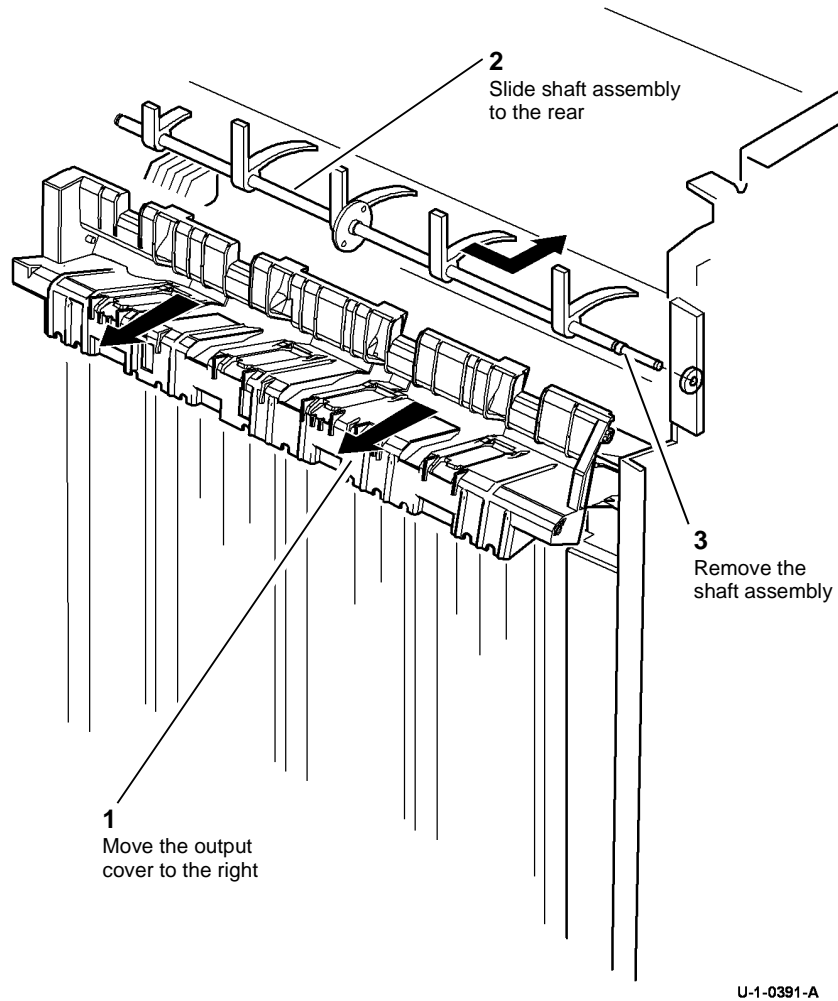

Figure 4 Paddle wheel shaft removal

Replacement

1. Install the paddle wheel shaft, front bearing and E-clip, refer to **Figure 3**.
2. Install the output cover, refer to **Figure 4**.
3. Install the rear bearing and E-clip, refer to **Figure 2**.
4. Install the gear and flag assembly, refer to **Figure 2**, ensuring that the gear locates onto the large "D" flat and the flag locates on the small "D" flat.

5. Install the flag and E-clip, refer to **Figure 2**.
6. **Figure 5**, ensure the paddles and flag are correctly aligned.

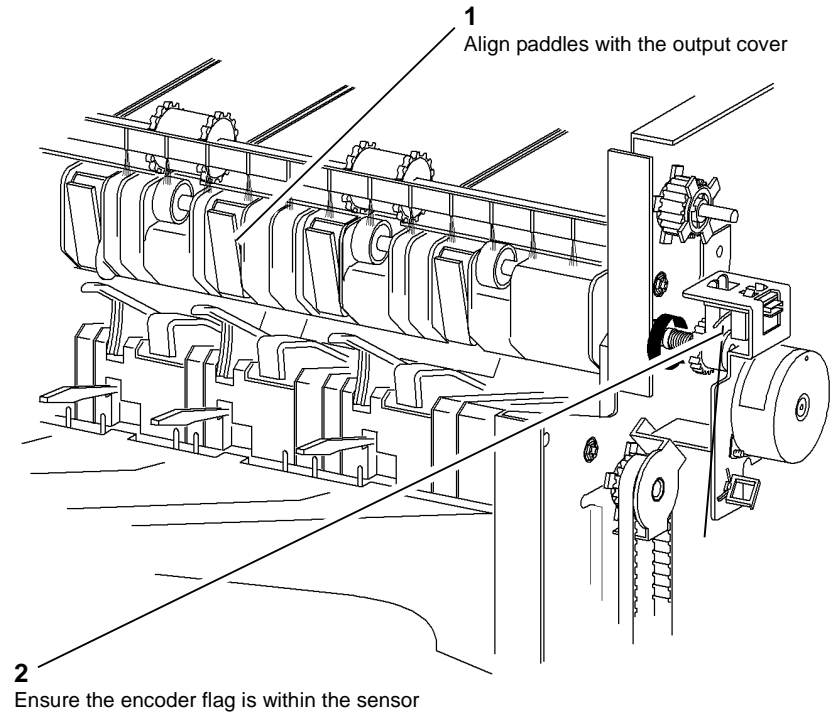

Figure 5 Paddle alignment

7. Install the motor assembly, refer to **Figure 1**.
8. Test the operation of the paddle roll, enter **dC330**, output code 12-238. When the code is cancelled the paddles must stop with both rubber blades inside of the output cover. If necessary, check that the gear assembly and flag are correctly located on the "D" flats.

REP 12.13-110 LCSS Un-Docking

Parts List on [PL 12.15](#).

Removal

WARNING

Switch off the electricity to the machine. Refer to [GP 14](#). Disconnect the power cord from the customer supply while performing tasks that do not need electricity. Electricity can cause death or injury. Moving parts can cause injury.

WARNING

Take care during this procedure. Sharp edges may be present that can cause injury.

WARNING

Take care not to topple the LCSS. The LCSS is unstable when un-docked from the machine. Do not show the customer how to un-dock the LCSS.

1. If necessary, disconnect the harnesses between the LCSS and the machine.
2. Open the LCSS front door.

3. [Figure 1](#), release the LCSS link bracket assembly.

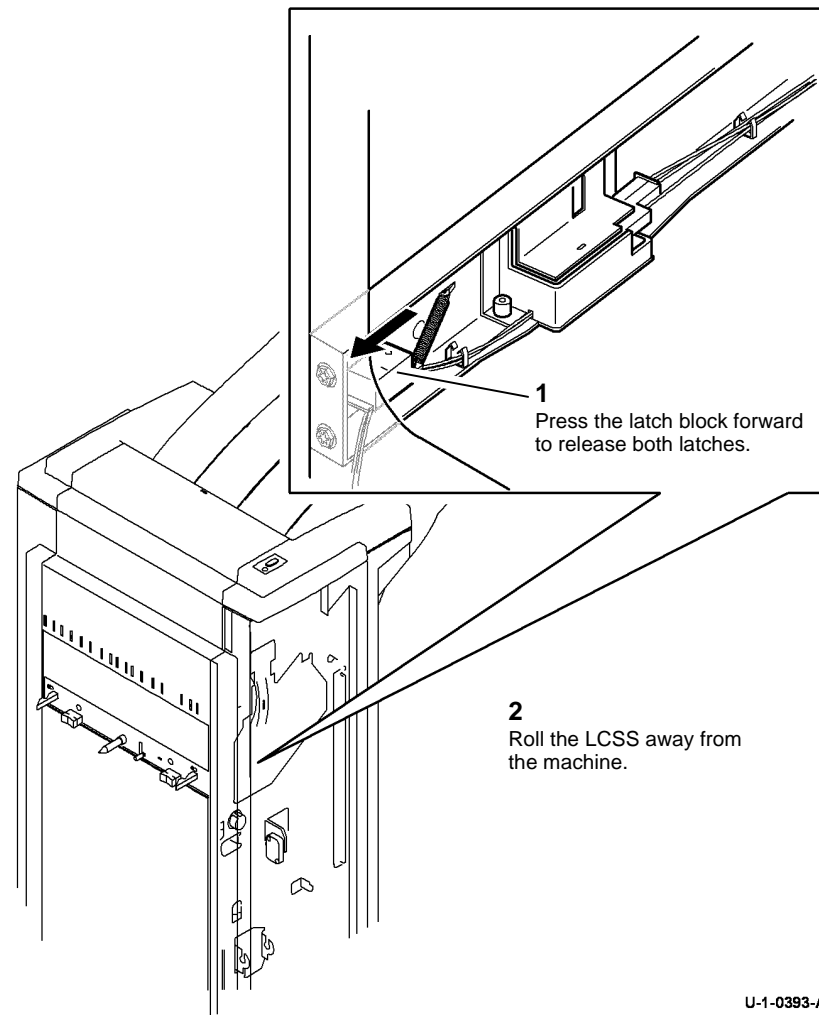

Figure 1 LCSS link bracket assembly

Replacement

Line up the LCSS latches to the machine apertures then push the two units firmly together until they latch.

REP 12.14-110 LCSS PWB

Parts List on [PL 12.75](#).

Removal

WARNING

Switch off the electricity to the machine. Refer to [GP 14](#). Disconnect the power cord from the customer supply while performing tasks that do not need electricity. Electricity can cause death or injury. Moving parts can cause injury.

WARNING

Take care during this procedure. Sharp edges may be present that can cause injury.

CAUTION

Do not install a new LCSS PWB until the cause of the damage to the old LCSS PWB has been determined, go to [12G-110 LCSS PWB Damage RAP](#).



Figure 1 ESD Symbol

CAUTION

Ensure that ESD procedures are observed during the removal and installation of the LCSS PWB.

1. Remove the LCSS rear cover assembly, [REP 12.1-110](#).
2. Disconnect all harness connectors from the LCSS PWB.
3. Remove the three screws and release the three standoffs securing the LCSS PWB.

Replacement

NOTE: Before replacing the LCSS rear cover assembly, perform [12F-110 LCSS PWB DIP Switch Settings RAP](#).

Reverse the removal procedure to replace the LCSS PWB.

REP 12.15-110 Entry Guide Cover

Parts List on [PL 12.70](#).

Removal

WARNING

Switch off the electricity to the machine. Refer to [GP 14](#). Disconnect the power cord from the customer supply while performing tasks that do not need electricity. Electricity can cause death or injury. Moving parts can cause injury.

WARNING

Take care during this procedure. Sharp edges may be present that can cause injury.

WARNING

Take care not to topple the LCSS. The LCSS is unstable when un-docked from the machine. Do not show the customer how to un-dock the LCSS.

1. Remove the LCSS top cover, front cover and rear cover, [REP 12.1-110](#).
2. Un-dock the LCSS, [REP 12.13-110](#) and move it away from the machine.
3. Disconnect the harness to the entry sensor, [PL 12.70 Item 3](#), at the rear frame.

4. **Figure 1**, remove the entry guide cover.

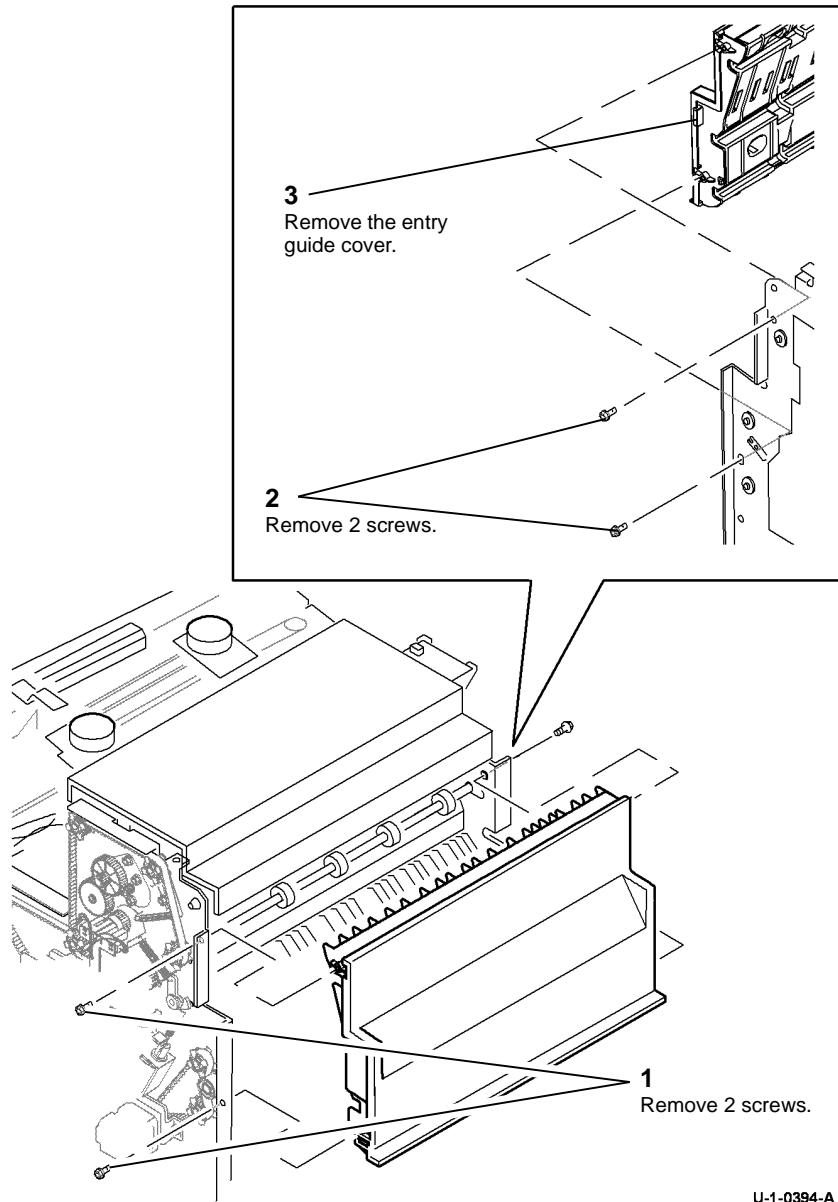

Figure 1 Entry guide cover removal

U-1-0394-A

Replacement

1. Bias the entry guide cover away from the paper guide when you tighten the screws.
2. The clearance between the entry guide cover and the paper guide must be a minimum of 1 mm. Refer to **Figure 2**.

NOTE: If the clearance is less than 1 mm, then install a new entry guide cover.

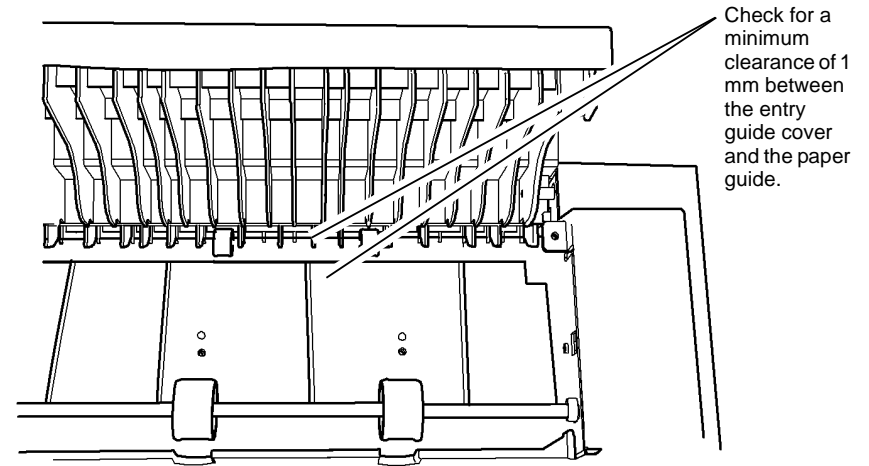

U-1-0395-A

Figure 2 Entry guide cover clearance

3. Run copies through the output device, if possible use heavy weight paper or labels. Check for marks on the print and for damage to the paper. If there are no marks or damage then install the covers.

REP 12.16-110 Docking Latch Assembly

Parts List on [PL 12.15](#).

Removal

WARNING

Switch off the electricity to the machine. Refer to [GP 14](#). Disconnect the power cord from the customer supply while performing tasks that do not need electricity. Electricity can cause death or injury. Moving parts can cause injury.

WARNING

Take care during this procedure. Sharp edges may be present that can cause injury.

WARNING

Take care not to topple the LCSS. The LCSS is unstable when un-docked from the machine. Do not show the customer how to un-dock the LCSS.

1. Remove the front and rear covers, [REP 12.1-110](#).
2. Un-dock the LCSS, [REP 12.13-110](#) and move it away from the machine.
3. [Figure 1](#), prepare to remove the docking latch assembly.

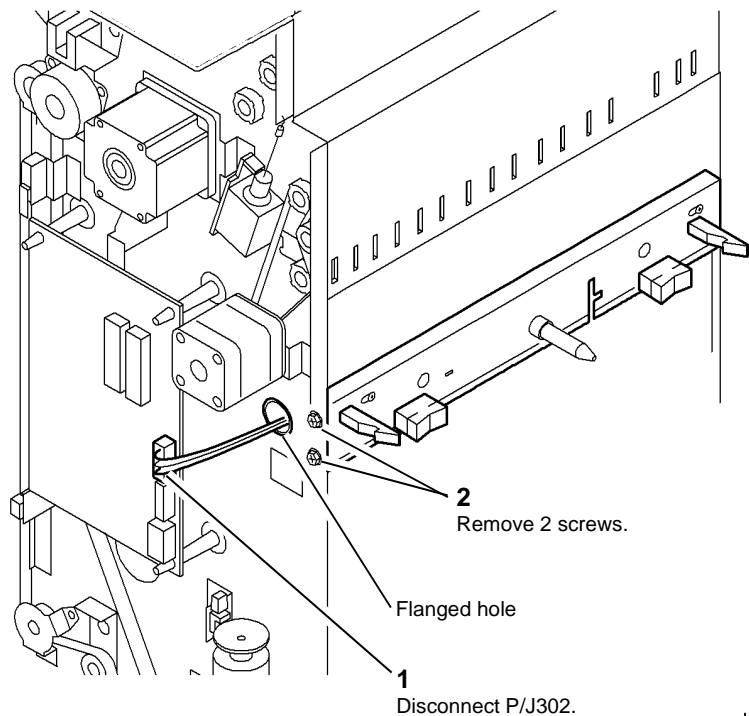

Figure 1 Prepare to remove the latch.

4. [Figure 2](#), remove the docking latch assembly.

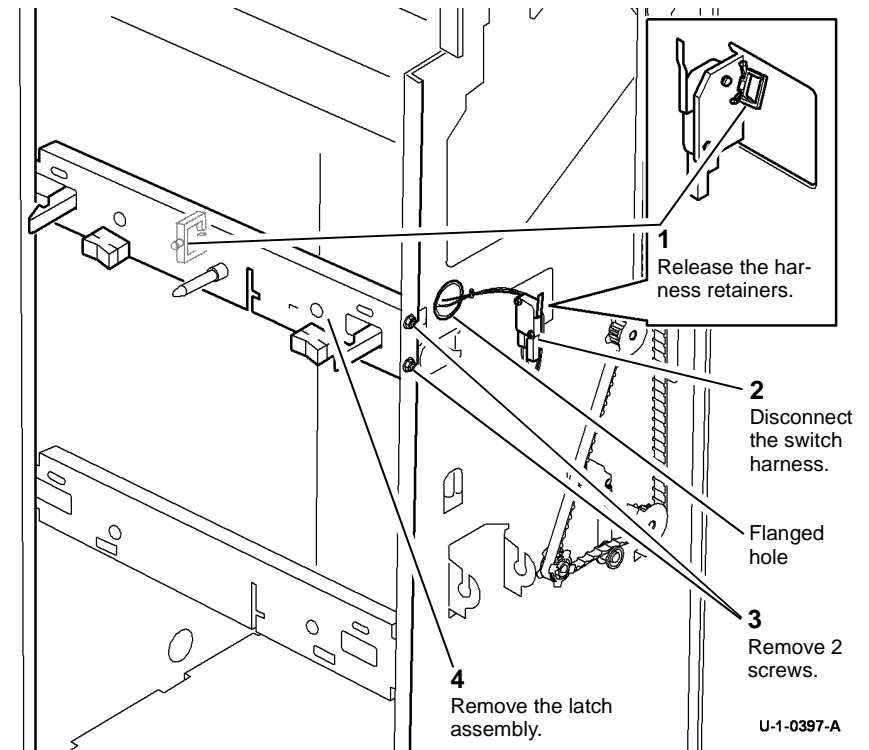

Figure 2 Latch assembly removal.

Replacement

Reverse the removal procedure to replace the docking latch assembly.

CAUTION

Ensure that the front and rear harness are routed through the flanged holes, refer to [Figure 1](#) and [Figure 2](#).

REP 12.17-110 Ejector Belt

Parts List on [PL 12.50](#).

Removal

WARNING

Switch off the electricity to the machine. Refer to [GP 14](#). Disconnect the power cord from the customer supply while performing tasks that do not need electricity. Electricity can cause death or injury. Moving parts can cause injury.

WARNING

Take care during this procedure. Sharp edges may be present that can cause injury.

1. Remove the ejector assembly, refer to [REP 12.10-110](#).

2. [Figure 1](#), remove the ejector belt.

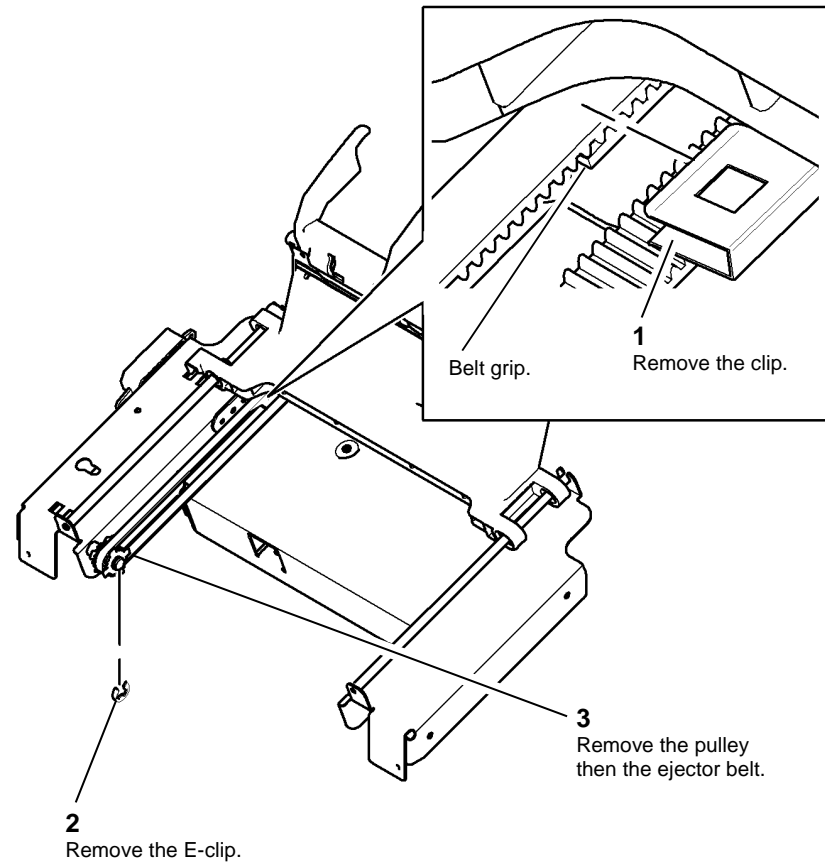

U-1-0398-A

Figure 1 Remove the ejector belt

Replacement

The replacement is the reverse of the removal procedure. Ensure that the ejector belt is correctly engaged with the belt grip on the ejector assembly before the clip is reinstalled. Refer to [Figure 1](#).

REP 12.18-110 Paddles

Parts List on [PL 12.25](#)

Removal

WARNING

Switch off the electricity to the machine. Refer to [GP 14](#). Disconnect the power cord from the customer supply while performing tasks that do not need electricity. Electricity can cause death or injury. Moving parts can cause injury.

NOTE: This procedure shows the replacement of the paddles with the paddle wheel shaft assembly installed. If necessary, remove the paddle wheel shaft assembly before replacing the paddles. Refer to [REP 12.12-110](#).

1. If necessary, lower bin 1. Enter code [dC330](#) 12-242 bin 1 elevator motor cycle. Press stop when the bin has lowered.
2. Rotate the paddle until the two rubber blades are visible.

CAUTION

To ensure that the correct home position of the paddle wheel shaft is maintained, install the new paddle wheels one at a time.

3. Squeeze the two rubber blades together and pull to remove the paddle wheel from the shaft, [Figure 1](#).

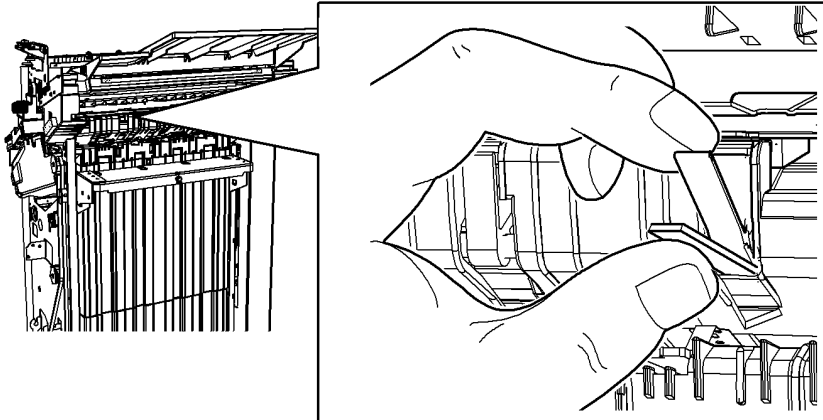

U-1-1684-A

Figure 1 Paddle removal

Replacement

1. Hold the paddle wheel by the two rubber blades and clip onto the shaft.

REP 12.1-171 HVF Covers

Parts List on [PL 12.100](#)

Removal

WARNING

Switch off the electricity to the machine. Refer to [GP 14](#). Disconnect the power cord from the customer supply while performing tasks that do not need electricity. Electricity can cause death or injury. Moving parts can cause injury.

WARNING

Take care during this procedure. Sharp edges may be present that can cause injury.

NOTE: All major HVF covers are dealt with in this procedure, only remove the covers listed for the procedure that you are performing.

Remove the HVF covers as follows:

1. Remove the front door, [Figure 1](#). If required, remove 5 screws to separate the door support from the front door.

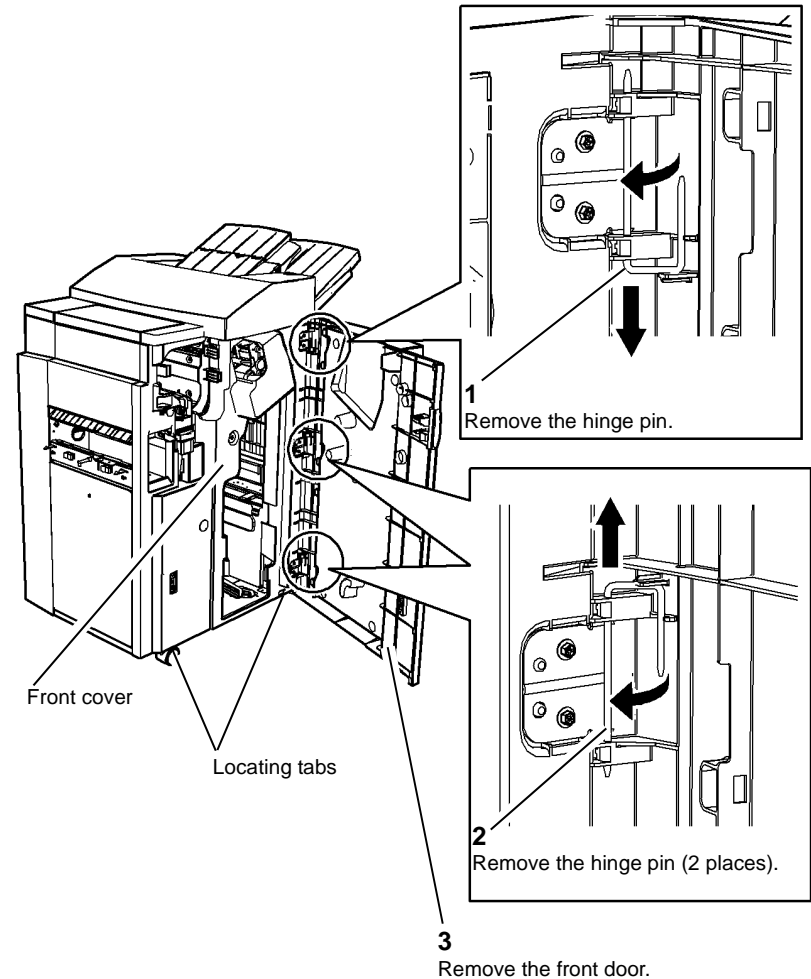

U-1-0426-A

Figure 1 Front door removal

2. Remove the top cover, [Figure 2](#).

NOTE: In step 1 remove the Inserter unit if fitted (See [REP 12.82-171](#)), or remove the Inserter removable cover, [PL 12.100 Item 8](#).

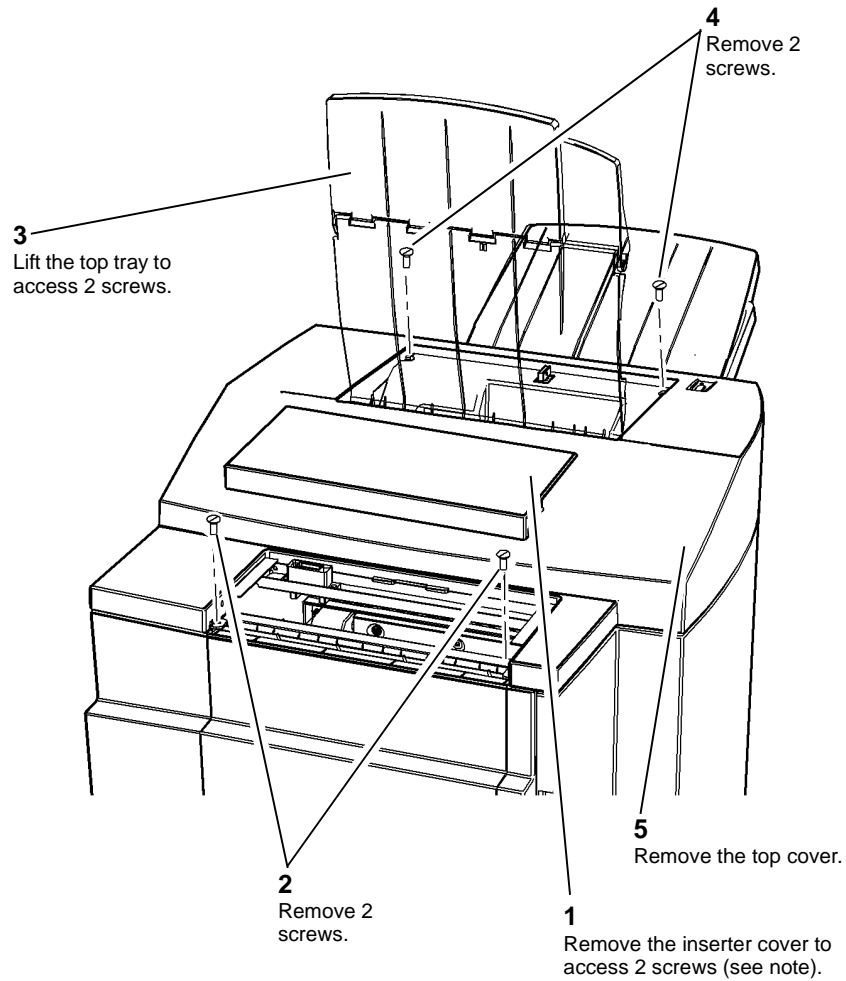

Figure 2 Top cover removal

U-1-0427-A

3. Remove the front cover, [Figure 3](#).

NOTE: The top cover must be removed before removing the front cover.

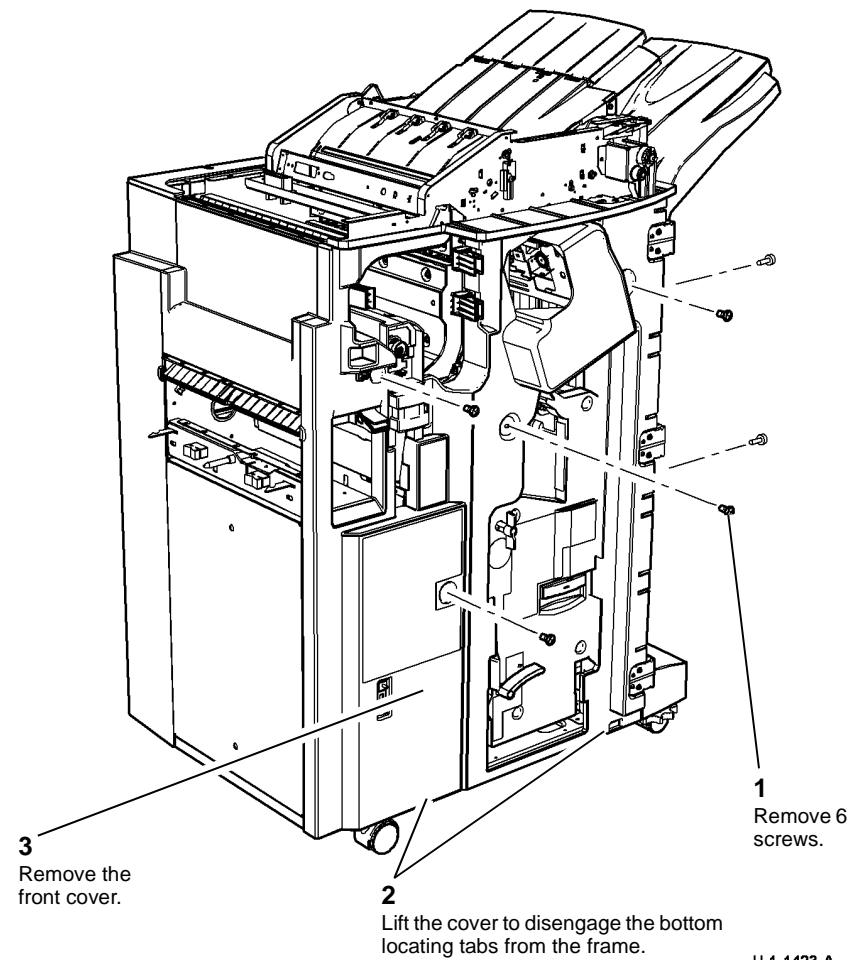

Figure 3 Front cover removal

U-1-1423-A

- Remove the rear cover, [Figure 4](#).

NOTE: The top cover must be removed before removing the rear cover.

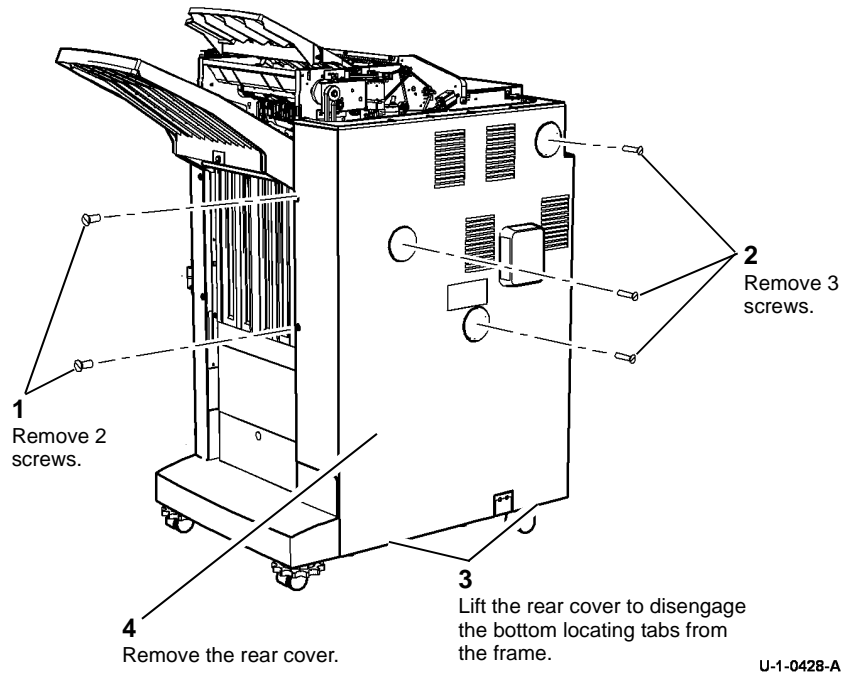

Figure 4 Rear cover removal

- Remove the vent cover and foot cover, [Figure 5](#). To provide enough room to remove the vent cover, undock the HVF, [REP 12.13-171](#).

NOTE: The top front cover and rear cover must be removed before removing the vent cover and foot cover.

NOTE: The foot cover is not installed if the tri-folder option is installed.

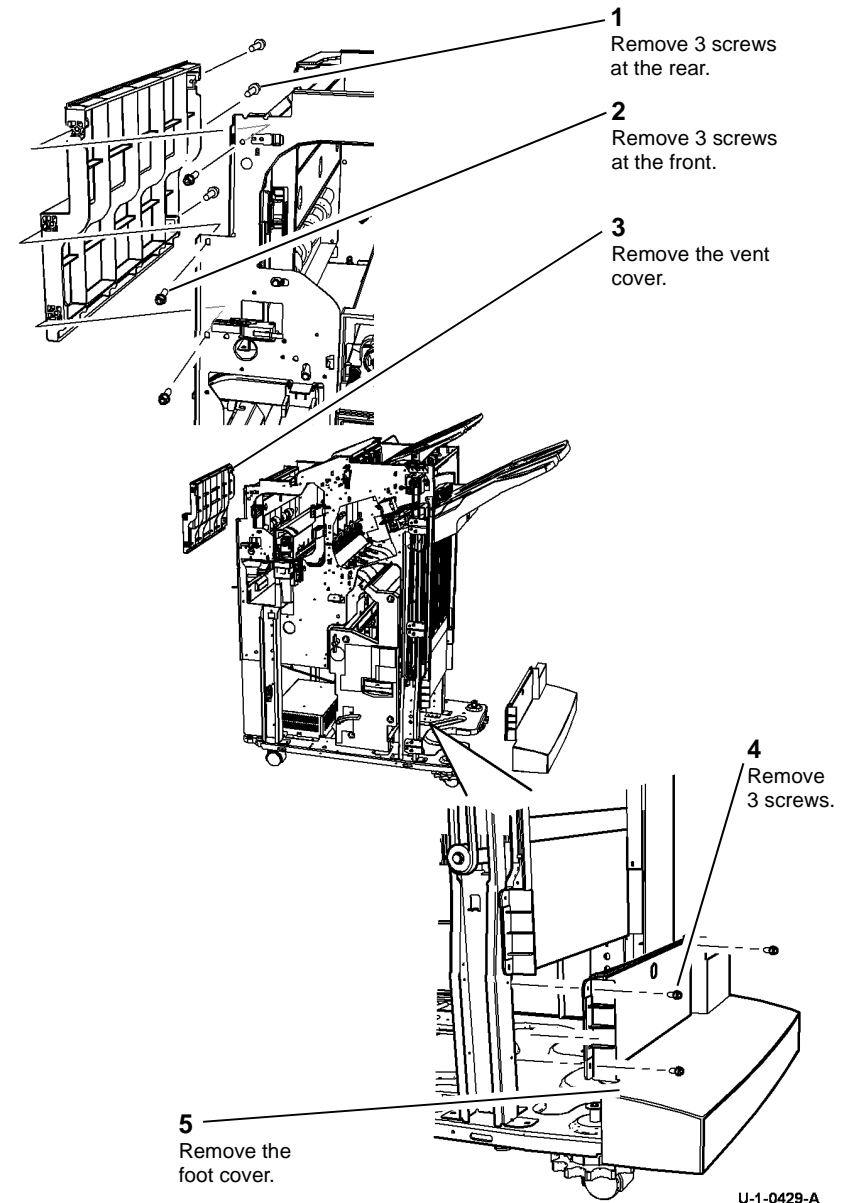

Figure 5 Vent and foot covers removal

Replacement

The replacement procedure is the reverse of the removal procedure.

Depending on the installed options and the covers removed, refit covers in the following sequence:

1. Vent cover, [PL 12.100 Item 6](#).
2. Foot cover (if no tri-folder installed), PL
3. Rear cover, [PL 12.100 Item 5](#).
4. Front cover, [PL 12.100 Item 2](#).
5. Top cover, [PL 12.100 Item 1](#).
6. Inserter cover (if no inserter installed). [PL 12.100 Item 8](#).
7. Front door, [PL 12.100 Item 3](#).

REP 12.2-171 HVF Stapler Assembly

Parts List on [PL 12.110](#).

Removal

WARNING

Switch off the electricity to the machine. Refer to [GP 14](#). Disconnect the power cord from the customer supply while performing tasks that do not need electricity. Electricity can cause death or injury. Moving parts can cause injury.

WARNING

Take care during this procedure. Sharp edges may be present that can cause injury.

1. Slide the HVF away from the machine.
2. Remove the HVF front door, [REP 12.1-171](#).
3. Remove the HVF top cover, [REP 12.1-171](#).
4. Remove the HVF front cover, [REP 12.1-171](#).
5. Remove the rear cover, [REP 12.1-171](#).
6. [Figure 1](#). At the rear of the HVF, disconnect three connectors and remove one screw securing the grounding strap.

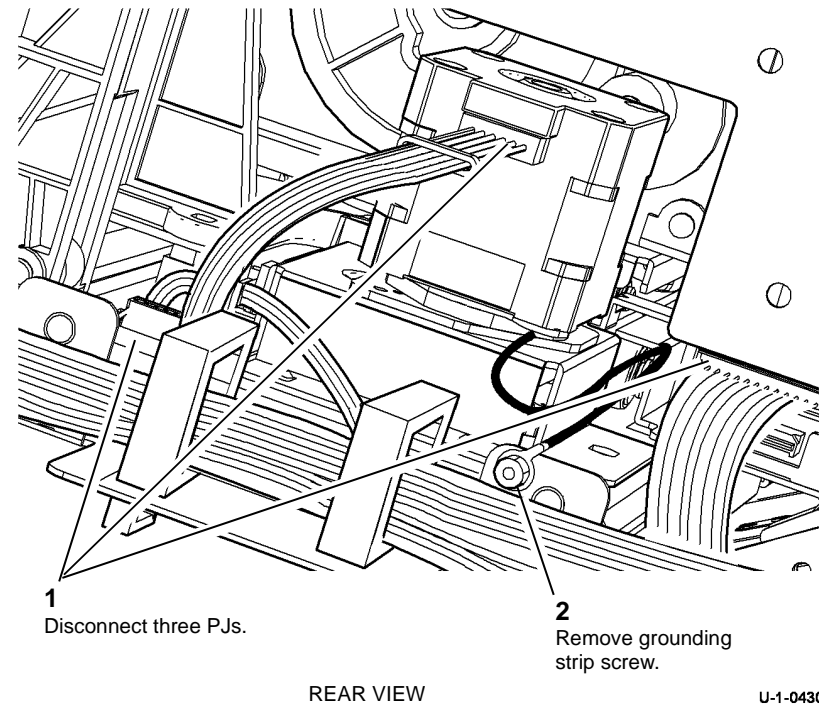

Figure 1 Disconnect PJs and remove screw

7. **Figure 2.** With the power cord disconnected, reach behind the stapler and move the ejector unit to the out position, by turning the encoder of the ejector unit motor, MOT12-236 in the direction indicated.

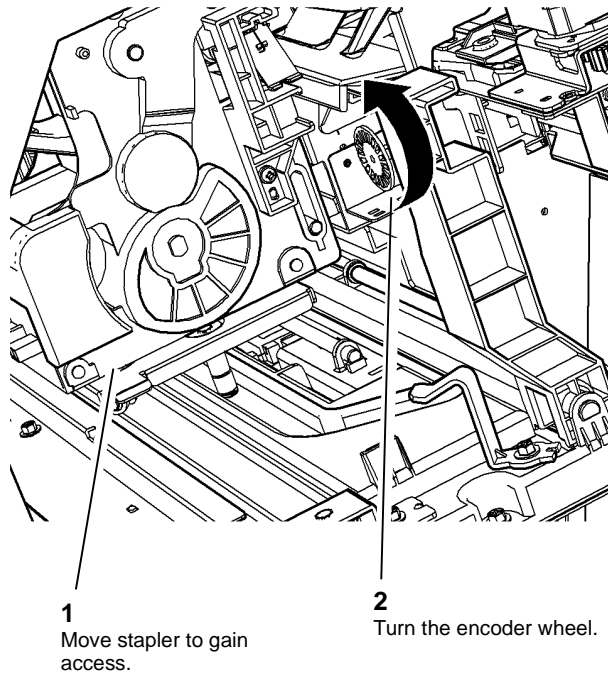

Figure 2 Move ejector to the out position

U-1-0431-A

8. **Figure 3.** Remove the stapler assembly.

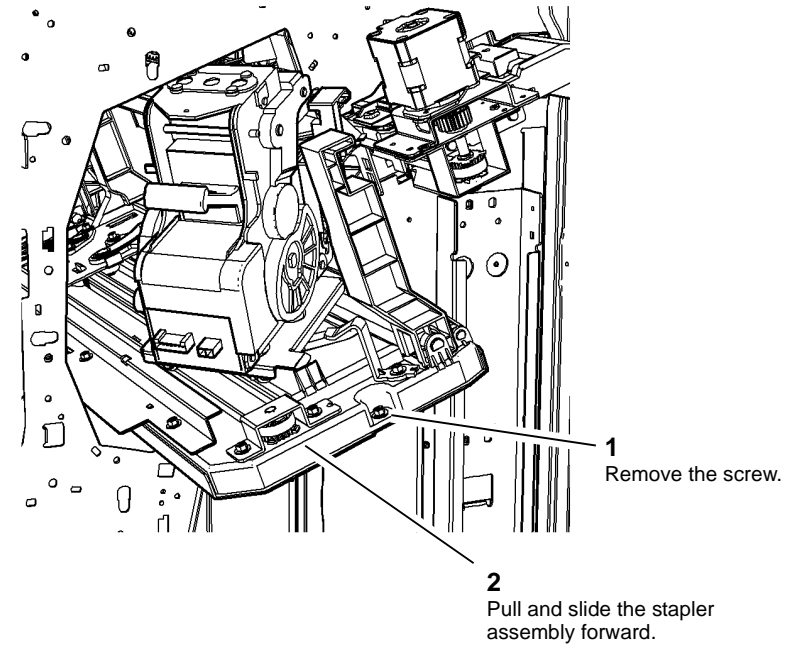

Figure 3 Removing the stapler assembly.

U-1-0433-A

Replacement

NOTE: The ejector unit returns to the home position when the HVF is initialized.

1. Slide the stapler assembly into the tray, taking care not to trap the earth wire at the rear.
2. The remainder of the replacement procedure is the reverse of the removal procedure.

REP 12.3-171 Top Tray

Parts List on [PL 12.100](#).

Removal

WARNING

Switch off the electricity to the machine. Refer to [GP 14](#). Disconnect the power cord from the customer supply while performing tasks that do not need electricity. Electricity can cause death or injury. Moving parts can cause injury.

WARNING

Take care during this procedure. Sharp edges may be present that can cause injury.

1. If fitted, undock the Inserter, [REP 12.82-171](#).
2. Remove the top and rear covers [REP 12.1-171](#).
3. Prepare to remove the top tray, [Figure 1](#).

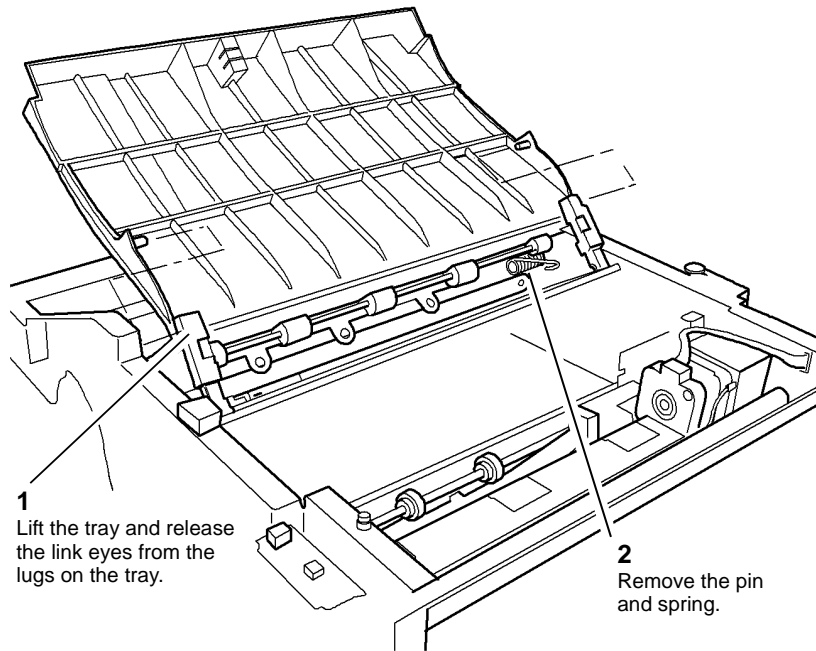
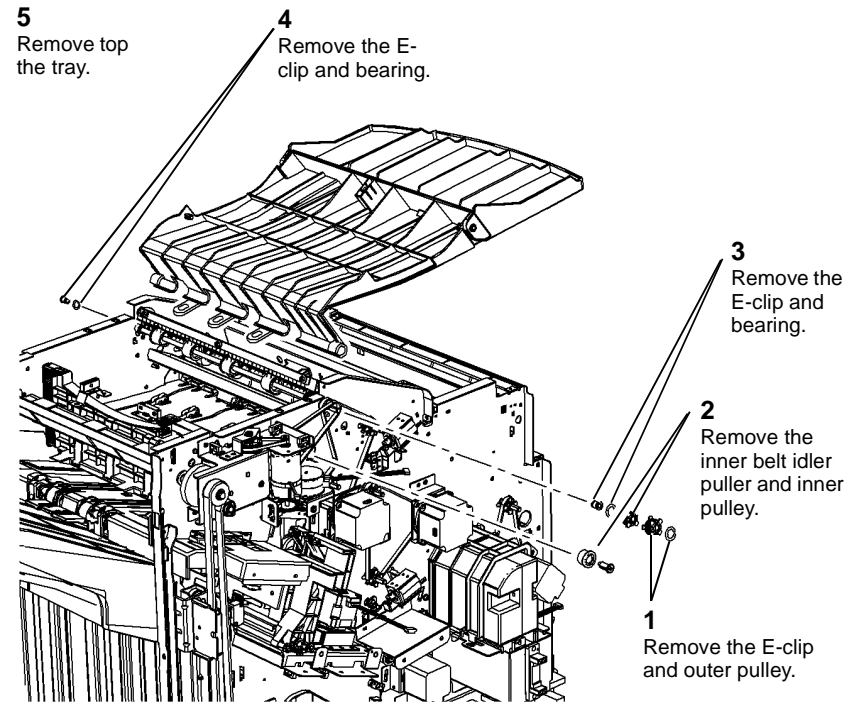

Figure 1 Preparation

U-1-0434-A

4. Remove the top tray, [Figure 2](#).



U-1-0435-A

Figure 2 Top tray removal

Replacement

The replacement procedure is the reverse of the removal procedure.

REP 12.4-171 Bin 1 Removal

Parts List on [PL 12.105](#).

Removal

WARNING

Take care during this procedure. Sharp edges may be present that can cause injury.

WARNING

Switch off the electricity to the machine. Refer to [GP 14](#). Disconnect the power cord from the customer supply while performing tasks that do not need electricity. Electricity can cause death or injury. Moving parts can cause injury.

1. Remove Bin 1. [Figure 1](#)

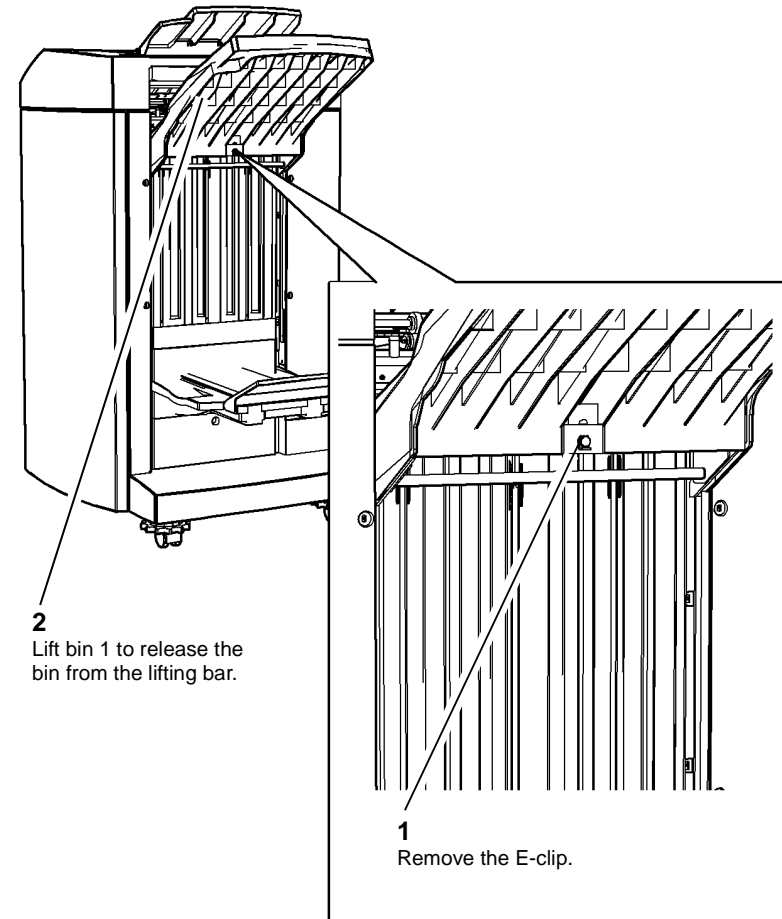

U-1-0436-A

Figure 1 Bin 1 removal

Replacement

The replacement procedure is the reverse of the removal procedure.

REP 12.5-171 Right Side-Cover Removal

Parts List on [PL 12.105](#).

Removal

WARNING

Take care during this procedure. Sharp edges may be present that can cause injury.

WARNING

Switch off the electricity to the machine. Refer to [GP 14](#). Disconnect the power cord from the customer supply while performing tasks that do not need electricity. Electricity can cause death or injury. Moving parts can cause injury.

1. With the machine powered on, use the PTU or [dC330](#) code 12-242 to lower Bin 1.
2. Remove Bin 1, [REP 12.4-171](#).
3. If a HVF unit only, remove the middle right side cover, [PL 12.105 Item 17](#).
If a HVF BM unit installed, remove the HVF BM bin 2 assembly, [PL 12.190 Item 8](#).

4. Remove the right side-cover, [Figure 1](#).

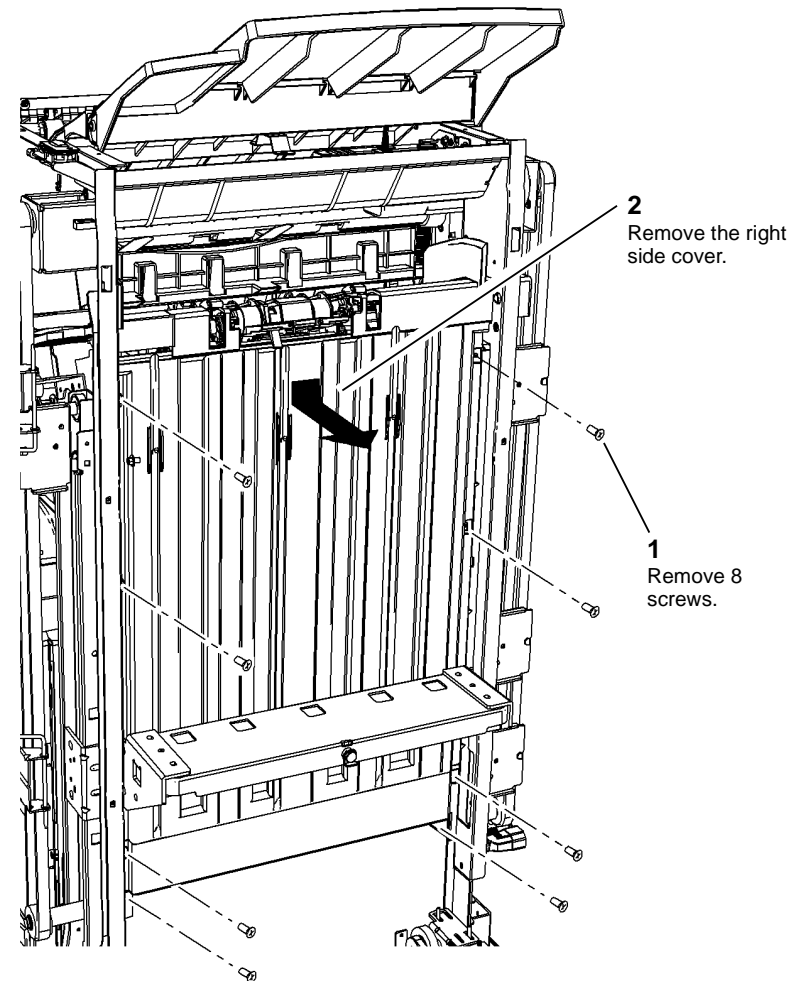

U-1-0437-A

Figure 1 Right side cover removal

Replacement

The replacement procedure is the reverse of the removal procedure.

REP 12.6-171 HVF Ejector Assembly

Parts List on [PL 12.110](#).

Removal

WARNING

Take care during this procedure. Sharp edges may be present that can cause injury.

WARNING

Switch off the electricity to the machine. Refer to [GP 14](#). Disconnect the power cord from the customer supply while performing tasks that do not need electricity. Electricity can cause death or injury. Moving parts can cause injury.

1. Remove Bin 1, [REP 12.4-171](#).
2. Remove the right side-cover [REP 12.5-171](#).
3. Remove the door and the front cover [REP 12.1-171](#).
4. Remove the front and rear pressing plate finger, [REP 12.7-171](#).
5. Disconnect the connectors, [Figure 1](#).

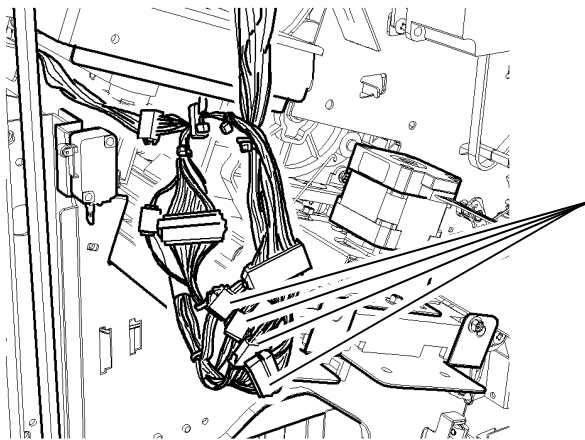

- 1 Disconnect 4 harness connectors to release the wiring.

U-1-0972-A

Figure 1 Disconnect the connectors

6. Remove the pressing plate and sensor support bracket. [Figure 2](#).

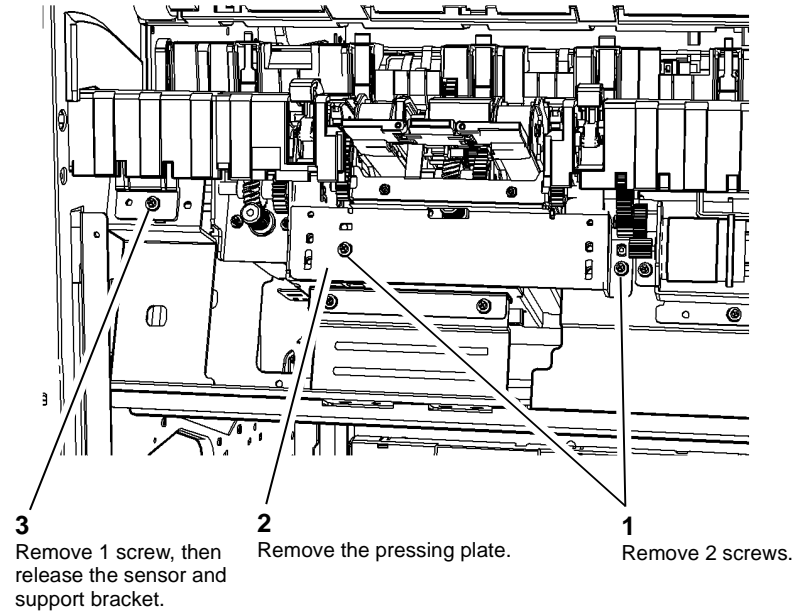

- 3 Remove 1 screw, then release the sensor and support bracket.
- 2 Remove the pressing plate.
- 1 Remove 2 screws.

U-1-0970-A

Figure 2 Pressing plate removal

7. Remove the support bracket and ejector assembly, [Figure 3](#).

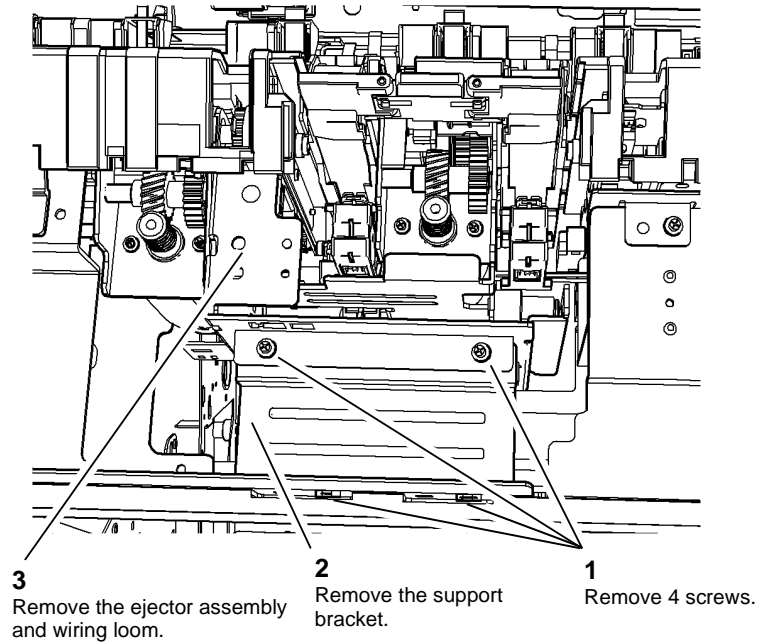

U-1-0971-A

Figure 3 Remove the ejector assembly

Replacement

1. Set the front and rear support fingers so that their ends are aligned when extended. See [REP 12.8-171](#).
2. When reinstalling the eject assembly ensure that the tag on the ejector locates into the slot in the frame.

3. When refitting the pressing plate, the shaft of the front support finger drive gear must fit in the ejector assembly, see [Figure 4](#). Replace the front pressing plate finger.

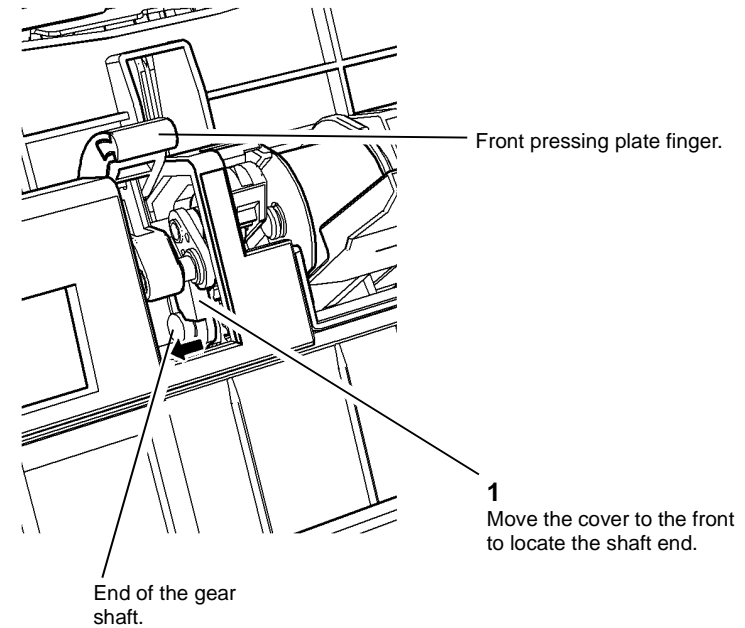

U-1-0441-A

Figure 4 Reinstalling the Pressing Plate

4. The remainder of the replacement procedure is the reverse of the removal procedure.
5. Locate the Mod/Tag plate on the metal panel under the HVF docking latch. Ensure that Tag 004 is struck off.

REP 12.7-171 Pressing Plate Fingers

Parts List on [PL 12.110](#).

Removal

WARNING

Take care during this procedure. Sharp edges may be present that can cause injury.

WARNING

Switch off the electricity to the machine. Refer to [GP 14](#). Disconnect the power cord from the customer supply while performing tasks that do not need electricity. Electricity can cause death or injury. Moving parts can cause injury.

1. Remove the right side-cover [REP 12.5-171](#).
2. Remove the screws and lower the fingers through the cover slots, [Figure 1](#).

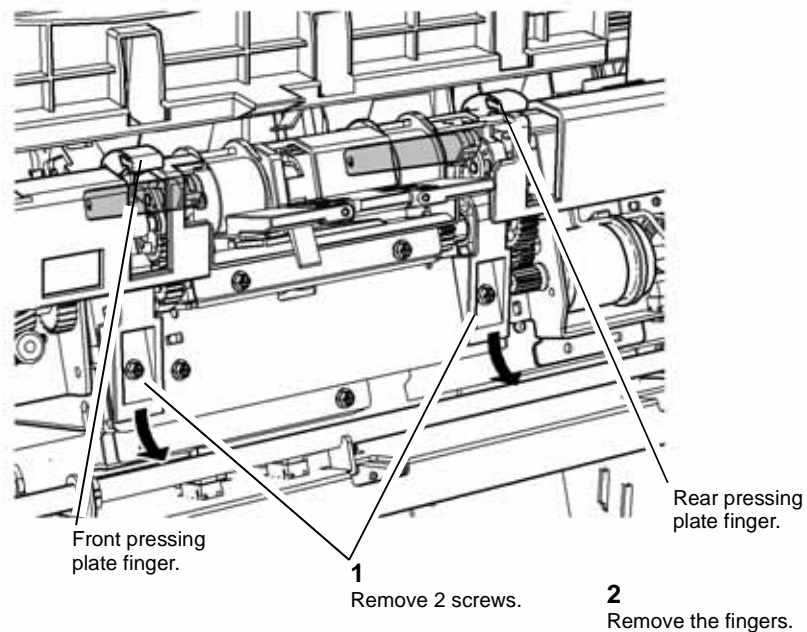

Figure 1 Pressing Plate Fingers

Replacement

Reverse the removal procedures to replace the front and rear pressing plate fingers.

REP 12.8-171 Front and Rear Support Fingers

Parts List on [PL 12.110](#).

Removal

WARNING

Take care during this procedure. Sharp edges may be present that can cause injury.

WARNING

Switch off the electricity to the machine. Refer to [GP 14](#). Disconnect the power cord from the customer supply while performing tasks that do not need electricity. Electricity can cause death or injury. Moving parts can cause injury.

1. Remove the right side cover [REP 12.5-171](#).
2. Remove the ejector assembly [REP 12.7-171](#).
3. Remove the ejector front plate and support finger assembly, [Figure 1](#).

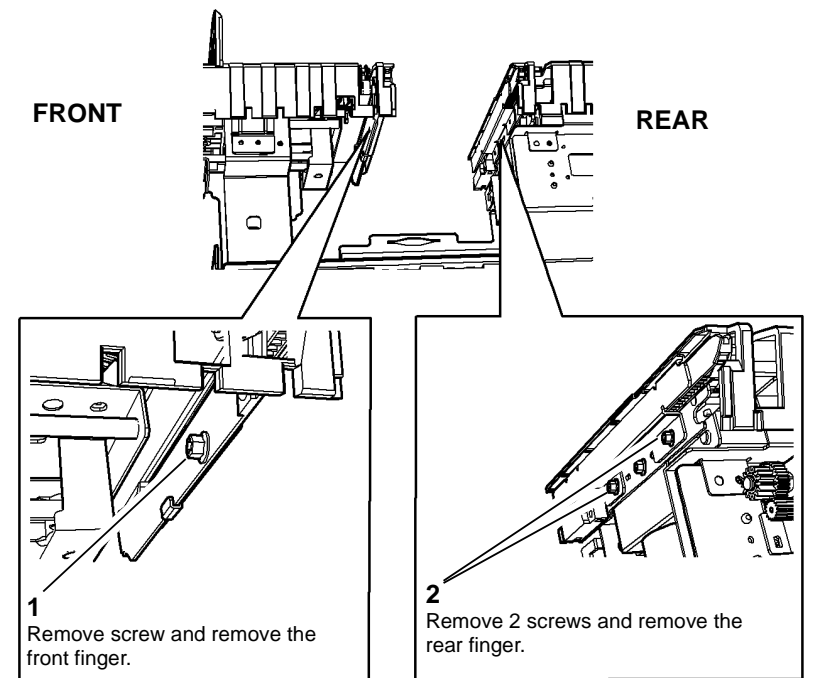

Figure 1 Remove front and rear support fingers

Replacement

Reverse the removal procedure to replace the front or rear support fingers.

NOTE: Set the front and rear support fingers so that their ends are aligned when extended. See [Figure 2](#).

With the pressing plate installed, set the front and rear support finger alignment, [Figure 2](#). If the fingers are not aligned, the compiler output will be uneven and cause exit jams.

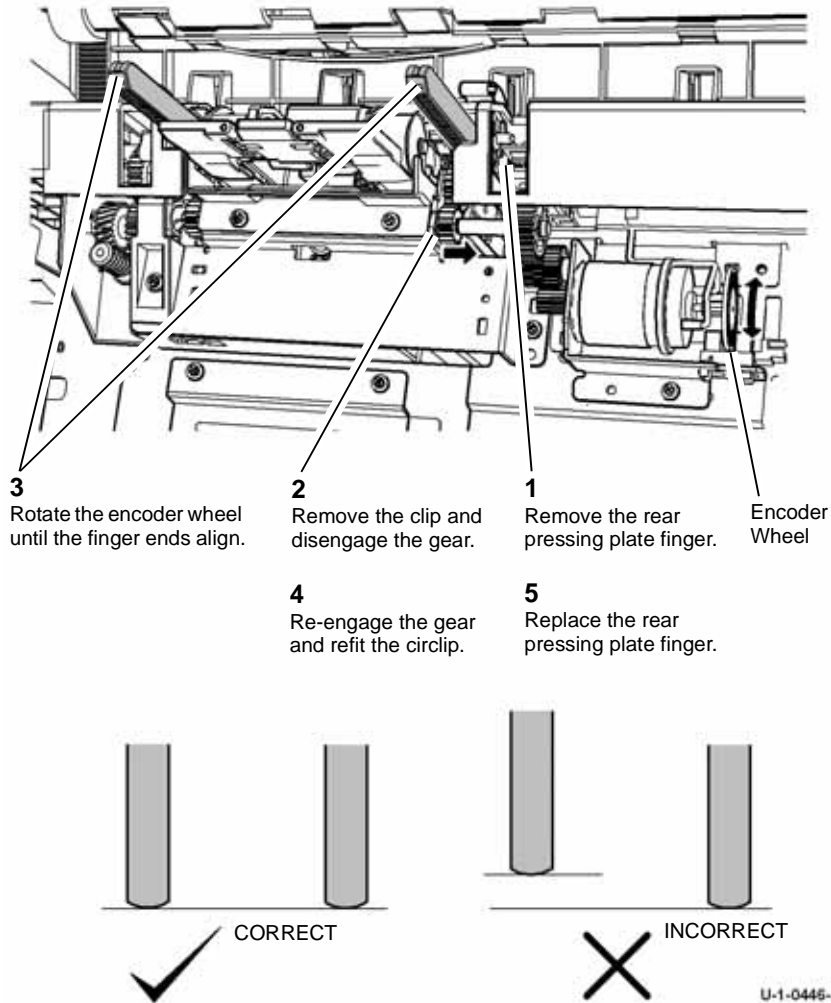

Figure 2 Support Finger End Alignment

REP 12.10-171 Stacker Idler Rolls

Parts List on [PL 12.115](#).

Removal

WARNING

Take care during this procedure. Sharp edges may be present that can cause injury.

WARNING

Switch off the electricity to the machine. Refer to [GP 14](#). Disconnect the power cord from the customer supply while performing tasks that do not need electricity. Electricity can cause death or injury. Moving parts can cause injury.

1. Lift the top tray
2. [Figure 1](#). Raise the paper pusher and remove the four stacker idler rolls.

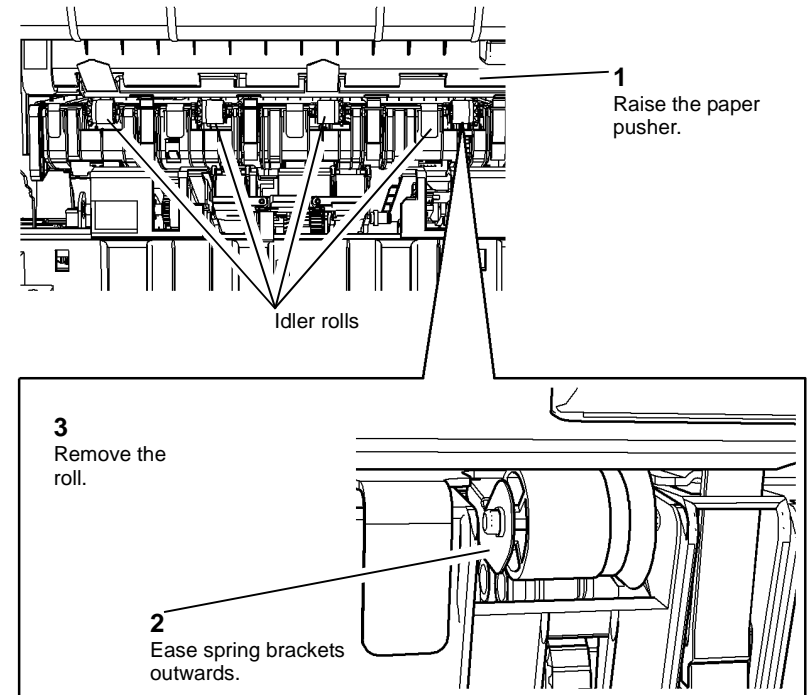

U-1-0448-A

Figure 1 Paper pusher and idler rolls.

Replacement

1. [Figure 2](#). Ensure the sprung brackets are parallel and re-install the idler rolls in the sprung brackets.

NOTE: To ease the installation of the idler roll, push the spring bracket downwards from the top. This will provide clearance from the drive roll above.



Figure 2 Correct spring bracket position.

2. Check that the rolls are held securely.

U-1-0449-A

REP 12.11-171 Front Tamper Motor Assembly

Parts List on [PL 12.125](#).

Removal

WARNING

Take care during this procedure. Sharp edges may be present that can cause injury.

WARNING

Switch off the electricity to the machine. Refer to [GP 14](#). Disconnect the power cord from the customer supply while performing tasks that do not need electricity. Electricity can cause death or injury. Moving parts can cause injury.

1. Remove the front door and front cover [REP 12.1-171](#).
2. Remove the ejector assembly, [REP 12.6-171](#).
3. Remove the tamper motor and bracket assembly, [Figure 1](#).

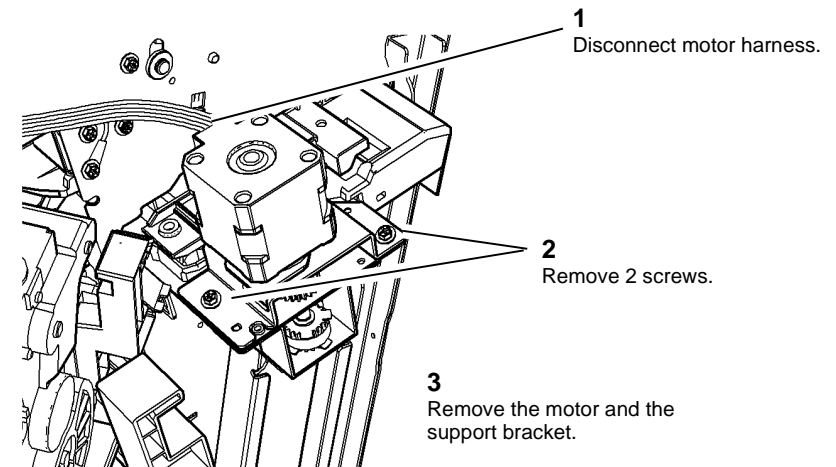

U-1-0973-A

Figure 1 Tamper motor

- Remove the front tamper assembly, [Figure 2](#).

NOTE: The front tamper home sensor is removed to prevent the sensor from being damaged when the front tamper assembly is removed.

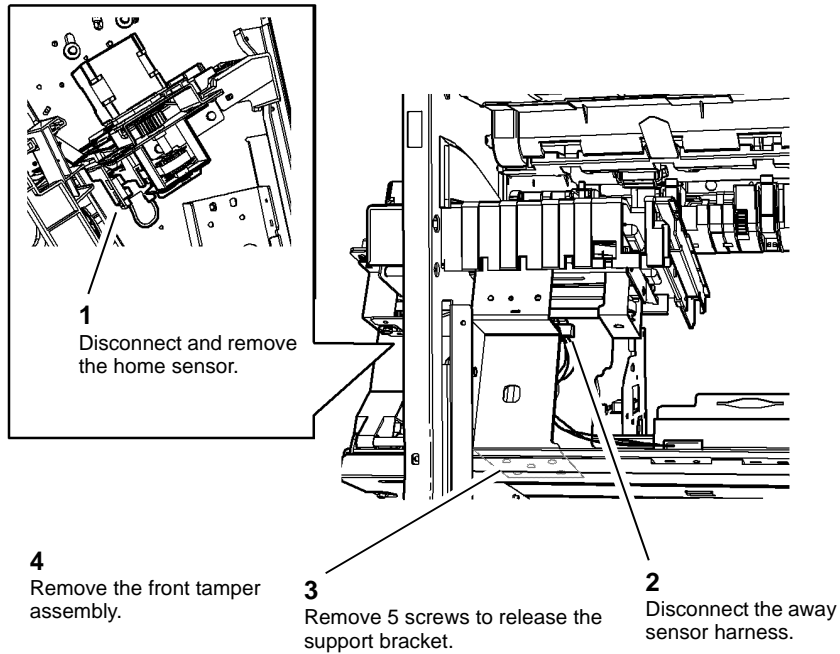

U-1-0974-A

Figure 2 Front tamper assembly

Replacement

Reverse the removal procedures to reinstall the front tamper motor assembly.

REP 12.12-171 Bin 1 Elevator Motor Assembly

Parts List on [PL 12.105](#).

Removal

WARNING

Take care during this procedure. Sharp edges may be present that can cause injury.

WARNING

Switch off the electricity to the machine. Refer to [GP 14](#). Disconnect the power cord from the customer supply while performing tasks that do not need electricity. Electricity can cause death or injury. Moving parts can cause injury.

- Remove the front and rear covers [REP 12.1-171](#).
- Remove the rear drive belt lower pulley to relieve the belt tension.
- Remove the bin 1 elevator motor assembly [Figure 1](#).

NOTE: The pulley pin may fall when the pulley is removed.

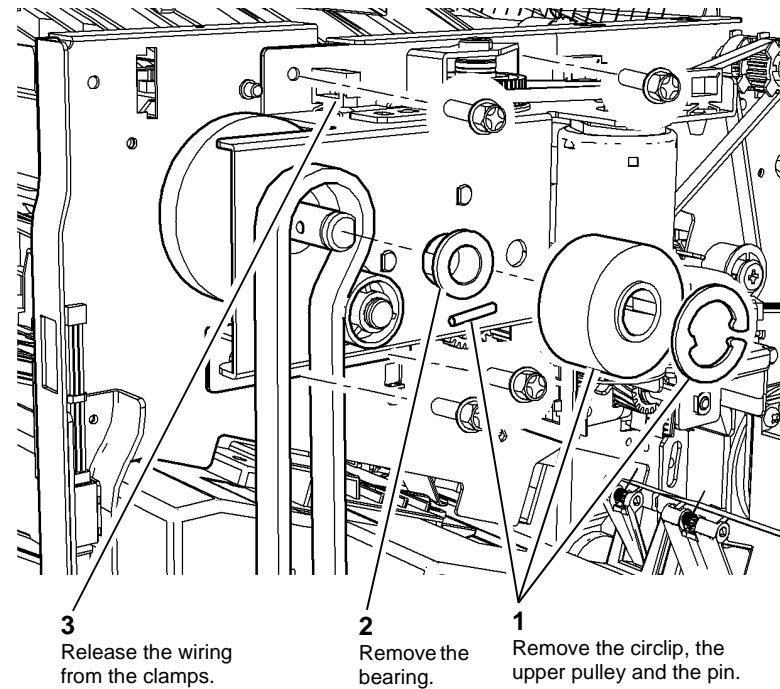

U-1-0451-A

Figure 1 Stacker Motor Gearbox Assembly

Replacement

Reverse the removal procedures to reinstall the bin 1 motor elevator motor assembly.

NOTE: Check that the 'flats' on the shaft bearing align with the cut-outs in the bracket. Check that the Bin 1 lift bar is level before refitting the stacker belt lower pulley.

REP 12.13-171 HVF/HVF BM Un-Docking

Removal

WARNING

Take care during this procedure. Sharp edges may be present that can cause injury.

WARNING

Switch off the electricity to the machine. Refer to GP 14. Disconnect the power cord from the customer supply while performing tasks that do not need electricity. Electricity can cause death or injury. Moving parts can cause injury.

CAUTION

Do not show the customer how to un-dock the HVF / HVF BM.

1. Open the front door.
2. Figure 1, release the docking latch and move the HVF/HVF BM to the right, away from the machine.

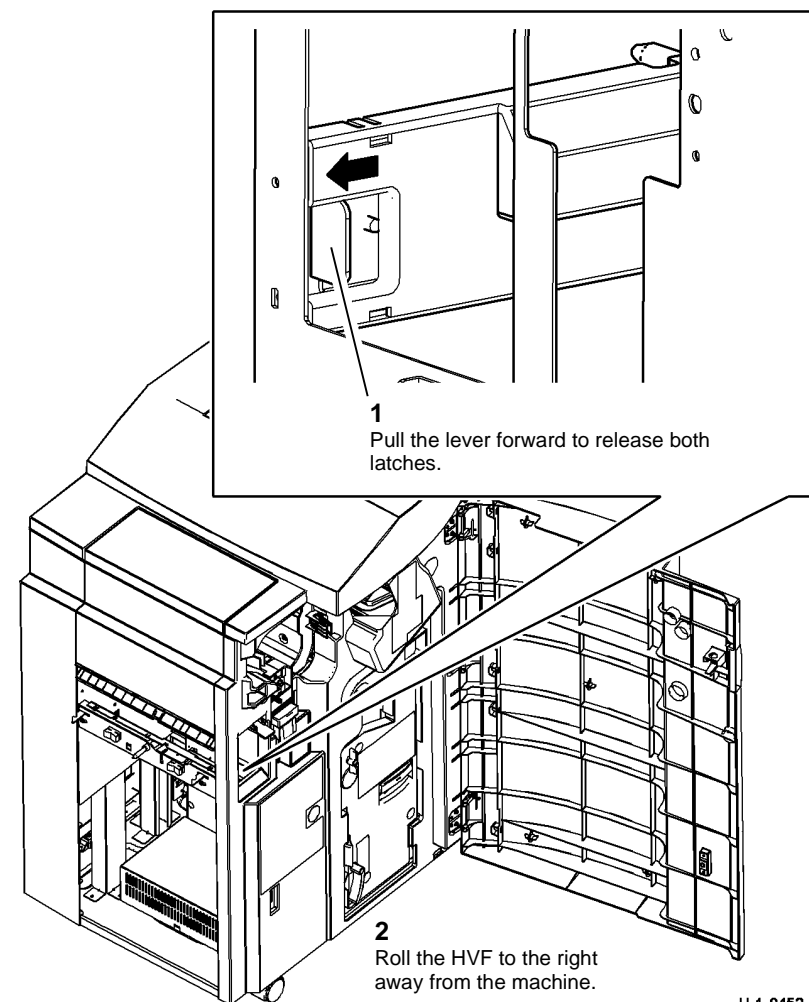

Figure 1 Docking latch location

NOTE: Where fitted, the tri folder may remain docked to, and moved with, the HVF.

3. Disconnect the harnesses between the machine and the HVF/HVF BM if necessary.

Replacement

CAUTION

Take care to align the HVF to the right side of the machine before rolling the HVF into position. Misalignment will damage or break the interlock actuator.

Reverse the removal procedure to dock the HVF/HVF BM.

REP 12.14-171 HVF Upper Exit Guide (5c)

Parts List on [PL 12.125](#).

Removal

WARNING

Take care during this procedure. Sharp edges may be present that can cause injury.

WARNING

Switch off the electricity to the machine. Refer to [GP 14](#). Disconnect the power cord from the customer supply while performing tasks that do not need electricity. Electricity can cause death or injury. Moving parts can cause injury.

1. Remove the HVF front door, [REP 12.1-171](#).
2. Remove the HVF top cover, [REP 12.1-171](#).
3. Remove the HVF front cover, [REP 12.1-171](#).
4. Remove the HVF rear cover, [REP 12.1-171](#).
5. [Figure 1](#). Remove the outboard pivot screw.

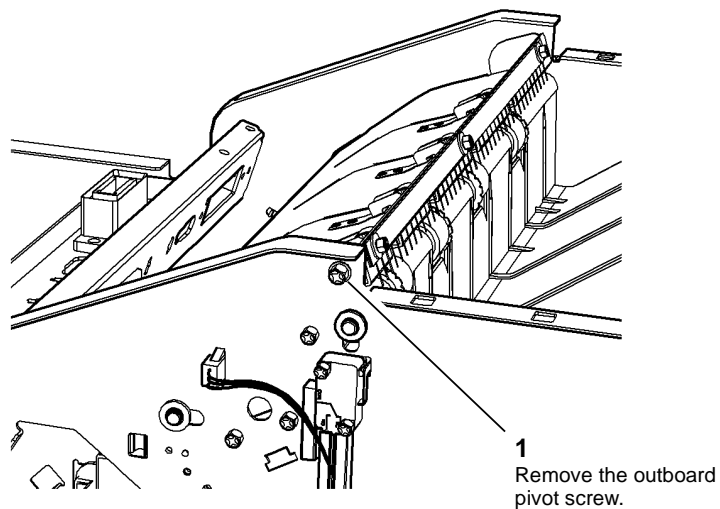

FRONT VIEW

U-1-0453-A

Figure 1 Outboard pivot screw.

6. [Figure 2](#). Remove the inboard pivot screw.

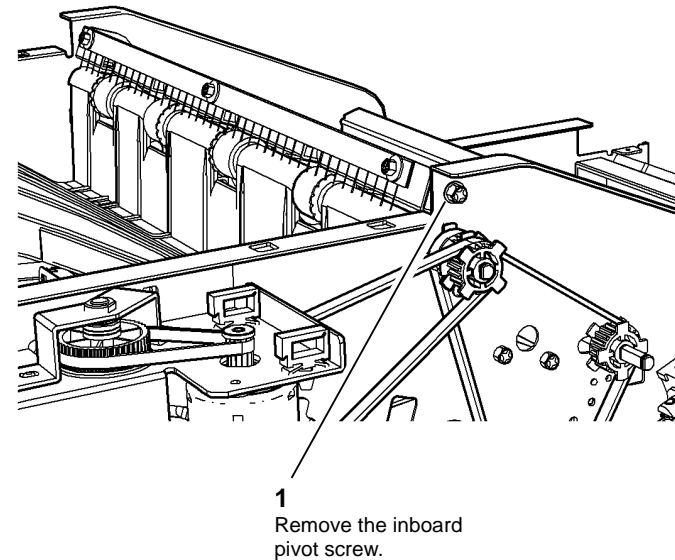

REAR VIEW

U-1-0454-A

Figure 2 Inboard pivot screw.

7. **Figure 3.** Remove the upper exit guide.

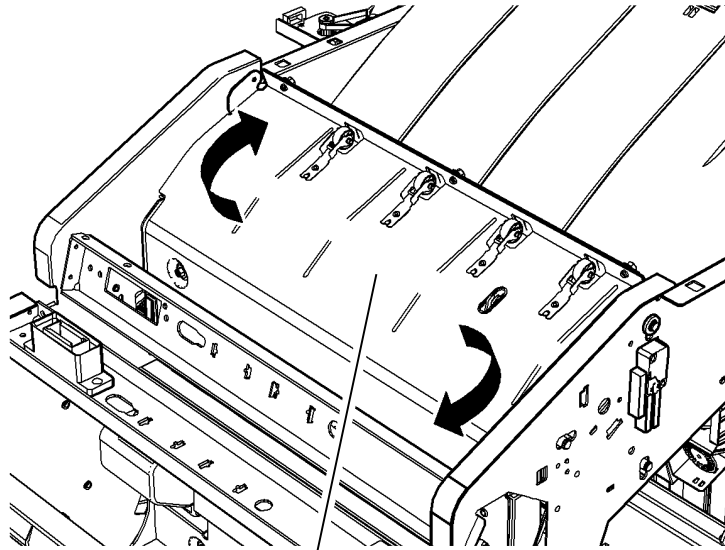

1
Twist the upper exit guide
and lift upwards.

Figure 3 Upper exit guide removal.

U-1-0455-A

Replacement

The replacement procedure is the reverse of the removal procedure.

REP 12.15-171 HVF Rear Tamper Assembly

Parts List on **PL 12.110.**

Removal

WARNING

Take care during this procedure. Sharp edges may be present that can cause injury.

WARNING

Switch off the electricity to the machine. Refer to **GP 14.** Disconnect the power cord from the customer supply while performing tasks that do not need electricity. Electricity can cause death or injury. Moving parts can cause injury.

1. Remove the rear cover **REP 12.1-171.**
2. Remove the right side-cover **REP 12.5-171.**
3. Remove the ejector assembly **REP 12.6-171.**
4. Remove the front tamper assembly, **REP 12.11-171.**
5. Remove the pressing and support motor, **Figure 1.**

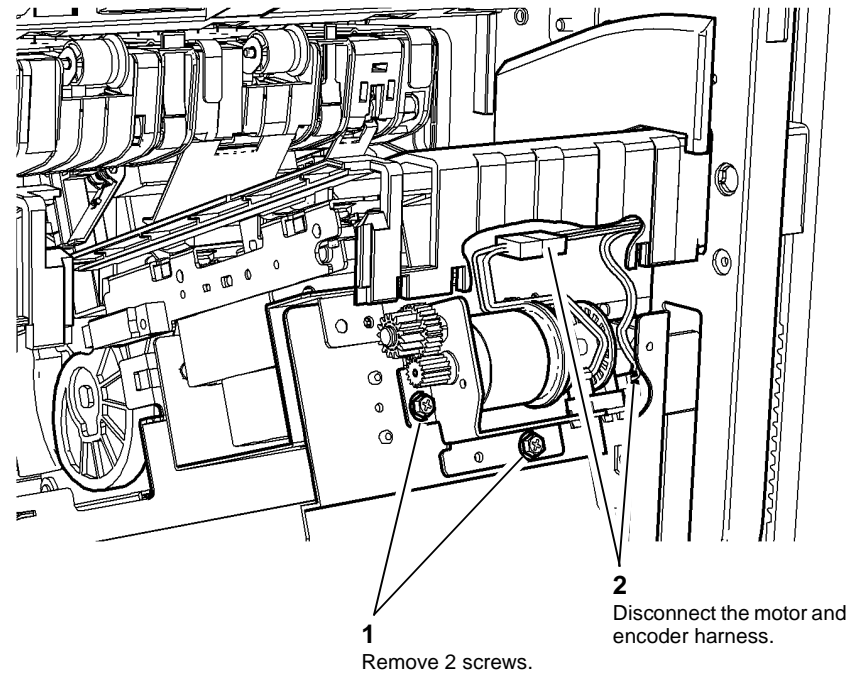

1
Remove 2 screws.

2
Disconnect the motor and
encoder harness.

U-1-0967-A

Figure 1 Motor removal

6. Remove the rear tamper assembly, [Figure 2](#).

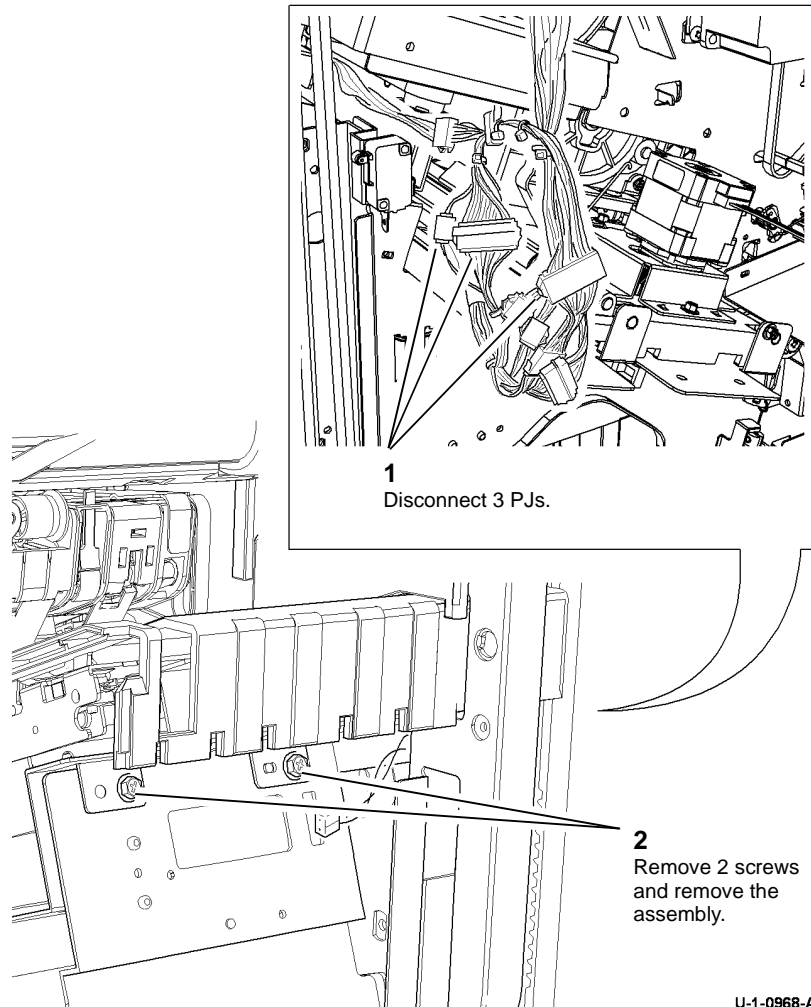

Figure 2 Remove rear tamper assembly

U-1-0968-A

Replacement

1. Reverse the removal procedures to reinstall the rear tamper assembly.
2. Ensure that the rear tamper assembly is located correctly, [Figure 3](#).

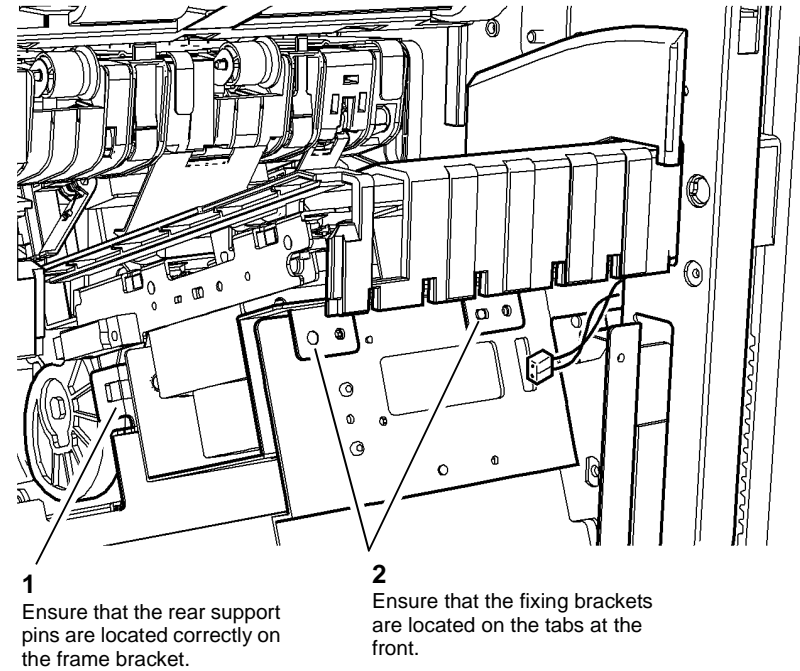

Figure 3 Rear tamper assembly location

U-1-0969-A

REP 12.16-171 BM Flapper

Parts List on [PL 12.150](#).

Removal

WARNING

Take care during this procedure. Sharp edges may be present that can cause injury.

WARNING

Switch off the electricity to the machine [GP 14](#). Disconnect the power cord from the customer supply while performing tasks that do not need electricity. Electricity can cause death or injury. Moving parts can cause injury.

1. Open the HVF BM front door and fully pull out the BM module.

2. [Figure 1](#), remove the BM flapper bracket assembly.

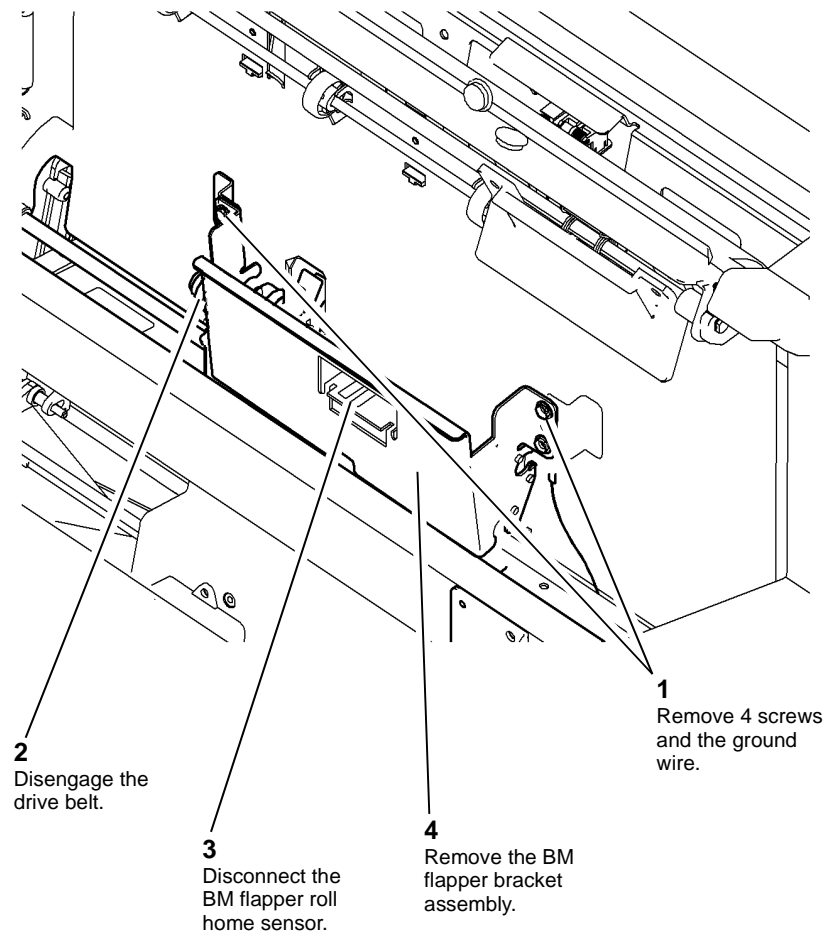

U-1-0457-A

Figure 1 Remove the BM flapper bracket

3. Figure 2, remove the BM flapper assembly.

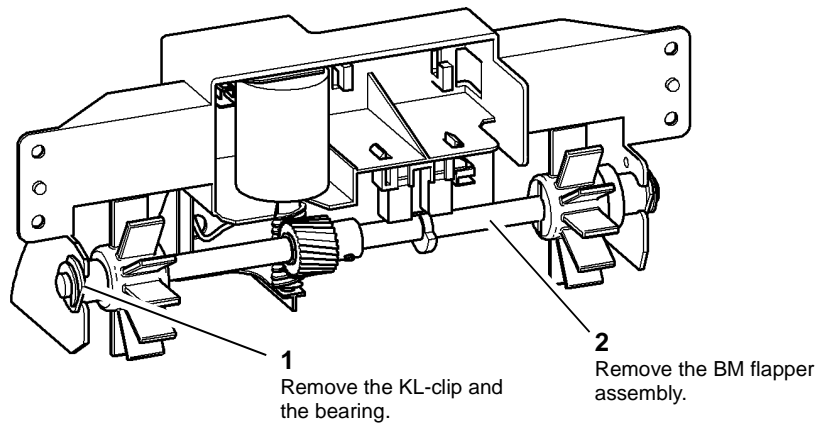

U-1-0458-A

Figure 2 BM flapper assembly removal

4. Figure 3, remove the BM flapper.

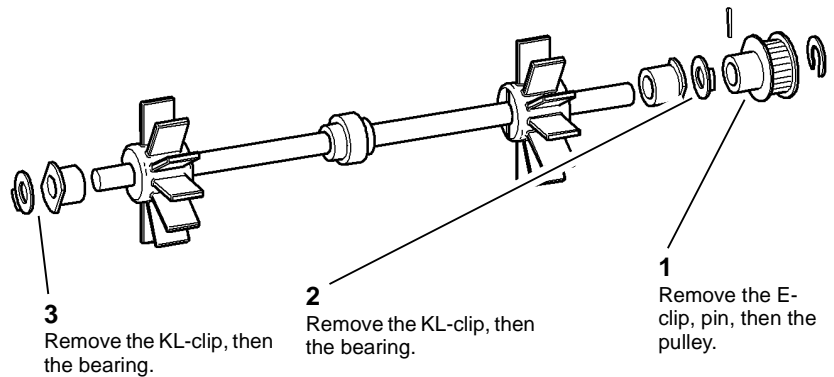

U-1-0459-A

Figure 3 BM flapper removal

Replacement

The replacement is the reverse of the removal procedure.

REP 12.17-171 BM PWB

Parts List on [PL 12.175](#).

Removal

WARNING

Take care during this procedure. Sharp edges may be present that can cause injury.

WARNING

Switch off the electricity to the machine [GP 14](#). Disconnect the power cord from the customer supply while performing tasks that do not need electricity. Electricity can cause death or injury. Moving parts can cause injury.



Figure 1 ESD Symbol

CAUTION

Ensure that ESD procedures are observed during the removal and installation of the BM PWB.

1. Remove the top cover, then the rear cover, [REP 12.1-171](#).

2. Figure 2, remove the BM PWB.

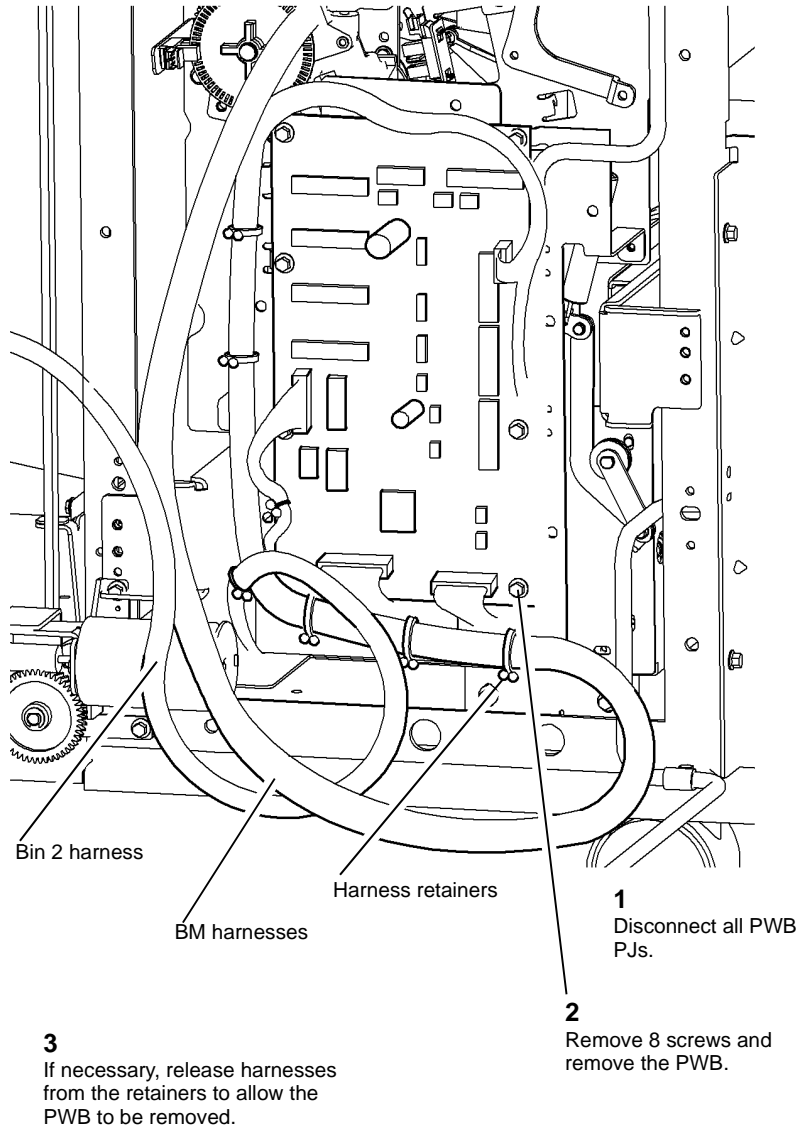

U-1-0460-A

Figure 2 PWB removal

Replacement

CAUTION

Figure 2, ensure the BM harness and bin 2 harness are correctly positioned in the retainers to prevent damaged when the BM is moved to the extremities of its travel.

1. Reverse the removal procedures to replace the BM PWB.
2. The booklet maker PWB is supplied with a label with the customized NVM values for the new BM PWB. Enter the values into the machine dC131 NVM Read/Write at Finisher/DFA Location 12.

Check and perform the adjustments that follow:

- ADJ 12.5-171 Booklet Tamping
- ADJ 12.6-171 Booklet Compiling Position.
- ADJ 12.7-171 Booklet Crease Position
- ADJ 12.8-171 Booklet Staple Position

REP 12.18-171 BM Crease Blade Motor

Parts List on [PL 12.170](#).

Purpose

This procedure is used to repair the following components:

- BM crease blade motor encoder sensor, [PL 12.170 Item 1](#).
- BM crease blade motor, [PL 12.170 Item 3](#).
- Motor encoder, [PL 12.170 Item 4](#).
- Bearing, [PL 12.120 Item 7](#).
- Crank, [PL 12.170 Item 8](#).

Removal

WARNING

Take care during this procedure. Sharp edges may be present that can cause injury.

WARNING

Switch off the electricity to the machine [GP 14](#). Disconnect the power cord from the customer supply while performing tasks that do not need electricity. Electricity can cause death or injury. Moving parts can cause injury.

1. Open the HVF BM front door and fully pull out the BM module.
2. Remove the crease blade knob (6d), [PL 12.150 Item 4](#).
3. Remove the crease roll handle (6c), [PL 12.150 Item 5](#).
4. Remove the BM front cover, [PL 12.150 Item 3](#).
5. Remove the left frame plate, [PL 12.155 Item 2](#).
6. Remove the motor cover, [PL 12.170 Item 11](#). It is easier to remove the screw using an open ended spanner, this means the removal of the BM PWB is not necessary.

7. Figure 1, remove the BM crease blade motor assembly.

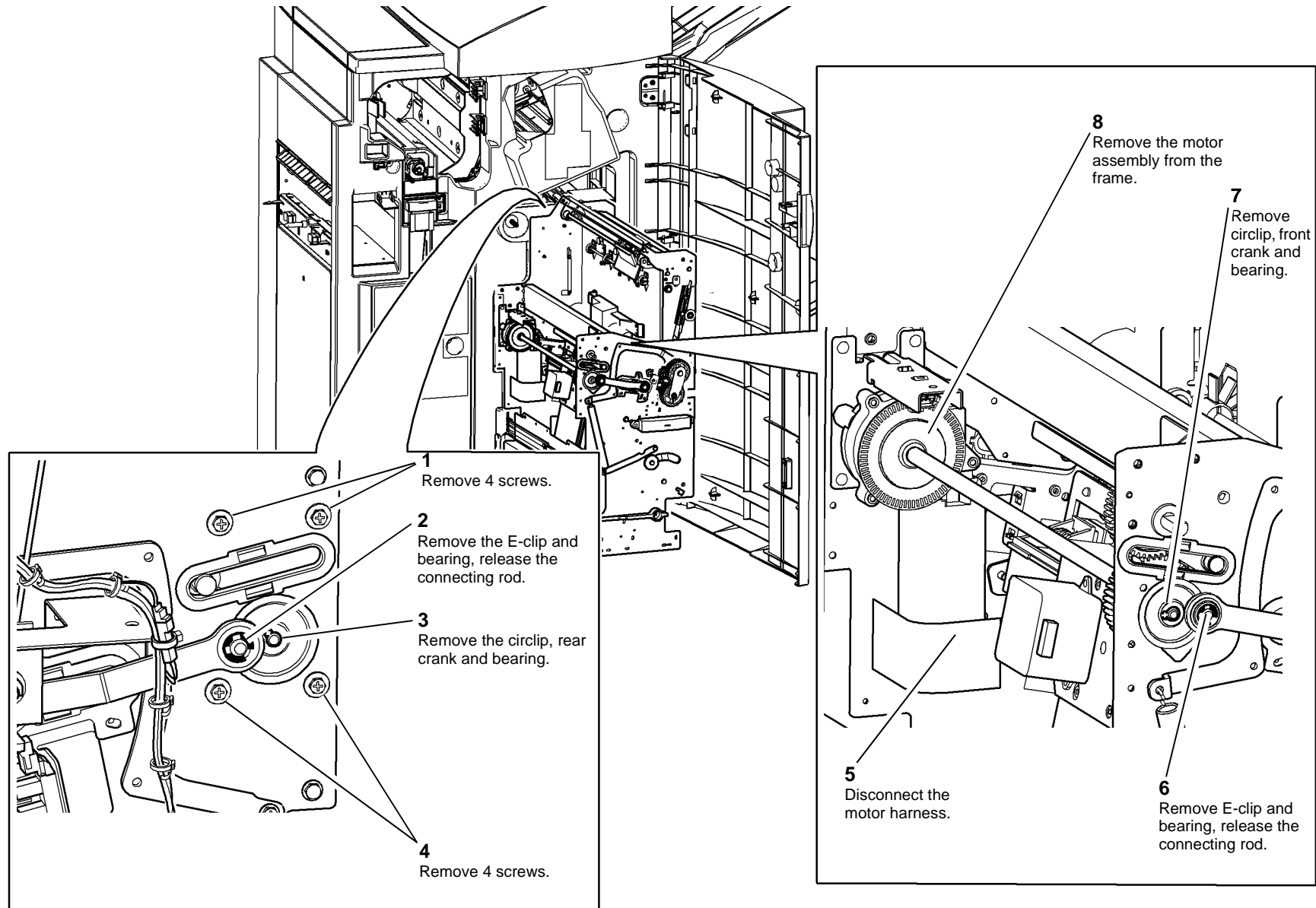

U-1-0461-A

Figure 1 Removing the motor assembly

8. Figure 2, remove the BM crease blade motor.

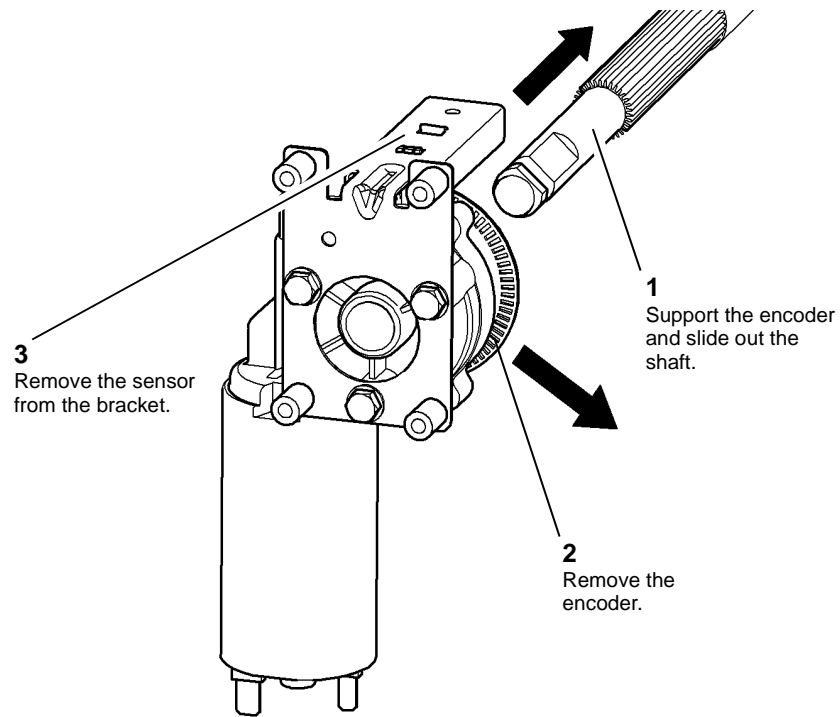

Figure 2 Removing the motor

U-1-0462-A

REP 12.19-171 BM Crease Roll Motor

Parts List on [PL 12.175](#).

Removal

WARNING

Take care during this procedure. Sharp edges may be present that can cause injury.

WARNING

Switch off the electricity to the machine [GP 14](#). Disconnect the power cord from the customer supply while performing tasks that do not need electricity. Electricity can cause death or injury. Moving parts can cause injury.

1. Remove the top cover, then the rear cover, [REP 12.1-171](#).
2. Remove 4 screws securing the BM PWB mounting plate to the frame, allow the PWB and mounting plate to hang down, giving access to the BM crease roll motor.

Replacement

Reverse the removal procedure to replace the BM crease blade motor.

NOTE: Ensure that the mark on the crease blade knob aligns with the arrow on the front infill cover when the crease blade is fully withdrawn.

3. Remove the crease roll motor assembly, [Figure 1](#).

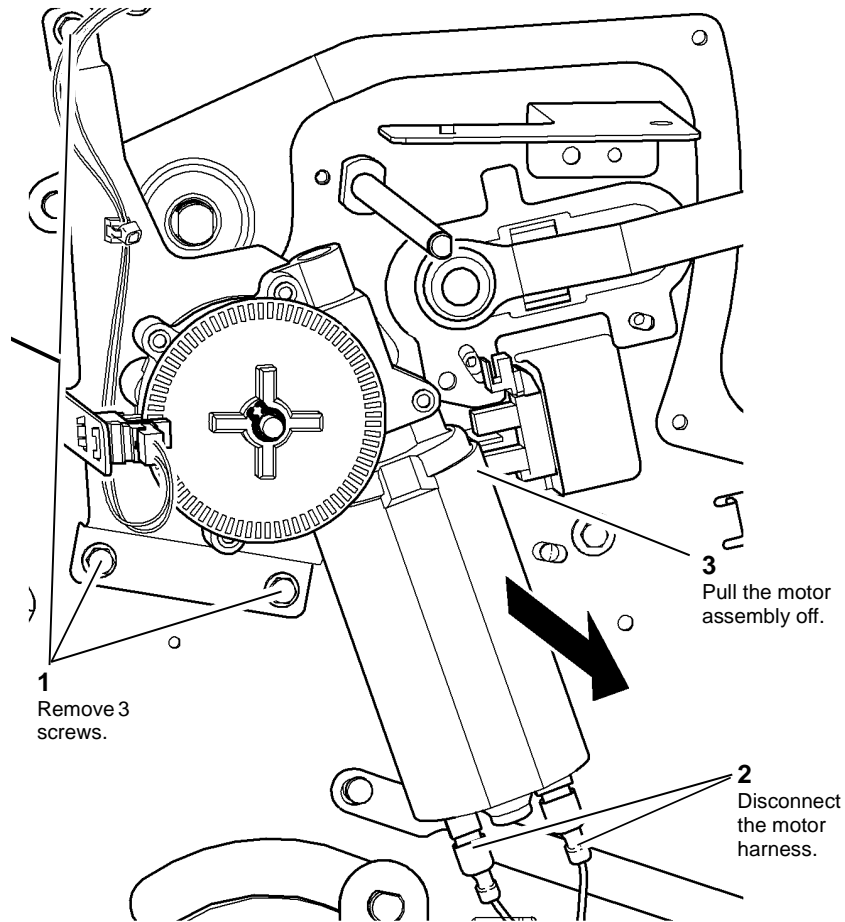

Figure 1 Motor assembly removal

U-1-0463-A

Replacement

1. Reverse the removal procedure to replace the BM crease roll motor.
2. Before installing the motor check that the bearing is located on the drive shaft, [Figure 2](#).

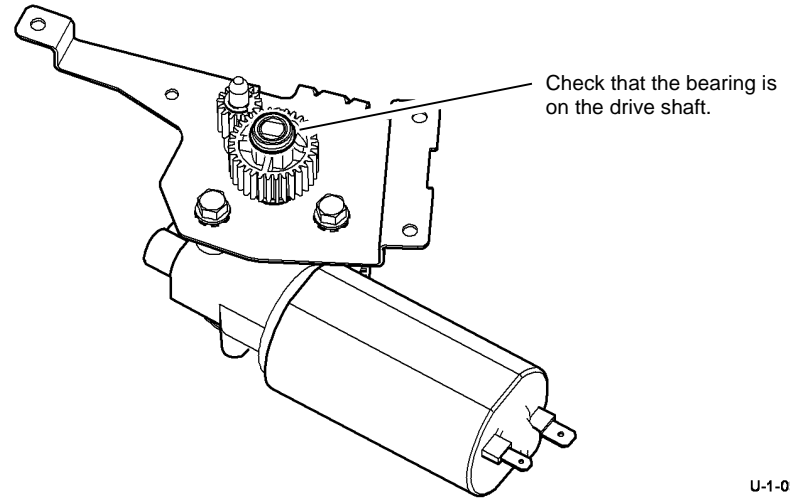

Figure 2 Location of bearing on drive shaft

U-1-0975-A

REP 12.20-171 BM Backstop Motor Assembly

Parts List on [PL 12.160](#).

Purpose

This procedure is used to repair the following components:

- Ground wire, [PL 12.160 Item 1](#).
- Motor damper, [PL 12.160 Item 3](#).
- BM backstop motor, [PL 12.160 Item 4](#).
- BM backstop drive belt, [PL 12.160 Item 7](#).

Removal

WARNING

Take care during this procedure. Sharp edges may be present that can cause injury.

WARNING

Switch off the electricity to the machine [GP 14](#). Disconnect the power cord from the customer supply while performing tasks that do not need electricity. Electricity can cause death or injury. Moving parts can cause injury.

1. Open the HVF BM front door and fully pull out the BM module.

2. [Figure 1](#), remove the BM backstop motor.

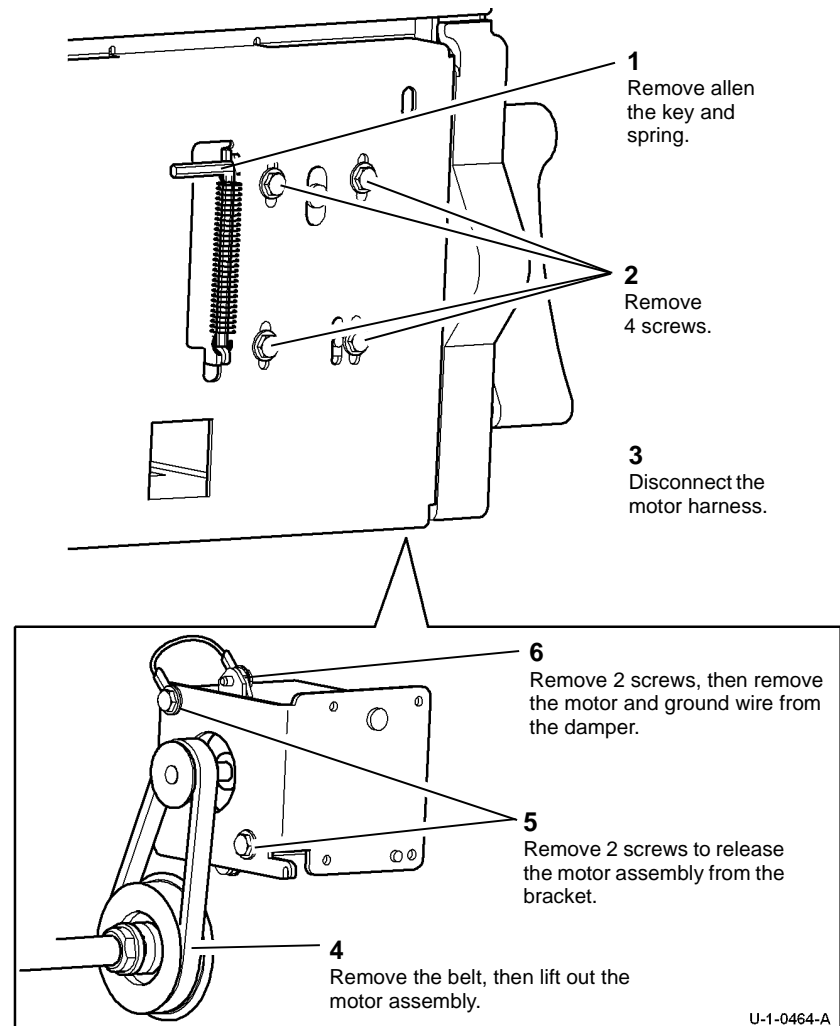

Figure 1 Motor removal

Replacement

Reverse the removal procedure to replace the BM backstop motor.

NOTE: Allow the spring to tension the drive belt while the screws are still loose, then tighten the 4 screws.

REP 12.21-171 BM Backstop Assembly

Parts List on [PL 12.165](#).

Removal

WARNING

Switch off the electricity to the machine. Refer to [GP 14](#). Disconnect the power cord from the customer supply while performing tasks that do not need electricity. Electricity can cause death or injury. Moving parts can cause injury.

WARNING

Take care during this procedure. Sharp edges may be present that can cause injury.

1. Remove the booklet maker, [REP 12.61-171](#).
2. Rotate the crease roll handle (6c), fully counter clockwise.
3. Remove the crease roll handle (6c), [PL 12.150 Item 5](#).
4. Remove the crease blade knob (6d), [PL 12.150 Item 4](#).
5. Remove the BM front cover, [PL 12.150 Item 3](#).

CAUTION

The BM harnesses and the backstop assembly harnesses are connected with a catch. Ensure the catch is released when disconnecting the solenoid harnesses.

6. Remove the two harness clamps, [Figure 1](#).

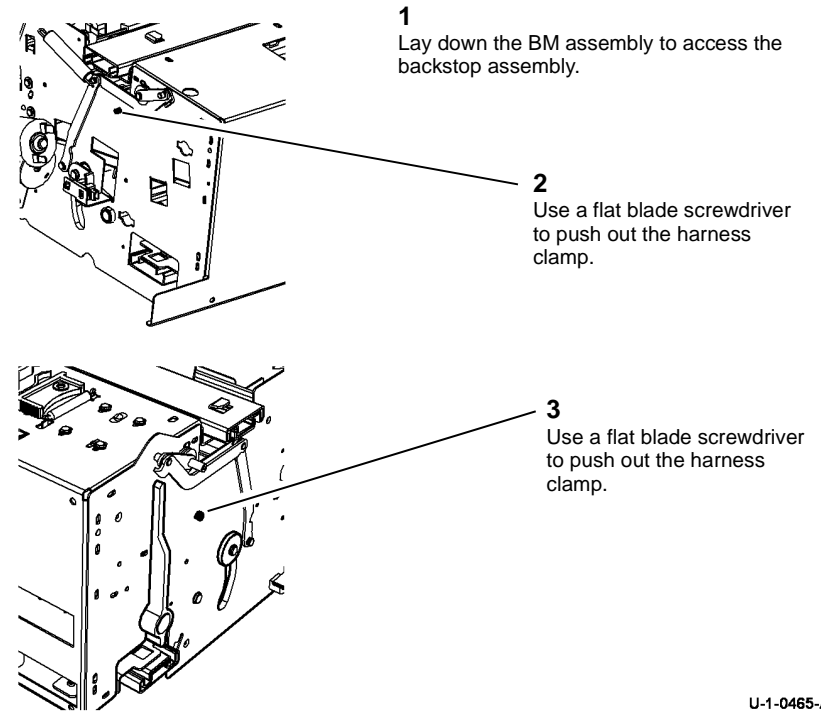

U-1-0465-A

Figure 1 Remove the two harness clamps

- Remove the belt clamp, [Figure 2](#).

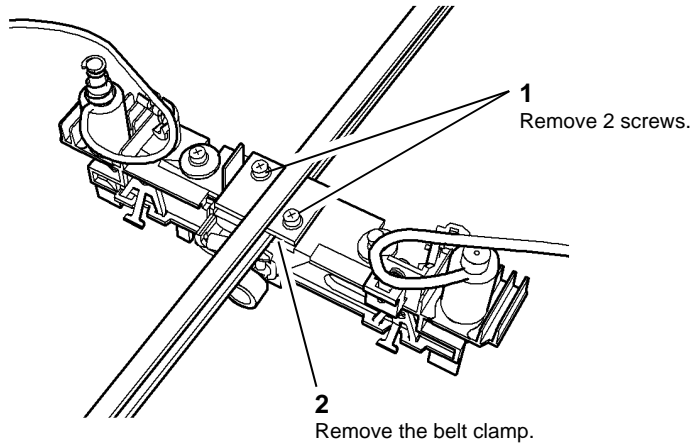

Figure 2 Belt clamp

U-1-0466-A

- Remove the shaft from the BM backstop assembly, [Figure 4](#).

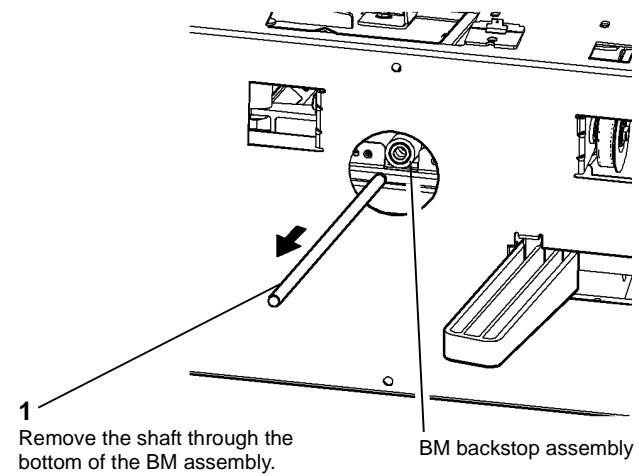

Figure 4 Remove the shaft

U-1-0468-A

- Use the allen key, [PL 12.160 Item 9](#) to remove the 2 screws and remove shaft support, [PL 12.165 Item 10](#).
- Prepare to remove the shaft from the frame, [Figure 3](#).

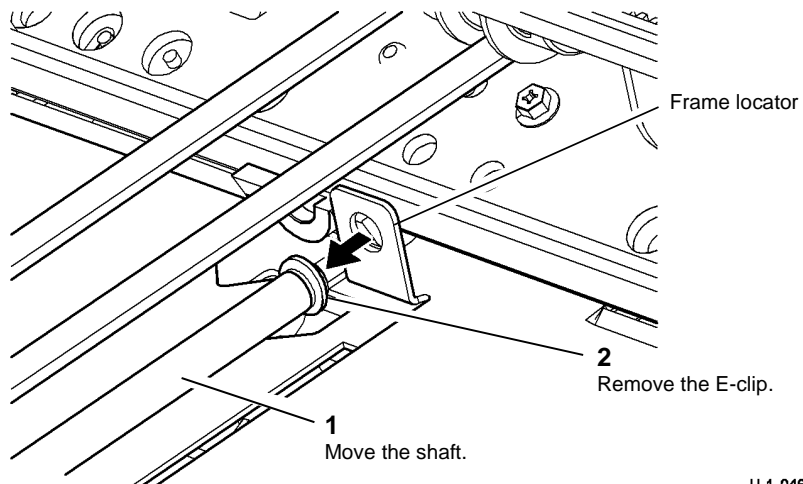

Figure 3 Preparation

U-1-0467-A

- Remove the BM backstop assembly, [Figure 5](#).

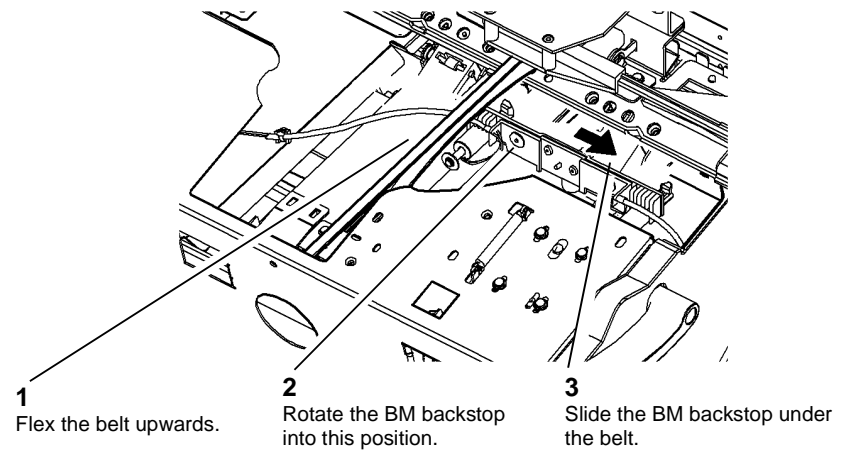

Figure 5 Remove the backstop assembly

U-1-0469-A

- Move the backstop assembly to the bottom of the BM assembly.

Replacement

- Reverse the removal procedure to replace the backstop assembly.

- When installing the shaft ensure that the anti-play shoe has not moved out of position, [Figure 6](#).

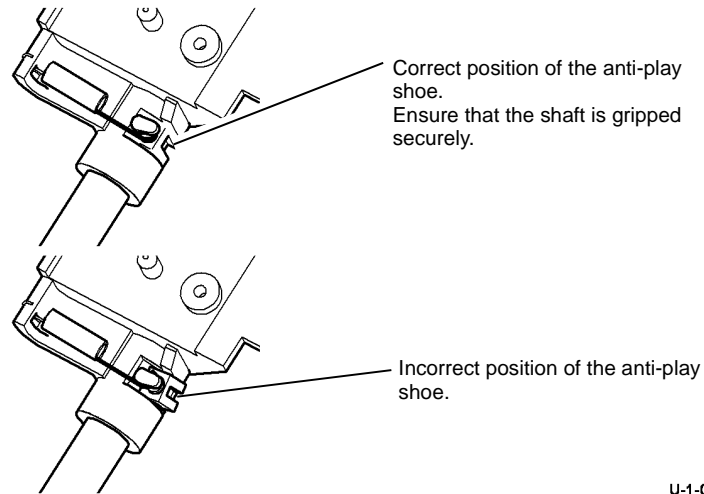

Figure 6 Location of the anti-play shoe.

- Ensure that all of the cable ties are installed and that the harnesses are in the correct position.
- Check that all of the PJ connections on the BM PWB are connected.
- Return the allen key to the storage position inside the drive belt tensioner spring, [PL 12.160 Item 9](#).
- Go to [ADJ 12.9-171](#) and complete the adjustments.

REP 12.22-171 BM Entry Roll

Parts List on [PL 12.150](#).

Purpose

This procedure is used to repair the following components:

- BM entry roll pulley, [PL 12.150 Item 14](#).
- BM entry roll, [PL 12.150 Item 15](#).

Removal

WARNING

Take care during this procedure. Sharp edges may be present that can cause injury.

WARNING

Switch off the electricity to the machine [GP 14](#). Disconnect the power cord from the customer supply while performing tasks that do not need electricity. Electricity can cause death or injury. Moving parts can cause injury.

- Open the HVF BM front door and fully pull out the BM module.
- Remove the crease blade knob (6d), [PL 12.150 Item 4](#).
- Remove the crease roll handle (6c), [PL 12.150 Item 5](#).
- Remove the BM front cover, [PL 12.150 Item 3](#).

5. [Figure 1](#), remove the BM Entry Roll.

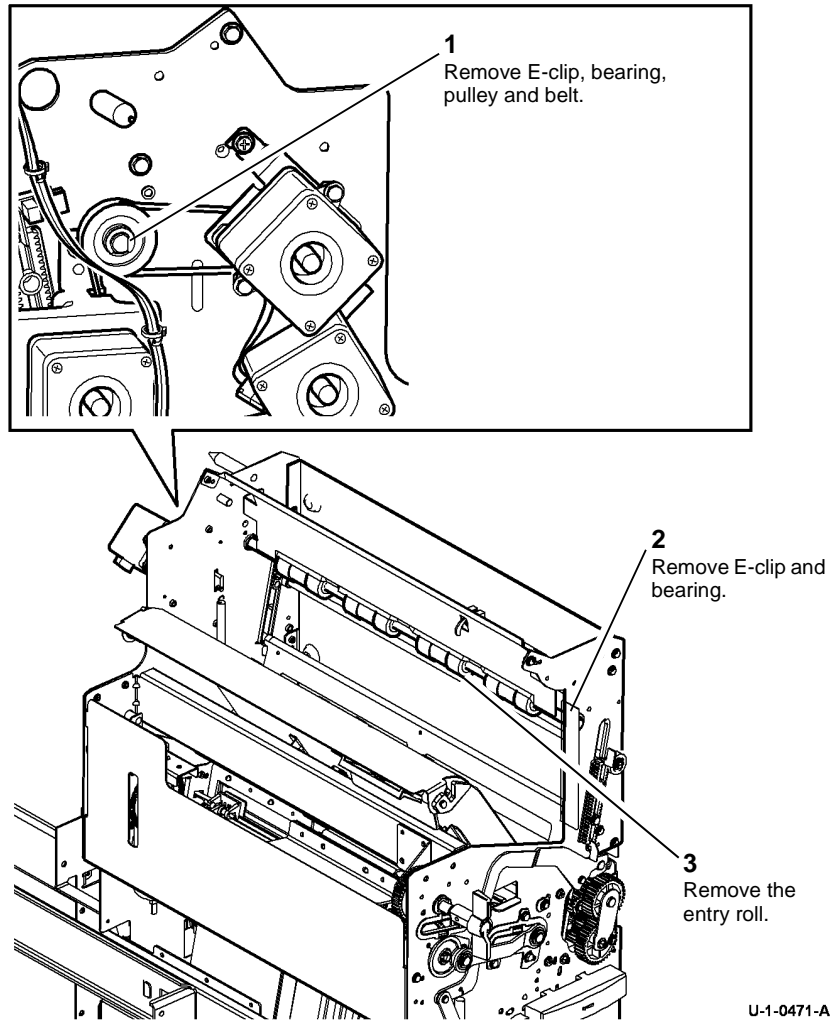

Figure 1 Roll removal

Replacement

Reverse the removal procedure to replace the BM entry roll.

NOTE: Tension the drive belt by loosening then tightening the screw, [ADJ 12.10-171](#)

REP 12.23-171 BM Entry Sensor

Parts List on [PL 12.150](#).

Removal

WARNING

Take care during this procedure. Sharp edges may be present that can cause injury.

WARNING

Switch off the electricity to the machine [GP 14](#). Disconnect the power cord from the customer supply while performing tasks that do not need electricity. Electricity can cause death or injury. Moving parts can cause injury.

1. Open the HVF BM front door and fully pull out the BM module.
2. Remove the crease blade knob (6d), [PL 12.150 Item 4](#).
3. Remove the crease roll handle (6c), [PL 12.150 Item 5](#).
4. Remove the BM front cover, [PL 12.150 Item 3](#).
5. [Figure 1](#), remove the BM entry sensor.

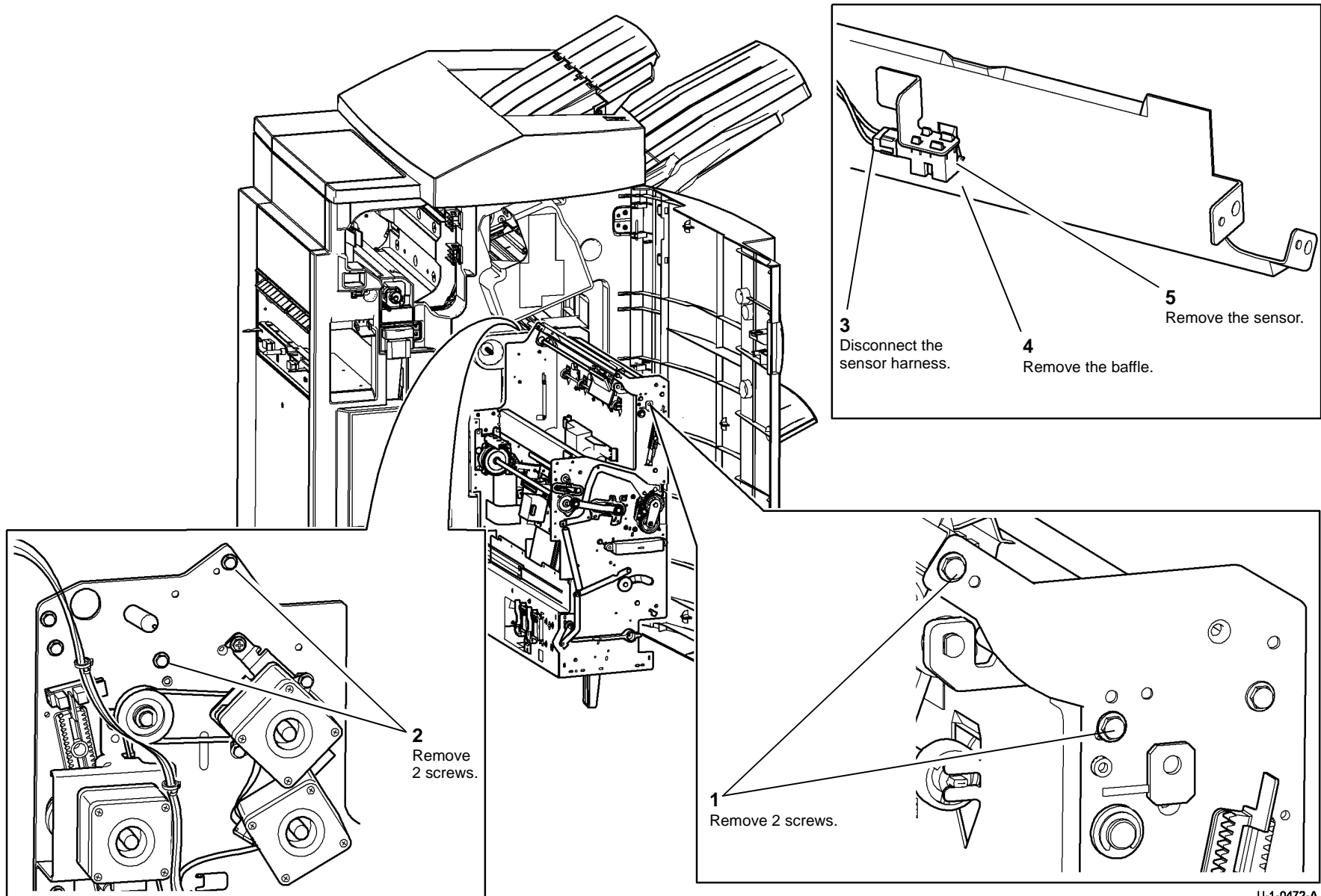

U-1-0472-A

Figure 1 Sensor removal

Replacement

Reverse the removal procedure to replace the BM entry sensor.

REP 12.24-171 BM Crease Roll Gate Motor

Parts List on [PL 12.175](#).

Removal

WARNING

Take care during this procedure. Sharp edges may be present that can cause injury.

WARNING

Switch off the electricity to the machine [GP 14](#). Disconnect the power cord from the customer supply while performing tasks that do not need electricity. Electricity can cause death or injury. Moving parts can cause injury.

1. Remove the top cover, then the rear cover, [REP 12.1-171](#).
2. Fully pull out the BM module.
3. [Figure 1](#), remove the motor assembly

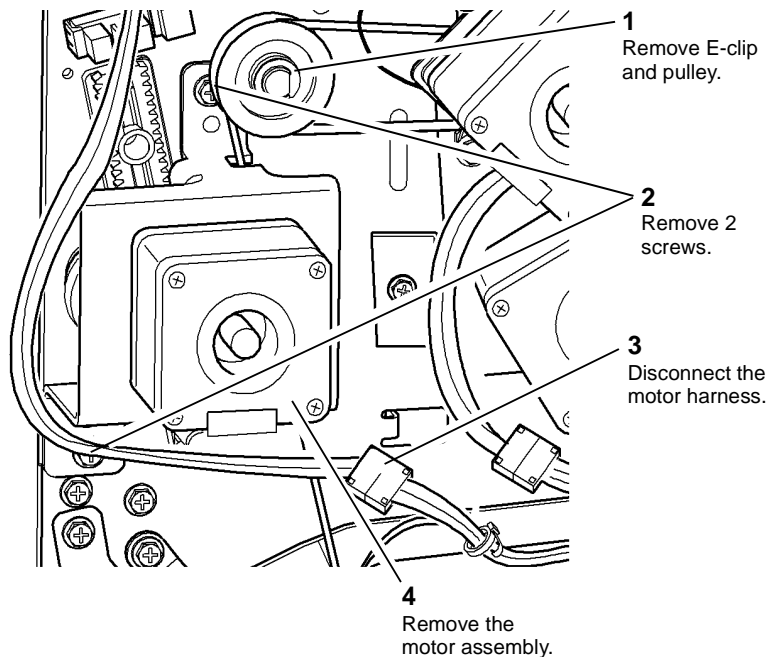

U-1-0473-A

Figure 1 Motor assembly removal

4. Remove 3 nuts to release the motor from the bracket.

Replacement

Reverse the removal procedure to replace the BM crease roll gate motor.

REP 12.25-171 BM Compiler Motor and BM Flapper Motor

Parts List on [PL 12.175](#).

Removal

WARNING

Take care during this procedure. Sharp edges may be present that can cause injury.

WARNING

Switch off the electricity to the machine [GP 14](#). Disconnect the power cord from the customer supply while performing tasks that do not need electricity. Electricity can cause death or injury. Moving parts can cause injury.

1. Remove the top cover, then the rear cover, [REP 12.1-171](#).
2. Fully pull out the BM module.
3. [Figure 1](#), remove the motor assembly.

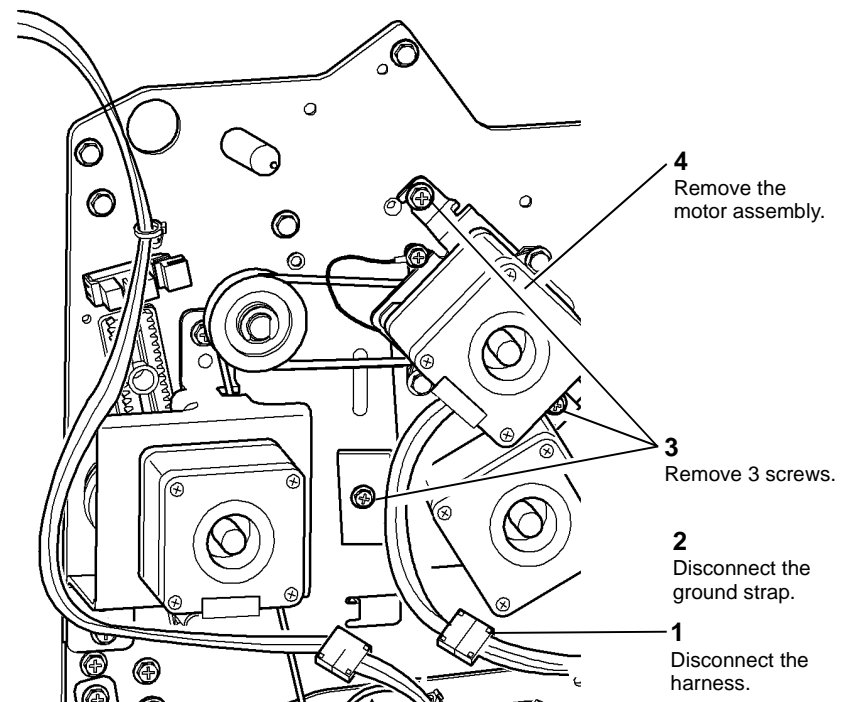

U-1-0474-A

Figure 1 Motor assembly removal

4. Remove 2 screws to remove the relevant motor from the bracket.
5. Remove 2 screws to remove the motor from the damper.

Replacement

Reverse the removal procedure to replace the BM compiler motor or BM flapper motor.

REP 12.26-171 Back Stop Drive Assembly

Parts List on [PL 12.165](#).

Purpose

This procedure is used to repair the following components:

- BM backstop link springs, [PL 12.160 Item 15](#).
- BM backstop link, [PL 12.160 Item 16](#).
- BM backstop drive shaft, [PL 12.165 Item 14](#).
- BM backstop belt, [PL 12.160 Item 7](#).
- BM back stop bearing, [PL 12.160 Item 11](#).
- BM back stop idler bracket, [PL 12.160 Item 12](#).

Removal

WARNING

Take care during this procedure. Sharp edges may be present that can cause injury.

WARNING

Switch off the electricity to the machine [GP 14](#). Disconnect the power cord from the customer supply while performing tasks that do not need electricity. Electricity can cause death or injury. Moving parts can cause injury.

1. Open the HVF BM front door and fully pull out the BM module.
2. Remove the crease blade knob (6d), [PL 12.150 Item 4](#).
3. Remove the crease roll handle (6c), [PL 12.150 Item 5](#).
4. Remove the BM front cover, [PL 12.150 Item 3](#).
5. Remove the LH frame plate, [PL 12.155 Item 2](#).
6. Remove the BM tamper assembly, [REP 12.30-171](#).
7. Remove the backstop motor assembly, [REP 12.20-171](#).
8. Remove the backstop assembly, [REP 12.21-171](#).
9. Remove the crease blade assembly, [REP 12.36-171](#).
10. [Figure 1](#), remove the BM backstop drive shaft and bearings.

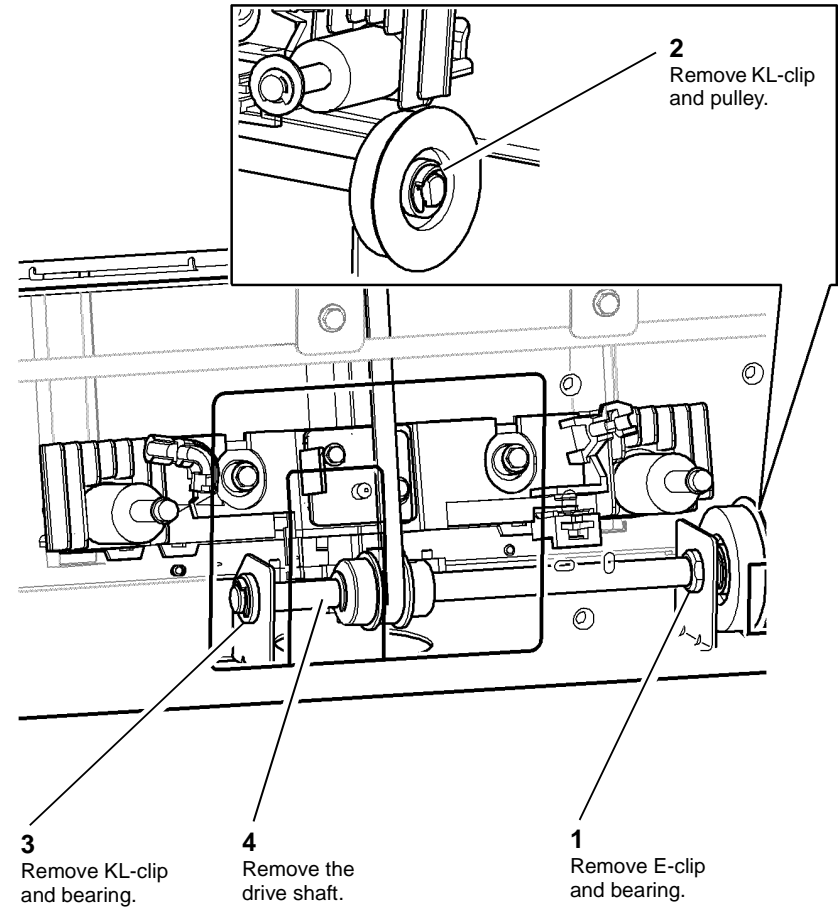

U-1-0475-A

Figure 1 Drive shaft removal

11. Figure 2, remove the backstop link.

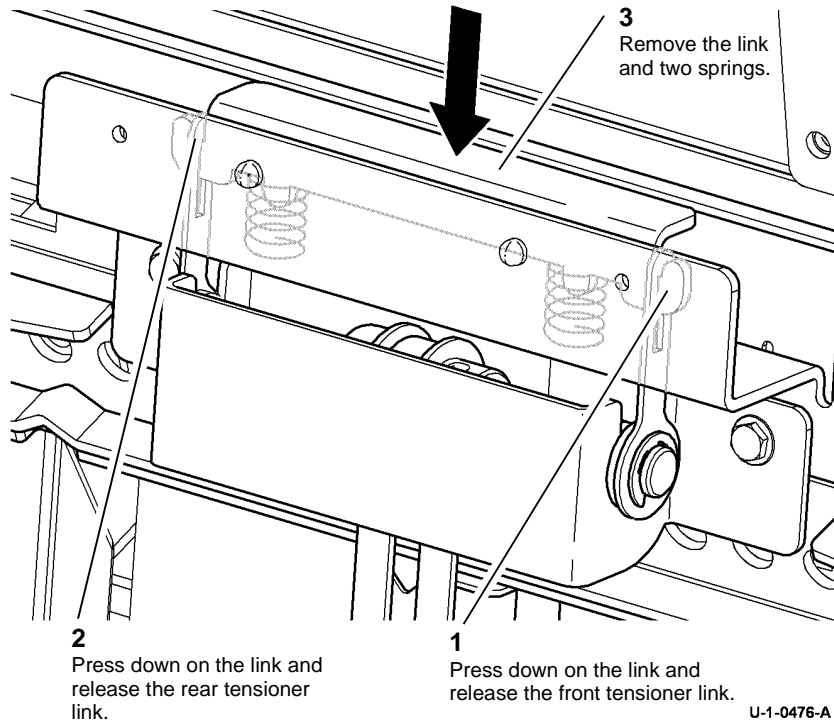

Figure 2 Backstop link removal

12. Figure 3, remove the BM backstop idler bracket assembly.

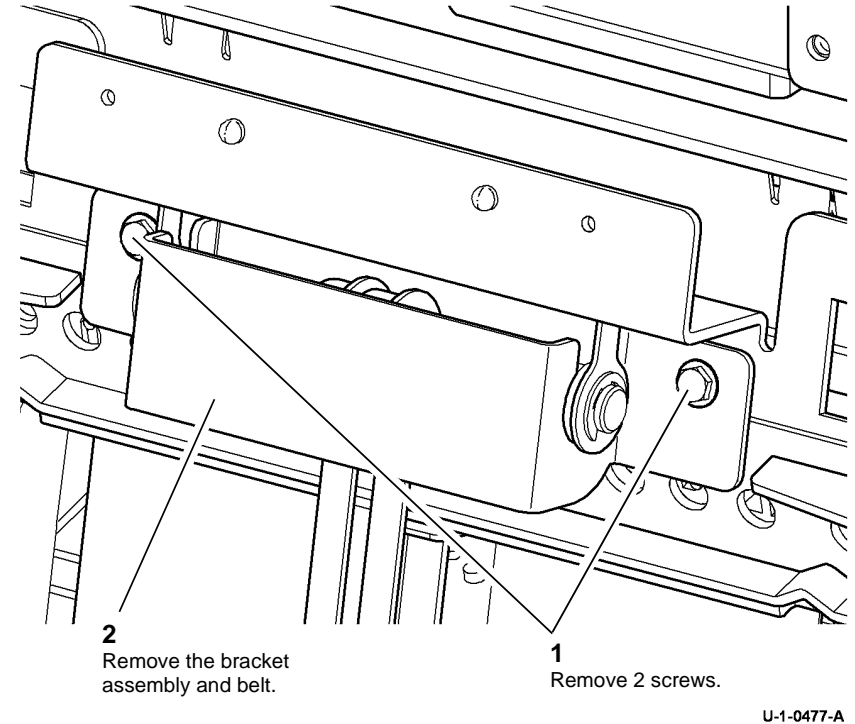

Figure 3 Idler bracket assembly removal

13. [Figure 4](#), remove the BM backstop belt.

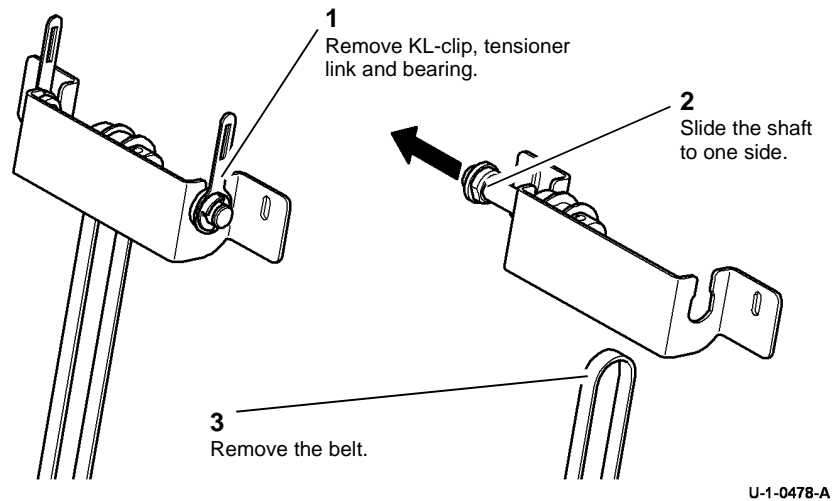

Figure 4 Backstop belt removal

Replacement

Reverse the removal procedure to replace the removed components. Allow the BM backstop belt to be tensioned correctly before the bracket assembly securing screws are tightened. Refer to [Figure 3](#).

REP 12.27-171 BM Staple Heads

Parts List on [PL 12.185](#).

Removal

WARNING

Take care during this procedure. Sharp edges may be present that can cause injury.

WARNING

Switch off the electricity to the machine [GP 14](#). Disconnect the power cord from the customer supply while performing tasks that do not need electricity. Electricity can cause death or injury. Moving parts can cause injury.

1. Fully pull out the BM module.
2. Remove the relevant staple head cover, [PL 12.185 Item 14](#).
3. Pull the stapler bracket handle, [PL 12.185 Item 9](#). Open the staplers fully.

4. **Figure 1**, remove a staple head.

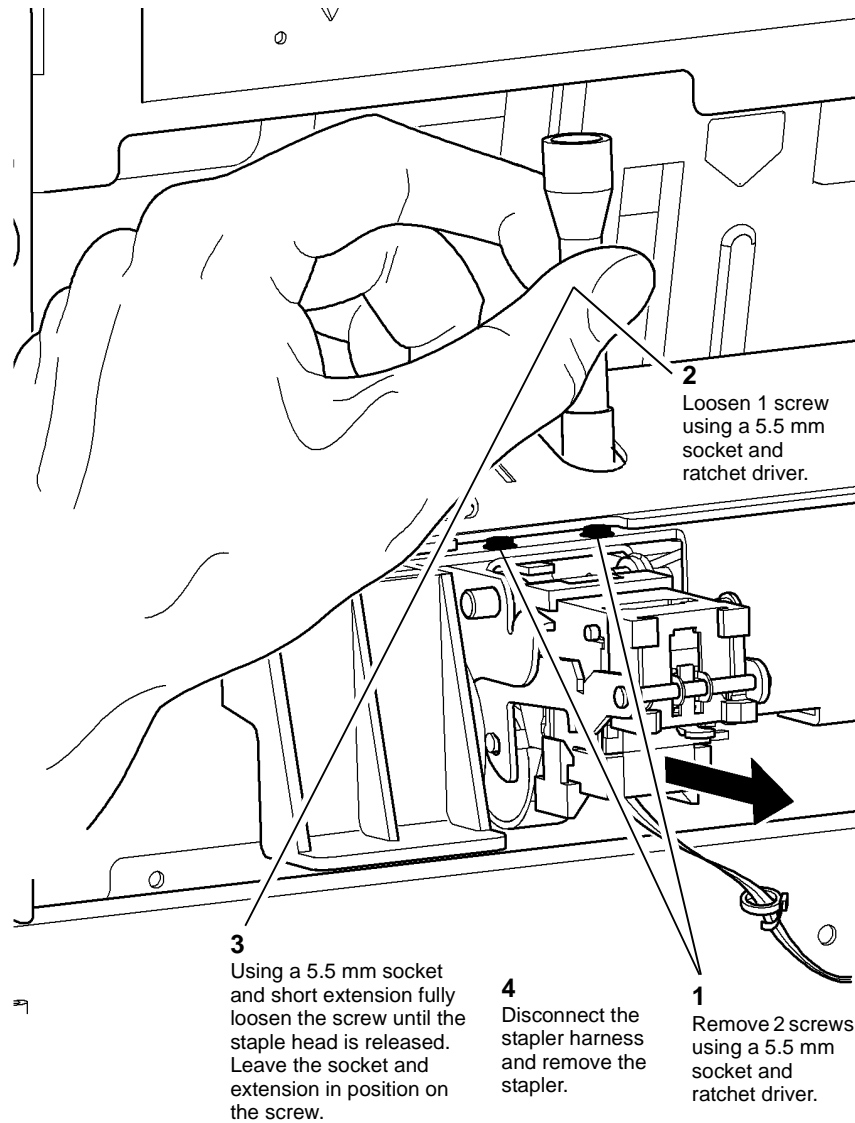

Replacement

1. Reverse the removal procedure to replace the BM staple heads.
2. Perform **ADJ 12.3-171**, Stapler Anvil Alignment.

Figure 1 Staple head removal

U-1-0479-A

REP 12.28-171 BM Stapler Bracket Assembly

Parts List on PL 12.185.

Purpose

This procedure is used to repair the following parts:

- Front follower, PL 12.185 Item 1.
- Actuator, PL 12.185 Item 2.
- Rear follower, PL 12.185 Item 3.
- Spring, PL 12.185 Item 4.
- BM paper present sensor Q12-190, PL 12.185 Item 5.
- Latch slide, PL 12.185 Item 6.
- Staple bracket handle, PL 12.185 Item 9.
- Stapler bracket assembly, PL 12.185 Item 10.
- Torsion spring, PL 12.185 Item 11.
- Bearing, PL 12.185 Item 12.
- Spring, PL 12.185 Item 13.
- BM stapler head carrier closed sensor Q12-421, PL 12.185 Item 18.
- Lower shaft, PL 12.185 Item 19.
- Upper shaft, PL 12.185 Item 20.

Removal

WARNING

Take care during this procedure. Sharp edges may be present that can cause injury.

WARNING

Switch off the electricity to the machine GP 14. Disconnect the power cord from the customer supply while performing tasks that do not need electricity. Electricity can cause death or injury. Moving parts can cause injury.

1. Remove the top cover, then the rear cover, REP 12.1-171.
2. Remove 4 screws securing the BM PWB mounting plate to the frame, allow the PWB and mounting plate to hang down, giving access to the BM staple head carrier closed sensor.

3. Figure 1, remove the BM staple head carrier closed sensor actuator.

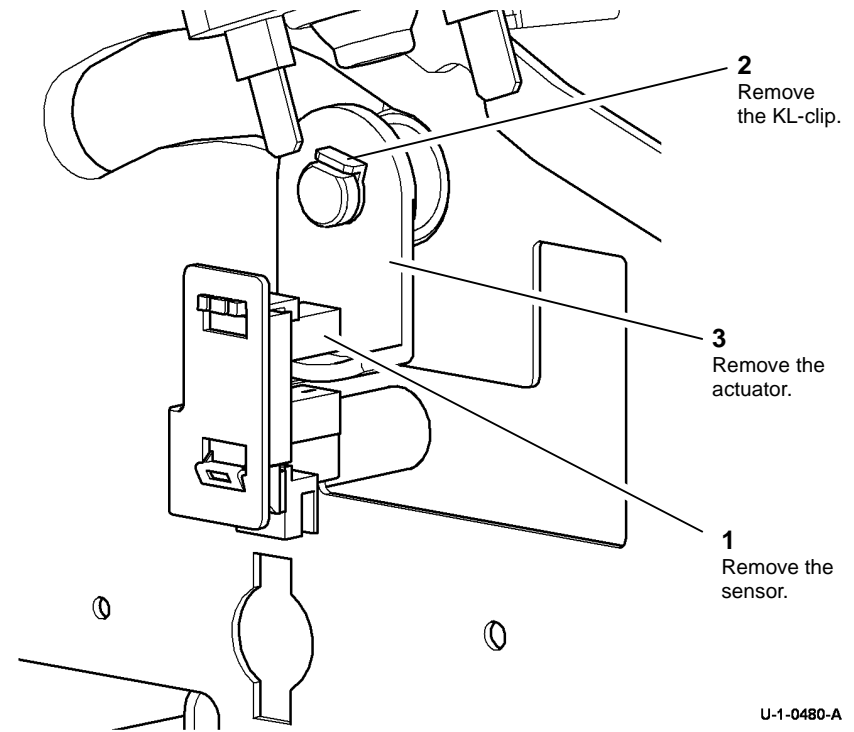

Figure 1 Actuator removal

4. Temporarily attach the PWB mounting plate using only the top two screws.
5. Open the HVF BM front door and fully pull out the BM module.
6. Remove the crease blade knob (6d), PL 12.150 Item 4.
7. Remove the crease roll handle (6c), PL 12.150 Item 5.
8. Remove the BM front cover, PL 12.150 Item 3.
9. Remove both staple head covers, PL 12.185 Item 14.

10. **Figure 2**, lower the stapler bracket.

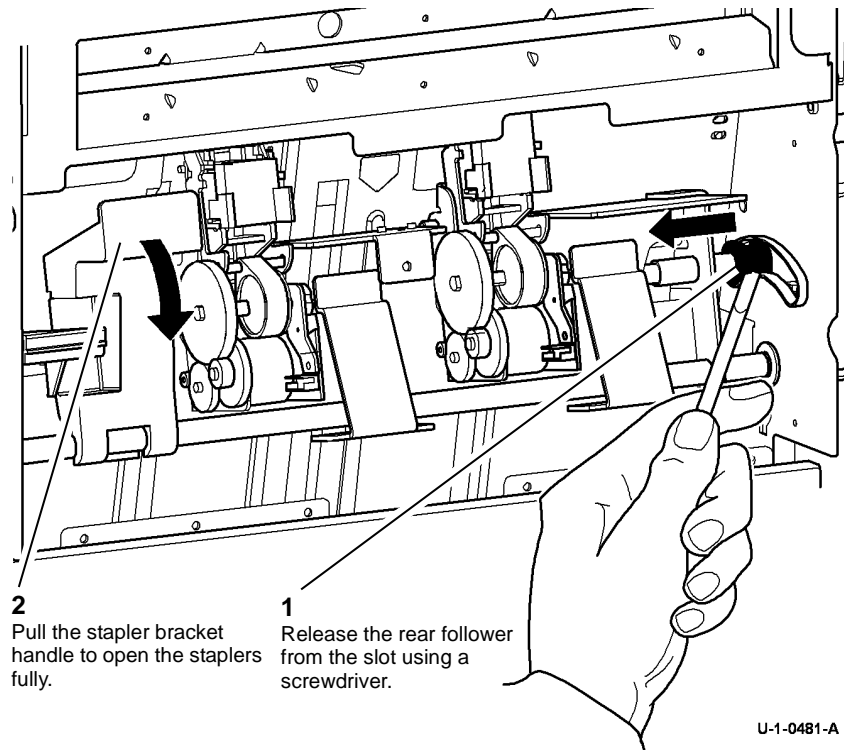
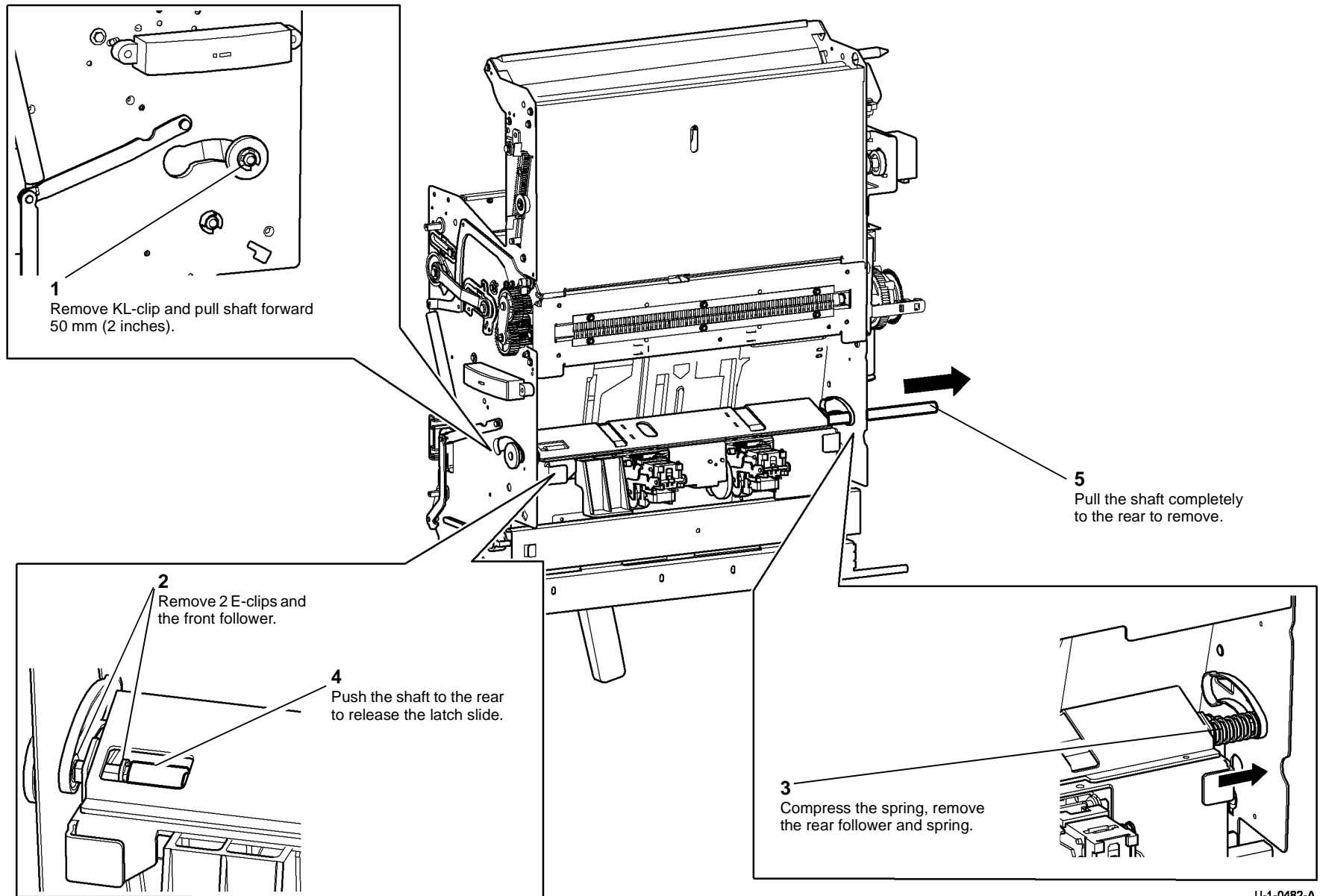

Figure 2 Lowering stapler bracket

11. Figure 3, remove the latch shaft.



U-1-0482-A

Figure 3 Latch shaft removal

12. Figure 4, prepare to remove the BM stapler bracket assembly.

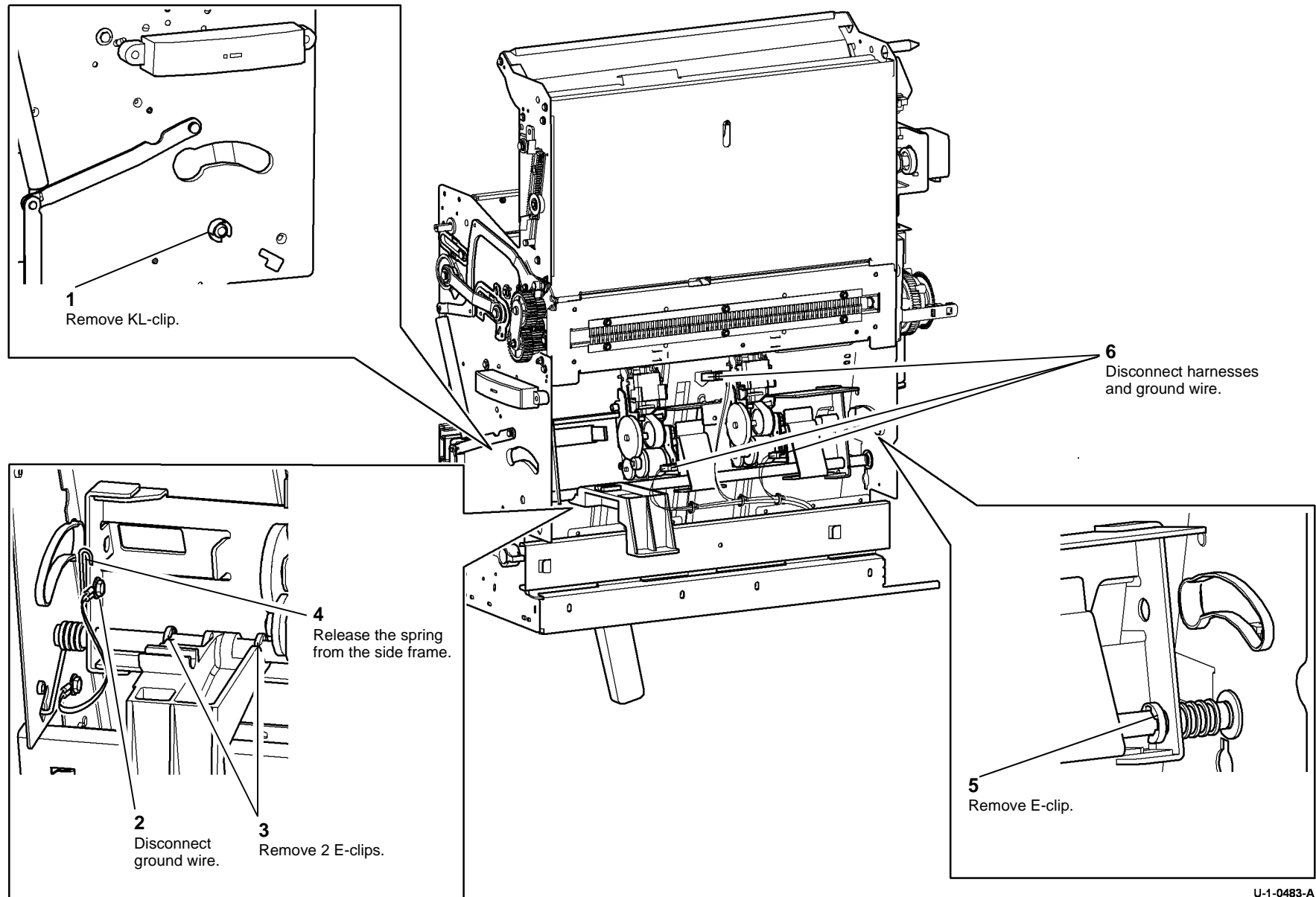

Figure 4 Preparation

U-1-0483-A

13. Figure 5, remove the BM stapler bracket assembly.

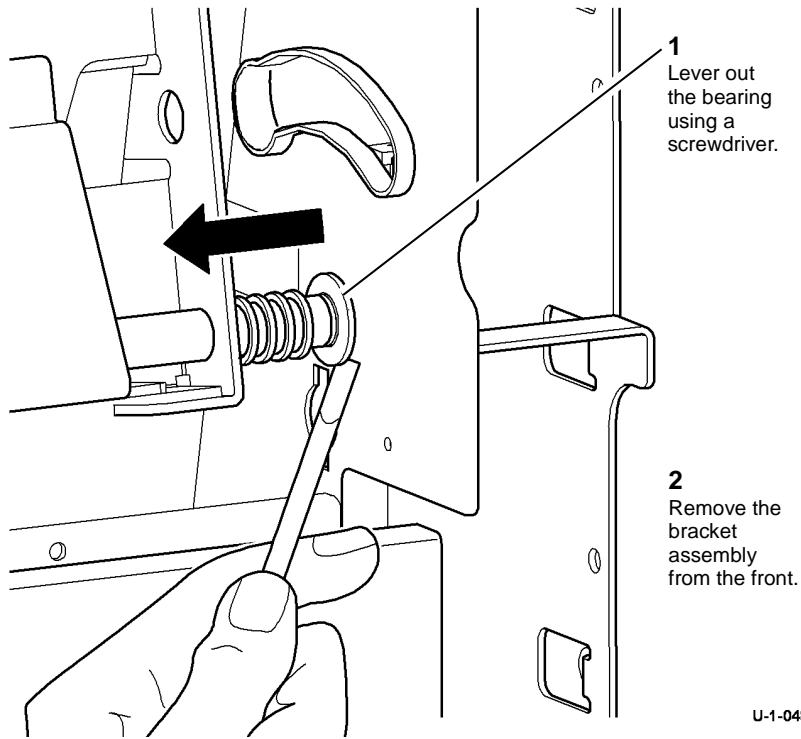

Figure 5 Assembly removal

Replacement

Reverse the removal procedure to replace the BM stapler bracket assembly and components.

REP 12.29-171 BM Conveyor Belts

Parts List on [PL 12.190](#).

Removal

WARNING

Take care during this procedure. Sharp edges may be present that can cause injury.

WARNING

Switch off the electricity to the machine [GP 14](#). Disconnect the power cord from the customer supply while performing tasks that do not need electricity. Electricity can cause death or injury. Moving parts can cause injury.

NOTE: The removal procedure illustrates how to remove the rear conveyor belt. The procedure for the front conveyor belt is similar.

1. Remove bin 2 by disconnecting the harness, removing the thumb screw then lifting the bin upwards to release.
2. Remove the BM bin 2 extension by aligning the pivot pins with the cutouts and snapping the extension out of engagement.
3. Turn over bin 2 and remove the base pan, 3 screws.
4. Remove the BM bin 2 connector from the base pan, 1 screw.

5. **Figure 1**, remove the idler roller.

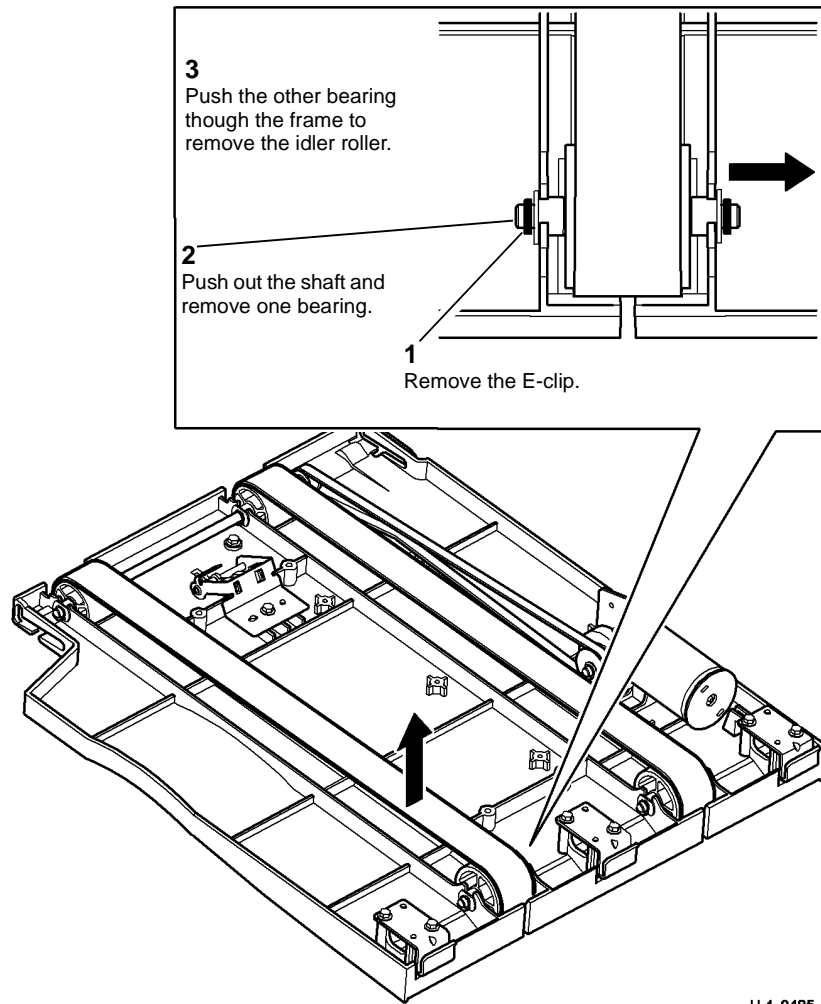

Figure 1 Idler roller removal

U-1-0485-A

6. **Figure 2**, remove the BM conveyor belt.

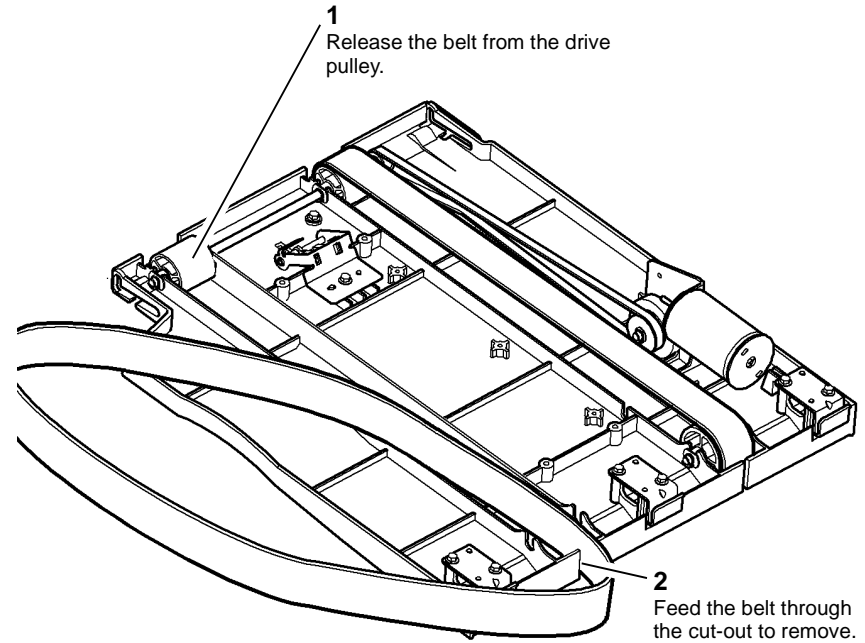

Figure 2 Belt removal

U-1-0486-A

Replacement

Reverse the removal procedure to replace the BM conveyor belts.

REP 12.30-171 BM Tamper Assembly and Tamper 1 Motor

Parts List on [PL 12.155](#).

Purpose

This procedure is used to repair the following components:

- BM tamper 1 motor, [PL 12.155 Item 3](#).
- BM rear tamper arm, [PL 12.155 Item 5](#).
- BM front tamper arm, [PL 12.155 Item 6](#).
- BM rear tamper rack, [PL 12.155 Item 7](#).
- BM front tamper rack, [PL 12.155 Item 8](#).
- BM rear tamper assembly, [PL 12.155 Item 9](#).
- BM front tamper assembly, [PL 12.155 Item 10](#).
- BM tamper gear, [PL 12.155 Item 11](#).
- BM tamper bracket, [PL 12.155 Item 12](#).
- BM tamper rack guide, [PL 12.155 Item 13](#).
- BM tamper guide plate, [PL 12.155 Item 15](#).
- BM rear tamper finger, [PL 12.155 Item 16](#).
- BM front tamper finger, [PL 12.155 Item 17](#).

Removal

WARNING

Switch off the electricity to the machine [GP 14](#). Disconnect the power cord from the customer supply while performing tasks that do not need electricity. Electricity can cause death or injury. Moving parts can cause injury.

WARNING

Take care during this procedure. Sharp edges may be present that can cause injury.

1. Open the HVF BM front door and fully pull out the BM module.
2. Remove the crease blade knob (6d), [PL 12.150 Item 4](#).
3. Remove the crease roll handle (6c), [PL 12.150 Item 5](#).
4. Remove the BM front cover, [PL 12.150 Item 3](#).
5. Remove the left frame plate, [PL 12.160 Item 17](#).

6. [Figure 1](#), remove the tamper assembly.

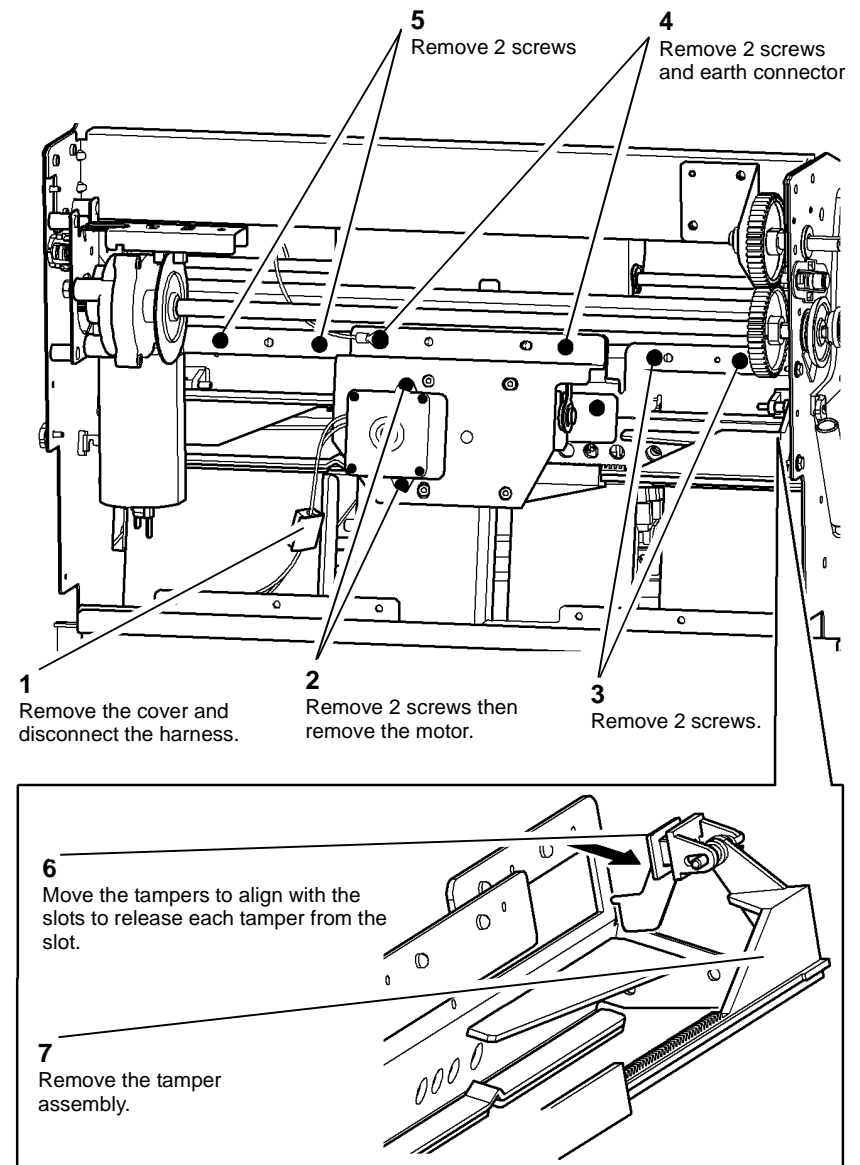

U-1-0487-A

Figure 1 Tamper assembly removal

7. **Figure 2**, remove the front and rear tamper assemblies. Also remove the tamper gear and tamper motor.

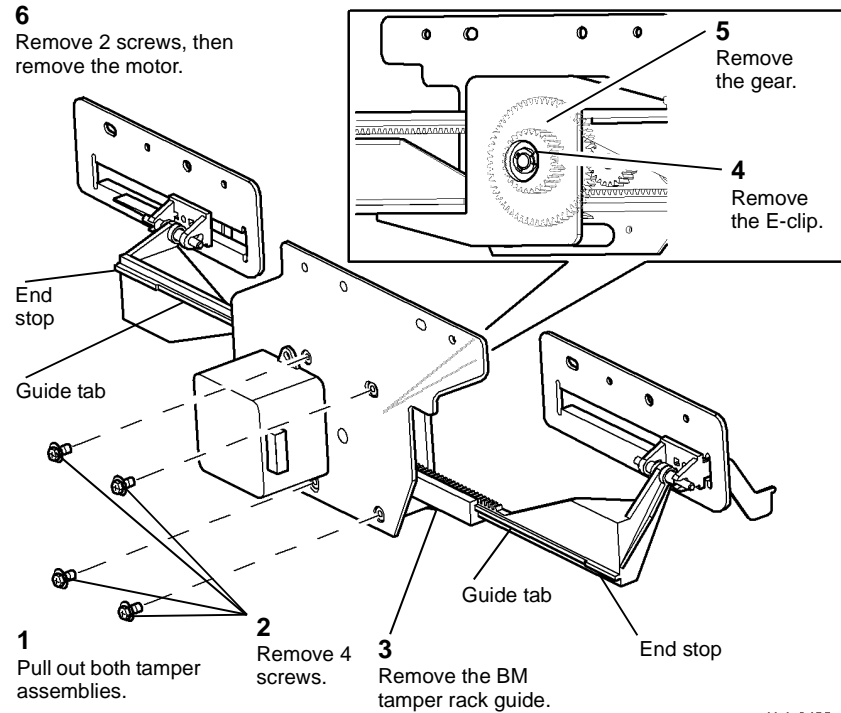

Figure 2 Dismantling the tamper assembly

8. **Figure 3**, remove the tamper guide plate from each of the tamper assemblies.

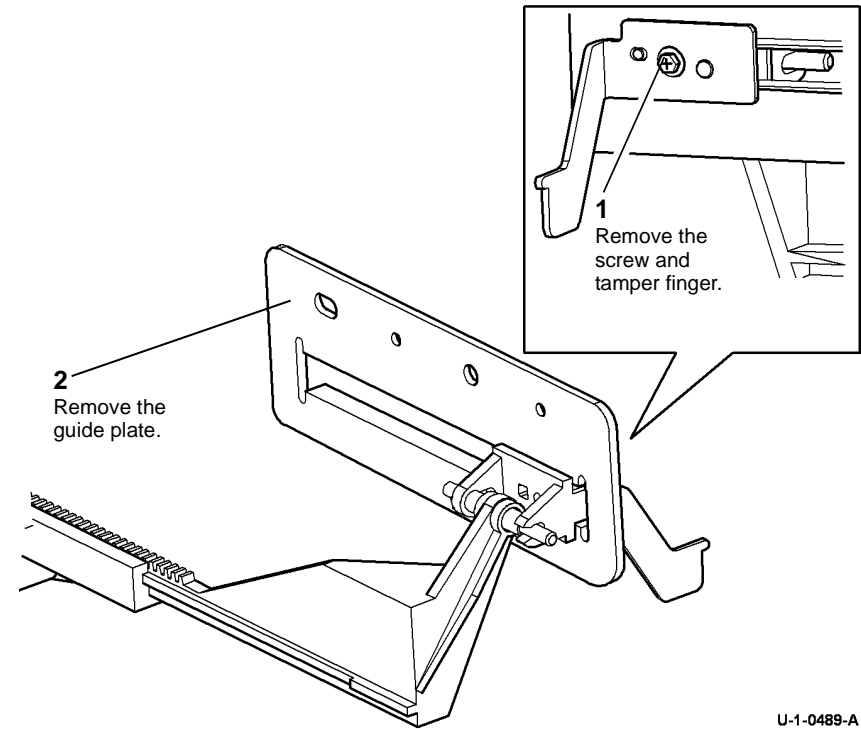

Figure 3 Guide plate removal

Replacement

1. If the tamper racks were removed from the BM tamper rack guide, perform the following:
 - a. Align the guide tabs on both tamper racks with the slots in the BM tamper rack guide. Refer to **Figure 2**.
 - b. Start both tamper racks into the BM tamper rack guide at the same time. Both tamper racks must engage with the BM tamper gear simultaneously. To check that the front and rear tampers are correctly aligned, perform the following:
 - Fully push in the tampers.
 - The distance between the end stop on each tamper and the ends of the BM tamper rack guide should be equal. Refer to **Figure 2**.
 - If the distances are different by more than 1 mm (0.040 inches). Perform again step B.
2. Reverse the removal procedure to replace the BM tamper assembly and tamper 1 motor.
3. Perform **ADJ 12.5-171** Booklet Tamping.

REP 12.31-171 HVF Buffer Guide Assembly

Parts List on [PL 12.125](#).

Removal

WARNING

Take care during this procedure. Sharp edges may be present that can cause injury.

WARNING

Switch off the electricity to the machine [GP 14](#). Disconnect the power cord from the customer supply while performing tasks that do not need electricity. Electricity can cause death or injury. Moving parts can cause injury.

1. Remove the HVF front door, [REP 12.1-171](#).
2. Remove the HVF top cover, [REP 12.1-171](#).
3. Remove the HVF front cover, [REP 12.1-171](#).
4. Remove the HVF rear cover, [REP 12.1-171](#).
5. [Figure 1](#). At the rear of the finisher, disconnect the two PJs.

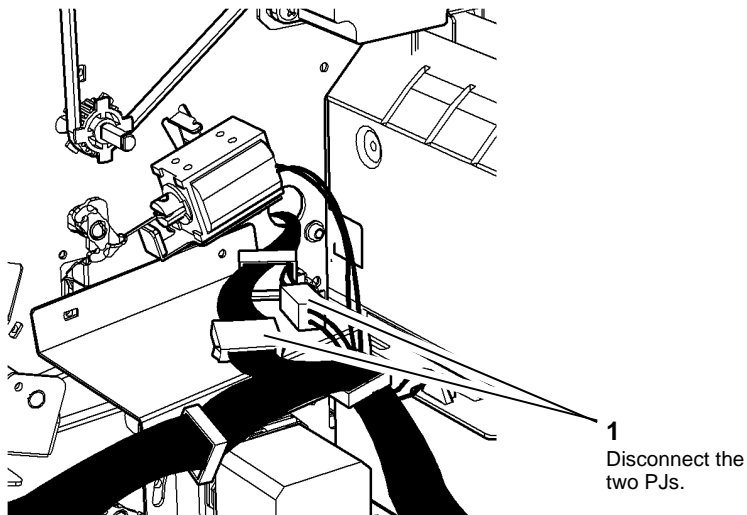

REAR VIEW

Figure 1 Disconnecting PJs.

U-1-0490-A

6. [Figure 2](#). Remove the pivot screw.

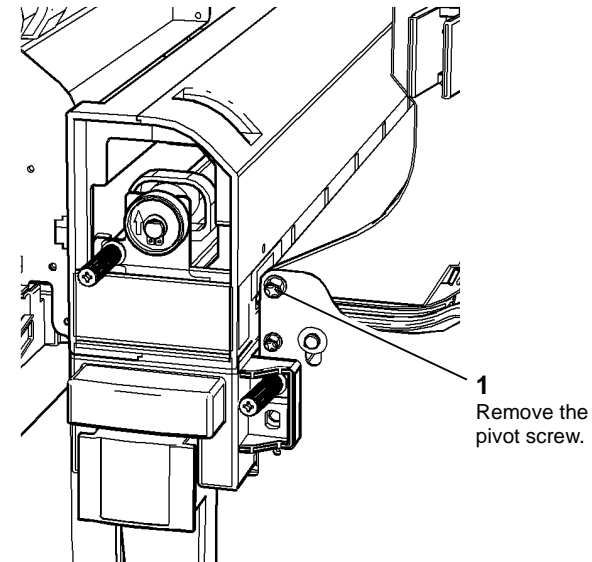

Figure 2 Pivot screw removal.

7. Pass the PJs through the cut-out in the rear frame.
8. Withdraw the guide through the front opening.

Replacement

Position the spigot at the guide rear in the hole in the rear frame. The rest of the replacement procedure is the reverse of the removal procedure.

U-1-0491-A

REP 12.32-171 HVF Input Jam Clearance Guide

Parts List on [PL 12.125](#).

Removal

WARNING

Take care during this procedure. Sharp edges may be present that can cause injury.

WARNING

Switch off the electricity to the machine [GP 14](#). Disconnect the power cord from the customer supply while performing tasks that do not need electricity. Electricity can cause death or injury. Moving parts can cause injury.

1. Remove the HVF front door, [REP 12.1-171](#).
2. Remove the HVF top cover, [REP 12.1-171](#).
3. Remove the HVF front cover, [REP 12.1-171](#).
4. [Figure 1](#). Remove the pivot screw at the front of the input guide.

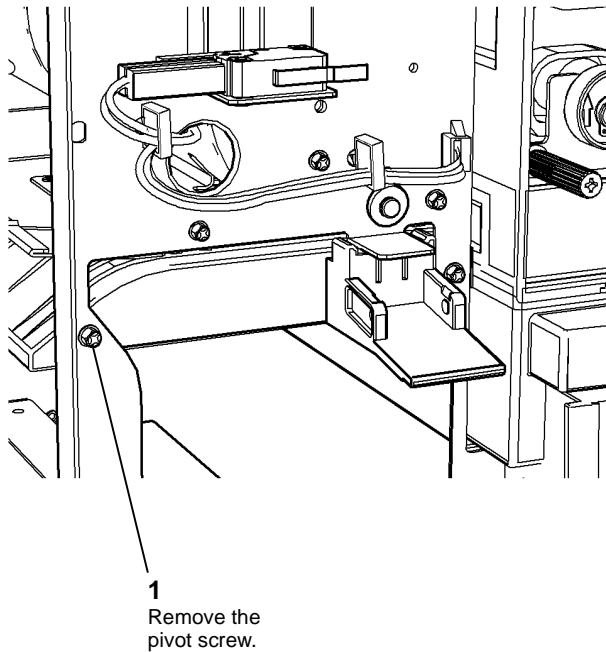

Figure 1 Pivot screw removal.

U-1-0492-A

5. Remove the guide through the front opening.

Replacement

Position the spigot at the guide rear in the hole in the rear frame. The rest of the replacement procedure is the reverse of the removal procedure.

REP 12.33-171 Buffer Pocket Jam Clearance Guide Assembly

Parts List on [PL 12.125](#).

Removal

WARNING

Take care during this procedure. Sharp edges may be present that can cause injury.

WARNING

Switch off the electricity to the machine [GP 14](#). Disconnect the power cord from the customer supply while performing tasks that do not need electricity. Electricity can cause death or injury. Moving parts can cause injury.

1. Remove the HVF front door, [REP 12.1-171](#).
2. Remove the HVF top cover, [REP 12.1-171](#).
3. Remove the HVF front cover, [REP 12.1-171](#).
4. Remove the HVF rear cover, [REP 12.1-171](#).
5. Remove the buffer pocket roll, [REP 12.42-171](#).
6. [Figure 1](#). At the rear of the HVF, prepare to remove the buffer pocket jam clearance guide.

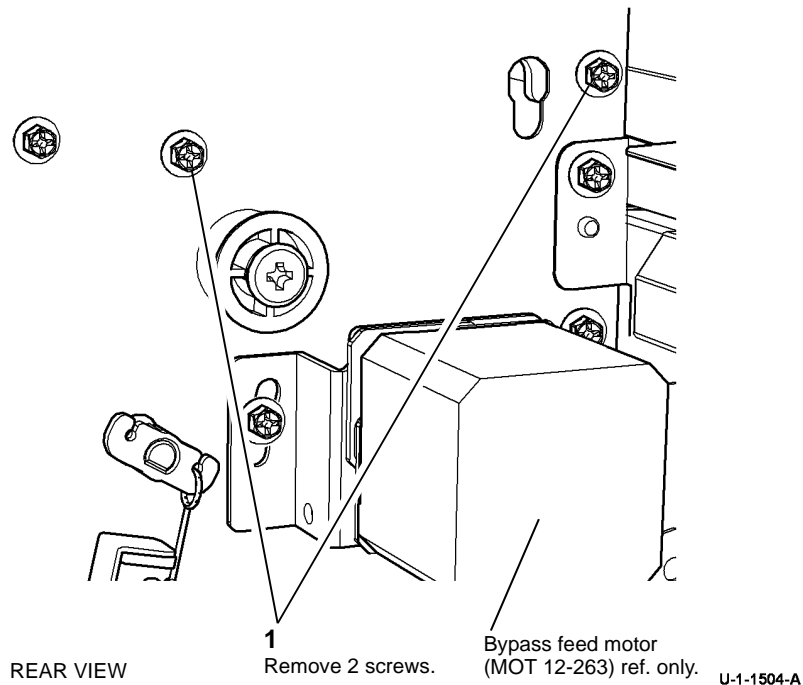

Figure 1 Rear screw removal.

7. [Figure 2](#). At the front of the HVF, remove the buffer pocket jam clearance guide.

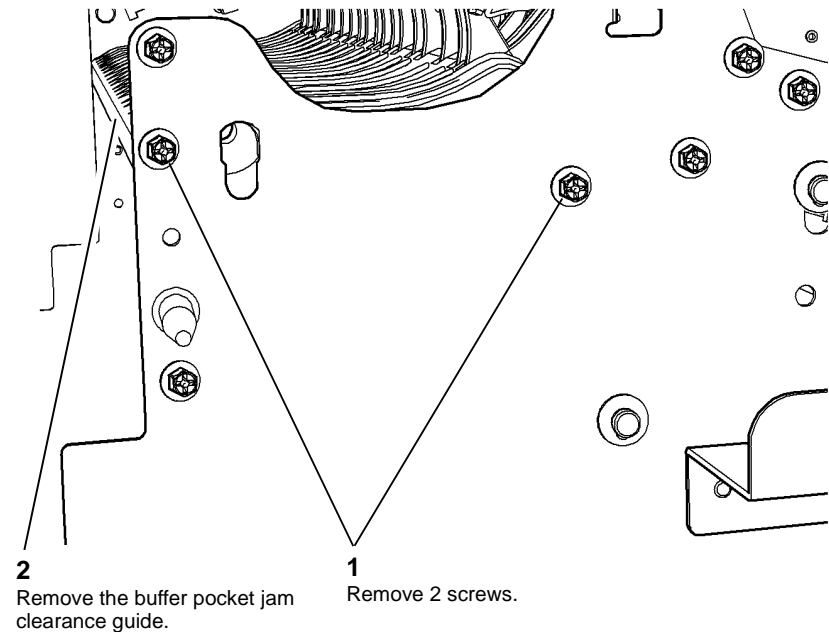

Figure 2 Guide removal.

Replacement

The replacement procedure is the reverse of the removal procedure.

REP 12.34-171 Inserter Jam Clearance Guide Assembly

Parts List on [PL 12.125](#).

Removal

WARNING

Take care during this procedure. Sharp edges may be present that can cause injury.

WARNING

Switch off the electricity to the machine [GP 14](#). Disconnect the power cord from the customer supply while performing tasks that do not need electricity. Electricity can cause death or injury. Moving parts can cause injury.

1. Remove the HVF front door, [REP 12.1-171](#)
2. Remove the HVF top cover, [REP 12.1-171](#).
3. Remove the HVF front cover, [REP 12.1-171](#).
4. [Figure 1](#). Remove the pivot screw from the front end of the Inserter jam clearance guide.

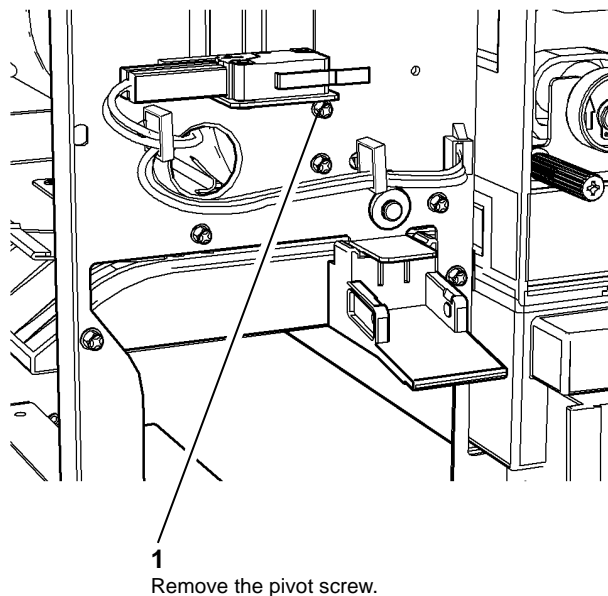

Figure 1 Pivot screw removal.

5. Remove the guide through the front opening.

Replacement

1. The replacement procedure is the reverse of the removal procedure.

REP 12.35-171 Diverter Exit Gate

Parts List on [PL 12.125](#).

Removal

WARNING

Take care during this procedure. Sharp edges may be present that can cause injury.

WARNING

Switch off the electricity to the machine [GP 14](#). Disconnect the power cord from the customer supply while performing tasks that do not need electricity. Electricity can cause death or injury. Moving parts can cause injury.

1. Remove the HVF front door, [REP 12.1-171](#).
2. Remove the HVF top cover, [REP 12.1-171](#).
3. Remove the HVF front cover, [REP 12.1-171](#).
4. Remove the HVF rear cover, [REP 12.1-171](#).
5. [Figure 1](#). At the rear of the HVF, remove the solenoid arm, the K-L clip and the bush from the diverter shaft.

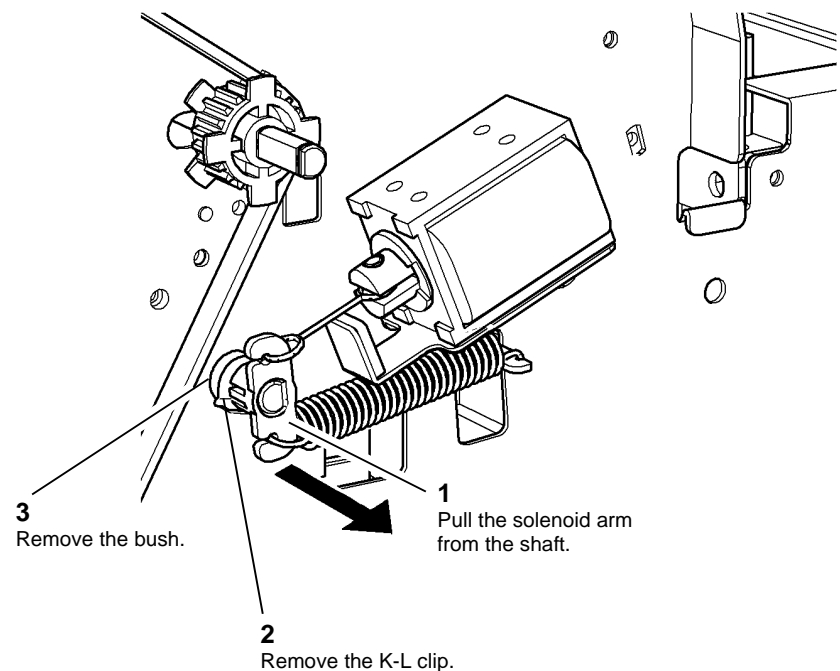

REAR VIEW

Figure 1 Removal preparation

6. **Figure 2.** Remove the diverter exit gate.

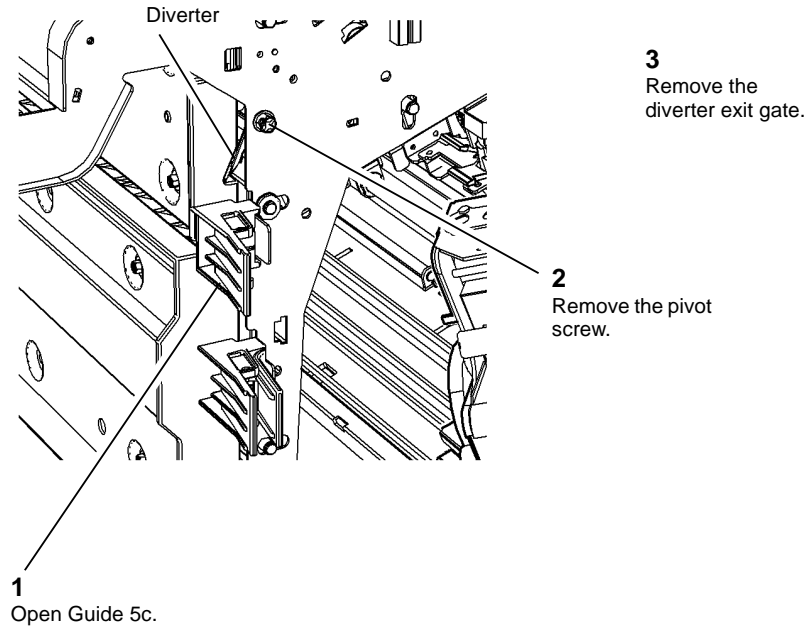

Figure 2 Diverter removal

U-1-0497-A

Replacement

CAUTION

After replacement, check the K-L clip is in the correct groove, and the bush cannot be pulled from the frame.

The replacement procedure is the reverse of the removal procedure.

REP 12.36-171 Crease Blade Assembly

Parts List on **PL 12.170.**

Purpose

This procedure is used to repair the following components:

- Connecting rod, **PL 12.170 Item 9.**
- Crease blade assembly, **PL 12.170 Item 13.**
- Crease blade support guide, **PL 12.170 Item 14.**

Removal

WARNING

Take care during this procedure. Sharp edges may be present that can cause injury.

WARNING

Switch off the electricity to the machine **GP 14. Disconnect the power cord from the customer supply while performing tasks that do not need electricity. Electricity can cause death or injury. Moving parts can cause injury.**

1. Open the HVF BM front door and fully pull out the BM module.
2. Remove the crease blade knob (6d), **PL 12.150 Item 4.**
3. Remove the crease roll handle (6c), **PL 12.150 Item 5.**
4. Remove the BM front cover, **PL 12.150 Item 3.**

5. **Figure 1**, remove the crease blade assembly.

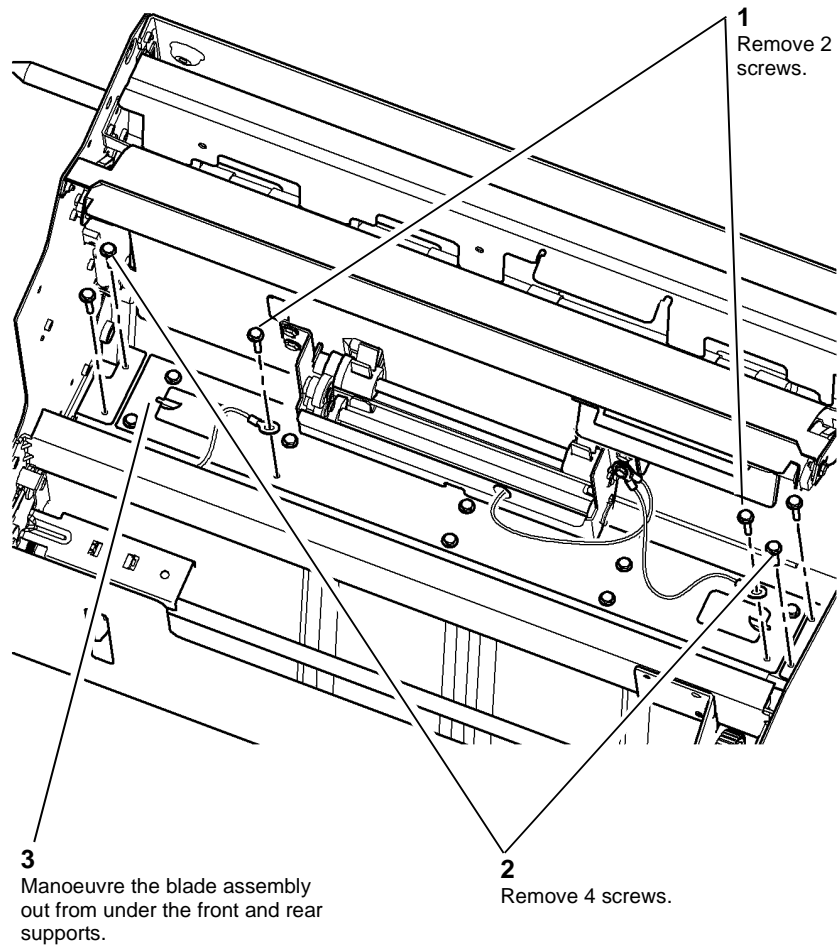

Figure 1 Crease blade assembly removal

U-1-0498-A

6. **Figure 2**, remove the front blade support.

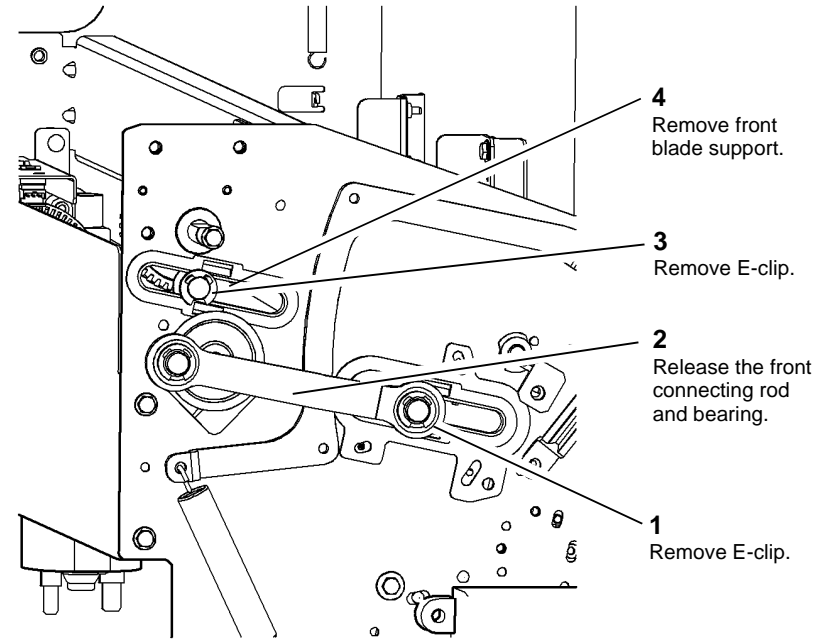

Figure 2 Front support removal

U-1-0499-A

7. Figure 3, remove the rear blade support.

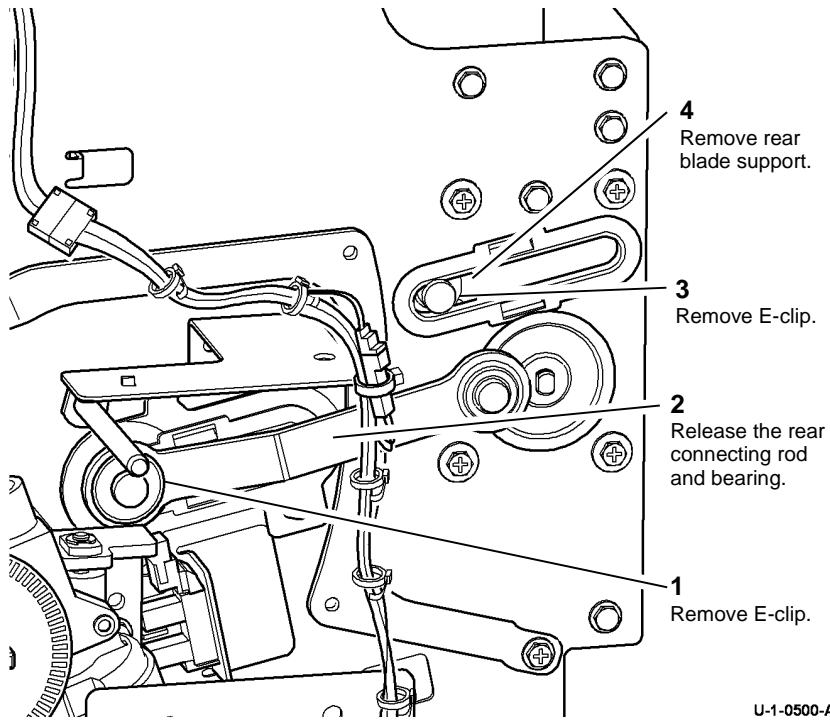

Figure 3 Rear support removal

U-1-0500-A

CAUTION

Do not loosen the three red screws that surround the lower support guides

8. Figure 4, remove the support guides (4 places).

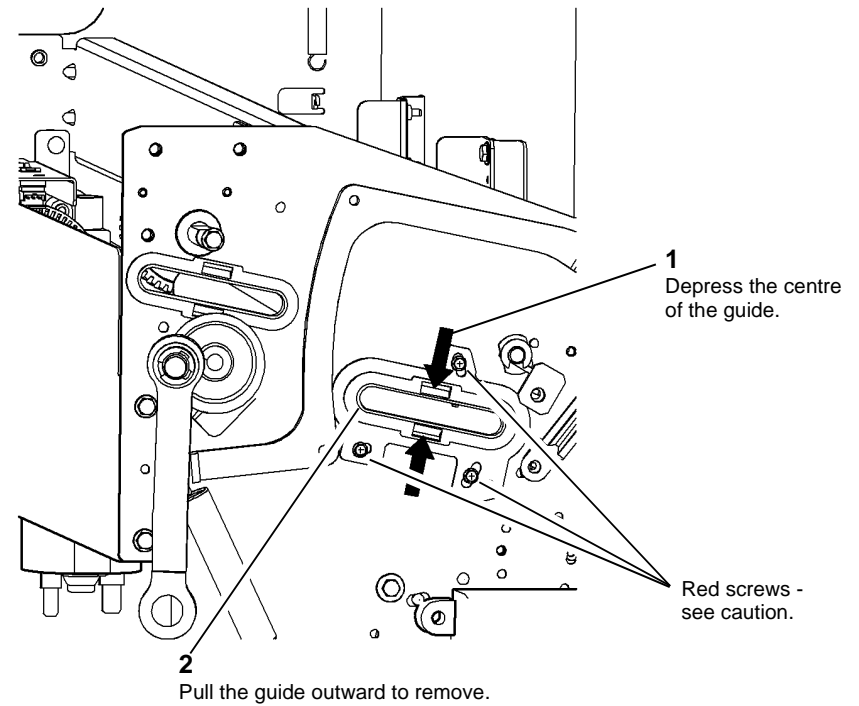

Figure 4 Support guide removal

U-1-0501-A

Replacement

Reverse the removal procedure to replace the crease blade assembly.

REP 12.37-171 Stacker Driving Shaft Bearings

Parts List on [PL 12.115](#).

Removal

WARNING

Take care during this procedure. Sharp edges may be present that can cause injury.

WARNING

Switch off the electricity to the machine. Refer to [GP 14](#). Disconnect the power cord from the customer supply while performing tasks that do not need electricity. Electricity can cause death or injury. Moving parts can cause injury.

1. Remove the front and rear covers [REP 12.1-171](#).
2. Remove the stacker motor and gear assembly [REP 12.12-171](#).
3. Remove the rear bearing, [Figure 1](#).

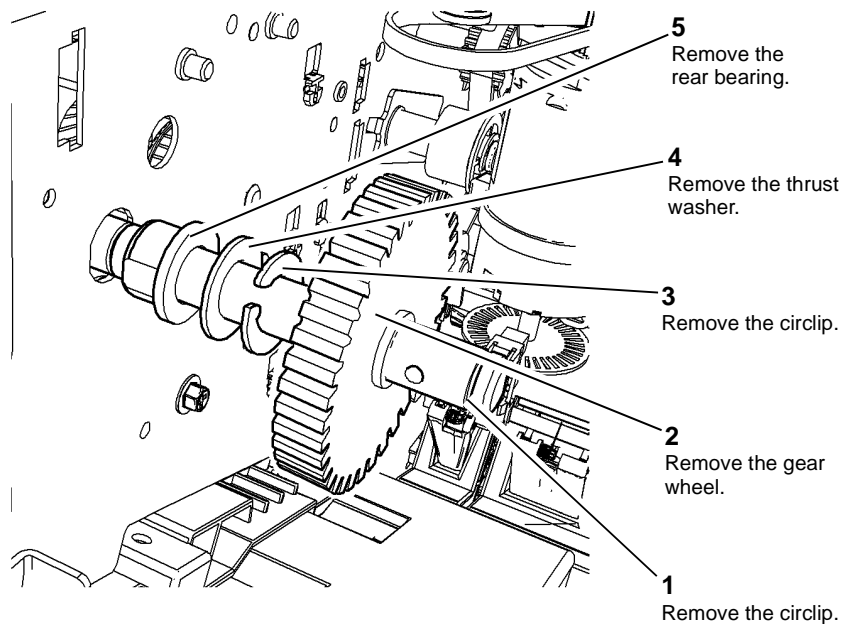

U-1-0502-A

Figure 1 Rear bearing removal

NOTE: The upper pulley pin may fall when the pulley is removed.

4. Remove the front bearings, [Figure 2](#).

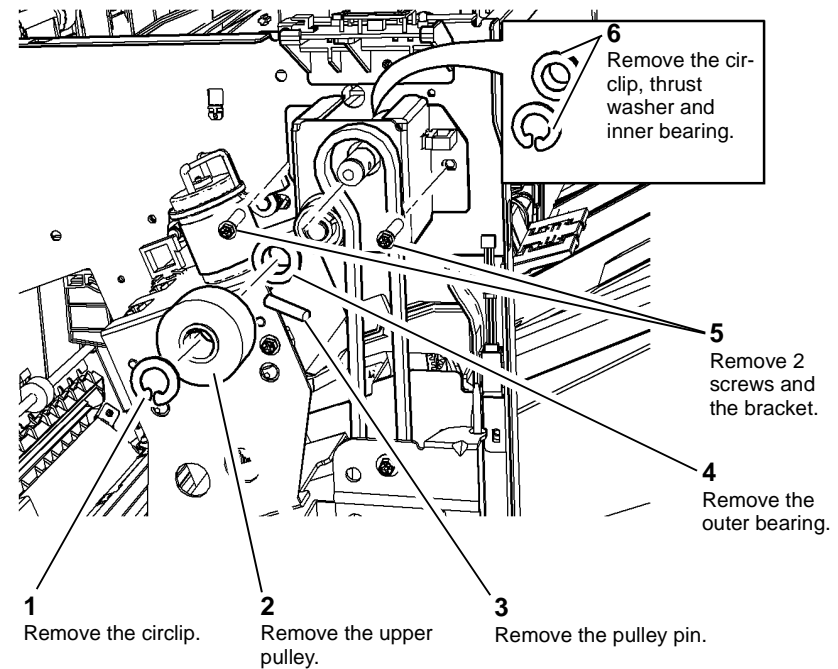

U-1-0503-A

Figure 2 Stacker Shaft Front Bearing

Replacement

Reverse the removal procedures to reinstall the stacker driving shaft front and rear bearings.

NOTE: Make sure that the 'flats' on the bearing align with the cut-outs in the bracket or frame.

REP 12.38-171 HVF Stacker Driving Belts

Parts List on [PL 12.105](#).

Removal

WARNING

Take care during this procedure. Sharp edges may be present that can cause injury.

WARNING

Switch off the electricity to the machine. Refer to [GP 14](#). Disconnect the power cord from the customer supply while performing tasks that do not need electricity. Electricity can cause death or injury. Moving parts can cause injury.

NOTE: The removal and replacement procedure for the front and rear stacker driving belts is the same. Support the Bin 1 lift bar if removing the front and rear belts at the same time

1. Remove the front or rear cover to access the front or rear driving belt [REP 12.1-171](#).
2. Remove the stacker bin 1 tray [REP 12.4-171](#).

3. Remove the stacker driving belt, [Figure 1](#).

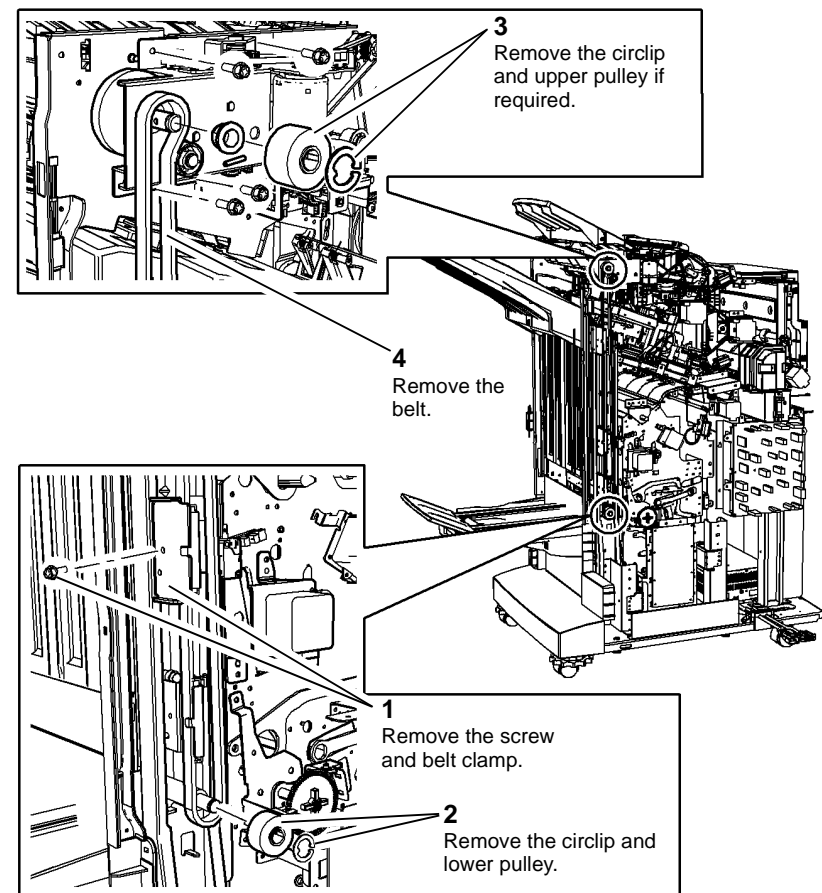

U-1-0504-A

Figure 1 Stacker Driving Belts

Replacement

NOTE: Check that the bin 1 lift bar is level before fitting the belt clamp.

Reverse the removal procedures to reinstall the front and rear stacker driving belts.

REP 12.39-171 HVF BM Diverter Gate

Parts List on [PL 12.125](#).

Removal

WARNING

Take care during this procedure. Sharp edges may be present that can cause injury.

WARNING

Switch off the electricity to the machine. Refer to [GP 14](#). Disconnect the power cord from the customer supply while performing tasks that do not need electricity. Electricity can cause death or injury. Moving parts can cause injury.

1. Remove the HVF front door, [REP 12.1-171](#).
2. Remove the HVF top cover, [REP 12.1-171](#).
3. Remove the HVF front cover, [REP 12.1-171](#).
4. Remove the HVF rear cover, [REP 12.1-171](#).
5. [Figure 1](#). prepare to remove the BM diverter gate.

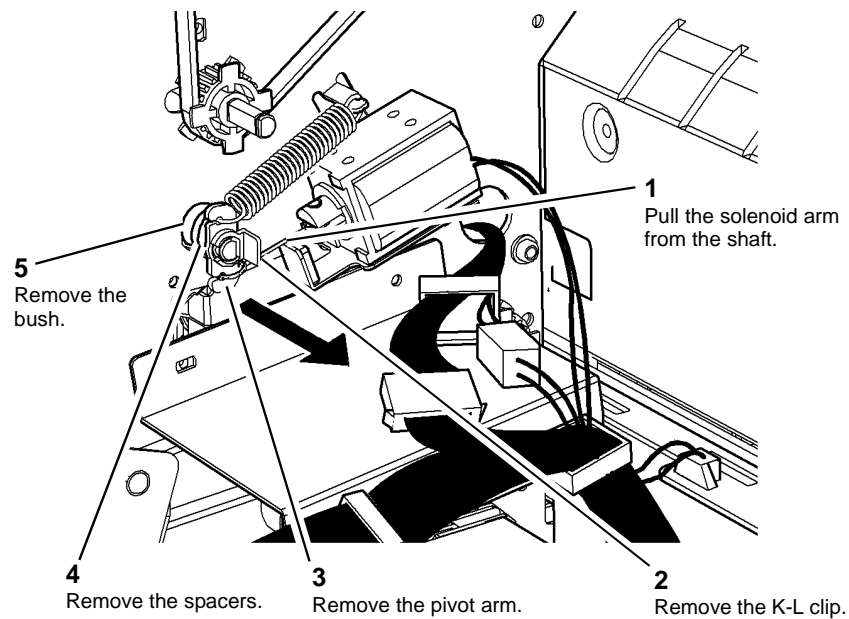

REAR VIEW

U-1-0505-A

Figure 1 Removal preparation

6. [Figure 2](#). Remove the BM diverter gate.

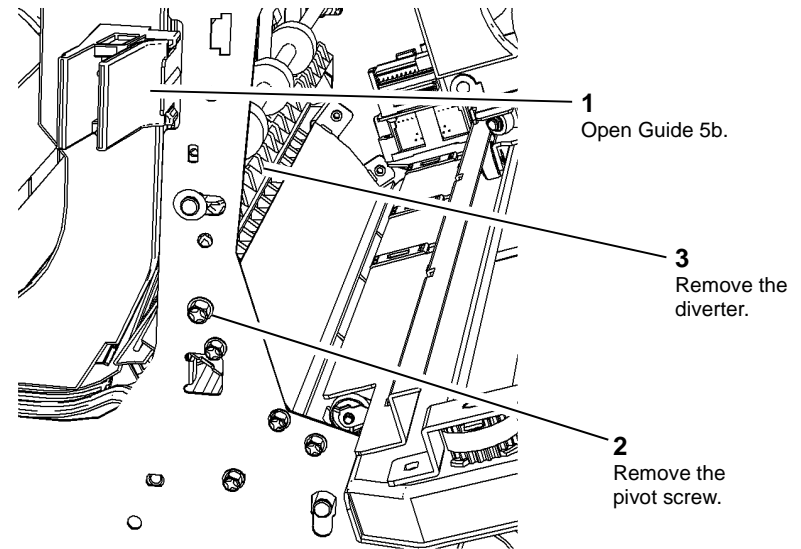

U-1-0506-A

Figure 2 Diverter removal.

Replacement

The replacement procedure is the reverse of the removal procedure.

REP 12.40-171 HVF Input Roll

Parts List on [PL 12.130](#).

Removal

WARNING

Take care during this procedure. Sharp edges may be present that can cause injury.

WARNING

Switch off the electricity to the machine [GP 14](#). Disconnect the power cord from the customer supply while performing tasks that do not need electricity. Electricity can cause death or injury. Moving parts can cause injury.

1. Remove the HVF front door, [REP 12.1-171](#).
2. Remove the HVF top cover, [REP 12.1-171](#).
3. Remove the HVF front cover, [REP 12.1-171](#).
4. Remove the HVF rear cover, [REP 12.1-171](#).
5. [Figure 1](#). Remove the black plastic cover.

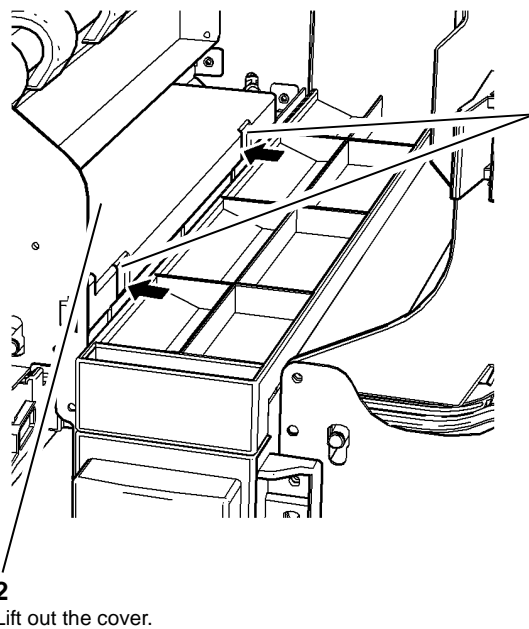

Figure 1 Cover removal.

U-1-0507-A

6. [Figure 2](#). At the front of the HVF, remove the circlip and bush.

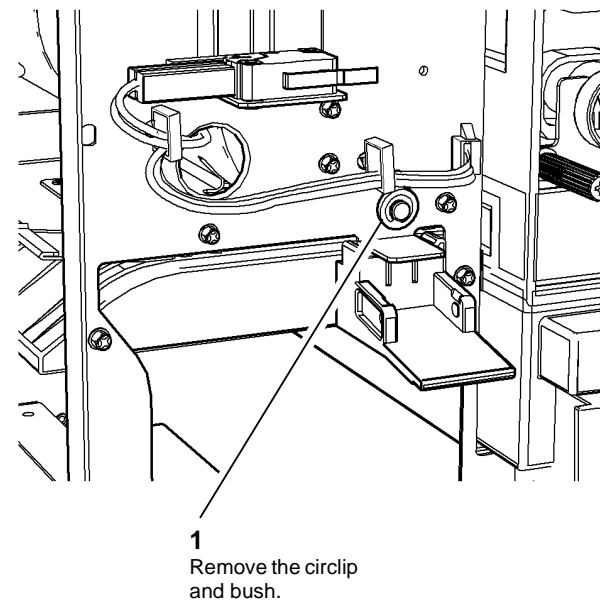

Figure 2 Circlip and bush removal.

U-1-0508-A

7. **Figure 3.** At the rear of the HVF, remove the input roll.

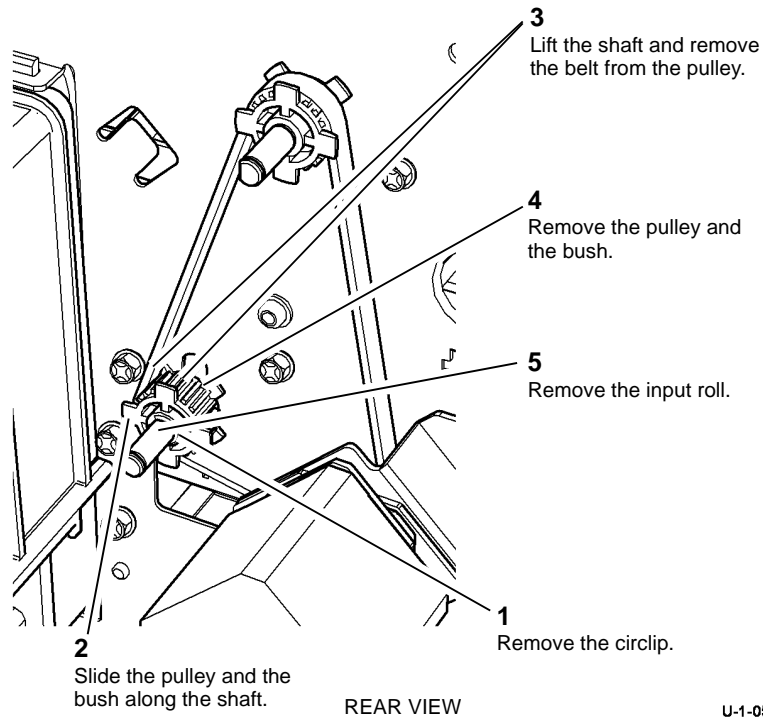

Figure 3 Input roll removal.

Replacement

The replacement procedure is the reverse of the removal procedure.

REP 12.41-171 HVF Inserter Guide Roll

Parts List on **PL 12.130.**

Removal

WARNING

Take care during this procedure. Sharp edges may be present that can cause injury.

WARNING

Switch off the electricity to the machine **GP 14.** Disconnect the power cord from the customer supply while performing tasks that do not need electricity. Electricity can cause death or injury. Moving parts can cause injury.

1. Remove the HVF front door, **REP 12.1-171.**
2. Remove the HVF top cover, **REP 12.1-171.**
3. Remove the HVF front cover, **REP 12.1-171.**
4. Remove the HVF rear cover, **REP 12.1-171.**
5. Open guide 8a.
6. **Figure 1.** At the front of the HVF, remove the circlip and the bush.

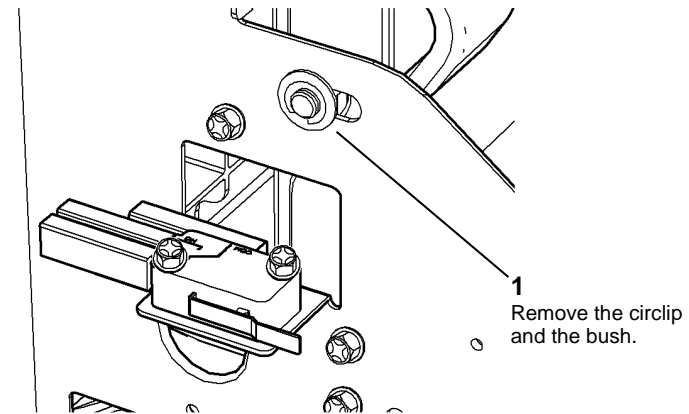
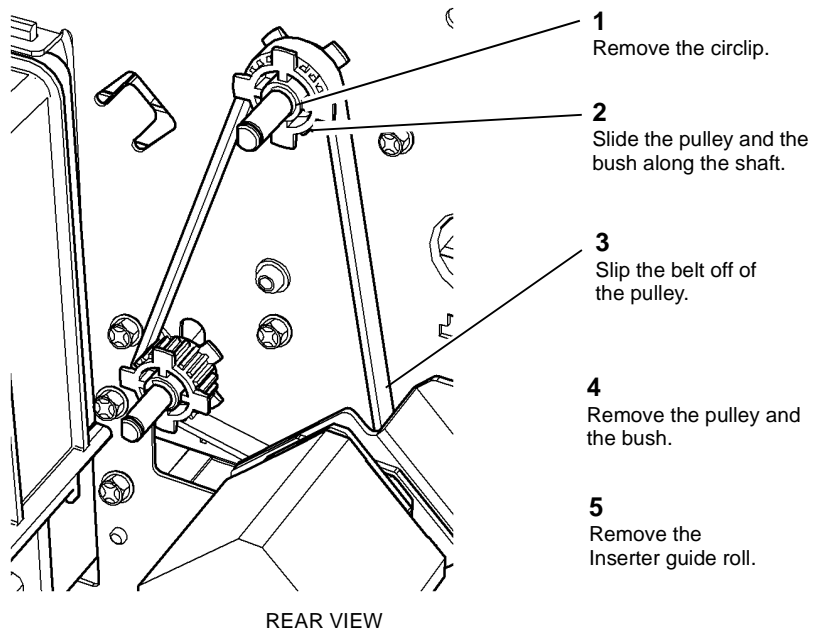

Figure 1 Circlip and bush removal.

7. **Figure 2.** At the rear of the HVF, remove the Inserter guide roll.



U-1-0511-A

Figure 2 Inserter guide roll removal

Replacement

The replacement procedure is the reverse of the removal procedure.

REP 12.42-171 HVF Buffer Pocket Roll

Parts List on **PL 12.130.**

Removal

WARNING

Take care during this procedure. Sharp edges may be present that can cause injury.

WARNING

Switch off the electricity to the machine **GP 14.** Disconnect the power cord from the customer supply while performing tasks that do not need electricity. Electricity can cause death or injury. Moving parts can cause injury.

1. Remove the HVF front door, **REP 12.1-171.**
2. Remove the HVF top cover, **REP 12.1-171.**
3. Remove the HVF front cover, **REP 12.1-171.**
4. Remove the HVF rear cover, **REP 12.1-171.**
5. Remove the punch unit, or the punch unit guide, as appropriate.
6. **Figure 1.** At the front of the HVF, remove the circlip and bush.

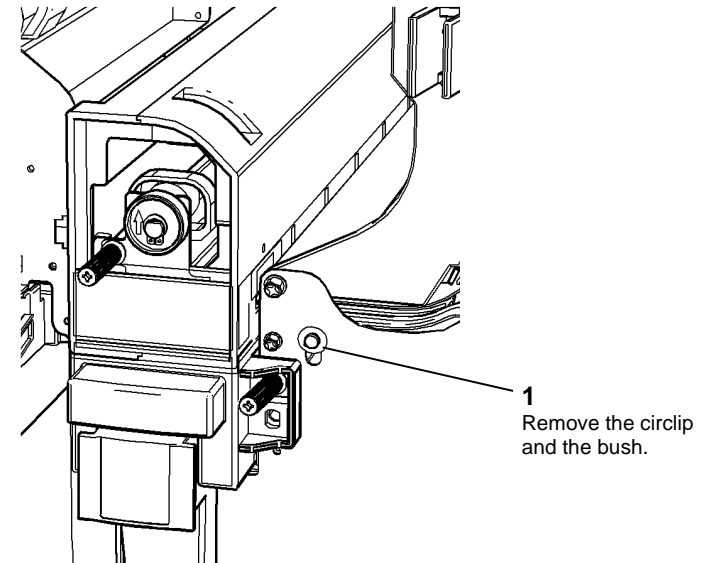

U-1-0512-A

Figure 1 Circlip and bush removal.

- At the rear of the HVF, remove the buffer pocket roll. The bracket can be moved if necessary, to improve access, (two screws), [Figure 2](#).

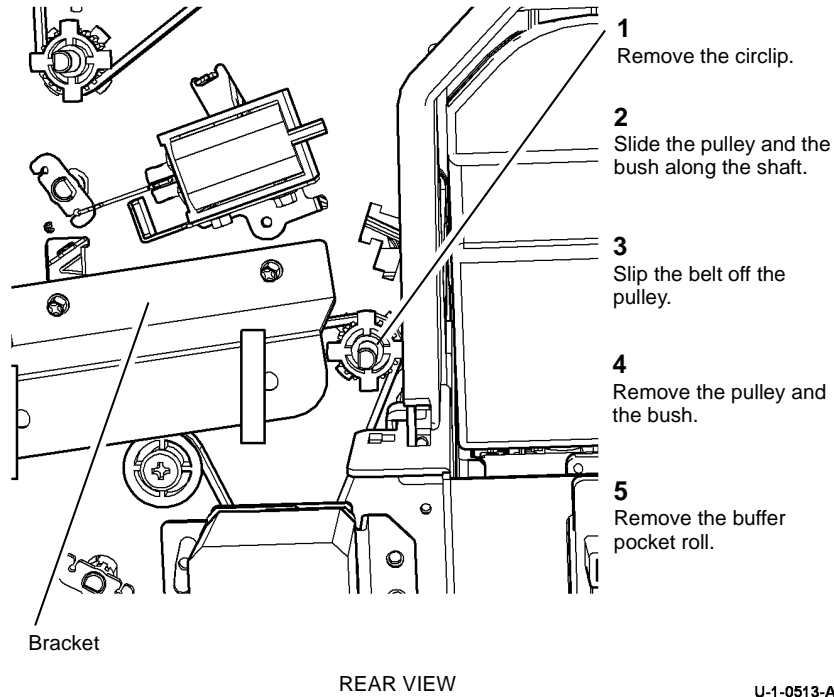

Figure 2 Buffer pocket roll removal.

Replacement

The replacement procedure is the reverse of the removal procedure.

REP 12.43-171 HVF Booklet Entrance Roll

Parts List on [PL 12.130](#).

Removal

WARNING

Take care during this procedure. Sharp edges may be present that can cause injury.

WARNING

Switch off the electricity to the machine [GP 14](#). Disconnect the power cord from the customer supply while performing tasks that do not need electricity. Electricity can cause death or injury. Moving parts can cause injury.

- Remove the HVF front door, [REP 12.1-171](#).
- Remove the HVF top cover, [REP 12.1-171](#).
- Remove the HVF front cover, [REP 12.1-171](#).
- Remove the HVF rear cover, [REP 12.1-171](#).
- [Figure 1](#). Remove the circlip and bush at the outboard end of the roll.

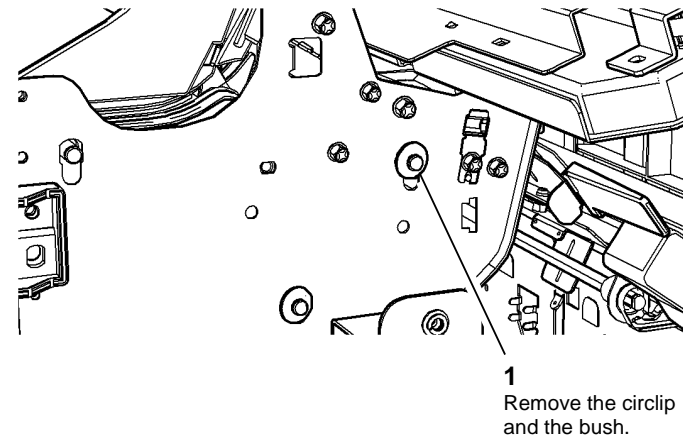

Figure 1 Circlip and bush removal.

6. **Figure 2.** At the rear of the HVF, remove the booklet entrance roll.

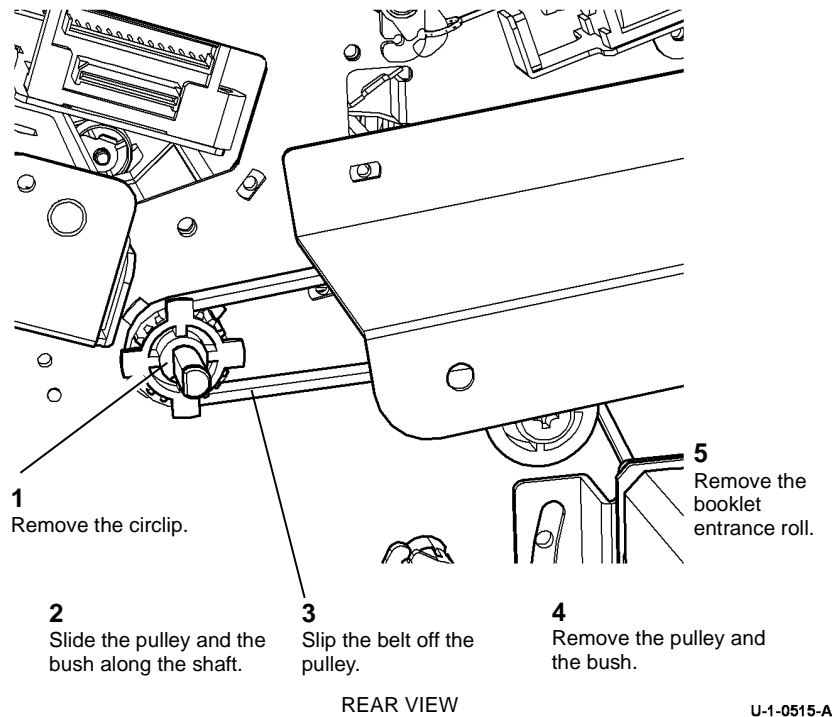

Figure 2 Booklet entrance roll removal.

Replacement

The replacement procedure is the reverse of the removal procedure.

REP 12.44-171 HVF Buffer Lower Roll

Parts List on **PL 12.130.**

Removal

WARNING

Take care during this procedure. Sharp edges may be present that can cause injury.

WARNING

Switch off the electricity to the machine **GP 14.** Disconnect the power cord from the customer supply while performing tasks that do not need electricity. Electricity can cause death or injury. Moving parts can cause injury.

1. Remove the HVF front door, **REP 12.1-171.**
2. Remove the HVF top cover, **REP 12.1-171.**
3. Remove the HVF front cover, **REP 12.1-171.**
4. Remove the HVF rear cover, **REP 12.1-171.**
5. Open jam clearance guide 5b.
6. **Figure 1.** Remove the circlip and the bush from the outboard end of the roll.

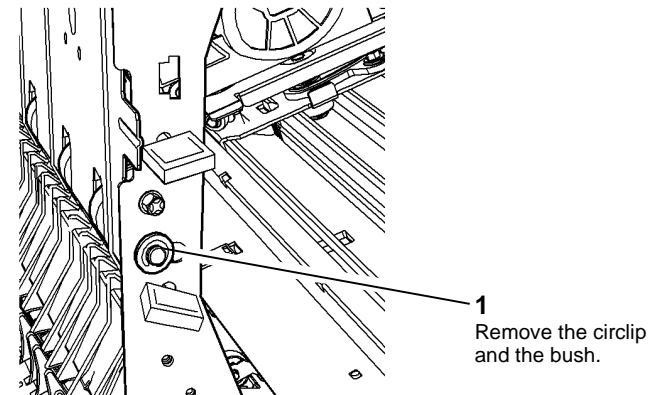

Figure 1 Circlip and bush removal.

7. **Figure 2.** At the rear of the HVF, remove the buffer lower roll.

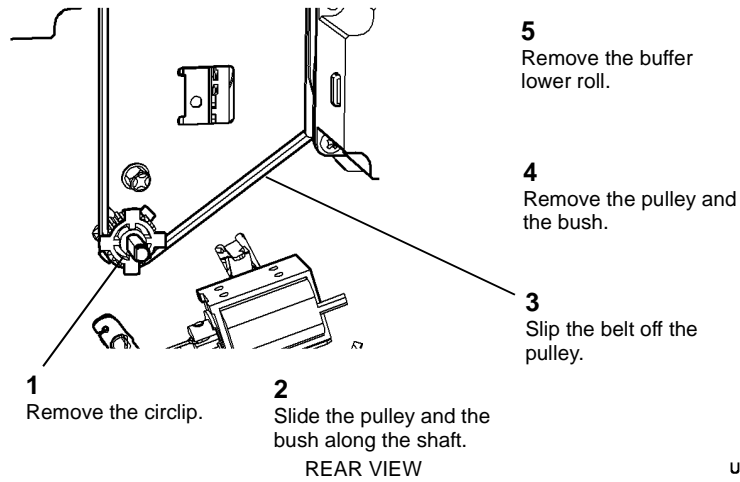

Figure 2 Buffer lower roll removal.

Replacement

The replacement procedure is the reverse of the removal procedure.

REP 12.45-171 HVF Buffer Upper Roll

Parts List on **PL 12.130.**

Removal

WARNING

Take care during this procedure. Sharp edges may be present that can cause injury.

WARNING

Switch off the electricity to the machine **GP 14.** Disconnect the power cord from the customer supply while performing tasks that do not need electricity. Electricity can cause death or injury. Moving parts can cause injury.

1. Remove the HVF front door, **REP 12.1-171.**
2. Remove the HVF top cover, **REP 12.1-171.**
3. Remove the HVF front cover, **REP 12.1-171.**
4. Remove the HVF rear cover, **REP 12.1-171.**
5. **Figure 1.** Remove the circlip and the bush.

U-1-0517-A

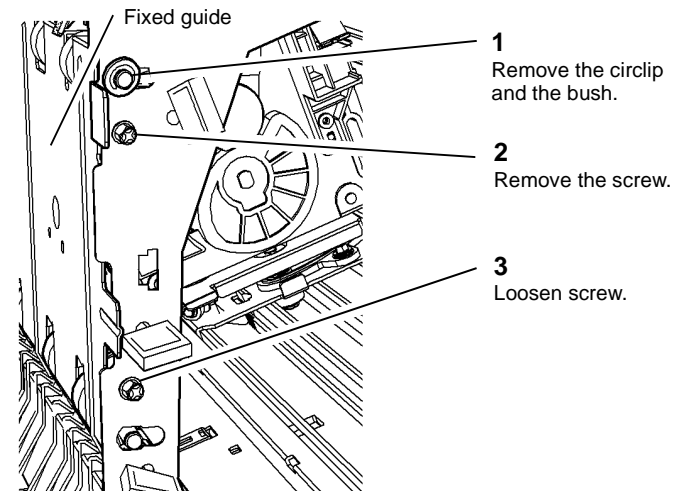

U-1-0518-A

Figure 1 Circlip and bush removal

6. **Figure 2.** Remove the buffer upper roll.

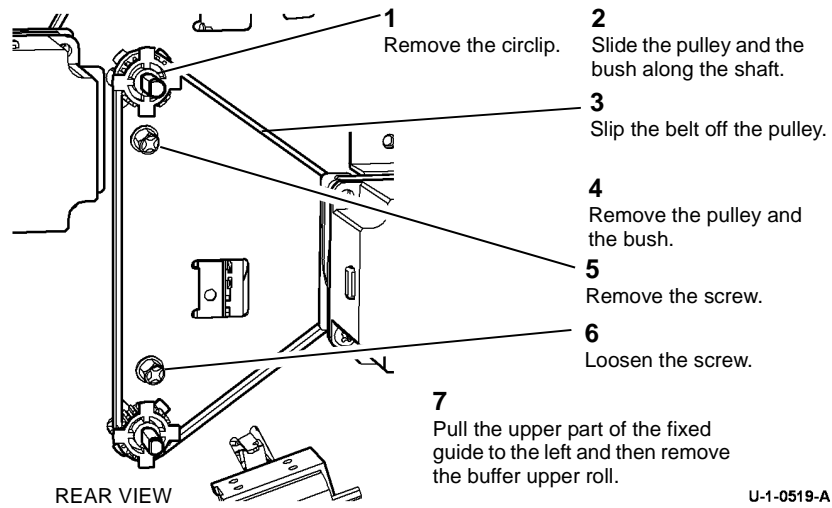

Figure 2 Buffer upper roll removal.

Replacement

The replacement procedure is the reverse of the removal procedure.

REP 12.46-171 HVF Stacker Exit Feed Roll

Parts List on **PL 12.130.**

Removal

WARNING

Take care during this procedure. Sharp edges may be present that can cause injury.

WARNING

Switch off the electricity to the machine **GP 14.** Disconnect the power cord from the customer supply while performing tasks that do not need electricity. Electricity can cause death or injury. Moving parts can cause injury.

1. Remove the HVF front door, **REP 12.1-171.**
2. Remove the HVF top cover, **REP 12.1-171.**
3. Remove the HVF front cover, **REP 12.1-171.**
4. Remove the HVF rear cover, **REP 12.1-171.**
5. **Figure 1.** Remove the circlip and bush

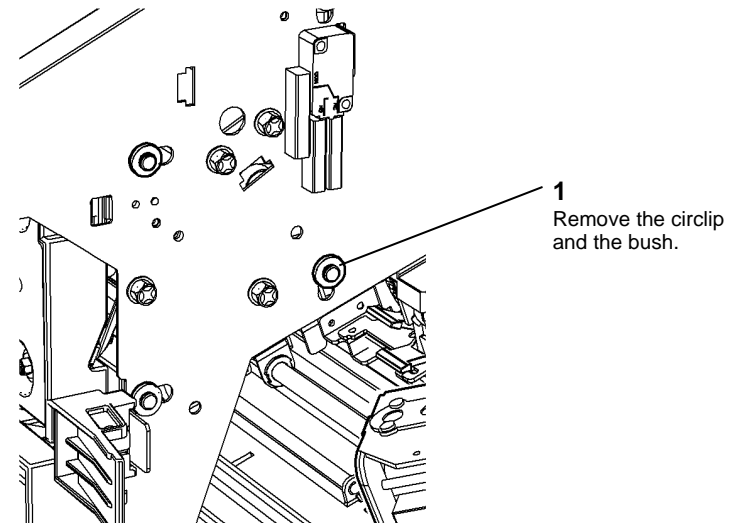
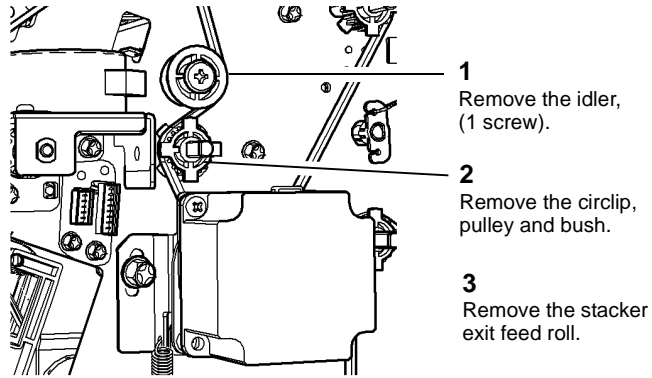

Figure 1 Circlip and bush removal.

6. [Figure 2](#). Remove the stacker exit feed roll.



REAR VIEW

Figure 2 Stacker exit feed roll removal.

Replacement

The replacement procedure is the reverse of the removal procedure.

REP 12.47-171 HVF Top Exit Feed Roll

Parts List on [PL 12.130](#).

Removal

WARNING

Take care during this procedure. Sharp edges may be present that can cause injury.

WARNING

Switch off the electricity to the machine [GP 14](#). Disconnect the power cord from the customer supply while performing tasks that do not need electricity. Electricity can cause death or injury. Moving parts can cause injury.

1. If fitted, undock the Inserter, [REP 12.82-171](#).
2. Remove the HVF front door, [REP 12.1-171](#).
3. Remove the HVF top cover, [REP 12.1-171](#).
4. Remove the HVF front cover, [REP 12.1-171](#).
5. Remove the HVF rear cover, [REP 12.1-171](#).
6. [Figure 1](#). Raise the top tray and lower the plate beneath it.

U-1-0521-A

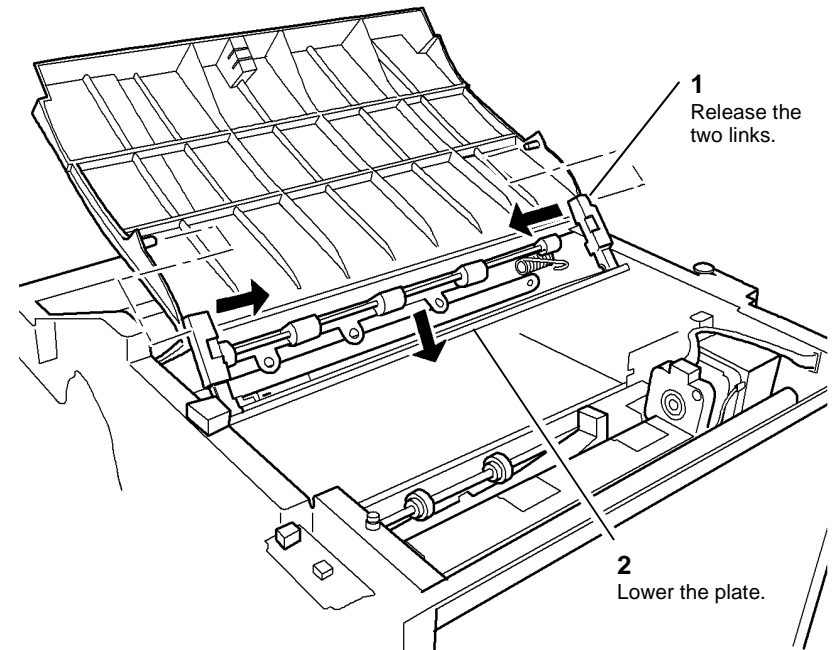

U-1-0522-A

Figure 1 Lowering the plate.

7. **Figure 2.** Remove the circlip and bush. Remove the front magnet bracket screws.

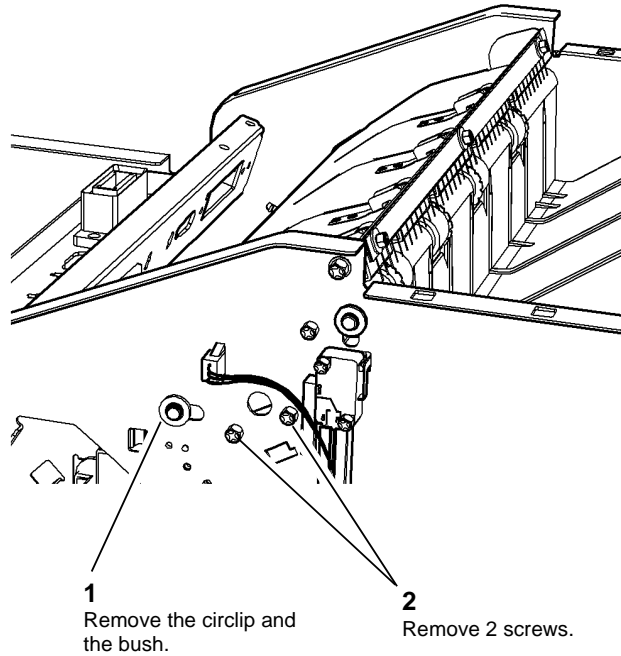
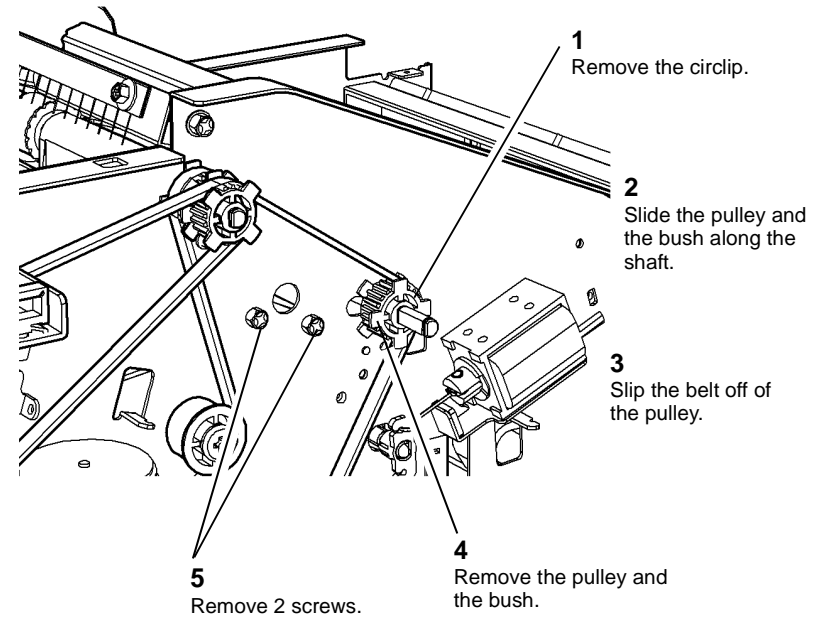

Figure 2 Feed Roll Front Fasteners.

U-1-0523-A

8. **Figure 3.** At the rear of the HVF, Remove the circlip, bush, pulley and the rear screws from the magnet bracket.



REAR VIEW

Figure 3 Rear component removal.

U-1-0524-A

9. [Figure 4](#). Remove the top exit feed roll.

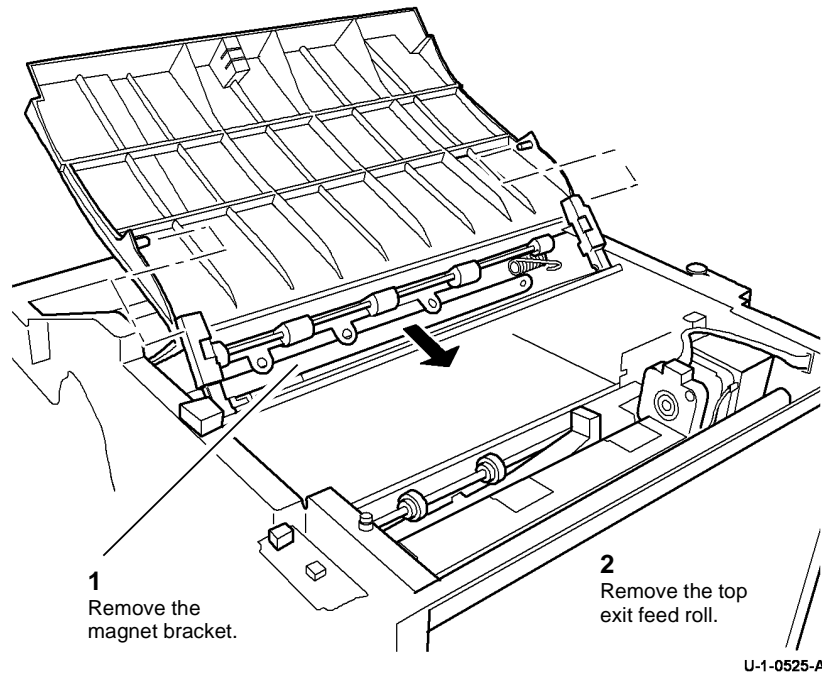

Figure 4 Top exit feed roll removal.

Replacement

The replacement procedure is the reverse of the removal procedure.

REP 12.48-171 Compiler Paddle Motor Assembly

Parts List on [PL 12.120](#)

Removal

WARNING

Take care during this procedure. Sharp edges may be present that can cause injury.

WARNING

Switch off the electricity to the machine. Refer to [GP 14](#). Disconnect the power cord from the customer supply while performing tasks that do not need electricity. Electricity can cause death or injury. Moving parts can cause injury.

1. Remove the rear cover [REP 12.1-171](#).
2. Remove the paddle motor assembly, [Figure 1](#).

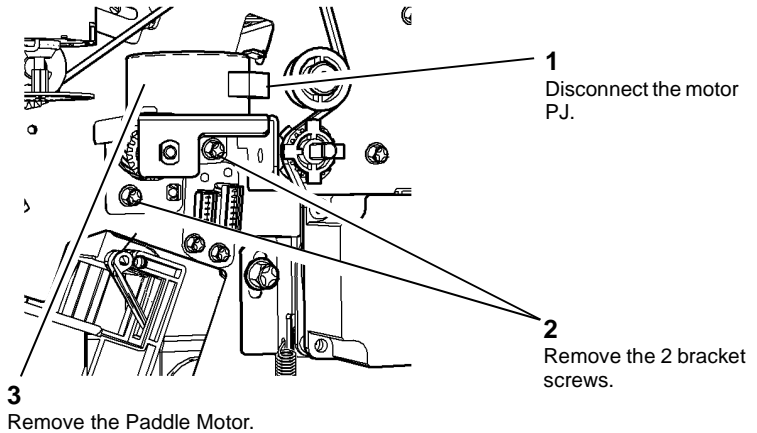

Figure 1 Paddle Motor Assembly

Replacement

Reverse the removal procedures to replace the compiler paddle motor assembly.

REP 12.49-171 Compiler Paddle Unit

Parts List on [PL 12.115](#).

Removal

WARNING

Take care during this procedure. Sharp edges may be present that can cause injury.

WARNING

Switch off the electricity to the machine. Refer to [GP 14](#). Disconnect the power cord from the customer supply while performing tasks that do not need electricity. Electricity can cause death or injury. Moving parts can cause injury.

1. Remove the front, rear and top covers [REP 12.1-171](#).
2. Remove the HVF stapler assembly, [REP 12.2-171](#).
3. Remove the compiler paddle motor assembly, [REP 12.48-171](#).

NOTE: The motor coupler should detach with the motor assembly. If the coupler fails to detach, remove the coupler from the paddle module assembly.

4. Remove the PJs and screws securing the ribbon cable connectors, [Figure 1](#). Carefully push the ribbon cable bulkhead connectors through the frame cut-outs.

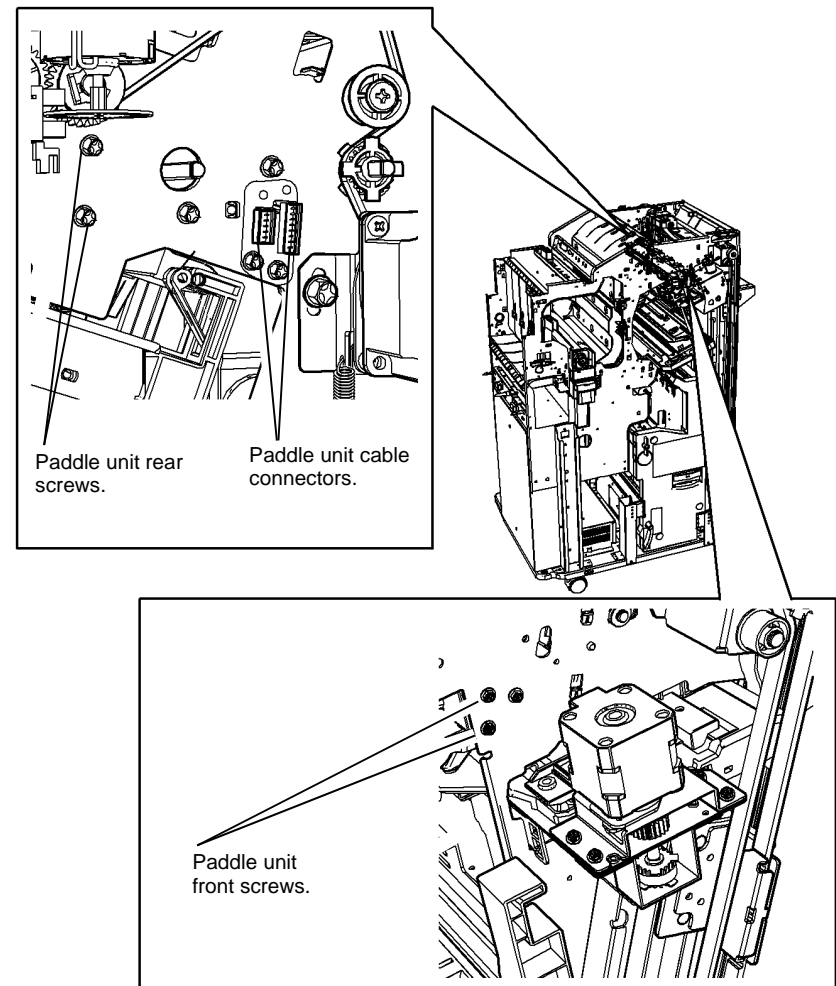

U-1-0527-A

Figure 1 Paddle Module Attachment

5. Remove the screws (front and rear) and the front grounding strap then manoeuvre the module downwards, Remove the module through the stapler aperture, [Figure 1](#).

Replacement

CAUTION

Do not damage or strain the paddle module ribbon cables or connectors

Reverse the removal procedures to replace the compiler paddle unit.

Use the correct screws to secure the compiler paddle unit; do not overtighten.

REP 12.50-171 BM Exit Sensor

Parts List on [PL 12.185](#).

Removal

WARNING

Take care during this procedure. Sharp edges may be present that can cause injury.

WARNING

Switch off the electricity to the machine [GP 14](#). Disconnect the power cord from the customer supply while performing tasks that do not need electricity. Electricity can cause death or injury. Moving parts can cause injury.

1. Remove the BM right hand cover, [REP 12.56-171](#).
2. Remove the exit plate, [Figure 1](#).

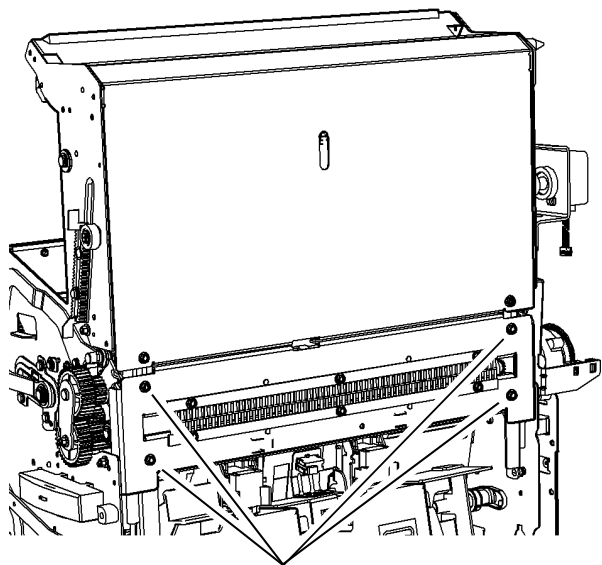

- 1 Remove 4 screws to release the exit plate.

Figure 1 Remove the exit plate

U-1-0962-A

3. [Figure 2](#), remove the BM exit sensor.

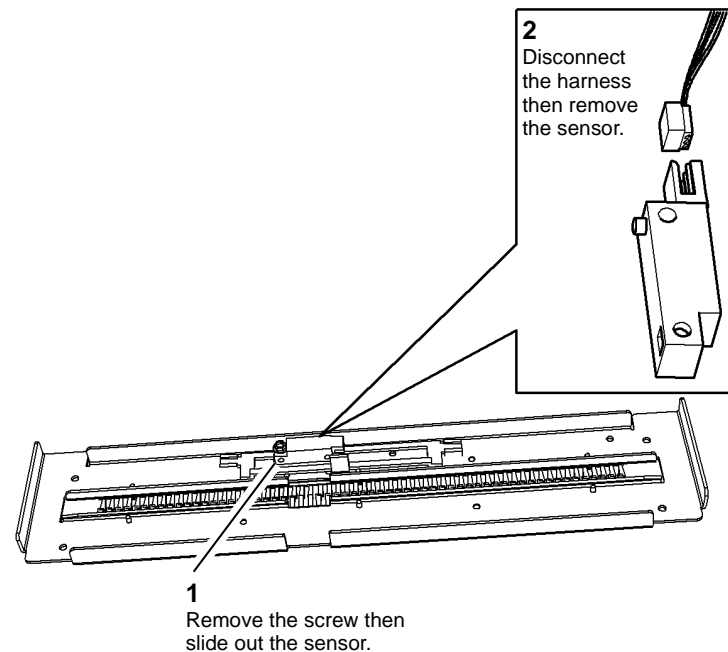

- 1 Remove the screw then slide out the sensor.

- 2 Disconnect the harness then remove the sensor.

Figure 2 Sensor removal

U-1-0528-A

Replacement

Reverse the removal procedure to replace the BM exit sensor.

REP 12.51-171 Compiler Paper Pusher Motor Assembly

Parts List on [PL 12.115](#).

Removal

WARNING

Take care during this procedure. Sharp edges may be present that can cause injury.

WARNING

Switch off the electricity to the machine. Refer to [GP 14](#). Disconnect the power cord from the customer supply while performing tasks that do not need electricity. Electricity can cause death or injury. Moving parts can cause injury.

1. Remove the top and rear covers [REP 12.1-171](#).
2. Remove the paper pusher motor assembly, [Figure 1](#).

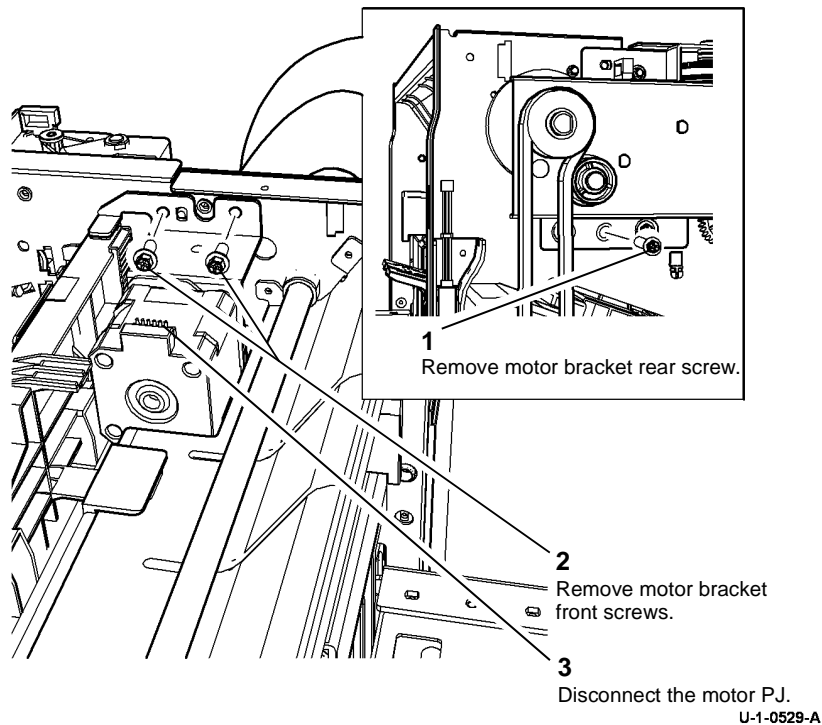

Figure 1 Paper Pusher Motor Assembly

Replacement

Reverse the removal procedures to reinstall the compiler paper pusher motor assembly.

REP 12.52-171 BM Crease Rolls

Parts List on [PL 12.180](#).

Removal

WARNING

Take care during this procedure. Sharp edges may be present that can cause injury.

WARNING

Switch off the electricity to the machine [GP 14](#). Disconnect the power cord from the customer supply while performing tasks that do not need electricity. Electricity can cause death or injury. Moving parts can cause injury.

1. Open the HVF BM front door and fully pull out the BM module.
2. Release the crease roll nip pressure by fully rotating the crease roll handle (6c) counter-clockwise.
3. Remove the crease blade knob (6d), [PL 12.150 Item 4](#).
4. Remove the crease roll handle (6c), [PL 12.150 Item 5](#).
5. Remove the BM front cover, [PL 12.150 Item 3](#).
6. Remove the BM right hand top cover, [REP 12.56-171](#).
7. Remove the BM crease roll motor, [REP 12.19-171](#), but do not disconnect the motor harness or remove the motor from the mounting plate.
8. Remove the exit plate

9. **Figure 1**, Release the crease roll assembly at the rear.

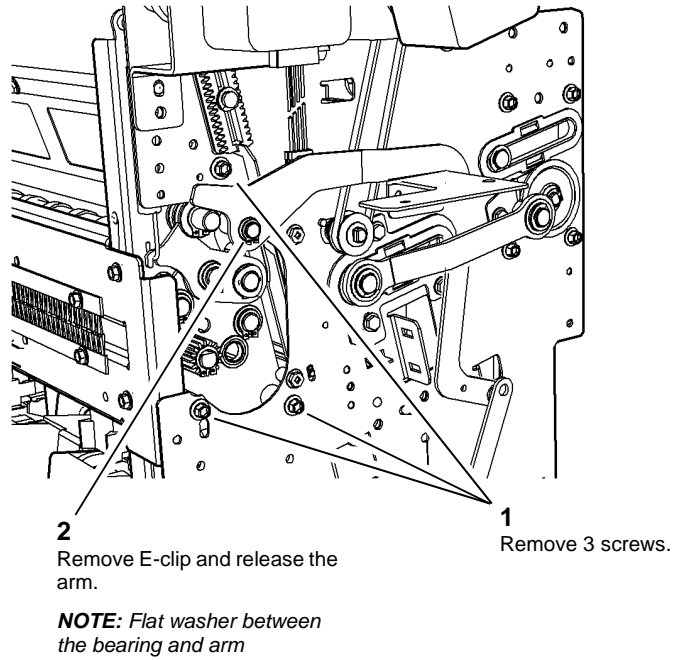

Figure 1 Release the assembly at the rear

U-1-0963-A

10. **Figure 2**, Release the crease roll assembly at the front.

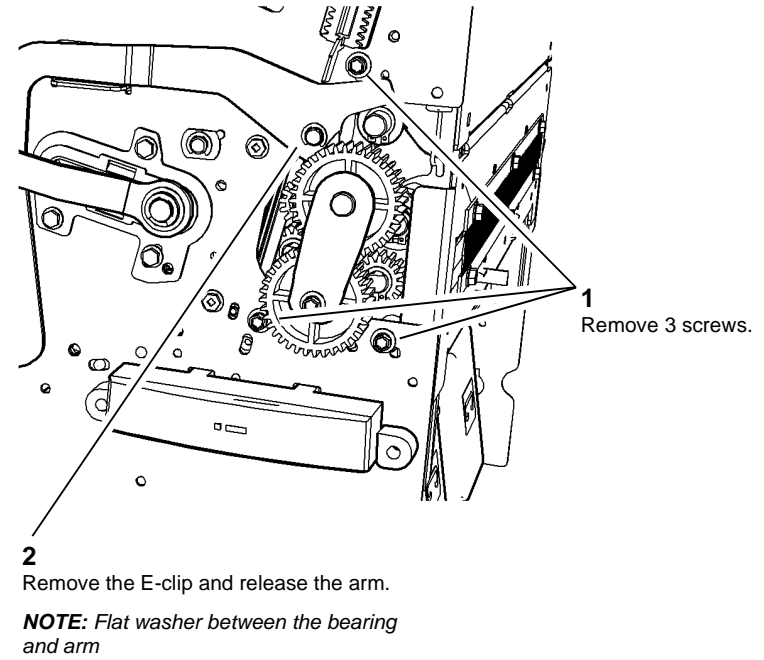

Figure 2 Release the assembly at the front

U-1-0964-A

11. **Figure 3**, Flex the front plate to remove the crease roll assembly.

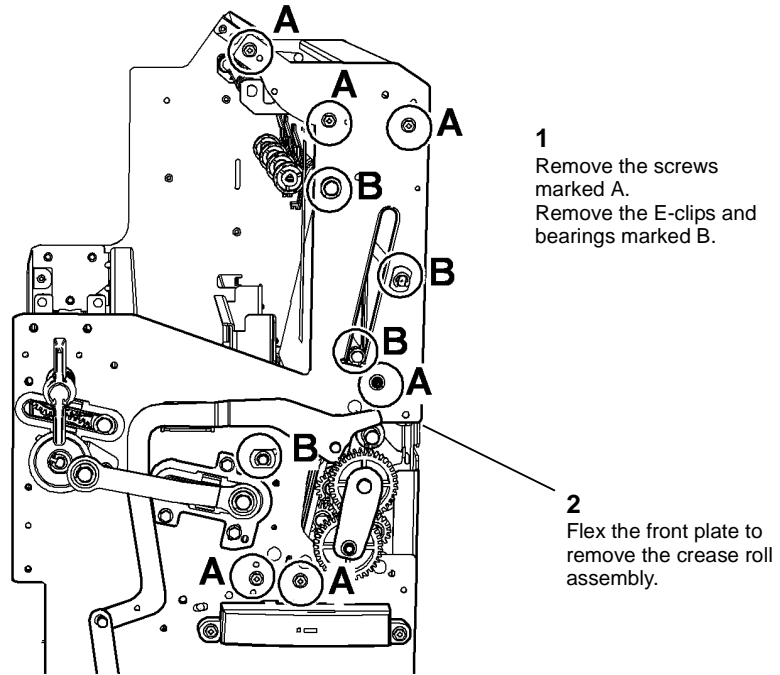

Figure 3 Release the front plate

U-1-0965-A

12. **Figure 4**, remove the crease rolls.

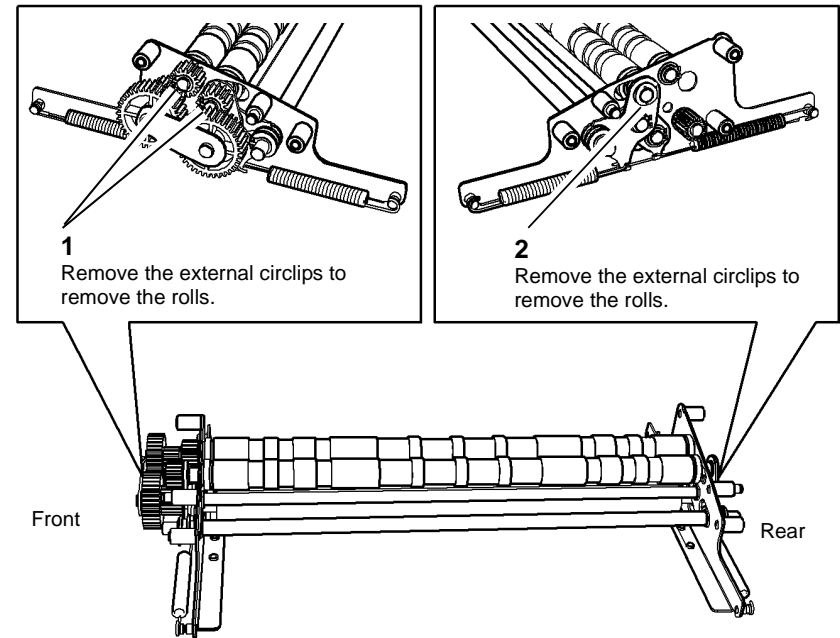

Figure 4 Remove the crease rolls

U-1-0961-A

Replacement

Reverse the removal procedures to reinstall the crease roll assembly.

REP 12.53-171 Compiler Paper Pusher

Parts List on [PL 12.115](#).

Removal

WARNING

Take care during this procedure. Sharp edges may be present that can cause injury.

WARNING

Switch off the electricity to the machine. Refer to [GP 14](#). Disconnect the power cord from the customer supply while performing tasks that do not need electricity. Electricity can cause death or injury. Moving parts can cause injury.

1. Remove the front, rear and top covers [REP 12.1-171](#).
2. Remove the stacker motor gearbox, [REP 12.12-171](#).
3. Remove the stacker shaft front bearing bracket and the exit guide plate front and rear screws, [Figure 1](#).

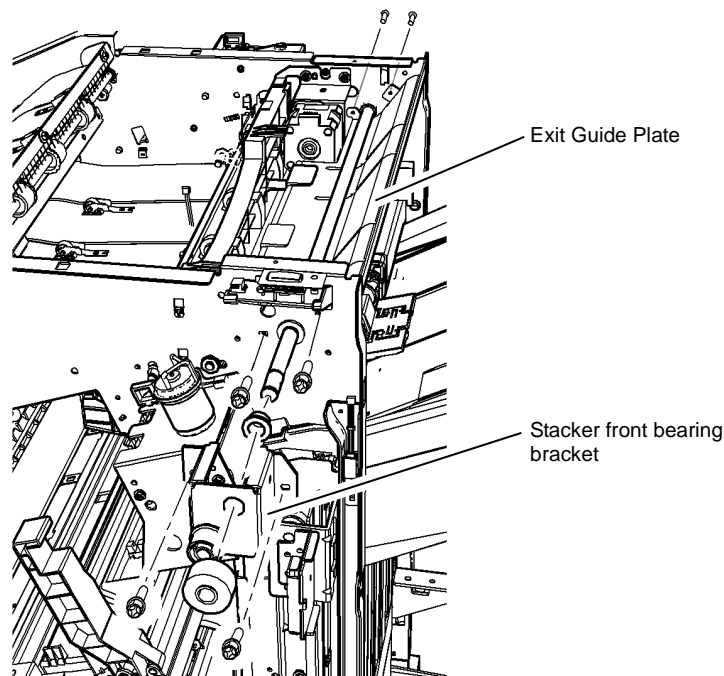

Figure 1 Stacker Shaft Front Bearing Bracket

4. Remove the pusher driving motor assembly, [REP 12.51-171](#).
5. Remove the pusher sensor assembly, [REP 12.54-171](#).

6. Remove the front and rear screws and push the left edge of the compiler exit guide plate downward away from the pinion shaft, [Figure 2](#).

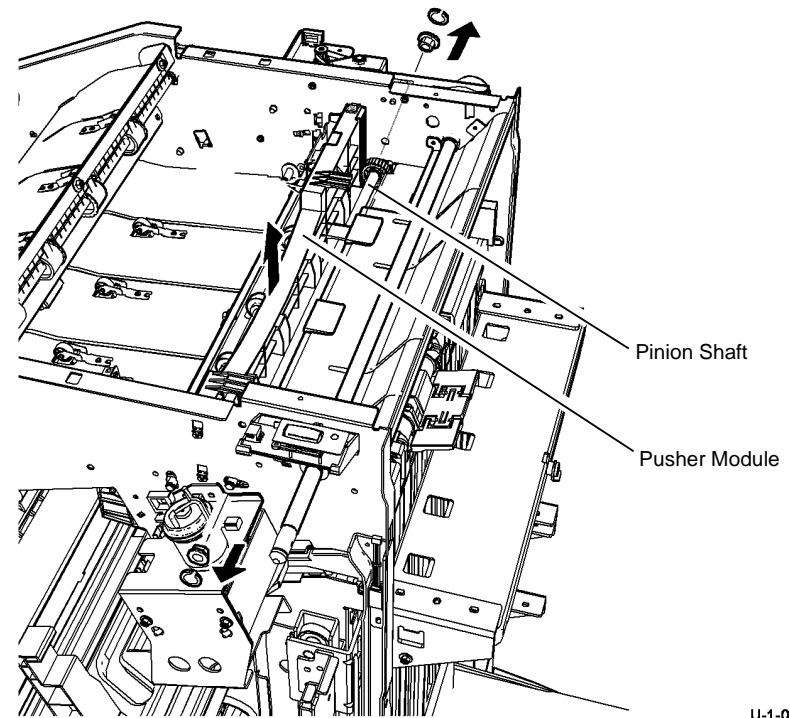

Figure 2 Pusher Guide and Pinion Shaft

7. Remove the pinion shaft front and rear circlips, the shaft bearings and the front bearing thrust washers then remove the pinion shaft, [Figure 2](#).
8. Lift the pusher module out of the guides. The mylar strips and dampers are attached to the pusher module, [Figure 2](#).

Replacement

Reverse the removal procedures to reinstall the compiler paper pusher.

REP 12.54-171 Pusher Upper and Lower Sensors

Parts List on [PL 12.115](#).

Removal

WARNING

Take care during this procedure. Sharp edges may be present that can cause injury.

WARNING

Switch off the electricity to the machine. Refer to [GP 14](#). Disconnect the power cord from the customer supply while performing tasks that do not need electricity. Electricity can cause death or injury. Moving parts can cause injury.

1. Remove the top cover [REP 12.1-171](#).
2. Remove the upper and lower sensor assembly, [Figure 1](#).

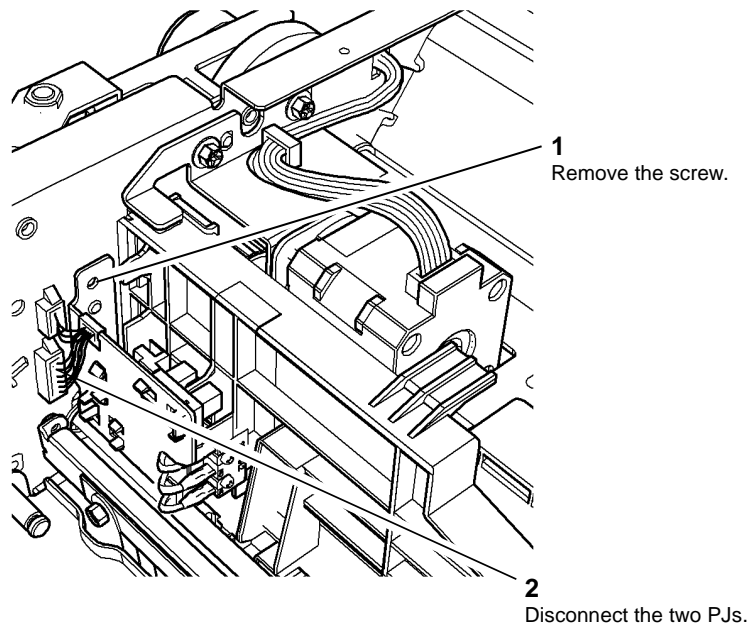

U-1-0540-A

Figure 1 Pusher Sensor Assembly

Replacement

Reverse the removal procedures to replace the Pusher sensor assembly.

REP 12.55-171 HVF PSU Assembly

Parts List on [PL 12.140](#).

Removal

WARNING

Take care during this procedure. Sharp edges may be present that can cause injury.

WARNING

Switch off the electricity to the machine. Refer to [GP 14](#). Disconnect the power cord from the customer supply while performing tasks that do not need electricity. Electricity can cause death or injury. Moving parts can cause injury.

1. Remove the front and rear covers [REP 12.1-171](#).
2. Remove the PSU module, [Figure 1](#).

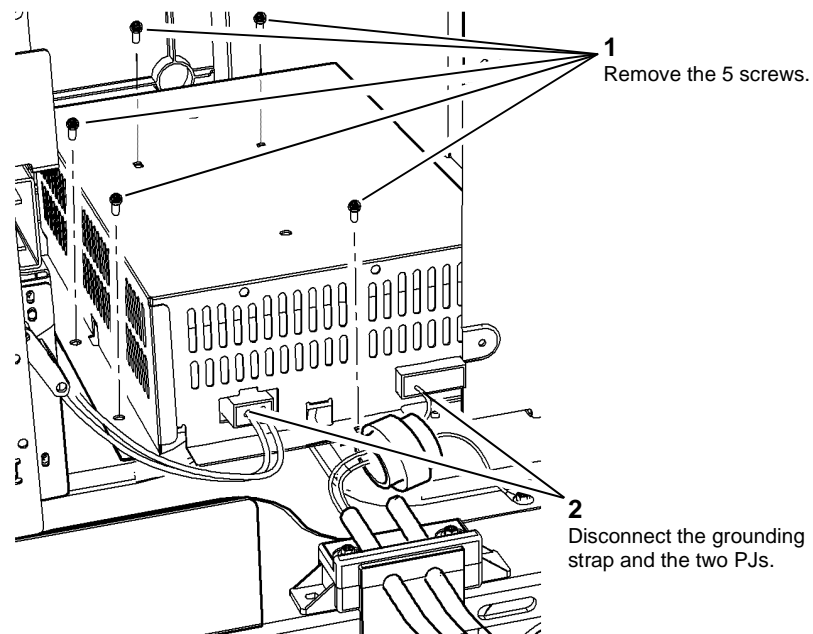

U-1-0541-A

Figure 1 HVF PSU

Replacement

Reverse the removal procedures to replace the HVF PSU module.

REP 12.56-171 BM Right Hand Cover

Parts List on [PL 12.185](#).

Removal

WARNING

Take care during this procedure. Sharp edges may be present that can cause injury.

WARNING

Switch off the electricity to the machine [GP 14](#). Disconnect the power cord from the customer supply while performing tasks that do not need electricity. Electricity can cause death or injury. Moving parts can cause injury.

1. Remove the top cover, then the rear cover, [REP 12.1-171](#).
2. Open the BM front door and fully pull out the BM module.
3. Remove the crease blade knob (6d), [PL 12.150 Item 4](#).
4. Remove the crease roll handle (6c), [PL 12.150 Item 5](#).
5. Remove the BM front cover, [PL 12.150 Item 3](#).
6. [Figure 1](#), remove the BM top cover.

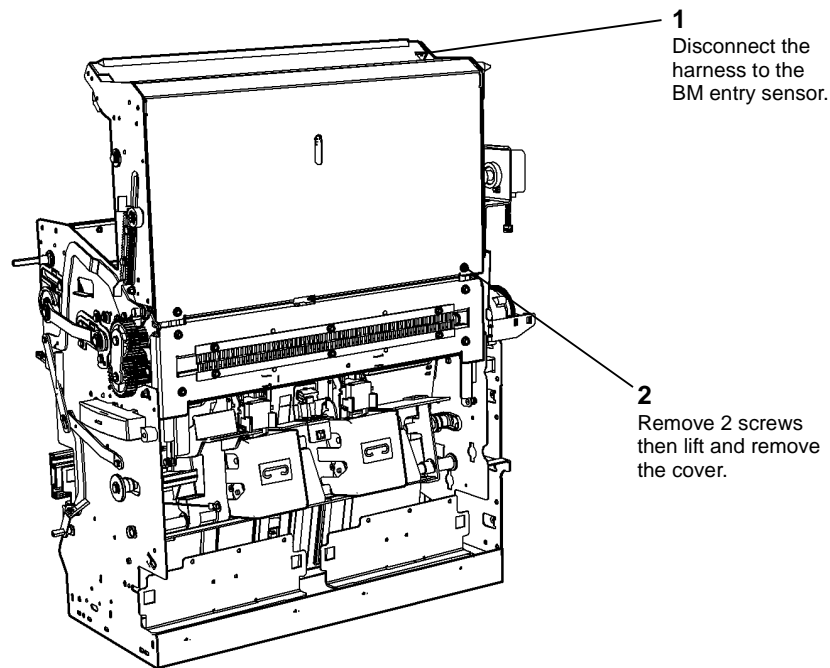

Figure 1 Top cover removal

U-1-0543-A

Replacement

Reverse the removal procedure to replace the BM right hand cover.

REP 12.57-171 HVF Main PWB

Parts List on [PL 12.140](#).

Removal

WARNING

Take care during this procedure. Sharp edges may be present that can cause injury.



Figure 1 ESD Symbol

CAUTION

Ensure that ESD procedures are observed during the removal and installation of the HVF main PWB.

WARNING

Switch off the electricity to the machine. Refer to [GP 14](#). Disconnect the power cord from the customer supply while performing tasks that do not need electricity. Electricity can cause death or injury. Moving parts can cause injury.

1. Remove the rear cover [REP 12.1-171](#).

2. Disconnect the PJs, remove 9 screws and remove the PWB assembly, [Figure 2](#).

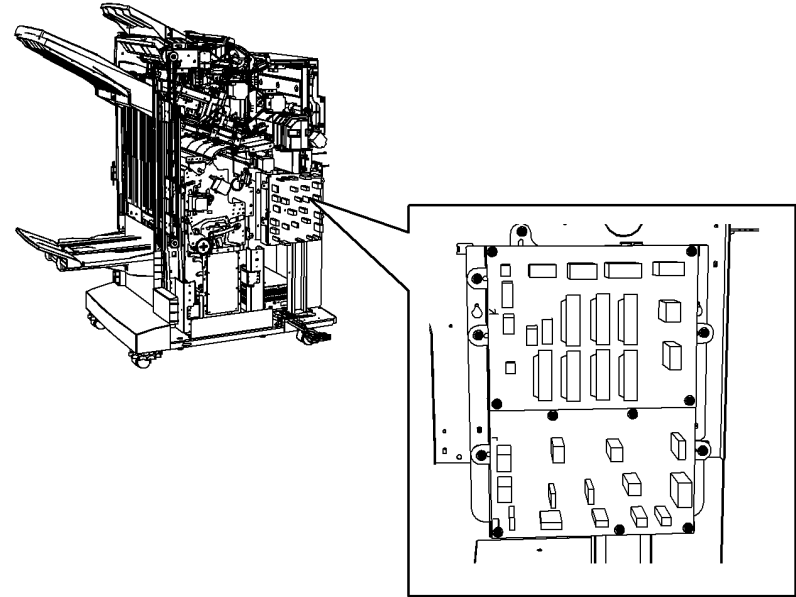

Figure 2 HVF Main PWB

U-1-0544-A

Replacement

Reverse the removal procedures to replace the HVF Main PWB.

Parts List on [PL 12.180](#).

Purpose

This procedure is used to repair the following components:

- Crease roll gate rack gear, [PL 12.180 Item 8](#).
- Crease roll gate rack drive gear, [PL 12.180 Item 13](#).
- Crease roll gate rack, [PL 12.180 Item 14](#).
- Crease roll gate front guide, [PL 12.180 Item 15](#).
- Crease roll gate rear guide, [PL 12.180 Item 16](#).
- Crease roll gate, [PL 12.180 Item 19](#).

Removal

WARNING

Take care during this procedure. Sharp edges may be present that can cause injury.

WARNING

Switch off the electricity to the machine [GP 14](#). Disconnect the power cord from the customer supply while performing tasks that do not need electricity. Electricity can cause death or injury. Moving parts can cause injury.

1. Open the HVF BM front door and fully pull out the BM.
2. Remove the crease blade knob (6d), [PL 12.150 Item 4](#).
3. Remove the crease roll handle (6c), [PL 12.150 Item 5](#).
4. Remove the BM front cover, [PL 12.150 Item 3](#).
5. Remove the BM right hand cover, [REP 12.56-171](#).
6. Remove the crease roll assembly, [REP 12.52-171](#).
7. Remove the crease roll gate motor, [REP 12.24-171](#).

8. Figure 1, remove the crease roll gate rack drive gear and both crease roll gate rack gears.

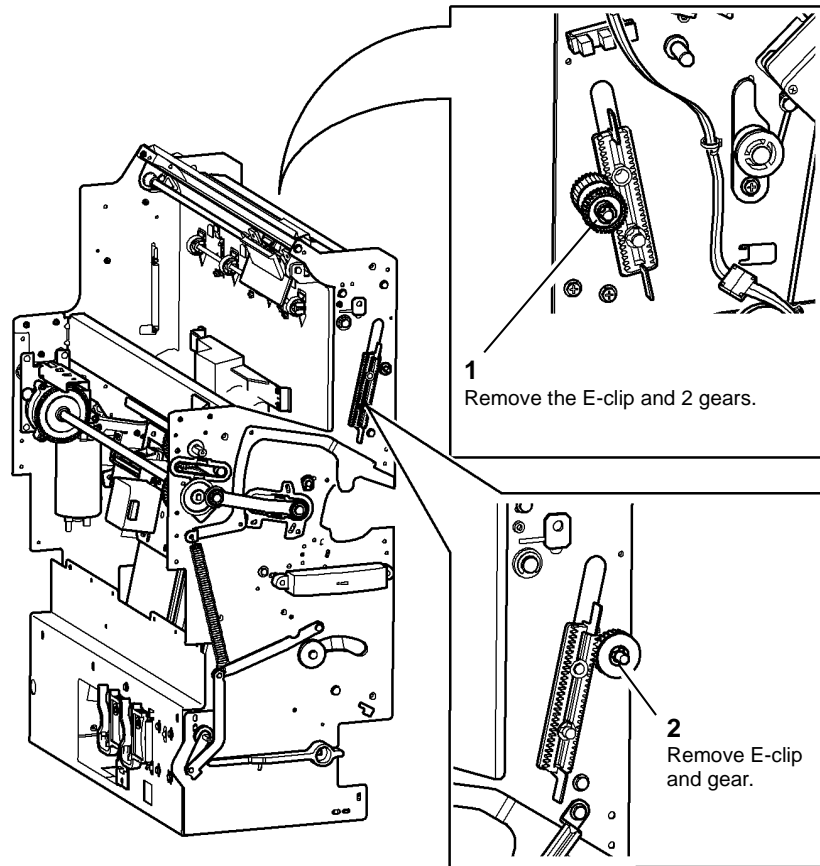

U-1-0549-A

Figure 1 Removing gears

9. Figure 2, Remove the front and rear crease roll gate racks.

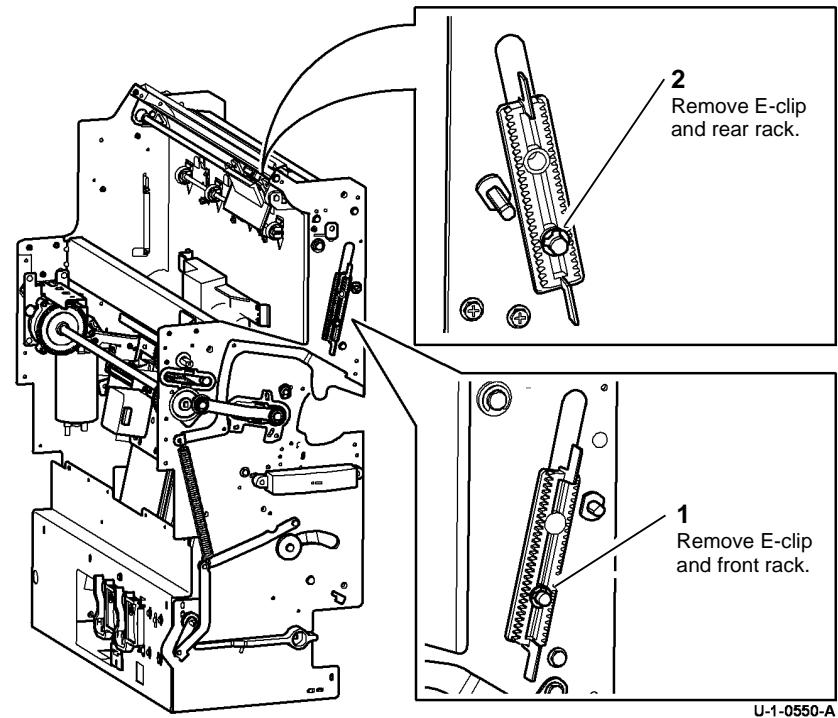

U-1-0550-A

Figure 2 Removing the racks

10. Figure 3, remove the crease roll gate.

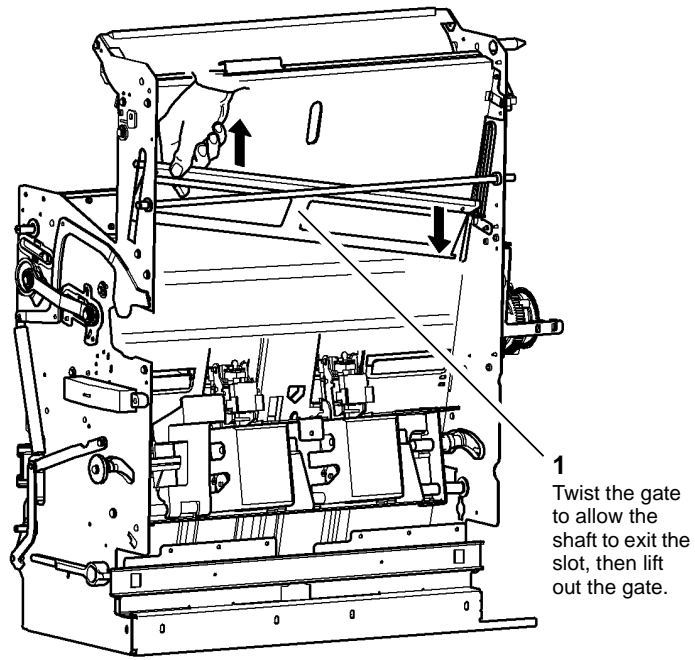

U-1-0551-A

Figure 3 Gate removal

11. Figure 4, remove the grease roll gate front guide.

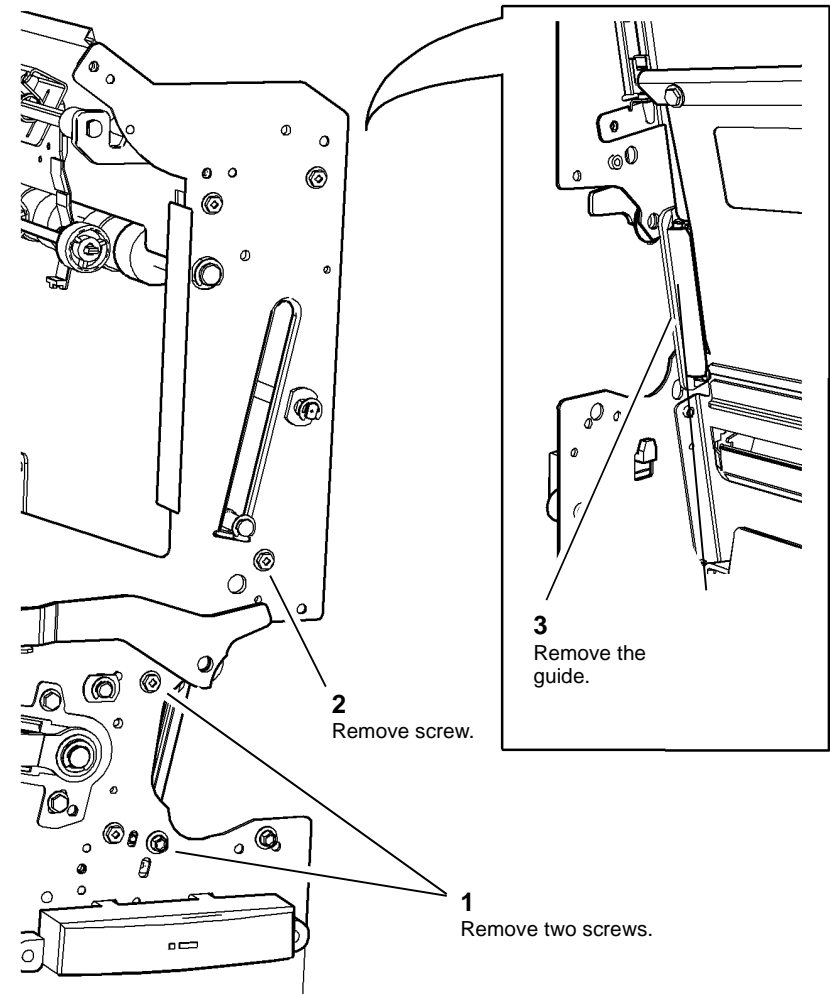

U-1-0552-A

Figure 4 Front guide removal

12. Figure 5, remove the grease roll gate rear guide.

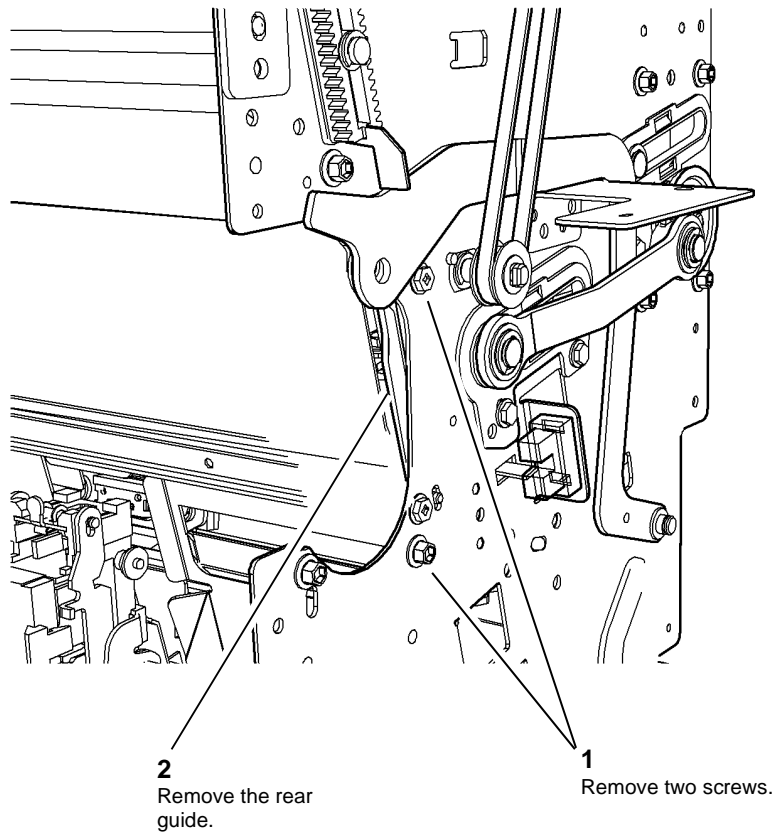

U-1-0553-A

Figure 5 Rear guide removal

13. Loosen 3 screws to remove the crease roll gate shaft from the crease roll gate.

Replacement

Reverse the removal procedure to replace the crease roll gate assembly.

CAUTION

Ensure that the crease roll gate shaft is positioned centrally within the crease roll gate.

REP 12.60-171 BM Paper Guide Assembly

Parts List on [PL 12.150](#).

Purpose

This procedure is used to repair the following components:

- Paper guide, [PL 12.150 Item 7](#).
- Nip spring, [PL 12.150 Item 9](#).
- Nip roll, [PL 12.150 Item 10](#).
- Nip shaft, [PL 12.150 Item 11](#).

NOTE: If only new nip components are being installed, the BM paper guide assembly does not need to be removed.

Removal

WARNING

Take care during this procedure. Sharp edges may be present that can cause injury.

WARNING

Switch off the electricity to the machine [GP 14](#). Disconnect the power cord from the customer supply while performing tasks that do not need electricity. Electricity can cause death or injury. Moving parts can cause injury.

1. Open the BM front door and fully pull out the BM.
2. Rotate the crease roll handle (6c) fully counterclockwise.
3. Remove the crease blade knob (6d), [PL 12.150 Item 4](#).
4. Remove the crease roll handle (6c), [PL 12.150 Item 5](#).
5. Remove the BM front cover, [PL 12.150 Item 3](#).

6. Figure 1, remove the front bearing.

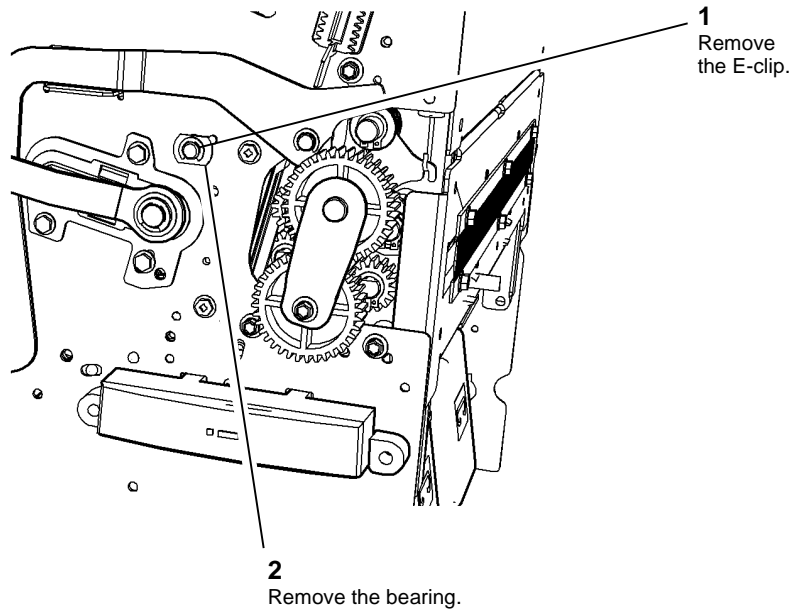

U-1-0554-A

Figure 1 Front bearing removal

7. Figure 2, remove the rear bearing.

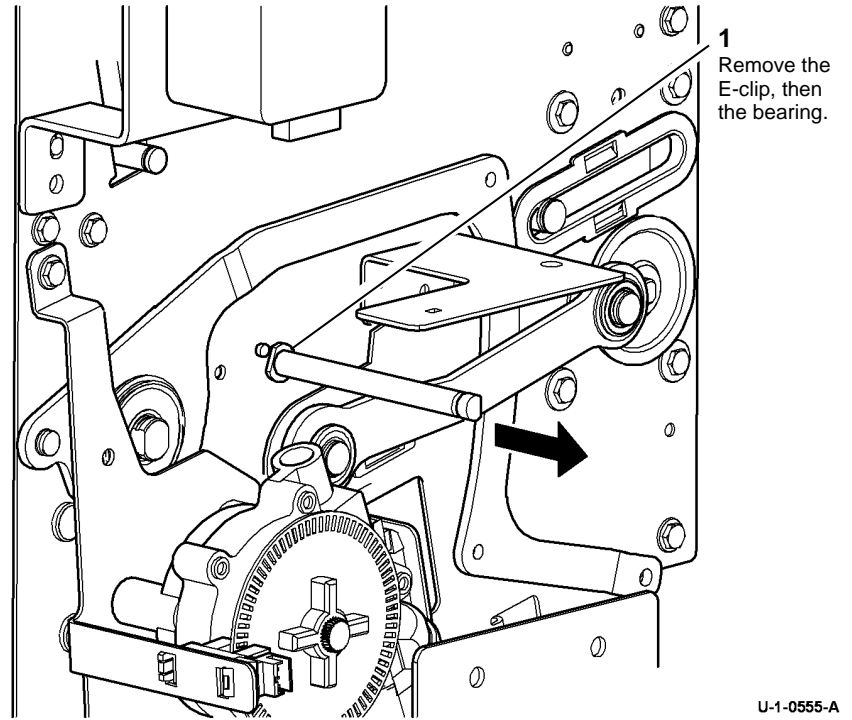

U-1-0555-A

Figure 2 Rear bearing removal

8. **Figure 3**, remove the BM paper guide assembly.

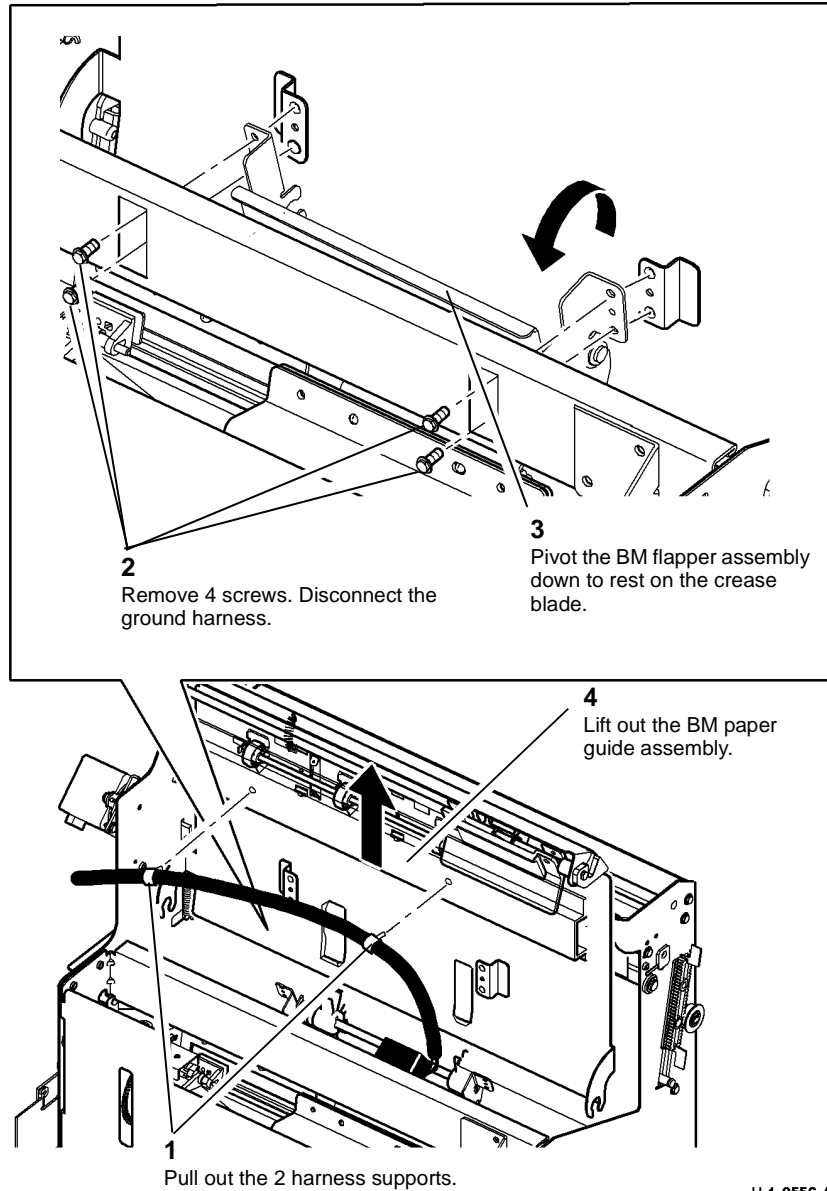

Figure 3 Paper guide assembly removal

9. **Figure 4**, remove the components from the BM paper guide assembly.

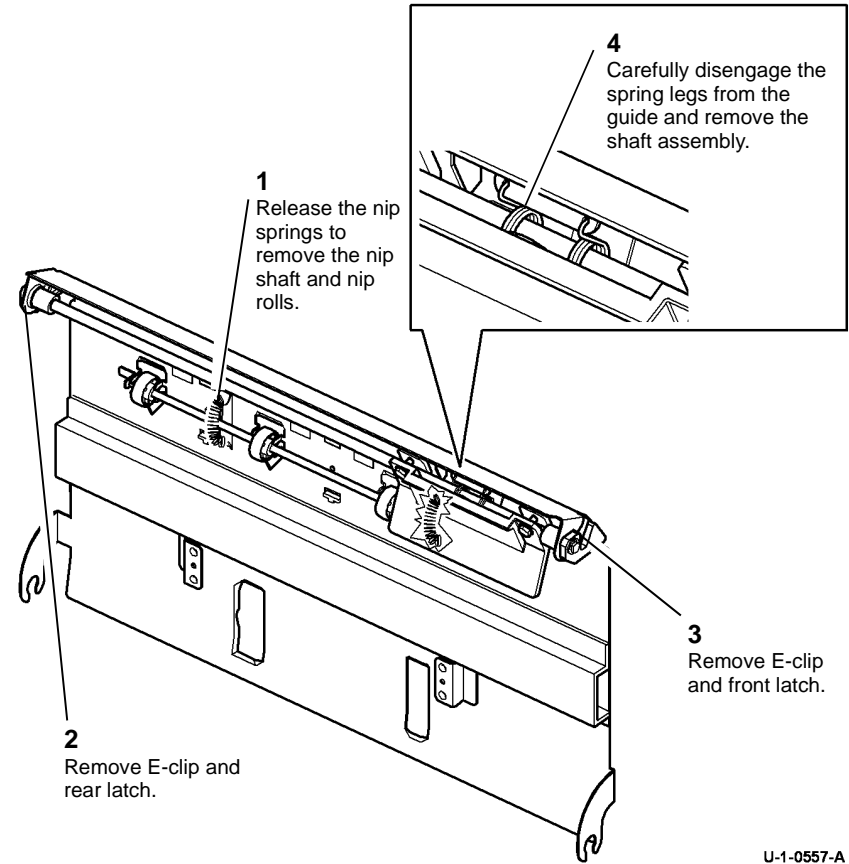

Figure 4 Paper guide dismantling

Replacement

Reverse the removal procedure to replace the BM paper guide assembly.

U-1-0557-A

REP 12.61-171 BM Module

Parts List on [PL 12.145](#).

Removal

WARNING

Mandatory safety warning. This procedure must be performed by 2 people. The module is heavy.

WARNING

Do not undock the HVF BM from the machine. The HVF BM is unstable when undocked from the machine. Do not show the customer how to undock the HVF BM.

WARNING

Switch off the electricity to the machine. Refer to [GP 14](#). Disconnect the power cord from the customer supply while performing tasks that do not need electricity. Electricity can cause death or injury. Moving parts can cause injury.

WARNING

Take care during this procedure. Sharp edges may be present that can cause injury.

1. Remove the top cover, then the rear cover, [REP 12.1-171](#).

2. [Figure 1](#), disconnect PJ562 and PJ559 from the BM PWB.

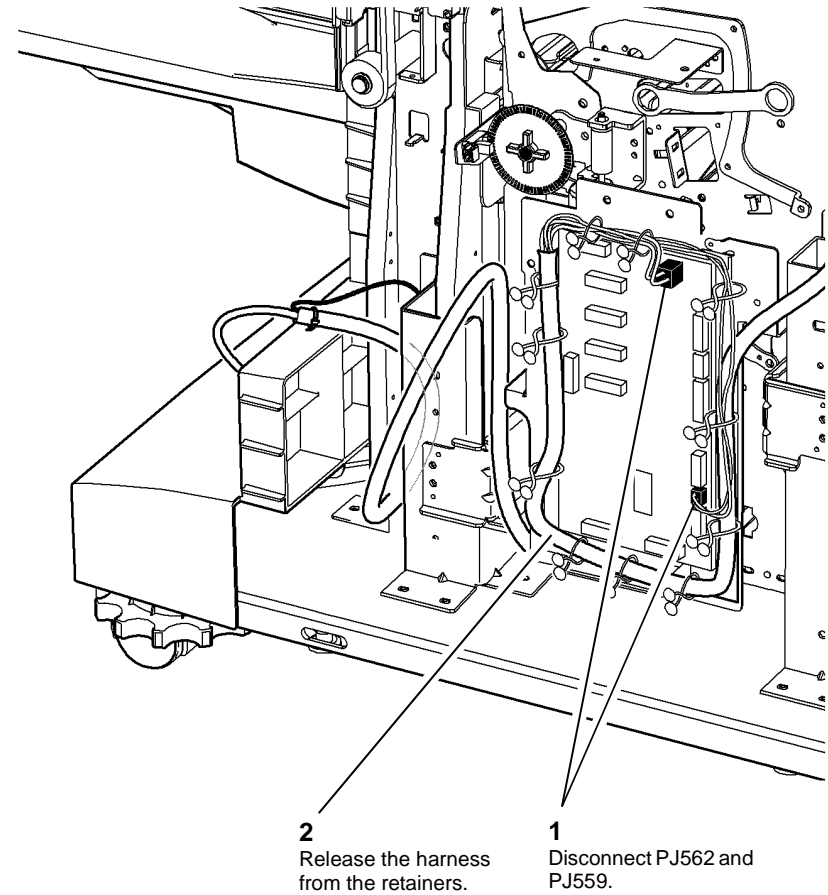

U-1-0558-A

Figure 1 Disconnect the PJs

3. **Figure 2**, disconnect the harness from bin 2.

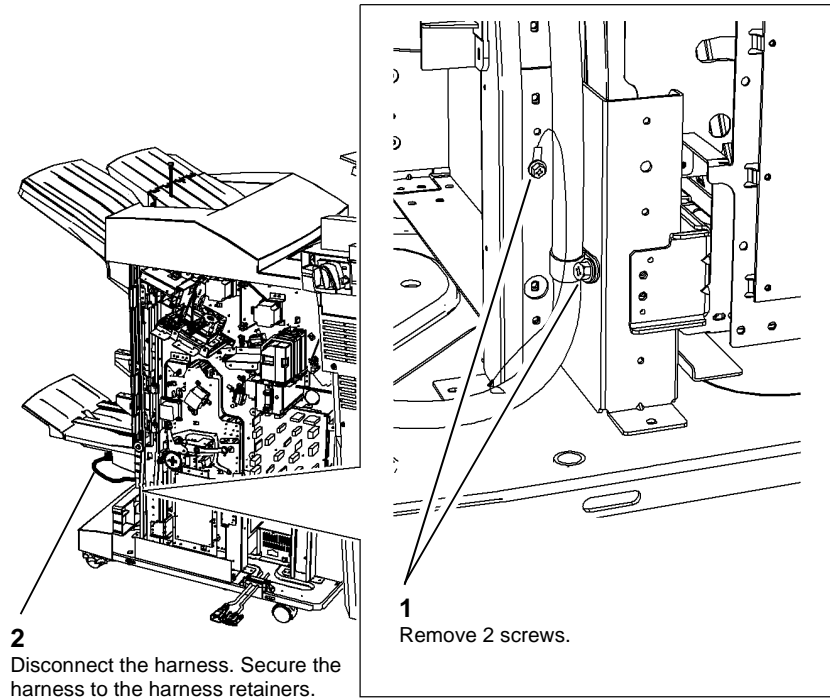

2
Disconnect the harness. Secure the harness to the harness retainers.

1
Remove 2 screws.

U-1-0559-A

Figure 2 Disconnect the harness

4. **Figure 3**, prepare to remove the BM module.

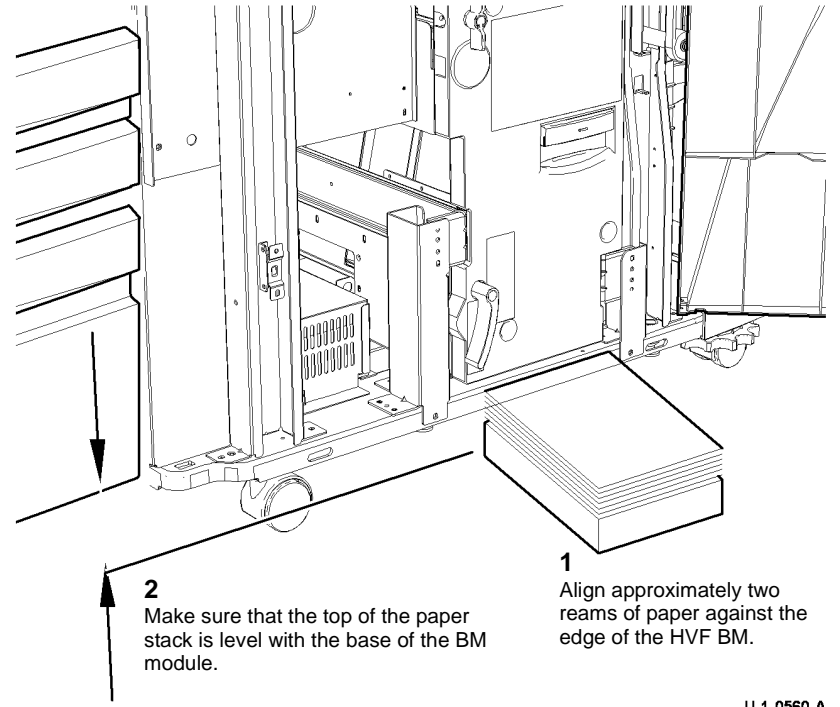

2
Make sure that the top of the paper stack is level with the base of the BM module.

1
Align approximately two reams of paper against the edge of the HVF BM.

U-1-0560-A

Figure 3 Preparation

5. Figure 4, prepare to remove the BM module.

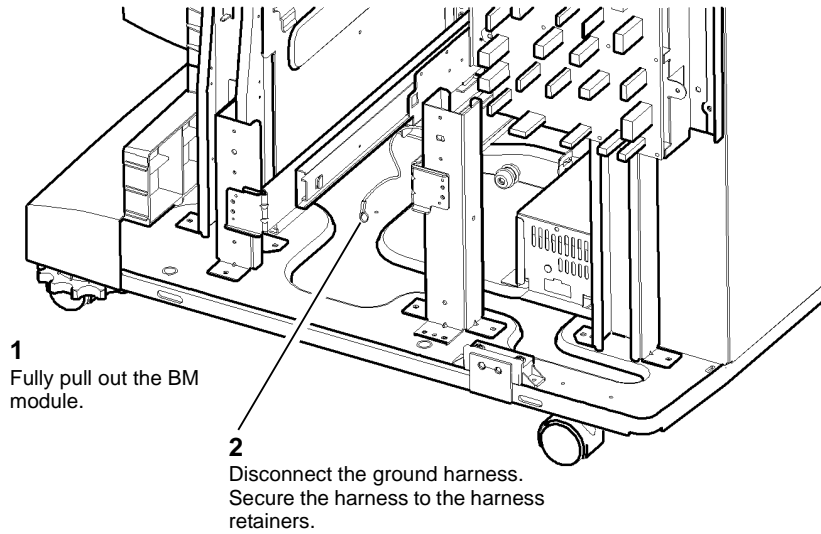

U-1-0561-A

Figure 4 Preparation

6. Figure 5, Release the latches.

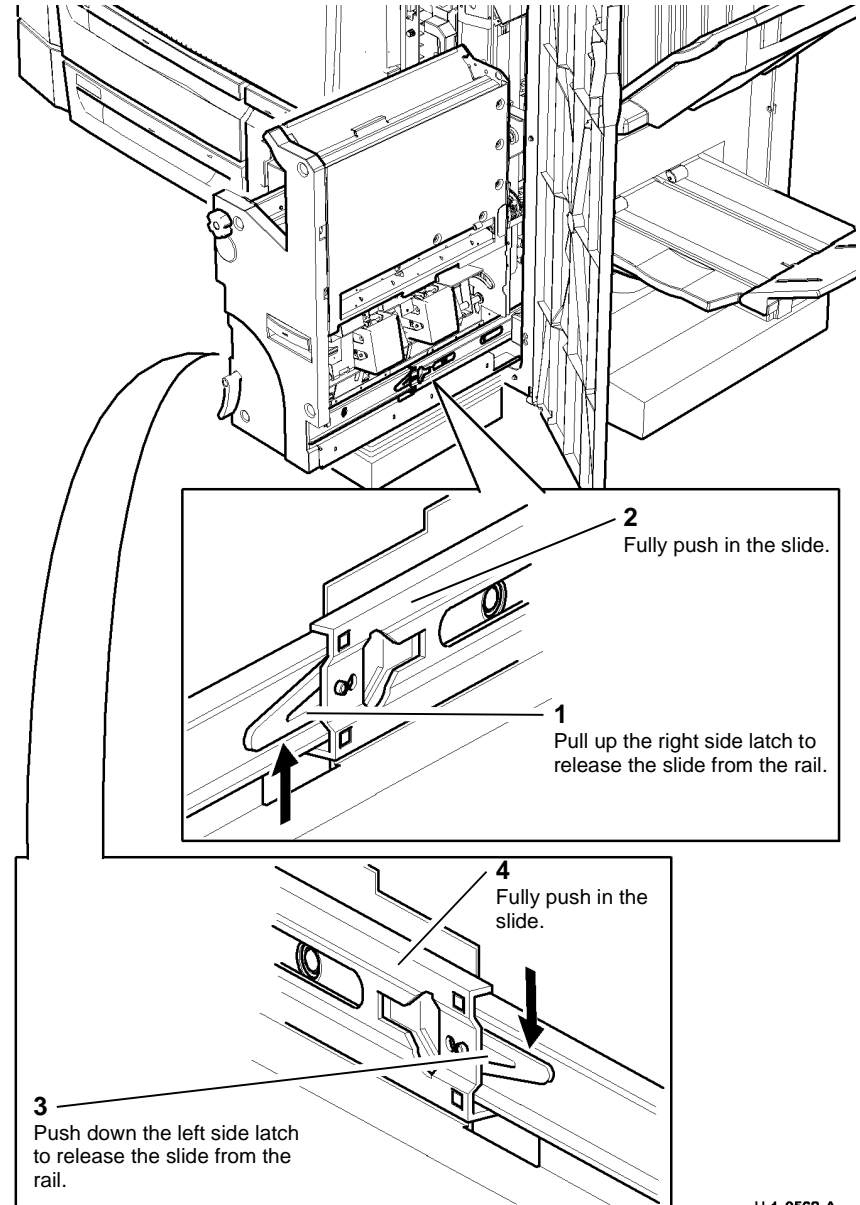

U-1-0562-A

Figure 5 Releasing the slides

WARNING

Use safe handling procedures when removing the module. Refer to GP 16. The module is heavy.

WARNING

Mandatory safety warning. This procedure must be performed by 2 people. The module is heavy.

CAUTION

Do not damage the BM front cover when the BM module is removed.

NOTE: The BM module weight is 23 Kg (50.6 lb.).

NOTE: The BM catch will spring to the rear when the BM module is removed. Refer to Figure 7.

7. Figure 6, remove the BM module.

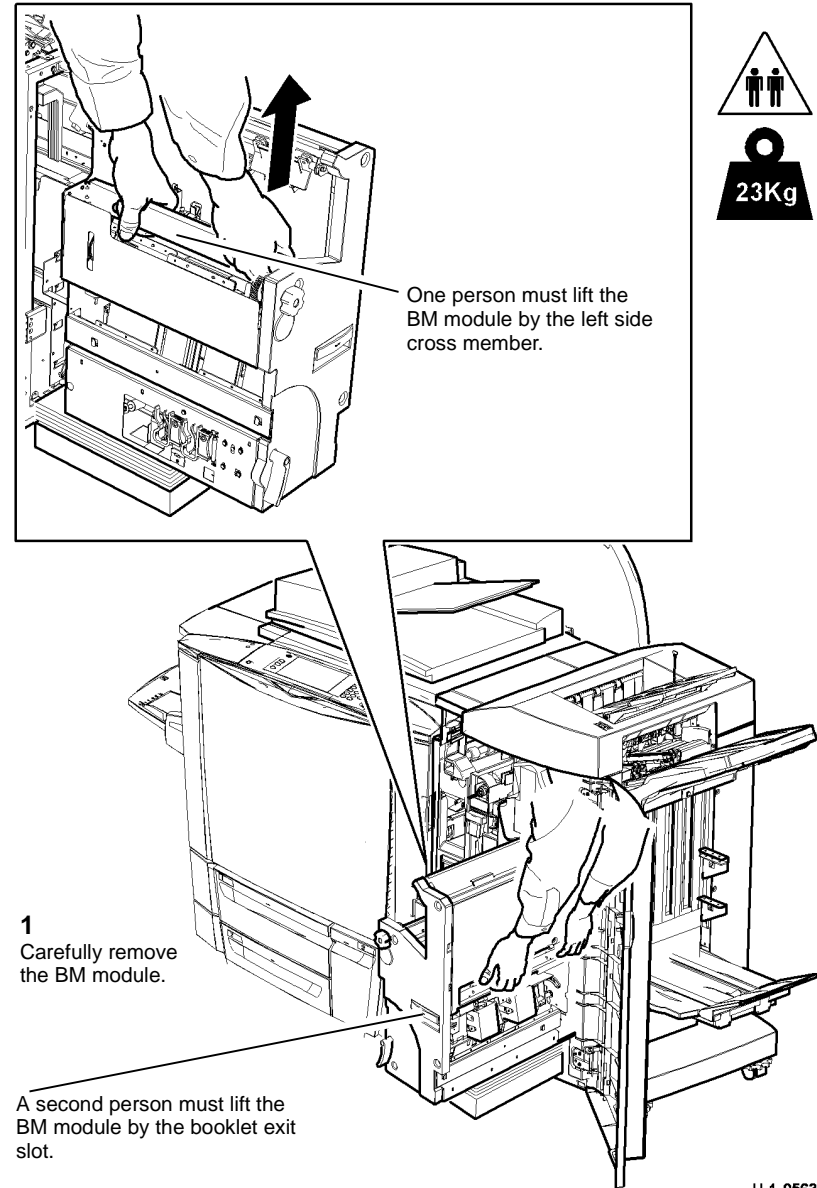

Figure 6 Remove the BM module

Replacement

CAUTION

Do not damage the harnesses when the BM module is installed. Ensure that the rails are correctly aligned with the slides.

1. Put the BM module on the paper stack in front of the HVF BM.
2. Route the bin 2 harness and the ground harness to the rear of the HVF BM.
3. If a new BM is to be installed, perform the following:
 - a. Unlatch the slides from the new BM module. Refer to [Figure 5](#).
 - b. Install the new BM module onto the existing rails in the HVF BM.

4. [Figure 7](#), prepare to install the BM module.

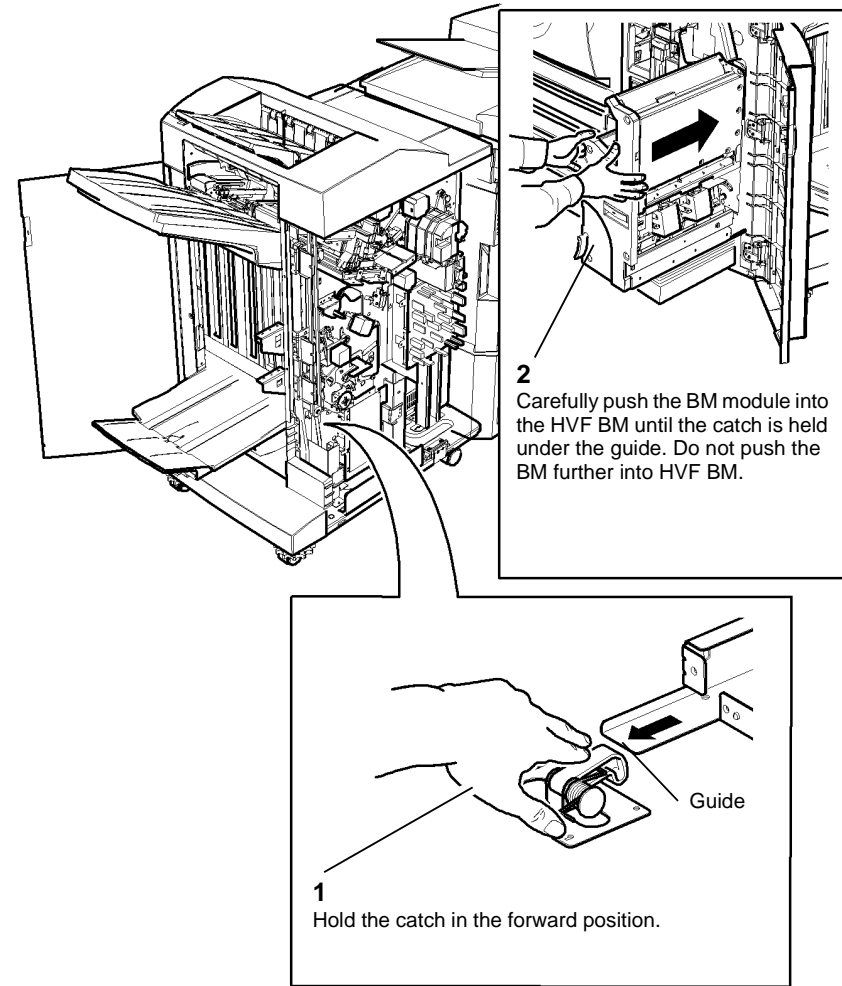

Figure 7 Position of the catch

5. Reverse the removal procedure to replace the BM module.

CAUTION

Ensure the BM harness and bin 2 harness are correctly positioned in the harness retainers so that harnesses are not damaged when the BM is moved to the extremities of its travel.

6. Perform the [12D-171](#) Booklet Quality RAP.

REP 12.62-171 BM Slide Assembly

Parts List on [PL 12.145](#).

Removal

WARNING

Switch off the electricity to the machine. Refer to [GP 14](#). Disconnect the power cord from the customer supply while performing tasks that do not need electricity. Electricity can cause death or injury. Moving parts can cause injury.

WARNING

Take care during this procedure. Sharp edges may be present that can cause injury.

1. Remove the BM module, [REP 12.61-171](#).
2. Remove the BM front cover, [PL 12.150](#) Item 3.

3. [Figure 1](#), Remove the slide assembly from the HVF BM frame.

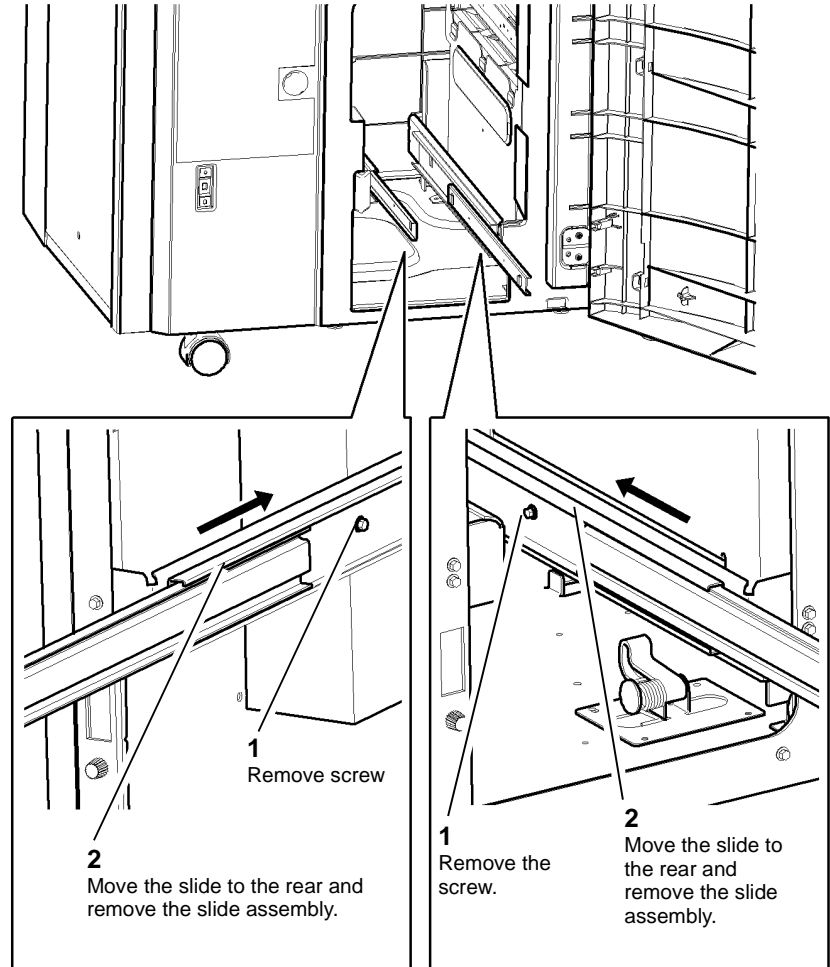

U-1-0565-A

Figure 1 Remove the slide assembly

4. **Figure 2.** Remove the bracket and the slide rail from the right side of the BM module.

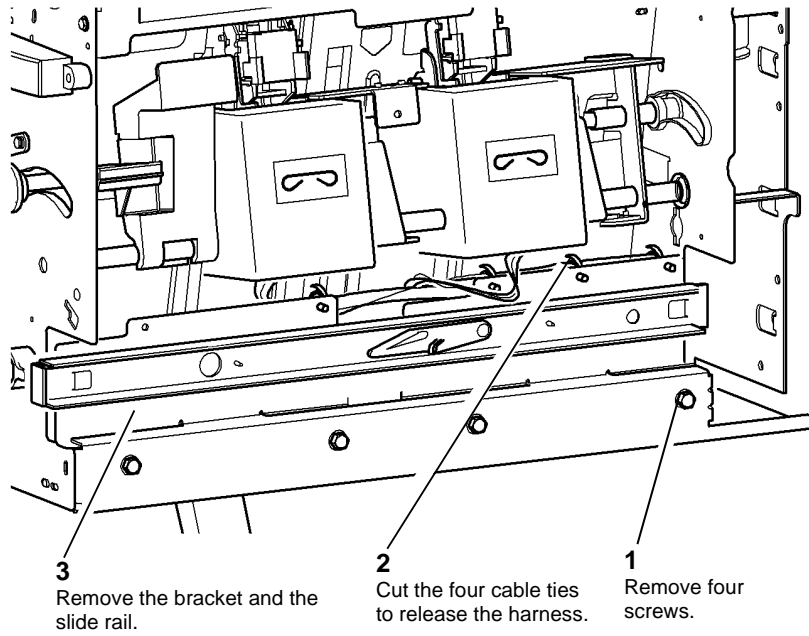

U-1-0566-A

Figure 2 Remove the bracket and the slide rail

5. **Figure 3.** Remove the two brackets from the slide rail.

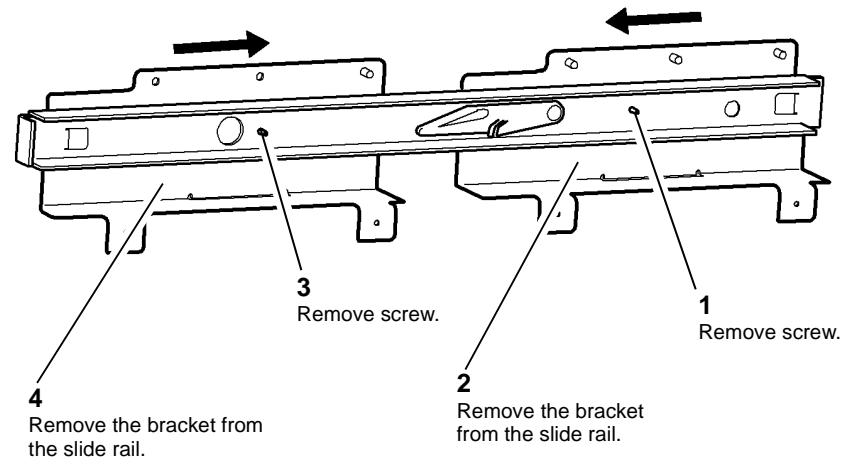

U-1-0567-A

Figure 3 Remove the bracket from the slide rail

6. **Figure 4**, Remove the bracket and the slide rail from the left side of the BM module.

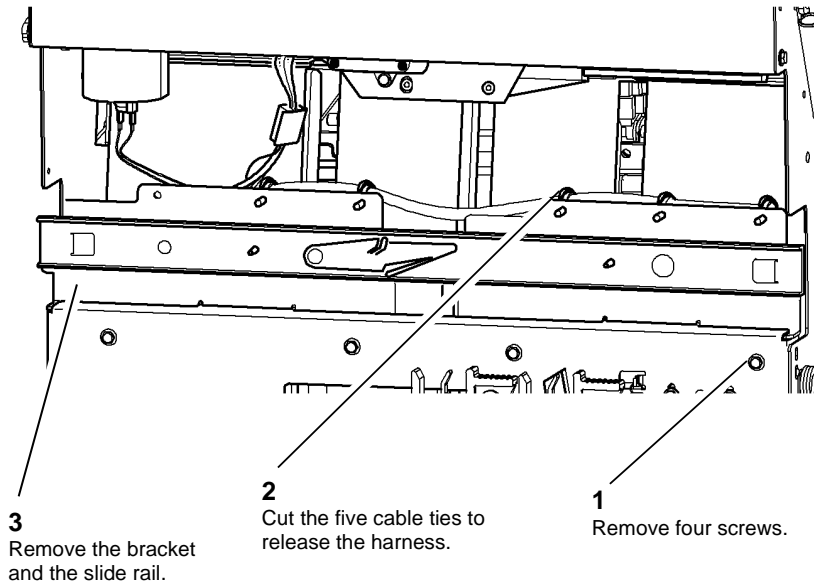

U-1-0568-A

Figure 4 Remove the bracket and slide rail

7. **Figure 5**, Remove the two brackets from the slide rail

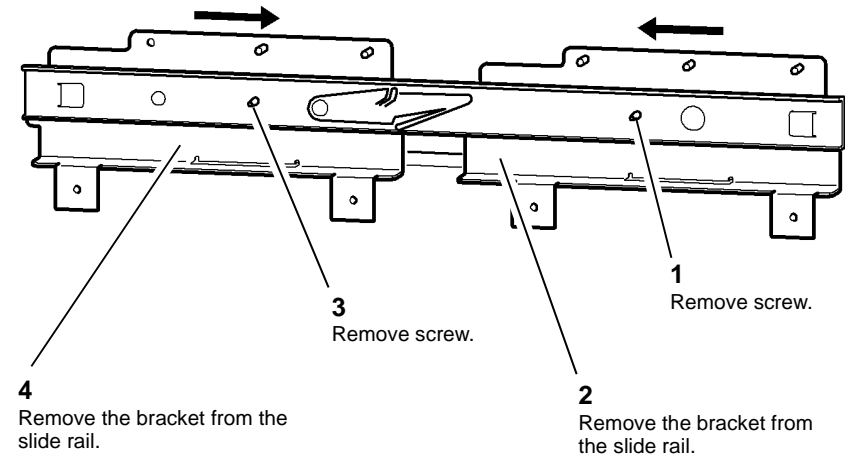

U-1-0569-A

Figure 5 Remove the bracket from the slide rail

Replacement

1. Reverse the removal procedure to replace the slide assembly.
2. Ensure that all of the cable ties are installed and the harness are in the correct position.
3. Check that all of the PJ connections are connected.

REP 12.63-171 Transport Motor 1

Parts List on [PL 12.120](#).

Removal

WARNING

Take care during this procedure. Sharp edges may be present that can cause injury.

WARNING

Switch off the electricity to the machine. Refer to [GP 14](#). Disconnect the power cord from the customer supply while performing tasks that do not need electricity. Electricity can cause death or injury. Moving parts can cause injury.

1. Remove the rear cover [REP 12.1-171](#).
2. Remove the transport motor 1 and bracket assembly, [Figure 1](#).

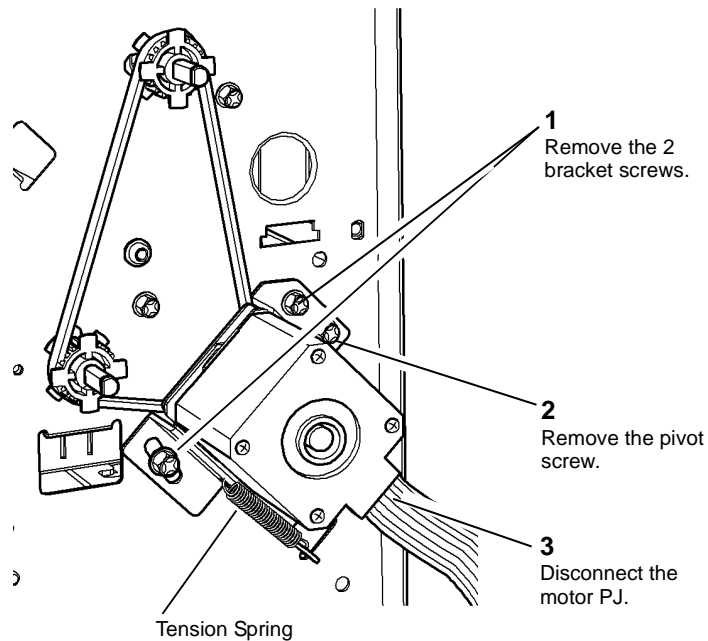

U-1-0570-A

Figure 1 Transport Motor 1 and Bracket

3. Remove 2 screws and the grounding wire to remove the motor and damper from the bracket.

Replacement

Reverse the removal procedures to replace the transport motor 1.

Set the belt tension [ADJ 12.10-171](#).

REP 12.64-171 Bypass Feed Motor

Parts List on [PL 12.120](#).

Removal

WARNING

Take care during this procedure. Sharp edges may be present that can cause injury.

WARNING

Switch off the electricity to the machine. Refer to [GP 14](#). Disconnect the power cord from the customer supply while performing tasks that do not need electricity. Electricity can cause death or injury. Moving parts can cause injury.

1. Remove the rear cover [REP 12.1-171](#).
2. Remove the bypass feed motor and bracket assembly, [Figure 1](#).

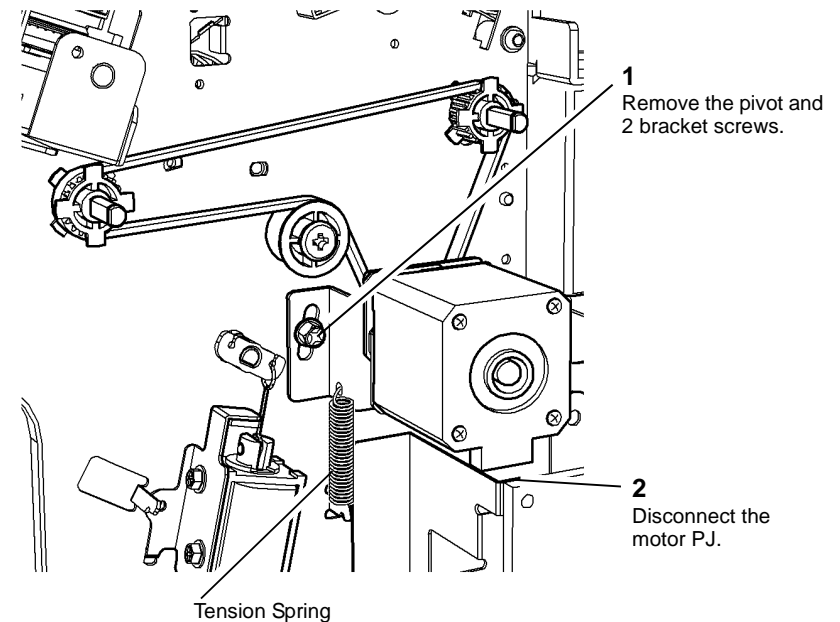

U-1-0571-A

Figure 1 Bypass Feed Motor and Bracket

3. Remove 2 screws and the grounding wire to remove the motor and damper from the bracket.

Replacement

Reverse the removal procedures to replace the bypass feed motor.

Set the belt tension, [ADJ 12.10-171](#).

REP 12.65-171 Buffer Motor

Parts List on [PL 12.120](#).

Removal

WARNING

Take care during this procedure. Sharp edges may be present that can cause injury.

WARNING

Switch off the electricity to the machine. Refer to [GP 14](#). Disconnect the power cord from the customer supply while performing tasks that do not need electricity. Electricity can cause death or injury. Moving parts can cause injury.

1. Remove the rear cover [REP 12.1-171](#).
2. Remove the buffer motor and bracket assembly, [Figure 1](#).

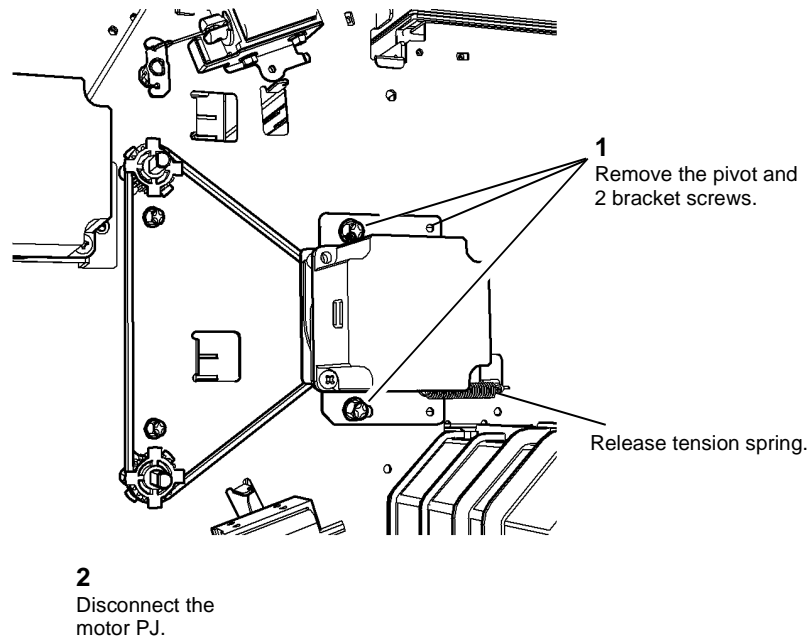

Figure 1 Buffer Feed Motor and Bracket

U-1-0572-A

3. Remove 2 screws and the grounding wire to remove the motor and damper from the bracket.

Replacement

Reverse the removal procedures to replace the buffer motor.

Fit the pivot screw and set the belt tension, [ADJ 12.10-171](#). Do not tighten the motor bracket screws fully until the belt is tensioned by the spring.

REP 12.66-171 Transport Motor 2

Parts List on [PL 12.120](#).

Removal

WARNING

Take care during this procedure. Sharp edges may be present that can cause injury.

WARNING

Switch off the electricity to the machine. Refer to [GP 14](#). Disconnect the power cord from the customer supply while performing tasks that do not need electricity. Electricity can cause death or injury. Moving parts can cause injury.

1. Remove the rear cover [REP 12.1-171](#).
2. Remove the exit feed motor and bracket assembly, [Figure 1](#).

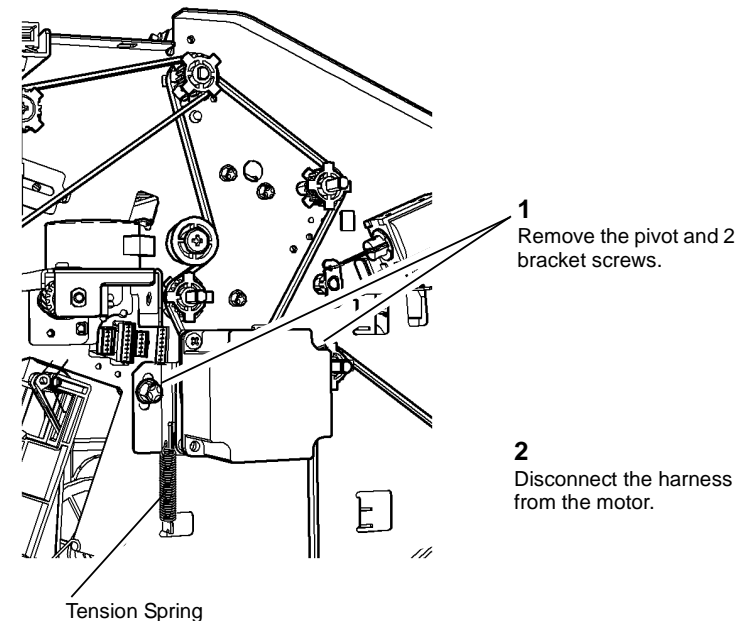

Figure 1 Exit Feed Motor and Bracket

U-10573-A

3. Remove 2 screws and the grounding wire to remove the motor and damper from the bracket.

Replacement

Reverse the removal procedures to replace the exit feed motor.

Fit the bracket pivot screw and set the belt tension, [ADJ 12.10-171](#).

REP 12.67-171 Tri Folder Covers

Parts List on [PL 12.200](#).

Removal

WARNING

Take care during this procedure. Sharp edges may be present that can cause injury.

WARNING

Switch off the electricity to the machine. Refer to [GP 14](#). Disconnect the power cord from the customer supply while performing tasks that do not need electricity. Electricity can cause death or injury. Moving parts can cause injury.

1. Remove the screw and front door hinge pin then move the door from the upper pivot. Remove 4 screws and remove the front cover [Figure 1](#).

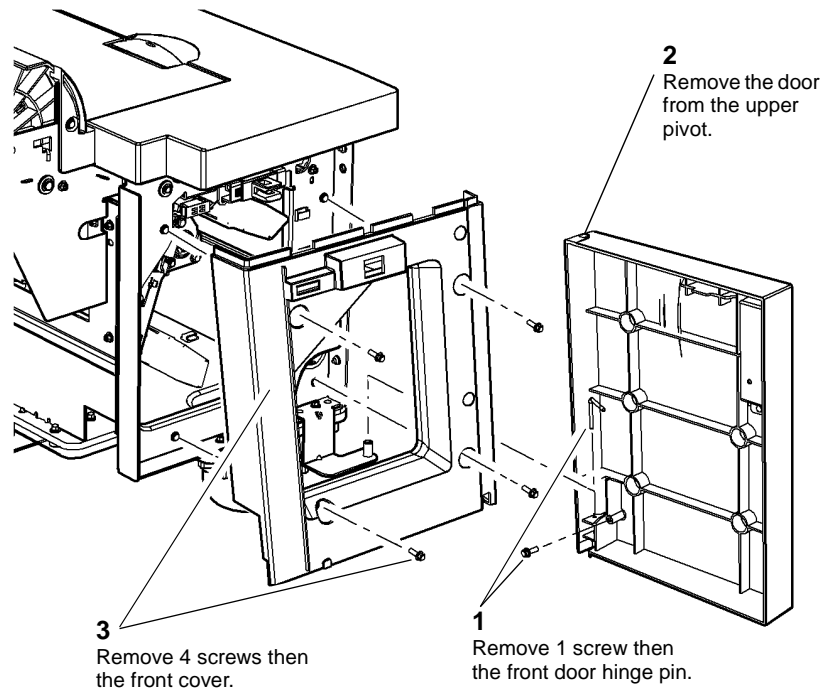

U-1-0574-A

Figure 1 Tri-folder Front Door and Cover

2. Remove the rear cover, the top cover and the right side cover as required, [Figure 2](#).

NOTE: Open the top cover and remove the rear cover to access to the top cover rear fasteners and the top cover interlock sensor connector.

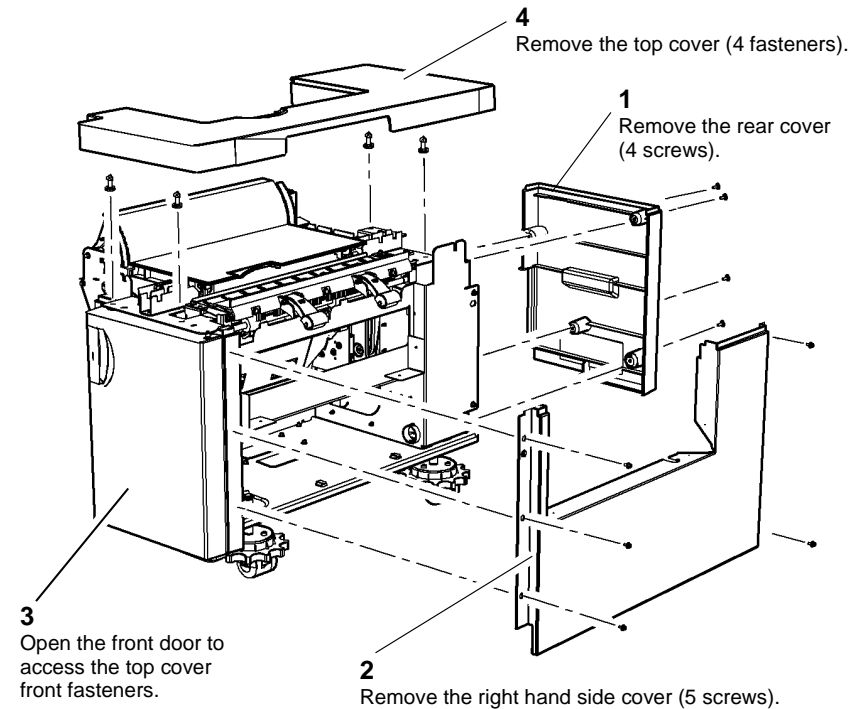

U-1-0575-A

Figure 2 Top, Rear and Right side covers

Replacement

Reverse the removal procedures to reinstall the Tri-Folder covers.

REP 12.68-171 Tri-Folder Drive Assembly

Parts List on [PL 12.205](#).

Removal

WARNING

Take care during this procedure. Sharp edges may be present that can cause injury.

WARNING

Switch off the electricity to the machine. Refer to [GP 14](#). Disconnect the power cord from the customer supply while performing tasks that do not need electricity. Electricity can cause death or injury. Moving parts can cause injury.

1. Remove the HVF rear cover, [REP 12.1-171](#).
2. Remove the tri-folder rear cover [REP 12.67-171](#).
3. Remove the tri-folder drive assembly, [Figure 1](#).

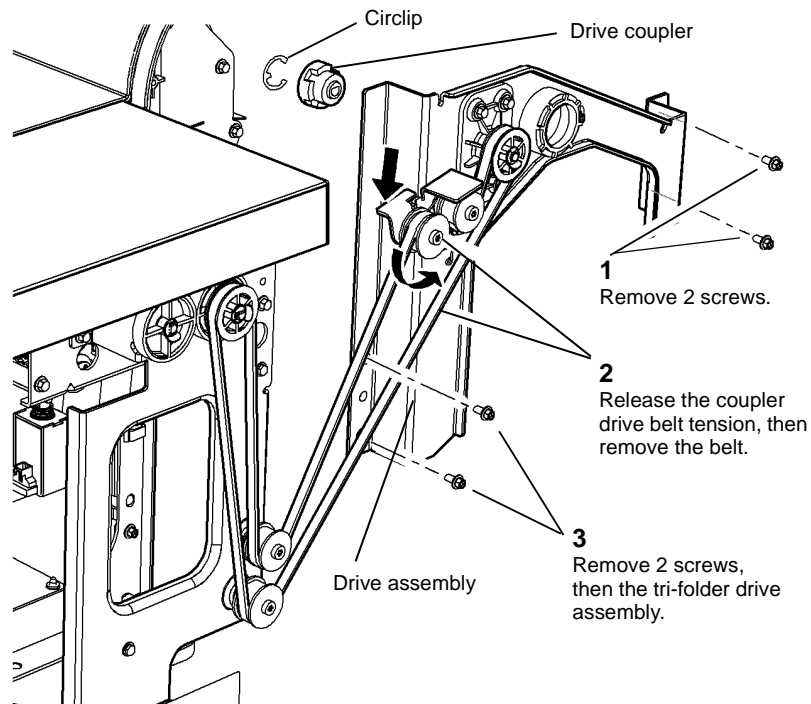

U-1-0576-A

Figure 1 Drive assembly

4. If necessary, remove the circlip then remove the drive coupler, refer to [Figure 1](#).

Replacement

1. Detach the coupler alignment tool from the drive unit, refer to [Figure 1](#).
2. Install the drive assembly, [Figure 2](#).

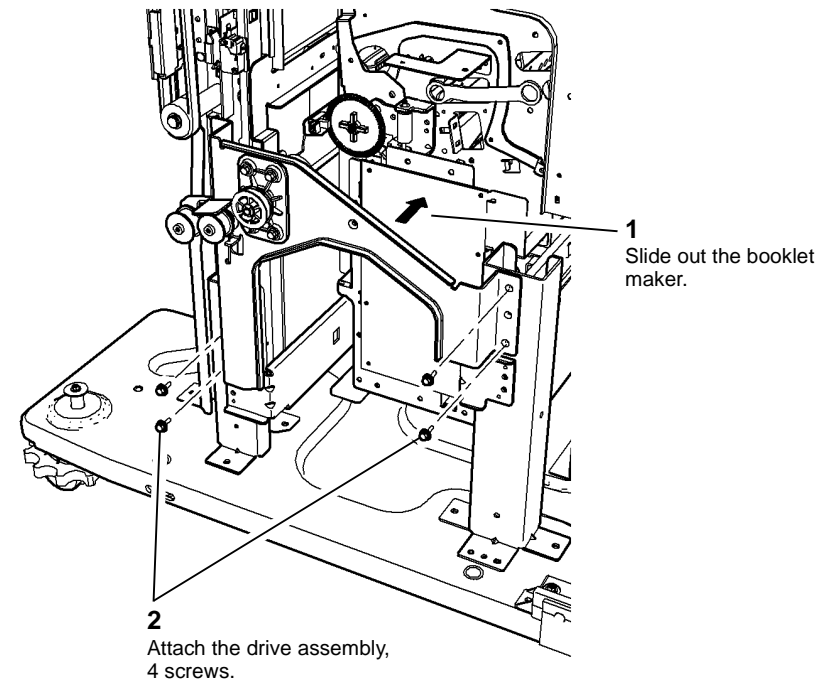

U-1-1439-A

Figure 2 Attach the drive assembly

3. Centralize the coupler alignment tool onto the crease roll motor encoder disc, [PL 12.175 Item 13](#) and [Figure 3](#).
5. Slacken off the drive unit retaining screws, [Figure 4](#).

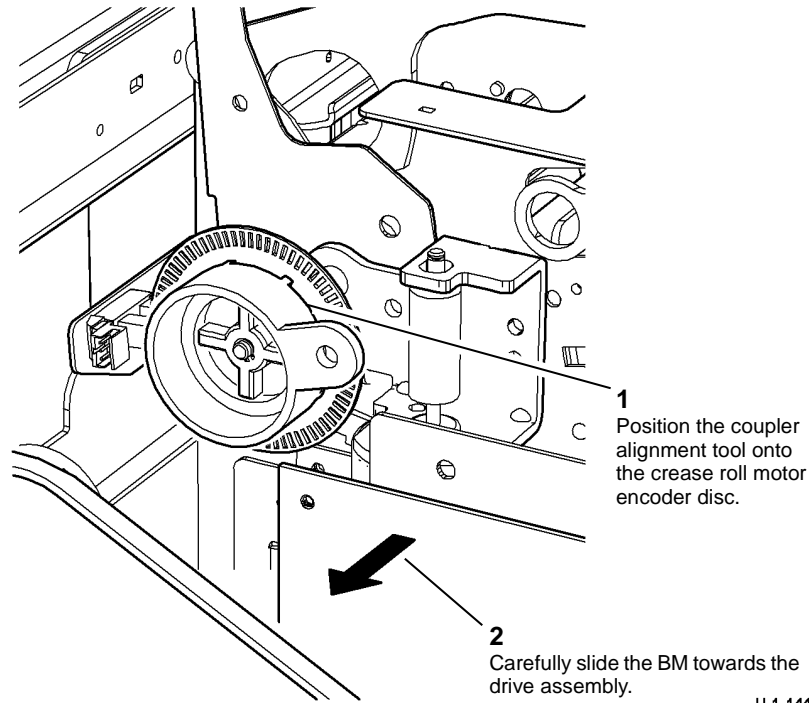

Figure 3 Centralize the alignment tool

U-1-1440-A

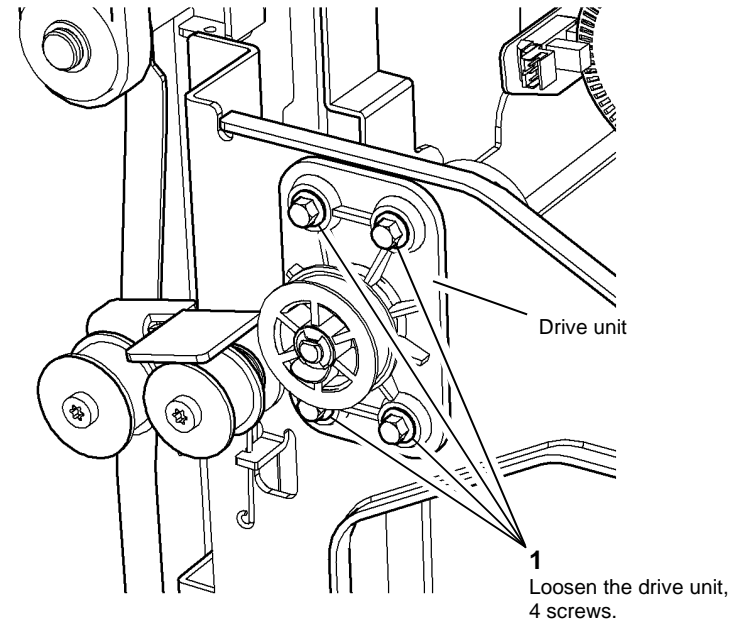

Figure 4 Loosen the drive unit

U-1-1441-A

4. Prepare to centralize the drive coupler, refer to [Figure 1](#), with the HVF BM crease roll motor encoder disc, [Figure 3](#).

6. Centralize the coupler alignment tool with the drive unit coupler, [Figure 5](#).

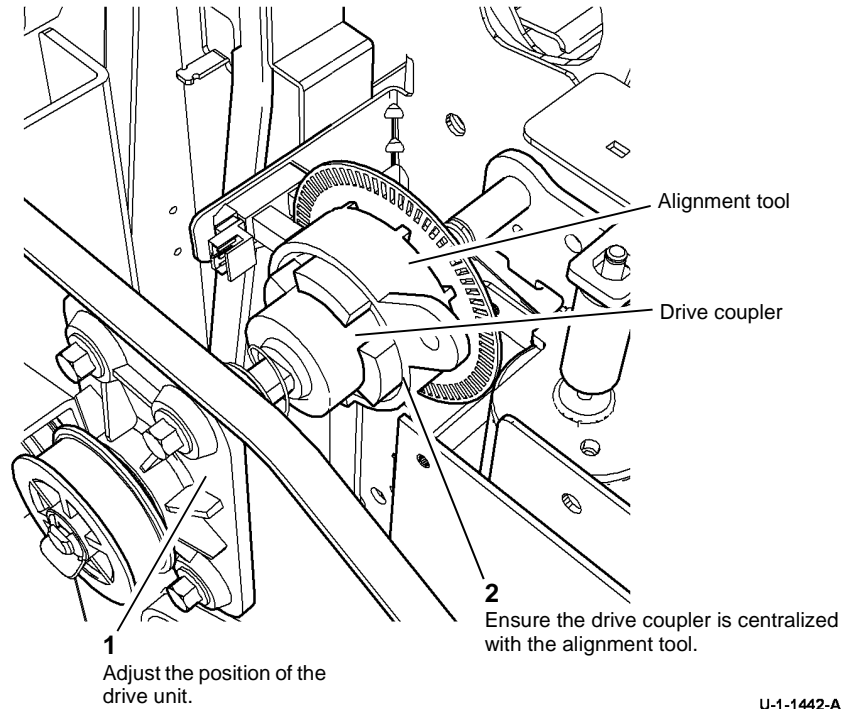

Figure 5 Centralize the drive coupler

7. Secure the drive unit in the centralized position, [Figure 6](#).

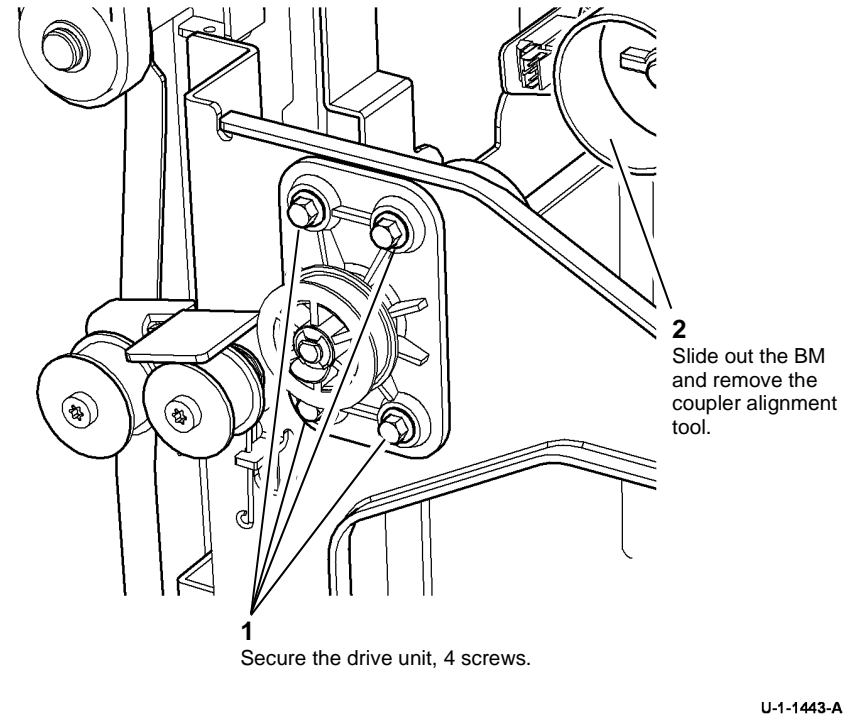

Figure 6 Secure the drive unit

8. Attach the alignment tool onto the drive assembly for future use.
9. Carefully slide back the BM and engage the drive unit coupler.
10. Check that the harnesses do not obstruct the BM crease roll motor encoder disc.
11. Reverse the removal procedures to replace the tri-folder

REP 12.69-171 Tri Folder Crease Roll Drive Assembly

Parts List on [PL 12.205](#).

Removal

WARNING

Take care during this procedure. Sharp edges may be present that can cause injury.

WARNING

Switch off the electricity to the machine. Refer to [GP 14](#). Disconnect the power cord from the customer supply while performing tasks that do not need electricity. Electricity can cause death or injury. Moving parts can cause injury.

1. Remove the Tri Folder rear cover, [REP 12.67-171](#). Access is improved by removing the top cover.
2. Remove the drive coupling assembly bracket, [Figure 1](#).

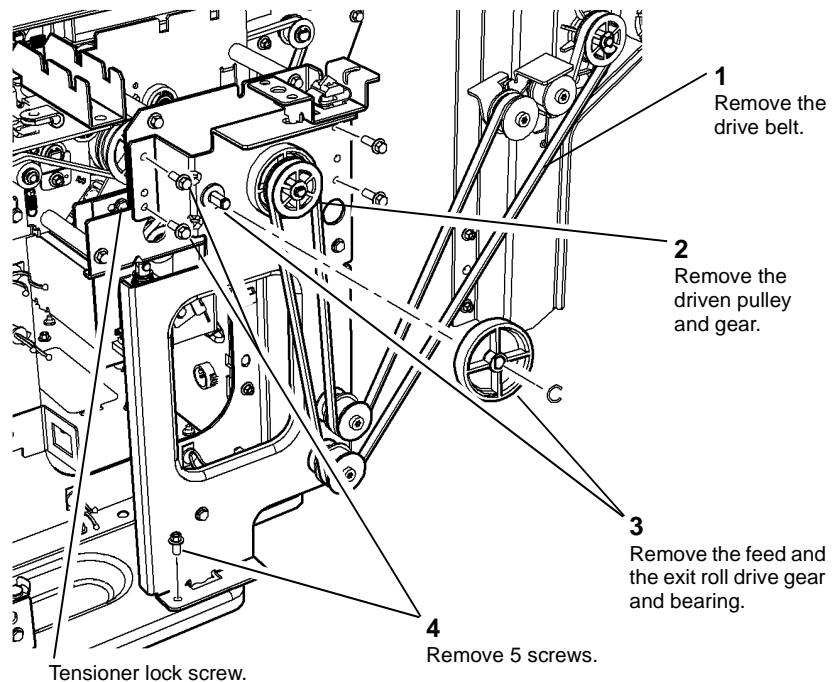

Figure 1 Drive Coupling Assembly

3. Slacken the tensioner lock screw and move the crease roll tensioner pulley to the left, then tighten the lock screw, [Figure 1](#).

4. Remove the clutch and bearing from the idler bracket, [Figure 2](#).

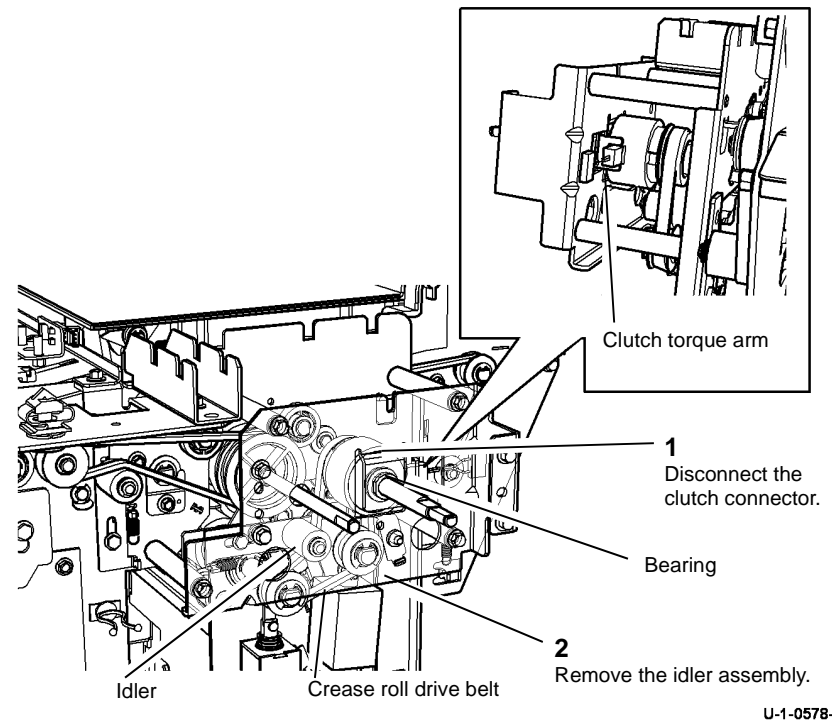

Figure 2 Idler Assembly and Crease Roll Clutch

Replacement

1. Reverse the removal procedures to reinstall the crease roll clutch and drive coupling assembly.
2. Replace the idler assembly with the smooth side of the crease roll drive belt towards the idler, then fit the drive belt over the clutch gear, [Figure 2](#).
3. Position the clutch torque arm in the slot in the idler bracket, See [Figure 2](#) insert.
4. Perform [ADJ 12.10-171](#) Motor Drive Belt Tensioning.

REP 12.70-171 Tri-Folder Feed Roller and Drive Belt

Parts List on [PL 12.205](#).

Removal

WARNING

Take care during this procedure. Sharp edges may be present that can cause injury.

WARNING

Switch off the electricity to the machine. Refer to [GP 14](#). Disconnect the power cord from the customer supply while performing tasks that do not need electricity. Electricity can cause death or injury. Moving parts can cause injury.

1. Undock the Tri-Folder from the HVF and move the unit to the right to access the left side of the frame, [REP 12.99-171](#).
2. Remove the drive belt, [Figure 1](#).

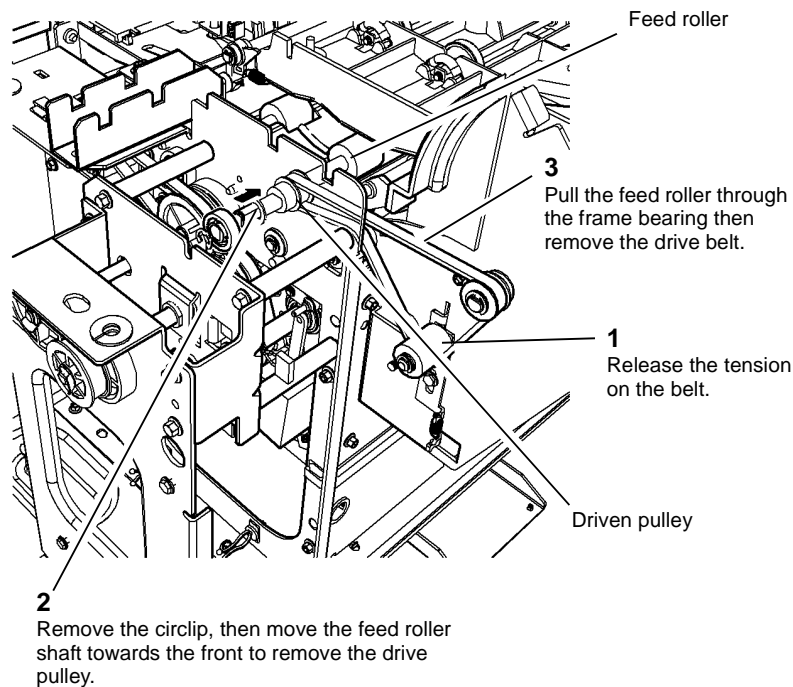

U-1-0579-A

Figure 1 Feed Roller and Drive Belt

3. If required, remove the feed roller shaft front circlip and bearing and remove the feed roller assembly from the Tri-Folder.

Replacement

1. Reverse the removal procedures to replace the feed roller and drive belt.
2. Before docking the Tri-Folder unit to the HVF, perform [ADJ 12.10-171](#), Motor Driven Belt Tensioning

REP 12.71-171 TF Assist Gate Solenoid

Parts List on [PL 12.215](#).

Removal

WARNING

Take care during this procedure. Sharp edges may be present that can cause injury.

WARNING

Switch off the electricity to the machine. Refer to [GP 14](#). Disconnect the power cord from the customer supply while performing tasks that do not need electricity. Electricity can cause death or injury. Moving parts can cause injury.

1. Open the TF front door, or remove the Bin 2 assembly, then remove the Tri-Folder rear cover, [REP 12.67-171](#).
2. Disconnect the harness and remove the solenoid and spring, [Figure 1](#). Remove the armature and lever if required.

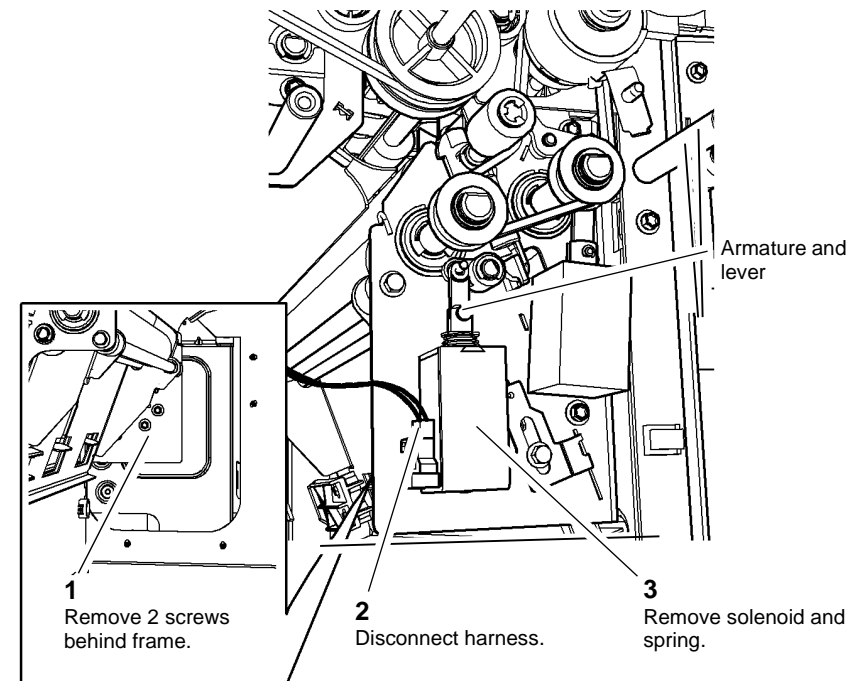

U-1-0580-A

Figure 1 Assist Gate Solenoid

Replacement

1. Reverse the removal procedures to replace the entry solenoid.
2. Refit the armature and lever before replacing the spring and solenoid coil. If necessary, get assistance to hold the armature coil in position when replacing the screws.

REP 12.72-171 Tri Folder Crease Roll Springs

Parts List on [PL 12.215](#).

Removal

WARNING

Take care during this procedure. Sharp edges may be present that can cause injury.

WARNING

Switch off the electricity to the machine. Refer to [GP 14](#). Disconnect the power cord from the customer supply while performing tasks that do not need electricity. Electricity can cause death or injury. Moving parts can cause injury.

1. Remove the front door, front cover and rear cover [REP 12.67-171](#).
2. Remove the circlip and remove the front or rear spring, [Figure 1](#).

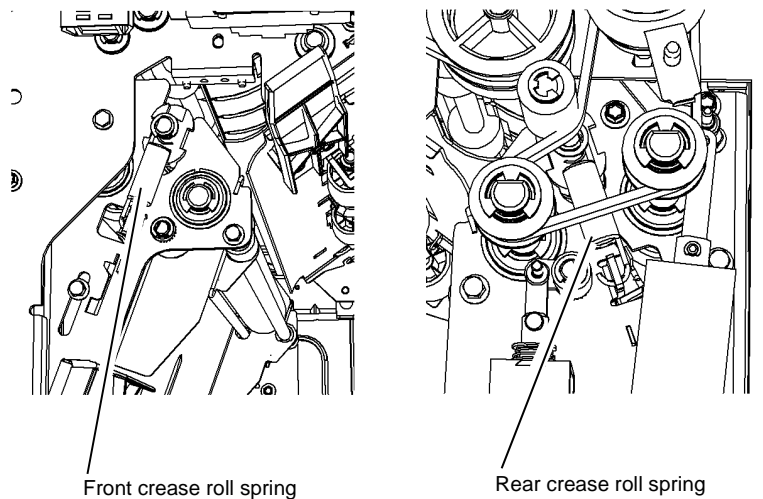

U-1-0581-A

Figure 1 Front and Rear Crease Roll Springs

Replacement

Reverse the removal procedures to replace the front or rear crease roll spring.

REP 12.73-171 Tri Folder Top Cover and Idler Assemblies

Parts List on [PL 12.210](#).

Removal

WARNING

Take care during this procedure. Sharp edges may be present that can cause injury.

WARNING

Switch off the electricity to the machine. Refer to [GP 14](#). Disconnect the power cord from the customer supply while performing tasks that do not need electricity. Electricity can cause death or injury. Moving parts can cause injury.

1. Undock the tri-folder from the HVF and move it to the right to gain access to the left side of the tri-folder frame, [REP 12.99-171](#).

NOTE: The wiring harnesses to the HVF do not need to be disconnected.

2. Remove the top cover door assembly, [Figure 1](#).

NOTE: Control the movement of the torsion spring.

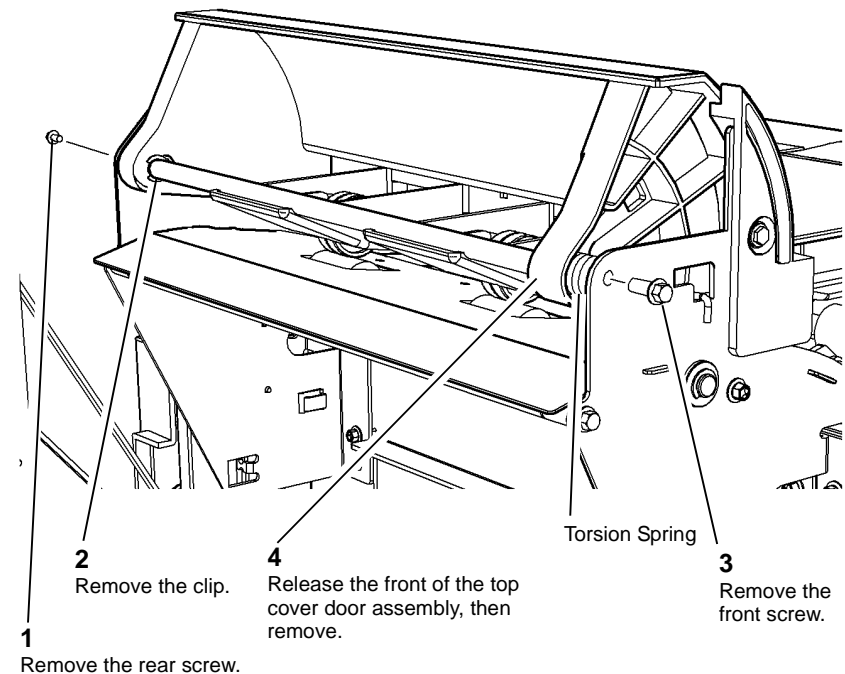

U-1-0583-A

Figure 1 Top Cover Removal

3. Remove the idler assemblies, [Figure 2](#).

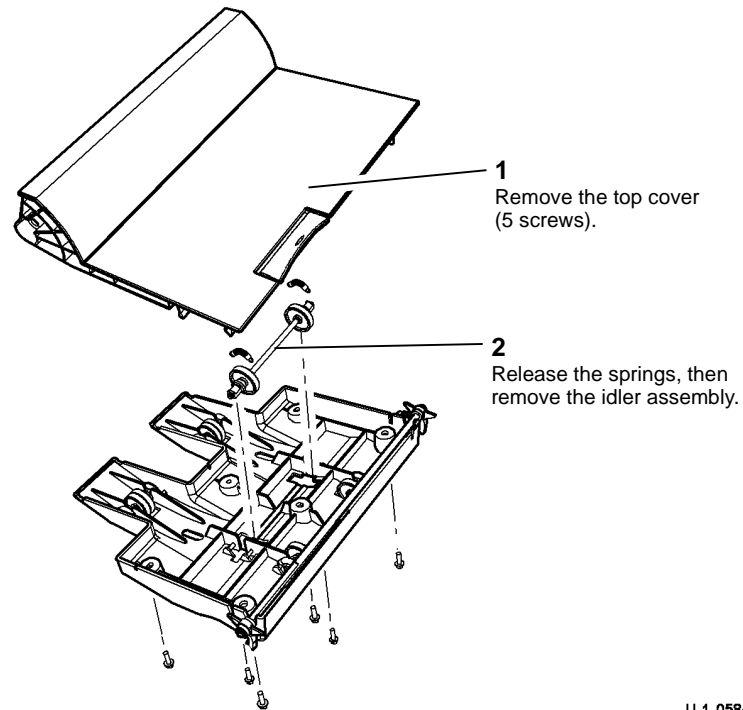

U-1-0584-A

Figure 2 Idler assembly removal

Replacement

1. Reverse the removal procedures to reinstall the idler assemblies and top cover door assembly.
2. Make sure that the correct self-tapping screws are used to replace the cover base; do not overtighten the screws.
3. Replace, but do not tighten, the rear pivot shaft screw. Position the cover and torsion spring then fit the front of the pivot shaft in the frame. Replace and tighten both front and rear pivot shaft screws.
4. Check that the cable harnesses are not obstructed or touching moving parts when the tri-folder is docked to the HVF.

REP 12.74-171 Tri Folder Roller Assembly and Diverter Solenoid

Parts List on [PL 12.215](#).

Removal

WARNING

Take care during this procedure. Sharp edges may be present that can cause injury.

WARNING

Switch off the electricity to the machine. Refer to [GP 14](#). Disconnect the power cord from the customer supply while performing tasks that do not need electricity. Electricity can cause death or injury. Moving parts can cause injury.

1. Undock the Tri-Folder assembly from the HVF, [REP 12.99-171](#). Position and support the Tri-Folder so that it is safely accessible from the front, rear and left side.
2. Release the crease roll drive belt tension, [REP 12.69-171](#). Disconnect the harness from the diverter and assist gate solenoids.

NOTE: First remove the lower front and rear screws. Support the roller assembly and remove the upper front and rear screws. If not supported the assembly will fall inside the Tri Folder frame.

3. Remove the roller assembly through the front door, [Figure 1](#).

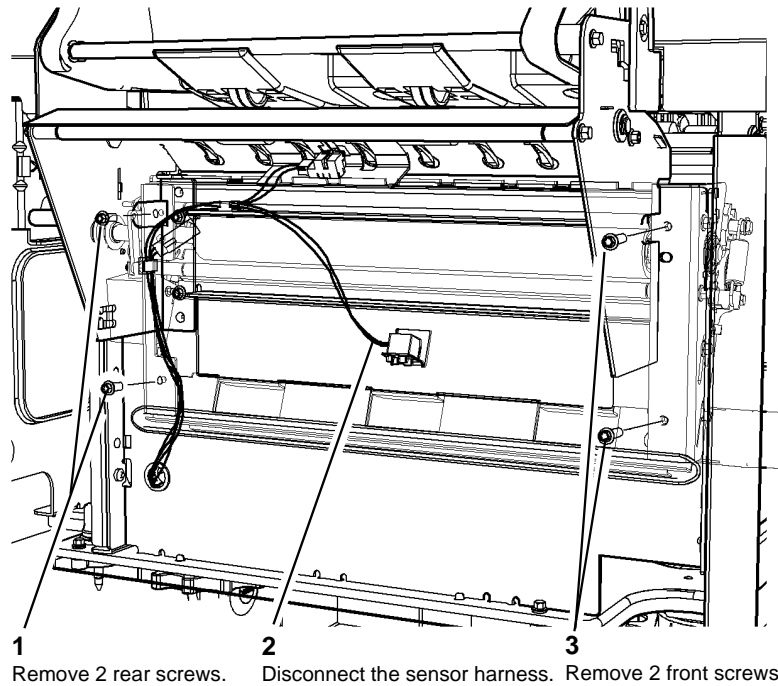

- 1 Remove 2 rear screws. 2 Disconnect the sensor harness. 3 Remove 2 front screws.

U-1-0585-A

Figure 1 Tri Folder Roller Assembly

4. Remove the diverter gate solenoid and crease roll pulleys as required, [Figure 2](#).

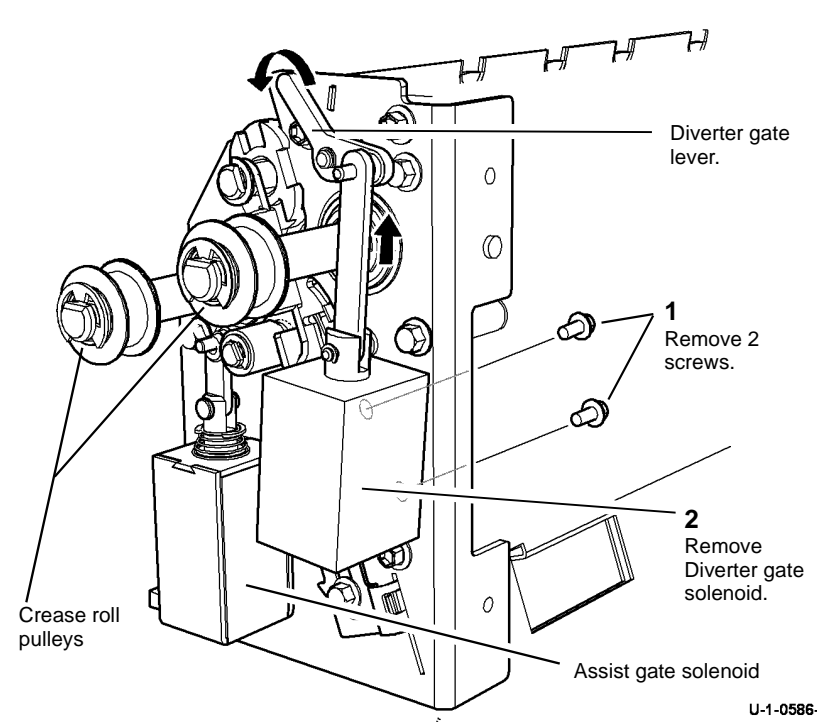

U-1-0586-A

Figure 2 Positioning The Diverter Gate Lever

Replacement

1. Reverse the removal procedures to reinstall the pulleys, diverter gate solenoid and Tri Folder roller assembly.
2. Before replacing the roller assembly set the diverter operating lever to the forward (solenoid armature extended) position to engage with the right side of the diverter shaft lever, [Figure 2](#).
3. Check that the diverter gate operates correctly before tensioning the crease roll drive belt.

REP 12.75-171 Bin 1 Limit Switches

Parts List on [PL 12.105](#).

Removal

WARNING

Take care during this procedure. Sharp edges may be present that can cause injury.

WARNING

Switch off the electricity to the machine. Refer to [GP 14](#). Disconnect the power cord from the customer supply while performing tasks that do not need electricity. Electricity can cause death or injury. Moving parts can cause injury.

1. Remove the HVF rear cover, [REP 12.1-171](#).

2. Disconnect the PJs and remove the upper or lower limit switch and bracket as required, [Figure 1](#).

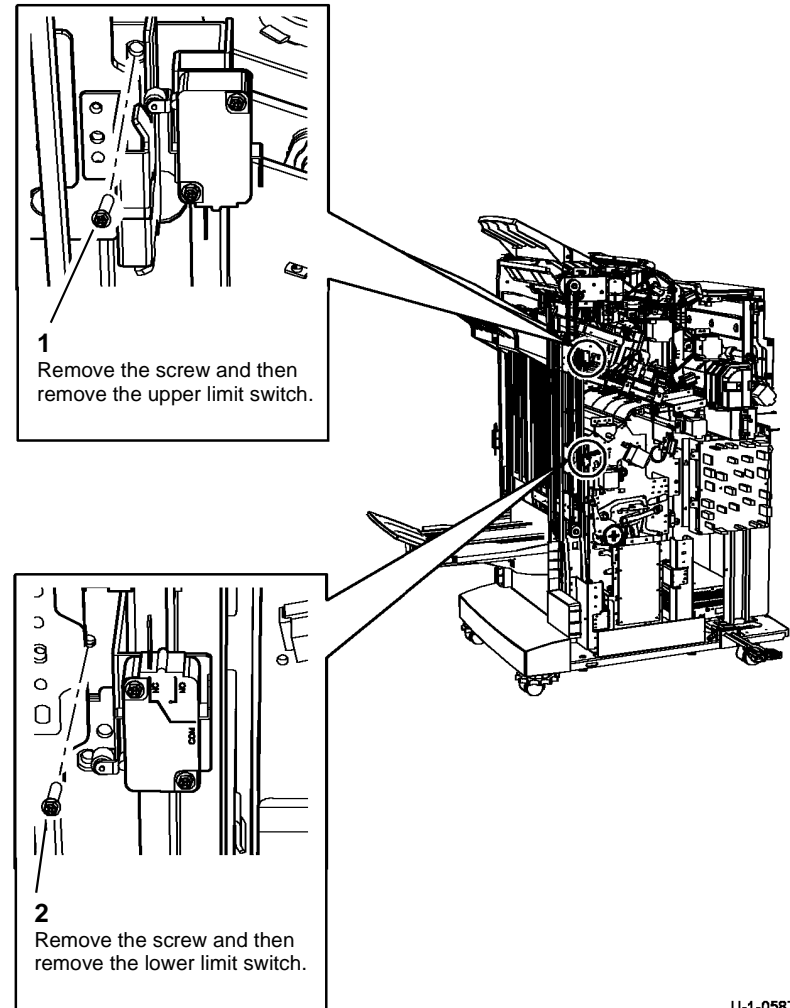

U-1-0587-A

Figure 1 Bin 1 Limit Switches

Replacement

Reverse the removal procedures to replace the Bin 1 upper and lower limit switches.

REP 12.76-171 Bin 1 Upper Level Sensor

Parts List on [PL 12.110](#).

Removal

WARNING

Take care during this procedure. Sharp edges may be present that can cause injury.

WARNING

Switch off the electricity to the machine. Refer to [GP 14](#). Disconnect the power cord from the customer supply while performing tasks that do not need electricity. Electricity can cause death or injury. Moving parts can cause injury.

1. Remove the HVF front and rear covers, [REP 12.1-171](#).
2. Disconnect the PJs and remove the receiver or transmitter as necessary, [Figure 1](#).

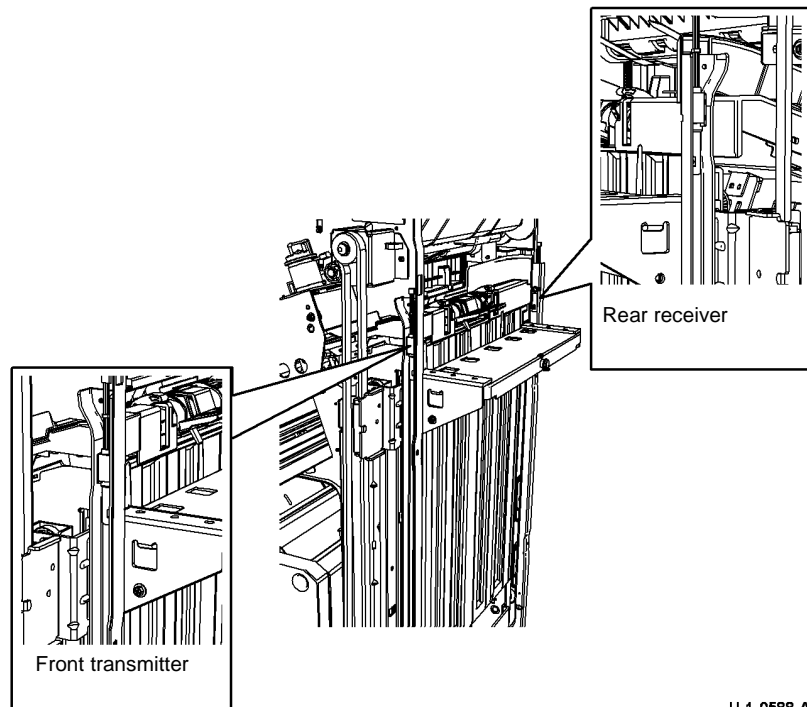

Figure 1 Bin 1 Upper level sensor

U-1-0588-A

Replacement

Reverse the removal procedures to replace the transmitter or receiver of the bin 1 upper level sensor.

REP 12.77-171 Tri Folder Door Interlock Switches and Sensor

Parts List on [PL 12.215](#).

Removal

WARNING

Take care during this procedure. Sharp edges may be present that can cause injury.

WARNING

Switch off the electricity to the machine. Refer to [GP 14](#). Disconnect the power cord from the customer supply while performing tasks that do not need electricity. Electricity can cause death or injury. Moving parts can cause injury.

1. Remove the tri folder front and top covers, [REP 12.67-171](#).
2. Remove the front door and top cover interlock switches and the top cover sensor, [Figure 1](#).

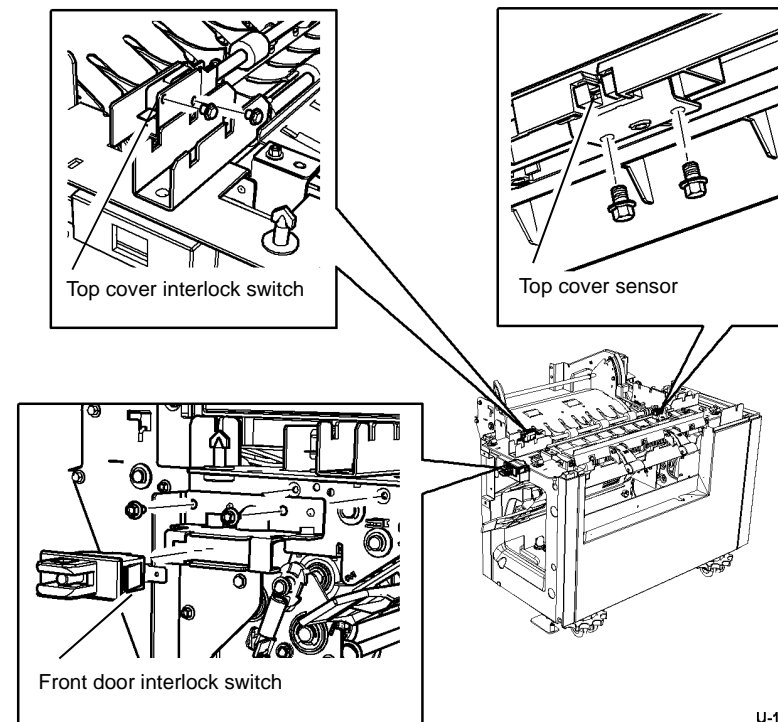

Figure 1 TF Interlock Switches and Cover Sensor

U-1-0589-A

Replacement

Reverse the removal procedures to replace the front door and top cover interlock switches and the top access cover sensor.

REP 12.78-171 Tri Folder Entry and Assist Gate Sensors

Parts List on [PL 12.215](#).

Removal

WARNING

Take care during this procedure. Sharp edges may be present that can cause injury.

WARNING

Switch off the electricity to the machine. Refer to [GP 14](#). Disconnect the power cord from the customer supply while performing tasks that do not need electricity. Electricity can cause death or injury. Moving parts can cause injury.

1. Undock the tri folder unit from the HVF, [REP 12.73-171](#).
2. Disconnect the PJs and remove the entry and assist gate sensors, [Figure 1](#).

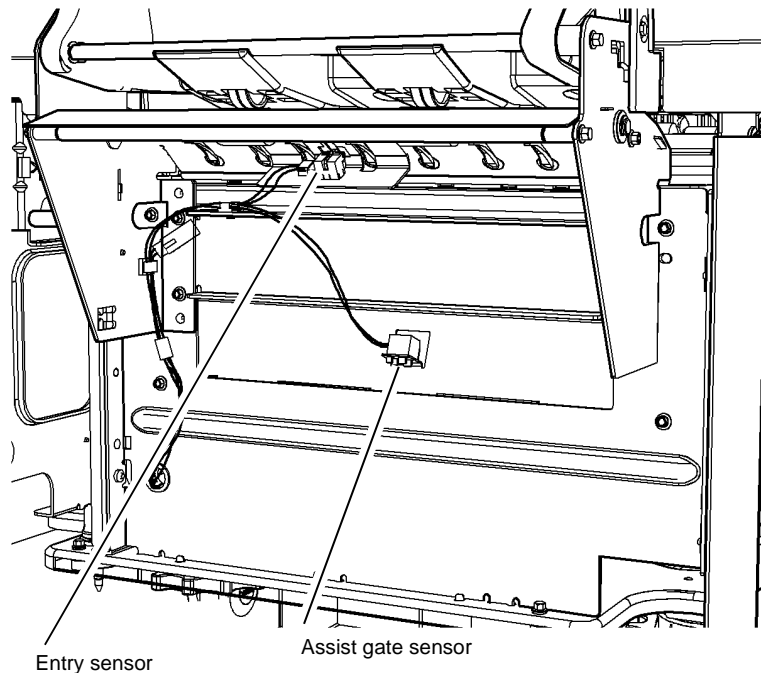

LEFT SIDE VIEW

U-1-0590-A

Figure 1 TF Entry and Assist Gate Sensors

Replacement

Reverse the removal procedures to replace the entry and assist gate sensors.

REP 12.79-171 Tri Folder Exit Sensor

Parts List on [PL 12.215](#).

Removal

WARNING

Take care during this procedure. Sharp edges may be present that can cause injury.

WARNING

Switch off the electricity to the machine. Refer to [GP 14](#). Disconnect the power cord from the customer supply while performing tasks that do not need electricity. Electricity can cause death or injury. Moving parts can cause injury.

1. Remove the tri folder top cover, [REP 12.67-171](#).
2. Remove the exit sensor, [Figure 1](#).

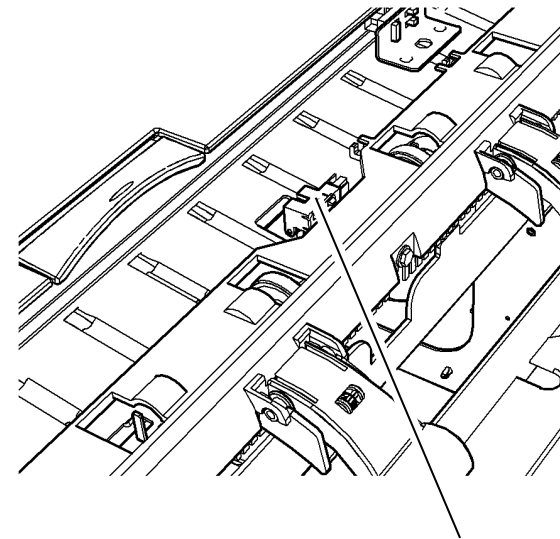

1
Disconnect the harness and
remove the exit sensor.

U-1-0591-A

Figure 1 Tri Folder Exit Sensor

Replacement

Reverse the removal procedures to replace the exit sensor.

REP 12.80-171 Tri Folder PWB

Parts List on [PL 12.205](#).

Removal

WARNING

Take care during this procedure. Sharp edges may be present that can cause injury.

WARNING

Switch off the electricity to the machine. Refer to [GP 14](#). Disconnect the power cord from the customer supply while performing tasks that do not need electricity. Electricity can cause death or injury. Moving parts can cause injury.



Figure 1 ESD Symbol

CAUTION

Ensure that ESD procedures are observed during the removal and installation of the tri folder PWB.

1. Remove tri folder rear cover, [REP 12.67-171](#).

2. Remove the PWB, [Figure 2](#).

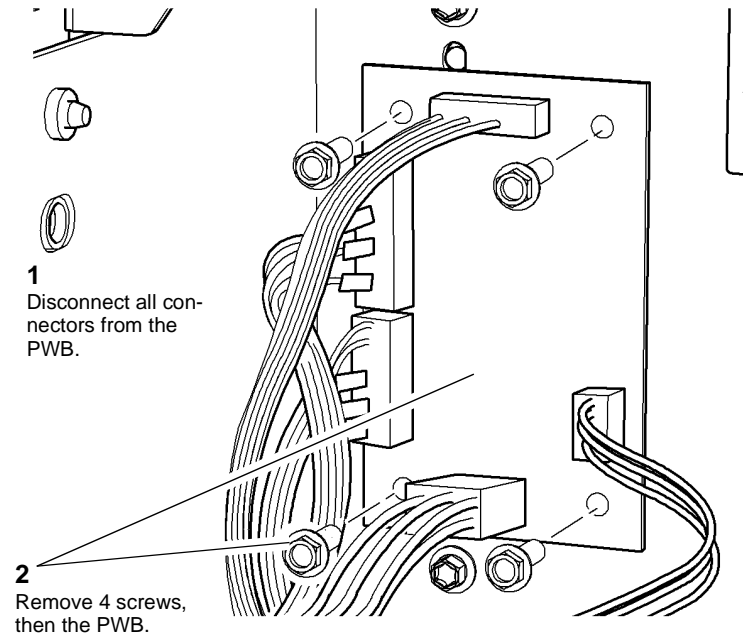

Figure 2 Tri Folder PWB

U-1-0592-A

Replacement

Reverse the removal procedures to replace the tri folder PWB.

REP 12.81-171 Tri Folder Main and Bin 2 Tray Harnesses

Parts List on [PL 12.205](#).

Removal

WARNING

Take care during this procedure. Sharp edges may be present that can cause injury.

WARNING

Switch off the electricity to the machine. Refer to [GP 14](#). Disconnect the power cord from the customer supply while performing tasks that do not need electricity. Electricity can cause death or injury. Moving parts can cause injury.

1. Remove the tri folder rear cover, [REP 12.67-171](#). If removing the bookletmaker PWB to tri-folder PWB harness, remove the HVF rear cover, [REP 12.1-171](#).
2. Disconnect the PJs then remove the bookletmaker PWB to tri-folder PWB harness, [Figure 1](#).

3. Remove the bin 2 tray harness, [Figure 1](#).

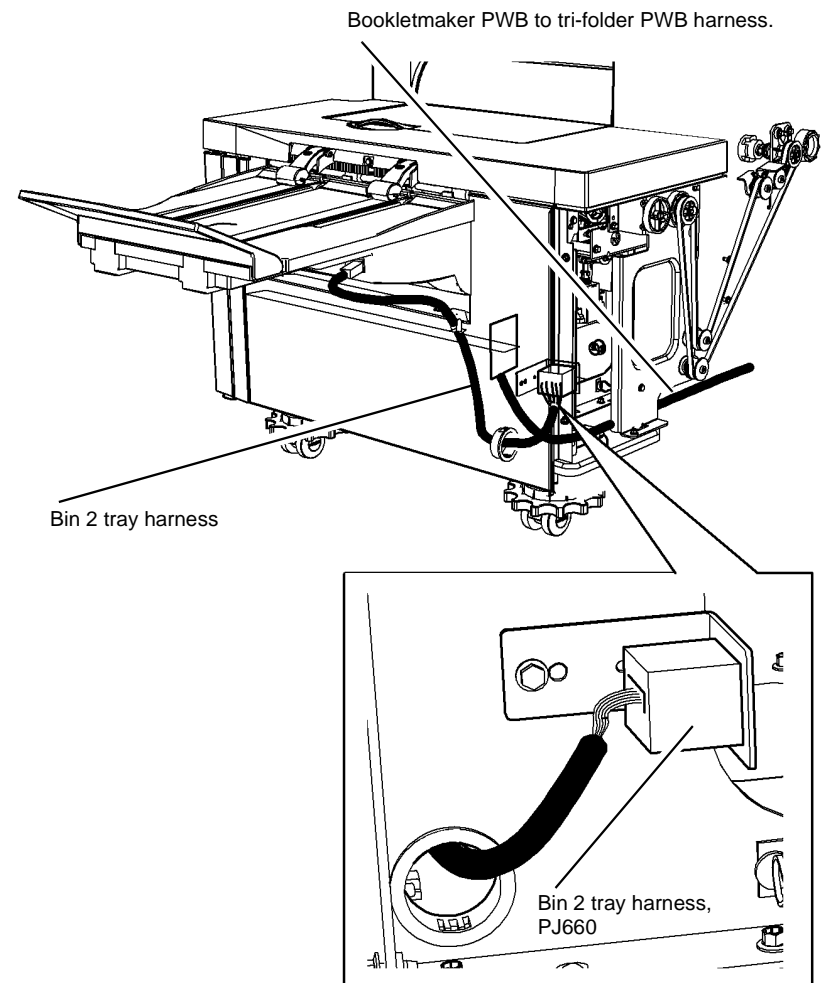

U-1-0593-A

Figure 1 Tri folder and Bin 2 harnesses

Replacement

Reverse the removal procedures to replace the bookletmaker PWB to tri-folder PWB and bin 2 tray harnesses.

REP 12.82-171 Inserter Undocking

Parts List on [PL 12.300](#).

Removal

WARNING

Take care during this procedure. Sharp edges may be present that can cause injury.

WARNING

Switch off the electricity to the machine. Refer to [GP 14](#). Disconnect the power cord from the customer supply while performing tasks that do not need electricity. Electricity can cause death or injury. Moving parts can cause injury.

CAUTION

Place the Inserter on a suitable surface. Do not damage the Inserter locating pins.

CAUTION

Do not show the customer how to undock or dock the Inserter.

1. Open the HVF front door.
2. Undock the inserter, [Figure 1](#).

Replacement

1. Reverse the undocking procedure to dock the Inserter unit to the HVF.
2. Lock the Inserter onto the HVF by sliding the latch handle towards the front, [Figure 1](#).

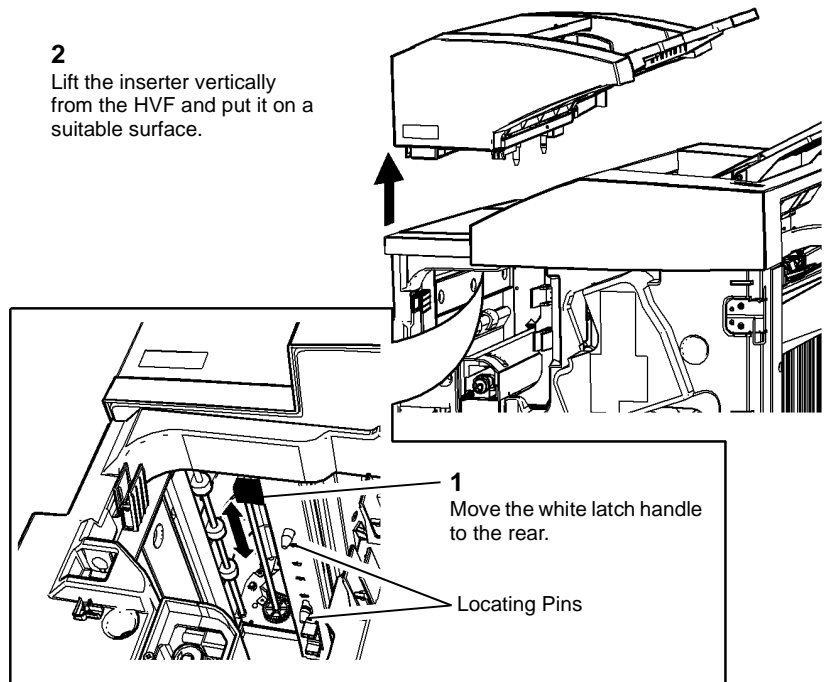

Figure 1 Tray 6 Inserter Undocking

REP 12.83-171 Inserter Front and Rear Covers

Parts List on [PL 12.300](#).

Removal

WARNING

Take care during this procedure. Sharp edges may be present that can cause injury.

WARNING

Switch off the electricity to the machine. Refer to [GP 14](#). Disconnect the power cord from the customer supply while performing tasks that do not need electricity. Electricity can cause death or injury. Moving parts can cause injury.

1. Undock the Inserter and put it on a suitable surface, [REP 12.82-171](#).
2. Remove the front and rear covers, [Figure 1](#).

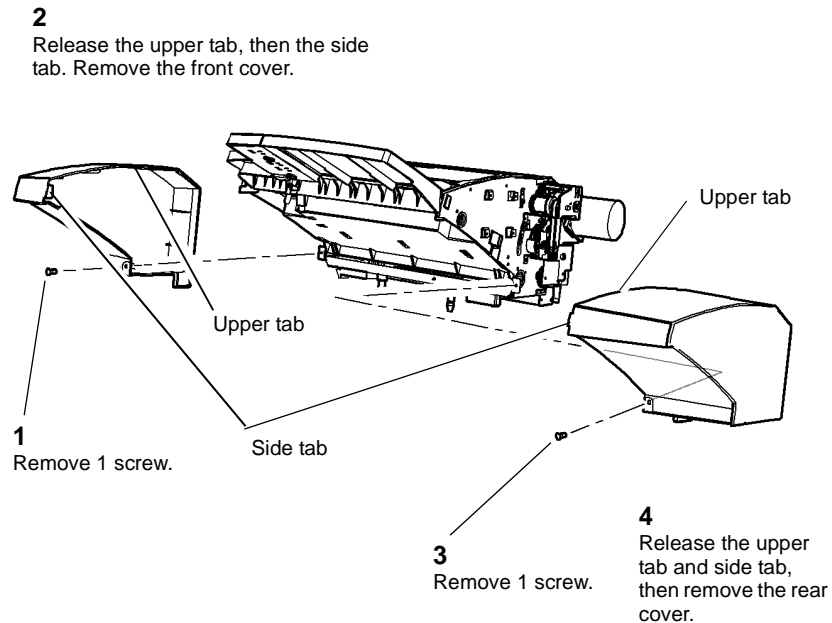

U-1-0595-A

Figure 1 Inserter Front and Rear Covers

Replacement

Reverse the removal procedures to replace the Inserter front and rear covers.

REP 12.84-171 Inserter Motor

Parts List on [PL 12.315](#).

Removal

WARNING

Take care during this procedure. Sharp edges may be present that can cause injury.

WARNING

Switch off the electricity to the machine. Refer to [GP 14](#). Disconnect the power cord from the customer supply while performing tasks that do not need electricity. Electricity can cause death or injury. Moving parts can cause injury.

1. Remove the Inserter rear cover, and open the top left door, [REP 12.83-171](#).
2. Remove the inserter motor and bracket, [Figure 1](#).

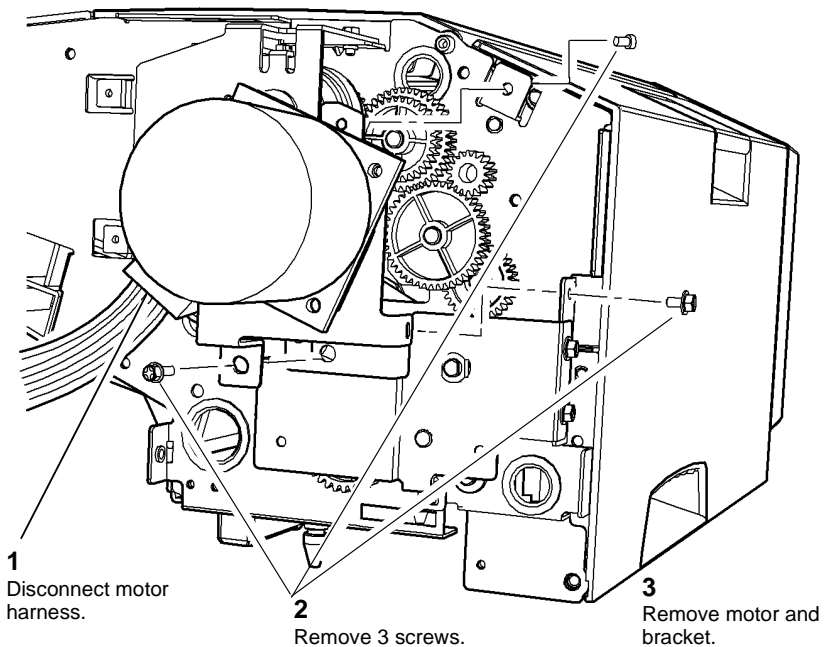

U-1-0596-A

Figure 1 Inserter Motor

Replacement

1. Reverse the removal procedures to replace the Inserter motor.
2. Make sure that the correct screws are used to replace the inserter motor.

REP 12.85-171 Inserter PWB

Parts List on [PL 12.310](#).

Removal

WARNING

Take care during this procedure. Sharp edges may be present that can cause injury.



Figure 1 ESD Symbol

CAUTION

Ensure that ESD procedures are observed during the removal and installation of the inserter PWB.

WARNING

Switch off the electricity to the machine. Refer to [GP 14](#). Disconnect the power cord from the customer supply while performing tasks that do not need electricity. Electricity can cause death or injury. Moving parts can cause injury.

1. Remove the inserter rear cover. [REP 12.83-171](#).
2. Remove the inserter PWB, [Figure 2](#).

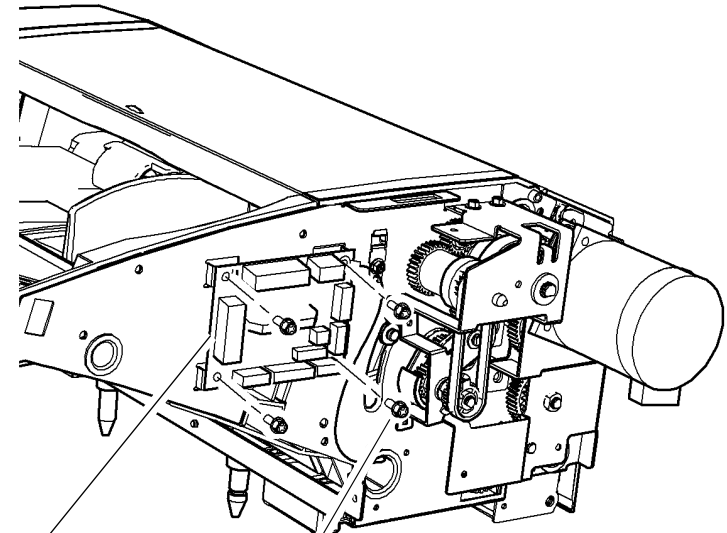

3
Remove the inserter PWB.

2
Remove 4 screws and the ground strap.

1
Disconnect all the PJs from the PWB.

U-1-0597-A

Figure 2 Inserter PWB

Replacement

1. Reverse the removal procedures to replace the Inserter PWB.
2. Ensure that the ground strap is secured by one of the fixing screws.

REP 12.86-171 Inserter Clutch

Parts List on [PL 12.310](#).

Removal

WARNING

Take care during this procedure. Sharp edges may be present that can cause injury.

WARNING

Switch off the electricity to the machine. Refer to [GP 14](#). Disconnect the power cord from the customer supply while performing tasks that do not need electricity. Electricity can cause death or injury. Moving parts can cause injury.

1. Remove the Inserter rear cover. [REP 12.83-171](#).
2. Remove the inserter clutch, [Figure 1](#).

NOTE: The reverse roll drive idler and the drive belt are not attached to the clutch bracket or the Inserter frame.

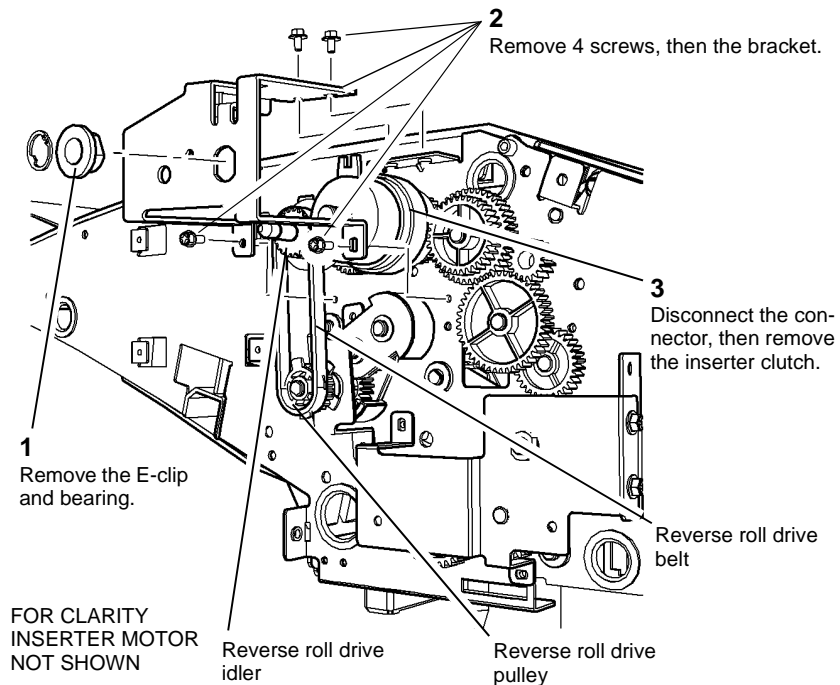

U-1-0598-A

Figure 1 Inserter Clutch Removal

Replacement

1. Reverse the removal procedures to replace the Inserter clutch.
2. When replacing the bracket, check that the clutch torque arm locates in the locating tab.
3. Put the reverse roll drive belt over the drive idler and check that the reverse roll idler gear shaft locates properly into the frame.
4. When the bracket is secured, temporarily remove the circlip and the reverse roll drive pulley to replace the drive belt over the reverse roll drive pulley.

REP 12.87-171 Inserter Top Cover Interlock Switch

Parts List on [PL 12.305](#).

Removal

WARNING

Take care during this procedure. Sharp edges may be present that can cause injury.

WARNING

Switch off the electricity to the machine. Refer to [GP 14](#). Disconnect the power cord from the customer supply while performing tasks that do not need electricity. Electricity can cause death or injury. Moving parts can cause injury.

1. Remove the Inserter front cover, [REP 12.83-171](#).
2. Remove the top cover interlock switch, [Figure 1](#).

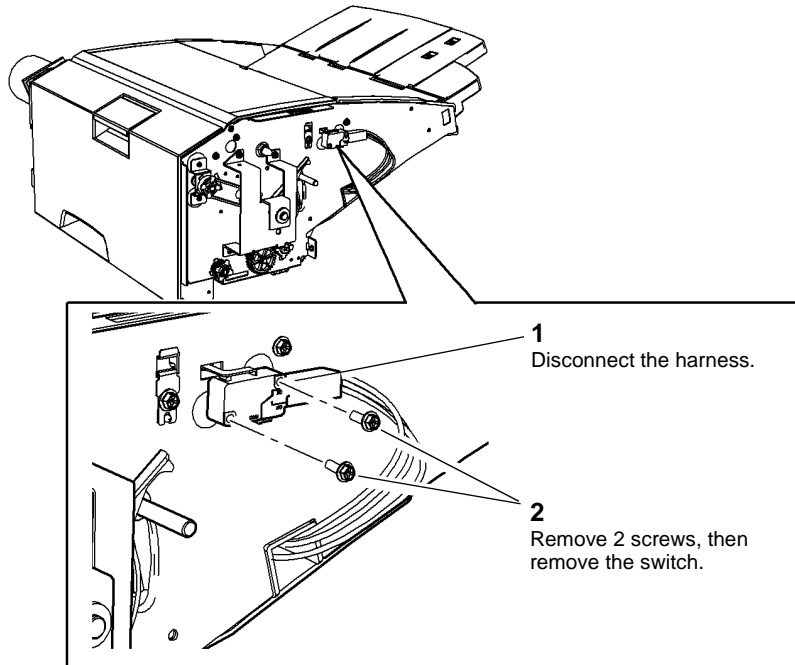

U-1-0599-A

Figure 1 Top Cover Interlock Switch

Replacement

Reverse the removal procedures to replace the Inserter top cover interlock switch.

REP 12.88-171 Inserter Jam Cover Interlock Switch

Parts List on [PL 12.300](#).

Removal

WARNING

Take care during this procedure. Sharp edges may be present that can cause injury.

WARNING

Switch off the electricity to the machine. Refer to [GP 14](#). Disconnect the power cord from the customer supply while performing tasks that do not need electricity. Electricity can cause death or injury. Moving parts can cause injury.

1. Remove the Inserter front and rear covers, [REP 12.83-171](#).
2. Remove the inserter motor, [REP 12.84-171](#).

- Remove the top cover door and the interlock switch, [Figure 1](#).

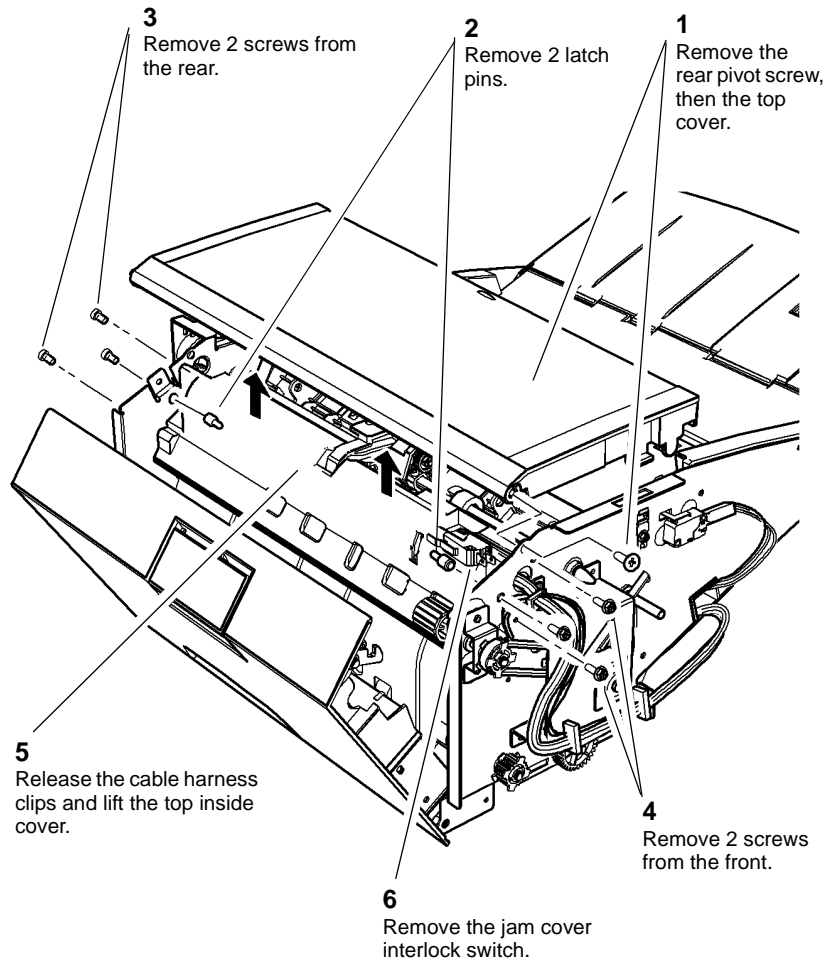

U-1-0600-A

Figure 1 Jam cover Interlock Switch

Replacement

- Reverse the removal procedures to replace the jam cover interlock switch.
- When reinstalling the top inside cover and the top cover door make sure that the correct screws are used and that the screws are not overtightened.

REP 12.89-171 Main Tray and Paper Length Sensors

Parts List on [PL 12.300](#).

Removal

WARNING

Take care during this procedure. Sharp edges may be present that can cause injury.

WARNING

Switch off the electricity to the machine. Refer to [GP 14](#). Disconnect the power cord from the customer supply while performing tasks that do not need electricity. Electricity can cause death or injury. Moving parts can cause injury.

- Pull the lug on one side of the tray to disconnect from the frame pivot. Remove the cover plate then disconnect the PJs and remove the sensors from the bracket clips, [Figure 1](#)

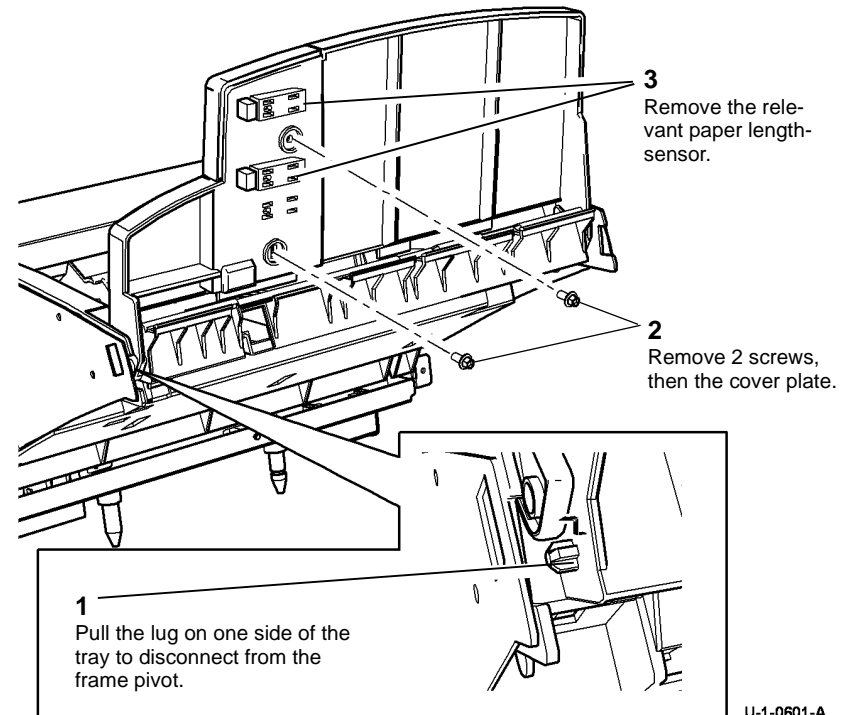

U-1-0601-A

Figure 1 Main Tray Assembly

Replacement

Reverse the removal procedures to replace the Inserter main tray and paper length sensors.

REP 12.90-171 Bottom Tray and Paper Sensors

Parts List on [PL 12.300](#).

Removal

WARNING

Take care during this procedure. Sharp edges may be present that can cause injury.

WARNING

Switch off the electricity to the machine. Refer to [GP 14](#). Disconnect the power cord from the customer supply while performing tasks that do not need electricity. Electricity can cause death or injury. Moving parts can cause injury.

1. Undock the Inserter, [REP 12.82-171](#).

2. Remove the bottom tray sensor bracket, [Figure 1](#).

NOTE: Observe the position of the two springs when lifting the bottom tray.

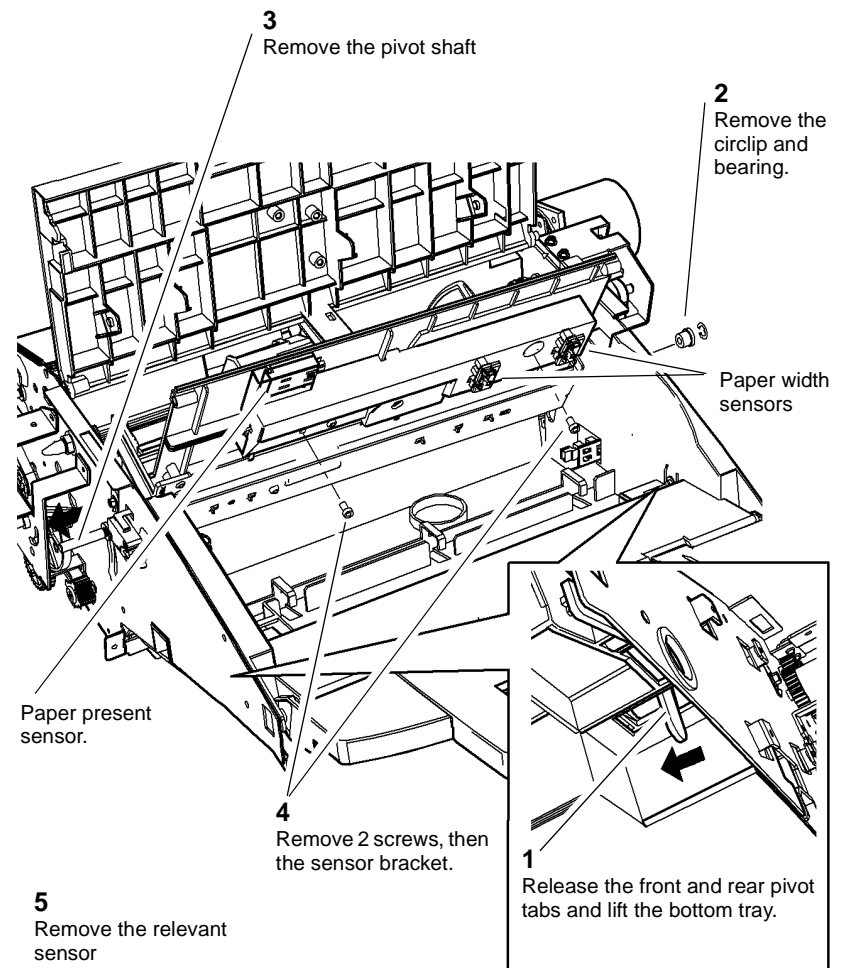

U-1-0602-A

Figure 1 Bottom Tray and Sensors

Replacement

1. Reverse the removal procedure to replace the bottom tray and paper sensors.
2. Check that the loading levers are at the same angle and that the tray pivot shaft passes below the front and rear loading levers. Check that the bottom tray is supported horizontally in the frame.
3. Make sure that the bottom tray springs are correctly aligned before engaging the front and rear pivot tabs.

REP 12.91-171 Inserter Top Cover and Inserter Pickup Sensor

Parts List on [PL 12.310](#).

Removal

WARNING

Take care during this procedure. Sharp edges may be present that can cause injury.

WARNING

Switch off the electricity to the machine. Refer to [GP 14](#). Disconnect the power cord from the customer supply while performing tasks that do not need electricity. Electricity can cause death or injury. Moving parts can cause injury.

1. Remove the Inserter Front Cover, [REP 12.83-171](#).
2. To release the top cover, remove the pivot screw, [Figure 1](#).
3. Remove the inserter pickup sensor, [Figure 1](#).

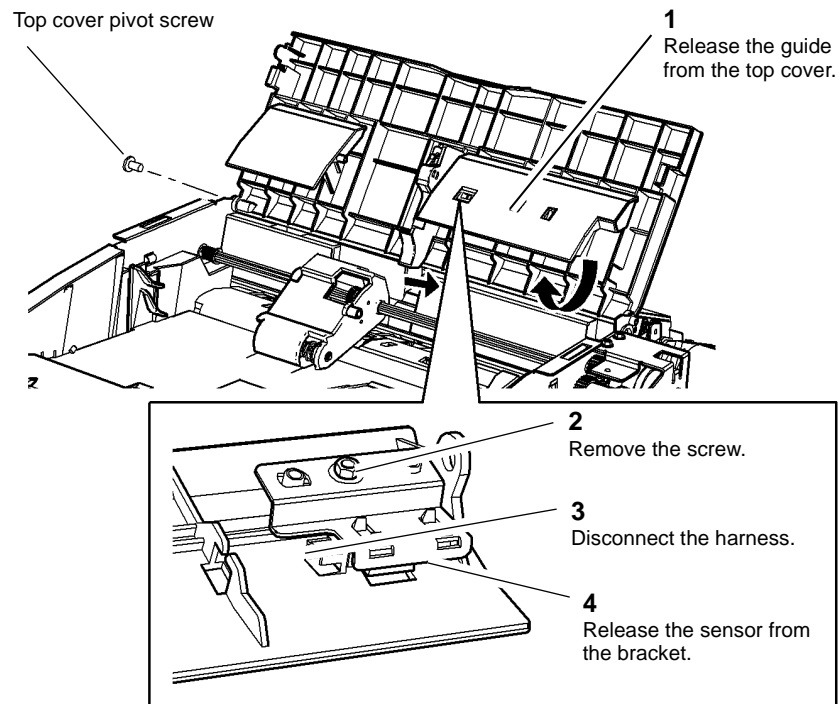

Figure 1 Cover and Inserter Pickup Sensor

Replacement

Reverse the removal procedure to replace the inserter pickup sensor and top cover.

REP 12.92-171 Lower Jam Cover and Acceleration Sensor

Parts List on [PL 12.300](#).

Removal

WARNING

Take care during this procedure. Sharp edges may be present that can cause injury.

WARNING

Switch off the electricity to the machine. Refer to [GP 14](#). Disconnect the power cord from the customer supply while performing tasks that do not need electricity. Electricity can cause death or injury. Moving parts can cause injury.

1. Remove the front and rear covers, [REP 12.83-171](#).
2. Remove the acceleration sensor. [Figure 1](#).

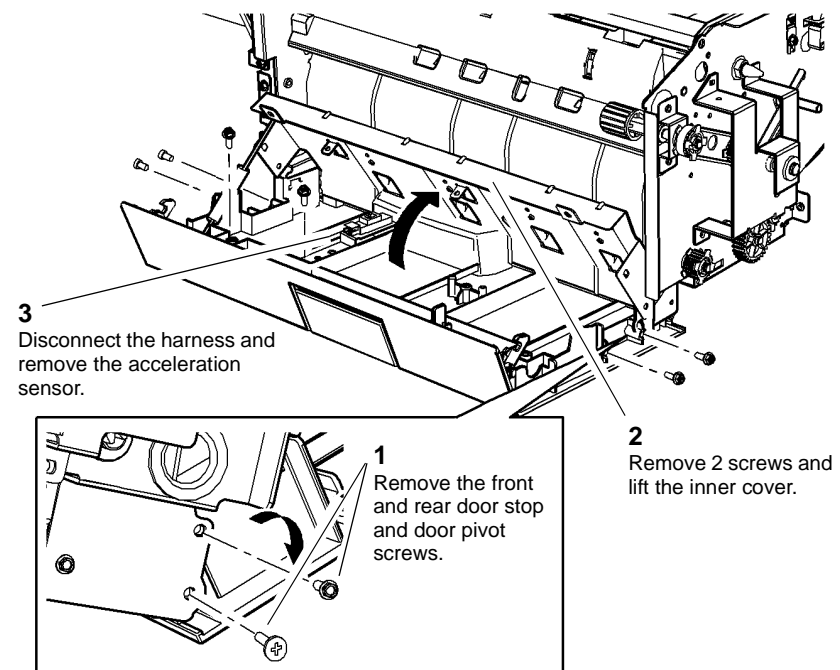

Figure 1 Acceleration sensor

Replacement

Reverse the removal procedure to replace the Inserter lower jam cover and the acceleration sensor.

REP 12.93-171 Inserter LE and TE Sensors

Parts List on [PL 12.310](#).

Removal

WARNING

Take care during this procedure. Sharp edges may be present that can cause injury.

WARNING

Switch off the electricity to the machine. Refer to [GP 14](#). Disconnect the power cord from the customer supply while performing tasks that do not need electricity. Electricity can cause death or injury. Moving parts can cause injury.

1. Remove the Inserter front and rear covers, [REP 12.83-171](#).
2. Remove the inserter motor, [REP 12.84-171](#).
3. Remove the pickup roll assembly, [REP 12.95-171](#).
4. Remove the top cover, [REP 12.91-171](#).
5. Remove the top inside cover, [REP 12.88-171](#).
6. Remove the LE sensor or TE sensor, [Figure 1](#).

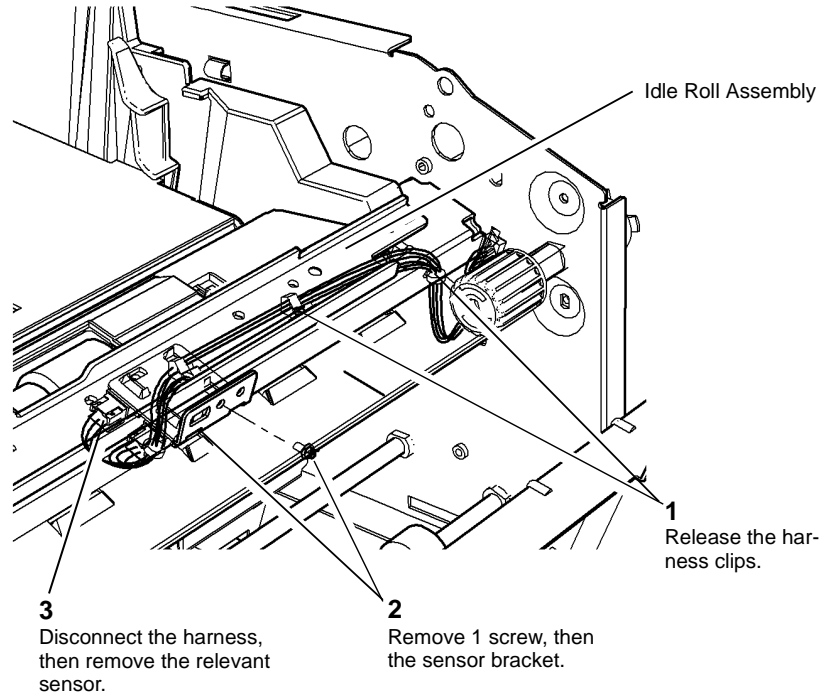

Figure 1 LE and TE Sensors

U-1-0606-A

Replacement

Reverse the removal procedure to replace the LE and TE paper path sensors.

REP 12.94-171 Inserter Bottom Plate Sensor

Parts List on [PL 12.300](#).

Removal

WARNING

Take care during this procedure. Sharp edges may be present that can cause injury.

WARNING

Switch off the electricity to the machine. Refer to [GP 14](#). Disconnect the power cord from the customer supply while performing tasks that do not need electricity. Electricity can cause death or injury. Moving parts can cause injury.

1. Undock the Inserter, [REP 12.82-171](#), and release the front and rear pivot tabs then lift the bottom tray. Control the movement of the bottom tray springs.
2. Remove the sensor from the bracket, [Figure 1](#).

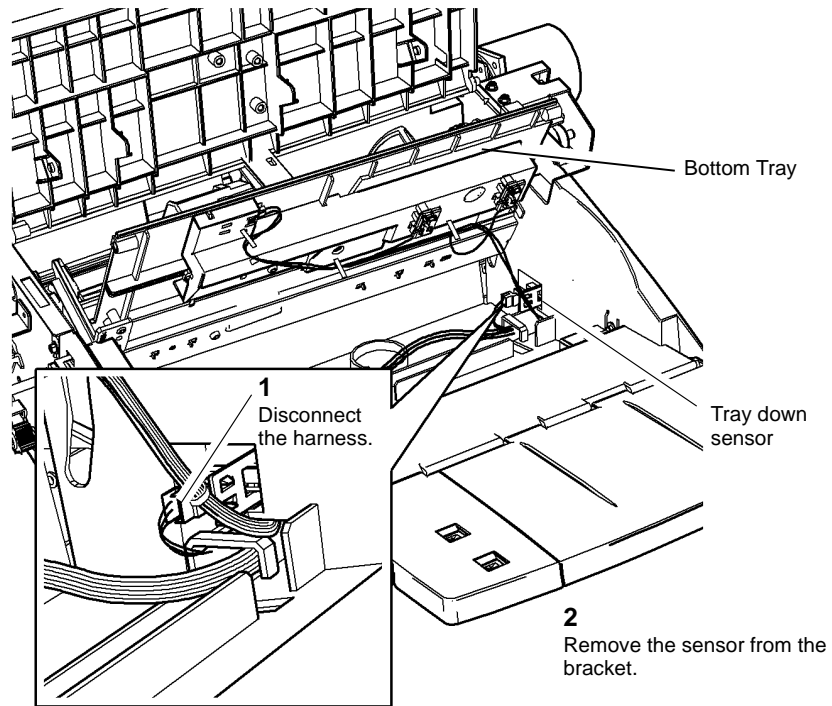

U-1-0607-A

Figure 1 Inserter Tray Down Sensor

Replacement

Reverse the removal procedure to replace the Inserter bottom plate sensor.

REP 12.95-171 Inserter Pickup Assembly and Reverse Feed Roller

Parts List on [PL 12.310](#)

Removal

WARNING

Take care during this procedure. Sharp edges may be present that can cause injury.

WARNING

Switch off the electricity to the machine. Refer to [GP 14](#). Disconnect the power cord from the customer supply while performing tasks that do not need electricity. Electricity can cause death or injury. Moving parts can cause injury.

1. Remove the pickup roller assembly from the inserter, [Figure 1](#).

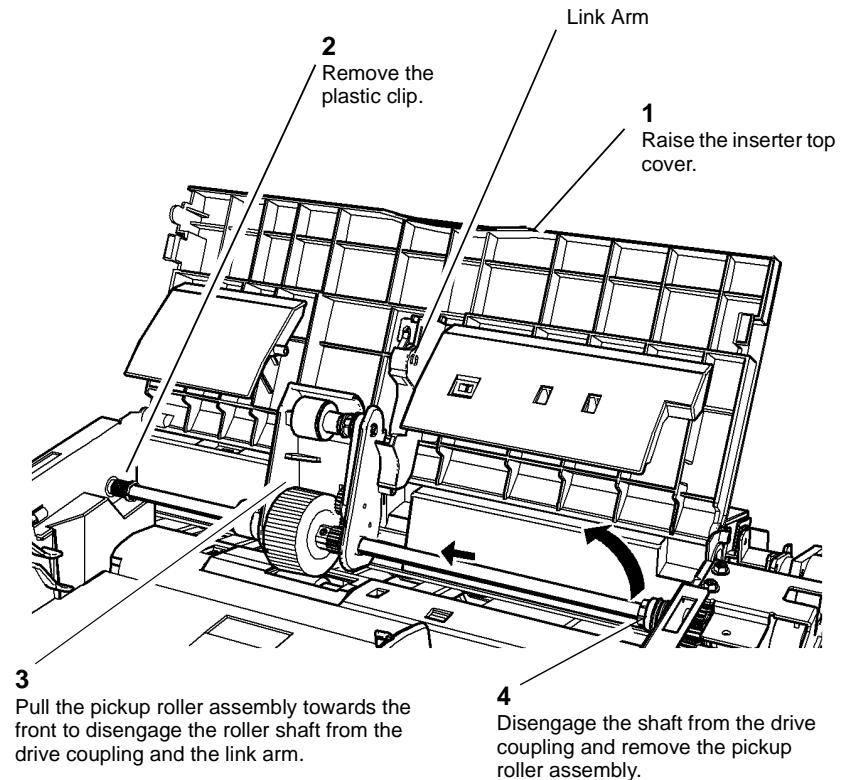

U-1-0608-A

Figure 1 Pickup roller assembly removal

2. Remove the reverse roller and coupling from the reverse roller shaft, [Figure 2](#).

For clarity the top cover is not shown.

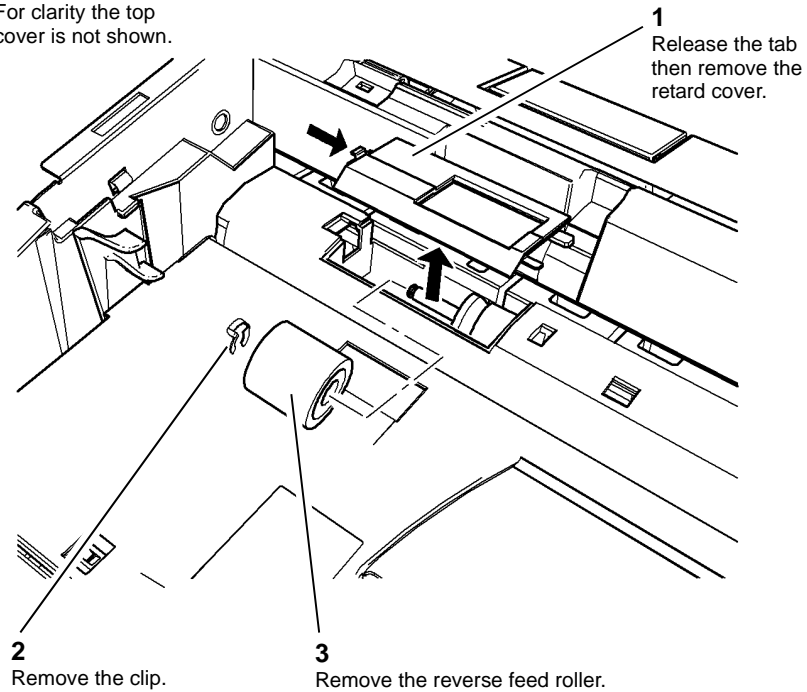

U-1-0609-A

Figure 2 Reverse roller removal

Replacement

1. Reverse the removal procedure to replace the reverse and the pickup roller assemblies.
2. After replacing the pickup roller assembly close the Inserter top cover fully to engage the link arm with the pickup roller.
3. If a new inserter pickup assembly is installed, reset the inserter feed count to zero. Refer to [dC135 CRU / HFSI Status](#).

REP 12.96-171 HVF Fixed and Adjustable Casters

Parts List on [PL 12.100](#).

Removal

WARNING

Take care during this procedure. Sharp edges may be present that can cause injury.

WARNING

Switch off the electricity to the machine. Refer to [GP 14](#). Disconnect the power cord from the customer supply while performing tasks that do not need electricity. Electricity can cause death or injury. Moving parts can cause injury.

CAUTION

Do not remove more than one caster at a time unless the HVF frame is properly supported and stable.

1. Undock the Tri Folder from the HVF, [REP 12.82-171](#).
2. Undock the HVF from the copier and remove the HVF front and rear covers, [REP 12.1-171](#).
3. Get help to lift and support the HVF frame securely at a position close to where the caster is to be removed, [GP 16](#). Support the frame approximately 4 inches (approximately 2 reams of paper) above the floor so that the caster is not supporting the unit.

4. Remove the 2 screws and remove the fixed caster, [Figure 1](#).

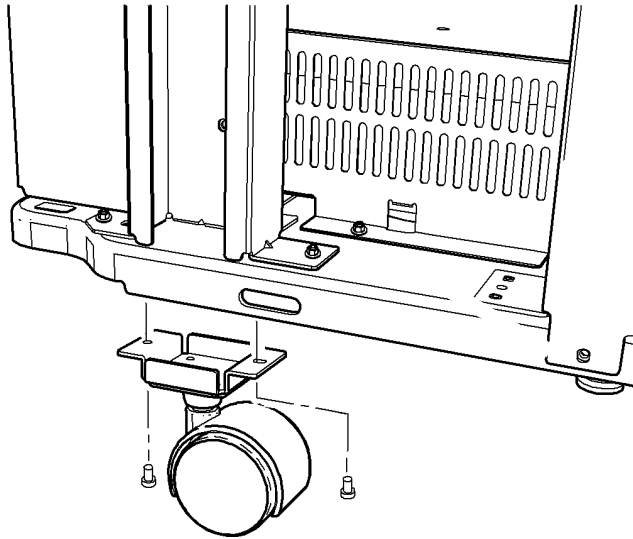

U-1-0610-A

Figure 1 HVF Fixed Caster Removal

5. Support the HVF frame. Remove the screw and stop plate and rotate the caster adjustment wheel to unscrew the caster from the frame, [Figure 2](#).

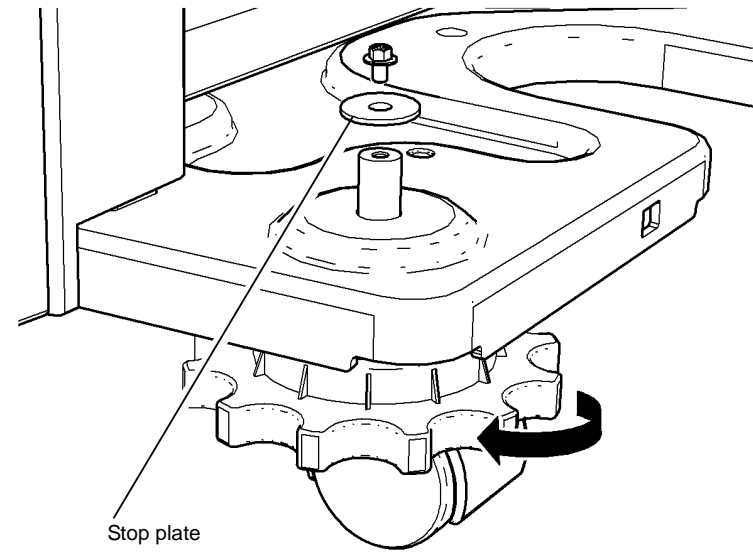

U-1-0611-A

Figure 2 HVF Adjustable Caster Removal

Replacement

Reverse the removal procedure to replace the HVF fixed and adjustable casters.

REP 12.97-171 Pause To Unload PWB Assembly

Parts List on [PL 12.140](#).

Removal

WARNING

Take care during this procedure. Sharp edges may be present that can cause injury.

WARNING

Switch off the electricity to the machine. Refer to [GP 14](#). Disconnect the power cord from the customer supply while performing tasks that do not need electricity. Electricity can cause death or injury. Moving parts can cause injury.

1. Remove the front door, front cover and top cover, [REP 12.1-171](#).
2. Remove the pause to unload (PTU) PWB, [Figure 1](#).

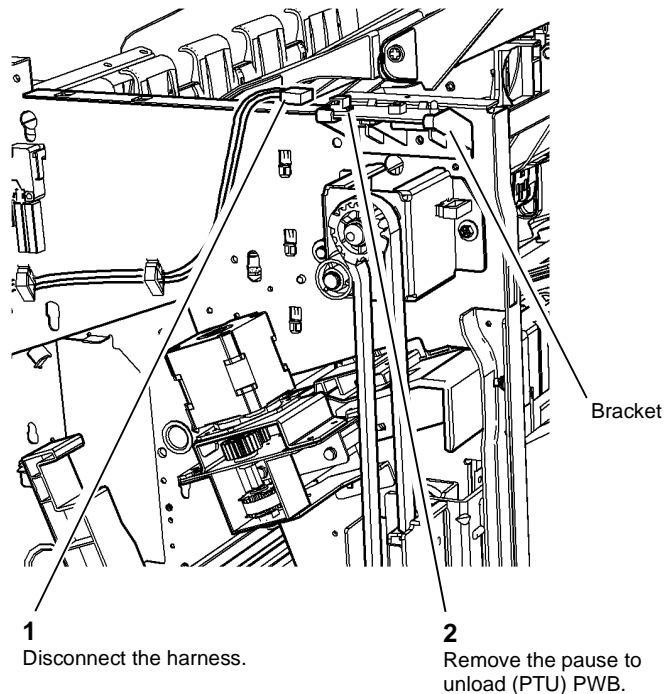

U-1-0612-A

Figure 1 Remove the PTU PWB

Replacement

Reverse the removal procedure to replace the PTU PWB.

REP 12.98-171 Inserter Idle Roller Assembly

Parts List on [PL 12.310](#).

Removal

WARNING

Take care during this procedure. Sharp edges may be present that can cause injury.

WARNING

Switch off the electricity to the machine. Refer to [GP 14](#). Disconnect the power cord from the customer supply while performing tasks that do not need electricity. Electricity can cause death or injury. Moving parts can cause injury.

1. Remove the Inserter front and rear covers., [REP 12.83-171](#).
2. Remove the inserter motor, [REP 12.84-171](#).
3. Remove the inserter clutch, [REP 12.86-171](#).
4. Remove the top cover assembly, [REP 12.91-171](#).
5. Remove the inside top cover and top left door interlock switch, [REP 12.88-171](#).

6. Remove the 2 screws at the rear of the idle roller assembly, [Figure 1](#).

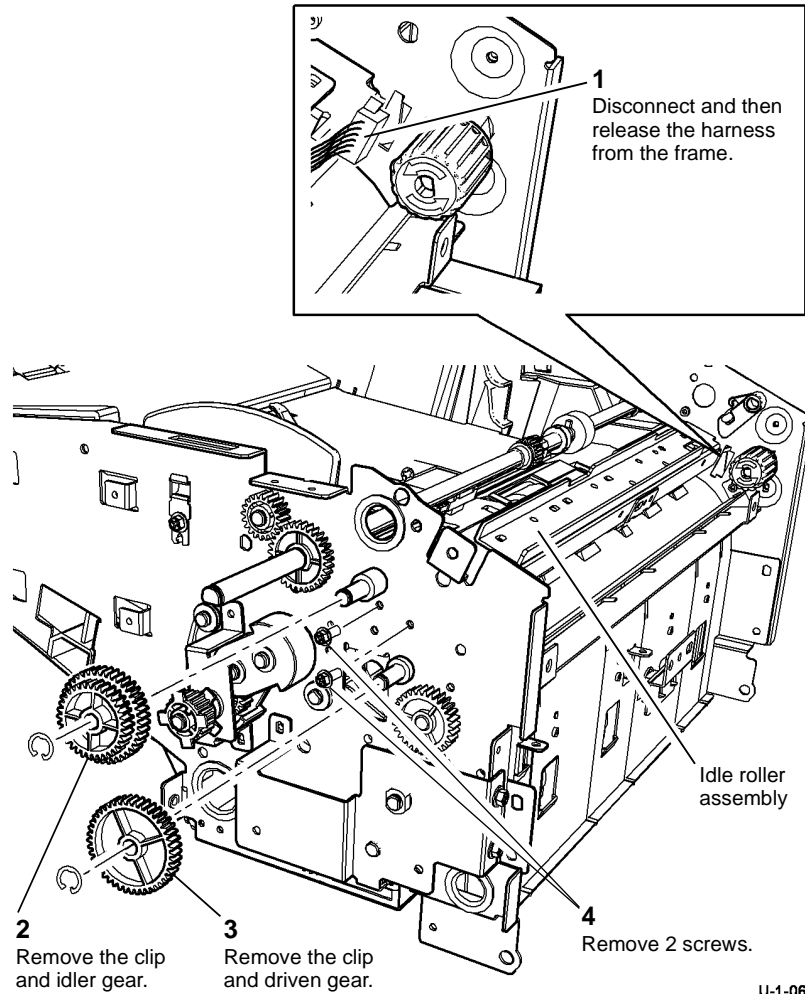

U-1-0613-A

Figure 1 Idler Assembly Rear Screws

7. Relieve the torsion spring tension by moving the loading lever and remove 3 of the four front loading bracket screws. Remove the idle roller assembly, [Figure 2](#).

NOTE: Check that the loading gear remains engaged with the loading shaft gear.

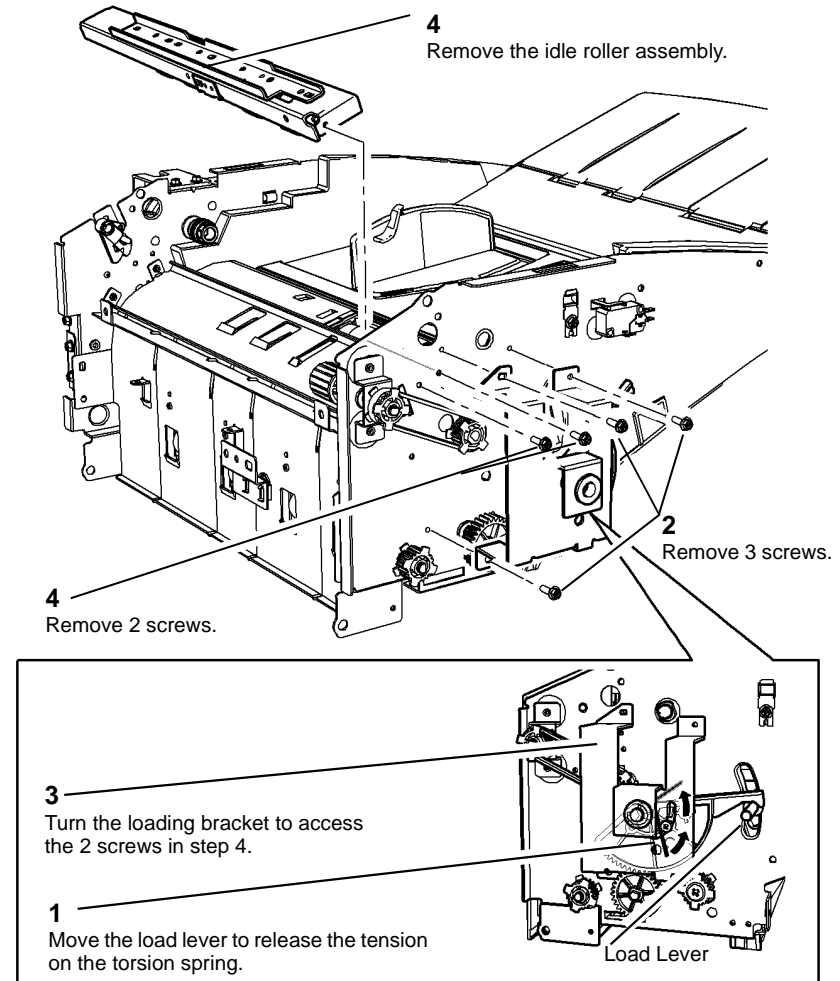

U-1-0614-A

Figure 2 Idle Roller Assembly

Replacement

Reverse the removal procedure to replace the Idle roller assembly.

Replace the loading bracket screws and check that the front loading lever is at the same angle as the rear loading lever then tension the torsion spring. The loading tray will not operate correctly if it is not supported horizontally in the Inserter frame.

REP 12.99-171 Tri-Folder Removal

Parts List on [PL 12.200](#), [PL 12.205](#)

Removal

WARNING

Take care during this procedure. Sharp edges may be present that can cause injury.

WARNING

Switch off the electricity to the machine, [GP 14](#). Disconnect the power cord from the customer supply while performing tasks that do not need electricity. Electricity can cause death or injury. Moving parts can cause injury.

1. Remove the HVF rear cover, [REP 12.1-171](#).
2. Remove the tri-folder rear cover, [REP 12.67-171](#).
3. Remove the coupler drive belt, [REP 12.68-171](#).
4. Open the tri-folder front door, then remove the front and rear thumb screws, [Figure 1](#).

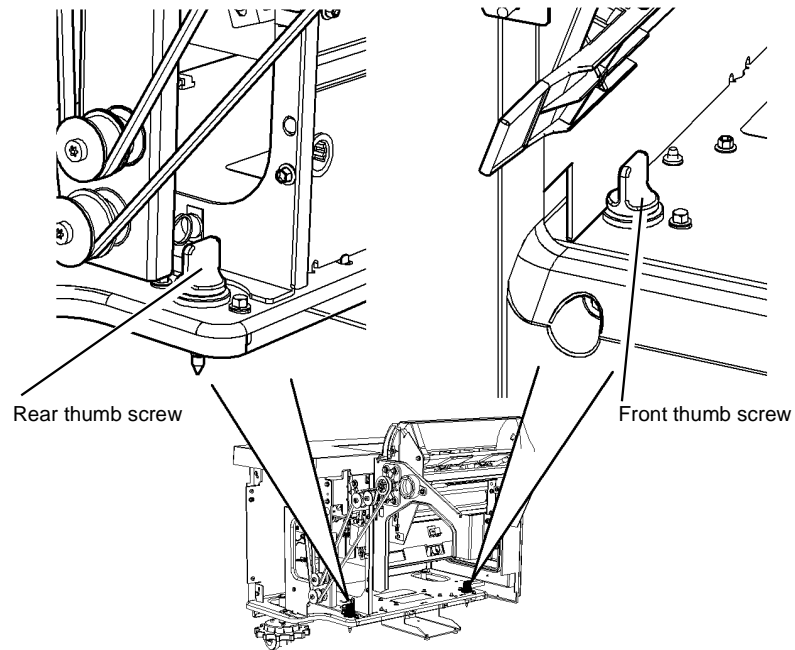

U-1-0582-A

Figure 1 Thumb Screw Removal

5. Disconnect the bookletmaker PWB to tri-folder PWB and bin 2 tray harnesses from the tri-folder module, [REP 12.81-171](#).
6. Disconnect the harness from PJ 553 & PJ 563 on the BM PWB, [PL 12.175 Item 10](#).

7. Undock the tri-folder from the HVF.

Replacement

Reverse the removal procedures to replace the tri-folder module.

REP 12.100-171 Ejector Paddle Assembly (W/TAG V-004)

Parts List on [PL 12.110](#)

Removal

WARNING

Switch off the electricity to the machine, [GP 14](#). Disconnect the power cord from the customer supply while performing tasks that do not need electricity. Electricity can cause death or injury. Moving parts can cause injury.

WARNING

Take care during this procedure. Sharp edges may be present that can cause injury.

1. Rotate the ejector paddle assembly until the two short tabs are visible.
2. Squeeze the two short tabs together and pull to remove the ejector paddle assembly, [Figure 1](#).

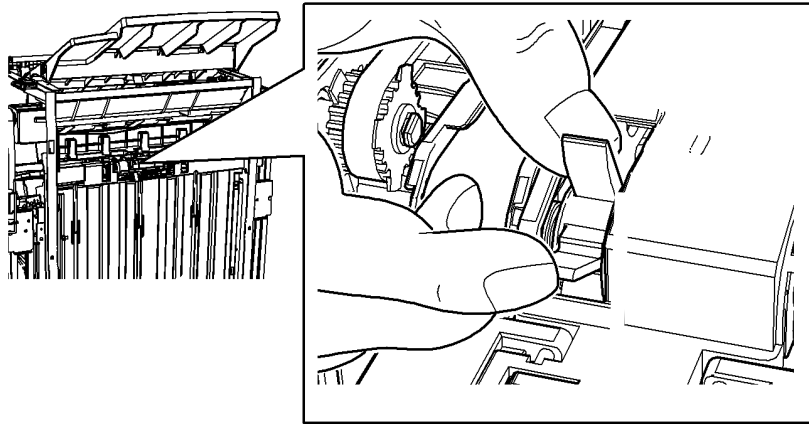

U-1-1631-A

Figure 1 Ejector paddle assembly

Replacement

1. Rotate the paddle shaft to ensure that the locating tab is uppermost, [Figure 2](#).
2. Ensure that the longest paddle is positioned towards the stacker tray.
3. Hold the paddle assembly by the two short tabs and clip onto the shaft.

NOTE: Ensure that the paddle assembly is correctly oriented to fit onto the plastic locating tab.

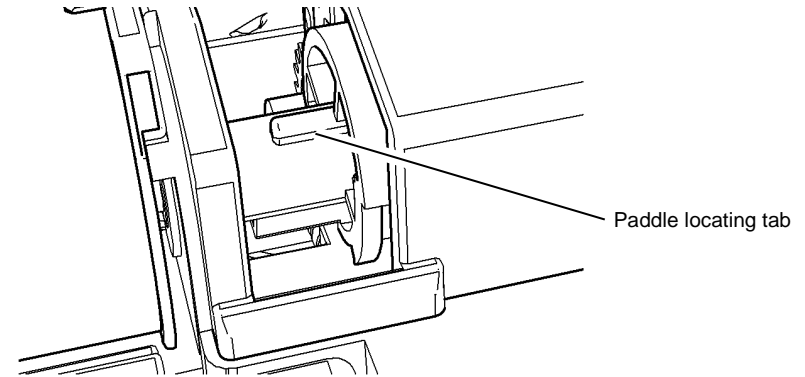

U-1-1632-A

Figure 2 Paddle locating tab

REP 12.101-171 Paddle Wheel

Parts List on [PL 12.115](#)

Removal

WARNING

Switch off the electricity to the machine. Refer to [GP 14](#). Disconnect the power cord from the customer supply while performing tasks that do not need electricity. Electricity can cause death or injury. Moving parts can cause injury.

WARNING

Take care during this procedure. Sharp edges may be present that can cause injury.

NOTE: This procedure shows the replacement of the paddle wheels with the compiler paddle unit installed. If necessary, remove the compiler paddle unit before replacing the paddle wheels. Refer to [REP 12.49-171](#).

1. Rotate the paddle until the two rubber blades are visible.

CAUTION

To ensure that the correct home position of the paddle wheel shaft is maintained, install the new paddle wheels one at a time.

CAUTION

Ensure all defective paddles are replaced with a paddle of the same type. The two outer paddles are a different type to the three inner paddles.

2. Squeeze the two rubber blades together and pull to remove the paddle wheel from the shaft, [Figure 1](#).

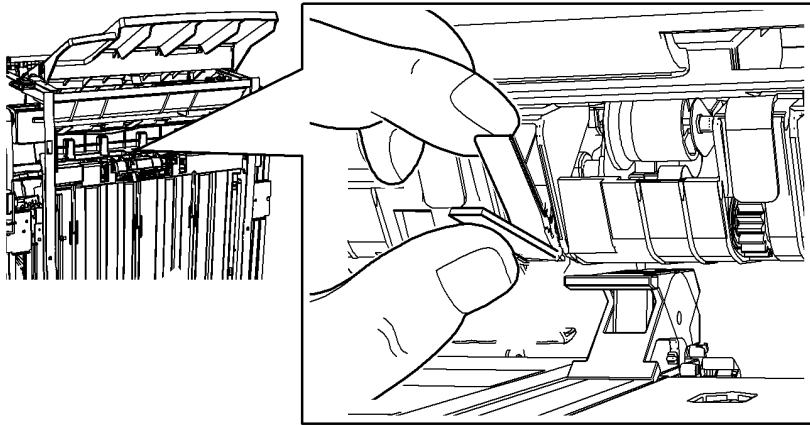

U-1-1661-A

Figure 1 Paddle removal

Replacement

1. Hold the paddle wheel by the two rubber blades and clip onto the shaft.

REP 62.1 Scanner Module

Parts List on [PL 62.10](#)

Removal

WARNING

Switch off the electricity to the machine. Refer to [GP 14](#). Disconnect the power cord from the customer supply while performing tasks that do not need electricity. Electricity can cause death or injury. Moving parts can cause injury.

WARNING

Take care during this procedure. Sharp edges may be present that can cause injury.

WARNING

Mandatory safety warning. This procedure must be performed by 2 people. The module is heavy.

1. Remove the DADH, [REP 5.19](#).

2. Prepare to remove the scanner, [Figure 1](#).

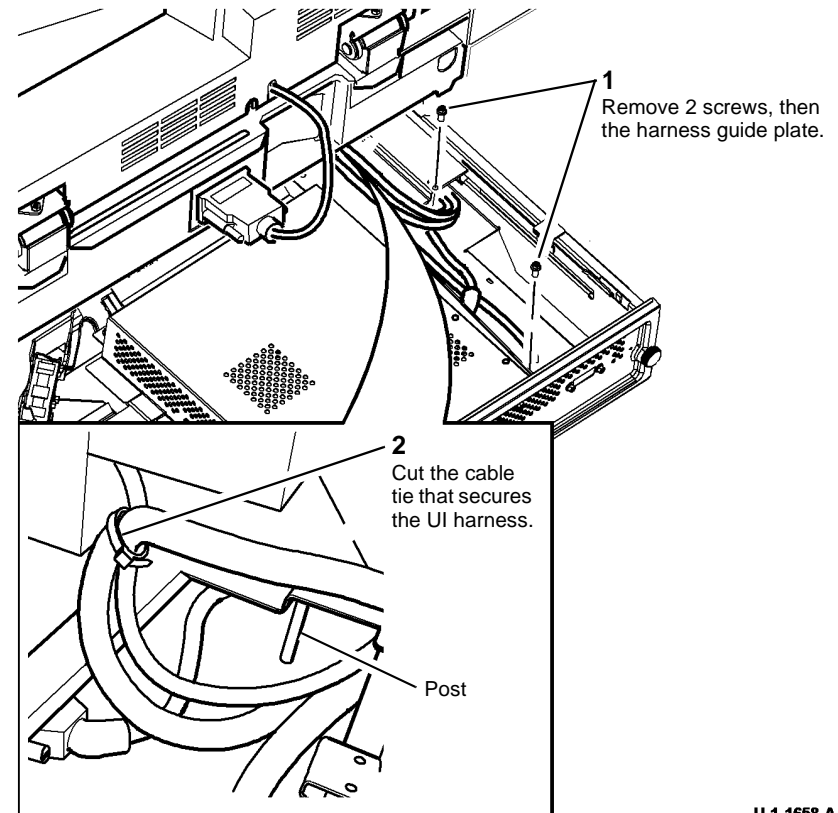

U-1-1658-A

Figure 1 Preparation

3. Remove the SBC PWB cover, [PL 3.11 Item 11](#).
4. Disconnect PJ15, PJ18, PJ19 and PJ223 from the single board controller PWB.
5. Disconnect PJ8 from the power distribution PWB.
6. Release the harnesses from around the post, refer to [Figure 1](#).

WARNING

Use safe handling procedures when removing the module. Refer to [GP 16](#). The module is heavy.

NOTE: The weight of the scanner is 15Kg (33lb).

7. Remove the scanner module, [Figure 2](#).

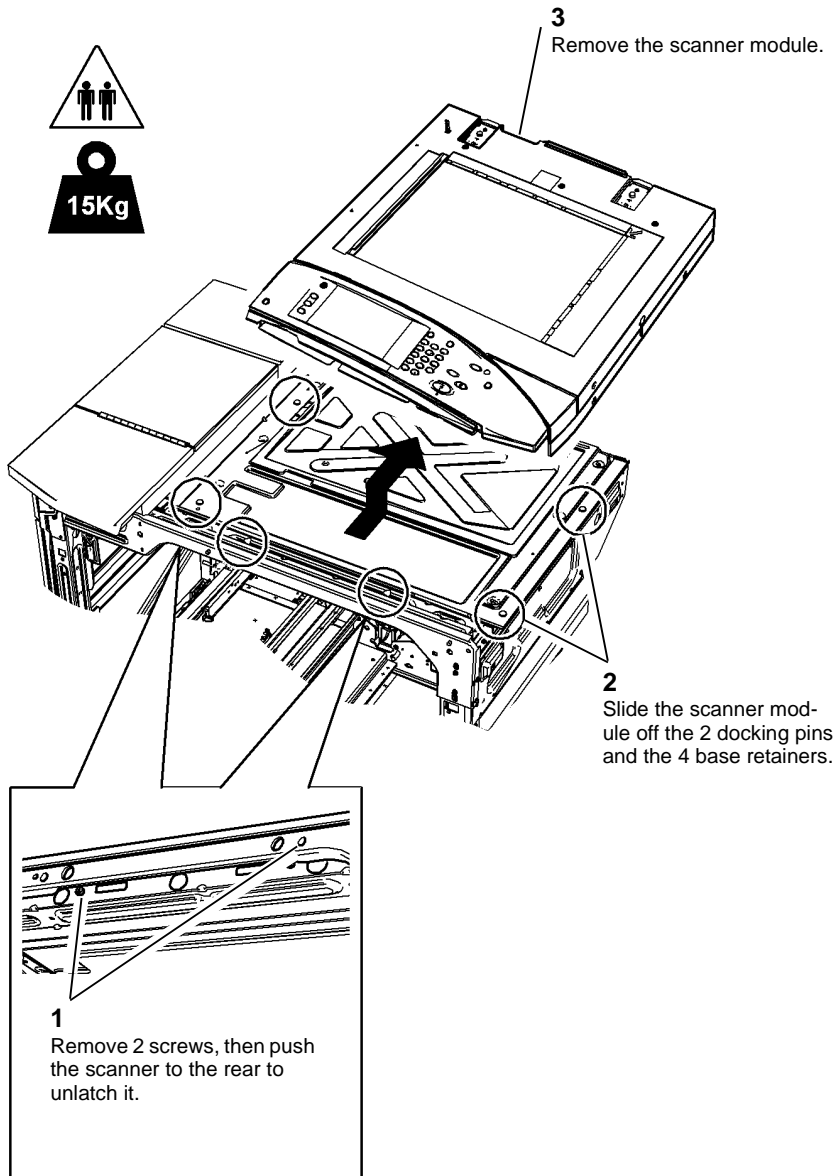

U-1-0692-A

Figure 2 Scanner module removal

- a. Remove the scanner rear cover, [PL 62.10 Item 14](#).
- b. Remove the scanner side cover, [PL 62.10 Item 15](#).
- c. Remove the user interface assembly, [REP 2.1](#).

Replacement

1. The replacement procedure is the reverse of the removal procedure.
2. Ensure that the SBC PWB and power distribution PWB harnesses are correctly wound round the post, [Figure 3](#).

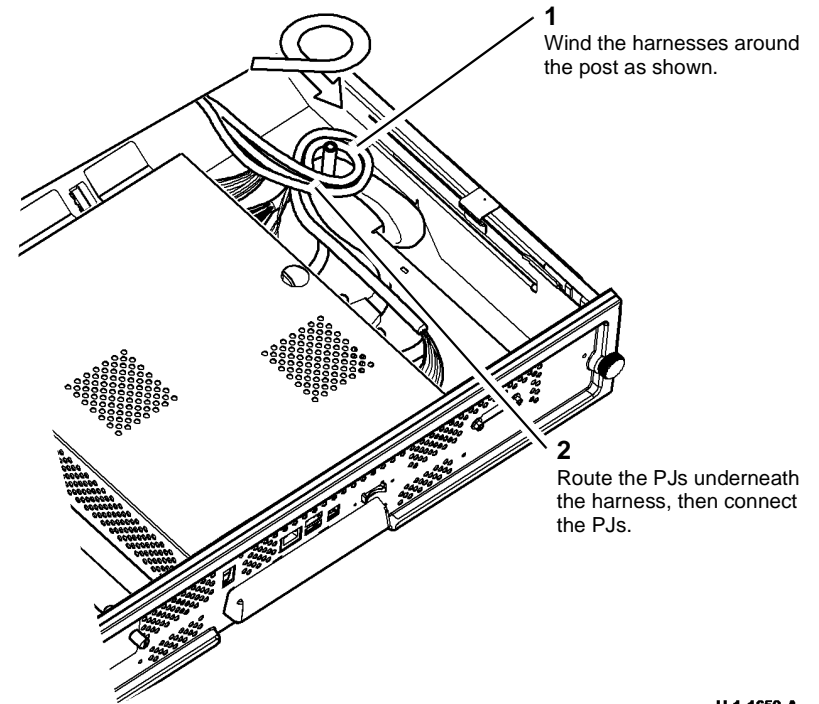

U-1-1659-A

Figure 3 Harness winding

8. If a replacement scanner is to be installed, remove the following components:

3. Re-install the harness guide plate. Ensure the harnesses are correctly positioned, [Figure 4](#).

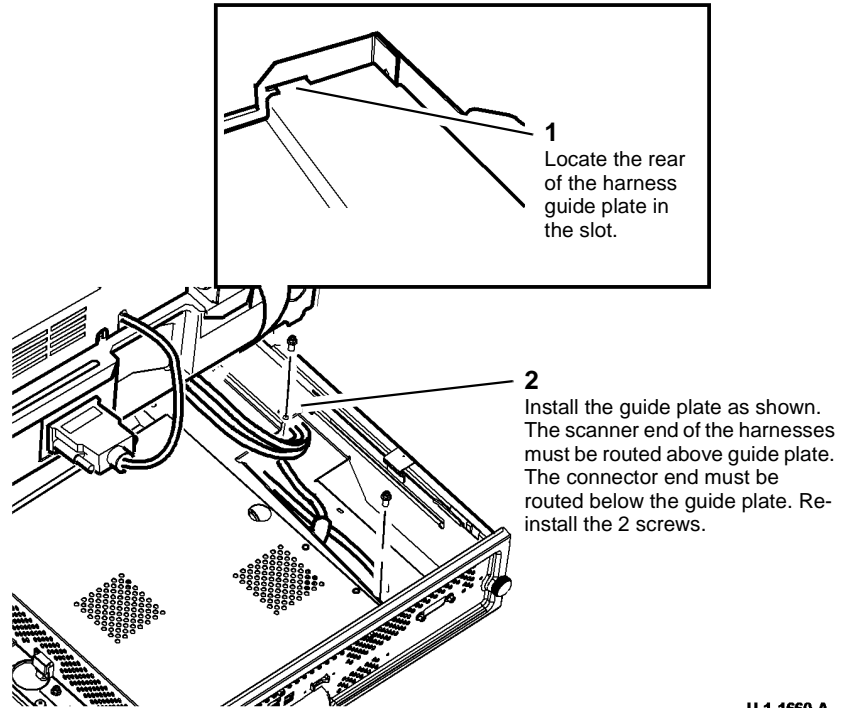

Figure 4 Guide plate replacement

4. Check that the image processor module opens and closes smoothly without trapping the harnesses. If necessary, repeat replacement steps 2 and 3.
5. If a new scanner module has been installed, perform the following:
 - a. [dC608](#) Document Feeder Registration.
 - b. [dC609](#) Document Glass Registration.
 - c. Enter [dC131](#) NVM Read/Write. Make sure the following IIT DADH NVM settings are set to default:
 - 800-005
 - 800-006
 - 800-007
 - 800-008
 - 800-009
 - 801-005
 - 801-006
 - 801-007
 - 801-008

- 801-009
- 801-010
- 801-011
- 801-012
- 801-013
- 801-014
- 801-015
- 801-016
- 801-017
- 801-018
- 801-019
- 801-020
- 801-021
- 801-022
- 801-023
- 801-024
- 801-025
- 801-026

REP 62.2 Top Cover

Parts List on [PL 62.10](#)

Removal

WARNING

Switch off the electricity to the machine. Refer to [GP 14](#). Disconnect the power cord from the customer supply while performing tasks that do not need electricity. Electricity can cause death or injury. Moving parts can cause injury.

WARNING

Take care during this procedure. Sharp edges may be present that can cause injury.

1. Remove the DADH, [REP 5.19](#).
2. Remove the scanner module, [REP 62.1](#).
3. Remove the top cover, [Figure 1](#).

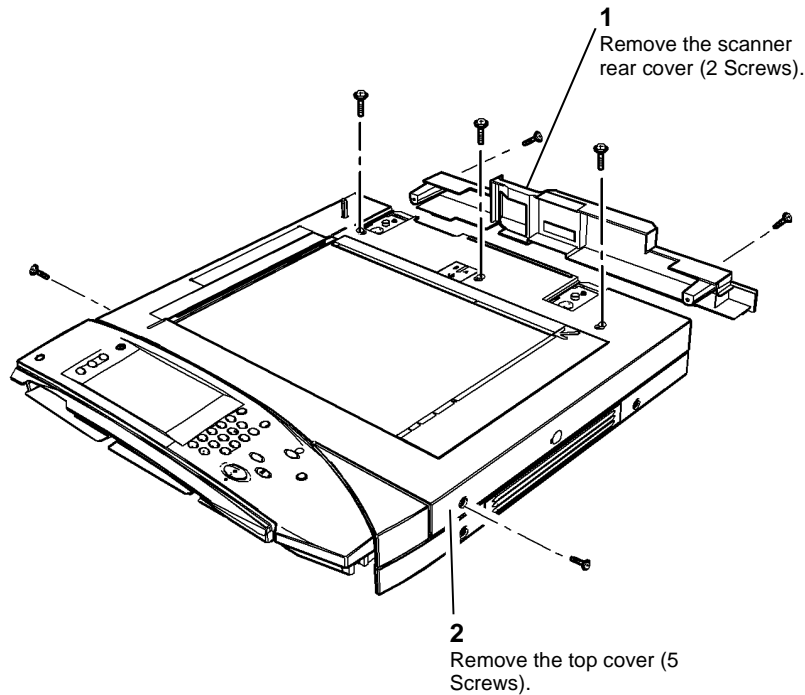

Figure 1 Top cover removal

U-1-0693-A

Replacement

1. The replacement procedure is the reverse of the removal procedure.
2. Perform the following procedures:
 - [ADJ 62.1](#) Optics Cleaning.
 - [dC609](#) Document Glass Registration.

REP 62.3 CVT Glass, CVT Ramp and Document Glass Assembly

Parts List on [PL 62.10](#)

Removal

WARNING

Switch off the electricity to the machine. Refer to [GP 14](#). Disconnect the power cord from the customer supply while performing tasks that do not need electricity. Electricity can cause death or injury. Moving parts can cause injury.

WARNING

Take care during this procedure. Sharp edges may be present that can cause injury.

1. Remove the top cover, [REP 62.2](#).
2. Remove the CVT glass, [PL 62.10](#) Item 3.
3. Remove the CVT ramp and document glass assembly, [Figure 1](#).

REP 62.4 Scan Carriage Home Sensor

Parts List on [PL 62.15](#)

Removal

WARNING

Switch off the electricity to the machine. Refer to [GP 14](#). Disconnect the power cord from the customer supply while performing tasks that do not need electricity. Electricity can cause death or injury. Moving parts can cause injury.

WARNING

Take care during this procedure. Sharp edges may be present that can cause injury.

1. Remove the User Interface assembly, [REP 2.1](#).

CAUTION

Do not remove the document glass.

Do not loosen the two screws securing the setting plate, shown in [Figure 1](#).

2. [Figure 1](#), remove the scan carriage home sensor.

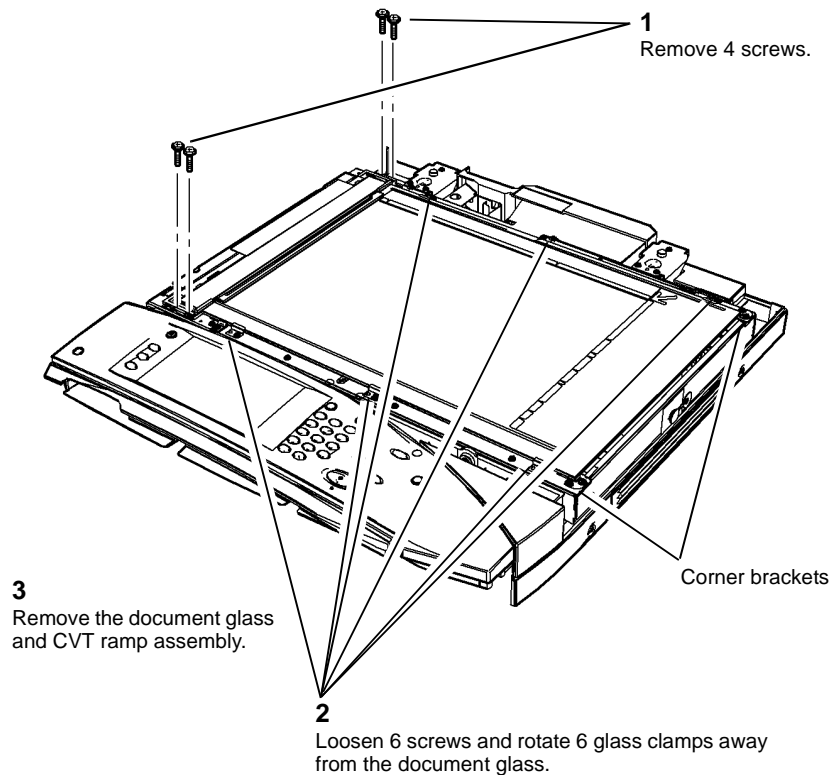

Figure 1 CVT glass and document glass assembly

Replacement

1. The replacement procedure is the reverse of the removal procedure.
2. Ensure that the white AGC strips on the document glass and the CVT glass are at the front and underside of the glass.
3. Ensure that the document glass is located in the corner brackets, [Figure 1](#). Check that the CVT ramp is located correctly in the pips on the frame.
4. Perform [ADJ 62.1](#) Optics Cleaning as necessary.
5. If a new document glass assembly has been installed, perform the following:
 - a. [dC608](#) Document Feeder Registration.
 - b. [dC609](#) Document Glass Registration.

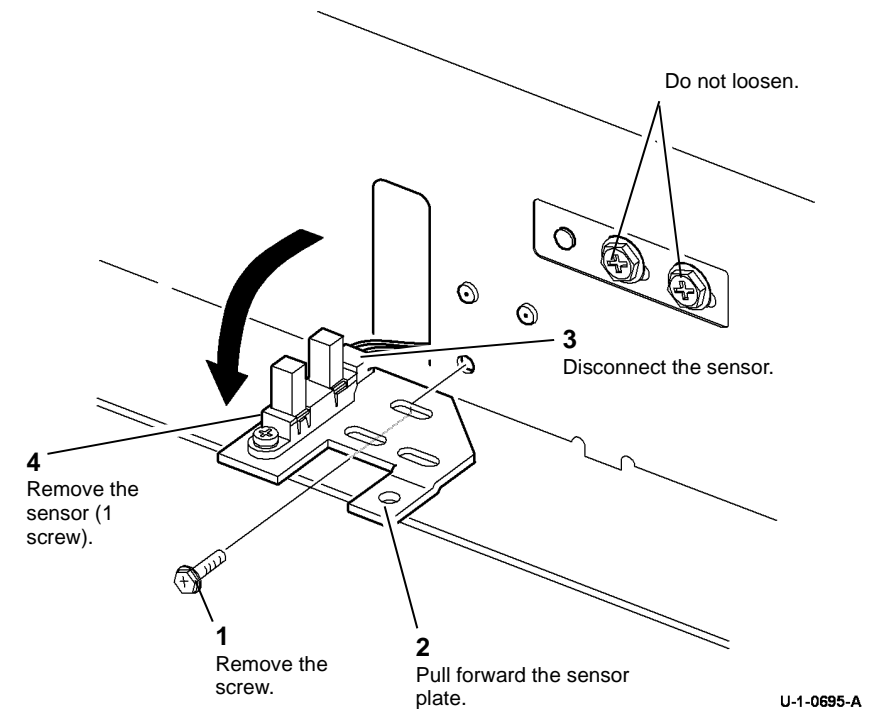

Figure 1 Scan carriage home sensor

Replacement

1. Install the sensor on to the sensor plate, ensuring the lugs locate correctly in the slot.

2. Re-connect the sensor.
3. Install the sensor plate. Ensure that the three locating lugs are correctly located in the slots of the mounting plate.
4. The replacement of the removed components in the reverse of the removal procedure.

REP 62.5 Scan Carriage Assembly

Parts List on [PL 62.15](#)

Removal

WARNING

Switch off the electricity to the machine. Refer to [GP 14](#). Disconnect the power cord from the customer supply while performing tasks that do not need electricity. Electricity can cause death or injury. Moving parts can cause injury.

WARNING

Take care during this procedure. Sharp edges may be present that can cause injury.

1. Remove the CVT glass, [REP 62.3](#).
2. Remove the CVT ramp and document glass assembly, [REP 62.3](#).
3. Disconnect the LED exposure lamps ribbon cable, [REP 62.11](#).
4. [Figure 1](#). Remove the scan carriage assembly.

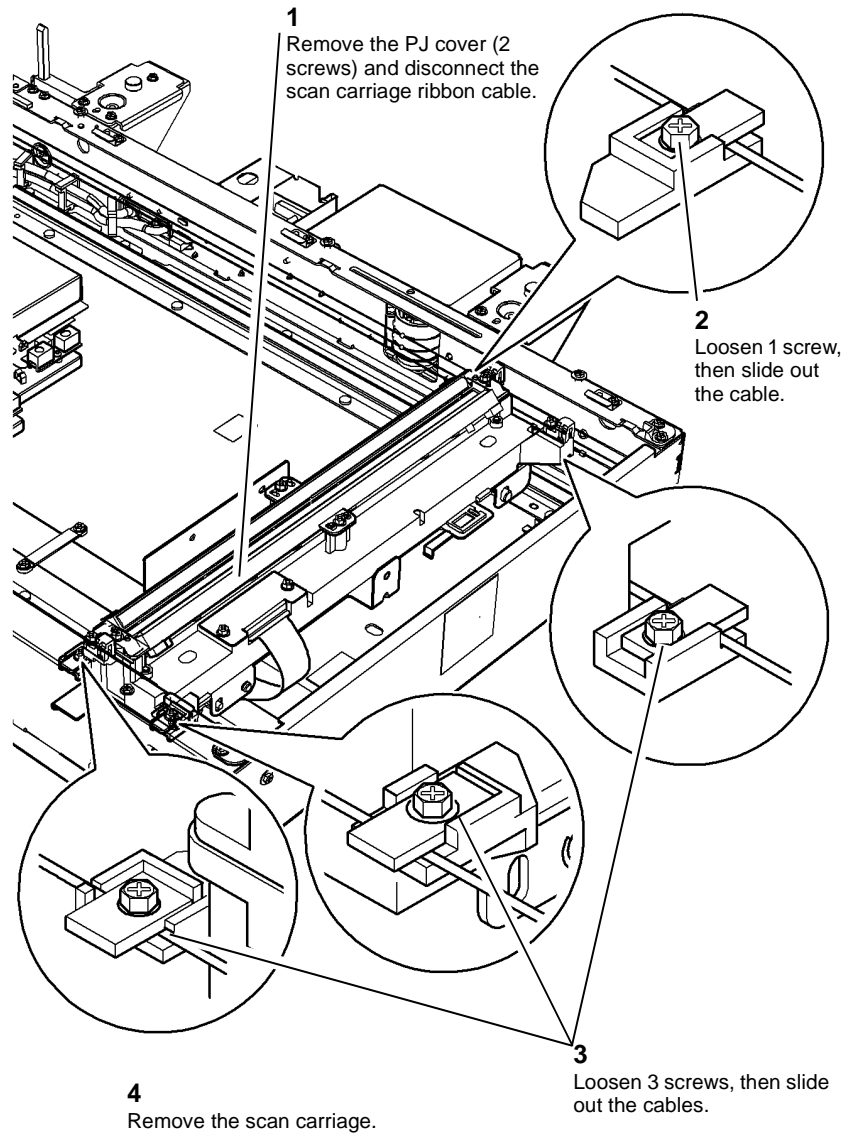

U-1-0696-A

Figure 1 Carriage removal

Replacement

1. Insert the scan carriage ribbon cable through the securing clamp and the square hole.

2. **Figure 2.** Place the scan carriage assembly centrally over the springs on the scan cables. Slide the scan cables under the fixing tabs.

NOTE: Observe the spring position between the fixing tabs on the scan carriage assembly.

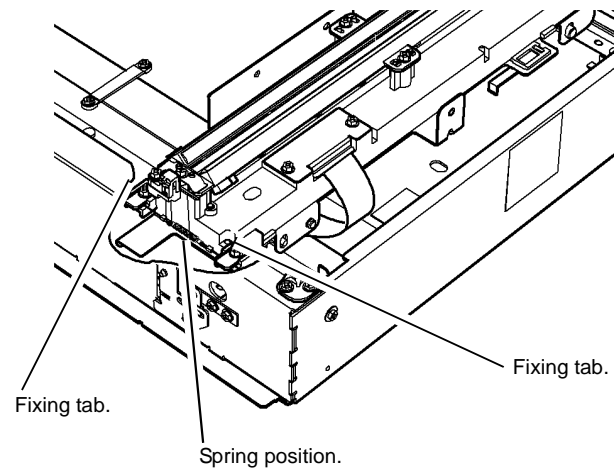

U-1-0697-A

Figure 2 Alignment of the scan carriage

3. Reconnect the scan carriage ribbon cable.
4. Reinstall the PJ cover.
5. Reconnect the exposure lamp ribbon cable. Ensure that the metal connections face towards the PWB. Secure the cable clamps.
6. Close the exposure lamp ribbon harness securing clip.
7. Perform [ADJ 62.2](#) Scan Carriage Adjustment.
8. Perform [ADJ 62.1](#) Optics Cleaning Procedure.
9. The replacement procedure is the reverse of the removal procedure.

REP 62.6 Carriage Motor and Mounting

Parts List on [PL 62.16](#)

Removal

WARNING

Switch off the electricity to the machine. Refer to [GP 14](#). Disconnect the power cord from the customer supply while performing tasks that do not need electricity. Electricity can cause death or injury. Moving parts can cause injury.

1. Remove the scanner top cover, [REP 62.2](#).
2. Remove the carriage motor cover, (2 screws).
3. [Figure 1](#). Prepare to remove the carriage motor.

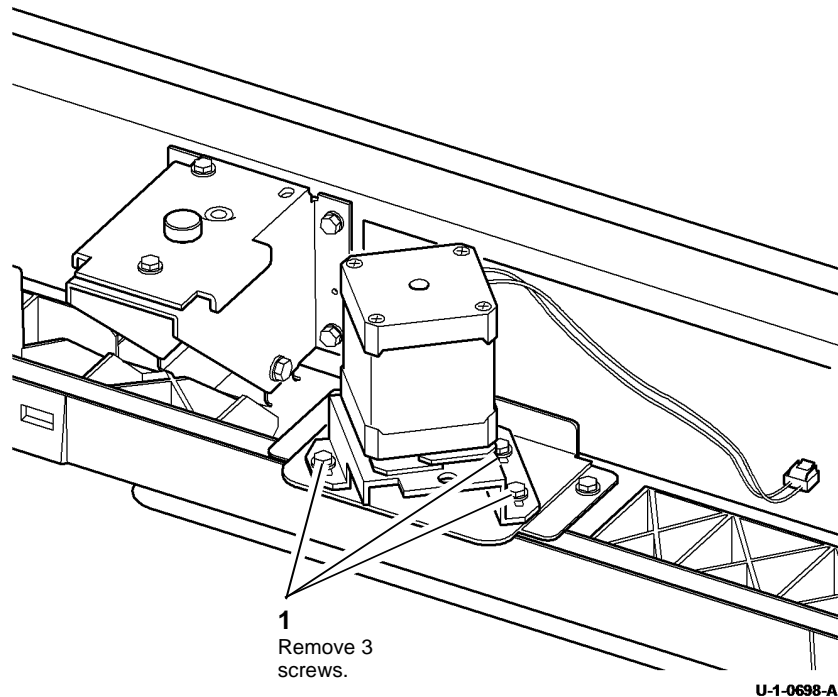

Figure 1 Preparation

4. Remove the scanner harness bracket, [PL 62.16 Item 14](#), to allow access to PJ 929.
5. [Figure 2](#). Remove the carriage motor and mounting. Note the orientation of the bracket and the mounting.

1. Release the wiring and disconnect PJ 929. (Press the top of the PJ)

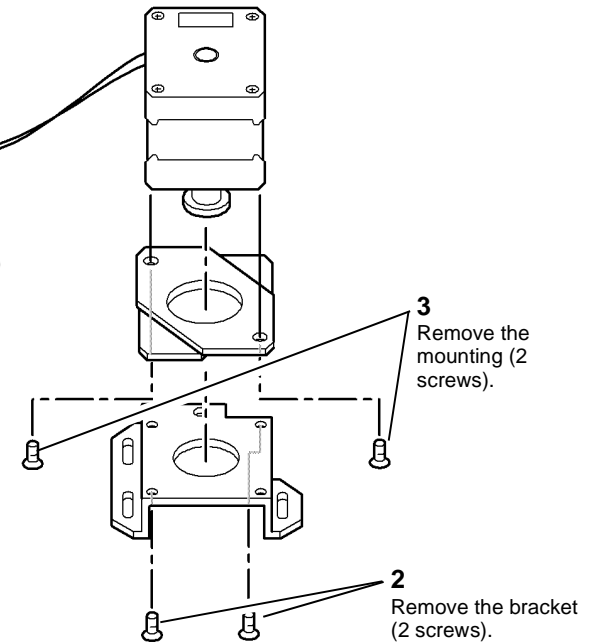

Figure 2 Motor and mounting

Replacement

1. The replacement procedure is the reverse of the removal procedure.
2. Perform [ADJ 62.3](#) Carriage Motor and Scanner Drive Belt.

REP 62.7 Scan Cables

Parts List on [PL 62.16](#)

Removal

WARNING

Switch off the electricity to the machine. Refer to [GP 14](#). Disconnect the power cord from the customer supply while performing tasks that do not need electricity. Electricity can cause death or injury. Moving parts can cause injury.

WARNING

Take care during this procedure. Sharp edges may be present that can cause injury.

1. Remove the scan carriage, [REP 62.5](#).
2. Remove the scan motor cover, (2 screws).
3. Slide the cables off the pulleys or capstan.
4. Remove the springs and lift out the cables.

Replacement

1. [Figure 1](#) shows the general arrangement of the scan cables, when correctly installed.

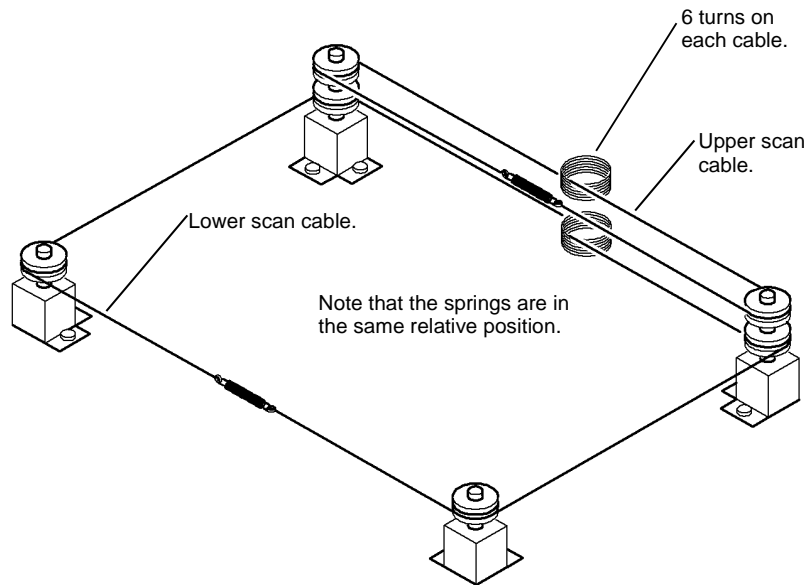

Figure 1 Scan cable arrangement

2. [Figure 2](#). Prepare to install the lower scan cable.

NOTE: The lower scan cable is black and is longer than the upper scan cable.

NOTE: The anchor ball is not installed centrally on the scan cables.

NOTE: To assist in holding the scan cables in position, use adhesive tape.

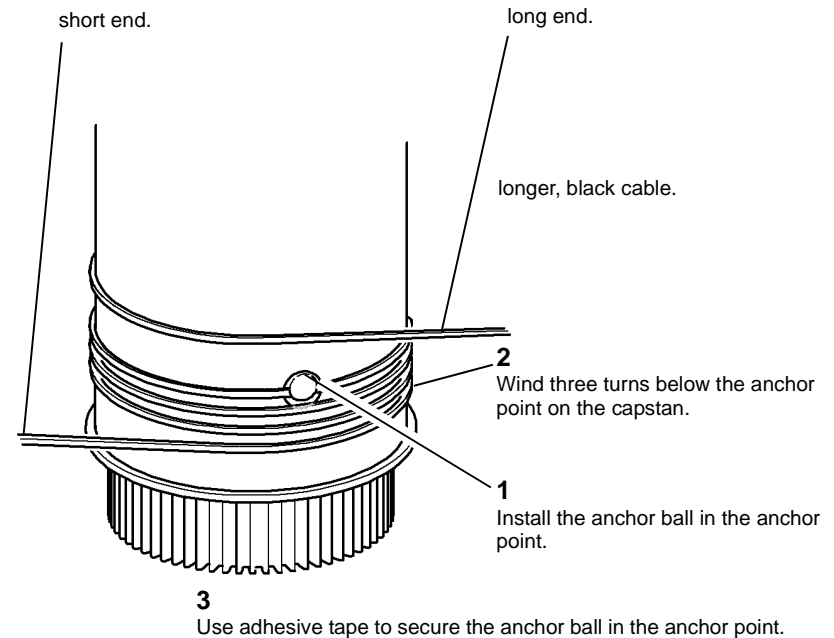

U-1-0701-A

Figure 2 Mount lower scan cable on the capstan

3. **Figure 3.** Install the lower scan cable on the rear pulleys.

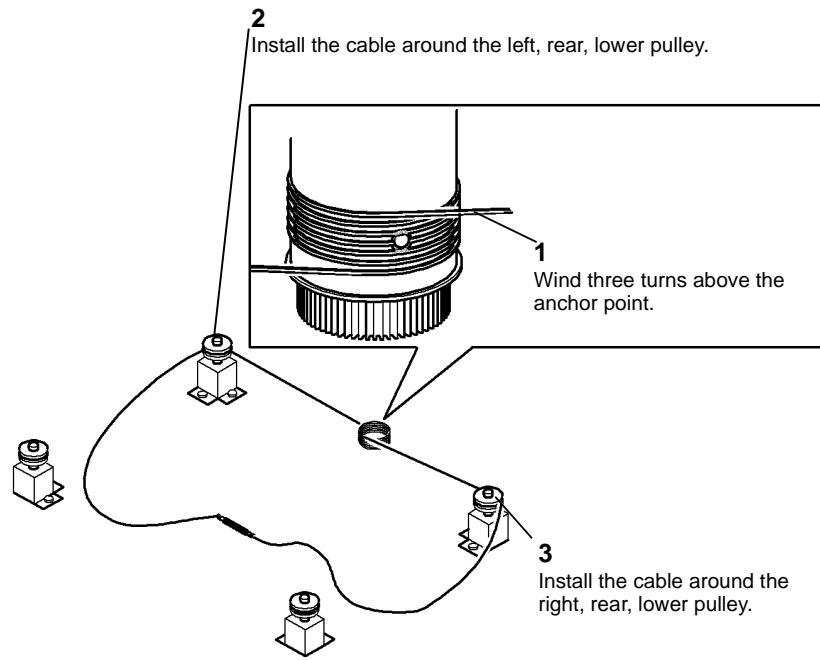

U-1-0702-A

Figure 3 Installation of the lower scan cable

4. **Figure 4.** Prepare to install the upper scan cable.

NOTE: The anchor ball is not installed centrally on the scan cable.

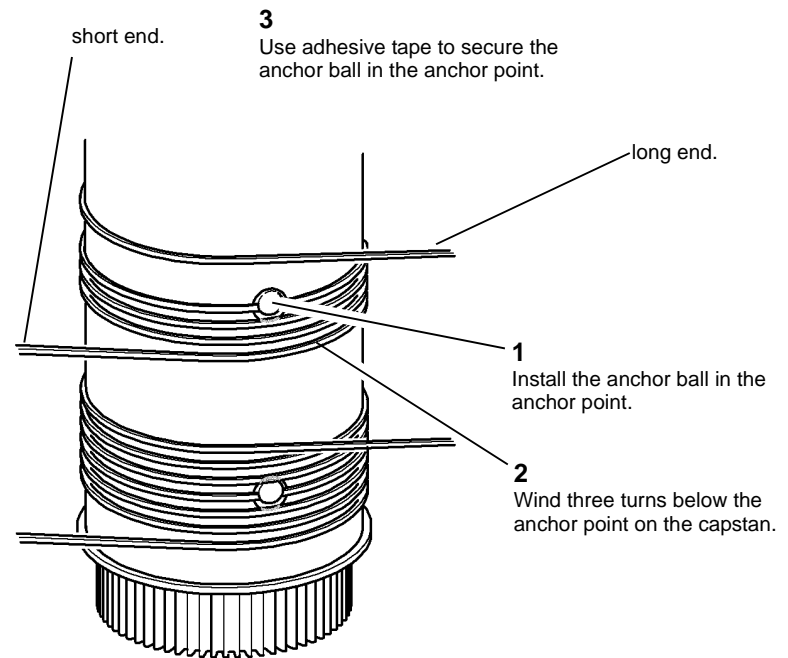

U-1-0703-A

Figure 4 Mount upper scan cable on the capstan

5. **Figure 5.** Install the lower scan cable.

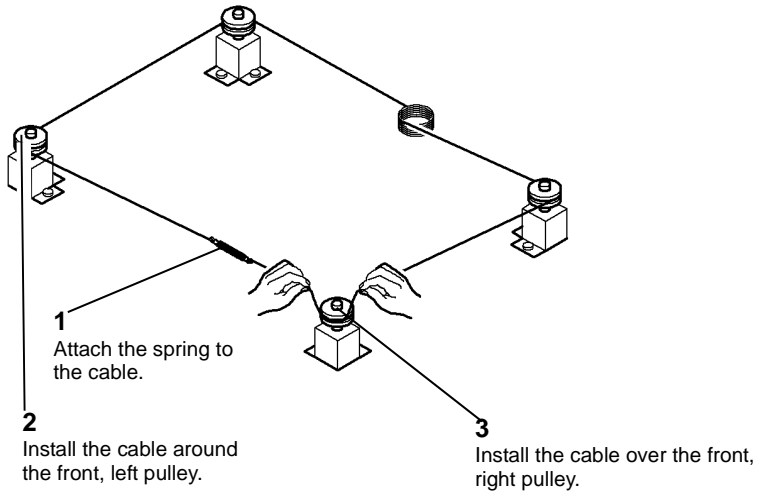

U-1-0704-A

Figure 5 Installation of the lower scan cable

6. **Figure 6.** Prepare to install the upper scan cable.

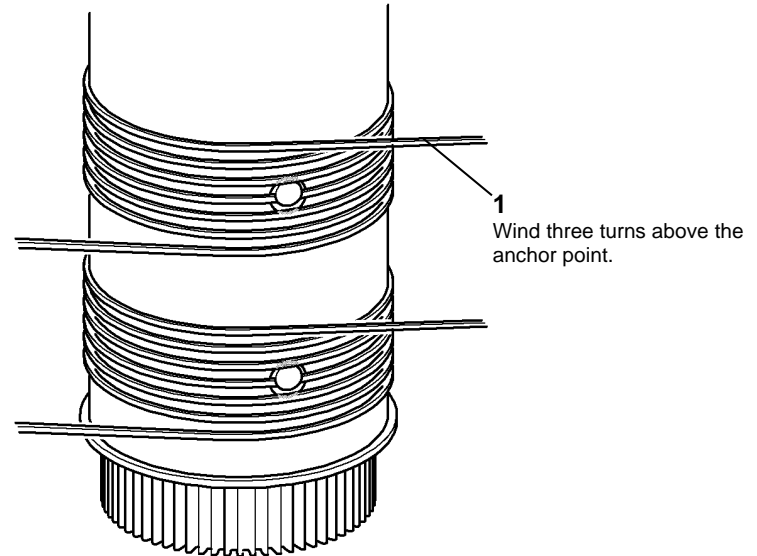

U-1-0705-A

Figure 6 Installation of the upper scan cable

7. **Figure 7.** Prepare to install the upper scan cable on the pulleys.

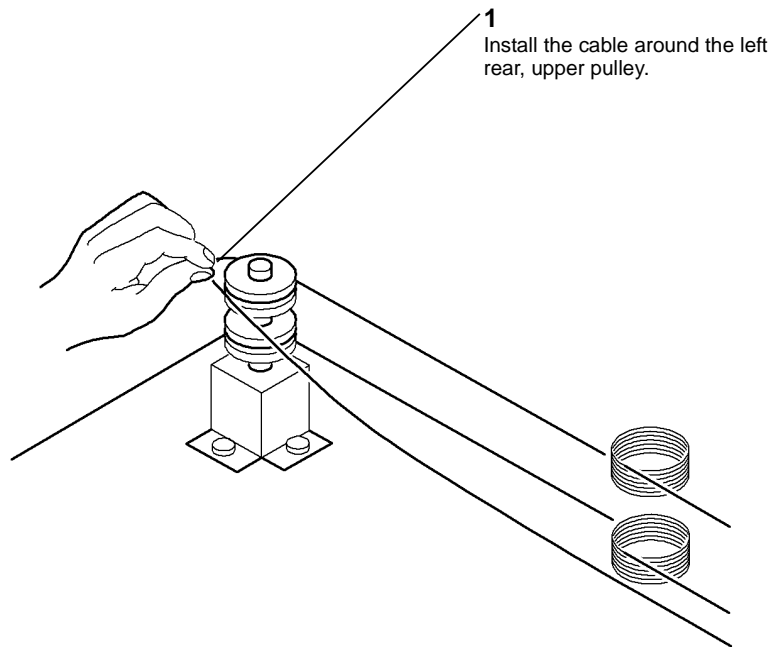

U-1-0706-A

Figure 7 Installation of the upper scan cable

8. **Figure 8.** Install the upper scan cable.

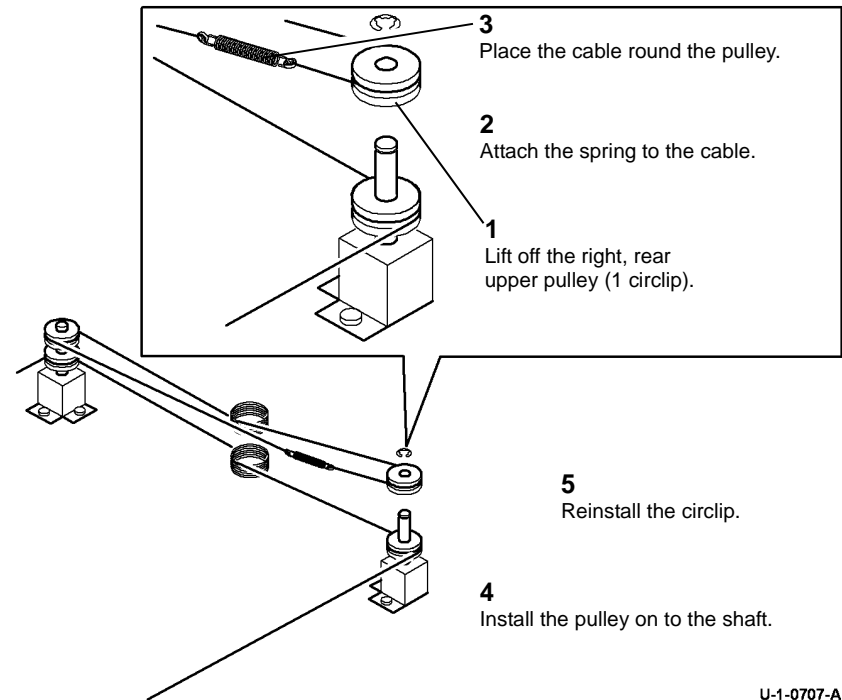

U-1-0707-A

Figure 8 Installation of the upper scan cable

9. Remove the adhesive tape used to secure the anchor balls in the anchor points.
10. Reinstall the scan carriage, [REP 62.5](#).
11. Perform [ADJ 62.2](#) scan carriage assembly.
12. Reinstall the CVT glass and document glass, [REP 62.3](#).
13. Reinstall the scanner top cover, [REP 62.2](#).
14. Reinstall the scan motor cover, (2 screws).
15. Reinstall the scanner module, [REP 62.1](#).
16. Reinstall the DADH, [REP 5.19](#).

REP 62.8 Scan Drive Belt

Parts List on [PL 62.16](#)

Removal

WARNING

Switch off the electricity to the machine. Refer to [GP 14](#). Disconnect the power cord from the customer supply while performing tasks that do not need electricity. Electricity can cause death or injury. Moving parts can cause injury.

WARNING

Take care during this procedure. Sharp edges may be present that can cause injury.

1. Remove the scan carriage assembly, [REP 62.5](#).
2. Remove the scan motor, [REP 62.6](#).
3. Secure the scan cables, [Figure 1](#).

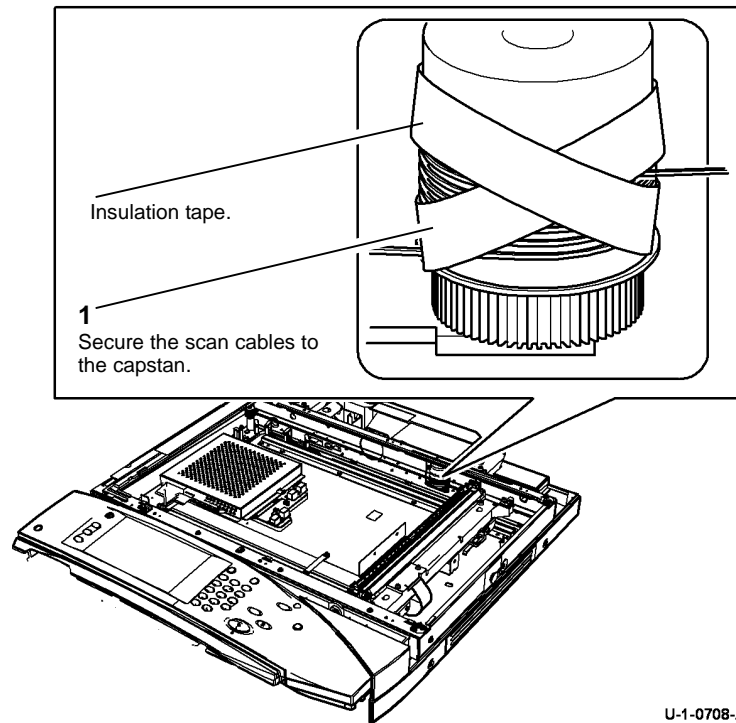

Figure 1 Scan cables and capstan

NOTE: When removing the scan cables from the pulleys, it is not necessary to lift out the cables from the scanner.

4. Remove the scan cables from the pulleys, [REP 62.7](#).
5. Remove the scan drive belt, [Figure 2](#).

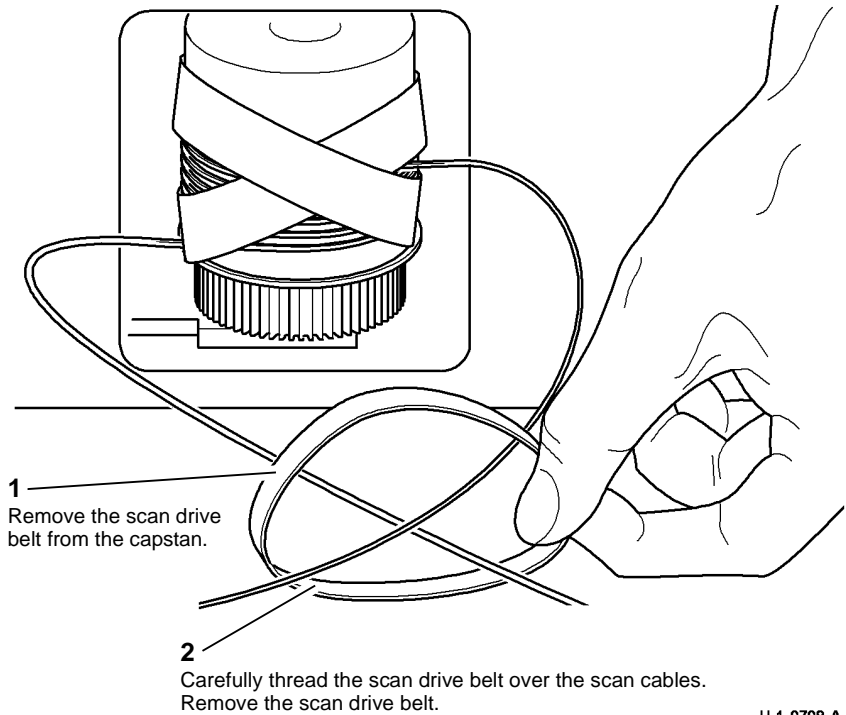

Figure 2 Removal of the scan drive belt

Replacement

1. The replacement procedure is the reverse of the removal procedure.
2. Perform [ADJ 62.3](#) Scanner Motor.

REP 62.9 Input Module Angle Sensor

Parts List on [PL 62.15](#)

Removal

WARNING

Switch off the electricity to the machine. Refer to [GP 14](#). Disconnect the power cord from the customer supply while performing tasks that do not need electricity. Electricity can cause death or injury. Moving parts can cause injury.

WARNING

Take care during this procedure. Sharp edges may be present that can cause injury.

1. Remove the scanner top cover, [REP 62.2](#).
2. [Figure 1](#), remove the input module angle sensor.

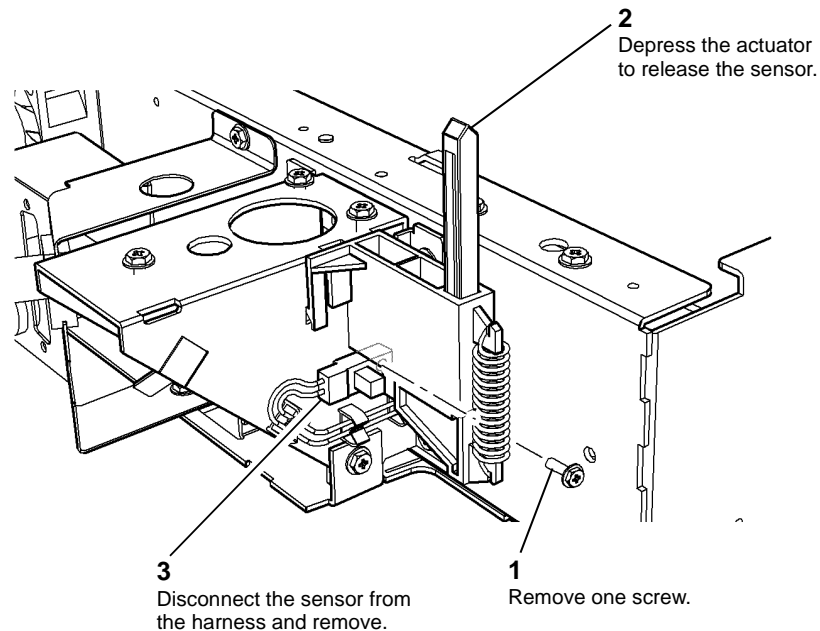

U-1-0710-A

Figure 1 Input module angle sensor

Replacement

1. Reverse the removal procedures to replace the input module angle sensor.
2. When replacing the input module angle sensor, ensure that the lugs on the sensor are located in the slot of the frame before tightening the screw.

REP 62.10 LED Exposure Lamps

Parts List on [PL 62.15](#)

Removal

WARNING

Switch off the electricity to the machine. Refer to [GP 14](#). Disconnect the power cord from the customer supply while performing tasks that do not need electricity. Electricity can cause death or injury. Moving parts can cause injury.

WARNING

Take care during this procedure. Sharp edges may be present that can cause injury.

1. Remove the CVT glass, [REP 62.3](#).
2. Remove the CVT ramp and document glass assembly [REP 62.3](#).
3. [Figure 1](#). Remove the LED exposure lamp(s).

REP 62.11 Exposure Lamp Ribbon Harness

Parts List on [PL 62.15](#)

Removal

WARNING

Switch off the electricity to the machine. Refer to [GP 14](#). Disconnect the power cord from the customer supply while performing tasks that do not need electricity. Electricity can cause death or injury. Moving parts can cause injury.

WARNING

Take care during this procedure. Sharp edges may be present that can cause injury.

1. Remove the CVT glass, [REP 62.3](#).
2. Remove the CVT ramp and document glass assembly [REP 62.3](#).
3. Remove the scanner PWB cover, [PL 62.16 Item 9](#) (three screws).
4. Disconnect the exposure lamp ribbon harness, PJ926 on the scanner PWB, [PL 62.16 Item 8](#).
5. [Figure 1](#). Remove the exposure lamp ribbon harness.

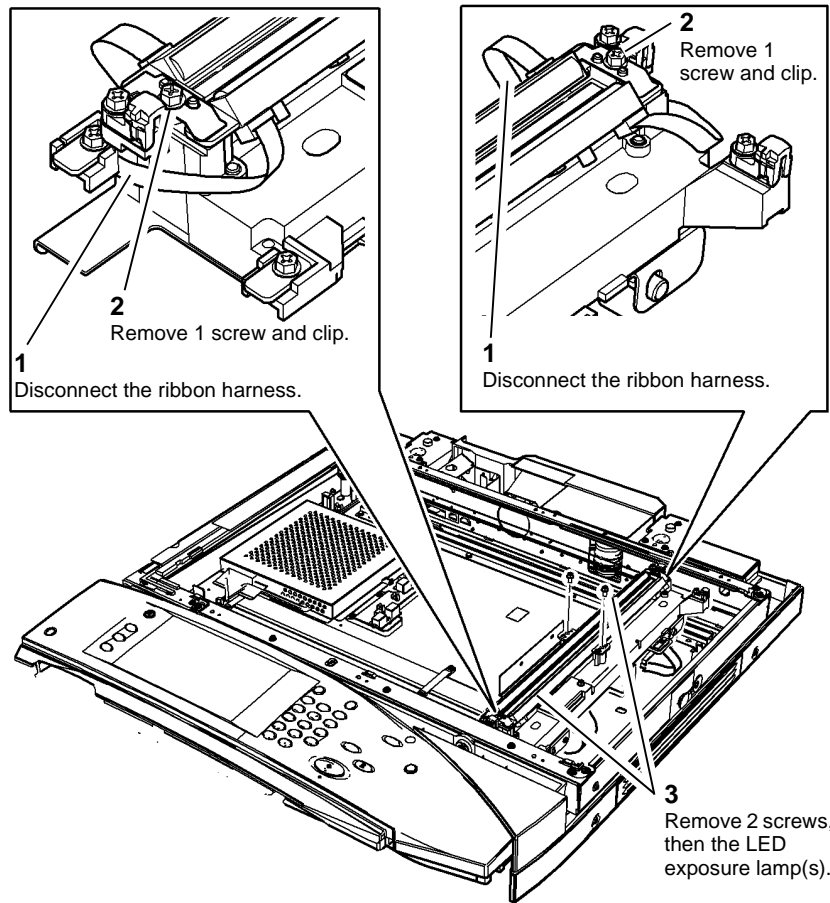

U-1-0711-A

Figure 1 Removal of the LED exposure lamps

Replacement

1. The replacement procedure is the reverse of the removal procedure.
2. Ensure that the ribbon harness is routed flat on the under side of the scan carriage to avoid rubbing on the scanner PWB cover. When re-connected, the metal contacts on the ribbon cable must face down, away from the scan carriage.
3. Perform [ADJ 62.1](#) Optics Cleaning.

1
If necessary, carefully move the scan carriage assembly to the left.

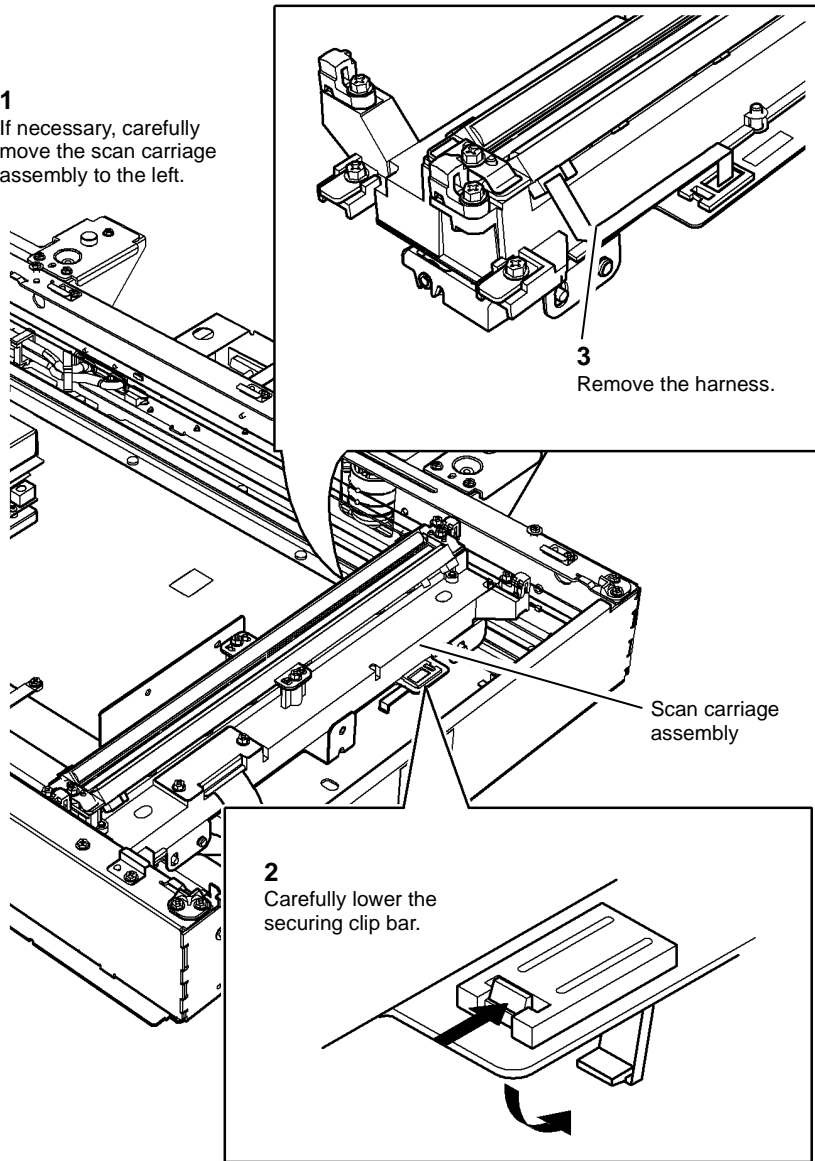

2. Ensure that the ribbon harness is routed flat on the under side of the scan carriage to avoid rubbing on the scanner PWB cover. When re-connected, the metal contacts on the ribbon cable must face down, away from the scan carriage.
3. Perform [ADJ 62.1](#) Optics Cleaning.

Figure 1 Removal

U-1-0713-A

Replacement

1. The replacement procedure is the reverse of the removal procedure.

REP 62.12 Scanner PWB

Parts List on [PL 62.16](#)

Removal

WARNING

Switch off the electricity to the machine. Refer to [GP 14](#). Disconnect the power cord from the customer supply while performing tasks that do not need electricity. Electricity can cause death or injury. Moving parts can cause injury.

WARNING

Take care during this procedure. Sharp edges may be present that can cause injury.



Figure 1 ESD Symbol

CAUTION

Ensure that ESD procedures are observed during the removal and installation of the scanner PWB.

1. Remove the document glass, [REP 62.3](#).
2. Remove the CVT ramp and document glass assembly [REP 62.3](#).
3. Remove the scanner PWB cover, [PL 62.16 Item 9](#).
4. Disconnect all of the harness connectors from the scanner PWB, [PL 62.16 Item 8](#).
5. Remove four screws securing the scanner PWB.
6. Remove the scanner PWB.

Replacement

1. The replacement procedure is the reverse of the removal procedure.
2. Perform [ADJ 62.1](#) Optics Cleaning.
3. If a new scanner PWB has been installed, enter [dC131](#) NVM Read/Write. Make sure the following IIT DADH NVM settings are set to default:
 - 800-005
 - 800-006
 - 800-007
 - 800-008
 - 800-009
 - 801-005
 - 801-006
 - 801-007
 - 801-008
 - 801-009
 - 801-010

- 801-011
- 801-012
- 801-013
- 801-014
- 801-015
- 801-016
- 801-017
- 801-018
- 801-019
- 801-020
- 801-021
- 801-022
- 801-023
- 801-024
- 801-025
- 801-026

REP 62.13 Scan Carriage Ribbon Cable

Parts List on [PL 62.15](#)

Removal

WARNING

Switch off the electricity to the machine. Refer to [GP 14](#). Disconnect the power cord from the customer supply while performing tasks that do not need electricity. Electricity can cause death or injury. Moving parts can cause injury.

WARNING

Take care during this procedure. Sharp edges may be present that can cause injury.

1. Remove the CVT glass, [REP 62.3](#).
2. Remove the CVT ramp and document glass assembly [REP 62.3](#).
3. Remove the scanner PWB cover, [PL 62.16 Item 9](#).
4. Prepare to remove the scan carriage ribbon cable, [PL 62.15 Item 4](#).
5. [Figure 1](#). Remove the scan carriage ribbon cable.

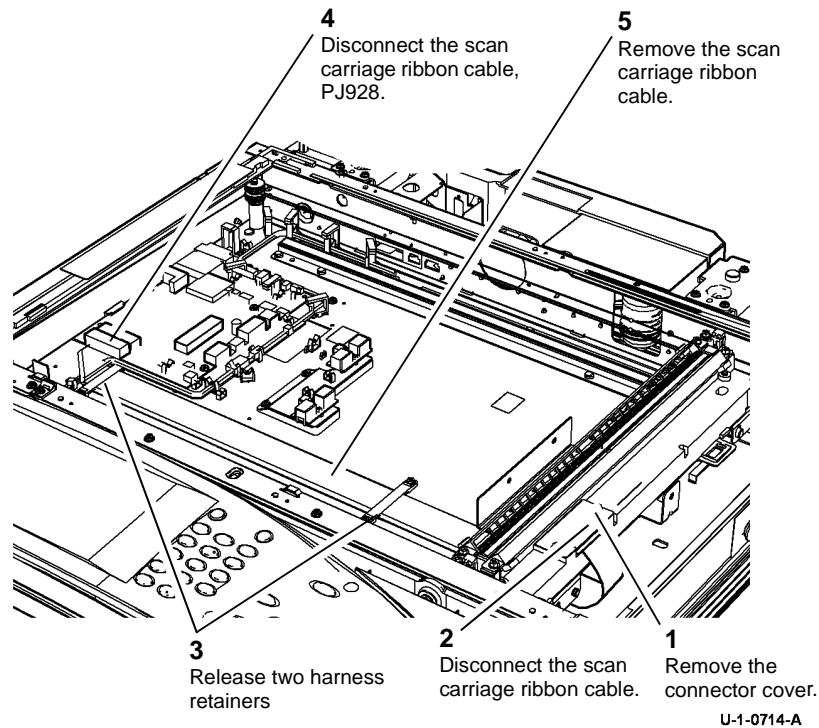

Figure 1 Ribbon cable removal

Replacement

CAUTION

Take care when replacing the scan carriage ribbon cable. The scan carriage ribbon cable is easily damaged.

1. The replacement procedure is the reverse of the removal procedure.
2. Perform [ADJ 62.1](#) Optics Cleaning.

REP 62.14 Document Size Sensor 1 and Document Size Sensor 2

Parts List on [PL 62.16](#)

Removal

WARNING

Switch off the electricity to the machine. Refer to [GP 14](#). Disconnect the power cord from the customer supply while performing tasks that do not need electricity. Electricity can cause death or injury. Moving parts can cause injury.

WARNING

Take care during this procedure. Sharp edges may be present that can cause injury.

1. Remove the CVT glass, [REP 62.3](#).
2. Remove the CVT ramp and document glass assembly [REP 62.3](#).
3. [Figure 1](#). Remove document size sensor 1 (Q62-251).

NOTE: The removal of document size sensor 1 (Q62-251) is shown. The removal of document size sensor 2 (Q62-253) is identical.

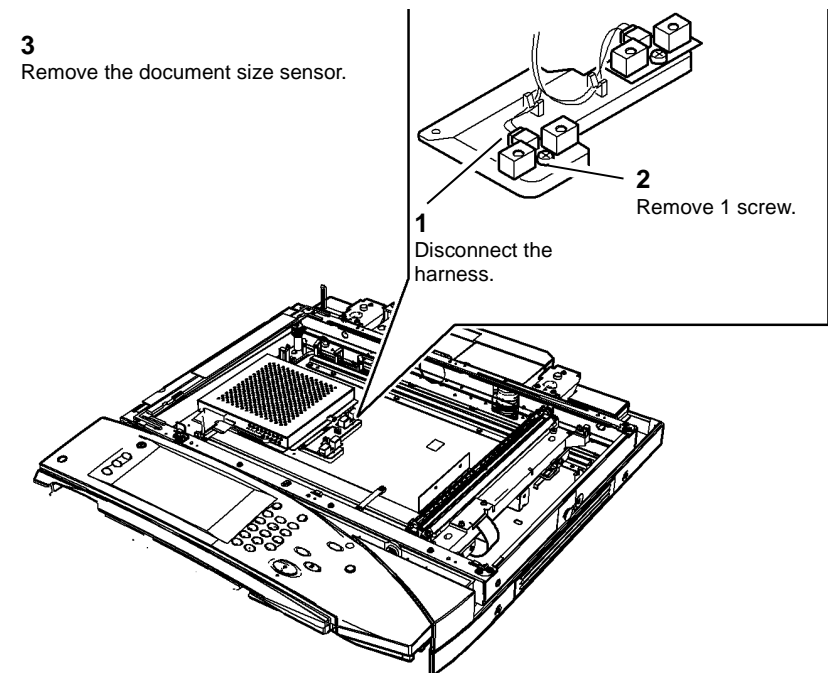

Figure 1 Removal

Replacement

1. The replacement procedure is the reverse of the removal procedure.
2. Perform [ADJ 62.1](#) Optics Cleaning.

REP 70.1 3 Tray Module PWB

Parts List on [PL 73.16](#)

Removal

WARNING

Switch off the electricity to the machine. Refer to [GP 14](#). Disconnect the power cord from the customer supply while performing tasks that do not need electricity. Electricity can cause death or injury. Moving parts can cause injury.



Figure 1 ESD Symbol

CAUTION

Ensure that ESD procedures are observed during the removal and installation of the 3 tray module PWB.

1. Remove the (upper) rear cover, [PL 81.10 Item 1](#) and the (lower) rear cover, [PL 70.25 Item 8](#).

2. Remove the 3 tray module PWB, [Figure 2](#).

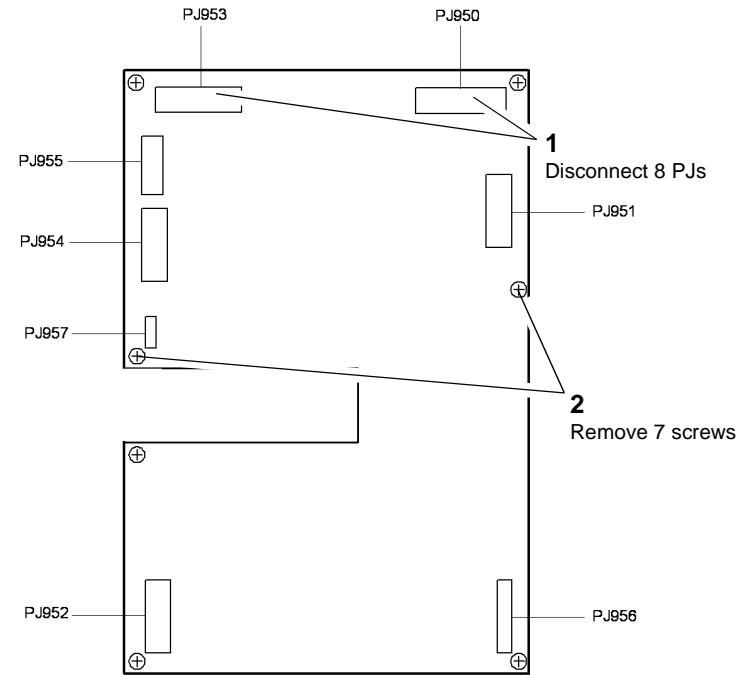

U-1-0760-A

Figure 2 Remove the 3 tray module PWB

Replacement

1. Replacement is the reverse of the removal procedure.
2. Perform [dC625](#) Registration / Preheat calibration.

REP 70.2 Upper Left Hand Door Assembly

Parts List on [PL 70.30](#)

Removal

WARNING

Switch off the electricity to the machine. Refer to [GP 14](#). Disconnect the power cord from the customer supply while performing tasks that do not need electricity. Electricity can cause death or injury. Moving parts can cause injury.

WARNING

Take care during this procedure. Sharp edges may be present that can cause injury.

1. Remove bypass tray feed assembly, [REP 81.3](#).
2. Remove the upper left hand door assembly, [Figure 1](#).

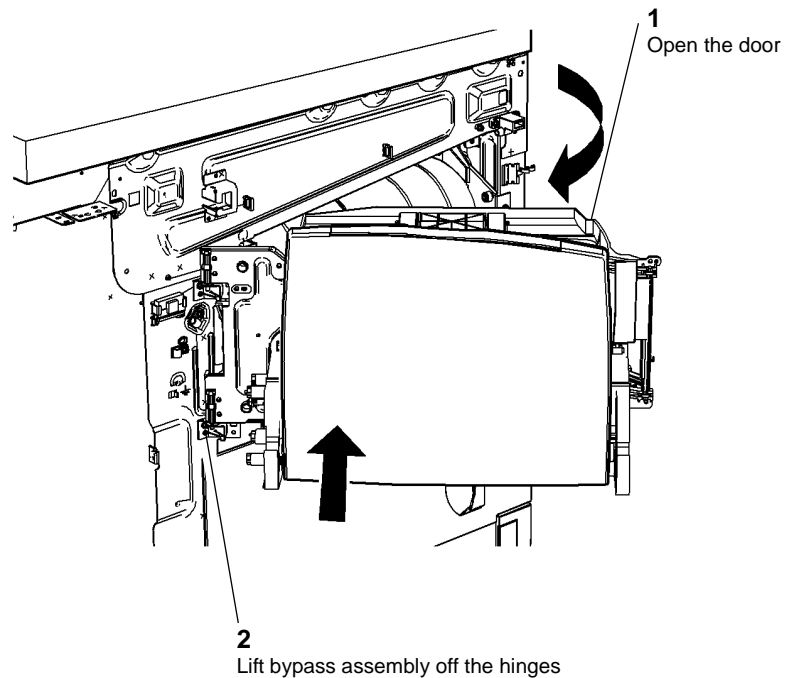

Figure 1 Upper left hand door removal

U-1-0762-A

Replacement

CAUTION

When replacing the hinge pin, do not damage the wire harness.

1. The replacement is the reverse of the removal procedure.
2. Make sure that the upper left door assembly is correctly aligned.

REP 71.1 Tray 1 and Tray 2 Removal

Parts List on [PL 70.10](#)

Removal

WARNING

Take care during this procedure. Sharp edges may be present that can cause injury.

CAUTION

Do not stack the trays one on top of the other tray. The top tray can damage the bottom tray, which cause misfeeds or paper jams.

1. Remove the tray 1 or tray 2, [Figure 1](#).

NOTE: The removal procedure for tray 1 and tray 2 is the same.

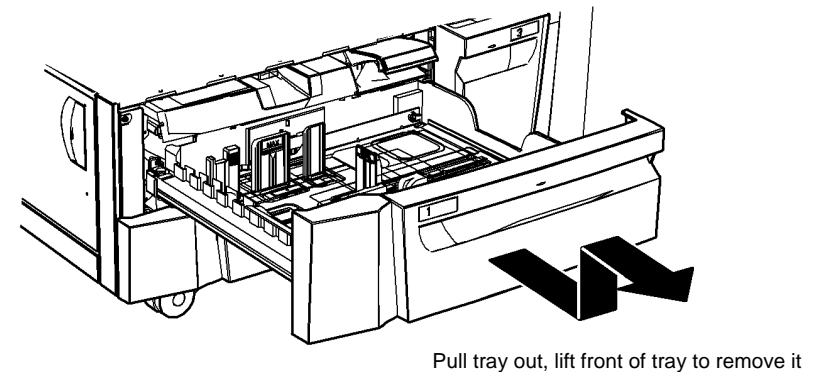

Figure 1 Tray 1 and tray 2 removal

U-1-0782-A

Replacement

The replacement is the reverse of the removal procedure. Make sure that the left tray slide is located inside the tray stop before inserting the right side of the tray. Refer to [Figure 1](#).

REP 71.2 Tray 1 and Tray 2 Paper Guides

Parts List on [PL 70.10](#)

Removal

WARNING

Take care during this procedure. Sharp edges may be present that can cause injury.

NOTE: The removal procedure is the same for tray 1 and for tray 2.

1. Remove the paper then remove the tray, [REP 71.1](#).
2. To remove the elevate plate assemble, [Figure 1](#).

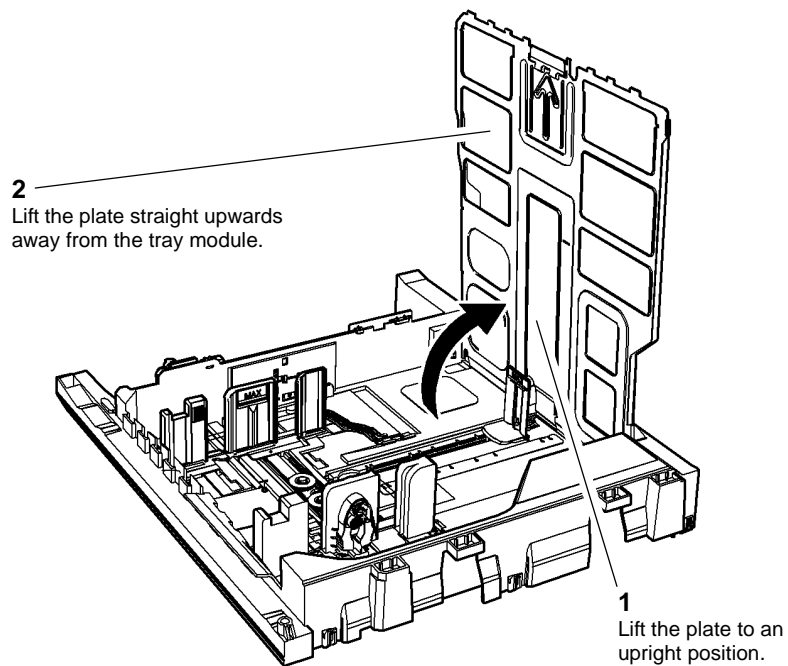

U-1-0763-A

Figure 1 Remove the paper lift plate

3. To remove the paper width guide, [Figure 2](#).

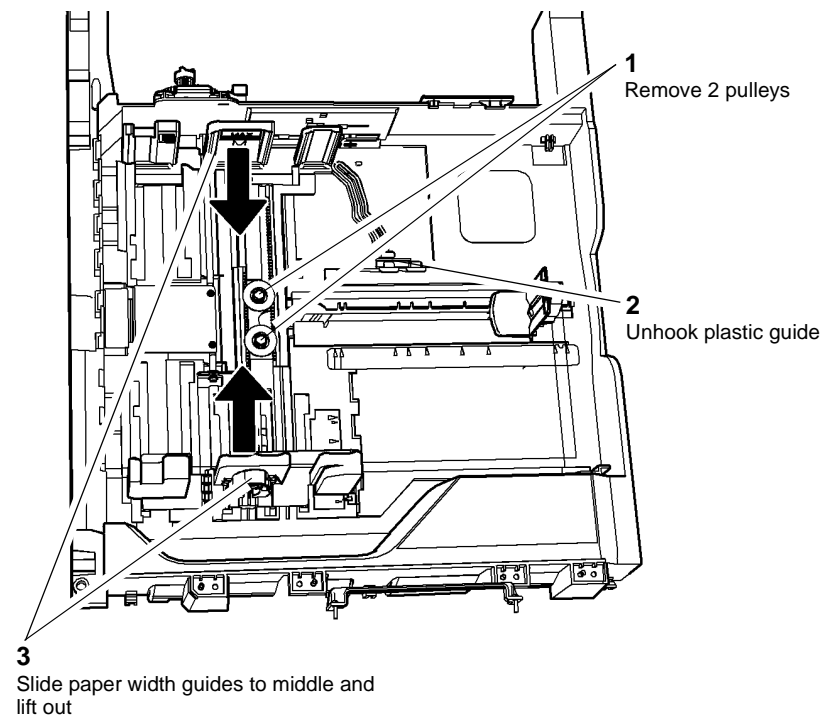

U-1-0764-A

Figure 2 Remove the paper width guide

- Remove the paper width guide and the paper tray, [Figure 3](#).

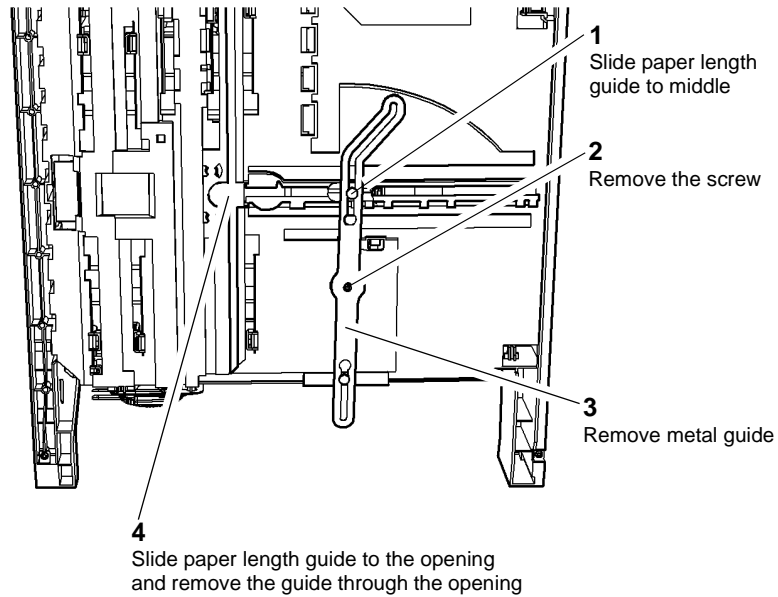

U-1-0765-A

Figure 3 Remove the paper length guide

Replacement

- The replacement is the reverse of the removal procedure.

REP 71.3 Tray 1 and Tray 2 Lift Gear Assembly

Parts List on [PL 70.10](#)

Removal

WARNING

Switch off the electricity to the machine. Refer to [GP 14](#). Disconnect the power cord from the customer supply while performing tasks that do not need electricity. Electricity can cause death or injury. Moving parts can cause injury.

WARNING

Take care during this procedure. Sharp edges may be present that can cause injury.

- Remove the paper tray, [REP 71.1](#).
- Remove the paper lift plate, [REP 71.2](#).
- Remove the metal plate, [Figure 1](#).

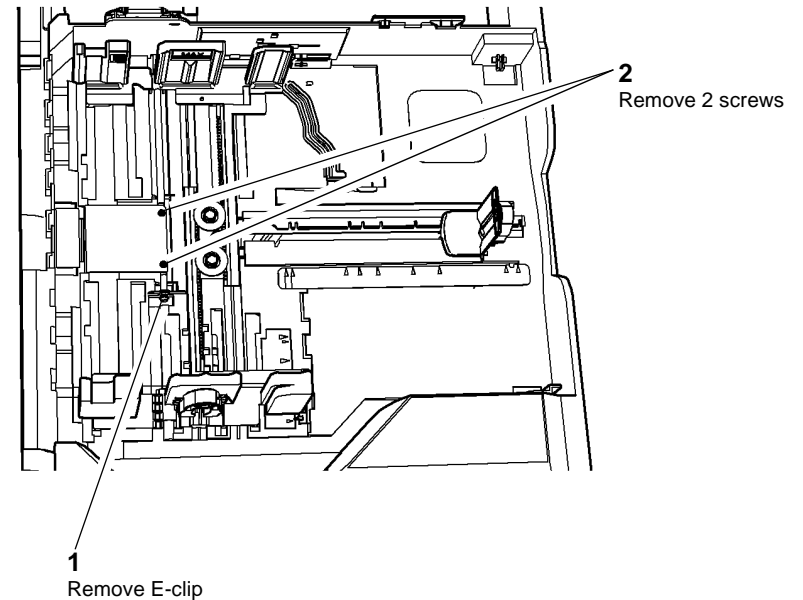

U-1-0783-A

Figure 1 E-clip removal

4. Remove the gear assembly, [Figure 2](#).

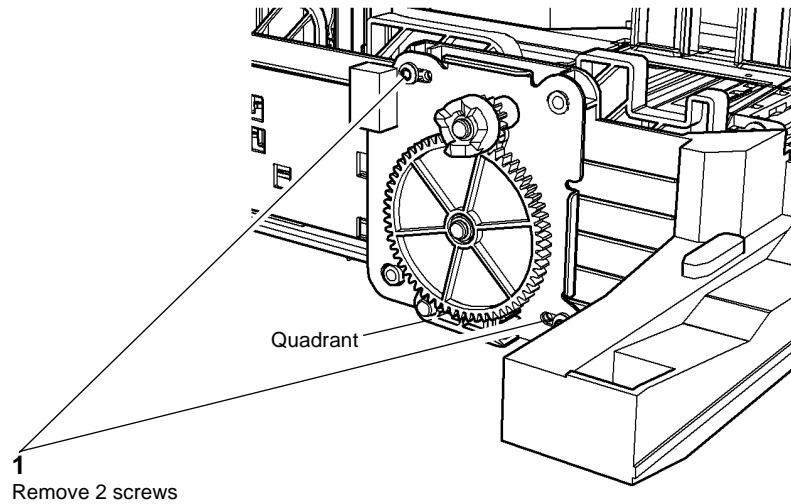

1
Remove 2 screws

- 2**
Remove the gear assembly, quadrant and the bush behind the quadrant

U-1-0766-A

Figure 2 Lift gear removal

Replacement

Engage the lift gear assembly with the spigots on the rear of the tray. The remainder of the replacement procedure is the reverse of the removal procedure.

REP 73.1 Tray 3 Removal

Parts List on [PL 73.15](#)

Removal

WARNING

Take care during this procedure. Sharp edges may be present that can cause injury.

1. Pull out tray 3.
2. Remove the paper from the tray.
3. Remove the right side cover, [PL 70.25 Item 4](#).
4. Remove tray 1 and 2, [REP 71.1](#).

5. Remove the screws to release the tray rails, [Figure 1](#).

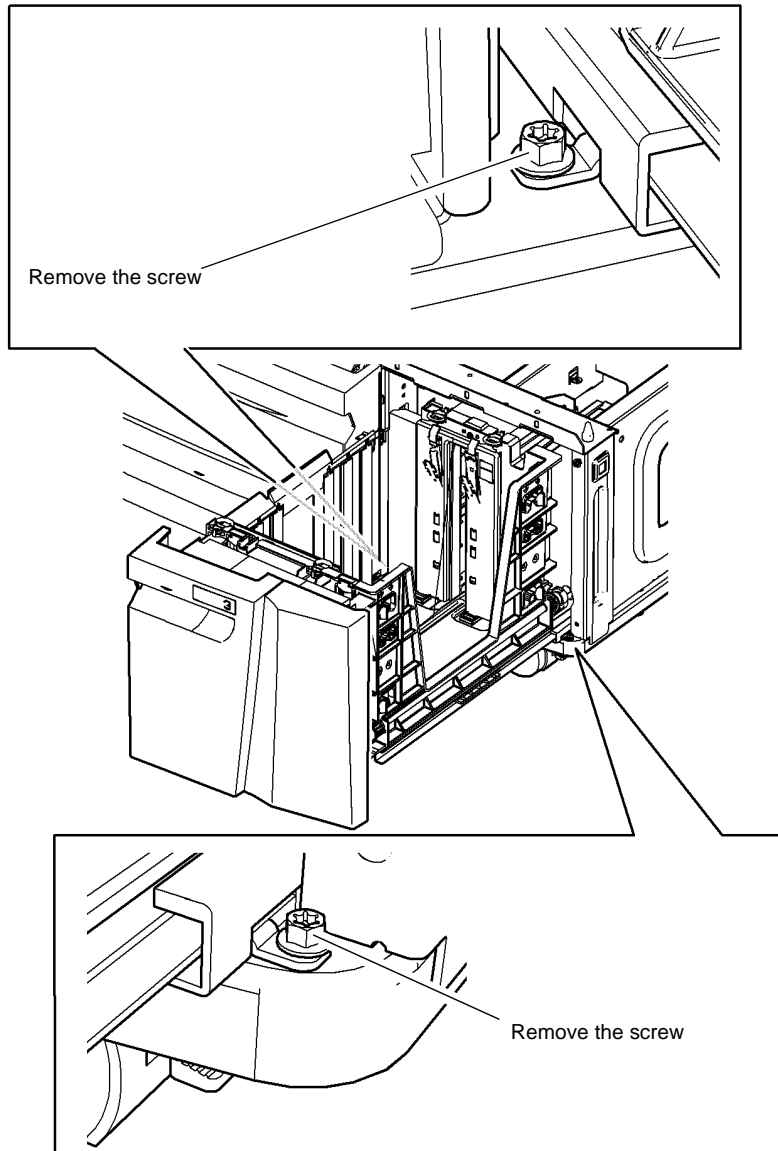

U-1-0767-A

Figure 1 Remove tray 3 guide rails

6. Lift and pull to remove the tray complete with the guide rails.

Replacement

The replacement is the reverse of the removal procedure.

NOTE: When installing tray 3 ensure that the tray rails are located correctly in the base, [Figure 2](#).

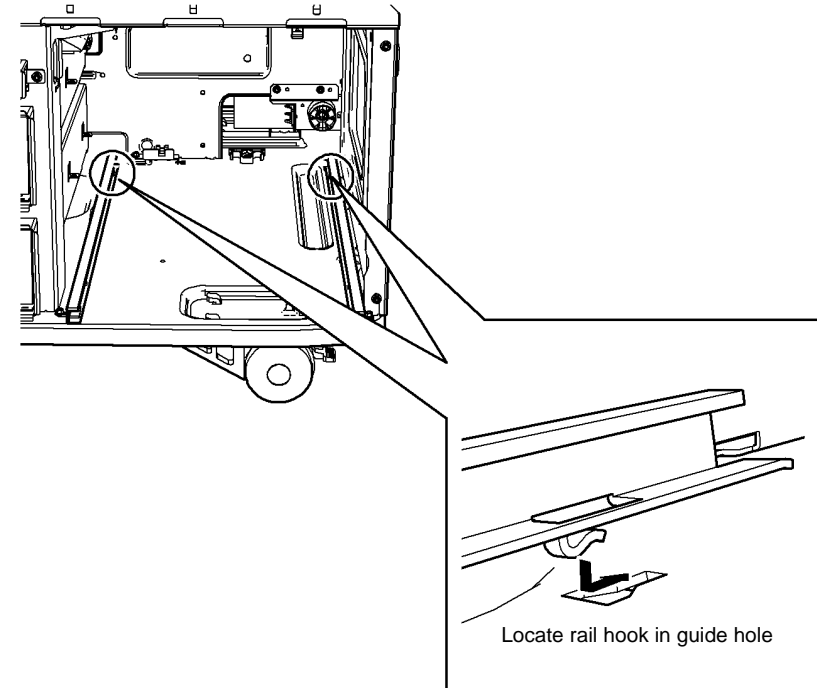

U-1-0768-A

Figure 2 Location of the tray rails

REP 73.2 Tray 3 Elevator Motor

Parts List on [PL 73.16](#)

Removal

WARNING

Switch off the electricity to the machine. Refer to [GP 14](#). Disconnect the power cord from the customer supply while performing tasks that do not need electricity. Electricity can cause death or injury. Moving parts can cause injury.

WARNING

Take care during this procedure. Sharp edges may be present that can cause injury.

1. Pull out tray 3.
2. Remove the right side cover. [PL 70.25 Item 4](#).
3. Remove the tray 3 motor, [Figure 1](#).

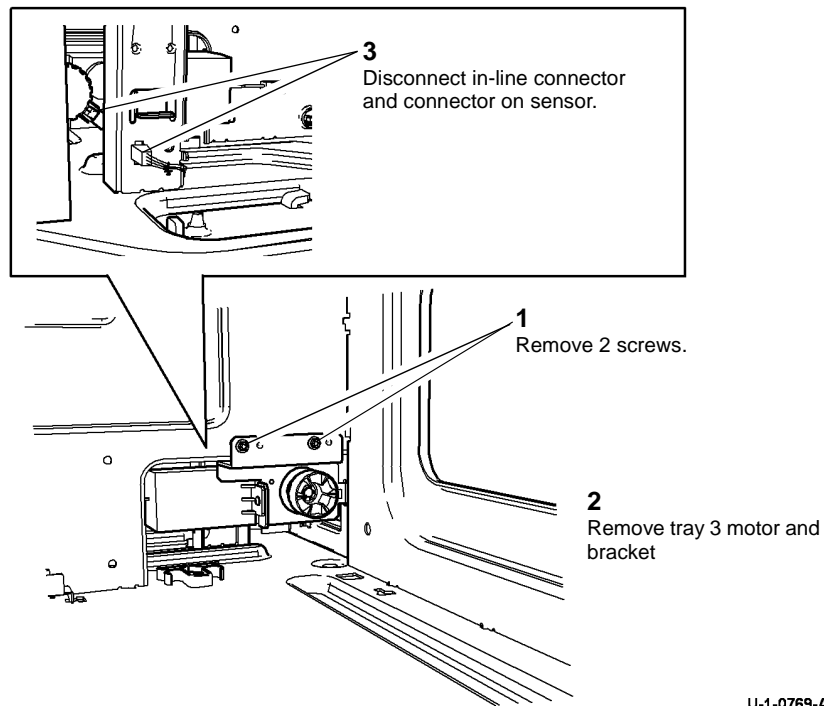

U-1-0769-A

Figure 1 Elevator motor removal

Replacement

The replacement is the reverse of the removal procedure.

REP 73.3 Tray 3 Elevator Cables

Parts List on [PL 73.15](#)

Removal

WARNING

Switch off the electricity to the machine. Refer to [GP 14](#). Disconnect the power cord from the customer supply while performing tasks that do not need electricity. Electricity can cause death or injury. Moving parts can cause injury.

WARNING

Take care during this procedure. Sharp edges may be present that can cause injury.

NOTE: The elevator drives at the front and at the rear are similar for both trays.

1. Remove tray 3, [REP 73.1](#).
2. Remove the tray 3 front cover, [PL 70.25 Item 3](#) (2 screws from below the cover).
3. Remove the cables from the front drive pulley, [Figure 1](#).

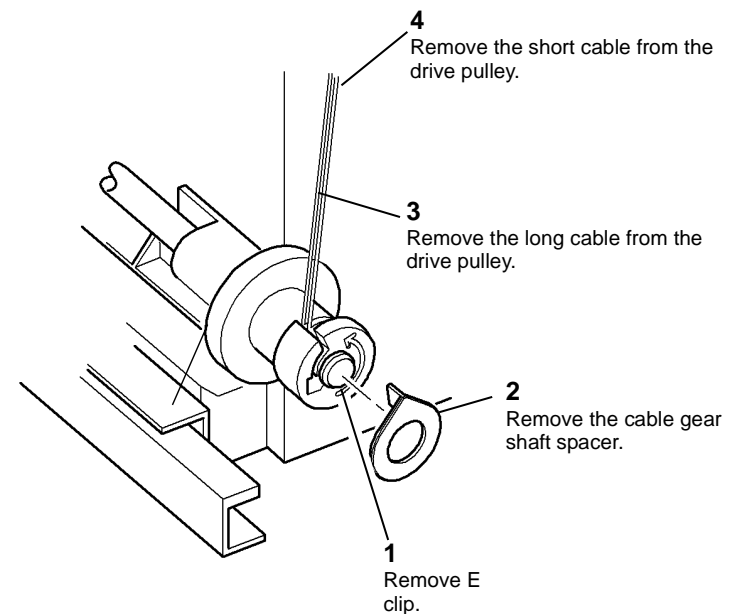

U-1-0253-A

Figure 1 Front elevator cable removal

4. Remove the pulley carriers and pass the cables through the base of the tray, [Figure 2](#).

NOTE: Short cable over the outer pulley and the long cable over the inner pulley.

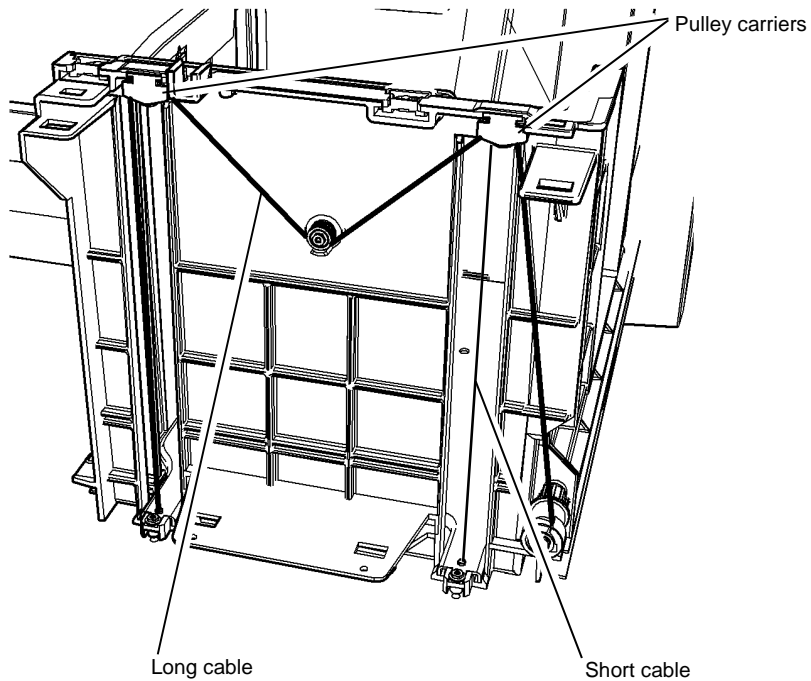

Figure 2 Remove front elevator cables

U-1-0770-A

5. Remove the tray 3 rear elevator cable, [Figure 3](#).

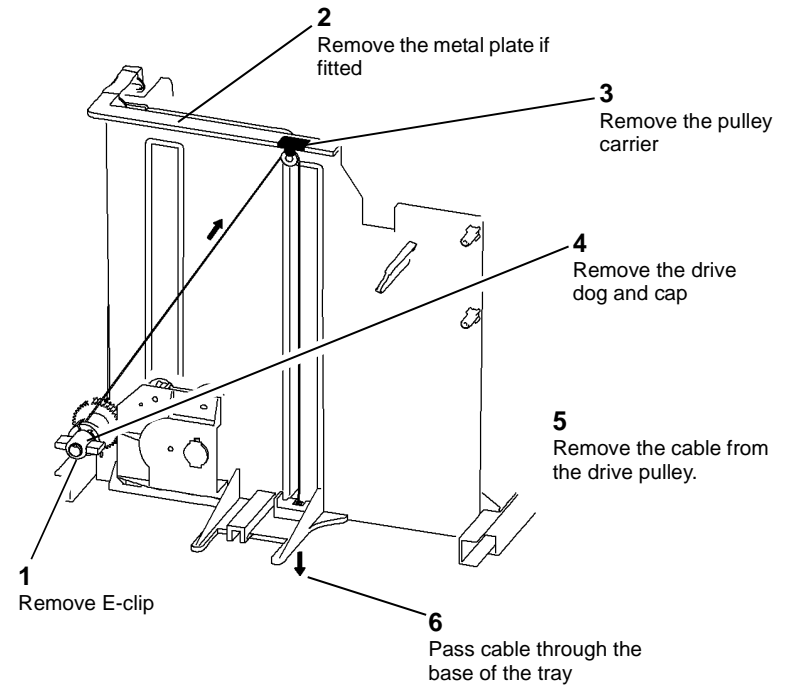

Figure 3 Tray 3 rear cable removal

U-1-0255-A

Replacement

The replacement is the reverse of the removal procedure.

Tray 3 front cables.

1. Thread the front short cable (silver) over the inner groove on the pulley
2. Thread the front long cable (yellow) over the outer groove on the pulley.

Tray 3 rear cable.

- Thread the rear cable (black) over the inner groove on the pulley.

REP 73.4 Tray 3 Stack Height Sensor

Parts List on [PL 81.30](#)

Removal

WARNING

Switch off the electricity to the machine. Refer to [GP 14](#). Disconnect the power cord from the customer supply while performing tasks that do not need electricity. Electricity can cause death or injury. Moving parts can cause injury.

WARNING

Take care during this procedure. Sharp edges may be present that can cause injury.

1. Pull out tray 3.
2. Remove Tray 3 paper feed assembly, [REP 81.2](#).
3. Disconnect and remove the stack height sensor, [Figure 1](#).

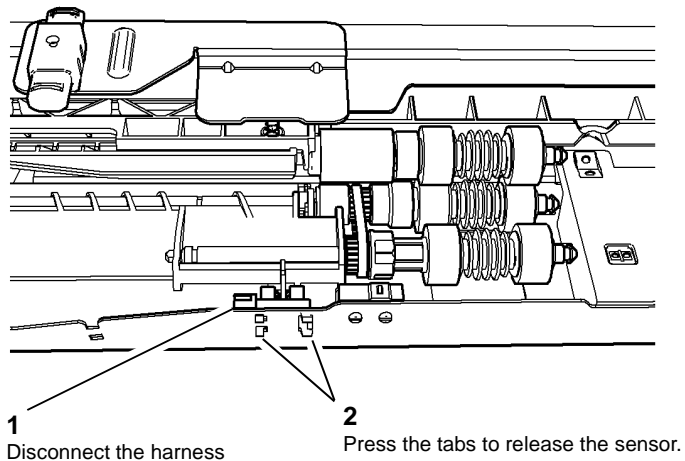

Figure 1 Stack height sensor

Replacement

The replacement is the reverse of the removal procedure.

REP 73.5 Tray 3 Home Sensor

Parts List on [PL 73.15](#)

Removal

WARNING

Switch off the electricity to the machine. Refer to [GP 14](#). Disconnect the power cord from the customer supply while performing tasks that do not need electricity. Electricity can cause death or injury. Moving parts can cause injury.

WARNING

Take care during this procedure. Sharp edges may be present that can cause injury.

The removal procedure is the same for tray 3 and tray 4.

1. Pull out Tray 3
2. Remove the right side cover, [PL 70.25 Item 4](#).
3. Remove the tray 3 home sensor and holder, [Figure 1](#).

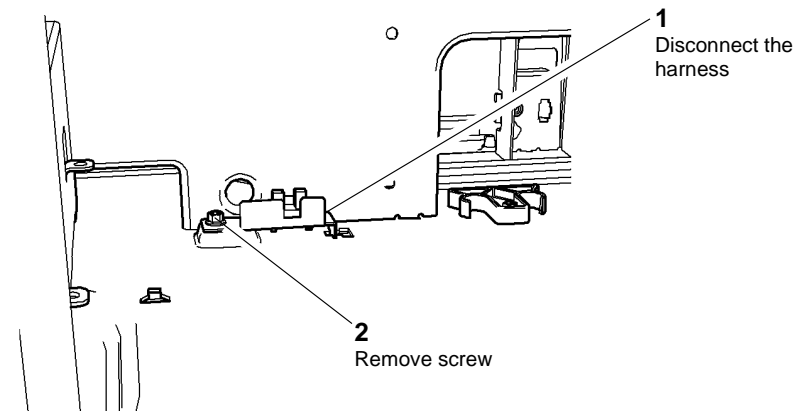

Figure 1 Tray home switch and holder

Replacement

Replacement is the reverse of the removal procedure.

REP 73.6 Tray 3 Elevator Damper and Gears

Parts List on [PL 73.15](#)

Removal

WARNING

Switch off the electricity to the machine. Refer to [GP 14](#). Disconnect the power cord from the customer supply while performing tasks that do not need electricity. Electricity can cause death or injury. Moving parts can cause injury.

WARNING

Take care during this procedure. Sharp edges may be present can cause injury.

1. Remove tray 3, [REP 73.1](#).
2. To remove the damper from tray 3, [Figure 1](#).

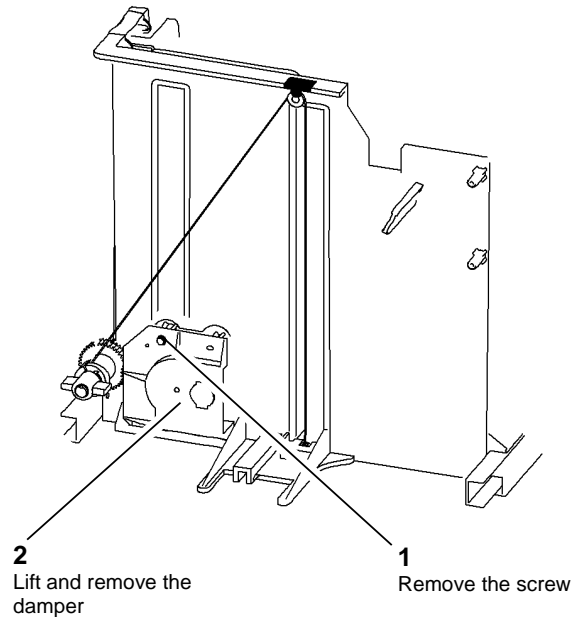
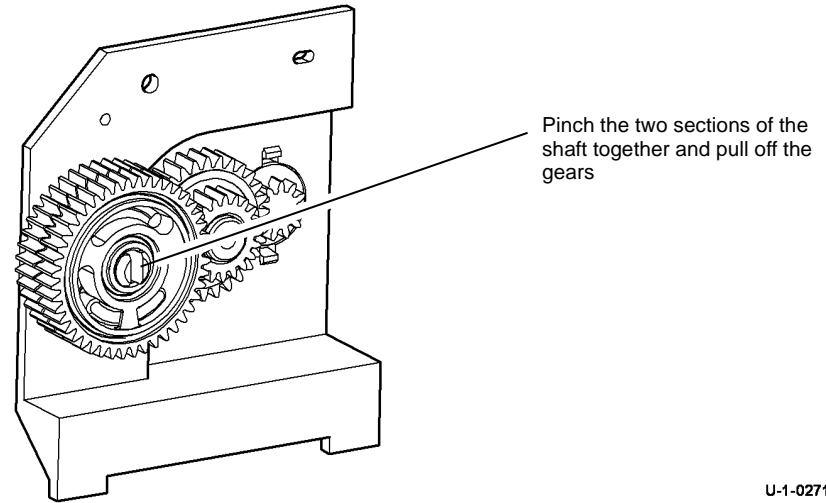

Figure 1 Tray 3 damper

U-1-0269-A

3. To remove the drive gears, [Figure 2](#).



U-1-0271-A

Figure 2 Remove the gears

Replacement

1. The replacement is the reverse of the removal procedure.
2. Ensure the gears are correctly aligned, [Figure 3](#).

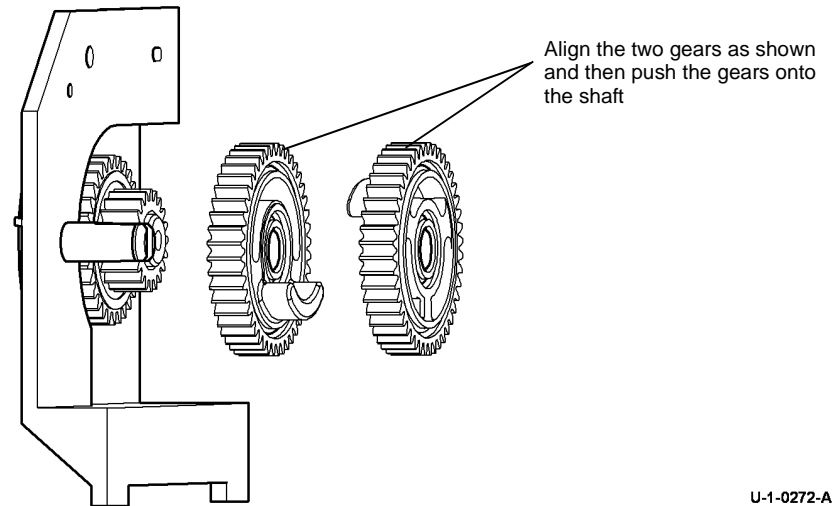

U-1-0272-A

Figure 3 Install the gears

REP 75.1 Tray 5 Empty Sensor

Parts List on [PL 81.45](#)

Removal

WARNING

Switch off the electricity to the machine. Refer to [GP 14](#). Disconnect the power cord from the customer supply while performing tasks that do not need electricity. Electricity can cause death or injury. Moving parts can cause injury.

WARNING

Take care during this procedure. Sharp edges may be present can cause injury.

1. Remove the top cover, [REP 75.8](#).
2. Prepare to remove the tray 5 empty sensor, [Figure 1](#).

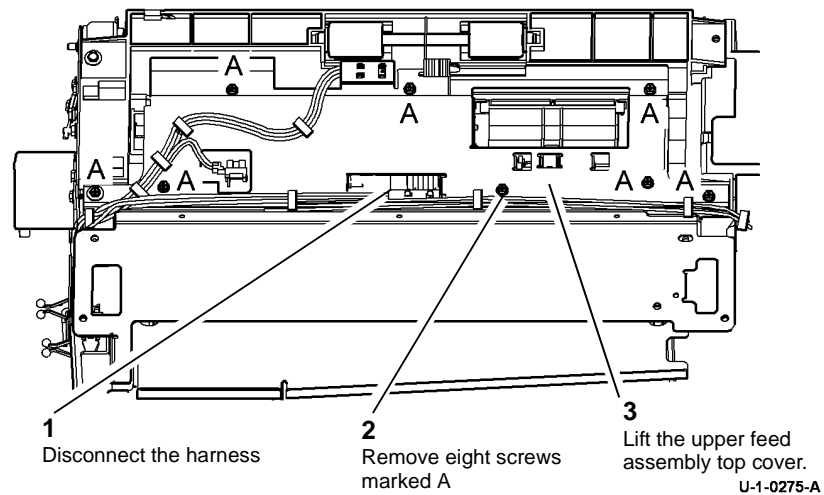

Figure 1 Preparation

U-1-0275-A

3. Remove tray 5 empty sensor, [Figure 2](#).

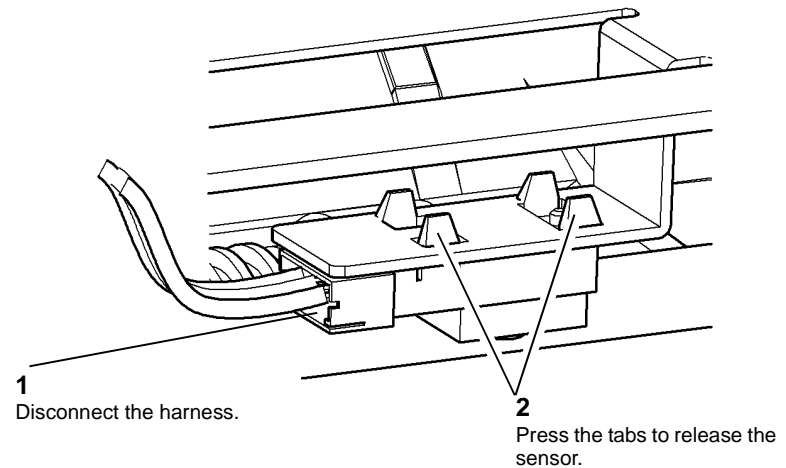

Figure 2 Remove tray 5 empty sensor

U-1-0276-A

Replacement

1. The replacement is the reverse of the removal procedure.
2. Make sure that the torsion nudger spring on the paper feed assembly is in the correct position, [Figure 3](#).

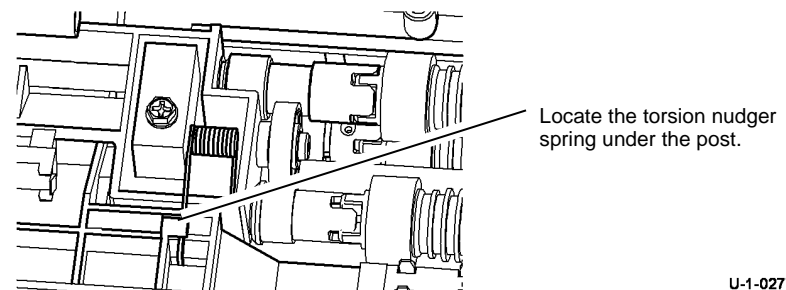

Figure 3 Spring location

U-1-0277-A

3. Make sure that the housing spring is positioned on top of the takeaway idler roller shaft when the upper feed assembly top cover is installed, [Figure 4](#).

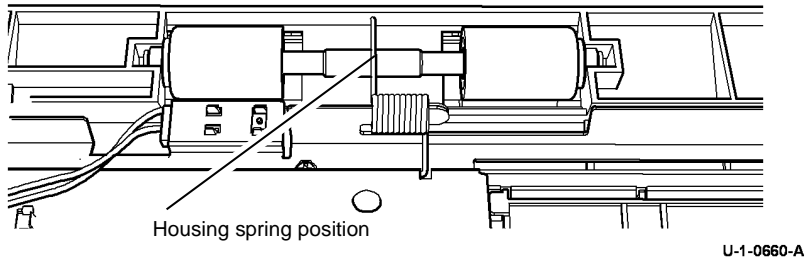

Figure 4 Spring position

4. Check that the correct screw is used to attach the upper feed assembly top cover.
5. Make sure that the torsion chute spring is positioned on top of the chute upper insert, [Figure 5](#).

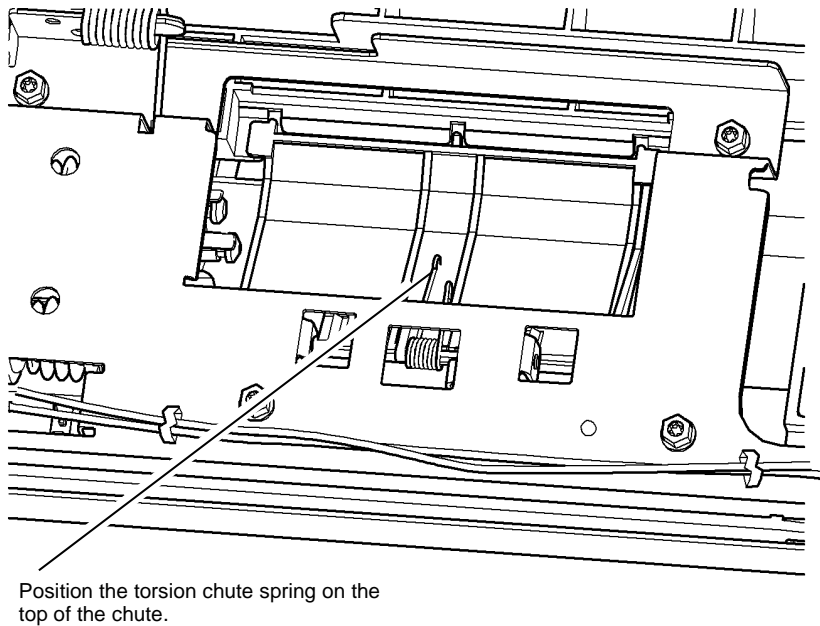

Figure 5 Spring position

6. Check that the harness routing is correct, [Figure 1](#).

REP 75.2 Tray 5 Stack Height Sensor

Parts List on [PL 81.45](#)

Removal

WARNING

Switch off the electricity to the machine. Refer to [GP 14](#). Disconnect the power cord from the customer supply while performing tasks that do not need electricity. Electricity can cause death or injury. Moving parts can cause injury.

WARNING

Take care during this procedure. Sharp edges may be present can cause injury.

1. Remove the top cover, [REP 75.8](#).
2. Prepare to remove the tray 5 stack height sensor, [Figure 1](#).

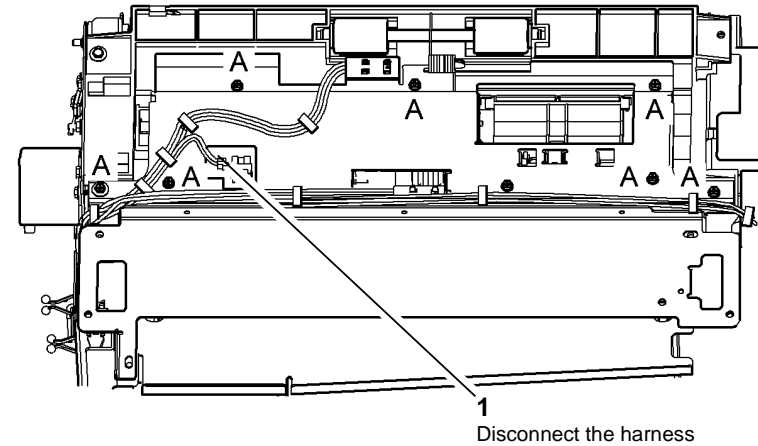

Figure 1 Preparation

3. Remove tray 5 stack height sensor, [Figure 2](#).

REP 75.3 Tray 5 Down Sensor

Parts List on [PL 75.68](#)

Removal

WARNING

Switch off the electricity to the machine. Refer to [GP 14](#). Disconnect the power cord from the customer supply while performing tasks that do not need electricity. Electricity can cause death or injury. Moving parts can cause injury.

WARNING

Take care during this procedure. Sharp edges may be present can cause injury.

1. Remove the rear cover, [REP 75.8](#).
2. Remove the tray 5 down sensor, [Figure 1](#).

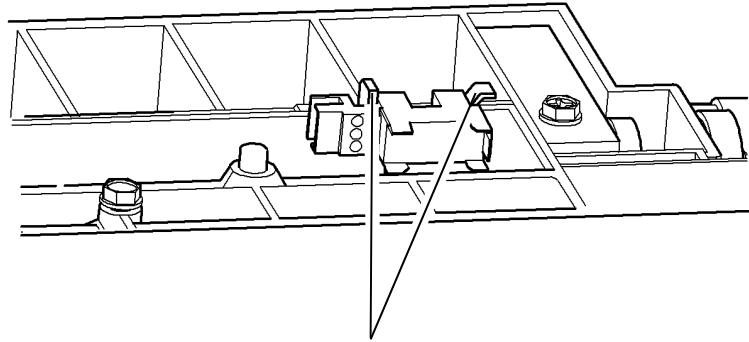

Press the tabs to release the sensor

U-1-0280-A

Figure 2 Remove the sensor

Replacement

1. The replacement is the reverse of the removal procedure.
2. Check that the harness routing is correct, [Figure 1](#).

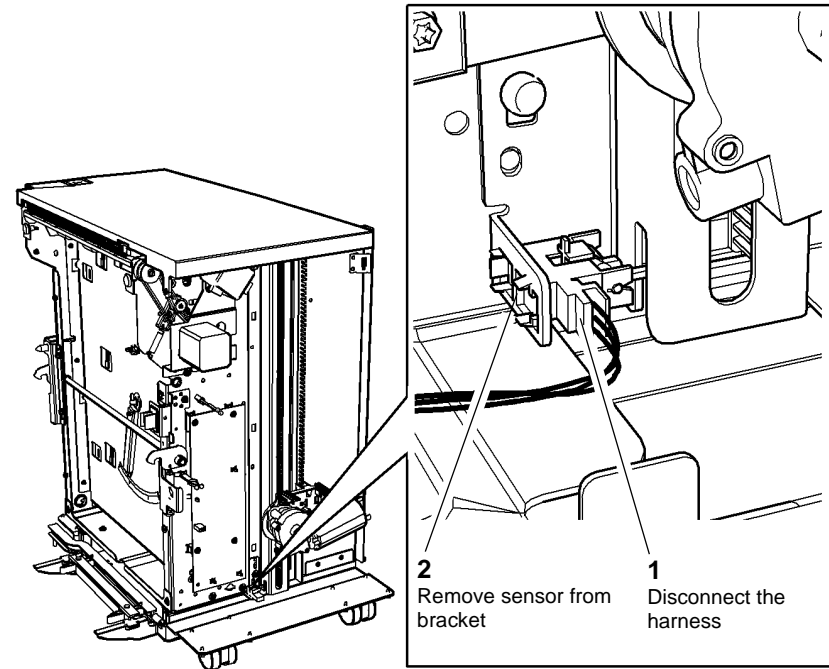

U-1-0281-A

Figure 1 Remove the sensor

Replacement

The replacement is the reverse of the removal procedure.

REP 75.4 Tray 5 Elevator Motor Assembly

Parts List on [PL 75.68](#)

Removal

WARNING

Switch off the electricity to the machine. Refer to [GP 14](#). Disconnect the power cord from the customer supply while performing tasks that do not need electricity. Electricity can cause death or injury. Moving parts can cause injury.

WARNING

Take care during this procedure. Sharp edges may be present can cause injury.

1. Remove the paper from the tray.
2. Remove the rear cover, [REP 75.8](#).
3. Remove the tray 5 elevator motor assembly, [Figure 1](#).

NOTE: The tray 5 paper tray must be supported before the elevator motor assembly is removed.

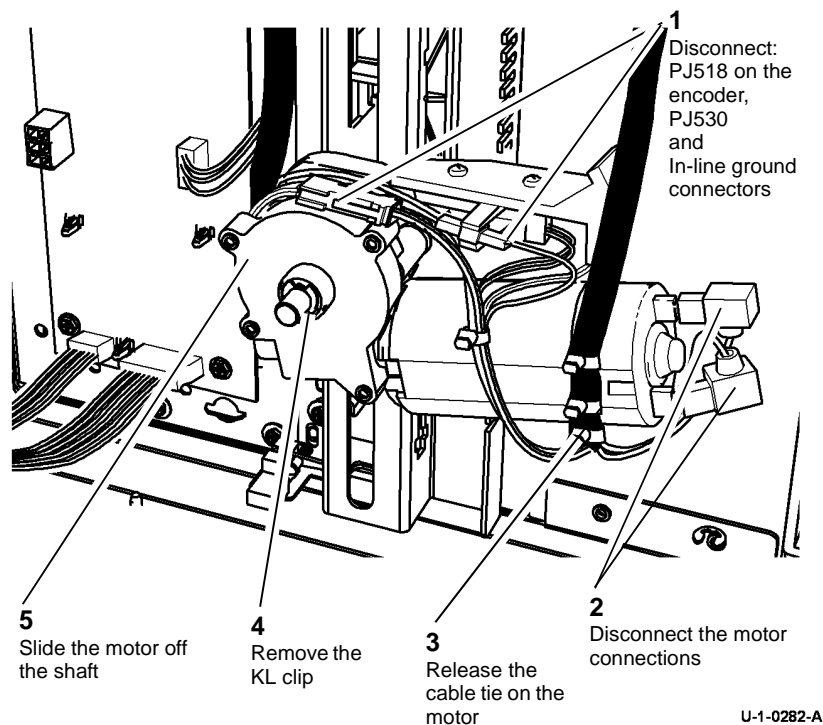

Figure 1 Remove the elevator motor assembly

4. If required remove the encoder sensor from the plastic bracket, [Figure 2](#).

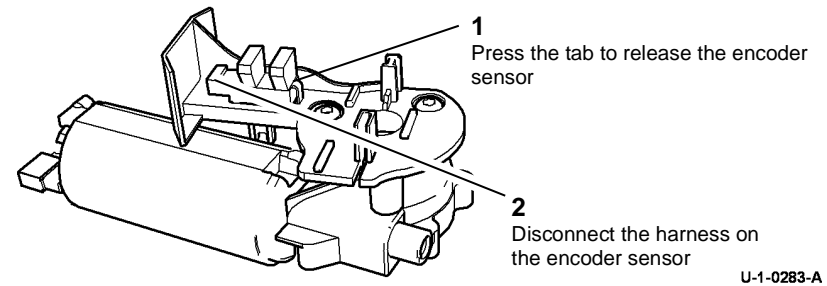

Figure 2 Remove the encoder sensor

Replacement

1. To help with the installing of a new elevator motor, support the paper tray on two reams of paper.
2. Make sure that the encoder sensor is position on the elevator motor assembly, [Figure 2](#).
3. The replacement is the reverse of the removal procedure.
4. Check that the harness is routed in the channel on the plastic bracket, [Figure 3](#).

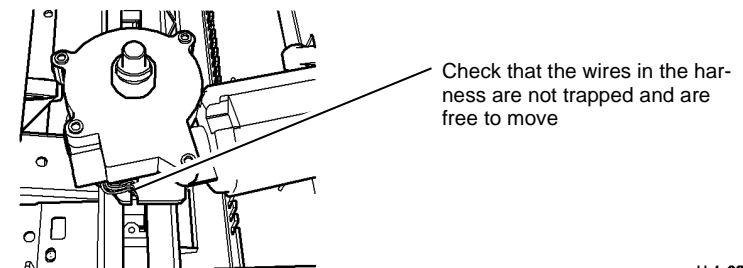
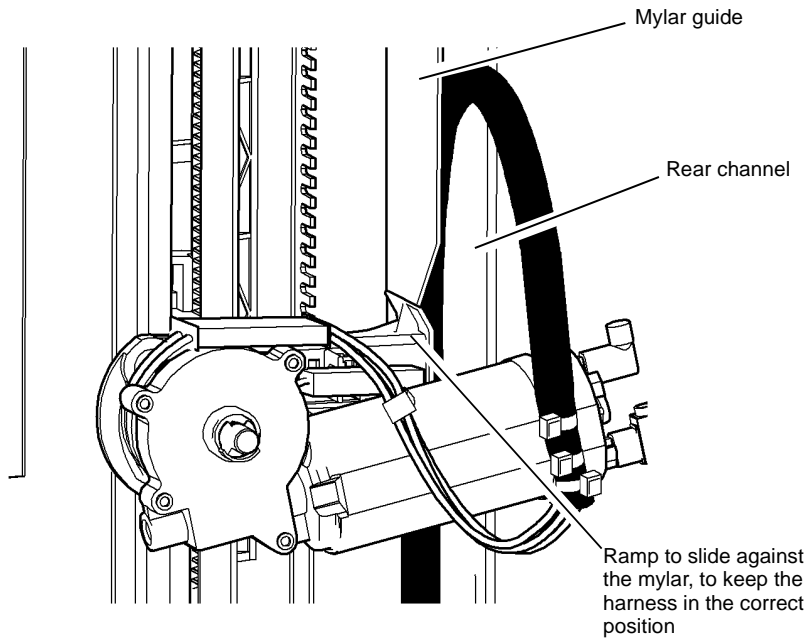

Figure 3 Harness position

5. Ensure that there are no twists in the harness when installing the elevator motor.
6. When the motor is installed, remove the paper supporting the paper tray.

7. Exercise the elevator motor with one sheet of paper in the tray. Observe that the harness tracks properly between the mylar guide and the rear channel. [Figure 4](#).



U-1-0285-A

Figure 4 Location of the harness

8. Check the registration, perform [dC625](#) Registration / preheat Calibration if necessary.

REP 75.5 Tray 5 Upper Limit Switch

Parts List on [PL 75.68](#)

Removal

WARNING

Switch off the electricity to the machine. Refer to [GP 14](#). Disconnect the power cord from the customer supply while performing tasks that do not need electricity. Electricity can cause death or injury. Moving parts can cause injury.

WARNING

Take care during this procedure. Sharp edges may be present can cause injury.

1. Remove the rear cover, [REP 75.8](#).
2. Remove the top cover, [REP 75.8](#).
3. Prepare to remove the tray 5 upper limit switch, [Figure 1](#).

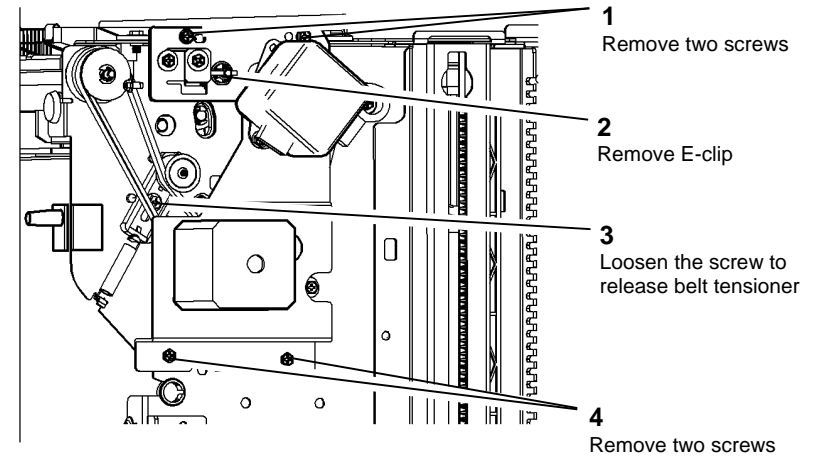

U-1-0286-A

Figure 1 Preparation

4. Remove the tray 5 upper limit switch and the actuator if required, [Figure 2](#).

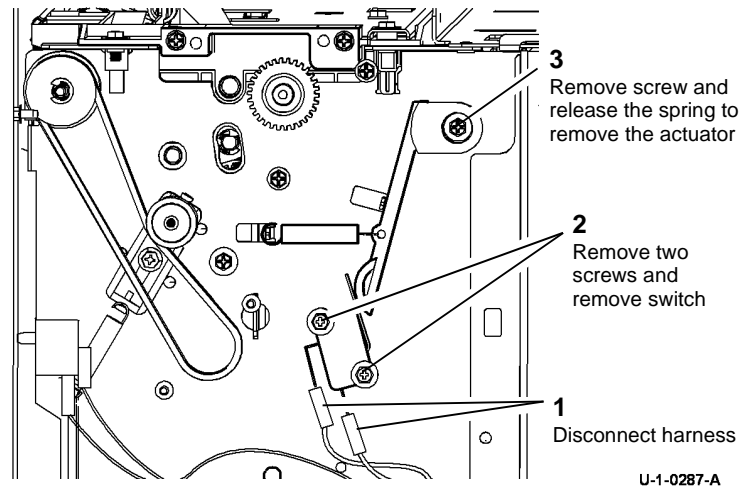

Figure 2 Remove tray upper limit switch

Replacement

1. The replacement is the reverse of the removal procedure.

REP 75.6 Tray 5 Down Limit Switch

Parts List on [PL 75.70](#)

Removal

WARNING

Switch off the electricity to the machine. Refer to [GP 14](#). Disconnect the power cord from the customer supply while performing tasks that do not need electricity. Electricity can cause death or injury. Moving parts can cause injury.

WARNING

Take care during this procedure. Sharp edges may be present can cause injury.

1. If the tray must be repositioned, refer to [REP 75.4](#). Disengage the elevator motor from the tray and move the tray to the required position. Re-engage the elevator motor to hold the tray.
2. Release the paper tray to gain access to the tray 5 down limit switch, [Figure 1](#).

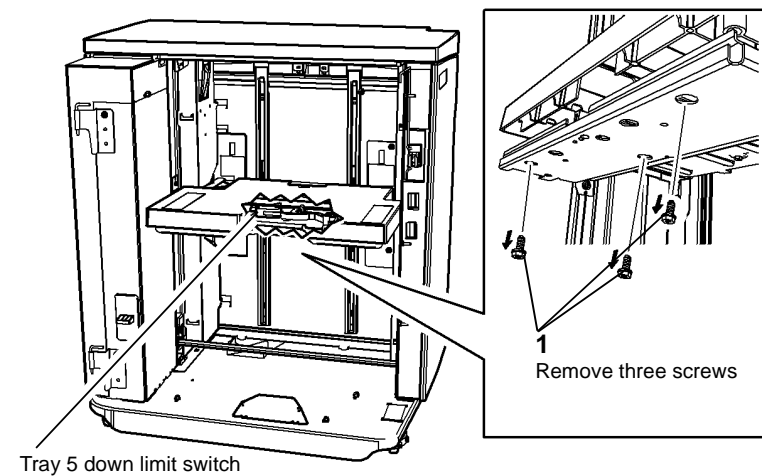

Figure 1 Release the paper tray

3. Lift the tray to access to the tray 5 down limit switch and the actuator if required, [Figure 2](#).

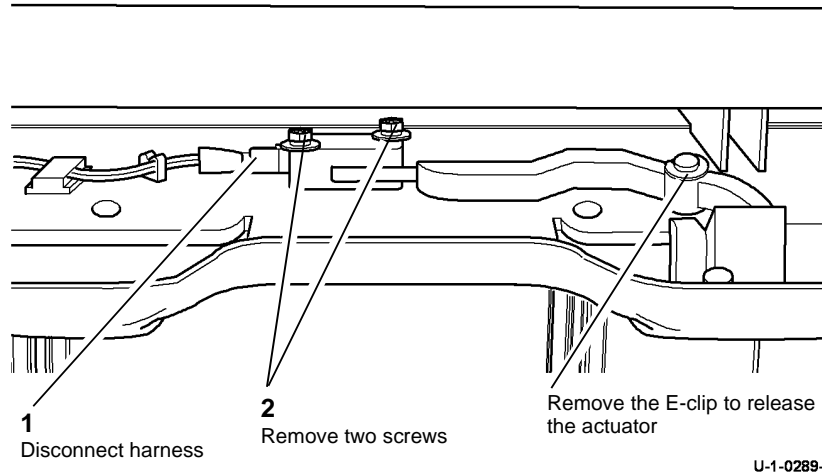

Figure 2 Remove tray 5 down limit switch

Replacement

1. The replacement is the reverse of the removal procedure.
2. Check that the wires are not trapped when refitting the tray.

REP 75.7 Un-docking and Docking Tray 5

Parts List on [PL 75.62](#)

Removal

WARNING

Switch off the electricity to the machine. Refer to [GP 14](#). Disconnect the power cord from the customer supply while performing tasks that do not need electricity. Electricity can cause death or injury. Moving parts can cause injury.

WARNING

Take care during this procedure. Sharp edges may be present can cause injury.

WARNING

Take care not to topple Tray 5. Tray 5 is unstable when undocked from the machine. Do not show the customer how to undock Tray 5.

1. Remove the paper from the tray.
2. Engage the transit lock and pull the tray 5 module away from the machine until the lock engages, [Figure 1](#).

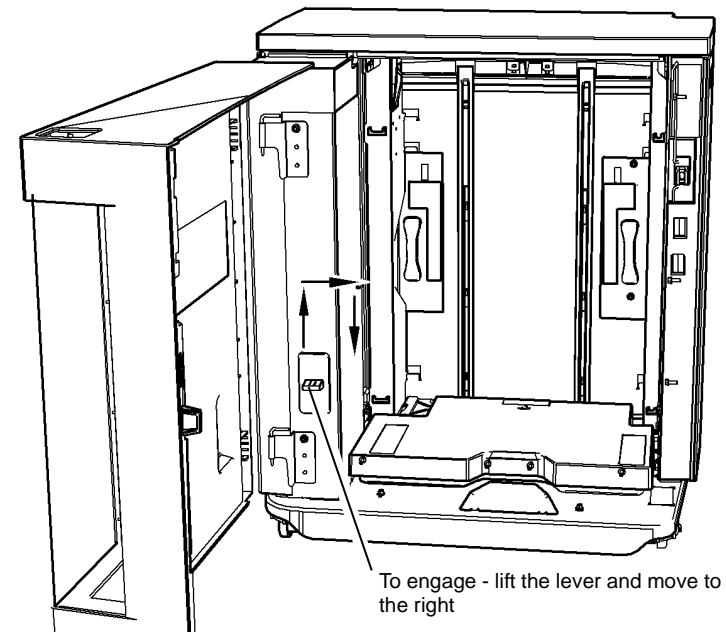

Figure 1 Engage transit lock

3. At the rear of the machine release the latch and pull the tray 5 module away from the machine, [Figure 2](#).

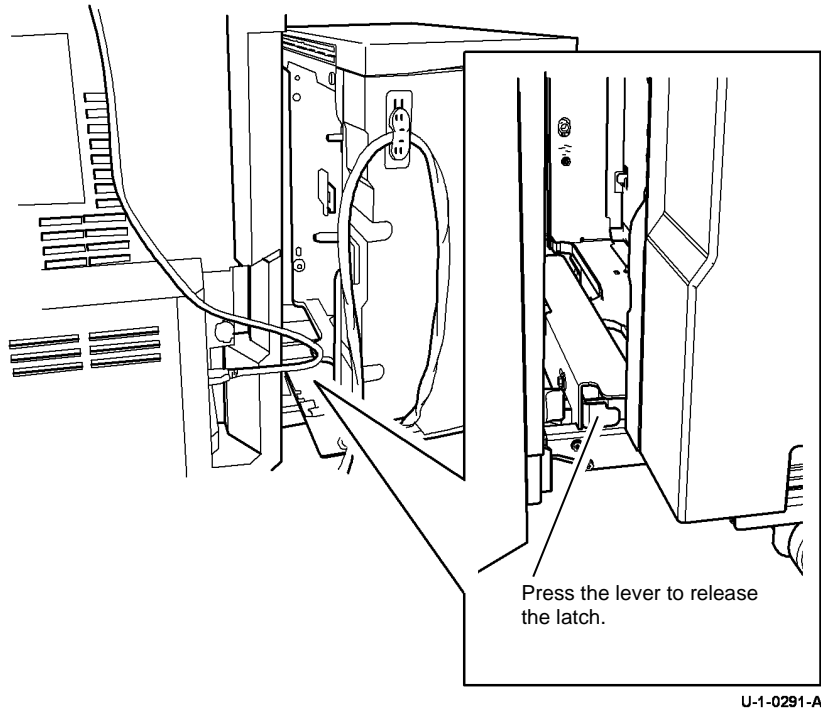

Figure 2 Un-dock the tray 5 module

Replacement

1. The replacement is the reverse of the removal procedure.
2. Position the tray 5 module and align the docking guides with the machine, [Figure 3](#).

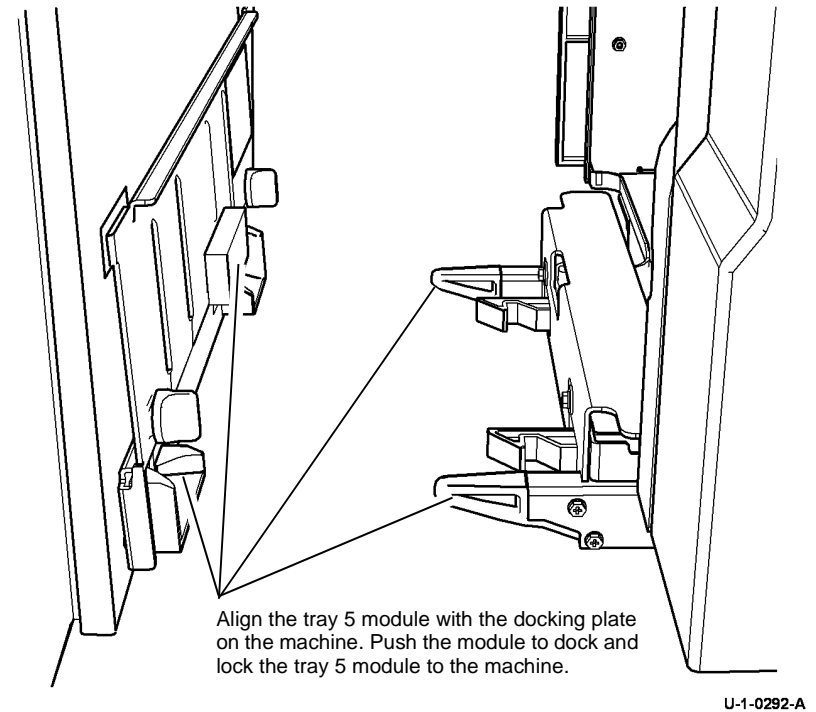
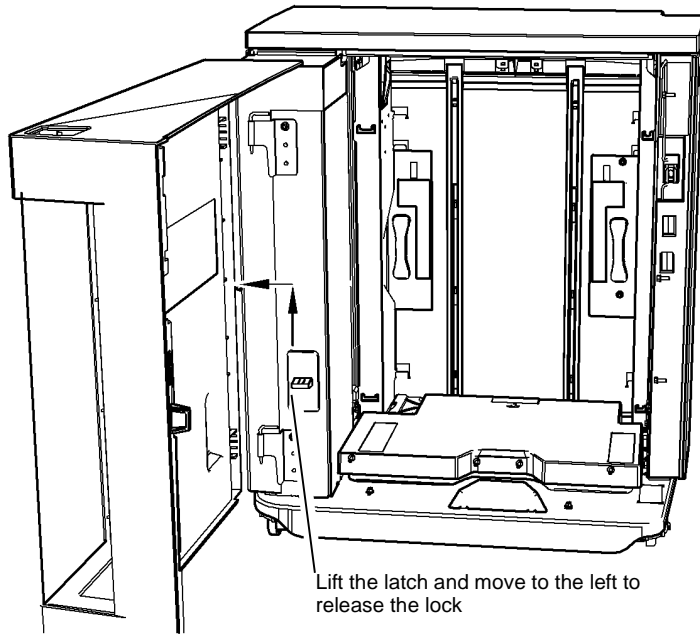

Figure 3 Docking the Tray 5 module

3. Release the transit lock and push the tray 5 module into the docked position against the machine, [Figure 4](#).



U-1-0293-A

Figure 4 Release transit lock

4. Go to [ADJ 75.2](#) Machine to Tray 5 Alignment and complete the adjustment.

REP 75.8 Tray 5 Covers

Parts List on [PL 75.60](#)

Removal

WARNING

Switch off the electricity to the machine. Refer to [GP 14](#). Disconnect the power cord from the customer supply while performing tasks that do not need electricity. Electricity can cause death or injury. Moving parts can cause injury.

WARNING

Take care during this procedure. Sharp edges may be present can cause injury.

1. To remove the top cover, [Figure 1](#).

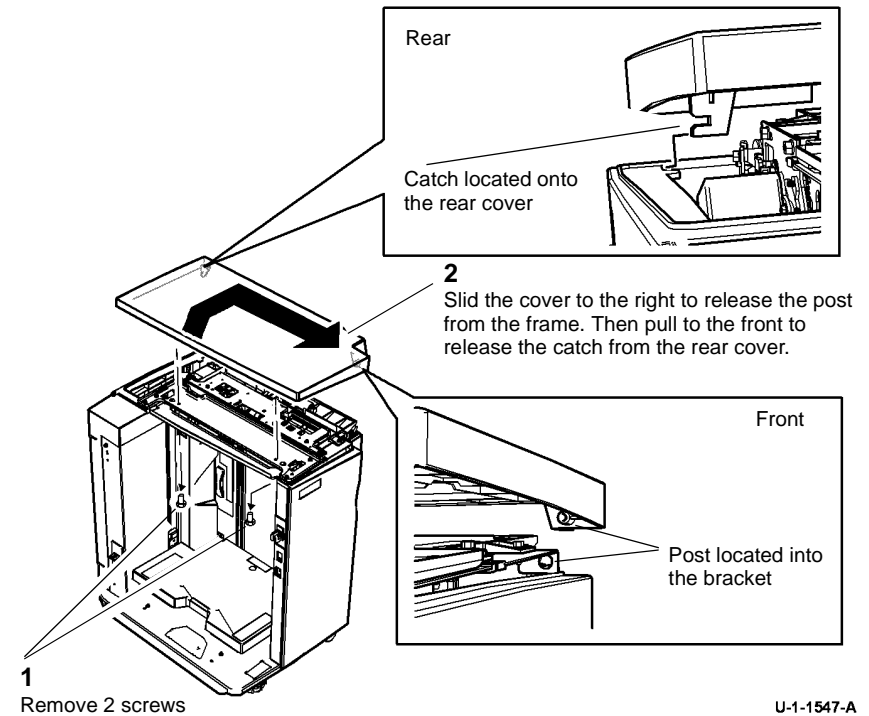

U-1-1547-A

Figure 1 Top cover

- Remove the front or rear cover, [Figure 2](#).

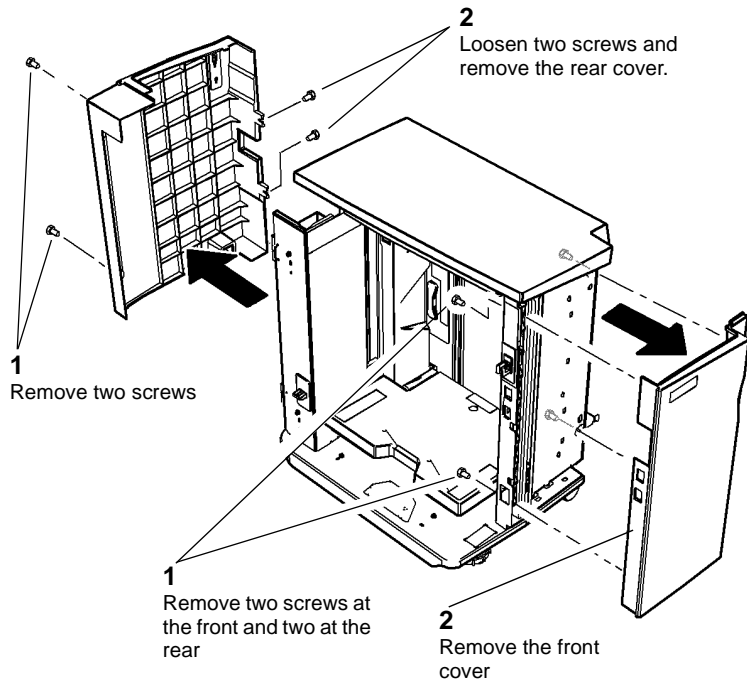

Figure 2 Front and rear cover

U-1-1546-A

Replacement

- The replacement is the reverse of the removal procedure.
- Check that the top cover is located correctly, [Figure 1](#).

REP 75.9 Tray 5 Docking Latch

Parts List on [PL 75.62](#)

Removal

WARNING

Switch off the electricity to the machine. Refer to [GP 14](#). Disconnect the power cord from the customer supply while performing tasks that do not need electricity. Electricity can cause death or injury. Moving parts can cause injury.

WARNING

Take care during this procedure. Sharp edges may be present can cause injury.

- Remove the paper and un-dock the tray 5 module, [REP 75.7](#).
- Remove the two screws and unhook the spring, [Figure 1](#).

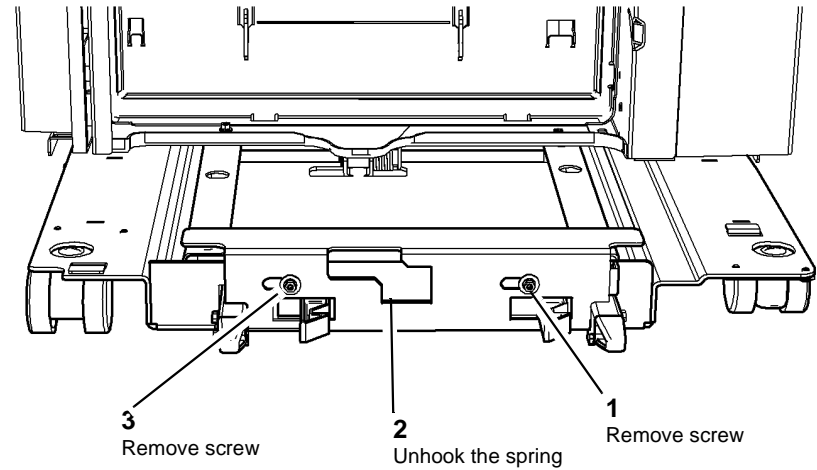
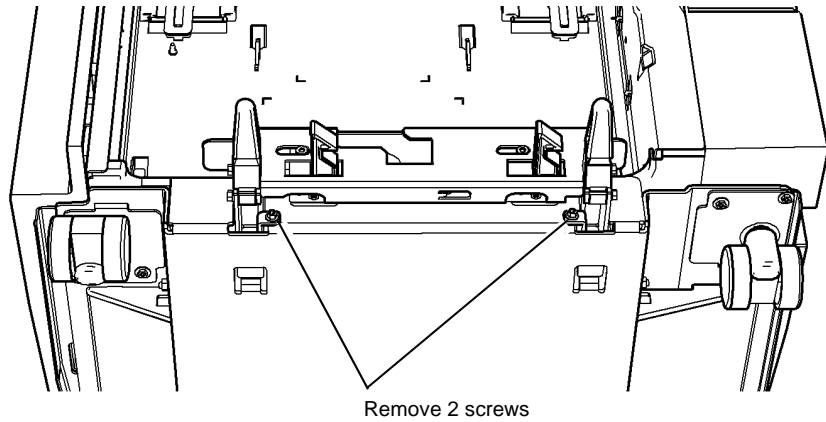

Figure 1 Preparation

U-1-1654-A

- Turn tray 5 onto its end to access the fixing screws on the docking latch main bracket. If tray 5 has a 11x17 / A3 or 8.5 x 11 / 14 kit then turn the tray 5 on it's side. [Figure 2](#).



U-1-1655-A

Figure 2 Remove the latch assembly

- Note the orientation of the latches and then remove the docking latches, [Figure 3](#).

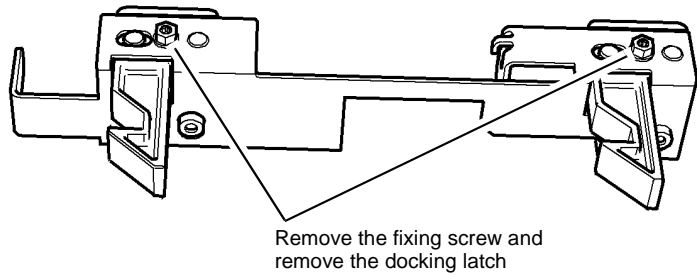

U-1-1656-A

Figure 3 Remove docking latch

Replacement

- The replacement is the reverse of the removal procedure.
- Check that the tabs are located correctly on the base plate when refitting the latch assembly, [Figure 4](#).

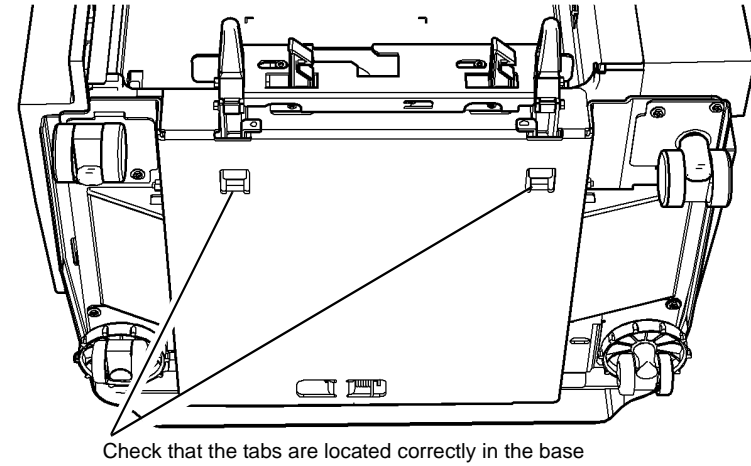

U-1-1657-A

Figure 4 Location of the tabs

- Check that the docking latch spring is located correctly.

REP 75.10 Tray 5 Elevator Rack Assembly

Parts List on [PL 75.68](#)

Removal

WARNING

Switch off the electricity to the machine. Refer to [GP 14](#). Disconnect the power cord from the customer supply while performing tasks that do not need electricity. Electricity can cause death or injury. Moving parts can cause injury.

WARNING

Take care during this procedure. Sharp edges may be present can cause injury.

1. Release the cable clamp from the rear cover, [Figure 1](#).

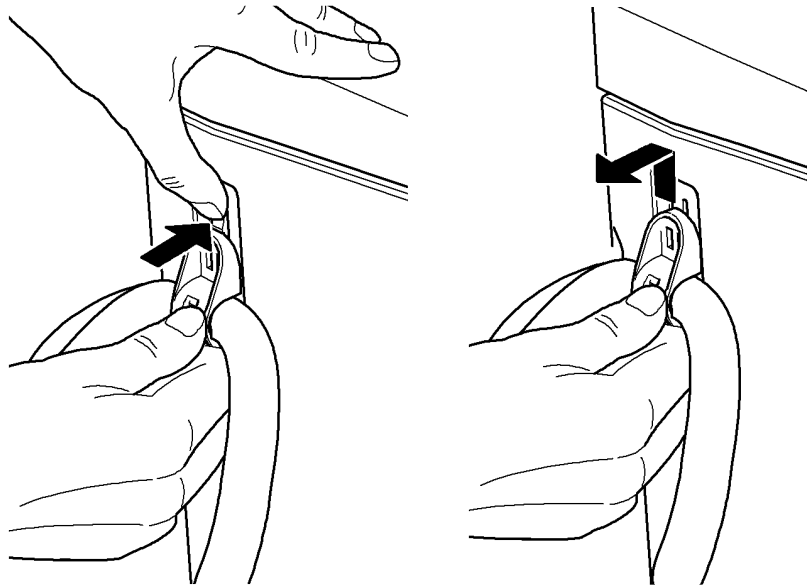

- 1 Press the locking clip towards the module.

- 2 Slide the cable clamp off the module, in an upwards direction.

U-1-1663-A

Figure 1 Cable clamp

2. Remove any paper from tray 5, then un-dock the module, [REP 75.7](#).
3. Remove the two front door hinge pins, [PL 75.60 Item 3](#), then remove the front door assembly, [PL 75.60 Item 1](#).
4. Remove the top, front and rear covers, [REP 75.8](#).
5. Remove the elevator motor assembly, [REP 75.4](#).
6. Remove the frame top brace, [PL 75.68 Item 3](#).

7. Remove the crash bar, [PL 75.68 Item 2](#).
8. Disconnect the transport motor, [PL 81.40 Item 2](#).
9. Disconnect the feed motor, [PL 81.40 Item 3](#).
10. Remove the upper feeder assembly, [PL 81.40 Item 1](#), refer to [REP 82.7](#).
11. Prepare to remove the tray assembly, [Figure 2](#) and [Figure 3](#).

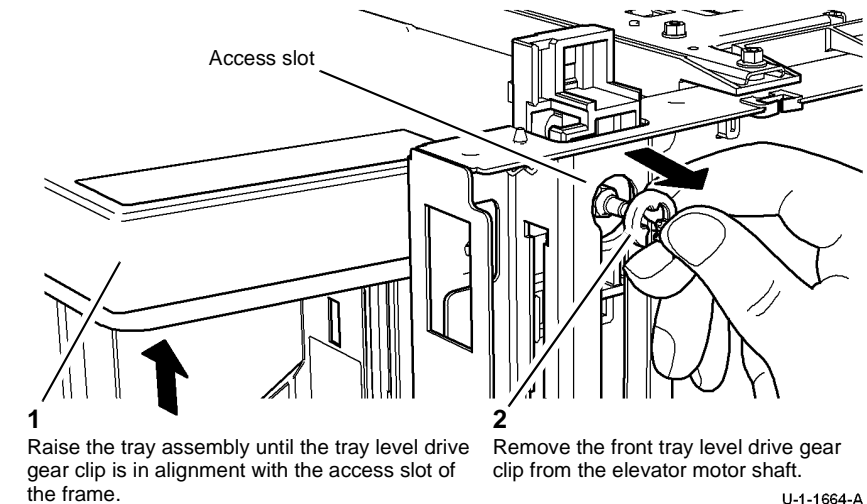

Figure 2 Tray assembly front view

U-1-1664-A

NOTE: Only the front elevator rack has a clearance cut-out to accommodate the tray 5 door switch, [Figure 4](#).

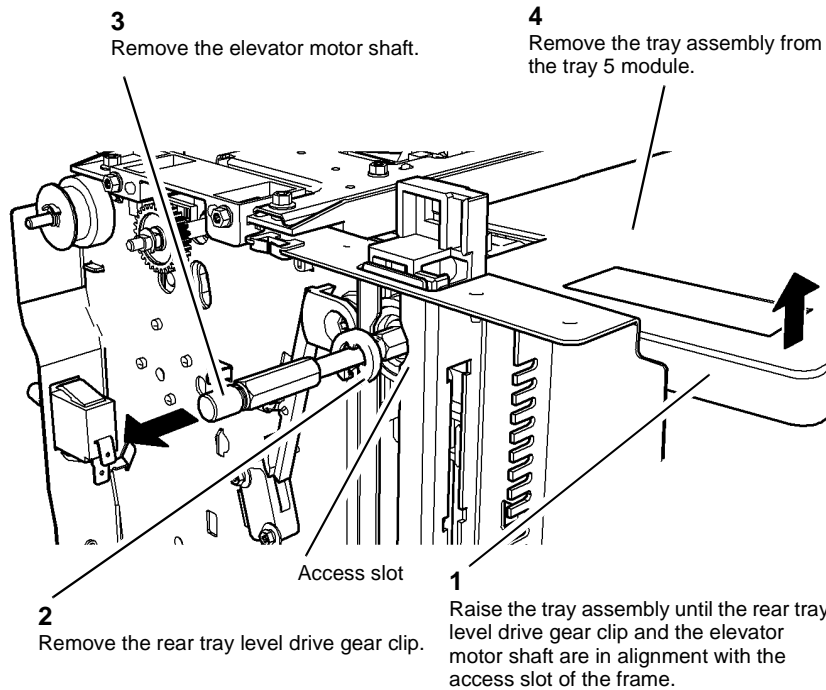

Figure 3 Tray assembly rear view

12. Remove the front and rear drive gears, [PL 75.68 Item 28](#).
13. Remove the front elevator rack, [PL 75.68 Item 14](#). Slide the rack upwards within the frame then lift the rack away from the tray 5 module.

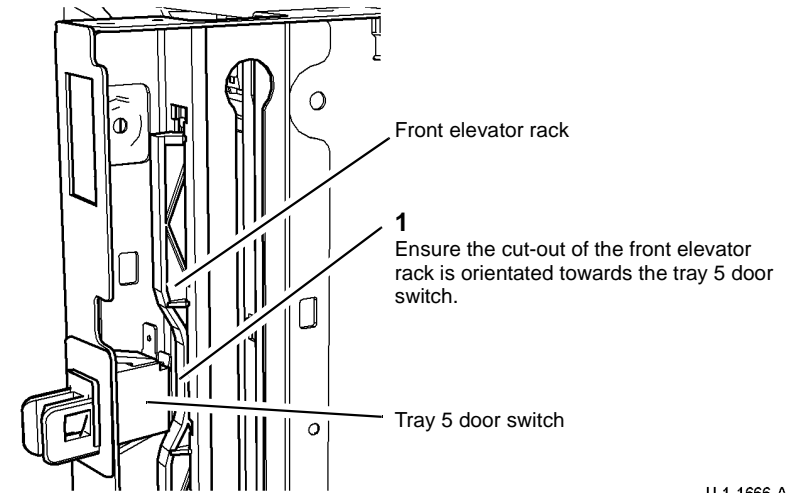
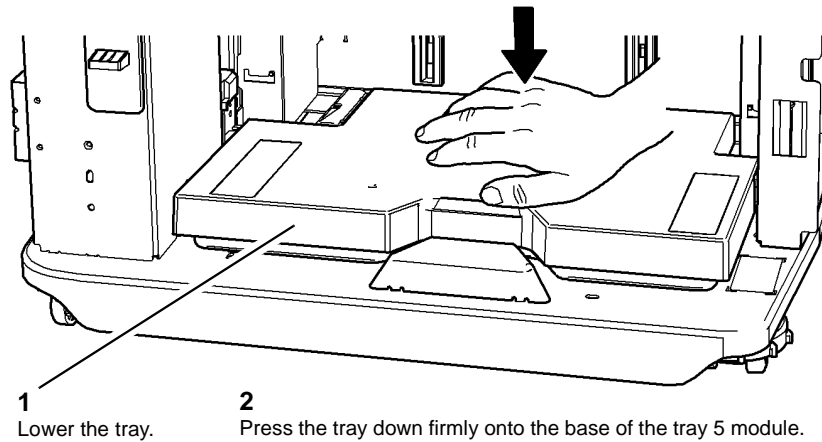

Figure 4 Front elevator rack

14. Remove the rear elevator rack, [PL 75.68 Item 13](#). Slide the rear elevator rack upwards within the frame, then lift the rack away from the tray 5 module.

Replacement

1. The replacement is the reverse of the removal procedure.
2. After the front and rear drive gears are re-installed ensure that the tray assembly is re-installed in the same horizontal plane as the base of the tray 5 module, [Figure 5](#).



U-1-1667-A

Figure 5 Install the tray

3. Keep the tray assembly against the base of the tray 5 module, then reinstall the elevator motor shaft.

4. Raise the tray to ensure that it is in horizontal alignment with the lower feeder assembly, [Figure 6](#). If necessary remove the elevator motor shaft then repeat the replacement procedure from step 2.

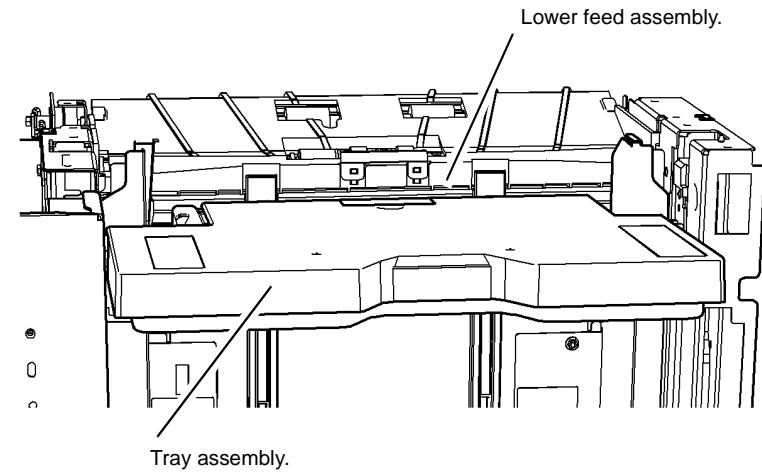

U-1-1668-A

Figure 6 Tray alignment

REP 81.1 Tray 1 and Tray 2 Paper Feed Assembly

Parts List on [PL 81.25](#), [PL 81.26](#)

Removal

WARNING

Switch off the electricity to the machine. Refer to [GP 14](#). Disconnect the power cord from the customer supply while performing tasks that do not need electricity. Electricity can cause death or injury. Moving parts can cause injury.

WARNING

Take care during this procedure. Sharp edges may be present that can cause injury.

1. Remove tray 1 or tray 2 as required, [REP 71.1](#).
2. Remove the rear left cover, [PL 70.25 Item 7](#).
3. Remove the lower left door assembly, [Figure 1](#).

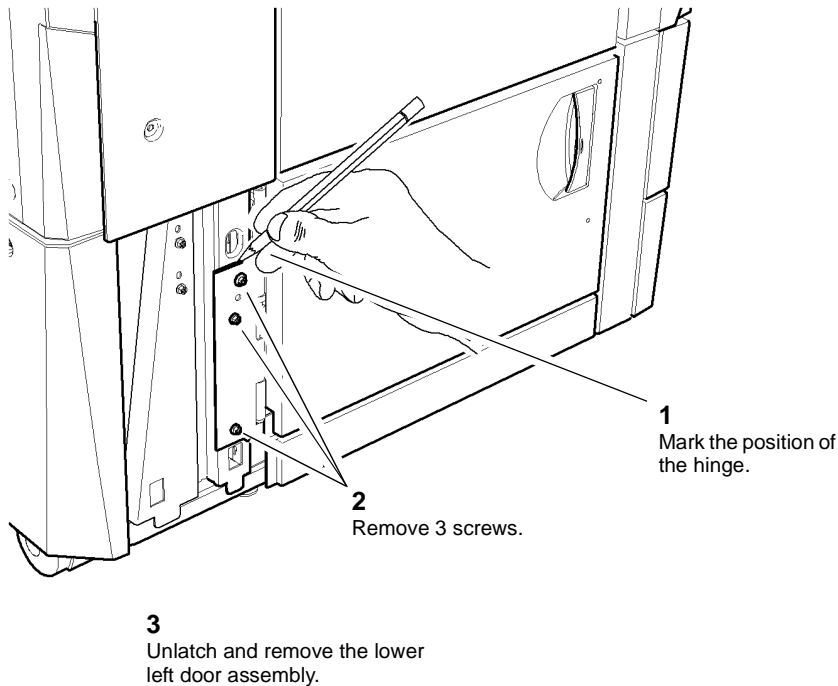

Figure 1 Lower left door assembly

4. Remove the rear cover, [PL 70.25 Item 8](#).

5. Disconnect the harness from the feed motor as required, [Figure 2](#).

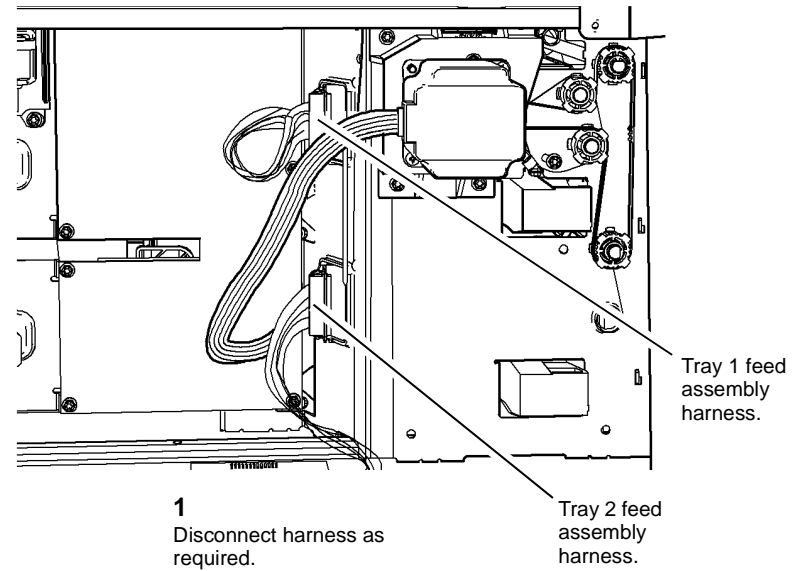

Figure 2 Disconnect harness

U-1-0801-A

U-1-1626-A

- Remove tray 1 or tray 2 feed assembly. [Figure 3](#).

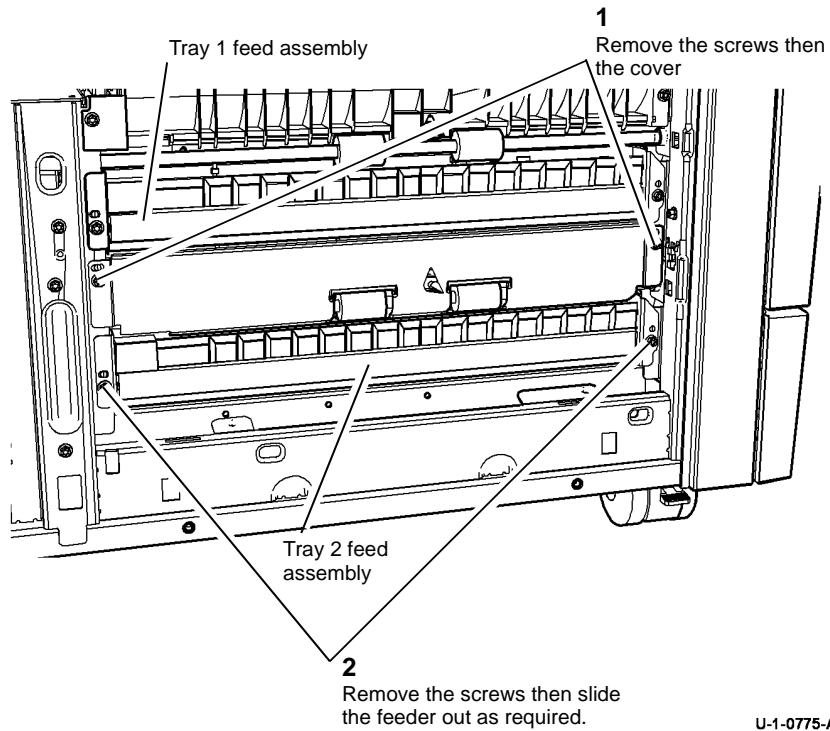

Figure 3 Removal

U-1-0775-A

Replacement

- Replacement is the reverse of the removal procedure.
- To install the lower left door assembly. Install the three screws, close the door and align the hinge with the marking on the frame. Secure the screws and check that the door opens and closes correctly, [Figure 1](#).
- If new feed rolls are installed, reset the tray 1 or tray 2 feed count to zero. Refer to [dC135 CRU / HFSI Status](#).

REP 81.2 Tray 3 Paper Feed Assembly

Parts List on [PL 81.30](#)

Removal

WARNING

Switch off the electricity to the machine. Refer to [GP 14](#). Disconnect the power cord from the customer supply while performing tasks that do not need electricity. Electricity can cause death or injury. Moving parts can cause injury.

WARNING

Take care during this procedure. Sharp edges may be present that can cause injury.

- Pull out tray 3.
- Remove tray 1 and the horizontal transport, [REP 82.3](#).
- Remove the paper feed assembly, [Figure 1](#).

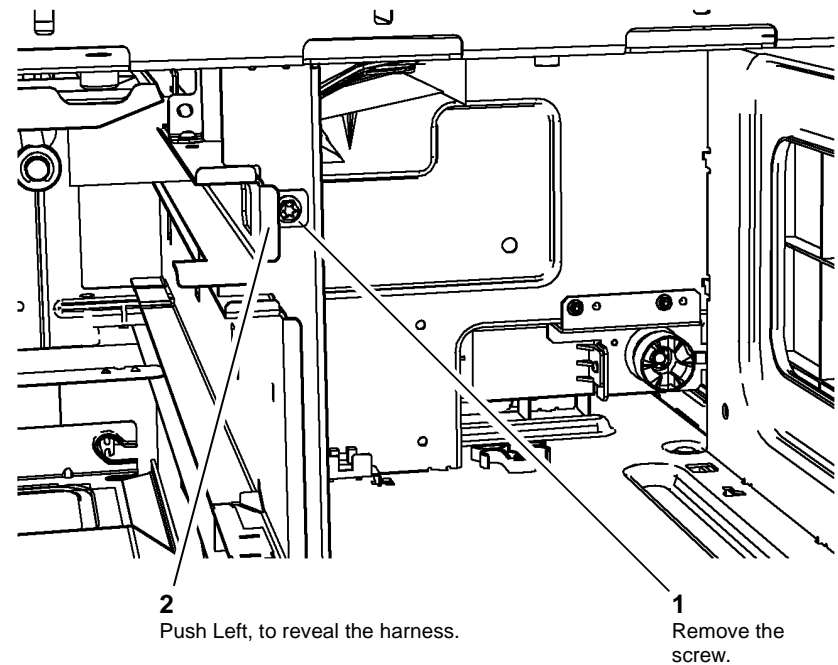

Figure 1 Tray 3 feed assembly

U-1-0776-A

4. Disconnect the harness, [Figure 2](#).

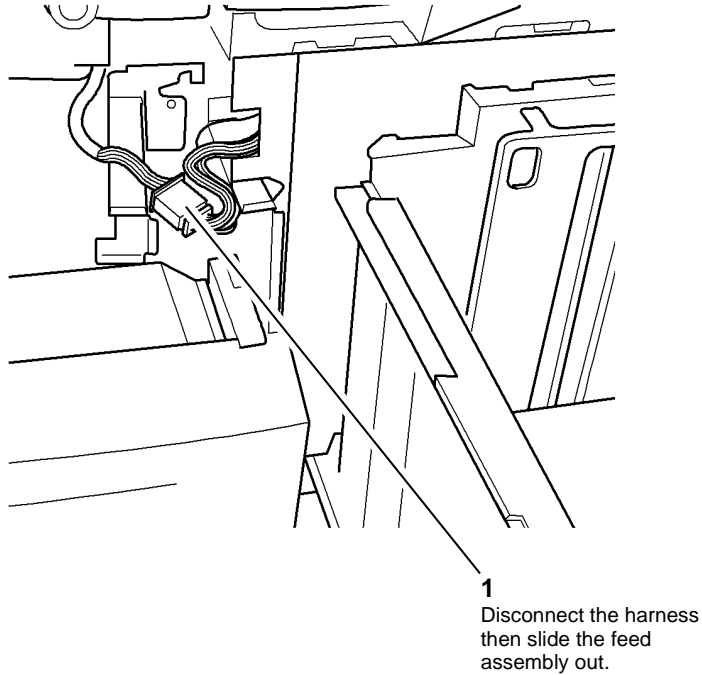

Figure 2 Disconnect harness

Replacement

Replacement is the reverse of the removal procedure.

1. Install the paper feed assembly and push the tray in slowly.
NOTE: Check that the tray does not touch the feed assembly.
2. If a new feed roll assembly is installed, reset the tray 3 feed count to zero. Refer to [dC135 CRU / HFSI Status](#).

U-1-0804-A

REP 81.3 Bypass Module

Parts List on [PL 70.30](#)

Removal

WARNING

Switch off the electricity to the machine. Refer to [GP 14](#). Disconnect the power cord from the customer supply while performing tasks that do not need electricity. Electricity can cause death or injury. Moving parts can cause injury.

WARNING

Take care during this procedure. Sharp edges may be present that can cause injury.

CAUTION

Take care when removing the cover. The clips that secure the latch are easily broken.

1. Remove the bypass upper left door cover, [Figure 1](#).

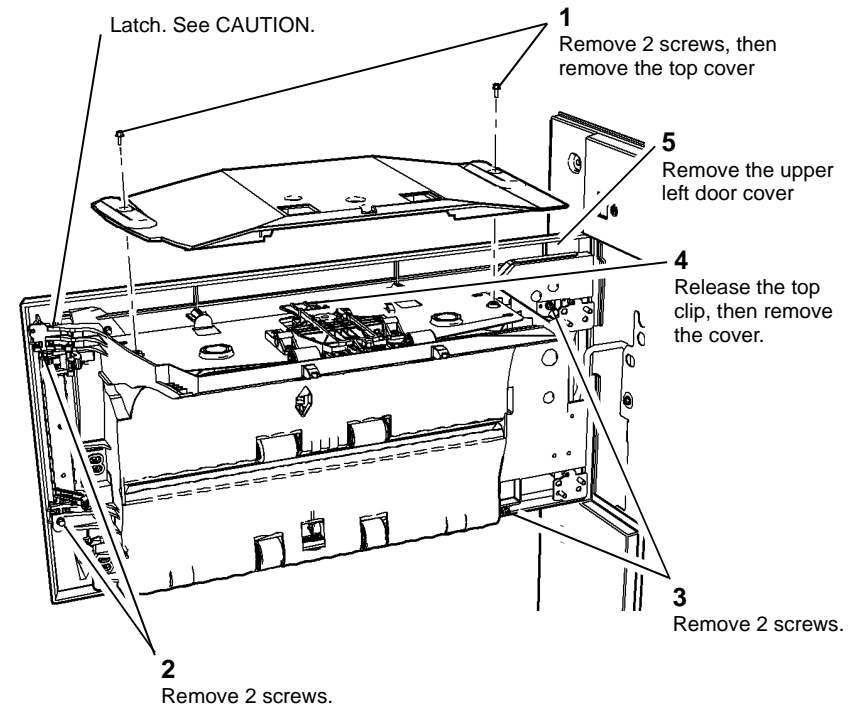

U-1-0960-A

Figure 1 Bypass cover

2. Remove the left cover, [PL 81.10 Item 2](#)

3. Disconnect the PJ's, harness clips and harness to nip D solenoid, **Figure 2**.

4. Release the bypass module, **Figure 3**.

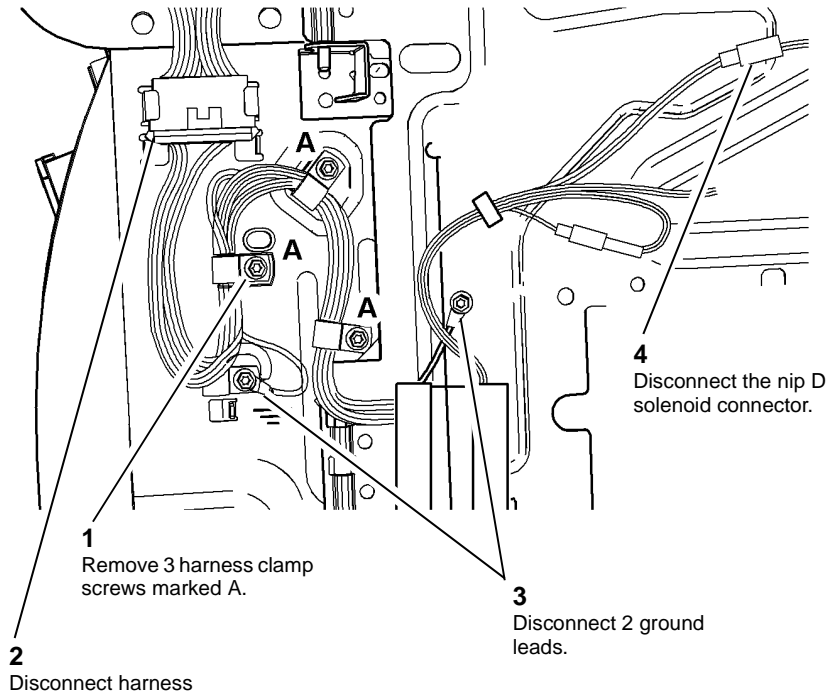

Figure 2 Disconnect harness

U-1-0761-A

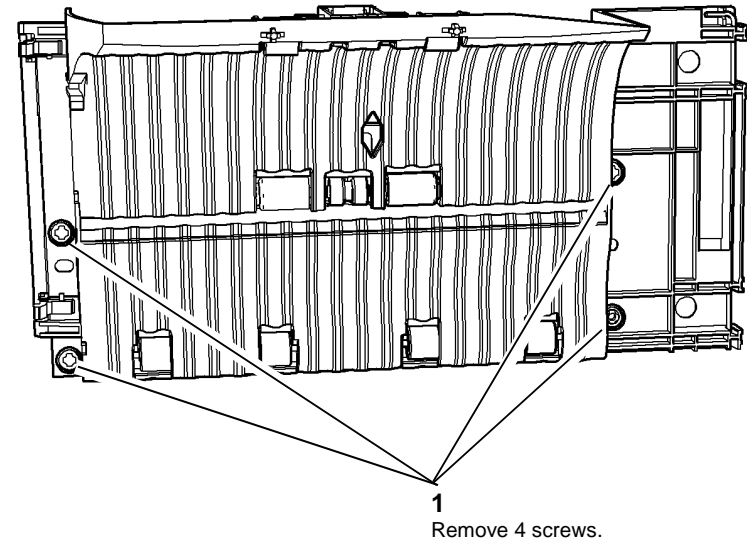

Figure 3 Bypass module

U-1-0802-A

5. Remove the bypass module, [Figure 4](#).

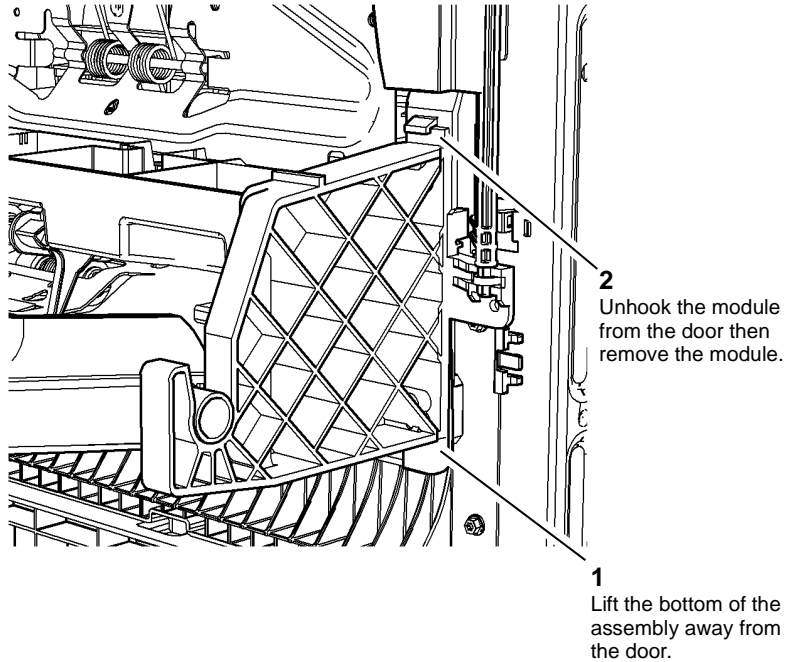

Figure 4 Bypass module

Replacement

Replacement is the reverse of the removal procedure.

REP 81.4 Tray 1 and Tray 2 Feed Rolls

Parts List on [PL 81.25](#), [PL 81.26](#)

Removal

WARNING

Switch off the electricity to the machine. Refer to [GP 14](#). Disconnect the power cord from the customer supply while performing tasks that do not need electricity. Electricity can cause death or injury. Moving parts can cause injury.

WARNING

Take care during this procedure. Sharp edges may be present that can cause injury.

1. Remove tray 1 or tray 2 as required, [REP 71.1](#).
2. Un-clip and release the guide, [Figure 1](#).

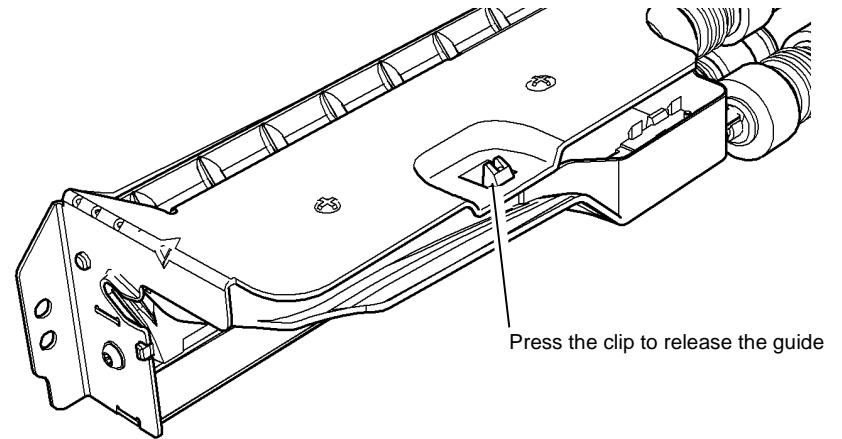

Figure 1 Release guide

3. Remove tray 1 or tray 2 feed rolls, [Figure 2](#).

NOTE: The removal procedure is the same for tray 1 or tray 2. The feed and nudger rolls are the same diameter but the retard roll has a larger diameter.

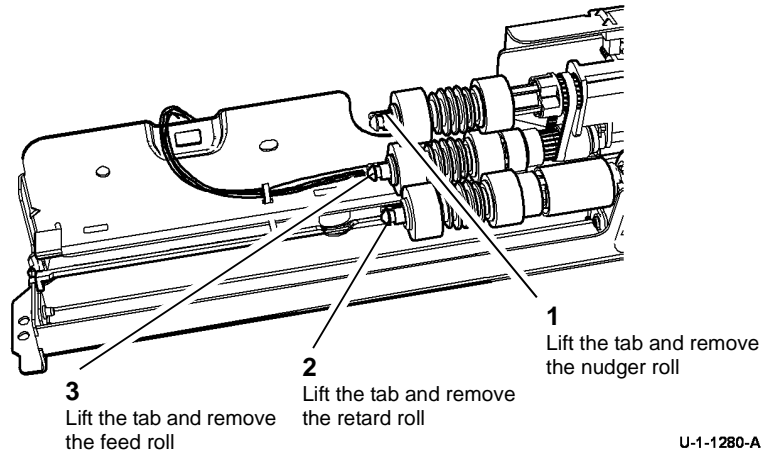

Figure 2 Remove the feed rolls

Replacement

1. The replacement is the reverse of the removal procedure.
2. Make sure that the tabs on the feed roll are located in the drive shaft.
3. Ensure that the guide is located correctly on the feeder assembly, [Figure 3](#).

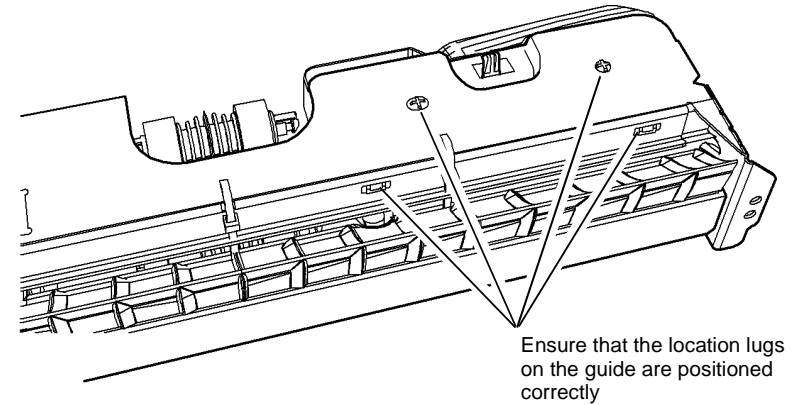

Figure 3 Locate the guide

4. Check the registration, refer to [dC625 Registration / Preheat calibration](#).
5. When new feed rolls are installed, reset the tray 1 or tray 2 feed count to zero. Refer to [dC135 CRU / HFSI Status](#).

REP 81.5 Tray 3 Feed Rolls

Parts List on [PL 81.30](#)

Removal

WARNING

Switch off the electricity to the machine. Refer to [GP 14](#). Disconnect the power cord from the customer supply while performing tasks that do not need electricity. Electricity can cause death or injury. Moving parts can cause injury.

WARNING

Take care during this procedure. Sharp edges may be present that can cause injury.

1. Remove tray 3 feed assembly, [REP 81.2](#).
2. Remove tray 3 feed rolls, [Figure 1](#).

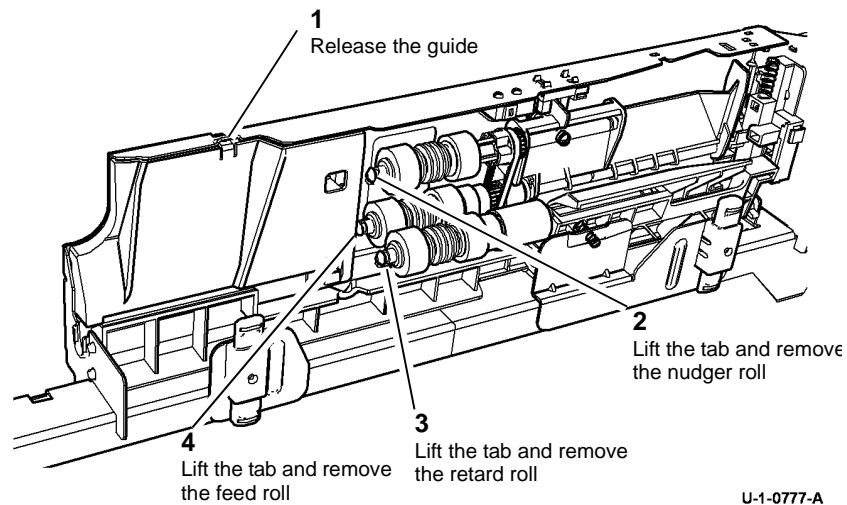

Figure 1 Remove the feed rolls

Replacement

1. The replacement is the reverse of the removal procedure.
2. Make sure that the tabs on the feed roll are located in the drive shaft.
3. Check the registration, refer to [dC625](#) Registration / Preheat calibration.
4. When new feed rolls are installed, reset the tray 3 feed count to zero. Refer to [dC135](#) CRU / HFSI Status.

REP 81.6 Bypass Tray Feed Rolls

Parts List on [PL 74.10](#)

Removal

WARNING

Switch off the electricity to the machine. Refer to [GP 14](#). Disconnect the power cord from the customer supply while performing tasks that do not need electricity. Electricity can cause death or injury. Moving parts can cause injury.

WARNING

Take care during this procedure. Sharp edges may be present that can cause injury.

1. Remove the bypass tray cover, refer to [REP 81.3](#).
2. Remove the feed rolls, [Figure 1](#).

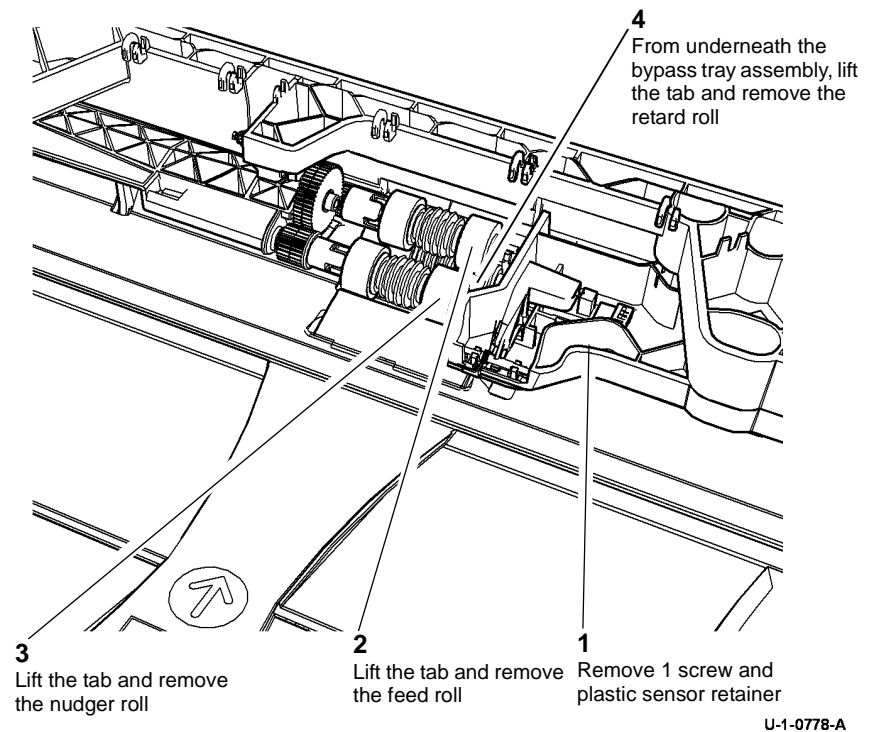

Figure 1 Remove feed rolls

Replacement

1. Replacement is the reverse of the removal procedure.
2. If a new nudger / feed and retard roll are installed, reset the bypass feed count to zero. Refer to [dC135](#) CRU / HFSI Status.

REP 81.7 Tray 5 Feed Rollers

Parts List on [PL 81.45](#), [PL 81.46](#)

Removal

WARNING

Switch off the electricity to the machine. Refer to [GP 14](#). Disconnect the power cord from the customer supply while performing tasks that do not need electricity. Electricity can cause death or injury. Moving parts can cause injury.

WARNING

Take care during this procedure. Sharp edges may be present that can cause injury.

1. Open the tray 5 door and allow the tray to move down.
2. Remove the nudger and the feed roller from the front. Slide the tray 5 module away from the machine and remove the retard roller, [Figure 1](#).

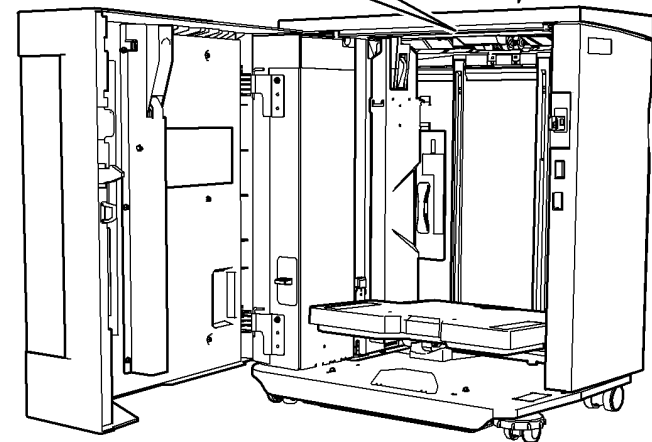
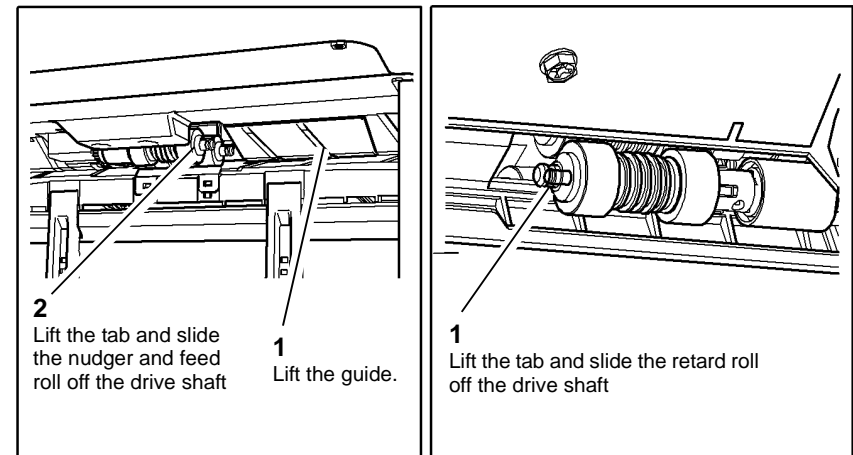

U-1-0784-A

Figure 1 Remove the feed rolls

Replacement

1. The replacement is the reverse of the removal procedure.
2. Ensure that the tabs on the feed roll are located in the drive shaft.
3. Check the registration, refer to [dC625](#) Registration / Preheat calibration.
4. If a new nudger / feed and retard roll are installed, reset the tray 5 feeds count to zero. Refer to [dC135](#) CRU / HFSI Status.

REP 81.8 Tray 1 or Tray 2 Feed Sensor

Parts List on [PL 81.25](#), [PL 81.26](#)

Removal

WARNING

Switch off the electricity to the machine. Refer to [GP 14](#). Disconnect the power cord from the customer supply while performing tasks that do not need electricity. Electricity can cause death or injury. Moving parts can cause injury.

WARNING

Take care during this procedure. Sharp edges may be present that can cause injury.

1. Remove the Tray 1 or tray 2 paper feed assembly [REP 81.1](#),
2. Un-clip and release the guide, [Figure 1](#).

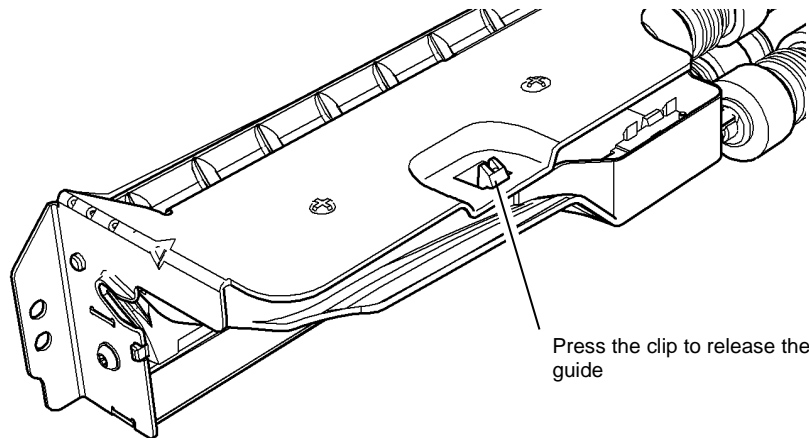

U-1-1276-A

Figure 1 Paper guide

3. Remove tray 1 or tray 2 feed sensor, [Figure 2](#).

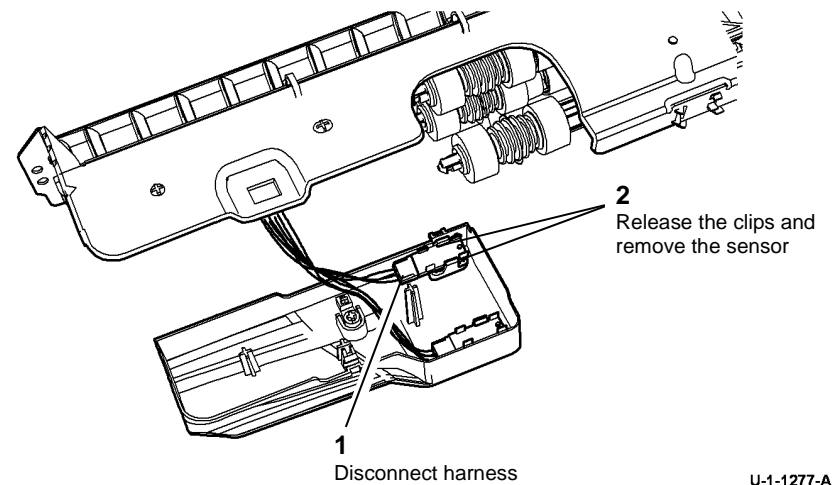

U-1-1277-A

Figure 2 Remove the feed sensor

Replacement

1. Replacement is the reverse of the removal procedure.
2. Ensure that the guide is located correctly on the feeder assembly, [Figure 3](#).

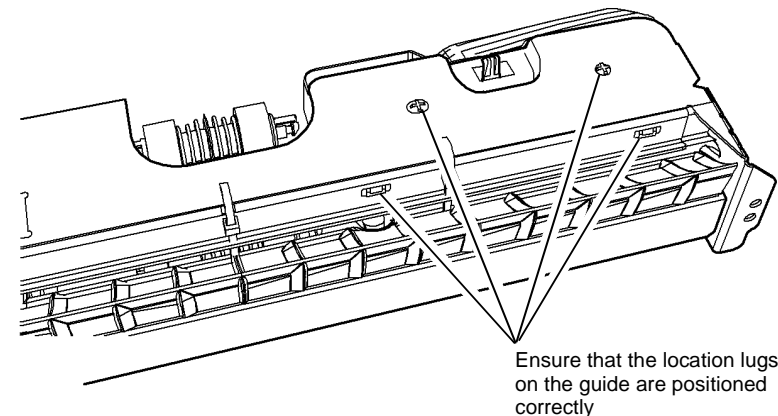

U-1-1278-A

Figure 3 Locate the guide

REP 81.9 Tray 3 Feed Sensor

Parts List on [PL 81.30](#)

Removal

WARNING

Switch off the electricity to the machine. Refer to [GP 14](#). Disconnect the power cord from the customer supply while performing tasks that do not need electricity. Electricity can cause death or injury. Moving parts can cause injury.

WARNING

Take care during this procedure. Sharp edges may be present that can cause injury.

1. Remove tray 3 paper feed assembly, [REP 81.2](#).
2. Un-clip and release the guide, [Figure 1](#).

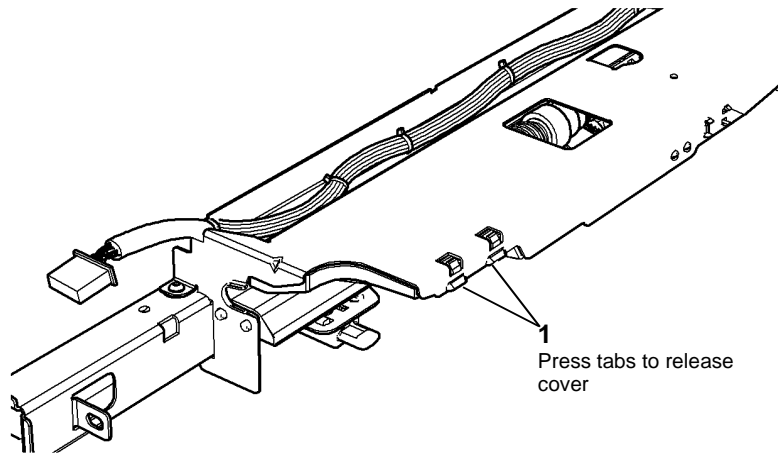
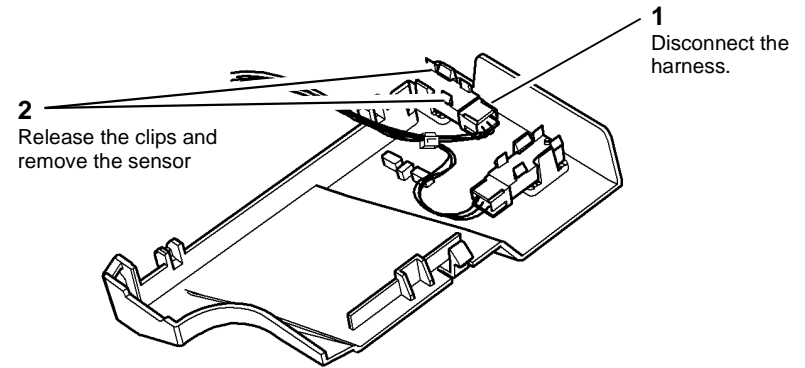

Figure 1 Release guide

U-1-1282-A

3. Remove tray 3 feed sensor, [Figure 2](#).



U-1-1283-A

Figure 2 Remove the sensor

Replacement

1. Replacement is the reverse of the removal procedure.
2. Ensure that the guide is located correctly on the feeder assembly, [Figure 3](#).

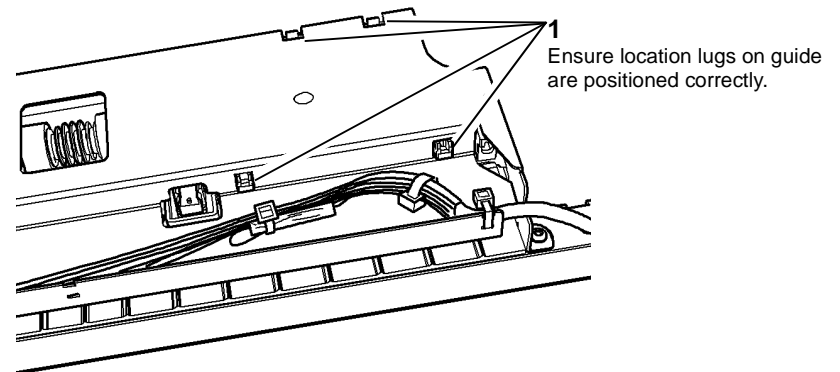

U-1-1284-A

Figure 3 Position the cover

REP 81.10 Bypass Tray Empty Sensor

Parts List on [PL 74.10](#)

Removal

WARNING

Switch off the electricity to the machine. Refer to [GP 14](#). Disconnect the power cord from the customer supply while performing tasks that do not need electricity. Electricity can cause death or injury. Moving parts can cause injury.

WARNING

Take care during this procedure. Sharp edges may be present that can cause injury.

1. Remove the bypass tray upper left door cover, [PL 70.30 Item 14](#).
2. Remove the tray empty sensor, [Figure 1](#).

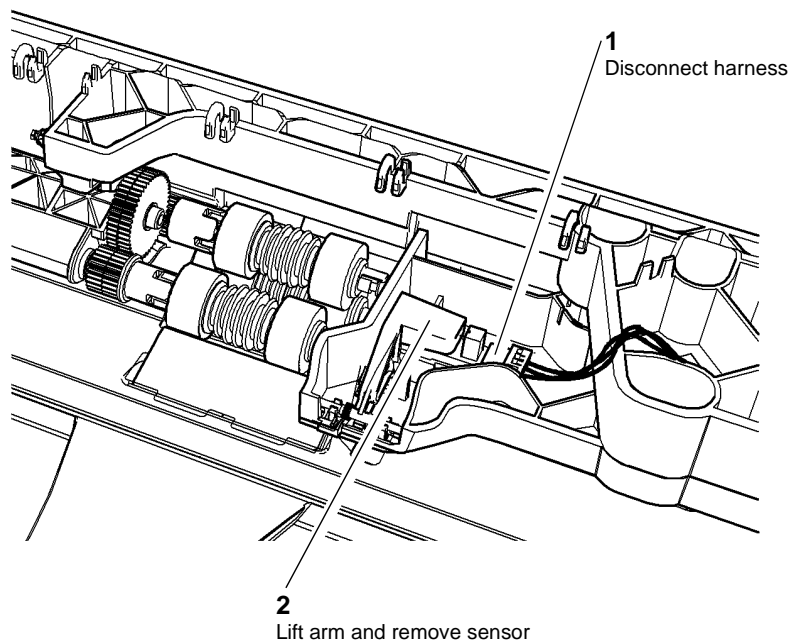

Figure 1 Tray empty sensor

Replacement

Replacement is the reverse of the removal procedure.

REP 81.11 Tray 5 Feed Sensor

Parts List on [PL 81.45](#)

Removal

WARNING

Switch off the electricity to the machine. Refer to [GP 14](#). Disconnect the power cord from the customer supply while performing tasks that do not need electricity. Electricity can cause death or injury. Moving parts can cause injury.

WARNING

Take care during this procedure. Sharp edges may be present that can cause injury.

1. Remove the top cover, [PL 75.60 Item 10](#).
2. Prepare to remove the tray 5 feed sensor, [Figure 1](#).

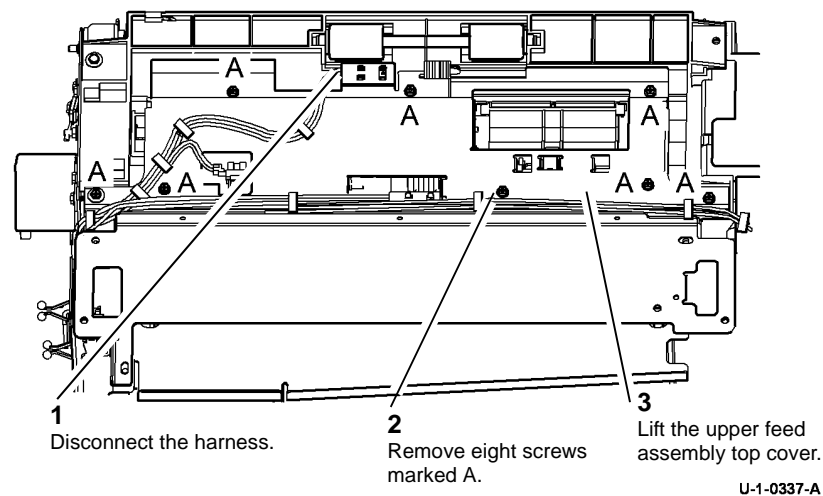
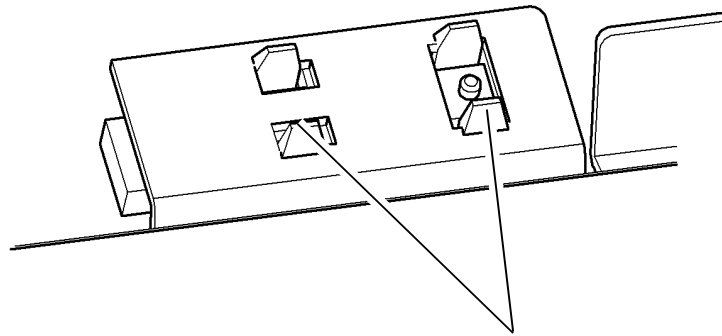

Figure 1 Preparation

- Remove tray 5 feed sensor, [Figure 2](#).



- Press the tabs to release the sensor

U-1-0338-A

Figure 2 Remove the feed sensor

Replacement

- The replacement is the reverse of the removal procedure.
- Make sure that the torsion nudger spring on the paper feed assembly is in the correct position, [Figure 3](#).

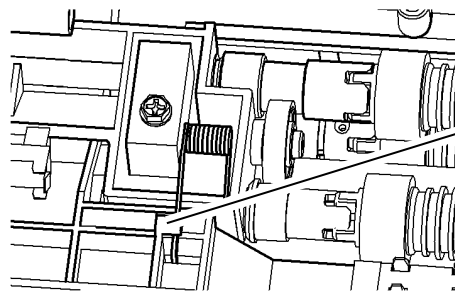

Locate the torsion nudger spring under the post

U-1-0339-A

Figure 3 Spring location

- Make sure that the housing spring is positioned on top of the takeaway idler roller shaft when the upper feed assembly top cover is installed, [Figure 4](#).

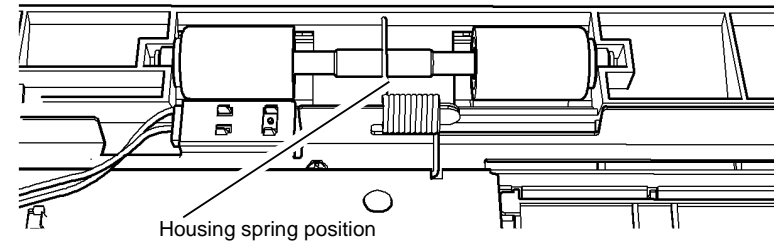

Housing spring position

U-1-0340-A

Figure 4 Spring position

- Make sure that the torsion chute spring is positioned on top of the chute upper insert, [Figure 5](#).

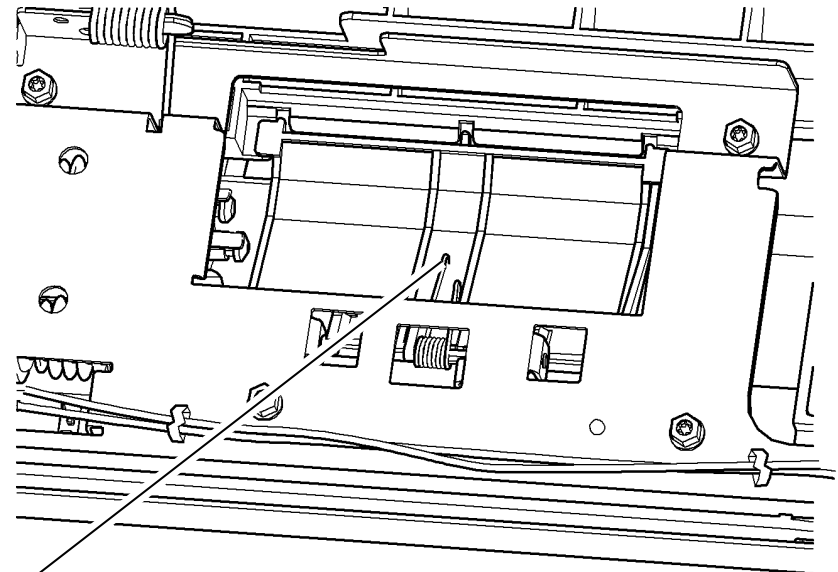

Position the torsion chute spring on the top of the chute

U-1-0341-A

Figure 5 Spring position

- Check that the correct screw is used to attach the upper feed assembly top cover.
- Check that the harness routing is correct, [Figure 1](#).

REP 81.12 Tray 5 Feed Motor

Parts List on [PL 81.40](#)

Removal

WARNING

Switch off the electricity to the machine. Refer to [GP 14](#). Disconnect the power cord from the customer supply while performing tasks that do not need electricity. Electricity can cause death or injury. Moving parts can cause injury.

WARNING

Take care during this procedure. Sharp edges may be present that can cause injury.

1. Remove the rear cover, [PL 75.60 Item 9](#).
2. Remove tray 5 feed motor, [Figure 1](#).

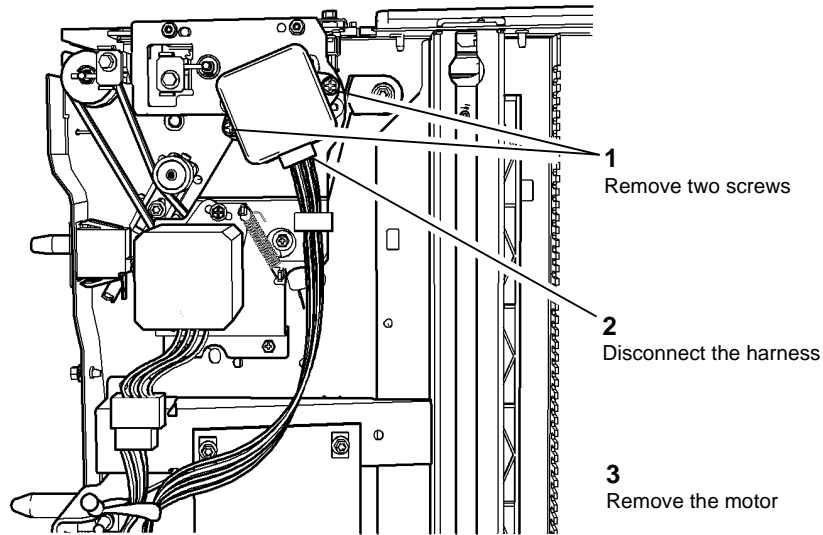

U-1-0367-A

Figure 1 Remove the feed motor

Replacement

1. The replacement is the reverse of the removal procedure.

REP 81.13 Nip D Release Solenoid

Parts List on [PL 70.30](#)

Removal

WARNING

Switch off the electricity to the machine. Refer to [GP 14](#). Disconnect the power cord from the customer supply while performing tasks that do not need electricity. Electricity can cause death or injury. Moving parts can cause injury.

WARNING

Take care during this procedure. Sharp edges may be present that can cause injury.

1. Remove the upper left door cover, [PL 70.30 Item 14](#).
2. Remove the bypass top cover, [PL 70.30 Item 9](#).
3. Remove the nip D release solenoid, [Figure 1](#).

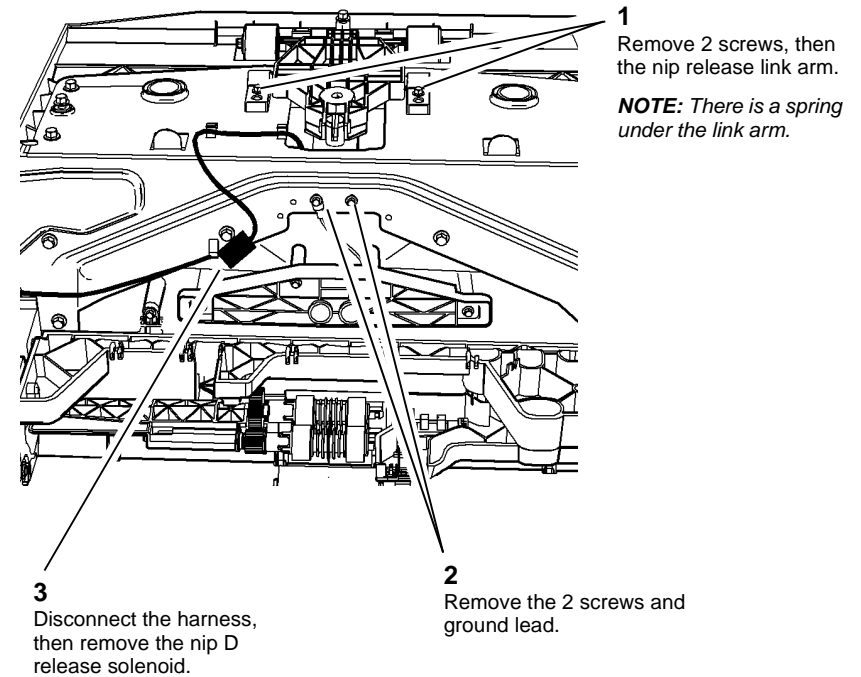

U-1-1028-A

Figure 1 Solenoid removal

Replacement

1. The replacement is the reverse of the removal procedure.

REP 82.1 3 Tray Module Transport Motor

Parts List on [PL 73.16](#)

Removal

WARNING

Switch off the electricity to the machine. Refer to [GP 14](#). Disconnect the power cord from the customer supply while performing tasks that do not need electricity. Electricity can cause death or injury. Moving parts can cause injury.

WARNING

Take care during this procedure. Sharp edges may be present that can cause injury.

1. Remove the rear cover, [PL 70.25 Item 8](#).
2. Remove the 3 tray transport motor, [Figure 1](#).

NOTE: It is important to mark the position of the motor before the motor is removed.

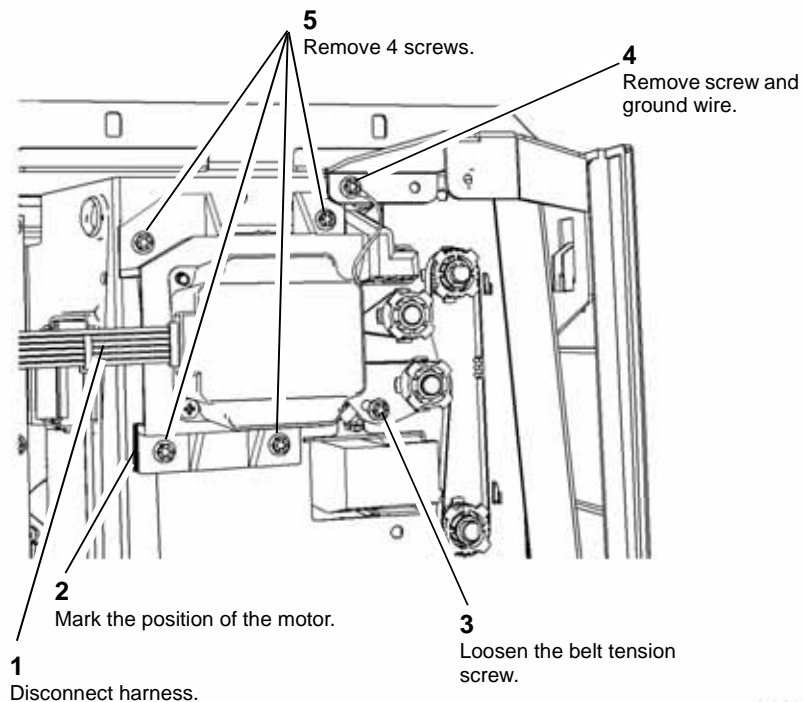

U-1-0780-A

Figure 1 3 tray module transport motor

Replacement

1. Relocate the 3 tray module transport drive belt.
2. Replacement is the reverse of the removal procedure. Ensure that the motor is aligned with the mark.
3. After completing the replacement procedure, perform the [dC625](#) Registration / Preheat calibration.

REP 82.2 3 Tray Module Transport Drive Belt

Parts List on [PL 73.16](#)

Removal

WARNING

Switch off the electricity to the machine. Refer to [GP 14](#). Disconnect the power cord from the customer supply while performing tasks that do not need electricity. Electricity can cause death or injury. Moving parts can cause injury.

WARNING

Take care during this procedure. Sharp edges may be present that can cause injury.

1. Remove the rear cover, [PL 70.25 Item 8](#).
2. Remove the 3 tray module transport motor, [REP 82.1](#).
3. Remove the transport drive belt, [Figure 1](#).

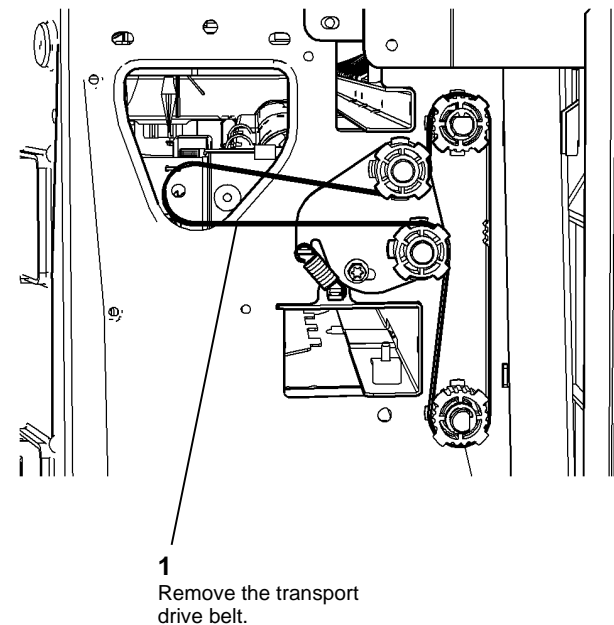

U-1-0781-A

Figure 1 Transport drive belt

Replacement

1. Reverse the removal procedure to replace the transport drive belt.
2. After completing the replacement procedure, perform the [dC625](#) Registration / Preheat calibration.

REP 82.3 Tray 3 Horizontal Transport Assembly

Parts List on [PL 81.35](#)

Removal

WARNING

Switch off the electricity to the machine. Refer to [GP 14](#). Disconnect the power cord from the customer supply while performing tasks that do not need electricity. Electricity can cause death or injury. Moving parts can cause injury.

WARNING

Take care during this procedure. Sharp edges may be present that can cause injury.

CAUTION

Take care when removing tray 3 support bracket from its snap in mounting.

1. Remove tray 1, [REP 71.1](#).
2. Remove horizontal transport assembly, [Figure 1](#)

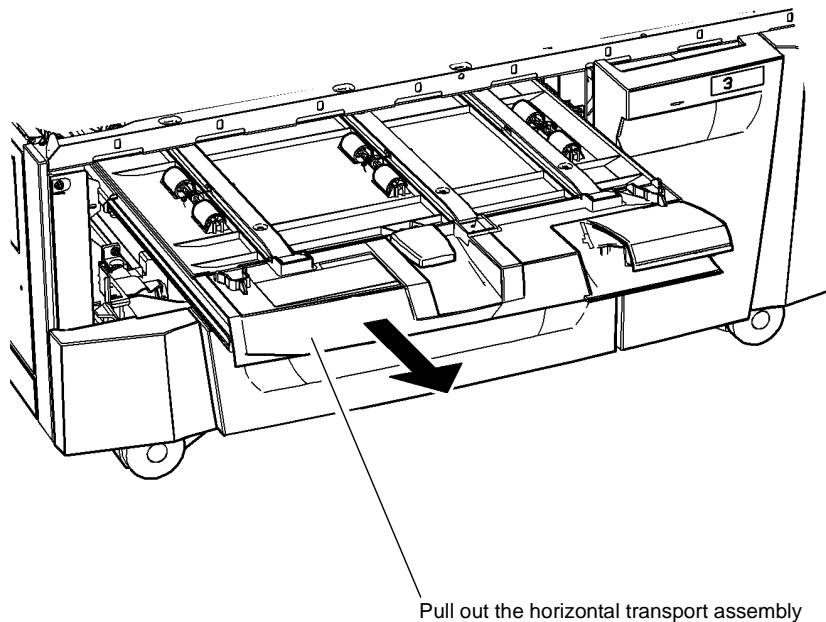

U-1-0785-A

Figure 1 Remove transport assembly

Replacement

Replacement is the reverse of the removal procedure.

REP 82.4 Tray 3 Horizontal Transport Rolls

Parts List on [PL 81.35](#)

Removal

WARNING

Switch off the electricity to the machine. Refer to [GP 14](#). Disconnect the power cord from the customer supply while performing tasks that do not need electricity. Electricity can cause death or injury. Moving parts can cause injury.

WARNING

Take care during this procedure. Sharp edges may be present that can cause injury.

1. Remove the tray 3 horizontal transport assembly, [REP 82.3](#).

2. Prepare to remove the transport rolls, **Figure 1**.

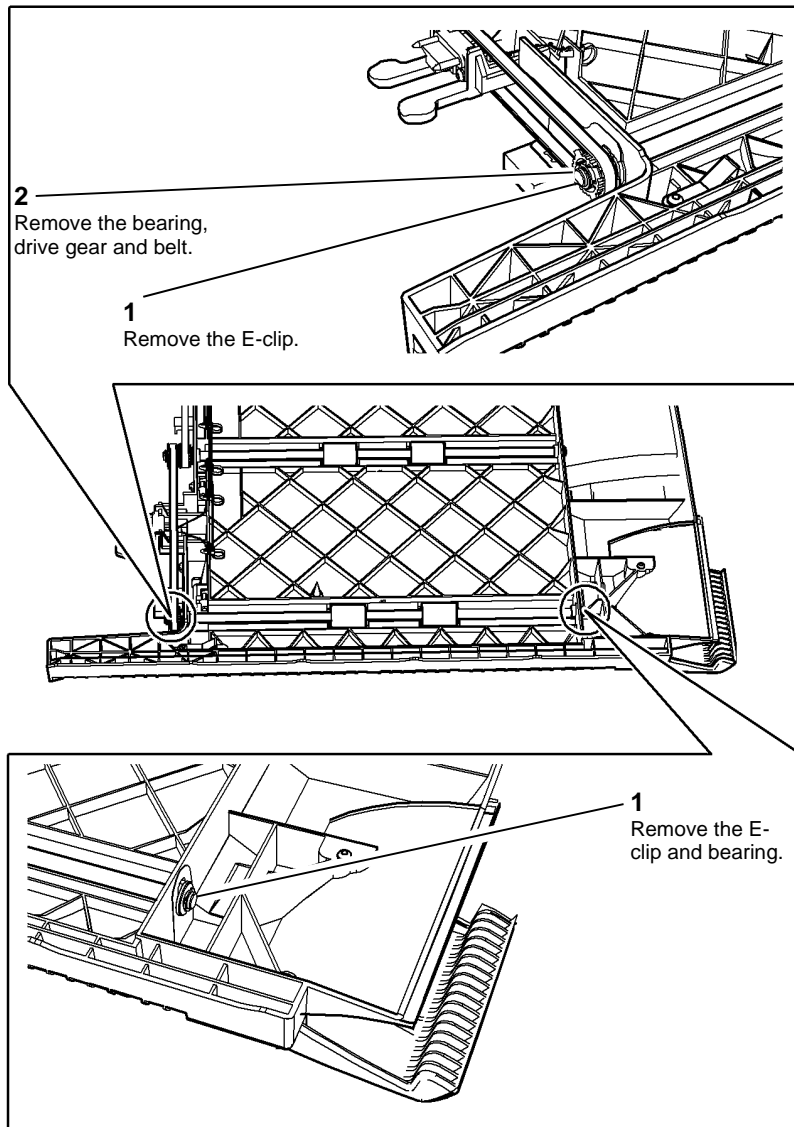

U-1-0786-A

Figure 1 Preparation

3. Remove the takeaway rolls, **Figure 2**.

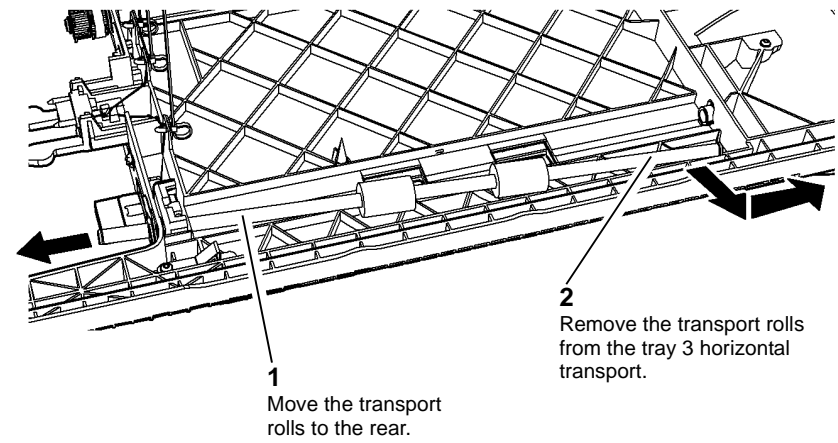

U-1-0787-A

Figure 2 Remove the transport rolls

Replacement

Replacement is the reverse of the removal procedure.

REP 82.5 Tray 5 Transport motor

Parts List on [PL 81.40](#)

Removal

WARNING

Switch off the electricity to the machine. Refer to [GP 14](#). Disconnect the power cord from the customer supply while performing tasks that do not need electricity. Electricity can cause death or injury. Moving parts can cause injury.

WARNING

Take care during this procedure. Sharp edges may be present that can cause injury.

1. Remove the rear cover, [REP 75.8](#).
2. Remove the drives plate, [Figure 1](#).

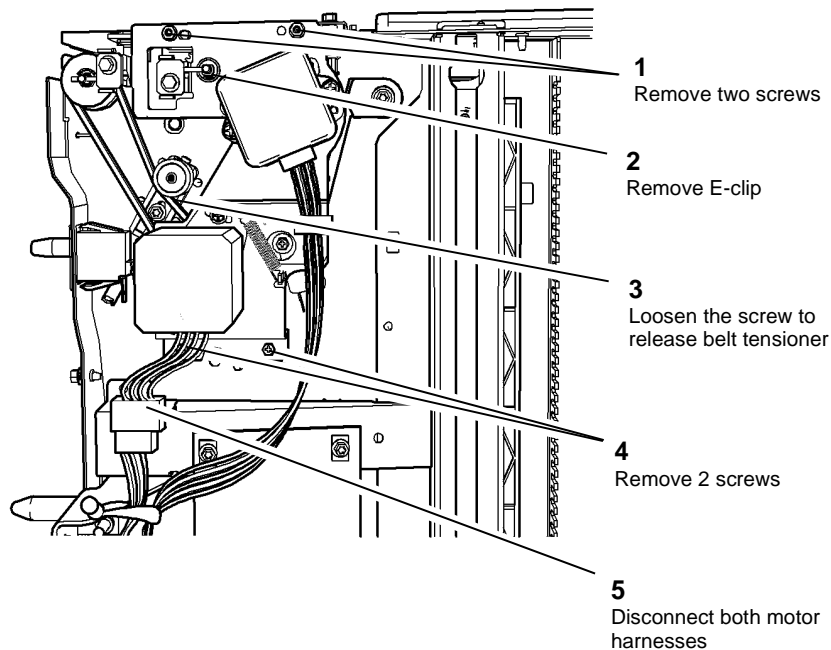

U-1-0368-A

Figure 1 Remove the drives plate

3. Remove tray 5 transport motor, [Figure 2](#).

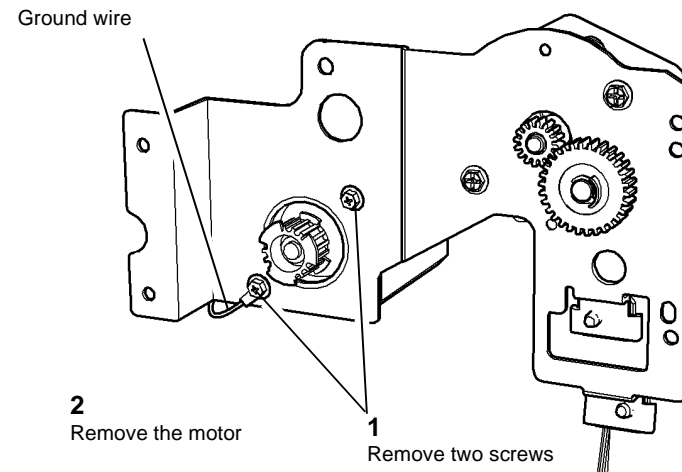

U-1-0369-A

Figure 2 Remove the transport motor

Replacement

1. The replacement is the reverse of the removal procedure.
2. Ensure that the ground wire terminal is located under the motor securing screw, [Figure 2](#).

REP 82.6 Tray 5 Transport Drive Belt

Parts List on [PL 81.40](#)

Removal

WARNING

Switch off the electricity to the machine. Refer to [GP 14](#). Disconnect the power cord from the customer supply while performing tasks that do not need electricity. Electricity can cause death or injury. Moving parts can cause injury.

WARNING

Take care during this procedure. Sharp edges may be present that can cause injury.

1. Remove the rear cover, [REP 75.8](#).
2. Prepare to remove the drive belt, [Figure 1](#).

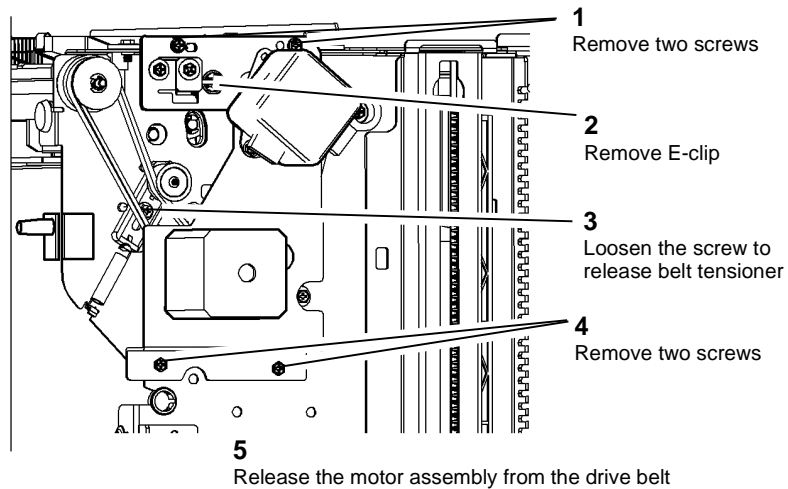

Figure 1 Preparation

U-1-0363-A

3. Remove the transport drive belt, [Figure 2](#).

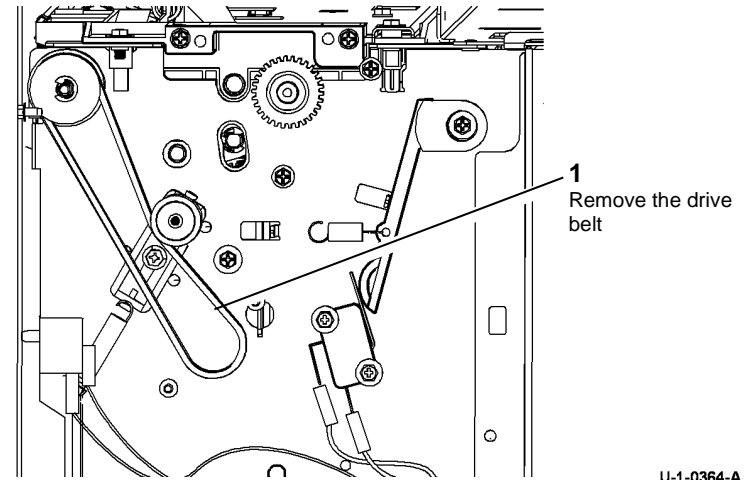

Figure 2 Remove the drive belt

U-1-0364-A

Replacement

1. Replacement is the reverse of the removal procedure.
2. Allow the tension idler to tension the belt and then tighten the screw, [Figure 1](#).

REP 82.7 Tray 5 Takeaway Roller

Parts List on [PL 81.45](#), [PL 81.46](#)

Removal

WARNING

Switch off the electricity to the machine. Refer to [GP 14](#). Disconnect the power cord from the customer supply while performing tasks that do not need electricity. Electricity can cause death or injury. Moving parts can cause injury.

WARNING

Take care during this procedure. Sharp edges may be present that can cause injury.

1. Remove the rear cover, [REP 75.8](#).
2. Remove the top cover, [REP 75.8](#).
3. Remove the transport drive belt, [REP 82.6](#).
4. Disconnect the tray 5 door switch harness, [PL 75.60 Item 6](#).
5. Prepare to remove the upper feeder assembly, [Figure 1](#).

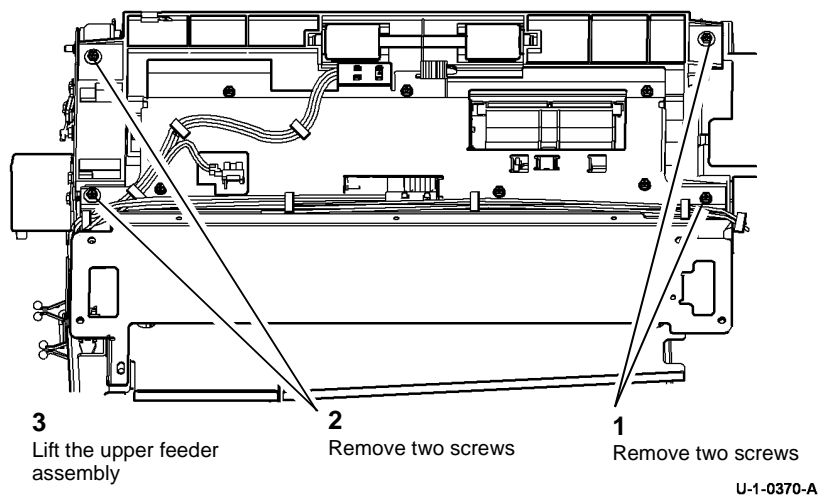

Figure 1 Preparation

6. Lift off the upper feeder assembly, then remove the lower feed assembly, [Figure 2](#).

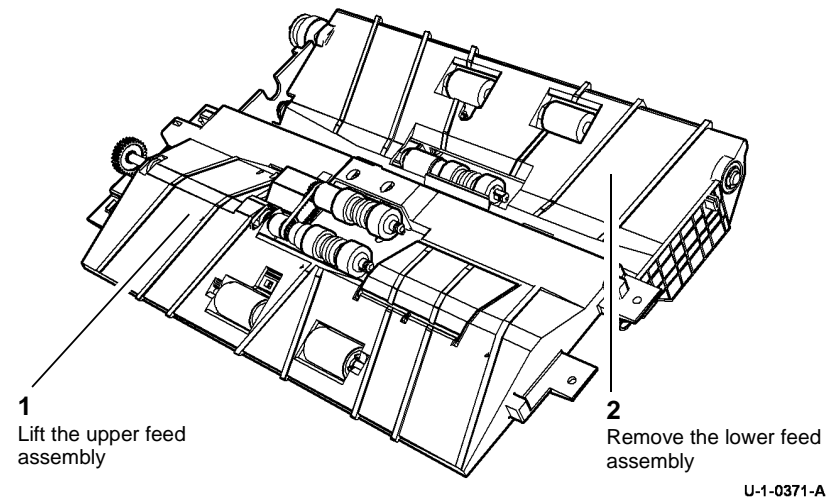

Figure 2 Remove lower feed assembly

7. Remove the one way pulley clutch, [Figure 3](#).

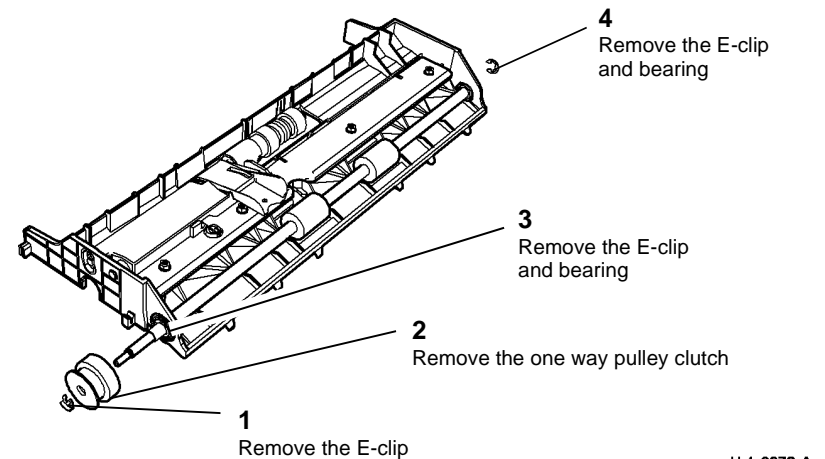
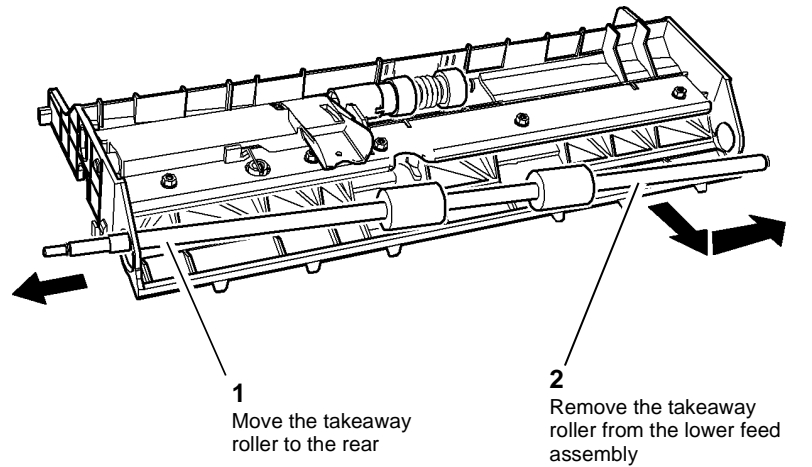

Figure 3 Remove the one-way pulley clutch

8. Remove the takeaway roller, [Figure 4](#).



U-1-0373-A

Figure 4 Remove the takeaway roller

Replacement

1. The replacement is the reverse of the removal procedure.
2. Check that the cable routing is correct, [Figure 1](#).

REP 82.8 Confirm Sensor

Parts List on [PL 82.10](#)

Removal

WARNING

Switch off the electricity to the machine. Refer to [GP 14](#). Disconnect the power cord from the customer supply while performing tasks that do not need electricity. Electricity can cause death or injury. Moving parts can cause injury.

WARNING

Take care during this procedure. Sharp edges may be present that can cause injury.

1. Open the front door and remove the inner cover, [PL 81.11 Item 2](#).
2. Pull out the marking engine, refer to Marking Unit Service Positions, [GP 6](#).
3. Remove the marking engine plastic guide, [Figure 1](#).

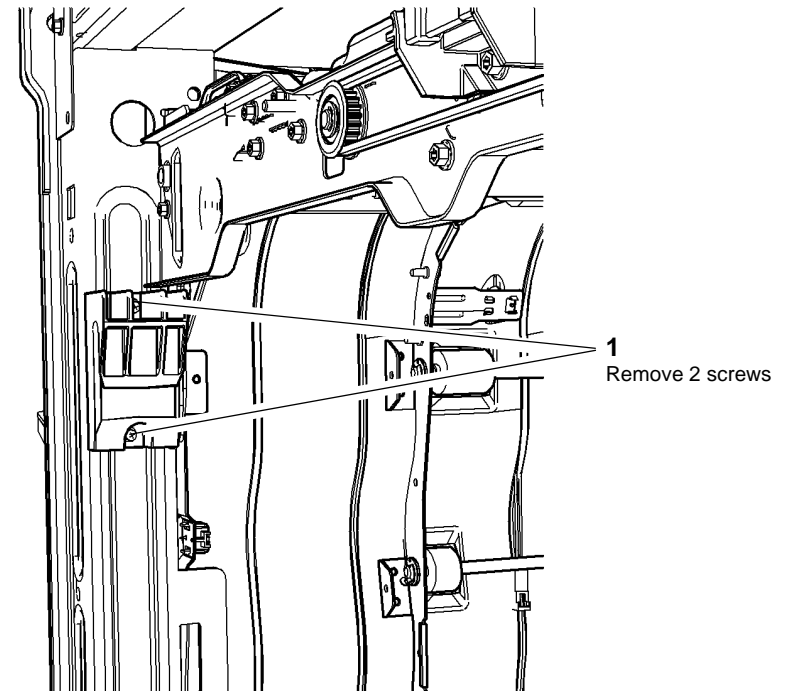

U-1-0788-A

Figure 1 Remove marking engine plastic guide

4. Remove the confirm sensor, [Figure 2](#).

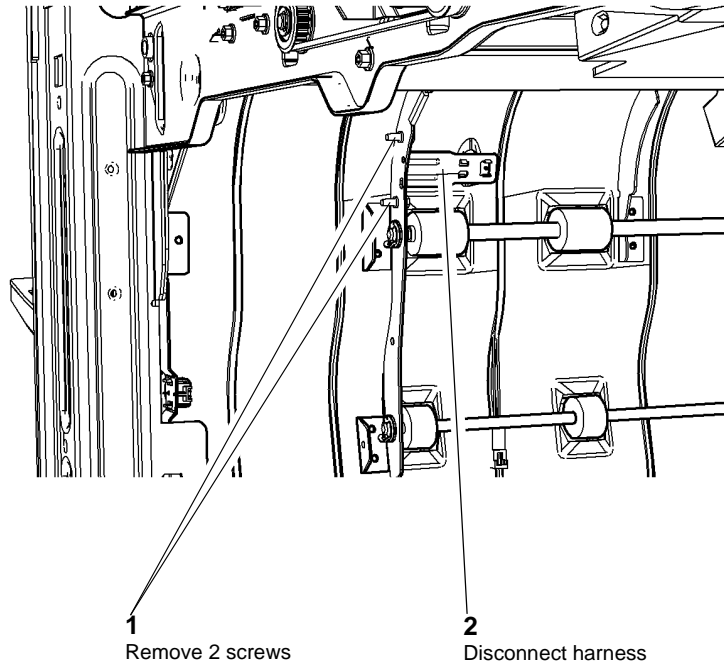

Figure 2 Remove Confirm sensor and bracket

U-1-0789-A

Replacement

1. Replacement is the reverse of the removal procedure.
2. After completing the replacement procedure, perform the [dC625](#) Registration / Preheat calibration.

REP 82.9 Vertical Transport

Parts List on [PL 82.10](#)

Removal

WARNING

Switch off the electricity to the machine. Refer to [GP 14](#). Disconnect the power cord from the customer supply while performing tasks that do not need electricity. Electricity can cause death or injury. Moving parts can cause injury.

WARNING

Take care during this procedure. Sharp edges may be present that can cause injury.

1. Open the front door and remove the inner cover, [PL 81.11](#) Item 2.
2. Remove the bypass tray upper left door cover, refer to [REP 81.3](#).
3. Remove the left cover, [PL 81.10](#) Item 2.
4. Remove the mid left door assembly hinge pin, [PL 70.30](#) Item 22, then remove the mid left door assembly, [PL 70.30](#) Item 16.
5. Slide out the marking unit. [GP 6](#).
6. Release the harness from the cable clips and disconnect the harness from the vertical transport, [Figure 1](#).

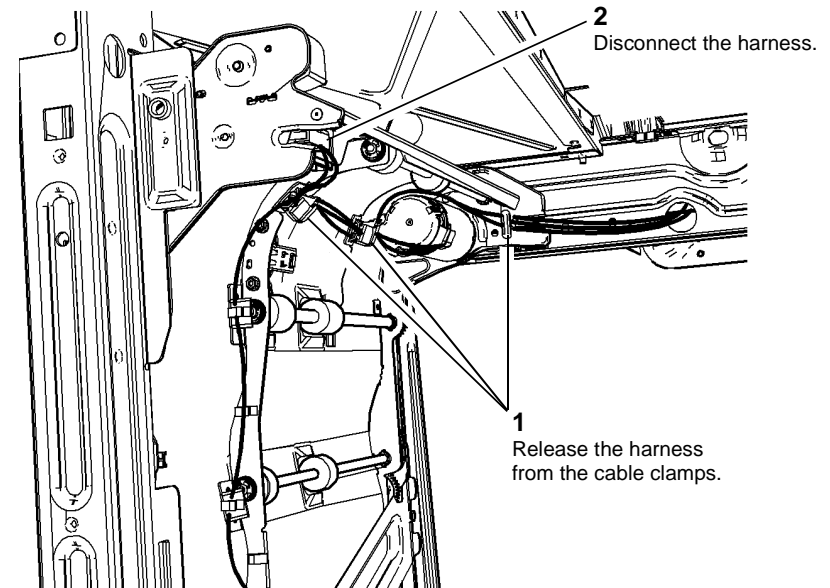
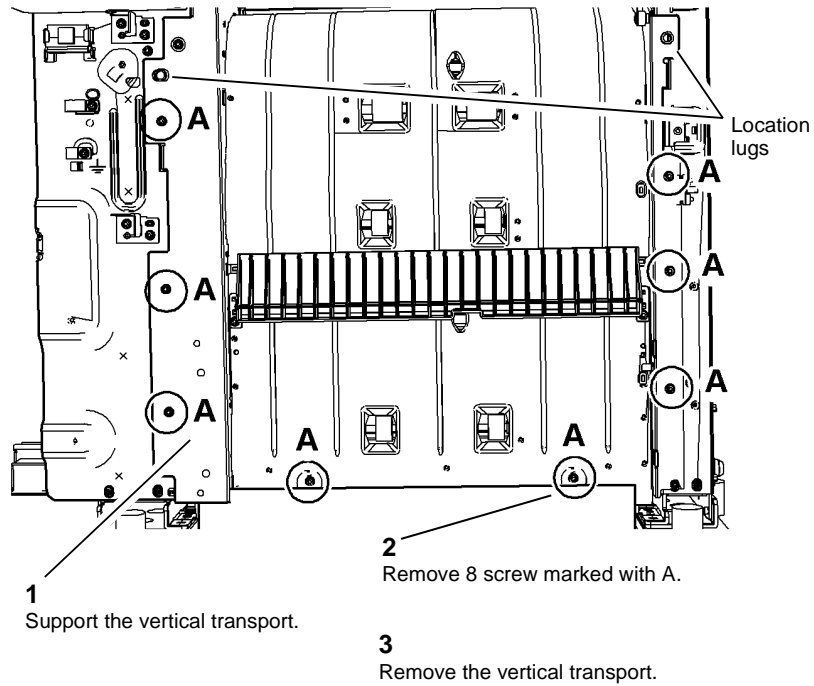

Figure 1 Release the harness

U-1-1177-A

7. Remove the vertical transport, [Figure 2](#).



U-1-1176-A

Figure 2 Release the vertical transport

8. If required to install new components on the vertical transport, refer to [Figure 3](#).

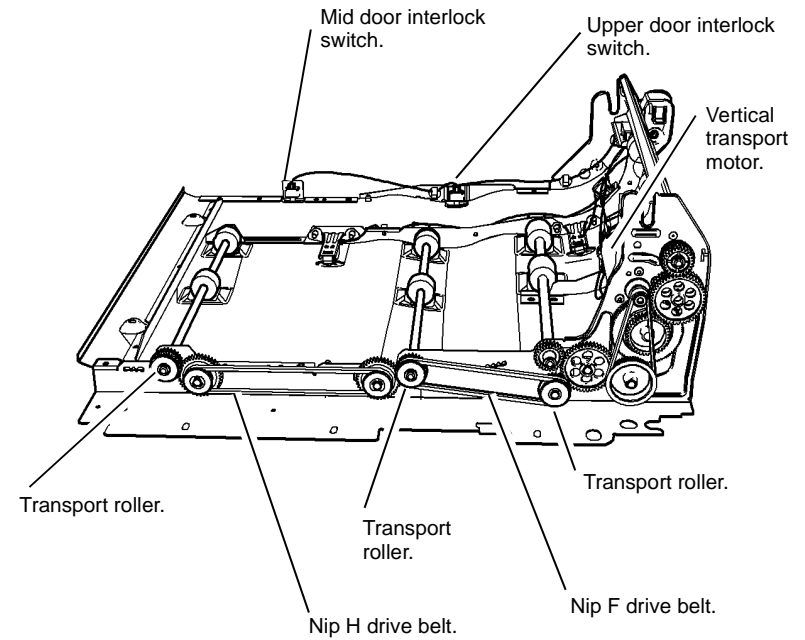

U-1-1178-A

Figure 3 Vertical transport

Replacement

1. Replacement is the reverse of the removal procedure.
2. Ensure that the harness is correctly routed, refer to [Figure 1](#).
3. Ensure that the vertical transport is correctly located in the location lugs, refer to [Figure 2](#).
4. After completing the replacement procedure, perform the [dC625](#) Registration / Preheat calibration.

REP 83.1 Horizontal Paper Path

Parts List on [PL 82.15](#)

Removal

WARNING

Switch off the electricity to the machine. Refer to [GP 14](#). Disconnect the power cord from the customer supply while performing tasks that do not need electricity. Electricity can cause death or injury. Moving parts can cause injury.

WARNING

Take care during this procedure. Sharp edges may be present that can cause injury.

1. Open the front door and remove the inner cover, [PL 81.11 Item 2](#).
2. Open the left hand upper door, [PL 70.30](#).
3. Remove the horizontal paper path, [Figure 1](#).

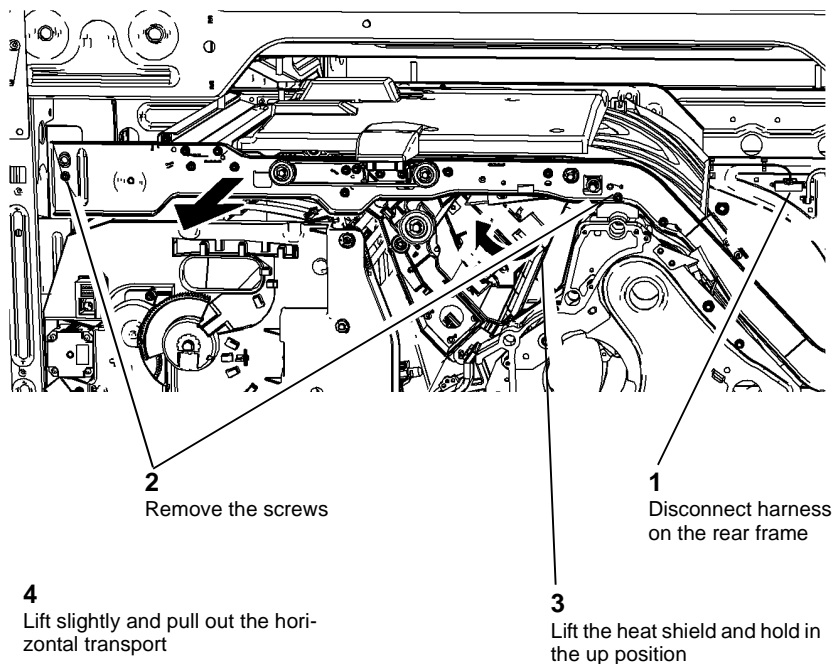

U-1-0790-A

Figure 1 Remove the horizontal paper path

Replacement

1. Replacement is the reverse of the removal procedure.
2. Hold the heat shield up. Locate the rear left hand 'V' slots on the horizontal transport with the guide on the top of the marking unit. Holding the unit level slide back in. Do not force it, try to align the transport location holes with the location pins and it should fall into place.
3. Run the relevant diagnostic routines, refer to [GP 37](#) Post Part Replacement Routines.

REP 83.2 Duplex End Sensor, Nip C Solenoid and HPP Diverter Solenoid

Parts List on [PL 82.15](#)

Removal

WARNING

Switch off the electricity to the machine. Refer to [GP 14](#). Disconnect the power cord from the customer supply while performing tasks that do not need electricity. Electricity can cause death or injury. Moving parts can cause injury.

WARNING

Take care during this procedure. Sharp edges may be present that can cause injury.

WARNING

Take care during this procedure. Motors will become hot during normal operation.

1. Remove the horizontal paper path, [REP 83.1](#).
2. Prepare to remove the duplex end sensor, [Figure 1](#).

NOTE: Hold down the cover against the force of the spring when removing screws.

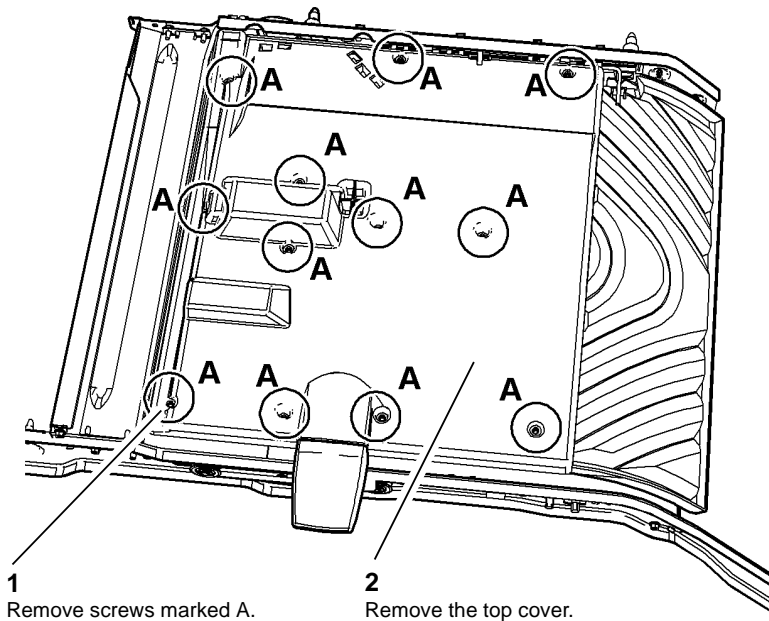

U-1-1291-A

Figure 1 Preparation

3. Remove the duplex end sensor, [Figure 2](#).

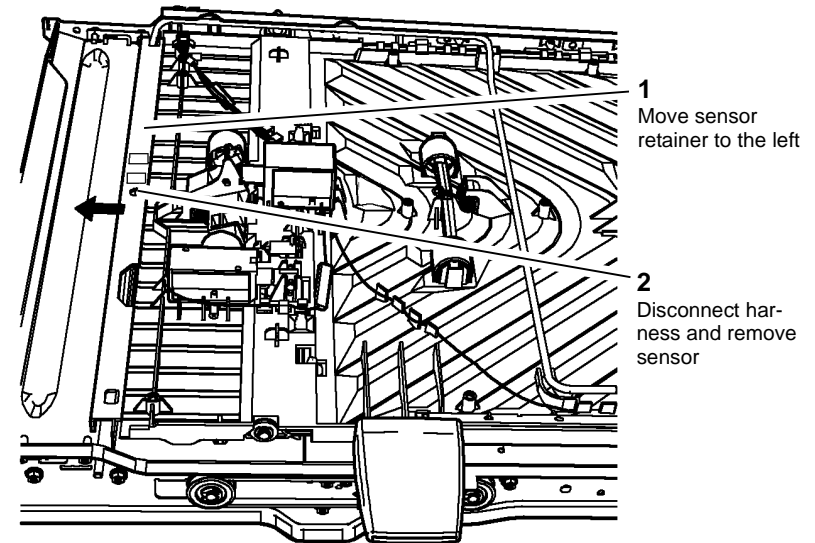

U-1-0792-A

Figure 2 Duplex end sensor removal

- Remove the nip C solenoid and HPP diverter solenoid, [Figure 3](#).

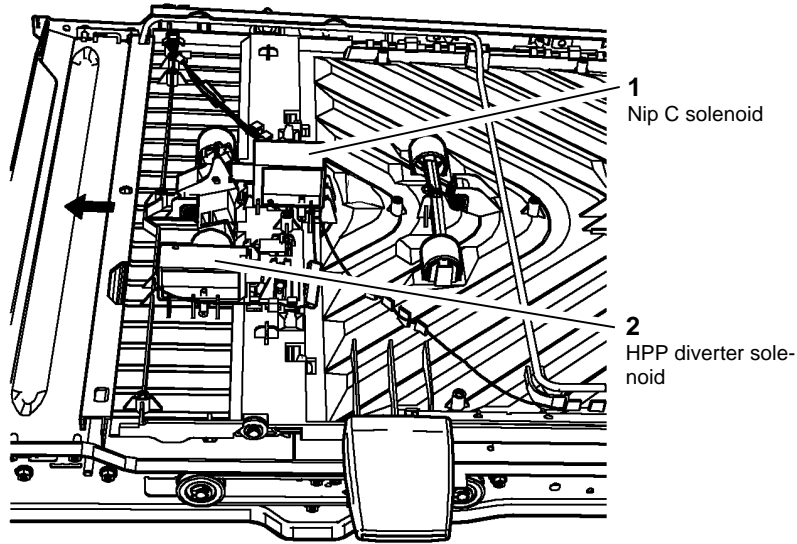

U-1-1232-A

Figure 3 Solenoid removal

Replacement

- The replacement is the reverse of the removal procedure.
- When replacing the top cover, place the assembly on a flat surface i.e. a desk with the curled portion hanging off the desk.
- Hold the top cover down in the correct position the entire time the screws are being installed.
- Install and tighten down the screws in each corner first, then install and tighten the remaining screws.
- Perform [dC625](#) Registration / Preheat Calibration.

REP 83.3 Duplex Sensor (17)

Parts List on [PL 82.15](#)

Removal

WARNING

Switch off the electricity to the machine. Refer to [GP 14](#). Disconnect the power cord from the customer supply while performing tasks that do not need electricity. Electricity can cause death or injury. Moving parts can cause injury.

WARNING

Take care during this procedure. Sharp edges may be present that can cause injury.

WARNING

Take care during this procedure. Motors will become hot during normal operation.

- Remove the horizontal paper path, [REP 83.1](#).
- Prepare to remove the duplex sensor (17), [Figure 1](#),

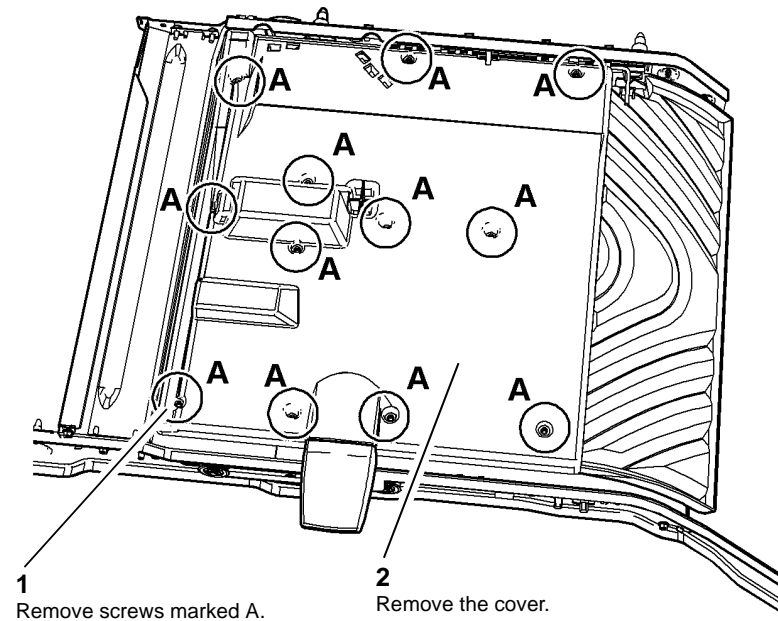

U-1-0791-A

Figure 1 Preparation

3. Remove the duplex sensor from the underside of the top cover, [Figure 2](#).

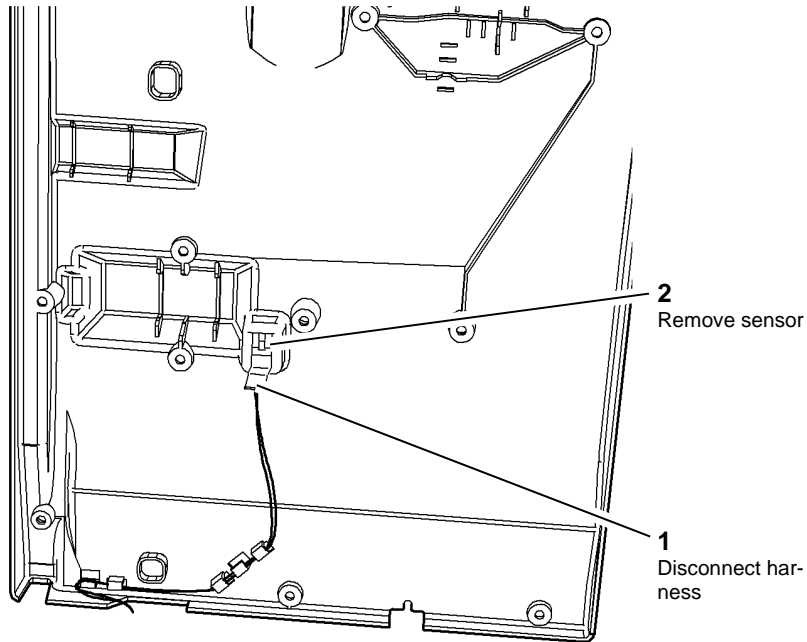

U-1-0793-A

Figure 2 Duplex sensor (17) removal

Replacement

1. The replacement is the reverse of the removal procedure.
2. When replacing the top cover, place the assembly on a flat surface i.e. a desk with the curled portion hanging off the desk.
3. Hold the top cover down in the correct position the entire time the screws are being installed.
4. Install and tighten down the screws in each corner first, then install and tighten the remaining screws.
5. Perform [dC625](#) Registration / Preheat Calibration.

REP 83.4 Horizontal Transport Motor

Parts List on [PL 82.15](#)

Removal

WARNING

Switch off the electricity to the machine. Refer to [GP 14](#). Disconnect the power cord from the customer supply while performing tasks that do not need electricity. Electricity can cause death or injury. Moving parts can cause injury.

WARNING

Take care during this procedure. Sharp edges may be present that can cause injury.

WARNING

Take care during this procedure. Motors will become hot during normal operation.

1. Remove the horizontal paper path, [REP 83.1](#).
2. Prepare to remove the motor, [Figure 1](#).

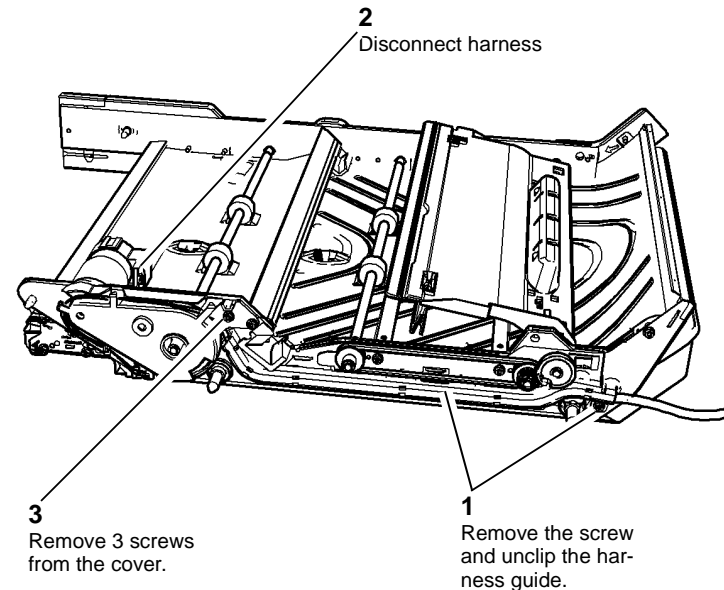

U-1-0794-A

Figure 1 Cover removal

3. Remove the motor, [Figure 2](#).

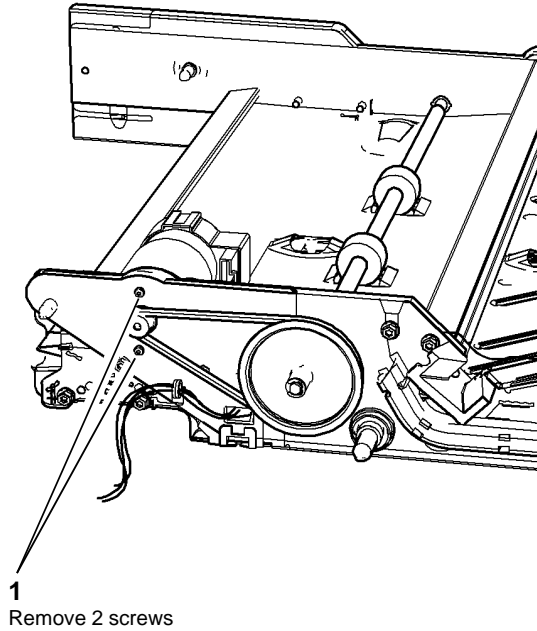

Figure 2 Transport motor removal

Replacement

Replacement is the reverse of the removal procedure.

REP 83.5 Horizontal Transport Drive Belts And Takeaway Rolls

Parts List on [PL 82.15](#)

Removal

WARNING

Switch off the electricity to the machine. Refer to [GP 14](#). Disconnect the power cord from the customer supply while performing tasks that do not need electricity. Electricity can cause death or injury. Moving parts can cause injury.

WARNING

Take care during this procedure. Sharp edges may be present that can cause injury.

WARNING

Take care during this procedure. Motors will become hot during normal operation.

1. Remove the horizontal paper path, [REP 83.1](#).
2. Prepare to remove the duplex drive belts, [Figure 1](#).

U-1-0795-A

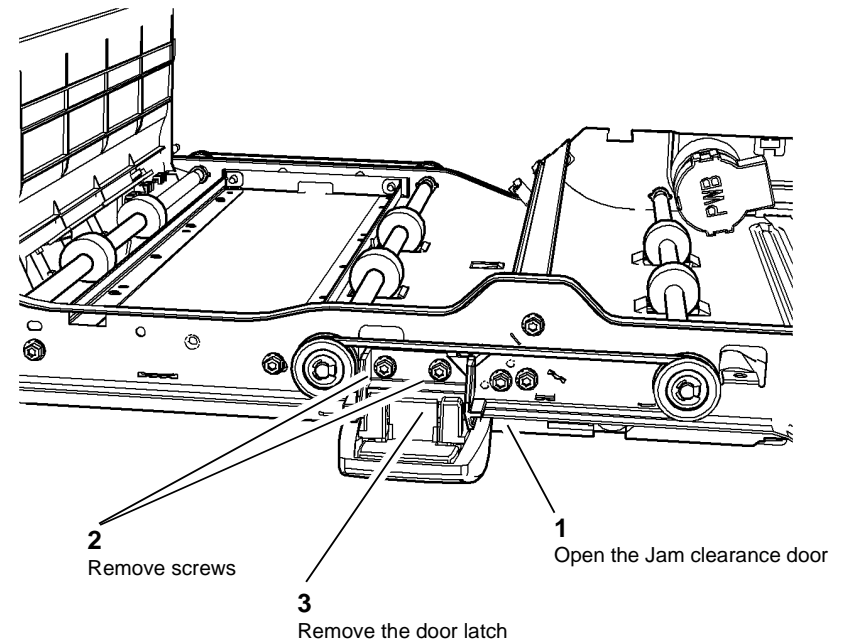

U-1-0797-A

Figure 1 Door latch removal

3. Remove the duplex drive belts and takeaway rolls, [Figure 2](#).

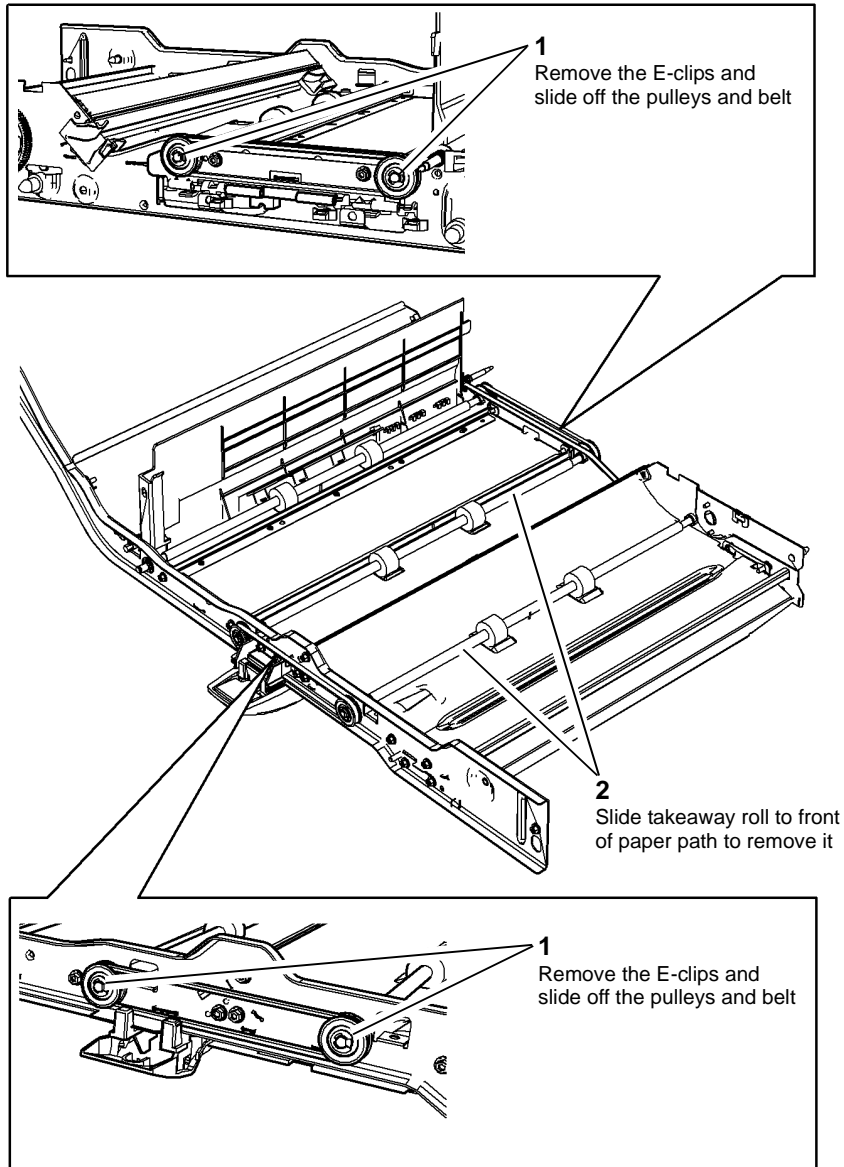

U-1-0796-A

Figure 2 Drive belts and takeaway rolls removal

Replacement

Replacement is the reverse of the removal procedure.

REP 89.1 Registration / Preheat Assembly and Lower Platelet Assembly

Parts List on [PL 88.10](#)

Procedure

WARNING

Switch off the electricity to the machine. Refer to [GP 14](#). Disconnect the power cord from the customer supply while performing tasks that do not need electricity. Electricity can cause death or injury. Moving parts can cause injury.

WARNING

Take care during this procedure. Sharp edges may be present that can cause injury.

Go to the relevant procedure:

- [Registration / Preheat Assembly Removal](#)
- [Lower Platelet Assembly Removal](#)

Registration / Preheat Assembly Removal

CAUTION

Do not touch the printheads.

CAUTION

Protect the surface of the drum with paper.

1. Open the front door. Remove the inner cover, [PL 81.11 Item 2](#).
2. Remove the horizontal transport, [REP 83.1](#).

3. Remove the registration transport, [Figure 1](#).

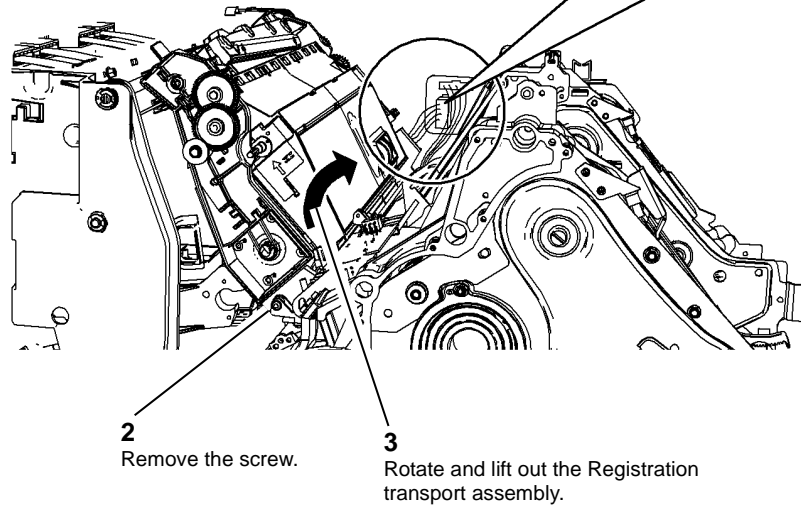
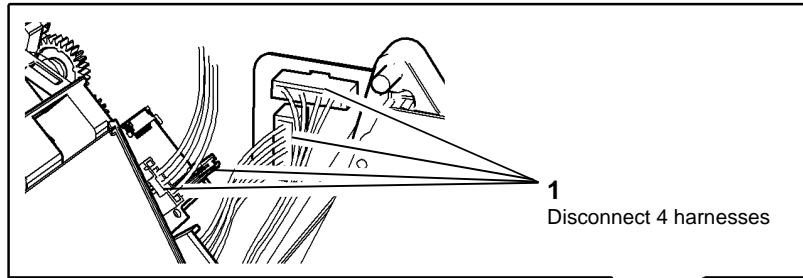

Figure 1 Registration transport removal

U-1-0798-A

Replacement

1. Replacement is the reverse of the removal procedure.
2. Ensure the ribbon cable is routed and connected before installation, [Figure 2](#).

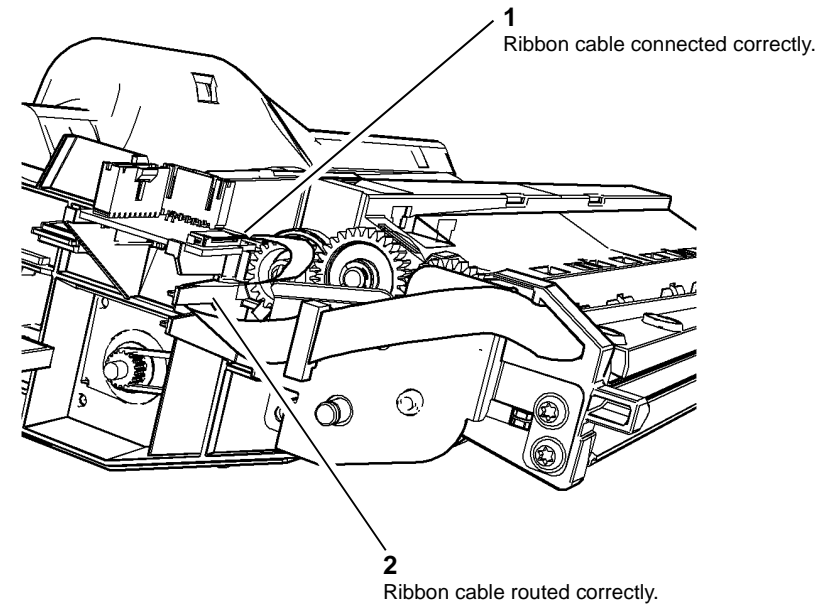
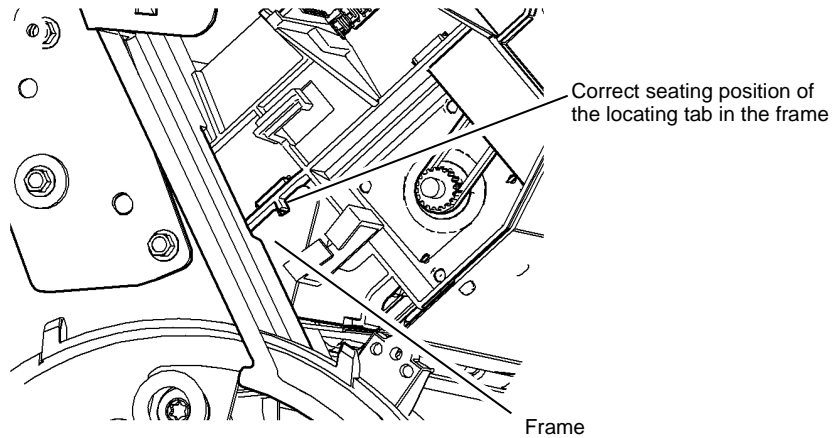

Figure 2 Location of the ribbon cable

U-1-0907-A

- If the registration / preheat assembly does not seat properly, verify that the locating tab on the rear of the registration / preheat assembly is correctly seated in the frame, [Figure 3](#).



U-1-0908-A

Figure 3 Locating tab on rear of machine

- When installing the horizontal transport leave the single mounting screw for the registration / preheat assembly loose. Use the top of the registration / preheat assembly as a guide for when sliding the horizontal transport into position. Tighten the screw after the horizontal transport is installed.
- Enter diagnostics [dC131](#) and enter NVM ID 435-13, 435-14 and 435-15 and reset the values to zero.

NOTE: Only perform step 5 if new parts (new registration / preheat assembly or new nip A rollers) are installed and before the [dC625](#) routine is run.

- Run the relevant diagnostic routines, refer to [GP 37](#) Post Part Replacement Routines.

Lower Platelet Assembly Removal

- Open the front door. Remove the inner cover, [PL 81.11 Item 2](#).
- Remove the lower platelet assembly, [Figure 4](#).

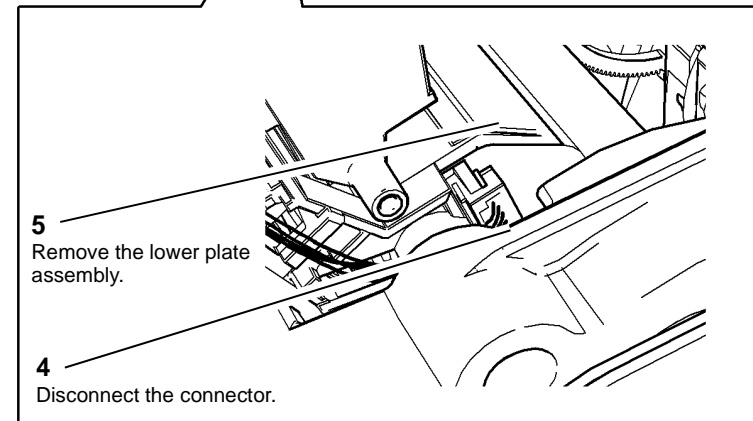
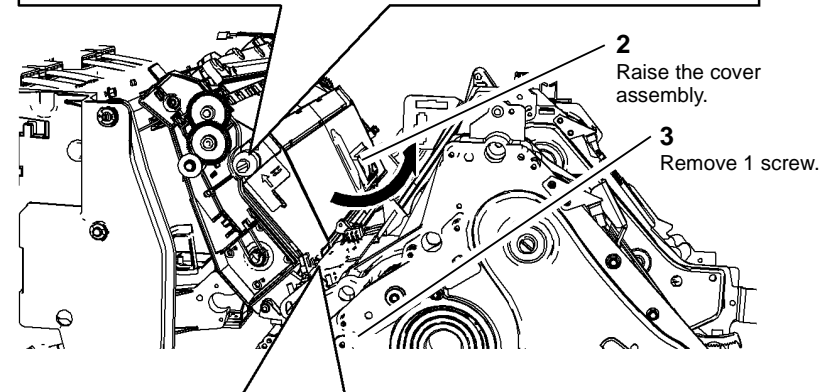
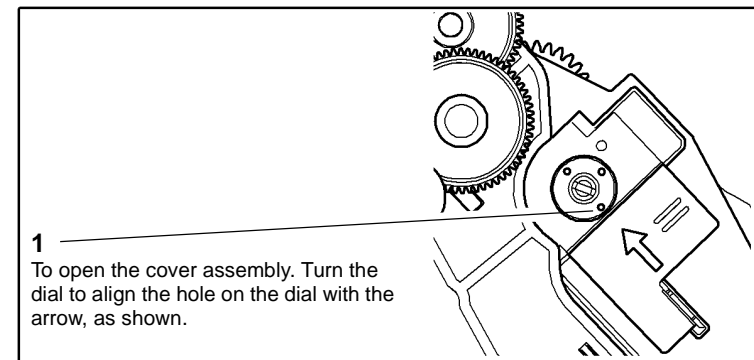

U-1-1396-A

Figure 4 Removal

Replacement

- Replacement is the reverse of the removal procedure.

REP 89.2 Registration / Preheat Pumps

Parts List on [PL 88.10](#)

Removal

WARNING

Switch off the electricity to the machine. Refer to [GP 14](#). Disconnect the power cord from the customer supply while performing tasks that do not need electricity. Electricity can cause death or injury. Moving parts can cause injury.

WARNING

Take care during this procedure. Sharp edges may be present that can cause injury.

- To remove the upper air pump.
 - Remove the registration / pre-heat transport, [REP 89.1](#).
 - Remove the pump cover, [PL 88.10 Item 8](#).
 - Remove the registration / pre-heat air pump, [PL 88.10 Item 5](#).
- To remove the lower air pump.
 - Remove the lower air pump assembly. Refer to [REP 10.7](#) and follow steps 1 and 2.
 - Remove the air pump cover, [PL 88.10 Item 7](#).
 - Remove the registration / pre-heat air pump, [PL 88.10 Item 5](#).

Replacement

- Replacement is the reverse of the removal procedure.
- If the registration / preheat assembly has been removed, perform the [dC625](#) Registration / Preheat Calibration.

REP 89.3 Registration / Preheat Assembly Nip A Kit

Parts List on [PL 88.11](#)

Removal

WARNING

Switch off the electricity to the machine. Refer to [GP 14](#). Disconnect the power cord from the customer supply while performing tasks that do not need electricity. Electricity can cause death or injury. Moving parts can cause injury.

WARNING

Take care during this procedure. Sharp edges may be present that can cause injury.

- Remove the registration / preheat transport, [REP 89.1](#).
- Remove the bearing cover, [Figure 1](#).

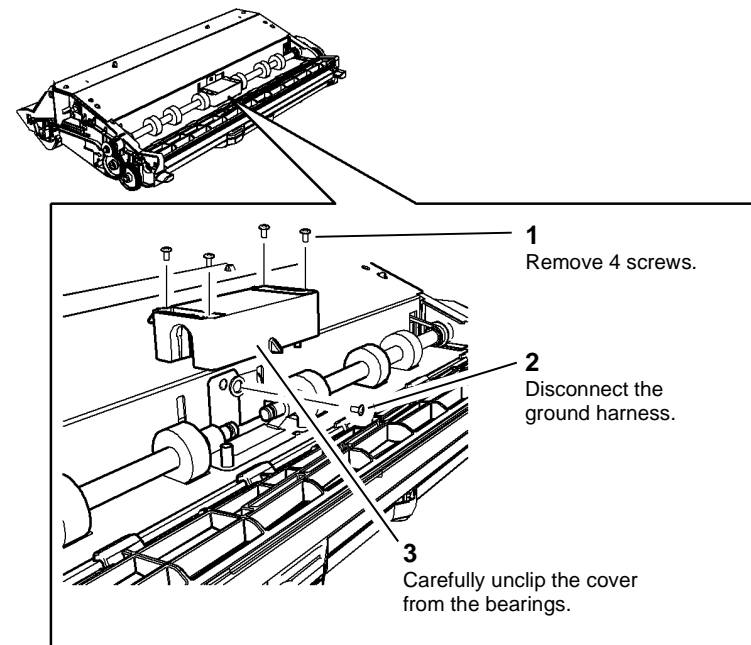

U-1-1193-A

Figure 1 Bearing cover removal

3. Remove the front nip A drive belt and roller, [Figure 2](#).

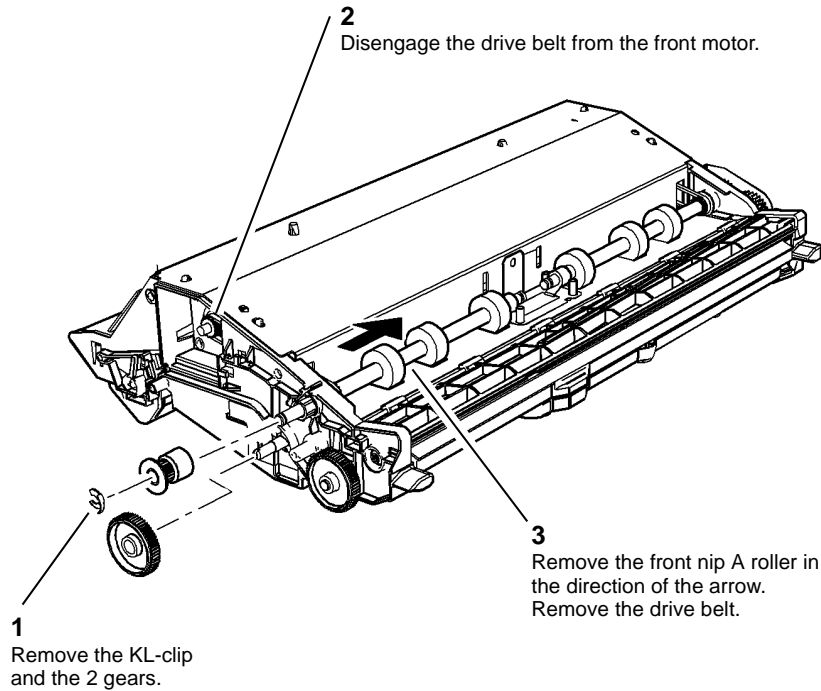

U-1-1194-A

Figure 2 Front belt and roller removal

4. Remove the rear nip A drive belt and roller, [Figure 3](#).

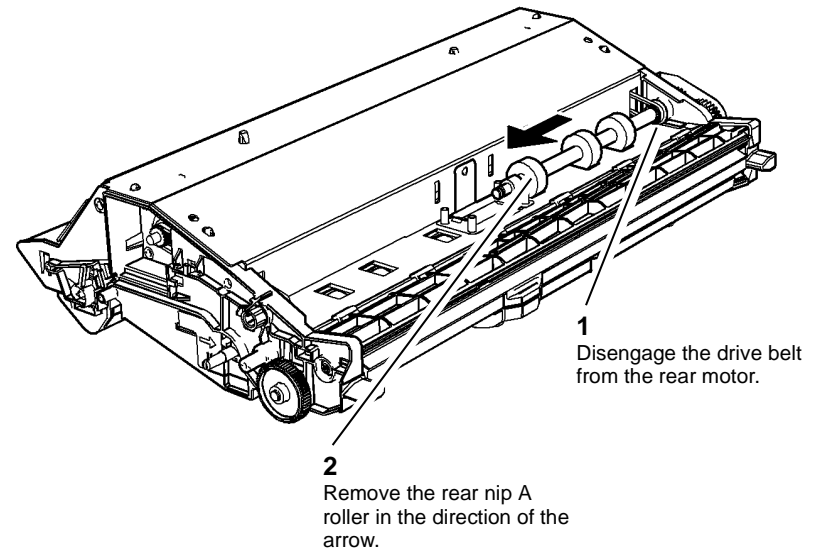

U-1-1195-A

Figure 3 Rear belt and roller removal

Replacement

1. Replacement is the reverse of the removal procedure.
2. Enter diagnostics [dC131](#) and enter NVM ID 435-13, 435-14 and 435-15 and reset the values to zero.

NOTE: Only perform step 2 if new parts (nip A kit or new registration / preheat assembly) are installed and before the [dC625](#) routine is run.

3. Perform the [dC625](#) Registration / Preheat Calibration procedure.

REP 91.1 Carriage Drive Train

Parts List on [PL 91.10](#)

Removal

WARNING

Switch off the electricity to the machine. Refer to [GP 14](#). Disconnect the power cord from the customer supply while performing tasks that do not need electricity. Electricity can cause death or injury. Moving parts can cause injury.

WARNING

Take care during this procedure. Sharp edges may be present that can cause injury.

1. Slide out the marking unit to the maintenance position, Refer to [GP 6](#).
2. Remove the marking unit enclosure, [Figure 1](#).

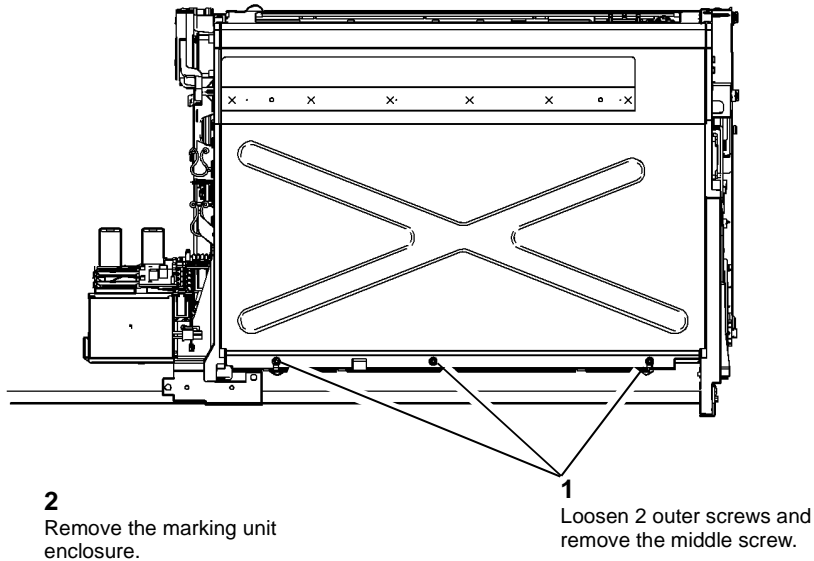
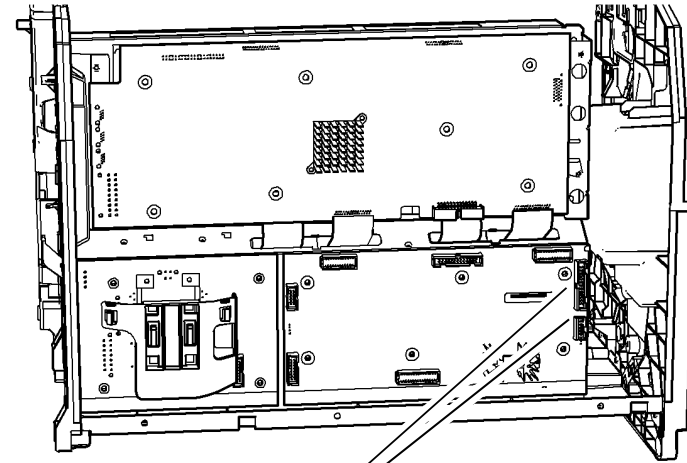

Figure 1 Enclosure removal

U-1-0810-A

3. Disconnect the harnesses from the marking unit driver PWB, [Figure 2](#).



- 1 Disconnect PJ605 and PJ607.

Figure 2 Disconnect harnesses

U-1-0811-A

4. Remove the carriage drive train, [Figure 3](#).

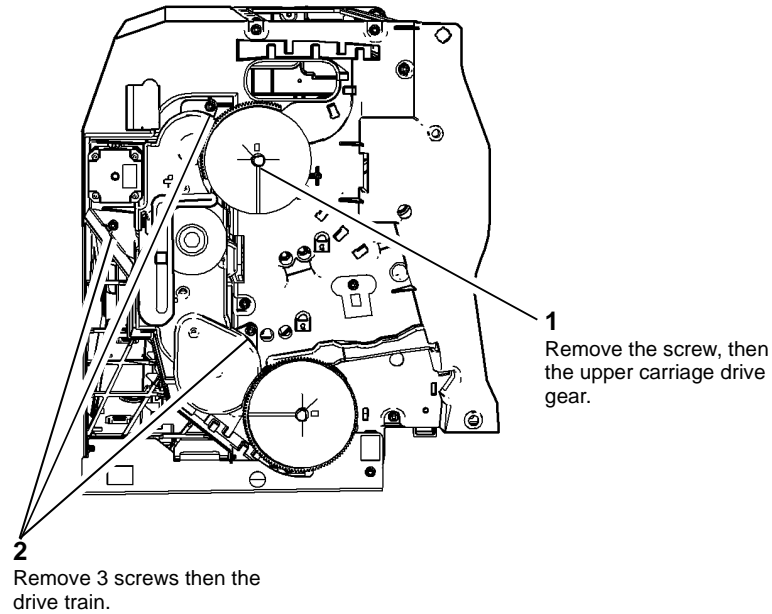

Figure 3 Carriage drive train removal

U-1-0812-A

Replacement

1. Replacement is the reverse of the removal procedure.
2. The screw thread is at an angle. Tabs on the gear stop prevent the screw from being driven in straight, refer to [Figure 3](#) step 1.

REP 91.2 Vertical Gearbox and Motor

Parts List on [PL 91.15](#)

Removal

WARNING

Switch off the electricity to the machine. Refer to [GP 14](#). Disconnect the power cord from the customer supply while performing tasks that do not need electricity. Electricity can cause death or injury. Moving parts can cause injury.

WARNING

Take care during this procedure. Sharp edges may be present that can cause injury.

CAUTION

Do not touch the exposed face of the printheads. Surface contamination or minor damage can destroy the printhead.

1. Slide out the marking unit to the maintenance position, Refer to [GP 6](#).
2. Remove the marking unit cover, [Figure 1](#).

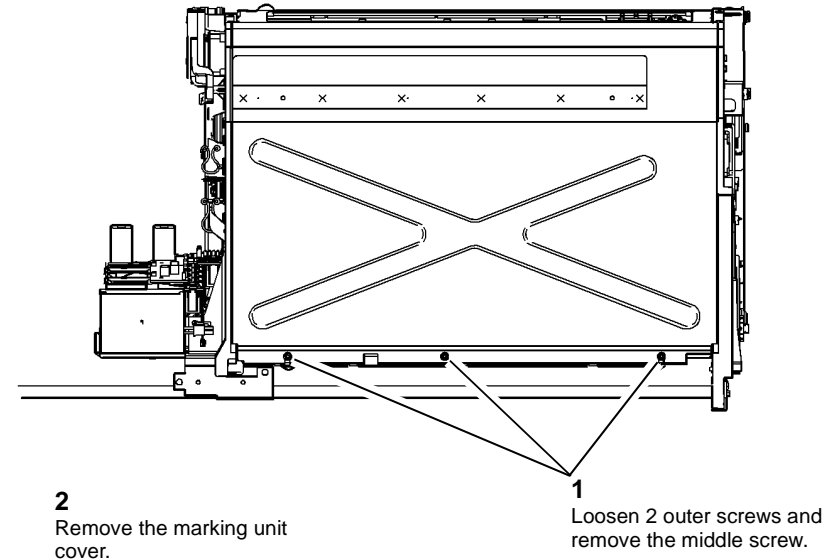
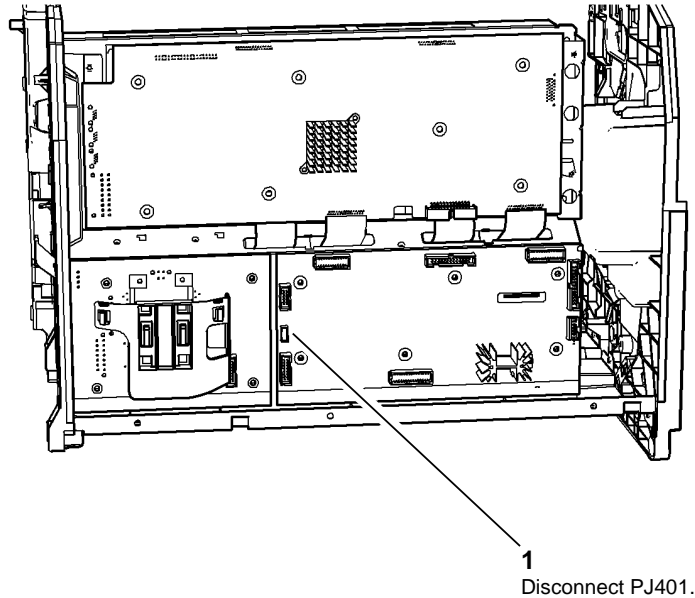

Figure 1 Enclosure removal

U-1-0813-A

3. Disconnect the PJ401 from the marking unit driver PWB, [Figure 2](#).



U-1-0814-A

Figure 2 Disconnect harness

4. Remove the vertical gearbox and motor, [Figure 3](#).

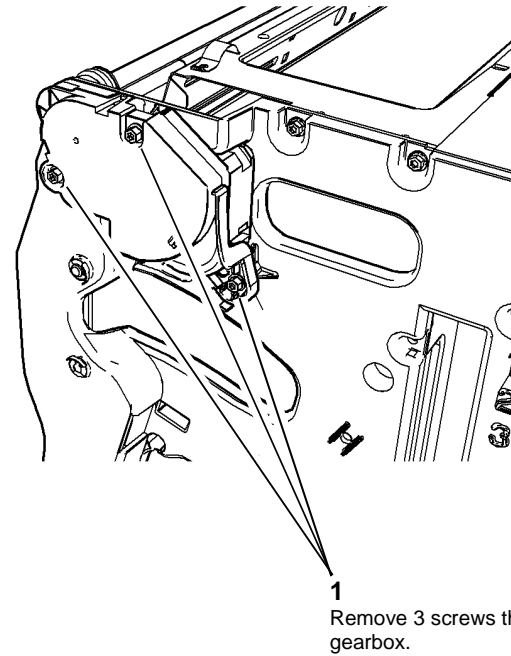

U-1-0815-A

Figure 3 Vertical gearbox removal

Replacement

1. Replacement is the reverse of the removal procedure.
2. To ensure the wiper is level:
 - a. Lower the head maintenance wiper by rotating the upper drive shaft until sufficient clicking (belt jumping teeth is heard to assure horizontally level).
 - b. Rotate the upper drive shaft in the opposite direction until the belt clips are at the top of the tracks.
 - c. Check that both front and rear belt clips are touching the upper end of the track limit.[Figure 4](#) shows the head maintenance wiper fitted level and not level.

REP 91.3 Head Maintenance Wiper

Parts List on [PL 91.15](#)

Removal

WARNING

Switch off the electricity to the machine. Refer to [GP 14](#). Disconnect the power cord from the customer supply while performing tasks that do not need electricity. Electricity can cause death or injury. Moving parts can cause injury.

WARNING

Take care during this procedure. Sharp edges may be present that can cause injury.

CAUTION

Do not touch the exposed face of the printheads. Surface contamination or minor damage can destroy the printhead.

CAUTION

Do not touch the wiper pads.

1. Slide out the marking unit to the maintenance position, Refer to [GP 6](#).
2. Move the head maintenance wiper shaft down to and out of the removal slots, [Figure 1](#).

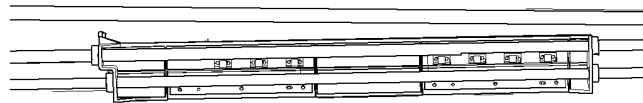
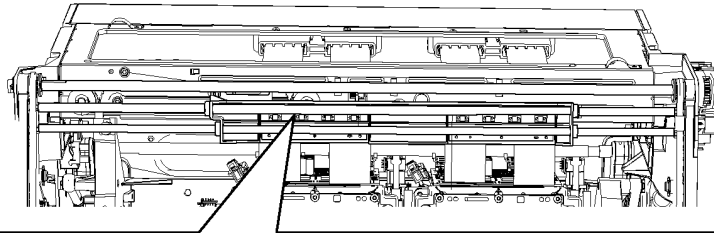

1
Example of the head maintenance wiper not level.



2
Correctly seated and level head maintenance wiper.

U-1-1214-A

Figure 4 Level head maintenance wiper

3. Ensure that both carriages are parked and the wiper is in the home position, all the way up or down.

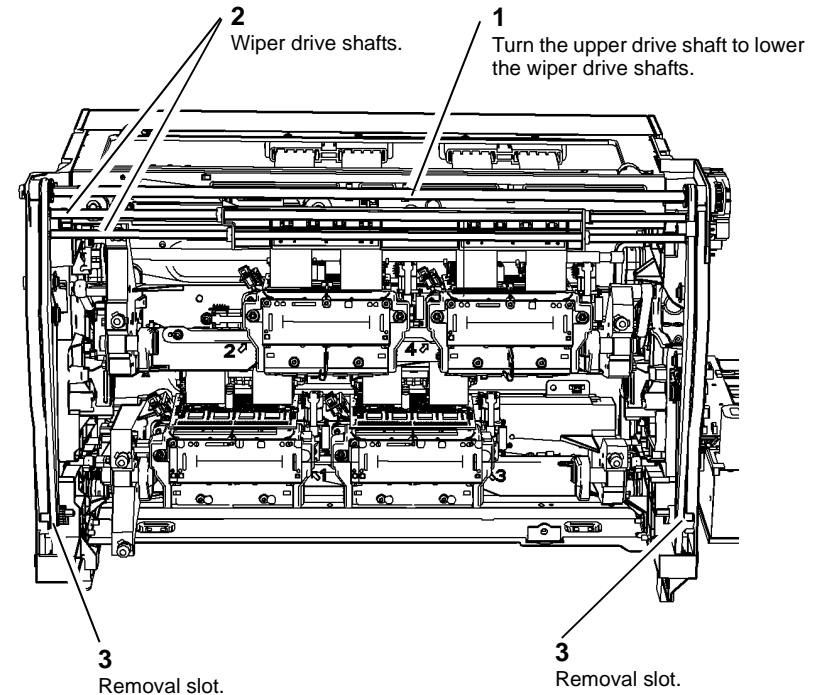

U-1-0816-A

Figure 1 Move the HM wiper shafts

3. Remove the head maintenance wiper shaft, [Figure 2](#).

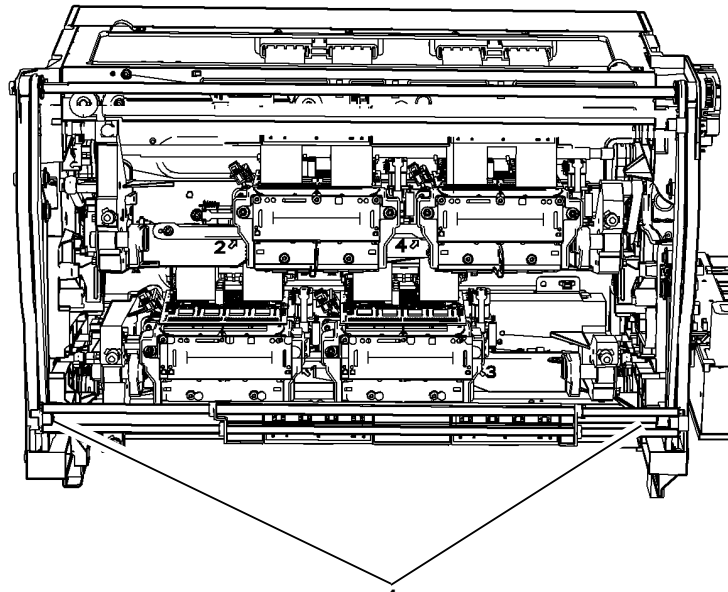

1
Remove the upper and lower wiper shafts from the slots and belt clips.

U-1-0817-A

Figure 2 HM wiper removal

4. Remove the head maintenance wiper from shafts, [Figure 3](#).

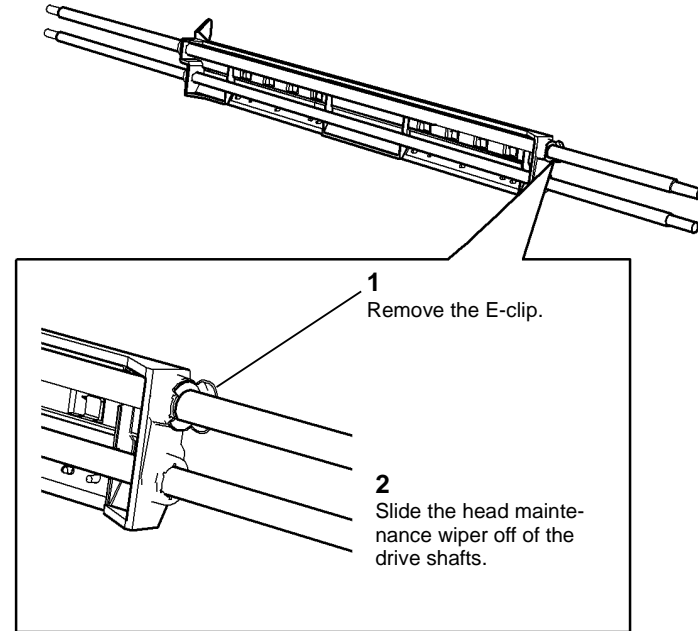

1
Remove the E-clip.

2
Slide the head maintenance wiper off of the drive shafts.

U-1-0818-A

Figure 3 Remove wiper

Replacement

CAUTION

Ensure the head maintenance wiper is in the correct orientation with the wiper facing up, Figure 4.

1. Replacement is the reverse of the removal procedure.
2. Before installing the head maintenance wiper check the orientation of the wiper pads, Figure 4.

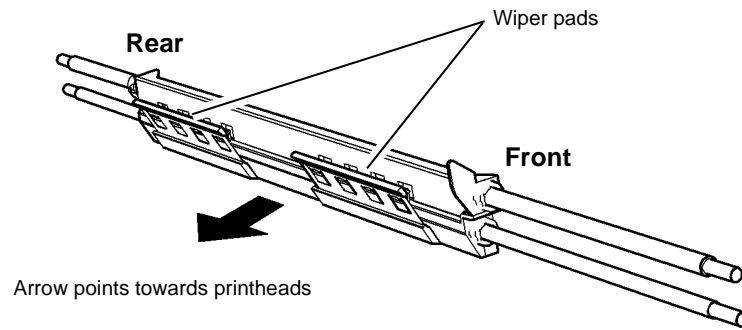

U-1-1155-A

Figure 4 Wiper orientation

3. To ensure the wiper is level:
 - a. Lower the head maintenance wiper by rotating the upper drive shaft until sufficient clicking (belt jumping teeth is heard to assure horizontally level).
 - b. Rotate the upper drive shaft in the opposite direction until the belt clips are at the top of the tracks.
 - c. Check that both front and rear belt clips are touching the upper end of the track limit.

Figure 5 shows the head maintenance wiper fitted level and not level.

4. Ensure that both carriages are parked and the wiper is in the home position, all the way up or down.

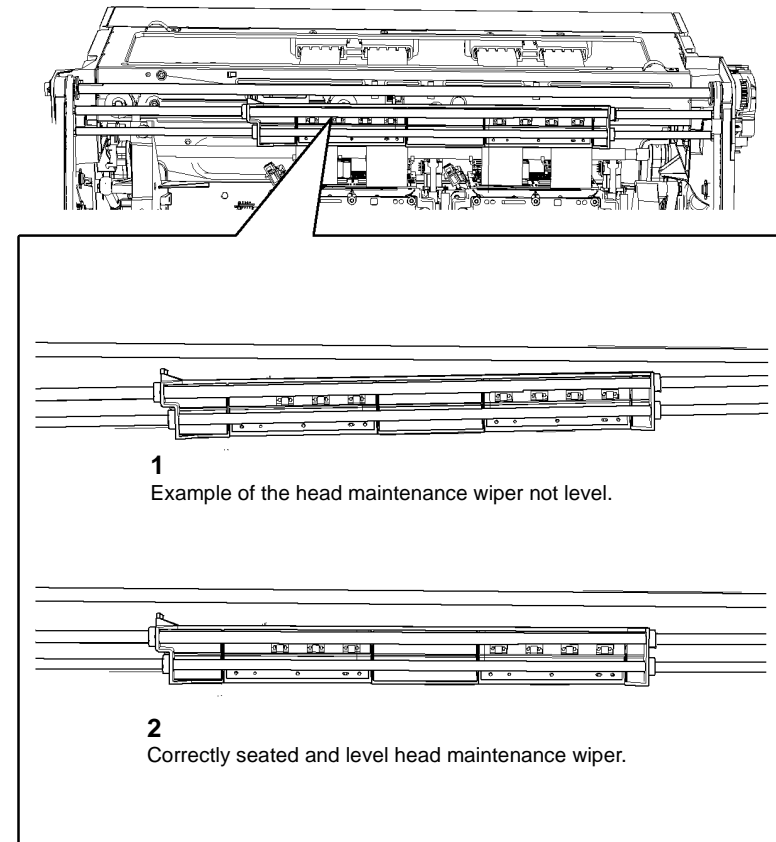

U-1-1156-A

Figure 5 Level head maintenance wiper

REP 91.4 Front and Rear Tensioner Base

Parts List on [PL 91.15](#)

Removal

WARNING

Switch off the electricity to the machine. Refer to [GP 14](#). Disconnect the power cord from the customer supply while performing tasks that do not need electricity. Electricity can cause death or injury. Moving parts can cause injury.

WARNING

Take care during this procedure. Sharp edges may be present that can cause injury.

CAUTION

Do not touch the exposed face of the printheads. Surface contamination or minor damage can destroy the printhead.

1. Slide out the marking unit to the maintenance position, Refer to [GP 6](#).
2. Lower the head maintenance wiper, [Figure 1](#).

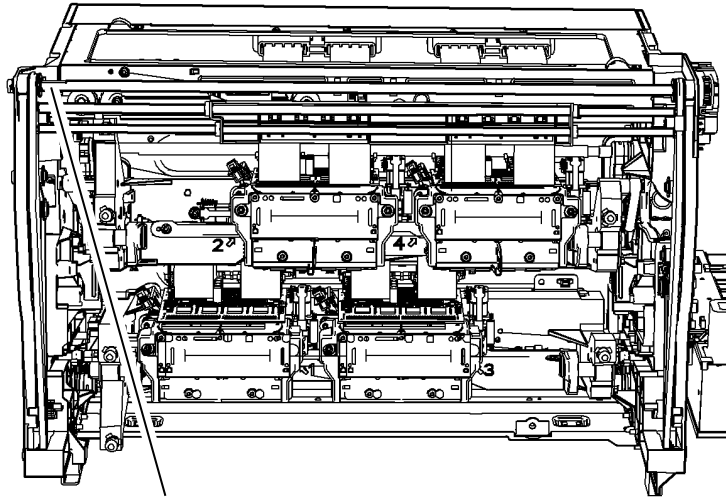

1
To lower the head maintenance wiper: Turn the upper drive shaft until the belts slip.

U-1-0819-A

Figure 1 Lower the head maintenance wiper

3. Release the tension springs, [Figure 2](#).

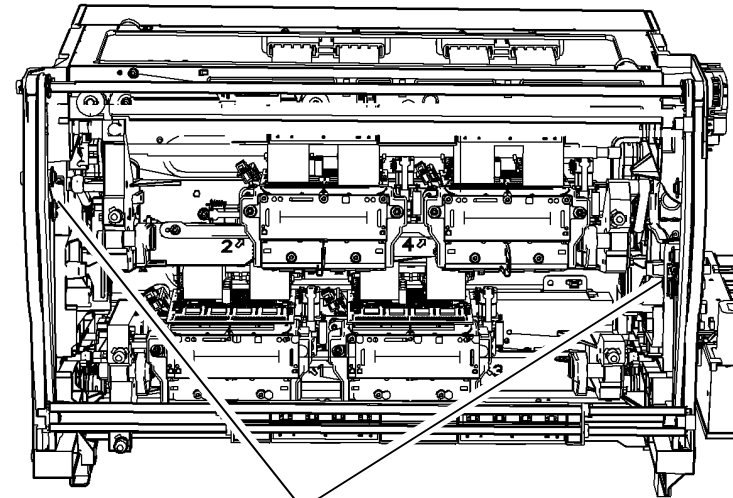

1
Release the tension springs.

Figure 2 Spring release

U-1-0820-A

4. Remove the front and rear tensioner bases, [Figure 3](#).

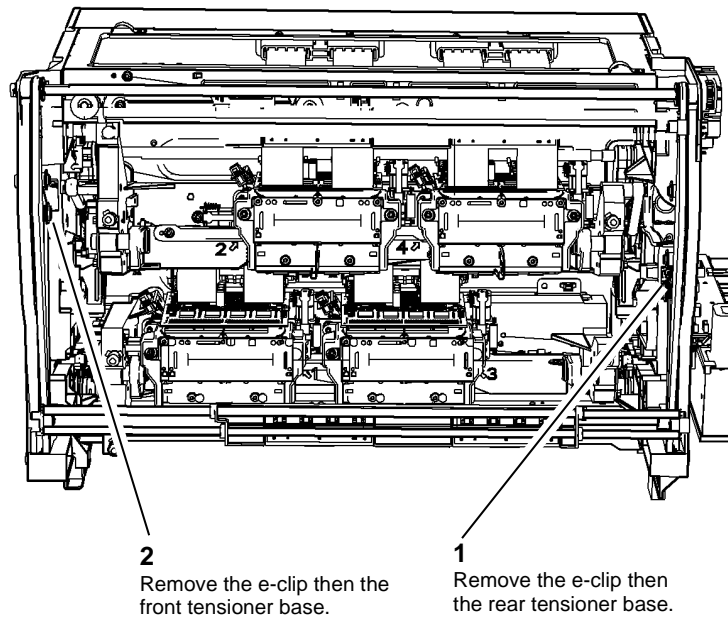

2
Remove the e-clip then the front tensioner base.

1
Remove the e-clip then the rear tensioner base.

U-1-0821-A

Figure 3 Tensioner base removal

Replacement

1. Replacement is the reverse of the removal procedure.
2. [Figure 4](#) shows the correct route for the front and rear belts.
3. Ensure that both carriages are parked and the wiper is in the home position, all the way up or down.

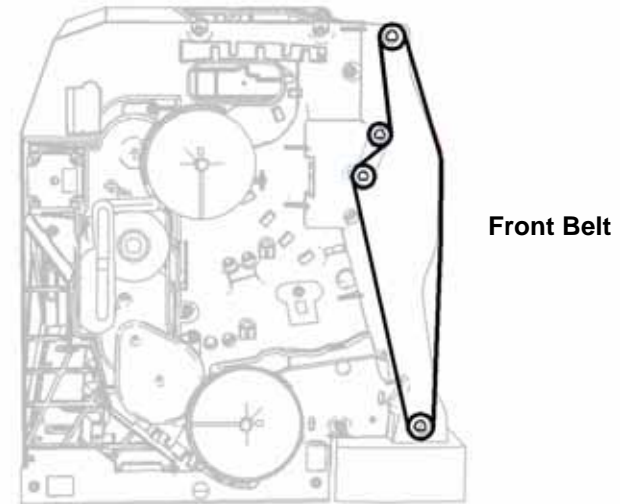

Front Belt

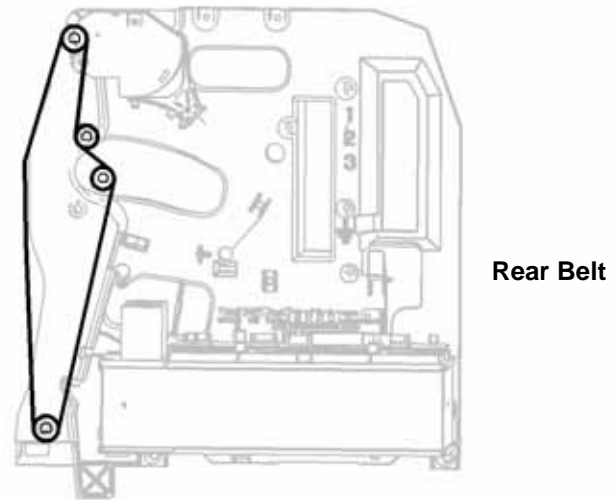

Rear Belt

U-1-1219-A

Figure 4 Belt routing

REP 91.5 Head Maintenance Belts and Belt Retainer Clips

Parts List on PL 91.15

Removal

WARNING

Switch off the electricity to the machine. Refer to GP 14. Disconnect the power cord from the customer supply while performing tasks that do not need electricity. Electricity can cause death or injury. Moving parts can cause injury.

WARNING

Take care during this procedure. Sharp edges may be present that can cause injury.

CAUTION

Do not touch the exposed face of the printheads. Surface contamination or minor damage can destroy the printhead.

1. Remove the head maintenance wiper, refer to REP 91.3 only perform the steps necessary to remove the head maintenance wiper from the marking unit.
2. Remove the front and rear head maintenance belts, Figure 1.

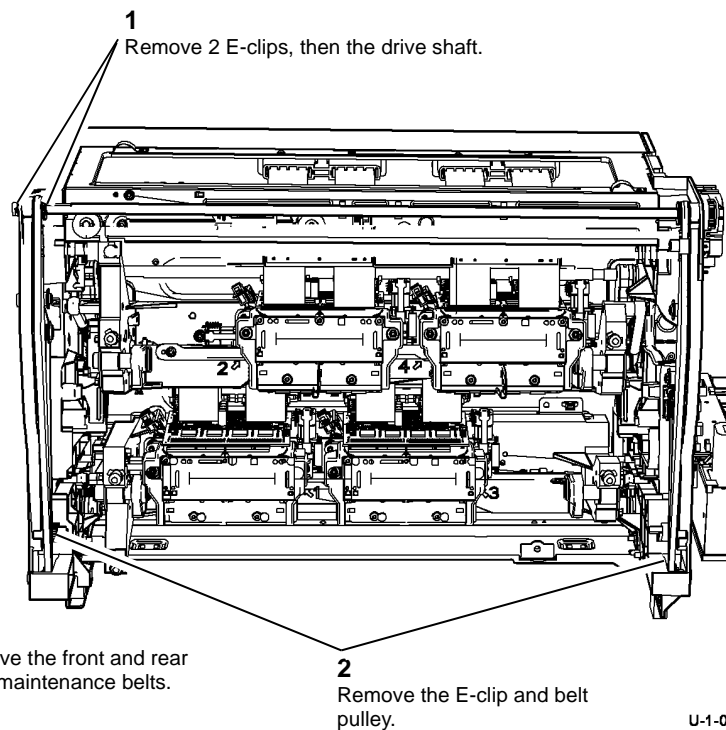

Figure 1 Head maintenance belt removal

3. Remove the head maintenance belt clips, Figure 2.

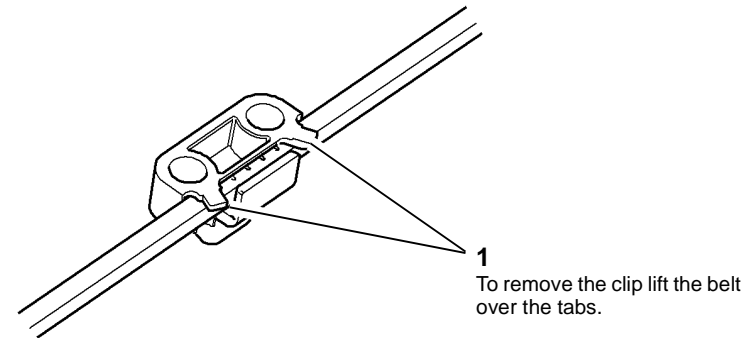

Figure 2 Head maintenance belt clip

Replacement

1. Replacement is the reverse of the removal procedure.
2. The drive shaft is a tight fit in the vertical drive motor.
3. Ensure that both carriages are parked and the wiper is in the home position, all the way up or down.

REP 91.6 Head Maintenance Horizontal Motion Motor

Parts List on PL 91.15

Removal

WARNING

Switch off the electricity to the machine. Refer to GP 14. Disconnect the power cord from the customer supply while performing tasks that do not need electricity. Electricity can cause death or injury. Moving parts can cause injury.

WARNING

Take care during this procedure. Sharp edges may be present that can cause injury.

CAUTION

Do not touch the exposed face of the printheads. Surface contamination or minor damage can destroy the printhead.

1. Slide out the marking unit to the maintenance position, Refer to GP 6.
2. Lower the head maintenance wiper, Figure 1.

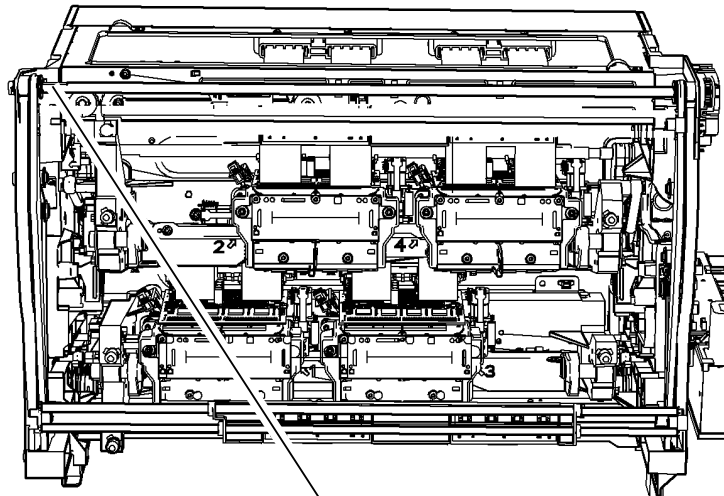

- 1 To lower the head maintenance wiper: Turn the upper drive shaft until the belts slip.

U-1-0824-A

Figure 1 Lower the head maintenance wiper

3. Remove the wiper shuttling yoke, Figure 2.

NOTE: Keeping the wiper shuttling yoke and horizontal drive cable connected will make reinstallation easier.

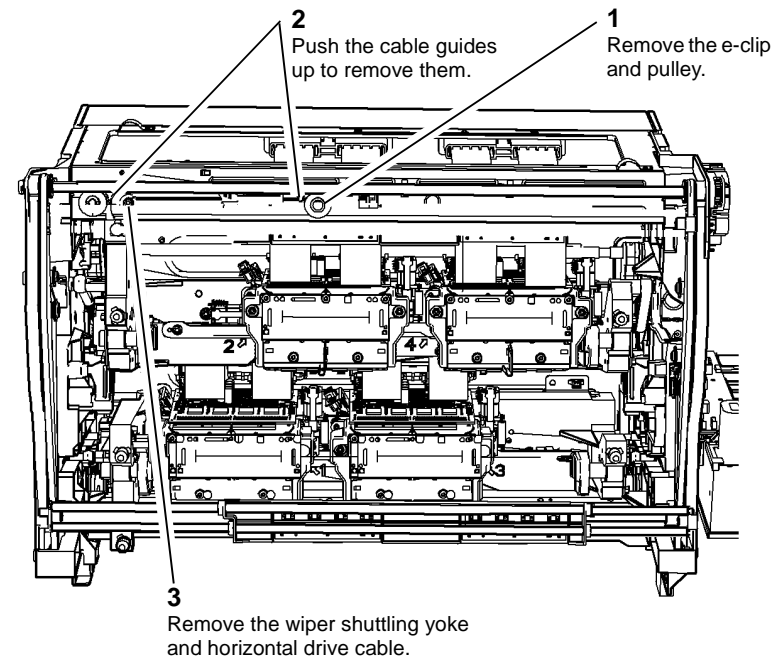

U-1-0825-A

Figure 2 Wiper shuttling yoke removal

- Remove the horizontal motion motor, [Figure 3](#).

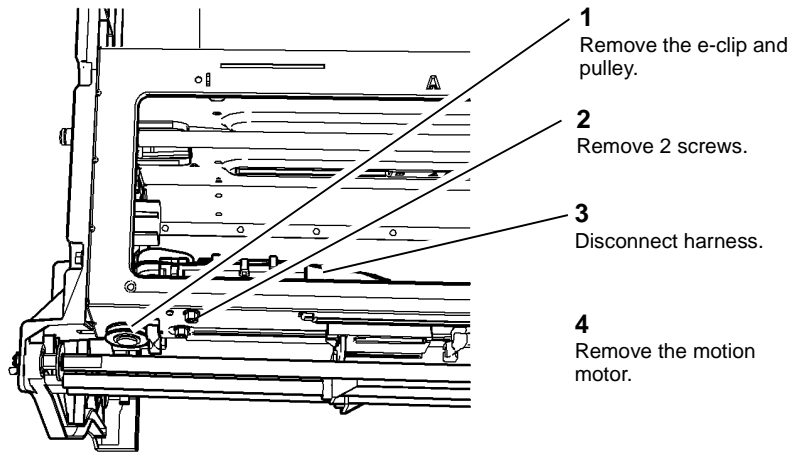

- Remove the e-clip and pulley.
- Remove 2 screws.
- Disconnect harness.
- Remove the motion motor.

U-1-0826-A

Figure 3 Motion motor removal

Replacement

- Replacement is the reverse of the removal procedure.
- [Figure 4](#) shows the correct wiper shuttling yoke position.

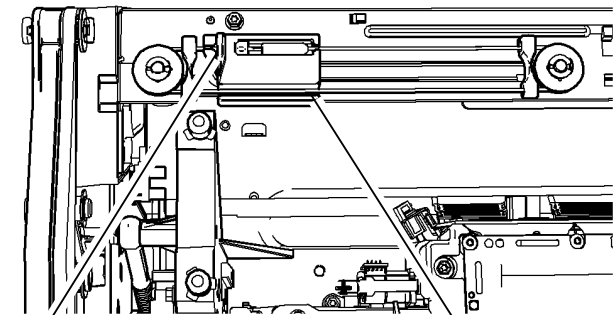

- Ensure the tab is located at the top left.
- Ensure the cable sits in this slot.

U-1-1220-A

Figure 4 Wiper shuttling yoke position

- Ensure that both carriages are parked and the wiper is in the home position, all the way up or down.

REP 91.7 Marking Unit Upper Carriage

Parts List on [PL 91.20](#)

Removal

WARNING

Switch off the electricity to the machine. Refer to [GP 14](#). Disconnect the power cord from the customer supply while performing tasks that do not need electricity. Electricity can cause death or injury. Moving parts can cause injury.

WARNING

Take care during this procedure. Sharp edges may be present that can cause injury.

CAUTION

Do not touch the exposed face of the printheads. Surface contamination or minor damage can destroy the printhead.

NOTE: Rotate the wiper drive shaft, move the head maintenance wiper to the front of the lower printheads. This is to provide protection during the procedure. Move the head maintenance wiper back when the procedure is complete.

- If possible print the initial test print pages, [TP 1](#). These test pages are used to check the print quality after the machine has been repaired. Refer to [GP 37](#).
- Remove upper printheads, [REP 91.29](#).

3. Disconnect the carriage harness, [Figure 1](#).

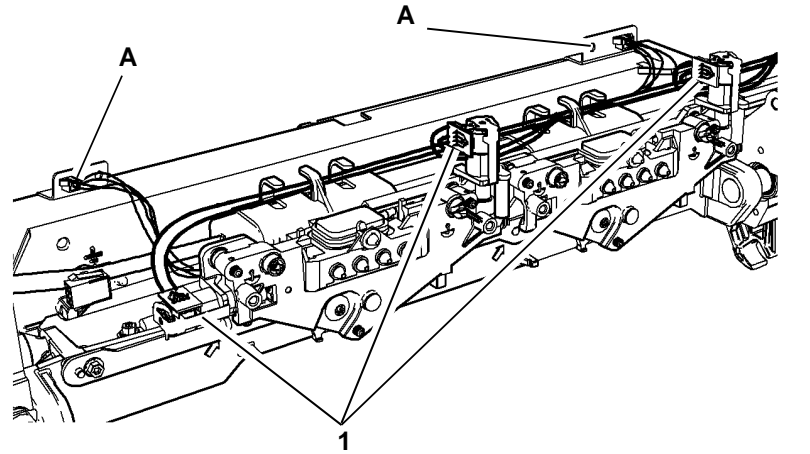

2
Disconnect harnesses from the in-line connectors on the carriage marked A and release the cable clips.

1 Disconnect harnesses from the stitch/roller motors.

U-1-1208-A

Figure 1 Disconnect harness

4. Disconnect the umbilical from the carriage, [Figure 2](#).

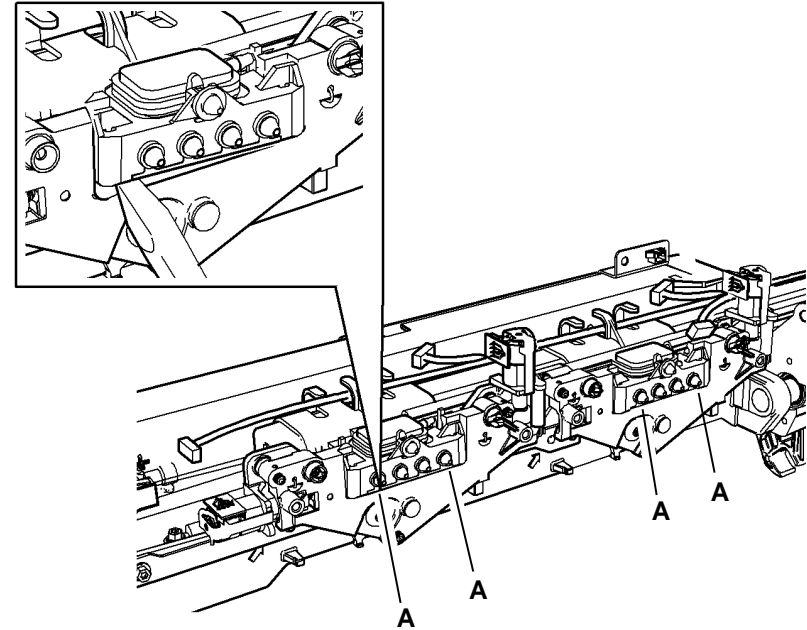

1
Use a bladed screwdriver to unclip the umbilical from the carriage. Insert the screwdriver between the umbilical and carriage then rotate the blade to release the umbilical (4 positions marked A).

U-1-1209-A

Figure 2 Unclip the umbilical

5. Disconnect the ground lead, **Figure 3**.

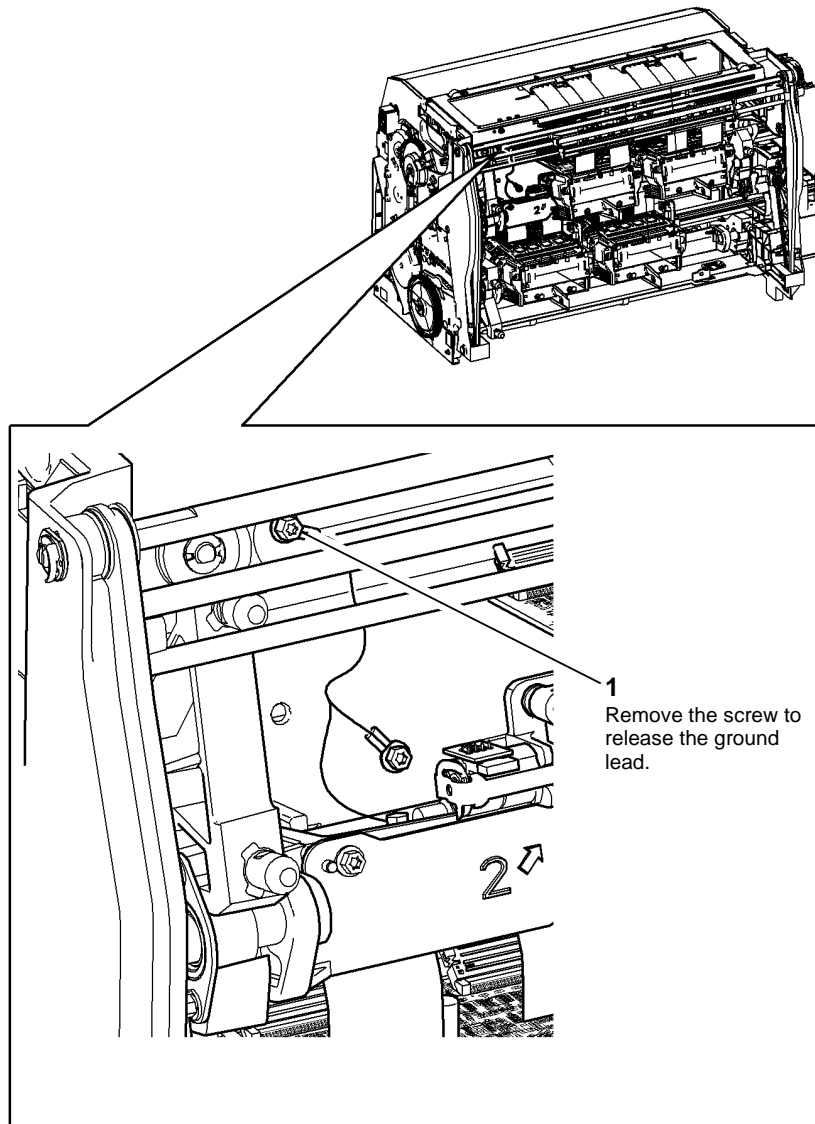

U-1-1216-A

Figure 3 Disconnect ground lead

6. Remove the marking unit upper carriage, **Figure 4**.

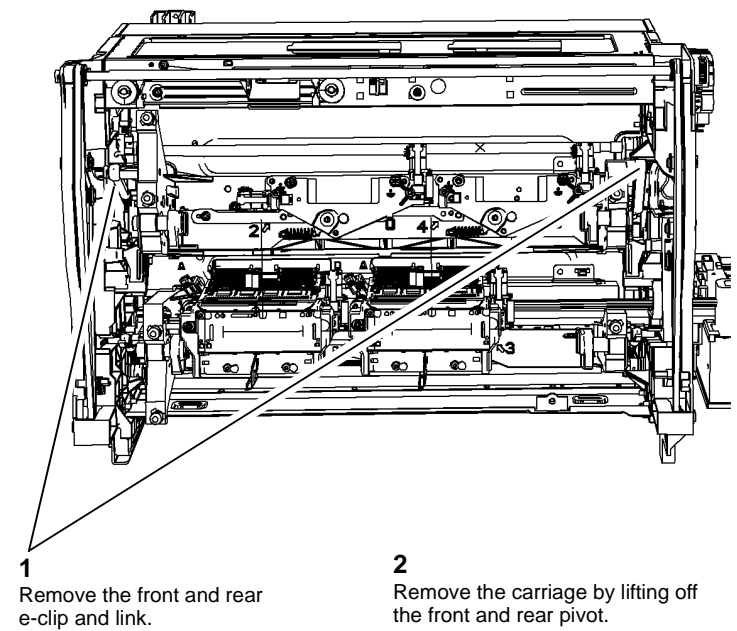

U-1-0833-A

Figure 4 Upper carriage removal

Replacement

1. Replacement is the reverse of the removal procedure.
2. Ensure all ground lead connections are firmly remade.
3. When installing a new carriage, ensure the shipping restraint clips are removed before installation, [Figure 5](#).

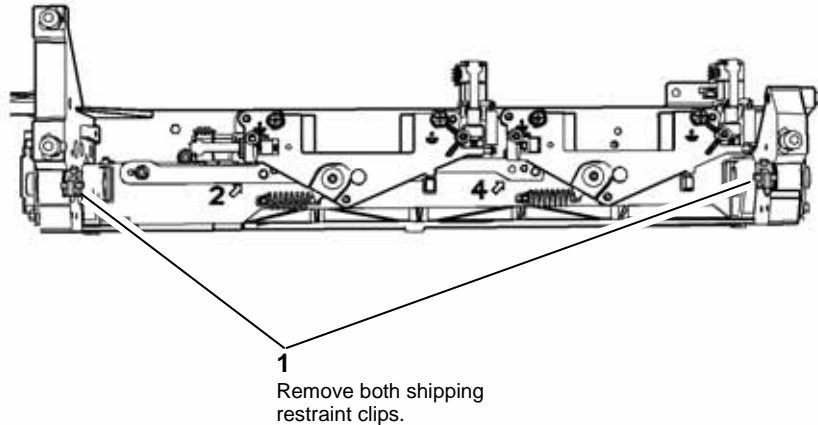

Figure 5 Shipping restraint clips

U-1-1206-A

4. Ensure the harnesses are routed correctly, refer to [GP 28](#).
5. Run the relevant diagnostic routines, refer to [GP 37](#) Post Part Replacement Routines.
6. Ensure that both carriages are parked and the wiper is in the home position, all the way up or down.

REP 91.8 Upper Carriage Drive Shaft, Cranks, Upper Front and Rear Compliant Links

Parts List on [PL 91.10](#)

Removal

WARNING

Switch off the electricity to the machine. Refer to [GP 14](#). Disconnect the power cord from the customer supply while performing tasks that do not need electricity. Electricity can cause death or injury. Moving parts can cause injury.

WARNING

Take care during this procedure. Sharp edges may be present that can cause injury.

CAUTION

Do not touch the exposed face of the printheads. Surface contamination or minor damage can destroy the printhead.

1. Remove marking unit upper printheads, [REP 91.29](#).
2. Remove marking unit upper carriage, [REP 91.7](#).
3. Remove marking unit upper drive gear, [Figure 1](#).

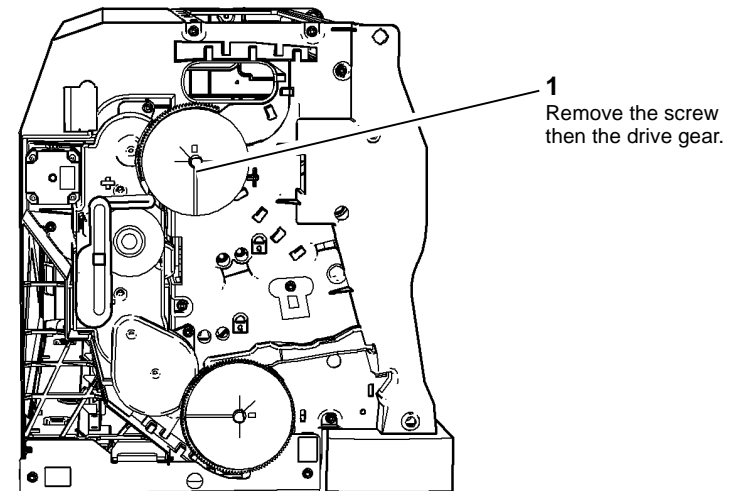
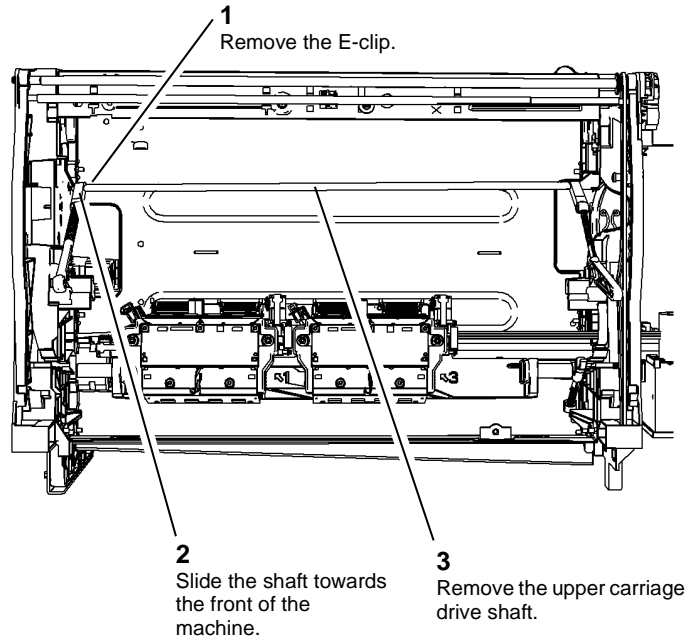

Figure 1 Drive gear removal

U-1-0834-A

- Remove the upper carriage drive shaft, cranks and compliant links, [Figure 2](#).



U-1-0835-A

Figure 2 Drive shaft assembly removal

Replacement

- Replacement is the reverse of the removal procedure.
- Ensure that the bearings are reinstalled at both ends of the drive shaft.
- The drive gear screw is angled. Tabs on the gear prevent the screw from being driven in at 90 degrees.
- Ensure that both carriages are parked and the wiper is in the home position, all the way up or down.

REP 91.9 X Axis Drive Motor

Parts List on [PL 91.20](#), [PL 91.25](#)

Removal

WARNING

Switch off the electricity to the machine. Refer to [GP 14](#). Disconnect the power cord from the customer supply while performing tasks that do not need electricity. Electricity can cause death or injury. Moving parts can cause injury.

WARNING

Take care during this procedure. Sharp edges may be present that can cause injury.

CAUTION

Do not touch the exposed face of the printheads. Surface contamination or minor damage can destroy the printhead.

- Remove the marking unit carriage, refer to [REP 91.7](#) for upper carriage and [REP 91.14](#) for lower carriage.
- Remove the x axis drive motor, [Figure 1](#).

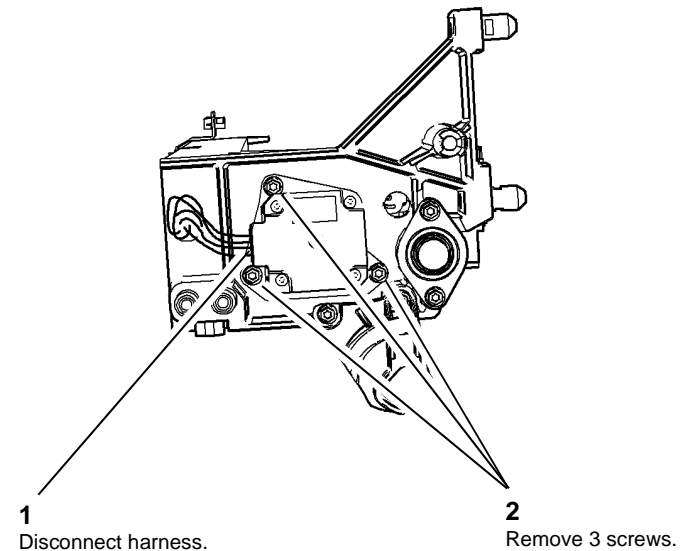

U-1-0836-A

Figure 1 Printhead motor removal

Replacement

1. Replacement is the reverse of the removal procedure.
2. Ensure the rotation stop is correctly located when securing the motor to the frame, [Figure 2](#).

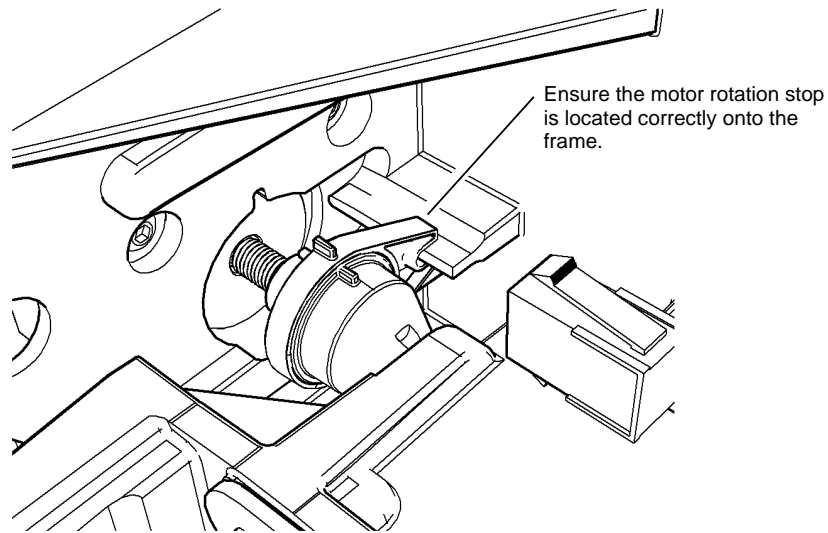

U-1-1438-A

Figure 2 Motor Location

3. Run the relevant diagnostic routines, refer to [GP 37](#) Post Part Replacement Routines.

REP 91.10 Lower Carriage Drive Shaft, Cranks, Lower Front and Rear Compliant Links

Parts List on [PL 91.10](#)

Removal

WARNING

Switch off the electricity to the machine. Refer to [GP 14](#). Disconnect the power cord from the customer supply while performing tasks that do not need electricity. Electricity can cause death or injury. Moving parts can cause injury.

WARNING

Take care during this procedure. Sharp edges may be present that can cause injury.

CAUTION

Do not touch the exposed face of the printheads. Surface contamination or minor damage can destroy the printhead.

1. Remove marking unit lower printheads, [REP 91.29](#)
2. Remove marking unit lower carriage, [REP 91.14](#)
3. Remove the lower drive gear, [Figure 1](#).

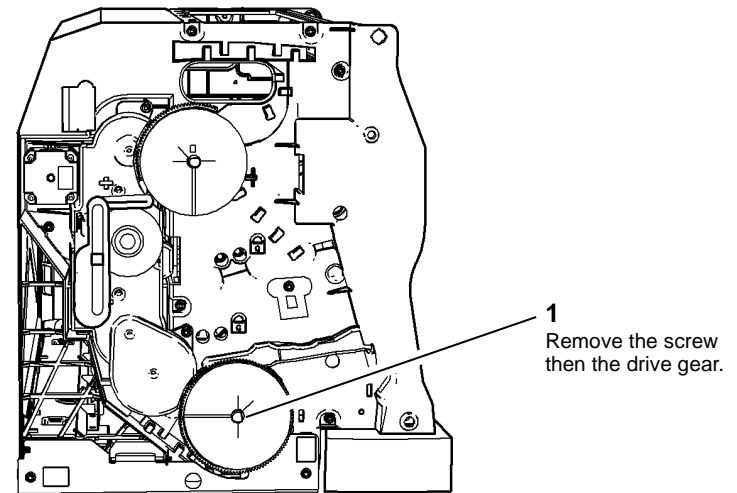

U-1-1215-A

Figure 1 Lower drive gear

- Remove the lower carriage drive shaft, cranks and compliant links, [Figure 2](#).

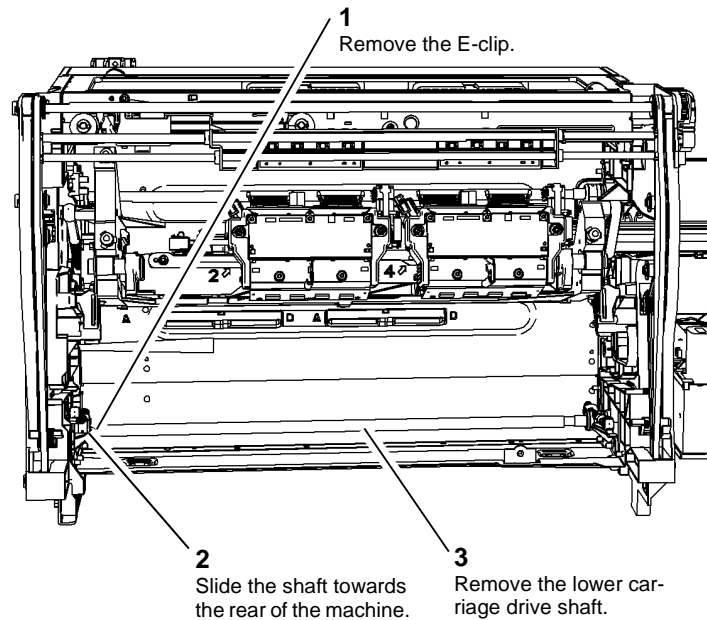

U-1-1218-A

Figure 2 Drive shaft assembly removal

Replacement

- Replacement is the reverse of the removal procedure.
- Ensure that the bearings are reinstalled at both ends of the drive shaft.
- The drive gear screw is angled. Tabs on the gear prevent the screw from being driven in at 90 degrees.
- Ensure that both carriages are parked and the wiper is in the home position, all the way up or down.

REP 91.11 Service Loop

Parts List on [PL 92.10](#)

Removal

WARNING

Switch off the electricity to the machine. Refer to [GP 14](#). Disconnect the power cord from the customer supply while performing tasks that do not need electricity. Electricity can cause death or injury. Moving parts can cause injury.

WARNING

Take care during this procedure. Sharp edges may be present that can cause injury.

CAUTION

Do not touch the exposed face of the printheads. Surface contamination or minor damage can destroy the printhead.

- Remove the inner cover, [PL 81.11 Item 2](#).
- Remove the marking unit, [REP 91.28](#).

3. Release the service loop from the draw slide and cable clamps, [Figure 1](#).

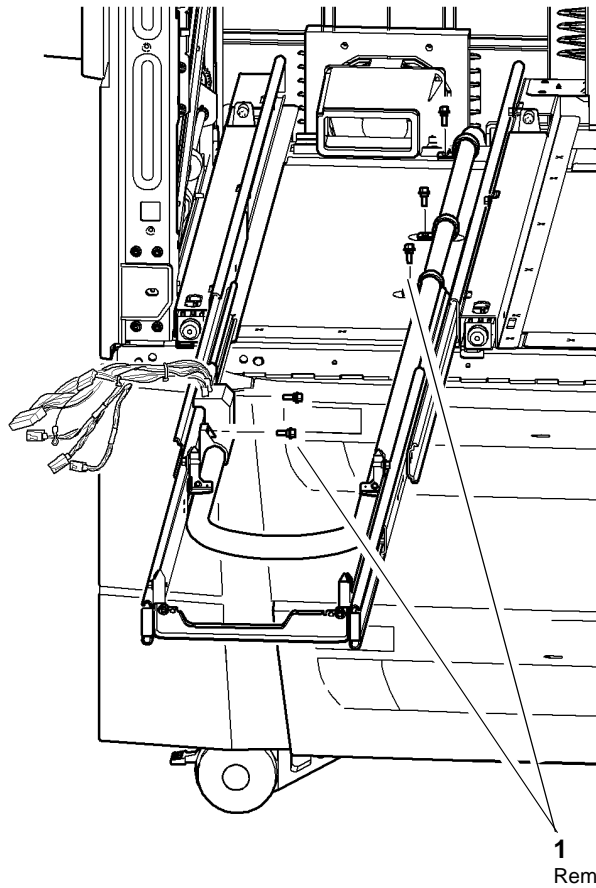

1 Remove the screws.

Figure 1 Release Service loop

U-1-1201-A

4. Disconnect the following harnesses:
 - PJ 408, media path PWB.
 - PJ 603, drum driver PWB.
5. Remove the PSU, [PL 1.15 Item 2](#).

6. Remove the service loop, [Figure 2](#).

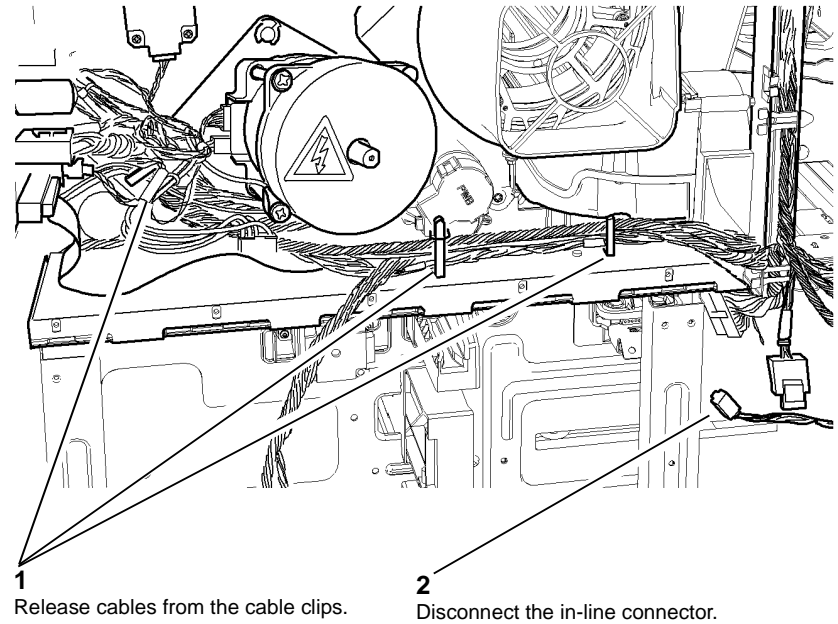

1 Release cables from the cable clips.

2 Disconnect the in-line connector.

U-1-1202-A

Figure 2 Service loop removal

Replacement

1. Replacement is the reverse of the removal procedure.
2. Push the marking unit slides into the machine with the marking unit removed.

CAUTION

Take care not to insert twists into the cable during installation.

3. Install the service loop using the slides as a guide, [Figure 3](#).

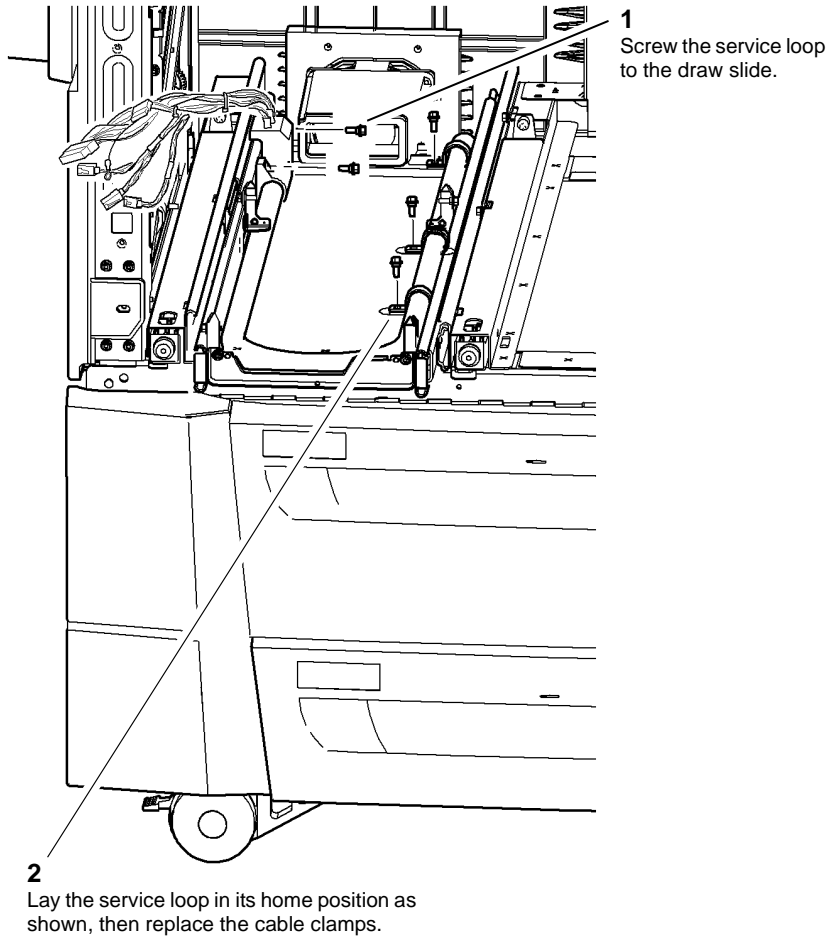

U-1-1203-A

Figure 3 Service loop replacement

4. Check the operation of the marking unit slides before replacing the marking unit assembly. Ensure it fully extends and that the service loop does not get trapped when the slides are returned into the machine.

REP 91.12 Purge Line Filter

Parts List on [PL 91.20](#)

Removal

WARNING

Switch off the electricity to the machine. Refer to [GP 14](#). Disconnect the power cord from the customer supply while performing tasks that do not need electricity. Electricity can cause death or injury. Moving parts can cause injury.

WARNING

Take care during this procedure. Sharp edges may be present that can cause injury.

CAUTION

Do not touch the exposed face of the printheads. Surface contamination or minor damage can destroy the printhead.

1. Remove the printheads, [REP 91.29](#).
2. Remove the purge line filter, [Figure 1](#).

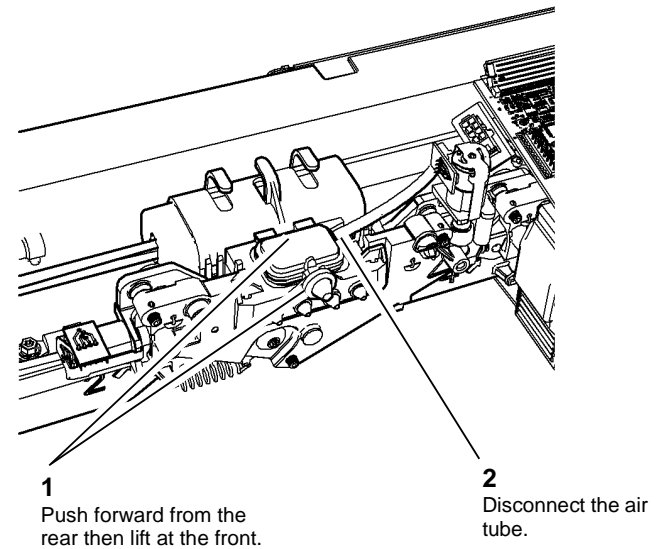

U-1-0839-A

Figure 1 Purge line filter removal

Replacement

1. Replacement is the reverse of the removal procedure.

2. Insert the 2 tabs on the filter into the black housing. Apply a slight downward force on the filter while sliding the filter into the housing. Ensure there is no gap between the rear of the cone and the front of the housing, refer to [Figure 2](#). Check that the filter is securely held in the housing.
3. If the umbilical snap feature breaks off during replacement of the filter, use the replacement clip included with the replacement filter. If necessary, remove the cap from the filter, [Figure 2](#).

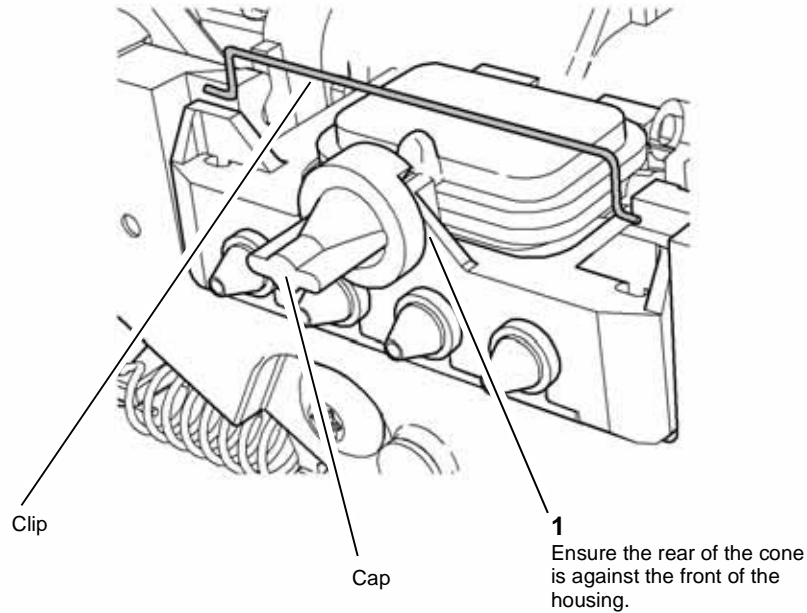

U-1-1205-A

Figure 2 Replacement

4. Run the relevant diagnostic routines, refer to [GP 37](#) Post Part Replacement Routines.

REP 91.13 Stitch / Roll Motor

Parts List on [PL 91.20](#)

Removal

WARNING

Switch off the electricity to the machine. Refer to [GP 14](#). Disconnect the power cord from the customer supply while performing tasks that do not need electricity. Electricity can cause death or injury. Moving parts can cause injury.

WARNING

Take care during this procedure. Sharp edges may be present that can cause injury.

1. Remove the stitch / roll motor, [Figure 1](#).

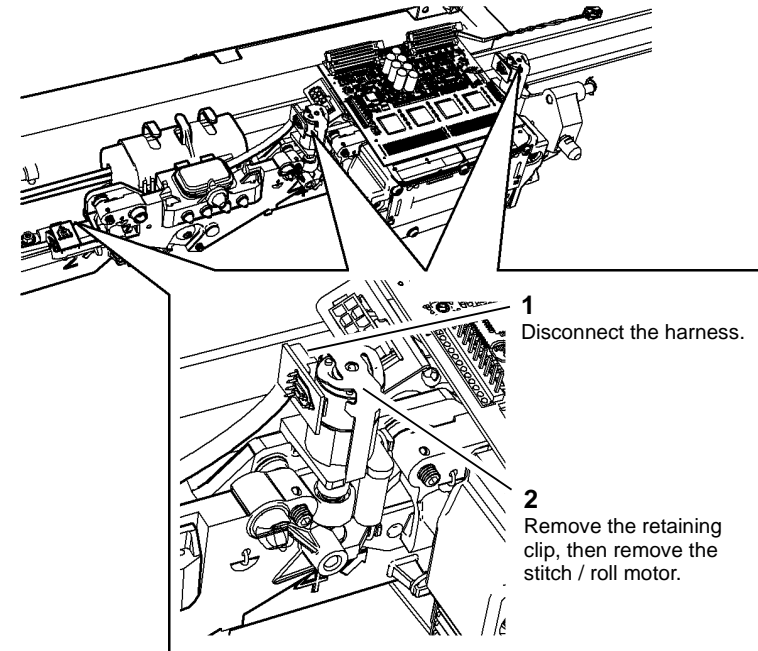

U-1-0840-A

Figure 1 Stitch / roll motor removal

Replacement

1. Replacement is the reverse of the removal procedure.
2. Verify the motor assembly cannot rotate relative to the carriage.
3. Check that there is no gap between the carriage and the motor face. If there is a gap, check the guide pin is located in the hole.
4. Ensure that both carriages are parked and the wiper is in the home position, all the way up or down.
5. Run the relevant diagnostic routines, refer to [GP 37](#) Post Part Replacement Routines.

REP 91.14 Marking Unit Lower Carriage

Parts List on [PL 91.25](#)

Removal

WARNING

Switch off the electricity to the machine. Refer to [GP 14](#). Disconnect the power cord from the customer supply while performing tasks that do not need electricity. Electricity can cause death or injury. Moving parts can cause injury.

WARNING

Take care during this procedure. Sharp edges may be present that can cause injury.

CAUTION

Do not touch the exposed face of the printheads. Surface contamination or minor damage can destroy the printhead.

NOTE: Rotate the wiper drive shaft, move the head maintenance wiper to the front of the upper printheads. This is to provide protection during the procedure. Move the head maintenance wiper back when the procedure is complete.

1. If possible print the initial test print pages, [TP 1](#). These test pages are used to check the print quality after the machine has been repaired. Refer to [GP 37](#).
2. Remove lower printheads, [REP 91.29](#).

NOTE: After the printheads are removed leave the carriage in the lower service position.

3. Disconnect the carriage harness, [Figure 1](#).

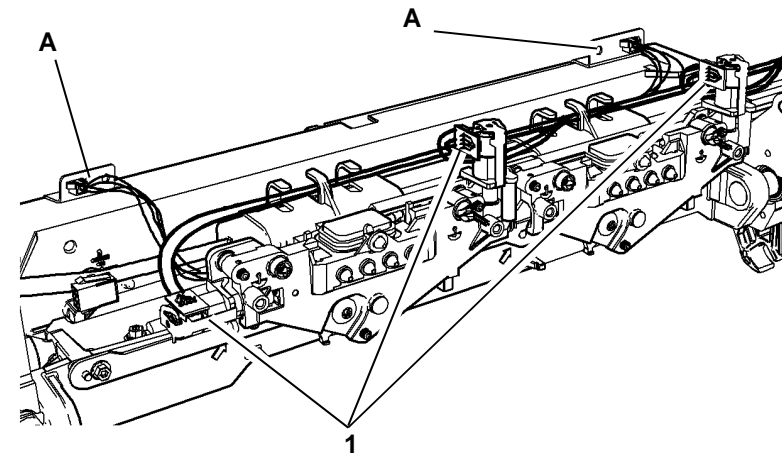

1. Disconnect harnesses from the stitch/roller motors.
2. Disconnect harnesses from the in-line connectors on the carriage marked A and release the cable clips.

U-1-1210-A

Figure 1 Disconnect harness

4. Disconnect the umbilical from the carriage, [Figure 2](#).

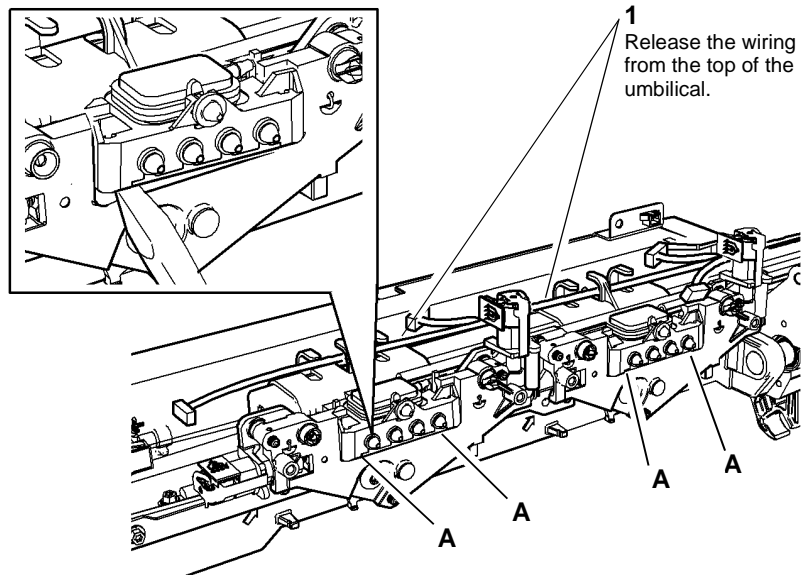

2
Use a flat bladed screwdriver to unclip the umbilical from the carriage. Insert the screwdriver between the umbilical and carriage then rotate the blade to release the umbilical (4 positions marked A).

U-1-1211-A

Figure 2 Unclip the umbilical

5. Disconnect the ground lead, [Figure 3](#).

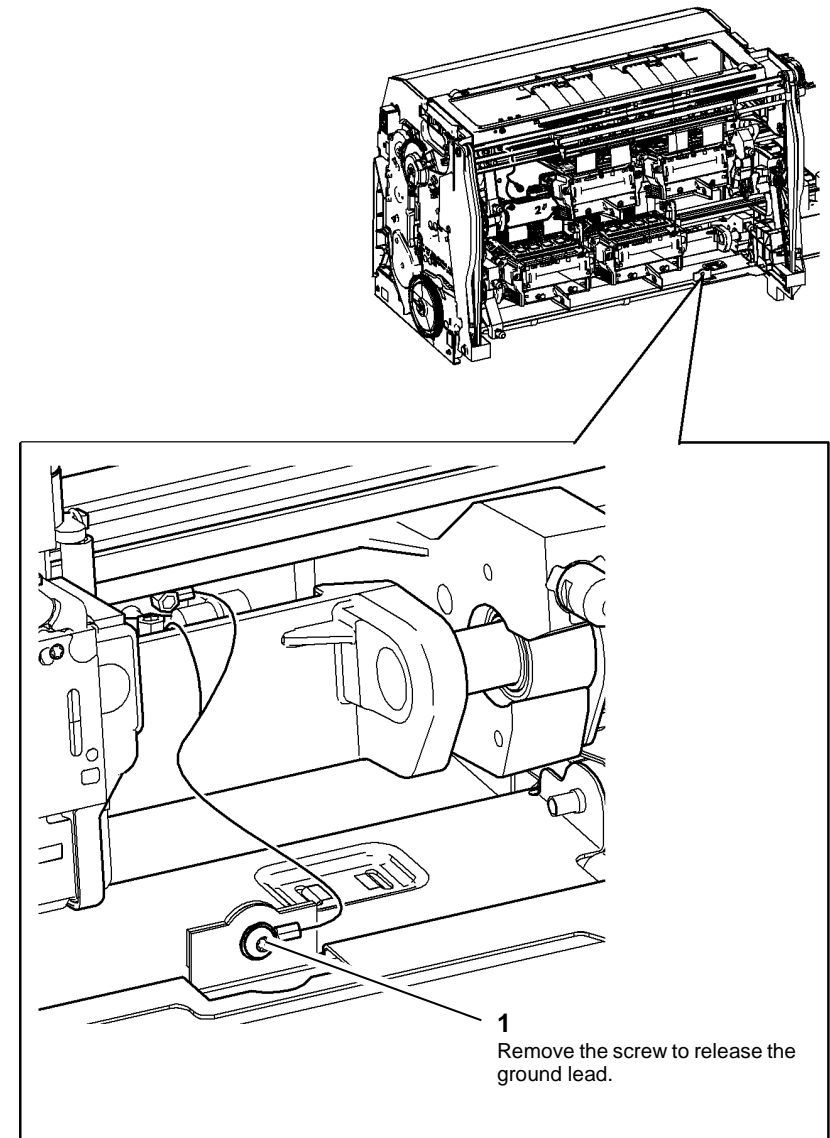

U-1-1217-A

Figure 3 Disconnect ground lead

6. Remove the marking unit lower carriage, [Figure 4](#).

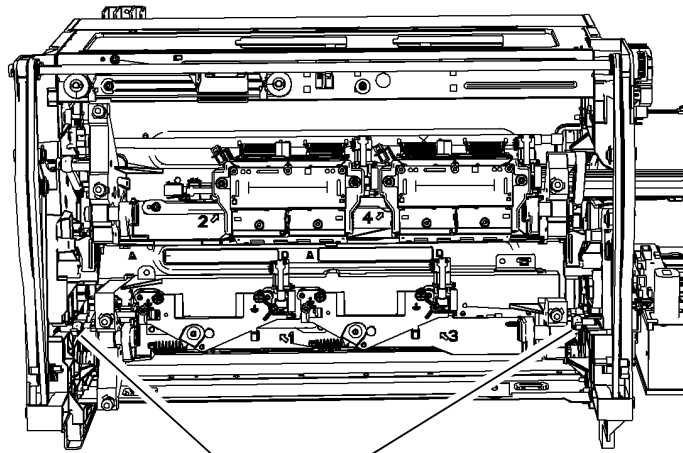

- 1 Remove the carriage by unclipping the front and rear links then lifting out the carriage.

U-1-0846-A

Figure 4 Lower carriage removal

Replacement

1. Replacement is the reverse of the removal procedure.
2. Ensure all ground lead connections are firmly remade.
3. When installing a new carriage, ensure the shipping restraint clips are removed before installation, [Figure 5](#).

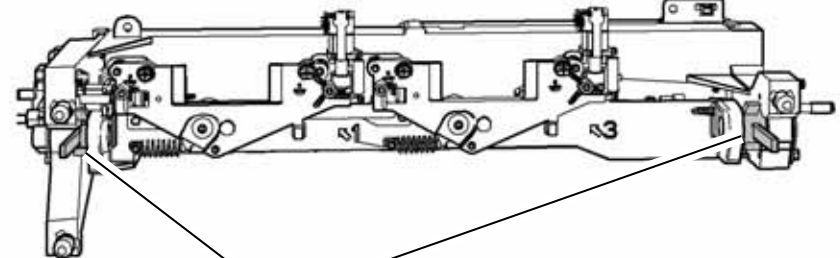

- 1 Remove both shipping restraint clips.

U-1-1207-A

Figure 5 Shipping restraint clips

4. Ensure the harnesses are routed correctly, refer to [GP 28](#).
5. Run the relevant diagnostic routines, refer to [GP 37 Post Part Replacement Routines](#).
6. Ensure that both carriages are parked and the wiper is in the home position, all the way up or down.

REP 91.15 Ink Loader Assembly

Parts List on [PL 93.10](#)

Removal

WARNING

Switch off the electricity to the machine. Refer to [GP 14](#). Disconnect the power cord from the customer supply while performing tasks that do not need electricity. Electricity can cause death or injury. Moving parts can cause injury.

WARNING

Take care during this procedure. Sharp edges may be present that can cause injury.

1. Open the front door.
2. Remove the rear cover, [PL 81.10 Item 1](#).
3. Remove the ink loader access cover rear, [PL 81.10 Item 7](#). The cover is secured by a clip on the left side, [Figure 1](#).

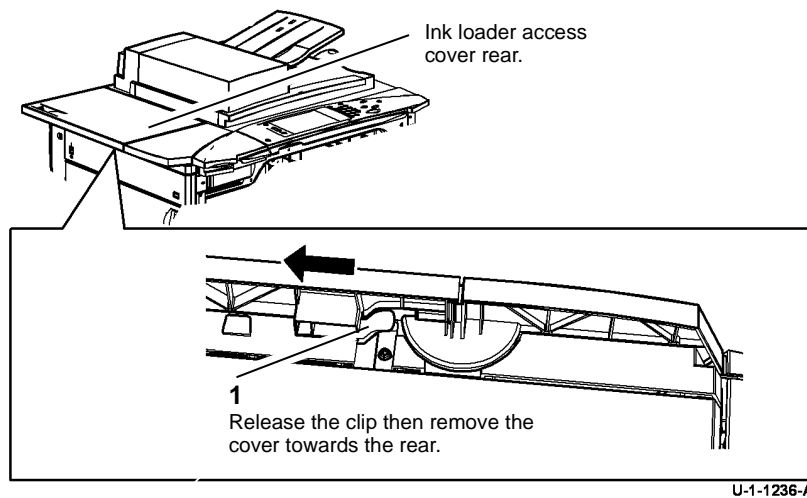

Figure 1 Release the access cover

4. Remove the ink loader backup cover, [PL 81.10 Item 8](#) and ink loader top, [PL 81.10 Item 6](#). Refer to [Figure 2](#).

3

Remove 3 screws marked A.

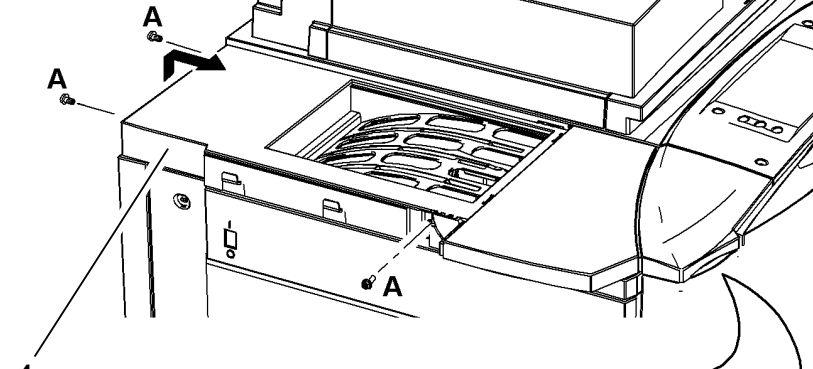

Figure 2 Ink loader backup cover and top cover

5. Disconnect the media path driver PWB, [Figure 3](#). See note.

Note: View on the underside of the media path driver PWB.

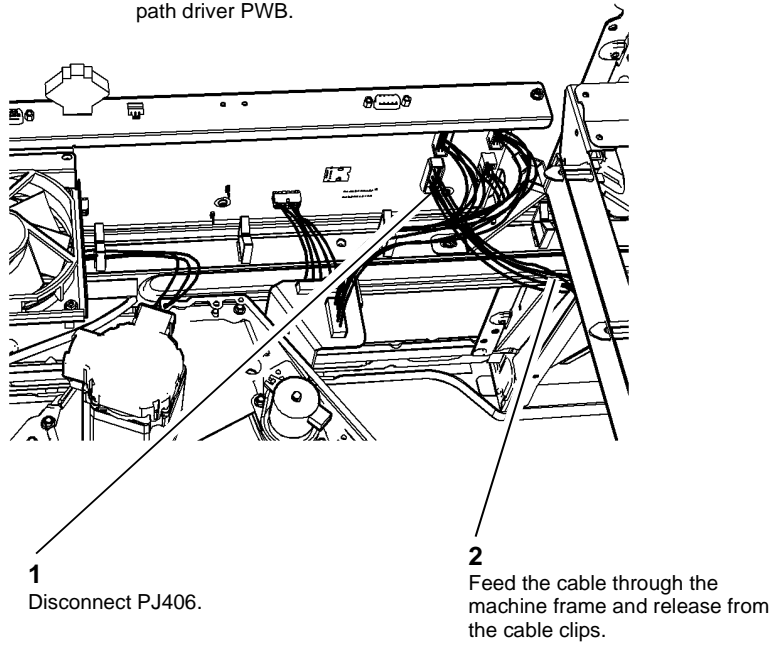

Figure 3 Disconnect harness

U-1-0847-A

6. Disconnect the ink loader upper assembly, [Figure 4](#).

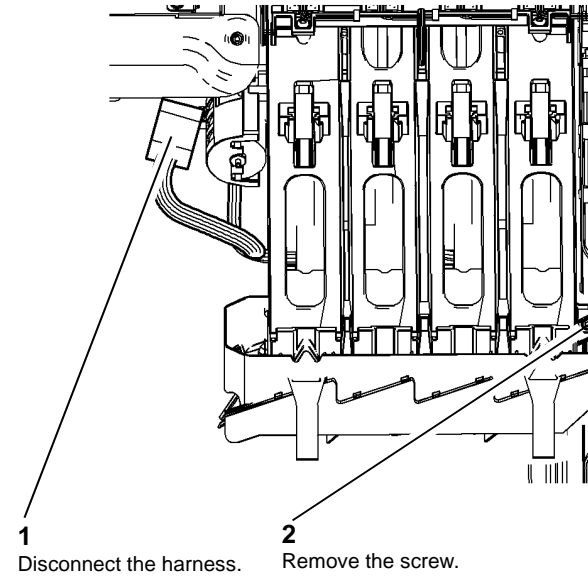

Figure 4 Disconnect the assembly

U-1-0848-A

7. Release the ink loader bracket, [PL 81.10 Item 9, Figure 5](#).

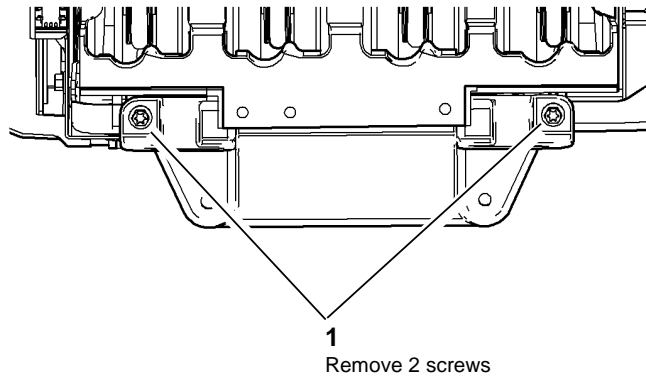

Figure 5 Release the ink load bracket

8. Remove the ink loader upper assembly, [Figure 6](#).

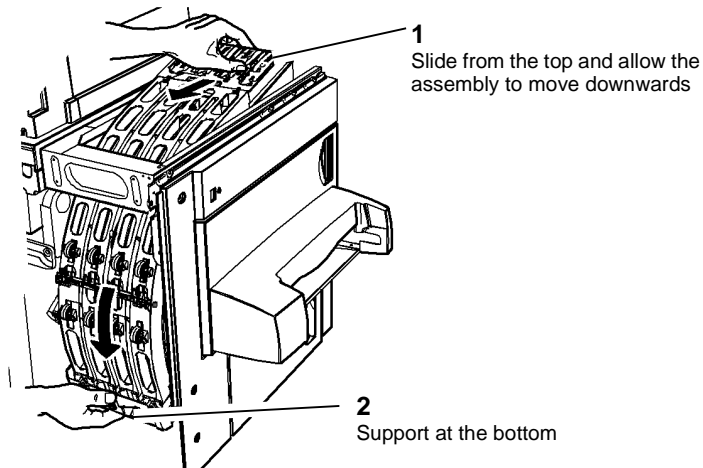
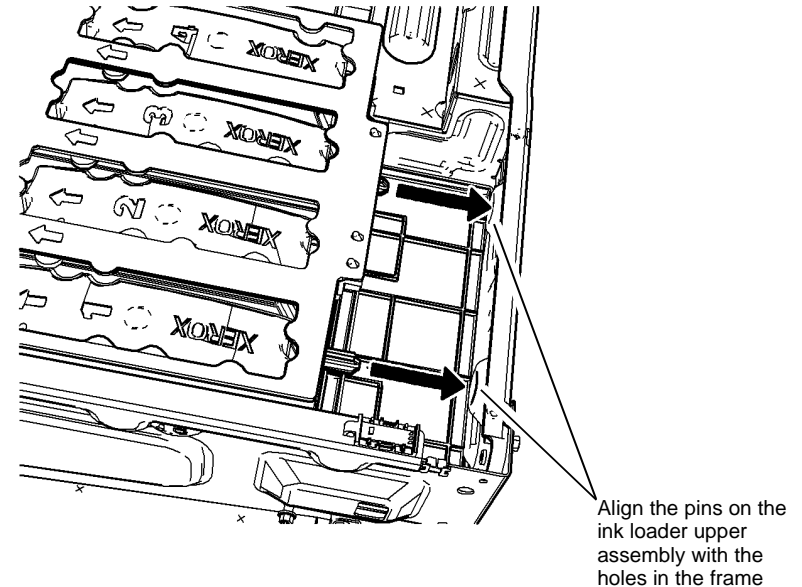

Figure 6 Ink loader upper assembly removal

Replacement

1. Replacement is the reverse of the removal procedure.

2. Ensure that the locating pins on the ink loader upper assembly are fully seated into the holes in the chassis, [Figure 7](#).



U-1-1395-A

U-1-1224-A

Figure 7 Ink loader locating pins

CAUTION

Do not re-use partially melted ink sticks as this may result in cross contamination of the ink melt reservoir.

3. Check the following to reset the ink level:
 - a. If you replace part of the ink loader upper assembly and leave the ink level close to the original (within one ink stick of each color), there is no need to interact with the NVM values. This should be the majority of cases.
 - b. If you replace part of the ink loader upper assembly and are going to power up the machine with a big difference from the original ink level (over one ink stick of a given color), do the following:
 - i. Remove all of the ink sticks from the ink loader upper assembly.
 - ii. Power up the machine, which will reset the NVM values to zero.
 - iii. Reload the ink sticks.

This scenario would also apply for cases where the ink level gauges on the UI are way off (the NVM values have been corrupted). If the NVM values have been corrupted, refer to [OF 9 Ink Stick Count Mismatch](#).

REP 91.16 Ink Loader Melt Plate Assembly

Parts List on [PL 93.10](#)

Removal

WARNING

Switch off the electricity to the machine. Refer to [GP 14](#). Disconnect the power cord from the customer supply while performing tasks that do not need electricity. Electricity can cause death or injury. Moving parts can cause injury.

WARNING

Take care during this procedure. Sharp edges may be present that can cause injury.

WARNING

Do not touch the ink loader melt plates while the machine is switched on. Dangerous voltages may be present that could cause death or injury.

CAUTION

Do not break off the partial used ink block. Do not re-use the partial used ink blocks.

1. Remove the ink loader assembly, [REP 91.15](#).
2. Remove the ink loader melt plate assembly, [Figure 1](#).

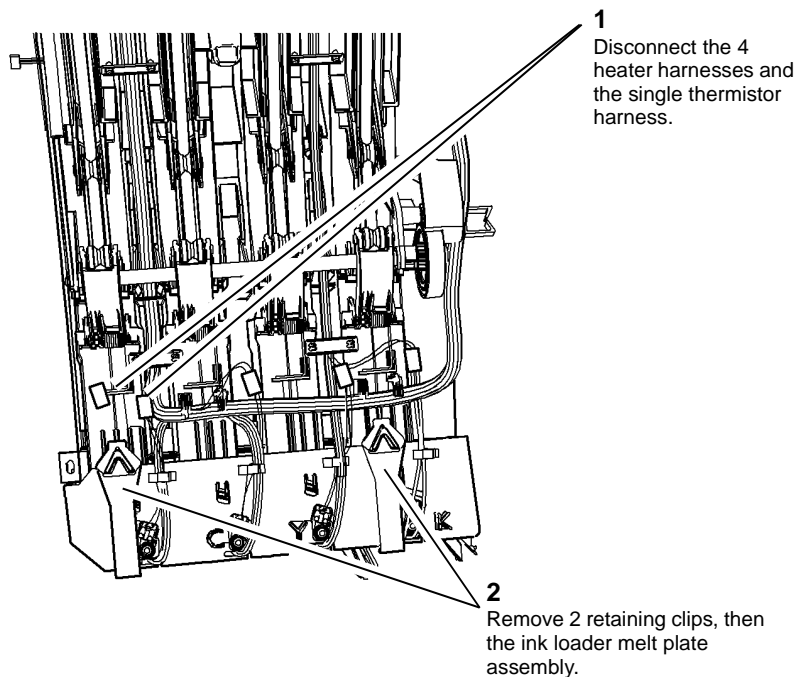

U-1-0849-A

Figure 1 Melt plate assembly removal

Replacement

1. Replacement is the reverse of the removal procedure.
2. The 4 heater harnesses are colour coded to the corresponding letter on the ink melt plate assembly. Ensure the correct harness is connected to the correct colour.
3. When installing the retaining clips, ensure that the slots on the base of the clips are fully seated on the plastic tabs on the new ink melt plate assembly, [Figure 2](#).

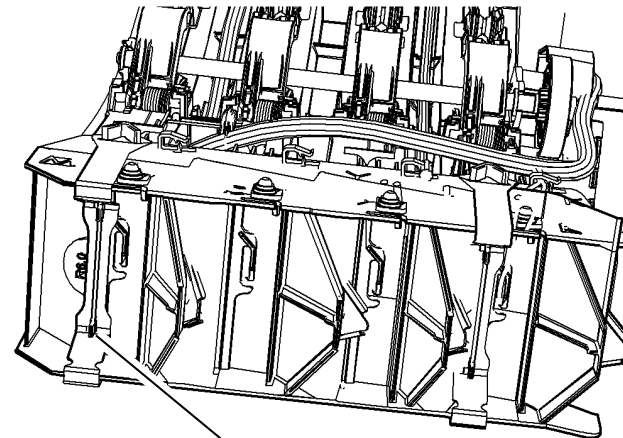

- 1 Ensure the clips are seated over the locating tabs on the ink melt plate assembly.

U-1-1225-A

Figure 2 Clip alignment

4. Refer to the replacement of the ink loader assembly [REP 91.15](#), to reset the ink levels.

REP 91.17 Ink Load Sensor Assembly

Parts List on [PL 93.10](#)

Removal

WARNING

Switch off the electricity to the machine. Refer to [GP 14](#). Disconnect the power cord from the customer supply while performing tasks that do not need electricity. Electricity can cause death or injury. Moving parts can cause injury.

WARNING

Take care during this procedure. Sharp edges may be present that can cause injury.

WARNING

Do not touch the ink loader melt plates while the machine is switched on. Dangerous voltages may be present that could cause death or injury.

CAUTION

Record the location of the ink load entry PWB connectors before disconnecting them.

1. Remove the ink loader assembly, [REP 91.15](#).
2. Remove the ink load sensor assembly, [Figure 1](#).

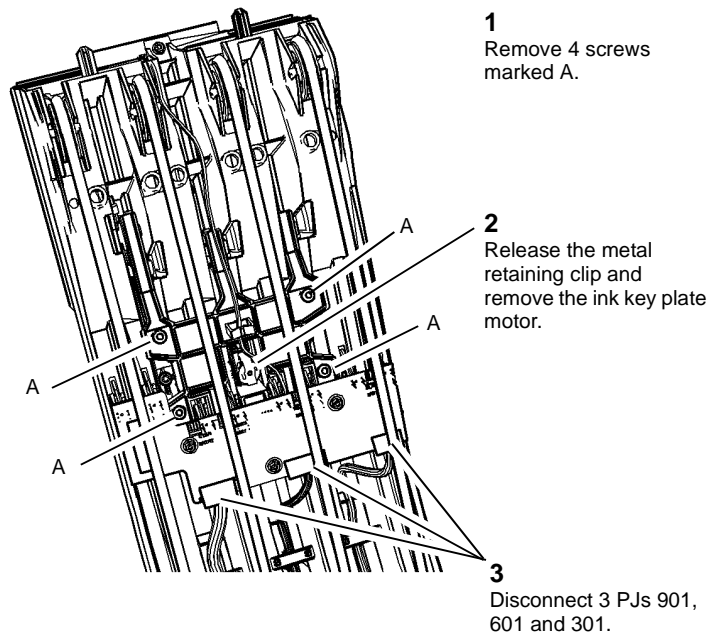

U-1-0850-A

Figure 1 Ink load sensor assembly

Replacement

1. Replacement is the reverse of the removal procedure.
2. Take care not to bump or damage the plastic flags on the assembly while inserting it under the belts.
3. When reinstalling the key plate motor, ensure the locator pin is seated correctly before installing the retaining clip.
4. Ensure that the motor harness is connected to the motor before reinstallation.
5. Refer to the replacement of the ink loader assembly [REP 91.15](#), to reset the ink levels.
6. Verify that the key plate moves by entering one of the following diagnostics codes 93-051, 93-052 or 93-053.

REP 91.18 Ink Transport Motor and Drive Gear

Parts List on [PL 93.10](#)

Removal

WARNING

Switch off the electricity to the machine. Refer to [GP 14](#). Disconnect the power cord from the customer supply while performing tasks that do not need electricity. Electricity can cause death or injury. Moving parts can cause injury.

WARNING

Take care during this procedure. Sharp edges may be present that can cause injury.

WARNING

Do not touch the ink loader melt plates while the machine is switched on. Dangerous voltages may be present that could cause death or injury.

1. Remove the ink loader assembly, [REP 91.15](#).
2. Remove the ink transport motor, cover and gear, [Figure 1](#).

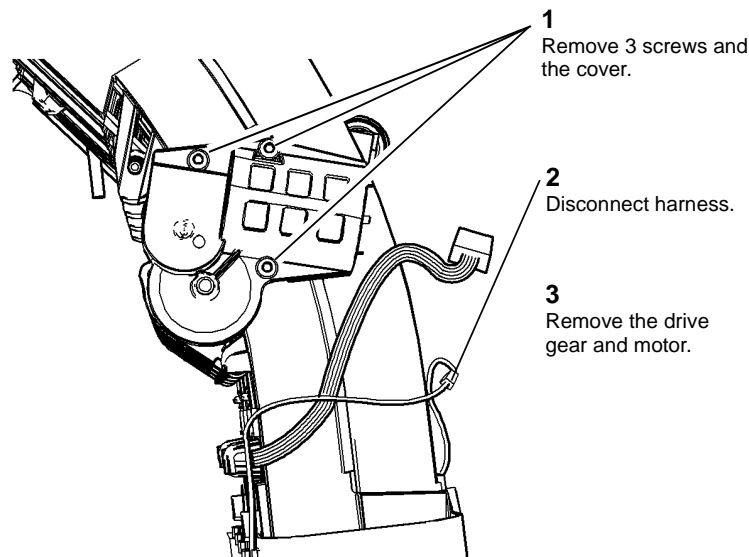

U-1-0851-A

Figure 1 Transport motor removal

NOTE: After removal, inspect the compound gear pin and boss for cracks or damage, [Figure 2](#).

Replacement

1. Replacement is the reverse of the removal procedure.
2. Refer to [Figure 2](#). Use NYE Rheolube grease [PL 26.11 Item 4](#) to grease the following points before reinstalling:
 - a. Worm gear.
 - b. Compound gear boss.
 - c. Drive shaft.
 - d. Ink transport drive cover shaft hole.
 - e. Ink transport drive gear, [PL 93.10 Item 6](#).

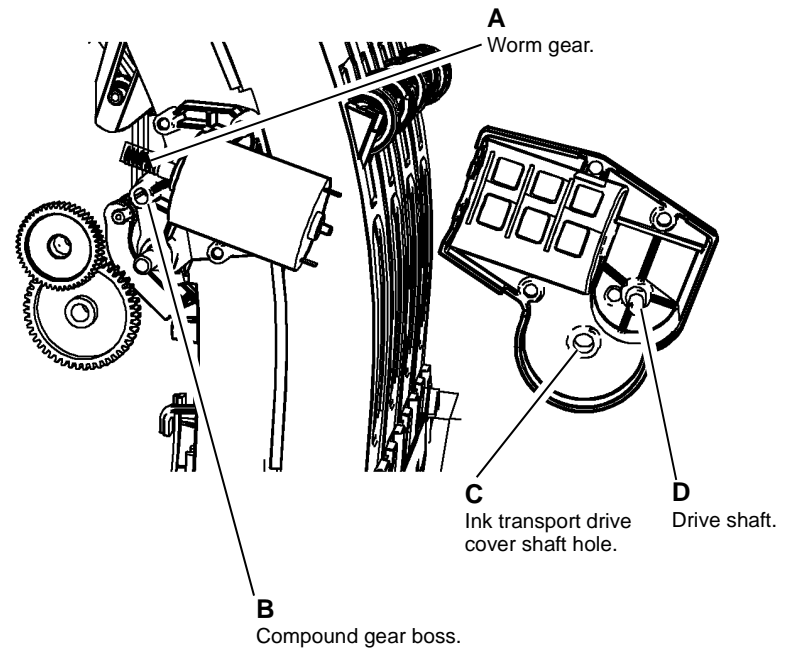

U-1-1226-A

Figure 2 Grease points

REP 91.19 Ink Low Sensor Assembly

Parts List on [PL 93.10](#)

Removal

WARNING

Switch off the electricity to the machine. Refer to [GP 14](#). Disconnect the power cord from the customer supply while performing tasks that do not need electricity. Electricity can cause death or injury. Moving parts can cause injury.

WARNING

Take care during this procedure. Sharp edges may be present that can cause injury.

WARNING

Do not touch the ink loader melt plates while the machine is switched on. Dangerous voltages may be present that could cause death or injury.

1. Remove the ink loader assembly, [REP 91.15](#).
2. Disconnect PJ601 from the ink load entry PWB, [Figure 1](#).

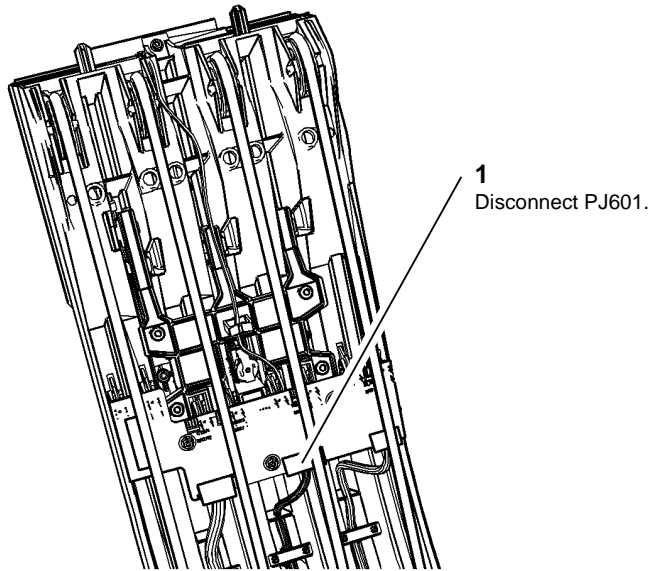
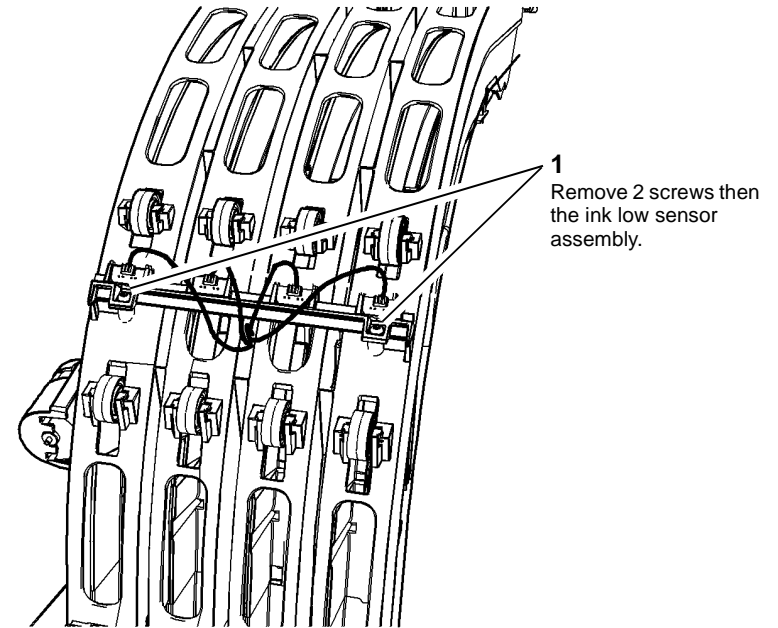

Figure 1 Disconnect harness

U-1-0853-A

3. Remove sensor assembly, [Figure 2](#).



U-1-0852-A

Figure 2 Sensor assembly removal

Replacement

1. Replacement is the reverse of the removal procedure.
2. Refer to the replacement of the ink loader assembly [REP 91.15](#), to reset the ink levels.

REP 91.20 Ink Reservoir Assembly

Parts List on **PL 93.10**

Removal

WARNING

Switch off the electricity to the machine. Refer to **GP 14**. Disconnect the power cord from the customer supply while performing tasks that do not need electricity. Electricity can cause death or injury. Moving parts can cause injury.

WARNING

Take care during this procedure. Sharp edges may be present that can cause injury.

CAUTION

Do not touch the exposed face of the printheads. Surface contamination or minor damage can destroy the printhead.

CAUTION

The drum is exposed when the marking unit is pulled out.

CAUTION

Allow 30 minutes for the umbilicals and reservoir to cool down before starting this repair. It takes 30 minutes for the ink to solidify.

1. Slide out the marking unit to the maintenance position, refer to **GP 6**.
2. Remove the side and umbilical end insulation from the ink reservoir, **Figure 1**.

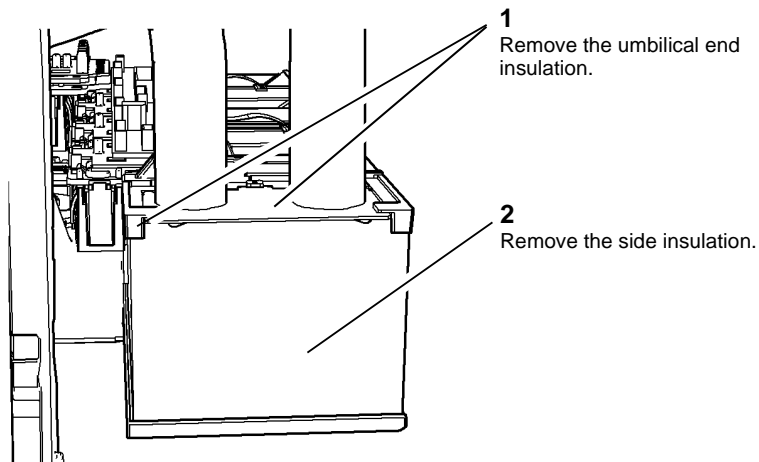

Figure 1 Insulation removal

U-1-0854-A

3. Disconnect the upper and lower umbilicals from the ink reservoir, **Figure 2**.

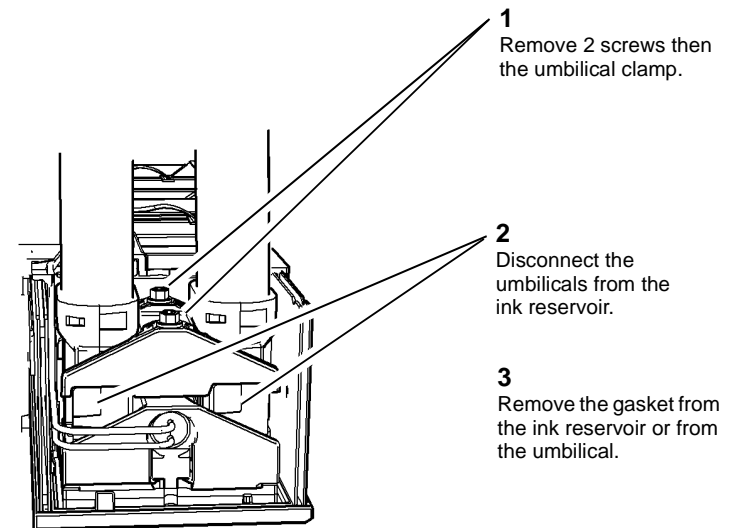

Figure 2 Umbilical removal

U-1-0855-A

4. Remove the marking unit enclosure, [Figure 3](#).

5. Disconnect PJ201 from the marking unit heater PWB and PJ801 from the marking unit driver PWB, [Figure 4](#).

NOTE: A new marking unit heater PWB to solenoid patch PWB harness is supplied with a new ink reservoir.

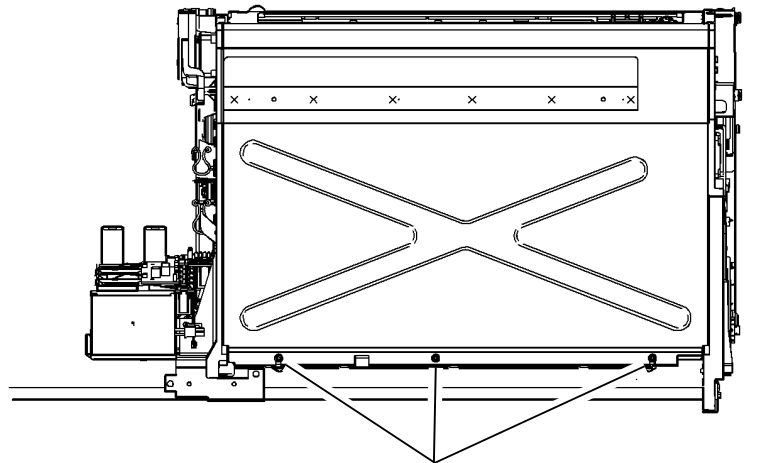

2
Remove the enclosure.

1
Loosen 2 outer screws then remove
the middle screw.

U-1-0856-A

Figure 3 Marking unit enclosure removal

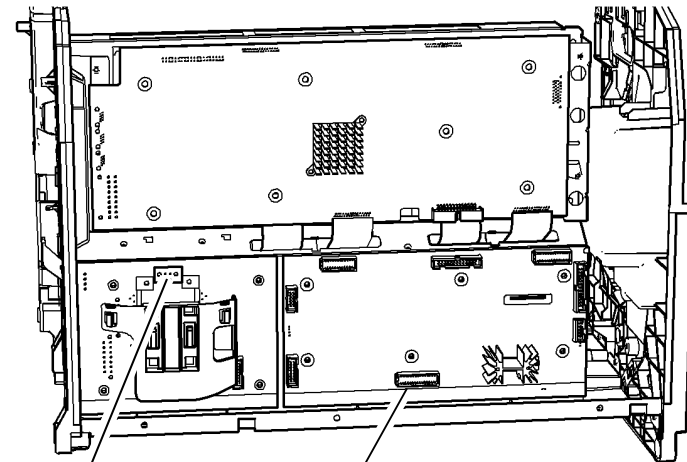

1
Disconnect PJ201.

2
Disconnect PJ801 (see NOTE).

U-1-0857-A

Figure 4 Disconnect harness

- Remove the ink reservoir, [Figure 5](#).

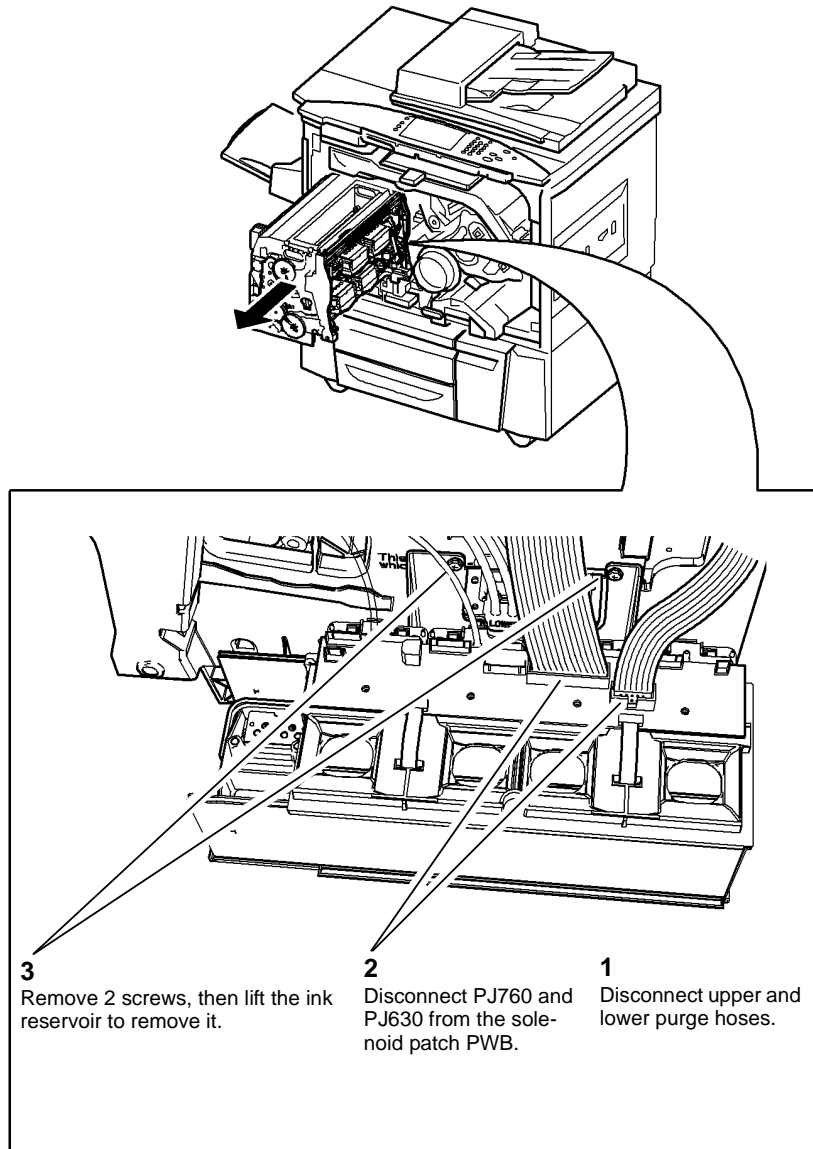

U-1-0858-A

Figure 5 Ink reservoir removal

- Take note of the routing of the harness. Remove the old marking unit driver PWB to solenoid patch PWB harness from the marking unit.

Replacement

- Replacement is the reverse of the removal procedure.
- Ensure the new marking unit heater PWB to solenoid patch PWB harness is correctly routed along the marking unit.
- Ensure that the ink debris is cleared away from the purge hose connections before removing or re-attaching the hoses to the reservoir.
- Ensure that the purge hoses are located correctly and that the rib on the tube points towards the drum, [Figure 6](#).

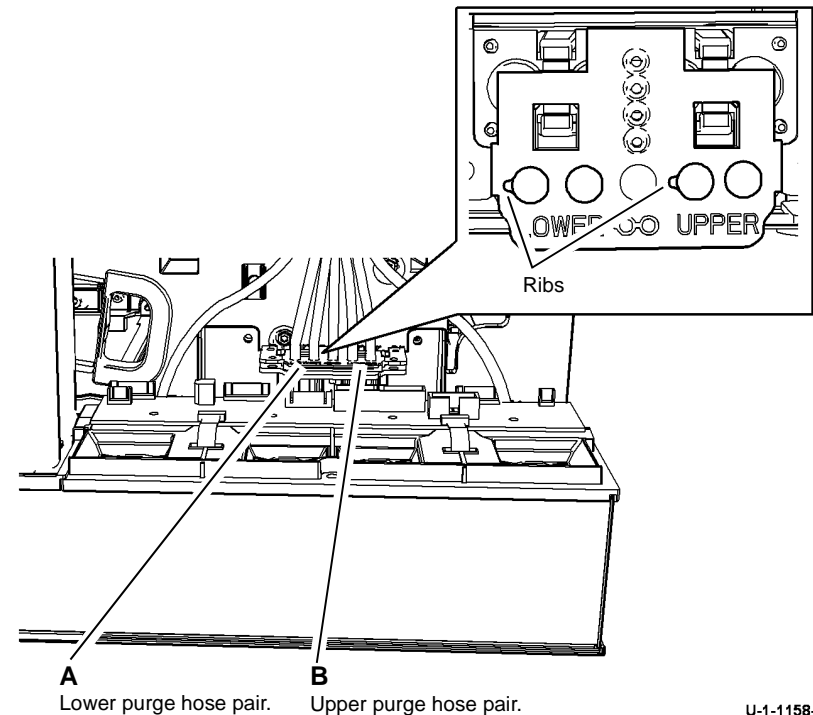

U-1-1158-A

Figure 6 Air tube replacement

- When replacing the umbilical, ensure that there is only one silicone gasket between the ink reservoir and umbilical.

CAUTION

Do not use a metal tool to clean the interface area between the umbilical and ink reservoir. Doing so may cause ink leakage.

- Ensure there is no ink debris between the ink reservoir and the umbilical before connection.

7. Ensure that the umbilicals are seated correctly, [Figure 7](#).

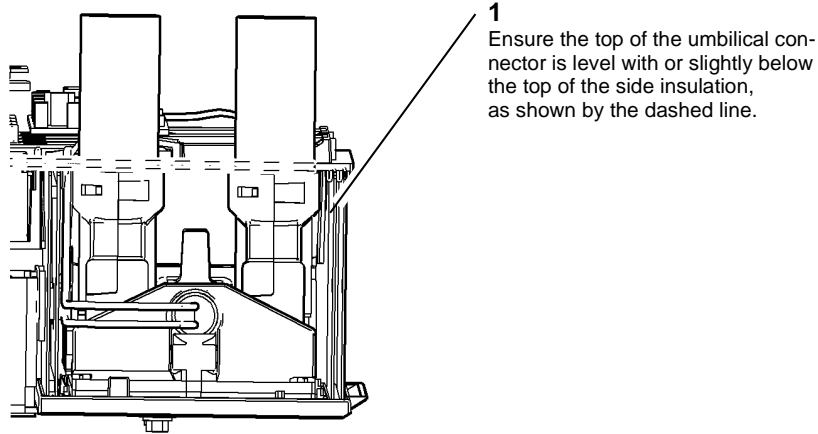

U-1-1159-A

Figure 7 Umbilical seating

8. Firmly tighten the screws on the umbilical clamp, failure to do so can result in ink leaks.

CAUTION

Failure to properly prime the new umbilical will lead to permanent damage to the ink reservoir and the new umbilical.

NOTE: Only perform Step 9 if a new umbilical has been installed at the same time as the ink reservoir. If only the ink reservoir has been replaced then go to Step 10 and do not run **dC976**.

9. Power the machine directly into IME diagnostics mode, refer to [GP 1](#). This will prevent the thermals from warming up and delivering / pumping ink from the reservoir through the umbilicals. When the machine has booted into IME diagnostics mode, log into diagnostics and perform **dC976** Ink Delivery Fault Recovery, to prime the umbilicals.
10. Run the relevant diagnostic routines, refer to [GP 37](#) Post Part Replacement Routines.

REP 91.21 Reservoir Pump

Parts List on [PL 93.10](#)

Removal

WARNING

Switch off the electricity to the machine. Refer to [GP 14](#). Disconnect the power cord from the customer supply while performing tasks that do not need electricity. Electricity can cause death or injury. Moving parts can cause injury.

WARNING

Take care during this procedure. Sharp edges may be present that can cause injury.

CAUTION

Do not touch the exposed face of the printheads. Surface contamination or minor damage can destroy the printhead.

1. Open the front door.
2. Remove the inner cover, [PL 81.11 Item 2](#).
3. Slide out the marking unit to the maintenance position, Refer to [GP 6](#).
4. Disconnect PJ130 and the air tube from the ink reservoir assembly, [Figure 1](#).

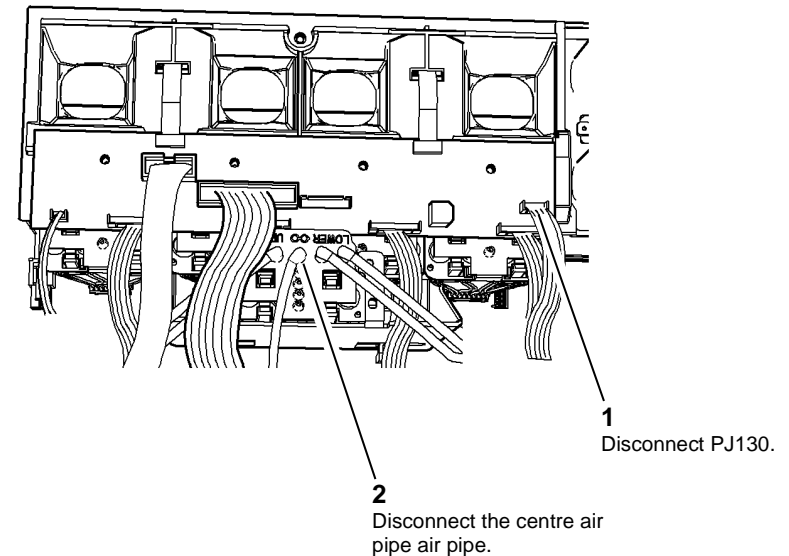

U-1-0859-A

Figure 1 Disconnect harness and air tube.

- Remove the reservoir pump, [Figure 2](#).

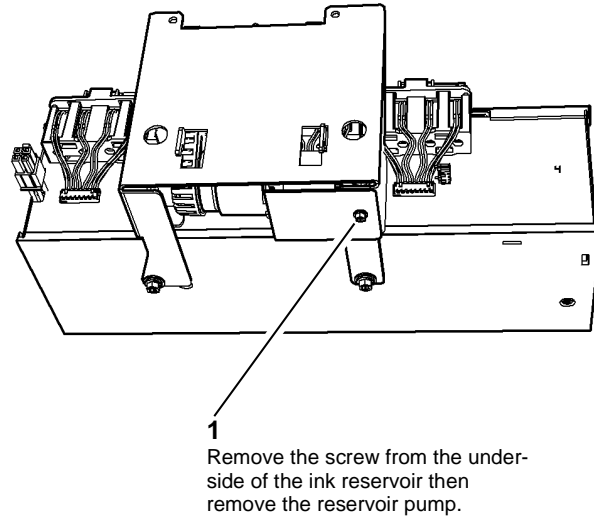

Figure 2 Reservoir pump removal

Replacement

- Replacement is the reverse of the removal procedure.
- Perform [dC976 Ink Delivery Recovery](#).

REP 91.22 IOD Assembly

Parts List on [PL 94.15](#)

Removal

WARNING

Switch off the electricity to the machine. Refer to [GP 14](#). Disconnect the power cord from the customer supply while performing tasks that do not need electricity. Electricity can cause death or injury. Moving parts can cause injury.

WARNING

Take care during this procedure. Sharp edges may be present that can cause injury.

CAUTION

Use care when working near the drum. The drum can be damaged easily, which will cause print quality defects.

- Open the front door.
- Remove the inner cover, [PL 81.11 Item 2](#).
- Remove the cleaning unit, refer to [REP 94.1](#).
- Remove abatement plenum, [Figure 1](#).

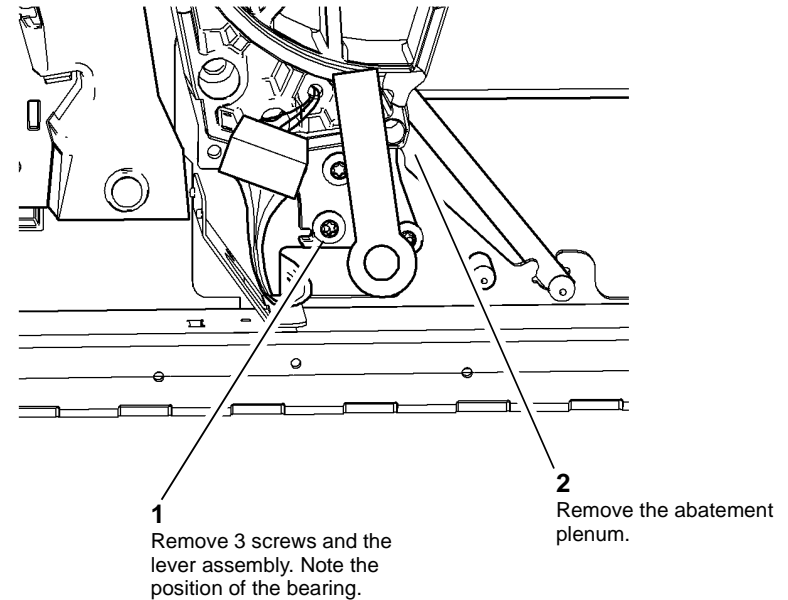

Figure 1 Abatement plenum removal

U-1-0860-A

U-1-0861-A

5. Protect the underside of the drum with media to prevent damage.
6. Remove the IOD assembly, [Figure 2](#).

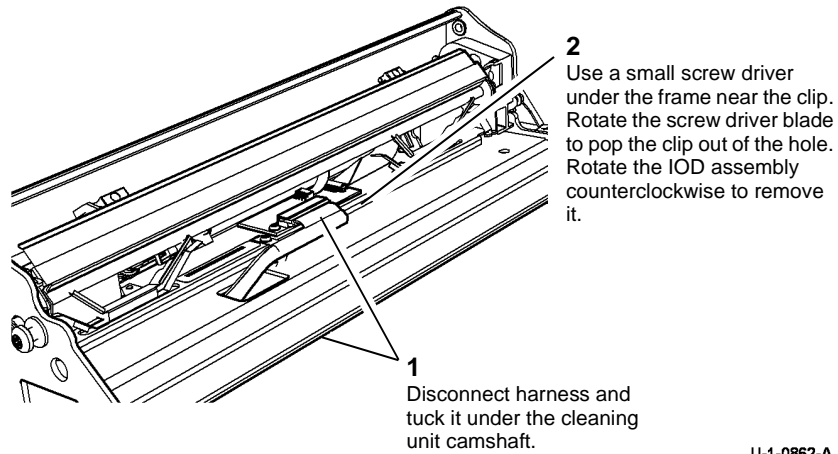

Figure 2 IOD assembly removal

U-1-0862-A

Replacement

CAUTION

Do not disconnect and reconnect the flex cables at the IOD PWB. The flex cables are easily damaged. The cable must only be handled in the area of the blue backer.

1. Replacement is the reverse of the removal procedure.
2. Position the front of the IOD even with the back of the IOD, lying over the cable harness. Slide the assembly into place, allowing the IOD to rotate up and into position, [Figure 3](#).

NOTE: *If the assembly begins to bind/wedge during installation, stop and pull the assembly back. Then restart the installation.*

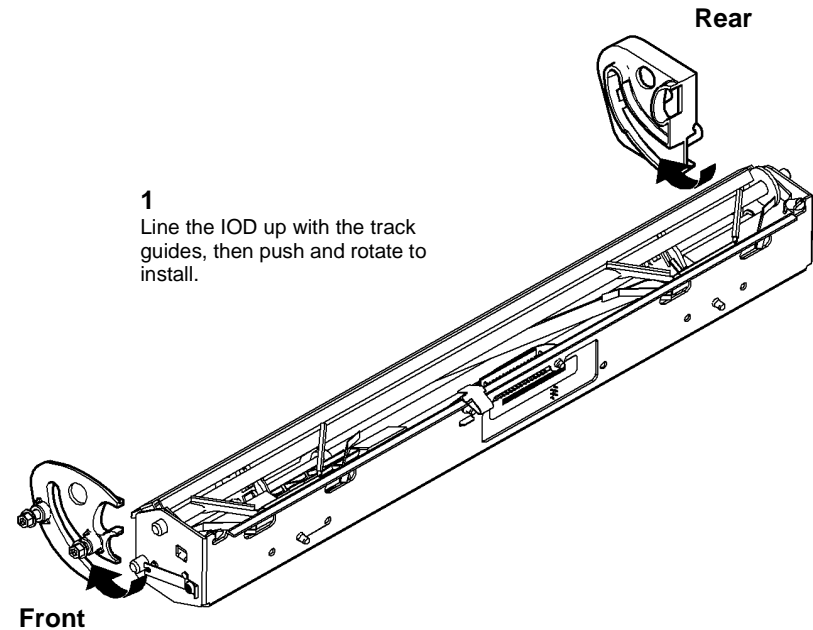

Figure 3 IOD replacement

U-1-1160-A

3. Press the retainer clip to seat it into its hole in the IME chassis.
4. Connect the harness. Ensure the connector is fully seated.

- When refitting the plenum. Ensure that the location lug on the plenum aligns with the pin on the rear frame, [Figure 4](#).

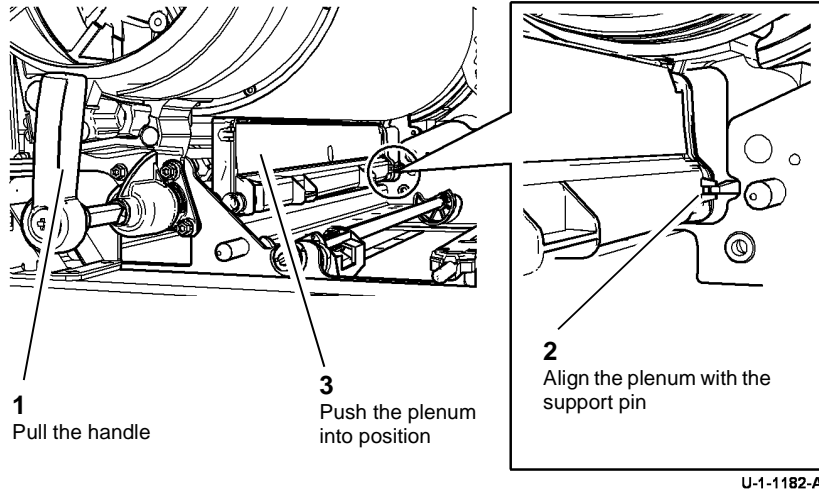

Figure 4 Install the plenum

- Run the relevant diagnostic routines, refer to [GP 37](#) Post Part Replacement Routines.

REP 91.23 Front and Rear Track Guide

Parts List on [PL 94.15](#)

Removal

WARNING

Switch off the electricity to the machine. Refer to [GP 14](#). Disconnect the power cord from the customer supply while performing tasks that do not need electricity. Electricity can cause death or injury. Moving parts can cause injury.

WARNING

Take care during this procedure. Sharp edges may be present that can cause injury.

- Remove the IOD assembly, [REP 91.22](#).
- Remove the front track guide, [Figure 1](#).

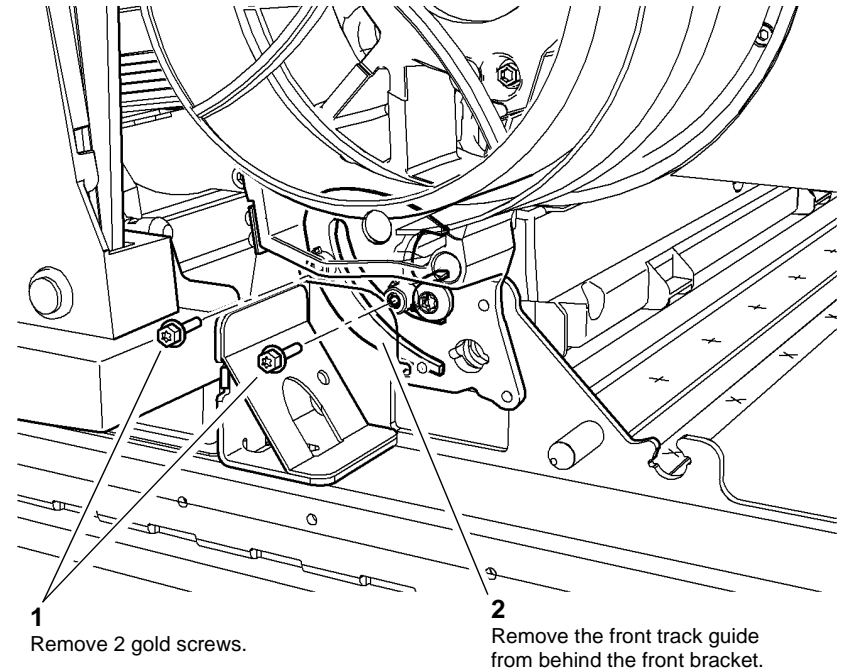
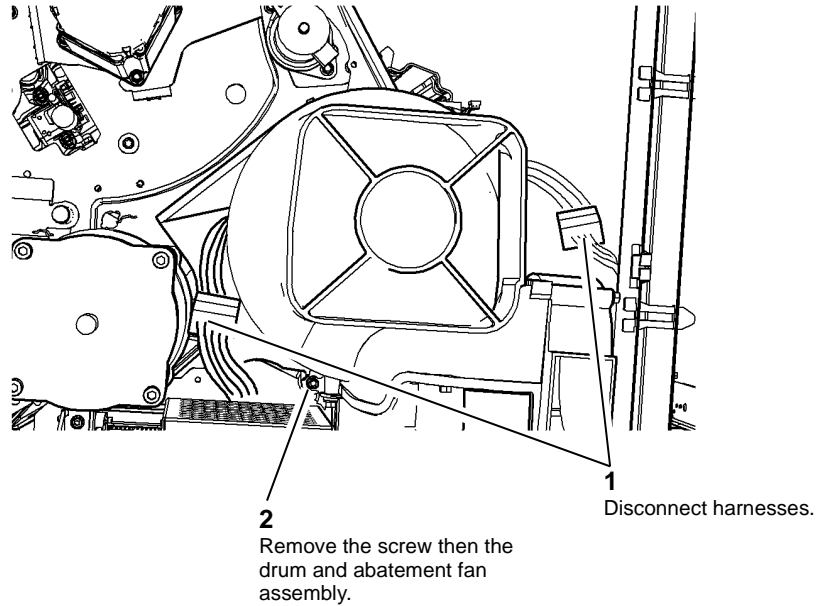

Figure 1 Front track guide removal

3. Remove the drum and abatement fan assembly from the rear of the machine, [Figure 2](#).

4. Remove the rear track guide, [Figure 3](#).



U-1-0864-A

Figure 2 Drum and abatement fan removal

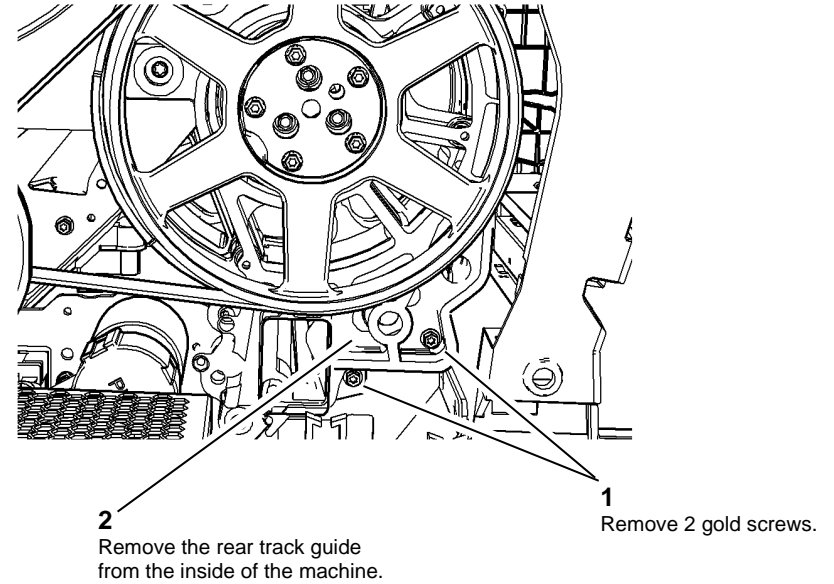

U-1-0865-A

Figure 3 Rear track guide removal

Replacement

CAUTION

Do not over tighten the screws as the track guide will crack.

1. Replacement is the reverse of the removal procedure.
2. Run the relevant diagnostic routines, refer to [GP 37](#) Post Part Replacement Routines.

REP 91.24 Drum Drive Motor and Belt

Parts List on [PL 94.20](#)

Removal

WARNING

Switch off the electricity to the machine. Refer to [GP 14](#). Disconnect the power cord from the customer supply while performing tasks that do not need electricity. Electricity can cause death or injury. Moving parts can cause injury.

WARNING

Take care during this procedure. Sharp edges may be present that can cause injury.

1. Remove the rear cover, [PL 81.10 Item 1](#).
2. Remove the drum and abatement fan assembly from the rear of the machine, [Figure 1](#).

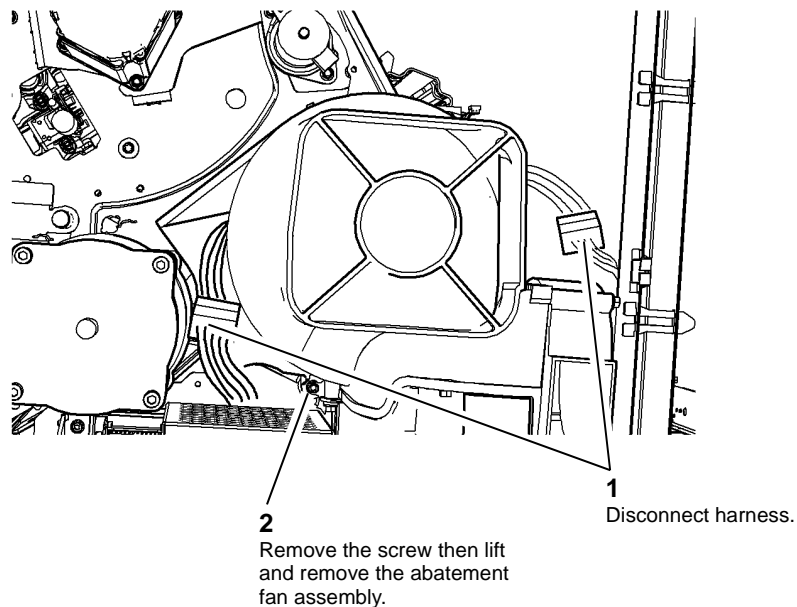

Figure 1 Drum and abatement fan removal

U-1-0869-A

CAUTION

Take care when releasing or tensioning the drive belt not to trap or damage the adjacent wiring harness.

CAUTION

Ensure that the inside surface of the drive belt does not become contaminated with oil, ink or paper debris during removal or installation. Clean the drive belt as necessary, refer to [GP 27](#).

3. Remove the drum drive belt, [Figure 2](#).

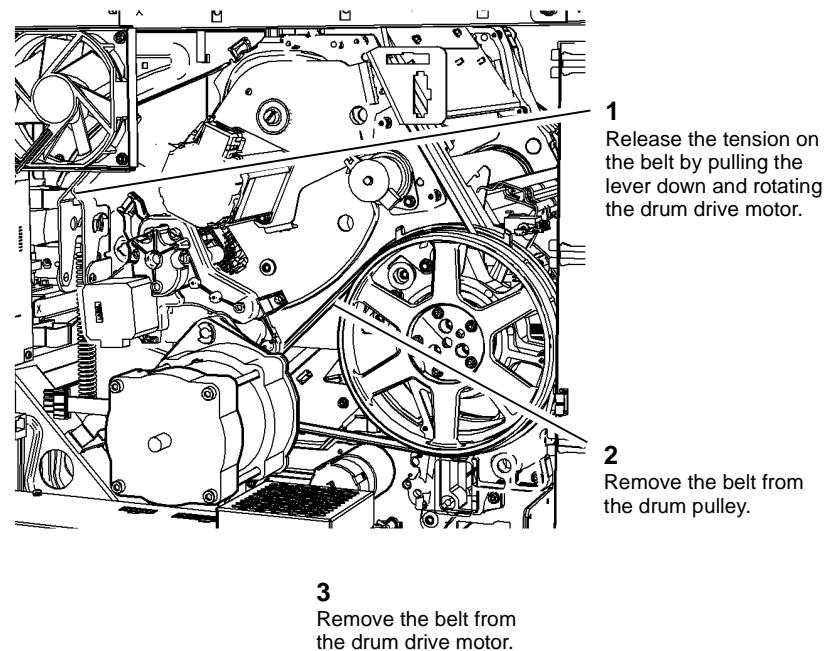

Figure 2 Drum drive belt removal

U-1-0870-A

- Remove the drum drive motor, [Figure 3](#).

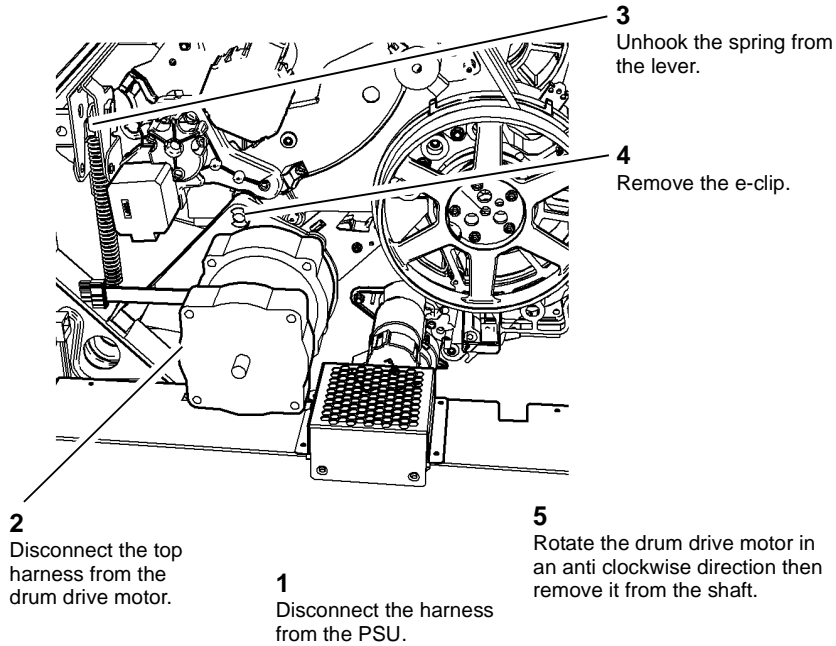

Figure 3 Drum drive motor removal

U-1-0871-A

Replacement

- Replacement is the reverse of the removal procedure.
- Before installing the drum drive belt, clean the drum pulley, [PL 94.20 Item 3](#). Refer to [GP 27](#).

- When installing the motor, first rotate it counter clockwise before pushing onto the shaft. Refer to [Figure 4](#).

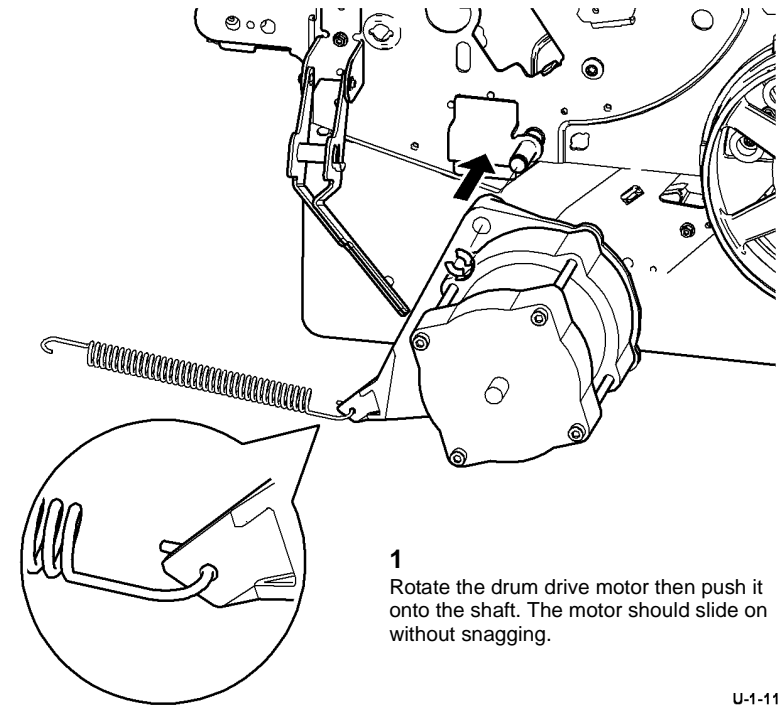

Figure 4 Motor installation

U-1-1161-A

CAUTION

Ensure that the inside surface of the drive belt does not become contaminated with oil, ink or paper debris during removal or installation. Clean the drive belt as necessary, refer to [GP 27](#).

- Ensure the ribbed side of the belt faces inward when replacing it.
- Check when tensioning the drive belt not to trap or damage the adjacent wiring harness.
- Run the relevant diagnostic routines, refer to [GP 37 Post Part Replacement Routines](#).

REP 91.25 Drum and Front Drum Frame Assembly

Parts List on [PL 94.20](#)

Removal

WARNING

Switch off the electricity to the machine. Refer to [GP 14](#). Disconnect the power cord from the customer supply while performing tasks that do not need electricity. Electricity can cause death or injury. Moving parts can cause injury.

WARNING

Take care during this procedure. Sharp edges may be present that can cause injury.

CAUTION

Do not touch the exposed face of the printheads. Surface contamination or minor damage can destroy the printhead.

1. Remove the inner cover, [PL 81.11 Item 2](#).
2. Remove the rear cover, [PL 81.10 Item 1](#).
3. Remove the horizontal paper path assembly, [REP 83.1](#).
4. Remove the exit paper path assembly, [REP 10.20](#).
5. Remove the registration / preheat assembly, [REP 89.1](#).

NOTE: Removing the marking unit is optional. If space to store the marking unit is limited then the unit can be left in the machine. But the removal does allow more space to remove the drum unit.

6. Remove the marking unit, [REP 91.28](#).
7. Remove the transfix roll, [REP 10.1](#).
8. Remove the IOD front track guide, [REP 91.23](#).
9. Remove the front drum fan shroud, [PL 94.20 Item 7](#).
10. Remove the front drum thermistor, [REP 91.35](#).
11. Remove the drum position encoder, [REP 91.30](#).
12. Remove the stripper blade and store in a safe place. Refer to [REP 10.21](#).
13. Cover the drum with the drum protector, [PL 94.20 Item 13](#).
14. Remove the drum pulley, [REP 91.34](#).
15. Remove the rear drum thermistor, [REP 91.35](#).
16. Unplug the front transfix motor harnesses, [REP 10.4](#).

17. Install the removal drum alignment tool on the rear of the drum prior to removal, [Figure 1](#).

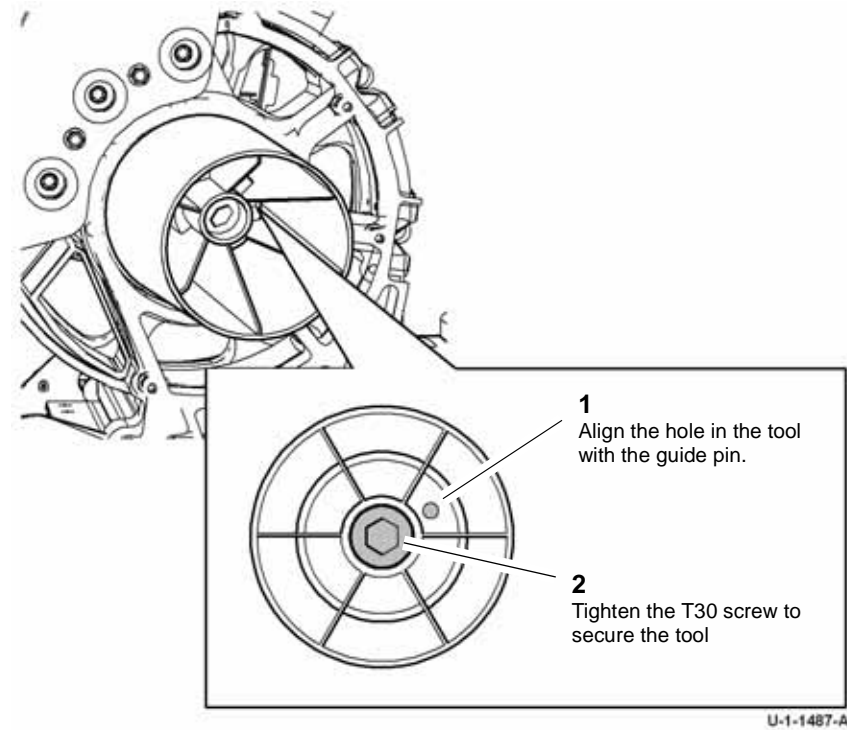
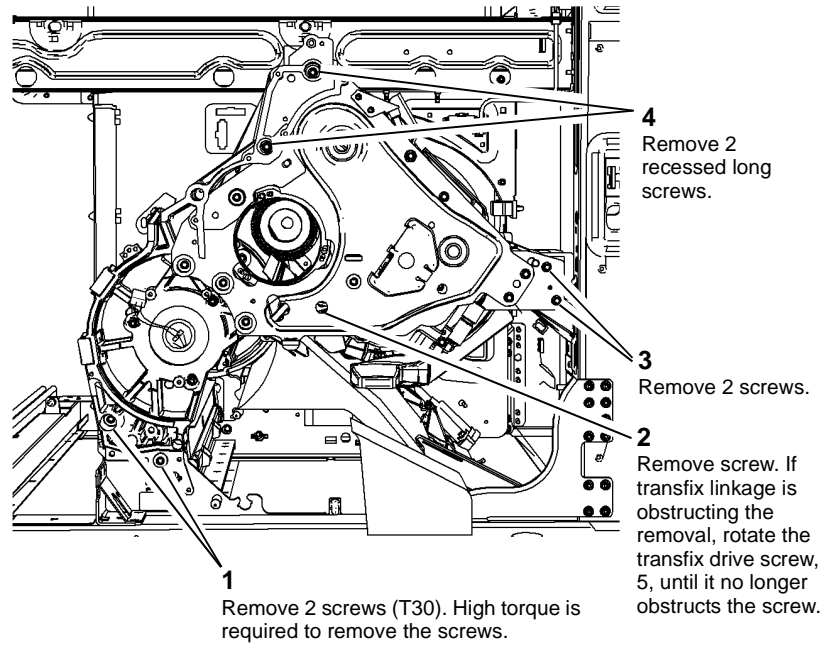

Figure 1 Drum alignment tool

U-1-1487-A

18. Prepare to remove drum and front drum frame assembly, [Figure 2](#).



U-1-0878-A

Figure 2 Preparation

CAUTION

If the marking unit has not been removed. Take care not to contact the printheads with the drum during removal.

19. Remove drum and front drum frame assembly, [Figure 3](#).

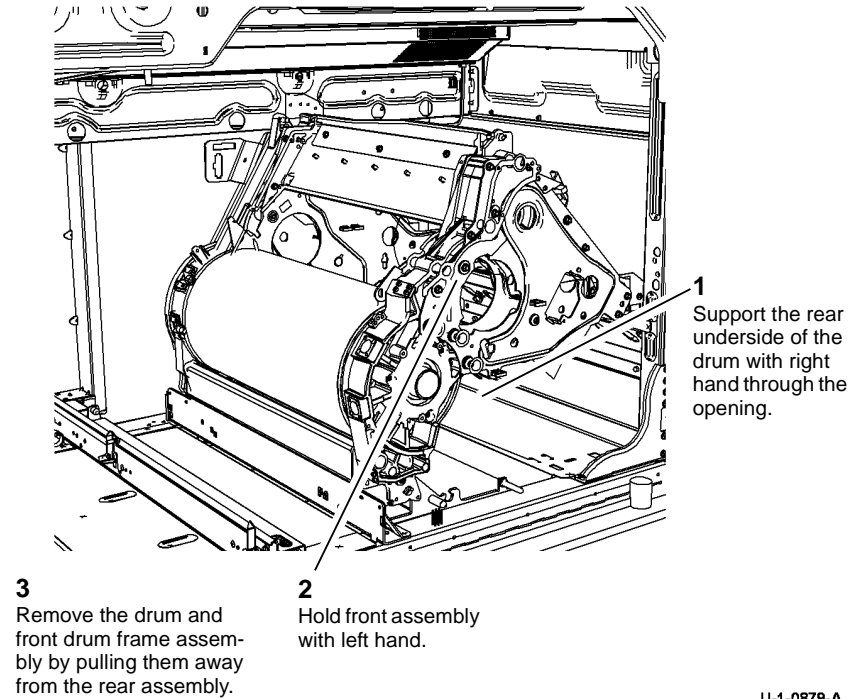

U-1-0879-A

Figure 3 Removal

20. Release the drum from the front drum frame assembly, [Figure 4](#).

NOTE: Use the top section of the replacement drum packaging to support the old drum. This will help to keep the drum stable during the separation.

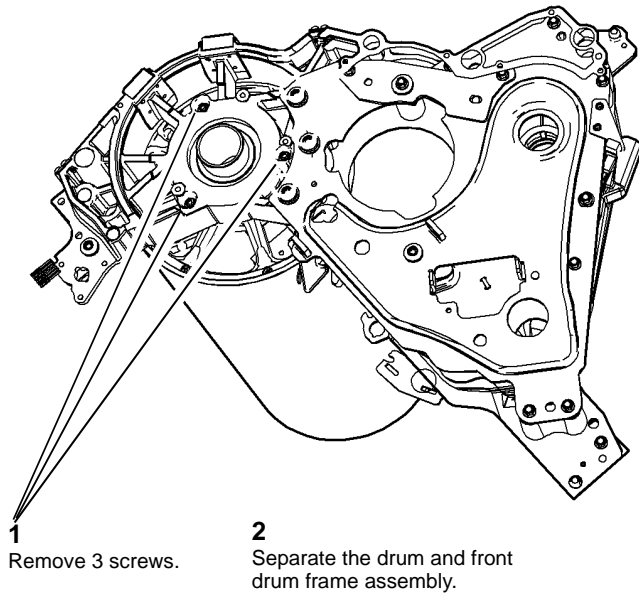

Figure 4 Release the drum

U-1-0880-A

Replacement

Replacement is the reverse of the removal procedure. Observe the following points at the appropriate steps.

NOTE: High pressure bearing grease, [PL 26.11 Item 3](#), is used in the following locations.

- Drum bearing housing in the front drum frame casting.
- Drum pulley bearing housing in the rear drum frame casting.
- Outside diameter of the transfix roller bearing holder at the front of the transfix roller.

During normal removal and replacement the existing bearing grease used during manufacture will be sufficient. Only apply grease when both sides of any bearing surface are being replaced, or if the surfaces have been wiped clean. Apply the grease very sparingly.

1. A replacement drum will have a drum protector and drum alignment tool supplied with the drum. Install these items onto the drum before installing the drum.
2. Attach the drum to the front drum frame assembly.

NOTE: When installing new drum assembly, the three screw holes referenced in [Figure 4](#) are not pre-tapped. There will be resistance when the screws cut new threads. Ensure the screws are fully seated.

CAUTION

If the marking unit has not been removed. Take care not to contact the printheads with the drum during the replacement.

Take care not to contact the drum or pinch the encoder wiring when installing the front frame assembly.

3. Place the drum and front frame assembly in the machine.
4. Reinstall the screws in the front assembly, [Figure 5](#). Before tightening all the screws, ensure the pin and bearing are seated correctly, [Figure 6](#). Open and close the stripper gate, [GP 31](#) checking that the stripper latch mechanism moves freely, [Figure 6](#). If not then loosen the screws and correct the location of the latching arm before tightening the screws.

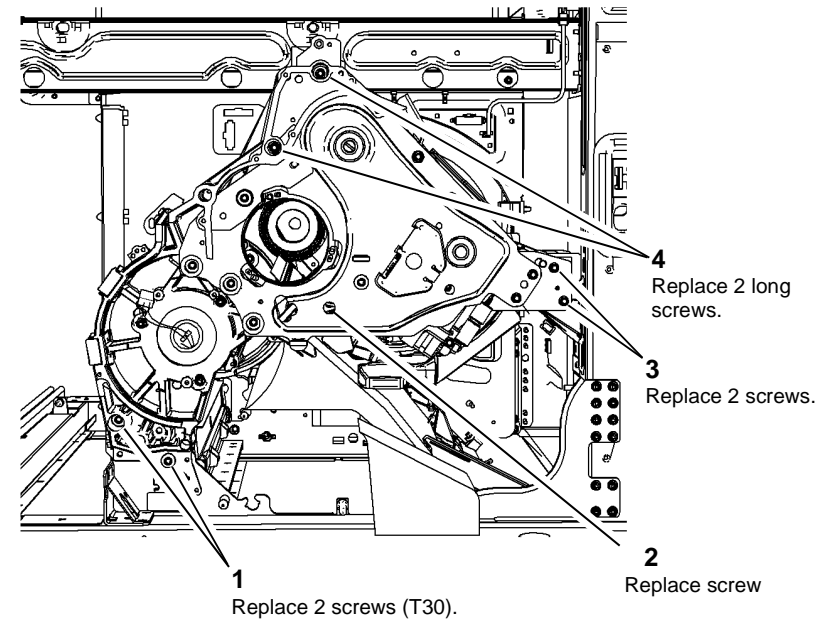
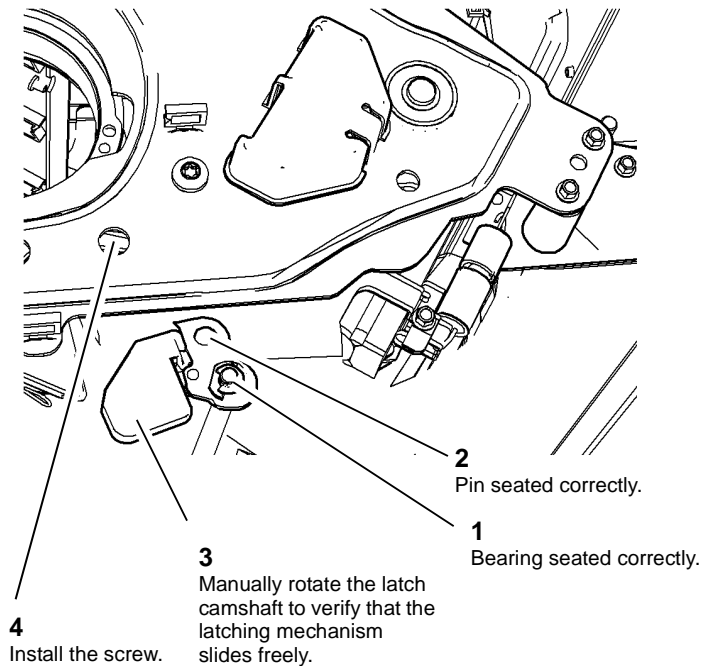

Figure 5 Screw Replacement

U-1-1643-A



U-1-0881-A

Figure 6 Correct seating

5. Remove the drum pulley replacement tool.

CAUTION

Take care to reinstall the static eliminator correctly. Refer to REP 91.34. If the static eliminator is not installed correctly ESD events will result that can cause a build-up of cleaning unit gel that permanently damages the printheads.

6. Replace the drum pulley, REP 91.34.
7. Reinstall the drum drive motor and belt, REP 91.24. Ensure the inner belt surface and outer pulley surface are thoroughly cleaned before replacement.
8. Reinstall the rear drum thermistor, REP 91.35.
9. Reinstall the stripper blade. Check that the blade cover is sitting in the guide at the rear of the machine, REP 10.21.
10. Reinstall the drum encoder, REP 91.30.
11. Reinstall the front drum thermistor, REP 91.35.
12. Reinstall the front shroud, PL 94.20 Item 7.
13. Reinstall the front IOD track guide, REP 91.23.
14. Reinstall the IOD assembly, cleaning unit latch handle and abatement plenum, REP 91.22. Check that the harness is connected.
15. Remove the protective drum cover, PL 94.20 Item 13.

16. Connect the harnesses on the front transfix motor, REP 10.4.
17. Reinstall the transfix roll, REP 10.1.
18. Reinstall the transfix blade, REP 10.6.
19. Reinstall the marking unit if removed, REP 91.28.
20. Reinstall the registration transport, REP 89.1.
21. Reinstall the exit transport, REP 10.20.
22. Reinstall the horizontal paper path transport, REP 83.1.
23. Run the relevant diagnostic routines, refer to GP 37 Post Part Replacement Routines.
24. If a new drum was installed. Enter dC131 NVM Read/Write location 492-70 Prints On This Drum and reset the value to zero.

REP 91.26 Marking Unit Slide Assembly

Parts List on [PL 91.05](#)

Removal

WARNING

Switch off the electricity to the machine. Refer to [GP 14](#). Disconnect the power cord from the customer supply while performing tasks that do not need electricity. Electricity can cause death or injury. Moving parts can cause injury.

WARNING

Take care during this procedure. Sharp edges may be present that can cause injury.

CAUTION

Do not touch the exposed face of the printheads. Surface contamination or minor damage can destroy the printhead.

1. Open the front door.
2. Remove the inner cover, [PL 81.11 Item 2](#).
3. Remove marking unit assembly, [REP 91.28](#).
4. Remove marking unit fan, [PL 1.15 Item 23](#).
5. Prepare to remove drawer slide assembly, [Figure 1](#).

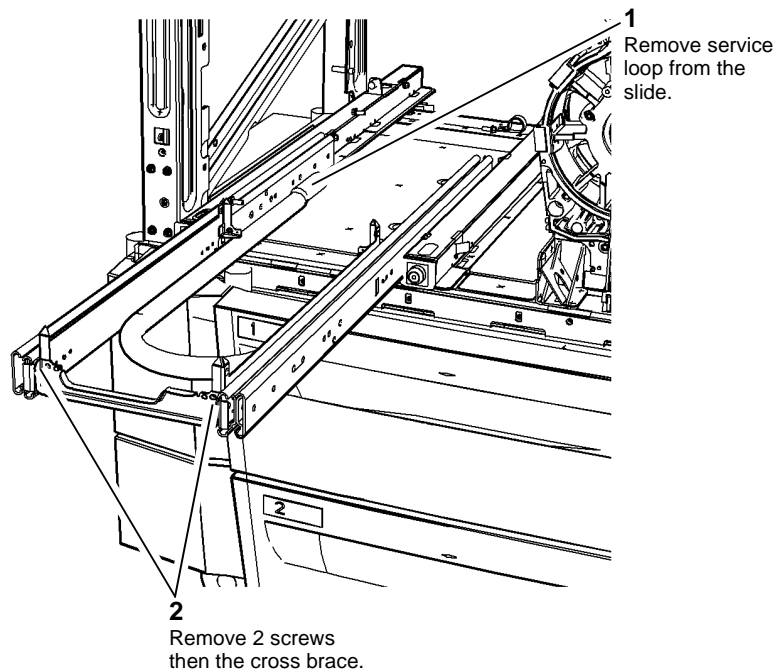

Figure 1 Preparation

U-1-0892-A

6. Remove slide drawer assembly, [Figure 2](#).

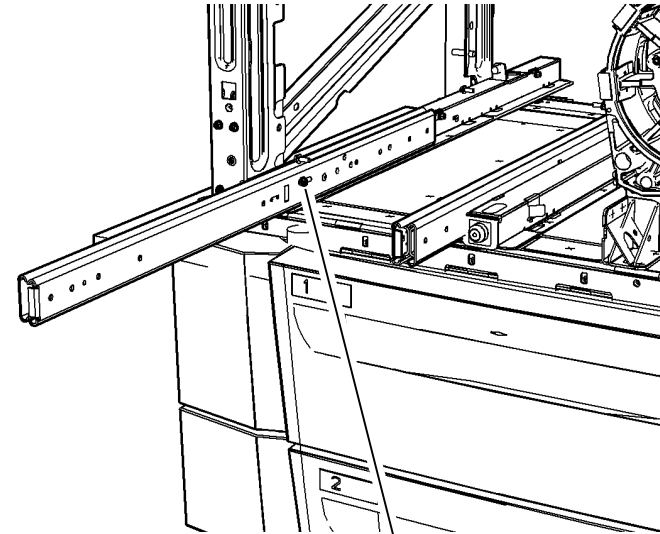

Figure 2 drawer slide removal

U-1-0893-A

Replacement

1. Replacement is the reverse of the removal procedure.
2. Take care not to insert any twists into the cable, refer to [Figure 1](#) for correct cable route.

REP 91.27 Cleaning Unit Motor Assembly and Home Sensor

Parts List on [PL 94.10](#)

Removal

WARNING

Switch off the electricity to the machine. Refer to [GP 14](#). Disconnect the power cord from the customer supply while performing tasks that do not need electricity. Electricity can cause death or injury. Moving parts can cause injury.

WARNING

Take care during this procedure. Sharp edges may be present that can cause injury.

1. Remove the rear covers, [PL 81.10 Item 1](#).
2. Remove the rear drum fan shroud, [PL 94.20 Item 5](#).
3. Lower the power supply. Removing the 4 screws that restrain the power supply. Lift the power supply so the supporting hooks are no longer seated then lower the power supply onto the machine base. It is not necessary to disconnect the power supply wiring for this procedure.
4. Remove the cleaning unit motor assembly, [Figure 1](#).

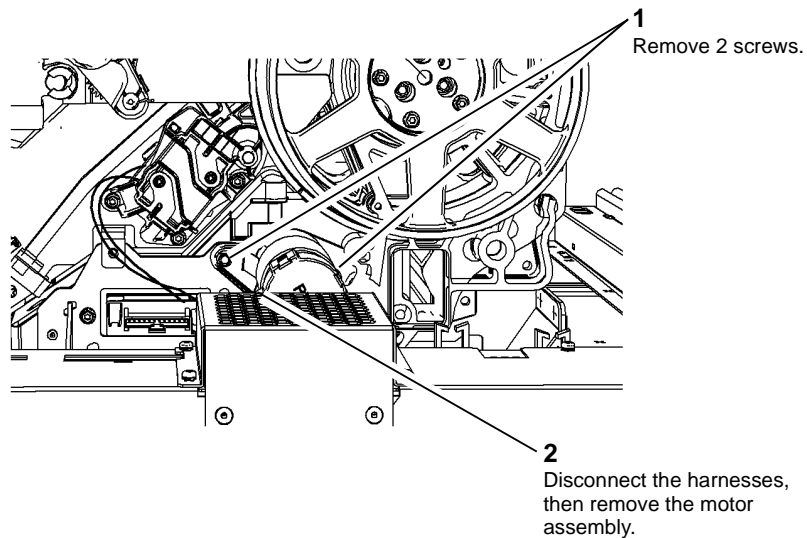

U-1-0896-A

Figure 1 Motor assembly removal

5. If necessary, remove the cleaning unit home sensor, [PL 94.10 Item 17](#) from the motor assembly.

Replacement

1. Replacement is the reverse of the removal procedure.
2. After reinstalling the power supply, ensure there are no wires trapped between the rear of the power supply and the machine frame.

REP 91.28 Marking Unit Assembly

Parts List on [PL 91.05](#)

Removal

WARNING

Switch off the electricity to the machine. Refer to [GP 14](#). Disconnect the power cord from the customer supply while performing tasks that do not need electricity. Electricity can cause death or injury. Moving parts can cause injury.

WARNING

Take care during this procedure. Sharp edges may be present that can cause injury.

CAUTION

Do not touch the exposed face of the printheads. Surface contamination or minor damage can destroy the printhead.

NOTE: If the frame has been damaged then the enclosure assembly is available as a spare, [PL 91.10 Item 12](#). The marking unit components can be transferred to a new marking unit enclosure by following the appropriate repairs.

1. Open front door.
2. Remove the inner cover, [PL 81.11 Item 2](#).
3. Slide out the marking unit to the maintenance position, Refer to [GP 6](#).

4. Disconnect the harnesses and ground lead to the rear of the marking unit, [Figure 1](#).

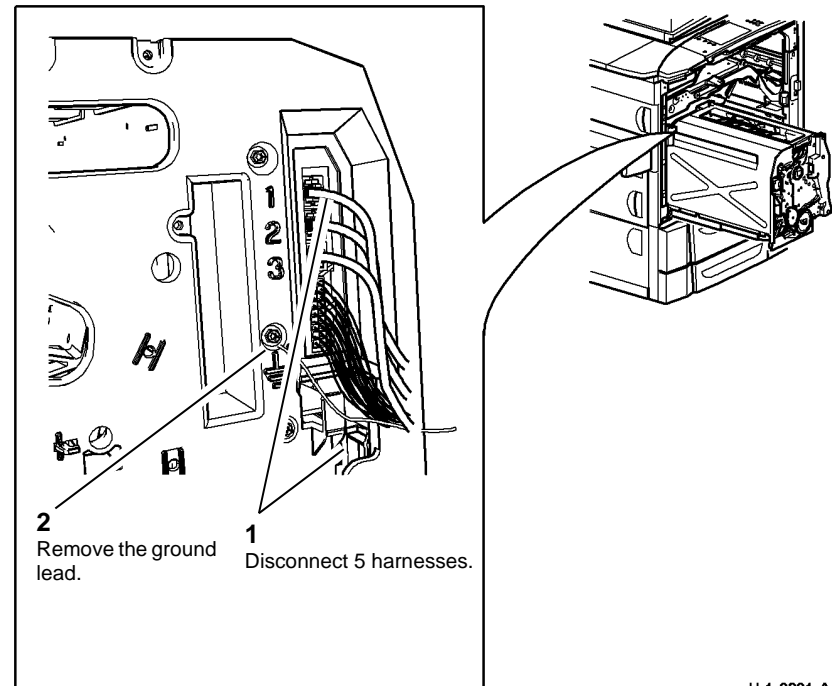

U-1-0901-A

Figure 1 Disconnect harnesses

5. Remove the right marking unit securing screws, [Figure 2](#).

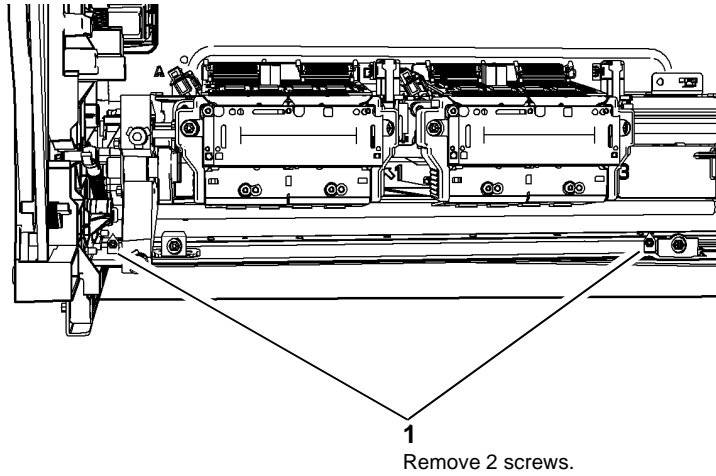

U-1-0902-A

Figure 2 Remove screws

6. Remove the left marking unit securing screws, [Figure 3](#).

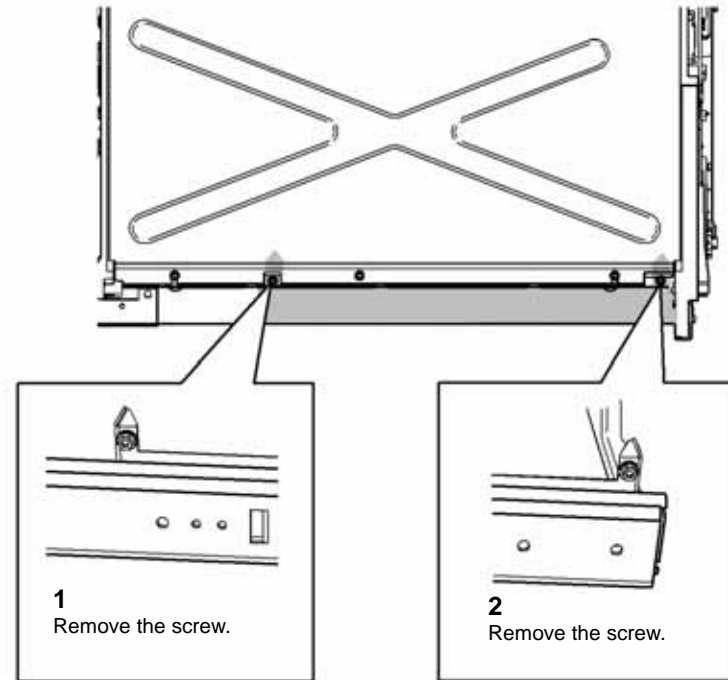

U-1-0903-A

Figure 3 Remove screws

CAUTION

Do not touch the printhead faces.

7. Remove the marking unit, [Figure 4](#).

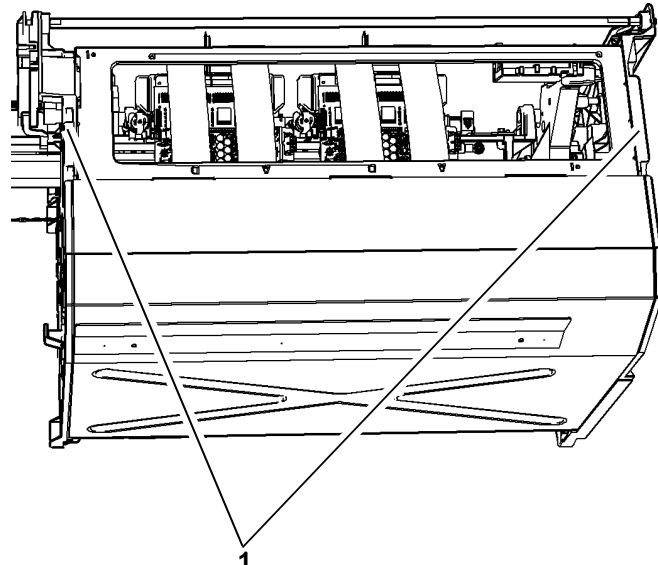

1
Lift from the left side of the marking unit to avoid damage to the printheads. Lift the marking unit using front and rear handles.

U-1-0904-A

Figure 4 Marking unit removal

Replacement

1. Replacement is the reverse of the removal procedure.
2. When locating the marking unit onto the rails line up the service loop so that it goes through the gap between the reservoir and marking unit, refer to [Figure 5](#).

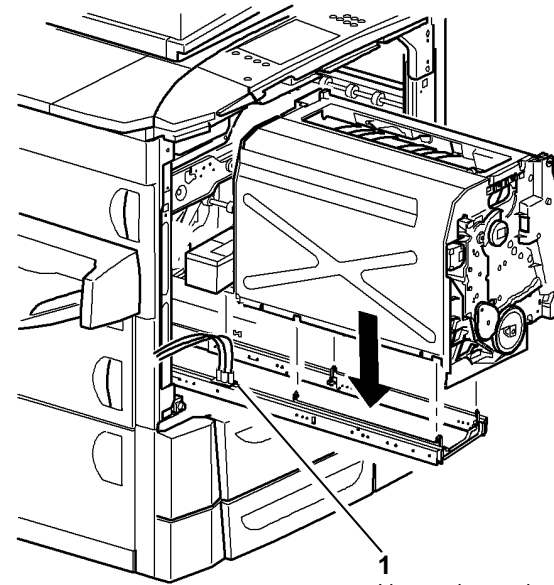

1
Line up the service loop with the gap between the reservoir and the marking unit.

U-1-1165-A

Figure 5 Marking unit replacement

REP 91.29 Printhead

Parts List on PL 91.20

General Guidelines

Be aware of the following:

- Do not use printheads as troubleshooting tools. Do not install, then remove the new printhead.
- When unpacked, install the new printhead immediately.
- Complete, then return the checklist supplied with the new printhead.
- Two types of printhead and cables can be installed in the machine. Refer to GP 46 to identify both types. This procedure is clearly marked where a step is relevant to a specific type of printhead.

Removal

WARNING

Switch off the electricity to the machine. Refer to GP 14. Disconnect the power cord from the customer supply while performing tasks that do not need electricity. Electricity can cause death or injury. Moving parts can cause injury.

WARNING

Take care during this procedure. Sharp edges may be present that can cause injury.

CAUTION

Do not touch the exposed face of the printheads. Surface contamination or minor damage can destroy the printhead. Keep hot printheads level.

1. Open front door.
2. Remove the inner cover, PL 81.11 Item 2.
3. Slide out the marking unit to the maintenance position, Refer to GP 6.

NOTE: For lower printheads, move the lower carriage into its service position to allow access to the harness connections, refer to GP 6.

4. **Type A printhead only.** Release the cable clips from the relevant flex cables, Figure 1.

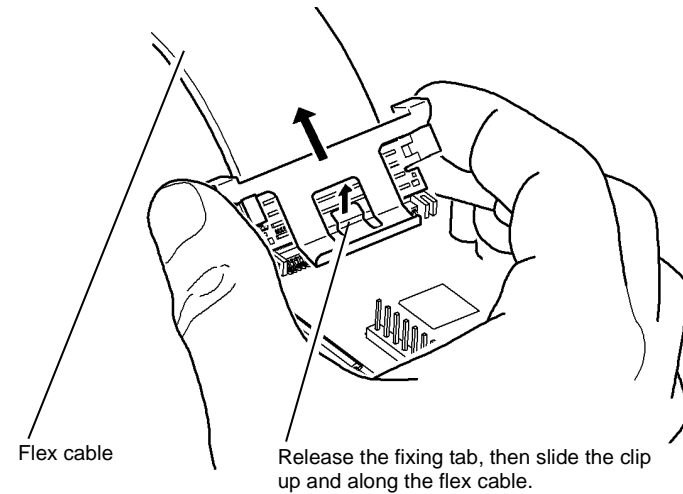

Figure 1 Clip removal (type A)

U-1-1528-A

5. **Type A printheads only.** Disconnect the flex cables, [Figure 3](#).

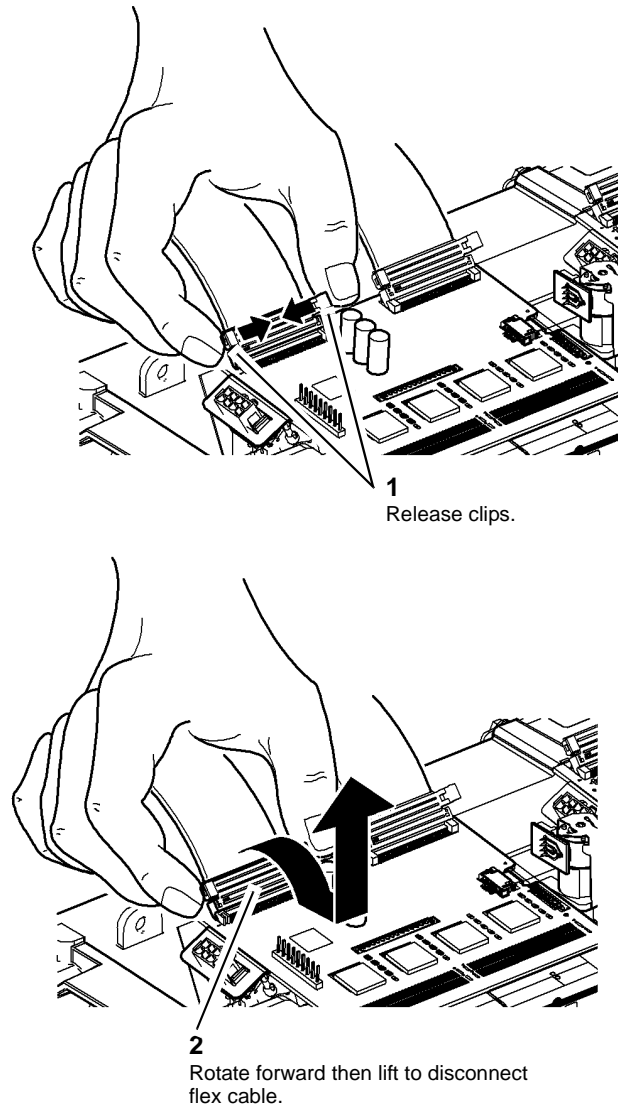
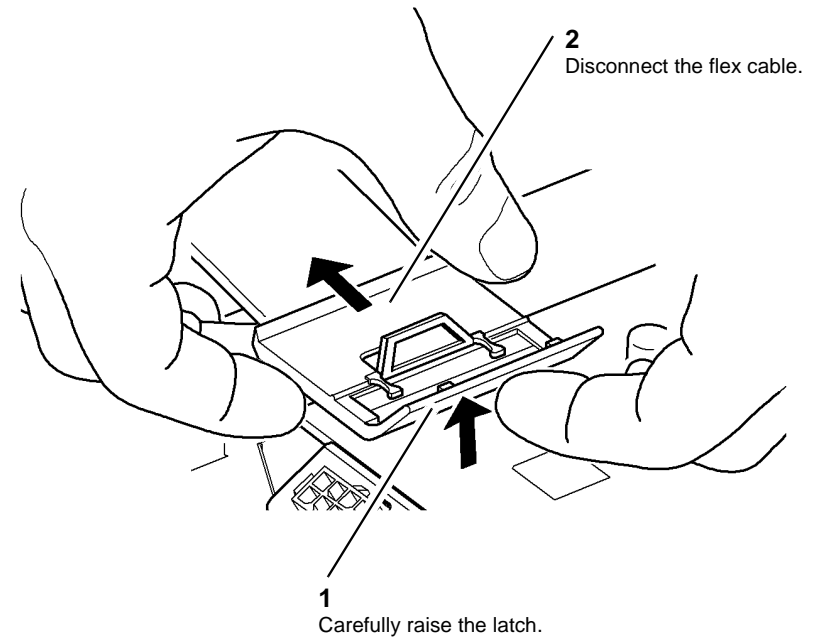

Figure 2 Cable disconnection (type A)

U-1-1166-A

6. **Type B printheads only.** Disconnect the flex cables, [Figure 3](#).



U-1-1681-A

Figure 3 Cable disconnection (type B)

NOTE: Hooks on the printhead will prevent it from falling after the screws are loosened.

7. Remove the printhead, [Figure 4](#).

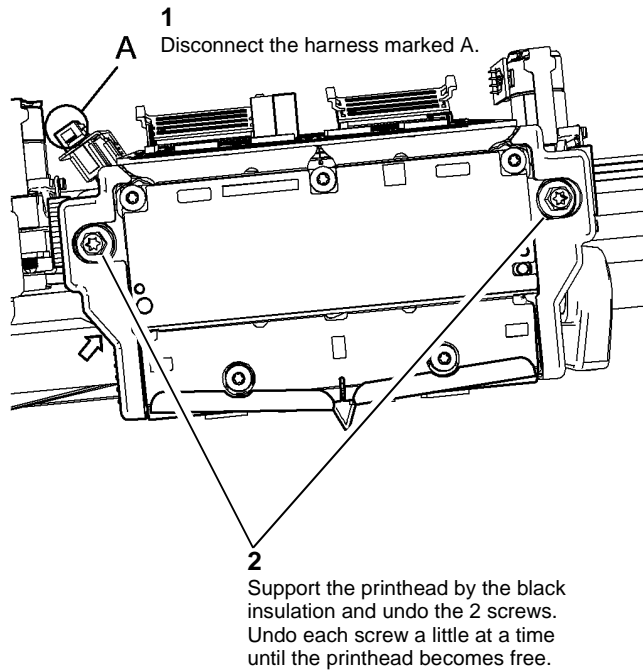

Figure 4 Printhead removal

8. Set the printhead down on a level surface.

CAUTION

Do not adjust the ball plate screws (A), Refer to [Figure 5](#).

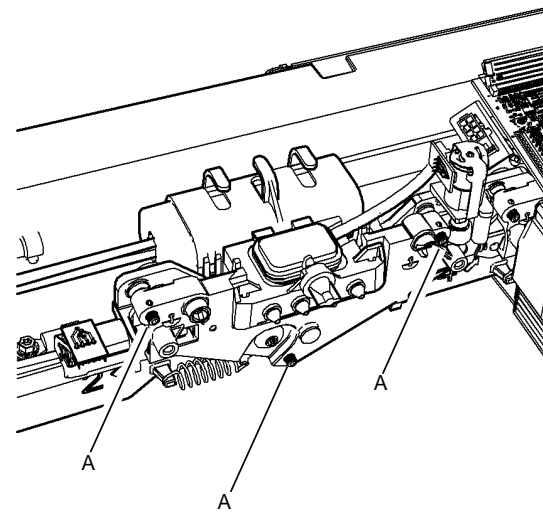

Figure 5 Ball plate screws

U-1-0905-A

U-1-0990-A

Replacement

1. Replacement is the reverse of the removal procedure.

CAUTION

Failure to do the following may result in printhead or drum damage.

2. Remove the faceplate cover and umbilical port cover from a new printhead.
3. If there is solidified ink on the umbilical nozzles, carefully remove the ink.
4. Gently push in on printhead when starting screws.
5. When screwing the printhead back onto the carriage start by rotating the left screw 2 revolutions, then alternate between the screws doing about 2 revolutions per screw.

6. **Type A printheads only.** Connect the flex cables, [Figure 6](#).

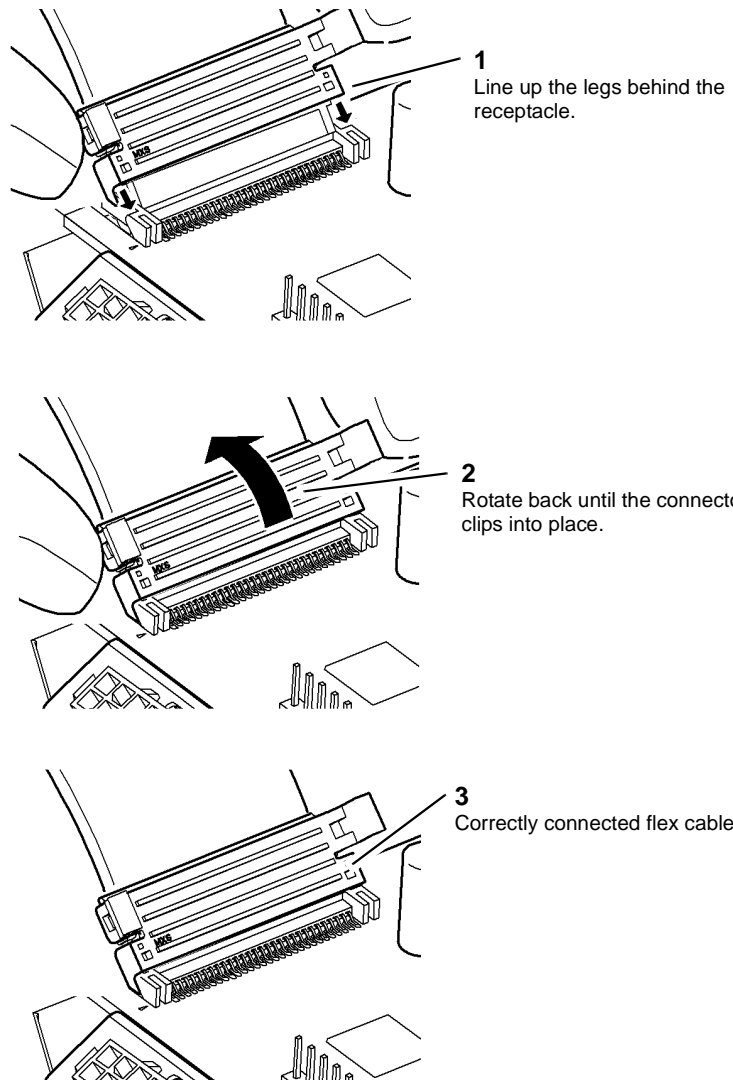

U-1-1167-A

Figure 6 Cable connection (type A)

7. **Type A printheads only.** Secure the flex cables with the cable clips, [Figure 7](#).

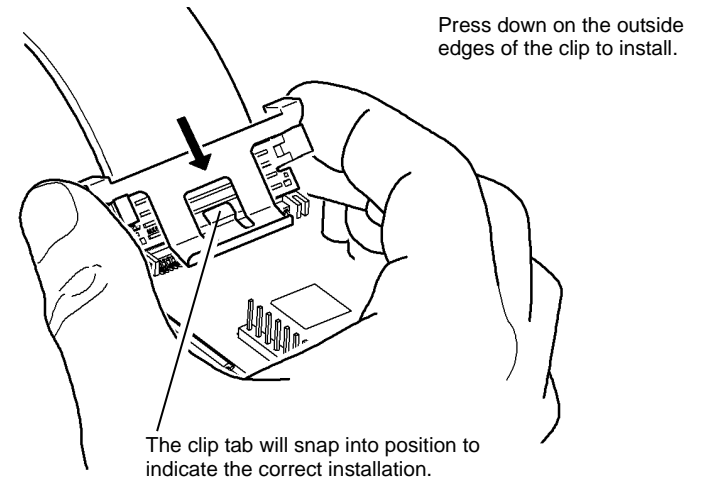

U-1-1533-A

Figure 7 Reinstall the cable clips

8. **Type B printheads only.** Connect the flex cables, [Figure 8](#).

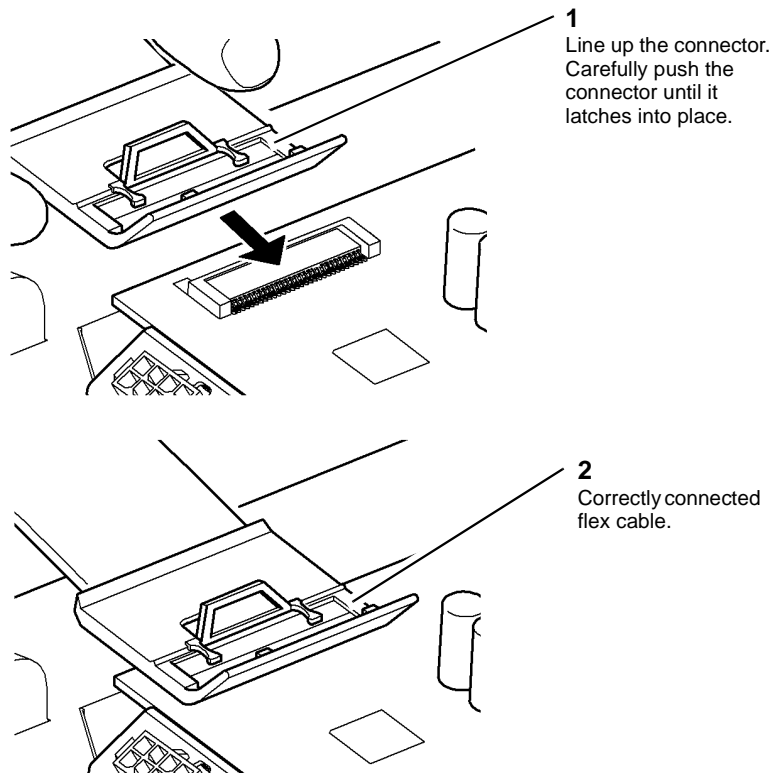

U-1-1682-A

Figure 8 Cable connection (type B)

CAUTION

Failure to do the following may result in printhead or drum damage.

9. If reinstalling the same printhead in the same position, boot the machine directly into IME diagnostics mode, [GP 1](#). When the machine has booted into IME diagnostics mode, log into diagnostics and perform [dC967](#) to check head to drum spacing.

NOTE: Booting into IME diagnostics will prevent the normal power up / docking sequence.

10. Ensure that both carriages are parked and the wiper is in the home position, all the way up or down.
11. Run the relevant diagnostic routines, refer to [GP 37](#) Post Part Replacement Routines.

NOTE: New printheads may not have all sections of NVRAM initialized. This may cause a fault when the machine is switched on, refer to [91-519-00 to 91-522-00](#), [91-655-00 to 91-658-00](#), [91-683-00 to 91-690-00](#), [91-807 to 91-811-00](#) Printhead NVM Read or Write Error RAP. These faults will be cleared after performing [dC972](#).

REP 91.30 Drum Position Encoder Assembly

Parts List on [PL 94.20](#)

Removal

WARNING

Switch off the electricity to the machine. Refer to [GP 14](#). Disconnect the power cord from the customer supply while performing tasks that do not need electricity. Electricity can cause death or injury. Moving parts can cause injury.

WARNING

Take care during this procedure. Sharp edges may be present that can cause injury.

1. Open front door.
2. Remove the inner cover, [PL 81.11](#) Item 2.
3. Remove the front drum shroud, [PL 94.20](#) Item 7.

CAUTION

Do not remove gold coloured screws from the encoder.

4. Remove the drum position encoder, [Figure 1](#).

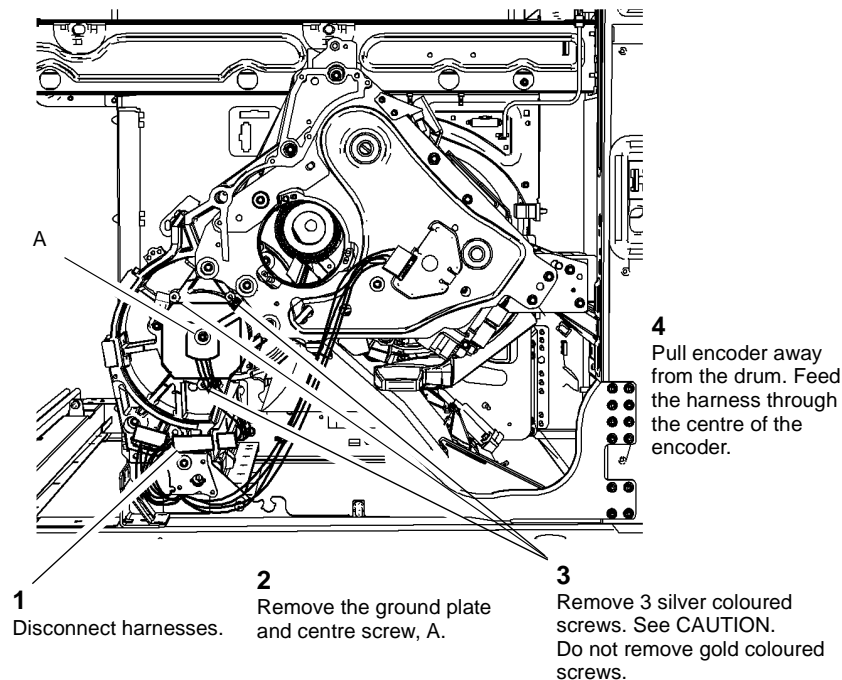
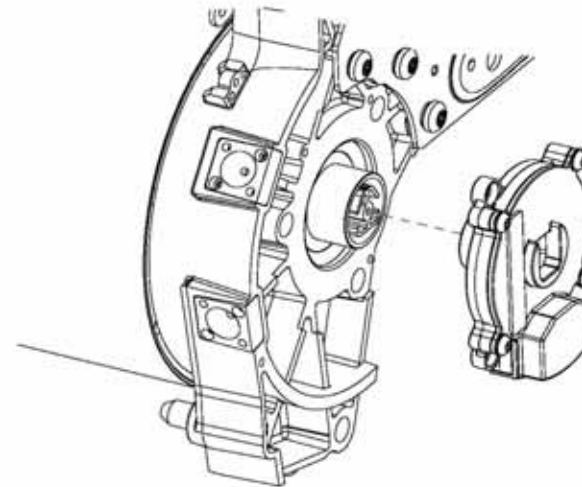

Figure 1 Encoder removal

Replacement

1. Replacement is the reverse of the removal procedure.
2. Orientate the encoder as shown in [Figure 2](#). Feed the harness through the centre of the encoder and align the drum heater bar with the centre opening.



U-1-0906-A

Figure 2 Encoder replacement

3. Rotate the encoder until the screw holes line up and then press it on fully in this orientation.
4. Replace the lower and upper left screws. Replace the grounding plate, along with the centre and upper right screws.
5. Reconnect the harness.
6. Ensure the wiring is not pinched when replacing the ground plate and screw, [Figure 1](#).
7. Run the relevant diagnostic routines, refer to [GP 37](#) Post Part Replacement Routines.

REP 91.31 Umbilical Assembly

Parts List on [PL 91.20](#)

Removal

WARNING

Switch off the electricity to the machine. Refer to [GP 14](#). Disconnect the power cord from the customer supply while performing tasks that do not need electricity. Electricity can cause death or injury. Moving parts can cause injury.

WARNING

Take care during this procedure. Sharp edges may be present that can cause injury.

CAUTION

Do not touch the exposed face of the printheads. Surface contamination or minor damage can destroy the printhead.

CAUTION

Allow 30 minutes for the umbilicals and reservoir to cool down before starting this repair. It takes 30 minutes for the ink to solidify.

1. Slide out the marking unit to the maintenance position, refer to [GP 6](#).
2. Remove the upper or lower printheads as required, [REP 91.29](#).

NOTE: For lower printheads, move the lower carriage into its service position to allow access to the harness connections, refer to [GP 6](#).

3. Release the wiring harness from the required umbilical, [Figure 1](#).

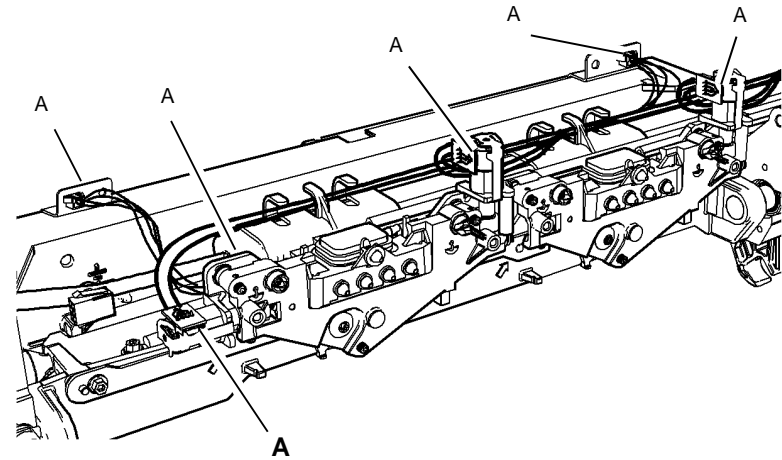

1

Disconnect harnesses from the stitch/roll adjust motors, carriage and the end of the umbilical, Refer to locations marked A.

U-1-1168-A

Figure 1 Disconnect harnesses

4. Remove the required umbilical from the carriage, [Figure 2](#).

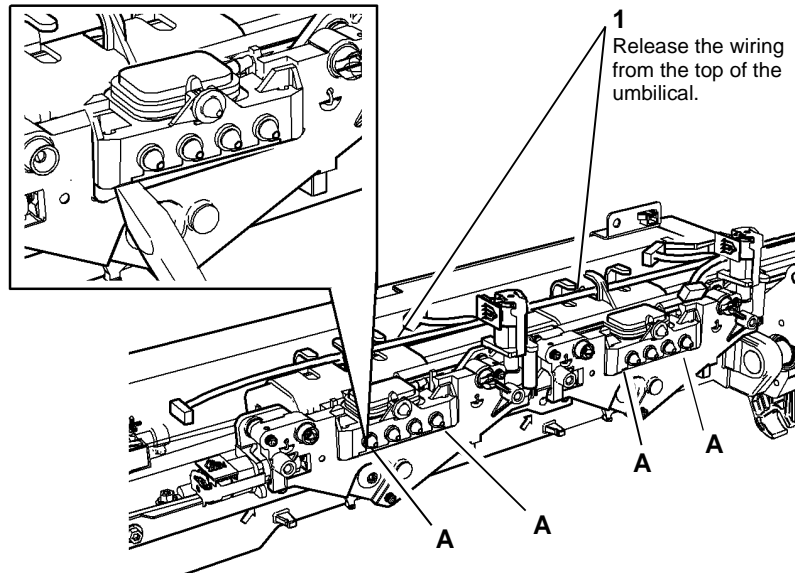

- 2**
Use a flat bladed screwdriver to unclip the umbilical from the carriage. Insert the screwdriver between the umbilical and carriage then rotate the blade to release the umbilical (4 positions marked A).

U-1-0829-A

Figure 2 Unclip the umbilical

5. Remove the side and end insulation from around the umbilical on the ink reservoir, [Figure 3](#).

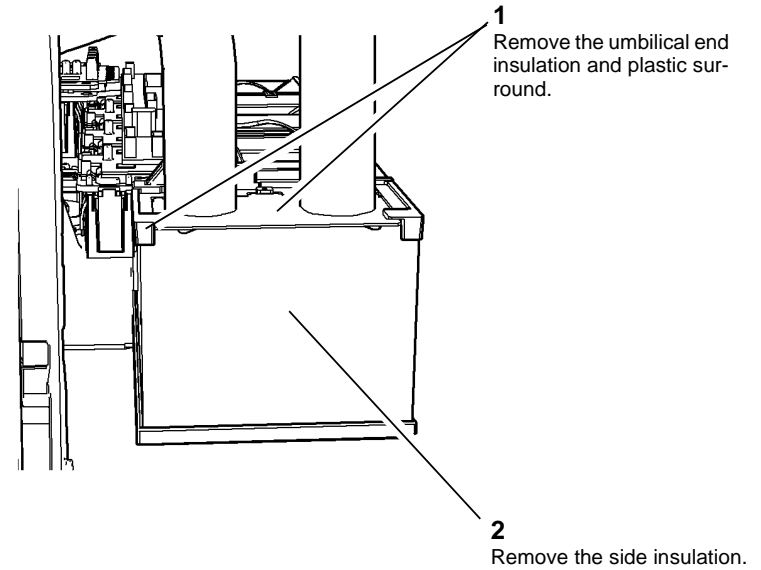

U-1-0830-A

Figure 3 Insulation removal

6. Remove the required umbilical, [Figure 4](#).

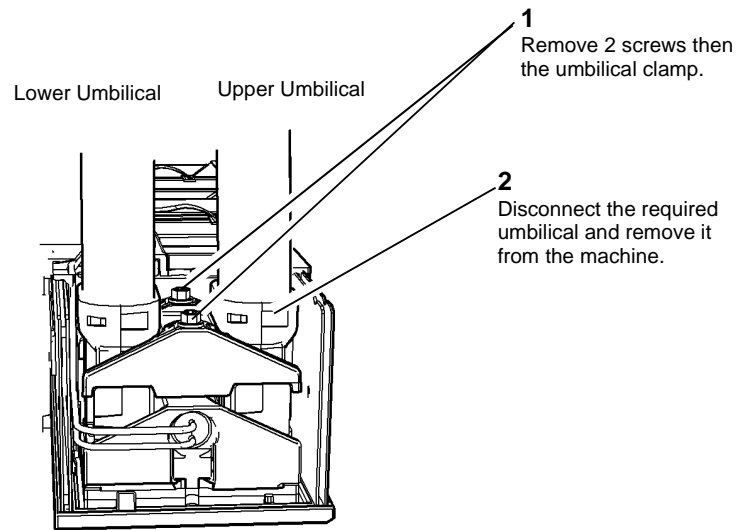

Figure 4 Umbilical removal

U-1-0831-A

7. Remove the purge hoses from the reservoir, [Figure 5](#).

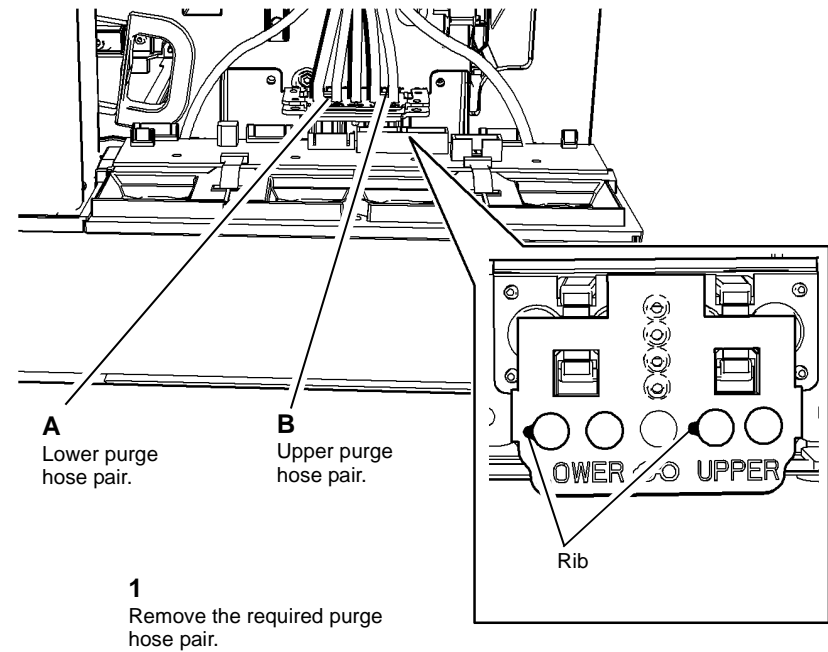

Figure 5 purge hose removal

U-1-0832-A

Replacement

1. Replacement is the reverse of the removal procedure.
2. Ensure that the ink debris is cleared away from above and around the purge hose connections before removing or re-attaching the hoses to the reservoir.
3. Ensure that the purge hoses are located correctly and that the rib on the tube points towards the drum, refer to [Figure 5](#).
4. When replacing umbilicals, ensure that there is only one gasket between the umbilical and the ink reservoir (new umbilicals come with a gasket installed).
5. Ensure there is no ink debris between the ink reservoir and the umbilical before connection.

- Ensure that the umbilicals are seated correctly, [Figure 6](#).

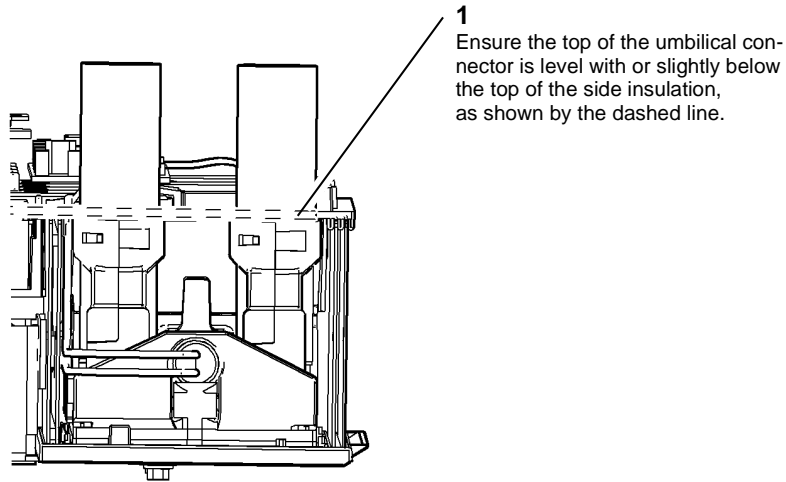

1 Ensure the top of the umbilical connector is level with or slightly below the top of the side insulation, as shown by the dashed line.

U-1-1163-A

Figure 6 Umbilical seating

- Firmly tighten the screws on the umbilical clamp, failure to do so can result in ink leaks.
- Ensure that both carriages are parked and the wiper is in the home position, all the way up or down.
- Ensure the harnesses are routed correctly, refer to [GP 28](#).

CAUTION

Failure to properly prime the new umbilical will lead to permanent damage to the ink reservoir and the new umbilical.

- Power the machine directly into IME diagnostics mode, refer to [GP 1](#). This will prevent the thermals from warming up and delivering / pumping ink from the ink reservoir through the umbilicals. When the machine has booted into IME diagnostics mode, log into diagnostics and perform [dC976](#) Ink Delivery Fault Recovery, to prime the umbilicals.

NOTE: *If a new umbilical has been installed then run the routine a second time. A single priming routine may not be sufficient in all cases.*

- Run the relevant diagnostic routines, refer to [GP 37](#) Post Part Replacement Routines.

REP 91.32 Cleaning Unit Cam Shaft Assembly

Parts List on [PL 94.10](#)

Removal

WARNING

Switch off the electricity to the machine. Refer to [GP 14](#). Disconnect the power cord from the customer supply while performing tasks that do not need electricity. Electricity can cause death or injury. Moving parts can cause injury.

WARNING

Take care during this procedure. Sharp edges may be present that can cause injury.

- Open the front door.
- Remove the inner cover, [PL 81.11](#) Item 2.
- Remove the cleaning unit, refer to [REP 94.1](#).
- Remove the cleaning unit cam shaft, [Figure 1](#).

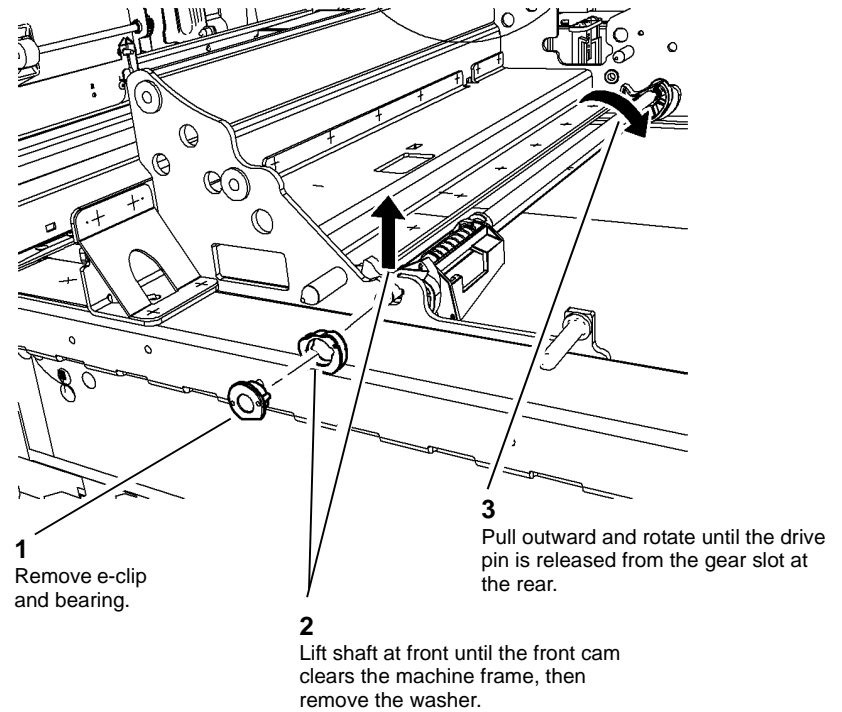

U-1-1132-A

Figure 1 Cam shaft removal

Replacement

- Replacement is the reverse of the removal procedure.

2. Before installing a new camshaft, ensure that the slot in the drive gear is aligned with the slot in the machine frame, [Figure 2](#).

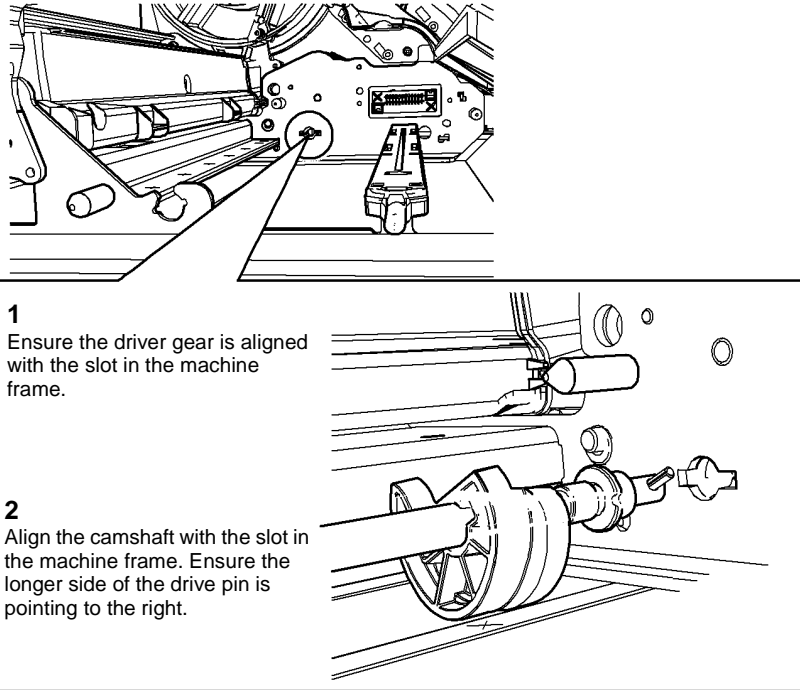

U-1-1221-A

Figure 2 Camshaft alignment

3. Ensure that the black cam on the new camshaft points towards the rear of the machine. Align the drive pin with the slot in the drive gear, longer side pointing to the right. Press the camshaft into the drive gear until the pin is fully seated, [Figure 2](#).

4. Lower the camshaft into place at the front of the machine. Align the washer with the machine frame, at the same time as aligning the locating tags on the bottom of the lock mount with the holes in the machine frame, [Figure 3](#).

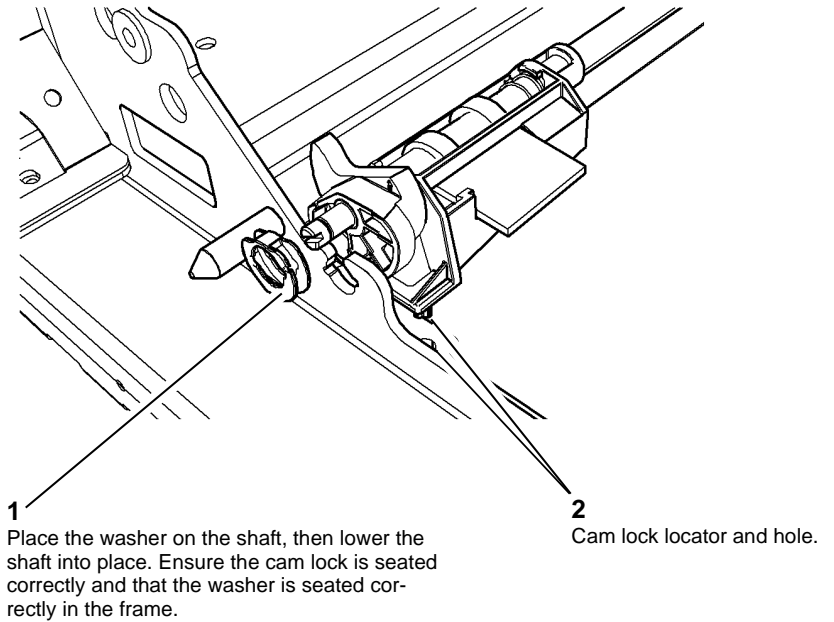

U-1-1222-A

Figure 3 Camshaft relocation

5. Ensure the camshaft is seated correctly and that the cam lock is engaged, [Figure 4](#).

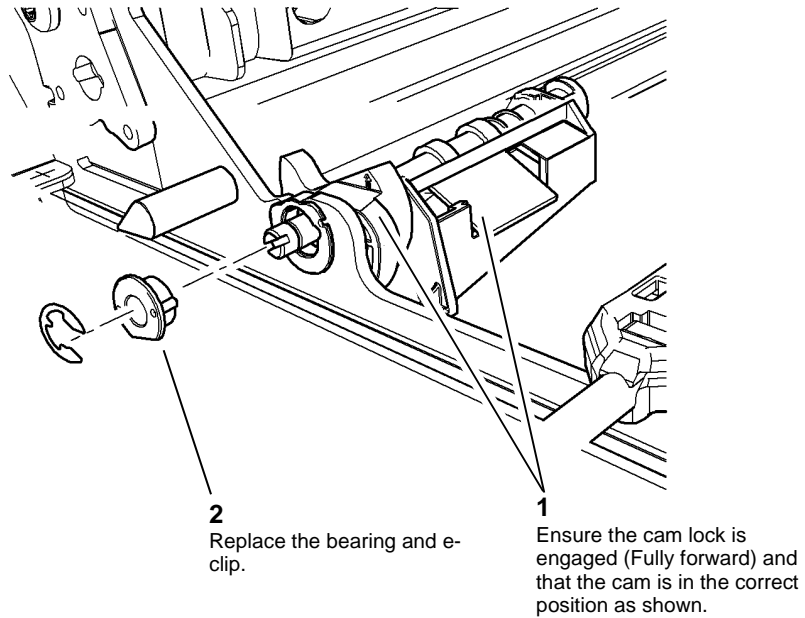

Figure 4 Cam lock check

U-1-1223-A

REP 91.33 Cleaning Unit Plug Connector

Parts List on [PL 94.10](#)

Removal

WARNING

Switch off the electricity to the machine. Refer to [GP 14](#). Disconnect the power cord from the customer supply while performing tasks that do not need electricity. Electricity can cause death or injury. Moving parts can cause injury.

WARNING

Take care during this procedure. Sharp edges may be present that can cause injury.

1. Remove the rear cover, [PL 81.10 Item 1](#).
2. Remove the cleaning unit, refer to [REP 94.1](#).
3. Remove the drum drive motor and belt, [REP 91.24](#).
4. Remove the cleaning unit plug connector, [Figure 1](#).

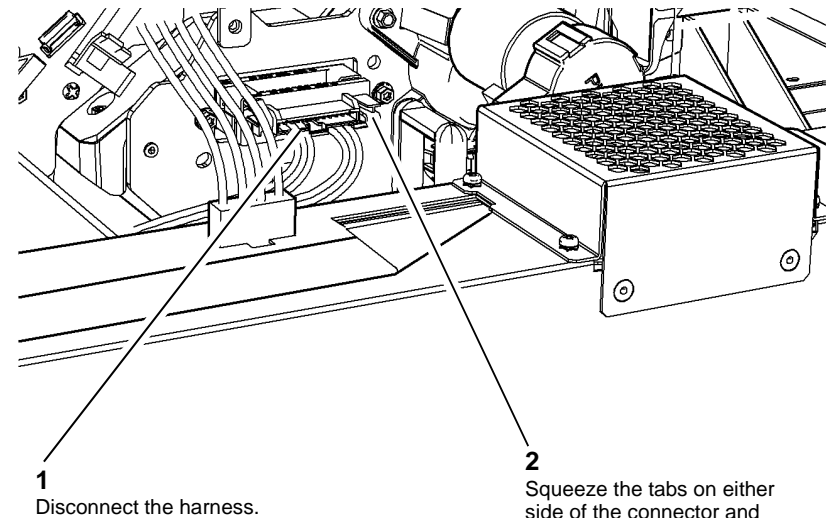

Figure 1 Plug connector removal

U-1-1133-A

Replacement

Replacement is the reverse of the removal procedure.

REP 91.34 Drum Pulley

Parts List on [PL 94.20](#)

Removal

WARNING

Switch off the electricity to the machine. Refer to [GP 14](#). Disconnect the power cord from the customer supply while performing tasks that do not need electricity. Electricity can cause death or injury. Moving parts can cause injury.

WARNING

Take care during this procedure. Sharp edges may be present that can cause injury.

1. The drum pulley removal kit, [PL 31.11 Item 9](#) is required to remove the drum pulley. Do not proceed with this procedure if the kit is unavailable.
2. Remove the rear cover, [PL 81.10 Item 1](#).
3. Remove the rear drum fan shroud, refer to [REP 91.24](#), figure 1.
4. Release the tension on the drum drive belt by pulling the lever down. Remove the drum drive motor and belt, [REP 91.24](#).
5. Move the drum static eliminator away from the drum shaft, [Figure 1](#).

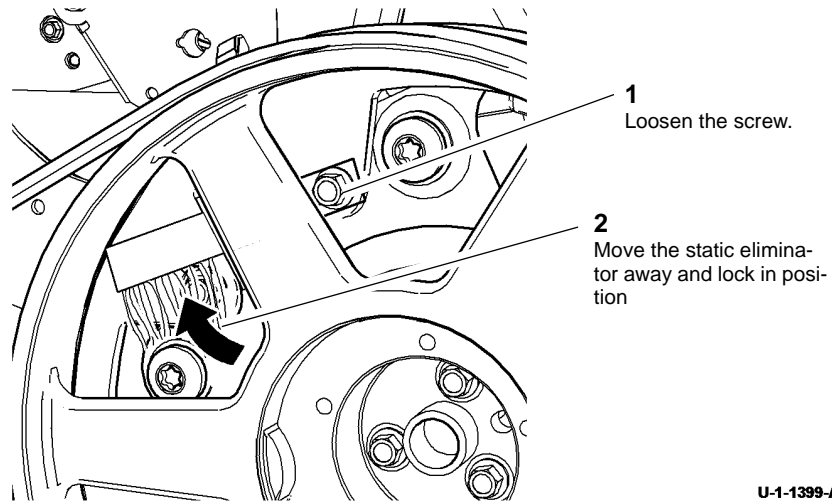

Figure 1 Move the static eliminator

U-1-1399-A

6. Refer to [Figure 2](#). From the drum pulley removal kit:
 - a. Install the T30 screw into the centre hole of the pulley.
 - b. Use the 5 screws to secure the plate to the pulley.

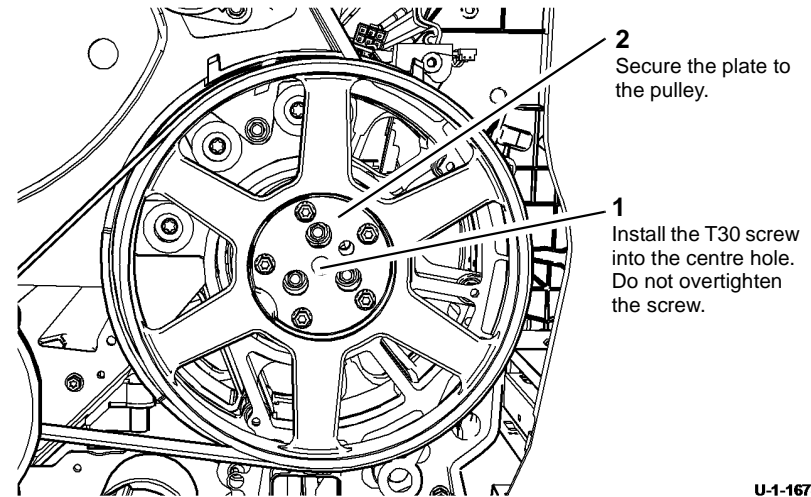

Figure 2 Kit installation

U-1-1678-A

7. Prepare to remove the drum pulley, [Figure 3](#).

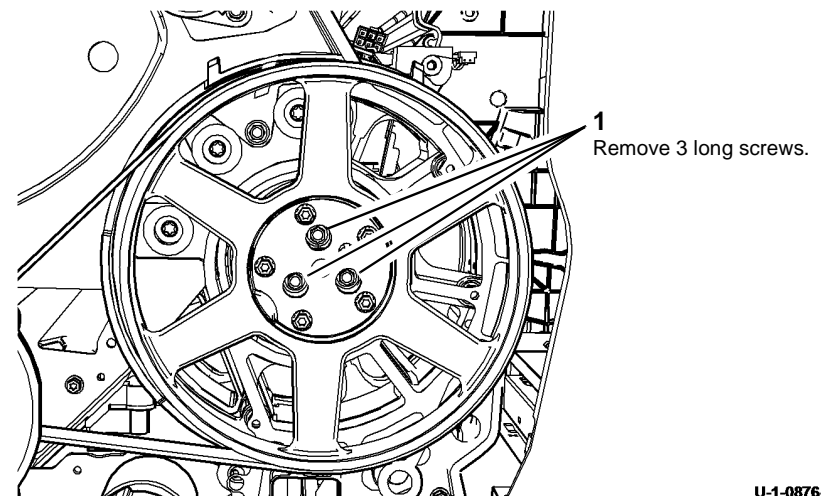

Figure 3 Preparation

U-1-0876-A

CAUTION

Take care not to insert the screw driver handle too far into the drum as damage to the heater may occur.

8. Remove the drum pulley, [Figure 4](#).

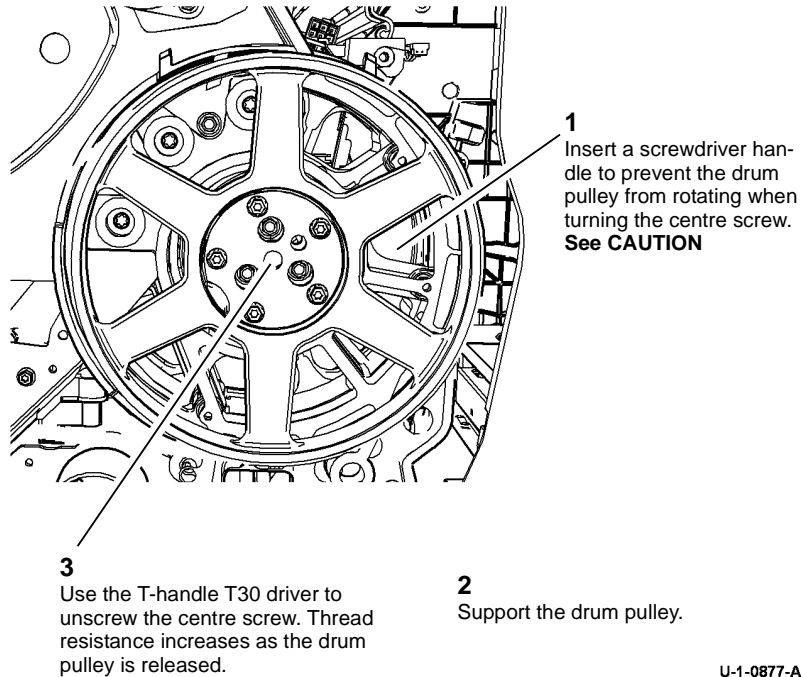

Figure 4 Drum pulley removal

Replacement

1. Replacement is the reverse of the removal procedure.
2. If a new drum pulley is to be installed, remove the 5 securing screws, plate and T30 screw from the old drum pulley, then install them onto the new drum pulley.
3. Ensure the guide pin is at 12:00.

CAUTION

Do not force the pulley on. If there is any resistance, remove the pulley and start again. The pulley must go on smoothly.

4. Ensure the pulley centre is straight, then push evenly into the machine until it is almost flush with the assembly.
5. Finish seating the pulley by tightening the T30 centre screw.
6. Secure the pulley with the 3 long screws.

CAUTION

Take care to reinstall the static eliminator correctly. If the static eliminator is not installed correctly ESD events will result that can cause cleaning unit slime that permanently damages the printheads.

7. Check that the drum static eliminator is positioned correctly. Bias the static eliminator against the black plastic to position the static eliminator in the correct position. [Figure 5](#).

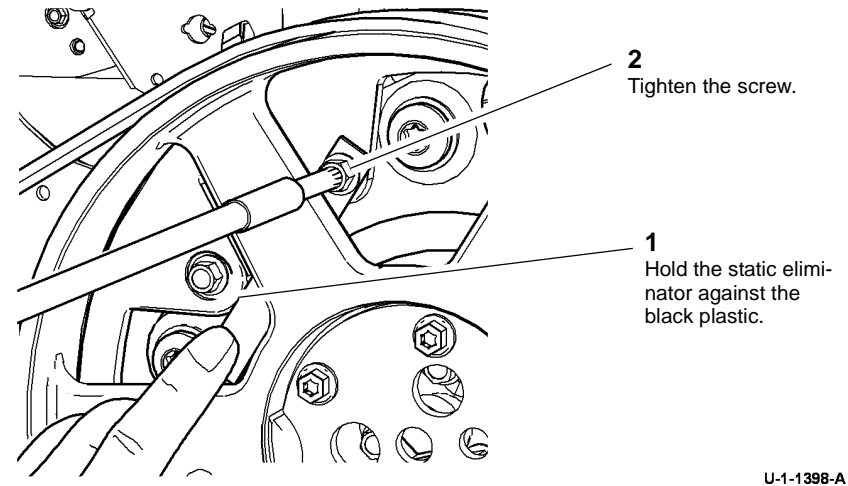

Figure 5 Static eliminator position

8. Remove the 5 securing screws, plate and T30 screw from the drum pulley for future use.
9. Run the relevant diagnostic routines, refer to [GP 37](#) Post Part Replacement Routines.

REP 91.35 Front and Rear Drum Thermistor

Parts List on [PL 94.20](#)

Removal

WARNING

Switch off the electricity to the machine. Refer to [GP 14](#). Disconnect the power cord from the customer supply while performing tasks that do not need electricity. Electricity can cause death or injury. Moving parts can cause injury.

WARNING

Take care during this procedure. Sharp edges may be present that can cause injury.

1. Remove the inner cover, [PL 81.11 Item 2](#).
2. Remove the front drum thermistor, [Figure 1](#).

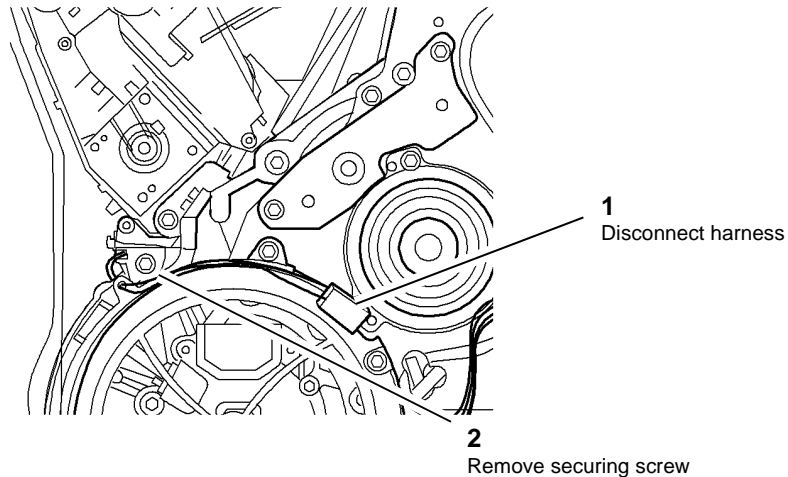

Figure 1 Front thermistor

3. Remove the rear cover, [PL 81.10 Item 1](#).

4. Remove the rear thermistor, [Figure 2](#).

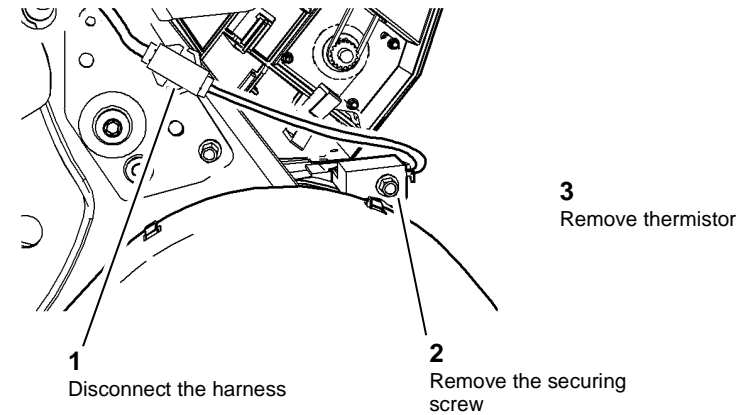

Figure 2 Rear thermistor

U-1-1190-A

Replacement

CAUTION

Take care not to damage or bend the thermistor.

1. Replacement is the reverse of the removal procedure.
2. Ensure that the location lugs on the front thermistor locate in the holes on the support bracket, [Figure 3](#).

NOTE: Ensure that the thermistor points in the same direction as the rotation of the drum.

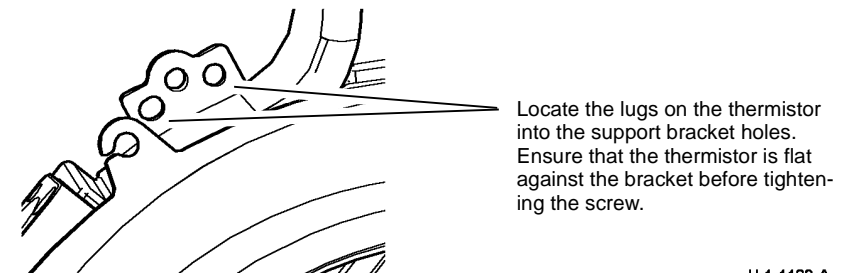
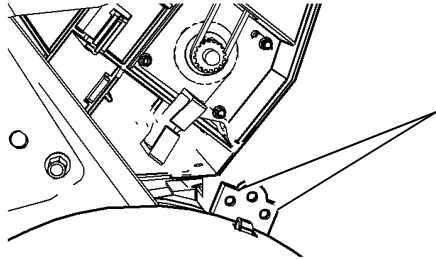

Figure 3 Front thermistor location

U-1-1189-A

3. Ensure that the location lugs on the rear thermistor locate in the holes on the support bracket, [Figure 4](#).

NOTE: Ensure that the thermistor points in the same direction as the rotation of the drum.



Locate the lugs on the thermistor into the support bracket holes. Ensure that the thermistor is flat against the bracket before tightening the screw.

U-1-1191-A

Figure 4 Rear thermistor location

REP 91.36 Abatement Plenum

Parts List on [PL 94.20](#)

Removal

WARNING

Switch off the electricity to the machine. Refer to [GP 14](#). Disconnect the power cord from the customer supply while performing tasks that do not need electricity. Electricity can cause death or injury. Moving parts can cause injury.

WARNING

Take care during this procedure. Sharp edges may be present that can cause injury.

1. Remove the inner cover, [PL 81.11 Item 2](#).
2. Remove the cleaning unit, refer to [REP 94.1](#).
3. Remove the abatement plenum, [Figure 1](#).

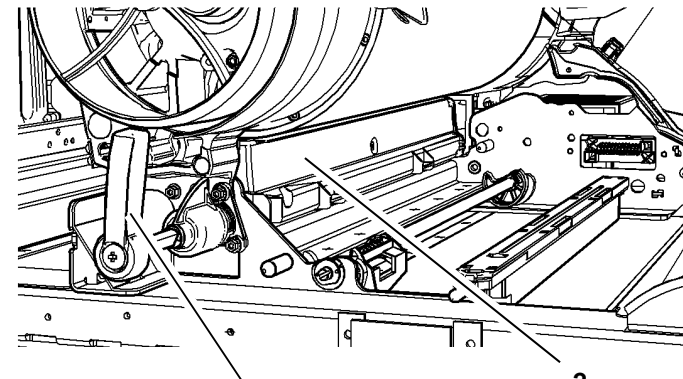

1
Pull the lever to release the abatement plenum

2
Remove the abatement plenum

U-1-1180-A

Figure 1 Removal

Replacement

CAUTION

Ensure that the plenum is correctly located in the support housing on the rear frame.

1. Replacement is the reverse of the removal procedure.
2. Ensure that the location lug on the abatement plenum aligns with the pin on the rear frame, [Figure 2](#).

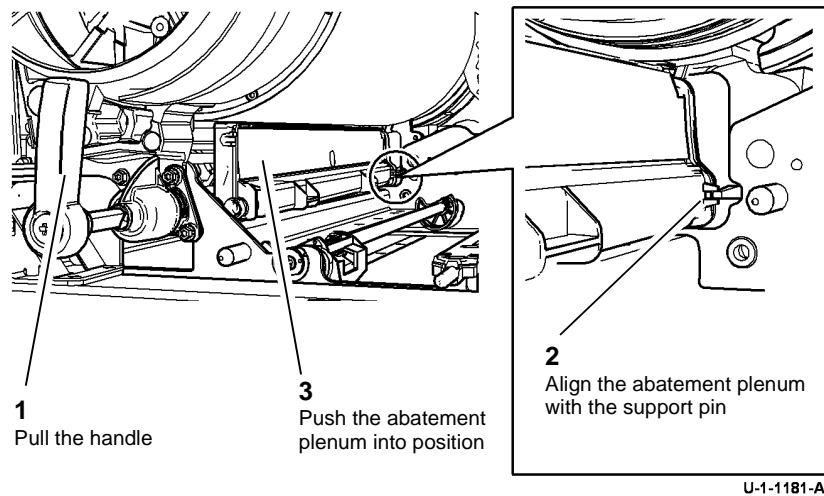

Figure 2 Replacement

REP 94.1 Cleaning Unit

Parts List on [PL 94.10](#).

Removal

Use this repair when replacing a cleaning unit that has failed.

WARNING

Immediately clean an oil spill. Spilt oil is a slip hazard. Do not walk in the contaminated area. Walking in the contaminated area will spread the contamination and contaminate footwear. Contaminated footwear is a slip hazard.

WARNING

Do not attempt to mop up the spilt oil with conventional mops and water. This will spread the contamination and will extend the slip hazard.

1. If fault codes 94-611-00, 94-616-00 or 94-629-00 are present, the cleaning unit has failed in a way that may have spilled oil inside the machine, continue at step 2. Otherwise, continue at step 3.
2. Prepare an area in front of the machine by placing a barrier layer over the customer floor.
3. Remove the new cleaning unit from the shipping box. Take care not to damage the zipper bag. Place the new cleaning unit away from any oil contamination.
4. The failed cleaning unit must be removed from the machine with extreme care to prevent oil dripping onto the customers floor. If the cleaning unit is locked in place and cannot be removed, go to [GP 36](#) and unlock the cleaning unit.
5. Place the failed cleaning unit into the zipper bag and seal the bag with the zip. Place the failed cleaning unit into the shipping box. Follow the instructions included in the shipping box to return the failed cleaning unit. Use the shipping label supplied in the shipping box.
6. Inspect the chassis pan directly below the cleaning unit cavity for a pool of oil. A thin film of oil is normal. Clean up any oil pool, [GP 27](#) Cleaning Procedure.

Replacement

Install the new cleaning unit.

ADJ 4.1 Machine Lubrication

Purpose

To correctly lubricate the machine to prevent noise and wear.

Lubrication

Refer to [GP 18](#) Machine Lubrication for general guidance on the use of lubricants.

WARNING

Ensure that the electricity to the machine is switched off while performing tasks that do not need electricity. Refer to [GP 14](#). Disconnect the power cord. Electricity can cause death or injury. Moving parts can cause injury.

The following list gives the parts of the machine where lubrication is permitted. Go to the relevant procedure:

- [LCSS Drive Belt Tensioners](#).
- [LCSS Bin 1 Drive Belt Pulleys and Idler](#).
- [LCSS Bin 1 Elevator Motor Worm and Gear](#).
- [LCSS Tamper Assembly](#).
- [HVF BM Support Pin](#).

LCSS Drive Belt Tensioners

1. Remove the LCSS top cover and rear cover, [REP 12.1-110](#).
2. Remove the relevant belt tensioner:
 - Intermediate paper drive belt tensioner, [PL 12.60 Item 17](#).
 - Bin 1 drive belt tensioner, [PL 12.30 Item 13](#).
3. Remove the E-clip and pulley from the belt tensioner. Apply plastislip grease, [PL 26.10 Item 4](#) to the shaft and pulley bore. Re-assemble the pulley and E-clip on the belt tensioner.
4. Clean off the old lubricant and any contamination from the belt tensioner and LCSS frame using a micro fiber wiper, [PL 26.10 Item 6](#). Apply Molub grease 777, [PL 26.10 Item 12](#), to the whole contact face of the belt tensioner.
5. Reinstall the belt tensioner.

LCSS Bin 1 Drive Belt Pulleys and Idler

1. Remove the LCSS top cover and rear cover, [REP 12.1-110](#).
2. Remove the relevant pulley or idler:
 - Bin 1 drive belt idler, [PL 12.30 Item 1](#).
 - Bin 1 drive belt pulleys, [PL 12.30 Item 6](#).
3. Remove the E-clip and pulley or idler from the belt tensioner. Apply plastislip grease, [PL 26.10 Item 4](#) to the shaft and pulley or idler bore. Re-assemble the pulley or idler and E-clip on the belt tensioner.
4. Reinstall the belt tensioner.

LCSS Bin 1 Elevator Motor Worm and Gear

1. Remove the LCSS top cover and rear cover, [REP 12.1-110](#).
2. Use plastislip grease, [PL 26.10 Item 4](#), to lubricate the worm and gear on the Bin 1 elevator home motor, [PL 12.30 Item 8](#).

LCSS Tamper Assembly

1. Remove the LCSS top cover, [REP 12.1-110](#).
2. [Figure 1](#), use plastislip grease, [PL 26.10 Item 4](#), to lubricate the tamper assembly.

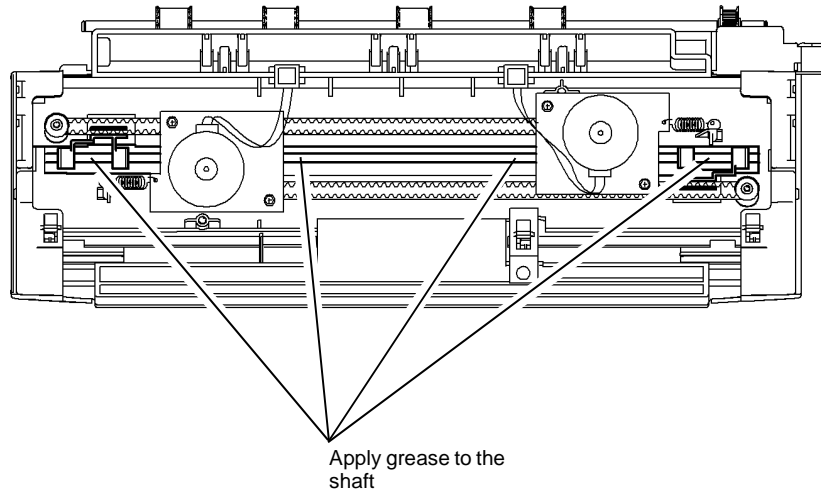

U-1-0619-A

Figure 1 Lower vertical slides

HVF BM Support Pin

1. Open the BM front door.
2. Fully pull out the BM unit.
3. [Figure 2](#), use plastislip grease, [PL 26.10 Item 4](#), to lubricate the BM support pin.

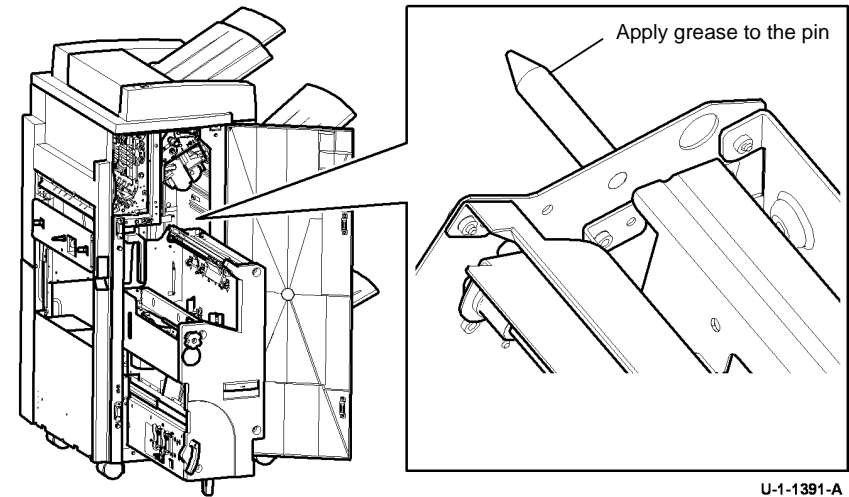

U-1-1391-A

Figure 2 Support pin lubrication

4. Fully push in the BM unit and close the HVF BM front door.

ADJ 5.1 DADH Drive Belt Adjustment

Parts List on [PL 5.15](#), [PL 5.25](#) and [PL 5.35](#)

Purpose

To correctly set the tension of the feed motor and the CVT motor drive belts.

Adjustment

WARNING

Ensure that the electricity to the machine is switched off while performing tasks that do not need electricity. Refer to [GP 14](#). Disconnect the power cord. Electricity can cause death or injury. Moving parts can cause injury.

CAUTION

Before this adjustment is performed, make sure all components removed in the repair procedure are installed correctly.

NOTE: This procedure shows how to adjust the feed motor drive belt. The adjustment procedure for the CVT motor drive belt is identical.

1. Remove the rear cover, [PL 5.10 Item 1](#).
2. Adjust the correct motor drive belt, [Figure 1](#). When the feed motor is adjusted correctly, engage the gears on the feed motor and the feed clutch. Check that the pitch rings just touch.

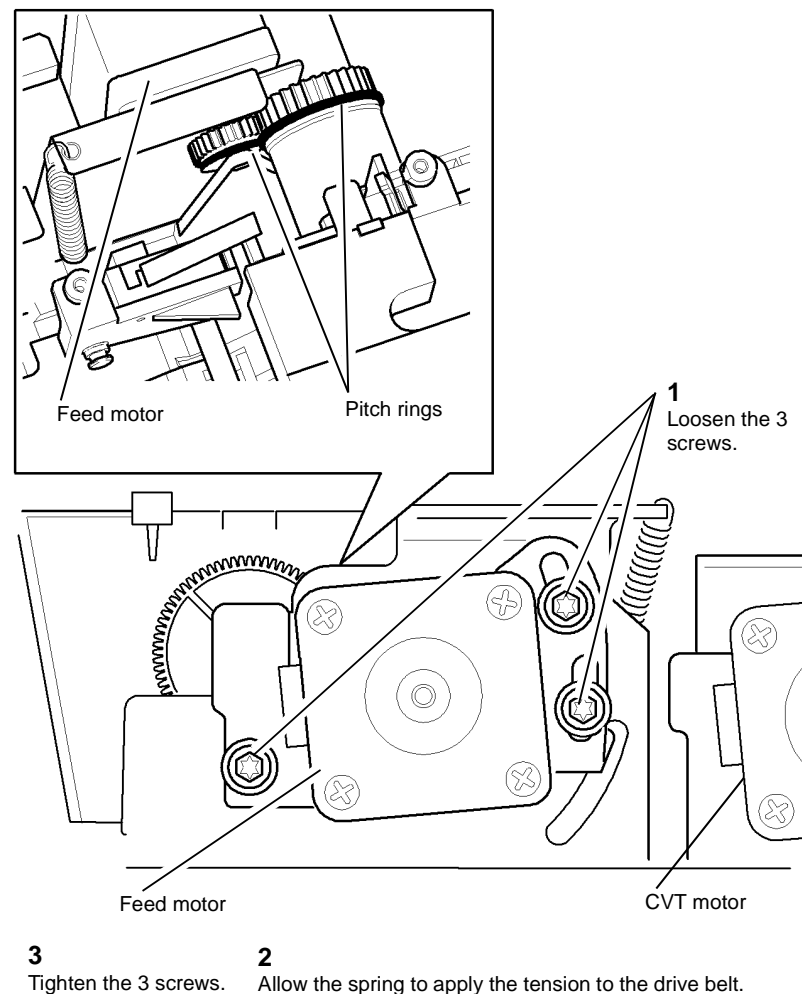

U-1-0621-A

Figure 1 Drive belt

ADJ 5.2 DADH Height Adjustment

Parts List on [PL 5.10](#) and [PL 5.25](#)

Purpose

To correctly set the distance between the scanner module and the DADH.

Check

WARNING

Ensure that the electricity to the machine is switched off while performing tasks that do not need electricity. Refer to [GP 14](#). Disconnect the power cord. Electricity can cause death or injury. Moving parts can cause injury.

NOTE: The DADH standoffs include the CVT roll bearings, [PL 5.25 Item 4](#) and [PL 5.25 Item 13](#).

1. Check the height of the DADH. The two standoffs touch the CVT glass when the DADH is closed, [Figure 1](#). Check that the DADH is parallel to the scanner module. Perform the steps that follow. Refer to [Figure 2](#):
 - a. Put a strip of paper on the CVT glass below the back DADH standoff.
 - b. Close the DADH.
 - c. Carefully pull the paper. Make sure that the paper was pressed between the CVT glass and back DADH standoff.
 - d. Repeat A to C for the front DADH standoff.
2. If the DADH height is incorrect, perform the [Adjustment](#).

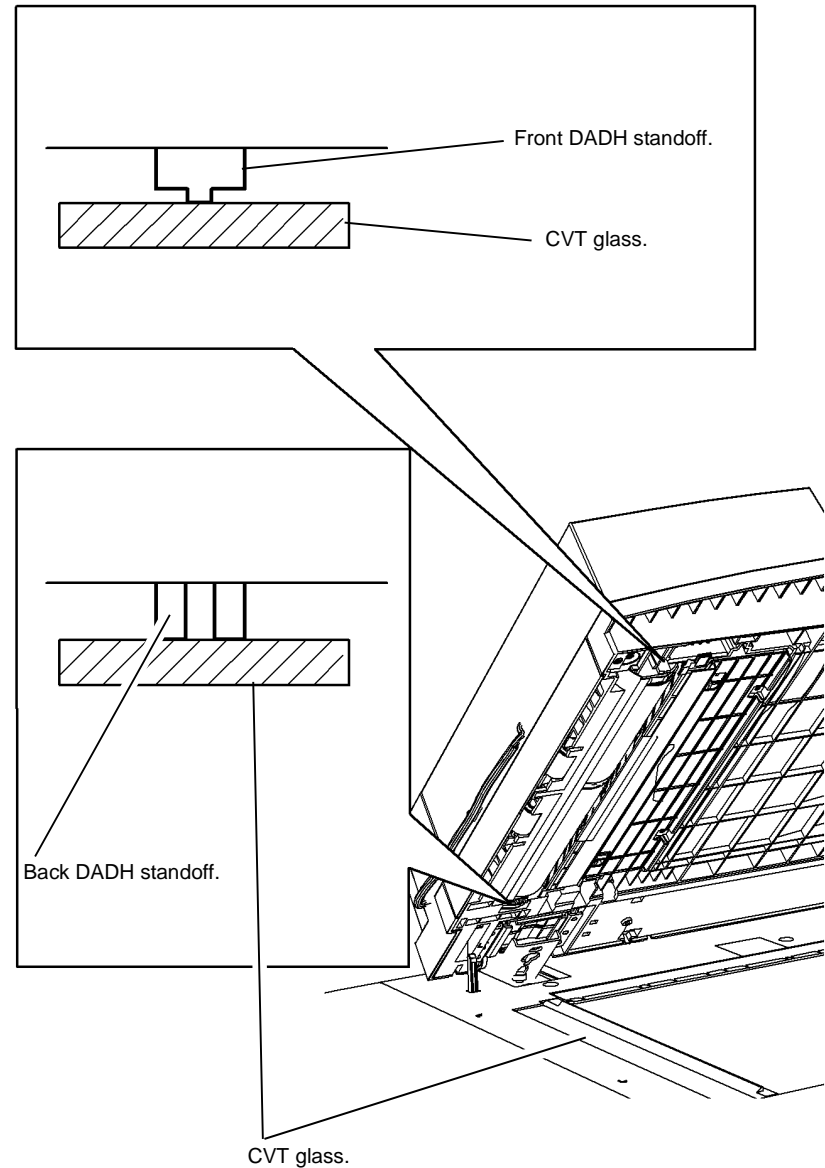

U-1-0622-A

Figure 1 DADH standoffs

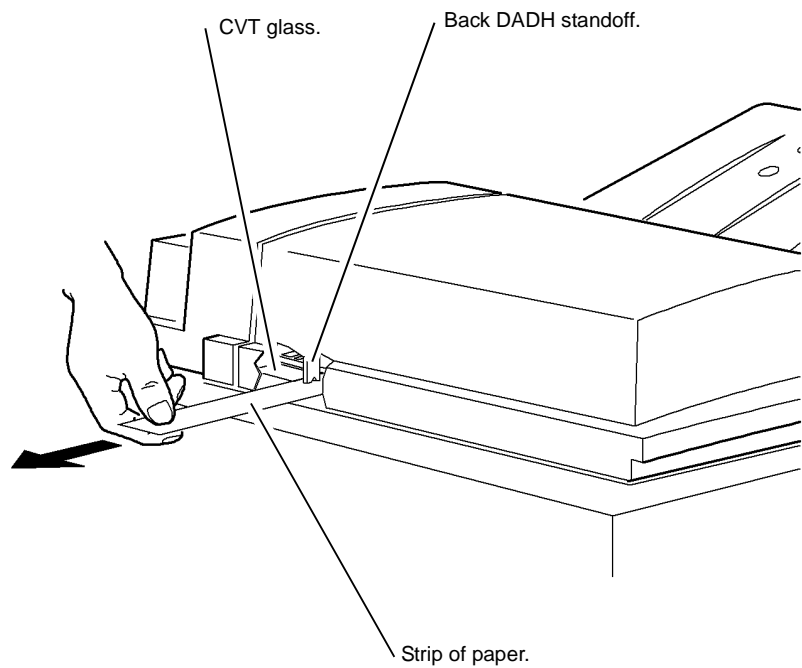

Figure 2 Clearance check

U-1-0623-A

Adjustment

NOTE: The factory setting of the counterbalances is approximately 3 mm (0.125 inch), refer to [Figure 3](#). The same adjustment applies to the left counterbalance and right counterbalance. Adjust the two counterbalances.

1. If the height of the DADH is wrong, adjust the counterbalances, [Figure 3](#).

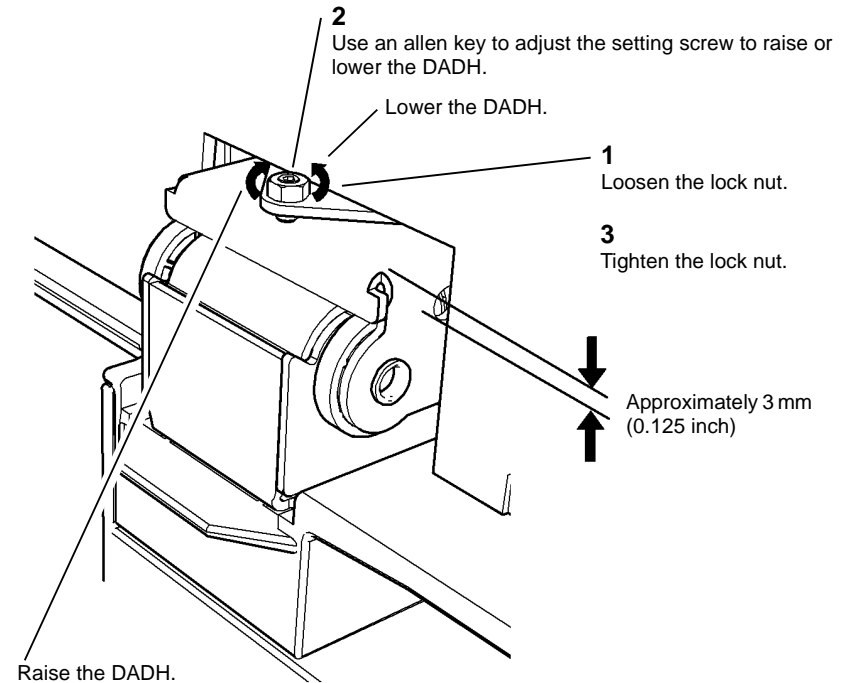

Figure 3 Counterbalances

U-1-0624-A

2. If mis-registration is found after the DADH is set to the correct height, go to [ADJ 5.5](#) DADH Registration Adjustment.

ADJ 5.3 DADH Skew Adjustment

Parts List on PL 5.10

Purpose

To correct document feed skew induced by the DADH.

Preparation

Perform the following:

1. Clean the CVT glass. Refer to [ADJ 5.4 DADH cleaning procedure](#).
2. Check that the document width guides are adjusted correctly.
3. Make sure that the DADH is set to the correct height. Go to [ADJ 5.2 DADH Height Adjustment](#).
4. Check the document path for obstructions or foreign objects.
5. Perform the [Skew Check](#).

Skew Check

1. Use the DADH to make 5 copies. Check the skew, refer to [IQS 1 Registration and Skew](#).

NOTE: Skew is always measured on the lead edge, irrespective of paper orientation.

2. If necessary, perform the [Adjustment](#).

Adjustment

WARNING

Ensure that the electricity to the machine is switched off while performing tasks that do not need electricity. Refer to [GP 14](#). Disconnect the power cord. Electricity can cause death or injury. Moving parts can cause injury.

1. Raise the DADH.
2. Loosen both DADH thumbscrews, [PL 5.10 Item 12](#).

3. Adjust the setting screw on the right counterbalance to correct the skew, [Figure 1](#).

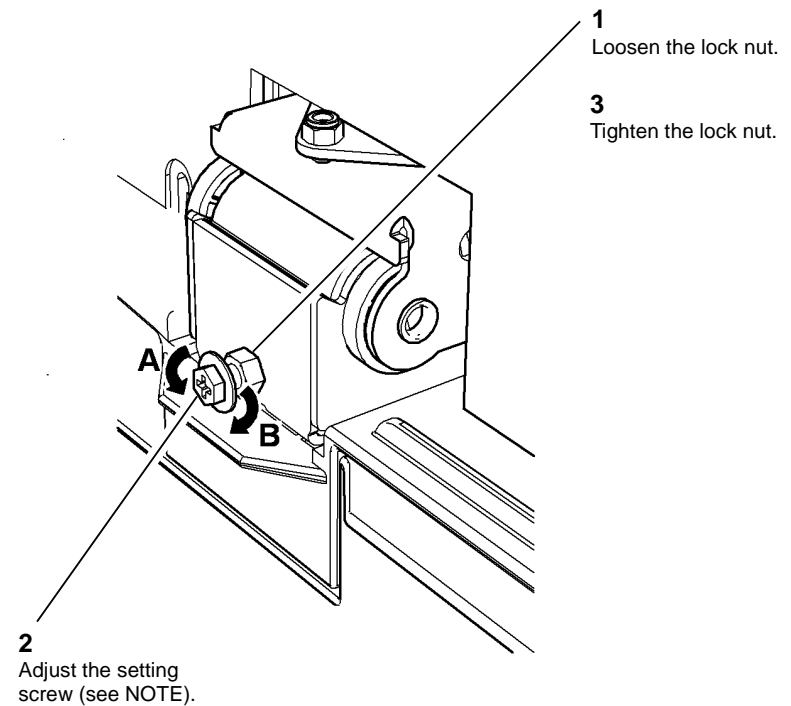

U-1-0627-A

Figure 1 Skew adjustment

NOTE: Turn the setting screw in direction A to move the right side of the DADH to the front. Turn the setting screw in direction B to move the right side of the DADH to the rear.

4. Pull the DADH forward, then tighten the thumbscrews.
5. Perform again the [Skew Check](#).
6. When the DADH skew is good, check the DADH registration. Go to [ADJ 5.5 DADH registration Adjustment](#).

ADJ 5.4 DADH Cleaning Procedure

Parts List on PL 5.10

Purpose

This procedure describes how to clean the DADH. The wear of the feed rolls, paper dust and dirt in the environment can cause copy quality defects.

The supplies required:

- Dry micro fiber wiper, PL 26.10 Item 6.
- Brush.
- Cleaning fluid, PL 26.10 Item 1.
- Antistatic fluid, PL 26.10 Item 11.

Adjustment

WARNING

Ensure that the electricity to the machine is switched off while performing tasks that do not need electricity. Refer to GP 14. Disconnect the power cord. Electricity can cause death or injury. Moving parts can cause injury.

Perform the steps that follow:

1. Use a brush to clean the document length sensors, PL 5.35 Item 8.
2. Use a brush to clean the DADH feed sensor and the area around the sensor, PL 5.15 Item 2.
3. Open the DADH top cover.
4. Use a dry micro fiber wiper, or brush to clean the document path area, top and bottom. Remove all loose material.
5. Clean the CVT roll, PL 5.25 Item 5 with a micro fiber wiper and water.
6. Clean the CVT idlers and the takeaway idlers, PL 5.20 Item 3 with a micro fiber wiper and water.
7. Remove the DADH rear cover, PL 5.10 Item 1. Clean the takeaway rolls, PL 5.35 Item 17 with a micro fiber wiper and water.
8. Clean the exit rolls, PL 5.35 Item 6 with a micro fiber wiper and water.

CAUTION

When the feed rolls are installed, make sure the lowest roll, (retard roll), is correctly positioned on the assembly as shown in Figure 1.

9. Remove the feed roll assembly, REP 5.14. Clean the 3 rolls and the pad, PL 5.35 Item 2 with a micro fiber wiper and water. Use a brush to clean the paper dust from the assembly and from the area around the assembly. Install the feed roll assembly.
10. Leave the top cover open and raise the DADH assembly.
11. Lower the lower baffle assembly, PL 5.30 Item 14. Clean the post scan idlers, PL 5.30 Item 4 with a micro fiber wiper and water.
12. Clean the exit roll idlers, PL 5.30 Item 6 with a micro fiber wiper and water.
13. Clean the document pad, PL 5.10 Item 3 with a micro fiber wiper and water.
14. Lower the DADH assembly. Install the DADH rear cover.

CAUTION

When the under side of the input tray is cleaned, do not damage the restack arm, PL 5.35 Item 3.

15. Clean the input tray assembly, PL 5.35 Item 1 and the exit area below the input tray with a micro fiber wiper and antistatic fluid.
16. Clean the CVT glass and the document glass. Refer to ADJ 62.1 Optics Cleaning Procedure.

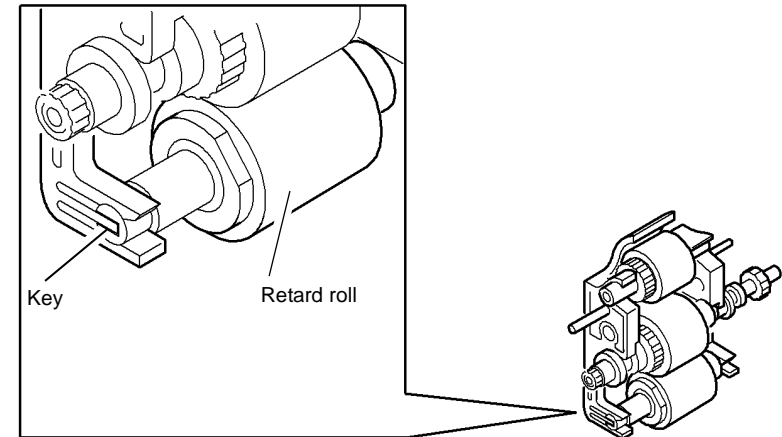

U-1-0625-A

Figure 1 Retard roll position

ADJ 5.5 DADH Registration Adjustment

Parts List on [PL 5.10](#)

Purpose

To measure and adjust the image to paper registration.

Adjustment

WARNING

Ensure that the electricity to the machine is switched off while performing tasks that do not need electricity. Refer to [GP 14](#). Disconnect the power cord. Electricity can cause death or injury. Moving parts can cause injury.

Perform the following as required:

- [dC608](#) DADH Registration.
- [dC609](#) Document Glass Registration.

ADJ 5.6 DADH Document Pad

Parts List on [PL 5.10](#)

Purpose

To correctly align the DADH document pad with the document glass.

Adjustment

WARNING

Ensure that the electricity to the machine is switched off while performing tasks that do not need electricity. Refer to [GP 14](#). Disconnect the power cord. Electricity can cause death or injury. Moving parts can cause injury.

NOTE: If a new document pad is installed, make sure that the protective paper is removed from the adhesive pads.

1. Raise the DADH. Put the document pad with the adhesive pads face-up on the document glass.
2. Align the document pad with the document registration guides as shown in [Figure 1](#).

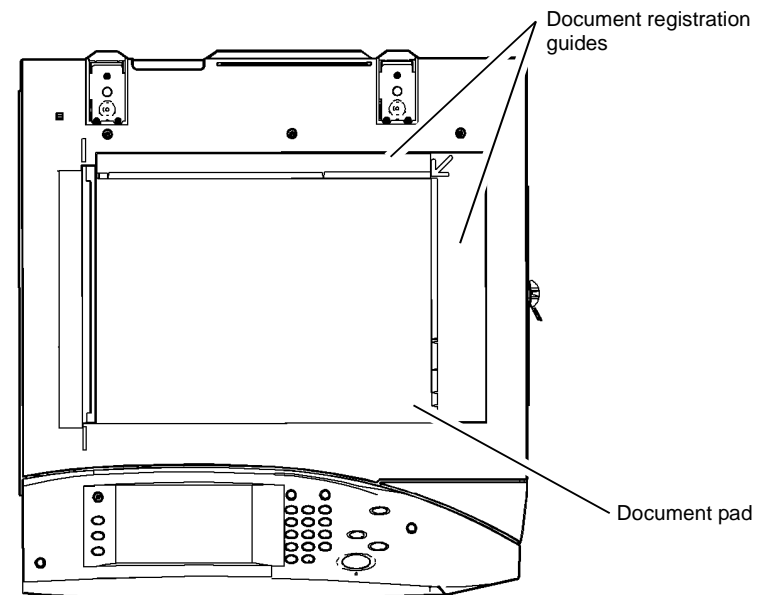

U-1-0626-A

Figure 1 Document pad alignment

3. Carefully lower then raise the DADH. Make sure the document pad is attached correctly.

ADJ 12.1-110 LCSS Bin 1 Level

Parts List on [PL 12.10](#)

Purpose

To ensure bin 1 is level, and achieve the best stacking performance.

Adjustment

WARNING

Ensure that the electricity to the machine is switched off while performing tasks that do not need electricity. Refer to [GP 14](#). Disconnect the power cord. Electricity can cause death or injury. Moving parts can cause injury.

1. Remove the rear cover and bin 1 motor, refer to [REP 12.5-110](#).
2. Move bin 1 to the lowest position.
3. Remove the rear clamp, ensure the bin is fully down on both sides, then install the rear clamp.
4. Re-install the bin 1 motor, refer to [REP 12.5-110](#).
5. Switch on the machine, [GP 14](#).
6. Enter [dC330](#) code 12-242, bin 1 elevator motor cycle. Check that bin 1 cycles without giving any fault indications.

ADJ 12.2-110 Machine to LCSS Alignment

Parts List on [PL 12.10](#)

Purpose

To correctly align the LCSS to achieve reliable transfer of paper from the machine to the LCSS.

Adjustment

WARNING

Ensure that the electricity to the machine is switched off while performing tasks that do not need electricity. Refer to [GP 14](#). Disconnect the power cord. Electricity can cause death or injury. Moving parts can cause injury.

Turn the hand wheels above the castors below bin 1 to adjust the alignment:

- [Figure 1](#), turn both hand wheels in the same direction to adjust the vertical alignment between the LCSS and the machine. The LCSS should be in vertical alignment with the machine, viewed from the front and rear.

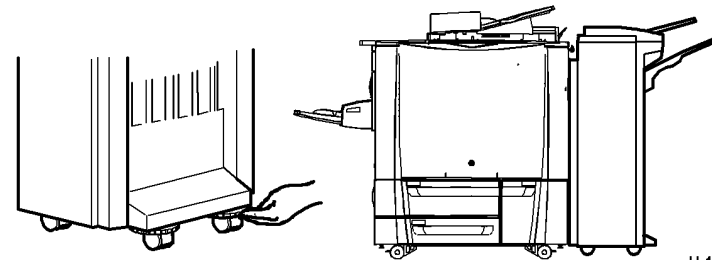

Figure 1 Machine to LCSS alignment

ADJ 12.3-110 Hole Punch Position

Parts List on [PL 12.20](#)

Purpose

To optimize the position of the hole punch.

Check

1. Ask the customer which trays are used to feed from for hole punching.
2. Load the indicated trays with A4 (8.5x11 inch) paper.
3. Make a set of five punched copies or prints from each of the indicated trays. Mark the top edge (towards the front of the machine) of each set to indicate the tray from which it was fed.
4. Evaluate the average hole positions in each set, referring to [Figure 1](#). The distances shown should be equal at the top and bottom of the sheet. If the distances are different by more than 1 mm (0.040 inches), perform the adjustment.

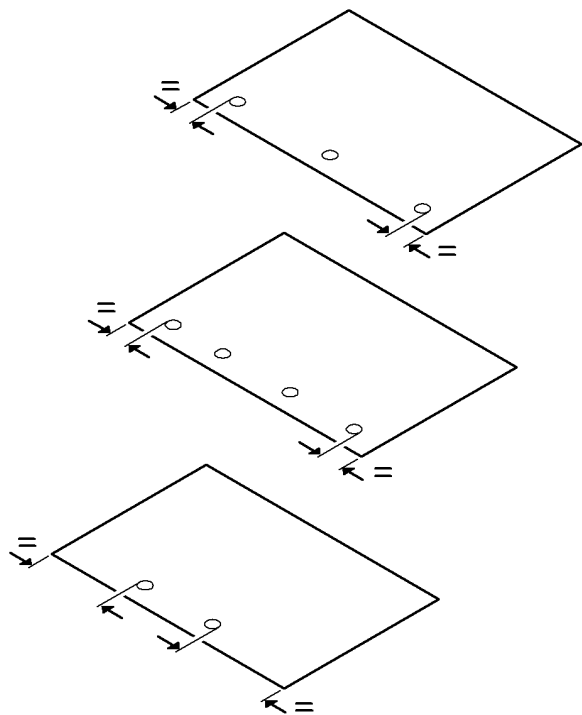

Figure 1 Hole positions

U-1-0638-A

Adjustment

WARNING

Ensure that the electricity to the machine is switched off while performing tasks that do not need electricity. Refer to [GP 14](#). Disconnect the power cord. Electricity can cause death or injury. Moving parts can cause injury.

1. Remove the chad bin and unscrew the thumb screw retaining the hole punch assembly.
2. Pull out the hole punch assembly a short distance to access the spacer, if installed, refer to [Figure 2](#). The following settings can be made:

NOTE: If the spacer cannot be found, suitable washers up to a total thickness of 2 mm (0.080 inches) may be used.

- With no spacer installed the holes are punched closest to the bottom of the sheet.
- With the spacer installed unfolded the holes are punched 1 mm (0.040 inches) closer to the top of the sheet.
- With the spacer installed folded the holes are punched 2 mm (0.080 inches) closer to the top of the sheet.

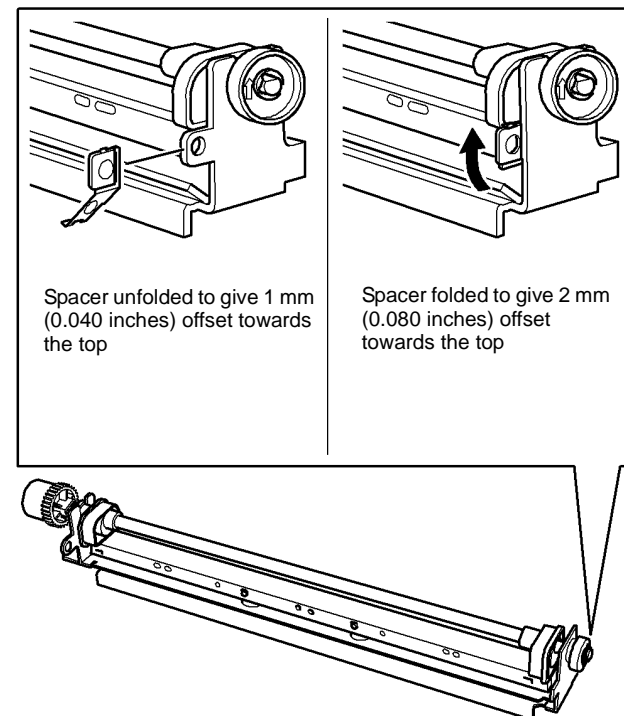

Figure 2 Hole punch spacer

U-1-0639-A

3. Evaluate the movement needed and re-position the hole punch assembly. If the spacer is removed, tape it next to the TAG label on the LCSS frame for future use.

4. Make sets from each of the indicated trays once more and ensure that the hole alignment is now optimized, make further adjustment if necessary.
5. If necessary, re-load the paper trays as they were before the adjustment was performed.

ADJ 12.4-110 Motor Drive Belt Tensioning

Parts List on [PL 12.40](#)

Purpose

To set the tension of directly or indirectly driven belts that are tensioned by a spring attached to the motor.

Check

1. The shafts and pulleys are installed and properly located.
2. The drive belt is undamaged and correctly routed.
3. The adjustable motor or tensioning pulley bracket is positioned with fastening screws not tightened fully.

NOTE: For motors with pivoted brackets, the pivot screw must be fitted and tightened.

4. The tensioning spring is fitted between the bracket and frame locating point.

Adjustment

WARNING

Ensure that the electricity to the machine is switched off while performing tasks that do not need electricity. Refer to [GP 14](#). Disconnect the power cord. Electricity can cause death or injury. Moving parts can cause injury.

1. [Figure 1](#) shows a typical arrangement. Press the belt midway between pulleys and check that the bracket moves in the direction of the spring pull; slacken the bracket screws if necessary.
2. Release the belt and allow the spring to pull the bracket and tension the drive belt then tighten the lock and bracket screws.

NOTE: Check the belt condition and routing if the tension spring is not extended or the locking screw is at the end of the bracket adjustment slot.

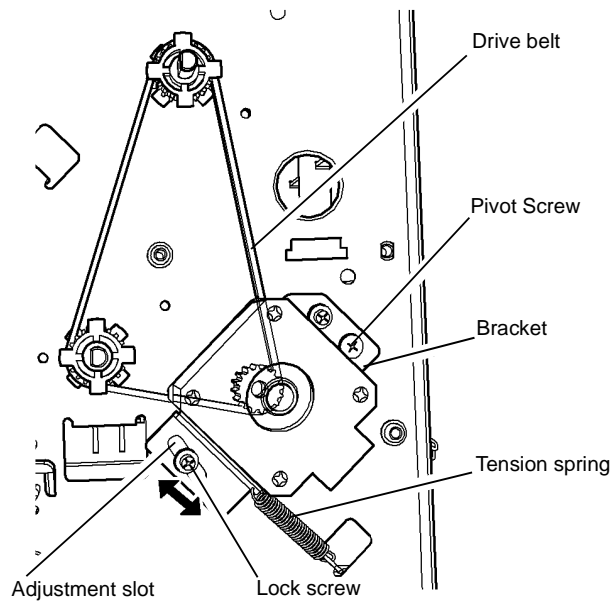

Typical spring tensioning arrangement

U-1-0640-A

Figure 1 Drive Belt Tensioning

ADJ 12.1-171 Machine to HVF / HVF BM, HVF BM to Tri-Folder Alignment

Purpose

To correctly align the HVF / HVF BM to achieve reliable transfer of paper from the machine to the output tray.

To correctly align the tri-folder, to achieve reliable transfer of paper from the HVF BM to the output tray.

Check

- Ensure the HVF / HVF BM is aligned both vertically and horizontally with the machine. If necessary perform the adjustment, [Figure 1](#).
- Ensure the Tri-folder is aligned vertically and horizontally with the HVF / HVF BM. If necessary perform the adjustment, [Figure 2](#).

Adjustment

WARNING

Ensure that the electricity to the machine is switched off while performing tasks that do not need electricity. Refer to [GP 14](#). Disconnect the power cord. Electricity can cause death or injury. Moving parts can cause injury.

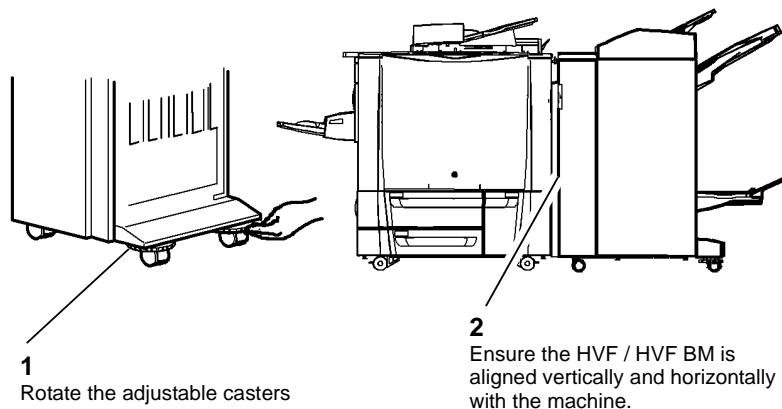

U-1-0642-A

Figure 1 Machine to HVF BM alignment

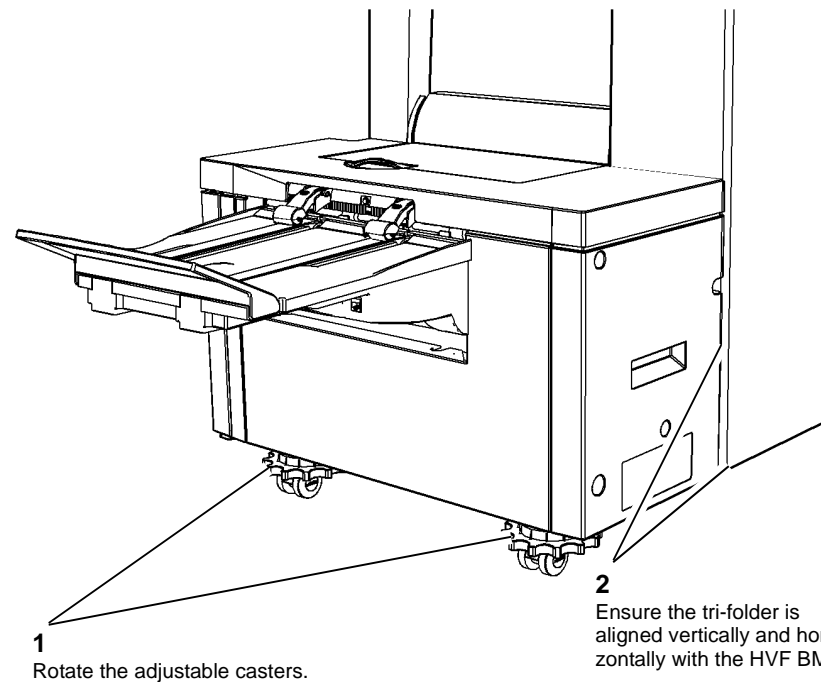

U-1-0957-A

Figure 2 Tri-folder to HVF BM alignment

ADJ 12.2-171 Tri-Folder Paper Settings

Purpose

The purpose of the procedure is to place the fold in the correct position on 8.5 x 11 inch and A4 paper.

Check

1. Ensure that the tri-folder is at the same height as the HVF, [ADJ 12.1-171](#).
2. Run a copy job 4 sheets and check that the folds are in the correct place.
3. The paper should be folded into three equal parts and the folds parallel to the edge of the paper. If necessary perform the adjustment.

Adjustment

WARNING

Ensure that the electricity to the machine is switched off while performing tasks that do not need electricity. Refer to [GP 14](#). Disconnect the power cord. Electricity can cause death or injury. Moving parts can cause injury.

1. Remove the front door, [PL 12.100 Item 3](#).
2. Remove the front cover, [PL 12.100 Item 2](#).
3. Remove the rear cover, [PL 12.100 Item 5](#).

4. Set the folder to the appropriate paper size:
 - To set the folder for A4 paper, [Figure 1](#).
 - To set the folder for 8.5 x 11 inch paper, [Figure 2](#).

NOTE: Do not over loosen the adjuster screws. The adjusters can detach from the backstop. Make sure the position of the backstop changes when the adjusters are moved.

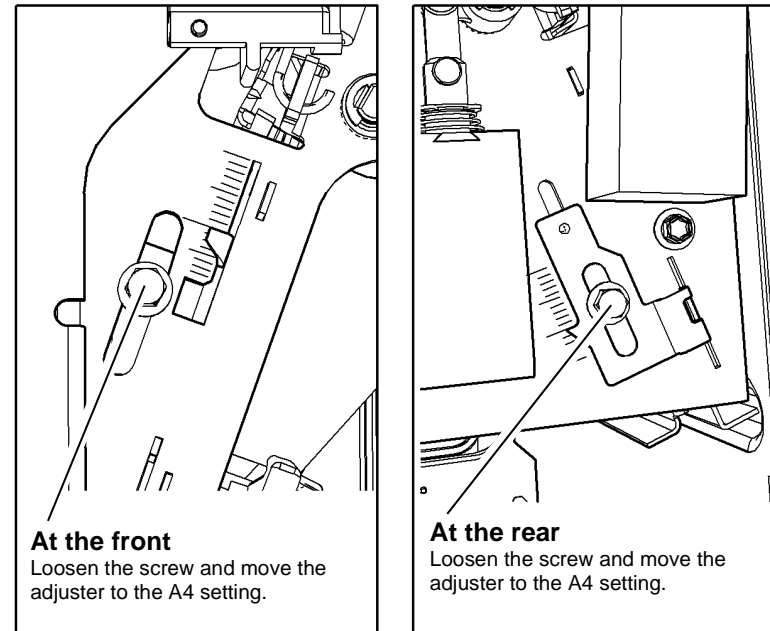

U-1-0643-A

Figure 1 A4 paper setting

ADJ 12.3-171 Stapler Anvil Alignment

Parts List on [PL 12.185](#)

Purpose

To ensure the correct alignment of the stapler anvil to the stapler throat.

Special Tools Required

Stapler alignment tool, supplied with the HVF BM, located on the left of the BM frame.

NOTE: This procedure illustrates the front stapler. The procedure for adjusting the rear stapler is identical.

Adjustment

WARNING

Ensure that the electricity to the machine is switched off while performing tasks that do not need electricity. Refer to [GP 14](#). Disconnect the power cord. Electricity can cause death or injury. Moving parts can cause injury.

WARNING

Take care during this procedure. Sharp edges may be present that can cause injury.

1. To improve the access to the two clamp screws for the anvil, remove the tamper assembly, [REP 12.30-171](#).
2. Fully pull out the BM module. Remove the stapler cover(s), one screw on each. Pull the stapler bracket handle and swing open the stapler bracket.

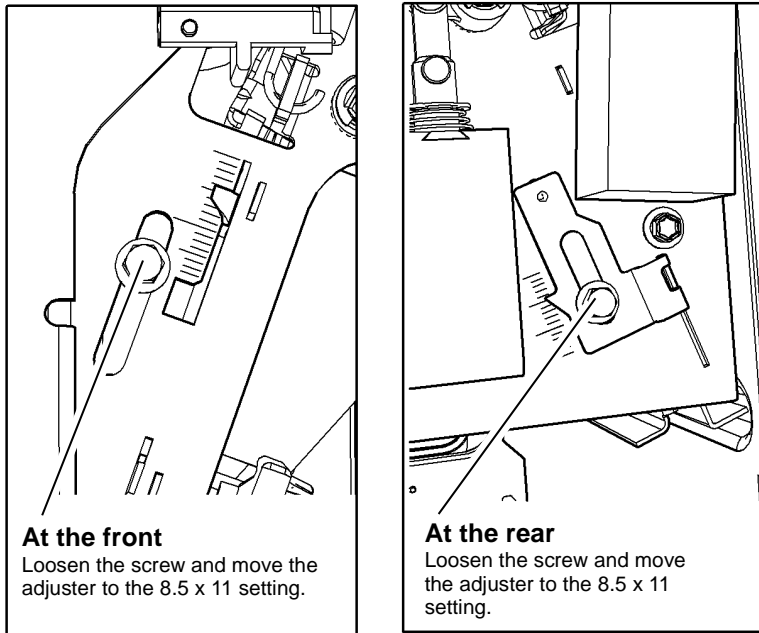

U-1-0644-A

Figure 2 8.5 x 11 inch paper setting

5. Ensure the front door interlock switch is cheated, [PL 12.115 Item 24](#). Run a four sheet C fold and Z fold copy job. Check that the copies are folded into three approximately equal parts, with the folds parallel to the edge of the paper.
6. Check the C and Z folded copies meet the customer requirements. If necessary make fine adjustments to the position of the folds. [ADJ 12.12-171 Tri-Folder Fold Adjustment](#).

3. **Figure 1**, insert the alignment tool.

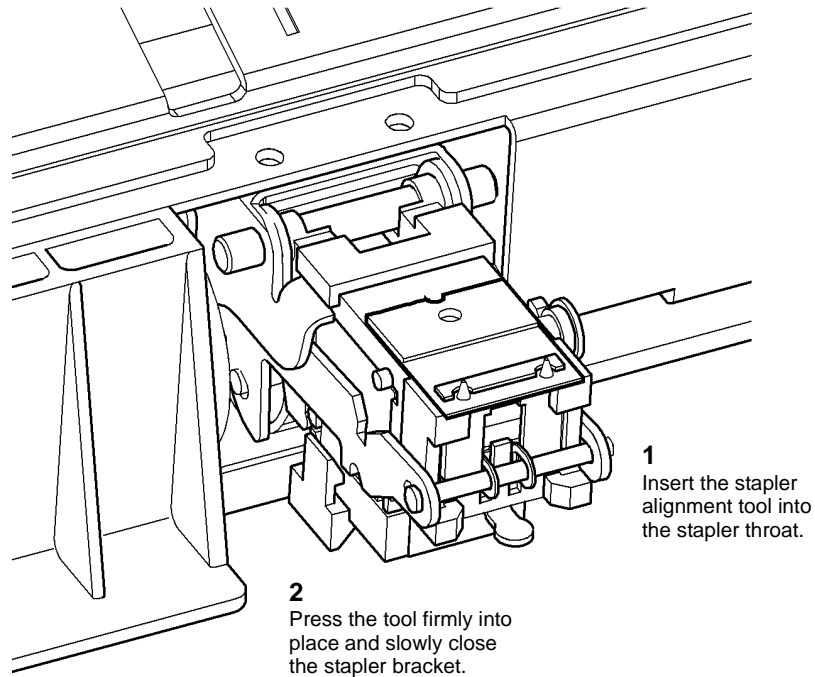

Figure 1 Alignment tool insertion

U-1-0646-A

4. **Figure 2**, loosen the anvil.

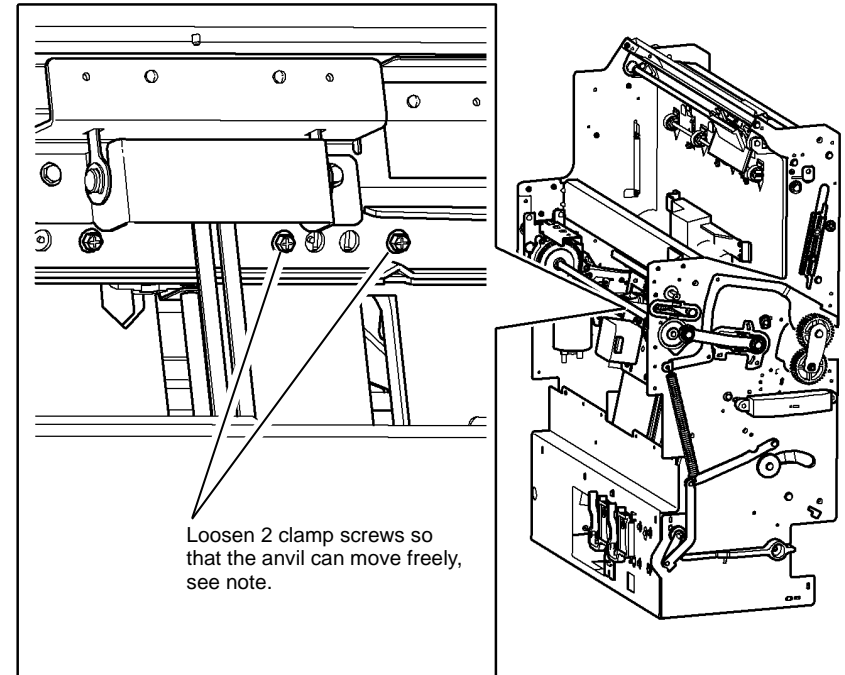
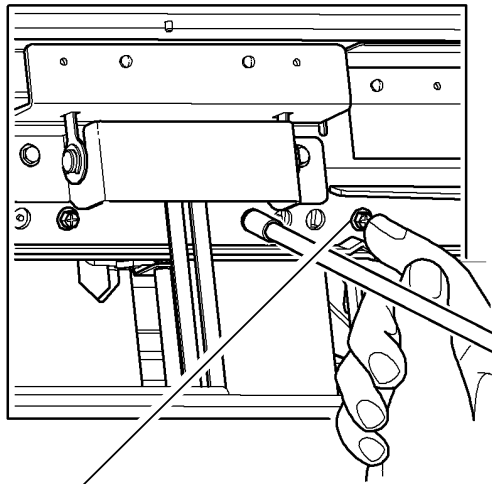
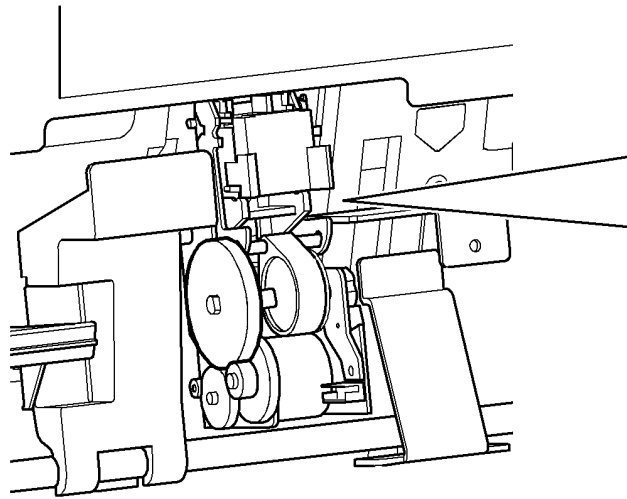

Figure 2 Loosening the anvil

U-1-0647-A

NOTE: Take great care not to drop the anvil, spacer or clamp plate, **Figure 3**, as they can fall to the bottom of the BM module. If parts need to be retrieved from the bottom of the BM module it may be necessary to tilt the whole HVF BM to make the loose parts slide to the centre of the base, from where they can be easily removed.

5. **Figure 3**, close the stapler.



4

Tighten the two screws alternately a little at a time, while holding the free screw with a finger. Ensure that the anvil does not move as the screws are tightened.

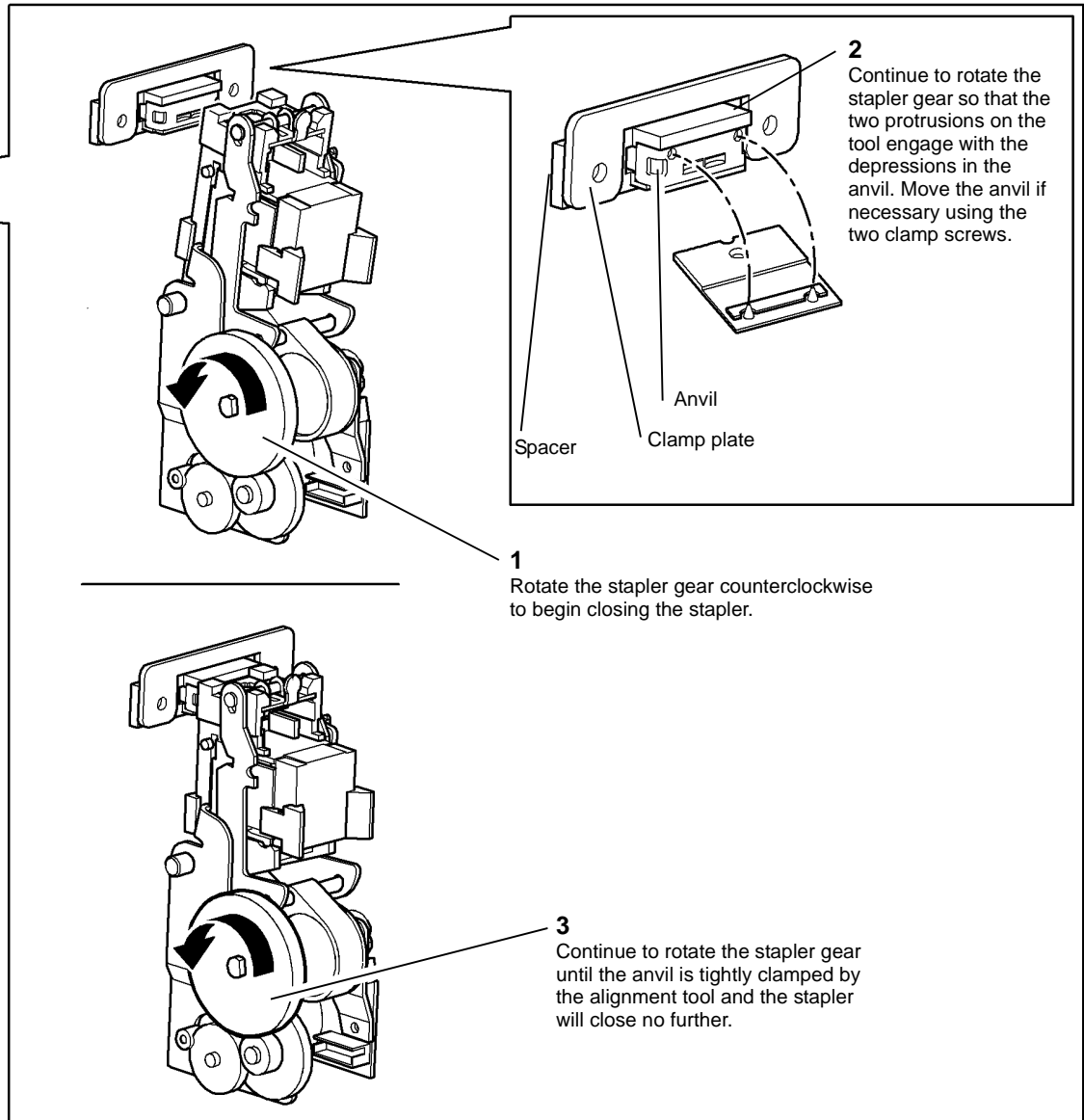

1

Rotate the stapler gear counterclockwise to begin closing the stapler.

3

Continue to rotate the stapler gear until the anvil is tightly clamped by the alignment tool and the stapler will close no further.

2
Continue to rotate the stapler gear so that the two protrusions on the tool engage with the depressions in the anvil. Move the anvil if necessary using the two clamp screws.

Spacer

Clamp plate

Anvil

Figure 3 Closing the stapler

U-1-0648-A

6. Open the stapler fully by use of the stapler gear, [Figure 3](#), then remove the alignment tool.
7. Perform the adjustment on the other stapler anvil if necessary.
8. Check the operation of the stapler by making a few stapled sets using 2 sheets of 80gsm (20 pound) paper. check the quality of the staple clinch.

ADJ 12.4-171 Crease Blade Position

Purpose

NOTE: There is no adjustment needed for the crease blade position.

The crease blade assembly is supplied with the blade set at the nominal position.

If the crease blade assembly is damaged or requires adjustment, install a new crease blade assembly, [PL 12.170 Item 13](#).

ADJ 12.5-171 Booklet Tamping

Purpose

To set the tamper travel to give neat booklets without edge damage.

Procedure

WARNING

Ensure that the electricity to the machine is switched off while performing tasks that do not need electricity. Refer to [GP 14](#). Disconnect the power cord. Electricity can cause death or injury. Moving parts can cause injury.

Go to the appropriate check and adjustment from the following options:

- If only A4 paper is available, go to [A4 Paper Procedure](#).
- If only 8.5 X 11 inch paper is available, go to [8.5 X 11 Inch Procedure](#).

A4 Paper Procedure

Check

1. Open the HVF BM front door and insert an interlock cheater into the front door interlock switch.
2. Fully pull out the BM module and release the jam clearance handle [PL 12.150 Item 8](#), fully open the paper guide, [PL 12.150 Item 7](#).
3. Do the following:
 - a. Enter Service mode [GP 1](#).
 - b. Select Adjustment Routines.
 - c. Select [dC131](#) NVM Read / Write.
 - d. Enter NVMID 12-006 BookMkrTampRdyOff-set.
 - e. Select Read / Write and reduce the original value by 8.
 - f. Select Save, select OK, select Close, select Exit.
4. Enter Diagnostic Routine [dC330](#) code 12-255 BM Backstop Motor, select Start, allow the backstop to raise to the receive position (where it will pause), select Stop.
5. Enter [dC330](#) code 12-256 BM tamper 1 motor. Select Start to run the tamper motor, allow the tampers to move into the tamped position (where they will pause), select Stop.
6. Insert a single sheet of A4 paper, short edge downward into the booklet maker compiling area, so that it rests on the backstop and is located between the two tampers
7. Bias the sheet towards the rear of the machine until the sheet touches the rear tamper, [Figure 1](#).
8. Observe the position of the sheet between the tampers, [Figure 1](#).
 - If the sheet cannot reach the backstop because the tampers are too close together, the NVM value will need to be decreased to move the tampers further apart, perform the adjustment.
 - If the front tamper is not within 0.5 mm (0.02 inch) of the sheet edge without touching the sheet, the NVM value will need to be increased to move the tampers closer together, perform the adjustment.
 - If the tampers are in the correct position, within 0.5 mm (0.02 inch) of the sheet edge without touching the sheet, do the following:
 - a. Enter Service Mode [GP 1](#).
 - b. Select Adjustment Routines.

- c. Select **dC131** NVM Read / Write.
- d. Enter NVMID 12-006 BookMkrTampRdyOff-set.
- e. Select Read / Write and increase the value by 8.
- f. Select Save, select OK, select Close, select Exit.

Adjustment

1. Do the following:
 - a. Enter Service Mode **GP 1**.
 - b. Select Adjustment Routines.
 - c. Select **dC131** NVM Read / Write.
 - d. Enter NVMID 12-006 BookMkrTampRdyOff-set.
 - e. Select Read / Write and enter the new value to correct the error found during the check. Increasing the value lengthens the tamping stroke (tamps to a narrower dimension between the tampers. Decreasing the value shortens the tamping stroke (tamps to a wider dimension between the tampers). One step = 0.53 mm.
 - f. Select Save, select OK, select Close, select Exit.
2. Repeat the check to ensure the tampers are set correctly.
3. When the tamper travel is correct, do the following:
 - a. Enter Service Mode **GP 1**.
 - b. Select Adjustment Routines.
 - c. Select **dC131** NVM Read / Write.
 - d. Enter NVMID 12-006 BookMkrTampRdyOff-set.
 - e. Select Read / Write and increase the value by 8.
 - f. Select Save, select OK, select Close, select Exit.
4. Switch the machine off then on, **GP 14**.

8.5 X 11 Inch Procedure

Check

1. Open the HVF BM front door and insert an interlock cheater into the front door interlock switch.
2. Fully pull out the booklet maker and release the jam clearance handle **PL 12.150 Item 8**, fully open the paper guide **PL 12.150 Item 7**.
3. Do the following:
 - a. Enter Service Mode **GP 1**.
 - b. Select Adjustment Routines.
 - c. Select **dC131** NVM Read / Write.
 - d. Enter NVMID 12-006 BookMkrTampRdyOff-set.
 - e. Select Read/Write and reduce the original value by 19.
 - f. Select Save, select OK, select Close, select Exit.
4. Enter Diagnostic Routine **dC330** code 12-255 BM Backstop Motor, select Start, allow the backstop to raise to the receive position (where it will pause), select Stop.
5. Enter Diagnostic Routine **dC330** code 12-256 BM tamper 1 motor. Select Start to run the tamper motor, allow the tampers to move into the tamped position (where they will pause), select Stop.
6. Insert a single sheet of 8.5 X 11 inch paper, short edge downward into the booklet maker compiling area, so that it rests on the backstop and is located between the two tampers

7. Bias the sheet towards the rear of the machine until the sheet touches the rear tamper, **Figure 1**.
8. Observe the position of the sheet between the tampers, **Figure 1**.
 - If the sheet cannot reach the backstop because the tampers are too close together, the NVM value will need to be decreased to move the tampers further apart, perform the adjustment.
 - If the front tamper is not within 0.5 mm (0.02 inch) of the sheet edge without touching the sheet, the NVM value will need to be increased to move the tampers closer together, perform the adjustment.
 - If the tampers are in the correct position, within 0.5 mm (0.02 inch) of the sheet edge without touching the sheet, do the following:
 - a. Enter Service Mode **GP 1**.
 - b. Select Adjustment Routines.
 - c. Select **dC131** NVM Read / Write.
 - d. Enter NVMID 12-006 BookMkrTampRdyOff-set.
 - e. Select Read / Write and increase the value by 19.
 - f. Select Save, select OK, select Close, select Exit.

Adjustment

1. Do the following:
 - a. Enter Service Routine **GP 1**.
 - b. Select Adjustment Routines.
 - c. Select **dC131** NVM Read / Write.
 - d. Enter NVMID 12-006 BookMkrTampRdyOff-set.
 - e. Select Read / Write and enter the new value to correct the error found during the check. Increasing the value lengthens the tamping stroke (tamps to a narrower dimension between the tampers. Decreasing the value shortens the tamping stroke (tamps to a wider dimension between the tampers). One step = 0.53 mm.
 - f. Select Save, select OK, select Close, select Exit.
2. Repeat the check to ensure the tampers are set correctly.
3. When the tamper travel is correct, do the following:
 - a. Enter Service Mode **GP 1**.
 - b. Select Adjustment Routines.
 - c. Select **dC131** NVM Read / Write.
 - d. Enter NVMID 12-006 BookMkrTampRdyOff-set.
 - e. Select Read / Write and increase the value by 19.
 - f. Select Save, select OK, select Close, select Exit.
4. Switch the machine off then on, **GP 14**.

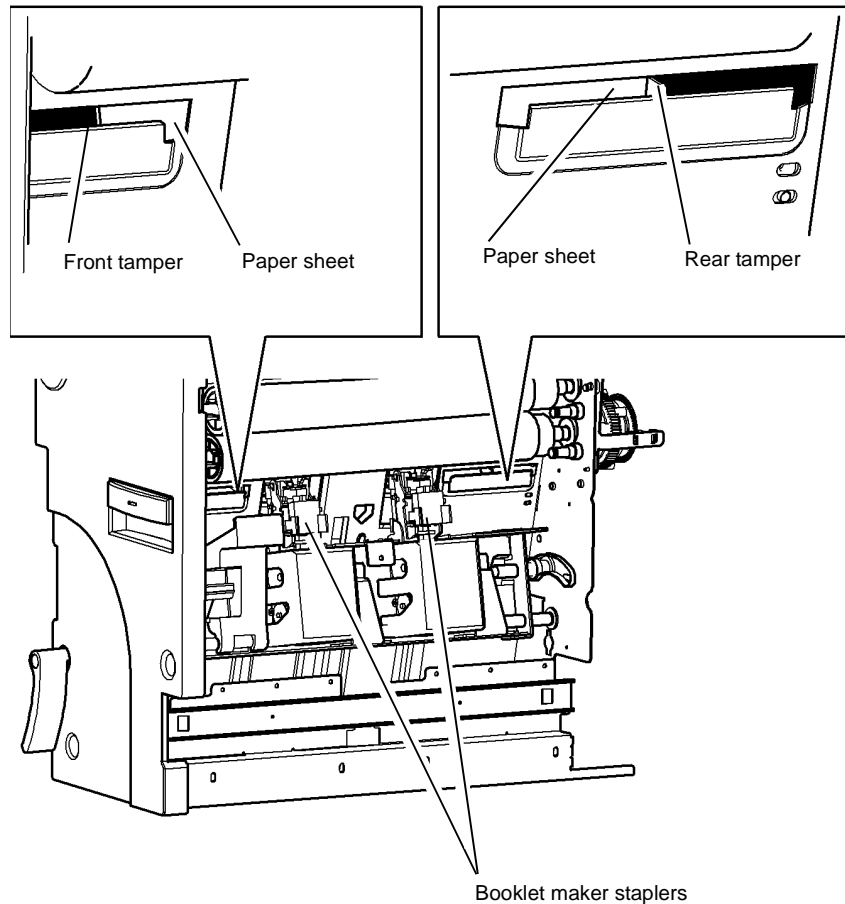

U-1-0653-A

Figure 1 Observing the tamper positions.

ADJ 12.6-171 Booklet Compiling Position

Purpose

To set the compiling position to ensure correct compiling without damage. When the compiling position is correctly set, each sheet is fed behind the BM entry roll to rest against the right side of the compiler.

Procedure

WARNING

Ensure that the electricity to the machine is switched off while performing tasks that do not need electricity. Refer to [GP 14](#). Disconnect the power cord. Electricity can cause death or injury. Moving parts can cause injury.

Go to the appropriate check and adjustment from the following options:

- If only A4 paper is available, go to [A4 Paper Procedure](#).
- If only 8.5 X 11 inch paper is available, go to [8.5 X 11 Inch Procedure](#).

A4 Paper Procedure

Check

1. Open the HVF BM front door and insert an interlock cheater into the front door interlock switch.
2. Fully pull out the BM module and release the jam clearance handle [PL 12.150 Item 8](#), fully open the paper guide [PL 12.150 Item 7](#).
3. Enter Diagnostic Routine [dC330](#) code 12-255 BM Backstop Motor, select Start, allow the backstop to raise to the receive position (where it will pause), select Stop.
4. Insert a single sheet of A4 paper short edge downward into the booklet maker compiling area, so that it rests on the backstop and is approximately central front to back. Tuck the top of the sheet behind the BM entry roll, [PL 12.150 Item 15](#).
5. If the BM right hand cover does not have a viewing hole, remove the BM right hand cover, [REP 12.56-171](#).

6. [Figure 1](#), check the alignment of the sheet against the scale.

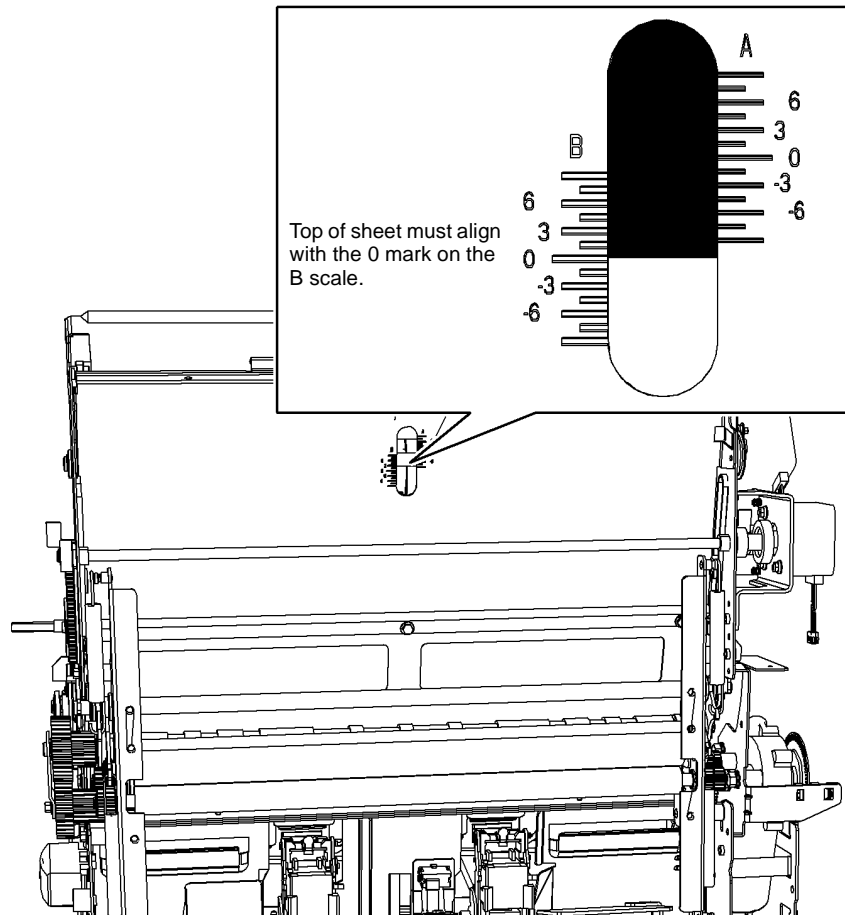

U-1-0654-A

Figure 1 Top edge alignment

7. If the sheet is correctly aligned, exit diagnostics and re-install the BM right hand cover, if removed in step 5. If the sheet is not correctly aligned, perform the adjustment.

Adjustment

1. Do the following
 - a. Enter Service Mode [GP 1](#).
 - b. Select Adjustment Routines.
 - c. Select [dC131](#) NVM Read / Write.
 - d. Enter NVMIID 12-003 BookMkrCompileOff-set.
 - e. Select Read / Write and enter the new value to correct the error found during the check. Increasing the value will raise the sheet. Decreasing the value will lower the sheet. One step = 0.1137 mm.
 - f. Select Save, select OK, select Close, select Exit.
2. Repeat the Check to ensure the compiling position is correctly set.
3. When the compiling position is correct, switch the machine off then on, [GP 14](#).

8.5 X 11 Inch Procedure

Check

1. Open the HVF BM front door and insert an interlock cheater into the front door interlock switch.
2. Fully pull out the BM module and release the jam clearance handle [PL 12.150 Item 8](#). fully open the paper guide [PL 12.150 Item 7](#).
3. Do the following
 - a. Enter Service Mode [GP 1](#).
 - b. Select Adjustment Routines.
 - c. Select [dC131](#) NVM Read / Write.
 - d. Enter NVMIID 12-003 BookMkrCompileOff-set.
 - e. Select Read / Write and increase the original value by 80.
 - f. Select Save, select OK, select Close, select Exit.
4. Enter Diagnostic Routine [dC330](#) code 12-255 BM Backstop Motor, select Start, allow the backstop to raise to the receive position (where it will pause), select Stop.
5. Insert a single sheet of 8.5 X 11 inch paper short edge downward into the booklet maker compiling area, so that it rests on the backstop and is approximately central front to back. Tuck the top of the sheet behind the BM entry roll, [PL 12.150 Item 15](#).
6. If the BM right hand cover does not have a viewing hole, remove the BM right hand cover, [REP 12.56-171](#).

7. **Figure 2**, check the alignment of the sheet against the scale.

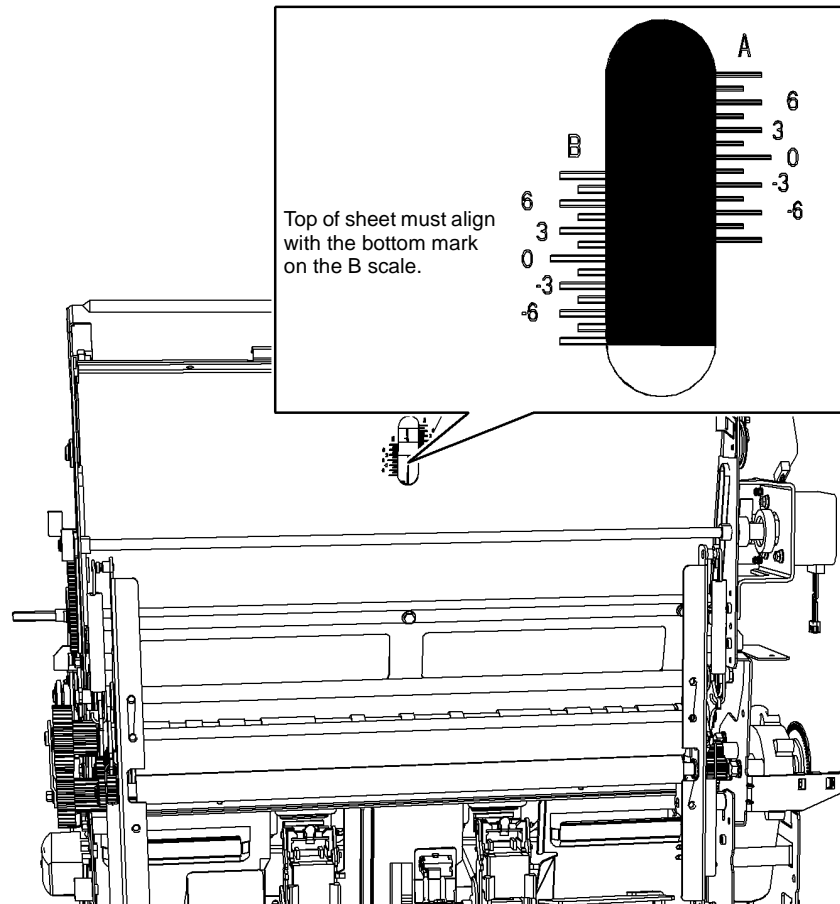

U-1-0655-A

Figure 2 Top edge alignment

8. If the sheet is correctly aligned, do the following:
 - a. Enter Service Mode **GP 1**.
 - b. Select Adjustment Routines.
 - c. Select **dC131** NVM Read / Write.
 - d. Enter NVMID 12-003 BookMkrCompileOff-set.

- e. Select Read / Write and decrease the value by 80, this will return the NVM value to the original setting.
 - f. Select Save, select OK, select Close, select Exit.
 - g. Re-install the BM right hand cover, if removed in step 5.
9. If the sheet is not correctly aligned, perform the adjustment.

Adjustment

1. Do the following
 - a. Enter Service Routine **GP 1**.
 - b. Select Adjustment Routines.
 - c. Select **dC131** NVM Read / Write.
 - d. Enter NVMID 12-003 BookMkrCompileOff-set.
 - e. Select Read/Write and enter the new value to correct the error found during the check. Increasing the value will raise the sheet. Decreasing the value will lower the sheet. One step = 0.1137 mm.
 - f. Select Save, select OK, select Close, select Exit.
2. Repeat the Check to ensure the compiling position is correctly set.
3. Do the following:
 - a. Enter Service Mode **GP 1**.
 - b. Select Adjustment Routines.
 - c. Select **dC131** NVM Read / Write.
 - d. Enter NVMID 12-003 BookMkrCompileOff-set.
 - e. Select Read / Write and decrease the value by 80.
 - f. Select Save, select OK, select Close, select Exit.
 - g. Re-install the BM right hand cover, if removed in step 5.
4. When the compiling position is correct, switch the machine off then on, **GP 14**.

ADJ 12.7-171 Booklet Crease Position

Purpose

To set the crease position of the booklet in relation to the left edge of the top sheet of the booklet.

Check

1. Run a copy job of 3 stapled 4 sheet booklets.
2. Observe the position of the crease in relation to the open end of the booklet. The fold should be central, so that the open end of the booklet pages are equal from the fold. If necessary perform the adjustment.

3. Check the backstop home sensor bracket is in the correct position. Ensure the flag is central to the locator, [Figure 1](#).

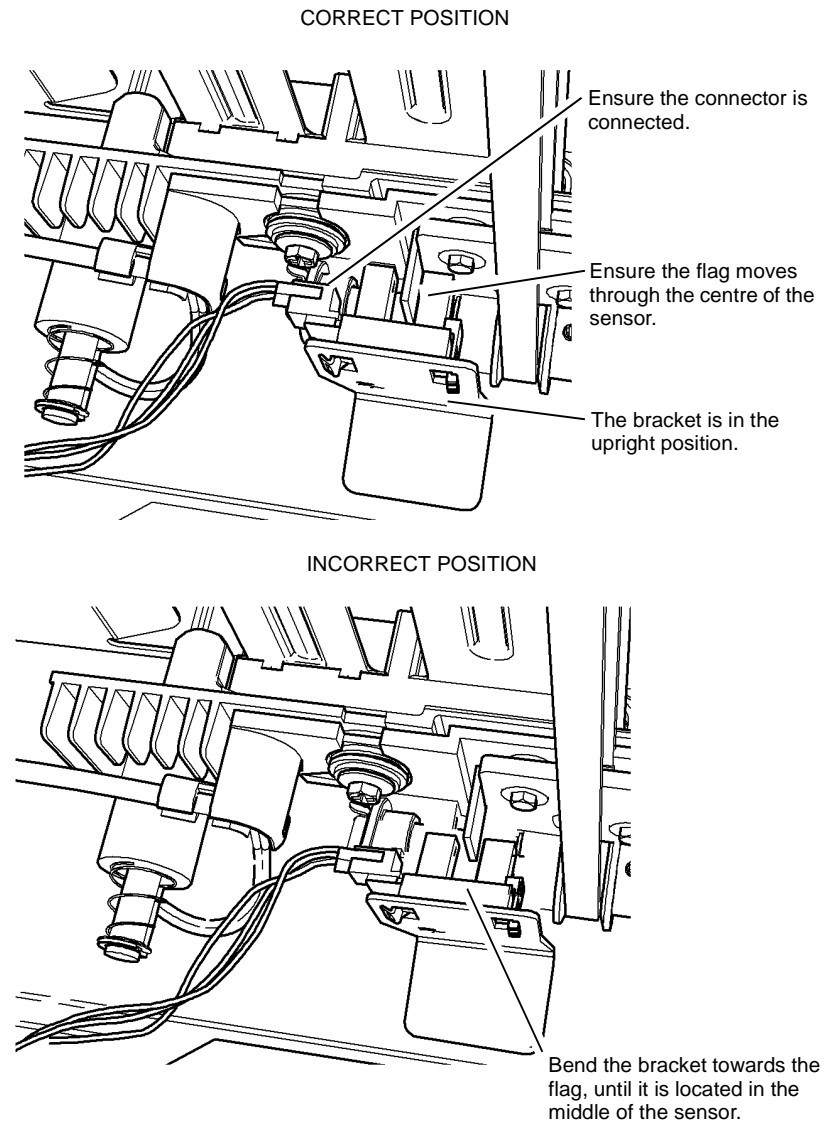

U-1-1486-A

Figure 1 Booklet maker back stop sensor bracket

Adjustment

WARNING

Ensure that the electricity to the machine is switched off while performing tasks that do not need electricity. Refer to GP 14. Disconnect the power cord. Electricity can cause death or injury. Moving parts can cause injury.

1. Perform the following:
 - a. Enter Service Mode GP 1
 - b. Select Adjustment Routines.
 - c. Select 131 NVM Read / Write...
 - d. Enter NVMID 12-005 BookMrkFoldOffset.
 - e. Select Read/Write.
 - f. Enter the new value to correct the error found during the check.

NOTE: Increasing the value increases the width of the top sheet of the booklet (moves the fold away from the left edge). Decreasing the value decreases the width of the top sheet of the booklet (moves the fold towards the left edge). One step = 0.1137 mm.

- g. Select Save, then OK.
2. Select Save, then select OK.
3. When the crease position is correct, switch the machine off then on, GP 14.

ADJ 12.8-171 Booklet Staple Position

Purpose

To set the position of the staples so that they are positioned on the fold of the booklet.

Check

1. Run a copy job of 3 stapled 4 sheet booklets.
2. Observe the position of the staple in relation to the fold of the booklet. The staple should be positioned in the middle of the fold. If necessary perform the adjustment.

Adjustment

WARNING

Ensure that the electricity to the machine is switched off while performing tasks that do not need electricity. Refer to GP 14. Disconnect the power cord. Electricity can cause death or injury. Moving parts can cause injury.

1. Perform the following:
 - a. Enter Service Mode GP 1.
 - b. Select Adjustment Routines.
 - c. Select dC131 NVM Read / Write.
 - d. Enter the NVMID as required:
 - 12-004 BookMrkStapleOffset for 8.5 x 11 inch and A4.
 - 12-012 BookMrkStapleOffsetM for 8.5 x 13 inch and 8.5 x 14 inch.
 - 12-013 BookMrkStapleOffsetL for 11 x 17 inch and A3.
 - e. Select Read / Write.
 - f. Enter the new value to correct the error found during the check.

NOTE: One step = 0.1137 mm. If it is necessary to change the value for one size, the values of other sizes may also be incorrect. If paper is available, perform the Check for all size settings.

- g. Select Save, then OK.
- h. Enter NVMID 12-005 BookMrkFoldOffset.
- i. Select Read / Write.
- j. Change the value by the same amount as the BookMrkStapleOffset value.

NOTE: Increasing both values moves the staple position toward the left edge of the top sheet. Decreasing both values moves the staple position away. Changing only the BookMrkStapleOffset value will move the staple position and fold position the same amount.

- k. Select Save, then OK.
2. Repeat the Check to ensure the staple position is correct.
3. When the staple position is correct, switch the machine off then on, GP 14.

ADJ 12.9-171 Booklet Maker Skew

Purpose

To adjust the skew of the booklet crease.

Check and complete the following adjustments:

- ADJ 12.6-171 Booklet compiling position.
- ADJ 12.8-171 Booklet staple position.
- ADJ 12.7-171 Booklet crease position.

Check

1. Run a copy job of 3 stapled 4 sheet booklets.
2. Observe the position of the crease in relation to the open end of the booklet. The fold should be central, so that the open end of the booklet pages are equal from the fold. If necessary perform the adjustment.

Adjustment

1. Slide out the booklet maker and locate the adjustment screw on the booklet backstop, [Figure 1](#).
2. Use a 2.5 mm allen head driver and turn the adjustment screw as follows:
 - Turn the screw clockwise to rotate the crease clockwise relative to the centre line.
 - Turn the screw anti-clockwise to rotate the crease anti-clockwise relative to the centre line.
 - One half turn of the adjustment screw will change the crease angle approximately 3 to 4 mm over the length of the crease.
3. Run a copy job of 3 stapled 4 sheet booklets to check that the crease is in the centre of the book. Repeat the adjustment if necessary.

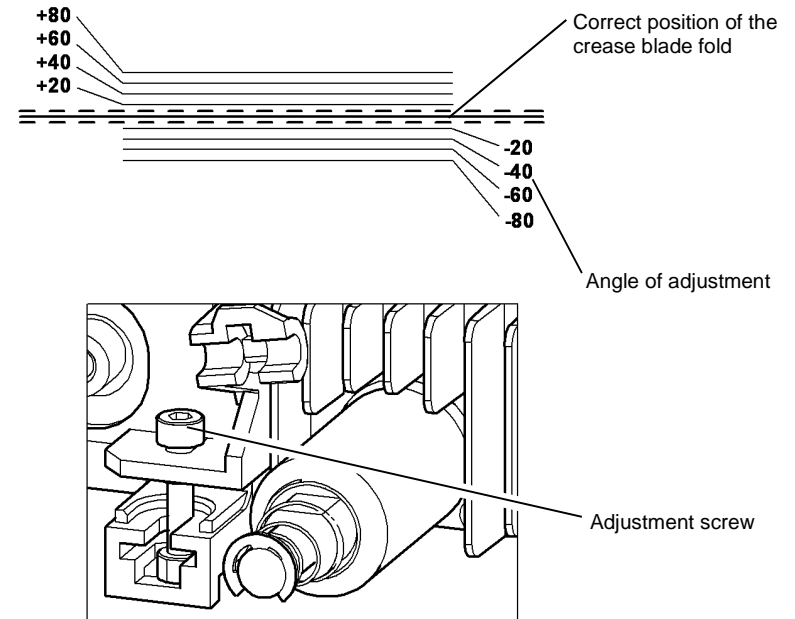

U-1-0656-A

Figure 1 Booklet crease adjustment

ADJ 12.10-171 HVF Motor Drive Belt Tensioning

Purpose

To set the tension of belts that are tensioned by a spring attached to a motor. See also [ADJ 12.11-171 Idler Drive Belt Tensioning](#).

Check

1. The shafts and pulleys are installed and properly located.
2. The drive belt is undamaged and correctly routed.
3. The adjustable motor or tensioning pulley bracket is positioned with fastening screws not tightened fully.

NOTE: For motors with pivoted brackets, the pivot screw must be fitted and tightened.

4. The tensioning spring is fitted between the bracket and frame locating point.

Adjustment

WARNING

Ensure that the electricity to the machine is switched off while performing tasks that do not need electricity. Refer to [GP 14](#). Disconnect the power cord. Electricity can cause death or injury. Moving parts can cause injury.

1. [Figure 1](#) shows a typical arrangement. Press the belt midway between pulleys and check that the bracket moves in the direction of the spring pull; slacken the bracket screws if necessary.
2. Release the belt and allow the spring to pull the bracket and tension the drive belt then tighten the lock and bracket screws.

NOTE: Check the belt condition and routing if the tension spring is not extended or the locking screw is at the end of the bracket adjustment slot.

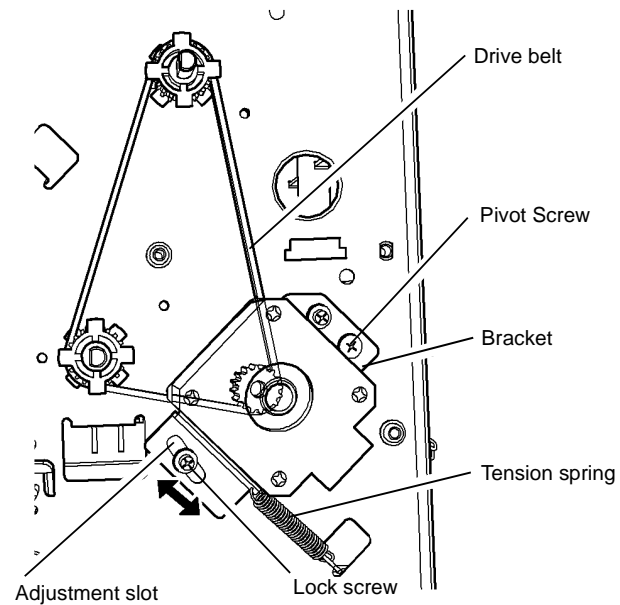

Typical spring tensioning arrangement

U-1-0657-A

Figure 1 Drive Belt Tensioning

ADJ 12.11-171 HVF Idler Drive Belt Tensioning

Purpose

To set the tension of drive belts that are tensioned by a spring attached to an idler. See also [ADJ 12.10-171 Motor Drive Belt Tensioning](#).

Check

1. The shafts and pulleys are installed and properly located.
2. The drive belt is undamaged and correctly routed.
3. The tensioning spring is fitted between the idler bracket and frame locating point.

Adjustment

WARNING

Ensure that the electricity to the machine is switched off while performing tasks that do not need electricity. Refer to [GP 14](#). Disconnect the power cord. Electricity can cause death or injury. Moving parts can cause injury.

1. [Figure 1](#) shows a typical arrangement. Loosen the adjustment screw and allow the spring to tension the belt.
2. Tighten the adjustment screw.
3. If no more adjustment is available, install new components as necessary.

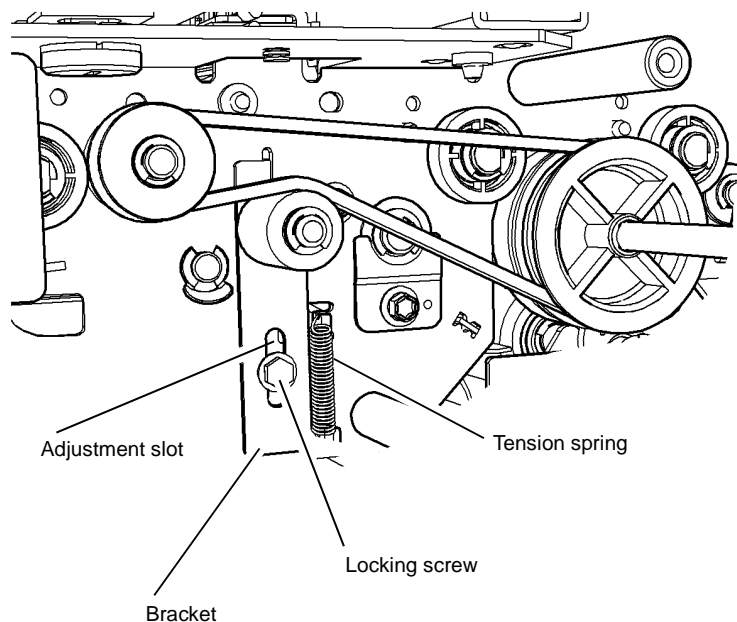

Typical idler tensioning arrangement

U-1-0658-A

Figure 1 Drive Belt Tensioning

ADJ 12.12-171 Tri-Folder Fold Adjustment

Purpose

To adjust C or Z folded copies in accordance with the customer requirements.

Check

1. Ensure the tri-folder and the HVF BM are aligned correctly, [ADJ 12.1-171 Machine to HVF / HVF BM, HVF BM to Tri-Folder Alignment](#).
2. Ensure the tri-folder is set for the correct size of paper, [ADJ 12.2-171 Tri-Folder Paper Size Setting](#).
3. The NVM settings. Enter [dC131](#) then check the values for NVMID 12-009 (C folds), 12-010 (Z folds) and 12-011 (Trifold deskew) are set in accordance with the values on the HVF/BM label, [Figure 1](#).
 - If necessary, enter [dC131](#) and change the NVM values for codes 12-009, 12-010 and 12-011 to match with the values on the HVF BM label.
4. Ensure the front door interlock switch is cheated, [PL 12.115 Item 24](#). Run a four sheet C fold and Z fold copy job. Check that the copies are folded into three approximately equal parts, with the folds parallel to the edge of the paper.
5. Check that the C and Z folded copies meet with the customer requirements. If necessary make fine adjustments to the length of folds A and / or B. [Figure 2](#).

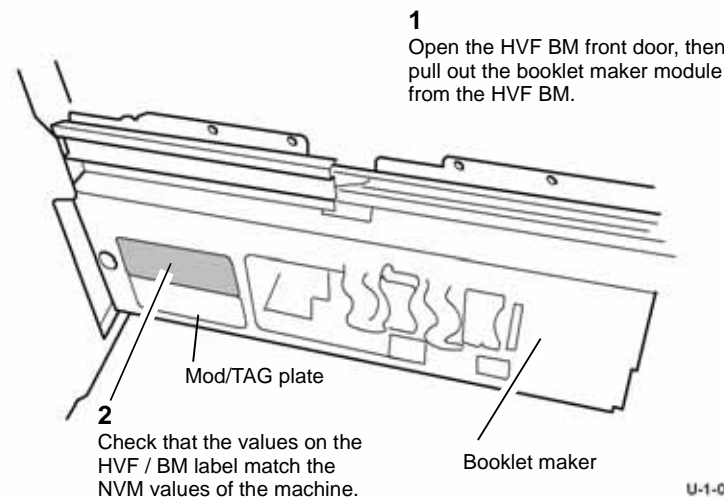

U-1-0954-A

Figure 1 HVF/BM NVM Value Label Location

Adjustment

WARNING

Ensure that the electricity to the machine is switched off while performing tasks that do not need electricity. Refer to GP 14. Disconnect the power cord. Electricity can cause death or injury. Moving parts can cause injury.

1. Perform the adjustments that follow as necessary to meet with the customer C fold and Z fold requirements, Figure 2.

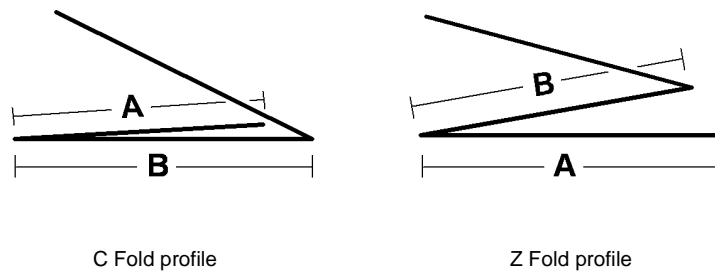

U-1-0955-A

Figure 2 C folded and Z folded output copy profiles

NOTE: Figure 2. Shows the orientation of a C and Z folded copy on the tri-folder output tray, as viewed from the front of the machine.

A Folds

Figure 2. The folds marked A are created within the booklet maker module. The length of the A fold is determined by the NVM values in dC131. An increase to the NVM value by 30 will decrease the A fold by 1 mm. A decrease to the NVM value by 30 will increase the A fold by 1 mm.

- Use dC131 code 12-009 to make adjustments to C folded copies.
- Use dC131 code 12-010 to make adjustments to Z folded copies.

B Folds

Figure 2. The folds marked B are created within the tri-folder module. The length of the B fold is determined by the position of the paper setting adjusters. If necessary remove the front door, PL 12.200 Item 2, front cover PL 12.200 Item 12 and the rear cover PL 12.200 Item 3, then reposition the paper setting adjusters. Figure 3. An adjustment of 1 graduation on the paper size adjuster scale will adjust the position of fold B by 1 mm.

- Raise the paper setting adjusters to decrease fold B.

- Lower the paper setting adjusters to increase fold B.

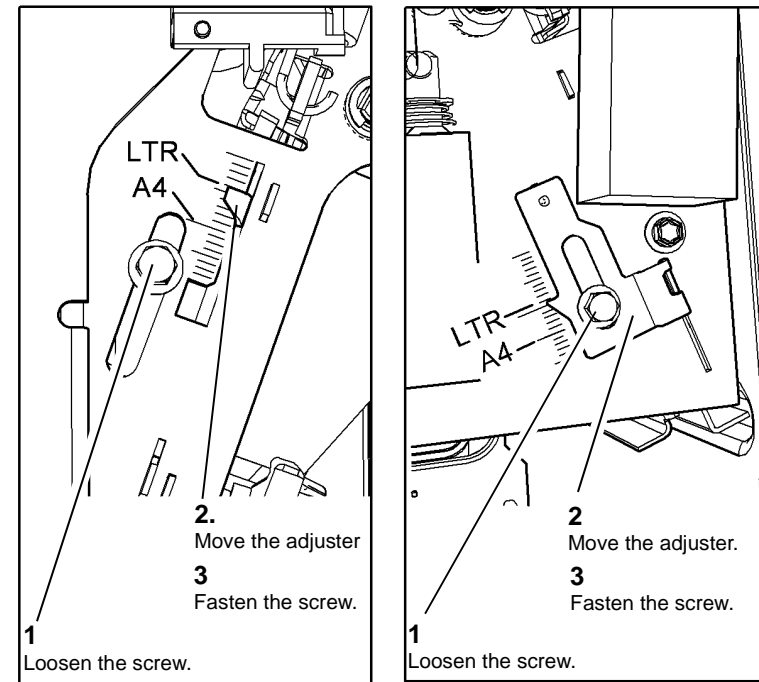

U-1-0956-A

Figure 3 Set the paper size adjusters.

ADJ 62.1 Optics Cleaning Procedure

Parts List on PL 62.15

Purpose

To clean the optical components of the scanner ensuring optimum image quality.

NOTE: This adjustment must only be performed if directed to it from an Image Quality RAP, or if the optics cavity was opened to install a new component and contamination can be seen.

Procedure

WARNING

Ensure that the electricity to the machine is switched off while performing tasks that do not need electricity. Refer to GP 14. Disconnect the power cord. Electricity can cause death or injury. Moving parts can cause injury.

CAUTION

Observe ESD precautions during this procedure.

1. Remove the DADH, REP 5.19.
 2. Remove the CVT ramp, CVT glass and document glass assembly, REP 62.3.
 3. Inspect the LED exposure lamps, Figure 1. If necessary, clean them as follows:
 - a. Vacuum clean the area to remove all visible contamination. Take care not to touch the LED exposure lamps with the cleaning nozzle. It may be necessary to move the scan carriage assembly gently to the left. It is advisable to leave it in this position, but it can be returned to the home position by depressing slightly to allow the flag to enter the gap in the scan carriage home sensor.
 - b. Wash your hands.
 - c. Carefully clean the LED exposure lamps, with a micro fibre cleaning cloth, PL 26.10 Item 6, dampened with antistatic fluid, PL 26.10 Item 11.
 - d. Polish the LED lamps and top of the scan carriage with a dry micro fibre cleaning cloth, PL 26.10 Item 6.
 4. Clean the lenses of the document size sensors, PL 62.16 Item 10, with a micro fibre cleaning cloth, PL 26.10 Item 6.
 5. Inspect the document glass and CVT glass and if necessary, clean them as follows:
 - a. Clean the under side of document glass and CVT glass using a micro fibre cleaning cloth, PL 26.10 Item 6, dampened with antistatic fluid, PL 26.10 Item 11.
 - b. Polish the under side of document glass and CVT glass with a dry micro fibre cleaning cloth, PL 26.10 Item 6.
 - c. Install the document glass and CVT glass, taking care not to smear the cleaned underside, REP 62.3.
- NOTE:** Ensure that the white AGC strip on both the CVT glass and the document glass, are at the front of the machine and on the underside of the glass.
- d. Clean the upper side of document glass and CVT glass using a micro fibre cleaning cloth, dampened with film remover, PL 26.11 Item 14.
 - e. Polish the upper side of document glass and CVT glass using a dry, micro fibre cleaning cloth.
6. Re-install the remainder of the removed components.

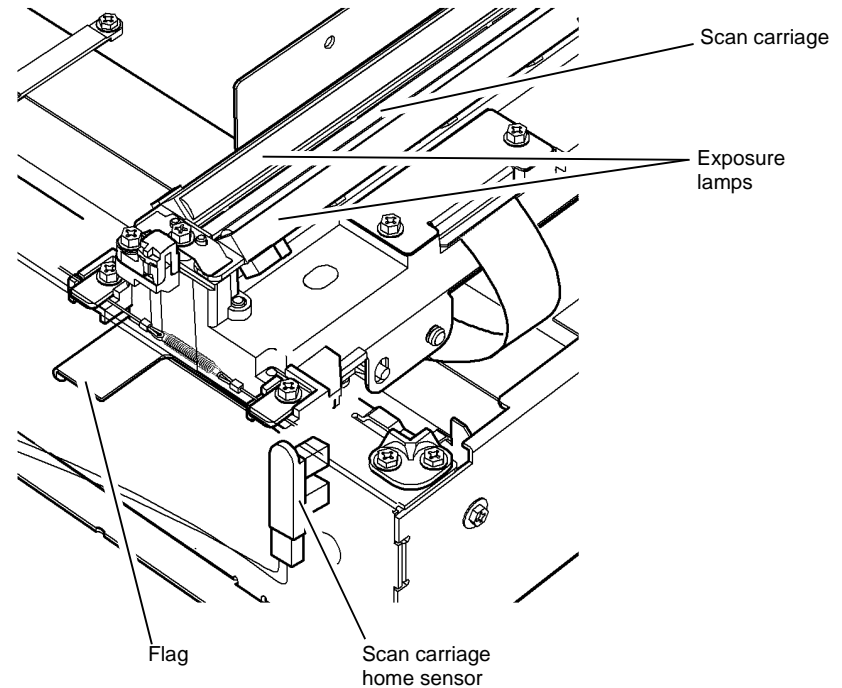

U-1-0716-A

Figure 1 Optics cleaning

ADJ 62.2 Scan Carriage Assembly

Parts List on PL 62.15

Purpose

To align the scan carriage assembly correctly in relation to the right hand edge of the document glass.

NOTE: Perform the Preparation, then the Check if entering this procedure from the Image Quality section. Otherwise, perform the Adjustment only.

Preparation

1. Remove the DADH, REP 5.19.
2. Remove the scanner top cover, REP 62.2.
3. Remove the CVT ramp, CVT glass and document glass assembly, REP 62.3.

Check

1. Gently move the scan carriage to the right, lowering it so the flag at the front passes into the slot in the scan carriage home sensor, PL 62.15 Item 7.
2. Check that the scan carriage touches both alignment stops, Figure 1. If they do not both touch, perform the Adjustment.

Adjustment

WARNING

Ensure that the electricity to the machine is switched off while performing tasks that do not need electricity. Refer to GP 14. Disconnect the power cord. Electricity can cause death or injury. Moving parts can cause injury.

1. Gently move the carriage away from the alignment stops.
2. Loosen the four screws securing the fixing tabs, Figure 1.
3. Ensure the scan cable is in the slot under the front, left fixing tab.
4. Tighten the rear, left fixing tab screw.
5. Slide the carriage towards the alignment stops, lowering it so the flag on the front of the carriage enters the slot in the scan carriage home sensor.
6. Press the scan carriage against the alignment stops at the right end of its travel and hold it there.
7. Tighten the other three fixing tab screws.

NOTE: The scan carriage is correctly positioned on the cables, when the scan carriage is lightly biased towards the front of the machine, and runs against the guide rail.

8. Run prints from all trays in all modes. Check the registration, refer to dC608 Registration Setup and check the copy quality, refer to IQ 1 Image Quality Entry RAP.

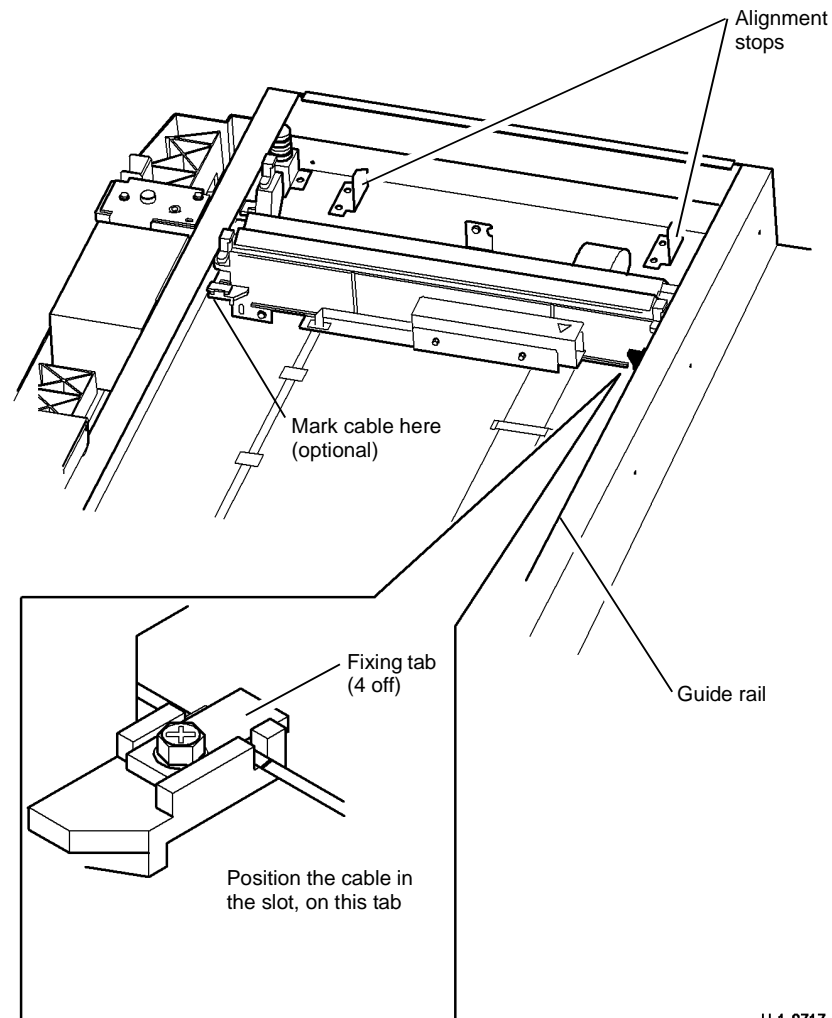

U-1-0717-A

Figure 1 Scan carriage alignment

ADJ 62.3 Carriage Motor and Scanner Drive Belt

Parts List on [PL 62.16](#)

Purpose

To ensure the carriage motor will drive the capstan without strain or slipping.

Adjustment

WARNING

Ensure that the electricity to the machine is switched off while performing tasks that do not need electricity. Refer to [GP 14](#). Disconnect the power cord. Electricity can cause death or injury. Moving parts can cause injury.

1. Remove the DADH, [REP 5.19](#).
2. Remove the scanner top cover, [REP 62.2](#).
3. Remove the carriage motor cover, (2 screws).
4. Perform the adjustment, [Figure 1](#).

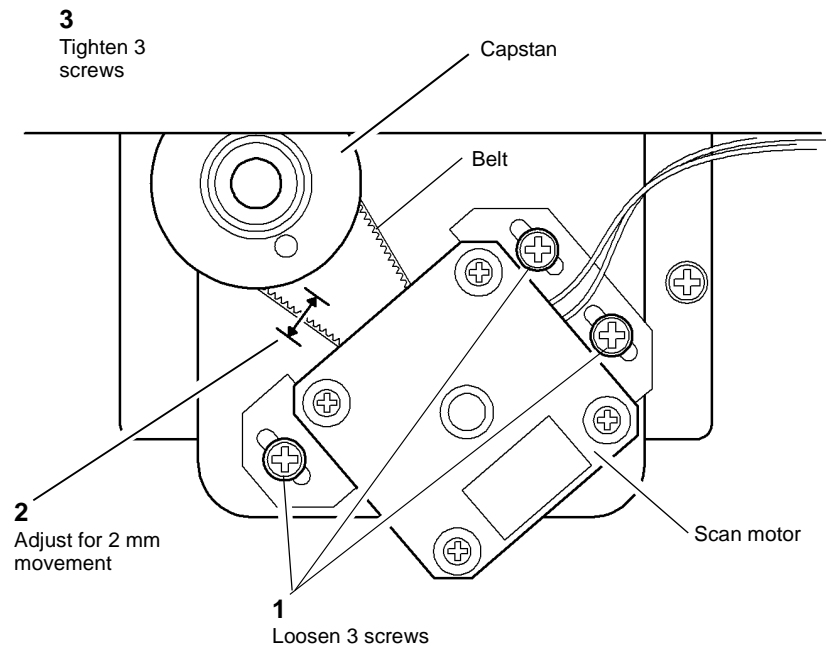

U-1-0718-A

Figure 1 Carriage motor drive belt adjustment

5. Turn the capstan several turns to centre the scanner drive belt on the pulleys. Check the play of the scanner drive belt and re-adjust if necessary.

ADJ 62.4 Document Glass Registration Adjustment

Parts List on [PL 62.10](#)

Purpose

To measure and adjust the image to paper registration.

Adjustment

WARNING

Ensure that the electricity to the machine is switched off while performing tasks that do not need electricity. Refer to [GP 14](#). Disconnect the power cord. Electricity can cause death or injury. Moving parts can cause injury.

Go to [dC609](#) Document Glass Registration.

ADJ 73.1 Tray 3 Paper Tray Guide Setting

Parts List on [PL 73.15](#)

Purpose

To adjust the paper tray guide in tray 3 and tray 4 for A4 or 8.5 x 11 inch paper.

Adjustment

WARNING

Ensure that the electricity to the machine is switched off while performing tasks that do not need electricity. Refer to [GP 14](#). Disconnect the power cord. Electricity can cause death or injury. Moving parts can cause injury.

1. Pull out the tray to be adjusted and remove the paper from the tray.
2. Push in the retaining clips and release the paper tray guides, [Figure 1](#).

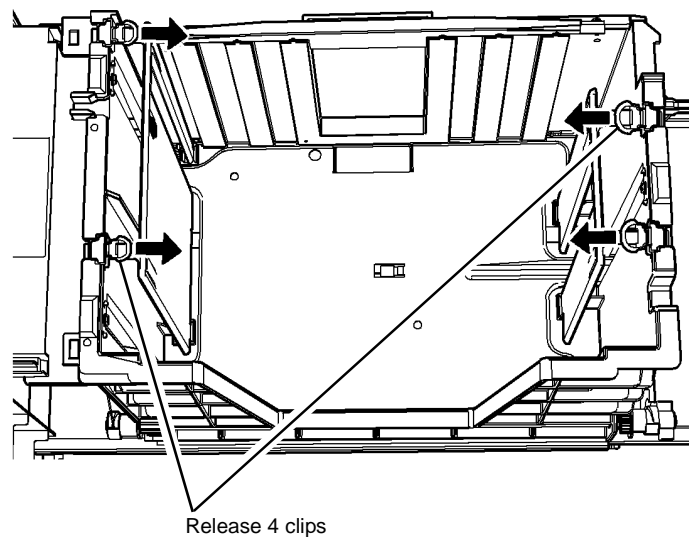

U-1-0751-A

Figure 1 Remove the paper guides

3. To reset the front and rear paper tray guides:
 - Go to [Figure 2](#), to set the paper tray guides to A4 paper size and reposition the retaining clips.
 - Go to [Figure 3](#), to set the paper tray guides to 8.5 x 11 paper size and reposition the retaining clips.

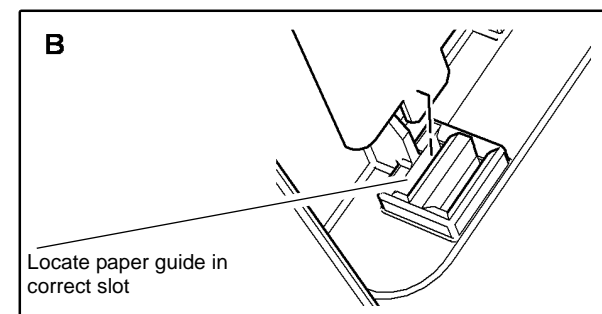
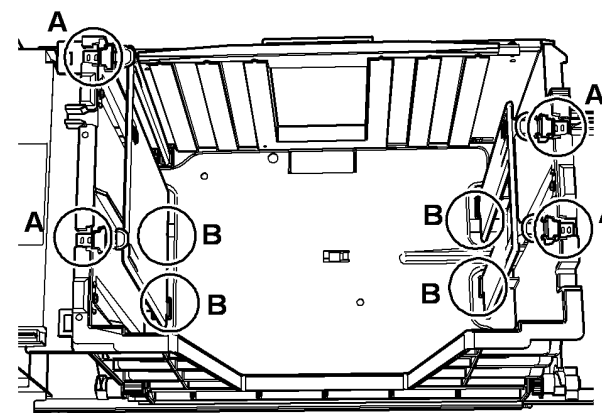
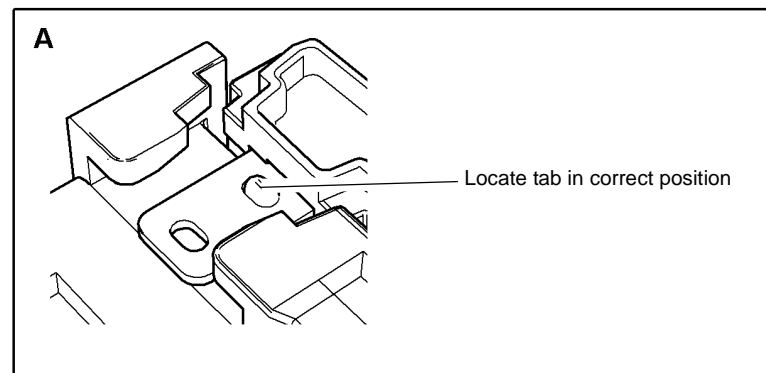

U-1-0752-A

Figure 2 A4 size

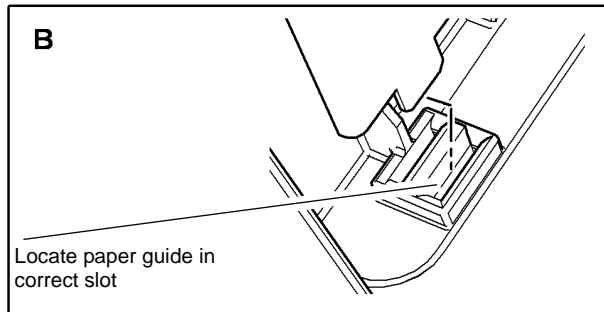
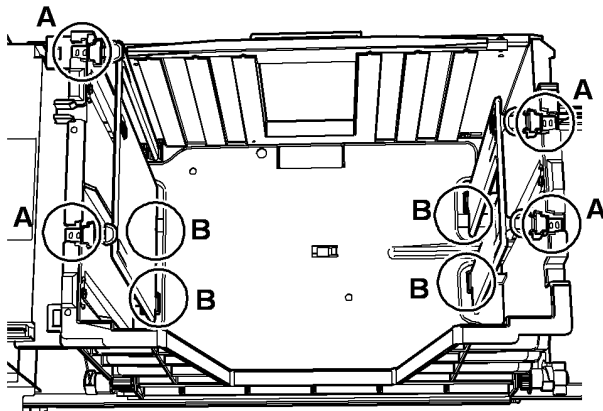
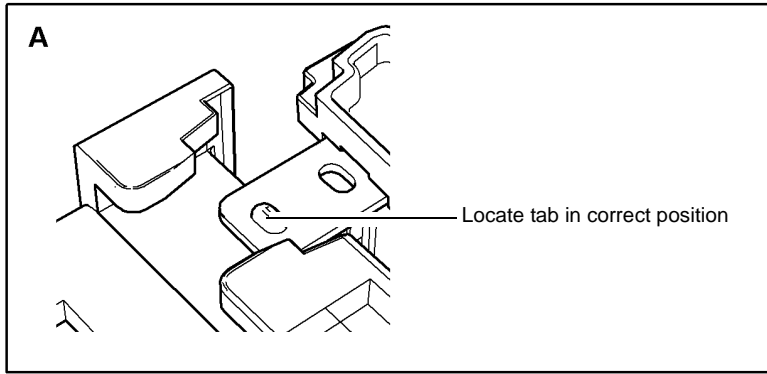

U-1-0753-A

Figure 3 8.5 x 11 size

4. To lock the paper tray guide in position, push the retaining clips in the reverse direction as shown in [Figure 1](#).
5. To reset the right side paper tray guides, [Figure 4](#):
 - (A) to set the paper tray guides to A4 paper size.
 - (B) to set the paper tray guides to letter size.

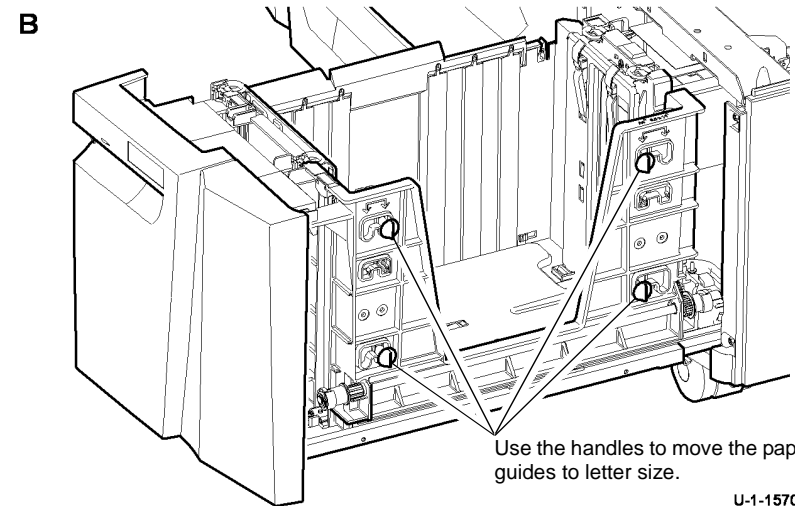
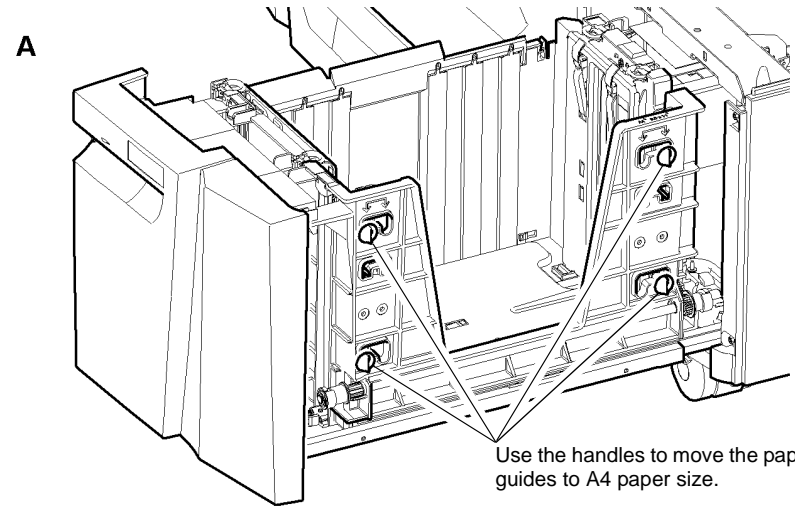

U-1-1570-A

Figure 4 Right side paper tray guides

ADJ 75.1 Tray 5 Paper Tray Guide Setting

Parts List on [PL 75.64](#)

Purpose

To adjust the paper tray guides in tray 5 for A4 / A3 or 8.5 x 11 / 11 x 17 inch paper.

Adjustment

WARNING

Ensure that the electricity to the machine is switched off while performing tasks that do not need electricity. Refer to [GP 14](#). Disconnect the power cord. Electricity can cause death or injury. Moving parts can cause injury.

1. Open tray 5 door and allow the tray to lower and remove the paper stack.
2. Adjust the paper guide to the required paper size, [Figure 1](#).
 - To set the paper tray guide to A4 / A3 paper size, move the paper guide to the outer position.
 - To set the paper tray guide to 8.5 x 11 / 11 x 17 inch paper size, move the paper guide to the inner position.
3. Check the registration, refer to [dC625](#) Registration / Preheat Calibration.

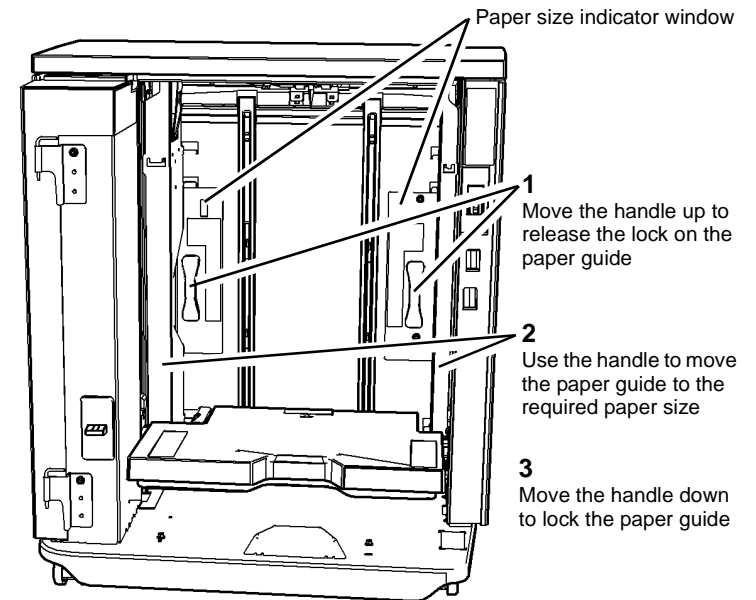

U-1-0754-A

Figure 1 Paper guide adjustment

ADJ 75.2 Tray 5 Module to Machine Alignment

Parts List on [PL 75.62](#)

Purpose

To correctly align the tray 5 module to achieve correct top edge registration and reliable transfer of paper from the tray 5 module to the machine.

Adjustment

WARNING

Ensure that the electricity to the machine is switched off while performing tasks that do not need electricity. Refer to [GP 14](#). Disconnect the power cord. Electricity can cause death or injury. Moving parts can cause injury.

The adjustment must be performed in the following order:

1. [Figure 1](#), turn the hand wheel in the centre of the tray 5 module to raise the casters off of the floor.
2. Check the registration, refer to [dC625 Registration / Preheat Calibration](#).

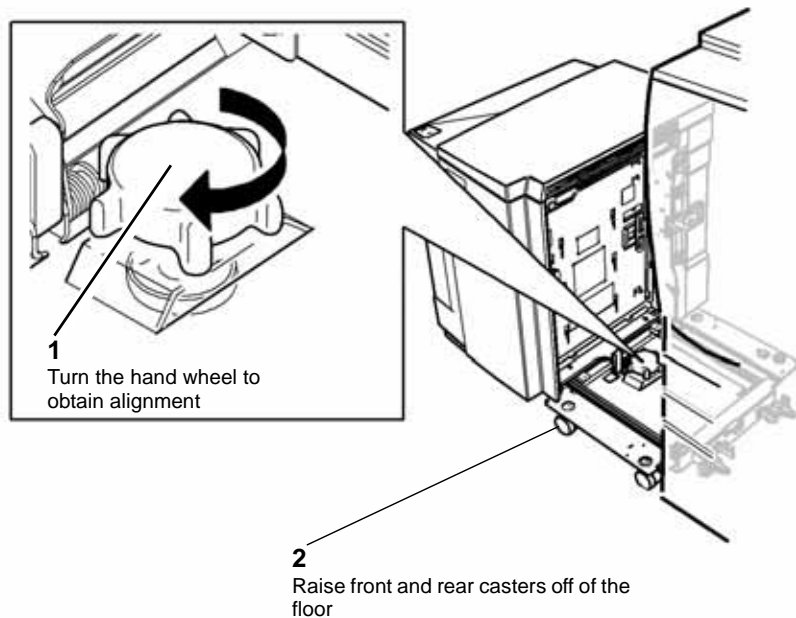

Figure 1 Machine to tray 5 alignment

ADJ 75.3 Tray 5 Module Tray Alignment

Parts List on [PL 75.64](#)

Purpose

To align the tray 5 module paper tray with the paper trays in the IOT module. Use this adjustment when the top edge registration cannot be achieved using [dC625 Registration / Preheat Calibration](#).

NOTE: Perform [ADJ 75.2, Tray 5 Module to Machine Alignment](#), before starting this adjustment procedure. Use both [ADJ 75.2](#) and this adjustment to achieve correct hole punch alignment.

Before performing this adjustment return the NVM values for tray 5 to the nominal values.

Adjustment

WARNING

Ensure that the electricity to the machine is switched off while performing tasks that do not need electricity. Refer to [GP 14](#). Disconnect the power cord. Electricity can cause death or injury. Moving parts can cause injury.

Make a sample print and determine which way and how far the tray needs to be moved. After the adjustment is made, take a sample print.

1. Loosen the two screws on the docking pin bracket, [Figure 1](#).

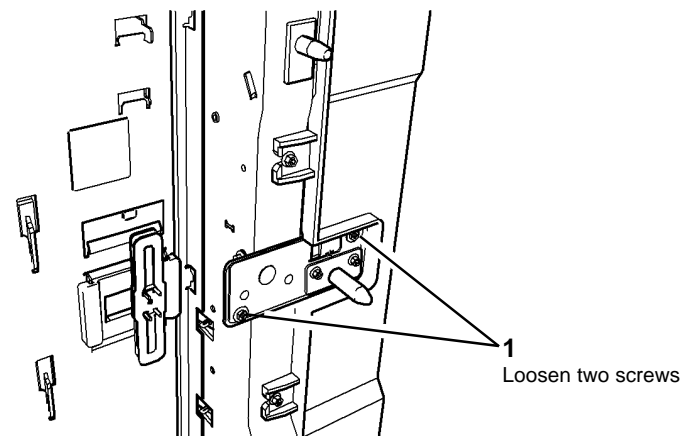
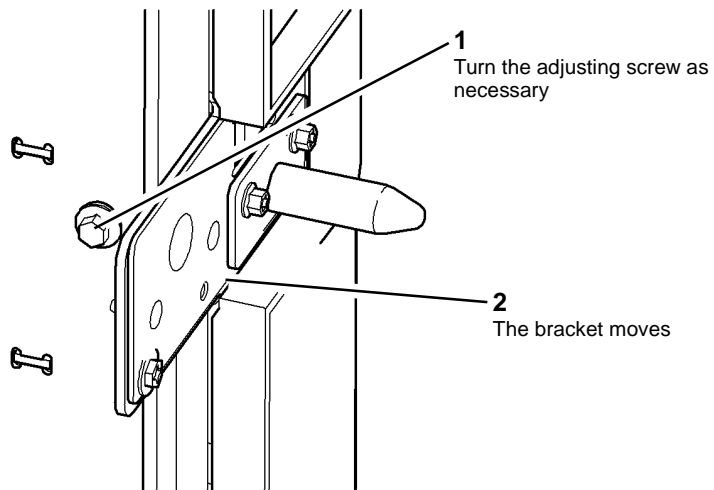

Figure 1 Docking pin bracket

2. Turn the adjusting screw to move the docking pin bracket to the front or to the rear, [Figure 2](#)



U-1-0757-A

Figure 2 Adjusting screw

Use the scribed indicator to determine the amount of movement, [Figure 3](#).

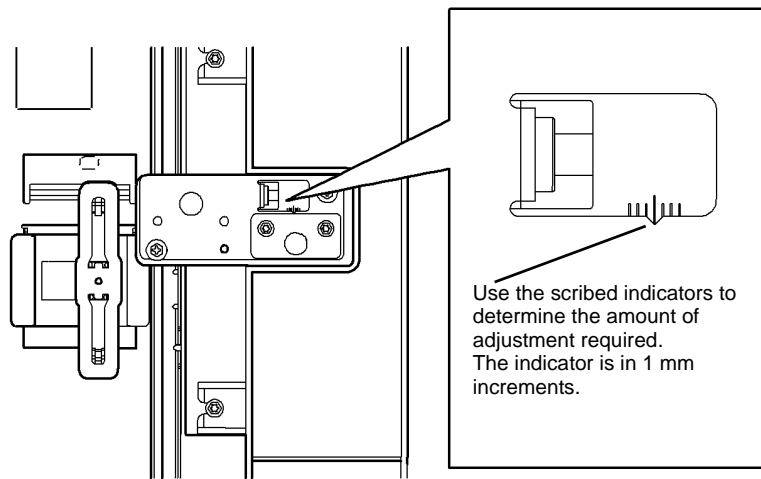

U-1-0758-A

Figure 3 Adjustment indicator

3. Secure the docking pin bracket, [Figure 4](#).

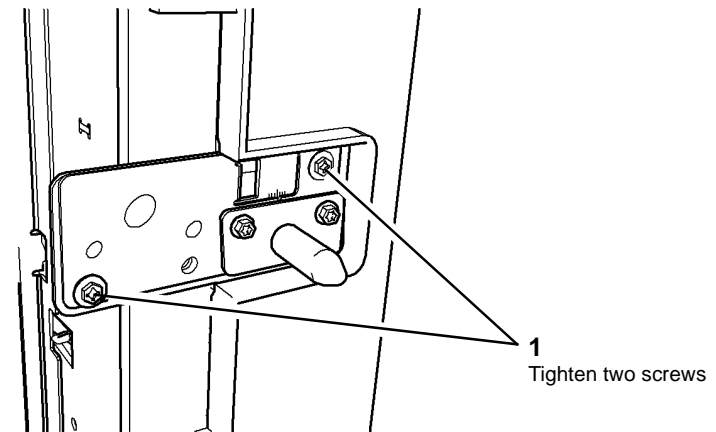

U-1-0759-A

Figure 4 Secure the docking pin bracket

4. Make sample prints and check the top edge registration.
5. Enter **dC625** Registration / Preheat Calibration.
6. If the top edge registration is still out of range, then repeat the adjustment.

ADJ 82.1 Media Registration Calibration

Purpose

To set the media registration and skew to the image set on the drum. Refer to [dC625 Registration / Preheat calibration](#).

ADJ 91.1 Printhead Attachment Check

Purpose

To check the attachment of the printheads to the carriages. This procedure should be performed if the **dC967** Head to Drum Spacing Check has failed.

Adjustment

WARNING

Ensure that the electricity to the machine is switched off while performing tasks that do not need electricity. Refer to GP 14. Disconnect the power cord. Electricity can cause death or injury. Moving parts can cause injury.

NOTE: The **dC967** routine will stop if a faulty or incorrectly fitted printhead is identified.

Perform the following:

1. Check that the suspect printhead is securely attached to the ball plate, refer to **REP 91.29**.
2. Check for obstructions or debris blocking movement of the suspect printhead.
3. Make sure the harnesses are correctly routed along the carriage with the suspect printhead, refer to **GP 28**.
4. Remove the suspect printhead, refer to **REP 91.29**. Check for debris on the ball plate and the back surface of the printhead. Remove any excess ink from umbilical ink nozzles, then re-install the printhead. Re-run **dC967**. If the spacing check again fails, perform the following:
 - a. Swap the faulty printhead with a printhead from a different position.
 - b. Re-run **dC967**.
 - c. If the fault follows the printhead, install a new printhead, **PL 91.20 Item 2** or **PL 91.25 Item 2**.
 - d. If the fault remains with the printhead position, check the ball plate and SFWA frame. Install new components as necessary, **PL 91.20** or **PL 91.25**.

5 Parts Lists

PL 1 - Standby Power

PL 1.15 Main Power Supply 5-3

PL 2 - User Interface and Secure Access

PL 2.00 Secure Access Additions 5-4

PL 2.10 User Interface 5-5

PL 3 - Machine Run Control

PL 3.11 Image Processing Module 5-6

PL 5 - DADH

PL 5.10 DADH (Complete), Covers, DADH PWB 5-7

PL 5.15 Feed Assembly 5-8

PL 5.20 Top Cover Assembly 5-9

PL 5.25 CVT 5-10

PL 5.30 Baffle Assembly 5-11

PL 5.35 Input Tray Assembly 5-12

PL 10 - Transfix and Copy/Print Transportation

PL 10.10 Stripper System (1 of 2) 5-13

PL 10.12 Stripper System (2 of 2) 5-14

PL 10.15 Exit Paper Path 5-15

PL 10.20 Transfix Roller Assembly 5-16

PL 12 - OCT

PL 12.00 OCT 5-17

PL 12 - LCSS

PL 12.10 LCSS Covers 5-18

PL 12.15 LCSS Docking Latch 5-19

PL 12.20 LCSS Hole Punch Unit 5-20

PL 12.25 LCSS Paddle Wheel 5-21

PL 12.30 LCSS Bin 1 Control Components (1 of 2) 5-22

PL 12.35 LCSS Bin 1 Control Components (2 of 2) 5-23

PL 12.40 LCSS Paper Entry Transport 5-24

PL 12.45 LCSS Tamper Assembly 5-25

PL 12.50 LCSS Ejector Assembly 5-26

PL 12.55 LCSS Staple Head Unit/Traverse Assembly 5-27

PL 12.60 LCSS Bin 0 Entry 5-28

PL 12.65 LCSS Bin 1 Entry 5-29

PL 12.70 LCSS Entry Guide Cover/Jam Clearance Guide 5-30

PL 12.75 LCSS Electrical 5-31

PL 12 - HVF

PL 12.100 HVF Covers and Docking 5-32

PL 12.105 HVF Stacker 5-33

PL 12.110 HVF Ejector, Pressing and Support (1 of 2) 5-34

PL 12.115 HVF Ejector, Pressing and Support (2 of 2) 5-35

PL 12.120 HVF Main Drives 5-36

PL 12.125 HVF Feed Assembly and Punch (1 of 3) 5-37

PL 12.130 HVF Feed Assembly and Punch (2 of 3) 5-38

PL 12.135 HVF Feed Assembly and Punch (3 of 3) 5-39

PL 12.140 HVF Power and Control 5-40

PL 12 - HVF Booklet Maker

PL 12.145 HVF BM Module (Complete) 5-41

PL 12.150 HVF BM Entry and Front Cover 5-42

PL 12.155 HVF BM Tamper Assembly 5-43

PL 12.160 HVF BM Back Stop Motor 5-44

PL 12.165 HVF BM Back Stop assembly 5-45

PL 12.170 HVF BM Crease Blade Motor 5-46

PL 12.175 HVF BM Crease Rolls Motor and PWB 5-47

PL 12.180 HVF BM Crease Rolls and Support Leg 5-48

PL 12.185 HVF BM Stapler Assemblies 5-49

PL 12.190 HVF BM Bin 2 5-50

PL 12 - Tri-Folder

PL 12.200 Tri-Folder Covers 5-51

PL 12.205 Tri-Folder Drives Module 5-52

PL 12.210 Tri-Folder Top Door Cover Assembly 5-53

PL 12.215 Tri-Folder Main Drives Assembly 5-54

PL 12 - Inserter

PL 12.300 Inserter Covers 5-55

PL 12.305 Inserter Main Drives (1 of 3) 5-56

PL 12.310 Inserter Main Drives (2 of 3) 5-57

PL 12.315 Inserter Main Drives (3 of 3) 5-58

PL 20 - Fax

PL 20.05 Fax Module 5-59

PL 20.10 Line 1 & 2 Fax Kits 5-60

PL 25 - Accessories

PL 25.10 Convenience Stapler 5-61

PL 26 - Consumables and Tools

PL 26.10 Consumables and Tools (1 of 2) 5-62

PL 26.11 Consumables and Tools (2 of 2) 5-63

PL 28 - Covers

PL 28.10 Covers 5-64

PL 31 - Maintenance/Installation/Removal Kits

PL 31.10 Maintenance/Installation/Removal Kits (1 of 3) 5-65

PL 31.11 Maintenance/Installation/Removal Kits (2 of 3) 5-66

PL 31.12 Maintenance/Installation/Removal Kits (3 of 3) 5-67

PL 62 - Scanner

PL 62.10 Scanner Module, CVT/Document Glass	5-68
PL 62.15 Electrical Components (1 of 2)	5-69
PL 62.16 Electrical Components (2 of 2)	5-70

PL 70 - Paper Supply

PL 70.10 Tray 1 and 2 Assembly	5-71
PL 70.25 3 Tray Module Covers	5-72
PL 70.30 Left Hand Upper Door Assembly	5-73

PL 73 - Paper Supply

PL 73.15 Tray 3 Assembly	5-74
PL 73.16 3 Tray Module	5-75

PL 74 - Paper Supply

PL 74.10 Bypass Module (Tray 4)(1 of 2)	5-76
PL 74.11 Bypass Module (Tray 4) (2 of 2)	5-77

PL 75 - Paper Supply

PL 75.60 Tray 5 Covers	5-78
PL 75.62 Tray 5 Base	5-79
PL 75.64 Tray 5 Guides	5-80
PL 75.68 Tray 5 Lift Assembly (1 of 2)	5-81
PL 75.70 Tray 5 Lift Assembly (2 of 2)	5-82

PL 81 - Paper Transport

PL 81.10 Main Covers	5-83
PL 81.11 Front Door Assembly	5-84
PL 81.25 Tray 1 Paper Feed Assembly	5-85
PL 81.26 Tray 2 Paper Feed Assembly	5-86
PL 81.30 Tray 3 Paper Feed Assembly	5-87
PL 81.35 3 Tray Module Transport Assembly	5-88
PL 81.40 Tray 5 Feed Assembly (1 of 3)	5-89
PL 81.45 Tray 5 Feed Assembly (2 of 3)	5-90
PL 81.46 Tray 5 Feed Assembly (3 of 3)	5-91

PL 82 - Paper Transport

PL 82.10 Vertical Paper Path	5-92
PL 82.15 Horizontal Paper Path	5-93

PL 88 - Registration/Preheat Assembly

PL 88.10 Registration/Preheat Assembly (1 of 2)	5-94
PL 88.11 Registration/Preheat Assembly (2 of 2)	5-95

PL 91 - Marking Unit

PL 91.05 Marking Unit Slide Assembly	5-96
PL 91.10 Marking Unit Drive Assembly	5-97
PL 91.15 Marking Unit Belt and Drive	5-98
PL 91.20 Marking Unit Upper Carriage Assembly	5-99
PL 91.25 Marking Unit Lower Carriage Assembly	5-100

PL 92 - IOT Process Control

PL 92.10 Marking Unit Electronic PWB's	5-101
--	-------

PL 93 - Ink Delivery

PL 93.10 Ink Loader Assembly	5-102
------------------------------------	-------

PL 94 - Ink Transfer

PL 94.10 Cleaning Unit	5-103
PL 94.15 IOD Assembly	5-104
PL 94.20 Drum Assembly	5-105
Common Hardware	5-106

PL 1.15 Main Power Supply

Item	Part	Description
1	-	Main power cord (see below for variants)
-	152S06414	United Kingdom
-	152S06400	USSG/XCL
-	152S06413	XE
-	152S06402	Argentina
-	152S06415	Denmark
-	152S06416	Switzerland
2	112K01010	Power supply unit (REP 1.9)
3	110K21010	Main power rocker switch
4	960K71860	Drum driver PWB (REP 3.6)
5	960K46460	Media path driver PWB (REP 3.5)
6	127E16360	Enclosure fan (MOT42-063)
7	110K21111	Front door interlock switch (S01-103) (REP 1.8)
8	117E35720	Bypass extension harness (PJ405)
9	117E35610	Drum driver MR sensor harness (PJ701)
10	117E35590	Drum driver power supply interface cable (PJ902)
11	117E35560	Chassis interlock harness
12	-	Drum driver PWB bracket (P/O PL 1.15 Item 4)
13	117E35550	AC chassis heater harness (PJ5AC)
14	117E35581	Drum driver to front components harness (PJ501)
15	117E35600	Drum driver/Media path power harness (PJ602, PJ803)
16	117E35620	Engine fan harness (PJ901)
17	117E35650	Cleaning unit interface harness (PJ601, PJ802)
18	117E35690	Media path driver PWB to RALPH harness (PJ202)
19	117E35710	Media path exit/horizontal harness (PJ905)
20	117E35750	Transfix roller harness (PJ401)
21	117E35530	Media path driver PWB to 3 tray module PWB harness (PJ401)
22	117E35700	Midrail front door switch harness
23	127K62260	Marking unit cooling fan

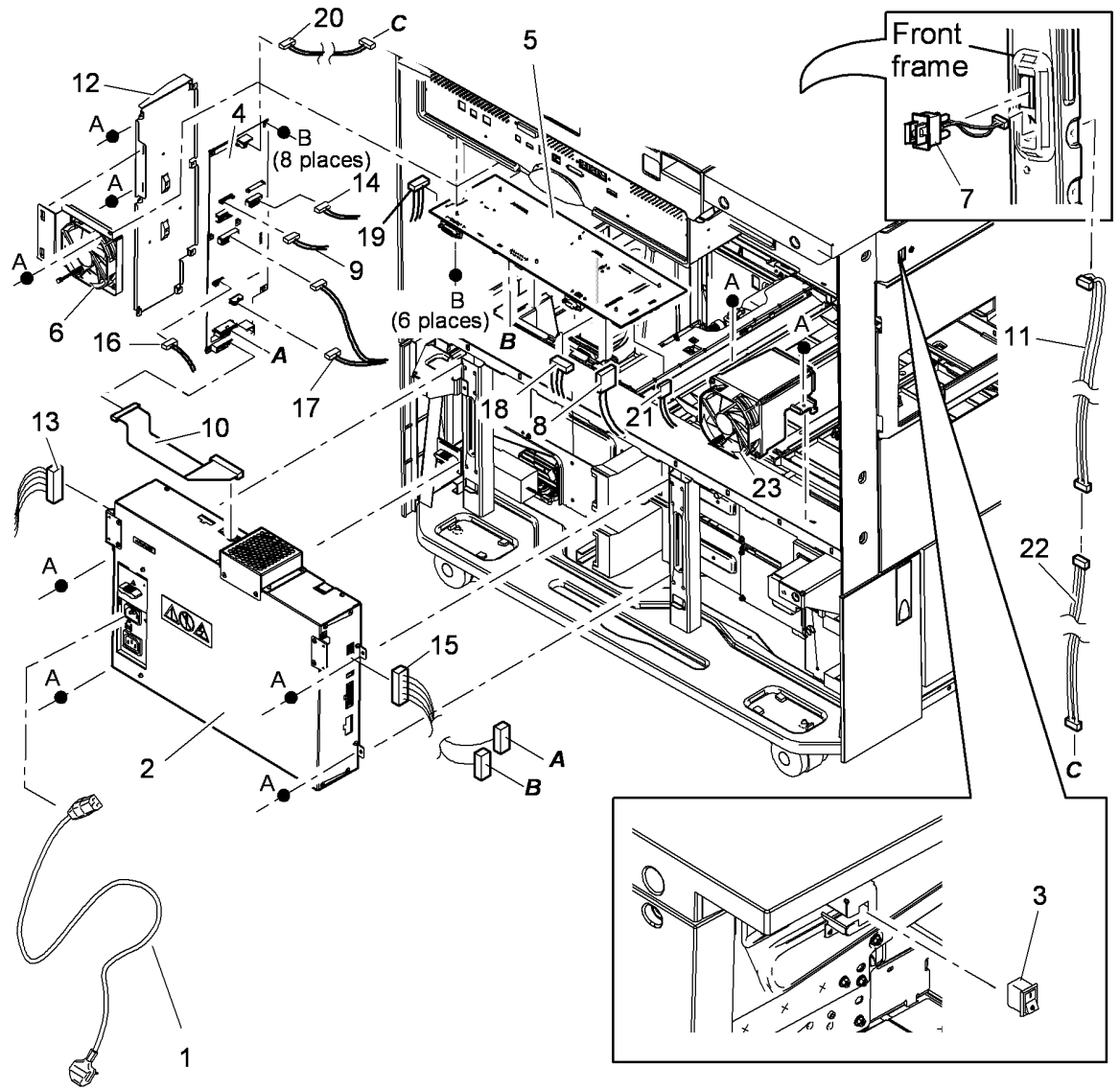

U-8-0109-A

PL 2.00 Secure Access Additions

Item	Part	Description
1	101E28760	Secure access controller
2	105E24030	Xerox secure access power supply
3	146E02130	Xerox secure access card reader (HID)
-	146E02140	Xerox secure access card reader (MAGSTRIPE)
-	146E02150	Xerox secure access card reader (MIFARE)
-	146E02160	Xerox secure access card reader (LEGIC)
4	117E35360	Xerox secure access power cord (UK)
-	117E35340	Xerox secure access power cord (NA)

**NO EXPLODED
VIEW PROVIDED**

U-8-0092-A

PL 2.10 User Interface

Item	Part	Description
1	-	User interface control panel housing (XE) (P/O PL 2.10 Item 17)
-	-	User interface control panel housing (USSG/XCL) (P/O PL 2.10 Item 17)
2	960K66480	User interface control PWB (REP 2.3)
3	123K08481	User interface touch screen (REP 2.2)
4	960K52290	User interface status PWB
5	-	French/Canadian overlay label (P/O PL 31.11 Item 8)
6	-	Retainer touch screen (Not spared)
7	952K00890	User interface harness (PJ19 to PJ905, PJ223 to PJ900)
8	-	UI harness cover (Not spared)
9	962K76550	User interface control PWB to user interface status PWB harness (PJ907 to PJ908)
10	848E40401	UI inlay
11	962K76560	LCD to PWB harness
12	-	Harness clip (Not spared)
13	-	User interface harness clip (P/O PL 31.10 Item 12)
14	-	Numeric keys (P/O PL 2.10 Item 17)
15	-	Service keys (P/O PL 2.10 Item 17)
16	-	Not used
17	848K31214	UI assembly (XE) (REP 2.1)
-	848K31224	UI assembly (USSG/XCL) (REP 2.1)

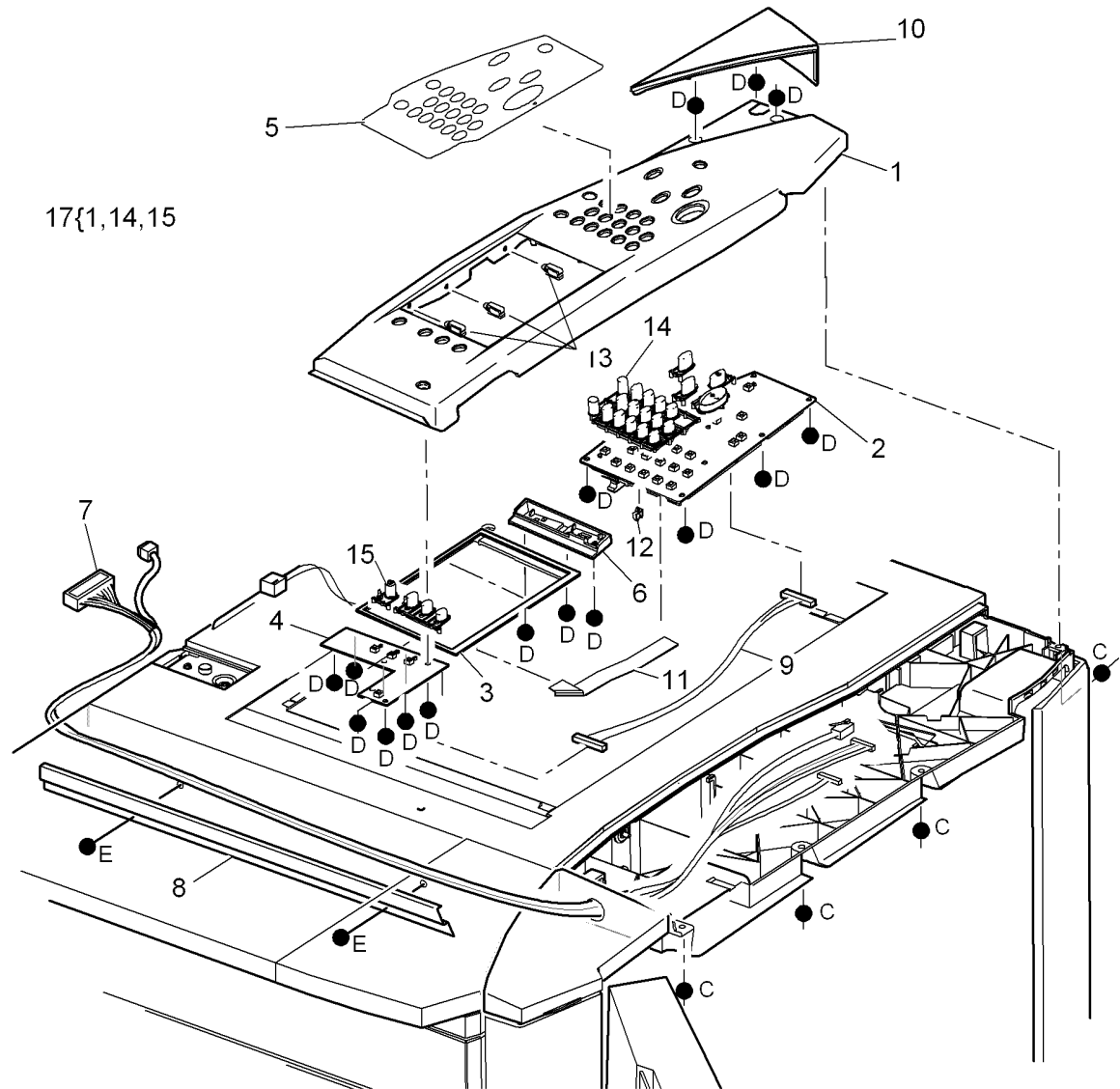

U-8-0038-A

PL 3.11 Image Processing Module

Item	Part	Description
1	960K66422	Power distribution PWB
2	121E27531	Hard disk drive (REP 3.8)
3	960K66471	Hard disk drive/Single board controller PWB harness (PJ222)
4	960K66440	System memory PWB (DDR2 1GB) (PJ10)
5	127K68672	Chassis fan assembly
6	-	Inner fan duct (P/O PL 3.11 Item 5)
7	-	Fax connector PWB ribbon cable (PJ49) (Not spared)
8	-	Heatsink assembly (Not spared)
9	-	Hard disk drive damper kit (P/O PL 3.11 Item 15)
10	-	PDB to SBC harness (PJ17) (Not spared)
11	-	PWB Cover (Not spared)
12	-	Hard disk drive power harness (PJ3)(P/O PL 3.11 Item 15)
13	960K66412	Single board controller PWB (REP 3.7)
14	960K27451	Foreign device interface PWB
15	-	Single board controller PWB module (Not spared)
16	012E21850	SBC drawer service loop harness (PJ1, PJ13, PJ5, PJ8, PJ223)
17	960K66433	NVM module PWB (REP 3.9)
18	105K36240	Battery
19	-	Shoulder screw (P/O PL 3.11 Item 9)
20	-	Grommet (P/O PL 3.11 Item 9)
21	960K66450	EPC memory PWB (DDR 1GB) (U98)
22	-	Product enablement key (SIM) (P/O PL 31.12 Item 2)
23	952K00240	Foreign device interface harness (PJ16)
24	-	Harness guide plate (Not spared)

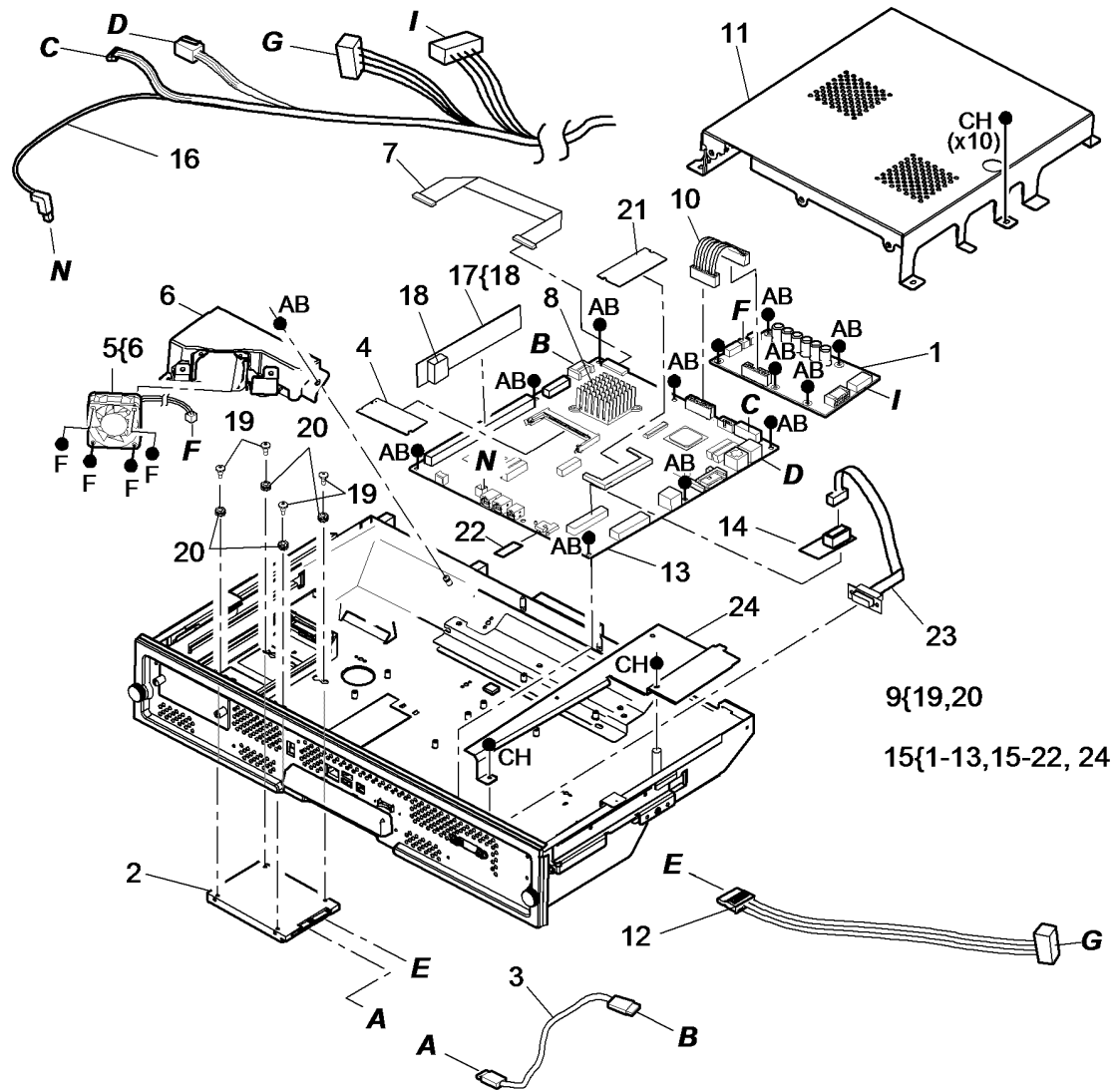

U-8-0128-A

PL 5.10 DADH (Complete), Covers, DADH PWB

Item	Part	Description
1	802E19352	Rear cover
2	036K01701	Right counterbalance (REP 5.12, ADJ 5.2, ADJ 5.5)
3	019K13350	Document pad (ADJ 5.6)
4	036K01630	Left counterbalance (REP 5.12, ADJ 5.2, ADJ 5.5)
5	960K51762	DADH PWB
6	962K62932	Communication/power cable (PJ188, PJ851)
7	-	Harness support (P/O PL 5.10 Item 9)
8	-	Top cover (REF: PL 5.20 Item 15)
9	084K36765	DADH (complete) (REP 5.19, ADJ 5.2, ADJ 5.5)
10	121E17510	DADH Platen down sensor magnet (See NOTE)
11	-	DADH ground harness (P/O PL 5.10 Item 9)
12	-	Thumbscrew (Not spared)
13	017E11300	End stop

NOTE: To clean the DADH, refer to ADJ 5.4. For the platen down sensor (Q62-019) refer to PL 62.16 Item 5.

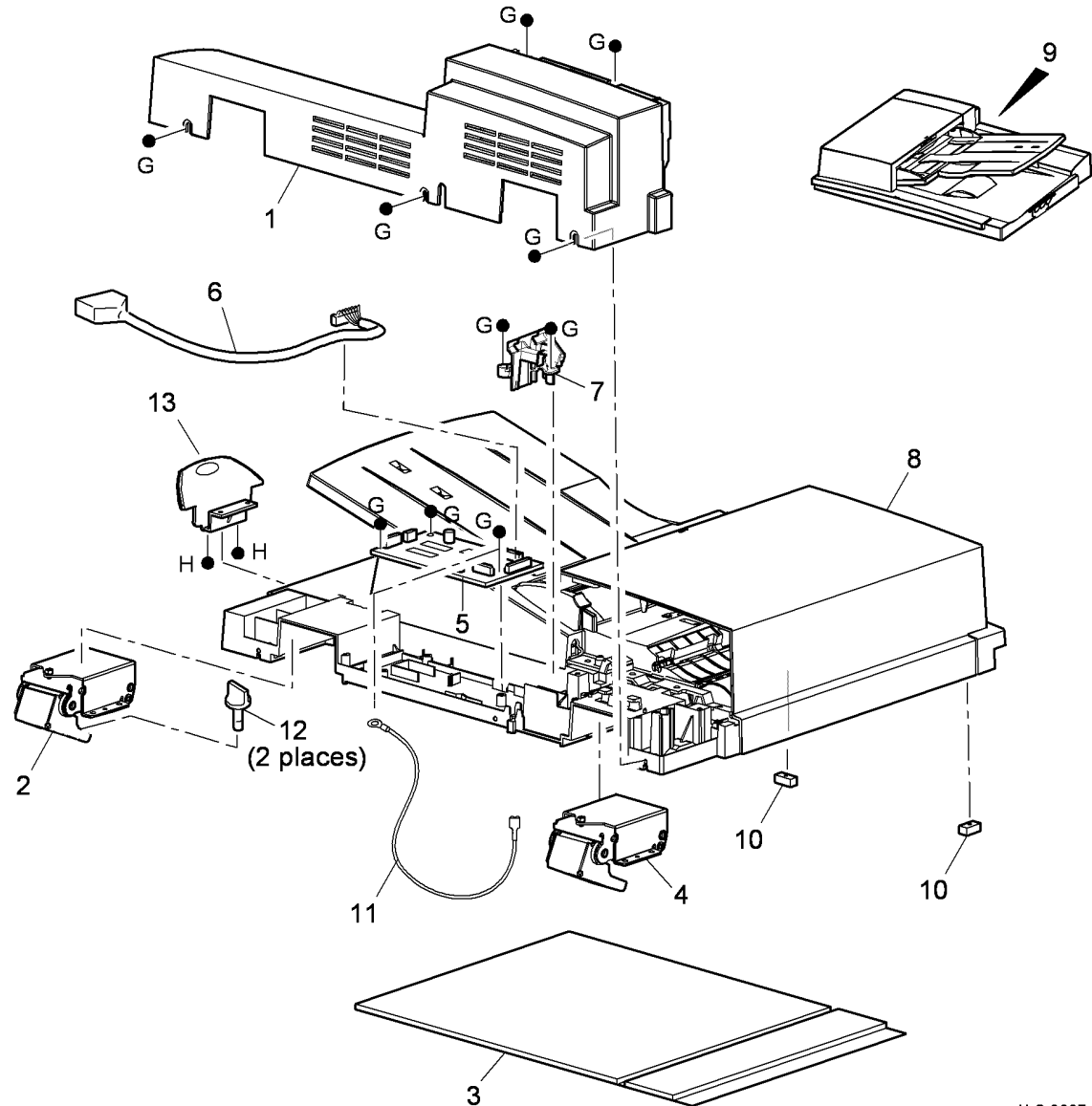

U-8-0007-A

PL 5.15 Feed Assembly

Item	Part	Description
1	113R00718	Feed roll assembly (REP 5.14) (See NOTE 2)
2	130E11200	DADH feed sensor (Q05-204)
3	-	Front cover (P/O PL 5.15 Item 18)
4	-	Feed housing (P/O PL 5.15 Item 18)
5	-	Nudger Motor (MOT05-098) (P/O PL 5.15 Item 18)
6	-	Feed yoke (P/O PL 5.15 Item 18)
7	-	Spring (P/O PL 5.15 Item 18)
8	-	Bearing (P/O PL 5.15 Item 18)
9	-	DADH feed clutch (CL05-062) (W/O TAG D-005) (Not spared)
10	-	Rear cover (P/O PL 5.15 Item 18)
11	110E13480	DADH cover interlock switch (S05-212)
12	-	Front feed gate (P/O PL 5.15 Item 18)
13	-	Rear feed gate (P/O PL 5.15 Item 18)
14	125E00430	Static eliminator
15	-	Gear (P/O PL 5.15 Item 26)
16	127K53770	DADH feed motor (MOT05-074) (ADJ 5.1)
17	-	Feed motor tension spring (red) (P/O PL 5.10 Item 9)
18	-	Feed assembly (complete) (P/O PL 31.10 Item 15) (REP 5.3)
19	-	Shaft (P/O PL 5.15 Item 26)
20	-	Bracket (P/O PL 5.15 Item 18)
21	802E87730	Feed roll assembly cover
22	-	Intermediate feed bearing (P/O PL 5.15 Item 26)
23	-	Bearing (P/O PL 5.15 Item 26)
24	004E22560	Feed motor bracket
25	-	Ground harness (P/O PL 5.15 Item 18)
26	-	DADH feed bearing kit (REF: PL 31.11 Item 4)
27	-	Motor bracket (P/O PL 5.15 Item 18)
28	604K61440	Feed clutch and spacer kit (W/TAG D-005)
29	-	Spacer (P/O PL 5.15 Item 28) (W/TAG D-005)
30	-	Feed clutch (P/O PL 5.15 Item 28) (W/TAG D-005)

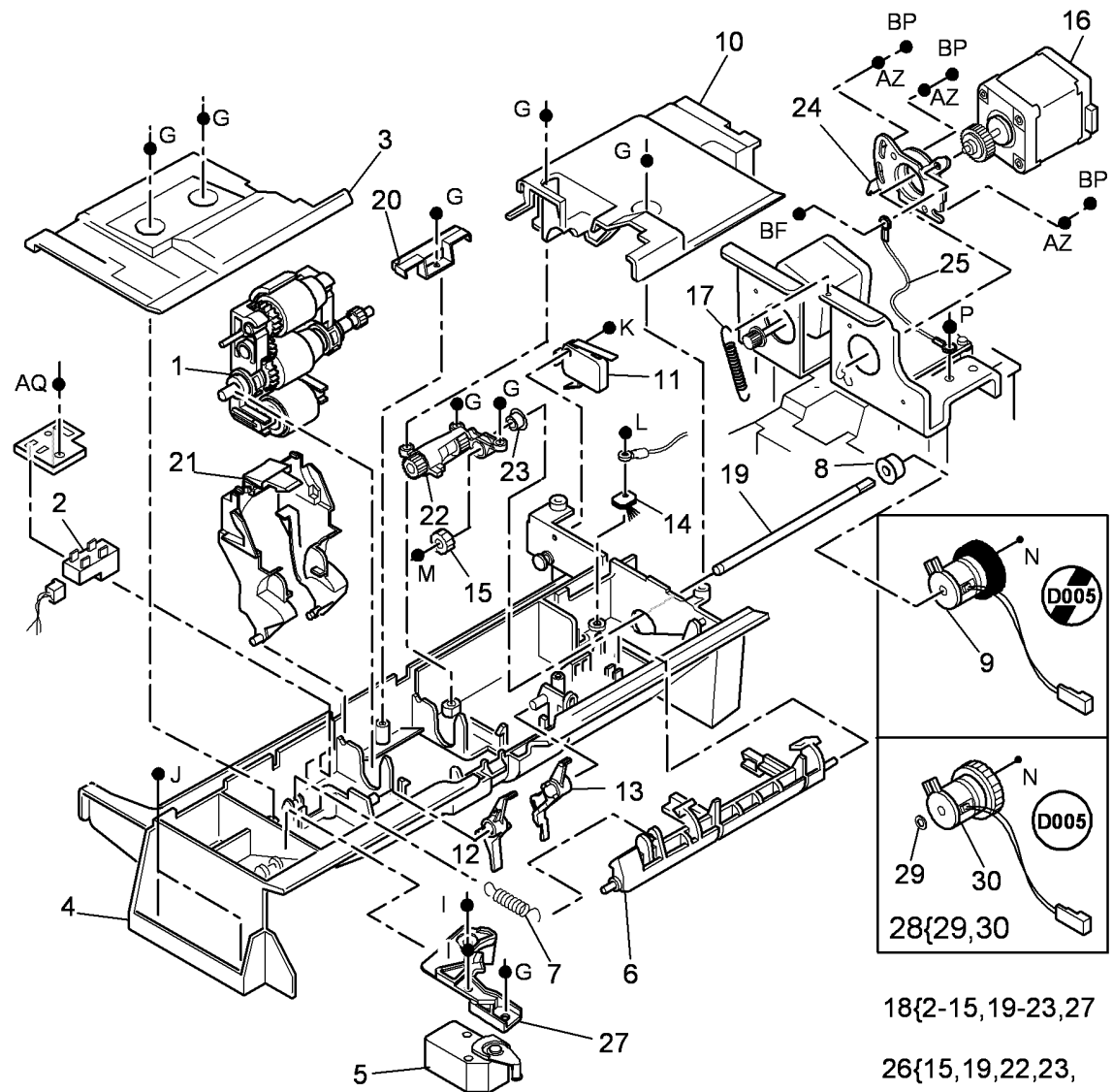

18{2-15,19-23,27

26{15,19,22,23,

U-8-0008-A

NOTE: 1: For the feed motor drive belt, refer to PL 5.35 Item 5.

NOTE: 2: To reset the count, go to dC135.

PL 5.20 Top Cover Assembly

Item	Part	Description
1	–	Hinge (P/O PL 5.20 Item 16)
2	–	Bushing (P/O PL 5.20 Item 16)
3	022E25061	CVT/Takeaway idler
4	806E19680	Shaft
5	–	Torsion spring (green) (P/O PL 5.20 Item 17)
6	038E22914	Base
7	–	Spring (P/O PL 5.20 Item 17)
8	–	Torsion spring (silver) (P/O PL 5.20 Item 17)
9	029E37810	Latch pin
10	–	Spring plate (P/O PL 5.20 Item 17)
11	130K73960	DADH TAR sensor (Q05-096) (REP 5.8)
12	130K73970	DADH CVT Sensor (Q05-097) (REP 5.8)
13	–	Sensor support (P/O PL 5.20 Item 17)
14	–	Shaft securing bracket (P/O PL 5.20 Item 17)
15	802K62453	Top cover
16	802K93770	Top cover assembly (REP 5.1)
17	055K37570	Top access cover assembly (REP 5.2)

NOTE: For the top cover interlock switch (S05-212), refer to PL 5.15 Item 11.

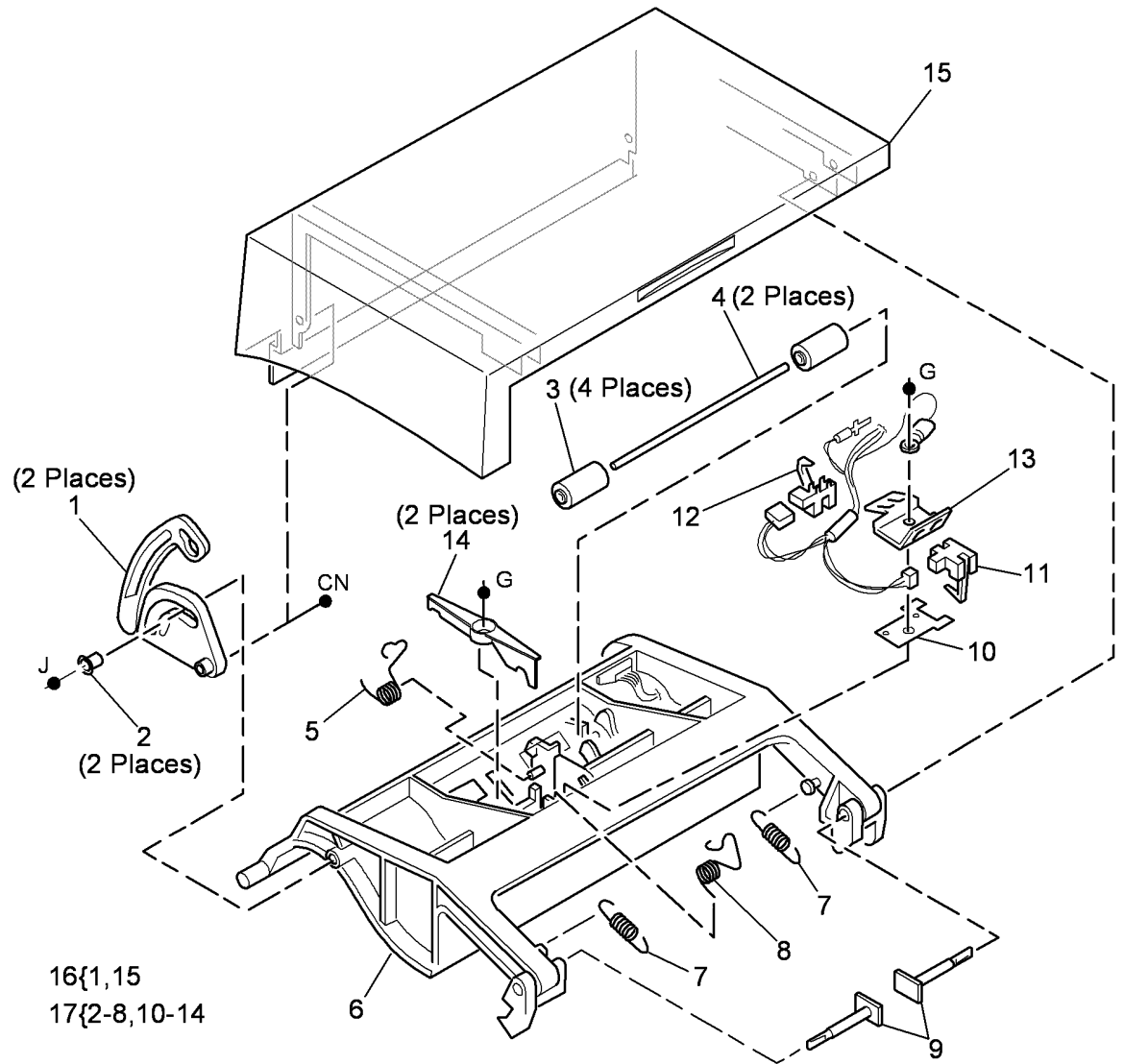

U-8-0009-A

PL 5.25 CVT

Item	Part	Description
1	130K73980	DADH pre registration sensor (Q05-206) (REP 5.10)
2	-	Sensor support (P/O PL 5.10 Item 9)
3	-	Torsion spring (P/O PL 5.10 Item 9)
4	013E21103	Front CVT roll bearing
5	-	CVT Roll (P/O PL 31.10 Item 11) (REP 5.15)
6	022E25061	Pre-scan idler
7	-	Base (P/O PL 5.10 Item 9)
8	-	Shaft (Not spared)
9	127K53780	DADH CVT Motor (MOT05-099) (ADJ 5.1)
10	-	CVT Motor tension spring (silver) (P/O PL 5.10 Item 9)
11	023E25420	CVT Motor drive belt (195T) (REP 5.15, ADJ 5.1)
12	050E14972	Duplex gate (REP 5.15)
13	013E21094	Rear CVT roll bearing
14	-	Spacer (white) (P/O PL 5.10 Item 9)
15	004E22560	CVT Motor bracket
16	-	Ground harness (Not spared)
17	-	CVT roll pulley (P/O PL 5.25 Item 5)

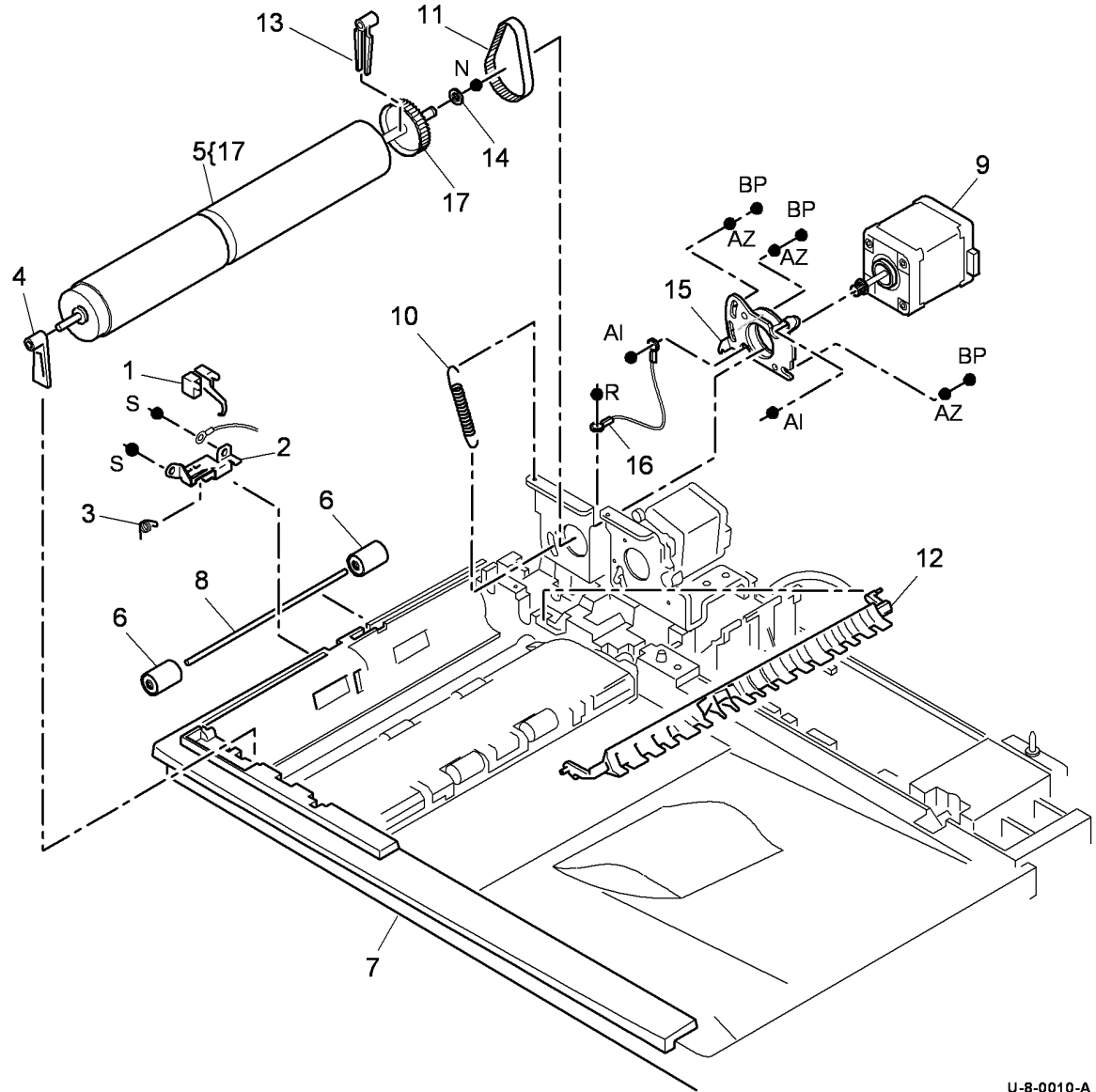

U-8-0010-A

PL 5.30 Baffle Assembly

Item	Part	Description
1	–	Lower cover (P/O PL 5.30 Item 14)
2	038E34361	Lower baffle
3	121E20060	DADH Duplex solenoid (SOL05-100) (REP 5.7)
4	022E25061	Post scan idlers
5	–	Shaft (P/O PL 5.30 Item 14)
6	059K43910	Exit roll idlers (REP 5.18)
7	–	Bearing (P/O PL 5.30 Item 14)
8	–	Document finger (P/O PL 5.30 Item 14)
9	–	Torsion spring (P/O PL 5.30 Item 14)
10	–	Lift bar (P/O PL 5.30 Item 14)
11	–	Link arm (P/O PL 5.30 Item 14)
12	–	Mylar guide strip (P/O PL 31.11 Item 14) (REP 5.20)
13	130E11500	DADH exit sensor (Q05-209) (REP 5.11)
14	055K37583	Lower baffle assembly (REP 5.5)
15	–	Solenoid spring (P/O PL 5.30 Item 16)
16	121K44520	DADH Duplex solenoid assembly

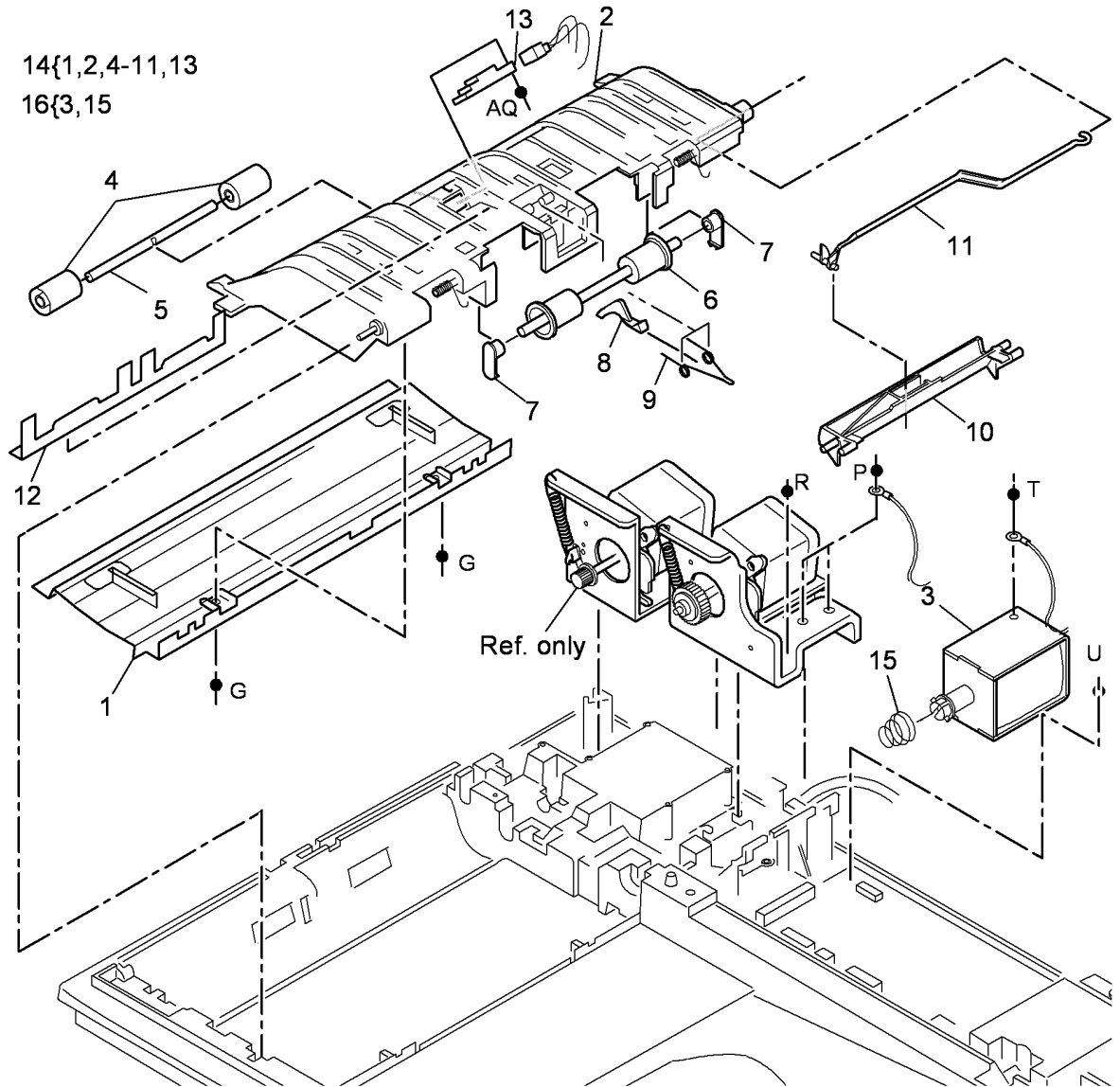

U-8-0011-A

PL 5.35 Input Tray Assembly

Item	Part	Description
1	050K67464	Input tray assembly (complete) (REP 5.4)
2	004K00971	Pad
3	031E11310	Restack arm
4	050E22922	Input tray
5	023E31190	Feed Motor Drive Belt (86T) (ADJ 5.1)
6	059K50920	Exit roll assembly (REP 5.13)
7	125E00430	Static eliminator (small) (REP 5.17)
8	130E18340	DADH Tray size sensor 1 (Q05- 221)/DADH Tray size sensor 2 (Q05-222) (See NOTE) (REP 5.9)
9	-	Lower cover (right) (P/O PL 5.35 Item 1)
10	115K02540	Static eliminator (large)
11	103K01511	DADH width sensor (Potentiometer) (Q05-095) (REP 5.16)
12	-	Bearing (P/O PL 5.35 Item 1)
13	014E61020	Spacer (black)
14	-	Nylon washer (P/O PL 5.35 Item 1)
15	-	Pulley (P/O PL 5.35 Item 1)
16	-	Sensor bracket (P/O PL 5.35 Item 1)
17	059K43920	Takeaway roll assembly (REP 5.6)
18	-	Input guide rack assembly (P/O PL 5.35 Item 1)
19	130E11200	DADH Document sensor (Q05-102)
20	-	Lower cover (left) (P/O PL 5.35 Item 1)

NOTE: This item is also supplied as a pair as a kit PL 31.11 Item 17.

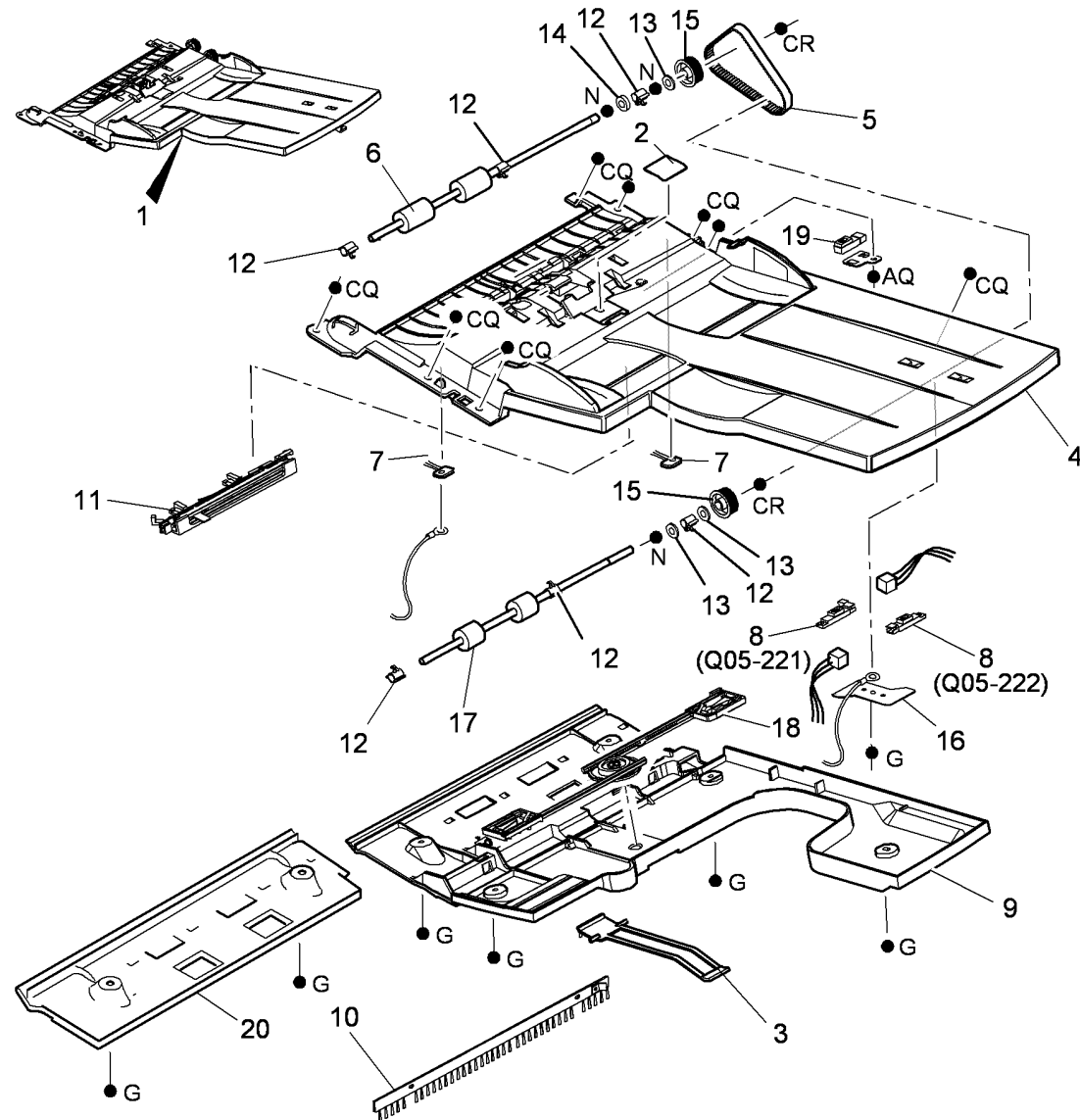

U-8-0012-A

PL 10.10 Stripper System (1 of 2)

Item	Part	Description
1	059E10700	Roller drive 'J' (REP 10.10)
2	059E10890	Roller drive 'L' (REP 10.11)
3	121K50591	Stripper solenoid assembly (SOL10-021) (REP 10.9)
4	–	Gearbox (P/O PL 10.10 Item 16) (REP 10.8)
5	–	Post transfix motor (M4) (MOT10-018) (P/O PL 10.10 Item 16) (REP 10.8)
6	130E12950	Post transfix sensor (11) (Q10-015)/Pre exit sensor (12) (Q10-016)
7	–	Sensor cover (Not spared)
8	–	Bushing roller (Not spared)
9	055K43331	Upper baffle assembly (See NOTE) (REP 10.22)
10	–	Stripper jam clearance LED assembly (P/O PL 10.10 Item 9)
11	803E13460	Front latchfork
12	803E13451	Back latchfork
13	807E29000	Gear drive (25T Symetric)
14	809E34520	Return spring
15	–	Stripper latch cam (P/O PL 10.10 Item 18)
16	007K19810	Motor drive and gearbox assembly (REP 10.8)
17	130E12940	Stripper latch sensor (Q10-014)
18	006K32500	Stripper guide latch cam shaft assembly (REP 10.23)
19	–	Upper baffle (P/O PL 10.10 Item 9)
20	–	Camshaft (P/O PL 10.10 Item 18)

NOTE: HFSI. This component must be cleaned at regular intervals, refer to SCP 4 subsystem maintenance. To reset the HFSI count, go to dC135.

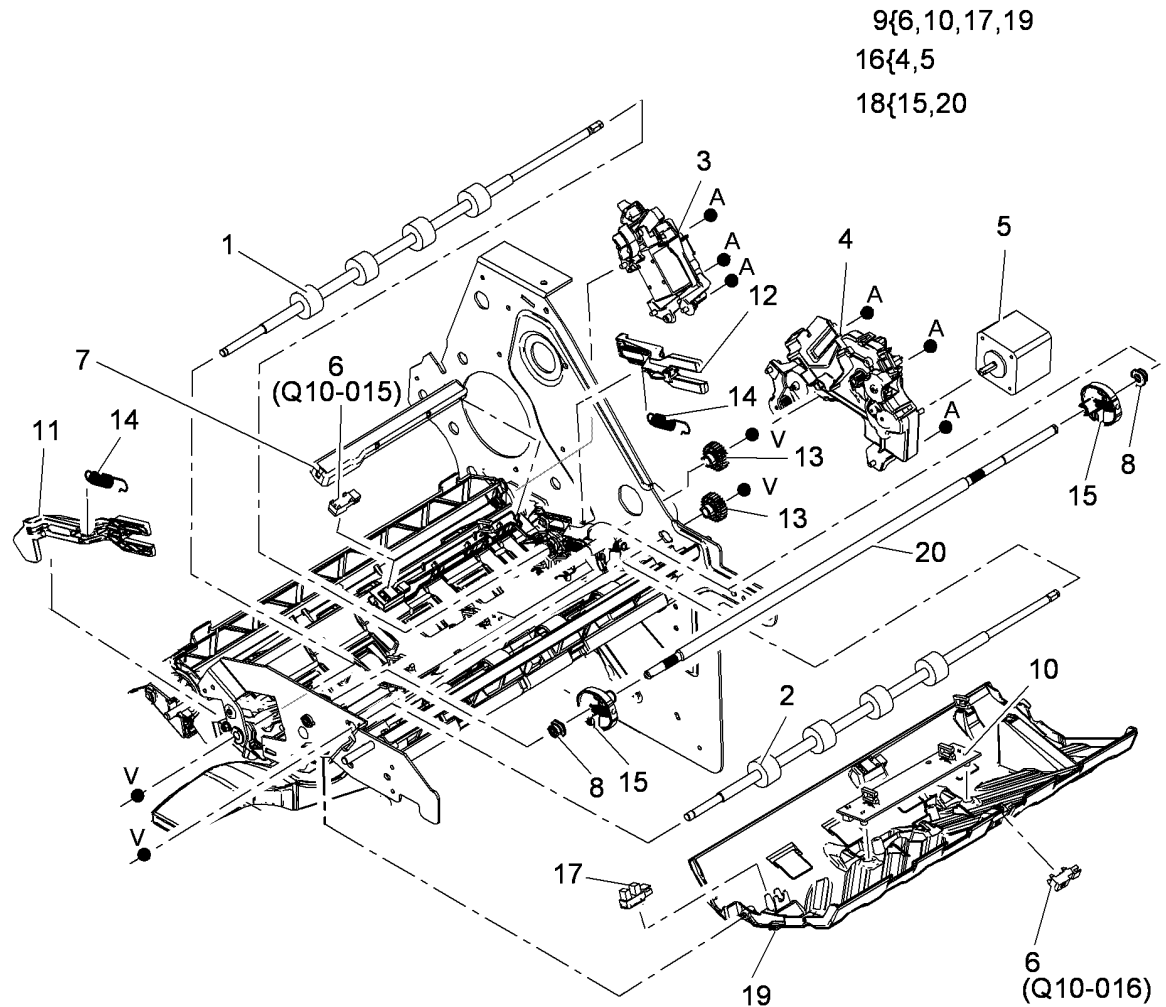

9{6,10,17,19

16{4,5

18{15,20

U-8-0064-A

PL 10.12 Stripper System (2 of 2)

Item	Part	Description
1	055K43271	Stripper gate and baffle assembly (REP 10.21)
2	–	Gate and baffle shaft (Not spared)
3	–	Stripper blade assembly (P/O PL 10.12 Item 5) (See NOTE) (REP 10.21)
4	–	Stripper shaft (Not spared)
5	604K73430	Stripper blade kit
6	–	Stripper blade retaining tool (P/O PL 10.12 Item 5)
7	–	Grounding strip (Not spared)

NOTE: Supplied with a stripper retaining tool, PL 10.12 Item 6.

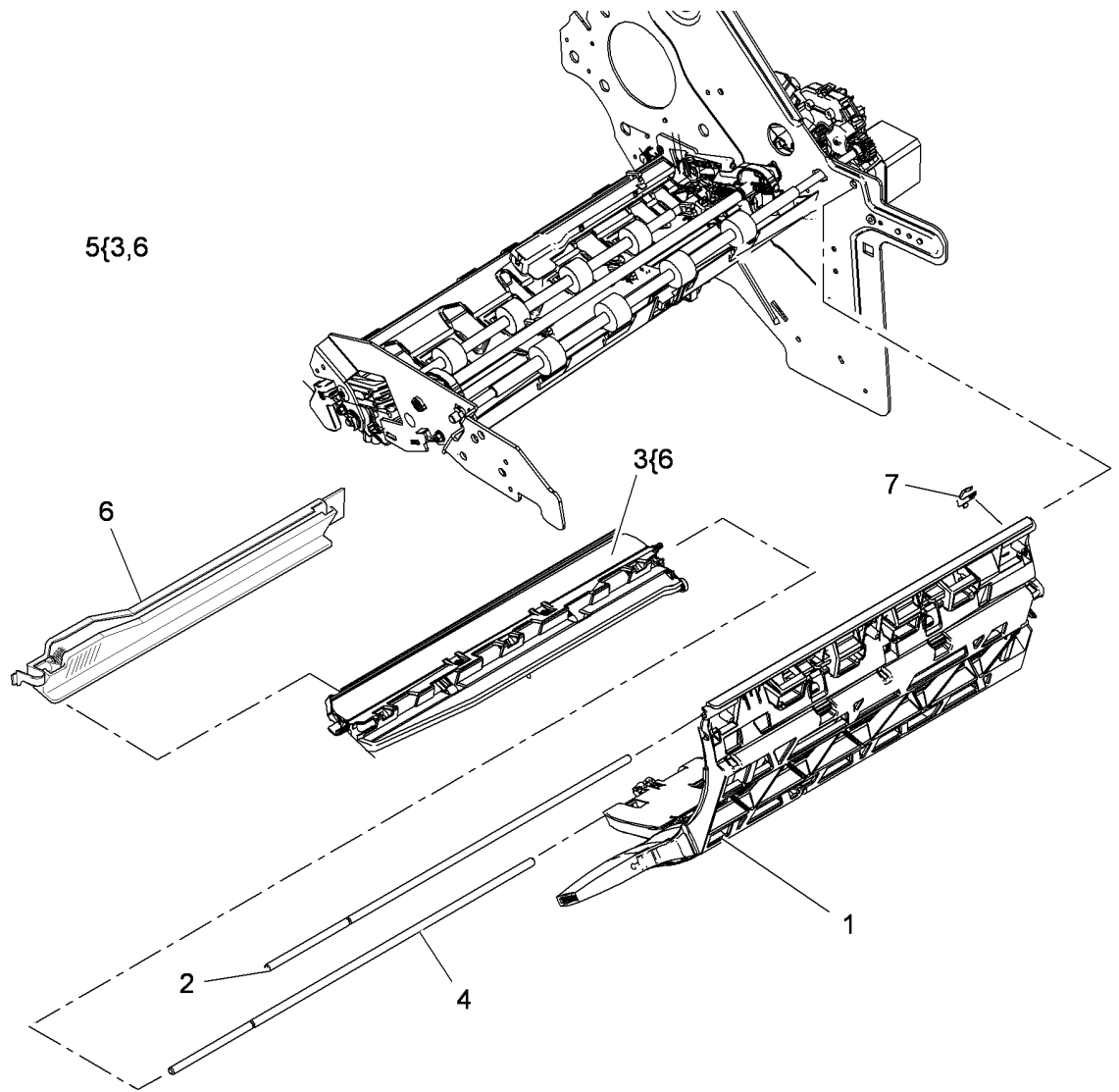

U-8-0114-A

PL 10.15 Exit Paper Path

Item	Part	Description
1	059E10720	Roller nip 'N' (REP 10.18)
2	-	Sensor cover (Not spared)
3	130E12950	Exit sensor (15)(Q10-017)(REP 10.16)/Duplex start sensor (13)(Q83-110)(REP 10.15)
4	-	Handle (Not spared)
5	-	Static brush (P/O PL 10.15 Item 19)
6	059E10730	Roller nip 'P' (REP 10.17)
7	020K20480	Pulley 3mm (driven)
8	023E31390	Belt 3mm (112T)
9	023E31400	Belt 3mm (92T)
10	020K20460	Pulley 3mm (21T one way)
11	127E16370	Exit Motor (M5) (MOT83-001) (REP 10.14)
12	807E28980	Driven compound gear
13	807E28990	Idler compound gear
14	121E26500	Exit/duplex solenoid (SOL83-006) (REP 10.12)
15	-	Upper exit guide (P/O PL 10.15 Item 19)
16	-	Exit illuminator PWB (P/O PL 10.15 Item 19) (REP 10.19)
17	-	Diverter gate assembly (P/O PL 10.15 Item 19) (REP 10.13)
18	-	Top exit baffle (P/O PL 10.15 Item 19)
19	038K23770	Exit paper path assembly (REP 10.20)
20	-	Upper exit idler (P/O PL 10.15 Item 19)
21	-	Upper baffle idler (P/O PL 10.15 Item 19)
22	-	Upper baffle idler spring (P/O PL 10.15 Item 19)

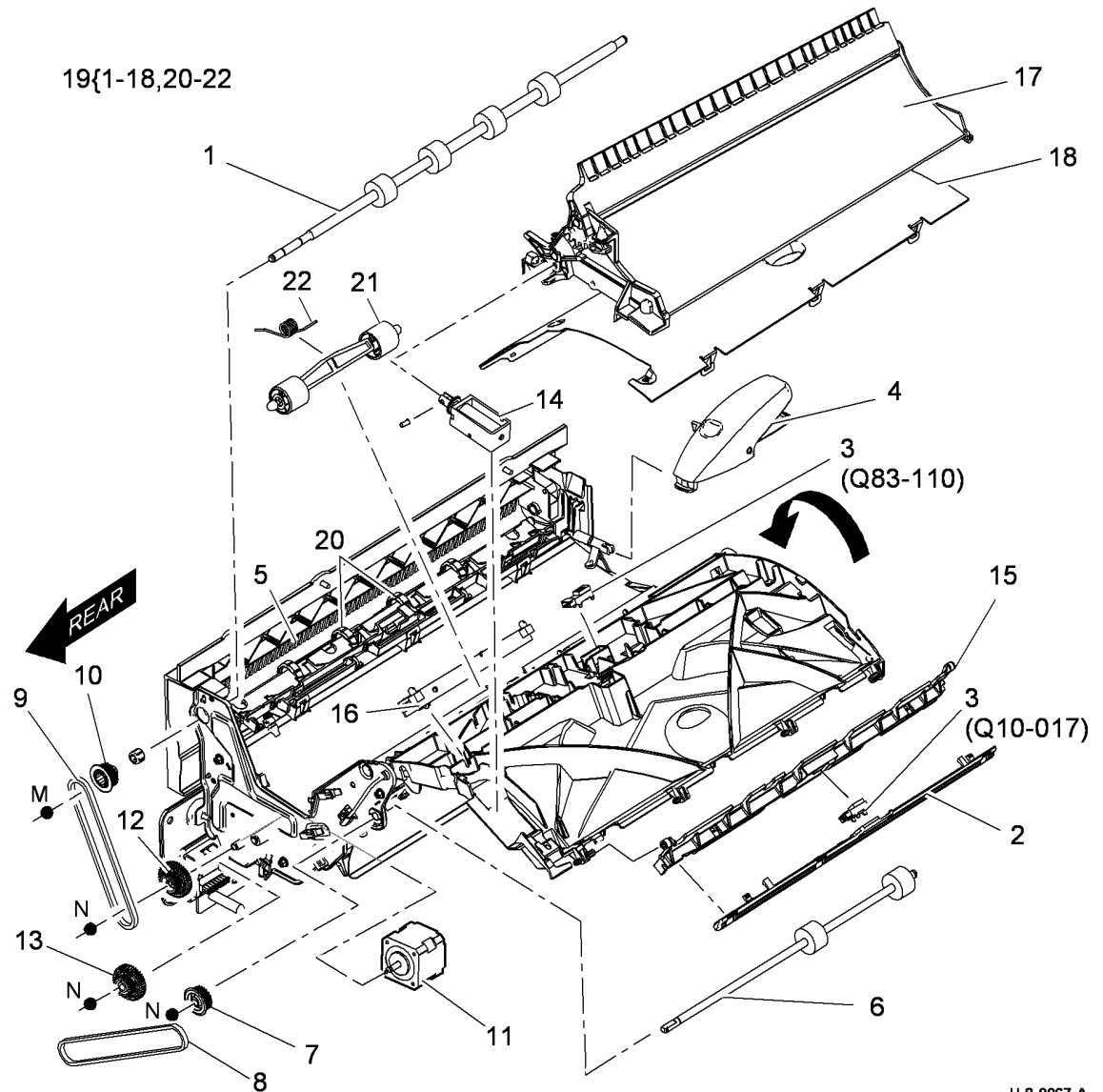

PL 10.20 Transfix Roller Assembly

Item	Part	Description
1	059K78250	Transfix roller (REP 10.1)
2	-	Bearing retainer (P/O PL 10.20 Item 1)
3	-	Transfix bearing carrier (P/O PL 10.20 Item 1)
4	848E34280	Transfix encoder cover
5	146K01011	Front transfix flexure encoder/Rear transfix flexure encoder (REP 10.24)
6	-	Bearing (P/O PL 10.20 Item 12)
7	-	Front compound gear (P/O PL 10.20 Item 16)
8	-	Front transfix linkage assembly (P/O PL 10.20 Item 16) (REP 10.2)
9	-	Rear compound gear (P/O PL 10.20 Item 18) (REP 10.3)
10	-	Rear transfix linkage assembly (P/O PL 10.20 Item 18) (REP 10.3)
11	127K62320	Front transfix motor (MOT10-019) (REP 10.4), Rear transfix motor (MOT10-020) (REP 10.5)
12	801K37690	Front drum frame assembly (REP 10.2)
13	801K37940	Rear outer frame (REP 10.3)
14	041K06800	Transfix stripper assembly (See NOTE) (REP 10.6)
15	-	Not used
16	-	Front transfix linkage and gear kit (REF: PL 31.11 Item 21) (REP 10.2)
17	117E35760	Transfix bearing ground cable
18	-	Rear transfix linkage and gear kit (REF: PL 31.11 Item 22) (REP 10.3)
19	-	Front outer frame (P/O PL 10.20 Item 12)
20	-	Front inner frame (P/O PL 10.20 Item 12)
21	-	Latch (P/O PL 10.20 Item 12)
22	-	Spring (Not spared)

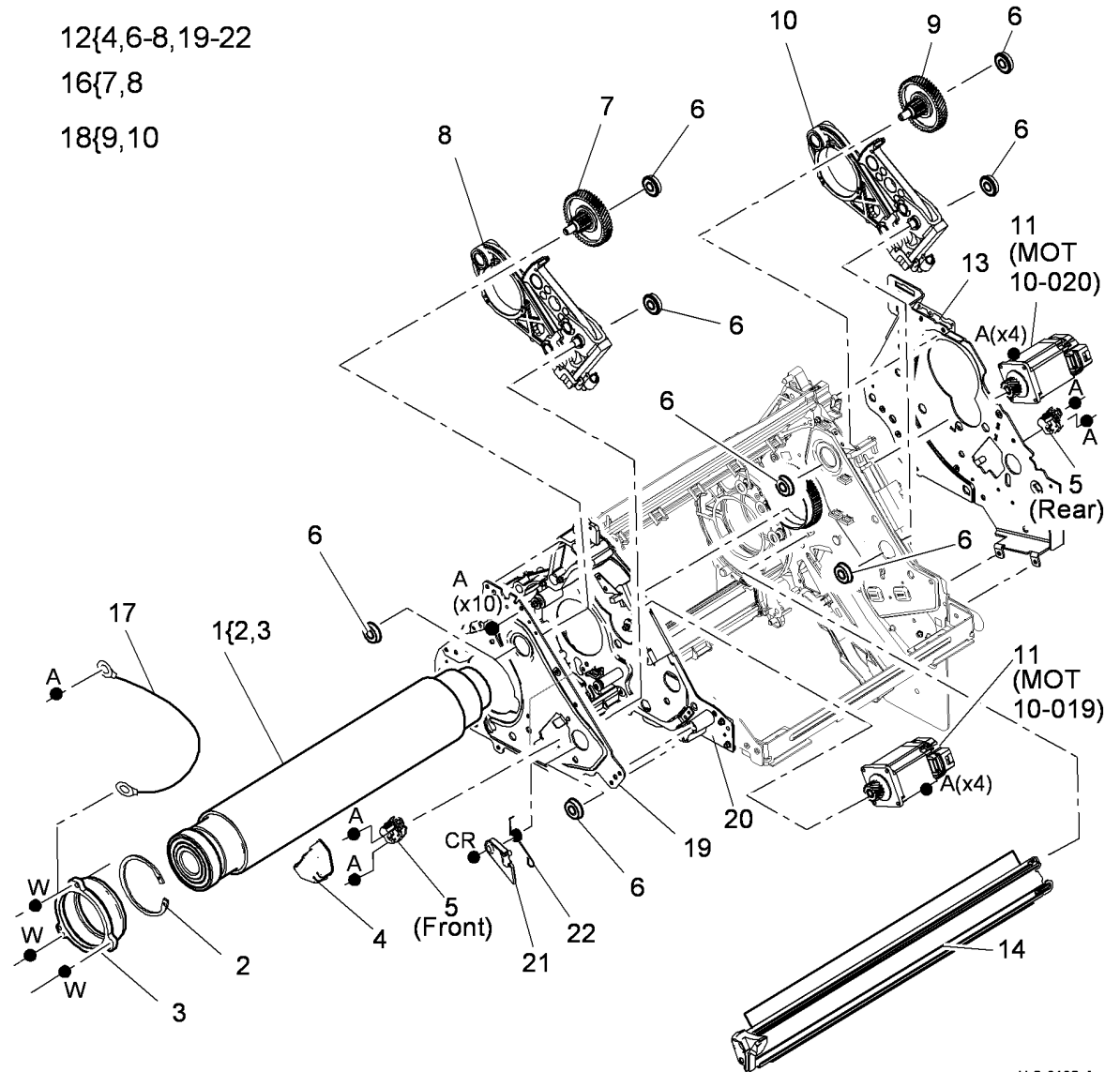

NOTE: To reset the HFSI count go to dC135.

U-8-0108-A

PL 12.00 OCT

Item	Part	Description
1	-	OCT (complete) (P/O PL 31.11 Item 1)
2	-	Tray (P/O PL 12.00 Item 1)
3	826E32840	Thumbscrew
4	-	OCT 90% full sensor (Q12-211) (P/O PL 12.00 Item 1)

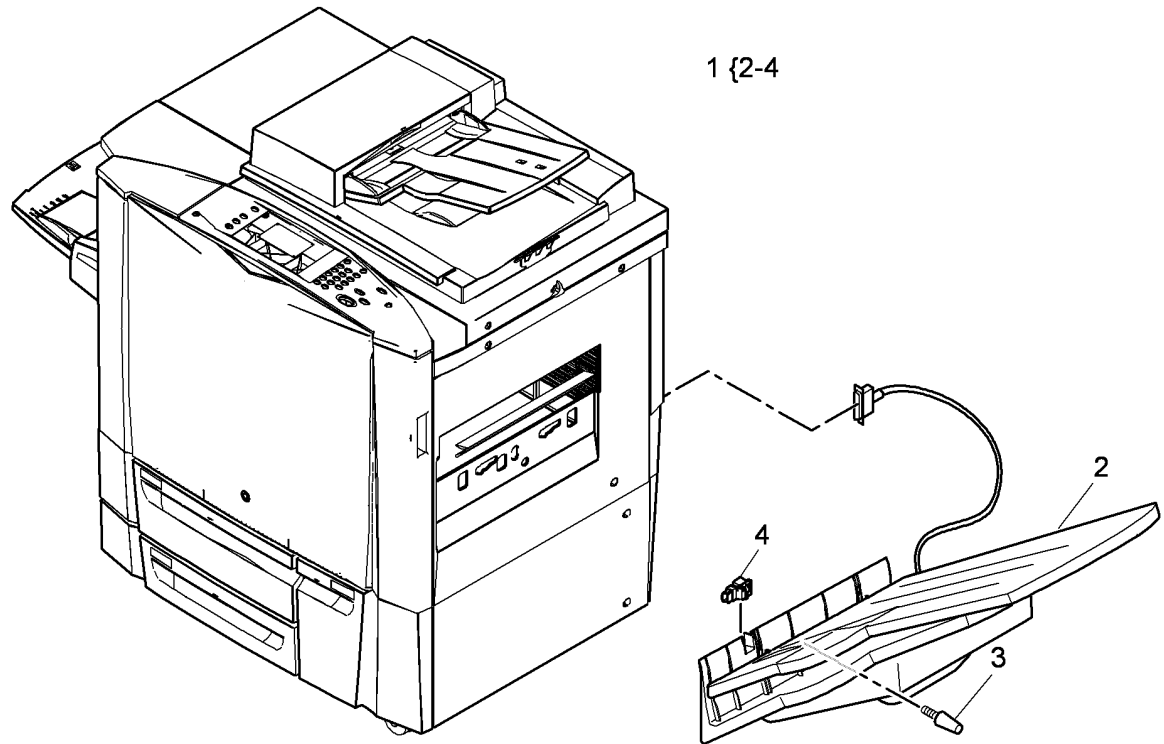

U-8-0040-A

PL 12.10 LCSS Covers

Item	Part	Description
1	802K31380	Exit cover
2	848K31340	Top cover (REP 12.1-110)
3	-	Entry guide cover (REF: PL 12.70 Item 5) (REP 12.15-110)
4	-	Front door cover assembly (P/O PL 31.11 Item 2) (REP 12.1-110)
5	017K03750	Fixed caster
6	017K04520	Adjustable caster
7	-	Output cover (Not spared)
8	802K48320	Lower right hand cover
9	050K67380	Bin 0
10	050K68490	Bin 1 (ADJ 12.1-110)
11	848K31320	Rear cover assembly (REP 12.1-110)
12	-	Upper right hand cover (Not spared)
13	019K13380	Bin 1 alignment clip

NOTE: Refer to ADJ 12.2-110 to align the LCSS to the machine.

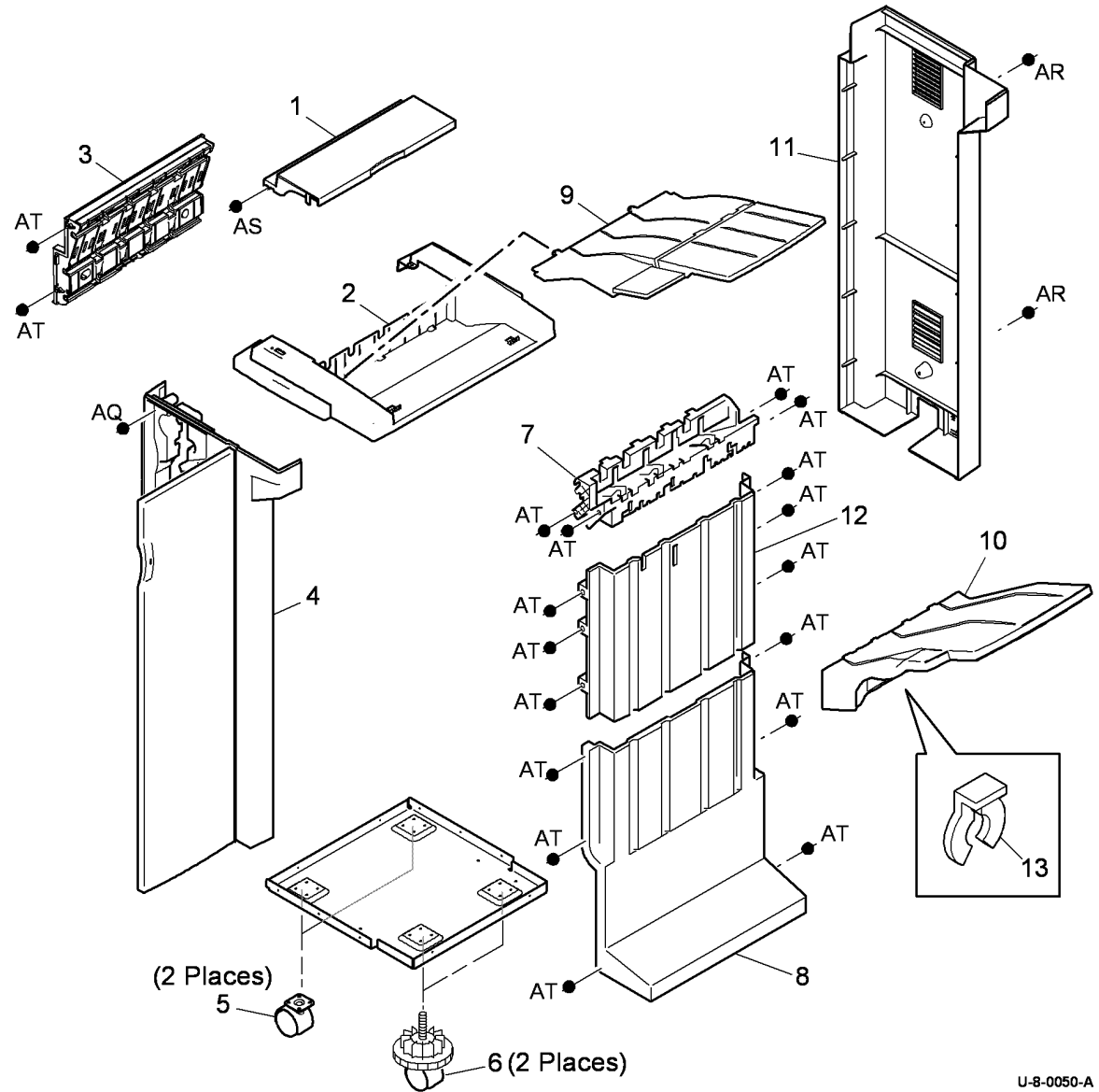

U-8-0050-A

PL 12.15 LCSS Docking Latch

Item	Part	Description
1	-	Sensor cover (P/O PL 12.15 Item 9)
2	110K13980	Docking interlock (S12-177) (See NOTE)
3	-	Link bracket assembly (P/O PL 12.15 Item 8)
4	-	Stopper (P/O PL 12.15 Item 9)
5	-	Docking latch (P/O PL 12.15 Item 8)
6	-	Not used
7	120K03450	Docking actuator (See NOTE)
8	003K20930	Docking latch assembly (See NOTE) (REP 12.16-110)
9	003K20940	Mounting stay assembly

NOTE: Also comes as part of mounting stay assembly PL 12.15 Item 9.

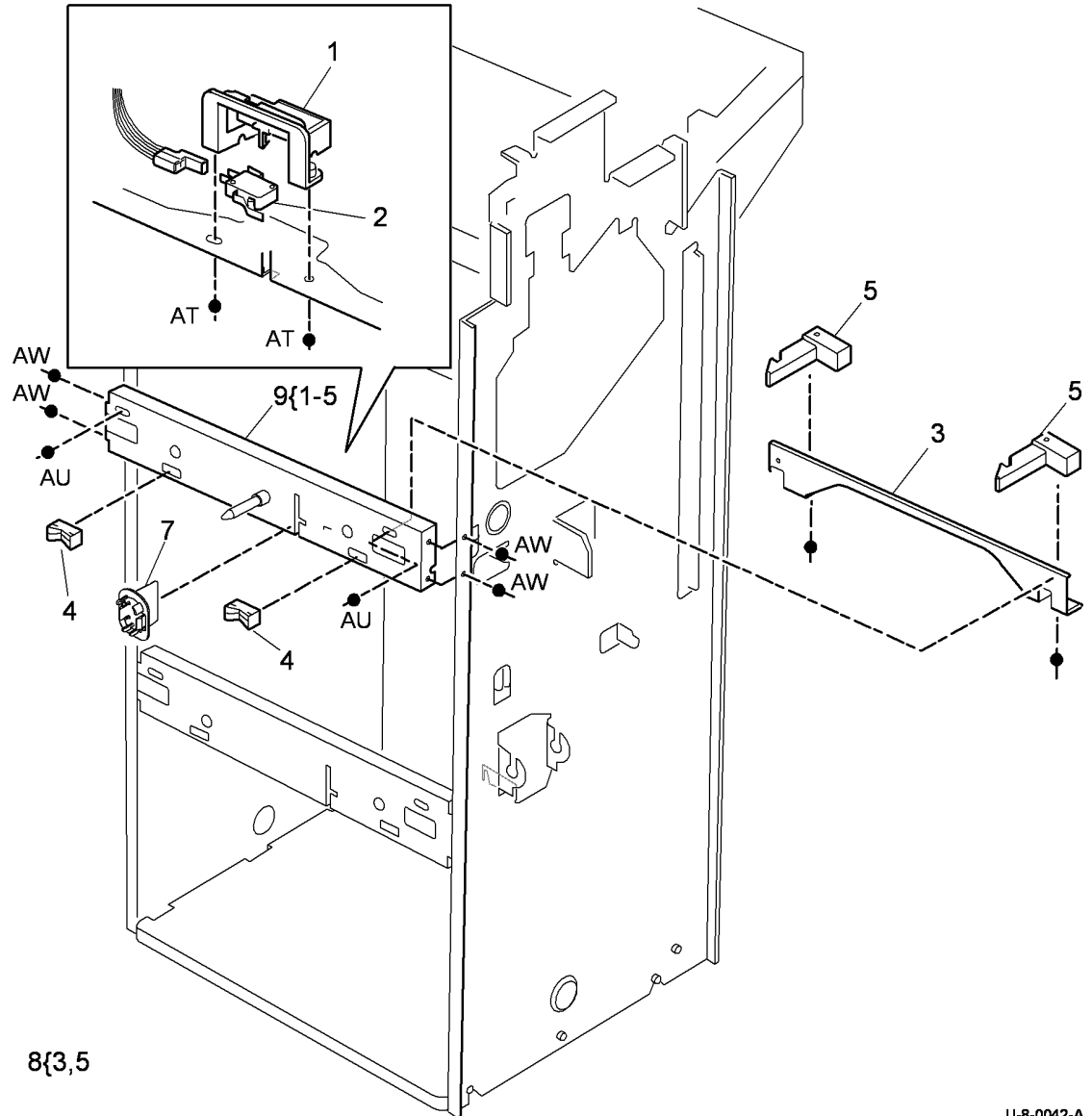

U-8-0042-A

PL 12.20 LCSS Hole Punch Unit

Item	Part	Description
1	130E10360	Punch head home sensor (Q12-194), Punch head present sensor (Q12-195) (REP 12.7-110)
2	127K55900	Punch head motor assembly (MOT12-243) (REP 12.7-110)
3	-	Hole punch unit (see below for variants) (REP 12.7-110, ADJ 12.3-110) (See NOTE)
-	180K01330	2 Hole (XE)
-	180K01340	3 Hole (USSG/XCL)
4	093E03930	Chad bin
5	-	Thumbscrew (Not spared)
6	-	Bracket (P/O PL 12.20 Item 14)
7	130E10380	Punch sensor 1 (Q12-078), Chad bin level sensor (Q12-193) (P/O PL 12.20 Item 14) (REP 12.7-110)
8	-	Sensor bracket (Not spared)
9	-	Not used
10	-	Bracket (Not spared)
11	-	Punch drive gear (Not spared)
12	-	Punch cam (Not spared)
13	-	Punch spacer (Not spared)
14	-	Punch sensor assembly (Not spared)
15	014K10610	Hole punch assembly cover

NOTE: Refer to PL 31.10 Item 5 for other LCSS hole punch kits.

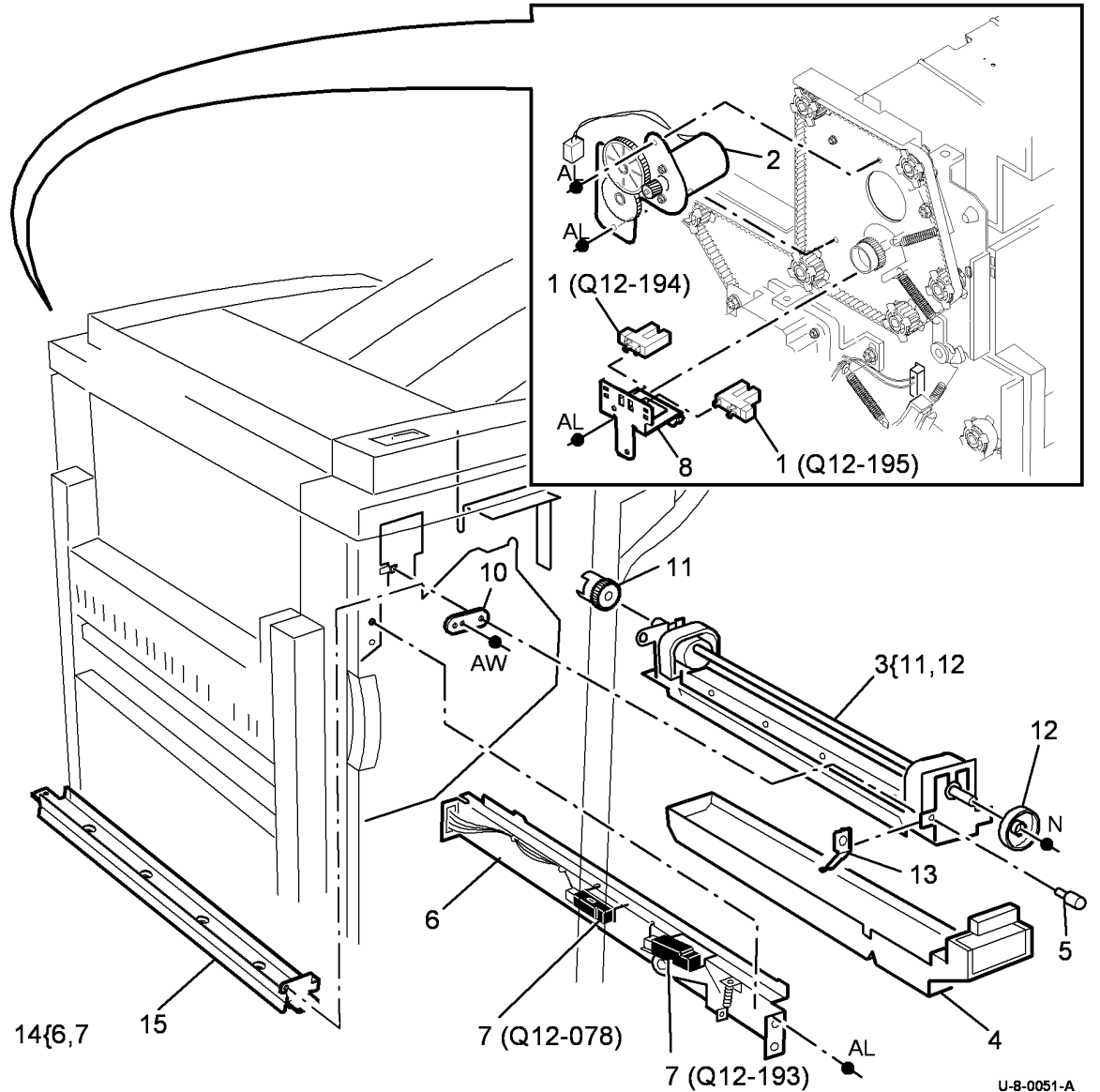

U-8-0051-A

PL 12.25 LCSS Paddle Wheel

Item	Part	Description
1	-	Bushing (Not spared)
2	-	Shaft (P/O PL 12.25 Item 4)
3	-	Paddle wheel (P/O PL 12.25 Item 4) (REP 12.18-110)(See NOTE)
4	-	Paddle wheel shaft assembly (REF: PL 31.11 Item 6)(REP 12.12-110)
5	013E25790	Nylon bearing
6	-	Gear (Not spared)
7	-	Flag (Not spared)
8	-	Cable clamp (Not spared)
9	-	Output cover (REF: PL 12.10 Item 7)
10	127K62580	Paddle roll motor assembly (MOT12-238)
11	130E10360	Paddle roll home sensor (Q12-186)

NOTE: Paddle wheels are also supplied (4 off) as a kit PL 31.10 Item 4.

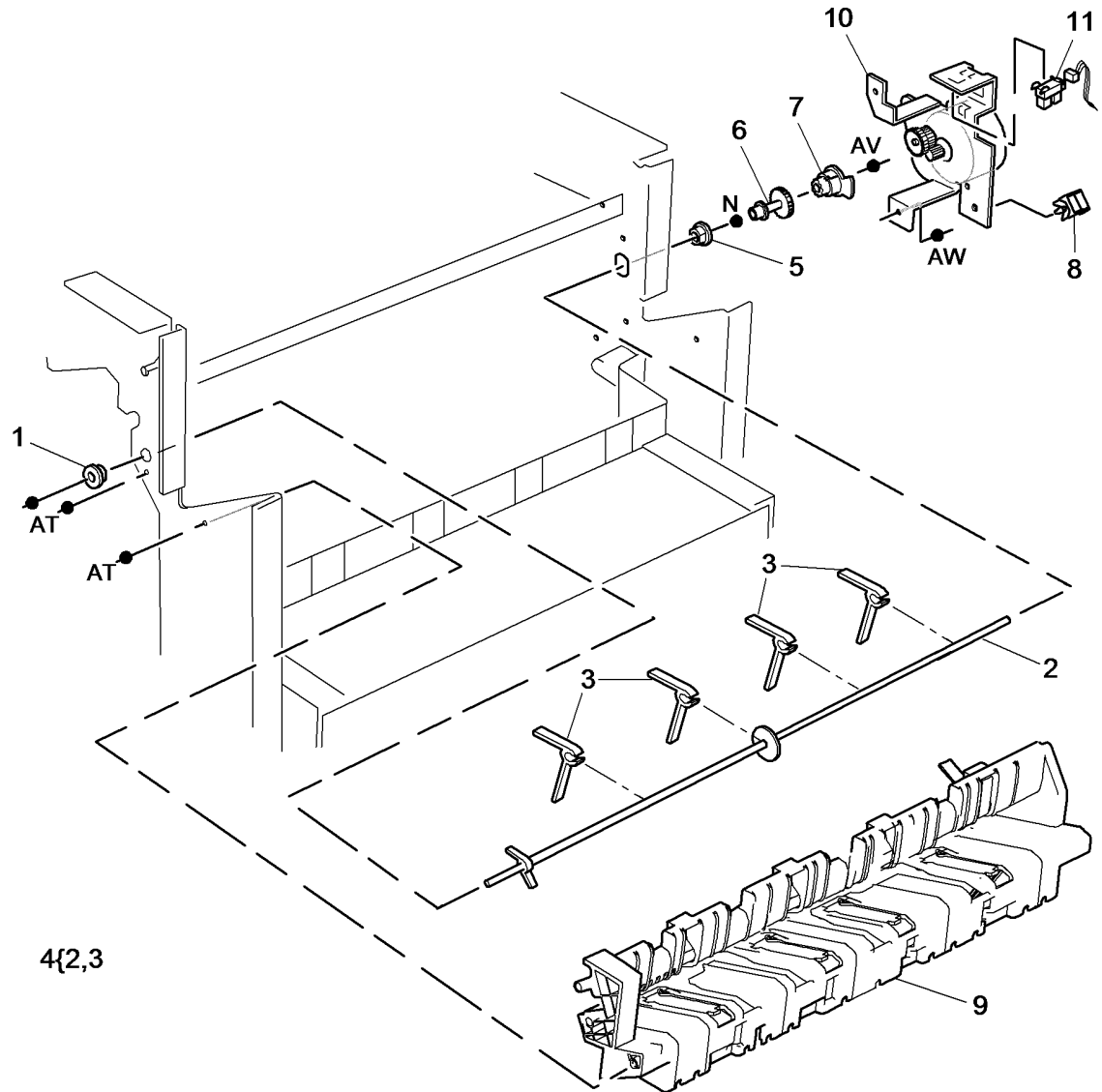

U-8-0043-A

PL 12.30 LCSS Bin 1 Control Components (1 of 2)

Item	Part	Description
1	023E24320	Bin 1 drive belt (REP 12.5-110)
2	-	Rear belt clamp (Not spared) (ADJ 12.1-110)
3	110E20180	Bin 1 upper limit switch (S12-190)
4	-	Sensor bracket (Not spared)
5	130E10360	Bin 1 90% full sensor (Q12-187)
6	-	Pulley (Not spared)
7	-	Bearing (Not spared)
8	127K55890	Bin 1 elevator motor (MOT12-241)
9	-	Front belt clamp (Not spared) (ADJ 12.1-110)
10	-	Motor bracket (Not spared)
11	130E12330	Bin 1 motor encoder sensor (Q12-163)
12	-	Pulley assembly (Not spared)
13	-	Belt tensioner (Not spared)
14	-	Spring (Not spared)
15	-	Idler (Not spared)

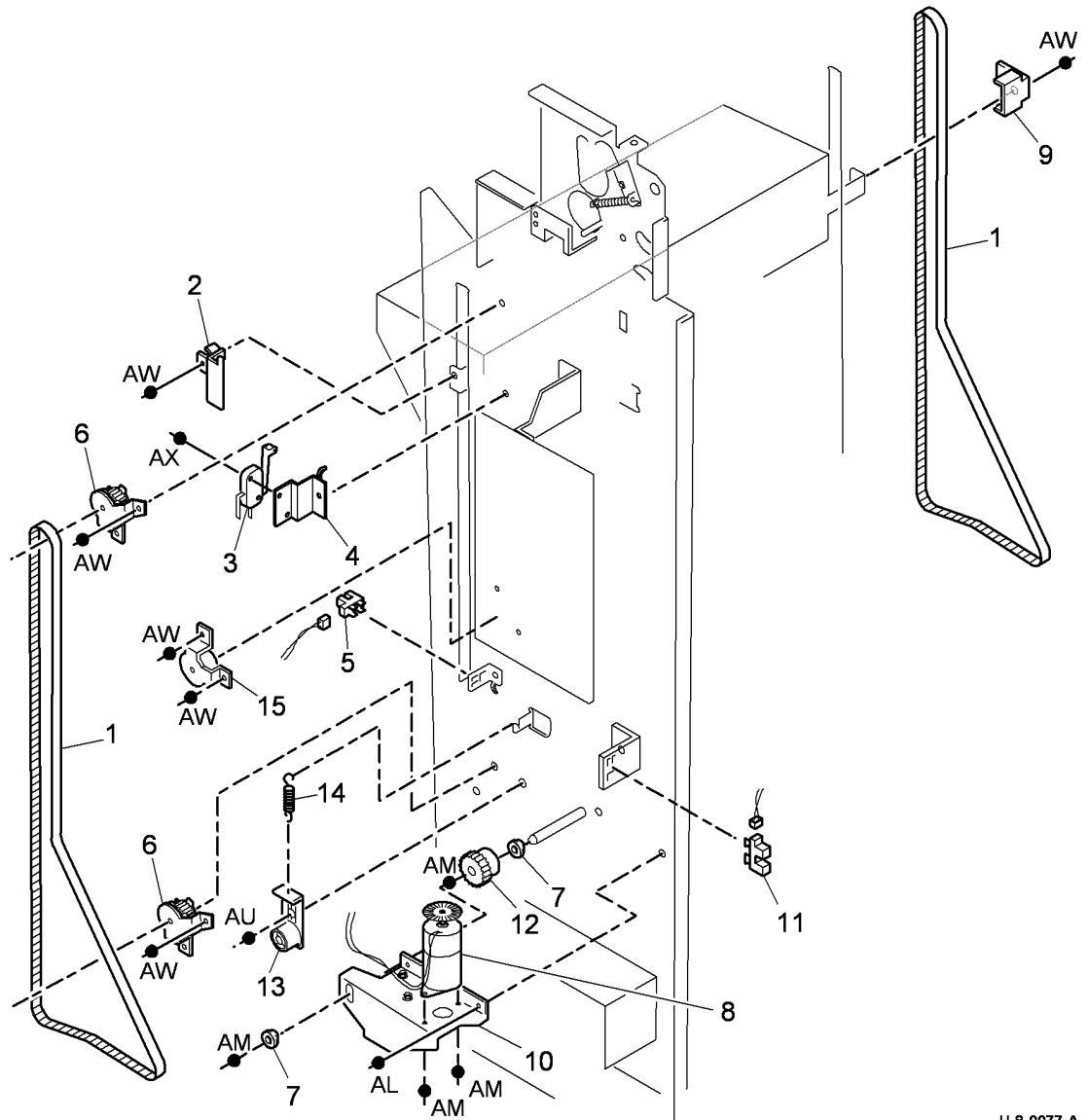

U-8-0077-A

PL 12.35 LCSS Bin 1 Control Components (2 of 2)

Item	Part	Description
1	110K13990	Bin 1 lower limit switch (S12-191)
2	-	Not used
3	130E10360	Bin 1 Upper level sensor (Q12-188) (REP 12.11-110)
4	-	Actuator (Not spared)
5	-	Sensor support assembly (Not spared)

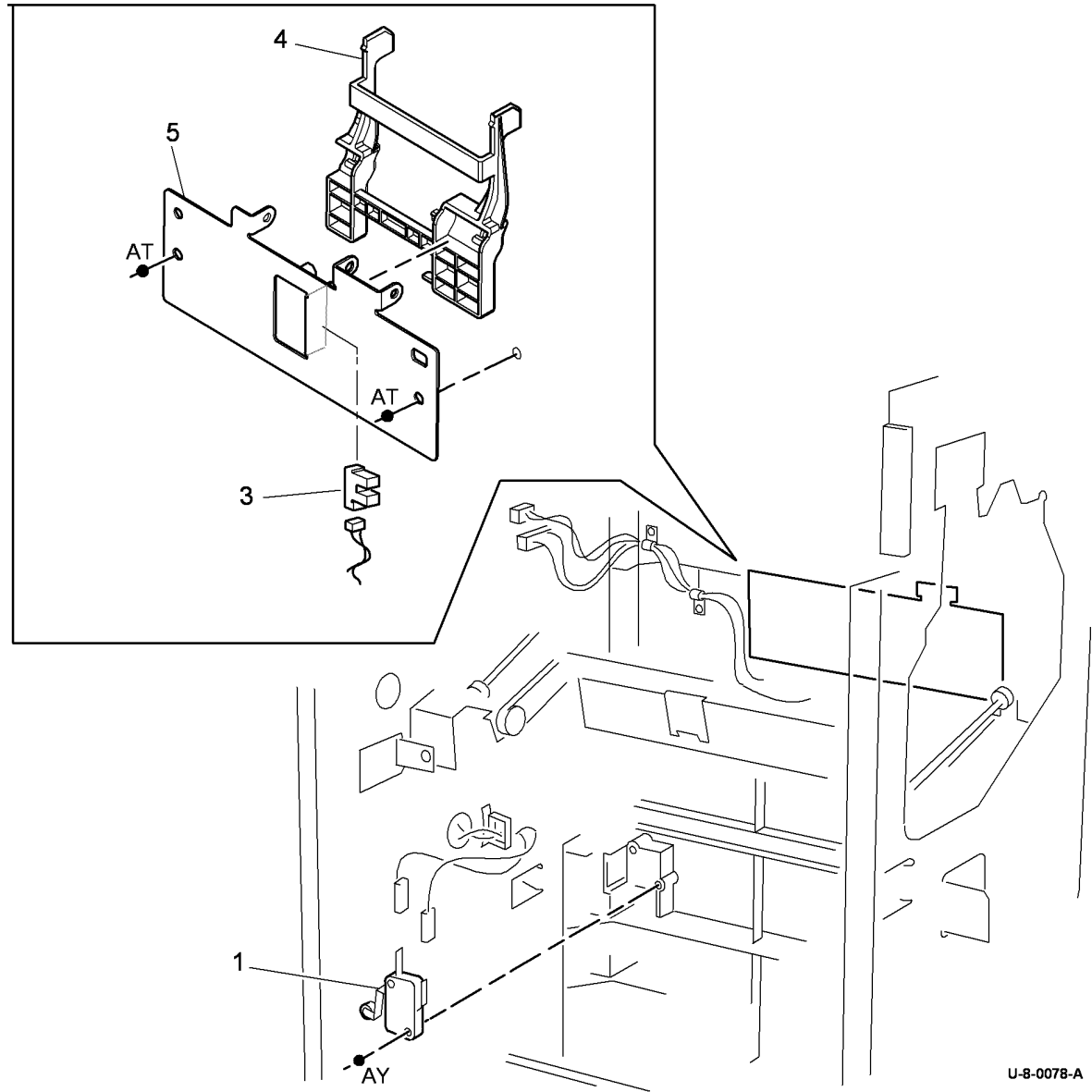

PL 12.40 LCSS Paper Entry Transport

Item	Part	Description
1	023E24340	Input drive belt (REP 12.2-110)
2	127K55860	Transport motor 1 (MOT12-223) (REP 12.2-110)
3	-	Spring (Not spared)
4	-	Pulley (Not spared)
5	013E37460	Dry bearing
6	-	Feed roll shaft (short) (Not spared)
7	013E37470	Bearing
8	-	Paper entry guide assembly (REF: PL 12.70 Item 1)
9	-	Feed roll shaft (long) (Not spared)
10	006K32780	Thumb wheel

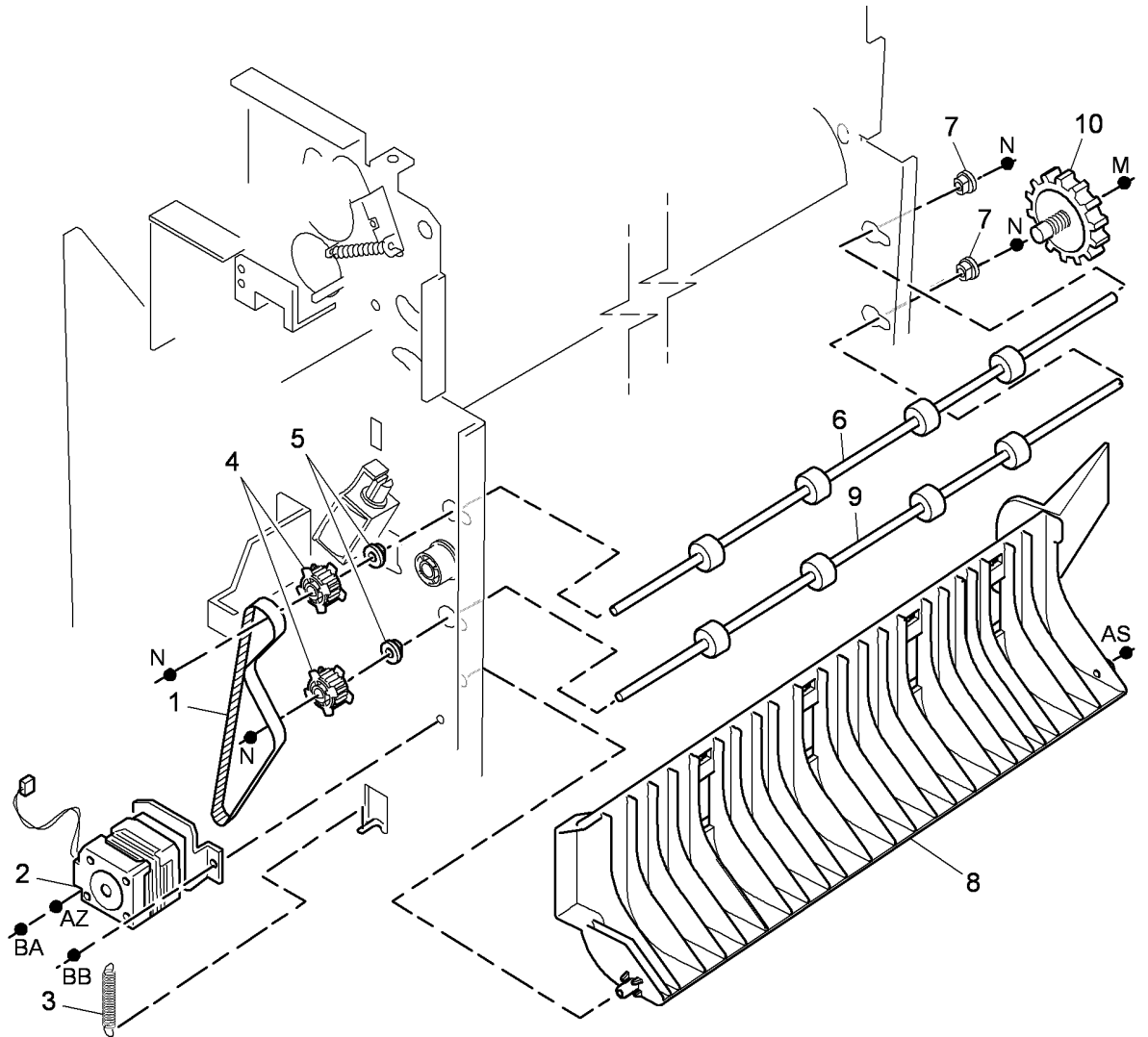

U-8-0044-A

PL 12.45 LCSS Tamper Assembly

Item	Part	Description
1	049K12120	Tamper assembly (REP 12.6-110)
2	-	Tamper unit (P/O PL 12.45 Item 1)
3	130E10360	Front tamper home sensor (Q12-180), Front tamper away sensor (Q12-182), Rear tamper home sensor (Q12-181), Rear tamper away sensor (Q12-183) (See NOTE)
4	-	Sensor bracket (P/O PL 12.45 Item 1)
5	-	Static eliminator (stacker) (REF: PL 12.65 Item 7)
6	-	Sensor retainer (P/O PL 12.45 Item 1)

NOTE: The front tamper home sensor (Q12-180) and rear tamper home sensor (Q12-181) are bonded onto the tamper unit and are not replaceable. Failure of either of these sensors will require the replacement of the tamper assembly.

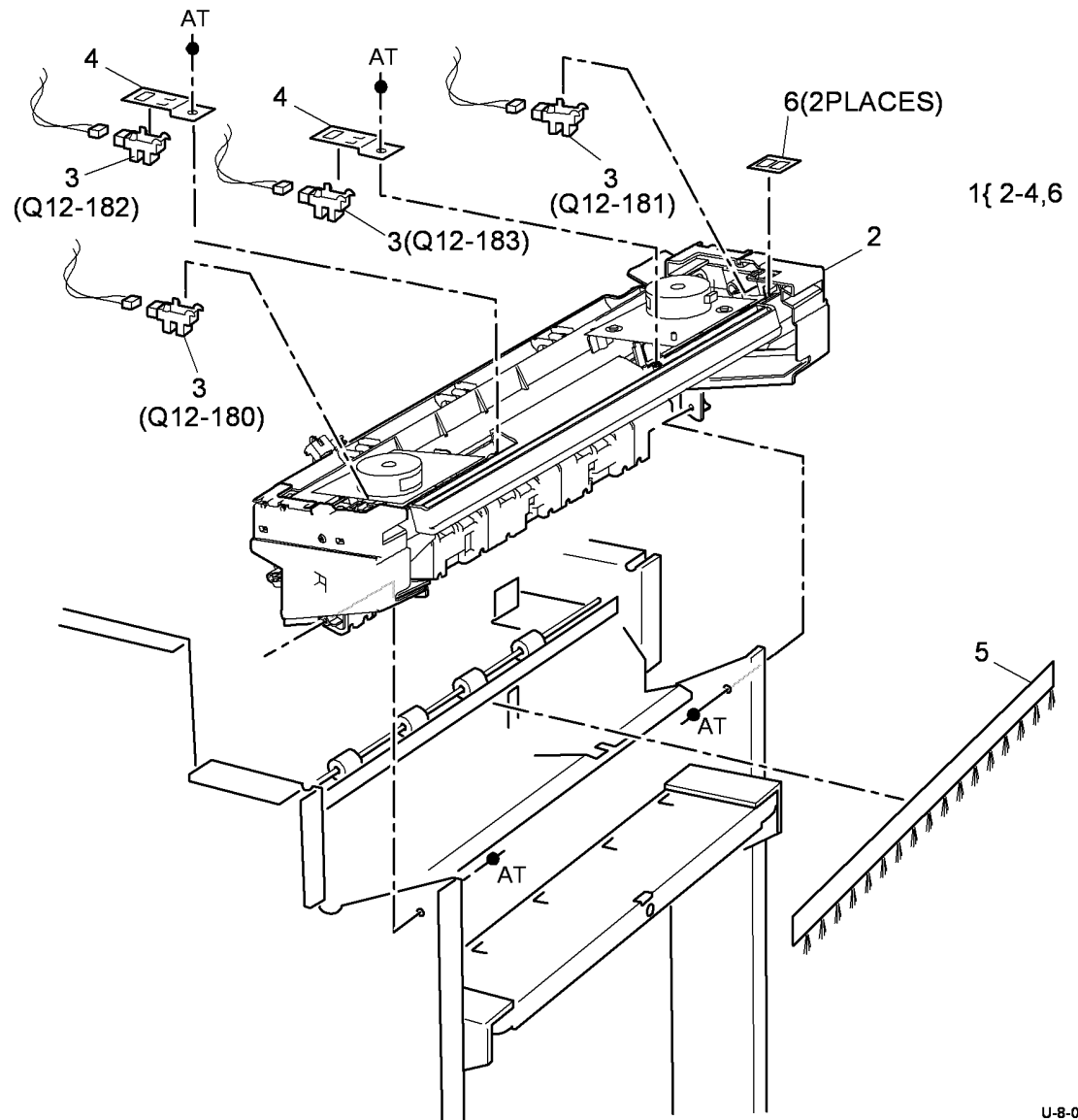

U-8-0079-A

PL 12.50 LCSS Ejector Assembly

Item	Part	Description
1	054K43580	Ejector assembly (REP 12.10-110)
2	-	Ejector base (P/O PL 12.50 Item 1)
3	130E10360	Ejector home sensor (Q12-184), Ejector out sensor (Q12-185), Ejector motor encoder sensor (Q12-096) (REP 12.10-110)
4	-	Pulley (P/O PL 12.50 Item 1)
5	023E24330	Ejector belt (REP 12.17-110)
6	-	Clip (P/O PL 12.50 Item 1)
7	019K13390	Support finger set (Qty. 4)
8	020E54090	Pulley/drive gear

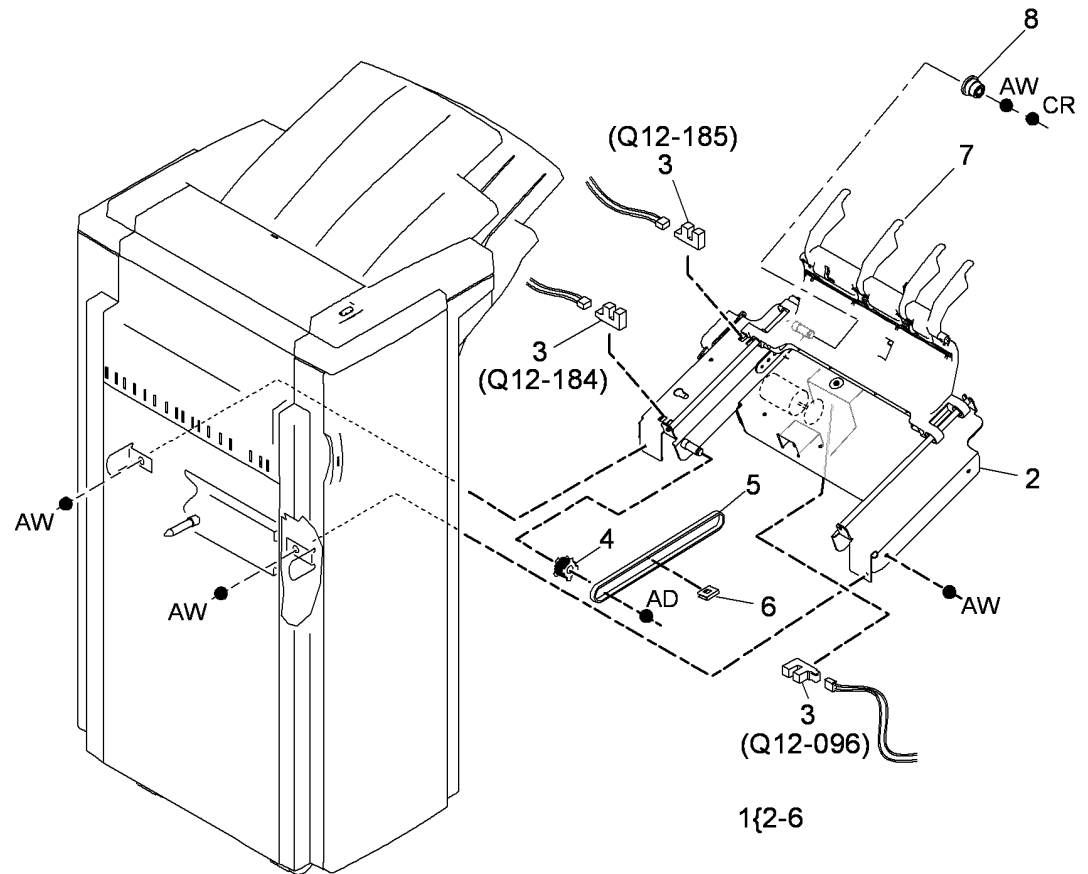

U-8-0080-A

PL 12.55 LCSS Staple Head Unit/ Traverse Assembly

Item	Part	Description
1	-	Stapler traverse assembly (P/O PL 31.11 Item 15) (REP 12.8-110)
2	-	Head traverse unit (P/O PL 12.55 Item 1)
3	130E10360	Stapler home sensor (Q12-135), Stapler index sensor (Q12-168)
4	130E10380	SH1 Paper sensor (Q12-196)
5	029K04690	Staple head unit (REP 12.9-110)
6	-	Stapler cover (P/O PL 12.55 Item 1)
7	008R12941	Staple cartridge
8	-	Staple head assembly (P/O PL 12.55 Item 1)

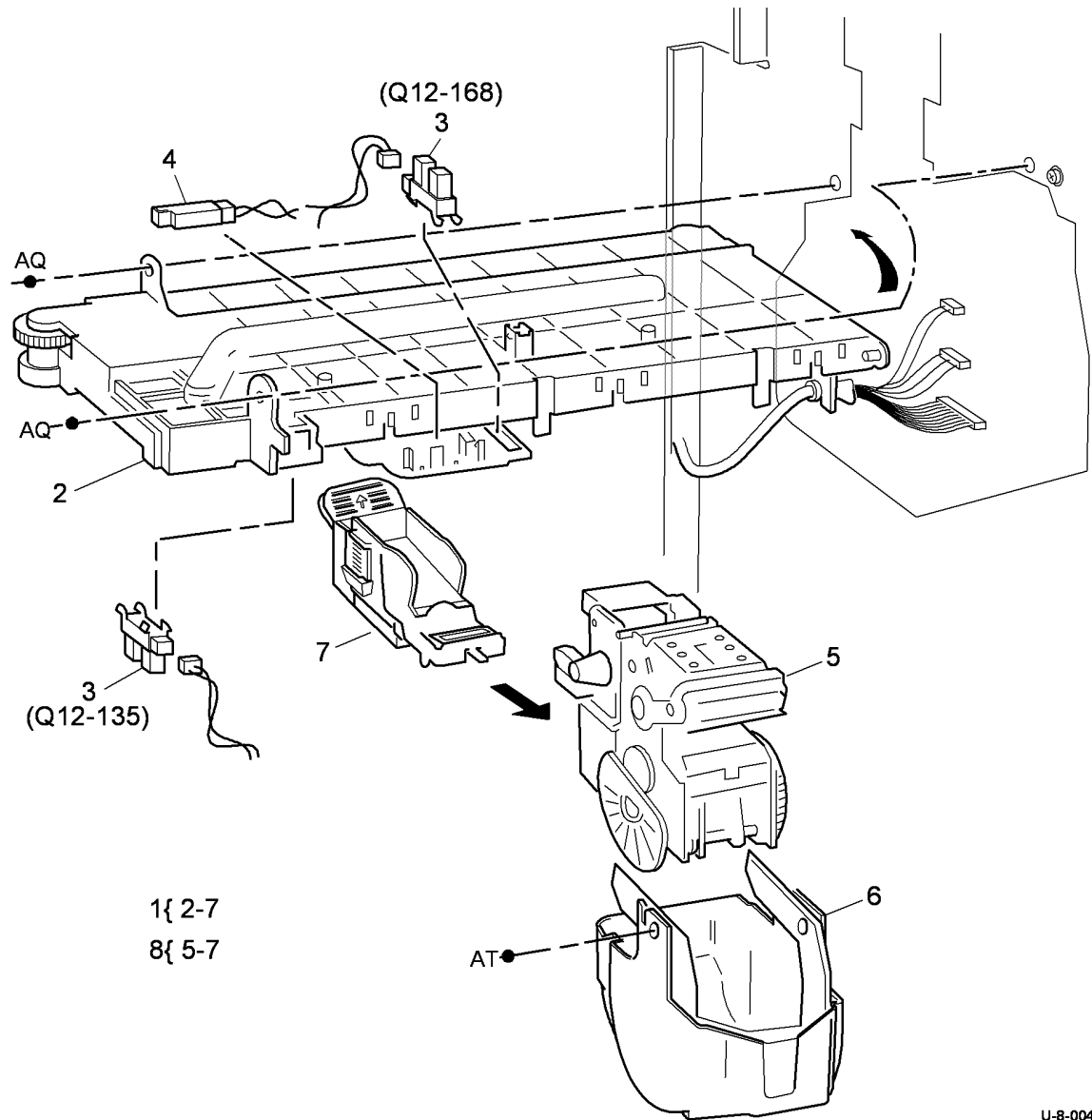

U-8-0047-A

PL 12.60 LCSS Bin 0 Entry

Item	Part	Description
1	006K32810	Top tray exit shaft
2	013E25790	Nylon bearing
3	-	Pulley (Not spared)
4	023E24330	Intermediate paper drive belt (REP 12.3-110)
5	127K55870	Transport motor 2 (MOT12-224) (REP 12.4-110)
6	-	Spring (Not spared)
7	115E13440	Static eliminator
8	-	Feed roll shaft (short) (Not spared)
9	013E25800	Copper bearing
10	032K04580	Paper guide
11	130E11440	Top tray exit sensor (Q12-107)
12	121K45010	Exit diverter solenoid (SOL12-225)
13	006K32760	Shaft diverter assembly
14	023E24340	Paper output drive belt (REP 12.4-110)
15	006K32800	Drive shaft assembly
16	006K32770	Drive shaft assembly knob
17	-	Belt tensioner (Not spared)
18	-	Spring (Not spared)
19	-	Washer (Not spared)
20	-	Actuator (Not spared)

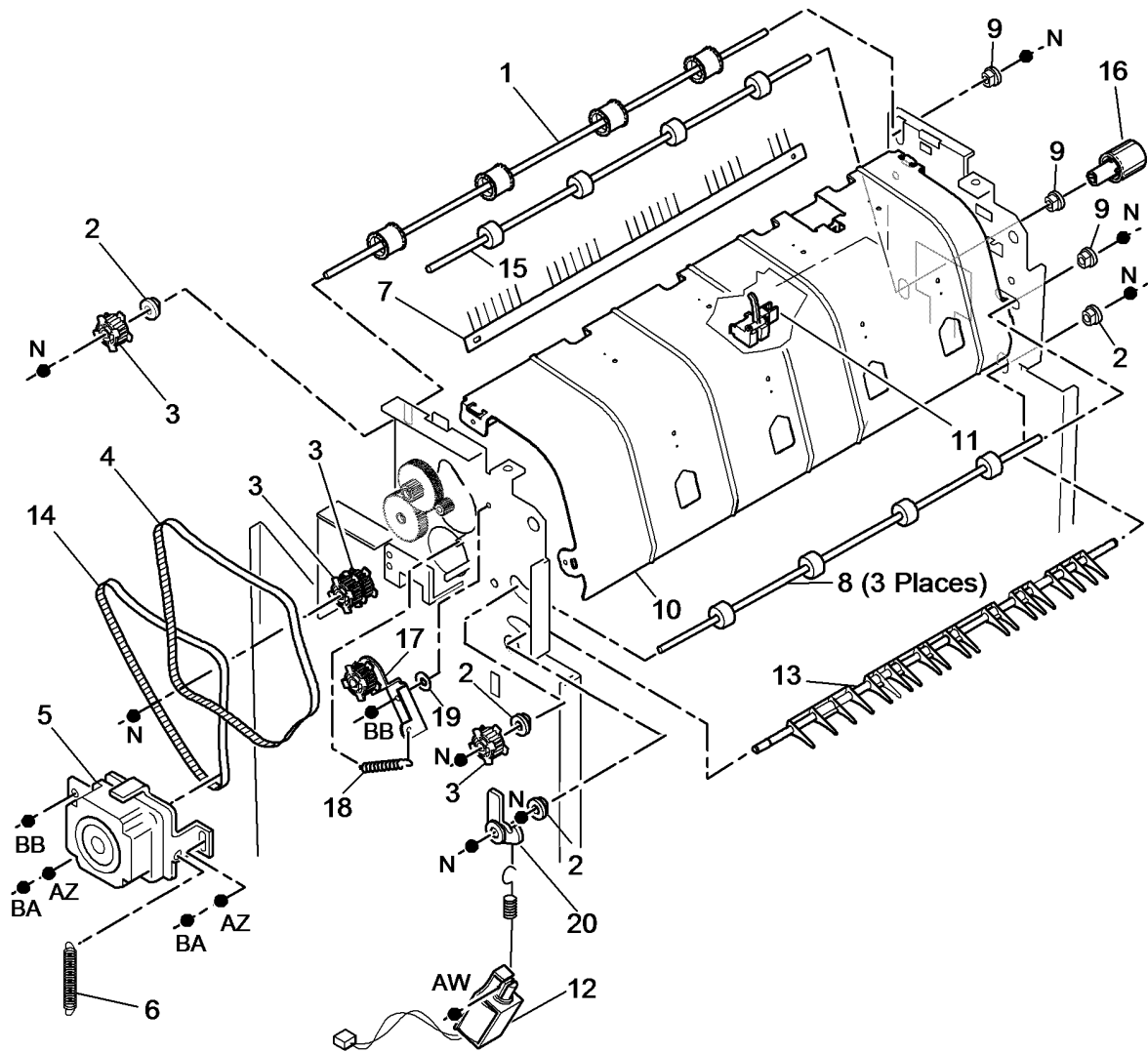

U-8-0045-A

PL 12.65 LCSS Bin 1 Entry

Item	Part	Description
1	032K04610	Left hand paper guide
2	032K04590	Lower right hand paper guide
3	006K32790	Ejector drive shaft
4	130E11440	Compiler exit sensor (Q12-107)
5	013E25790	Nylon bearing
6	-	Pulley (Not spared)
7	115E11810	Static eliminator (stacker)
8	023E24340	Paper output drive belt
9	-	Upper right hand paper guide (Not spared)
10	013E25800	Copper bearing
11	-	Mylar safety cover (P/O PL 12.65 Item 1)

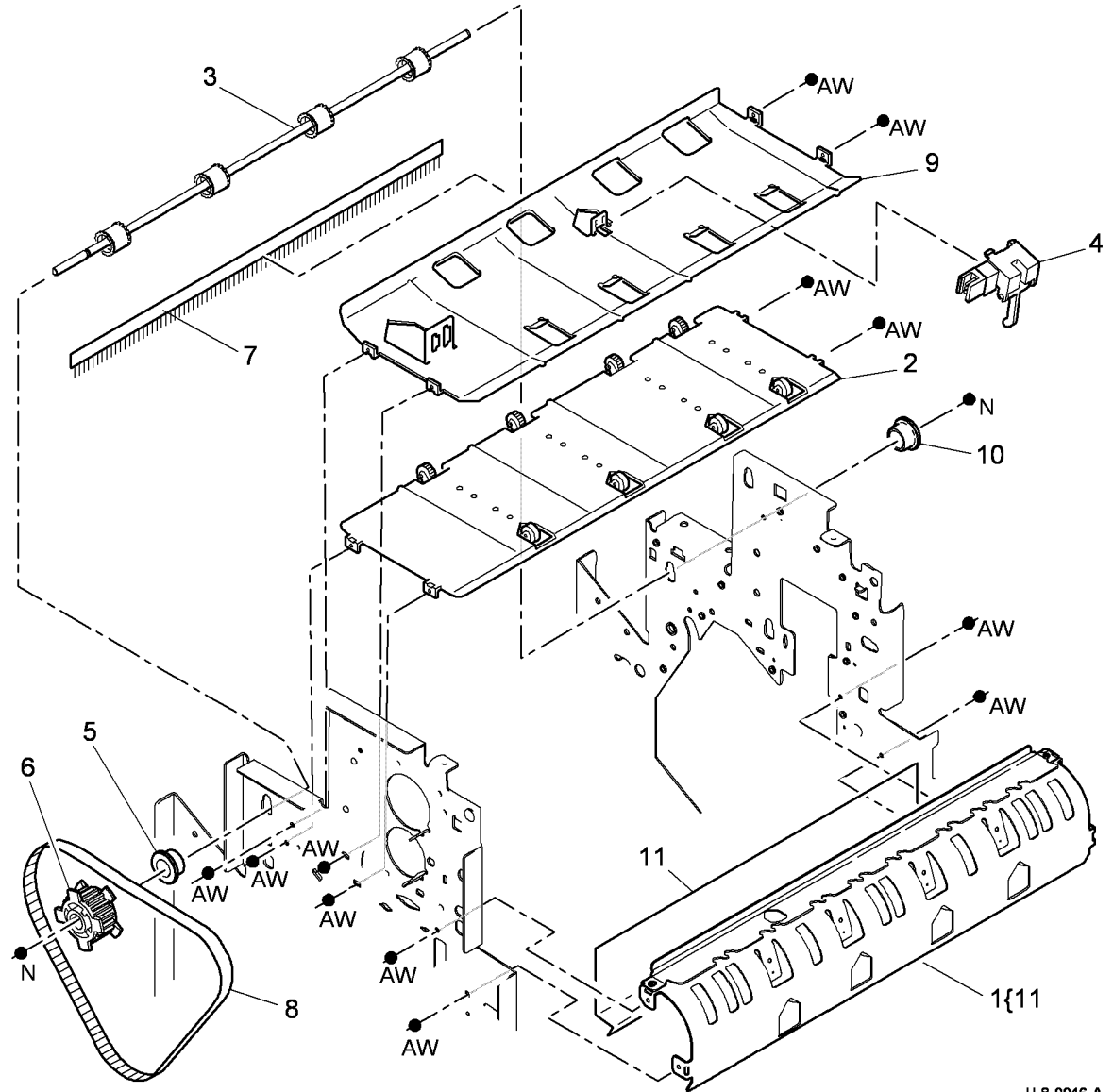

U-8-0046-A

PL 12.70 LCSS Entry Guide Cover/ Jam Clearance Guide

Item	Part	Description
1	032K09670	Jam clearance guide assembly
2	003K17531	Jam clearance handle
3	130E10380	Entry sensor (Q12-077)
4	-	Sensor bracket (Not spared)
5	848K31330	Entry guide cover (REP 12.15-110)
6	-	Jam clearance guide (P/O PL 12.70 Item 1)
7	-	Latch (Not spared)

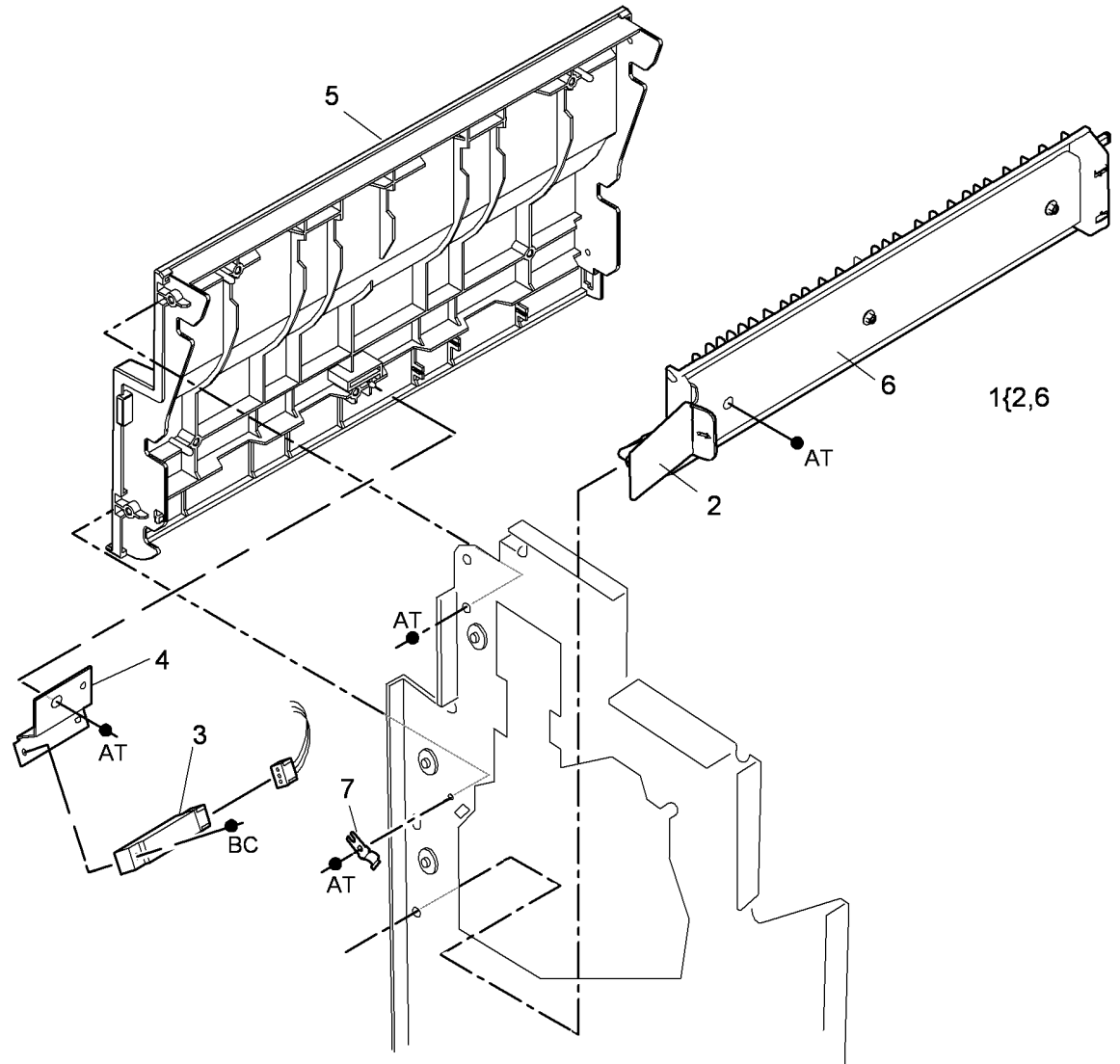

U-8-0036-A

PL 12.75 LCSS Electrical

Item	Part	Description
1	960K58410	LCSS PWB (CAUTION) (REP 12.14-110)
2	105K35841	Power supply module
3	960K34490	Pause to unload PWB
4	962K56951	Cord bracket assembly
5	110K13980	Front door interlock switch (S12-303)
6	110K13970	Top cover interlock switch (S12-197)
7	-	LCSS communications harness (Not spared)
8	-	LCSS power cord (Not spared)

CAUTION

Do not install a new LCSS PWB until the cause of the damage to the old LCSS PWB has been determined. Go to the [12G-110 LCSS PWB Damage RAP](#).

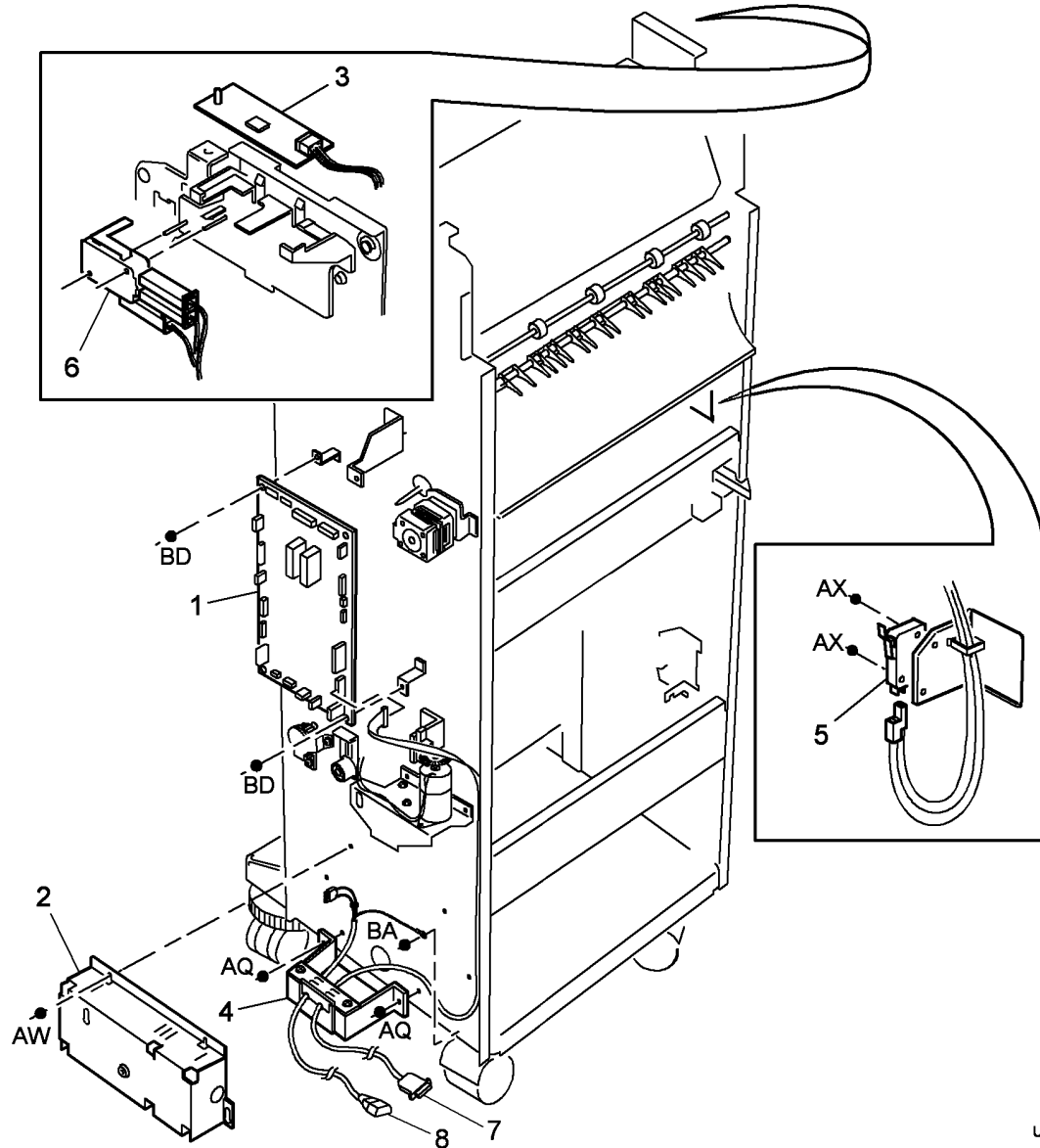

U-8-0055-A

PL 12.100 HVF Covers and Docking

Item	Part	Description
1	848E40510	Top cover (REP 12.1-171)
2	848K12501	Front cover (REP 12.1-171)
3	848E17790	Front door (REP 12.1-171)
4	848K12510	Door support (REP 12.1-171)
5	848E40521	Rear cover (REP 12.1-171)
6	848K12530	Vent cover (REP 12.1-171)
7	848E17800	Foot cover (REP 12.1-171)
8	848E17810	Inserter cover (REP 12.1-171)
9	848E40500	Top tray (REP 12.3-171)
10	-	Seal (Not spared)
11	017K04830	Fixed caster assembly (REP 12.96-171)
12	-	Fixed caster bracket (P/O PL 12.100 Item 11)
13	017K04630	Adjustable caster (REP 12.96-171)
14	-	Adjustable caster washer (P/O PL 12.100 Item 13)
15	017K04760	Mounting bracket assembly
16	110K13980	Docking interlock switch (S12-177)
17	120K03450	Docking actuator (P/O PL 12.100 Item 15)
18	049K13570	Bookletmaker interlock bracket

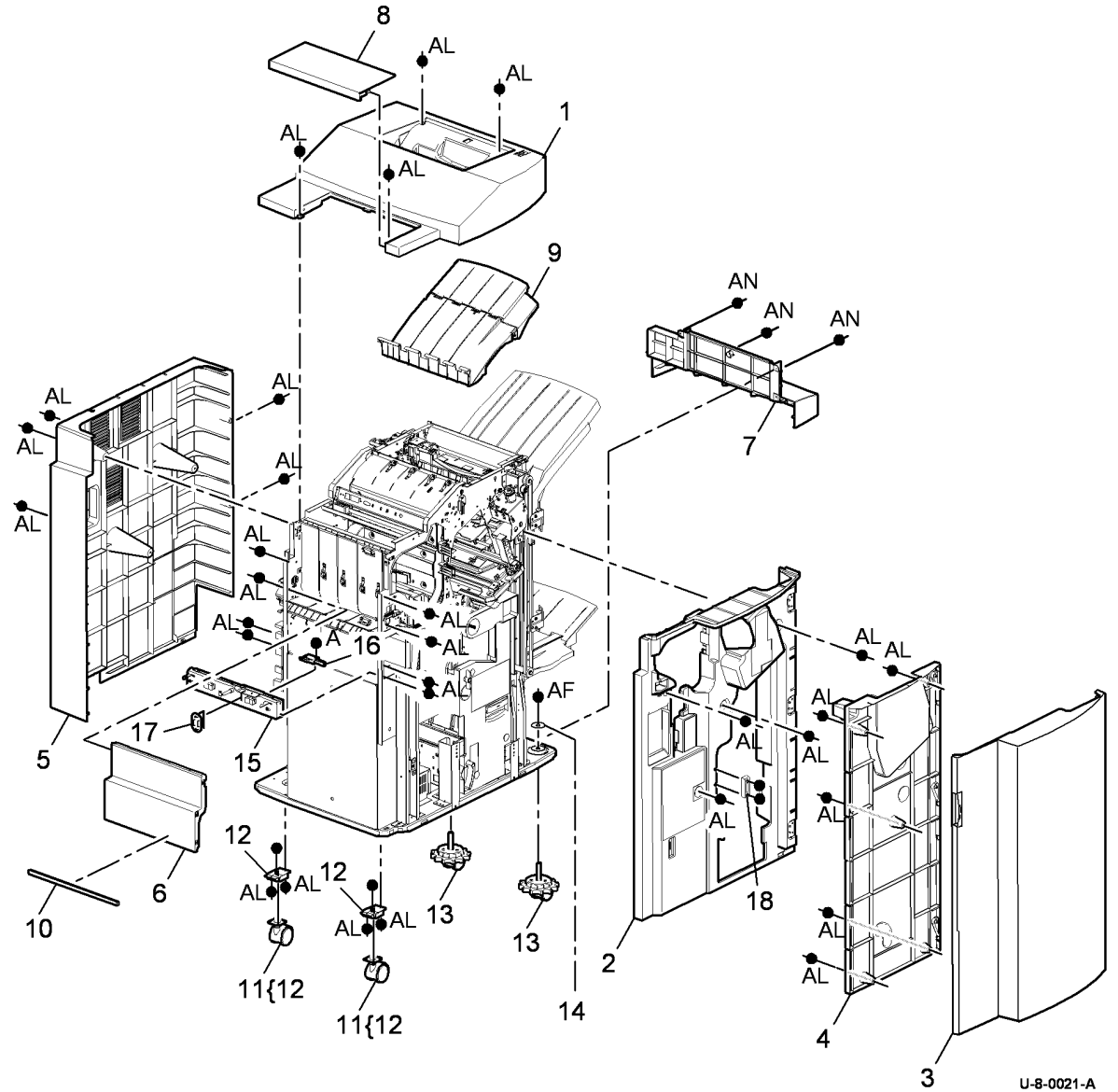

PL 12.105 HVF Stacker

Item	Part	Description
1	848E40530	Upper right side cover (REP 12.5-171)
2	848E17840	Lower right side cover
3	130E12830	Bin 1 90% full sensor (Q12-187)/ Bin 1 motor encoder sensor (Q12-163)
4	-	Rear main belt clamp (1 of 2) (Not spared)
5	-	Rear main belt clamp (2 of 2) (Not spared)
6	023E31220	Bin 1 main drive belt (REP 12.38-171)
7	110K20890	Bin 1 upper limit switch (REP 12.75-171) (S12-190)/Bin 1 lower limit switch (REP 12.75-171) (S12-191)
8	-	Main belt pulley (Not spared)
9	-	Main belt tensioner (Not spared)
10	127K56591	Bin 1 elevator motor assembly (MOT12-241) (REP 12.12-171)
11	-	Bin 1 rear lift bar bracket (Not spared)
12	-	Bin 1 front lift bar bracket (Not spared)
13	-	Bin 1 lift bar (Not spared)
14	-	Front main belt clamp (2 of 2) (Not spared)
15	-	Front main belt clamp (1 of 2) (Not spared)
16	050E28941	Bin 1 (REP 12.4-171)
17	848E17830	Middle right side cover
18	-	Bin 1 lift bar brace (Not spared)
19	110K20880	Stacker full sensor and lower limit switch assembly (REP 12.75-171)
20	019K13380	Bin 1 retaining clip (REP 12.4-171)
21	-	Sensor/switch bracket (Not spared)
22	110K21060	Stacker channel bracket
23	-	Pulley (P/O PL 12.105 Item 22)

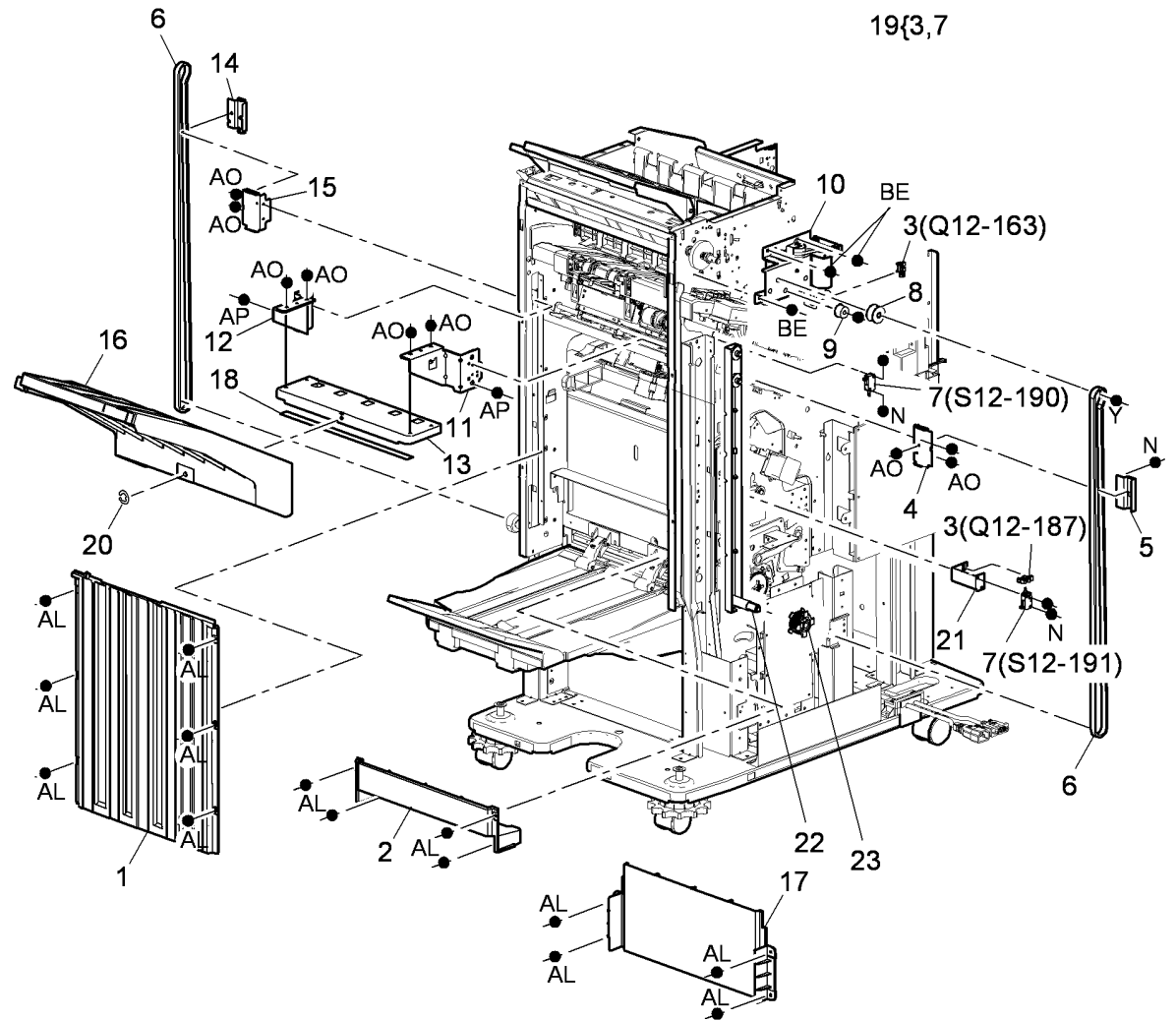

U-8-0022-A

PL 12.110 HVF Ejector, Pressing and Support (1 of 2)

Item	Part	Description
1	–	Ejector front cover (Not spared)
2	059K69943	Ejector assembly (REP 12.6-171)
3	–	Rear tamper support bracket (P/O PL 12.110 Item 29)
4	–	Front pressing plate finger (P/O PL 12.110 Item 33) (REP 12.7-171)
5	–	Rear pressing plate finger (P/O PL 12.110 Item 33) (REP 12.7-171)
6	–	Pressing plate bracket (P/O PL 12.110 Item 18)
7	003K20651	Front support finger (REP 12.8-171)
8	003K20661	Rear support finger (REP 12.8-171)
9	–	Pressing and support motor (MOT12-323) (Not spared)
10	–	Offset rod (Not spared)
11	019K13380	Offset rod KL clip
12	–	Stapler unit (P/O PL 12.110 Item 14) (REP 12.2-171)
13	–	Front tamper (Not spared) (REP 12.11-171)
14	029K04671	Stapler assembly (REP 12.2-171)
15	130E12830	Pressing and support encoder sensor (Q12-093)/Stapler unit home sensor (Q12-135)/Stapler unit mid home sensor (Q12-176)/Stapler unit index sensor (Q12-168)/Rear tamper away sensor (Q12-183)/Rear tamper home sensor (Q12-181)
16	130K75480	Bin 1 upper level sensor (receiver) (Q12-188) (REP 12.76-171)
17	130K75900	Paper pressing sensor (Q12-322)
18	127K56550	Motor encoder assembly
19	–	Rear tamper motor (MOT12-227) (P/O PL 12.110 Item 29) (REP 12.15-171)
20	130K75470	Bin 1 upper level sensor (transmitter) (Q12-188) (REP 12.76-171)
21	–	Ejector paper present sensor (Q12-202) (P/O PL 12.110 Item 2)
22	033K04850	Ejector paddle assembly (W/TAG V-004) (REP 12.100-171)
23	032E35301	Rear tamper arm
24	–	Rear tamper pulley (P/O PL 12.110 Item 29)
25	–	Pressing and support sensor A (Q12-172), B (Q12-171), C (Q12-173) (P/O PL 12.110 Item 29)
26	868E36871	Front tamper arm
27	–	Stapler unit 1 motor (MOT12-249) (P/O PL 12.110 Item 14)
28	–	Rear tamper (P/O PL 12.110 Item 29)
29	032K09681	Rear tamper assembly (REP 12.15-171)
30	032E35341	Set of front and rear tamper arms
31	–	Staple cartridge (REF: PL 26.10 Item 15)
32	–	Support bracket (Not spared)
33	003K21100	Pressing plate kit
34	962K82410	Stapler harness and P-clip
35	–	Ejector assembly safety cover (P/O PL 31.11 Item 10)
36	–	Rear tamper drive belt (Not spared)

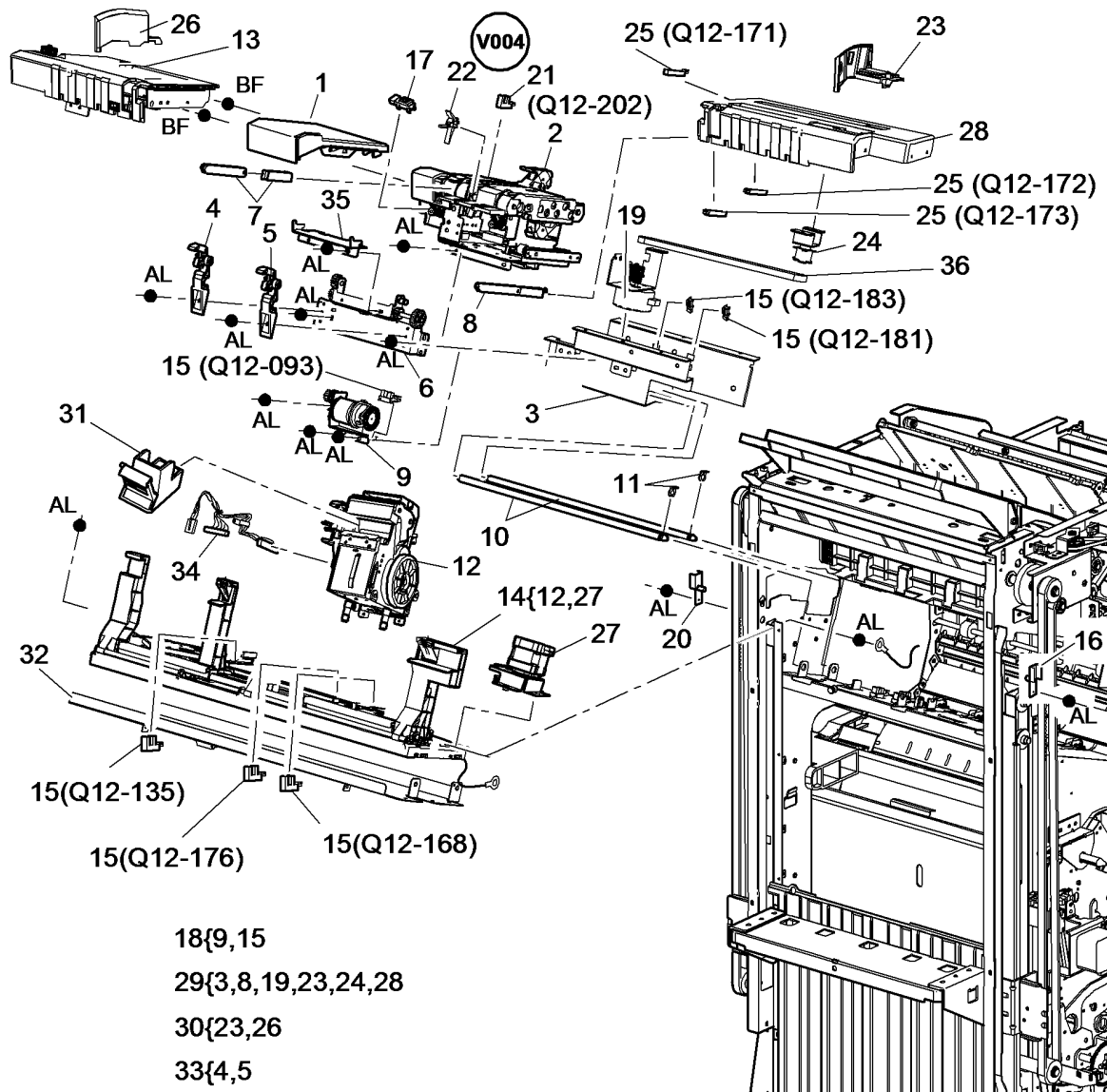

18{9,15
 29{3,8,19,23,24,28
 30{23,26
 33{4,5

U-8-0023-A

PL 12.115 HVF Ejector, Pressing and Support (2 of 2)

Item	Part	Description
1	-	Paper pusher (P/O PL 12.115 Item 8)
2	033K04641	Paddle unit (REP 12.49-171)
3	-	Pusher mylar (P/O PL 12.115 Item 8)
4	-	Timing belt pulley (Not spared)
5	-	Timing belt tensioner (Not spared)
6	-	Front stacker pulley bracket (Not spared)
7	-	Thrust washer (Not spared)
8	050K68500	Paper pusher assembly (REP 12.53-171)
9	-	Not used
10	-	Compile exit upper guide (Not spared)
11	-	Stacker main drive gear shaft (Not spared) (REP 12.37-171)
12	-	Stacker main drive gear (Not spared) (REP 12.37-171)
13	674K03550	Paper pusher motor assembly (MOT12-265) (REP 12.51-171)
14	-	Pinion gear (Not spared)
15	-	Pinion gear shaft (Not spared)
16	130E12830	Paper pusher upper sensor (Q12-092)/Paper pusher lower sensor (Q12-094) (REP 12.54-171)
17	-	Stapler gate safety switch (S12-319) (P/O PL 12.115 Item 22)
18	-	Sensor screw (P/O PL 12.115 Item 22)
19	-	Sensor assembly bracket (P/O PL 12.115 Item 22)
20	006K32980	Stacker idler roll (REP 12.10-171)
21	-	Pusher dampers (P/O PL 12.115 Item 8)
22	674K03540	Sensor assembly (REP 12.54-171)
23	013E37150	Stacker driving shaft bearing (REP 12.37-171)
24	110K20900	Top cover interlock switch (S12-197)
25	033K04651	Paddles (A) outer 2 off, (B) inner 3 off (REP 12.101-171)
26	059K69931	Top jam clearance guide assembly
27	013E25800	Copper bearing
28	110K13980	Front door interlock switch (S12-303)
29	-	Lower exit guide (Not spared)
30	006K33390	Exit idler roller (x4)

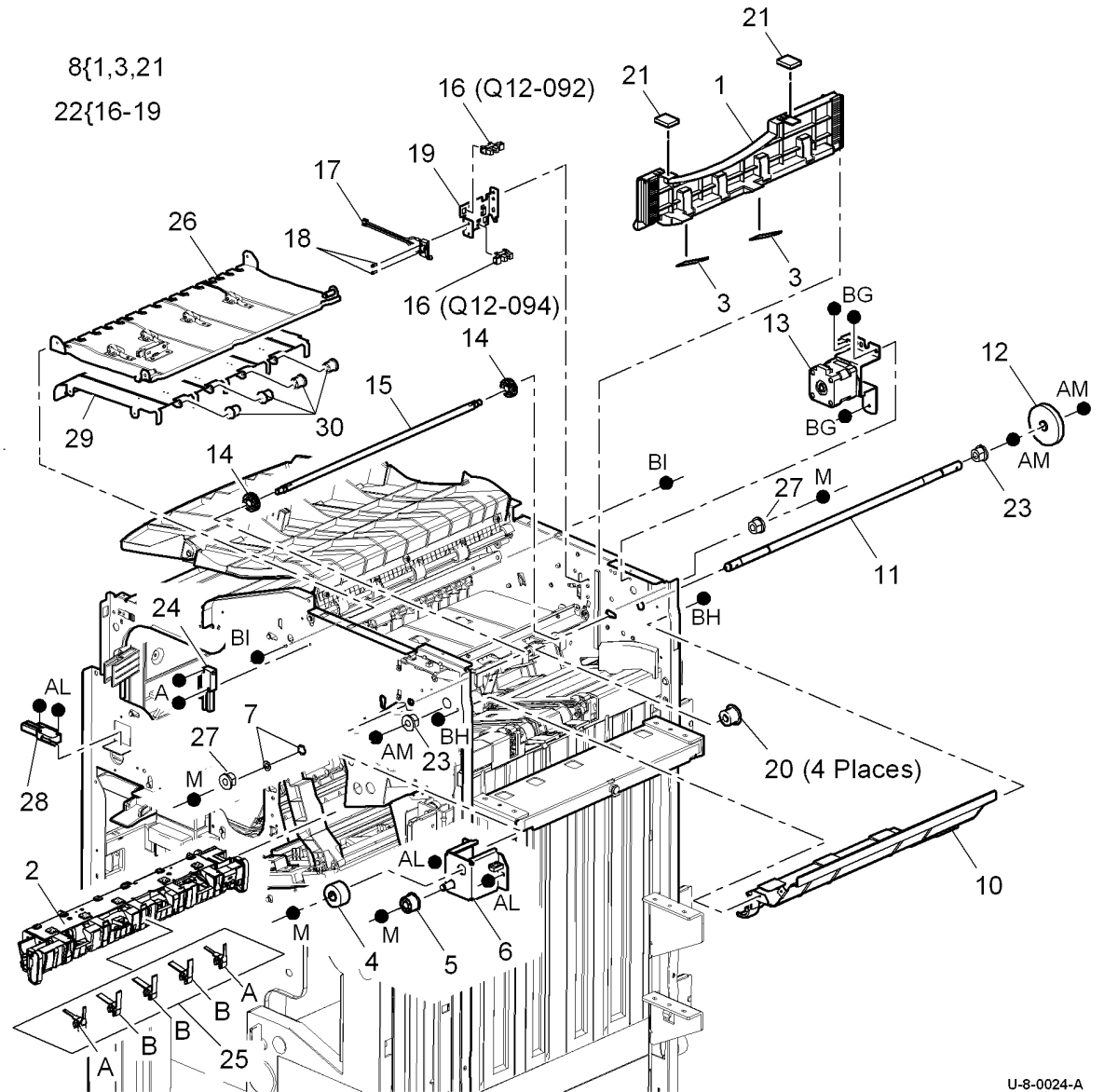

U-8-0024-A

PL 12.120 HVF Main Drives

Item	Part	Description
1	127K56570	Buffer motor (MOT12-262) (REP 12.65-171)/Transport motor 2 (MOT12-224) (REP 12.66-171)
2	127K56560	Transport motor 1 (MOT12-223)(REP 12.63-171)/Bypass feed motor (MOT12-263)(REP 12.64-171)
3	-	Solenoid bracket (P/O PL 12.120 Item 4)
4	121K45290	BM diverter solenoid (SOL12-258)/Exit diverter solenoid(SOL12-225)/Set clamp solenoid (SOL12-056)
5	-	Solenoid connector (Not spared)
6	127K56610	Paddle unit motor assembly (MOT12-239) (REP 12.48-171)
7	-	Transport motor 1 drive belt (Not spared)
8	-	Bypass feed motor drive belt (Not spared)
9	-	Buffer feed motor drive belt (Not spared)
10	-	Transport motor 2 drive belt (A) (Not spared)
11	-	Transport motor 2 drive belt (B) (Not spared)

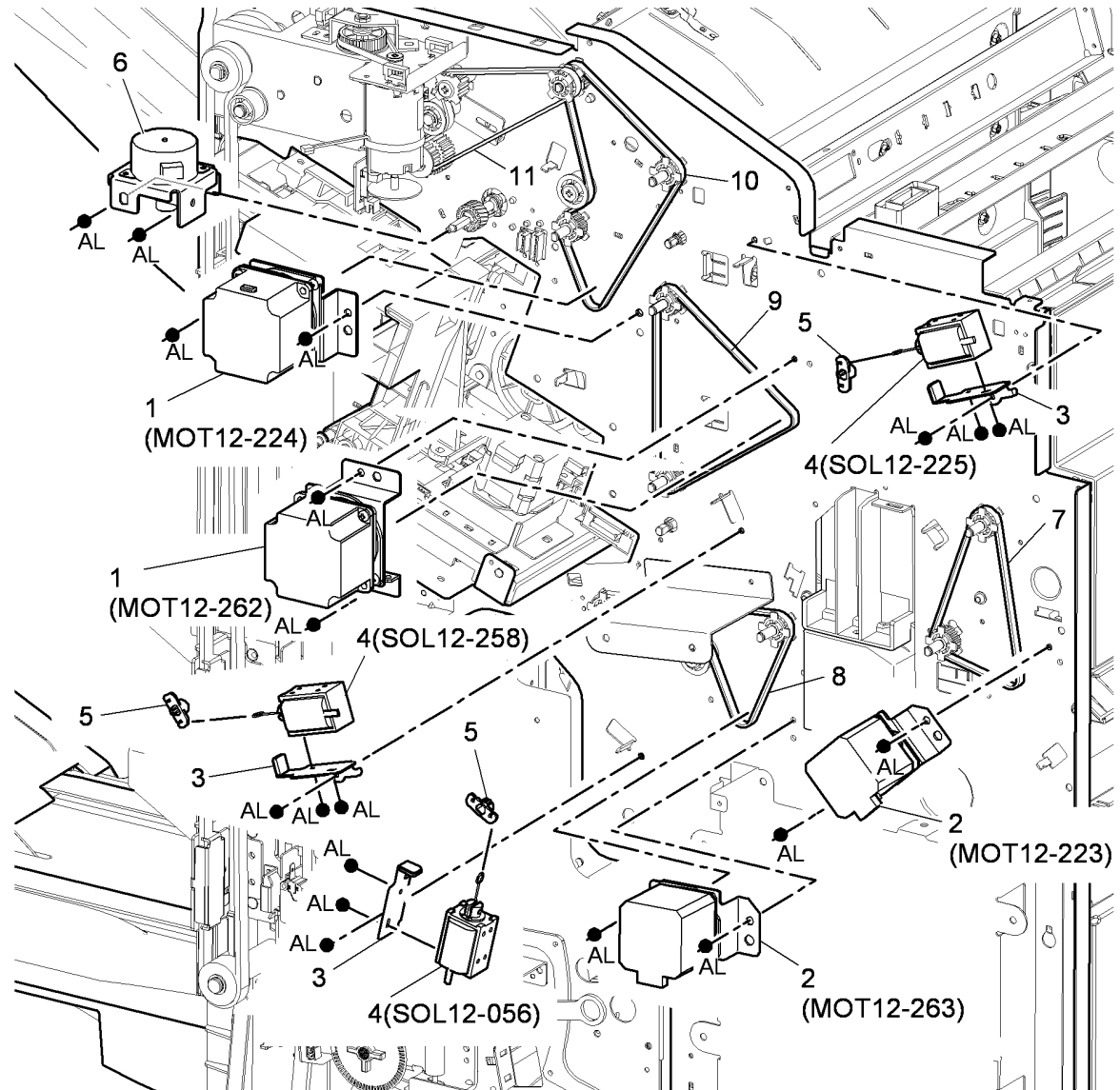

U-8-0116-A

PL 12.125 HVF Feed Assembly and Punch (1 of 3)

Item	Part	Description
1	-	HVF 2 hole punch assembly (P/O PL 31.10 Item 5)
-	-	HVF 3 hole punch assembly (P/O PL 31.10 Item 5)
2	-	HVF chad bin (P/O PL 12.125 Item 19)
3	-	Hole punch thumb screw (P/O PL 12.125 Item 1)
4	059K59551	Hole punch blanking assembly
5	-	Front tamper arm (Not spared)
6	127K62570	Front tamper motor assembly (MOT12-226) (REP 12.11-171)
7	038E41350	Diverter exit gate (REP 12.35-171)
8	-	Upper exit guide (5c) (Not spared) (REP 12.14-171)
9	038E41341	BM diverter gate (REP 12.39-171)
10	059K69950	Buffer pocket jam clearance guide (REP 12.33-171)
11	059K69981	Inserter jam clearance guide assembly (8a) (REP 12.34-171)
12	059K69961	Input jam clearance guide (5a) (REP 12.32-171)
13	059K69972	Buffer guide assembly (5b) (REP 12.31-171)
14	-	Nip split motor cover (P/O PL 12.125 Item 13)
15	-	Nip split motor (MOT12-264) (P/O PL 12.125 Item 13)
16	121K45300	Magnet
17	130E12810	Chad bin level sensor (Q12-193)/Punch sensor 1 (Q12-078)/Punch sensor 2(Q12-075)/Punch sensor 3(Q12-076)
18	130E12840	Chad bin present sensor (Q12-118)
19	604K55210	2 hole punch module (XE)
-	498K17930	4 hole punch module (XE)
-	498K17940	4 hole punch module (Swedish)

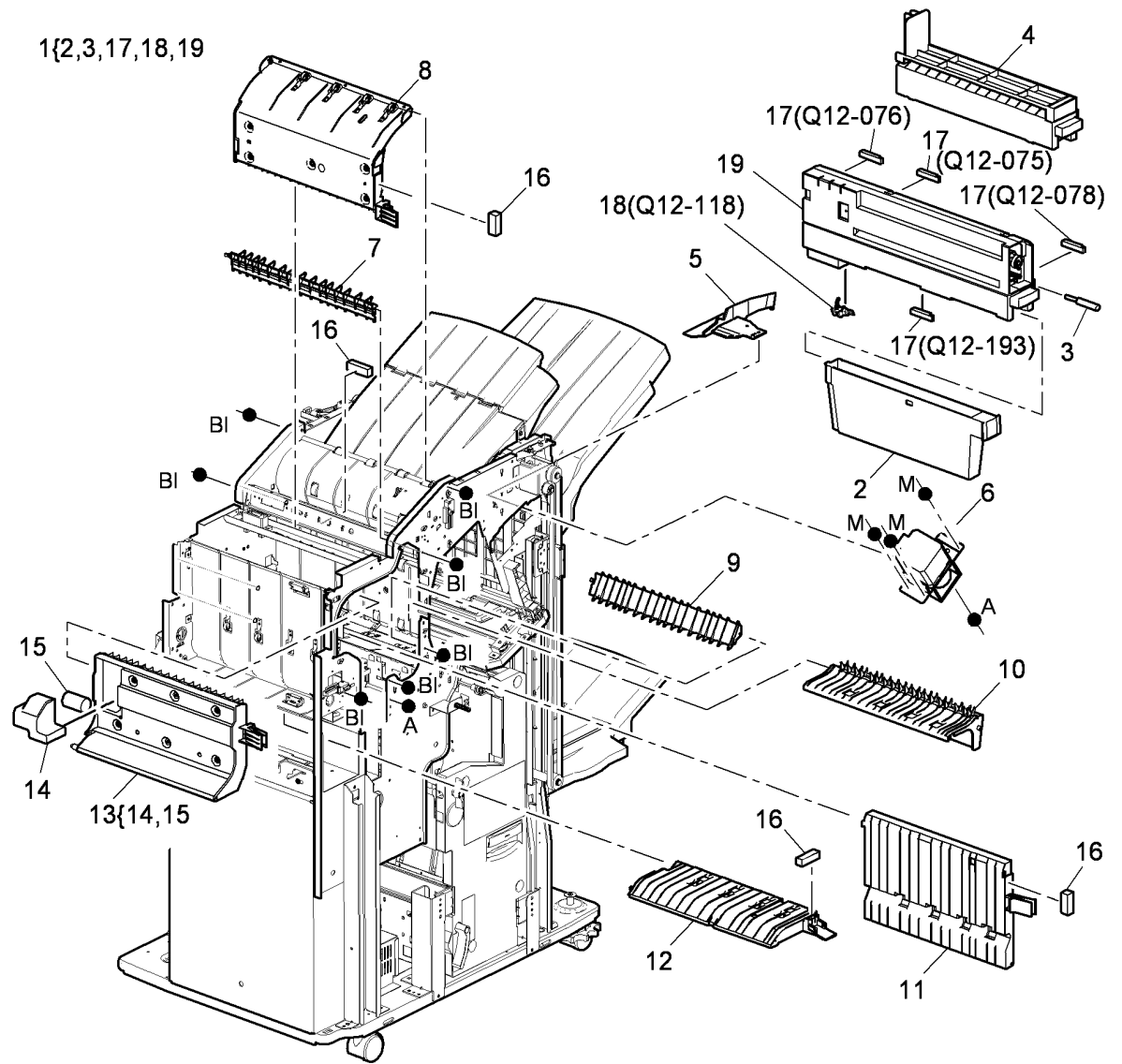

U-8-0026-A

PL 12.130 HVF Feed Assembly and Punch (2 of 3)

Item	Part	Description
1	006K32840	Feed roll assembly (Short shaft type)
-	-	Buffer upper roll (1A) (REP 12.45-171)
-	-	Inserter guide roll (1B) (REP 12.41-171)
-	-	Buffer pocket roll (1C) (REP 12.42-171)
-	-	Input roll (1D) (REP 12.40-171)
-	006K32980	Top exit feed roll (1E) (REP 12.47-171)
2	006K32850	Feed roll assembly
-	-	Stacker exit feed roll (2A) (REP 12.46-171)
-	-	Buffer lower roll (2B) (REP 12.44-171)
-	-	Booklet entrance roll (2C) (REP 12.43-171)
3	-	Buffer clamp assembly (Not spared)
4	006K32820	Stacker exit roll
5	006K32810	Top exit roll
6	013E25800	Copper bearing
7	-	Buffer clamp shaft (P/O PL 12.130 Item 3)
8	019K14420	Buffer clamp

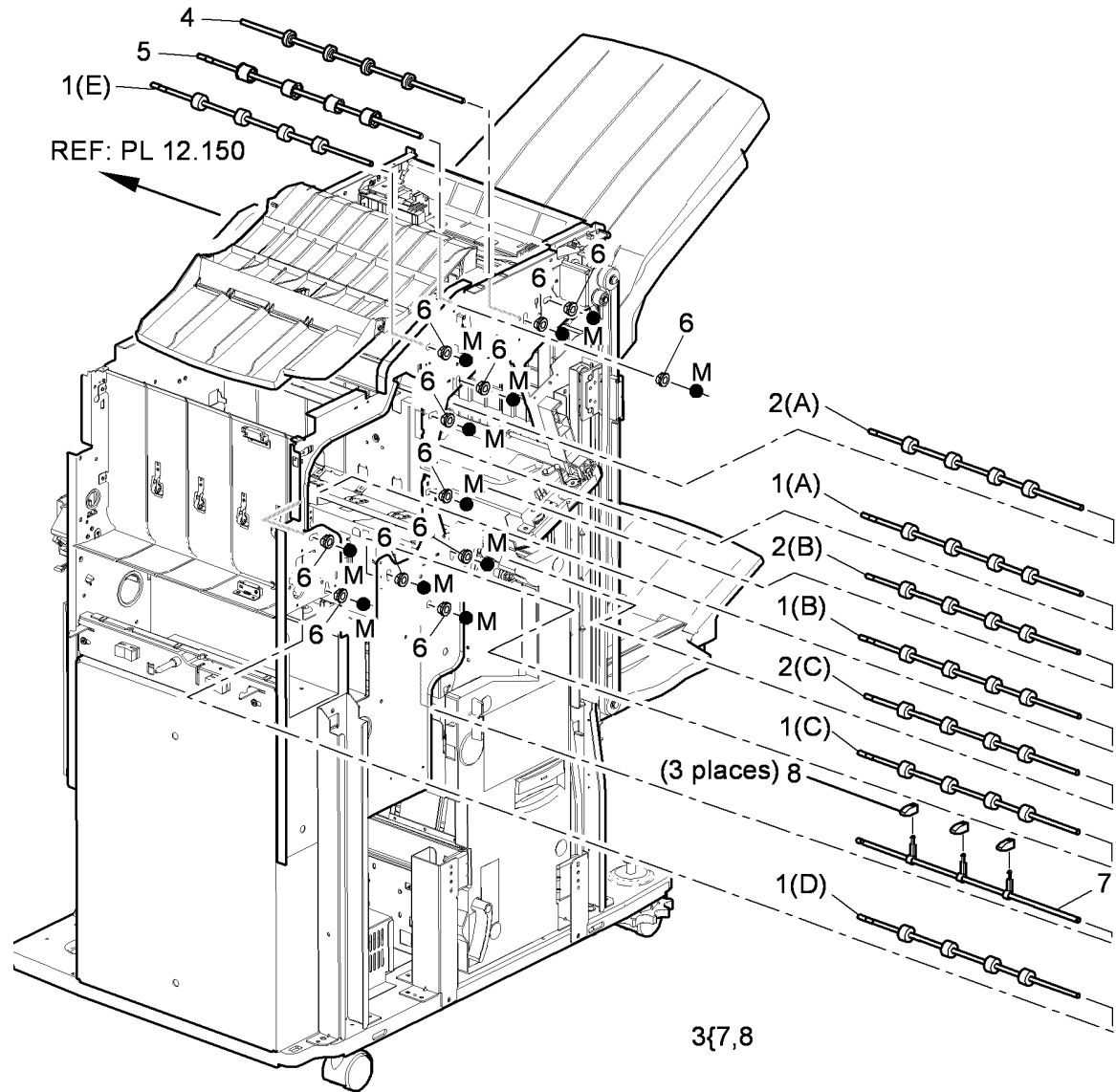

U-8-0027-A

PL 12.135 HVF Feed Assembly and Punch (3 of 3)

Item	Part	Description
1	130E12830	Tamper front home sensor (Q12-180)/Tamper front away sensor (Q12-182)/Nip split sensor (Q12-091)/Nip home sensor (Q12-088)
2	130E12810	Entry sensor (Q12-077)/Compiler exit sensor (Q12-106)/Buffer position sensor (Q12-086)/Buffer path sensor (Q12-321)/Inserter standby sensor(Q12-320)
3	130E12840	Top tray exit sensor (Q12-107)/HVF Booklet exit sensor (Q12-087)

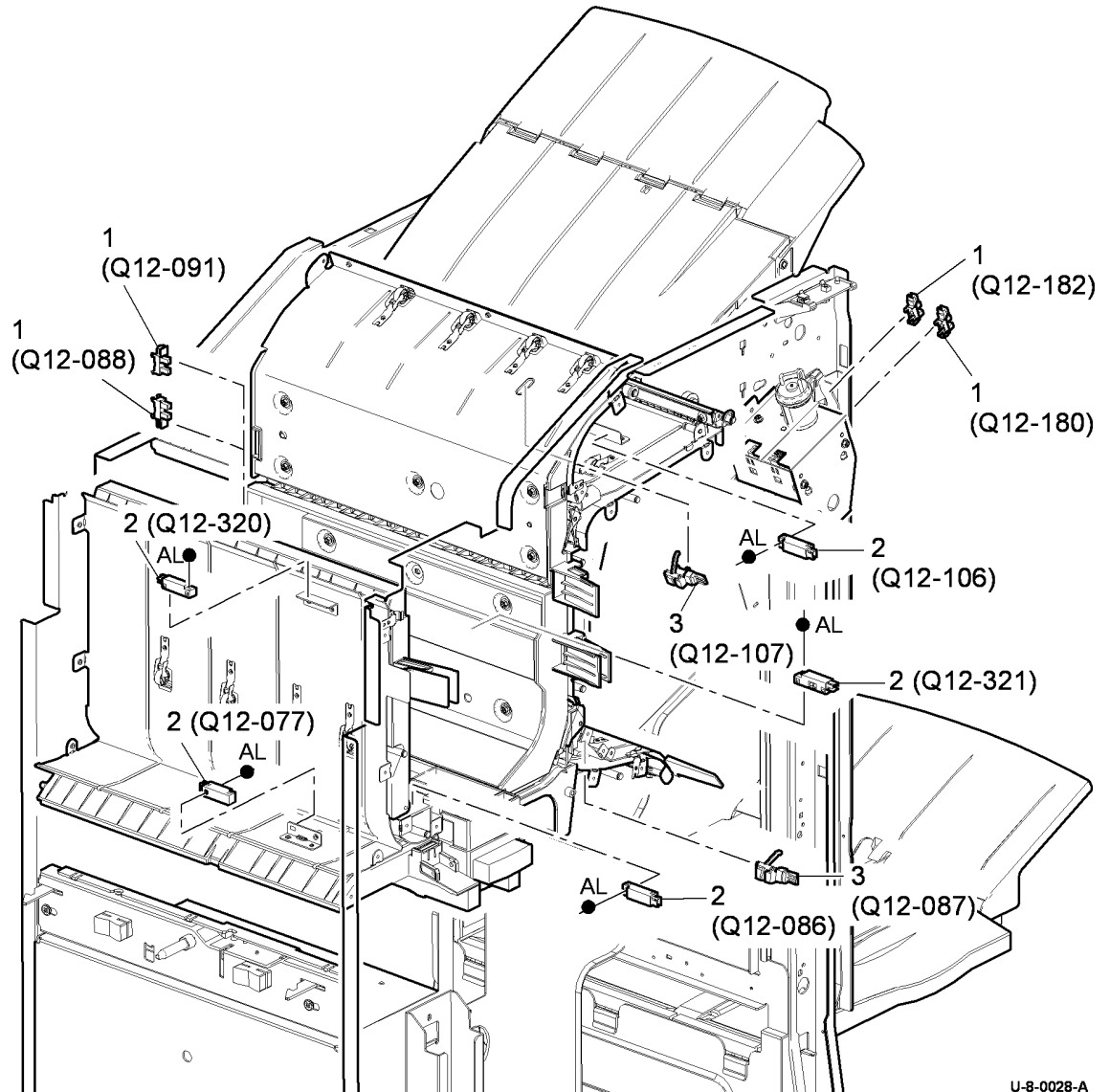

U-8-0028-A

PL 12.140 HVF Power and Control

Item	Part	Description
1	105K35831	HVF power supply unit (REP 12.55-171)
2	960K52570	HVF PWB (REP 12.57-171)
3	960K41780	Pause to unload (PTU) PWB (REP 12.97-171)
4	105K36840	Power cord
5	–	In-line fuse (10A slo-blow) (Not spared)
6	–	Harness (Not spared)
7	952K00410	Power communications cable

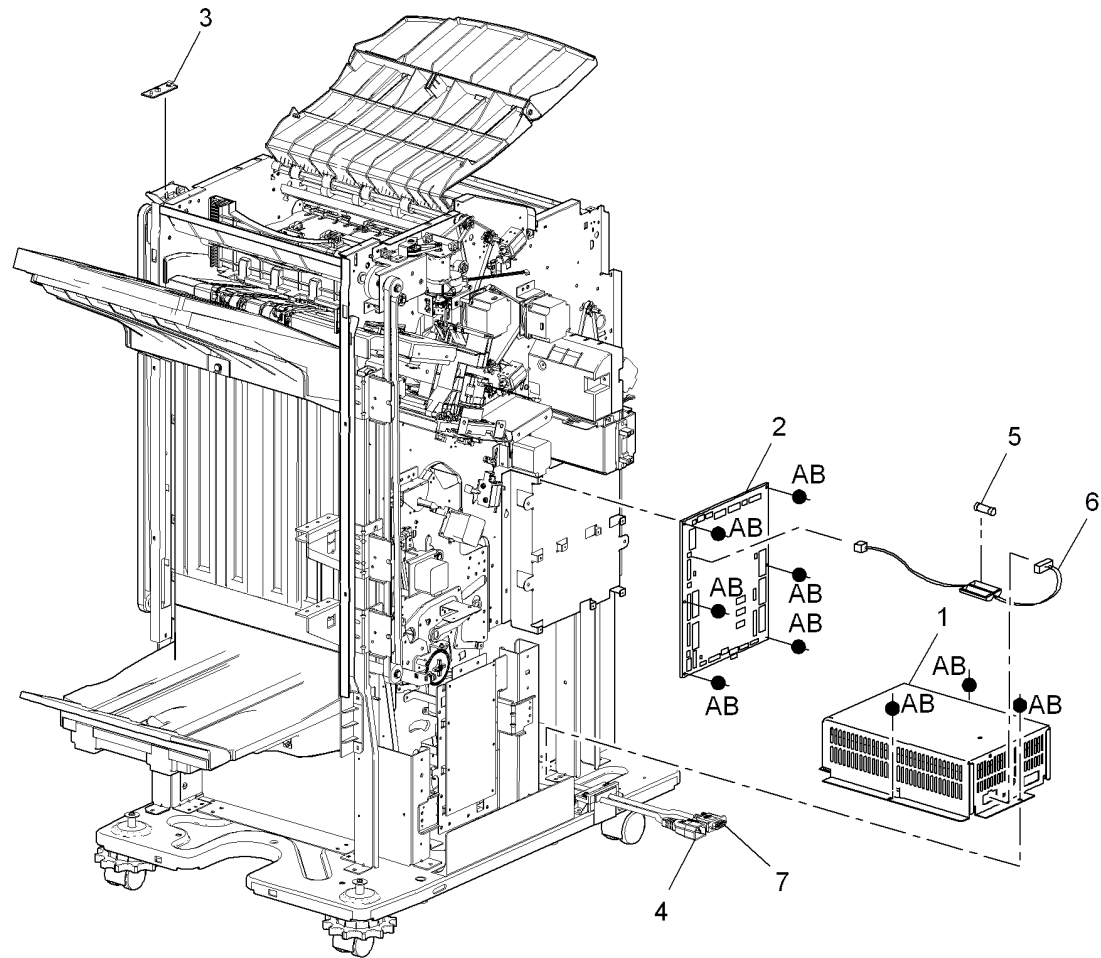

U-8-0029-A

PL 12.145 HVF BM Module (Complete)

Item	Part	Description
1	084K37050	BM Module (REP 12.61-171)
2	-	Slide assembly (Not spared) (REP 12.62-171)

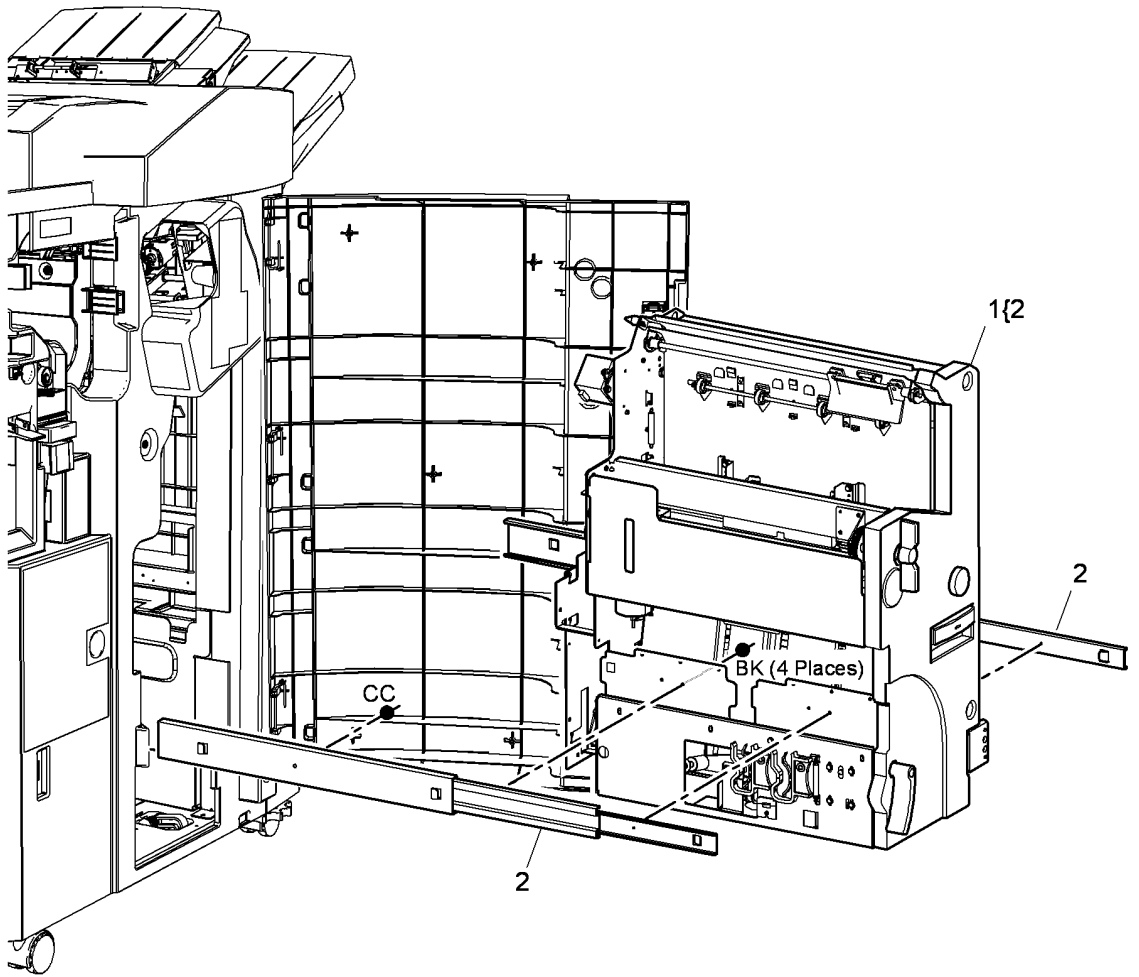

U-8-0081-A

PL 12.150 HVF BM Entry and Front Cover

Item	Part	Description
1	003E69092	Drawer handle
2	-	Crease roll leaf spring (Not spared)
3	848E40470	BM Front cover
4	803E14110	Crease blade knob (6d)
5	803E13850	Crease roll handle (6c)
6	013E12610	Nylon bearing
7	-	Paper guide (6e) (P/O PL 12.150 Item 22) (REP 12.60-171)
8	-	Jam clearance handle (Not spared) (REP 12.60-171)
9	-	Nip spring (P/O PL 12.150 Item 22) (REP 12.60-171)
10	022E30620	Nip roll (REP 12.60-171)
11	-	Nip shaft (P/O PL 12.150 Item 22) (REP 12.60-171)
12	130K74072	Flapper home sensor (Q12-207) (REP 12.16-171)
13	-	Bearing (Not spared)
14	020E39990	BM Entry roll pulley (REP 12.22-171)
15	006K28660	BM Entry roll (REP 12.22-171)
16	130K74110	BM Entry sensor (Q12-089) (REP 12.23-171)
17	125E00430	Static eliminator
18	-	Rear latch (Not spared)
19	-	Shaft (Not spared)
20	809E46411	Latch spring
21	-	Front latch (Not spared)
22	-	Entrance baffle assembly (Not spared) (REP 12.60-171)
23	-	BM Flapper (P/O PL 12.150 Item 30) (REP 12.16-171)
24	-	BM flapper bracket (P/O PL 12.150 Item 30)
25	-	BM Compiler shaft (Not spared)
26	125K03831	Static eliminator
27	-	Top baffle (Not spared)
28	-	Pulley (Not spared)
29	-	BM flapper drive belt (Not spared)
30	059K52940	BM Flapper assembly (REP 12.16-171)

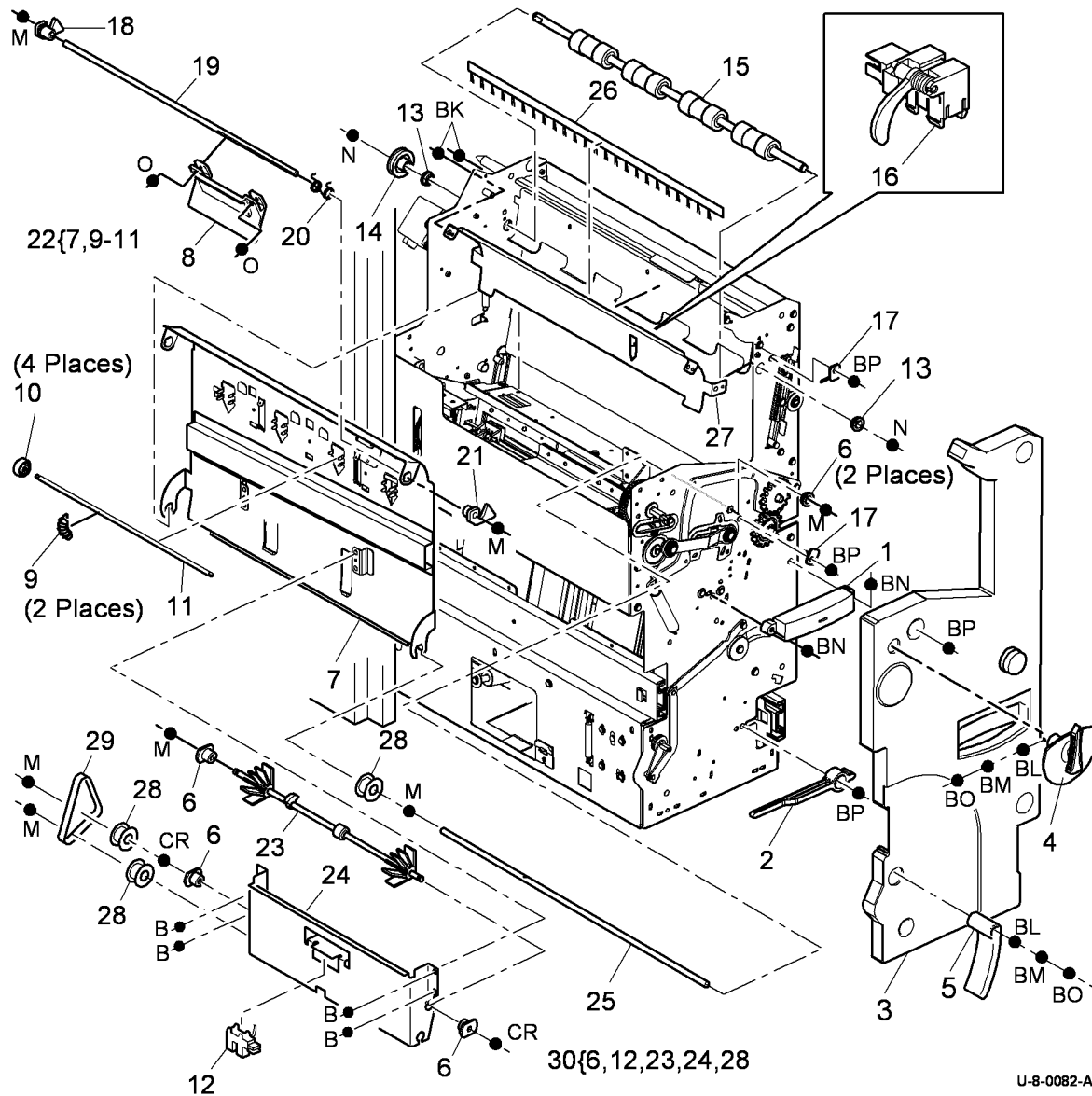

U-8-0082-A

PL 12.155 HVF BM Tamper Assembly

Item	Part	Description
1	107E22600	BM Tamper 1 home sensor (Q12-205)
2	-	LH Frame plate (Not spared)
3	127K47660	BM Tamper 1 motor (MOT12-256) (REP 12.30-171)
4	-	BM Tamper spring (P/O PL 12.155 Item 10)
5	-	BM Rear tamper arm (P/O PL 12.155 Item 9) (REP 12.30-171)
6	-	BM Front tamper arm (P/O PL 12.155 Item 10) (REP 12.30-171)
7	-	BM Rear tamper rack (P/O PL 12.155 Item 9) (REP 12.30-171)
8	-	BM Front tamper rack (P/O PL 12.155 Item 10) (REP 12.30-171)
9	007K13190	BM Rear tamper assembly (REP 12.30-171)
10	007K13180	BM Front tamper assembly (REP 12.30-171)
11	807E15450	BM Tamper gear (REP 12.30-171)
12	-	BM Tamper bracket (Not spared) (REP 12.30-171)
13	-	BM Tamper rack guide (Not spared) (REP 12.30-171)
14	802E59410	BM Connector cover
15	-	BM Tamper guide plate (Not spared) (REP 12.30-171)
16	-	BM Rear tamper finger (Not spared) (REP 12.30-171)
17	-	BM Front tamper finger (Not spared) (REP 12.30-171)
18	125K03593	BM Static eliminator

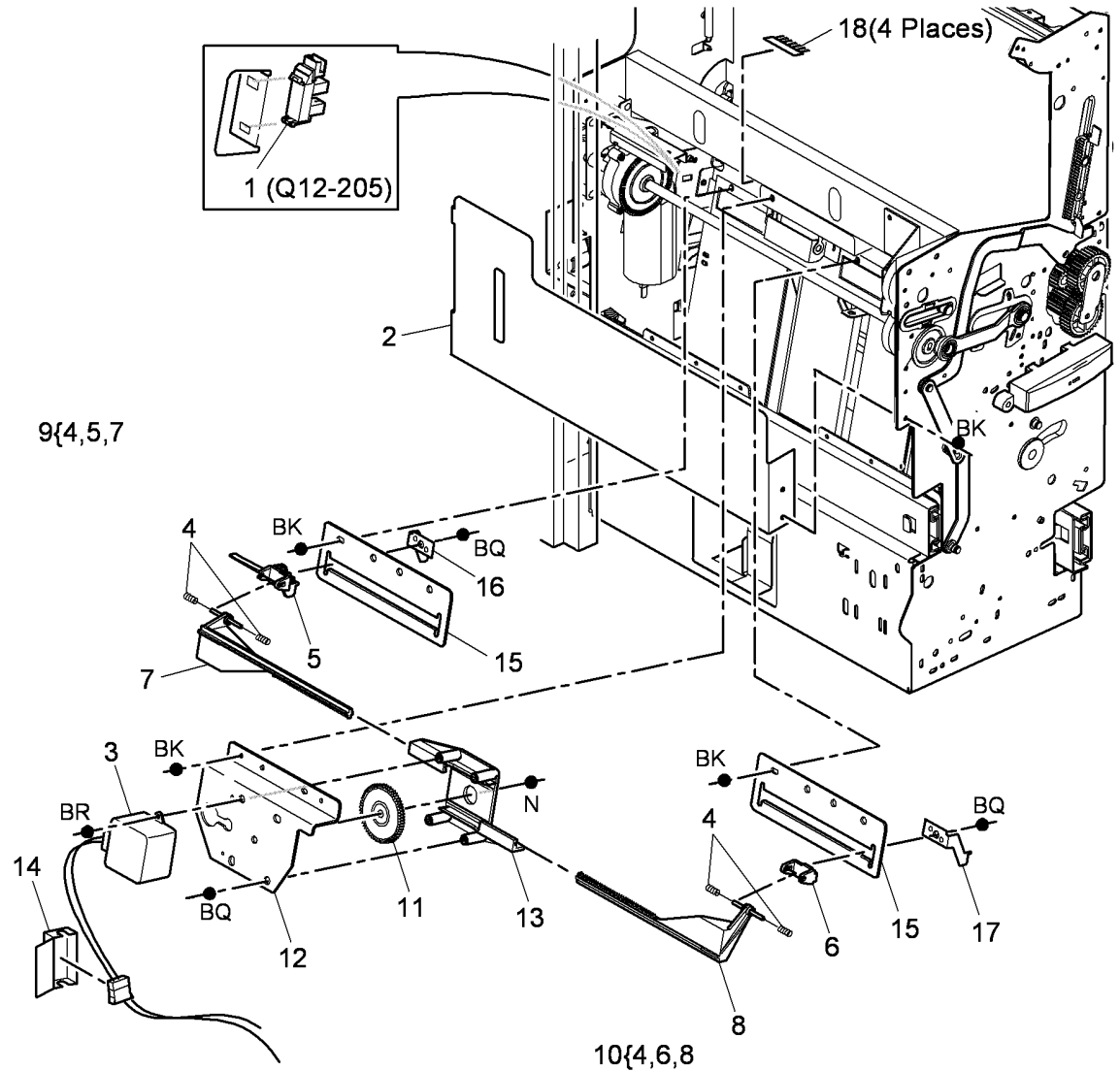

U-8-0083-A

PL 12.160 HVF BM Back Stop Motor

Item	Part	Description
1	-	Ground wire (P/O PL 12.160 Item 19)
2	-	Motor bracket (Not spared)
3	-	Motor damper (P/O PL 12.160 Item 19) (REP 12.20-171)
4	-	BM back stop motor (MOT12-255) (P/O PL 12.160 Item 19) (REP 12.20-171)
5	-	Pulley (Not spared)
6	-	BM back stop bearing (Not spared) (REP 12.26-171)
7	023E23300	BM back stop drive belt (REP 12.20-171)
8	809E78370	BM back stop tensioner spring (REP 12.20-171)
9	-	Allen key (3mm) (Not spared)
10	848E40480	Sensor cover
11	-	BM back stop bearing (Not spared) (REP 12.26-171)
12	-	BM back stop idler bracket (Not spared) (REP 12.26-171)
13	-	BM back stop idler shaft (Not spared)
14	-	BM back stop tensioner link (Not spared)
15	809E25100	BM back stop link spring (REP 12.26-171)
16	012E20870	BM back stop link (REP 12.26-171)
17	-	LH frame plate (Not spared)
18	107E22600	BM guide home sensor (Q12-204)
19	127K54710	BM back stop motor assembly (REP 12.20-171)

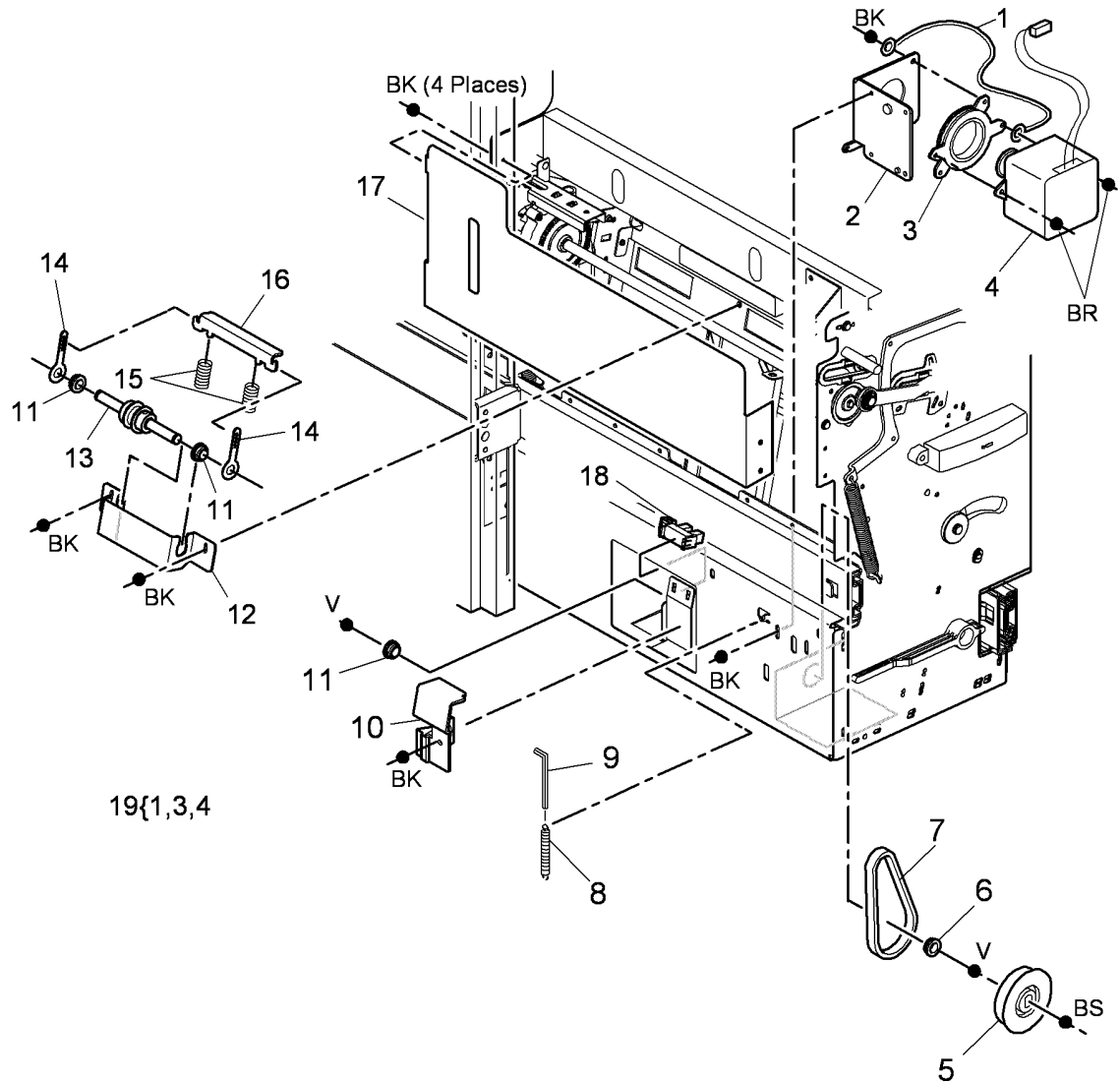

U-8-0084-A

PL 12.165 HVF BM Back Stop assembly

Item	Part	Description
1	019E74451	Anti-play shoe
2	-	BM back stop lock washer (P/O PL 12.165 Item 18)
3	-	Cable fastener (P/O PL 12.165 Item 18)
4	031E11300	Anti-rattle arm
5	-	Screw (P/O PL 12.165 Item 18)
6	-	Flanged hex nut (P/O PL 12.165 Item 18)
7	-	Back stop adjust spring (P/O PL 12.165 Item 18)
8	809E71970	Antiplay spring
9	-	Solenoid spring (P/O PL 12.165 Item 18)
10	-	Shaft support (Not spared)
11	-	Belt clamp (P/O PL 12.165 Item 18)
12	-	BM back stop solenoid nut (P/O PL 12.165 Item 18)
13	-	Pivoting clamp (P/O PL 12.165 Item 18)
14	006K30790	BM back stop drive shaft (REP 12.26-171)
15	023E23140	BM back stop belt (REP 12.26-171)
16	-	BM back stop shaft (Not spared)
17	-	BM stack hold solenoid (SOL12-259) (P/O PL 12.165 Item 18)
18	019K14160	BM back stop assembly (REP 12.21-171)

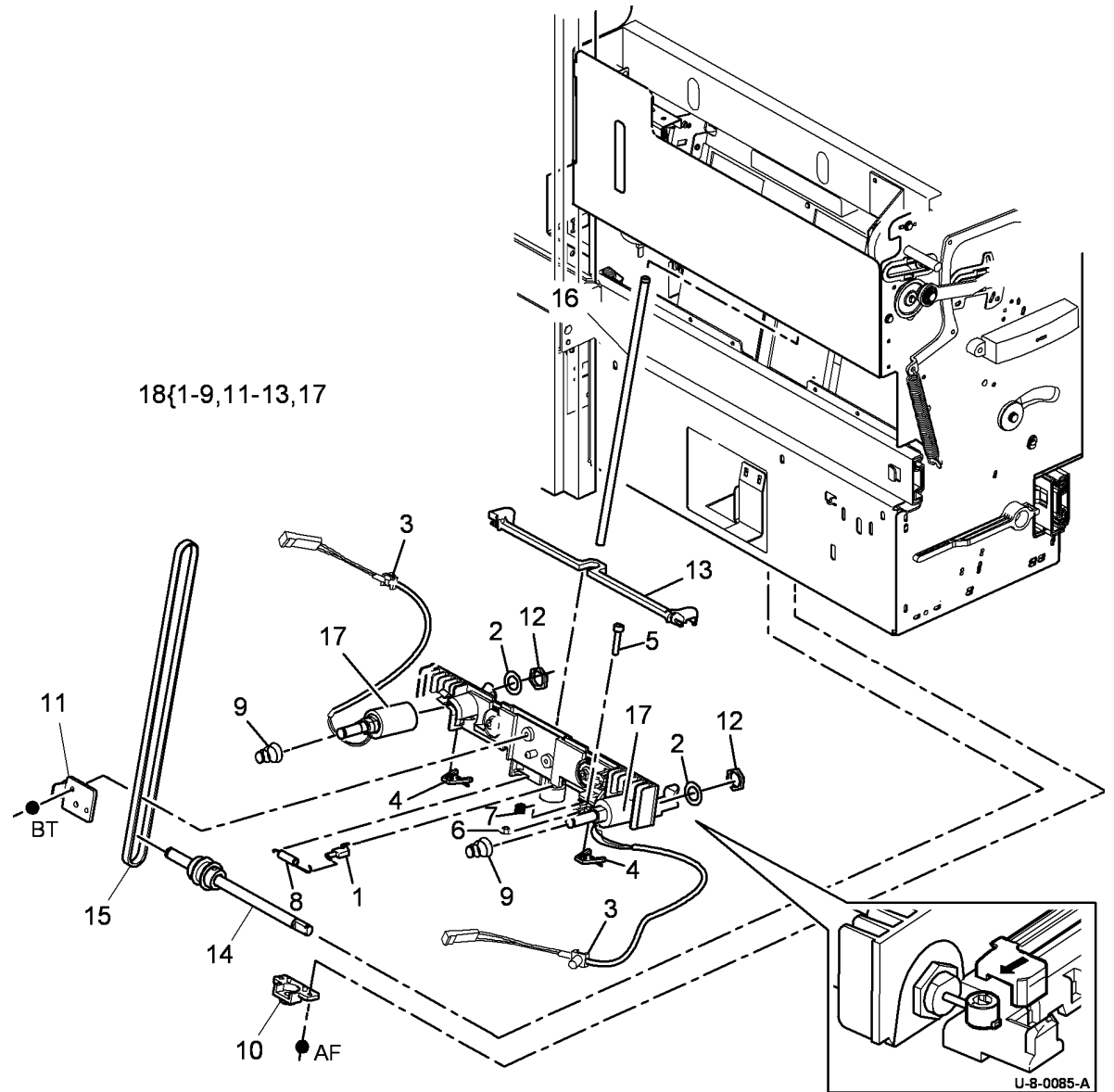

PL 12.170 HVF BM Crease Blade Motor

Item	Part	Description
1	107E22600	BM Crease blade motor encoder sensor (Q12-215), BM Crease blade home sensor (Q12-214) (REP 12.18-171)
2	-	Motor bracket (P/O PL 12.170 Item 3)
3	127K54690	BM Crease blade motor assembly (MOT12-252) (REP 12.18-171)
4	014E47460	Motor encoder (REP 12.18-171)
5	806E36200	Drive shaft
6	007E69830	Drive gear (40T)
7	413W30654	Bearing (REP 12.18-171)
8	008E08220	Crank (REP 12.18-171)
9	012E20860	Connecting rod (REP 12.36-171)
10	-	Bearing (Not spared)
11	802E59171	Motor cover
12	809E42861	Crease nip spring (REP 12.36-171)
13	-	Crease blade assembly (Not spared) (REP 12.36-171, ADJ 12.4-171)
14	032E19330	Crease blade support guide (REP 12.36-171)
15	-	Crease blade home sensor bracket (Not spared)
16	-	Lower mounting plate (P/O PL 12.170 Item 13)
17	815E56520	Crease blade folder plate
18	-	Upper mounting plate (P/O PL 12.170 Item 13)

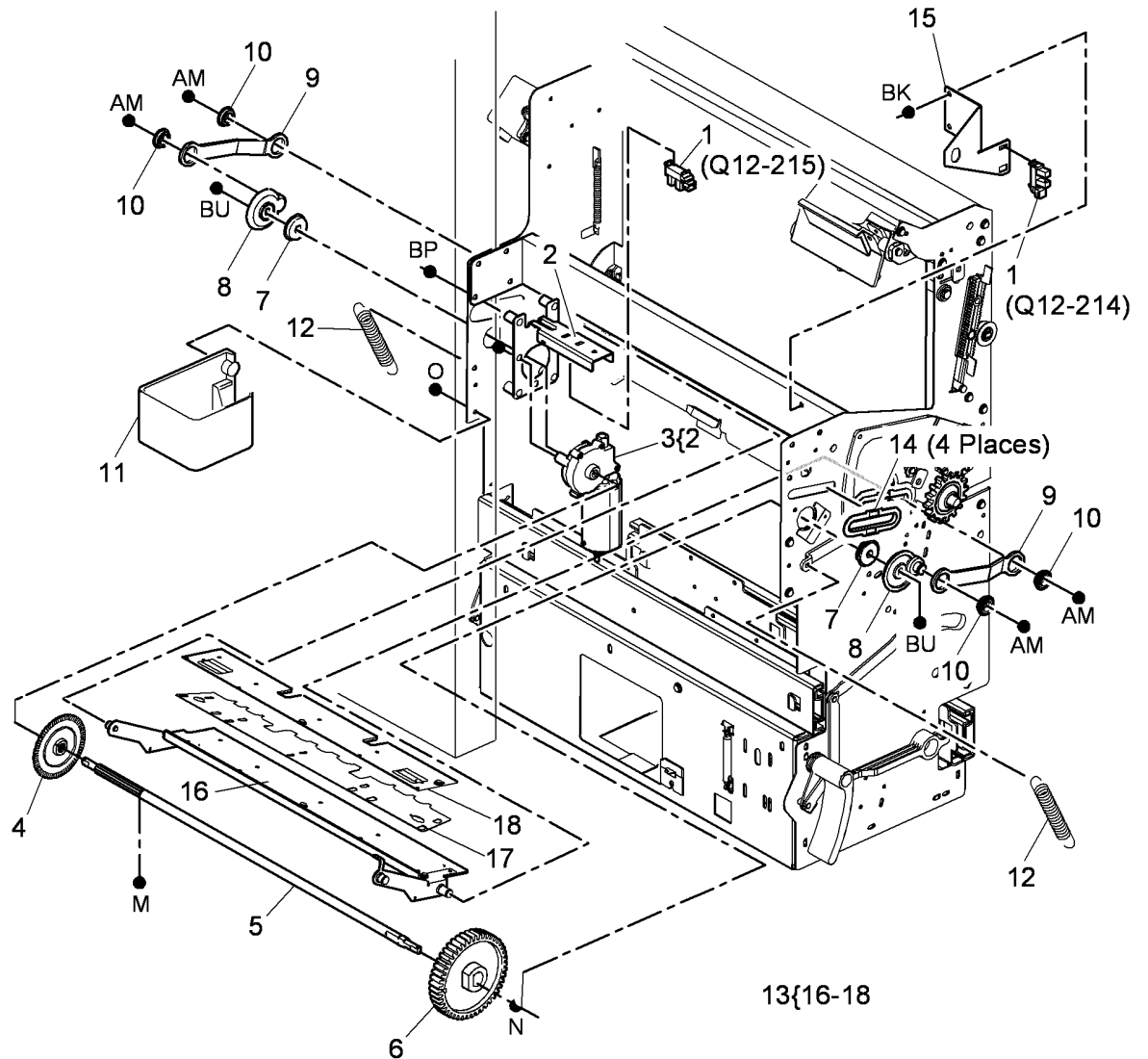

U-8-0086-A

PL 12.175 HVF BM Crease Rolls Motor and PWB

Item	Part	Description
1	127K43751	BM compiler motor (MOT12-251)/ BM flapper motor (MOT12-271) (REP 12.25-171)
2	-	Damper bracket (P/O PL 12.175 Item 16) (REP 12.25-171)
3	-	Motor bracket (Not spared)
4	-	Ground wire (P/O PL 12.175 Item 16)
5	007E69000	Gear (50T)/pulley (24T)
6	-	Tri-folder logic cheat (PJ563) (Not spared)
7	127K54680	BM Crease roll motor assembly
8	127K53620	BM crease roll gate motor (MOT12- 273) (REP 12.24-171)
9	107E22600	BM Crease roll gate home sensor (Q12-222), BM Crease roll motor encoder sensor (Q12-216)
10	960K52781	BM PWB (REP 12.17-171)
11	-	Motor bracket (P/O PL 12.175 Item 12)
12	127K62560	BM Crease roll motor (MOT12-253) (REP 12.19-171)
13	014E47460	BM Crease roll motor encoder
14	-	Support bracket (Not spared)
15	023E25430	Compiler motor belt
16	127K55520	BM Compiler motor assembly (REP 12.25-171)
17	-	BM flapper motor pulley (Not spared)
18	-	BM flapper motor drive belt (Not spared)
19	-	Tri-folder interlock cheat (PJ553) (Not spared)

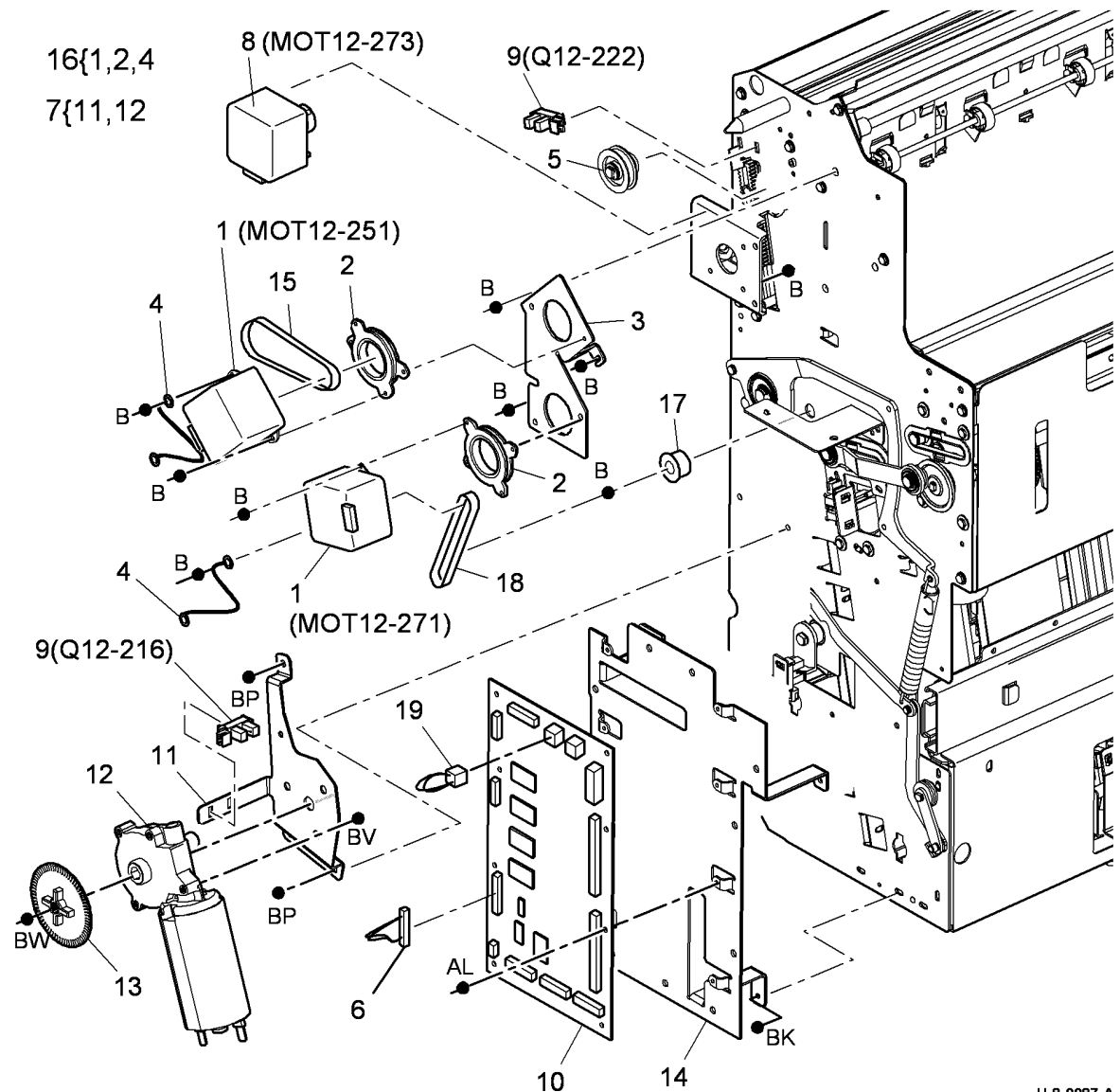

U-8-0087-A

PL 12.180 HVF BM Crease Rolls and Support Leg

Item	Part	Description
1	006K32721	Crease roll assembly 1 (REP 12.52-171)
2	006K32731	Crease roll assembly 2 (REP 12.52-171)
3	006K32740	Crease roll assembly 3 (REP 12.52-171)
4	006K32750	Crease roll assembly 4 (REP 12.52-171)
5	807E34231	Gear crease roll 4
6	807E34240	Lower compound gear
7	807E34280	Upper compound gear
8	007E69081	Crease roll gate rack gear (REP 12.59-171)
9	-	Gear plate (Not spared)
10	-	Bearing (Not spared)
11	807E34261	Gear (16T)
12	-	Drive shaft (Not spared)
13	007E69070	Crease roll gate rack drive gear (REP 12.59-171)
14	007E68951	Crease roll gate rack (REP 12.59-171)
15	020E54110	Crease roll gate front guide
16	020E54120	Crease roll gate rear guide
17	-	Crease roll drive shaft (Not spared)
18	-	Crease roll gate shaft (Not spared)
19	050E23160	Crease roll gate (REP 12.59-171)
20	-	Front frame assembly (Not spared)
21	809E95060	Spring arm nip 1
22	809E95071	Spring arm nip 2
23	-	Rear frame assembly (Not spared)
24	-	Nip release shaft (Not spared)
25	016E20010	Bush roll release
26	413W88650	Bearing flanged
27	807E34251	Gear (15T)
28	807E34270	Gear (30T)
29	016E20000	Bush follower

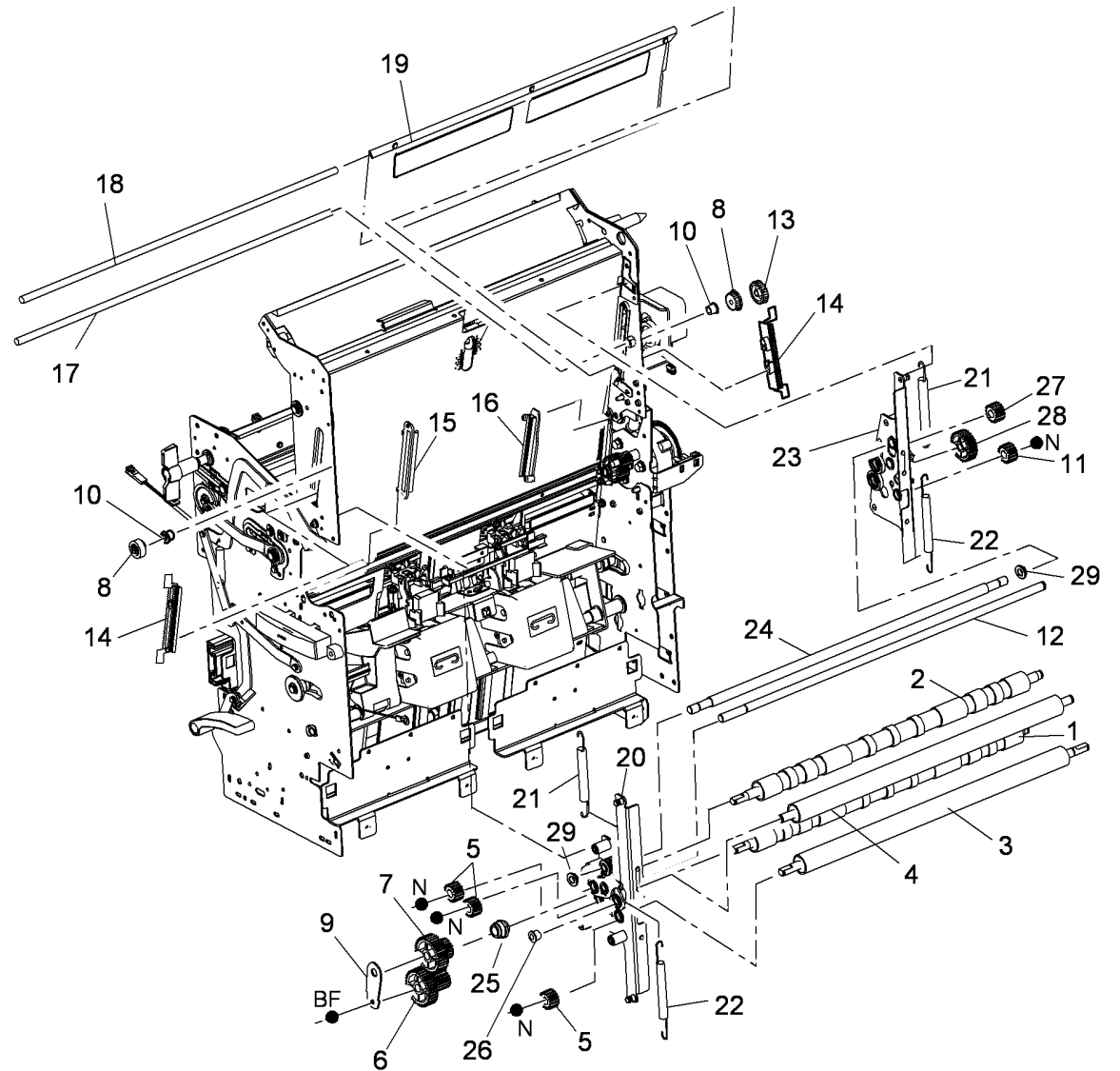

U-8-0088-A

PL 12.185 HVF BM Stapler Assemblies

Item	Part	Description
1	020E38513	Front follower
2	016E17731	Actuator
3	-	Rear follower (Not spared)
4	809E44010	Spring
5	130K74090	BM Paper present sensor (Q12-170)
6	008E06850	Latch slide
7	029K03232	BM Staple head assembly (REP 12.27-171, ADJ 12.3-171)
8	-	Staple cartridge (REF: PL 26.10 Item 17)
9	-	Staple bracket handle (Not spared) (REP 12.28-171)
10	-	Stapler bracket assembly (Not spared) (REP 12.28-171)
11	809E48830	Torsion spring (REP 12.28-171)
12	-	Bearing (Not spared) (REP 12.28-171)
13	-	Spring (Not spared) (REP 12.28-171)
14	802E42770	Staple head cover
15	-	BM right hand cover (Not spared) (REP 12.56-171)
16	125K03831	Static eliminator
17	130E11640	BM exit sensor (Q12-213) (REP 12.50-171)
18	107E22600	BM Stapler head carrier closed sensor (Q12-217) (REP 12.28-171)
19	-	Lower shaft (Not spared) (REP 12.28-171)
20	-	Upper shaft (Not spared) (REP 12.28-171)
21	055E51870	Mylar guide
22	-	Exit plate (Not spared)

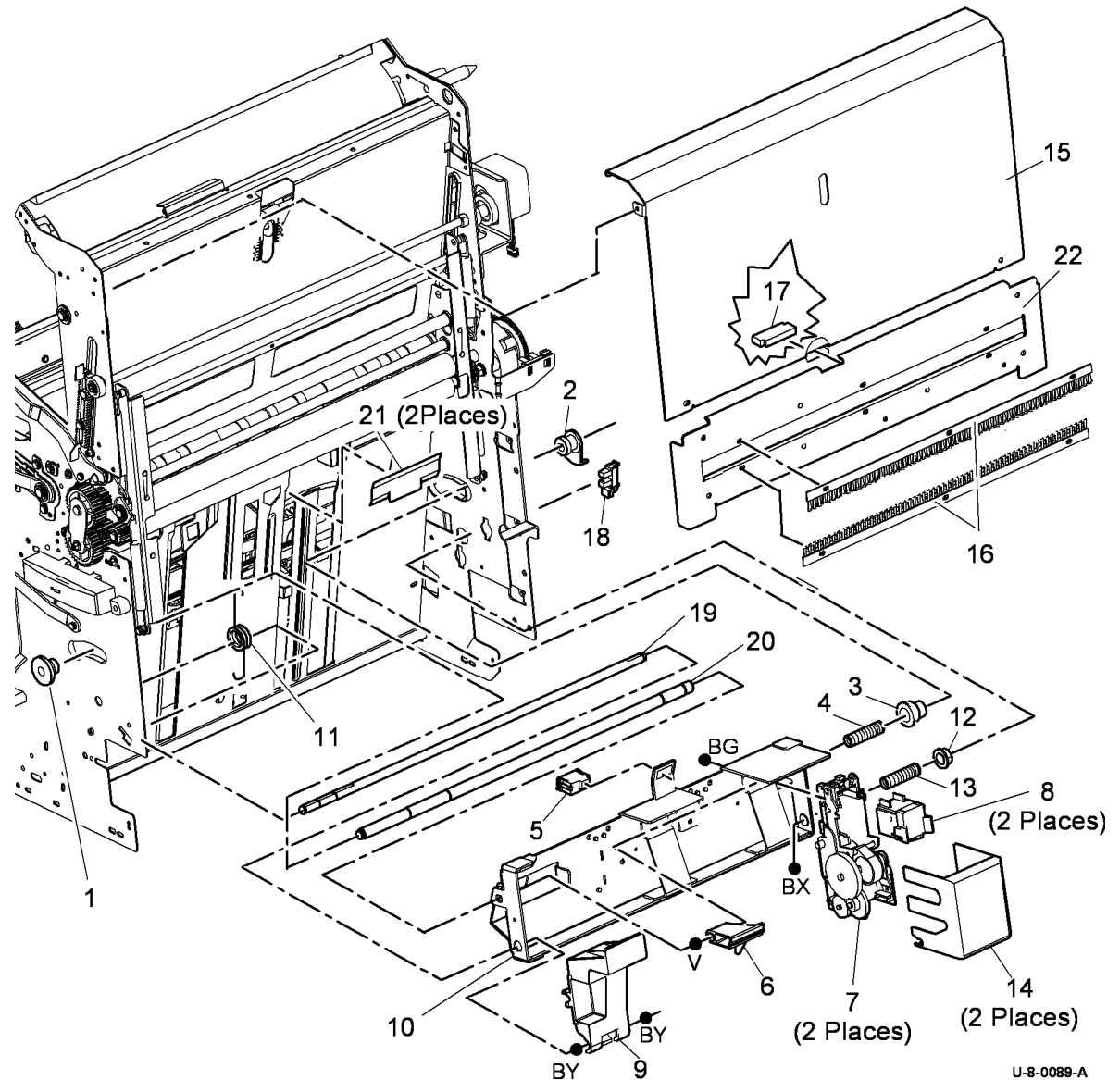

PL 12.190 HVF BM Bin 2

Item	Part	Description
1	023E18612	Conveyor belt (REP 12.29-171)
2	050E21971	HVF BM Bin 2 extension
3	-	HVF BM Bin 2 upper cover (P/O PL 12.190 Item 8)
4	127K53630	BM Conveyor drive motor (MOT12-274)
5	019E61171	HVF BM Bin 2 90% full sensor (Q12-206)
6	-	HVF BM Bin 2 lower cover (P/O PL 12.190 Item 8)
7	826E32840	Thumbscrew
8	050K67740	HVF BM Bin 2 assembly
9	-	HVF BM Bin 2 connector (Not spared)
10	809E47341	HVF Bin 2 actuator spring
11	007E69000	Gear (50T)/pulley (24T)

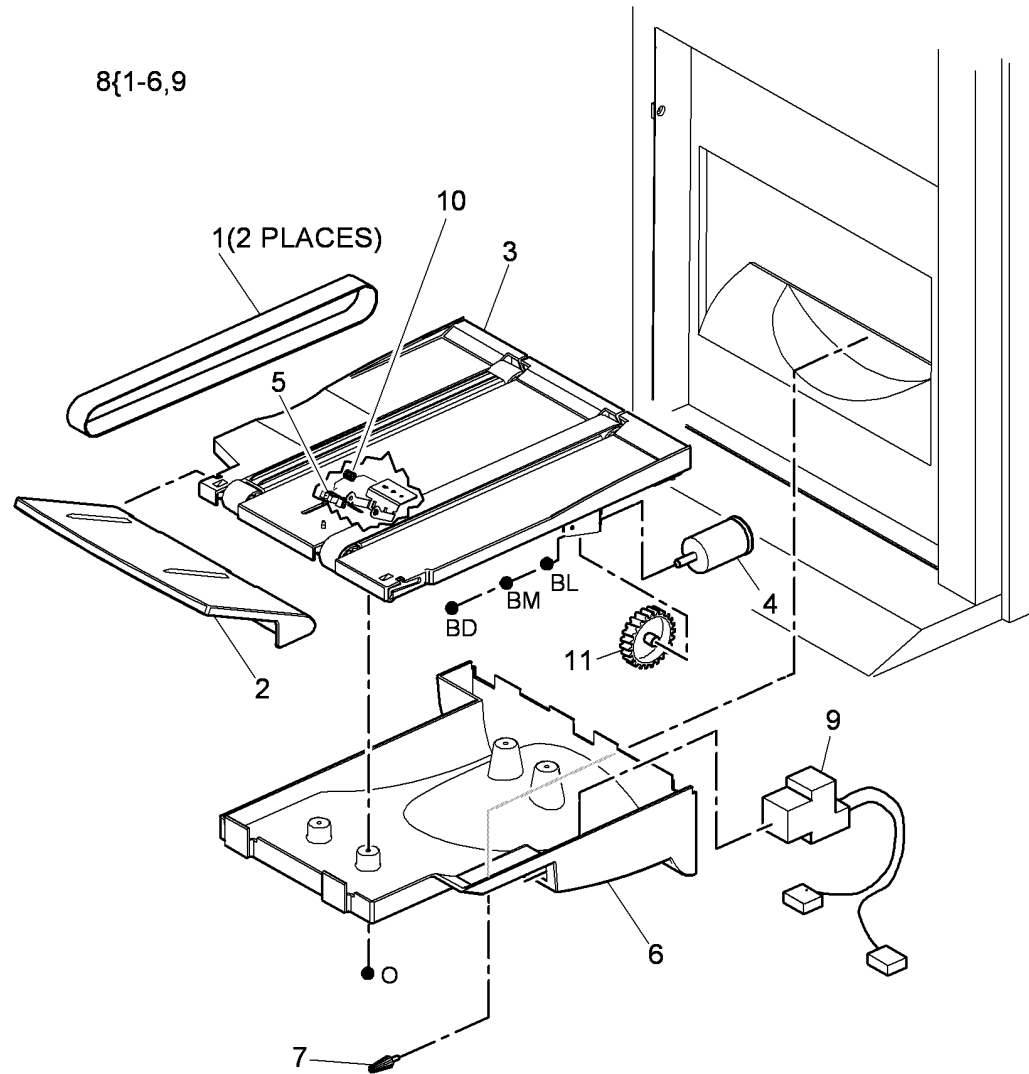

U-8-0090-A

PL 12.200 Tri-Folder Covers

Item	Part	Description
1	–	Door pin (Not spared)
2	802K94010	Front cover assembly (REP 12.67-171)
3	848K11740	Rear cover (REP 12.67-171)
4	–	Top cover door assembly (P/O PL 12.200 Item 8) (REP 12.73-171)
5	–	Top cover door assembly spring (P/O PL 12.200 Item 8)
6	802E93931	Top cover
7	848E17430	Right hand side cover (REP 12.67-171)
8	–	Tri-Folder (complete) (Not spared)
9	–	Top cover door assembly shaft (P/O PL 12.200 Item 8)
10	107E26490	Tri fold top cover interlock sensor (Q12-210) (REP 12.77-171)
11	–	Top cover locking stud (Not spared)
12	802E99581	Front cover
13	017K04190	Caster

NOTE: For detail of bin 2, refer to PL 12.190.

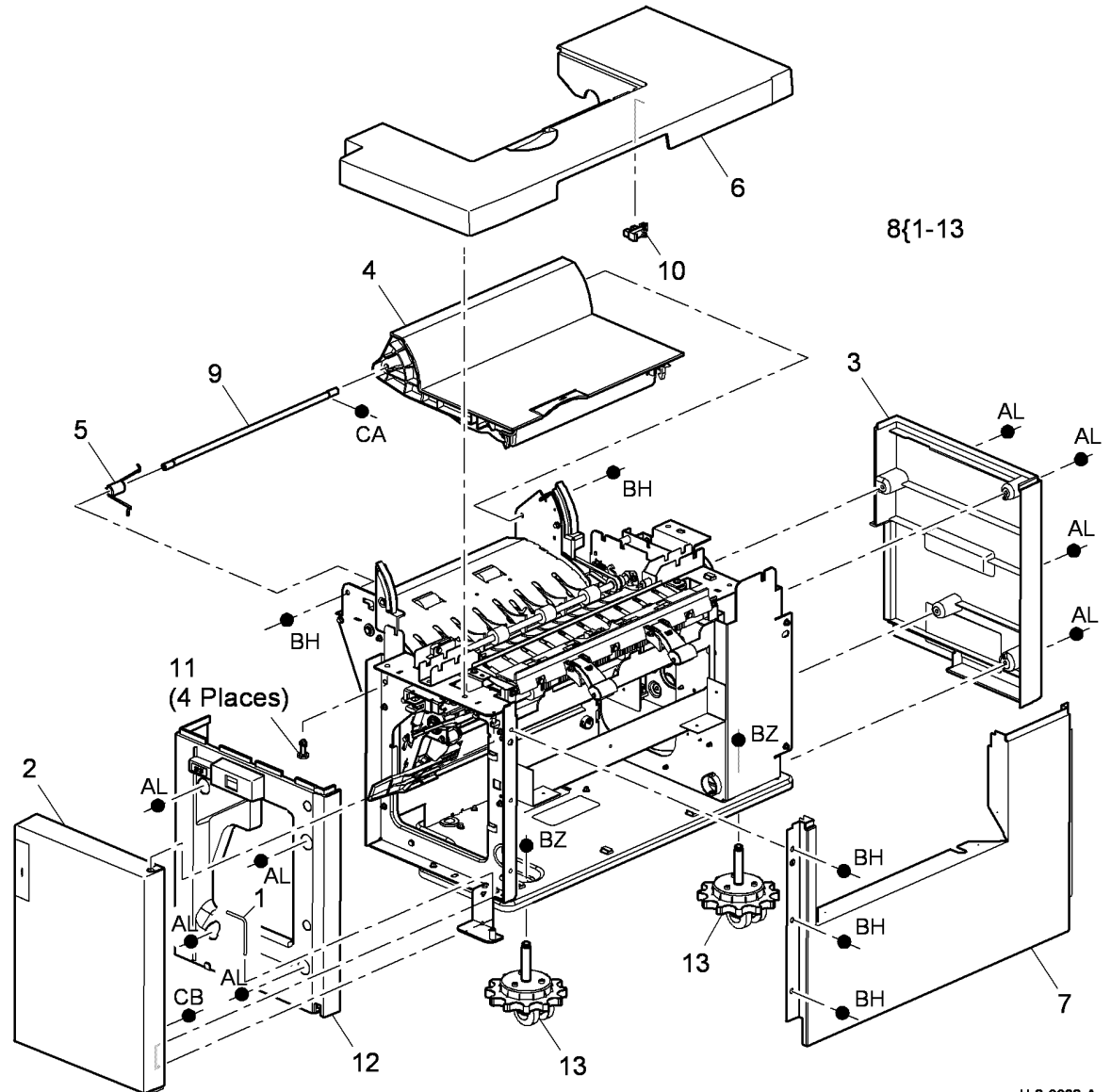

PL 12.205 Tri-Folder Drives Module

Item	Part	Description
1	-	Drive coupling assembly bracket (P/O PL 12.205 Item 13)
2	-	Bearing (P/O PL 12.205 Item 13)
3	-	Feed/exit roll drive gear (40T) (P/O PL 12.205 Item 13)
4	-	Gear (40T) (Black) (P/O PL 12.205 Item 13)
5	-	Driven pulley (P/O PL 12.205 Item 13)
6	-	Bearing (P/O PL 12.205 Item 13)
7	-	Bearing (P/O PL 12.205 Item 13)
8	-	Idler assembly bracket (P/O PL 12.205 Item 13)
9	-	Drive clutch (CL12-269) (P/O PL 12.205 Item 13)
10	-	Crease roll belt (Not spared)
11	023E30780	Coupler drive belt (REP 12.68-171)
12	007K14460	Install kit drive assembly
13	005K12690	Drive coupling assembly (REP 12.69-171)
14	675K53640	Tri-Folder install kit (REP 12.68-171)
15	-	Thumb screw (P/O PL 12.205 Item 14)
16	960K24000	Tri-folder PWB (REP 12.80-171)
17	-	Drive coupler (Not spared)
18	-	Align gauge coupler (Not spared)
19	962K49592	Bin 2 tray harness (REP 12.81-171)
20	962K49571	Bookletmaker PWB to Tri-folder PWB harness (PJ602)
21	-	Drive belt tensioner pulley (Not spared)
22	-	Feed roller bearing (Not spared)
23	-	Feed roll pulley (Not spared) (REP 12.70-171)
24	-	Feed roll belt (Not spared) (REP 12.70-171)
25	023E23370	Feed roll drive belt
26	020E39921	Pulley gear (19T/20T) (BM)
27	020E39930	Pulley (38T)

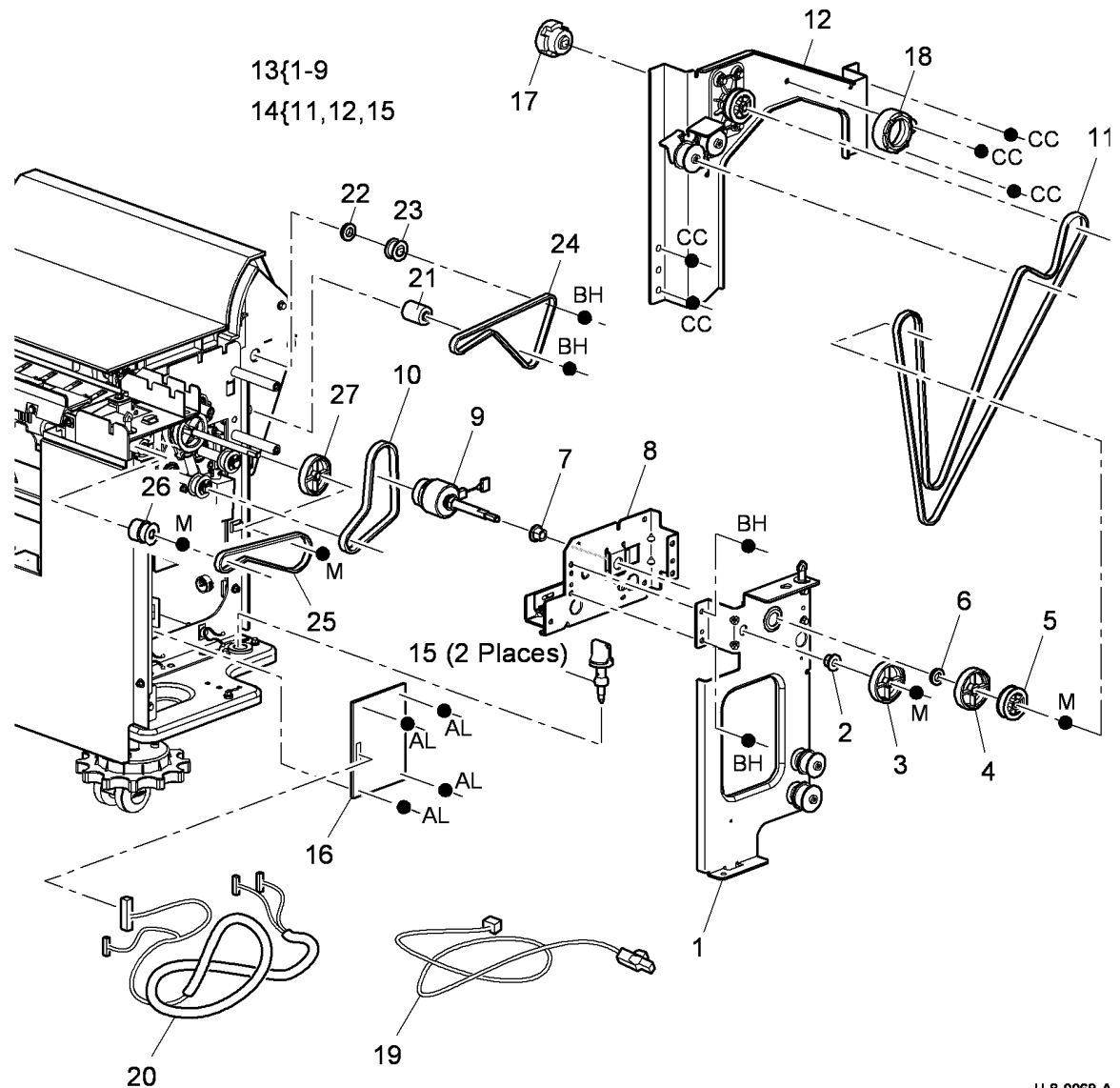

U-8-0069-A

PL 12.210 Tri-Folder Top Door Cover Assembly

Item	Part	Description
1	-	Top access cover (P/O PL 12.210 Item 10)
2	-	Top cover door assembly spring (P/O PL 12.210 Item 10)
3	-	Top cover door assembly shaft (P/O PL 12.210 Item 10)
4	-	Latch hook (P/O PL 12.210 Item 10)
5	-	Top door cover assembly base (P/O PL 12.210 Item 10)
6	-	Latch handle (P/O PL 12.210 Item 10)
7	-	Latch spring (P/O PL 12.210 Item 10)
8	059K58690	Idler assembly (REP 12.73-171)
9	-	Idler spring (P/O PL 12.210 Item 10)
10	848K11680	Top cover door assembly (REP 12.73-171)
11	-	Idler assembly (P/O PL 12.210 Item 10)

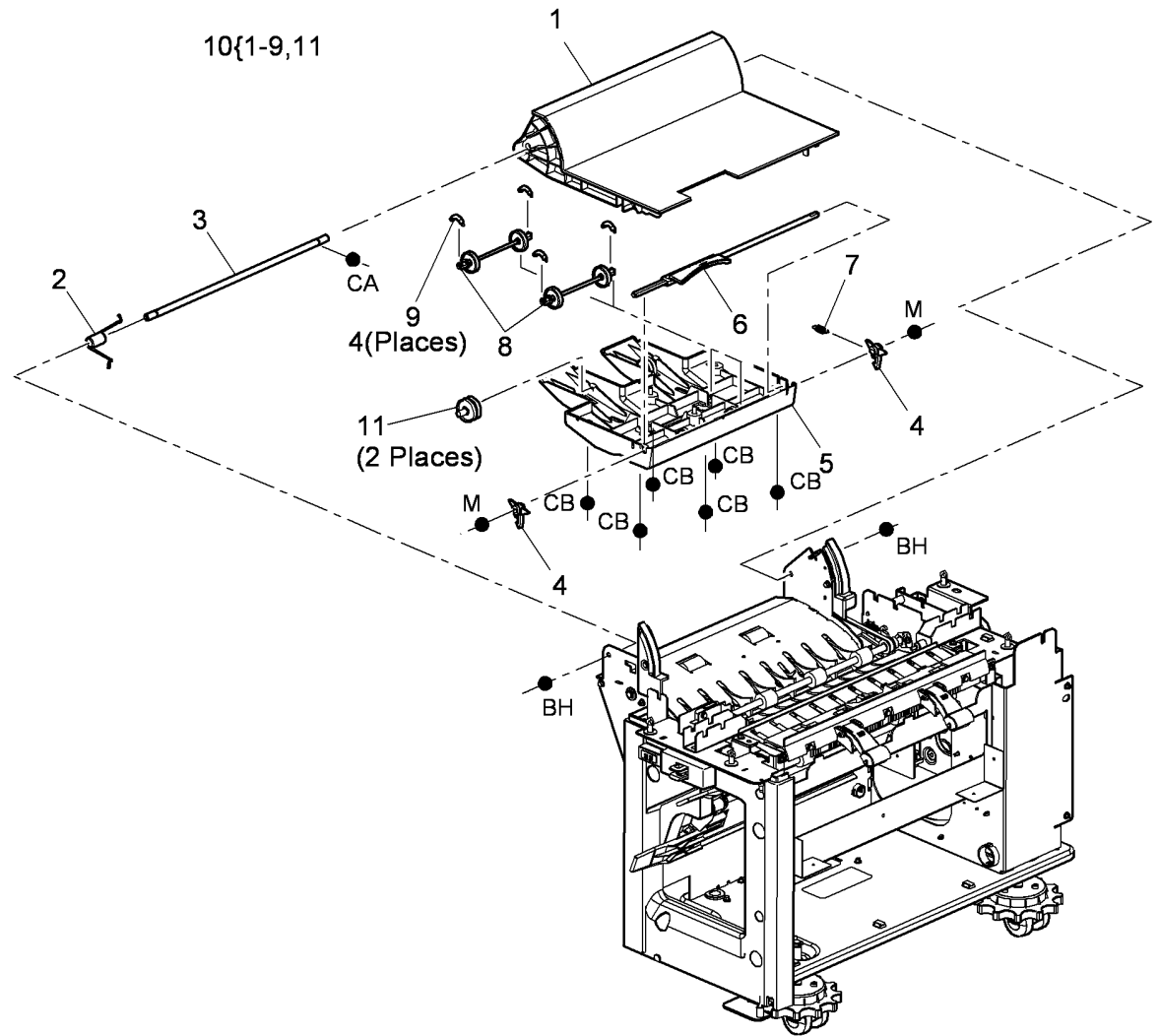

U-8-0070-A

PL 12.215 Tri-Folder Main Drives Assembly

Item	Part	Description
1	-	Roller assembly (Not spared) (REP 12.74-171)
2	110E19840	Front door interlock switch (S12-209) (REP 12.77-171)
3	110E19831	Top cover interlock switch (S 12-210) (REP 12.77-171)
4	-	Top access cover docking catch (Not spared)
5	-	Pressing and stacking assembly (Not spared)
6	130E11861	Assist gate sensor (Q12-165) (REP 12.78-171)
7	020E38480	Centerfold pulley (REP 12.74-171)
8	121K44660	Assist gate solenoid (SOL12-268) (REP 12.71-171)
9	011E13832	Centerfold entry gate lever (REP 12.74-171)
10	809E44040	Crease roll spring (REP 12.72-171)
11	130K74920	Tri folder entry sensor (Q12-164) (REP 12.78-171)
12	130K74051	Tri folder exit sensor (Q12-166) (REP 12.79-171)
13	-	Static eliminator (Not spared)
14	-	Feed roller bearing (Not spared)
15	-	Feed roller (Not spared) (REP 12.70-171)
16	121K44650	Tri folder diverter solenoid (SOL12-267) (REP 12.74-171)
17	050E23180	Diverter gate
18	050E28950	Diverter gate spring clip
19	809E95080	Nip spring

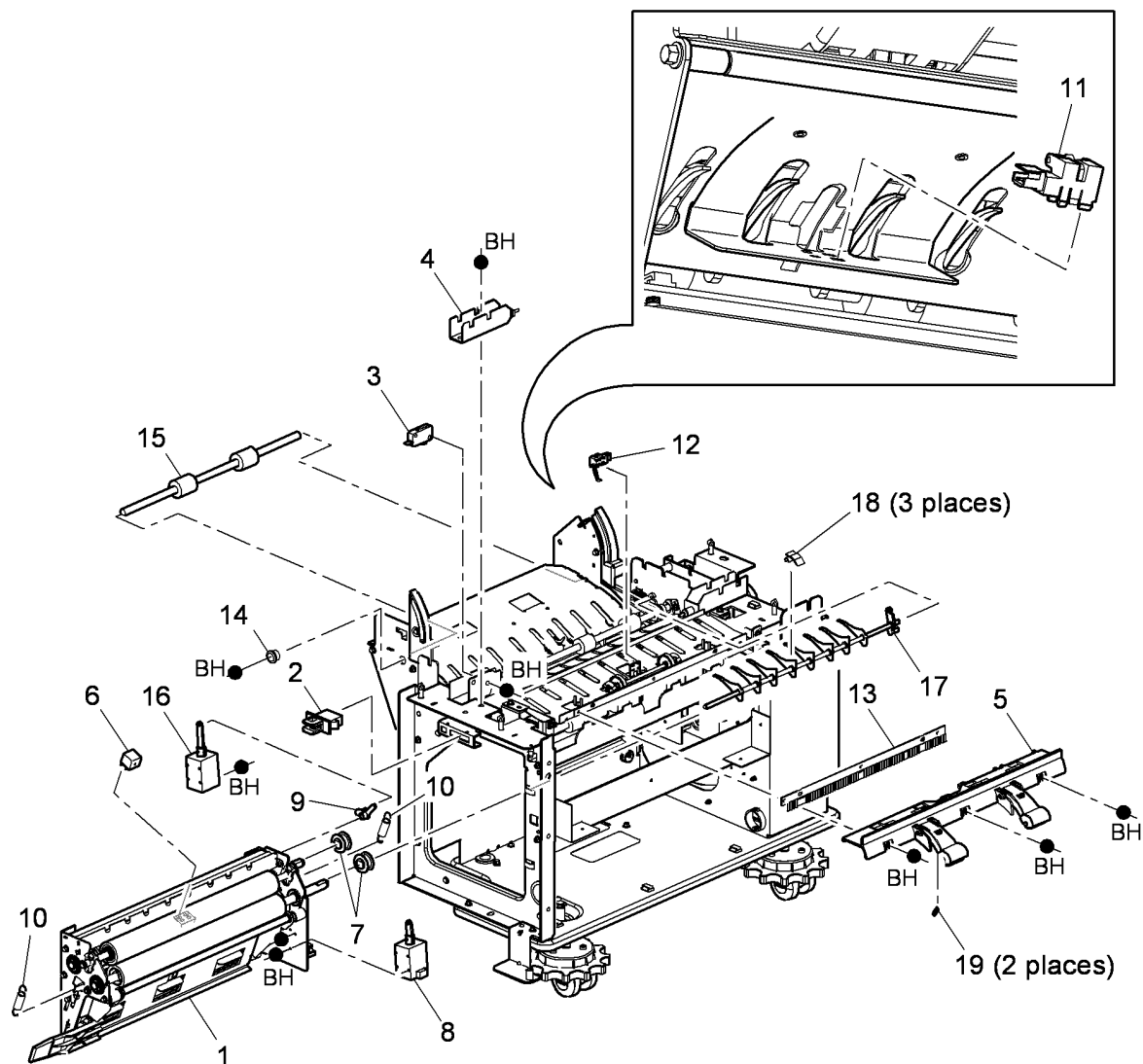

U-8-0071-A

PL 12.300 Inserter Covers

Item	Part	Description
1	-	Front cover (Not spared) (REP 12.83-171)
2	-	Rear cover (Not spared) (REP 12.83-171)
3	-	Sensor tray (P/O PL 12.300 Item 20) (REP 12.89-171)
4	-	Bottom tray spring (Not spared)
5	-	Bottom tray shaft (Not spared)
6	-	Bottom tray (P/O PL 12.300 Item 19) (REP 12.90-171)
7	-	Lower jam cover (P/O PL 12.300 Item 21) (REP 12.92-171)
8	848K31360	Top cover door (REF: PL 12.310 Item 17)
9	-	Pivot pin (Not spared)
10	-	Inserter acceleration sensor (Q12-316) (P/O PL 12.300 Item 21) (REP 12.92-171)
11	-	Inserter unit empty sensor (Q12-082) (Not spared) (REP 12.90-171)
12	-	Inserter paper length 1 sensor (Q12-079)/Inserter paper length 2 sensor (Q12-080), Inserter paper length sensor 3 (Q12-090) (Not spared) (REP 12.89-171)
13	-	Paper width sensor 1 (Q12-081), Paper width sensor 2 (Q12-169) (Not spared) (P/O PL 12.300 Item 19) (REP 12.90-171)
14	-	Bottom tray bracket (P/O PL 12.300 Item 19)
15	-	Bottom tray rack (P/O PL 12.300 Item 19)
16	-	Inserter bottom plate sensor (Q12-085) (P/O PL 12.300 Item 19) (REP 12.94-171)
17	050K68510	Top inside cover (Not spared)
18	-	Inserter jam cover interlock switch (S12-179) (Not spared) (REP 12.88-171)
19	050K68510	Bottom tray assembly
20	848K31350	Sensor tray assembly
21	-	Lower jam cover assembly (Not spared)
22	848K31370	Main tray assembly
23	-	Bracket (P/O PL 12.300 Item 21)
24	-	Lower jam inner cover (P/O PL 12.300 Item 21)

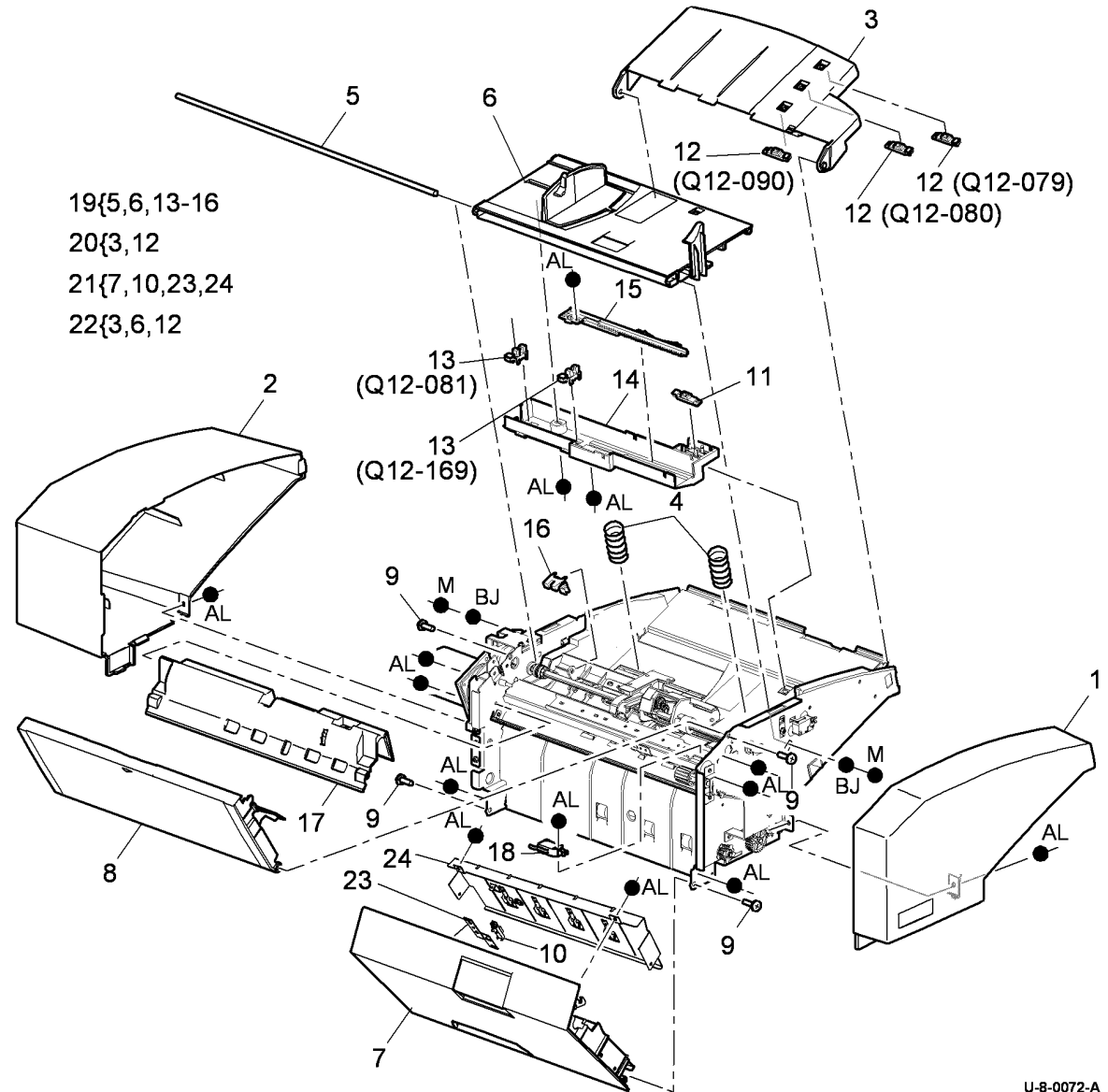

U-8-0072-A

PL 12.305 Inserter Main Drives (1 of 3)

Item	Part	Description
1	–	Idler (Not spared)
2	–	Idler pin (Not spared)
3	–	Gear (Not spared)
4	–	Pulley (Not spared)
5	–	Belt (Not spared)
6	–	Bracket (Not spared)
7	–	Jam drive belt (Not spared)
8	–	Inserter top cover interlock switch (S12-178) (Not spared) (REP 12.87-171)
9	–	Loading lever (Not spared)
10	–	Loading gear (Not spared)
11	–	Bearing (Not spared)
12	–	Torsion spring (Not spared)
13	–	Loading shaft (Not spared)
14	–	Front loading bracket (Not spared)

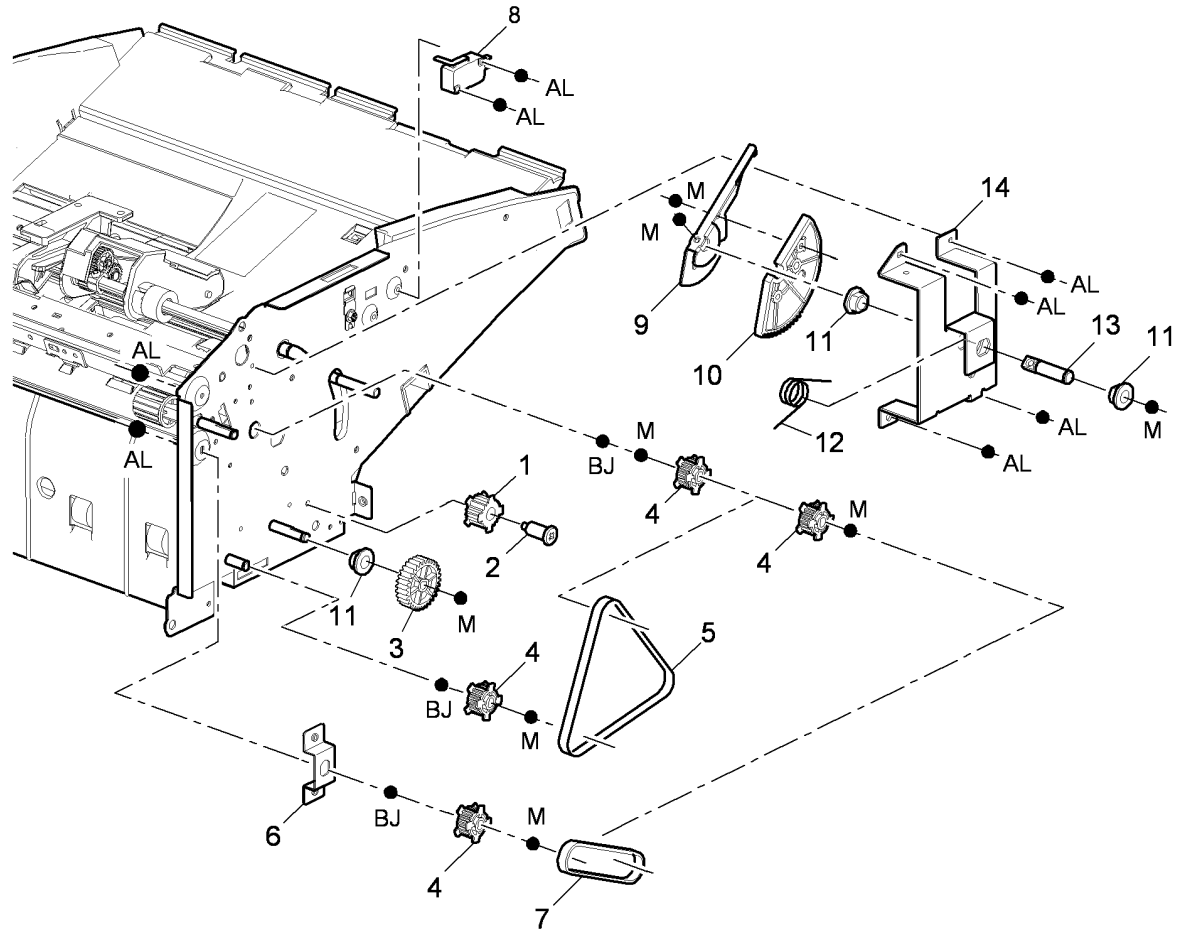

U-8-0073-A

PL 12.310 Inserter Main Drives (2 of 3)

Item	Part	Description
1	050K68520	Pickup assembly (REP 12.95-171) (See NOTE)
2	-	Pickup gear (Not spared)
3	005K12890	Inserter clutch (CL12-260) (REP 12.86-171)
4	-	Reverse roller drive idler (Not spared)
5	-	Pickup assembly bracket (Not spared)
6	-	Bearing (Not spared)
7	-	Reverse roller drive belt (Not spared)
8	-	Reverse roller drive (Not spared)
9	960K46170	Inserter PWB (REP 12.85-171)
10	-	Inserter pickup sensor (Q12-315) (REP 12.91-171)
11	-	Inserter LE sensor (Q12-083)/ Inserter TE sensor (Q12-084) (REP 12.93-171)
12	-	Idle roller (Not spared) (REP 12.98-171)
13	-	Idle roller bracket (Not spared)
14	-	Idle roller spring (Not spared)
15	-	Top inside cover (Not spared)
16	-	Idle roller cover
17	-	Top cover (REP 12.91-171)
18	050K68090	Reverse feed roller (REP 12.95-171)
19	006K32860	Idle roller assembly (REP 12.98-171)
20	848K31360	Top cover door assembly
21	848K37330	Retard cover
22	-	Drive coupling (Not spared)
23	-	Reverse feed roll core (Not spared)
24	-	Pin (Not spared)
25	-	Shaft (Not spared)

NOTE: To reset the HFSI count, go to dC135.

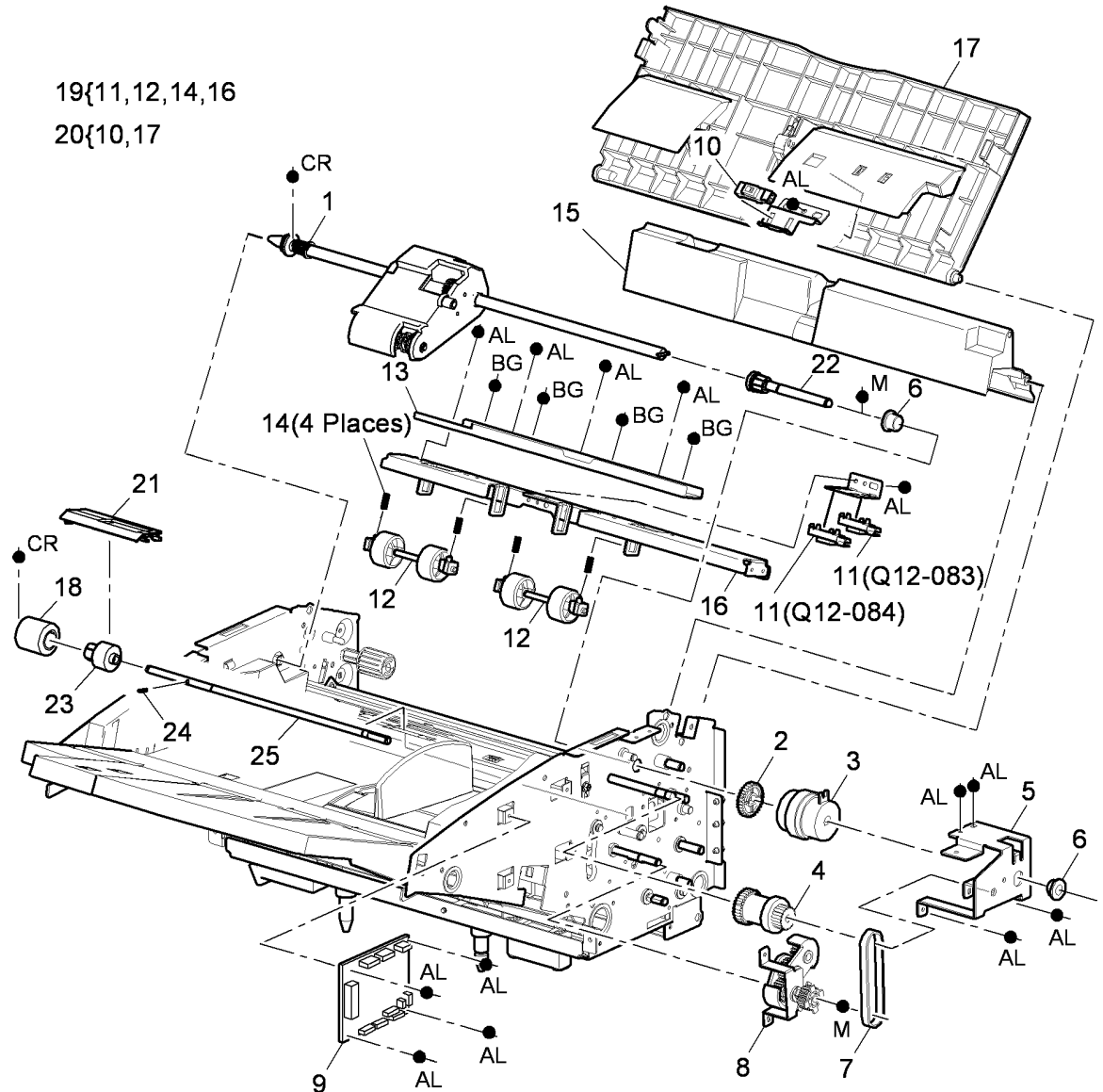

U-8-0074-A

PL 12.315 Inserter Main Drives (3 of 3)

Item	Part	Description
1	127K61990	Inserter motor (MOT12-261) (REP 12.84-171)
2	-	Idler (Not spared)
3	-	Driver gear (Not spared)
4	-	Idler (Not spared)
5	-	Tray down gear (Not spared)
6	-	Gear cover bracket (Not spared)
7	-	Idler (Not spared)
8	-	Bottom shaft drive (Not spared)
9	-	Feed roller drive gear (Not spared)
10	-	Tray down clutch (Not spared)
11	-	Tray down clutch assembly (Not spared)

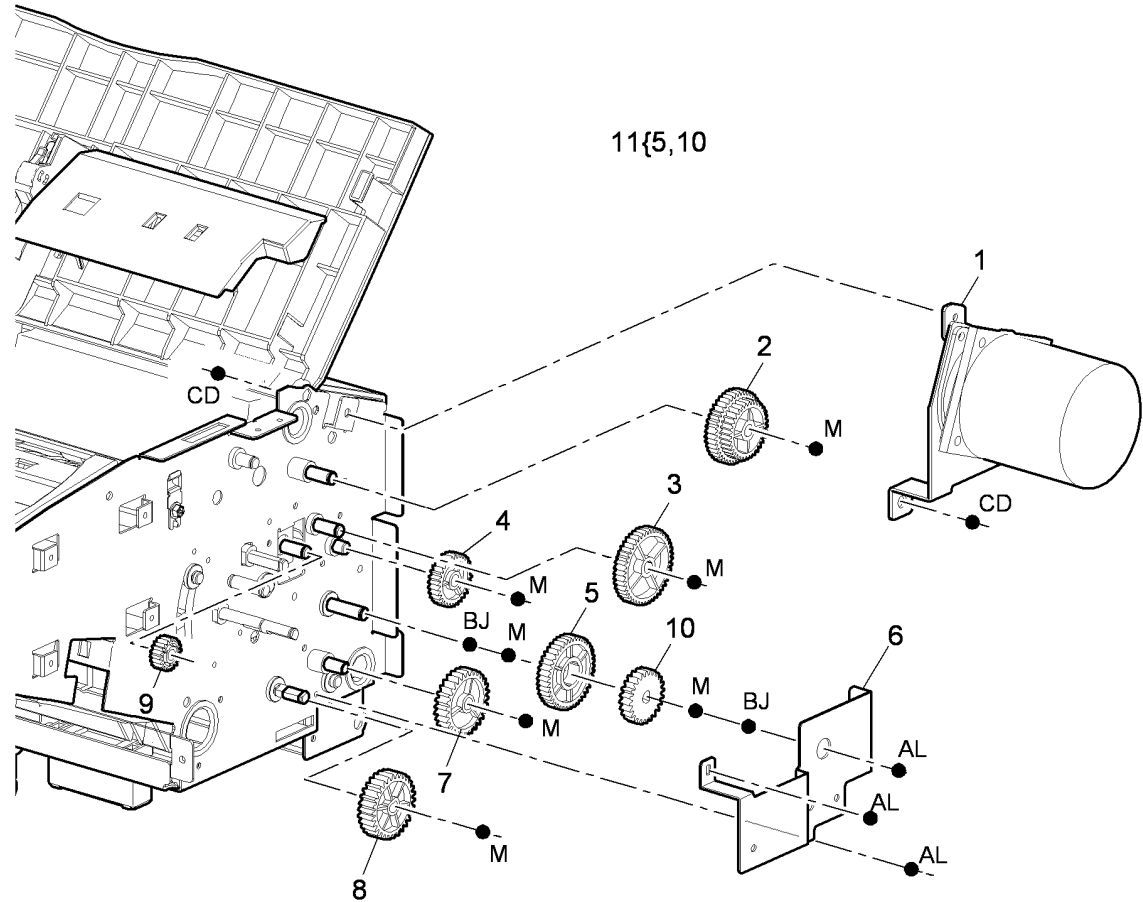

U-8-0075-A

PL 20.05 Fax Module

Item	Part	Description
1	-	Fax module
-	-	1 line (P/O PL 20.10 Item 1)
-	-	2 line (P/O PL 20.10 Item 2)
2	-	Fax connector PWB (Not spared)
3	-	Telephone cable (not shown on illustration, see below for variants)
-	117K45260	United Kingdom
-	117K45390	USSG/XCL
-	117K45270	Germany
-	117K45280	Italy
-	117K45290	Netherlands
-	-	Belgium
-	117K45310	Switzerland
-	117K45320	Denmark
-	117K45330	Austria
-	117K45340	Sweden
-	117K45350	France
-	117K45360	Norway
-	117K45370	Portugal/Spain
-	117K45380	Finland
4	-	Thumbscrew

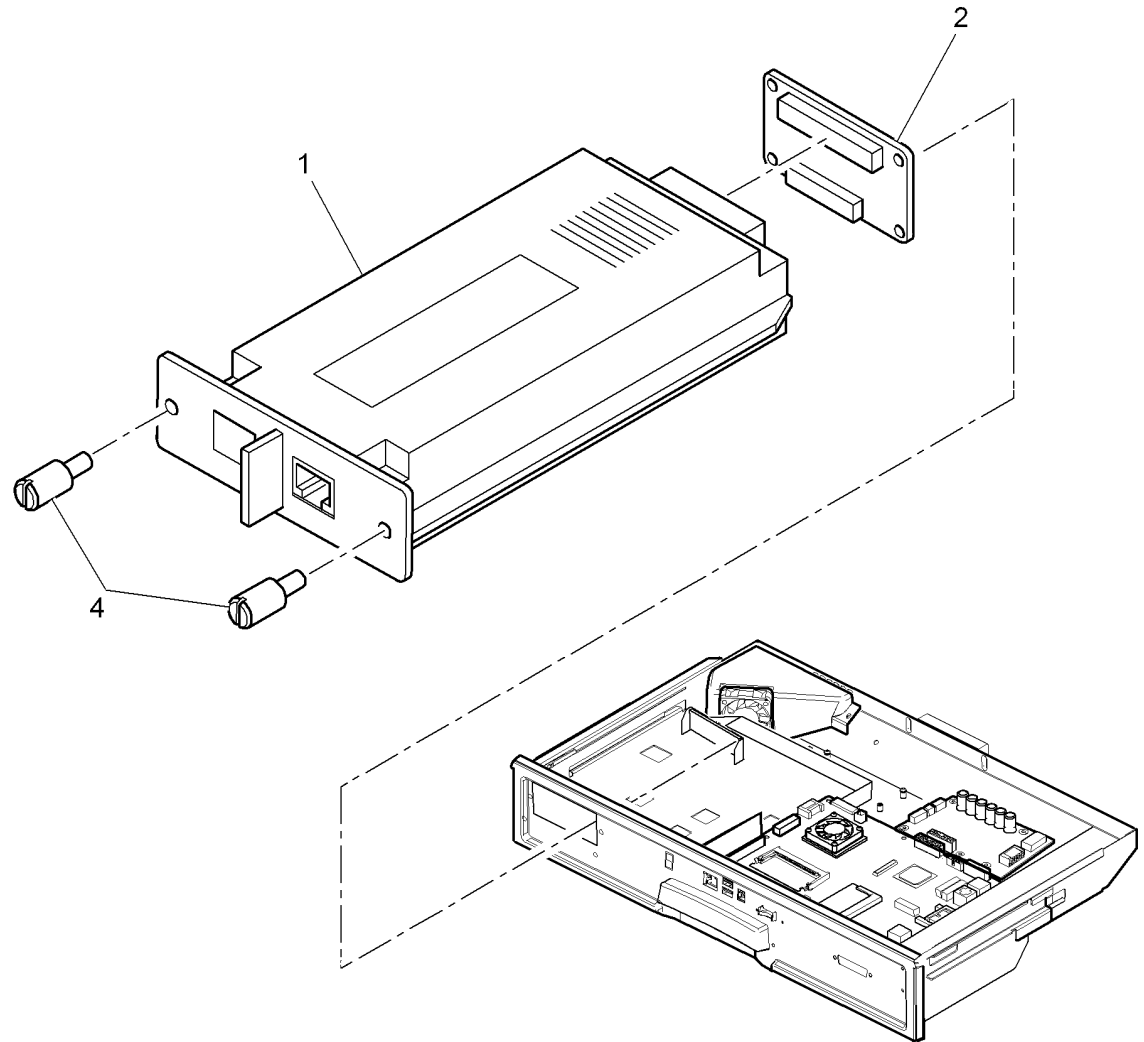

U-8-0112-A

PL 20.10 Line 1 & 2 Fax Kits

Item	Part	Description
1	-	Line 1 Fax Kits (see below for variants)
-	497K06230	USSG/XCL
-	497K06250	XE (CIF)
-	497K07550	United Kingdom/Spain/Portugal/ Greece/Ireland
-	497K07490	Austria/Germany/Switzerland/Italy
-	497K07500	Sweden /Norway/Finland/Denmark
-	497K07480	Netherlands/Belgium/France
2	-	Line 2 Fax Kits (see below for variants)
-	497K06240	USSG/XCL
-	497K06260	XE (CIF)
-	497K07510	United Kingdom/Spain/Portugal/ Greece/Ireland
-	497K07530	Austria/Germany/Switzerland/Italy
-	497K07540	Sweden /Norway/Finland/Denmark
-	497K07520	Netherlands/Belgium/France

**NO EXPLODED
VIEW PROVIDED**

U-8-0095-A

PL 25.10 Convenience Stapler

Item	Part	Description
1	-	Convenience stapler kit (REF: PL 31.11 Item 3)
2	-	Power cord (P/O PL 25.10 Item 1)
3	-	PSU (P/O PL 25.10 Item 1)
4	-	Staple cartridge (REF: PL 26.10 Item 16)
5	-	Convenience stapler (P/O PL 25.10 Item 1) (XE)

NOTE: The convenience stapler has no serviceable parts.

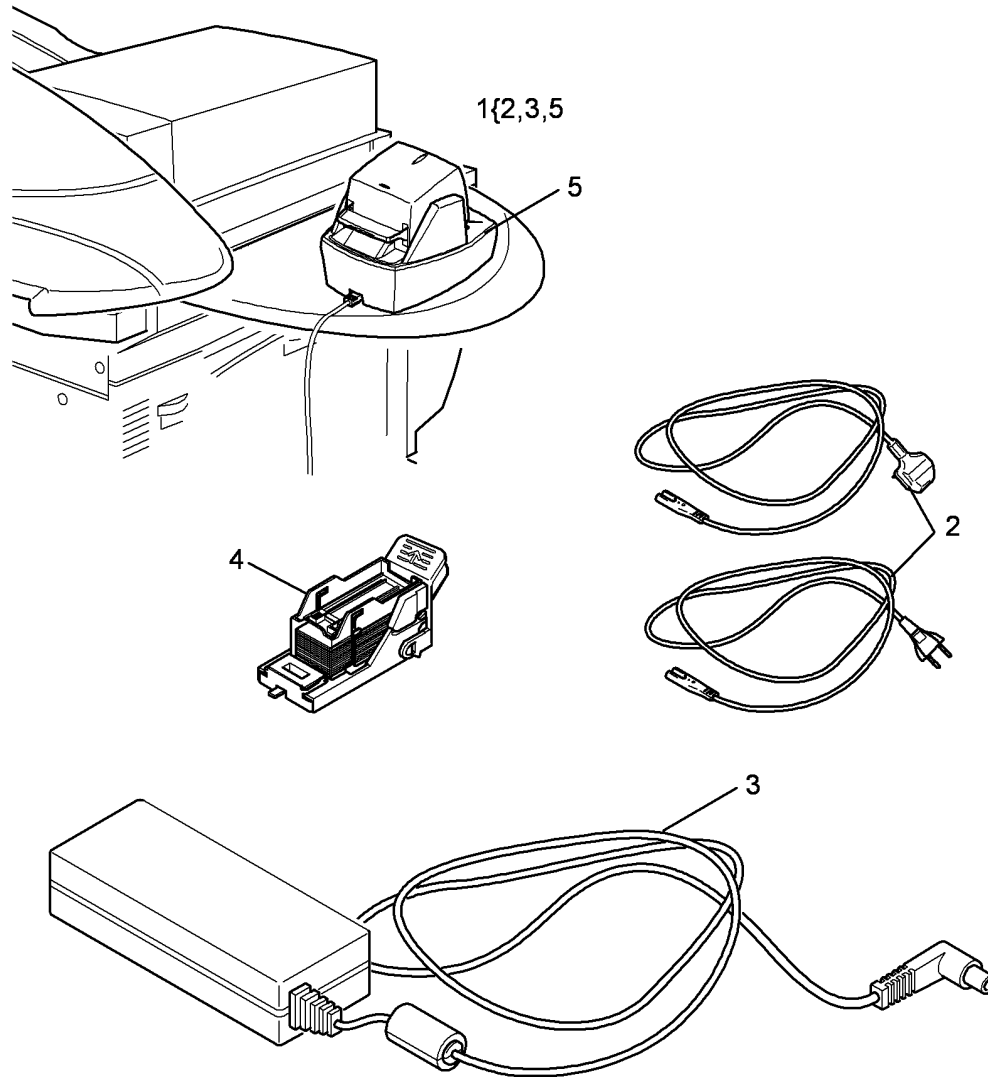

U-8-0111-A

PL 26.10 Consumables and Tools (1 of 2)

Item	Part	Description
1	008R90176	Cleaning fluid (IPA & water)(WARNING)
2	–	Ethernet crossover cable (PWS to SBC PWB) (Not spared)
3	–	Finisher bypass connector (Not spared)
4	–	Plastislip grease (Not spared)
5	–	Disposable gloves (general protection- see below for varaints) (Qty. 100) (WARNING)
–	099P03227	Small
–	099P03228	Medium
–	099P03229	Large
–	099P03230	Extra large
6	019P03025	Microfibre cleaning cloth
7	108R00834	Magenta solid ink stick (Metered)
–	108R00830	Magenta solid ink stick (Sold)
–	108R00838	Magenta solid ink stick (Sold DMO)
8	108R00833	Cyan solid ink stick (Metered)
–	108R00829	Cyan solid ink stick (Sold USSG/ XCL/XE)
–	108R00837	Cyan solid ink stick (Sold DMO)
9	108R00835	Yellow solid ink stick (Metered)
–	108R00831	Yellow solid ink stick (Sold)
–	108R00839	Yellow solid ink stick (Sold DMO)
10	108R00836	Black solid ink stick (Metered)
–	108R00832	Black solid ink stick (Sold)
–	108R00840	Black solid ink stick (Sold DMO)
11	–	Antistatic fluid (Not spared)
12	–	Molub grease 777 (Not spared)
13	–	Cable tie (P/O PL 31.10 Item 12)
14	–	Foreign interface test tool (USSG/ XC)
15	008R12912	Staple cartridge (HVF - 100 sheet) (1 x 5000)
–	008R12898	Staple cartridge (HVF- 100 sheet) (3 x 5000)
–	008R12919	Staple cartridge (HVF - 50 sheet) (1 x 5000)
–	008R12920	Staple cartridge (HVF - 50 sheet) (3 x 5000)
16	008R12964	Staple cartridge (LCSS) (1 x 5000)
–	108R00493	Staple cartridge (LCSS) (3 x 5000)
17	050K21270	Staples (1 x 2000)
–	008R12897	Staples (8 x 2000)
–	008R12941	Staples (3 x 5000)

WARNING

Wear protective gloves when using solvents and cleaning agents, PL 26.10 Item 5.

**NO EXPLODED
VIEW PROVIDED**

U-8-0091-A

PL 26.11 Consumables and Tools (2 of 2)

Item	Part	Description
1	600T91961	Stripper blade retaining tool
2	–	Drum alignment tool (P/O PL 31.11 Item 25)
3	070E01000	High pressure bearing grease
4	070E00890	Grease (NYE Rheolube 368F- 10oz tube)
5	600T91960	Drum removal wrench (T30)
6	–	USB Flash drive (2GB memory stick) (Not spared)
7	600T00563	Safety glasses
8	043P00067	Xerox Clean - ups (IPA & water)
9	–	Cleaning cloth (P/O PL 31.11 Item 32)
10	–	Oil spillage syringe (P/O PL 31.11 Item 32)
11	600T91959	Drum protective cover
12	–	Oil spillage plastic bottle (1.5L) (P/O PL 31.11 Item 32)
13	–	Absorbent fabric mat (P/O PL 31.11 Item 32)
14	–	Film remover (Not spared)
15	082E14750	Service test pattern
16	–	Line test tool (Not spared)
17	114E24550	Scanner transport lock
18	146E02700	USB reader

WARNING

Wear protective gloves when using solvents and cleaning agents, PL 26.10 Item 5.

**NO EXPLODED
VIEW PROVIDED**

U-8-0122-A

PL 28.10 Covers

Item	Part	Description
1	–	DADH covers (REF: PL 5.10)
2	–	Main covers (REF: PL 81.10)
3	–	LCSS covers (REF: PL 12.10)
4	–	Scanner covers (REF: PL 62.10)
5	–	HVF covers (REF: PL 12.100)
6	–	Tray 5 covers (REF: PL 75.60)
7	–	Tri-folder covers (REF: PL 12.200)

**NO EXPLODED
VIEW PROVIDED**

U-8-0093-A

PL 31.10 Maintenance/Installation/ Removal Kits (1 of 3)

Item	Part	Description
1	–	Fax adapter kit (see below for variants)
–	604K67590	United Kingdom, Ireland, Spain, Portugal, Greece
–	604K67600	France, Netherlands, Belgium
–	604K67610	Germany, Austria, Italy, Switzerland
–	604K67620	Sweden, Norway, Finland, Denmark
2	497K07760	Foreign device interface kit
3	130K75900	HVF Low level sensor - spares pack
4	604K73050	LCSS paddle spares kit
5	–	Hole punch kit (see below for variants)
–	604K55160	2 hole punch kit (XE)
–	604K55190	2 hole punch kit (legal) (XE)
–	604K55170	3 hole punch kit (USSG/XCL)
–	498K14040	3 hole punch kit (XE)
–	604K55200	4 hole punch kit (Sweden)
–	604K55180	4 hole punch kit (XE)
6	–	USB print connectivity kit (Not spared)
7	–	Finishing devices (variants below)
–	–	LCSS (no hole punch) (Not spared)
–	–	LCSS (no hole punch) (Not spared) (30 ppm)
8	–	Tray 5 (Not spared)
9	498K12130	Tray 5 paper feed kit (A3 SEF option) (Not spared)
10	498K12150	Tray 5 paper feed kit (A4 SEF option) (Not spared)
11	604K48370	CVT Roll Kit
12	604K61780	GUI gasket kit
13	498K17780	Generic installation request kit (XE)
14	604K54972	Umbilical kit
15	604K67570	Feedhead assembly kit (REP 5.3)

NOTE: 498K part numbers should not be ordered by the CSE. 498K part numbers are customer install kits and are shown for reference only.

**NO EXPLODED
VIEW PROVIDED**

U-8-0094-A

PL 31.11 Maintenance/Installation/ Removal Kits (2 of 3)

Item	Part	Description
1	604K54580	OCT centre registration kit
2	604K41411	LCSS Front cover Kit
3	604K35700	Stapler kit (XE)
–	604K35710	Stapler kit (USSG/XCL)
4	–	DADH feed bearing kit (Not spared)
5	497K04690	Tri-folder install kit (complete)
6	604K73060	LCSS paddle shaft assembly kit
7	604K54870	Registration/Pre-heat pump kit (Contains 2 air pumps)
8	897E31770	French/Canadian UI overlay kit
9	604K67940	Drum pulley removal kit
10	604K73230	HVF ejector assembly safety cover kit
11	604K73340	Drum repair kit
12	604K67130	Tray 3 guide kit
13	604K61410	Wave amp cable and clip kit (Type A)
14	604K60701	DADH mylar guide kit
15	604K67230	LCSS traverse kit
16	–	Smartcard enablement kit (Not spared)
17	604K62080	DADH sensor replacement kit
18	–	Not used
19	604K54990	Nip A replacement kit (Contains 2 belts and 2 Nip A roller assemblies)
20	130K75140	LCSS stapler edge registration sensor kit
21	604K54320	Front transfix linkage and gear kit
22	604K54330	Rear transfix linkage and gear kit
23	604K54100	Hardware kit
24	498K19200	20 Amp adapter kit
25	–	Drum kit (REF: PL 94.20 Item 1, PL 26.11 Item 11, PL 26.11 Item 2)
26	604K55480	Feed roll kit
27	–	Install NAT kit (XE) (Not spared)
28	–	Install NAT kit (USSG/XCL) (Not spared)
29	604K61420	Video cable and clip kit (Type A)
30	604K61370	3TM Cable kit
31	604K61710	Tray 3 kit
32	604K61640	Silicon oil removal kit
33	650K33140	UI overlay kit (English)

NOTE: 1: 498K part numbers should not be ordered by the CSE. 498K part numbers are customer install kits and are shown for reference only.

NOTE: 2: Refer to GP 24 for contents of the hardware kit.

**NO EXPLODED
VIEW PROVIDED**

U-8-0094-A

PL 31.12 Maintenance/Installation/ Removal Kits (3 of 3)

Item	Part	Description
1	–	Initialisation kits (variants below)
–	–	9301 (2 tier) (Metered) (Not spared)
–	–	9302 (2 tier) (Metered) (Not spared)
–	–	9303 (2 tier) (Metered) (Not spared)
–	–	9301 (3 tier) (Metered) (Not spared)
–	–	9302 (3 tier) (Metered) (Not spared)
–	–	9303 (3 tier) (Metered) (Not spared)
–	–	9301 (3 tier) (Sold DMO) (Not spared)
2	–	Product enablement kits (variants below)
–	–	9301 (2 tier) (Metered) (Not spared)
–	–	9302 (2 tier) (Metered) (Not spared)
–	–	9303 (2 tier) (Metered) (Not spared)
–	–	9301 (3 tier) (Not spared)
–	–	9302 (3 tier) (Metered) (Not spared)
–	–	9303 (3 tier) (Metered) (Not spared)
–	–	9301 (Sold USSG/XCL/XE) (Not spared)
–	–	9302 (Sold USSG/XCL/XE) (Not spared)
–	–	9303 (Sold USSG/XCL/XE) (Not spared)
–	–	9301 (Sold DMO) (Not spared)
–	–	9302 (Sold DMO) (Not spared)
–	–	9303 (Sold DMO) (Not spared)
3	–	Scan to PC desktop kits (variants below)
–	301K23410	Standard (USSG/XCL) (V10)
–	301K23420	Standard (XE) (V10)
–	301K23470	Professional (USSG /XCL) (V10)
–	301K23480	Professional (XE) (V10)
–	301K19430	Workgroup edition (XE)
4	–	Xerox copier assistant kit (USSG/XCL) (Not spared)
–	–	Xerox copier assistant kit (XE) (Not spared)

NOTE: 498K part numbers should not be ordered by the CSE. 498K part numbers are customer install kits and are shown for reference only.

**NO EXPLODED
VIEW PROVIDED**

U-8-0094-A

PL 62.10 Scanner Module, CVT/ Document Glass

Item	Part	Description
1	062K28321	Scanner module (REP 62.1)
2	-	Top cover (P/O PL 62.10 Item 1) (REP 62.2, ADJ 62.4)
3	090E02581	CVT Glass (See NOTE) (REP 62.3)
4	090K02560	Document glass assembly (REP 62.3)
5	032K09770	CVT Ramp assembly (REP 62.3)
6	-	Grommet (Not spared)
7	-	Not used
8	-	Nut (Not spared)
9	-	Harness clamp (Not spared)
10	-	Top cover plug (Not spared)
11	-	Document glass securing bracket (P/O PL 62.10 Item 1)
12	-	DADH/IIT power comms harness (PJ8, PJ18, PJ920) (REF: PL 62.16 Item 7)
13	952K00380	IIT video/SBC PWB harness (PJ15, PJ922)
14	848E69071	Scanner rear cover
15	-	Scanner side cover (RH) (Not spared)
16	-	UI harness cover (Not spared)
17	-	Latch plate (Not spared)
18	-	Not used
19	-	UI Base (Not spared) (REP 2.1)
20	-	Rubber stop (Not spared)

NOTE: 1. Refer to ADJ 62.1 for the optics cleaning procedure.

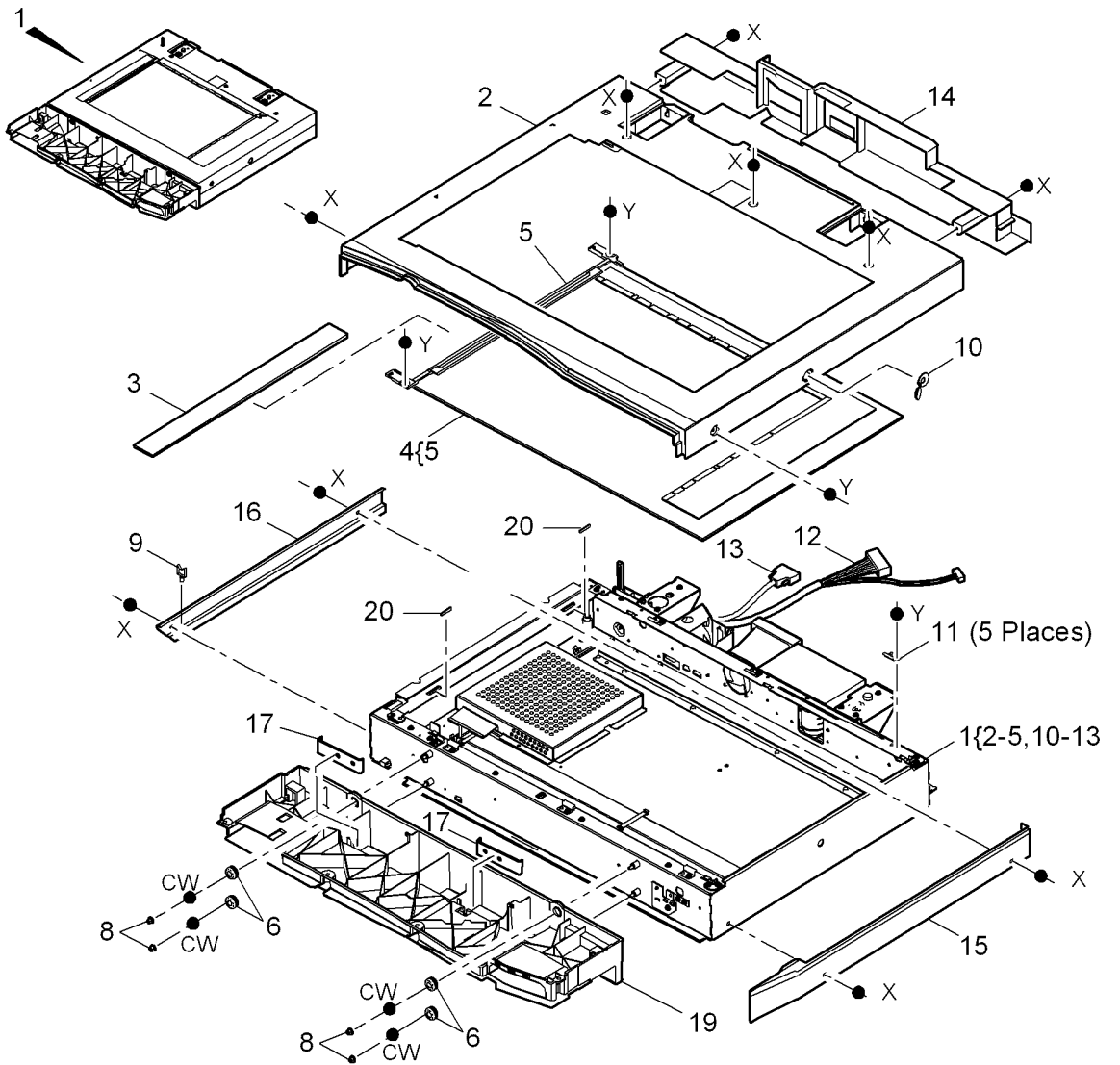

U-8-0031-A

PL 62.15 Electrical Components (1 of 2)

Item	Part	Description
1	062K28310	Scan carriage assembly (REP 62.5, ADJ 62.2)
2	122E03430	LED exposure lamp (REP 62.10)
3	-	Inline ribbon harness (P/O PL 62.10 Item 1)
4	962K50450	Scan carriage ribbon cable (PJ928) (REP 62.13)
5	962K26830	LED lamp ribbon harness (PJ926, CN1) (REP 62.11)
6	-	Scan carriage (P/O PL 62.15 Item 1)
7	130K75130	Carriage home sensor (Q62-018) (REP 62.4), Angle sensor (Q62-301)
8	-	Actuator support (Not spared)
9	-	Actuator spring (Not spared)
10	110K14010	Input module angle sensor actuator (REP 62.9)
11	-	Cable clamp (P/O PL 62.15 Item 1)
12	-	Harness retainer (Not spared)
13	-	Connector cover (P/O PL 62.15 Item 1)
14	-	Sensor bracket (Not spared)
15	-	Lower skid (P/O PL 62.15 Item 6) (See NOTE)
16	-	Upper skid (P/O PL 62.15 Item 6)
17	-	Clip (Not spared)

NOTE: Refer to ADJ 62.1 for the optics cleaning procedure.

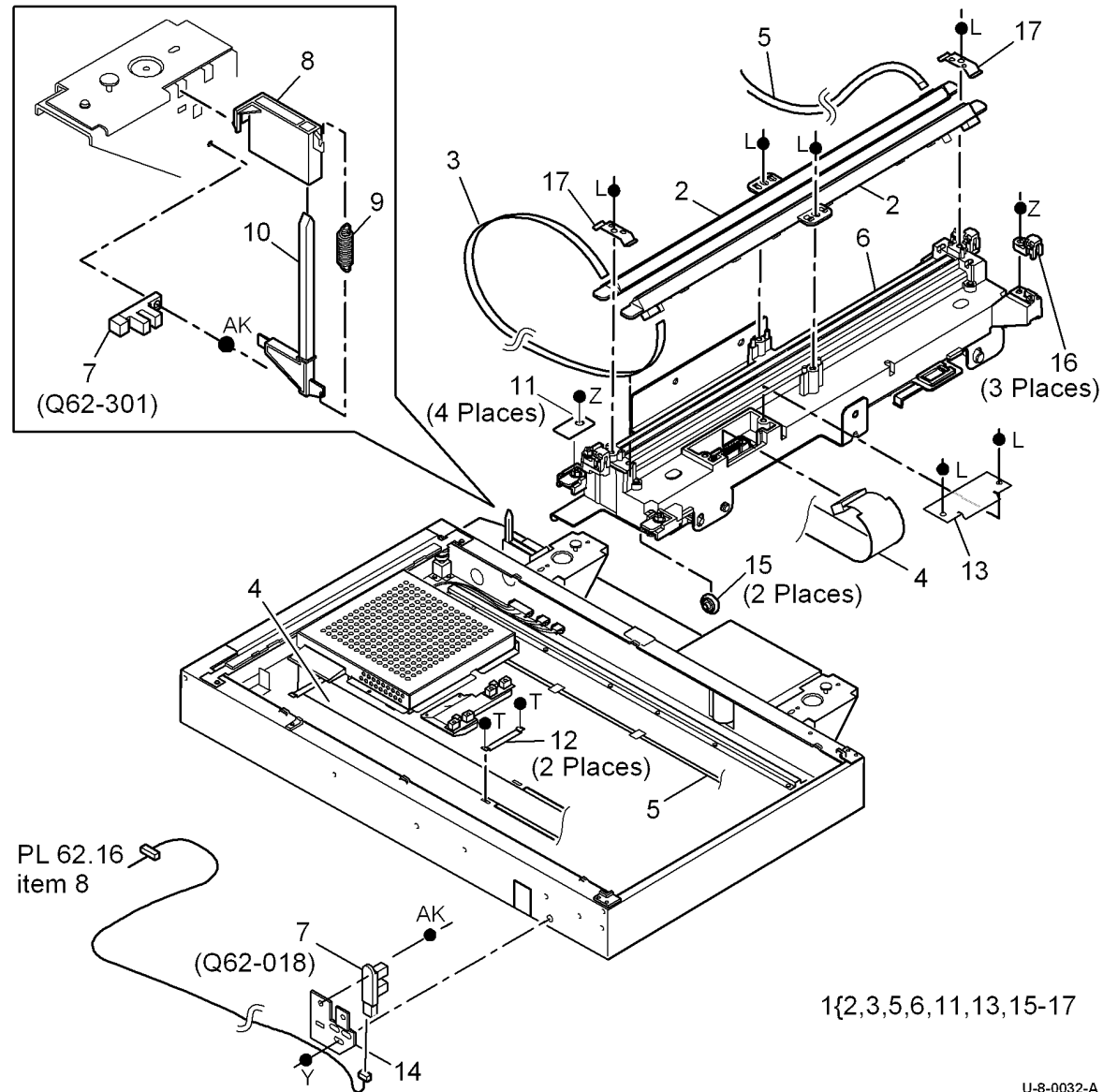

PL 62.16 Electrical Components (2 of 2)

Item	Part	Description
1	-	Carriage motor bracket (P/O PL 62.16 Item 15)
2	-	Carriage motor mounting (P/O PL 62.16 Item 15) (REP 62.6)
3	-	Carriage motor (MOT62-023) (P/O PL 62.16 Item 15) (REP 62.6, ADJ 62.3)
4	020K12510	Scan idler pulley
5	130E18530	Platen down sensor (Q62-019)
6	952K00380	IIT video/SBC PWB harness (PJ922)
7	952K00400	DADH/IIT power comms harness (PJ920, PJ921, PJ852)
8	960K66391	Scanner PWB (REP 62.12)
9	-	Scanner PWB cover (Not spared)
10	130E12320	Document size sensor 1 (Q62-251), Document size sensor 2 (Q62-253) (REP 62.14)
11	-	Scan cables (Not spared) (REP 62.7)
12	023E25140	Scan drive belt (REP 62.8)
13	-	Not used
14	-	Scanner harness bracket (Not spared)
15	127K44880	Carriage motor and bracket assembly

NOTE: Refer to ADJ 62.1 for the optics cleaning procedure.

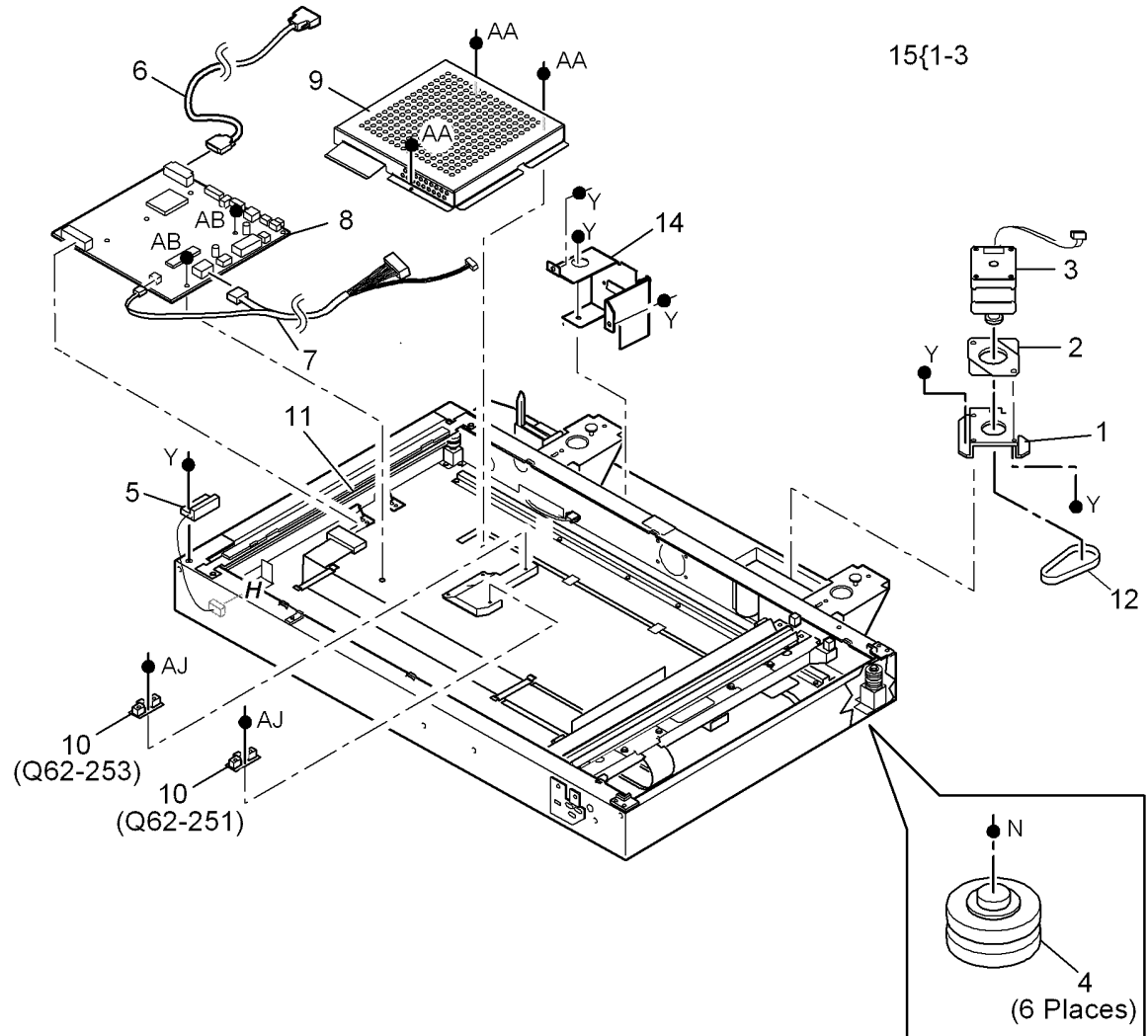

U-8-0033-A

PL 70.10 Tray 1 and 2 Assembly

Item	Part	Description
1	-	Tray 1 and 2 tray assembly (P/O PL 70.10 Item 21) (REP 71.1)
2	-	Paper tray (P/O PL 70.10 Item 1)
3	-	Plate arm (P/O PL 70.10 Item 1)
4	-	Paper width guide (P/O PL 70.10 Item 1) (REP 71.2)
5	-	Latch guide right (P/O PL 70.10 Item 1)
6	-	Latch guide left (P/O PL 70.10 Item 1)
7	-	Handle release (P/O PL 70.10 Item 1)
8	-	Gear 60 (P/O PL 70.10 Item 1) (REP 71.3)
9	-	Gear 13/60 (P/O PL 70.10 Item 1) (REP 71.3)
10	-	Gear 13 dog (P/O PL 70.10 Item 1)
11	-	Elevate plate assembly (P/O PL 70.10 Item 1) (REP 71.2)
12	-	Length sensing bracket (P/O PL 70.10 Item 1)
13	-	Width sensing bracket (P/O PL 70.10 Item 1)
14	-	Actuator bracket (P/O PL 70.10 Item 1)
15	-	E-clip (P/O PL 70.10 Item 1)
16	-	Metal link arm (P/O PL 70.10 Item 1)
17	003E77651	Tray location catch
18	130E18220	Lower door interlock sensor (Q01-102)
19	-	Spring (P/O PL 70.10 Item 1)
20	-	Spring (P/O PL 70.10 Item 1)
21	604K55411	Tray 1 & 2 Kit (Contains tray assembly and front cover)
22	-	Paper length guide (P/O PL 70.10 Item 1) (REP 71.2)
23	-	Rear plate (P/O PL 70.10 Item 1)

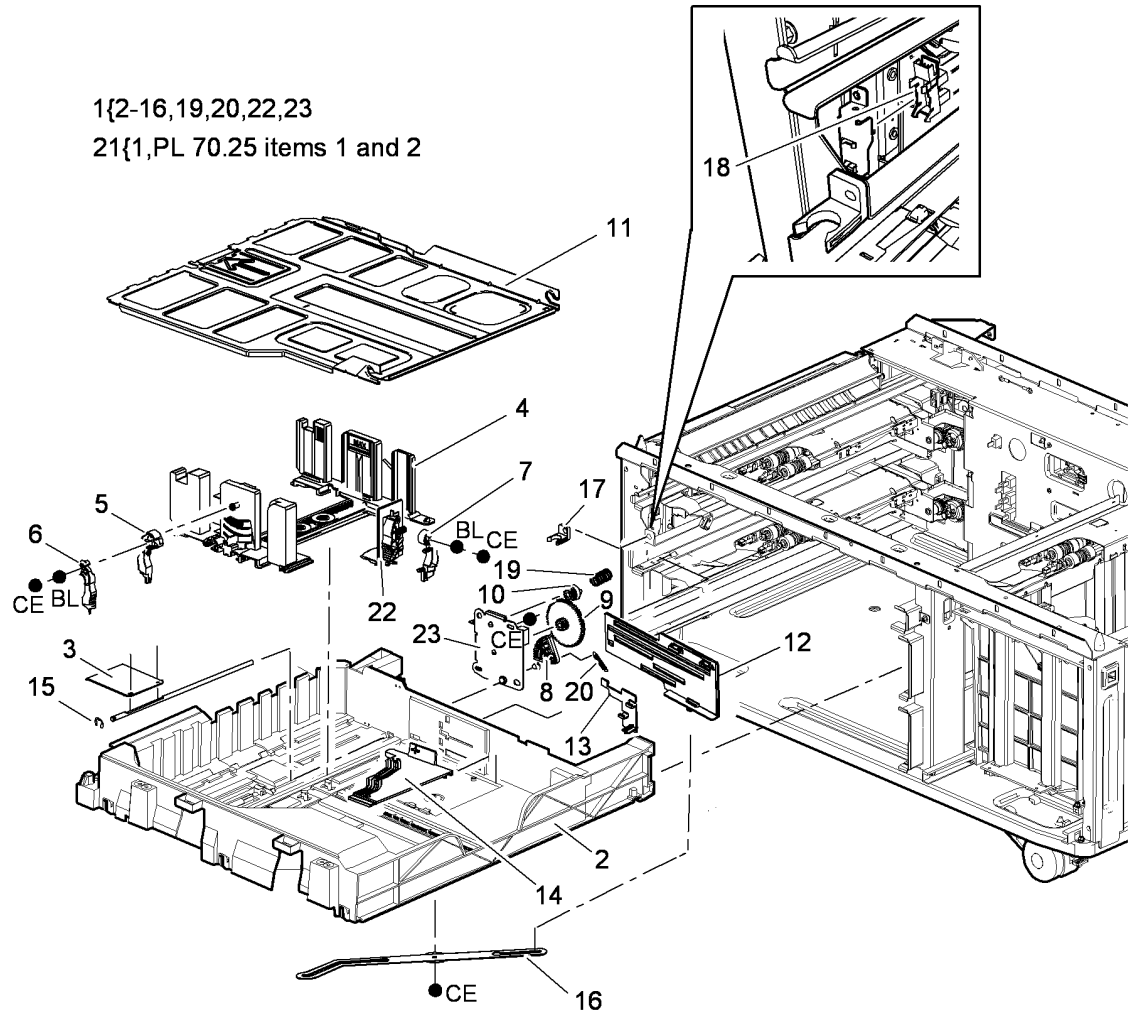

U-8-0005-A

PL 70.25 3 Tray Module Covers

Item	Part	Description
1	-	Tray 1 front cover (P/O PL 70.10 Item 21)
2	-	Tray 2 front cover (P/O PL 70.10 Item 21)
3	-	Tray 3 front cover (P/O PL 31.11 Item 31)
4	848E23153	Right side cover
5	802K93695	Lower left door assembly
6	-	Lower left door latch (P/O PL 70.25 Item 5)
7	-	Rear left cover (P/O PL 70.25 Item 13)
8	-	Rear cover (Not spared)
9	848E23142	Cover front LH
10	848E23161	Cover infill
11	-	Left lower door latch retainer plate (Not spared)
12	-	Rear left cover infill (P/O PL 70.25 Item 13)
13	604K55440	Rear left cover assembly

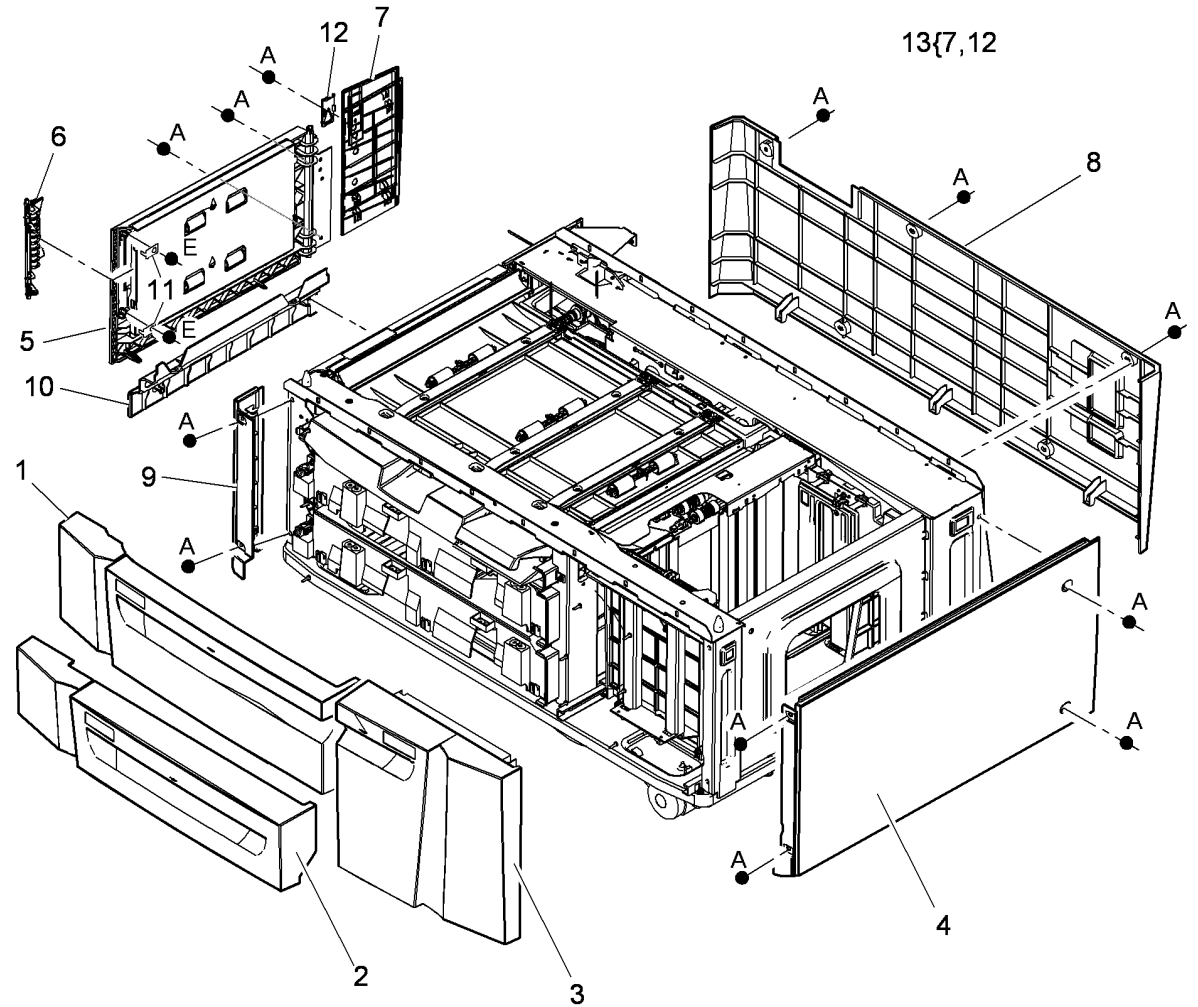

U-8-0039-A

PL 70.30 Left Hand Upper Door Assembly

Item	Part	Description
1	-	Bypass assembly (Not spared) (REP 70.2)
2	-	Bypass Module (P/O PL 70.30 Item 1) (REP 81.3)
3	-	Upper door stiffener plate (P/O PL 70.30 Item 18)
4	-	Nip 'D' roller (A)/Nip 'F' roller (B) (P/O PL 70.30 Item 18)
5	-	Tension spring (P/O PL 70.30 Item 18)
6	-	Nip E support (P/O PL 70.30 Item 18)
7	-	Upper door base (P/O PL 70.30 Item 18)
8	-	Spring (P/O PL 70.30 Item 18)
9	-	Top cover (P/O PL 70.30 Item 18)
10	-	Nip release link arm (P/O PL 70.30 Item 18)
11	-	Pivot block (P/O PL 70.30 Item 18)
12	-	Nip 'E' roller (P/O PL 70.30 Item 18)
13	-	Nip 'D' release solenoid (SOL82-008) (P/O PL 70.30 Item 18) (REP 81.13)
14	848E40430	Upper left door cover
15	-	Upper door divider (P/O PL 70.30 Item 1)
16	848K24550	Mid left door assembly
17	038E41190	Lower guide (PFP)
18	848K24560	Upper left door assembly (REP 70.2)
19	-	Latch (P/O PL 70.30 Item 18)
20	-	Latch spring (P/O PL 31.11 Item 23)
21	-	Latch clip (P/O PL 31.11 Item 23)
22	-	Hinge pin (Not spared)

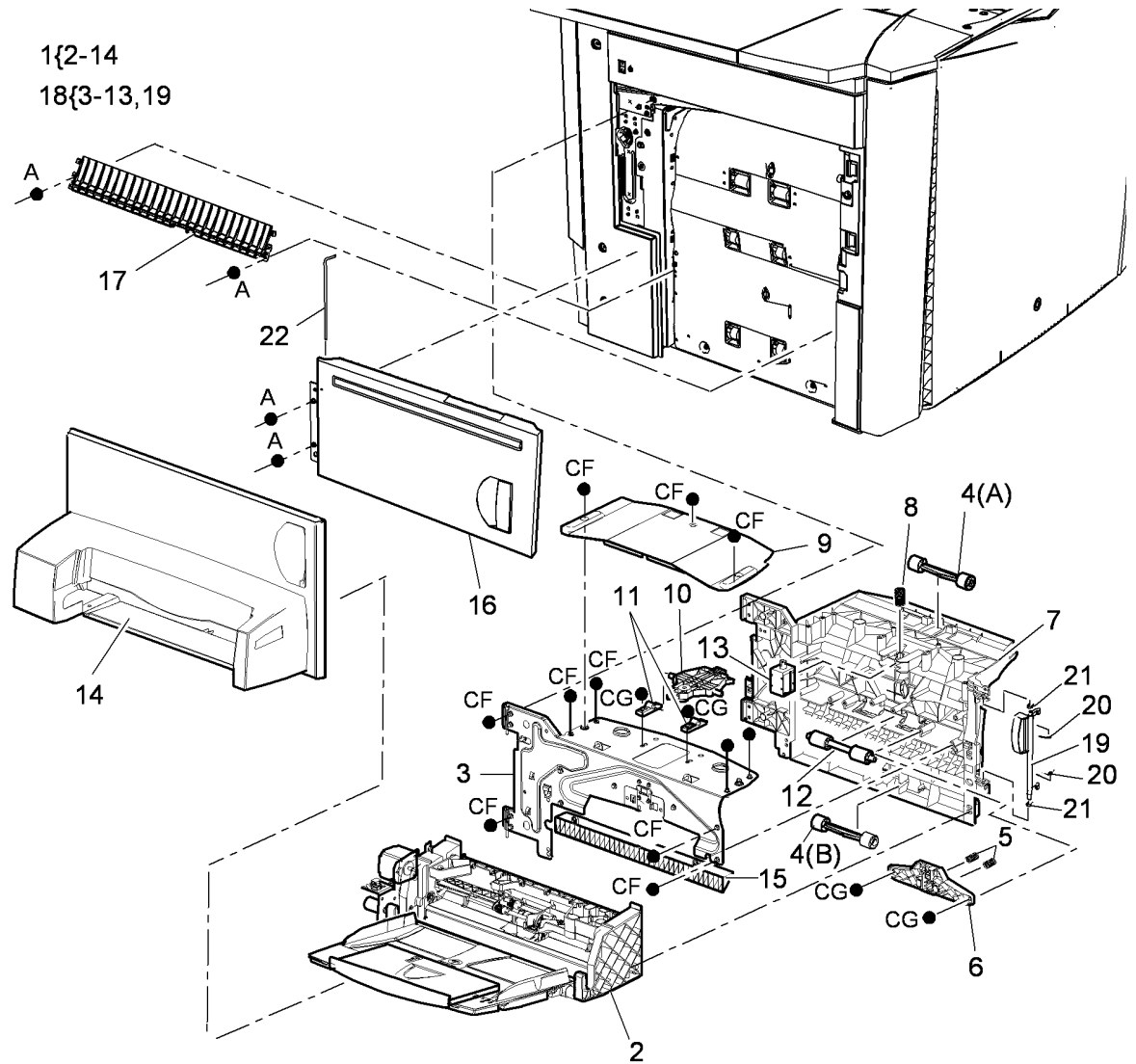

U-8-0002-A

PL 73.15 Tray 3 Assembly

Item	Part	Description
1	-	Tray 3 assembly (Complete) (REF: PL 31.11 Item 31) (See NOTE) (REP 73.1)
2	-	LH Slide (P/O PL 73.15 Item 1)
3	-	RH Slide (P/O PL 73.15 Item 1)
4	055E55332	Baffle lead edge
5	019K13770	Pad Tray bottom
6	-	Front cable gear (Black) (P/O PL 73.15 Item 1)
7	-	Bearing (P/O PL 73.15 Item 1)
8	-	Cable gear shaft spacer (P/O PL 73.15 Item 1)
9	-	Rear cable gear (White) (P/O PL 73.15 Item 1)
10	-	Dog drive elevate (P/O PL 73.15 Item 1)
11	-	Damper and gear assembly (P/O PL 73.15 Item 1) (REP 73.6)
12	-	Cable gear shaft (P/O PL 73.15 Item 1)
13	-	Washer elevate (Not spared)
14	-	Gear (P/O PL 73.15 Item 1)
15	-	Retainer roller (P/O PL 73.15 Item 1)
16	-	Clip guide retainer (P/O PL 73.15 Item 1)
17	-	Front short cable (Silver) (P/O PL 31.11 Item 30) (REP 73.3)
18	-	Front long cable (Yellow) (P/O PL 31.11 Item 30) (REP 73.3)
19	-	Rear cable (Black) (P/O PL 31.11 Item 30) (REP 73.3)
20	-	Paper edge guide (P/O PL 31.11 Item 12)
21	-	Guide securing stud (P/O PL 31.11 Item 12)

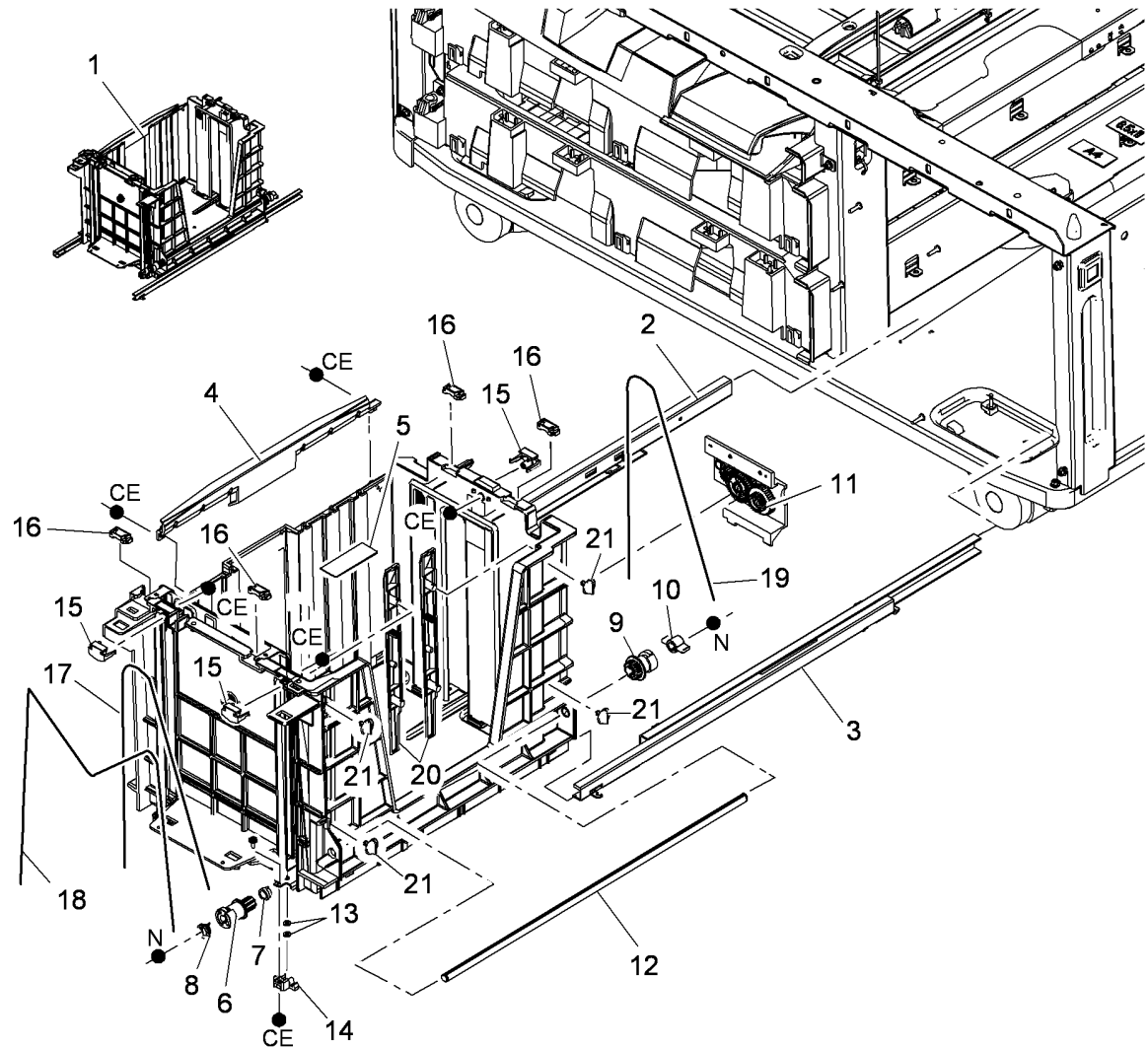

NOTE: Refer to ADJ 73.1 to set the tray 3 paper guides.

U-8-0006-A

PL 73.16 3 Tray Module

Item	Part	Description
1	003E71520	Latch stop (See NOTE)
2	127K62350	Tray 3 elevate motor (MOT 73-002) (REP 73.2)
3	127K53792	3 Tray transport motor (MOT70-025) (REP 82.1)
4	960K52111	3 Tray module PWB (REP 70.1)
5	017K04222	Rear caster
6	017K04232	Front caster (Brake)
7	-	Drive belt (P/O PL 73.16 Item 13) (REP 82.2)
8	130E18220	Tray 3 home sensor (Q73-303) (REP 73.5)
9	059K50851	Takeaway roll 1 (A) / Takeaway roll 2 (B)
10	-	Not used
11	130E11610	TAR sensor 1 (Q 71-395), TAR sensor 2 (Q72-396)
12	-	Lower guide (Not spared)
13	604K55421	TAR Drives kit
14	-	Pulley (P/O PL 73.16 Item 13)
15	-	Idler pulley (P/O PL 73.16 Item 13)
16	-	Spring (P/O PL 73.16 Item 13)
17	-	Bearing (P/O PL 73.16 Item 13)
18	003K20701	HT & main harness latch

NOTE: The Latch stop is also supplied as part of tray 3 assembly kit PL 31.11 Item 31.

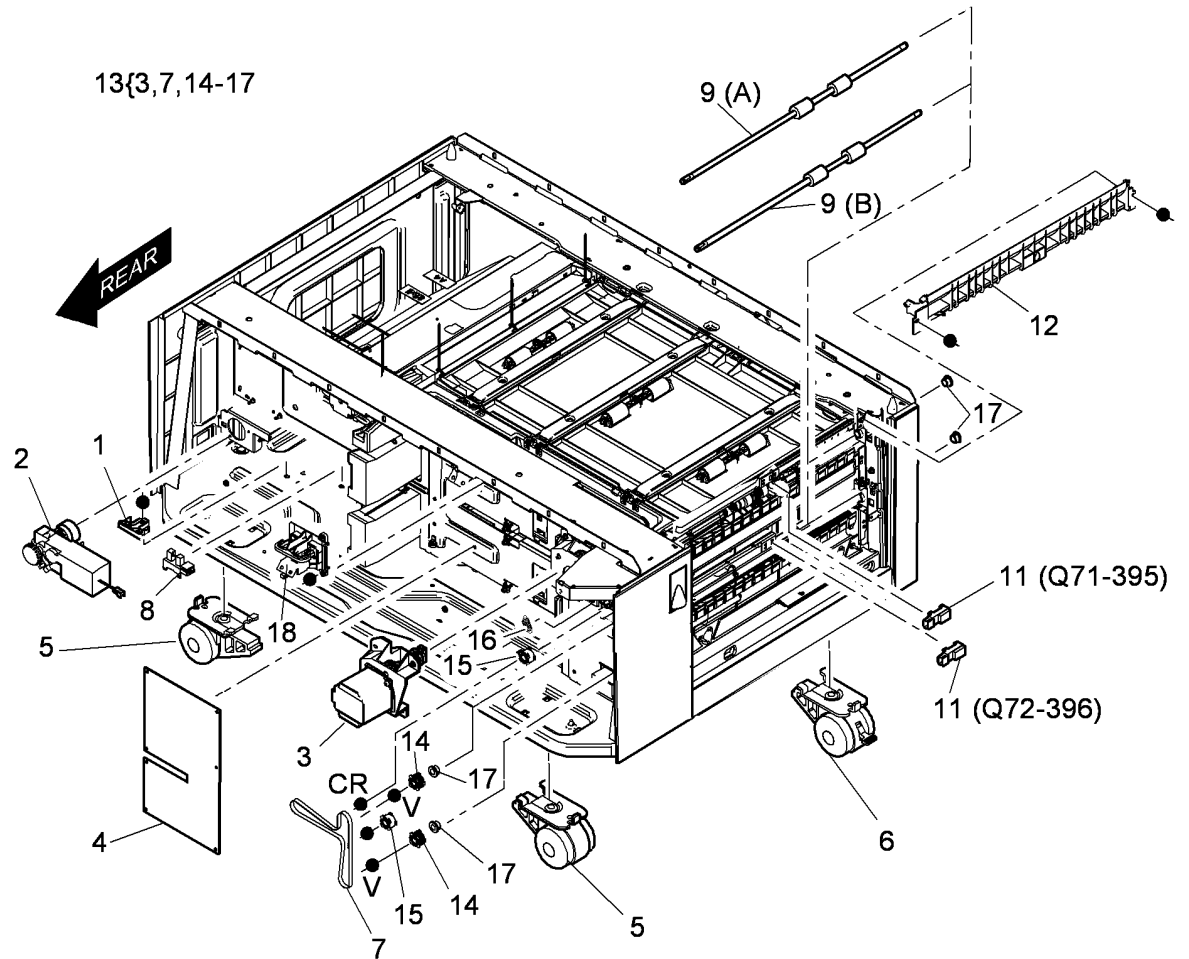

U-8-0105-A

PL 74.10 Bypass Module (Tray 4)(1 of 2)

Item	Part	Description
1	–	Bypass Module (Not spared) (REP 81.3)
2	–	Bypass feed motor (MOT74-420) (P/O PL 74.10 Item 1)
3	–	Support retard (P/O PL 74.10 Item 1)
4	–	Spring retard (P/O PL 74.10 Item 1)
5	–	Clutch (P/O PL 74.10 Item 1)
6	–	Coupling (P/O PL 74.10 Item 1)
7	–	Retard roll assembly (REP 81.6) (P/O PL 31.11 Item 26) (See NOTE)
8	–	Guide lower (P/O PL 74.10 Item 1)
9	019K13770	Pad tray bottom
10	–	Support nudger (P/O PL 74.10 Item 1)
11	–	Spring nudger (P/O PL 74.10 Item 1)
12	–	Pulley nudger (P/O PL 74.10 Item 1)
13	–	Nudger roll assembly (REP 81.6) (P/O PL 31.11 Item 26) (See NOTE)
14	–	Feed roll assembly (REP 81.6) (P/O PL 31.11 Item 26) (See NOTE)
15	–	Clutch assembly (P/O PL 74.10 Item 1)
16	–	Guide upper detach (P/O PL 74.10 Item 1)
17	–	Flag media present (P/O PL 74.10 Item 1)
18	130E18220	Bypass empty sensor (Q74-335)/ Nudger home sensor (Q74-413) (REP 81.10)
19	130E11610	Bypass feed sensor (Q74-406) (XBRA)
20	–	Guide upper (P/O PL 74.10 Item 1)
21	–	Roller assembly housing (P/O PL 74.10 Item 1) (REP 81.3)
22	–	Drive belt (Not spared)

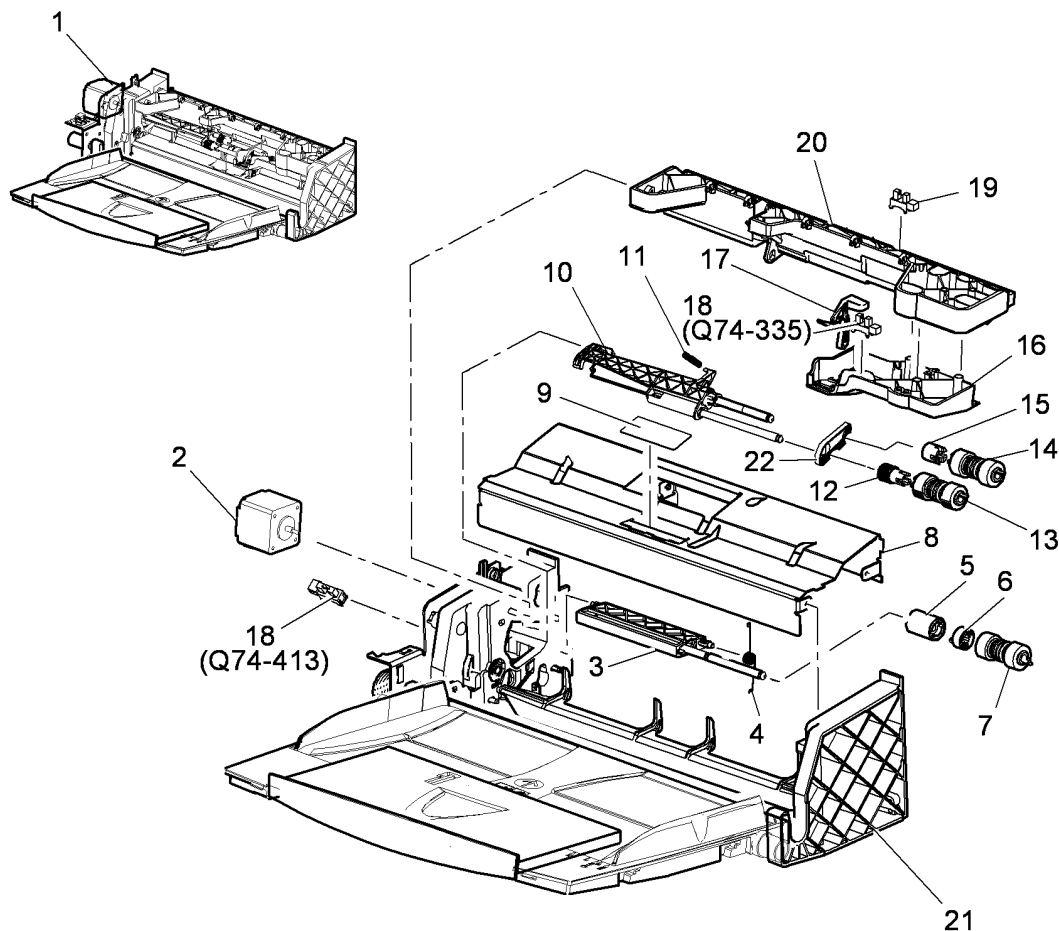

NOTE: To reset the HFSI count, go to dC135.

U-8-0106-A

PL 74.11 Bypass Module (Tray 4) (2 of 2)

Item	Part	Description
1	–	Tray extension (P/O PL 74.10 Item 1)
2	–	Tray base (P/O PL 74.10 Item 1)
3	–	Tray deck (P/O PL 74.10 Item 1)
4	–	Rack front (P/O PL 74.10 Item 1)
5	–	Rack rear (P/O PL 74.10 Item 1)
6	130E18220	Bypass width sensor (Q74-350)
7	–	Mounting bracket (P/O PL 74.10 Item 1)
8	–	Lever (P/O PL 74.10 Item 1)
9	–	Gear (P/O PL 74.10 Item 1)
10	–	Potentiometer (P/O PL 74.10 Item 1)
11	–	Spring (P/O PL 74.10 Item 1)

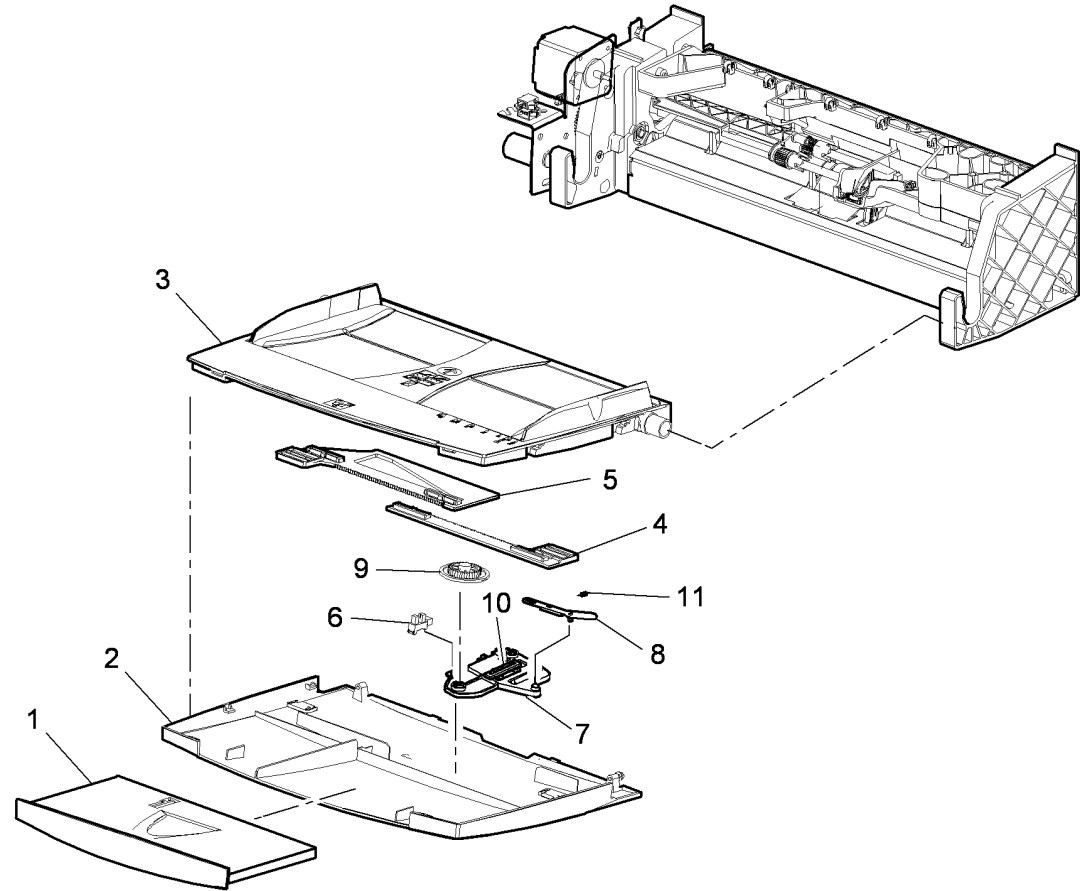

U-8-0117-A

PL 75.60 Tray 5 Covers

Item	Part	Description
1	802K93561	Front door assembly
2	-	Front door hinge (P/O PL 75.60 Item 1)
3	-	Front door hinge pin (P/O PL 75.60 Item 1)
4	-	Trail edge guide assembly (P/O PL 75.60 Item 1)
5	-	Front door latch (P/O PL 75.60 Item 1)
6	110E20570	Tray 5 door switch (S75-010)
7	-	Interlock switch plate (Not spared)
8	848K19110	Front cover (REP 75.8)
9	802E82351	Rear cover (REP 75.8)
10	802E82363	Top cover (REP 75.8)
11	-	Label (Tray 5) (P/O PL 75.60 Item 8)
12	848E05863	Bias knuckle cover
13	-	Front door interlock harness (Not spared) (PJ507)
14	-	Tamper guide lever (P/O PL 75.60 Item 1)
15	-	Tamper lever compression spring (P/O PL 75.60 Item 1)
16	-	Label (Max) (P/O PL 75.60 Item 8)
17	-	Cable clamp (P/O PL 75.60 Item 9)

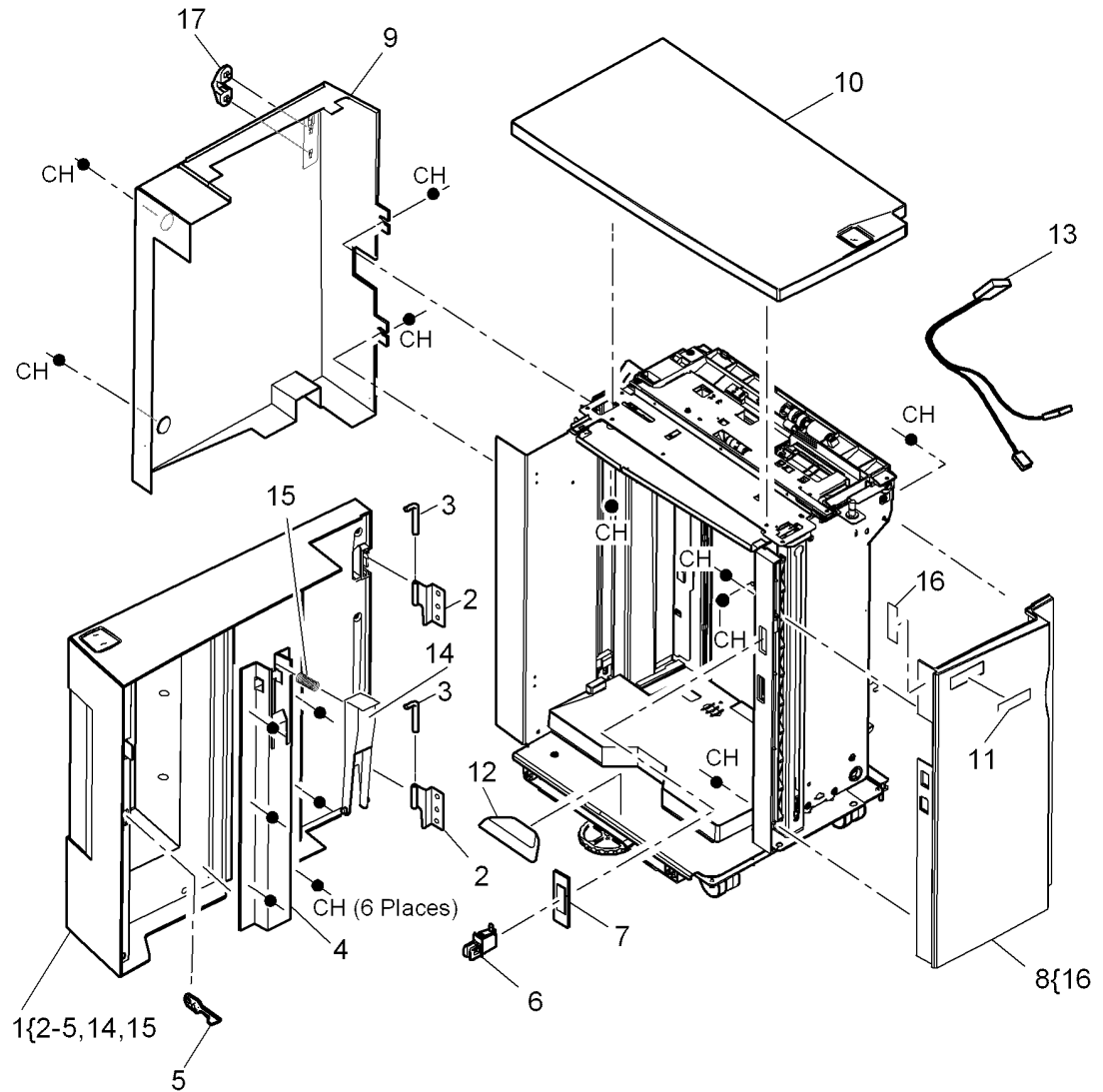

U-8-0014-A

PL 75.62 Tray 5 Base

Item	Part	Description
1	-	Adjustable caster (Not spared)
2	-	Caster (Not spared)
3	-	Platform assembly (Not spared)
4	009E74211	Spring Bias
5	003E76870	Latch bias
6	003E78020	Docking latch (REP 75.9)
7	-	Docking latch spring (P/O PL 75.62 Item 16)
8	-	Docking latch bracket (P/O PL 75.62 Item 16)
9	-	Docking latch main bracket (P/O PL 75.62 Item 16)
10	803E13680	Docking latch thumb screw
11	068K54910	Docking plate
12	-	Slide assembly (Not spared)
13	-	Docking guides (P/O PL 75.62 Item 16)
14	-	Slide assembly locking nut (Not spared)
15	049K00270	Docking kit
16	003K20681	Latch assembly
17	-	Adjuster wheel (Not spared)

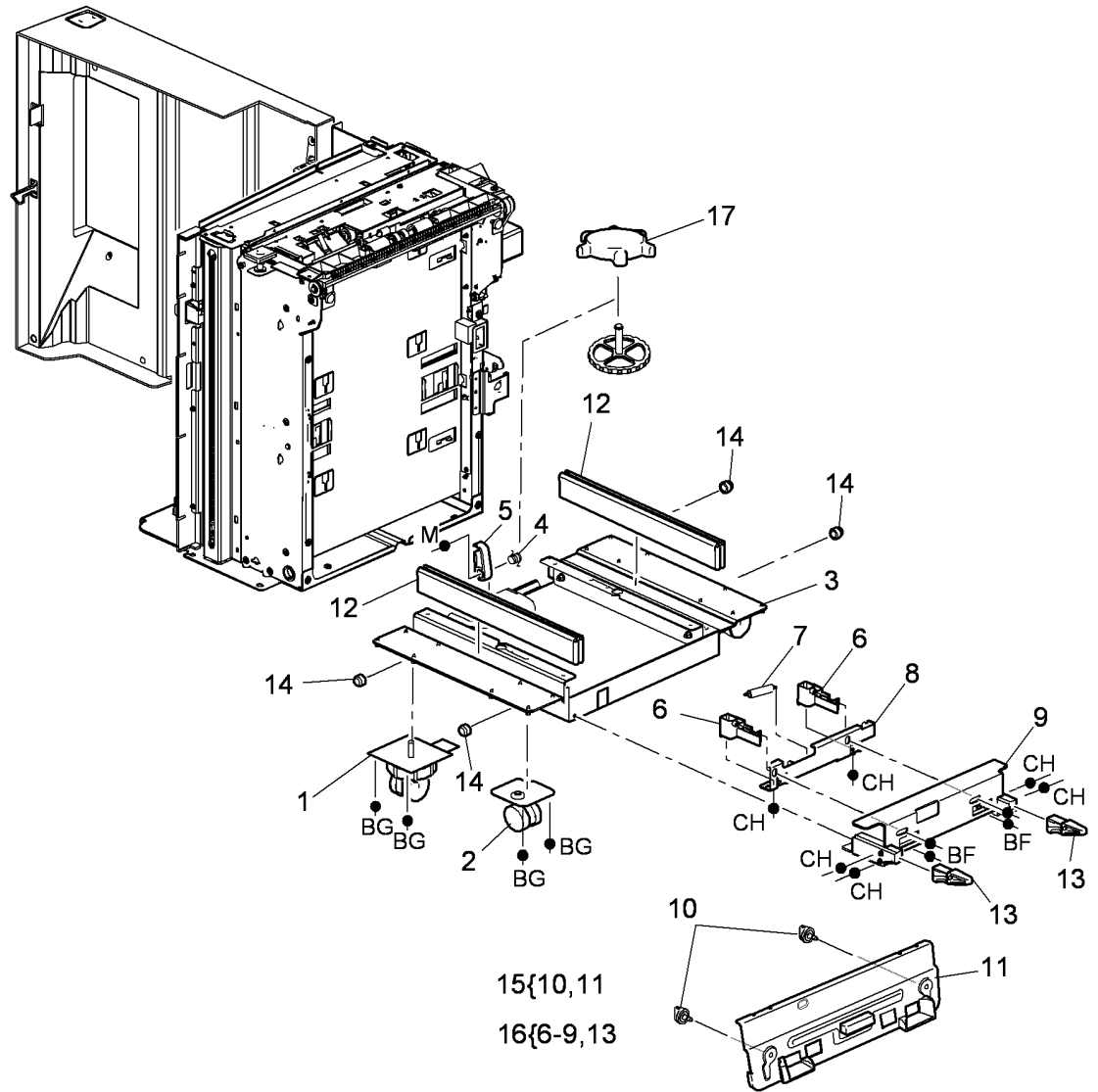

U-8-0015-A

PL 75.64 Tray 5 Guides

Item	Part	Description
1	110K21080	Tray 5 docking interlock switch (S75-017)
2	-	Handle latch (Not spared)
3	-	Latch spacer (Not spared)
4	-	Slide latch (Not spared)
5	-	Spring leaf (Not spared)
6	-	Rear guide (P/O PL 75.64 Item 12)
7	-	Front guide assembly (Not spared)
8	038E34401	Guide strip
9	-	Adjustment plate (Not spared)
10	-	Interlock guide (Not spared)
11	-	Rear guide assembly spring (P/O PL 75.64 Item 12)
12	038K17713	Rear guide assembly
13	029K04680	Docking pin assembly

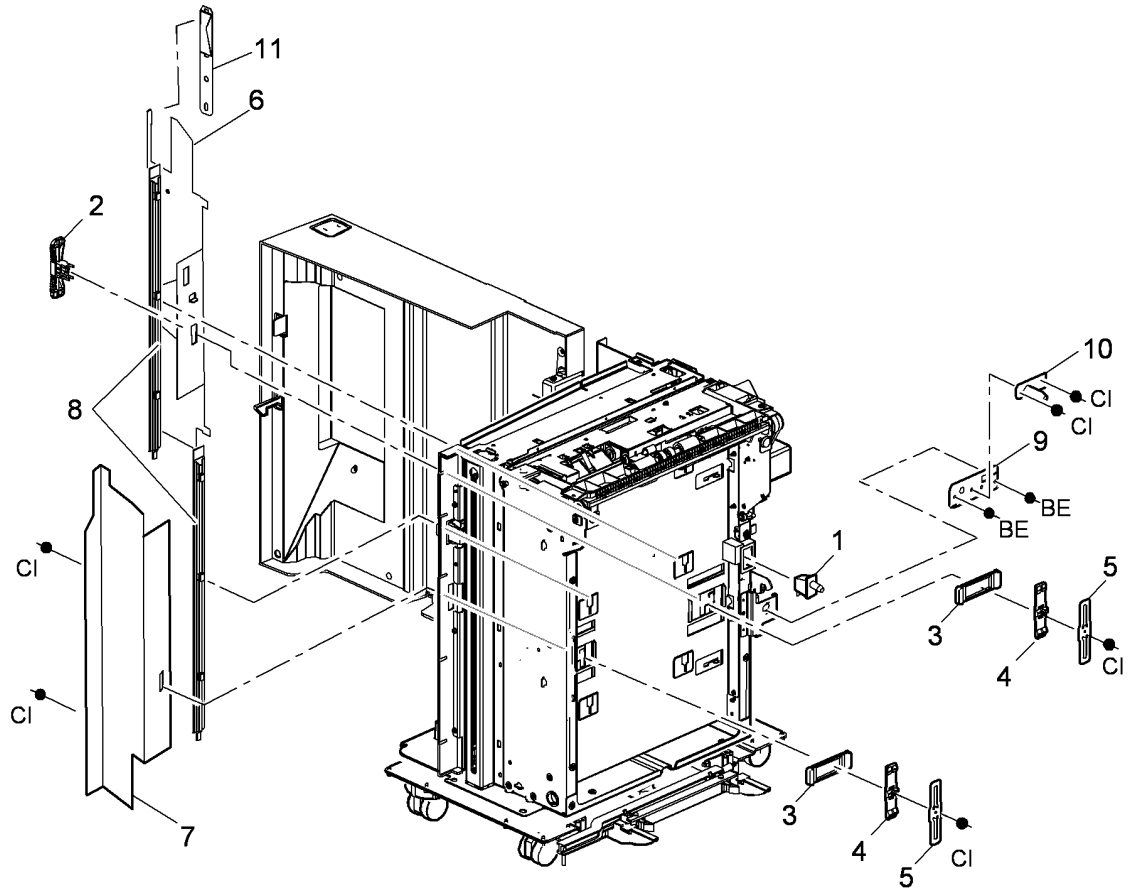

12{6,11

13{9,10

R-8-0016-A

PL 75.68 Tray 5 Lift Assembly (1 of 2)

Item	Part	Description
1	-	Tray assembly (complete) (Not spared)
2	-	Crash bar (Not spared)
3	-	Frame top brace (Not spared)
4	-	Elevator motor (MOT75-019) (P/O PL 75.68 Item 23)
5	130K74380	Elevator encoder sensor (Q75-015)
6	-	Elevator motor bracket (P/O PL 75.68 Item 23)
7	-	Elevator motor shaft (Not spared)
8	960K34453	Tray 5 Control PWB (Centre reg)
9	130K75511	Tray down sensor (Q75-012) (REP 75.3)
10	-	Standoff (Not spared)
11	-	Tray level drive gear clip (Not spared)
12	110E06961	Upper limit switch (S75-412)
13	-	Rear elevator rack (P/O PL 75.68 Item 24)
14	-	Front elevator rack (P/O PL 75.68 Item 24)
15	-	Retard roller shield (P/O PL 81.46 Item 1)
16	-	Shipping pin bearing (Not spared)
17	-	Shipping pin spring (Not spared)
18	-	Shipping pin (Not spared)
19	-	Shipping pin handle (Not spared)
20	-	Cable tie (Not spared)
21	-	Clinch stud (Not spared)
22	-	Cable holder (Not spared)
23	127K56330	Elevator motor assembly (REP 75.4)
24	007K19660	Elevator rack assembly (REP 75.10)
25	003K20950	Shipping pin handle assembly
26	962K82710	Media path driver PWB to Tray 5 PWB harness (PJ502, PJ513)
27	-	Upper limit switch actuator (Not spared)
28	-	Tray level drive gear (Not spared)
29	-	Actuator spring (Not spared)

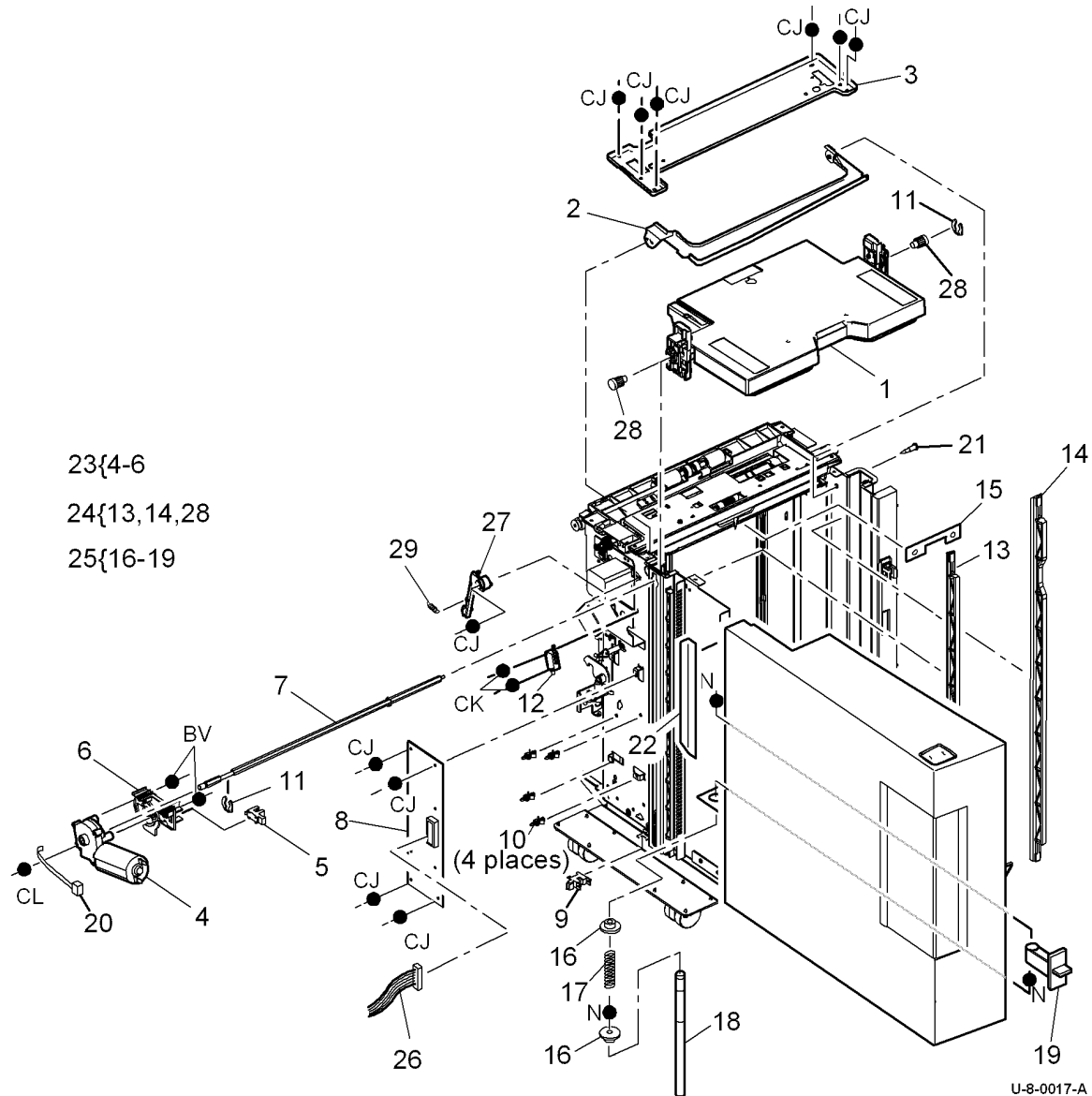

PL 75.70 Tray 5 Lift Assembly (2 of 2)

Item	Part	Description
1	-	Tray lift assembly (Not spared)
2	110E06961	Tray down limit switch (S75-415) (REP 75.6)
3	025E06871	Lower safety bar
4	-	Lift plate (Not spared)
5	-	Fixing plate (Not spared)
6	-	Infill plate (P/O PL 75.70 Item 19)
7	019K13470	Cork pad
8	-	Tray lift top cover (Not spared)
9	-	Lift plate crash bar actuator 2 (Not spared)
10	-	Lift plate crash bar actuator 1 (Not spared)
11	-	Crash bar actuator spring (Not spared)
12	-	Not used
13	-	Infill actuator arm (P/O PL 75.70 Item 19)
14	-	Infill actuator arm spring (P/O PL 75.70 Item 19)
15	-	Infill actuator arm pin (P/O PL 75.70 Item 19)
16	-	Infill plate spring (P/O PL 75.70 Item 19)
17	-	Lower safety spring (Not spared)
18	612W25655	Tray down limit switch screw
19	815K11380	Infill plate assembly
20	962K50461	Tray 5 elevator harness (PJ504)

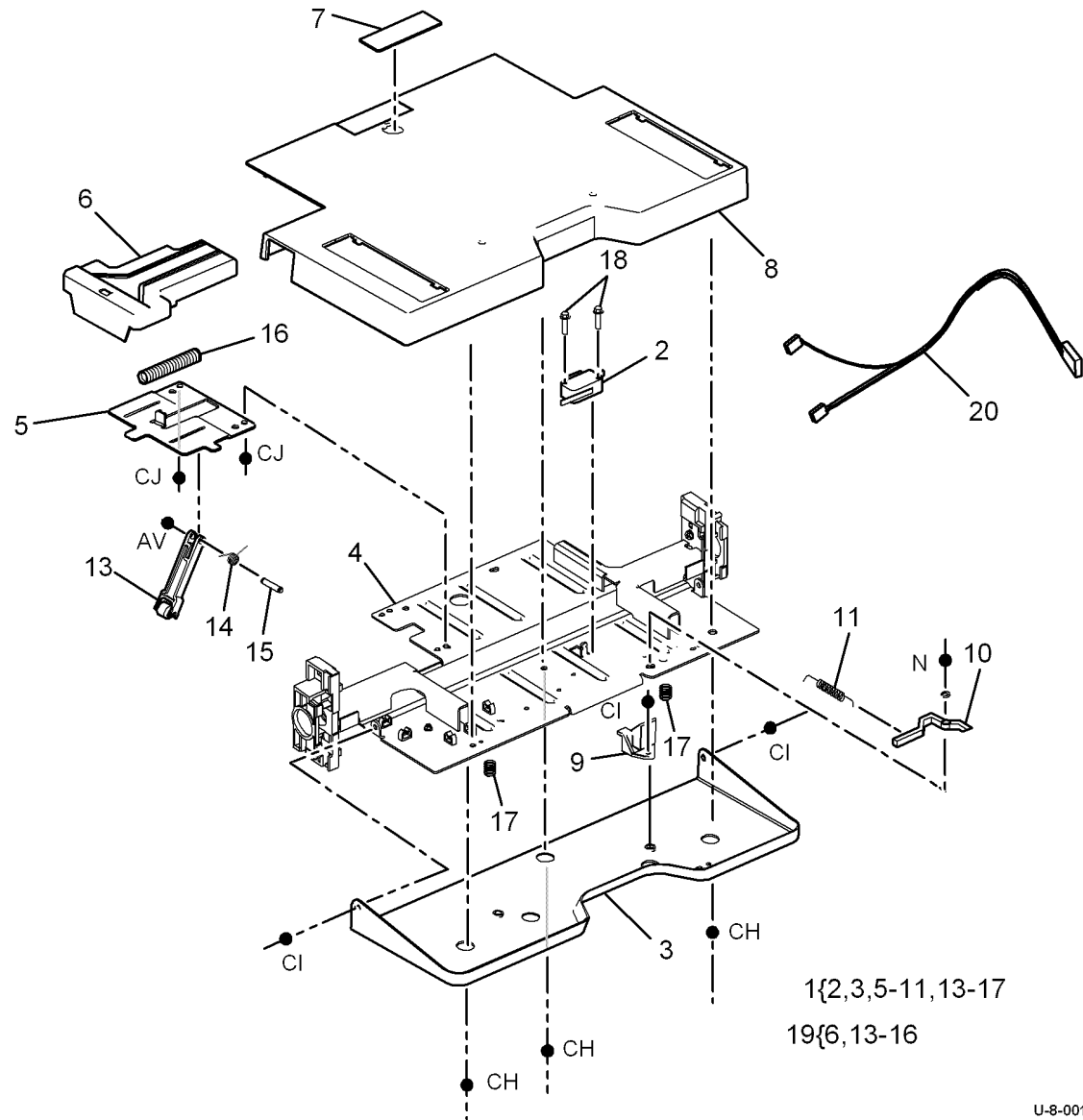

PL 81.10 Main Covers

Item	Part	Description
1	848K66280	Rear cover
2	848E15831	Left cover
3	848E45840	Right cover
4	—	Front door assembly (REF: PL 81.11 Item 11)
5	848K31762	Ink loader access cover
6	848E45881	Ink loader top
7	848E45890	Ink loader access cover rear
8	848E45950	Ink loader backup cover
9	848E45961	Ink loader bracket
10	—	Not used
11	014E68060	Rear standoff (duct)
12	019E81431	Ink loader rotary damper clip
13	016E20080	Ink loader rotary damper

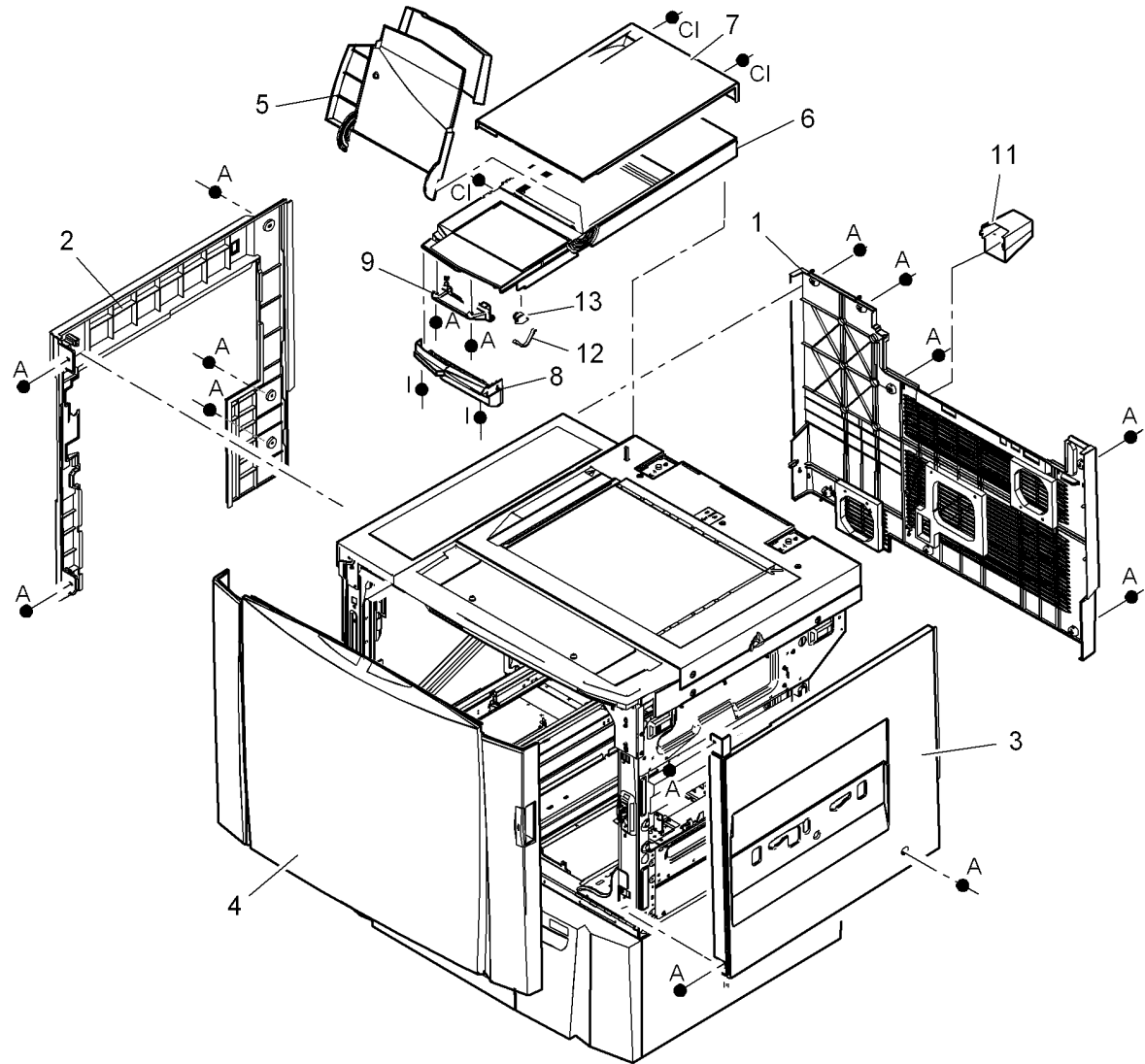

U-8-0030-A

PL 81.11 Front Door Assembly

Item	Part	Description
1	-	Front door shield (P/O PL 81.11 Item 13)
2	848K31753	Inner cover
3	-	Hinge assembly (P/O PL 81.11 Item 13)
4	-	Foam seal (P/O PL 81.11 Item 13)
5	848E45930	Dongle cover
6	848E45940	Shipping restraint cover
7	-	Front door moulding (P/O PL 81.11 Item 13)
8	-	Access magnetic catch (P/O PL 81.11 Item 11)
9	848E45920	Front door handle
10	848E46011	Front door bracket (attached to frame)
11	848K66270	Front door assembly
12	-	Xerox logo (P/O PL 81.11 Item 11)
13	-	Door shield assembly (P/O PL 81.11 Item 11)
14	-	Name plate label (see below for variants)
-	-	9301 Label (Not spared)
-	-	9302 Label (Not spared)
-	-	9303 Label (Not spared)

11{8,9,12,13
13{1,3,4,7

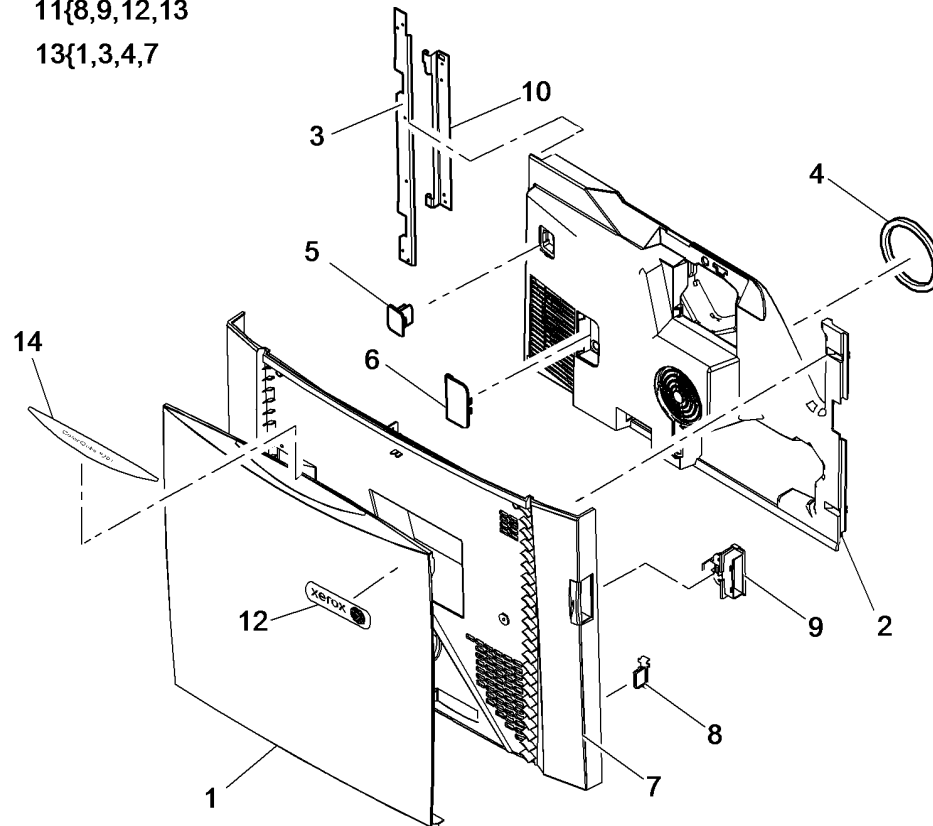

U-8-0034-A

PL 81.25 Tray 1 Paper Feed Assembly

Item	Part	Description
1	059K64454	Feedhead assembly (REP 81.1)
2	-	Retard roll support (P/O PL 81.25 Item 1)
3	-	Retard roll shaft (P/O PL 81.25 Item 1)
4	-	Clutch assembly (P/O PL 81.25 Item 1)
5	-	Coupling (P/O PL 81.25 Item 1)
6	-	Retard roll assembly (REP 81.4) (P/O PL 81.25 Item 28) (See NOTE)
7	-	Nudger roll support (P/O PL 81.25 Item 1)
8	-	Nudger pulley (P/O PL 81.25 Item 1)
9	-	Nudger roll assembly (REP 81.4) (P/O PL 81.25 Item 28) (See NOTE)
10	809E95240	Spring
11	-	Feed roll assembly (REP 81.4) (P/O PL 81.25 Item 28) (See NOTE)
12	-	Drive belt (P/O PL 81.25 Item 1)
13	-	Drive clutch (P/O PL 81.25 Item 1)
14	-	Feed pulley (P/O PL 81.25 Item 1)
15	-	Washer (P/O PL 81.25 Item 1)
16	-	Bearing (P/O PL 81.25 Item 1)
17	130E18220	Stack height sensor (Q71-336)
18	038E41151	Guide
19	130E11610	Tray 1 empty sensor (Q71-201)/ Feed sensor (Q71-101) (REP 81.8)
20	-	Cover (P/O PL 81.25 Item 1)
21	-	Elevator coupling assembly (P/O PL 81.25 Item 1)
22	-	T1 feed/elevator motor (MOT71-002) (P/O PL 81.25 Item 1)
23	-	Spring (P/O PL 81.25 Item 1)
24	-	Nudger roll shaft (P/O PL 81.25 Item 1)
25	-	Spring (P/O PL 81.25 Item 1)
26	-	Dog spacer (P/O PL 81.25 Item 1)
27	-	Gear 31 (P/O PL 81.25 Item 1)
28	-	Feed roll kit (REF: PL 31.11 Item 26)
29	014E68410	Shim
30	019E74540	Slide pad

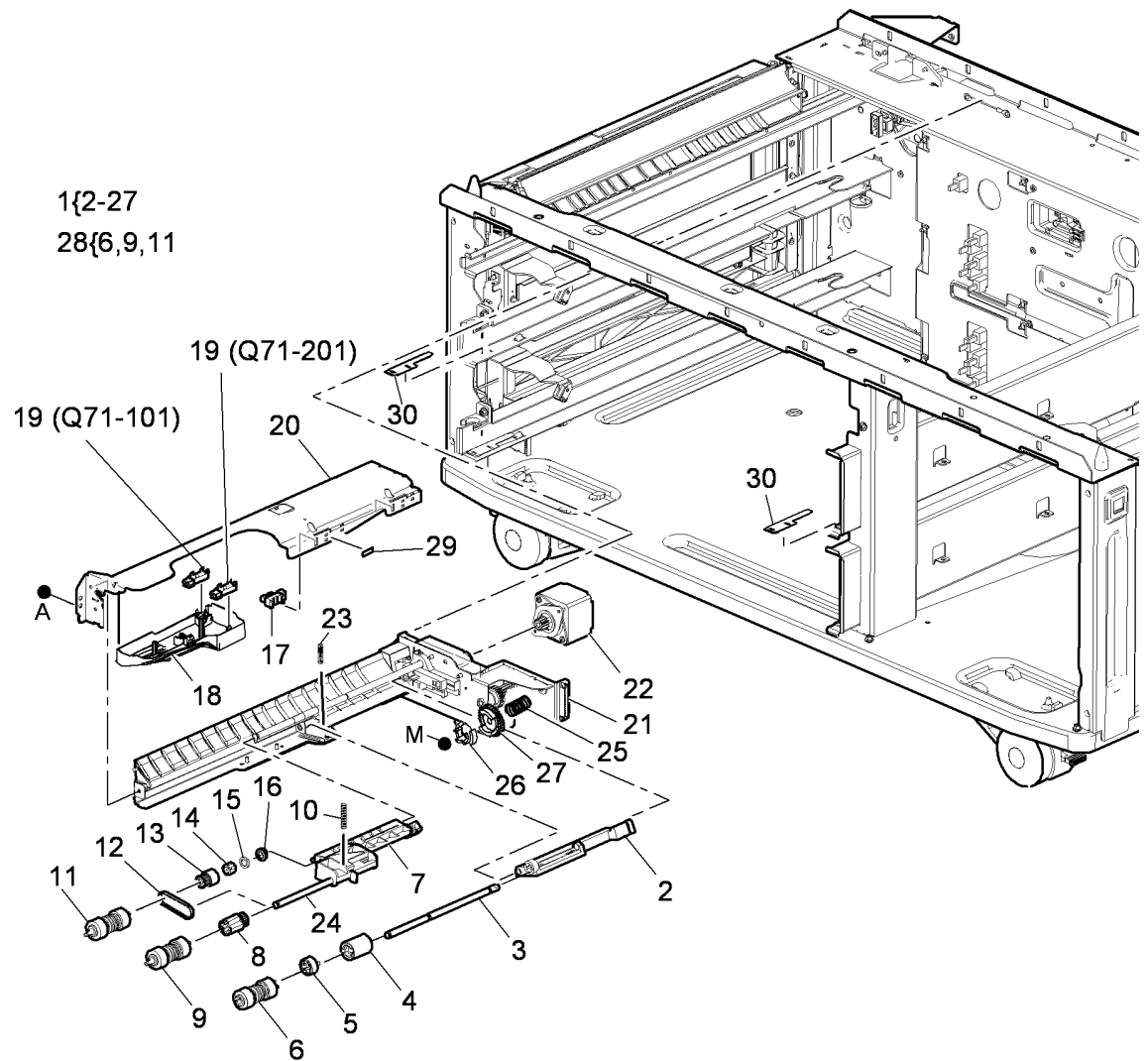

NOTE: To reset the HFSI count, go to dC135.

U-8-0004-A

PL 81.26 Tray 2 Paper Feed Assembly

Item	Part	Description
1	059K64454	Feedhead assembly (REP 81.1)
2	-	Retard roll support (P/O PL 81.26 Item 1)
3	-	Retard roll shaft (P/O PL 81.26 Item 1)
4	-	Clutch assembly (P/O PL 81.26 Item 1)
5	-	Coupling (P/O PL 81.26 Item 1)
6	-	Retard roll assembly (REP 81.4) (P/O PL 81.26 Item 28) (See NOTE)
7	-	Nudger roll support (P/O PL 81.26 Item 1)
8	-	Nudger pulley (P/O PL 81.26 Item 1)
9	-	Nudger roll assembly (REP 81.4) (P/O PL 81.26 Item 28) (See NOTE)
10	809E95240	Spring
11	-	Feed roll assembly (REP 81.4) (P/O PL 81.26 Item 28) (See NOTE)
12	-	Drive belt (P/O PL 81.26 Item 1)
13	-	Drive clutch (P/O PL 81.26 Item 1)
14	-	Feed pulley (P/O PL 81.26 Item 1)
15	-	Washer (P/O PL 81.26 Item 1)
16	-	Bearing (P/O PL 81.26 Item 1)
17	130E18220	Stack height sensor (Q72-337)
18	038E41151	Guide
19	130E11610	Tray 2 empty sensor (Q72-201)/ Feed sensor (Q72-102) (REP 81.8)
20	-	Cover (P/O PL 81.26 Item 1)
21	-	Elevator coupling assembly (P/O PL 81.26 Item 1)
22	-	T2 feed/elevator motor (MOT72-001) (P/O PL 81.26 Item 1)
23	-	Spring (P/O PL 81.26 Item 1)
24	-	Nudger roll shaft (P/O PL 81.26 Item 1)
25	-	Spring (P/O PL 81.26 Item 1)
26	-	Dog spacer (P/O PL 81.26 Item 1)
27	-	Gear 31 (P/O PL 81.26 Item 1)
28	-	Feed roll kit (REF: PL 31.11 Item 26)
29	014E68410	Shim
30	019E74540	Slide pad

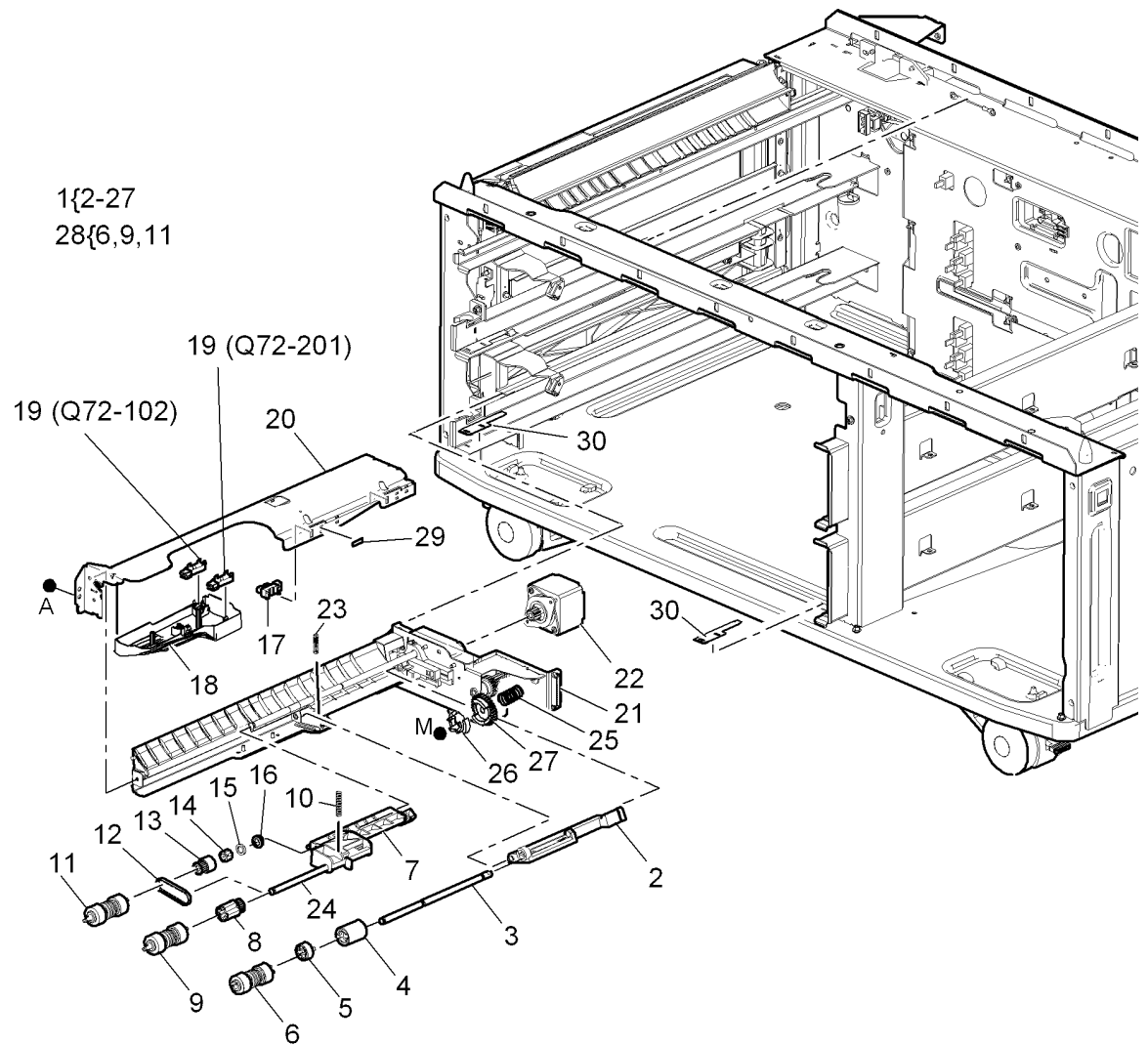

NOTE: To reset the HFSI count, got to dC135

U-8-0100-A

PL 81.30 Tray 3 Paper Feed Assembly

Item	Part	Description
1	059K64464	Feedhead assembly (REP 81.2)
2	-	Retard roll support (P/O PL 81.30 Item 1)
3	-	Retard roll shaft (P/O PL 81.30 Item 1)
4	-	Clutch assembly (P/O PL 81.30 Item 1)
5	-	Coupling (P/O PL 81.30 Item 1)
6	-	Retard roll assembly (REP 81.5) (P/O PL 81.30 Item 26) (See NOTE)
7	-	Nudger roll support (P/O PL 81.30 Item 1)
8	-	Nudger pulley (P/O PL 81.30 Item 1)
9	-	Nudger roll assembly (REP 81.5) (P/O PL 81.30 Item 26) (See NOTE)
10	809E94921	Spring
11	-	Feed roll assembly (REP 81.5) (P/O PL 81.30 Item 26) (See NOTE)
12	-	Drive belt (P/O PL 81.30 Item 1)
13	-	Drive clutch (P/O PL 81.30 Item 1)
14	-	Feed pulley (P/O PL 81.30 Item 1)
15	-	Washer (P/O PL 81.30 Item 1)
16	-	Bearing (P/O PL 81.30 Item 1)
17	130E18220	Stack height sensor (Q73-383) (REP 73.4)
18	038E41311	Guide
19	130E11610	Tray empty sensor (Q73-201)/Feed sensor (Q73-103) (REP 81.9)
20	-	Cover (P/O PL 81.30 Item 1)
21	-	Elevator coupling assembly (P/O PL 81.30 Item 1)
22	-	T3 feed motor (MOT73-001) (P/O PL 81.30 Item 1)
23	-	Spring (P/O PL 81.30 Item 1)
24	-	Nudger roll shaft (P/O PL 81.30 Item 1)
25	-	Tray up limit switch (S73-384) (P/O PL 81.30 Item 1)
26	-	Feed roll kit (REF: PL 31.11 Item 26)
27	014E68410	Shim

1{2-24
26{6,9,11

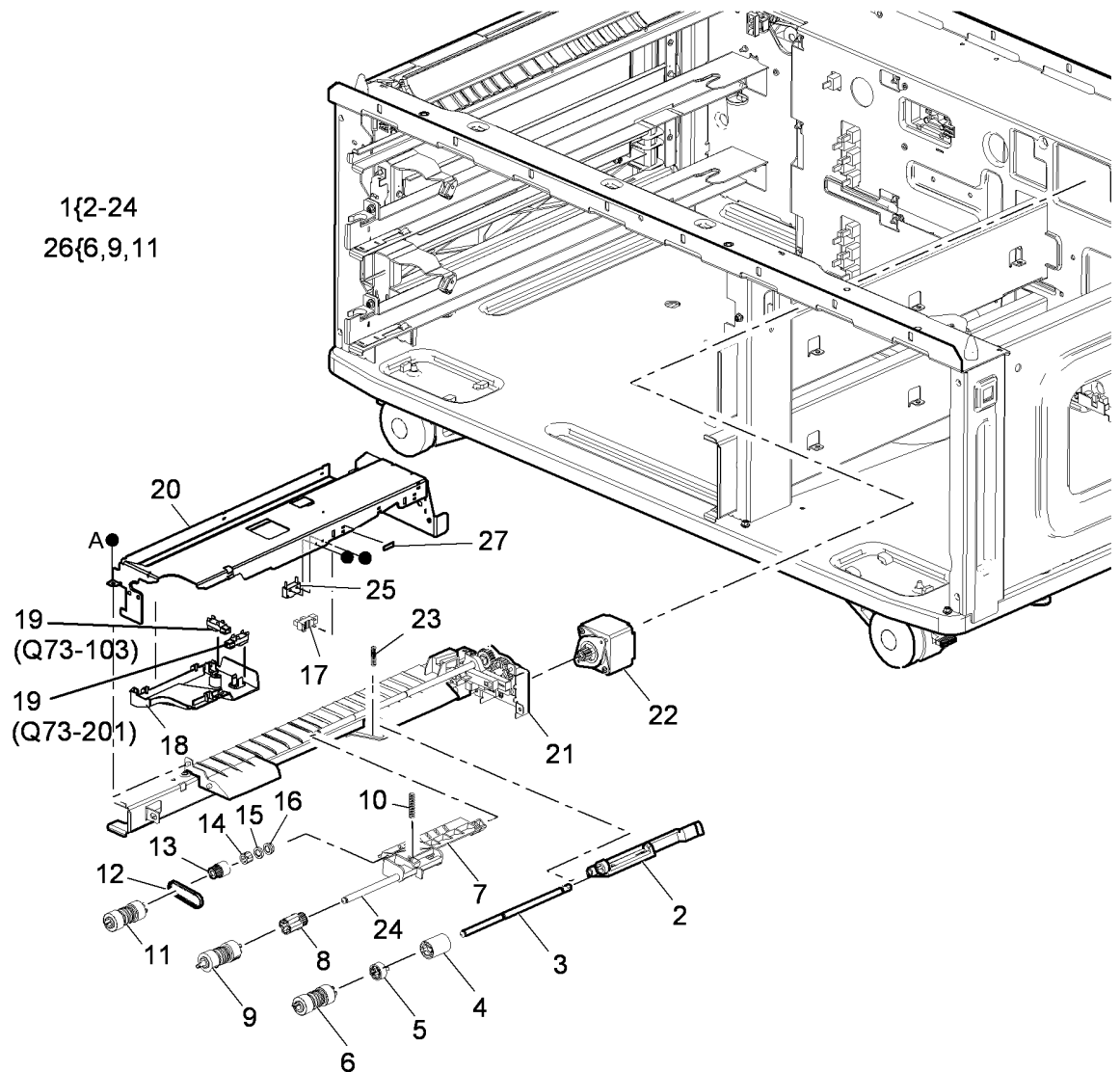

NOTE: To reset the HFSI count, go to dC135

U-8-0101-A

PL 81.35 3 Tray Module Transport Assembly

Item	Part	Description
1	059K50816	Horizontal transport assembly (REP 82.3)
2	-	Horizontal transport base (P/O PL 81.35 Item 1)
3	-	Bearing (P/O PL 73.16 Item 13)
4	-	Pulley (P/O PL 73.16 Item 13)
5	-	Sleeve spring location (P/O PL 73.16 Item 13)
6	-	Drive belt (P/O PL 73.16 Item 13)
7	-	Spring (P/O PL 73.16 Item 13)
8	-	Coupling (P/O PL 73.16 Item 13)
9	-	Horizontal transport lid (P/O PL 81.35 Item 1)
10	-	Idler roll (P/O PL 81.35 Item 1)
11	-	Spring (P/O PL 81.35 Item 1)
12	-	Clip (P/O PL 81.35 Item 1)
13	-	Cover (P/O PL 81.35 Item 1)
14	-	Transport roll 1 (P/O PL 81.35 Item 1) (REP 82.4)
15	-	Transport roll 2 (P/O PL 81.35 Item 1) (REP 82.4)
16	806E19670	Transport roll 3 (REP 82.4)
17	-	Pulley DD (P/O PL 81.35 Item 1)
18	130E11610	Tray 3 transport sensor (2)(Q70-398)/TAR 3 sensor (Q73-397)

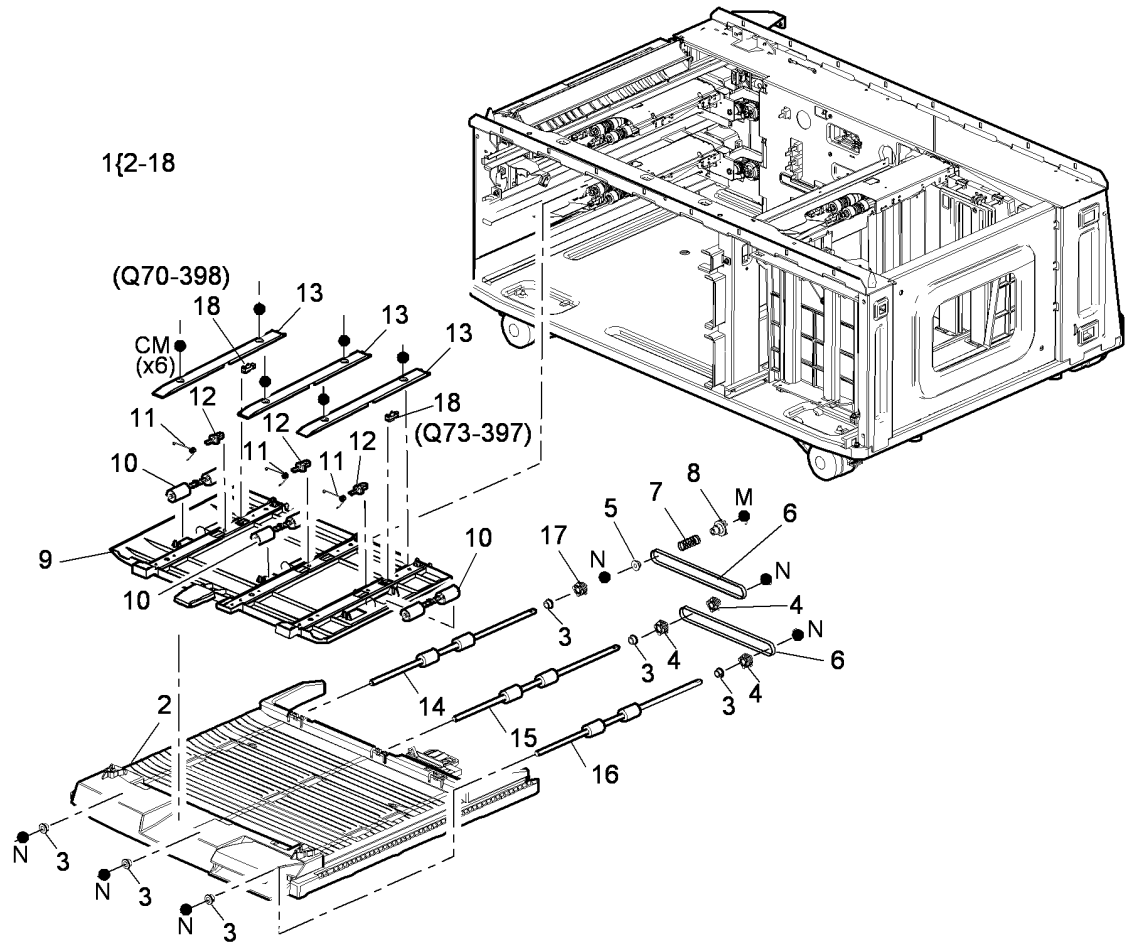

U-8-0102-A

PL 81.40 Tray 5 Feed Assembly (1 of 3)

Item	Part	Description
1	-	Upper feeder assembly (REF: PL 81.45 Item 1)
2	127K56453	Tray 5 transport motor (MOT75-018) (REP 82.5)
3	127K61980	Feed motor (MOT75-117) (REP 81.12)
4	-	Bearing (Not spared)
5	-	Gear 14T (P/O PL 81.40 Item 3)
6	-	Feed/elevator motor harness (Not spared)
7	423W09050	Drive belt (REP 82.6)
8	-	Upper limit actuator spring (Not spared)
9	-	Upper limit actuator (Not spared)
10	-	Belt tensioner (Not spared)
11	-	Belt tensioner spring (Not spared)
12	-	Elevator harness shield (Not spared)
13	125E00430	Static eliminator
14	-	Transport motor harness (Not spared) (PJ511)
15	-	Tray 5 upper feeder assembly harness (Not spared) (PJ505)
16	962K50475	Elevator motor harness (PJ504)
17	962K82710	Centre reg interface harness
18	007K14401	Gear 30T Bearing

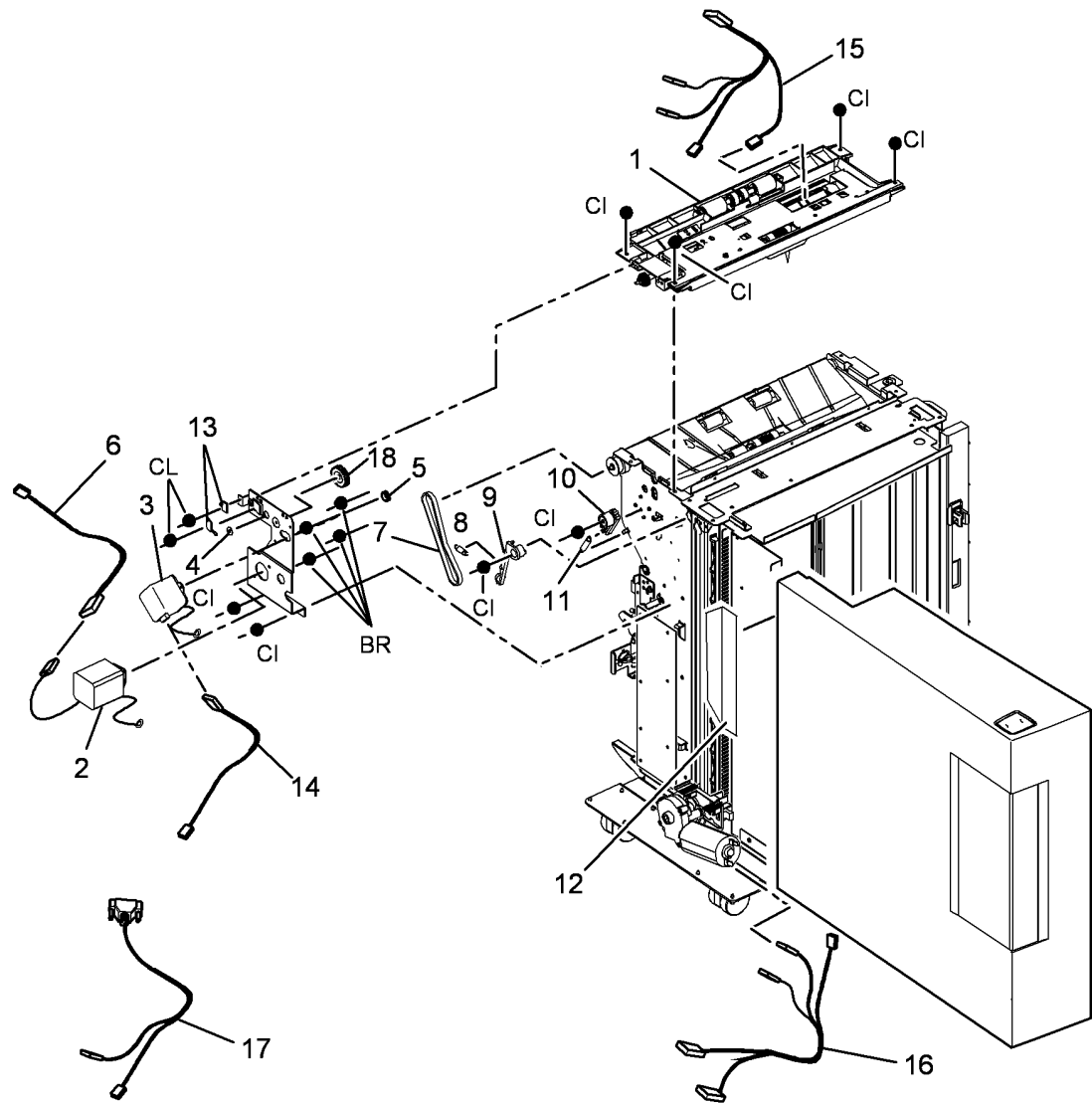

U-8-0019-A

PL 81.45 Tray 5 Feed Assembly (2 of 3)

Item	Part	Description
1	059K69991	Upper feeder assembly (REP 82.7)
2	-	Feed roller (REP 81.7) (P/O PL 81.45 Item 20) (See NOTE)
3	-	Nudger pulley (P/O PL 81.45 Item 1)
4	-	One way coupling (P/O PL 81.45 Item 1)
5	-	Take away idler roller (P/O PL 81.45 Item 1)
6	130E11610	Tray 5 empty sensor (Q75-016)(REP 75.1)/Feed sensor (Q75-105)(REP 81.11)
7	130E12060	Stack height sensor (Q75-011) (REP 75.2)
8	-	Nudger roller (P/O PL 81.45 Item 20) (REP 81.7)
9	-	Torsion spring (P/O PL 81.45 Item 1)
10	-	Clutch (P/O PL 81.45 Item 1)
11	-	Gear (29T) (P/O PL 81.45 Item 1)
12	-	Housing spring (P/O PL 81.45 Item 1)
13	-	Torsion chute spring (P/O PL 81.45 Item 1)
14	-	Bearing (P/O PL 81.45 Item 1)
15	-	Roller belt (P/O PL 81.45 Item 1)
16	-	Washer (P/O PL 81.45 Item 1)
17	-	Upper feed assembly top cover (P/O PL 81.45 Item 1)
18	-	Upper feed assembly base (P/O PL 81.45 Item 1)
19	-	Torsion nudger spring (P/O PL 81.45 Item 1)
20	-	Feed roll kit (Pack of 3) (REF: PL 31.11 Item 26) (REP 81.7)

NOTE: To reset the HFSI count, go to dC135.

1{2-19
20{2,8

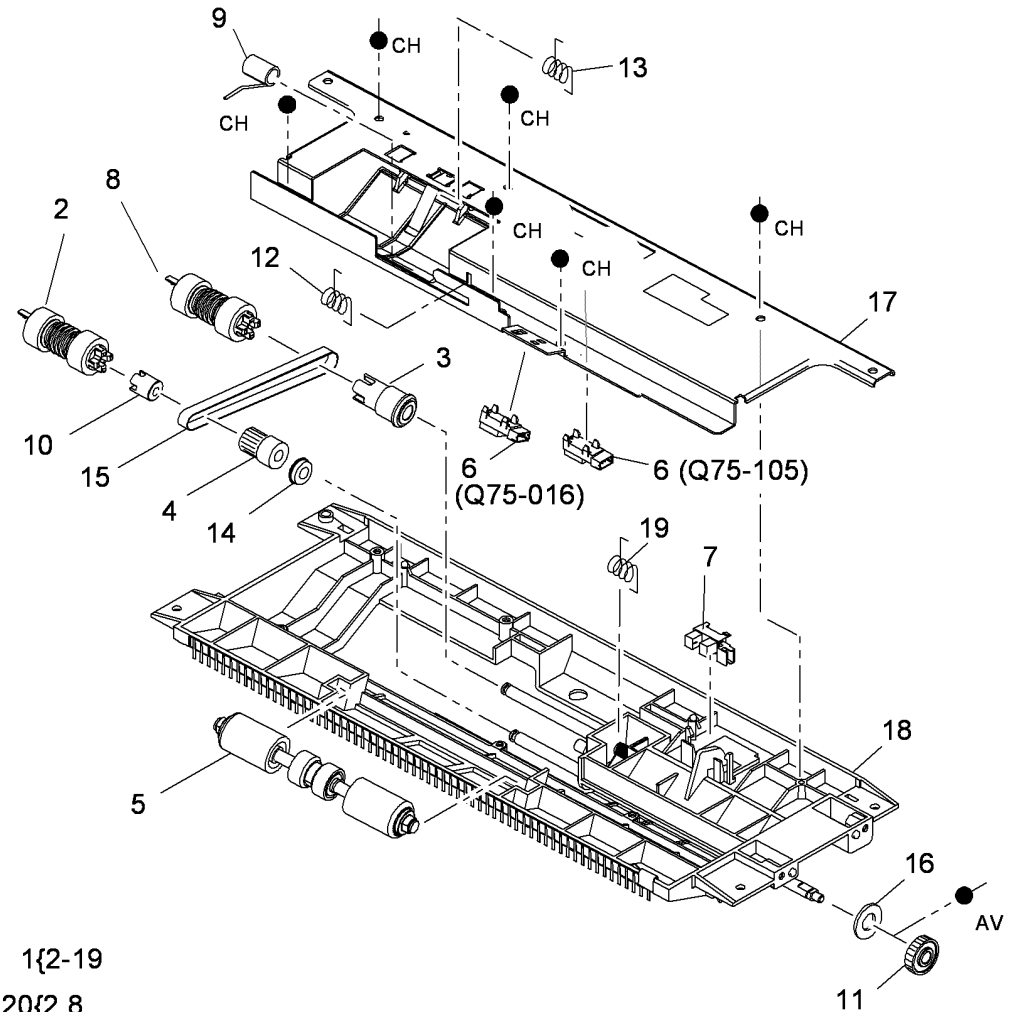

U-8-0020-A

PL 81.46 Tray 5 Feed Assembly (3 of 3)

Item	Part	Description
1	059K70530	Lower feed assembly (REP 82.7)
2	-	Retard roller (P/O PL 81.45 Item 20)
3	-	Retard clutch (P/O PL 81.46 Item 1)
4	-	One way pulley clutch (P/O PL 81.46 Item 1)
5	-	Take away roller (P/O PL 81.46 Item 1) (REP 82.7)
6	-	Bearing (P/O PL 81.46 Item 1)
7	-	Clutch (P/O PL 81.46 Item 1)
8	-	Torsion retard spring (P/O PL 81.46 Item 1)
9	-	Retard roller shaft (P/O PL 81.46 Item 1)
10	-	Lower feed assembly base (P/O PL 81.46 Item 1)
11	-	Actuator pivot shaft bearing (P/O PL 81.46 Item 1)
12	-	Actuator pivot shaft (P/O PL 81.46 Item 1)

NOTE: To reset the HFSI count, go to dC135.

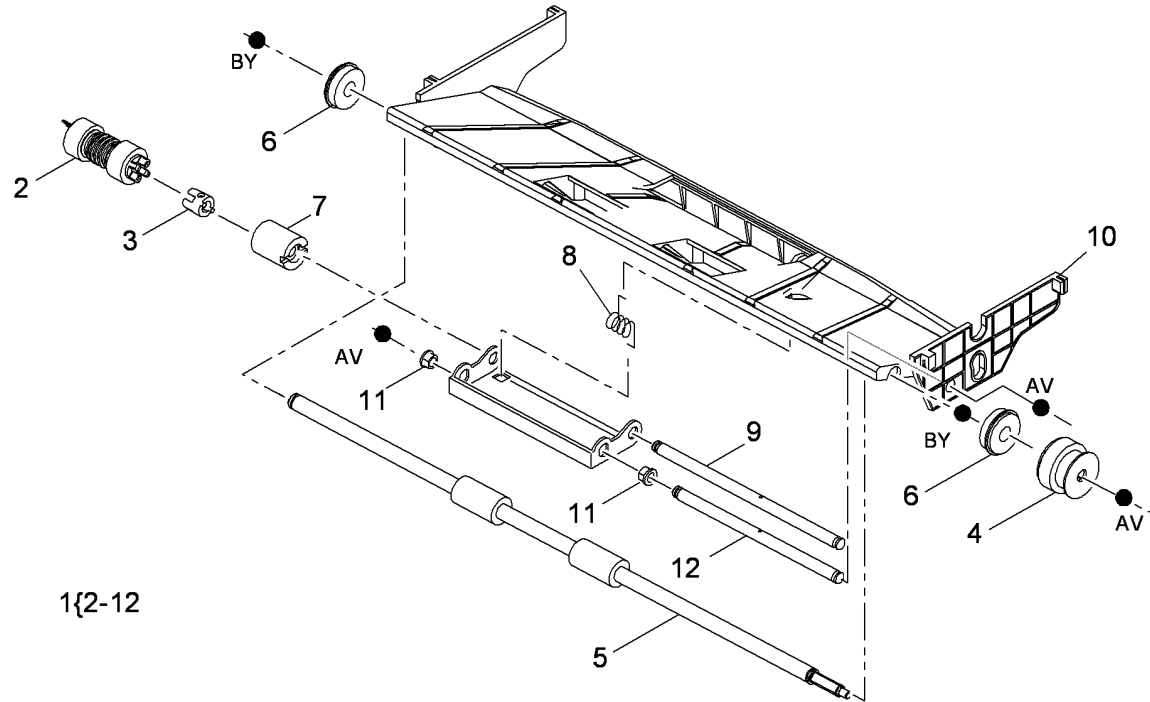

1{2-12

U-8-0123-A

PL 82.10 Vertical Paper Path

Item	Part	Description
1	059E10710	Transport roller drive 2
2	059K63990	Transport roller TAR vertical
3	807E28960	Pulley M2 (90T)
4	807E28950	Gear 25T M08
5	807E28970	Nip F idler pulley
6	023E31410	Nip 'H' drive belt
7	130E12950	Confirm sensor (16) (Q82-125)/ Vertical transport sensor (5) (Q82-110) (REP 82.8)
8	023E31470	Nip F drive belt (90T)
9	-	Sensor bracket (Not spared)
10	110E20810	Upper door interlock switch (S01-100)/Mid door interlock switch (S01-101)
11	020K20450	Nip H drive pulley
12	127K62280	Vertical transport motor (M2) (MOT82-001) (M2)
13	807E29010	Gear 46T-M08
14	807E28940	Gear 58T
15	038K23290	Vertical paper path
16	020K20620	Nip F drive pulley
17	023E31480	Motor M2 drive belt
18	-	Inner frame assembly (Not spared)

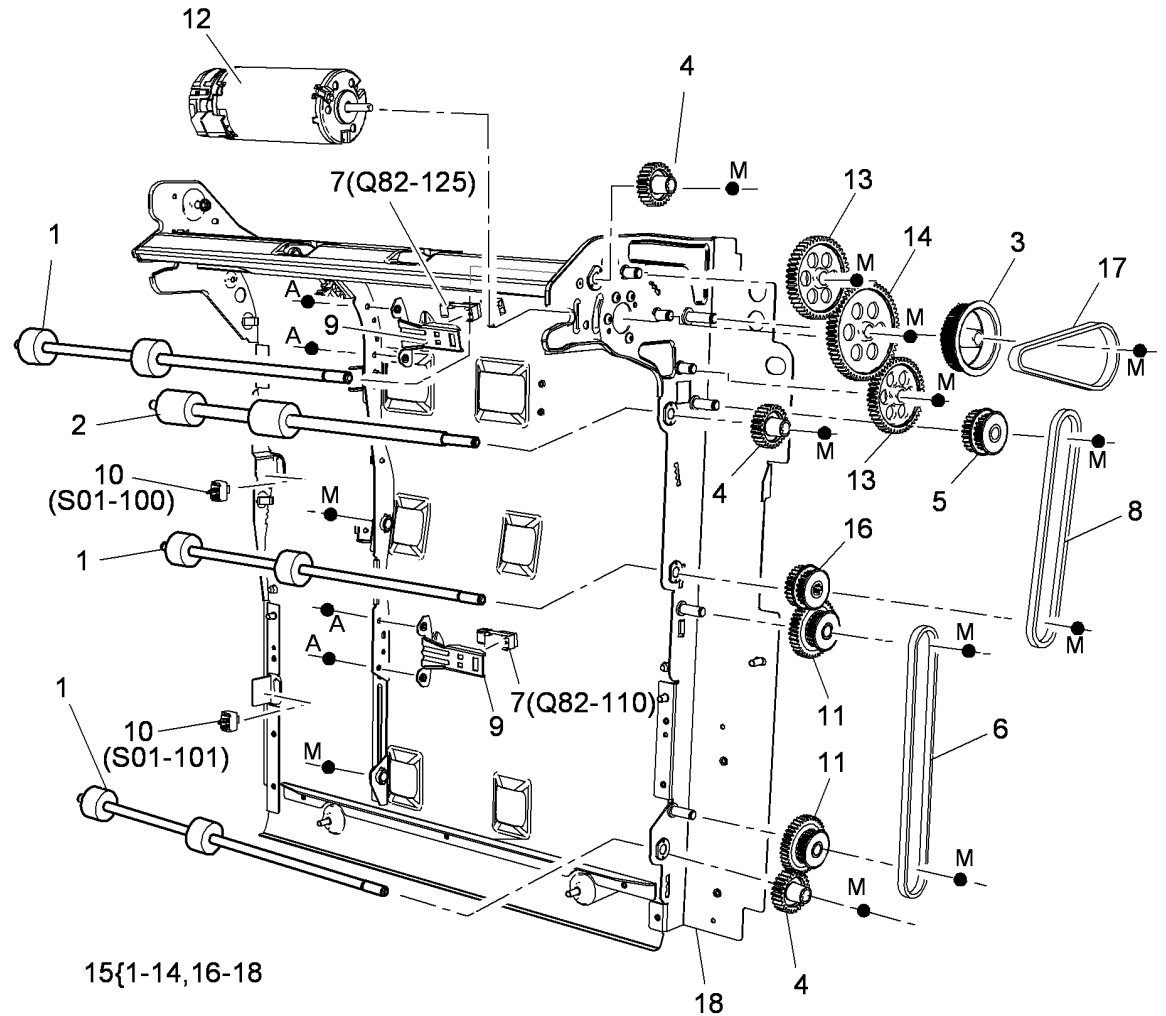

U-8-0065-A

PL 82.15 Horizontal Paper Path

Item	Part	Description
1	038K23500	Horizontal paper path assembly (REP 83.1)
2	-	Top cover (P/O PL 82.15 Item 1)
3	130E12950	Duplex sensor (17)(Q83-010)(REP 83.3)/Duplex end sensor (14)(Q83-125)(REP 83.2)
4	121E26510	Nip 'C' release solenoid (SOL82-007) (REP 83.2)
5	121E26500	HPP diverter solenoid (SOL83-004) (REP 83.2)
6	020K20480	Pulley M6 (21T)
7	023E31410	Horizontal transport drive belt front (REP 83.5)
8	023E31490	Drive belt M6
9	127K62290	Horizontal transport motor (M6) (MOT82-003) (REP 83.4)
10	059E10740	Nip R,C and Q takeaway rolls (REP 83.5)
11	-	Horizontal illuminator (Q82-005) (P/O PL 82.15 Item 1)
12	-	Heatshield (P/O PL 82.15 Item 1)
13	807E29170	Heatshield lift gear
14	-	Bearing (Not spared)
15	-	Spacer (Not spared)
16	807E29160	Heatshield sector gear
17	-	Reg/Preheat illuminator PWB (P/O PL 82.15 Item 12)
18	020E53880	Pulley M6 (80T)
19	868E53910	Release latch
20	-	Spring (Not spared)

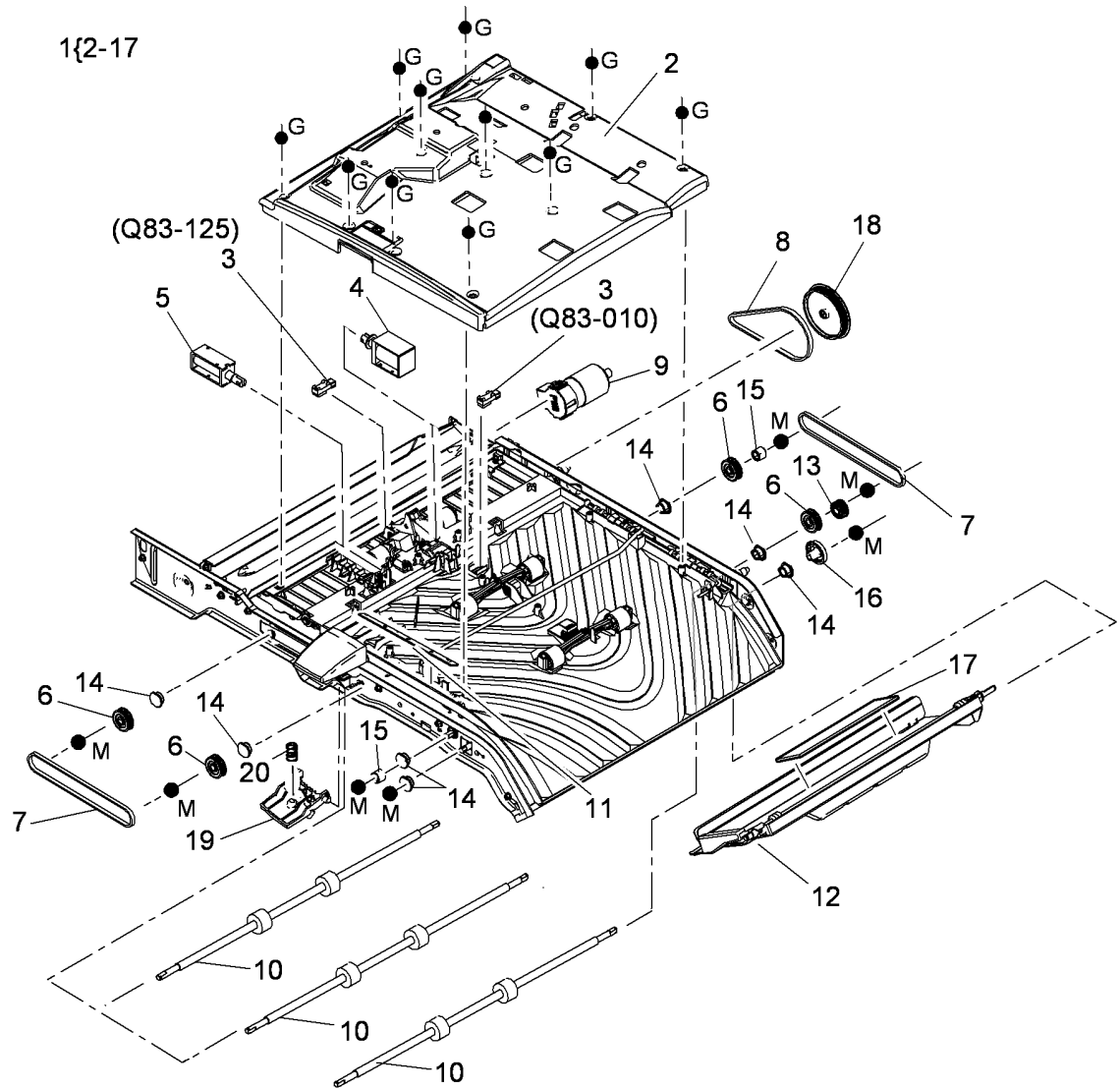

U-8-0066-A

PL 88.10 Registration/Preheat Assembly (1 of 2)

Item	Part	Description
1	801K37710	Registration/Preheat assembly (complete) (REP 89.1)
2	-	Registration scan bar (Q89-005) (Not spared)
3	604K54870	Registration/Preheat pump kit (REP 89.2)
4	-	Rubber mounting (Not spared)
5	-	Registration/Preheat air pump (MOT 88-008) (P/O PL 31.11 Item 7) (REP 89.2)
6	-	Rubber mounting (Not spared)
7	-	Lower platelet assembly cover (Not spared)
8	-	Pump cover (Not spared)
9	-	Sensor cover (Not spared)
10	-	Registration/Preheat interface PWB (Not spared)
11	-	Thermal cutout PWB (Not spared)
12	130E12950	Pre transfix sensor (20) (Q89-006) (REP 10.7)
13	-	Lower heat plate (Not spared)
14	-	Lower platelet base assembly (Not spared)
15	-	Lower platelet assembly (Not spared) (REP 89.1)
16	-	Frame and jam clearance assembly (Not spared)
17	-	Registration scan bar cover (Not spared)
18	-	Upper heat plate (Not spared)
19	-	Idler assembly spring (Not spared)
20	-	Idler assembly (Not spared)
21	-	Front inverter (Not spared)
22	-	Rear inverter (Not spared)
23	-	Grounding plate (Not spared)
24	-	Upper housing (Not spared)
25	-	Shaft (Not spared)
26	-	Suction plate (Not spared)
27	-	Gear (Not spared)
28	-	Shaft (Not spared)
29	-	Bearing (Not spared)
30	-	Gear (Not spared)

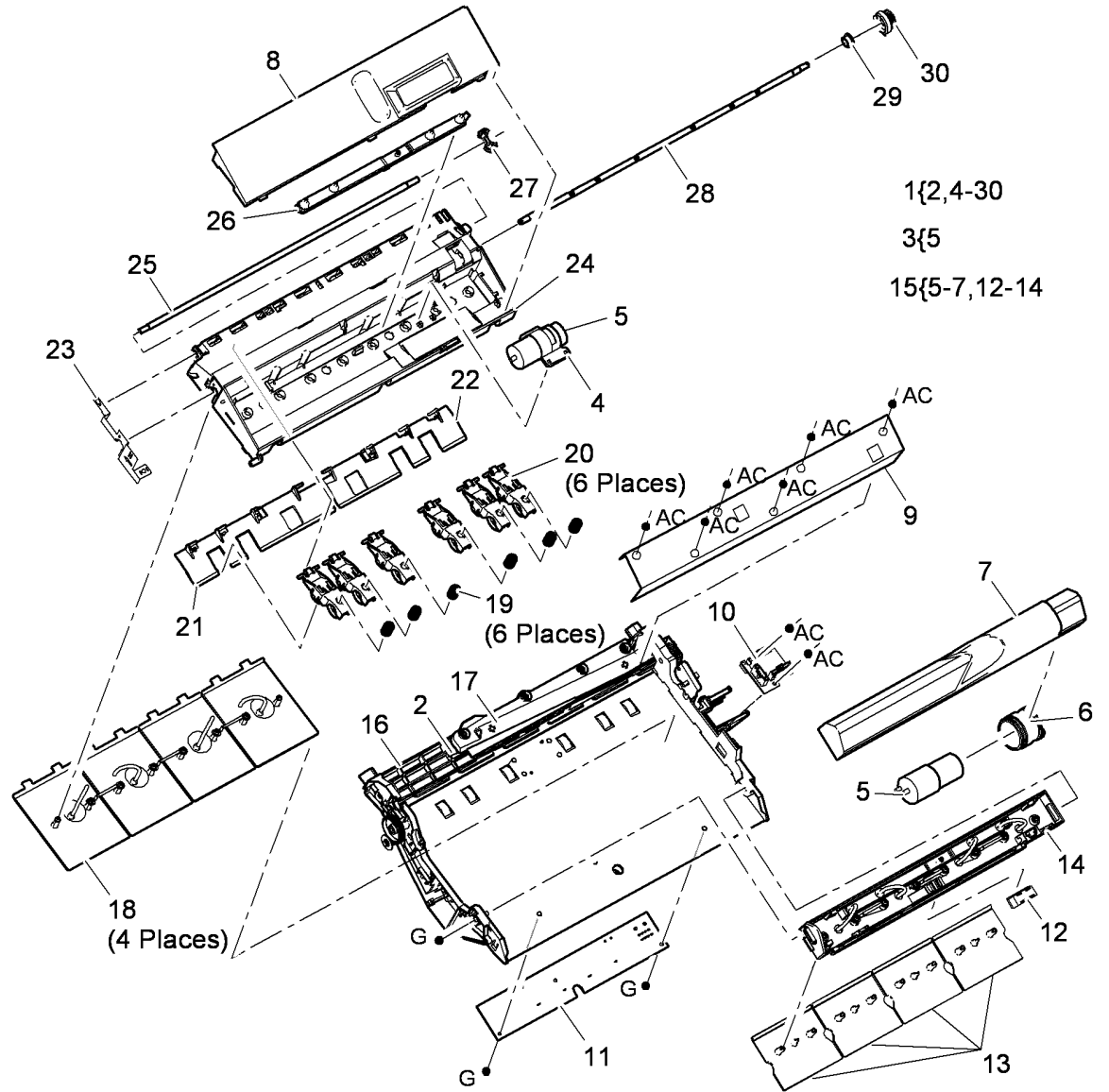

1{2,4-30
3{5
15{5-7,12-14

U-8-0061-A

PL 88.11 Registration/Preheat Assembly (2 of 2)

Item	Part	Description
1	-	Nip 'A' replacement kit (REF: PL 31.11 Item 19) (REP 89.3)
2	-	Bearing cover (Not spared)
3	-	Front drive gear (Not spared)
4	-	Drive belt (P/O PL 88.11 Item 1)
5	-	Nip 'A' roller (P/O PL 88.11 Item 1)
6	-	Compound gear (Not spared)
7	-	Bearing (Not spared)
8	-	Registration motor A1 (M3)(MOT 89-007)/Registration motor A2(M3)(MOT 89-008) (Not spared)
9	-	Cover (Not spared)
10	-	Nip 'A' pulley (Not spared)
11	-	One way gear (Not spared)
12	-	Nip 'A' ground plate (Not spared)

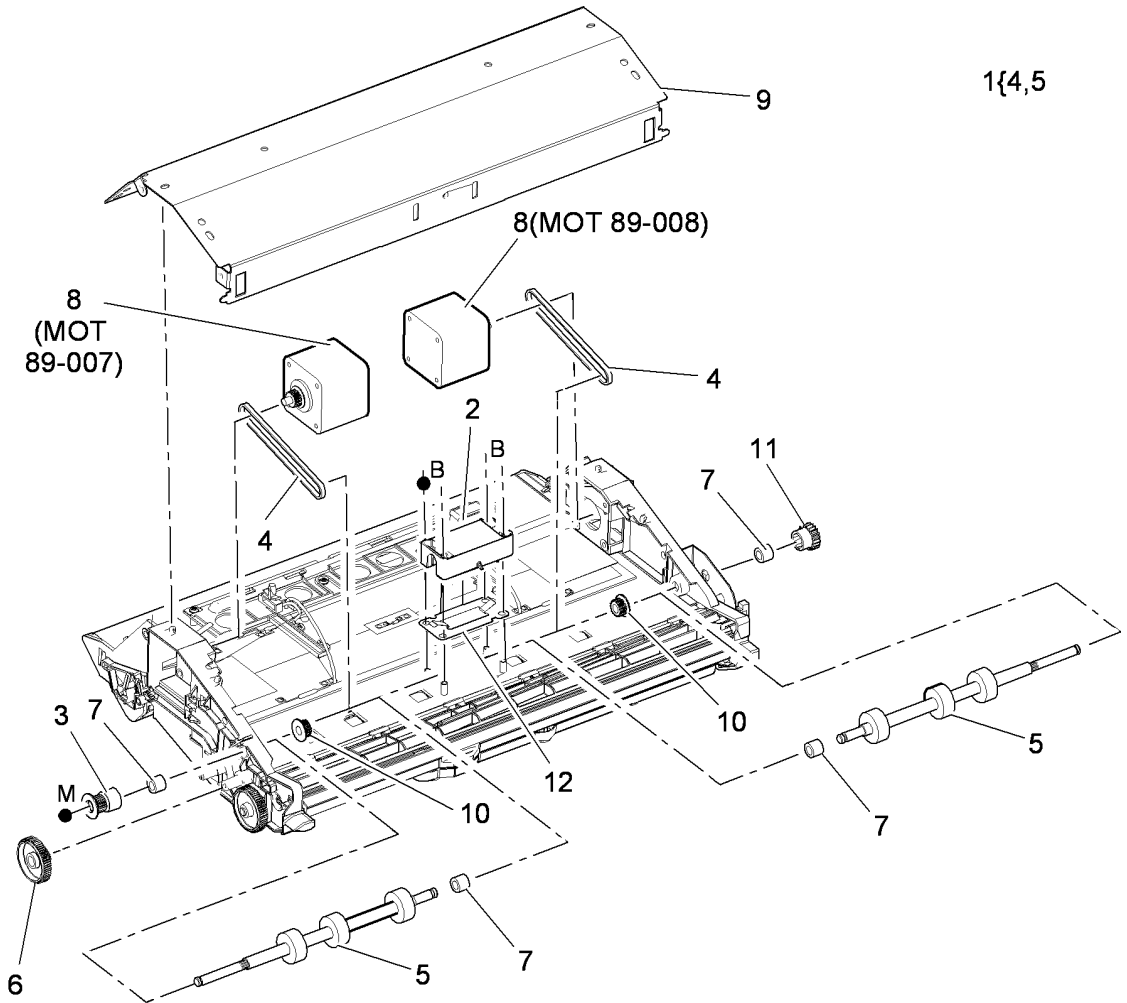

U-8-0115-A

PL 91.05 Marking Unit Slide Assembly

Item	Part	Description
1	010K04820	Left hand slide assembly (REP 91.26)
2	010K04830	Right hand slide assembly (REP 91.26)
3	674E02850	Slide assembly cross brace (REP 91.26)
4	130E18210	Waste tray sensor (Q91-019)
5	-	Marking unit assembly (Not spared) (REP 91.26)

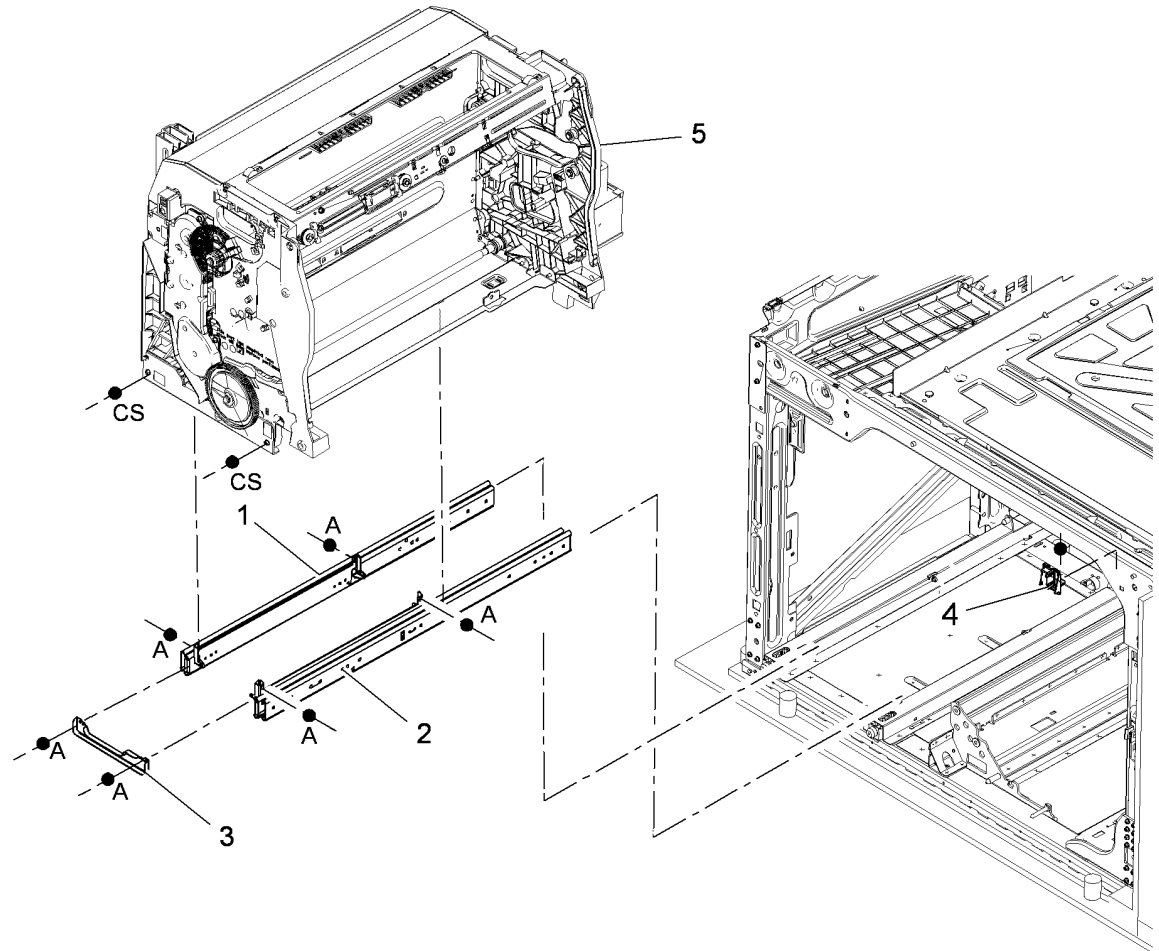

U-8-0110-A

PL 91.10 Marking Unit Drive Assembly

Item	Part	Description
1	041K06600	Carriage drive train (REP 91.1)
2	012K06940	Upper front compliant link (REP 91.8)
3	-	Upper carriage drive shaft (Not spared) (REP 91.8)
4	012K06950	Upper rear compliant link (REP 91.8)
5	012K06930	Lower rear compliant link (REP 91.10)
6	-	Lower carriage drive shaft (Not spared) (REP 91.10)
7	012K06920	Lower front compliant link (REP 91.10)
8	130E12970	Lower carriage home sensor (Q91-011)/Upper carriage home sensor (Q91-012)
9	807E29030	Lower carriage drive gear
10	807E29040	Upper carriage drive gear
11	120K03490	Waste tray lock solenoid assembly
12	116K00812	Marking unit enclosure (frame only)
13	011K03140	Upper carriage crank (See NOTE) (REP 91.8)
14	011K03130	Lower carriage crank (See NOTE)
15	050E28780	Waste tray
16	-	Carriage docking motor (MOT 91-031) (P/O PL 91.10 Item 1)
17	-	Waste tray lock solenoid (SOL91-044) (P/O PL 91.10 Item 11)
18	-	Marking unit enclosure cover (Not spared)
19	-	Carriage drive bushing (P/O PL 31.11 Item 23)

NOTE: If an entire crank (PL 91.10 Item 13 or PL 91.10 Item 14) needs to be replaced then 2 parts need to be ordered.

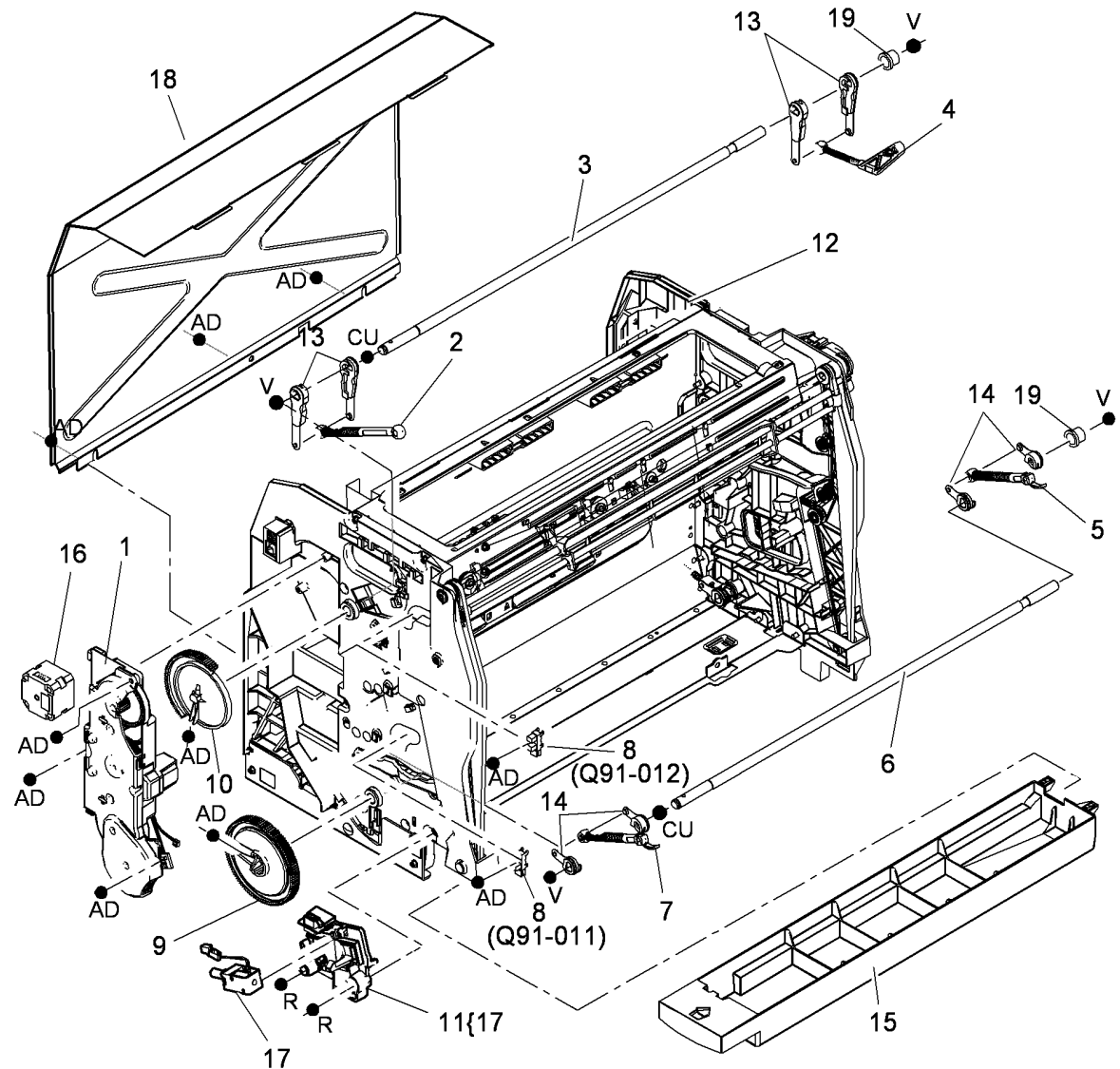

U-8-0056-A

PL 91.15 Marking Unit Belt and Drive

Item	Part	Description
1	007K19800	Vertical gearbox (REP 91.2)
2	023E31420	HM belt (REP 91.5)
3	019E80820	HM belt clip (REP 91.5)
4	801E11470	Front tensioner base (REP 91.4)
5	033K04550	Horizontal drive paddle
6	-	Horizontal drive shaft (Not spared)
7	-	Upper drive shaft (Not spared)
8	020K20630	Drive pulley
9	020K20470	Belt pulley
10	022E38380	Tensioner pulley
11	801E11480	Back tensioner base (REP 91.4)
12	-	HM vertical motion motor (MOT91-023) (P/O PL 91.15 Item 1) (REP 91.2)
13	033K04560	HM wiper (REP 91.3)
14	009K02440	HM tensioner spring
15	007K19790	HM Horizontal motion motor (MOT91-025) (REP 91.6)
16	023K01420	Horizontal drive cable
17	130E18200	HM position sensor (Q91-014)
18	020K20560	HM drive pulley
19	020K20570	HM idler pulley
20	-	HM drive cable stop (Not spared)
21	-	Bearing (Not spared)
22	-	Belt pulley shaft (Not spared)

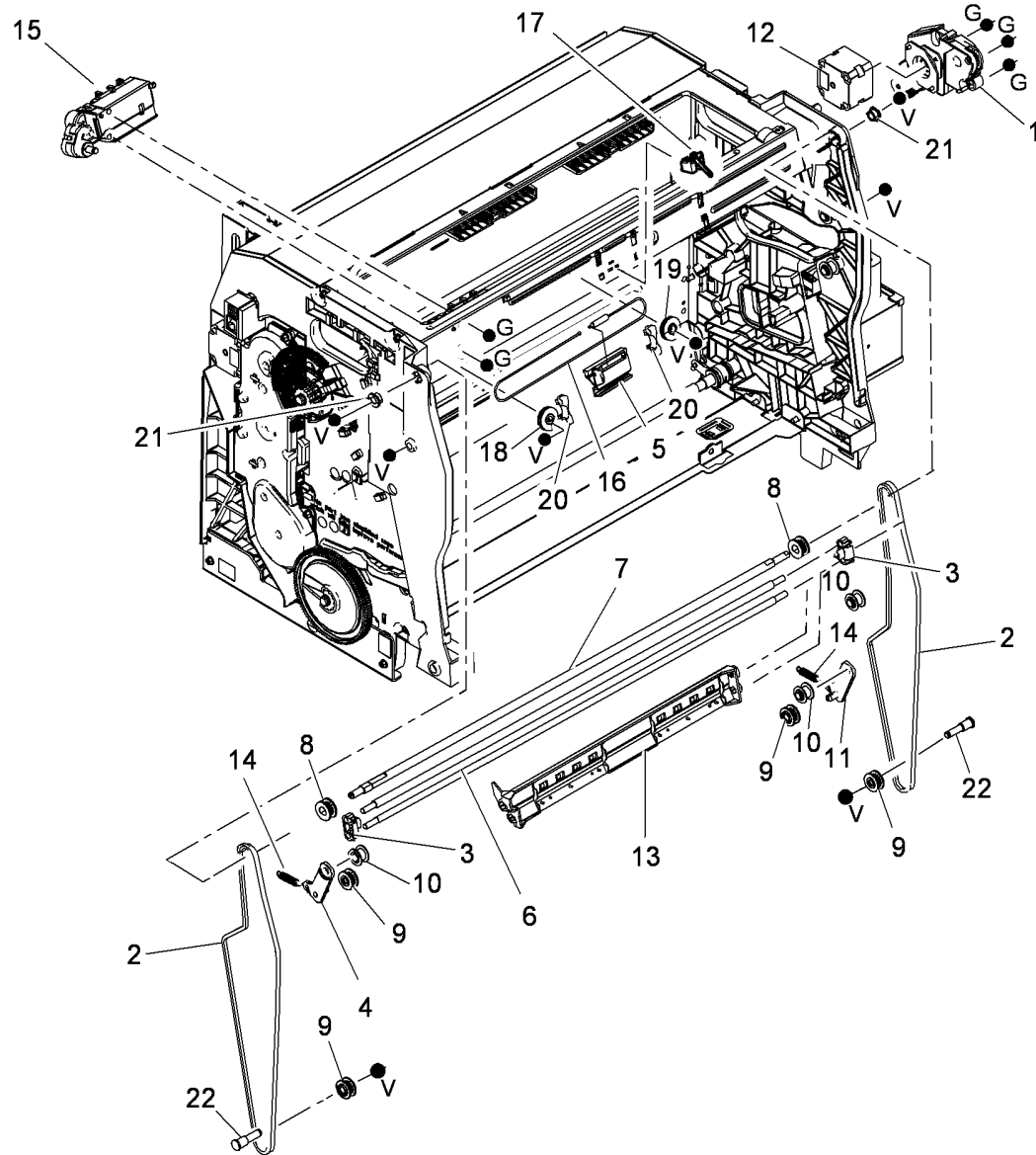

U-8-0057-A

PL 91.20 Marking Unit Upper Carriage Assembly

Item	Part	Description
1	041K06790	Upper carriage assembly (REP 91.7)
2	604K61672	Printhead (Type A) (see NOTE) (REP 91.29)
-	-	Printhead (Type B) (see NOTE) (REP 91.29)
3	-	Printhead PWB (P/O PL 91.20 Item 2)
4	127K62310	Printhead stitch adjust motor 2 (MOT91-030)/Printhead roll adjust motor 2 (MOT91-026)/Printhead roll adjust motor 4 (MOT91-028) (127K62310) (REP 91.13)
5	127K62300	X-axis drive motor upper (MOT91-033) (REP 91.9)
6	-	Printhead drive motor bracket (P/O PL 91.20 Item 5)
7	-	Not used
8	-	Mounting bracket (Not spared) (REP 91.10)
9	-	Purge line filter (P/O PL 91.20 Item 17, PL 91.20 Item 20) (REP 91.12)
10	-	Umbilical (P/O PL 91.20 Item 20) (REP 91.31)
11	-	Purge line (P/O PL 91.20 Item 17, PL 91.20 Item 20) (REP 91.12)
12	117E35770	Upper carriage harness (PJ102, PJ401)
13	-	Upper carriage frame assembly (P/O PL 91.20 Item 1)
14	-	Purge line filter cap (P/O PL 91.20 Item 17)
15	-	SFWA upper frame (P/O PL 91.20 Item 1)
16	-	Cable clip (Type A) (P/O PL 31.11 Item 29, PL 31.11 Item 13) (see NOTE)
17	604K54961	Purge line filter assembly
18	-	Reservoir gasket (P/O PL 91.20 Item 20)
19	-	Check valve unit (P/O PL 91.20 Item 20)
20	-	Umbilical kit (REF: PL 31.10 Item 14)

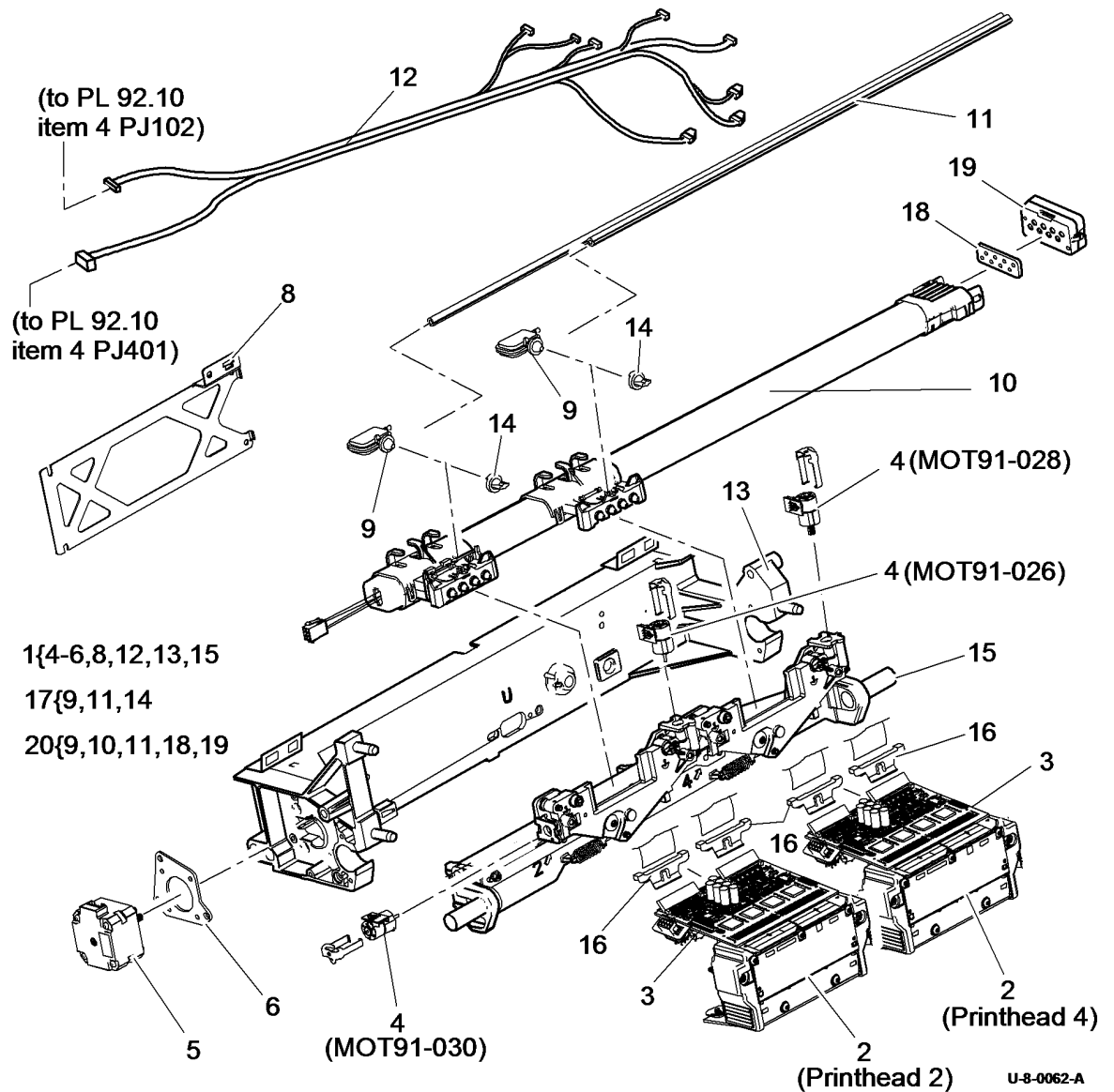

NOTE: To identify the type of printhead, refer to GP 46.

PL 91.25 Marking Unit Lower Carriage Assembly

Item	Part	Description
1	041K06780	Lower carriage assembly (REP 91.14)
2	604K61672	Printhead (Type A) (see NOTE) (REP 91.29)
-	-	Printhead (Type B) (see NOTE)
3	-	Printhead PWB (P/O PL 91.25 Item 2)
4	127K62310	Printhead stitch adjust motor 1 (MOT91-029)/Printhead roll adjust motor 1 (MOT91-024)/Printhead roll adjust motor 3 (MOT91-027) (REP 91.13)
5	127K62300	X-axis drive motor lower (MOT91-034)
6	-	Printhead drive motor bracket (P/O PL 91.25 Item 5)
7	-	Not used
8	-	Mounting bracket (Not spared)
9	-	Purge line filter (P/O PL 91.25 Item 17)
10	-	Umbilical (P/O PL 91.25 Item 20) (REP 91.31)
11	-	Purge line (P/O PL 91.25 Item 17)
12	117E35660	Lower carriage harness (PJ303, PJ701)
13	-	Lower carriage frame assembly (P/O PL 91.25 Item 1)
14	-	Purge line filter cap (P/O PL 91.25 Item 17)
15	-	SFWA lower frame (P/O PL 91.25 Item 1)
16	-	Cable clip (Type A) (P/O PL 31.11 Item 29, PL 31.11 Item 13) (see NOTE)
17	604K54961	Purge line filter assembly
18	-	Reservoir gasket (P/O PL 91.25 Item 20)
19	-	Check valve unit (P/O PL 91.25 Item 20)
20	-	Umbilical kit (P/O PL 31.10 Item 14)

NOTE: To identify the type of printhead, refer to GP 46.

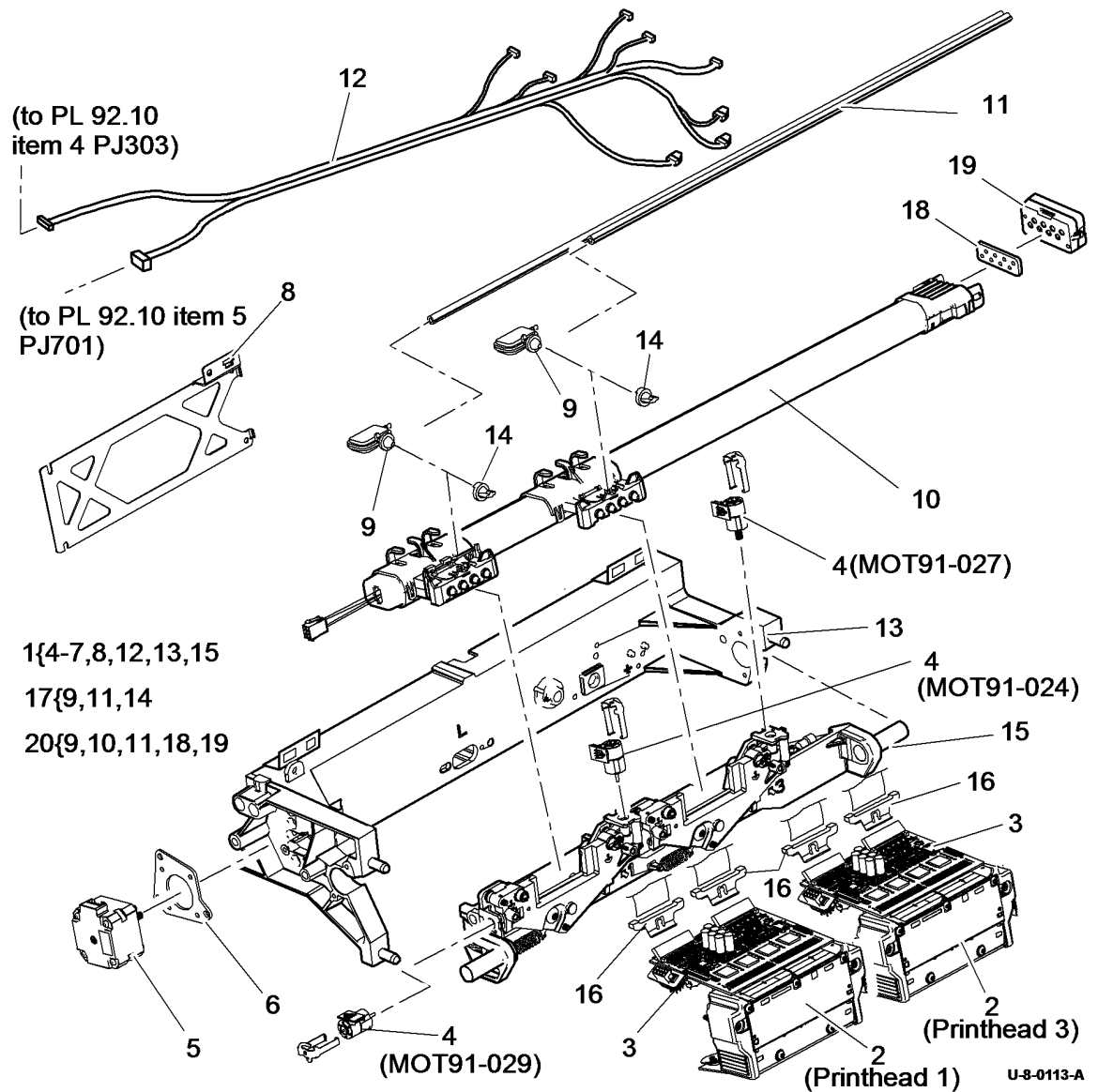

PL 92.10 Marking Unit Electronic PWB's

Item	Part	Description
1	960K66590	IME Controller PWB (REP 3.1)
2	-	Mounting Plate (P/O PL 92.10 Item 1)
3	960K46471	Quad Wave amp PWB (REP 3.2)
4	960K46440	Marking unit driver PWB (REP 3.4)
5	960K46451	Marking unit heater PWB (REP 3.3)
6	-	Clamp (Not spared)
7	-	Video cable (Type A) (P/O PL 31.11 Item 29) (see NOTE)
-	-	Video Cable (Type B) (see NOTE)
8	-	Wave amp cable (Type A) (P/O PL 31.11 Item 13) (see NOTE)
-	-	Wave amp cable (Type B) (see NOTE)
9	130E18790	Service loop (REP 91.11)
10	-	Not used
11	237E23880	8 Pin NVRAM
12	117E35680	Marking unit heater PWB cable (PJ901)
13	117E35800	Quad Wave amp PWB cable (PJ590)
14	117E35670	Marking unit driver PWB cable (PJ203)
15	117E35730	Marking unit front components harness (PJ304)
16	133K27860	Memory module (256 MB)

NOTE: To identify the type of cable, refer to GP 46.

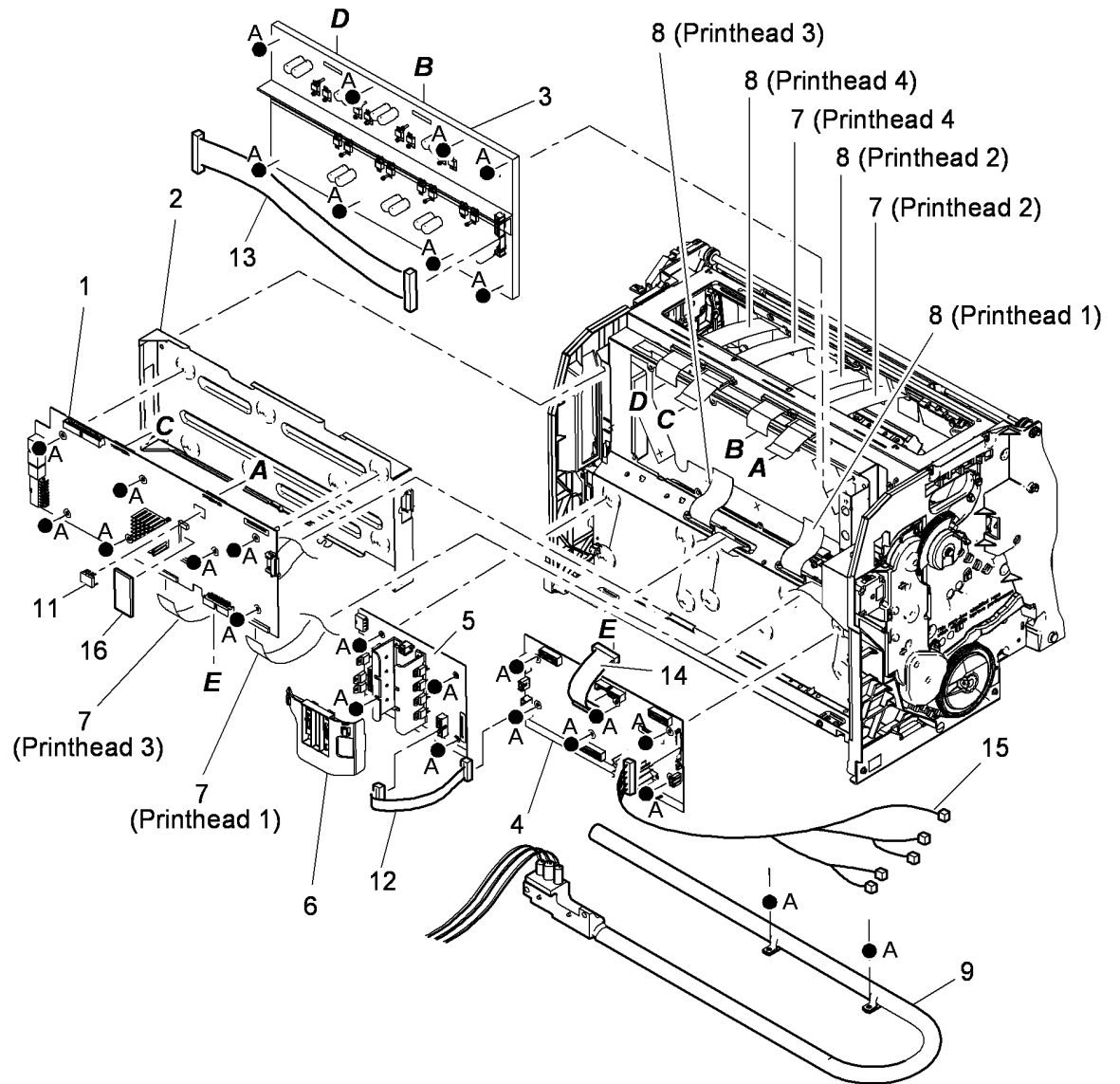

U-8-0058-A

PL 93.10 Ink Loader Assembly

Item	Part	Description
1	815K11623	Ink loader upper assembly (REP 91.15)
2	130K15852	Ink low sensor assembly (REP 91.19)
3	815K11610	Ink loader melt plate assembly (REP 91.16)
4	848E34260	Ink transport drive cover
5	127K62270	Ink transport motor (MOT93-048) (REP 91.18)
6	807E29020	Ink transport drive gear (REP 91.18)
7	130K15870	Ink load sensor assembly (REP 91.17)
8	-	Ink load entry PWB (P/O PL 93.10 Item 7) (REP 91.17)
9	-	Solenoid patch PWB (P/O PL 93.10 Item 26)
10	-	Ink reservoir (P/O PL 93.10 Item 26) (REP 91.20)
11	-	Reservoir pump (MOT93-050) (P/O PL 93.10 Item 16) (REP 91.21)
12	-	Reservoir mounting bracket (P/O PL 93.10 Item 26)
13	057E03690	Side insulation
14	127K62310	Ink keyplate motor (MOT93-051)
15	-	LPA valve solenoid (SOL91-045) (P/O PL 93.10 Item 16)
16	-	Reservoir pump assembly (P/O PL 93.10 Item 26)
17	057E03700	Umbilical end insulation
18	117E35640	Ink level sensor cable (PJ760)
19	130E12930	Ink loader door switch
20	-	Magenta solid ink stick (REF: PL 26.10 Item 7)
21	-	Cyan solid ink stick (REF: PL 26.10 Item 8)
22	-	Yellow solid ink stick (REF: PL 26.10 Item 9)
23	-	Black solid ink stick (REF: PL 26.10 Item 10)
24	-	Ink loader housing (P/O PL 93.10 Item 1)
25	-	Harness, Solenoid patch PWB to Marking unit heater PWB (PJ630 to PJ801) (P/O PL 93.10 Item 26)
26	604K67920	Ink reservoir assembly (REP 91.20)

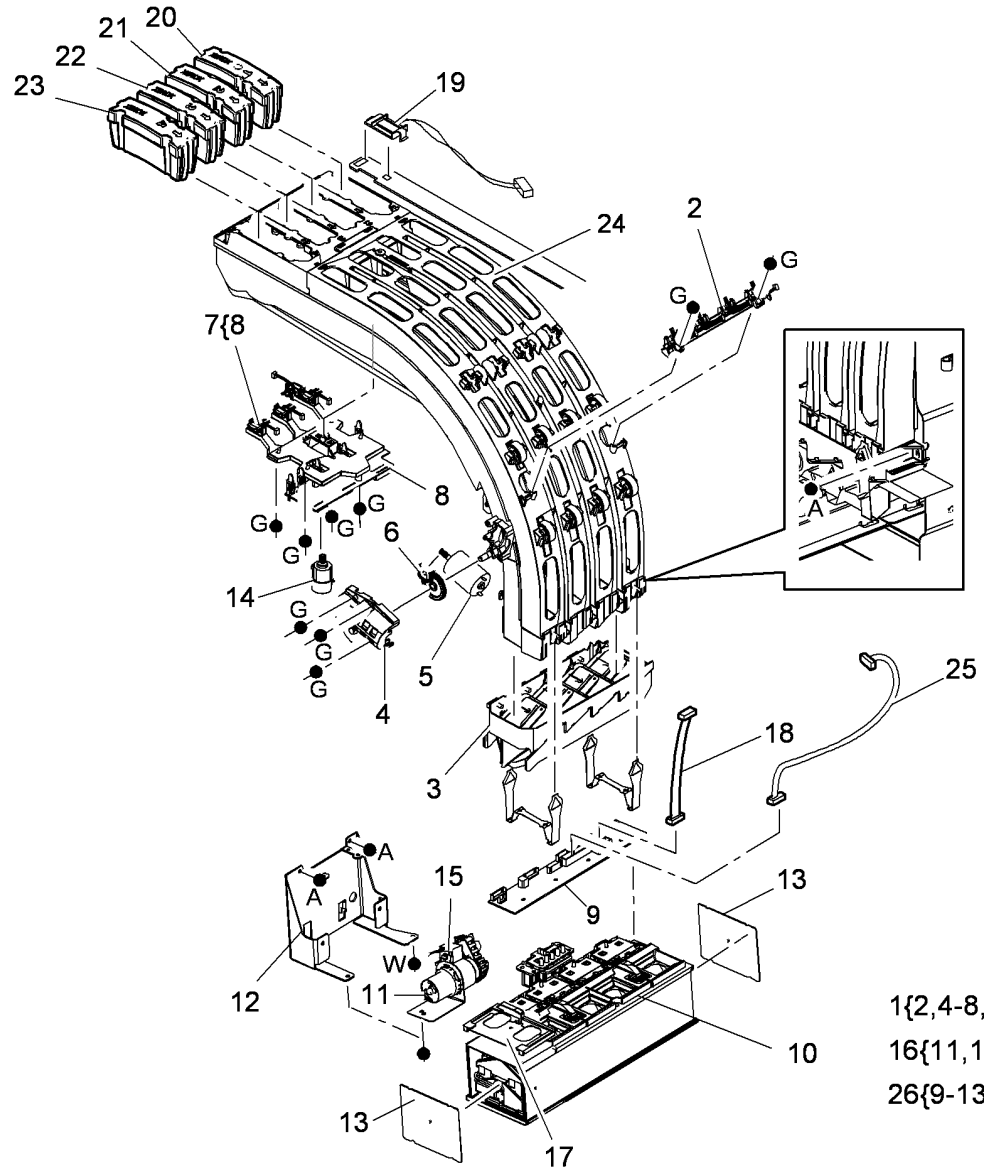

1{2,4-8,14,24
16{11,15
26{9-13,15-17,25

U-8-0060-A

PL 94.10 Cleaning Unit

Item	Part	Description
1	-	Cleaning unit lid (P/O PL 94.10 Item 21)
2	-	Return reservoir pump (P/O PL 94.10 Item 21)
3	-	Delivery reservoir pump (P/O PL 94.10 Item 21)
4	020K20530	Cam shaft assembly
5	-	Reservoir (P/O PL 94.10 Item 21)
6	114E24380	Connector 12 pin (REP 91.33)
7	-	Thrust washer (P/O PL 31.11 Item 23)
8	-	Bushing roller (P/O PL 31.11 Item 23)
9	008E08570	Cam front
10	-	Spring lock cam (P/O PL 94.10 Item 4)
11	-	Mount lock cam (P/O PL 94.10 Item 4)
12	-	Shaft (P/O PL 94.10 Item 4)
13	-	Cam rear (P/O PL 94.10 Item 4)
14	-	Bushing shaft (P/O PL 94.10 Item 4)
15	-	Pin dowel (P/O PL 94.10 Item 4)
16	-	Lift gear (Not spared)
17	130E12940	Cleaning unit home sensor (Q94-105) (REP 91.27)
18	-	Gear train housing (P/O PL 94.10 Item 19)
19	020K20543	Cleaning unit motor assembly (See NOTE 1)
20	-	Encoder (P/O PL 94.10 Item 19)
21	108R00989	Cleaning unit (complete) (REP 94.1)
22	-	Connector housing (Not spared)
23	-	Drive gear (P/O PL 94.10 Item 19)
24	-	Cleaning unit motor (P/O PL 94.10 Item 19)

NOTE: 1: Drum cleaning motor assembly is mounted onto rear frame.

NOTE: 2: A Cleaning unit handle kit is also available, refer to PL 94.20 Item 27 .

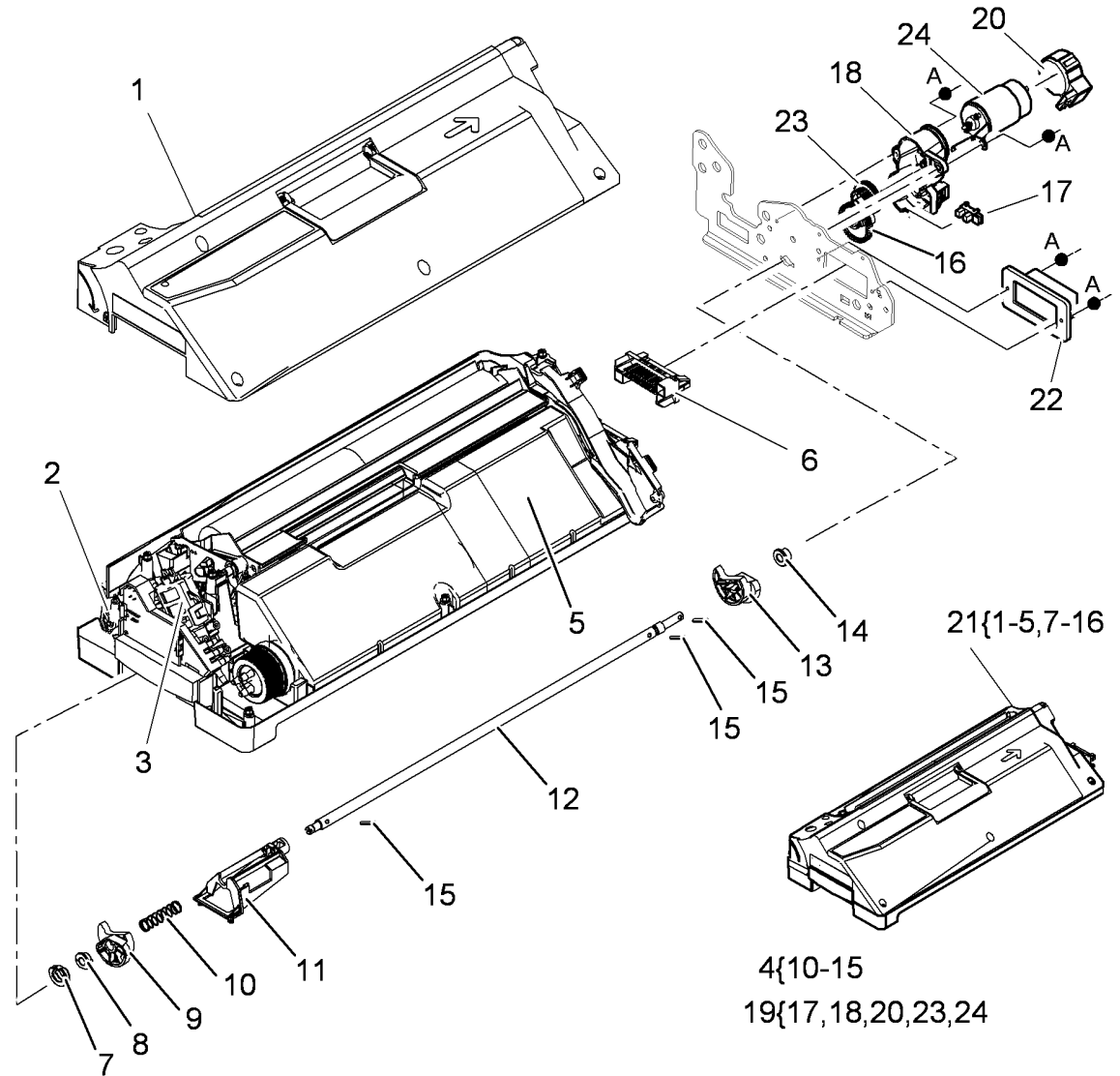

U-8-0059-A

PL 94.15 IOD Assembly

Item	Part	Description
1	020K20580	IOD assembly (REP 91.22)
2	032E35160	Front guide track (REP 91.23)
3	032E35170	Rear guide track (REP 91.23)
4	-	IOD Pre-amplifier PWB (P/O PL 94.15 Item 1)
5	117E35570	IOD to drum driver PWB cable

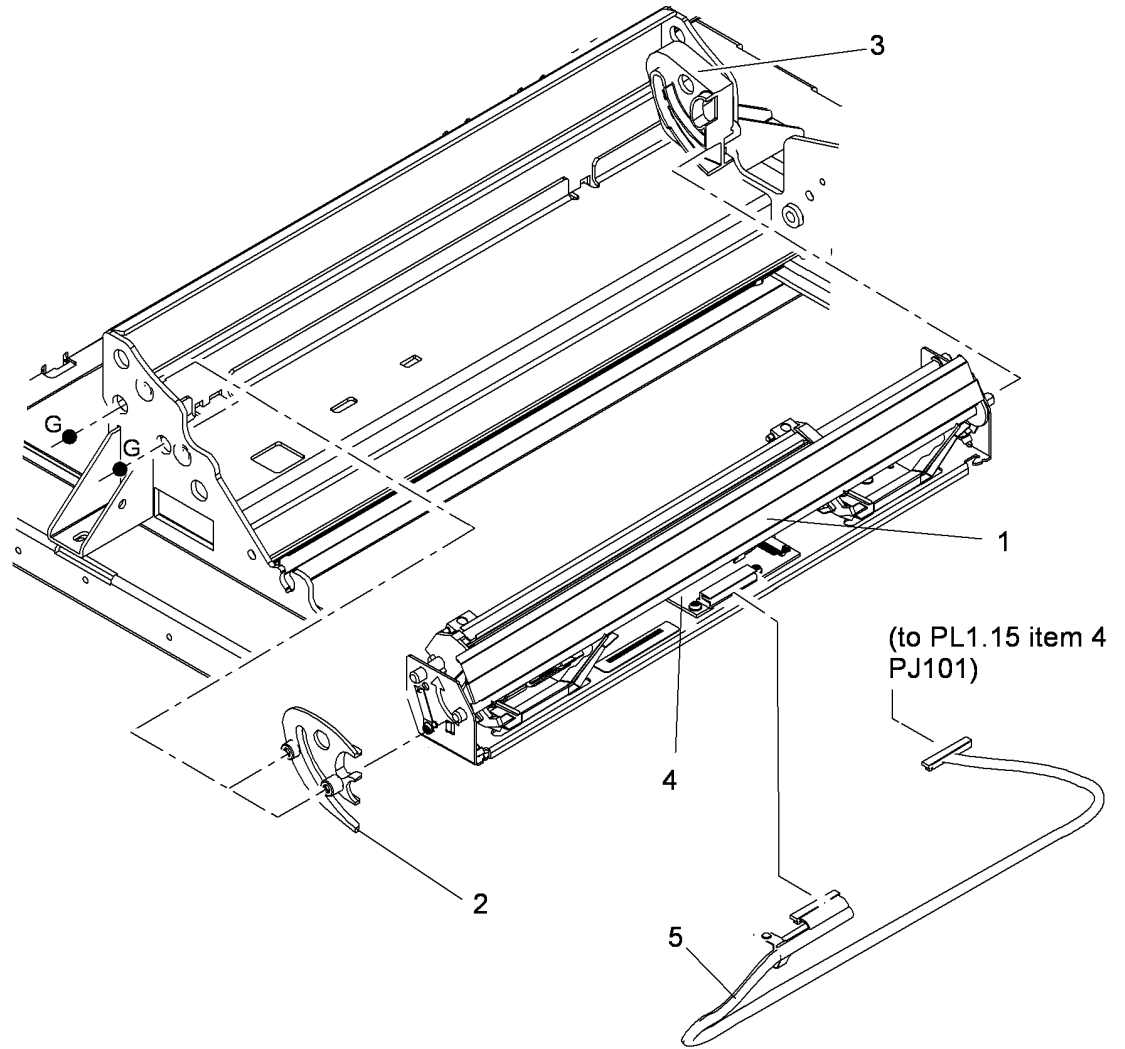

PL 94.20 Drum Assembly

Item	Part	Description
1	-	Drum (P/O PL 31.11 Item 25) (REP 91.25)
2	-	Drum belt (023E31430) (REP 91.24)
3	020K20551	Drum pulley (REP 91.34)
4	-	Drum fan (MOT42-064) (P/O PL 94.20 Item 15)
5	-	Drum fan shroud (P/O PL 94.20 Item 15) (See NOTE)
6	020K20510	Drum drive motor (MOT94-009) (REP 91.24)
7	054E43470	Front drum shroud
8	020K20520	Drum position encoder assembly (Q94-101) (REP 91.30)
9	130K15841	Front drum thermistor (REP 91.35)
10	130K15860	Rear drum thermistor (REP 91.35)
11	-	Abatement fan assembly (MOT42-062) (P/O PL 94.20 Item 15)
12	054E43480	Abatement plenum (REP 91.36)
13	-	Drum protector cover (REF: PL 26.11 Item 11)
14	-	Drum encoder bracket (Not spared)
15	127K68890	Drum and abatement fan assembly
16	801K37690	Front drum frame assembly (REP 91.25)
17	-	Mounting bracket (Not spared)
18	115E13060	Static eliminator
19	-	Locating screw (P/O PL 94.20 Item 27)
20	-	Handle (P/O PL 94.20 Item 27)
21	-	Shaft (P/O PL 94.20 Item 27)
22	-	Latch cam (P/O PL 94.20 Item 27)
23	-	Latch base (P/O PL 94.20 Item 27)
24	-	Spring (P/O PL 94.20 Item 27)
25	-	Retaining washer (P/O PL 94.20 Item 27)
26	-	Bearing (Not spared)
27	604K60830	Cleaning unit handle kit
28	-	Drum heater (P/O PL 94.20 Item 1)
29	-	Not used
30	-	Rear drum support (P/O PL 94.20 Item 1)
31	-	Drum fan retaining plate (P/O PL 94.20 Item 15)

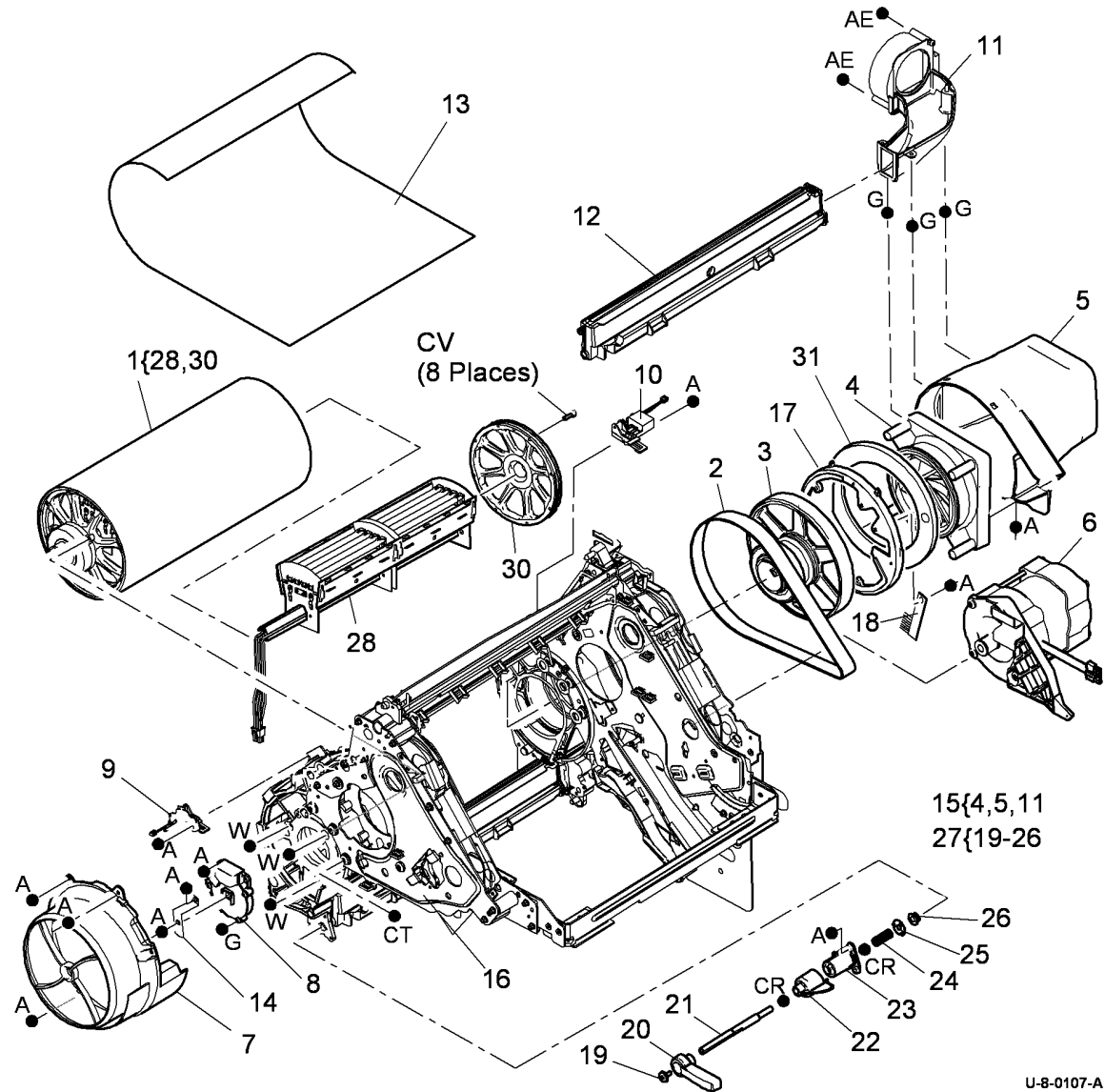

U-8-0107-A

NOTE: HFSI. This component must be cleaned at regular intervals refer to SCP 4 subsystem maintenance. To reset the HFSI count go to dC135.

Common Hardware

Item	Part	Description
A	–	Screw M4x10 Torx (P/O PL 31.11 Item 23) (Silver finish)
B	–	Screw M3x6 Torx (Silver finish)
C	–	Screw M4.5x12 Hex head
D	–	Screw M3x7 Torx (Silver finish)
E	–	Screw M3x7.5 Hex head (Silver finish)
F	–	Screw M4x30 Torx (Black finish)
G	–	Screw M4x12 Torx (P/O PL 31.11 Item 23)
H	–	Screw M4x 12 Slot
I	–	Screw M3x16 Phillips
J	–	Screw M4x16 Torx (Black finish)
K	–	Screw M3x16 Torx
L	–	Screw M4x10 Torx
M	–	E-Clip M4 (P/O PL 31.11 Item 23)
N	–	E-Clip M5
O	–	Screw M4x12 Self Tapping
P	–	Screw M4x7.5 Torx (Zinc finish)
Q	–	Screw M3x12 Torx (Silver finish)
R	–	Screw M4x12 Torx (Silver finish)
S	–	Screw M4x11.5 Torx
T	–	Screw M3x6 Phillips (Black finish)
U	–	Screw M4x11 Phillips (Black finish)
V	–	KL clip M5 (P/O PL 31.11 Item 23)
W	–	Screw M4x20 Torx (P/O PL 31.11 Item 23)
X	–	Screw M4x8 Phillips
Y	–	Screw M3x5.5 Phillips (Black finish)
Z	–	Screw M4x12 Phillips (Black finish)
AA	–	Screw M3x4.5 Phillips (Black finish)
AB	–	Screw M3x6 Phillips (Silver finish)
AC	–	Screw M3x7 Torx (Zinc finish)
AD	–	Screw M4x25 Torx (P/O PL 31.11 Item 23) (Zinc finish)
AE	–	Screw M4x40 Torx (Black finish)
AF	–	Screw M3x8 Torx
AG	–	Screw M4x7 Torx (Silver finish)
AH	–	Washer M4
AI	–	Screw M3x5.5
AJ	–	Screw M3x8 Phillips
AK	–	Screw M3x6 Phillips (Black finish)
AL	–	Screw M3x6 Taptite (Zinc finish)
AM	–	E clip M8
AN	–	Screw M4x8 Machine
AO	–	Screw M4x6 Machine
AP	–	Screw M4x10 Machine
AQ	–	Screw M3x8 Taptite
AR	–	Screw M4x8 Machine
AS	–	Screw M4x10 Self Tapping
AT	–	Screw M4x10 Self Tapping
AU	–	Screw 3x5 machine
AV	–	E-Clip M3.5
AW	–	Screw M3x5.5 Taptite
AX	–	Screw M3x14 Machine
AY	–	Screw M3x18 Self Tapping
AZ	–	Washer M4
BA	–	Screw M4x16 Machine
BB	–	Screw M4x5 Machine
BC	–	Screw M3x10 Machine
BD	–	Screw M3x6 Machine
BE	–	Screw M4x6 Machine
BF	–	Screw M3x8 Self Tapping
BG	–	Screw M4x5 Machine
BH	–	Screw M4x7 Taptite
BI	–	Pivot pin M4x10 Hex Head
BJ	–	6mm x 10mm x 13 bush (bronze)
BK	–	Screw M3x6 Self Tapping
BL	–	Washer M3
BM	–	Spring Washer M3
BN	–	Screw M4x16 Taptite
BO	–	Screw M3x10 Machine
BP	–	Screw M4x7 Self Tapping
BQ	–	Screw M3x5.5 Self Tapping
BR	–	Screw M3x6 Self Tapping
BS	–	Washer M4
BT	–	Screw M3x10 Self tapping
BU	–	Circlip M5
BV	–	Screw M5x12 Self Tapping
BW	–	Circlip M7
BX	–	Screw M3x8 Self Tapping
BY	–	Screw M4x8 Self Tapping
BZ	–	Circlip M10
CA	–	Circlip M6
CB	–	Screw M4x13 Self Tapping
CC	–	Screw M4x6 Self Tapping
CD	–	Screw M5x6 Machine
CE	–	Screw M3x6 Self Tapping
CF	–	Screw M4x12 Torx (Zinc finish)
CG	–	Screw M4x16 Torx (Silver finish)
CH	–	Screw 3.5x10 Self Tapping
CI	–	Screw 3.5x10 Torx
CJ	–	Screw M2.5x8 Taptite
CK	–	Screw M3x17 Taptite
CL	–	Screw M4x8 Machine
CM	–	Screw M3x11.5 Torx (Pan head)
CN	–	Screw M4x7 Self Tapping
CO	–	Screw 3x9.5 Self Tapping
CP	–	Screw M3x14 Self Tapping
CQ	–	Screw 4x 15 Torx (Black finish)
CR	–	KL clip M6
CS	–	Screw M4 x12 Machine, capture washer (P/O PL 31.11 Item 23)
CT	–	Screw M6x15 Machine, Button head (P/O PL 31.11 Item 23)
CU	–	KL clip M8 (P/O PL 31.11 Item 23)
CV	–	Screw M3x23 Torx
CW	–	Washer M6

6 General Procedures/Information

GP 1 to GP 9

GP 1 Service Mode	6-3
GP 2 Fault Codes and History Files	6-4
GP 3 Service Information	6-6
GP 4 Machine Software	6-7
GP 5 Customer Administration Tools	6-11
GP 6 Marking Unit Maintenance Positions	6-14
GP 7 System Grounding Verification	6-20
GP 8 Special Tools and Consumables	6-32
GP 9 UI Services User Menu Map	6-32

GP 10 to GP 19

GP 10 How to Check a Motor	6-37
GP 11 How to Check a Sensor	6-40
GP 12 How to Check a Solenoid or Clutch	6-41
GP 13 How to Check a Switch	6-42
GP 14 How to Switch Off the Machine or Switch On the Machine	6-43
GP 15 Location and Function of PWB LEDs	6-44
GP 16 How to Safely Lift or Move Heavy Modules	6-51
GP 17 Network Clone Procedure	6-52
GP 18 Machine Lubrication	6-53
GP 19 Machine SIM Card Matrix	6-53

GP 20 to GP 29

GP 20 Paper and Media Size Specifications	6-55
GP 21 Installation Space Requirements	6-71
GP 22 Electrical Power Requirements	6-73
GP 23 Environmental Data	6-74
GP 24 Hardware Kit Contents	6-74
GP 25 First Copy/Print Out Time and Power On/Off Time	6-75
GP 26 Restriction of Hazardous Substances (RoHS)	6-75
GP 27 Cleaning Procedure	6-76
GP 28 Marking Unit Assembly Wiring Harnesses	6-79
GP 29 Component Locations	6-80

GP 30 to GP 39

GP 30 How to Mask Jets / Jet Substitution	6-87
GP 31 How to Open and Close the Stripper Gate	6-88
GP 32 User Interface Panel Diagnostics	6-89
GP 33 Machine Features	6-93
GP 34 Service Plan	6-95
GP 35 Copy and Print Speeds	6-97
GP 36 How to Unlock the Cleaning Unit	6-99
GP 37 Post Part Replacement Routines	6-99
GP 38 How to Set the Date and Time	6-101
GP 39 How to Enable HTTP	6-102

GP 40 to GP 46

GP 40 Glossary of Terms, Acronyms and Abbreviations	6-103
GP 41 How to Configure the PWS to Ping a Device	6-114
GP 42 How to Set the IP Address of the PWS	6-115
GP 43 How to Change Ethernet Speed	6-116
GP 44 How to Disable the Firewall of the PWS	6-116
GP 45 How to Check the Battery on the NVM Module PWB	6-118
GP 46 How to Identify the Different Printhead Connectors	6-119

Diagnostic Codes dC103 to dC123

dC103 Billing Plan	6-121
dC104 Usage Counters	6-121
dC108 Software Version	6-122
dC113 Fast Time to Ready	6-122
dC120 Fault Counters	6-123
dC122 Fault History	6-123
dC123 PEST Fault History	6-124

Diagnostic Code dC131

dC131 NVM Read/Write	6-125
----------------------------	-------

Diagnostic Codes dC132 to dC140

dC132 Serial Number	6-251
dC134 Market Region	6-252
dC135 CRU/HFSI Status	6-252
dC136 Service Plan	6-254
dC137 Page Pack	6-254
dC140 Analog Monitor	6-255

Diagnostic Codes dC301 to dC361

dC301 NVM Initialization	6-257
dC312 Network Echo Test	6-259
dC330 Component Control	6-259
dC335 Heater Monitor and Exerciser	6-275
dC361 NVM Save and Restore	6-276

Diagnostic Codes dC608 to dC640

dC608 Document Feeder Registration	6-277
dC609 Document Glass Registration	6-277
dC612 Print Test Pattern	6-278
dC625 Registration / Preheat Calibration	6-278
dC640 Video Path Integrity	6-279

Diagnostic Codes dC708 to dC715

dC708 Drum Drive Control Test	6-281
dC715 Active Registration Control	6-281

Diagnostic Codes dC914 to dC978

dC914 Head to Head Alignment Test	6-283
dC959 Cleaning Unit Exerciser	6-284

dC962 Transfix Load Test.....	6-284
dC965 Printhead Maintenance Cycle Test.....	6-285
dC967 Head to Drum Spacing Check.....	6-286
dC968 Head Purge	6-286
dC969 Clean Ink Smears.....	6-287
dC971 Head to Head Alignment Adjustment	6-287
dC972 Printhead Uniformity	6-288
dC976 Ink Delivery Fault Recovery.....	6-293
dC977 Drum Runout Calibration.....	6-294
dC978 Transfix Calibration Values.....	6-294

Change Tags

Tags	6-295
Processor Tags	6-296
DADH Tags	6-296
Finisher (2K LCSS) Tags	6-297
Finisher (HVF) Tags.....	6-299
Post Process Inserter Tray 6 (PPI) Tags	6-300
Fax Tags	6-300
Tray 5 Tags.....	6-301

GP 1 Service Mode

Purpose

This procedure describes the following items:

- [How to Enter Service Mode.](#)
- [How to Boot/Power Up Directly into IME Diagnostics Mode.](#)
- [Service Info Tab.](#)
- [Diagnostics Tab.](#)
- [Adjustments Tab.](#)
- [Maintenance Tab.](#)
- [Call Closeout Tab.](#)
- [User Interface Diagnostics.](#)
- [Service Copy Mode.](#)

NOTE: When service mode is entered, all existing copy jobs are cancelled. The network controller will stop accepting jobs and a 'Offline' screen message is displayed. When exiting service mode an 'Online' screen message is displayed.

How to Enter Service Mode

1. Switch on the machine, [GP 14.](#)
2. When the machine is ready, press and hold the # key, * key and the Stop key.
3. Enter the passcode 1991. Touch the Enter button on the UI.

NOTE: . An invalid passcode causes a delay of five seconds before another passcode can be entered.

4. Select the required tab from the service mode screen.
5. To return to Ready to scan, select Exit Only or Exit and Reboot.

How to Boot/Power Up Directly into IME Diagnostics Mode

This mode will allow the system controller to boot but not the IME. The IME will have power but will not go through initialization, POST or PEST. The IME will not initiate movement of components until commanded to do so via Service Mode DC routines (e.g. component control) or rebooted into normal customer mode. The IME will be dormant and the heaters are not switched on. The drum will not rotate and the print head carriages remain parked. The machine has no marking capabilities.

1. Switch off the machine, [GP 14.](#)
2. Open the left hand upper door assembly, [PL 70.30.](#)
3. Open the front door.
4. Remove the waste tray.
5. Switch on the machine, [GP 14.](#)
6. Follow the on screen instructions, install the waste tray, close the front door and close the left hand upper door.
7. The UI displays Ready to scan and an error code 000-000 (takes a few minutes).
8. Press and hold the # key, * key and the Stop key.
9. Enter the passcode 1991. Touch the Enter button on the UI.

NOTE: . An invalid passcode causes a delay of five seconds before another passcode can be entered.

10. Select the required tab from the service mode screen.
11. To return to Ready to scan, select Exit Only or Exit and Reboot.

Service Info Tab

The service info routines are used to track faults that have occurred in the machine. Refer to [Table 1.](#)

Table 1 Service Info Tab

Routine	Description
dC104	Usage Counters
dC108	Software Version
dC113	Fast Time to Ready
dC120	Fault Counters
dC122	Fault History
dC123	PEST Fault History
dC135	CRU/HSFI Status

Diagnostics Tab

The diagnostic routines are used to test specific areas of the machine. Refer to [Table 2.](#)

Table 2 Diagnostics Tab

Routine	Description
dC140	Analog Monitor
dC312	Network Echo Test
dC330	Component Control
dC335	Heater Monitor and Exerciser
dC612	Print Test Pattern
dC640	Video Path Integrity
dC708	Drum Drive Control Test
dC715	Active Registration Control
dC914	Head to Head Alignment Test
dC959	Cleaning Unit Exerciser
dC962	Transfix Load Test
dC965	Printhead Maintenance Cycle Test
dC967	Head to Drum Spacing Check

Adjustments Tab

Adjustment routines are used to modify the set-up or to calibrate specific areas of the machine. Refer to [Table 3.](#)

Table 3 Adjustments Tab

Routine	Description
dC131	NVM Read / Write
dC301	NVM Initialization
dC361	NVM Save and Restore
dC608	Document Feeder Registration
dC609	Document Glass Registration
dC625	Registration / Preheat Calibration
dC971	Head to Head Alignment Adjustment

Table 3 Adjustments Tab

Routine	Description
dC972	Printhead Uniformity
dC977	Drum Runout Calibration
dC978	Transfix Calibration Values

Maintenance Tab

Refer to [Table 4](#).

Table 4 Maintenance Tab

Routine	Description
dC103	Billing Plan
dC132	Serial Number
dC136	Service Plan
dC137	Page Pack
dC968	Head Purge
dC969	Clean Ink Smears
dC976	Ink Delivery Fault Recovery

Call Closeout Tab

NOTE: Do not exit service mode until the machine has recovered from all diagnostic routines.

1. Touch the Call Closeout button to exit service mode.
2. Touch the appropriate button to complete the exit procedure.
 - Reset Waste Counter
 - Reset Counters.
Touch the button to reset the following counters:
 - Faults.
 - Last 40 faults.
 - Total Images made after the last service call.
 - Exit. If the button is touched the machine will exit diagnostics.
 - Exit and Reboot. If the button is touched, the network controller is reset.

NOTE: . If the machine is rebooted, the exit time from diagnostics is increased.

NOTE: . It will be necessary to select Exit and Reboot to clear a system fault from the UI and return the machine to an operational state.

User Interface Diagnostics

To access user interface diagnostics press and hold the # key, * key and the 'phone' key together. Refer to [GP 32](#) User Interface Panel Diagnostics and check the functions of the UI.

Follow the on screen instructions.

Service Copy Mode

To access normal user privileges when the machine is password protected. Perform the following:

1. Press and hold the # key, * key and the Stop key.
2. Enter the passcode 2732. Touch the Enter button on the UI.

NOTE: In service copy mode, the customer administration tools are also available.

GP 2 Fault Codes and History Files

Purpose

To describe access to fault history information and explain the fault code structure.

- History files can be accessed from the UI using the [Machine Status Button](#) or from Service Mode under the Service Info tab, refer to [Fault Data Available from Service Mode](#).
- For information on fault codes, refer to [Function, Fault, Component Codes](#).
- For information on service codes which indicate non critical faults that do not stop the machine, refer to [OF 12](#) Service Code RAP.
- For information on status codes, refer to [OF 4](#) Status Codes and Messages RAP.
- For information on power on self test (POST) refer to [OF 16](#) POST Error RAP.
- For information on the machine usage and history, refer to [TP 17](#) Service Usage Profiles.

Machine Status Button

The most recent fault and status codes can be displayed on the UI by pressing the Machine Status button. Touch the Faults tab on the UI then select the appropriate option:

- Fault History.
- Current Messages - status codes and a status message.
- Current Faults.

Fault Data Available from Service Mode

Service Mode ([GP 1](#)) gives access to 3 fault history options:

- Fault Counters ([dC120](#)) - Displays the titles of all faults separated into chains, sortable by chain or frequency.
- Fault History ([dC122](#)) - Displays the last 40 faults. Selecting a fault will display it in detail.
- PEST Fault History ([dC123](#)) - Displays the history of faults recorded during Print Engine Self Tests.

Function, Fault, Component Codes

Refer to:

- [Table 1](#) Function and fault code prefixes. Also known as the chain code.
- [Table 2](#) Fault and control code suffixes. Also known as the link code.
- [Table 3](#) Finisher fault code and status code suffixes. Also known as the extension code.

For example. Displayed code 373-215 Tray 3 hoist failure:

- 3 - This serves no purpose and can be ignored. This digit is not shown on any fault codes in this manual.
- 73 - The fault is located in chain 7, 'Paper supply and tray 3', [Table 1](#).
- 215 - The first digit 2 indicates it is a 'System timing' code, [Table 2](#). The 1 and the 5 are sequence numbers and have no other significance.

NOTE: Where possible, the component related fault codes are the same as the component control codes.

Table 1 Function and fault code prefixes

Chain Code	Function
01	Standby power

Table 1 Function and fault code prefixes

Chain Code	Function
02	User interface
03	Machine run control
05	Document transport
10	Transfix and copy/print transportation
12	Finishers
16	Network controller
19	Video image manipulation
20	Fax
22	System Errors
42	Fans and cooling
63	Scanner
7X (X = tray No.)	Paper supply (paper trays and bypass)
81	Paper feed
82	Pre registration transport
83	Duplex paper path
88	Media premarking conditioning
89	Paper registration
91	Marking Unit
92	IOT Process control
93	Ink delivery
94	Ink transfer
99	PEST

Table 2 Fault and control code suffixes

Link Code	Description
000 to 099	Output
100 to 199	Jams
200 to 299	System timing
300 to 399	Controls
400 to 499	Spare or overflow
500 to 599	Status codes
600 to 699	Marking copy / print quality
700 to 799	Non-declared defects
800 to 899	Optional use
900 to 999	Operator messages

Table 3 Finisher fault code and status code extensions

Suffix No.	Finisher Identifier
65	OCT
110	2K LCSS
171	HVF
172	HVF BM (see NOTE)
173	HVF BM + tri-fold (see NOTE)
174	HVF BM + inserter (see NOTE)
175	HVF BM + tri-fold (see NOTE)
176	HVF BM + tri-fold + inserter (see NOTE)

NOTE: The finisher status code extensions are not normally visible. Throughout this manual, the code extension 171 is used for all HVF variants.

GP 3 Service Information

Purpose

To provide machine hardware and software information.

Service Information From The Service Mode Screen

Enter service mode, [GP 1](#). Select the Service Info tab. This gives the following options:

- Information Routines.
 - dC108 Software Version
 - dC113 Fast Time to Ready
 - dC120 Fault Counters
 - dC122 Fault History
 - dC123 PEST Fault History
 - dC135 CRU/HFSI Status
 - TP 17 Service Usage Profiles.
- General Information
 - Product Code:
 - Serial Number:
 - Total Images:
 - Images since Last Call:
 - Software Set Version:
 - IP Address:
 - Service Code:

Service Information From The UI Machine Information Tab

Press the machine information key to the left of the UI to display the machine information tab. This gives the following options:

- General Information
 - Customer Support
Website: www.xerox.com
Phone:
 - Machine Serial Number. See [Machine Serial Number](#)
 - Current System Software
000.00.000
 - Service Code: see [OF 12](#) Service Codes RAP.
- Paper Tray Status
- Information Pages
- Installed Options
- Maintenance Assistant

Machine Serial Number

The machine serial number is also on the machine TAG label.

The serial number for the US markets is in the format

XXX #####, where XXX is the product code and ##### is the rolling serial number, for example a US machine might be BRE230511.

The serial number for the XE markets is in the format YYY #####C, where YYY is the location code, ##### is the rolling serial number and C is a check digit, for example 3642005012.

Product Code

Primary Build

- BRE: ColorQube, IOT with Scanner and DADH (XC).102 to 140VAC
- BRF: ColorQube, GSA Compliant IOT with scanner and DADH (XC).102 to 140VAC

GP 4 Machine Software

Purpose

To provide machine software information and explain the software loading procedure.

Description

Software sets are compilations of the various software modules and together with a SCD (software compatibility database) are bundled into a DLM file, available on the CSE USB flash drive, [PL 26.11 Item 6](#). The method of upgrading the machine software is via a software upgrade or an AltBoot software loading procedure.

Refer to the following items for additional information about machine software:

- [Modules](#)
- [Software Compatibility Database \(SCD\)](#)
- [Common Upgrade Behavior](#)
- [Software Loading Procedure](#)
- [Troubleshooting](#)

Modules

A software module is defined as a programmable piece of software existing as a file in its own right. Software modules reside on hardware modules.

The 3 tray module contains firmware and cannot have software upgrades loaded.

NOTE: The software for the DADH, 3 tray module or tray 5 can only be upgraded by installing a newer version of the relevant PWB on each hardware module.

Software Compatibility Database (SCD)

The SCD is used to describe the machine system software. The SCD comprises of the system software version in the format ColourQube_9301-9303_system-sw#(PPP)(MMM)(YYY)(DDD)(RR)#.dlm and a list of software versions for the different modules.

The description of the system software file name is:

- PPP - is the platform identifier.
- MMM - is the machine identifier.
- YYY - is the year of release.
- DDD - is the day, in the year, of release.
- RR - is the daily revision number.

NOTE: The system software version is displayed on the UI under Machine Details and on the Service Info screen in service mode.

The primary function of an SCD is to ensure that all software on the machine is compatible.

Common Upgrade Behavior

A software upgrade is requested if a new hardware module is installed which has an earlier or later software version.

When an upgrade has been initiated the machine will reboot with all modules in upgrade mode.

Progress and errors are displayed on the UI screen.

When the upgrade is complete, the machine will reboot.

When a machine is switched on, the single board controller PWB (SBC) compares its SCD with the software in the hardware modules. If necessary, a software upgrade or downgrade is instigated by the single board controller PWB.

NOTE: If a component is installed that has a later version of software than the software set on the single board controller PWB, at machine startup the software on the new component is downgraded.

The SCD is updated on successful completion of the upgrade.

Software Loading Procedure

Before loading software, the following are necessary:

- If possible, the machine must be in a fully operational condition. Any active faults or jams must be resolved before starting this procedure if possible.
- A USB flash drive, [PL 26.11 Item 6](#). The ColorQube 9303 family approved USB flash drive is recommended with a minimum capacity of 1GB.
- The latest ColourQube_9301-9303_system-sw#pppmmmyyddrr#.dlm file.

NOTE: The procedure will take approximately 30 minutes. If the software loading procedure fails, go to [OF 5 Boot Up Failure RAP](#).

Go to the relevant procedure:

- [AltBoot Software Loading](#)
- [System Software Loading](#)

AltBoot Software Loading

AltBoot loads machine software. It is used to upgrade, downgrade or reload software onto a machine that will not come to a ready state. It can also be used to upgrade or downgrade the software on options fitted to the machine e.g HVF. To force an upgrade or downgrade of all installed options, a folder titled FORCED_UPGRADE must be put in the Altboot folder with the .dlm file on the USB thumbdrive. The FORCED_UPGRADE folder can be created or downloaded from GSN library 10480.

AltBoot should be only be used under the following circumstances:

- To attempt to recover a corrupt:
 - Hard disk drive, [PL 3.11 Item 2](#).
 - Single board controller PWB, [PL 3.11 Item 13](#).
 - NVM module PWB, [PL 3.11 Item 17](#).
- After installing a new hard disk drive, [PL 3.11 Item 2](#).
- To upgrade machine software without running multiple software upgrades.
- To downgrade machine software.

CAUTION

The AltBoot software load procedure erases customers unique network configuration settings. A backup of this data must be saved and must be performed during this procedure.

NOTE: To restore the XSA data, use the customers XSA data backup (clone) file on the customers PC. Refer to the Customer Administrators Guide CD.

Procedure

NOTE: If the machine appears to hang during the AltBoot process (stay on one screen without apparent progress), wait 10 minutes before switching the machine off, GP 14. The machine may still be loading software in the background and switching the machine off during this phase will corrupt the hard disc. A new hard disc is required to recover.

Perform the following:

1. Create a top level folder on the USB flash drive named AltBoot (this is not case sensitive).
2. Copy the unzipped ColourQube_9301-9303_system-sw#ppmmmyyddrr#.dlm file from the system software CD into the AltBoot folder on the USB flash drive. Make sure that there is only one .dlm file in the Altboot folder.

NOTE: Ensure the Microsoft Windows Safely remove hardware procedure is followed before the USB flash drive is removed.

3. Perform an NVM Save, refer to NVM Save and Restore, dC361. Ensure that the NVM data is saved to the USB flash drive.

NOTE: The same USB thumbdrive that has the .dlm file can be used to store the NVM.

4. Perform GP 17 Network Clone Procedure.
5. If possible, complete or delete all pending print jobs. If the prints jobs cannot be deleted, warn the customer that all pending jobs will be lost.
6. Switch off the machine, GP 14.
7. Connect the USB flash drive into any of the USB ports.
8. Switch on the machine, GP 14. The Altboot process will start automatically. No button presses are required to initiate the Altboot.
9. The upgrade start screen is displayed, Figure 1.

NOTE: Occasionally the USB flash drive will be incompatible with the machine and the upgrade start screen, Figure 1 will be continually displayed. If after 10 minutes the screen has not changed, replace the USB flash drive with a Xerox approved model, PL 26.11 Item 6. Restart the process.

10. The upgrade will begin and the progress screen will open in approximately 2 minutes, Figure 2.

NOTE: If the upgrade process screen is not displayed after 4 minutes, restart the process.

11. The AltBoot process should complete after approximately 5 minutes and the AltBoot complete screen will open, Figure 3. Follow the on screen instructions.
12. If the AltBoot process fails, the AltBoot failed screen will open, Figure 4. Follow the on screen instructions. Restart the procedure and refer to Troubleshooting as necessary.

NOTE: Do not switch off the machine unless directed to on the UI. During the next 2 reboots, the hard disk drive is encrypted. Switching off the machine can cause only partial encryption of the partitions on this component. The AltBoot process may need to be re-run if power is removed at this step.

13. The machine will reboot several times before returning to a ready state. In some instances, a second upgrade progress screen may be displayed, Figure 2 or the Data Encryption/Decryption in progress screen, Figure 5. If a power on failure screen appears, Figure 6, switch off, then switch on the machine, GP 14.
14. Check that the software set has been installed. Refer to the printed software upgrade report, Figure 7 or by pressing the machine status button.
15. Perform an NVM Restore, refer to NVM Save and Restore, dC361.
16. Perform a Network Clone Restore, refer to GP 17.



U-1-1405-A

Figure 1 Upgrade start screen



U-1-1404-A

Figure 2 Upgrade progress



U-1-1403-A

Figure 4 AltBoot failed



U-1-1402-A

Figure 3 AltBoot complete



U-1-1409-A

Figure 5 Encryption progress



U-1-1401-A

Figure 6 Power on failed

Troubleshooting

Listed below are possible problems that may stop AltBoot software loading:

Possible causes and solutions are:

- Incompatible USB flash drive. Use a Xerox approved model of USB flash drive, [PL 26.11 Item 6](#).
- Corrupt.dlm file. Replace the .dlm file.
- Incorrect spelling of the AltBoot directory on USB flash drive.
- Bad data connection to the HDD. Reseat the HDD harnesses, [PL 3.11 Item 3](#) and [PL 3.11 Item 12](#).
- Hard disk drive corruption or failure.
- The machine has a PEST fault causing it to re-start PEST. This removes power from the single board controller PWB when the Altboot process is initiating. Boot the machine directly into IME Diagnostics Mode [GP 1](#).
- USB port or cable damage, [PL 3.11](#). Use a different USB port or cable.
- UI failure, [PL 2.10](#).
- Single board controller PWB, [PL 3.11 Item 13](#).
- Check the +5V supply to the USB ports at PJ 17 pin 14 on the single board controller PWB. Refer to [WD 3.2](#).

System Software Loading

There are 2 ways to upgrade software:

- [Software Loading Procedure Via USB Flash Drive](#)
- [Software Loading Procedure Via Network](#)

NOTE: The software loading procedure can only be used to upgrade the machine. Downgrading and reloading must be performed via the AltBoot procedure. If the software loading procedure fails, go to the [OF 5 Boot Up Failure RAP](#).

Software Loading Procedure Via USB Flash Drive

Perform the following:

1. Create a top level folder on the USB flash drive or network named upgrade (this is not case sensitive)
2. Copy the ColourQube_9301-9303_system-sw#ppppmmmyyddrr#.dlm file from the system software CD into the upgrade folder of the USB flash drive.

NOTE: Make sure there is only one file in the upgrade folder.

3. If possible, complete or delete all pending print jobs. If the prints jobs cannot be deleted, warn the customer that all pending jobs will be lost.
4. Before software is loaded, ensure that the machine is in a fully operational condition. Any active faults or jams must be resolved before starting this procedure.
5. Check the Release Notes and the current software already loaded on the machine. Ensure that the upgrade can be applied.
6. Connect the USB flash drive into any of the USB ports.

NOTE: It is not necessary to switch off the machine to perform a software upgrade.

Occasionally the USB flash drive will be incompatible with the machine. Replace the USB flash drive with a Xerox approved model, [PL 26.11 Item 6](#). Restart the process.

7. The UI power on light will Intermittently light.
8. The upgrade start screen is displayed, [Figure 1](#).
9. The upgrade will begin and the progress screen will open, [Figure 2](#).
10. The system upgrade process should complete after approximately 5 minutes and the machine will come to a ready state.
11. If the system upgrade process fails, the hard disk drive has become corrupt. Perform an [AltBoot Software Loading](#).
12. The machine will reboot several times before returning to a ready state. The machine may also display the upgrade progress screen, [Figure 2](#). If the power on failure screen is displayed, [Figure 6](#), switch off, then switch on the machine, [GP 14](#).
13. After the software has upgraded a software upgrade report will be printed, [Figure 7](#).

Software Loading Procedure Via Network

1. Connect to the machines web pages either from a PC connected to the network or using the PWS and an ethernet crossover cable.
2. On the customers workstation, open the web browser. Enter the machines IP address in the web browser Address field, then press the enter key. The machine web page will open.

NOTE: Refer to the configuration report for the machines IP address.

3. Enter the Administrator User ID and Password.
4. Click on Properties.
5. Select General Setup.
6. Select machine software.

7. Select upgrades. Then check the Enabled check box.
8. Select manual upgrade, then browse. Select the .dlm file from the Upgrade directory.
9. Select install software.

NOTE: All network connectivity to the machine will be lost. Progress can be monitored from the UI, [Figure 2](#).

10. The machine will reboot before returning to a ready state.

Xerox ColorQube 9301 Software Upgrade Report



Report Date: Jan 26, 2011 at 12:44 PM
 Report Time: 12:44

Device Name: XRX_0000AADC9107
 Device Serial Number: 3642005048

Software Upgrade Date: 26/01/11
 Software Upgrade Time: 12:28
 Software Before Upgrade: 000.000.000.00000
 Software Upgrade Requested: 061.180.101.02601

Software Upgrade Result: Success

Module	Fault Code	Debug Code	Status	Dependent Module	Version	Min

U-1-1411-A

Figure 7 Software upgrade report

GP 5 Customer Administration Tools

Purpose

To gain access to customer administration tools.

How to Enter Customer Administrator Tools

Perform the following:

1. Switch on the machine, [GP 14](#).
2. When the machine is ready, select login / out (key symbol) on the key pad or select guest on the UI.
3. Enter User Name 'admin' (case sensitive).
4. Select Next.
5. Enter the Password '1111' (default setting).
6. Select Enter.
7. Select machine status key (machine symbol key). To access the customer administration screen.

When the machine is password protected. To access device setting, network setting and trouble shooting. Perform the following:

1. Press and hold the # key, * key and the Stop key.
2. Enter the passcode 2732.
3. Select Enter.
4. Select machine status key (machine symbol key) and tools. To access the customer administration screen.

NOTE: In service copy mode, the customer administration tools are also available.

NOTE: After entering customer administration tools, all existing copy jobs are cancelled. The network controller will stop accepting jobs and a 'Offline' screen message is displayed. When exiting service mode an 'Online' screen message is displayed.

The tools menu map is also available in the information pages. Select Machine Status / Machine Information / Information Pages and select the Tools Menu Map.

The customer administration Tools menu contains the following features:

- Device Setting - [Table 1](#).
- Service Setting - [Table 2](#).
- Network Setting - [Table 3](#).
- Account Setting - [Table 4](#).
- Security Setting - [Table 5](#)
- Troubleshooting - [Table 6](#).

Table 1 Device Settings

Feature	Feature options	Selection
General	Energy Saver	Intelligent Ready Job Activated Scheduled Fast Resume Off/On
	Date and Time	Time Zone (GMT Offset) Date Time
	Languages / Keyboard Selection	Languages Keyboard Layout
	Custom Keyboard Button	-
	Xerox Customer Support	Phone number
	Entry Screen Defaults	Default Pathway Services Pathway Default Job Status Pathway Default
	Measurements	Units Numeric Separator
	Paper Size Preference	Inches / Metric
	Audio Tones	Fault Tone Conflict Tone Selection Tone
	Low Supply Warning	Number of days
	Supply Counter Reset	-
Paper Management	Paper Type and Color	Plain / Recycled / Colour
	Paper Substitution	Enable / Disable
	Paper Size Preference	Inches / Metric
	Standard Size Required	Enable / Disable
	Tray Settings	Edit settings
	Tray Contents	Paper Size / Type
Timers	Auto Resume Timer	Auto Resume / Wait for User
	Held Job Timeout	Enable / Disable
	System Timeout	Enable / Disable
Input	Auto Color Detection	Scan from Document Glass / Scan from Document Feeder
	Photo / Text Settings	Recognition

Table 1 Device Settings

Feature	Feature options	Selection
Output	Contention Management	Priority / First In, First Out
	Out of Staples Options	Complete job without stapling Fault / Hold Job
	Output Location	Copy / Fax / Print
	Within Job Offsetting	Enable / Disable
	Staple Productivity Mode	Enable / Disable
Quick Setup Home	IP Address / contact number	-
Display Brightness	Brighter / Darker	-
Configuration / Information Pages	-	Administrator Only Open to All UsersPrint Configuration at Power OnPrint Now
Reset UI to Factory Settings	- Cancel / Reboot	-
Interrupt Printing Enablement	-	Enable / Disable

Table 2 Service Settings

Feature	Feature options	Selection
Copy Service Settings	Feature Defaults	Reset / Save
	Edge Erase Presets	Undo / Reset / Save
	Image Shift Presets	Undo / Reset / Save
	Reduce/Enlarge Presets	Undo / Reset / Save
	Reading Order Options	Scan Order Print Order
	Auto Image Rotation	When Auto R/E Selected When Auto Paper Selected
Embedded Fax Settings	Fax Setup	Enable / Disable
	Feature Defaults	-
	Fax Country Setting	-
	Line 1 Setup	-
	Line 2 Setup	-
	Incoming Fax Defaults	Auto Answer Delay Junk Fax Prevention Paper Settings Ring Volume Secure Receive Default Output Options
	Transmission Defaults	Automatic Redial Setup Automatic Resend Audio Line Monitor Send Header Text Batch Send

Table 2 Service Settings

Feature	Feature options	Selection
	Mailbox and Polling Policies	Received Documents Stored Documents
	Mailbox Setup	-
	Setup Fax Reports	Activity Report Confirmation Report Broadcast and Multipoll Report
	Print Fax Reports	Activity Report Protocol Report Dial Directory Report Group Directory Report Options Report Pending Jobs Report Print Now
Job Sheets	Banner Sheets	Print Banner Sheet Yes / No Print Driver Override Yes / No Banner Sheet Identification
	Output Error Sheets	Enable / Disable
	Paper Type and Color	Paper Type Paper Color
Service Plan	-	-

Table 3 Network Settings

Feature	Feature Options
Online/Offline	Online / Offline
TCP/IP Settings	TCP/IP Enablement Dynamic Addressing IP Address / Host Name Subnet and Gateway DNS Configuration
Advanced Settings	Ethernet Physical Media HTTP Settings 802.1x
Network Logs	Basic Enhanced Download Basic Log File

Table 4 Accounting Settings

Feature	Feature Options
Accounting Mode	None Auxiliary Access Xerox Standard Accounting Network Accounting
Copy Activity Report	Enable / Disable

Table 5 Security Settings

Feature	Feature Options	Selection
Authentication	Job Deletion	All Users System Administrator Only
Image Overwrite Security	Immediate Overwrite	Disable / Enable
	On Demand Overwrite	Standard Full Overwrite Now
	Valid Recipients	Allow any valid E-mail Address Limit to Address Book entries only
	IP Sec	Disable IP Sec

Table 6 Troubleshooting

Feature	Feature options	Selection
Support Pages	Troubleshooting Print Quality Page Jet Test Pages Print	-
Fix Image Quality	Fix Options: Light Lines Smears Advanced	Print Test Pages
Automatic Light Lines Fix	Quick Fix Full Fix	On / Off Eco / Always / Off
Resets	Software Reset	All Software Network Software Copy Software Reset
	Supply Counter Reset	Document Feeder Feed Roller
Network	Echo Test	Protocol Start Test
Fax	Fax Protocol Report	Protocol Report Print Now

Call Closeout

Perform the following:

1. Select admin on the UI button to exit Customer Administration Tools.
2. Select Logout.

GP 6 Marking Unit Maintenance Positions

Purpose

- To explain how to move the marking unit into the maintenance position.
- To explain how to move the marking unit into the operational position.
- To explain how to park the printhead carriages.
- To explain how to dock the printhead carriages.
- To explain how to move the HM wiper blade
- To explain how to move the lower printhead carriage into the maintenance position.

NOTE: Definitions of the positions described in this procedure.

- The marking unit service position is defined as when the marking unit is withdrawn from the machine on the slide rails.
- The marking unit operation position is defined as when the marking unit is fully home within the machine as it is when printing.
- The printhead parked position is defined as when the carriages are away from the drum.
- The printhead docked position is defined as when the printheads are against the drum and the carriages are docked in contact with the frame.
The printhead carriages can be moved into the docked position when the marking unit is in the service position. This gives access to the rear of the printheads. In this case the printheads will not dock as the marking unit is moved away from the frame. Caution is advised in this situation as the upper printhead can contact the lower printheads.
- The lower printhead carriage service position extends the travel of the lower carriage to allow better access to the top of the lower printheads.

Procedure

WARNING

Switch off the electricity to the machine. Refer to GP 14. Disconnect the power cord from the customer supply while performing tasks that do not need electricity. Electricity can cause death or injury. Moving parts can cause injury.

Preparation

WARNING

Take care during this procedure. Sharp edges may be present that can cause injury.

1. Open the front door.
2. Remove the inner cover, PL 81.11 Item 2.
3. Go to the relevant procedure:
 - Move the Marking Unit into the Maintenance Position
 - Move the Marking Unit into the Operation Position
 - Move the Carriages to the Parked Position
 - Move the Carriages into the Docked Position
 - Move the HM Wiper Blade
 - Move the Lower Printhead Carriage into the Maintenance Position

Move the Marking Unit into the Maintenance Position

CAUTION

Move the marking unit slowly on the rails. If the machine has not been allowed to cool for 30 minutes the ink in the reservoir will be fluid and can spill.

1. Prepare to move the marking unit into the service position, Figure 1.

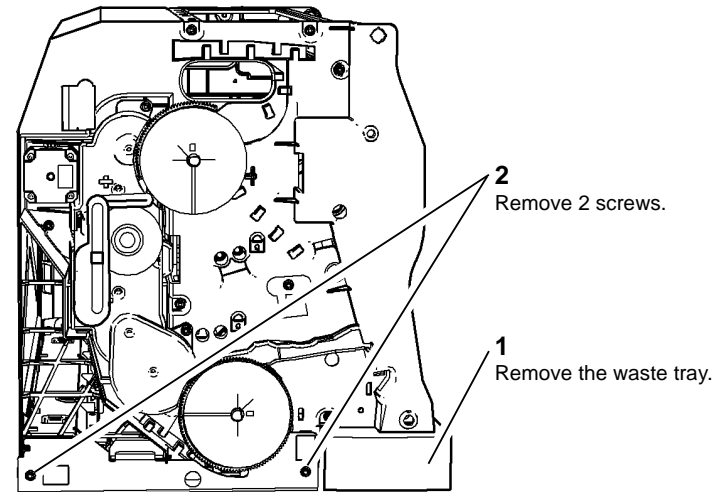

U-1-0900-A

Figure 1 Preparation

CAUTION

Ensure the carriages are both in the parked position. If the marking unit is moved while the carriages are not parked the printheads can contact the drum.

2. Ensure the carriages are in the parked position, Figure 4 and Figure 5.

CAUTION

Do not touch the face plates of the print heads.

3. Move the marking unit into the service position, Figure 2.

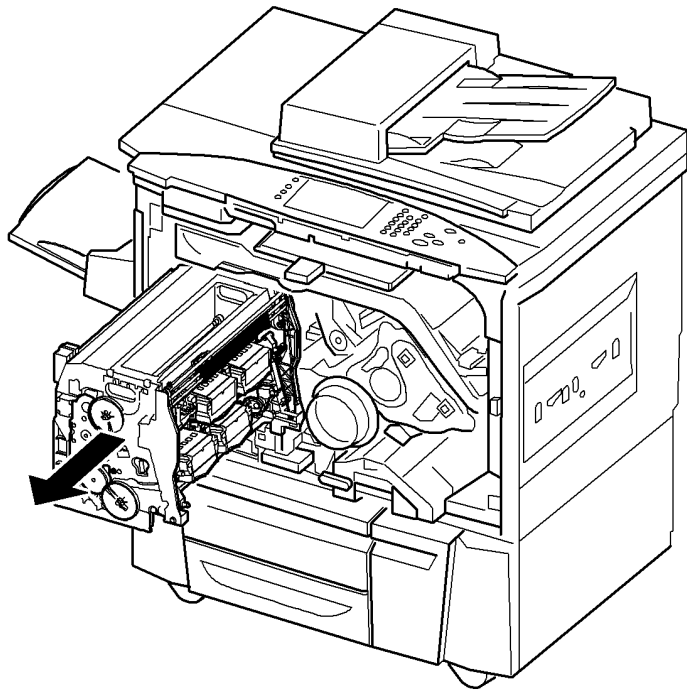

- 1**
Gently pull the handle to move the marking unit into the service position.

Figure 2 Marking unit into service position

U-1-1143-A

4. Reinstall the waste tray.

NOTE: The waste tray is attached to the underside of the marking unit assembly by 2 lugs at the rear and 1 lug at the front.

Move the Marking Unit into the Operation Position

1. Remove the waste tray.

CAUTION

Ensure the carriages are both in the parked position. If the marking unit is moved while the carriages are not parked the printheads can contact the drum.

2. Ensure the carriages are in the parked position, **Figure 4** and **Figure 5**.
3. Move the marking unit into the operation position, **Figure 3**.

NOTE: The marking unit often sticks during the last bit of travel going into the operating position. Push directly on the two screw hole locations, located at the bottom of the frame to fully seat the marking unit.

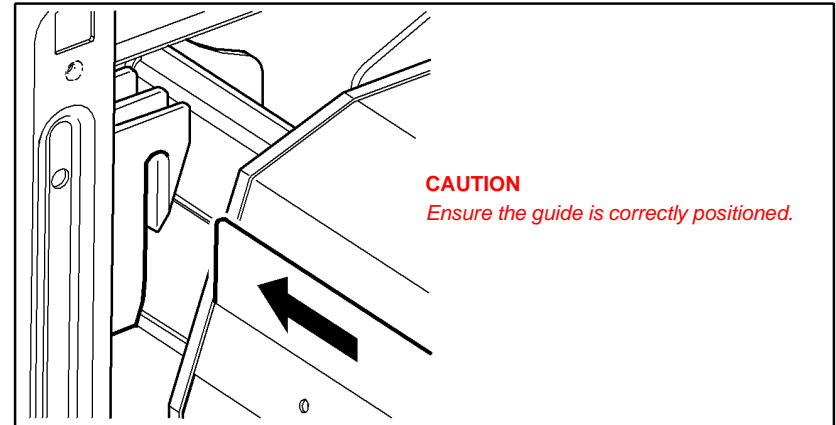

CAUTION
Ensure the guide is correctly positioned.

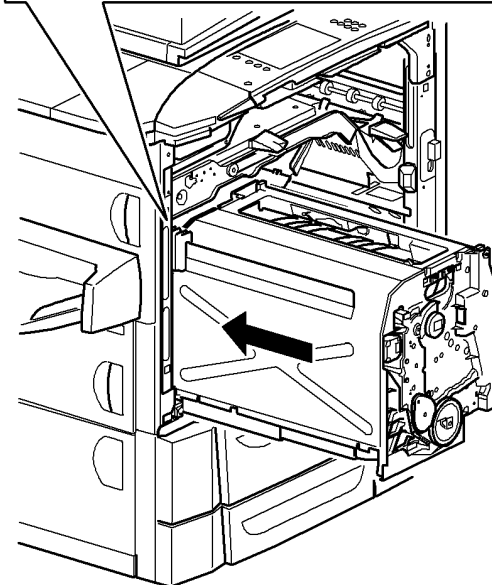

- 1**
Push the marking unit into the machine.

U-1-1144-A

Figure 3 Marking unit into operation position

4. Reinstall the waste tray.
5. Reinstall the two screws to secure the marking unit.
6. Reinstall the inner cover.

Move the Carriages to the Parked Position

1. Move the upper carriage to the parked position, [Figure 4](#).

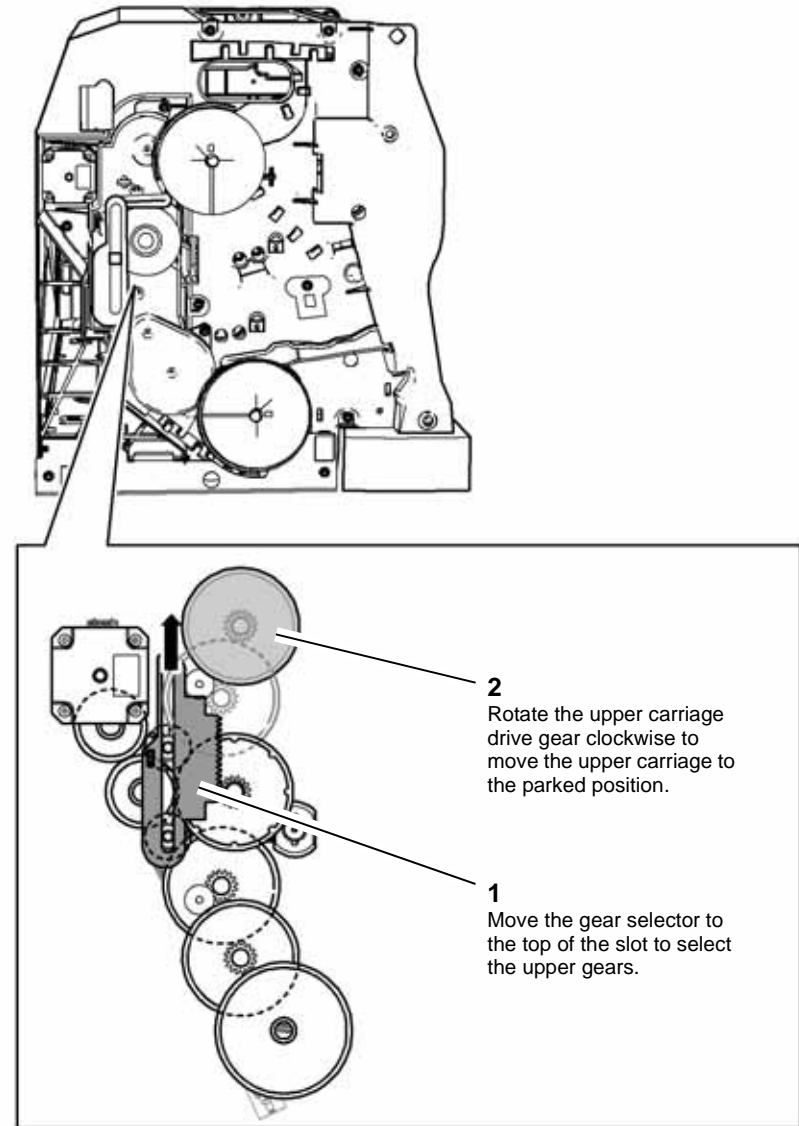

U-1-0898-A

Figure 4 How to park the upper carriage

2. Move the lower carriage to the parked position, [Figure 5](#).

Move the Carriages into the Docked Position

CAUTION

Do not move the upper and lower carriages into the docked position at the same time if the marking unit is in the service position. The printheads can contact each other if the locator pins do not stop against the frame.

1. Move the upper carriage into the docked position, [Figure 6](#).

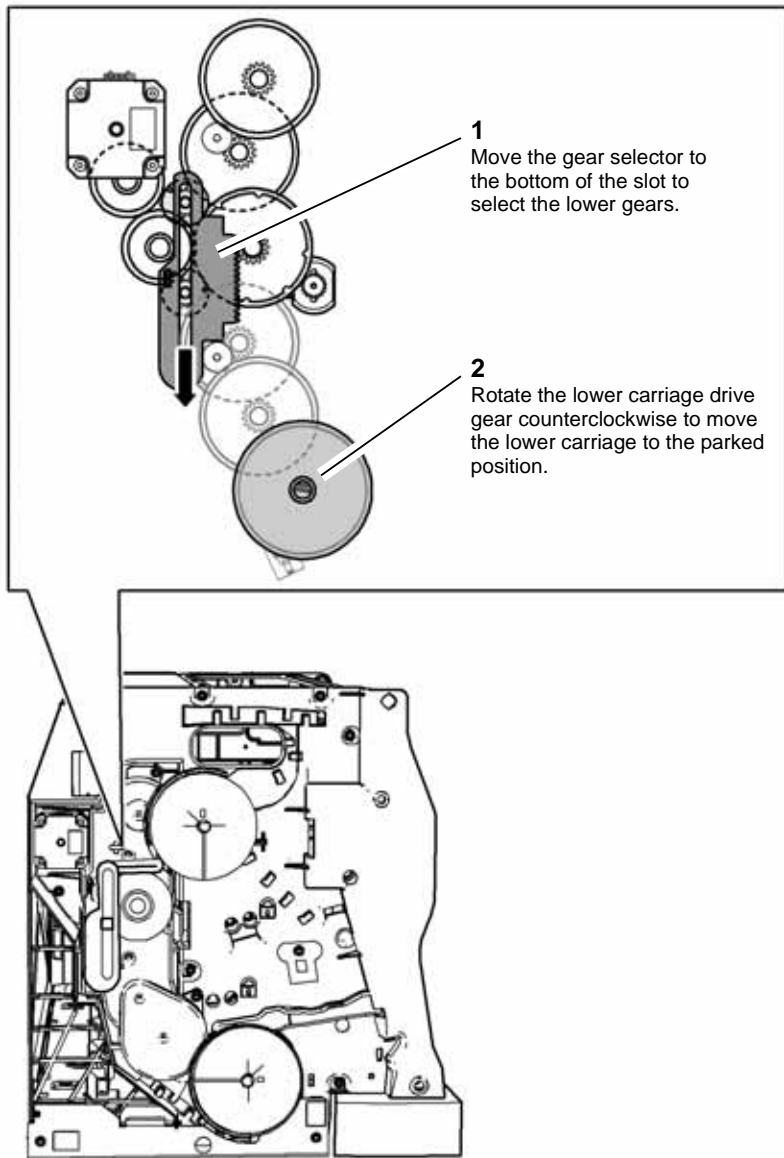

U-1-0899-A

Figure 5 How to park the lower carriage

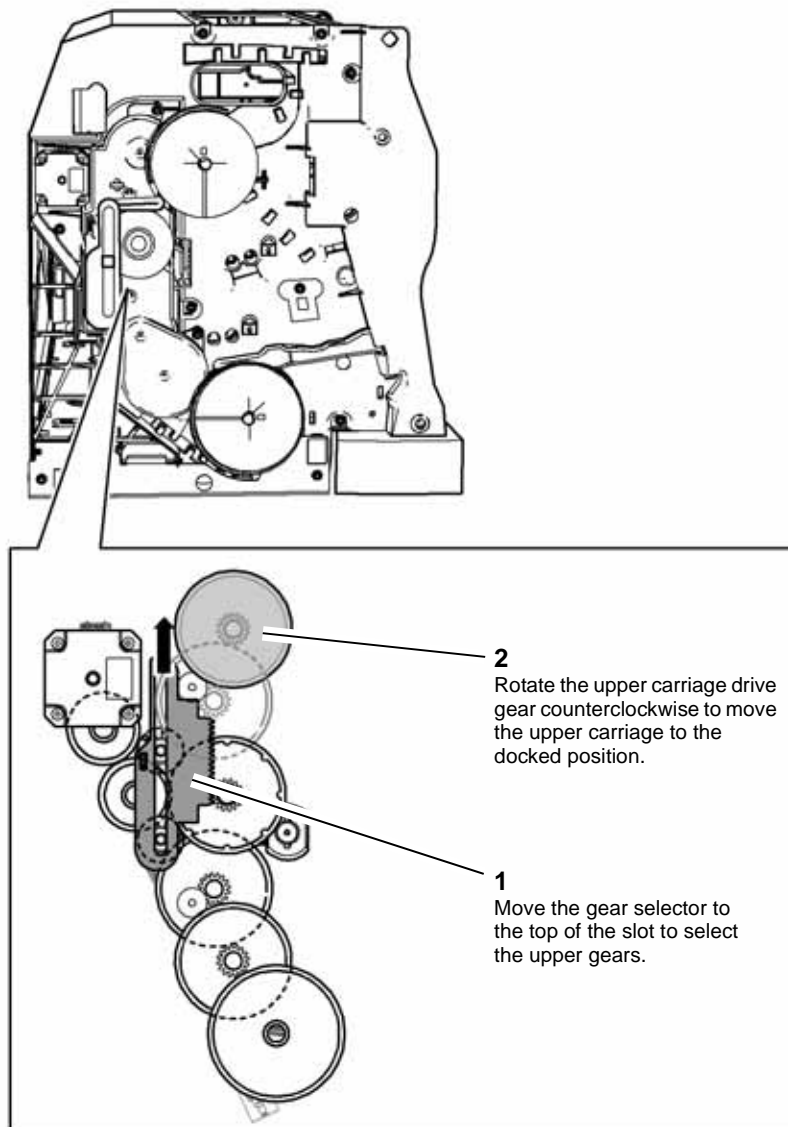

U-1-1170-A

Figure 6 How to dock the upper carriage

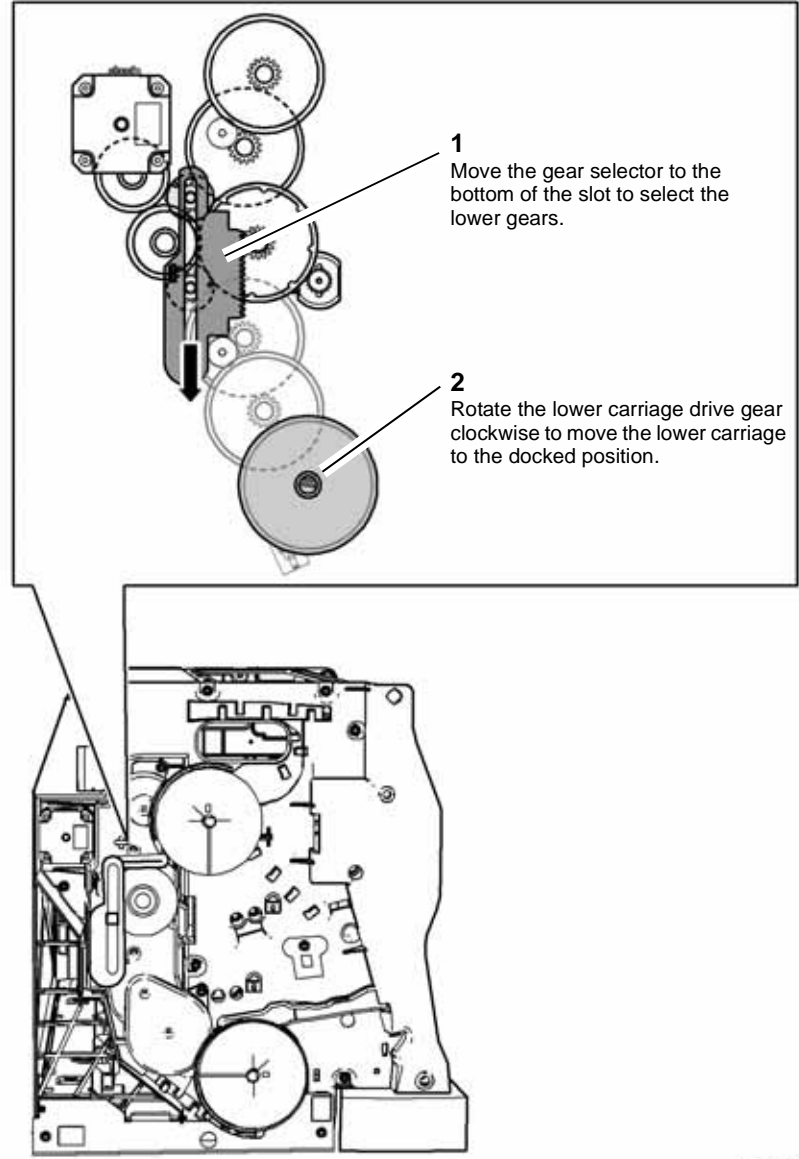

U-1-1171-A

Figure 7 How to dock the lower carriage

2. Move the lower carriage to the docked position, [Figure 7](#).

Move the HM Wiper Blade

1. Move the marking unit into the service position.
2. Rotate the upper drive shaft, [PL 91.15 Item 7](#), so that the HM wiper blade moves to the required position.

Move the Lower Printhead Carriage into the Maintenance Position

1. Move the marking unit into the service position.
2. Move the HM wiper to the top of its travel.
3. Move the lower printhead carriage into the docked position.
4. Release the lower front compliant link ([PL 91.10 Item 7](#)) from the lower carriage assembly ([PL 91.25 Item 1](#)), [Figure 8](#).
5. Release the lower rear compliant link ([PL 91.10 Item 5](#)) from the lower carriage assembly ([PL 91.25 Item 1](#)), [Figure 8](#).

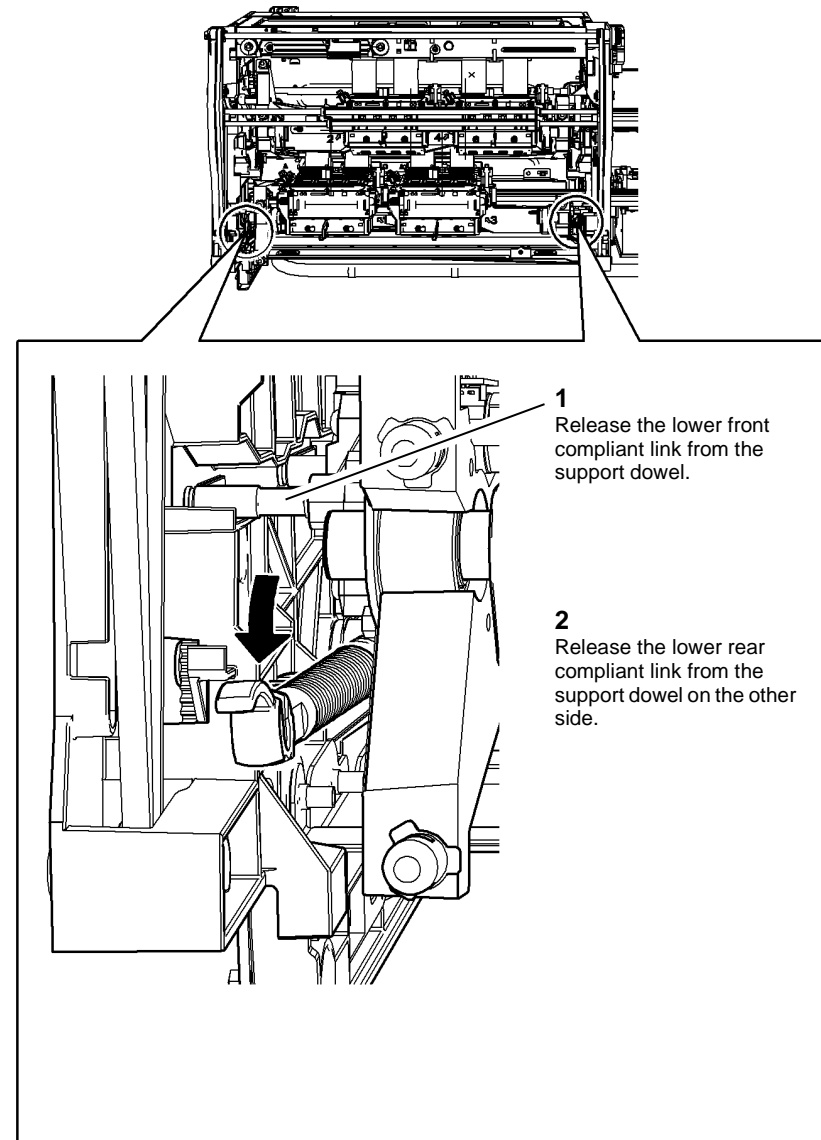

U-1-1212-A

Figure 8 Links released from lower carriage

6. Lift the lower carriage support dowels over the stops to lower the carriage into the service position, [Figure 9](#).

GP 7 System Grounding Verification

Purpose

Use this procedure to verify correct system grounding

Procedure

WARNING

Do not switch on the electricity to the machine while a ground circuit is disconnected. Ground circuits ensure that the machine remains safe during a fault condition.

NOTE: Ground distribution faults must be isolated by continuity checks and visual inspection. Check all circuits between each connection and ground. When appropriate, insert the meter probe tip into the head of the screw.

- Switch off the machine, GP 14. Disconnect the main power cord from the wall outlet and the machine. Check the ground conductor of the main power cord for continuity or damage, if necessary install a new main power cord, PL 1.15 Item 1.
- Check that the ground connections that follow are secure:
 - Stripper system
 - Transfix
 - Registration / Preheat assembly
 - Marking Unit
 - Drum
 - Horizontal Paper Path
 - Exit transport
 - DADH
 - Tray 5
 - Bypass Tray
 - 3 Tray Module

Stripper system

- Figure 1, stripper hinge shafts and stripper baffle. Check for continuity of less than 10 Ohms between the shaft and the machine base with the baffle closed and latched. Check for continuity of less than 10 Ohms between the baffle and the machine base. To improve continuity, remove and clean. If necessary, install a new stripper gate and baffle assembly, REP 10.21, PL 10.12 Item 1.

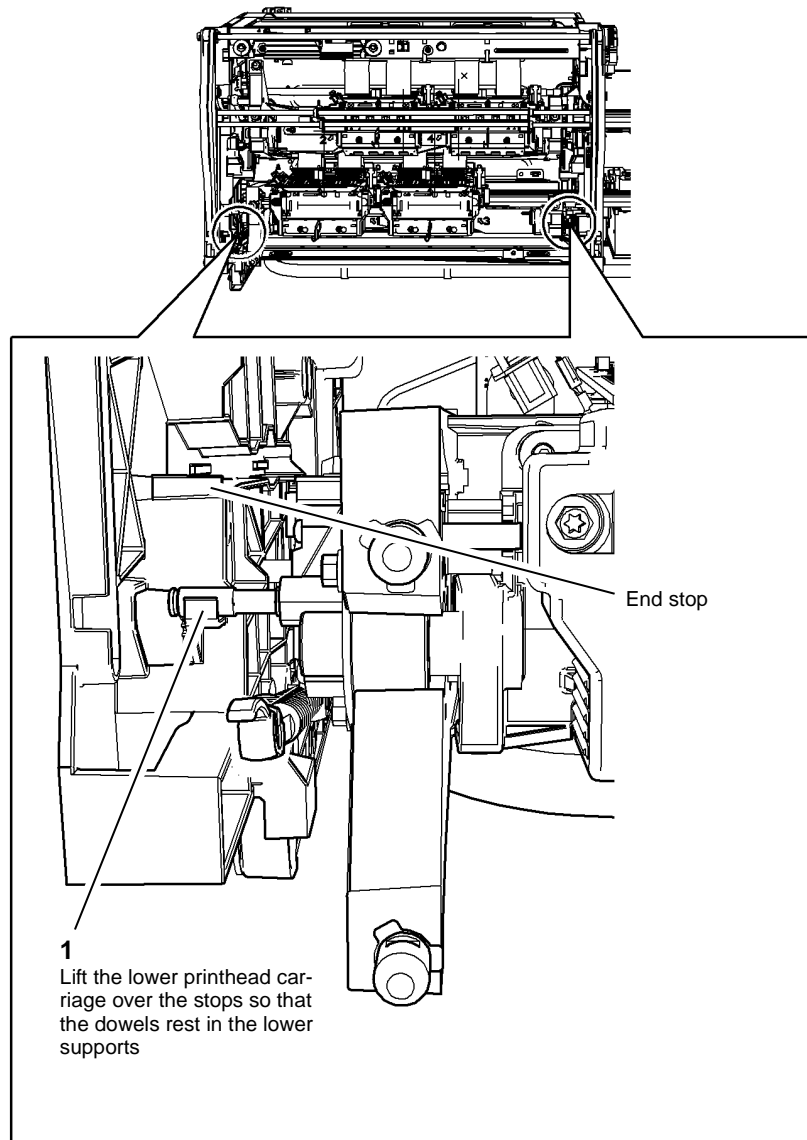

U-1-1213-A

Figure 9 Lower carriage in service position

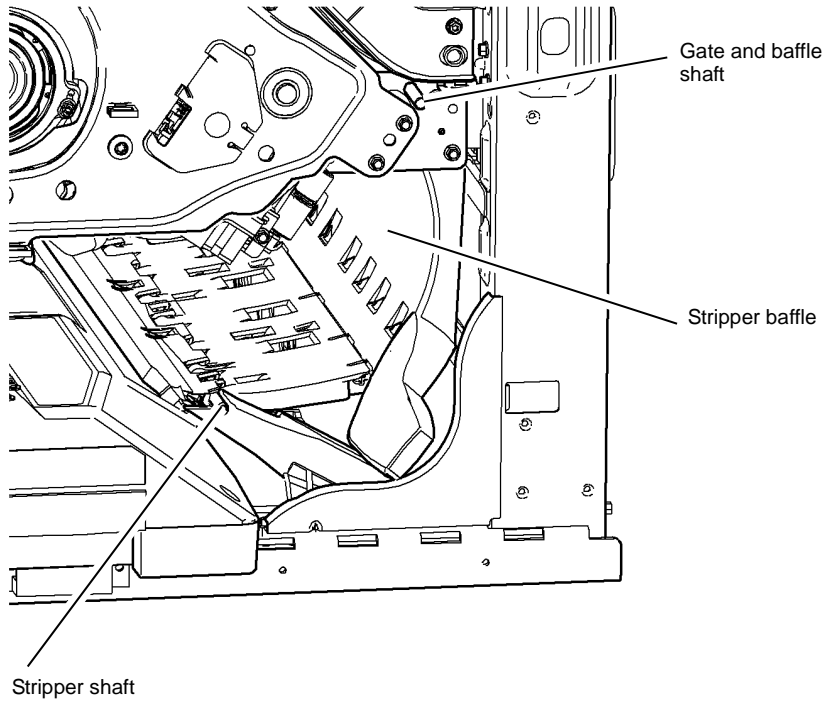

U-1-1011-A

Figure 1 Stripped baffle

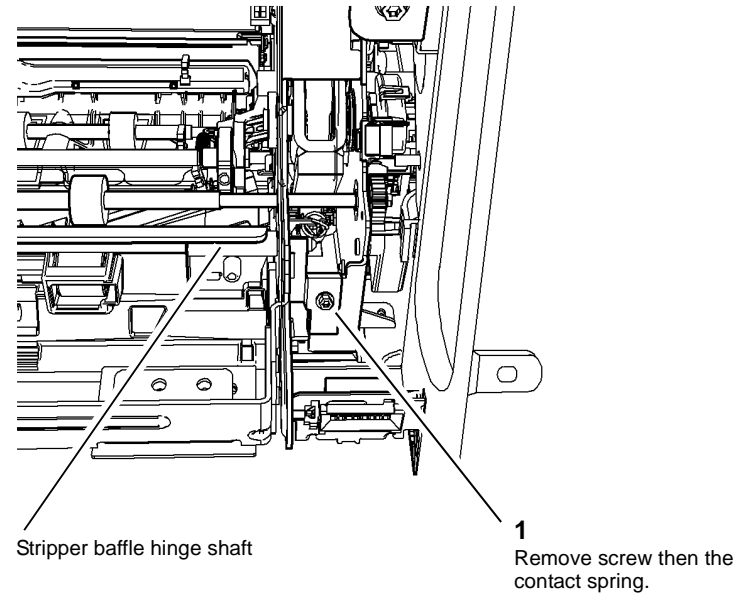

U-1-1027-A

Figure 2 shaft ground spring

- **Figure 2**, stripper baffle hinge shaft ground contact spring. Remove the exit module to see the contact spring. Remove, clean and reform the spring as necessary.

Transfix

- **Figure 3**, transfix blade. Check for continuity of less than 10 Ohms between the blade frame and the machine base. To improve continuity, remove and clean or install a new transfix stripper assembly, **PL 10.20 Item 14** as necessary.

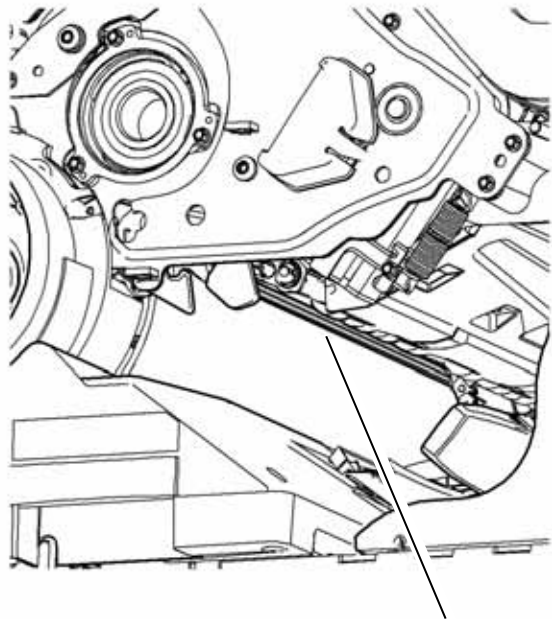

Transfix blade

Figure 3 Transfix blade

U-1-1012-A

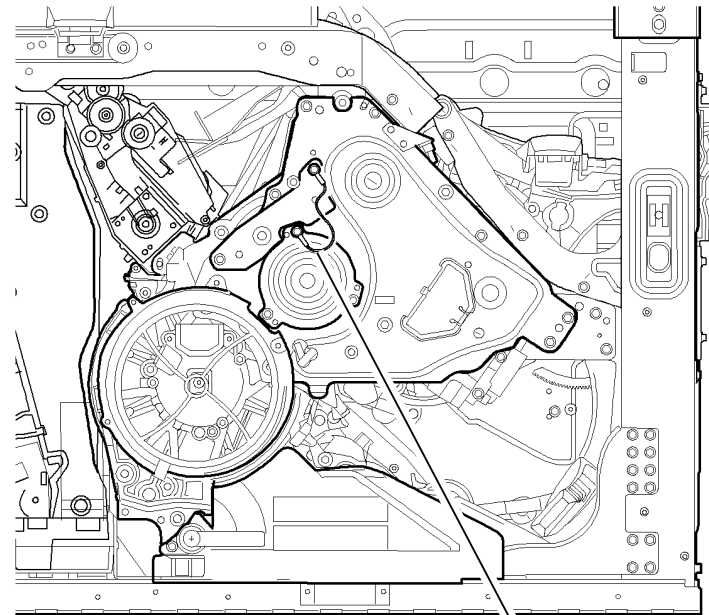

Transfix roller ground wire.

Figure 4 Transfix roller

U-1-1013-A

- **Figure 4**, transfix roller. Check for continuity of less than 10 Ohms between the inner roller core and the machine base and 10 Ohms between the outer roller and the machine base. To improve continuity, disconnect the ground strap, clean the contact faces and re-assemble.

Registration / Preheat assembly

- **Figure 5**, open the registration / pre heat jam hatch by rotating the gear until the hatch is unlocked. Check for continuity of less than 10 Ohms between each preheat plate and the machine base.

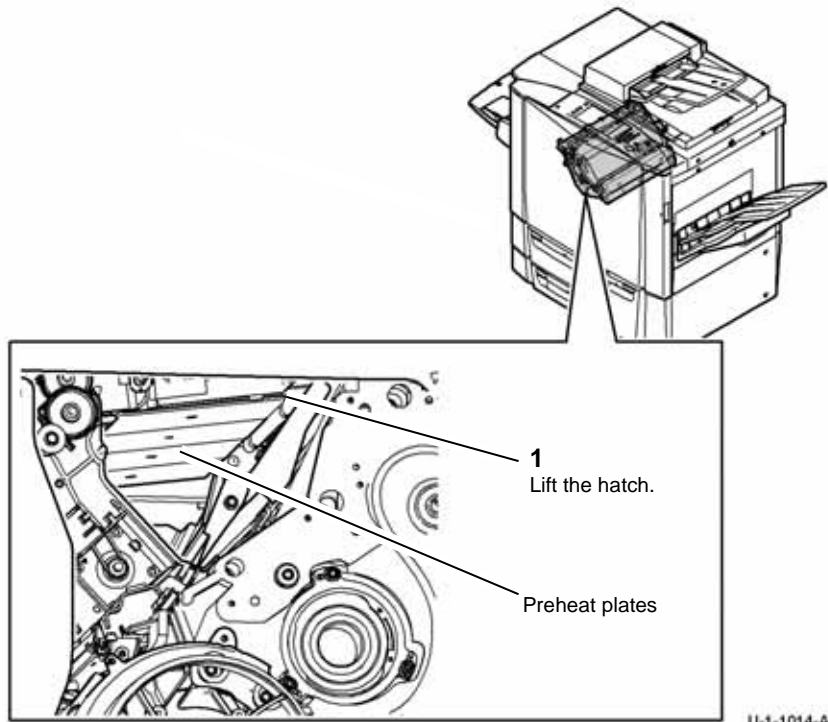

Figure 5 Preheat plates

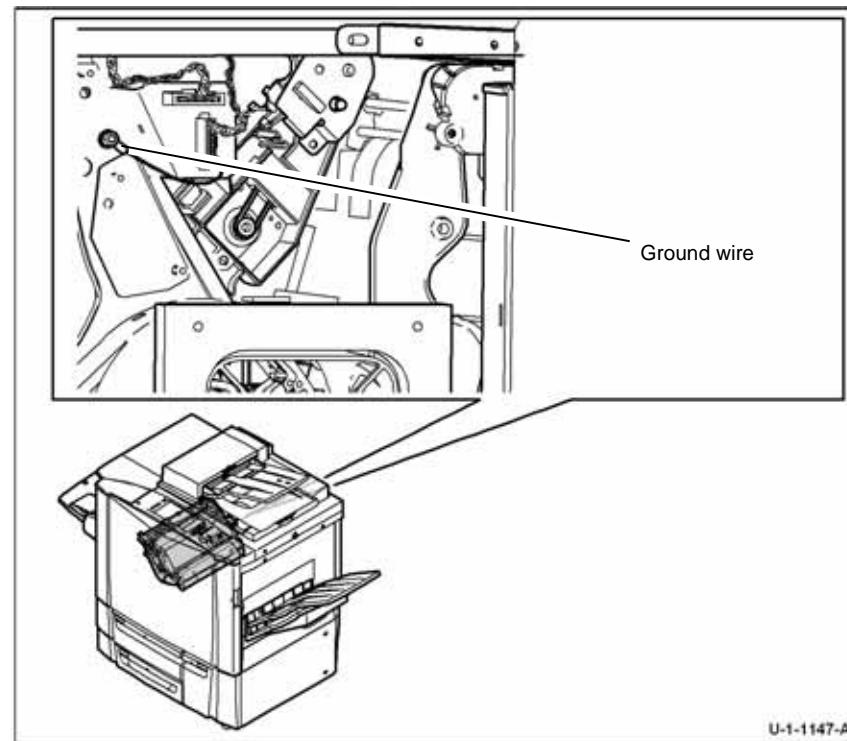

Figure 6 Rear frame connection

- **Figure 6**, to improve continuity, remove, clean the contact faces and re-install the following:
 - Ground connection to rear outer frame, **Figure 6**.
 - Internal ground connections of registration / preheat assembly, **Figure 7**.
- **Figure 7**, registration / preheat internal ground. Check the reg/preheat assembly internal ground wire terminals. If necessary disconnect and clean the contact faces then re-install.

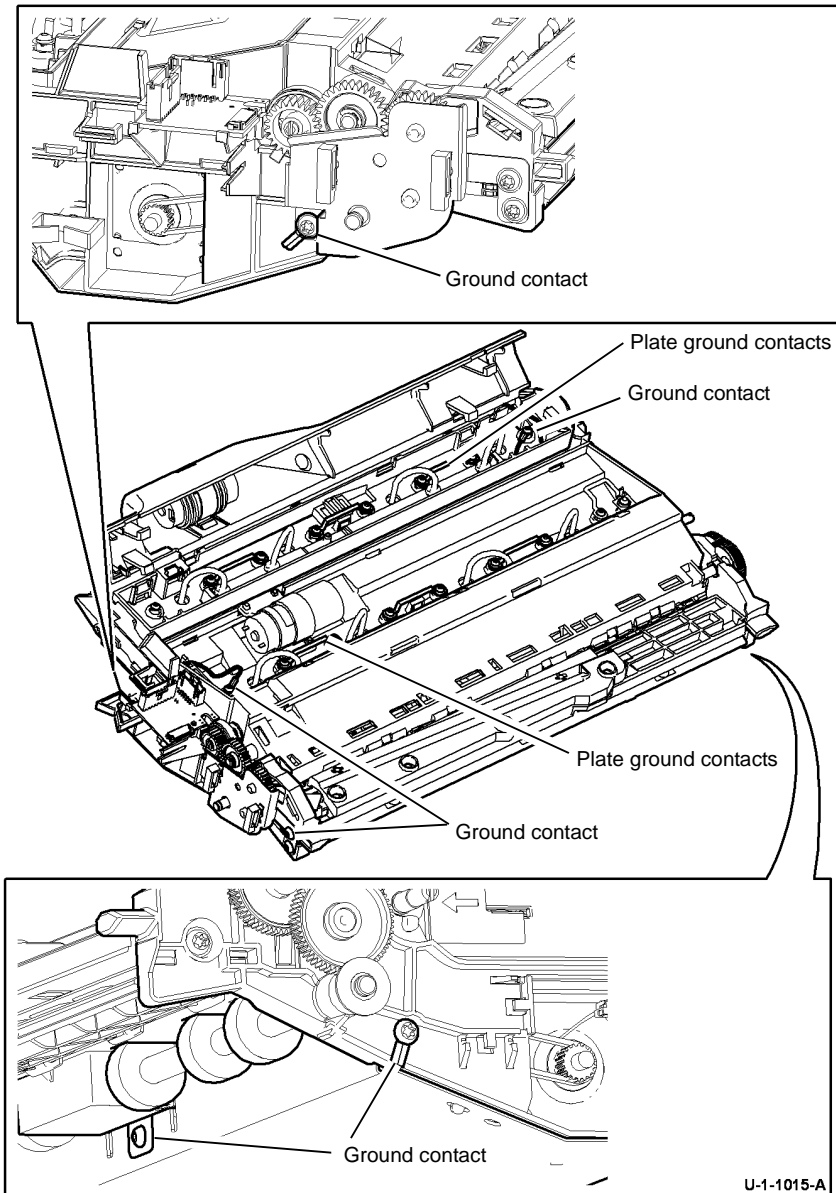

Figure 7 Reg/preheat assembly connections

Marking Unit

- Figure 8 and Figure 9, marking unit enclosure. Check for continuity of less than 10 Ohms between the enclosure and the machine base. To improve continuity, disconnect the terminals, clean the contact faces and re-assemble.

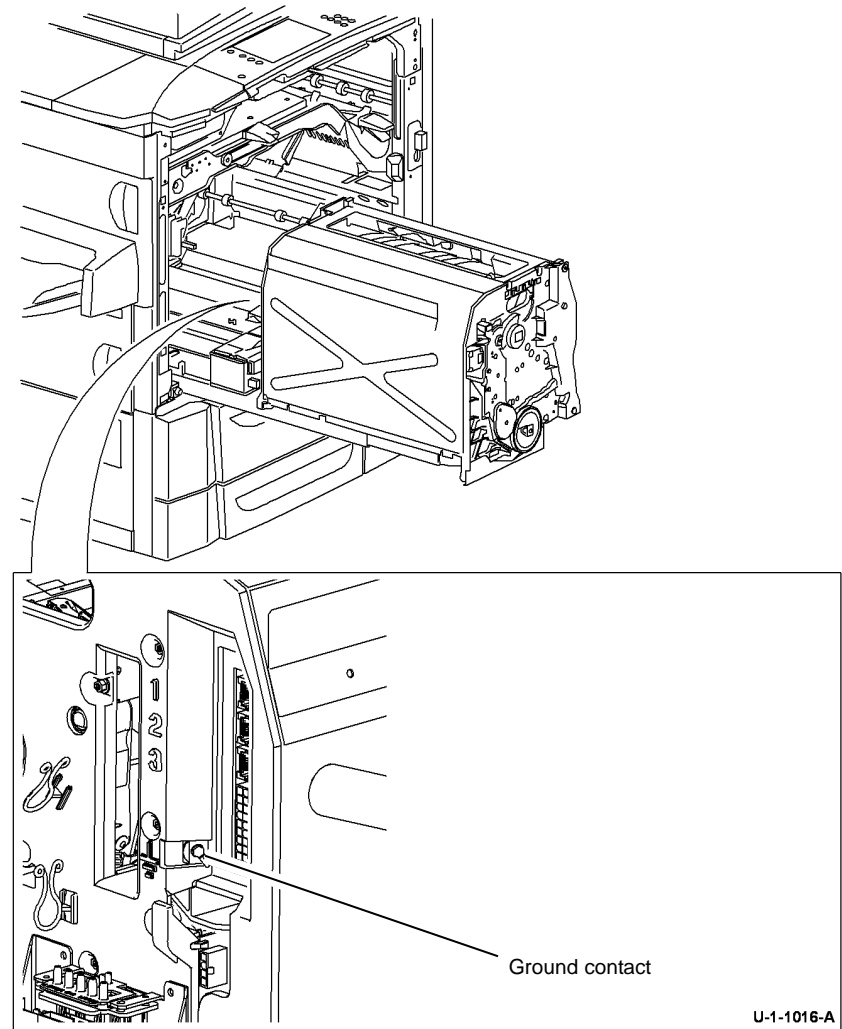
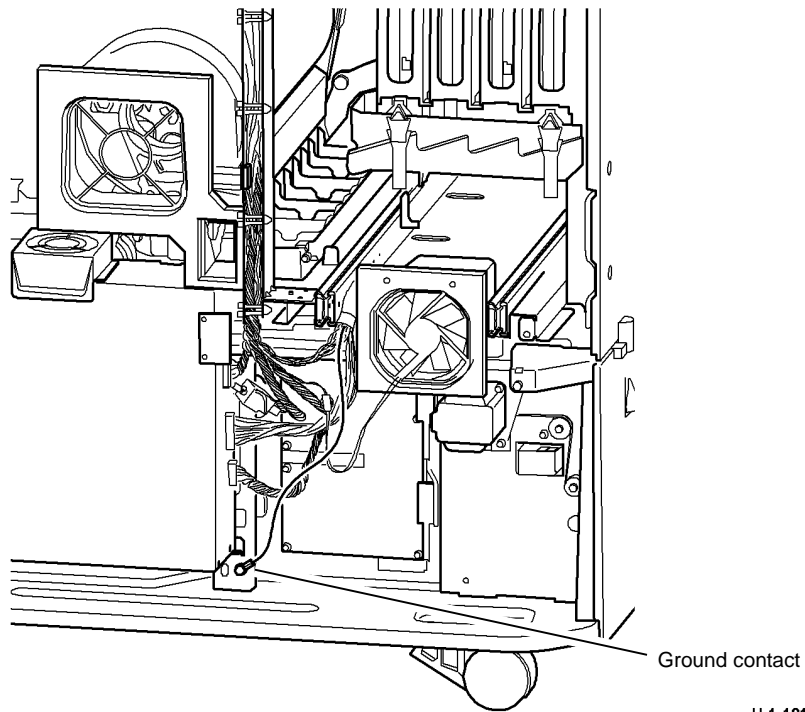
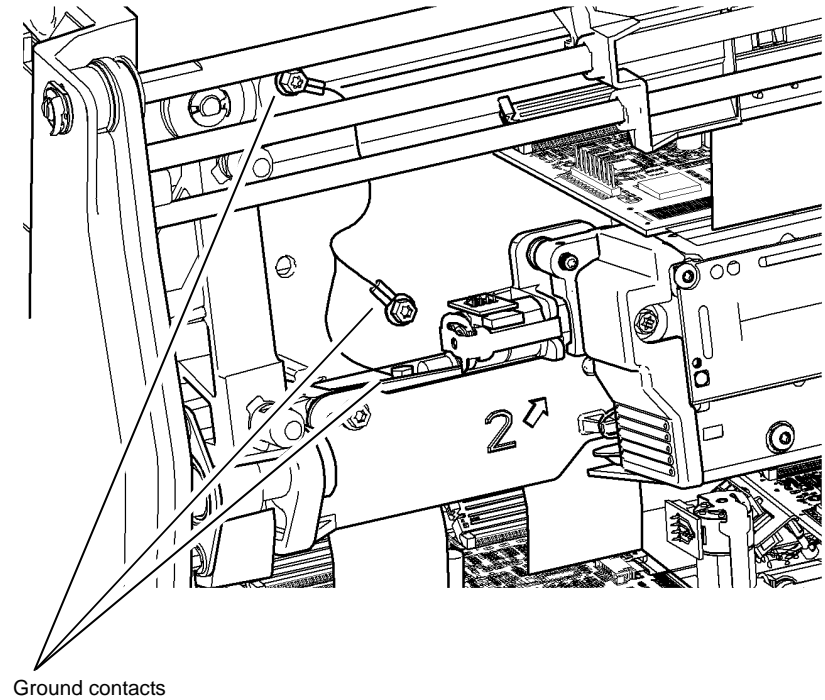

Figure 8 Marking unit enclosure ground



U-1-1017-A

Figure 9 Marking unit machine ground



U-1-1018-A

Figure 10 Upper carriage ground

- **Figure 10**, upper carriage. Check for continuity of less than 10 Ohms between the upper carriage and the machine base. To improve continuity, disconnect the terminals, clean the contact faces and re-install.
- **Figure 11**, lower carriage. Check for continuity of less than 10 Ohms between the lower carriage and the machine base. To improve continuity, disconnect the terminals, clean the contact faces and re-install.

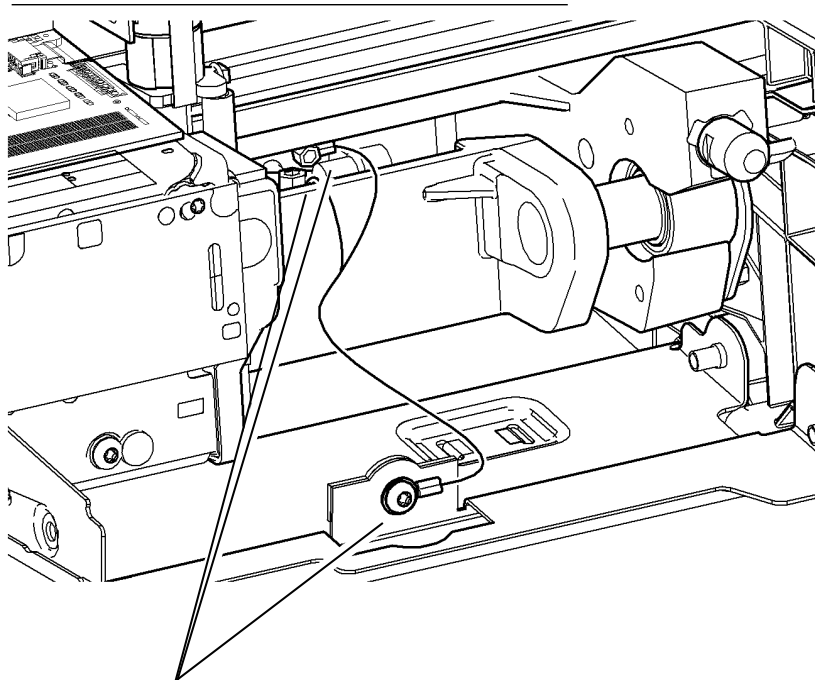

Ground contacts

U-1-1019-A

Figure 11 Lower carriage ground

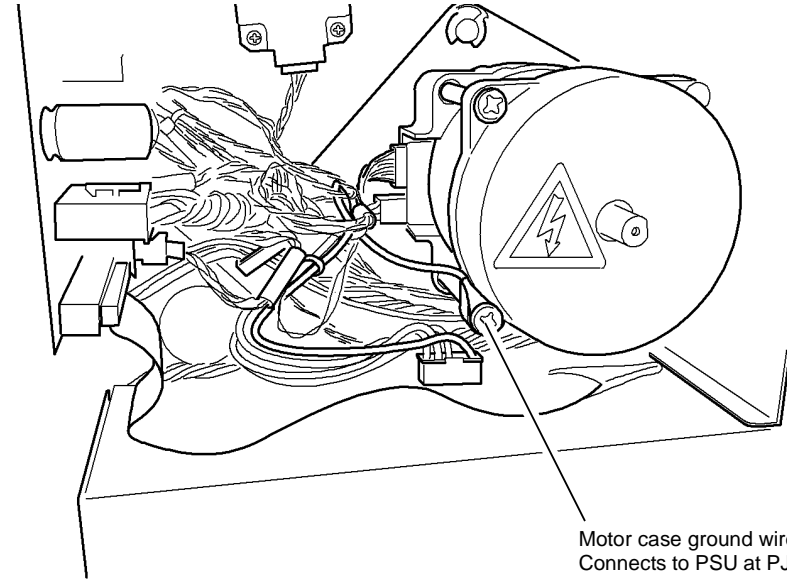

Motor case ground wire.
Connects to PSU at PJ6AC.

U-1-1020-A

Figure 12 Drum drive motor ground

Drum

- **Figure 12**, drum motor. Check for continuity of less than 10 Ohms between the motor and the machine base. To improve continuity, clean the contact faces and connections of the ground lead.

Figure 13, drum static eliminator. Check the condition of the brush and that the drum static eliminator brush has contact with the drum shaft. **PL 94.20 Item 18.**

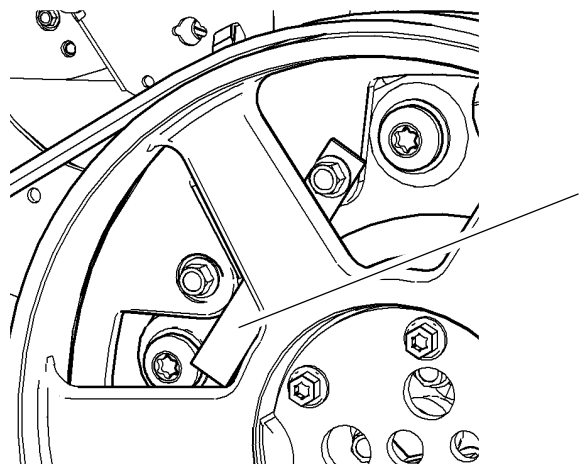

Check that the static eliminator is biased against the black plastic. This locates the static eliminator in the correct position.

U-1-1400-A

Figure 13 Drum static eliminator

Horizontal Paper Path

- **Figure 14**, horizontal paper path internal ground. Remove the horizontal paper path, **REP 83.1**. Remove the top cover, refer to **REP 83.2**. Check for continuity of less than 10 Ohms between the solenoids, sensor cover and the horizontal paper path ground contact. To improve continuity, clean the contact faces and connections of the ground leads.

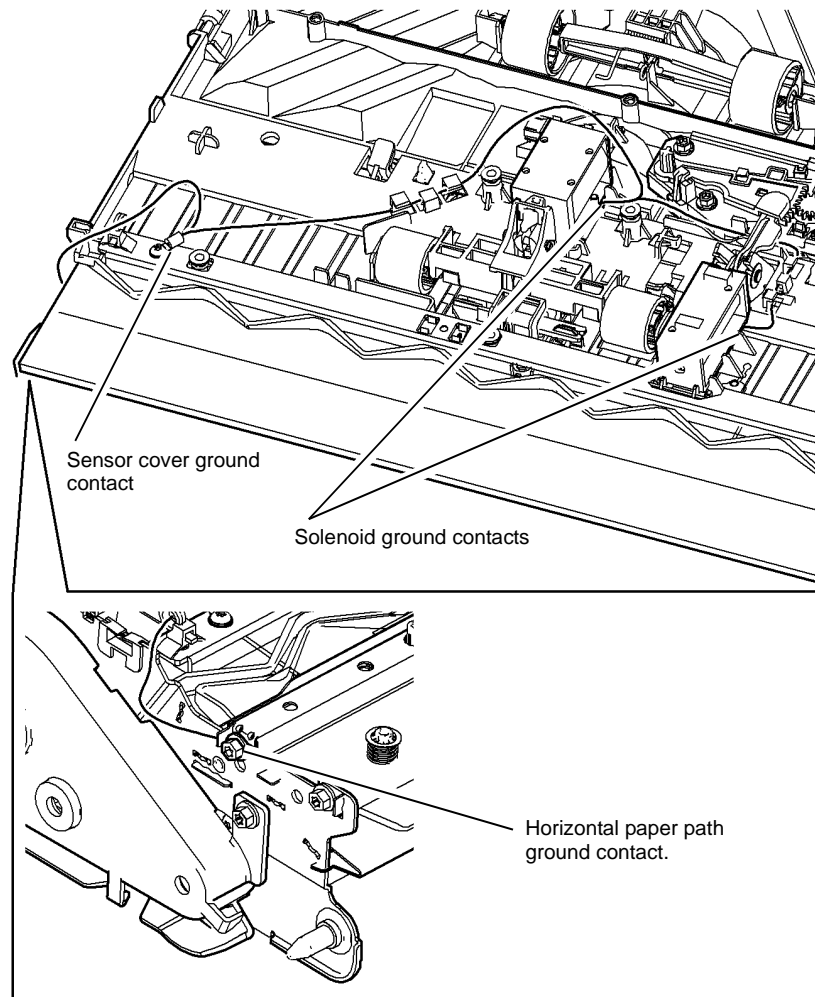

U-1-1021-A

Figure 14 Horizontal paper path ground

Exit transport

- **Figure 15**, exit transport internal ground lead. Remove the exit module, **REP 10.20**. Check for continuity of less than 10 Ohms between the solenoid, baffle and the ground contacts. To improve continuity, disconnect the terminals, clean the contact faces, re-install.

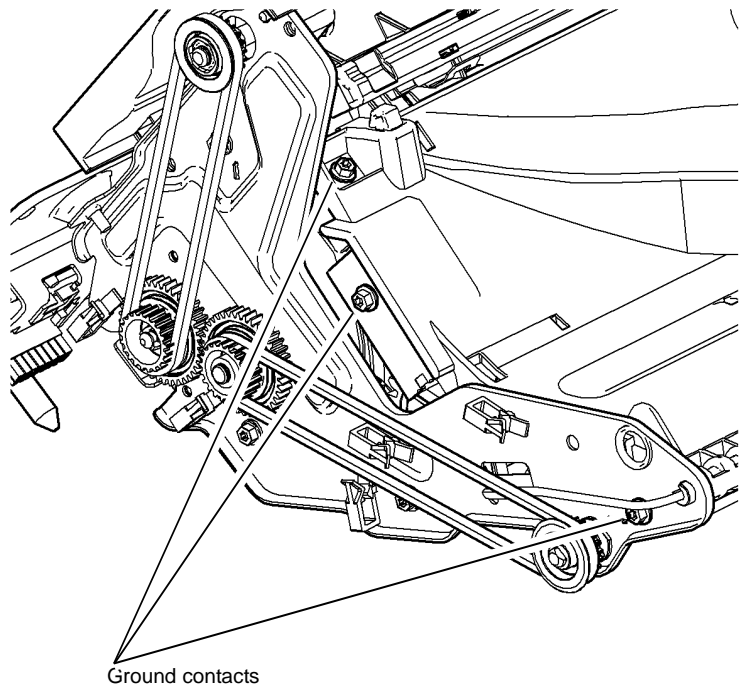

Ground contacts

U-1-1192-A

Figure 15 Exit transport internal grounds

DADH

- **Figure 16**, DADH ground connection. Remove the DADH rear cover, **PL 5.10 Item 1**. Check for continuity of less than 10 ohm between the DADH frame and the main frame ground connection. To improve continuity, check that the hardware is tight and the harness crimping is good. If necessary disconnect the terminals, clean the contact faces and re-assemble.

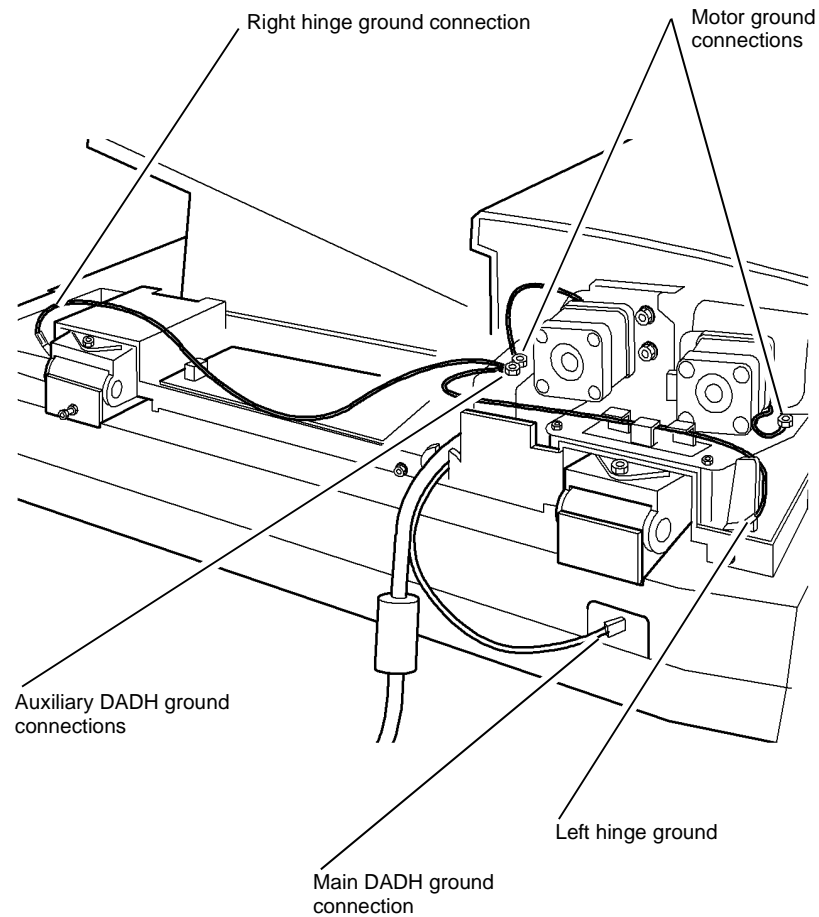

U-1-1002-A

Figure 16 DADH ground connection

Tray 5

- **Figure 17**, tray 5 ground connections. Check the ground connection on the frame, the elevator motor and on the base of the paper tray. Ensure that the in-line connectors are connected.

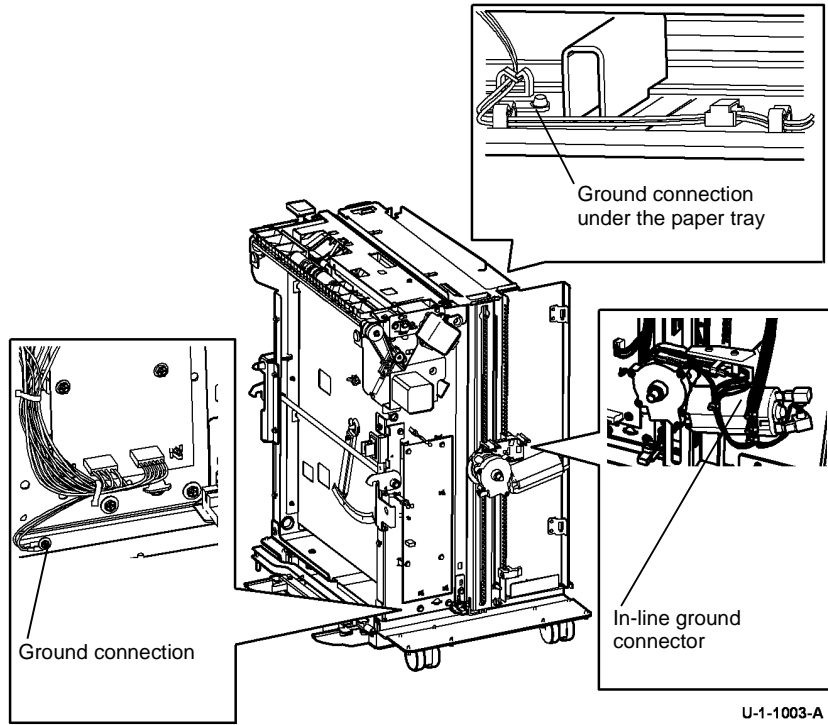

Figure 17 Tray 5 ground connections

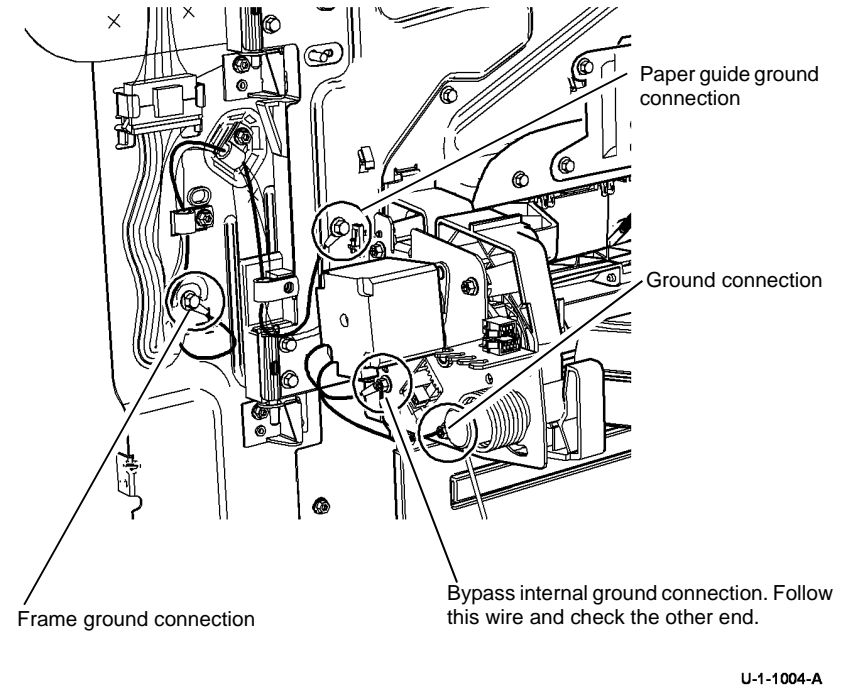

Figure 18 Bypass tray ground connections

Bypass Tray

- [Figure 18](#), bypass tray ground connections. Check for continuity of less than 10 Ohm between the bypass paper guide and the main frame ground connection. To improve continuity, disconnect the ground terminals, clean the contact faces and re-assemble.

3 Tray Module

- [Figure 19](#), 3 tray module motor ground connection. Check for continuity of less than 10 Ohm between the motor case and the main frame. To improve continuity, disconnect the ground terminals, clean the contact faces and re-assemble.

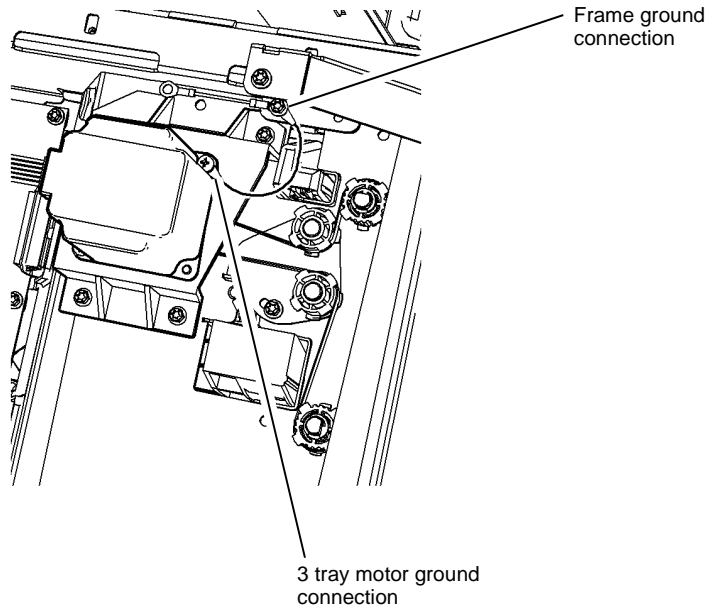

U-1-1006-A

Figure 19 3TM motor

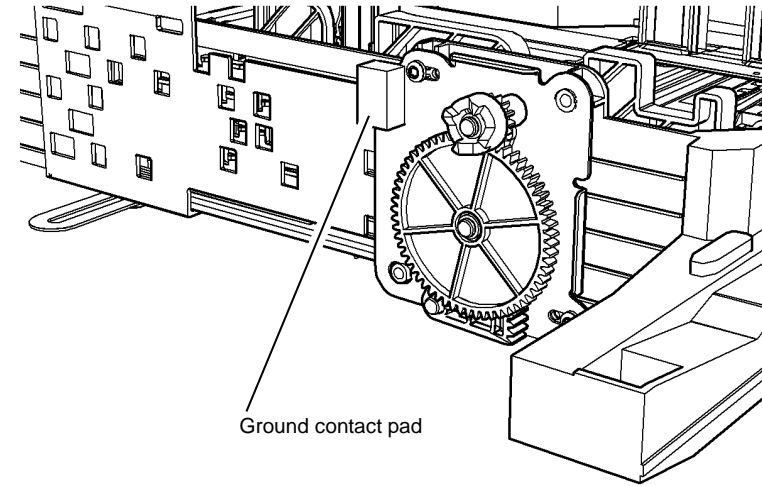

U-1-1008-A

Figure 20 Tray 1 and 2 ground

- **Figure 20**, tray 1 and 2 ground contact pad. To improve continuity, remove the tray and clean the contact face. The tray must be elevated to check for continuity between the metal tray and the ground pad. Check for continuity of less than 10 Ohm between the tray and the ground pad.
- **Figure 21**, tray 3 horizontal transport. To improve continuity, remove the transport and clean the contact faces. Check for continuity of less than 10 Ohm between the paper transport shafts and the main frame.

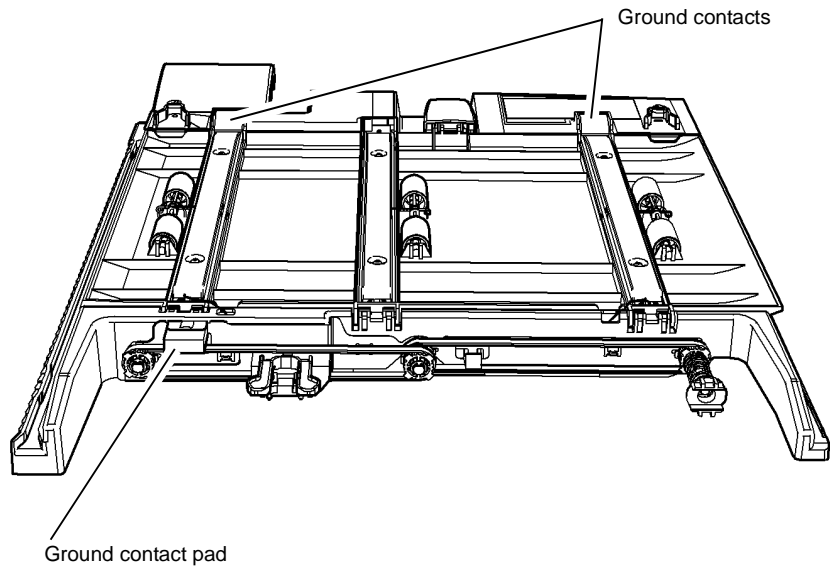

U-1-1007-A

Figure 21 Tray 3 horizontal transport

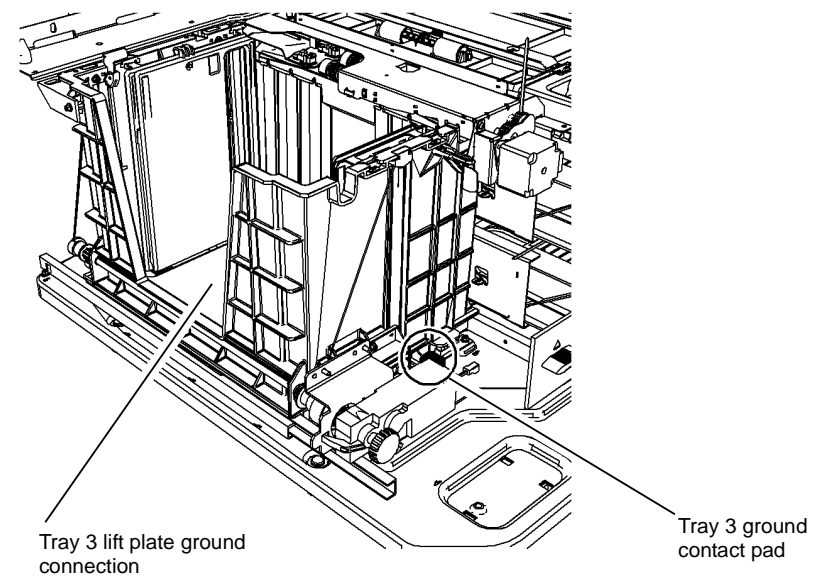

U-1-1009-A

Figure 22 Tray 3 ground connections

- **Figure 22**, tray 3 ground connections. Check for continuity of less than 10 Ohms between the tray lift plate and the tray base. To improve continuity, disconnect the ground terminals, clean the contact faces and re-assemble.

GP 8 Special Tools and Consumables

For all special tools and consumables refer to the following:

- [PL 26.10](#) Consumables and Tools (1 of 2).
- [PL 26.11](#) Consumables and Tools (2 of 2).

GP 9 UI Services User Menu Map

Purpose

To show the features available on the UI screen in the services mode. The tables below show the features, options and the selections.

The User Menu Map is also available in the information pages. Select Machine Status / Machine Information / Information Pages and select the User Menu Map.

The UI services user menu contains the following features:

- Copy - [Table 1](#).
- Fax - [Table 2](#).
- Server Fax - [Table 3](#).
- Workflow Scanning - [Table 4](#)
- Reprint Saved Jobs - [Table 5](#).
- E-Mail - [Table 6](#).
- Internet Fax - [Table 7](#).

Table 1 Copy features

Feature	Feature options	Selection
Copy	Output Color	Auto Detect Black and White Color Single Color
	Reduce / Enlarge	Proportional% Independent X-Y% Auto Center Variable% Presets
	Paper Supply	Tray / Paper Size
	2-Sided Copying	1-1 Sided 1-2 Sided 2-2 Sided 2-1 Sided Rotate Side 2
	Copy Output	Collated Uncollated Stapling (optional) Folding (optional)
Image Quality	Original Type	Content Type How Original was Produced
	Image Options	Lighten/Darken Sharpness Saturation
	Image Enhancement	Background Suppression Manual Contrast Auto Contrast

Table 1 Copy features

Feature	Feature options	Selection
	Color Presets	Lively Bright Warm Cool
	Color Balance	Normal Basic Color Advanced Color
Layout Adjustment	Original Orientation	Upright Images Sideways Images Portrait Originals Landscape Originals
	Original Size	Auto Detect Preset Scan Areas Custom Scan Area Mixed Size Originals
	Book Copying	Both Pages Left Page Only Right Page Only Binding Edge Erase Reading Order (optional)
	Image Shift	Auto Center Margin Shift Presets
	Edge Erase	All Edges Individual Edges Presets
	Invert Image	Mirror Image Negative Image
Output Format	Booklet Creation	Off / On Reading Order (optional) Fold and Staple (optional) Original Input
	Special Pages	Covers Chapter Starts Inserts Exceptions
	Annotations	Page Numbers Comment Date Bates Stamp
	Transparency Separators	-
	Page Layout	Pages Per Slide Repeat Image

Table 1 Copy features

Feature	Feature options	Selection
Job Assembly	Build Job	Off / On
	Sample Job	Off / On
	Save Current Settings	Setting name
	Retrieve Saved Settings	Load / Delete setting

Table 2 FAX features

Feature	Feature options	Selection
Fax	Fax Number and Recipient List	Speed Dial Recipient List
	Dialing Characters	Character List
	Address Book	Individuals
	Cover Sheet	Off / On
	2-Sided Scanning	1-Sided 2-Sided 2-Sided, Rotate Side 2
	Original Type	Photo and Text Photo Text
	Resolution	Standard (200x100 dpi) Fine (200 dpi) Super Fine (600 dpi)
Image Quality	Image Options	Lighten/Darken Sharpness
	Image Enhancement	Background Suppression Manual Contrast Auto Contrast
Layout Adjustment	Original Size	Auto Detect Preset Scan Areas Custom Scan Area Mixed Size Originals
	Reduce / Split	Reduce to Fit Split Across Pages
	Book Faxing	Both Pages Left Page Only Right Page Only Binding Edge Erase Reading Order (optional)

Table 2 FAX features

Feature	Feature options	Selection
Fax Options	Confirmation Report	Print Confirmation Print on Error Only (Optional)
	Starting Rate	Super G3 (33.6 Kbps) G3 (14.4 Kbps) Forced (4800 bps)
	Delay Send	Off / Specified Time
	Send Header Text	Off / On
	Mailboxes	Off Send to Remote Mailbox Store to Local Mailbox Print Local Mailbox Documents Delete Local Mailbox Documents
	Local Polling	Off Non-Secure Polling Secure Polling Stored Local Documents - Print All / Delete All
	Remote Polling	Poll a Remote Fax Poll a Remote Mailbox
Job Assembly	Build Job	Off / On

Table 3 Server Fax features

Feature	Feature options	Selection
Server Fax	Fax Number and Recipient List	-
	Dialing Characters	-
	Fax Directory	-
	2-Sided Scanning	1-Sided 2-Sided 2-Sided, Rotate Side 2
	Original Type	Photo and Text Photo Text
	Resolution	Standard (200 x 100 dpi) Fine (200 dpi)
Image Quality	Image Options	Lighten / Darken
	Image Enhancement	Background Suppression Manual Contrast Auto Contrast

Table 3 Server Fax features

Feature	Feature options	Selection
Layout Adjustment	Original Orientation	Upright Images Sideways Images Portrait Originals Landscape Originals
	Original Size	Auto Detect Preset Scan Area Custom Scan Area Mixed Size Originals
Fax Options	Delay Send	Off / Specified Time
Job Assembly	Build Job	Off / On

Table 4 Workflow scanning features

Feature	Feature options	Selection
Workflow Scanning	Template List	All Templates Local Templates Network Templates Scan To Home Templates Public/Private Templates
	Output Color	Auto Detect Black and White Gray scale Color
	2-Sided Scanning	1-Sided 2-Sided 2-Sided, Rotate Side 2
	Original Type	Photo and Text Photo Text Map Newspaper/Magazine How Original was Produced
	Scan Presets	Sharing and Printing Archival - Small File Size OCR High Quality Printing Simple Scan
Advanced Settings	Image Options	Lighten/Darken Sharpness Saturation
	Image Enhancement	Background Suppression Manual Contrast Auto Contrast

Table 4 Workflow scanning features

Feature	Feature options	Selection
	Resolution	72 dpi 100 dpi 150 dpi 200 dpi 300 dpi 400 dpi 600 dpi
	Quality / File Size	Normal Quality / Highest Quality Small File Size / Largest File Size
	Update Templates	Update Now
Layout Adjustment	Original Orientation	Upright Images Sideways Images Portrait Originals Landscape Originals
	Original Size	Auto Detect Preset Scan Areas Custom Scan Area Mixed Size Originals
	All Edges	All Edges Individual Edges
Filing Options	File Name	-
	File Format	PDF PDF/A XPS Multi-Page TIFF TIFF (1 File per Page) JPEG (1 File per Page)
	If File Already Exists	Add Number to Name Add Date and Time to Name Add to TIFF/JPEG Folder Overwrite Existing File Do Not Save
	Document Management	-
	Add File Destinations	-
Job Assembly	Build Job	-

Table 5 Reprint Saved Jobs

Reprint Saved Jobs feature
Saved Jobs

Table 6 E-mail features

Feature	Feature options	Selection
E-mail	New Recipient	-
	Address Book	-

Table 6 E-mail features

Feature	Feature options	Selection
	From	-
	Subject	-
	Output Color	Auto Detect Black and White Gray scale Color
	2-Sided Scanning	1-Sided 2-Sided 2-Sided, Rotate Side 2
	Original Type	Photo and Text Photo Text Map Newspaper/Magazine How Original was Produced
	Scan Presets	Sharing and Printing Archival - Small File Size OCR High Quality Printing Simple Scan
Advanced Settings	Image Options	Lighten/Darken Sharpness Saturation
	Image Enhancement	Background Suppression Manual Contrast Auto Contrast
	Resolution	72 dpi 100 dpi 150 dpi 200 dpi 300 dpi 400 dpi 600 dpi
	Quality/File Size	Normal Quality / Highest Quality Small File Size / Largest File Size
Layout Adjustment	Original Orientation	Upright Images Sideways Images Portrait Originals Landscape Originals
	Original Size	Auto Detect Preset Scan Areas Custom Scan Area Mixed Size Originals
	Edge Erase	All Edges Individual Edges

Table 6 E-mail features

Feature	Feature options	Selection
E-mail Options	File Name	Scan from a xerox multifunction unit Undo / Save
	File Format	PDF PDF/A XPS Multi-Page TIFF TIFF (1 File per Page) JPEG (1 File per Page)
	Message	Undo / Save
	Reply To	-
Job Assembly	Build Job	Off / On

Table 7 Internet Fax features

Feature	Feature options	Selection
Internet Fax	New Recipient	-
	Address Book	-
	From	-
	Subject	-
	Output Color	Auto Detect Black and White Gray scale Color
	2-Sided Scanning	1-Sided 2-Sided 2-Sided, Rotate Side 2
	Original Type	Photo and Text Photo Text Map Newspaper/Magazine How Original was Produced
Advanced Settings	Image Options	Lighten/Darken Sharpness Saturation
	Image Enhancement	Background Suppression Manual Contrast Auto Contrast
	Resolution	72 dpi 100 dpi 150 dpi 200x100 dpi 200 dpi 300 dpi 400 dpi 600 dpi

Table 7 Internet Fax features

Feature	Feature options	Selection
	Quality / File Size	Normal Quality / Highest Quality Small File Size / Largest File Size
Layout Adjustment	Original Orientation	Upright Images Sideways Images Portrait Originals Landscape Originals
	Original Size	Auto Detect Preset Scan Areas Custom Scan Area Mixed Size Originals
Internet Fax Options	File Format	Multi-Page TIFF PDF PDF/A
	Message	Undo / Save
	Reply To	Search / Save
	Acknowledgement Report	Off / Print Report
Job Assembly	Build Job	Off / On

GP 10 How to Check a Motor

This procedure describes how to check the following motors:

- Two Wire DC Motor.
- DC Motor with Integral Encoder
- Four Wire Stepper Motor
- Six Wire Stepper Motor.

Initial Actions

WARNING

Switch off the electricity to the machine. Refer to GP 14. Disconnect the power cord from the customer supply while performing tasks that do not need electricity. Electricity can cause death or injury. Moving parts can cause injury.

1. Check that the motor is free to rotate.
2. Check that all the motors mechanisms are clean, free to move and lubricated correctly.
3. Enter the component control code for the motor, refer to **dC330**. Run the motor for 30 seconds, if the motor shows signs of or can be heard to slow down, then the motor is defective. Install a new motor.
4. Perform the appropriate procedure:
 - Two Wire DC Motor.
 - DC Motor with Integral Encoder
 - Four Wire Stepper Motor.
 - Six Wire Stepper Motor.

NOTE: The voltages, PJ numbers, pin numbers and PWB names shown are an example only. Go to the wiring diagram associated with the RAP for the correct information.

Two Wire DC Motor

NOTE: In cases where the motor may be driven forward or backward, the same two feed wires are used, but the voltages on them are reversed, to reverse the motor direction. Such motors may have two component control codes, for forward and reverse. A typical application is a tray lift motor with a tray-up and a tray-down direction.

- Go to the wiring diagram shown in **Figure 1**. Disconnect R011. Check that the drive voltage, in this case +24V, is measured when the component control code for the motor is entered. If the drive voltage is measured, install a new motor. If the drive voltage is not measured, continue to the next step.
- Disconnect PJ202. Check that the drive voltage can be measured on the PWB when the component control code for the motor forward is entered. If no drive voltage is measured, check the power to the PWB. If the power is good install a new PWB. If the drive voltage is measured at the PWB, check the wiring to the motor. Repair or install new wiring.

References:

- **01H** +24V Distribution RAP.
- **01L** 0V Distribution RAP.
- **REP 1.1** Wiring Harness Repairs.

DC Motor with Integral Encoder

NOTE: This type of motor has the normal drive voltages for a DC motor, plus the +5V and 0V lines for the encoder. The encoder has two outputs, A and B, producing +5V pulses when the motor is on. When the motor is running in one direction, the encoder A pulses lead the encoder B pulses. In the other direction, encoder B pulses lead encoder A pulses. In this way the controller can detect that the motor is running in the correct direction.

Check the operation of the motor as follows:

- Go to wiring diagram shown in **Figure 1**. Disconnect PJA. Check that the drive voltage, in this case +50V, is measured between pins 5 and 7 when the component control code for the motor is entered. If the drive voltage is present, install a new motor.
- Disconnect PJ104. Check that the drive voltage is measured between pins 1 and 6, when the component control code for the motor is entered. If the drive voltage is present, check the wiring and connectors to the motor. If the drive voltage is not present, check the power to the media path driver PWB. If the power to the PWB is good, install a new media path driver PWB.

References:

- **01J** +50V Distribution RAP.
- **01D** +5V Distribution RAP.
- **REP 1.1** Wiring Harness Repairs.

NOTE: When checking for the presence of +5V pulses, use the standard digital multimeter. Using the DC volts range, or the AC volts range, expect to obtain a reading greater than 1V and less than 4 volts, while the motor is running. The actual value will depend on the meter's reaction to square waves and to the particular frequency of the pulses. It is common to obtain a reading of 2 to 3 volts. If the meter has a minimum and maximum recording facility, expect a maximum value of around +4.9V, and a minimum value of around +0.2V.

Check the operation of the encoder as follows:

- Go to wiring diagram shown in **Figure 1**. At PJA, check for pulses on pins 2 and 4 to GND when the motor is running. If pulses are not present, go to the next step on this list. If pulses are present, check for pulses at PJ104, pins 13 and 15 to GND. If pulses are not present at PJ104, check the wiring to the motor and repair to install new wiring. If pulses are present at PJ104, install a new media path driver PWB.
- Pulses are not present at PJA, pins 2 and 4, when the motor is running. Disconnect PJA and check for +5V between pins 1 and 3. If +5V is measured, install a new motor. If +5V is not measured, disconnect PJ104. Check for +5V between pins 2 and 14 on the PWB. If +5V is measured, check the wiring to the motor, and repair or install new wiring. If +5V is not measured at the PWB, check the power to the PWB. If the power is good, install a new media path driver PWB.

References:

- **01D** +5V Distribution RAP.
- **01L** 0V Distribution RAP.
- **REP 1.1** Wiring Harness Repairs.

Four Wire Stepper Motor

NOTE: A stepper motor with an internal open circuit may appear to be fully functional under dC330 component control. However, under normal operation it will run with intermittent failure. Use the standard digital meter to check that the resistance of the stepper motor coils are similar.

- Go to wiring diagram shown in [Figure 1](#). Disconnect PJB. Check the phase pulses to GND on the harness when the component control code for the motor is entered. If the pulses are present, install a new motor.
- Disconnect PJ202. Check the phase pulses to GND at the PWB when the component control code for the motor is entered. If the pulses are present, check the connections and wiring. Repair or install new wiring as necessary. If pulses are not present at the PWB, install a new PWB.

References:

- [01H](#) +24V Distribution RAP.
- [01L](#) 0V Distribution RAP.
- [REP 1.1](#) Wiring Harness Repairs.

Six Wire Stepper Motor

NOTE: A stepper motor with an internal open circuit may appear to be fully functional under dC330 component control. However, under normal operation it will run with intermittent failure. Use the standard digital meter to check that the resistance of the stepper motor coils are similar.

- Go to wiring diagram shown in [Figure 1](#). Disconnect T012. Check the +24V supply and the phase pulses to GND when the component control code for the motor is entered. If the supply and pulses are present, install a new motor.
- Check the connectors and wiring to the motor. Repair or install new wiring, as necessary.
- Disconnect PJ102. Check the +24V. If +24V is not present, check the power to the PWB. If the power is good, install a new PWB. Check the phase pulses at the PWB. If the phase pulses are not present at the PWB, install a new PWB.

References:

- [01H](#) +24V Distribution RAP.
- [01L](#) 0V Distribution RAP.
- [REP 1.1](#) Wiring Harness Repairs.

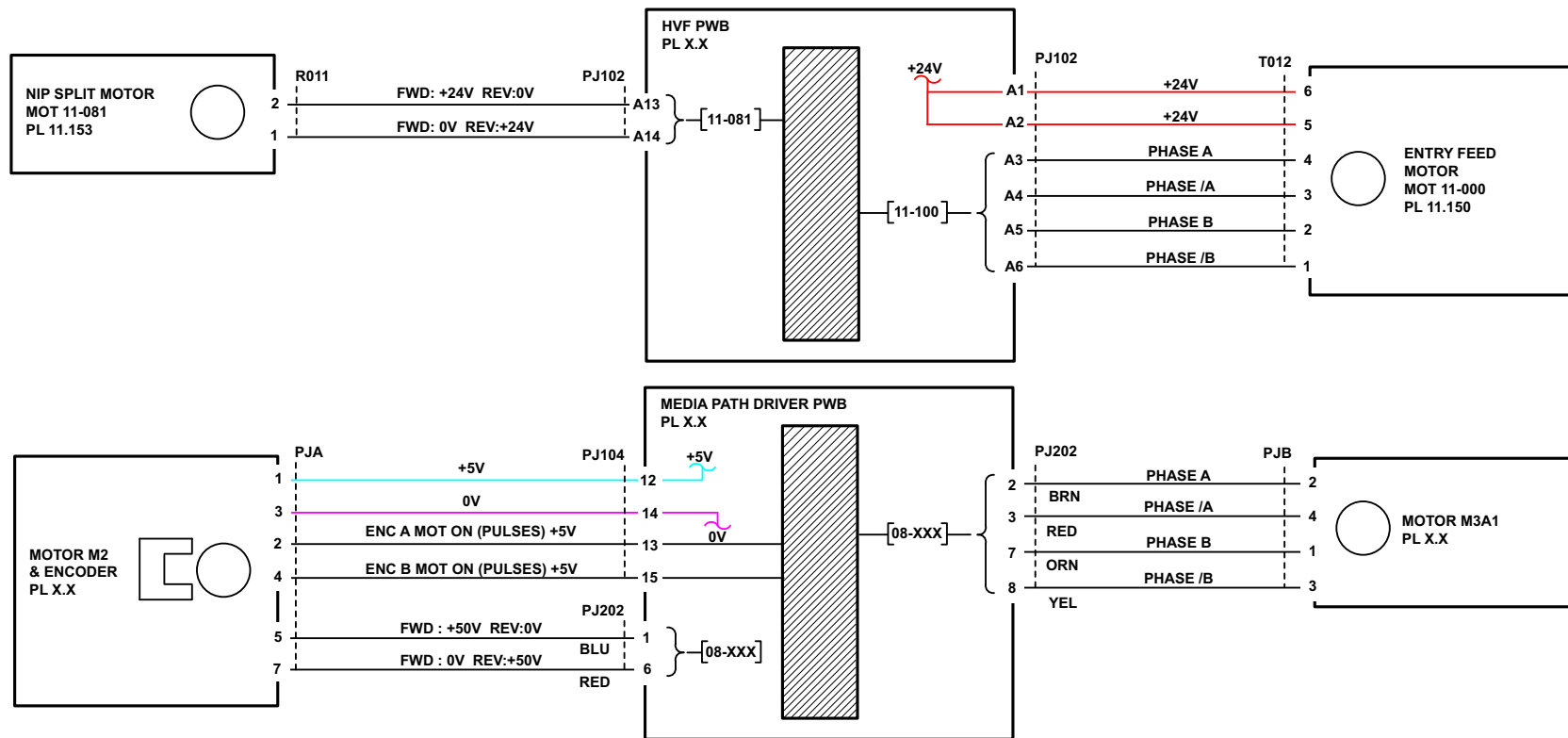

TU-1-0170-A

Figure 1 Wiring diagram

GP 11 How to Check a Sensor

Description

Use this procedure to check the operation of all types of sensor.

NOTE: The upper circuit diagram, in [Figure 1](#) shows a reflective sensor and the lower sensor is a flag sensor. Some sensors have a resistor within the sensor, as in the upper sensor, and other sensors require a resistor on the PWB, as in the case of the lower sensor. The resistor limits the current through the LED. The voltage to the sensor LED with an external resistor, is typically 1.2V.

NOTE: The voltages, PJ numbers, pin numbers and PWB names shown are examples only. Go to the wiring diagram associated with the RAP for the correct information.

NOTE: In some cases, two sensors are used to form an interruptible beam of light. In these cases, the LED of one sensor and the sensing element of the other sensor are used. Treat the two sensors as if they were housed in the same body for diagnostic purposes, ignoring the unused part of each sensor. If the combined sensors do not operate correctly and the beam path is clear of obstruction, it may be necessary to install both new sensors.

Initial Actions

WARNING

Switch off the electricity to the machine. Refer to [GP 14](#). Disconnect the power cord from the customer supply while performing tasks that do not need electricity. Electricity can cause death or injury. Moving parts can cause injury.

Perform the steps that follow:

1. Make sure that the sensor is installed correctly.
2. Clean the sensor and the area around the sensor.
3. If a flag actuator is installed, check that it has free movement and is aligned correctly with the sensor.
4. Check that the paper path is clear.
5. If the sensor actuates by a surface that reflects, check that the surface is clean. Also make sure that there is not an obstruction between the sensor and the surface.
6. If the sensor actuates by an encoder disc, ensure the holes or gaps in the disc are aligned correctly with the sensor.

Sensor Action

In the upper sensor in [Figure 1](#), when light from the LED is reflected by the paper onto the photo-sensitive transistor, the sensing line, PJ1, pin 1 is low. When no paper is present, no light falls on the transistor and the sensing line is high.

In the lower sensor, in [Figure 1](#), when light from the LED is allowed to fall on the photo-sensitive transistor, the sensing line, PJ192, pin1, is low. When light from the LED is blocked by the flag, the sensing line is high.

Quick Sensor Check

Enter the component control code for the sensor, refer to [dC330](#). Actuate the sensor. If the display changes, the sensor operates correctly. If the display does not change, perform the procedure.

Procedure

This procedure applies to both sensor types, but here the upper sensor is used as an example.

For the upper sensor in the wiring diagram shown in [Figure 1](#):

- Actuate the sensor and check for a change in voltage at PJ184, pin 5. If the voltage changes, install a new PWB. If the voltage does not change, continue to the next step.
- Disconnect PJ1. Check for +5V and 0V at PJ1 on the harness.
- Disconnect PJ184. Check the wiring and the connectors for the sensor circuit.
- Check for +5V and 0V at PJ184 on the DADF PWB.
- If necessary, install new components or repair the wiring.

References:

- 01L 0V Distribution RAP.
- 01C +3.3V Distribution RAP.
- 01D +5V Distribution RAP.
- REP 1.1 Wiring Harness Repairs.

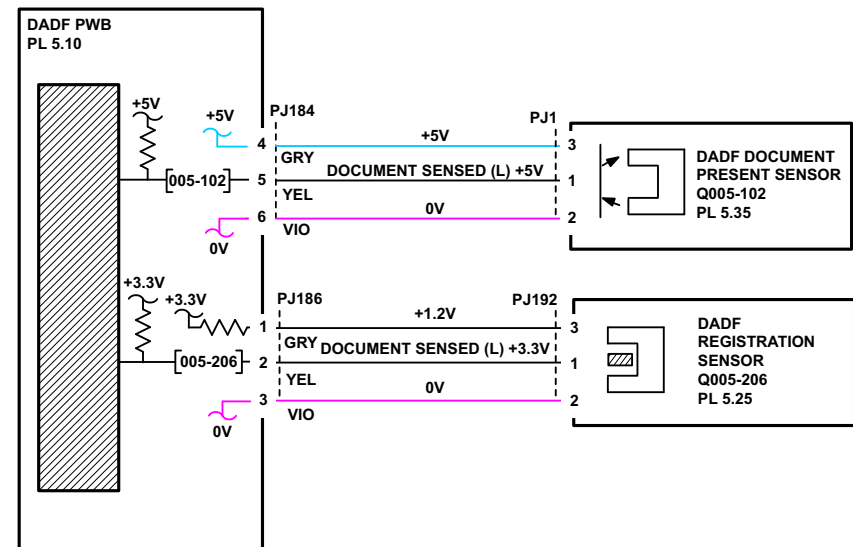

Figure 1 Wiring diagram

TU-1-0171-A

GP 12 How to Check a Solenoid or Clutch

Description

Use this procedure to check a clutch or solenoid.

Initial Actions

WARNING

Switch off the electricity to the machine. Refer to GP 14. Disconnect the power cord from the customer supply while performing tasks that do not need electricity. Electricity can cause death or injury. Moving parts can cause injury.

1. For a clutch, check that the shafts, gears, rolls etc., associated with the clutch are free to rotate, clean and lubricated where applicable.
2. For a solenoid, check that the solenoid is free to actuate and that the mechanisms associated with the solenoid are free to move.

Procedure

NOTE: The voltages, PJ numbers, pin numbers and PWB names shown are an example only. Go to the wiring diagram associated with the RAP for the correct information.

NOTE: When a solenoid is energized in diagnostics, movement is seen. When a clutch is energized in diagnostics, the sound of the clutch action is heard. If possible, run the motor connected to the clutch to confirm when the clutch is energized.

1. Enter the **dC330** output code for the clutch or solenoid. If the clutch or solenoid does not energize, continue at step2. If the energize of the clutch or solenoid is good, perform **SCP 5** Final actions.
2. **Figure 1**, disconnect PJ202, check for +24V at PJ202 pin 1 on the wiring side of the connector, If the voltage is not correct, perform **01H** +24V Distribution RAP.
3. Reconnect PJ202, enter the **dC330** output code for the clutch or solenoid, while measuring the voltage between PJ183 pin 4 and the machine frame. If the voltage does not change when the code is entered, Install a new DADH PWB, **PL 5.10**.
4. There may be an intermittent fault, perform the actions that follow:
 - Check the wiring associated with this circuit. Repair or install new components as necessary
 - Check that all connectors associated with this circuit are correctly and securely connected.
 - Operate the clutch or solenoid under normal machine running conditions. If the clutch or solenoid operates intermittently or with hesitation, install new parts.
 - Check that the clutch or solenoid has enough drive to operate the mechanism to which it is attached, if necessary install a new clutch or solenoid.

References:

- **01L** 0V Distribution RAP.
- **01H** +24V Distribution RAP.
- **REP 1.1** Wiring Harness Repairs.

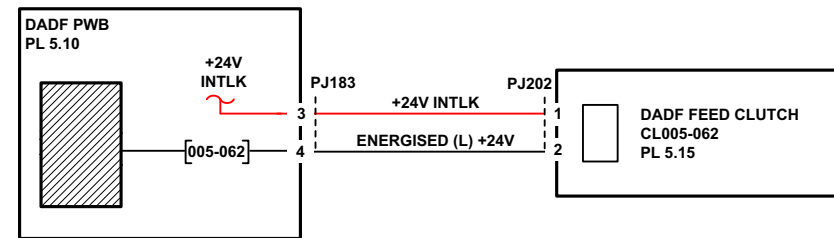

Figure 1 Wiring diagram

TU-1-0178-A

GP 13 How to Check a Switch

Description

Use this procedure to check the operation of a switch.

NOTE: The wiring diagram in [Figure 1](#) shows an home position switch actuated by the movement of a paddle.

Initial Actions

WARNING

Switch off the electricity to the machine. Refer to GP 14. Disconnect the power cord from the customer supply while performing tasks that do not need electricity. Electricity can cause death or injury. Moving parts can cause injury.

Manually check that the switch operates. Ensure that the magnet or other actuator has enough mechanical movement to operate the switch.

NOTE: The voltages, PJ numbers, pin numbers and PWB names shown are an example only. Go to the wiring diagram associated with the RAP for the correct information.

Procedure

Enter **dC330** code for the switch, actuate and deactuate the switch. **The display changes.**

Y N
Refer to [Figure 1](#). Disconnect T072. **+5V is available between pin 1 and pin 2 on the wiring side of the connector.**

Y N
Disconnect PJ5. **+5V is available at PJ5 between pins 3 and 4 on the HVF PWB.**

Y N
Perform **01D** +5V distribution RAP and **01L** 0V Distribution RAP. If both voltage supplies are good, install a new HVF PWB.

Check the wiring between PJ5 and T072. Repair or install new parts as necessary.

Install a new ejector lower paddle home switch S11-180, PL 11.140.

The switch is operating correctly, check and adjust if necessary, the mechanism that actuates the switch.

References:

- **01L** 0V Distribution RAP.
- **01D** +5V Distribution RAP.
- **REP 1.1** Wiring Harness Repairs.

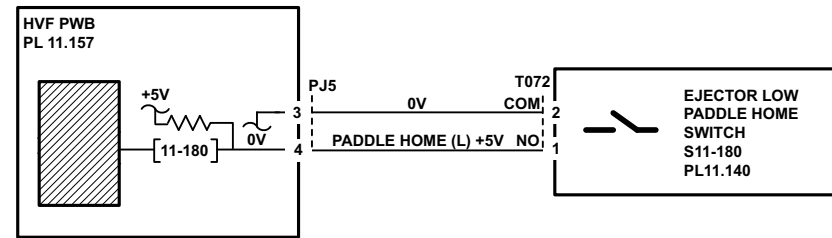

Figure 1 Wiring diagram

TU-1-0179-A

GP 14 How to Switch Off the Machine or Switch On the Machine

Purpose

To show how to switch off or switch on the machine, without the loss of customer data or damage to the system hardware.

WARNING

Do not use the on/off switch as a safety disconnect device. The on/off switch is not a disconnect device. Disconnect the power cord from the supply to isolate the equipment.

Refer to:

- [Switch Off Procedure.](#)
- [Switch On Procedure.](#)
- [Power Saver Modes](#)

Switch Off Procedure

CAUTION

To prevent internal ink spillage, allow 30 minutes before the machine is moved after switching off.

CAUTION

Do not disconnect the power lead or interrupt the electricity supply before the power down is complete. The data and software can become damaged.

1. Press the on/off switch. A confirmation window will open.

NOTE: *If the machine is in power save mode, the machine will exit to Ready To Scan before commencing the switch off procedure. If the machine is in software upgrade mode, a message is displayed to warn against switching off the machine.*

NOTE: *If the UI is unavailable, the power down request cannot be confirmed. The machine will power down automatically after 60 seconds.*

2. Confirm by selecting Power Down on the UI.

NOTE: *If the on/off switch is pressed again before either confirm has been selected or 60 seconds has elapsed, power off will be cancelled. The machine will return to normal operation.*

3. When a standard power off has been initiated, the machine will:

- Display a power off message.
- Power button on the UI will blink.
- Go off line and stop receiving jobs.

NOTE: *The machine will attempt to print the current sheet and send all sheets in the paper path to the output tray.*

- Stop processing any remaining jobs in the print queue.
- Send the scan carriage assembly to the home position.
- Send the marking unit upper and lower carriages to the parked position. The carriage locking pins will engage.
- Send the head maintenance wiper assembly to the parked position.

4. When the machine has switched off, remove the power lead from the outlet.

NOTE: *If the power lead is removed from the outlet due to a POPO. Wait for at least 1 minute before reinstalling the power lead. This allows time for the power supplies to discharge and reset.*

Switch On Procedure

1. After a machine has been switched off, wait a minimum of one minute before the machine is switched on.
2. After a service call, ensure that all service tools are removed from the machine.
3. Connect the power lead from the power supply outlet to the machine.
4. Press the on/off switch.

NOTE: *Pressing the on/off switch a second time will cancel the power on request. The machine will attempt to switch off correctly.*

5. The machine will perform the following:
 - A power on self test (POST). The POST checks that the hardware resources are available to run the operating system. If a POST fault is detected, the machine is prevented from booting. The fault is communicated via a blinking LED on the image marking engine PWB. Refer to [OF 16](#) POST Error Rap.
 - A print engine self test (PEST). The PEST checks the heaters, sensors, motors and mechanical subsystems. If the PEST fails, the most critical fault code is logged in the fault history. The full list of fault codes is logged in the PEST error log. Refer to [dC123](#).
6. The machine is ready to print after:
 - The drum, pre-heaters and printheads have reached operational temperature.
 - Ink purge then wipe of the printheads has been completed.
 - The printheads have been docked.
 - Cleaning page and ink on drum routines have been completed.
7. If the machine does not initialize, go to the appropriate RAP:
 - If the machine switches on, but the UI is blank. Go to the [OF 2](#) UI Touch Screen Failure RAP.
 - If the machine does not respond, go to the [OF 3](#) Unresponsive Machine RAP.
 - If the machine switches on, but does not respond, go to the [OF 5](#) Boot Up Failure RAP.

Service Mode

The machine can be switched on directly into Service Mode, refer to [GP 1](#).

Power Saver Modes

The power saver modes are selected from the Tools menu. For the power saver default settings, refer to [Table 1](#).

Table 1 Default settings

Mode	Low Power Timeout	Sleep Mode Timeout
Intelligent ready with Fast resume Off	5 minutes	60 minutes
Intelligent ready with Fast resume On	60 minutes	120 minutes

Table 1 Default settings

Mode	Low Power Timeout	Sleep Mode Timeout
Job activated with Fast resume Off	5 minutes	60 minutes
Job activated with Fast resume On	60 minutes	120 minutes
Scheduled mode (within scheduled times)	Not applicable (no low power entry)	Not applicable (no low power entry)
Scheduled mode (outside scheduled times)	60 minutes	120 minutes

Low Power Mode

Entry to low power mode is from Ready to Copy mode. In low power mode, the following conditions apply:

- The Power button on the UI will flash.
- All 5V, 12V and 24V supplies are off.
- The single board controller hard disk is powered down.
- The UI backlight and display are powered down.
- The image marking engine thermal system is at low power settings. The printheads are lowered onto the drum and the drum heated.
- The DADH and scanner are powered down.
- The AC supply to the LCSS or HVF is switched off.
- All power to the USB ports is switched off.
- The image marking engine fans are switched off

Sleep Mode

Entry to sleep mode is from low power mode. In sleep mode, the following conditions apply:

- The Power button on the UI is lit.
- All 5V, 12V and 24V supplies are off.
- The single board controller hard disk is powered down.
- The UI backlight and display are powered down.
- The image marking engine thermal system is at sleep settings. The printheads are retracted. The drum heaters are powered down and the drum will not rotate.
- The DADH and scanner are powered down.
- Except for the door sensors, the 3 tray module is powered down.
- The AC supply to the LCSS or HVF is switched off.
- All power to the USB ports is switched off.
- The image marking engine fans are switched off

NOTE: Refer to [GP 22 Electrical Power Requirements](#) for further information.

GP 15 Location and Function of PWB LEDs

Purpose

Use this procedure to check the voltage and the communication status on the PWB.

Refer to

- [Power Supply Unit](#)
- [Media Path Driver PWB](#)
- [Drum Driver PWB](#)
- [Marking Unit Driver PWB](#)
- [Printhead PWB](#)
- [IME Control PWB](#)
- [Single Board Controller PWB](#)
- [3 Tray Module PWB](#)
- [LCSS PWB](#)
- [HVF PWB](#)
- [HVF Booklet Maker PWB](#)
- [Scanner PWB](#)

Power Supply Unit

[Table 1](#) indicates the states of the LED's on a good working power supply unit, [PL 1.15 Item 2](#).

Table 1 Power supply unit

LED ID	LED colour	Status	Description
DS2	Green	On	+3.3V ESTAR present
DS7	Yellow	On	+5V present
DS1	Red	On	+50V present

Refer to [Figure 1](#) for the location of the LED's on the power supply.

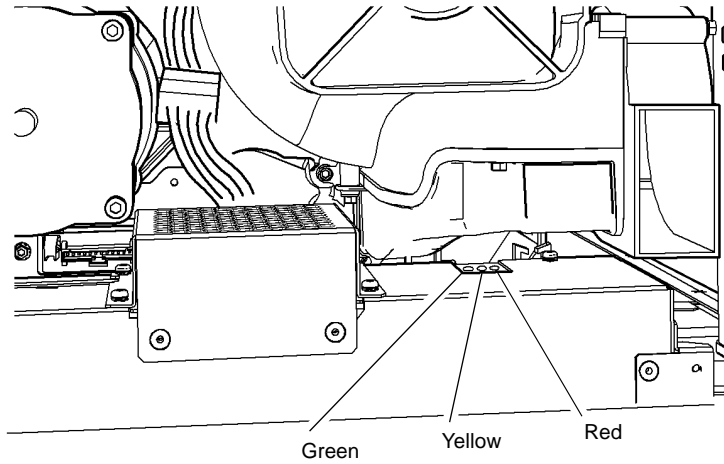

U-1-1613-A

Figure 1 Power supply unit

Media Path Driver PWB

[Table 2](#) indicates the state of the LED's on a good working media path driver PWB, [PL 1.15](#) [Item 5](#).

Table 2 Media Path Driver PWB

LED ID	LED colour	Status	Description
DS802	Red	Off	On during initialization and at IME fault
DS801	Green	On	No IME faults detected
DS901	Green	On	+50V present
DS902	Green	On	+5V present

Refer to [Figure 2](#) for the location of the LED's on the media path driver PWB.

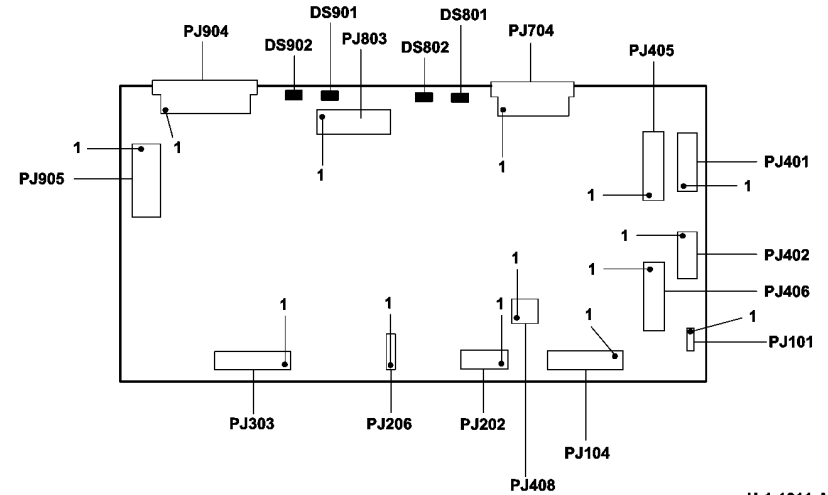

U-1-1611-A

Figure 2 Media path

Drum Driver PWB

[Table 3](#) indicates the state of the LED's on a good working drum driver PWB, [PL 1.15](#) [Item 4](#).

Table 3 Drive Driver PWB

LED ID	LED colour	Status	Description
DS601	Green	On	+3.3V ESTAR present
DS602	Green	On	+12V present
DS603	Green	On	+50V present

Refer to [Figure 3](#) for the location of the LED's on the drum driver PWB.

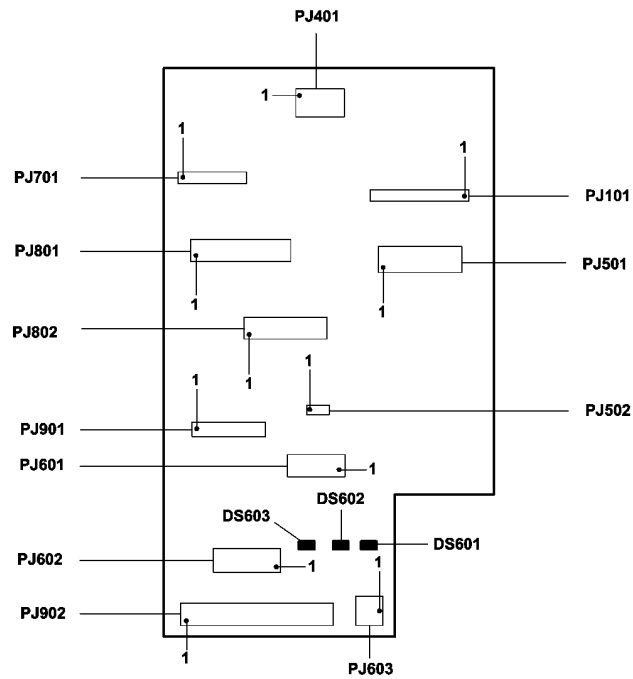

Figure 3 Drum driver PWB

U-1-1612-A

Marking Unit Driver PWB

[Table 4](#) indicates the state of the LED's on a good working marking unit driver PWB, [PL 92.10](#) Item 4.

Table 4 Marking Unit Driver PWB

LED ID	LED colour	Status	Description
DS201	Green	On	CPU activity

Refer to [Figure 4](#) for the location of the LED's on the marking unit driver PWB.

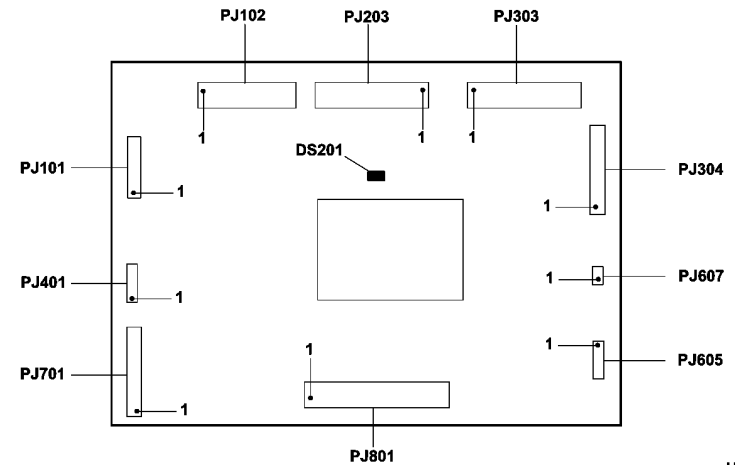

U-1-1614-A

Figure 4 Marking unit driver PWB

Printhead PWB

The [Table 5](#) indicates the state of the LED on a good working printhead PWB, [PL 91.20](#) Item 3.

Table 5 Printhead PWB

LED ID	LED colour	Status	Description
DS401	Green	On	+3.3V present

Refer to [Figure 5](#) for the location of the LED on the printhead PWB.

Refer to [Figure 6](#) for the location of the LED's on the IME control PWB.

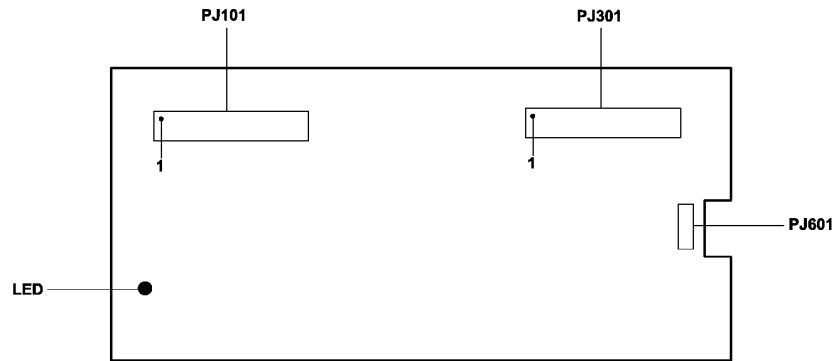

U-1-1616-A

Figure 5 Printhead PWB

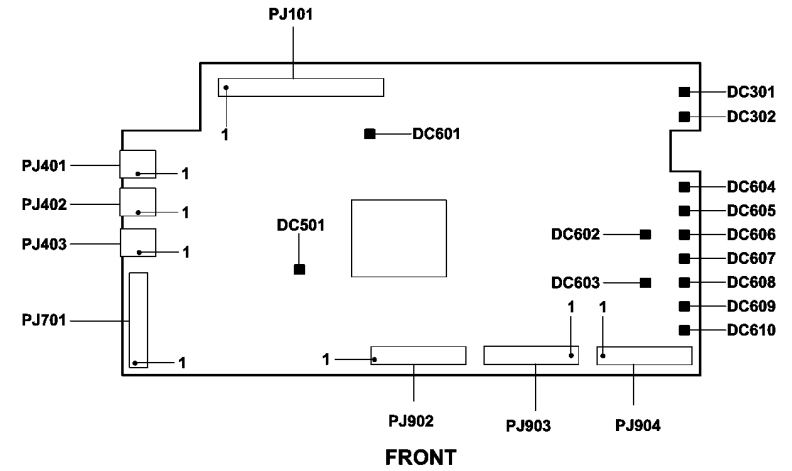

U-1-1618-A

Figure 6 IME controller PWB

IME Control PWB

[Table 6](#) indicates the state of the LED's on a good working IME control PWB, [PL 92.10 Item 1](#).

Table 6 IME controller PWB

LED ID	LED colour	Status	Description
DS610	Green	On	+3.3V ESTAR present
DS609	Green	On	+5V present
DS608	Green	On	+12V present
DS603	Green	On	-12v present
DS607	Green	On	+24Vpresent
DS606	Green	On	+50V present
DS602	Green	On	-50V present
DS601	Green	On	Lit equals CPU ready
DS501	Green	On	Lit equals CPU asleep
DS605	Red	Off	On when a CPU fault
DS604	Red	Off	On when Cable fault detected
DS301	Red	Off	On when IME error detected
DS302	Green	Flashing	IME good

Single Board Controller PWB

Table 7 indicates the state of the LED's on a good working single board controller PWB, PL 3.11 Item 13.

Table 7 Single board controller PWB

LED ID	LED colour	States	Description
CR1	Green	On	1.8V power is on
CR2	Green	Off On	SIM is good Indicates a SIM error
CR3	Green	On Off	SIM active No SIM present
CR4	Green	On	3.3V SLEEP present
CR5	Green	On	3.3V present
CR7	Green	On / Puls- ing	Various alpha-numeric codes, refer to OF 16 . The decimal point is the heartbeat and pulses.
CR8	Green	On	+1.8V SLEEP present
CR9	Green	On	Image clock enabled
CR12	Green	On	All power good. Appears too as an I/O for SW assurance that SLEEP power rails are restored.
CR14	Red	Off On	Normal state Indicates power failure
CR24	Green	Off	FPGA is programmed
CR10, CR11, CR13	-	-	Not used
Internet connector left side PJ14	Green / Yellow	On	Internet link made. Green: 1000 Yellow: 100 OFF: 10
Internet connector right side PJ14	Green / Yellow	On Flashing	Internet activity Any link Transmitting or receiving data

Refer to Figure 7 for the location of the LED's on the single board controller PWB.

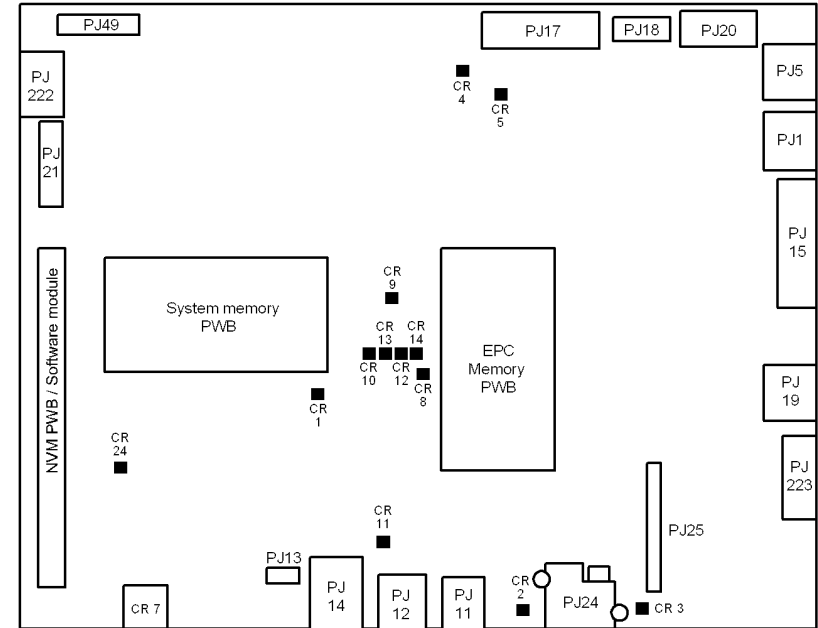

U-1-1634-A

Figure 7 Single board controller PWB

3 Tray Module PWB

Table 8 indicates the state of the LED's on a good working 3 tray module PWB, PL 73.16 Item 4.

Table 8 Three Trays Module PWB

LED ID	LED colour	Status	Description
CR19	Green	On	+5V present
CR18	Green	On	+24V present
CR20	Green	Flashes	LED flashes for 3TM activity

Refer to [Figure 8](#) for the location of the LED's on the 3 tray module PWB.

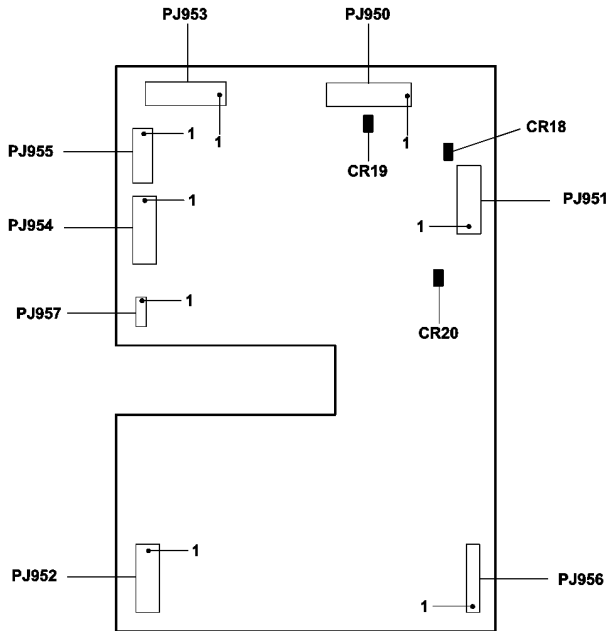

U-1-1615-A

Figure 8 3 tray module PWB

Refer to [Figure 9](#) for the location of the LED's on the LCSS PWB.

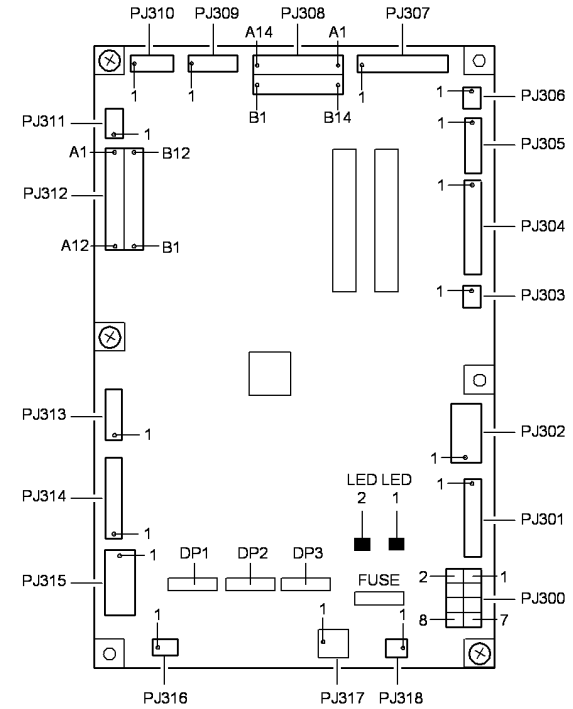

U-1-1623-A

Figure 9 LCSS PWB

LCSS PWB

[Table 9](#) indicates the state of the LED on a good working LCSS PWB, [PL 12.75 Item 1](#).

Table 9 HVF PWB

LED ID	LED colour	Status	Description
LED 1	Red	Flashes	LED flashes twice a second indicates the software is running.
LED 2	Red	On	Indicates that all interlocks are made (+24V)

HVF PWB

[Table 10](#) indicates the state of the LED's on a good working HVF PWB, [PL 12.140 Item 2](#).

Table 10 HVF PWB

LED ID	LED colour	Status	Description
LED 1, 2	Red		Not used
LED 3	Red	Flashes	LED flashes at 2Hz for software operating in normal mode. This indicates the functioning of the CPU. If this LED is OFF, the CPU does not function and a new HVF control PWB is required.
LED 4, 5, 6, 7	Red		Not used
LED 8	Red	On	+24V present and all interlocks are closed
LED 9	Red	On	+5V present

Refer to [Figure 10](#) for the location of the LED's on the HVF PWB.

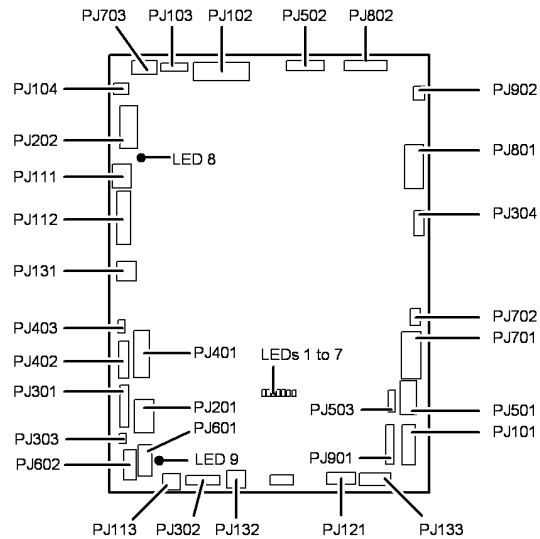

U-1-1617-A

Figure 10 HVF PWB

Refer to [Figure 11](#) for the location of the LED's on the PWB.

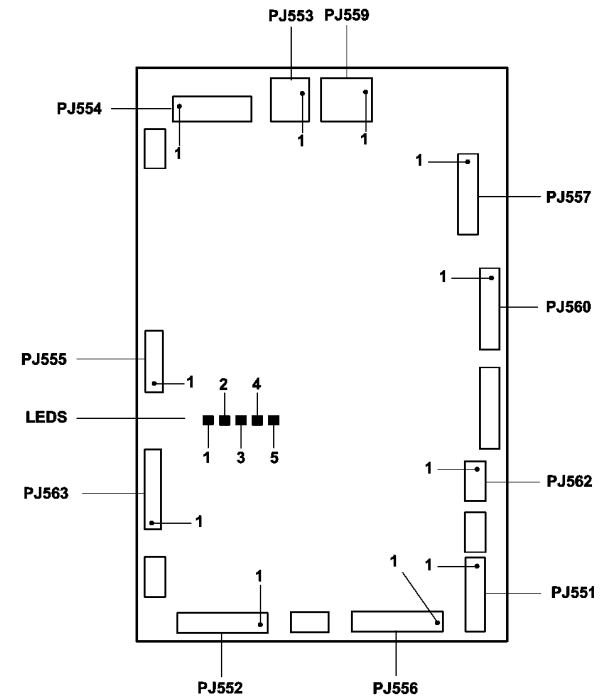

U-1-1619-A

Figure 11 HVF booklet maker PWB

HVF Booklet Maker PWB

[Table 11](#) indicates the state of the LED's on a good working HVF booklet maker PWB, [PL 12.175 Item 10](#).

Table 11 HVF BM PWB

LED ID	LED colour	Status	Description
LED 1	Red	Off	Steady indicates a fault or other abnormal status
LED 2	Yellow	Flashing	Flashing indicates software operating in normal mode
LED 3	Orange	On	+24V present and tri-folder door and top cover interlocks closed. Or without tri-folder interlock cheat in PJ553 and logic cheat in PJ563.
LED 4	Orange	On	+24V is within the voltage and current limits
LED 5	Blue	On	+5V present

Scanner PWB

[Table 12](#) indicates the state of the LED's on a good scanner PWB, [PL 62.16 Item 8](#).

Table 12 Media Path Driver PWB

LED ID	LED colour	Status	Description
D13	Red	On	+24V present
D14	Red	On	+12 V present
D15	Red	On	+3.3V present
D16	Red	On	+5V present
LED 1	Green	Flashing	Heartbeat, flashes for software operating in normal mode
LED 2	Red	Off	If there is a hardware reset, e.g. a voltage dip on the 3.3V power line, the LED will turn on and only switch off when the software re-initializes.

Refer to [Figure 12](#) for the location of the LED's on the scanner PWB.

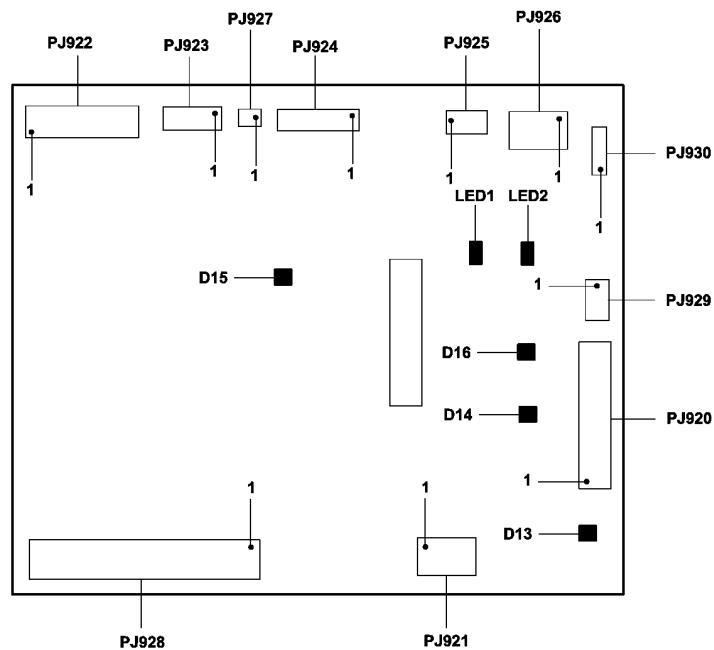

U-1-1624-A

Figure 12 Scanner PWB

GP 16 How to Safely Lift or Move Heavy Modules

Purpose

Use this procedure when lifting or moving heavy modules.

Procedure

WARNING

Switch off the electricity to the machine. Refer to [GP 14](#). Disconnect the power cord from the customer supply while performing tasks that do not need electricity. Electricity can cause death or injury. Moving parts can cause injury.

WARNING

Take care during this procedure. Sharp edges may be present that can cause injury.

When removing heavy modules from the machine, the following instructions must be observed:

1. Ensure that a suitable stable surface to support the module after removal is located in close proximity to the machine.

NOTE: Other parts of the machine are not a suitable stable surface.

2. Ensure that the height of the support surface is between 750 mm and 1000 mm (30 inches and 39 inches).
3. Ensure that there are no hazards or obstacles between the machine and the support surface.
4. If instructed to remove the module toward the rear of the machine and only one person is available, the module must be removed while standing at the rear of the machine. If two people are available, the module may be removed while standing at the front of the machine.
5. Two people are required if the module is to be lifted on to the floor or lifted from the floor.

GP 17 Network Clone Procedure

Purpose

To save and restore the customers unique network configuration setting.

The clone file (to hard disk) must be performed at the first service call and whenever the customer changes the network settings or after the system software is changed.

Procedure

How to Save a Clone File

1. On the customer's workstation, open the web browser. Enter the machines IP address in the web browser Address field, then press the enter key. The machine web page will open.

NOTE: Refer to the configuration report for the machines IP address.

2. Click on Properties.
3. Enter the Administrator User ID and Password.
4. Select General Setup.
5. Select Cloning.
6. Select the relevant settings to clone.
7. In the Cloning Instructions area, right click on the (Cloning.dlm) link. Select Save Target As.
8. Ask the customer to specify a file name and location.

NOTE: Ensure the file extension is .dlm.

9. Select Save.

How to Install a Clone File - Option 1

1. On the customers workstation, open the web browser. Enter the machine IP address in the web browser address field. Then press the Enter key. The machine web page will open.

NOTE: Refer to the configuration report for the machine IP address.

2. Click on Status.
3. Select Welcome.
4. Click on the I Have A Cloning File button.
5. Enter the Administrator User ID and Password.
6. Scroll down to the Install Clone File area. Click on Browse to locate the relevant clone file.
7. Click on Save.

NOTE: The machine will reboot and be unavailable for several minutes.

How to Install a Clone File - Option 2

1. On the customers workstation, open the web browser. Enter the machine IP address in the web browser address field. Then press the Enter key. The machine web page will open.

NOTE: Refer to the configuration report for the machine IP address.

2. Click on Properties, then General Setup, then Cloning.

3. Scroll down to the Install Clone File area. Click on Browse to locate the relevant clone file.
4. Click on Install.

NOTE: The machine will reboot and be unavailable for several minutes.

GP 18 Machine Lubrication

Purpose

To give information on the use of lubricants.

Procedure

CAUTION

Only use lubricants as directed. Incorrect use of lubricants could seriously affect the performance of the machine.

Take the following precautions when performing machine lubrication:

- Wear disposable gloves, [PL 26.10 Item 5](#).
- Only use lubricants that are specified in the Parts List.
- Only lubricate parts of the machine as directed in the relevant RAPs, Repairs and Adjustments etc.
- Apply only the smallest amount of lubricant, sufficient to lubricate the parts. To prevent contamination, remove any surplus lubricant before the machine is run.
- Take great care not to contaminate other parts of the machine with the lubricant.

GP 19 Machine SIM Card Matrix

Purpose

To identify the correct SIM card with the correct machine configuration, [Figure 1](#).

Procedure

Install the SIM card that is compatible with the machine:

- 9301 machine indicated by the letter **A** or no coloured strip.
- 9302 machine indicated by the letter **B** or a green strip.
- 9303 machine indicated by the letter **C** or a yellow strip.

NOTE: *When the machine is installed, the machine will only recognize a SIM with the machines serial number written to it. If your customer has lost the SIM or the SIM has been damaged, a pre-programmed SIM must be ordered. This can be obtained by escalating the problem through normal channels, and a pre-programmed SIM with the customer's serial number will be sent.*

NOTE: *The SIM card is also referred to as the product enablement key.*

The following information is required when ordering a pre-programmed SIM:

- Machine serial number.
- Machine speed, 9301, 9302 or 9303.
- Billing plan, 2 tier or 3 tier.
- Service plan, WW metered, XC / XE sold or DMO sold.

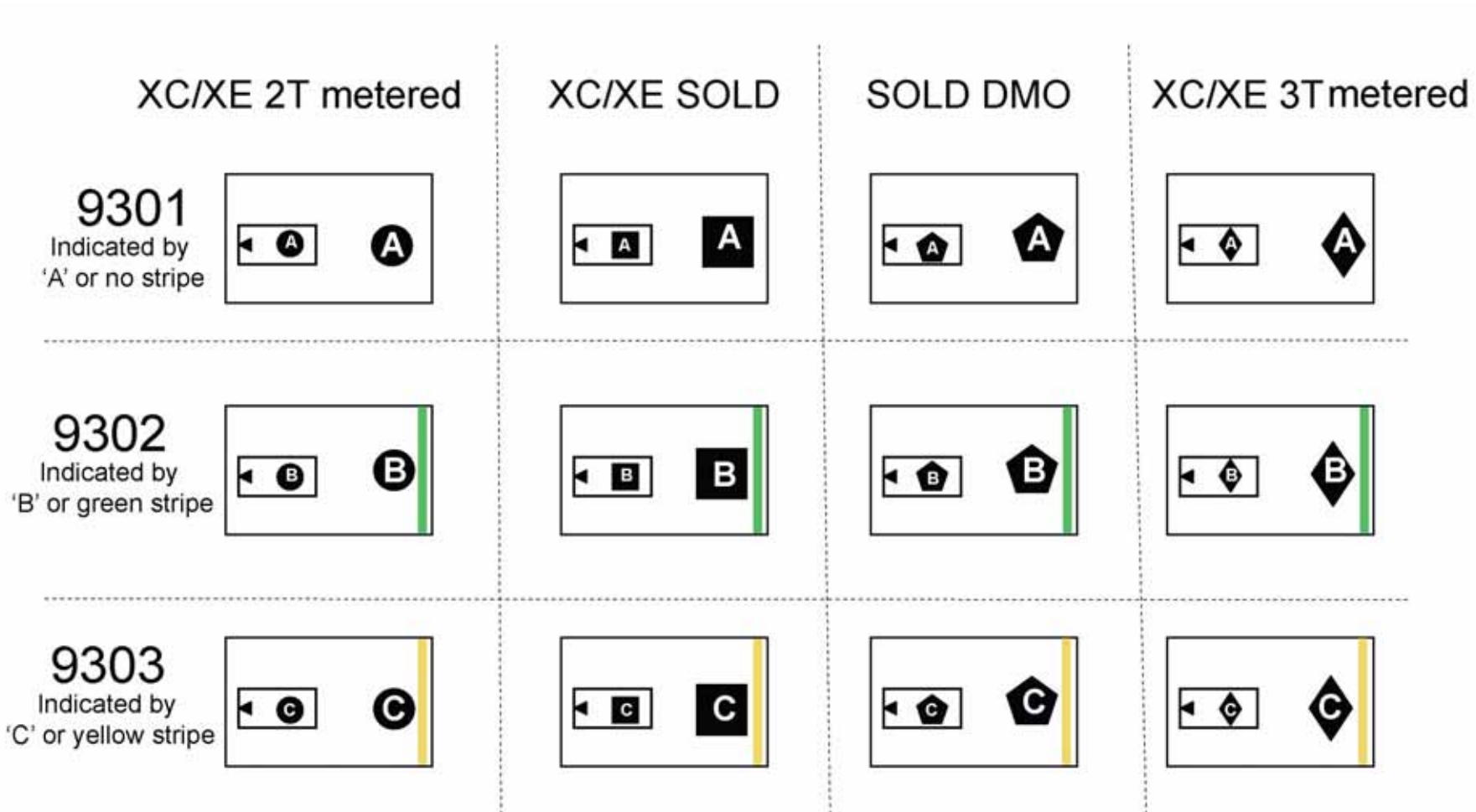

U-1-1636-A

Figure 1 SIM card matrix

GP 20 Paper and Media Size Specifications

Purpose

To list the paper and media specifications.

Specifications

The machine design and performance is optimized for:

- Xerox 4200 (20lb / 75 gsm) 8.5 x 11 inch paper.
- Xerox Premier TCF 80 gsm A4 paper.

Refer to the following:

- [Table 1](#). Performance indication.
- [Table 2](#) European papers.
- [Table 3](#) American papers.
- [Table 4](#) Input / output paper sizes. The table defines the paper sizes that are recognized by the DADH, document glass and the paper trays when using an OCT output device.
- [Table 5](#) LCSS output paper sizes. The table defines the paper sizes that can be delivered to the output trays of a LCSS.
- [Table 6](#) HVF output paper sizes. The table defines the paper sizes that can be delivered to the output bins of the HVF.
- [Table 7](#) Output stock performance. The table shows the media (stock) performance constraints for the output. Performance will not be guaranteed for media not listed in the table. Media that is smaller than 139 mm (5.5 inches) in either the process or cross process direction cannot be duplexed.
- [Table 8](#) Input document categories definitions.
- [Table 9](#) Input document condition definitions.
- [Table 10](#) Degraded performance paper list.
- [Table 11](#) European envelope sizes
- [Table 12](#) American envelope sizes
- [Table 13](#) U.S. paper weight conversion. Use this table to determine approximate equivalent points in weight specifications other than for U.S. bond weight.

Table 1 Performance indication

Code	Description
1	Degraded performance (image quality defects, increased jams or bad stacking)
2	Good performance (good image quality, some jams and poor stacking)
3	Excellent performance
C	Size set by customer
M	Differentiated by market
N	Size unrecognized and not acceptable
U	Size unrecognized but acceptable
X	Not recommended (outside specification)
Y	Size recognized and accepted

Table 2 European papers

Paper Size	Nominal gsm	Description	Paper Type
A3	100	Xerox DigitalColour Colotech	Bond
SRA3	100	Xerox DigitalColour Colotech	Bond
A3	120	Xerox DigitalColour Colotech	Bond
SRA3	120	Xerox DigitalColour Colotech	Bond
A3	90	Xerox DigitalColour Colotech	Bond
SRA3	90	Xerox DigitalColour Colotech	Bond
A4	80	Exclusive	Bond
A4	90	Exclusive	Bond
A3	90	Exclusive	Bond
A4	80	Performer	Bond
A4	80	Xerox Recycled Supreme	Bond
A4	80	Xerox Premier	Bond
A4	80	Xerox Business	Bond
A3	80	Xerox Business	Bond
A5	80	Xerox Premier	Bond
A4	90	Xerox Premier	Bond
A4	120	Xerox Premier	Bond
A4	100	Exclusive	Bond
A4	90	Xerox DigitalColour Colotech +	Bond
A4	100	Xerox DigitalColour Colotech +	Bond
A4	120	Xerox DigitalColour Colotech +	Bond
A4	80	Xprint	Bond
A4	90	Xprint	Bond
A3	90	Xprint	Bond
A4	100	Xprint	Bond
A4	120	Xprint	Bond
A4	100	Xerox Colotech + Natural White	Bond
A4	80	Xerox Colour Impressions	Bond
A4	90	Xerox Colour Impressions	Bond
A4	100	Xerox Colour Impressions	Bond
A4	120	Xerox Colotech + (Gold)	Bond
A4	90	Xerox Colotech + (Gold)	Bond
A4	100	Xerox Colotech + (Gold)	Bond
A4	78	Carbonless (W / P)	Carbonless
A4	78	Carbonless (W / C)	Carbonless
A4	78	Carbonless (W / C / P, str collated)	Carbonless
A3	160	Xerox Digital Colour Colotech +	Cover
SRA3	160	Xerox Digital Colour Colotech +	Cover
A3	200	Xerox Digital Colour Colotech +	Cover
SRA3	200	Xerox Digital Colour Colotech +	Cover
A4	160	Xerox Digital Colour Colotech +	Cover

Table 2 European papers

Paper Size	Nominal gsm	Description	Paper Type
A4	200	Xerox Digital Colour Colotech +	Cover
A4	160	Xerox Colotech + Natural White	Cover
A4	200	Xerox Colotech + Natural White	Cover
A4	176	Phaser Trifold Brochures	Cover
A4	160	Xerox Colotech + (Gold)	Cover
A4	200	Xerox Colotech + (Gold)	Cover
A4	160	Xerox Colour Impressions	Cover
A3	160	Xerox Colour Impressions	Cover
A4	200	Xerox Premier 200 White Card	Index
A4	160	Xerox Colour Copier / Laser Labels	Label
A4	169	Professional Solid Ink High Resolution Photo Paper	Specially
A4	220	Professional Solid Ink Business Cards	Specially
A4	140	Colotech + Supergloss	Specially
A4	140	Colotech + gloss coated	Specially
A3	140	Colotech + gloss coated	Specially
50 x 10	160	Dividers White 5 Tab Reverse Colated	Tab
50 x 10	160	Dividers White 10 Tab Reverse Colated	Tab
50 x 10	160	Dividers White 10 Tab Reverse Colated - 4 Hole	Tab
50 x 10	160	Dividers White 5 Tab Reverse Colated - 4 Hole	Tab
A4	5 mil	Xerox Digital Transparency Type CLD	Transparency

Table 3 American papers

Paper Size inches	Paper Weight US bond lb.	Nominal gsm	Description	Paper Type
8.5 x 11	24	90	Xerox Graphic Xpressions	Bond
8.5 x 17	24	90	Xerox Graphic Xpressions	Bond
8.5 x 11	28	105	Xerox Graphic Xpressions	Bond
8.5 x 17	28	105	Xerox Graphic Xpressions	Bond
12 x 18	28	105	Xerox Graphic Xpressions	Bond
8.5 x 11	24	90	Digital Color Parchment	Bond
8.5 x 11	24	90	Xerox Color Xpressions +	Bond
8.5 x 14	24	90	Xerox Color Xpressions +	Bond
11 x 17	24	90	Xerox Color Xpressions +	Bond
8.5 x 11	28	105	Xerox Color Xpressions +	Bond
12 x 18	28	105	Xerox Color Xpressions +	Bond

Table 3 American papers

Paper Size inches	Paper Weight US bond lb.	Nominal gsm	Description	Paper Type
11 x 17	28	105	Xerox Color Xpressions +	Bond
11 x 8.5	32	120	Xerox Color Xpressions +	Bond
11 x 17	32	120	Xerox Color Xpressions +	Bond
12 x 18	32	120	Xerox Color Xpressions +	Bond
8.5 x 11	20	75	Xerox Business Plus	Bond
8.5 x 14	20	75	Xerox Business Plus	Bond
11 x 17	20	75	Xerox Business Plus	Bond
8.5 x 11	24	90	Xerox Business Plus	Bond
8.5 x 11	28	105	DuraDocument	Bond
8.5 x 11	20	75	Xerox Business 4200	Bond
8.5 x 14	20	75	Xerox Business 4200	Bond
8.5 x 11	28	105	Xerox Business 4200	Bond
8.5 x 11	24	90	Xerox Business 4200	Bond
8.5 x 11	20	75	Xerox Business 4200	Bond
11 x 17	20	75	Xerox Business 4200	Bond
11 x 17	24	90	Xerox Business 4200	Bond
11 x 17	28	105	Xerox Business 4200	Bond
8.5 x 11	24	90	Premium Multipurpose 4024 (Security) PMP	Bond
8.5 x 11	24	90	Premium Multipurpose 4024 (Security) PMP	Bond
8.5 x 11	28	105	Xerox Graphic Xpressions	Bond
11 x 17	28	105	Xerox Graphic Xpressions	Bond
12 x 18	28	105	Xerox Graphic Xpressions	Bond
8.5 x 11	20	75	Digital Laser Opaque	Bond
8.5 x 11	24	90	Digital Laser Opaque	Bond
8.5 x 14	24	90	Digital Laser Opaque	Bond
8.5 x 11	18	68	Digital Laser Opaque	Bond
8.5 x 11	28	105	Digital Laser Opaque	Bond
8.5 x 11	24	90	Premium Multipurpose 4024 (Security) PMP	Bond
8.5 x 11	20	75	Recycled Multipurpose	Bond
8.5 x 14	20	75	Recycled Multipurpose	Bond
8.5 x 17	20	75	Xerox Business Recycled	Bond
8.5 x 11	80	216	Xerox Graphic Impressions	Cover
11 x 17	80	216	Xerox Graphic Impressions	Cover
12 x 18	80	216	Xerox Graphic Impressions	Cover
12 x 18	80	216	Xerox Graphic Impressions	Cover
8.5 x 11	60	163	Xerox Color Impressions +	Cover
11 x 17	60	163	Xerox Color Impressions +	Cover

Table 3 American papers

Paper Size inches	Paper Weight US bond lb.	Nominal gsm	Description	Paper Type
12 x 18	60	163	Xerox Color Impressions +	Cover
8.5 x 11	80	216	Xerox Color Impressions +	Cover
11 x 17	80	216	Xerox Color Impressions +	Cover
12 x 18	80	216	Xerox Color Impressions +	Cover
8.5 x 11	65	176	Phaser Premium Postcards	Cover
8.5 x 11	65	176	Phaser Trifold Brochures	Cover
8.5 x 11	65	176	Xerox 65# Cover	Cover
8.5 x 11	65	176	Xerox Graphic Impressions	Cover
11 x 17	65	176	Xerox Graphic Impressions	Cover
12 x 18	65	176	Xerox Graphic Impressions	Cover
8.5 x 11	80	216	Xerox Graphic Impressions	Cover
11 x 17	80	216	Xerox Graphic Impressions	Cover
12 x 18	80	216	Xerox Graphic Impressions	Cover
8.5 x 11	90 Index	163	Xerox Multipurpose Whit Index	Index
11 x 17	90 Index	163	Xerox Business 4200	Index
8.5 x 11	110 Index	200	Xerox 110# Index Stock	Index
8.5 x 11	NA	160	Xerox Ink Jet / Laser White Labels	Label
8.5 x 11	24	90	Xerox Premium Multipurpose 4024 PMP	Punched / Perfed
8.5 x 11	20	80	Xerox Premium Multipurpose 4024 PMP	Punched / Perfed
8.5 x 11	24	90	Xerox Premium Multipurpose 4024 PMP	Punched / Perfed
8.5 x 11	20	80	Xerox Premium Multipurpose 4024 PMP	Punched / Perfed
8.5 x 11	20	78	Premium Digital Carbonless	Speciality
8.5 x 11	63 Cover	169	Professional Solid Ink High Resolution Photo Paper	Speciality
8.5 x 11	NA	220	Professional Solid Ink Business Cards	Speciality
8.5 x 11	NA	165	Phaser solid ink glossy (2 sided)	Speciality
8.5 x 11	NA	150	Digital colour elite gloss	Speciality
9 x 11	60 Cover	160	Xerox Tabs 5 Bank Single Reverse Collated / 250 ctn	Tab
9 x 11	60 Cover	160	Xerox Tabs 3 Bank Single Reverse Collated / 420 ctn	Tab
9 x 11	60 Cover	160	Xerox Tabs 4 Bank Single Reverse Collated / 320 ctn	Tab
9 x 11	60 Cover	160	Xerox Tabs 8 Bank Single Reverse Collated / 150 ctn	Tab
8.5 x 11		5 mil	Digital Color Clear Transparency	Transparency

Table 3 American papers

Paper Size inches	Paper Weight US bond lb.	Nominal gsm	Description	Paper Type
8.5 x 11		5 mil	Xerox Professional Solid Ink Transparency	Transparency
8.5 x 5.5			Statement SEF	
7.25 x 10.5			Executive SEF	
8.5 x 13			Folio SEF	

Table 4 Input / output Paper sizes

Paper size			Orientation	Paper tray size sensing				DADH size sensing			Document glass size sensing			Output device	Notes
Common Name	Inch (W x L) +/-1/32 inch	mm (W x L) +/-1 mm	LEF / SEF	Tray 1 and 2	Bypass tray	Tray 3	Tray 5	NASG	Eur / Asia	Latin	NASG	Eur / Asia	Latin	OCT	-
Letter	8.5 x 11	216 x 279	SEF	Y	M	N	Y*	Y	Y	Y	Y	Y	Y	Y	* Requires kit
Letter	8.5 x 11	216 x 279	LEF	Y	M	Y	Y	Y	Y	Y	Y	Y	Y	Y	
Ledger/Tabloid	11 x 17	279 x 432	SEF	Y	U	N	Y*	Y	Y	Y	Y	Y	Y	Y	* Requires kit
Invoice (statement)	8.5 x 5.5	216 x 138	SEF	N	M	N	N	Y*	Y*	Y*	Y	Y	Y	Y	*ISO A5 or 8.5 x 5.5 cannot be detected at the same time - market differentiated
Invoice (statement)	8.5 x 5.5	216 x 138	LEF	N	N	N	N	Y*	Y*	Y*	Y	Y	Y	U	*ISO A5 or 8.5 x 5.5 cannot be detected at the same time - market differentiated
Postcard	4.25 x 5.5	108 x 139	SEF	N	N	N	N	N	N	N	Y	Y	Y	U	-
Postcard	4.25 x 5.5	108 x 139	LEF	N	N	N	N	N	N	N	U	U	U	U	Cannot be fed in IME
Legal	8.5 x 14	216 x 356	SEF	Y	U	N	Y*	Y	Y	Y	Y*	U*	Y*	Y	*Legal and Folio (8.5 x 13) cannot be detected at the same time - market differentiated
ISO A4	8.26 x 11.69	210 x 297	SEF	Y	M	N	Y**	Y*	Y*	Y*	Y	Y	Y	Y	*ISO A4 or 8.5 x 13 cannot be detected at the same time - market differentiated ** Requires kit
ISO A4	8.26 x 11.69	210 x 297	LEF	Y	M	Y	Y	Y	Y	Y	Y	Y	Y	Y	
ISO A3	11.69 x 16.54	297 x 420	SEF	Y	U	N	Y*	Y	Y	Y	Y	Y	Y	Y	* Requires kit
ISO A5	5.83 x 8.27	148 x 210	SEF	N	M	N	N	Y*	Y*	Y*	Y	Y	Y	U	*ISO A5 or 8.5 x 5.5 cannot be detected at the same time - market differentiated
ISO A5	5.83 x 8.27	148 x 210	LEF	N	N	N	N	Y*	Y*	Y*	Y	Y	Y	Y	Cannot be fed in the IME *ISO A5 or 8.5 x 5.5 cannot be detected at the same time - market differentiated
ISO A6	4.13 x 5.83	105 x 148	SEF	N	Y	N	N	N	N	N	Y	Y	Y	U	-
ISO A6	4.13 x 5.83	105 x 148	LEF	N	N	N	N	N	N	N	U	U	U	U	-
Foolscap or Euroletter	8.5 x 13	216 x 330	SEF	Y	U	N	N	Y*	Y*	Y*	Y**	Y**	Y**	Y	*ISO A4 or 8.5 x 13 cannot be detected at the same time - market differentiated ** Legal and Folio (8.5 x 13) cannot be detected at the same time - market differentiated
JIS B5	7.17 x 10.12	182 x 257	SEF	U / C	U / C	N	N	Y*	Y*	Y*	Y*	Y*	Y*	Y	* Executive and JIS B5 cannot be detected at the same time - market differentiated

Table 4 Input / output Paper sizes

Paper size			Orientation	Paper tray size sensing				DADH size sensing			Document glass size sensing			Output device	Notes
Common Name	Inch (W x L) +/-1/32 inch	mm (W x L) +/-1 mm	LEF / SEF	Tray 1 and 2	Bypass tray	Tray 3	Tray 5	NASG	Eur / Asia	Latin	NASG	Eur / Asia	Latin	OCT	-
JIS B5	7.17 x 10.12	182 x 257	LEF	N	N	N	N	Y*	Y*	Y*	Y*	Y*	Y*	U	* Executive and JIS B5 cannot be detected at the same time - market differentiated Cannot be fed in the IME
JIS B4	10.12 x 14.33	257 x 364	SEF	U/C	U/C	N	N	U	U	U	Y	Y	Y	Y	-
JIS B6	5.08 x 7.17	128 x 182	SEF	N	N	N	N	U	U	U	Y	Y	Y	U	-
JIS B6	5.08 x 7.17	128 x 182	LEF	N	N	N	N	U	U	U	U	U	U	U	-
JIS B6	4.29 x 6.93	128x 176	SEF	N	N	N	N	N	N	N	N	N	N	U	-
ISO B5	6.93 x 9.84	176 x 250	SEF	U	U	N	N	U	U	U	U	U	U	Y	-
ISO B5	6.93 x 9.84	176 x 250	LEF	N	N	N	N	U	U	U	U	U	U	U	Cannot feed in the IME
ISO B4	9.84 x 13.9	250 x 353	SEF	U	U	N	N	U	U	U	U	U	U	Y	-
SB4	9.9 x 14.09	252 x 358	SEF	C	C	N	N	U	U	U	U	U	U	Y	-
Postcard-Lakes	4.5 x 6	114 x 152	SEF	N	N	N	N	N	N	N	U	U	U	U	-
Postcard-Lakes	4.5 x 6	114 x 152	LEF	N	N	N	N	N	N	N	U	U	U	U	-
Postcard	5 x 7	127 x 178	SEF	N	N	N	N	N	N	N	U	U	U	U	-
Postcard	5 x 7	127 x 178	LEF	N	N	N	N	N	N	N	U	U	U	U	Cannot be fed in the IME
Oufuku-Hagaki Postcard	5.83 x 7.87	148 x 200	SEF	N	N	N	N	U	U	U	U	U	U	U	-
Oufuku-Hagaki Postcard	5.83 x 7.87	148 x 200	LEF	N	N	N	N	U	U	U	U	U	U	U	-
6 x 9 inch	6 x 9	152 x 229	SEF	C	C	N	N	U	U	U	U	U	U	Y	-
6 x 9 inch	6 x 9	152 x 229	LEF	N	N	N	N	U	U	U	U	U	U	U	-
Royal Octavo	6 x 9.5	152 x 241	SEF	C	C	N	N	U	U	U	U	U	U	Y	-
Royal Octavo	6 x 9.5	152 x 241	LEF	N	N	N	N	U	U	U	U	U	U	U	-
Foolscap Quarto	6.5 x 8.25	165 x 206	SEF	N	N	N	N	U	U	U	U	U	U	U	-
Foolscap Quarto	6.5 x 8.25	165 x 206	LEF	N	N	N	N	U	U	U	U	U	U	U	-
Crown Quarto	7.25 x 9.5	184 x 241	SEF	C	C	N	N	U	U	U	U	U	U	Y	-
Crown Quarto	7.25 x 9.5	184 x 241	LEF	N	N	N	N	U	U	U	U	U	U	U	-

Table 4 Input / output Paper sizes

Paper size			Orientation	Paper tray size sensing				DADH size sensing			Document glass size sensing			Output device	Notes
Common Name	Inch (W x L) +/-1/32 inch	mm (W x L) +/-1 mm	LEF / SEF	Tray 1 and 2	Bypass tray	Tray 3	Tray 5	NASG	Eur / Asia	Latin	NASG	Eur / Asia	Latin	OCT	-
Executive	7.25 x 10.5	184 x 267	SEF	Y	Y	N	N	Y*	Y*	Y*	Y*	U*	Y*	Y	* Executive and ISO B5 cannot be detected at the same time - market differentiated
Executive	7.25 x 10.5	184 x 267	LEF	N	N	N	N	Y*	Y*	Y*	Y*	U*	Y*	U	* Executive and ISO B5 cannot be detected at the same time - market differentiated
16K Taiwan	7.64 x 10.51	194 x 267	SEF	C	C	N	N	U	U	U	U	U	U	Y	-
16K Taiwan	7.64 x 10.51	194 x 267	LEF	N	N	N	N	U	U	U	U	U	U	U	-
Quarto	8 x 10	203 x 254	SEF	C	C	N	N	U	U	U	U	U	U	Y	-
Quarto	8 x 10	203 x 254	LEF	N	N	N	N	U	U	U	U	U	U	U	-
-	8 x 10.5	203 x 267	SEF	C	C	N	N	U	U	U	U	U	U	Y	-
-	8 x 10.5	203 x 267	LEF	N	N	N	N	U	U	U	U	U	U	U	-
8 x 13 inch foolscap	8 x 13	203 x 330	SEF	C	C	N	N	U	U	U	U	U	U	Y	-
-	8.26 x 10	210 x 254	SEF	C	C	N	N	U	U	U	U	U	U	Y	-
-	8.26 x 10	210 x 254	LEF	C	C	N	N	U	U	U	U	U	U	Y	-
-	8.26 x 10.63	210 x 270	SEF	C	C	N	N	U	U	U	U	U	U	Y	-
-	8.26 x 10.63	210 x 270	LEF	C	C	N	N	U	U	U	U	U	U	Y	-
-	8.26 x 13	210 x 330	SEF	C	C	N	N	U	U	U	U	U	U	Y	-
Foolscap Folio	8.25 x 13.06	209 x 333	SEF	C	C	N	N	U	U	U	U	U	U	Y	-
Demi Quarto	8.46 x 10.7	215 x 273	SEF	C	C	N	N	U	U	U	U	U	U	Y	-
Demi Quarto	8.46 x 10.7	215 x 273	LEF	C	C	N	N	U	U	U	U	U	U	Y	-
-	8.46 x 10.83	215 x 275	SEF	C	C	N	N	U	U	U	U	U	U	Y	-
-	8.46 x 10.83	215 x 275	LEF	C	C	N	N	U	U	U	U	U	U	Y	-
Folio (Spain)	8.46 x 12.4	215 x 315	SEF	C	C	N	N	U	U	U	U	U	U	Y	-
-	8.66 x 13	220 x 330	SEF	C	C	N	N	U	U	U	U	U	U	Y	-
-	8.75 x 11.69	223 x 297	SEF	C	C	N	N	U	U	U	U	U	U	Y	-
-	8.75 x 11.69	223 x 297	LEF	C	C	N	N	U	U	U	U	U	U	Y	-
Arch A	9 x 12	229 x 305	SEF	C	C	N	N	U	U	U	U	U	U	Y	-
Accounting	10 x 14	254 x 356	SEF	C	C	N	N	U	U	U	U	U	U	Y	-
-	10 x 15	254 x 381	SEF	C	C	N	N	U	U	U	U	U	U	Y	-
8K Taiwan	10.51 x 15.28	267 x 388	SEF	C	C	N	N	U	U	U	U	U	U	Y	-
12 x 8 (Tab- loid Extra)	12 x 18	305 x 457	SEF	N	M	N	N	N	N	N	N	N	N	Y	
SRA3	12.6 x 17.72	320 x 450	SEF	N	M	N	N	N	N	N	N	N	N	Y	
Commercial #10 Enve- lopes	4.13 x 9.49	105 x 241	SEF	U	M	N	N	N	N	N	N	N	N	Y	

Table 4 Input / output Paper sizes

Paper size			Orientation	Paper tray size sensing				DADH size sensing			Document glass size sensing			Output device	Notes
Common Name	Inch (W x L) +/-1/32 inch	mm (W x L) +/-1 mm	LEF / SEF	Tray 1 and 2	Bypass tray	Tray 3	Tray 5	NASG	Eur / Asia	Latin	NASG	Eur / Asia	Latin	OCT	-
6 x 9 Envelopes	6.00 x 9.00	152 x 229	SEF	U	M	N	N	N	N	N	N	N	N	Y	
DL Envelopes	4.33 x 8.27	110 x 210	SEF	U	M	N	N	N	N	N	N	N	N	Y	
C5 Envelopes	6.34 x 9.00	162 x 229	SEF	U	M	N	N	N	N	N	N	N	N	Y	
C4 Envelopes	9.00 x 12.76	229 x 324	SEF	U	M	N	N	N	N	N	N	N	N	Y	
9 x 12 Envelopes	9.00 x 12.00	152 x 305	SEF	U	M	N	N	N	N	N	N	N	N	Y	

1. For paper sizes designated Y, no user action will be required beyond correct positioning of the paper in the input device and confirmation of size loaded on the GUI.
2. For paper sizes designated U, the user will be able to select the size from a pre-programmed list on the UI.
3. For paper sizes designated C, the user will have to enter the paper dimensions at the UI.

LCSS Output Paper Sizes

The following table defines the size which can be delivered to the 2K LCSS.

Table 5 LCSS output paper sizes

Paper Size			Orientation	Output		Staple position			Option
Common Name	Inch (W x L)	mm (W x L)	LEF / SEF	Top Tray Stack	Main Tray Stack	Front Edge	Front Corner	Dual	Hole punch (all types)
Letter	8.5 x 11	216 x 279	SEF	Y	Y	N	Y	N	Y
Letter	8.5 x 11	216 x 279	LEF	Y	Y	N	Y	Y	Y
Ledger	11 x 17	279 x 432	SEF	Y	Y	N	N	Y	Y
Invoice (statement)	8.5 x 5.5	216 x 140	SEF	Y	Y	Y	N	N	N
Invoice (statement)	8.5 x 5.5	216 x 140	LEF	Y	N	N	Y	N	Y
Legal	8.5 x 14	216 x 356	SEF	Y	Y	N	Y	N	Y
ISO A4	8.26 x 11.69	210 x 297	SEF	Y	Y	N	Y	N	N
ISO A4	8.26 x 11.69	210 x 297	LEF	Y	Y	N	Y	Y	Y
ISO A3	11.69 x 16.54	297 x 420	SEF	Y	Y	N	Y	Y	Y
ISO A5	5.83 x 8.27	148 x 210	SEF	Y	N	Y	N	N	N
Foolscap or Euroletter	8.5 x 13	216 x 330	SEF	Y	Y	Y	Y	N	Y
JIS B5	7.17 x 10.12	182 x 257	SEF	Y	N	N	N	N	N
JIS B5	7.17 x 10.12	182 x 257	LEF	N	N	N	N	N	N
JIS B4	10.12 x 14.33	257 x 364	SEF	Y	Y	N	Y	N	Y
SB4	9.92 x 14.09	252 x 358	SEF	Y	Y	N	Y	N	N
ISO A4 Cover	8.78 x 11.69	297 x 223	SEF	N	Y	N	Y	N	Y
ISO A4 Cover	8.78 x 11.69	297 x 223	LEF	Y	Y	N	Y	N	Y
ISO A4 Tab Stock	8.78 x 11.69	297 x 223	LEF	Y	Y	N	Y	N	Y
Letter Cover	9 x 11	229 x 279	LEF	Y	Y	N	Y	N	Y
8.5 x 11 inch (Tab stock)			LEF	Y	Y	Y	N	N	N
Postcard-Lakes	4.5 x 6	114 x 152	SEF	N	N	N	N	N	Y
Postcard	5 x 7	127 x 178	SEF	N	N	N	N	N	Y
Oufuku-Hagaki Postcard	5.83 x 7.87	148 x 200	SEF	N	N	N	N	N	N
Oufuku-Hagaki Postcard	5.83 x 7.87	148 x 200	LEF	N	N	N	N	N	N
6 x 9 inch	6 x 9	152 x 229	SEF	Y	Y	Y	N	N	N
6 x 9 inch	6 x 9	152 x 229	LEF	N	N	N	N	N	N
Royal Octavo	6 x 9.5	152 x 241	SEF	Y	Y	Y	N	N	N
Royal Octavo	6 x 9.5	152 x 241	LEF	N	N	N	N	N	N
Foolscap Quarto	6.5 x 8.25	165 x 206	SEF	Y	N	N	N	N	N
Foolscap Quarto	6.5 x 8.25	165 x 206	LEF	N	N	N	N	N	N
Crown Quarto	7.25 x 9.5	184 x 241	SEF	Y	N	N	N	N	N
Crown Quarto	7.25 x 9.5	184 x 241	LEF	N	N	N	N	N	N
Executive	7.25 x 10.5	184 x 267	SEF	Y	N	N	N	N	N
Executive	7.25 x 10.5	184 x 267	LEF	N	N	N	N	N	N
16K Taiwan	7.64 x 10.51	194 x 267	SEF	Y	N	N	N	N	N
16K Taiwan	7.64 x 10.51	194 x 267	LEF	N	N	N	N	N	N

Table 5 LCSS output paper sizes

Paper Size			Orientation	Output		Staple position			Option
Common Name	Inch (W x L)	mm (W x L)	LEF / SEF	Top Tray Stack	Main Tray Stack	Front Edge	Front Corner	Dual	Hole punch (all types)
Quarto	8 x 10	203 x 254	SEF	Y	Y	N	Y	N	N
Quarto	8 x 10	203 x 254	LEF	N	N	N	N	N	N
-	8 x 10.5	203 x 267	SEF	Y	Y	N	Y	N	N
-	8 x 10.5	203 x 267	LEF	N	N	N	N	N	N
-	8 x 13	203 x 330	SEF	Y	Y	N	Y	N	N
-	8.26 x 10	210 x 254	SEF	Y	Y	N	Y	N	N
-	8.26 x 10	210 x 254	LEF	Y	Y	N	Y	N	N
-	8.26 x 10.63	210 x 270	SEF	Y	Y	N	Y	N	N
-	8.26 x 10.63	210 x 270	LEF	Y	Y	N	Y	N	N
Foolscap Folio	8.25 x 13.06	209 x 333	SEF	Y	Y	N	Y	N	N
	8.26 x 13	210 x 330	SEF	Y	Y	N	Y	N	N
Demi Quarto	8.46 x 10.7	215 x 273	SEF	Y	Y	N	Y	N	N
Demi Quarto	8.46 x 10.7	215 x 273	LEF	Y	Y	N	Y	N	N
-	8.46 x 10.83	215 x 275	SEF	Y	Y	N	Y	N	N
-	8.46 x 10.83	215 x 275	LEF	Y	Y	N	Y	N	N
Folio (Spain)	8.46 x 12.4	215 x 315	SEF	Y	Y	N	Y	N	N
-	8.66 x 13	220 x 330	SEF	Y	Y	N	Y	N	N
-	8.75 x 11.69	223 x 297	SEF	Y	Y	N	Y	Y	N
-	8.75 x 11.69	223 x 297	LEF	Y	Y	N	Y	Y	N
Arch A	9 x 12	229 x 305	SEF	Y	Y	N	Y	N	N
Accounting	10 x 14	254 x 356	SEF	Y	Y	N	Y	N	N
-	10 x 15	254 x 381	SEF	Y	Y	N	Y	N	N
8K Taiwan	10.51 x 15.28	267 x 388	SEF	Y	Y	N	Y	N	N
	12 X 18	305 X 457	SEF	Y	N	N	N	N	N
SRA3	12.6 X 17.72	320 X 450	SEF	Y	N	N	Y	N	N

HVF/HVF Booklet Maker Output Paper Sizes

The following table defines the size which can be delivered to the HVF and HVF Booklet Maker

Table 6 HVF/HVF Booklet Maker output paper sizes

Paper Size			Orientation	Output	Output			Staple position					Option	Option	Option
Common Name	Inch (W x L)	mm (W x L)	LEF / SEF	Stack	Top Tray	Booklet maker	Front Corner (45°)	Parallel Corner Front	Parallel Corner Rear	Parallel Dual	Parallel Multiple	Hole punch (all types)	Insert	Tri-Fold	
Letter	8.5 x 11	216 x 279	SEF	Y	Y	Y	N	Y	Y	Y	Y	Y	Y	Y	
Letter	8.5 x 11	216 x 279	LEF	Y	Y	N	Y	Y	Y	Y	Y	Y	Y	N	
Ledger	11 x 17	279 x 432	SEF	Y	Y	Y	Y	Y	Y	Y	Y	Y	Y	N	
Invoice (statement)	8.5 x 5.5	216 x 140	SEF	N	Y	N	N	N	N	N	N	N	N	N	
Invoice (statement)	8.5 x 5.5	216 x 140	LEF	N	N	N	N	N	N	N	N	N	N	N	
Postcard	4.25 x 5.5	108 x 140	SEF	N	N	N	N	N	N	N	N	N	N	N	
Postcard	4.25 x 5.5	108 x 140	LEF	N	N	N	N	N	N	N	N	N	N	N	
Legal	8.5 x 14	216 x 356	SEF	Y	Y	Y	N	Y	Y	Y	Y	Y	Y	N	
ISO A4	8.26 x 11.69	210 x 297	SEF	Y	Y	Y	N	Y	Y	Y	Y	N	Y	Y	
ISO A4	8.26 x 11.69	210 x 297	LEF	Y	Y	N	Y	N	Y	Y	Y	Y	Y	N	
ISO A3	11.69 x 16.54	297 x 420	SEF	Y	Y	Y	Y	N	Y	Y	Y	Y	Y	N	
ISO A5	5.83 x 8.27	148 x 210	SEF	N	Y	N	N	N	N	N	N	N	N	N	
ISO A5	5.83 x 8.27	148 x 210	LEF	N	N	N	N	N	N	N	N	N	N	N	
ISO A6	4.13 x 5.83	105 x 148	SEF	N	N	N	N	N	N	N	N	N	N	N	
ISO A6	4.13 x 5.83	105 x 148	LEF	N	N	N	N	N	N	N	N	N	N	N	
Foolscap or Euroletter	8.5 x 13	216 x 330	SEF	Y	Y	Y	N	Y	Y	Y	Y	Y	Y	N	
JIS B5	7.17 x 10.12	182 x 257	SEF	Y	Y	N	N	Y	Y	N	N	N	N	N	
JIS B5	7.17 x 10.12	182 x 257	LEF	N	N	N	N	N	N	N	N	N	N	N	
JIS B4	10.12 x 14.33	257 x 364	SEF	Y	Y	N	N	Y	Y	Y	Y	N	N	N	
JIS B6	5.08 x 7.17	128 x 182	SEF	N	N	N	N	N	N	N	N	N	N	N	
JIS B6	5.08 x 7.17	128 x 182	LEF	N	N	N	N	N	N	N	N	N	N	N	
ISO B5	6.93 x 9.84	176 x 250	SEF	Y	Y	N	N	Y	Y	Y	Y	N	N	N	
ISO B5	6.93 x 9.84	176 x 250	LEF	N	N	N	N	N	N	N	N	N	N	N	
ISO B4	9.84 x 13.9	250 x 353	SEF	Y	Y	N	N	Y	Y	Y	Y	N	N	N	
ISO A4 Cover	8.78 x 11.69	297 x 223	SEF	Y	Y	N	N	Y	Y	Y	Y	N	N	N	
ISO A4 Cover	8.78 x 11.69	297 x 223	LEF	Y	Y	N	Y	Y	Y	Y	Y	Y	N	N	
ISO A4 Tab Stock	-	-	LEF	Y	Y	N	Y	N	Y	Y	Y	Y	N	N	
Letter Cover	9 x 11	229 x 279	SEF	Y	Y	N	N	Y	Y	Y	Y	N	N	N	
Letter Cover	9 x 11	229 x 279	LEF	Y	Y	N	Y	N	Y	Y	Y	Y	N	N	
8.5 x 11 inch Tab Stock	-	-	LEF	Y	Y	N	Y	N	Y	Y	Y	Y	N	N	
Postcard-Lakes	4.5 x 6	114 x 152	SEF	N	N	N	N	N	N	N	N	N	N	N	
Postcard-Lakes	4.5 x 6	114 x 152	LEF	N	N	N	N	N	N	N	N	N	N	N	
Postcard	5 x 7	127 x 178	SEF	N	N	N	N	N	N	N	N	N	N	N	
Postcard	5 x 7	127 x 178	LEF	N	N	N	N	N	N	N	N	N	N	N	
Oufuku-Hagaki Postcard	5.83 x 7.87	148 x 200	SEF	N	N	N	N	N	N	N	N	N	N	N	

Table 6 HVF/HVF Booklet Maker output paper sizes

Paper Size			Orientation	Output	Output		Staple position					Option	Option	Option
Common Name	Inch (W x L)	mm (W x L)	LEF / SEF	Stack	Top Tray	Booklet maker	Front Corner (45°)	Parallel Corner Front	Parallel Corner Rear	Parallel Dual	Parallel Multiple	Hole punch (all types)	Insert	Tri-Fold
Oufuku-Hagaki Postcard	5.83 x 7.87	148 x 200	LEF	N	N	N	N	N	N	N	N	N	N	N
6 x 9 inch	6 x 9	152 x 229	SEF	N	Y	N	N	N	N	N	N	N	N	N
6 x 9 inch	6 x 9	152 x 229	LEF	N	N	N	N	N	N	N	N	N	N	N
Royal Octavo	6 x 9.5	152 x 241	SEF	N	Y	N	N	N	N	N	N	N	N	N
Royal Octavo	6 x 9.5	152 x 241	LEF	N	N	N	N	N	N	N	N	N	N	N
Foolscap Quarto	6.5 x 8.25	165 x 206	SEF	N	Y	N	N	N	N	N	N	N	N	N
Foolscap Quarto	6.5 x 8.25	165 x 206	LEF	N	N	N	N	N	N	N	N	N	N	N
Crown Quarto	7.25 x 9.5	184 x 241	SEF	Y	Y	N	N	Y	N	N	N	N	N	N
Crown Quarto	7.25 x 9.5	184 x 241	LEF	N	N	N	N	N	N	N	N	N	N	N
Executive	7.25 x 10.5	184 x 267	SEF	Y	Y	N	N	Y	N	N	N	N	N	N
Executive	7.25 x 10.5	184 x 267	LEF	N	N	N	N	N	N	N	N	N	N	N
16K Taiwan	7.64 x 10.51	194 x 267	SEF	Y	Y	N	N	Y	N	N	N	N	N	N
16K Taiwan	7.64 x 10.51	194 x 267	LEF	N	N	N	N	N	N	N	N	N	N	N
Quarto	8 x 10	203 x 254	SEF	Y	Y	N	N	Y	Y	Y	Y	N	N	N
Quarto	8 x 10	203 x 254	LEF	N	N	N	N	N	N	N	N	N	N	N
-	8 x 10.5	203 x 267	SEF	Y	Y	N	Y	Y	Y	Y	Y	N	N	N
-	8 x 10.5	203 x 267	LEF	N	N	N	N	N	N	N	N	N	N	N
-	8 x 13	203 x 330	SEF	Y	Y	N	N	Y	Y	Y	Y	N	N	N
-	8.26 x 10	210 x 254	SEF	Y	Y	N	N	Y	Y	Y	Y	N	N	N
-	8.26 x 10	210 x 254	LEF	Y	Y	N	N	Y	Y	Y	Y	N	N	N
-	8.26 x 10.63	210 x 270	SEF	Y	Y	N	N	Y	Y	Y	Y	N	N	N
-	8.26 x 10.63	210 x 270	LEF	Y	Y	N	N	Y	Y	Y	Y	N	N	N
Foolscap Folio	8.25 x 13.06	209 x 333	SEF	Y	Y	N	N	Y	Y	Y	Y	N	N	N
-	8.26 x 13	210 x 330	SEF	Y	Y	N	N	Y	Y	Y	Y	N	N	N
Demi Quarto	8.46 x 10.7	215 x 273	SEF	Y	Y	N	N	Y	Y	Y	Y	N	N	N
Demi Quarto	8.46 x 10.7	215 x 273	LEF	Y	Y	N	N	Y	Y	Y	Y	N	N	N
-	8.46 x 10.83	215 x 275	SEF	Y	Y	N	N	Y	Y	Y	Y	N	N	N
-	8.46 x 10.83	215 x 275	LEF	Y	Y	N	N	Y	Y	Y	Y	N	N	N
Folio (Span)	8.46 x 12.40	215 x 315	SEF	Y	Y	N	N	Y	Y	Y	Y	N	N	N
-	8.66 x 13.00	220 x 330	SEF	Y	Y	N	N	Y	Y	Y	Y	N	N	N
Arch A	9 x 12	229 x 305	SEF	Y	Y	N	N	Y	Y	Y	Y	N	N	N
SB4	9.92 x 14.09	252 x 358	SEF	Y	Y	N	N	Y	Y	Y	Y	N	N	N
SB4	9.92 x 14.09	252 x 358	LEF	Y	Y	N	N	Y	Y	Y	Y	N	N	N
Accounting	10 x 14	254 x 356	SEF	Y	Y	N	N	Y	Y	Y	Y	N	N	N
-	10 x 15	254 x 381	SEF	Y	Y	N	N	Y	Y	Y	Y	N	N	N
8K Taiwan	10.51 x 15.28	267 x 388	SEF	Y	Y	N	N	Y	Y	Y	Y	N	N	N
-	12 X 18	305 X 457	SEF	N	Y	N	N	N	N	N	N	N	N	N
SRA3	12.6 X 17.72	320 X 450	SEF	N	Y	N	N	N	N	N	N	N	N	N

Table 6 HVF/HVF Booklet Maker output paper sizes

Paper Size			Orientation	Output	Output		Staple position					Option	Option	Option
Common Name	Inch (W x L)	mm (W x L)	LEF / SEF	Stack	Top Tray	Booklet maker	Front Corner (45°)	Parallel Corner Front	Parallel Corner Rear	Parallel Dual	Parallel Multiple	Hole punch (all types)	Insert	Tri-Fold
Custom sizes	Various	Various	N/A	N	Y	N	N	N	N	N	N	N	N	N

1. Staple positions do not apply to Booklet Maker or Top Tray
2. Hole punch positions do not apply to Booklet Maker.
3. Correct hole location is dependant on having the correct hole punch module fitted.

Media Constraints

Media that is smaller than 140 mm (5.5 inches) in the cross process direction and 210 mm (8.27 inches) in the process direction cannot be duplexed.

Media that is larger than 297 mm (11.7 inches) in the cross process direction and 432 mm (17 inches) in the process direction cannot be duplexed.

The input media types and condition are as follows:

- Categories:
 - The DADH will be capable of feeding documents in groups 1, III, IV, VI.
 - The DADH will not feed Group V documents except for paste ups (without loose ages), hole punched documents, laser print documents and burst CFF.

- Conditions:
 - The DADH will feed documents of Condition I and II.
 - The DADH will not feed documents of Condition III.
- Additional limitations:
 - Some degradation in feeding performance may occur.
 - Documents must be in good condition
 - Extensive use of NCR paper may increase the rate of roll wear.

The following table shows the media (stock) performance constraints for output. Performance will not be guaranteed for media not listed in the table below.

NOTE: The stock types in Bold will be programmable via the paper tray attributes.

Table 7 Output stock performance

Stock Type	Trays 1 and 2	Tray 3	Bypass	Tray 5	Duplex	Offset	Stack	Staple	Hole punch	Booklet Maker	Tri-folder	Inserter	Notes
Bond / standard	Y	Y	Y	Y	Y	Y(1)	Y(1)	Y(2)	Y	Y	Y	Y	(1) Possible performance degradation if small documents and stacked on large. (2) For stapled sets, staple build up may affect stack quality.
Index	Y	Y	Y	Y	Y	Y	Y(1)	Y(2)	Y	Y	Y	Y	
Recycled	Y	Y	Y	Y	Y	Y	Y(1)	Y(2)	Y	Y	Y	Y	
Transparency (paper backed not supported)	Y	N	Y	N	N	Y(1)	Y(1)	N	N	N	N	Y	(1) An increase in set scatter or set to set registration may occur with greater than 20 sheets
Labels	Y	N	Y	N	N	N	Y(1)	N	N	N	N	N	(1) Top tray only.
Card stock , 120 gsm to 200 gsm	Y	Y	Y	Y	Y	Y	Y	Y	Y	Y	N	Y	Pro-rata reduction in capacity with weight of stock.
Card stock , 200 to 216 gsm	Y	Y	Y	N	Y	Y	Y	Y	Y	Y	N	Y	
Tab stock	Y	N	Y	N	N	Y	Y	Y	Y	N	N	N	Tabs must be on trail edge when fed from trays and bypass, but lead edge when arriving at the output. Therefore tab stock will be inverted before output. Hole punch registration performance may be degraded
Pre-Punched	Y	Y	Y	Y	Y	Y	Y	Y	N	N	N	N	Must be loaded with punched holes at trailing edge
Pre-Printed	Y	Y	Y	Y	Y	Y	Y	Y	Y	Y	Y	Y	-
Envelopes	N	N	Y	N	N	Y (1)	N	N	N	N	N	N	(1) Top tray only. Refer to Envelope Specifications
Carbonless paper	Y (1)	Y (1)	Y (1)	N	N	N	Y (2)	N	N	N	N	N	(1) Degraded performance (2) Top tray only
Glossy paper	N	N	Y	N	N	Y	Y	Y	Y	Y	Y	N	(1) Degraded performance

Table 8 Input document categories definitions

Category	Material	Image Type
Group I. Common usage input.	80 gsm (20lb.) to 120gsm (32lb.) or equivalent weight range (rag bond offset and ledger paper). This group includes 4040 paper.	Impact typewriter, offset image, Xerographic image, gravure image, Letterpress image, pencil 2H or harder, ballpoint pen, ink pen.
Group II. Heavy weight common usage input.	121gsm (32.1lb.) to 200gsm (110lb.) index or equivalent weight range (rag bond and ledger paper).	Impact typewriter, offset image, Xerographic image, gravure image, Letterpress image, pencil 2H or harder, ballpoint pen, ink pen.
Group III. Light weight common usage input.	60gsm (16lb) to 79gsm (19.9lb.) bond or equivalent weight range (rag bond, offset, mimo / duplicator, and NCR paper).	Impact typewriter, offset image, Xerographic image, gravure image, Letterpress image, pencil 2H or harder, ballpoint pen, ink pen.
Group IV. Common surface finished paper.	60gsm (16lb) to 200gsm (110lb.) index or equivalent (Bristol text, magazine, cover, vellum, safety paper)	Impact typewriter, offset image, Xerographic image, gravure image, Letterpress image, pencil 2H or harder, ballpoint pen, ink pen.
Group V. Uncommon and other input.	80 gsm (20lb.) to 200gsm (110lb.) or equivalent weight: plastic laminated paper: metallic cover stock: tag stock: plastic transparencies: Telecopier paper: label stock: silver photographic paper: Electrofax paper (ZnO) race-erase: paste ups with loose edges type 1, 2 & 3: XE approved punched or perforated stock: Continuous computer forms.	Impact typewriter, offset image, Xerographic image, gravure image, Letterpress image, pencil 2H or harder, ballpoint pen, ink pen. Liquid developed electrostatic image.
Group VI. Light weight input.	49gsm (13lb.) to 59gsm 15.9lb.) bond or equivalent weight range (rag bond, ledger mimeo or GSE papers).	Impact typewriter, offset image, Xerographic image, gravure image, Letterpress image, pencil 2H or harder, ballpoint pen, ink pen.
Group VII.	34gsm (9lb) to 48gsm (12.9lb) bond or equivalent weight range (rag bond, ledger mimeo or GSE papers).	Impact typewriter, offset image, Xerographic image, gravure image, Letterpress image, pencil 2H or harder, ballpoint pen, ink pen.

Table 9 Input document condition definitions

Defect	Acceptable Condition 1B	Marginal Condition II	Unacceptable Condition III	Notes
Holes.	Maximum of three cleanly punched holes up to 6 mm. (0.25 inch) diameter.	Four to nine cleanly punched holes.	Rough or torn holes.	-
Staples.	Cleanly removed staples.	Poorly removed staples resulting in dog-ears*.	Staples not removed.	-
Edge defects.	None.	Any cut or tear near a corner less than 3 mm. (0.125 inch) in length.	Any cut or tear not at a corner or greater than 3 mm. (0.125 inch) in length,	-
Folds* (in the feed direction).	Two letter folds less than 1.5 mm. (0.062 inch) high.	Two letter folds less than 3 mm. (0.125 inch) high.	Any fold greater than 3 mm. (0.125 inch) high.	* Folds must be flattened to within 6 mm (0.25 inch) height before placing in the input device.
Folds* (across the feed direction)	None.	One fold not to exceed 3 mm. (0.125 inch) high.	Any fold greater than 3 mm. (0.125 inch) high.	* Folds must be flattened to within 6 mm (0.25 inch) height before placing in the input device.
Curl (measured from a flat surface).	None.	In-ream or inherent curl up to 13 mm. (0.5 inch) maximum.	-	Curl greater than 13 mm.
Wrinkle.	None.	Multiple moderate wrinkles, up to 38 mm. (1.5 inch) long in any direction, 3 mm. (0.125 inch) in height.	Severe wrinkles greater than 38 mm. (1.5 inch) long in any direction, greater than 3 mm. (0.125 inch) in height	-
Foreign material on the surface.	None.	Hole reinforcement, correction fluid or dry glue no greater than 13 square millimeters. (0.02 square inch) per correction.	Correction tape major paste-up or correction fluid greater than 13 square millimeters. (0.02 square inch) per correction.	-

Table 9 Input document condition definitions

Defect	Acceptable Condition 1B	Marginal Condition II	Unacceptable Condition III	Notes
Bent corners (dog-ears)*	No bent corners	One bent corner up to 75 mm. (3 inch) diagonal length	One or more bent corner exceeding 75 mm. (3 inch) diagonal length.	* Dog ears must be flattened to within 6 mm (0.25 inch) height before placing in the input device.
Computer fan fold sheets	-	Perforated tractor feed edges cleanly removed.	Perforated tractor feed edges not removed.	-

Table 10 Degraded performance paper list

Media	Weight (gsm)	Size	Undesirable performance characteristics
40# Starbrite	59 gsm	Letter	Stiffness is too low (<50 mgf) Buckles and jams in the media path.
Nisshinbo, SER 60	75 gsm	A4	Stiffness is too low (<50mgf) Buckles and jams in the media path. Hi static cling sheet to sheet results in multipacks.
Xerox OPB Phaser 860	148 gsm	Letter, A4	Sticks tenaciously to urethane transfix roller surface.
Never-Tear	154 gsm	Letter	Hi static cling sheet resulting in multi packs
Nisshinbo SET 130	155 gsm	A4	Hi static cling sheet to sheet resulting in multipacks.
Crown Vintage, Curtis BrightWater 100# cover	270 gsm	Letter	Hi weight and stiffness (4809mgf)
White Stripe transparencies	any	Letter, A4	May cause paper jams at the imaging drum.

Envelope Specifications

Standard Envelopes - Bypass Tray only

Refer to [Table 11](#) and [Table 12](#) for the envelope sizes that can be fed from the bypass tray.

Table 11 European envelope sizes

ID	Size	Feed orientation
DL	110 x 220 mm (4.33 x 8.66 inch)	SEF, Flap closed, Flap outboard (front) or leading
C5	162 x 229 mm (6.38 x 9.02 inch)	SEF, Flap closed, Flap outboard (front) or leading
C4	229 x 324 mm (9.02 x 12.75 inch)	SEF, Flap closed, Flap outboard (front) or leading

Table 12 American envelope sizes

ID	Size	Feed orientation
10#	104.8 x 241.3 mm (4.13 x 9.5 inch)	SEF, Flap closed, Flap outboard (front)
6 x 9	152.4 x 228.6 mm (6 x 9 inch)	SEF, Flap closed, Flap outboard (front) or leading
9 x 12	228.6 x 304.8 mm (9 x 12 inch)	SEF, Flap closed, Flap outboard (front) or leading

NOTE: All envelope sizes quoted are with the flap closed.

Envelopes must be loaded face down in the bypass tray.

Refold of the flap is likely, if this occurs the specification is 2.5 mm up to a maximum of 4 mm from the original fold of the envelope.

Acceptable flap types:

- Diamond / Banker
- Wallet

Weight:

- Lightweight
- Medium weight

Acceptable sealing:

- Gummed
- Press and seal

Exclusions:

- Side seam construction
- Self adhesive with release strips.
- Any type of clasp device
- Any type of window

Capacity:

- 15 envelopes

Table 13 U.S. paper weight conversion

US post card thickness (mm) (see NOTE)	US bond weight (lb.)	US text / book weight (lb.)	US cover weight (lb.)	US Bristol weight (lb.)	US index weight (lb.)	US tag weight (lb.)	Metric weight (gsm)
-	16	41	22	27	33	37	60
-	17	43	24	29	35	39	64
-	20	50	28	34	42	46	75
-	21	54	30	36	44	49	80
-	22	56	31	38	46	51	83
-	24	60	33	41	50	55	90
-	27	68	37	45	55	61	100
-	28	70	39	49	58	65	105
-	32	80	44	55	67	74	120
-	34	86	47	58	71	79	128
-	36	90	50	62	75	83	135
0.18	39	100	55	67	82	91	148
0.19	42	107	58	72	87	97	158
0.20	43	110	60	74	90	100	163
0.23	47	119	65	80	97	108	176
0.25	51	128	70	86	105	117	190
0.26	53	134	74	90	110	122	199
0.27	54	137	75	93	113	125	203
0.29	58	146	80	98	120	133	216
0.32	65	165	90	111	135	150	244
0.33	66	169	92	114	138	154	250
0.34	67	171	94	115	140	155	253
0.35	70	178	98	120	146	162	264
0.36	72	183	100	123	150	166	271

NOTE: U.S. Post Card measurements are approximate. Use for reference only.

GP 21 Installation Space Requirements

Purpose

To outline the general space requirements to enable safe use and adequate access for service.

WARNING

Do not work in a confined space. 1 m (39 inches) space is needed for safe working.

WARNING

USA and Canada. Do not install this machine in a hallway or exit route that does not have 1.12 m (44 inches) of space additional to the normal space requirements in front of the machine. To conform with fire regulations this additional 1.12 m (44 inches) of space is needed in front of the machine in hallway and exit routes.

Machine Height

- Machine height with the DADH lowered = 1155 mm (45.5 inches)
- Machine height with the DADH raised = 1467 mm (58 inches)

Machine Weight

- Basic machine with DADH weight = 218.5 kg (480.7 lbs.)

NOTE: Basic machine weight does not include the weight of a finisher or tray 5.

Optional Tray

- Tray 5 = 30 kg (66 lbs.)

Finishers

- OCT = 2 kg (4.5 lbs.)
- 2K LCSS = 30 kg (66.5 lbs.)
- HVF = 72.8 kg (160 lbs.)
- HVF BM with PPI and Tri-folder = 100.3 kg (220.7 lbs.)

Machine dimensions and Installation Space Requirements

ColorQube Standalone Digital Copier

Table 1 shows the dimensions of the ColorQube 9301/9302/9303 standalone digital copier (no media shelf) machines and the installation space required for safe operation.

Table 1 ColorQube Standalone Digital Copier

Configuration	Machine width (A)	Machine depth (B)	Moveable install width required (C)	Fixed install width required (C)	Moveable install depth required (D)	Fixed install depth required (D)	Moveable install airflow / service workspace (E)	Fixed install airflow / service workspace (E)
ColorQube 9301/9302/9303 with OCT	1389 mm (54.7in.)	722 mm (28.5in.)	2398 mm (94.1in.)	3391 mm (133.5in.)	1829 mm (72in.)	2722 mm (107in.)	100 mm (4in.)	1000 mm (39.4in.)
ColorQube 9301/9302/9303 with OCT and Tray 5	1607 mm (63.25in.)	722 mm (28.5in.)	2606 mm (103in.)	3619 mm (142.5in.)	1829 mm (72in.)	2722 mm (107in.)	100 mm (4in.)	1000 mm (39.4in.)
ColorQube 9301/9302/9303 with 2K LCSS	1651 mm (65in.)	722 mm (28.5in.)	2642 mm (104in.)	3632 mm (143in.)	1829 mm (72in.)	2722 mm (107in.)	100 mm (4in.)	1000 mm (39.4in.)
ColorQube 9301/9302/9303 with 2K LCSS and Tray 5	1880 mm (74in.)	722 mm (28.5in.)	2874 mm (113.2in.)	3875 mm (152.5in.)	1829 mm (72in.)	2722 mm (107in.)	100 mm (4in.)	1000 mm (39.4in.)
ColorQube 9301/9302/9303 with HVF	2075 mm (81.7in.)	722 mm (28.5in.)	3076 mm (121.1in.)	4077 mm (160.5in.)	1829 mm (72in.)	2722 mm (107in.)	100 mm (4in.)	1000 mm (39.4in.)

NOTE: The dimensions shown in Table 1 allow for a 1 metre (39.4 inches) minimum safety workspace around the machine. To acquire the minimum safety workspace it may be necessary to move the machine within the area specified.

A gap of 100 mm is required at the rear of the IOT for airflow to the fans. This is also sufficient for the DADH when raised.

Figure 1 represents a plan view of a machine installation and is to be read in conjunction with Table 1. The dimensions A and B outline a footprint of the machine within the boundary of safe operation, dimensions C and D. The dimension E indicates the area required for airflow / workspace at the rear of the machine.

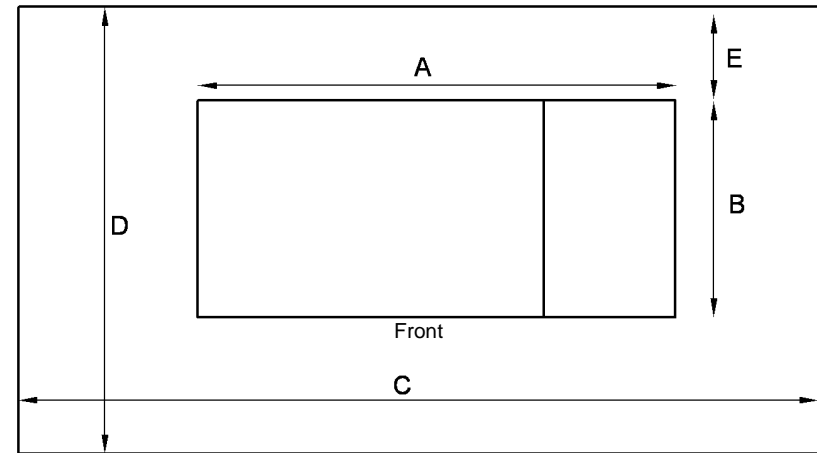

U-1-1394-A

Figure 1 Installation plan

Table 1 ColorQube Standalone Digital Copier

Configuration	Machine width (A)	Machine depth (B)	Moveable install width required (C)	Fixed install width required (C)	Moveable install depth required (D)	Fixed install depth required (D)	Moveable install airflow / service workspace (E)	Fixed install airflow / service workspace (E)
ColorQube9301/9302/9303 with HVF and tray 5	2311 mm (91in.)	722 mm (28.5in.)	3312 mm (130.4in.)	4313 mm (169.8in.)	1829 mm (72in.)	2722 mm (107in.)	100 mm (4in.)	1000 mm (39.4in.)
ColorQube 9301/9302/9303 with HVF BM and tri-fold	2443 mm (96.2in.)	722 mm (28.5in.)	3444 mm (135.6in.)	4445 mm (175in.)	1829 mm (72in.)	2722 mm (107in.)	100 mm (4in.)	1000 mm (39.4in.)
ColorQube 9301/9302/9303 with HVF BM, tri-fold and tray 5	2678 mm (105.45in.)	722 mm (28.5in.)	3680 mm (144.9in.)	4680 mm (184.25in.)	1829 mm (72in.)	2722 mm (107in.)	100 mm (4in.)	1000 mm (39.4in.)

GP 22 Electrical Power Requirements

Go to the relevant section.

- [Power Requirements](#)
- [Power Save Modes](#)

Power Requirements

For voltage and current requirements refer to [Table 1](#) and [Table 2](#).

Table 1 Supply voltage requirements

Nominal Voltage (VAC)	Maximum (VAC)	Minimum (VAC)	Frequency upper (Hz)	Frequency lower (Hz)
110 to 127	140	99	63	47
220 to 240	254	187	63	47

Table 2 Supply current requirements

Nominal Voltage (VAC)	Frequency (Hz)	Current (A)	Comments
110	60	Less than or equal to 15	Specific XLA markets only.
127	60	Less than or equal to 15	Mandatory for Saudi Arabia only.
127	60	Less than or equal to 15	To operate at 127V +10% for long term periods. Mandatory for Mexico only.
120 in run mode	60	Less than or equal to 12	120V is nominal for USA and Canada.
120 in warm up	60	Less than or equal to 15	All 60Hz markets including USA and Canada.
220	50	Less than or equal to 10	Europe and other 50Hz markets.
230	50	Less than or equal to 10	Europe and other 50Hz markets.
240	50	Less than or equal to 10	Europe and other 50Hz markets.

Power Save Modes

There are two customer adjustable power save modes:

- [Low Power Mode](#)
- [Sleep Mode](#)

The power usage for all product configuration at nominal and maximum usage for a base configuration with OCT, LCSS and HVF finisher options, refer to [Table 3](#).

Low Power Mode

The low power mode is automatically entered after a period of non-activity or by pressing the Energy Saver key on the user interface. The period of non-activity can be set to between 1 and 120 minutes by the system administrator. The mode of power is returned to standby following a user request, a key press on the user interface or by network activity.

Sleep Mode

The sleep mode is automatically entered after a period of non-activity after entry into low power mode. The period of non-activity can be set to between 1 and 120 minutes by the system administrator. The mode of power is returned to standby following a user request, a key press on the user interface or by network activity.

Table 3 Power consumption

Configuration	PPM	Run mode average (Watt @ 120V)	Run mode maximum (Watt @ 120V)	Standby (Watt @ 120V)	Low power (Watt @ 120V)	Sleep (Watt @ 120V)	Plug-in mode (Watt @ 120V)
9301 base machine	40	848	1275	479	220	112	1
9302 base machine	45	878	1392	479	220	112	1
9303 base machine	50	908	1410	479	220	112	1
9301 plus LCSS	40	923	1380	489	220	112	1
9302 plus LCSS	45	953	1497	489	220	112	1
9303 plus LCSS	50	983	1515	489	220	112	1
9301 plus HVF	40	993	1565	499	220	112	1
9302 plus HVF	45	1023	1582	499	220	112	1
9303 plus HVF	50	1053	1600	499	220	112	1

- Plug-in mode: This is US Presidential Order requirement specifies that any product when plugged into a mains supply outlet shall consume less than 1W when the product is switched off.
- Sleep mode: Average measurement taken over 2 hours.

GP 23 Environmental Data

Operating

- Temperature range: 10 to 32 degrees C (50 to 89 degrees F)
- Humidity: 15% to 85% RH.
- Noise:

NOTE: Blue Angel criteria measured in accordance with ISO 7779

Table 1 Maximum noise limits (dBA), basic machine

PPM	Standby	Run continuous	Run impulse
38/50 ppm	40	58	63
45/55 ppm	40	58	63
55/60 ppm	40	58	63

Table 2 Maximum noise limits (dBA), all configurations

PPM	Standby	Run continuous	Run impulse
38/50 ppm	40	65	70
45/55 ppm	40	65	70
55/60 ppm	40	65	70

- Altitude: 0 to 1829 metres (0 to 6000 feet)

Storage

- Temperature and humidity range:
 - 60 degrees C (140 degrees F) 85% RH max.
 - -30 degrees C (-22 degrees F) 15% RH max.
- Altitude: 0 to 3048 metres (0 to 10000 feet).

GP 24 Hardware Kit Contents

Purpose

To list the contents of the hardware kit, [PL 31.11 Item 23](#).

Kit Contents

- Screw M4x12. Delta point. Torx head. Yellow zinc - 5 off.
- Screw M3.5x10. Taptite. Cross head - 5 off.
- Screw M4x25. Delta point. Torx head. Yellow zinc - 2 off.
- Screw M4x20. Taptite. Torx head. Zinc chromate - 2 off.
- Screw M6x15. Machine. Button head - 2 off.
- Screw M4x12. Machine. Captive washer - 2 off.
- Screw M4x10. Taptite. Torx head - 5 off.
- KL-clip M5 - 5 off.
- KL-clip M8 - 2 off.
- E-clip M4 - 5 off.
- E-clip M5 - 5 off.
- Bushing M6 - 2 off.
- Carriage drive bushing. Refer to [PL 91.10 Item 19](#).
- Thrust washer - 1 off. Refer to [PL 94.10 Item 7](#).
- Latch spring - 2 off. Refer to [PL 70.30 Item 20](#).
- Latch clip - 2 off. Refer to [PL 70.30 Item 21](#).

GP 25 First Copy/Print Out Time and Power On/Off Time

The first copy out time (FCOT) is from the start copy request to the delivery of the first copy in the OCT. Values in [Table 1](#) are based on a standard job where the original is copied at 100% from the document glass or DADH onto A4 LEF paper fed from the bypass tray.

The first print out time (FPOT) is from the print job request to the delivery of the print in the OCT. FPOT values in [Table 1](#) are based on a 1 byte ASCII text file sent using TCP/IP and LPR, from a Pentium II 128Mb NT 4.0 PC with 100Mb Ethernet.

Power on / off figures in [Table 1](#) are quoted on the basis that the machine is working in a nominal ambient environment. It has been fully installed and connected to a nominal mains supply. Is in a fully working condition (no faults or warnings present) and has had all 'other' model compatible components fully installed and pre-configured. All SAKO settings should be set to the manufacturing default condition.

Table 1 Machine Response Time

Description	9301/9302/9303 (15A)	9301/9302/9303 (20A)	Notes
FCOT from the document glass.	9 seconds	9 seconds	A4 sheet, bypass tray to OCT in enhanced mode.
FCOT from the DADH.	11 seconds	11 seconds	A4 sheet, bypass tray to OCT in enhanced mode.
FPOT	8 seconds	8 seconds	A4 sheet, bypass tray to OCT in enhanced mode.
Warm up from low power mode.	26 seconds	26 seconds	From low power mode to ready to copy or scan.
Warm up time from sleep mode. Ready to print or copy	2 minutes 46 seconds.	2 minutes 30 seconds.	Ready to print or copy (scan and mark)
Power on time to ready to copy.	9 minutes 24 seconds.	9 minutes 24 seconds.	Ready to copy (scan and mark)
Power on time to ready to print.	9 minutes 24 seconds.	9 minutes 24 seconds.	Ready to print (receive and mark)
Power on time to ready to Fax.	1 minute 28 seconds.	1 minute 28 seconds.	Ready to Fax (receive and mark)
Power off time	45 seconds	45 seconds	From touch of confirmation button on UI
Quick restart time to ready to print	3 minutes 8 seconds.	3 minutes 8 seconds.	From re-start option confirmed, to ready to print (receive and mark).
Ready to Fax time from sleep mode time.	2 minutes 46 seconds.	2 minutes 30 seconds.	From activity detected on the Fax line to start of paper feed.

GP 26 Restriction of Hazardous Substances (RoHS)

Purpose

To give information on the RoHS Directive.

The RoHS Directive restricts the use of certain hazardous substances in electrical and electronic equipment. It applies to equipment placed in the European Union (EU) market. The directive takes effect from 1st July 2006.

NOTE: Currently these restrictions are only for the European Union (EU) market and some associated countries. For more information go to www.Xerox.com.

The hazardous substances are:

- Lead (Pb)
- Mercury (Hg)
- Cadmium (Cd)
- Hexavalent Chromium (Cr 6+, Cr [VI])
- Polybrominated Diphenyl Ethers (PBDE's)
- Polybrominated Biphenyls (PBB's)

Identification of a RoHS Compliant Machine

Xerox will maintain a central list of RoHS compliant machines.

This general procedure is for information only. All ColorQube 9301/9302/9303 machines are RoHS compliant.

GP 27 Cleaning Procedure

Purpose

Use this procedure when cleaning is required.

Procedure

WARNING

Ensure that the electricity to the machine is switched off while performing tasks that do not need electricity. Refer to GP 14. Disconnect the power cord. Electricity can cause death or injury. Moving parts can cause injury.

WARNING

Wear protective gloves when using solvents and cleaning agents, PL 26.10 Item 5.

After correcting all causes of contamination perform any of the following procedures as required:

- Oil Spillage
- Drum Fan Shroud and Drum Belt
- Upper Baffle
- Transfix Stripper Assembly
- Pre Transfix Sensor (20)
- DADH
- Optics
- Paper Trays and Feed Rolls
- Internal Cleaning
- Vertical Paper Path
- Horizontal Paper Path
- Registration / Preheat Assembly
- Marking Unit
- Drum
- Transfix Roller
- Stripper Gate and Baffle
- IOD
- Cleaning Unit and Abatement Plenum

Oil Spillage

Go to the relevant procedure:

- Floor Spillage
- Machine Spillage

Floor Spillage

Materials:

- Cleaning cloth, PL 26.11 Item 9.
- Safety glasses, PL 26.11 Item 7.
- Nitrile gloves, PL 26.10 Item 5.

WARNING

Immediately clean an oil spill. Spilt oil is a slip hazard. Do not walk in the contaminated area. Walking in the contaminated area will spread the contamination and contaminate footwear. Contaminated footwear is a slip hazard.

WARNING

Do not attempt to mop up the spilt oil with conventional mops and water. This will spread the contamination and will extend the slip hazard.

Procedure

1. Close off the contaminated area. If available place warning signs around the area.
2. Use a dry cloth, paper towel or cleaning cloth to blot any residue.
3. Remove all visible material by blotting instead of rubbing.
4. Inform the customer of the spillage.
5. Refer to your local process regarding cleaning spillage / customer compensation.
6. Dispose of all contaminated towels in a covered metal container.

Machine Spillage

Materials:

- Silicon oil removal kit, PL 31.11 Item 32.

WARNING

Wear the protective gloves included in the silicon oil removal kit when using the syringe to remove the oil.

CAUTION

Ensure that the cleaning unit is kept level on removal to avoid oil spillage.

Procedure

1. Close off the contaminated area. If available, place warning signs around the area.
2. Place the absorbent fabric mat on the floor in front of the machine to catch drips when the cleaning unit is removed.
3. Check the 3 tray horizontal transport assembly PL 81.35 Item 1 and trays 1 and 2 for oil spillage, discard any damaged media and remove oil from the trays using a cleaning cloth.
4. Ensuring that it remains level to avoid oil spillage, remove the cleaning unit and place directly onto the absorbent fabric mat.
5. Remove as much oil as possible from the drip tray with a syringe and empty into the container.
6. When no more silicon oil can be removed using the syringe, remove the remaining oil using cleaning cloths.
7. Ensure the area around the machine has no residual silicon oil and that spillages are thoroughly cleaned up.
8. Dispose of the oil in the container and the absorbent material in accordance with safety guidelines.

Drum Fan Shroud and Drum Belt

The drum shroud is a HFSI and must be cleaned at regular intervals, refer to SCP 4 Sub-system Maintenance. To reset the HFSI count, go to dC135.

Materials:

- Cleaning cloth, [PL 26.10 Item 6](#).
- Cleaning fluid, [PL 26.10 Item 1](#).

Procedure

1. Remove debris from the drum fan shroud, [PL 94.20 Item 5](#) and clean with a clean dry cloth.
2. Clean the drum belt, [PL 94.20 Item 2](#) using cleaning fluid. Refer to [REP 91.24](#).
3. Clean the drum pulley, [PL 94.20 Item 3](#) using cleaning fluid.
4. Clean the drum drive motor pulley, [PL 94.20 Item 6](#) using cleaning fluid.

Upper Baffle

This component is a HFSI and must be cleaned at regular intervals, refer to [SCP 4 Subsystem Maintenance](#). To reset the HSFI count, go to [dC135](#).

Procedure

1. To gain access to the upper baffle, [PL 10.10 Item 9](#) remove the exit paper path assembly, [REP 10.20](#). Remove paper dust with a clean, dry cloth.

Transfix Stripper Assembly

Materials:

- Cleaning cloth, [PL 26.10 Item 6](#).
- Cleaning fluid, [PL 26.10 Item 1](#).

Procedure

1. Clean the transfix stripper assembly, [REP 10.6](#) and the transfix stripper blade area with a cloth dampened with cleaning fluid.
2. Check the transfix stripper blade for damage and deformation. If necessary, install a new transfix stripper assembly, [PL 10.20 Item 14](#).

Pre Transfix Sensor (20)

NOTE: Failure to clean paper dust from the pre transfix sensor (20) will result in paper jams.

Procedure

1. Switch off the machine, [GP 14](#).
2. Remove the lower platelet assembly, [REP 89.1](#).
3. Clean the pre transfix sensor (20), [PL 88.10 Item 12](#) and surrounding platelet surfaces of all accumulated paper dust using a lint free cleaning cloth, [PL 26.10 Item 6](#).

DADH

Refer to [ADJ 5.4 DADH Cleaning Procedure](#).

Optics

Refer to [ADJ 62.1 Optics Cleaning Procedure](#).

Paper Trays and Feed Rolls

Materials:

- Cleaning cloth, [PL 26.10 Item 6](#).

Procedure

1. Clean the paper trays and sensors with a clean, dry cloth.

2. Clean the feed rolls with a cleaning cloth, dampened with water.

For access to tray 1 and 2 feed rolls, use [REP 81.4](#).

For access to tray 3 feed rolls, use [REP 81.5](#).

For access to the 3 trays module horizontal transport rolls, remove tray 1, [REP 71.1](#) and pull out the transport.

For access to the bypass tray feed rolls, use [REP 81.6](#).

For access to the tray 5 feed rolls, use [REP 81.7](#).

For access to the inserter pick up and reverse roller assemblies, use [REP 12.95-171](#).

Internal Cleaning

Materials:

- Cleaning cloth, [PL 26.10 Item 6](#).
- Cleaning fluid, [PL 26.10 Item 1](#).

Procedure

1. Empty the waste tray and reset waste tray count in the Call Closeout menu or [dC968](#) in service mode.
2. Remove the inner cover, [PL 81.11 Item 2](#).
3. Remove all loose debris and paper dust.

Vertical Paper Path

Materials:

- Cleaning cloth, [PL 26.10 Item 6](#).
- Cleaning fluid, [PL 26.10 Item 1](#).

Procedure

1. Un-dock tray 5 and open the upper, lower and mid left doors, [PL 70.30](#).
2. Clean the takeaway sensors 1 and 2, [PL 73.16 Item 11](#).
3. Clean the vertical transport sensor (5), [PL 82.10 Item 7](#).
4. Clean the confirm sensor (16), [PL 82.10 Item 7](#).
5. Clean the vertical transport with a clean, dry cloth.
6. Clean the rollers with a cleaning cloth, dampened with water.

Horizontal Paper Path

Materials:

- Cleaning cloth, [PL 26.10 Item 6](#).

Procedure

1. Open the horizontal paper path, [PL 82.15](#), and clean with a dry, cleaning cloth.
2. Clean the rollers with a cleaning cloth dampened with water.

Registration / Preheat Assembly

Materials:

- Cleaning cloth, [PL 26.10 Item 6](#).
- Cleaning fluid, [PL 26.10 Item 1](#).

Procedure

WARNING

Take care during this procedure. The registration/preheat assembly will become hot during normal operation.

1. Run dC969 Clean Ink Smears. Repeat the routine until the output blank sheets are free of contamination.
2. Make copies as normal and inspect the result for contamination. If contamination is present repeat dC969.
3. If contamination is still present, switch off the machine, GP 14. Allow the registration / preheat assembly to cool. Refer to REP 89.1, clean the platelets with a cleaning cloth dampened with cleaning fluid.
4. If the registration / preheat assembly has been removed, perform dC625 Registration / Preheat Calibration.

Marking Unit

CAUTION

Do not touch the exposed face of the printheads. Surface contamination or minor damage can destroy the printhead. Printheads must only be cleaned by a purge cycle.

Procedure

1. Perform dC965 Printhead Maintenance Cycle Test.
2. Empty the waste tray and reset waste tray count in the Call Closeout window in service mode.

Drum

Materials:

- Cleaning cloth, PL 26.10 Item 6.
- Cleaning fluid, PL 26.10 Item 1.

CAUTION

Do not use anything sharp or abrasive on the drum as this will damage the drum surface.

Procedure

1. Enter dC612 and print TP 12 chase pages to clear ink from the drum.
2. Switch off the machine, GP 14.
3. Rotate the drum clockwise while cleaning it with a cleaning cloth dampened with cleaning fluid.
4. Use a dull plastic edge to remove any solid ink from the drum.
5. Once the fault has been rectified, enter dC612 and print TP 14 to check that the stripper blade is working correctly.

Transfix Roller

Materials:

- Cleaning cloth, PL 26.10 Item 6.
- Cleaning fluid, PL 26.10 Item 1.

Procedure

1. Switch off the machine, GP 14.
2. Clean the transfix roller, REP 10.1 with a cloth dampened with cleaning fluid.

Stripper Gate and Baffle

Materials:

- Cleaning cloth, PL 26.10 Item 6.

Procedure

WARNING

Take care during this procedure. The stripper blade is very sharp and can cause injury.

WARNING

Do not clean the stripper blade. The stripper blade is very sharp and can cause injury. If the stripper blade is dirty a new blade must be installed.

1. Open the stripper gate and baffle assembly, GP 31.
2. If the stripper blade is dirty or damaged then install a new stripper blade, PL 10.12 Item 3.
3. Clean the rollers J PL 10.10 Item 1 and L PL 10.10 Item 2 with a cloth dampened with water.

IOD

Materials:

- Cleaning cloth, PL 26.10 Item 6.

CAUTION

Do not use any liquid on the IOD sensor.

Procedure

1. Remove the abatement plenum, REP 91.36.
2. Only if the IOD appears contaminated should it be removed, REP 91.22.
3. Remove ink or debris from the gears and encoding wheel.
4. Manual rotate the motor to open the cover shield and reveal the sensor.
5. Figure 1, Gently clean the IOD sensor, with a dry, cleaning cloth.
6. Figure 1. Clean the cover shield using a dry cleaning cloth.
7. Reinstall the IOD assembly, REP 91.22.

GP 28 Marking Unit Assembly Wiring Harnesses

Purpose

To show the correct routing of the marking unit wiring harnesses.

Wire Routing

Figure 1 shows the correct harness routing along the upper and lower carriages. Figure 2 shows the correct harness routing at the rear of the marking unit. Ensure the harnesses are secured by the harness clamps. To move the marking unit into the service position, go to GP 6.

NOTE: For clarity, the printheads are not shown in Figure 1. The marking unit is shown in the service position in Figure 2.

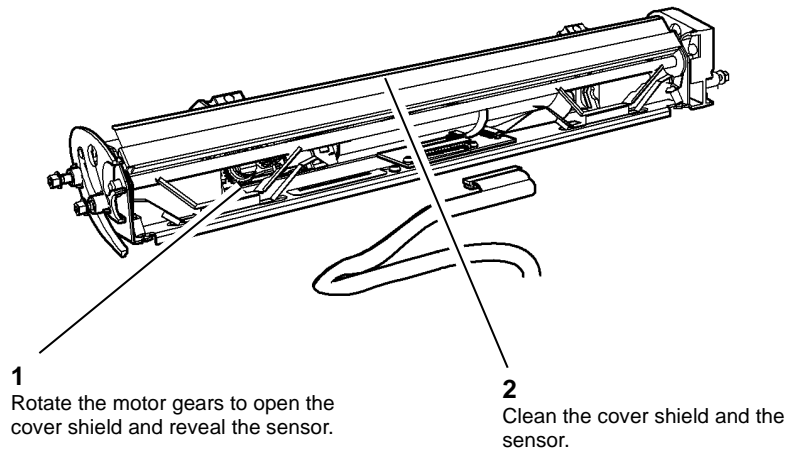

U-1-1233-A

Figure 1 IOD Assembly

Cleaning Unit and Abatement Plenum

Materials:

- Cleaning cloth, PL 26.10 Item 6.
- Cleaning fluid, PL 26.10 Item 1.

Procedure

1. Remove the cleaning unit, refer to REP 94.1. Wipe the top and bottom surfaces with a clean, dry cloth. Place the cleaning unit on several sheets of paper on a level surface. Remove any paper debris from the metering blade.
2. Remove the abatement plenum, REP 91.36. Clean the top surfaces with a clean, dry cloth.
3. Reinstall the abatement plenum and then the cleaning unit.

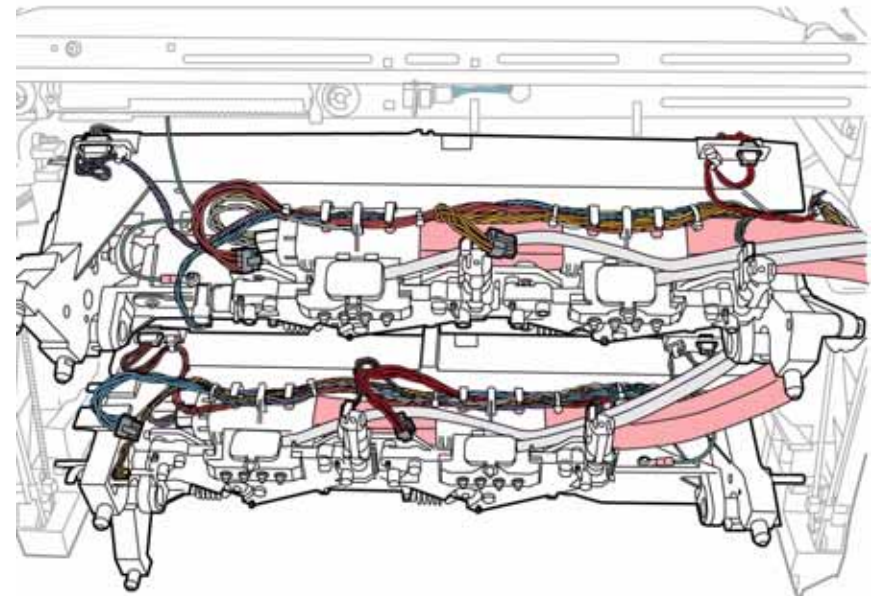

U-1-1430-A

Figure 1 Harness routing

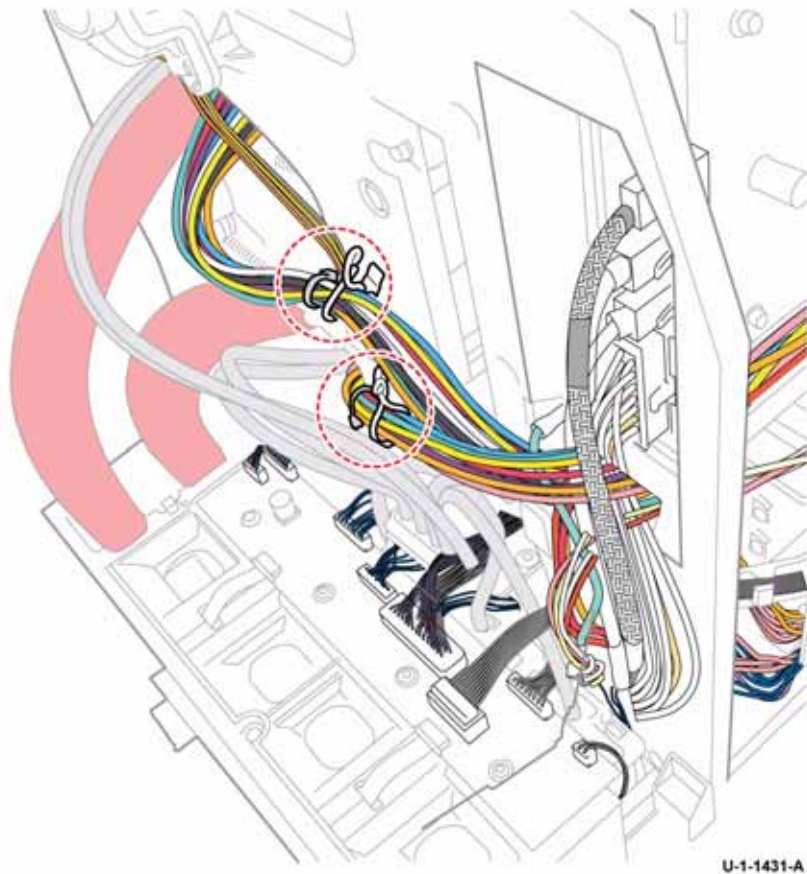

Figure 2 Harness routing

GP 29 Component Locations

Purpose

- To identify the locations of major assemblies within the machine
- To identify the locations of rollers, sensors and jam zones along the paper path.

Refer to the relevant section:

- [Front Component Location](#)
- [Rear Component Location](#)
- [Roller Locations, Sensor Locations and Jam Zones](#)
- [Document Handler \(DADH\)](#)
- [Low Capacity Stapler Stacker \(LCSS\)](#)
- [High Volume Finisher \(HVF\)](#)

Front Component Location

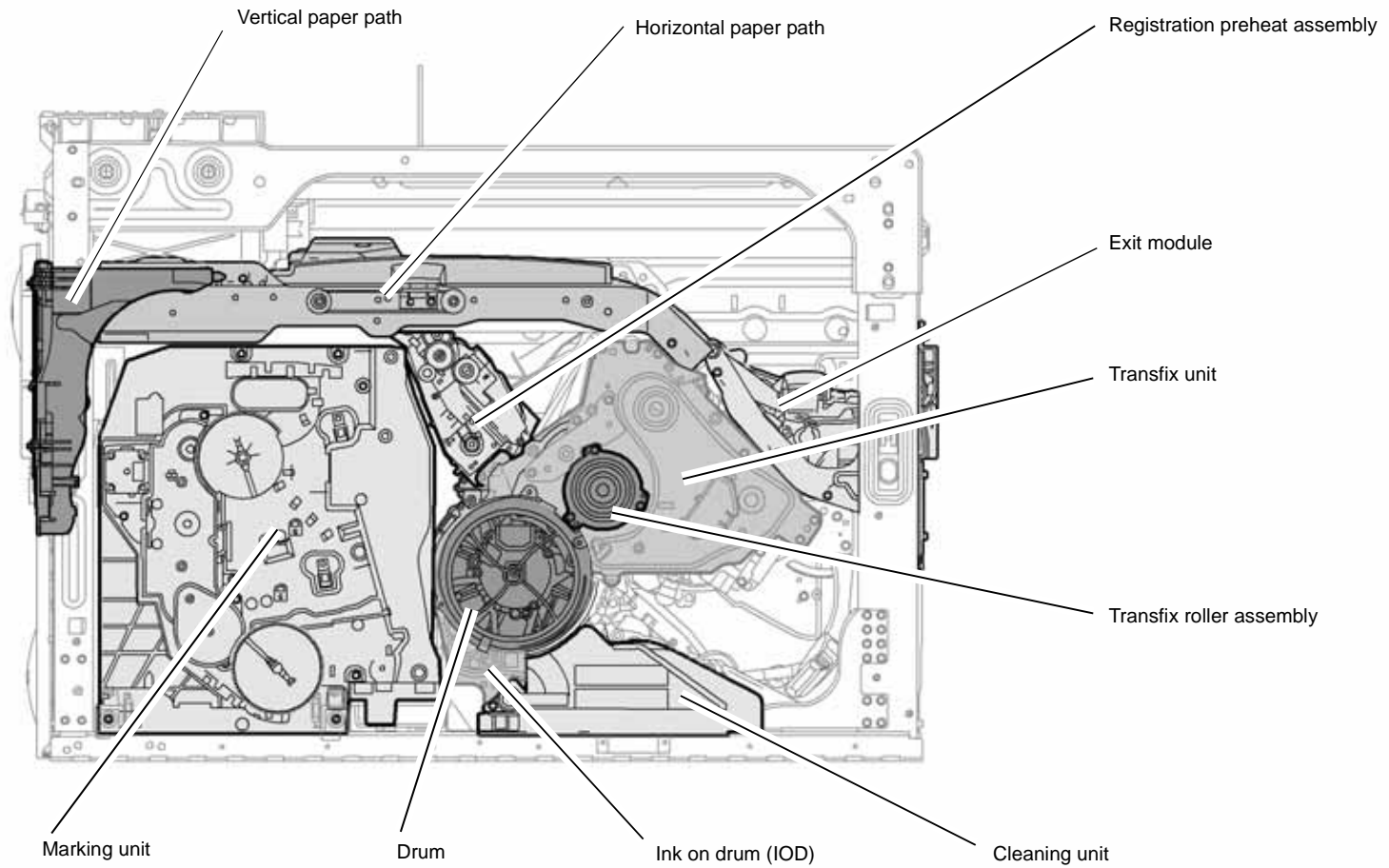

U-1-1311-A

Figure 1 Major assemblies

Rear Component Location

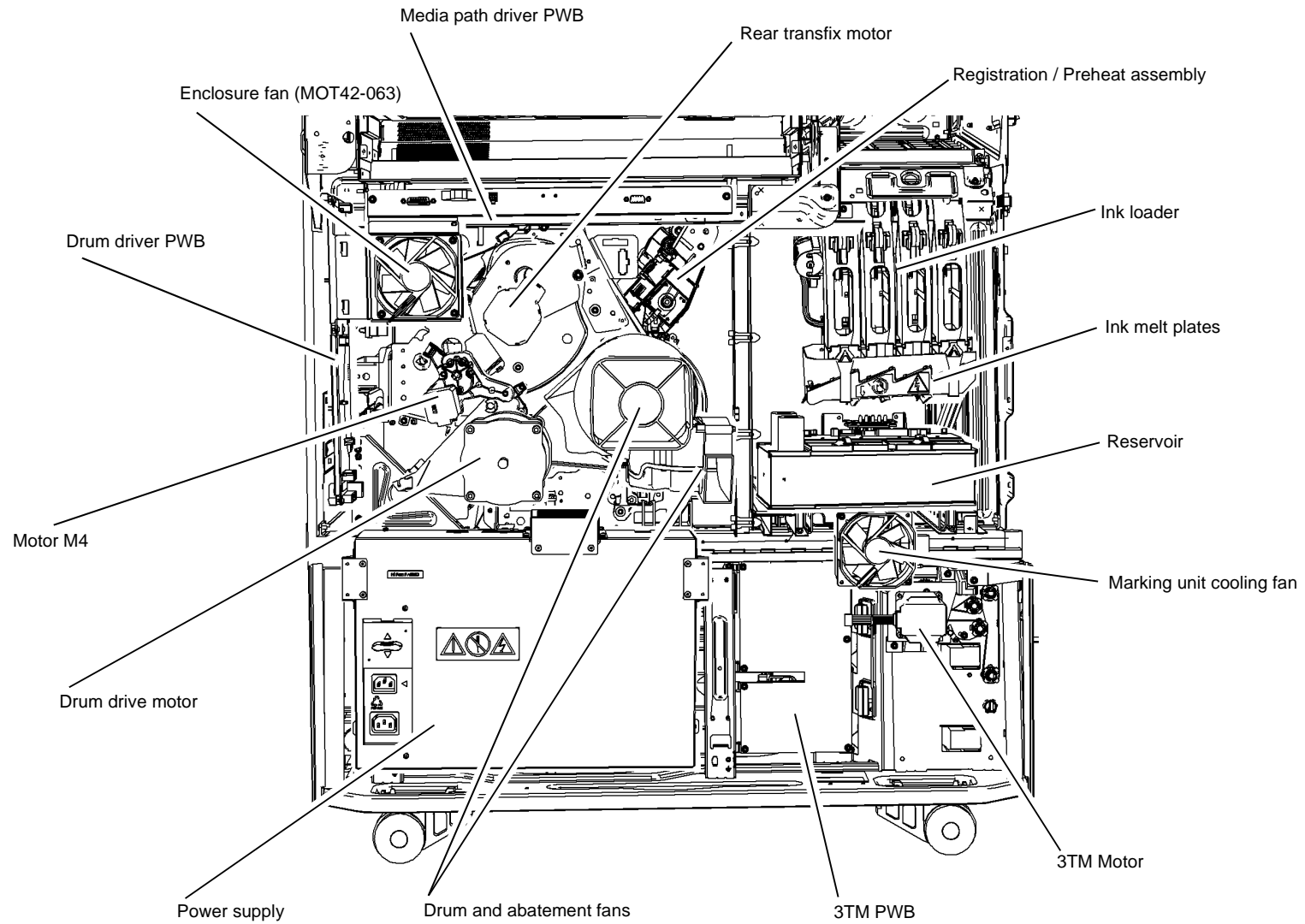

U-1-1314-A

Figure 2 Rear component location

Roller Locations, Sensor Locations and Jam Zones

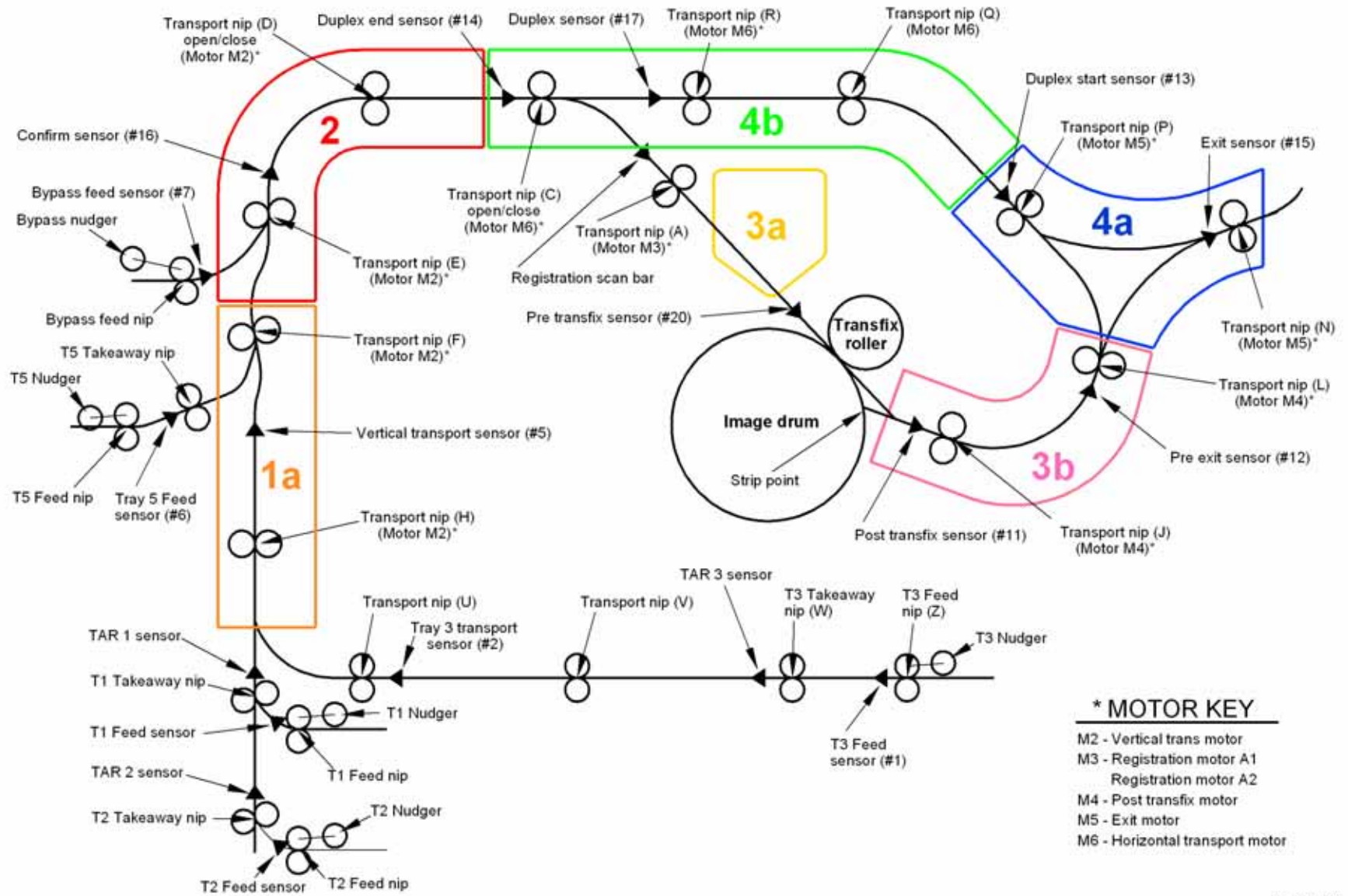

TU-1-0223-A

Figure 3 Rollers, sensors and jam zones

Document Handler (DADH)

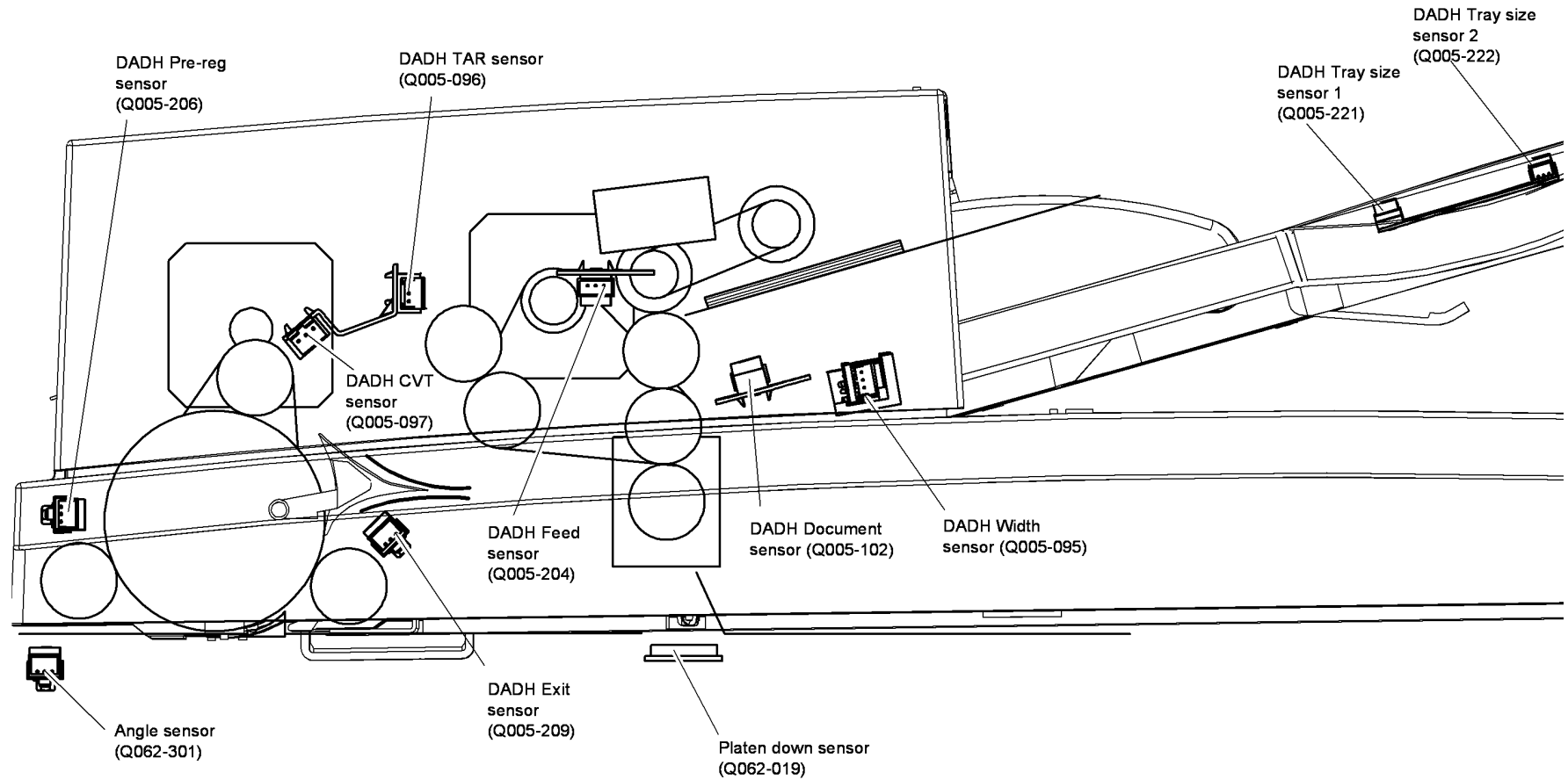

TU-1-0229-A

Figure 4 DADH Sensor Map

Low Capacity Stapler Stacker (LCSS)

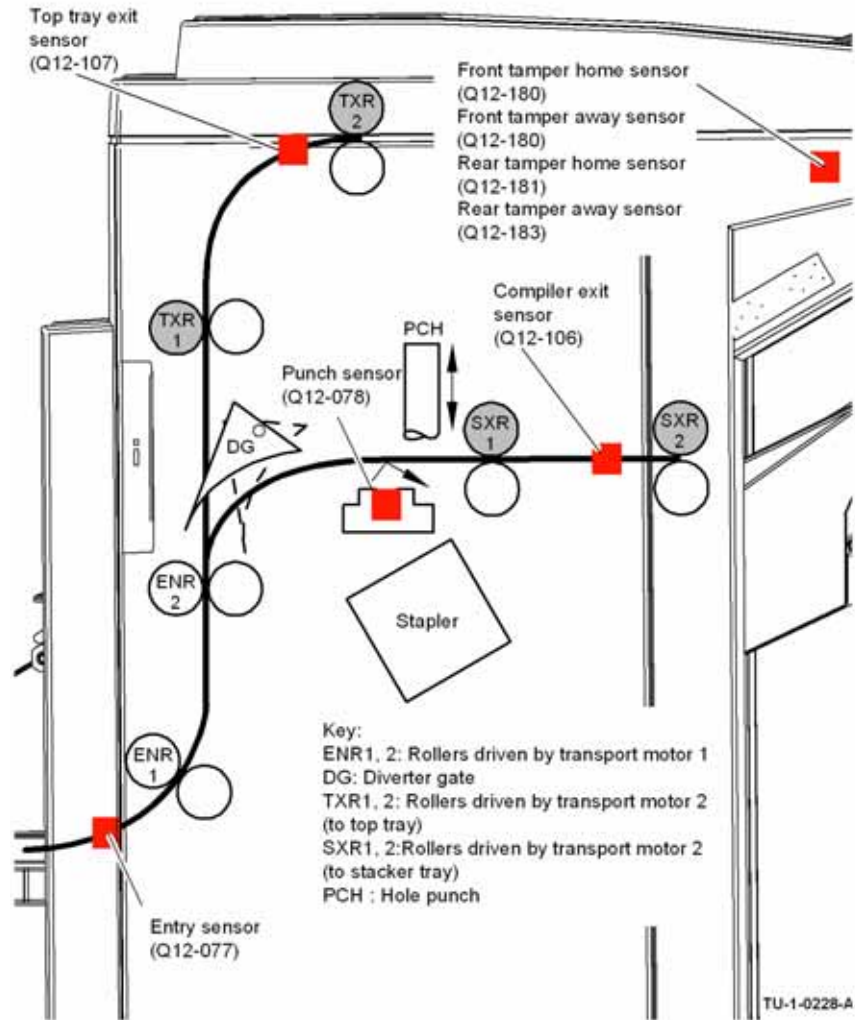
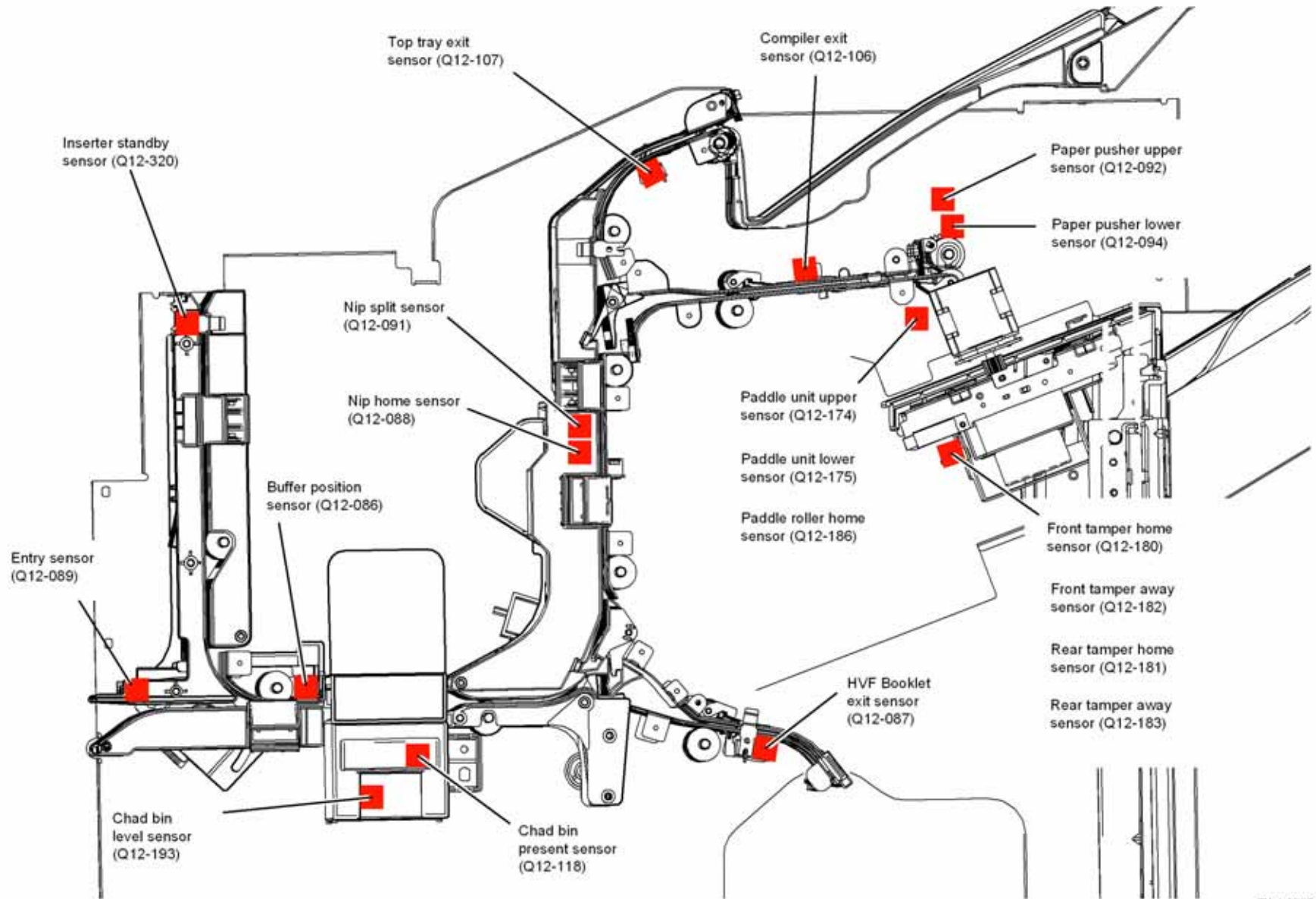

Figure 5 LCSS Sensor Map

High Volume Finisher (HVF)



TU-1-0227-A

Figure 6 HVF Sensor Map

GP 30 How to Mask Jets / Jet Substitution

Purpose

Use this procedure to manually mask jets. The masked jet will be substituted by an adjacent jet.

Procedure

- Enter Service Mode, [GP 1](#).
- Select the Adjustments routine.
- Select [dC131](#) NVM Read / Write.
- Enter the appropriate NVM location.
- Select Read.

Selecting an unused link

The NVM locations used for manually masking jets is 445-9 through 445-48. When manually masking a jet, the specific location to use is not important provided the value in the location where you wish to enter a 5 digit masking value is 0. If a value other than 0 is seen, do not enter a new value. Keep moving to the next location until a value of 0 is found.

Masking the jet

Enter Chain 445, links (9-48)

Jets are masked in NVM locations 445-9 through 445-48 by entering a 5 digit number which represents the head, color and number of the jet to be masked. This 5 digit number uses the format 'HCJJJ' where H = head number, C = colour (Cyan = 1, Magenta = 2, Yellow = 3, Black (K) = 4) and JJJ = jet. Jet numbers must be 3 digits in length – zero-fill as necessary (jet 4 would be 004).

Example: to mask yellow jet 44 on head 2 enter: 23044. Select write.

Verify the masking by printing the service jet test pages from [dC968](#) Head Purge.

The masked jet number should be marked in green text. Refer to [TP 21](#) Jet Test Pages for more details.

Identify a Masked Jet

To identify the particular masked jet to be cleared, enter the chain 445 and cycle through the link numbers 9 to 48. Select read every time the link number is changed. Compare the desired jet to the output. If they matched then proceed to next step, if not enter the next link number and repeat procedure.

Clearing the masked jet (reset)

Once the link of the desired jet is identified, enter 0 and select write.

Verify the masking by printing the service jet test pages from [dC968](#) Head Purge.

The jet number should be marked in black / purple / red text. Refer to [TP 21](#) Jet Test Pages for more details.

Marking restrictions and recommendations

The software will restrict the following:

- Masking more than 40 jets.
- Masking a jet adjacent to another masked jet.
- Masking a jet adjacent to another chronic jet.

Do not mask black or colour jets that are within the A4 LEF print zone (i.e. the chronic jet is not in Head 1 between 1 to 12 or Head 4 between 208 to 220). The software will not restrict masking. The masking of black jets in the print zone is not recommended, but if required the software will allow it. Verify the jet location by printing the service jet test pages from [dC968](#) Head Purge.

GP 31 How to Open and Close the Stripper Gate

Purpose

To allow access to the stripper jam area.

Procedure

WARNING

Do not clean the stripper blade. The stripper blade is very sharp and can cause injury. If the stripper blade is dirty a new blade must be installed.

WARNING

Take care during this procedure. Sharp edges may be present that can cause injury.

Go to the relevant procedure

NOTE: In general use, the power must be on to open the stripper gate.

- Open and Close the Stripper Gate When the Power is On
- Open and Close the Stripper Gate When the Power is Off

Open and Close the Stripper Gate When the Power is On

1. Open the front door.
2. Push down handle 3b.
3. Move up handle 3b to close the gate.

Open and Close the Stripper Gate When the Power is Off

WARNING

Switch off the electricity to the machine. Refer to GP 14. Disconnect the power cord from the customer supply while performing tasks that do not need electricity. Electricity can cause death or injury. Moving parts can cause injury.

1. Open the front door.
2. Remove the inner cover, PL 81.11 Item 2.
3. Unlock then open the stripper gate, Figure 1.

NOTE: The screw slot will be approximately horizontal.

4. Move up handle 3b to close the gate. There is no need to rotate the screw.

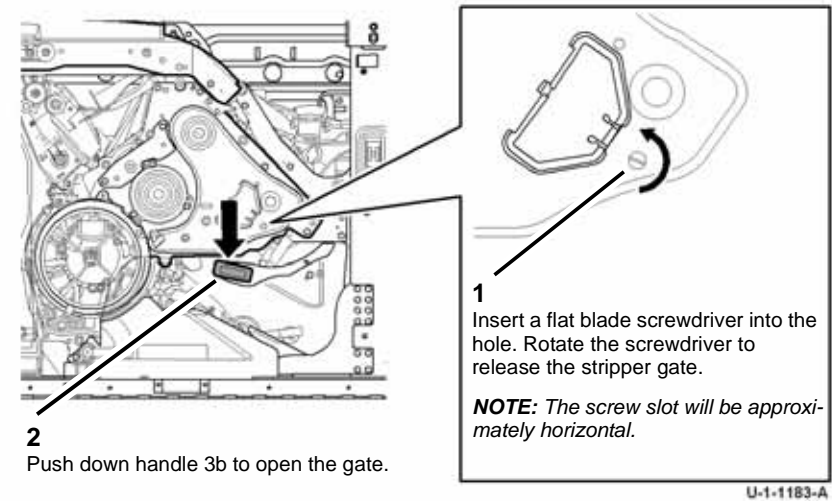

Figure 1 Unlock the stripper gate

GP 32 User Interface Panel Diagnostics

Purpose

Use this procedure to calibrate and to test components on the UI.

Description

To enter the user interface diagnostics, simultaneously press the #, * and Dial Pause keys.

The panel diagnostics consists of seven elements. Each element can be selected by pressing the relevant hard key or selecting the option on the UI. [Table 1](#).

Table 1 Panel Diagnostics

Key	Description	Purpose
1	LCD Pixel Test	To display a solid fill of the selected colour
2	Touch Panel Calibration	To position the screen in the correct position
3	Touch Panel Test	To check touch panel and keypad
4	Button Test	To check operation of the buttons
5	Display Vertical Test	Check colour test bars
6	LED Test	Check that the LED's lit
7	Audio Tone Test	To check the audible tones used by the machine.

The UI will then display the selected test.

Procedure

LCD Pixel Test

The purpose of the test is to determine whether the pixels in the display are functioning correctly. Select the colour displays in order to identify pixel faults as missing areas in the solid fill, [Figure 1](#).

1. The LCD pixel test will be displayed as in [Table 1](#).

Table 2 LCD Pixel Test

Key	Pixel Test
1	Red Pixel Test
2	Green Pixel Test
3	Blue Pixel Test
4	All White Pixel Test
5	All Black Pixel Test
0	Back

2. Select the test by pressing the hard key number or selecting the test on the UI. The UI will then display the relevant colour. By pressing the hard keys in sequence will index through each test.
3. Press the hard key 0 to close the window and return to the main menu.
4. Each pixel test routine will activate or de-activate the selected pixels. This will check each pixel on the display.

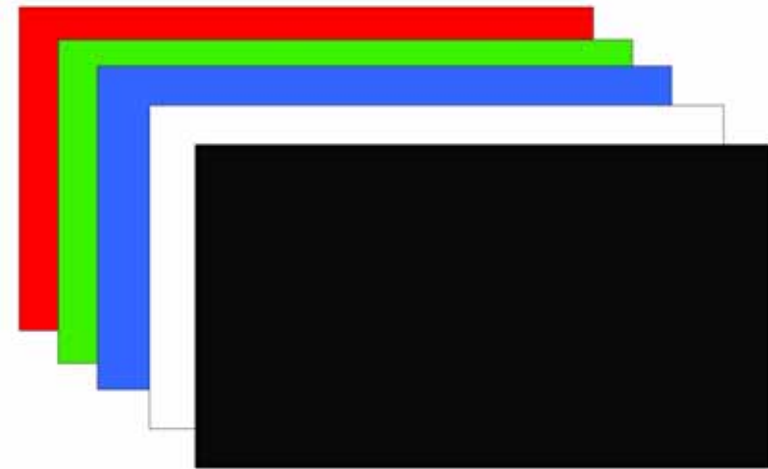

U-1-1506-A

Figure 1 LCD pixel test

Touch Panel Calibration

The purpose of this test is to perform a 9 point calibration of the UI panel. The calibration points are arranged in a 3 high by 3 wide pattern. Once the routine starts, the user should press targeted points on the touch panel, [Figure 2](#).

1. Select the hard key 1 to start the calibration.
2. Touch the centre of the cross hairs as they appear on the screen. Complete the 9 locations.
3. Press the hard key 0 to return to the main menu.

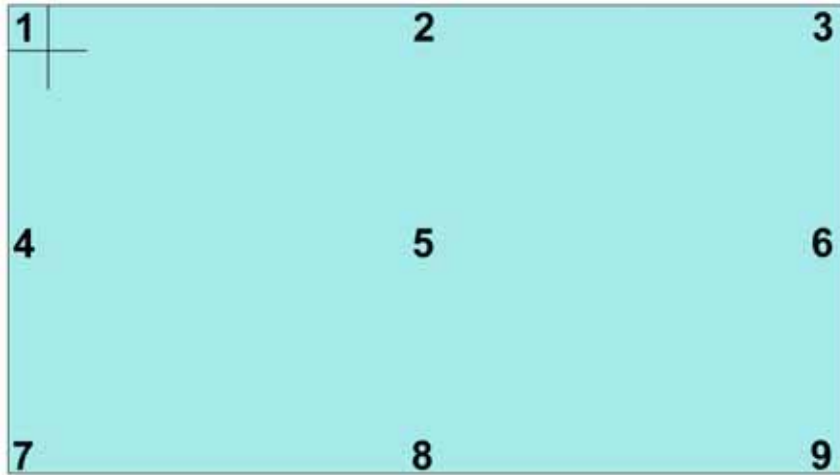

U-1-1507-A

Figure 2 Calibration screen

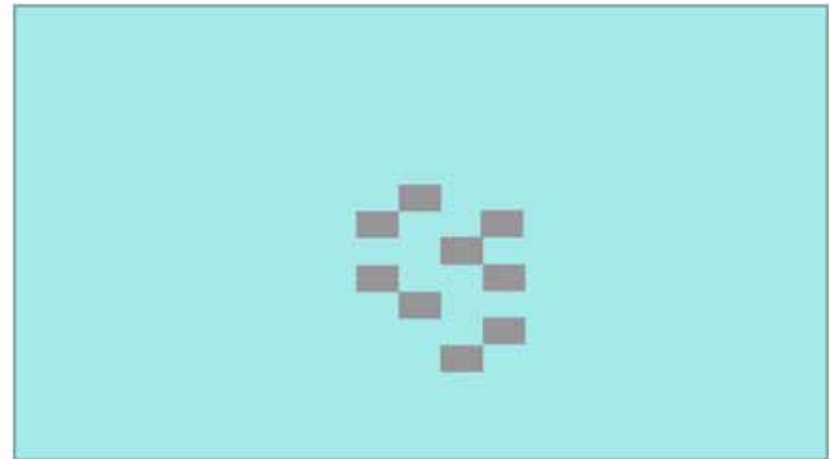

U-1-1508-A

Figure 3 Touch panel screen

Touch Panel Test

The purpose of the test is to check that the touch panel and touch panel keypad is functioning correctly.

1. Press hard key 1 to start the Touch Panel Test.
As the screen is touched the button will be red and once selected turns to grey, [Figure 3](#).
Press hard key 0 to return to the main menu.
2. Press hard key 2 to start touch panel key test.
The touch panel key panel will appear. Select each key and the number or letter will appear in the text box, [Figure 4](#).
3. Select Back to return the main menu.

Panel Diagnostics > Touch Panel Key Test



U-1-1509-A

Figure 4 Touch panel key test

Button Test

The purpose of this test is to provide a mechanism to check that the hard keys associated with the UI are operating correctly. Upon activation of this test, the UI will display a graphic representation of the hard panel buttons and provide user visual feedback.

1. Select Button Test

A button panel will appear on the UI. When a button is select then the correlating UI button will change to red. When a different button is selected the red button will change to green and the selected button to red, Figure 5.

2. Select Back to return to the main menu.

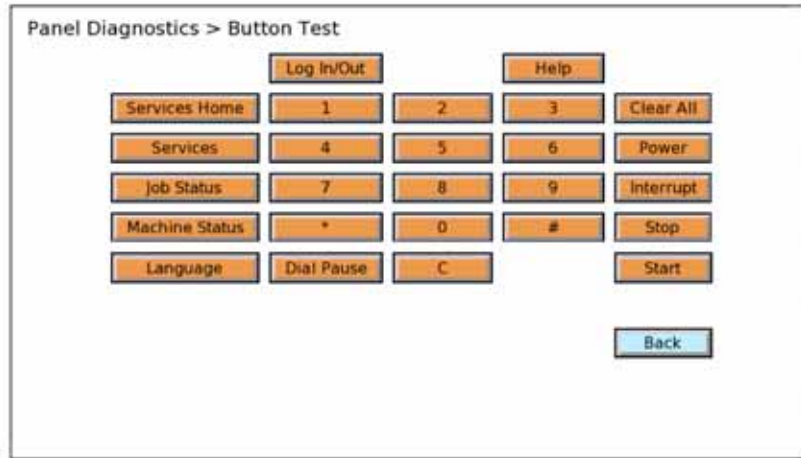

U-1-1510-A

Figure 5 Button test

Display Vertical Test

The purpose of this test is to allow the user to visually detect luminosity defects in the LCD display. The user can select eight different vertical display screens.

Table 3 Vertical test menu

Key	Scale	Description
1	Red Gray Scale	15 equal sized vertical strips ranging from 0% Red to 100% Red. Figure 6.
2	Green Gray Scale	15 equal sized vertical strips ranging from 0% Green to 100% Green. Figure 6.
3	Blue Gray Scale	15 equal sized vertical strips ranging from 0% Blue to 100% Blue. Figure 6.
4	Display 3 Vertical	3 equal sized vertical strips of 100% Red, then 100% Green and 100% Blue, Figure 6.
5	Display 33 Vertical	33 equal sized vertical stripes, 11 allocated to each of the colours (red, green, blue) showing a gray scale for each colour over the 11 stripes, Figure 7.

Table 3 Vertical test menu

Key	Scale	Description
6	Display 50 Vertical	50 equal sized vertical stripes, 16 allocated to the red gray scale, 16 to the green gray scale and 18 to the blue gray scale, Figure 7.
7	Display 100 Vertical	100 equal sized vertical stripes, 33 allocated to the red gray scale, 33 to the green gray scale and 34 to the blue gray scale, Figure 7.
8	Display 200 Vertical	200 equal sized vertical stripes, 66 allocated to the red gray scale, 66 to the green gray scale and 68 to the blue gray scale, Figure 7.
0	Back	

1. Press the hard key number to select the test. By pressing the hard keys in sequence will index through each test.
2. Select hard key 0 to return to the main menu.

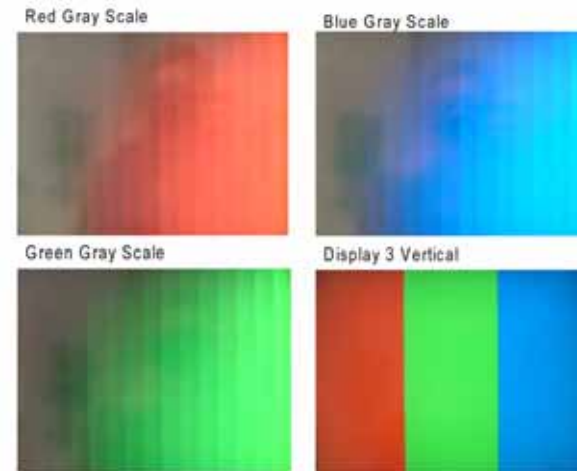

U-1-1511-A

Figure 6 Grey scale and 3 vertical display

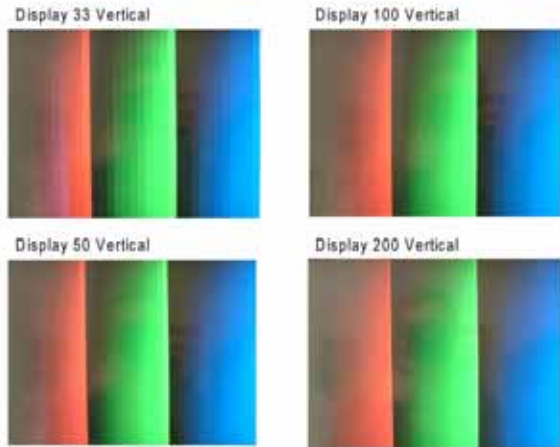

Figure 7 Vertical displays

U-1-1512-A

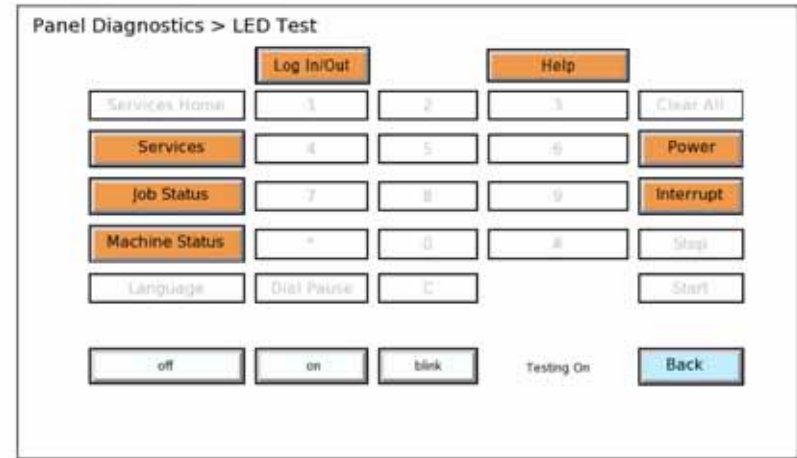

Figure 8 LED test display

U-1-1513-A

LED Test

This test verifies that all LED's are functioning properly. On pressing the associated hard key the LED will be switched on. Each LED can be instructed to turn on, off or blink.

1. Select the test.
2. Select the function on the UI screen and observe that the LED is lit, [Figure 8](#).
3. Select Back to return to the main menu.

Audio Tone Test

This test is used for verifying that the audio tone on the UI is working correctly. Upon activation of the test, the UI will emit a selection of sound tones and sound level tests.

Table 4 Audio tone test

Key	Test	Description
1	Sound Test	Nominal (high)
2	Sound 1 Test	500Hz (high)
3	Sound 2 Test	1000Hz (medium)
4	Sound 3 Test	2500Hz (medium)
5	Sound 4 Test	4000Hz (high)
6	Set Level Low	Modifies the volume used in the Test 1 to 5
7	Set Level Medium	Modifies the volume used in the Test 1 to 5
8	Set Level High	Modifies the volume used in the Test 1 to 5
9	All Tones Test	Perform each of the following tests sequentially: sound test, sound 1, sound test 3 sound test 4
0	Back	

1. Press hard key 1 to select Sound Test.
The audio duration ranges from 2 seconds for sound 1 to 4 tests, 5 seconds for the basic sound and approximately 10 seconds for the All tones tests. Audio levels can be verified by setting them low, medium or high.
2. Press the hard key 0 to return to the main menu.

GP 33 Machine Features

Configuration Options

The machine is available in various configurations using the options that follow:

General

For the space requirements, environment range and the print out time. Refer to:

- GP 21 Installation Space Requirements
- GP 23 Environmental Data.
- GP 25 First Copy / Print Out Time and Power On / Off Time.

Paper supply and paper handling options

- 100 sheet duplex automatic document handler (DADH).
- 4100 sheet high capacity feeder (Tray 5)

Output options

- 500 sheet offsetting catch tray (OCT).
- 2250 sheet 2 bin stapler stacker tray (LCSS).
- 3000 sheet 2 bin stapler stacker with 100 sheet finishing (HVF).
- 250 sheet post print inserter, PPI Tray 6 inserter (HVF)
- Tri-folder (HVF).
- 2000 sheet 2 bin stapler stacker (HVF BM).

Accessories and Kits

- 2 hole punch kit.
- 3 hole punch kit.
- 4 hole punch kit.
- Legal 2 hole punch kit.
- Swedish 4 hole punch kit.
- 2 hole punch kit.(HVF only)
- 3 hole punch kit (HVF only).
- 4 hole punch kit (HVF only)
- Swedish 4 hole punch kit (HVF only)
- 50 sheet convenience stapler.
- Tray 5 short edge registration kit (A4 / 8.5 x 11 inch / 8.5 x 14 inch SEF).
- Tray 5 short edge registration kit (A3 / 17 inch SEF).
- Xerox copier assistant software Kits.
- Xerox copier assistant printing Kits.
- Foreign interface kit.
- Xerox Secure Access Mifare card reader
- Xerox Secure Access Legic card reader
- Xerox Secure Access Magstripe card reader
- Xerox Secure Access MD card reader
- Xerox Secure Access Media doc kit
- 1 Line Fax kit (Embedded Fax)
- 2 Line Fax kit (Embedded Fax)
- Scan to PC desktop SE - standard.

- Scan to PC desktop SE - professional.
- FreeFlow Standard
- FreeFlow Professional.
- Nationalization kits.

NOTE: The service manual covers all of the above configurations. Within the manual, ignore any references to options that are not installed.

Machine Identification

The diagrams that follow illustrate some of the various machine configurations:

- ColorQube 9301 with offsetting catch tray, Figure 1.
- ColorQube 9302 with tray 5 and LCSS, Figure 2.
- ColorQube 9303 with tray 5 and HVF, Figure 3.
- ColorQube 9303 with tray 5, HVF, inserter and tri-folder, Figure 4.

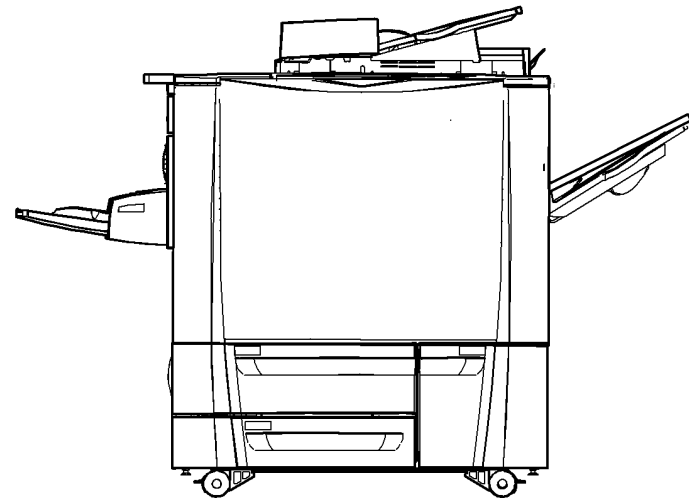

U-1-1537-A

Figure 1 9301 with OCT

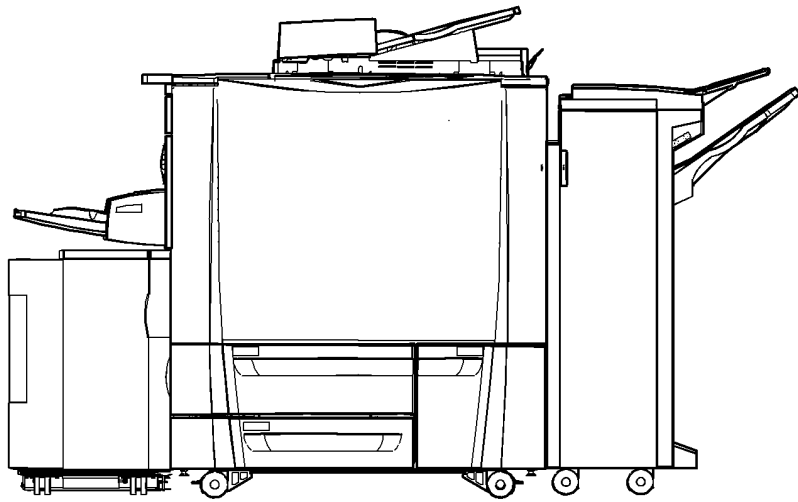

U-1-1538-A

Figure 2 9302 with tray 5 and LCSS

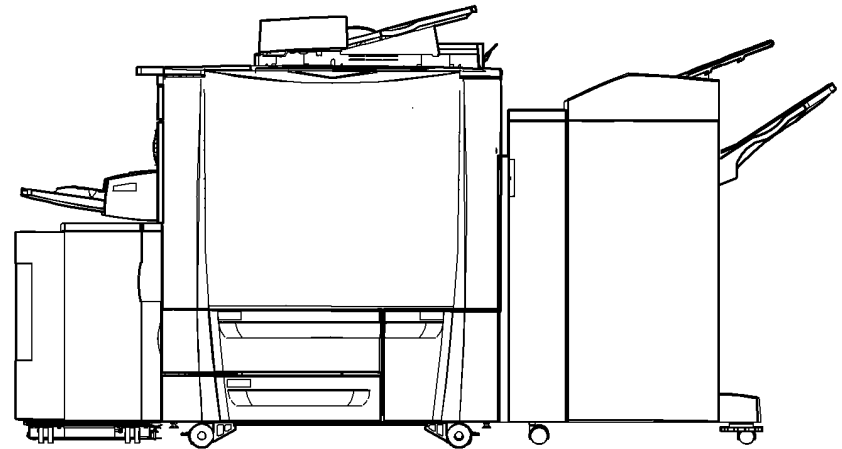

U-1-1539-A

Figure 3 9303 with tray 5 and HVF

GP 34 Service Plan

Purpose

To change the machine service plan from metered to sold.

Description

On receiving the change of contract request, the CCS validates the authorization code to change the service contract from metered to sold. The CCS updates and saves the new service contract in the CCS NVM.

Procedure

WARNING

Switch off the electricity to the machine. Refer to GP 14. Disconnect the power cord from the customer supply while performing tasks that do not need electricity. Electricity can cause death or injury. Moving parts can cause injury.

To change the service plan, go to dC136.

Refer to dC131 CCS NVM 606-269 and use Table 1 to identify which plan the machine is currently on.

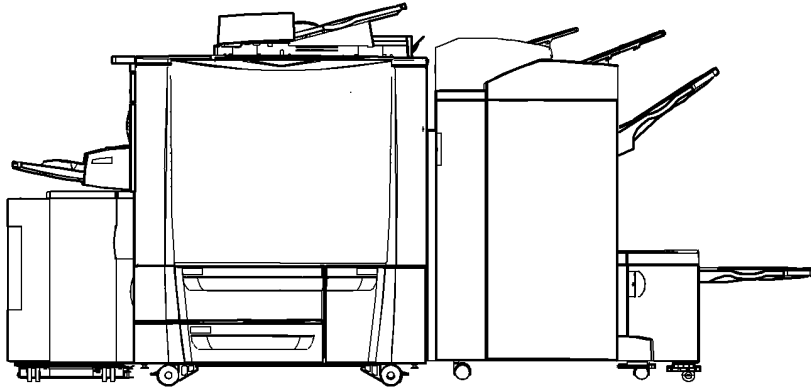

U-1-1540-A

Figure 4 9303, tray 5, HVF, inserter, tri-folder

Table 1 Service plan

Item #	Type of Service Plan	Service Plan which can be changed	Service Plan which cannot be changed
1.	Sold = 0	Xerox Managed Supplies = 3	Page Pack = 4, DMO Sold = 5
2.	Non Sold = 1	Sold = 0	Third Party = 2 Xerox Managed Supplies = 3 Page Pack = 4, DMO Sold = 5
3.	Third Party = 2	Not applicable	Sold = 0, Non Sold = 1, Xerox Managed Supplies = 3 Page Pack = 4, DMO Sold = 5
4.	Xerox Managed Supplies = 3	Sold = 0	Non Sold = 1, Third Party = 2 Page Pack = 4, DMO Sold = 5
5.	Page Pack = 4	Sold = 0	Non Sold = 1, Third Party = 2 Xerox Managed Supplies = 3 DMO Sold = 5
6.	DMO Sold = 5	Not Applicable	Sold = 0, Non Sold = 1, Third Party = 2 Xerox Managed Supplies = 3 Page Pack = 4

Key plate Adapter Locations

To identify which ink stick locates into the corresponding key plate. These illustrate the notches and shapes present that suit the specification of each plan.

- Xerox North America / Europe Sold (XNA / EU Sold) [Figure 1](#).
- Worldwide Metered [Figure 2](#).

- DMO Sold **Figure 3.**

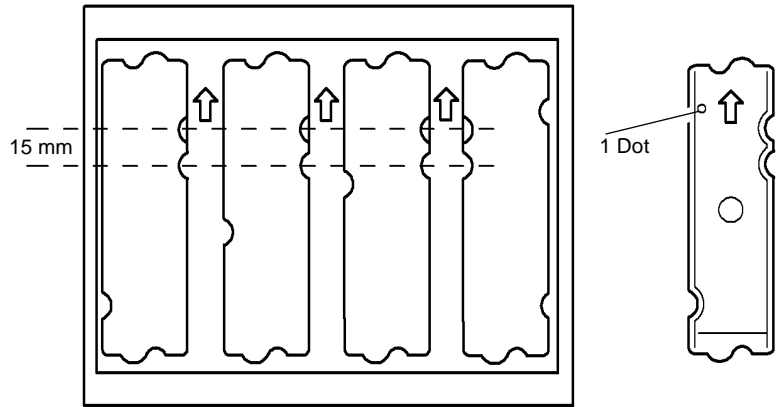

Figure 1 Xerox North America / Europe Sold

U-1-1238-A

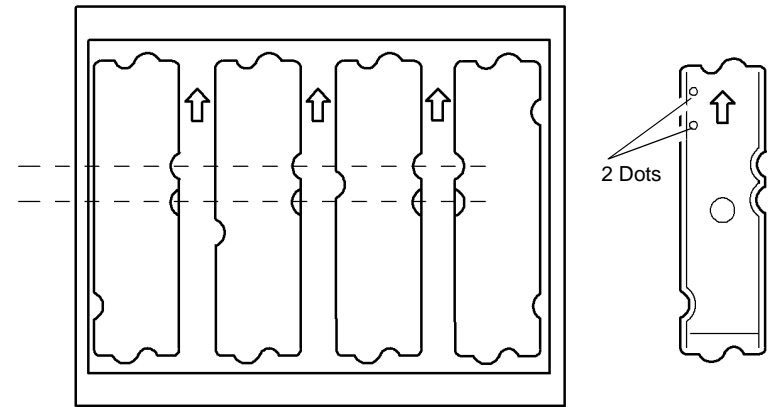

Figure 3 DMO Sold

U-1-1240-A

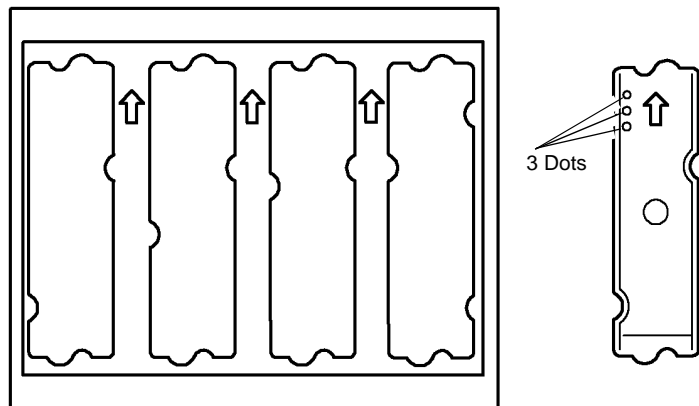

Figure 2 Worldwide Metered

U-1-1239-A

GP 35 Copy and Print Speeds

Purpose

To define copy and print speeds for all models.

Procedure

Go to the relevant section. Also, refer to [General Notes](#):

- [Print Modes](#)
- [Copy Speeds](#)
- [Print Speeds](#)

General Notes

1. For systems with weak or missing jets and jet substitution switched on, the productivity figures will be reduced as the system performs additional image passes to compensate for the missing jet.
2. Halve all print speeds for SEF media, except where the SEF media is less than 8.5 inches in length and greater than or equal to 8.27 inches not including envelopes.
3. In Standard mode the print rate will be reduced by up to 50% as the percent fill of any colour increases above 55%.
4. If photographic original subtype is selected in Photo and Text original type then the enhanced output quality is selected. Refer to [Table 1](#).
5. All user selected black and white output modes are always accounted as black and white pages. Refer to [Table 3](#).
6. ColorQube 9301 standard colour: Productivity may be reduced for jobs greater than 1200 pages with continuous area coverage greater than 190% for configurations with a HVF.
7. ColorQube 9302 standard colour: Productivity may be reduced for jobs greater than 1200 pages with continuous area coverage greater than 150% for configurations without a HVF.
8. ColorQube 9303 standard colour: Productivity may be reduced for jobs greater than 1200 pages with continuous area coverage greater than 110% for configurations with a HVF.
9. For modes that run faster than standard colour, there may be some reduction in productivity as area coverage increases.

Print Modes

Refer [Table 1](#).

Table 1 Print Modes

Fast Colour	Postscript Print quality output is faster, less dense and at a lower resolution than Standard Mode.
Standard	Postscript Print quality output is faster, less dense and at a lower resolution than Enhanced Mode.
Enhanced (default)	Postscript and PCL Print output quality is the highest speed possible for widely acceptable print quality.
High Resolution / Photo	Postscript and PCL Print output quality is the highest quality output

Copy Speeds

Maximum copy speeds attained by various models and settings. Refer [Table 2](#).

Table 2 Copy Speeds

			Simplex / Duplex / Letter / A4 pages per minute	
Copy Mode Name	Colour / Mono Selection	Resolution (dpi)	All Models	
			Simplex	Duplex
Enhanced (Default)	Colour	450 x 567	51	23
High Resolution / Photo	Colour	600 x 600	51	23
Enhanced (Default)	Mono	450 x 500	75	38
High Resolution / Photo	Mono	600 x 600	75	38

Print Speeds

Maximum print speeds attained by various models and settings. Refer to [Table 3](#).

Table 3 Print Speeds

			Simplex / Duplex / Letter / A4 pages per minute					
Print Mode Name	Colour / Mono Selection	Resolution (dpi)	9301		9302		9303	
			Simplex	Duplex	Simplex	Duplex	Simplex	Duplex
Fast Colour	Colour	225 x 450	60	40	70	46	85 (see note)	53
Standard	Colour	300 x 500	50	40	60	44	70	50
Enhanced (Default)	Colour	450 x 567	38	38	45	41	55	45
High Resolution / Photo	Colour	600 x 600	30	20	40	30	50	38
Fast Colour	Mono	225 x 450	85 (see note)	39	85 (see note)	46	85 (see note)	53
Standard	Mono	300 x 500	70	41	70	44	70	50
Enhanced (Default)	Mono	450 x 500	50	39	55	45	60	48
High Resolution / Photo	Mono	600 x 600	50	38	50	38	50	38

NOTE: The 85 page per minute speed is achieved from trays 1 to 4 in plain paper mode and output to OCT, LCSS or HVF top tray only.

These are maximum steady state print speeds. There are many factors that will reduce performance from these values including image complexity, job length, paper size, tray selection and driver type.

GP 36 How to Unlock the Cleaning Unit

Purpose

To manually unlock and release the cleaning unit.

Procedure

WARNING

Take care during this procedure. Sharp edges may be present that can cause injury.

1. Open the front door.
2. Unlock the cleaning unit, [Figure 1](#).

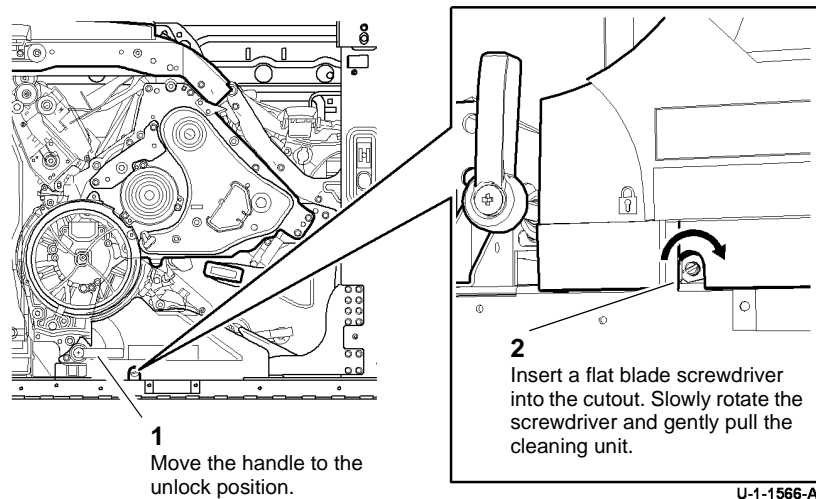

Figure 1 Unlock the cleaning unit

GP 37 Post Part Replacement Routines

Use this procedure to determine which service mode routines to run after a part reinstallation or replacement.

Go to the relevant part:

- Printhead (New Head)
- Printhead (Original Head Reinstalled)
- Umbilical Assembly (Original Head Reinstalled)
- Upper Carriage Assembly (Original Head Reinstalled)
- Lower Carriage Assembly (Original Head Reinstalled)
- X Axis Drive Motor
- Stitch Roller Motor
- Purge Line Filter
- Reservoir
- Drum
- Front Drum Frame Assembly
- Drum Drive Motor
- Drum Position Encoder
- Drum Pulley
- IOD Assembly
- Front Guide Track
- Rear Guide Track
- Registration/Pre-heat Assembly
- Horizontal Paper Path Assembly

Printhead (New Head)

Refer to [PL 91.20 Item 2](#) and [PL 91.25 Item 2](#).

Perform the following procedures in the order shown:

1. [dC972](#) Printhead Uniformity. Select Option 1. Select the manual procedure and all 4 printheads.
2. [dC131](#). Check the following NVM values:
 - 490-020. The value must be 0. If necessary change the value to 0.
 - 490-021. If the value is 2, change the value to 1. If the value is 0, 1 or 3, do not change the value.

Printhead (Original Head Reinstalled)

Refer to [PL 91.20 Item 2](#) and [PL 91.25 Item 2](#).

Perform the following procedures in the order shown:

1. [dC967](#) Head to Drum Spacing Check.
2. [dC971](#) Head to Head Alignment Adjustment.
3. Print test pattern 1, [dC612](#). If print quality is unsatisfactory, also perform [dC972](#) Printhead Uniformity. Select Option 1. Select the manual procedure and all 4 printheads.

Umbilical Assembly (Original Head Reinstalled)

Refer to [PL 91.20 Item 10](#), [PL 91.25 Item 10](#).

Perform the following procedures in the order shown:

1. [dC967](#) Head to Drum Spacing Check.
2. [dC971](#) Head to Head Alignment Adjustment.
3. Print test pattern 1, [dC612](#). If print quality is unsatisfactory, also perform [dC972](#) Printhead Uniformity. Select Option 1. Select the manual procedure and all 4 printheads.

Upper Carriage Assembly (Original Head Reinstalled)

Refer to [PL 91.20 Item 1](#).

Perform the following procedures in the order shown:

1. [dC967](#) Head to Drum Spacing Check.
2. [dC971](#) Head to Head Alignment Adjustment.
3. Print test pattern 1, [dC612](#). If print quality is unsatisfactory, also perform [dC972](#) Printhead Uniformity. Select Option 1. Select the manual procedure and all 4 printheads.

Lower Carriage Assembly (Original Head Reinstalled)

Refer to [PL 91.25 Item 1](#).

Perform the following procedures in the order shown:

1. [dC967](#) Head to Drum Spacing Check.
2. [dC971](#) Head to Head Alignment Adjustment.
3. Print test pattern 1, [dC612](#). If print quality is unsatisfactory, also perform [dC972](#) Printhead Uniformity. Select Option 1. Select the manual procedure and all 4 printheads.

X Axis Drive Motor

Refer to [PL 91.20 Item 5](#), [PL 91.25 Item 5](#).

Perform [dC971](#) Head to Head Alignment Adjustment.

Stitch Roller Motor

Refer to [PL 91.20 Item 4](#), [PL 91.25 Item 4](#).

Perform [dC971](#) Head to Head Alignment Adjustment.

Purge Line Filter

Refer to [PL 91.20 Item 9](#).

Perform [dC971](#) Head to Head Alignment Adjustment.

Reservoir

Refer to [PL 93.10 Item 10](#).

Perform the following procedures in the order shown:

1. [dC971](#) Head to Head Alignment Adjustment.

Drum

Refer to [PL 94.20 Item 1](#).

Perform the following procedures in the order shown:

1. [dC967](#) Head to Drum Spacing Check.
2. [dC971](#) Head to Head Alignment Adjustment.
3. [dC977](#) Drum Runout Calibration.
4. [dC625](#) Registration / Preheat Calibration.
5. [dC972](#) Printhead Uniformity. Select Options;
 - Option 3 Head to Head Uniformity - manual.
 - Option 4 TRC Generation.
 - Option 5 Y Dot Position Correction, select all 4 printheads.

Front Drum Frame Assembly

Refer to [PL 94.20 Item 16](#).

Perform the following procedures in the order shown:

1. [dC967](#) Head to Drum Spacing Check.
2. [dC971](#) Head to Head Alignment Adjustment.
3. [dC977](#) Drum Runout Calibration.
4. [dC972](#) Printhead Uniformity. Select Options;
 - Option 3 Head to Head Uniformity - manual.
 - Option 4 TRC Generation.
 - Option 5 Y Dot Position Correction, select all 4 printheads.

Drum Drive Motor

Refer to [PL 94.20 Item 6](#).

Perform [dC971](#) Head to Head Alignment Adjustment.

Drum Position Encoder

Refer to [PL 94.20 Item 8](#).

Perform the following procedures in the order shown:

1. Perform [dC971](#) Head to Head Alignment Adjustment.
2. Perform [dC977](#) Drum Runout Calibration.

Drum Pulley

Refer to [PL 94.20 Item 3](#).

Perform the following procedures in the order shown:

1. [dC967](#) Head to Drum Spacing Check.
2. [dC971](#) Head to Head Alignment Adjustment.
3. [dC977](#) Drum Runout Calibration.
4. [dC972](#) Printhead Uniformity. Select Option 5 Y dot position correction. Select all 4 print-heads.

IOD Assembly

Refer to [PL 94.15 Item 1](#).

Perform [dC971](#) Head to Head Alignment Adjustment.

Front Guide Track

Refer to [PL 94.15 Item 2](#).

Perform [dC971](#) Head to Head Alignment Adjustment.

Rear Guide Track

Refer to [PL 94.15 Item 3](#).

Perform [dC971](#) Head to Head Alignment Adjustment.

Registration/Pre-heat Assembly

Refer to [PL 88.10 Item 1](#).

Perform [dC625](#) Registration / Preheat Calibration.

Horizontal Paper Path Assembly

Refer to [PL 82.15 Item 1](#).

Perform [dC625](#) Registration / Preheat Calibration.

GP 38 How to Set the Date and Time

Purpose

To set the machines date and time.

Procedure

Perform the following:

1. Enter Customer Administration Tools, [GP 5](#).
2. Press the Machine Status button.
3. Select the Tools tab.
4. Select Device Settings.
5. Select the General folder.
6. Select Date & Time.
7. Set the correct date and time, then select Save.
8. Log out of Customer Administration Tools.

GP 39 How to Enable HTTP

Purpose

To enable the hyper text transfer protocol (HTTP) networking protocol.

Procedure

Perform the following:

1. Enter Customer Administration Tools, GP 5.
2. Press the Machine Status button.
3. Select the Tools tab.
4. Select Network Settings.
5. Select Advanced Settings.
6. Select Continue.
7. Select HTTP Settings.
8. Select Enable.
9. Select Save.
10. Select Close.
11. Log out of Customer Administration Tools.

GP 40 Glossary of Terms, Acronyms and Abbreviations

Where possible unit designations as appear in ISO 1000 (International Organization for Standardization) and Xerox Standard MN2-905 have been used. All measurement appear in ISO units followed by any conversion in brackets e.g.; 22.5 mm (0.885 inches)

Refer to [Table 1](#).

Table 1 Terms, Acronyms and Abbreviations

Term	Description
3TM	3 paper tray module - the base paper system (also call TTM for Three Tray Module).
Abatement	Air system to reduce contaminates on the IOD (Ink On Drum) sensor. Runs only during print - collects contaminates at bottom of the drum, before PHs.
ABS	Automatic Background Suppression.
ADC	Analog to Digital Converter
ADF	Automatic Document Feeder
ADU	Automatic Duplexing Unit
AGC	Automatic Gain Control
AHA	Advanced Hardware Architecture
AIF	Automated Information Forwarding - sends usage profile to Xerox.
AMCV	Average Monthly Copy Volume
AMF	Advanced Multi Function device
AMPV	Average Monthly Print Volume
AMR	Automatic Meter Read
AMS	Automatic Magnification Selection
ANSI	American National Standards Institute
AP	Advanced Purge
API	Application Programming Interface
APS	Auto Paper Selection
ARP	Address Resolution Protocol. Converts an IP address to a MAC address. See RARP.
ASIC	Application Specific Integrated Circuit
ASP	Authorized Service Provider
BC	Similar to Lakes KIA application
BEUI	BIOS Extended User Interface
BIST	Built In Self Tests
Bit Depth	1 = Black or white; 4 bit = 16 colours; 8 bits = 256 colours
Bitmap fonts	Made of pixels that form the shape of letters. Created in specific sizes and cannot be resized
Bluetooth	Wireless local area network
BM	Booklet Maker
BMF	Basic Multi Function device
BootP	Boot Protocol. AN IP protocol for automatically assigning IP addresses.

Table 1 Terms, Acronyms and Abbreviations

Term	Description
BPS	Bits Per Second
BT	Busy Tone
Burst Mode	Copy mode in which two letter / A4 images are on the drum at the same time - so minimum time to retract / re-engage the Drum stripper / Transfix.
C	Celsius
Calibration Characterization Conversion	Colour Management factors: Calibration - turning of the device for optimal performance and maintaining that 'quality'. Characterization - how colour gamuts are described for a device. Conversion - how an image is translated from one device to the next.
CAP	Cold Abnormal Purge (temp dropped to low for purging while in standby, low power or sleep - won't happen unless a hardware problem.)
CAT	Customer Admin Tool
CBC	Combined Board Controller (or Common Board Controller) - Linux based.
CBE	Chip Boundary Error - refers to possible mis-read of ink on drum if image aligns with the chip boundary (every 54 'bits').
CC	Copy Centre
CC	Copy Controller: controller for input and output and a large portion on the image path.
CCA	Customer Call Assistance
CCD	Charged Coupled Device
CCM	Copy Controller Module
CCS	Copy Control Software - generally used to describe SW crashes in copy control.
CD	Copy Darker. A copy density setting
CDI	Common Device Interface
CD-ROM	Compact Disk - Read Only Memory
CED	Customer Expectations Document - Used by sales/marketing to set Customer expectations - how machine will function under various conditions.
CED	Customer Expectations Document (quick ref. that customer may sign stating equipment capabilities and any expectations to normal expectations)
CEH&S	Corporate Environmental Health and Safety
CentreWare	CentreWare internet services is the embedded HTTP server application that is available on network enabled machines. It enables access to printing, faxing and scanning over the internet.
CFR	Confirmation To Receive

Table 1 Terms, Acronyms and Abbreviations

Term	Description
Chase Sheets	A piece of paper that is run through the paper path without receiving an image. The paper is passed through the roller/drum nip under the same conditions as for an actual print, except that the drum maintenance cycle is not performed. The chase sheet is run after a printed image and will collect untransferred pixels that are left on the drum or transfix roller. The amount of ink on the chase sheet can be measured to the quantify image transfer efficiency.
CIE Illuminants	Standardize light sources
CIE L*C*H*	L* = lightness, a* = red/green, b* = yellow blue value - based on theory that a colour cannot be red and green or yellow and blue at the same time (most widely used colour model).
CIE XYZ	Basic CIE 3 dimensional colour space. X = Red, Y = Green, Z = Blue (based on human capabilities.)
CIG	Calling Subscriber Identification
CIS	Contact Image Sensor
CL	Copy Lighter. A copy density setting
CLD	Closed Loop Drift (CLD). CLD makes a baseline measurement each time dc972 Option 3 Manual is run. CLD runs automatically on a schedule in extended Idle time. The measurement is similar to Y Dot position and is dependent on head to drum and drum size and docking of the heads.
Cleaning Page	See Mud Page
Click Charge	Charge by copy/print rate
CMM	Colour Management Module - Software application. That performs the conversions from one colour space to another
CMS	Colour Management Systems - helps provide colour consistency via calibration and colour characterization - utilizes profiles (characterizations) for various devices (scanner, monitor and printer)
CMY	Cyan / Magenta / Yellow - subtractive primary colours from RGB CMY used by printers since they are dependant upon reflective light. Two overlapping subtractive primary colours = R,G or B i.e. M+Y = R; M+C=B; C+Y=G. (CMY are process primaries.) C is opposite R; M is opposite G, Y is opposite B. Vary spot size, balance and angle to create appearance of colours.
CMYK	Cyan Magenta Yellow and Black
Cohesive Failure	Ink fractures or disintegrates during deformation and heating in the transfixing process. This results in part of the pixel remaining on the drum and part transferring to the media. Cohesive failure is the loss of the internal strength of the ink above a critical (drum) temperature.
Colour	Results from interaction between light, object and viewer perception. Consists of Hue, Saturation and Lightness.
Colour Management	Calibration: Measure and adjust the performance of a device Conversion: Accomplished via SW (i.e. convert RGB to CMYK) Characterization: How the colour gamut of a devices described

Table 1 Terms, Acronyms and Abbreviations

Term	Description
Colourmeters	Measure colour by imitating the eye to calculate level or RGB. Tristimulus device. Breaks light down into its RGB components. Using one of the CIE standards - used on monitors / light emitters.
Contone	Image Format (short for continuous tone) - during RIP contones are converted to halftone dots in each of the four separations.
CP	Cold Purge (normal power up from cold purge)
CPM	Copies per minute
CPQD	Customer perceived Print Quality Defect
CPSR	Capture / Print, Save and Reprint
CQ	Copy Quality
CRD	Colour Rendering Dictionary - used to convert RGB to CMYK data during RIP
CRU	Customer Replaceable Unit
CRUM	Customer Replaceable Unit Monitor
CSE	Customer Service Engineer
CSMS	Customer Satisfaction Management System
Customer Drivers	Customer drivers are specially developed generally made with a driver toolkit. These drivers can provide a full set of features for Xerox printers. In the past, customers drivers have been provided for all major operating systems. A customer print driver is costly to develop, and does not use standard operating system components. For this reason, PPD / GPD solutions will be used in future whenever possible.
CTC	Continue To Correct
CTF	Contrast Transfer Function
CTO	Change Try Out - testing of changes on machine
CTR	Response For Continue To Correct
CTS	Clear To Send
CU Slime	The accumulation of ink in the drum maintenance unit. This can build up on the wiper blade or in the reclaim path.
CU	Cleaning Unit - presently expected to last ~ 240K - DMU is most likely to casual for side 1 gloss (low gloss = high oil) (high gloss = low oil). Cleaning unit is part of the FSMA contract as a CRU. Customer has option to return or trash it. Also known as the Drum Maintenance Unit (DMU).
CVT	Constant Velocity Transport
CVU	Check Valve Unit - on lower end of umbilicals - keeps air & ink from flowing back into ink reservoir - but only functions fully after being primed. Failure to prime may lead to ink in air system and reservoir r/r
CW	CentreWare
CWM	Continuously Weak or Missing Jet/s
CWW	CentreWare Web
DAC	Digital to Analog converter
DADF	Duplex Automatic Document Feeder (feeds documents to a different stack)

Table 1 Terms, Acronyms and Abbreviations

Term	Description
DADH	Duplex Automatic Document Handler (feeds documents to bottom of existing feed stack)
dB	Decibel (applies to sound pressure level units)
DDB	Drum Driver Board
dC	Diagnostic code
DC	Digital Copier
DC	Device Controller, generic term for any module that acts as a image handling device e.g., SIP, Digital Copier
DC	Direct Current
DC + Fax	Digital Copier with embedded Fax card
DCN	Disconnect
DCS	Digital Command Signal
DDF	Device Description File
Delta TRC	Measures the relative intensity between heads at area coverages less than 100%. If needed, will adjust the image density for improvement.
Densimeter	Measures simple density. Photoelectric device, simply measures and computes how much of a known amount of light is reflected from - or transmitted through an object. Works on reflectance
Device Profile	Determines what colours a device is capable of producing - also known as profiling or characterization. Only accurate if device is working as designed.
DHCP	Dynamic Host Config Protocol (similar to BootP)
DIMM	Dual In Line Memory Module
Discovery	Base operating system
Dithers	Non solid image area (half ones on B/W)
DLM	Dynamically Loadable Module
DM	Drum Module - Drum is anodized Aluminium and is expected to last approximately 3 million prints (life of product?) requires a breaking of 15 minutes at new install.
DMO-E	Developing Markets Operations East (was part of RX)
DMO-W	Developing Markets Operations West (was part of ACO)
DMU	Drum Maintenance Unit, also known as the Cleaning Unit (CU)
DOS	Disk Operating Systems
Dosing	Amount of ink which was sent from the ink reservoir to print heads == measured in grams.
Dot Spread or Dot Gain	A measure of the final size of a single ink pixel on media after the transfixing process. (Dots may 'grow' depending on paper etc.)
DIS	Digital Identification Signal
DMA	Direct Memory Access
DMO	Developing Markets Operations
DOF	Direction Of Feed, paper width sensors
DPI	Dots per inch

Table 1 Terms, Acronyms and Abbreviations

Term	Description
DRAM	Dynamic Random Access Memory
Drooling	Small amounts of ink 'oozing' out of the Print Head, this may eventually lead to clogged jets and may stain the face plate. If it only happen when the same SWFA is purging the other head - then 1 PH purges should be avoided.
Drop Mass	The mass of an individual drop of ink that has been ejected by the print head. Measured during Print Head 'normalising' process. Not field measurable since it requires lab grade scales in zero wind conditions. Drop mass goes down as a PH ages so compensations / calibration is necessary.
Drop Mass Parameters	Measures the sensitivity of drop mass and drop position to voltage, in preparation for running "Drop mass reset"
Drum Ghosting	Looks somewhat like ink stains.
DSR	Data Set Ready
DSP, DSP2	Digital Signal Processing
DST	Daylight Saving Time
DT	Dial Tone
DTC	Digital Transmit Command
DTMF	Dual Tone Multiple Frequency
DU	Density Units
DUI	Dumb UI - all processing located offline to the UI
Duplex Dropout	Loss of pixels on side 2 - generally due to 1st side oiling of media issues
Dust Off	Routine to return machine to pre-install state
EAA	Electron Auditron Administrator
EBS	Electronic Billing Service
EC	European Community
ECM	(1) Electronics Control Module. (2) Error Correction Mode.
ECAT	External Customer Acceptance Test
EHS	Environmental Health and Safety
ELOG	Electronic Log
Embedded Fax	A fax system included in a system device
Embossing	Outlines of the first printed side seen on the second printed side of a duplex image. The outlines are at the edge of ink restrictions. The embossing artifact is highly image dependant.
EME	Electromagnetic Emission
Engine Block	The Drum/Transfix/Drive motor unit together is called the engine block.
EOL	End Of Line
EOM	End Of Message
EOP	End Of Procedure
EOR	End Of Retransmission
EPA	Environmental Protection Agency

Table 1 Terms, Acronyms and Abbreviations

Term	Description
EPC	Electronic Page Collation (memory dedicated to temporary retention of images captured from the scanner and network controller)
EPROM	Erasable / Programmable Read Only Memory
EP-SV	Electronic Partnership Supervisor (kit)
ERR	End Retransmission Response
ERU	Engineer Replaceable Unit
ESD	Electrostatic Discharge
ESG	European Solutions Group
ESP	Encoded Skew and Process - refers to RaIPH functions of skew and register throughout media.
ESS	Electronic Sub-System. For this machine use NC
ETP	Electronic Test Pattern
EU	European Union
EUR	Europe
Fault Tolerant	Limp mode
FAX	Facsimile
FCC	Federal Communications Commission
FCD	Facsimile Coded Data
FCS	Facsimile Checking Sequence
FCOT	First Copy Out Time
FD	Functional Description
FDI	Foreign Device Interface
FIFO	First In First Out
FireWire	IEEE 1349. High speed serial communications system, comprising hardware plus protocol. Operates at 100, 200 or 400 Mbits/s, with 800 Mbits/s under development. See USB and RS-232
Firmware	Software in a ROM
FLASH	On board erasable and re programmable non volatile memory
FLUSH	Flush routine to purge contaminated ink reservoir, via multiple purges - if there is too much mixing the may take over an hour to fully purger reservoirs and PHs, approximately 1 stick of each colour.
FMEA	Failure Modes and Effects Analysis
FOIP	FAX Over Internet Protocol
Foldability	Refers to how well a print withstands folding
FPGA	Field Programmable Gate Array
FPOT	First Print Out Time
Freckle / Freckling	A pixel from a previous image that shows up on the next image, usually left from the drum cleaning.
FRU	Field Replacement Unit
FSK	Frequency Shift Keying
FSMA	Field Service Maintenance Agreement
FTP	File Transfer Protocol

Table 1 Terms, Acronyms and Abbreviations

Term	Description
FTTR	Fast Time to Ready - allows running paper through machine without print head use.
FWA	Full Width Array
FX	Fuji Xerox
Gamut	Range of colours that a device can reproduce, the larger the better. RGB gamut is larger than CMYK
Garfield	IME simulates a function i.e. paperless pump. IME does not contain a MU, IOD or abatement plenum etc.
GCR	Grey Component Replacement. Black replace greys that would otherwise be created using all three CMYK colours.
GDI	Graphical Display Interface
GEL	Gel (oil and ink mixture) that is removed from the drum by the metering blade.
Ghosting	A print quality artifact where a previous image can be seen on the current image.
GIS	Global Imaging Systems
GLCD	Graphic Liquid Crystal Display
Gloss Variance	Mainly duplex - especially at very low usage rates.
GND	Ground
GPD Minidrivers	A Generic Printer Description file has a function similar to PPD files. This format was developed by Microsoft to provide a simple method to develop drivers for non-postScript printers. Standard GPD mini drivers share the same lamentations as the PPD mini drivers, but they too can be enhanced using plug-ins. GPD Mini drivers are a new technology introduced for Windows 2000 and they will also be supported Windows NT 4. In Windows 95/98, a similar, but less powerful 'unidriver' format was used.
GS	German safety
GSM	Grams per square metre
GUI	Graphics User Interface
H2H	Head to Head alignment
HAM	Head Alignment Machine - used to align print heads on the SWFA
HAU	Head Adjustment Uniformity (refers to printhead NVM data)
HAY	Head Adjustment Y delay (refers to printhead NVM data)
HC	High Capacity
HCD	Head Configuration Data. Written during manufacture, read at switch on. Failure prevents machine operation.
HCF	High Capacity Feeder
HCSS	High Capacity Stapler Stacker (3K)
HCSS BM	High Capacity Stapler Stacker Booklet Maker
HDD	Hard Disk Drive
Head to head uniformity	Measure relative intensity between heads at 100% area coverage. If needed, will adjust head voltage or norm clicks for improvement.

Table 1 Terms, Acronyms and Abbreviations

Term	Description
HDLC	High Level Data Link Control
HFC	Head Field Corrections. Log file of manual and automatic HAU corrections. Failure has no customer impact.
HFD	Head Field Data
HFLN	High - Frequency (random) Line - Edge Noise. image quality metric.
HFSI	High Frequency Service Intervals
HLD	High Level Design. A document that defines the software high level design.
HM	Head Maintenance
HSL	Hue, Saturation and Lightness chart (tristimulus colour space)
HTD	Head to drum spacing (critical specification) - also used to name the sandwich frames of the engine block since it sets the drum and the PH stop points of reference.
HTTP	Hyper Text Transfer Protocol
Hue	Basic colour such as red, pink, blue or orange (determined by wavelength). White, black and grey are not considered to have 'hue' and are considered 'neutral' colours.
HUI	Hybrid User Interface
HVF	High Volume Finisher
HVF / BM	High Volume Finisher Booklet Maker
HVPS	High Voltage Power Supply
Hz	Hertz
IB or I/B	InBoard
I2C-bus	Inter Integrated Circuit bus. This provides a simple bidirectional 2-wire bus for efficient inter-IC control. All I2C-bus compatible devices incorporate an interface which allows them to communicate directly with each other via the I2C-bus.
ICAT	Internal Customer Acceptance Test
ICE	Internal Customer Engagement
ID	Identification
IDHF	Industrial Design Human Factor, relates to how UI display / labels are used / presented to the Customer.
IEC	International Electrotechnical Commission
IF	Interface. Small Pwba on subassemblies
IFAX	Internet Fax
IIT	Image Input Terminal
IIZ	Inter Image Zone, are between images on the drum
IM	Interim Maintenance
IME	Image Marking Engine
Ink blocking	Undesired transference of image from one sheet to another. Generally in the output tray while copies are still hot but may be at other times as well.
Ink Cooking	A change in the colour of ink. Due to the ink being at elevated temperature the printer for extended periods of time. 'Darkens' ink.

Table 1 Terms, Acronyms and Abbreviations

Term	Description
Ink Squeegee	Ink smeared down the page. This is generally due to excessive pressure or pre-heat temperature.
Intlk	Interlock
IOD	Ink On Drum sensor (scanner array being used to monitor the drum surface and to aid in troubleshooting of the drum area). IOD may also be used to provide an 'image' on the drum surface for analysis.
IOP	Ink On Paper
IOT	Image Output Terminal
IOTC	Image Output Terminal Controller (IOT PWB, LVPS and HVPS). Sometimes referred to as the Power and Control Assembly.
IP	Internet Protocol
IPA	Image Processing Accelerator. Used by the machine scanning services to convert scanned images to a standard format e.g. for scan to file / scan to E-mail for network transmission.
IPD	Installation Preparation Document
IPM	Images per minute
IPP	Internet Printing Protocol
IPS	Image Processing Service
IPS1	Image Processing System
IPX	Internetwork Protocol eXchange
IQ	Image Quality
IQ with Cold Drum	Spotty looking. Low dot fill, similar to low transfix pressure
IQ with Hot Drum	Cohesive failures (ink on drum).
IR	Infra Red
ISDN	Integrated Services Digital Network / International Standard Data Network
ISO	International Standards Organization
Interrupt Storm	level-triggered interrupt signal that remains in an asserted state
ITP	Internal Test Pattern
IWM	Intermittent Weak or Missing Jet/s
JBA	Job Based Accounting (Network Accounting)
Jitter	A line of missing or corrupted information in the fast scan direction.
JPEG	Joint Photographic Experts Group file interchange format
kg	kilogram
kHz	kilohertz
Kill All	Routine to return all NVM, including protected NVM, to a virgin state. Factory use only
KO	Key Operator
LAN	Local Area Network
LCD	Liquid Crystal Display
LCDM	Liquid Crystal Display Module
LCS	Line Conditioning Signal

Table 1 Terms, Acronyms and Abbreviations

Term	Description
LCSS	Low Capacity Stapler Stacker
LDAP	Lightweight Directory Access Protocol (allows sharing of corporate phone book information)
LE	Lead edge
LED	Light Emitting Diode
LEF	Long Edge Feed
LETO	Lead Edge Time Out
LG	Legal
Light	Visible part of the electromagnetic spectrum. Consists of waves measure in nanometers (nanometer = 1 millionth of a meter) 700nm correlates to Red on high end and 400nm correlates to violet.
Lightness	Brightness or darkness, determined by wave amplitude.
Line Cross	A line crossing circuit detects the moment when the mains (line) supply crosses the zero volts point. This is a safe moment to switch on a mains operated item, e.g. a heater.
Link Error	Serial communications fault
LOA	Load Object Attributes
Lossy	Files that lose data when compressed (i.e. JPG). When lossy files are restored to their original size pixels are permanently lost.
Low power mode	Print Head (PH) jetstack, PH reservoir, Drum and RaIPH pre-heater are on at a slightly reduced temperature. Other heaters are off.
LPA	Low Pressure Assist. Low pressure applied to print head to allow 'lubrication' of print head with ink for cleaning blade operation
lpi	Lines per inch
LSI	Large Scale Integration
LSL	Low Spec Limit
LT	Letter
LVDS	Low Voltage Differential Signal (noise tolerant) Custom in house protocol - data transmission including video from CBC to IME.
LVPS	Low Voltage Power Supply
Lwr	Lower
LUI	Local user Interface
m	metre
MAC Address	Media Access Code. This is the basic, unique identifier of a networked device. An incoming message is analysed and an address in another form, such as an IP address, is resolved by a lookup table to a MAC address. The message is then directed to, and accepted by the equipment thus identified. It is the burnt-in, hardware address of a NIC.
Matting	the first printed side of a duplex print will have less gloss compared to the second printed side.
Maxwell	IME without many critical subsystems - used for limited testing of sub-systems, not really an IME since no marking can occur. I.e. used for life testing of an engine block components.

Table 1 Terms, Acronyms and Abbreviations

Term	Description
MB	Megabyte (one MB = 1,048,576 bytes = 1024 kilobytes). Mail Box
Mb	Mega bit (one million bits)
MCF	Message Confirmation
Measure head sensitivity	Measures the sensitivity of intensity to voltage and norm clicks, in preparation for running "head to head uniformity".
Mem-Mem	Memory to Memory
Metamerism	Perceived colour changes under varying light sources
MF	Multifunction
MFD	Multi-Function Device
MFLLEN	Mid - Frequency (random) Lines - Edge Noise
MIB	Machine Information Block. SNMP database element
MJ	Modular Jack
mm	millimetre
MMC	Microsoft Management Console
MMR	Modified Modified Read compression
MN	Multi - National
Modem	MOdulator/DEModulator. Hardware unit that converts the 'one' and 'zero' binary values from the computer to two frequencies for transmission over the public telephone network (modulation). It also converts the two frequencies received from the telephone network to the binary values for the computer (demodulation).
Moire	Undesirable dot patterns
Monochrome	Composite black (uses all ink colours - YMCK)
MPB	Media Path Board for paper path, sometimes MPD - Media Path Driver
MPS	Multi-Page Signal
MR	Modified Read compression
MR	Melt Rate
MRD	Machine Resident Diskette
MRC	Modified Read Compression
ms	millisecond
MSI	Multi-Sheet Inserter, also Multi Sheet Input
MSO	Mixed Size Originals
MU	Marking Unit (drawer that contain the PHs and most PH related circuits).
Mud Page	Page of all colours and some combinations to help 'clean' the print head area.
MUT	Marking Unit Test Bed, generally for testing of the marking unit only.
N	Newton
NA	North America
NASG-N	North American Solutions Group (equivalent to XCI)
NASG-S	North American Solutions Group (equivalent to USCO)
NC	Network Controller (equivalent to ESS).
NC	Normal Contrast. Copy contrast setting

Table 1 Terms, Acronyms and Abbreviations

Term	Description
NcCv	Normally closed Check valve
NoCv	Normally open Check valve
NCP	Network Core Protocol
NCR	No Copying Required
NCU	Network Control Unit
NDS	NetWare Domain Services or Novell Directory Services
NDS Context	NetWare Domain Services Context
NDS Tree	NetWare Domain Services Tree
NetBEUI	NetBIOS Extended User Interface. A network device driver or transport protocol that is the transport driver supplied with LAN Manager. It can bind with as many as eight media access control drivers.
NetBIOS	Network Basic Input / Output System. Software developed by IBM that provides the interface between the PC operating system, the I/O bus, and the network. Since its design, NetBIOS has become a de-facto standard.
NGI	Next Generation Infrastructure (new files and mail servers)
NIC	Network Interface Card. Converts the data to a form suitable for transmission and reception. Uses ARP and RARP.
Nm	Newton metre
NOHAD	Noise, Ozone, Heat, Airflow and Dust
Normalization	Term the refers to PHs being fully calibrated for drop mass, intensity etc.
NP	Printer configuration
NRSB	No response to start button
NS	Normal Sharpness. Copy sharpness setting
NSC	Non-Standard Facilities Command
NSF	Non-Standard Facilities
NSS	Non-Standard Set-Up
NSSD	Network. The SESS and CentreWare development team based in Rochester NY. This group is now named CDDU.
NVM	Non-Volatile Memory
NXI	Non Xerox Ink
OA	Open Architecture
OB or O/B	Out Board
OCT	Offsetting Catch Tray
ODIO	On Demand Image Overwrite
OEM	Original Equipment Manufacturer
Offsetting	Ink or coloured regions transferred to the backside of a print during or after duplex printing.
OGM	On Going Maintenance
OHP	Over Head Projection media (transparency)
OOM	Out Of Media
OOP	Out Of Paper

Table 1 Terms, Acronyms and Abbreviations

Term	Description
OpCo	Operating Company
OSA	Online support Assistant
OSCG	Office Systems Component Group
PABX	Private Automatic Branch Exchange
PC	Personal Computer
PC Fax	Personal Computer Fax
PCI	Peripheral Component Interconnect - Internal BUS used for communications between components and boards within CBC
PCI	Personal Computer Interface
PCL	Printer Control Language
PCMCIA	Personal Computer Memory Card International Association
PCS	Profile Connection Space - converts colour data as it moves from one device to the next to stay within the devices colour space
PCT	Product Certification Test, manufacturing line term
PD	Process Direction
PDB	Power Distribution Board
PDF	Adobe Acrobat Portable Document Format
PDL	Page Description Language
Pels	Picture Data (Pixel)
PEST	Print Engine Self Test, monitors for shorts and opens via current load parameters
PFM	Paper Feed Module
PFP	Paper Feed Platform
PIN	Procedural Interrupt Negative
PIN	Personal Identification Number
ping	Packet InterNet Groper. Tool to test connections between nodes by sending and returning test data.
PIP	Procedural Interrupt Positive
Pixel Picking	The ability to the transfixing system to transfer pixels from the drum to the media. Variables that affect pixel picking are ink properties, image topography, paper porosity, temperature, nip pressure and adequate release agent on the drum.
Pixel Sharing or Pixel Borrowing	Method used to hide missing jets by 'borrowing' pixels from nearest jet- basically try to fill the void with neighboring jets without doing jet substitution which requires an additional pass.
PLD	Programmable Logic Device
PJL	Printed Job Language. Hewlett Packard page description language.
PMC	Programme Management Committee
POPO	Power Off Power On
POO or P of O	Principles of Operation
POST	Power On Self Test
PPC	Power PC. A EPROM manufacturer

Table 1 Terms, Acronyms and Abbreviations

Term	Description
PPD	Postscript Printer Description. A PPD file is a simple formatted text file that contains a description of the printers features and the corresponding PostScript 'code' needed to activate each feature. Apple LaserWrite drivers and application programs such as Adobe PageMaker can use PPD files. With a OOD file, many of the printing features of a network printer can be made available to users. However advanced features such as LAN Fax, Accounting and Exception Page Programming cannot be provided.
PPD Minidrivers	PPD minidrivers are available in Windows operating systems (from Windows 95 onwards). With these, a Xerox - supplied PPD file is used in conjunction with an operating system supplied driver to create a Post-Script driver tailored for a specific device. In windows 95/98, a driver provided by this method has lamentations and not all devices features can be made available to the user. With Windows NT 4 and Windows 2000, it is possible to make more features available by using a user interface rendering plug - in. In this document, if the driver is to be provided with If no plug-ins are provided, then it is called a standard minidriver.
PPHI	Problems Per Hundred Installs
PPI	Post Process Inserter - capable of inserting sheets (i.e. cover stock or coloured sheets to mark boundaries within the output set)
PPM	Prints per minute / Parts Per Million
PPR	Partial page Request
pps	Partial Page Signal / pulses per second
PPS	Product Performance Specification
PQ	Print Quality - PQ is the post-pixel placement, i.e. transfix / mechanical which differs from IQ which is pre pixel placement.
PQM	Print Quality Maintenance
PRD	Product Requirements Document
PRI-EOM	Procedure Interrupt-EOM
PRI-EOP	Procedure Interrupt-EOP
PRI-MPS	Procedure Interrupt-MPS
PSM1	Power Save Mode 1 (low power mode)
PSM 3	Power Save Mode 3 (sleep mode)
PS	Post Script
PS	Power Supply
PSTN	Private Switched Telephone Network
PSW	Portable Service Workstation
PTC	Positive Temp Coefficient (current limiting/protective) - as heat goes up resistance goes up and current goes down - safety feature.
PTT	Post, Telephone, Telegraph (national public utilities)
PVC	Poly Vinyl Chloride
PVT	Product Verification Test
PWB	Printed Wiring Board
PWB A	Printed Wiring Board Assembly

Table 1 Terms, Acronyms and Abbreviations

Term	Description
PWS	Portable Work Station
RaLPH	Registration and Long Pre Heater (to warm and register the media prior to meeting the image on the Drum) - detects and corrects skew to within 2.5 Millie-radians. Has three sets of rollers - each set is selected and used only for certain widths of paper / throughput (i.e. when running small throughput you would only use the inner pair). The RaLPH is referred to as the Registration / Preheat assembly in the service documentation.
RAM	Random Access Memory
RARP	Reverse Address Resolution. Reverse of ARP. Converts a MAC address to an IP address. The document centre resolves its address using RARP. See also MAC, NIC and ARP.
RBT	Ring Back Tone
RCA	Remote Customer Assistance
RDT	Remote Data Transfer
R/E	Reduction / Enlargement
REN	Ringer Equivalence Number
Reset head sensitivity data	Undo the effects of "Measure head sensitivity" and "Head to head uniformity"
Resolution	Scanning resolution - generally in PPI or pixels per inch
Reverse Text	Text that is created by printing an ink field around the text letters, leaving the text visible as the media colour (generally white media).
RGA	Tool for projecting reliability
RGB	Red/Green/Blue - colours additive primaries - used by emissive devices.
RPC	Remote Procedure Call
RH	Relative humidity
RIP	Raster Image Processing - Software creates four separate maps or patterns of dots called Raster images for each page of output - one for each CMYK - called colour separations
RIS	Raster Input Scanner
RJ 45	Phone type network connector
RM	Requirements Management
RML	Recommended Media List
RMS	Root Mean Square (AC effective voltage)
RNR	Receive Not Ready
RO	Regional Operations
Roll	Alignment of the print heads (levelling direction)
Roll Off	Refers to transfix roller rolling off the trailing edge (presently maintains transfix position if in burst mode but releases in say single print mode)
Roll On	Refers to transfix roller rolling over the leading edge (presently at 90% of normal pressure) changes somewhat in burst mode.
Roller Ghosting	Inherent to product - generally on duplex - contributors are oiling and transfix roller
ROM	Read Only Memory

Table 1 Terms, Acronyms and Abbreviations

Term	Description
ROS	Raster Output Scanner
Roving Jet	Refers to random missing jets - which the root cause is largely unknown.
RR	Receive Ready
RS-232, RS-423, RS-422, RS-485	Series of standards for serial communication of data by wire. RS-232 operates at 20 kbits/s, RS-423 operates at 100 kbits/s, RS-422 and RS-485 operate at 10 Mbits / s. See FireWire and USB.
RTF	Run Test Fixture
RTN	Retrain Negative
RTP	Retrain Positive
RTS	Request To Send
Rx	Receive
Runout	Concentricity inconsistency in the drum - which may result in PQ defects unless the IOD fully and correctly compensates for the runout. Runout as a defect may look like a bump in a line or a non circular circle.
S2E	Scan-to-E-mail
S2F	Scan-to-File
S2X	Scan-to-Export
SA	Systems Administration
SAD	Solid Area Density
SAKO	Systems Administration Key Operator
SAP	Service Advertising Protocol. a network device will broadcast its capabilities onto the network at a defined intervals.
SAF	Safety
SAP	Service Advertising Protocol
SAR	Semi-Active Retard feeder
Saturation	Colours vividness or dullness. Highly saturated are bright colours whereas low saturation are close to grey.
SBC	Single Board Controller
SCD	Software Compatibility Database
SCM	Software Configuration Management
SCN	Specification Change Notice
SCR	Software Change Request
Screen Frequency	Distance between each line of pixels or dots in a raster image. Also known as screen ruling or line screen.
SCSI	Small computer Systems Interface
SCT	Simple Catch Tray
S/D	Shut Down
SDK	Software Development Kit
SDP	Software Development Plan
SDR	Shut Down Rate
SDRAM	Static Dynamic Remote Access Memory

Table 1 Terms, Acronyms and Abbreviations

Term	Description
Server Fax	A fax system that uses a remote Fax server. Faxes transmit as a Scan to File job sent to the server. Fax receive as print jobs submitted to the Connection Device.
Service Loop	Electrical to MU - we would generally say umbilical but we do not want to confuse with umbilicals so this electrical harnessing is called the 'service loop'
SEF	Short Edge Feed
SESS	Strategic Electronic Sub-System
SFWA	Staggered Full Width Array (Four print heads are used to get the full printing width 1 and 3 are offset from 2 and 4)
SIM	Scanner Input Module
SIP	Scanning and Image Processing
SIR	Standard Image Reduction
SKU	Stock Keeping Unit
SLP	Service Location Protocol (finds servers)
SM	Scheduled Maintenance
SIM card	Subscriber Identity Module
SMART	Systematic Material Acquisition Release Technique
SMB	Server Message Block. Microsoft Server / Client Communications protocol
SMEPTIC	Size Media Environment Product Time usage Image customer
SMP1	Service Maintenance Pack 1 (contains a software package)
SPAR	Software Problem Action Request
SNMP	Simple Network Management Protocol
Snr	3 Secondary colours solid fill colours the cyan
SOD	System Operating Description
SOPM	Scan Once Print Multiple
Spectral Data	Pattern of wavelengths leaving an object - the colour's "fingerprint" - reflectance value. Can be plotted - wavelength = horizontal axis and reflectance intensity the vertical axis. Has several advantages over tristimulus - it is the only true description of the actual colour. Independent of device and illuminant. Measures composition of light reflected from object before interpreted by a viewer or device.
Spectrophotometer	Used to measure colour - plots its spectral curve (uses multiple wavelengths) Spectral data device. Amount of light energy reflected from an object at several intervals along the visible spectrum. Can be used to translate into colourimetric or desitometric data. Most accurate, useful and flexible instrument available.
SPL	Sound Pressure Level
SPP	Short Paper Path
spi	Spots per inch
SPID	Service Profile Identification
SQA	Software Quality Assurance

Table 1 Terms, Acronyms and Abbreviations

Term	Description
Squirm	IQ Defect - Related to transfix roller
SR	Service Representative
SRAM	Static Random Access Memory
SRC	Software Requirements Change
SS or S/S	Sub System
ST	System Terminal Device. Multi-functional device as defined by Energy Star (includes DC / NC and DC / NC / Fax)
Status Region	The three line display at the top of the user interface. SR1 - the top line displays critical information, e.g. machine stopped - call for service. SR2 - the middle line displays middle ranking information, e.g. action needed to prevent stoppage. SR3 - the bottom line displays non critical information, e.g. empty paper trays or low ink levels.
Stitch	The front to back alignment of the print heads for print quality (determined by IOD)
STP	Standard Test Pattern
STS	Side To Side, paper width sensors
STS	Symptom to Solution
SW	Switch
SW or S/W	Software
SWL	Sound Power Level
system kernel	Minimal operating system
T & M	Time and Materials
TAR	Take away Roller
TBC	To Be Confirmed
TBD	To Be Defined
TCP / IP	Transmission Control Protocol / Internet Protocol
TE	Trail Edge
Template	A collection of Scan to File attributes that can be conveniently re-used.
TEC	Total Electricity Consumption
TEI	Terminal Endpoint Identifier
TETO	Trail Edge Time Out
TFD	Time First Drip
TIFF	Tagged Image File Format
TIFF FX	TIFF Fax eXtended
TIFFX	Tagged Image File Format - for internet FAX
TOF	Transfix On Fly
TP	Test Point
TPM	Technical Programme Manager

Table 1 Terms, Acronyms and Abbreviations

Term	Description
Transfix Process	The process of transferring and adhering ink from the print drum to media by means of passing the media between the nip formed by the imaged print drum and a roller. During the process, the ink is spread out and is given a flat and smooth surface.
Transfix Stripper	Mainly for light media and low ink conditions - mylar and is always loaded.
Transmissive LCD	Liquid Crystal Display lit from the back
Trapping	Overlapping colours slightly so that a small degree of mis-registration does not cause gaps where the paper colour shows through.
TRC	Tonal Reproduction Curve
TRC Generation	Measures the relative intensity between jets at area coverages less than 100%. If needed will adjust the image density for improvement.
Tri-Folder	Output device that creates C and Z folds
Tristimulus	Three dimensional colour values. Must define the illuminance as well.
TSH	Technical Service Hours
TSI	Transmit Subscriber Identification
TTM	Time To Market for Three Tray Module (paper trays)
TTY	Teletype Terminal
TUI	Textual User Interface
Tx	Transmit
UCR	Under Cover Removal. When a hue requires all three CMY colours for creation, the printers RIP may use UCR to remove a portion of the three colours from the formula = black and replace with pure black
UGD	An upgrade file, i.e. filename.ugd
UART	Universal Asynchronous Receiver Transmitter
UDP	User Datagram Protocol
UI	User Interface (display screen)
UK	United Kingdom
UM	Unscheduled Maintenance
UMR	Unscheduled Maintenance Rate
UNK	Unknown - generally in reference to why a Purge has occurred.
UP	User Profile - (i.e. average coverage, how many legal pages, prints vs., copies to finisher main tray, to finisher aux tray.)
URL	Universal Resource Locator
USB	Universal Serial Bus. High speed successor to parallel port for local device communications. Operates at 12 Mbits / s. See FireWire and RS-232.
USCO	United States Customer Operations
USL	Upper Spec Limit
UTP	Un-shielded Twisted Pair
V.17 / V.29 / V.34	Modem standards
VALO	Value Added Logistic Organization - machines configured prior to shipment to customer.

Table 1 Terms, Acronyms and Abbreviations

Term	Description
Value	Level of colours 'brightness'.
VAR	Value Added Reseller
Vector Fonts	Composed of outlines of letters - shapes defined by formulas. Are scalable - meaning they can be sized up or down w/o deterioration.
VGA	Video Graphics Array
VOC	Visible Orifice Contamination (Print Head term) - multiple meanings for the acronym, must be deduced by context in which it is being used.
VOC	Volatile Organic Compound
VOC	Voice Of Customer
VOIP	Voice Over Internet Protocol
Voyager	Program utilized in manufacturing to assure 4 print heads act and produce a copy as if there were one. Utilizes a scanner to read output.
VPR	Vector Pattern Replacement - improves image quality.
VxWorks	VxWorks is a Unix-like real time operating system.
WAG	Term used to define what the paper does in RaLPH - paper is often skewed twice to align front to rear and remove skew.
WAP	Warm Auto Purge - automatic attempt to recover IWM/CWM jets
Wave Amp	Drives print head piezo electrical devices - these devices are what activates an individual colour jet in the print head - also called Quad Wave Amp
WGC	Welwyn Garden City (England)
WEB UI	CentreWare Internet Services
Widget	JAVA term for shape and shading of buttons on UI display for features / command buttons - etc.
WINS	Window Internet Name Service
WMP	Warm Manual Purge (user requested purge)
Wrinkles	Most likely transfix roller / pressure related
WYSIWYG	What You See Is What You Get
XAP	Xerox Asia Pacific
X - Axis	Cross Process direction (front to back)
X- Axis Direction on Print	The X - axis direction on the print is along the length of the drum. This is also the direction that the print head traverses during printing.
XCL	Xerox Canada Limited
XCFI	Xerox Common Management Interface
XCRU	Xerographic CRU (also known as XRU)
XE	Xerox Europe
XI	Xerox Initiated
XL	Xerox Limited
XLA	Xerox Latin America
XOG	Xerox Office Group
XRU	Xerographic Replacement Unit
XSA	Xerox Standard Accounting

Table 1 Terms, Acronyms and Abbreviations

Term	Description
XUL	Xerox Unique Login enables use of the xerox corporate directory
Y - Axis	Process direction (left side to right side or right side to left side)
Y dot position	Measures the Y dot position of each jet. If needed, it will adjust the firing time for improvement.
Y runoff	Compensates for variances in diameter of a drum. Computed every 6 degrees. If this value is incorrect and inboard to outboard. Line may have steps in it.
Y - axis Direction on Print	The Y axis direction on the print is in the direction of drum rotation.
Ydp	Relates to drop mass (measured at the Print Head via manual setup - but is a calculated value vs. the actual drop mass measured at PH normalization.
yNorm	Adjusts the norm values in the PH to correct y dot positions difference printer to printer. This make horizontal lines not be jagged. Timing of each jet.
Z - Axis	Up and down direction (generally refers to movement or direction)

GP 41 How to Configure the PWS to Ping a Device

Purpose

To configure the PWS to ping a device on a network.

Procedure

Perform the following:

1. Set the IP address of the PWS one digit higher or lower than the device to be pinged. For example, if the IP address of the device is 192.168.10.15, set the PWS to 192.168.10.14 or 192.168.10.16. To set the IP address of the PWS, refer to [GP 42](#).
2. Set the subnet mask of the PWS the same as the device to be pinged.
3. On the PWS, Select Start, then Run.
4. In the Run dialog box, type cmd.
5. Select OK. A command window will open.
6. In the command window, type ping and the address of the device. Refer to number 1 in [Figure 1](#).
7. If the ping command is successful, a reply from the device will be received. Refer to number 2 in [Figure 1](#).

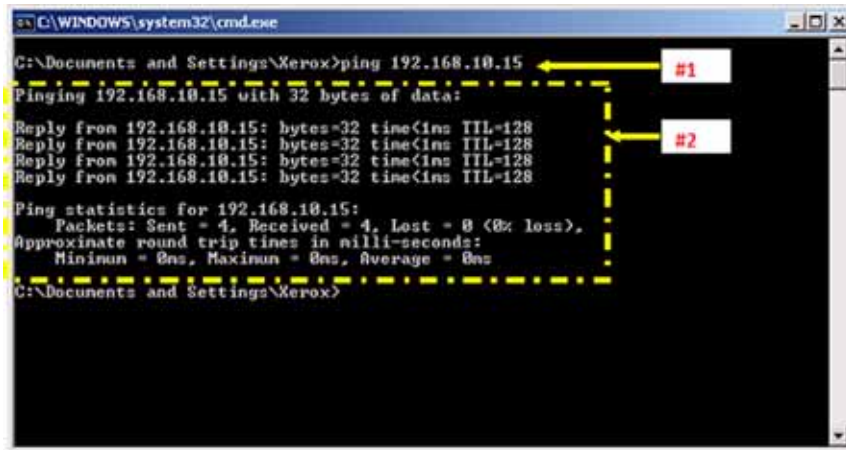

Figure 1 Successful ping command

8. If the ping command is unsuccessful, a timed out message will be received, [Figure 2](#).

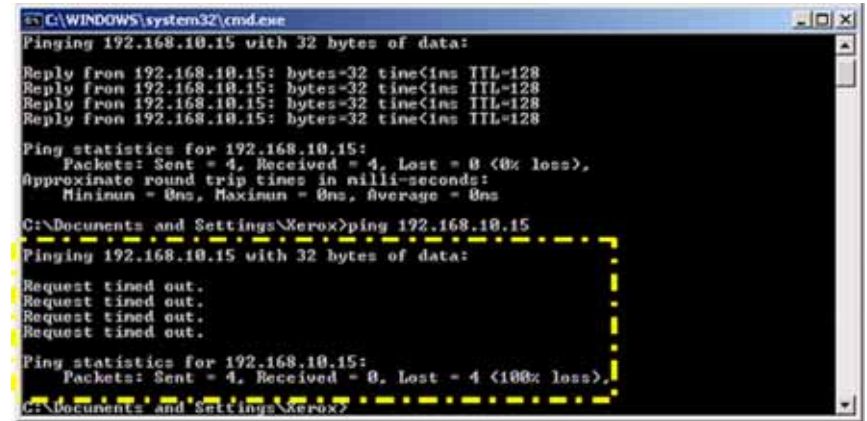

Figure 2 Unsuccessful ping command

U-1-1669-A

U-1-1670-A

GP 42 How to Set the IP Address of the PWS

Purpose

To set the IP address of the PWS.

Procedure

NOTE: This procedure applies to the Windows XP operating system.

Perform the following:

1. On the PWS, right click on the My Network Places desktop icon or select Start, then My Network Places. Select Properties from the menu. The Network and Dial-up Connections window will open.
2. Right click on Local Area Connection icon, then select Properties. The Local Area Connection Properties window will open.
3. Highlight Internet Protocol (TCP/IP), then select Properties, refer to [Figure 1](#). The Internet Protocol (TCP/IP) Properties window will open.

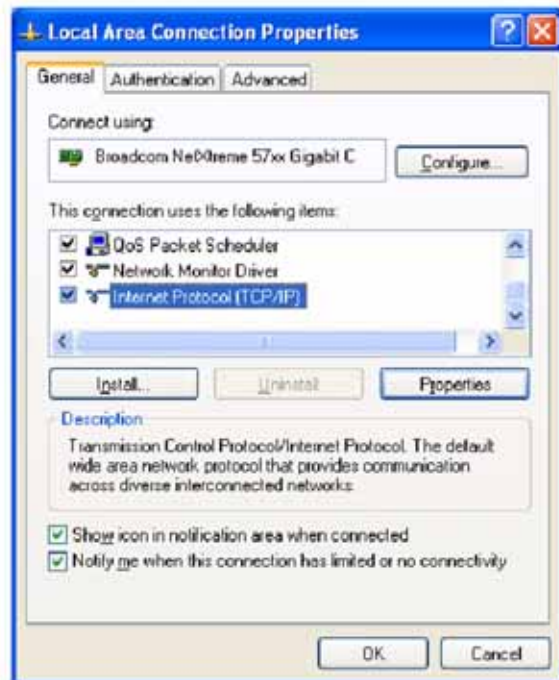

Figure 1 Properties window

U-1-1671-A

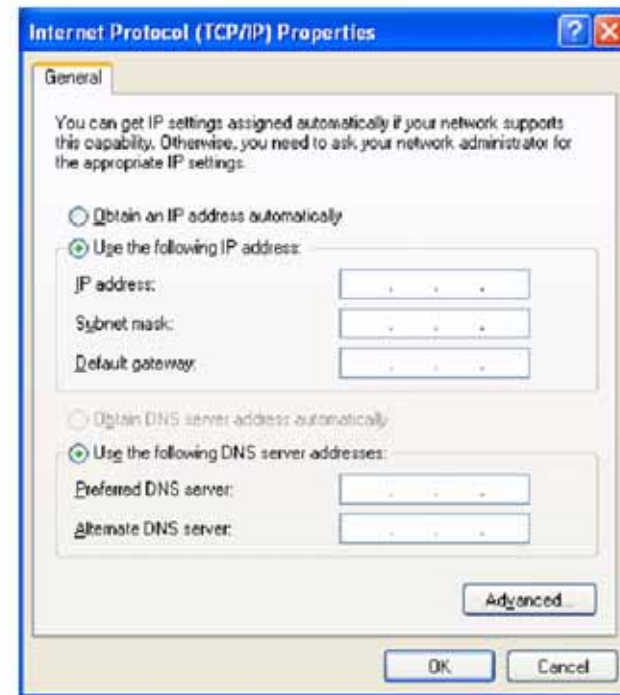

Figure 2 Properties window

U-1-1672-A

4. Select Use the following IP address. Enter the IP address and Subnet mask, [Figure 2](#).

GP 43 How to Change Ethernet Speed

Purpose

To change the machines ethernet speed.

Procedure

Perform the following:

1. Enter Customer Administration Tools, GP 5.
2. Press the Machine Status button.
3. Select the Tools tab.
4. Select Network Settings.
5. Select Advanced Settings.
6. Select Continue
7. Select Ethernet Physical Media.
8. Select the speed, then Save.
9. Select Close.
10. Log out of Customer Administration Tools.

GP 44 How to Disable the Firewall of the PWS

Purpose

To disable the firewall of the PWS.

Procedure

NOTE: This procedure applies to the Windows XP operating system.

Perform the following:

1. On the PWS, right click on the My Network Places desktop icon or select Start, then My Network Places. Select Properties from the menu. The Network and Dial-up Connections window will open.
2. Check if the firewall is enabled or disabled. If the Local Area Connection icon has a padlock symbol, the firewall is enabled, Figure 1. If the firewall is enabled, continue with this procedure.

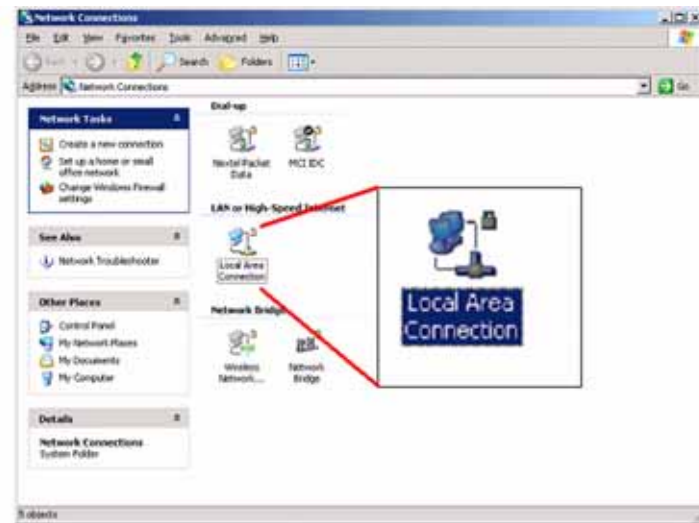

U-1-1673-A

Figure 1 Padlock symbol

3. Right click on Local Area Connection icon, then select Properties. The Local Area Connection Properties window will open, Figure 2.

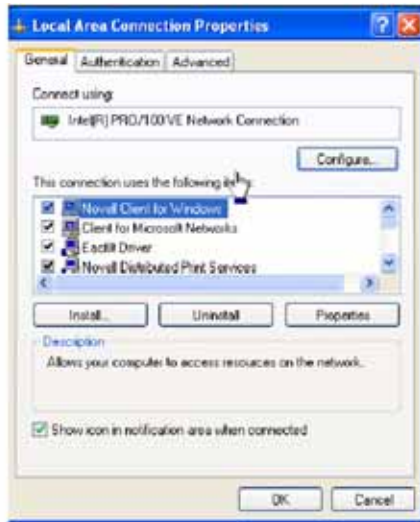

Figure 2 Properties window

U-1-1674-A



Figure 4 Settings button

U-1-1676-A

4. Select the Advanced tab, then the Settings button, Figure 3. If available, uncheck Protect my computer and network by limiting or preventing access to the computer from the Internet. Select OK. The Windows Firewall window will open.
6. Close all open windows.
7. Disable any other Firewall software or utilities that may be running.



Figure 3 Settings button

U-1-1675-A

5. Select the Off (not recommended) radio button to disable the windows firewall, Figure 4.

GP 45 How to Check the Battery on the NVM Module PWB

Purpose

To correctly check the battery on the NVM module PWB.

Procedure

WARNING

Switch off the electricity to the machine. Refer to GP 14. Disconnect the power cord from the customer supply while performing tasks that do not need electricity. Electricity can cause death or injury. Moving parts can cause injury.

CAUTION

Ensure that ESD procedures are observed during the removal and installation of the NVM module PWB.



Figure 1 ESD Symbol

1. Remove the NVM module PWB and battery assembly, REP 3.9.
2. Use a multimeter to check the voltage of the battery while it is installed on the NVM module PWB, Figure 2. The nominal voltage range of an installed battery is between 2.7 volts and 2.9 volts.
3. Install a new battery if the multimeter reading is lower than 2.7 volts. A multimeter reading higher than 2.9 volts indicates that the battery is unloaded. Check that the battery is located correctly on the NVM module PWB.

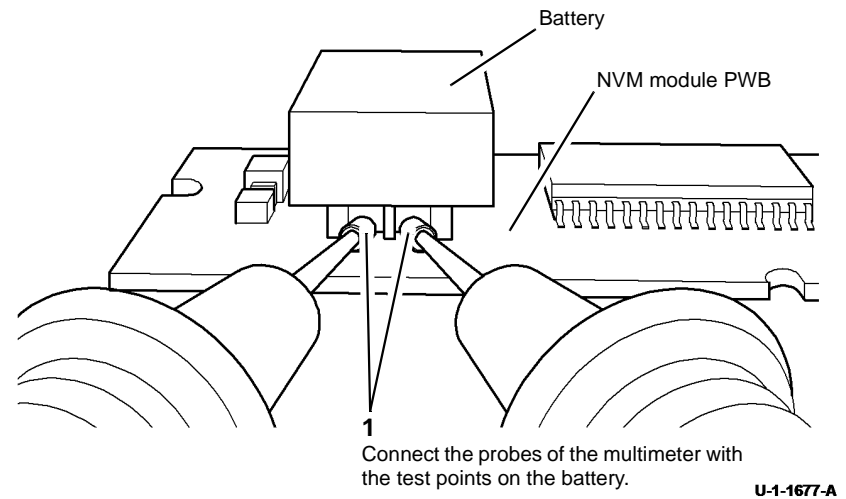

Figure 2 Battery test points

GP 46 How to Identify the Different Printhead Connectors

Purpose

To identify both types of connector that can be used to connect the video and wave amp cables to the printheads.

Description

Two types of connector, type A and type B, can be used to secure the video and wave amp cables to the printheads. Type A cables can only be used with type A printheads and type B cables with type B printheads. Both types of cables and printheads may be present in the machine.

To identify both types of connector, refer to:

- Type A
- Type B

Type A

Type A connectors are shown in [Figure 1](#). They are secured to the printhead by cable clips.

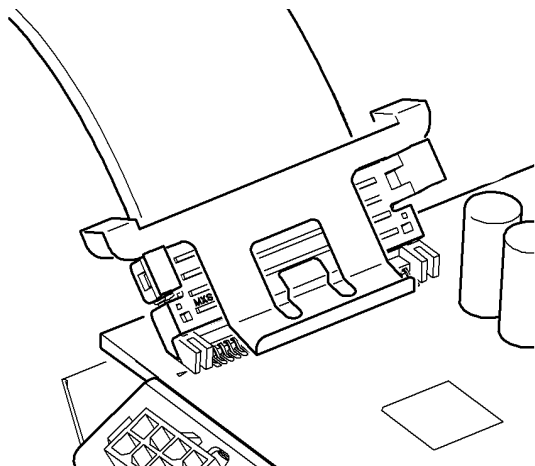

U-1-1679-A

Figure 1 Type A

Type B

Type B connectors are shown in [Figure 2](#). They are secured to the printheads by a latch mechanism.

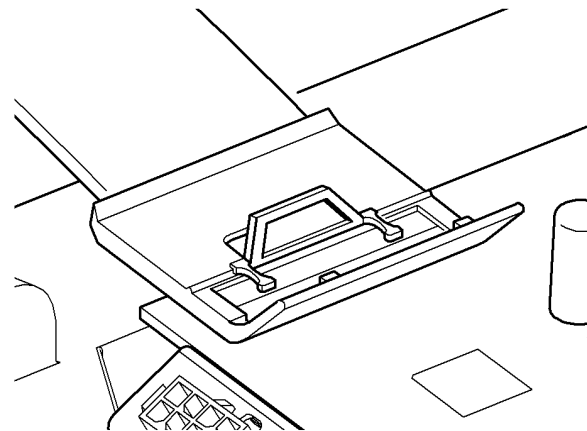

U-1-1680-A

Figure 2 Type B

dC103 Billing Plan

Purpose

To change the tiered billing plan.

Procedure

Check that the correct SIM card is installed for the correct machine configuration, go to [GP 19](#) Machine SIM Card Matrix.

1. Enter Service Mode, [GP 1](#).
2. Select the Maintenance tab.
3. Select dC103 Billing Plan.
4. Enter a valid billing plan authorization code.
5. Follow the on screen instructions.
6. Select Close to exit the routine.
7. Select Call Closeout to exit Service Mode.
8. Switch Off the machine and Switch On the machine, [GP 14](#).

To restore a customer's billing plan, use the following codes.

- To restore a machine to a 1 tier billing plan use code 1791.
- To restore a machine to a 2 tier billing plan use code 2487.
- To restore a machine to a 3 tier billing plan use code 3258.

NOTE: *These codes may be used to restore a customers billing plan if it should become corrupted. To change a customers billing plan will require the Billing Plan Conversion Kit which the customer will need to order from the Xerox sales department.*

dC104 Usage Counters

Purpose

To display the various usage counters.

Procedure

1. Enter Service Mode, [GP 1](#).
2. Select the Service Info tab.
3. Select dC104 Usage Counters.
4. Select the relevant counters from the pull down menu.
5. Select Close to exit the routine.
6. Select Call Closeout to exit Service Mode.

dC108 Software Version

Purpose

To identify the version of the installed software on all major modules.

Procedure

1. Enter Service Mode, [GP 1](#).
2. Select the Service Info tab.
3. Select dC108 Software Versions.

The dC108 Software Versions screen will display the software and version numbers installed on the machine.

4. Select Close to exit the routine.
5. Select Call Closeout to exit Service Mode.

dC113 Fast Time to Ready

Purpose

dC113 Fast Time to Ready avoids waiting for the IME to heat-up the ink system.

When dC113 is selected the heaters will still come up to printing temperature but functions that would not normally be enabled are made available before printing temperature is reached.

Procedure

1. Enter Service Mode, [GP 1](#).
2. Select the Service Info tab.
3. Select dC113 Fast Time to Ready. The UI shows The machine is offline.

NOTE: dC113 Fast Time to Ready Mode has the following characteristics:

- When dC113 is selected, no routine or further settings are displayed.
- Selecting dC113 after the machine has warmed up will have no effect on the machine except that the dC113 list item will become greyed out. When the heaters are up to temperature the feature has no function.
- When dC113 has been selected the warming up message is no longer displayed. When Service Mode is exited the status region displays a message indicating that scanning and printing are available.
- dC113 can only be selected once for each power on cycle and once selected it cannot be cancelled.

4. Select Close to exit the routine.
5. Select Call Closeout to exit Service Mode.

dC120 Fault Counters

Purpose

To view the faults raised by the machine. dC120 Fault Counters records the number of occurrences of a fault, allows the counters to be sorted by occurrences and allows a specific fault to be found by chain.

Procedure

1. Enter Service Mode, [GP 1](#).
2. Select the Service Info tab.
3. Select dC120 Fault Counters.

NOTE: *There will be a delay while the machine retrieves the fault counter data.*

4. A list of faults that have occurred on the machine are displayed.
 - The list can be sorted by number of occurrences and to include zero occurrences. Selecting these options will resort the list upon selection.

NOTE: *When selecting Zero Occurrences there may be a delay as the list is reconfigured.*

- The list can be sorted by chain.
 - a. Select the chain field.
 - b. Enter a 3 digit chain number on the numeric keypad.
 - c. Select Find.
5. Select Close to exit the routine.
 6. Select Call Closeout to exit Service Mode.

dC122 Fault History

Purpose

To view shutdown faults in chronological order and more detail than is shown in [dC120](#) Fault Counters.

Procedure

1. Enter Service Mode, [GP 1](#).
2. Select the Service Info tab.
3. Select dC122 Fault History.
4. The dC122 Fault History screen is displayed with the last 40 faults shown in chronological order. The most recent fault is at the top of the list.
5. To observe the details of the fault, select the fault and select Details on the pop-up window. Select Close to return to the fault table.
6. Select Close to exit the routine.
7. Select Call Closeout to exit Service Mode.

dC123 PEST Fault History

Purpose

To display the Print Engine Self Test (PEST) Fault History. PEST errors identify all faults (categorized as hard PEST faults) and anomalies (categorized as soft PEST faults).

- Hard PEST faults are defined as faults that stop the machine.
- Soft PEST faults are defined as faults that do not stop the machine. These might be components that are operational but not within expected limits. The machine will operate but the change in the condition of the component might help identify changes or potential faults in the machine.
- The PEST fault history grows upwards. The top entry is the latest entry.
- Each time the machine starts an entry is entered into the PEST fault history. The entry format is XX-YYY.
 - XX is a numerical chain number.
 - YYY is a numerical chain link.
- 99-000 is a delimiter that indicates the start of the PEST. If no faults are detected 99-000 is the only entry in the PEST fault history for that start up.
- If there are no faults the next entry will be 99-000 indicating the start of the previous PEST.
- If faults are detected they are entered in the fault history above the 99-000 for the start of the PEST.
- Soft faults are listed directly above the 99-000 start of PEST entry.
- Hard faults are listed above the soft faults with a delimiter of 99-999 between the hard and soft faults.

Examples

See [Table 1](#), [Table 2](#) and [Table 3](#).

Table 1 PEST fault history with no soft or hard faults

99-000	Start of latest PEST
99-000	Start of previous PEST
99-000	Start of previous PEST
99-000	Start of previous PEST

Table 2 PEST fault history with soft faults only

99-213	Soft fault
99-442	Soft fault
99-230	Soft fault
99-000	Start of latest PEST
99-000	Start of previous PEST

Table 3 PEST fault history with soft and hard faults

99-365	Hard fault
99-283	Hard fault
99-272	Hard fault
99-999	Separator indicating start of Hard Faults list

Table 3 PEST fault history with soft and hard faults

99-213	Soft fault
99-442	Soft fault
99-230	Soft fault
99-000	Start of latest PEST
99-000	Start of previous PEST

Procedure

1. Enter Service Mode, [GP 1](#).
2. Select the Service Info tab.
3. Select dC123 PEST Fault History.
The dC123 PEST Fault History is displayed.
4. Select Close to exit the routine.
5. Select Call Closeout to exit Service Mode.

dC131 NVM Read/Write

Purpose

To review and modify values within the machine configuration and control parameters stored in NVM.

NOTE: This does not include customer administration or accounting data, these are accessible from the billing facility, refer to the User Guide.

Description

Each NVM item is identified using an NVM ID and NVM index numbers in the form XXX-XXX, where XXX- is the ID prefix, and -XXX is the NVM ID. Index numbers range from 0 to 999. For example 441-001. Refer to [GP 2](#) Fault Codes and History Files.

Procedure

1. Save the NVM to disk, refer to NVM Save and Restore, [dC361](#).
2. Enter Service Mode, [GP 1](#).
3. Select the Adjustments tab.
4. Select dC131 NVM Read/Write.
 - To read NVM:
 1. Enter the required 3 digit NVM ID in the first field.
 2. Enter the NVM Index in the second field.
 3. Select Read.
 4. Use the Up/Down arrows to move between memory locations.
 - To write NVM:
 1. Enter the required 3 digit NVM ID in the first field.
 2. Enter the NVM Index in the second field.
 3. Enter a new value in the field beneath the heading 'Value of xxxx' where xxxx is the description of the NVM location.

NOTE: Select +/- to switch between positive and negative values.
4. Select write.

Refer to the tables that follow for NVM locations and parameters:

- NVM Tables for the HVF, IIT and IOT (IME) refer to [NVM Read / Write Tables](#).

NOTE: The Edoc CD must be in the CD drive to use the link below.

- For fax NVM tables [Refer to Fax Document](#)

When NVM values have been changed, exit Service Mode, switch off the machine, then switch on the machine, [GP 14](#).

NOTE: If the NVM default characters exceed 10 characters only the first eight characters are displayed in the list. The full string is displayed in the Read/Write window.

NOTE: The CSE cannot read or modify any NVM that contains customer administrative or accounting data.

NVM Read / Write Tables

1. Refer to the following for NVM parameters:
 - HVF NVM ID 12-xxx, [Table 1](#)
 - IIT DADH NVM ID 800-xxx, [Table 2](#)
 - IOT NVM (IME) ID Range 400 to 439-xxx, [Table 3](#)
 - IOT NVM (IME) ID Range 440 to 459-xxx, [Table 4](#)
 - IOT NVM (IME) ID Range 460 to 470-xxx, [Table 5](#)
 - IOT NVM (IME) ID Range 489 to 499-xxx, [Table 6](#)
 - CCS NVM ID 600-xxx, [Table 7](#)
 - CCS NVM ID 602-xxx, [Table 8](#)
 - CCS NVM ID 603-xxx, [Table 9](#)
 - CCS NVM ID 604-001 to 604-299, [Table 10](#)
 - CCS NVM ID 604-300 to 604-656, [Table 11](#)
 - CCS NVM ID 604-657 to 604-900, [Table 12](#)
 - CCS NVM ID 605-xxx, [Table 13](#)
 - CCS NVM ID 606-001 to 606-269, [Table 14](#)
 - CCS NVM ID 606-270 to 606-999, [Table 15](#)
 - CCS NVM ID 607-xxx, [Table 16](#)
 - CCS NVM ID 608-xxx, [Table 17](#)
 - CCS NVM ID 610-xxx, [Table 18](#)
 - CCS NVM ID 612-xxx, [Table 19](#)
 - CCS NVM ID 616-xxx, [Table 20](#)
 - CCS NVM ID 617-xxx, [Table 21](#)
 - CCS NVM ID 620-001 to 620-099, [Table 22](#)
 - CCS NVM ID 620-100 to 620-199, [Table 23](#)
 - CCS NVM ID 620-200 to 620-299, [Table 24](#)
 - CCS NVM ID 620-300 to 620-399, [Table 25](#)
 - CCS NVM ID 620-400 to 620-499, [Table 26](#)
 - CCS NVM ID 620-500 to 620-560, [Table 27](#)
 - CCS NVM ID 621-xxx, [Table 28](#)
 - CCS NVM ID 625-xxx, [Table 29](#)
 - CCS NVM ID 633-xxx, [Table 30](#)
 - CCS NVM ID 641-xxx, [Table 31](#)
 - CCS NVM ID 648-xxx, [Table 32](#)
 - CCS NVM ID 649-xxx, [Table 33](#)
 - CCS NVM ID 652-xxx, [Table 34](#)
 - CCS NVM ID 656-xxx, [Table 35](#)
 - CCS NVM ID 657-xxx, [Table 36](#)
 - CCS NVM ID 658-xxx, [Table 37](#)

- CCS NVM ID 665-xxx, [Table 38](#)
- CCS NVM ID 671-xxx, [Table 39](#)
- CCS NVM ID 672-xxx, [Table 40](#)
- CCS NVM ID 673-xxx, [Table 41](#)
- CCS NVM ID 674-xxx, [Table 42](#)

Table 1 HVF NVM ID 12-xxx

NVM ID	NVM Name	NVM Description	Settings	Default
12-003	BookMkrCompile-Offset	Used to adjust the compiler position of the booklet maker back stop to receive paper.	0.1137 mm / step (100 = mid position) Range = 0 to 200	100
12-004	BookMkrStaple-Offset	Used to adjust the staple and fold position (together), relative to the Lead Edge of the sheets	0.1137 mm / step (100 = mid position) Range = 0 to 200	100
12-005	BookMkrFoldOffset	Used to adjust the fold only, relative to the Lead Edge of the sheets	0.1137 mm / step (100 = mid position) Range = 0 to 200	100
12-006	BookMkrTamp-pRdyOffset	Used to adjust the booklet tamping ready position. (Sets home to ready position)	0.265 mm / step (100 = mid position) Range = 0 to 200	100
12-009	BookMkrTriFold-CFold	Used to position upper tri-fold. Moves fold relative to lead edge of C Fold.	0.1137 mm / step (40 = mid position) Range = 60 to 140	100
12-010	BookMkrTriFoldZ-Fold	Used to position upper tri-fold. Moves fold relative to lead edge of Z Fold.	0.1137 mm / step (40 = mid position) Range = 60 to 140	100
12-011	BookMkrTriFold-Deskew	Used to adjust the amount of deskew for the 2nd fold in a tri-fold by varying the amount of buckle length in registration for the paper entering tri-folder	1.745 mm / step Range = 90 to 110	100
12-012	BookMkrStaple-OffsetM	Used to control the staple offset position for 8.5 x 13 and 8.5 x 14 inch	0.1137 mm / step (100 = mid position) Range = 0 to 200	100
12-013	BookMkrStaple-OffsetL	Used to control the staple offset position for 11 x 17 inch and A3	0.1137 mm / step (100 = mid position) Range = 0 to 200	100

Table 2 IIT DADH NVM ID 800-xxx

NVM ID	NVM Name	NVM Description	Settings	Default
800-005	DADH LE Hotline	DADH LE hot line	Adj ± 8 mm (increments 0.1 mm) Range = 0 to 160	90

Table 2 IIT DADH NVM ID 800-xxx

NVM ID	NVM Name	NVM Description	Settings	Default
800-006	DADH TE Hotline	DADH TE Hot line	Adj ± 8 mm (increments 0.1 mm) Range = 0 to 160	100
800-007	Detect Paper Size 1	A4 or 8.5 x 13 inch	0 = A4 1 = 8.5 x 13 2 = Auto Market Region Set Range = 0 to 2	2
800-008	Detect Paper Size 2	A5 or 8.5 x 5.5 inch	0 = A5 1 = 8.5 x 5.5 2 = Auto Market Region Set Range = 0 to 2	2
800-009	DADH Duplex Speed Mode	DADH duplex speed (Performance / Noise)	0 = Normal performance 1 = Quiet mode (Reduced speed) Range = 0 to 1	0
801-001	DADH Centre Reg	CVT centre registration	Pixels Range = 3600 to 3800	3707
801-002	DADH LE Reg	DADH LE registration	Scan Lines Range = 0 to 150	91
801-003	Platen Top Edge Reg	Platen top registration	Pixels Range = 7200 to 7440	7266
801-004	Platen Lead Edge Reg	Platen LE registration	Scan Lines Range = 0 to 150	80
801-005	Cal Strip Posn	Calibration strip position (0.1 mm)	0.1 mm increments Range = 0 to 2715	165
801-006	Test A Posn	Test A position	0.1 mm increments Range = 0 to 4923	1000
801-007	Test B Posn	Test B position	0.1 mm increments Range = 0 to 4923	1500
801-008	Test C Posn	Test C position	0.1 mm increments Range = 0 to 4923	2000
801-009	IIT Power Save	IIT power save	1 = Enabled 0 = Disabled Range = 0 to 1	1
801-010	AGC Enable	AGC enable	1 = Enable 0 = Disable Range = 0 to 1	1
801-011	DarkSetPoint	Dark set point	Grey Level in whole number Range = 0 to 50	0
801-012	Scanner CVT position	Scan CVT position	0.1 mm increments Range 500 to 4923	4913
801-013	Scanner Doc Size Pos	Doc size position	0.1 mm increments Range = 0 to 2715	700

Table 2 IIT DADH NVM ID 800-xxx

NVM ID	NVM Name	NVM Description	Settings	Default
801-014	Scan LE Hotline	Scan LE hot line	0.1 mm increments Range = 100 to 900	280
801-015	Mono Set Point	Mono set point	Grey Level in whole number Range = 170 to 255	198
801-016	Red Set Point	Red set point	Grey Level in whole number Range = 170 to 255	191
801-017	Green Set Point	Green set point	Grey Level in whole number Range = 170 to 255	197
801-018	Blue Set Point	Blue set point	Grey Level in whole number Range = 170 to 255	205
801-019	ReCalMag200	ReCalMag200	0 = Never 1 = Re-calibrate for non-mixed originals 2 = Always Calibrate Range = 0 to 2	1
801-020	CvtMonoAgcAdjust	CvtMonoAgcAdjus	% whole numbers. 100 corresponds to no DADH offset compensation. Setting greater than 100 compensates for DADH darker than platen. Range = 80 to 120	103
801-021	CvtRedAgcAdjust	CvtRedAgcAdjus	% whole numbers. 100 corresponds to no DADH offset compensation. Setting greater than 100 compensates for DADH darker than platen. Range = 80 to 120	104
801-022	CvtGrnAgcAdjust	CvtGrnAgcAdjus	% whole numbers. 100 corresponds to no DADH offset compensation. Setting greater than 100 compensates for DADH darker than platen. Range = 80 to 120	104
801-023	CvtBlueAgcAdjust	CvtBlueAgcAdjus	Tenths of %. 1000 (100%) corresponds to no DADH offset compensation. Setting greater than 1000 compensate for DADH darker than platen. Range = 80 to 120	103

Table 2 IIT DADH NVM ID 800-xxx

NVM ID	NVM Name	NVM Description	Settings	Default
801-024	Speed Mode	Speed mode	0 = 257 mm/s 1 = 234 mm/s 2 = 234 mm/s Range = 0 to 3	0
801-025	Scanner Type	Scanner type, full width array or charged coupled device	1 = FWA 2 = CCDS Range = 0 to 255	1
801-026	IQ Parameter Version	IQ parameter version	Holds the scan parameter version index and distinguishes between minor variations within a scanner family, e.g. filter change, lens change. Set to 1 for ColorQube at launch. Range = 0 to 255	1
801-027	DADH / Platen Configuration	DADH / platen configuration	0 = DADH / Platen present 1 = Platen only Range = 0 to 1	1

Table 3 IOT NVM (IME) ID Range 400 to 439-xxx

NVM ID	NVM Name	NVM Description	Settings	Default
410-001	Transfix calibration front	Transfix front load calibration factor	Range = -1,500 to 3,500	2,200
410-002	Transfix calibration rear	Transfix rear load calibration factor	Range = -1,500 to 3,500	2,200
410-003	Transfix cal invalid	Invalidate transfix calibration	Range = 0 to 1	1
410-004	Transfix Load for Large Envelope	Transfix load value for large envelopes	Range = 2,000 to 5,100	2,000
420-001	Ink Level Cyan	Track ink mass - cyan	(+) when sticks added (-) when pixels print Range = 0 to 4,294,967,295	0
420-002	Ink Level Magenta	Track ink mass - magenta	(+) when sticks added (-) when pixels print Range = 0 to 4,294,967,295	0
420-003	Ink Level Yellow	Track ink mass - yellow	(+) when sticks added (-) when pixels print Range = 0 to 4,294,967,295	0

Table 3 IOT NVM (IME) ID Range 400 to 439-xxx

NVM ID	NVM Name	NVM Description	Settings	Default
420-004	Ink Level Black	Track ink mass - black	(+) when sticks added (-) when pixels print Range = 0 to 4,294,967,295	0
420-005	Metered Sticks Cyan	Track metered stick counts - cyan	Range = 0 to 65,535	0
420-006	Metered Sticks Magenta	Track metered stick counts - magenta	Range = 0 to 65,535	0
420-007	Metered Sticks Yellow	Track metered stick counts - yellow	Range = 0 to 65,535	0
420-008	Metered Sticks Black	Track metered stick counts - black	Range = 0 to 65,535	0
420-009	Sold Sticks Cyan	Track Sold stick counts - cyan	Range = 0 to 65,535	0
420-010	Sold Sticks Magenta	Track Sold stick counts - magenta	Range = 0 to 65,535	0
420-011	Sold Sticks Yellow	Track Sold stick counts - yellow	Range = 0 to 65,535	0
420-012	Sold Sticks Black	Track Sold stick counts - black	Range = 0 to 65,535	0
420-013	DMO Sticks Black	Track DMO stick counts	Range = 0 to 65,535	0
420-014	DMO Sticks Cyan	Track DMO stick counts	Range = 0 to 65,535	0
420-015	DMO Sticks Magenta	Track DMO stick counts	Range = 0 to 65,535	0
420-016	DMO Sticks Yellow	Track DMO stick counts	Range = 0 to 65,535	0
420-017	SKU4 Sticks Cyan	Track SKU4 stick counts	Range = 0 to 65,535	0
420-018	SKU4 Sticks Magenta	Track SKU4 stick counts	Range = 0 to 65,535	0
420-019	SKU4 Sticks Yellow	Track SKU4 stick counts	Range = 0 to 65,535	0
420-020	SKU4 Sticks Black	Track SKU4 stick counts	Range = 0 to 65,535	0
420-021	SKU5 Sticks Cyan	Track SKU5 stick counts	Range = 0 to 65,535	0
420-022	SKU5 Sticks Magenta	Track SKU5 stick counts	Range = 0 to 65,535	0
420-023	SKU5 Sticks Yellow	Track SKU5 stick counts	Range = 0 to 65,535	0
420-024	SKU5 Sticks Black	Track SKU5 stick counts	Range = 0 to 65,535	0

Table 3 IOT NVM (IME) ID Range 400 to 439-xxx

NVM ID	NVM Name	NVM Description	Settings	Default
425-001	Startup Mode	Startup Mode	0 = Customer mode 1 = Developer mode 2 = Diagnostics mode 3 = Non-thermal mode 4 = not used 5 = Fast time to ready mode 255 = default mode Range = 0 to 255	255
425-002	Jet Fix Purge	JetFix Purge	0 = Disabled 1 = Purge Always 2 = Purge Ext Idle Range = 0 to 2	2
425-003	Non-Thermal Mode	Thermal Mode	0 = Enable 1 = Disabled Range = 0 to 1	0
425-004	Jet Fix Substitute	Jet Fix substitute	0 = Enabled 1 = Disabled Range = 0 to 1	1
425-005	Max Pages before IODAlign	Force alignment after this many pages if alignment has not occurred	0 = Disabled n = Number of pages Range = 0 to 4,294,967,295	500
425-006	Board Required	Defines which boards are required for this system	Range = 0 to 11	1
425-007	Simulated Motors	Defines simulated or real motors	Range = 0 to 8	0
425-008	Comm channel for command data	Communication channel for command data	Range = 1 to 3	1
425-009	Comm channel for image data	Communication channel for image data	Range = 2 to 4	4
425-010	Delay until nomad connects	Startup blocks until nomad connects	0 = Do not require 1 = Require connection Range = 0 to 1	0
425-011	Nomad IP address	Specifies the IP address that of the nomad server	Range = 0 to 4,294,967,295	488,717,837
425-012	Port number for nomad connection	Specifies the well known port number for nomad connection	Range = 0 to 65,535	25,000
425-013	Jet Fix Substitute Chronic	Jet Fix Substitute Chronic	0 = Disabled 1 = Enabled Range = 0 to 1	1

Table 3 IOT NVM (IME) ID Range 400 to 439-xxx

NVM ID	NVM Name	NVM Description	Settings	Default
425-014	Not currently used	Not used	0 = Disabled 1 = Enabled Range = 0 to 1	1
425-015	9301 Chronic CMY Report Level	For 9301, minimum Consecutive Chronic CMY Jets needed to inform CBC	Range = 0 to 255	2
425-016	9301 Chronic Mono Report Level	For 9301, minimum Total Chronic Mono Jets needed to inform CBC	Range = 0 to 255	1
425-017	9302 Chronic CMY Report Level	For 9302, minimum Consecutive Chronic CMY Jets needed to inform CBC	Range = 0 to 255	2
425-018	9302 Chronic Mono Report Level	For 9302, minimum Total Chronic Mono Jets needed	Range = 0 to 255	1
425-019	9303 Chronic CMY Report Level	For 9303, minimum Consecutive Chronic CMY Jets needed to inform CBC	Range = 0 to 255	1
425-020	9303 Chronic Mono Report Level	For 9303, minimum Total Chronic Mono Jets needed	Range = 0 to 255	1
425-021	Jet Fix soft substitute black	Enable soft jet substitution for black jets	0 = Enabled 1 = Disabled	1
425-022	Soft Jet Substitution	Algorithm for soft jet substitution	0 = Disabled 1 = Enabled Range = 0 to 1	1
425-023	NOMAD Enabled	Enable / disable NOMAD logging	0 = Do not log to NOMAD 1 = Log to NOMAD Range = 0 to 1	1
426-001	#	Data Used by CCS for backup storage. Print Speed	Range = 0 to 255	0
430-001	Service Reason Chain	Service call reason chain	Range = 0 to 65,535	0
430-002	Service Reason Link	Service call reason link	Range = 0 to 65,535	0
435-001	Ralph scan bar skew angle medium	Ralph scan bar skew angle medium	Range = 350 to 650	500
435-002	Centerline - medium media	Center line of paper for medium width media	Range = 1,660,000 to 1,740,000	1,700,000
435-003	Sensor 10 - medium media	Sensor 10 Location for medium width media	Range = - 2,550,000 to - 2,350,000	- 2,450,000

Table 3 IOT NVM (IME) ID Range 400 to 439-xxx

NVM ID	NVM Name	NVM Description	Settings	Default
435-004	Ralph Dark Level	Ralph Dark Level	Range = 0 to 4,294,967,295	80
435-005	Sensor 10 to 14 Delta	Distance from Sensor 10 to 14	Range = 1,234,000 to 1,334,000	1,284,000
435-006	Sensor 10 - narrow media	Sensor 10 Location for narrow media	Range = - 2,550,000 to - 2,350,000	- 2,450,000
435-007	Ralph scan bar skew angle narrow	Ralph scan bar skew angle narrow media	Range = 350 to 650	500
435-008	Centerline - narrow media	Center line of the path for narrow media	Range = 1,660,000 to 1,740,000	1,700,000
435-009	Sensor 10 - wide media	Sensor 10 location for wide media	Range = - 2,550,000 to - 2,350,000	- 2,450,000
435-010	Ralph scan bar skew angle wide	Ralph scan bar skew angle wide media	Range = 350 to 650	500
435-011	Centerline - wide media	Center line of paper path for wide media	Range = 1,660,000 to 1,740,000	1,700,000
435-012	Ralph cal invalid	Invalidate ralph calibration	Range = 0 to 1	1
435-013	nip A Scale Factor Adjust Narrow	The scale factors for Nip A rollers for narrow media	Range = -1000 to 1000	0
435-014	nip A Scale Factor Adjust Medium	The scale factors for Nip A rollers for medium media	Range = -1000 to 1000	0
435-015	nip A Scale Factor Adjust Wide	The scale factors for Nip A rollers for wide media	Range = -1000 to 1000	0
435-016	Exit skew correction for punch	Use skew correction at exit for punched media	Range = 0 to 1	0

Table 4 IOT NVM (IME) ID Range 440 to 459-xxx

NVM ID	NVM Name	NVM Description	Settings	Default
441-001	Validation01	Used for validation	Range = 0 to 4,294,967,295	413,943,794
441-002	NVRAM format	NVRAM format	Range = 0 to 255	24
441-003	NVRAM constants rev	NVRAM constants revision number	Range = 0 to 255	80
441-004	NVRAM dynamics rev	NVRAM dynamics revision number	Range = 0 to 255	28
441-005	Code minor revision number	Code minor revision number	Range = 0 to 255	18
441-006	Number of faults encountered	Number of faults encountered	Range = 0 to 65,535	0

Table 4 IOT NVM (IME) ID Range 440 to 459-xxx

NVM ID	NVM Name	NVM Description	Settings	Default
441-007	Reset count	Reset count	Range = 0 to 4,294,967,295	0
441-008	Total print count	Total print count	Range = 0 to 4,294,967,295	0
441-011	Constants CRC	Constants CRC	Range = 0 to 4,294,967,295	0
441-012	Service Constants CRC	Service Constants CRC	Range = 0 to 4,294,967,295	0
441-013	IME Serial Number	Marking Engine Serial Number	Range = 0 to 0	0
441-014	NVRAM serviced constants rev	NVRAM constants which need service to reset: revision number	Range = 0 to 255	28
443-001	NVMRAM CRC Err Count	Number of NVRAM CRC errors encountered	Range = 0 to 65,535	0
445-001	Printhead 1 Voltage Scaling	Printhead 1 voltage scale factor	Range = 0 to 255	128
445-002	Printhead 2 Voltage Scaling	Printhead 2 voltage scale factor	Range = 0 to 255	128
445-003	Printhead 3 Voltage Scaling	Printhead 3 voltage scale factor	Range = 0 to 255	128
445-004	Printhead 4 Voltage Scaling	Printhead 4 voltage scale factor	Range = 0 to 255	128
445-005	Head 1 Serial Num	Head 1 Serial Number	Range = 0 to 0	0
445-006	Head 2 Serial Num	Head 2 Serial Number	Range = 0 to 0	0
445-007	Head 3 Serial Num	Head 3 Serial Number	Range = 0 to 0	0
445-008	Head 4 Serial Num	Head 4 Serial Number	Range = 0 to 0	0
445-009	badJet1	Value identifies the location of a jet that will not be used	Set with bad jet format: HCJet Read - XYZZZ X = head (1-4): Y = Colour (CMYK = 1-4) Z = Jet number (1-220) Example 23044 = head 2, Y, jet 44 Clear by writing 0 Range = 0 to 65,535	0

Table 4 IOT NVM (IME) ID Range 440 to 459-xxx

NVM ID	NVM Name	NVM Description	Settings	Default
445-010	badJet2	Value identifies the location of a jet that will not be used	Set with bad jet format: HCJet Read - XYZZZ X = head (1-4): Y = Colour (CMYK = 1-4) Z = Jet number (1-220) Example 23044 = head 2, Y, jet 44 Clear by writing 0 Range = 0 to 65,535	0
445-011	badJet3	Value identifies the location of a jet that will not be used	Set with bad jet format: HCJet Read - XYZZZ X = head (1-4): Y = Colour (CMYK = 1-4) Z = Jet number (1-220) Example 23044 = head 2, Y, jet 44 Clear by writing 0 Range = 0 to 65,535	0
445-012	badJet4	Value identifies the location of a jet that will not be used	Set with bad jet format: HCJet Read - XYZZZ X = head (1-4): Y = Colour (CMYK = 1-4) Z = Jet number (1-220) Example 23044 = head 2, Y, jet 44 Clear by writing 0 Range = 0 to 65,535	0
445-013	badJet5	Value identifies the location of a jet that will not be used	Set with bad jet format: HCJet Read - XYZZZ X = head (1-4): Y = Colour (CMYK = 1-4) Z = Jet number (1-220) Example 23044 = head 2, Y, jet 44 Clear by writing 0 Range = 0 to 65,535	0

Table 4 IOT NVM (IME) ID Range 440 to 459-xxx

NVM ID	NVM Name	NVM Description	Settings	Default
445-014	badJet6	Value identifies the location of a jet that will not be used	Set with bad jet format: HCJet Read - XYZZZ X = head (1-4): Y = Colour (CMYK = 1-4) Z = Jet number (1-220) Example 23044 = head 2, Y, jet 44 Clear by writing 0 Range = 0 to 65,535	0
445-015	badJet7	Value identifies the location of a jet that will not be used	Set with bad jet format: HCJet Read - XYZZZ X = head (1-4): Y = Colour (CMYK = 1-4) Z = Jet number (1-220) Example 23044 = head 2, Y, jet 44 Clear by writing 0 Range = 0 to 65,535	0
445-016	badJet8	Value identifies the location of a jet that will not be used	Set with bad jet format: HCJet Read - XYZZZ X = head (1-4): Y = Colour (CMYK = 1-4) Z = Jet number (1-220) Example 23044 = head 2, Y, jet 44 Clear by writing 0 Range = 0 to 65,535	0
445-017	badJet9	Value identifies the location of a jet that will not be used	Set with bad jet format: HCJet Read - XYZZZ X = head (1-4): Y = Colour (CMYK = 1-4) Z = Jet number (1-220) Example 23044 = head 2, Y, jet 44 Clear by writing 0 Range = 0 to 65,535	0

Table 4 IOT NVM (IME) ID Range 440 to 459-xxx

NVM ID	NVM Name	NVM Description	Settings	Default
445-018	badJet10	Value identifies the location of a jet that will not be used	Set with bad jet format: HCJet Read - XYZZZ X = head (1-4): Y = Colour (CMYK = 1-4) Z = Jet number (1-220) Example 23044 = head 2, Y, jet 44 Clear by writing 0 Range = 0 to 65,535	0
445-019	badJet11	Value identifies the location of a jet that will not be used	Set with bad jet format: HCJet Read - XYZZZ X = head (1-4): Y = Colour (CMYK = 1-4) Z = Jet number (1-220) Example 23044 = head 2, Y, jet 44 Clear by writing 0 Range = 0 to 65,535	0
445-020	badJet12	Value identifies the location of a jet that will not be used	Set with bad jet format: HCJet Read - XYZZZ X = head (1-4): Y = Colour (CMYK = 1-4) Z = Jet number (1-220) Example 23044 = head 2, Y, jet 44 Clear by writing 0 Range = 0 to 65,535	0
445-021	badJet13	Value identifies the location of a jet that will not be used	Set with bad jet format: HCJet Read - XYZZZ X = head (1-4): Y = Colour (CMYK = 1-4) Z = Jet number (1-220) Example 23044 = head 2, Y, jet 44 Clear by writing 0 Range = 0 to 65,535	0

Table 4 IOT NVM (IME) ID Range 440 to 459-xxx

NVM ID	NVM Name	NVM Description	Settings	Default
445-022	badJet14	Value identifies the location of a jet that will not be used	Set with bad jet format: HCJet Read - XYZZZ X = head (1-4): Y = Colour (CMYK = 1-4) Z = Jet number (1-220) Example 23044 = head 2, Y, jet 44 Clear by writing 0 Range = 0 to 65,535	0
445-023	badJet15	Value identifies the location of a jet that will not be used	Set with bad jet format: HCJet Read - XYZZZ X = head (1-4): Y = Colour (CMYK = 1-4) Z = Jet number (1-220) Example 23044 = head 2, Y, jet 44 Clear by writing 0 Range = 0 to 65,535	0
445-024	badJet16	Value identifies the location of a jet that will not be used	Set with bad jet format: HCJet Read - XYZZZ X = head (1-4): Y = Colour (CMYK = 1-4) Z = Jet number (1-220) Example 23044 = head 2, Y, jet 44 Clear by writing 0 Range = 0 to 65,535	0
445-025	badJet17	Value identifies the location of a jet that will not be used	Set with bad jet format: HCJet Read - XYZZZ X = head (1-4): Y = Colour (CMYK = 1-4) Z = Jet number (1-220) Example 23044 = head 2, Y, jet 44 Clear by writing 0 Range = 0 to 65,535	0

Table 4 IOT NVM (IME) ID Range 440 to 459-xxx

NVM ID	NVM Name	NVM Description	Settings	Default
445-026	badJet18	Value identifies the location of a jet that will not be used	Set with bad jet format: HCJet Read - XYZZZ X = head (1-4): Y = Colour (CMYK = 1-4) Z = Jet number (1-220) Example 23044 = head 2, Y, jet 44 Clear by writing 0 Range = 0 to 65,535	0
445-027	badJet19	Value identifies the location of a jet that will not be used	Set with bad jet format: HCJet Read - XYZZZ X = head (1-4): Y = Colour (CMYK = 1-4) Z = Jet number (1-220) Example 23044 = head 2, Y, jet 44 Clear by writing 0 Range = 0 to 65,535	0
445-028	badJet20	Value identifies the location of a jet that will not be used	Set with bad jet format: HCJet Read - XYZZZ X = head (1-4): Y = Colour (CMYK = 1-4) Z = Jet number (1-220) Example 23044 = head 2, Y, jet 44 Clear by writing 0 Range = 0 to 65,535	0
445-029	badJet21	Value identifies the location of a jet that will not be used	Set with bad jet format: HCJet Read - XYZZZ X = head (1-4): Y = Colour (CMYK = 1-4) Z = Jet number (1-220) Example 23044 = head 2, Y, jet 44 Clear by writing 0 Range = 0 to 65,535	0

Table 4 IOT NVM (IME) ID Range 440 to 459-xxx

NVM ID	NVM Name	NVM Description	Settings	Default
445-030	badJet22	Value identifies the location of a jet that will not be used	Set with bad jet format: HCJet Read - XYZZZ X = head (1-4): Y = Colour (CMYK = 1-4) Z = Jet number (1-220) Example 23044 = head 2, Y, jet 44 Clear by writing 0 Range = 0 to 65,535	0
445-031	badJet23	Value identifies the location of a jet that will not be used	Set with bad jet format: HCJet Read - XYZZZ X = head (1-4): Y = Colour (CMYK = 1-4) Z = Jet number (1-220) Example 23044 = head 2, Y, jet 44 Clear by writing 0 Range = 0 to 65,535	0
445-032	badJet24	Value identifies the location of a jet that will not be used	Set with bad jet format: HCJet Read - XYZZZ X = head (1-4): Y = Colour (CMYK = 1-4) Z = Jet number (1-220) Example 23044 = head 2, Y, jet 44 Clear by writing 0 Range = 0 to 65,535	0
445-033	badJet25	Value identifies the location of a jet that will not be used	Set with bad jet format: HCJet Read - XYZZZ X = head (1-4): Y = Colour (CMYK = 1-4) Z = Jet number (1-220) Example 23044 = head 2, Y, jet 44 Clear by writing 0 Range = 0 to 65,535	0

Table 4 IOT NVM (IME) ID Range 440 to 459-xxx

NVM ID	NVM Name	NVM Description	Settings	Default
445-034	badJet26	Value identifies the location of a jet that will not be used	Set with bad jet format: HCJet Read - XYZZZ X = head (1-4): Y = Colour (CMYK = 1-4) Z = Jet number (1-220) Example 23044 = head 2, Y, jet 44 Clear by writing 0 Range = 0 to 65,535	0
445-035	badJet27	Value identifies the location of a jet that will not be used	Set with bad jet format: HCJet Read - XYZZZ X = head (1-4): Y = Colour (CMYK = 1-4) Z = Jet number (1-220) Example 23044 = head 2, Y, jet 44 Clear by writing 0 Range = 0 to 65,535	0
445-036	badJet28	Value identifies the location of a jet that will not be used	Set with bad jet format: HCJet Read - XYZZZ X = head (1-4): Y = Colour (CMYK = 1-4) Z = Jet number (1-220) Example 23044 = head 2, Y, jet 44 Clear by writing 0 Range = 0 to 65,535	0
445-037	badJet29	Value identifies the location of a jet that will not be used	Set with bad jet format: HCJet Read - XYZZZ X = head (1-4): Y = Colour (CMYK = 1-4) Z = Jet number (1-220) Example 23044 = head 2, Y, jet 44 Clear by writing 0 Range = 0 to 65,535	0

Table 4 IOT NVM (IME) ID Range 440 to 459-xxx

NVM ID	NVM Name	NVM Description	Settings	Default
445-038	badJet30	Value identifies the location of a jet that will not be used	Set with bad jet format: HCJet Read - XYZZZ X = head (1-4): Y = Colour (CMYK = 1-4) Z = Jet number (1-220) Example 23044 = head 2, Y, jet 44 Clear by writing 0 Range = 0 to 65,535	0
445-039	badJet31	Value identifies the location of a jet that will not be used	Set with bad jet format: HCJet Read - XYZZZ X = head (1-4): Y = Colour (CMYK = 1-4) Z = Jet number (1-220) Example 23044 = head 2, Y, jet 44 Clear by writing 0 Range = 0 to 65,535	0
445-040	badJet32	Value identifies the location of a jet that will not be used	Set with bad jet format: HCJet Read - XYZZZ X = head (1-4): Y = Colour (CMYK = 1-4) Z = Jet number (1-220) Example 23044 = head 2, Y, jet 44 Clear by writing 0 Range = 0 to 65,535	0
445-041	badJet33	Value identifies the location of a jet that will not be used	Set with bad jet format: HCJet Read - XYZZZ X = head (1-4): Y = Colour (CMYK = 1-4) Z = Jet number (1-220) Example 23044 = head 2, Y, jet 44 Clear by writing 0 Range = 0 to 65,535	0

Table 4 IOT NVM (IME) ID Range 440 to 459-xxx

NVM ID	NVM Name	NVM Description	Settings	Default
445-042	badJet34	Value identifies the location of a jet that will not be used	Set with bad jet format: HCJet Read - XYZZZ X = head (1-4): Y = Colour (CMYK = 1-4) Z = Jet number (1-220) Example 23044 = head 2, Y, jet 44 Clear by writing 0 Range = 0 to 65,535	0
445-043	badJet35	Value identifies the location of a jet that will not be used	Set with bad jet format: HCJet Read - XYZZZ X = head (1-4): Y = Colour (CMYK = 1-4) Z = Jet number (1-220) Example 23044 = head 2, Y, jet 44 Clear by writing 0 Range = 0 to 65,535	0
445-044	badJet36	Value identifies the location of a jet that will not be used	Set with bad jet format: HCJet Read - XYZZZ X = head (1-4): Y = Colour (CMYK = 1-4) Z = Jet number (1-220) Example 23044 = head 2, Y, jet 44 Clear by writing 0 Range = 0 to 65,535	0
445-045	badJet37	Value identifies the location of a jet that will not be used	Set with bad jet format: HCJet Read - XYZZZ X = head (1-4): Y = Colour (CMYK = 1-4) Z = Jet number (1-220) Example 23044 = head 2, Y, jet 44 Clear by writing 0 Range = 0 to 65,535	0

Table 4 IOT NVM (IME) ID Range 440 to 459-xxx

NVM ID	NVM Name	NVM Description	Settings	Default
445-046	badJet38	Value identifies the location of a jet that will not be used	Set with bad jet format: HCJet Read - XYZZZ X = head (1-4): Y = Colour (CMYK = 1-4) Z = Jet number (1-220) Example 23044 = head 2, Y, jet 44 Clear by writing 0 Range = 0 to 65,535	0
445-047	badJet39	Value identifies the location of a jet that will not be used	Set with bad jet format: HCJet Read - XYZZZ X = head (1-4): Y = Colour (CMYK = 1-4) Z = Jet number (1-220) Example 23044 = head 2, Y, jet 44 Clear by writing 0 Range = 0 to 65,535	0
445-048	badJet40	Value identifies the location of a jet that will not be used	Set with bad jet format: HCJet Read - XYZZZ X = head (1-4): Y = Colour (CMYK = 1-4) Z = Jet number (1-220) Example 23044 = head 2, Y, jet 44 Clear by writing 0 Range = 0 to 65,535	0
445-049	H2H uniformity type selection	Select dC972 uniformity and TRC calculation methods.	0 = Centre pass turned off 1 = Centre pass on 4 strip TRC pattern 2 = Centre pass on 8 strip TRC pattern Range = 0 to 2	1

Table 4 IOT NVM (IME) ID Range 440 to 459-xxx

NVM ID	NVM Name	NVM Description	Settings	Default
450-001	PFP Kit Type	Type of kits installed on PFP	0 = Standard (A4 and Letter LEF) 1 = Kit A (A3 SEF and A4 LEF) 2 = Kit A (11 x 17 SEF and 8.5 x 11 LEF) 3 = Kit B (A4, SEF) 4 = Kit B (Letter, Legal SEF) Range = 0 to 4	0
450-002	MSI motor type	MSI motor type	Range = 0 to 65,535	1
450-003	Tray 1 HW revision	Hardware version for tray 1 of the TTM	Range = 0 to 1	1
450-004	Tray 2 HW revision	Hardware version for tray 2 of the TTM	Range = 0 to 1	1
450-005	TTM HW revision	Hardware version of the TTM	Range = 0 to 2	2
451-001	Sheets Until OC Tray Full	Number of Sheets after OCT sensor is met when tray full is declared	Range = 0 to 100	50

Table 5 IOT NVM (IME) ID Range 460 to 470-xxx

NVM ID	NVM Name	NVM Description	Settings	Default
463-002	DrumTemp: Paper prints	Temperature of drum when printing on paper	Range = 0 to 2,000	555
463-003	DrumTemp: Transparency prints	Temperature of drum when printing on transparency	Range = 0 to 2,000	555
463-004	DrumTemp: Low power mode	Temperature of drum when in low power mode	Range = 0 to 2,000	460
463-005	DrumTemp: Sleep mode	Temperature of drum when in sleep mode	Range = 0 to 2,000	0
464-001	Upper head stitch factor	Upper head stitch factor	The default is deliberately out of range Range = -600,000,000 to 600,000,000	2,147,483,647
464-002	Upper left head roll factor	Upper left head roll factor	The default is deliberately out of range Range = -400,000,000 to 400,000,000	2,147,483,647

Table 5 IOT NVM (IME) ID Range 460 to 470-xxx

NVM ID	NVM Name	NVM Description	Settings	Default
464-003	Upper right head roll factor	Upper right head roll factor	The default is deliberately out of range Range = -400,000,000 to 400,000,000	2,147,483,647
464-004	Upper cross process head offset	Upper cross process head offset	Range = -100,000,000 to 100,000,000	- 30,000
464-005	Lower head stitch factor	Lower head stitch factor	The default is deliberately out of range Range = -600,000,000 to 600,000,000	2,147,483,647
464-006	Lower left head roll factor	Lower left head roll factor	The default is deliberately out of range Range = -400,000,000 to 400,000,000	2,147,483,647
464-007	Lower right head roll factor	Lower right head roll factor	The default is deliberately out of range Range = -400,000,000 to 400,000,000	2,147,483,647
464-008	Lower cross process head offset	Lower cross process head offset	Range = -100,000,000 to 100,000,000	- 30,000
464-009	Head 1 process stitch factor	Head 1 process stitch factor	Range = -600,000,000 to 600,000,000	0
464-010	Head 2 process stitch factor	Head 2 process stitch factor	Range = -600,000,000 to 600,000,000	0
464-011	Head 3 process stitch factor	Head 3 process stitch factor	Range = -600,000,000 to 600,000,000	0
464-012	Head 4 process stitch factor	Head 4 process stitch factor	Range = -600,000,000 to 600,000,000	0
464-013	Purge needed head 1	Purge needed head 1	Range = 0 to 1	1
464-014	Purge needed head 2	Purge needed head 2	Range = 0 to 1	1
464-015	Purge needed head 3	Purge needed head 3	Range = 0 to 1	1
464-016	Purge needed head 4	Purge needed head 4	Range = 0 to 1	1

Table 5 IOT NVM (IME) ID Range 460 to 470-xxx

NVM ID	NVM Name	NVM Description	Settings	Default
464-017	Upper SFWA heads need flush	Upper SFWA heads need flush	Range = 0 to 1	0
464-018	Lower SFWA heads need flush	Lower SFWA heads need flush	Range = 0 to 1	0
464-019	Amount of waste ink in tray	Amount of waste ink in tray	Range = 0 to 4,294,967,295	500,000
464-022	Xaxis Scaling: Upper 2 heads	Cross-process movement scale factor for mechanism that holds upper two heads	Range = 35,535 to 85,535	65,850
464-023	Xaxis Scaling: Lower 2 heads	Cross-process movement scale factor for mechanism that holds lower two heads	Range = 35,535 to 85,535	65,850
464-024	LPA Step Time	Time delay to switch to secondary pump duty cycle	Range = 0 to 4,294,967,295	0
464-025	Initial LPA Duty	Low pressure initial assist pump duty cycle	Range = 0 to 255	60
464-026	Second LPA Duty	Low pressure secondary pump duty cycle	Range = 0 to 255	60
464-027	Single head purge pre-wipe LPA	The initial lpa pwm value for the wipe when purging only one head	Range = 0 to 255	0
464-028	Single head purge post-wipe LPA	The value of the lpa pwm that is set after lpaStepTime has expired when purging only one head	Range = 0 to 255	0
465-001	Umbilical Upr Temp: Printing	Temperature of upper umbilical for printing	Range = 0 to 2,000	1,103
465-002	Umbilical Upr Temp: Low Power	Temperature of upper umbilical for low power	Range = 0 to 2,000	930
465-003	Umbilical Upr Temp: Sleep mode	Temperature of upper umbilical for sleep mode	Range = 0 to 2,000	0
465-004	Umbilical Lwr Temp: Printing	Temperature of lower umbilical for printing	Range = 0 to 2,000	1,020
465-005	Umbilical Lwr Temp: Low Power	Temperature of lower umbilical for low power mode	Range = 0 to 2,000	930
465-006	Umbilical Lwr Temp: Sleep mode	Temperature of lower umbilical for sleep mode	Range = 0 to 2,000	0
465-007	Melt Reservoir Temp: Printing	Temperature of melt reservoir for printing	Range = 0 to 2,000	1,500
465-008	Melt Reservoir Temp: Low Power	Temperature of melt reservoir for low power mode	Range = 0 to 2,000	930

Table 5 IOT NVM (IME) ID Range 460 to 470-xxx

NVM ID	NVM Name	NVM Description	Settings	Default
465-009	Melt Reservoir Temp: Sleep mode	Temperature of melt reservoir for sleep mode	Range = 0 to 2,000	0
465-010	Umb Upr Temp: non-TEC Sleep mode	Temperature of upper umbilical for non-TEC sleep mode.	Range = 0 to 2,000	0
465-011	Umb Lwr Temp: non-TEC Sleep mode	Temperature of lower umbilical for non-TEC sleep mode.	Range = 0 to 2,000	0
465-012	MeltRes Temp: non-TEC Sleep mode	Temperature of melt reservoir for non-TEC sleep mode.	Range = 0 to 2,000	0
465-013	Umbilical Lwr Temp: Pre-Ready	Temperature of lower umbilical when in ink delivery on demand pre-ready mode.	Range 0 to 2,000	930
465-014	Umbilical Upr Temp: Pre-Ready	Temperature of upper umbilical when in ink delivery on demand pre-ready mode.	Range 0 to 2,000	930
465-015	Melt Reservoir Temp: Pre-Ready	Temperature of melt reservoir when in ink delivery on demand pre-ready mode.	Range 0 to 2,000	930

Table 6 IOT NVM (IME) ID Range 489 to 499-xxx

NVM ID	NVM Name	NVM Description	Settings	Default
489-003	PreheatTemp: Paper prints	Temperature of pre-heater when printing on paper	Range = 0 to 2,000	610
489-004	PreheatTemp: Transparency prints	Temperature of pre-heater when printing on transparency prints	Range = 0 to 2,000	610
489-005	PreheatTemp: PaperPath cleaning	Temperature of pre-heater when performing paper path cleaning	Range = 0 to 2,000	850
489-006	PreheatTemp: For jam in prehr	Temperature of pre-heater when jam in pre-heater	Range = 0 to 2,000	560
489-007	PreheatTemp: Low pwr mode	Temperature of pre-heater when in low power mode	Range = 0 to 2,000	500
489-008	PreheatTemp: Sleep mode	Temperature of pre-heater when in sleep mode	Range = 0 to 2,000	0
490-001	IOD Sensitivity fail count	Count of failures since last success of IOD sensitivity	Range = 0 to 255	0

Table 6 IOT NVM (IME) ID Range 489 to 499-xxx

NVM ID	NVM Name	NVM Description	Settings	Default
490-002	Sensitivity tool State	Sensitivity tool State	Read: auto status 0 = optimal 1 = non optimal 2 = disabled Write: control 3 = disabled auto 4 = enable auto Range = 0 to 4	1
490-003	IOD Sensitivity pass timestamp	Time stamp for last successful IOD sensitivity	Range = 0 to 4,294,967,295	0
490-004	IOD YDotPositionCorrect count	Count of failures since last success of IOD YDotPositionCorrect	Range = 0 to 255	0
490-005	YDotPositionCorrection tool Stat	YDotPositionCorrection tool State	Read: auto status 0 = optimal 1 = non optimal 2 = disabled Write: control 3 = disabled auto 4 = enable auto Range = 0 to 4	1
490-006	IOD YDotPosCorect pass timestamp	Time stamp for last successful IOD IODYDotPostionCorrect	Range = 0 to 4,294,967,295	0
490-007	IOD H2Uniformity fail count	Count of failures since last success of IOD H2HUniformity	Range = 0 to 255	0
490-008	H2HUniformity tool State	H2HUniformity tool State	Read: auto status 0 = optimal 1 = non optimal 2 = disabled Write: control 3 = disabled auto 4 = enable auto Range = 0 to 4	1
490-009	IOD H2Uniformity pass timestamp	Time stamp for last success of IOD H2HUniformity	Range = 0 to 4,294,967,295	0
490-010	IOD DeltaTRC fal count	Count of failures since last success of IOD Delta TRC	Range = 0 to 255	0
490-011	TRC tool State	TRC tool State	Read: auto status 0 = optimal 1 = non optimal 2 = disabled Write: control 3 = disabled auto 4 = enable auto Range = 0 to 4	0

Table 6 IOT NVM (IME) ID Range 489 to 499-xxx

NVM ID	NVM Name	NVM Description	Settings	Default
490-012	IOD DeltaTRC pass timestamp	Timestamp for last success of IOD Delta TRC	Range = 0 to 4,294,967,295	0
490-019	H2HAlignAdjust tool State	H2HAlignAdjust tool State	Read: auto status 0 = optimal 1 = non optimal 2 = disabled Write: control 3 = disabled auto 4 = enable auto Range = 0 to 4	1
490-020	UTP index	Index into selected uniformity time out profile	When changing profile choice, set to 0 Range = 0 to 4	0
490-021	UTP choice	Choice of uniformity time out profiles	Profile 0: 14.28.56.0.0 Profile 1: 14.28.56.126.0 Profile 2: 28.56.112.0 Profile 3: programable in NVRAM below Range = 0 to 3	1
490-022	UTP Choice 3 Index 0 Day Count	Uniformity Time out Profile 3, index 0	0 means end of list Range = 0 to 255	0
490-023	UTP Choice 3 Index 1 Day Count	Uniformity Time out Profile 3, index 1	0 means end of list Range = 0 to 255	0
490-024	UTP Choice 3 Index 2 Day Count	Uniformity Time out Profile 3, index 2	0 means end of list Range = 0 to 255	0
490-025	UTP Choice 3 Index 3 Day Count	Uniformity Time out Profile 3, index 3	0 means end of list Range = 0 to 255	0
490-026	UTP Choice 3 Index 4 Day Count	Uniformity Time out Profile 3, index 4	0 means end of list Range = 0 to 255	0
490-027	9301 Purge for x Bad Color Jets	9301 Minimum color bad jet count for jet fix purging	Range = 0 to 255	255
490-028	9301 Purge after x Bad Mono Jets	9301 Minimum mono bad jet count for jet fix purging	Range = 0 to 255	2
490-029	9302 Purge for x Bad Color Jets	9302 Minimum color bad jet count for jet fix purging	Range = 0 to 255	6
490-030	9302 Purge after x Bad Mono Jets	9302 Minimum mono bad jet count for jet fix purging	Range = 0 to 255	2

Table 6 IOT NVM (IME) ID Range 489 to 499-xxx

NVM ID	NVM Name	NVM Description	Settings	Default
490-031	9303 Purge for x Bad Color Jets	9303 Minimum color bad jet count for jet fix purging	Range = 0 to 255	2
490-032	9303 Purge after x Bad Mono Jets	9303 Minimum mono bad jet count for jet fix purging	Range = 0 to 255	1
490-033	30Day Discoloration Purge Enable	30-day discoloration purge enable (to address ink-cooking in the umbilicals)	0 = disabled 1 = enabled Range = 0 to 255	0
490-034	Consec Purge-Clean Sheet Errs	When PQM requested purge fails, including mud-page failures... increment this count. Clear on success	0 to clear Range = 0 to 255	0
490-035	Unif Maint Abort: Bad Jets	Uniformity work begun at night, and insufficient jets becomes an impediment: increment this count.	0 to clear Range = 0 to 255	0
490-036	Unif Maint Abort: No paper	Uniformity work begun at night, but no-Paper becomes an impediment: Increment this count	0 to clear Range = 0 to 255	0
490-037	Unif Maint Abort: Needs Ink	Uniformity work begun at night, but insufficient Ink becomes an impediment: Increment this count	0 to clear Range = 0 to 255	0
490-038	Unif Maint Abort: CleanPage Err	Uniformity work begun at night, but Mud pages Fail: Increment this count	0 to clear Range = 0 to 255	0
490-039	Unif Maint Abort: Align Errors	Uniformity work begun at night, but Align Fails: Increment this count	0 to clear Range = 0 to 255	0
490-040	IOD Align Cal tool State	IOD Align Calibration tool State	Read: auto status.0 = optimal, 1 = non optimal, 2 = disabled. Write: control3 = disable auto, 4 = enable auto	0
490-041	Count of failures since last success of IOD Align Calibration	IOD Align Cal Fail count	Range = 0 to 4	1
490-042	A correction offset value applied to X stitch front measurements for stitch interface 1.	Stitch Measure Offset X1 Front	Range = -1000 to 1000	0

Table 6 IOT NVM (IME) ID Range 489 to 499-xxx

NVM ID	NVM Name	NVM Description	Settings	Default
490-043	A correction offset value applied to X stitch front measurements for stitch interface 2.	Stitch Measure Offset X2 Front	Range = -1000 to 1000	0
490-044	A correction offset value applied to X stitch rear measurements for stitch interface 2.	Stitch Measure Offset X2 Rear	Range = -1000 to 1000	0
490-045	A correction offset value applied to X stitch rear measurements for stitch interface 3.	Stitch Measure Offset X3 Rear	Range = -1000 to 1000	0
490-046	A correction offset value applied to Y stitch front measurements for stitch interface 1.	Stitch Measure Offset Y1 Front	Range = -1000 to 1000	0
490-047	A correction offset value applied to Y stitch front measurements for stitch interface 2.	Stitch Measure Offset Y2 Front	Range = -1000 to 1000	0
490-048	A correction offset value applied to Y stitch rear measurements for stitch interface 2.	Stitch Measure Offset Y2 Rear	Range = -1000 to 1000	0
490-049	A correction offset value applied to Y stitch rear measurements for stitch interface 3.	Stitch Measure Offset Y3 Rear	Range = -1000 to 1000	0
490-050	TMP:H1Fix Jets Purge Needed	TMP = too many purges feature TMP: count of semi-consecutive nights in which head 1 sees purge needed to fix jets.	Range = 0 to 255	0
490-051	TMP:H2Fix Jets Purge Needed	TMP: count of semi-consecutive nights in which head 2 sees purge needed to fix jets.	Range = 0 to 255	0
490-052	TMP:H3Fix Jets Purge Needed	TMP: count of semi-consecutive nights in which head 3 sees purge needed to fix jets.	Range = 0 to 255	0

Table 6 IOT NVM (IME) ID Range 489 to 499-xxx

NVM ID	NVM Name	NVM Description	Settings	Default
490-053	TMP:H4Fix Jets Purge Needed	TMP: count of semi-consecutive nights in which head 4 sees purge needed to fix jets.	Range = 0 to 255	0
490-054	TMP:H1Fix Jets Prg NOT Needed	TMP: count of semi-consecutive nights in which head 1 sees purge NOT needed to fix jets.	Range = 0 to 255	0
490-055	TMP:H2Fix Jets Prg NOT Needed	TMP: count of semi-consecutive nights in which head 2 sees purge NOT needed to fix jets.	Range = 0 to 255	0
490-056	TMP:H3Fix Jets Prg NOT Needed	TMP: count of semi-consecutive nights in which head 3 sees purge NOT needed to fix jets.	Range = 0 to 255	0
490-057	TMP:H4Fix Jets Prg NOT Needed	TMP: count of semi-consecutive nights in which head 4 sees purge NOT needed to fix jets.	Range = 0 to 255	0
490-058	TMP:Max Fix Jets Purge Needed	TMP: A threshold of purge maintenance sessions that had purges to correct bad jets. If this threshold is exceeded a Head x Too Many Purges informational fault is raised and the heads jet fix purging is blocked.	Range = 0 to 255	16
490-059	TMP:Max Fix Jets Prg NOT Needed	TMP: When the number of purge maintenance sessions which requires no purges to fix bad jets exceeds this value the Head x Too Many Purges Dev-Fault is lowered	Range = 0 to 255	2
490-060	Unif-CLD Baseline Status	CLD = CloseLoopDrift = a new way to achieve uniformity via IOD. CLD baseline (via IOD) is a new calibration required by uniformity (CLDAdjust). This is PQM status for CLD baseline.	Range = 0 to 255	0
490-061	Unif-CLD Baseline Failure	PQM consecutive failure count for CLD baseline	Range = 0 to 4	1
490-062	Unif-CLD Baseline Last Success	What is the youngest heads time at temp when CLD baseline last succeeded	Range = 0 to 4,294,967,295	0
490-063	Wait GelMaint until CU-PC	Min CU print count before PQM begins running automatic CU Gel Maintenance at night.	Range = 0 to 4,294,967,295	25,000

Table 6 IOT NVM (IME) ID Range 489 to 499-xxx

NVM ID	NVM Name	NVM Description	Settings	Default
490-064	Override Uniformity Algorithm	Switch to go back to old uniformity algorithm vs new closed loop drift algorithm.	0 = New CLD uniformity 1 = Old uniformity Range = 0 to 225	0
490-065	Delta CU-PC between Gel-Maint	Min CU print count between automatic CU Gel maintenances at night	Range = 0 to 4,294,967,295	5,000
492-001	Image on drum	Image on drum	Range = 0 to 1	0
492-002	DM can scrape off image	DM can scrape off image	Range = 0 to 1	0
492-003	Drum image is 2 pitch	Drum image is 2 pitch	Range = 0 to 1	0
492-004	Position of dirty drum image	Drum dirty start position	Range = 0 to 65,535	0
492-005	Size of drum image X	Size of drum image	Range = 0 to 65,535	0
492-006	Size of drum image Y	Size of drum image	Range = 0 to 65,535	0
492-007	Position of drum image	Cross process drum offset position	Range = -32,768 to 32,767	0
492-008	Drum runout cal #01	Calibration values of the drum y-run out	Range = -32,768 to 32,767	0
492-009	Drum runout cal #02	Calibration values of the drum y-run out	Range = -32,768 to 32,767	0
492-010	Drum runout cal #03	Calibration values of the drum y-run out	Range = -32,768 to 32,767	0
492-011	Drum runout cal #04	Calibration values of the drum y-run out	Range = -32,768 to 32,767	0
492-012	Drum runout cal #05	Calibration values of the drum y-run out	Range = -32,768 to 32,767	0
492-013	Drum runout cal #06	Calibration values of the drum y-runout	Range = -32,768 to 32,767	0
492-014	Drum runout cal #07	Calibration values of the drum y-runout	Range = -32,768 to 32,767	0
492-015	Drum runout cal #08	Calibration values of the drum y-runout	Range = -32,768 to 32,767	0
492-016	Drum runout cal #09	Calibration values of the drum y-runout	Range = -32,768 to 32,767	0
492-017	Drum runout cal #10	Calibration values of the drum y-runout	Range = -32,768 to 32,767	0
492-018	Drum runout cal #11	Calibration values of the drum y-runout	Range = -32,768 to 32,767	0
492-019	Drum runout cal #12	Calibration values of the drum y-runout	Range = -32,768 to 32,767	0

Table 6 IOT NVM (IME) ID Range 489 to 499-xxx

NVM ID	NVM Name	NVM Description	Settings	Default
492-020	Drum runout cal #13	Calibration values of the drum y-runout	Range = -32,768 to 32,767	0
492-021	Drum runout cal #14	Calibration values of the drum y-runout	Range = -32,768 to 32,767	0
492-022	Drum runout cal #15	Calibration values of the drum y-runout	Range = -32,768 to 32,767	0
492-023	Drum runout cal #16	Calibration values of the drum y-runout	Range = -32,768 to 32,767	0
492-024	Drum runout cal #17	Calibration values of the drum y-runout	Range = -32,768 to 32,767	0
492-025	Drum runout cal #18	Calibration values of the drum y-runout	Range = -32,768 to 32,767	0
492-026	Drum runout cal #19	Calibration values of the drum y-runout	Range = -32,768 to 32,767	0
492-027	Drum runout cal #20	Calibration values of the drum y-runout	Range = -32,768 to 32,767	0
492-028	Drum runout cal #21	Calibration values of the drum y-runout	Range = -32,768 to 32,767	0
492-029	Drum runout cal #22	Calibration values of the drum y-runout	Range = -32,768 to 32,767	0
492-030	Drum runout cal #23	Calibration values of the drum y-runout	Range = -32,768 to 32,767	0
492-031	Drum runout cal #24	Calibration values of the drum y-runout	Range = -32,768 to 32,767	0
492-032	Drum runout cal #25	Calibration values of the drum y-runout	Range = -32,768 to 32,767	0
492-033	Drum runout cal #26	Calibration values of the drum y-runout	Range = -32,768 to 32,767	0
492-034	Drum runout cal #27	Calibration values of the drum y-runout	Range = -32,768 to 32,767	0
492-035	Drum runout cal #28	Calibration values of the drum y-runout	Range = -32,768 to 32,767	0
492-036	Drum runout cal #29	Calibration values of the drum y-runout	Range = -32,768 to 32,767	0
492-037	Drum runout cal #30	Calibration values of the drum y-runout	Range = -32,768 to 32,767	0
492-038	Drum runout cal #31	Calibration values of the drum y-runout	Range = -32,768 to 32,767	0
492-039	Drum runout cal #32	Calibration values of the drum y-runout	Range = -32,768 to 32,767	0
492-040	Drum runout cal #33	Calibration values of the drum y-runout	Range = -32,768 to 32,767	0
492-041	Drum runout cal #34	Calibration values of the drum y-runout	Range = -32,768 to 32,767	0

Table 6 IOT NVM (IME) ID Range 489 to 499-xxx

NVM ID	NVM Name	NVM Description	Settings	Default
492-042	Drum runout cal #35	Calibration values of the drum y-runout	Range = -32,768 to 32,767	0
492-043	Drum runout cal #36	Calibration values of the drum y-runout	Range = -32,768 to 32,767	0
492-044	Drum runout cal #37	Calibration values of the drum y-runout	Range = -32,768 to 32,767	0
492-045	Drum runout cal #38	Calibration values of the drum y-runout	Range = -32,768 to 32,767	0
492-046	Drum runout cal #39	Calibration values of the drum y-runout	Range = -32,768 to 32,767	0
492-047	Drum runout cal #40	Calibration values of the drum y-runout	Range = -32,768 to 32,767	0
492-048	Drum runout cal #41	Calibration values of the drum y-runout	Range = -32,768 to 32,767	0
492-049	Drum runout cal #42	Calibration values of the drum y-runout	Range = -32,768 to 32,767	0
492-050	Drum runout cal #43	Calibration values of the drum y-runout	Range = -32,768 to 32,767	0
492-051	Drum runout cal #44	Calibration values of the drum y-runout	Range = -32,768 to 32,767	0
492-052	Drum runout cal #45	Calibration values of the drum y-runout	Range = -32,768 to 32,767	0
492-053	Drum runout cal #46	Calibration values of the drum y-runout	Range = -32,768 to 32,767	0
492-054	Drum runout cal #47	Calibration values of the drum y-runout	Range = -32,768 to 32,767	0
492-055	Drum runout cal #48	Calibration values of the drum y-runout	Range = -32,768 to 32,767	0
492-056	Drum runout cal #49	Calibration values of the drum y-runout	Range = -32,768 to 32,767	0
492-057	Drum runout cal #50	Calibration values of the drum y-runout	Range = -32,768 to 32,767	0
492-058	Drum runout cal #51	Calibration values of the drum y-runout	Range = -32,768 to 32,767	0
492-059	Drum runout cal #52	Calibration values of the drum y-runout	Range = -32,768 to 32,767	0
492-060	Drum runout cal #53	Calibration values of the drum y-runout	Range = -32,768 to 32,767	0
492-061	Drum runout cal #54	Calibration values of the drum y-runout	Range = -32,768 to 32,767	0
492-062	Drum runout cal #55	Calibration values of the drum y-runout	Range = -32,768 to 32,767	0
492-063	Drum runout cal #56	Calibration values of the drum y-runout	Range = -32,768 to 32,767	0

Table 6 IOT NVM (IME) ID Range 489 to 499-xxx

NVM ID	NVM Name	NVM Description	Settings	Default
492-064	Drum runout cal #57	Calibration values of the drum y-runout	Range = -32,768 to 32,767	0
492-065	Drum runout cal #58	Calibration values of the drum y-runout	Range = -32,768 to 32,767	0
492-066	Drum runout cal #59	Calibration values of the drum y-runout	Range = -32,768 to 32,767	0
492-067	Drum runout cal #60	Calibration values of the drum y-runout	Range = -32,768 to 32,767	0
492-068	Drum run out offset	Drum y- run out offset	Range = 0 to 4,294,967,295	18
492-069	Drum runout tool State	Drum runout tool State	Range = 0 to 1	1
492-070	Prints On This Drum	Number of prints on the drum	Range = 0 to 4,294,967,295	0
493-001	Identification ID for the DMU	Identification ID for the DMU unit	Range = 0 to 4,294,967,295	0
493-002	SKU of the installed unit	SKU of the installed unit	Range = 0 to 255	0
498-001	Disable Hard Faults for PEST	If this flag is true, then when PEST is running the normal hard faults will behave as soft faults.	Range = 0 to 1	0
498-002	Pest Fault Override Parameter 1	Space reserved for PEST fault override	Range = - 32,768 to 32,767	- 1
498-003	Pest Fault Override Parameter 2	Space reserved for PEST fault override	Range = - 32,768 to 32,767	- 1
498-004	Pest Fault Override Parameter 3	Space reserved for PEST fault override	Range = - 32,768 to 32,767	- 1
498-005	Pest Fault Override Parameter 4	Space reserved for PEST fault override	Range = - 32,768 to 32,767	- 1
498-006	Pest Fault Override Parameter 5	Space reserved for PEST fault override	Range = - 32,768 to 32,767	- 1
498-007	Pest Fault Override Parameter 6	Space reserved for PEST fault override	Range = - 32,768 to 32,767	- 1
498-008	Pest Fault Override Parameter 7	Space reserved for PEST fault override	Range = - 32,768 to 32,767	- 1
498-009	Pest Fault Override Parameter 8	Space reserved for PEST fault override	Range = - 32,768 to 32,767	- 1
498-010	Pest Fault Override Parameter 9	Space reserved for PEST fault override	Range = - 32,768 to 32,767	- 1
498-011	Pest Fault Override Parameter 10	Space reserved for PEST fault override	Range = - 32,768 to 32,767	- 1
498-012	Pest Fault Override Parameter 11	Space reserved for PEST fault override	Range = - 32,768 to 32,767	- 1

Table 6 IOT NVM (IME) ID Range 489 to 499-xxx

NVM ID	NVM Name	NVM Description	Settings	Default
498-013	Pest Fault Override Parameter 12	Space reserved for PEST fault override	Range = - 32,768 to 32,767	- 1
498-014	Pest Fault Override Parameter 13	Space reserved for PEST fault override	Range = - 32,768 to 32,767	- 1
498-015	Pest Fault Override Parameter 14	Space reserved for PEST fault override	Range = - 32,768 to 32,767	- 1
498-016	Pest Fault Override Parameter 15	Space reserved for PEST fault override	Range = - 32,768 to 32,767	- 1
498-017	Pest Fault Override Parameter 16	Space reserved for PEST fault override	Range = - 32,768 to 32,767	- 1
498-018	Suppress PEST Fault Overrides	Space reserved for PEST fault override	0 = Do not suppress warning 1 = Suppress warnings Range = 0 to 1	0
499-001	LVDS frame format	Set LVDS frame format	Range = 0 to 2	2
499-002	Air accumulator is installed	Ink purge air accumulator is installed	1 = installed Range = 0 to 1	1
499-003	Lower carriage wiper engage	Lower printhead carriage when engaging wiper	Range = - 600 to 0	0
499-004	Upper carriage wiper engage	Upper printhead carriage when engaging wiper	Range = - 400 to 0	0
499-005	Fast decay stripper is installed	Fast decay stripper is installed	Range = 0 to 1	1
499-006	Spring damper stripper installed	Spring damper stripper mod is installed	Range = 0 to 1	0
499-007	Head adjust motor type	Head adjust motor type	Range = 0 to 65,535	1
499-008	Ink SKU motor type	Ink SKU motor type	Range = 0 to 65,535	1
499-009	Lp4c paper path motor2 installed	Lp4c paper path motor 2 is installed	Range = 0 to 1	0
499-010	Lp4c paper path motor6 installed	Lp4c paper path motor 6 is installed	Range = 0 to 1	0
499-011	Ink plate thermistor type	Ink plate thermistor PT312 is installed	Range = 0 to 1	1
499-012	Printhead carriage sensor post	Printhead carriage sensor flags are on the carriage frame	Range = 0 to 1	1
499-013	Finisher type	Type of finisher installed	Range = 0 to 65,535	255
499-014	PP1 Rev Melt Plate installed	The PP1 revision melt plate is installed	1 = installed Range = 0 to 1	0
499-015	PP1 Rev Ink Loader installed	The PP1 revision ink loader is installed	1 = installed Range = 0 to 1	0

Table 6 IOT NVM (IME) ID Range 489 to 499-xxx

NVM ID	NVM Name	NVM Description	Settings	Default
499-016	MSI HW Revision	Hardware Version of the MSI	Range = 0 to 1	1
499-017	Upper Stripper Guide Installed	Upper Stripper Guide is installed	Range = 0 to 1	1
499-018	Low Friction Stripper Installed	Low Friction Stripper Drive is installed	Range = 0 to 1	1
499-019	Finisher Input Skew Installed	Finisher Input Skew Upgrade has been installed	Range = 0 to 1	0
499-020	HW Config Spare 5	Hardware Config Spare value 5	Range = - 2,147,483,648 to 2,147,483,647	0
499-021	HW Config Spare 6	Hardware Config Spare value 6	Range = - 2,147,483,648 to 2,147,483,647	0
499-022	HW Config Spare 7	Hardware Config Spare value 7	Range = - 2,147,483,648 to 2,147,483,647	0
499-023	HW Config Spare 8	Hardware Config Spare value 8	Range = - 2,147,483,648 to 2,147,483,647	0
499-024	Upgrade Sensor 12 Location	Sensor 12 location with Idler Upgrade	Range = 25,440 to 26,740	26,240
499-025	Upgrade Sensor 15 Location	Sensor 15 location with Idler Upgrade	Range = 43,481 to 44,781	44,281
499-026	Manufacturing Use Only 1	Manufacturing Use Only 1	Range = 0 to 255	0
499-027	Manufacturing Mode	Indicates the system is in special manufacturing mode used during initial build of IME.	0 = Not in initial manufacturing mode 1 = Initial manufacturing mode Range = 0 to 1	0

Table 7 CCS NVM ID 600-xxx

NVM ID	NVM Name	NVM Description	Settings	Default
600-001	Compression Mode	Compression Mode	Range = 0 to 1	0
600-002	Reserved Blocks	Reserved blocks	Range = 0 to 5	0
600-003	Megs of Memory	Megs of memory	Range = 0 to 65,535	16
600-004	EPC memory low percent	EPC memory low percent	Range = 1 to 99	38
600-005	Disk Mode	Disk Mode	Range = 0 to 1	1
600-006	Memory Out Bound	Memory Out Bound	Range = 0 to 6	6

Table 7 CCS NVM ID 600-xxx

NVM ID	NVM Name	NVM Description	Settings	Default
600-007	EPC memory full percent	EPC memory full percent	Range = 1 to 99	12
600-008	Use Partial Blocks	Use Partial Blocks	Range = 0 to 1	1
600-009	BlockSize in K	Block size in K	Range = 200 to 200	200
600-010	Initial Blocks	initial blocks	Range = 12 to 24	12
600-011	Blocks Needed	Blocks Needed	Range = 8 to 20	8
600-012	Frame Size	Frame Size	Range = 923 to 923	923
600-013	Percent of Frame Size	Percent of frame size	Range = 1 to 99	70
600-014	Making mode when EPC full	Making mode when EPC full	Range = 0 to 3	0
600-015	Ram Size Mismatch Fault	Fault counter 19-750-00: Video EPC Size Mismatch Cntr	Range = 0 to 255	0
600-016	Disk Mode Mismatch Fault	Fault counter 19-754-00: Video Disk Mismatch Cntr	Range = 0 to 255	0
600-017	Out Memory Fault - StrNC docFC	Fault counter 19-401-00: Out memory fault - stress document	Range = 0 to 255	0
600-018	Compressor DVMA Timeout Fault	Fault counter 19-402-00: Fault Video DVMST Timeout fault (Compressor DVMA timeout fault)	Range = 0 to 255	0
600-019	Memory on Target	Amount of EPC memory	Range = 0 to 65535	512
600-020	AHA End of Record Fault	Fault counter 22-300-00: AHA end of record fault	Range = 0 to 255	0
600-021	Disk spin up delay time	Time before image disk receives power (sec)	Range = 0 to 30	10
600-022	Platinum Board Full Concurrency	Platinum board full concurrency	Range = 0 to 1	1
600-023	Image disk partition size	Image disk partition size	Range = 0 to 30	4
600-024	Image Disk Dirty	Image Disk Dirty	Range = 0 to 1	0
600-025	IJO Enabled	IJO Enabled	Range = 0 to 1	0
600-026	Disk Dirty at power up	Disk Dirty at power up	Range = 0 to 1	0
600-027	Maximum network read attempts	Value of maximum network read attempts	Range = 0 TO 255	3
600-028	KDrumPixelCount	K Drum Pixel Count	Range = 0 to 4,294,967,295	0
600-029	CDrumPixelCount	C Drum Pixel Count	Range = 0 to 4,294,967,295	0

Table 7 CCS NVM ID 600-xxx

NVM ID	NVM Name	NVM Description	Settings	Default
600-030	MDrumPixelCount	M Drum Pixel Count	Range = 0 to 4,294,967,295	0
600-031	YDrumPixelCount	Y Drum Pixel Count	Range = 0 to 4,294,967,295	0
600-032	vramLevel1RecThreshhold	vram Level1 Rec Threshold	Range = 0 to 4,294,967,295	471859200
600-033	vramLevel1TripThreshhold	vram Level 1 Trip Threshold	Range = 0 to 4,294,967,295	419430400
600-034	vramLevel2RecThreshhold	vram Level 2 Rec Threshold	Range = 0 to 4,294,967,295	367001600
600-035	vramLevel2TripThreshhold	vram Level 2 Trip Threshold	Range = 0 to 4,294,967,295	314572800
600-036	vramLevel3RecThreshhold	vram Level 3 Rec Threshold	Range = 0 to 4,294,967,295	256901120
600-037	vramLevel3TripThreshhold	vram Level 3 Trip Threshold	Range = 0 to 4,294,967,295	209715200
600-038	vramLevel4RecThreshhold	vram Level 4 Rec Threshold	Range = 0 to 4,294,967,295	175112192
600-039	vramLevel4TripThreshhold	vram Level 4 Trip Threshold	Range = 0 to 4,294,967,295	140509184
600-040	vramLevel5RecThreshhold	vram Level 5 Rec Threshold	Range = 0 to 4,294,967,295	105906176
600-041	vramLevel5TripThreshhold	vram Level 5 Trip Threshold	Range = 0 to 4,294,967,295	70254592
600-042	vramLevel6RecThreshhold	vram Level 6 Rec Threshold	Range = 0 to 4,294,967,295	35651584
600-043	vramLevel6TripThreshhold	vram Level 6 Trip Threshold	Range = 0 to 4,294,967,295	1048576
600-044	cacheAllImagesToDisk	CacheAllImagesToDisk	Range = 0 to 1	0
600-045	Total Black Pixel Count Low	Total black pixel count low	Range = 0 to 4,294,967,295	0
600-046	Total Black Pixel Count Up	Total black pixel count up	Range = 0 to 4,294,967,295	0
600-047	Total Cyan Pixel Count Low	Total cyan pixel count low	Range = 0 to 4,294,967,295	0
600-048	Total Cyan Pixel Count Up	Total cyan pixel count up	Range = 0 to 4,294,967,295	0
600-049	Total Magenta Pixel Count Low	Total magenta pixel count low	Range = 0 to 4,294,967,295	0
600-050	Total Magenta Pixel Count Up	Total magenta pixel count up	Range = 0 to 4,294,967,295	0
600-051	Total Yellow Pixel Count Low	Total yellow pixel count low	Range = 0 to 4,294,967,295	0

Table 7 CCS NVM ID 600-xxx

NVM ID	NVM Name	NVM Description	Settings	Default
600-052	Total yellow Pixel Count Up	Total yellow pixel count up	Range = 0 to 4.294.967,295	0
600-053	Total Black Run Mode AC INT	Total Black Run Mode AC INT	Range = 0 to 4.294.967,295	0
600-054	Total Cyan Color Mode AC INT	Total Cyan Color Mode AC INT	Range = 0 to 4.294.967,295	0
600-055	Total Magenta Color Mode AC INT	Total Magenta Color Mode AC INT	Range = 0 to 4.294.967,295	0
600-056	Total Yellow Color Mode AC INT	Total Yellow Color Mode AC INT	Range = 0 to 4.294.967,295	0
600-057	Total Black Color Mode AC INT	Total Black Color Mode AC INT	Range = 0 to 4.294.967,295	0
600-058	Toner Coverage Plane1-1	Toner Coverage Plane1-1	Range = 0 to 4.294.967,295	0
600-059	Toner Coverage Plane1-2	Toner Coverage Plane1-2	Range = 0 to 4.294.967,295	0
600-060	Toner Coverage Plane1-3	Toner Coverage Plane1-3	Range = 0 to 4.294.967,295	0
600-061	Toner Coverage Plane1-4	Toner Coverage Plane1-4	Range = 0 to 4.294.967,295	0
600-062	Toner Coverage Plane1-5	Toner Coverage Plane1-5	Range = 0 to 4.294.967,295	0
600-063	Toner Coverage Plane1-6	Toner Coverage Plane1-6	Range = 0 to 4.294.967,295	0
600-064	Toner Coverage Plane1-7	Toner Coverage Plane1-7	Range = 0 to 4.294.967,295	0
600-065	Toner Coverage Plane1-8	Toner Coverage Plane1-8	Range = 0 to 4.294.967,295	0
600-066	Toner Coverage Plane1-9	Toner Coverage Plane1-9	Range = 0 to 4.294.967,295	0
600-067	Toner Coverage Plane1-10	Toner Coverage Plane1-10	Range = 0 to 4.294.967,295	0
600-068	Toner Coverage Plane1-11	Toner Coverage Plane1-11	Range = 0 to 4.294.967,295	0
600-069	Toner Coverage Plane1-12	Toner Coverage Plane1-12	Range = 0 to 4.294.967,295	0
600-070	Toner Coverage Plane1-13	Toner Coverage Plane1-13	Range = 0 to 4.294.967,295	0
600-071	Toner Coverage Plane1-14	Toner Coverage Plane1-14	Range = 0 to 4.294.967,295	0
600-072	Toner Coverage Plane1-15	Toner Coverage Plane1-15	Range = 0 to 4.294.967,295	0

Table 7 CCS NVM ID 600-xxx

NVM ID	NVM Name	NVM Description	Settings	Default
600-073	Toner Coverage Plane1-16	Toner Coverage Plane1-16	Range = 0 to 4.294.967,295	0
600-074	Toner Coverage Plane1-17	Toner Coverage Plane1-17	Range = 0 to 4.294.967,295	0
600-075	Toner Coverage Plane1-18	Toner Coverage Plane1-18	Range = 0 to 4.294.967,295	0
600-076	Toner Coverage Plane1-19	Toner Coverage Plane1-19	Range = 0 to 4.294.967,295	0
600-077	Toner Coverage Plane2-1	Toner Coverage Plane2-1	Range = 0 to 4.294.967,295	0
600-078	Toner Coverage Plane2-2	Toner Coverage Plane2-2	Range = 0 to 4.294.967,295	0
600-079	Toner Coverage Plane2-3	Toner Coverage Plane2-3	Range = 0 to 4.294.967,295	0
600-080	Toner Coverage Plane2-4	Toner Coverage Plane2-4	Range = 0 to 4.294.967,295	0
600-081	Toner Coverage Plane2-5	Toner Coverage Plane2-5	Range = 0 to 4.294.967,295	0
600-082	Toner Coverage Plane2-6	Toner Coverage Plane2-6	Range = 0 to 4.294.967,295	0
600-083	Toner Coverage Plane2-7	Toner Coverage Plane2-7	Range = 0 to 4.294.967,295	0
600-084	Toner Coverage Plane2-8	Toner Coverage Plane2-8	Range = 0 to 4.294.967,295	0
600-085	Toner Coverage Plane2-9	Toner Coverage Plane2-9	Range = 0 to 4.294.967,295	0
600-086	Toner Coverage Plane2-10	Toner Coverage Plane2-10	Range = 0 to 4.294.967,295	0
600-087	Toner Coverage Plane2-11	Toner Coverage Plane2-11	Range = 0 to 4.294.967,295	0
600-088	Toner Coverage Plane2-12	Toner Coverage Plane2-12	Range = 0 to 4.294.967,295	0
600-089	Toner Coverage Plane2-13	Toner Coverage Plane2-13	Range = 0 to 4.294.967,295	0
600-090	Toner Coverage Plane2-14	Toner Coverage Plane2-14	Range = 0 to 4.294.967,295	0
600-091	Toner Coverage Plane2-15	Toner Coverage Plane2-15	Range = 0 to 4.294.967,295	0
600-092	Toner Coverage Plane2-16	Toner Coverage Plane2-16	Range = 0 to 4.294.967,295	0
600-093	Toner Coverage Plane2-17	Toner Coverage Plane2-17	Range = 0 to 4.294.967,295	0
600-094	Toner Coverage Plane2-18	Toner Coverage Plane2-18	Range = 0 to 4.294.967,295	0

Table 7 CCS NVM ID 600-xxx

NVM ID	NVM Name	NVM Description	Settings	Default
600-095	Toner Coverage Plane2-19	Toner Coverage Plane2-19	Range = 0 to 4.294.967,295	0
600-096	Toner Coverage Plane3-1	Toner Coverage Plane3-1	Range = 0 to 4.294.967,295	0
600-097	Toner Coverage Plane3-2	Toner Coverage Plane3-2	Range = 0 to 4.294.967,295	0
600-098	Toner Coverage Plane3-3	Toner Coverage Plane3-3	Range = 0 to 4.294.967,295	0
600-099	Toner Coverage Plane3-4	Toner Coverage Plane3-4	Range = 0 to 4.294.967,295	0
600-100	Toner Coverage Plane3-5	Toner Coverage Plane3-5	Range = 0 to 4.294.967,295	0
600-101	Toner Coverage Plane3-6	Toner Coverage Plane3-6	Range = 0 to 4.294.967,295	0
600-102	Toner Coverage Plane3-7	Toner Coverage Plane3-7	Range = 0 to 4.294.967,295	0
600-103	Toner Coverage Plane3-8	Toner Coverage Plane3-8	Range = 0 to 4.294.967,295	0
600-104	Toner Coverage Plane3-9	Toner Coverage Plane3-9	Range = 0 to 4.294.967,295	0
600-105	Toner Coverage Plane3-10	Toner Coverage Plane3-10	Range = 0 to 4.294.967,295	0
600-106	Toner Coverage Plane3-11	Toner Coverage Plane3-11	Range = 0 to 4.294.967,295	0
600-107	Toner Coverage Plane3-12	Toner Coverage Plane3-12	Range = 0 to 4.294.967,295	0
600-108	Toner Coverage Plane3-13	Toner Coverage Plane3-13	Range = 0 to 4.294.967,295	0
600-109	Toner Coverage Plane3-14	Toner Coverage Plane3-14	Range = 0 to 4.294.967,295	0
600-110	Toner Coverage Plane3-15	Toner Coverage Plane3-15	Range = 0 to 4.294.967,295	0
600-111	Toner Coverage Plane3-16	Toner Coverage Plane3-16	Range = 0 to 4.294.967,295	0
600-112	Toner Coverage Plane3-17	Toner Coverage Plane3-17	Range = 0 to 4.294.967,295	0
600-113	Toner Coverage Plane3-18	Toner Coverage Plane3-18	Range = 0 to 4.294.967,295	0
600-114	Toner Coverage Plane3-19	Toner Coverage Plane3-19	Range = 0 to 4.294.967,295	0
600-115	Toner Coverage Plane4-1	Toner Coverage Plane4-1	Range = 0 to 4.294.967,295	0
600-116	Toner Coverage Plane4-2	Toner Coverage Plane4-2	Range = 0 to 4.294.967,295	0

Table 7 CCS NVM ID 600-xxx

NVM ID	NVM Name	NVM Description	Settings	Default
600-117	Toner Coverage Plane4-3	Toner Coverage Plane4-3	Range = 0 to 4.294.967,295	0
600-118	Toner Coverage Plane4-4	Toner Coverage Plane4-4	Range = 0 to 4.294.967,295	0
600-119	Toner Coverage Plane4-5	Toner Coverage Plane4-5	Range = 0 to 4.294.967,295	0
600-120	Toner Coverage Plane4-6	Toner Coverage Plane4-6	Range = 0 to 4.294.967,295	0
600-121	Toner Coverage Plane4-7	Toner Coverage Plane4-7	Range = 0 to 4.294.967,295	0
600-122	Toner Coverage Plane4-8	Toner Coverage Plane4-8	Range = 0 to 4.294.967,295	0
600-123	Toner Coverage Plane4-9	Toner Coverage Plane4-9	Range = 0 to 4.294.967,295	0
600-124	Toner Coverage Plane4-10	Toner Coverage Plane4-10	Range = 0 to 4.294.967,295	0
600-125	Toner Coverage Plane4-11	Toner Coverage Plane4-11	Range = 0 to 4.294.967,295	0
600-126	Toner Coverage Plane4-12	Toner Coverage Plane4-12	Range = 0 to 4.294.967,295	0
600-127	Toner Coverage Plane4-13	Toner Coverage Plane4-13	Range = 0 to 4.294.967,295	0
600-128	Toner Coverage Plane4-14	Toner Coverage Plane4-14	Range = 0 to 4.294.967,295	0
600-129	Toner Coverage Plane4-15	Toner Coverage Plane4-15	Range = 0 to 4.294.967,295	0
600-130	Toner Coverage Plane4-16	Toner Coverage Plane4-16	Range = 0 to 4.294.967,295	0
600-131	Toner Coverage Plane4-17	Toner Coverage Plane4-17	Range = 0 to 4.294.967,295	0
600-132	Toner Coverage Plane4-18	Toner Coverage Plane4-18	Range = 0 to 4.294.967,295	0
600-133	Toner Coverage Plane4-19	Toner Coverage Plane4-19	Range = 0 to 4.294.967,295	0
600-134	Total Black Marked Images	Total Black Marked Images	Range = 0 to 4.294.967,295	0
600-135	Total Black Marked Color Images	Total Black Marked Color Images	Range = 0 to 4.294.967,295	0
600-136	Total Cyan Marked Color Images	Total Cyan Marked Color Images	Range = 0 to 4.294.967,295	0
600-137	Total Magenta Marked Color Images	Total Magenta Marked Color Images	Range = 0 to 4.294.967,295	0

Table 7 CCS NVM ID 600-xxx

NVM ID	NVM Name	NVM Description	Settings	Default
600-138	Total Yellow Marked Color Images	Total Yellow Marked Color Images	Range = 0 to 4.294.967,295	0
600-139	Total Black Run Mode AC FP	Total Black Run Mode AC FP	Range = 0 to 4.294.967,295	0
600-140	Total Cyan Color Mode AC FP	Total Cyan Color Mode AC FP	Range = 0 to 4.294.967,295	0
600-141	Total Yellow Color Mode AC FP	Total Yellow Color Mode AC FP	Range = 0 to 4.294.967,295	0
600-142	Total Magenta Color Mode AC FP	Total Magenta Color Mode AC FP	Range = 0 to 4.294.967,295	0
600-143	Total Black Color Mode AC FP	Total Black Color Mode AC FP	Range = 0 to 4.294.967,295	0
600-145	10 to 11% Black Area Coverage	Black area coverage impressions > 10 to 11% Total number of impressions between 10 - 11% Black page coverage. Image area coverage Plane 1-20	Range = 0 to 4.294.967,295	0
600-147	11 to 12% Black Area Coverage	Black area coverage impressions > 11 to 12% Total number of impressions between 11 - 12% Black page coverage. Image area coverage Plane 1-21	Range = 0 to 4.294.967,295	0
600-149	13 to 16% Black Area Coverage	Black area coverage impressions > 13 to 16% Total number of impressions between 13 - 16% Black page coverage. Image area coverage Plane 1-22	Range = 0 to 4.294.967,295	0
600-151	17 to 20% Black Area Coverage	Black area coverage impressions > 17 to 20% Total number of impressions between 17 - 20% Black page coverage. Image area coverage Plane 1-23	Range = 0 to 4.294.967,295	0

Table 7 CCS NVM ID 600-xxx

NVM ID	NVM Name	NVM Description	Settings	Default
600-153	10 to 11% Cyan Area Coverage	Cyan area coverage impressions > 10 to 11% Total number of impressions between 10 - 11% Cyan page coverage. Image area coverage Plane 2-20	Range = 0 to 4.294.967,295	0
600-155	11 to 12% Cyan Area Coverage	Cyan area coverage impressions > 11 to 12% Total number of impressions between 10 - 11% Cyan page coverage. Image area coverage Plane 2-21	Range = 0 to 4.294.967,295	0
600-157	13 to 16% Cyan Area Coverage	Cyan area coverage impressions > 13 to 16% Total number of impressions between 13 - 17% Cyan page coverage. Image area coverage Plane 2-22	Range = 0 to 4.294.967,295	0
600-159	17 to 20% Cyan Area Coverage	Cyan area coverage impressions > 17 to 20% Total number of impressions between 17 - 20% Cyan page coverage. Image area coverage Plane 2-23	Range = 0 to 4.294.967,295	0
600-161	10 to 11% Magenta Area Coverage	Magenta area coverage impressions > 10 to 11% Total number of impressions between 10 - 11% Magenta page coverage. Image area coverage Plane 3-20	Range = 0 to 4.294.967,295	0
600-163	11 to 12% Magenta Area Coverage	Magenta area coverage impressions > 11 to 12% Total number of impressions between 11 - 12% Magenta page coverage. Image area coverage Plane 3-21	Range = 0 to 4.294.967,295	0

Table 7 CCS NVM ID 600-xxx

NVM ID	NVM Name	NVM Description	Settings	Default
600-165	13 to 16% Magenta Area Coverage	Magenta area coverage impressions > 13 to 16% Total number of impressions between 13 - 16% Magenta page coverage. Image area coverage Plane 3-22	Range = 0 to 4,294,967,295	0
600-167	17 to 20% Magenta Area Coverage	Magenta area coverage impressions > 17 to 20% Total number of impressions between 17 - 20% Magenta page coverage. Image area coverage Plane 3-23	Range = 0 to 4,294,967,295	0
600-169	10 to 11% Yellow Area Coverage	Yellow area coverage impressions > 10 to 11% Total number of impressions between 10 - 11% Yellow page coverage. Image area coverage Plane 4-20	Range = 0 to 4,294,967,295	0
600-171	11 to 12% Yellow Area Coverage	Yellow area coverage impressions > 11 to 12% Total number of impressions between 11 - 12% Yellow page coverage. Image area coverage Plane 4-21	Range = 0 to 4,294,967,295	0
600-173	13 to 16% Yellow Area Coverage	Yellow area coverage impressions > 13 to 16% Total number of impressions between 13 - 16% Yellow page coverage. Image area coverage Plane 4-22	Range = 0 to 4,294,967,295	0
600-175	17 to 20% Yellow Area Coverage	Yellow area coverage impressions > 17 to 20% Total number of impressions between 17 - 20% Yellow page coverage. Image area coverage Plane 4-23	Range = 0 to 4,294,967,295	0

Table 8 CCS NVM ID 602-xxx

NVM ID	NVM Name	NVM Description	Settings	Default
602-001	DiagJobIDGenerator		Range = 1 to 999	1
602-002	Head Purge Mode Policy	Head purge mode Automatic head fix - Clean printheads setting	0 = Never (auto head purge disabled) 1 = Immediately (Perform an auto head purge immediately when blocked jets detected) 2 = When idle (Perform a head purge during the next idle time window) Range = 0 to 2	1
602-003	Jet Substitution Policy	Jet substitution mode Automatic head fix - temporary fix setting	0 = Never (jet substitution is disabled) 1 = Immediately (Initiate jet substitution immediately a blocked jet is detected) Range = 0 to 1	1
602-004	Cust init Jetfix Jet Sub	Customer initiated Jetfix Substitution Integer count of customer selecting 'Quick fix banding' that resulted in Jet substitution numTotalJetFixJetSubstitution	Range = 0 to 65535	0
602-005	Cust Init Jetfix Purge	Customer initiated Jetfix Purge Integer count of customer selecting 'Quick fix banding' that resulted in a purge numTotalJetFixPurge	Range = 0 to 65535	0
602-006	Cust Init Jetfix No Problem	Customer initiated Jetfix No Problem Integer count of customer selecting 'Quick fix banding' that resulted in no problem found by IOD numTotalJetFixNoProblem	Range = 0 to 65535	0

Table 8 CCS NVM ID 602-xxx

NVM ID	NVM Name	NVM Description	Settings	Default
602-007	Cust Init Jetfix Head Align	Customer initiated Jetfix Head Align Adjust Integer count of customer selecting 'Quick fix banding' that resulted head alignment adjusted numTotalJetFixHeadAlign-Adjust	Range = 0 to 65535	0

Table 9 CCS NVM ID 603-xxx

NVM ID	NVM Name	NVM Description	Settings	Default
603-001	ARPSPaper-Sizeinterval	Interval of APS recognition of standard size (mm)	Range = 1 to 65535	5
603-002	APSStandardSizeRequired	Determines whether APS requires input to be a standard size.	0 = False (off) 1 = True (On) Range = 0 to 1	0
603-003	CopySimplexOutputStart	Number of images inputted before simplex copy job is released for marking	Range = 0 to 65535	1
603-004	CopyDuplexOutputStart	Number of images inputted before duplex copy job is released for marking	Range = 0 to 65535	4
603-005	CopyJobPriority	The priority set by SA / KO of copy job (used for job contention)	Range = 0 to 65535	3
603-006	NextCopyJobID	Value of next copy jobs ID	Range = 1 to 999	1
603-007	Counter-COPY-Markedimages-COPYMarkedImages	Counter - copy marked images	Range = 0 to 16777215	0
603-008	COPYMarkedImagesDisplayable	Determines whether copy marked images counter is displayable.	0 = False 1 = True Range = 0 to 1	1
603-009	Counter-COPY-Sheets	Counter-COPY Sheets	Range = 0 to 16777215	0
603-010	COPYSheetsDisplayable	Determines whether copy sheets counter is displayable	0 = False 1 = True Range = 0 to 1	0
603-011	Counter-COPY-DuplexSheets	Counter-COPY Duplex Sheets	Range = 0 to 16777215	0

Table 9 CCS NVM ID 603-xxx

NVM ID	NVM Name	NVM Description	Settings	Default
603-012	COPYDuplex-SheetsDisplayable	Determines whether copy duplex sheets counter is displayable	0 = False 1 = True Range = 0 to 1	0
603-013	Counter-COPY-LargeSheets	Counter-COPY large sheets	Range = 0 to 16777215	0
603-014	COPY-LargeSheetsDisplayable	Determines whether copy 11x17 inch and A3 sheets counter is displayable	0 = False 1 = True Range = 0 to 1	0
603-015	Not displayed	Counter-COPY simplex platen jobs	Range = 0 to 16777215	0
603-016	Not displayed	Counter-COPY duplex platen jobs	Range = 0 to 16777215	0
603-017	Not displayed	Counter-COPY DADH jobs	Range = 0 to 16777215	0
603-018	Not displayed	Counter-COPY build jobs	Range = 0 to 16777215	0
603-019	Not displayed	Counter-COPY set from jobs	Range = 0 to 16777215	0
603-020	Not displayed	Counter-COPY single set jobs	Range = 0 to 16777215	0
603-021	Not displayed	Counter-COPY platen scans	Range = 0 to 16777215	0
603-022	Not displayed	Counter-COPY DADH side 1 scans	Range = 0 to 16777215	0
603-023	Not displayed	Counter-COPY DADH side 2 scans	Range = 0 to 16777215	0
603-024	crashRecovery-Enabled	Determines whether copy job recovery is enabled	0 = False 1 = True Range = 0 to 1	1
603-025	ABSPres-canAllowed	Disable and enable ABS pre-scan	0 = False 1 = True Range = 0 to 1	0
603-026	Not displayed	Counter-Copy Job CR Data	Range = 0 to 16777215	0
603-027	Not displayed	Counter-Scan document programme data	Range = 0 to 16777215	0
603-028	Not displayed	Counter-Processing document programme	Range = 0 to 16777215	0
603-029	Not displayed	Counter-Mark document programme data	Range = 0 to 16777215	0
603-030	Not displayed	Counter-Job programme data	Range = 0 to 16777215	0
603-031	Not displayed	Counter-Scan Job CR Data	Range = 0 to 16777215	0

Table 9 CCS NVM ID 603-xxx

NVM ID	NVM Name	NVM Description	Settings	Default
603-032	Not displayed	Counter-Processing job programme	Range = 0 to 16777215	0
603-033	Not displayed	Counter-Mark job programme data	Range = 0 to 16777215	0
603-034	Not displayed	Counter-Copy job defaults	Range = 0 to 16777215	0
603-035	Not displayed	Counter-Copy documents default	Range = 0 to 16777215	0
603-036	COPYMarkedColorImagesDisplay	Determines whether copy image counter is displayable	0 = False 1 = True Range = 0 to 1	1
603-037	COPYColorSheetsDisplay	Determines whether color copy sheets counter is displayable	0 = False 1 = True Range = 0 to 1	0
603-038	COPYDuplexColorSheetsDisplay	Determines whether color copy duplex sheets counter is displayable	0 = False 1 = True Range = 0 to 1	0
603-039	COPYLargeColorSheetsDisplay	Determines whether large copy sheets counter is displayable	0 = False 1 = True Range = 0 to 1	0
603-040	Not displayed	Counter-Copy color sheets	Range = 0 to 16777215	0
603-041	Not displayed	Counter-Copy large color sheets	Range = 0 to 16777215	0
603-042	Not displayed	Counter-Copy duplex color sheets	Range = 0 to 16777215	0
603-043	Not displayed	Counter-Copy marked color images	Range = 0 to 16777215	0
603-044	Not displayed	Counter-SJ job info	Range = 0 to 16777215	0
603-045	Not displayed	Counter-SJ doc info	Range = 0 to 16777215	0
603-046	CopyJobReleaseThreshold	CopyJobReleaseThreshold	Range = 1 to 4	1
603-048	Platen Copied Lifetime Images	Platen Copied Lifetime ImagesNumber of images that have been scanned off the platen glass that were for Copy jobs.	Range = 0 to 16777215	0
603-049	ADF Copied Lifetime Images	ADF Copied Lifetime ImagesNumber of images that have been scanned from the ADF that were for Copy jobs.	Range = 0 to 16777215	0

Table 10 CCS NVM ID 604-001 to 604-299

NVM ID	NVM Name	NVM Description	Settings	Default
604-001	Feeder Module Type	Defines the feeder module types	0 = Invalid Module 55 = SMH 57 = HCF 58 = HCF with covers 60 = PFP (tray 5) 62 = Envelope Feeder 221 = Standard PFP (tray 5) 223 = Large Kit PFP A4 LEF / A3 SEF 224 = Short edge kit A4 SEF 225 = Short edge kit Letter SEF / Legal SEF Range = 0 to 255	0
604-002	Finisher Module Type	Defines the finisher module type that has been detected by the system (Read only)	65 = OCT 100 = No finisher 110 = 2K LCSS 171 = HVF 172 = HVF BM 173 = HVF inserter 174 = HVF BM Inserter 175 = HVF Tri-folder 176 = HVF Tri-folder Inserter Range = 65 to 255	
604-004	MSDefaultColor	Defines the default color	0 = White 1 = Green 2 = Buff 3 = Yellow 4 = Golden rod 5 = Blue 6 = Pink 7 = Transparent 8 = Ivory 9 = Gray 10 = Red 11 = Orange Range = 0 to 20	0

Table 10 CCS NVM ID 604-001 to 604-299

NVM ID	NVM Name	NVM Description	Settings	Default
604-006	MSDefaultType	Defines default type	0 = Standard 1 = Drilled (pre-punched) 2 = Envelopes 4 = Transparency 5 = Letter head 6 = Labels 7 = Recycled Range = 0 to 60	0
604-008	MSDefaultWeight	Defines medium weight (not used) (gsm)	Range = 56 to 203	75
604-010	PEAutoResume	Resume time out settings in seconds	0 = Disabled > 0 = time in seconds (sec) Range = 0 to 120	30
604-017	PrintModuleInfo	Debug switch settings	0 = Off 1 = On Range = 0 to 1	0
604-019	Counter-Marked-Images	Stores the count of all small / medium black printed images when traditional billing configuration is set	Range = 0 to 16777215	0
604-021	Total Images Displayable	Enable display of total images 0 = false, 1 = true	0 = Off 1 = On Range = 0 to 1	1
604-025	Not displayed	Counter - Collated Sheets	Range = 0 to 16777215	0
604-028	Not displayed	Counter - Dual Staples	Range = 0 to 16777215	0
604-031	Not displayed	Counter - Envelopes	Range = 0 to 16777215	0
604-034	Not displayed	Counter-Folded Sheets	Range = 0 to 16777215	0
604-037	Not displayed	Counter-Punched Sheets	Range = 0 to 16777215	0
604-040	Not displayed	Counter - Outboard Staples	Range = 0 to 16777215	0
604-043	Not displayed	Counter - Inboard Staples	Range = 0 to 16777215	0
604-046	Not displayed	Counter -Staples sheets	Range = 0 to 16777215	0
604-049	Not displayed	Counter - Tabs	Range = 0 to 16777215	0
604-052	Not displayed	Counter - Transparencies	Range = 0 to 16777215	0

Table 10 CCS NVM ID 604-001 to 604-299

NVM ID	NVM Name	NVM Description	Settings	Default
604-055	Not displayed	Counter - Collated staples	Range = 0 to 16777215	0
604-058	Not displayed	Counter - Single Pitch Images	Range = 0 to 16777215	0
604-061	Not displayed	Counter - Dual Pitch Images	Range = 0 to 16777215	0
604-064	Not displayed	Counter - Stapled 2_15	Range = 0 to 16777215	0
604-067	Not displayed	Counter - Stapled 16_30	Range = 0 to 16777215	0
604-070	MSDefaultFinisherAR	Default finisher auto resume settings	0 = Disabled > 0 = time in seconds (sec) Range = 0 to 120	30
604-084	MSFaceUpEnabled	Enable face up setting	0 = Off (normal delivery) 1 = Deliver face up Range = 0 to 1	0
604-090	Not displayed	Images During Service Call	Range = 0 to 16777215	0
604-092	Not displayed	Images During Service Call	Range = 0 to 16777215	0
604-094	Not displayed	Sheet Out Of Sequence	Range = 0 to 16777215	0
604-099	Not displayed	Module Registration Error	Range = 0 to 16777215	0
604-101	Not displayed	No Completions Error	Range = 0 to 16777215	0
604-105	Not displayed	Completion While Idle	Range = 0 to 16777215	0
604-107	Not displayed	Tray Does not Exist	Range = 0 to 16777215	0
604-109	Not displayed	No Finisher Capability Found	Range = 0 to 16777215	0
604-111	Not displayed	No IOT Capability Found	Range = 0 to 16777215	0
604-112	MSDefaultTray-Train		Range 0 to 2	0
604-113	MSDefaultTray-Stack		Range 0 to 1	0
604-114	MSDefaultTrayId		Range 0 to 4	0
604-115	Propose Count No Finisher		Range 2 to 16	12
604-116	LastJobIDToRecover	Last job ID to recover	Range 0 to 65535	0

Table 10 CCS NVM ID 604-001 to 604-299

NVM ID	NVM Name	NVM Description	Settings	Default
604-117	Not displayed	Last document ID to recover - doc to recover	Range 0 to 65535	0
604-118	LastImage-IDToRecover	Last image ID to recover	Range 0 to 65535	0
604-119	IOTCommFault-Count	IOT Comm Fault Count	Range 0 to 3	0
604-120	PrintPagesCompleted	Print Pages Completed	Range 0 to 65535	0
604-121	SetsCompleted	Last set Completed	Range 0 to 65535	0
604-122	LastService-IDToRecover	Last service ID to recover	Range 0 to 65535	0
604-123	QtyToRecover	Quantity to recover	Range 0 to 65535	0
604-124	Not displayed	Tag matrix	Range 0 to 65535	0
604-125	MSDefaultDecurler	Default decurler level settings	0 = Low decurler 1 = Normal decurler 2 = High decurler Range 0 to 2	1
604-126	Not displayed	Serial number	Range 0 to 1	0
604-127	MSOffsetEnabledPolicy	Enable offset policy	0 = Off 1 = On Range 0 to 1	0
604-128	SerNumSet	Serial number set	Range 0 to 1	0
604-129	MSOutOfStaplesPolicy	Out of staples policy setting	0 = Hold 1 = Stapling defeated Range 0 to 1	1
604-131	ProdCfgNvm	ProdCfgNvm	Range 0 to 65535	0
604-132	Last sheet to recover	Last sheet to recover	Range 0 to 108	106
604-133	TotalQuantity-Made	Total quantity requested for the current job	Range 0 to 65535	0
604-134	ModuleHas-BeenSetUp	Module has been set up	Range 0 to 1	0
604-135	Not displayed	Counter - Stapled31_50	Range 0 to 16777215	0
604-136	Not displayed	Counter - Stapled51_100	Range 0 to 16777215	0
604-137	Propose Count MCSS Finisher	Propose Count MCSS Finisher	Range 2 to 16	12
604-138	IOT Diag Enter TO SEC	IOT Diag Enter TO SEC	Range = 0 to 1800	30
604-139	IOT Diag Exit TO SEC	IOT Diag Exit TO SEC	Range = 0 to 1800	30
604-140	IOT Diag Test Pattern TO SEC	IOT Diag Test Pattern TO SEC	Range = 0 to 1800	0
604-141	IOT Diag Device Status TO SEC	IOT Diag Device Status TO SEC	Range = 0 to 1800	0

Table 10 CCS NVM ID 604-001 to 604-299

NVM ID	NVM Name	NVM Description	Settings	Default
604-142	IOT Diag Analog Monitor TO SEC	IOT Diag Analog Monitor TO SEC	Range = 0 to 1800	0
604-143	IOT Diag In Out Manual TO SEC	IOT Diag In Out Manual TO SEC	Range = 0 to 1800	0
604-144	IOT Diag PP Timing TO SEC	IOT Diag PP Timing TO SEC	Range = 0 to 1800	0
604-145	IOT Diag MSI Side Guide TO SEC	IOT Diag MSI side guide TO SEC	Range = 0 to 1800	0
604-146	IOT Diag Sys Regi TO SEC	IOT Diag Sys Regi TO SEC	Range = 0 to 1800	0
604-147	IOT Diag Reg Setup TO SEC	IOT Diag Reg Setup TO SEC	Range = 0 to 1800	0
604-148	IOT Diag Reg Check TO SEC	IOT Diag Reg Check TO SEC	Range = 0 to 1800	0
604-149	IOT Diag Reg Sens Check TO SEC	IOT Diag Reg Sens Check TO SEC	Range = 0 to 1800	0
604-150	IOT ATC Sensor Setup TO SEC	IOT ATC Sensor Setup TO SEC	Range = 0 to 1800	0
604-151	IOT Diag Belt Edge Learn TO SEC	IOT Diag Belt Edge Learn TO SEC	Range = 0 to 1800	0
604-152	IOT TRC Adjust TO SEC	IOT TRC Adjust TO SEC	Range = 0 to 1800	0
604-153	IOT Diag Tone Up Down TO SEC	IOT Diag Tone Up Down TO SEC	Range = 0 to 1800	0
604-154	IOT Diag No Paper Run TO SEC	IOT Diag No Paper Run TO SEC	Range = 0 to 1800	0
604-155	IOT Diag ProCon On Off TO SEC	IOT Diag ProCon ON Off TO SEC	Range = 0 to 1800	0
604-156	IOT Diag Binary Cal TO SEC	IOT Diag Binary Cal TO SEC	Range = 0 to 1800	0
604-157	IOT Diag Fold Position TO SEC	IOT Diag Fold Position TO SEC	Range = 0 to 1800	0
604-158	IOT Diag CTRACS TO SEC	IOT Diag CTRACS TO SEC	Range = 0 to 1800	0
604-159	IOT Diag Comp Ctrl TO SEC	IOT Diag Comp Ctrl TO SEC	Range = 0 to 1800	0
604-160	CCMCannotCommunicateWithlotFC	Fault counter 03-316: CCM Cannot Communicate With lot FC	Range = 0 to 255	0

Table 10 CCS NVM ID 604-001 to 604-299

NVM ID	NVM Name	NVM Description	Settings	Default
604-171	BookletInSnrOnJamFault-CountFC	Fault counter 12-113: Booklet in Snr On Jam Fault-Count FC	Range = 0 to 255	0
604-172	BookletInSnrOffJamFault-CountFC	Fault counter 12-114: Booklet in Snr Off Jam Fault-Count FC	Range = 0 to 255	0
604-174	GateSnrOnJamFaultCountFC	Fault counter 12-125: Gate Snr On Jam Fault Count FC	Range = 0 to 255	0
604-175	XportEntSnrOnJamFault-CountFC	Xport Ent Snr On Jam Fault Count FC	Range = 0 to 255	0
604-176	BufferPathSnrOnJamFault-CountFC	Fault counter 12-142: Buffer Path Snr On Jam Fault Count FC	Range = 0 to 255	0
604-177	CompilerExitSnrOffJamFC	Fault counter 12-151: Compiler Exit Snr Off Jam FC	Range = 0 to 255	0
604-178	CompilerExitSnrOnJamFault-CountFC	Fault counter 12-152: Compiler Exit Snr On Jam Fault Count FC	Range = 0 to 255	0
604-181	TopTrayExitSnrOnJamFault-CountFC	Fault counter 12-171: Top Tray Exit Snr On Jam Fault Count FC	Range = 0 to 255	0
604-182	TopTrayExitSnrOffJamFault-CountFC	Fault counter 12-172: Top Tray Exit Snr Off Jam Fault Count FC	Range = 0 to 255	0
604-241	OCTOffsetFail-CountFC	Fault counter 12-701: OCT Offset Fail Count FC	Range = 0 to 255	0
604-271	Tray1MisfeedJamCountFC	Fault counter 71-101: Tray 1 Misfeed Jam Count FC	Range = 0 to 255	0
604-275	Tray2MisfeedJamCountFC	Fault counter 72-101: Tray 2 Misfeed Jam Count FC	Range = 0 to 255	0
604-280	Tray3MisfeedJamCountFC	Fault counter 73-101: Tray 3 Misfeed Jam Count FC	Range = 0 to 255	0
604-285	Tray4MisfeedJamCountFC	Fault counter 74-101: Tray 4 Misfeed Jam Count FC	Range = 0 to 255	0

Table 11 CCS NVM ID 604-300 to 604-656

NVM ID	NVM Name	NVM Description	Settings	Default
604-372	DFinBufferPathSnrOffJam FC	Fault Counter 12-141: DFin-BufferPathSnrOffJam FC	Range = 0 to 255	0
604-397	Not displayed	TotalIOTJamsC30-TotalIOTJamsC30	Range = 0 to 16777215	0

Table 11 CCS NVM ID 604-300 to 604-656

NVM ID	NVM Name	NVM Description	Settings	Default
604-398	Not displayed	AttemptedFeedsfromBypassTrayC39-AttemptedFeedsfromBypassTrayC39	Range = 0 to 16777215	0
604-399	Not displayed	ActualFeedsfromBypassTrayC40-ActualFeedsfromBypassTrayC40	Range = 0 to 16777215	0
604-400	Not displayed	AttemptedPaperFeedsC32-AttemptedPaperFeedsC32	Range = 0 to 16777215	0
604-401	Not displayed	ActualPaperFeedsC33-ActualPaperFeedsC33	Range = 0 to 16777215	0
604-402	Not displayed	KnownJamsinFinishingdevicesC31-KnownJamsinFinishingdevicesC31	Range = 0 to 16777215	0
604-403	Not displayed	AllsheetsfedfromTray1-AllsheetsfedfromTray1	Range = 0 to 16777215	0
604-404	Not displayed	AllsheetsfedfromTray2-AllsheetsfedfromTray2	Range = 0 to 16777215	0
604-405	Not displayed	AllsheetsfedfromTray3-AllsheetsfedfromTray3	Range = 0 to 16777215	0
604-406	Not displayed	AllsheetsfedfromTray4-AllsheetsfedfromTray4	Range = 0 to 16777215	0
604-407	Not displayed	AllsheetsfedfromBypassTray-AllsheetsfedfromBypassTray	Range = 0 to 16777215	0
604-408	Not displayed	TotalSheetsside1-TotalSheetsside1	Range = 0 to 16777215	0
604-409	Not displayed	TotalSheetsside1and2-TotalSheetsside1and2	Range = 0 to 16777215	0
604-410	Not displayed	TotalFeedsTray1-TotalFeedsTray1	Range = 0 to 16777215	0
604-411	Not displayed	TotalFeedsTray2-TotalFeedsTray2	Range = 0 to 16777215	0
604-412	Not displayed	TotalFeedsTray3-TotalFeedsTray3	Range = 0 to 16777215	0
604-413	Not displayed	TotalFeedsTray4-TotalFeedsTray4	Range = 0 to 16777215	0
604-414	Not displayed	TotalFeedsBypassTray-TotalFeedsBypassTray	Range = 0 to 16777215	0
604-415	MSDefaultPrint-Bin	# of Bins	Range = 0 to 5	4
604-416	MSDefaultCopy-Bin	# of bins	Range = 0 to 5	4
604-417	MSDefaultFaxBin	# of bins	Range = 0 to 5	0

Table 11 CCS NVM ID 604-300 to 604-656

NVM ID	NVM Name	NVM Description	Settings	Default
604-418	MSDefault-OtherBin	# of bins	Range = 0 to 5	4
604-419	MSAutoHoldEnable	Enable auto hold	Enable Auto Hold settings: 0 = Off 1 = On Range = 0 to 1	1
604-420	InterruptingJobID-ToRecover	Interrupt job to recover # of jobs	Range = 0 to 65535	0
604-421	Not displayed	Interrupt document to recover # of documents-docToRecover	Range = 0 to 65535	0
604-422	InterruptImage-IDToRecover	Interrupt image to recover # of images	Range = 0 to 65535	0
604-423	InterruptPagesCompleted	Interrupt pages completed	Range = 0 to 65535	0
604-424	Interrupting-SetsCompleted	Interrupt set to recover # of sets	Range = 0 to 65535	0
604-425	InterruptingLast-ServiceID	Interrupt service to recover # of services	Range = 0 to 65535	0
604-426	QtyToRecover;	Interrupt quantity to recover	Range = 0 to 65535	0
604-427	lastSheetToRecover	Interrupt last sheet to recover	Range = 0 to 65535	0
604-428	MSMediaSize-ConvPolicy	Media Size Conversion Policy	Media Size Conversion Policy settings: 0=Off 1=On Range = 0 to 1	1
604-429	LastFinishing-CapIDToRecover	Last capability ID that sheet were being delivered to for a normal job. Used to ensure sheets are delivered to the correct tray after crash recovery	Range = 0 to 65535	0
604-430	LastIntFinishing-CapIDToRecover	Last capability ID that sheet were being delivered to for an interrupt job. Used to ensure sheets are delivered to the correct tray after crash recovery	Range = 0 to 65535	0
604-431	InterruptingQuantityMade	Interrupting quantity made	Range = 0 to 65535	0
604-432	MSInvertDuplex		Range = 0 to 1	0
604-433	MSMirrorInvert-Duplex		Range = 0 to 1	0
604-434	Total Color Images Displayable		Range = 0 to 1	0

Table 11 CCS NVM ID 604-300 to 604-656

NVM ID	NVM Name	NVM Description	Settings	Default
604-435	Total BW and Color Images Displayable	Total BW and Color Images Displayable	Range = 0 to 1	0
604-436	Not displayed	MarkedColorImages	Range = 0 to 16777215	0
604-437	Not displayed	MarkedBWColorImages	Range = 0 to 16777215	0
604-438	Not displayed	OCT Total Sheets	Range = 0 to 16777215	0
604-439	Not displayed	LargeMarkedBlackImages	Range = 0 to 16777215	0
604-440	Not displayed	LargeMarkedColorImages	Range = 0 to 16777215	0
604-441	Not displayed	LargeMarkedImages	Range = 0 to 16777215	0
604-442	MSMediaSize-Group	Media Order Group	1 = MSGXc 2 = MSGXe 3 = MSGFx 4 = MSGFxap 5 = MSGGco 6 = MSGDmoEast 7 = MSGDmoWest Range = 0 to 7	1
604-443	MSMediaSizeConvPolicy85x14	Media size conversion policy 8.5 x 14 inch to larger size	0 = Off 1 = On Range 0 to 1	1
604-444	T5MisfeedJamCount	Fault counter 75-101: Fault Counter:T5 Misfeed Jam	Number of faults Range = 0 to 255	0
604-445	LElateT1ToTAR1FC	Fault counter 71-106: LE late to TAR1 sensor from T1 Fault Counter-LElateT1ToTAR1FC	Number of faults Range = 0 to 255	0
604-446	LElateT2ToTAR1FC	Fault counter 72-110: LE late to TAR1 sensor from T2 Fault Counter-LElateT2ToTAR1FC	Number of faults Range = 0 to 255	0
604-447	LElateToTAR2FC	Fault counter 72-106: LE late to TAR2 sensor Fault Counter-LElateToTAR2FC	Number of faults Range = 0 to 255	0
604-448	LElateToTAR3FC	Fault counter 73-106: LE late to TAR3 sensor Fault Counter-LElateToTAR3FC	Number of faults Range = 0 to 255	0
604-449	LElateToFeederHTFC	Fault counter 73-110: LE late to Feeder HT sensor Fault Counter-LElateToFeederHTFC	Number of faults Range = 0 to 255	0

Table 11 CCS NVM ID 604-300 to 604-656

NVM ID	NVM Name	NVM Description	Settings	Default
604-450	MSINudgerFailureFC	Fault counter 74-214: MSI Nudger failure Fault Counter-MSINudgerFailureFC	Number of faults Range = 0 to 255	0
604-451	T1HoistFailureFC	Fault counter 71-215: T1 hoist failure Fault Counter-T1HoistFailureFC	Number of faults Range = 0 to 255	0
604-452	T2HoistFailureFC	Fault counter 72-215: T2 hoist failure Fault Counter-T2HoistFailureFC	Number of faults Range = 0 to 255	0
604-453	T3HoistFailureFC	Fault counter 73-215: T3 hoist failure Fault Counter-T3HoistFailureFC	Number of faults Range = 0 to 255	0
604-454	T3HoistEncoderFailFC	Fault counter 73-212: T3 encoder failure on hoist Fault Counter-T3HoistEncoderFailFC	Number of faults Range = 0 to 255	0
604-455	T4LowerEncoderFailFC	Fault counter 75-213: T5 encoder failure on lower Fault Counter-T4LowerEncoderFailFC	Number of faults Range = 0 to 255	0
604-456	T4HoistEncoderFailFC	Fault counter 75-212: T5 encoder failure on hoist Fault Counter-T4HoistEncoderFailFC	Number of faults Range = 0 to 255	0
604-457	MSIGuides-MoveInRunFC	Fault counter 74-120: MSI guides move in run Fault Counter-MSIGuidesMoveInRunFC	Number of faults Range = 0 to 255	0
604-458	T1OpenInRunFC	Fault counter 71-320: T1 opened in run Fault Counter-T1OpenInRunFC	Number of faults Range = 0 to 255	0
604-459	T2OpenInRunFC	Fault counter 72-320: T2 opened in run Fault Counter-T2OpenInRunFC	Number of faults Range = 0 to 255	0
604-460	T3OpenInRunFC	Fault counter 73-320: T3 opened in run Fault Counter-T3OpenInRunFC	Number of faults Range = 0 to 255	0
604-461	T4UndockedInRunFC	Fault counter 75-325: T5 undocked in run Fault Counter-T4UndockedInRunFC	Number of faults Range = 0 to 255	0
604-462	FeederHTOpenInRunFC	Fault counter 73-325: Feeder HT drawer opened in run Fault Counter-FeederHTOpenInRunFC	Number of faults Range = 0 to 255	0

Table 11 CCS NVM ID 604-300 to 604-656

NVM ID	NVM Name	NVM Description	Settings	Default
604-463	FeederVTOpenInRunFC	Fault counter 70-325: Feeder VT door opened in run Fault Counter-FeederVTOpenInRunFC	Number of faults Range = 0 to 255	0
604-464	IMEtoT123CommsFailFC	Fault counter 70-312: IME to T1-3 comms failure Fault Counter-IMEtoT123CommsFailFC	Number of faults Range = 0 to 255	0
604-465	IMEtoT5CommsFailFC	Fault counter 75-312: IME to T5 comms failure Fault Counter-IMEtoT5CommsFailFC	Number of faults Range = 0 to 255	0
604-467	ImeOvercurr24VSupplyFC	Fault counter for 01-525: Over current 24V supply-ImeOvercurr24VSupplyFC	Number of faults Range = 0 to 255	0
604-468	ImeOvercurr48VSupplyFC	Fault counter for 01-530: Over current 48V supply-ImeOvercurr48VSupplyFC	Number of faults Range = 0 to 255	0
604-469	ImeMPS11SheetTooLongFC	Fault counter for 10-110: IME Media Path Sensor 11 sheet too long-ImeMPS11SheetTooLongFC	Number of faults Range = 0 to 255	0
604-470	ImeMPS11SheetTooShortFC	Fault counter for 10-111: IME Media Path Sensor 11 sheet too short-ImeMPS11SheetTooShortFC	Number of faults Range = 0 to 255	0
604-471	ImeMPS11LETimeoutFC	Fault counter for 10-112: IME Media Path Sensor 11 LE timeout-ImeMPS11LETimeoutFC	Number of faults Range = 0 to 255	0
604-472	ImeMPS11TETimeoutFC	Fault counter for 10-113: IME Media Path Sensor 11 TE timeout-ImeMPS11TETimeoutFC	Number of faults Range = 0 to 255	0
604-473	ImeMPS12SheetTooLongFC	Fault counter for 10-125: IME Media Path Sensor 12 sheet too long-ImeMPS12SheetTooLongFC	Number of faults Range = 0 to 255	0
604-474	ImeMPS12SheetTooShortFC	Fault counter for 10-126: IME Media Path Sensor 12 sheet too short-ImeMPS12SheetTooShortFC	Number of faults Range = 0 to 255	0
604-475	ImeMPS12LETimeoutFC	Fault counter for 10-127: IME Media Path Sensor 12 LE timeout-ImeMPS12LETimeoutFC	Number of faults Range = 0 to 255	0
604-476	ImeMPS12TETimeoutFC	Fault counter for 10-128: IME Media Path Sensor 12 TE timeout-ImeMPS12TETimeoutFC	Number of faults Range = 0 to 255	0

Table 11 CCS NVM ID 604-300 to 604-656

NVM ID	NVM Name	NVM Description	Settings	Default
604-477	ImeMPS15SheetTooLongFC	Fault counter for 10-140: IME Media Path Sensor 15 sheet too long-ImeMPS15SheetTooLongFC	Number of faults Range = 0 to 255	0
604-478	ImeMPS15SheetTooShortFC	Fault counter for 10-141: IME Media Path Sensor 15 sheet too short-ImeMPS15SheetTooShortFC	Number of faults Range = 0 to 255	0
604-479	ImeMPInvS15SheetTooLongFC	Fault counter for 10-142: IME Media Path Invert Sensor 15 sheet too long-ImeMPInvS15SheetTooLongFC	Number of faults Range = 0 to 255	0
604-480	ImeMPInvS15SheetTooShortFC	Fault counter for 10-143: IME Media Path Invert Sensor 15 sheet too short-ImeMPInvS15SheetTooShortFC	Number of faults Range = 0 to 255	0
604-481	ImeMPS15LETimeoutFC	Fault counter for 10-144: IME Media Path Sensor 15 LE timeout-ImeMPS15LETimeoutFC	Number of faults Range = 0 to 255	0
604-482	ImeMPS15TETimeoutFC	Fault counter for 10-145: IME Media Path Sensor 15 TE timeout	Number of faults Range = 0 to 255	0
604-483	ImeMPInvS15LETimeoutFC	Fault counter for 10-146: IME Media Path Invert Sensor 15 LE timeout	Number of faults Range = 0 to 255	0
604-484	ImeTfixLoadFrontForceFailFC	Fault counter for 10-500: IME Transfix Load front force failure	Number of faults Range = 0 to 255	0
604-485	ImeTfixLoadRearForceFailFC	Fault counter for 10-505: IME Transfix Load rear force failure	Number of faults Range = 0 to 255	0
604-486	ImeTfixLoadTimingErrFC	Fault counter for 10-510: IME Transfix Load timing error	Number of faults Range = 0 to 255	0
604-489	ImeTfixLoadMotorFailFC	Fault counter for 10-525: IME Transfix Load Home Motor disable failure	Number of faults Range = 0 to 255	0
604-490	ImeTfixGapSetFailedFC	Fault counter for 10-530: IME Transfix gap set failed	Number of faults Range = 0 to 255	0
604-491	ImeTfixLoadCalFailFC	Fault counter for 10-535: IME Transfix Load calibration failure	Number of faults Range = 0 to 255	0
604-492	ImeTfixTaskLateFC	Fault counter for 10-540: IME Transfix task late	Number of faults Range = 0 to 255	0
604-493	ImeTfixDrumInitPosWrongFC	Fault counter for 10-545: IME Transfix Drum initial position wrong	Number of faults Range = 0 to 255	0

Table 11 CCS NVM ID 604-300 to 604-656

NVM ID	NVM Name	NVM Description	Settings	Default
604-494	ImeTfixDrumStallFC	Fault counter for 10-550: IME Transfix Drum stall	Number of faults Range = 0 to 255	0
604-495	ImePostTransfixMtr(M4)OvercurrFC	Fault counter for 10-555: IME M4 over current	Number of faults Range = 0 to 255	0
604-496	ImeTfixFrontOvercurrFC	Fault counter for 10-560: IME Transfix front over current	Number of faults Range = 0 to 255	0
604-497	ImeTfixRearOvercurrFC	Fault counter for 10-565: IME Transfix rear over current	Number of faults Range = 0 to 255	0
604-499	ImeAbatFanOvercurrFC	Fault counter for 42-505: IME Abatement fan over current	Number of faults Range = 0 to 255	0
604-500	ImeVertTransS5SheetTooEarlyFC	Fault counter for 82-110: IME Media Path Sensor 5 sheet too early	Number of faults Range = 0 to 255	0
604-501	ImeVertTransS5SheetMisLongFC	Fault counter for 82-111: IME Media Path Sensor 5 sheet mismatch long	Number of faults Range = 0 to 255	0
604-502	ImeVertTransS5SheetMisShortFC	Fault counter for 82-112: IME Media Path Sensor 5 sheet mismatch short	Number of faults Range = 0 to 255	0
604-503	ImeVertTransS5LETimeoutFC	Fault counter for 82-113: IME Media Path Sensor 5 LE timeout	Number of faults Range = 0 to 255	0
604-504	ImeVertTransS5TETimeoutFC	Fault Counter 82-114: IME Vertical Trans Sensor 5 TE timeout	Number of faults Range = 0 to 255	0
604-505	ImeConfirms16SheetTooEarlyFC	Fault counter for 82-125: IME Media Path Sensor 16 sheet too early	Number of faults Range = 0 to 255	0
604-506	ImeConfirms16SheetTooLongFC	Fault counter for 82-126: IME Media Path Sensor 16 sheet too long	Number of faults Range = 0 to 255	0
604-507	ImeMPS16SheetTooShortFC	Fault counter for 82-127: IME Media Path Sensor 16 sheet too short	Number of faults Range = 0 to 255	0
604-508	ImeConfirms16SheetMisLongFC	Fault counter for 82-128: IME Media Path Sensor 16 sheet mismatch long	Number of faults Range = 0 to 255	0
604-509	ImeConfirms16SheetMisShortFC	Fault counter for 82-129: IME Media Path Sensor 16 sheet mismatch short	Number of faults Range = 0 to 255	0
604-510	ImeConfirms16LETimeoutFC	Fault counter for 82-130: IME Media Path Sensor 16 LE timeout	Number of faults Range = 0 to 255	0

Table 11 CCS NVM ID 604-300 to 604-656

NVM ID	NVM Name	NVM Description	Settings	Default
604-511	ImeConfirms16TETimeoutFC	Fault counter for 82-131: IME Media Path Sensor 16 TE timeout	Number of faults Range = 0 to 255	0
604-512	ImeConfirmDuplexS16LETimeoutFC	Fault counter for 82-132: IME Media Path Duplex Sensor 16 LE timeout	Number of faults Range = 0 to 255	0
604-513	ImeDuplexEndSheetTooWideFC	Fault counter for 82-140: IME Media Path sheet too wide	Number of faults Range = 0 to 255	0
604-514	ImeDuplexEndS14SheetTooEarlyFC	Fault counter for 82-141: IME Media Path Sensor 14 sheet too early	Number of faults Range = 0 to 255	0
604-515	ImeMPSheetTooNarrowFC	Fault counter for 82-142: IME Media Path sheet too narrow	Number of faults Range = 0 to 255	0
604-516	ImeDuplexEndS14SheetTooLongFC	Fault counter for 82-145: IME Media Path Sensor 14 sheet too long	Number of faults Range = 0 to 255	0
604-517	ImeDuplexEndS14SheetTooShortFC	Fault counter for 82-146: IME Media Path Sensor 14 sheet too short	Number of faults Range = 0 to 255	0
604-518	ImeDuplexEndS14LETimeoutFC	Fault counter for 82-147: IME Media Path Sensor 14 LE timeout	Number of faults Range = 0 to 255	0
604-519	ImeDuplexEndS14TETimeoutFC	Fault counter for 82-148: IME Media Path Sensor 14 TE timeout	Number of faults Range = 0 to 255	0
604-521	ImeDuplexEndS14LETimeoutFCa	Fault counter for 82-150: IME Media Path Duplex Sensor 14 LE timeout	Number of faults Range = 0 to 255	0
604-522	ImeDuplexEndS14TETimeoutFCa	Fault counter for 82-151: IME Media Path Duplex Sensor 14 TE timeout	Number of faults Range = 0 to 255	0
604-523	ImeVertTransMotor (M2)OvercurrFC	Fault counter for 82-500: IME M2 over current	Number of faults Range = 0 to 255	0
604-524	ImeVertTransMotor(M2)StalledFC	Fault Counter 82-501: IME Vert Trans Motor (M2) stalled	Number of faults Range = 0 to 255	0
604-525	ImeHorzTransMotor (M6)OvercurrFC	Fault Counter 82-502: IME Horiz Trans Motor (M6) over current	Number of faults Range = 0 to 255	0
604-526	ImeHorzTransMotor(M6)StalledFC	Fault counter for 82-503: IME M6 stalled	Number of faults Range = 0 to 255	0
604-527	ImeNipCSolOvercurrFC	Fault counter for 82-507: IME Nip C solenoid over current	Number of faults Range = 0 to 255	0

Table 11 CCS NVM ID 604-300 to 604-656

NVM ID	NVM Name	NVM Description	Settings	Default
604-528	ImeNipDSolOvercurrFC	Fault counter for 82-508: IME Nip D solenoid over current	Number of faults Range = 0 to 255	0
604-529	ImeTrailerCalcFailFC	Fault counter for 82-510: IME Trailer slowdown calculation fail	Number of faults Range = 0 to 255	0
604-530	ImeMPS13SheetTooLongFC	Fault counter for 83-110: IME Media Path Sensor 13 sheet too long	Number of faults Range = 0 to 255	0
604-531	ImeMPS13SheetTooShortFC	Fault counter for 83-111: IME Media Path Sensor 13 sheet too short	Number of faults Range = 0 to 255	0
604-532	ImeMPInvS13SheetTooLongFC	Fault counter for 83-112: IME Media Path Invert Sensor 13 sheet too long	Number of faults Range = 0 to 255	0
604-533	ImeDupStartInvS13SheetTooShortFC	Fault counter for 83-113: IME Media Path Invert Sensor 13 sheet too short	Number of faults Range = 0 to 255	0
604-534	ImeDupStartS13LETimeoutFC	Fault counter for 83-114: IME Media Path Sensor 13 LE timeout	Number of faults Range = 0 to 255	0
604-535	ImeDupStartS13TETimeoutFC	Fault Counter 83-115: IME Duplex Start Sensor 13 TE timeout	Number of faults Range = 0 to 255	0
604-536	ImeDupStartInvS13LETimeoutFC	Fault Counter 83-116: IME Duplex Start Invert Sensor 13 LE timeout	Number of faults Range = 0 to 255	0
604-537	ImeDupStartInvS13TETimeoutFC	Fault Counter 83-117: IME Duplex Start Invert Sensor 13 TE timeout	Number of faults Range = 0 to 255	0
604-538	ImeExitMotorFwd(M5)OvercurrFC	Fault counter for 83-500: IME M5 over current	Number of faults Range = 0 to 255	0
604-539	ImeDiverterSolOvercurrFC	Fault counter for 83-504: IME Diverter solenoid over current	Number of faults Range = 0 to 255	0
604-540	ImeDuplexSolOvercurrFC	Fault counter for 83-506: IME Duplex solenoid over current	Number of faults Range = 0 to 255	0
604-541	ImePreheatTooHotFC	Fault counter for 88-500: IME Preheat heater is too hot	Number of faults Range = 0 to 255	0
604-542	ImePreheatTooSlowFC	Fault counter for 88-501: IME Preheat is heating too slow	Number of faults Range = 0 to 255	0
604-543	ImePreheatThermFailFC	Fault counter for 88-502: IME Preheat thermistor failure	Number of faults Range = 0 to 255	0
604-544	ImeRegAirPumpOverCurrFC	Fault counter for 88-508: IME RALPH Air PuM Over Curr	Number of faults Range = 0 to 255	0

Table 11 CCS NVM ID 604-300 to 604-656

NVM ID	NVM Name	NVM Description	Settings	Default
604-545	ImeMPS10SheetTooLongFC	Fault counter for 89-110: IME Media Path Sensor 10 sheet too long	Number of faults Range = 0 to 255	0
604-546	ImeMPS10SheetTooShortFC	Fault counter for 89-111: IME Media Path Sensor 10 sheet too Short	Number of faults Range = 0 to 255	0
604-547	ImeMPS10LETimeoutFC	Fault counter for 89-112: IME Media Path Sensor 10 LE timeout	Number of faults Range = 0 to 255	0
604-548	ImeMPS10TETimeoutFC	Fault counter for 89-113: IME Media Path Sensor 10 TE timeout	Number of faults Range = 0 to 255	0
604-549	ImeMPS20SheetTooLongFC	Fault counter for 89-125: IME Media Path Sensor 20 sheet too Long	Number of faults Range = 0 to 255	0
604-550	ImeMPS20SheetTooShortFC	Fault counter for 89-126: IME Media Path Sensor 20 sheet too Short	Number of faults Range = 0 to 255	0
604-551	ImeMPS20LETimeoutFC	Fault counter for 89-127: IME Media Path Sensor 20 LE timeout	Number of faults Range = 0 to 255	0
604-552	ImeMPS20TETimeoutFC	Fault counter for 89-128: IME Media Path Sensor 20 TE timeout	Number of faults Range = 0 to 255	0
604-553	ImeMPSheetTooTateAtNipAFC	Fault counter for 89-129: IME Media Path sheet too tate at Nip A	Number of faults Range = 0 to 255	0
604-554	ImeM3_1OvercurrFC	Fault counter for 89-500: IME M3_1 over current	Number of faults Range = 0 to 255	0
604-555	ImeM3_2OvercurrFC	Fault counter for 89-502: IME M3_2 over current	Number of faults Range = 0 to 255	0
604-556	ImeLatDriveOvercurrFC	Fault counter for 89-504: IME Lat sensor drive over current	Number of faults Range = 0 to 255	0
604-560	ImeStanceSensorTimeoutFC	Fault counter for 89-520: IME Stance sensor timeout	Number of faults Range = 0 to 255	0
604-562	ImeRegFailedDetectLateralEdgeFC	Fault counter for 89-531: IME Registration Scanner failed to detect lateral edge	Number of faults Range = 0 to 255	0
604-563	ImeScanTimedOutFC	Fault counter for 89-532: IME Scan timed out and failed to complete normally	Number of faults Range = 0 to 255	0
604-564	ImeRegProcFailFC	Fault counter for 89-540: IME Registration processing failure	Number of faults Range = 0 to 255	0

Table 11 CCS NVM ID 604-300 to 604-656

NVM ID	NVM Name	NVM Description	Settings	Default
604-565	ImeRegProcLENotDetectedFC	Fault counter for 89-541: IME Registration processing leading edge not detected	Number of faults Range = 0 to 255	0
604-566	ImeRegProcLateralEdgeNotDetFC	Fault counter for 89-542: IME Registration processing lateral edge not detected	Number of faults Range = 0 to 255	0
604-567	ImeRegProcLEErrFC	Fault counter for 89-543: IME Registration processing leading edge error	Number of faults Range = 0 to 255	0
604-568	ImeRegProcLateralEdgeErrFC	Fault counter for 89-544: IME Registration processing lateral edge error	Number of faults Range = 0 to 255	0
604-569	ImeRegProcLECrossingToSmallFC	Fault counter for 89-545: IME Registration processing leading edge crossing to small	Number of faults Range = 0 to 255	0
604-570	ImeRegSkewExcessiveFC	Fault counter for 89-550: IME Registration skew excessive	Number of faults Range = 0 to 255	0
604-571	ImeRegOffsetExcessiveFC	Fault counter for 89-551: IME Registration offset excessive	Number of faults Range = 0 to 255	0
604-572	ImeHeadInitPosErrFC	Fault counter for 91-500: IME Printheads initial position error	Number of faults Range = 0 to 255	0
604-573	ImeHeadImagingTimingErrFC	Fault counter for 91-501: IME Printheads imaging timing error	Number of faults Range = 0 to 255	0
604-574	ImeMarkingSequenceTimingErrFC	Fault counter for 91-502: IME Marking sequence timing error	Number of faults Range = 0 to 255	0
604-575	ImePrintImageDataTimeoutFC	Fault counter for 91-503: IME Print image data timeout	Number of faults Range = 0 to 255	0
604-576	ImeHead3StitchOvercurrFC	Fault counter for 91-504: IME Printhead 3 stitch over current	Number of faults Range = 0 to 255	0
604-577	ImeHead4StitchOvercurrFC	Fault counter for 91-505: IME Printhead 4 stitch over current	Number of faults Range = 0 to 255	0
604-578	ImeHead1RollOvercurrFC	Fault counter for 91-506: IME Printhead 1 roll over current	Number of faults Range = 0 to 255	0
604-579	ImeHead2RollOvercurrFC	Fault counter for 91-507: IME Printhead 2 roll over current	Number of faults Range = 0 to 255	0
604-580	ImeHead3RollOvercurrFC	Fault counter for 91-508: IME Printhead 3 roll over current	Number of faults Range = 0 to 255	0
604-581	ImeHead4RollOvercurrFC	Fault counter for 91-509: IME Printhead 4 roll over current	Number of faults Range = 0 to 255	0
604-582	ImeUpperXAOvercurrFC	Fault counter for 91-510: IME Upper XA over current	Number of faults Range = 0 to 255	0
604-583	ImeLowerXAOvercurrFC	Fault counter for 91-511: IME Lower XA over current	Number of faults Range = 0 to 255	0

Table 11 CCS NVM ID 604-300 to 604-656

NVM ID	NVM Name	NVM Description	Settings	Default
604-584	ImeCarriageDriveOvercurrFC	Fault counter for 91-512: IME Carriage drive over current	Number of faults Range = 0 to 255	0
604-585	ImeIODDriveOvercurrFC	Fault counter for 91-513: IME IOD drive over current	Number of faults Range = 0 to 255	0
604-586	ImeIODDriveStallFC	Fault counter for 91-514: IME IOD drive stall	Number of faults Range = 0 to 255	0
604-587	ImeHMVertOvercurrFC	Fault counter for 91-515: IME HM vertical over current	Number of faults Range = 0 to 255	0
604-588	ImeLowPressureAssistOvercurrFC	Fault counter for 91-516: IME Low Pressure Assist over current	Number of faults Range = 0 to 255	0
604-589	ImeMUAirPumOvercurrFC	Fault counter for 91-517: IME MU Air Pum over current	Number of faults Range = 0 to 255	0
604-591	ImeHead1NvramErrFC	Fault counter for 91-519: IME Printhead 1 NVRam error	Number of faults Range = 0 to 255	0
604-592	ImeHead2NvramErrFC	Fault counter for 91-520: IME Printhead 2 NVRam error	Number of faults Range = 0 to 255	0
604-593	ImeHead3NvramErrFC	Fault counter for 91-521: IME Printhead 3 NVRam error	Number of faults Range = 0 to 255	0
604-594	ImeHead4NvramErrFC	Fault counter for 91-522: IME Printhead 4 NVRam error	Number of faults Range = 0 to 255	0
604-595	ImeHead1LHeaterTooHotFC	Fault counter for 91-523: IME Printhead 1 left jet heater is too hot	Number of faults Range = 0 to 255	0
604-596	ImeHead2LHeaterTooHotFC	Fault counter for 91-524: IME Printhead 2 left jet heater is too hot	Number of faults Range = 0 to 255	0
604-597	ImeHead3LHeaterTooHotFC	Fault counter for 91-525: IME Printhead 3 left jet heater is too hot	Number of faults Range = 0 to 255	0
604-598	ImeHead4LHeaterTooHotFC	Fault counter for 91-526: IME Printhead 4 left jet heater is too hot	Number of faults Range = 0 to 255	0
604-599	ImeHead1LHeaterTooSlowFC	Fault counter for 91-527: IME Printhead 1 left jet heater is too slow	Number of faults Range = 0 to 255	0
604-600	ImeHead2LHeaterTooSlowFC	Fault Counter 91-528: IME Print Head 2 left jet heater is too slow	Number of faults sRange = 0 to 255	0
604-601	ImeHead3LHeaterTooSlowFC	Fault counter for 91-529: IME Printhead 3 left jet heater is too slow	Number of faults Range = 0 to 255	0
604-602	ImeHead4LHeaterTooSlowFC	Fault counter for 91-530: IME Printhead 4 left jet heater is too slow	Number of faults Range = 0 to 255	0

Table 11 CCS NVM ID 604-300 to 604-656

NVM ID	NVM Name	NVM Description	Settings	Default
604-603	ImeHead1LeftThermBadReadingFC	Fault counter for 91-531: IME Printhead 1 left jet thermistor bad reading	Number of faults Range = 0 to 255	0
604-604	ImeHead2LeftThermBadReadingFC	Fault counter for 91-532: IME Printhead 2 left jet thermistor bad reading	Number of faults Range = 0 to 255	0
604-605	ImeHead3LeftThermBadReadingFC	Fault counter for 91-533: IME Printhead 3 left jet thermistor bad reading	Number of faults Range = 0 to 255	0
604-606	ImeHead4LeftThermBadReadingFC	Fault counter for 91-534: IME Printhead 4 left jet thermistor bad reading	Number of faults Range = 0 to 255	0
604-607	ImeHead1RHeaterTooHotFC	Fault counter for 91-535: IME Printhead 1 right jet heater too hot	Number of faults Range = 0 to 255	0
604-608	ImeHead2RHeaterTooHotFC	Fault counter for 91-536: IME Printhead 2 right jet heater too hot	Number of faults Range = 0 to 255	0
604-609	ImeHead3RHeaterTooHotFC	Fault counter for 91-537: IME Printhead 3 right jet heater too hot	Number of faults Range = 0 to 255	0
604-610	ImeHead4RHeaterTooHotFC	Fault counter for 91-538: IME Printhead 4 right jet heater too hot	Number of faults Range = 0 to 255	0
604-611	ImeHead1RHeaterTooSlowFC	Fault counter for 91-539: IME Printhead 1 right jet heater too slow	Number of faults Range = 0 to 255	0
604-612	ImeHead2RHeaterTooSlowFC	Fault counter for 91-540: IME Printhead 2 right jet heater too slow	Number of faults Range = 0 to 255	0
604-613	ImeHead3RHeaterTooSlowFC	Fault counter for 91-541: IME Printhead 3 right jet heater too slow	Number of faults Range = 0 to 255	0
604-614	ImeHead4RHeaterTooSlowFC	Fault counter for 91-542: IME Printhead 4 right jet heater too slow	Number of faults Range = 0 to 255	0
604-615	ImeHead1RightThermBadReadingFC	Fault counter for 91-543: IME Printhead 1 right jet thermistor bad reading	Number of faults Range = 0 to 255	0
604-616	ImeHead2RightThermBadReadingFC	Fault counter for 91-544: IME Printhead 2 right jet thermistor bad reading	Number of faults Range = 0 to 255	0
604-617	ImeHead3RightThermBadReadingFC	Fault counter for 91-545: IME Printhead 3 right jet thermistor bad reading	Number of faults Range = 0 to 255	0

Table 11 CCS NVM ID 604-300 to 604-656

NVM ID	NVM Name	NVM Description	Settings	Default
604-618	ImeHead4RightThermBadReadingFC	Fault counter for 91-546: IME Printhead 4 right jet thermistor bad reading	Number of faults Range = 0 to 255	0
604-619	ImeHead1ResHeaterTooHotFC	Fault counter for 91-547: IME Printhead 1 reservoir heater too hot	Number of faults Range = 0 to 255	0
604-620	ImeHead2ResHeaterTooHotFC	Fault counter for 91-548: IME Printhead 2 reservoir heater too hot	Number of faults Range = 0 to 255	0
604-621	ImeHead3ResHeaterTooHotFC	Fault counter for 91-549: IME Printhead 3 reservoir heater too hot	Number of faults Range = 0 to 255	0
604-622	ImeHead4ResHeaterTooHotFC	Fault counter for 91-550: IME Printhead 4 reservoir heater too hot	Number of faults Range = 0 to 255	0
604-623	ImeHead1ResHeaterTooSlowFC	Fault counter for 91-551: IME Printhead 1 reservoir heater too slow	Number of faults Range = 0 to 255	0
604-624	ImeHead2ResHeaterTooSlowFC	Fault counter for 91-552: IME Printhead 2 reservoir heater too slow	Number of faults Range = 0 to 255	0
604-625	ImeHead3ResHeaterTooSlowFC	Fault counter for 91-553: IME Printhead 3 reservoir heater too slow	Number of faults Range = 0 to 255	0
604-626	ImeHead4ResHeaterTooSlowFC	Fault counter for 91-554: IME Printhead 4 reservoir heater too slow	Number of faults Range = 0 to 255	0
604-627	ImeHead1ResHeaterThermBadFC	Fault counter for 91-555: IME Printhead 1 reservoir heater thermistor bad	Number of faults Range = 0 to 255	0
604-628	ImeHead2ResHeaterThermBadFC	Fault counter for 91-556: IME Printhead 2 reservoir heater thermistor bad	Number of faults Range = 0 to 255	0
604-629	ImeHead3ResHeaterThermBadFC	Fault counter for 91-557: IME Printhead 3 reservoir heater thermistor bad	Number of faults Range = 0 to 255	0
604-630	ImeHead4ResHeaterThermBadFC	Fault counter for 91-558: IME Printhead 4 reservoir heater thermistor bad	Number of faults Range = 0 to 255	0
604-631	ImeMD-SysWrong-StateFC	Fault counter for 91-559: IME MD Manager, System not in correct state for requested service	Number of faults Range = 0 to 255	0
604-632	ImeHeadCarriageTimeoutFC	Fault counter for 91-560: IME Printhead carriage timeout	Number of faults Range = 0 to 255	0

Table 11 CCS NVM ID 604-300 to 604-656

NVM ID	NVM Name	NVM Description	Settings	Default
604-634	ImeHeadCarriageNoEdge-FoundFC	Fault counter for 91-562: IME Printhead Carriage no edge found	Number of faults Range = 0 to 255	0
604-635	ImeUpperHead-CarrUnexpected-EvtFC	Fault counter for 91-563: IME Upper Printhead Carriage unexpected event	Number of faults Range = 0 to 255	0
604-636	ImeUpperHead-CarrMovRestrFC	This NVM ID shown for information only. The machine does not have carriage restraint motors.	Number of faults Range = 0 to 255	0
604-637	ImeUpperHead-CarrRestrStallFC	This NVM ID shown for information only. The machine does not have carriage restraint motors.	Number of faults Range = 0 to 255	0
604-638	ImeLowerHead-CarrNoEdge-FoundFC	Fault counter for 91-567: IME Lower Printhead Carriage no edge found	Number of faults Range = 0 to 255	0
604-639	ImeLowerHead-CarrUnexpected-EvFC	Fault counter for 91-568: IME Lower Printhead Carriage unexpected event	Number of faults Range = 0 to 255	0
604-640	ImeLowerHead-CarrTOMovRestrFC	This NVM ID shown for information only. The machine does not have carriage restraint motors.	Number of faults Range = 0 to 255	0
604-641	ImeLowerHead-CarrRestrStallFC	This NVM ID shown for information only. The machine does not have carriage restraint motors.	Number of faults Range = 0 to 255	0
604-642	ImeHeadWiper-VertNoEdgeFC	Fault counter for 91-572: IME Printhead wiper vertical motion edge not found	Number of faults Range = 0 to 255	0
604-643	ImeHeadWiper-VertUnexpected-EvFC	Fault counter for 91-573: IME Printhead Wiper vertical motion unexpected event	Number of faults Range = 0 to 255	0
604-644	ImeHeadWiper-VertMotionTimeoutFC	Fault counter for 91-574: IME Printhead wiper vertical motion timeout	Number of faults Range = 0 to 255	0
604-645	ImeHeadWiper-VertInvMoveFC	Fault counter for 91-575: IME Printhead wiper vertical motion invalid move requested	Number of faults Range = 0 to 255	0
604-646	ImeHeadWiper-HorizInvalid-PosFC	Fault counter for 91-576: IME Printhead wiper horizontal motion invalid position	Number of faults Range = 0 to 255	0
604-651	ImeIODHome-TimeoutFC	Fault counter for 91-581: IME IOD home timeout	Number of faults Range = 0 to 255	0

Table 11 CCS NVM ID 604-300 to 604-656

NVM ID	NVM Name	NVM Description	Settings	Default
604-653	ImeWaveAM-ShortFC	Fault counter for 91-586: IME Wave AM short	Number of faults Range = 0 to 255	0
604-654	ImeWaveAMTooHotFC	Fault counter for 91-587: IME Wave AM too hot	Number of faults Range = 0 to 255	0
604-655	ImeWaveAMTherm-ReadingInvalidFC	Fault counter for 91-588: IME Wave AM thermistor reading invalid	Number of faults Range = 0 to 255	0
604-656	ImeHorizWiper- Stalled- TooSoonFC	Fault counter for 91-598: IME Horizontal Wiper Motion stalled too soon	Number of faults Range = 0 to 255	0

Table 12 CCS NVM ID 604-657 to 604-999

NVM ID	NVM Name	NVM Description	Settings	Default
604-657	ImeHeadAdjM- otUnitFC	Fault counter for 91-600: IME SFWA Adjustment Motor Uninitialized	Number of faults Range = 0 to 255	0
604-659	ImeMuSerialLink- DownFC	Fault counter for 92-505: IME Serial Link Down	Number of faults Range = 0 to 255	0
604-660	ImeMuSerialLink- SafetyFC	Fault counter for 92-506: IME Serial Link Safety	Number of faults Range = 0 to 255	0
604-661	ImeMuidSerial- LinkDownFC	Fault counter for 92-510: IME Drum Unit Serial Link Failure	Number of faults Range = 0 to 255	0
604-662	ImeMuidSerial- LinkSafetyFC	Fault counter for 92-511: IME Drum Unit Serial Link Safety	Number of faults Range = 0 to 255	0
604-663	ImeDdSerialLink- DownFC	Fault counter for 92-515: IME Drum Driver communications failure	Number of faults Range = 0 to 255	0
604-664	ImeDdSerialLink- SafetyFC	Fault counter for 92-516: IME Drum Driver communications error	Number of faults Range = 0 to 255	0
604-665	ImePsSerialLink- DownFC	Fault counter for 92-520: IME Power Supply communications failure	Number of faults Range = 0 to 255	0
604-666	ImeMpSerialLink- DownFC	Fault counter for 92-525: IME Media Path communications failure	Number of faults Range = 0 to 255	0
604-667	ImeMpSerialLink- SafetyFC	Fault counter for 92-526: IME Media Path communications error	Number of faults Range = 0 to 255	0
604-668	Ime3TMSerialLin kSafetyFC	Fault counter for 92-531: IME Paper Tray Module communications error	Number of faults Range = 0 to 255	0

Table 12 CCS NVM ID 604-657 to 604-999

NVM ID	NVM Name	NVM Description	Settings	Default
604-669	ImePfpSerialLink- SafetyFC	Fault counter for 92-536: IME High Capacity Feeder communications error	Number of faults Range = 0 to 255	0
604-671	ImeSafetyTimer- TimeoutFC	Fault counter for 92-550: IME Safety Timer timeout	Number of faults Range = 0 to 255	0
604-672	ImeSystemTimer- SkippedFC	Fault counter for 92-555: IME System timer skipped	Number of faults Range = 0 to 255	0
604-673	ImeIntStormFC	Fault counter for 92-570: IME Interrupt Storm Fault	Number of faults Range = 0 to 255	0
604-674	ImeSWFaultFC	Fault counter for 92-571: IME Software fault	Number of faults Range = 0 to 255	0
604-675	ImeAdcTherm- RangeFC	Fault counter for 92-575: IME ADC Thermal Out of range	Number of faults Range = 0 to 255	0
604-677	ImeImageTrans- ferFailFC	Fault counter for 92-581: IME Image Transfer failure	Number of faults Range = 0 to 255	0
604-678	ImeEngNvCrcDy- namicsFC	Fault counter for 92-598: IME NVM dynamic data corrupted	Number of faults Range = 0 to 255	0
604-679	ImeEngNvCrc- NormConstsFC	Fault counter for 92-599: IME NVM system constants corrupted	Number of faults Range = 0 to 255	0
604-680	ImeEngNvCrc- ServiceConstsFC	Fault counter for 92-600: IME NVM critical settings corrupted	Number of faults Range = 0 to 255	0
604-681	ImeMeltResHeat- erTooHotFC	Fault counter for 93-520: IME Melter reservoir heater is too hot	Number of faults Range = 0 to 255	0
604-682	ImeMeltResHeat- ingTooSlowFC	Fault counter for 93-521: IME Melter reservoir is heating too slow	Number of faults Range = 0 to 255	0
604-683	ImeMeltResTherm- BadFC	Fault counter for 93-522: IME Melter reservoir thermistor is bad	Number of faults Range = 0 to 255	0
604-684	ImeCyInkMelt- TooHotFC	Fault counter for 93-523: IME Cyan ink melter is too hot	Number of faults Range = 0 to 255	0
604-685	ImeCyInkMelt- TooSlowFC	Fault counter for 93-524: IME Cyan ink melter is too slow	Number of faults Range = 0 to 255	0
604-686	ImeCyInkMelt- ThermBadFC	Fault counter for 93-525: IME Cyan ink melter thermistor is bad	Number of faults Range = 0 to 255	0
604-687	ImeMagInkMelt- TooHotFC	Fault counter for 93-526: IME Magenta ink melter is too hot	Number of faults Range = 0 to 255	0
604-688	ImeMagInkMelt- TooSlowFC	Fault counter for 93-527: IME Magenta ink melter is too slow	Number of faults Range = 0 to 255	0
604-689	ImeMagInkMelt- ThermBadFC	Fault counter for 93-528: IME Magenta ink melter thermistor is bad	Number of faults Range = 0 to 255	0

Table 12 CCS NVM ID 604-657 to 604-999

NVM ID	NVM Name	NVM Description	Settings	Default
604-690	ImeYellInkMelt-TooHotFC	Fault counter for 93-529: IME Yellow ink melter is too hot	Number of faults Range = 0 to 255	0
604-691	ImeYellInkMelt-TooSlowFC	Fault counter for 93-530: IME Yellow ink melter is too slow	Number of faults Range = 0 to 255	0
604-692	ImeYellInkMelt-ThermBadFC	Fault counter for 93-531: IME Yellow ink melter thermistor is bad	Number of faults Range = 0 to 255	0
604-693	ImeBlkInkMelt-TooHotFC	Fault counter for 93-532: IME Black ink melter is too hot	Number of faults Range = 0 to 255	0
604-694	ImeBlkInkMelt-TooSlowFC	Fault counter for 93-533: IME Black ink melter is too slow	Number of faults Range = 0 to 255	0
604-695	ImeBlkInkMelt-ThermBadFC	Fault counter for 93-534: IME Black ink melter thermistor is bad	Number of faults Range = 0 to 255	0
604-696	ImeUpperUmb-HeaterTooHotFC	Fault counter for 93-535: IME Upper Umbilical heater is too hot	Number of faults Range = 0 to 255	0
604-697	ImeUpperUmb-Heater-TooSlowFC	Fault counter for 93-536: IME Upper Umbilical heater is too slow	Number of faults Range = 0 to 255	0
604-698	ImeUpperUmb-ThermBadFC	Fault counter for 93-537: IME Upper Umbilical thermistor is bad	Number of faults Range = 0 to 255	0
604-699	ImeLowerUmb-HeaterTooHotFC	Fault counter for 93-538: IME Lower Umbilical heater is too hot	Number of faults Range = 0 to 255	0
604-700	ImeLowerUmb-Heater-TooSlowFC	Fault counter for 93-539: IME Lower Umbilical heater is too slow	Number of faults Range = 0 to 255	0
604-701	ImeLowerUmb-ThermBadFC	Fault counter for 93-540: IME Lower Umbilical thermistor is bad	Number of faults Range = 0 to 255	0
604-706	ImeBlkMelt-ResLevelSense-FailFC	Fault counter for 93-545: IME Black melt reservoir level sense failure	Number of faults Range = 0 to 255	0
604-707	ImeMagMelt-ResLevelSense-FailFC	Fault counter for 93-546: IME Magenta melt reservoir level sense failure	Number of faults Range = 0 to 255	0
604-708	ImeCyMelt-ResLevelSense-FailFC	Fault counter for 93-547: IME Cyan melt reservoir level sense failure	Number of faults Range = 0 to 255	0
604-709	ImeYellMelt-ResLevelSense-FailFC	Fault counter for 93-548: IME Yellow melt reservoir level sense failure	Number of faults Range = 0 to 255	0

Table 12 CCS NVM ID 604-657 to 604-999

NVM ID	NVM Name	NVM Description	Settings	Default
604-710	ImeHead1BlkResFillTimeoutFC	Fault counter for 93-549: IME Head 1 Black reservoir fill timeout	Number of faults Range = 0 to 255	0
604-711	ImeHead1MagResFillTimeoutFC	Fault counter for 93-550: IME Head 1 Magenta reservoir fill timeout	Number of faults Range = 0 to 255	0
604-712	ImeHead1CyResFillTimeoutFC	Fault counter for 93-551: IME Head 1 Cyan reservoir fill timeout	Number of faults Range = 0 to 255	0
604-713	ImeHead1YellResFillTimeoutFC	Fault counter for 93-552: IME Head 1 Yellow reservoir fill timeout	Number of faults Range = 0 to 255	0
604-714	ImeHead2BlkResFillTimeoutFC	Fault counter for 93-553: IME Head 2 Black reservoir fill timeout	Number of faults Range = 0 to 255	0
604-715	ImeHead2MagResFillTimeoutFC	Fault counter for 93-554: IME Head 2 Magenta reservoir fill timeout	Number of faults Range = 0 to 255	0
604-716	ImeHead2CyResFillTimeoutFC	Fault counter for 93-555: IME Head 2 Cyan reservoir fill timeout	Number of faults Range = 0 to 255	0
604-717	ImeHead2YellResFillTimeoutFC	Fault counter for 93-556: IME Head 2 Yellow reservoir fill timeout	Number of faults Range = 0 to 255	0
604-718	ImeHead3BlkResFillTimeoutFC	Fault counter for 93-557: IME Head 3 Black reservoir fill timeout	Number of faults Range = 0 to 255	0
604-719	ImeHead3MagResFillTimeoutFC	Fault counter for 93-558: IME Head 3 Magenta reservoir fill timeout	Number of faults Range = 0 to 255	0
604-720	ImeHead3CyResFillTimeoutFC	Fault counter for 93-559: IME Head 3 Cyan reservoir fill timeout	Number of faults Range = 0 to 255	0
604-721	ImeHead3YellResFillTimeoutFC	Fault counter for 93-560: IME Head 3 Yellow reservoir fill timeout	Number of faults Range = 0 to 255	0
604-722	ImeHead4BlkResFillTimeoutFC	Fault counter for 93-561: IME Head 4 Black reservoir fill timeout	Number of faults Range = 0 to 255	0
604-723	ImeHead4MagResFillTimeoutFC	Fault counter for 93-562: IME Head 4 Magenta reservoir fill timeout	Number of faults Range = 0 to 255	0
604-724	ImeHead4CyResFillTimeoutFC	Fault counter for 93-563: IME Head 4 Cyan reservoir fill timeout	Number of faults Range = 0 to 255	0

Table 12 CCS NVM ID 604-657 to 604-999

NVM ID	NVM Name	NVM Description	Settings	Default
604-725	ImeHead4YellResFillTimeoutFC	Fault counter for 93-564: IME Head 4 Yellow reservoir fill timeout	Number of faults Range = 0 to 255	0
604-726	ImeHead1BlkResLevelFailFC	Fault counter for 93-565: IME Head 1 Black reservoir level sense failure	Number of faults Range = 0 to 255	0
604-727	ImeHead1MagResLevelFailFC	Fault counter for 93-566: IME Head 1 Magenta reservoir level sense failure	Number of faults Range = 0 to 255	0
604-728	ImeHead1CyResLevelSense-FailFC	Fault counter for 93-567: IME Head 1 Cyan reservoir level sense failure	Number of faults Range = 0 to 255	0
604-729	ImeHead1YellResLevelFailFC	Fault counter for 93-568: IME Head 1 Yellow reservoir level sense failure	Number of faults Range = 0 to 255	0
604-730	ImeHead2BlkResLevelFailFC	Fault counter for 93-569: IME Head 2 Black reservoir level sense failure	Number of faults Range = 0 to 255	0
604-731	ImeHead2MagResLevelFailFC	Fault counter for 93-570: IME Head 2 Magenta reservoir level sense failure	Number of faults Range = 0 to 255	0
604-732	ImeHead2CyResLevelSense-FailFC	Fault counter for 93-571: IME Head 2 Cyan reservoir level sense failure	Number of faults Range = 0 to 255	0
604-733	ImeHead2YellResLevelFailFC	Fault counter for 93-572: IME Head 2 Yellow reservoir level sense failure	Number of faults Range = 0 to 255	0
604-734	ImeHead3BlkResLevelFailFC	Fault counter for 93-573: IME Head 3 Black reservoir level sense failure	Number of faults Range = 0 to 255	0
604-735	ImeHead3MagResLevelFailFC	Fault counter for 93-574: IME Head 3 Magenta reservoir level sense failure	Number of faults Range = 0 to 255	0
604-736	ImeHead3CyResLevelSense-FailFC	Fault counter for 93-575: IME Head 3 Cyan reservoir level sense failure	Number of faults Range = 0 to 255	0
604-737	ImeHead3YellResLevelFailFC	Fault counter for 93-576: IME Head 3 Yellow reservoir level sense failure	Number of faults Range = 0 to 255	0
604-738	ImeHead4BlkResLevelFailFC	Fault counter for 93-577: IME Head 4 Black reservoir level sense failure	Number of faults Range = 0 to 255	0
604-739	ImeHead4MagResLevelFailFC	Fault counter for 93-578: IME Head 4 Magenta reservoir level sense failure	Number of faults Range = 0 to 255	0

Table 12 CCS NVM ID 604-657 to 604-999

NVM ID	NVM Name	NVM Description	Settings	Default
604-740	ImeHead4CyResLevelSense-FailFC	Fault counter for 93-579: IME Head 4 Cyan reservoir level sense failure	Number of faults Range = 0 to 255	0
604-741	ImeHead4YellResLevelFailFC	Fault counter for 93-580: IME Head 4 Yellow reservoir level sense failure	Number of faults Range = 0 to 255	0
604-742	ImeHead1BlkResLevelSenseOpenFC	Fault counter for 93-581: IME Head 1 Black reservoir level sense open	Number of faults Range = 0 to 255	0
604-743	ImeHead1MagResLevelSenseOpenFC	Fault counter for 93-582: IME Head 1 Magenta reservoir level sense open	Number of faults Range = 0 to 255	0
604-744	ImeHead1CyResLevelSenseOpenFC	Fault counter for 93-583: IME Head 1 Cyan reservoir level sense open	Number of faults Range = 0 to 255	0
604-745	ImeHead1YellResLevelSenseOpenFC	Fault counter for 93-584: IME Head 1 Yellow reservoir level sense open	Number of faults Range = 0 to 255	0
604-746	ImeHead2BlkResLevelSenseOpenFC	Fault counter for 93-585: IME Head 2 Black reservoir level sense open	Number of faults Range = 0 to 255	0
604-747	ImeHead2MagResLevelSenseOpenFC	Fault counter for 93-586: IME Head 2 Magenta reservoir level sense open	Number of faults Range = 0 to 255	0
604-748	ImeHead2CyResLevelSenseOpenFC	Fault counter for 93-587: IME Head 2 Cyan reservoir level sense open	Number of faults Range = 0 to 255	0
604-749	ImeHead2YellResLevelSenseOpenFC	Fault counter for 93-588: IME Head 2 Yellow reservoir level sense open	Number of faults Range = 0 to 255	0
604-750	ImeHead3BlkResLevelSenseOpenFC	Fault counter for 93-589: IME Head 3 Black reservoir level sense open	Number of faults Range = 0 to 255	0
604-751	ImeHead3MagResLevelSenseOpenFC	Fault counter for 93-590: IME Head 3 Magenta reservoir level sense open	Number of faults Range = 0 to 255	0
604-752	ImeHead3CyResLevelSenseOpenFC	Fault counter for 93-591: IME Head 3 Cyan reservoir level sense open	Number of faults Range = 0 to 255	0
604-753	ImeHead3YellResLevelSenseOpenFC	Fault counter for 93-592: IME Head 3 Yellow reservoir level sense open	Number of faults Range = 0 to 255	0
604-754	ImeHead4BlkResLevelSenseOpenFC	Fault counter for 93-593: IME Head 4 Black reservoir level sense open	Number of faults Range = 0 to 255	0

Table 12 CCS NVM ID 604-657 to 604-999

NVM ID	NVM Name	NVM Description	Settings	Default
604-755	ImeHead4MagResLev-eISenseOpenFC	Fault counter for 93-594: IME Head 4 Magenta reservoir level sense open	Number of faults Range = 0 to 255	0
604-756	ImeHead4CyResLev-eISenseOpenFC	Fault counter for 93-595: IME Head 4 Cyan reservoir level sense open	Number of faults Range = 0 to 255	0
604-757	ImeHead4YellResLev-eISenseOpenFC	Fault counter for 93-596: IME Head 4 Yellow reservoir level sense open	Number of faults Range = 0 to 255	0
604-758	ImeHead1BlkResLevelSense-ShortFC	Fault counter for 93-597: IME Head 1 Black reservoir level sense short	Number of faults Range = 0 to 255	0
604-759	ImeHead1MagResLevelSense-ShortFC	Fault counter for 93-598: IME Head 1 Magenta reservoir level sense short	Number of faults Range = 0 to 255	0
604-760	ImeHead1CyResLevelSense-ShortFC	Fault counter for 93-599: IME Head 1 Cyan reservoir level sense short	Number of faults Range = 0 to 255	0
604-761	ImeHead1YellResLevelShortFC	Fault counter for 93-800: IME Head 1 Yellow reservoir level sense short	Number of faults Range = 0 to 255	0
604-762	ImeHead2BlkResLevelSense-ShortFC	Fault counter for 93-801: IME Head 2 Black reservoir level sense short	Number of faults Range = 0 to 255	0
604-763	ImeHead2MagResLevelSense-ShortFC	Fault counter for 93-802: IME Head 2 Magenta reservoir level sense short	Number of faults Range = 0 to 255	0
604-764	ImeHead2CyResLevelSense-ShortFC	Fault counter for 93-803: IME Head 2 Cyan reservoir level sense short	Number of faults Range = 0 to 255	0
604-765	ImeHead2YellResLevelShortFC	Fault counter for 93-804: IME Head 2 Yellow reservoir level sense short	Number of faults Range = 0 to 255	0
604-766	ImeHead3BlkResLevelSense-ShortFC	Fault counter for 93-805: IME Head 3 Black reservoir level sense short	Number of faults Range = 0 to 255	0
604-767	ImeHead3MagResLevelSense-ShortFC	Fault counter for 93-806: IME Head 3 Magenta reservoir level sense short	Number of faults Range = 0 to 255	0
604-768	ImeHead3CyResLevelSense-ShortFC	Fault counter for 93-807: IME Head 3 Cyan reservoir level sense short	Number of faults Range = 0 to 255	0
604-769	ImeHead3YellResLevelShortFC	Fault counter for 93-808: IME Head 3 Yellow reservoir level sense short	Number of faults Range = 0 to 255	0

Table 12 CCS NVM ID 604-657 to 604-999

NVM ID	NVM Name	NVM Description	Settings	Default
604-770	ImeHead4BlkResLevelSense-ShortFC	Fault counter for 93-809: IME Head 4 Black reservoir level sense short	Number of faults Range = 0 to 255	0
604-771	ImeHead4MagResLevelSense-ShortFC	Fault counter for 93-810: IME Head 4 Magenta reservoir level sense short	Number of faults Range = 0 to 255	0
604-772	ImeHead4CyResLevelSense-ShortFC	Fault counter for 93-811: IME Head 4 Cyan reservoir level sense short	Number of faults Range = 0 to 255	0
604-773	ImeHead4YellResLevelShortFC	Fault counter for 93-812: IME Head 4 Yellow reservoir level sense short	Number of faults Range = 0 to 255	0
604-774	ImeBlkMelt-ResLev-eISenseOpenFC	Fault counter for 93-813: IME Black melt reservoir level sense open	Number of faults Range = 0 to 255	0
604-775	ImeMagMelt-ResLev-eISenseOpenFC	Fault counter for 93-814: IME Magenta melt reservoir level sense open	Number of faults Range = 0 to 255	0
604-776	ImeCyMelt-ResLev-eISenseOpenFC	Fault counter for 93-815: IME Cyan melt reservoir level sense open	Number of faults Range = 0 to 255	0
604-777	ImeYellMelt-ResLev-eISenseOpenFC	Fault counter for 93-816: IME Yellow melt reservoir level sense open	Number of faults Range = 0 to 255	0
604-778	ImeBlkMelt-ResLevelSense-ShortFC	Fault counter for 93-817: IME Black melt reservoir level sense short	Number of faults Range = 0 to 255	0
604-779	ImeMagMelt-ResLevelSense-ShortFC	Fault counter for 93-818: IME Magenta melt reservoir level sense short	Number of faults Range = 0 to 255	0
604-780	ImeCyMelt-ResLevelSense-ShortFC	Fault counter for 93-819: IME Cyan melt reservoir level sense short	Number of faults Range = 0 to 255	0
604-781	ImeYellMelt-ResLevelSense-ShortFC	Fault counter for 93-820: IME Yellow melt reservoir level sense short	Number of faults Range = 0 to 255	0
604-782	ImeInk-SKUSelOvercurrFaultFC	Fault counter for 93-825: IME Ink SKU sel over current fault	Number of faults Range = 0 to 255	0
604-795	ImeDrumImage-InitPosFC	Fault counter for 94-510: IME Drum Image initial position fault	Number of faults Range = 0 to 255	0
604-796	ImeDrumImage-StallFC	Fault counter for 94-512: IME Drum Image stalled	Number of faults Range = 0 to 255	0
604-797	ImeDrumImageRaceTimingFC	Fault counter for 94-514: IME Drum Image race timing fault	Number of faults Range = 0 to 255	0

Table 12 CCS NVM ID 604-657 to 604-999

NVM ID	NVM Name	NVM Description	Settings	Default
604-798	ImeDrumImageTimingFC	Fault counter for 94-518: IME Drum Image timing fault	Number of faults Range = 0 to 255	0
604-799	ImeDMDriveOvercurrFaultFC	Fault counter for 94-520: IME Drum Management Unit drive over current	Number of faults Range = 0 to 255	0
604-800	ImeDMDriveStallFaultFC	Fault counter for 94-522: IME Drum Management Unit drive stall fault	Number of faults Range = 0 to 255	0
604-801	ImeYAOvercurrFaultFC	Fault counter for 94-524: IME YA over current fault	Number of faults Range = 0 to 255	0
604-802	ImeYASTallFaultFC	Fault counter for 94-526: IME YA stall fault	Number of faults Range = 0 to 255	0
604-803	ImeDDOilPump1OvercurrFC	Fault counter for 94-528: IME Drum Driver oil pump 1 over current	Number of faults Range = 0 to 255	0
604-804	ImeStripSolOvercurrFC	Fault counter for 94-530: IME Stripper solenoid over current	Number of faults Range = 0 to 255	0
604-805	ImeDDOilPump2OvercurrFC	Fault counter for 94-532: IME Drum Driver oil pump 2 over current	Number of faults Range = 0 to 255	0
604-806	ImeDDOilValveBOverCurrFC	Fault counter for 94-533: IME Drum driver oil valve B over current	Number of faults Range = 0 to 255	0
604-807	ImeYABeltSlipFaultFC	Fault counter for 94-534: IME YA belt slip fault	Number of faults Range = 0 to 255	0
604-808	ImeDrumFrontHeaterTooHotFC	Fault counter for 94-536: IME Drum front heater is too hot	Number of faults Range = 0 to 255	0
604-809	ImeDrumFrontHeaterTooSlowFC	Fault counter for 94-538: IME Drum front heater is heating too slow	Number of faults Range = 0 to 255	0
604-810	ImeDrumFrontThermBadFC	Fault counter for 94-540: IME Drum front thermistor is bad	Number of faults Range = 0 to 255	0
604-811	ImeDrumRearHeaterTooHotFC	Fault counter for 94-542: IME Drum rear heater is too hot	Number of faults Range = 0 to 255	0
604-812	ImeDrumRearHeaterTooSlowFC	Fault counter for 94-544: IME Drum rear heater is heating too slow	Number of faults Range = 0 to 255	0
604-813	ImeDrumRearThermBadFC	Fault counter for 94-546: IME Drum rear thermistor is bad	Number of faults Range = 0 to 255	0
604-814	ImeYPosErrFC	Fault counter for 94-548: IME Y-axis Position error	Number of faults Range = 0 to 255	0
604-816	ImeYHomeCalcErrFC	Fault counter for 94-551: IME Y-axis Home Calc error	Number of faults Range = 0 to 255	0

Table 12 CCS NVM ID 604-657 to 604-999

NVM ID	NVM Name	NVM Description	Settings	Default
604-817	ImeYInitializationErrFC	Fault counter for 94-552: IME Y-axis Initialization error	Number of faults Range = 0 to 255	0
604-818	ImeYHomeDataErrFC	Fault counter for 94-553: IME Y-axis Home Data error	Number of faults Range = 0 to 255	0
604-819	ImeStripLatchTimeoutFC	Fault counter for 94-554: IME Stripper Latch Sensor timeout	Number of faults Range = 0 to 255	0
604-820	ImeStripLatchBadSstateFC	Fault counter for 94-556: IME Stripper Latch Bad Sensor State	Number of faults Range = 0 to 255	0
604-821	ImeCleaningUnitTimingErrFC	Fault Counter 94-558: IME Cleaning Unit timing error	Number of faults Range = 0 to 255	0
604-822	ImeCleaningUnitPosErrFC	Fault Counter 94-560: IME Cleaning Unit position error	Number of faults Range = 0 to 255	0
604-823	ImeCleaningUnitFFHomeTimeoutFC	Fault Counter 94-562: IME Cleaning Unit fast forward home timeout	Number of faults Range = 0 to 255	0
604-824	ImeCleaningUnitFwdHomeTimeoutFC	Fault Counter 94-564: IME Cleaning Unit slow forward home timeout	Number of faults Range = 0 to 255	0
604-825	ImeCleaningUnitRevHomeTimeoutFC	Fault Counter 94-566: IME Cleaning Unit reverse home timeout	Number of faults Range = 0 to 255	0
604-826	ImeCleanUnitseDataReadErrFC	Fault Counter 94-568: IME Cleaning Unit usage data read error	Number of faults Range = 0 to 255	0
604-827	ImeCleanUnitseDataWriteErrFC	Fault Counter 94-570: IME Cleaning Unit usage data write error	Number of faults Range = 0 to 255	0
604-828	ImeCleanUnitseDataDetectErrFC	Fault Counter 94-572: IME Cleaning Unit usage data detect error	Number of faults Range = 0 to 255	0
604-829	ImeCleanUnitUsageDataVerErrFC	Fault Counter 94-573: IME Cleaning Unit usage data version error	Number of faults Range = 0 to 255	0
604-831	T5HoistFailureFC	T5 hoist failure Fault Counter	Number of faults Range = 0 to 255	0
604-832	T5LowerFailureFC	T5 lower failure Fault Counter	Number of faults Range = 0 to 255	0
604-833	PaddleHomeFC	Fault Counter for 12-024: Paddle Home Fault	Number of faults Range = 0 to 255	0
604-834	PaddleMoveFC	Fault Counter for 12-025: Paddle Move Fault	Number of faults Range = 0 to 255	0
604-835	PunchMotorMoveFC	Fault Counter for 12-043: Hole Punch Motor Move Fault	Number of faults Range = 0 to 255	0

Table 12 CCS NVM ID 604-657 to 604-999

NVM ID	NVM Name	NVM Description	Settings	Default
604-836	PunchHead-HomeFC	Fault Counter for 12-044: Hole Punch Head Home Fault	Number of faults Range = 0 to 255	0
604-837	PunchHead-MoveFC	Fault Counter for 12-045: Hole Punch Head Move Fault	Number of faults Range = 0 to 255	0
604-838	PunchMotor-HomeFC	Fault Counter for 12-046: Hole Punch Motor Home Fault	Number of faults Range = 0 to 255	0
604-839	PunchUnit-MoveFC	Fault Counter for 12-047: Punch Unit Move Fault	Number of faults Range = 0 to 255	0
604-840	InsertBottPltH-omeFC	Fault Counter 12-056: Inserter Bottom Plate Home Fault	Number of faults Range = 0 to 255	0
604-841	PPIBottPltLiftFC	Fault Counter 12-057: Inserter Bottom Plate Lift Fault	Number of faults Range = 0 to 255	0
604-842	CreaseBladeMoveFC	Fault Counter for 12-061: Crease Blade Move Fault.	Number of faults Range = 0 to 255	0
604-843	CreaseRollMotor-FailFC	Fault Counter for 12-062: Crease Roll Motor Failed	Number of faults Range = 0 to 255	0
604-844	BMStapler-MoveFC	Fault Counter for 12-063: Booklet Maker Stapler Move Fault	Number of faults Range = 0 to 255	0
604-845	BackStopMotor-MoveFC	Fault Counter for 12-065: Back Stop Motor Move Fault	Number of faults Range = 0 to 255	0
604-846	TampermoveFC	Fault Counter for 12-066: Tamper Move Fault	Number of faults Range = 0 to 255	0
604-847	PaperPushMotor-StalledFC	Fault Counter for 12-083: Paper Pusher Motor Stalled	Number of faults Range = 0 to 255	0
604-848	EntSnsOfJamFC	Fault Counter for 12-126: Entrance Sensor OFF Jam	Number of faults Range = 0 to 255	0
604-849	PunchSnrOn-JamFC	Fault Counter for 12-127: Punch Sensor ON Jam	Number of faults Range = 0 to 255	0
604-850	BuffPointSnsOn-JamFC	Fault Counter for 12-157: Buffer Point Sensor ON Jam	Number of faults Range = 0 to 255	0
604-851	BuffPointSnsOff-JamFC	Fault Counter for 12-158: Buffer Point Sensor OFF Jam	Number of faults Range = 0 to 255	0
604-852	BookletCompExit-SenOffJamFC	Fault Counter for 12-166: Booklet Compiler Exit Sensor OFF Jam	Number of faults Range = 0 to 255	0
604-853	BMExitSnrOn-JamFC	Fault Counter for 12-181: Booklet Maker Exit Sensor ON Jam	Number of faults Range = 0 to 255	0
604-854	BMExitSnrOff-JamFC	Fault Counter for 12-182: Booklet Maker Exit Sensor OFF Jam	Number of faults Range = 0 to 255	0
604-855	BMUnexpected-SheetFC	Fault Counter for 12-183: Booklet Maker Unexpected Sheet	Number of faults Range = 0 to 255	0

Table 12 CCS NVM ID 604-657 to 604-999

NVM ID	NVM Name	NVM Description	Settings	Default
604-856	BMStraySheetFC	Fault Counter for 12-184: Booklet Maker Stray Sheet	Number of faults Range = 0 to 255	0
604-857	TrifoldExitSnrOn-JFC	Fault Counter for 12-185: Trifold Exit Sensor ON Jam	Number of faults Range = 0 to 255	0
604-858	TrifoldExitSnrOffJFC	Fault Counter for 12-186: Trifold Exit Sensor OFF Jam	Number of faults Range = 0 to 255	0
604-859	TrifoldAssistSnrOnJFC	Fault Counter for 12-187: Trifold Assist Sensor ON Jam	Number of faults Range = 0 to 255	0
604-860	LELateBBEntrySnrFC	Fault Counter for 12-190: Sheet late to BB entry sensor	Number of faults Range = 0 to 255	0
604-861	LELatetoInserter-TabStandbySFC	Fault Counter 12-191: Lead edge late to Inserter Tab Standby Sensor	Number of faults Range = 0 to 255	0
604-862	TELatefromBBEntrySFC	Fault Counter for 12-192: Sheet late from BB entry sensor	Number of faults Range = 0 to 255	0
604-863	TELateInserterTabSnrFC	Fault Counter 12-193: Trail edge late from Inserter Tab Standby Sensor	Number of faults Range = 0 to 255	0
604-864	LeadedgelatetoInserterPickUpSFC	Fault Counter 12-194: Lead edge late to Inserter Pick Up Sensor	Number of faults Range = 0 to 255	0
604-865	TELatefromInserterPickUpSFC	Fault Counter 12-196: Trail edge late from Inserter Tray Pick Up Sensor	Number of faults Range = 0 to 255	0
604-866	FinStraySheetFC	Fault Counter for 12-198: Stray sheet is detected after jam clearance	Number of faults Range = 0 to 255	0
604-867	Unexpected-SheetatFinEntFC	Fault Counter for 12-199: Unexpected Sheet at Finisher Entry	Number of faults Range = 0 to 255	0
604-868	OffsetUnitInitFC	Fault Counter for 12-273: Offset Unit Init Fault	Number of faults Range = 0 to 255	0
604-869	OffsetUnitHomeFC	Fault Counter for 12-274: Offset Unit Home Fault	Number of faults Range = 0 to 255	0
604-870	OffsetUnitHomeMvFC	Fault Counter for 12-275: Offset Unit Home Move Fault	Number of faults Range = 0 to 255	0
604-871	OffsetUnitAwayHomeFC	Fault Counter for 12-276: Offset Unit Away Home Fault	Number of faults Range = 0 to 255	0
604-872	OffsetUnitAwayHomeMvFC	Fault Counter for 12-277: Offset Unit Away Home Move Fault	Number of faults Range = 0 to 255	0
604-873	NipSplitFC	Fault Counter for 12-288: Nip Split Failure	Number of faults Range = 0 to 255	0

Table 12 CCS NVM ID 604-657 to 604-999

NVM ID	NVM Name	NVM Description	Settings	Default
604-874	NipHomeFC	Fault Counter for 12-289: Nip Home Failure	Number of faults Range = 0 to 255	0
604-875	FinUndockedDuringRFC	Fault Counter for 12-310: Finisher Undocked During Run	Number of faults Range = 0 to 255	0
604-876	TopCoverOpenInRFC	Fault Counter for 12-312: Top Cover Open in Run	Number of faults Range = 0 to 255	0
604-877	FinDoorOpenInRFC	Fault Counter for 12-313: Finisher Door Open In Run	Number of faults Range = 0 to 255	0
604-878	InsertertopCoverOpenInRFC	Fault Counter 12-316: Insertertop Cover Open In Run	Number of faults Range = 0 to 255	0
604-879	TrifoldCoverOpenInRFC	Fault Counter for 12-317: Trifold Cover Open In Run	Number of faults Range = 0 to 255	0
604-880	TrifoldFDoorOpenInRFC	Fault Counter for 12-318: Trifold Front Door Open In Run	Number of faults Range = 0 to 255	0
604-881	InsertertHandDoorOpenInRFC	Fault Counter 12-319: Insertert Hand Door Open In run	Number of faults Range = 0 to 255	0
604-882	CompHomeFC	Fault Counter for 12-340: Compiler Home Fault	Number of faults Range = 0 to 255	0
604-883	CompOutFC	Fault Counter for 12-341: Compiler Out Fault	Number of faults Range = 0 to 255	0
604-884	CompMvFC	Fault Counter for 12-342: Compiler Move Fault	Number of faults Range = 0 to 255	0
604-885	StapleMvFC	Fault Counter for 12-371: Stapler Move Fault	Number of faults Range = 0 to 255	0
604-886	StapleHomeFC	Fault Counter for 12-372: Stapler Home Fault	Number of faults Range = 0 to 255	0
604-887	StapleMiddleHomeFC	Fault Counter for 12-373: Stapler Middle Home Fault	Number of faults Range = 0 to 255	0
604-888	StapleMiddleMvFC	Fault Counter for 12-374: Stapler Middle Move Fault	Number of faults Range = 0 to 255	0
604-889	StapleJawHomeFC	Fault Counter for 12-375: Stapler Jaw Home Fault	Number of faults Range = 0 to 255	0
604-890	StapleJawMvFC	Fault Counter for 12-376: Stapler Jaw Move Fault	Number of faults Range = 0 to 255	0
604-891	StaplePrimingFC	Fault Counter for 12-377: Stapler Priming Fault	Number of faults Range = 0 to 255	0
604-892	LCSSStapleIndexFC	Fault Counter for 12-378: LCSS Stapler index Fault	Number of faults Range = 0 to 255	0
604-893	PunchUnitSideEdgeDetectFC	Fault Counter for 12-380: Punch Unit Side Edge Detect Fault	Number of faults Range = 0 to 255	0
604-894	BackStopHomeFC	Fault Counter for 12-383: Back Stop Home Fault.	Number of faults Range = 0 to 255	0

Table 12 CCS NVM ID 604-657 to 604-999

NVM ID	NVM Name	NVM Description	Settings	Default
604-895	TampHomeFC	Fault Counter for 12-384: Tamper Home Fault	Number of faults Range = 0 to 255	0
604-896	FTampMvFC	Fault Counter for 12-392: Front Tamper Move Fault	Number of faults Range = 0 to 255	0
604-897	FTampHomeFC	Fault Counter for 12-393: Front Tamper Home Fault	Number of faults Range = 0 to 255	0
604-898	FTampAwayFromHomeFC	Fault Counter for 12-394: Front Tamper Away From Home Fault	Number of faults Range = 0 to 255	0
604-899	FTampAwayFromHomeMvFC	Fault Counter for 12-395: Front Tamper Away From Home Move Fault	Number of faults Range = 0 to 255	0
604-900	RTampMvFC	Fault Counter for 12-396: Rear Tamper Move Fault	Number of faults Range = 0 to 255	0
604-901	RTampHomeFC	Fault Counter for 12-397: Rear Tamper Home Fault	Number of faults Range = 0 to 255	0
604-902	RTampAwayFromHomeMvFC	Fault Counter for 12-398: Rear Tamper Away From Home Move Fault	Number of faults Range = 0 to 255	0
604-903	RTampAwayFromHomeFC	Fault Counter for 12-399: Rear Tamper Away From Home Fault	Number of faults Range = 0 to 255	0
604-904	BMStapleHead2MvFC	Fault Counter for 12-403: Booklet Staple Head 2 Move Fault	Number of faults Range = 0 to 255	0
604-905	BMStapleHomeFC	Fault Counter for 12-411: Booklet Stapler Home Fault	Number of faults Range = 0 to 255	0
604-906	BMStapleHead2HomeFC	Fault Counter for 12-413: Booklet Staple Head 2 Home Fault	Number of faults Range = 0 to 255	0
604-907	BMStapleNotHomeForInFC	Fault Counter for 12-414: Booklet Stapler Not Home For Init	Number of faults Range = 0 to 255	0
604-908	RollGateHomeFC	Fault Counter for 12-415: Roll Gate Home Fault	Number of faults Range = 0 to 255	0
604-909	CreaseBladeHomeFC	Fault Counter for 12-416: Crease Blade Home Fault	Number of faults Range = 0 to 255	0
604-910	BMFlapperHomeFC	Fault Counter for 12-417: Booklet Maker Flapper Home Fault	Number of faults Range = 0 to 255	0
604-911	BMFlappermvFC	Fault Counter for 12-418: Booklet Maker Flapper Move Fault	Number of faults Range = 0 to 255	0

Table 12 CCS NVM ID 604-657 to 604-999

NVM ID	NVM Name	NVM Description	Settings	Default
604-912	BMTamp2HomeFC	Fault Counter for 12-419: Booklet Maker Tamper 2 Home Fault	Number of faults Range = 0 to 255	0
604-913	BMTamp2MvFC	Fault Counter for 12-420: Booklet Maker Tamper 2 Move Fault	Number of faults Range = 0 to 255	0
604-914	PapPush-HomeFC	Fault Counter for 12-440: Paper Pusher Home Fault	Number of faults Range = 0 to 255	0
604-915	PapPushHomeMvFC	Fault Counter for 12-441: Paper Pusher Home Move Fault	Number of faults Range = 0 to 255	0
604-916	PapPushAway-HomeFC	Fault Counter for 12-442: Paper Pusher Away Home Fault	Number of faults Range = 0 to 255	0
604-917	PapPushAway-HomeMvFC	Fault Counter for 12-443: Paper Pusher Away Home Move Fault	Number of faults Range = 0 to 255	0
604-918	EjectModMotor-StallFC	Fault Counter for 12-450: Ejector Module Motor Stall	Number of faults Range = 0 to 255	0
604-919	EjectPlateMotor-StallFC	Fault Counter for 12-451: Ejector Plate Motor Stall	Number of faults Range = 0 to 255	0
604-920	EjectPlate-HomeFC	Fault Counter for 12-452: Ejector Plate Home Fault	Number of faults Range = 0 to 255	0
604-921	EjectPlateMvFC	Fault Counter for 12-453: Ejector Plate Move Fault	Number of faults Range = 0 to 255	0
604-922	LwrPaddHomeFC	Fault Counter for 12-454: Lower Paddle Home Fault	Number of faults Range = 0 to 255	0
604-923	LwrPaddMvFC	Fault Counter for 12-455: Lower Paddle Move Fault	Number of faults Range = 0 to 255	0
604-924	EjectMod-HomeFC	Fault Counter for 12-456: Ejector Module Home Fault	Number of faults Range = 0 to 255	0
604-925	EjectModHomeMvFC	Fault Counter for 12-457: Ejector Module Home Move Fault	Number of faults Range = 0 to 255	0
604-926	EjectModOut-PosFC	Fault Counter for 12-458: Ejector Module Out Position Fault	Number of faults Range = 0 to 255	0
604-927	EjectModOut-PosMvFC	Fault Counter for 12-459: Ejector Module Out Position Move Fault	Number of faults Range = 0 to 255	0
604-928	StackBin1MotorStallFC	Fault Counter 12-460: Stacker Bin 1 Motor Stall	Number of faults Range = 0 to 255	0
604-929	StackBin1LevelFC	Fault Counter for 12-461: Stacker Level Fault	Number of faults Range = 0 to 255	0
604-930	StackBin1ElevatorFC	Fault Counter for 12-462: Stacker Bin 1 Elevator Failure	Number of faults Range = 0 to 255	0

Table 12 CCS NVM ID 604-657 to 604-999

NVM ID	NVM Name	NVM Description	Settings	Default
604-931	BMPwrNotPresentFC	Fault Counter for 12-463: Booklet Maker Power Not Present Fault	Number of faults Range = 0 to 255	0
604-932	BMPwrFC	Fault Counter for 12-464: Booklet Maker Power Fault	Number of faults Range = 0 to 255	0
604-933	PaddUpprPosFC	Fault Counter for 12-465: Paddle Upper Position Fault	Number of faults Range = 0 to 255	0
604-934	PaddUpprPosMvFC	Fault Counter for 12-466: Paddle Upper Position Move Fault	Number of faults Range = 0 to 255	0
604-935	PaddLwrPosFC	Fault Counter for 12-467: Paddle Lower Position Fault	Number of faults Range = 0 to 255	0
604-936	PaddLwrPosMvFC	Fault Counter for 12-468: Paddle Lower Position Move Fault	Number of faults Range = 0 to 255	0
604-937	CurlSupprHomeFC	Fault Counter for 12-469: Curl Suppressor Home Fault	Number of faults Range = 0 to 255	0
604-938	CurlSupprMvFC	Fault Counter for 12-470: Curl Suppressor Move Fault	Number of faults Range = 0 to 255	0
604-939	CurlSupprAway-PosFC	Fault Counter for 12-471: Curl Suppressor Away Position Fault	Number of faults Range = 0 to 255	0
604-940	CurlSupprAway-PosMvFC	Fault Counter for 12-472: Curl Suppressor Away Position Move Fault	Number of faults Range = 0 to 255	0
604-941	PressMotorInitFC	Fault Counter for 12-473: Pressing Motor Init Fault	Number of faults Range = 0 to 255	0
604-942	PressMotorInitMvFC	Fault Counter for 12-474: Pressing Motor Init Move Fault	Number of faults Range = 0 to 255	0
604-943	PressMotor-HomeFC	Fault Counter for 12-475: Pressing Motor Home Fault	Number of faults Range = 0 to 255	0
604-944	PressMotor-HomeMvFC	Fault Counter for 12-476: Pressing Motor Home Move Fault	Number of faults Range = 0 to 255	0
604-945	PressMotorOut-PosFC	Fault Counter for 12-477: Pressing Motor Out Position Fault	Number of faults Range = 0 to 255	0
604-946	PressMtrOut-PosMvFC	Fault Counter for 12-478: Pressing Motor Out Position Move Fault	Number of faults Range = 0 to 255	0
604-947	InsSht-TooShortFC	Fault Counter for 12-479: Insert Sheet Too Short	Number of faults Range = 0 to 255	0
604-948	ImeMPS11LETooEarlyFC	Fault Counter for 10-147-00: Media Path Sensor 11 LE Too Early	Number of faults Range = 0 to 255	0

Table 12 CCS NVM ID 604-657 to 604-999

NVM ID	NVM Name	NVM Description	Settings	Default
604-949	ImeMPS12LETooEarlyFC	Fault Counter for 10-148-00: Media Path Sensor 12 LE Too Early	Number of faults Range = 0 to 255	0
604-950	ImeMPS15LETooEarlyFC	Fault Counter for 10-149-00: Media Path Sensor 15 LE Too Early	Number of faults Range = 0 to 255	0
604-951	ImeMPInvS15LETooEarlyFC	Fault Counter for 10-150-00: Media Path Invert Sensor 15 LE Too Early	Number of faults Range = 0 to 255	0
604-952	ImeMPS5LETooEarlyFC	Fault Counter for 82-152-00: Media Path Sensor 5 LE Too Early	Number of faults Range = 0 to 255	0
604-953	ImeMPS16LETooEarlyFC	Fault Counter for 82-153-00: Media Path Sensor 16 LE Too Early	Number of faults Range = 0 to 255	0
604-954	ImeMPS14LETooEarlyFC	Fault Counter for 82-154-00: Media Path Sensor 14 LE Too Early	Number of faults Range = 0 to 255	0
604-955	ImeMPDupS16LETooEarlyFC	Fault Counter for 82-155-00: Media Path Duplex Sensor 16 LE Too Early	Number of faults Range = 0 to 255	0
604-956	ImeMPDupS14LETooEarlyFC	Fault Counter for 82-156-00: Media Path Duplex Sensor 14 LE Too Early	Number of faults Range = 0 to 255	0
604-957	ImeMPS13LETooEarlyFC	Fault Counter for 83-118-00: Media Path Sensor 13 LE Too Early	Number of faults Range = 0 to 255	0
604-958	ImeMPInvS13LETooEarlyFC	Fault Counter for 83-119-00: Media Path Invert Sensor 13 LE Too Early	Number of faults Range = 0 to 255	0
604-959	ImeMPS20LETooEarlyFC	Fault Counter for 89-130-00: Media Path Sensor 20 LE Too Early	Number of faults Range = 0 to 255	0
604-962	ImeDrumImage-FailFC	Fault Counter for 94-519-00: Drum Imaging Failure	Number of faults Range = 0 to 255	0
604-963	ImeDrumDrvCmdCurrErrFC	Fault Counter for 94-535-00: Drum Drive Command Current Error	Number of faults Range = 0 to 255	0
604-964	ECMInitFailedFC	Fault Counter for 92-568-00: ECM Initialization Failed	Number of faults Range = 0 to 255	0
604-965	ImeMPS16LETooMSIFC	Fault Counter for 82-133-00: Media Path Sensor 16 LE Timeout from MSI	Number of faults Range = 0 to 255	0

Table 12 CCS NVM ID 604-657 to 604-999

NVM ID	NVM Name	NVM Description	Settings	Default
604-967	ImeHtrReqUpd-FailFC	Fault Counter for 82-134-00: AC Power Manger heater requests are not being updated	Number of faults Range = 0 to 255	0
604-968	ImeMPS17ShToLongFC	Fault Counter for 82-134-00: Media Path Sensor 17 Too Long	Number of faults Range = 0 to 255	0
604-969	ImeMPS17ShToShortFC	Fault Counter for 82-134-00: Media Path Sensor 17 Too Short	Number of faults Range = 0 to 255	0
604-970	ImeMPS17LELateFC	Fault Counter for 82-134-00: Media Path Sensor 17 LE Timeout	Number of faults Range = 0 to 255	0
604-971	ImeMPS17TELateFC	Fault Counter for 82-134-00: Media Path Sensor 17 TE Timeout	Number of faults Range = 0 to 255	0
604-972	ImeMPS17InvTELateFC	Fault Counter for 82-134-00: Media Path Invert Sensor 17 TE Timeout	Number of faults Range = 0 to 255	0
604-973	ImeMPS17LEEarlyFC	Fault Counter for 82-134-00: Media Path Sensor 17 LE Too Early	Number of faults Range = 0 to 255	0
604-974	ImeIODStallRec-FailFC	Fault Counter for 82-134-00: IOD Stall Recovery Failed	Number of faults Range = 0 to 255	0
604-975	ImeBikMeltLvl-FailFC	Fault Counter for 82-134-00: Black melt reservoir level sense failure	Number of faults Range = 0 to 255	0
604-976	ImeMagMeltLvl-FailFC	Fault Counter for 82-134-00: Magenta melt reservoir level sense failure	Number of faults Range = 0 to 255	0
604-977	ImeCyMeltLvl-FailFC	Fault Counter for 82-134-00: Cyan melt reservoir level sense failure	Number of faults Range = 0 to 255	0
604-978	ImeYelMeltLvl-FailFC	Fault Counter for 82-134-00: Yellow melt reservoir level sense failure	Number of faults Range = 0 to 255	0
604-980	ImeFinComms-FailFC	Fault Counter for 12-762-00: Cannot communicate with finisher.	Number of faults Range = 0 to 255	0
604-981	ImeFinMissingFC	Fault Counter for 12-764-00: Finisher is not present.	Number of faults Range = 0 to 255	0
604-982	Total Large Marked Images Disp	Enable Display of Large Marked Images Counter	0 = No Display 1 = Displayed Range = 0 to 1	1

Table 12 CCS NVM ID 604-657 to 604-999

NVM ID	NVM Name	NVM Description	Settings	Default
604-983	Total Large Blk Marked Imgs Disp	Enable Display of Large Black Marked Images Counter	0 = No Display 1 = Displayed Range = 0 to 1	1
604-984	Total Large Col Marked Imgs Disp	Enable Display of Large Colour Marked Images Counter	0 = No Display 1 = Displayed Range = 0 to 1	1
604-985	IODEXCESSIVEYPOS-NOISEFC	Fault Counter 91-695: IOExcessiveYPosNoiseFC	Number of faults Range = 0 to 255	0
604-986	IODEXCESSIVEXPOS-NOISEFC	Fault Counter 91-696: IOExcessiveXPosNoiseFC	Number of faults Range = 0 to 255	0
604-987	IODEXCESSIVEROLLPOS-NOISEFC	Fault Counter 91-697: IOExcessiveRollPositionNoiseFC	Number of faults Range = 0 to 255	0
604-988	IODSTITCHOR-ROLLMISALIGNMENTFC	Fault Counter 91-698: IOExcessiveStitchAndRollMisAlignmentFC	Number of faults Range = 0 to 255	0
604-989	IODSTITCHOR-ROLLMOTORS-NOTZEROEDFC	Fault Counter 91-699: IOStitchorRollMotorNotZeroedFC	Number of faults Range = 0 to 255	0
604-990	IMELOWCURRENTFANOVERCURRENTFC	Fault Counter 42-504-00: Low Current fan over-current	Number of faults Range = 0 to 255	0
604-991	IMEMPSENSOR15TELATEFC	Fault Counter 10-151-00: MP Sensor15 TE Timeout	Number of faults Range = 0 to 255	0
604-992	IMEDRUMFAN-STALLEDFC	Fault Counter 94-620-00: Drum Fan Stalled	Number of faults Range = 0 to 255	0
604-993	IMEABATEMENTFAN-STALLEDFC	Fault Counter 94-621-00: Abatement fan stalled	Number of faults Range = 0 to 255	0
604-994	PRINTENGRUNNINGATDEFAULTSPEEDFC	Fault Counter 92-586-00: Print Engine running at default speed	Number of faults Range = 0 to 255	0
604-995	FINISHERCDI-COMMSFAILFC	Fault Counter 12-492-00: CDI communications failure with finisher.	Number of faults Range = 0 to 255	0
604-996	FINISHERFAILURETOCYCLEUPFC	Fault Counter 12-493-00: Finisher failure to Cycle Up in time	Number of faults Range = 0 to 255	0
604-997	FINISHERFAILURETORETURNPREPFC	Fault Counter 12-494-00: Finisher failure to return prep time	Number of faults Range = 0 to 255	0

Table 13 CCS NVM ID 605-xxx

NVM ID	NVM Name	NVM Description	Settings	Default
605-001	NextPrintJobID	Value of next MFPrint job's id.	Range = 0 to 999	1
605-002	PrintCrashRecoveryEnable	Enable Print Job Recovery	Print Job Recovery enable Settings 0 = No Recovery 1 = Recovered Range = 0 to 1	1
605-003	MFPrintCompletedJob Log Location	This holds the crash recovery print job information on the alta side.	Range = 0 to 12	0
605-004	Not displayed	Job log-MFPrintCompleted Job Log	Range = 0 to 0	0
605-005	Not displayed	Counter-MFPRINTMarkedImages	Range = 0 to 16777215	0
605-006	MFPRINT-MarkedImages-Displayable	Enable Option to export marked image counter information to clients	0 = No export 1 = Exported Range = 0 to 1	1
605-007	Not displayed	Counter-MFPRINTSheets	Range = 0 to 16777215	0
605-008	MFPRINTSheets-Displayable	Enable Option to export marked image counter information to clients	0 = No export 1 = Exported Range 0 to 1	0
605-009	Not displayed	Counter-MFPRINTDuplex-Sheets	Range = 0 to 16777215	0
605-010	MFPRINTDuplex-SheetsDisplayable	Enable Option to export Duplexed counter information to clients	0 = No export 1 = Exported Range 0 to 1	0
605-011	Not displayed	Counter-MFPRINT-LargeSheets	Range = 0 to 16777215	0
605-012	MFPRINT-LargeSheetsDisplayable	Enable Option to export Large Sheet counter information to clients	0 = No export 1 = Exported Range = 0 to 1	0
605-013	disturbance time	Maximum time allowed for ESS to resync before deleting orphaned print jobs	Range 0 to 240	12
605-014	Not displayed	Counter-PrintServerFAXJobs	Range = 0 to 16777215	0
605-015	Not displayed	Counter-PrintIFAXJobs	Range = 0 to 16777215	0
605-016	MFPRINT-MarkedColorImagesDisplay	Enable Option to export Colour images counter information to clients	0 = No export 1 = Exported Range = 0 to 1	0
605-017	MFPRINTColor-SheetsDisplay	Enable Option to export Colour Sheet counter information to clients	0 = No export 1 = Exported Range = 0 to 1	0

Table 13 CCS NVM ID 605-xxx

NVM ID	NVM Name	NVM Description	Settings	Default
605-018	MFPRINTDuplex-ColorSheetsDisplay	Enable Option to export Duplex Colour Sheet counter information to clients	0 = No export 1 = Exported Range 0 to 1	0
605-019	MFPRINTLarge-ColorSheetsDisplay	Enable Option to export Large Colour Sheet counter information to clients	0 = No export 1 = Exported Range 0 to 1	0
605-020	MFPSuccessImgRecServerFaxDisplay	Counter	Range 0 to 1	0
605-021	MFPSuccessful-FaxImagesRecDisplay	Enable Option to export Large Success Ifax images counter information to clients	0 = No export 1 = Exported Range 0 to 1	0
605-022	Not displayed	Counter-MFPRINTMarkedColorImages	Range = 0 to 16777215	0
605-023	Not displayed	Counter-MFPRINTColor-Sheets	Range = 0 to 16777215	0
605-024	Not displayed	Counter-MFPRINTDuplexColorSheets	Range = 0 to 16777215	0
605-025	Not displayed	Counter-MFPRINTLargeColor-Sheets	Range = 0 to 16777215	0
605-026	Not displayed	Counter-MFPRINTSuccessfulImagesReceivedFromServerFax	Range = 0 TO 16777215	0
605-027	Not displayed	Counter-MFPRINTSuccessfulFaxImagesReceived	Range = 0 to 16777215	0
605-028	PrintJobReleaseThreshold		Range 0 to 4	4
605-029	Print Fast Impressions	Print Output Quality Fast Lifetime Impressions Total Number of print path impressions that were selected by user at the print driver as Fast or Draft Mode	Range 0 to 16777215	0
605-030	Print Standard Impressions	Print Output Quality Standard Lifetime Impressions Total Number of print path impressions that were selected by user at the print driver as Standard Mode	Range = 0 to 16777215	0
605-031	Print Enhanced Impressions	Print Output Quality Enhanced Lifetime Impressions Total Number of print path impressions that were selected by user at the print driver as Enhanced Mode	Range = 0 to 16777215	0

Table 13 CCS NVM ID 605-xxx

NVM ID	NVM Name	NVM Description	Settings	Default
605-032	Print Standard PCL Impressions	Print Output Quality Standard PCL Lifetime Impressions. Total Number of print path impressions that were selected by user at the print driver as Standard PCL Mode	Range = 0 to 16777215	0
605-033	Print Enhanced PCL Impressions	Print Output Quality Enhanced PCL Lifetime Impressions. Total Number of print path impressions that were selected by user at the print driver as Enhanced PCL Mode	Range = 0 to 16777215	0
605-034	Print Transparency Impressions	Print Output Quality OHP / Transparency Lifetime Impressions. Total Number of print path impressions that were selected by user as using OHP / Transparency media	Range = 0 to 16777215	0
605-035	BlackReprintImages	Black reprint image counter	Usage counter Range = 0 to 16777215	0
605-036	BlackReprintImagesDisp	Black reprint image counter displayable	Usage counter Range = 0 to 1	0
605-037	ColorReprintImages	Color reprint image counter	Usage counter Range = 0 to 16777215	0
605-038	ColorReprintImagesDisp	Color reprint image counter displayable	Usage counter Range = 0 to 16777215	0
605-039	Print Hi Res / Photo Impressions	Print Output Quality Hi Resolution / Photo Lifetime Impressions Total Number of print path impressions that were selected by user at the print driver as Hi Resolution / Photo Mode	Range = 0 to 16777215	0
605-040	Print High Speed PCL Impressions Not displayed	Print output quality high speed PCL lifetime impressions	Total number of print path impressions marked that were selected by user at the client PCL print driver as a high speed mode. Range = 0 to 16777215	0

Table 13 CCS NVM ID 605-xxx

NVM ID	NVM Name	NVM Description	Settings	Default
605-041	Print High Speed Impressions Not displayed	Print output quality high speed lifetime impressions	Total number of print path impressions marked that were selected by user at the client print driver in high speed mode. Range = 0 to 16777215	0

Table 14 CCS NVM ID 606-001 to 606-269

NVM ID	NVM Name	NVM Description	Settings	Default
606-001	Tray 1 Media Type	Tray 1 Media Type MTStandard = 0,MTDrilled = 1,MTEnvelope = 3,MTTransparency = 4,MTLetterhead = 5,MTLabels = 6,MTRecycled = 7,MTOtherType = 9,MTBond = 12,MTPrePrinted = 13,MTCardStock = 14,MTCustom1 = 15,MTCustom2 = 16,MTCustom3 = 17,MTCustom4 = 19,MTCustom5 = 20,MTCustom6 = 21,MTCustom7 = 22,MTUnspecified = 18,MTSystemDefault = 23,MTPrecutTabs = 37,MTCovers = 38,MTTabs = 39,MTPaperBackedTransparency = 40,MTThin = 41,MTLightCardStock = 42,MTLightGlossy = 43,MTHeavyGlossy = 44,MTLightCardStockSide2 = 45,MTLightGlossySide2 = 46,MTHeavyGlossySide2 = 47,MTCardStockSide2 = 48,MTThinSide2 = 49,MTHeavyLabels = 50,MTHeavyPrecutTabs = 51,MTHeavyCardStock = 52,MTHeavyCardStockSide2 = 53,MTExtraHeavyGlossy = 54,MTExtraHeavyGlossySide2 = 55,MTExtraHeavyLabels = 56,MTUsedStandard = 57,MTROUGHStock = 58,MTPhoto = 59,MTPostcard = 60	Range = 0 to 102	0

Table 14 CCS NVM ID 606-001 to 606-269

NVM ID	NVM Name	NVM Description	Settings	Default
606-002	Tray 1 Media Color	Tray 1 Media Color MCWhite = 0, MCGreen = 1, MCBuff = 2, MCYellow = 3, MCGoldenrod = 4, MCBlue = 5, MCPink = 6, MCTransparent = 7, MClvory = 8, MCGray = 9, MCRed = 10, MCOrange = 11, MCOtherColor = 12, MCCustom1 = 13, MCCustom2 = 14, MCCustom3 = 15, MCCustom4 = 17, MCCustom5 = 18, MCCustom6 = 19, MCCustom7 = 20, MCUnspecified = 16, MCSystemDefault = 21	Range = 0 to 34	0
606-003	Tray 1 Media Weight	Tray 1 Media Weight	Range = 60 to 216	75
606-004	Tray 1 Direct Select	Tray 1 Direct Select	0 = TS Direct Only 1 = TS Direct and Auto Range = 0 to 1	1
606-005	Tray 1 Priority	Tray 1 Priority	Range = 0 to 99	30
606-006	Tray 1 Width	Tray 1 Width Range and default size in mm	Range = 182 to 432	216
606-007	Tray 1 Length	Tray 1 Length Range and default size in mm	Range = 140 to 297	279
606-008	Tray 1 Percent Full	Tray 1 Percent Full	Range = 0 to 100	0
606-009	Tray 1 User Type	Tray 1 User Type	0 = TA Fixed 1 = TA AdjustableAll 2 = TA Adjustable Size Only Range = 0 to 1	1
606-010	Tray 1 Modulus	Tray 1 Modulus	Range = 0 to 100	0
606-011	Tray 1 Modulus Position	Tray 1 Modulus Position	Range = 0 to 100	0

Table 14 CCS NVM ID 606-001 to 606-269

NVM ID	NVM Name	NVM Description	Settings	Default
606-021	Tray 2 Media Type	Tray 2 Media Type MTStandard = 0, MTDilled = 1, MTEvelope = 3, MTTransparency = 4, MTLetterhead = 5, MTLabels = 6, MTRecycled = 7, MTOtherType = 9, MTBond = 12, MTPrePrinted = 13, MTCardStock = 14, MTCustom1 = 15, MTCustom2 = 16, MTCustom3 = 17, MTCustom4 = 19, MTCustom5 = 20, MTCustom6 = 21, MTCustom7 = 22, MTUnspecified = 18, MTSystemDefault = 23, MTPrecutTabs = 37, MTCovers = 38, MTTabs = 39, MTPaperBackedTransparency = 40, MTThin = 41, MTLightCardStock = 42, MTLightGlossy = 43, MTHeavyGlossy = 44, MTLightCardStockSide2 = 45, MTLightGlossySide2 = 46, MTHeavyGlossySide2 = 47, MTCardStockSide2 = 48, MTThinSide2 = 49, MTHeavyLabels = 50, MTHeavyPrecutTabs = 51, MTHeavyCardStock = 52, MTHeavyCardStockSide2 = 53, MTEltraHeavyGlossy = 54, MTEltraHeavyGlossySide2 = 55, MTEltraHeavyLabels = 56, MTUsedStandard = 57, MTRoughStock = 58, MTPhoto = 59, MTPostcard = 60	Range = 0 to 102	0

Table 14 CCS NVM ID 606-001 to 606-269

NVM ID	NVM Name	NVM Description	Settings	Default
606-022	Tray 2 Media Color	Tray 2 Media Color MCWhite = 0, MCGreen = 1, MCBuff = 2, MCYellow = 3, MCGoldenrod = 4, MCBlue = 5, MCPink = 6, MCTransparent = 7, MClvory = 8, MCGray = 9, MCRed = 10, MCOrange = 11, MCOtherColor = 12, MCCustom1 = 13, MCCustom2 = 14, MCCustom3 = 15, MCCustom4 = 17, MCCustom5 = 18, MCCustom6 = 19, MCCustom7 = 20, MCUnspecified = 16, MCSystemDefault = 21	Range = 0 to 34	0
606-023	Tray 2 Media Weight	Tray 2 Media Weight	Range = 60 to 216	75
606-024	Tray 2 Direct Select	Tray 2 Direct Select	0 = TS Direct Only 1 = TS Direct And Auto Range = 0 to 1	1
606-025	Tray 2 Priority	Tray 2 Priority	Range = 0 to 99	40
606-026	Tray 2 Width	Tray 2 Width Range and default size in mm	Range = 182 to 432	216
606-027	Tray 2 Length	Tray 2 Length Range and default size in mm	Range = 140 to 297	279
606-028	Tray 2 Percent Full	Tray 2 Percent Full	Range = 0 to 100	0
606-029	Tray 2 User Type	Tray 2 User Type	0 = TA Fixed 1 = TA Adjustable All 2 = TA AdjustableSize Only Range = 0 to 1	1
606-030	Tray 2 Modulus	Tray 2 Modulus	Range = 0 to 100	0
606-031	Tray 2 Modulus Position	Tray 2 Modulus Position	Range = 0 to 100	0

Table 14 CCS NVM ID 606-001 to 606-269

NVM ID	NVM Name	NVM Description	Settings	Default
606-041	Tray 3 Media Type	Tray 3 Media Type MTStandard = 0, MTDrilled = 1, MTEvelope = 3, MTTransparency = 4, MTLetterhead = 5, MTLabels = 6, MTRecycled = 7, MTOtherType = 9, MTBond = 12, MTPrePrinted = 13, MTCardStock = 14, MTCustom1 = 15, MTCustom2 = 16, MTCustom3 = 17, MTCustom4 = 19, MTCustom5 = 20, MTCustom6 = 21, MTCustom7 = 22, MTUnspecified = 18, MTSystemDefault = 23, MTPrecutTabs = 37, MTCovers = 38, MTTabs = 39, MTPaperBackedTransparency = 40, MTThin = 41, MTLightCardStock = 42, MTLightGlossy = 43, MTHeavyGlossy = 44, MTLightCardStockSide2 = 45, MTLightGlossySide2 = 46, MTHeavyGlossySide2 = 47, MTCardStockSide2 = 48, MTThinSide2 = 49, MTHeavyLabels = 50, MTHeavyPrecutTabs = 51, MTHeavyCardStock = 52, MTHeavyCardStockSide2 = 53, MTEExtraHeavyGlossy = 54, MTEExtraHeavyGlossySide2 = 55, MTEExtraHeavyLabels = 56, MTUsedStandard = 57, MTRoughStock = 58, MTPhoto = 59, MTPostcard = 60	Range = 0 to 102	0

Table 14 CCS NVM ID 606-001 to 606-269

NVM ID	NVM Name	NVM Description	Settings	Default
606-042	Tray 3 Media Color	Tray 3 Media Color MCWhite = 0, MCGreen = 1, MCBuff = 2, MCYellow = 3, MCGoldenrod = 4, MCBlue = 5, MCPink = 6, MCTransparent = 7, MClvory = 8, MCGray = 9, MCRed = 10, MCOrange = 11, MCOtherColor = 12, MCCustom1 = 13, MCCustom2 = 14, MCCustom3 = 15, MCCustom4 = 17, MCCustom5 = 18, MCCustom6 = 19, MCCustom7 = 20, MCUnspecified = 16, MCSystemDefault = 21	Range = 0 to 34	0
606-043	Tray 3 Media Weight	Tray 3 Media Weight	Range = 60 to 216	75
606-044	Tray 3 Direct Select	Tray 3 Direct Select	0 = TS Direct Only 1 = TS Direct And Auto Range = 0 to 1	1
606-045	Tray 3 Priority	Tray 3 Priority	Range = 0 to 99	10
606-046	Tray 3 Width	Tray 3 Width Range and default size in mm A4 = 210 8.5 x 11 = 216	Range = 182 to 432	216 for US 210 for Europe
606-047	Tray 3 Length	Tray 3 Length Range and default size in mm A4 = 297 8.5 x 11 = 279	Range = 257 to 297	279 for US 297 for Europe
606-048	Tray 3 Percent Full	Tray 3 Percent Full	Range = 0 to 100	0
606-049	Tray 3 User Type	Tray 3 User Type (fixed size) Note that the GUI uses the range to determine if other selections should be possible	0 = TA Fixed	0
606-050	Tray 3 Modulus	Tray 3 Modulus	Range = 0 to 100	0
606-051	Tray 3 Modulus Position	Tray 3 Modulus Position	Range = 0 to 100	0

Table 14 CCS NVM ID 606-001 to 606-269

NVM ID	NVM Name	NVM Description	Settings	Default
606-061	Tray 4 Media Type	Tray 4 Media Type MTStandard = 0, MTDilled = 1, MTEvelope = 3, MTTransparency = 4, MTLetterhead = 5, MTLabels = 6, MTRecycled = 7, MTOtherType = 9, MTBond = 12, MTPrePrinted = 13, MTCardStock = 14, MTCustom1 = 15, MTCustom2 = 16, MTCustom3 = 17, MTCustom4 = 19, MTCustom5 = 20, MTCustom6 = 21, MTCustom7 = 22, MTUnspecified = 18, MTSystemDefault = 23, MTPrecutTabs = 37, MTCovers = 38, MTTabs = 39, MTPaperBackedTransparency = 40, MTThin = 41, MTLightCardStock = 42, MTLightGlossy = 43, MTHeavyGlossy = 44, MTLightCardStockSide2 = 45, MTLightGlossySide2 = 46, MTHeavyGlossySide2 = 47, MTCardStockSide2 = 48, MTThinSide2 = 49, MTHeavyLabels = 50, MTHeavyPrecutTabs = 51, MTHeavyCardStock = 52, MTHeavyCardStockSide2 = 53, MTEExtraHeavyGlossy = 54, MTEExtraHeavyGlossySide2 = 55, MTEExtraHeavyLabels = 56, MTUsedStandard = 57, MTRoughStock = 58, MTPhoto = 59, MTPostcard = 60	Range = 0 to 102	0

Table 14 CCS NVM ID 606-001 to 606-269

NVM ID	NVM Name	NVM Description	Settings	Default
606-062	Tray 4 Media Color	Tray 4 Media Color MCWhite = 0,MCGreen = 1,MCBuff = 2,MCYellow = 3,MCGoldenrod = 4,MCBlue = 5, MCPink = 6,MCTransparent = 7,MC Ivory = 8,MCGray = 9,MCRed = 10, MCOrange = 11, MCOtherColor = 12, MCCustom1 = 13, MCCustom2 = 14, MCCustom3 = 15, MCCustom4 = 17, MCCustom5 = 18, MCCustom6 = 19, MCCustom7 = 20, MCUnspecified = 16, MCSystemDefault = 21	Range = 0 to 34	0
606-063	Tray 4 Media Weight	Tray 4 Media Weight	Range = 60 to 216	75
606-064	Tray 4 Direct Select	Tray 4 Direct Select	0 = TS Direct Only 1 = TS Direct And Auto Range = 0 to 1	1
606-065	Tray 4 Priority	Tray 4 Priority	Range = 0 to 99	99
606-066	Tray 4 Width	Tray 4 Width Range and default size in mm	Range = 182 to 432	216
606-067	Tray 4 Length	Tray 4 Length Range and default size in mm	Range = 140 to 320	279
606-068	Tray 4 Percent Full	Tray 4 Percent Full	Range = 0 to 100	0
606-069	Tray 4 User Type	Tray 4 User Type (Bypass tray) Note that the GUI uses the range to determine if other selections should be possible	1 = TA Adjustable All Range = 1 to 1	1
606-070	Tray 4 Modulus	Tray 4 Modulus	Range = 0 to 100	0
606-071	Tray 4 Modulus Position	Tray 4 Modulus Position	Range = 0 to 100	0

Table 14 CCS NVM ID 606-001 to 606-269

NVM ID	NVM Name	NVM Description	Settings	Default
606-081	Tray 5 Media Type	Tray 5 Media Type MTStandard = 0,MTDrilled = 1,MTEnvelope = 3,MTTransparency = 4,MTLetterhead = 5,MTLabels = 6,MTRecycled = 7,MTOtherType = 9,MTBond = 12,MTPrePrinted = 13,MTCardStock = 14,MTCustom1 = 15,MTCustom2 = 16,MTCustom3 = 17,MTCustom4 = 19,MTCustom5 = 20,MTCustom6 = 21,MTCustom7 = 22,MTUnspecified = 18,MTSystemDefault = 23,MTPrecutTabs = 37,MTCovers = 38,MTTabs = 39,MTPaperBackedTransparency = 40,MTThin = 41,MTLightCardStock = 42,MTLightGlossy = 43,MTHeavyGlossy = 44,MTLightCardStockSide2 = 45,MTLightGlossySide2 = 46,MTHeavyGlossySide2 = 47,MTCardStockSide2 = 48,MTThinSide2 = 49,MTHeavyLabels = 50,MTHeavyPrecutTabs = 51,MTHeavyCardStock = 52,MTHeavyCardStockSide2 = 53,MTExtraHeavyGlossy = 54,MTExtraHeavyGlossySide2 = 55,MTExtraHeavyLabels = 56,MTUsedStandard = 57,MT RoughStock = 58,MTPhoto = 59,MTPostcard = 60	Range = 0 to 102	0

Table 14 CCS NVM ID 606-001 to 606-269

NVM ID	NVM Name	NVM Description	Settings	Default
606-082	Tray 5 Media Color	Tray 5 Media Color MCWhite = 0, MCGreen = 1, MCBuff = 2, MCYellow = 3, MCGoldenrod = 4, MCBlue = 5, MCPink = 6, MCTransparent = 7, MClvory = 8, MCGray = 9, MCRed = 10, MCOrange = 11, MCOtherColor = 12, MCCustom1 = 13, MCCustom2 = 14, MCCustom3 = 15, MCCustom4 = 17, MCCustom5 = 18, MCCustom6 = 19, MCCustom7 = 20, MCUnspecified = 16, MCSystemDefault = 21	Range = 0 to 34	0
606-083	Tray 5 Media Weight	Tray 5 Media Weight	Range = 60 to 216	75
606-084	Tray 5 Direct Select	Tray 5 Direct Select	0 = TS Direct Only 1 = TS Direct And Auto Range = 0 to 1	1
606-085	Tray 5 Priority	Tray 5 Priority	Range = 0 to 99	5
606-086	Tray 5 Width	Tray 5 Width Range and default size in mm	Range = 182 to 432	216
606-087	Tray 5 Length	Tray 5 Length Range and default size in mm	Range = 140 to 297	279
606-088	Tray 5 Percent Full	Tray 5 Percent Full	Range = 0 to 100	0
606-089	Tray 5 User Type	Tray 5 User Type	0 = TA Fixed 1 = TA Adjustable All 2 = TA Adjustable Size Only Range = 0 to 1	0
606-090	Tray 5 Modulus	Tray 5 Modulus	Range = 0 to 100	0
606-091	Tray 5 Modulus Position	Tray 5 Modulus Position	Range = 1 to 100	1

Table 14 CCS NVM ID 606-001 to 606-269

NVM ID	NVM Name	NVM Description	Settings	Default
606-101	Tray 6 Media Type	Tray 6 Media Type MTStandard = 0, MTDrilled = 1, MTEvelope = 3, MTTransparency = 4, MTLetterhead = 5, MTLabels = 6, MTRecycled = 7, MTOtherType = 9, MTBond = 12, MTPrePrinted = 13, MTCardStock = 14, MTCustom1 = 15, MTCustom2 = 16, MTCustom3 = 17, MTCustom4 = 19, MTCustom5 = 20, MTCustom6 = 21, MTCustom7 = 22, MTUnspecified = 18, MTSystemDefault = 23, MTPrecutTabs = 37, MTCovers = 38, MTTabs = 39, MTPaperBackedTransparency = 40, MTThin = 41, MTLightCardStock = 42, MTLightGlossy = 43, MTHeavyGlossy = 44, MTLightCardStockSide2 = 45, MTLightGlossySide2 = 46, MTHeavyGlossySide2 = 47, MTCardStockSide2 = 48, MTThinSide2 = 49, MTHeavyLabels = 50, MTHeavyPrecutTabs = 51, MTHeavyCardStock = 52, MTHeavyCardStockSide2 = 53, MTEExtraHeavyGlossy = 54, MTEExtraHeavyGlossySide2 = 55, MTEExtraHeavyLabels = 56, MTUsedStandard = 57, MTRoughStock = 58, MTPhoto = 59, MTPostcard = 60	Range = 0 to 102	0

Table 14 CCS NVM ID 606-001 to 606-269

NVM ID	NVM Name	NVM Description	Settings	Default
606-102	Tray 6 Media Color	Tray 6 Media Color MCWhite = 0,MCGreen = 1,MCBuff = 2,MCYellow = 3,MCGoldenrod = 4,MCBlue = 5, MCPink = 6,MCTransparent = 7,MC Ivory = 8,MCGray = 9,MCRed = 10, MCOrange = 11, MCOtherColor = 12, MCCustom1 = 13, MCCustom2 = 14, MCCustom3 = 15, MCCustom4 = 17, MCCustom5 = 18, MCCustom6 = 19, MCCustom7 = 20, MCUnspecified = 16, MCSystemDefault = 21	Range = 0 to 34	0
606-103	Tray 6 Media Weight	Tray 6 Media Weight	Range = 60 to 216	75
606-104	Tray 6 Direct Select	Tray 6 Direct Select	0 = TS Direct Only 1 = TS Direct And Auto Range = 0 to 1	1
606-105	Tray 6 Priority	Tray 6 Priority	Range = 1 to 99	99
606-106	Tray 6 Width	Tray 6 Width Range and default size in mm	Range = 182 to 432	216
606-107	Tray 6 Length	Tray 6 Length Range and default size in mm	Range = 182 to 297	279
606-108	Tray 6 Percent Full	Tray 6 Percent Full	Range = 0 to 100	0
606-109	Tray 6 User Type	Tray 6 User Type	0 = TA Fixed 1 = TA Adjustable All 2 = TA Adjustable Size Only Range = 0 to 1	1
606-110	Tray 6 Modulus	Tray 6 Modulus	Range = 0 to 100	0
606-111	Tray 6 Modulus Position	Tray 6 Modulus Position	Range = 1 to 100	1
606-152	Print Engine Lifetime Jams	Print Engine Lifetime Jam- sNumber of Marking Engine Jams since activation	Range = 0 to 4,294,967,295	0
606-153	Black Lifetime Ink Sticks Used	Black Lifetime Ink Sticks Consumed Total Number of black ink sticks consumed since Activation	Range = 0 to 4,294,967,295	0

Table 14 CCS NVM ID 606-001 to 606-269

NVM ID	NVM Name	NVM Description	Settings	Default
606-154	Cyan Lifetime Ink Sticks Used	Cyan Lifetime Ink Sticks Consumed Total Number of cyan ink sticks consumed since Activation	Range = 0 to 4,294,967,295	0
606-155	Magenta Lifetime Ink Sticks Used	Magenta Lifetime Ink Sticks Consumed Total Number of magenta ink sticks consumed since Activation	Range = 0 to 4,294,967,295	0
606-156	Yellow Lifetime Ink Sticks Used	Yellow Lifetime Ink Sticks Consumed Total Number of yellow ink sticks consumed since Activation	Range = 0 to 4,294,967,295	0
606-157	Total Maintenance Kits Installed	Total Maintenance Kits Installed Identifies the total number of maintenance kits that have been installed on the machine since activation	Range = 0 to 4,294,967,295	0
606-159	Cleaning Pages	Cleaning Pages Total cleaning sheets reported by marking engine since activation numCleaning Pages	Range = 0 to 16777215	0
606-160	Printhead Clean WarmPurge	Printhead Clean Count - Warm Purge Identifies the number of times any printhead has been cleaned by a Warm Purge numTotalStandbyTimeHours	Range = 0 to 16777215	0
606-161	Printhead Clean ColdPurge	Printhead Clean Count - Cold Purge Identifies the number of times any printhead has been cleaned by a Cold Purge. numTotalStandbyTimeHours	Range = 0 to 16777215	0
606-162	Printhead Clean FreezeOff Purge	Printhead Clean Count - Freeze-off Purge Identifies the number of times any printhead has been cleaned by a Freeze Off Purge. numTotalStandbyTimeHours	Range = 0 to 16777215	0

Table 14 CCS NVM ID 606-001 to 606-269

NVM ID	NVM Name	NVM Description	Settings	Default
606-167	Plain Sheets Used	Plain Sheets Used Total of normal size Plain media sheets since activation date. numNormalPlainMedia	Range = 0 to 16777215	0
606-168	Bond Sheets Used	Bond Sheets Used Total of normal size Bond media sheets since activation date numNormalBondMedia	Range = 0 to 16777215	0
606-169	LetterHead Sheets Used	LetterHead Sheets Used Total of normal size Letter-Head media sheets since activation date numNormalLetterHeadMedia	Range = 0 to 16777215	0
606-170	Pre-Printed Sheets Used	Pre-Printed Sheets Used Total of normal size Pre-Printed media sheets since activation date numNormalPrePrintedMedia	Range = 0 to 16777215	0
606-171	Heavyweight Sheets Used	Heavyweight Sheets Used Total of normal size Heavyweight media sheets since activation date numNormalHWMedia	Range = 0 to 16777215	0
606-172	Extra Heavyweight Sheets Used	Extra Heavyweight Sheets Used Total of normal size Extra heavyweight media sheets since activation date numNormalExtraHWMedia	Range = 0 to 16777215	0
606-173	Extra HW Reloaded Sheets Used	Extra Heavyweight Reloaded Sheets Used Total of normal size Heavyweight Reloaded media sheets since activation date numNormalExtraHWReloadedMedia	Range = 0 to 16777215	0
606-174	Extra HW Plus Sheets Used	Extra Heavyweight Plus Sheets Used Total of normal size Extra Heavyweight Plus media sheets since activation date numNormalExtraHWPlusMedia	Range = 0 to 16777215	0

Table 14 CCS NVM ID 606-001 to 606-269

NVM ID	NVM Name	NVM Description	Settings	Default
606-175	Extra HW Plus RL Sheets Used	Extra Heavyweight Plus Reloaded Sheets Used Total of normal size Extra Heavyweight Plus Reloaded media sheets since activation date numNormalExtraHWPlusReloadedMedia	Range = 0 to 16777215	0
606-176	Gloss Coating Sheets Used	Gloss Coating Sheets Used Total of normal size Gloss Coating media sheets since activation date numNormalGlossMedia	Range = 0 to 16777215	0
606-177	Gloss Coating Reloaded Sheets	Gloss Coating Reloaded Sheets Used Total of normal size Gloss Coating Reloaded media sheets since activation date numNormalGlossReloadedMedia	Range = 0 to 16777215	0
606-178	HW Gloss Coating Sheets Used	Heavyweight Gloss Coating Sheets Used Total of normal size Heavyweight Gloss Coating media sheets since activation date numNormalHWGlossMedia	Range = 0 to 16777215	0
606-179	HW Gloss Coating Reloaded Sheets	Heavyweight Gloss Coating Reloaded Sheets Used Total of normal size Heavyweight Gloss Coating Reloaded media sheets since activation date numNormalHWGlossReloadedMedia	Range = 0 to 16777215	0
606-180	Extra HW Gloss Coating Sheets	Extra Heavyweight Gloss Coating Sheets Used Total of normal size Extra Heavyweight Gloss Coating media sheets since activation date numNormalExtraHWGlossMedia	Range = 0 to 16777215	0

Table 14 CCS NVM ID 606-001 to 606-269

NVM ID	NVM Name	NVM Description	Settings	Default
606-181	Ex HW Gloss Coat Reload Sheets	Extra Heavyweight Gloss Coating Reloaded Sheets Used Total of normal size Extra Heavyweight Gloss Coating Reloaded media sheets since activation date numNormalExtraHWGlossReloadedMedia	Range = 0 to 16777215	0
606-182	Transparency Sheets Used	Transparency Sheets Used Total of normal size Transparency media sheets since activation date numNormalTransparencyMedia	Range = 0 to 16777215	0
606-183	Pre-Cut Tabs Sheets Used	Pre-Cut Tabs Sheets Used Total of normal size Pre-Cut Tabs media sheets since activation date numNormalPreCutTabMedia	Range = 0 to 16777215	0
606-184	Labels Sheets Used	Labels Sheets Used Total of normal size Labels media sheets since activation date numNormalLabelMedia	Range = 0 to 16777215	0
606-185	Heavyweight Labels Sheets Used	Heavyweight Labels Sheets Used Total of normal size Heavyweight Labels media sheets since activation date numNormalHWLabelMedia	Range = 0 to 16777215	0
606-186	Recycled Sheets Used	Recycled Sheets Used Total of normal size Recycled media sheets since activation date numNormalRecycledMedia	Range = 0 to 16777215	0
606-187	Hole Punched Sheets Used	Hole Punched Sheets Used Total of normal size Hole Punched media sheets since activation date numNormalHolePunchMedia	Range = 0 to 16777215	0
606-188	Custom Paper Type Sheets Used	Custom Paper Type Sheets Used Total of normal size Custom Paper media sheets since activation date numNormalCustomMedia	Range = 0 to 16777215	0

Table 14 CCS NVM ID 606-001 to 606-269

NVM ID	NVM Name	NVM Description	Settings	Default
606-189	Other Sheets Used	Other Sheets Used Total of Other media (not captured above) sheets since activation date numNormalOtherMedia	Range = 0 to 16777215	0
606-190	Plain Large Sheets Used	Plain Large Sheets Used Total of large size Plain media sheets since activation date numLargePlainMedia	Range = 0 to 16777215	0
606-191	Bond Large Sheets Used	Bond Large Sheets Used Total of large size Bond media sheets since activation date numLargeBondMedia	Range = 0 to 16777215	0
606-192	LetterHead Large Sheets Used	LetterHead Large Sheets Used Total of large size Letterhead media sheets since activation date numLargeLetterHeadMedia	Range = 0 to 16777215	0
606-193	Pre-Printed Large Sheets Used	Pre-Printed Large Sheets Used Total of large size Pre-Printed media sheets since activation date numLargePrePrintedMedia	Range = 0 to 16777215	0
606-194	Heavyweight Large Sheets Used	Heavyweight Large Sheets Used Total of large size Heavyweight media sheets since activation date numLargeHWMedia	Range = 0 to 16777215	0
606-195	Extra Heavyweight Large Sheets	Extra Heavyweight Large Sheets Used Total of large size Extra Heavyweight media sheets since activation date numLargeExtraHWMedia	Range = 0 to 16777215	0
606-196	Ex HW Reloaded Large Sheets Used	Extra Heavyweight Reloaded Large Sheets Used Total of large size Extra Heavyweight Reloaded media sheets since activation date numLargeExtraHWReloadedMedia	Range = 0 to 16777215	0

Table 14 CCS NVM ID 606-001 to 606-269

NVM ID	NVM Name	NVM Description	Settings	Default
606-197	Ex HW Plus Large Sheets Used	Extra Heavyweight Plus Large Sheets Used Total of large size Extra Heavyweight Plus media sheets since activation date numLargeExtraHWPlusMedia	Range = 0 to 16777215	0
606-198	Ex HW Plus Reloaded Large Sheets	Extra Heavyweight Plus Reloaded Large Sheets Used Total of large size Extra Heavyweight Plus Reloaded media sheets since activation date numLargeExtraHWPlusReloadedMedia	Range = 0 to 16777215	0
606-199	Gloss Coating Large Sheets Used	Gloss Coating Large Sheets Used Total of large size Gloss Coating media sheets since activation date numLargeGlossMedia	Range = 0 to 16777215	0
606-200	Gloss Reloaded Large Sheets	Gloss Coating Reloaded Large Sheets Used Total of large size Gloss Coating Reloaded media sheets since activation date numLargeGlossReloadedMedia	Range = 0 to 16777215	0
606-201	HW Gloss Large Sheets Used	Heavyweight Gloss Coating Large Sheets Used Total of large size Heavyweight Gloss Coating media sheets since activation date numLargeHWGlossMedia	Range = 0 to 16777215	0
606-202	HW Gloss Reload Large Sheets	Heavyweight Gloss Coating Reloaded Large Sheets Used Total of large size Heavyweight Gloss Coating Reloaded media sheets since activation date numLargeHWGlossReloadedMedia	Range = 0 to 16777215	0

Table 14 CCS NVM ID 606-001 to 606-269

NVM ID	NVM Name	NVM Description	Settings	Default
606-203	Ex HW Gloss Large Sheets	Extra Heavyweight Gloss Coating Large Sheets Used Total of large size Extra Heavyweight Gloss Coating media sheets since activation date numLargeExtraHWGlossMedia	Range = 0 to 16777215	0
606-204	Ex HW Gloss Reload Large Sheets	Extra Heavyweight Gloss Coating Reloaded Large Sheets Used Total of large size Extra Heavyweight Gloss Coating Reloaded media sheets since activation date numLargeExtraHWGlossReloadedMedia	Range = 0 to 16777215	0
606-205	Recycled Large Sheets Used	Recycled Large Sheets Used Total of large size Recycled media sheets since activation date numLargeRecycledMedia	Range = 0 to 16777215	0
606-206	Hole Punched Large Sheets Used	Hole Punched Large Sheets Used Total of large size Hole punched media sheets since activation date numLargeHolePunchMedia	Range = 0 to 16777215	0
606-207	Other Paper Type Large Sheets	Other Paper Type Large Sheets Used Total of large size Other media (not captured above) sheets since activation date numLargeOtherMedia	Range = 0 to 16777215	0
606-208	Letter Sheets Used	Letter (8.5 x 11) Sheets Used Total of 8.5x11 inch sheets since activation date numLetterSheets	Range = 0 to 16777215	0
606-209	Tabloid Sheets Used	Tabloid (11 x 17) Sheets Used Total of 11x17 inch sheets since activation date numTabloidSheets	Range = 0 to 16777215	0
606-210	Legal Sheets Used	Legal (8.5 x 14) Sheets Used Total of 8.5 x 14 inch sheets since activation date numLegalSheets	Range = 0 to 16777215	0

Table 14 CCS NVM ID 606-001 to 606-269

NVM ID	NVM Name	NVM Description	Settings	Default
606-211	Statement Sheets Used	Statement (5.5 x 8.5) Sheets Used Total of 5.5 x 8.5 inch sheets since activation date numStatementSheets	Range = 0 to 16777215	0
606-212	Executive Sheet-sUsed	Executive (7.25 x 10.5) Sheets Used Total of 7.25 x 10.5 inch sheets since activation date numExecutiveSheets	Range = 0 to 16777215	0
606-213	8 x 10 Sheets Used	8 x 10 inch Sheets Used Total of 8 x 10 inch sheets since activation date num8x10Sheets	Range = 0 to 16777215	0
606-214	12 x 18 Sheets Used	12 x 18 inch Sheets Used Total of 12 x 18 inch sheets since activation date num12x18Sheets	Range = 0 to 16777215	0
606-215	12 x 19 Sheets Used	12 x 19 inch Sheets Used Total of 12x19 inch sheets since activation date num12x19Sheets	Range = 0 to 16777215	0
606-216	13 x 19 Sheets Used	13 x 19 inch Sheets Used Total of 13 x 19 inch sheets since activation date num12x19Sheets	Range = 0 to 16777215	0
606-217	A4 Sheets Used	A4 Sheets Used Total of A4 sheets since activation date numA4Sheets	Range = 0 to 16777215	0
606-218	A3 Sheets Used	A3 Sheets Used Total of A3 sheets since activation date numA3Sheets	Range = 0 to 16777215	0
606-219	SRA3 Sheets Used	SRA3 Sheets Used Total of SRA3 sheets since activation date numSRA3Sheets	Range = 0 to 16777215	0
606-220	A5 Sheets Used	A5 Sheets Used Total of A5 sheets since activation date numA5Sheets	Range = 0 to 16777215	0
606-221	A6 Sheets Used	A6 Sheets Used Total of A6 sheets since activation date numA6Sheets	Range = 0 to 16777215	0

Table 14 CCS NVM ID 606-001 to 606-269

NVM ID	NVM Name	NVM Description	Settings	Default
606-222	Postcards Used	Postcards Used Total of Postcard sheets since activation date. numPostcardSheets	Range = 0 to 16777215	0
606-223	Tabbed Media Sheets Used	Tabbed Media Sheets Used Total of Tabbed sheets since activation date numTabbedSheets	Range = 0 to 16777215	0
606-224	Envelopes Used	Envelopes Used Total of Envelope sheets since activation date numEnvelopeSheets	Range = 0 to 16777215	0
606-225	Custom Size Sheets Used	Custom Size Sheets Used Total of Custom Size sheets since activation date numCustomSheets	Range = 0 to 16777215	0
606-226	Other Size Sheets Used	Other Size Sheets Used Total of Other Size sheets since activation date numOtherSheets	Range = 0 to 16777215	0
606-227	Number of Jobs of 1 page	Number of Jobs of 1 page since activation Total Number of Jobs Consisting of 1 sheet since activation numPagesPerJobCounters[0]	Range = 0 to 16777215	0
606-228	Number of Jobs of 2 - 4 pages	Number of Jobs of 2 - 4 pages since activation Total Number of Jobs Consisting of 2 - 4 sheets since activation numPagesPerJobCounters[1]	Range = 0 to 16777215	0
606-229	Number of Jobs of 5 - 9 pages	Number of Jobs of 5 - 9 pages since activation Total Number of Jobs Consisting of 5 - 9 sheets since activation numPagesPerJobCounters[2]	Range = 0 to 16777215	0
606-230	Number of Jobs of 10 - 19 pages	Number of Jobs of 10 - 19 pages since activation Total Number of Jobs Consisting of 10 - 19 sheets since activation numPagesPerJobCounters[3]	Range = 0 to 16777215	0

Table 14 CCS NVM ID 606-001 to 606-269

NVM ID	NVM Name	NVM Description	Settings	Default
606-231	Number of Jobs of 20 - 29 pages	Number of Jobs of 20 - 29 pages since activation Total Number of Jobs Consisting of 20 - 29 sheets since activation numPagesPerJobCounters[4]	Range = 0 to 16777215	0
606-232	Number of Jobs of 30 - 49 pages	Number of Jobs of 30 - 49 pages since activation Total Number of Jobs Consisting of 30 - 49 sheets since activation numPagesPerJobCounters[5]	Range = 0 to 16777215	0
606-233	Number of Jobs of 50 - 74 pages	Number of Jobs of 50 - 74 pages since activation Total Number of Jobs Consisting of 50 - 74 sheets since activation numPagesPerJobCounters[6]	Range = 0 to 16777215	0
606-234	Number of Jobs of 75 - 99 pages	Number of Jobs of 75 - 99 pages since activation Total Number of Jobs Consisting of 75 - 99 sheets since activation numPagesPerJobCounters[7]	Range = 0 to 16777215	0
606-235	Number of Jobs (100 - 249 pages)	Number of Jobs of 100 - 249 pages since activation Total Number of Jobs Consisting of 100 - 249 sheets since activation numPagesPerJobCounters[8]	Range = 0 to 16777215	0
606-236	Number of Jobs of 250+ pages	Number of Jobs of 250+ pages since activation Total Number of Jobs Consisting of 250 plus sheets since activation numPagesPerJobCounters[9]	Range = 0 to 16777215	0
606-237	Number of Jobs of 1 set	Number of Jobs of 1 set Total Number of Jobs Consisting of 1 Set since activation numSetsPerJobCounters[0]	Range = 0 to 16777215	0
606-238	Number of Jobs of 2 - 4 sets	Number of Jobs of 2 - 4 sets since activation Total Number of Jobs Consisting of 2 - 4 sets since activation numSetsPerJobCounters[1]	Range = 0 to 16777215	0

Table 14 CCS NVM ID 606-001 to 606-269

NVM ID	NVM Name	NVM Description	Settings	Default
606-239	Number of Jobs of 5 - 9 sets	Number of Jobs of 5 - 9 sets since activation Total Number of Jobs Consisting of 5 - 9 sets since activation numPagesPerJobCounters[2]	Range = 0 to 16777215	0
606-240	Number of Jobs of 10 - 19 sets	Number of Jobs of 10 - 19 sets since activation Total Number of Jobs Consisting of 10 - 19 sets since activation numSetsPerJobCounters[3]	Range = 0 to 16777215	0
606-241	Number of Jobs of 20 - 29 sets	Number of Jobs of 20 - 29 sets since activation Total Number of Jobs Consisting of 20 - 29 sets since activation numSetsPerJobCounters[4]	Range = 0 to 16777215	0
606-242	Number of Jobs of 30 - 49 sets	Number of Jobs of 30 - 49 sets since activation Total Number of Jobs Consisting of 30 - 49 sets since activation numSetsPerJobCounters[5]	Range = 0 to 16777215	0
606-243	Number of Jobs of 50 - 74 sets	Number of Jobs of 50 - 74 sets since activation Total Number of Jobs Consisting of 50 - 74 sets since activation numSetsPerJobCounters[6]	Range = 0 to 16777215	0
606-244	Number of Jobs of 75 - 99 sets	Number of Jobs of 75 - 99 sets since activation Total Number of Jobs Consisting of 75 - 99 sets since activation numSetsPerJobCounters[7]	Range = 0 to 16777215	0
606-245	Number of Jobs of 100 - 249 sets	Number of Jobs of 100 - 249 sets since activation Total Number of Jobs Consisting of 100 - 249 sets since activation numSetsPerJobCounters[8]	Range = 0 to 16777215	0
606-246	Number of Jobs of 250+ sets	Number of Jobs of 250+ sets since activation Total Number of Jobs Consisting of 250 plus sets since activation numSetsPerJobCounters[9]	Range = 0 to 16777215	0

Table 14 CCS NVM ID 606-001 to 606-269

NVM ID	NVM Name	NVM Description	Settings	Default
606-247	All sheets fed from Tray #5	All sheets fed from Tray #5 Total number of Sheets Fed from Tray 5 - Read Only Accumulated Value numTray5Sheets	Range = 0 to 16777215	0
606-248	All sheets fed from Tray #6	All sheets fed from Tray #6 Total number of Sheets Fed from Tray 6 - Read Only Accumulated Value numTray6Sheets	Range = 0 to 16777215	0
606-249	All sheets fed from Tray #7	All sheets fed from Tray #7 Total number of Sheets Fed from Tray 7 - Read Only Accumulated Value numTray7Sheets	Range = 0 to 16777215	0
606-250	All sheets fed from Tray #8	All sheets fed from Tray #8 Total number of Sheets Fed from Tray 8 - Read Only Accumulated Value numTray8Sheets	Range = 0 to 16777215	0
606-251	Color Maintenance Impressions	Color Maintenance Impressions. The total number of color impressions that were made while the machine was in service mode. For Jupiter this includes any MUD pages numColorMaintenanceImpressions	Range = 0 to 16777215	0
606-252	Black Maintenance Impressions	Black Maintenance Impressions The total number of black impressions that were made while the machine was in service mode. For Jupiter this includes any MUD pages numBlackMaintenanceImpressions	Range = 0 to 16777215	0
606-253	Lifetime Sheets	Lifetime Sheets Total sheets successfully delivered to output destination since activation numtotalSheets	Range = 0 to 16777215	0
606-254	Black in Color Mode Impressions	Black in Color Mode Impressions Total black impressions made in Mixed or Color Mode since activation	Range = 0 to 16777215	0

Table 14 CCS NVM ID 606-001 to 606-269

NVM ID	NVM Name	NVM Description	Settings	Default
606-255	Level 1 Impressions	Level 1 Impressions This counter supports tiered billing numTieredBillingLevel1Impressions	Range = 0 to 16777215	0
606-256	Level 2 Impressions	Level 2 Impressions This counter supports tiered billing numTieredBillingLevel2Impressions	Range = 0 to 16777215	0
606-257	Level 3 Impressions	Level 3 Impressions This counter supports tiered billing numTieredBillingLevel3Impressions	Range = 0 to 16777215	0
606-258	Number of Jobs of 2 pages	Number of Jobs of 2 pages since activation Total Number of Jobs Consisting of 2 sheets since activation numPagesPerJobCounters[10]	Range = 0 to 16777215	0
606-259	Number of Jobs of 3 pages	Number of Jobs of 3 pages since activation Total Number of Jobs Consisting of 3 sheets since activation numPagesPerJobCounters[11]	Range = 0 to 16777215	0
606-260	Number of Jobs of 4 pages	Number of Jobs of 4 pages since activation Total Number of Jobs Consisting of 4 sheets since activation numPagesPerJobCounters[12]	Range = 0 to 16777215	0
606-267	TransFixLdRevHomeTimeOutFrontFC	Fault Counter for 10-537-00: Transfix Load Reverse Home Timeout Front	Range = 0 to 255	0
606-268	TransFixLdRevHomeTimeOutRearFC	Fault Counter for 10-538-00: Transfix Load Reverse Home Timeout Rear	Range = 0 to 255	0
606-269	Service Plan	Service Plan (Contract) - ColorQube Family - 0 = XE/NA Sold, 1 = Default (has been set by SIM), 2 = Not used, 3 = Metered, 4 = XE Page Pack, 5 = DMO sold.	Range = 0 to 5	1

Table 15 CCS NVM ID 606-270 to 606-900

NVM ID	NVM Name	NVM Description	Settings	Default
606-270	BW & Color Level 1 Impressions Not displayed	This NVM location is incremented when ever the calculated % area coverage for the impression is less than or equal to the 2 Tier Billing Threshold value	Range = 0 to 16777215	0
606-271	Color Level 2 Impressions Not displayed	Color Level 2 Impression_T2This counter supports 2 tier billing	Range = 0 to 16777215	0
606-272	TB Configuration	Billing Configuration. This counter supports tier billing	0 = BC traditional 1 = BC 2 tier 2 = BC 3 tier Range = 0 to 2	2
606-273	3TB Val 1 Not displayed	3 Tier Billing Threshold 1. This NVM supports the Threshold value between Level 1 and 2 for the 3 tier billing counters.	Range = 0 to 3,000	9
606-274	3TB Val 2 Not displayed	3 Tier Billing Threshold 2. This NVM supports the threshold value between Level 2 and 3 for the 3 tier billing counters.	Range = 0 to 3,000	68
606-275	2TB Val 1 Not displayed	2 Tier Billing Threshold. This NVM supports the Threshold value between Level 1 and 2 for the 2 tier billing counters.	Range = 0 to 3,000	9
606-276	Not displayed	Paper Trays Last 30 Jams NVM allocated to maintain this Log	Range = 0 to 0	0
606-277	Not displayed	Printhead 1 Installation Time and Date NVM allocated to maintain this Log	Range = 0 to 0	0
606-278	Not displayed	Printhead 2 Installation Time and Date NVM allocated to maintain this Log	Range = 0 to 0	0
606-279	Not displayed	Printhead 3 Installation Time and Date NVM allocated to maintain this Log	Range = 0 to 0	0
606-280	Not displayed	Printhead 4 Installation Time and Date NVM allocated to maintain this Log	Range = 0 to 0	0
606-281	Not displayed	Printhead 1 Clean Log NVM allocated to maintain this Log	Range = 0 to 0	0
606-282	Not displayed	Printhead 2 Clean Log NVM allocated to maintain this Log	Range = 0 to 0	0

Table 15 CCS NVM ID 606-270 to 606-900

NVM ID	NVM Name	NVM Description	Settings	Default
606-283	Not displayed	Printhead 3 Clean Log NVM allocated to maintain this Log	Range = 0 to 0	0
606-284	Not displayed	Printhead 4 Clean Log NVM allocated to maintain this Log	Range = 0 to 0	0
606-285	Not displayed	Missing Jet Printhead 1 Impression Number Log NVM allocated to maintain this Log	Range = 0 to 0	0
606-286	Not displayed	Missing Jet Printhead 2 Impression Number Log NVM allocated to maintain this Log	Range = 0 to 0	0
606-287	Not displayed	Missing Jet Printhead 3 Impression Number Log NVM allocated to maintain this Log	Range = 0 to 0	0
606-288	Not displayed	Missing Jet Printhead 4 Impression Number Log NVM allocated to maintain this Log	Range = 0 to 0	0
606-289	Not displayed	Chronic Jet Date Log Head 1NVM allocated to maintain this Log	Range = 0 to 0	0
606-290	Not displayed	Chronic Jet Date Log Head 2NVM allocated to maintain this Log	Range = 0 to 0	0
606-291	Not displayed	Chronic Jet Date Log Head 3NVM allocated to maintain this Log	Range = 0 to 0	0
606-292	Not displayed	Chronic Jet Date Log Head 4NVM allocated to maintain this Log	Range = 0 to 0	0
606-293	Printhead 1 Chronic Jet Flag	Chronic Jet Flag Head 1NVM allocated to maintain this Log	Range = 0 to 1	0
606-294	Printhead 2 Chronic Jet Flag	Chronic Jet Flag Head 2NVM allocated to maintain this Log	Range = 0 to 1	0
606-295	Printhead 3 Chronic Jet Flag	Chronic Jet Flag Head 3NVM allocated to maintain this Log	Range = 0 to 1	0
606-296	Printhead 4 Chronic Jet Flag	Chronic Jet Flag Head 4NVM allocated to maintain this Log	Range = 0 to 1	0
606-298	24VFailFC	Fault Counter for 1-540-00: 24V Fail	Number of faults Range = 0 to 255	0
606-299	50VFailFC	Fault Counter for 1-542: 50V Fail	Number of faults Range = 0 to 255	0
606-300	24VTurnOnFailFC	Fault Counter for 1-544: 24V TurnOn Fail	Number of faults Range = 0 to 255	0
606-301	50VTurnOnFailFC	Fault Counter for 1-546: 50V TurnOn Fail	Number of faults Range = 0 to 255	0

Table 15 CCS NVM ID 606-270 to 606-900

NVM ID	NVM Name	NVM Description	Settings	Default
606-302	TransfixCalNvramResetFC	Fault Counter for 10-536: Transfix Calibration NVRAM Reset	Number of faults Range = 0 to 255	0
606-303	MPS5TooLongFC	Fault Counter for 82-157: MP Sensor 5 Too Long	Number of faults Range = 0 to 255	0
606-304	MPS5TooShortFC	Fault Counter for 82-158: MP Sensor 5 Too Short	Number of faults Range = 0 to 255	0
606-305	MpMp2StallBridgedSheetZone1AFC	Fault Counter for 82-159: MP MP2 Stall Bridged Sheet Zone 1A	Number of faults Range = 0 to 255	0
606-306	MPMP2StallBridgedSheetZone2FC	Fault Counter for 82-160: MP MP2 Stall Bridged Sheet Zone 2	Number of faults Range = 0 to 255	0
606-307	NipESolOverCurrFC	Fault Counter for 82-509: Nip E Sol Over Curr	Number of faults Range = 0 to 255	0
606-308	ScanHWFailedFC	Fault Counter for 89-534: Scan HW failed	Number of faults Range = 0 to 255	0
606-309	RegCorrParmOutOfRangeFC	Fault Counter for 89-555: Registration correction parm out of range	Number of faults Range = 0 to 255	0
606-311	MediaRegParmResetFC	Fault Counter for 89-561: Media Registration Parm Reset, RALPH Calibration Needed	Number of faults Range = 0 to 255	0
606-312	MuMotorShortedFC	Fault Counter for 91-605: MU Motor Shorted	Number of faults Range = 0 to 255	0
606-313	HeadtoDrumContactFC	Fault Counter for 91-607: Head to drum contact	Number of faults Range = 0 to 255	0
606-314	HeadtoDrumMeasurementOutsideToleranceFC	Fault Counter for 91-608: Head to drum measurement is outside tolerance	Number of faults Range = 0 to 255	0
606-315	Head1WaveAmpCalErrFC	Fault Counter for 91-610: Head 1 Wave Amp Calibration Error	Number of faults Range = 0 to 255	0
606-316	Head2WaveAmpCalErrFC	Fault Counter for 91-611: Head 2 Wave Amp Calibration Error	Number of faults Range = 0 to 255	0
606-317	Head3WaveAmpCalErrFC	Fault Counter for 91-612: Head 3 Wave Amp Calibration Error	Number of faults Range = 0 to 255	0
606-318	Head4WaveAmpCalErrFC	Fault Counter for 91-613: Head 4 Wave Amp Calibration Error	Number of faults Range = 0 to 255	0
606-319	Head1FieldDataCorruptFC	Fault Counter for 91-614: Head #1 Head Field Data Corrupt	Number of faults Range = 0 to 255	0
606-320	Head2FieldDataCorruptFC	Fault Counter for 91-615: Head #2 Head Field Data Corrupt	Number of faults Range = 0 to 255	0
606-321	Head3FieldDataCorruptFC	Fault Counter for 91-616: Head #3 Head Field Data Corrupt	Number of faults Range = 0 to 255	0

Table 15 CCS NVM ID 606-270 to 606-900

NVM ID	NVM Name	NVM Description	Settings	Default
606-322	Head4FieldDataCorruptFC	Fault Counter for 91-617: Head #4 Head Field Data Corrupt	Range = 0 to 255	0
606-323	IODScanProcessFailedFC	Fault Counter for 91-630: IOD Scan process failed	Number of faults Range = 0 to 255	0
606-324	IODDarkAdjustFailedFC	Fault Counter for 91-631: IOD Dark Adjust failed	Number of faults Range = 0 to 255	0
606-325	IODDegradedModeFC	Fault Counter for 91-636: IOD in Degraded Mode	Number of faults Range = 0 to 255	0
606-326	IODYRunoutNvramResetFC	Fault Counter for 91-637: IOD Y Runout NVRAM Reset	Number of faults Range = 0 to 255	0
606-327	IODChronicJetsDetectedFC	Fault Counter for 91-638: IOD Chronic Jets Detected	Number of faults Range = 0 to 255	0
606-328	IODHead1RollNotConvergingFC	Fault Counter for 91-701: IOD Head 1 roll: not converging	Number of faults Range = 0 to 255	0
606-329	IODHead1RollPositionLimitFC	Fault Counter for 91-702: IOD Head 1 roll: position limit	Number of faults Range = 0 to 255	0
606-330	IODHead1XNotConvergingFC	Fault Counter for 91-703: IOD Head 1 X: not converging	Number of faults Range = 0 to 255	0
606-331	IODHead1XPositionLimitFC	Fault Counter for 91-704: IOD Head 1 X: position limit	Number of faults Range = 0 to 255	0
606-332	IODHead1YNotConvergingFC	Fault Counter for 91-705: IOD Head 1 Y: not converging	Number of faults Range = 0 to 255	0
606-333	IODHead1YPositionLimitFC	Fault Counter for 91-706: IOD Head 1 Y: position limit	Number of faults Range = 0 to 255	0
606-334	IODHead2RollNotConvergingFC	Fault Counter for 91-707: IOD Head 2 roll: not converging	Number of faults Range = 0 to 255	0
606-335	IODHead2RollPositionLimitFC	Fault Counter for 91-708: IOD Head 2 roll: position limit	Number of faults Range = 0 to 255	0
606-336	IODHead2XNotConvergingFC	Fault Counter for 91-709: IOD Head 2 X: not converging	Number of faults Range = 0 to 255	0
606-337	IODHead2XPositionLimitFC	Fault Counter for 91-710: IOD Head 2 X: position limit	Number of faults Range = 0 to 255	0
606-338	IODHead2YNotConvergingFC	Fault Counter for 91-711: IOD Head 2 Y: not converging	Number of faults Range = 0 to 255	0
606-339	IODHead2YPositionLimitFC	Fault Counter for 91-712: IOD Head 2 Y: position limit	Number of faults Range = 0 to 255	0
606-340	IODHead3RollNotConvergingFC	Fault Counter for 91-713: IOD Head 3 roll: not converging	Number of faults Range = 0 to 255	0
606-341	IODHead3RollPositionLimitFC	Fault Counter for 91-714: IOD Head 3 roll: position limit	Number of faults Range = 0 to 255	0
606-342	IODHead4RollNotConvergingFC	Fault Counter for 91-715: IOD Head 4 roll: not converging	Number of faults Range = 0 to 255	0
606-343	IODHead4RollPositionLimitFC	Fault Counter for 91-716: IOD Head 4 roll: position limit	Number of faults Range = 0 to 255	0

Table 15 CCS NVM ID 606-270 to 606-900

NVM ID	NVM Name	NVM Description	Settings	Default
606-344	IODHead4XNotConvergingFC	Fault Counter for 91-717: IOD Head 4 X: not converging	Number of faults Range = 0 to 255	0
606-345	IODHead4XPositionLimitFC	Fault Counter for 91-718: IOD Head 4 X: position limit	Number of faults Range = 0 to 255	0
606-346	IODHead4YNotConvergingFC	Fault Counter for 91-719: IOD Head 4 Y: not converging	Number of faults Range = 0 to 255	0
606-347	IODHead4YPositionLimitFC	Fault Counter for 91-720: IOD Head 4 Y: position limit	Number of faults Range = 0 to 255	0
606-348	IODCalFC	Fault Counter for 91-721: IOD calibration	Number of faults Range = 0 to 255	0
606-349	IODCal2DFC	Fault Counter for 91-722: IOD calibration 2D	Number of faults Range = 0 to 255	0
606-351	IODTargetFC	Fault Counter for 91-725: IOD target	Number of faults Range = 0 to 255	0
606-352	IODTargetMissingFC	Fault Counter for 91-726: IOD target: missing	Number of faults Range = 0 to 255	0
606-353	IODTargetCorruptedFC	Fault Counter for 91-727: IOD target: corrupted	Number of faults Range = 0 to 255	0
606-354	IODTargetMissingOrCorruptedFC	Fault Counter for 91-728: IOD target: missing or corrupted	Number of faults Range = 0 to 255	0
606-355	IODTargetYPosOutOfRangeFC	Fault Counter for 91-729: IOD target: Y position out of range	Number of faults Range = 0 to 255	0
606-356	IODTargetYPosOutOfFarRangeFC	Fault Counter for 91-730: IOD target: Y position out of far range	Number of faults Range = 0 to 255	0
606-358	IODHead3YPositionLimitFC	Fault Counter for 91-732: IOD Head 3 Y: position limit	Number of faults Range = 0 to 255	0
606-359	IODNonStaticScanbarArtifactFC	Fault Counter for 91-735: IOD non-static scanbar artifact	Number of faults Range = 0 to 255	0
606-360	IODStaticScanbarArtifactFC	Fault Counter for 91-736: IOD static scanbar artifact	Number of faults Range = 0 to 255	0
606-361	EcmPciAccessFailedFC	Fault Counter for 92-556: EcmPciAccessFailed	Number of faults Range = 0 to 255	0
606-362	EcmAdcFailedFC	Fault Counter for 92-557: EcmAdcFailed	Number of faults Range = 0 to 255	0
606-363	EcmPsLineCrossFailedFC	Fault Counter for 92-558: EcmPsLineCrossFailed	Number of faults Range = 0 to 255	0
606-364	EcmCallistoAccessErrorFC	Fault Counter for 92-559: EcmCallistoAccessError	Number of faults Range = 0 to 255	0
606-365	BlackheartVerMismatchFC	Fault Counter for 92-569: BlackheartVerMismatch	Number of faults Range = 0 to 255	0
606-366	MUAirSolOverCurrFC	Fault Counter for 93-890: MU Air Sol Over Currant	Number of faults Range = 0 to 255	0

Table 15 CCS NVM ID 606-270 to 606-900

NVM ID	NVM Name	NVM Description	Settings	Default
606-367	InkLoadMotorOverCurrFC	Fault Counter for 93-891: Ink Load Motor Over Current	Number of faults Range = 0 to 255	0
606-368	InkSKU Sel DriverOverCurrFC	Fault Counter for 93-892: Ink SKU Sel Driver Over Current	Number of faults Range = 0 to 255	0
606-373	BlackMeltResOverFillFailFC	Fault Counter for 93-901: black melt reservoir over fill failure	Number of faults Range = 0 to 255	0
606-374	MagentaMeltResOverFillFailFC	Fault Counter for 93-902: magenta melt reservoir over fill failure	Number of faults Range = 0 to 255	0
606-375	CyanMeltResOverFillFailFC	Fault Counter for 93-903: cyan melt reservoir over fill failure	Number of faults Range = 0 to 255	0
606-376	YellowMeltResOverFillFailFC	Fault Counter for 93-904: yellow melt reservoir over fill failure	Number of faults Range = 0 to 255	0
606-377	CleanUnitResPressLowFC	Fault Counter 94-504: Cleaning Unit Res Press Low	Number of faults Range = 0 to 255	0
606-378	CleanUnitResPressHighFC	Fault Counter 94-505: Cleaning Unit Res Press High	Number of faults Range = 0 to 255	0
606-379	CleanUnitSynchAccessErrorFC	Fault Counter 94-574: Cleaning Unit Synch Access Error	Number of faults Range = 0 to 255	0
606-380	CleanUnitDeliveryPumpTestFailFC	Fault Counter 94-610: Cleaning Unit Delivery Pump Test Fail	Number of faults Range = 0 to 255	0
606-381	CleanUnitRemovePumpTestFailFC	Fault Counter 94-611: Cleaning Unit Removal Pump Test Fail	Number of faults Range = 0 to 255	0
606-382	CleanUnitValveTestFailFC	Fault Counter 94-612: Cleaning Unit Valve Test Fail	Number of faults Range = 0 to 255	0
606-384	ImeUnitFirmwareVerMismatchFC	Fault Counter for 92-560: Marking Unit firmware version mismatch.	Number of faults Range = 0 to 255	0
606-385	ImeDeliveryFirmwareVerMismatchFC	Fault Counter for 92-561: Marking Unit Ink Delivery firmware version mismatch	Number of faults Range = 0 to 255	0
606-386	DrumDriverFirmwareVerMismatchFC	Fault Counter for 92-562: Drum Driver firmware version mismatch	Number of faults Range = 0 to 255	0
606-387	PowerSupplyFirmwareVerMismatchFC	Fault Counter for 92-563: Power supply firmware version mismatch	Number of faults Range = 0 to 255	0
606-388	MediaPathFirmwareVerMismatchFC	Fault Counter for 92-564: Media Path firmware version mismatch	Number of faults Range = 0 to 255	0

Table 15 CCS NVM ID 606-270 to 606-900

NVM ID	NVM Name	NVM Description	Settings	Default
606-389	PaperTrayFirmwareVerMismatchFC	Fault Counter for 92-565: Paper Tray Module firmware version mismatch.	Number of faults Range = 0 to 255	0
606-390	PfpFirmwareVerMismatchFC	Fault Counter for 92-566: Paper Feeder Platform firmware version mismatch.	Number of faults Range = 0 to 255	0
606-391	CcsSwVerMismatchFC	Fault Counter for 92-567: single board Controller software version mismatch	Number of faults Range = 0 to 255	0
606-392	PrePunchMediaEraseValue	Default sheet edge erase value for pre-punched, pre-cut tab stock. Please refer FS 16.020 for more details related to this feature. Also refer to IDs 2680 and 2681	Number of faults Range = 0 to 255	20
606-393	Tray 1 Jams	Tray 1 Jams - Usage Counter	Range = 0 to 4294967295	0
606-394	Tray 2 Jams	Tray 2 Jams - Usage Counter	Range = 0 to 4294967295	0
606-395	Tray 3 Jams	Tray 3 Jams - Usage Counter	Range = 0 to 4294967295	0
606-396	Tray 4 Jams	Tray 4 Jams - Usage Counter	Range = 0 to 4294967295	0
606-397	Tray 5 Jams	Tray 5 Jams - Usage Counter	Range = 0 to 4294967295	0
606-398	Tray 6 Jams	Tray 6 Jams - Usage Counter	Range = 0 to 4294967295	0
606-399	Tray 7 Jams	Tray 7 Jams - Usage Counter	Range = 0 to 4294967295	0
606-400	Tray 8 Jams	Tray 8 Jams - Usage Counter	Range = 0 to 4294967295	0
606-401	IOT comm faults counter	IOT comm faults counter	Range = 0 to 4294967295	0
606-402	Finisher comm faults counter	Finisher comm faults counter	Range = 0 to 4294967295	0
606-403	Protocol comm faults counter	Protocol comm faults counter	Range = 0 to 4294967295	0
606-404	Paper trays currently installed	Paper trays currently installed	Range = 0 to 4294967295	0
606-405	Output jams	Output jams	Range = 0 to 4294967295	0
606-406	Compile jams	Compile jams	Range = 0 to 4294967295	0
606-407	Staple errors	Staple errors	Range = 0 to 4294967295	0

Table 15 CCS NVM ID 606-270 to 606-900

NVM ID	NVM Name	NVM Description	Settings	Default
606-408	Booklet maker errors	Booklet maker errors	Range = 0 to 4294967295	0
606-409	Registration Jams	Registration Jams	Range = 0 to 4294967295	0
606-410	Installed Maint Kit Impressions	Maintenance Kit Installation ImpressionsTotal number of sheets that have been successfully delivered to output destination since the current kit was installed.	Range = 0 to 4294967295	0
606-411	BW Color 1 Copy Impressions T3	Black + Color Level 1 Copied Impressions_T3	Range = 0 to 4294967295	0
606-412	Color 2 Copy Impressions_T3	Color Level 2 Copied Impressions_T3	Range = 0 to 4294967295	0
606-413	Color 3 Copy Impressions T3	Color Level 3 Copied Impressions_T3	Range = 0 to 4294967295	0
606-414	BW Color 1 Print Impressions T3	Black + Color Level 1 Printed Impressions_T3	Range = 0 to 4294967295	0
606-415	Color 2 Print Impressions T3	Color 2 Print Impressions T3	Range = 0 to 4294967295	0
606-416	Color 3 Print Impressions T3	Color Level 3 Printed Impressions_T3	Range = 0 to 4294967295	0
606-417	BW Color 1 Copy Impressions T2	Black + Color Level 1 Copied Impressions_T2	Range = 0 to 4294967295	0
606-418	Color 2 Copied Impressions T2	Color Level 2 Copied Impressions_T2	Range = 0 to 4294967295	0
606-419	BW Color 1 Print Impressions T2	Black + Color Level 1 Printed Impressions_T2	Range = 0 to 4294967295	0
606-420	Color 2 Print Impressions T2	Color Level 2 Printed Impressions_T2	Range = 0 to 4294967295	0
606-421	0% Total Color Coverage Not displayed	0% Total Color Coverage Identifies the number of impressions with 0% Total Coverage for all CMY colors.numTotalColorPixelCoverage[0]	Range = 0 to 16777215	0
606-422	0 To 0.2% Total Color Coverage Not displayed	0>and <=0.2% Total Color Coverage Identifies the number of impressions greater than 0% and <=.2% Total Coverage for all CMY colors.numTotalColorPixelCoverage[1]	Range = 0 to 16777215	0

Table 15 CCS NVM ID 606-270 to 606-900

NVM ID	NVM Name	NVM Description	Settings	Default
606-423	0.2 To 0.4% Tot Color Coverage Not displayed	0.2 > and <=0.4% Total Color Coverage Identifies the number of impressions greater than .2% and <= .4% Total Coverage for all CMY colors.numTotalColorPixelCoverage[2]	Range = 0 to 16777215	0
606-424	0.4 To 0.6% Tot Color Coverage Not displayed	0.4> and <=0.6% Total Color Coverage Identifies the number of impressions greater than .4% and <= .6% Total Coverage for all CMY colors.numTotalColorPixelCoverage[3]	Range = 0 to 16777215	0
606-425	0.6 To 0.8% Tot Color Coverage Not displayed	0.6 > and <=0.8% Total Color Coverage Identifies the number of impressions greater than .6% and <= .8% Total Coverage for all CMY colors.numTotalColorPixelCoverage[4]	Range = 0 to 16777215	0
606-426	0.8 To 1% Tot Color Coverage Not displayed	0.8> and <= 1% Total Color Coverage Identifies the number of impressions greater than .8% and <= 1% Total Coverage for all CMY colors.numTotalColorPixelCoverage[5]	Range = 0 to 16777215	0
606-427	1 To 2% Tot Color Coverage Not displayed	1 > and <= 2% Total Color Coverage Identifies the number of impressions greater than 1% and <= 2% Total Coverage for all CMY colors.numTotalColorPixelCoverage[6]	Range = 0 to 16777215	0
606-428	2 To 3% Tot Color Coverage Not displayed	2 > and <= 3% Total Color Coverage Identifies the number of impressions greater than 2% and <= 3% Total Coverage for all CMY colors.numTotalColorPixelCoverage[7]	Range = 0 to 16777215	0
606-429	3 To 4% Tot Color Coverage Not displayed	3 > and <= 4% Total Color Coverage Identifies the number of impressions greater than 3% and <= 4% Total Coverage for all CMY colors.numTotalColorPixelCoverage[8]	Range = 0 to 16777215	0

Table 15 CCS NVM ID 606-270 to 606-900

NVM ID	NVM Name	NVM Description	Settings	Default
606-430	4 To 5% Tot Color Coverage Not displayed	4 > and <= 5% Total Color Coverage Identifies the number of impressions greater than 4% and <= 5% Total Coverage for all CMY colors.numTotalColorPixelCoverage[9]	Range = 0 to 16777215	0
606-431	5 To 6% Tot Color Coverage Not displayed	5> and <= 6% Total Color Coverage Identifies the number of impressions greater than 5% and <= 6% Total Coverage for all CMY colors.numTotalColorPixelCoverage[10]	Range = 0 to 16777215	0
606-432	6 To 7% Tot Color Coverage Not displayed	6 > and <= 7% Total Color Coverage Identifies the number of impressions greater than 6% and <= 7% Total Coverage for all CMY colors.numTotalColorPixelCoverage[11]	Range = 0 to 16777215	0
606-433	7 To 8% Tot Color Coverage Not displayed	7 > and <= 8% Total Color Coverage Identifies the number of impressions greater than 7% and <= 8% Total Coverage for all CMY colors.numTotalColorPixelCoverage[12]	Range = 0 to 16777215	0
606-434	8 To 9% Tot Color Coverage Not displayed	8 > and <= 9% Total Color Coverage Identifies the number of impressions greater than 8% and <= 9% Total Coverage for all CMY colors.numTotalColorPixelCoverage[13]	Range = 0 to 16777215	0
606-435	9 To 10% Tot Color Coverage Not displayed	9 > and <= 10% Total Color Coverage Identifies the number of impressions greater than 9% and <= 10% Total Coverage for all CMY colors.numTotalColorPixelCoverage[14]	Range = 0 to 16777215	0
606-436	10 To 11% Tot Color Coverage Not displayed	10 > and <= 11% Total Color Coverage Identifies the number of impressions greater than 10% and <= 11% Total Coverage for all CMY colors.numTotalColorPixelCoverage[15]	Range = 0 to 16777215	0

Table 15 CCS NVM ID 606-270 to 606-900

NVM ID	NVM Name	NVM Description	Settings	Default
606-437	11 To 12% Tot Color Coverage Not displayed	11 > and <= 12% Total Color Coverage Identifies the number of impressions greater than 11% and <= 12% Total Coverage for all CMY colors.numTotalColorPixelCoverage[16]	Range = 0 to 16777215	0
606-438	12 To 13% Tot Color Coverage Not displayed	12 > and <= 13% Total Color Coverage Identifies the number of impressions greater than 12% and <= 13% Total Coverage for all CMY colors.numTotalColorPixelCoverage[17]	Range = 0 to 16777215	0
606-439	13 To 14% Tot Color Coverage Not displayed	13 > and <= 14% Total Color Coverage Identifies the number of impressions greater than 13% and <= 14% Total Coverage for all CMY colors.numTotalColorPixelCoverage[18]	Range = 0 to 16777215	0
606-440	14 To 15% Tot Color Coverage Not displayed	14 > and <= 15% Total Color Coverage Identifies the number of impressions greater than 14% and <= 15% Total Coverage for all CMY colors.numTotalColorPixelCoverage[19]	Range = 0 to 16777215	0
606-441	15 To 16% Tot Color Coverage Not displayed	15 > and <= 16% Total Color Coverage Identifies the number of impressions greater than 15% and <= 16% Total Coverage for all CMY colors.numTotalColorPixelCoverage[20]	Range = 0 to 16777215	0
606-442	16 To 17% Tot Color Coverage Not displayed	16 > and <= 17% Total Color Coverage Identifies the number of impressions greater than 16% and <= 17% Total Coverage for all CMY colors.numTotalColorPixelCoverage[21]	Range = 0 to 16777215	0
606-443	17 To 18% Tot Color Coverage Not displayed	17 > and <= 18% Total Color Coverage Identifies the number of impressions greater than 17% and <= 18% Total Coverage for all CMY colors.numTotalColorPixelCoverage[22]	Range = 0 to 16777215	0

Table 15 CCS NVM ID 606-270 to 606-900

NVM ID	NVM Name	NVM Description	Settings	Default
606-444	18 To 19% Tot Color Coverage Not displayed	18 > and <= 19% Total Color Coverage Identifies the number of impressions greater than 18% and <= 19% Total Coverage for all CMY colors.numTotalColorPixelCoverage[23]	Range = 0 to 16777215	0
606-445	19 To 20% Tot Color Coverage Not displayed	19 > and <= 20% Total Color Coverage Identifies the number of impressions greater than 19% and <= 20% Total Coverage for all CMY colors.numTotalColorPixelCoverage[24]	Range = 0 to 16777215	0
606-446	20 To 21% Tot Color Coverage Not displayed	20 > and <= 21% Total Color Coverage Identifies the number of impressions greater than 20% and <= 21% Total Coverage for all CMY colors.numTotalColorPixelCoverage[25]	Range = 0 to 16777215	0
606-447	21 To 22% Tot Color Coverage Not displayed	21 > and <= 22% Total Color Coverage Identifies the number of impressions greater than 21% and <= 22% Total Coverage for all CMY colors.numTotalColorPixelCoverage[26]	Range = 0 to 16777215	0
606-448	22 To 23% Tot Color Coverage Not displayed	22 > and <= 23% Total Color Coverage Identifies the number of impressions greater than 22% and <= 23% Total Coverage for all CMY colors.numTotalColorPixelCoverage[27]	Range = 0 to 16777215	0
606-449	23 To 24% Tot Color Coverage Not displayed	23 > and <= 24% Total Color Coverage Identifies the number of impressions greater than 23% and <= 24% Total Coverage for all CMY colors.numTotalColorPixelCoverage[28]	Range = 0 to 16777215	0
606-450	24 To 25% Tot Color Coverage Not displayed	24 > and <= 25% Total Color Coverage Identifies the number of impressions greater than 24% and <= 25% Total Coverage for all CMY colors.numTotalColorPixelCoverage[29]	Range = 0 to 16777215	0

Table 15 CCS NVM ID 606-270 to 606-900

NVM ID	NVM Name	NVM Description	Settings	Default
606-451	25 To 30% Tot Color Coverage Not displayed	25 > and <= 30% Total Color Coverage Identifies the number of impressions greater than 25% and <= 30% Total Coverage for all CMY colors.numTotalColorPixelCoverage[30]	Range = 0 to 16777215	0
606-452	30 To 35% Tot Color Coverage Not displayed	30 > and <= 35% Total Color Coverage Identifies the number of impressions greater than 30% and <= 35% Total Coverage for all CMY colors.numTotalColorPixelCoverage[31]	Range = 0 to 16777215	0
606-453	35 To 40% Tot Color Coverage Not displayed	35 > and <= 40% Total Color Coverage Identifies the number of impressions greater than 35% and <= 40% Total Coverage for all CMY colors.numTotalColorPixelCoverage[32]	Range = 0 to 16777215	0
606-454	40 To 45% Tot Color Coverage Not displayed	40 > and <= 45% Total Color Coverage Identifies the number of impressions greater than 40% and <= 45% Total Coverage for all CMY colors.numTotalColorPixelCoverage[33]	Range = 0 to 16777215	0
606-455	45 To 50% Tot Color Coverage Not displayed	45 > and <= 50% Total Color Coverage Identifies the number of impressions greater than 45% and <= 50% Total Coverage for all CMY colors.numTotalColorPixelCoverage[34]	Range = 0 to 16777215	0
606-456	50 To 75% Tot Color Coverage Not displayed	50 > and <= 75% Total Color Coverage Identifies the number of impressions greater than 50% and <= 75% Total Coverage for all CMY colors.numTotalColorPixelCoverage[35]	Range = 0 to 16777215	0
606-457	75 To 100% Tot Color Coverage Not displayed	75 > and <= 100% Total Color Coverage Identifies the number of impressions greater than 75% and <= 100% Total Coverage for all CMY colors.numTotalColorPixelCoverage[36]	Range = 0 to 16777215	0

Table 15 CCS NVM ID 606-270 to 606-900

NVM ID	NVM Name	NVM Description	Settings	Default
606-458	100 To 125% Tot Color Coverage Not displayed	100 > and <= 125% Total Color Coverage Identifies the number of impressions greater than 100% and <= 125% Total Coverage for all CMY colors.numTotalColorPixelCoverage[37]	Range = 0 to 16777215	0
606-459	125 To 150% Tot Color Coverage Not displayed	125 > and <= 150% Total Color Coverage Identifies the number of impressions greater than 125% and <= 150% Total Coverage for all CMY colors.numTotalColorPixelCoverage[38]	Range = 0 to 16777215	0
606-460	150 To 175% Tot Color Coverage Not displayed	150 > and <= 175% Total Color Coverage Identifies the number of impressions greater than 150% and <= 175% Total Coverage for all CMY colors.numTotalColorPixelCoverage[39]	Range = 0 to 16777215	0
606-461	175 To 200% Tot Color Coverage Not displayed	175 > and <= 200% Total Color Coverage Identifies the number of impressions greater than 175% and <= 200% Total Coverage for all CMY colors.numTotalColorPixelCoverage[40]	Range = 0 to 16777215	0
606-462	200 To 225% Tot Color Coverage Not displayed	"200 > and <= 225% Total Color Coverage Identifies the number of impressions greater than 200% and <= 225% Total Coverage for all CMY colors.numTotalColorPixelCoverage[41]"	Range = 0 to 16777215	0
606-463	225 To 250% Tot Color Coverage Not displayed	225 > and <= 250% Total Color Coverage Identifies the number of impressions greater than 225% and <= 250% Total Coverage for all CMY colors.numTotalColorPixelCoverage[42]	Range = 0 to 16777215	0
606-464	250 To 275% Tot Color Coverage Not displayed	250 > and <= 275% Total Color Coverage Identifies the number of impressions greater than 250% and <= 275% Total Coverage for all CMY colors.numTotalColorPixelCoverage[43]	Range = 0 to 16777215	0

Table 15 CCS NVM ID 606-270 to 606-900

NVM ID	NVM Name	NVM Description	Settings	Default
606-465	275 To 300% Tot Color Coverage Not displayed	275 > and <= 300% Total Color CoverageIdentifies the number of impressions greater than 275% and <= 300% Total Coverage for all CMY colors.numTotalColorPixelCoverage[44]	Range = 0 to 16777215	0
606-466	Actual K Pix In BW Mode Up Not displayed	Actual Black Pixels Marked-Black & White Up (1K) This item conveys the Actual total number of Black pixels printed on Black and White impressions for any media size as reported by the IME Values are given in K (1000) units.numTotActualBWModeKPixelCountUp	Range = 0 to 4294967295	0
606-467	Actual K Pix In BW Mode Low	Actual Black Pixels Marked-Black & White Low (1K) This item conveys the Actual total number of Black pixels printed on Black and White impressions for any media size as reported by the IME Values are given in K (1000) units.numTotActualBWModeKPixelCountLow	Range = 0 to 4294967295	0
606-468	Actual C Pix In BW Mode Up	Actual Cyan Pixels Marked-Black & White Up (1K) This item conveys the Actual total number of Cyan pixels printed on Black and White impressions for any media size as reported by the IME Values are given in K (1000) units.numTotActualBWModeCPixelCountUp	Range = 0 to 4294967295	0
606-469	Actual C Pix In BW Mode Low	Actual Cyan Pixels Marked-Black & White Low (1K) This item conveys the Actual total number of Cyan pixels printed on Black and White impressions for any media size as reported by the IME Values are given in K (1000) units.numTotActualBWModeCPixelCountLow	Range = 0 to 4294967295	0

Table 15 CCS NVM ID 606-270 to 606-900

NVM ID	NVM Name	NVM Description	Settings	Default
606-470	Actual M Pix In BW Mode Up	Actual Magenta Pixels Marked-Black & White Up (1K) This item conveys the Actual total number of Magenta pixels printed on Black and White impressions for any media size as reported by the IME Values are given in K (1000) units.numTotActualBWModeM-PixelCountUp	Range = 0 to 4294967295	0
606-471	Actual M Pix In BW Mode Low	Actual Magenta Pixels Marked-Black & White Low (1K) This item conveys the Actual total number of Magenta pixels printed on Black and White impressions for any media size as reported by the IME Values are given in K (1000) units.numTotActualBWModeM-PixelCountLow	Range = 0 to 4294967295	0
606-472	Actual Y Pix In BW Mode Up	Actual Yellow Pixels Marked-Black & White Up (1K) This item conveys the Actual total number of Yellow pixels printed on Black and White impressions for any media size as reported by the IME Values are given in K (1000) units.numTotActualBWModeYPixelCountUp	Range = 0 to 4294967295	0
606-473	Actual Y Pix In BW Mode Low	Actual Yellow Pixels Marked-Black & White Low (1K) This item conveys the Actual total number of Yellow pixels printed on Black and White impressions for any media size as reported by the IME Values are given in K (1000) units.numTotActualBWModeYPixelCountLow	Range = 0 to 4294967295	0
606-474	Actual K Pix In Color Mode Up	Actual Black Pixels Marked-Color Up (1K) This item conveys the Actual total number of Black pixels printed on color impressions for any media size as reported by the IME Values are given in K (1000) units.numTotActualColorMode-KPixelCountUp	Range = 0 to 4294967295	0

Table 15 CCS NVM ID 606-270 to 606-900

NVM ID	NVM Name	NVM Description	Settings	Default
606-475	Actual K Pix In Color Mode Low	Actual Black Pixels Marked-Color Low (1K) This item conveys the Actual total number of Black pixels printed on color impressions for any media size as reported by the IME Values are given in K (1000) units.numTotActualColorMode-KPixelCountLow	Range = 0 to 4294967295	0
606-476	Actual C Pix In Color Mode Up	Actual Cyan Pixels Printed-Color Up (1K) This item conveys the Actual total number of Cyan pixels printed on color impressions for any media size as reported by the IME Values are given in K (1000) units.numTotActualColorModeCPixelCountUp	Range = 0 to 4294967295	0
606-477	Actual C Pix In Color Mode Low	Actual Cyan Pixels Marked-Color Low (1K) This item conveys the Actual total number of Cyan pixels printed on color impressions for any media size as reported by the IME Values are given in K (1000) units.numTotActualColorModeCPixelCountLow	Range = 0 to 4294967295	0
606-478	Actual M Pix In Color Mode Up	Actual Magenta Pixels Marked-Color Up (1K) This item conveys the Actual total number of Magenta pixels printed on color impressions for any media size as reported by the IME Values are given in K (1000) units.numTotActualColorModeMPixelCountUp	Range = 0 to 4294967295	0
606-479	Actual M Pix In Color Mode Low	Actual Magenta Pixels Printed-Black & White Low (1K) This item conveys the Actual total number of Magenta pixels printed on Black and White impressions for any media size as reported by the IME Values are given in K (1000) units.numTotActualColorModeMPixelCountLow	Range = 0 to 4294967295	0

Table 15 CCS NVM ID 606-270 to 606-900

NVM ID	NVM Name	NVM Description	Settings	Default
606-480	Actual Y Pix In Color Mode Up	Actual Yellow Pixels Marked-Color Up (1K) This item conveys the Actual total number of Yellow pixels printed on color impressions for any media size as reported by the IME Values are given in K (1000) units.numTotActualColor-ModeYPixelCountUp	Range = 0 to 4294967295	0
606-481	Actual Y Pix In Color Mode Low	Actual Yellow Pixels Marked-Color Low (1K) This item conveys the Actual total number of Yellow pixels printed on color impressions for any media size as reported by the IME Values are given in K (1000) units.numTotActualColor-ModeYPixelCountLow	Range = 0 to 4294967295	0
606-482	DADHRollFeeds	DADH Feed Roll Number of feeds	Range = 0 to 4294967295	0
606-483	PPIRollFeeds	PPI Feed Roll Number of feeds	Range = 0 to 4294967295	0
606-484	3TMtray1RollFeeds	3TM Tray1 Feed Roll - Number of feeds	Range = 0 to 4294967295	0
606-485	3TMtray2RollFeeds	3TM Tray2 Feed Roll - Number of feeds	Range = 0 to 4294967295	0
606-486	3TMtray3RollFeeds	3TM Tray3 Feed Roll - Number of feeds	Range = 0 to 4294967295	0
606-487	MSIRollFeeds	MSI Feed Roll nbr of feeds	Range = 0 to 4294967295	0
606-488	InserterRollReplacements	Inserter Feed Roll - Number of replacements	Range = 0 to 4294967295	0
606-492	DADHRollReplacements	DADH Feed Roll nbr of replacements	Range = 1 to 65535	1
606-493	InserterRollReplacements	Inserter Feed Roll - Number of replacements	Range = 1 to 65535	1
606-494	3TMtray1RollReplacements	3TM Tray1 Feed Roll nbr of replacements	Range = 1 to 65535	1
606-495	3TMtray2RollReplacements	3TM Tray2 Feed Roll nbr of replacements	Range = 1 to 65535	1
606-496	3TMtray3RollReplacements	3TM Tray3 Feed Roll nbr of feeds	Range = 1 to 65535	1
606-497	MSIRollReplacements	MSI Feed Roll nbr of replacements	Range = 1 to 65535	1
606-498	PFPRollReplacements	PFH Feed Roll nbr of replacements	Range = 1 to 65535	1

Table 15 CCS NVM ID 606-270 to 606-900

NVM ID	NVM Name	NVM Description	Settings	Default
606-515	Cleaning Unit Life Expectancy	DMU Life Expectancy	Range = 0 to 4294967295	140000
606-516	DADHRollLife	DADH Feed Roll Life Expectancy	Range = 0 to 4294967295	150000
606-517	InsertRollLife	Insert Feed Roll Life Expectancy	Range = 0 to 4294967295	80000
606-518	3TMtray1Life	3TM Tray1 Feed Roll Life Expectancy	Range = 0 to 4294967295	600000
606-519	3TMtray2Life	3TM Tray2 Feed Roll Life Expectancy	Range = 0 to 4294967295	600000
606-520	3TMtray3Life	3TM Tray3 Feed Roll Life Expectancy	Range = 0 to 4294967295	600000
606-521	MSIRollLife	MSI Feed Roll Life Expectancy	Range = 0 to 4294967295	600000
606-522	PFPRollLife	PFP Feed Roll Life Expectancy	Range = 0 to 4294967295	600000
606-526	Not displayed	DADH Feed Roll Install Date	Range = 0 to 4294967295	0
606-527	Not displayed	PPI Feed Roll Life Install Date	Range = 0 to 4294967295	0
606-528	Not displayed	3TM Tray1 Feed Roll Install Date	Range = 0 to 4294967295	0
606-529	Not displayed	3TM Tray2 Feed Roll Install Date	Range = 0 to 4294967295	0
606-530	Not displayed	3TM Tray3 Feed Roll Install Date	Range = 0 to 4294967295	0
606-531	Not displayed	MSI Feed Roll Life Install Date	Range = 0 to 4294967295	0
606-532	Not displayed	PFP Feed Roll Life Install Date	Range = 0 to 4294967295	0
606-537	Last Auto Maintenance Update	Last Auto Maintenance Update	Range = 0 to 4294967295	0
606-539	InhibitMarkOnTabsPolicy	Inhibit Mark On Tabs Policy	Range = 0 to 1	1
606-541	Head 1 Link Broken	Fault Counter 91-660: Head 1 Link Broken	Number of faults Range = 0 to 255	0
606-542	Head 2 Link Broken	Fault Counter 91-661: Head 2 Link Broken	Number of faults Range = 0 to 255	0
606-543	Head 3 Link Broken	Fault Counter 91-662: Head 3 Link Broken	Number of faults Range = 0 to 255	0
606-544	Head 4 Link Broken	Fault Counter 91-663: Head 4 Link Broken	Number of faults Range = 0 to 255	0

Table 15 CCS NVM ID 606-270 to 606-900

NVM ID	NVM Name	NVM Description	Settings	Default
606-545	Head 1 Field Corrections Corrupt	Fault Counter 91-655: Head 1 Head Field Corrections Corrupt	Number of faults Range = 0 to 255	0
606-546	Head 2 Field Corrections Corrupt	Fault Counter 91-656: Head 2 Head Field Corrections Corrupt	Number of faults Range = 0 to 255	0
606-547	Head 3 Field Corrections Corrupt	Fault Counter 91-657: Head 3 Head Field Corrections Corrupt	Number of faults Range = 0 to 255	0
606-548	Head 4 Field Corrections Corrupt	Fault Counter 91-658: Head 4 Head Field Corrections Corrupt	Number of faults Range = 0 to 255	0
606-549	Head 1 Thermal Fail	Fault Counter 91-664: Head 1 Thermal Fail	Number of faults Range = 0 to 255	0
606-550	Head 2 Thermal Fail	Fault Counter 91-665: Head 2 Thermal Fail	Number of faults Range = 0 to 255	0
606-551	Head 3 Thermal Fail	Fault Counter 91-666: Head 3 Thermal Fail	Number of faults Range = 0 to 255	0
606-552	Head 4 Thermal Fail	Fault Counter 91-667: Head 4 Thermal Fail	Number of faults Range = 0 to 255	0
606-553	DSP2 overlay setup timeout	Fault Counter 92-803: DSP2 overlay setup timeout	Number of faults Range = 0 to 255	0
606-554	DSP2 overlay cleanup timeout	Fault Counter 92-804: DSP2 overlay cleanup timeout	Number of faults Range = 0 to 255	0
606-608	Not displayed	MSBLACKRUNLENGTH1This supports the AIF counter 1 Black Impression Run Length	Range = 0 to 4294967295	0
606-609	Not displayed	MSBLACKRUNLENGTH24This supports the AIF counter 2 to 4 Black Impression Run Length	Range = 0 to 4294967295	0
606-610	Not displayed	MSBLACKRUNLENGTH59This supports the AIF counter 5 to 9 Black Impression Run Length	Range = 0 to 4294967295	0
606-611	Not displayed	MSBLACKRUNLENGTH1019T his supports the AIF counter 10 to 19 Black Impression Run Length	Range = 0 to 4294967295	0
606-612	Not displayed	MSBLACKRUNLENGTH2029T his supports the AIF counter 20 to 29 Black Impression Run Length	Range = 0 to 4294967295	0
606-613	Not displayed	MSBLACKRUNLENGTH3049T his supports the AIF counter 30 to 49 Black Impression Run Length	Range = 0 to 4294967295	0

Table 15 CCS NVM ID 606-270 to 606-900

NVM ID	NVM Name	NVM Description	Settings	Default
606-614	Not displayed	MSBLACKRUNLENGTH5074This supports the AIF counter 50 to 74 Black Impression Run Length	Range = 0 to 4294967295	0
606-615	Not displayed	MSBLACKRUNLENGTH7599This supports the AIF counter 75 to 99 Black Impression Run Length	Range = 0 to 4294967295	0
606-616	Not displayed	MSBLACKRUNLENGTH100249This supports the AIF counter 100 to 249 Black Impression Run Length	Range = 0 to 4294967295	0
606-617	Not displayed	MSBLACKRUNLENGTH250This supports the AIF counter 250+ Black Impression Run Length	Range = 0 to 4294967295	0
606-618	Not displayed	MSCOLORRUNLENGTH1This supports the AIF counter 1 Color Impression Run Length	Range = 0 to 4294967295	0
606-619	Not displayed	MSCOLORRUNLENGTH24This supports the AIF counter 2 to 4 Color Impression Run Length	Range = 0 to 4294967295	0
606-620	Not displayed	MSCOLORRUNLENGTH59This supports the AIF counter 5 to 9 Color Impression Run Length	Range = 0 to 4294967295	0
606-621	Not displayed	MSCOLORRUNLENGTH1019This supports the AIF counter 10 to 19 Color Impression Run Length	Range = 0 to 4294967295	0
606-622	Not displayed	MSCOLORRUNLENGTH2029This supports the AIF counter 20 to 29 Color Impression Run Length	Range = 0 to 4294967295	0
606-623	Not displayed	MSCOLORRUNLENGTH3049This supports the AIF counter 30 to 49 Color Impression Run Length	Range = 0 to 4294967295	0
606-624	Not displayed	MSCOLORRUNLENGTH5074This supports the AIF counter 50 to 74 Color Impression Run Length	Range = 0 to 4294967295	0
606-625	Not displayed	MSCOLORRUNLENGTH7599This supports the AIF counter 75 to 99 Color Impression Run Length	Range = 0 to 4294967295	0

Table 15 CCS NVM ID 606-270 to 606-900

NVM ID	NVM Name	NVM Description	Settings	Default
606-626	Not displayed	MSCOLORRUNLENGTH100249This supports the AIF counter 100 to 249 Color Impression Run Length	Range = 0 to 4294967295	0
606-627	Not displayed	MSCOLORRUNLENGTH1This supports the AIF counter 250+ Color Impression Run Length	Range = 0 to 4294967295	0
606-689	Total Standby Time (hours) Not displayed	Total Standby Time (hours)Total number of hours the machine has been in Standby Mode since activationnumTotalStandbyTimeHours	Range = 0 to 16777215	0
606-690	0 to 6 Minutes Standby Time Not displayed	0 to 6 Minutes Standby TimeTotal number of times the machine has been in Standby Mode between 0 and 14 minutes.numTotalStandbyTimeHours	Range = 0 to 16777215	0
606-691	6 to 15 Minutes Standby Time Not displayed	>6 to 15 Minutes Standby TimeTotal number of times the machine has been in Standby Mode between 15 and 25 minutes.numTotalStandbyTimeHours	Range = 0 to 16777215	0
606-692	15 to 60 Minutes Standby Time Not displayed	>15 to 60 Minutes Standby TimeTotal number of times the machine has been in Standby Mode between 20 and 119 minutes.numTotalStandbyTimeHours	Range = 0 to 16777215	0
606-693	60 to 120 Minutes Standby Time Not displayed	>60 to 120 Minutes Standby TimeTotal number of times the machine has been in Standby Mode between 120 and 299 minutes.numTotalStandbyTimeHours	Range = 0 to 16777215	0
606-694	120 to 240 Minutes Standby Time Not displayed	>120 to 240 Minutes Standby TimeTotal number of times the machine has been in Standby Mode between 300 and 599 minutes.numTotalStandbyTimeHours	Range = 0 to 16777215	0
606-695	240+ Minutes Standby Time Not displayed	>240 Minutes Standby TimeTotal number of times the machine has been in Standby Mode for 600 minutes or more-numTotalStandbyTimeHours	Range = 0 to 16777215	0

Table 15 CCS NVM ID 606-270 to 606-900

NVM ID	NVM Name	NVM Description	Settings	Default
606-696	Not displayed	All sheets fed from Tray #1Total number of Sheets Fed from Tray 1 - Read Only Accumulated ValuenumTray5Sheets	Range = 0 to 16777215	0
606-697	Not displayed	All sheets fed from Tray #2Total number of Sheets Fed from Tray 1 - Read Only Accumulated ValuenumTray5Sheets	Range = 0 to 16777215	0
606-698	Not displayed	All sheets fed from Tray #3Total number of Sheets Fed from Tray 1 - Read Only Accumulated ValuenumTray5Sheets	Range = 0 to 16777215	0
606-699	Not displayed	All sheets fed from Tray #4Total number of Sheets Fed from Tray 1 - Read Only Accumulated ValuenumTray5Sheets	Range = 0 to 16777215	0
606-700	Total Black impressions. Not displayed	Internal Use Only - Total Black Marked Images	Range = 0 to 4294967295	0
606-701	Total Black in Color Imp. Not displayed	Internal Use Only - Total Black Marked Color Images	Range = 0 to 4294967295	0
606-702	Total Cyan Impressions. Not displayed	Internal Use Only - Total Cyan Marked Color Images	Range = 0 to 4294967295	0
606-703	Total Magenta Impressions. Not displayed	Internal Use Only - Total Magenta Marked Color Images	Range = 0 to 4294967295	0
606-704	Total Yellow Impressions. Not displayed	Internal Use Only - Total Yellow Marked Color Images	Range = 0 to 4294967295	0
606-705	Avg AC Black. FP Not displayed	Internal Use Only - Total Black Run Mode AC FP	Range = 0 to 4294967295	0
606-706	Avg AC Cyan. FP Not displayed	Internal Use Only - Total Cyan Color Mode AC FP	Range = 0 to 4294967295	0
606-707	Avg AC Magenta. FP Not displayed	Internal Use Only - Total Magenta Color Mode AC FP	Range = 0 to 4294967295	0
606-708	Avg AC Yellow. FP Not displayed	Internal Use Only - Total Yellow Color Mode AC FP	Range = 0 to 4294967295	0
606-709	Avg AC Black in Color FP Not displayed	Internal Use Only - Total Black Color Mode AC FP	Range = 0 to 4294967295	0
606-710	Average AC Black. Int.	Average Area Coverage for Black channel in black mode for life of machine. Integer value.	Range = 0 to 4294967295	0

Table 15 CCS NVM ID 606-270 to 606-900

NVM ID	NVM Name	NVM Description	Settings	Default
606-711	Average AC Cyan. Int.	Average Area Coverage for Cyan channel for life of machine. Integer value.	Range = 0 to 4294967295	0
606-712	Average AC Magenta. Int.	Average Area Coverage for Magenta channel for life of machine. Integer value.	Range = 0 to 4294967295	0
606-713	Average AC Yellow. Int.	Average Area Coverage for Yellow channel for life of machine. Integer value.	Range = 0 to 4294967295	0
606-714	Avg AC Black in Color Int.	Average Area Coverage for Black channel in color mode for life of machine. Integer value.	Range = 0 to 4294967295	0
606-715	Not displayed	Standby Counter Overflow Tracking Register	Range = 0 to 255	0
606-716	ImeTfixUnLoadTimingErrFC	Fault Counter 10-512: IME Transfix UnLoad timing error	Number of faults Range = 0 to 255	0
606-718	ImeSubmitSheetErrorFC	Fault Counter 92-579: IME CDI Submit sheet Error	Number of faults Range = 0 to 255	0
606-719	Not displayed	DMU (Cleaning Unit) Install Date	Range = 0 to 4294967295	0
606-720	UnusableCleanUnitDetectedFC	Fault Counter 94-622-00: IME-UnusableCleanUnitDetectedFC	Number of faults Range = 0 to 255	0
606-721	IME24VOLTAFuseFailedFC	Fault Counter 92-805-00: IME24VOLTAFuseFailedFC	Number of faults Range = 0 to 255	0
606-723	IME24VOLTBFuseFailedFC	Fault Counter 92-806-00: IME24VOLTBFuseFailedFC	Number of faults Range = 0 to 255	0
606-724	IMEDiagRoutineNotImplementedFC	Fault Counter 92-807-00: IME-DiagRoutineNotImplementedFC	Number of faults Range = 0 to 255	0
606-725	IMEHead1NVRAMErrorFC	Fault Counter 91-807-00: IMEHead1NVRAMErrorFC	Number of faults Range = 0 to 255	0
606-726	IMEHead2NVRAMErrorFC	Fault Counter 91-808-00: IMEHead2NVRAMErrorFC	Number of faults Range = 0 to 255	0
606-727	IMEHead3NVRAMErrorFC	Fault Counter 91-809-00: IMEHead3NVRAMErrorFC	Number of faults Range = 0 to 255	0
606-728	IMEHead4NVRAMErrorFC	Fault Counter 91-810-00: IMEHead4NVRAMErrorFC	Number of faults Range = 0 to 255	0
606-729	IMEHeadNVRAMSyncErrorFC	Fault Counter 91-811-00: IME-HeadNVRAMSyncErrorFC	Number of faults Range = 0 to 255	0
606-730	IMEHead1AdjustmentExceedsMaxFC	Fault Counter 91-812-00: IMEHead1AdjustmentExceedsMaxFC	Number of faults Range = 0 to 255	0
606-732	IMEHead2AdjustmentExceedsMaxFC	Fault Counter 91-813-00: IMEHead2AdjustmentExceedsMaxFC	Number of faults Range = 0 to 255	0

Table 15 CCS NVM ID 606-270 to 606-900

NVM ID	NVM Name	NVM Description	Settings	Default
606-733	IMEHead3AdjustmentExceedsMaxFC	Fault Counter 91-814-00: IMEHead3AdjustmentExceedsMaxFC	Number of faults Range = 0 to 255	0
606-734	IMEHead4AdjustmentExceedsMaxFC	Fault Counter 91-815-00: IMEHead4AdjustmentExceedsMaxFC	Number of faults Range = 0 to 255	0
606-735	IMEHead1AdjustCoverageFailedFC	Fault Counter 91-816-00: IMEHead1AdjustCoverageFailedFC	Number of faults Range = 0 to 255	0
606-736	IMEHead2AdjustCoverageFailedFC	Fault Counter 91-817-00: IMEHead2AdjustCoverageFailedFC	Number of faults Range = 0 to 255	0
606-737	IMEHead3AdjustCoverageFailedFC	Fault Counter 91-818-00: IMEHead3AdjustCoverageFailedFC	Number of faults Range = 0 to 255	0
606-738	Fault Counter 91-819-00: IMEHead4AdjustCoverageFailedFC	IMEHead4AdjustCoverageFailedFC	Number of faults Range = 0 to 255	0
606-739	IMETransfixLoadFrontPosErrorFC	Fault Counter 10-521-00: IMETransfixLoadFrontPosErrorFC	Number of faults Range = 0 to 255	0
606-740	IMETransfixLoadRearPosErrorFC	Fault Counter 10-522-00: IMETransfixLoadRearPosErrorFC	Number of faults Range = 0 to 255	0
606-741	IMETransfixUnloadFrontPosErrorFC	Fault Counter 10-523-00: IMETransfixUnloadFrontPosErrorFC	Number of faults Range = 0 to 255	0
606-742	IMETransfixUnloadRearPosErrorFC	Fault Counter 10-524-00: IMETransfixUnloadRearPosErrorFC	Number of faults Range = 0 to 255	0
606-743	IMEUnexpectedACPowerLossFC	Fault Counter 92-554-00: IMEUnexpectedACPowerLoss	Number of faults Range = 0 to 255	0
606-748	IMEMiddleLeftDoorOpenInRunFC	Fault Counter 01-505-00: IMEMiddleLeftDoorOpenInRun	Number of faults Range = 0 to 255	0
606-749	IMEUpperLeftDoorOpenInRunFC	Fault Counter 01-506-00: IMEUpperLeftDoorOpenInRun	Number of faults Range = 0 to 255	0
606-750	IMEFrontDoorOpenInRunFC	Fault Counter 01-510-00: IMEFrontDoorOpenInRun	Number of faults Range = 0 to 255	0
606-751	YAxisBeltRatioErrorFC	Fault Counter 94-547-00: Y-Axis Belt Ratio Error	Number of faults Range = 0 to 255	0
606-752	CleanUnitPressureSensorOpen	Fault Counter 94-506-00: DMU pressure sensor open	Number of faults Range = 0 to 255	0

Table 15 CCS NVM ID 606-270 to 606-900

NVM ID	NVM Name	NVM Description	Settings	Default
606-753	OilDelivPumpEarlyLifeOverCurrFC	Fault Counter 94-527-00: Oil Delivery Pump early life over current	Number of faults Range = 0 to 255	0
606-754	OilRemovPumpEarlyLifeOverCurrFC	Fault Counter 94-531-00: Oil Removal Pump Early Life Over Current	Number of faults Range = 0 to 255	0
606-755	YAxisCalibrationHalSensorErrorFC	Fault Counter 94-545-00: Y-Axis Calibration Hal Sensor Error	Number of faults Range = 0 to 255	0
606-756	YAxisCalibrationEncodrSensorErrorFC	Fault Counter 94-549-00: Y-Axis Calibration Encoder Sensor Error	Number of faults Range = 0 to 255	0
606-757	ATSWithFinishingEnable	Folding job with Tray selected switches to another tray when selected tray runs out of media:When the default is off a minority of users may have to reload the tray they asked for more often.When the default is on some jobs may come out on media they explicitly did not select.	Folding job with Tray selected switches to another tray when selected tray runs out of media Set via Web UI. 1 = Enabled Range = 0 to 1	0
606-758	IMEHead1LinkErrorFC	Fault Counter 91-820-00: Head1 link error	Number of faults Range = 0 to 255	0
606-759	IMEHead2LinkErrorFC	Fault Counter 91-821-00: Head2 link error	Number of faults Range = 0 to 255	0
606-760	IMEHead3LinkErrorFC	Fault Counter 91-822-00: Head3 link error	Number of faults Range = 0 to 255	0
606-761	IMEHead4LinkErrorFC	Fault Counter 91-823-00: Head4 link error	Number of faults Range = 0 to 255	0
606-762	IMEADCInterruptStormFC	Fault Counter 92-541-00: ADC Interrupt Storm	Number of faults Range = 0 to 255	0
606-763	IMEPSInterruptStormFC	Fault Counter 92-542-00: PS Interrupt Storm	Number of faults Range = 0 to 255	0
606-764	IMEMUInterruptStormFC	Fault Counter 92-543-00: MU Interrupt Storm	Number of faults Range = 0 to 255	0
606-765	IMEMUIDInterruptStormFC	Fault Counter 92-544-00: MUID Interrupt Storm	Number of faults Range = 0 to 255	0
606-766	IMEDDInterruptStormFC	Fault Counter 92-545-00: DD Interrupt Storm	Number of faults Range = 0 to 255	0
606-767	IMEMPInterruptStormFC	Fault Counter 92-546-00: MP Interrupt Storm	Number of faults Range = 0 to 255	0
606-768	IMEIMDInterruptStormFC	Fault Counter 92-547-00: IMD Interrupt Storm	Number of faults Range = 0 to 255	0

Table 15 CCS NVM ID 606-270 to 606-900

NVM ID	NVM Name	NVM Description	Settings	Default
606-769	IMETTMInterrupt-StormFC	Fault Counter 92-548-00: TTM Interrupt Storm	Number of faults Range = 0 to 255	0
606-770	IMEFPPIInterrupt-StormFC	Fault Counter 92-549-00: PFP Interrupt Storm	Number of faults Range = 0 to 255	0
606-771	IMECISInterrupt-StormFC	Fault Counter 92-551-00: CIS Interrupt Storm	Number of faults Range = 0 to 255	0
606-772	IMESBCInterrupt-StormFC	Fault Counter 92-552-00: SBC Interrupt Storm	Number of faults Range = 0 to 255	0
606-773	IMECaScanDetectedFPExceptionFC	Fault Counter 89-567-00: Calibration scan detected floating point exception	Number of faults Range = 0 to 255	0
606-774	PQM Insufficient Ink	Fault Counter 91-824-00: PQM Insufficient Ink	Number of faults Range = 0 to 255	0
606-775	PQM Insufficient Jets	Fault Counter 91-826-00: PQM Insufficient Jets	Number of faults Range = 0 to 255	0
606-776	PQM Insufficient Jets	Fault Counter 91-826-00: PQM Insufficient Jets	Number of faults Range = 0 to 255	0
606-777	PQM Align Needed	Fault Counter 91-827-00: PQM Align Needed	Number of faults Range = 0 to 255	0
606-778	PQM Y Dot Position Needed	Fault Counter 91-828-00: PQM Y Dot Position Needed	Number of faults Range = 0 to 255	0
606-779	PQM Drum Runout Needed	Fault Counter 91-829-00: PQM Drum Runout Needed	Number of faults Range = 0 to 255	0
606-780	PQM Uniformity Needed	Fault Counter 91-830-00: PQM Uniformity Needed	Number of faults Range = 0 to 255	0
606-781	PQM Uniformity Reset Needed	Fault Counter 91-831-00: PQM Uniformity Reset Needed	Number of faults Range = 0 to 255	0
606-782	PQM Empty Waste Tray	Fault Counter 91-832-00: PQM Empty Waste Tray	Number of faults Range = 0 to 255	0
606-783	PQM Cleaning Pages Needed	Fault Counter 91-833-00: PQM Cleaning Pages Needed	Number of faults Range = 0 to 255	0
606-784	PQM Tool Not Usable	Fault Counter 91-834-00: PQM Tool Not Usable	Number of faults Range = 0 to 255	0
606-785	PQM Tool Manually Disabled	Fault Counter 91-835-00: PQM Tool Manually Disabled	Number of faults Range = 0 to 255	0
606-786	PQM: System Busy	Fault Counter 91-836-00: PQM-00: System Busy	Number of faults Range = 0 to 255	0
606-787	FS23.201 Table Version	Default is the version number of the Excel table used to create the NVM	Range = 0 to 65535	1249
606-788	DrumFanShroudUsage	Drum Fan Shroud - Number of impressions	Range = 0 to 4294967295	0
606-789	TransfixStripperUsage	Transfix Stripper - Number of impressions	Range = 0 to 4294967295	0

Table 15 CCS NVM ID 606-270 to 606-900

NVM ID	NVM Name	NVM Description	Settings	Default
606-790	UpperJLBaffle-Usage	Upper JL Baffle - Number of impressions	Range = 0 to 4294967295	0
606-791	DrumFanShroud-Cleanings	Drum Fan Shroud - Number of cleanings	Range = 1 to 65535	1
606-792	TransfixStripper-Cleanings	Transfix Stripper - Number of cleanings	Range = 1 to 65535	1
606-793	UpperJLBaffle-Cleanings	Upper JL Baffle - Number of cleanings	Range = 1 to 65535	1
606-794	DrumFanShroud-MaintThreshold	Drum Fan Shroud - Maintenance threshold	Range = 1 to 4294967295	500000
606-795	TransfixStripper-MaintThreshold	Transfix Stripper - Maintenance threshold	Range = 1 to 4294967295	125000
606-796	UpperJLBaffle-MaintThreshold	Upper JL Baffle - Maintenance threshold	Range = 1 to 4294967295	400000
606-797	Not displayed	Drum Fan Shroud Last Cleaned Date	Range = 1 to 4294967295	0
606-798	Not displayed	Transfix Stripper Last Cleaned Date	Range = 1 to 4294967295	0
606-799	Not displayed	Upper JL Baffle Last Cleaned Date	Range = 1 to 4294967295	0
606-801	PapPusher-SwitchFC	Fault Counter 12-444: Paper Pusher Switch Fault	Number of faults Range = 0 to 255	0
606-802	BlackInkLoader-JammedFC	Fault Counter 93-501-00: Black Ink loader Jammed	Number of faults Range = 0 to 255	0
606-803	MagentaInkLoaderJammedFC	Fault Counter 93-506-00: Magenta Ink loader Jammed	Number of faults Range = 0 to 255	0
606-804	CyanInkLoader-JammedFC	Fault Counter 93-511-00: Cyan Ink loader Jammed	Number of faults Range = 0 to 255	0
606-805	YellowInkLoader-JammedFC	Fault Counter 93-516-00: Yellow Ink loader Jammed	Number of faults Range = 0 to 255	0
606-806	Default Staple Position	Default Staple position (HVF only)(Staple positioning: trades best position verses best productivity) Default set to best productivity to give best BLI test result. Customer can then select which mode best suites them.	Range = 1 to 2	2
606-807	Head1NvramJetMaskReadErrorFC	Fault Counter 91-842-00: Head #1 Nvram jet mask section read or decode error	Number of faults Range = 0 to 255	0
606-808	Head2NvramJetMaskReadErrorFC	Fault Counter 91-843-00: Head #1 Nvram jet mask section read or decode error	Number of faults Range = 0 to 255	0

Table 15 CCS NVM ID 606-270 to 606-900

NVM ID	NVM Name	NVM Description	Settings	Default
606-809	Head3NvramJetMaskReadErrorFC	Fault Counter 91-844-00: Head #1 Nvram jet mask section read or decode error	Number of faults Range = 0 to 255	0
606-810	Head4NvramJetMaskReadErrorFC	Fault Counter 91-845-00: Head #1 Nvram jet mask section read or decode error	Number of faults Range = 0 to 255	0
606-811	MP16TooLongAutoPurgeFC	Fault Counter 82-162: MP16 Too Long Auto Purge	Number of faults Range = 0 to 255	0
606-812	MP16TooShortAutoPurgeHC	Fault Counter 82-163: MP16 Too Short Auto Purge	Number of faults Range = 0 to 255	0
606-813	MP5TooLongAutoPurgeFC	Fault Counter 82-164: MP5 Too Long Auto Purge	Number of faults Range = 0 to 255	0
606-814	MP5TooShortAutoPurgeFC	Fault Counter 82-165: MP5 Too Short Auto Purge	Number of faults Range = 0 to 255	0
606-823	Not displayed	Print Standard (300x500) mode colour coverage scaler	Range = 0 to 4000	588
606-824	Not displayed	Print Fast (225x450) mode colour coverage scaler	Range = 0 to 4000	397
606-825	Not displayed	Print Enhanced (450x567) mode colour coverage scaler	Range = 0 to 4000	1000
606-826	Not displayed	Print Hi Res mode (600x600) colour coverage scaler	Range = 0 to 4000	1339
606-827	Not displayed	Print Transparency mode (525x400) colour coverage scaler	Range = 0 to 4000	823
606-828	Not displayed	Copy Photo mode (600x600) colour coverage scaler	Range = 0 to 4000	1339
606-829	Not displayed	Copy Default mode (450x567) colour coverage scaler	Range = 0 to 4000	1000
606-830	Not displayed	Copy Transparency mode (525x400) colour coverage scaler	Range = 0 to 4000	823
606-831	Head Not Warming Up	Fault counter 91-804: Head not warming up	Number of faults Range = 0 to 255	0
606-832	8.5x13 Sheets Used Not displayed	8.5 x 13 Sheets used total of 8.5 x 13 sheets since activation date num85x13Sheets	Range = 0 to ###	0
606-833	9x11 Sheets Used Not displayed	9 x 11 Sheets used total of 9 x 11 sheets since activation date num9x11Sheets	Range = 0 to ###	0
606-834	B4 Sheets Used Not displayed	B4 Sheets used total of B4 sheets since activation date numB4Sheets	Range = 0 to ###	0

Table 15 CCS NVM ID 606-270 to 606-900

NVM ID	NVM Name	NVM Description	Settings	Default
606-835	B5 Sheets Used Not displayed	B5 Sheets used total of B5 sheets since activation date numB5Sheets	Range = 0 to ###	0
606-836	JIS B4 Sheets Used Not displayed	JIS B4 Sheets used total of JIS B4 sheets since activation date numJISB4Sheets	Range = 0 to ###	0
606-837	JIS B5 Sheets Used Not displayed	JIS B5 Sheets used total of JIS B5 sheets since activation date numJISB5Sheets	Range = 0 to ###	0
606-852	1.0 to 1.2% Tot Color Coverage Not displayed	1.0 > and < =1.2 Total color coverage identifies the number of impressions greater than 1.0 >and < =1.2 total coverage for all CMY colors. numTotalColorPixelCoverage(45)	Range = 0 to ###	0
606-853	1.2 to 1.4% Tot Color Coverage Not displayed	1.2 > and < =1.4 Total color coverage identifies the number of impressions greater than 1.2 >and < =1.4 total coverage for all CMY colors. numTotalColorPixelCoverage(46)	Range = 0 to ###	0
606-854	1.4 to 1.6% Tot Color Coverage Not displayed	1.4 > and < =1.6 Total color coverage identifies the number of impressions greater than 1.4 >and < =1.6 total coverage for all CMY colors. numTotalColorPixelCoverage(47)	Range = 0 to ###	0
606-855	1.6 to 1.8% Tot Color Coverage Not displayed	1.6 > and < =1.8 Total color coverage identifies the number of impressions greater than 1.6 >and < =1.8 total coverage for all CMY colors. numTotalColorPixelCoverage(48)	Range = 0 to ###	0
606-856	1.8 to 2.0% Tot Color Coverage Not displayed	1.8 > and < =2.0 Total color coverage identifies the number of impressions greater than 1.8 >and < =2.0 total coverage for all CMY colors. numTotalColorPixelCoverage(49)	Range = 0 to ###	0

Table 15 CCS NVM ID 606-270 to 606-900

NVM ID	NVM Name	NVM Description	Settings	Default
606-857	BlackNeutral(1)Countdown	Number of Black neutral ink sticks allowed (1)	Limits neutral usage to 5 units. Starts at the high limit (4) and counts down with each replacement. At value of 0, no more neutral replacements allowed. Range = 0 to 4	4
606-858	BlackNeutral(2)Countdown	Number of Black neutral ink sticks allowed (2)	Limits neutral usage to 5 units. Starts at the high limit (4) and counts down with each replacement. At value of 0, no more neutral replacements allowed. Range = 0 to 4	4
606-859	YellowNeutral-Countdown	Number of Yellow neutral ink sticks allowed	Limits neutral usage to 5 units. Starts at the high limit (4) and counts down with each replacement. At value of 0, no more neutral replacements allowed. Range = 0 to 4	4
606-860	MagentaNeutral-Countdown	Number of Magenta neutral ink sticks allowed	Limits neutral usage to 5 units. Starts at the high limit (4) and counts down with each replacement. At value of 0, no more neutral replacements allowed. Range = 0 to 4	4

Table 15 CCS NVM ID 606-270 to 606-900

NVM ID	NVM Name	NVM Description	Settings	Default
606-861	CyanNeutral-Countdown	Number of Cyan neutral ink sticks allowed	Limits neutral usage to 5 units. Starts at the high limit (4) and counts down with each replacement. At value of 0, no more neutral replacements allowed. Range = 0 to 4	4
606-889	Not displayed	Print toner saver mode colour coverage scaler	Range = 0 to ###	0
606-890	Machine GUID for Nomad Server Not displayed	Entry to store the machine GUID assigned by the Nomad-Server after connecting	Byte array of 37 characters including a terminating Null. Range = 0 to 0	0

Table 16 CCS NVM ID 607-xxx

NVM ID	NVM Name	NVM Description	Settings	Default
607-001	Not displayed	Support for Job recovery-Fax image number 1	Range = 0 to 0	0
607-002	Not displayed	Support for Job recovery-Fax image number 2	Range = 0 to 0	0

Table 17 CCS NVM ID 608-xxx

NVM ID	NVM Name	NVM Description	Settings	Default
608-001	Boardlink-MUDLinkBrokenFC	Fault Counter 99-052-00: BOARDLINKHEAD1SLOWLINKBROKEN	Number of faults Range = 0 to 255	0
608-002	BoardlinkPSLink-BrokenFC	Fault Counter 99-053-00: BOARDLINKHEAD1SLOWLINKBROKEN	Number of faults Range = 0 to 255	0
608-003	BoardlinkHead1SlowLinkBrokenFC	Fault Counter 99-055-00: BOARDLINKHEAD1SLOWLINKBROKEN	Number of faults Range = 0 to 255	0
608-004	BoardlinkHead2SlowLinkBrokenFC	Fault Counter 99-056-00: BOARDLINKHEAD2SLOWLINKBROKEN	Number of faults Range = 0 to 255	0
608-005	BoardlinkHead3SlowLinkBrokenFC	Fault Counter 99-057-00: BOARDLINKHEAD3SLOWLINKBROKEN	Number of faults Range = 0 to 255	0

Table 17 CCS NVM ID 608-xxx

NVM ID	NVM Name	NVM Description	Settings	Default
608-006	BoardlinkHead4SlowLinkBrokenFC	Fault Counter 99-058-00: BOARDLINKHEAD4SLOWLINKBROKEN	Number of faults Range = 0 to 255	0
608-007	BoardlinkHead1FastLinkBadFC	Fault Counter 99-059-00: BOARDLINKHEAD1FASTLINKBAD	Number of faults Range = 0 to 255	0
608-008	BoardlinkHead2FastLinkBadFC	Fault Counter 99-060-00: BOARDLINKHEAD2FASTLINKBAD	Number of faults Range = 0 to 255	0
608-009	BoardlinkHead3FastLinkBadFC	Fault Counter 99-061-00: BOARDLINKHEAD3FASTLINKBAD	Number of faults Range = 0 to 255	0
608-010	BoardlinkHead4FastLinkBadFC	Fault Counter 99-062-00: BOARDLINKHEAD4FASTLINKBAD	Number of faults Range = 0 to 255	0
608-011	BoardlinkWaveAmpCableDetectFailFC	Fault Counter 99-063-00: BOARDLINKWAVEAMPCALETECTFAILURE	Number of faults Range = 0 to 255	0
608-012	BoardlinkTTMLinkBrokenFC	Fault Counter 99-066-00: BOARDLINKTTMLINKBROKEN	Number of faults Range = 0 to 255	0
608-013	BoardlinkPFPLinkBrokenFC	Fault Counter 99-067-00: BOARDLINKPFP LINKBROKEN	Number of faults Range = 0 to 255	0
608-014	BoardlinkDDBSafemodeFC	Fault Counter 99-100-00: BOARDLINKDDBSAFEMODE	Number of faults Range = 0 to 255	0
608-015	MotorHBridgeenableDDBOpenFC	Fault Counter 99-101-00: MOTORHBRIDGEENABLEDDBOPEN	Number of faults Range = 0 to 255	0
608-016	MotorHBridgeenableDDBShortFC	Fault Counter 99-102-00: MOTORHBRIDGEENABLEDDBSHORT	Number of faults Range = 0 to 255	0
608-017	SolenoidCleanUnitValveOClogicFC	Fault Counter 99-110-00: SOLENOID Cleaning Unit VALVEOCLOGIC	Number of faults Range = 0 to 255	0
608-018	SolenoidStripperOClogicFC	Fault Counter 99-111-00: SOLENOIDSTRIPPEROCLOGIC	Number of faults Range = 0 to 255	0
608-019	CleanUnitPumpDelOClogicFC	Fault Counter 99-112-00: PUMP Cleaning Unit DELIVERYOCLOGIC	Number of faults Range = 0 to 255	0
608-020	CleanUnitPumpReturnOClogicFC	Fault Counter 99-113-00: PUMP Cleaning Unit RETURNOCLOGIC	Number of faults Range = 0 to 255	0
608-021	FanRearEnclosureOClogicFC	Fault Counter 99-114-00: FANREAREN CLOSUREOCLOGIC	Number of faults Range = 0 to 255	0

Table 17 CCS NVM ID 608-xxx

NVM ID	NVM Name	NVM Description	Settings	Default
608-022	BoardlinkMPDSafemodeFC	Fault Counter 99-120-00: BOARDLINKMPDSAFEMODE	Number of faults Range = 0 to 255	0
608-023	MotorHBridgeenableMPDOpenFC	Fault Counter 99-121-00: MOTORHBRIDGEENABLEMPDOPEN	Number of faults Range = 0 to 255	0
608-024	MotorHBridgeenableMPDShortFC	Fault Counter 99-122-00: MOTORHBRIDGEENABLEMPDSHORT	Number of faults Range = 0 to 255	0
608-025	SolenoidNipCOCloticFC	Fault Counter 99-130-00: SOLENOIDNIPCOCLOTIC	Number of faults Range = 0 to 255	0
608-026	SolenoidNipDOCloticFC	Fault Counter 99-131-00: SOLENOIDNIPDOCLOTIC	Number of faults Range = 0 to 255	0
608-027	SolenoidNipEOCloticFC	Fault Counter 99-132-00: SOLENOIDNIPEOCLOTIC	Number of faults Range = 0 to 255	0
608-028	SolenoidDuplexOClogicFC	Fault Counter 99-133-00: SOLENOIDDUPLEXOCLOGIC	Number of faults Range = 0 to 255	0
608-029	SolenoidCARDiverterOClogicFC	Fault Counter 99-134-00: SOLENOIDCARDIVERTEROCLOTIC	Number of faults Range = 0 to 255	0
608-030	BoardlinkMUDSafemodeFC	Fault Counter 99-140-00: BOARDLINKMUDSAFEMODE	Number of faults Range = 0 to 255	0
608-031	MotorHBridgeenableMUDOpenFC	Fault Counter 99-141-00: MOTORHBRIDGEENABLEMUDOPEN	Number of faults Range = 0 to 255	0
608-032	MotorHBridgeenableMUDShortFC	Fault Counter 99-142-00: MOTORHBRIDGEENABLEMUDSHORT	Number of faults Range = 0 to 255	0
608-033	SolenoidInkValvesOClogicFC	Fault Counter 99-150-00: SOLENOIDINKDELIVERYVALVESOCLOGIC	Number of faults Range = 0 to 255	0
608-034	SolenoidLPAValveOClogicFC	Fault Counter 99-151-00: SOLENOIDLPAVALVEOCLOGIC	Number of faults Range = 0 to 255	0
608-035	PumpInkDeliveryAirOClogicFC	Fault Counter 99-153-00: PUMPINKDELIVERYAIROCLOTIC	Number of faults Range = 0 to 255	0
608-036	BoardlinkTTMSafemodeFC	Fault Counter 99-180-00: BOARDLINKTTMSAFEMODE	Number of faults Range = 0 to 255	0
608-037	BoardlinkPFP-SafemodeFC	Fault Counter 99-185-00: BOARDLINKPFP SAFEMODE	Number of faults Range = 0 to 255	0
608-038	Power50Vstartup shutdownFC	Fault Counter 99-200-00: POWER50VSTARTUPSHUTDOWN	Number of faults Range = 0 to 255	0

Table 17 CCS NVM ID 608-xxx

NVM ID	NVM Name	NVM Description	Settings	Default
608-039	Power50Vstartup enableopenFC	Fault Counter 99-201-00: POWER50VSTARTUPENABLEOPEN	Number of faults Range = 0 to 255	0
608-040	Power24VBaseAboveMaxFC	Fault Counter 99-212-00: POWER24VBASEABOVEMAX	Number of faults Range = 0 to 255	0
608-041	Power50VBaseAboveMaxFC	Fault Counter 99-216-00: POWER50VBASEABOVEMAX	Number of faults Range = 0 to 255	0
608-042	PowerDDBADC5.0VOff-missingFC	Fault Counter 99-240-00: POWERDDBADC5VOFFMISSING	Number of faults Range = 0 to 255	0
608-043	PowerDDBADC+12VOff-missingFC	Fault Counter 99-241-00: POWERDDBADCPLUS12VOFFMISSING	Number of faults Range = 0 to 255	0
608-044	PowerDDBADC-12VOff-missingFC	Fault Counter 99-242-00: POWERDDBADCMINUS12VOFFMISSING	Number of faults Range = 0 to 255	0
608-045	PowerDDBADC+50VOff-missingFC	Fault Counter 99-243-00: POWERDDBADC50VOFFMISSING	Number of faults Range = 0 to 255	0
608-046	PowerIMECADC-50VOff-missingFC	Fault Counter 99-244-00: POWERIMECADCMINUS50VOFFMISSING	Number of faults Range = 0 to 255	0
608-047	FuseDDB5VOpenFC	Fault Counter 99-270-00: FUSEDDB5VOPEN	Number of faults Range = 0 to 255	0
608-048	FuseDDB12VOpenFC	Fault Counter 99-271-00: FUSEDDB12VOPEN	Number of faults Range = 0 to 255	0
608-049	FuseDDB24VAOpenFC	Fault Counter 99-272-00: FUSEDDB24VAOPEN	Number of faults Range = 0 to 255	0
608-050	FuseDDB24VBOpenFC	Fault Counter 99-273-00: FUSEDDB24VBOPEN	Number of faults Range = 0 to 255	0
608-051	FuseDDB50VOpenFC	Fault Counter 99-274-00: FUSEDDB50VOPEN	Number of faults Range = 0 to 255	0
608-052	FuseMPD3.3VOpenFC	Fault Counter 99-280-00: FUSEMPD33VOPEN	Number of faults Range = 0 to 255	0
608-053	FuseMPD5VOpenFC	Fault Counter 99-281-00: FUSEMPD5VOPEN	Number of faults Range = 0 to 255	0
608-054	FuseMPD12VOpenFC	Fault Counter 99-282-00: FUSEMPD12VOPEN	Number of faults Range = 0 to 255	0
608-055	FuseMPD24VAOpenFC	Fault Counter 99-283-00: FUSEMPD24VAOPEN	Number of faults Range = 0 to 255	0
608-056	FuseMPD24VBOpenFC	Fault Counter 99-284-00: FUSEMPD24VBOPEN	Number of faults Range = 0 to 255	0

Table 17 CCS NVM ID 608-xxx

NVM ID	NVM Name	NVM Description	Settings	Default
608-057	FuseMPD24VCOpenFC	Fault Counter 99-285-00: FUSEMPD24VCOPEN	Number of faults Range = 0 to 255	0
608-058	FuseMPD50VAOpenFC	Fault Counter 99-286-00: FUSEMPD50VAOPEN	Number of faults Range = 0 to 255	0
608-059	FuseMPD50VBOpenFC	Fault Counter 99-287-00: FUSEMPD50VBOPEN	Number of faults Range = 0 to 255	0
608-060	FuseMPD50VCOpenFC	Fault Counter 99-288-00: FUSEMPD50VCOPEN	Number of faults Range = 0 to 255	0
608-061	FuseMUD3.3VOpenFC	Fault Counter 99-290-00: FUSEMUD33VOPEN	Number of faults Range = 0 to 255	0
608-062	FuseMUD12VOpenFC	Fault Counter 99-291-00: FUSEMUD12VOPEN	Number of faults Range = 0 to 255	0
608-063	FuseMUD24VOpenFC	Fault Counter 99-292-00: FUSEMUD24VOPEN	Number of faults Range = 0 to 255	0
608-064	FuseMUD50VOpenFC	Fault Counter 99-293-00: FUSEMUD50VOPEN	Number of faults Range = 0 to 255	0
608-065	Connector-MUotherOpenFC	Fault Counter 99-300-00: CONNECTORMUOTHEROPEN	Number of faults Range = 0 to 255	0
608-066	ConnectorMUD-toLwrcarrOpenFC	Fault Counter 99-301-00: CONNECTORMUDTOLWRCARROPEN	Number of faults Range = 0 to 255	0
608-067	ConnectorMUD-toUprcarrOpenFC	Fault Counter 99-302-00: CONNECTORMUDTOUPRCARROPEN	Number of faults Range = 0 to 255	0
608-068	ConnectorMUD-toHMH-WTLOpenFC	Fault Counter 99-303-00: CONNECTORMUDTOHMHWTLOPEN	Number of faults Range = 0 to 255	0
608-069	ConnectorMUD-toIdsolenoid-sOpenFC	Fault Counter 99-304-00: CONNECTORMUDTOIDSOLENOIDSOPEN	Number of faults Range = 0 to 255	0
608-070	ConnectorMUD-toInkResLevSenOpenFC	Fault Counter 99-305-00: CONNECTORMUDTOINKRESLEVELSENSEOPEN	Number of faults Range = 0 to 255	0
608-071	ConnectorMUH-toMUDOpenFC	Fault Counter 99-306-00: CONNECTORMUHTOMUDOPEN	Number of faults Range = 0 to 255	0
608-072	ConnectorMUH-toLwrhead-sOpenFC	Fault Counter 99-307-00: CONNECTORMUHTOLWRHEADSOPEN	Number of faults Range = 0 to 255	0
608-073	ConnectorMUH-toUprhead-sOpenFC	Fault Counter 99-308-00: CONNECTORMUHTOUPRHEADSOPEN	Number of faults Range = 0 to 255	0

Table 17 CCS NVM ID 608-xxx

NVM ID	NVM Name	NVM Description	Settings	Default
608-074	ConnectorMUH-toInkResOpenFC	Fault Counter 99-309-00: CONNECTORMUH-INKRESOPEN	Number of faults Range = 0 to 255	0
608-075	ConnectorMUSOLtoV1OpenFC	Fault Counter 99-310-00: CONNECTORMUSOLTOV1OPEN	Number of faults Range = 0 to 255	0
608-076	ConnectorMUSOLtoV2OpenFC	Fault Counter 99-311-00: CONNECTORMUSOLTOV2OPEN	Number of faults Range = 0 to 255	0
608-077	ConnectorMUSOLtoV3OpenFC	Fault Counter 99-312-00: CONNECTORMUSOLTOV3OPEN	Number of faults Range = 0 to 255	0
608-078	ConnectorMUSOLtoV4OpenFC	Fault Counter 99-313-00: CONNECTORMUSOLTOV4OPEN	Number of faults Range = 0 to 255	0
608-079	ConnectorMUSOLtoV5OpenFC	Fault Counter 99-314-00: CONNECTORMUSOLTOV5OPEN	Number of faults Range = 0 to 255	0
608-080	ConnectorMUSOLtoAP-LPAOpenFC	Fault Counter 99-315-00: CONNECTORMUSOLTOA-PLPAOPEN	Number of faults Range = 0 to 255	0
608-081	ConnectorMUSOLtoLevelY-BOpenFC	Fault Counter 99-316-00: CONNECTORMUSOLTOLEVELYBOPEN	Number of faults Range = 0 to 255	0
608-082	ConnectorMUSOLtoLevelC-MOpenFC	Fault Counter 99-317-00: CONNECTORMUSOLTOLEVELCMOPEN	Number of faults Range = 0 to 255	0
608-083	ConnectorIM-EotherOpenFC	Fault Counter 99-320-00: CONNECTORIMEOTHEROPEN	Number of faults Range = 0 to 255	0
608-084	ConnectorDDBtoPSdataOpenFC	Fault Counter 99-321-00: CONNECTORDBTOPS-DATAOPEN	Number of faults Range = 0 to 255	0
608-085	ConnectorDDBtoCleanUnitOpenFC	Fault Counter 99-322-00: CONNECTORDBTOCLEANUNITOPEN	Number of faults Range = 0 to 255	0
608-086	ConnectorDDBtoDM-StripperOpenFC	Fault Counter 99-323-00: CONNECTORDBTODM-STRIPPEROPEN	Number of faults Range = 0 to 255	0
608-087	ConnectorDDBtoRALPHOpenFC	Fault Counter 99-324-00: CONNECTORDBTORReg/PreheatOPEN	Number of faults Range = 0 to 255	0
608-088	ConnectorDDBtoTfixmotorOpenFC	Fault Counter 99-325-00: CONNECTORDBTOTFIX-MOTOROPEN	Number of faults Range = 0 to 255	0

Table 17 CCS NVM ID 608-xxx

NVM ID	NVM Name	NVM Description	Settings	Default
608-089	ConnectorDDBtoTfix-senseOpenFC	Fault Counter 99-326-00: CONNECTORDBTOTFIX-SENSEOPEN	Number of faults Range = 0 to 255	0
608-090	ConnectorDDBtofansOpenFC	Fault Counter 99-327-00: CONNECTORDBTOFAN-SOPEN	Number of faults Range = 0 to 255	0
608-091	ConnectorDDBtoDrum-FrontOpenFC	Fault Counter 99-328-00: CONNECTORDBTODRUM-FRONTOPEN	Number of faults Range = 0 to 255	0
608-092	ConnectorDDBtoIODOpenFC	Fault Counter 99-329-00: CONNECTORDBTOIODOPEN	Number of faults Range = 0 to 255	0
608-093	ConnectorIODtoCISOpenFC	Fault Counter 99-330-00: CONNECTORIODTOCISOPEN	Number of faults Range = 0 to 255	0
608-094	ConnectorCleanUnitOtpugOpenFC	Fault Counter 99-331-00: CONNECTORCleanUnitHOT-PLUGOPEN	Number of faults Range = 0 to 255	0
608-095	ConnectorReg/PreheattoMP-DOpenFC	Fault Counter 99-332-00: CONNECTORReg/Preheat-TOMPDOEN	Number of faults Range = 0 to 255	0
608-096	ConnectorReg-PreheatAirPumpOpenFC	Fault Counter 99-333-00: CONNECTORReg/Preheat-TOAIRPUMPSOPEN	Number of faults Range = 0 to 255	0
608-097	ConnectorReg/PreheattoCISOpenFC	Fault Counter 99-334-00: CONNECTORReg/Preheat-TOCISOPEN	Number of faults Range = 0 to 255	0
608-098	ConnectorMPDtoM2M3A1A2OpenFC	Fault Counter 99-340-00: CONNECTORMPDTOM2M3A1A2OPEN	Number of faults Range = 0 to 255	0
608-099	ConnectorMPD>M2enRegPreheatOpFC	Fault Counter 99-341-00: CONNECTORMPDTOM2ENCReg/PreheatOPEN	Number of faults Range = 0 to 255	0
608-100	ConnectorMPDtoM456solenoidOpenFC	Fault Counter 99-342-00: CONNECTORMPDTOM456SOLENOIDOPEN	Number of faults Range = 0 to 255	0
608-101	ConnectorMPDtoM6enc-LEDOpenFC	Fault Counter 99-343-00: CONNECTORMPDTOM6ENCLEDOPEN	Number of faults Range = 0 to 255	0
608-102	ConnectorMPDtoInkloaderOpenFC	Fault Counter 99-344-00: CONNECTORMPDTOINK-LOADEROPEN	Number of faults Range = 0 to 255	0
608-103	ConnectorMPDtoMSItray4OpenFC	Fault Counter 99-345-00: CONNECTORMPDTOMSITRAY4OPEN	Number of faults Range = 0 to 255	0

Table 17 CCS NVM ID 608-xxx

NVM ID	NVM Name	NVM Description	Settings	Default
608-104	ConnectorMPDHarnessM3OpenFC	Fault Counter 99-346-00: CONNECTORMPDHARNESM3OPEN	Number of faults Range = 0 to 255	0
608-105	ConnectorMPDHarnessM2OpenFC	Fault Counter 99-347-00: CONNECTORMPDHARNESM2OPEN	Number of faults Range = 0 to 255	0
608-106	ConnectorMPDHarnessM5dplxOpenFC	Fault Counter 99-348-00: CONNECTORMPDHARNESM5DPLXOPEN	Number of faults Range = 0 to 255	0
608-107	ConnectorMPDHarnessM6LEDOpenFC	Fault Counter 99-349-00: CONNECTORMPDHARNESM6LEDOPEN	Number of faults Range = 0 to 255	0
608-108	ConnectorTTMConn1OpenFC	Fault Counter 99-360-00: CONNECTORTTMCONN1OPEN	Number of faults Range = 0 to 255	0
608-109	ConnectorTTMConn2OpenFC	Fault Counter 99-361-00: CONNECTORTTMCONN2OPEN	Number of faults Range = 0 to 255	0
608-110	ConnectorTTMConn3OpenFC	Fault Counter 99-362-00: CONNECTORTTMCONN3OPEN	Number of faults Range = 0 to 255	0
608-111	PowerRelayP-StoFinisherOpenFC	Fault Counter 99-365-00: POWERRELAYPSTOFINISHEROPEN	Number of faults Range = 0 to 255	0
608-112	ConnectorMPDToFinisherOpenFC	Fault Counter 99-366-00: CONNECTORMPDTOFINISHEROPEN	Number of faults Range = 0 to 255	0
608-113	ConnectorACPSHeater1OpenFC	Fault Counter 99-370-00: CONNECTORACPSHEATER1OPEN	Number of faults Range = 0 to 255	0
608-114	ConnectorACPSHeater2OpenFC	Fault Counter 99-371-00: CONNECTORACPSHEATER2OPEN	Number of faults Range = 0 to 255	0
608-115	ConnectorACPSHeater3OpenFC	Fault Counter 99-372-00: CONNECTORACPSHEATER3OPEN	Number of faults Range = 0 to 255	0
608-116	ConnectorACPSFuse1OpenFC	Fault Counter 99-373-00: CONNECTORACPSFUSE1OPEN	Number of faults Range = 0 to 255	0
608-117	ConnectorACPSFuse2OpenFC	Fault Counter 99-374-00: CONNECTORACPSFUSE2OPEN	Number of faults Range = 0 to 255	0
608-118	ConnectorACPSFuse3OpenFC	Fault Counter 99-375-00: CONNECTORACPSFUSE3OPEN	Number of faults Range = 0 to 255	0

Table 17 CCS NVM ID 608-xxx

NVM ID	NVM Name	NVM Description	Settings	Default
608-119	FanPowerSupply-ShortFC	Fault Counter 99-380-00: FAN-POWERSUPPLYSHORT	Number of faults Range = 0 to 255	0
608-120	FanPowerSupply-OpenFC	Fault Counter 99-381-00: FAN-POWERSUPPLYOPEN	Number of faults Range = 0 to 255	0
608-121	PowerTriacsPSShortedTriacFC	Fault Counter 99-394-00: POWERTRIACSPSSHORT-EDTRIAC	Number of faults Range = 0 to 255	0
608-122	PowerTriacsMUSHortedTriacFC	Fault Counter 99-395-00: POWERTRIACSMUHSORT-EDTRIAC	Number of faults Range = 0 to 255	0
608-123	HeaterHeadSafetyCircuitErrorFC	Fault Counter 99-400-00: HEATERHEADHEAT-ERSSAFETYCIRCUITERROR	Number of faults Range = 0 to 255	0
608-124	PowerHeadThermH1SafeCircuitErrorFC	Fault Counter 99-401-00: POWERHEADTHERMISTORSH1SAFETYCIRCUITERROR	Number of faults Range = 0 to 255	0
608-125	PowerHeadThermH2SafeCircuitErrorFC	Fault Counter 99-402-00: POWERHEADTHERMISTORSH2SAFETYCIRCUITERROR	Number of faults Range = 0 to 255	0
608-126	PowerHeadThermH3SafCircuitErrorFC	Fault Counter 99-403-00: POWERHEADTHERMISTORSH3SAFETYCIRCUITERROR	Number of faults Range = 0 to 255	0
608-127	PowerHeadThermH4SafCircuitErrorFC	Fault Counter 99-404-00: POWERHEADTHERMISTORSH4SAFETYCIRCUITERROR	Number of faults Range = 0 to 255	0
608-128	PowerHead-ThermSafCircuitErrorFC	Fault Counter 99-405-00: POWERHEADTHERMISTORSSAFETYCIRCUIT-ERROR	Number of faults Range = 0 to 255	0
608-129	HeaterHeadReservoir1OpenFC	Fault Counter 99-410-00: HEATERHEADRESERVOIR1OPEN	Number of faults Range = 0 to 255	0
608-130	HeaterHeadReservoir2OpenFC	Fault Counter 99-411-00: HEATERHEADRESERVOIR2OPEN	Number of faults Range = 0 to 255	0
608-131	HeaterHeadReservoir3OpenFC	Fault Counter 99-412-00: HEATERHEADRESERVOIR3OPEN	Number of faults Range = 0 to 255	0
608-132	HeaterHeadReservoir4OpenFC	Fault Counter 99-413-00: HEATERHEADRESERVOIR4OPEN	Number of faults Range = 0 to 255	0
608-133	HeaterHeadReservoir1ShortFC	Fault Counter 99-414-00: HEATERHEADRESERVOIR1SHORT	Number of faults Range = 0 to 255	0

Table 17 CCS NVM ID 608-xxx

NVM ID	NVM Name	NVM Description	Settings	Default
608-134	HeaterHeadReservoir2ShortFC	Fault Counter 99-415-00: HEATERHEADRESERVOIR2 SHORT	Number of faults Range = 0 to 255	0
608-135	HeaterHeadReservoir3ShortFC	Fault Counter 99-416-00: HEATERHEADRESERVOIR3 SHORT	Number of faults Range = 0 to 255	0
608-136	HeaterHeadReservoir4ShortFC	Fault Counter 99-417-00: HEATERHEADRESERVOIR4 SHORT	Number of faults Range = 0 to 255	0
608-137	HeaterJetStackH1LeftOpenFC	Fault Counter 99-426-00: HEATERJETSTACKH1LEFTOPEN	Number of faults Range = 0 to 255	0
608-138	HeaterJetStackH1RightOpenFC	Fault Counter 99-427-00: HEATERJETSTACKH1RIGHTOPEN	Number of faults Range = 0 to 255	0
608-139	HeaterJetStackH2LeftOpenFC	Fault Counter 99-428-00: HEATERJETSTACKH2LEFTOPEN	Number of faults Range = 0 to 255	0
608-140	HeaterJetStackH2RightOpenFC	Fault Counter 99-429-00: HEATERJETSTACKH2RIGHTOPEN	Number of faults Range = 0 to 255	0
608-141	HeaterJetStackH3LeftOpenFC	Fault Counter 99-430-00: HEATERJETSTACKH3LEFTOPEN	Number of faults Range = 0 to 255	0
608-142	HeaterJetStackH3RightOpenFC	Fault Counter 99-431-00: HEATERJETSTACKH3RIGHTOPEN	Number of faults Range = 0 to 255	0
608-143	HeaterJetStackH4LeftOpenFC	Fault Counter 99-432-00: HEATERJETSTACKH4LEFTOPEN	Number of faults Range = 0 to 255	0
608-144	HeaterJetStackH4RightOpenFC	Fault Counter 99-433-00: HEATERJETSTACKH4RIGHTOPEN	Number of faults Range = 0 to 255	0
608-145	HeaterJetStackH1LeftShortFC	Fault Counter 99-434-00: HEATERJETSTACKH1LEFTSHORT	Number of faults Range = 0 to 255	0
608-146	HeaterJetStackH1RightShortFC	Fault Counter 99-435-00: HEATERJETSTACKH1RIGHTSHORT	Number of faults Range = 0 to 255	0
608-147	HeaterJetStackH2LeftShortFC	Fault Counter 99-436-00: HEATERJETSTACKH2LEFTSHORT	Number of faults Range = 0 to 255	0
608-148	HeaterJetStackH2RightShortFC	Fault Counter 99-437-00: HEATERJETSTACKH2RIGHTSHORT	Number of faults Range = 0 to 255	0

Table 17 CCS NVM ID 608-xxx

NVM ID	NVM Name	NVM Description	Settings	Default
608-149	HeaterJetStackH3LeftShortFC	Fault Counter 99-438-00: HEATERJETSTACKH3LEFTSHORT	Number of faults Range = 0 to 255	0
608-150	HeaterJetStackH3RightShortFC	Fault Counter 99-439-00: HEATERJETSTACKH3RIGHTSHORT	Number of faults Range = 0 to 255	0
608-151	HeaterJetStackH4LeftShortFC	Fault Counter 99-440-00: HEATERJETSTACKH4LEFTSHORT	Number of faults Range = 0 to 255	0
608-152	HeaterJetStackH4RightShortFC	Fault Counter 99-441-00: HEATERJETSTACKH4RIGHTSHORT	Number of faults Range = 0 to 255	0
608-153	HeaterUmbilicalUpperOpenFC	Fault Counter 99-460-00: HEATERUMBILICALUPPEROPEN	Number of faults Range = 0 to 255	0
608-154	HeaterUmbilicalLowerOpenFC	Fault Counter 99-461-00: HEATERUMBILICALLOWEROPEN	Number of faults Range = 0 to 255	0
608-155	HeaterUmbilicalUpperShortFC	Fault Counter 99-462-00: HEATERUMBILICALUPPERSHORT	Number of faults Range = 0 to 255	0
608-156	HeaterUmbilicalLowerShortFC	Fault Counter 99-463-00: HEATERUMBILICALLOWERSHORT	Number of faults Range = 0 to 255	0
608-157	HeaterMeltReservoir1OpenFC	Fault Counter 99-470-00: HEATERMELTRESERVOIR1OPEN	Number of faults Range = 0 to 255	0
608-158	HeaterMeltReservoir2OpenFC	Fault Counter 99-471-00: HEATERMELTRESERVOIR2OPEN	Number of faults Range = 0 to 255	0
608-159	HeaterMeltReservoir1ShortFC	Fault Counter 99-472-00: HEATERMELTRESERVOIR1SHORT	Number of faults Range = 0 to 255	0
608-160	HeaterMeltReservoir2ShortFC	Fault Counter 99-473-00: HEATERMELTRESERVOIR2SHORT	Number of faults Range = 0 to 255	0
608-161	HeaterInkMelterC1OpenFC	Fault Counter 99-480-00: HEATERINKMELTERC1OPEN	Number of faults Range = 0 to 255	0
608-162	HeaterInkMelterC2OpenFC	Fault Counter 99-481-00: HEATERINKMELTERC2OPEN	Number of faults Range = 0 to 255	0
608-163	HeaterInkMelterC3OpenFC	Fault Counter 99-482-00: HEATERINKMELTERC3OPEN	Number of faults Range = 0 to 255	0

Table 17 CCS NVM ID 608-xxx

NVM ID	NVM Name	NVM Description	Settings	Default
608-164	HeaterInkMelterC4OpenFC	Fault Counter 99-483-00: HEATERINKMELTERC4OPEN	Number of faults Range = 0 to 255	0
608-165	HeaterInkMelterC1ShortFC	Fault Counter 99-484-00: HEATERINKMELTERC1SHORT	Number of faults Range = 0 to 255	0
608-166	HeaterInkMelterC2ShortFC	Fault Counter 99-485-00: HEATERINKMELTERC2SHORT	Number of faults Range = 0 to 255	0
608-167	HeaterInkMelterC3ShortFC	Fault Counter 99-486-00: HEATERINKMELTERC3SHORT	Number of faults Range = 0 to 255	0
608-168	HeaterInkMelterC4ShortFC	Fault Counter 99-487-00: HEATERINKMELTERC4SHORT	Number of faults Range = 0 to 255	0
608-169	ThermistorInkMelterC1OpenFC	Fault Counter 99-500-00: THERMISTORINKMELTERC1OPEN	Number of faults Range = 0 to 255	0
608-170	ThermistorInkMelterC2OpenFC	Fault Counter 99-501-00: THERMISTORINKMELTERC2OPEN	Number of faults Range = 0 to 255	0
608-171	ThermistorInkMelterC3OpenFC	Fault Counter 99-502-00: THERMISTORINKMELTERC3OPEN	Number of faults Range = 0 to 255	0
608-172	ThermistorInkMelterC4OpenFC	Fault Counter 99-503-00: THERMISTORINKMELTERC4OPEN	Number of faults Range = 0 to 255	0
608-173	ThermistorInkMelterC1ShortFC	Fault Counter 99-504-00: THERMISTORINKMELTERC1SHORT	Number of faults Range = 0 to 255	0
608-174	ThermistorInkMelterC2ShortFC	Fault Counter 99-505-00: THERMISTORINKMELTERC2SHORT	Number of faults Range = 0 to 255	0
608-175	ThermistorInkMelterC3ShortFC	Fault Counter 99-506-00: THERMISTORINKMELTERC3SHORT	Number of faults Range = 0 to 255	0
608-176	ThermistorInkMelterC4ShortFC	Fault Counter 99-507-00: THERMISTORINKMELTERC4SHORT	Number of faults Range = 0 to 255	0
608-177	HeaterDrumFrontOpenFC	Fault Counter 99-510-00: HEATERDRUMFRONTOPEN	Number of faults Range = 0 to 255	0
608-178	HeaterDrumRearOpenFC	Fault Counter 99-511-00: HEATERDRUMREAROPEN	Number of faults Range = 0 to 255	0
608-179	HeaterDrumFrontShortFC	Fault Counter 99-512-00: HEATERDRUMFRONTSHORT	Number of faults Range = 0 to 255	0

Table 17 CCS NVM ID 608-xxx

NVM ID	NVM Name	NVM Description	Settings	Default
608-180	HeaterDrumRearShortFC	Fault Counter 99-513-00: HEATERDRUMREARSHORT	Number of faults Range = 0 to 255	0
608-181	HeaterMediaPreheat1and2OpenFC	Fault Counter 99-522-00: HEATERMEDIAPREHEAT1AND2OPEN	Number of faults Range = 0 to 255	0
608-182	HeaterMediaPreheat1ShortFC	Fault Counter 99-523-00: HEATERMEDIAPREHEAT1SHORT	Number of faults Range = 0 to 255	0
608-183	HeaterMediaPreheat2ShortFC	Fault Counter 99-524-00: HEATERMEDIAPREHEAT2SHORT	Number of faults Range = 0 to 255	0
608-184	ThermistorUmbilicalUpperOpenFC	Fault Counter 99-530-00: THERMISTORUMBILICALUPPEROPEN	Number of faults Range = 0 to 255	0
608-185	ThermistorUmbilicalLowerOpenFC	Fault Counter 99-531-00: THERMISTORUMBILICALLOWEROPEN	Number of faults Range = 0 to 255	0
608-186	ThermistorUmbilicalUpperShortFC	Fault Counter 99-532-00: THERMISTORUMBILICALUPPERSHORT	Number of faults Range = 0 to 255	0
608-187	ThermistorUmbilicalLowerShortFC	Fault Counter 99-533-00: THERMISTORUMBILICALLOWERSHORT	Number of faults Range = 0 to 255	0
608-188	ThermistorDrumFrontOpenFC	Fault Counter 99-534-00: THERMISTORDRUMFRONTOPEN	Number of faults Range = 0 to 255	0
608-189	ThermistorDrumRearOpenFC	Fault Counter 99-535-00: THERMISTORDRUMREAROPEN	Number of faults Range = 0 to 255	0
608-190	ThermistorDrumFrontShortFC	Fault Counter 99-536-00: THERMISTORDRUMFRONTSHORT	Number of faults Range = 0 to 255	0
608-191	ThermistorDrumRearShortFC	Fault Counter 99-537-00: THERMISTORDRUMREARSHORT	Number of faults Range = 0 to 255	0
608-192	ThermistorWaveAmpOpenFC	Fault Counter 99-538-00: THERMISTORWAVEAMPOPEN	Number of faults Range = 0 to 255	0
608-193	ThermistorWaveAmpShortFC	Fault Counter 99-539-00: THERMISTORWAVEAMPSHORT	Number of faults Range = 0 to 255	0
608-194	ThermistorJetStackH1RightOpenFC	Fault Counter 99-540-00: THERMISTORJETSTACKH1RIGHTOPEN	Number of faults Range = 0 to 255	0

Table 17 CCS NVM ID 608-xxx

NVM ID	NVM Name	NVM Description	Settings	Default
608-195	ThermistorJetStackH1LeftOpenFC	Fault Counter 99-541-00: THERMISTORJETSTACKH1LEFTOPEN	Number of faults Range = 0 to 255	0
608-196	ThermistorJetStackH2RightOpenFC	Fault Counter 99-542-00: THERMISTORJETSTACKH2RIGHTOPEN	Number of faults Range = 0 to 255	0
608-197	ThermistorJetStackH2LeftOpenFC	Fault Counter 99-543-00: THERMISTORJETSTACKH2LEFTOPEN	Number of faults Range = 0 to 255	0
608-198	ThermistorJetStackH3RightOpenFC	Fault Counter 99-544-00: THERMISTORJETSTACKH3RIGHTOPEN	Number of faults Range = 0 to 255	0
608-199	ThermistorJetStackH3LeftOpenFC	Fault Counter 99-545-00: THERMISTORJETSTACKH3LEFTOPEN	Number of faults Range = 0 to 255	0
608-200	ThermistorJetStackH4RightOpenFC	Fault Counter 99-546-00: THERMISTORJETSTACKH4RIGHTOPEN	Number of faults Range = 0 to 255	0
608-201	ThermistorJetStackH4LeftOpenFC	Fault Counter 99-547-00: THERMISTORJETSTACKH4LEFTOPEN	Number of faults Range = 0 to 255	0
608-202	ThermistorJetStackH1RightShortFC	Fault Counter 99-548-00: THERMISTORJETSTACKH1RIGHTSHORT	Number of faults Range = 0 to 255	0
608-203	ThermistorJetStackH1LeftShortFC	Fault Counter 99-549-00: THERMISTORJETSTACKH1LEFTSHORT	Number of faults Range = 0 to 255	0
608-204	ThermistorJetStackH2RightShortFC	Fault Counter 99-550-00: THERMISTORJETSTACKH2RIGHTSHORT	Number of faults Range = 0 to 255	0
608-205	ThermistorJetStackH2LeftShortFC	Fault Counter 99-551-00: THERMISTORJETSTACKH2LEFTSHORT	Number of faults Range = 0 to 255	0
608-206	ThermistorJetStackH3RightShortFC	Fault Counter 99-552-00: THERMISTORJETSTACKH3RIGHTSHORT	Number of faults Range = 0 to 255	0
608-207	ThermistorJetStackH3LeftShortFC	Fault Counter 99-553-00: THERMISTORJETSTACKH3LEFTSHORT	Number of faults Range = 0 to 255	0
608-208	ThermistorJetStackH4RightShortFC	Fault Counter 99-554-00: THERMISTORJETSTACKH4RIGHTSHORT	Number of faults Range = 0 to 255	0
608-209	ThermistorJetStackH4LeftShortFC	Fault Counter 99-555-00: THERMISTORJETSTACKH4LEFTSHORT	Number of faults Range = 0 to 255	0

Table 17 CCS NVM ID 608-xxx

NVM ID	NVM Name	NVM Description	Settings	Default
608-210	ThermistorHeadReservoirH1OpenFC	Fault Counter 99-556-00: THERMISTORHEADRESERVOIRH1OPEN	Number of faults Range = 0 to 255	0
608-211	ThermistorHeadReservoirH2OpenFC	Fault Counter 99-557-00: THERMISTORHEADRESERVOIRH2OPEN	Number of faults Range = 0 to 255	0
608-212	ThermistorHeadReservoirH3OpenFC	Fault Counter 99-558-00: THERMISTORHEADRESERVOIRH3OPEN	Number of faults Range = 0 to 255	0
608-213	ThermistorHeadReservoirH4OpenFC	Fault Counter 99-559-00: THERMISTORHEADRESERVOIRH4OPEN	Number of faults Range = 0 to 255	0
608-214	ThermistorHeadReservoirH1ShortFC	Fault Counter 99-560-00: THERMISTORHEADRESERVOIRH1SHORT	Number of faults Range = 0 to 255	0
608-215	ThermistorHeadReservoirH2ShortFC	Fault Counter 99-561-00: THERMISTORHEADRESERVOIRH2SHORT	Number of faults Range = 0 to 255	0
608-216	ThermistorHeadReservoirH3ShortFC	Fault Counter 99-562-00: THERMISTORHEADRESERVOIRH3SHORT	Number of faults Range = 0 to 255	0
608-217	ThermistorHeadReservoirH4ShortFC	Fault Counter 99-563-00: THERMISTORHEADRESERVOIRH4SHORT	Number of faults Range = 0 to 255	0
608-218	SensorADCinklevelHead1C1OpenFC	Fault Counter 99-568-00: SENSORADCINKLEVELHEAD1C1OPEN	Number of faults Range = 0 to 255	0
608-219	SensorADCinklevelHead1C2OpenFC	Fault Counter 99-569-00: SENSORADCINKLEVELHEAD1C2OPEN	Number of faults Range = 0 to 255	0
608-220	SensorADCinklevelHead1C3OpenFC	Fault Counter 99-570-00: SENSORADCINKLEVELHEAD1C3OPEN	Number of faults Range = 0 to 255	0
608-221	SensorADCinklevelHead1C4OpenFC	Fault Counter 99-571-00: SENSORADCINKLEVELHEAD1C4OPEN	Number of faults Range = 0 to 255	0
608-222	SensorADCinklevelHead2C1OpenFC	Fault Counter 99-572-00: SENSORADCINKLEVELHEAD2C1OPEN	Number of faults Range = 0 to 255	0
608-223	SensorADCinklevelHead2C2OpenFC	Fault Counter 99-573-00: SENSORADCINKLEVELHEAD2C2OPEN	Number of faults Range = 0 to 255	0
608-224	SensorADCinklevelHead2C4OpenFC	Fault Counter 99-575-00: SENSORADCINKLEVELHEAD2C4OPEN	Number of faults Range = 0 to 255	0

Table 17 CCS NVM ID 608-xxx

NVM ID	NVM Name	NVM Description	Settings	Default
608-225	SensorADCinklev elHead2C4Open FC	Fault Counter 99-575-00: SENSORADCINKLEVELHEA D2C4OPEN	Number of faults Range = 0 to 255	0
608-226	SensorADCinklev elHead3C1Open FC	Fault Counter 99-576-00: SENSORADCINKLEVELHEA D3C1OPEN	Number of faults Range = 0 to 255	0
608-227	SensorADCinklev elHead3C2Open FC	Fault Counter 99-577-00: SENSORADCINKLEVELHEA D3C2OPEN	Number of faults Range = 0 to 255	0
608-228	SensorADCinklev elHead3C3Open FC	Fault Counter 99-578-00: SENSORADCINKLEVELHEA D3C3OPEN	Number of faults Range = 0 to 255	0
608-229	SensorADCinklev elHead3C4Open FC	Fault Counter 99-579-00: SENSORADCINKLEVELHEA D3C4OPEN	Number of faults Range = 0 to 255	0
608-230	SensorADCinklev elHead4C1Open FC	Fault Counter 99-580-00: SENSORADCINKLEVELHEA D4C1OPEN	Number of faults Range = 0 to 255	0
608-231	SensorADCinklev elHead4C2Open FC	Fault Counter 99-581-00: SENSORADCINKLEVELHEA D4C2OPEN	Number of faults Range = 0 to 255	0
608-232	SensorADCinklev elHead4C3Open FC	Fault Counter 99-582-00: SENSORADCINKLEVELHEA D4C3OPEN	Number of faults Range = 0 to 255	0
608-233	SensorADCinklev elHead4C4Open FC	Fault Counter 99-583-00: SENSORADCINKLEVELHEA D4C4OPEN	Number of faults Range = 0 to 255	0
608-234	SensorADCinklev elHead1C1ShortF C	Fault Counter 99-584-00: SENSORADCINKLEVELHEA D1C1SHORT	Number of faults Range = 0 to 255	0
608-235	SensorADCinklev elHead1C2ShortF C	Fault Counter 99-585-00: SENSORADCINKLEVELHEA D1C2SHORT	Number of faults Range = 0 to 255	0
608-236	SensorADCinklev elHead1C3ShortF C	Fault Counter 99-586-00: SENSORADCINKLEVELHEA D1C3SHORT	Number of faults Range = 0 to 255	0
608-237	SensorADCinklev elHead1C4ShortF C	Fault Counter 99-587-00: SENSORADCINKLEVELHEA D1C4SHORT	Number of faults Range = 0 to 255	0
608-238	SensorADCinklev elHead2C1ShortF C	Fault Counter 99-588-00: SENSORADCINKLEVELHEA D2C1SHORT	Number of faults Range = 0 to 255	0
608-239	SensorADCinklev elHead2C2ShortF C	Fault Counter 99-589-00: SENSORADCINKLEVELHEA D2C2SHORT	Number of faults Range = 0 to 255	0

Table 17 CCS NVM ID 608-xxx

NVM ID	NVM Name	NVM Description	Settings	Default
608-240	SensorADCinklev elHead2C3ShortF C	Fault Counter 99-590-00: SENSORADCINKLEVELHEA D2C3SHORT	Number of faults Range = 0 to 255	0
608-241	SensorADCinklev elHead2C4ShortF C	Fault Counter 99-591-00: SENSORADCINKLEVELHEA D2C4SHORT	Number of faults Range = 0 to 255	0
608-242	SensorADCinklev elHead3C1ShortF C	Fault Counter 99-592-00: SENSORADCINKLEVELHEA D3C1SHORT	Number of faults Range = 0 to 255	0
608-243	SensorADCinklev elHead3C2ShortF C	Fault Counter 99-593-00: SENSORADCINKLEVELHEA D3C2SHORT	Number of faults Range = 0 to 255	0
608-244	SensorADCinklev elHead3C3ShortF C	Fault Counter 99-594-00: SENSORADCINKLEVELHEA D3C3SHORT	Number of faults Range = 0 to 255	0
608-245	SensorADCinklev elHead3C4ShortF C	Fault Counter 99-595-00: SENSORADCINKLEVELHEA D3C4SHORT	Number of faults Range = 0 to 255	0
608-246	SensorADCinklev elHead4C1ShortF C	Fault Counter 99-596-00: SENSORADCINKLEVELHEA D4C1SHORT	Number of faults Range = 0 to 255	0
608-247	SensorADCinklev elHead4C2ShortF C	Fault Counter 99-597-00: SENSORADCINKLEVELHEA D4C2SHORT	Number of faults Range = 0 to 255	0
608-248	SensorADCinklev elHead4C3ShortF C	Fault Counter 99-598-00: SENSORADCINKLEVELHEA D4C3SHORT	Number of faults Range = 0 to 255	0
608-249	SensorADCinklev elHead4C4ShortF C	Fault Counter 99-599-00: SENSORADCINKLEVELHEA D4C4SHORT	Number of faults Range = 0 to 255	0
608-250	ThermistorMelt- reservoirOpenFC	Fault Counter 99-564-00: THERMISTORMELTRESER- VOIROPEN	Number of faults Range = 0 to 255	0
608-251	ThermistorMelt- reservoirShortFC	Fault Counter 99-565-00: THERMISTORMELTRESER- VOIRSHORT	Number of faults Range = 0 to 255	0
608-252	SolenoidInkPurge ValveH1OpenFC	Fault Counter 99-600-00: SOLENOIDINKPURGEVALVE H1OPEN	Number of faults Range = 0 to 255	0
608-253	SolenoidInkPurge ValveH2OpenFC	Fault Counter 99-601-00: SOLENOIDINKPURGEVALVE H2OPEN	Number of faults Range = 0 to 255	0
608-254	SolenoidInkPurge ValveH3OpenFC	Fault Counter 99-602-00: SOLENOIDINKPURGEVALVE H3OPEN	Number of faults Range = 0 to 255	0

Table 17 CCS NVM ID 608-xxx

NVM ID	NVM Name	NVM Description	Settings	Default
608-255	SolenoidInkPurge ValveH4OpenFC	Fault Counter 99-603-00: SOLENOIDINKPURGEVALVE H4OPEN	Number of faults Range = 0 to 255	0
608-256	SolenoidInkDose ValveH1C1Open FC	Fault Counter 99-604-00: SOLENOIDINKDOSEVALVEH 1C1OPEN	Number of faults Range = 0 to 255	0
608-257	SolenoidInkDose ValveH1C2Open FC	Fault Counter 99-605-00: SOLENOIDINKDOSEVALVEH 1C2OPEN	Number of faults Range = 0 to 255	0
608-258	SolenoidInkDose ValveH1C3Open FC	Fault Counter 99-606-00: SOLENOIDINKDOSEVALVEH 1C3OPEN	Number of faults Range = 0 to 255	0
608-259	SolenoidInkDose ValveH1C4Open FC	Fault Counter 99-607-00: SOLENOIDINKDOSEVALVEH 1C4OPEN	Number of faults Range = 0 to 255	0
608-260	SolenoidInkDose ValveH2C1Open FC	Fault Counter 99-608-00: SOLENOIDINKDOSEVALVEH 2C1OPEN	Number of faults Range = 0 to 255	0
608-261	SolenoidInkDose ValveH2C2Open FC	Fault Counter 99-609-00: SOLENOIDINKDOSEVALVEH 2C2OPEN	Number of faults Range = 0 to 255	0
608-262	SolenoidInkDose ValveH2C3Open FC	Fault Counter 99-610-00: SOLENOIDINKDOSEVALVEH 2C3OPEN	Number of faults Range = 0 to 255	0
608-263	SolenoidInkDose ValveH2C4Open FC	Fault Counter 99-611-00: SOLENOIDINKDOSEVALVEH 2C4OPEN	Number of faults Range = 0 to 255	0
608-264	SolenoidInkDose ValveH3C1Open FC	Fault Counter 99-612-00: SOLENOIDINKDOSEVALVEH 3C1OPEN	Number of faults Range = 0 to 255	0
608-265	SolenoidInkDose ValveH3C2Open FC	Fault Counter 99-613-00: SOLENOIDINKDOSEVALVEH 3C2OPEN	Number of faults Range = 0 to 255	0
608-266	SolenoidInkDose ValveH3C3Open FC	Fault Counter 99-614-00: SOLENOIDINKDOSEVALVEH 3C3OPEN	Number of faults Range = 0 to 255	0
608-267	SolenoidInkDose ValveH3C4Open FC	Fault Counter 99-615-00: SOLENOIDINKDOSEVALVEH 3C4OPEN	Number of faults Range = 0 to 255	0
608-268	SolenoidInkDose ValveH4C1Open FC	Fault Counter 99-616-00: SOLENOIDINKDOSEVALVEH 4C1OPEN	Number of faults Range = 0 to 255	0
608-269	SolenoidInkDose ValveH4C2Open FC	Fault Counter 99-617-00: SOLENOIDINKDOSEVALVEH 4C2OPEN	Number of faults Range = 0 to 255	0

Table 17 CCS NVM ID 608-xxx

NVM ID	NVM Name	NVM Description	Settings	Default
608-270	SolenoidInkDose ValveH4C3Open FC	Fault Counter 99-618-00: SOLENOIDINKDOSEVALVEH 4C3OPEN	Number of faults Range = 0 to 255	0
608-271	SolenoidInkDose ValveH4C4Open FC	Fault Counter 99-619-00: SOLENOIDINKDOSEVALVEH 4C4OPEN	Number of faults Range = 0 to 255	0
608-272	SolenoidInkPurge ValveH1ShortFC	Fault Counter 99-620-00: SOLENOIDINKPURGEVALVE H1SHORT	Number of faults Range = 0 to 255	0
608-273	SolenoidInkPurge ValveH2ShortFC	Fault Counter 99-621-00: SOLENOIDINKPURGEVALVE H2SHORT	Number of faults Range = 0 to 255	0
608-274	SolenoidInkPurge ValveH3ShortFC	Fault Counter 99-622-00: SOLENOIDINKPURGEVALVE H3SHORT	Number of faults Range = 0 to 255	0
608-275	SolenoidInkPurge ValveH4ShortFC	Fault Counter 99-623-00: SOLENOIDINKPURGEVALVE H4SHORT	Number of faults Range = 0 to 255	0
608-276	SolenoidInkDose ValveH1C1ShortFC	Fault Counter 99-624-00: SOLENOIDINKDOSEVALVEH 1C1SHORT	Number of faults Range = 0 to 255	0
608-277	SolenoidInkDose ValveH1C2ShortFC	Fault Counter 99-625-00: SOLENOIDINKDOSEVALVEH 1C2SHORT	Number of faults Range = 0 to 255	0
608-278	SolenoidInkDose ValveH1C3ShortFC	Fault Counter 99-626-00: SOLENOIDINKDOSEVALVEH 1C3SHORT	Number of faults Range = 0 to 255	0
608-279	SolenoidInkDose ValveH1C4ShortFC	Fault Counter 99-627-00: SOLENOIDINKDOSEVALVEH 1C4SHORT	Number of faults Range = 0 to 255	0
608-280	SolenoidInkDose ValveH2C1ShortFC	Fault Counter 99-628-00: SOLENOIDINKDOSEVALVEH 2C1SHORT	Number of faults Range = 0 to 255	0
608-281	SolenoidInkDose ValveH2C2ShortFC	Fault Counter 99-629-00: SOLENOIDINKDOSEVALVEH 2C2SHORT	Number of faults Range = 0 to 255	0
608-282	SolenoidInkDose ValveH2C3ShortFC	Fault Counter 99-630-00: SOLENOIDINKDOSEVALVEH 2C3SHORT	Number of faults Range = 0 to 255	0
608-283	SolenoidInkDose ValveH2C4ShortFC	Fault Counter 99-631-00: SOLENOIDINKDOSEVALVEH 2C4SHORT	Number of faults Range = 0 to 255	0
608-284	SolenoidInkDose ValveH3C1ShortFC	Fault Counter 99-632-00: SOLENOIDINKDOSEVALVEH 3C1SHORT	Number of faults Range = 0 to 255	0

Table 17 CCS NVM ID 608-xxx

NVM ID	NVM Name	NVM Description	Settings	Default
608-285	SolenoidInkDose ValveH3C2ShortFC	Fault Counter 99-633-00: SOLENOIDINKDOSEVALVEH3C2SHORT	Number of faults Range = 0 to 255	0
608-286	SolenoidInkDose ValveH3C3ShortFC	Fault Counter 99-634-00: SOLENOIDINKDOSEVALVEH3C3SHORT	Number of faults Range = 0 to 255	0
608-287	SolenoidInkDose ValveH3C4ShortFC	Fault Counter 99-635-00: SOLENOIDINKDOSEVALVEH3C4SHORT	Number of faults Range = 0 to 255	0
608-288	SolenoidInkDose ValveH4C1ShortFC	Fault Counter 99-636-00: SOLENOIDINKDOSEVALVEH4C1SHORT	Number of faults Range = 0 to 255	0
608-289	SolenoidInkDose ValveH4C2ShortFC	Fault Counter 99-637-00: SOLENOIDINKDOSEVALVEH4C2SHORT	Number of faults Range = 0 to 255	0
608-290	SolenoidInkDose ValveH4C3ShortFC	Fault Counter 99-638-00: SOLENOIDINKDOSEVALVEH4C3SHORT	Number of faults Range = 0 to 255	0
608-291	SolenoidInkDose ValveH4C4ShortFC	Fault Counter 99-639-00: SOLENOIDINKDOSEVALVEH4C4SHORT	Number of faults Range = 0 to 255	0
608-292	SolenoidLPValveOpenFC	Fault Counter 99-680-00: SOLENOIDLPAVALVEOPEN	Number of faults Range = 0 to 255	0
608-293	SolenoidLPA-ValveShortFC	Fault Counter 99-681-00: SOLENOIDLPAVALVESHORT	Number of faults Range = 0 to 255	0
608-294	SenADCinklevMeItResRefC1OpenFC	Fault Counter 99-684-00: SENSORADCINKLEVELMELTRESREFC1OPEN	Number of faults Range = 0 to 255	0
608-295	SenADCinklevMeItResRefC2OpenFC	Fault Counter 99-685-00: SENSORADCINKLEVELMELTRESREFC2OPEN	Number of faults Range = 0 to 255	0
608-296	SenADCinklevMeItResRefC3OpenFC	Fault Counter 99-686-00: SENSORADCINKLEVELMELTRESREFC3OPEN	Number of faults Range = 0 to 255	0
608-297	SenADCinklevMeItResRefC4OpenFC	Fault Counter 99-687-00: SENSORADCINKLEVELMELTRESREFC4OPEN	Number of faults Range = 0 to 255	0
608-298	SenADCinklevMeItResFullC1OpenFC	Fault Counter 99-688-00: SENSORADCINKLEVELMELTRESFULLC1OPEN	Number of faults Range = 0 to 255	0
608-299	SenADCinklevMeItResFullC2OpenFC	Fault Counter 99-689-00: SENSORADCINKLEVELMELTRESFULLC2OPEN	Number of faults Range = 0 to 255	0
608-300	SenADCinklevMeItResFullC3OpenFC	Fault Counter 99-690-00: SENSORADCINKLEVELMELTRESFULLC3OPEN	Number of faults Range = 0 to 255	0

Table 17 CCS NVM ID 608-xxx

NVM ID	NVM Name	NVM Description	Settings	Default
608-301	SenADCinklevMeItResFullC4OpenFC	Fault Counter 99-691-00: SENSORADCINKLEVELMELTRESFULLC4OPEN	Number of faults Range = 0 to 255	0
608-302	SenADCinklevMeItResRefC1ShortFC	Fault Counter 99-692-00: SENSORADCINKLEVELMELTRESREFC1SHORT	Number of faults Range = 0 to 255	0
608-303	SenADCinklevMeItResRefC2ShortFC	Fault Counter 99-693-00: SENSORADCINKLEVELMELTRESREFC2SHORT	Number of faults Range = 0 to 255	0
608-304	SenADCinklevMeItResRefC3ShortFC	Fault Counter 99-694-00: SENSORADCINKLEVELMELTRESREFC3SHORT	Number of faults Range = 0 to 255	0
608-305	SenADCinklevMeItResRefC4ShortFC	Fault Counter 99-695-00: SENSORADCINKLEVELMELTRESREFC4SHORT	Number of faults Range = 0 to 255	0
608-306	SenADCinklevMeItResFullC1ShortFC	Fault Counter 99-696-00: SENSORADCINKLEVELMELTRESFULLC1SHORT	Number of faults Range = 0 to 255	0
608-307	SenADCinklevMeItResFullC2ShortFC	Fault Counter 99-697-00: SENSORADCINKLEVELMELTRESFULLC2SHORT	Number of faults Range = 0 to 255	0
608-308	SenADCinklevMeItResFullC3ShortFC	Fault Counter 99-698-00: SENSORADCINKLEVELMELTRESFULLC3SHORT	Number of faults Range = 0 to 255	0
608-309	SenADCinklevMeItResFullC4ShortFC	Fault Counter 99-699-00: SENSORADCINKLEVELMELTRESFULLC4SHORT	Number of faults Range = 0 to 255	0
608-310	PumpInkDelivery-AirOpenFC	Fault Counter 99-700-00: PUMPINKDELIVERYAIRO-PEN	Number of faults Range = 0 to 255	0
608-311	PumpInkDelivery-AirShortFC	Fault Counter 99-701-00: PUMPINKDELIVERYAIR-SHORT	Number of faults Range = 0 to 255	0
608-312	SenADCinkair-pumpcurrentOpenFC	Fault Counter 99-705-00: SENSORADCINKDELIVERY-AIRPUMPCURRENTOPEN	Number of faults Range = 0 to 255	0
608-313	SenADCinkair-pumpcurrent-ShortFC	Fault Counter 99-706-00: SENSORADCINKDELIVERY-AIRPUMPCURRENTSHORT	Number of faults Range = 0 to 255	0
608-314	FanRearEnclosureOpenFC	Fault Counter 99-710-00: FAN-REARENCLOSUREOPEN	Number of faults Range = 0 to 255	0
608-315	FanRearEnclosureShortFC	Fault Counter 99-711-00: FAN-REARENCLOSURESHORT	Number of faults Range = 0 to 255	0
608-316	FanMarkingDrawerShortFC	Fault Counter 99-716-00: FAN-MARKINGDRAWERSHORT	Number of faults Range = 0 to 255	0

Table 17 CCS NVM ID 608-xxx

NVM ID	NVM Name	NVM Description	Settings	Default
608-317	FanDrumCooling-ShortFC	Fault Counter 99-721-00: FAN-DRUMCOOLINGSHORT	Number of faults Range = 0 to 255	0
608-318	FanAbatement-ShortFC	Fault Counter 99-726-00: FANABATEMENTSHORT	Number of faults Range = 0 to 255	0
608-319	PumpReg/Pre-heatAirPumpsShortFC	Fault Counter 99-731-00: PUMPReg/PreheatAIR-PUMPSSHORT	Number of faults Range = 0 to 255	0
608-320	ThermistorMediaPreheatOpenFC	Fault Counter 99-735-00: THERMISTORMEDIAPRE-HEATOPEN	Number of faults Range = 0 to 255	0
608-321	ThermistorMediaPreheatShortFC	Fault Counter 99-736-00: THERMISTORMEDIAPRE-HEATSHORT	Number of faults Range = 0 to 255	0
608-322	SolenoidCARDiverterOpenFC	Fault Counter 99-740-00: SOLENOIDCARDIVERTERO-PEN	Number of faults Range = 0 to 255	0
608-323	SolenoidCARDiverterShortFC	Fault Counter 99-741-00: SOLENOIDCARDIVERTERSHORT	Number of faults Range = 0 to 255	0
608-324	SolenoidDuplex-OpenFC	Fault Counter 99-745-00: SOLENOIDDUPLEXOPEN	Number of faults Range = 0 to 255	0
608-325	SolenoidDuplex-ShortFC	Fault Counter 99-746-00: SOLENOIDDUPLEXSHORT	Number of faults Range = 0 to 255	0
608-326	SolenoidNipCOpenFC	Fault Counter 99-750-00: SOLENOIDNIPCOPEN	Number of faults Range = 0 to 255	0
608-327	SolenoidNipCShortFC	Fault Counter 99-751-00: SOLENOIDNIPCSHORT	Number of faults Range = 0 to 255	0
608-328	SolenoidNipDOpenFC	Fault Counter 99-755-00: SOLENOIDNIPDOPEN	Number of faults Range = 0 to 255	0
608-329	SolenoidNipDShortFC	Fault Counter 99-756-00: SOLENOIDNIPDSHORT	Number of faults Range = 0 to 255	0
608-330	SolenoidNipEOpenFC	Fault Counter 99-760-00: SOLENOIDNIPEO-PEN	Number of faults Range = 0 to 255	0
608-331	SolenoidNipEShortFC	Fault Counter 99-761-00: SOLENOIDNIPESHORT	Number of faults Range = 0 to 255	0
608-332	SolenoidStripperOpenFC	Fault Counter 99-765-00: SOLENOIDSTRIPPEROPEN	Number of faults Range = 0 to 255	0
608-333	SolenoidStripperShortFC	Fault Counter 99-766-00: SOLENOIDSTRIPPERSHORT	Number of faults Range = 0 to 255	0
608-334	SolenoidWasteTrayLockShortFC	Fault Counter 99-771-00: SOLENOIDWASTETRAY-LOCKSHORT	Number of faults Range = 0 to 255	0
608-335	SolenoidCleanUnitValveOpenFC	Fault Counter 99-775-00: SOLENOIDCleanUnitVALVE-OPEN	Number of faults Range = 0 to 255	0

Table 17 CCS NVM ID 608-xxx

NVM ID	NVM Name	NVM Description	Settings	Default
608-336	SolenoidCleanUnitValve-ShortFC	Fault Counter 99-776-00: SOLENOIDCleanUnitVALVE-SHORT	Number of faults Range = 0 to 255	0
608-337	PumpCleanUnit-DeliveryOpenFC	Fault Counter 99-780-00: PUMPCleanUnitDELIVERY-OPEN	Number of faults Range = 0 to 255	0
608-338	PumpCleanUnit-DeliveryShortFC	Fault Counter 99-781-00: PUMPCleanUnitDELIVERY-SHORT	Number of faults Range = 0 to 255	0
608-339	PumpCleanUnitReturnOpenFC	Fault Counter 99-785-00: PUMPCleanUnitRETURN-OPEN	Number of faults Range = 0 to 255	0
608-340	PumpCleanUnitReturnShortFC	Fault Counter 99-786-00: PUMPCleanUnitRETURN-SHORT	Number of faults Range = 0 to 255	0
608-341	ADCCleanUnitOilResLevSenOpenFC	Fault Counter 99-790-00: SENSORADCCleanUnitOIL-RESLEVELSENSEOPEN	Number of faults Range = 0 to 255	0
608-342	SenADCCleanUnitpresssenOpenFC	Fault Counter 99-791-00: SENSORADCCleanUnit-PRESSURESENSEOPEN	Number of faults Range = 0 to 255	0
608-343	ADCCleanUnitOilResLevSenShortFC	Fault Counter 99-792-00: SENSORADCCleanUnitOIL-RESLEVELSENSESHORT	Number of faults Range = 0 to 255	0
608-344	SenADCCleanUnitpresssensShortFC	Fault Counter 99-793-00: SENSORADCCleanUnit-PRESSURESENSESHORT	Number of faults Range = 0 to 255	0
608-345	SenCleanUnitIbuttonIICfailureFC	Fault Counter 99-795-00: SENSORCleanUnitIBUTTON-IICFAILURE	Number of faults Range = 0 to 255	0
608-346	SenCleanUnitIbuttonPresfailureFC	Fault Counter 99-796-00: SENSORCleanUnitIBUTTON-PRESENTFAILURE	Number of faults Range = 0 to 255	0
608-347	MotorDrumMaintOpenFC	Fault Counter 99-801-00: MOTORDRUMMAINTOPEN	Number of faults Range = 0 to 255	0
608-348	MotorDrumMaintShortFC	Fault Counter 99-802-00: MOTORDRUMMAINTSHORT	Number of faults Range = 0 to 255	0
608-349	MotorDrumMaintEncoderFC	Fault Counter 99-803-00: MOTORDRUMMAINTENCODER	Number of faults Range = 0 to 255	0
608-350	MotorHeadRoll1ShortFC	Fault Counter 99-811-00: MOTORHEADROLL1SHORT	Number of faults Range = 0 to 255	0
608-351	MotorHeadRoll2ShortFC	Fault Counter 99-813-00: MOTORHEADROLL2SHORT	Number of faults Range = 0 to 255	0

Table 17 CCS NVM ID 608-xxx

NVM ID	NVM Name	NVM Description	Settings	Default
608-352	MotorHeadRoll3ShortFC	Fault Counter 99-815-00: MOTORHEADROLL3SHORT	Number of faults Range = 0 to 255	0
608-353	MotorHeadRoll4ShortFC	Fault Counter 99-817-00: MOTORHEADROLL4SHORT	Number of faults Range = 0 to 255	0
608-354	MotorHeadStitch3ShortFC	Fault Counter 99-821-00: MOTORHEADSTITCH3SHORT	Number of faults Range = 0 to 255	0
608-355	MotorHeadStitch4ShortFC	Fault Counter 99-823-00: MOTORHEADSTITCH4SHORT	Number of faults Range = 0 to 255	0
608-356	MotorCar- rRestraintLower- ShortFC	This NVM ID shown for information only. The machine does not have carriage restraint motors.	Number of faults Range = 0 to 255	0
608-357	MotorCar- rRestraintUpper- ShortFC	This NVM ID shown for information only. The machine does not have carriage restraint motors.	Number of faults Range = 0 to 255	0
608-358	MotorCarriageSelectOpenFC	Fault Counter 99-830-00: MOTORCARRIAGESELECTOPEN	Number of faults Range = 0 to 255	0
608-359	MotorCarriageSelectShortFC	Fault Counter 99-831-00: MOTORCARRIAGESELECTSHORT	Number of faults Range = 0 to 255	0
608-360	MotorCarriagedriveOpenFC	Fault Counter 99-832-00: MOTORCARRIAGEDRIVEOPEN	Number of faults Range = 0 to 255	0
608-361	MotorCarriagedriveShortFC	Fault Counter 99-833-00: MOTORCARRIAGEDRIVESHORT	Number of faults Range = 0 to 255	0
608-362	MotorHead-MaintVerticalOpenFC	Fault Counter 99-835-00: MOTORHEADMAINTVERTICALOPEN	Number of faults Range = 0 to 255	0
608-363	MotorHead-MaintVerticalShortFC	Fault Counter 99-836-00: MOTORHEADMAINTVERTICALSHORT	Number of faults Range = 0 to 255	0
608-364	MotorHeadMain- tHorizontal- IOpenFC	Fault Counter 99-837-00: MOTORHEADMAINTHORIZONTALOPEN	Number of faults Range = 0 to 255	0
608-365	MotorHeadMain- tHorizontal- ShortFC	Fault Counter 99-838-00: MOTORHEADMAINTHORIZONTALSHORT	Number of faults Range = 0 to 255	0
608-366	MotorXaxisUp- perOpenFC	Fault Counter 99-840-00: MOTORXAXISUPPEROPEN	Number of faults Range = 0 to 255	
608-367	MotorXaxisUp- perShortFC	Fault Counter 99-841-00: MOTORXAXISUPPERSHORT	Number of faults Range = 0 to 255	

Table 17 CCS NVM ID 608-xxx

NVM ID	NVM Name	NVM Description	Settings	Default
608-368	MotorXaxisLowerOpenFC	Fault Counter 99-845-00: MOTORXAXISLOWEROPEN	Number of faults Range = 0 to 255	
608-369	MotorXaxisLowerShortFC	Fault Counter 99-846-00: MOTORXAXISLOWERSHORT	Number of faults Range = 0 to 255	
608-370	MotorIODShuttleShortFC	Fault Counter 99-861-00: MOTORIODSHUTTLESHORT	Number of faults Range = 0 to 255	
608-371	MotorInkSKUShortFC	Fault Counter 99-871-00: MOTORINKSKUSHORT	Number of faults Range = 0 to 255	
608-372	MotorInkLoad- BeltDriveShortFC	Fault Counter 99-876-00: MOTORINKLOADBELTDRIVESHORT	Number of faults Range = 0 to 255	
608-373	MotorDrumDrive- OpenFC	Fault Counter 99-880-00: MOTORDRUMDRIVEOPEN	Number of faults Range = 0 to 255	
608-374	MotorDrumDrive- ShortFC	Fault Counter 99-881-00: MOTORDRUMDRIVESHORT	Number of faults Range = 0 to 255	
608-375	MotorDrumDrive- MotorEncoderFC	Fault Counter 99-884-00: MOTORDRUMDRIVEMOTORENCODER	Number of faults Range = 0 to 255	
608-376	MotorDrumDrive- DrumEncoderFC	Fault Counter 99-885-00: MOTORDRUMDRIVEDRUMENCODER	Number of faults Range = 0 to 255	
608-377	MotorTransfix- FrontForceEn- coderFC	Fault Counter 99-888-00: MOTORTRANSFIXFRONTFORCEENCODER	Number of faults Range = 0 to 255	
608-378	MotorTrans- fixRearForceEn- coderFC	Fault Counter 99-889-00: MOTORTRANSFIXREARFORCEENCODER	Number of faults Range = 0 to 255	
608-379	MotorTransfixFr- ontOpenFC	Fault Counter 99-890-00: MOTORTRANSFIXFRONTOPEN	Number of faults Range = 0 to 255	
608-380	MotorTransfix- FrontShortFC	Fault Counter 99-891-00: MOTORTRANSFIXFRONTSHORT	Number of faults Range = 0 to 255	
608-381	MotorTransfix- FrontMotorEn- coderFC	Fault Counter 99-892-00: MOTORTRANSFIXFRONTMOTORENCODER	Number of faults Range = 0 to 255	
608-382	MotorTrans- fixRearOpenFC	Fault Counter 99-895-00: MOTORTRANSFIXREAROPEN	Number of faults Range = 0 to 255	
608-383	MotorTrans- fixRearShortFC	Fault Counter 99-896-00: MOTORTRANSFIXREARSHORT	Number of faults Range = 0 to 255	0

Table 17 CCS NVM ID 608-xxx

NVM ID	NVM Name	NVM Description	Settings	Default
608-384	MotorTransfixRe-arMotorEncoderFC	Fault Counter 99-897-00: MOTORTRANSFIXREARMO-TORENCODER	Number of faults Range = 0 to 255	0
608-385	MotorMP2OpenFC	Fault Counter 99-901-00: MOTORMP2OPEN	Number of faults Range = 0 to 255	0
608-386	MotorMP2ShortFC	Fault Counter 99-902-00: MOTORMP2SHORT	Number of faults Range = 0 to 255	0
608-387	MotorMP2EncoderFC	Fault Counter 99-903-00: MOTORMP2ENCODER	Number of faults Range = 0 to 255	0
608-388	MotorMP6OpenFC	Fault Counter 99-905-00: MOTORMP6OPEN	Number of faults Range = 0 to 255	0
608-389	MotorMP6ShortFC	Fault Counter 99-906-00: MOTORMP6SHORT	Number of faults Range = 0 to 255	0
608-390	MotorMP6EncoderFC	Fault Counter 99-907-00: MOTORMP6ENCODER	Number of faults Range = 0 to 255	0
608-391	RegistrationMotorA1M3OpenFC	Fault Counter 99-910-00: Registration Motor A1 (M3) OPEN	Number of faults Range = 0 to 255	0
608-392	RegistrationMotorA1M3ShortFC	Fault Counter 99-911-00: Registration Motor A1 (M3) SHORT	Number of faults Range = 0 to 255	0
608-393	RegistrationMotorA2M3OpenFC	Fault Counter 99-915-00: Registration Motor A2 (M3) OPEN	Number of faults Range = 0 to 255	0
608-394	RegistrationMotorA2M3ShortFC	Fault Counter 99-916-00: Registration Motor A2 (M3) SHORT	Number of faults Range = 0 to 255	0
608-395	MotorMP4OpenFC	Fault Counter 99-920-00: MOTORMP4OPEN	Number of faults Range = 0 to 255	0
608-396	MotorMP4ShortFC	Fault Counter 99-921-00: MOTORMP4SHORT	Number of faults Range = 0 to 255	0
608-397	MotorMP5OpenFC	Fault Counter 99-925-00: MOTORMP5OPEN	Number of faults Range = 0 to 255	0
608-398	MotorMP5ShortFC	Fault Counter 99-926-00: MOTORMP5SHORT	Number of faults Range = 0 to 255	0
608-399	MotorMSITray4FeedShortFC	Fault Counter 99-931-00: MOTORMSITRAY4FEEDSHORT	Number of faults Range = 0 to 255	0
608-400	MotorTTMHorizontalTransportShortFC	Fault Counter 99-936-00: MOTORTTMHORIZONTAL-TRANSPORTSHORT	Number of faults Range = 0 to 255	0
608-401	MotorTTMTray3ElevateShortFC	Fault Counter 99-938-00: MOTORTTMTRAY3ELEVATE SHORT	Number of faults Range = 0 to 255	0
608-402	MotorTTMTray1FeedShortFC	Fault Counter 99-941-00: MOTORTTMTRAY1FEEDSHORT	Number of faults Range = 0 to 255	0

Table 17 CCS NVM ID 608-xxx

NVM ID	NVM Name	NVM Description	Settings	Default
608-403	MotorTTMTray2FeedShortFC	Fault Counter 99-944-00: MOTORTTMTRAY2FEEDSHORT	Number of faults Range = 0 to 255	0
608-404	MotorTTMTray3FeedShortFC	Fault Counter 99-947-00: MOTORTTMTRAY3FEEDSHORT	Number of faults Range = 0 to 255	0
608-405	MotorPFPTTray5TransportShortFC	Fault Counter 99-951-00: MOTORPFPTTRAY5TRANSPORTSHORT	Number of faults Range = 0 to 255	0
608-406	MotorPFPTTray5ElevateShortFC	Fault Counter 99-954-00: MOTORPFPTTRAY5ELEVATE SHORT	Number of faults Range = 0 to 255	0
608-407	MotorPFPTTray5FeedShortFC	Fault Counter 99-957-00: MOTORPFPTTRAY5FEEDSHORT	Number of faults Range = 0 to 255	0
608-408	MotorOCTOffsetShortFC	Fault Counter 99-961-00: MOTOROCTOFFSETSHORT	Number of faults Range = 0 to 255	0
608-409	MISCAbortFC	Fault Counter 99-996-00: MISCABORT	Number of faults Range = 0 to 255	0
608-410	MISCErrrorFC	Fault Counter 99-997-00: MISCERROR	Number of faults Range = 0 to 255	0
608-411	Stapler End Home Failure	Fault Counter 12-370-00: Stapler End Home Failure	Number of faults Range = 0 to 255	0
608-412	Stapler Return End Home Failure	Fault Counter 12-369-00: Stapler Return End Home Failure	Number of faults Range = 0 to 255	0
608-413	Punch - side edge2 detect fail	Fault Counter 12-368-00: Punch Unit paper side edge 2 detecting failure	Number of faults Range = 0 to 255	0
608-414	Punch - side edge3 detect fail	Fault Counter 12-367-00: Punch Unit paper side edge 3 detecting failure	Number of faults Range = 0 to 255	0
608-415	No Specified Media available	Fault Counter 89-562-00: NOMEDIAOFSPECIFIEDTY-PEAVAILABLE	Number of faults Range = 0 to 255	0
608-416	IOD Alignment needed before cal	Fault Counter 89-563-00: IODALIGNMENTNEEDEDBEFORECAL	Number of faults Range = 0 to 255	0
608-417	Fault Counter 89-564-00: FAILED-TOCREATECAL-IMAGE	Cal image creation failed	Number of faults Range = 0 to 255	0
608-418	Intermediate cal not valid	Fault Counter 89-565-00: INTERMEDIATECALIBRATIONNOTVALID	Number of faults Range = 0 to 255	0

Table 17 CCS NVM ID 608-xxx

NVM ID	NVM Name	NVM Description	Settings	Default
608-419	Cal parameter out of range	Fault Counter 89-566-00: CAL-IBRATIONPARAMETER-OUTOFRANGE	Number of faults Range = 0 to 255	0
608-420	Head1 Black Rev Lev FP Excep.	Fault Counter 93-909-00: HEAD1BLACKRESERVOIRLEVESENSFPEXCEPTION	Number of faults Range = 0 to 255	0
608-421	Head1 Magenta Rev Lev FP Excep.	Fault Counter 93-910-00: HEAD1MAGENTARESEROIRLEVESENSFPEXCEPTION	Number of faults Range = 0 to 255	0
608-422	Head1 Cyan Rev Lev FP Excep	Fault Counter 93-911-00: HEAD1CYANRESERVOIRLEVESENSFPEXCEPTION	Number of faults Range = 0 to 255	0
608-423	Head1 Yellow Rev Lev FP Excep.	Fault Counter 93-912-00: HEAD1YELLOWRESERVOIRLEVESENSFPEXCEPTION	Number of faults Range = 0 to 255	0
608-424	Head2 Black Rev Lev FP Excep.	Fault Counter 93-913-00: HEAD2BLACKRESERVOIRLEVESENSFPEXCEPTION	Number of faults Range = 0 to 255	0
608-425	Head2 Magenta Rev Lev FP Excep.	Fault Counter 93-914-00: HEAD2MAGENTARESEROIRLEVESENSFPEXCEPTION	Number of faults Range = 0 to 255	0
608-426	Head2 Cyan Rev Lev FP Excep.	Fault Counter 93-915-00: HEAD2CYANRESERVOIRLEVESENSFPEXCEPTION	Number of faults Range = 0 to 255	0
608-427	Head2 Yellow Rev Lev FP Excep.	Fault Counter 93-916-00: HEAD2YELLOWRESERVOIRLEVESENSFPEXCEPTION	Number of faults Range = 0 to 255	0
608-428	Head3 Black Rev Lev FP Excep.	Fault Counter 93-917-00: HEAD3BLACKRESERVOIRLEVESENSFPEXCEPTION	Number of faults Range = 0 to 255	0
608-429	Head3 Magenta Rev Lev FP Excep.	Fault Counter 93-918-00: HEAD3MAGENTARESEROIRLEVESENSFPEXCEPTION	Number of faults Range = 0 to 255	0
608-430	Head3 Cyan Rev Lev FP Excep.	Fault Counter 93-919-00: HEAD3CYANRESERVOIRLEVESENSFPEXCEPTION	Number of faults Range = 0 to 255	0
608-431	Head3 Yellow Rev Lev FP Excep.	Fault Counter 93-920-00: HEAD3YELLOWRESERVOIRLEVESENSFPEXCEPTION	Number of faults Range = 0 to 255	0
608-432	Head4 Black Rev Lev FP Excep.	Fault Counter 93-921-00: HEAD4BLACKRESERVOIRLEVESENSFPEXCEPTION	Number of faults Range = 0 to 255	0
608-433	Head4 Magenta Rev Lev FP Excep.	Fault Counter 93-922-00: HEAD4MAGENTARESEROIRLEVESENSFPEXCEPTION	Number of faults Range = 0 to 255	0

Table 17 CCS NVM ID 608-xxx

NVM ID	NVM Name	NVM Description	Settings	Default
608-434	Head4 Cyan Rev Lev FP Excep.	Fault Counter 93-923-00: HEAD4CYANRESERVOIRLEVESENSFPEXCEPTION	Number of faults Range = 0 to 255	0
608-435	Head4 Yellow Rev Lev FP Excep.	Fault Counter 93-924-00: HEAD4YELLOWRESERVOIRLEVESENSFPEXCEPTION	Number of faults Range = 0 to 255	0
608-436	Oil Delivery pump stall	Fault Counter 94-617-00: OILDELIVERYPUMPSTALL	Number of faults Range = 0 to 255	0
608-437	Oil Removal pump stall	Fault Counter 94-618-00: OILREMOVALPUMPSTALL	Number of faults Range = 0 to 255	0
608-438	MaintenanceKit-InstallDate	Current Maintenance Kit Install Date	Range = 0 to 4294967295	0
608-450	CleaninUnitPrematureOilLowFC	Fault Counter 94-616-00: CLEANINGUNITPREMATUEROILLOW	Number of faults Range = 0 to 255	0
608-451	CleanUnitOilLineBlock-ageFC	Fault Counter 94-619-00: CLEANINGUNITOILLINEBLOCKAGE	Number of faults Range = 0 to 255	0
608-452	EarlyConfirmTimeOutFC	Fault Counter 82-161-00: EARLYCONFIRMTIMEOUT	Number of faults Range = 0 to 255	0
608-453	ESDCount1ExceededFC	Fault Counter 92-527-00: ESDCOUNT1EXCEEDED	Number of faults Range = 0 to 255	0
608-454	ESDCount2ExceededFC	Fault Counter 92-528-00: ESDCOUNT2EXCEEDED	Number of faults Range = 0 to 255	0
608-455	ExcessivePaperSkewFC	Fault Counter 91-669-00: ExcessivePaperSkew	Number of faults Range = 0 to 255	0
608-456	Scanned Image Out Of SequenceFC	Fault Counter 91-670-00: Scanned Image Out Of Sequence	Number of faults Range = 0 to 255	0
608-457	Fiducials could not be foundFC	Fault Counter 91-671-00: Fiducials could not be found	Number of faults Range = 0 to 255	0
608-458	Too Many missing JetsFC	Fault Counter 91-672-00: Too Many missing Jets	Number of faults Range = 0 to 255	0
608-459	Floating Point ErrorFC	Fault Counter 91-673-00: Floating Point Error	Number of faults Range = 0 to 255	0
608-460	HD1 adjustment exceeds maxFC	Fault Counter 91-674-00: HD1 adjustment exceeds max	Number of faults Range = 0 to 255	0
608-461	HD2 adjustment exceeds maxFC	Fault Counter 91-675-00: HD2 adjustment exceeds max	Number of faults Range = 0 to 255	0
608-462	HD3 adjustment exceeds maxFC	Fault Counter 91-676-00: HD3 adjustment exceeds max	Number of faults Range = 0 to 255	0
608-463	HD4 adjustment exceeds maxFC	Fault Counter 91-677-00: HD4 adjustment exceeds max	Number of faults Range = 0 to 255	0
608-464	HD1 adjust converge failedFC	Fault Counter 91-678-00: HD1 adjust converge failed	Number of faults Range = 0 to 255	0

Table 17 CCS NVM ID 608-xxx

NVM ID	NVM Name	NVM Description	Settings	Default
608-465	HD2 adjust converge failedFC	Fault Counter 91-679-00: HD2 adjust converge failed	Number of faults Range = 0 to 255	0
608-466	HD3 adjust converge failedFC	Fault Counter 91-680-00: HD3 adjust converge failed	Number of faults Range = 0 to 255	0
608-467	HD4 adjust converge failedFC	Fault Counter 91-681-00: HD4 adjust converge failed	Number of faults Range = 0 to 255	0
608-468	Amb. thermist reading invalidFC	Fault Counter 91-682-00: Ambient thermistor reading is invalid	Number of faults Range = 0 to 255	0
608-471	HD1 TRC read failedFC	Fault Counter 91-683-00: HD1 TRC read failed	Number of faults Range = 0 to 255	0
608-472	HD2 TRC read failedFC	Fault Counter 91-684-00: HD2 TRC read failed	Number of faults Range = 0 to 255	0
608-473	HD3 TRC read failedFC	Fault Counter 91-685-00: HD3 TRC read failed	Number of faults Range = 0 to 255	0
608-474	HD4 TRC read failedFC	Fault Counter 91-686-00: HD4 TRC read failed	Number of faults Range = 0 to 255	0
608-475	HD1 TRC write failedFC	Fault Counter 91-687-00: HD1 TRC write failed	Number of faults Range = 0 to 255	0
608-476	HD2 TRC write failedFC	Fault Counter 91-688-00: HD2 TRC write failed	Number of faults Range = 0 to 255	0
608-477	HD3 TRC write failedFC	Fault Counter 91-689-00: HD3 TRC write failed	Number of faults Range = 0 to 255	0
608-478	HD4 TRC write failedFC	Fault Counter 91-690-00: HD4 TRC write failed	Number of faults Range = 0 to 255	0
608-479	LVDSContoneErrorFC	Fault Counter 92-585-00: LVDS Contone Terminal Error During Image Transfer	Number of faults Range = 0 to 255	0
608-484	BlackMeltRes-LeakDetectedFC	Fault Counter 93-937-00: Black melt reservoir leak detected	Number of faults Range = 0 to 255	0
608-485	MagentaMeltRes-LeakDetectedFC	Fault Counter 93-938-00: Magenta melt reservoir leak detected	Number of faults Range = 0 to 255	0
608-486	CyanMeltRes-LeakDetectedFC	Fault Counter 93-939-00: Cyan melt reservoir leak detected	Number of faults Range = 0 to 255	0
608-487	YellowMeltRes-LeakDetectedFC	Fault Counter 93-940-00: Yellow melt reservoir leak detected	Number of faults Range = 0 to 255	0
608-488	Head 1 purge failureFC	Fault Counter 93-933-00: Head 1 purge failure	Number of faults Range = 0 to 255	0
608-489	Head 2 purge failureFC	Fault Counter 93-934-00: Head 2 purge failure	Number of faults Range = 0 to 255	0

Table 17 CCS NVM ID 608-xxx

NVM ID	NVM Name	NVM Description	Settings	Default
608-490	Head 3 purge failureFC	Fault Counter 93-935-00: Head 3 purge failure	Number of faults Range = 0 to 255	0
608-491	Head 4 purge failureFC	Fault Counter 93-936-00: Head 4 purge failure	Number of faults Range = 0 to 255	0
608-492	TtmSerialLink-DownFC	Fault Counter 92-530-00: Ttm-SerialLinkDown	Number of faults Range = 0 to 255	0
608-493	PfpSerialLink-DownFC	Fault Counter 92-535-00: PfpSerialLinkDown	Number of faults Range = 0 to 255	0
608-494	ColdTemperature-BootTimeoutFC	Fault Counter 92-583-00: Cold Temperature Boot Timeout	Number of faults Range = 0 to 255	0
608-506	HEAD1THERMALGLITCHFC	Fault Counter 91-800-00: Head1 Thermal Glitch	Number of faults Range = 0 to 255	0
608-507	HEAD2THERMALGLITCHFC	Fault Counter 91-801-00: Head2 Thermal Glitch	Number of faults Range = 0 to 255	0
608-508	HEAD3THERMALGLITCHFC	Fault Counter 91-802-00: Head3 Thermal Glitch	Number of faults Range = 0 to 255	0
608-509	HEAD4THERMALGLITCHFC	Fault Counter 91-803-00: Head4 Thermal Glitch	Number of faults Range = 0 to 255	0
608-510	HEADCOMMUNICATIONS-GLITCHFC	Fault Counter 91-805-00: Head Communications Glitch	Number of faults Range = 0 to 255	0
608-511	HEADCOMMUNICATIONSFAILUREFC	Fault Counter 91-806-00: Head Communications Failure	Number of faults Range = 0 to 255	0
608-512	CleanUnitPredictOilRemaining	Cleaning Unit - Maintenance Kit. Percent Remaining.CCS Counter used to keep track of the remaining DMU Oil Percent Remaining	Number of faults Range = 0 to 255	0
608-514	PQMAAlignCalError	Fault Counter 91-837: IMEPQ-MAAlignCalError	Number of faults Range = 0 to 255	0
608-515	IODAlignCalXerror	Fault Counter 91-848: IMEIO-DAAlignCalXerror	Number of faults Range = 0 to 255	0
608-516	IODAlignCalYerror	Fault Counter 91-849: IMEIO-DAAlignCalYerror	Number of faults Range = 0 to 255	0
608-517	IODAlignCalXOffsetError	Fault Counter 91-850: IMEIO-DAAlignCalXOffsetError	Number of faults Range = 0 to 255	0
608-518	IODAlignCalYOffsetError	Fault Counter 91-851: IMEIO-DAAlignCalYOffsetError	Number of faults Range = 0 to 255	0
608-519	Single pitch prints in Jet Sub	Jet Substitution Mode Single Pitch Impressions	Range = 0 to 4294967295	0
608-520	Dual pitch prints in Jet Sub	Jet Substitution Mode Dual Pitch Impressions	Range = 0 to 4294967295	0
608-521	Black - MeteredExp - SoldDet	Black Metered ink stick expected, Sold detected	Range = 0 to 65535	0

Table 17 CCS NVM ID 608-xxx

NVM ID	NVM Name	NVM Description	Settings	Default
608-522	Cyan - MeteredExp - SoldDet	Cyan Metered ink stick expected, Sold detected	Range = 0 to 65535	0
608-523	Magenta - MeteredExp - SoldDet	Magenta Metered ink stick expected, Sold detected	Range = 0 to 65535	0
608-524	Yellow - MeteredExp - SoldDet	Yellow Metered ink stick expected, Sold detected	Range = 0 to 65535	0
608-525	Black - MeteredExp - DMOdet	Black Metered ink stick expected, DMO detected	Range = 0 to 65535	0
608-526	Cyan - MeteredExp - DMOdet	Cyan Metered ink stick expected, DMO detected	Range = 0 to 65535	0
608-527	Magenta - MeteredExp - DMOdet	Magenta Metered ink stick expected, DMO detected	Range = 0 to 65535	0
608-528	Yellow - MeteredExp - DMOdet	Yellow Metered ink stick expected, DMO detected	Range = 0 to 65535	0
608-529	Black - SoldExp - MeteredDet	Black Sold ink stick expected, Metered detected	Range = 0 to 65535	0
608-530	Cyan - SoldExp - MeteredDet	Cyan Sold ink stick expected, Metered detected	Range = 0 to 65535	0
608-531	Magenta Sold ink stick expected, Metered detected	Magenta - SoldExp - Metered-Det	Range = 0 to 65535	0
608-532	Yellow - SoldExp - MeteredDet	Yellow Sold ink stick expected, Metered detected	Range = 0 to 65535	0
608-533	Black - SoldExp - DMOdet	Black Sold ink stick expected, DMO detected	Range = 0 to 65535	0
608-534	Cyan - SoldExp - DMOdet	Cyan Sold ink stick expected, DMO detected	Range = 0 to 65535	0
608-535	Magenta - SoldExp - DMOdet	Magenta Sold ink stick expected, DMO detected	Range = 0 to 65535	0
608-536	Yellow - SoldExp - DMOdet	Yellow Sold ink stick expected, DMO detected	Range = 0 to 65535	0
608-537	Black - DMOExp - MeteredDet	Black DMO ink stick expected, Metered detected	Range = 0 to 65535	0
608-538	Cyan - DMOExp - MeteredDet	Cyan DMO ink stick expected, Metered detected	Range = 0 to 65535	0
608-539	Magenta - DMOExp - MeteredDet	Magenta DMO ink stick expected, Metered detected	Range = 0 to 65535	0
608-540	Yellow - DMOExp - MeteredDet	Yellow DMO ink stick expected, Metered detected	Range = 0 to 65535	0
608-541	Black - DMOExp - SoldDet	Black DMO ink stick expected, Sold detected	Range = 0 to 65535	0

Table 17 CCS NVM ID 608-xxx

NVM ID	NVM Name	NVM Description	Settings	Default
608-542	Cyan - DMOExp - SoldDet	Cyan DMO ink stick expected, Sold detected	Range = 0 to 65535	0
608-543	Magenta - DMOExp - SoldDet	Magenta DMO ink stick expected, Sold detected	Range = 0 to 65535	0
608-544	Yellow - DMOExp - SoldDet	Yellow DMO ink stick expected, Sold detected	Range = 0 to 65535	0
608-545	Black - Unknown type Det	Black unsupported ink stick type detected	Range = 0 to 65535	0
608-546	Cyan - Unknown type Det	Cyan unsupported ink stick type detected	Range = 0 to 65535	0
608-547	Magenta - Unknown type Det	Magenta unsupported ink stick type detected	Range = 0 to 65535	0
608-548	Yellow - Unknown type Det	Yellow unsupported ink stick type detected	Range = 0 to 65535	0
608-549	WaveAmpCableVPPHead1Open	Fault Counter 99-080-00: WaveAmpCableVPPHead1Open	Number of faults Range = 0 to 255	0
608-550	WaveAmpCableVPPHead2Open	Fault Counter 99-081-00: WaveAmpCableVPPHead2Open	Number of faults Range = 0 to 255	0
608-551	WaveAmpCableVPPHead3Open	Fault Counter 99-082-00: WaveAmpCableVPPHead3Open	Number of faults Range = 0 to 255	0
608-552	WaveAmpCableVPPHead4Open	Fault Counter 99-083-00: WaveAmpCableVPPHead4Open	Number of faults Range = 0 to 255	0
608-553	WaveAmpCableVSSHead1Open	Fault Counter 99-084-00: WaveAmpCableVSSHead1Open	Number of faults Range = 0 to 255	0
608-554	WaveAmpCableVSSHead2Open	Fault Counter 99-085-00: WaveAmpCableVSSHead2Open	Number of faults Range = 0 to 255	0
608-555	WaveAmpCableVSSHead3Open	Fault Counter 99-086-00: WaveAmpCableVSSHead3Open	Number of faults Range = 0 to 255	0
608-556	WaveAmpCableVSSHead4Open	Fault Counter 99-087-00: WaveAmpCableVSSHead4Open	Number of faults Range = 0 to 255	0
608-557	WaveAmpCableVPPHead1Short	Fault Counter 99-088-00: WaveAmpCableVPPHead1Short	Number of faults Range = 0 to 255	0

Table 17 CCS NVM ID 608-xxx

NVM ID	NVM Name	NVM Description	Settings	Default
608-558	WaveAmpCableVPPHead2Short	Fault Counter 99-089-00: WaveAmpCableVPPHead2Short	Number of faults Range = 0 to 255	0
608-559	WaveAmpCableVPPHead3Short	Fault Counter 99-090-00: WaveAmpCableVPPHead3Short	Number of faults Range = 0 to 255	0
608-560	WaveAmpCableVPPHead4Short	Fault Counter 99-091-00: WaveAmpCableVPPHead4Short	Number of faults Range = 0 to 255	0
608-561	WaveAmpCableVSSHead1Short	Fault Counter 99-092-00: WaveAmpCableVSSHead1Short	Number of faults Range = 0 to 255	0
608-562	WaveAmpCableVSSHead2Short	Fault Counter 99-093-00: WaveAmpCableVSSHead2Short	Number of faults Range = 0 to 255	0
608-563	WaveAmpCableVSSHead3Short	Fault Counter 99-094-00: WaveAmpCableVSSHead3Short	Number of faults Range = 0 to 255	0
608-564	WaveAmpCableVSSHead4Short	Fault Counter 99-095-00: WaveAmpCableVSSHead4Short	Number of faults Range = 0 to 255	0
608-729	IOD Excessive H1 X pos noise	Fault Counter 99-929-00: IOD excessive head 1 X position noise	Number of faults Range = 0 to 255	0
608-730	IOD Excessive H2 X pos noise	Fault Counter 99-930-00: IOD excessive head 2 X position noise	Number of faults Range = 0 to 255	0
608-731	IOD Excessive H3 X pos noise	Fault Counter 99-931-00: IOD excessive head 3 X position noise	Number of faults Range = 0 to 255	0
608-732	IOD Excessive H4 X pos noise	Fault Counter 99-932-00: IOD excessive head 4 X position noise	Number of faults Range = 0 to 255	0
608-733	IOD Excessive H1 Y pos noise	Fault Counter 99-933-00: IOD excessive head 1 Y position noise	Number of faults Range = 0 to 255	0
608-734	IOD Excessive H2 Y pos noise	Fault Counter 99-934-00: IOD excessive head 2 Y position noise	Number of faults Range = 0 to 255	0
608-735	IOD Excessive H3 Y pos noise	Fault Counter 99-935-00: IOD excessive head 3 Y position noise	Number of faults Range = 0 to 255	0
608-736	IOD Excessive H4 Y pos noise	Fault Counter 99-936-00: IOD excessive head 4 Y position noise	Number of faults Range = 0 to 255	0

Table 17 CCS NVM ID 608-xxx

NVM ID	NVM Name	NVM Description	Settings	Default
608-737	IOD Excessive H1 roll pos noise	Fault Counter 99-937-00: IOD excessive head 1 roll position noise	Number of faults Range = 0 to 255	0
608-738	IOD Excessive H2 roll pos noise	Fault Counter 99-938-00: IOD excessive head 2 roll position noise	Number of faults Range = 0 to 255	0
608-739	IOD Excessive H3 roll pos noise	Fault Counter 99-939-00: IOD excessive head 3 roll position noise	Number of faults Range = 0 to 255	0
608-740	IOD Excessive H4 roll pos noise	Fault Counter 99-940-00: IOD excessive head 4 roll position noise	Number of faults Range = 0 to 255	0
608-833	ImeCleaningUnit-EoIFC	Fault counter 94-629-00 IME cleaning unit EOL due to gel	Number of faults Range = 0 to 255	0
608-835	TTM1 TE Late at TAR	Fault counter 71-130-00	Number of faults Range = 0 to 255	0
608-836	TTM1 LE Too Early at TAR	Fault counter 71-132-00	Number of faults Range = 0 to 255	0
608-837	TTM1 Too Long At TAR	Fault counter 71-150-00	Number of faults Range = 0 to 255	0
608-838	TTM1 Too Short At TAR	Fault counter 71-151-00	Number of faults Range = 0 to 255	0
608-839	TTM1 Too Long at TAR NoAutoPurge	Fault counter 71-152-00	Number of faults Range = 0 to 255	0
608-840	TTM1 TooShort at TAR NoAutoPurge	Fault counter 71-153-00	Number of faults Range = 0 to 255	0
608-841	TTM2 TE Late at TAR	Fault counter 72-130-00	Number of faults Range = 0 to 255	0
608-842	TTM2 LE Late at TAR1	Fault counter 72-131-00	Number of faults Range = 0 to 255	0
608-843	TTM2 LE Too Early at TAR	Fault counter 72-132-00	Number of faults Range = 0 to 255	0
608-844	TTM2 LE Too Early at TAR1	Fault counter 72-133-00	Number of faults Range = 0 to 255	0
608-845	TTM2 Too Long At TAR	Fault counter 72-150-00	Number of faults Range = 0 to 255	0
608-846	TTM2 Too Short At TAR	Fault counter 72-151-00	Number of faults Range = 0 to 255	0
608-847	TTM2 Too Long at TAR NoAutoPurge	Fault counter 72-152-00	Number of faults Range = 0 to 255	0

Table 17 CCS NVM ID 608-xxx

NVM ID	NVM Name	NVM Description	Settings	Default
608-848	TTM2 Too Short at TAR NoAutoPurge	Fault counter 72-153-00	Number of faults Range = 0 to 255	0
608-849	TTM3 TE Late at TAR	Fault counter 73-130-00	Number of faults Range = 0 to 255	0
608-850	TTM3 LE Too Early TAR	Fault counter 73-132-00	Number of faults Range = 0 to 255	0
608-851	TTM3 TE Late at HZ XP	Fault counter 73-140-00	Number of faults Range = 0 to 255	0
608-852	TTM3 LE Too Early HZ XP	Fault counter 73-141-00	Number of faults Range = 0 to 255	0
608-853	TTM3 Too Long At TAR	Fault counter 73-150-00	Number of faults Range = 0 to 255	0
608-854	TTM3 Too Short At TAR	Fault counter 73-151-00	Number of faults Range = 0 to 255	0
608-855	TTM3 Too Long at TAR NoAutoPurge	Fault counter 73-152-00	Number of faults Range = 0 to 255	0
608-856	TTM3 Too Short at TAR NoAutoPurge	Fault counter 73-153-00	Number of faults Range = 0 to 255	0
608-857	TTMHZxp Bridge Sheet Zone 1A	Fault counter 82-166-00	Number of faults Range = 0 to 255	0
608-858	PreheatHtr unstable during print	Fault counter 88-512-00	Number of faults Range = 0 to 255	0
608-859	MPSensor20stati cjam sensor dusty	Fault counter 89-131-00	Number of faults Range = 0 to 255	0
608-860	CLD Baseline Needed	Fault counter 91-838-00	Number of faults Range = 0 to 255	0
608-861	PQM:Unif Wait-ForYposSVD Complete	Fault counter 91-852-00	Number of faults Range = 0 to 255	0
608-862	PQM:Unif Wait-ForYposSVD Complete	Fault counter 91-853-00	Number of faults Range = 0 to 255	0
608-863	PQM:Ydp Wait-ForYposSVD Complete	Fault counter 91-854-00	Number of faults Range = 0 to 255	0
608-864	Thermal Safety Circuit Fail	Fault counter 91-855	Number of faults Range = 0 to 255	0
608-865	Head 1 Thermal Persistent Glitch	Fault counter 91-856-00	Number of faults Range = 0 to 255	0
608-866	Head 2 Thermal Persistent Glitch	Fault counter 91-857-00	Number of faults Range = 0 to 255	0

Table 17 CCS NVM ID 608-xxx

NVM ID	NVM Name	NVM Description	Settings	Default
608-867	Head 3 Thermal Persistent Glitch	Fault counter 91-858-00	Number of faults Range = 0 to 255	0
608-868	Head 4 Thermal Persistent Glitch	Fault counter 91-859-00	Number of faults Range = 0 to 255	0
608-869	PQM too many purges head1	Fault counter 91-941-00	Number of faults Range = 0 to 255	0
608-870	PQM too many purges head2	Fault counter 91-942-00	Number of faults Range = 0 to 255	0
608-871	PQM too many purges head3	Fault counter 91-943-00	Number of faults Range = 0 to 255	0
608-872	PQM too many purges head4	Fault counter 91-944-00	Number of faults Range = 0 to 255	0
608-873	IODInvalid-CLDow MeasmntAvgHead1	Fault counter 91-945-00	Number of faults Range = 0 to 255	0
608-874	IODInvalid-CLDow MeasmntAvgHead2	Fault counter 91-946-00	Number of faults Range = 0 to 255	0
608-875	IODInvalid-CLDow MeasmntAvgHead3	Fault counter 91-947-00	Number of faults Range = 0 to 255	0
608-876	IODInvalid-CLDow MeasmntAvgHead4	Fault counter 91-948-00	Number of faults Range = 0 to 255	0
608-877	IODCLDbaseline-MeasmntOORngeHead1	Fault counter 91-949-00	Number of faults Range = 0 to 255	0
608-878	IODCLDbaseline-MeasmntOORngeHead2	Fault counter 91-950-00	Number of faults Range = 0 to 255	0
608-879	IODCLDbaseline-MeasmntOORngeHead3	Fault counter 91-951-00	Number of faults Range = 0 to 255	0
608-880	IODCLDbaseline-MeasmntOORngeHead4	Fault counter 91-952-00	Number of faults Range = 0 to 255	0
608-881	IOD CLD Adj Measmnt OORnge Head1	Fault counter 91-953-00	Number of faults Range = 0 to 255	0
608-882	IOD CLD Adj Measmnt OORnge Head2	Fault counter 91-954-00	Number of faults Range = 0 to 255	0

Table 17 CCS NVM ID 608-xxx

NVM ID	NVM Name	NVM Description	Settings	Default
608-883	IOD CLD Adj Measmnt OORnge Head3	Fault counter 91-954-00	Number of faults Range = 0 to 255	0
608-884	IOD CLD Adj Measmnt OORnge Head4	Fault counter 91-955-00	Number of faults Range = 0 to 255	0
608-885	IOD CLD Fiducial searchErr Head1	Fault counter 91-957-00	Number of faults Range = 0 to 255	0
608-886	IOD CLD Fiducial searchErr Head2	Fault counter 91-958-00	Number of faults Range = 0 to 255	0
608-887	IOD CLD Fiducial searchErr Head3	Fault counter 91-959-00	Number of faults Range = 0 to 255	0
608-888	IOD CLD Fiducial searchErr Head4	Fault counter 91-960-00	Number of faults Range = 0 to 255	0
608-889	IOD CLDAdj MeasNotConvergedHead1	Fault counter 91-961-00	Number of faults Range = 0 to 255	0
608-890	IOD CLDAdj MeasNotConvergedHead2	Fault counter 91-962-00	Number of faults Range = 0 to 255	0
608-891	IOD CLDAdj MeasNotConvergedHead3	Fault counter 91-963-00	Number of faults Range = 0 to 255	0
608-892	IOD CLDAdj MeasNotConvergedHead4	Fault counter 91-964-00	Number of faults Range = 0 to 255	0
608-893	IOD CLD Sensitivity error Head1	Fault counter 91-965-00	Number of faults Range = 0 to 255	0
608-894	IOD CLD Sensitivity error Head2	Fault counter 91-966-00	Number of faults Range = 0 to 255	0
608-895	IOD CLD Sensitivity error Head3	Fault counter 91-967-00	Number of faults Range = 0 to 255	0
608-896	IOD CLD Sensitivity error Head4	Fault counter 91-968-00	Number of faults Range = 0 to 255	0
608-897	Head1RJetStckHtrUnstableinPrint	Fault counter 91-970-00	Number of faults Range = 0 to 255	0
608-898	Head2RJetStckHtrUnstableinPrint	Fault counter 91-971-00	Number of faults Range = 0 to 255	0
608-899	Head3RJetStckHtrUnstableinPrint	Fault counter 91-972-00	Number of faults Range = 0 to 255	0
608-900	Head4RJetStckHtrUnstableinPrint	Fault counter 91-973-00	Number of faults Range = 0 to 255	0
608-901	Head1LJetStckHtrUnstableinPrint	Fault counter 91-974-00	Number of faults Range = 0 to 255	0

Table 17 CCS NVM ID 608-xxx

NVM ID	NVM Name	NVM Description	Settings	Default
608-902	Head2LJetStckHtrUnstableinPrint	Fault counter 91-975-00	Number of faults Range = 0 to 255	0
608-903	Head3LJetStckHtrUnstableinPrint	Fault counter 91-976-00	Number of faults Range = 0 to 255	0
608-904	Head4LJetStckHtrUnstableinPrint	Fault counter 91-977-00	Number of faults Range = 0 to 255	0
608-905	Head1ResrvoirHtrUnstableinPrint	Fault counter 91-978-00	Number of faults Range = 0 to 255	0
608-906	Head2ResrvoirHtrUnstableinPrint	Fault counter 91-979-00	Number of faults Range = 0 to 255	0
608-907	Head3ResrvoirHtrUnstableinPrint	Fault counter 91-980-00	Number of faults Range = 0 to 255	0
608-908	Head4ResrvoirHtrUnstableinPrint	Fault counter 91-981-00	Number of faults Range = 0 to 255	0
608-909	MpSerialLink-SafetyTransient	Fault counter 91-501-00	Number of faults Range = 0 to 255	0
608-910	MuSerialLink-SafetyTransient	Fault counter 91-502-00	Number of faults Range = 0 to 255	0
608-911	MuidSerialLink-SafetyTransient	Fault counter 91-503-00	Number of faults Range = 0 to 255	0
608-912	DDSerialLink-SafetyTransient	Fault counter 91-504-00	Number of faults Range = 0 to 255	0
608-913	PsSerialLinkSafetyTransient	Fault counter 91-519-00	Number of faults Range = 0 to 255	0
608-914	Inval NVM MagicNo. Detect ByIME	Fault counter 91-610-00	Number of faults Range = 0 to 255	0
608-915	Inval NVM FormatNo. Detect ByIME	Fault counter 91-611-00	Number of faults Range = 0 to 255	0
608-916	IOT CDI NVM Factory Init Done	Fault counter 91-612-00	Number of faults Range = 0 to 255	0
608-917	IOT CDI NVM SysInit Performed	Fault counter 91-613-00	Number of faults Range = 0 to 255	0
608-918	IOT CDI NVM Usrlnit Performed	Fault counter 91-614-00	Number of faults Range = 0 to 255	0
608-919	MeltResrvoirHtrUnstableinPrint	Fault counter 91-957-00	Number of faults Range = 0 to 255	0
608-920	UpperUmbHtrUnstableinPrint	Fault counter 91-958-00	Number of faults Range = 0 to 255	0
608-921	LowerUmbHtrUnstableinPrint	Fault counter 91-959-00	Number of faults Range = 0 to 255	0
608-922	DM Connector-Persistent Failure	Fault counter 91-631-00	Number of faults Range = 0 to 255	0

Table 17 CCS NVM ID 608-xxx

NVM ID	NVM Name	NVM Description	Settings	Default
608-923	Drum Front Htr unstableinPrint	Fault counter 91-632-00	Number of faults Range = 0 to 255	0
608-924	Drum Rear Htr unstableinPrint	Fault counter 91-633-00	Number of faults Range = 0 to 255	0
608-925	TTM1 Mismatch Long At TAR	Fault counter 71-154-00	Number of faults Range = 0 to 255	0
608-926	TTM1 Mismatch Short At TAR	Fault counter 71-155-00	Number of faults Range = 0 to 255	0
608-927	TTM2 Mismatch Long At TAR	Fault counter 72-154-00	Number of faults Range = 0 to 255	0
608-928	TTM2 Mismatch Short At TAR	Fault counter 72-155-00	Number of faults Range = 0 to 255	0
608-929	TTM3 Mismatch Long At TAR	Fault counter 73-154-00	Number of faults Range = 0 to 255	0
608-930	TTM3 Mismatch Short At TAR	Fault counter 73-155-00	Number of faults Range = 0 to 255	0
608-931	ImelIncompatibleFinisherFC	Fault counter 12-765-00 Incompatible Finisher detected	Number of faults Range = 0 to 255	0
608-940	DMU Thermistor Fail	Fault counter 94-634-00	Number of faults Range = 0 to 255	0
608-941	DMU Pressure Sensor Fail	Fault counter 94-635-00	Number of faults Range = 0 to 255	0

Table 18 CCS NVM ID 610-xxx

NVM ID	NVM Name	NVM Description	Settings	Default
610-001	Copy ABS Detect Window FS Start	Background detection window fast scan start, defined in tenth of percentage point of document fast scan dimension. Values from 0 to 1000 (e.g. 1% is 10, 10% is 100, 100% is 1000).	Range = 0 to 1000	75
610-002	Copy ABS Detect Window FS Size	Background detection window fast scan dimension, defined in tenth of percentage point of document fast scan dimension. Values from 0 to 1000 (e.g. 1% is 10, 10% is 100, 100% is 1000).	Range = 0 to 1000	850
610-003	Copy ABS Level Platen	Auto Background Suppression level for platen	Range = 0 to 4	2
610-004	Copy ABS Level DADH	Auto Background Suppression level for DADH	Range = 0 to 4	2
610-005	Copy Auto Contrast Level Platen	Auto Contrast level for platen	Range = 0 to 4	2

Table 18 CCS NVM ID 610-xxx

NVM ID	NVM Name	NVM Description	Settings	Default
610-006	Copy Auto Contrast Level DADH	Auto Contrast level for DADH	Range = 0 to 4	2
610-007	Copy Auto Color Detect FS Start	Auto Color detection window fast scan start, defined in tenth of percentage point of document fast scan dimension. Values from 0 to 1000 (e.g. 1% is 10, 10% is 100, 100% is 1000).	Range = 0 to 1000	64
610-008	Copy Auto Color Detect SS Start	Auto Color detection window slow scan start, defined in tenth of percentage point of document slow scan dimension. Values from 0 to 1000 (e.g. 1% is 10, 10% is 100, 100% is 1000).	Range = 0 to 1000	64
610-009	Copy Auto Color Level Pixel Plat	Auto Color Detection Level for platen at pixel level. Defines a value that dictates how chromatic a pixel has to be in order to be considered color	Range = 0 to 4	2
610-010	Copy Auto Color Level Page Plat	Auto Color Detection Level for platen at page level. Defines a value that dictates how chromatic a pixel has to be in order to be considered color	Range = 0 to 4	2
610-011	Copy Auto Color Level Pixel DADH	Auto Color Detection Level for DADH at pixel level. Defines a value that dictates how many color pixels have to be on a page so that the document is considered color	Range = 0 to 4	2
610-012	Copy Auto Color Level Page DADH	Auto Color Detection Level for DADH at page level. Defines a value that dictates how many color pixels have to be on a page so that the document is considered color	Range = 0 to 4	2
610-013	K only (only black ink for B&W)	Dictates if black & white copies are printed in K-only or composite black	Range = 0 to 1	0
610-014	Copy Photo/Text Segmentat'n Ctrl	Photo/Text Segmentation Threshold will control the Galileo segmentation. When it changes, the part of the input that will be considered text will vary as well as the part that will be considered photo.	Range = 0 to 4	2

Table 18 CCS NVM ID 610-xxx

NVM ID	NVM Name	NVM Description	Settings	Default
610-015	Copy White Reference	Defines the type of paper used	Range = 0 to 127	0
610-016	Copy Im Path Type (bit depth)	Defines the binary vs. contone image path/printing	Range = 1 to 16	8
610-017	Scan ABS Detect Window FS Start	Background detection window fast scan start, defined in tenth of percentage point of document fast scan dimension. Values from 0 to 1000 (e.g. 1% is 10, 10% is 100, 100% is 1000).	Range = 0 to 1000	75
610-018	Scan ABS Detect Window FS Size	Background detection window fast scan dimension, defined in tenth of percentage point of document fast scan dimension. Values from 0 to 1000 (e.g. 1% is 10, 10% is 100, 100% is 1000).	Range = 0 to 1000	850
610-019	Scan ABS Level Platen	Auto Background Suppression level for platen	Range = 0 to 4	2
610-020	Scan ABS Level DADH	Auto Background Suppression level for DADH	Range = 0 to 4	2
610-021	Scan Auto Contrast Level Platen	Auto Contrast level for platen	Range = 0 to 4	2
610-022	Scan Auto Contrast Level DADH	Auto Contrast level for DADH	Range = 0 to 4	2
610-023	Scan Auto Color Detect FS Start	Auto Color detection window fast scan start, defined in tenth of percentage point of document fast scan dimension. Values from 0 to 1000 (e.g. 1% is 10, 10% is 100, 100% is 1000).	Range = 0 to 1000	64
610-024	Scan Auto Color Detect SS Start	Auto Color detection window slow scan start, defined in tenth of percentage point of document slow scan dimension. Values from 0 to 1000 (e.g. 1% is 10, 10% is 100, 100% is 1000).	Range = 0 to 1000	64
610-025	Scan Auto Color Level Pixel Plat	Auto Color Detection Level for platen at pixel level. Defines a value that dictates how chromatic a pixel has to be in order to be considered color	Range = 0 to 4	2

Table 18 CCS NVM ID 610-xxx

NVM ID	NVM Name	NVM Description	Settings	Default
610-026	Scan Auto Color Level Page Plat	Auto Color Detection Level for platen at page level. Defines a value that dictates how many color pixels have to be on a page so that the document is considered color	Range = 0 to 4	2
610-027	Scan Auto Color Level Pixel DADH	Auto Color Detection Level for DADH at pixel level. Defines a value that dictates how chromatic a pixel has to be in order to be considered color	Range = 0 to 4	2
610-028	Scan Auto Color Level Page DADH	Auto Color Detection Level for DADH at page level. Defines a value that dictates how many color pixels have to be on a page so that the document is considered color	Range = 0 to 4	2
610-029	Scan Photo/Text Segmentat'n Ctrl	Photo/Text Segmentation Threshold will control the Galileo segmentation. When it changes, the part of the input that will be considered text will vary as well as the part that will be considered	Range = 0 to 4	2
610-030	Scan White Reference	Defines the type of paper used (4024, 4200, Xpressions, recyclable, etc)	Range = 0 to 127	0
610-031	Fax ABS Detect Window FS Start	Background detection window fast scan start, defined in tenth of percentage point of document fast scan dimension. Values from 0 to 1000 (e.g. 1% is 10, 10% is 100, 100% is 1000).	Range = 0 to 1000	75
610-032	Fax ABS Detect Window FS Size	Background detection window fast scan dimension, defined in tenth of percentage point of document fast scan dimension. Values from 0 to 1000 (e.g. 1% is 10, 10% is 100, 100% is 1000).	Range = 0 to 1000	850
610-033	Fax ABS Level Platen	Auto Background Suppression level for platen	Range = 0 to 4	2
610-034	Fax ABS Level DADH	Auto Background Suppression level for DADH	Range = 0 to 4	2
610-035	Auto Contrast level for platen	Fax Auto Contrast Level Platen	Range = 0 to 4	2

Table 18 CCS NVM ID 610-xxx

NVM ID	NVM Name	NVM Description	Settings	Default
610-036	Fax Auto Contrast Level DADH	Auto Contrast level for DADH	Range = 0 to 4	2
610-037	Fax Photo/Text Segment'n Control	Photo/Text Segmentation Threshold will control the Galileo segmentation. When it changes, the part of the input that will be considered text will vary as well as the part that will be considered	Range = 0 to 4	2
610-038	Fax White Reference	Defines the type of paper used	Range = 0 to 127	0
610-047	Print ImagePath Type (bit depth)	Defines the binary vs. contone image path/printing	Range = 1 to 16	8

Table 19 CCS NVM ID 612-xxx

NVM ID	NVM Name	NVM Description	Settings	Default
612-001	Queue To NC Print TimeoutFC		Range = 0 to 255	0
612-002	Queue To S2F Timeout		Range = 0 to 255	0
612-003	Queue To Fax-Send Timeout		Range = 0 to 255	0
612-004	Queue To DCCopy Timeout		Range = 0 to 255	0
612-005	Queue To S2Distr Timeout		Range = 0 to 255	0

Table 20 CCS NVM ID 616-xxx

NVM ID	NVM Name	NVM Description	Settings	Default
616-001	Market region	Defines the market region. 0 = US (North America) 1 = XCL (Canada) 2 = FX (Fuji Xerox Japan) 3 = FXAPO (Fuji Xerox Asian Pacific) 4 = ACO (Latin) 5 = RX (Europe) 6 = MRDmo East 7 = MRDmo West <i>NOTE: Do not use see dC134</i>	Range = 0 to 7 <i>NOTE: Do not use see dC134</i>	0

Table 20 CCS NVM ID 616-xxx

NVM ID	NVM Name	NVM Description	Settings	Default
616-002	Power Saver Enabled	Enable Power Saver feature	0 = Disabled 1 = Enabled Range = 0 to 1	1
616-003	Product Configuration	ColorQube Family - Defines Product Configuration. 112 = 9301, 113 = 9302, 114 = 9303, 49 = Unknown (Default), 0 = Acquire Speed from non-serialized SIM	Range = 0 to 114	49
616-004	System Configuration	Defines System Configuration (type of system)	Range = 0 to 8	1
616-005	DST Start	Defines start day of daylight savings time	Range = 0 to 366	0
616-006	DST End	Defines end day of daylight savings time	Range = 0 to 366	0
616-007	Time Display Format	Defines time display format 0 = 12 hour format, 1 = 24 hour format	Range = 0 to 1	0
616-008	power off enabled	Determines whether power saver's power off option is enabled. 0 = False, 1 = True	Range = 0 to 1	1
616-009	power off timeout enabled	Determines whether power saver's power off option using timers is enabled. 0 = False, 1 = True	Range = 0 to 1	1
616-010	powersaver idle-time	Defines time in "normal" mode where system has been idle to enabled transition into power saver.	Range = 0 to 255	5
616-011	power saver in mode time	Defines time in "mode 1" before transitioning to "mode 3" for appropriate configurations.	Range = 0 to 255	60
616-012	power saver power off time	Defines time in "lowest" power saver mode before powering off.	Range = 0 to 255	45
616-013	Date Display Format	Defines date display format 0 = mm/dd/yy, 1 = dd/mm/yy, 3 = yy/mm/dd	Range = 0 to 3	0
616-014	system install phase	Defines system's current installation phase.	Range = 0 to 4	2
616-015	Not displayed	-SMFCustomerServiceNumber	Range = 0 to 0	0
616-016	power up reason	Defines reason for previous power off.	Range = 0 to 6	1

Table 20 CCS NVM ID 616-xxx

NVM ID	NVM Name	NVM Description	Settings	Default
616-017	Contention Algorithm	Defines the order algorithm for queues/ contention: FIFO vs. priority	Range = 0 to 1	1
616-018	Extra Time	Amount of additional time after power up before system can enter power saver.	Range = 0 to 5	5
616-019	system mode	Defines system's overall mode	Range = 0 to 12	0
616-020	auto configuration enabled	Determines if the system runs through auto configuration, detect at power on. 0 = False, 1 = True	Range = 0 to 1	1
616-021	line voltage	Defines system line voltage 0=Unknown, 1 = 100V, 2 = 115V, 3 = 230V	Range = 0 to 3	2
616-022	line frequency	Defines system line frequency 0 = 50Hz, 1 = 60Hz	Range = 0 to 1	1
616-023	Not displayed	system serial number	Range = 0 to 0	0
616-024	serial number enabled	Determines whether serial number has been set. 0 = False, 1 = True	Range = 0 to 1	1
616-025	promotion time	Defines time interval for increasing job's priority based on time in system.	Range = 15 to 1440	120
616-026	auto promotion enabled	Determines whether to increase job priority longer job is in system. 0 = False, 1 = True	Range = 0 to 1	1
616-027	previous market region	Defines previous market region 0=USCO, 1 = XCL, 2 = FX, 3 = FXAPO, 4 = ACO, 5 = RX	Range = 0 to 5	0
616-028	modeChangeClientId	Defines client who did the most recent system mode change.	Range = 0 to 9994	16
616-029	latest EOD event	Defines last day that an end of day was reached.	Range = 0 to 4294967295	0
616-030	previous product config	Defines previous product configuration (All Products)	Range = 0 to 255	106
616-031	previous line frequency	Defines previous line frequency 0 = 50Hz, 1 = 60Hz	Range = 0 to 1	1
616-032	previous line voltage	Defines previous line voltage 0=Unknown, 1 = 100V, 2 = 115V, 3 = 230V	Range = 0 to 3	2
616-033	nvm copyright years	List of system's copyright years.	Range = 0 to 4294967295	0

Table 20 CCS NVM ID 616-xxx

NVM ID	NVM Name	NVM Description	Settings	Default
616-034	desired install client	Defines current client of system installation.	Range = 0 to 255	0
616-035	remoteIntrusive-DiagEnabled	Determines whether remote intrusive diagnostics is enabled. 0 = False, 1 = True	Range = 0 to 1	1
616-036	value added reseller		Range = 0 to 255	255
616-037	GMT Offset	Used by platforms to insure system clocks are set to correct time zones.	Range = -43200 to 50400	0
616-038	NC OnlineNvm	Determines whether ESS is On (Off) line. 0 = False, 1 = True	Range = 0 to 1	1
616-039	Job Hold Time	Max time a job can be held before it is deleted by the system	Range = 0 to 7200	4320
616-040	Job Hold Timer enabled	SA/KO setting to enable/disable hold job timer	Range = 0 to 1	1
616-041	ScanToFileinstalled count	Counter used for secure install and remove operations of the optional features	Range = 0 to 65535	0
616-042	LanFaxinstalled count	Counter used for secure install and remove operations of the optional features	Range = 0 to 65535	0
616-043	JBAinstalled count	Counter used for secure install and remove operations of the optional features	Range = 0 to 65535	0
616-044	ScanToFileenabled		Range = 0 to 1	0
616-045	LanFaxenabled	Specifies whether Lan Fax is Enabled on the machine.	Range = 0 to 1	0
616-046	JBAenabled	Specifies whether JBA is allowed to be turned Enabled on the machine.	Range = 0 to 1	0
616-047	NC TTY enabled	Used by PWS to determine if ESS terminal window is enabled	Range = 0 to 1	0
616-048	NC Config - Type		Range = 0 to 99	42
616-049	NC Config - Option		Range = 0 to 99	42
616-050	NC Config - Storage		Range = 0 to 99	42
616-051	NC Config - Software Options		Range = 0 to 99	42

Table 20 CCS NVM ID 616-xxx

NVM ID	NVM Name	NVM Description	Settings	Default
616-052	Product Identifier	Product Identifier (Read Only - Returned by the network controller). Identifier 129 = 9301, 130 = 9302, 131 = 9303	Range = 0 to 255	0
616-053	HeapLimits F:MaxImages T:MaxJobs	HeapLimits F:max images T:max jobs	Range = 0 to 1	0
616-054	InternetFaxin- stalled count		Range = 0 to 65535	0
616-055	ScanToEmailin- stalled count		Range = 0 to 65535	0
616-056	InternetFaxen- abled		Range = 0 to 1	0
616-057	ScanToEmailena- bled		Range = 0 to 1	0
616-058	Software Upgrade Status		Range = 0 to 7	0
616-059	DeclassifySystem OperationStatus	declassify system - operation status	Range = 0 to 5	0
616-060	Declassify system - retry count		Range = 0 to 255	0
616-061	Declassify system - client id		Range = 0 to 255	0
616-062	DeclassifySystem PlatformMask	declassify system - platform mask	Range = 0 to 65535	0
616-063	Not displayed	declassify system - platform status array-declassify system - platform status array	Range = 0 to 0	0
616-064	Not displayed	-declassify system - pattern list	Range = 0 to 0	0
616-065	Declassify system- pattern length	declassify system - pattern list length	Range = 0 to 255	0
616-066	Declassify system # repetitions	declassify system - number of repetitions	Range = 0 to 255	0
616-067	Declassify system - # of retries	declassify system - number of retries	Range = 0 to 255	0
616-068	Declassify system - Timeout	declassify system - number of retries	Range = 0 to 4294967295	0
616-069	DiskOverwritein- stalled count		Range = 0 to 65535	0
616-070	DiskOverwriteen- abled		Range = 0 to 1	0
616-071	ScanToFilehsw available		Range = 0 to 1	1

Table 20 CCS NVM ID 616-xxx

NVM ID	NVM Name	NVM Description	Settings	Default
616-072	ScanToFilein- stalled	Scan to file always installed with ColorQube	Range = 0 to 1	1
616-073	LanFaxhsw available		Range = 0 to 1	1
616-074	LanFaxinstalled	Land fax always installed if hard ware installed with Col- orQube	Range = 0 to 1	1
616-075	JBAhsw avail- able		Range = 0 to 1	1
616-076	JBAinstalled	JBA always installed with Col- orQube	Range = 0 to 1	1
616-077	ScanToEmailh- sw available		Range = 0 to 1	1
616-078	ScanToEmailin- stalled	Scan to E-mail always installed with ColorQube	Range = 0 to 1	1
616-079	InternetFaxhsw available		Range = 0 to 1	1
616-080	InternetFaxin- stalled	Internet fax always installed with ColorQube	Range = 0 to 1	1
616-081	DiskOverwriteh- sw available		Range = 0 to 1	1
616-082	DiskOverwritein- stalled	Disk overwrite always installed with ColorQube	Range = 0 to 1	1
616-083	JobOverwriteh- sw available		Range = 0 to 1	1
616-084	JobOverwritein- stalled	Job overwrite always installed with ColorQube	Range = 0 to 1	1
616-085	JobOverwritein- stalled count		Range = 0 to 65535	0
616-086	JobOverwriteen- abled		Range = 0 to 1	0
616-087	EmbeddedFaxh- sw available		Range = 0 to 1	1
616-088	EmbeddedFaxin- stalled		Range = 0 to 1	0
616-089	EmbeddedFaxin- stalled count		Range = 0 to 65535	0
616-090	EmbeddedFaxen- abled		Range = 0 to 1	0
616-091	Heavy Weight Fuser Enabled		Range = 0 to 1	1
616-092	software upgrade monitor enabled		Range = 0 to 1	0
616-093	Not displayed		Range = 0 to 0	0

Table 20 CCS NVM ID 616-xxx

NVM ID	NVM Name	NVM Description	Settings	Default
616-094	Geographic region	Geographic region	0 = Unspecified 1 = Eastern 2 = Western 3 = Not Applicable A setting of 3 (GRNotApplicable) indicates the CRUs are not to be differentiated by geo Region, but by service plan Range = 0 to 3	0
616-095	Zone1Page1Byte0	SIM data mirror	Range = 0 to 255	0
616-096	Zone1Page1Byte1	SIM data mirror	Range = 0 to 255	0
616-097	Zone1Page1Byte2	SIM data mirror	Range = 0 to 255	0
616-098	Zone1Page1Byte3	SIM data mirror	Range = 0 to 255	0
616-099	Zone1Page1Byte4	SIM data mirror	Range = 0 to 255	0
616-100	Zone1Page1Byte5	SIM data mirror	Range = 0 to 255	0
616-101	Zone1Page1Byte6	SIM data mirror	Range = 0 to 255	0
616-102	Zone1Page2Byte0	SIM data mirror	Range = 0 to 255	0
616-103	Zone1Page2Byte1	SIM data mirror	Range = 0 to 255	0
616-104	Zone1Page2Byte2	SIM data mirror	Range = 0 to 255	0
616-105	Zone1Page2Byte3	SIM data mirror	Range = 0 to 255	0
616-106	Zone1Page2Byte4	SIM data mirror	Range = 0 to 255	0
616-107	Zone1Page2Byte5	SIM data mirror	Range = 0 to 255	0
616-108	Zone1Page2Byte6	SIM data mirror	Range = 0 to 255	0
616-109	Zone1Page3Byte0	SIM data mirror	Range = 0 to 255	0
616-110	Zone1Page3Byte1	SIM data mirror	Range = 0 to 255	0
616-111	Zone1Page3Byte2	SIM data mirror	Range = 0 to 255	0

Table 20 CCS NVM ID 616-xxx

NVM ID	NVM Name	NVM Description	Settings	Default
616-112	Zone1Page3Byte3	SIM data mirror	Range = 0 to 255	0
616-113	Zone1Page3Byte4	SIM data mirror	Range = 0 to 255	0
616-114	Zone1Page3Byte5	SIM data mirror	Range = 0 to 255	0
616-115	Zone1Page3Byte6	SIM data mirror	Range = 0 to 255	0
616-116	SWUP NVM Save Switch	SWUP NVM Save Switch	Range = 0 to 255	0
616-117	delete settings	delete settings	Range = 0 to 1	0
616-118	NC OnlineValidNvm	EssOnlineValidNvm	Range = 0 to 1	0
616-120	SearchPDFhsw available	SearchPDFhsw available	Range = 0 to 1	1
616-121	SearchPDFinstalled	SearchPDFinstalled	Range = 0 to 1	1
616-122	SearchPDFinstalled count	SearchPDFinstalled count	Range = 0 to 65535	0
616-123	SearchPDFenabled	SearchPDFenabled	Range = 0 to 1	0
616-124	Cpsrhsw available	Cpsrhsw available	Range = 0 to 1	1
616-125	Cpsrinstalled	Cpsrinstalled. Always installed with ColorQube	Range = 0 to 1	1
616-126	Cpsrinstalled count	Cpsrinstalled count	Range = 0 to 65535	0
616-127	Cpsrenabled	Cpsrenabled	Range = 0 to 1	0
616-128	Power on 0 to 1 Hours	Power on 0 to 1 HoursTotal number of times the machine has been powered on for 0 to 1 hoursnumPowerOnHours01	Range = 0 to 16777215	0
616-129	Power on 2 to 3 Hours	Power on 2 to 3 HoursTotal number of times the machine has been powered on for 2 to 3 hoursnumPowerOnHours23	Range = 0 to 16777215	0
616-130	Power on 4 to 9 Hours	Power on 4 to 9 HoursTotal number of times the machine has been powered on for 4 to 9 hoursnumPowerOnHours49	Range = 0 to 16777215	0
616-131	Power on 10 to 23 Hours	Power on 10 to 23 HoursTotal number of times the machine has been powered on for 10 to 23 hoursnumPowerOnHours1023	Range = 0 to 16777215	0

Table 20 CCS NVM ID 616-xxx

NVM ID	NVM Name	NVM Description	Settings	Default
616-132	Power on 24 to 167 Hours	Power on 24 to 167 Hours Total number of times the machine has been powered on for 24 to 167 hours numPowerOnHours24167	Range = 0 to 16777215	0
616-133	Power on 168+ Hours	Power on 168+ Hours Total number of times the machine has been powered on for 168 or more numPowerOnHours168Plus	Range = 0 to 16777215	0
616-134	Hours Since Last Power On	Hours Since Last Power On Total number of hours the machine has been powered on since last po/po.numPowerOnHoursSincePoPo	Range = 0 to 16777215	0
616-135	Total Time On (hours)	Total Time On (hours) Total number of hours the machine has been powered on since last po/po.numTotalPowerOnHours	Range = 0 to 16777215	0
616-143	Fast Resume status	Fast Resume status	0 = Disabled 1 = Enabled Range = 0 to 1	0
616-144	Power Management mode	Power Management mode	0 = Intelligent ready 1 = Job active 2 = Scheduled Range = 0 to 2	0
616-145	Scheduled wake time - Sunday	Power Management Scheduled wake time - Sunday	0 = 00hrs to 23 = 23hrs (hourly increments) Range = 0 to 23	9
616-146	Scheduled wake time - Monday	Power Management Scheduled wake time - Monday	0 = 00hrs to 23 = 23hrs (hourly increments) Range = 0 to 23	9
616-147	Scheduled wake time - Tuesday	Power Management Scheduled wake time - Tuesday	0 = 00hrs to 23 = 23hrs (hourly increments) Range = 0 to 23	9
616-148	Scheduled wake time - Wednesday	Power Management Scheduled wake time - Wednesday	0 = 00hrs to 23 = 23hrs (hourly increments) Range = 0 to 23	9

Table 20 CCS NVM ID 616-xxx

NVM ID	NVM Name	NVM Description	Settings	Default
616-149	Scheduled wake time - Thursday	Power Management Scheduled wake time - Thursday	0 = 00hrs to 23 = 23hrs (hourly increments) Range = 0 to 23	9
616-150	Scheduled wake time - Friday	Power Management Scheduled wake time - Friday	0 = 00hrs to 23 = 23hrs (hourly increments) Range = 0 to 23	9
616-151	Scheduled wake time - Saturday	Power Management Scheduled wake time - Saturday	0 = 00hrs to 23 = 23hrs (hourly increments) Range = 0 to 23	9
616-152	Scheduled pwr saver time Sunday	Power Management Scheduled power saver time - Sunday	0 = 00hrs to 23 = 23hrs (hourly increments) Range = 0 to 23	17
616-153	Scheduled pwr saver time Monday	Power Management Scheduled power saver time - Monday	0 = 00hrs to 23 = 23hrs (hourly increments) Range = 0 to 23	17
616-154	Scheduled pwr saver time Tuesday	Power Management Scheduled power saver time - Tuesday	0 = 00hrs to 23 = 23hrs (hourly increments) Range = 0 to 23	17
616-155	Scheduled pwr saver time Wed.	Power Management Scheduled power saver time - Wednesday	0 = 00hrs to 23 = 23hrs (hourly increments) Range = 0 to 23	17
616-156	Scheduled pwr saver time Thurs.	Power Management Scheduled power saver time - Thursday	0 = 00hrs to 23 = 23hrs (hourly increments) Range = 0 to 23	17
616-157	Scheduled pwr saver time Friday	Power Management Scheduled power saver time - Friday	0 = 00hrs to 23 = 23hrs (hourly increments) Range = 0 to 23	17
616-158	Scheduled pwr saver time Sat.	Power Management Scheduled power saver time - Saturday	0 = 00hrs to 23 = 23hrs (hourly increments) Range = 0 to 23	17
616-159	Schedule type - Sunday	Power Management daily Schedule type - Sunday	0 = Job activated 1 = Specified time Range = 0 to 1	0
616-160	Schedule type - Monday	Power Management daily Schedule type - Monday	0 = Job activated 1 = Specified time Range = 0 to 1	0

Table 20 CCS NVM ID 616-xxx

NVM ID	NVM Name	NVM Description	Settings	Default
616-161	Schedule type - Tuesday	Power Management daily Schedule type - Tuesday	0 = Job activated 1 = Specified time Range = 0 to 1	0
616-162	Schedule type - Wednesday	Power Management daily Schedule type - Wednesday	0 = Job activated 1 = Specified time Range = 0 to 1	0
616-163	Schedule type - Thursday	Power Management daily Schedule type - Thursday	0 = Job activated 1 = Specified time Range = 0 to 1	0
616-164	Schedule type - Friday	Power Management daily Schedule type - Friday	0 = Job activated 1 = Specified time Range = 0 to 1	0
616-165	Schedule type - Saturday	Power Management daily Schedule type - Saturday	0 = Job activated 1 = Specified time Range = 0 to 1	0
616-166	Yesterday's Activity IR1b array Not displayed	Intelligent Ready Yesterday's Activity IR1b array	Range = 0 to 0	
616-167	Yesterday's Activity IR2b array Not displayed	Intelligent Ready Yesterday's Activity IR2b array	Range = 0 to 0	0
616-168	Today's Activity IR1b array Not displayed	Intelligent Ready Today's Activity IR1b array	Range = 0 to 0	0
616-169	Today's Activity IR2b array Not displayed	Intelligent Ready Today's Activity IR2b array	Range = 0 to 0	0
616-170	IR3 week array Not displayed	Intelligent Ready IR3 week array	Range = 0 to 0	0
616-171	IR Low Power Timeout Not displayed	Intelligent Ready Low Power Timeout	Range = 1 to 120	5
616-172	IR Sleep Timeout Not displayed	Intelligent Ready Sleep Timeout	Range = 1 to 240	60
616-173	IR pre-populated usage flags Not displayed	Intelligent Ready - pre-populated array daily usage flags	Range = 0 to 0	0
616-180	Not displayed	Install Wizard (FS22.020):deviceSettings	Range = 0 to 1	1
616-181	Not displayed	Install Wizard (FS22.020):languageSelection	Range = 0 to 1	1
616-182	Not displayed	Install Wizard (FS22.020):timeAndDate	Range = 0 to 1	1
616-183	Not displayed	Install Wizard (FS22.020):NetworkConnection	Range = 0 to 1	1

Table 20 CCS NVM ID 616-xxx

NVM ID	NVM Name	NVM Description	Settings	Default
616-184	Not displayed	Install Wizard (FS22.020):pagePackPasscode	Range = 0 to 1	0
616-185	Not displayed	Install Wizard (FS22.020):mini-WizardHomepage	Range = 0 to 1	1
616-186	Not displayed	Install Wizard (FS22.020):customerSupport	Range = 0 to 1	1
616-187	Not displayed	Install Wizard (FS22.020):networkSettings	Range = 0 to 1	1
616-188	Not displayed	Install Wizard (FS22.020):eMailSettings	Range = 0 to 1	0
616-189	Not displayed	Install Wizard (FS22.020):scanSettings	Range = 0 to 1	0
616-190	Not displayed	Install Wizard (FS22.020):eFaxLine1	Range = 0 to 1	0
616-191	Not displayed	Install Wizard (FS22.020):eFaxLine2	Range = 0 to 1	0
616-192	Not displayed	Install Wizard (FS22.020):MediaSizes	Range = 0 to 1	1
616-193	Not displayed	Install Wizard (FS22.020):spare1	Range = 0 to 1	1
616-194	Not displayed	Install Wizard (FS22.020):spare2	Range = 0 to 1	0
616-195	Not displayed	Lockout Timer	Range = 0 to 4294967295	86400
616-196	Not displayed	Password Attempts	Range = 0 to 5	0
616-197	Not displayed	Days Until Expiration	Range = -1 to 2147483645	-1
616-198	Not displayed	SMFSuppliesTelephoneNumber	Range = 0 to 0	0
616-199	AIF Activation Counter	AIF Activation Counter	Range = 0 to 4294967295	0
616-200	Num-TimesPagePack-PinlockedFC	Fault Counter 22-330: number of times page pack pin has been locked out	Range = 0 to 255	0
616-201	Not displayed	SMFSuppliesTelephoneNumber	Range = 0 to 0	0

Table 20 CCS NVM ID 616-xxx

NVM ID	NVM Name	NVM Description	Settings	Default
616-202	Current language (as set on UI)	Current language (as set on UI) This is a copy of the language set on the UI. Predominantly needed as the CCS becomes ready at power on before the UI and needs to process language specific routines (e.g. maintenance pages etc)	Range = 0 to 255	4
616-203	Disk Encryption - hws available	Disk Encryption - hws available	Range = 0 to 1	1
616-204	Disk Encryption - Installed	Disk Encryption - Installed	Range = 0 to 1	1
616-205	Disk Encryption Installed Count	Disk Encryption Installed Count	Range = 0 to 65535	0
616-206	Disk Encryption Enabled/Disabled	Disk Encryption Enabled/Disabled	Range = 0 to 1	1
616-208	Not displayed	Tiered Billing Password - traditional	Range = -1 to 2147483645	1791
616-209	Not displayed	Tiered Billing Password - 2 tier	Range = -1 to 2147483645	2487
616-210	Not displayed	Tiered Billing Password - 3 tier	Range = -1 to 2147483645	3258
616-211	Not displayed	System serial number checksum	Range = 0 to 65535	0
616-212	Fast Resume popup enabled	Fast Resume popup message enabled status	Range = 0 to 1	0
616-213	FullODIOTimeout	defines system manager full ODIO timeout	Range = 0 to 255	110
616-214	StandardODIOTimeout	defines system manager standard ODIO timeout	Range = 0 to 255	50
616-215	Not displayed	SAKO tools - Install wizard - Restrict tool access screen	0 = Display screen 1 = Do not display Range = 0 to 1	1
616-216	Auto-Reset Count	Automatic System Reset Count	Range = 0 to 2	0
616-217	Not displayed	PagePack Grace Prints Left	Range = 0 to 2000	1000
616-218	Not displayed	Defines whether or not the machine is in Grace Period.	Range = 0 to 1	0
616-219	Not displayed	Navigation flag for Installer Profile screen in LUI install wizard Install Wizard (FS22.020)	Range = 0 to 1	1

Table 20 CCS NVM ID 616-xxx

NVM ID	NVM Name	NVM Description	Settings	Default
616-220	Not displayed	Navigation flag for Welcome screen in LUI install wizard Install Wizard (FS22.020)	Range = 0 to 1	1
616-221	Not displayed	Navigation flag for Completed screen in LUI install wizard Install Wizard (FS22.020)	Range = 0 to 1	1
616-222	Not displayed	Navigation flag for PagePack Grace Period confirm screen in LUI install wizard Install Wizard	Range = 0 to 1	1
616-223	Not displayed	Used by platforms to set the timezone link to ensure system clocks are set to correct	Range = 0 to 0	0
616-224	Not displayed	Intelligent Ready History Log	Range = 0 to 0	0
616-225	IR1a values day array Not displayed	IR1a byte array	Range = 0 to 0	0
616-226	IR2a values day array Not displayed	IR2a byte array	Range = 0 to 0	0
616-227	IR1a last bin updated Not displayed	IR1a last updated binId	Range = 0 to 0	0
616-228	IR2a last bin updated Not displayed	IR2a last updated binId	Range = 0 to 23	0
616-229	Display Snooze Message	When the CCS instructs the IME to enter Snooze mode, it needs to remember that snooze was initiated since the IME does not report this mode. When a new unit is detected, the flag should be reset. Note setting this NVM will not induce snooze mode, it merely determines whether the Status is set for displaying the UI message.	0 = IME not in snooze mode 1 = IME in snooze mode Range = 0 to 1	0
616-230	RefurbModeNVM	Indicates that the machine has been refurbished, therefore the activation date and CRU Install dates are not be updated upon completion of Install Wizard.	0 = Not refurbished 1 = Refurbished Range = 0 to 1	0

Table 20 CCS NVM ID 616-xxx

NVM ID	NVM Name	NVM Description	Settings	Default
616-232	powersaver fast resume idletime	Defines time in "normal" mode where system has been idle to enabled transition into power saver WITH fast resume set	The idle time in minutes before the machine will enter Low power with Fast resume set Range = 1 to 225	60
616-233	powersaver fast resume in mode1	Defines time in "mode 1" before transitioning to "mode 3" WITH fast resume set.	The idle time in minutes the machine will remain in Low power before entering Sleep with Fast Resume set Range = 0 to 225	120
616-234	UI system Timeout value	UI system Timeout value	Range = 15 to 3600	60
616-235	RegDiff	Regional Differentiator value	Initially this will be settable via DC131 - however it must be changed to RO once the secure mechanism for setting this is available. NA_Classic = 1 NA_Enterprise = 2 XE_Classic = 3 XE_Enterprise = 4 DMO_Classic = 5 DMO_Enterprise = 6 Metered = 7 FX_Classic = 8 FX_Enterprise = 9 SR_Classic = 10 SR_Enterprise = 11 WW_Classic = 12 WW_Enterprise = 13 NA_XE_Classic = 14 NA_XE_Enterprise = 15 Factory = 63	1
616-236	Not displayed	JBA Cost Control: Enable/Disable	0 = Disable JBA Cost Control 1 = Enable JBA Cost Control	0
616-238	UI System Timeout Warning Enabled	UI System Timeout Warning Enabled / Disabled	0 = Disable 1 = Enable	1
616-240	Not displayed	Tiered billing password (Pin) Bik+2 tier	##	##

Table 20 CCS NVM ID 616-xxx

NVM ID	NVM Name	NVM Description	Settings	Default
616-246	CheckVanillaRun-Result	Check vanilla routine has been executed on machine	0 = Unknown 1 = Pass 2 = Fail Range = 0 to 255	0

Table 21 CCS NVM ID 617-xxx

NVM ID	NVM Name	NVM Description	Settings	Default
617-001	Not displayed	-Fault Log	Range = 0 to 0	0
617-002	faults displayed on TTY		Range = 0 to 1	1
617-003	display faults		Range = 0 to 1	1
617-004	Not displayed	StapleMv	Range = 0 to 0	0
617-005	Not displayed	StapleMv	Range = 0 to 256	0
617-006	Not displayed	PunchUnitSideEdgeDetect	Range = 0 to 256	0
617-007	Not displayed	PunchUnitSideEdgeDetect	Range = 0 to 256	0

Table 22 CCS NVM ID 620-001 to 620-099

NVM ID	NVM Name	NVM Description	Settings	Default
620-001	IISS Version No Upper Level		Range = 0 to 65535	0
620-002	prescanType		Range = 0 to 1	0
620-003	photoTextSeparationLevel		Range = 0 to 4	2
620-004	photoReproLevel		Range = 0 to 2	1
620-005	bwSeparationLevel		Range = 0 to 4	2
620-006	RED chromaticValueLow		Range = 0 to 65535	0
620-007	RED chromaticValueHigh		Range = 0 to 65535	25700
620-008	RED aChromaticValueLow		Range = 0 to 65535	0
620-009	RED aChromaticValueHigh		Range = 0 to 65535	0
620-010	GRN chromaticValueLow		Range = 0 to 65535	25600
620-011	GRN chromaticValueHigh		Range = 0 to 65535	25600
620-012	GRN aChromaticValueLow		Range = 0 to 65535	0

Table 22 CCS NVM ID 620-001 to 620-099

NVM ID	NVM Name	NVM Description	Settings	Default
620-013	GRN aChromaticValueHigh		Range = 0 to 65535	0
620-014	BLU chromat-icValueLow		Range = 0 to 65535	25600
620-015	BLU chromat-icValueHigh		Range = 0 to 65535	63
620-016	BLU aChromaticValueLow		Range = 0 to 65535	0
620-017	BLU aChromaticValueHigh		Range = 0 to 65535	0
620-018	YEL chromat-icValueLow		Range = 0 to 65535	0
620-019	YEL chromat-icValueHigh		Range = 0 to 65535	25600
620-020	YEL aChromaticValueLow		Range = 0 to 65535	0
620-021	YEL aChromaticValueHigh		Range = 0 to 65535	0
620-022	MAG chromat-icValueLow		Range = 0 to 65535	0
620-023	MAG chromat-icValueHigh		Range = 0 to 65535	100
620-024	MAG aChromaticValueLow		Range = 0 to 65535	0
620-025	MAG aChromaticValueHigh		Range = 0 to 65535	0
620-026	CYA chromat-icValueLow		Range = 0 to 65535	25600
620-027	CYA chromat-icValueHigh		Range = 0 to 65535	0
620-028	CYA aChromaticValueLow		Range = 0 to 65535	0
620-029	CYA aChromaticValueHigh		Range = 0 to 65535	0
620-030	BLA chromat-icValueLow		Range = 0 to 65535	100
620-031	BLA chromat-icValueHigh		Range = 0 to 65535	0
620-032	BLA aChromaticValueLow		Range = 0 to 65535	0
620-033	BLA aChromaticValueHigh		Range = 0 to 65535	0
620-097	62-277 counter		Range = 0 to 255	0
620-099	62-310 counter		Range = 0 to 255	0

Table 23 CCS NVM ID 620-101 to 620-199

NVM ID	NVM Name	NVM Description	Settings	Default
620-101	Market Information		Range = 0 to 3	0
620-102	IISS Major Version		Range = 0 to 65535	0
620-103	IISS Minor Version		Range = 0 to 65535	0
620-104	IISS Revision Version		Range = 0 to 65535	0
620-105	IISS Patch Version		Range = 0 to 65535	0
620-106	ADF Major Version		Range = 0 to 65535	0
620-107	ADF Minor Version		Range = 0 to 65535	0
620-108	ADF Revision Version		Range = 0 to 65535	0
620-109	ADF Patch Version		Range = 0 to 65535	0
620-110	IPL Version		Range = 0 to 65535	0
620-111	IIT fail bypass		Range = 0 to 1	0
620-112	Fan control mode		Range = 0 to 1	0
620-113	the number of APS sensors		Range = 0 to 1	1
620-114	Lamp Fan fal bypass		Range = 0 to 1	0
620-115	Lamp Fan Low rotation ON time		Range = 0 to 60	15
620-116	Lamp Fan Off time		Range = 0 to 60	0
620-117	FL timer set		Range = 0 to 1	0
620-118	Lamp On interval		Range = 0 to 60	30
620-119	Lamp On time		Range = 0 to 60	1
620-120	IIT failure parts diagnosis		Range = 0 to 65535	0
620-121	Platen SS Registration Adjust	Platen SS Registration Adjustment	Range = 16 to 184	100
620-122	Platen SS Magnification Adjust	Platen SS Magnification Adjustment	Range = 44 to 56	50
620-123	Platen glass type		Range = 0 to 2	2
620-124	REGI corr value-FS dir on Platen	REGI correction value in FS direction on Platen	Range = 0 to 240	120

Table 23 CCS NVM ID 620-101 to 620-199

NVM ID	NVM Name	NVM Description	Settings	Default
620-125	CVT FS Off S1:S1-1 (139.7-148)	CVT FS Offset Side 1: Side1-1 (139.7 to 148)	Range = 0 to 240	120
620-126	CVT FS Off S2:S2-1 (139.7-148)	CVT FS Offset Side 2: Side2-1 (139.7 to 148)	Range = 0 to 240	120
620-127	CVT FS Off S1:S1-2 (182-194)	CVT FS Offset Side 1: Side1-2 (182 to 194)	Range = 0 to 240	120
620-128	CVT FS Off S2:S2-2 (182-194)	CVT FS Offset Side 2: Side2-2 (182 to 194)	Range = 0 to 240	120
620-129	CVT FS Off S1:S1-3 (203.2)	CVT FS Offset Side 1: Side1-3 (203.2)	Range = 0 to 240	120
620-130	CVT FS Off S2:S2-3 (203.2)	CVT FS Offset Side 2: Side2-3 (203.2)	Range = 0 to 240	120
620-131	CVT FS Off S1:S1-4 (210)	CVT FS Offset Side 1: Side1-4 (210)	Range = 0 to 240	120
620-132	CVT FS Off S2:S2-4 (210)	CVT FS Offset Side 2: Side2-4 (210)	Range = 0 to 240	120
620-133	CVT FS Off S1:S1-5 (214.9-215.9)	CVT FS Offset Side 1: Side1-5 (214.9 to 215.9)	Range = 0 to 240	120
620-134	CVT FS Off S2:S2-5 (214.9-215.9)	CVT FS Offset Side 2: Side2-5 (214.9 to 215.9)	Range = 0 to 240	120
620-135	CVT FS Off S1:S1-6 (254-257)	CVT FS Offset Side 1: Side1-6 (254 to 257)	Range = 0 to 240	120
620-136	CVT FS Off S2:S2-6 (254-257)	CVT FS Offset Side 2: Side2-6 (254 to 257)	Range = 0 to 240	120
620-137	CVT FS Off S1:S1-7 (266.7-267)	CVT FS Offset Side 1: Side1-7 (266.7 to 267)	Range = 0 to 240	120
620-138	CVT FS Off S2:S2-7 (266.7-267)	CVT FS Offset Side 2: Side2-7 (266.7 to 267)	Range = 0 to 240	120
620-139	CVT FS Off S1:S1-8 (279.4)	CVT FS Offset Side 1: Side1-8 (279.4)	Range = 0 to 240	120
620-140	CVT FS Off S2:S2-8 (279.4)	CVT FS Offset Side 2: Side2-8 (279.4)	Range = 0 to 240	120
620-141	CVT FS Off S1:S1-9 (297)	CVT FS Offset Side 1: Side1-9 (297)	Range = 0 to 240	120

Table 23 CCS NVM ID 620-101 to 620-199

NVM ID	NVM Name	NVM Description	Settings	Default
620-142	CVT FS Off S2:S2-9 (297)	CVT FS Offset Side 2: Side2-9 (297)	Range = 0 to 240	120
620-143	CVT FS Off S1:S3-1 (139.7-148)	CVT FS Offset Side 1: Side3-1 (139.7 to 148)	Range = 0 to 240	120
620-144	CVT FS Off S2:S4-1 (139.7-148)	CVT FS Offset Side 2: Side4-1 (139.7 to 148)	Range = 0 to 240	120
620-145	CVT FS Off S1:S3-2 (182-194)	CVT FS Offset Side 1: Side3-2 (182 to 194)	Range = 0 to 240	120
620-146	CVT FS Off S2:S4-2 (182-194)	CVT FS Offset Side 2: Side4-2 (182 to 194)	Range = 0 to 240	120
620-147	CVT FS Off S1:S3-3 (203.2)	CVT FS Offset Side 1: Side3-3 (203.2)	Range = 0 to 240	120
620-148	CVT FS Off S2:S4-3 (203.2)	CVT FS Offset Side 2: Side4-3 (203.2)	Range = 0 to 240	120
620-149	CVT FS Off S1:S3-4 (210)	CVT FS Offset Side 1: Side3-4 (210)	Range = 0 to 240	120
620-150	CVT FS Off S2:S4-4 (210)	CVT FS Offset Side 2: Side4-4 (210)	Range = 0 to 240	120
620-151	CVT FS Off S1:S3-5 (214.9-215.9)	CVT FS Offset Side 1: Side3-5 (214.9 to 215.9)	Range = 0 to 240	120
620-152	CVT FS Off S2:S4-5 (214.9-215.9)	CVT FS Offset Side 2: Side4-5 (214.9 to 215.9)	Range = 0 to 240	120
620-153	CVT FS Off S1:S3-6 (254-257)	CVT FS Offset Side 1: Side3-6 (254 to 257)	Range = 0 to 240	120
620-154	CVT FS Off S2:S4-6 (254-257)	CVT FS Offset Side 2: Side4-6 (254 to 257)	Range = 0 to 240	120
620-155	CVT FS Off S1:S3-7 (266.7-267)	CVT FS Offset Side 1: Side3-7 (266.7 to 267)	Range = 0 to 240	120
620-156	CVT FS Off S2:S4-7 (266.7-267)	CVT FS Offset Side 2: Side4-7 (266.7 to 267)	Range = 0 to 240	120
620-157	CVT FS Off S1:S3-8 (279.4)	CVT FS Offset Side 1: Side3-8 (279.4)	Range = 0 to 240	120
620-158	CVT FS Off S2:S4-8 (279.4)	CVT FS Offset Side 2: Side4-8 (279.4)	Range = 0 to 240	120

Table 23 CCS NVM ID 620-101 to 620-199

NVM ID	NVM Name	NVM Description	Settings	Default
620-159	CVT FS Off S1:S3-9 (297)	CVT FS Offset Side 1: Side3-9 (297)	Range = 0 to 240	120
620-160	CVT FS Off S2:S4-9 (297)	CVT FS Offset Side 2: Side4-9 (297)	Range = 0 to 240	120
620-161	W-Ref adjustment factor Red		Range = 70 to 255	140
620-162	W-Ref adjustment factor Green		Range = 70 to 255	140
620-163	W-Ref adjustment factor Blue		Range = 70 to 255	140
620-164	W-Ref adjustment factor BW-X		Range = 70 to 255	140
620-165	W-Ref adjustment factor BW-Y		Range = 70 to 255	140
620-166	W-Ref adj factor Red (sheet)	W-Ref adjustment factor Red (each sheet)	Range = 0 to 127	63
620-167	W-Ref adj factor Green (sheet)	W-Ref adjustment factor Green (each sheet)	Range = 0 to 127	63
620-168	W-Ref adj factor Blue (sheet)	W-Ref adjustment factor Blue (each sheet)	Range = 0 to 127	63
620-169	W-Ref adj factor BW (sheet)	W-Ref adjustment factor BW (each sheet)	Range = 0 to 127	63
620-170	IIT paper code		Range = 0 to 8	0
620-171	Optical axis adjustment: front		Range = 0 to 1980	990
620-172	Optical axis adjustment: rear		Range = 0 to 1980	990
620-173	CVT FS Offset Side 1: Side1		Range = 0 to 240	120
620-174	CVT FS Offset Side 2: Side2		Range = 0 to 240	120
620-175	CVT FS Offset Side 1: Side3		Range = 0 to 240	120
620-176	CVT FS Offset Side 2: Side4		Range = 0 to 240	120
620-177	BW/Color auto recognition level		Range = 0 to 1	0
620-178	Black line adj level (for COLOR)	Black line adjustment level (for COLOR)	Range = 0 to 15	8
620-179	Black line adj level (for BW)	Black line adjustment level (for BW)	Range = 0 to 15	8
620-180	Black line adjustment test mode		Range = 0 to 7	0

Table 23 CCS NVM ID 620-101 to 620-199

NVM ID	NVM Name	NVM Description	Settings	Default
620-181	BW adjustment table		Range = 0 to 7	0
620-182	HOSEI_SCAN (for detection)		Range = 0 to 6	3
620-183	HOSEI_SCAN (for image)		Range = 0 to 6	3
620-184	CCD Calib Y scan Red		Range = 0 to 1023	0
620-185	CCD Calib Y scanned: Green		Range = 0 to 1023	0
620-186	CCD Calib Y scanned: Blue		Range = 0 to 1023	0
620-187	CCD Calib M scanned: Red		Range = 0 to 1023	0
620-188	CCD Calib M scanned: Green		Range = 0 to 1023	0
620-189	CCD Calib M scanned: Blue		Range = 0 to 1023	0
620-190	CCD Calib C scanned: Red		Range = 0 to 1023	0
620-191	CCD Calib C scanned: Green		Range = 0 to 1023	0
620-192	CCD Calib C scanned: Blue		Range = 0 to 1023	0
620-193	CCD Calib PK scanned: Red		Range = 0 to 1023	0
620-194	CCD Calib PK scanned: Green		Range = 0 to 1023	0
620-195	CCD Calib PK scanned: Blue		Range = 0 to 1023	0
620-196	Switching A6/postcard detect	Switching A6 document / postcard detection	Range = 0 to 2	0
620-197	A4S/8.5in det. border switch 2	A4S/8.5in detection border switching 2	Range = 0 to 6	3
620-198	B5/8W10 detection switch		Range = 0 to 3	0
620-199	Switch 8.5W13/8.5W14 detections		Range = 0 to 3	0

Table 24 CCS NVM ID 620-200 to 620-299

NVM ID	NVM Name	NVM Description	Settings	Default
620-200	Select special-doc-detect table	Select special-document-detection table	Range = 0 to 2	0
620-201	Switch docu size detect tables	Switch document size detection tables	Range = 1 to 5	2
620-202	Switch A3/11W17 detections		Range = 0 to 3	0
620-203	Switch A4/8.5W11 detections		Range = 0 to 3	0
620-204	Document size detection.		Range = 0 to 1	0
620-205	GCO/TFX sizes switching		Range = 0 to 1	1
620-206	B4/8-kai FS threshold setting		Range = 0 to 6	3
620-207	8-kai/11W17SEF FS threshold	8-kai/11W17SEF FS threshold setting	Range = 0 to 6	3
620-208	Switch B6/5W7 detections		Range = 0 to 2	0
620-209	Lamp check NG counts		Range = 0 to 65535	0
620-210	Data taken at lamp check NG.		Range = 0 to 1023	0
620-211	AOC flow endings with error	the number of AOC flow endings with error	Range = 0 to 255	0
620-212	BW Copy BGR-AE adjustment level		Range = 0 to 4095	0
620-213	Color copy BGR-AE adjust level	Color copy BGR-AE adjustment level	Range = 0 to 4095	0
620-214	TP_BW_Copy BGR-AE-Level Speed	BW Copy BGR-AE adjustment - speed-prioritized	Range = 0 to 4095	0
620-215	TX_CL_Copy BGR-AE-Level Speed	Color copy BGR-AE adjustment - speed-prioritized AE (Text)	Range = 0 to 4095	0
620-216	TP_BW_Contone BGR-AE-Level Speed	BW contone scan BGR-AE adjustment level for speed-prioritized AE (Text photo)	Range = 0 to 4095	0
620-217	TP_CL_Contone BGR-AE-Level Speed	Color contone scan BGR-AE adjustment level for speed-prioritized AE (Text photo)	Range = 0 to 4095	0

Table 24 CCS NVM ID 620-200 to 620-299

NVM ID	NVM Name	NVM Description	Settings	Default
620-218	ABS; FS non-detected area 1	background suppression; FS non-detected area 1	Range = 0 to 65535	255
620-219	ABS; FS non-detected area 2	background suppression; FS non-detected area 2	Range = 0 to 65535	255
620-220	ABS; FS non-detected area 3	background suppression; FS non-detected area 3	Range = 0 to 65535	255
620-221	ABS; FS non-detected area 4	background suppression; FS non-detected area 4	Range = 0 to 65535	255
620-222	ABS; SS fixed position	background suppression; SS fixed position	Range = 0 to 65535	60
620-223	ABS; SS end position (for HAE)	background suppression; SS end position (for HAE)	Range = 0 to 65535	240
620-224	ABS; SS end position (for MAE)	background suppression; SS end position (for MAE)	Range = 0 to 65535	240
620-225	ABS; SS end position (for NAE)	background suppression; SS end position (for NAE)	Range = 0 to 65535	240
620-226	LIM control for BW COPY		Range = 0 to 1	1
620-227	LIM control for color COPY		Range = 0 to 1	1
620-228	BW_Copy Variation Control(1-bit)	LIM control for FAX and binary scan	Range = 0 to 1	1
620-229	LIM control for condone scan		Range = 0 to 1	1
620-230	ABS threshold (HAE)	background suppression threshold (HAE)	Range = 0 to 255	127
620-231	ABS threshold (NAE1)	background suppression threshold (NAE1)	Range = 0 to 255	33
620-232	ABS threshold (NAE2)	background suppression threshold (NAE2)	Range = 0 to 255	204
620-233	ABS threshold (NAE3)	background suppression threshold (NAE3)	Range = 0 to 65535	8
620-234	ABS threshold (NAE4)	background suppression threshold (NAE4)	Range = 0 to 65535	4
620-235	AE control of FS size detection		Range = 0 to 1	0
620-236	Not displayed	-Minimum FS detection size for AE	Range = 0 to 65535	500
620-237	AE param SS mag corr TopLimit 1	AE parameter SS magnification correction upper limit 1	Range = 0 to 4000	4000
620-238	AE param SS mag corr TopLimit 2	AE parameter SS magnification correction upper limit 2	Range = 0 to 4000	4000

Table 24 CCS NVM ID 620-200 to 620-299

NVM ID	NVM Name	NVM Description	Settings	Default
620-239	AE param SS mag corr TopLimit 3	AE parameter SS magnification correction upper limit 3	Range = 0 to 4000	4000
620-240	AE param SS mag corr TopLimit 4	AE parameter SS magnification correction upper limit 4	Range = 0 to 4000	4000
620-241	TX_BW_Fax Offset Lvl AE	FAX binary scan: background suppression Offset level; text mode (normal pencil)	Range = 0 to 8191	0
620-242	TP_BW_Copy_Fax Removal Lvl AE	level for BW COPY FAX and binary scan: Text/photo mode (print photographic paper copy)	Range = 0 to 4095	0
620-243	TP_BW_Copy_Fax Offset Lvl AE	OFFSET level for BW COPY FAX and binary scan: Text/photo mode (print photographic paper copy)	Range = 0 to 4095	273
620-244	TX_BW_Copy_Fax Removal Lvl AE	level for BW COPY FAX and binary scan: text mode (normal pencil)	Range = 0 to 4095	0
620-245	TX_BW_Copy_Fax Offset Lvl AE	OFFSET level for BW COPY FAX and binary scan: text mode (normal pencil)	Range = 0 to 4095	273
620-246	TPL_BW_Copy_Fax Removal Lvl AE	level for BW COPY FAX and binary scan: text/photo mode (pale-color document)	Range = 0 to 4095	0
620-247	TPL_BW_Copy_Fax Offset Lvl AE	OFFSET level for BW COPY FAX and binary scan: text/photo mode (pale-color document)	Range = 0 to 4095	273
620-248	TRP_BW_Copy_Fax Removal Lvl AE	level for BW COPY FAX and binary scan: text mode (tracing paper)	Range = 0 to 4095	0
620-249	TRP_BW_Copy_Fax Offset Lvl AE	OFFSET level for BW COPY FAX and binary scan: text mode (tracing paper)	Range = 0 to 4095	273
620-250	TP_CL_Copy Removal Lvl AE	level for Color COPY: text/photo mode (print photographic paper copy inkjet highlighter)	Range = 0 to 4095	0
620-251	TP_CL_Copy Offset Lvl AE	OFFSET level for Color COPY: text/photo mode (print photographic paper copy inkjet highlighter)	Range = 0 to 4095	0
620-252	TX_CL_Copy Removal Lvl AE	level for Color COPY: text (normal)	Range = 0 to 4095	0

Table 24 CCS NVM ID 620-200 to 620-299

NVM ID	NVM Name	NVM Description	Settings	Default
620-253	TX_CL_Copy Offset Lvl AE	OFFSET level for Color COPY: text (normal)	Range = 0 to 4095	0
620-254	TP_BW_Contone Removal Lvl AE	level for BW Contone Scan (text photo)	Range = 0 to 4095	819
620-255	TP_BW_Contone Offset Lvl AE	OFFSET level for BW Contone Scan: (text photo)	Range = 0 to 4095	0
620-256	notTP_BW_Contone Removal Lvl AE	level for BW Contone Scan (other than text photo)	Range = 0 to 4095	819
620-257	notTP_BW_Contone Offset Lvl AE	OFFSET level for BW Contone Scan: (other than text photo)	Range = 0 to 4095	0
620-258	TP_CL_Contone Removal Lvl AE	level for Color Contone Scan (text photo)	Range = 0 to 4095	0
620-259	TP_CL_Contone Offset Lvl AE	OFFSET level for Color Contone Scan: (text photo)	Range = 0 to 4095	0
620-260	notTP_CL_Contone Removal Lvl AE	level for Color Contone Scan (other than text photo)	Range = 0 to 4095	0
620-261	notTP_CL_Contone Offset Lvl AE	OFFSET level for Color Contone Scan (other than text photo)	Range = 0 to 4095	0
620-262	2F-AE LowLimit Multiplied Value	Two-face AE control parameter: lower limit of multiplier coefficient	Range = 0 to 255	0
620-263	2F-AE TopLimit Multiplied Value	Two-face AE control parameter: upper limit of multiplier coefficient	Range = 0 to 255	255
620-264	Offset for 2F AE Control	Two-face AE control parameter: comparison margin OFST	Range = 0 to 255	8
620-265	Threshold for 2F AE Control	Two-face AE control parameter: background level threshold LEVEL_N	Range = 0 to 255	16
620-266	Mode Control of 2F AE	Two-face AE control parameter: forced selection	Range = 0 to 3	0
620-267	Two color copy control		Range = 0 to 1	0
620-268	Tracing paper mode setting		Range = 0 to 1	0
620-269	Def. ColorBal adj Y: low den.	Default color balance adjustment level Y: low density	Range = 0 to 8	4
620-270	Def. ColorBal adj Y: med den.	Default color balance adjustment level Y: medium density	Range = 0 to 8	4
620-271	Def. ColorBal adj Y: hi den.	Default color balance adjustment level Y: high density	Range = 0 to 8	4

Table 24 CCS NVM ID 620-200 to 620-299

NVM ID	NVM Name	NVM Description	Settings	Default
620-272	Def. ColorBal adj M: low den.	Default color balance adjustment level M: low density	Range = 0 to 8	4
620-273	Def. ColorBal adj M: med den.	Default color balance adjustment level M: medium density	Range = 0 to 8	4
620-274	Def. ColorBal adj M: hi den.	Default color balance adjustment level M: high density	Range = 0 to 8	4
620-275	Def. ColorBal adj C: low den.	Default color balance adjustment level C: low density	Range = 0 to 8	4
620-276	Def. ColorBal adj C: med den.	Default color balance adjustment level C: medium density	Range = 0 to 8	4
620-277	Def. ColorBal adj C: hi den.	Default color balance adjustment level C: high density	Range = 0 to 8	4
620-278	Def. ColorBal adj K: low den	Default color balance adjustment level K: low density	Range = 0 to 8	4
620-279	Def. ColorBal adj K: med den	Default color balance adjustment level K: medium density	Range = 0 to 8	4
620-280	Def. ColorBal adj K: hi den	Default color balance adjustment level K: high density	Range = 0 to 8	4
620-281	FS mag corr (PLATEN/BELT DADF)	FS magnification correction (scanned on PLATEN/BELT DADF)	Range = 0 to 100	50
620-282	FS mag corr (CVT)	FS magnification correction (scanned on CVT)	Range = 0 to 100	50
620-283	IPS Through Bypass setting 1(A)		Range = 0 to 65535	0
620-284	IPS through (bypass) setting 2		Range = 0 to 65535	0
620-285	BW COPY: text; normal dens adj	BW COPY: text; normal density adjustment	Range = 0 to 256	128
620-286	BW COPY: text; Darker3 dens adj	BW COPY: text; Darker 3 density adjustment	Range = 0 to 256	128
620-287	Scan/FAX: text; normal dens adj	Scan/FAX: text; normal density adjustment	Range = 0 to 256	128
620-288	Scan/FAX: text; Darker3 dens adj	Scan/FAX: text; Darker 3 density adjustment	Range = 0 to 256	128
620-289	PLTN RAE SS Not Detect Area	Speed prioritized background suppression; SS non-detection area for Platen M/C	Range = 0 to 65535	0
620-290	DADF-P-Job RAE SSNotDetect Area	Speed prioritized background suppression; SS non-detection area for platen job on DADH M/C	Range = 0 to 65535	0

Table 24 CCS NVM ID 620-200 to 620-299

NVM ID	NVM Name	NVM Description	Settings	Default
620-291	DADF-D-Job RAE SSNotDetect Area	Speed prioritized background suppression; SS non-detection area for DADH job on DADH M/C	Range = 0 to 65535	0
620-292	Hue angle B start		Range = 0 to 360	270
620-293	Hue angle B end		Range = 0 to 360	320
620-294	Hue angle G start		Range = 0 to 360	110
620-295	Hue angle G end		Range = 0 to 360	200
620-296	Hue angle R start		Range = 0 to 360	350
620-297	Hue angle R end		Range = 0 to 360	60
620-298	Hue angle Y start		Range = 0 to 360	60
620-299	Hue angle Y end		Range = 0 to 360	120

Table 25 CCS NVM ID 620-300 to 620-399

NVM ID	NVM Name	NVM Description	Settings	Default
620-300	Hue angle M start		Range = 0 to 360	320
620-301	Hue angle M end		Range = 0 to 360	360
620-302	Hue angle C start		Range = 0 to 360	190
620-303	Hue angle C end		Range = 0 to 360	280
620-304	IISS-DADF communication Fail		Range = 0 to 65535	0
620-305	Not displayed	IISS-DADH communication Fail	Range = 0 to 65535	0
620-306	IISS-Controller comm Fai	IISS-Controller communication Fail	Range = 0 to 65535	0
620-307	Not displayed	IISS-Controller communication Fail	Range = 0 to 65535	0
620-308	DADF EEPROM Fail		Range = 0 to 65535	0
620-309	Not displayed	DADH EEPROM Fail	Range = 0 to 65535	0
620-310	IPS Fan Fail		Range = 0 to 65535	0
620-311	Not displayed	IPS Fan Fail	Range = 0 to 65535	0
620-312	CRG Position Fail		Range = 0 to 65535	0
620-313	Not displayed	CRG Position Fail	Range = 0 to 65535	0
620-314	IISS LOGIC Fail		Range = 0 to 65535	0
620-315	Not displayed	IISS LOGIC Fail	Range = 0 to 65535	0
620-316	Lamp Illumination Fail		Range = 0 to 65535	0
620-317	Not displayed	Lamp Illumination Fail	Range = 0 to 65535	0
620-318	CRG Over Run Fail		Range = 0 to 65535	0

Table 25 CCS NVM ID 620-300 to 620-399

NVM ID	NVM Name	NVM Description	Settings	Default
620-319	Not displayed	CRG Over Run Fail	Range = 0 to 65535	0
620-320	Lamp Fan Fail		Range = 0 to 65535	0
620-321	Not displayed	Lamp Fan Fail	Range = 0 to 65535	0
620-322	CCD Fan Fail		Range = 0 to 65535	0
620-323	Not displayed	CCD Fan Fail	Range = 0 to 65535	0
620-324	AGC Fail		Range = 0 to 65535	0
620-325	Not displayed	AGC Fail	Range = 0 to 65535	0
620-326	AOC Fail		Range = 0 to 65535	0
620-327	Not displayed	AOC Fail	Range = 0 to 65535	0
620-328	IPS PWBA Fail		Range = 0 to 65535	0
620-329	Not displayed	IPS PWBA Fail	Range = 0 to 65535	0
620-330	IISS-EXT communication Fail		Range = 0 to 65535	0
620-331	Not displayed	IISS-EXT communication Fail	Range = 0 to 65535	0
620-332	Extension EEPROM Fail		Range = 0 to 65535	0
620-333	Not displayed	Extension EEPROM Fail	Range = 0 to 65535	0
620-334	IPS-EXT Connection Fail		Range = 0 to 65535	0
620-335	Not displayed	IPS-EXT Connection Fail	Range = 0 to 65535	0
620-336	IPS-YATA Connection Fail		Range = 0 to 65535	0
620-337	Not displayed	IPS-YATA Connection Fail	Range = 0 to 65535	0
620-338	EXT-YATA Connection Fail		Range = 0 to 65535	0
620-339	Not displayed	EXT-YATA Connection Fail	Range = 0 to 65535	0
620-340	YATA PWBA Fail		Range = 0 to 65535	0
620-341	Not displayed	YATA PWBA Fail	Range = 0 to 65535	0
620-342	IPS PWBA Memory Fail		Range = 0 to 65535	0
620-343	Not displayed	IPS PWBA Memory Fail	Range = 0 to 65535	0
620-344	IIT Hot Line Fail		Range = 0 to 65535	0
620-345	Not displayed	IIT Hot Line Fail	Range = 0 to 65535	0
620-346	Scan Count replace life (upper)	Scan Count replacement life (upper)	Range = 0 to 65535	91
620-347	Scan Count replace life (lower)	Scan Count replacement life (lower)	Range = 0 to 65535	36224
620-348	Lamp-On time replace life (max)	Lamp-On time Count replacement life (upper)	Range = 0 to 65535	109
620-349	Lamp-On time replace life (min)	Lamp-On time Count replacement life (lower)	Range = 0 to 65535	56576

Table 25 CCS NVM ID 620-300 to 620-399

NVM ID	NVM Name	NVM Description	Settings	Default
620-350	Lamp-On Count replace life (max)	Lamp-On Count Replacement life (upper)	Range = 0 to 65535	91
620-351	Lamp-On Count replace life (min)	Lamp-On Count Replacement life (lower)	Range = 0 to 65535	36224
620-352	Fax doc Size detect DADF	Fax Document Size Detection for DADH	Range = 0 to 1	0
620-353	JAM bypass		Range = 0 to 1	0
620-354	8.5 W11 LEF threshold		Range = 1993 to 2193	2093
620-355	B5SEF / 8 W10 SEF switching		Range = 0 to 1	0
620-356	11x15 SEF/8-kai switch (AP Mkt)	11 W15 SEF / 8-kai switching in AP market	Range = 0 to 1	0
620-357	FS MAX value		Range = 1297 to 3070	2970
620-358	FS MIN value		Range = 1297 to 3070	2970
620-359	SS MAX value		Range = 1297 to 4418	2100
620-360	SS MIN value		Range = 1297 to 4418	2100
620-361	Document Size		Range = 3 to 20	8
620-362	Specify document feed direction		Range = 0 to 1	0
620-363	DADF Doc Size Detection Table	Select DADH document size detection table custom registration	Range = 0 to 1	0
620-364	S Size Side2 Lead Regi Adjust	S-size document Side2 Lead Regi correction value	Range = 217 to 283	250
620-365	M Size Side2 Lead Regi Adjust	M-size document Side2 Lead Regi correction value	Range = 217 to 283	250
620-366	L Size Side2 Lead Regi Adjust	L-size document Side2 Lead Regi correction value	Range = 217 to 283	250
620-367	Size Mismatch Set(Simp)	Size mismatch Jam detection setting (applicable to only Simplex Mode)	Range = 1 to 2	1
620-368	Alternate Size switching 1		Range = 1 to 2	1
620-369	Alternate Size switching 2		Range = 1 to 2	1
620-370	Alternate Size switching 3		Range = 0 to 2	0

Table 25 CCS NVM ID 620-300 to 620-399

NVM ID	NVM Name	NVM Description	Settings	Default
620-371	Alternate Size switching 4		Range = 0 to 2	0
620-372	Alternate Size switching 5		Range = 0 to 2	0
620-373	Alternate Size switching 6		Range = 0 to 3	0
620-374	Alternate Size switching 7		Range = 0 to 3	0
620-375	Alternate Size switching 8		Range = 0 to 4	0
620-376	Alternate Size switching 9		Range = 0 to 2	0
620-377	Alternate Size switching 10		Range = 0 to 2	0
620-378	Alternate Size switching 11		Range = 0 to 3	0
620-379	Size-Mix Mode Assumed Size	Size-Mix Mode temporary size direction	Range = 0 to 1	1
620-380	Fax job Mix Size Standard mode		Range = 0 to 1	0
620-381	DADF DPM selection		Range = 0 to 65535	80
620-382	Magnification correction control		Range = 0 to 1	0
620-383	Color BW judgment level		Range = 0 to 4	2
620-384	textmode Photo/Text RecogLvl	YATAGRS text mode Photo and Text Recognition level	Range = 0 to 4	2
620-385	BW copy (text photo) AE adj lvl	BW copy (text photo) AE adjustment level	Range = 0 to 4095	0
620-386	CL copy (text photo) AE adj lvl	Color copy (text photo) AE adjustment level	Range = 0 to 4095	0
620-387	BW Copy text AE adjustment level	BW Copy (text) AE adjustment level	Range = 0 to 4095	0
620-388	CL Copy (text) AE adj lvl	Color Copy (text) AE adjustment level	Range = 0 to 4095	0
620-389	BW CopyFor B AE adjust level	BW Copy for B AE adjustment level	Range = 0 to 4095	0
620-390	BW Copy G and R AE adj lvl	BW Copy for G and R AE adjustment level	Range = 0 to 4095	0
620-391	CL Copy B AE adj lvl	Color Copy for B AE adjustment level	Range = 0 to 4095	0
620-392	CL Copy G and R AE adj lvl	Color Copy for G and R AE adjustment level	Range = 0 to 4095	0

Table 25 CCS NVM ID 620-300 to 620-399

NVM ID	NVM Name	NVM Description	Settings	Default
620-393	BW Copy (text) B AE adj lvl	BW Copy (text) for B AE adjustment level	Range = 0 to 4095	0
620-394	BW Copy (text) G & R AE adj lvl	BW Copy (text) for G and R AE adjustment level	Range = 0 to 4095	0
620-395	CL Copy (text) B AE adj lvl	Color Copy (text) for B AE adjustment level	Range = 0 to 4095	0
620-396	CL Copy (text) G & R AE adj lvl	Color Copy (text) for G and R AE adjustment level	Range = 0 to 4095	0
620-397	EXT. Tail Reg. adj (55.0 mm/sec)	EXT. Tail Reg. adjustment (55.0 mm/sec)	Range = 0 to 244	122
620-398	EXT. Tail Reg. adj (73.3 mm/sec)	EXT. Tail Reg. adjustment (73.3 mm/sec)	Range = 0 to 244	122
620-399	EXT. Tail Reg. adj (82.5 mm/sec)	EXT. Tail Reg. adjustment (82.5 mm/sec)	Range = 0 to 244	122

Table 26 CCS NVM ID 620-400 to 620-499

NVM ID	NVM Name	NVM Description	Settings	Default
620-400	EXT. Tail Reg. adj (110.0 mm/sec)	EXT. Tail Reg. adjustment (110.0 mm/sec)	Range = 0 to 244	122
620-401	EXT. Tail Reg. adj (146.7 mm/sec)	EXT. Tail Reg. adjustment (146.7 mm/sec)	Range = 0 to 244	122
620-402	EXT. Tail Reg. adj (165.0 mm/sec)	EXT. Tail Reg. adjustment (165.0 mm/sec)	Range = 0 to 244	122
620-403	EXT. Tail Reg. adj (293.3 mm/sec)	EXT. Tail Reg. adjustment (293.3 mm/sec)	Range = 0 to 244	122
620-404	EXT. Tail Reg. adj (220 mm/sec)	EXT. Tail Reg. adjustment (220 mm/sec)	Range = 0 to 244	122
620-405	EXT. Tail Reg. adj (330 mm/sec)	EXT. Tail Reg. adjustment (330 mm/sec)	Range = 0 to 244	122
620-406	EXT. Tail Reg. adj (440 mm/sec)	EXT. Tail Reg. adjustment (440 mm/sec)	Range = 0 to 244	122
620-407	EXT. LE. adj (55.0 mm/sec)	EXT. Lead Edge. adjustment (55.0 mm/sec)	Range = 0 to 244	122
620-408	EXT. LE. adj (73.3 mm/sec)	EXT. Lead Edge. adjustment (73.3 mm/sec)	Range = 0 to 244	122
620-409	EXT. LE. adj (82.5 mm/sec)	EXT. Lead Edge. adjustment (82.5 mm/sec)	Range = 0 to 244	122
620-410	EXT. LE. adj (110.0 mm/sec)	EXT. Lead Edge. adjustment (110.0 mm/sec)	Range = 0 to 244	122
620-411	EXT. LE. adj (146.7 mm/sec)	EXT. Lead Edge. adjustment (146.7 mm/sec)	Range = 0 to 244	122
620-412	EXT. LE. adj (165.0 mm/sec)	EXT. Lead Edge. adjustment (165.0 mm/sec)	Range = 0 to 244	122

Table 26 CCS NVM ID 620-400 to 620-499

NVM ID	NVM Name	NVM Description	Settings	Default
620-413	EXT. LE. adj (293.3 mm/sec)	EXT. Lead Edge. adjustment (293.3 mm/sec)	Range = 0 to 244	122
620-414	EXT. LE. adj (220 mm/sec)	EXT. Lead Edge. adjustment (220 mm/sec)	Range = 0 to 244	122
620-415	EXT. LE. adj (330 mm/sec)	EXT. Lead Edge. adjustment (330 mm/sec)	Range = 0 to 244	122
620-416	EXT. LE. adj (440 mm/sec)	EXT. Lead Edge. adjustment (440 mm/sec)	Range = 0 to 244	122
620-417	CVT FS Offset 1p Duplex Side2-1		Range = 0 to 240	120
620-418	CVT FS Offset 1p Duplex Side2-2		Range = 0 to 240	120
620-419	CVT FS Offset 1p Duplex Side2-3		Range = 0 to 240	120
620-420	CVT FS Offset 1p Duplex Side2-4		Range = 0 to 240	120
620-421	CVT FS Offset 1p Duplex Side2-5		Range = 0 to 240	120
620-422	CVT FS Offset 1p Duplex Side2-6		Range = 0 to 240	120
620-423	CVT FS Offset 1p Duplex Side2-7		Range = 0 to 240	120
620-424	CVT FS Offset 1p Duplex Side2-8		Range = 0 to 240	120
620-425	CVT FS Offset 1p Duplex Side2-9		Range = 0 to 240	120
620-426	1p Duplex Center Regi position		Range = 0 to 7196	3598
620-427	CIS black level Avg # lines	CIS black level Average number of lines	Range = 0 to 3	3
620-428	Target black level auto adjust	Target for black level auto adjust	Range = 0 to 255	16
620-429	Target white level auto adjust	Target for white level auto adjust	Range = 0 to 1023	820
620-430	Digital Offset Level		Range = 0 to 1023	512
620-431	Black Level Correction Value		Range = 0 to 255	128
620-432	White Level Correction Value		Range = 0 to 255	255
620-433	DIPS white level; Avg # lines	DIPS white level; the average number of lines	Range = 0 to 4	4
620-434	white stability adj start point	white stability adjustment start point	Range = 0 to 4095	10

Table 26 CCS NVM ID 620-400 to 620-499

NVM ID	NVM Name	NVM Description	Settings	Default
620-435	white stability adj Avg area	white stability adjustment average area	Range = 0 to 255	217
620-436	white stability adj Ref value	white stability adjustment Reference value	Range = 0 to 1023	962
620-437	W-Ref density correction factor		Range = 100 to 255	158
620-438	Fine adj hilite WhiteStability	Fine adjustment factor for highlight at white stability adjustment	Range = 80 to 120	100
620-439	W-Ref den. corr factor set value	W-Ref density correction factor set value	Range = 0 to 255	255
620-440	EXT. Lead Reg. adj (460 mm/sec)	EXT. Lead Reg. adjustment (460 mm/sec)	Range = 0 to 244	122
620-441	EXT. Tail Edge. adj (460 mm/sec)	EXT. Tail Edge. adjustment (460 mm/sec)	Range = 0 to 244	122
620-442	Switching main / sub		Range = 0 to 1	1
620-443	Ship Garbage detection Thresh	Shading correction dust detection threshold at shipment	Range = 0 to 5000	500
620-444	EXT Fail bypass		Range = 0 to 1	0
620-445	Daimajin Fail bypass		Range = 0 to 1	0
620-446	Data on WhiteStability adj fail	Data obtained at white stability adjustment failure	Range = 0 to 1023	1023
620-447	Pre ASIC Through setting 1		Range = 0 to 8191	448
620-448	BW-PG density		Range = 0 to 255	128
620-449	FS non-detection area 1		Range = 0 to 65535	255
620-450	FS non-detection area 3		Range = 0 to 65535	255
620-451	SS fixed position		Range = 0 to 65535	60
620-452	LIM control for BW COPY		Range = 0 to 1	1
620-453	LIM control FAX and binary scan	LIM control for FAX and binary scan	Range = 0 to 1	1
620-454	LIM control for contone scan		Range = 0 to 1	1
620-455	AE FS size detection control		Range = 0 to 1	0
620-456	Not displayed	-Minimum FS detection size for AE	Range = 0 to 65535	500
620-457	TopLimit SS mag corr AE param1	Upper Limit of SS Magnification correction AE Parameter1	Range = 0 to 4000	4000

Table 26 CCS NVM ID 620-400 to 620-499

NVM ID	NVM Name	NVM Description	Settings	Default
620-458	ship Thresh of Garbage Detect	Shading correction dust detection threshold in market	Range = 0 to 5000	2000
620-459	Adjusting all Lead Regi at once		Range = 0 to 244	122
620-460	Adjusting all Taile Edge at once		Range = 0 to 244	122
620-461	Adjusting all FS offset at once		Range = 0 to 240	120
620-462	TP_BW_Copy_Fax Removal lvl AE	level for BW COPY FAX and binary scan: (print photographic paper copy)	Range = 0 to 4095	0
620-463	TP_BW_Copy_Fax Offset lvl AE	OFFSET level for BW COPY FAX and binary scan: (print photographic paper copy)	Range = 0 to 4095	273
620-464	TX_BW_Copy_Fax Removal lvl AE	level for BW COPY FAX and binary scan: (normal pencil)	Range = 0 to 4095	0
620-465	TX_BW_Copy_Fax Offset lvl AE	OFFSET level for BW COPY FAX and binary scan: (normal pencil)	Range = 0 to 4095	273
620-466	TPL_BW_Copy_Fax Removal lvl AE	level for BW COPY FAX and binary scan: (pale-color document)	Range = 0 to 4095	0
620-467	TPL_BW_Copy_Fax Offset lvl AE	OFFSET level for BW COPY FAX and binary scan: (pale-color document)	Range = 0 to 4095	273
620-468	TRP_BW_Copy_Fax Removal lvl AE	level for BW COPY FAX and binary scan: (tracing paper)	Range = 0 to 4095	0
620-469	TRP_BW_Copy_Fax Offset lvl AE	OFFSET level for BW COPY FAX and binary scan: (tracing paper)	Range = 0 to 4095	273
620-470	level BW Cont. Scan (TP)	level for BW Contone Scan (text photo)	Range = 0 to 4095	0
620-471	Off level BW Cont. Scan (TP)	OFFSET level for BW Contone Scan: (text photo)	Range = 0 to 4095	0
620-472	level BW Cont. Scan (not TP)	level for BW Contone Scan (other than text photo)	Range = 0 to 4095	0
620-473	Off level BW Cont. Scan (not TP)	OFFSET level for BW Contone Scan: (other than text photo)	Range = 0 to 4095	0
620-474	EXT Major Version		Range = 0 to 65535	0
620-475	EXT Minor Version		Range = 0 to 65535	0

Table 26 CCS NVM ID 620-400 to 620-499

NVM ID	NVM Name	NVM Description	Settings	Default
620-476	EXT Revision Version		Range = 0 to 65535	0
620-477	EXT Patch Version		Range = 0 to 65535	0
620-478	Def. ColorBal adj K: low den(2)	Default color balance adjustment level K: low density	Range = 0 to 8	4
620-479	Def. ColorBal adj K: med den(2)	Default color balance adjustment level K: medium density	Range = 0 to 8	4
620-480	Def. ColorBal adj K: hi den(2)	Default color balance adjustment level K: high density	Range = 0 to 8	4
620-481	Photo and Text Recognition level		Range = 0 to 4	2
620-482	FS mag Adjust (at CVT scan)	FS Magnification Adjustment (at CVT scan)	Range = 0 to 100	50
620-483	IPS Through Bypass setting 1(B)		Range = 0 to 511	0
620-484	BW COPY; text; normal den. adj	BW COPY; text; normal density adjustment	Range = 0 to 256	128
620-485	BWCOPYText-Darker 3 Density-Adjust	BW COPY; text; darker 3 density adjustment	Range = 0 to 256	128
620-486	Scan/FAX; text normal den. adj	Scan/FAX; text normal density adjustment	Range = 0 to 256	128
620-487	Scan/FAX; text darker3 den. adj	Scan/FAX; text darker 3 density adjustment	Range = 0 to 256	128
620-488	SS non-detection band		Range = 0 to 65535	0
620-489	SS end position (noise removal)	SS end position (for noise removal)	Range = 0 to 65535	240
620-490	param SS mag corr TopLimit	Parameter SS Magnification correction Upper Limit	Range = 0 to 4000	4000
620-491	dust detect threshold in market	Shading correction dust detection threshold in market	Range = 0 to 5000	500
620-492	ShadingData blackline remove	Selection of Shading data for removing black line	Range = 0 to 1	1
620-493	White Reference ValueAtShipment	White reference value at shipment	Range = 0 to 1000	636
620-494	White-corr multiplier coeff	White-correction multiplier coefficient	Range = 0 to 1	0
620-495	Paper dust detection threshold		Range = 0 to 10000	150
620-496	VALID starting position		Range = 0 to 1000	288

Table 27 CCS NVM ID 620-500 to 620-560

NVM ID	NVM Name	NVM Description	Settings	Default
620-500	Platen Lifetime Images Not displayed	Platen Lifetime Images Total number of images scanned off the platen glass in support of any service since activation	Range = 0 to 16777215	0
620-504	ADF Lifetime 1 Sided Sheets Not displayed	ADF Lifetime 1 Sided Sheets Total number of simplex sheets run through the ADF in support of any service since activation	Range = 0 to 16777215	0
620-505	ADF Lifetime 2 Sided Sheets	ADF Lifetime 2 Sided Sheets Total number of duplex sheets run through the ADF in support of any service since activation	Range = 0 to 16777215	0
620-509	72 x 72 Scanned Lifetime Docs Not displayed	72 x 72 Scanned Lifetime Documents Number of jobs (not impressions) that were scanned where the user selected 72 x 72 resolution	Range = 0 to 16777215	0
620-510	100 x 100 Scanned Lifetime Docs Not displayed	100 x 100 Scanned Lifetime Documents Number of jobs (not impressions) since activation that were scanned where the user selected 100 x 100 resolution	Range = 0 to 16777215	0
620-511	200 x 100 Scanned Lifetime Docs Not displayed	200 x 100 Scanned Lifetime Documents Number of jobs (not impressions) since activation that were scanned where the user selected 200 x 100 resolution	Range = 0 to 16777215	0
620-512	200 x 200 Scanned Lifetime Docs Not displayed	200 x 200 Scanned Lifetime Documents Number of jobs (not impressions) since activation that were scanned where the user selected 200 x 200 resolution	Range = 0 to 16777215	0
620-513	300 x 300 Scanned Lifetime Docs Not displayed	300 x 300 Scanned Lifetime Documents Number of jobs (not impressions) since activation that were scanned where the user selected 300 x 300 resolution	Range = 0 to 16777215	0

Table 27 CCS NVM ID 620-500 to 620-560

NVM ID	NVM Name	NVM Description	Settings	Default
620-514	400 x 400 Scanned Lifetime Docs Not displayed	400 x 400 Scanned Lifetime Documents Number of jobs (not impressions) since activation that were scanned where the user selected 400 x 400 resolution	Range = 0 to 16777215	0
620-515	600 x 600 Scanned Lifetime Docs Not displayed	600 x 600 Scanned Lifetime Documents Number of jobs (not impressions) since activation that were scanned where the user selected 600 x 600 resolution	Range = 0 to 16777215	0
620-516	Black Scanned Lifetime Docs Not displayed	Black Scanned Lifetime Documents Number of jobs (not impressions) since activation that were scanned while Black Mode is selected	Range = 0 to 16777215	0
620-517	Color Scanned Lifetime Docs Not displayed	Color Scanned Lifetime Documents Number of jobs (not impressions) since activation that were scanned while Color Mode is selected	Range = 0 to 16777215	0
620-518	Greyscale Scanned Lifetime Docs Not displayed	Greyscale Scanned Lifetime Documents Number of jobs (not impressions) since activation that were scanned while Greyscale Mode is selected	Range = 0 to 16777215	0
620-519	Text Scanned Lifetime Docs Not displayed	Text Scanned Lifetime Documents Number of jobs (not impressions) since activation that were scanned while Text Mode is selected	Range = 0 to 16777215	0
620-520	Photo Scanned Lifetime Docs Not displayed	Photo Scanned Lifetime Documents Number of jobs (not impressions) since activation that were scanned while Photo Mode is selected	Range = 0 to 16777215	0
620-521	Mixed Scanned Lifetime Docs Not displayed	Mixed Scanned Lifetime Documents Number of jobs (not impressions) since activation that were scanned while Mixed Mode is selected	Range = 0 to 16777215	0
620-522	DADH OpenDuringRunFC	05-300 Fault Counter: DADH open during run	Range = 0 to 255	0
620-523	DADHLHCovIntlockOpenDuringRunFC	05-307 Fault Counter: DADH LH cover interlock opened during run	Range = 0 to 255	0

Table 27 CCS NVM ID 620-500 to 620-560

NVM ID	NVM Name	NVM Description	Settings	Default
620-524	DADH Source Doc Too Short FC	05-310 Fault Counter: DADH Source Doc Too Short For DADH	Range = 0 to 255	0
620-525	LE late to post feed sensor S5 FC	05-330 Fault Counter: LE late to post feed sensor S5 (mis-feed)	Range = 0 to 255	0
620-526	TE late to post feed sensor S5 FC	05-331 Fault Counter: TE late to post feed sensor S5 (multi-feed)	Range = 0 to 255	0
620-527	LE late to TAR sensor S6 FC	05-335 Fault Counter: LE late to TAR sensor S6	Range = 0 to 255	0
620-528	LE late to Reg. Sensor S7 FC	05-340 Fault Counter: LE late to Reg. Sensor S7	Range = 0 to 255	0
620-529	LE late to Exit sensor S8 FC	05-345 Fault Counter: LE late to Exit sensor S8 (FWD)	Range = 0 to 255	0
620-530	TE late to Exit sensor S8 FC	05-346 Fault Counter: TE late to Exit sensor S8 (FWD)	Range = 0 to 255	0
620-531	LE late to CVT sensor S10 FWD FC	05-350 Fault Counter: LE late to CVT sensor S10 (FWD)	Range = 0 to 255	0
620-532	LE late to CVT sensor S10 REV FC	05-352 Fault Counter: LE late to CVT sensor S10 (REV)	Range = 0 to 255	0
620-533	IIT comm faults	IIT comm faults: Used to count a collection of IIT Comms faults that may occur.(e.g. not just linked to one single fault)	Range = 0 to 4294967295	0
620-535	Tot. Scanner Jams since power on	Total number of Scanner Jams since activation.	Range = 0 to 65535	0
620-548	KernelCheckSumErrorFC	Fault Counter 05-250-00: Kernel Checksum Error	Range = 0 to 255	0
620-549	ApplicationCheckSumErrorFC	Fault Counter 05-251-00: Application checksum error	Range = 0 to 255	0
620-550	StepperControllerCommsErrorFC	Fault Counter 05-252-00: Stepper Controller Comms Error	Range = 0 to 255	0
620-551	IIT-DADHcommsErrorFC	Fault Counter 05-253-00: IIT-DADH Comms Error	Range = 0 to 255	0
620-552	CommsSequenceErrorFC	Fault Counter 05-254-00: Comms Sequence Error	Range = 0 to 255	0
620-553	DADHhotlineErrorFC	Fault Counter 05-259-00: DADH Hotline Error	Range = 0 to 255	0

Table 27 CCS NVM ID 620-500 to 620-560

NVM ID	NVM Name	NVM Description	Settings	Default
620-554	DADHnotInStandbyFC	Fault Counter 05-260-00: DADH not in standby	Range = 0 to 255	0
620-556	Num of jobs scanned at 150 x 150	150 x 150 Scanned Lifetime DocumentsNumber of jobs (not impressions) since activation that were scanned where the user selected 150 x 150 resolution	Range = 0 to 4294967295	0

Table 28 CCS NVM ID 621-xxx

NVM ID	NVM Name	NVM Description	Settings	Default
621-001	NUP Layout Pattern		Range = 0 to 1	0
621-002	Rotation enabled for RE	Determines whether rotation is enabled for reduction/ enlargement. 0 = False, 1 = True	Range = 0 to 1	1
621-003	Rotation enabled for APS	Determines whether rotation is enabled for APS. 0 = False, 1 = True	Range = 0 to 1	1
621-004	Signature Layout Changeable		Range = 0 to 1	0
621-005	Use New Messaging		Range = 0 to 1	1
621-006	Rotation Debug		Range = 0 to 1	1
621-007	Not displayed	Number of Multiple Images	Range = 0 to 16777215	0
621-008	Not displayed	Number of Rotated Images	Range = 0 to 16777215	0
621-009	Previous Market Region	Defines previous market region 0 = USCO, 1 = XCL, 2 = FX, 3 = FXAPO, 4 = ACO, 5 = RX	Range = 0 to 5	0
621-010	Lakes Legacy Scan		Range = 0 to 1	1

Table 29 CCS NVM ID 625-xxx

NVM ID	NVM Name	NVM Description	Settings	Default
625-001		NextScanJobID	Range = 1 to 199	1

Table 29 CCS NVM ID 625-xxx

NVM ID	NVM Name	NVM Description	Settings	Default
625-002	Platen Scanned Lifetime Images	Platen Scanned Lifetime Images Number of images that have been scanned off the platen glass that were not for Copy or Embedded Fax jobs.	Range = 0 to 16777215	0
625-003	ADF Scanned Lifetime Images	ADF Scanned Lifetime Images Number of images that have been scanned from the ADF that were not for Copy or Embedded Fax jobs.	Range = 0 to 16777215	0

Table 30 CCS NVM ID 633-xxx

NVM ID	NVM Name	NVM Description	Settings	Default
633-001	spuiNeedsToInitNvm	spuiNeedsToInitNvm	Range = 0 to 1	1

Table 31 CCS NVM ID 641-xxx

NVM ID	NVM Name	NVM Description	Settings	Default
641-001	Internal Image-PrintJobPriority	internal image print job priority	Range = 1 to 65535	1
641-002	NextTestPattern-JobID	Value of next test pattern job's id.	Range = 1 to 999	1

Table 32 CCS NVM ID 648-xxx

NVM ID	NVM Name	NVM Description	Settings	Default
648-001	rs422 Configured	Determines whether RS422 is configured. 0=False, 1=True	Range = 0 to 1	0
648-002	accessory Card Configured	Determines whether accessory card is configured. 0=False, 1=True	Range = 0 to 1	1
648-003	foreign interface Configured	Determines whether foreign interface is configured. 0=False, 1=True	Range = 0 to 1	0
648-004	rdt Modem Configured	Determines whether RDT Modem is configured. 0=False, 1=True	Range = 0 to 1	0
648-005	RS422 (EPSV) Config Mismatch	Fault counter for RS422 configuration mismatch.	Range = 0 to 255	0

Table 32 CCS NVM ID 648-xxx

NVM ID	NVM Name	NVM Description	Settings	Default
648-006	Accessory Card Config Mismatch	Fault counter for accessory card configuration mismatch.	Range = 0 to 255	0
648-007	RDT Config Mismatch Fault	Fault counter for RDT configuration mismatch.	Range = 0 to 255	0
648-008	NC Comm Lost Fault	Fault counter for ESS communication lost fault.	Range = 0 to 255	0
648-009	DC Crash Detected Fault	Fault counter for detection of DC crash on power up.	Range = 0 to 255	0
648-010	UI Comm Lost Fault	Fault counter for UI communication lost fault.	Range = 0 to 255	0
648-011	Power Loss Detected Fault	Fault counter for power loss detected fault.	Range = 0 to 255	0
648-012	DC Platform Install Phase	Defines DC platform's current install phase.	Range = 0 to 4	4
648-013	UI Comms failureFC	Fault Counter 03-346-00: UI communication failure.	Range = 0 to 255	0
648-014	NC Comm Dead Fault	Fault Counter 03-332-00: ESS communication is down fault.	Range = 0 to 255	0
648-015	DCPMF.SPMGR.PWS	Defines current state of communication to the PWS.	Range = 0 to 10	0
648-016	Machine Phone Number Setup	Defines whether machine phone number has been set up. 0=False, 1=True	Range = 0 to 1	0
648-017	DC Platform Post Upgrade Phase		Range = 0 to 1	0
648-018	DCPlatformPostUpgradeRetry Cnt	DC Platform Post Upgrade Retry Count	Range = 0 to 255	0
648-019	Power On Initiated	Power On Initiated Total number of times that the machine was po/po-ed	Range = 0 to 16777215	0
648-020	Not displayed	PowerOn ImpressionsNVM allocated to maintain this Log	Range = 0 to 0	0
648-021	Controller comm faults	Controller comm faults: Used to count a collection of Controller Comms faults that may occur.(e.g. not just linked to one single fault)	Range = 0 to 4294967295	0
648-022	UI comm faults	UI comm faults: Used to count a collection of UI Comms faults that may occur.(e.g. not just linked to one single fault)	Range = 0 to 4294967295	0

Table 33 CCS NVM ID 649-xxx

NVM ID	NVM Name	NVM Description	Settings	Default
649-001	LargePaperCount	Determines whether double count is enabled 0=False, 1=True	Range = 0 to 1	0
649-002	CancelJobTimer-Value	This specifies the amount of time FI will wait (seconds) before deleting a job when authentication has been removed.	Range = 0 to 900	60
649-003	PreCountDuration		Range = 0 to 200	100
649-004	CountDuration		Range = 0 to 200	100
649-005	PostCountDuration		Range = 0 to 200	100
649-006	ExitDuration		Range = 0 to 200	100
649-007	EnableOnInternalCredits		Range = 0 to 1	0
649-008	DeviceType		Range = 0 to 4	0
649-009	PremiumSelect		Range = 0 to 5	0
649-010	CopyRestricted		Range = 0 to 1	1
649-011	PrintRestricted		Range = 0 to 1	0
649-012	s2fRestricted		Range = 0 to 1	0
649-013	EFaxSendRestricted		Range = 0 to 1	0
649-014	EFaxReceiveRestricted		Range = 0 to 1	0

Table 34 CCS NVM ID 652-xxx

NVM ID	NVM Name	NVM Description	Settings	Default
652-001	User Accounts	User Accounts	Range = 0 to 65535	2001
652-002	General Accounts	General Accounts	Range = 0 to 65535	501
652-003	Not displayed	AuditronAccounts	Range = 0 to 0	0
652-004	submitPolicy	submitPolicy	Range = 0 to 2	0
652-005	jobMgmtPolicy	jobMgmtPolicy	Range = 0 to 2	1
652-006	authPolicy	Copy Authentication Policy (none, internal, external, EPSV or JBA)	Range = 0 to 8	0
652-007	acctPolicy	Copy Accounting Policy (none, internal, external, EPSV, or JBA)	Range = 0 to 8	0
652-008	invalidAccountPolicy	invalidAccountPolicy	Range = 0 to 2	1

Table 34 CCS NVM ID 652-xxx

NVM ID	NVM Name	NVM Description	Settings	Default
652-009	nullAccountPolicy	nullAccountPolicy	Range = 0 to 2	1
652-010	PrintAuthenticationPolicy	Print Authentication Policy (none, internal, external, EPSV or JBA)	Range = 0 to 8	0
652-011	PrintAccountingPolicy	Print Accounting Policy (none, internal, external, EPSV or JBA)	Range = 0 to 8	0
652-012	InvalidAccountPolicy	InvalidAccountPolicy	Range = 0 to 2	1
652-013	NullAccountPolicy	NullAccountPolicy	Range = 0 to 2	1
652-014	ScanToFileAuthenticationPolicy	Scan to File Authentication Policy (none, internal, external, EPSV or JBA)	Range = 0 to 8	0
652-015	ScanToFileAccountingPolicy	Scan to File Accounting Policy (none, internal, external, EPSV or JBA)	Range = 0 to 8	0
652-016	ScanToFileInvalidPinPolicy	ScanToFileInvalidPinPolicy	Range = 0 to 2	1
652-017	ScanToFileNullPinPolicy	ScanToFileNullPinPolicy	Range = 0 to 2	1
652-018	Auditron - Set Hour	Auditron - Set Hour	Range = 0 to 23	0
652-019	Auditron - Set Minute	Auditron - Set Minute	Range = 0 to 59	0
652-020	Auditron - Set Second	Auditron - Set Second	Range = 0 to 59	0
652-021	Auditron - Set Month	Auditron - Set Month	Range = 0 to 12	1
652-022	Auditron - Set Day	Auditron - Set Day	Range = 0 to 31	1
652-023	Auditron - Set Year	Auditron - Set Year	Range = 70 to 135	70
652-024	Auditron - Wall Clock	Auditron - Wall Clock	Range = 0 to 4294967295	0
652-025	Fax Send Authenticity Policy	Fax Send Authentication Policy (none, internal, external, EPSV or JBA)	Range = 0 to 8	0
652-026	Fax Send Accounting Policy	Fax Send Accounting Policy (none, internal, external, EPSV or JBA)	Range = 0 to 8	0
652-027	Fax Send Invalid Pin Policy	Fax Send Invalid Pin Policy	Range = 0 to 2	1
652-028	Fax Send Null Pin Policy	Fax Send Null Pin Policy	Range = 0 to 2	1

Table 34 CCS NVM ID 652-xxx

NVM ID	NVM Name	NVM Description	Settings	Default
652-029	Fax Receive Authenticity Policy	Fax Receive Authentication Policy (none, internal, external, EPSV or JBA)	Range = 0 to 8	0
652-030	Fax Receive Accounting Policy	Fax Receive Accounting Policy (none, internal, external, EPSV or JBA)	Range = 0 to 8	0
652-031	Fax Receive Invalid Pin Policy	Fax Receive Invalid Pin Policy	Range = 0 to 2	1
652-032	Fax Receive Null Pin Policy	Fax Receive Null Pin Policy	Range = 0 to 2	1
652-033	CopyActivity	CopyActivity	Range = 0 to 4294967295	0
652-034	Not displayed	XSAAccountArray	Range = 0 to 0	0
652-035	Not displayed	CopyActivity	Range = 0 to 0	0
652-036	Not displayed	CopyActivity	Range = 0 to 0	0
652-037	Not displayed	CopyActivity	Range = 0 to 0	0
652-038	HolePunchCount	HolePunchCount	Range = 0 to 4294967295	0
652-039	StapleCount	StapleCount	Range = 0 to 4294967295	0
652-040	CustomerName	CustomerName	Range = 0 to 4294967295	0
652-041	Monolmpression-Count	MonolmpressionCount	Range = 0 to 4294967295	0
652-042	ColourImpressionCount	ColourImpressionCount	Range = 0 to 1	0
652-043	CopyActivityPen	CopyActivityPen	Range = 0 to 4	0
652-044	Not displayed	CopyActivity	Range = 0 to 0	0
652-045	Not displayed	JobIDGenerator	Range = 1 to 999	1
652-046	CopyActivityJobIDGenerator	CopyActivityJobIDGenerator	Range = 2 to 65535	256
652-047	Not displayed	AuditronAccounts	Range = 0 to 1	0
652-048	Not displayed	AuditronAccounts	Range = 1 to 65535	7
652-049	PermService-SOAValues	PermServiceSOAValues	Range = 0 to 255	1
652-050	PermCreateJob	PermCreateJob	Range = 0 to 255	7
652-051	PermCancelJob	PermCancelJob	Range = 0 to 255	23
652-052	PermInterruptJob	PermInterruptJob	Range = 0 to 255	3
652-053	PermPauseJob	PermPauseJob	Range = 0 to 255	3
652-054	PermQueryJob	PermQueryJob	Range = 0 to 255	7
652-055	PermResumeJob	PermResumeJob	Range = 0 to 255	3
652-056	PermSubmitJob	PermSubmitJob	Range = 0 to 255	7

Table 34 CCS NVM ID 652-xxx

NVM ID	NVM Name	NVM Description	Settings	Default
652-057	PermJobLOAValues	PermJobLOAValues	Range = 0 to 255	7
652-058	PermJobSOAValues	PermJobSOAValues	Range = 0 to 255	3
652-059	PermCreateDocument	PermCreateDocument	Range = 0 to 255	7
652-060	PermDeleteDocument	PermDeleteDocument	Range = 0 to 255	18
652-061	PermDocument-LOAValues	PermDocumentLOAValues	Range = 0 to 255	7
652-062	PermDocument-SOAValues	PermDocumentSOAValues	Range = 0 to 255	3
652-063	PermProofJob	PermProofJob	Range = 0 to 255	7
652-064	PermProofDocument	PermProofDocument	Range = 0 to 255	7
652-065	PermPromoteJob	PermPromoteJob	Range = 0 to 255	5
652-066	PermHoldJob	PermHoldJob		3
652-067	PermReleaseJob	PermReleaseJob	Range = 0 to 255	35
652-068	Not displayed	TripleAServicePolicies	Range = 0 to 0	0
652-069	Tiered level 1 copy accounting	Tiered level 1 copy	Range = 0 to 1	0
652-070	Tiered level 1 print	Tiered level 1 print accounting	Range = 0 to 1	0
652-071	JBA display restricted	JBA display restricted	Range = 0 to 1	1
652-072	Not displayed	JBA display restricted	Range = 0 to 0	0
652-073	Not displayed	JBA default value 1	Range = 0 to 0	0
652-074	Not displayed	JBA labels 0	Range = 0 to 0	0
652-075	Not displayed	JBA labels 1	Range = 0 to 0	0
652-076	JBA display fields 0	JBA display fields 0	Range = 0 to 1	1
652-077	JBA display fields 1	JBA display fields 1	Range = 0 to 1	1
652-078	JBA display masks 0	JBA Display masks 0	Range = 0 to 1	0
652-079	JBA display masks 1	JBA Display masks 1	Range = 0 to 1	0
652-080	Copy Feature Account Policy	Copy feature account policy (none, full service XSA, colour Only)	0 = NA 1 = Full service XSA 2 = Colour only Range = 0 to 2	0

Table 34 CCS NVM ID 652-xxx

NVM ID	NVM Name	NVM Description	Settings	Default
652-081	Print Feature Account Policy	Print feature account policy (none, full service XSA, colour Only)	0 = NA 1 = Full service XSA 2 = Colour only Range = 0 to 2	0
652-082	Scan Feature Account Policy	Scan to file feature account policy (none, full service XSA, colour Only)	0 = NA 1 = Full service XSA 2 = Colour only Range = 0 to 2	0
652-083	Fax Rx Feature Account Policy	Fax send feature account policy (none, full service XSA, colour Only)	0 = NA 1 = Full service XSA 2 = Colour only Range = 0 to 2	0
652-084	Fax Tx Feature Account Policy	Fax receive feature account policy (none, full service XSA, colour Only)	0 = NA 1 = Full service XSA 2 = Colour only Range = 0 to 2	0

Table 35 CCS NVM ID 656-xxx

NVM ID	NVM Name	NVM Description	Settings	Default
656-001	Image Disk READ Failure.	Fault Counter	Range = 0 to 255	0
656-002	Image Disk WRITE Failure.	Fault Counter	Range = 0 to 255	0
656-003	Image Disk BAD DATA ERROR.	Fault Counter	Range = 0 to 255	0
656-004	ImageDiskUnableToFormatError.	Fault Counter	Range = 0 to 255	0
656-005	Image Disk NoDiskCapacity-Error	Fault Counter	Range = 0 to 255	0

Table 36 CCS NVM ID 657-xxx

NVM ID	NVM Name	NVM Description	Settings	Default
657-001		Job Log Data-Completed Job Log	Range = 0 to 0	0

Table 37 CCS NVM ID 658-xxx

NVM ID	NVM Name	NVM Description	Settings	Default
658-001	TonerEmptyDspLoc	Toner empty display location	Range = 0 to 3	0
658-002	FdRollLife		Range = 0 to 200	150
658-003	PDRNNotify		Range = 0 to 16	0
658-004	SupplyInfoFlag	0 = UI, 1 = Network, 2 = Both, 3 = Neither	Range = 0 to 3	0
658-005	CruMgrDebug-Print	CRU manager debug print-outs 0 = False, 1 = True	Range = 0 to 1	0
658-006	PDRNNotifyProc	0 = False, 1 = True	Range = 0 to 1	0
658-007	FuserReorderMsgTrig	Reorder message displayed (days before End of Life)	Range = 1 to 25	3
658-008	XeroReorderMsgTrig	Reorder message displayed (days before End of Life)	Range = 1 to 25	3
658-009	FuserReorderDspLoc		Range = 0 to 3	0
658-010	XeroReorderDspLoc		Range = 0 to 3	0
658-011	FuserReplDspLoc		Range = 0 to 3	0
658-012	XeroReplDspLoc		Range = 0 to 3	0
658-013	ColorantReorderMsgTrig XC Market	Reorder Threshold value (days) for Ink (US market region setting)	Stores remaining threshold value to trigger low supplies warning. Range = 0 to 65535	8
658-014	DADHRollReorderMsgTrig XC Market	Reorder Threshold value for DADH Roller (if CRU) (US market region setting)	Stores remaining threshold value to trigger low supplies warning. Range = 0 to 65535	10
658-015	CleanUnitReorderMsgTrigXC-Market	Reorder Threshold value for Cleaning Unit (CU/DMU) (US market region setting)	Stores remaining threshold value to trigger low supplies warning. Range = 0 to 65535	17
658-016	ColorantReorderMsgTrig XE Market	Reorder Threshold value for Ink (European market region setting)	Stores remaining threshold value to trigger low supplies warning. Range = 0 to 65535	5
658-017	DADHRollReorderMsgTrig XE Market	Reorder Threshold value for DADH Roller (if CRU) (European market region setting)	Stores remaining threshold value to trigger low supplies warning. Range = 0 to 65535	6

Table 37 CCS NVM ID 658-xxx

NVM ID	NVM Name	NVM Description	Settings	Default
658-018	CleanUnitReorderMsgTrigXE-Market	Reorder Threshold value for Cleaning Unit (CU/DMU) (European market region setting)	Stores remaining threshold value to trigger low supplies warning. Range = 0 to 65535	13
658-023	DayCounter	Counts the number of days in which a threshold number of impressions have occurred. After {MarkUsageCalcDuration} days, this is reset to 0.	Range = 0 to 255	0
658-024	DayUsage	Stores the number of impressions made every day being counted for up to {MarkUsageCalcDuration} days	Range = 0 to 4294967295	0
658-025	adpvThreshold	Minimum number of impressions to consider the day to be a usage day. If the machine has not made at least n impressions, don't count the day	Range = 0 to 65535	20
658-026	ImpressionSnapshot	Captured at the end of each day, to be used for comparison to total impressions to determine daily usage	Range = 0 to 4294967295	0
658-027	adpv	Average daily volume	Range = 0 to 4294967295	1000
658-028	PagesBlackCRU	Pages per Black Colorant	Range = 0 to 4294967295	5680
658-029	PagesColorCRU	Pages per Color Colorant	Range = 0 to 4294967295	5520
658-030	Last ADPV Calc Date	Last ADPV Calc Date	Range = 0 to 4294967295	0
658-032	ScanFeedDayCounter	Counts the number of days in which a threshold number of DADH feeds have occurred. After {ScanFeedUsageCalcDuration} days, this is reset to 0.	Range = 0 to 255	0
658-033	ScanFeedDayUsage	Stores the number of scan feeds made every day being counted for up to {ScanFeedUsageCalcDuration} days	Range = 0 to 4294967295	0

Table 37 CCS NVM ID 658-xxx

NVM ID	NVM Name	NVM Description	Settings	Default
658-034	adsfvThreshold	Minimum number of DADH feeds to consider the day to be a usage day. If the machine has not made at least n feeds, don't count the day	Range = 0 to 65535	5
658-035	DADFFeedsSnapshot	Captured at the end of each day, to be used for comparison to total DADH feeds to determine daily usage	Range = 0 to 4294967295	0
658-036	adsfv	Average daily scan feed volume	Range = 0 to 4294967295	100
658-037	Last ADSFV Calc Date	Last ADSFV Calc DateDate captured when ADSFV is calculated	Range = 0 to 4294967295	0
658-038	ScanFeedUsageCalcDuration	This determines how often the ADSFV calculation is refreshed	Range = 1 to 255	10
658-039	MarkUsageCalcDuration	This determines how often the ADPV calculation is refreshed	Range = 1 to 255	5
658-040	ScanFeedUsageCalcFrequency	This determines how often ADSFV is calculated. This value should never exceed MarkUsageCalcDuration, but code will check for this condition	Range = 1 to 255	1
658-041	MarkUsageCalcFrequency	This determines how often ADPV is calculated. This value should never exceed ScanFeedUsageCalcDuration, but code will check for this condition	Range = 1 to 255	1
658-042	LowInkMsgTrigPercent	Low Ink threshold value (Percent %) for Ink warning.	Stores threshold value (in percent) to trigger low ink warning. Range = 0 to 255	10
658-043	day1MarkVolume	ADPV Day 1: Number of impressions made in day 1 of the adpv duration (ADPV Day Counter Index = 0)	Range = 0 to 10000	1000
658-044	day2MarkVolume	ADPV Day 2: Number of impressions made in day 2 of the adpv duration (ADPV Day Counter Index = 1)	Range = 0 to 10000	1000

Table 37 CCS NVM ID 658-xxx

NVM ID	NVM Name	NVM Description	Settings	Default
658-045	day3MarkVolume	ADPV Day 3: Number of impressions made in day 3 of the adpv duration (ADPV Day Counter Index = 2)	Range = 0 to 10000	1000
658-046	day4MarkVolume	ADPV Day 4: Number of impressions made in day 4 of the adpv duration (ADPV Day Counter Index = 3)	Range = 0 to 10000	1000
658-047	day5MarkVolume	ADPV Day 5: Number of impressions made in day 5 of the adpv duration (ADPV Day Counter Index = 4)	Range = 0 to 10000	1000
658-048	day6MarkVolume	ADPV Day 6: Number of impressions made in day 6 of the adpv duration (ADPV Day Counter Index = 5)	Range = 0 to 10000	1000
658-049	day7MarkVolume	ADPV Day 7: Number of impressions made in day 7 of the adpv duration (ADPV Day Counter Index = 6)	Range = 0 to 10000	1000
658-050	day8MarkVolume	ADPV Day 8: Number of impressions made in day 8 of the adpv duration (ADPV Day Counter Index = 7)	Range = 0 to 10000	1000
658-051	day9MarkVolume	ADPV Day 9: Number of impressions made in day 9 of the adpv duration (ADPV Day Counter Index = 8)	Range = 0 to 10000	1000
658-052	day10MarkVolume	ADPV Day 10: Number of impressions made in day 10 of the adpv duration (ADPV Day Counter Index = 9)	Range = 0 to 10000	1000
658-053	day1ScanFeedVolume	ADSFV Day 1: Number of impressions made in day 1 of the adsfv duration (ADSFV Day Counter Index 0)	Range = 0 to 10000	100
658-054	day2ScanFeedVolume	ADSFV Day 2: Number of impressions made in day 2 of the adsfv duration (ADSFV Day Counter Index 1)	Range = 0 to 10000	100
658-055	day3ScanFeedVolume	ADSFV Day 3: Number of impressions made in day 3 of the adsfv duration (ADSFV Day Counter Index 2)	Range = 0 to 10000	100

Table 37 CCS NVM ID 658-xxx

NVM ID	NVM Name	NVM Description	Settings	Default
658-056	day4ScanFeedVolume	ADSFV Day 4: Number of impressions made in day 4 of the adsfv duration (ADSFV Day Counter Index 3)	Range = 0 to 10000	100
658-057	day5ScanFeedVolume	ADSFV Day 5: Number of impressions made in day 5 of the adsfv duration (ADSFV Day Counter Index 4)	Range = 0 to 10000	100
658-058	day6ScanFeedVolume	ADSFV Day 6: Number of impressions made in day 6 of the adsfv duration (ADSFV Day Counter Index 5)	Range = 0 to 10000	100
658-059	day7ScanFeedVolume	ADSFV Day 7: Number of impressions made in day 7 of the adsfv duration (ADSFV Day Counter Index 6)	Range = 0 to 10000	100
658-060	day8ScanFeedVolume	ADSFV Day 8: Number of impressions made in day 8 of the adsfv duration (ADSFV Day Counter Index 7)	Range = 0 to 10000	100
658-061	day9ScanFeedVolume	ADSFV Day 9: Number of impressions made in day 9 of the adsfv duration (ADSFV Day Counter Index 8)	Range = 0 to 10000	100
658-062	day10ScanFeedVolume	ADSFV Day 10: Number of impressions made in day 10 of the adsfv duration (ADSFV Day Counter Index 9)	Range = 0 to 10000	100
658-063	Not displayed	Current K Toner Cartridge Total Area Coverage	Range = 0 to 10000	0
658-064	Not displayed	Current C Toner Cartridge Total Area Coverage		
658-065	Not displayed	Current M Toner Cartridge Total Area Coverage		
658-066	Not displayed	Current Y Toner Cartridge Total Area Coverage		
658-067	APPC ink level lower limit	Solid Ink - Average pages per chute - ink level lower limit for tracking algorithm	Range = 0 to 100	20
658-068	APPC Ink level upper limit	Solid Ink - Average pages per chute - ink level upper limit for tracking algorithm	Range = 0 to 100	70
658-069	APPC pages lower limit	Solid Ink - Average pages per chute - pages lower limit for tracking algorithm	Range = 0 to 20000	20

Table 37 CCS NVM ID 658-xxx

NVM ID	NVM Name	NVM Description	Settings	Default
658-070	APPC pages upper limit	Solid Ink - Average pages per chute - pages upper limit for tracking algorithm	Range 0 to 20000	10000
658-071	APPC chute constant	Solid Ink - Average pages per chute - chute constant for tracking algorithm (tenths)	Range 10 to 200	50
658-072	APPC Cyan ink life expectancy	Solid Ink - Average pages per chute - Cyan ink life expectancy	Range = 0 to 4294967295	46400
658-073	APPC Magenta ink life expectancy	Solid Ink - Average pages per chute - Magenta ink life expectancy	Range = 0 to 4294967295	46400
658-074	APPC Yellow ink life expectancy	Solid Ink - Average pages per chute - Yellow ink life expectancy	Range = 0 to 4294967295	46400
658-075	APPC Black ink life expectancy	Solid Ink - Average pages per chute - Black ink life expectancy	Range = 0 to 4294967295	47700
658-076	Hide Cleaning Unit Re-order Msg	Flag to indicate if the user chosen to acknowledge and temporarily suppress the Cleaning Unit Re-order message (displayed at the local UI). Intended to allow user to acknowledge the message and remove (from the local UI) temporarily. Reset when new Cleaning Unit is installed.FALSE => Msg Displayed (Default) TRUE => Msg suppressed	Range 0 to 1	0
658-083	Latch Cleaning Unit Re-order Msg	Latch for the re-order message on the cleaning unit (DMU).	FALSE = Re-order not raised (Default) TRUE = Re-order has been raised Range = 0 to 1	0
658-084	Previous DMU Life Remaining	Previous cleaning unit has % remaining	0 - 100% of life remaining at last power off Range = 0 to 100	100
658-085	New DMU Threshold	% threshold for new cleaning unit detection	0 - 100% of life remaining at last power off Range = 0 to 100	100

Table 38 CCS NVM ID 665-xxx

NVM ID	NVM Name	NVM Description	Settings	Default
665-001	Out Of Resource Policy	Specify what JBA should do when it runs out of space.	Range = 0 to 1	0
665-002	Comm Failed Policy	Specify what JBA should do if it can't communicate with the ESS.	Range = 0 to 2	0
665-003	EAS Validation Enable	Specify if JBA should Authorize logins and submit jobs with the ESS.	Range = 0 to 1	1
665-004	Not displayed	JBA Data-JBA Database	Range = 0 to 0	0
665-005	Not displayed	JBA User Data-Default JBA User	Range = 0 to 0	0
665-006	Not displayed	JBA Account Data-Default JBA Account	Range = 0 to 0	0

Table 39 CCS NVM ID 671-xxx

NVM ID	NVM Name	NVM Description	Settings	Default
671-001	EFaxSendJobPriority		Range = 1 to 65535	3
671-002	Not displayed	EmbeddedFaxSendDocumentsDefaults	Range = 0 to 0	0
671-003	Not displayed	EMBFAXSENDTransmitImages	Range = 0 to 16777215	0
671-004	EMBFAX-SENDTransmitImagesDisplayable	EMBFAXSENDTransmitImagesDisplayable	Range = 0 to 1	1
671-005	Not displayed	EMBFaxPlatenScans	Range = 0 to 16777215	0
671-006	Not displayed	EMBFaxDADHSide1Scans	Range = 0 to 16777215	0
671-007	Not displayed	EMBFaxDADHSide2Scans	Range = 0 to 16777215	0
671-008	Not displayed	EmbeddedFaxSendJobDefaults	Range = 0 to 0	0
671-009	Not displayed	EMBFaxStoredPollingImages	Range = 0 to 16777215	0
671-010	Not displayed	EMBFaxAllSendJobs	Range = 0 to 16777215	0
671-011	SendShortJobRecoveryWaitTime		Range = 1 to 255	5

Table 39 CCS NVM ID 671-xxx

NVM ID	NVM Name	NVM Description	Settings	Default
671-012	SendJobRecoverySendRespTimeout	SendJobRecoverySendResponseTimeout	Range = 1 to 255	120
671-013	SendJobRecoveryWaitTime		Range = 1 to 255	120
671-014	SendJobRecoveryImageRespTimeout	SendJobRecoveryImageResponseTimeout	Range = 1 to 255	120
671-015	SendJobRecoveryCompIQUUpdateTimeout	SendJobRecoveryCompletedQUUpdateTimeout	Range = 1 to 255	120
671-016	SendJobRecoveryCreateJobTimeout		Range = 1 to 255	3
671-017	SendLowFaxMemoryWaitTime		Range = 1 to 255	20
671-018	SendJobRecoveryRetryCounter		Range = 1 to 255	3
671-019	Platen Emb Fax Lifetime Images	Platen Embedded Fax Lifetime Images Number of images that have been scanned off the platen glass that were for Embedded Fax jobs.	Range = 0 to 16777215	0
671-020	ADF Embedded Fax Lifetime Images	ADF Embedded Fax Lifetime Images Number of images that have been scanned from the ADF that were for Embedded Fax jobs.	Range = 0 to 16777215	0

Table 40 CCS NVM ID 672-xxx

NVM ID	NVM Name	NVM Description	Settings	Default
672-001	EFaxReceiveJobPriority		Range = 1 to 65535	3
672-002	Not displayed	EFaxReceiveJobDefaults	Range = 0 to 0	0
672-003	Not displayed	EMBFAXRECEIVESheets	Range = 0 to 16777215	0
672-004	EMBFAXRECEIVESheetsDisplayable		Range = 0 to 1	0
672-005	Not displayed	EMBFAXRECEIVEDuplexSheets	Range = 0 to 16777215	0

Table 40 CCS NVM ID 672-xxx

NVM ID	NVM Name	NVM Description	Settings	Default
672-006	EFaxRecPlexSheetsDisplayable	EMBFAXRECEIVEDuplexSheetsDisplayable	Range = 0 to 1	0
672-007	Not displayed	EMBFAXRECEIVE-LargeSheets	Range = 0 to 16777215	0
672-008	EMBFAXRECEIVE-LargeSheetsDisplay	EMBFAXRECEIVE-LargeSheetsDisplayable	Range = 0 to 1	0
672-009	Not displayed	print crash recovery	Range = 0 to 1	1
672-010	Not displayed	EMBFaxReceiveMarkedJobs	Range = 0 to 16777215	0
672-011	Not displayed	EFaxRecieveDocumentDefaults	Range = 0 to 0	0
672-012	Not displayed	EMBFAXRECEIVEMarkedImages	Range = 0 to 16777215	0
672-013	Emb Fax Rec Marked Images Disp	EMBFAXRECEIVEMarkedImagesDisplayable	Range = 0 to 1	1
672-014	NextImageTimeOut		Range = 100 to 1000	300
672-015	Not displayed	EFPrintCompleted Job Log	Range = 0 to 0	0
672-016	EFPrintCompletedJob Log Location	EFPrintCompleted Job Log Location	Range = 0 to 70	0
672-017	EF Card Disturbance Timeout		Range = 1 to 255	12

Table 41 CCS NVM ID 673-xxx

NVM ID	NVM Name	NVM Description	Settings	Default
673-001	Postpone fax install		Range = 0 to 1	0
673-002	EmbeddedFax Basic Previous State		Range = 0 to 2	0
673-003	EmbeddedFaxExtendedPreviousState Not displayed	EmbeddedFaxExtendedPreviousState	Range = 0 to 2	0
673-004	Not displayed	-card installed id	Range = 0 to 0	0
673-005	Basic FAX Not Detected Fault		Range = 0 to 255	0

Table 41 CCS NVM ID 673-xxx

NVM ID	NVM Name	NVM Description	Settings	Default
673-006	Fax Phonebook Download Fault		Range = 0 to 255	0
673-007	Extended FAX Not Detected Fault		Range = 0 to 255	0
673-008	Fax Unexpected Reset Fault		Range = 0 to 255	0
673-009	Fax BasicCardUnrecoverable Fault	Fax BasicCardUnrecoverable Fault	Range = 0 to 255	0
673-010	Fax Sys Low Mem Unrecover Fault	Fax System Low Memory Unrecoverable Fault	Range = 0 to 255	0
673-011	Fax Not Cleared By Reset Fault		Range = 0 to 255	0
673-012	Fax Basic Card Failed Fault		Range = 0 to 255	0
673-013	Fax Extended Card Failed Fault		Range = 0 to 255	0
673-014	Fax NV Device Not Present Fault		Range = 0 to 255	0
673-015	Fax System Low Mem Recover Fault	Fax System Low Memory Recoverable Fault	Range = 0 to 255	0
673-016	Fax Out Of File Memory Fault		Range = 0 to 255	0
673-017	Fax File Integrity Fault		Range = 0 to 255	0
673-018	Fax Network Line 1 Fault		Range = 0 to 255	0
673-019	Fax Network Line 2 Fault		Range = 0 to 255	0
673-020	Fax Port 1 Fault		Range = 0 to 255	0
673-021	Fax Port 2 Fault		Range = 0 to 255	0
673-023	Fax comm faults	Fax comm faults: Used to count a collection of Fax Comms faults that may occur.(e.g. not just linked to one single fault)	Range = 0 to 4294967295	0

Table 42 CCS NVM ID 674-xxx

NVM ID	NVM Name	NVM Description	Settings	Default
674-001	LastXferImageServiceId	Efax recovery last image service ID	Range = 0 to 65535	0
674-002	LastXferImageJobId	Efax recovery last image job ID	Range = 0 to 65535	0
674-003	LastXferImageDocId	Efax recovery last image doc ID	Range = 0 to 65535	0
674-004	LastXferImageImageId	Efax recovery last image image ID	Range = 0 to 65535	0

dC132 Serial Number

Purpose

To display the machine serial number.

Procedure

1. Enter service mode, [GP 1](#).
2. Select the Maintenance tab.
3. Select dC132 Serial Number.
4. The machine serial number or '#####' is displayed.
5. If '#####' is displayed a 03-398-00 fault has occurred and the serial number is corrupt. Perform [Serial Number Restore](#).

Serial Number Restore

1. Locate the machine serial number label, [Figure 1](#).

NOTE: Take great care when entering the serial number. Ensure that you have correctly read the serial number label. If you enter an incorrect number it cannot be changed without performing an NVM reset. This will cause the machine to run at a default 30 pages per minute.

2. Enter the serial number.
3. Select Save.
4. Select Save on the confirmation screen.
5. Select Close to exit the routine.
6. Select Call Closeout to exit service mode.

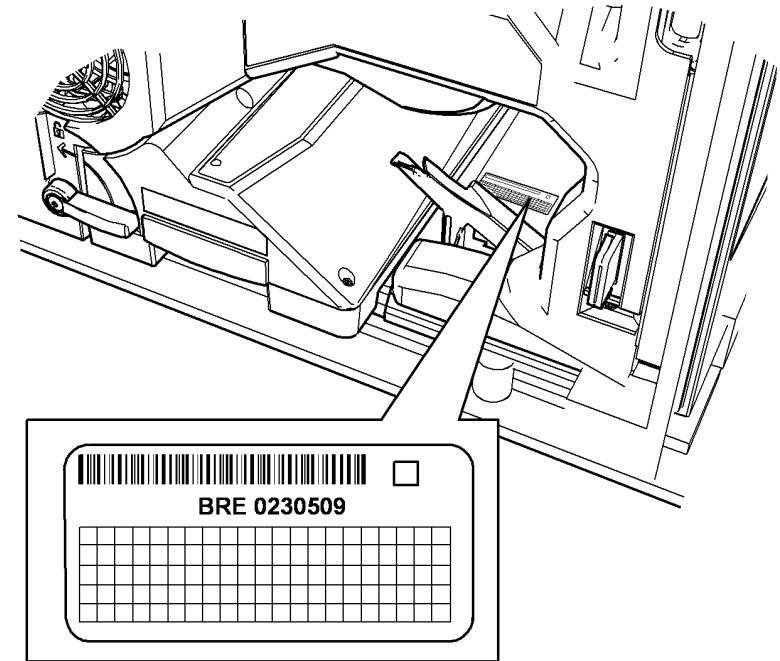

U-1-1410-A

Figure 1 Location of machine serial number label

dC134 Market Region

Purpose

To provide the option to select and set an interminable market region for the machine.

Procedure

1. Enter service mode, [GP 1](#).
2. Select the maintenance tab.
3. Select dC134 Market Region from the scroll list.
4. Select the 0 - US button for operation in North America or Canada.
Select the 5 - Europe button for operation in all other market regions.
5. Select Save.
6. Select Close to exit routine.
7. Select Call Closeout to exit service mode.
8. To apply the change, select Exit and Reboot.

dC135 CRU/HFSI Status

Purpose

To view the counters for customer replacement units and high frequency service items indicating the type, name and percent remaining.

There are two types of CRU's. Some of the CRU's are equipped with CRU Manager (CRUM) chips that are used for the management of data relevant to that particular CRU. Other CRU's do not have CRUMs; the management of these consumables is dependant upon the user to confirm replacement.

ERU's – Engineer Replaceable Units. These are typically replaced by service technician, and do not trigger user warnings as end of life is reached. Of these, some are classified as HFSI's – High Frequency Service Items, meaning that it can be anticipated that these will need to be replaced at some point during the normal life expectancy of the machine.

Procedure

1. Enter service mode, [GP 1](#).
2. Select the Service Info tab.
3. Select dC135 CRU / HFSI.
4. Refer to [Table 1](#) to observe the status of the items.
5. To reset the HFSI File:
 - a. Select the HFSI item.
 - b. Select Reset HFSI.
 - c. Select Reset to confirm.
6. Select Close to exit the routine.
7. Select Call Closeout to exit service mode.

Table 1 CRU / HFSI Details

Type	Name	Mgmt Type	Est Life	Cleaning Frequency	User Prompt to Replace	Gas Gauge	Reset Count	Reorder XC Threshold NVM	Reorder XE Threshold NVM	Reorder Threshold	XC Reorder Default	XE Reorder Default	Low Ink Refill warning	Low Ink Warning Default %
CRU	Magenta Ink stick	Mech Keyed CRU	Variable	N/A	Pages Remain	% Remain	No	658-013	658-016	0 to 20 Days Remain	8 Days	5 Days	658-42	10
	Cyan Ink Stick	Mech Keyed CRU	Variable	N/A	Pages Remain	% Remain	No	658-013	658-016	0 to 20 Days Remain	8 Days	5 Days	658-42	10
	Yellow Ink Stick	Mech Keyed CRU	Variable	N/A	Pages Remain	% Remain	No	658-013	658-016	0 to 20 Days Remain	8 Days	5 Days	658-42	10
	Black Ink Stick	Mech Keyed CRU	Variable	N/A	Pages Remain	% Remain	No	658-013	658-016	0 to 20 Days Remain	8 Days	5 Days	658-42	10
	Cleaning Unit	CRUM	140K	N/A	Pages Remain	% Remain	No	658-015	658-018	0 to 20 Days Remain	17 Days	13 Days	N/A	N/A
	Document Feeder Feed Roll	Customer confirmation	150K	N/A	None	% Remain	Yes	658-014	658-017	None	10 Days	6 Days	N/A	N/A
HFSI	PPI Feed Roll Set	ERU	80K	N/A	None	None	Yes	None	None	None	N/A	N/A	N/A	N/A

Table 1 CRU / HFSI Details

Type	Name	Mgmt Type	Est Life	Cleaning Frequency	User Prompt to Replace	Gas Gauge	Reset Count	Reorder XC Threshold NVM	Reorder XE Threshold NVM	Reorder Threshold	XC Reorder Default	XE Reorder Default	Low Ink Refill warning	Low Ink Warning Default %
	3TM Tray 1 Feed Roll Set	ERU	600K	N/A	None	None	Yes	None	None	None	N/A	N/A	N/A	N/A
	3TM Tray 2 Feed Roll Set	ERU	600K	N/A	None	None	Yes	None	None	None	N/A	N/A	N/A	N/A
	3TM Tray 3 Feed Roll Set	ERU	600K	N/A	None	None	Yes	None	None	None	N/A	N/A	N/A	N/A
	MSI Feed Roll Set	ERU	600K	N/A	None	None	Yes	None	None	None	N/A	N/A	N/A	N/A
	PFP Feed Roll Set	ERU	600K	N/A	None	None	Yes	None	None	None	N/A	N/A	N/A	N/A
	Transfix stripper	ERU	460K	N/A	N/A	N/A	Yes	None	None	None	N/A	N/A	N/A	N/A
	Drum fan shroud	N/A	N/A	500k	N/A	N/A	Yes	None	None	N/A	N/A	N/A	N/A	N/A
	Upper JL baffle	N/A	N/A	400k	N/A	N/A	Yes	None	None	N/A	N/A	N/A	N/A	N/A

dC136 Service Plan

Purpose

To allow the service plan to be changed from metered to sold. An authorization code is required from the Xerox service centre.

Procedure

NOTE: Refer to [GP 34](#) Service Plan for additional information.

1. Enter service mode, [GP 1](#).
2. Select the Maintenance tab.
3. Select dC136 Service Plan.
The service plan information is displayed.
4. Enter the authorization code to change the service plan.

NOTE: The authorization code generator can be down loaded from GSN library 10480.

NOTE: The service plan can be changed from and to any service plan.

5. Select Close to exit routine.
6. Select Call Closeout to exit service mode.
7. To apply the change switch the machine off and switch the machine on again, [GP 14](#).

dC137 Page Pack

Purpose

To enable or disable the page pack function. When enabled the page pack function, a customer typically pays a fixed amount per month, or per page, for supplies and / or service plan.

Procedure

1. Enter service mode, [GP 1](#).
2. Select the Maintenance tab.
3. Select dC137 Page Pack.
The Page Pack screen is displayed.

NOTE: The page pack function is only enabled in XE installations. Depending on the customer's full service maintenance agreement, the page pack function needs to be enabled when a USSG/XCL machine is installed in an XE region.

4. Select Disabled or Enabled.
5. Enter the PagePack passcode, a 4 digit authorization code. The authorization code can be found in the customers machine installation pack.
6. The Save button will appear. Select Cancel or Save.
7. Select Call Closeout to exit service mode.

dC140 Analog Monitor

Purpose

To provide tools to start (activate) and stop (deactivate) monitoring of specific analog components. The nominal range of the analog value and, when monitoring is active, the current value is displayed. The values are updated at least every second to allow the component state to be monitored.

Refer to [Table 1](#) for the component list.

Procedure

1. Enter service mode, [GP 1](#).
2. Select the Diagnostics tab.
3. Select dC140 Analog Monitor. The dC140 Analog Monitor screen is displayed.
4. Scroll the table to display the available analog components.
5. Select the required item from the table.
6. A popup menu will be displayed, select start to confirm.
 - The table will display a status against the selected component.
 - While service mode is activated the components are not active so the value will not change.
 - To check the component either manipulate the component manually or make a note of the value, exit Analog Monitor go to [dC330](#) Component Control, to run the component and return to dC140 Analog Monitor.
 - Multiple components may be selected.
 - To stop monitoring select the required component and select stop.
 - Selecting Close will stop monitoring all components.
7. Select Close to return to the Diagnostic Routine window.
8. Select Call Closeout to exit service mode.

Table 1 Component List

ID Code	Component Name	Range	Comments
091 - 017	IOD Shuttle Motor Encoder	0 - 65535	Display value in ticks
094 - 101	Drum Drive Motor Encoder	0 - 65535	Display value in ticks
094 - 102	Drum Position Encoder	0 - 65535	Display value in ticks
094 - 103	Cleaning Unit Motor Encoder	0 - 65535	Display value in ticks

Table 1 Component List

ID Code	Component Name	Range	Comments
010 - 010	Rear Transfix Flexure Encoder, PL 10.20 Item 5	0 - 65535	Display value in ticks
010 - 011	Rear Transfix Motor Encoder	0 - 65535	Display value in ticks
010 - 012	Front Transfix Flexure Encoder	0 - 65535	Display value in ticks
010 - 013	Front Transfix Motor Encoder	0 - 65535	Display value in ticks
042 - 100	Abatement Fan Tachometer	0 - 37500	Zero RPM with fan off
073 - 003	Tray 3 Elevator Encoder	0 - 255	Zero ticks with tray 3 down
074 - 415	Bypass Width Potentiometer	0 - 65535	Move guides to change tick value
075 - 015	Tray 5 Elevator Encoder	0 - 255	Zero ticks with tray 5 down
082 - 100	Vert Trans Motor Encoder (M2)	0 - 65535	Display value in ticks
082 - 102	Horiz Trans Motor Encoder (M6)	0 - 65535	Display value in ticks

dC301 NVM Initialization

General

The purpose of the NVM initialization routine is to reset the values of all applicable NVM parameters to default. There are three machine domains and three types of initialization.

The three machine domains are:

- [Copier NVM Initialization](#)
- Network Controller NVM Initialization
- [Fax NVM initialization](#)

NOTE: *The network controller does not contain any NVM values that are accessible by the NVM features. There is no NVM initialization for the network controller.*

The three types of initialization are:

- **User data** That data which defines the way the customer prefers that the equipment operates (i.e. customer preference, SA/KO settings, configuration).
- **System data** That data which defines the way the equipment operates in relation to its environment (i.e. machine variables).
- **All data:** That additional data (on top of System and User data) which may be initialized without significantly impacting the machines operation. (i.e. machine variables, SA/KO settings, Fault log).

Copier NVM Initialization

Purpose

To reset specific machine variable NVM or all machine variable NVM non-volatile memory (with the exception of protected NVM for which a password is required) to their default values.

NOTE: *Initialization does not affect the billing counter and accounting.*

Procedure

1. Save the NVM to disk, refer to NVM Save and Restore, [dC361](#).
2. Enter service mode, [GP 1](#).
3. Select the Adjustments tab.
4. Select dC301 NVM Initialization.
5. Select Copier.
6. Select the sub-domain. Refer to [Table 1](#) for the functions in each sub domain.
 - Copy Controller
 - Scanner
 - Print Engine
 - Finisher
7. Select the NVM data to reset. Refer to [Table 1](#) for the functions that are reset to default.
 - User
 - System
 - All
8. Select Initialize, when the pop-up window appears confirm the request.
A message will be displayed to indicate successful completion.
9. Exit [dC301](#) NVM initialization.

10. Select Call Closeout to exit service mode.
11. Reboot the machine for the changes to take effect.

NOTE: *If a Reset All has been performed then go to the [Post Reset All Procedure](#).*

Post Reset All Procedure

If a Reset All has been selected then perform the steps that follow:

1. The paper trays should be opened and allowed to go the bottom sensor and then closed to allow them to determine amount of paper correctly.
2. If there is a Tray 5 kit installed, the media type will need to be re-entered. Enter DC131 NVM Read / Write and location NVM ID 450.001. Enter the appropriate value, 0 = Standard (A4 or 8.5 x 11 LEF), 1 = Kit A (A3 SEF or A4 LEF), 2 = Kit A (11x17 SEF or 8.5 x 11 LEF), 3 = Kit B (A4 SEF) and 4 = Kit B (8.5 x 11 Legal SEF)
3. Perform the following calibrations in order and then reboot the system.
 - a. [dC978](#) Transfix Calibration Values
 - b. [dC971](#) Head to Head Alignment Adjustment
 - c. [dC977](#) Drum Runout Calibration
 - d. [dC971](#) Head to Head Alignment Adjustment
 - e. [dC625](#) Registration / Preheat Calibration

Fax NVM initialization

Purpose

To return to default the fax NVM settings that are stored on the fax card. [Refer to Fax Document](#).

NOTE: *The Edoc CD must be in the CD drive to use the Fax Document link.*

Procedure

1. Save the NVM to disk, refer to NVM Save and Restore, [dC361](#).
 2. Enter service mode, [GP 1](#).
 3. Select the Adjustments tab.
 4. Select dC301 NVM Initialization.
 5. Select Fax.
 6. Select the NVM data to reset. Refer to [Table 2](#) for the functions that are reset to default.
 - User
 - System
 - All
- NOTE:** *Deletion of all data.*
7. Select Initialize when the pop-up window appears confirm the request.
 8. A message will be displayed to indicate successful completion.
 9. Exit dC301 NVM Initialization.
 10. Select Call Closeout to exit service mode.
 11. Switch off and switch on the machine, [GP 14](#), for the changes to take effect.

Table 1 Copier NVM

Sub-Domain	NVM Initialization Type	User Data NVM	System Data NVM	All Data NVM	
Copy Controller	All	N	N	N	
	Billing Counter	N	N	N	
	System Usage Counter			Y	
	Fault Counter (1)			Y	
	Diagnostic Counter (1)			Y	
	SA / KO Setting	Y		Y	
	Fault Log			Y	
	Configuration			Y	
	Diagnostics			Y	
	Debug			Y	
	Machine Variable		Y	Y	
	Machine Variable Xero		Y	Y	
	Machine Variable Registration		Y	Y	
	Machine Variable Paper Path		Y	Y	
	Machine Variable DADH		Y	Y	
	Machine Variable Platen		Y	Y	
	Auditron	Y		Y	
	ESS	N	N	N	
	Crash Recovery Type			Y	
	Completed Job Log			Y	
	Controlled Access	N	N	N	
	Machine Speed, Market Region				
	JBA Database	Y		Y	
	JBA Configuration	Y		Y	
	Auditron Configuration	Y		Y	
	Xerox Standard Accounting	N	N	N	
	HFSI Counter	N	N	N	
	Scanner	NVM Machine Variable		Y	Y
		SA / KO Setting	Y		Y
		Configuration			Y
Printer	NVM Machine Variable		Y	Y	
	SA / KO Setting	Y		Y	
	Configuration			Y	
Finisher	NVM Machine Variable		Y	Y	
	SA / KO Setting	Y		Y	
	Configuration			Y	

(1) These counters are reset using the Reset Counters option provided in the Call Closeout feature.

NOTE: The booklet maker NVM is not reset as it is custom set for each unit.

Table 2 Fax NVM

NVM Initialization Type	User Data NVM	System Data NVM	All Data NVM
Controlled Access (2)			Y
Completed Job Log	Y		(Y)
Auditron	Y		(Y)
Configuration	Y	Y	(Y)
SA / KO Setting	Y		(Y)

(2) The Fax functionality for the NVM All Data Initialization will result in all of the NVM data being deleted, which is why the other categories are shown in brackets.

dC312 Network Echo Test

Purpose

To check network connectivity.

Procedure

1. Enter Service Mode, [GP 1](#).
2. Select the Diagnostics tab.
3. Select dC312 Network Echo Test.
4. Select the required protocol from TCP / IP, AppleTalk or Novel or IPX.
5. Select Start Test.

The status region at the top of the user interface will indicate that the test is in progress.

The status region will indicate the result of the test before returning to the previous display.

6. Select Close to exit the routine.
7. Select Call Closeout to exit Service Mode.

dC330 Component Control

Purpose

To show the status of input components e.g. sensors, and to run or energize output components e.g. motors, solenoids.

Description

Output and input component codes are entered into the Component Control Table on the UI, and then checked individually or in permitted groups. The codes in the tables are grouped in function chain order, refer to [GP 2](#) Fault Codes and History Files.

NOTE: To check the operation of motor encoders, abatement fan tachometer and the bypass width potentiometer refer to [dC140 Analog Monitor](#).

Go to the appropriate procedure:

- [Input Components](#)
- [Output Components](#)

Input Components

When the appropriate code is entered the status of the component will be shown on the UI.

NOTE: The logic level shown on the circuit diagrams with the signal name will be the actual signal as measured with a service meter. This will not necessarily be the same as the logic state shown on the UI, especially where the output is inverted. When testing components using these control codes, look for a change in state, not for a high or low.

The displayed status of the input component can be changed by causing the component status to change, e.g. operating a sensor with a sheet of paper.

Go to the appropriate table:

- [Table 1](#) Input codes 01
- [Table 2](#) Input Codes 05
- [Table 3](#) Input Codes 10
- [Table 4](#) Input Codes 12
- [Table 5](#) Input Codes 62
- [Table 6](#) Input Codes 70
- [Table 7](#) Input Codes 71
- [Table 8](#) Input Codes 72
- [Table 9](#) Input Codes 73
- [Table 10](#) Input Codes 74
- [Table 11](#) Input Codes 75
- [Table 12](#) Input Codes 82
- [Table 13](#) Input Codes 83
- [Table 14](#) Input Codes 89
- [Table 15](#) Input Codes 91
- [Table 16](#) Input Codes 93
- [Table 17](#) Input Codes 94

Output Components

When the appropriate code is entered, the component will run or energize for a set time. The default time-out for most components is set at 90 seconds, but can be as short as 5 seconds. Some components require that other components are run or energized at the same time. It is possible to enter and run or energize up to six component control codes (not fax), but only in permitted groups. If illegal combination of codes are entered the components will not run or energize.

Go to the appropriate table:

- [Table 18](#) Output Codes 05
- [Table 19](#) Output Codes 10
- [Table 20](#) Output Codes 12
- [Table 21](#) Output Codes 20
- [Table 22](#) Output Codes 42
- [Table 23](#) Output Codes 62
- [Table 24](#) Output Codes 70
- [Table 25](#) Output Codes 71
- [Table 26](#) Output Codes 72
- [Table 27](#) Output Codes 73
- [Table 28](#) Output Codes 74
- [Table 29](#) Output Codes 75
- [Table 30](#) Output Codes 82
- [Table 31](#) Output Codes 83
- [Table 32](#) Output Codes 88
- [Table 33](#) Output Codes 89
- [Table 34](#) Output Codes 91
- [Table 35](#) Output Codes 93
- [Table 36](#) Output Codes 94

Procedure

1. Enter service mode, [GP 1](#).
2. Select the Diagnostics tab.
3. Select dC330 Component Control.

CAUTION

Check the component control tables for components that will damage the machine if run together.

4. Select the required codes as follows:
 - If the component control code is not known:
 - a. Select a chain from the drop down list.
 - b. Select the required component and touch Add.
 - If the required component control code is known:
 - a. Touch the Chain field and enter the 3 digit chain number using the numeric key pad.
 - b. Touch the Link field and enter the required link number using the numeric key pad.
 - c. Touch Add.

5. Once the required component control codes are in the lower list select the required code and choose options from the menu as required.
6. Select close to exit dC330 Component Control.
7. Select Call Closeout to exit service mode.

Input Codes

Table 1 Input codes 01

Code	Displayed Name	Description	General
01-100	Upper Door Interlock	Sensor to detect Upper left hand door position	High = door closed, low = door open
01-101	Mid Door Interlock	Mid door interlock	High = door closed, low = door open
01-102	Lower Door Interlock	Lower Door Interlock	High = door closed, low = door open
01-103	Front Door Interlock	Front Door Interlock	High = door closed, low = door open

Table 2 Input codes 05

Code	Displayed Name	Description	General
05-095	DADH Width sensor	DADH input tray document width sensing potentiometer (Q05-095). Displayed as Zone 1 or Zone 2 or Zone 3...Zone 6	Zones 1-6
05-096	DADH TAR sensor	DADH takeaway roll sensor (Q05-096)	High = document present, low = no document
05-097	DADH CVT sensor	DADH upper CVT sensor (Q05-097)	High = document present, low = no document
05-102	DADH Document sensor	Paper detected on document sensor (Q05-102)	High = document present, low = no document
05-204	DADH feed sensor	Feed sensor (Q05-330).	High = document present, low = no document
05-206	DADH pre-reg sensor	Pre-registration Sensor (Q05-206).	High = document present, low = no document
05-209	DADH Exit sensor	DADH Exit sensor (Q05-209).	High = document present, low = no document
05-212	DADH cover interlock switch	DADH cover interlock open (S05-212).	High = door closed, low = door open
05-221	DADH Tray size sensor 1	Tray size sensor 1 (Q05-221).	High = document present, low = no document
05-222	DADH Tray size sensor 2	Tray size sensor 2 (Q05-222).	High = document present, low = no document

Table 3 Input codes 10

Code	Displayed Name	Description	General
10-014	Stripper latch sensor	Stripper latch sensor.	High/Low
10-015	Post transfix sensor (11)	Post transfix sensor (11)	High/Low
10-016	Pre exit sensor (12)	Pre exit sensor (12)	High/Low

Table 3 Input codes 10

Code	Displayed Name	Description	General
10-017	Exit sensor (15)	Exits sensor (15)	High/Low

Table 4 Input codes 12

Code	Displayed Name	Description	General
12-075	Punch sensor 2	HVF punch position sensor 2 (Q12-075).	On = Made
12-076	Punch sensor 3	HVF punch position sensor 3 (Q12-076).	On = Made
12-077	Entry sensor	LCSS and HVF entry sensor (Q12-077).	On = Made
12-078	Punch sensor	LCSS and HVF punch position sensor (Q12-078).	On = Made
12-079	Insertor paper length sensor 1	HVF insertor paper length sensor 1 (Q12-079) detects the DOF (Direction Of Feed) sheet size in insertor tray.	High = sheet size detected
12-080	Insertor paper length sensor 2	HVF insertor paper length sensor 2 (Q12-080) detects the DOF (Direction Of Feed) sheet size in insertor tray.	High = sheet size detected
12-081	Insertor paper width sensor 1	HVF insertor paper width sensor (Q12-081) detects STS (Side To Side) sheet size in insertor tray.	High = sheet size detected
12-082	Insertor unit empty sensor	HVF insertor unit empty sensor (Q12-082) detects paper present insertor tray.	High = paper present, low = no paper
12-083	Insertor LE sensor	HVF insertor LE sensor (Q12-083) detects the LE of the paper.	High = LE detected, low = LE not detected
12-084	Insertor TE sensor	HVF insertor TE sensor (Q12-084) detects the TE of the paper.	High = TE detected, low = TE not detected
12-085	Insertor bottom plate sensor	HVF insertor bottom plate sensor (Q12-085) detects the bottom plate in home position.	High = home position, low = not home
12-086	Buffer position sensor	HVF Buffer position sensor (Q12-086) detects paper.	High = paper present, low = no paper
12-087	HVF booklet exit sensor	HVF booklet exit sensor (Q12-087) detects paper exiting the finisher to enter into booklet maker.	High = paper present, low = no paper
12-088	Nip home sensor	HVF nip home sensor (Q12-088) detects the position of the buffer movement tray in descending.	High = Nip home
12-089	BM entry sensor	HVF BM entry sensor (Q12-089) detects paper entry to the booklet maker.	High = paper present, low = no paper

Table 4 Input codes 12

Code	Displayed Name	Description	General
12-090	Inserter paper length sensor 3	HVF BM inserter paper length sensor 3 (Q12-090) detects the DOF (Direction Of Feed) sheet size in inserter tray.	High = sheet size detected
12-091	Nip Split Sensor	HVF nip split sensor (Q12-091) detects the position of the buffer movement tray in ascending.	High = Nip split home
12-092	Paper Pusher Upper Sensor	HVF paper pusher upper sensor (Q12-092) detects if the pusher is in the upper position.	High = upper position
12-093	Pressing and Support Encoder Snr	HVF pressing and support encoder sensor (Q12-093) detects the timing for pressing and support motor.	High = made, low = not detected
12-094	Paper Pusher Lower Sensor	HVF paper pusher lower sensor (Q12-094) detects if paper pusher is in lower position.	High = made, low = not detected
12-096	Ejector motor encoder sensor	HVF/LCSS ejector module motor encoder sensor (Q12-096) detects the timing for ejector module motor.	High = made, low = not detected
12-097	Ejector roll motor encoder sensor	HVF ejector roll motor encoder sensor (Q12-097) detects the timing for ejector plate motor.	High = made, low = not detected
12-098	Ejector plate home sensor	HVF ejector plate home sensor (Q12-098) detects if ejector plate is in home position.	High = made, low = not detected
12-099	Ejector lower paddle home sensor	HVF ejector lower paddle home sensor (Q12-099) detects if eject unit lower paddle is in home position.	High = made, low = not detected
12-106	Compile exit sensor	HVF/LCSS Compile exit sensor (Q12-106)	On/Off
12-107	Top tray exit sensor	HVF/LCSS Top tray exit sensor (Q12-107)	On/Off
12-114	Punch unit home sensor	HVF Punch unit home sensor (Q12-114)	On/Off
12-118	Chad bin present sensor	HVF Chad bin present sensor (Q12-118)	On/Off
12-133	LO staple sensor	HVF/LCSS LO staple sensor (Q12-133)	On/Off
12-134	SELF PRIMING sensor	HVF/LCSS SELF PRIMING sensor (Q12-134)	On/Off
12-135	Staple home sensor	HVF/LCSS Staple home sensor (Q12-135)	On/Off

Table 4 Input codes 12

Code	Displayed Name	Description	General
12-163	Bin 1 Motor Encoder Sensor	HVF/LCSS bin 1 motor encoder sensor (Q12-162) detects the timing for stacker unit motor	High = made, low = not detected
12-164	Tri Folder Entry Sensor	HVF BM tri folder entry sensor (Q12-163) detects the booklet and tri folder entry. Trigger point for CL80	High = made, low = not detected
12-165	Tri Folder Assist Gate Sensor	HVF BM tri folder assist gate sensor (Q12-164) detects trigger point for L81	High = made, low = not detected
12-166	Tri Folder Exit Sensor	HVF BM tri folder exit sensor (Q12-165) detects booklet and tri folder exit to tray	High = made, low = not detected
12-168	Stapler index sensor	HVF/LCSS stapler unit is in index position (Q12-168)	On = made
12-169	Inserter paper width sensor 2	HVF inserter paper width sensor 2 (Q12-169) detects the DOF (Direction Of Feed) sheet size in inserter tray.	High = sheet size detected
12-170	BM paper present sensor	HVF BM paper present sensor (Q12-170)	On = made
12-171	Pressing and Support B Sensor	HVF pressing and support B sensor (Q12-171) detects the initial position sensor	High = made, low = not detected
12-172	Pressing and Support A Snr	HVF pressing and support A sensor (Q12-172) detects the home position sensor	High = made, low = not detected
12-173	Pressing and Support C Snr	HVF pressing and support C sensor (Q12-173) detects the out position sensor	High = made, low = not detected
12-174	Paddle Unit Upper Sensor	HVF paddle unit upper sensor (Q12-174) detects the paddle unit position	High = made, low = not detected
12-175	Paddle Unit Lower Sensor	HVF paddle unit lower sensor (Q12-175) detects paddle unit lower position	High = made, low = not detected
12-176	Stapler unit mid home sensor	HVF stapler unit mid home sensor (Q12-175) detects if stapler unit is in mid home position	High = made, low = not detected
12-177	Docking interlock	LCSS and HVF docking interlock switch (S12-176)	High = docked, low = un-docked
12-178	Inserter top cover interlock	HVF inserter top cover interlock sensor (Q12-178) detects if inserter tray top cover is closed	High = made, low = not detected

Table 4 Input codes 12

Code	Displayed Name	Description	General
12-179	Inserter jam cover interlock	HVF inserter jam cover interlock sensor (Q12-179) detects if inserter jam cover is closed	High = made, low = not detected
12-180	Tamp front home sensor	LCSS and HVF front tamper home sensor (Q12-180) detects if front tamper is home	High = home, low = not home
12-181	Tamp rear home sensor	LCSS and HVF rear tamper home sensor (Q12-181), detects if rear tamper is home	High = home, low = not home
12-182	Tamp front away sensor	LCSS and HVF front tamper away sensor (Q12-182), detects if front tamper is away	High = home, low = not home
12-183	Tamp rear away sensor	LCSS and HVF rear tamper away sensor (Q12-183), detects if rear tamper is away	High = home, low = not home
12-184	Ejector home sensor	HVF ejector home sensor (Q12-184) detects the home (closed) position of the ejector housing. LCSS ejector home sensor (Q12-184) detects the home position of the ejector assembly	High = home, low = not home
12-185	Ejector out sensor	LCSS and HVF Ejector out sensor (Q12-185) detects the out position of the ejector assembly	High = out, low = not out
12-186	Paddle roll home sensor	LCSS paddle roll position sensor, HVF paddle roll home sensor (Q12-186) detects the home position of the paddle roll	High = home, low = not home
12-187	Bin1 90% full sensor	LCSS and HVF bin 1 90% full sensor (Q12-187) detects when bin 1 is 90% or more full	High = 90% or more full, low = less than 90% full
12-188	Bin1 upper level sensor	LCSS and HVF bin 1 upper level sensor (Q12-188) detects the top of the paper stack in bin 1	High = stack sensed, low = stack not sensed
12-190	Bin1 upper limit switch	LCSS and HVF bin 1 upper limit switch (S12-190) detects the upper limit of bin 1 movement	High = bin detected, low = bin not detected
12-191	Bin1 lower limit switch	LCSS and HVF bin 1 upper limit switch (S12-191) detects the lower limit of bin 1 movement	High = bin detected, low = bin not detected
12-193	Chad bin Lvl sensor	LCSS and HVF chad bin full sensor (Q12-193) detects when the level of the chad reaches a pre-set value	High = bin full, low = bin not full
12-194	Punch head home sensor	LCSS and HVF punch head home sensor (Q12-194) detects the home position of the punch head	High = punch home, low = punch not home

Table 4 Input codes 12

Code	Displayed Name	Description	General
12-195	Punch hd present sensor	LCSS punch head present sensor (Q12-195) detects if a hole punch is installed	High = punch installed, low = punch not installed
12-196	SH1 paper sensor	LCSS staple head 1 home sensor (Q12-196) detects when the staple head is fully open (home position)	High = home, low = not home
12-197	Top cover interlock	Detects if finisher top cover is open	High = closed
12-202	Ejector paper present sensor	HVF ejector paper present sensor (Q12-202) detects compiled paper for stapling	On = made
12-204	BM guide home sensor	HVF BM backstop guide home sensor (Q12-204) detects when the backstop is in the home position	High = home, low = not home
12-205	BM tamper 1 home sensor	HVF BM tamper 1 home sensor (Q12-205) detects when the BM tampers are in the home position	High = home, low = not home
12-206	BM Bin2 90% full sensor	HVF BM bin 2 90% full sensor (Q12-206) detects when bin 2 is 90% or more full	High = 90% or more full, low = less than 90% full
12-207	Flapper home sensor	HVF booklet maker flapper home sensor (Q12-207)	High = home
12-208	PTU switch	HVF PTU switch (S12-208) detects if pause to unload button is pressed	High = made, low = not detected
12-209	TriFold front dr interlock	HVF tri fold door interlock (S12-209) detects if the tri fold front door is closed	High = closed, low = door open
12-210	TriFold top cover interlock	HVF tri fold top cover interlock (S12-210) detects if the tri fold top cover is closed	High = closed, low = cover open
12-211	OCT 90% Full sensor	OCT level sensor (Q12-211) detects when the tray is 90% full	High = 90% full
12-212	OCT index sensor	OCT index sensor (Q12-212) detects when a tray is in an index position	High = at index position
12-213	BM exit sensor	HVF BM exit sensor (Q12-213) detects booklets exiting the booklet maker	High = detected, low = not detected
12-214	BM crease blade home	HVF BM crease blade home sensor (Q12-214) detects when the crease blade is fully retracted	High = home, low = not home
12-215	BM crease blade motor encoder	HVF BM crease blade motor encoder (Q12-215) generates motor speed pulses	High = bar in encoder wheel, low = gap in encoder wheel

Table 4 Input codes 12

Code	Displayed Name	Description	General
12-216	BM crease roll motor encoder	HVF BM crease roll motor encoder sensor (Q12-216) generates motor speed pulses	High = bar in encoder wheel, low = gap in encoder wheel
12-217	BM SH carrier closed	HVF BM staple head carrier closed sensor (Q12-217) detects when the carrier is in the closed position	High = closed, low = not closed
12-218	BM SH1 home sensor	HVF BM staple head 1 home sensor (Q12-218) detects when the staple head is fully open (home position)	High = home, low = not home
12-219	BM SH1 staples low	HVF BM staple head 1 staples low sensor (Q12-219) detects when staple cartridge is almost empty	High = almost empty, low = plentiful staples
12-220	BM SH2 home sensor	HVF BM staple head 2 home sensor (Q12-220) detects when the staple head is fully open (home position)	High = home, low = not home
12-221	BM SH2 staples low	HVF BM staple head 2 staples low sensor (Q12-221) detects when staple cartridge is almost empty	High = almost empty, low = plentiful staples
12-222	BM crease roll gate home	HVF BM crease roll gate home sensor (Q12-222) detects when the gate is fully raised (home position)	High = gate raised, low = gate not raised
12-303	Front door interlock	LCSS and HVF front door interlock (Q12-303) detects if the finisher front door is open	High = closed, low = open
12-315	Inserter pickup sensor	Inserter pickup sensor (Q12-315) detects trail edge of paper	On = made
12-316	Inserter acceleration sensor	Inserter acceleration sensor (Q12-316) detects acceleration position of paper	On = made
12-317	Stapler cartridge sensor	HVF Stapler cartridge sensor	On = made Off = clear
12-318	Stapler jaw home sensor	HVF/LCSS Stapler jaw home sensor	On = made Off = clear
12-319	Stapler safety switch	HVF Stapler safety switch	On = made Off = clear
12-320	Inserter standby sensor	Inserter standby sensor	On = made Off = clear
12-321	Buffer path sensor	HVF Buffer path sensor	On = made Off = clear
12-322	Paper pressing sensor	HVF Paper pressing sensor	On = made Off = clear

Table 5 Input codes 62

Code	Displayed Name	Description	General
62-018	Carriage Home Sensor	Scan carriage home sensor (Q62-018) detects the home position of the scan carriage	High = Home, low = not home
62-019	Platen down sensor	Scanner platen down sensor (Q62-019) detects DADH is closed.	High = closed, low = open
62-020	24v detect	Detects 24v in scanner	High = +24v present, low = +24v not present
62-021	12v detect	Detects 12v in scanner	High = +12v present, low = +12v not present
62-022	DADH hotline detect	DADH active hotline detection sensor	High = Hotline active Low = Hotline inactive
62-251	Document size sensor 1	Document size sensor 1(Q62-251) located under the platen glass	High = paper present
62-253	Document size sensor 2	Document size sensor 2(Q62-253) located under the platen glass	High = paper present
62-301	Angle sensor	Scanner angle sensor (Q62-301)	High/Low

Table 6 Input codes 70

Code	Displayed Name	Description	General
70-100	Horz transport home switch	3TM. Detects presence of horizontal transport in home position	High/low
70-101	Vert transport home sensor	3TM. Detects presence of vertical transport in home position.	High/low
70-398	Tray 3 transport sensor	3TM. Detects presence of sheet in horizontal position	High = paper present

Table 7 Input codes 71

Code	Displayed Name	Description	General
71-101	T1 Feed Sensor	3TM. Detects when lead edge of paper at Tray 1 feed sensor (Q71-101)	High = paper present
71-201	Tray 1 Empty Sensor	3TM. To detect Tray 1 empty sensor on (Q71-201). Not used for SAR feeders.	High/low
71-311	T1 Size Switch 1	Size switch 1 (S71-311)	High = made
71-312	T1 Size Switch 2	Size switch 2 (S71-312)	High = made
71-313	T1 Size Switch 3	Size switch 3 (S71-313)	High = made
71-314	T1 Size Switch 4	Size switch 4 (S71-314)	High = made
71-315	T1 Size Switch 5	Size switch 5 (S71-314)	High = made
71-336	T1 Stack Height Sensor	3TM. Detects paper stack is in correct position to feed from tray 1 (Q71-336)	High = stack up

Table 7 Input codes 71

Code	Displayed Name	Description	General
71-395	TAR 1 sensor	3TM. Detects presence of paper at TAR 1 sensor (Q71-395)	High = made

Table 8 Input codes 72

Code	Displayed Name	Description	General
72-102	T2 feed sensor	3TM. Detects when lead edge of paper at tray 2 feed sensor (Q72-101)	High = paper present
72-201	Tray 2 empty sensor	3TM. To detect tray 2 empty sensor on (Q72-201). Not used for SAR feeders.	High/low
72-321	T2 Size Switch 1	Size switch 1 (S72-321)	High = made
72-322	T2 Size Switch 2	Size switch 2 (S72-322)	High = made
72-323	T2 Size Switch 3	Size switch 3 (S72-323)	High = made
72-324	T2 Size Switch 4	Size switch 4 (S72-324)	High = made
72-325	T2 Size Switch 5	Size switch 5 (Q72325), Not used for SAR feeders	High = made
72-337	T2 Stack Height Sensor	3TM. Detects paper stack is in correct position to feed from T2 (Q72-337)	High = stack up
72-396	TAR 2 sensor	3TM. Detects presence of paper sheet at TAR 2 sensor (Q72-396)	High = made

Table 9 Input codes 73

Code	Displayed Name	Description	General
73-103	T3 feed sensor	Detects when lead edge of paper at tray 3 feed sensor	High = paper present
73-201	T3 empty sensor	To detect tray 3 empty sensor on	High/low
73-303	T3 home sensor	Detects when tray 3 home	High/low
73-383	T3 stack height sensor	Tray 3 elevated to feed position	High/low
73-397	TAR 3 sensor	Detects presence of paper sheet at TAR 3 sensor	High/low

Table 10 Input codes 74

Code	Displayed Name	Description	General
74-335	Bypass empty sensor	Bypass paper empty sensor (Q74-335)	High = paper present
74-350	Bypass width sensor	Bypass analogue width sensor (Q74-350)	Voltage range (for p1) width (in mm/inch post p1)
74-406	Bypass feed sensor	Detects the lead edge of paper at bypass feed sensor	High = paper present

Table 10 Input codes 74

Code	Displayed Name	Description	General
74-413	Bypass nudger home sensor	Bypass nudger home sensor (Q74-413)	On/off
74-415	Bypass width pot value	Returns actual width size based on width sensor state (Q74-415)	Value between 0 and 3.65

Table 11 Input codes 75

Code	Displayed Name	Description	General
75-010	Tray 5 door switch	Detects presence of tray 5 door in closed position / toggle switch up position	High = door closed = toggle switch up
75-011	Tray 5 stack height sensor	Detects paper stack is in correct position to feed from tray 5	High = stack up
75-012	Tray 5 down sensor	Detects when tray 5 is lowered	High = paper tray lowered
75-016	Tray 5 empty sensor	Detects when the tray is empty	High = tray empty
75-017	Tray 5 docking switch	Detects when the tray is docked against the machine	High = tray docked

Table 12 Input codes 82

Code	Displayed Name	Description	General
82-110	Vertical transport sensor (5)	IME vertical transport sensor (5)	High/low
82-125	Confirm sensor (16)	IME confirm sensor (16)	High/low

Table 13 Input codes 83

Code	Displayed Name	Description	General
83-010	Duplex sensor (17)	Duplex sensor (17)	High/Low
83-110	Duplex start sensor (13)	IME duplex start sensor (13)	High/low
83-125	Duplex end sensor (14)	IME duplex end sensor (14)	High/low

Table 14 Input codes 89

Code	Displayed Name	Description	General
89-004	Reg / Preheat Home sensor	IME RLPH reg / preheat home sensor	High/low
89-005	Registration scan bar	IME registration scan bar	On/off
89-006	Pretransfix sensor (20)	IME pretransfix sensor (20)	High/low

Table 15 Input codes 91

Code	Displayed Name	Description	General
91-011	Lower carriage home sensor	IME lower carriage home sensor	High/low
91-012	Upper carriage home sensor	IME upper carriage home sensor	High/low
91-014	HM Position Sensor	IME HM position sensor	High/low
91-019	Waste tray sensor	IME waste tray sensor	High/low

Table 16 Input codes 93

Code	Displayed Name	Description	General
93-025	Ink load door switch	IME ink load door switch	High/low
93-026	Ink load entry snr Magenta 1	IME Ink load entry sensor Magenta 1	High/low
93-027	Ink load entry snr Cyan 2	IME Ink load entry sensor Cyan 2	High/low
93-028	Ink load entry snr Yellow 3	IME Ink load entry sensor Yellow 3	High/low
93-029	Ink load entry snr Black 4	IME Ink load entry sensor Black 4	High/low
93-030	Ink load low snr Magenta 1	IME Ink load low sensor Magenta 1	High/low
93-031	Ink load low snr Cyan 2	IME Ink load low sensor Cyan 2	High/low
93-032	Ink load low snr Yellow 3	IME Ink load low sensor Yellow 3	High/low
93-033	Ink load low snr Black 4	IME Ink load low sensor Black 4	High/low
93-034	Ink load sensor Black 1	IME Ink load sensor K1	High/low
93-035	Ink load sensor Magenta 1	IME Ink load sensor M1	High/low
93-036	Ink load sensor Cyan 1	IME Ink load sensor C1	High/low
93-037	Ink load sensor Yellow 1	IME Ink load sensor Y1	High/low
93-038	Ink load sensor Black 2	IME Ink load sensor K2	High/low
93-039	Ink load sensor Magenta 2	IME Ink load sensor M2	High/low
93-040	Ink load sensor Cyan 2	IME Ink load sensor C2	High/low
93-041	Ink load sensor Yellow 2	IME Ink load sensor Y2	High/low

Table 17 Input codes 94

Code	Displayed Name	Description	General
94-105	Cleaning unit home sensor	IME cleaning unit home sensor	High/low

Output Codes

Table 18 Output codes 05

Code	Displayed Name	Description	General
05-062	DADH feed clutch	DADH feed clutch (CL05-062)	On/off. Normally linked with feed motor. 30 seconds time-out.
05-074	DADH feed motor	DADH feed motor (MOT05-074)	On/off. 90 seconds timeout
05-098	DADH nudger motor	DADH nudger motor (MOT05-098)	On/off. 10 seconds time out
05-099	DADH CVT motor	DADH CVT stepper motor (MOT05-099)	On/off. 90 seconds timeout
05-100	DADH duplex solenoid	DADH duplex/exit solenoid (SOL05-101)	On/off. 90 seconds timeout
05-101	DADH Active Hotline	DADH Active Hotline. Required to keep alive until DADH Hotline Detect sensor can be run.	High = Active. 90 seconds time out

Table 19 Output codes 10

Code	Displayed Name	Description	General
10-018	Post Transfix motor (M4)	Post transfix motor M4 (MOT10-018)	On/off.
10-019	Front Transfix Motor	Front Transfix Motor (MOT10-019)	On/off.
10-020	Rear Transfix Motor	Rear Transfix Motor (MOT10-020)	On/off.
10-021	Stripper Solenoid	Stripper Solenoid (SOL10-021)	On/off.
10-022	Stripper Jam Clearance LED	Stripper Jam Clearance LED	On/off.
10-023	Strip Gate Latch	Strip Gate Latch	On/off.
10-024	Transfix Front and Back	Transfix Front and Back	On/off.
10-025	Strip Gate Unlatch	Strip Gate Unlatch	On/off.

Table 20 Output codes 12

Code	Displayed Name	Description	General
12-045	SU1 motor backward	HVF/LCSS Staple unit 1 motor reverse (MOT12-045) CAUTION <i>Do not run the following codes together: 12-045, 12-233, 12-236, 12-242, 12-244, 12-249, 12-250. Running these codes at the same time can cause damage to the machine.</i>	On/off. 110 milliseconds time out.
12-056	SetCamp SolenoidOn	HVF SetClamp SolenoidOn (SOL12-056)	On/off. 100 milliseconds time out.
12-059	Elevator motor up	HVF/LCSS Elevator motor up	On/off. 500 milliseconds time out.
12-060	Elevator motor down	HVF/LCSS Elevator motor down	On/off. 500 milliseconds time out.
12-223	Transport Motor 1	Runs the LCSS transport Motor 1, and HVF transport motor 1A and Transport motor 1B (MOT12-223)	On/off. 90 seconds time out
12-224	Transport Motor 2	Runs the LCSS, and HVF transport motor 2 (MOT12-224)	On/off. 90 seconds time out
12-225	Exit Diverter Solenoid	Runs the LCSS, HVF exit diverter gate solenoid and HVF BM upper diverter solenoid (SOL12-225)	On/off. 5 seconds time out
12-226	Front Tamper Motor Home	Runs the LCSS and HVF front tamper motor (MOT12-227) to the home position.	On/off. 5 seconds time-out
12-227	Rear Tamper Motor Home	Runs the LCSS and HVF rear tamper motor (MOT12-228) to home position	On/off. 5 seconds time out
12-228	Front Tamper Motor Move	Runs the LCSS and HVF front tamper motor (MOT11-003) move inbound.	On/off. 5 seconds time out
12-229	Rear Tamper Motor Move	Runs the LCSS and HVF rear tamper motor (MOT11-004) move inbound.	On/off. 5 seconds time out
12-230	Tampers to A4LEF	Moves the LCSS tampers to A4LEF position.	On/off. 5 seconds time out
12-231	Tampers to 8.5x11LEF	Move the LCSS tampers to 8.5"x11" LEF position.	On/off. 5 seconds time out
12-232	Tamper Motor Cycle	Cycles the LCSS tampers in and out until time-out or stop.	On/off. 90 seconds time out

Table 20 Output codes 12

Code	Displayed Name	Description	General
12-233	Ejector Roll Motor	Runs the HVF ejector roll motor (MOT12-235) CAUTION <i>Do not run the following codes together: 12-045, 12-233, 12-236, 12-242, 12-244, 12-249, 12-250. Running these codes at the same time can cause damage to the machine.</i>	On/off. 90 seconds time out
12-234	Ejector Motor Home	Runs the LCSS ejector motor (MOT12-236) to the home position	On/off. 5 seconds time out
12-235	Ejector Motor Move	Runs the LCSS ejector motor (MOT12-237) to the out position	On/off. 5 seconds time out
12-236	Ejector Motor Cycle	Runs the LCSS and HVF ejector motor (MOT12-238) cycle routine until time out or stop. CAUTION <i>Do not run the following codes together: 12-045, 12-233, 12-236, 12-242, 12-244, 12-249, 12-250. Running these codes at the same time can cause damage to the machine.</i>	On/off. 90 seconds time out
12-237	Paddle Roll Motor Home	Runs the LCSS paddle roll motor (MOT12-239) to the home position	On/off. 15 seconds time out
12-238	Paddle Roll Motor Run	Runs the LCSS and HVF paddle roll motor (MOT12-240) until timeout or stop	On/off. 15 seconds time out
12-239	Paddle Unit Motor Descend	Runs the HVF lower paddle unit motor (MOT12-241) in reverse.	On/off. 90 seconds time out
12-240	Paddle Unit Motor Lift	Runs the HVF paddle unit motor (MOT12-242) to lift the paddle unit	On/off. 90seconds timeout
12-241	Bin 1 Elevator Motor Home	Runs the LCSS and HVF bin 1 elevate motor (MOT12-241) to the home position.	On/off. 15 seconds time out
12-242	Bin1 Elevator Motor Cycle	Runs the LCSS and HVF bin 1 elevate motor (MOT12-242) to cycle bins up/down until time-out or stop. CAUTION <i>Do not run the following codes together: 12-045, 12-233, 12-236, 12-242, 12-244, 12-249, 12-250. Running these codes at the same time can cause damage to the machine.</i>	On/off. 90 seconds time out.
12-243	Punch Head Move Home	Runs the LCSS hole punch motor (MOT12-243) to the home position	On/off. 15 seconds time out

Table 20 Output codes 12

Code	Displayed Name	Description	General
12-244	Punch Head Run	Runs the LCSS and HVF hole punch motor (MOT12-244) continuously CAUTION <i>Do not run the following codes together: 12-045, 12-233, 12-236, 12-242, 12-244, 12-249, 12-250. Running these codes at the same time can cause damage to the machine.</i>	On/off. 15 seconds time out
12-245	Punch Unit Motor Forward	Runs the HVF punch unit motor (MOT12-245) forward	On/off.
12-246	Punch Unit Motor Reverse	Runs the HVF punch unit motor (MOT12-245) in reverse	On/off.
12-247	Staple Head 1 Motor	Runs the LCSS and HVF staple head 1 motor (MOT12-247) CAUTION <i>Do not run code 12-247 without 2 sheets of paper in the stapler jaws. Running this code without the paper in position can cause damage to the machine.</i>	On/off. 15 seconds time out
12-248	SH 1 Motor Reverse Home	Runs the LCSS and HVF staple head 1 motor (MOT12-248) in reverse to the home position	On/off. 15 seconds time out
12-249	SU 1 Motor Forward	Runs the LCSS and HVF stapling unit 1 motor (MOT12-249) increment forward. CAUTION <i>Do not run the following codes together: 12-045, 12-233, 12-236, 12-242, 12-244, 12-249, 12-250. Running these codes at the same time can cause damage to the machine.</i>	On/off. 15 seconds time out
12-250	SU1 Motor Cycle	Runs the LCSS and HVF stapling unit 1 motor (MOT12-250) cycle routine CAUTION <i>Do not run the following codes together: 12-045, 12-233, 12-236, 12-242, 12-244, 12-249, 12-250. Running these codes at the same time can cause damage to the machine.</i>	On/off. 90 seconds time out
12-251	BM Compiler Motor	Runs the HVF BM compiler motor (MOT12-251)	On/off. 90 seconds time out
12-252	BM Crease Blade Motor	Runs the HVF BM crease blade motor (MOT12-252) cycle routine	On/off. 90 seconds time out
12-253	BM Crease Roll Motor	Runs the HVF BM crease roll motor (MOT12-253)	On/off. 6 seconds timeout

Table 20 Output codes 12

Code	Displayed Name	Description	General
12-254	BM Staple Head 1 Motor	Runs the HVF BM staple head 1 motor (MOT12-254)	On/off. 5 seconds time out
12-255	BM Back Stop Motor	Runs the HVF BM backstop motor (MOT12-255) to receive, staple, then crease positions	On/off. 90 seconds time out
12-256	BM Tamper 1 Motor	Runs the HVF BM tamper 1 motor (MOT12-256)	On/off. 90 seconds time out
12-258	BM Diverter Solenoid	Energizes the HVF BM diverter solenoid (SOL12-258)	On/off. 5 seconds timeout
12-259	BM Stack Hold Solenoid	Energizes the HVF BM stack hold solenoids (SOL12-259) part of back stop assembly	On/off. 5 seconds time out
12-260	Insertor Clutch.	Energizes the HVF insertor clutch (CL12-260) to drive the pickup roll	On/off.
12-261	Insertor Motor	Runs the HVF insertor motor (MOT12-261) to drive the insertor rolls	On/off.
12-262	Buffer Motor	Runs the HVF Buffer motor (MOT12-262) to drive the buffer rolls	On/off.
12-263	Bypass Feed Motor	Runs the HVF bypass feed motor (MOT12-263) to drive the feed rolls	On/off.
12-264	Nip Split Motor	Runs the HVF nip split motor (MOT12-264) to activate the buffer movement tray	On/off.
12-265	Paper Pusher Motor	Runs the HVF paper pusher motor (MOT12-265) to drive the paper pusher	On/off.
12-266	Curl Suppressor Solenoid	Energizes the HVF curl suppressor solenoid (SOL12-266) to activate the pressing device	On/off.
12-267	Tri Folder Diverter Solenoid	Energizes the HVF tri folder diverter solenoid (SOL12-267) to activate the tri folder diverter gate to divert paper to tri fold path	On/off.
12-268	Tri Folder Assist Gate Solenoid	Energizes the HVF tri folder assist gate solenoid (SOL12-268) to activate the tri folder assist gate to assist C fold into second nip	On/off.
12-269	Clutch Drive	Energizes the HVF clutch drive (CL12-269) to drive tri folding rolls	On/off. 5 seconds timeout
12-271	BM Flapper Motor	Runs the HVF Booklet maker flapper motor (MOT12-271)	On/off. 90 seconds timeout
12-273	BM Crease Roll Gate Motor	Runs the HVF BM crease roll gate motor (MOT12-273) cycle routine	On/off. 15 seconds time out
12-274	BM Conveyor Drive Motor	Runs the HVF BM conveyor drive motor (MOT12-274)	On/off. 90 seconds time out

Table 20 Output codes 12

Code	Displayed Name	Description	General
12-275	BM Staple Hd 2 Motor	Runs the HVF BM staple head 2 motor (MOT12-275)	On/off. 5 seconds time out
12-276	BM Crease Roll Gate Motor Open	Runs the HVF BM crease roll gate motor (MOT12-276) to the open position	On/off. 90 seconds time out
12-300	OCT feed offset motor	Runs the OCT feed offset motor (MOT12-300)	On/off.
12-323	Pressing and Support Motor	Runs the pressing and support motor (MOT12-323)	On/off. 90 seconds timeout.
12-324	PTU LED	Energizes the pause to unload LED.	On/off
12-325	Insertor Bottom Plate Sensor	Runs the HVF inserter unit motor to lower the inserter bottom plate sensor.	On/off. 90 seconds timeout.

Table 21 Output codes 20

Code	Displayed Name	Description	General
20-002	Diag. LED 30 Red	Switches diagnostic LED 30 red	On/off
20-003	Diag. LED 30 green	Switches diagnostic LED 30 green	On/off
20-010	Sngl Tone 0Hz Ln1	Emits single tone 0Hz on line 1	On/off
20-011	Sngl Tone 400Hz Ln1	Emits single tone 400Hz on line 1	On/off
20-012	Sngl Tone 1100Hz Ln1	Emits single tone 1100Hz on line 1	On/off
20-013	Sngl Tone 1300Hz Ln1	Emits single tone 1300Hz on line 1	On/off
20-014	Sngl Tone 1650Hz Ln1	Emits single tone 1650Hz on line 1	On/off
20-015	Sngl Tone 1850Hz Ln1	Emits single tone 1850Hz on line 1	On/off
20-016	Sngl Tone 2100Hz Ln1	Emits single tone 2100Hz on line 1	On/off
20-017	ANSAM Ln1		On/off
20-018	CI Ln1		On/off
20-020	DTMF # Line1	Emits DTMF # on line 1	On/off
20-021	DTMF * Line1	Emits DTMF * on line 1	On/off
20-022	DTMF 0 Line1	Emits DTMF 0 on line 1	On/off
20-023	DTMF 1 Line1	Emits DTMF 1 on line 1	On/off
20-024	DTMF 2 Line1	Emits DTMF 2 on line 1	On/off
20-025	DTMF 3 Line1	Emits DTMF 3 on line 1	On/off
20-026	DTMF 4 Line1	Emits DTMF 4 on line 1	On/off
20-027	DTMF 5 Line1	Emits DTMF 5 on line 1	On/off
20-028	DTMF 6 Line1	Emits DTMF 6 on line 1	On/off
20-029	DTMF 7 Line1	Emits DTMF 7 on line 1	On/off
20-030	DTMF 8 Line1	Emits DTMF 8 on line 1	On/off
20-031	DTMF 9 Line1	Emits DTMF 9 on line 1	On/off
20-032	DTMF A Line1	Emits DTMF A on line 1	On/off
20-033	DTMF B Line1	Emits DTMF B on line 1	On/off
20-034	DTMF C Line1	Emits DTMF C on line 1	On/off

Table 21 Output codes 20

Code	Displayed Name	Description	General
20-035	DTMF D Line1	Emits DTMF D on line 1	On/off
20-040	V.21 300 bps Line1	Emits V.21 300 bps on line 1	On/off
20-041	V.27ter 2400 bps Line1	Emits V.27ter 2400 bps on line 1	On/off
20-042	V.27ter 4800 bps Line1	Emits V.27ter 4800 bps on line 1	On/off
20-043	V.29 7200 bps Line1	Emits V.29 7200 bps on line 1	On/off
20-044	V.29 9600 bps Line1	Emits V.29 9600 bps on line 1	On/off
20-045	V.17 7200 bps Line1	Emits V.17 7200 bps on line 1	On/off
20-046	V.17 9600 bps Line1	Emits V.17 9600 bps on line 1	On/off
20-047	V.17 12000 bps Line1	Emits V.17 12000 bps on line 1	On/off
20-048	V.17 14400 bps Line1	Emits V.17 14400 bps on line 1	On/off
20-049	V.34 2400 bps Line1	Emits V.34 2400 bps on line 1	On/off
20-050	V.34 4800 bps Line1	Emits V.34 4800 bps on line 1	On/off
20-051	V.34 7200 bps Line1	Emits V.34 7200 bps on line 1	On/off
20-052	V.34 9600 bps Line1	Emits V.34 9600 bps on line 1	On/off
20-053	V.34 12000 bps Line1	Emits V.34 12000 bps on line 1	On/off
20-054	V.34 14400 bps Line1	Emits V.34 14400 bps on line 1	On/off
20-055	V.34 16800 bps Line1	Emits V.34 16800 bps on line 1	On/off
20-056	V.34 19200 bps Line1	Emits V.34 19200 bps on line 1	On/off
20-057	V.34 21600 bps Line1	Emits V.34 21600 bps on line 1	On/off
20-058	V.34 24000 bps Line1	Emits V.34 24000 bps on line 1	On/off
20-059	V.34 26400 bps Line1	Emits V.34 26400 bps on line 1	On/off
20-060	V.34 28800 bps Line1	Emits V.34 28800 bps on line 1	On/off
20-061	V.34 31200 bps Line1	Emits V.34 31200 bps on line 1	On/off
20-062	V.34 33600 bps Line1	Emits V.34 33600 bps on line 1	On/off
20-070	ISDN mode Loopback	Applies a loop back of both B channels to the network	On/off
20-071	ISDN tst mode info 1	Provides INFO 1 signals on both B channels	On/off
20-072	ISDN tst mode info 0	Provides INFO 0 signals on both B channels	On/off
20-073	ISDN PH-ACT-REQ	Able to initiate activation procedures (PH-ACTIVATE REQUEST) primitive	On/off
20-074	ISDN LED 10/18 Red	Switches ISDN LED 10/18 red	On/off
20-075	ISDN LED 10/18 Grn	Switches ISDN LED 10/18 green	On/off
20-076	ISDN line relay	Switches SDN line relay	On/off
20-080	Sngl Tone 0Hz Ln2	Emits single tone 0Hz on line 2	On/off
20-081	Sngl Tone 400Hz Ln2	Emits single tone 400Hz on line 2	On/off
20-082	Sngl Tone 1100Hz Ln2	Emits single tone 1100Hz on line 2	On/off
20-083	Sngl Tone 1300Hz Ln2	Emits single tone 1300Hz on line 2	On/off
20-084	Sngl Tone 1650Hz Ln2	Emits single tone 1650Hz on line 2	On/off
20-085	Sngl Tone 1850Hz Ln2	Emits single tone 1850Hz on line 2	On/off
20-086	Sngl Tone 2100Hz Ln2	Emits single tone 2100Hz on line 2	On/off
20-087	ANSAM Ln2	-	On/off

Table 21 Output codes 20

Code	Displayed Name	Description	General
20-088	Cl Ln2	-	On/off
20-090	DTMF # Line2	Emits DTMF # on line 2	On/off
20-091	DTMF * Line2	Emits DTMF * on line 2	On/off
20-092	DTMF 0 Line2	Emits DTMF 0 on line 2	On/off
20-093	DTMF 1 Line2	Emits DTMF 1 on line 2	On/off
20-094	DTMF 2 Line2	Emits DTMF 2 on line 2	On/off
20-095	DTMF 3 Line2	Emits DTMF 3 on line 2	On/off
20-096	DTMF 4 Line2	Emits DTMF 4 on line 2	On/off
20-097	DTMF 5 Line2	Emits DTMF 5 on line 2	On/off
20-098	DTMF 6 Line2	Emits DTMF 6 on line 2	On/off
20-099	DTMF 7 Line2	Emits DTMF 7 on line 2	On/off
20-100	DTMF 8 Line2	Emits DTMF 8 on line 2	On/off
20-101	DTMF 9 Line2	Emits DTMF 9 on line 2	On/off
20-102	DTMF A Line2	Emits DTMF A on line 2	On/off
20-103	DTMF B Line2	Emits DTMF B on line 2	On/off
20-104	DTMF C Line2	Emits DTMF C on line 2	On/off
20-105	DTMF D Line2	Emits DTMF D on line 2	On/off
20-110	V.21 300 bps Line2	Emits V.21 300 bps on line 2	On/off
20-111	V.27ter 2400 bps Line2	Emits V.27ter 2400 bps on line 2	On/off
20-112	V.27ter 4800 bps Line2	Emits V.27ter 4800 bps on line 2	On/off
20-113	V.29 7200 bps Line2	Emits V.29 7200 bps on line 2	On/off
20-114	V.29 9600 bps Line2	Emits V.29 9600 bps on line 2	On/off
20-115	V.17 7200 bps Line2	Emits V.17 7200 bps on line 2	On/off
20-116	V.17 9600 bps Line2	Emits V.17 9600 bps on line 2	On/off
20-117	V.17 12000 bps Line2	Emits V.17 12000 bps on line 2	On/off
20-118	V.17 14400 bps Line2	Emits V.17 14400 bps on line 2	On/off
20-119	V.34 2400 bps Line2	Emits V.34 2400 bps on line 2	On/off
20-120	V.34 4800 bps Line2	Emits V.34 4800 bps on line 2	On/off
20-121	V.34 7200 bps Line2	Emits V.34 7200 bps on line 2	On/off
20-122	V.34 9600 bps Line2	Emits V.34 9600 bps on line 2	On/off
20-123	V.34 12000 bps Line2	Emits V.34 12000 bps on line 2	On/off
20-124	V.34 14400 bps Line2	Emits V.34 14400 bps on line 2	On/off
20-125	V.34 16800 bps Line2	Emits V.34 16800 bps on line 2	On/off
20-126	V.34 19200 bps Line2	Emits V.34 19200 bps on line 2	On/off
20-127	V.34 21600 bps Line2	Emits V.34 21600 bps on line 2	On/off
20-128	V.34 24000 bps Line2	Emits V.34 24000 bps on line 2	On/off
20-129	V.34 26400 bps Line2	Emits V.34 26400 bps on line 2	On/off
20-130	V.34 28800 bps Line2	Emits V.34 28800 bps on line 2	On/off
20-131	V.34 31200 bps Line2	Emits V.34 31200 bps on line 2	On/off
20-132	V.34 33600 bps Line2	Emits V.34 33600 bps on line 2	On/off

Table 22 Output codes 42

Code	Displayed Name	Description	General
42-062	Abatement fan	Runs the abatement fan	On/off
42-063	Enclosure fan	Runs the enclosure fan	On/off
42-064	Drum fan	Runs the drum fan	On/off

Table 23 Output codes 62

Code	Displayed Name	Description	General
62-002	Exposure lamp	Energizes the exposure lamp	On/off. 300 seconds timeout. Can stop before timeout
62-023	Carriage move home	Moves scanner carriage to home position.	On/off. can only be run independently of other carriage move components
62-024	Carriage mv doc size	Moves scanner carriage to document size sensing position	On/off. can only be run independently of other carriage move components
62-025	Carriage Mv CVT	Moves scanner carriage to CVT position	On/off. can only be run independently of other carriage move components
62-026	Carriage Mv A pos	Moves scanner carriage to scan audit position A	On/off. can only be run independently of other carriage move components
62-027	Carriage Mv B pos	Moves scanner carriage to scan audit position B	On/off. can only be run independently of other carriage move components
62-028	Carriage Mv C pos	Moves scanner carriage to scan audit position C	On/off. can only be run independently of other carriage move components

Table 24 Output codes 70

Code	Displayed Name	Description	General
70-025	3 Tray transport motor	Feeds paper to vertical transport of 3TM	On/off. 60 seconds timeout

Table 25 Output codes 71

Code	Displayed Name	Description	General
71-002	T1 feed / elevate motor	Runs the tray 1 feed / elevate motor (MOT 71-002).	On/off. Linked to tray 1 home sensor. Paper tray must be open when motor is running. 90 seconds timeout

Table 26 Output codes 72

Code	Displayed Name	Description	General
72-001	T2 feed / elevate motor	Runs the tray 2 feed / elevate motor. (MOT72-001)	On/off. Linked to tray 2 home sensor. Paper tray must be open when motor is running. 90 seconds timeout

Table 27 Output codes 73

Code	Displayed Name	Description	General
73-001	T3 feed motor	Runs the tray 3 feed motor (MOT73-001)	On/off. Linked to tray 3 home sensor. Paper tray must be open when motor is running. 90 seconds timeout
73-002	T3 elevate motor	Runs the tray 3 elevator motor (MOT73-002) up.	On/off. Linked to tray 3 home sensor. Only run with tray out. 10 seconds timeout

Table 28 Output codes 74

Code	Displayed Name	Description	General
74-420	Bypass feed motor	Runs the MSI feed motor (MOT74-420) in the feed direction.	On/off. 2 seconds timeout

Table 29 Output codes 75

Code	Displayed Name	Description	General
75-018	Tray 5 transport motor	Feeds paper to middle door vertical transport	On = Running Off = Stop 60 seconds timeout
75-019	Tray 5 elevator motor up	Runs the tray 5 elevator motor (MOT75-019) up	On = Running Off = Stop 10 seconds timeout

Table 29 Output codes 75

Code	Displayed Name	Description	General
75-020	Tray 5 elevator motor down	Runs the tray 5 elevator motor (MOT75-019) down	On = Running Off = Stop 10 seconds timeout
75-117	Tray 5 feed motor	Runs the tray 5 feed motor (MOT75-117) to drive the nudger and feed rolls	On=running Off = stop. 60 seconds timeout

Table 30 Output codes 82

Code	Displayed Name	Description	General
82-001	Vertical Trans Motor Fwd (M2)	Runs vertical transport motor M2 forward (MOT82-001)	On/off
82-002	Vertical Trans Motor Rev (M2)	Runs vertical transport motor M2 reverse (MOT82-001)	On/off
82-003	Horizontal Trans Motor Fwd (M6)	Runs horizontal transport motor M6 forward (MOT82-003)	On/off
82-004	Horizontal Trans Motor Rev (M6)	Runs horizontal transport motor M6 reverse (MOT82-003)	On/off
82-005	Horizontal illuminator	Energizes the horizontal paper path illuminator	On/off
82-007	Nip C release solenoid	Energizes the nip C release solenoid (SOL83-007).	On/off
82-008	Nip D solenoid	Energizes the nip D solenoid (SOL82-008)	On/off

Table 31 Output codes 83

Code	Displayed Name	Description	General
83-001	Exit Motor Fwd (M5)	Exit motor M5 forward (MOT83-001)	On/off
83-002	Exit Motor Rev (M5)	Exit motor M5 reverse (MOT83-001)	On/off
83-003	Exit illuminator	Exit illuminator	On/off
83-004	HPP diverter solenoid	HPP diverter solenoid	On/off
83-006	Exit duplex diverter solenoid	Exit duplex diverter solenoid	On/off

Table 32 Output codes 88

Code	Displayed Name	Description	General
88-008	Reg / Preheat Air Pumps	Reg / preheat air pumps	On/off

Table 33 Output codes 89

Code	Displayed Name	Description	General
89-007	Registration Motor A1	Runs registration motor A1 (MOT89-007)	On/off

Table 33 Output codes 89

Code	Displayed Name	Description	General
89-008	Registration Motor A2	Runs registration motor A2 (MOT89-008)	On/off
89-009	Reg / Preheat illuminator	Reg / preheat illuminator	On/off
89-011	Nip A: open	Nip A: open	On/off
89-012	Nip A: narrow	Nip A: narrow	On/off
89-013	Nip A: medium	Nip A: medium	On/off
89-014	Nip A: wide	Nip A: wide	On/off
89-015	Reg / Preheat Hatch close	Reg / preheat hatch close	On/off
89-016	Reg / Preheat Hatch open	Reg / Preheat hatch open	On/off

Table 34 Output codes 91

Code	Displayed Name	Description	General
91-016	IOD scanbar	Energizes the IOD scanbar	On/off
91-021	Carriage drive select motor	Runs the carriage drive select motor (MOT91-021) CAUTION <i>Do not run the following codes together: 91-021, 91-023, 91-031, 91-032, 91-035, 91-036. Running these codes at the same time can cause damage to the machine.</i>	On/off
91-023	HM vertical motion motor	Runs the HM vertical motion motor (MOT91-023) CAUTION <i>Do not run the following codes together: 91-021, 91-023, 91-031, 91-032, 91-035, 91-036. Running these codes at the same time can cause damage to the machine.</i>	On/off. Carriage needs to be parked prior to running this test
91-024	Printhead roll adjust motor 1	Runs the printhead roll adjust motor 1 (MOT91-024)	On/off
91-025	HM horizontal motion motor	Runs the HM horizontal motion motor (MOT91-025)	On/off
91-026	Printhead roll adjust motor 2	Runs the printhead roll adjust motor 2 (MOT91-026)	On/off
91-027	Printhead roll adjust motor 3	Runs the printhead roll adjust motor 3 (MOT91-027)	On/off
91-028	Printhead roll adjust motor 4	Runs the printhead roll adjust motor 4 (MOT91-028)	On/off
91-029	Printhead stitch adjust motor 1	Runs the printhead stitch adjust motor 1 (MOT91-029)	On/off

Table 34 Output codes 91

Code	Displayed Name	Description	General
91-030	Printhead stitch adjust motor 2	Runs the printhead stitch adjust motor 2 (MOT91-030)	On/off
91-031	Upper carriage docking	Upper carriage docking NOTE: <i>Both carriages will be docked when running either upper or lower docking sequence</i> CAUTION <i>Do not run the following codes together: 91-021, 91-023, 91-031, 91-032, 91-035, 91-036. Running these codes at the same time can cause damage to the machine.</i>	On/off
91-032	Lower carriage docking	Lower carriage docking NOTE: <i>Both carriages will be docked when running either upper or lower docking sequence</i> CAUTION <i>Do not run the following codes together: 91-021, 91-023, 91-031, 91-032, 91-035, 91-036. Running these codes at the same time can cause damage to the machine.</i>	On/off
91-033	X axis drive motor U	Runs the X axis drive motor U (MOT91-033)	On/off
91-034	X axis drive motor L	Runs the X axis drive motor L (MOT91-034)	On/off
91-035	Upper carriage ship restraint	This code is shown for information only. The machine does not have carriage restraint motors.	
91-036	Lower carriage ship restraint	This code is shown for information only. The machine does not have carriage restraint motors.	
91-043	IOD shuttle motor	Runs the IOD shuttle motor (MOT91-043)	On/off
91-044	Waste tray lock solenoid	Energizes the waste tray lock solenoid (SOL91-044)	On/off
91-045	Low pressure assist valve	Energizes low pressure assist valve (SOL91-045)	On/off

Table 35 Output codes 93

Code	Displayed Name	Description	General
93-048	Ink transport motor fwd	Ink transport motor fwd	On/off. 5 seconds timeout

Table 35 Output codes 93

Code	Displayed Name	Description	General
93-049	Ink transport motor backward	Ink transport motor backward	On/off. 5 seconds timeout
93-050	Reservoir pump	Runs the ink load air pump CAUTION <i>Do not run 93-050 at the same time as running 93-059 to 93-078. Running these codes at the same time can cause damage to the machine.</i>	On/off. Do not run at the same time as the air router solenoids
93-051	Ink key plate position 1	Ink key plate position 1	On/off
93-052	Ink key plate position 2	Ink key plate position 2	On/off
93-053	Ink key plate position 3	Ink key plate position 3	On/off
93-059	Purge Solenoid Valve 1	Purge solenoid valve 1 (printhead 2) CAUTION <i>Do not run 93-050 at the same time as running 93-059 to 93-078. Running these codes at the same time can cause damage to the machine.</i>	On/off. Do not energize at the same time as the inkload air pump
93-060	Purge Solenoid Valve 2	Purge solenoid valve 2 (printhead 4) CAUTION <i>Do not run 93-050 at the same time as running 93-059 to 93-078. Running these codes at the same time can cause damage to the machine.</i>	On/off. Do not energize at the same time as the inkload air pump
93-061	Purge Solenoid Valve 3	Purge solenoid valve 3 (printhead 1) CAUTION <i>Do not run 93-050 at the same time as running 93-059 to 93-078. Running these codes at the same time can cause damage to the machine.</i>	On/off. Do not energize at the same time as the inkload air pump
93-062	Purge Solenoid Valve 4	Purge solenoid valve 4 (printhead 3) CAUTION <i>Do not run 93-050 at the same time as running 93-059 to 93-078. Running these codes at the same time can cause damage to the machine.</i>	On/off. Do not energize at the same time as the inkload air pump
93-063	Black Ink Solenoid Valve 5	Black ink solenoid valve 5 (printhead 3) CAUTION <i>Do not run 93-050 at the same time as running 93-059 to 93-078. Running these codes at the same time can cause damage to the machine.</i>	On/off. Do not energize at the same time as the inkload air pump

Table 35 Output codes 93

Code	Displayed Name	Description	General
93-064	Black Ink Solenoid Valve 6	Black ink solenoid valve 6 (printhead 4) CAUTION <i>Do not run 93-050 at the same time as running 93-059 to 93-078. Running these codes at the same time can cause damage to the machine.</i>	On/off. Do not energize at the same time as the inkload air pump
93-065	Black Ink Solenoid Valve 7	Black ink solenoid valve 7 (printhead 1) CAUTION <i>Do not run 93-050 at the same time as running 93-059 to 93-078. Running these codes at the same time can cause damage to the machine.</i>	On/off. Do not energize at the same time as the inkload air pump
93-066	Black Ink Solenoid Valve 8	Black ink solenoid valve 8 (printhead 2) CAUTION <i>Do not run 93-050 at the same time as running 93-059 to 93-078. Running these codes at the same time can cause damage to the machine.</i>	On/off. Do not energize at the same time as the inkload air pump
93-067	Yellow Ink Solenoid Valve 9	Yellow Ink Solenoid Valve 9 (printhead 4) CAUTION <i>Do not run 93-050 at the same time as running 93-059 to 93-078. Running these codes at the same time can cause damage to the machine.</i>	On/off. Do not energize at the same time as the inkload air pump
93-068	Yellow Ink Solenoid Valve 10	Yellow ink solenoid valve 10 (printhead 2) CAUTION <i>Do not run 93-050 at the same time as running 93-059 to 93-078. Running these codes at the same time can cause damage to the machine.</i>	On/off. Do not energize at the same time as the inkload air pump
93-069	Yellow Ink Solenoid Valve 11	Yellow ink solenoid valve 11 (printhead 3) CAUTION <i>Do not run 93-050 at the same time as running 93-059 to 93-078. Running these codes at the same time can cause damage to the machine.</i>	On/off. Do not energize at the same time as the inkload air pump
93-070	Yellow Ink Solenoid Valve 12	Yellow ink solenoid valve 12 (printhead 1) CAUTION <i>Do not run 93-050 at the same time as running 93-059 to 93-078. Running these codes at the same time can cause damage to the machine.</i>	On/off. Do not energize at the same time as the inkload air pump

Table 35 Output codes 93

Code	Displayed Name	Description	General
93-071	Cyan Ink Solenoid Valve 13	Cyan ink solenoid valve 13 (printhead 4) CAUTION <i>Do not run 93-050 at the same time as running 93-059 to 93-078. Running these codes at the same time can cause damage to the machine.</i>	On/off. Do not energize at the same time as the inkload air pump
93-072	Cyan Ink Solenoid Valve 14	Cyan ink solenoid valve 14 (printhead 2) CAUTION <i>Do not run 93-050 at the same time as running 93-059 to 93-078. Running these codes at the same time can cause damage to the machine.</i>	On/off. Do not energize at the same time as the inkload air pump
93-073	Cyan Ink Solenoid Valve 15	Cyan ink solenoid valve 15 (printhead 3) CAUTION <i>Do not run 93-050 at the same time as running 93-059 to 93-078. Running these codes at the same time can cause damage to the machine.</i>	On/off. Do not energize at the same time as the inkload air pump
93-074	Cyan Ink Solenoid Valve 16	Cyan ink solenoid valve 16 (printhead 1) CAUTION <i>Do not run 93-050 at the same time as running 93-059 to 93-078. Running these codes at the same time can cause damage to the machine.</i>	On/off. Do not energize at the same time as the inkload air pump
93-075	Magenta Ink Solenoid Valve 17	Magenta ink solenoid valve 17 (printhead 1) CAUTION <i>Do not run 93-050 at the same time as running 93-059 to 93-078. Running these codes at the same time can cause damage to the machine.</i>	On/off. Do not energize at the same time as the inkload air pump
93-076	Magenta Ink Solenoid Valve 18	Magenta ink solenoid valve 18 (printhead 2) CAUTION <i>Do not run 93-050 at the same time as running 93-059 to 93-078. Running these codes at the same time can cause damage to the machine.</i>	On/off. Do not energize at the same time as the inkload air pump

Table 35 Output codes 93

Code	Displayed Name	Description	General
93-077	Magenta Ink Solenoid Valve 19	Magenta ink solenoid valve 19 (printhead 3) CAUTION <i>Do not run 93-050 at the same time as running 93-059 to 93-078. Running these codes at the same time can cause damage to the machine.</i>	On/off. Do not energize at the same time as the inkload air pump
93-078	Magenta Ink Solenoid 20	Magenta ink solenoid 20 (printhead 4) CAUTION <i>Do not run 93-050 at the same time as running 93-059 to 93-078. Running these codes at the same time can cause damage to the machine.</i>	On/off. Do not energize at the same time as the inkload air pump

Table 36 Output codes 94

Code	Displayed Name	Description	General
94-009	Drum Drive Motor Slew Speed	Runs the drum drive motor (MOT94-009) at slew speed	On/off. Motor must be home before running
94-012	Drum Drive Motor Rev	Runs the drum drive motor (MOT94-009) in reverse	On/off. Motor must be home before running. If slewing is stopped, the drum heater needs to be turned off
94-017	Drum Drive Motor Transfix Speed	Runs the drum drive motor (MOT94-009) at transfix speed	On/off. Motor must be home before running. If slewing is stopped, the drum heater needs to be turned off
94-018	Drum Drive Motor Imaging Speed	Runs the drum drive motor (MOT94-009) at imaging speed	On/off. Motor must be home before running. If slewing is stopped, the drum heater needs to be turned off

dC335 Heater Monitor and Exerciser

Purpose

To allow the heater systems of the machine to be run in specified modes and to measure the temperature of those systems. The systems include the following components:

- Printheads - operation of the reservoir and jetstack heaters for each thermal setpoint on the printheads.
- Drum - operation of the front and rear drum surface heaters.
- Registration preheat assembly (RaLPH) - operation of the registration preheat assembly heater. Select RaLPH in the component list, refer to [GP 40](#).
- Umbilical - operation of the upper and lower umbilical heaters.
- Ink loader melt plate assembly and ink melt reservoir - operation of the ink loader melt plates and the ink melt reservoir heater.

dC335 generates a graph showing the temperature of the chosen component against the target temperature.

The term 'setpoint mode' is used to describe the machine mode which defines the temperature of the heater being exercised. The four modes are:

- Ready = The heaters will run at the same operational temperature as printing copies.
- Low = Heaters running at low temperature mode. Used to conserve electrical power while still being able to quickly return to Ready / Standby
- Sleep = Very conservative heater low temperature mode. Keeping only the printheads slightly warm while the rest of the machine is allowed to cool to room temperature.
- Off = Heaters are turned off (setpoint mode value = ambient temperature)

The temperatures for each component with the associated setpoint modes are listed in [Table 1](#).

Table 1 Setpoint Temperatures

Component	Setpoint Ready	Setpoint Low	Setpoint Sleep	Setpoint Off
Printhead reservoir	115 C	105 C	95 C	Ambient
Printhead left jetstack	117 C	107 C	95 C	Ambient
Printhead right jetstack	117 C	107 C	95 C	Ambient
Drum front	55 C	51 C	Ambient	Ambient
Drum rear	55 C	51 C	Ambient	Ambient
Registration pre-heat assembly (RaLPH)	61 C	50 C	Ambient	Ambient
Umbilical upper	110 C	93 C	Ambient	Ambient
Umbilical lower	102 C	93 C	Ambient	Ambient
Ink melt reservoir	115 C	93 C	Ambient	Ambient

The ink melt plate heaters only have options for On and Off as listed in [Table 2](#).

Table 2 Ink Melt Temperatures

Component	Setpoint on	Setpoint off
Ink melt Y	120 C	Ambient
Ink melt M	120 C	Ambient
Ink melt C	120 C	Ambient
Ink melt K	120 C	Ambient

NOTE: The ink melt heater Setpoint Mode for On is displayed as 120 degrees C. This is a target temperature only. The heater will turn on for a few seconds each time it is activated. It is not intended to reach 120 degrees. Due to the risk of overflow if the ink melt is continuously activated the software will ignore the command.

Procedure

1. Enter service mode, [GP 1](#).
2. Select the Diagnostics tab.
3. Select dC335 Heater Monitor and Exerciser.
The screen displays a blank graph with options to select the required component.
4. Select a component from the menu at the bottom left of the screen.
As each component is selected the corresponding buttons will change to match the options for that component.

NOTE: If the setpoint mode of any of the printhead heaters (reservoir, left jetstack or right jetstack) is changed, the other two heaters will change to the same setpoint mode automatically. This is to ensure that the printhead is not subjected to undue stress due to temperature variation between the different heaters.

5. Select the component and options required.
6. Select the Graph button
 - The graph will display a trace indicating the temperature change in real time.
 - The green line indicates the time.
 - The blue line indicates the current temperature.
 - The yellow line indicates the target temperature.
7. To view the graph in more detail, touch the UI to zoom in. Touch the screen again to zoom out.
8. Analyze the results and take the appropriate action as required.
9. Select stop to finish monitoring the temperature of the component.
10. Select Close to return to the service mode window.
11. Select Call Closeout to exit service mode.

dC361 NVM Save and Restore

Purpose

To restore the NVM parameters of the machine to their previous values following a service action; i.e. NVM expansion, Single Board Controller (SBC) Printed Wiring Board (PWB) replacement, or any others that would necessitate a full NVM initialization. It can also be used to recover a machine's NVM values to a recent service call, in the event that a complete NVM failure occurred. As an additional tool, the ability to copy files between the hard drive and a USB drive is provided.

The NVM save to hard disk must be performed at the first service call and whenever the system software is changed.

This procedure will save and restore only the SBC, IIT and IME NVM.

NOTE: After a USB flash drive is first connected to the machine a UI screen message offering scan to and print from USB options will display. This screen message can be closed or left open before entering diagnostics without effecting the NVM save / restore processes. If you choose to close the scan to and print from USB screen message it will not reappear on exit from diagnostics. Therefore, leave this message screen open if the scan to and print from USB options are to be required after a NVM save / restore.

Procedure

NVM Save

1. If necessary, connect the USB flash drive to the USB port on the left side of the machine.
2. Enter service mode, [GP 1](#).
3. Select the Adjustments tab.
4. Select dC361 NVM Save and Restore.

The screen displays the NVM data.

NOTE:

- The top entry displays the live NVM data for the machine.
- If the data has previously been saved to the hard disk these will be displayed in a list below the live data.
- If a USB device containing NVM data is connected these will be displayed below the hard disk data. To be recognized by the machine the USB device must be connected at the time dC361 is started.

5. Save the NVM data.
 - To save the live data to the hard disk select the live data entry and select save to hard disk.
 - To save the hard disk data to a USB device select the hard disk entry and select save to USB device.
 - To save the USB data to the hard disk select the USB entry and select save to HDD.

NOTE: Data cannot be saved or restored directly to or from the USB device to the machine.

6. Select Close to return to the service mode window.
7. Select Call Closeout to exit service mode

NVM Restore

1. If necessary, connect the USB drive to the USB port on the left side of the machine.
2. Enter service mode, [GP 1](#).
3. Select the Adjustments tab.
4. Select dC361 NVM Save and Restore.

The screen displays the NVM data.

5. Restore the NVM data.
 - a. Select the entry from the available NVM data on the hard drive.

NOTE: NVM data on a USB device should be copied to the hard drive before it can be restored.

- b. Select Restore Machine NVM.

The status region at the top of the screen will report that the NVM was restored successfully.
6. Select Close to return to the service mode window.
 7. Select Call Closeout to exit service mode.

dC608 Document Feeder Registration

Purpose

This feature checks the registration of the document feeder and corrects any misalignments. The process runs automatically and does not require any user intervention other than inserting three blank sheets in the document feeder.

Procedure

1. Enter service mode, [GP 1](#).
2. Select the Adjustments tab.
3. Select dC608 Document Feeder Registration.
The screen displays the current registration values
4. Insert 3 blank A4 (or 8.5 x 11 inch) white sheets, any orientation, into the document feeder.
5. Ensure the document feeder guides are correctly adjusted.
6. Select Start.
The document feeder feeds the documents.
The screen displays the values for before and after registration.
7. Select Close to exit the routine.
8. Select Call Closeout to exit service mode

dC609 Document Glass Registration

Purpose

This feature checks the registration of the document glass and corrects any misalignments. The process runs automatically and does not require any user intervention other than keeping the document feeder open during the operation.

Procedure

1. Enter service mode, [GP 1](#).
2. Select the Adjustments tab.
3. Select dC609 Document Glass Registration
The screen displays the current registration values.
4. Open the document feeder and remove any paper from the document glass.
NOTE: *The document feeder should remain open until this procedure is complete.*
5. Select Start to run the routine.
The screen displays the values for before and after registration.
6. Select Close to exit the routine.
7. Select Call Closeout to exit service mode

dC612 Print Test Pattern

Purpose

To print the internal test patterns.

NOTE: All test prints should be printed long edge feed.

Procedure

1. Enter service mode, [GP 1](#).
2. Select the Diagnostics tab.
3. Select dC612 Print Test Pattern
4. Select the test pattern required. Refer to [IQ 1 Image Quality Entry RAP](#).
Select from the available options for the required test pattern.

NOTE: In most instances the recommended paper size is Letter/A4, but the test can be run from all trays, paper sizes or paper types.

5. Select Close to exit the routine
6. Select Call Closeout to exit service mode

NOTE: For details of test patterns, descriptions of their application, media size and other features refer to [IQ 1 Image Quality Entry RAP](#).

The test patterns that follow can be printed from dC612:

- [TP 1](#)
- [TP 2 to TP 10](#)
- [TP 11](#)
- [TP 12](#)
- [TP 13](#)
- [TP 14](#)
- [TP 15](#)
- [TP 16](#)
- [TP 17](#)

dC625 Registration / Preheat Calibration

Purpose

To manually initiate calibration of the registration / preheat assembly with the rest of the print engine.

Initial Action

Perform the following procedures:

- [dC971 Head to Head Alignment Adjustment](#).
- [dC977 Drum Runout Calibration](#).
- Ensure no missing black jets with jet substitution routine.
- Ensure the IME is ready to print by exiting service mode.

NOTE: Switch off, then switch on the machine, [GP 14](#).

NOTE: The dC625 Registration / Preheat Calibration procedure is required after replacing, removing or reinstalling:

- Registration / preheat assembly
- Horizontal paper path
- IOD sensor

Procedure

NOTE: If dC625 is run directly after the machine is switched on, a cleaning unit pump diagnostic cycle may run during calibration. After printing several calibration printouts, the machine may raise a cleaning unit communication error instructing the cleaning unit be re-installed. This causes the calibration to fail. After re-installing the cleaning unit, the machine raises fault 94-532 DMU oil pump over current. If this occurs, re-install the cleaning unit, switch off, then switch on the machine, [GP 14](#). Make at least 20 copies then re-start dC625.

1. If performing this procedure directly after installing a new cleaning unit or switching on the machine, make at least 20 copies before performing dC625.
2. Enter service mode, [GP 1](#).
3. Select the Adjustments tab.
4. Select dC625 Registration / Preheat Calibration.
5. Follow the on screen instructions.
6. Select Start and the process runs.
7. The Registration / Preheat Calibration in Progress screen appears.
 - Prints a registration image on up to 30 sheets of plain white paper (A4 or 8.5 x 11 LEF) as per chase sheet selection.
 - The printed registration calibration pages ([TP 24](#)) are fed back through the registration / preheat assembly via the duplex paper path.
 - Registration image is read by the CIS scan bar located on the registration / preheat assembly:
 - The adjustment is made automatically after 30 successful scans are analyzed.
8. Select Close to exit the routine.
9. Select Call Closeout to exit service mode.

dC640 Video Path Integrity

Purpose

The Video Path Integrity test validates the video path within the single board controller.

Procedure

1. Enter service mode, [GP 1](#).
2. Select the Diagnostics tab.
3. Select dC640 Video Path Integrity.
4. Select Start to run the test. A screen displays the progress. During the test, the machine performs the following check:
 - a. A golden test pattern is held within the machine. This pattern is not a printable image but is data that is used as a standard for comparison to data generated by, and transmitted through the machine.
 - b. A test pattern is generated and transferred to EPC memory. The test pattern is compared to the golden test pattern for verification.
 - c. An image is then transferred from EPC to the single board controller PWB. The image is then compared to the golden test pattern.
5. At the end of the test a pass / fail result is returned on the UI.
6. Select Close to exit the routine.
7. Select Call Closeout to exit service mode and return to the original procedure.

dC708 Drum Drive Control Test

Purpose

The Drum Drive Control Test is used to perform diagnostic tests on the Drum Drive Subsystem.

Before running the Drum Drive Control Test the following PEST (Print Engine Self Test) errors should be checked and cleared. The PEST Fault History can be accessed at [dC123](#).

- 99-880 Motor, Drum drive open
- 99-881 Motor, Drum drive short
- 99-882 Motor, Drum drive power low
- 99-883 Motor, Drum drive power high
- 99-886 Motor, Drum drive current feedback
- 99-887 Motor, Drum drive thermal fuse

For any of these faults perform [99-872-00](#) to [99-887-00](#) PEST Error 40 RAP.

NOTE: On issue of the service manual (March 2011), [dC708](#) was considered to be unreliable. Therefore, it is advisable to go to [dC122](#) Fault History and [dC123](#) PEST Fault History then check for drum drive related faults.

Procedure

1. Enter service mode, [GP 1](#).
2. Select the Diagnostics tab.
3. Select dC708 Drum Drive Control Test.
4. Select Start.
5. At the end of the routine the test results will be displayed. Refer to [94B](#) Drum Drive Control Test Actions RAP for actions resulting from faults indicated by the test.
6. Select Close to exit the routine.
7. Select Call Closeout to exit service mode.

dC715 Active Registration Control

Purpose

Active registration is a feature of the machine that ensures the media is in the best registration by correcting inboard and outboard variance and eliminating skew.

Procedure

Active registration is normally set to on. However, if a paper feed problem occurs, active registration can make it difficult to identify where a problem is occurring.

The dC715 Active Registration Control enables the engineer to disable active registration to help diagnose paper feed problems. When active registration is disabled, the machine will operate in a degraded mode until re-enabled or reset. Once the paper path is optimized, active registration would be set back to enabled before ending the service call.

If the engineer forgets to re-enable active registration, the system will automatically return to enabled during machine power on or system reset. A message will indicate when active registration has been disabled.

Perform the following:

1. Enter service mode, [GP 1](#).
2. Select the Diagnostics tab.
3. Select dC715 Active Registration Control.
4. Select Disabled and follow the on screen instructions.
5. Select Close to exit the routine.
6. If required select Call Closeout to exit service mode while determining the source of the paper feed problem.
7. Run a series of copy / print jobs, from different trays, simplex and duplex pathways.
8. Identify the cause of the problem and take the appropriate action.
9. When the problem has been corrected return to dC715 and select Enable in the routine.
10. Select Close to exit the routine.
11. Select Call Closeout to exit service mode.

dC914 Head to Head Alignment Test

Purpose

The dC914 Head to Head Alignment Test is a set of internal test routines to help identify head to head alignment issues.

NOTE: Ensure that the front door interlock switch is cheated when running the routines.

Procedure

1. Enter service mode, [GP 1](#).
2. Select the Diagnostics tab.
3. Select dC914 Head to Head Alignment Test.
4. There are 10 routines listed under Test Options.

Select the component to test from the list.

• Move IOD Scan Bar

- a. Remove the cleaning unit, refer to [REP 94.1](#).
- b. Remove the abatement plenum, [REP 91.36](#).
- c. Select the required position from the drop down menu:
 - Home
 - Park
 - Front
 - Rear
- d. Select Set Position to begin the test and move the IOT scan bar to the selected position.

NOTE: If an error occurs the IME will stop the test and report the appropriate error message.

- e. Reinstall the cleaning unit and the abatement plenum.
- f. Select another test or Close the window and select Call Closeout.

• Move Upper Stitch Motor/Move Lower Stitch Motor

NOTE: The procedure is the same for each stitch motor.

- a. Fully open the marking unit for observation, [GP 6](#).
- b. Select the required test option to move the motor and observe the motion

NOTE: If an error occurs the IME will stop the test and report the appropriate error message.

- c. Close the marking unit after observing the motor, [GP 6](#).
- d. Select another test or Close the window and select Call Closeout.

NOTE: The printheads will be unaligned whenever a stitch motor is moved. Refer to [dC971 Head to Head Alignment Adjustment](#) to align printheads.

• Move Roll Motor 1, 2, 3 or 4

NOTE: There is one roll motor per printhead (1, 2, 3 and 4).
The procedure is the same for each motor.

- a. Fully open the marking unit for observation, refer to [GP 6](#).

- b. Select the required test option to move the motor:

- Start Motion
- Observe Motion

NOTE: If an error occurs the IME will stop the test and report the appropriate error message.

- c. Close the marking unit after observing the motor, refer to [GP 6](#).
- d. Select another test or Close the window and select Call Closeout.

NOTE: The printheads will be unaligned whenever a roll motor is moved. Refer to [dC971 Head to Head Alignment Adjustment](#) to align printheads.

NOTE: If a large roll motion is performed, Y norm (process direction) may be out of calibration.

• Move Upper Carriage Motor/Move Lower Carriage Motor

NOTE: There is one motor for each carriage:

- Lower carriage – directly attached to head 3 (anchor head)
- Upper carriage – directly attached to head 4

The procedure is the same for each motor.

- a. Fully open the marking unit for observation, [GP 6](#).
- b. Select the required test option to move the motor.
 - Home Motor
 - Observe Motion

NOTE: If an error occurs the IME will stop the test and report the appropriate error message.

- c. Close the marking unit after observing the motor.
- d. Select another test or close the window and select Call Closeout.

NOTE: The printheads will be unaligned whenever a carriage motor is moved. Refer to [dC971 Head to Head Alignment Adjustment](#) to align printheads.

• Measure Head Alignment

NOTE: This routine will measure the head alignment using a front scan and then a rear scan. No adjustments will be made. If a fault occurs on either scan, the scan will terminate and the appropriate chain-link-extension will be returned.

- a. Select Measure to measure the head alignment.
- b. The results are combined into a table for analysis (values that are not applicable to a particular scan are left blank for clarity).
- c. Select another test or Close the window and select Call Closeout.

5. After moving any motor run [dC971 Head to Head Alignment Adjustment](#)

dC959 Cleaning Unit Exerciser

Purpose

To observe the cleaning unit routines in action to troubleshoot problems with drum cleaning, lubrication, copy quality and paper handling.

The Cleaning Unit Exerciser provides the following features:

- To cycle and observe operation of the cleaning unit while in the normal installed position.
- To operate drum cleaning in slow speed mode for difficult to observe problems.
- To perform an internal cleaning unit self test.
- To print specific test patterns to diagnose problems related to drum maintenance.

Procedure

1. Enter service mode, [GP 1](#).
2. Select the Diagnostics tab.
3. Select dC959 Cleaning Unit Exerciser.
4. Select a routine:

NOTE: Follow the instructions on screen before starting these routines. The cleaning unit must be installed before running the self test.

- Self Test - the result will be displayed on the screen, see [Table 1](#).
- Full Speed Exerciser - the drum will rotate at full speed for about 2 seconds.
- Slow Speed Exerciser - the drum will rotate at slow speed for about 8 seconds.

Print Test Patterns:

- Black Solid Fill ([TP 2 to TP 10](#))
- Oil Bar Chase Test Page ([TP 20](#))

NOTE: Before printing test pattern [TP 5](#) or [TP 20](#), ensure that A4 or 8.5 x 11 inch plain paper is loaded LEF into tray 4. Use the best quality media available. Do not use hole punched paper.

NOTE: The cleaning unit self test requires approximately 2 minutes and the result will be shown on the UI screen. Refer to [Table 1](#).

5. When the tests are complete, select Close to exit routine.
6. Select Call Closeout to exit service mode.

Table 1 Self test results

Self Test Result	Self Test Result Message
0	Self Test was successful
1	Vacuum control failure
2	Fluid flow rate failure
3	Cleaner unit / drum contact test failure
4	Cleaner unit lift test failure
5	Delivery pump test failure
6	Removal pump test failure

dC962 Transfix Load Test

Purpose

To test the transfix load system by performing the following:

- Home the transfix load system and verify the position
- Load transfix system – record load of the transfix front and rear
- Unload transfix system – record unload of the transfix front and rear

NOTE: The transfix load test does not run media as part of the test. If a fault has been indicated while printing but that fault cannot be replicated when running this test then a media related problem may be indicated.

NOTE: The transfix load test may return no failure results even when a transfix load issue is present. Print quality, noise or other symptoms may not be captured by this test.

Procedure

1. Enter service mode, [GP 1](#).
2. Select the Diagnostics tab.
3. Select dc962 Transfix Load Test.
4. Select Start to automatically begin the transfix load test.
 - Home the transfix load system (approximately 2 seconds)
 - Load the transfix system (approximately 30 seconds)
 - Unload the transfix system (approximately 30 seconds)
5. On completion of the test the results table opens. Refer to [Table 1](#).

Table 1 Test results

Reference	Fault Description
10-500	Insufficient front transfix load force
10-505	Insufficient rear transfix load force
10-510	Transfix load timing error
10-515	Transfix load position error
10-521	Transfix load front position error
10-522	Transfix load rear position error
10-523	Transfix unload front position error
10-524	Transfix unload rear position error
10-525	Transfix load home motor disable failure
10-530	Transfix gap set failure
10-535	Transfix load calibrate failure
10-537	Transfix load reverse home timeout front
10-538	Transfix load reverse home timeout rear

6. If errors are indicated go to [10-500-00](#) to [10-540-00](#) Transfix Error RAP after exiting service mode.
7. Select Close to return to dc962 Transfix Load Test window.
8. Select Close to return to service mode window.
9. Select Call Closeout to exit service mode.

dC965 Printhead Maintenance Cycle Test

Purpose

To run the printhead wiping cycle while the marking unit drawer is in the open position.

Procedure

WARNING

Switch off the electricity to the machine. Refer to GP 14. Disconnect the power cord from the customer supply while performing tasks that do not need electricity. Electricity can cause death or injury. Moving parts can cause injury.

To enable the marking unit drawer to operate in the open position requires the waste tray to be in position. The waste tray interlock will be ignored (bypassed by software) and normal purge replaced by low pressure assist (LPA).

Perform the following:

1. Open the front door.
2. Remove the inner cover, [PL 81.11 Item 2](#).
3. Insert an interlock cheater in the front door interlock switch assembly.
4. Enter service mode, [GP 1](#).
5. Select the Diagnostics tab.
6. Select dC965 Printhead Maintenance Cycle Test.
7. Select Start.

The IME will position the printhead carriages away from the drum in the parked position.

Once the two carriage assemblies are parked, follow the instructions on the screen.

- a. Move the marking unit into the service position, [GP 6](#).
- b. Reinstall the waste tray under the marking unit.

CAUTION

The waste tray must be installed under the opened marking unit during the wiping cycle test to capture melted ink.

NOTE: *The waste tray is attached to the underside of the marking unit assembly by 2 lugs at the rear and 1 lug at the front.*

- c. Select Continue on the user interface.
 - d. Select which carriage (upper, lower or both) to perform the wiping action.
 - Upper = Printheads 2 and 4
 - Lower = Printheads 1 and 3
 - Both = Printheads 1, 2, 3, 4
- The Printhead wiping cycle will run for approximately 3 minutes for 1 carriage or 5 minutes for 2 carriages.
- e. On completion of the printhead wiping cycle, select a different carriage if required.
 - f. Select Finish on the user interface.
 - g. Move the marking unit back into the operational position, [GP 6](#).
8. Select [dC968 Head Purge](#) to print a cleaning page.

NOTE: *It is not necessary to perform a full head purge.*

9. Return to dC965 once the cleaning pages have printed.

10. Select Close to return to the service mode window.
11. Exercise all colors by printing test print TP 1, refer to [dC612 Print Test Patterns](#).
12. Select Call Closeout to exit service mode.

dC967 Head to Drum Spacing Check

Purpose

To check the head to drum spacing. The procedure checks for contact between each printhead and the drum.

This check will run automatically if a new printhead serial number is detected during power-up. The dc967 window will not be present, but a status message will reflect this check is taking place.

If a printhead is reinstalled (not replaced) in the same position on a carriage, the machine will not recognize it as new during power-up, and this check will not automatically occur. To prevent carriages from automatically docking during power-up, boot the machine directly into IME Diagnostics Mode, [GP 1](#) and then proceed to step 1 anytime a printhead has been reinstalled.

Procedure

The procedure normally takes approximately 7 - 10 minutes to run and cannot be stopped once in operation.

NOTE: The dC967 routine will stop if potential printhead to drum contact is detected. If potential printhead to drum contact is identified, perform [ADJ 91.1 Printhead Attachment Check](#).

Perform the following:

1. Enter service mode, [GP 1](#).
2. Select the Diagnostics tab.
3. Select dC967 Head to Drum Spacing Check.
4. Select Start. The following sequence of events are controlled by the IME:
 - The IME brings the printhead and drum to operating temperature.
 - The drum is stopped.
 - Both the upper and lower carriage assemblies are placed into the docked position.
 - The upper carriage assembly is parked while the lower carriage is docked and the process is reversed.
 - Once the temperature measurements are complete, the IME will move the carriage assemblies into the parked position.
 - Results are reported:
 - Passed.
 - Head to Drum Spacing Check Failed.
5. Select Start to repeat the process or Close to exit the procedure.
6. Select Close to return to the service mode window.
7. Select Call Closeout to exit service mode.

dC968 Head Purge

Purpose

To force ink through all jets on the selected printheads.

Initial Actions

Before running this routine check the following:

- Sufficient ink must be available for each colour.
- The waste tray must not be full.
- A4 or letter size paper should be loaded.
- The IME is ready to print.

NOTE: All test prints should be printed long edge feed.

Procedure

1. Enter service mode, [GP 1](#).
2. Select the Maintenance tab.
3. Select dC968 Head Purge.

The dC968 Head Purge window opens. Follow the on screen instructions.

NOTE: The main head purge screen has 3 selectable routines:

- Jet test pages ([TP 21](#))
 - Cleaning pages ([TP 22](#))
 - Purge head routine
4. Select Jet Test Pages. The machine will run the jet test routine which will print 2 pages for each colour.

NOTE: Before printing the jet test page, ensure that A4 or 8.5 x11 inch plain paper is loaded LEF into tray 4. Use the best quality media available. Do not use hole punched paper.
 5. Use the jet test pages to identify any defective heads. Refer to [TP 21](#) Jet Test Pages to interpret the jet test output.

CAUTION

Empty the waste tray before purging the heads. When the waste tray has been emptied touch the Reset Waste Counter button.

6. Select head 1, 2, 3 or 4 from the Purge Heads buttons and touch the Purge button to start the purge routine.

NOTE: The Head Purge routine takes from 4 to 8 minutes depending on the number of heads selected.

When the heads have finished purging the machine will run a cleaning page for the purged heads. Depending on the number of heads purged the machine will print 1 or 2 cleaning pages with 2 heads cleaned on each page.

7. Select Jet Test Pages.

The machine will run the jet test routine which will print 2 pages for each colour.
8. Inspect the Jet Test Pages. If a defect is found repeat the procedure.
9. Select Close to return to the maintenance window.
10. Select Call Closeout.

dC969 Clean Ink Smears

Purpose

To remove all unwanted ink from the registration / preheat assembly to liquefy any unwanted ink.

NOTE: All test prints should be printed long edge feed.

Procedure

1. Enter service mode, GP 1.
2. Select the Maintenance tab.
3. Select dC969 Clean Ink Smears.

NOTE: This procedure must run to completion. To stop the routine would require excessive time to recover and add to customer/service cost. The full procedure takes approximately 6 minutes to complete.

4. Select Start. The following actions occur:
 - The temperature of the registration / preheat assembly is increased to loosen ink for removal. The warm-up procedure takes approximately 30 seconds.
 - 10 sheets of A4 size (or 8.5 x 11) plain paper are fed in long edge feed through the duplex path to absorb and remove the unwanted ink:
 - The first 5 sheets are biased inboard (toward the rear).
 - The next 5 sheets are biased outboard (toward the front).

NOTE: Running the 10 sheets takes approximately 1 minute.

- The temperature is set to return to normal.
- A number of sheets, up to 25 are fed through the simplex path to cool the registration / preheat assembly to normal operating temperature:

NOTE: Running the cool down chase sheets requires approximately 2 minutes but will vary according to local conditions.

5. If a chase sheet paper jam occurs during the procedure the registration / preheat assembly is locked until it cools to a safe normal operating temperature.

NOTE: The procedure can be repeated as necessary until all ink smears are removed.

6. Select Close to return to the maintenance window.
7. Select Call Closeout to exit service mode.

dC971 Head to Head Alignment Adjustment

Purpose

To adjust the head to head alignment for all four printheads.

Procedure

The procedure normally takes approximately 2 minutes to run and cannot be stopped once in operation. If it is necessary to run dC968 Head Purge the total procedure for Head to Head Alignment Adjustment will increase to 10 minutes.

Perform the following:

1. Enter service mode, GP 1.

NOTE: To adjust head to head alignment there can be no more than 10 missing jets in total across all 4 printheads. To find out the number of missing jets:

- a. Select the Maintenance tab.
- b. Select dC968 Head Purge to print jet test pages.
- c. If there are excessive missing jets run the Head Purge routine before adjusting.

2. Select the Adjustments tab
3. Select dC971 Head to Head Alignment Adjustment. The Head to Head Alignment Adjustment window opens.
4. Select the relevant routine:
 - Head to Head Alignment Adjust
 - Head to Head Without Recovery
 - Set Alignment Baseline
5. Follow the on screen instructions. Select Start to run the routine.

NOTE: A head purge is required before head alignment can be performed. If a head purge has not been carried out prior to the head alignment dC971 will automatically purge the printheads and report head to head alignment failure. Running dC971 after the heads have been purged will complete the alignment procedure.

6. If head to head alignment fails refer to dC122, Fault History, and perform the RAP for the error code indicated.
7. Select Close to exit the routine.
8. Select Call Closeout to exit service mode.

dC972 Printhead Uniformity

Purpose

To adjust the printheads and jets to maintain uniform image quality.

Printhead Uniformity adjusts individual printheads and jets for image quality. Printhead characteristics change during use and at different rates. This procedure adjusts the printheads to compensate for any change in their characteristics.

Media Requirements

The required media size is A4 or 8.5x11 inch. Use the best quality, bright white plain paper available. Do not use glossy, colored, preprinted or punched media. Do not mix media types.

Use media that is as close as possible to 90gsm (24lb) and 98 brightness.

NOTE: In North America only, the brightness rating is printed on the paper ream wrapper.

Do not use card stock or media less than or equal to 18lbs (68 gsm). Failure to follow media requirements may result in incorrect adjustments.

Refer to [Table 1](#) for the required media quantity and routine duration.

Table 1 Media and time requirements

Option	Required Media Quantity	Duration (minutes)
1. Printhead Uniformity - Manual (runs options 2 through 5)	17 sheets.	18 - 32
1. Printhead Uniformity - Automatic (runs options 2 through 5)	8 sheets.	9 -24
2. Head to Head Alignment Adjust	N/A	1 -3
3. Head to Head Uniformity - Manual	13 sheets.	6 -18
3. Head to Head Uniformity - Automatic	6 sheets.	2
4. TRC Generation - Manual	2 sheets.	6
4. TRC Generation - Automatic	N/A	N/A
5. Y Dot Position Correction	N/A	4 - 8
6. Reset Head Uniformity Data	N/A	Less than 1

General Guidelines

NOTE: The order of adjustments is important and must be performed in numerical order (except option 6) unless instructed otherwise.

- When instructed to run dC972 without any options specified, run the manual Printhead Uniformity (Option 1).
- When instructed to run dC972 without manual or automatic specified, choose manual.
- The Reset Head Uniformity Data routine (option 6) deletes the current adjustments (non-recoverable) and restores the manufacturing settings. Only perform this routine if instructed.
- The printer will save the adjustments after each option. If something interrupts the completion of a selected option, restart from the beginning of the interrupted option.

- The automatic dC972 runs periodically in the background during periods of inactivity and does not require user intervention. It is only to be used when specifically directed.

Procedure

Perform the following:

1. Load at least 40 sheets of the required media into tray 3. To guarantee that tray 3 is used, open all other trays.
2. Enter service mode, [GP 1](#).
3. Select the Adjustments tab.
4. Select dC972 Printhead Uniformity.
5. The routine provides 6 options:
 - a. [Option 1 - Printhead Uniformity](#)
 - b. [Option 2 - Head to Head Alignment Adjust](#)
 - c. [Option 3 - Head to Head Uniformity](#)
 - d. [Option 4 - TRC Generation](#)
 - e. [Option 5 - Y Dot Position Correction](#)
 - f. [Option 6 - Reset Head Uniformity Data](#)
6. Select Close to return to the Adjustment routines window.
7. Select Call Closeout, then Exit Only to exit service mode.

NOTE: If an option fails to complete, go to [Fault Recovery](#).

Option 1 - Printhead Uniformity

NOTE: The Printhead Uniformity routine (option 1) runs options 2 through 5.

The routine provides the following options:

- Select Heads 1, 2, 3 or 4 - Select required printheads. It is recommended that all printheads are selected, irrespective of which printhead was replaced.
- Manual - Select for best results, this requires test patterns to be scanned using the DADH. Manual operation is recommended for printhead calibration.
- Auto - Refer to [General Guidelines](#).
- Start - Select to run the routine. Follow the instructions on the UI.

For additional information and checks that must be performed before running Option 1, refer to:

- [Option 2 - Head to Head Alignment Adjust](#)
- [Option 3 - Head to Head Uniformity](#)
- [Option 4 - TRC Generation](#)
- [Option 5 - Y Dot Position Correction](#)

Option 2 - Head to Head Alignment Adjust

The routine aligns the printheads with X-stitch, Y-stitch and roll adjustments automatically and requires no intervention. This is the same routine as [dC971](#) Head to Head Alignment Adjust.

Start - Select to run the routine.

During the routine:

1. The test image is printed and scanned on the drum, then cleaned off. No pages are printed.

Option 3 - Head to Head Uniformity

The routine balances the color intensity in solid fills across all 4 printheads. The routine provides the following options:

- Manual - Select for best results - Internal test patterns are printed. Manual is recommended for printhead calibration.
- Auto - Refer to [General Guidelines](#).
- Print Test - Select to print the colour bands test print, refer to [TP 26 Printhead Uniformity / Colour Bands Test Page](#).

NOTE: Before printing TP 26, ensure that A4 or 8.5 x 11 inch plain paper is loaded LEF into tray 4. Use the best quality media available. Do not use hole punched paper.

NOTE: TP 26 can be printed to check image quality before or after running the routine. TP 26 is not scanned when the routine is run.

- Start - Select to run the routine. Follow the instructions on the UI.

Before the starting the routine:

1. Ensure enough of the correct media is loaded, refer to [Media Requirements](#).
2. To prevent registration errors, ensure nothing is placed on the DADH top cover.
3. Check that at least 1 full ink stick of each colour is loaded. If necessary, load additional ink sticks.
4. To prevent document skew, ensure the DADH document width guides are correctly adjusted.
5. Check that the CVT glass is clean. If necessary, clean the CVT glass, refer to [ADJ 62.1 Optics Cleaning Procedure](#).

During the routine:

1. The machine performs automatic checks. If necessary, an error window will open requesting a [dC968 Head Purge](#), a [dC971 Head to Head Alignment Adjustment](#) or a [dC977 Drum Runout Calibration](#). After performing the requested routines, re-enter [dC972](#), option 3.
2. The machine will print 3 sets of cleaning pages. A [dC971 Head to Head Alignment Adjustment](#) will then run. A new CLD baseline is created.
3. An internal test pattern is printed, [Figure 1](#). The test pattern must be scanned using the DADH. Scan the test pattern SEF in the orientation shown in [Figure 2](#) with the arrows pointing in the direction of feed. If this fails, a new test pattern will be printed. Use the new test pattern each time this step is repeated. This step may have to be repeated up to 10 times, not including test patterns printed after failed attempts.

After successful completion of the routine:

1. Perform Option 4 TRC Generation - Manual, then Option 5 Y Dot Position Correction.

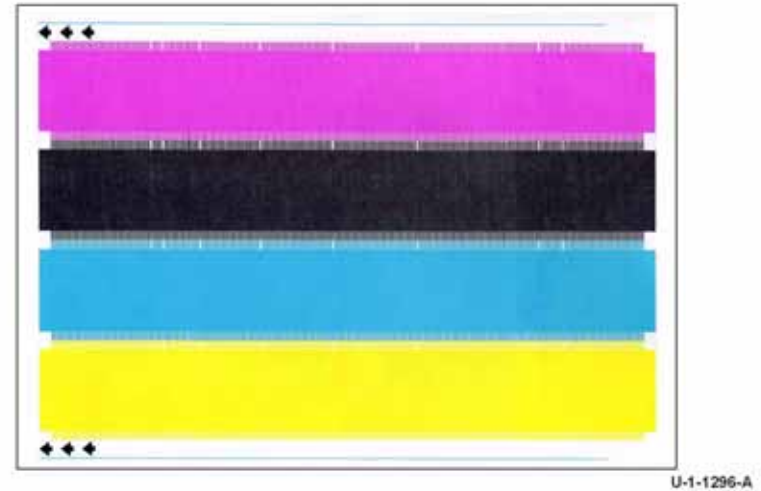
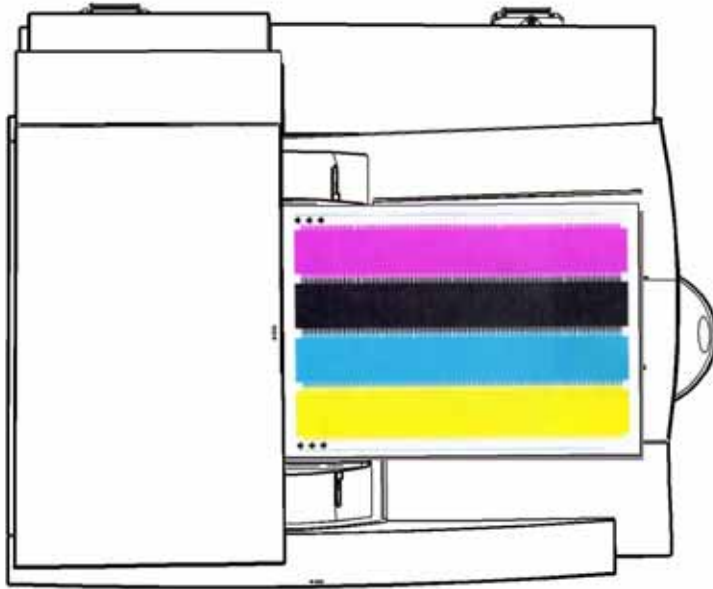

Figure 1 Test print order



U-1-1407-A

Figure 2 Test prints orientation

Option 4 - TRC Generation

The routine balances the color intensity in dithers across all 4 printheads. The routine provides the following options:

- Print Test button - Select to print Test Pattern 18. Refer to [TP 18 TRC Generation Test Pages](#).

NOTE: Before printing TP 18, ensure that A4 or 8.5 x 11 inch plain paper is loaded LEF into tray 4. Use the best quality media available. Do not use hole punched paper.

NOTE: TP 18 can be printed to check image quality before or after running the routine. TP 18 is not scanned when the routine is run.

- Start - Select to run the routine.

Before starting the routine:

1. Ensure enough of the correct media is loaded, refer to [Media Requirements](#).
2. To prevent registration errors, ensure nothing is placed on the DADH top cover.
3. Check that at least 1 full ink stick of each colour is loaded. If necessary, load additional ink sticks.
4. To prevent document skew, ensure the DADH document width guides are correctly adjusted.

5. Check that the CVT glass is clean. If necessary, clean the CVT glass, perform [ADJ 62.1 Optics Cleaning Procedure](#).

During the routine:

1. The machine performs automatic checks. If necessary, an error window will open requesting a [dC968 Head Purge](#), a [dC971 Head to Head Alignment Adjustment](#) or a [dC977 Drum Runout Calibration](#). After performing the requested routines, re-enter [dC972](#), option 4.
2. The machine will print 3 sets of cleaning pages. A [dC971 Head to Head Alignment Adjustment](#) will then run.
3. Two internal test patterns are printed. The test patterns must be scanned using the DADH. Scan the test patterns SEF in the order shown in [Figure 3](#) and in the orientation shown in [Figure 4](#) with the arrows pointing in the direction of feed.

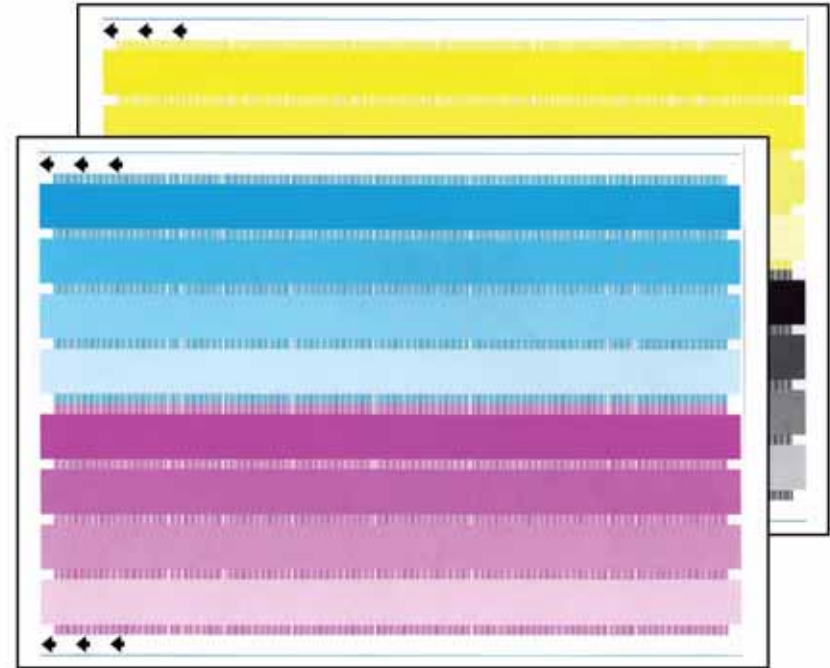

U-1-1295-A

Figure 3 Test prints order

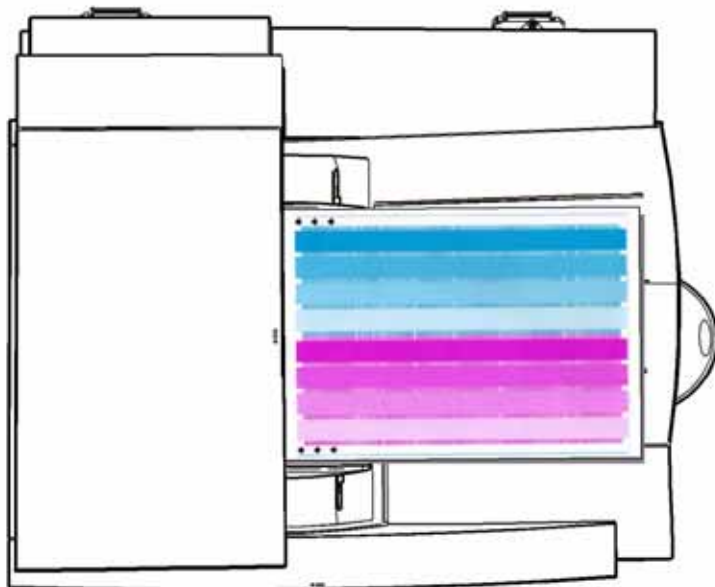

U-1-1408-A

Figure 4 Test prints orientation

Option 5 - Y Dot Position Correction

The routine ensures that all ink drops are deposited on the drum in the correct location in the process direction. The routine provides the following options

- Select Heads 1, 2, 3 or 4 - Select all printheads unless specifically directed otherwise.
- Print test - Select to print test pattern 19. Refer to [TP 19](#) Y-Dot Position Correction Test Page.

NOTE: Before printing TP 19, ensure that A4 or 8.5 x 11 inch plain paper is loaded LEF into tray 4. Use the best quality media available. Do not use hole punched paper.

NOTE: TP 19 can be printed to check image quality before or after running the routine. TP 19 is not scanned when the routine is run.

- Start - Select to run the routine.

Before starting the routine:

1. The machine will perform a head to head alignment.

During the routine:

1. The test image is printed and scanned on the drum, then cleaned off. No pages are printed.

Option 6 - Reset Head Uniformity Data

CAUTION

The routine deletes the current adjustments (non-recoverable) and restores the manufacturing settings. Only perform this routine if specifically instructed.

The routine provides the following options:

- Printheads 1, 2, 3 or 4 - Select the required printheads.
- Start - Select to run the routine.

After completion of the routine:

1. Perform Printhead Uniformity - Manual (option 1) to re-calibrate the printheads.

Fault Recovery

If the adjustment routine fails or an error is displayed, perform the relevant action in [Table 2](#).

Table 2 Fault recovery

Fault	Action
A Service Code may indicate faults with dC972 adjustments.	Go to OF 12 Service Code RAP. Perform the relevant procedures. Correct the service fault, then re-enter the adjustment procedure at the step that was interrupted.
A generic fault window, Figure 5 .	The text in the fault window has suggestions for identifying and correcting common faults. It is not a checklist of everything that must be corrected. Specific faults can be: <ul style="list-style-type: none"> • A calibration related device fault. Refer to Calibration Related Device Faults. • Colour mixing. Go to the IQ 14 Some Colours Uneven RAP. Perform each corrective action, then re-enter the adjustment procedure at the step that was interrupted.
A fault window with one of these error messages: <ul style="list-style-type: none"> • Ink needs to be added. • Load 8.5 x 11 or A4 LEF paper into a paper tray. • Head purge needs to be performed. • Head to head alignment adjust needs to be performed. • Drum run out needs to be performed. 	Perform the corrective actions, then retry the adjustment procedure.
A fault window with this warning message: Step 1 Unable to Scan Test Prints - Iteration <#>.	Correctly load the test prints, refer to Figure 1 , Figure 2 , Figure 3 and Figure 4 . Follow the instructions on the UI. If the test prints were loaded correctly, check for a calibration related device fault. Refer to Calibration Related Device Faults .

Table 2 Fault recovery

Fault	Action
The progress bar stops at 99% or stops updating.	An internal communications error occurred. Re-run the incomplete dC972 adjustment. If canceling the adjustment does not work, switch the machine off, then on, GP 14. Retry the adjustment procedure from the step that was interrupted.
The UI reboots during dC972 adjustment and machine goes offline.	Login in as, or contact the system administrator, then put the machine back online. Re-run the dC972 adjustment.



U-1-1424-A

Figure 5 Generic fault window

Calibration Related Device Faults

Check dC122 Fault History for any of the faults listed below. If any of the fault codes are found, perform the relevant RAP:

- 91-513-00 IOD shuttle motor current inconsistent with expected value.
- 91-514-00 IOD drive stall.
- 91-519-00 Printhead 1 NVM error detected.
- 91-520-00 Printhead 2 NVM error detected.
- 91-521-00 Printhead 3 NVM error detected.
- 91-522-00 Printhead 4 NVM error detected.
- 91-581-00 IOD home timeout.
- 91-583-00 IOD stall recovery failed.
- 91-630-00 IOD scan process failed.
- 91-636-00 IOD in degraded mode.
- 91-637-00 IOD Y runout adjustment needed.
- 91-638-00 IOD detects chronic jet error.
- 91-655-00 Printhead 1 field corrections corrupt.

- 91-656-00 Printhead 2 field corrections corrupt.
- 91-657-00 Printhead 3 field corrections corrupt.
- 91-658-00 Printhead 4 field corrections corrupt.
- 91-669-00 The registration / preheat assembly could not correct for media skew.
- 91-670-00 The expected image did not match the scanned image.
- 91-671-00 The test pattern fiducials (on/off line pattern) for jet alignment could not be found.
- 91-672-00 Too many missing jets were detected to perform the operation.
- 91-673-00 The machine has detected a floating point calculation error.
- 91-674-00 The required voltage or normal adjustment exceeds the maximum on printhead 1.
- 91-675-00 The required voltage or normal adjustment exceeds the maximum on printhead 2.
- 91-676-00 The required voltage or normal adjustment exceeds the maximum on printhead 3.
- 91-677-00 The required voltage or normal adjustment exceeds the maximum on printhead 4.
- 91-678-00 Voltage and/or norm adjustment can not bring printhead 1 into tolerance.
- 91-679-00 Voltage and/or norm adjustment can not bring printhead 2 into tolerance.
- 91-680-00 Voltage and/or norm adjustment can not bring printhead 3 into tolerance.
- 91-681-00 Voltage and/or norm adjustment can not bring printhead 4 into tolerance.
- 91-683-00 Printhead 1 TRC read failed.
- 91-684-00 Printhead 2 TRC read failed.
- 91-685-00 Printhead 3 TRC read failed.
- 91-686-00 Printhead 4 TRC read failed.
- 91-687-00 Printhead 1 TRC write failed.
- 91-688-00 Printhead 2 TRC write failed.
- 91-689-00 Printhead 3 TRC write failed.
- 91-690-00 Printhead 4 TRC write failed.
- 91-695-00 IOD excessive Y position noise.
- 91-696-00 IOD excessive X position noise.
- 91-697-00 IOD excessive roll position noise.
- 91-698-00 IOD excessive stitch or roll misalignment.
- 91-699-00 IOD stitch / roll motors not zeroed.
- 91-701-00 IOD head 1 roll: not converging.
- 91-702-00 IOD head 1 roll: position limit.
- 91-703-00 IOD head 1 X: not converging.
- 91-704-00 IOD head 1 X: position limit.
- 91-705-00 IOD head 1 Y: not converging.
- 91-706-00 IOD head 1 Y: position limit.
- 91-707-00 IOD head 2 roll: not converging.
- 91-708-00 IOD head 2 roll: position limit.
- 91-709-00 IOD head 2 X: not converging.
- 91-710-00 IOD head 2 X: position limit.
- 91-711-00 IOD head 2 Y: not converging.
- 91-712-00 IOD head 2 Y: position limit.
- 91-713-00 IOD head 3 roll: not converging.
- 91-714-00 IOD head 3 roll: position limit.
- 91-715-00 IOD head 4 roll: not converging.
- 91-716-00 IOD head 4 roll: position limit.
- 91-717-00 IOD head 4 X: not converging.
- 91-718-00 IOD head 4 X: position limit.

- 91-719-00 IOD head 4 Y: not converging.
- 91-720-00 IOD head 4 Y: position limit.
- 91-721-00 IOD calibration.
- 91-722-00 IOD calibration 2D.
- 91-725-00 IOD target.
- 91-726-00 IOD target: missing.
- 91-727-00 IOD target: corrupted.
- 91-728-00 IOD target: missing or corrupted.
- 91-729-00 IOD target: Y position out of range.
- 91-730-00 IOD target: Y position out of far range.
- 91-732-00 The IOD detects printhead 3 Y axis is at the limit of travel.
- 91-735-00 IOD non-static scanbar artifact.
- 91-736-00 IOD static scanbar artifact.
- 91-807-00 Attempt to read or write printhead 1 NVM HAY or HAU sections failed.
- 91-808-00 Attempt to read or write printhead 2 NVM HAY or HAU sections failed.
- 91-809-00 Attempt to read or write printhead 3 NVM HAY or HAU sections failed.
- 91-810-00 Attempt to read or write printhead 4 NVM HAY or HAU sections failed.
- 91-811-00 Machine has timed out waiting for the adjustment load task to complete reading printhead NVM.
- 91-812-00 The required voltage adjustment exceeds the maximum on printhead 1.
- 91-813-00 The required voltage adjustment exceeds the maximum on printhead 2.
- 91-814-00 The required voltage adjustment exceeds the maximum on printhead 3.
- 91-815-00 The required voltage adjustment exceeds the maximum on printhead 4.
- 91-816-00 Voltage adjustment can not bring printhead 1 into tolerance.
- 91-817-00 Voltage adjustment can not bring printhead 2 into tolerance.
- 91-818-00 Voltage adjustment can not bring printhead 3 into tolerance.
- 91-819-00 Voltage adjustment can not bring printhead 4 into tolerance.
- 91-824-00 MARKDWR-PQM insufficient ink.
- 91-825-00 MARKDWR-PQM insufficient paper.
- 91-826-00 MARKDWR-PQM insufficient jets.
- 91-827-00 MARKDWR-PQM align needed.
- 91-828-00 MARKDWR-PQM Y dot position needed.
- 91-829-00 MARKDWR-PQM drum runout needed.
- 91-830-00 MARKDWR-PQM uniformity needed.
- 91-831-00 MARKDWR-PQM uniformity reset needed.
- 91-832-00 MARKDWR-PQM empty waste tray.
- 91-833-00 MARKDWR-PQM cleaning pages needed.
- 91-834-00 MARKDWR-PQM tool not usable.
- 91-835-00 MARKDWR-PQM tool manually disabled.
- 91-836-00 MARKDWR-PQM: system busy.
- 92-803-00 DSP2 overlay setup time-out.
- 92-804-00 DSP2 overlay cleanup time-out.
- 92-807-00 In dC972 automatic TRC generation is not implemented.

dC976 Ink Delivery Fault Recovery

Purpose

To prime the umbilical assembly and check valve unit after replacement of the umbilical assembly, check valve unit (CVU), attached to and included with the umbilical assembly.

Failure to prime the CVU and umbilical assembly may result in:

- Purge air pressure leaking backwards through the assembly.
- Ink bubbling up from the reservoir into the ink reservoir air manifold.
- Reservoir assembly replacement.
- Umbilical replacement, if ink enters the purge line.

After umbilical or ink melt reservoir replacement, purge line connections to the reservoir must be physically verified. The correct orientation of the connections is shown in [REP 91.20](#).

Procedure

1. Enter service mode, [GP 1](#).
2. Select the Maintenance tab.
3. Select dC976 Ink Delivery Fault Recovery.
4. Select the component that has been replaced:
 - Lower Umbilical
 - Upper Umbilical
 - Ink Reservoir (This option has no benefit, use the other two options).
5. Select the start button to begin the procedure.
6. On completion of the procedure a message will be displayed of the success or failure.

NOTE: If a new umbilical has been installed then run the routine a second time. A single priming routine may not be sufficient in all cases.
7. Select Close to return to the Maintenance routine window.
8. Select Call Closeout to exit service mode.

dC977 Drum Runout Calibration

Purpose

To measure minute inaccuracies in the concentricity of the drum, then adjust the printheads as necessary.

If the following parts are removed or replaced the Drum Runout Calibration routine is required:

- Drum
- Drum encoder
- Drum pulley
- Transfix linkages

Procedure

NOTE: Before printing test pages, ensure that A4 or 8.5 x11 inch plain paper is loaded LEF into tray 4. Use the best quality media available. Do not use hole punched paper.

Perform the following:

1. Enter service mode, [GP 1](#).
2. Select the Adjustments tab.
3. Select dC977 Drum Runout Calibration.
4. Select the Runout Test Page button.
The machine will print a drum runout test page. Check the test page to confirm that calibration is required, ([TP 23](#)) and ([IQ 5](#)).
If calibration is not required select Close to exit the routine.
5. Select Jet Test Page. The machine will run the jet test routine which will print 2 pages for each colour.
6. Use the jet test pages to identify any defective heads. Check the test page to interpret the jet test output ([TP 21](#)) and ([IQ 9](#)).
 - If more than 10 jets are missing run [dC968](#) Head Purge before continuing with this procedure.
 - If less than 10 jets are missing select Calibrate Runout.

NOTE: Calibration requires the following:

- Sufficient ink in all reservoirs.
 - The waste tray must not be full.
 - The marking unit must be ready to print.
7. Select Calibrate Runout. The calibration routine takes approximately 5 minutes.
 8. On completion of the Calibration Runout routine. Select Close to return to the Adjustments window.
 9. Select Call Closeout to exit service mode.

dC978 Transfix Calibration Values

Purpose

To display and update the transfix calibration load values to ensure proper operation of the transfix load system.

This procedure is required when replacing transfix load arm assemblies or if incorrect transfix calibration values are suspected.

Procedure

1. Enter service mode, [GP 1](#).
2. Select the Adjustments tab.
3. Select dC978 Transfix Calibration Values.
4. The transfix calibration values are displayed with an option to write new values if required.

NOTE: New transfix calibration values must also be written on the calibration label on the front drum frame, refer to [REP 10.3](#) or [REP 10.2](#).

5. Follow the on screen instructions to read and amend the values as necessary.
6. Select Close to return to the Adjustments window.
7. Select Call Closeout to exit service mode.

Tags

Purpose

To provide a list of all the tag numbers used together with a description of each of the machine modifications.

Description

Each modification to the system is assigned a unique tag number. This section of the service documentation contains a listing and brief description of all change tags.

Change tags listed in this section are listed by machine module. The module to which the tag relates is identified by the tag prefix letter, for example; Tag F048 applies to the Finisher - module. The module prefixes are:

- Processor module - 001 to 100 (no prefix).
- DADH module - D-001 to D-100.
- Finisher (LCSS) module - F-001 to F-100.
- Finisher (HVF) module - V-001 to V-100.
- Fax module - X-001 to X-050.
- Inserter tray 6 module - I-001 to I-020.
- Tray 5 module - P-001 to P-100.

Tag Information

Information that may be included with each tag item is as follows:

- Tag - gives the control number for the tag.
- Class - gives the classification codes as listed in [Table 1](#).
- Use - indicates the multinational operating markets affected by the modification.
- Manufacturing Serial Number - gives the serial number of the factory built machines with the modification installed.
- Purpose - gives a brief description of the modification.
- Name - gives the name of the part or modification.
- Kit Number - gives the part number of the kit or part required to install the modification.
- Reference or Parts List On - indicates the parts list where the kit or modification part can be found.

Mod/Tag Plate Location

- The processor module. Open the front door and the Mod/Tag plate is located on the right side of the machine frame above the 4a jam clearance area.
- The scanner module. The Mod/Tag plate is located on the rear cover of the scanner unit.
- The tray 5 module. Un-dock tray 5 and the Mod/Tag plate is located on the back plate of the module.
- The DADH module. Lift up the DADH and the Mod/Tag plate is located on the rear of the DADH.
- The LCSS module. Un-dock the LCSS and the Mod/Tag plate is located in the base pan of the LCSS.
- The HVF module. Un-dock the HVF and the Mod/Tag plate is located on the metal panel under the docking latch.
- Embedded Fax. The Mod/Tag plate is located on the cover, [PL 20.05](#).

- Inserter Tray 6. Remove the inserter module and turn it upside down. The Mod/Tag plate is located on the bottom cover.

Classification Codes

The Class or Classification code is explained in [Table 1](#)

Table 1 Classification codes

NASG code	XE code	Description
-	1	Safety: Install this tag immediately.
M	2	Mandatory: Install this tag at the next opportunity.
R	3	Repair: Install this tag as a repair, at the failure of a component.
O	4	Optional: Install as a customer option or a field engineering decision.
S	4	Situational: Install as the situation demands.
N	5	Manufacturing: Cannot be installed in the field.
	6	Refurbishing only.

Processor Tags

TAG: 004

CLASS: 4

NAME: 3 Tray Module latch and tray

PURPOSE: Replacement tray 3 assembly

KIT NUMBER: 604K61710

PARTS LIST ON: [PL 31.11 Item 31](#)

TAG: 050

CLASS: 5

NAME: Restriction of Hazardous Substances (RoHS)

PURPOSE: To identify RoHS compliant machines. Refer to [GP 26](#).

KIT NUMBER: -

PARTS LIST ON: -

DADH Tags

TAG: D-001

CLASS: 3

NAME: Feed yoke kit

PURPOSE: Applicable to machines with a TAG D002 DADH only. To improve actuation of the DADH feed gates.

KIT NUMBER: -

PARTS LIST ON: [PL 5.15 Item 6](#)

TAG: D-002

CLASS: 5

NAME: Introduction of the Quiet 100 sheet DADH

PURPOSE: Features a motorized nudger in place of the feed solenoid to give a quieter working performance.

New DADH PWB introduced with driver circuitry to support the motorized nudger.

KIT NUMBER: -

PARTS LIST ON: [PL 5.10 Item 5](#) and [PL 5.15 Item 5](#)

TAG: D-003

CLASS: 3

NAME: Shim washer added to the quiet 100 sheet DADH motorized nudger

PURPOSE: Applicable to machines with a TAG D002 DADH only. Nylon shim washer added to the motorized nudger to improve nudger cam reliability.

KIT NUMBER: -

PARTS LIST ON: [P/O PL 5.15 Item 5](#)

TAG: D-004

CLASS: 4

NAME: White CVT roll Kit

PURPOSE: To eliminate grey circles appearing on prints when copying hole punched originals.

KIT NUMBER: -

PARTS LIST ON: [PL 5.25](#)**TAG: D-005**

CLASS: 3

NAME: Feed clutch and spacer kit

PURPOSE: Design improvement on the original clutch

KIT NUMBER: -

PARTS LIST ON: [PL 5.15 Item 28](#)**TAG: D-007**

CLASS: 4

NAME: DADH sensor replacement kit

PURPOSE: New style DADH input tray sensors which are less sensitive to bright overhead lighting which causes wrong size detection, wrong size Fax sent, enlarge or reduce the document size.

KIT NUMBER: -

PARTS LIST ON: [PL 31.11 Item 17](#)**TAG: D-050**

CLASS: 5

NAME: Restriction of Hazardous Substances (RoHS)

PURPOSE: To identify RoHS compliant machines. Refer to [GP 26](#).

KIT NUMBER: -

PARTS LIST ON: -

Finisher (2K LCSS) Tags**TAG: F-001**

CLASS: 5

NAME: New LCSS graphic labels

PURPOSE: New jam clearance instructions

KIT NUMBER: -

PARTS LIST ON: -

TAG: F-002

CLASS: 5

NAME: LCSS tamper arms and exit sensor timing

PURPOSE: To improve stacking performance

KIT NUMBER: -

PARTS LIST ON: -

TAG: F-003

CLASS: 5

NAME: LCSS entry guide cover change

PURPOSE: Improve performance

KIT NUMBER: -

PARTS LIST ON: -

TAG: F-004

CLASS: 5

NAME: LCSS noise reduction kit

PURPOSE: Reduction of operational noises

KIT NUMBER: -

PARTS LIST ON: -

TAG: F-005

CLASS: 5

NAME: LCSS elevator motor encoder sensor.

PURPOSE: A new sensor with an improved response time.

KIT NUMBER: -

PARTS LIST ON: -

TAG: F-011

CLASS: 4

NAME: Re-routed harness

PURPOSE: To improve the routing of the staple harness by using a longer harness.

KIT NUMBER: -

PARTS LIST ON: -

TAG: F-007

CLASS: 5

NAME: LCSS rear frame cutout modified.

PURPOSE: Change to the cutout in the rear frame to accommodate all configurations of hole punches

KIT NUMBER: -

PARTS LIST ON: -

TAG: F-013

CLASS: 4

NAME: LCSS bin 1 kit

PURPOSE: Modified angle to the output tray to reduce problem with paper curl.

KIT NUMBER: -

PARTS LIST ON: [PL 12.10 Item 10](#)**TAG: F-009**

CLASS: 4

NAME: Sharp edges removed from area 5 (safety)

PURPOSE: To make safe the customer interaction area around the hole punch.

KIT NUMBER: -

PARTS LIST ON: -

TAG: F-016

CLASS: 3

NAME: LCSS Paddle assembly

PURPOSE: New paddle wheel shaft assembly featuring increased grip paddles that are now a clip in fitting.

KIT NUMBER: -

PARTS LIST ON: [PL 12.25 Item 4](#)**TAG: F-010**

CLASS: 4

NAME: 20 ohm tamper motor

PURPOSE: To eliminate the tamper motor from stalling.

KIT NUMBER: -

PARTS LIST ON: [PL 12.45](#)**TAG: F-050**

CLASS: 5

NAME: Restriction of Hazardous Substances (RoHS)

PURPOSE: To identify RoHS compliant machines. Refer to [GP 26](#).

KIT NUMBER: -

PARTS LIST ON: -

Finisher (HVF) Tags

TAG: V-001

CLASS: 2

NAME: **Modification to the inserter connector**

PURPOSE: Pin 3 (ground 24V) and pin 4 (24V) on the bulk head connector on the HVF for the inserter unit are to close together and could be shorted.

On the HVF PWB, PJ703 pins 2 and 3 are changed position. On the Inserter PWB, PJ 5 pins 2 and 3 are changed position. This changes the position of the ground 24V.

KIT NUMBER: -

PARTS LIST ON: -

TAG: V-002

CLASS: 5

NAME: **Lower paddle switch**

PURPOSE: Mod TAG002 may have been struck in manufacturing, but is not a valid mod tag.

KIT NUMBER: -

PARTS LIST ON: -

TAG: V-003

CLASS: 5

NAME: **Guide hinge pin**

PURPOSE: Mod TAG003 may have been struck in manufacturing, but is not a valid mod tag.

KIT NUMBER: -

PARTS LIST ON: -

TAG: V-004

CLASS: 5

NAME: **Ejector with removable paddle assembly**

PURPOSE: Allows replacement of Ejector paddle assembly without needing to replace entire ejector.

KIT NUMBER: -

PARTS LIST ON: [PL 12.110 Item 2](#), [PL 12.110 Item 22](#)

TAG: V-005

CLASS: 5

NAME: **Three blade lower paddle.**

PURPOSE: Located in the paddle unit to improve the contact force on documents in the ejector assembly.

KIT NUMBER: -

PARTS LIST ON: [PL 12.115 Item 2](#)

TAG: V-050

CLASS: 5

NAME: **Restriction of Hazardous Substances (RoHS)**

PURPOSE: To identify RoHS compliant machines. Refer to [GP 26](#).

KIT NUMBER:

PARTS LIST ON:

Post Process Inserter Tray 6 (PPI) Tags

TAG: I-001

CLASS: 2

NAME: Modification to the inserter connector

PURPOSE: Pin 3 (ground 24V) and pin 4 (24V) on the bulk head connector on the HVF for the inserter unit are to close together and could be shorted.

On the HVF PWB, PJ703 pins 2 and 3 are changed position. On the Inserter PWB, PJ 5 pins 2 and 3 are changed position. This changes the position of the ground 24V.

KIT NUMBER: -

PARTS LIST ON: -

Fax Tags

TAG: X-050

CLASS: 5

NAME: Restriction of Hazardous Substances (RoHS)

PURPOSE: To identify RoHS compliant machines. Refer to [GP 26](#).

KIT NUMBER: -

PARTS LIST ON: -

Tray 5 Tags

TAG: P-001

CLASS: 5

NAME: Central foot

PURPOSE: To facilitate top edge registration set-up.

KIT NUMBER: -

PARTS LIST ON: -

TAG: P-002

CLASS: 3

NAME: Feed roll retrofit kit

PURPOSE: Spares kit

KIT NUMBER:

PARTS LIST ON: [PL 31.11 Item 26](#)

TAG: P-050

CLASS: 5

NAME: Restriction of Hazardous Substances (RoHS)

PURPOSE: To identify RoHS compliant machines. Refer to [GP 26](#).

KIT NUMBER: -

PARTS LIST ON: -

Plug Jack Locations

PJ Locations..... 7-3

Wiring Diagrams

Wiring Diagrams..... 7-23

PJ Locations

PJ Location Tables

To locate a PJ, go to the appropriate table.

- PJ1 to PJ99, [Table 1](#).
- PJ100 to PJ149, [Table 2](#).
- PJ150 to PJ199, [Table 3](#).
- PJ200 to PJ299, [Table 4](#).
- PJ300 to PJ399, [Table 5](#).
- PJ400 to PJ449, [Table 6](#).
- PJ450 to PJ499, [Table 7](#).
- PJ500 to PJ549, [Table 8](#).
- PJ550 to PJ599, [Table 9](#).
- PJ600 to PJ899, [Table 10](#).
- PJ900 to PJ999, [Table 11](#).
- PJDC1 to PJDC4, [Table 12](#).

Location Figures for PWB Connectors and In-line Connectors

NOTE: Part list references are given with each figure.

1. 3 tray module PWB, [Figure 9](#).
2. BM PWB, [Figure 25](#).
3. DADH PWB, [Figure 4](#).
4. Drum driver PWB, [Figure 12](#).
5. Fax connector PWB, [Figure 7](#).
6. Foreign device interface PWB, [Figure 28](#)
7. HVF PWB, [Figure 21](#).
8. IME Controller PWB, [Figure 14](#).
9. Ink load entry PWB, [Figure 19](#).
10. Inserter PWB, [Figure 24](#).
11. IOD pre amplifier PWB, [Figure 13](#).
12. In-line connector PJ140 and in-line PJ, [Figure 30](#).
13. In-line connector PJ530, [Figure 22](#).
14. In-line connectors PJ704, PJ851, PJ904, [Figure 6](#).
15. LCSS PWB, [Figure 26](#).
16. Marking unit driver PWB, [Figure 16](#).
17. Marking unit heater PWB, [Figure 15](#).
18. Media path driver PWB, [Figure 10](#).
19. Offline staple PWB (LCSS), [Figure 27](#).
20. Power Supply Unit, [Figure 1](#).
21. Power Distribution PWB, [Figure 2](#).
22. Printhead, [Figure 20](#).
23. Quad wave amplifier PWB, [Figure 17](#).

24. Registration / preheat Interface PWB, [Figure 11](#).
25. Scanner PWB, [Figure 5](#).
26. Single board controller PWB, [Figure 29](#).
27. Solenoid patch PWB, [Figure 18](#).
28. Tray 5 control PWB, [Figure 8](#).
29. Tri folder PWB, [Figure 23](#).
30. UI PWB's, [Figure 3](#).

Table 1 PJ1 to PJ99

PJ number	PJ location figure	PJ location	Wiring diagram
1	Figure 2	Power Distribution PWB	WD 1.6
1	Figure 11	Registration / Preheat Interface PWB	WD 8.6
1	Figure 13	IOD pre amplifier board PWB	WD 9.1
1	Figure 24	Inserter PWB	WD 12.21
1	Figure 29	Single board controller PWB	N/A
1	Figure 7	Fax connector PWB	WD 3.1
2	Figure 2	Power Distribution PWB	WD 1.6
2	Figure 11	Registration / Preheat Interface PWB	WD 8.6
2	Figure 13	IOD pre amplifier board PWB	WD 9.1
2	Figure 24	Inserter PWB	WD 12.21
2	Figure 7	Fax connector PWB	WD 3.1
3	Figure 2	Power Distribution PWB	WD 1.7
3	Figure 11	Registration / Preheat Interface PWB	WD 8.6
3	Figure 24	Inserter PWB	WD 12.21
4AC	Figure 1	Power Supply Unit	WD 1.1
4	Figure 11	Registration / Preheat Interface PWB	WD 8.6
4	Figure 24	Inserter PWB	WD 12.21, WD 12.22
5AC	Figure 1	Power Supply Unit	WD 1.2
5	Figure 11	Registration / Preheat Interface PWB	WD 8.6
5	Figure 24	Inserter	WD 12.21
5	Figure 29	Single board controller PWB	WD 3.1
6AC	Figure 1	Power Supply Unit	WD 1.1
6	Figure 24	Inserter PWB	WD 12.21
7	Figure 24	Inserter PWB	WD 12.21
8AC	Figure 1	Power Supply Unit	WD 1.1
8	Figure 2	Power Distribution PWB	WD 1.7
8	Figure 24	Inserter PWB	WD 12.21, WD 12.22
9	Figure 2	Power Distribution PWB	WD 1.7
9	Figure 24	Inserter PWB	WD 12.22

Table 1 PJ1 to PJ99

PJ number	PJ location figure	PJ location	Wiring diagram
10	Figure 24	Inserter PWB	WD 12.22
10	Figure 29	Single board controller PWB	WD 3.1
11	Figure 24	Inserter PWB	WD 12.22
11	Figure 29	Single board controller PWB	N/A
12	Figure 24	Inserter PWB	WD 12.22
12	Figure 29	Single board controller PWB	N/A
13	Figure 24	Inserter PWB	WD 12.22
13	Figure 29	Single board controller PWB	WD 3.1
15	Figure 29	Single board controller PWB	WD 3.1
16	Figure 28	Foreign Device Interface PWB	WD 3.3
16	Figure 29	Single board controller PWB	WD 3.2
17	Figure 29	Single board controller PWB	WD 3.2
18	Figure 29	Single board controller PWB	WD 3.2
19	Figure 29	Single board controller PWB	WD 3.2
20	Figure 29	Single board controller PWB	WD 3.3
21	Figure 29	Single board controller PWB	N/A
24	Figure 29	Single board controller PWB	WD 3.3
25	Figure 29	Single board controller PWB	WD 3.3
45	Figure 29	Single board controller PWB	WD 3.3
49	Figure 29	Single board controller PWB	WD 3.1

Table 2 PJ100 to PJ149

PJ number	PJ location figure	PJ location	Wiring diagram
100	Figure 28	Foreign Device Interface PWB	WD 3.3
101	Figure 20	Printhead 1 PWB	WD 9.20
101	Figure 20	Printhead 2 PWB	WD 9.20
101	Figure 20	Printhead 3 PWB	WD 9.21
101	Figure 20	Printhead 4 PWB	WD 9.21
101	Figure 12	Drum Driver PWB	WD 9.1
101	Figure 10	Media path driver PWB	WD 8.2
101	Figure 15	Marking unit heater board PWB	WD 9.8
101	Figure 16	Marking unit driver PWB	WD 9.9
101	Figure 21	HVF PWB	WD 12.7
102	Figure 16	Marking unit driver PWB	WD 9.9
102	Figure 21	HVF PWB	WD 12.7, WD 12.8
103	Figure 21	HVF PWB	WD 12.8
104	Figure 10	Media path driver PWB	WD 8.1

Table 2 PJ100 to PJ149

PJ number	PJ location figure	PJ location	Wiring diagram
104	Figure 21	HVF PWB	WD 12.8
105	Figure 14	IME controller PWB	WD 9.5
110	Figure 17	Quad wave amplifier PWB	WD 9.13
110	Figure 18	Solenoid patch PWB	WD 9.14
111	Figure 21	HVF PWB	WD 12.8
112	Figure 21	HVF PWB	WD 12.6, WD 12.8
113	Figure 21	HVF PWB	WD 12.6, WD 12.8
121	Figure 21	HVF PWB	WD 12.9
130	Figure 18	Solenoid patch PWB	WD 9.14
131	Figure 21	HVF PWB	WD 12.6, WD 12.9
132	Figure 21	HVF PWB	WD 12.6, WD 12.9
133	Figure 21	HVF PWB	WD 12.9
140	Figure 30	In line connector (on the rear frame)	WD 1.2

Table 3 PJ150 to PJ199

PJ number	PJ location figure	PJ location	Wiring diagram
150	Figure 17	Quad wave amplifier PWB	WD 9.13
181	Figure 4	DADH PWB	WD 5.1
183	Figure 4	DADH PWB	WD 5.1
184	Figure 4	DADH PWB	WD 5.1
186	Figure 4	DADH PWB	WD 5.1
187	Figure 4	DADH PWB	WD 5.1
188	Figure 4	DADH PWB	WD 5.2
189	Figure 4	DADH PWB	WD 5.2
190	Figure 4	DADH PWB	WD 5.2

Table 4 PJ200 to PJ299

PJ number	PJ location figure	PJ location	Wiring diagram
201	Figure 14	IME Controller PWB	WD 9.5
201	Figure 15	Marking unit heater PWB	WD 9.8
201	Figure 19	Ink load entry PWB	WD 9.17
202	Figure 10	Media path driver PWB Refer to in-line PJ connector at Figure 30	WD 8.1

Table 4 PJ200 to PJ299

PJ number	PJ location figure	PJ location	Wiring diagram
202	Figure 21	HVF PWB	WD 12.9, WD 12.10
203	Figure 16	Marking unit driver PWB	WD 9.10
206	Figure 10	Media path driver PWB	WD 8.2
210	no link	Hard Disc Drive	WD 3.3
211	no link	Hard Disc Drive	WD 3.3
222	Figure 29	Single board controller PWB	WD 3.3
223	Figure 29	Single board controller PWB	WD 3.2

Table 5 PJ300 to PJ399

PJ number	PJ location figure	PJ location	Wiring diagram
300	Figure 26	LCSS PWB	WD 12.1
301	Figure 20	Printhead 1 PWB	WD 9.20
301	Figure 20	Printhead 2 PWB	WD 9.20
301	Figure 20	Printhead 3 PWB	WD 9.21
301	Figure 20	Printhead 4 PWB	WD 9.21
301	Figure 14	IME Controller PWB	WD 9.5
301	Figure 19	Ink load entry PWB	WD 9.17
301	Figure 21	HVF PWB	WD 12.10
301	Figure 26	LCSS PWB	WD 12.1
302	Figure 21	HVF PWB	WD 12.11
302	Figure 26	LCSS PWB	WD 12.1
303	Figure 10	Media path driver PWB Refer to in-line PJ connector located on the rear frame above A4 jam clearance guide	WD 8.1, WD 8.2
303	Figure 16	Marking unit driver PWB	WD 9.10, WD 9.11
303	Figure 21	HVF PWB	WD 12.11
303	Figure 26	LCSS PWB	WD 12.1
304	Figure 16	Marking unit driver PWB	WD 9.11
304	Figure 21	HVF PWB	WD 12.11
304	Figure 26	LCSS PWB	WD 12.1
305	Figure 26	LCSS PWB	WD 12.1
306	Figure 26	LCSS PWB	WD 12.2
307	Figure 26	LCSS PWB	WD 12.2
308	Figure 26	LCSS PWB	WD 12.2, WD 12.3
309	Figure 26	LCSS PWB	WD 12.3
310	Figure 26	LCSS PWB	WD 12.3

Table 5 PJ300 to PJ399

PJ number	PJ location figure	PJ location	Wiring diagram
311	Figure 26	LCSS PWB	WD 12.3
312	Figure 26	LCSS PWB	WD 12.3, WD 12.4
313	Figure 26	LCSS PWB	WD 12.4
314	Figure 26	LCSS PWB	WD 12.4
315	Figure 26	LCSS PWB	WD 12.4
316	Figure 26	LCSS PWB	WD 12.5
317	Figure 26	LCSS PWB	WD 12.5
318	Figure 26	LCSS PWB	WD 12.5
350	Figure 27	LCSS Pause to unload PWB	WD 12.4
380	Figure 18	Solenoid patch PWB	WD 9.16

Table 6 PJ400 to PJ449

PJ number	PJ location figure	PJ location	Wiring diagram
401	Figure 12	Drum Driver PWB	WD 9.1
401	Figure 10	Media path driver PWB	WD 8.2
401	Figure 21	HVF PWB	WD 12.11, WD 12.12
401	Figure 14	IME Controller PWB	WD 9.5
401	Figure 15	Marking unit heater PWB	WD 9.8
401	Figure 16	MU driver PWB	WD 9.11
402	Figure 10	Media path driver PWB	WD 8.2
402	Figure 14	IME Controller PWB	WD 9.5
402	Figure 21	HVF PWB	WD 12.12
403	Figure 14	IME Controller PWB	WD 9.6
403	Figure 21	HVF PWB	WD 12.12
405	Figure 10	Media path driver PWB	WD 8.3
406	Figure 10	Media path driver PWB	WD 8.4
408	Figure 10	Media path driver PWB	WD 8.4
410	Figure 18	Solenoid patch PWB	WD 9.15
430	Figure 18	Solenoid patch PWB	WD 9.14

Table 7 PJ450 to PJ499

PJ number	PJ location figure	PJ location	Wiring diagram
495	no link	OCT PWB	WD 12.23
496	PJ at component	OCT 90% full sensor	WD 12.23
497	PJ at component	OCT index sensor	WD 12.23

Table 7 PJ450 to PJ499

PJ number	PJ location figure	PJ location	Wiring diagram
496	PJ at component	OCT offset motor	WD 12.23

Table 8 PJ500 to PJ549

Connection	PJ location figure	PJ location	Wiring diagram
501	Figure 12	Drum Driver PWB	WD 9.1
501	Figure 19	Ink load entry PWB	WD 9.17
501	Figure 21	HVF PWB	WD 12.12
502	Figure 8	Tray 5 control PWB	WD 7.1
502	Figure 19	Ink load entry PWB	WD 9.17
502	Figure 21	HVF PWB	WD 12.13
503	Figure 8	Tray 5 control PWB	WD 7.1
504	Figure 8	Tray 5 control PWB	WD 7.1
505	Figure 8	Tray 5 control PWB	WD 7.2
506	Figure 8	Tray 5 control PWB	WD 7.2
507	Figure 8	Tray 5 control PWB	WD 7.2
511	Figure 8	Tray 5 control PWB	WD 7.2
513	Figure 8	Tray 5 control PWB	WD 7.1
530	Figure 22	In-line connector	WD 7.1

Table 9 PJ550 to PJ599

Connection	PJ location figure	PJ location	Wiring diagram
551	Figure 25	BM PWB	WD 12.16
552	Figure 25	BM PWB	WD 12.16, WD 12.17
553	Figure 25	BM PWB	WD 12.16, WD 12.17
554	Figure 25	BM PWB	WD 12.17
555	Figure 25	BM PWB	WD 12.17, WD 12.18
556	Figure 25	BM PWB	WD 12.18
557	Figure 25	BM PWB	WD 12.18
559	Figure 25	BM PWB	WD 12.6, WD 12.19
560	Figure 25	BM PWB	WD 12.19
562	Figure 25	BM PWB	WD 12.19
563	Figure 25	BM PWB	WD 12.19
566	PJ at component	BM Backstop Guide Home Sensor	WD 12.18

Table 9 PJ550 to PJ599

Connection	PJ location figure	PJ location	Wiring diagram
567	PJ at component	BM Tamper Home Sensor	WD 12.18
568	PJ at component	BM Paper Present Sensor	WD 12.18
570	PJ at component	BM Exit Sensor	WD 12.18
571	PJ at component	BM Stapler Head Carrier Closed Sensor	WD 12.16
572	PJ at component	BM Crease Blade Home Sensor	WD 12.16
573	PJ at component	BM Crease Roll Gate Home Sensor	WD 12.16
574	PJ at component	BM Crease Blade Motor Encoder Sensor	WD 12.16
575	PJ at component	BM Crease Roll Motor Encoder Sensor	WD 12.17
576	PJ at component	Bin 2	WD 12.17
577	PJ at component	Bulkhead Connector	WD 12.18
581	PJ at component	Backstop Assembly	WD 12.17
582	PJ at component	Backstop Assembly	WD 12.17
583	PJ at component	Tri-folder attachment	WD 12.18
585	PJ at component	BM Stapler Head 1	WD 12.16
586	PJ at component	BM Stapler Head 2	WD 12.16
590	Figure 17	Quad wave amplifier PWB	WD 9.13

Table 10 PJ600 to PJ899

Connection	PJ location figure	PJ location	Wiring diagram
601	Figure 12	Drum Driver PWB	WD 9.2
601	no link	Cleaning Unit PWB	WD 9.19
601	Figure 21	HVF PWB	WD 12.13
601	Figure 10	Media path driver PWB	Not used
601	Figure 19	Ink load entry PWB	WD 9.18
601	Figure 23	Tri folder PWB	WD 12.6, WD 12.20
601	Figure 20	Printhead PWB	WD 9.20, WD 9.21
602	Figure 12	Drum Driver PWB	WD 9.2
602	no link	Cleaning Unit PWB	WD 9.19
602	Figure 21	HVF PWB	WD 12.13
602	Figure 23	Tri folder PWB	WD 12.20
603	Figure 12	Drum Driver PWB	WD 9.2
603	Figure 23	Tri folder PWB	WD 12.20
604	Figure 23	Tri folder PWB	WD 12.20
604	no link	Inline connector between PS and HDD	WD 1.5
605	Figure 16	Marking unit driver PWB	WD 9.11
605	Figure 23	Tri folder PWB	WD 12.20

Table 10 PJ600 to PJ899

Connection	PJ location figure	PJ location	Wiring diagram
607	Figure 16	Marking unit driver PWB	WD 9.11
610	Figure 18	Solenoid patch PWB	WD 9.15
630	Figure 18	Solenoid patch PWB	WD 9.14, WD 9.15 WD 9.16
660	PJ at component	Bin 2	WD 12.18
660	Figure 13	IOD pre amplifier PWB	WD 9.1
701	Figure 12	Drum Driver PWB	WD 9.2
701	no link	Cleaning Unit PWB	WD 9.19
701	Figure 14	IME Controller PWB	WD 9.6
701	Figure 15	Marking unit heater PWB	WD 9.8
701	Figure 16	Marking unit driver PWB	WD 9.12
701	Figure 21	HVF PWB	WD 12.13, WD 12.14
702	Figure 21	HVF PWB	WD 12.14
703	Figure 21	HVF PWB	WD 12.6, WD 12.14
704	Figure 6	In-line Connector from tray 5	WD 8.4
760	Figure 18	Solenoid patch PWB	WD 9.16
780	Figure 18	Solenoid patch PWB	WD 9.16
801	Figure 12	Drum Driver PWB	WD 9.3
801	Figure 10	Media path driver PWB	Not used
801	Figure 16	Marking unit driver PWB	WD 9.12
801	Figure 19	Ink load entry PWB	WD 9.17
801	Figure 21	HVF PWB	WD 12.14, WD 12.15
802	Figure 12	Drum Driver PWB	WD 9.3, WD 9.4
802	Figure 21	HVF PWB	WD 12.15
803	Figure 10	Media path driver PWB	WD 8.5
810	Figure 18	Solenoid patch PWB	WD 9.15
851	Figure 6	In-line Connector from DADH	WD 5.2
860	PJ at component	Foreign Interface Device	WD 3.3

Table 11 PJ900 to PJ999

Connection	PJ location figure	PJ location	Wiring diagram
900	Figure 3	UI PWB	WD 3.1
901	Figure 12	Drum Driver PWB	WD 9.4
901	Figure 21	HVF PWB	WD 12.15
901	Figure 3	UI PWB	WD 3.1
901	Figure 15	Marking unit heater PWB	WD 9.8

Table 11 PJ900 to PJ999

Connection	PJ location figure	PJ location	Wiring diagram
901	Figure 19	Ink load entry PWB	WD 9.17 WD 9.18
902	Figure 12	Drum Driver PWB	WD 9.4
902	Figure 14	IME Controller PWB	WD 9.6
902	Figure 21	HVF PWB	WD 12.15
903	Figure 14	IME Controller PWB	WD 9.7
903	Figure 3	UI PWB	WD 3.1
904	Figure 10	Media path driver PWB	WD 8.5
904	Figure 14	IME Controller PWB	WD 9.7
904	Figure 6	In-line Connector from output device	WD 8.5
905	Figure 3	UI PWB	WD 3.1
905	Figure 10	Media path driver PWB	WD 8.5
906	Figure 3	UI PWB	WD 3.1
907	Figure 3	UI PWB	WD 3.1
910	Figure 18	Solenoid patch PWB	WD 9.16
920	Figure 5	Scanner PWB	WD 6.1
921	Figure 5	Scanner PWB	WD 6.1
922	Figure 5	Scanner PWB	WD 6.1
923	Figure 5	Scanner PWB	WD 6.2
924	Figure 5	Scanner PWB	WD 6.2
925	Figure 5	Scanner PWB	Not used
926	Figure 5	Scanner PWB	WD 6.2
927	Figure 5	Scanner PWB	WD 6.2
928	Figure 5	Scanner PWB	WD 6.3
929	Figure 5	Scanner PWB	WD 6.2
930	Figure 5	Scanner PWB	WD 6.2
930	Figure 17	Quad wave amplifier PWB	WD 9.13
950	Figure 9	3 tray module PWB	WD 7.3
951	Figure 9	3 tray module PWB	WD 7.3
952	Figure 9	3 tray module PWB	WD 7.3
953	Figure 9	3 tray module PWB	WD 7.4
954	Figure 9	3 tray module PWB	WD 7.4
955	Figure 9	3 tray module PWB	WD 7.4
956	Figure 9	3 tray module PWB	WD 7.5
957	Figure 9	3 tray module PWB	WD 7.5
970	Figure 17	Quad wave amplifier PWB	WD 9.13

Table 12 PJDC1 to PJDC4

PJ number	PJ location figure	PJ location	Wiring diagram
DC1	Figure 1	Power Supply Unit	WD 1.4
DC2	Figure 1	Power Supply Unit	WD 1.4
DC3	Figure 1	Power Supply Unit	WD 1.5
DC4	Figure 1	Power Supply Unit	WD 1.5

Power Supply Unit

Location: [PL 1.15 Item 2](#)

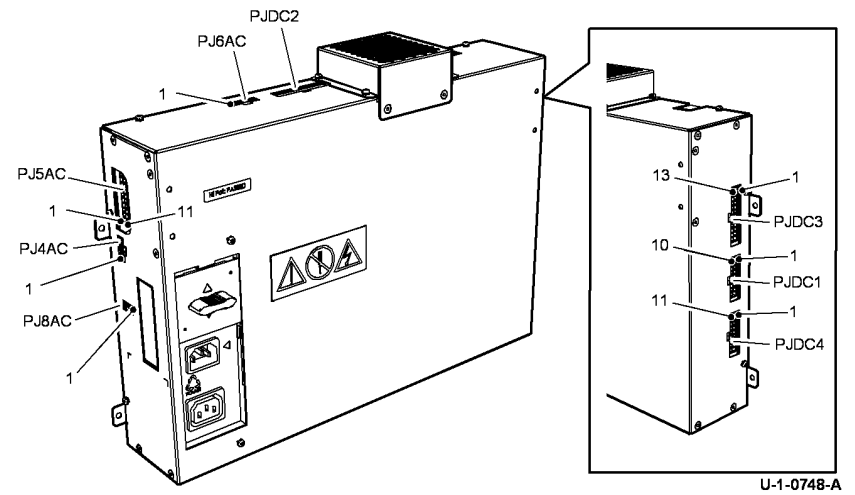
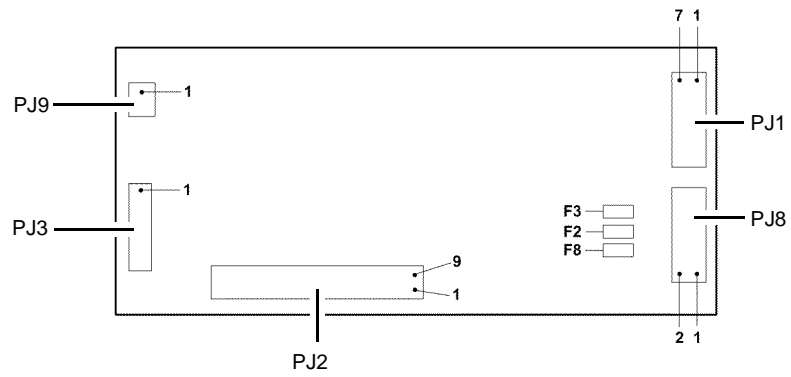

Figure 1 Power supply unit

Power Distribution PWB

Location: PL 3.11 Item 1



U-1-0732-A

Figure 2 Power distribution PWB

User Interface PWB

Location: PL 2.10 Item 2 and PL 2.10 Item 4

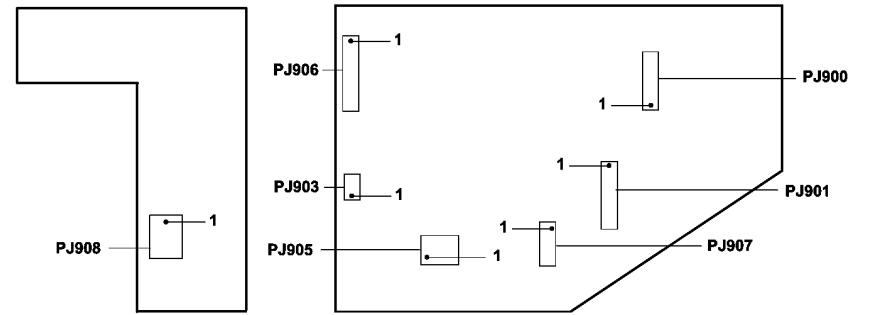

U-1-0740-A

Figure 3 UI PWB's

DADH PWB

Location: PL 5.10 Item 5

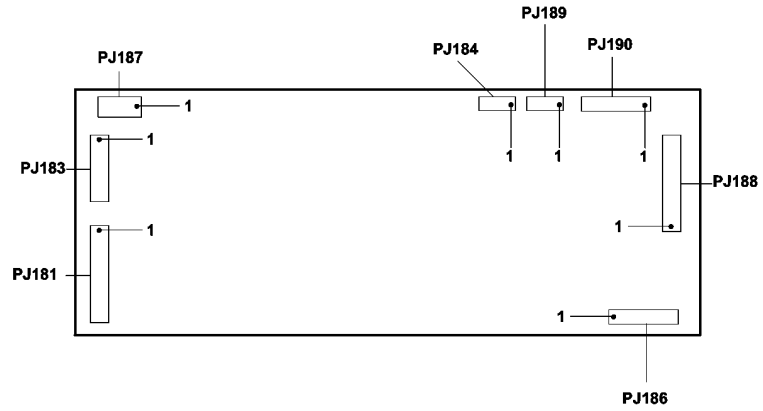

Figure 4 DADH PWB

U-1-0728-A

Scanner PWB

Location: PL 62.16 Item 8

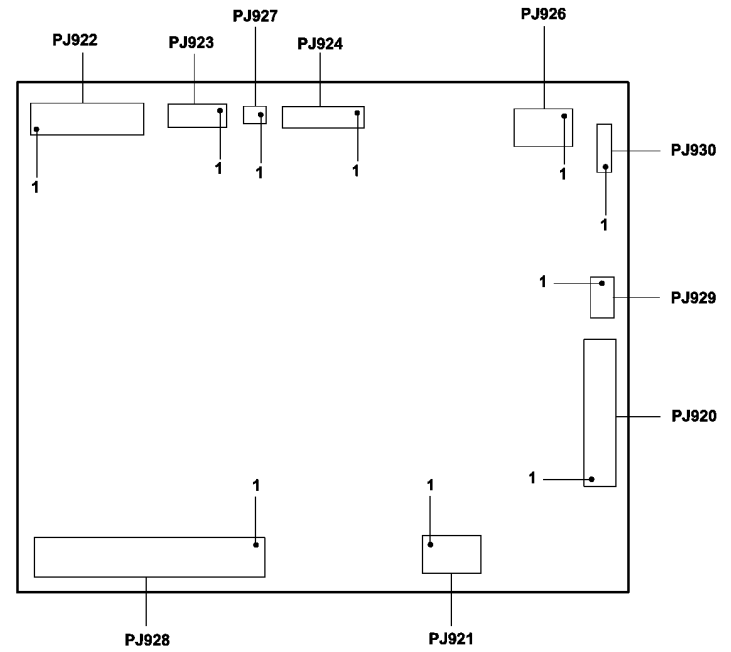
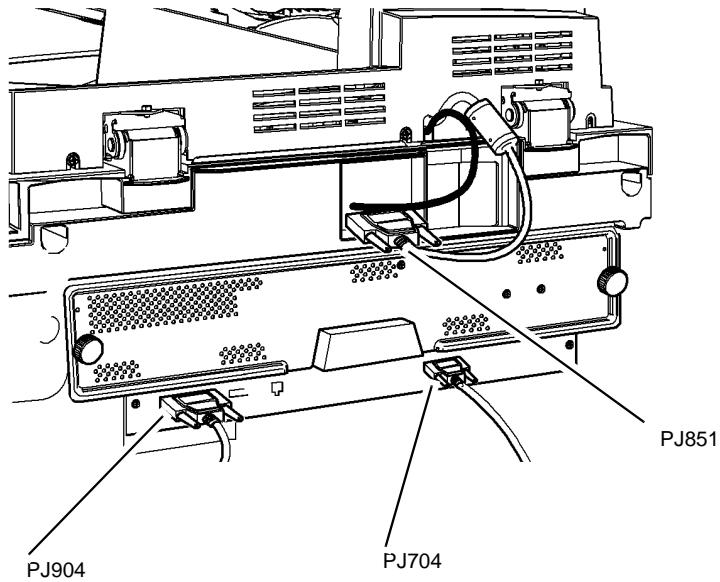

Figure 5 Scanner PWB

U-1-0739-A

In-line Connectors PJ704, PJ851, PJ904

Location: [PL 75.68](#), [PL 5.10 Item 6](#), [PL 12.00 \(OCT\)](#), [PL 12.75 \(LCSS\)](#), [PL 12.140 \(HVF\)](#),



U-1-0809-A

Figure 6 PJ704, PJ851, PJ904

Fax Connector PWB

Location: [PL 20.05 Item 2](#)

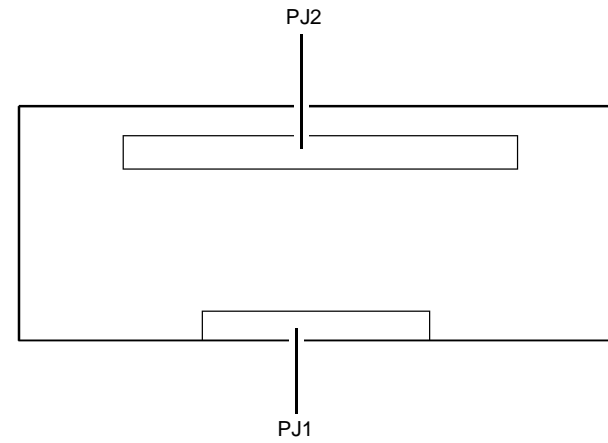

U-1-1648-A

Figure 7 Fax connector PWB

Tray 5 Control PWB

Location: PL 75.68 Item 8

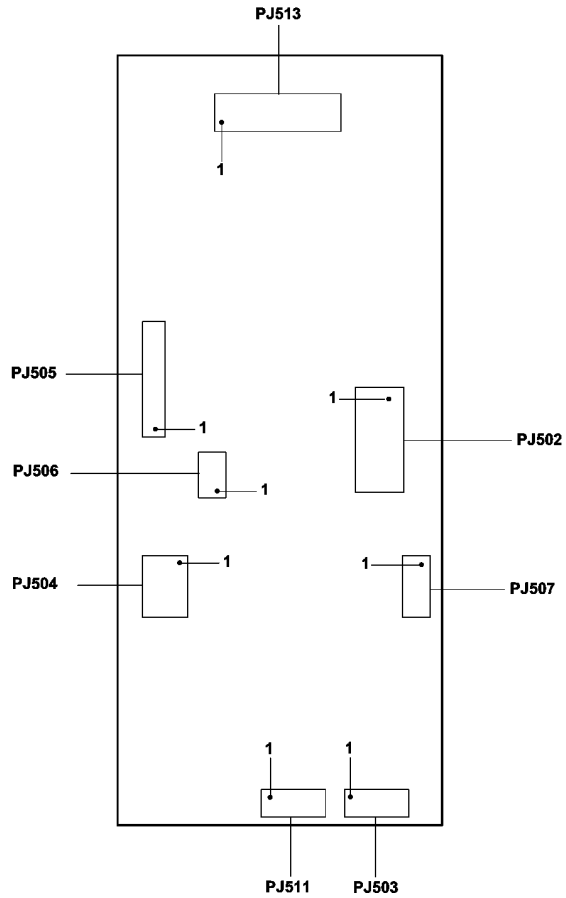

Figure 8 Tray 5 control PWB

U-1-0734-A

3 Tray Module PWB

Location: PL 73.16 Item 4.

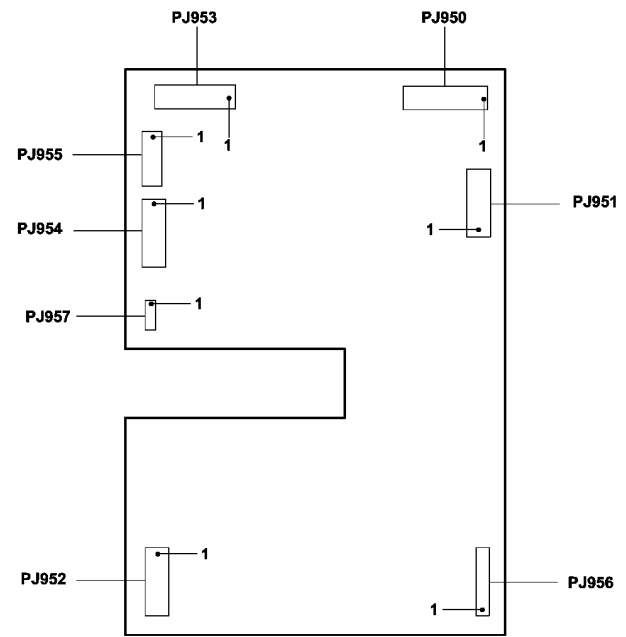

Figure 9 3 Tray module PWB

U-1-0730-A

Media Path Driver PWB

Location: PL 1.15 Item 21

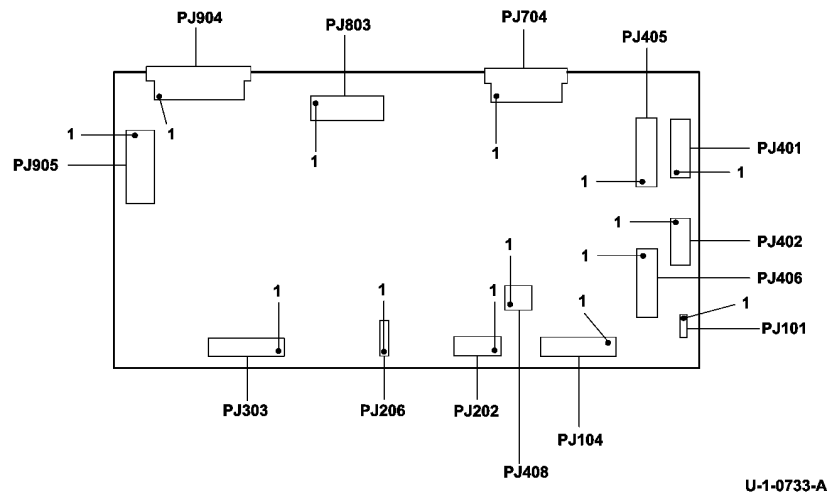

Figure 10 Media path driver PWB

Registration / Preheat Interface PWB

Location: PL 88.10 Item 10

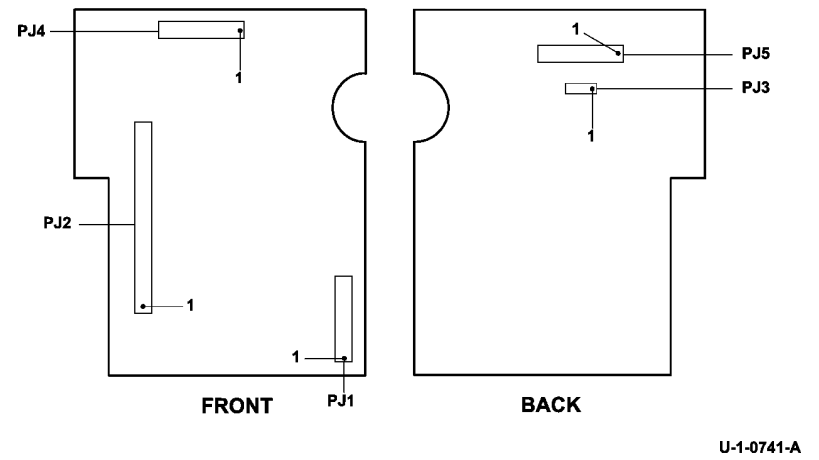

Figure 11 Registration / preheat interface PWB

Drum Driver PWB

Location: PL 1.15 Item 4

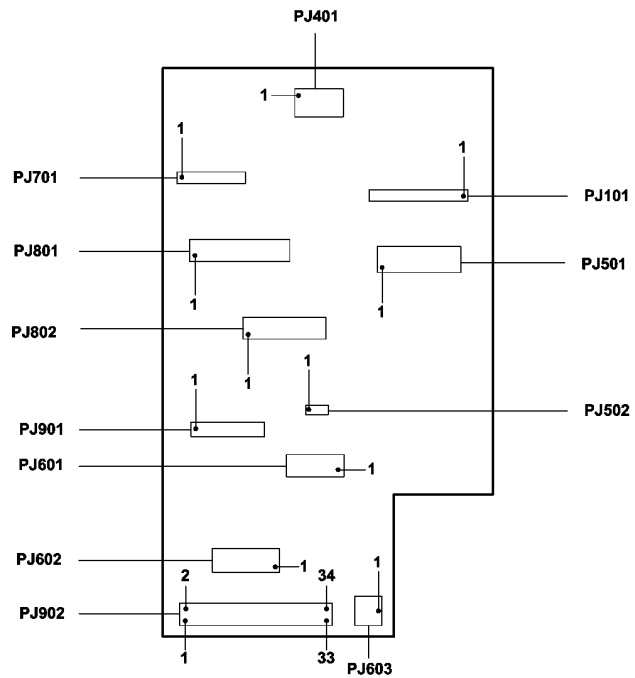

Figure 12 Drum driver PWB

U-1-0729-A

IOD Pre Amplifier PWB

Location: PL 94.15

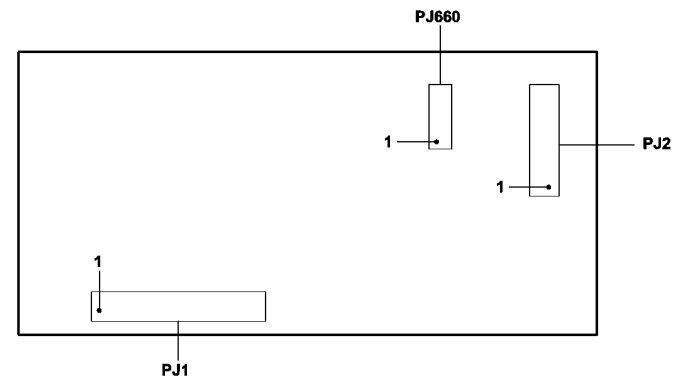

Figure 13 IOD pre amplifier PWB

U-1-0743-A

IME Controller PWB

Location: PL 92.10 Item 1

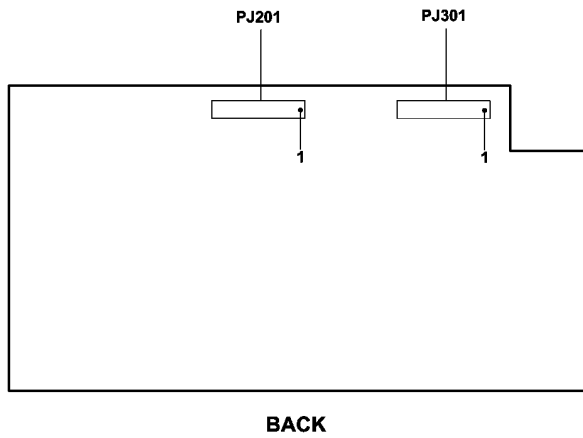
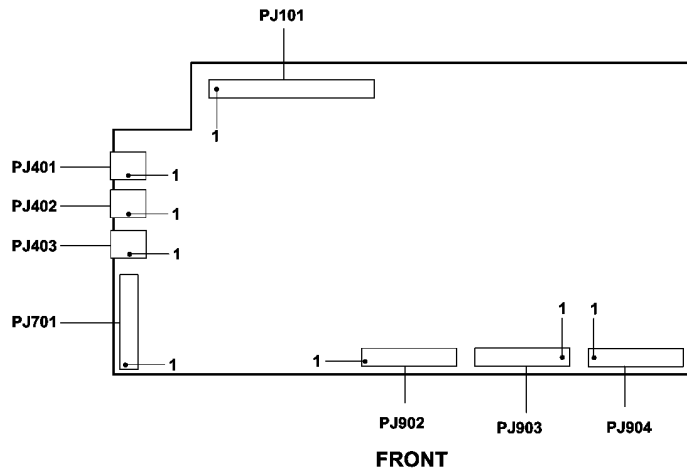
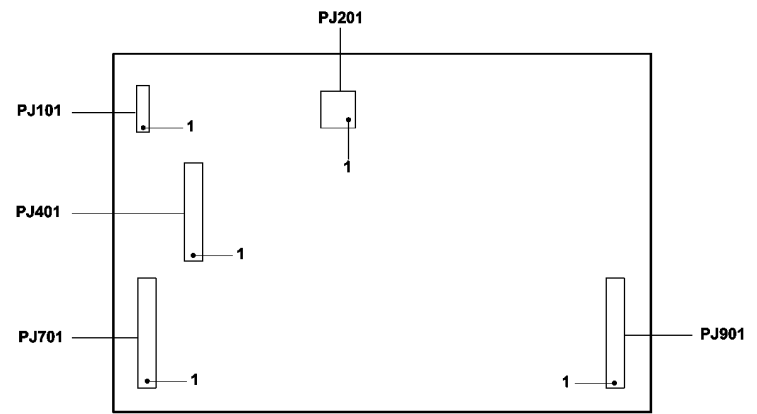

Figure 14 IME controller PWB

U-1-0731-A

Marking Unit Heater PWB

Location: PL 92.10 Item 5



U-1-0747-A

Figure 15 Marking unit heater PWB

Marking Unit Driver PWB

Location: PL 92.10 Item 4

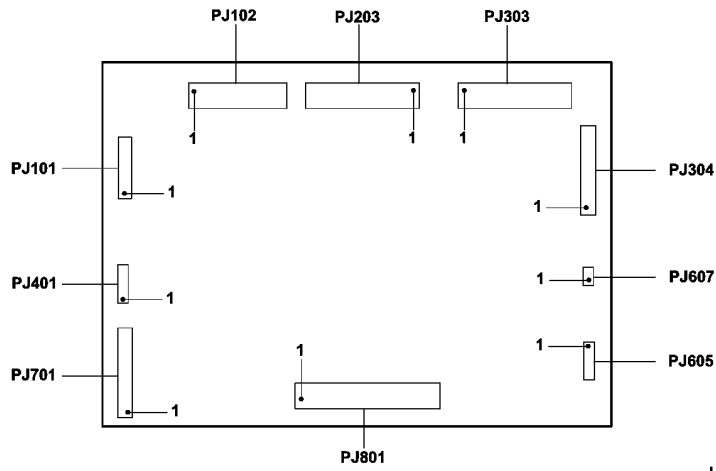

U-1-0746-A

Figure 16 Marking unit driver PWB

Quad wave amp PWB

Location: PL 92.10 Item 3

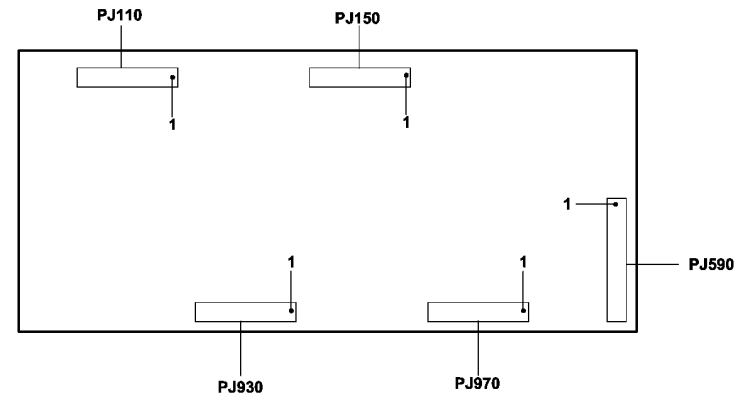

U-1-0738-A

Figure 17 Quad wave amp PWB

Solenoid Patch PWB

Location: [PL 93.10 Item 9.](#)

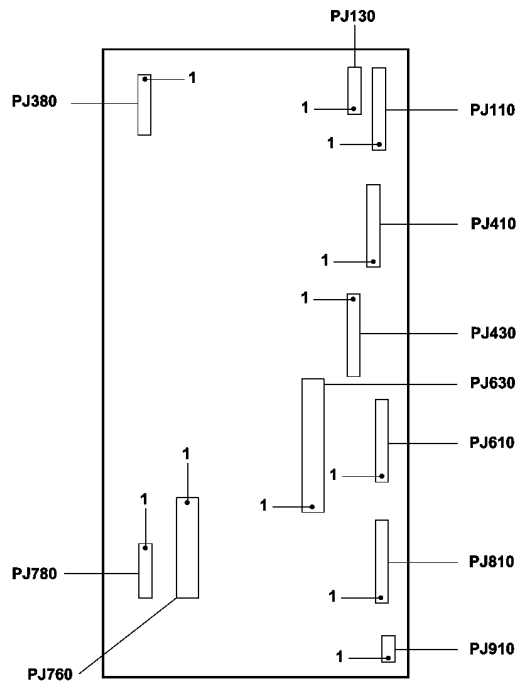
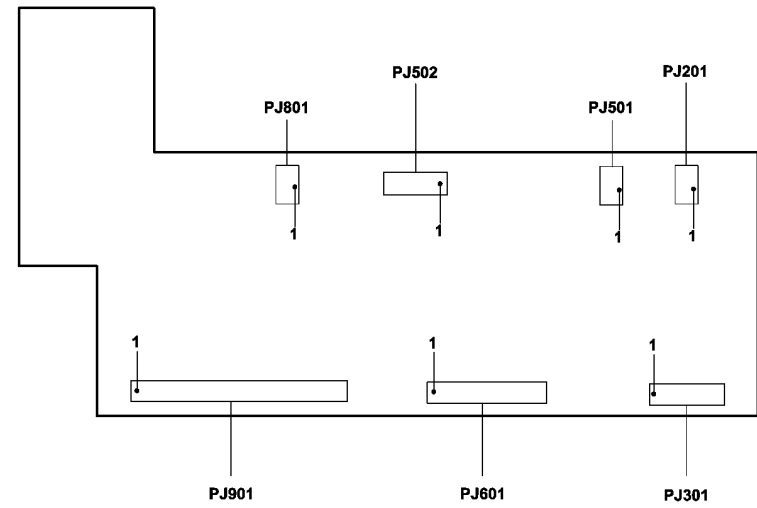

Figure 18 Solenoid patch PWB

Ink Load Entry PWB

Location: [PL 93.10 Item 8.](#)



U-1-0745-A

U-1-0736-A

Figure 19 Ink load entry PWB

Printhead PWB

Location: [PL 91.20 Item 3](#).

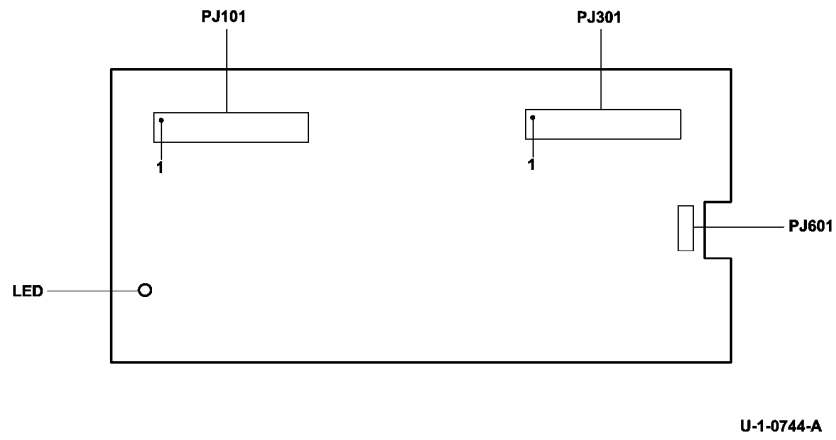

Figure 20 Printhead PWB

U-1-0744-A

HVF PWB

Location [PL 12.140 Item 2](#)

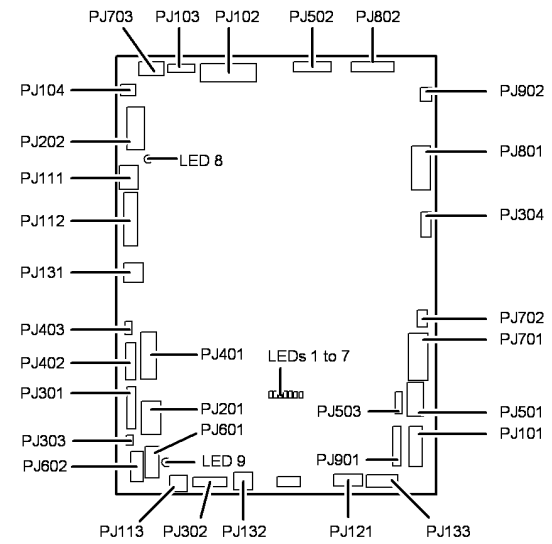
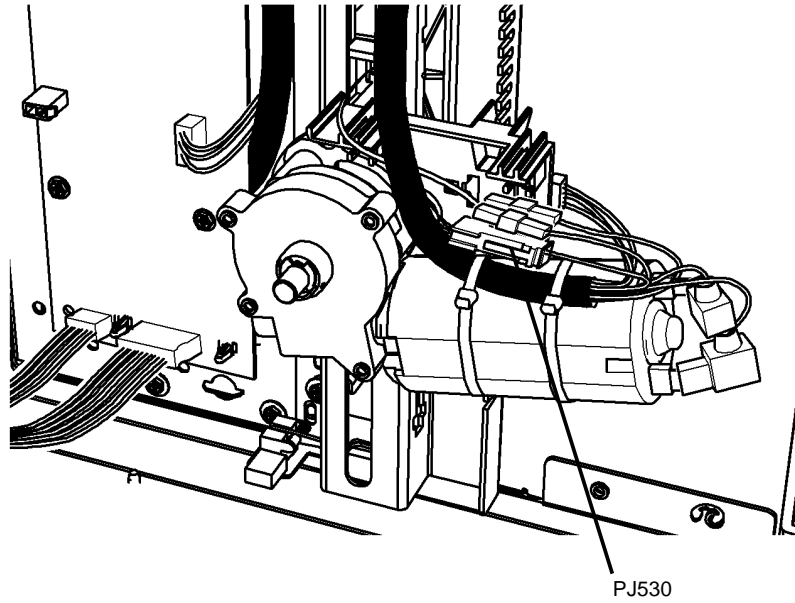

Figure 21 HVF PWB

U-1-0724-A

In-Line Connector PJ530

Location: PL 75.68 Item 4.



U-1-0945-A

Figure 22 PJ530

Tri Folder PWB

Location: PL 12.205 Item 16.

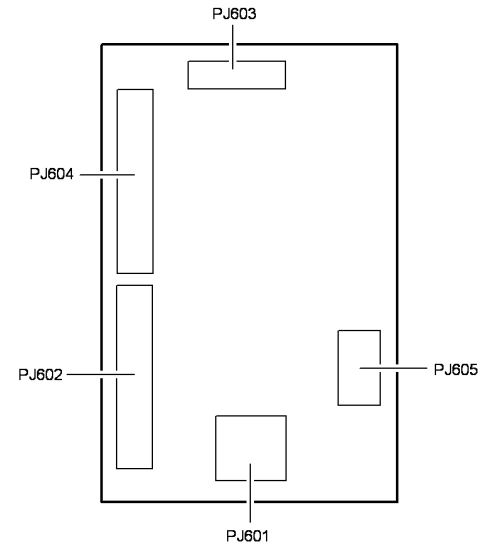

U-1-0946-A

Figure 23 Tri folder PWB

Inserter PWB

Location: PL 12.310 Item 9

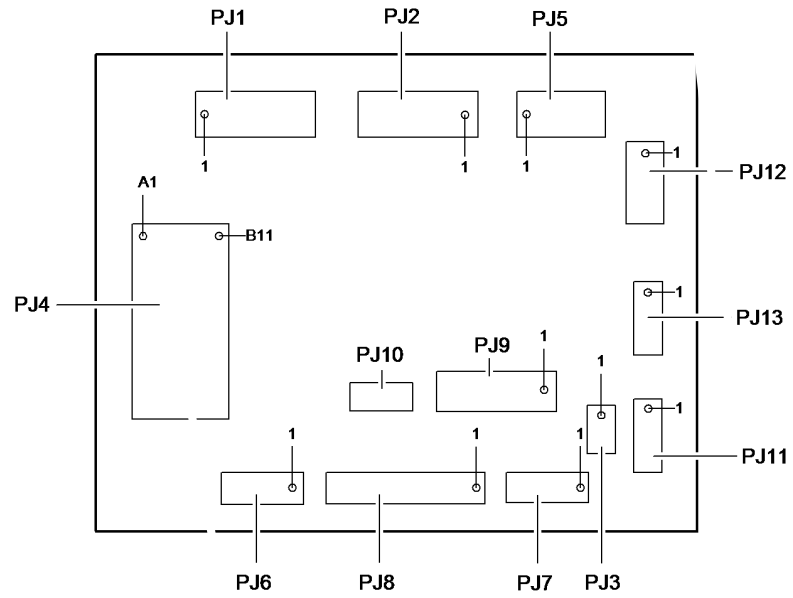

U-1-0808-A

Figure 24 Inserter PWB

BM PWB

Location: PL 12.175 Item 10

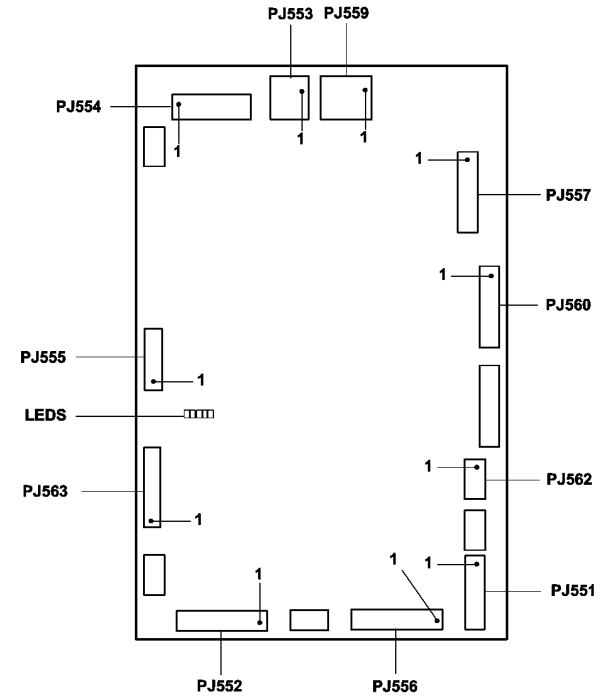

U-1-0750-A

Figure 25 BM PWB

LCSS PWB

Location: [PL 12.75 Item 1](#)

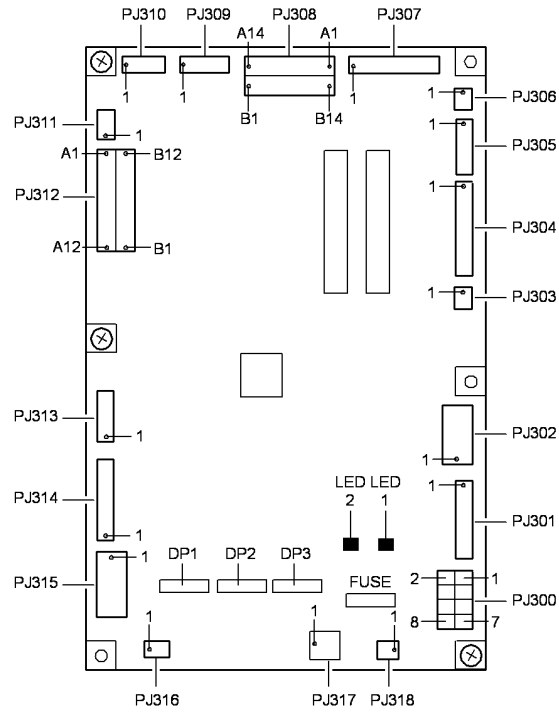

Figure 26 LCSS PWB

U-1-0947-A

Pause to Unload PWB (LCSS)

Location: [PL 12.75 Item 3](#)

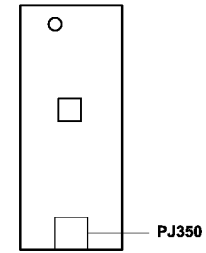

Figure 27 Pause to unload PWB

U-1-0749-A

Foreign Device Interface PWB

Location: [PL 3.11 Item 14](#)

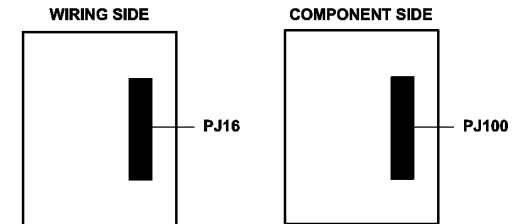
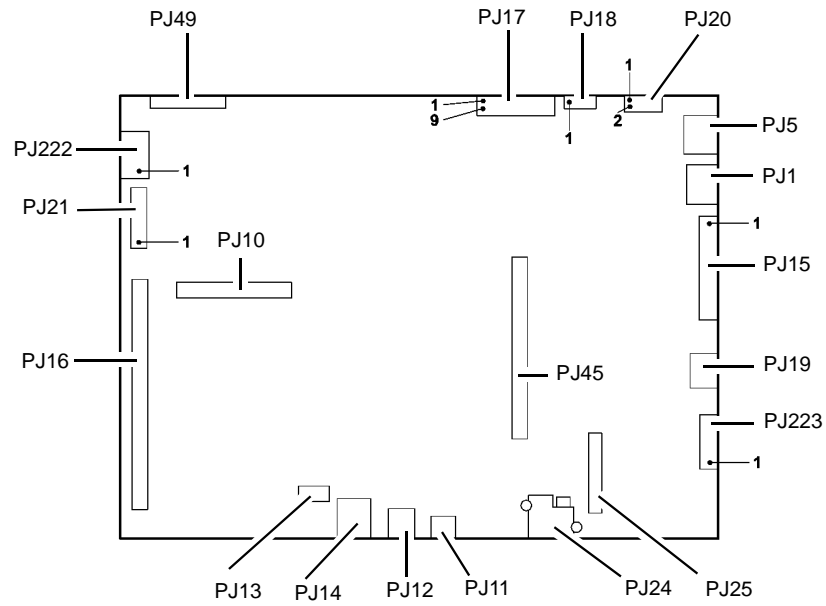

Figure 28 Foreign device interface PWB

U-1-1437-A

Single Board Controller PWB

Location: PL 3.11 Item 13



U-1-1606-A

Figure 29 Single board controller PWB

In-Line Connector PJ140 and In-Line PJ

Bracket located on the rear frame that supports two in line connectors.

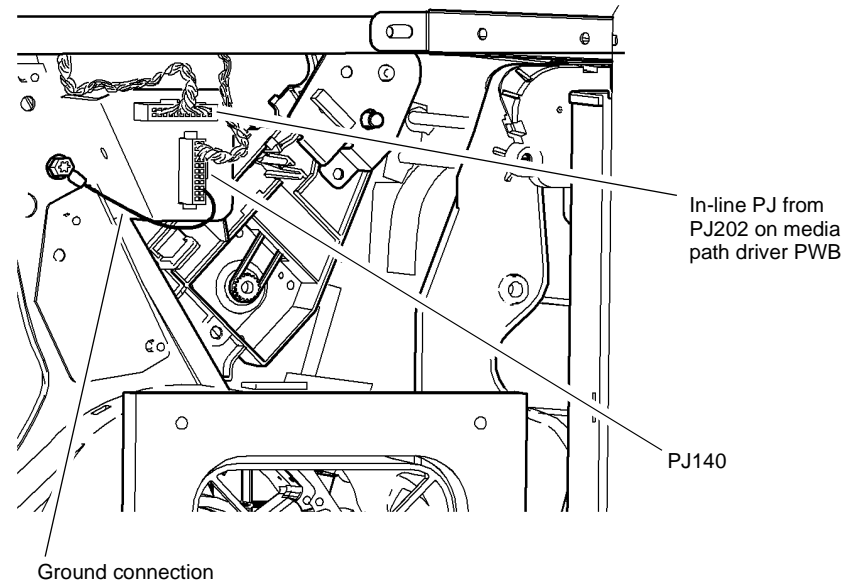

U-1-1638-A

Figure 30 PJ140 and in-line PJ

Wiring Diagrams

Introduction

The main PWB connections are in the following wiring diagrams:

- WD 1.1 Power Supply Unit (1 of 5) [Figure 1](#)
- WD 1.2 Power Supply Unit (2 of 5) [Figure 2](#)
- WD 1.3 Power Supply Unit (3 of 5) [Figure 3](#)
- WD 1.4 Power Supply Unit (4 of 5) [Figure 4](#)
- WD 1.5 Power Supply Unit (5 of 5) [Figure 5](#)
- WD 1.6 Power Distribution PWB (1 of 2) [Figure 6](#)
- WD 1.7 Power Distribution PWB (2 of 2) [Figure 7](#)
- WD 3.1 Single Board Controller PWB (1 of 3) [Figure 8](#)
- WD 3.2 Single Board Controller PWB (2 of 3) [Figure 9](#)
- WD 3.3 Single Board Controller PWB (3 of 3) [Figure 10](#)
- WD 5.1 DADH PWB (1 of 2) [Figure 11](#)
- WD 5.2 DADH PWB (2 of 2) [Figure 12](#)
- WD 6.1 Scanner PWB (1 of 3) [Figure 13](#)
- WD 6.2 Scanner PWB (2 of 3) [Figure 14](#)
- WD 6.3 Scanner PWB (3 of 3) [Figure 15](#)
- WD 7.1 Tray 5 Control PWB (1 of 2) [Figure 16](#)
- WD 7.2 Tray 5 Control PWB (2 of 2) [Figure 17](#)
- WD 7.3 Tray 3 Module PWB (1 of 3) [Figure 18](#)
- WD 7.4 Tray 3 Module PWB (2 of 3) [Figure 19](#)
- WD 7.5 Tray 3 Module PWB (3 of 3) [Figure 20](#)
- WD 8.1 Media Path Driver PWB (1 of 5) [Figure 21](#)
- WD 8.2 Media Path Driver PWB (2 of 5) [Figure 22](#)
- WD 8.3 Media Path Driver PWB (3 of 5) [Figure 23](#)
- WD 8.4 Media Path Driver PWB (4 of 5) [Figure 24](#)
- WD 8.5 Media Path Driver PWB (5 of 5) [Figure 25](#)
- WD 8.6 Reg/Preheat IF PWB [Figure 26](#)
- WD 9.1 Drum Driver PWB (1 of 4) [Figure 27](#)
- WD 9.2 Drum Driver PWB (2 of 4) [Figure 28](#)
- WD 9.3 Drum Driver PWB (3 of 4) [Figure 29](#)
- WD 9.4 Drum Driver PWB (4 of 4) [Figure 30](#)
- WD 9.5 IME Controller PWB (1 of 3) [Figure 31](#)
- WD 9.6 IME Controller PWB (2 of 3) [Figure 32](#)
- WD 9.7 IME Controller PWB (3 of 3) [Figure 33](#)
- WD 9.8 Marking Unit Heater PWB [Figure 34](#)
- WD 9.9 Marking Unit Driver PWB (1 of 4) [Figure 35](#)
- WD 9.10 Marking Unit Driver PWB (2 of 4) [Figure 36](#)
- WD 9.11 Marking Unit Driver PWB (3 of 4) [Figure 37](#)
- WD 9.12 Marking Unit Driver PWB (4 of 4) [Figure 38](#)
- WD 9.13 Quad Wave Amplifier PWB [Figure 39](#)
- WD 9.14 Solenoid Patch PWB (1 of 3) [Figure 40](#)

- WD 9.15 Solenoid Patch PWB (2 of 3) [Figure 41](#)
- WD 9.16 Solenoid Patch PWB (3 of 3) [Figure 42](#)
- WD 9.17 Ink Load Entry PWB (1 of 2) [Figure 43](#)
- WD 9.18 Ink Load Entry PWB (2 of 2) [Figure 44](#)
- WD 9.19 Cleaning Unit PWB [Figure 45](#)
- WD 9.20 Printhead 1 PWB and Printhead 2 PWB [Figure 46](#)
- WD 9.21 Printhead 3 PWB and Printhead 4 PWB [Figure 47](#)
- WD 9.22 IOD Pre Amp PWB [Figure 48](#)
- WD 12.1 LCSS PWB (1 of 5) [Figure 49](#)
- WD 12.2 LCSS PWB (2 of 5) [Figure 50](#)
- WD 12.3 LCSS PWB (3 of 5) [Figure 51](#)
- WD 12.4 LCSS PWB (4 of 5) [Figure 52](#)
- WD 12.5 LCSS PWB (5 of 5) [Figure 53](#)
- WD 12.6 HVF PWB (1 of 11) [Figure 54](#)
- WD 12.7 HVF PWB (2 of 11) [Figure 55](#)
- WD 12.8 HVF PWB (3 of 11) [Figure 56](#)
- WD 12.9 HVF PWB (4 of 11) [Figure 57](#)
- WD 12.10 HVF PWB (5 of 11) [Figure 58](#)
- WD 12.11 HVF PWB (6 of 11) [Figure 59](#)
- WD 12.12 HVF PWB (7 of 11) [Figure 60](#)
- WD 12.13 HVF PWB (8 of 11) [Figure 61](#)
- WD 12.14 HVF PWB (9 of 11) [Figure 62](#)
- WD 12.15 HVF PWB (10 of 11) [Figure 63](#)
- WD 12.16 BM PWB (1 of 4) [Figure 64](#)
- WD 12.17 BM PWB (2 of 4) [Figure 65](#)
- WD 12.18 BM PWB (3 of 4) [Figure 66](#)
- WD 12.19 BM PWB (4 of 4) [Figure 67](#)
- WD 12.20 Tri Folder PWB [Figure 68](#)
- WD 12.21 Inserter PWB (1 of 2) [Figure 69](#)
- WD 12.22 Inserter PWB (2 of 2) [Figure 70](#)
- WD 12.23 OCT PWB [Figure 71](#)
- WD 12.24 HVF PWB (11 of 11) [Figure 72](#)

The diagrams have the following features:

- The connections on the PWB's are in PJ numerical sequence where possible.
- The complete component to PWB wiring is shown. All interconnecting connectors are shown, in part or in whole. Connectors shown in part have reference to other wiring diagrams as necessary.
- The following colours are used to differentiate the voltages shown on the wiring diagrams:
 - Purple = 0V.
 - Green = +3.3V.
 - Blue = +5V.
 - Yellow = +12V.
 - Black = +17V.

- Red = +24V.
- Where necessary, components have references to show additional connections to them.
- Straight through tracks on the PWB's are shown.

How to use Wiring Diagrams

NOTE: *All adjustment, repair and part list references are shown in the relevant RAP.*

Wiring diagrams are used in conjunction with their supporting RAPs. The steps that follow should be used:

1. From the RAP, note the name of the PWB.
2. Note the component and its harness connection on the PWB.
3. Go to the relevant Wiring Diagram.
4. Locate the connector on the PWB.
5. Assess the dependency of other components in the same harness connected to the PWB.
6. Isolate and repair the wiring fault.

WD 1.1 Power Supply Unit (1 of 5)

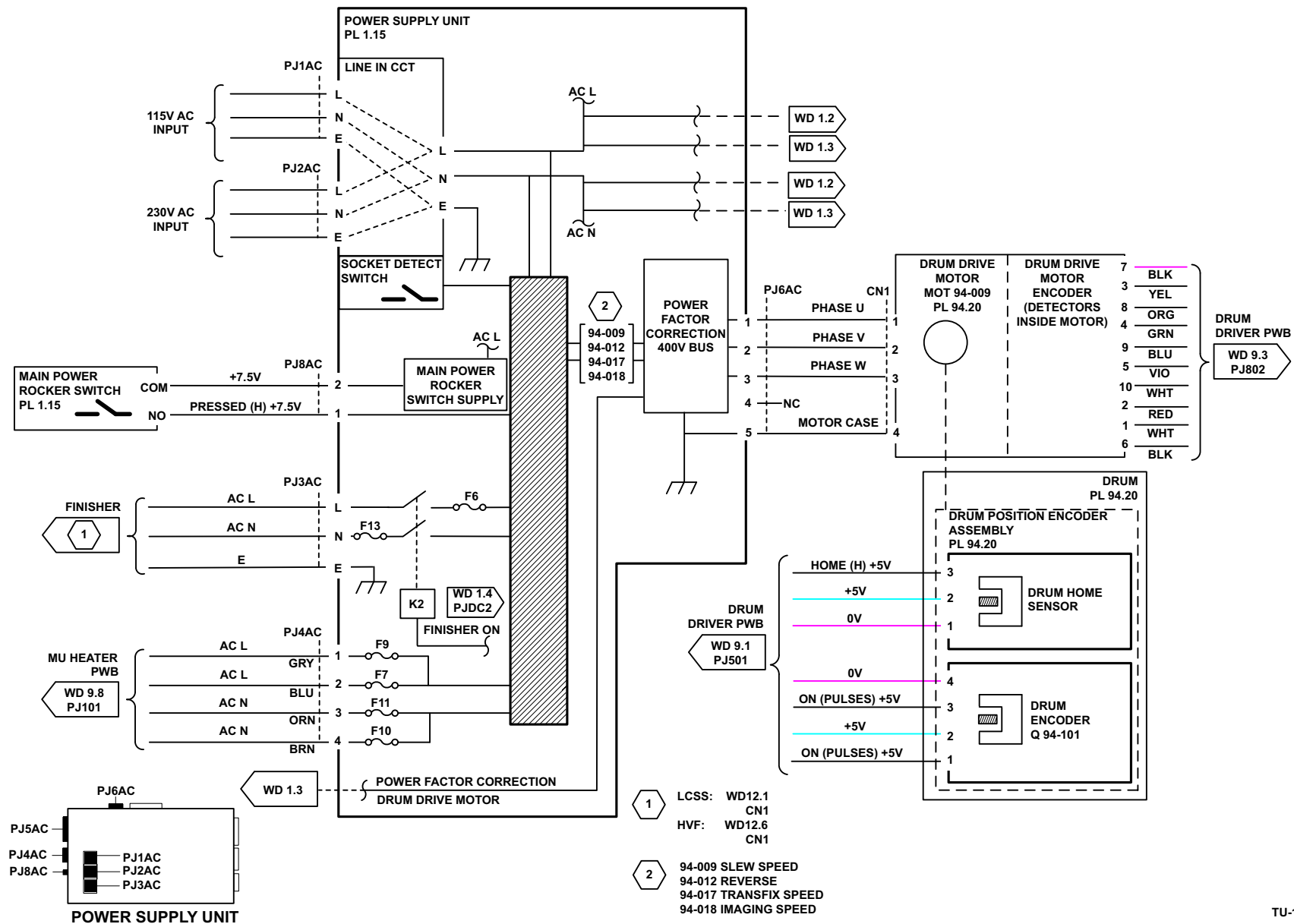

Figure 1 Wiring diagram 1.1

TU-1-0181-A

WD 1.2 Power Supply Unit (2 of 5)

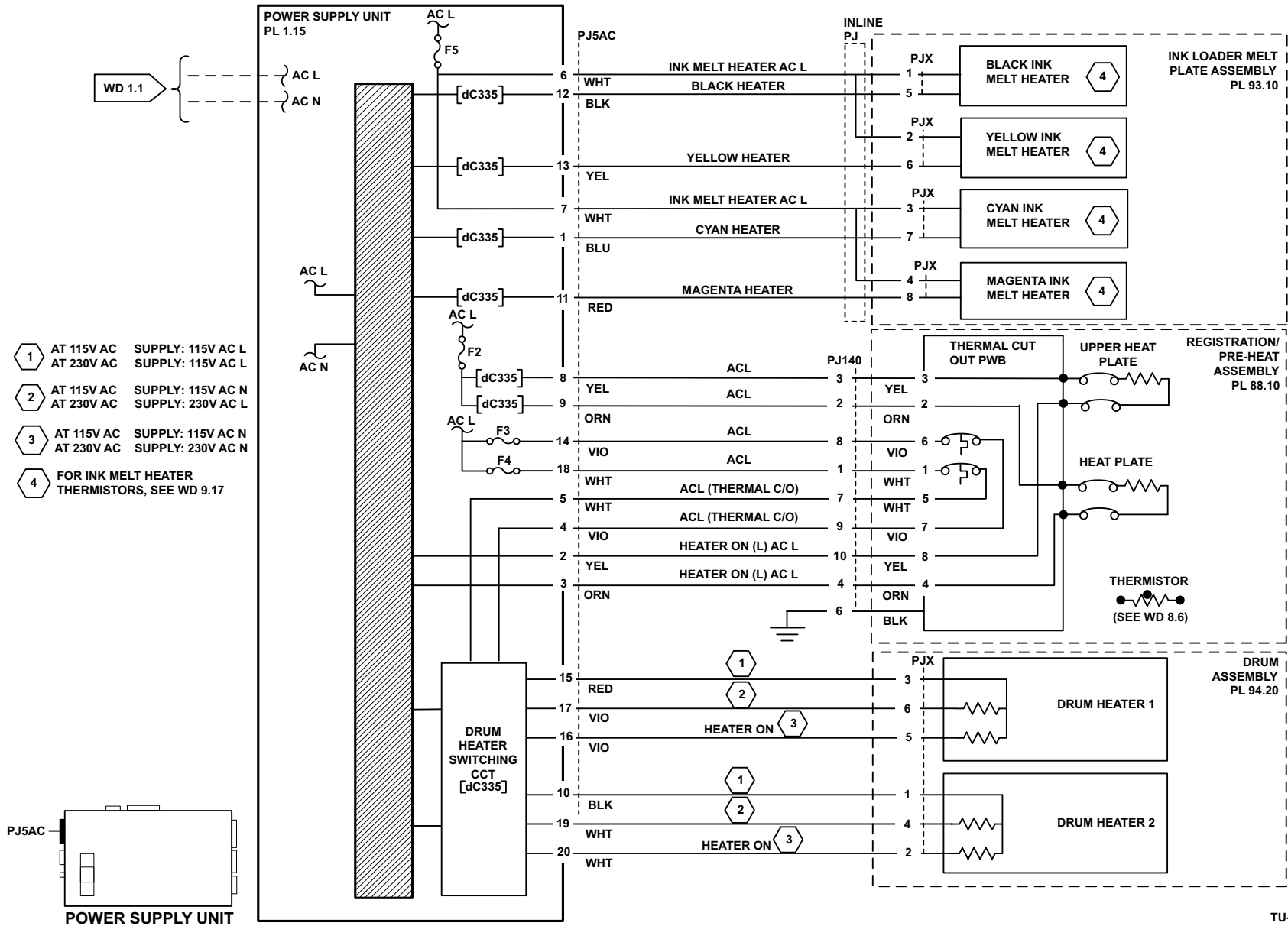

Figure 2 Wiring diagram 1.2

TU-1-0213-A

WD 1.3 Power Supply Unit (3 of 5)

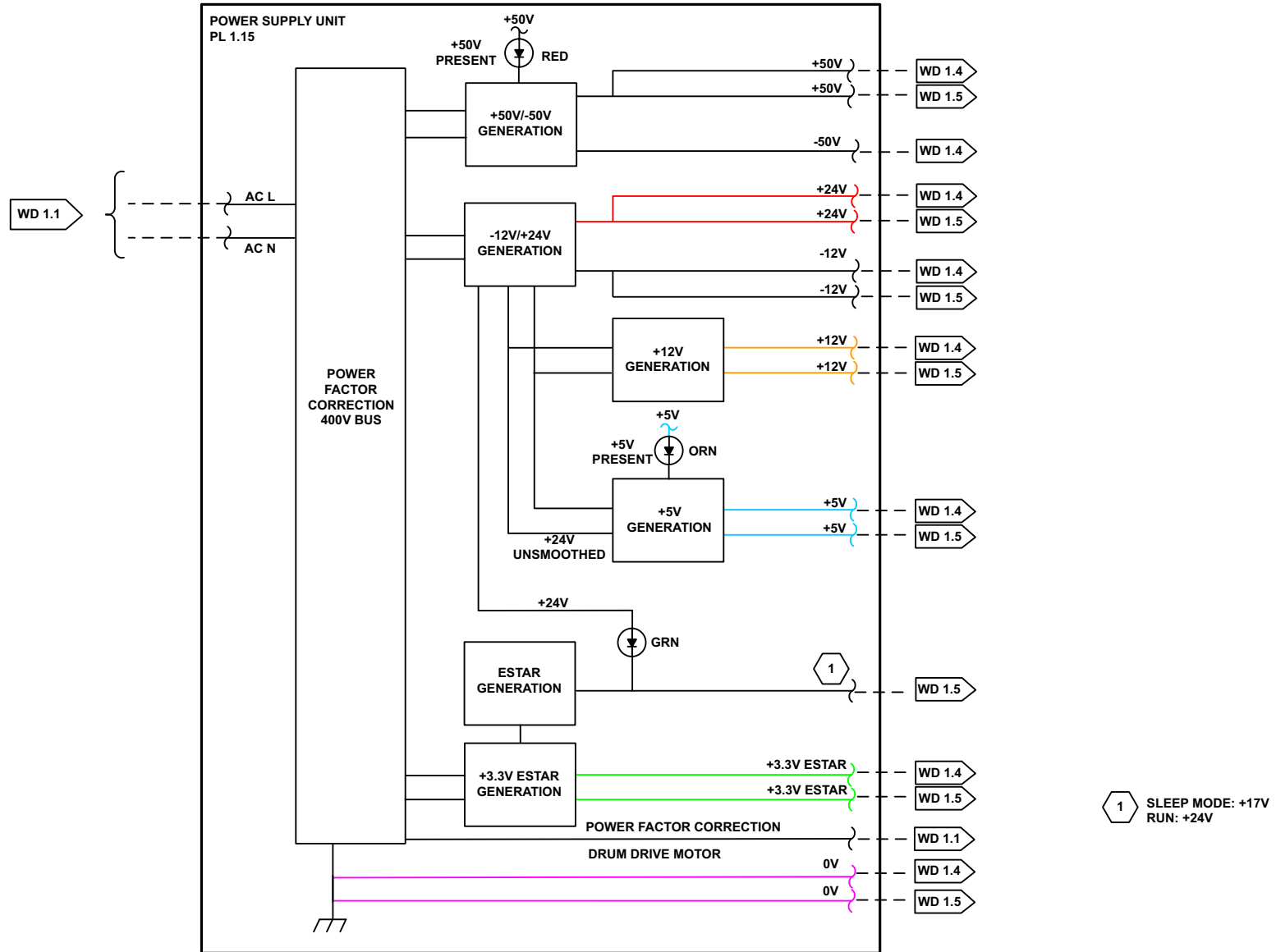

Figure 3 Wiring diagram 1.3

TU-1-0212-A

WD 1.4 Power Supply Unit (4 of 5)

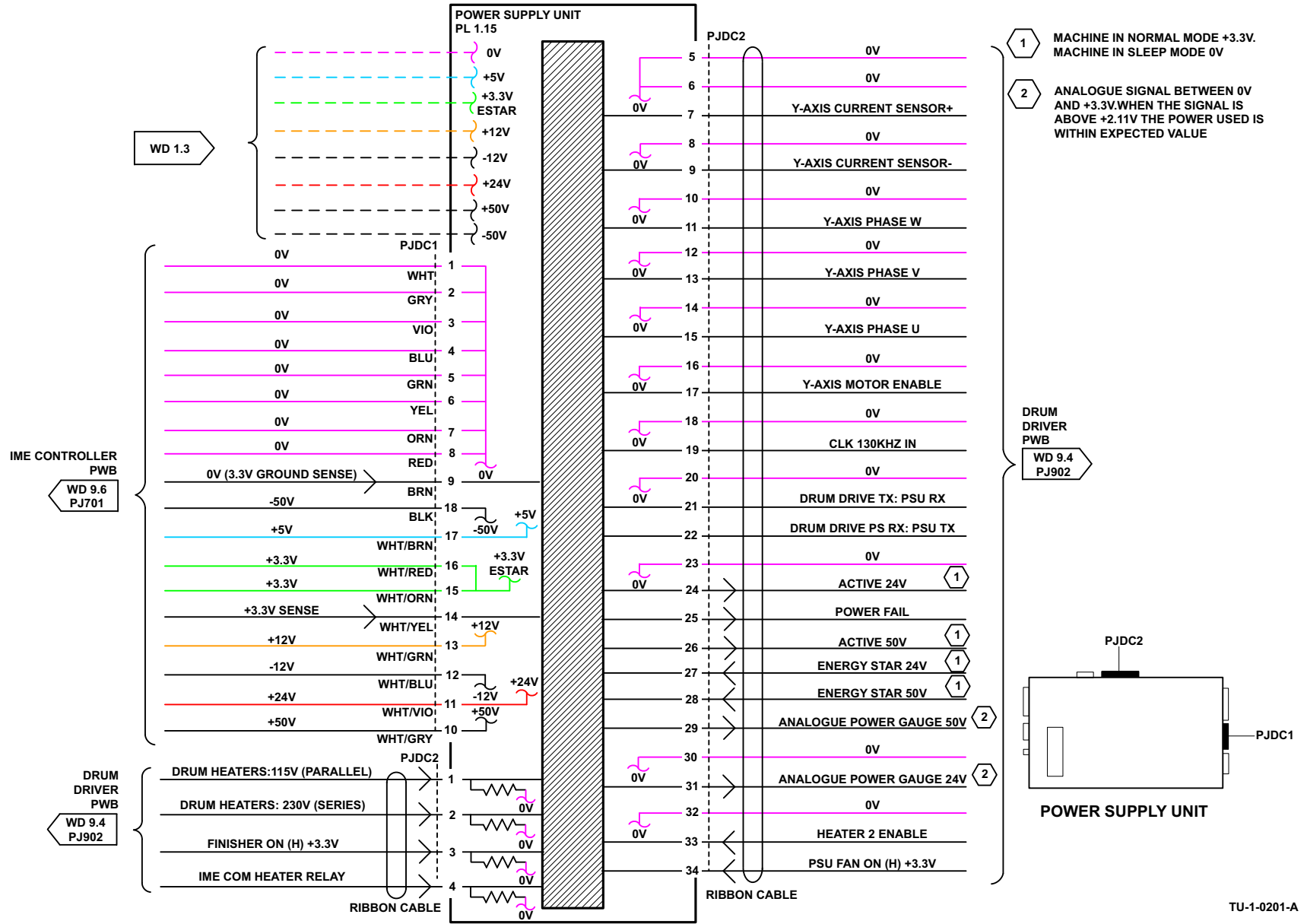

Figure 4 Wiring diagram 1.4

TU-1-0201-A

WD 1.5 Power Supply Unit (5 of 5)

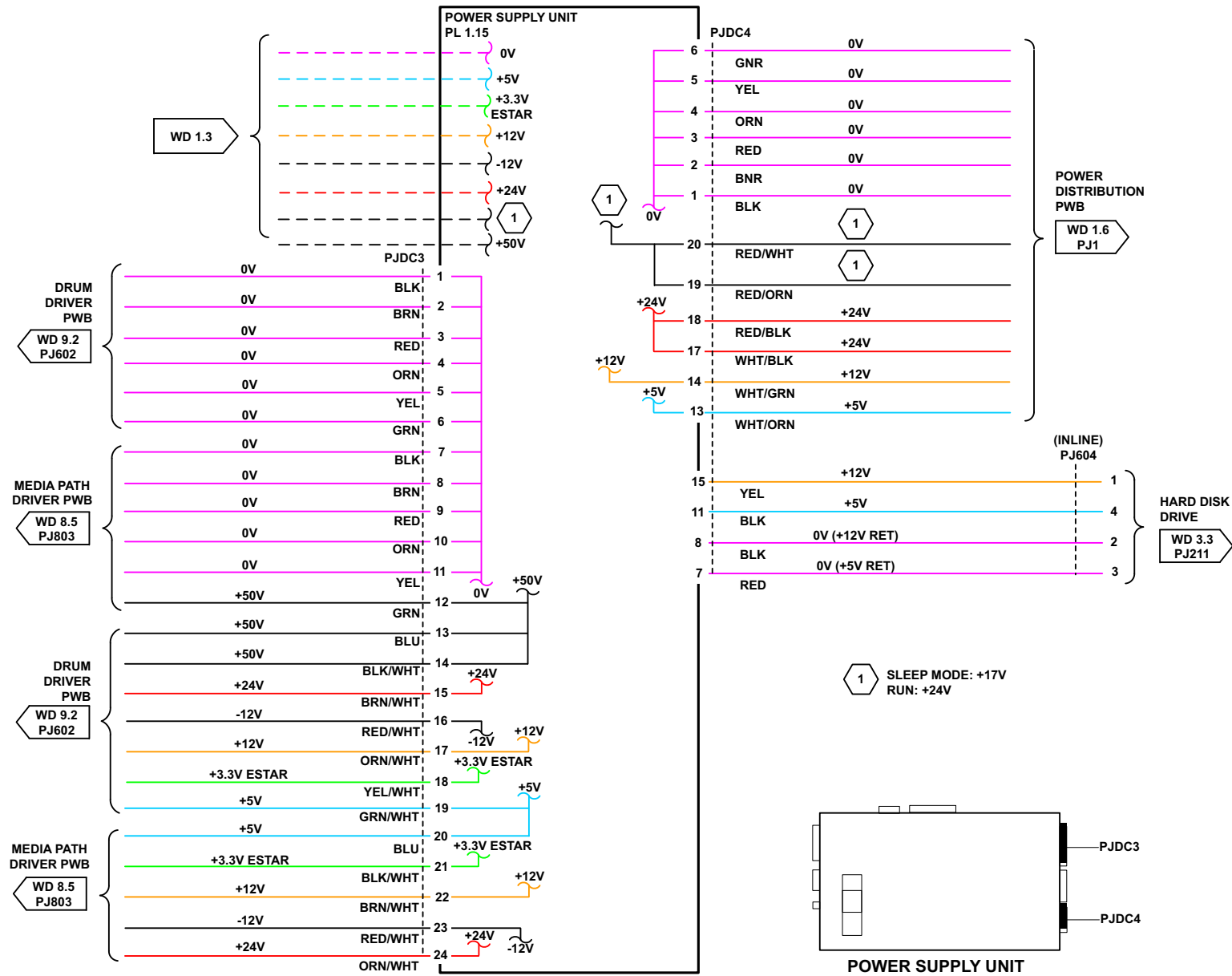
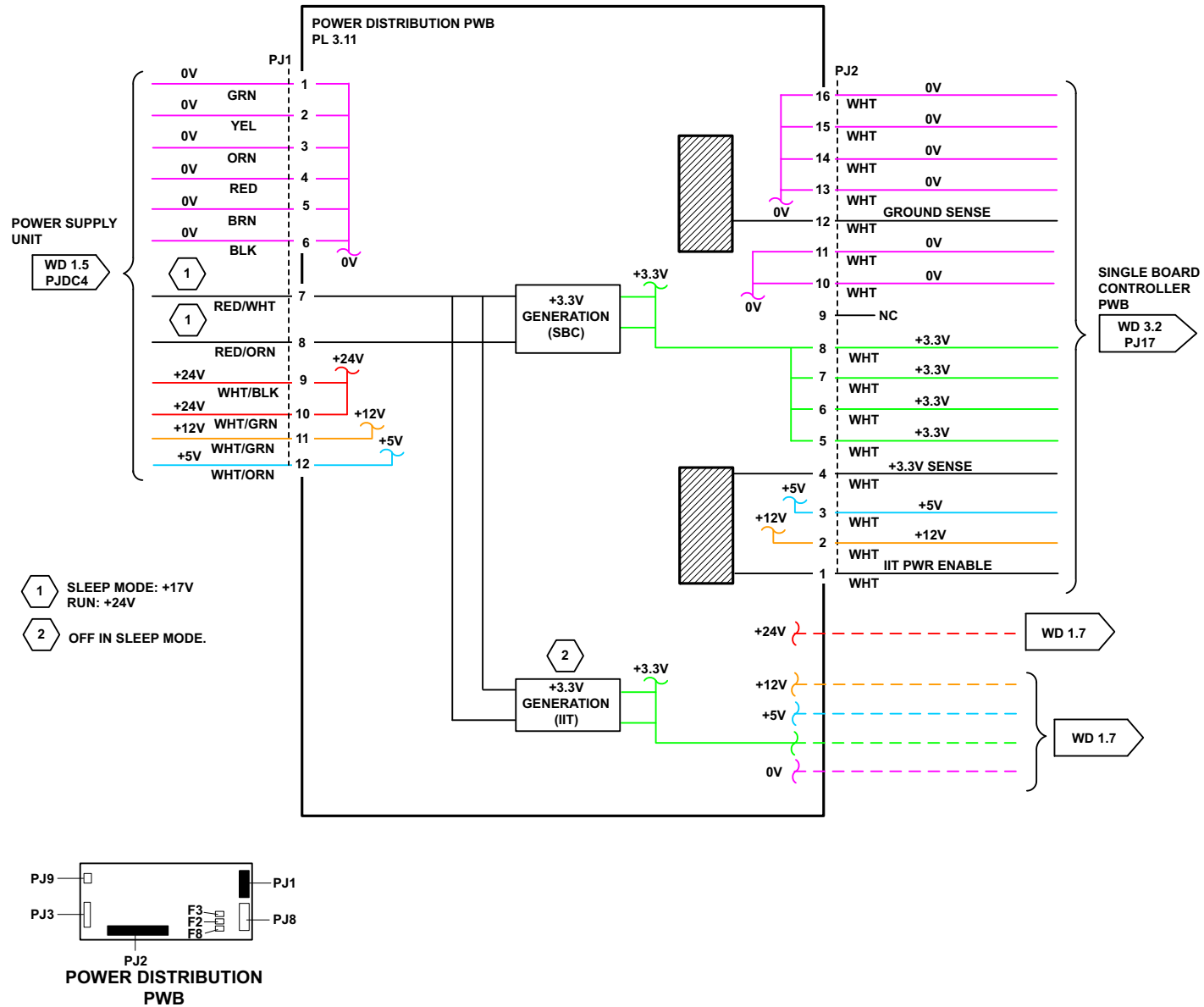

Figure 5 Wiring diagram 1.5

WD 1.6 Power Distribution PWB (1 of 2)



TU-1-0238-A

Figure 6 Wiring diagram 1.6

WD 1.7 Power Distribution PWB (2 of 2)

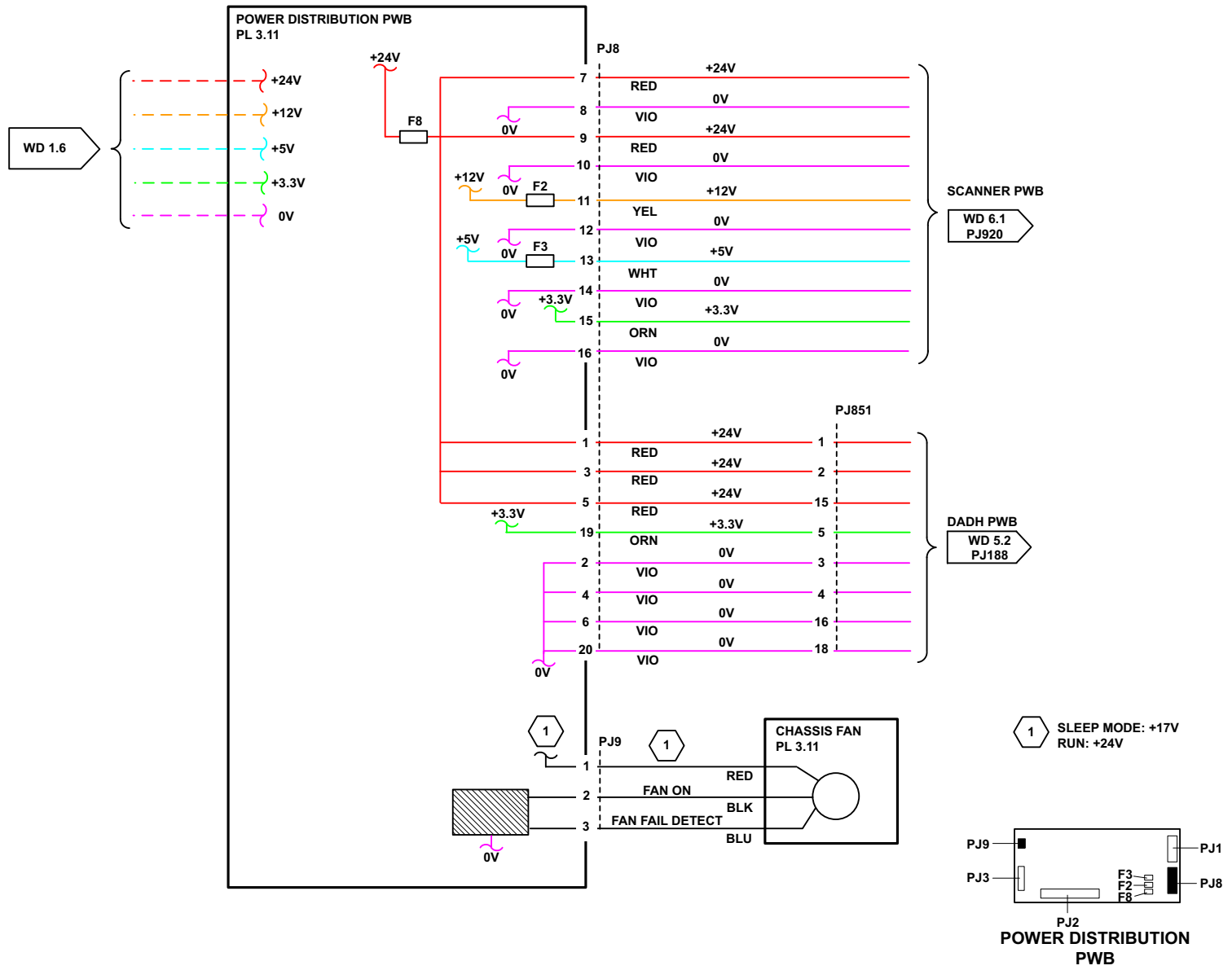

Figure 7 Wiring diagram 1.7

TU-1-0233-A

WD 3.1 Single Board Controller PWB (1 of 3)

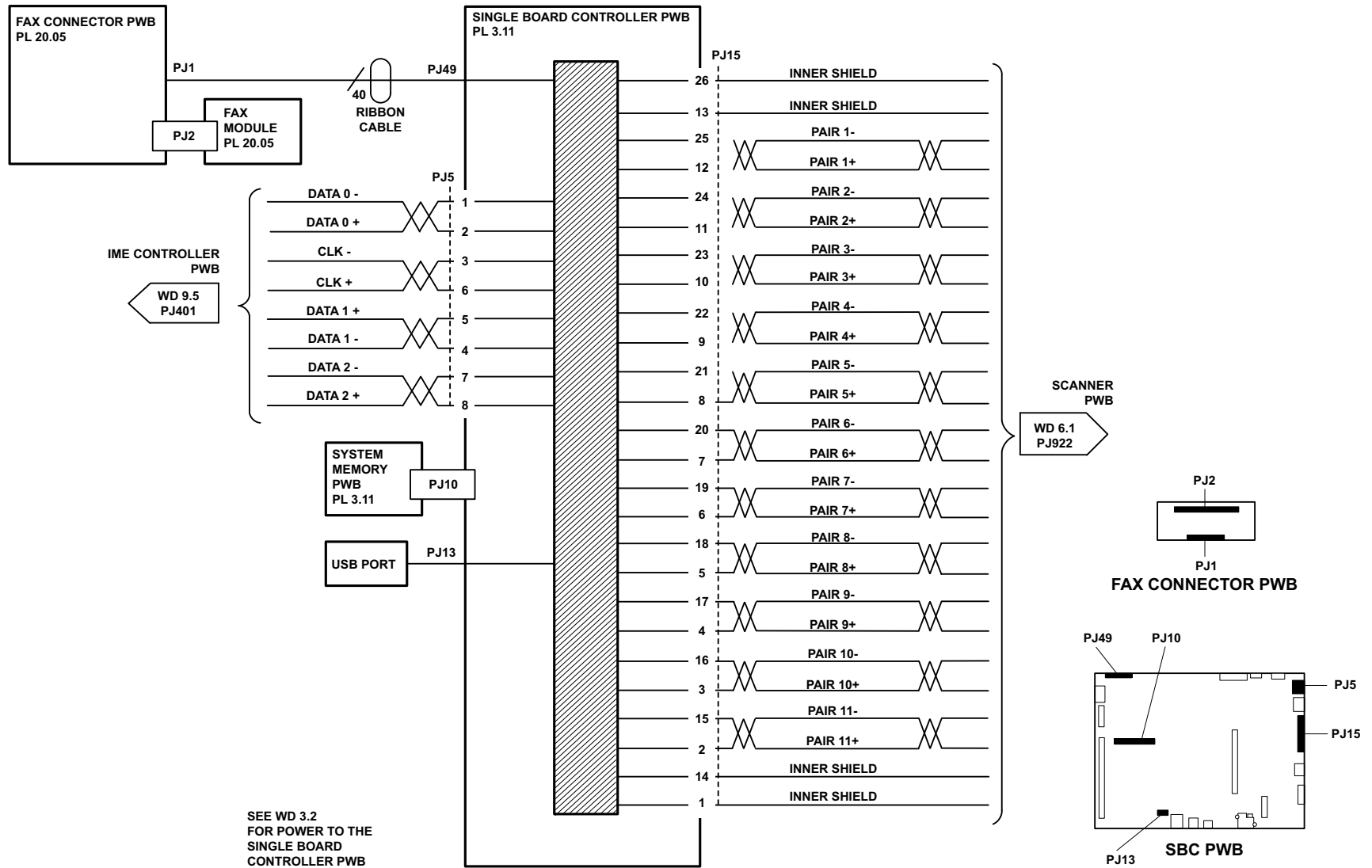

Figure 8 Wiring diagram 3.1

TU-1-0234-A

WD 3.2 Single Board Controller PWB (2 of 3)

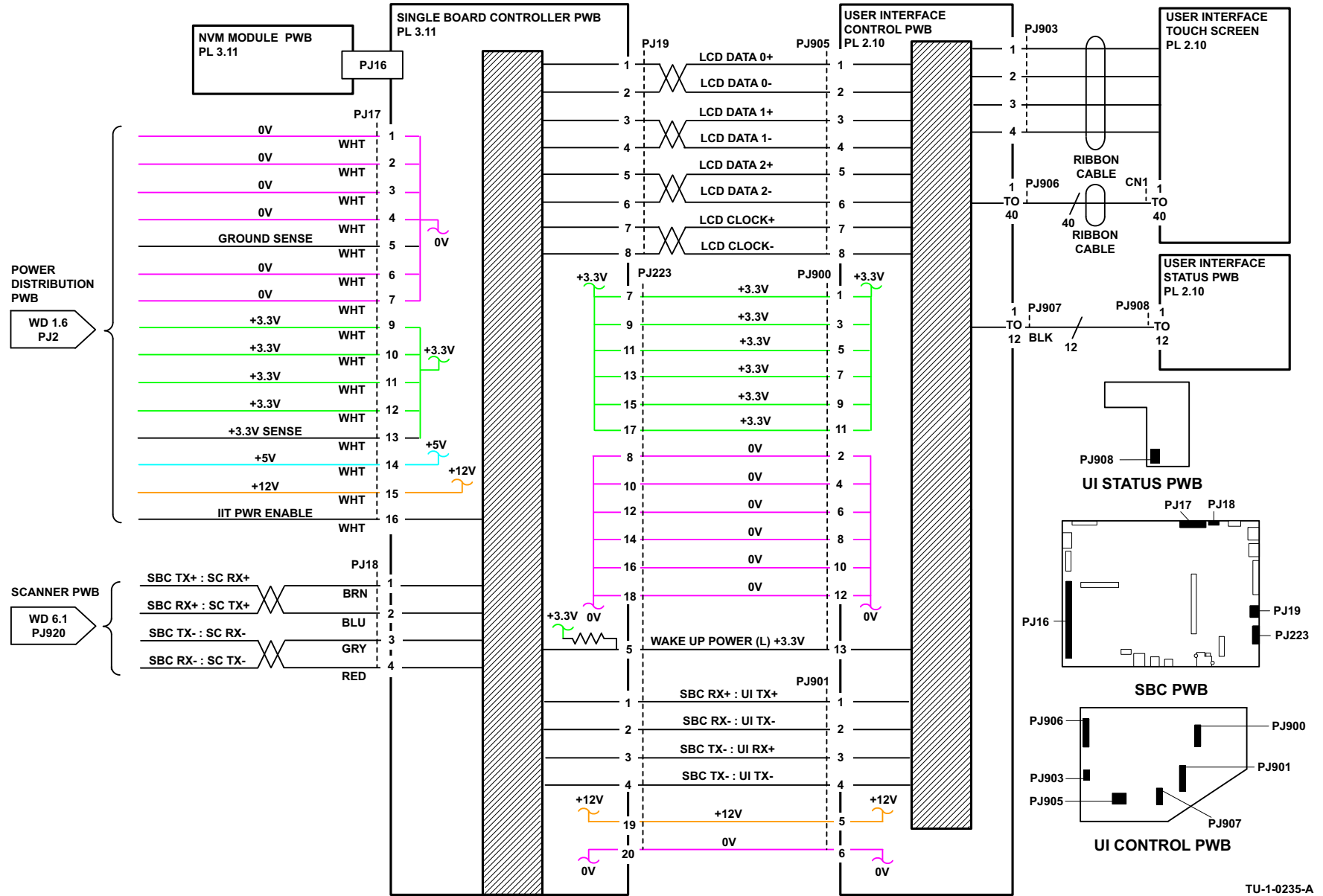
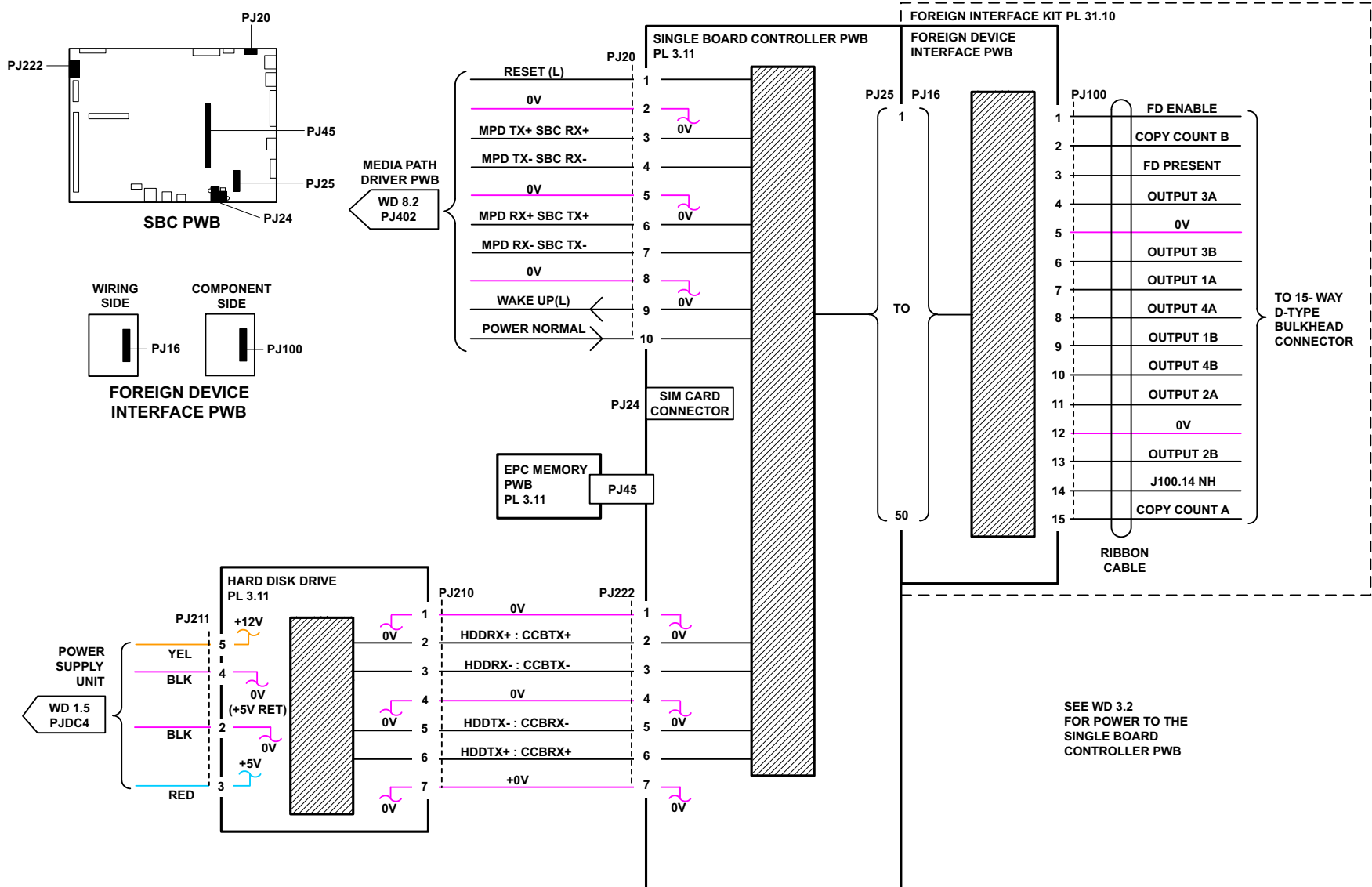

Figure 9 Wiring diagram 3.2

TU-1-0235-A

WD 3.3 Single Board Controller PWB (3 of 3)



TU-1-0236-A

Figure 10 Wiring diagram 3.3

WD 5.1 DADH PWB (1 of 2)

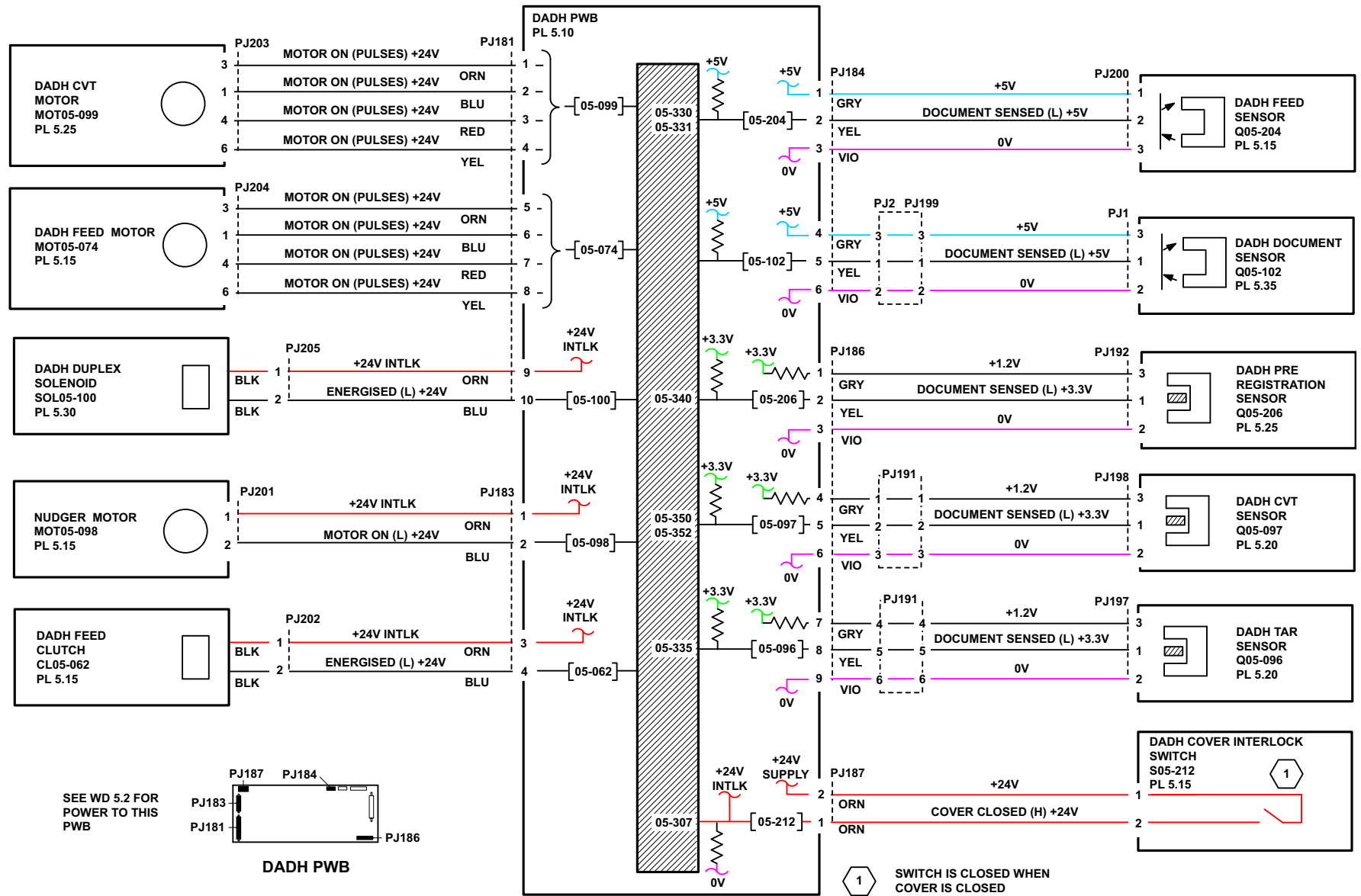

TU-1-0001-A

Figure 11 Wiring diagram 5.1

WD 5.2 DADH PWB (2 of 2)

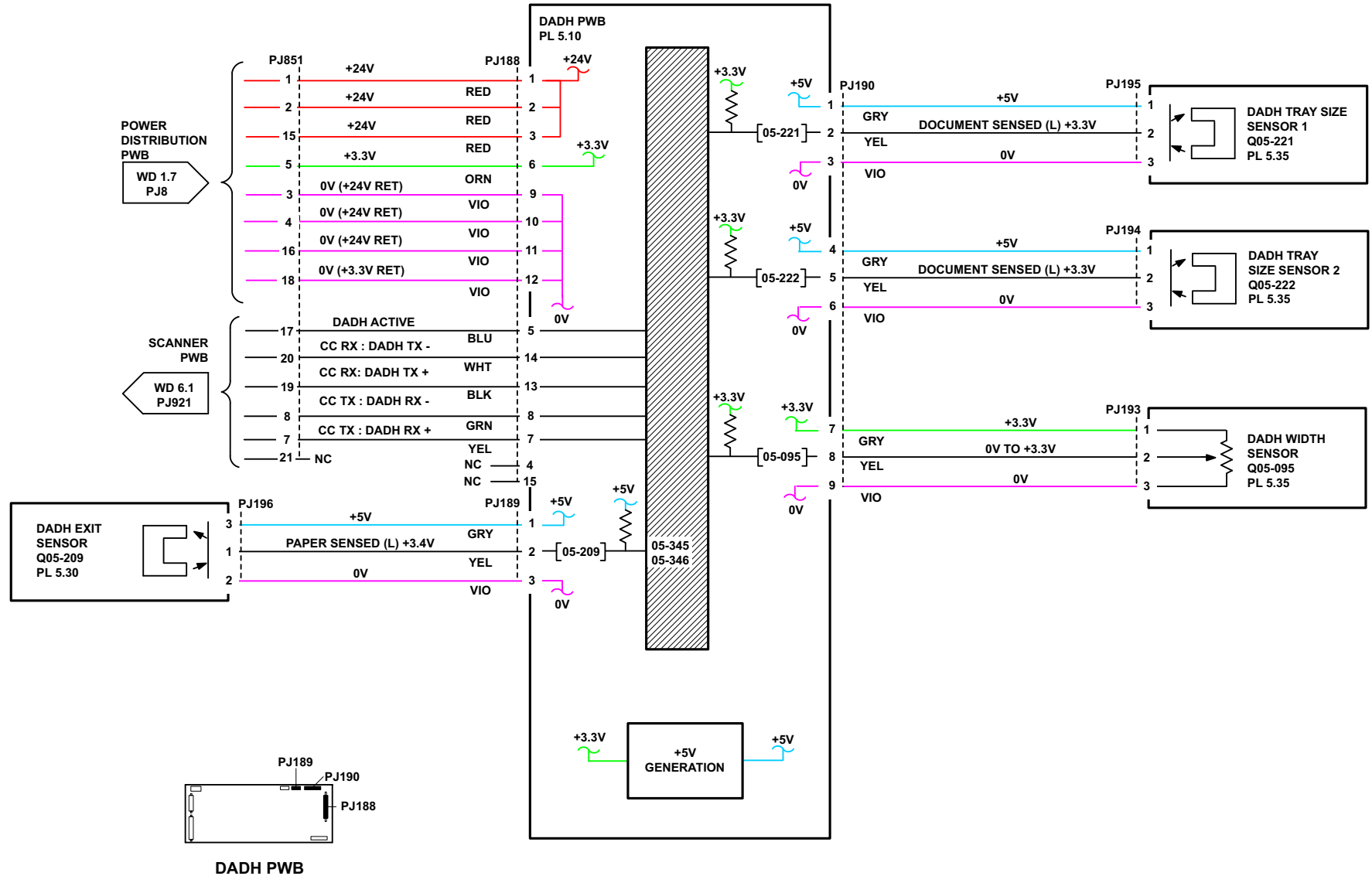

Figure 12 Wiring diagram 5.2

TU-1-0244-A

WD 6.1 Scanner PWB (1 of 3)

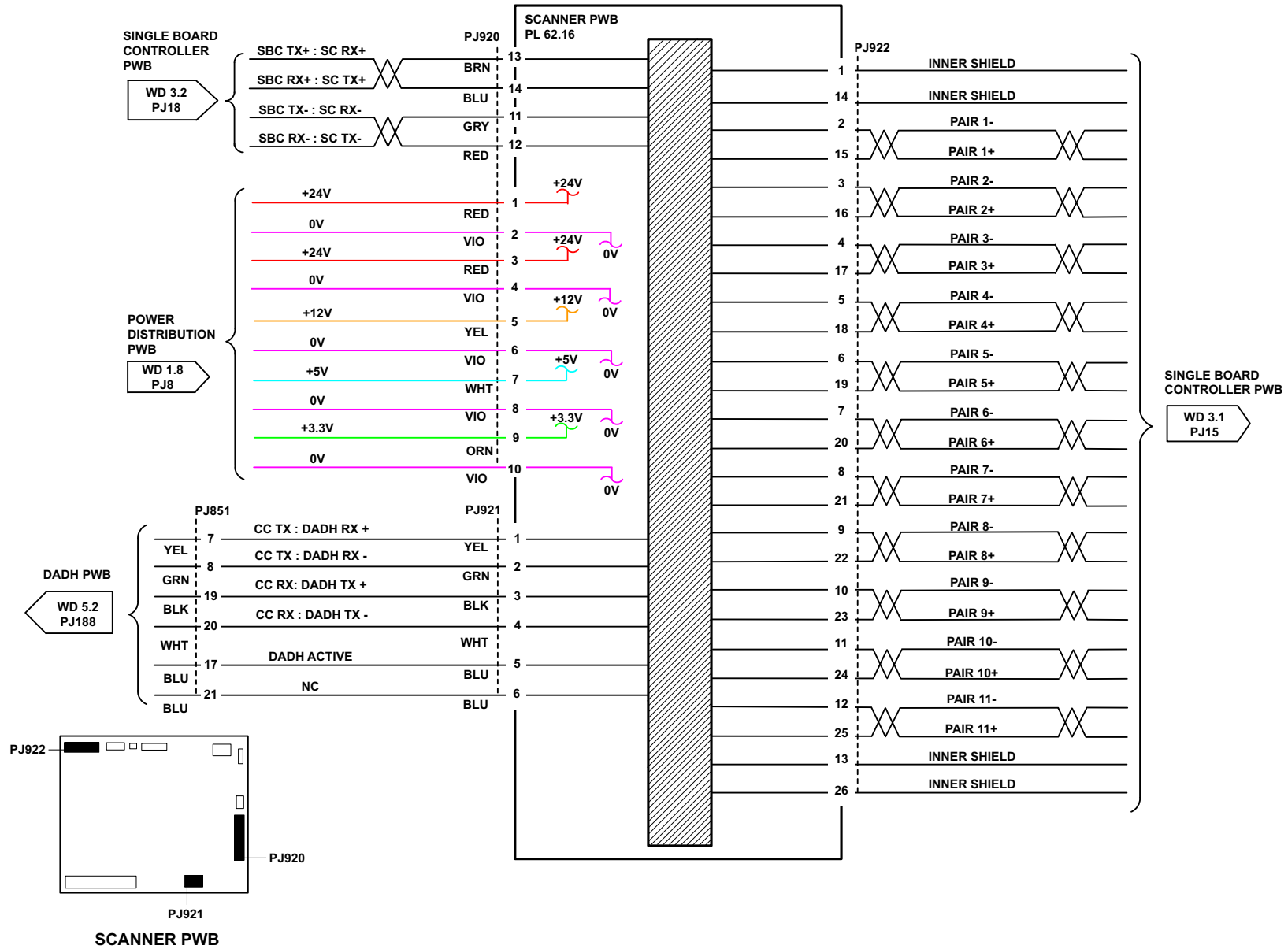
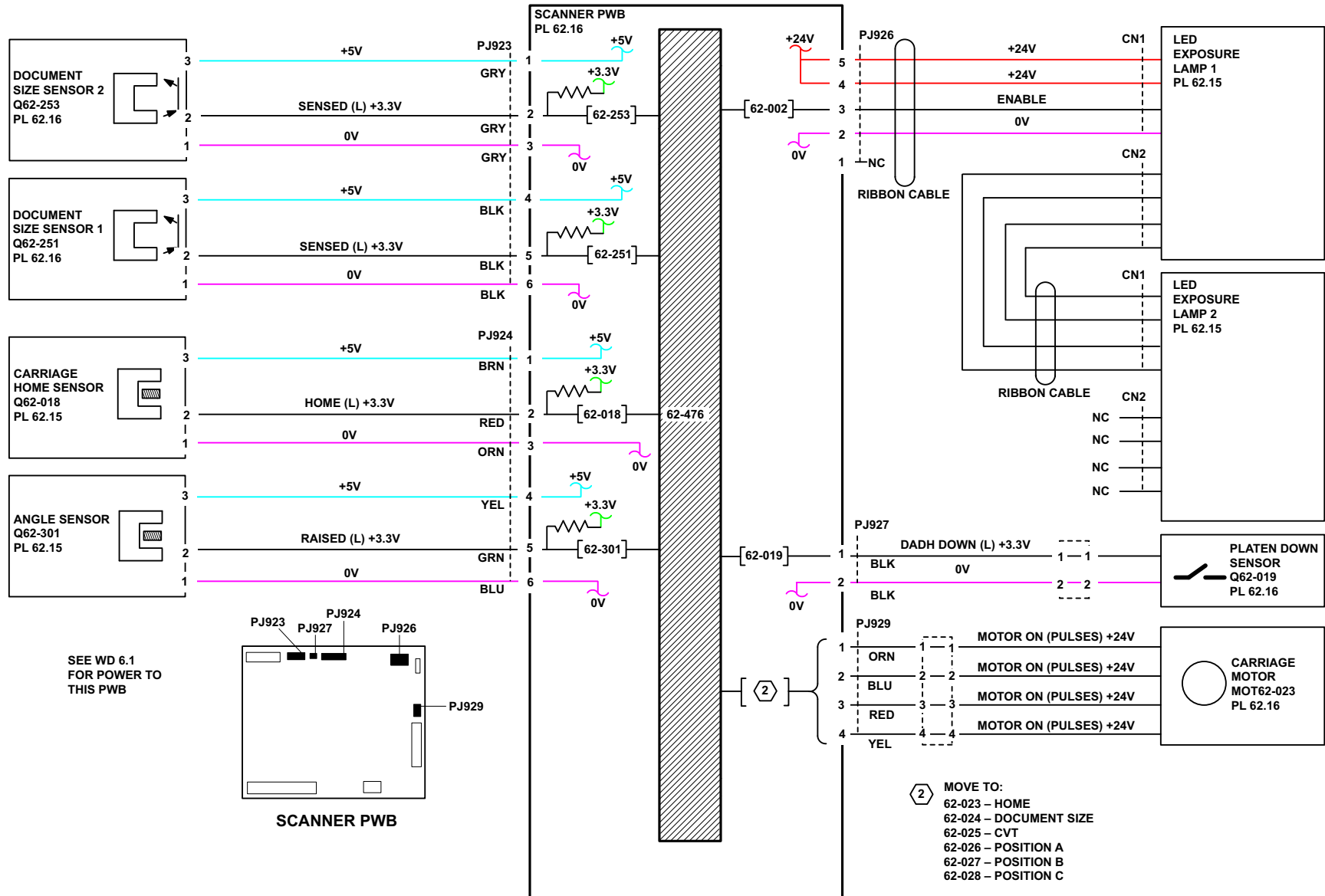

Figure 13 Wiring diagram 6.1

TU-1-0245-A

WD 6.2 Scanner PWB (2 of 3)



TU-1-0246-A

Figure 14 Wiring diagram 6.2

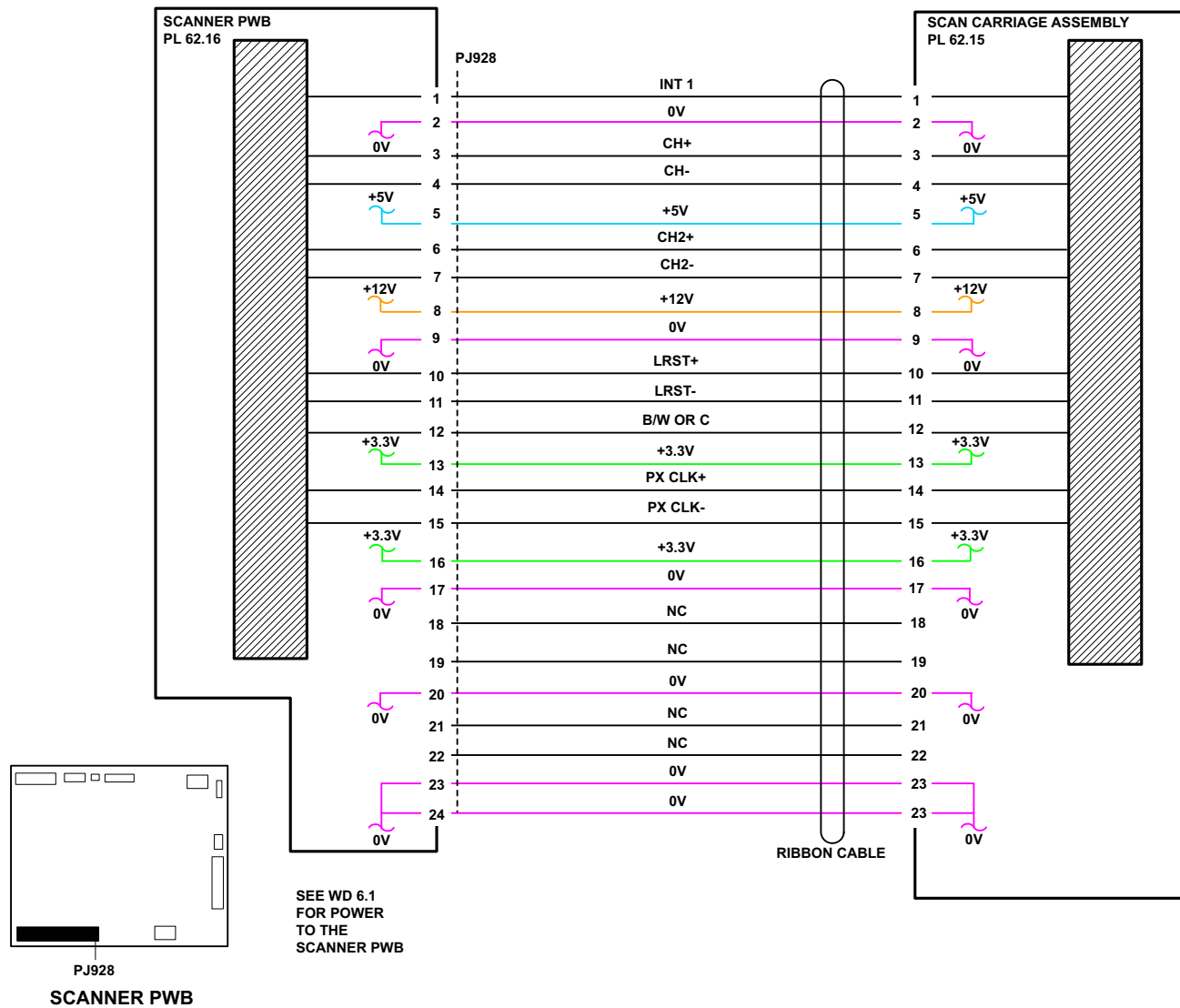

Figure 15 Wiring diagram 6.3

WD 7.1 Tray 5 Control PWB (1 of 2)

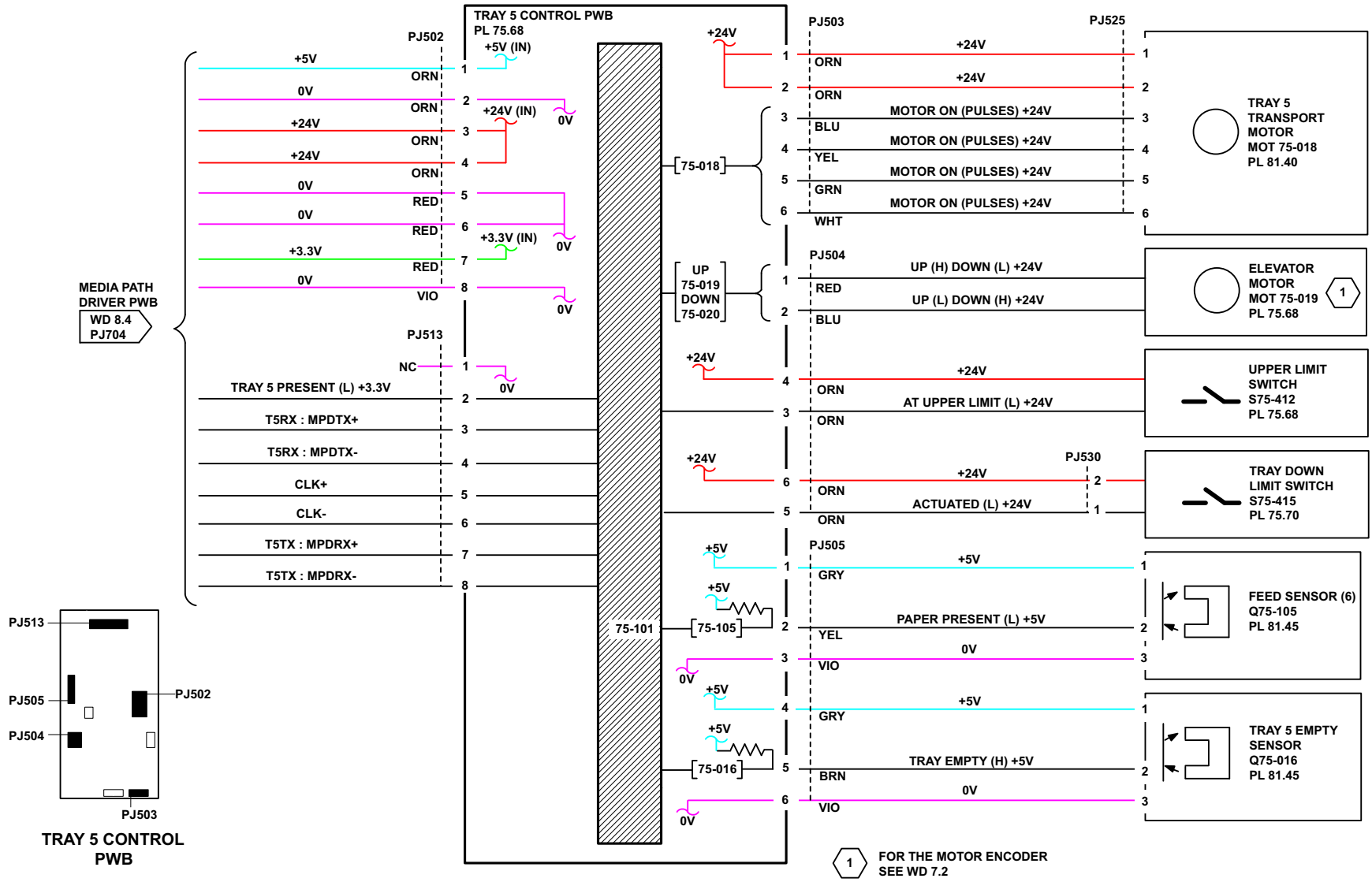
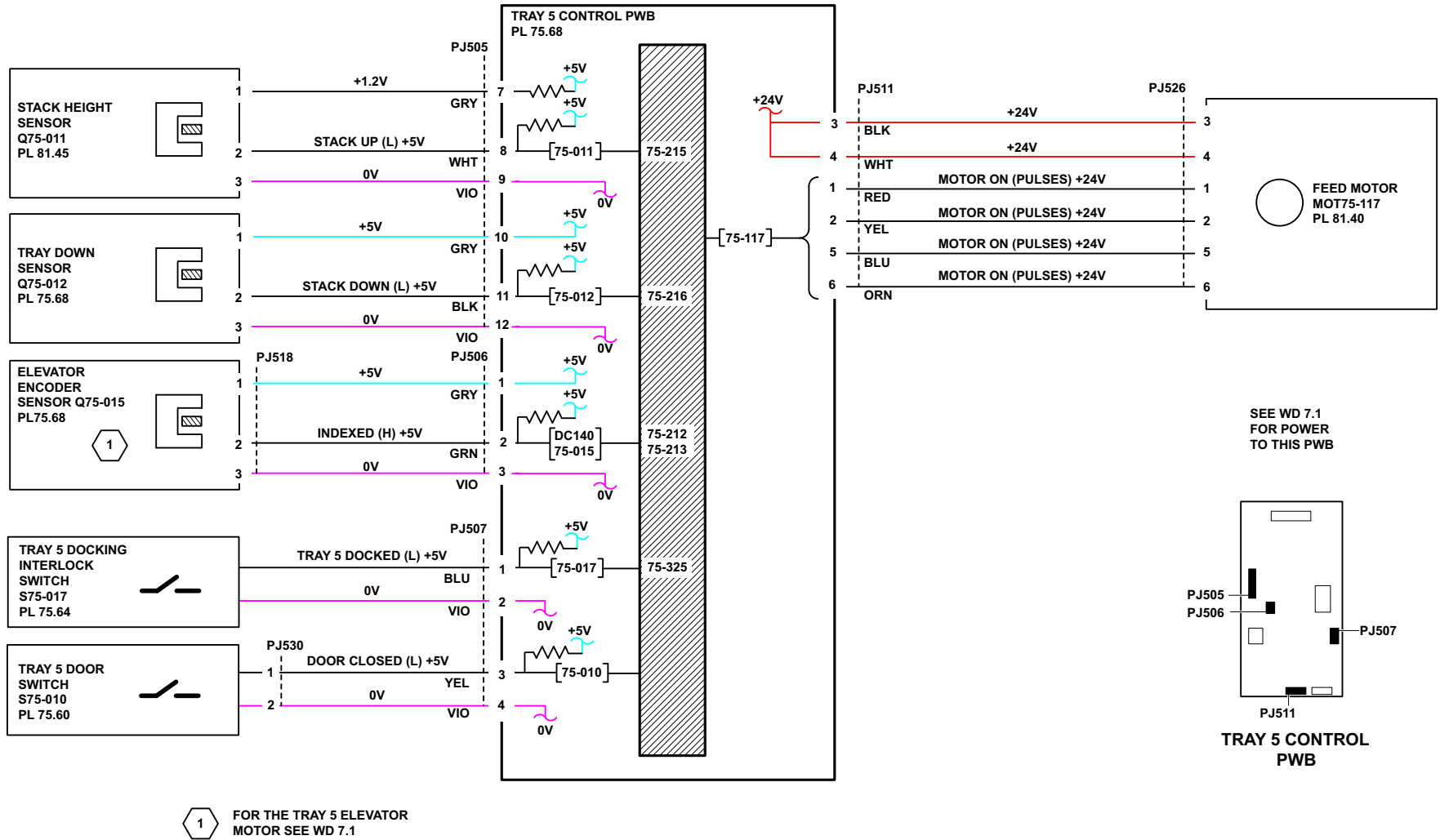

Figure 16 Wiring diagram 7.1

WD 7.2 Tray 5 Control PWB (2 of 2)



SEE WD 7.1 FOR POWER TO THIS PWB

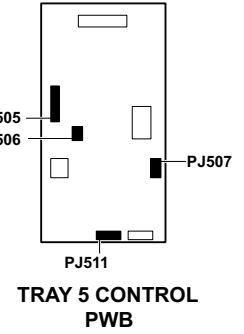

Figure 17 Wiring diagram 7.2

TU-1-0173-A

WD 7.3 Tray 3 Module PWB (1 of 3)

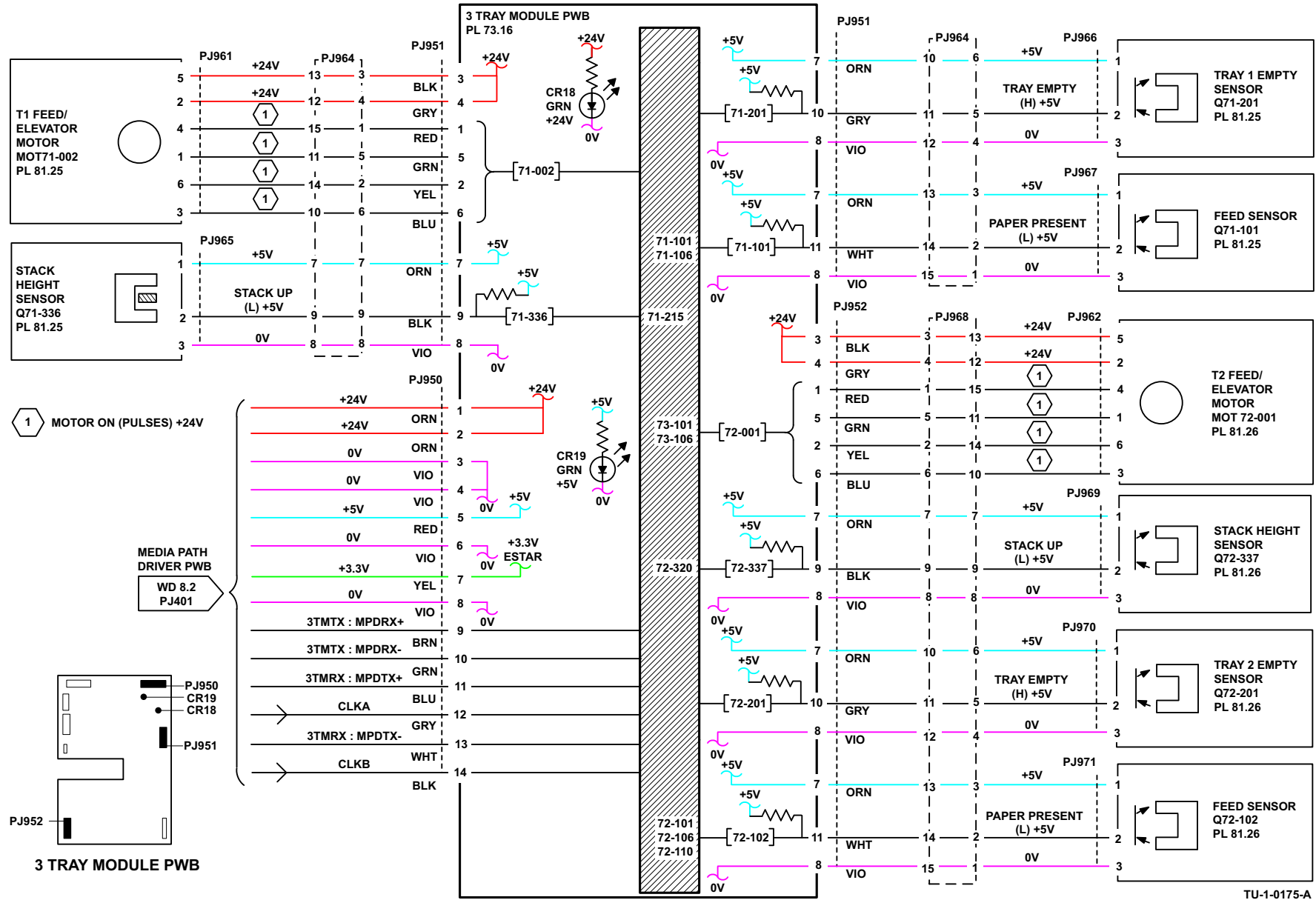

Figure 18 Wiring diagram 7.3

WD 7.4 Tray 3 Module PWB (2 of 3)

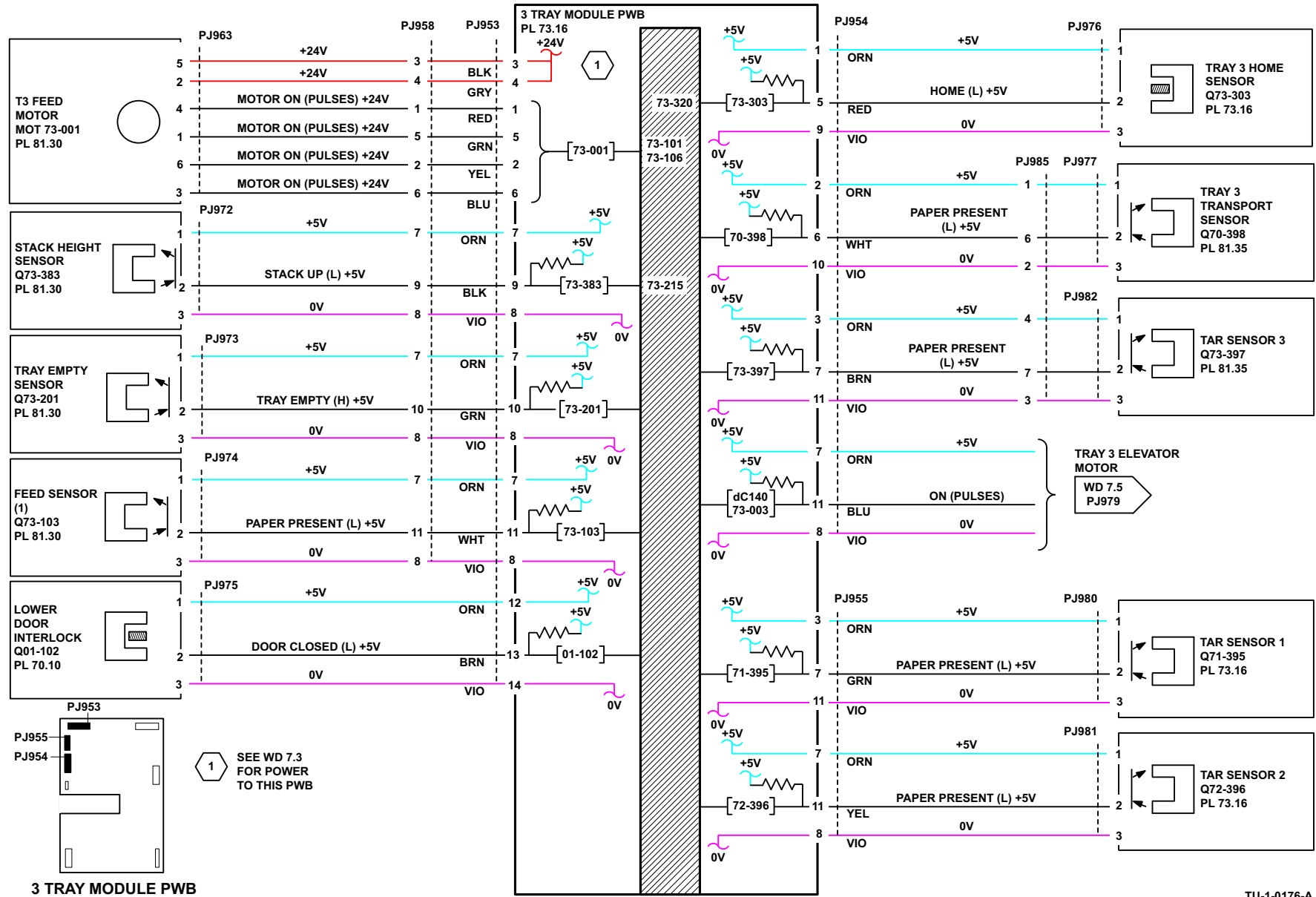
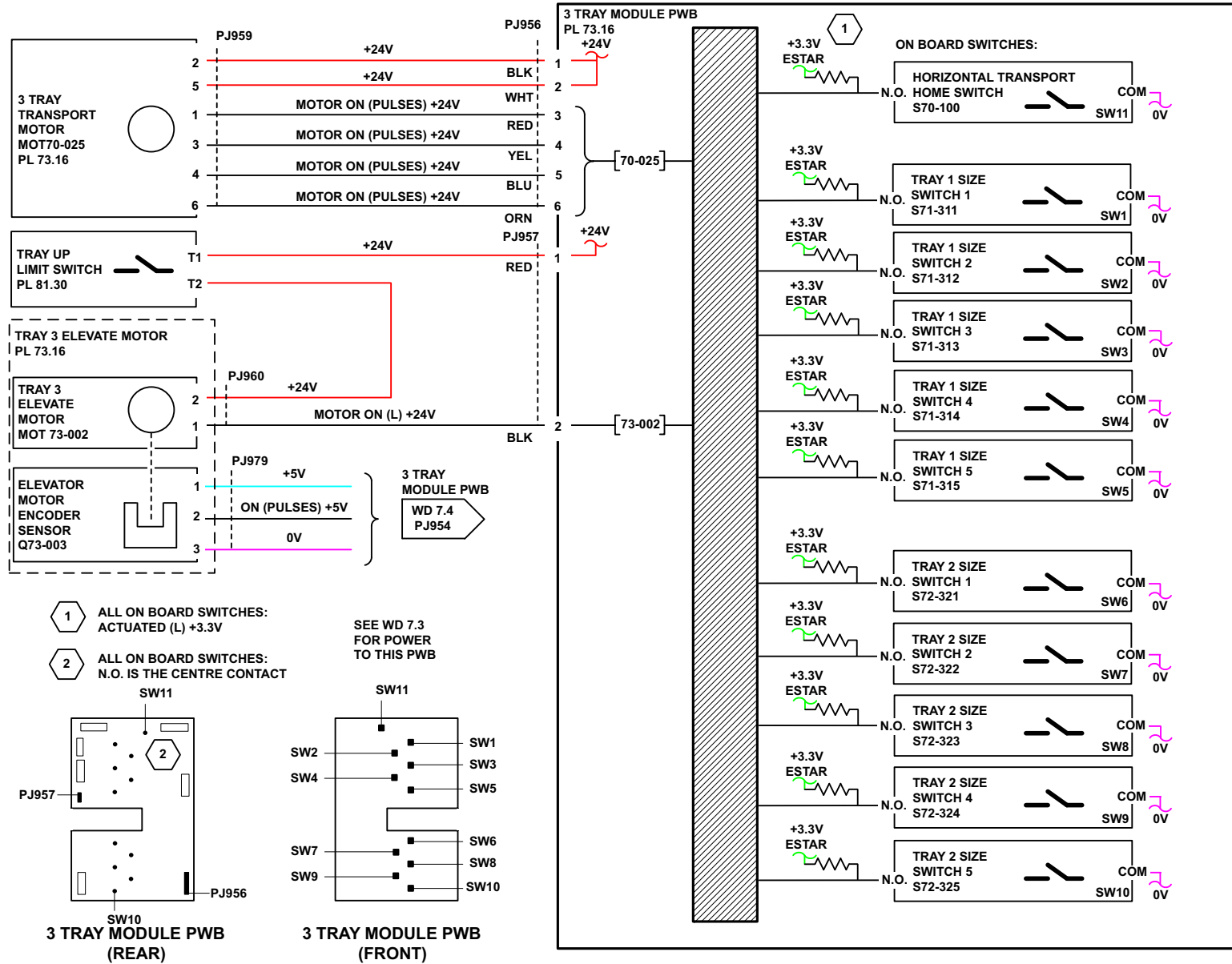

Figure 19 Wiring diagram 7.4

WD 7.5 Tray 3 Module PWB (3 of 3)



TU-1-0177-A

Figure 20 Wiring diagram 7.5

WD 8.1 Media Path Driver PWB (1 of 5)

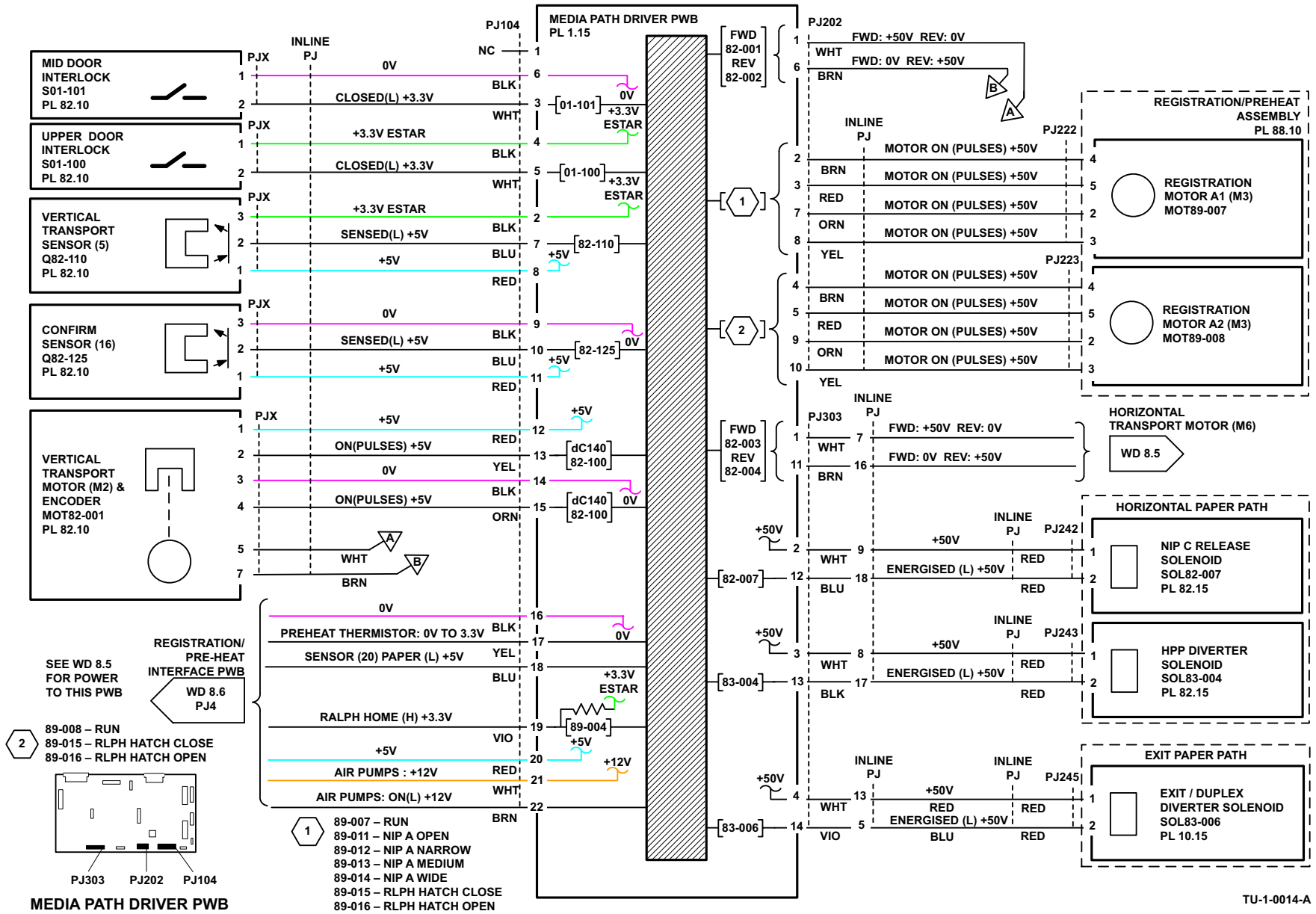

Figure 21 Wiring diagram 8.1

WD 8.2 Media Path Driver PWB (2 of 5)

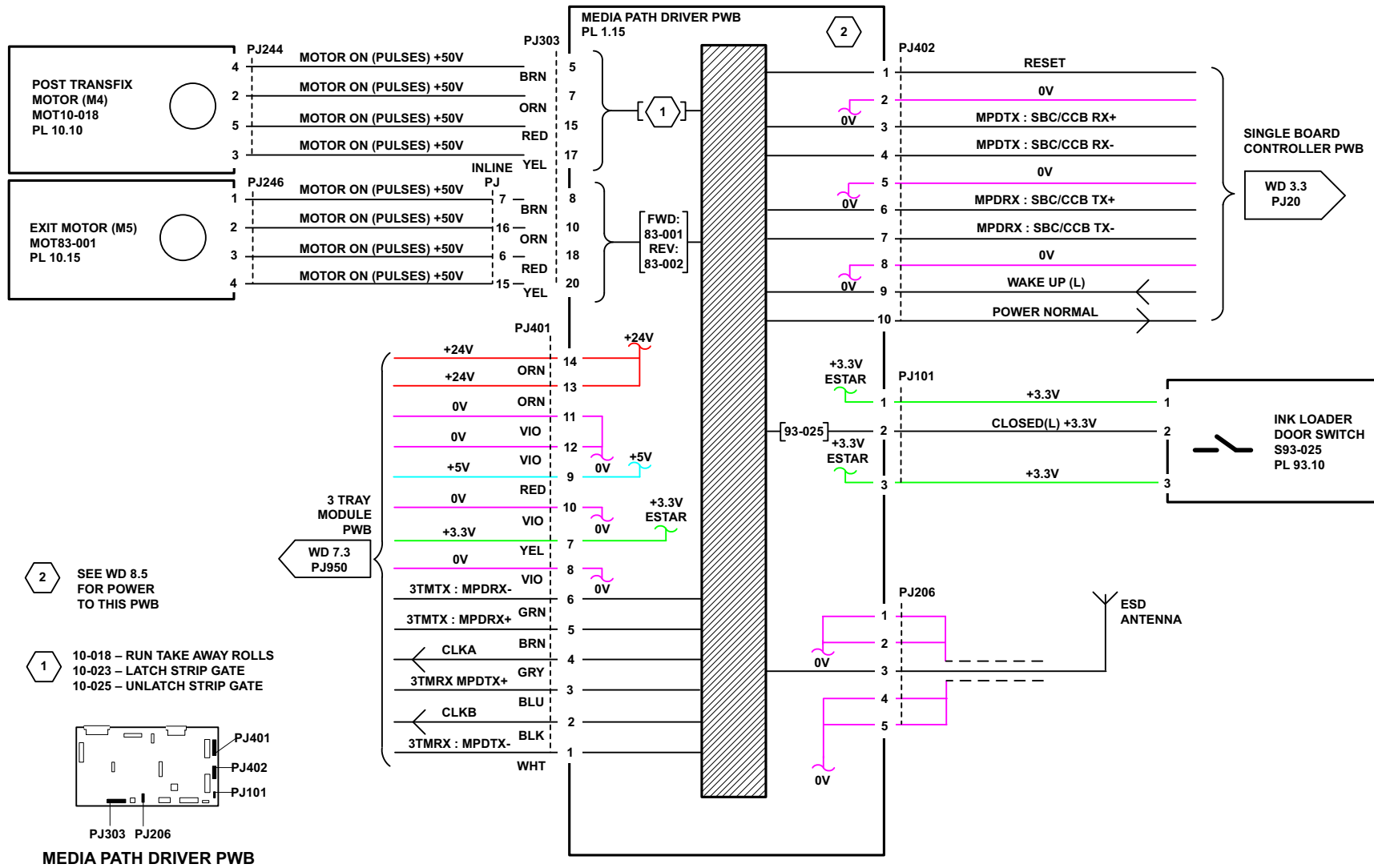
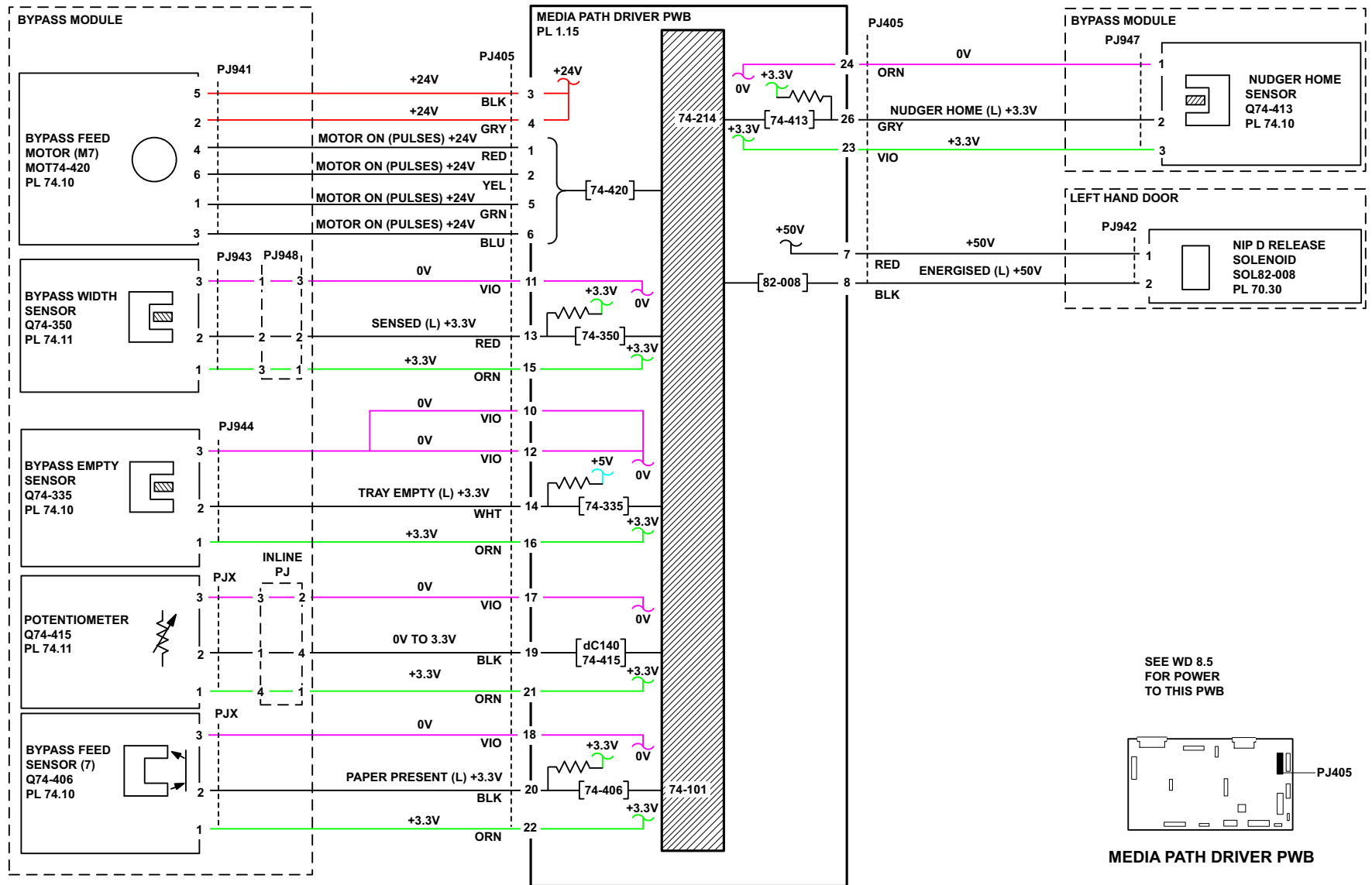

Figure 22 Wiring diagram 8.2

TU-1-0248-A

WD 8.3 Media Path Driver PWB (3 of 5)



TU-1-0180-A

Figure 23 Wiring diagram 8.3

WD 8.4 Media Path Driver PWB (4 of 5)

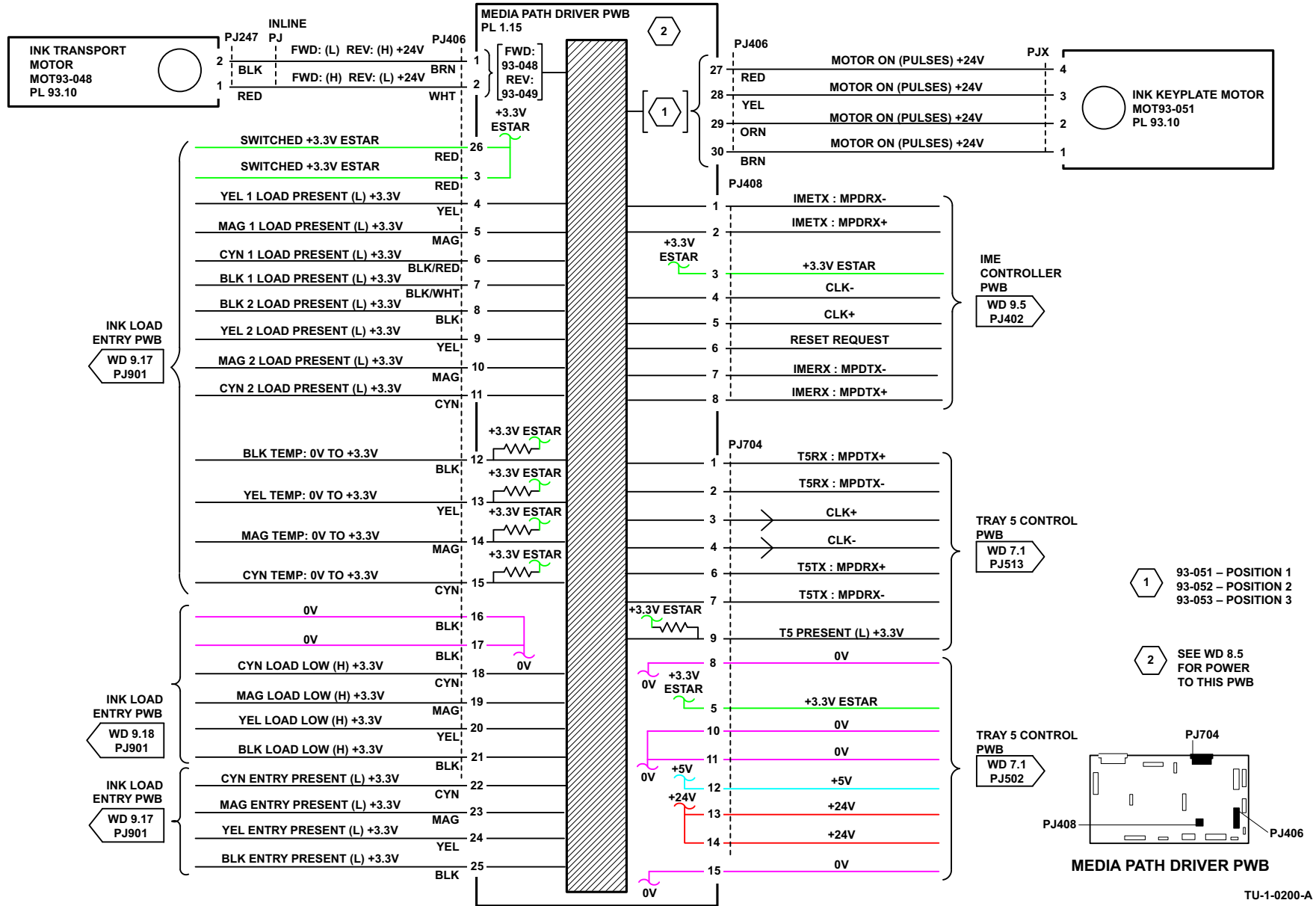
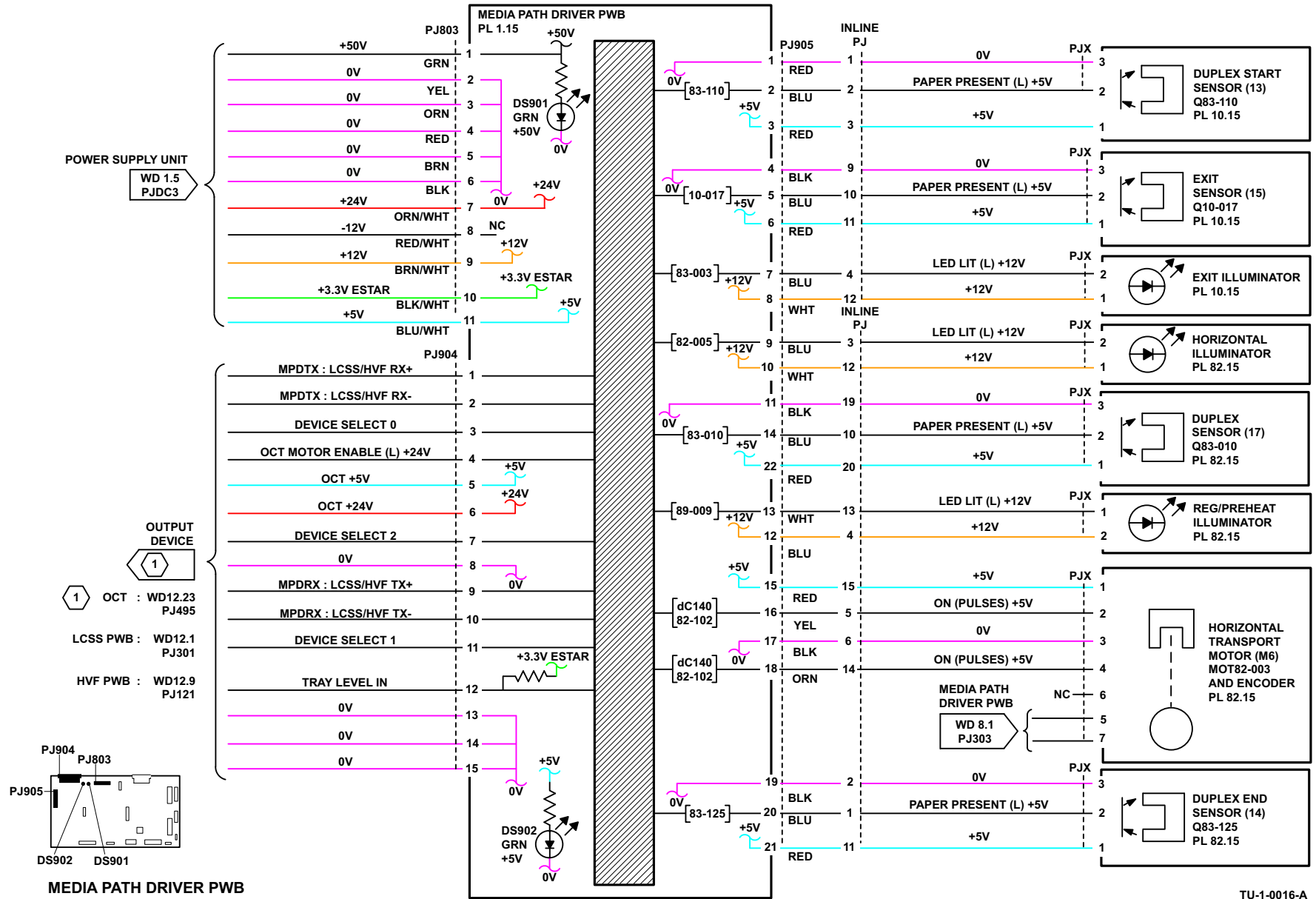

Figure 24 Wiring diagram 8.4



TU-1-0016-A

Figure 25 Wiring diagram 8.5

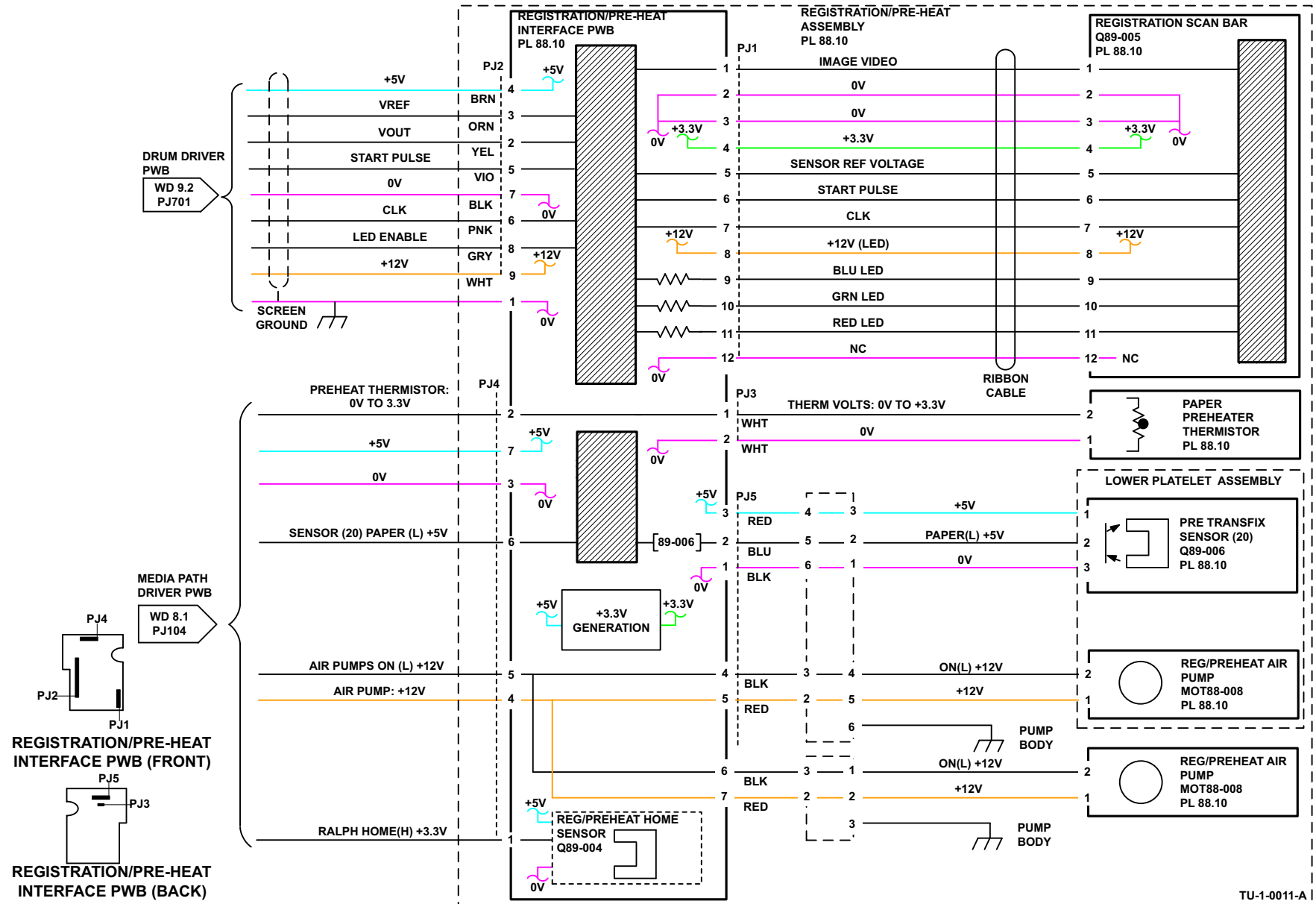

Figure 26 Wiring diagram 8.6

WD 9.1 Drum Driver PWB (1 of 4)

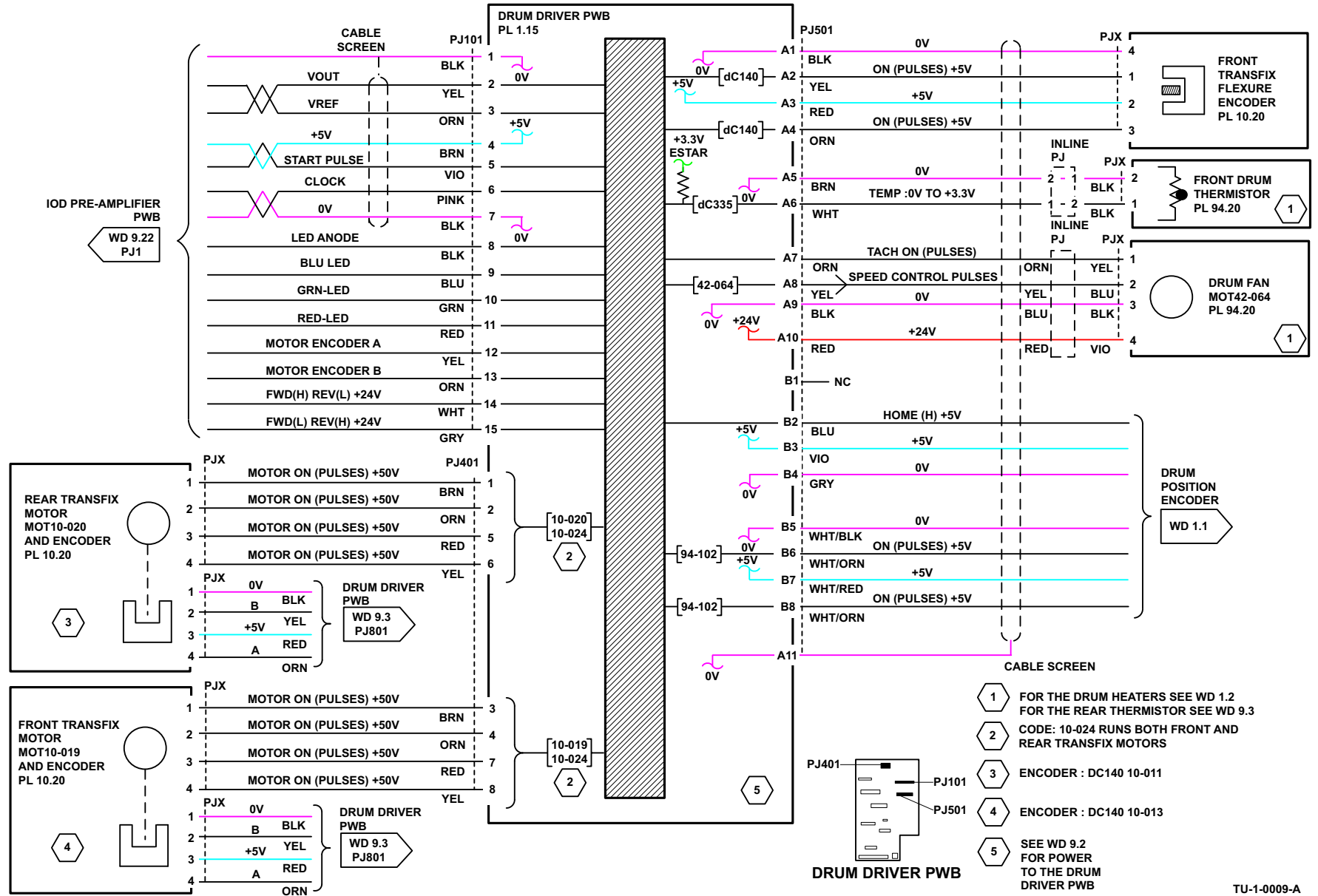

Figure 27 Wiring diagram 9.1

WD 9.2 Drum Driver PWB (2 of 4)

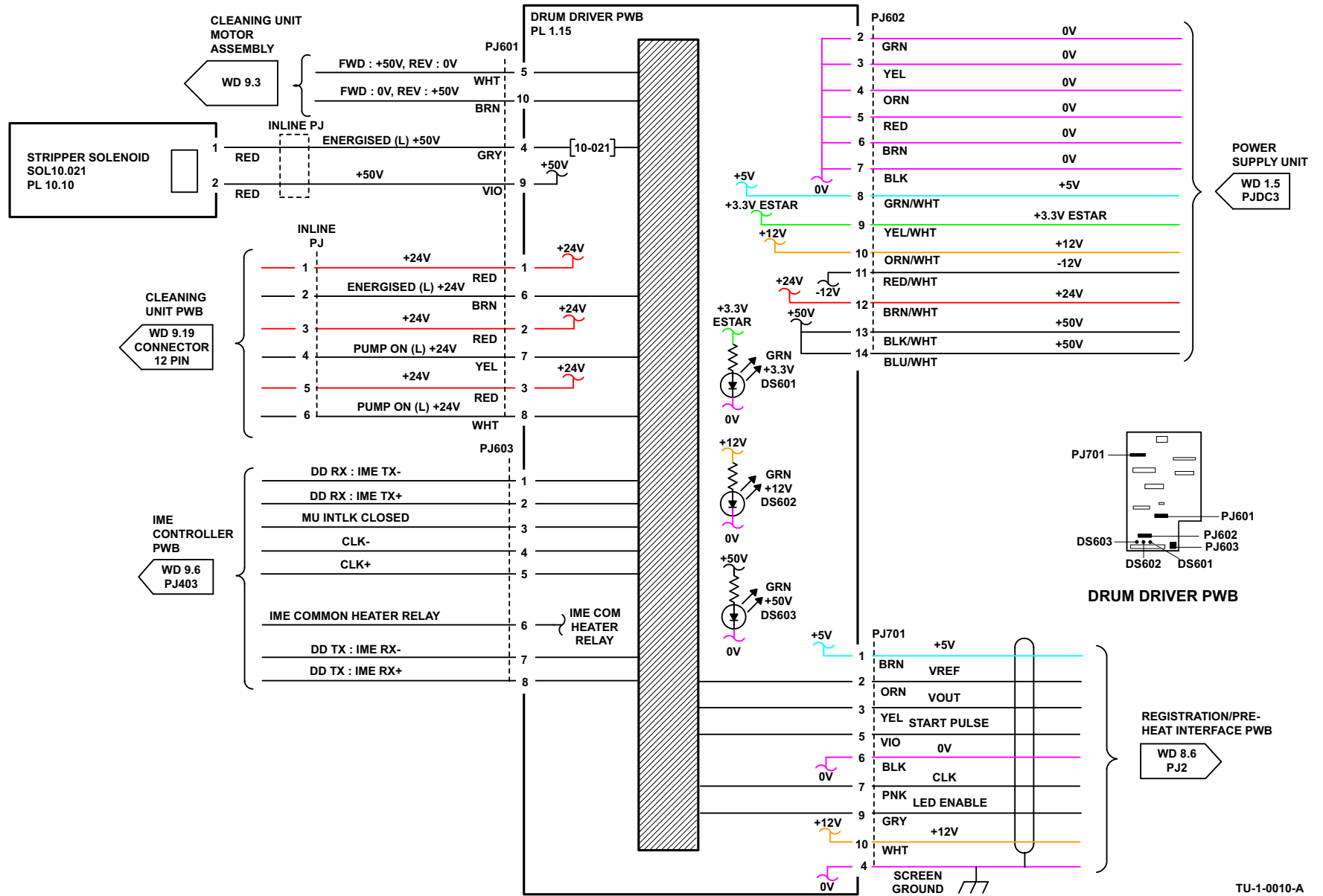

Figure 28 Wiring diagram 9.2

WD 9.3 Drum Driver PWB (3 of 4)

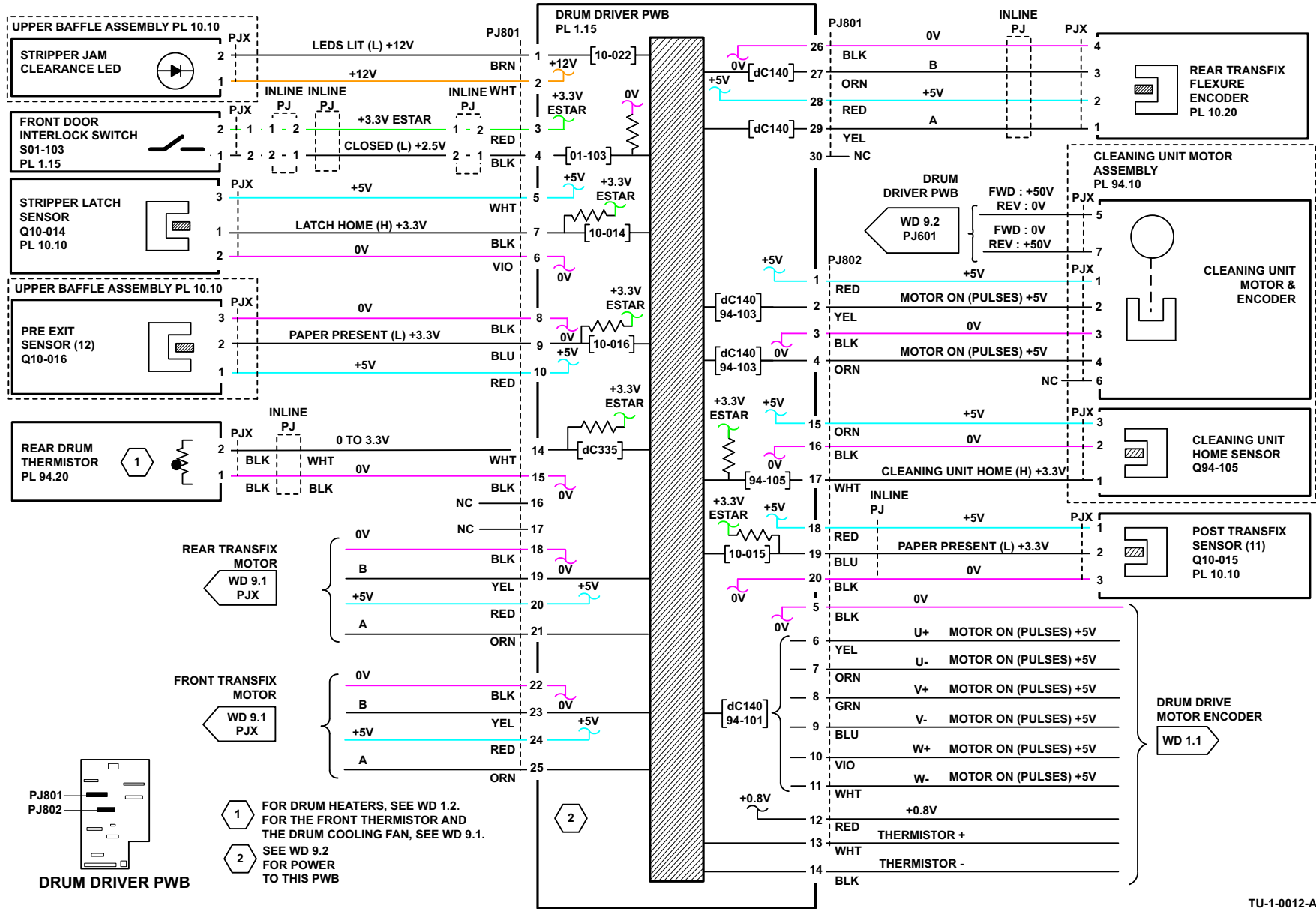

Figure 29 Wiring diagram 9.3

TU-1-0012-A

WD 9.4 Drum Driver PWB (4 of 4)

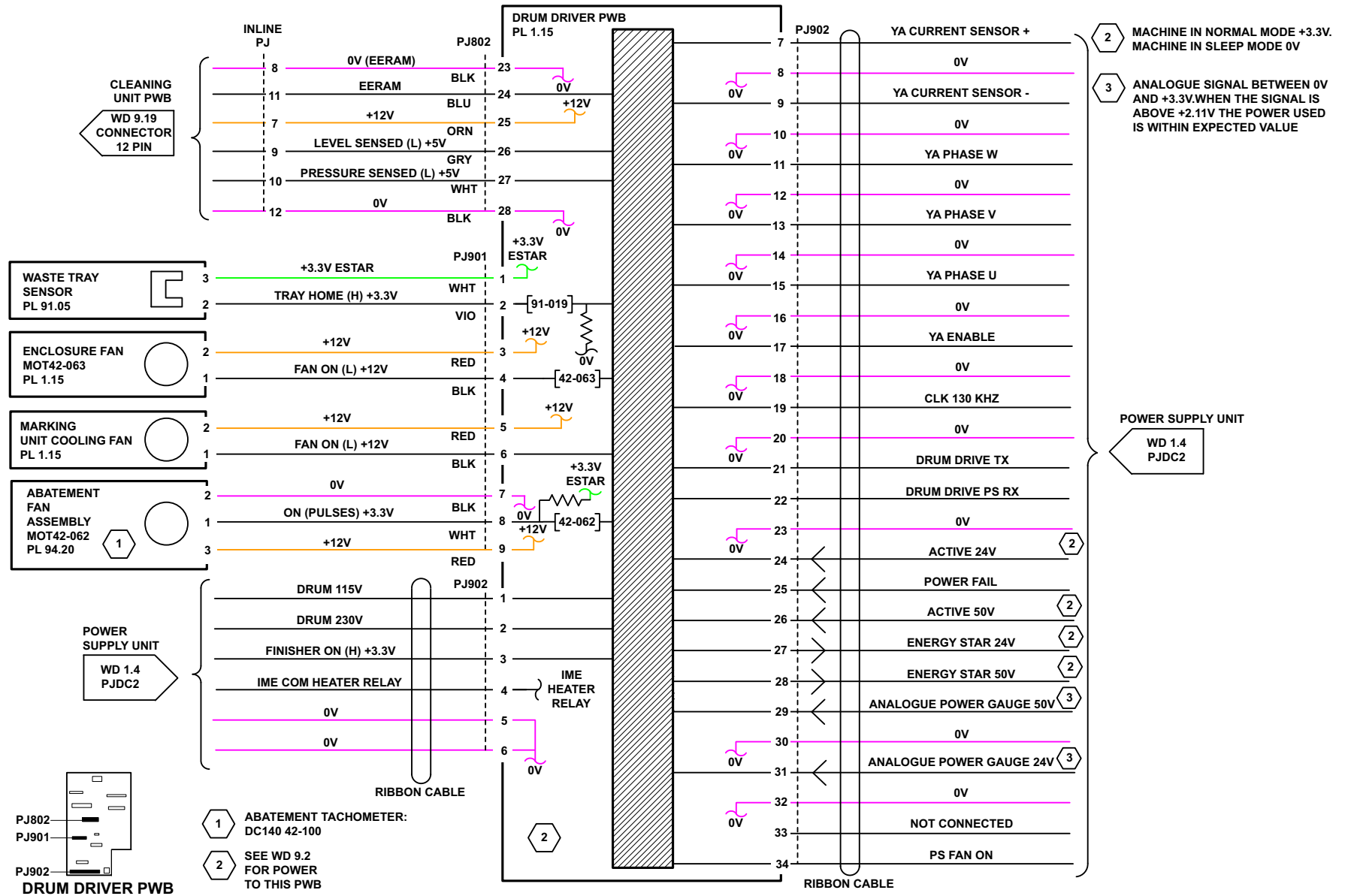

Figure 30 Wiring diagram 9.4

TU-1-0013-A

WD 9.5 IME Controller PWB (1 of 3)

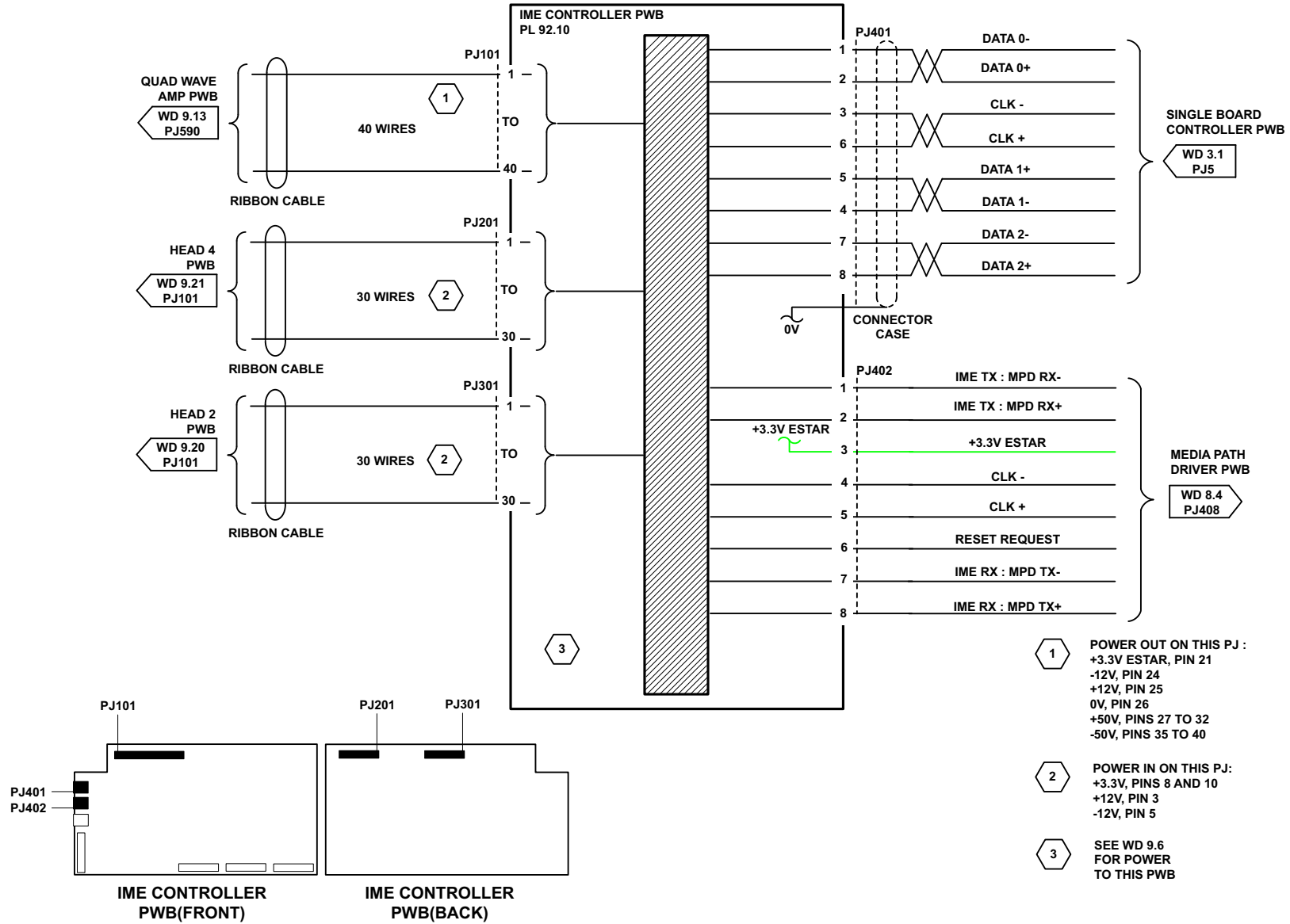

Figure 31 Wiring diagram 9.5

TU-1-0249-A

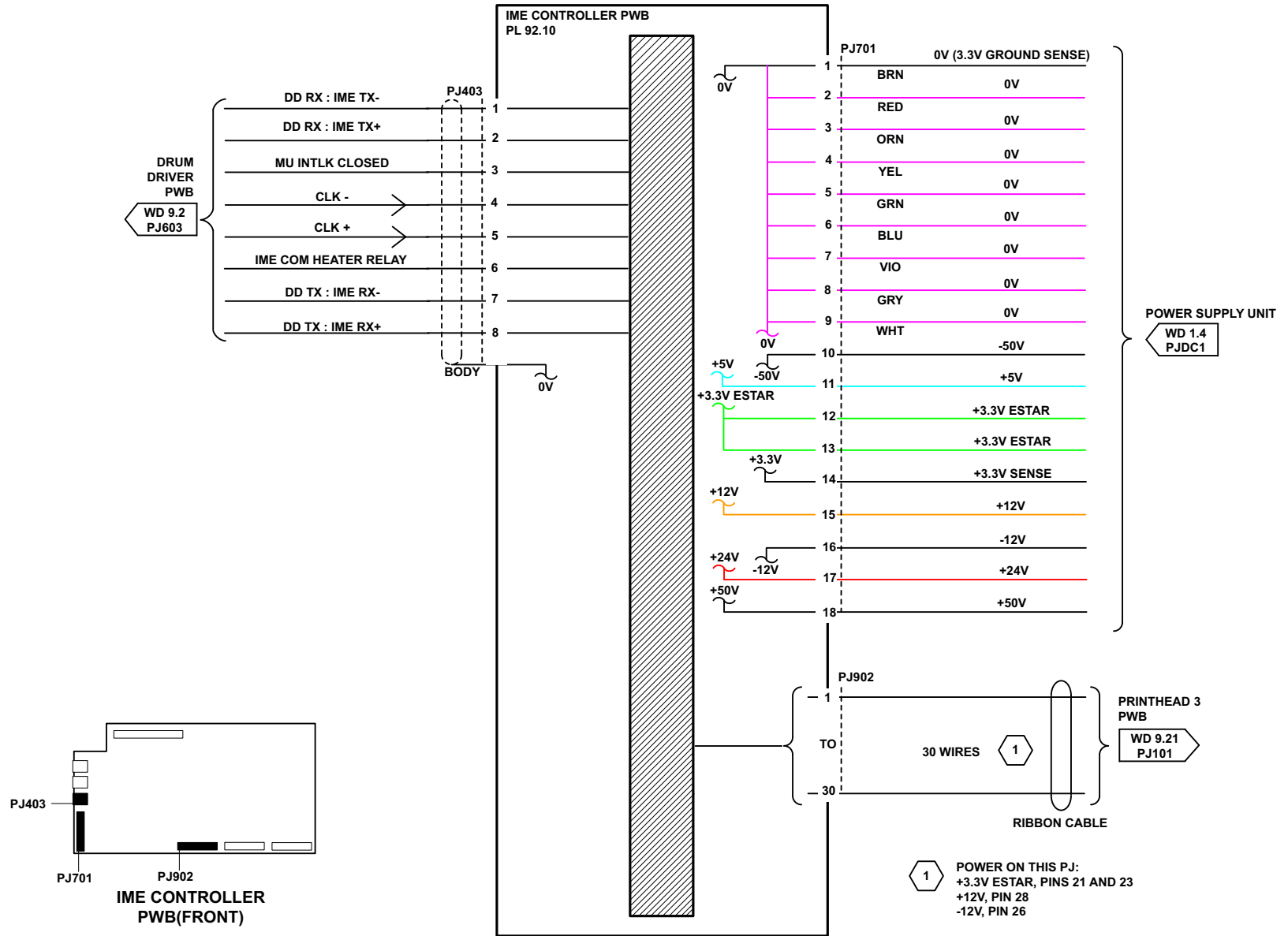

Figure 32 Wiring diagram 9.6

TU-1-0188-A

WD 9.7 IME Controller PWB (3 of 3)

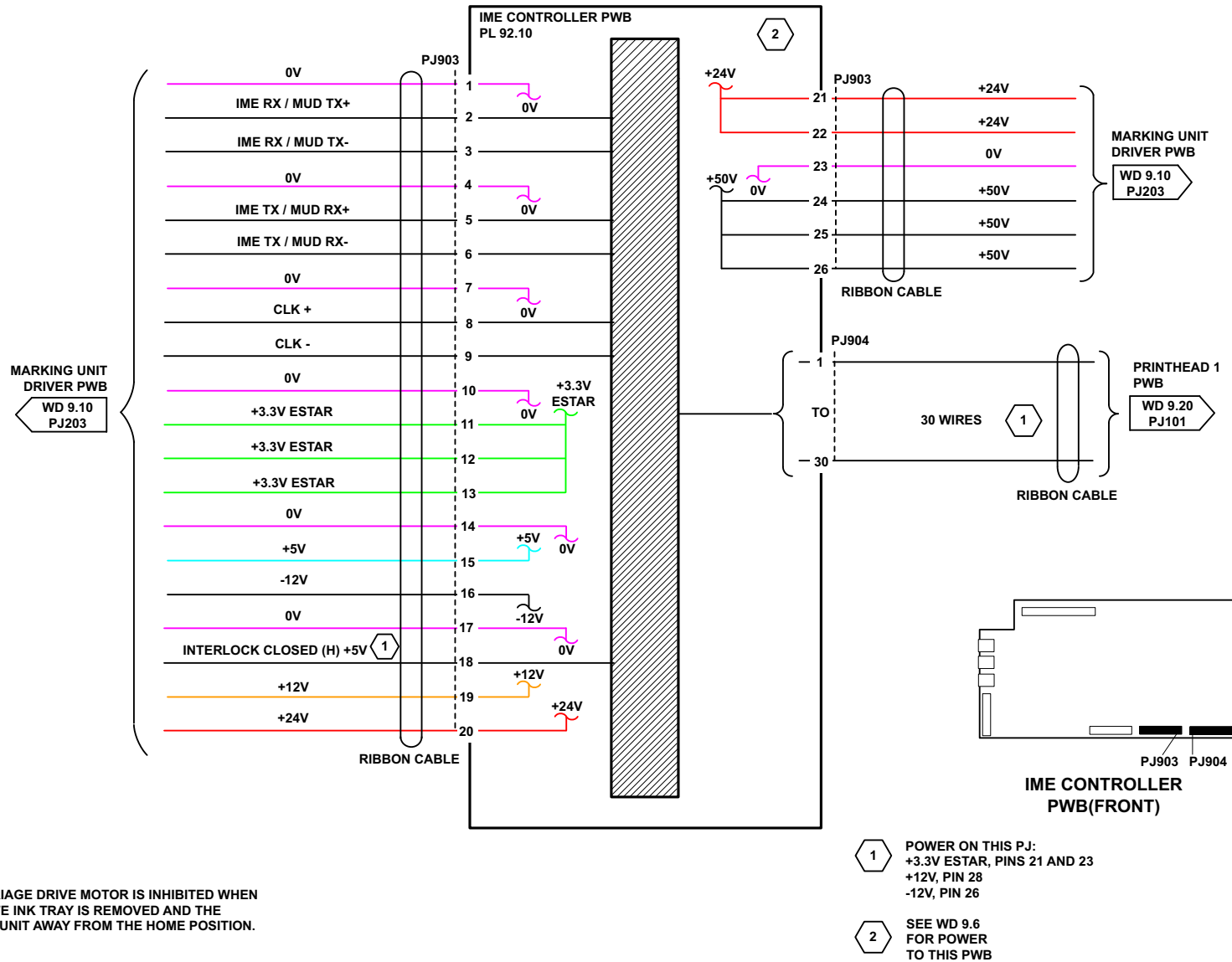
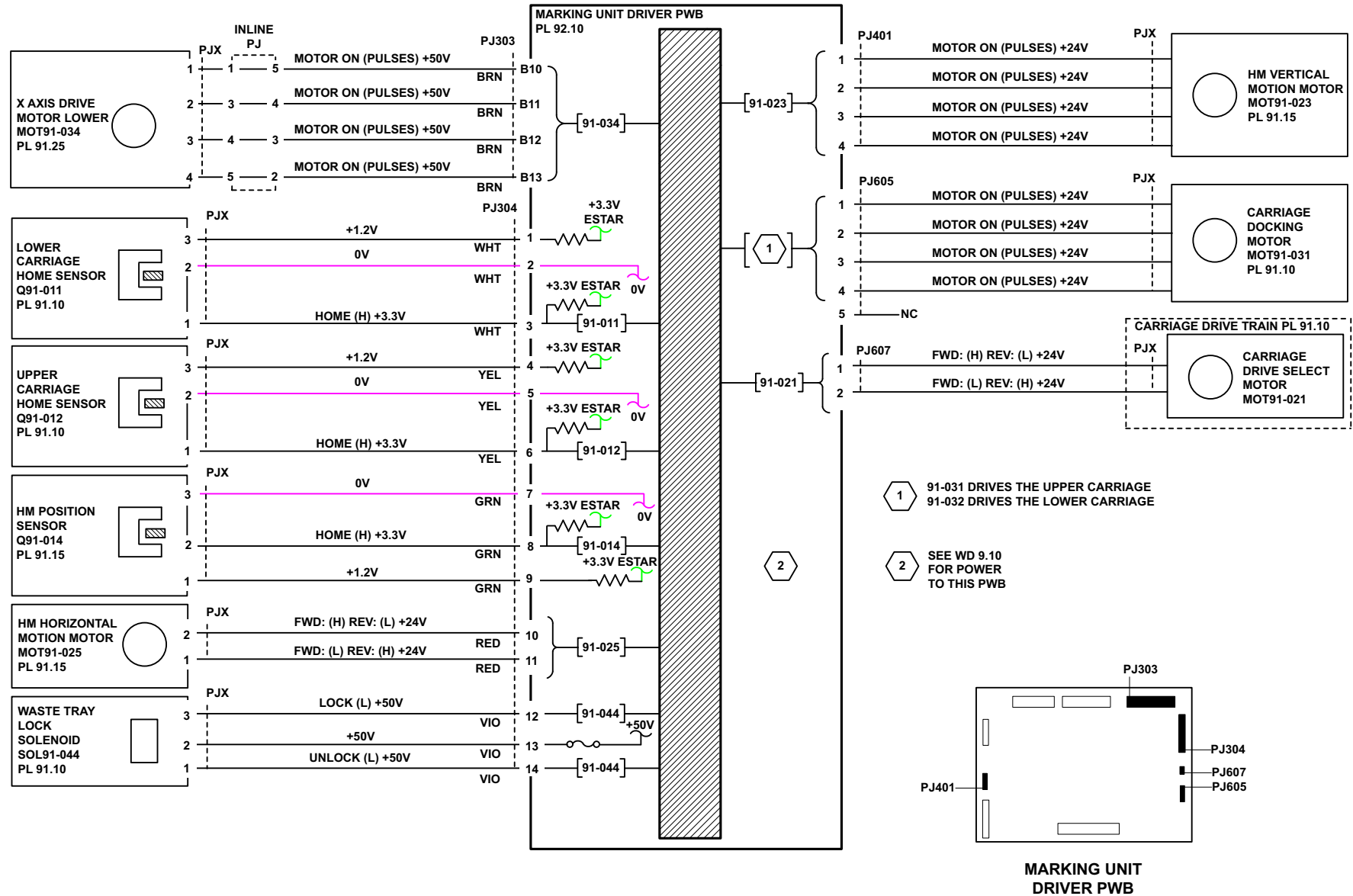

Figure 33 Wiring diagram 9.7

TU-1-0189-A

WD 9.11 Marking Unit Driver PWB (3 of 4)



TU-1-0191-A

Figure 37 Wiring diagram 9.11

WD 9.13 Quad Wave Amplifier PWB

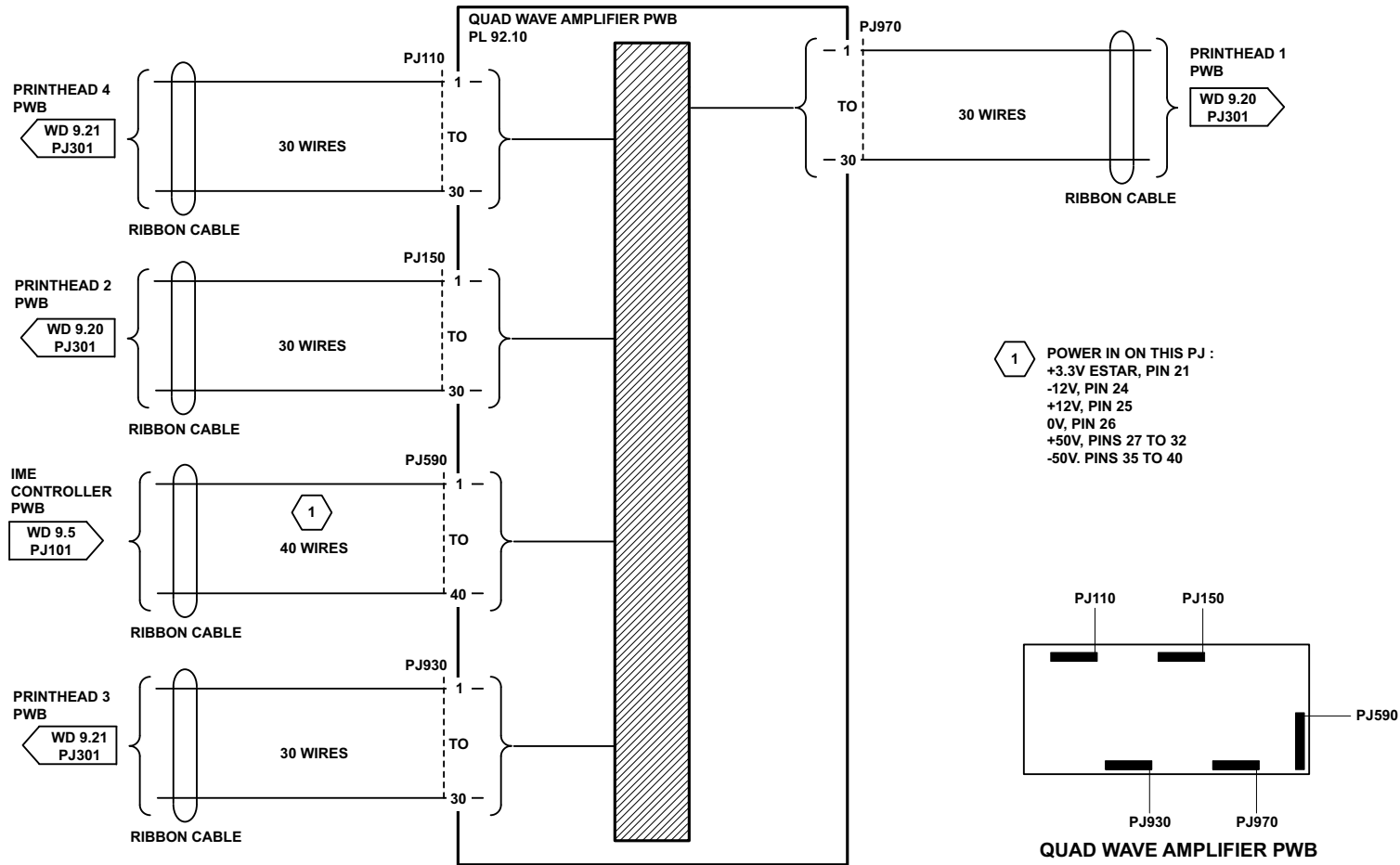

Figure 39 Wiring diagram 9.13

TU-1-0193-A

WD 9.14 Solenoid Patch PWB (1 of 3)

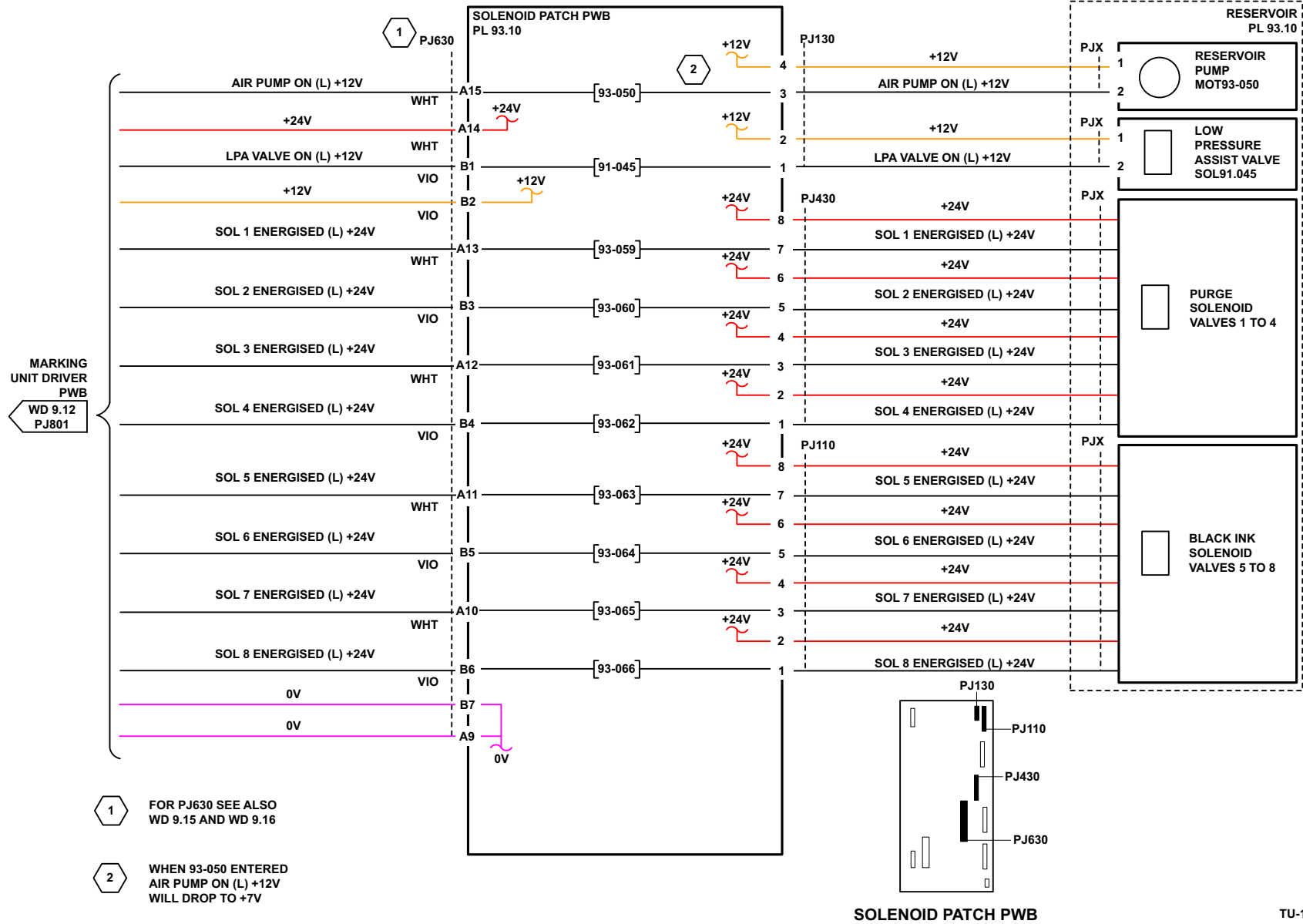

Figure 40 Wiring diagram 9.14

WD 9.15 Solenoid Patch PWB (2 of 3)

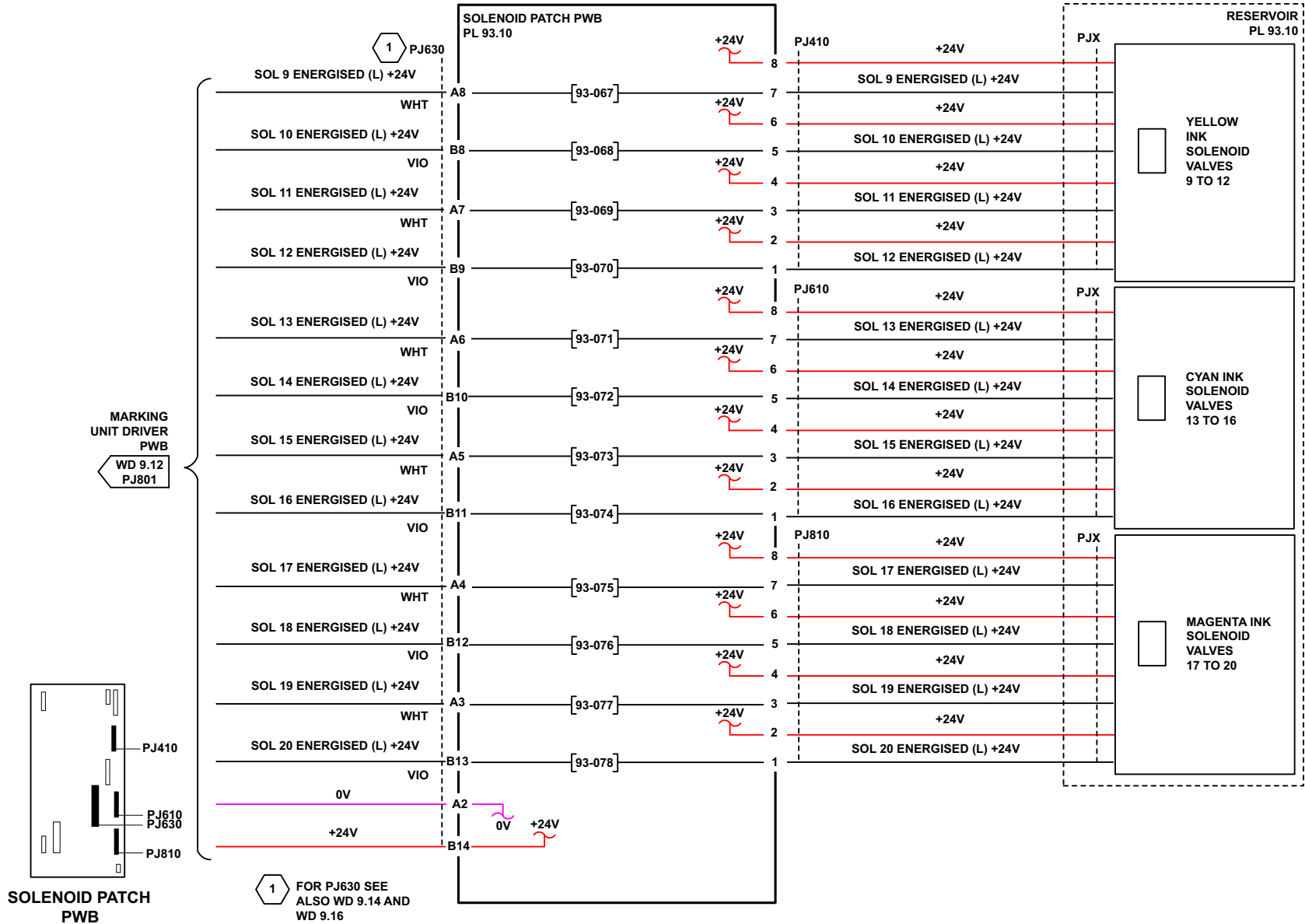

Figure 41 Wiring diagram 9.15

TU-1-0198-A

WD 9.16 Solenoid Patch PWB (3 of 3)

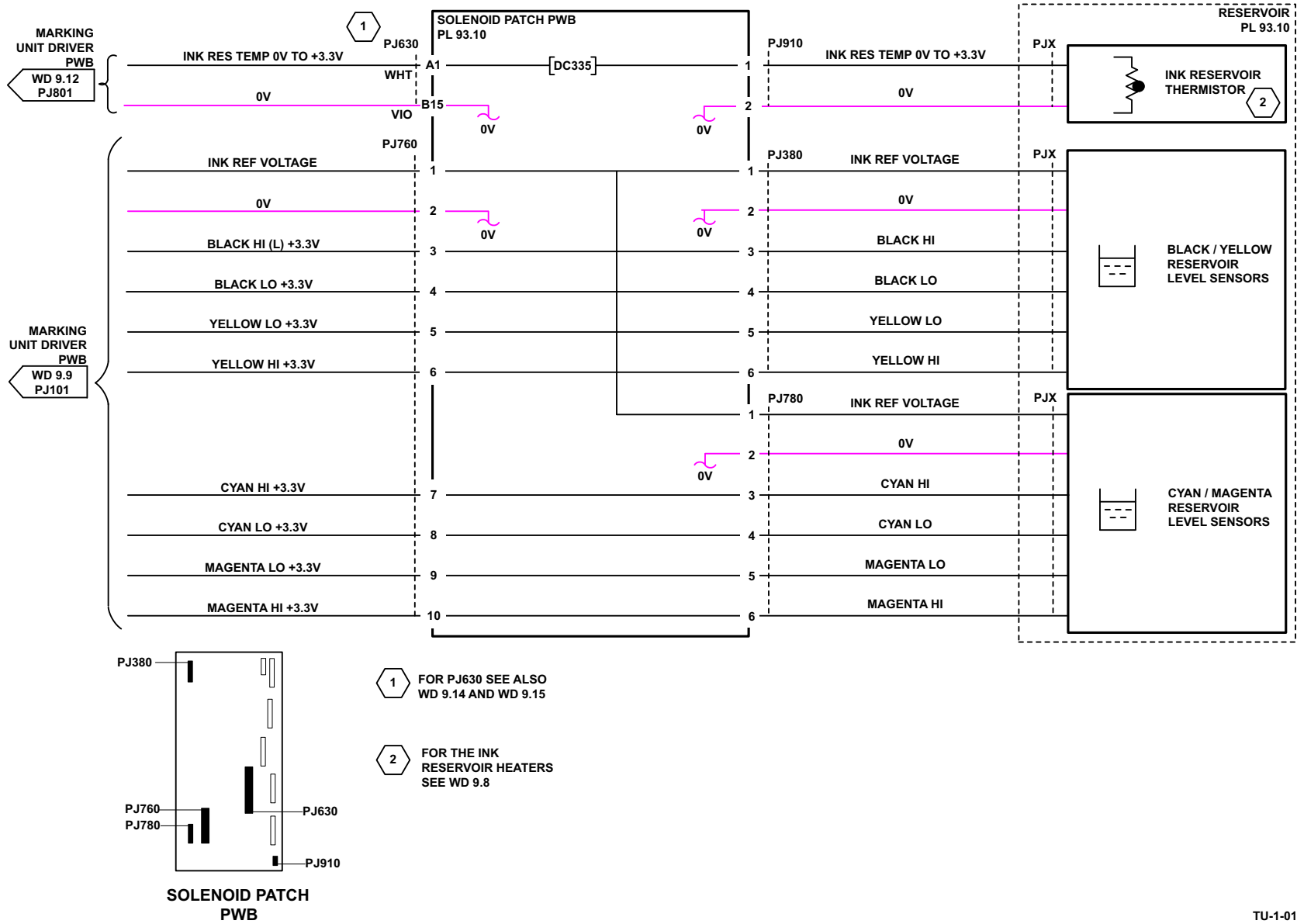

Figure 42 Wiring diagram 9.16

WD 9.17 Ink Load Entry PWB (1 of 2)

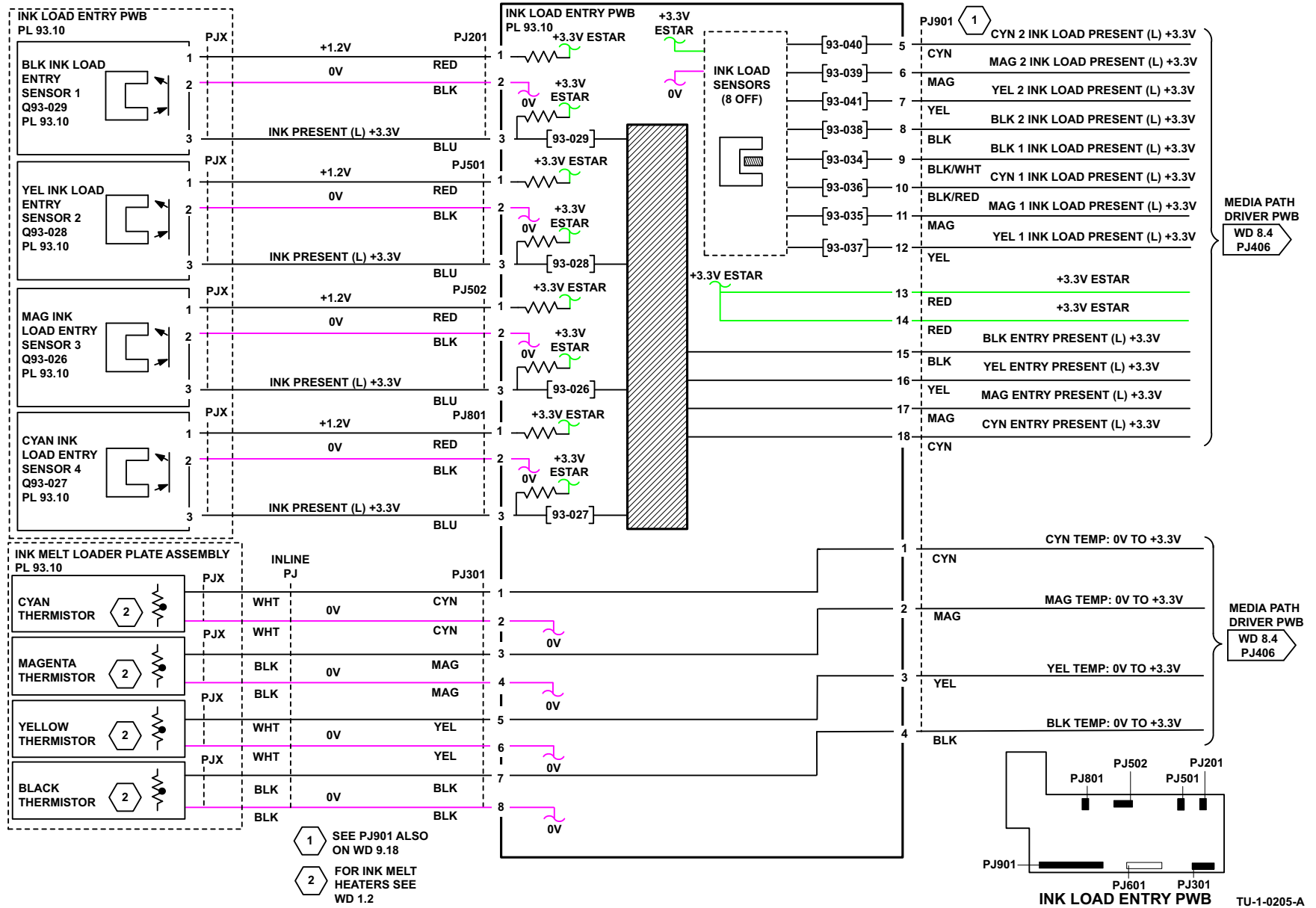

Figure 43 Wiring diagram 9.17

WD 9.18 Ink Load Entry PWB (2 of 2)

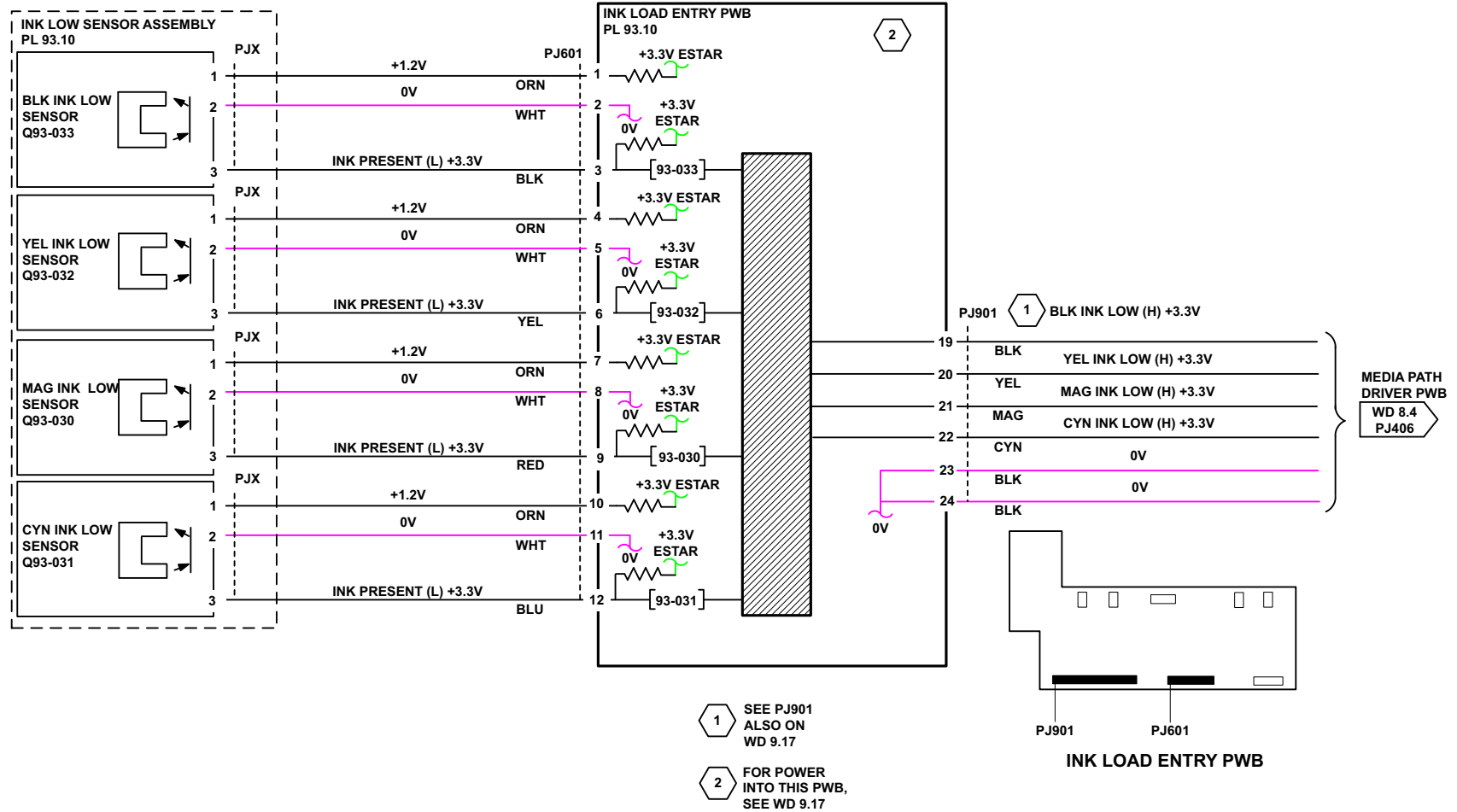
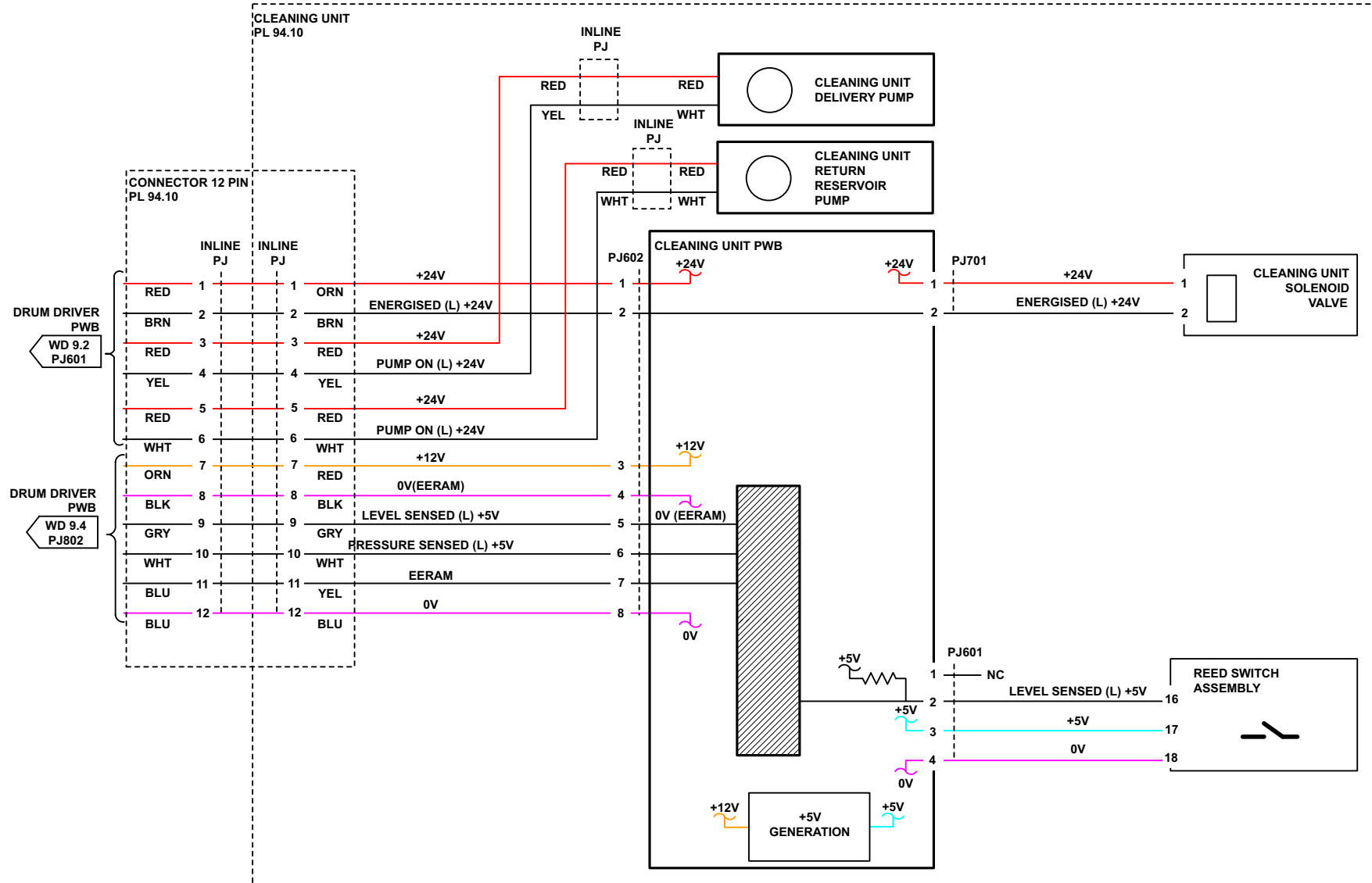

Figure 44 Wiring diagram 9.18

WD 9.19 Cleaning Unit PWB



TU-1-0207-A

Figure 45 Wiring diagram 9.19

WD 9.20 Printhead 1 PWB and Printhead 2 PWB

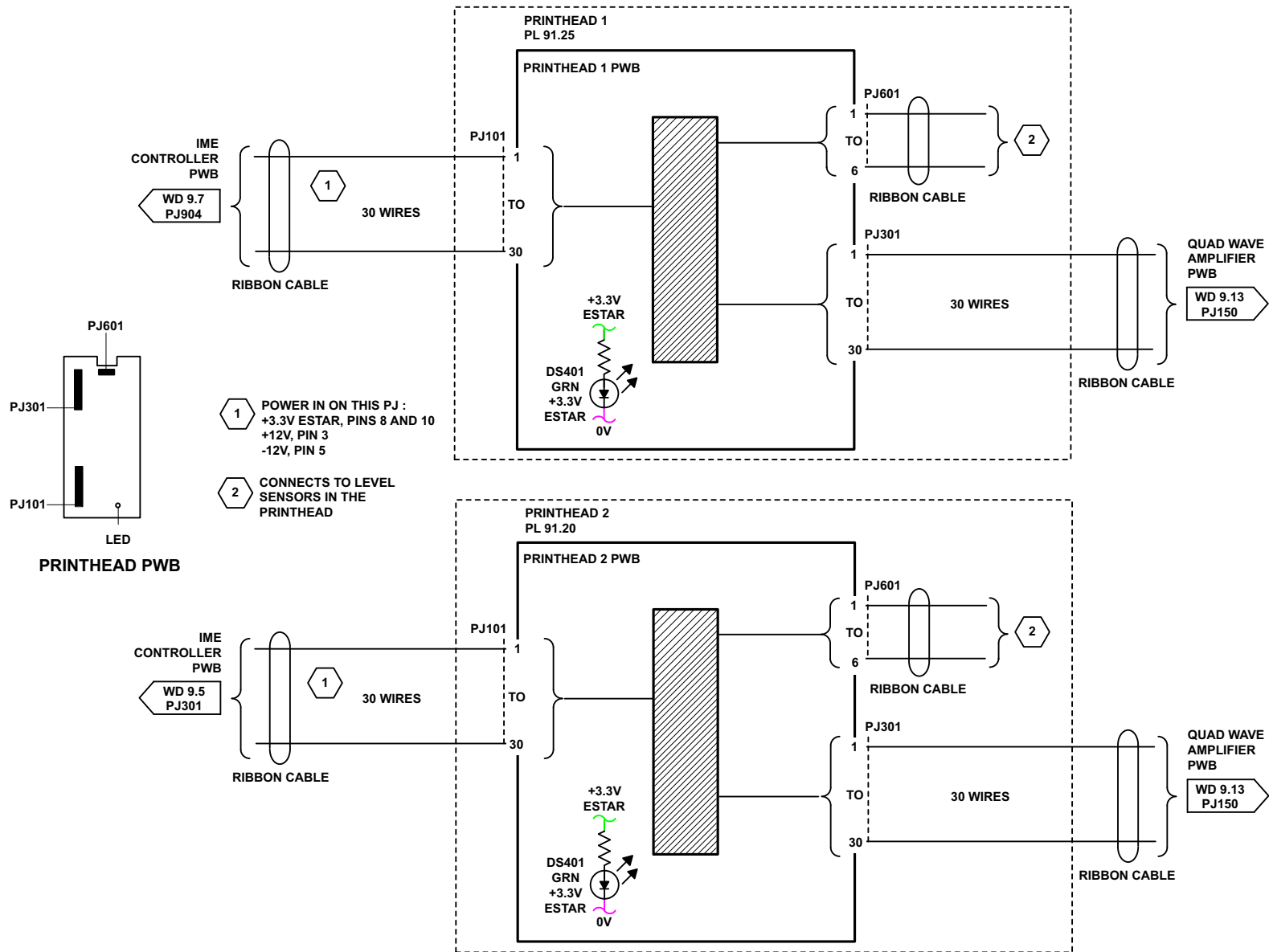
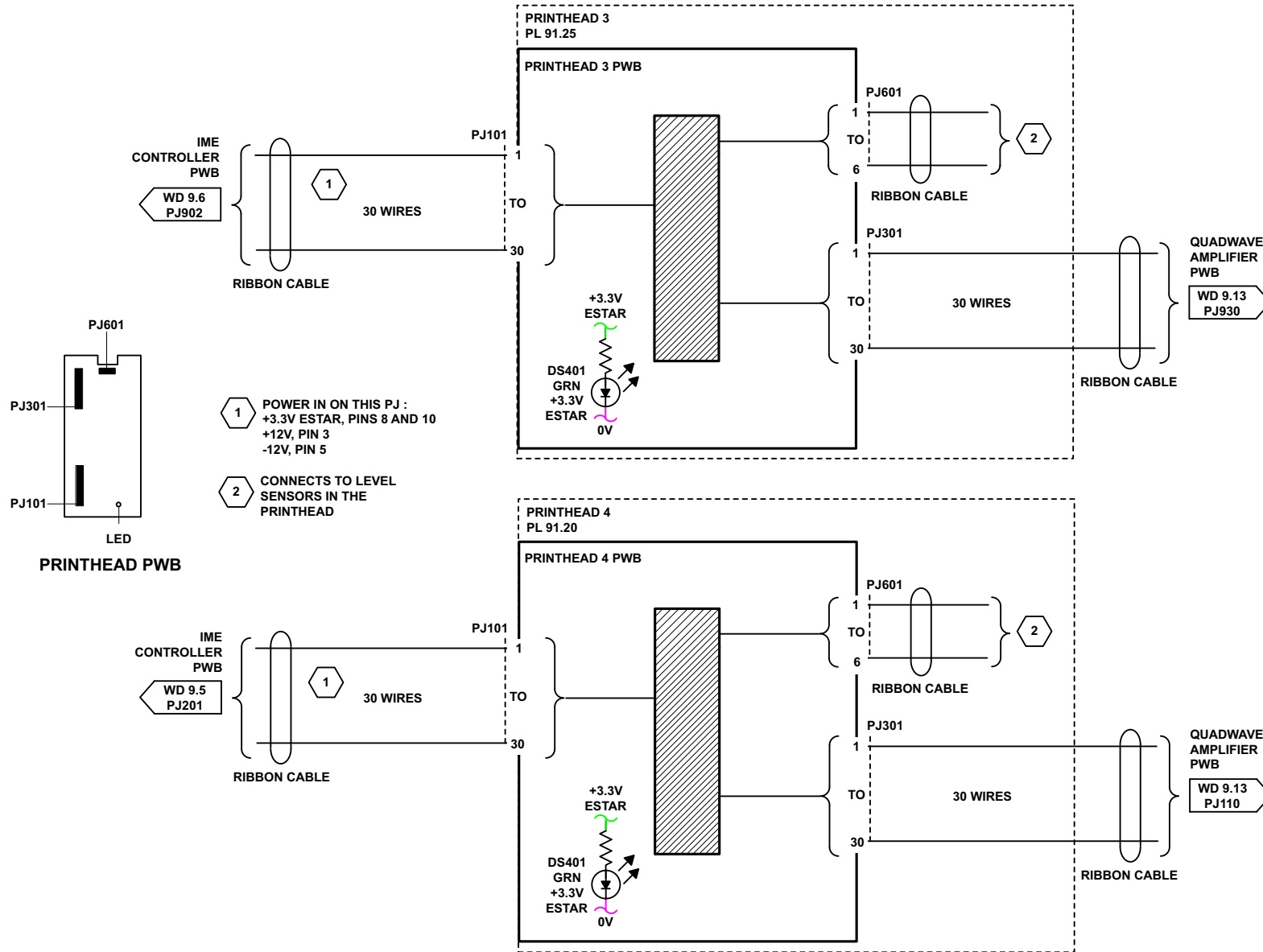

Figure 46 Wiring diagram 9.20

TU-1-0186-A

WD 9.21 Printhead 3 PWB and Printhead 4 PWB



TU-1-0190-A

Figure 47 Wiring diagram 9.21

WD 9.22 IOD Pre Amp PWB

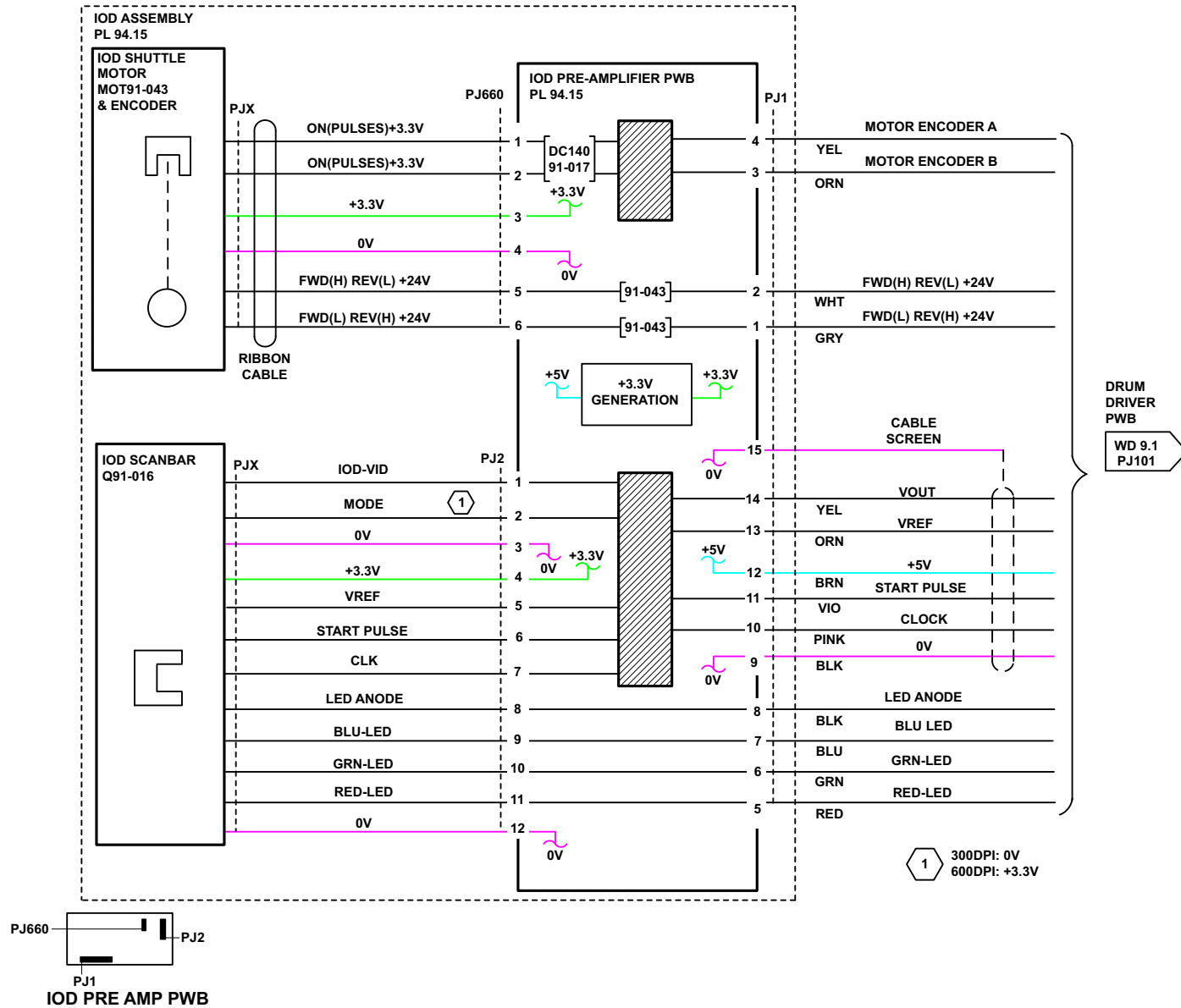

Figure 48 Wiring diagram 9.22

WD 12.1 LCSS PWB (1 of 5)

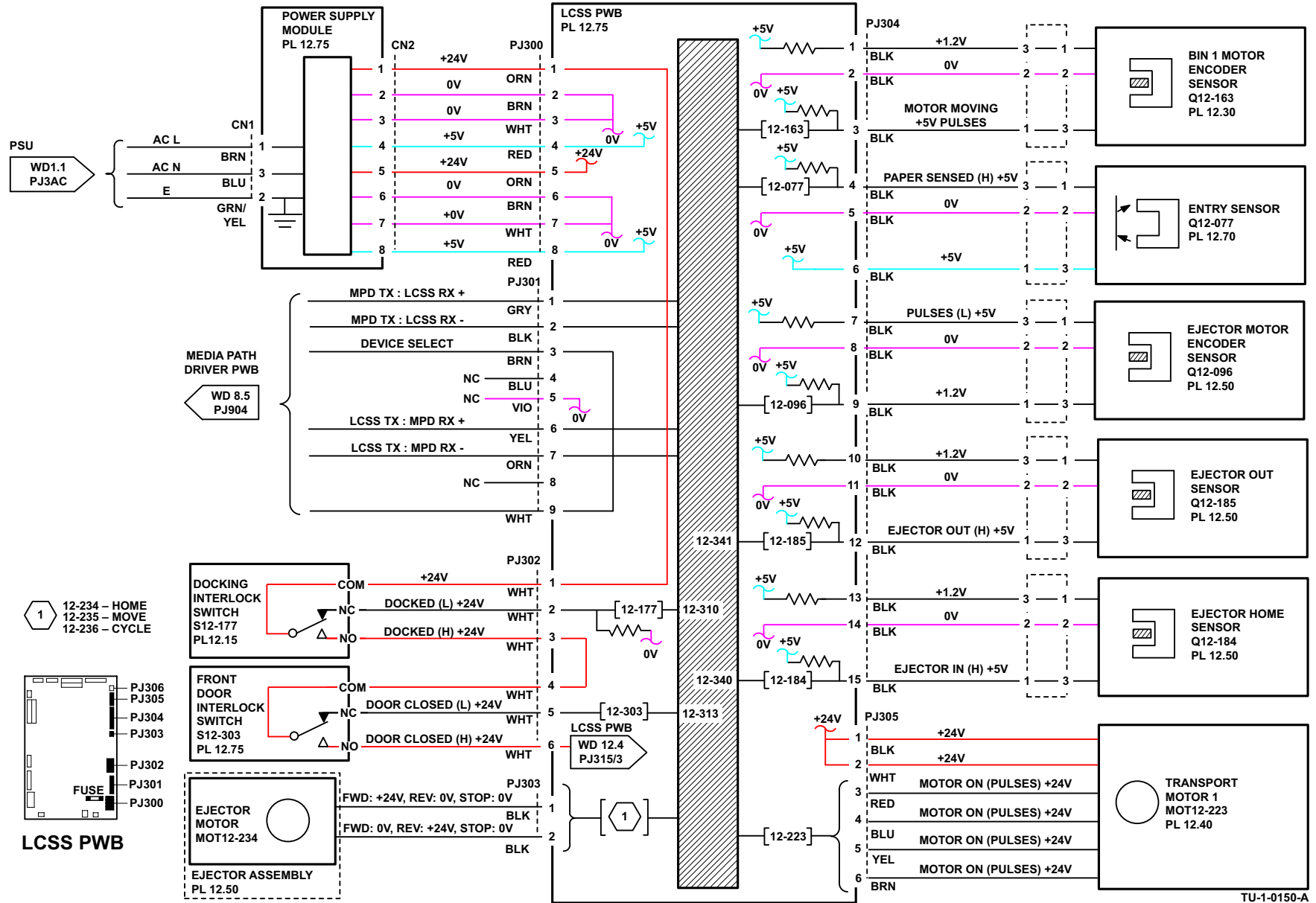
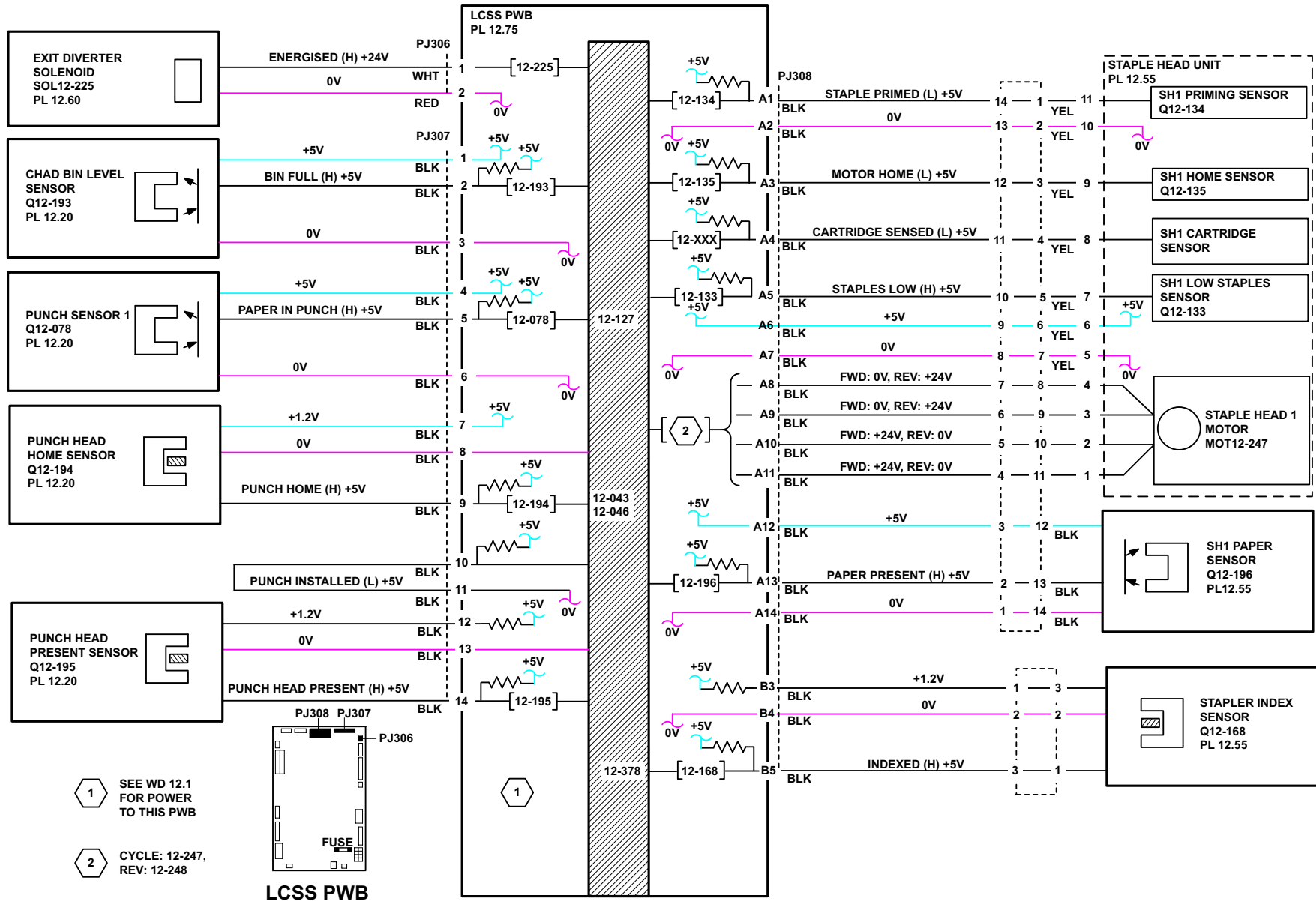

Figure 49 Wiring diagram 12.1

WD 12.2 LCSS PWB (2 of 5)



TU-1-0151-A

Figure 50 Wiring diagram 12.2

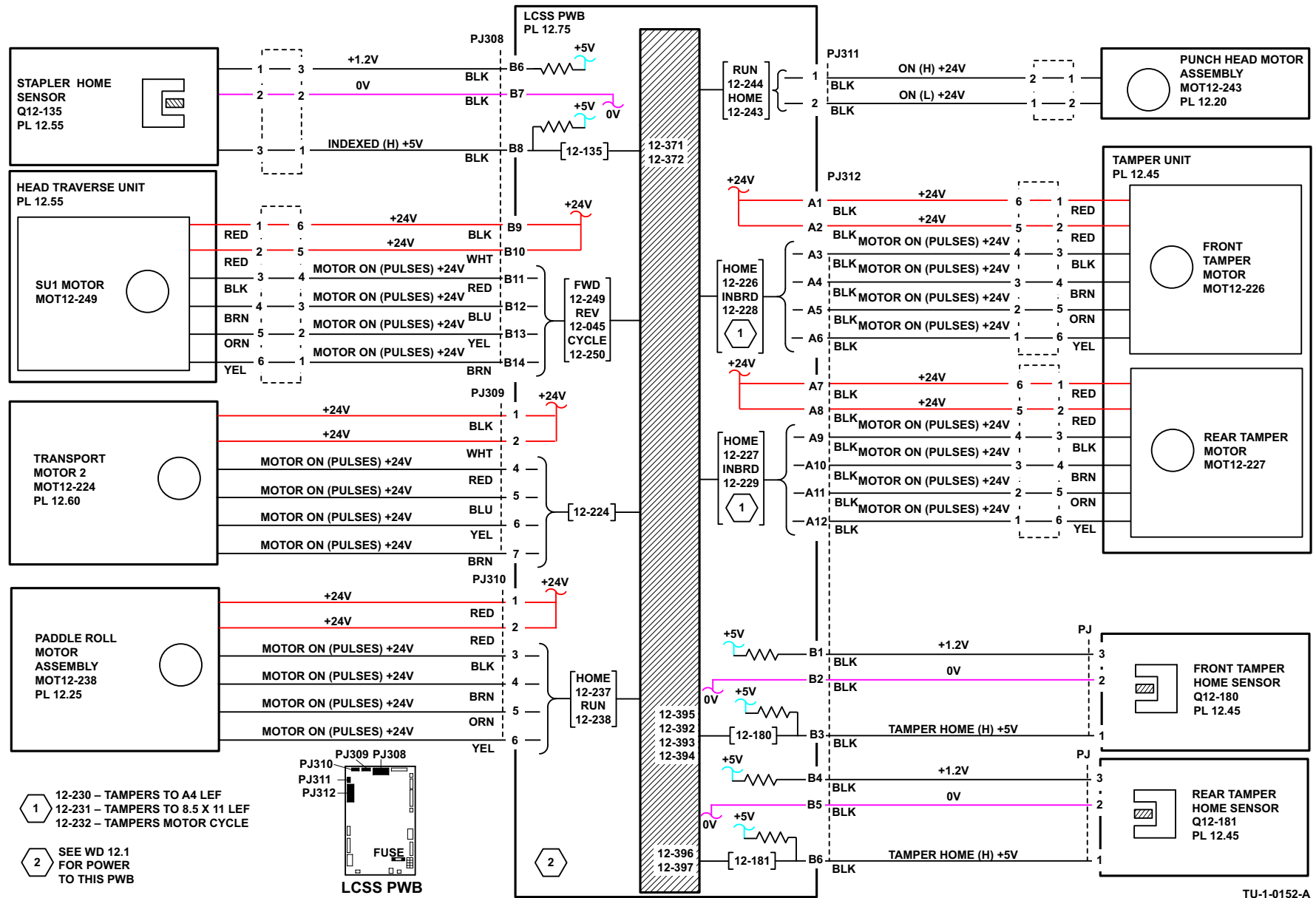

TU-01052-A

Figure 51 Wiring diagram 12.3

WD 12.4 LCSS PWB (4 of 5)

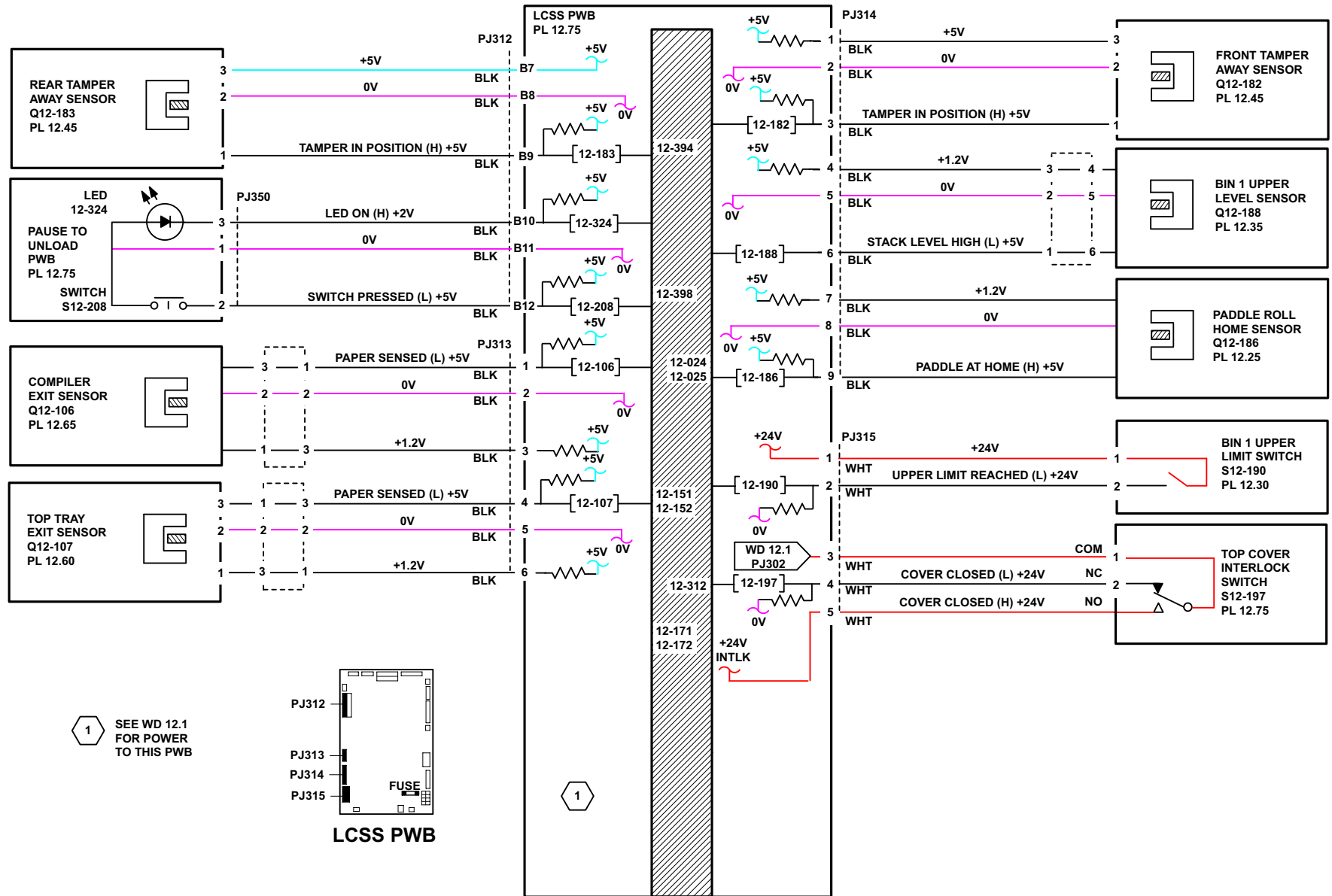

Figure 52 Wiring diagram 12.4

TU-1-0153-A

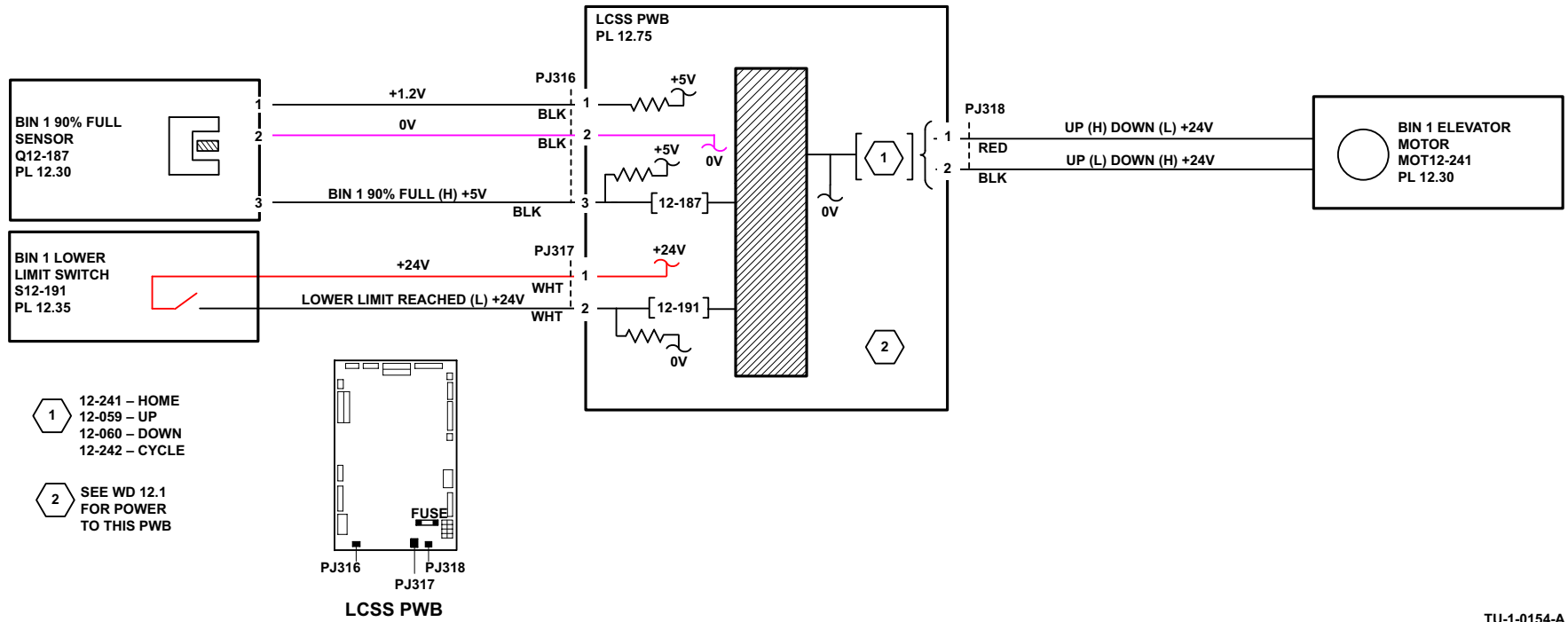
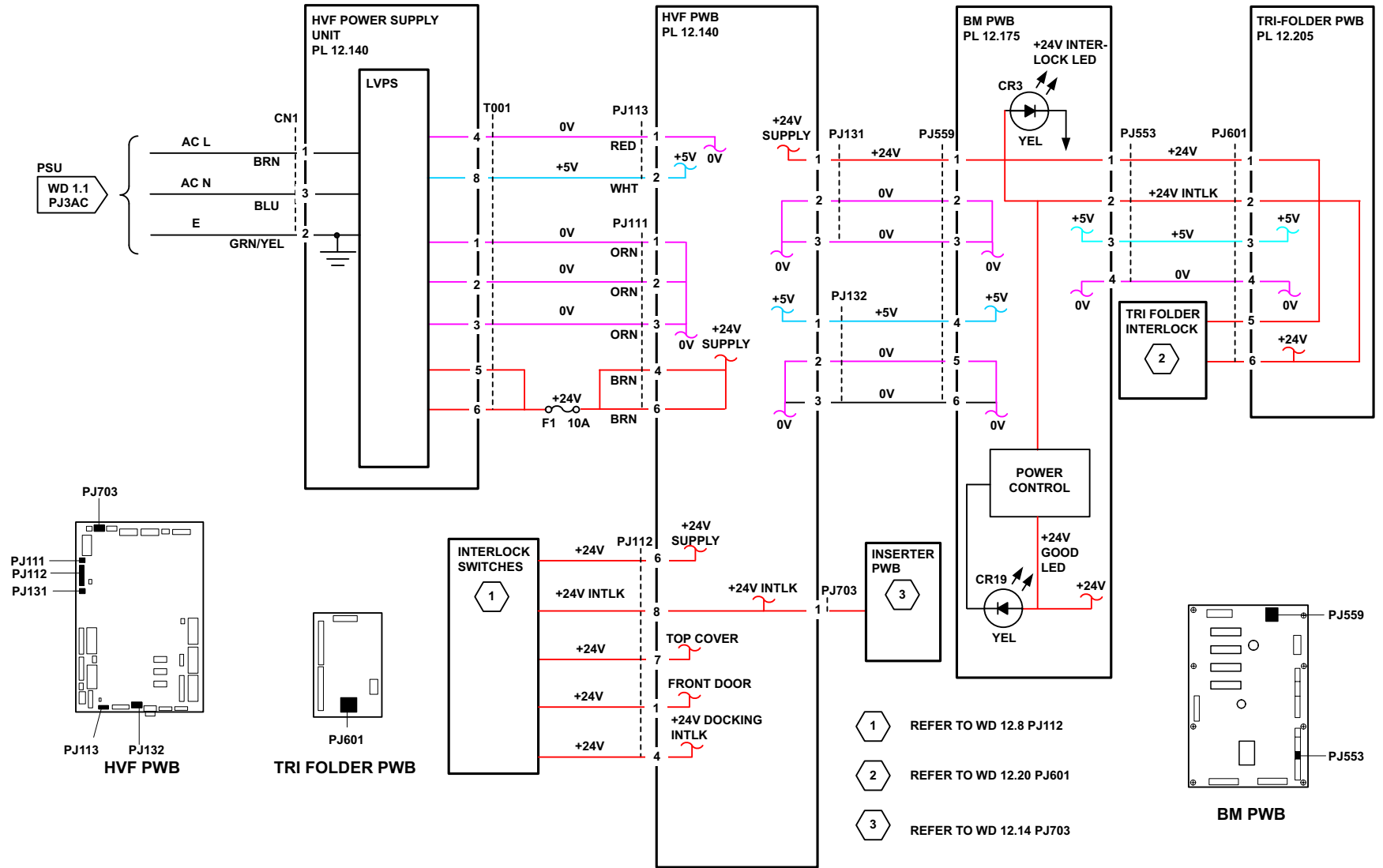

Figure 53 Wiring diagram 12.5

TU-1-0154-A



TU-1-0204-A

Figure 54 Wiring diagram 12.6

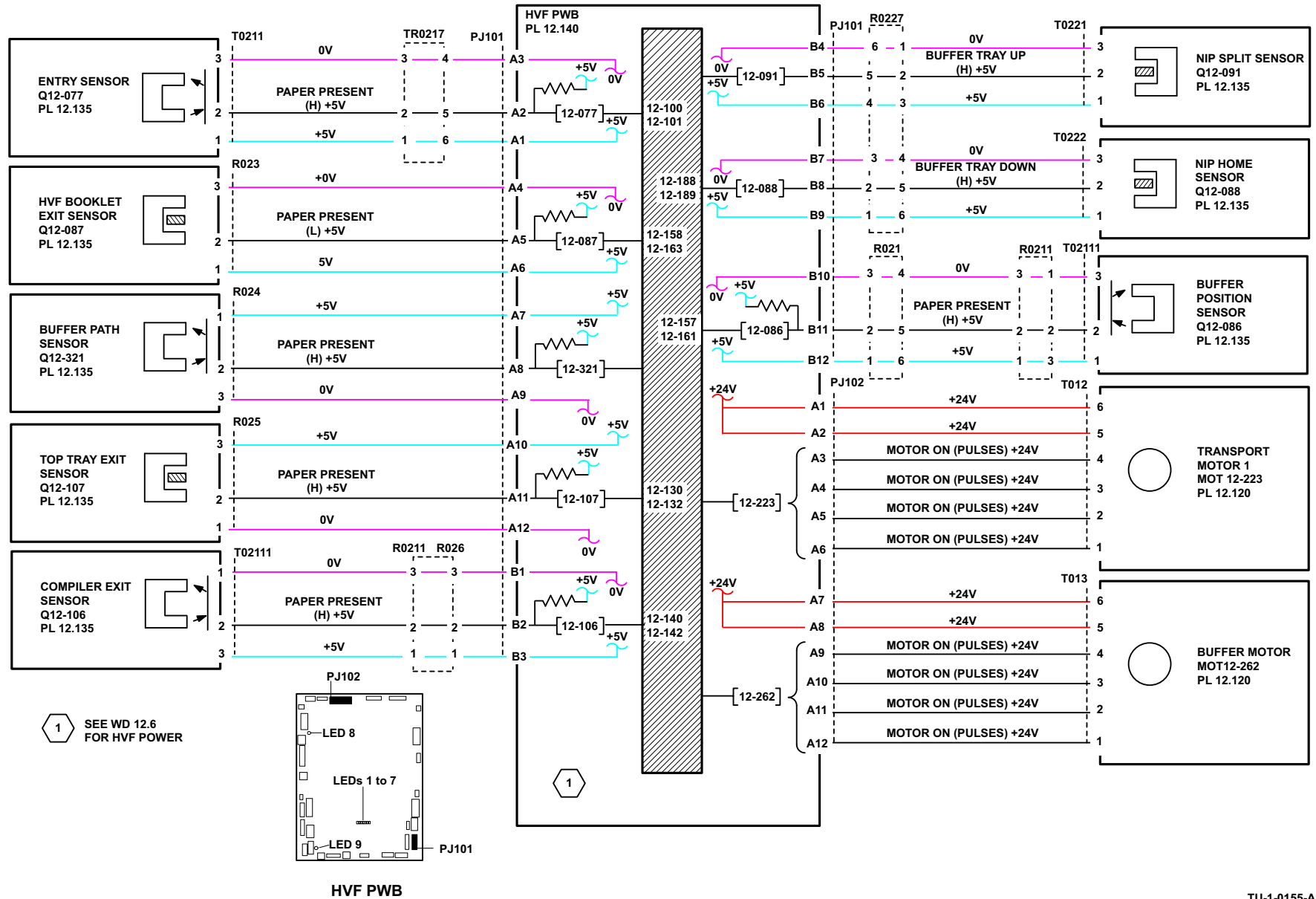

Figure 55 Wiring diagram 12.7

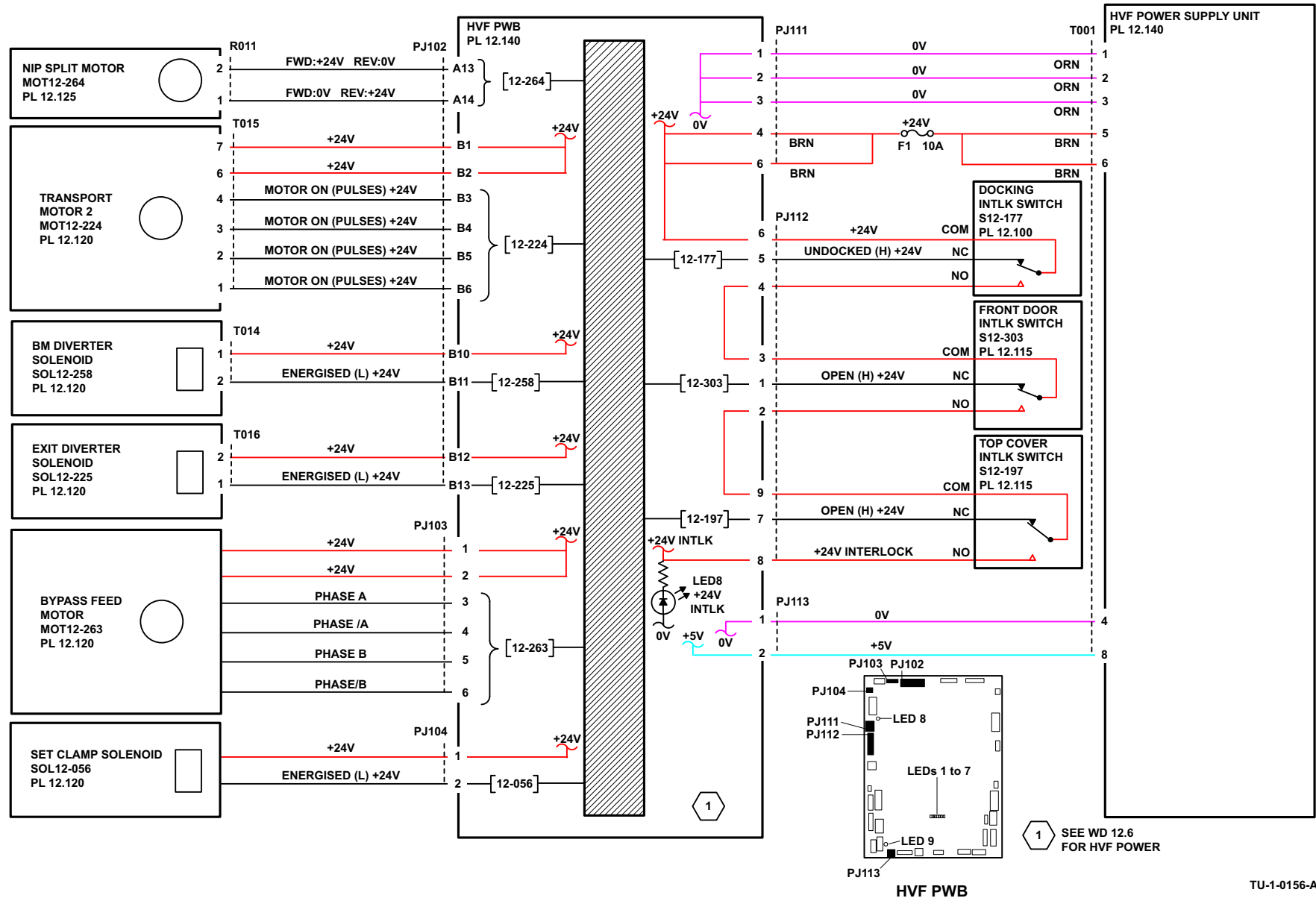
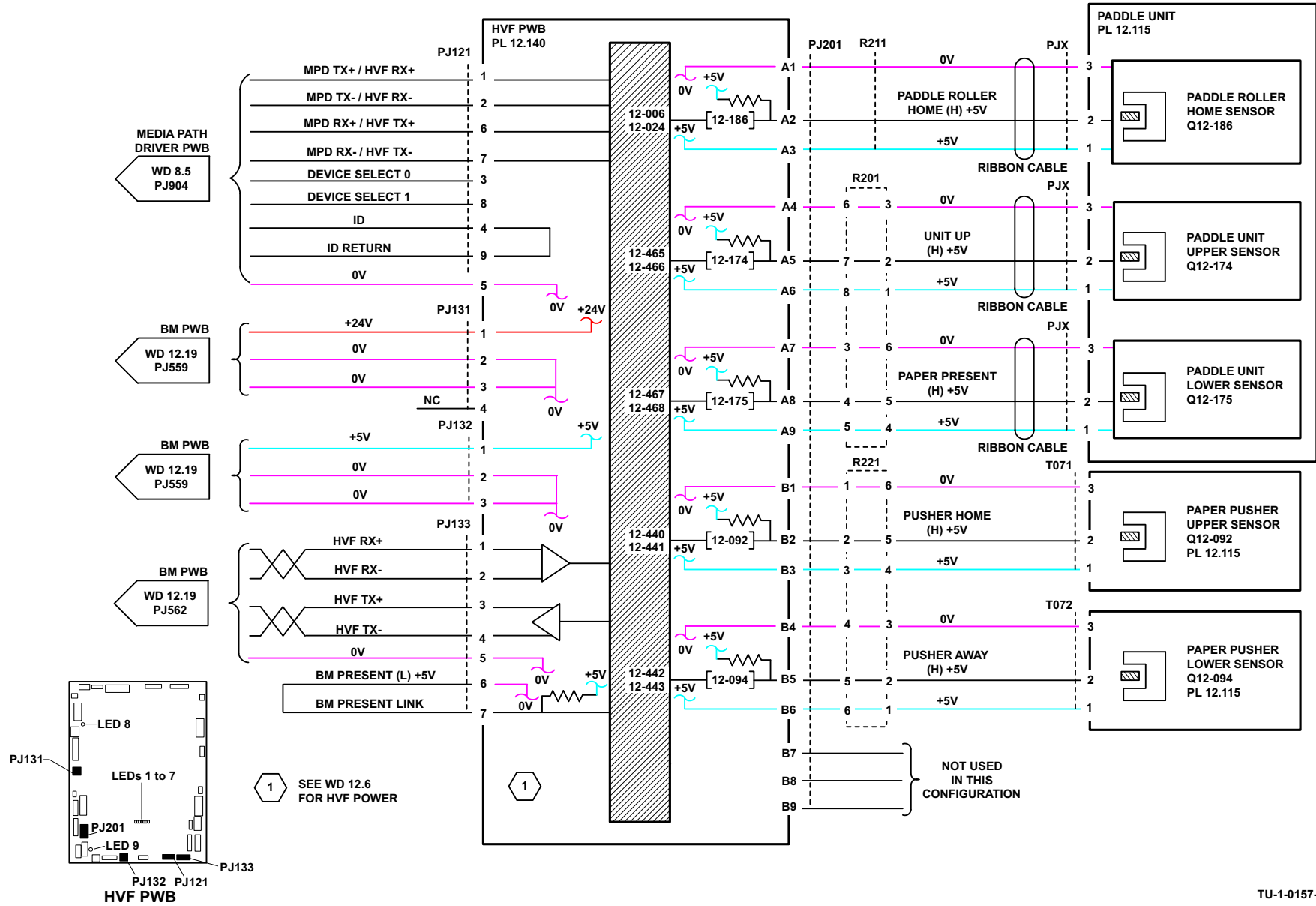
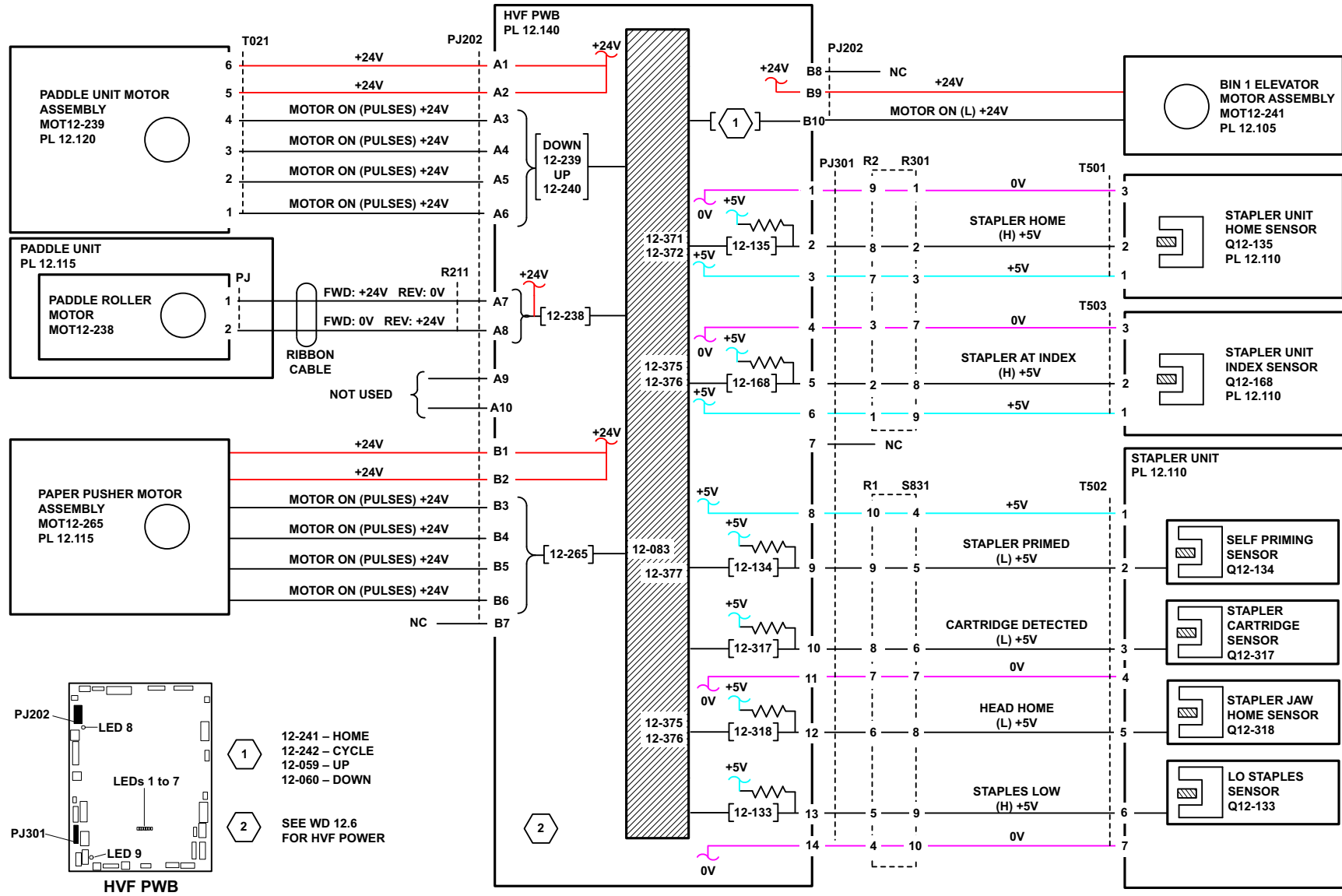

Figure 56 Wiring diagram 12.8



TU-1-0157-A

Figure 57 Wiring diagram 12.9



TU-1-0158-A

Figure 58 Wiring diagram 12.10

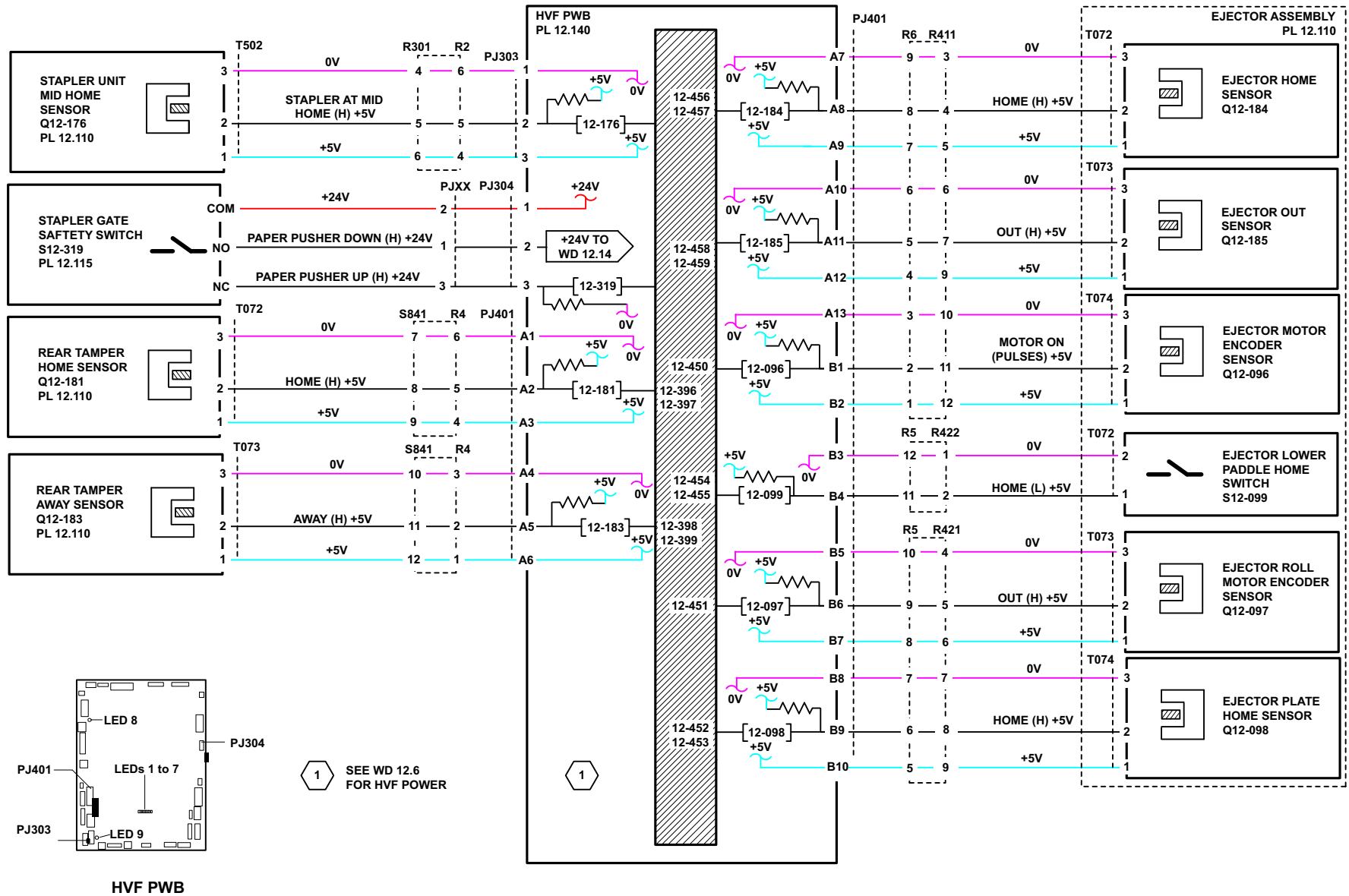

TU-1-0159-A

Figure 59 Wiring diagram 12.11

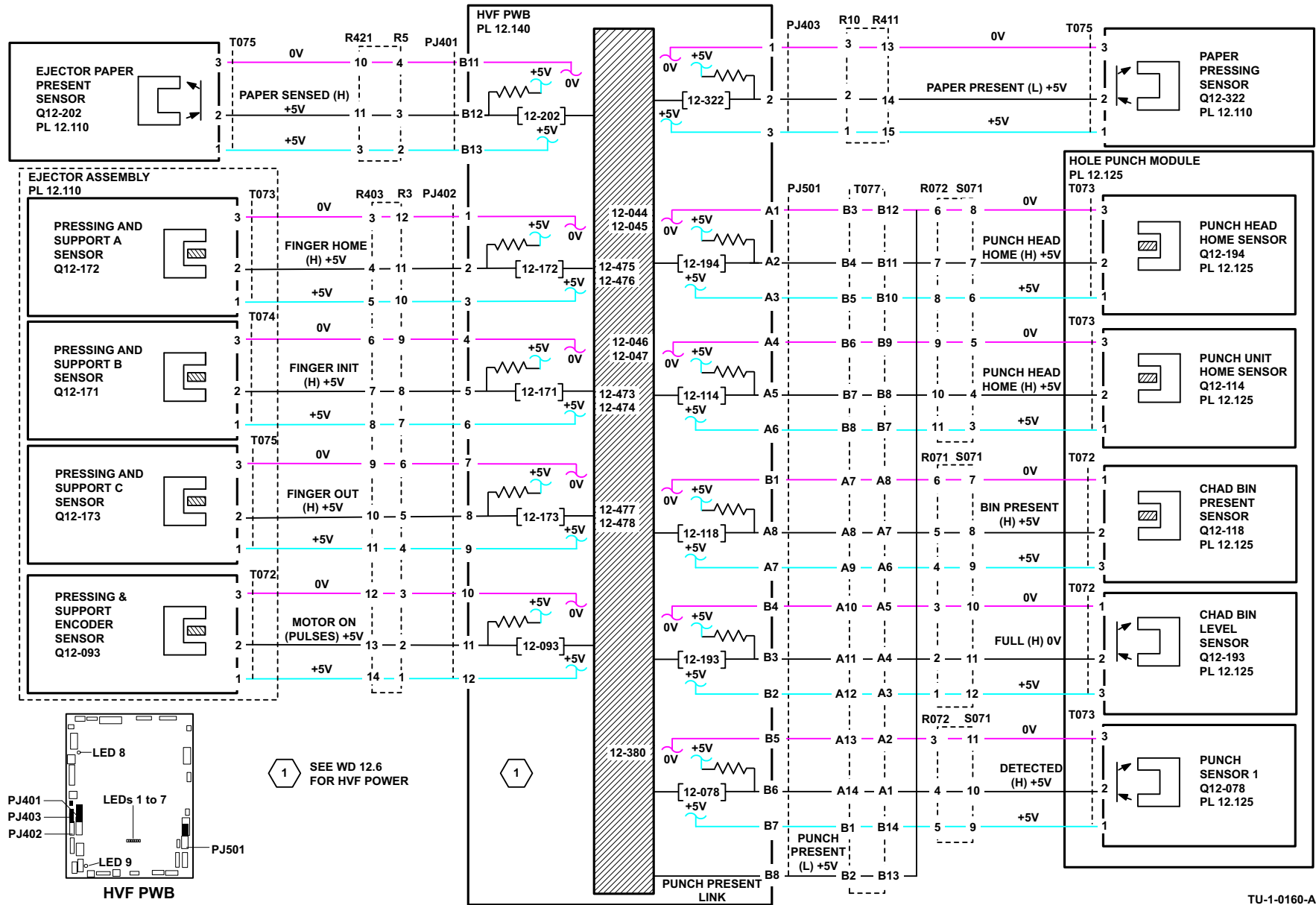

Figure 60 Wiring diagram 12.12

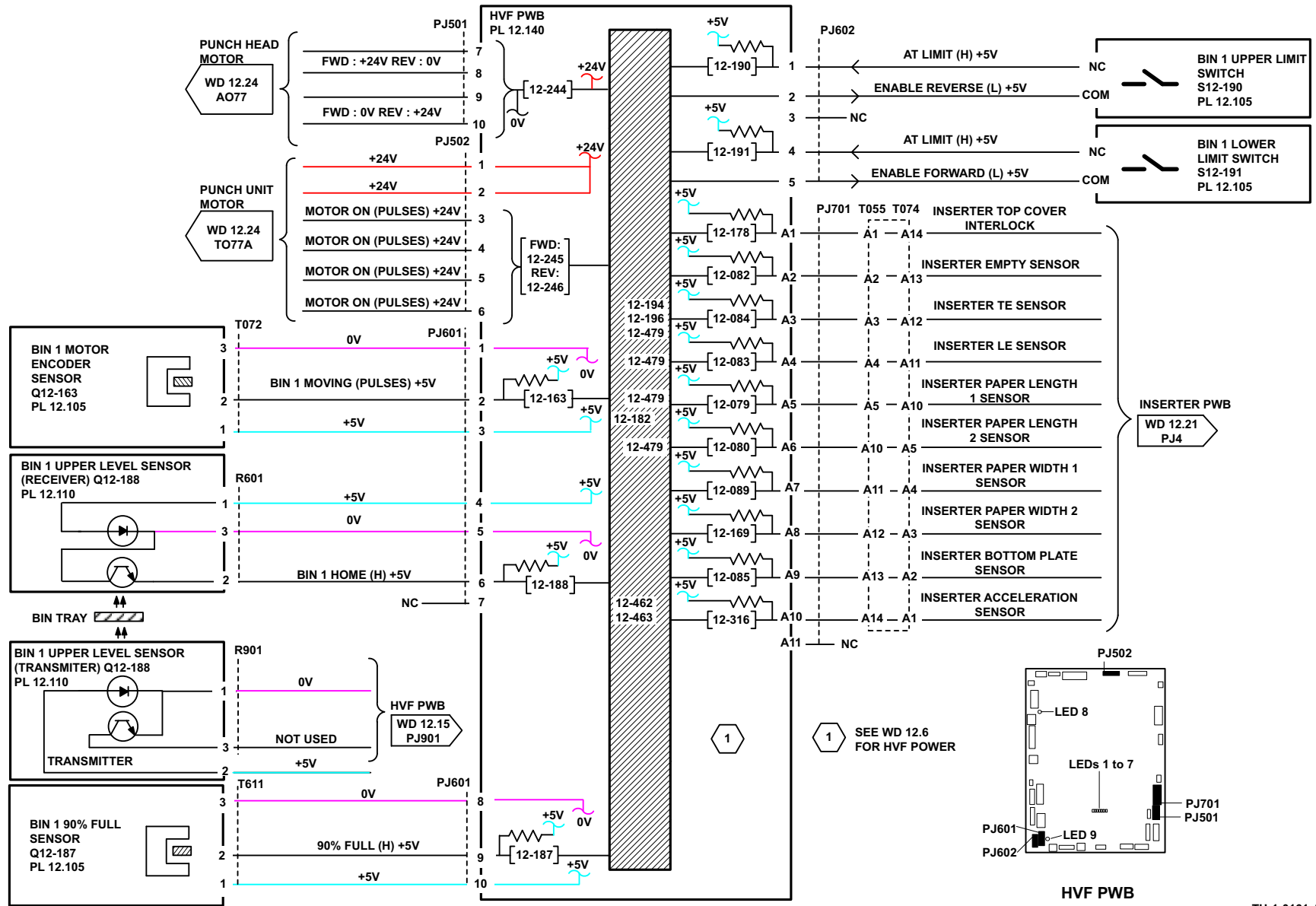

Figure 61 Wiring diagram 12.13

TU-1-0161-A

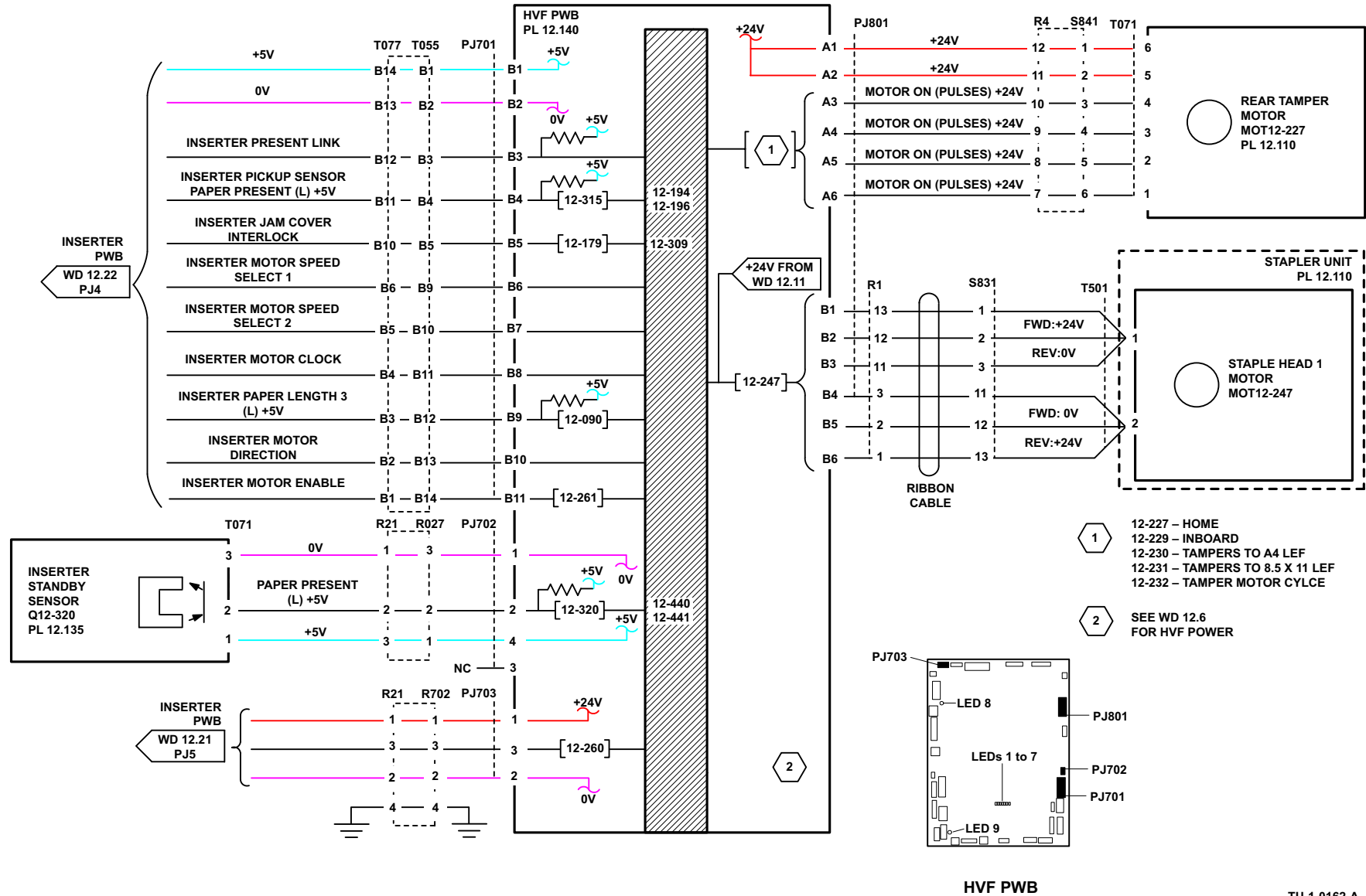
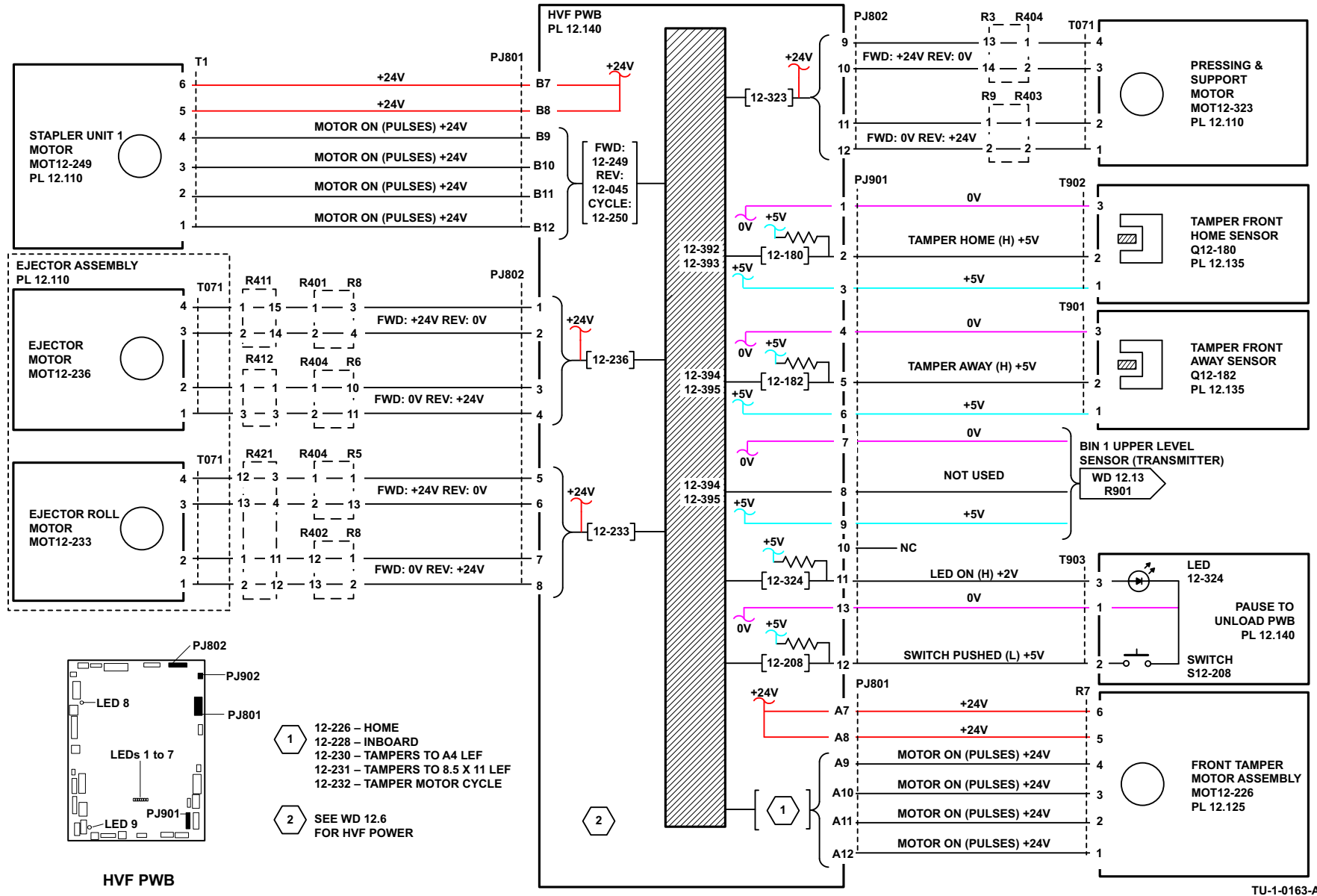
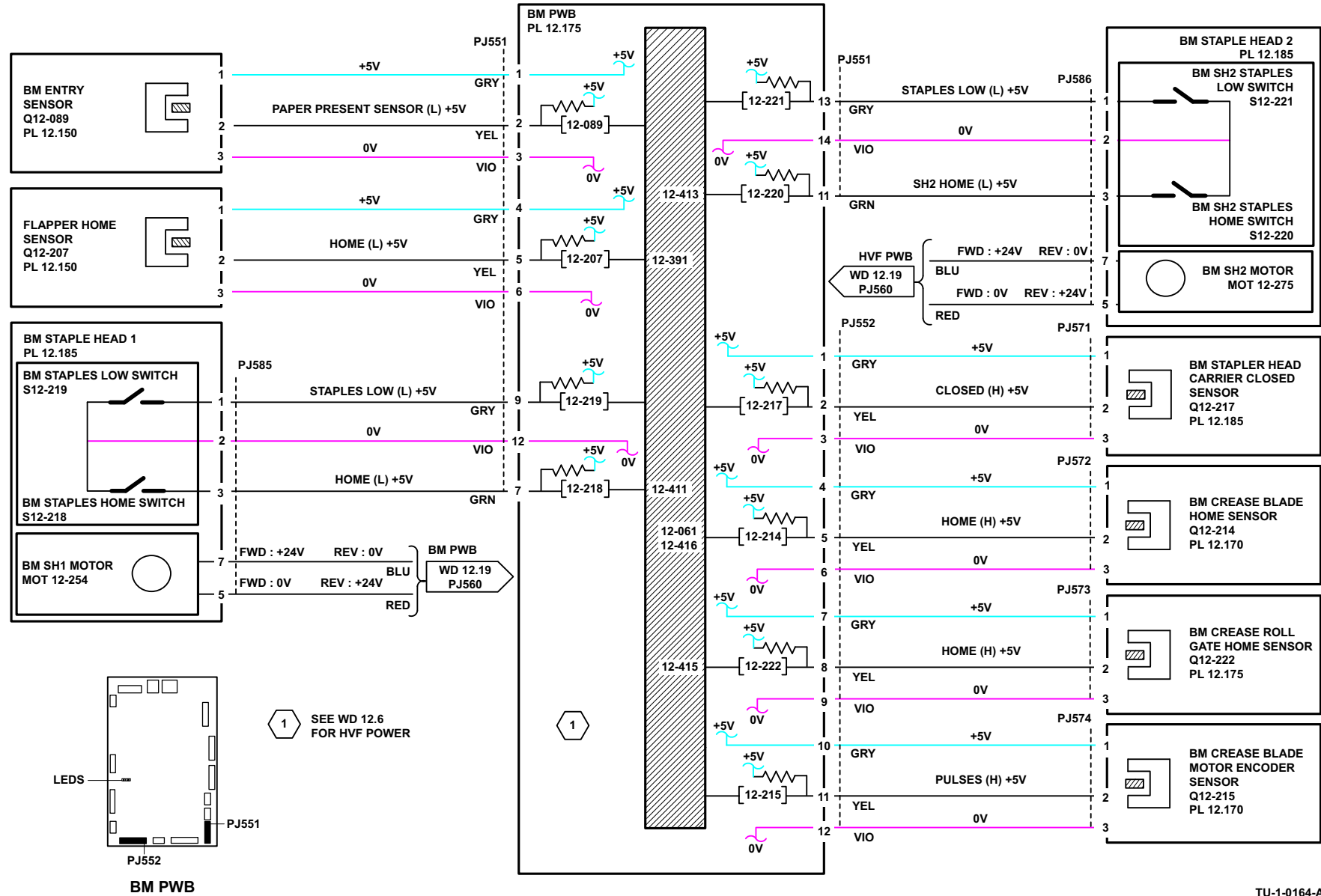

Figure 62 Wiring diagram 12.14



TU-1-0163-A

Figure 63 Wiring diagram 12.15



TU-1-0164-A

Figure 64 Wiring diagram 12.16

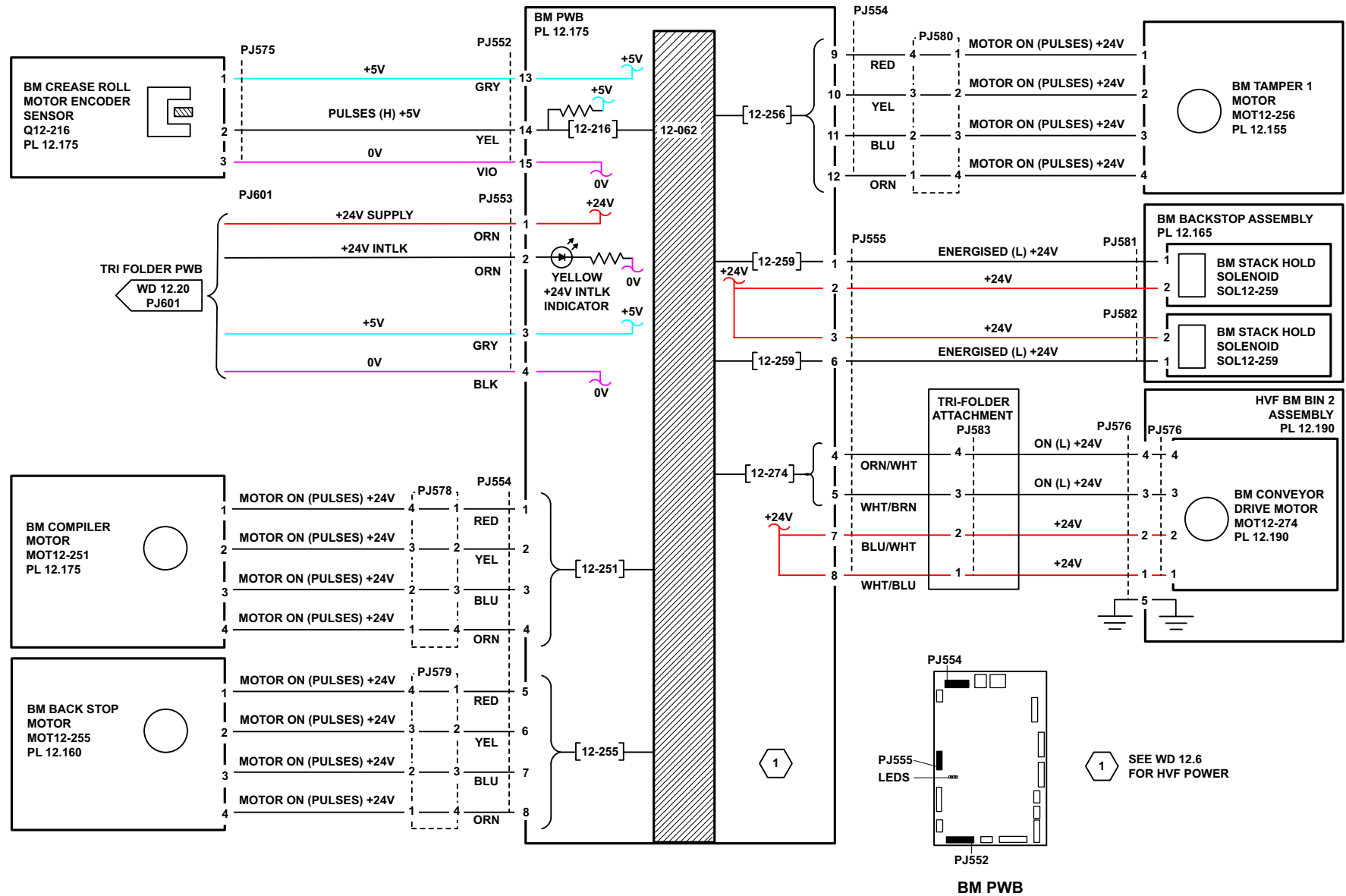

Figure 65 Wiring diagram 12.17

TU-1-0165-A

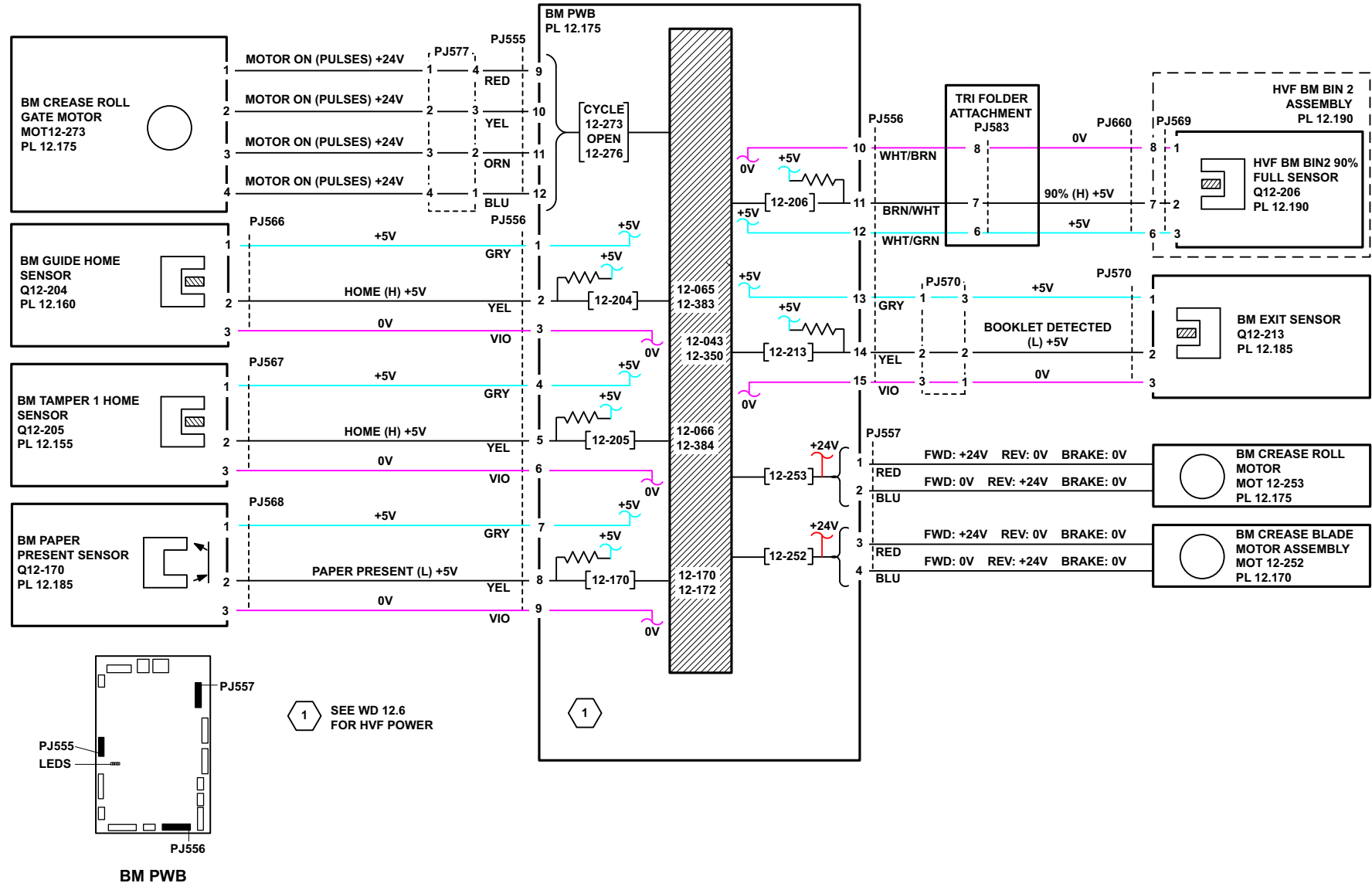

Figure 66 Wiring diagram 12.18

TU-1-0166-A

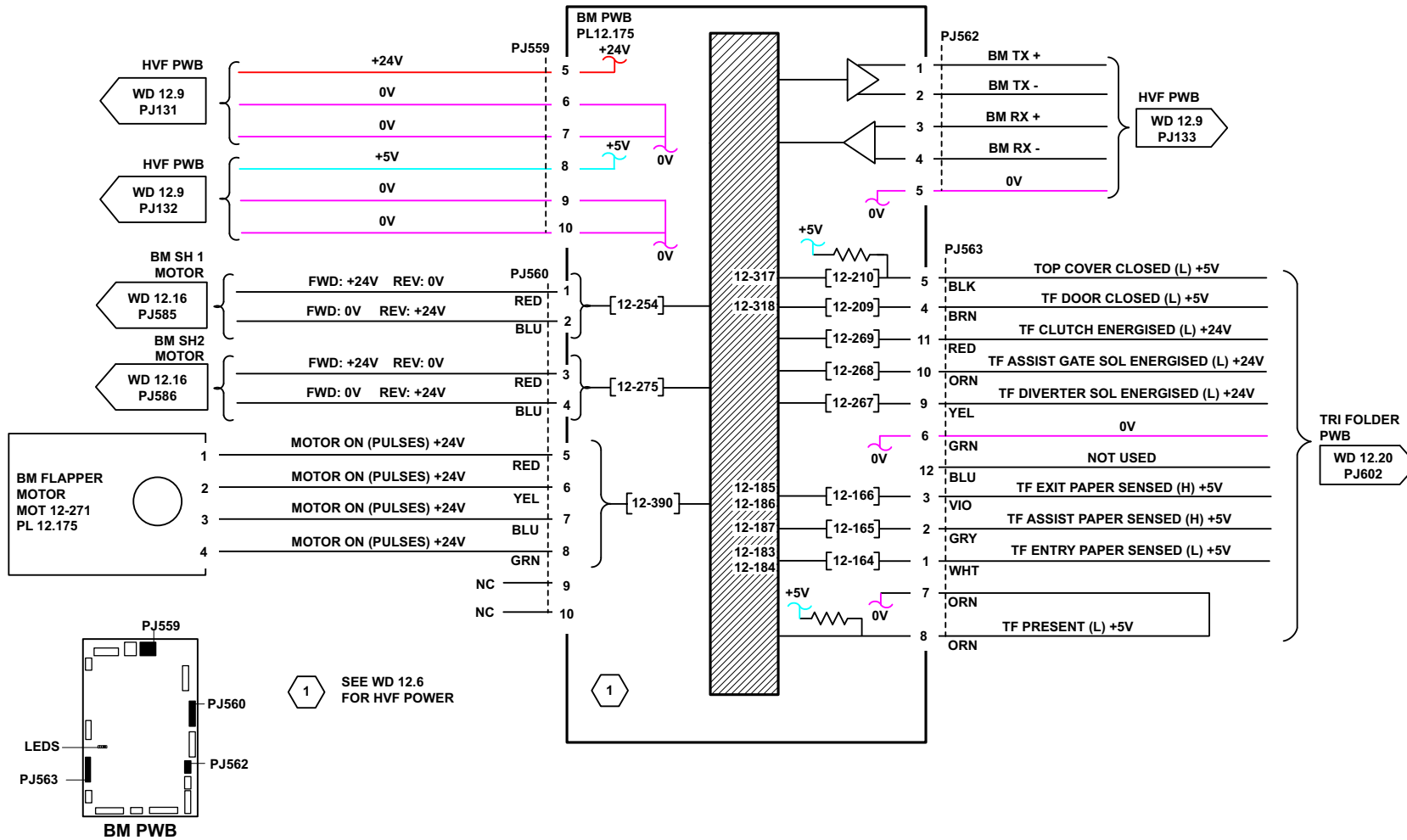

Figure 67 Wiring diagram 12.19

TU-1-0167-A

WD 12.21 Inserter PWB (1 of 2)

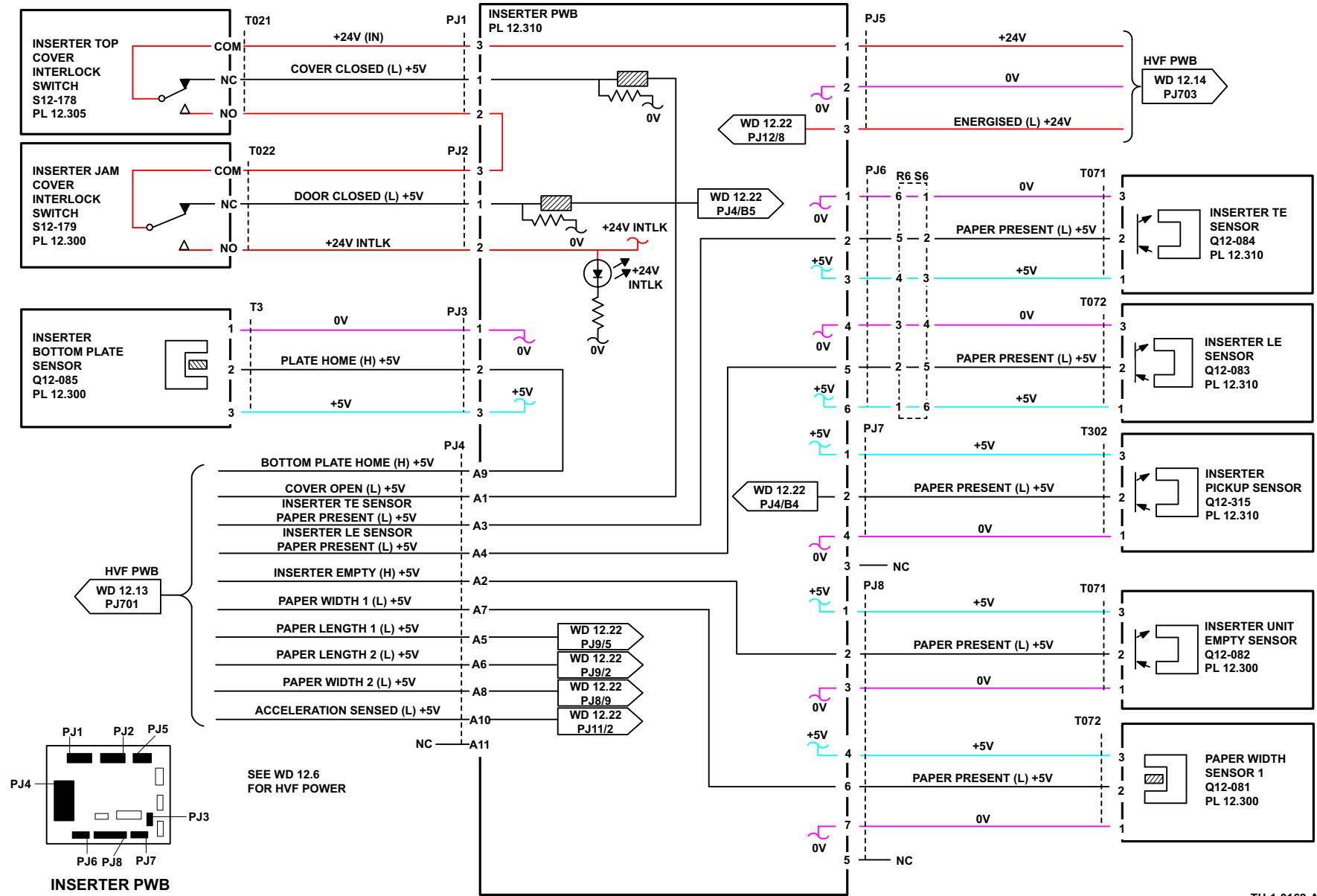

Figure 69 Wiring diagram 12.21

TU-1-0169-A

WD 12.22 Inserter PWB (2 of 2)

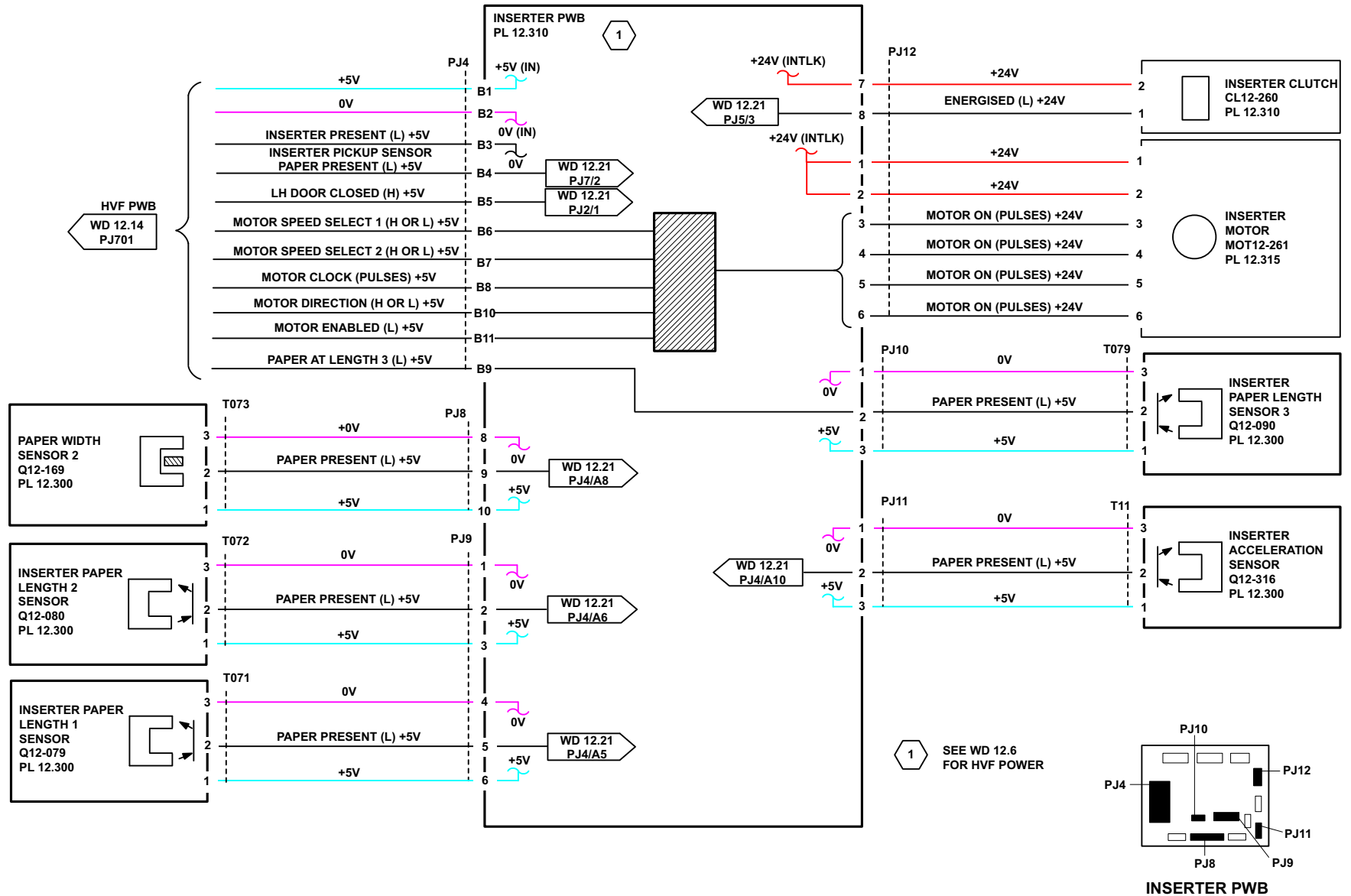
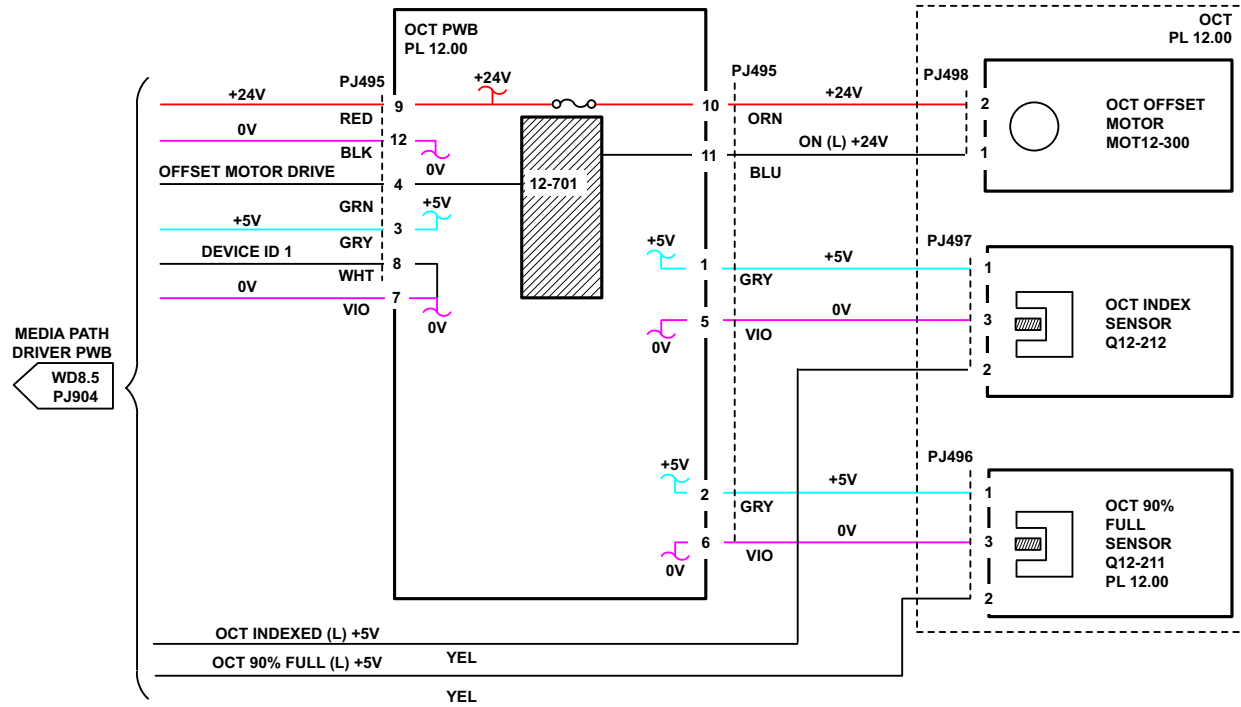

Figure 70 Wiring diagram 12.22



TU-1-0210-A

Figure 71 Wiring diagram 12.23

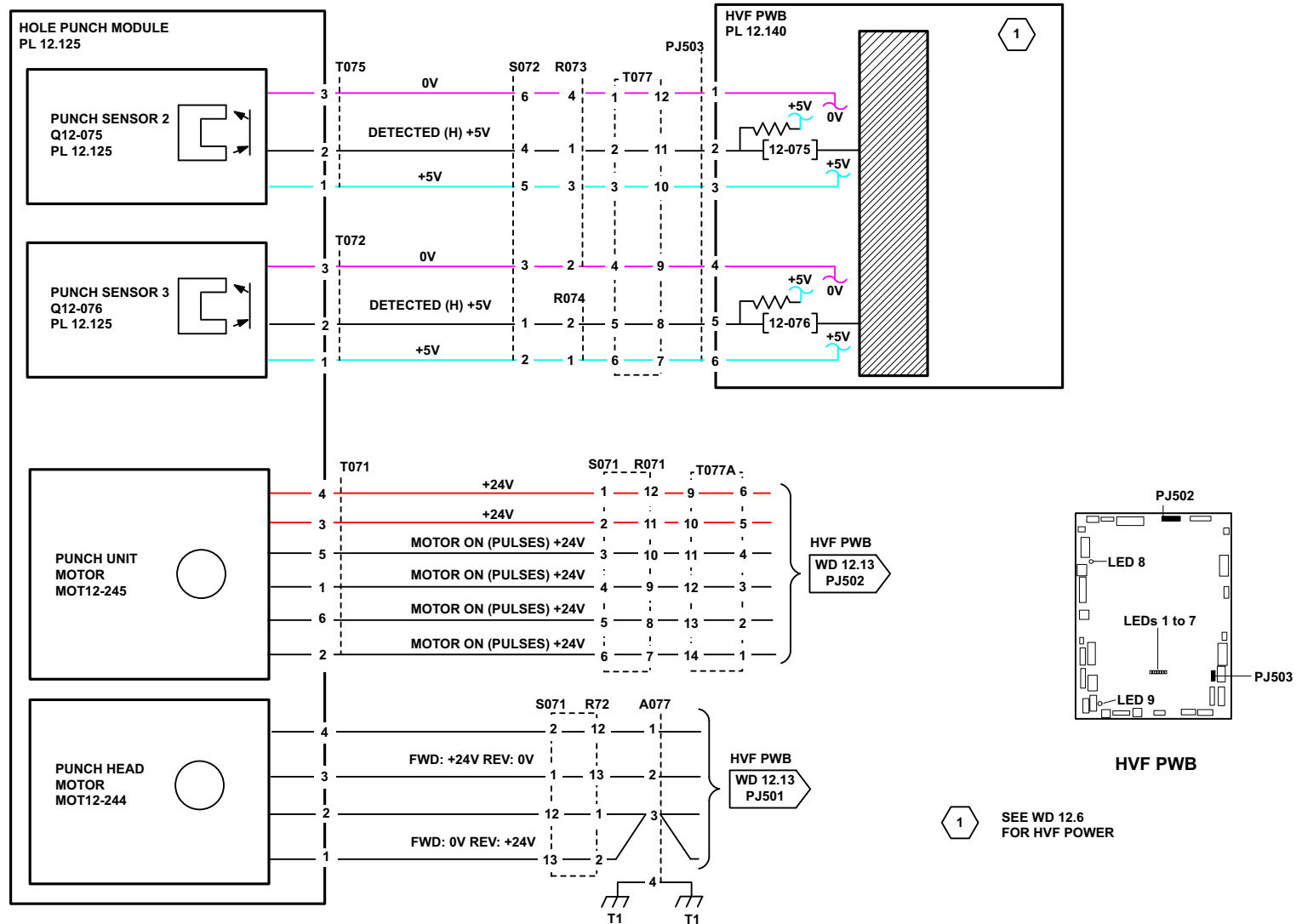

Figure 72 Wiring diagram 12.24

8 Principles of Operation

System Overview	8-3
System Electronics.....	8-14
System Communications	8-21
Power On Self Test (POST).....	8-21
Print Engine Self Test (PEST).....	8-22
Sensor Types and Function	8-22
Print Process.....	8-25
Media Paths	8-32
Image Input Terminal	8-33
Image Output Terminal	8-34
Duplex Automatic Document Handler (DADH)	8-35
Full Width Array Raster Input Scanner.....	8-40
Fax	8-42
Three Tray Module (3TM)	8-43
Bypass tray 4	8-48
Tray 5 Module	8-53
Image Marking Engine (IME)	8-57
Print Marking Unit and Drum Assembly	8-64
Output Transport	8-83
Offsetting Catch Tray (OCT)	8-85
Low Capacity Stapler Stacker (LCSS)	8-85
High Volume Finisher (HVF)	8-93

System Overview

NOTE: To ensure complete understanding of the product, participation in ColorQube 9301/02/03 Service Training is strongly recommended.

The ColorQube 9301/02/03 is an A3 color MFP platform utilizing Xerox's Solid Ink marking technology.

The ColorQube is available in three speed combinations with the following major attributes

- 50 ppm mono on all models
- 40, 45 and 50 ppm color - depending upon model
- 85 ppm high speed draft mode
- Duplex capable document handler
- Scanner with document illumination
- 1 or 2-Line fax module
- 100 sheet bypass tray
- 3 trays (3200 sheet total capacity at 75 gsm)
- Optional Paper Feed Platform (4000 sheets at 75 gsm (18 lb.))
- A wide range of available Finishing Options

Print speed ranges from 30 pages per minute (ppm) for the ColorQube 9301 up to 38 ppm for the ColorQube 9303 at 600 x 600 dpi in single or duplex modes. Table 1 lists the main printing modes and associated resolutions / speeds for sheets 8.5 inches or less in the process direction that can be fed and imaged 2-up (burst mode). Speeds are half those given below for media sizes that cannot be imaged 2-up.

Table 1 Print Speed by Model and Mode

Print Mode	ColorQube 9303 Simplex/Duplex	ColorQube 9302 Simplex/Duplex	ColorQube 9301 Simplex/Duplex
Fast Color	85*/53	70/46	60/40
Fast Black/White	85*/53	85*/46	85*/39
Standard Color	70/50	60/44	50/40
Standard Black/White	70/50	70/44	70/41
Enhanced Color (Default)	55/45	45/41	38/38
Enhanced Black/White (Default)	60/48	55/45	50/39
High Resolution / Photo color	50/38	40/30	30/20
High Resolution / Photo Black/White	50/38	50/38	50/38

NOTE: The 85 page per minute speed is achieved from trays 1 to 4 in plain paper mode and output to OCT, LCSS or HVF top tray only.

These are maximum steady state print speeds. There are many factors that will reduce performance from these values including image complexity, job length, paper size, tray selection and driver type.

The base configuration (ColorQube 9301) includes three paper trays (Trays 1, 2, and 3) providing 3200-sheet input capacity, a 100-sheet bypass tray from which specialty media, card stock, larger format paper, and envelopes are fed. Also included is a DADH / Scanner. Network connectivity for all models is available utilizing Ethernet or USB.

ColorQube 9302/03 options add memory, media capacity and functionality. A selection of memory upgrades are available to increase the base configuration memory to the 2 GB maximum. A 4000-Sheet Feeder (Tray 5) is available. On the output side, a 2000-sheet, low-capacity stapler/punch/stacker is available, or a high-volume finisher with optional booklet-maker, tri-fold, punch, and inserter.

Refer to Table 2 for Acronym definitions.

Table 2 Acronym Definitions

Acronyms	Definition
3TM	3 Tray Module (Trays 1 to 3)
CVU	Check Valve Unit
EOL	End Of Life
FRU	Field Replaceable Unit
H2H	Head to Head
HVF	High Volume Finisher
IIT	Image Input Terminal
IMD	Ink Module Driver
IME	Integrated Marking Engine
IOT	Image Output Terminal
LCSS	Low Capacity Stacker/Stapler
LCSS	Low Capacity Stacker/Stapler
LPA	Low Pressure Assistance (valve)
LVDS	Low Voltage Differential Signalling
MFP	Multi Functional Printer
MPD	Media Path Driver board
MPT	Multi Purpose Tray
MSI	Multi-sheet Inserter
MU	Marking Unit
OCT	Offset Catch Tray
PFP	Paper Feed Platform (tray 5)
PLD	Programmable Logic Device
PTC	Positive Temperature Coefficient (heater)
PWM	Pulse Width Modulation
RTC	Real Time Clock
SBC	Single Board Controller
SFWA	Staggered Full Width Array

Image Input Terminal

The Image Input Terminal (IIT) includes the following components:

- Duplex Automatic Document Handler (DADH)
- Scanner with Platen
- Control Panel with Graphical User Interface (GUI)

Duplex Automatic Document Handler

The DADH offers the capability to feed a document stack of up to 100 sheets. The DADH contains its own software, which controls the hardware to move input documents between pre-defined locations within the DADH. [Figure 1](#).

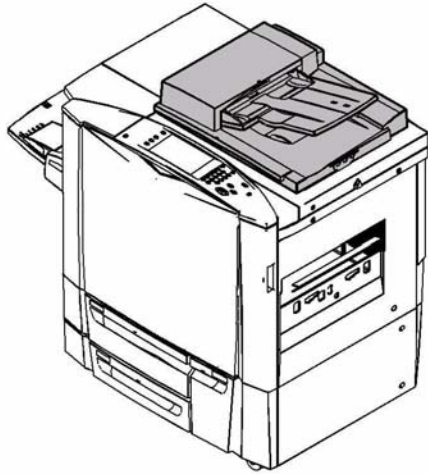
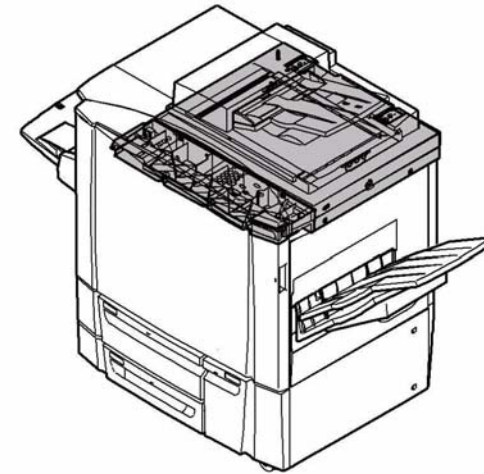

Figure 1 DADH location

U-5-0086-A

Scanner and Platen

The scanner will support a monochrome scan speed of 361 mm/sec and a colour scan speed of 234 mm/sec. The scanner also includes more illumination for the higher colour speeds. Refer to [Figure 2](#).



U-5-0087-A

Figure 2 Scanner location

Control Panel

The control panel is housed in a plastic housing containing:

- 800 by 600 pixel display
- 20 by 8 touch screen overlay
- 25 hard keys
- 6 status LEDs

Hard Button Functions

The hard buttons activate functionality, change between services and control the machine.

- Numeric keypad: to enter numeric information (e.g. copy count, fax phone number, etc.)
- Additional characters: asterisk, hash and dial pause for fax functionality
- Cancel: to cancel any numeric information input via the keypad
- Start: to commence copying, scanning and job recovery cycles
- Stop: to stop the machine while running
- Clear All: to cancel selected features and return them to their default values
- Job Interrupt: to suspend the current job and allow another job to be carried out. Pressing Job Interrupt a second time returns to the original job. An LED, next to the button, illuminates to indicate when Job Interrupt is active
- ? (Help button): to provide information about features provided on the machine. An LED positioned next to the button illuminates to indicate when Help is active
- Language: toggle the display text between different languages resident on the machine.
- Key Symbol (Log In/Out button): to access secure areas, e.g. Key Operator set ups

- Machine Status: to access status information on the machine
 - Job Status: to access information on the job queues
 - Features: to access the Copy, Fax etc. features soft buttons
 - Power Saver: puts the machine into Low Power mode or reboot
- Status LEDs

The Status LEDs indicate active functionality, refer to [Table 3](#).

Table 3 LED function

LED	Function	Color
1	Feature path selected	Blue
2	Job status path selected	Blue
3	Machine status path selected	Blue
4	Help mode	Green
5	Interrupt mode	Green
6	Power saver key	Green

The arrangement of control panel hard buttons is illustrated in the following figures.

Control Panel Left

[Figure 3](#) illustrates the functions available on the left side of the control panel.

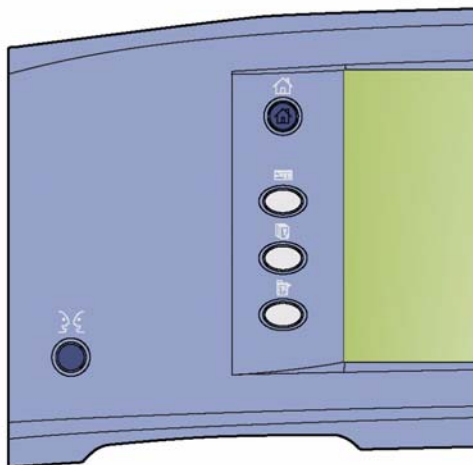

U-5-0533-A

Figure 3 Control panel left

Control Panel Right

[Figure 4](#) shows the controls located on the right side of the control panel.

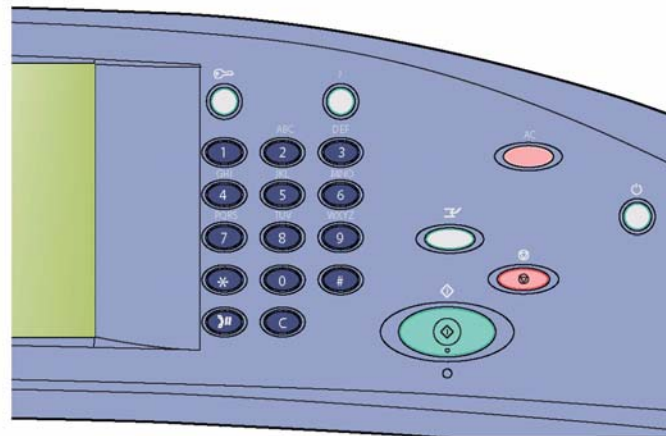

U-5-0535-A

Figure 4 Control panel right

Control Panel Display

The touch-sensitive control panel is the primary system interface. [Figure 5](#) illustrates areas of the display. The display is divided into pathways, as illustrated in the following sub-sections. To access the tools option it is necessary to log in as an administrator. The default screen displayed is set in Screen Defaults of the Tools area. Different feature menus are selected with the hard buttons. Refer to [GP 5 Customer Administration Tools](#).

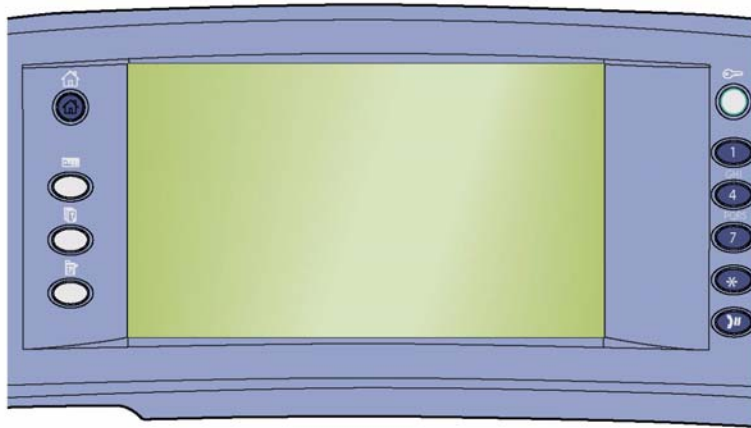

U-5-0534-A

Figure 5 Control panel display

Fax

The ColorQube 9301/02/03 can be used to send and receive fax information via the optional 1 or 2-line fax module located in the controller drawer beneath the scanner. Fax functionality is selected and controlled via the main control panel.

Image Output Terminal

The Image Output Terminal (IOT) is an integrated module consisting of the following major components:

- Bypass tray 4
- 3TM adjustable trays (Trays 1 and 2)
- 3TM fixed-size tray (Tray 3)
- Power supply
- IME that includes
 - Vertical transport
 - Horizontal transport
 - Registration / Preheat assembly
 - Marking unit
 - Printheads
 - Ink loader
 - Ink delivery system
 - Drum and transfix roller
 - Drum maintenance unit
 - Print engine electronics

Bypass Tray 4

The bypass tray is located on the left side of the IME and accepts standard or specialty media. The user can fold the bypass tray upward when not in use. Bypass tray capacity is 100 sheets.

Figure 6

Sensors in the bypass tray detect the presence and approximate size of input media. When media is detected by the input sensor, the IME prompts the user, via the control panel display, to confirm media characteristics. The IME estimates the cross-process width of the sheet in the bypass tray when the side guide has been correctly positioned. The bypass tray guide position is zoned, with each zone attributed with a default media size(s). For certain sizes, the default is dependent on market region. The default media size is also associated with a collection of similar sizes. The user will be allowed to select the default media size indicated by the bypass tray guide position, or to select from the list of similar sizes and types.

If the user loads envelopes, the bypass tray will initially detect them as one of the standard media. The user will then have to select the 'envelope' option, which will trigger the bypass tray to default to one of the standard envelope types. If the user loads custom size media, the bypass tray will initially detect it as one of the standard media. The user will then have to select the 'custom size' option and enter the exact size of the custom media loaded.

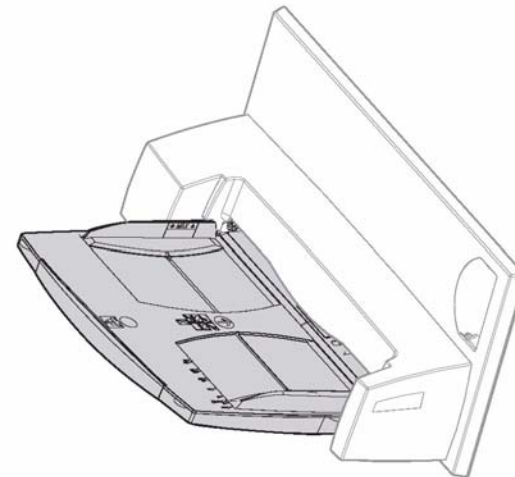

U-5-0545-A

Figure 6 Bypass tray

Tray 1 and Tray 2

Figure 7. Trays 1 and 2 are fully adjustable and many supported media sizes are detected via automatic size sensing. The tray side guides feature detent positions at the supported media sizes (refer to GP 20 Paper and Media Size Specifications) for the guides to lock to. In between these standard sizes, the guides will still lock in position via a ratchet / pawl feature to support custom sized media.

Power Supply
See Figure 9

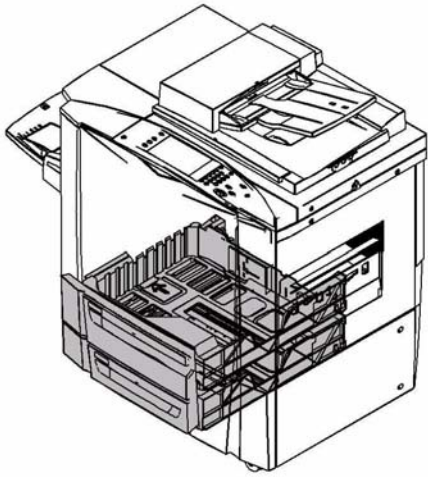

U-5-0088-A

Figure 7 Tray 1 and tray 2

Tray 3 and Horizontal Transport

Figure 8. Tray 3 is a fixed size (A4 / Letter) tray with a 2100-sheet capacity. An integrated horizontal transport moves picked media across the 3TM to the vertical transport.

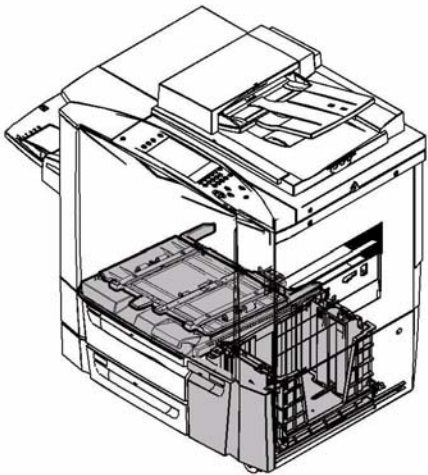

U-5-0089-A

Figure 8 Tray 3

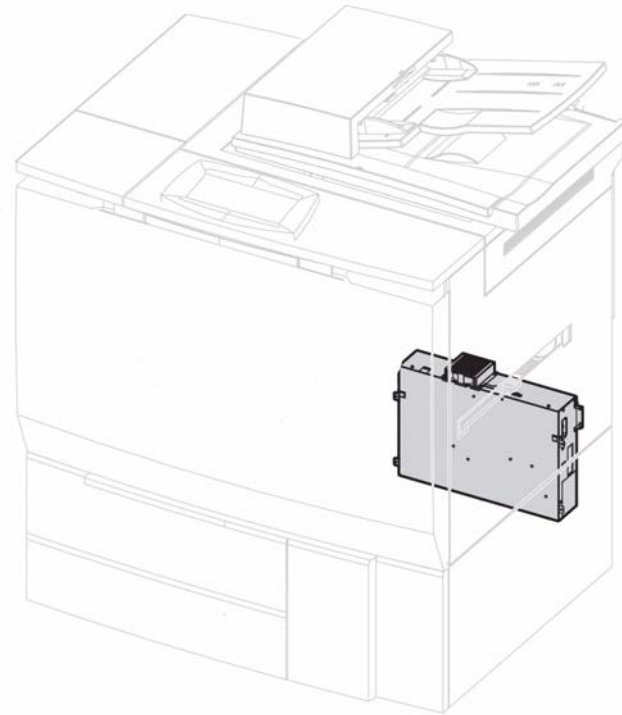

U-5-0544-A

Figure 9 Power supply location

Image Marking Engine

The IME contains several modules responsible for media transport and imaging. [Figure 10](#).

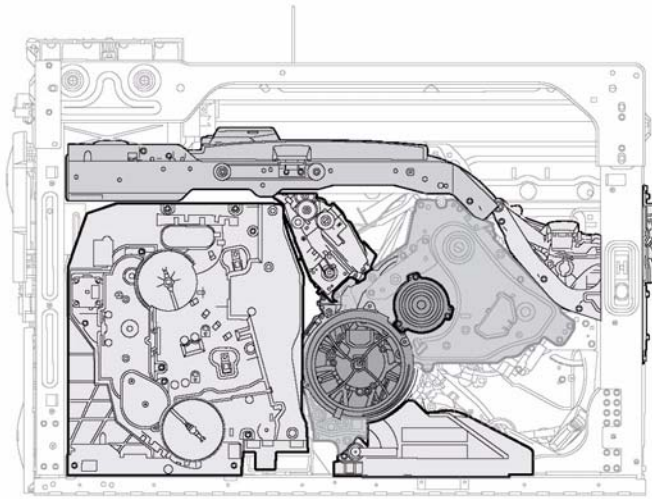

Figure 10 IME components

U-5-0527-A

Vertical Transport

The vertical transport moves media upwards along the left side of the IME to the horizontal transport. Several access points along the vertical transport are provided for jam clearance. [Figure 11](#).

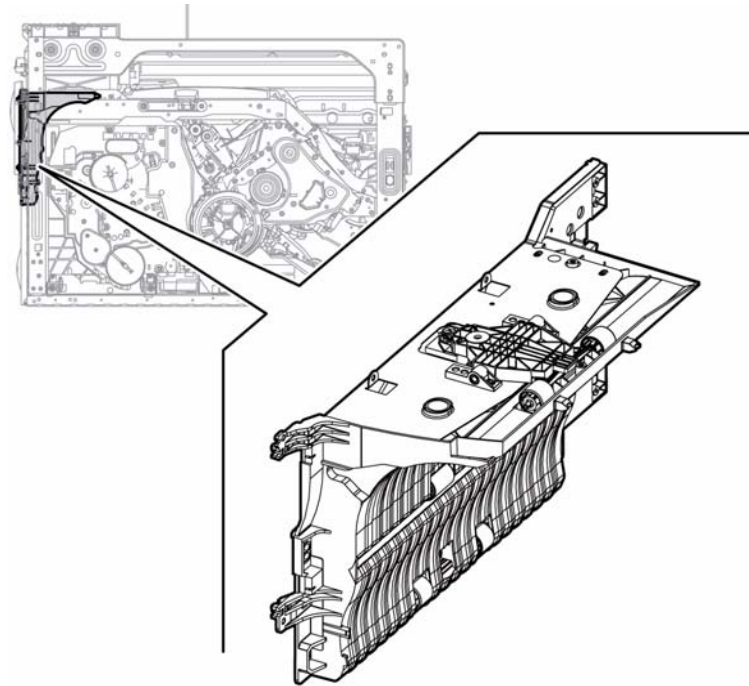
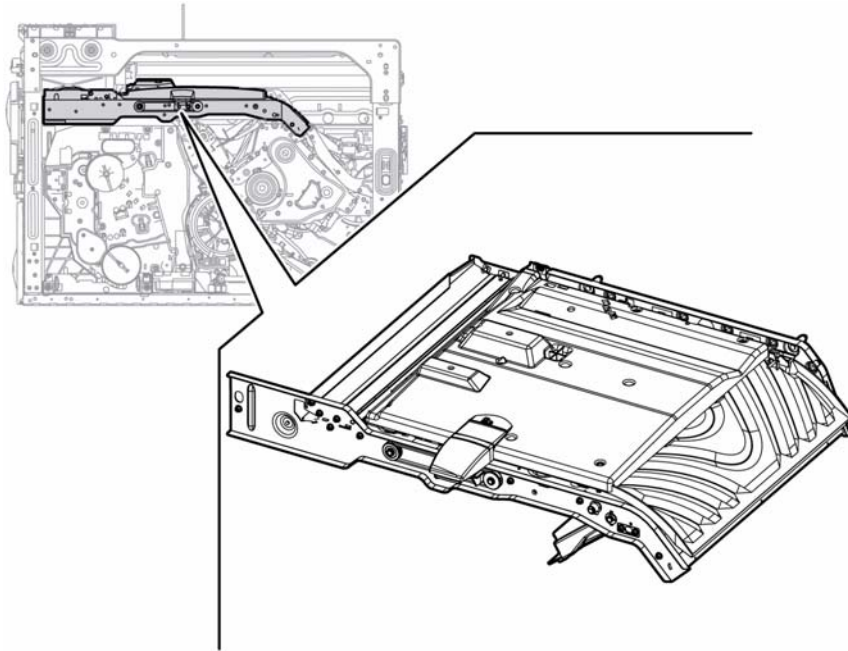

Figure 11 Vertical transport

U-5-0572-A

Horizontal Transport

The horizontal transport moves media from the vertical transport to the entrance of the registration / preheat assembly. The horizontal transport also serves as part of the duplex media path. [Figure 12](#).



U-5-0573-A

Figure 12 Horizontal transport

Registration / Preheat Assembly

The registration / preheat assembly receives media from the horizontal transport. Using multiple sets of driven rollers, the media is registered, centered in the path, and subjected to heat in preparation for image transfix. [Figure 13](#) shows the location of the registration / preheat assembly in the IME.

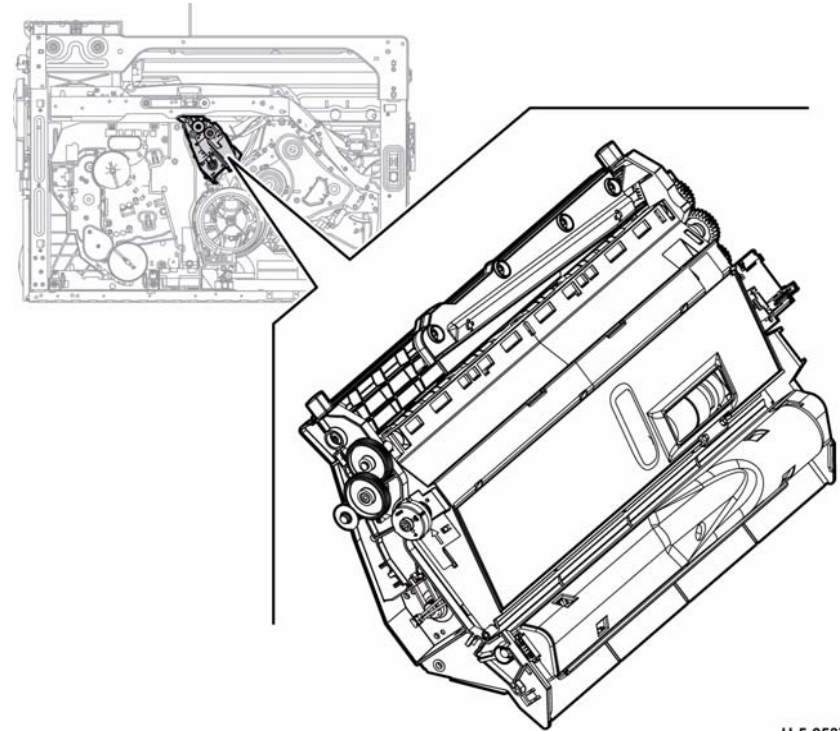

U-5-0537-A

Figure 13 Registration / Preheat assembly location

Drum Assembly

The drum and enclosed heaters form the key area of the system where imaging takes place. The drum assembly and transfix system are separate, but interrelated. This section discusses the drum assembly. The next section goes into more detail on the transfix system. [Figure 14](#).

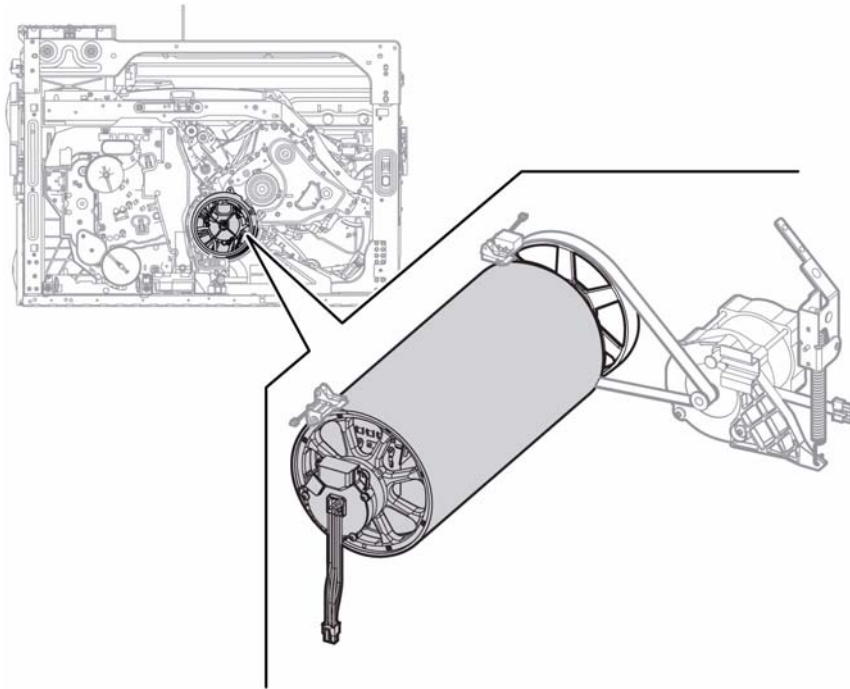

Figure 14 Drum assembly location

U-5-0571-A

Drum Heaters

The drum heater consists of two independent heating sections (front and rear). Each section contains four heating coils wrapped externally over glass rods. The drum heaters take approximately five minutes to go from room temperature to operating temperature. As the ink reservoir takes 20 minutes to reach operating temperature, drum heating is not a limiting factor in the machine start-up time.

If line voltage is below 180V, the front four coils are configured in series and then placed in parallel to the rear four coils. If voltage is greater than 180V, all eight coils are placed in series. This ensures that the current drawn by the coils remains consistent regardless of the operating voltage. The automatic re-configuration of the coils is accomplished by a relay located within the power supply and activated when detected line voltage exceeds 180V.

In the event of a single coil failure, 110 VAC machines will still have one heater section working (front and rear connected in parallel). However, 220VAC machines would lose all drum heating in the event of a single coil failure (all coils connected in series).

Drum temperature is critical for print quality and because of this, the temperature is closely monitored. Since melted ink (132 degrees C which is 270 degrees F) is hotter than the drum surface (55.5 C or 139 F) when applied, long, high area coverage print runs may raise the temperature of the drum to the point where no drum heating is required and eventually the drum cooling fan cannot maintain the correct drum operating temperature. System software should slow the machine down or inhibit printing temporarily while the drum cools to the proper temperature range. This should only happen with jobs of >150% coverage and > 350 copies.

The drum heating AC circuits are routed through the thermal cutout board that forms part of the registration / preheat assembly. The thermal cutout board sits directly above the drum and should the drum overheat, the thermal cutouts should permanently open and remove power from the drum heater circuits. Drum Heaters also are inhibited unless the drum is turning.

Drum Encoder

The drum encoder helps to track runout variations in the drum surface which can result in a distance variance between the drum and the printheads. The encoder keeps track of the home position of the encoder and the IOD reads the drum distance at six degree intervals. This information is used by the system to help set printhead 'Y' direction compensation to properly set the jet firing timing. Drum home position may also be used in fault tolerance mode if it is known there is a defect in the drum surface. The encoder signal can be used to prevent printing in the defect area whenever possible. [Figure 15](#).

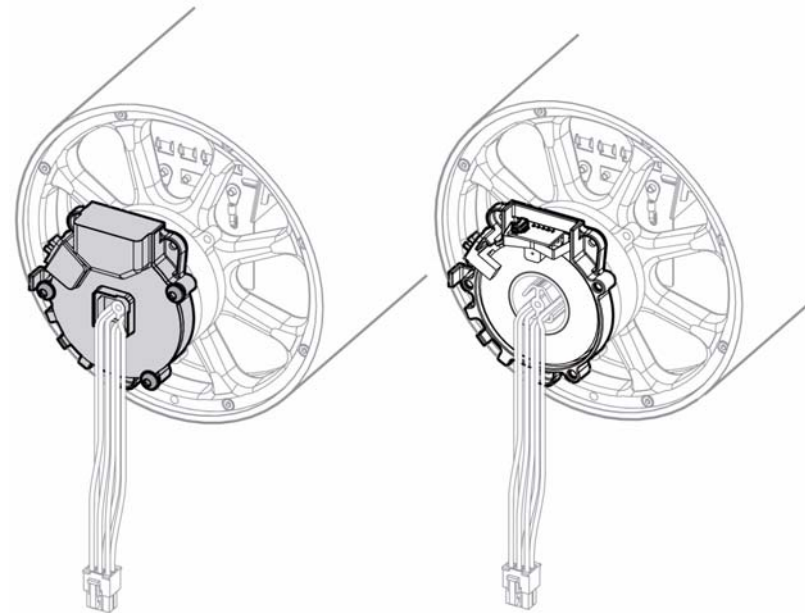

Figure 15 Drum encoder

U-5-0566-A

Cleaning Unit

The Cleaning Unit (CU) is a Customer Replaceable Unit (CRU) that cleans and applies a release agent to the drum. The customer periodically replaces the CU as directed by status messages.

The CU operates until the release agent is depleted from the internal reservoir and roller. The CU actively maintains 'life remaining' and other information in an internal memory device. This 'life' information is calculated from the initial amount of release agent in the reservoir, data from two level sensors contained within the cleaning unit, and software algorithms in the machine. One sensor is a float with a magnet and reed switch that is triggered when approximately 75% of the oil is used. The second sensor is a pressure transducer that detects when the reservoir is completely empty. The percentage of 'life remaining' and 'number of prints remaining' information is frequently sent to the Single Board Controller PWB. Since the 'life remaining' data is stored on a memory device internal to the CU, it is retained if the CU is moved from one machine to another. [Figure 16](#).

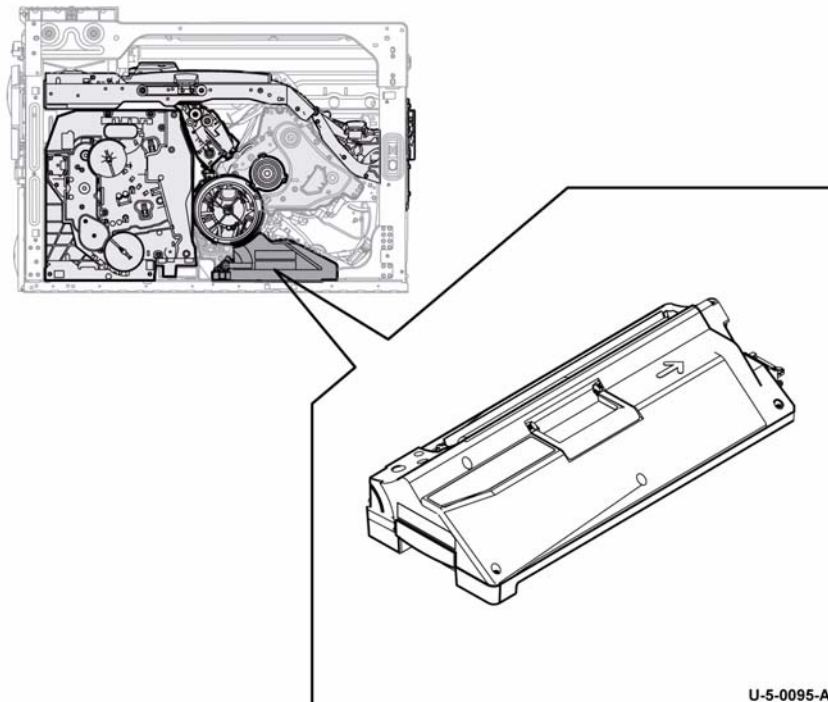

Figure 16 Cleaning unit location

Transfix Assembly

The transfix linkages apply force to the transfix roller to bond the image to the media. [Figure 17](#) illustrates the transfix linkages.

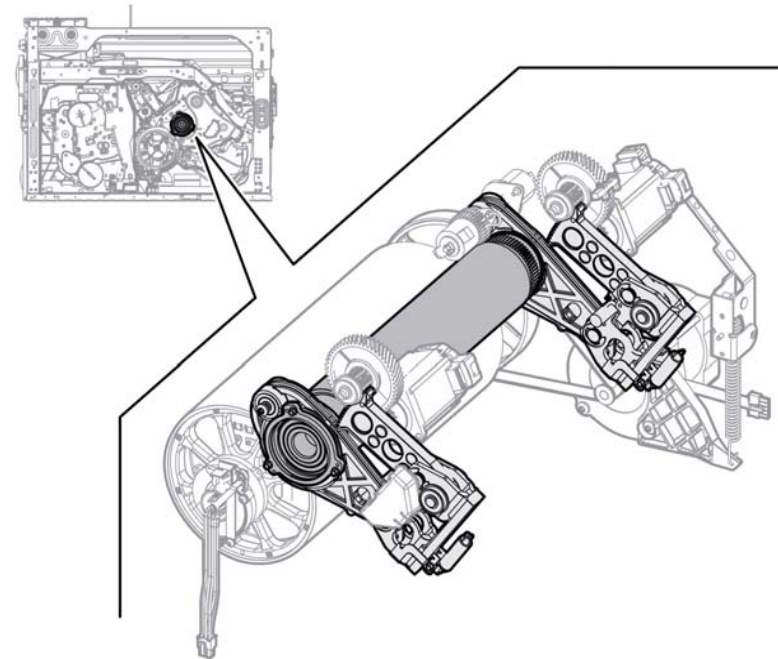

Figure 17 Transfix assembly location

Stripper Assembly

The stripper assembly is actuated and placed against the drum just prior to paper arrival. The stripper assembly is necessary to break the bond of the media with the drum surface. Once the edge is lifted the stripper blade is retracted until the next lead edge is almost to the stripper. The stripper blade is grounded via the conductive plastic in the assembly. This provides the path back to the metal paper path plate and back to the ground of the electrical connector on the stripper latch assembly. Failure of this ground may lead to ESD hits to the communications lines. [Figure 18.](#)

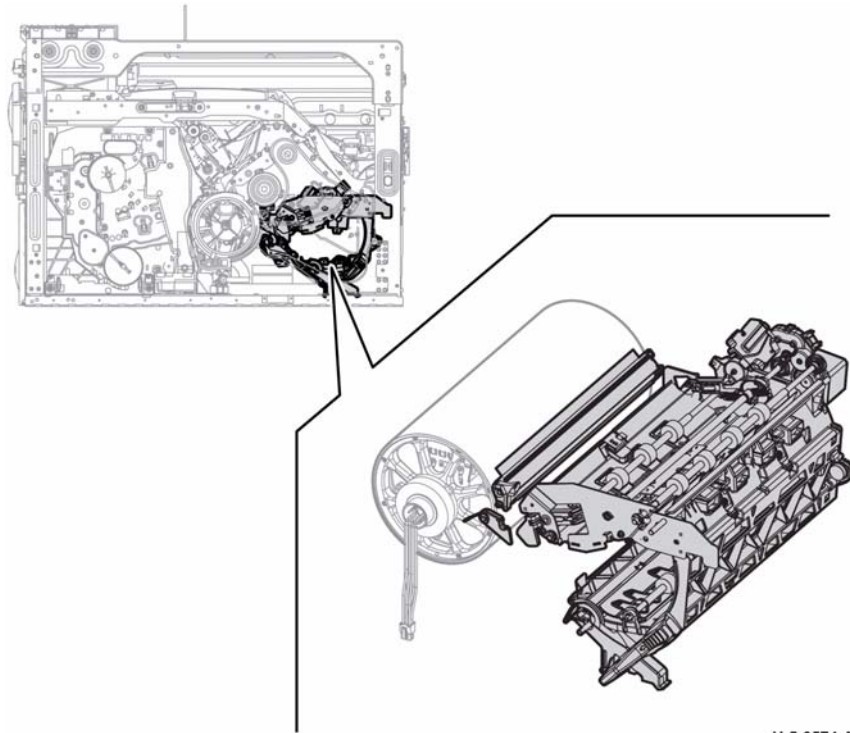

Figure 18 Stripper assembly location

U-5-0574-A

The M4 drive motor is run in reverse to lock and unlock the stripper assembly. M4 also provides drive to the 'J' and 'L' paper path nips (part of the stripper assembly). Unlatching can also be achieved via a screw at the front of the motor block. Placing the screw slot at approximately the horizontal position will unlock the stripper assembly. During normal machine operation the mechanism will automatically move to the unlocked position when a jam occurs.

The stripper cam home sensor sits behind the front stripper cam latch arm. This is an optical sensor which is blocked by a flag when in the stripper operation position. However, the stripper assembly can be unlatched and still have the arm in the home position. Since the stripper handle must be in the operational position before the front door is closed, this is not considered an issue by the PDT but means that the operator cannot be informed they have failed to close the stripper assembly.

During normal operation, the stripper assembly is locked in position. When the front door is opened while a jam is present in the stripper area, the stripper cam arm should move to the home position which allows the stripper assembly to be unlatched. There is a concern that this may confuse customers and this latch may be broken. Should the stripper fail to home and unlatch, there is a screw slot accessible through the front motor block frame (to the right and below the transfix flexure encoder) which will allow the technician to manually turn the M4 motor to home the cams.

The stripper blade is coated with Teflon to reduce the build up of ink. However, debris on the stripper blade can contribute to damage on the lead edge of the media. Additionally the contamination on the blade may come off the blade when it is brought off contact with the drum and comes up, striking the media approximately 15 mm from the leading edge. The stripper blade mechanism is ordinarily locked and does not release until the front door is opened. This is necessary due to the mass of the stripper transport and blade assembly. If it is necessary to unlock the stripper assembly with power off, a screw slot within the front drum plates that allows the drives to be turned to an unlocked position (screw slot will be approximately horizontal). The stripper blade is manufactured with a blunt point to greatly reduce the possibility of personal injury while handling the stripper blade by service personnel for the purposes of removal and installation. Care should still be taken when handling the unsaddled stripper blade assembly.

Exit Module

[Figure 19.](#)

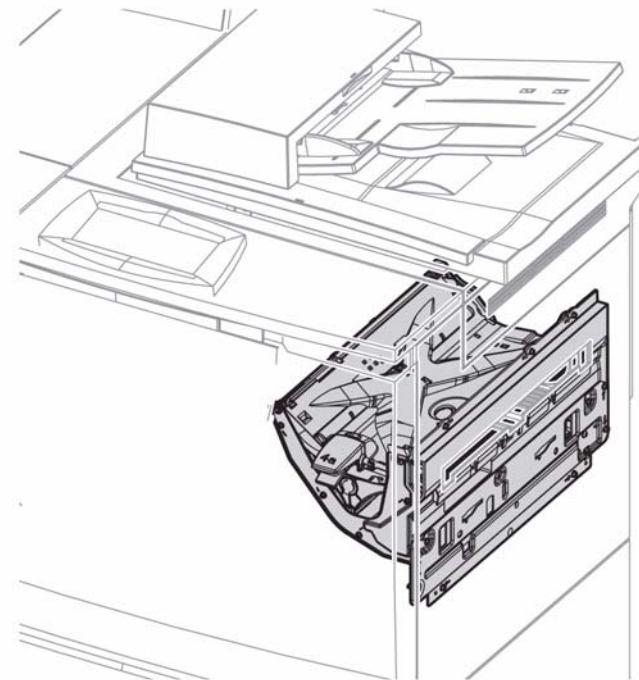

Figure 19 Exit module location

U-5-0543-A

Tray 5

The optional Tray 5, [Figure 20](#), is positioned on the left-hand side of the IME (when viewed from the front) and feeds media into the IME through a slot in Door A, below the bypass tray. The unit undocks from the IME to allow jam access through Door A.

The PFP consists of the following major elements:

- Single media tray
- Media lift drive
- Feeder
- Controller Board

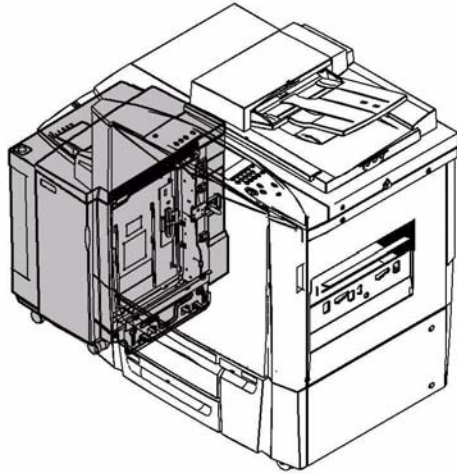

U-5-0082-A

Figure 20 Tray 5 location

Finishing Options

The following finishing options are available:

- Offset Catch Tray (OCT)
- Low Capacity Stacker / Stapler (LCSS)
- High Volume Finisher (HVF).

Offset Catch Tray (OCT)

[Figure 21](#). The Offsetting Catch Tray (OCT) is an optional output device attached to the right hand side of the IME. Output is stacked face down or face up in the tray. The user can select to have alternate sets offset from one another to provide set distinction, including single sheet sets. A fill sensor is activated when the tray reaches 90% capacity.

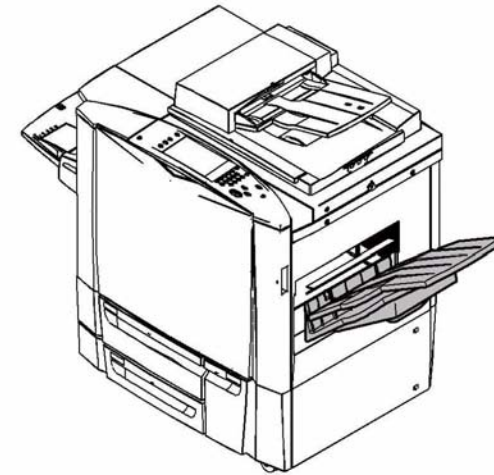

U-5-0083-A

Figure 21 OCT location

Low Capacity Stacker/Stapler (LCSS)

[Figure 22](#). The LCSS provides collating, stacking, stapling and hole punching operations on paper delivered center registered, face-up or face-down from the IME. The LCSS offers two trays: a stacker tray with a capacity of up to 2000 sheets, and a top tray with a capacity of up to 100 sheets. The user may select from up to three stapling options (single front corner, single front edge and dual) dependant on paper size and orientation. Punch operations include two, three or four-hole options in accordance with the selected mode.

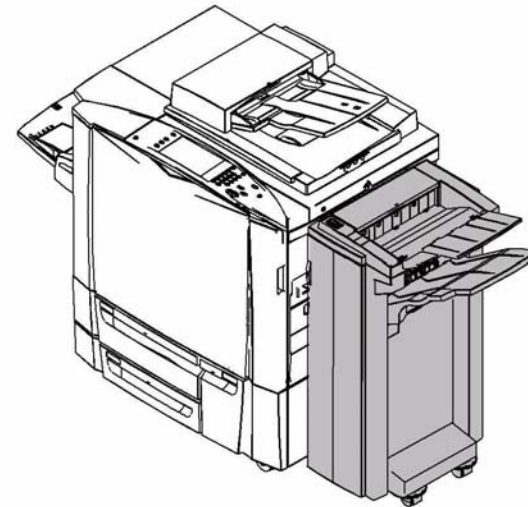

U-5-0084-A

Figure 22 LCSS location

High Volume Finisher (HVF)

Figure 23. The HVF performs collating, stacking, stapling and optional hole punching operations on paper delivered (face-up or face-down) from the IME. The HVF offers two trays: a stacker tray with a capacity of up to 3000 sheets (reduced to 2000 if Tri-Folder is installed), and a top tray with a capacity of up to 250 sheets.

The HVF has several optional components:

- **Booklet Maker** - collects and processes IME output to form booklets from A3, A4, 11 x 17, 8.5 x 14, 8.5 x 13 and 8.5 x 11 short feed stock to form A4, A5, 11 x 8.5, 8.5 x 7, 8.5 x 6.5 and 8.5 x 5.5 booklets respectively (stapled or unstapled) and stack booklets on a single tray. Staple and fold modes are user-selectable.
- **Post-Process Inserter (PPI) Tray 6** - allows a minimum of 250 sheets, such as cover stock, to be inserted into a build job, without having been passed through the IME. The PPI cannot handle tab stock.
- **Tri-Folder** - mounted to the right-hand side of the HVF Booklet Maker, provides either a straight-through path to accommodate the production of booklets, or an additional fold to create C or Z folds (the first fold being created by the Booklet Maker).

NOTE: When a Tri-Folder is fitted, the stacking capacity of the main HVF tray is reduced to 2000 sheets.

- **Hole Punch Modules (LCSS or HVF)** - These are options providing 2 or 3 hole options, 4 hole, Swedish 4 and Legal 2 hole. For the LCSS, the user may select any of the five hole punch options without restriction. For the HVF, the hole punch kits are located in a mount. Therefore the user must purchase one of the two basic hole punch kits (2 or 3 hole) as a prerequisite to permit fitting the 4, Swedish and Legal hole punch kits.

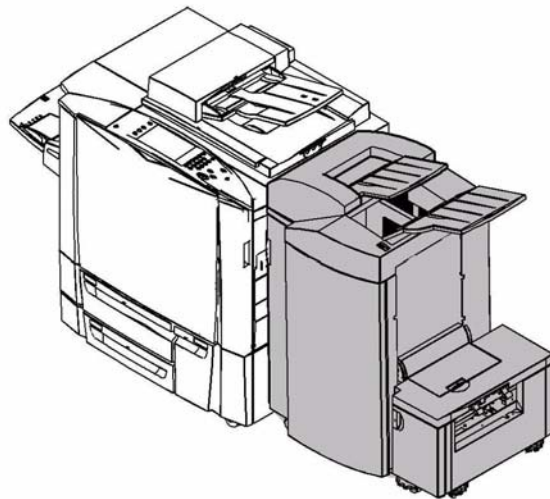

U-5-0085-A

Figure 23 HVF location

System Electronics

What follows is an overview of the primary electronic components. The discussions begin with the power supply.

Power Supply

The auto-ranging power supply provides AC and DC power for all systems electronics, motors and heaters. The power supply employs three separate switching supplies. The 3.3V ESTAR and +17V outputs are supplied whenever the power switch is closed (the green LED on the power supply indicates these outputs are available). The remaining outputs are supplied by two separate converters when requested by the printer. +24V, 12V, and +5V outputs are supplied by one converter (as indicated by the amber LED), and the 50V outputs are supplied by the other (as indicated by the red LED). No other outputs are available unless the 3.3V ESTAR and 17V outputs are on. Refer to WD 1.3 for more details.

AC Input

The Power Supply's AC input specifications are listed in [Table 1](#).

Table 1 AC Input Specifications

Line Operation Requirement	Nominal Value	Limits and Condition
120 Volt Operation	115 VAC	99 - 140 Volts AC
240 Volt Operation	230 VAC	187 - 254 Volts AC
Frequency Range	50-60 Hz	47 - 63 Hz
In-Rush Current	Less than 60 A	Full Load
Leakage Current	Less than 2.4 mA	250 Volts AC 50Hz Operation
Sustained Current at 115VAC	12 ~ 16 A	15 ~ 20 A max during warm-up
Sustained Current at 230VAC	10 A	Warm-up and high area coverage jobs

If the AC power is interrupted for any period of time, the power supply powers up based on the power switch position. If a current limit is exceeded, or an over voltage occurs, the power supply can be re-started by cycling the AC line. The power AC line is required to be a minimum of 250ms when cycled.

AC Output

Refer to [WD 1.6](#) and [WD 1.7](#) Power Distribution PWB. The power supply has eight, triac-controlled AC output channels. Each channel is controlled by the IOT on a half-line-cycle basis. The IOT enables the triacs according to the heater demand and input voltage. A half line cycle dropping algorithm is used (for example, the heater will be on for one half line cycle, followed by off for seven half line cycles) to control the average power supplied to the heater.

The IOT measures the line current and voltage to schedule heater requests. The line current measured includes the DC converter and finisher currents. The IOT limits heater requests when required so that the line current rating is not exceeded. [Table 2](#) lists heater electrical characteristics.

Table 2 Power Supply Output Ratings

Channel and Function	Heater Ohms	Average Wattage	RMS Current @ 115VAC
Ink Melt Color 1	92	109 W	1.1 A
Ink Melt Color 2	92	109 W	1.1 A
Ink Melt Color 3	92	109 W	1.1 A
Ink Melt Color 4	92	109 W	1.1 A
Pre-Heater 1	53	250 W	2.17 A
Pre-Heater 2	53	250 W	2.17 A
Drum 1	22/88	600 W	5.2 / 2.6 A
Drum 2	22/88	600 W	5.2 / 2.6 A

NOTE: Drum channels have relays to put two heaters in parallel or series depending upon AC input line voltage 115/230VAC.

AC Output Load Control

The eight heater channels are controlled by a serial data link isolated from the secondary. Each channel's output Triac has an associated relay used to disable the channel when the power switch is opened or when the Heater2_ON signal is not present. The Heater2_ON signal is a 3.3V TTL signal. The serial data link reports line voltage and current back to the IME.

Printhead Heater Control

The Common Heater Relay Enable signal controls the Printhead heaters. In the event of a thermistor short or thermal runaway, the relay disconnects the printhead heaters by disabling the power to the marking unit heater board. This relay is driven by the 3.3V TTL signal, Common Heater Relay. This relay is intended to disconnect the heaters in case of a shorted triac and thermal run-away of heaters.

Drum Heater Selection

The high-level on the Drum 115-1 signal activates the drum heaters in parallel. A high-level on the Drum 230-1 puts the drum heaters in series. These relays are controlled by a 3.3V TTL signal.

Drum Drive Motor Inverter

The 3-phase drum drive motor inverter is implemented in the AC section. This output uses the 400V DC link from the power factor connector as its power source. The inverter phase current is 3A, with a maximum phase current of 5A. The inverter is controlled by three phase signals and an enable signal that are optically coupled from the secondary. The power supply also sends a motor phase current sense signal back to the IOT. The required combination of signals is computed by the IOT according to drum drive motor position and current. Refer to [WD 1.3](#).

DC Output

The power supply's DC outputs are listed in [Table 3](#).

Table 3 DC Output Specifications

DC Voltage	Min/Nom/Max Peak Current (A)	Regulation, PARD	Min/Nom/Max Peak Power (W)
3.3V ESTAR	2/4/7	3.3±2.5%, 300mv at 2MHz	7/13/23
+ 17VDC	0.55/2.7/3.4	N/A, source from+24 V supply, 500mV at 2MHz BW	13/63/80
+5 VDC	0.25/3.9/6	5.15± 2%, 300mv at 2MHz	1/20/30
+12VDC	0.2/6/10	12 ± 5%, 300mv at 2MHz	2/72/120
-12VDC	0.1/0.5/1	-12 ± 5%, 300mv at 2MHz	1/6/12
+24VDC	0.55/7.7/13	+24.5 ± 5%, 300mv at 2MHz	13/190/320
+50VDC	0.2/3.5/6 peak for 30ms, all at 0.6hz rate	+50 ± 2%, 500mv at 2MHz	10/175/300
-50VDC	0.0/1.5/3	-50 ± 2%, 500mv at 2MHz	0/175/150

Thermal Protection

The power supply includes thermal protection that shuts down the power supply if the temperature exceeds the set point. If the set point is reached and thermal protection activated, cycle the power switch to reset the power supply.

DC Interlock

An interlock is present in the power supply to protect the Quad Wave Amp. The 50V outputs are disabled any time the +24V, 12V, and +5V outputs are disabled.

Over Voltage and Over Current Protection

During over-voltage or current limit conditions of the 3.3V ESTAR or 17V supplies, the power supply shuts off and requires a cycling of the AC power switch to restart. If an over current or over voltage occurs on +24V, 12V, or 5V, these outputs will be disabled in addition to the 50V outputs. If an over current on 50V occurs, only these outputs will be disabled. The shutdowns will be indicated by faults 01-525-00 through 01-546-00. [Table 4](#) lists the voltage and current limits.

Table 4 Over voltage and current limits

DC Voltage	Shutdown Voltage	Shutdown Current
+3.3 V	+ 4.5 V	12 A
+ 5 V	+ 6.2 V	9 A
+ 12 V	+ 16 V	16 A
-12 V	-16 V	-

Table 4 Over voltage and current limits

DC Voltage	Shutdown Voltage	Shutdown Current
+17 V	N/A, limited by 3V3/24V OVP	4 A
+24 V	+30 V	16 A
+50 V	+54 V	12 A for 1 second max, and 20 A for 200ms max
-50 V	-54 V	6 A

Control Signal Descriptions

Each power supply control signals is defined in [Table 5](#)

Table 5 Power supply information

Signal Name	Description
115V Drum Relay Enable	A 3.3V high level activates the drum heater relays for parallel operation. A low level disconnects the drum heater connections.
230V Drum Relay Enable	A 3.3V high level activates the drum heater relays for series operation. A low level disconnects the drum heater connections.
Finisher Relay Enable	A 3.3V high level activates the relay to connect the finisher output to neutral and line. A low level disconnects both neutral and line.
Common Heater Relay Enable	A 3.3V high level activates the relays to connect the marking unit (J4AC) heaters' to neutral and line. It also activates the relays controlled by the Heater2 On signal. A low level disconnects both neutral and line. This signal disconnects the power to the marking unit, in case of thermal run-away.
Heater2 On	A 3.3V TTL high level activates the relays to connect the AC Outputs (other than to J4AC) to Line. A low level deactivates these relays.
130kHz Clock	A 3.3V TTL 130kHz clock signal is input to the power supply. This signal must be low or clocked. It cannot be held high for any period of time.
Data In	A 3.3V 130kHz data signal is input to the power supply. This signal directly drives an opto coupler in the power supply, so it will not be at TTL levels. This signal carries heater request data to the power supply.
Data Out	A 3.3V TTL signal is output from the power supply. This signal is transmitted via an optically isolated data path from the power supply triac PLD. This signal contains zero cross timing, line current, and line voltage information.
Drum Motor Inverter Enable	A 3.3V TTL high level signal is input to enable the drum motor inverter. A low level disables the inverter by opening all inverter transistors. This signal is optically isolated from the drum motor inverter.
Inverter Phase U Control	A 3.3V TTL signal is input to control the inverter phase U half-bridge. This signal is optically isolated.

Table 5 Power supply information

Signal Name	Description
Inverter Phase V Control	As phase U, but controls the phase V half-bridge of the drum motor inverter.
Inverter Phase W Control	As phase U, but controls the phase W half-bridge of the drum motor inverter.
Drum Motor CS+	A differential current is output between this signal and drum Motor CS-. This current is proportional to drum motor phase at a ratio of 1:100.
Drum Motor CS-	As CS+
24V Active	A 3.3V TTL-compatible high-level signal is output to indicate that the +24V, 12V, and 5V outputs are active. A low-level signal indicates these outputs are disabled (due to 24V Enable in low state, over voltage or over current on the +24V, 12V, or +5V outputs).
50V Active	A 3.3V TTL-compatible high-level signal is output to indicate the 50V outputs are active. A low-level signal indicates these outputs are disabled (due to 50V Enable in low state, 24V Enable in low state, over voltage or over current on the 50V, +24V, 12V, or +5V outputs).
Power Fail	A 3.3V TTL-compatible low-level signal is output from the power supply to indicate that a limited amount of time remains before loss of 3.3V ESTAR and 17V regulation, based on the DC link voltage. An open state indicates that supply operation should continue indefinitely.
24V Enable	A 3.3V TTL low-level signal low-level signal disables 50V, +24V, 12V, and +5V outputs. A high level enables the +24V, 12V, and +5V outputs.
50V Enable	A 3.3V TTL low-level signal disables 50V outputs. A high level enables these outputs.
Analog Power Gauge 50	This analog output indicates the 50V output power at approximately 400 watts/volt, 5%, with a source impedance of 20 k ohms. The power supply outputs at least 2.2V when output is within 5% of shutdown (this signals the printer to reduce power consumption to prevent shutdown).
Analog Power Gauge 24	This analog output indicates the +24V, 12V, and 5V output power at approximately 400 watts/volt, 5%, with a source impedance of 20 K ohms. The power supply outputs at least 2.2V when the power output is within 5% of shutdown (this signals the printer to reduce power consumption to prevent shutdown).
3V3 Remote Volt Sense	This analog input is connected to the IME Controller Board to remotely sense 3.3V ESTAR voltage. The power supply operates with an open sense line.
3V3 Remote Ground Sense	This analog input is connected to the IME Controller Board to remotely sense ground. The power supply operates with an open sense line.

Table 5 Power supply information

Signal Name	Description
Fan Enable	A 3.3V high-level signal enables the power supply fan. A low level signal disables the fan.

Circuit Board Descriptions

Refer to Section 7 of the service manual for wiring diagrams for the boards listed below.

IME Controller Board

The IME controller generates and sends control information to the printhead driver, drum driver, media path driver, marking unit driver boards, and the wave amplifiers. It also receives and processes image data and control signals sent from the system controller board specific connector information including specific signal names, quantities, supply voltages being sent across the interfaces, and pinouts are contained in Section 7.

Single Board Controller

The single board controller consists of two sections:

- Copy and process controller
- Network controller.

The copy and process control circuitry comprises a dedicated processor, complete with hard disk drive, whose main function is to provide overall control, (inter-device communications), and to handle the flow of data to and from the following modules and devices:

- Scanner
- DADH
- Control panel
- IME
- Foreign device interface
- Power supply and distribution

This is the equivalent of a combination of the main controller PWB and the SIP, (Scanned Image Processor), in previous machines.

The network controller provides control of the communications data entering and leaving the machine via the following:

- Ethernet 10/100/1000 port, using a standard, RJ-45 connection,
- USB 2.0 ports, using standard, 4-pin connections,
- Serial port, using a standard, DB-9 connection.

Media Path Driver Board

The Media Path Driver board (MPD) contains circuitry that performs the following functions:

- Drives various motors and contains associated circuitry,
- Drives various solenoids and contains associated circuitry,
- Reads various sensors, thermistors etc.
- Communications link interface for IMD, PFP, OCT, LCSS, HVF, 3TM, and SBC.

Marking Unit Heater Board

The marking unit heater board controls the four AC printhead heaters, AC heaters for the ink reservoir, and the ink umbilical heaters.

Ink Entry Board

Located on the ink loader, the ink entry board connects the Ink Loader and its functions to the IME Controller Board through the media path driver board.

The ink entry board receives analog input from the ink thermistors and the ink entry, ink stick low, and ink SKU sensors. This board also drives the ink SKU motor, ink drive motor, and processes input from the ink drive motor encoder. The thermistor data is input to four A/D converters. Sensor data from the ink stick level sensors, ink drive motor encoder, and the digitized thermistor data is transmitted from the ink entry board to the media path driver board through a serial interface. Ink drive motor control data is received from the media path driver board.

Drum Driver Board

The drum driver board is located behind the marking engine on the right, inboard side of the IME. The circuit board's primary function is to provide the interface for the drum drive motor, power supply, drive the transfix motors, digitize video from the IOD and registration / preheater scan bars. Other functions include driving the stripper solenoid, fans, cleaning unit, and monitoring several sensors.

Thermal Cutout Board

Fuses on the thermal cutout board protect the drum from overheating.

Figure 1, illustrates the location of the thermal cutout board mounted on the registration / pre-heat assembly.

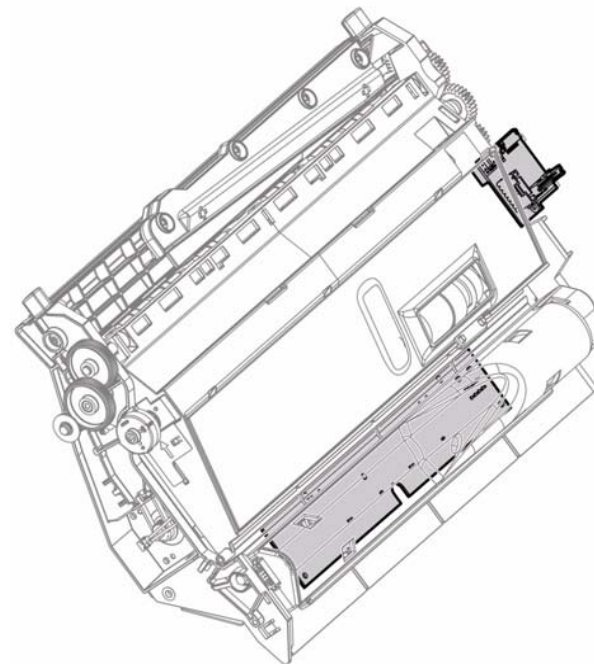

Figure 1 Thermal cutout board

U-5-0502-A

Solenoid Patch PWB

The solenoid patch PWB is located on the ink reservoir assembly and connects the ink reservoir solenoid valves, purge solenoid valve, reservoir pump and ink reservoir level sensors and their functions to the marking unit driver PWB.

Motors

Registration / Preheat Assembly

The registration / preheat assembly contains two stepper motors that drive the rollers to transport and align the media in the path:

- Registration motor A1 (M3), MOT89-007. Refer to [WD 8.1 Media Path Driver PWB](#),
- Registration motor A2 (M3), MOT89-008. Refer to [WD 8.1 Media Path Driver PWB](#).

[Figure 2](#) shows the location of the registration motors.

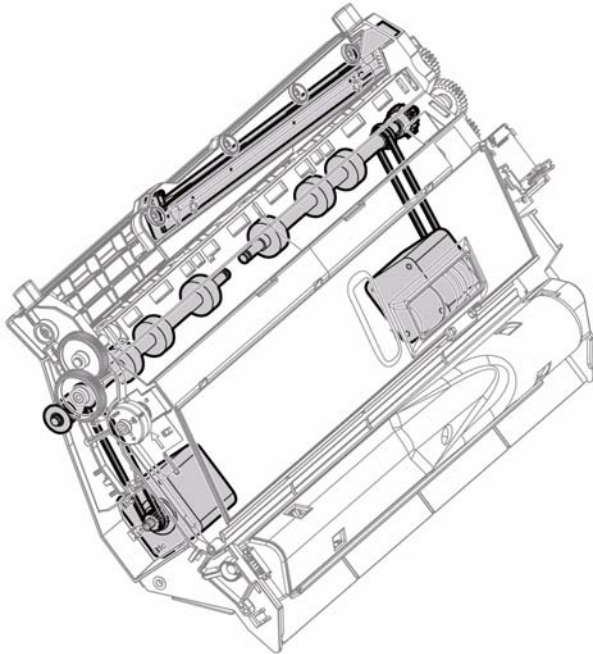

U-5-0501-A

Figure 2 Registration motors

Two Air Pumps generate pressure to keep the media from contacting the heater plates:

- Reg/preheat air pump, MOT88-008. Refer to [WD 8.6 Reg/Preheat IF PWB](#).

Vertical Transport Motor

The vertical transport uses a series of rollers, a belt, and a single motor to move media from the 3TM and PFP to the horizontal transport:

- Vertical transport motor (M2) and encoder, MOT82-001. Refer to [WD 8.1 Media Path Driver PWB](#).

Horizontal Transport Motor

The horizontal transport uses a series of rollers, a belt, and a single motor to move media from the vertical transport to the registration / preheat Assembly:

- Horizontal transport motor (M6), MOT82-003. Refer to [WD 8.5 Media Path Driver PWB](#).

Post Transfix Transport Motor

The post transfix transport assembly uses a series of gears and a single motor to deliver the printed sheet from the drum to the output transport:

- Post transfix transport Motor (M4), MOT10-018. Refer to [WD 8.2 Media Path Driver PWB](#).

Exit Motor

The exit module uses a single motor, multiple rollers pairs, and a gate to move media to either the IME exit or back into the Horizontal Transport for duplex prints:

- Exit motor (M5), MOT83-001. Refer to [WD 8.2 Media Path Driver PWB](#).

Bypass Feed Motor

The bypass tray uses a single motor and multiple rollers, to move media to the vertical transport:

- Bypass feed motor (M7), MOT74-420. Refer to [WD 8.3 Media Path Driver PWB](#).

Carriage Motors

The marking unit uses multiple carriage motors to move the printheads along the X-Axis:

- X Axis drive motor upper, MOT91-033. Refer to [WD 9.9 Marking Unit Driver PWB](#).
- X Axis drive motor lower, MOT91-034. Refer to [WD 9.11 Marking Unit Driver PWB](#).

Drum Drive Motor

The drum drive motor rotates the drum using a belt and pulley system. The drum drive motor receives power directly from the power supply at PJ6AC:

- Drum motor, MOT94-009. Refer to [WD 1.1 Power Supply Unit](#).

Cleaning Unit Motor

The cleaning unit motor drives the cleaning unit using a series of gears.

- Cleaning unit motor assembly, [PL 94.10 Item 19](#).

IOD Shuttle Motor

The IOD shuttle motor drives the IOD sensor in the cross-process direction to scan the drum:

- IOD shuttle motor, MOT91-043. Refer to [WD 9.22 IOD Pre Amp PWB](#).

Front and Rear Transfix Motors

The transfix motors drive the transfix flexure linkage through a system of gears:

- Front transfix motor, MOT10-019. Refer to [WD 9.1 Drum Driver PWB](#)
- Rear transfix motor, MOT10-020. Refer to [WD 9.1 Drum Driver PWB](#)

Ink Transport Motor

The ink transport motor drives a series of belts to transport ink sticks through the ink loader to the ink melt heaters:

- Ink transport motor, MOT93-048. Refer to [WD 8.4 Media Path Driver PWB](#).

Ink Key Plate Motor

The ink key plate motor positions the key plate to allow insertion of the correct ink stick type (SKU) based on product information stored in NVRAM.

- Ink key plate motor, MOT93-051. Refer to [WD 8.4 Media Path Driver PWB](#).

Solenoids

Solenoids activate gates and engage rollers. Refer to [GP 29 Component Locations](#).

C Nip Release Solenoid

The electrical characteristics of the c nip release solenoid are listed in [Table 6](#).

Table 6 C Nip Release Solenoid

Parameter	Min	Typical	Maximum
Terminal Voltage			48 V
Continuous Current		260 mA	1 A
Transient Current			2 A

D Nip Release Solenoid

The electrical characteristics of the d release solenoid are listed in [Table 7](#).

Table 7 D Nip Release Solenoid

Parameter	Min	Typical	Maximum
Terminal Voltage			48 V
Continuous Current		260 mA	1 A
Transient Current			2 A

HPP Diverter Solenoid

The electrical characteristics of the hpp diverter solenoid are listed in [Table 8](#).

Table 8 HPP diverter Solenoid

Parameter	Min	Typical	Maximum
Terminal Voltage			48 V
Continuous Current		260 mA	1 A
Transient Current			2 A

Car Diverter Solenoid

The electrical characteristics of the car diverter solenoid are listed in [Table 9](#).

Table 9 Car Diverter Solenoid

Parameter	Min	Typical	Maximum
Terminal Voltage			48 V
Continuous Current		1 A	2 A
Transient Current			3 A

Duplex Solenoid

The electrical characteristics of the duplex solenoid are listed in [Table 10](#).

Table 10 Duplex Solenoid

Parameter	Min	Typical	Maximum
Terminal Voltage			48 V
Continuous Current		1.2 A	2 A
Transient Current			3 A

Bypass Tray Nudge Solenoid

The electrical characteristics of the bypass tray nudge solenoid are listed in [Table 11](#).

Table 11 Bypass Tray Nudge Solenoid

Parameter	Min	Typical	Maximum
Terminal Voltage			24 V
Continuous Current			.7 A
Transient Current			1.4 A

Thermal Lock Solenoid

The electrical characteristics of the thermal lock solenoid are listed in [Table 12](#).

Table 12 Thermal Lock Solenoid

Parameter	Min	Typical	Maximum
Terminal Voltage			24 V
Continuous Current			.75 A
Transient Current			1.5 A

Fans

Several Fans are used to cool system components and evacuate particulates.

- Drum Fan
- Abatement Fan
- Top Enclosure Fans
- Bottom Enclosure Fan
- Marking Unit Fan
- Power Supply Fan [Figure 3](#).

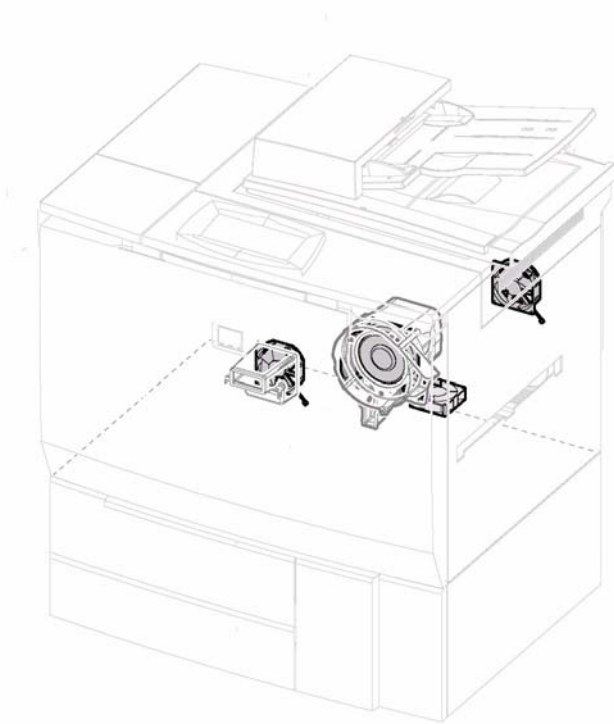

Figure 3 IME Fan Locations

U-5-0507-A

Airflow through the chassis is indicated in [Figure 4](#).

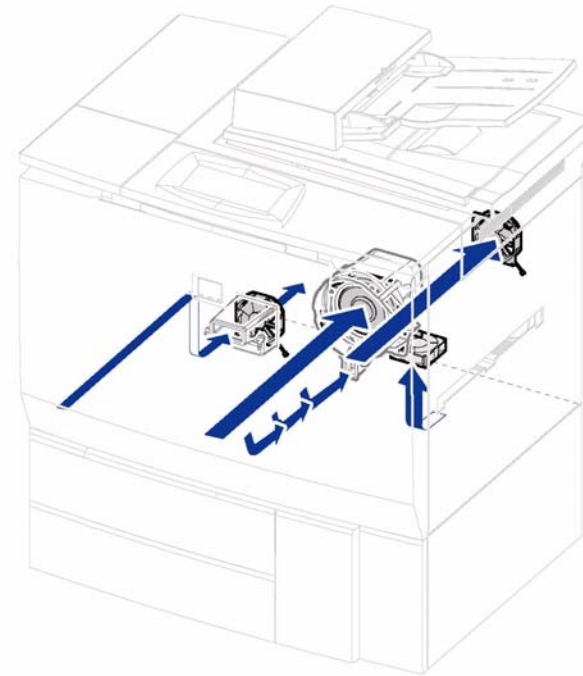

Figure 4 Chassis airflow

U-5-0508-A

System Communications

Communications

This section describes the system-wide Low-voltage differential signaling (LVDS) serial communications links.

LVDS Serial Data / Control

The serial I/O bus provides communication between the IME controller board, drum driver board, marking unit driver board, media path driver board, individual printhead driver boards, and system controller boards. Each of these interfaces implements one dedicated serial path. The serial bus is comprised of differential clock, differential receive, and differential transmit pairs. These are generically called clk/clk*, rx/rx*, and tx/tx*. It should be noted that each interface signal group may differ slightly; for instance, the system controller has only a transmit path to the IME Controller.

The system controller communicates control information to each of the above interfaces over the serial bus, and also accepts return data. This information is organized in data frames. Each frame contains 64 time slots, one serial clock in duration each and beginning with frame signal encoded throughout the frame set. The LVDS switching levels are centered around +1.25V, with each side of the differential pair switching between +1.1V and +1.4V.

In the LVDS scheme, the logic state of the transmitted bit is represented by the difference between Vout+ and Vout-, with a 1 represented by a positive difference (greater than +100mV) of the two, and a 0 represented by a negative difference (greater than -100mV) of the two. This scheme has the advantage of common-mode noise rejection, since such noise will be filtered out by the signal differential.

Image Data

The objective of this interface is to provide a high bandwidth path to transfer images to the IME in the format and at the time required. Image data is sent by a four channel LVDS interface. Three of the channels transfer 6 bits per clock cycle. The fourth channel is a 33.3 MHz clock. The start of serial frame is indicated by the rising edge of the clock. The receiver must create a 6x clock (200MHz) from the LVDS clock to clock in the six data bits on each channel. They are then combined to form an 18 bit serial frame.

Since the image data is post processed on the IME controller board, it does not need to be transmitted in sync with marking unit activity. Rather, an entire image is transmitted at approximately four times the average data bandwidth to minimize the transfer latency to improve FCOT/FPOT. The entire interface is unidirectional (output from SBC, input to IME). Any status and setup information is communicated over the command interface.

High Speed Communications

The communications link between the IME controller board and the media path driver (MPD) board is a standard ColorQube fast link. Originally for LP1 this link was based on a 66.3 MHz clock. Data frames of 1s were sent between the IME controller and the MPD. Each data frame contained 64 slots of data. These data frames contained drive signals, sensor signals etc. to and from the MPD.

Low Speed Communications

For satellite boards of the MPD, and various peripherals, a slower link of 1.036 MHz is used. Devices on the slow link decode their data on the positive edge of the 1.036MHz clock. Data is transferred to the media path driver on the positive edge of the 1.036MHz clock. The actual decoding of data received occurs on IME controller board.

Power On Self Test (POST)

The ColorQube Power On Self Test (POST) checks the following:

- Communication between the main IME PWBs including:
 - Single board controller PWB, [PL 3.11 Item 13](#).
 - IME controller PWB, [PL 92.10 Item 1](#)
 - Media path driver PWB, [PL 1.15 Item 5](#)
 - Marking unit driver PWB, [PL 92.10 Item 4](#)
- The system memory and NVRAM.
- Compatible software and firmware versions are installed.
- Power supply to the main IME components.

The POST runs automatically as part of the machine power-on sequence and is performed before higher level machine functions, such as the user interface (UI), are operational. The POST can therefore be used to diagnose faults on a machine with an unresponsive UI which prevents access to the fault lists and service messages.

The POST results are displayed using the LED's on the front of the IME controller PWB, the media path driver PWB and the single board controller PWB. Refer to [OF 16 POST Error RAP](#) for details of the LED locations.

LEDs on the IME controller PWB:

- ENG OK (green, DS302) - Displays IME firmware status.
- ENG error (red, DS301) - Displays IME firmware error blink codes, the first digit is 3 or 4.
- Cable error (red, DS604) - Displays status of major cables in the IME and of the -12V needed for the printhead PWBs.
- CPU error (red, DS605) - Displays IME operating system status and error blink codes, the first digit is 2.

LED's on the media path driver PWB:

- IME OK (green, DS801) - Displays IME firmware status.
- IME error (red, DS802) - Displays IME firmware error blink codes.

If a loss of communication to the media path driver PWB occurs, only the IME controller PWB LEDs displays POST results.

The 7-segment LED display unit on the rear of the machine attached to the single board controller PWB. The LED display should show just a pulsing decimal point when the machine boots correctly. The main codes are displayed for short periods of time during power up depending on how long each test takes. If any code is left displayed during power up and the machine appears not to have powered on correctly then this should point to the problem component.

Refer to [OF 16 POST Error RAP](#) for information on interpreting the POST error codes.

Print Engine Self Test (PEST)

The ColorQube Print Engine Self Test (PEST), which runs automatically as part of the image marking engine (IME) boot-up sequence, detects basic electrical wiring or electro-mechanical faults in the IME. The PEST raises error codes to identify the IME component where the fault has occurred.

The PEST activates each of the primary components in the IME and monitors the power consumed during the test along with any associated sensor or feedback signals. The test induces only limited component motion, does not feed any media through the IME and cannot test sensors activated by media or door and cover interlocks. Media sensor and door interlock errors or more advanced calibrations and mechanical defects are detected by the IME's run-time firmware. An advantage of the PEST over run-time error detection is the PEST's ability to test individual components in isolation, allowing more accurate pin-pointing of the fault location. PEST can also detect partially damaged components that might pass run-time component control tests.

Both 'hard' and 'soft' faults can be detected by the PEST:

- Hard errors indicate that a fault has occurred in a component critical to marking functionality and/or damage could occur to the machine if it continues to operate with the fault present. Hard errors prevent the IME from booting and are viewable via the user interface (UI) fault list or by entering **dC123** PEST Fault History.
- Soft errors indicate that a fault has occurred in a non-critical component of the IME or that the component may still retain some level of functionality. Soft errors do not prevent the machine from booting, allowing the machine to continue being used at a reduced level of functionality instead of keeping the IME shutdown until attended by the CSE. Soft PEST fault codes are only viewable by entering **dC123** PEST Fault History.

Sensor Types and Function

The system contains sensors of various types that perform a variety of functions. One group of sensors track the progress of the media along the media path, and detects if a jam occurs. Other sensors detect the presence of the Ink Sticks, stop system activity if a door is open (interlock), detect the presence and size of media, and monitor system temperatures.

Sensor Types

The types of sensors used vary with function. In general, there are several types in use:

- Photo Sensors
- Microswitches
- Hall Effect Sensors
- Temperature Sensors
- Scan Bars

Two types of photo sensors are used, photo-reflective and photo-receptive. Photo-reflective sensors use light reflected back from an object to detect its presence. Photo-receptive sensors use an actuator or the object itself to block the light path to detect an object or condition. Photo-reflective sensors have the light emitter and light receiver aligned on a single surface. Output of the photo-receptor is High when light is being reflected back and Low when it isn't. Photo-receptive sensors consist of a LED in one arm of a U-shaped holder, and a photo-transistor in the other arm. When the sensing area is vacant, nothing is between the arms of the sensor, light falls on the photo-receptor sending a high signal. If the light is interrupted, the photo-transistor goes low.

Microswitches are used primarily as paper size sensors and cover interlocks. They are in a normally open state, and close when actuated. A bank of microswitches is used to detect paper size in the universal trays. Microswitches also employ hooks or catches for retention in the bracket or frame.

Hall effect sensors are used to detect the presence of the waste tray, the status of the ink loader door and to detect the drum motor position.

Temperature sensors (thermistors) have a known value of resistance whose value varies with temperature. Used primarily in the preheater, drum, ink melt heaters, ink reservoir, and print-heads for temperature sensing.

The IOD sensor and registration / preheat assembly scan bar outputs are digitized with a high speed ADC. The ADC is implemented with a 10-bit CCD image digitizer. The IOD scan bar connects to the drum driver circuit board with a 28-pin connector. The registration / preheat assembly scan bar connects to the drum driver circuit board with an 11-pin connector.

IME Sensors

Refer to [Table 1](#).

Table 1 IME Sensor Functions

Sensor	Function	Type	Output
IOD Scanbar	Scan images on the Drum	Optical	Analog
Registration Scan Bar (#10)	Detect media edge	Optical	Analog

Table 1 IME Sensor Functions

Sensor	Function	Type	Output
Drum Position Encoder	Provide Drum position	Hall	Analog
Rear Drum Thermistor	Provide temperature data	Thermistor	Analog
Front Drum Thermistor	Provide temperature data	Thermistor	Analog
Drum Motor Hall Encoder	Provide differential phase information	Magnetic	Analog
Drum Motor Temperature	Provide temperature data	Thermistor	Analog
Drum Home	Provide Drum position	Optical	Digital
Cleaning Unit Motor Encoder	Cleaning unit motor position	Optical	Digital
Cleaning Unit Home Sensor	Cleaning unit position	Optical	Digital
Front Transfix Motor Encoder	Front Transfix Motor shaft position	Optical	Digital
Rear Transfix Motor Encoder	Rear Transfix Motor shaft position	Optical	Digital
Front Transfix Flexure Encoder	Front Transfix Linkage motion	Optical	Analog
Rear Transfix Flexure Encoder	Rear Transfix Linkage motion	Optical	Analog
Post Transfix Sensor (#11)	Media exiting transfix and stripper blade	Optical	Digital
Pre-exit Sensor (#12)	Media at Stripper Gate	Optical	Digital
Stripper Latch Sensor	Stripper latch position	Optical	Digital
Bypass Width Sensor	Bypass media width detection	Resistive	Analog
Bypass empty sensor	Bypass tray empty	Optical	Digital
Bypass Feed Sensor (#7)	Media fed from bypass tray to vertical transport	Optical	Digital
Tray 5 feed sensor (#6)	Media fed from Tray 5 to vertical transport	Optical	Digital
Tray 5 Empty	No media in Tray 5	Optical	Digital
Tray 5 Docking	Tray 5 docking status	Optical	Digital
Tray 5 Stack-up	Tray at upper limit, feed position	Optical	Digital
Tray 5 Stack-down	Tray at lower limit of travel	Optical	Digital
Tray 5 Door Switch	Status of Tray 5 door	Optical	Digital
TAR 1 Sensor	Media past Tray 1 take away rollers	Optical	Digital
TAR 2 Sensor	Media past Tray 2 take away rollers	Optical	Digital
T1 Feed Sensor	Media fed from Tray 1 of 3TM	Optical	Digital
T2 Feed Sensor	Media fed from Tray 2 of 3TM	Optical	Digital
T3 Feed Sensor (#1)	Media fed from Tray 3 of 3TM	Optical	Digital
TAR 3 sensor	Media in 3TM in horizontal path	Optical	Digital
Tray 3 Transport Sensor (#2)	Media stuck in 3TM horizontal path	Optical	Digital
3TM Horizontal Home	Position of the 3TM horizontal path	Optical	Digital
T1 Stack Height Sensor	Media Stack Height in Tray 1	Optical	Digital
T2 Stack Height Sensor	Media Stack Height in Tray 2	Optical	Digital

Table 1 IME Sensor Functions

Sensor	Function	Type	Output
T3 Stack Height Sensor	Media Stack Height in Tray 3	Optical	Digital
Tray 1 Empty Sensor	No Media in Tray 1	Optical	Digital
Tray 2 Empty Sensor	No Media in Tray 2	Optical	Digital
Tray 3 Empty Sensor	No Media in Tray 3	Optical	Digital
Tray 1 Media Size Switch	Tray 1 Media size (5 switches) Open/Close	Mechanical	Digital
Tray 2 Media Size Switch	Tray 2 Media size (5 switches) Open/Close	Mechanical	Digital
Tray 3 Home Sensor	Tray 3 Open/Close	Optical	Digital
Vertical Transport Sensor (#5)	Media stuck in Vertical Transport	Optical	Digital
Confirm Sensor (#16)	Media at top of Vertical Transport	Optical	Digital
Duplex End Sensor (#14)	Media edge at start of Horizontal Transport	Optical	Digital
Duplex Sensor (#17)	Media edge at Upper Duplex Gate	Optical	Digital
Duplex Start Sensor (#13)	Media past Lower Duplex Gate	Optical	Digital
Pre-transfix Sensor (#20)	Media exiting Registration / Preheat Assy	Optical	Digital
Exit Sensor (#15)	Media past Exit Module	Optical	Digital
Front Door Interlock	Front Door status	Mechanical	Analog
Upper door interlock	Upper door status	Mechanical	Analog
Mid door interlock	Mid door status	Mechanical	Analog
Lower door interlock	Lower door status	Mechanical	Analog
Inkload Door Switch	Inkload Door status	Magnetic	Digital
Waste Tray Sensor	Waste Tray / MU Drawer position	Mechanical	Digital
Preheater	Registration / Preheat temperature data	Thermistor	Analog
Ink Load Low Sensor	Ink Stick level in Ink Loader (1 board)	Optical	Digital
Ink Load Sensor	Ink Stick level full in Ink Loader	Optical	Digital
Ink key plate Position	Ink Stick Type (3 sensors)	Optical	Digital
Ink Melt Temperature	Provide ink melt heat temperature data	Thermistor	Analog
Upper Carriage Home Sensor	Provide Upper Carriage position	Optical	Digital
Lower Carriage Home Sensor	Provide Lower Carriage position	Optical	Digital
Head Maintenance Home	Provide head maintenance Wiper position	Optical	Digital
Ink Reservoir Thermistor	Provide Ink Reservoir temperature data	Thermistor	Analog
Cleaning unit Home Sensor	Provide cleaning unit Camshaft position	Optical	Digital

Sensors in the Media Path

The movement of media through the media path is monitored by a number of sensors. [Figure 1.](#)

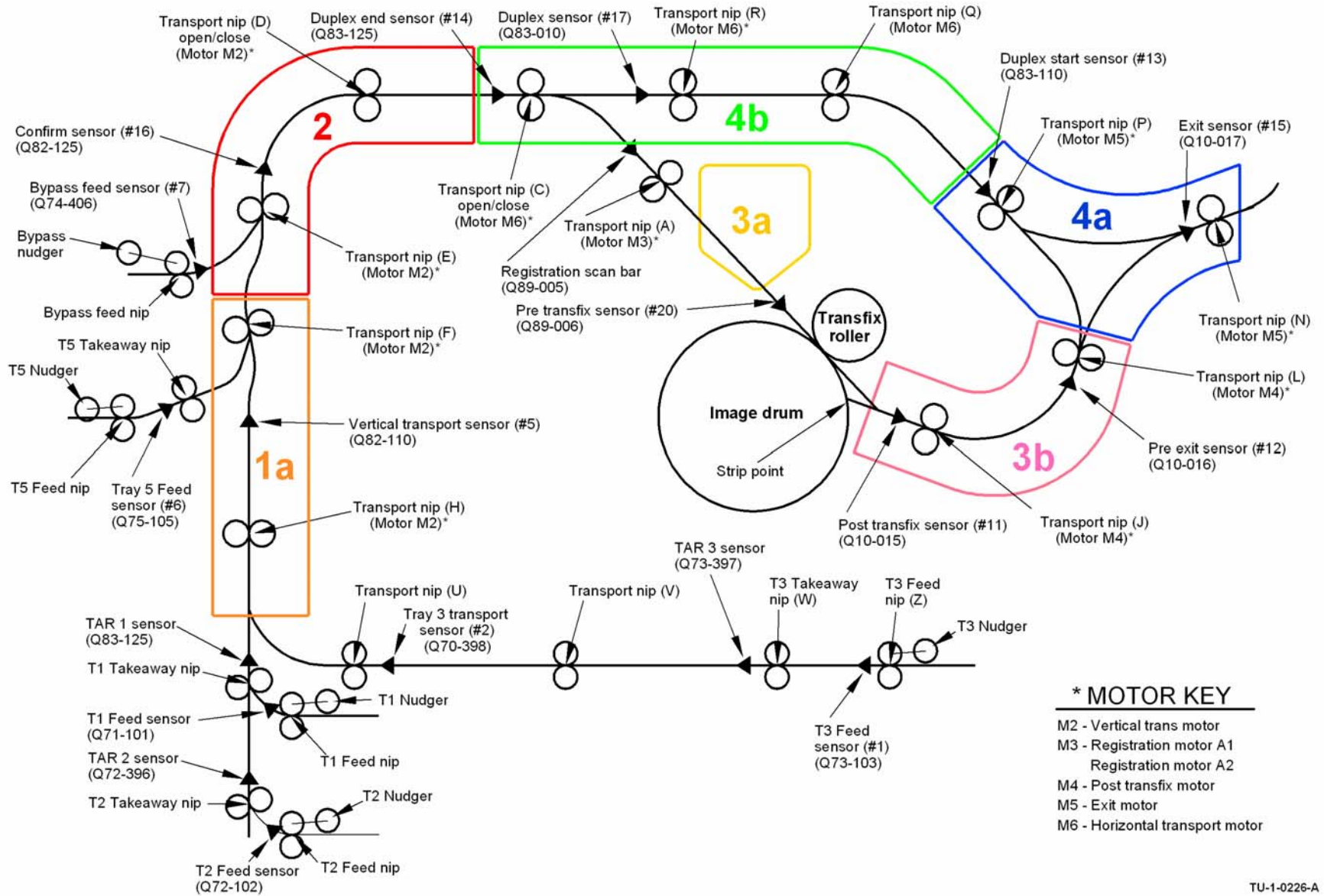

TU-1-0226-A

Figure 1 Sensors in the media path

Interlock Switches

Interlock switches are safety switches positioned on the main access doors of the machine. When the access doors are opened the interlock switches interrupt power to the machine's components ensuring that no moving parts that might cause injury are operational. [Figure 2](#) shows the locations of the main system interlock switches.

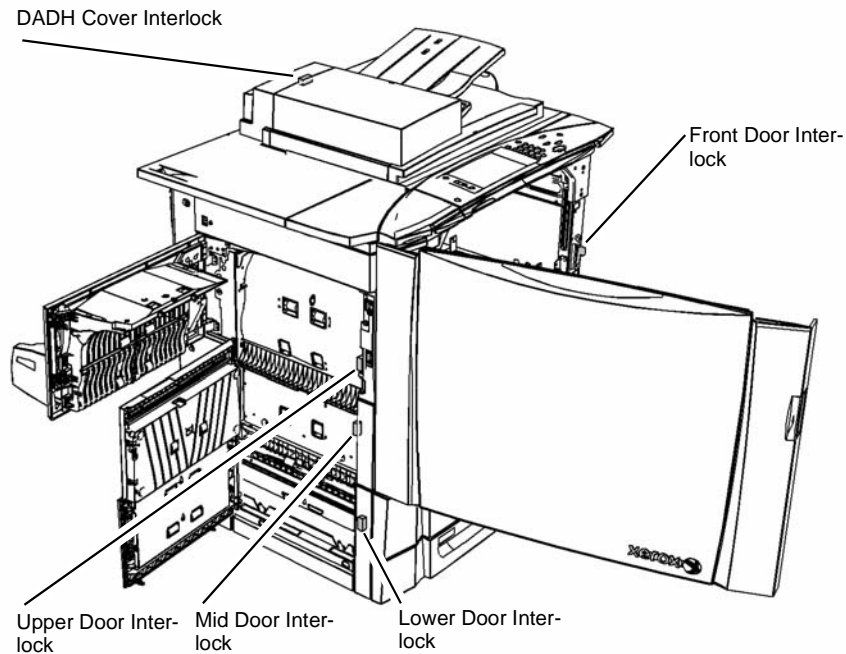

U-5-0094-A

Figure 2 Main system interlock switches.

Print Process

Once an image is processed, the print cycle begins. The printheads and drum are brought to their operating temperatures and the ink levels are checked.

In the ready state, the print process consists of the following steps:

- Image Processing
- Ink Delivery
- Printhead Alignment
- Drum Oiling
- Printing
 - Registration and Preheat
 - Image Marking
 - Transfix/Strip
- Purge System
- Duplex and Exit

Ink Delivery

The ink delivery system is comprised of four subsystems: ink loader, ink melt heaters, melt reservoir and umbilicals. The system interacts directly with the customer at one end and with the printheads at the other. The ink loader receives the ink from the customer and transports it to the ink melter. The ink moves towards the melter via belt drive and gravity as it transitions from the horizontal plane to the vertical. One melt plate per color, a total of four, acts to change the ink from solid to liquid. The ink is forced on to the melt plate by gravity. The melt plates are positioned at an angle to the horizontal and are shaped as to promote the liquid ink to flow off of the plate and into the melt reservoir. The purpose of the melt reservoir is to route the ink from four inputs to sixteen outputs, four colors to each of the four printheads. The melt reservoir provides a means of transporting the ink from the phase-change location to the printhead. Air pressure is used to route the ink through the melt reservoir and into the umbilical on its way to the printhead. The umbilical attaches to the melt reservoir at one end and the printhead at the other. There are two umbilicals, each provides ink to two print heads. [Figure 1](#)

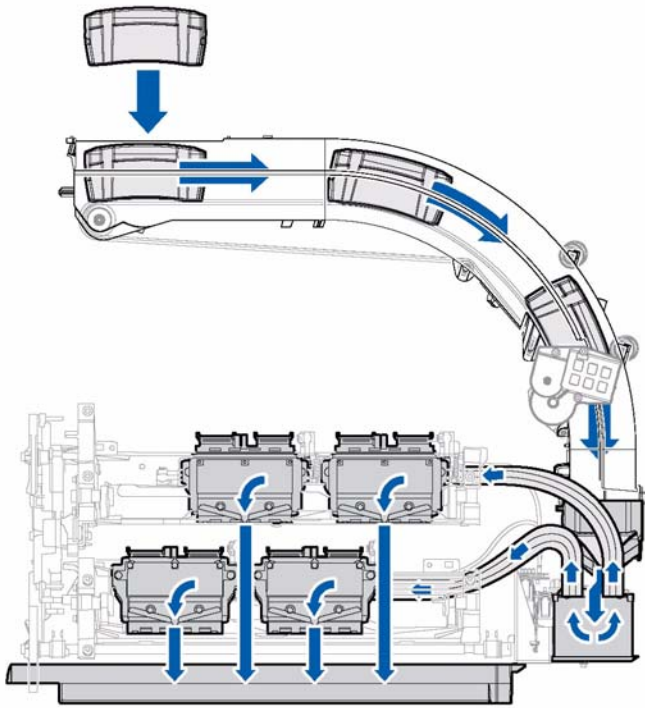

U-5-0548-A

Figure 1 Ink Flow

Ink Sticks

Ink sticks are loaded into the IME through an access door near the control panel. The ink sticks pass through the ink loader key plate as they drop into the ink loader. The shapes of the ink sticks are keyed to prevent an incorrect stick from being loaded. There are four sets of ink stick shapes; NA, EU, metered, and DMO sold. Each Stock Keeping Unit (SKU) set is unique to the market segment. Figure 2 shows the various ink stick shapes.

Each SKU family consists of 4 colors, resulting in a total of 16 unique ink stick shapes. In all cases, features unique to each color of ink prevent insertion into the wrong color key plate opening. The ink loader uses an adaptable key plate, mechanically actuated by software to adjust the key plate opening to accept the appropriate SKU version. The adaptable key plate allows insertion of NA/EU and DMO sticks into a metered printer, but does not allow any other cross-SKU insertions.

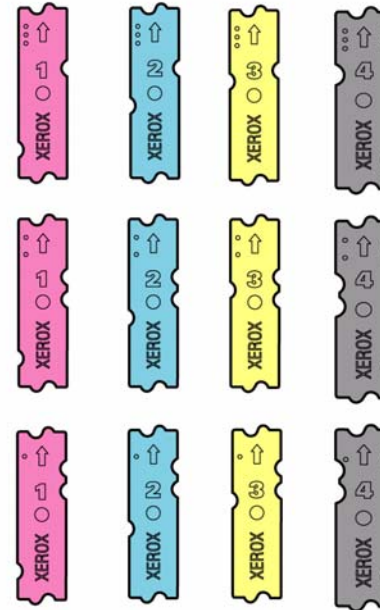

U-5-0509-A

Figure 2 Ink stick shapes

Ink Melt Heaters

Ink sticks are delivered by the ink loader and held against the ink melt plates by gravity. The system contains four melt heater / plate assemblies, one for each ink stick colour (cyan, magenta, yellow and black). The ink melt plate is heated using a ceramic Positive Thermal Coefficient (PTC) disk as a safety measure in the ink melt system; as the temperature of the melt plate rises, the electrical resistance increases reducing the electrical current drawn by the heater. When the melt heater reaches the correct temperature the end of the ink stick contacting the plate melts and the liquid ink runs into the low pressure ink reservoir below.

Ink Reservoir

The function of the ink reservoir is to:

- Receive melted ink from the Ink melt heaters
- Maintain liquefied ink at the set point temperature
- Deliver liquefied ink to the Umbilicals

Figure 3 shows the ink reservoir attached to the inboard side of the marking unit.

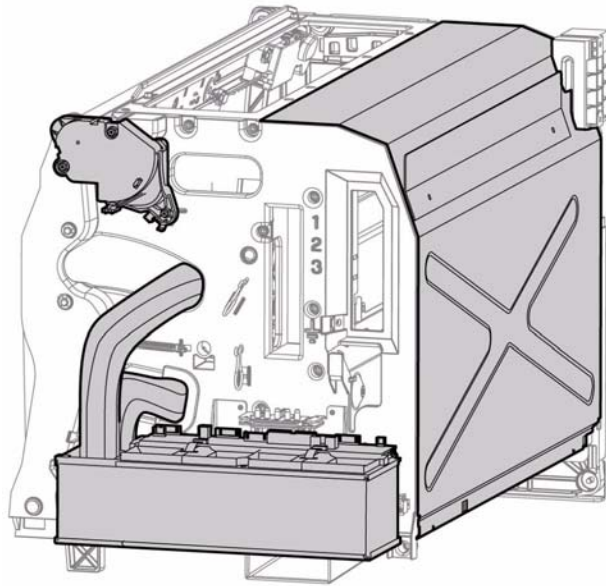

U-5-0520-A

Figure 3 Ink reservoir and umbilicals

The Ink reservoir requires AC and DC connections. Drive signals for the air solenoids come from the Marking Unit Driver Board via PJ480 and PJ130. AC for the umbilicals and reservoir heaters comes from the Marking Unit Heater Board. [Figure 4](#)

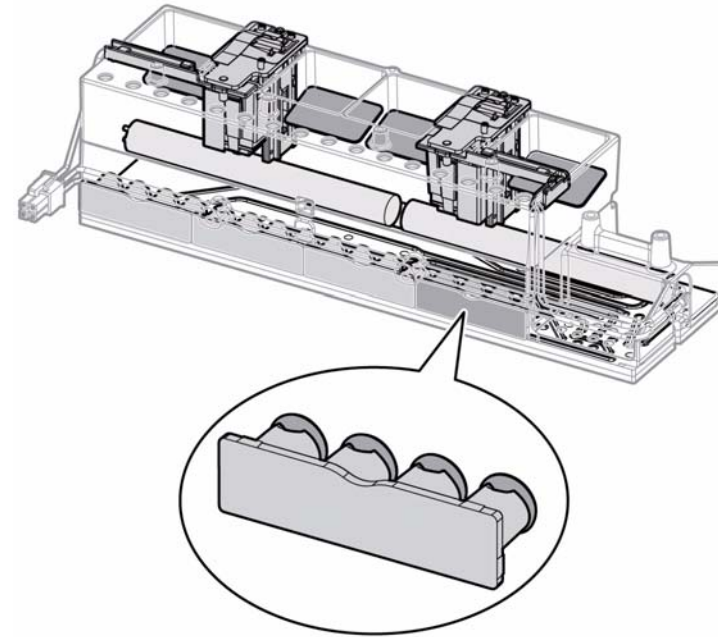

U-5-0551-A

Figure 4 Ink reservoir components

Umbilicals

The umbilical provides a flexible, heated distribution conduit between the melt reservoir and printhead reservoirs. A total of 16 ink conduits and 4 air purge conduits are used to feed the four printheads. Snapped to the melt reservoir end of the umbilical is a check valve unit, (CVU). A gasket is placed between the CVU and the umbilical. During installations of the umbilical, a gasket is placed between the CVU and the melt reservoir.

The Umbilicals are manufactured from a flexible, silicon-based material and contain eight heated ink tubes to maintain the ink in a liquid state as it travels from the reservoir to the printheads. Each umbilical attaches to one of the carriages. Each carriage contains two printheads. The upper carriage contains printheads 2 and 4, the lower carriage contains printheads 1 and 3. [Figure 5](#)

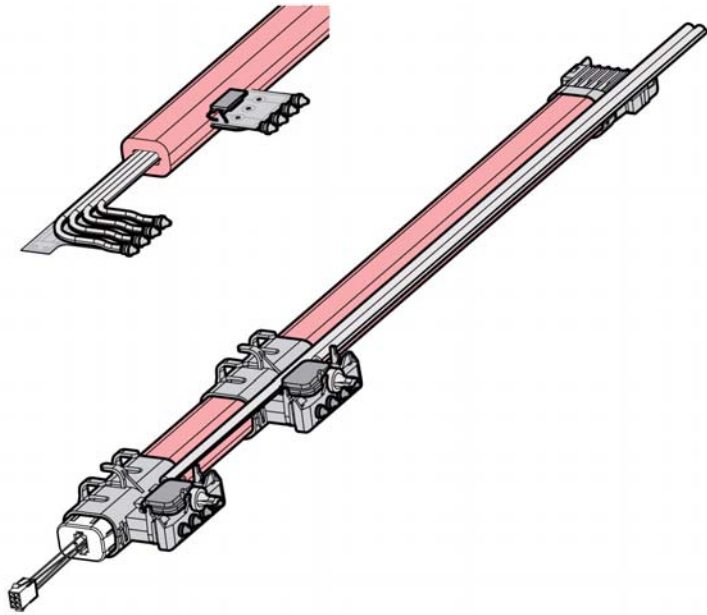

U-5-0557-A

Figure 5 Umbilical components

The CVU contains valves which will allow ink to flow toward the printhead but not back toward the reservoir. This valve is primarily used by the system during an air purge of the printheads without a CVU, ink would be forced back into the air router and replacement of the reservoir and umbilical assembly would be necessary.

NOTE: For the CVU to work properly it must be 'primed' with ink prior to a purge. Failure to 'prime' the CVU will likely lead to a replacement of the ink reservoir when ink and air are forced back into the reservoir and air router during a purge routine.

Printhead Alignment

The Ink On Drum (IOD) detection system collects data used for printhead interlacing alignment, missing jet detection, jet substitution and to check for the presence of stray pixels left behind on the drum after transfix. The latter is required to ensure good image quality and also to prevent the build up of residual ink on the drum, which could eventually damage the printheads.

Printheads

The printheads apply the image to the drum, [Figure 6](#).

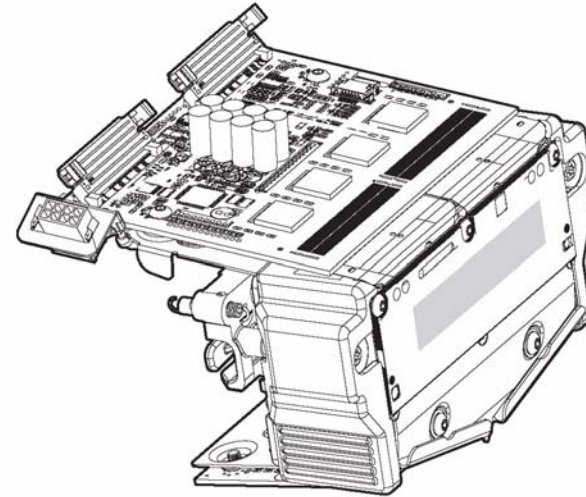

U-5-0552-A

Figure 6 Printhead components

Stitch Motion

[Figure 7](#)

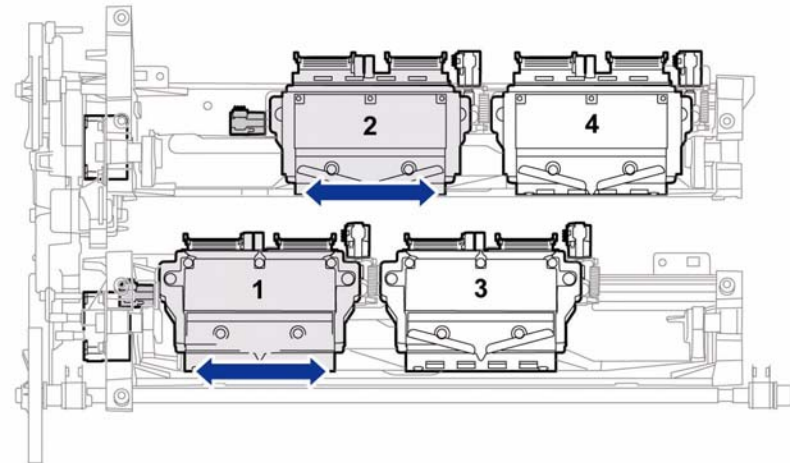

U-5-0515-A

Figure 7 Stitch motor motion

Roll Motion

Figure 8

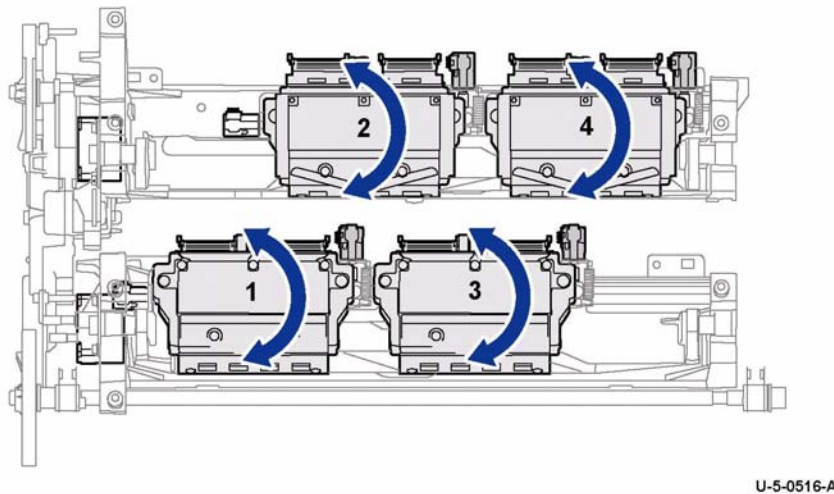

Figure 8 Roll motor motion

Printhead Maintenance

To clear jets that have been identified by the IOD system as being partially or completely blocked by waste ink or paper debris, the printheads are purged by forcing air at a pressure of 4psi through the jets. The function of the printhead maintenance assembly is to wipe the printheads after the purge to remove waste ink and debris. The wiper moves within a wiper track that guides the vertical motion of the wiper parallel to the printhead face during the jetstack wipe. The wiper carriage wipes two heads at a time, either both upper heads or both lower heads. The lower part of the printhead face is shaped so that any excess ink will be directed into the waste tray below, Figure 6.

Registration / Preheat Assembly

Cleaning Cycle

Duplex printing leaves ink residues on the preheater plates in the registration / preheater assembly. A preheater cleaning cycle removes ink residues from the preheater plates.

Preheater cleaning involves three steps:

1. Heat the preheater plates. The air pump is turned off and preheater plate's temperature is raised to 85 degrees Centigrade.
2. Clean the preheater plates. Sheets are run through the assembly in simplex mode. Media is alternately shifted off center to maximize the cleaning area.
3. Cool the pre heater plates. The air pump is turned on and sheets are run through the assembly in duplex mode until the set point of 65° C is reached.

Cleaning Cycle Error Handling

Error handling for a preheater cleaning cycle requires cooling down the preheater to 65 degrees Centigrade, and then handling the error before returning the system to the standby state.

Possible errors that can occur during preheater cleaning cycle are:

- Resource not available - media tray empty.
- Paper jams - Any occurrence that prevents the machine from printing a blank sheet and passing it through the paper path.

During any jam, if the MediaSeq catches it, then it will raise the fault to EngMgr for action. EngMgr will first cool down the preheater to CoolTemp, scrub the pre heater cleaning service, recover from the jam and clear the DevFault flags (both preheater clean flag and jam flag). Pre heater clean command's status is reported as failure to SC while scrubbing the service. In this case, the system enters into recovery mode for first cooling down the pre heater to CoolTemp degree C and then to recover from the paper not available, jam faults. After recovering the system goes into the standby state.

When the printer is not in a printable state for printing blank sheets (which clean and cool the preheater), the preheater clean service handles the cooling of preheater by simply waiting until the temperature drops. Then the service reports the failure status to SC. In this case the cooling down is handled by preheater clean service, so the system goes into standby state directly if any other subsystems hasn't raised any faults to EngMgr.

Dust Abatement

The purpose of the abatement system, Figure 9, is to minimize the contamination found in the vicinity of the printheads. This debris can cause print quality problems and printhead failures by partially or completely blocking the ink jets. Reducing the amount of contamination in this area improves printhead reliability. The abatement system is active during printing (off in Standby or Sleep modes).

A small vacuum plenum is mounted in close proximity to the drum. The output port of the plenum is connected to duct and a blower creates the required vacuum. The vacuum created removes particles and fibers from the surface of the drum and airborne contamination that might make its way to the face of the printhead.

Additionally, the abatement system provides a small cooling effect on the drum when it is actively pulling air. This cooling is slightly beneficial during drum over-temperature conditions. Power for the blower is supplied from the Media Path Driver Board. The blower fan operates at 12VDC. Air is exhausted out the back of the chassis.

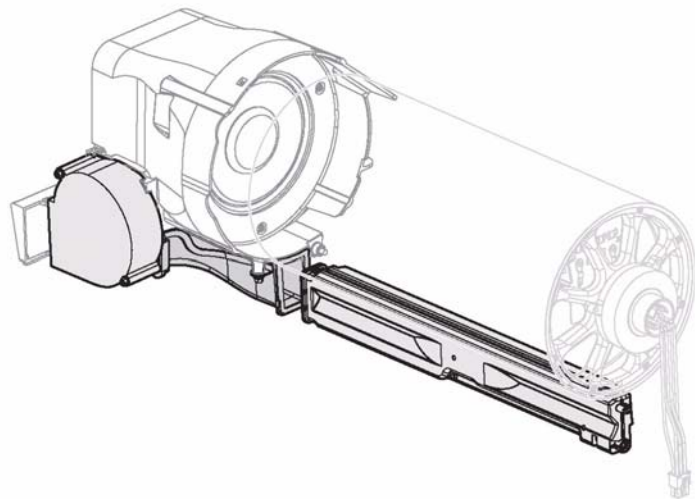

U-5-0541-A

Figure 9 Dust abatement system

Service Access

The abatement plenum is located directly below the drum between the IOD and the cleaning unit. It is removed by removing the cleaning unit, then pull the cleaning unit handle while pulling the abatement plenum to the right.

Drum Imaging

Drum Oiling

Figure 10. To prepare the Drum to receive an image, a thin coating of silicone oil is applied to the Drum surface. To oil the Drum, the Drum is rotated by the Drum Motor. The drum maintenance camshaft is rotated. Cams on each end of the drum maintenance camshaft contact followers on the oil roller and blade forcing both against the drum. The blade followers, independent of the oil roller followers, use small springs to regulate the pressure being applied to the surface of the drum.

As the drum continues to rotate, excess oil is removed by the blade and captured in the cleaning unit reservoir. The blade distributes an even coat of oil across the surface of the drum.

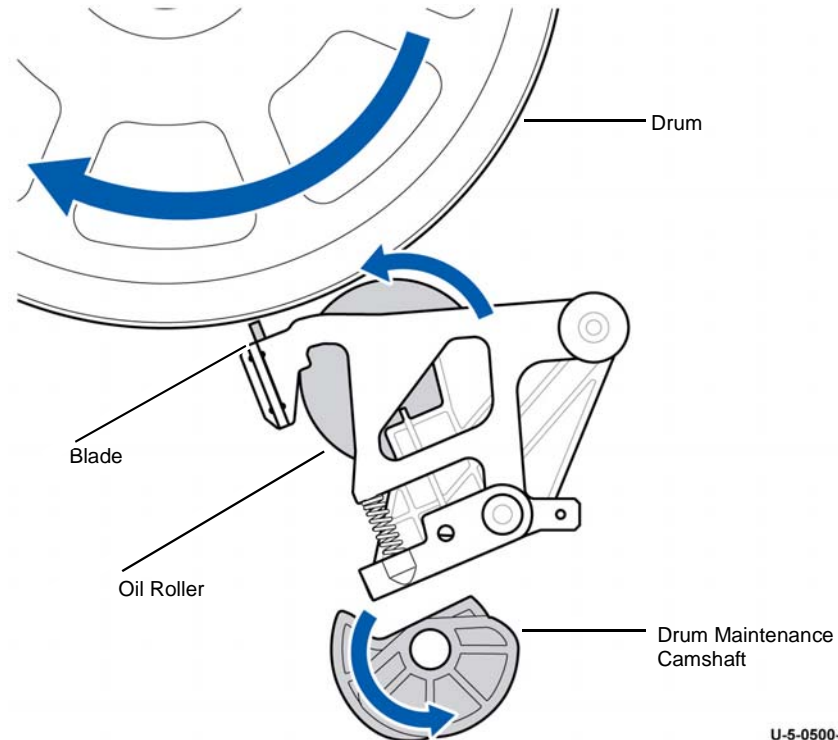

U-5-0500-A

Figure 10 Drum Oiling

Imaging Resolution

Four printheads create an image on the drum. Each printhead contains 300 jets per inch arranged in an array, providing a total jet count per printhead of 880 (3520 jets for the complete 4-head imaging system). The printheads operate at 41kHz, jetting ink onto the drum. Each Printhead creates a portion of the image. Pixel matching, monitored by the IOD Sensor, ensures a seamless stitching together of Printhead output to deliver a single image. The image resolution achievable using a single pass is 75dpi.

To increase image resolution in the cross process direction, the image is built up using several passes to achieve the required image resolution. At each pass of the image by the printheads, the printheads are slightly offset to avoid the build-up of ink drops on top of each other.

NOTE: PCL input is typically 600x600. The ColorQube scales this to 450x500 at normal mode resolution to provide Normal mode performance.

Transfix

Transfix Roller

The transfix linkages apply force to the transfix roller to bond the image to the media.

Transfix Stripper Blade

The transfix stripper blade removes adhered paper from the transfix roller and directs it to the exit portion of the paper path. The assembly is constrained in proximity to the transfix roller such that the blade is always in contact with the roller surface.

Output Transport

The output transport delivers sheets to the output module (LCSS, HVF or OCT). The output transport is also responsible for returning sheets to the duplex path for second-side marking.

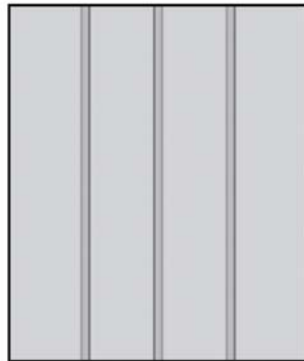
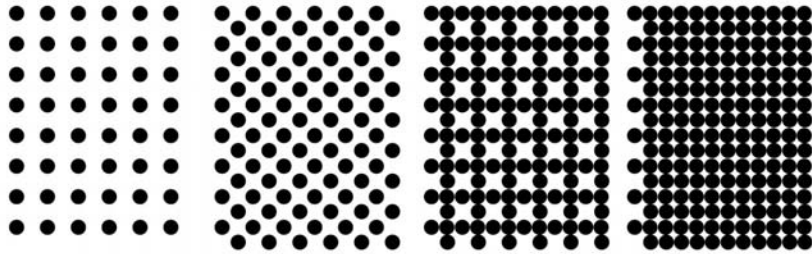

U-5-0553-A

Figure 11 Multi-pass image development

As an example, to develop an image of 375dpi on the drum, the image is built up over 5 passes (75dpi x 5 passes = 375dpi). [Figure 11](#).

The image resolution in the process direction is determined by the speed of the Drum while in the imaging cycle. The expression below shows the relationship: Y-resolution (in DPI) = 25.4 x head frequency (Hz) / imaging speed (mm/s). In order to achieve any different resolution in the process direction the speed of the drum must change, therefore the imaging time will change for each revolution.

Media Paths

The following describes the sequence of events as media moves through the IME media path. Refer to [Figure 1](#).

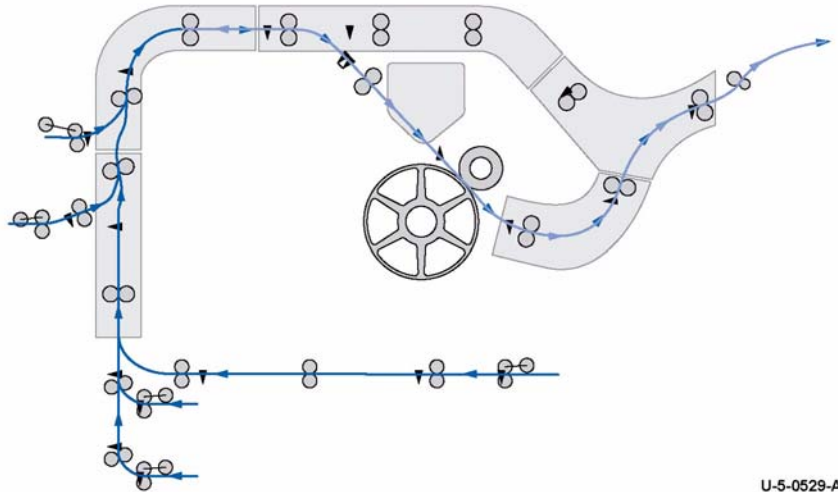

Figure 1 Simplex path

Sheets enter the IME media path from the optional Tray 5, Tray 4 (bypass tray), or one of Trays in the 3TM. Sheets enter the vertical transport on the left side and are fed into the horizontal transport. Sheets exit the feeders at a regular pitch. If the machine is operating in burst mode, the first sheet in a burst mode pair is held at nip C reducing the inter-document gap between the pair.

Following traversal of a portion of the horizontal transport, the media enters the registration / preheat assembly. Within the registration / preheat assembly are plates that warm the sheets to improve the transfer of the image to the media. Heavier media moves more slowly through the preheater in order for it to reach the required temperature.

The skew and position of the media is determined by a scan bar. This information is then used to determine how to get the paper to be de-skewed and orientated correctly from inboard to outboard. This is generally accomplished by intentionally skewing the paper twice. The sum of the two actions causes the media to be both aligned inboard to outboard and the lead edge to be de-skewed. The movement of the paper through the registration / preheat assembly is called 'wag' because of these unusual movements.

This intentional skewing of the paper is accomplished by the steering rollers. These shafts align with one another but are separate and are driven by separate stepper motors. Depending upon the width of the media, various idlers are engaged to provide drive to the paper. This is accomplished with the rear drive motor by running it in reverse.

The sheet then enters the transfix area. The transfix sub-system consists of two major elements:

- Transfix linkages that apply force to the transfix roller.
- A transfix roller, which presses the sheet to the drum so that image transfer occurs.

Just beyond the transfix point the stripper blade is located, which strips the lead edge of the media from the drum to ensure that it enters output portion of the paper path. If a sheet is not successfully stripped, it can wrap around the drum and collide with the printheads, which are mounted in close proximity to the drum. This can cause blocked jets due to the transfer of paper fibres to the printheads. Damage to the printheads is undesirable as they are expensive to replace.

At nip L the paper path divides. Sheets can either be sent to the exit module, or diverted into the duplex path, [Figure 3](#). The duplex path is used both for sheets to be duplexed and for sheets that require inverting prior to exit (e.g. tab stock which must be fed tab-trailing through the IME, but tab-leading into a finisher). The duplex path extends all the way back beyond nip F in the left-hand vertical paper path. Once sheets have been reversed down the vertical paper path, they then proceed as for the first side. However transfix is performed at half speed to avoid damage to the image already marked (solid ink images are vulnerable to scratching and burnishing when still tacky from the transfix process).

When operating in burst mode, the second sheet of a pair is held back once it is through transfix in order that sheets are delivered to the finisher at a regular pitch. Timing sensors are placed throughout the paper path in order to facilitate the timely movement of sheets. The sensors are also used for jam detection.

Input Paper Path

Media is delivered to the IME from the following sources:

- Trays 1 to 3
- Tray 4 (bypass tray)
- Tray 5

Output Paper Path

Media exits the IME through the exit module.

IME Simplex Path

[Figure 2](#) shows the media path through the IME.

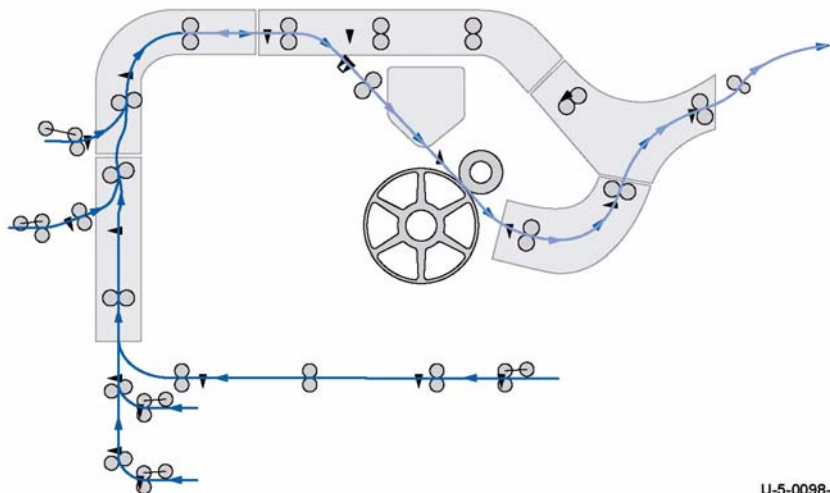

U-5-0098-A

Figure 2 Simplex path

IME Duplex Path

Figure 3 shows the duplex media path through the IME.

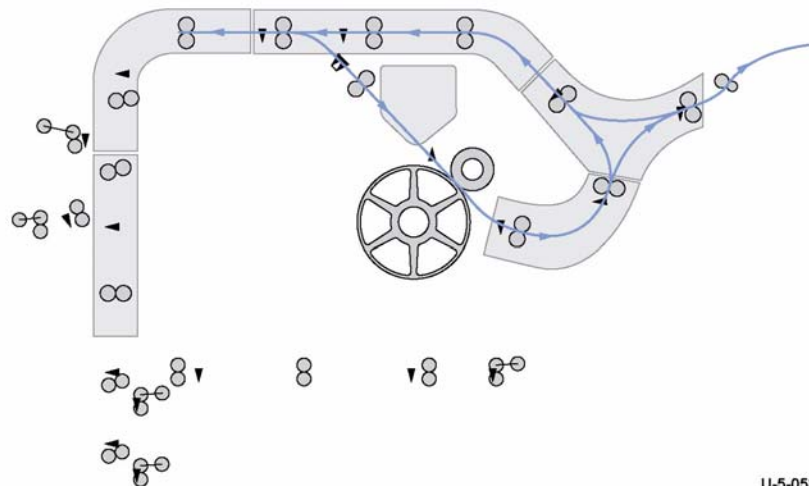

U-5-0530-A

Figure 3 Duplex Path

Image Input Terminal

Figure 1. The IIT generates the image data for copies and scans and is made up of three major subsystems:

- Duplex Automatic Document Handler (DADH)
- Scanner Assembly
- Control Panel

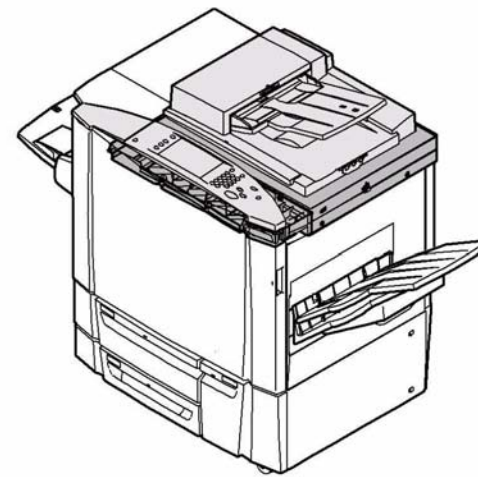

U-5-0091-A

Figure 1 IIT

Image Output Terminal

The image output terminal consists of the following elements:

- Bypass Tray
- Three Tray Module
- Offset Catch Tray
- Low Volume Staple Stacker (LCSS)
- High Volume Finisher Booklet Maker (HVF)

Bypass Tray 4

Figure 1

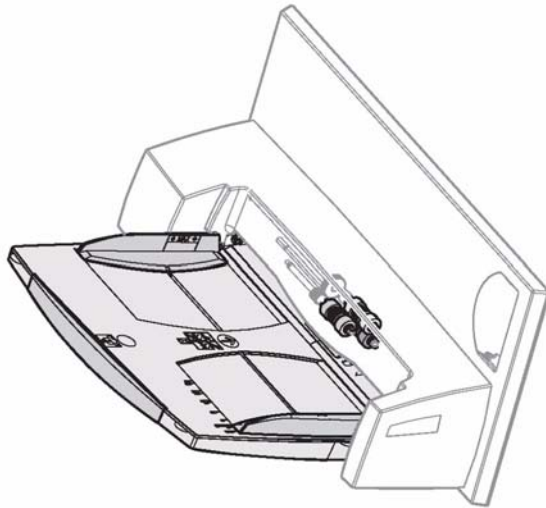

Figure 1 Bypass Tray 4

Bypass Tray 4 rollers are shown in Figure 2.

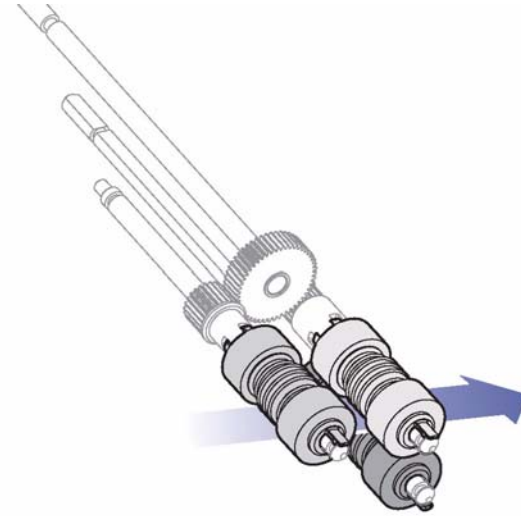

Figure 2 Tray 4 rollers

U-5-0546-A

U-5-0547-A

Duplex Automatic Document Handler (DADH)

Overview

The Duplex Automatic Document Handler (DADH) is described under the following headings:

- Counterbalances
- Input Tray
- Feeder
- De-skew - Takeaway Rolls (TAR)
- Constant Velocity Transport (CVT)
- Duplex Inverter
- Re-stack
- Drives
- Covers
- Interlocks

Figure 1 and Figure 2 show the component locations.

Counterbalances

Two counterbalance assemblies secure the document handler to the scanner frame. They are the primary locators for the DADH to the scanner. Counterbalancing force is generated by compression springs acting on a cam-follower arrangement, all housed within sheet metal brackets. Above a set drop-down angle, the DADH will hold or rise slowly to the maximum opening angle. Below the set drop-down angle, the DADH will gently close onto the scanner. In addition, the counterbalance assemblies are double-hinged to allow a customer to close the DADH onto books of up to 25 mm in thickness without applying excessive force to the document glass of the scanner. This feature is known as book-mode operation

Input Tray

Copies are placed into the tray, face up, 1 to N order. The nominal capacity of the input tray is 50 originals of 75 GSM (20 lb.) weight. The minimum size original is A5 (5.5 X 8.5 inch), SEF or LEF. The maximum size of original is A3 (11 X 17 inch), SEF only. The maximum weight is 120 GSM (30 lb.) The input tray is capable of accepting of 100 good condition originals, size up to A4 or 8.5 X 11 inch, SEF or LEF, weight up to 80 gsm. Table 1 lists recognized paper sizes and orientations. Intermixed lengths (feed direction) are acceptable for a limited number of document pairs, which are described below in the 'Mixed Size Mode' section. The tray will provide for centre feeding in 1 to N sequence. Movable tray guides for the width condition are provided. Correct guide adjustment by the operator is imperative for reliable feeding and auto paper select. The DADH document sensor, Q005-102, detects originals loaded against an input gate. The gate moves out of the way prior to the feed of the first original and it remains so for the entire job (see Feeder).

Table 1 Document size

Document Size	SEF Document	LEF Document
A5	Y	Y
5.5 x 8.5	Y	Y
B5	Y	Y
A4	Y	Y

Table 1 Document size

Document Size	SEF Document	LEF Document
8.5 X 11	Y	Y
8.5 X 13	Y	N
8.5 X 14	Y	N
B4	Y	N
A3	Y	N
11 X 17	Y	N

Document Size Sensing and Selection

Document size sensing and selection is achieved by a combination of:

- Width sensing (cross-process direction).
- Static and active length detection (process direction).
- Customer selectable NVM settings.
- "Mixed Length Mode" selection by operator.

Width Detection

Width sensing is accomplished by means of a variable linear potentiometer Q005-095. The potentiometer slide is directly connected to one of the two paper width guides. The output signal from the potentiometer is converted into a physical dimension of the paper guide from the paper path centre line.

This sensing method is sufficiently accurate to differentiate between document widths that differ by 8 mm or more.

Length Detection

Static length detection is used to determine document length for most (high percentage use) document sizes and orientations. This is accomplished with two sensors, Q005-221 & Q005-222, located in the input tray, which are at appropriate distances from the lead edge of the paper stack. The state of these two stack length sensors, when documents are loaded in the input tray at start of a job will determine the stack length range.

Active length detection is used to distinguish between 8.5 X 11 inch SEF and A5 (5.5 X 8.5 inch) LEF. Discrimination between these two sizes is accomplished by checking whether the DADH feed sensor, Q005-204, is covered as the first document passes the DADH pre-reg Sensor, Q005-206. If the DADH feed sensor senses a document at this point, then the 8.5 X 11 inch. size is indicated. If the sensor is clear, then A5 (5.5 X 11 inch) is indicated. Active length detection is used only when conditions at the input guides and tray sensors indicate that there is not enough information to determine document size and orientation.

An active "minimum length" check is also included, and any sheets shorter than 110 mm (corresponding to the longest distance between two successive nip rolls) will not be allowed to proceed beyond the upper portion of the paper path. A fault is declared and the customer is informed to use the document glass to copy or scan the original(s).

Size Sensing NVM Settings

In addition to the above, two of the system's NVM settings are used to set customer preferences with respect to two "low percentage use" document size pairs. These document pairs are very close in either one or both dimensions and cannot be distinguished with the above length and width size detection methods. The customer must decide, in each case, which document size is automatically selected when either of the two sizes is placed in the input tray.

NVM1 will allow the customer to choose between automatic detection of A4 SEF or 8.5 X 13 inch. The DADH will automatically recognize only the selected size when either of these documents is placed in the input tray. Auto-detection of A4 LEF would be unaffected by either choice in setting. The default setting of NVM1 = 0 is for A4 SEF and a customer or CSE change to 1 will enable the 8.5 X 13 inch choice.

NVM2 will allow the customer to choose between automatic detection of A5 or 5.5 X 8.5 inch. Depending on the setting, the DADH will recognize documents within the size range of A5 or 5.5 X 8.5 inch as only the preferred size. This preference will apply to both SEF and LEF orientations. The default is NVM2 = 0 and will enable A5, whereas a customer or CSE setting to 1 will enable the 5.5 X 8.5 inch preference.

Mixed Length Mode Job Setting

There are 6 pairs of mixed length document sizes that will automatically be distinguished when the operator selects the mixed length mode job. They are:

- A3 inch SEF and A4 LEF
- 8.5 x 14 inch SEF and 8.5 x 11 inch SEF
- 8.5 x 5 inch LEF and 8.5 x 11 inch SEF
- A4 inch SEF and A5 LEF
- B4 SEF and B5 LEF
- 11 x 17 inch SEF and 8.5 x 11 inch LEF

Sensing the largest document in each pair in the input tray will identify the document pair.

Uncommon Document Sizes

Many uncommon sizes will be recognized by the DADH as being the same as the nearest standard size.

Document Sizes not Recognized in Auto-detect Mode

For those sensor combinations not recognized by the DADH, the operator is alerted to perform the following actions:

- Re-sort (or re-stack / realign) and then reload originals.
- Ensure guides in the input tray are positioned snugly against the sides of the document stack.
- If the document remains unrecognized, select the document size manually and load the correct paper size into a tray if necessary.
- Press start to continue.

Sensor Location

Figure 1 shows the locations of the DADH sensors.

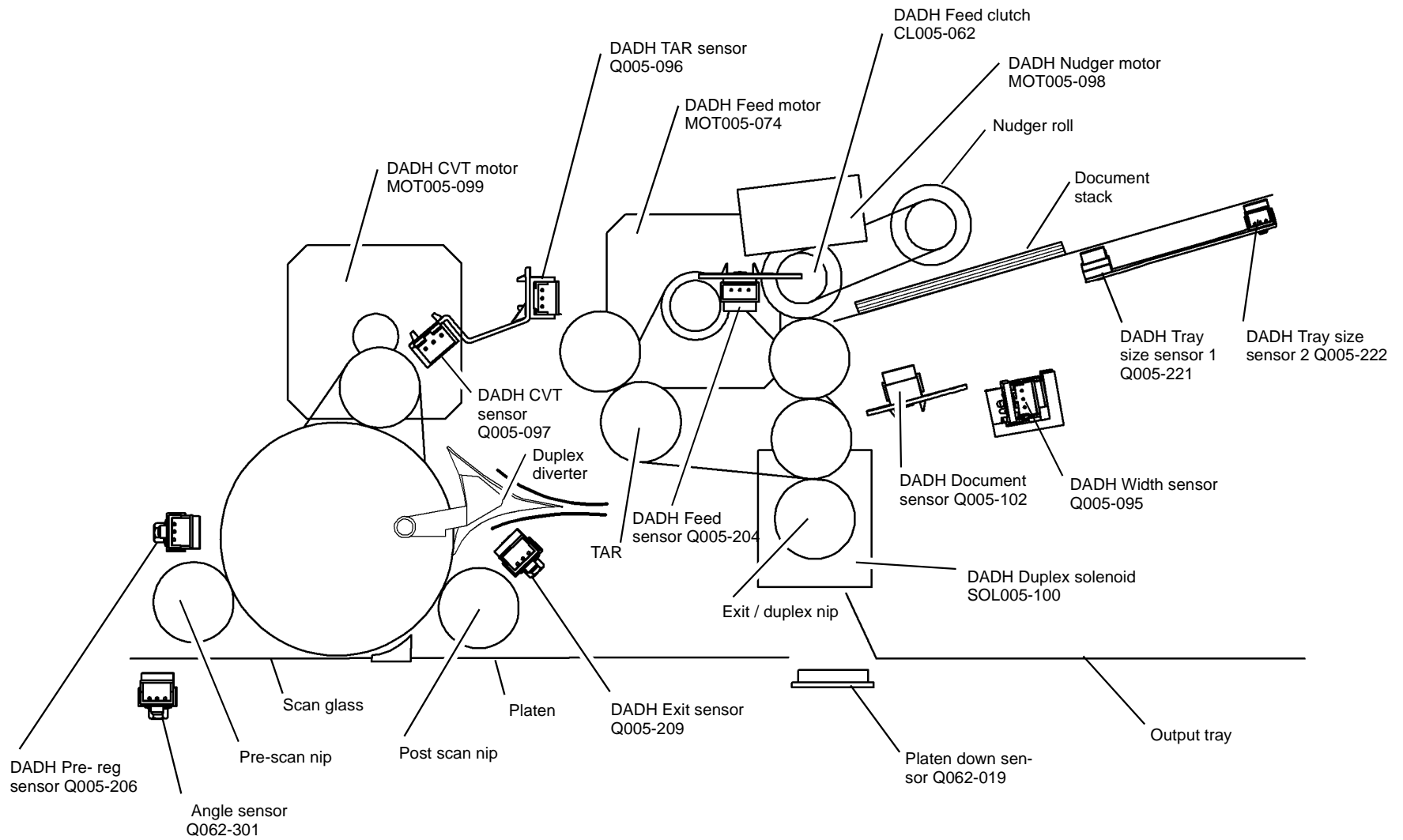

U-5-0062-A

Figure 1 DADH component location 2

Feeder

The feed mechanism is a top friction feeder with semi-active retard. The feeder consists of an input gate, nudger roll, feed roll, and a retard roll. The nudger, feed and retard rolls are Customer Replaceable Units, (CRUs).

The nudger and feed rolls are driven by the DADH feed motor, MOT005-074, through an electromechanical friction feed clutch, CL005-062. A DADH nudger motor, MOT005-098, is operated to lower the nudger roll to contact the top sheet of the stack while simultaneously disengaging the input gates until the first sheet is acquired from the stack. The input gates are prevented from returning to their reset position until after the last sheet is fed off the stack.

The clutch de-energizes and the DADH nudger motor returns to the nudger roll up position, when the lead edge of the document arrives at the DADH feed sensor, Q005-204, except in the case of the first sheet, when both the clutch remains energized and the DADH nudger motor remains at its current position, until the LE of the sheet arrives at the DADH TAR sensor, Q005-096. When the document is called for, this event being triggered by the TE departure of the previous sheet from the takeaway sensor, the clutch is re-energized and the (DADH nudger motor returns to the nudger roll down position), until the LE reaches the take away sensor.

The semi-active retard roll consists of an elastomer-covered outer member and a stationary inner member, with a wrap spring slip clutch between them. Spring loaded against the feed roll to provide the required force, the retard rotates during feed and the wrap spring winds until it's slip torque is developed, at which point it overruns in the feed direction. The device maintains this condition when a single sheet is in the pinch. When two sheets are fed into the nip, the torsion spring unwinds, thus turning the retard roll in the reverse direction and driving the multi-fed sheet backwards out of the feed/retard nip and towards the stack. In the case of singly fed sheets, the semi-active retard roll is driven in the direction of feed by the motion of the drive roll.

De-skew - Takeaway Rolls (TAR)

Document de-skew and lead edge registration for both simplex and duplex paths are accomplished by a combination of the following methods:

- Document lead edge buckle at TAR - By driving the document with the feed roll assembly at a higher speed than the TAR rolls, a buckle is formed. This allows the document lead edge to help correct any skew that exists during this first stage of feeding.
- Width Guides - The position of the width guides relative to the edges of the stack is the most important factor in the control of skew within the DADH. Easy movement of the guides is a requirement to ensure customers can easily obtain a "tight" stack.

Constant Velocity Transport (CVT)

The document is scanned as it passes over the CVT glass with the scan carriage parked beneath. During this time the document is driven by one large diameter CVT roll and is in contact with a minimum of 2 double nip rolls. The DADH CVT sensor, Q005-097, positioned before the scan zone, detects the document's arrival to begin the scan. This sensor also detects the document's departure for end of scan or jam detection. Image registration correction occurs at the image processing PWB.

Duplex Inverter

The inverter function is provided by a reversing roll nip. The elements include the nip, a duplex gate, the feed motor, MOT005-074, and the DADH duplex solenoid, SOL005-100. The document is inverted after the trail edge is sensed by the DADH exit sensor, Q005-209. By controlling the time beyond the DADH exit sensor, the document is stopped by the DADH feed motor, Q005-074, after the trail edge passes the duplex gate, but prior to leaving the nip. At this time, the DADH feed motor is reversed. The DADH feed motor continues to drive the document along the duplex path, so that it re-enters the original input path. The document lead edge arriving at the DADH CVT sensor causes the DADH duplex solenoid, SOL005-100, to open. The DADH CVT Motor continues to feed the document past the scanning position, as in simplex mode. After side 2 is scanned, the document is re-inverted, prior to being re-stacked for correct document orientation. This is accomplished by sending the document through the duplex path at maximum speed, without scanning, to the exit.

Re-stack

The document re-stack function is provided by passing the documents through the inverter nip into a catch tray above the manual platen cover. The profile of the exit tray together with a re-stack arm ensures an orderly document re-stack.

Drives

Refer to [Figure 2](#). The DADH is driven by two 24V DC stepper motors. The DADH CVT motor, MOT005-099, drives the CVT roll by means of a synchronous belt. The DADH feed motor, Q005-074, provides drive to the feed assembly rolls, TAR assembly and exit roll. The feed shaft is isolated from the motor by the DADH feed clutch, CL005-062. The DADH feed motor, Q005-074, drives the exit roll assembly in both forward (exit) and reverse (duplex) directions. In addition, the DADH duplex solenoid SOL005-100, is required to open the exit / duplex nip during document inversion in duplex mode. This is necessary because the document is wrapped around the CVT roll and both the leading and trailing edges are passing through the exit / duplex nip.

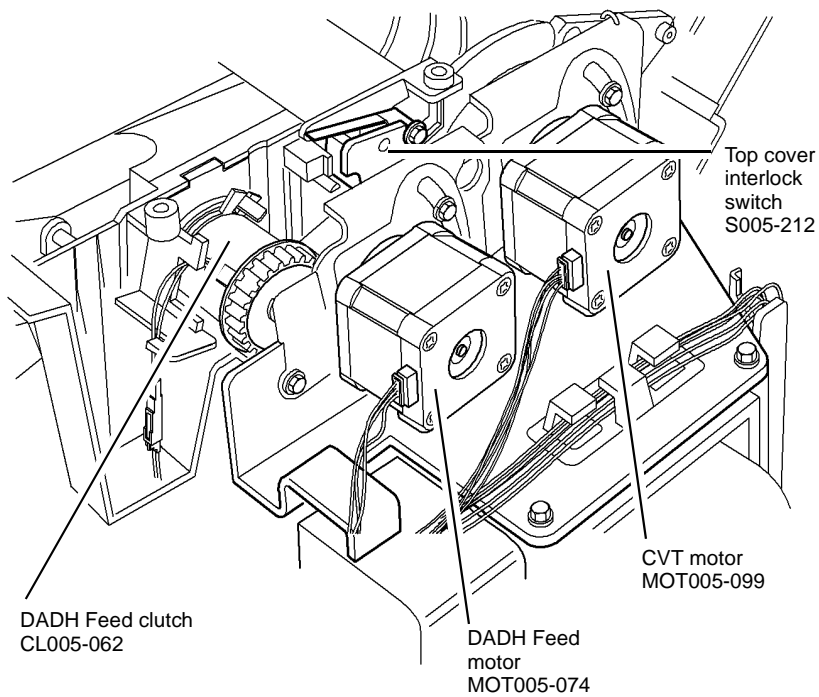

U-5-0063-A

Figure 2 DADH component location

Covers

The DADH covers set consist of four main enclosures:

- the top cover assembly,
- the baffle assembly,
- the rear cover and
- input tray.

The top cover assembly pivots on the left for jam clearance to the upper paper path. Access to the exit/duplex paper path is achieved through the baffle assembly, which can be opened after raising the DADH. Access to the drives requires the removal of the rear cover. Access to the input tray components requires removal of the input tray. The top cover assembly and baffle assembly are for customer access to jam clearance areas. Access inside all other covers requires the removal of screws and is intended for Xerox service personnel only.

Interlocks

The DADH top cover interlock switch, S005-212, is located at the rear of the DADH. This supplies the DADH PWB with +24V for clutches solenoids and motors. There is no +24V indicator on the DADH PWB.

The platen down sensor, Q062-019, is located at the front of the scanner module. It is actuated by a magnet at the front of the DADH. It is not a power interlock, but it monitors of the DADH open or closed condition.

The angle sensor, Q062-301, is located in the scanner module. It detects that the DADH is currently open more or less than a fixed angle.

Full Width Array Raster Input Scanner

Overview

The 600dpi scanner uses a full width array and minimal optical path between the document and the light sensing devices. The full width array is mounted on the scan carriage together with the LED exposure lamps.

The scanner has two modes of operation. In CVT mode, the scan assembly stays fixed in place while documents are moved over it. In document glass mode, the document remains stationary while the scan carriage moves beneath the document.

The scanner uses mechanical drives to scan documents on the document glass, or to position the scan carriage under the CVT glass, when the document handler is used in CVT mode.

Document registration on the document glass is from the right rear corner of the glass. Documents up to A3 or 11 by 17 inches can be accommodated.

Scan Carriage Assembly

The scan carriage assembly, [Figure 2](#), is arranged to slide on front and rear rails, being controlled by scan cables driven by the scan motor. The scan carriage has three upper skids that are held in contact with the lower surface of the document glass, by two spring loaded lower skids. This arrangement gives a constant length of light path between the document and the full width array.

A ribbon cable supplies power from the scanner PWB to the exposure lamp inverter. A shielded ribbon cable supplies the analogue image data from the full width array to the scanner PWB.

Scan Carriage Drive

Scan cables connected to a capstan are routed around the periphery of the scanner cavity, by scan idler pulleys. The scan carriage is clamped to these cable, so that rotation of the capstan causes the scan carriage to translate to the left or right. The capstan is driven by the scan drive belt from the scan motor. The scan motor power and control comes from the scanner PWB located in the scanner assembly.

Full Width Array Calibration

At power on initialization and every pattern scan and start of DADH job a calibration is performed. The scan carriage is positioned so that the full width array is below the calibration strip on the underside of the document glass.

The reflected light from the calibration strip is received by the elements of the full width array. The resulting analogue signal is sent from the full width array PWB to the scanner PWB where the analogue signals are converted to a digital video signal and then a gain adjustment is applied for each individual element, each individual element of the full width array to achieve a uniform gain for the whole array.

When the exposure lamp switches off, further readings are taken that represent a black image. These values are used to set the automatic offset control (AOC). These values are automatically calculated, but can be adjusted using the Image Quality Adjustment routine in the tools menu.

Document Glass

The document glass can accept documents up to A3 or 11 x 17 inches, [Figure 1](#). A registration scale is provided on the right and rear of the document glass and the registration position is at the right rear corner.

CVT Glass

The CVT (Constant Velocity Transport) glass is a separate piece of glass positioned to the left of the document glass, [Figure 1](#). In CVT mode, the scan carriage is positioned under the CVT glass. Documents from the DADH pass over the glass and are returned to the DADH.

Document size Sensing

Two document size sensors are located in the base of the scanner. The output of the sensors together with edge position data from full width array sensors is used by the scanner PWB to send document size information to the image processing PWB when in scanning mode. The signal from the input module angle sensor is used to provide timing information to the scanner PWB, so that the document size measurement is taken before the DADH is closed.

LED illuminator

Two LED exposure lamps are mounted on the scan carriage, one on each side of the light sensor. The surface of each lamp is shaped to diffuse the light from the LEDs, and together they produce a light of even intensity and generate negligible heat when energized. The LED supply is +24V, via a ribbon cable from the scanner PWB to lamp 1. A second ribbon cable takes the supply from lamp 1 to lamp 2.

Optical Path

Light from the exposure lamps on the scan carriage, is directed through the document glass to illuminate the document. Light from the document passes vertically downwards through the document glass, through the selfoc lens to the full width array.

Full Width Array

The full width array contains an array of twenty silicon detector chips which are bonded to the full width array PWB. Each detector chip contains 384 detectors of 43 microns diameter. The total width of the array being 330 mm or 7680 pixels. The silicon detectors convert the light levels reflected from the document into analogue voltage levels.

Each silicon detector produces one pixel (picture element) of image information. Each pixel represents one spot of white, grey or black corresponding to the image on the document.

Selfoc Lens

The Selfoc (self focusing) lens consists of 650 Selfoc rods of 0.5 mm diameter, [Figure 2](#). Each rod is set in to a resin-type material to form a 325 mm wide lens. The lens sits above the full width array in the scan carriage.

Scanner Initialization

At power on initialization and at timed intervals between jobs, scanner initialization is performed. The scan carriage moves to the scan carriage home sensor to set the home position of the carriage. This is used as a reference from which all scan carriage movements are calculated.

Image Processing

Digital image information from the scanner PWB passes to the single board controller PWB and stored on the EPC memory. Storage in the EPC allows multiple copies and the image can be modified according to the selections made by the user, such as reduction / enlargement, copy lighter / darker or booklet mode. The image is then sent to the Fax module, the network controller or the IME for processing or printing.

The single board controller PWB provides scanner control and processing of the scanned image. Communications with the scanner components use an RS422 asynchronous serial interface in full duplex mode. The link is used to send commands to the scanner to control actions such as a document glass or scanner calibration.

The single board controller PWB has a NVM module PWB.

The NVM module PWB contains the local machine settings and the image processing NVM, which are maintained by an integral battery.

Interfaces for foreign devices are also provided.

Component Location

Figure 1

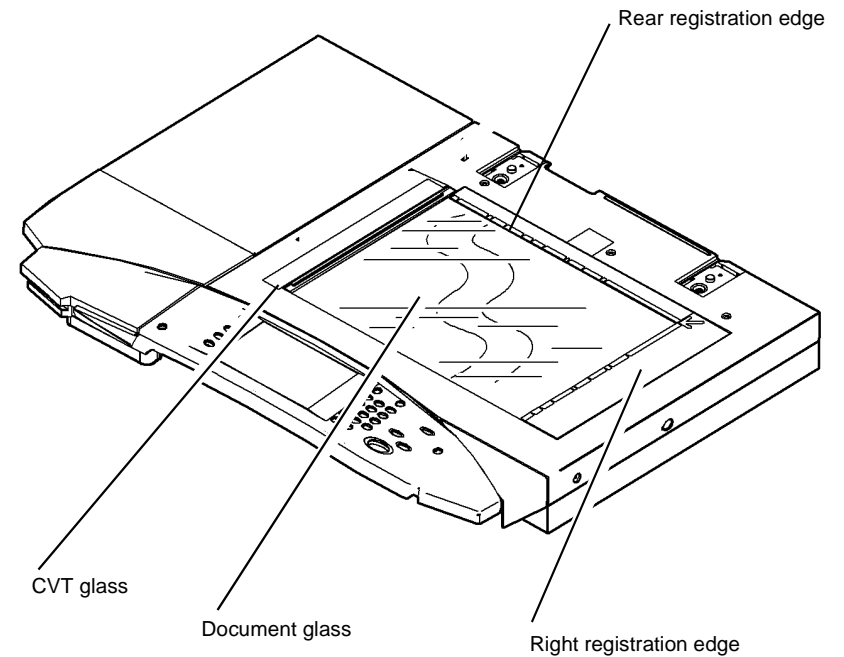

U-5-0037-A

Figure 1 External view of the scanner

Figure 2

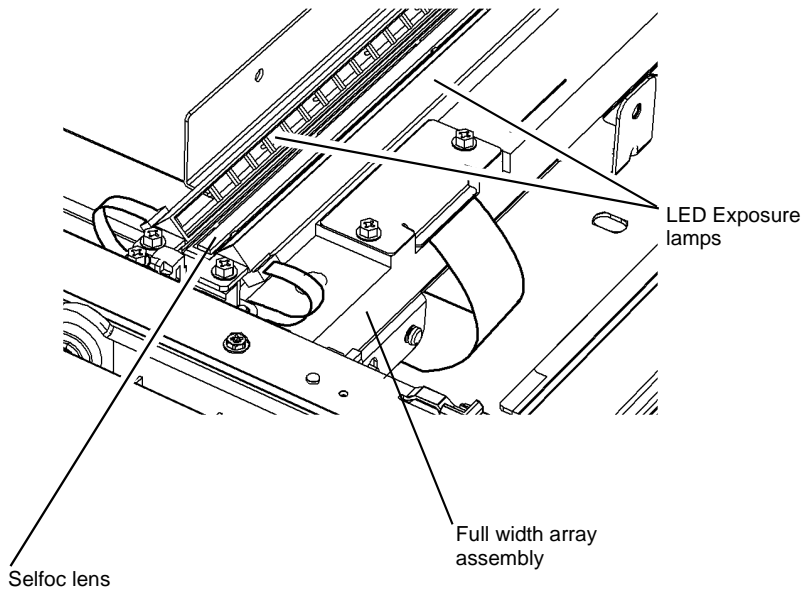

Figure 2 Cross section of the scan carriage

Figure 3

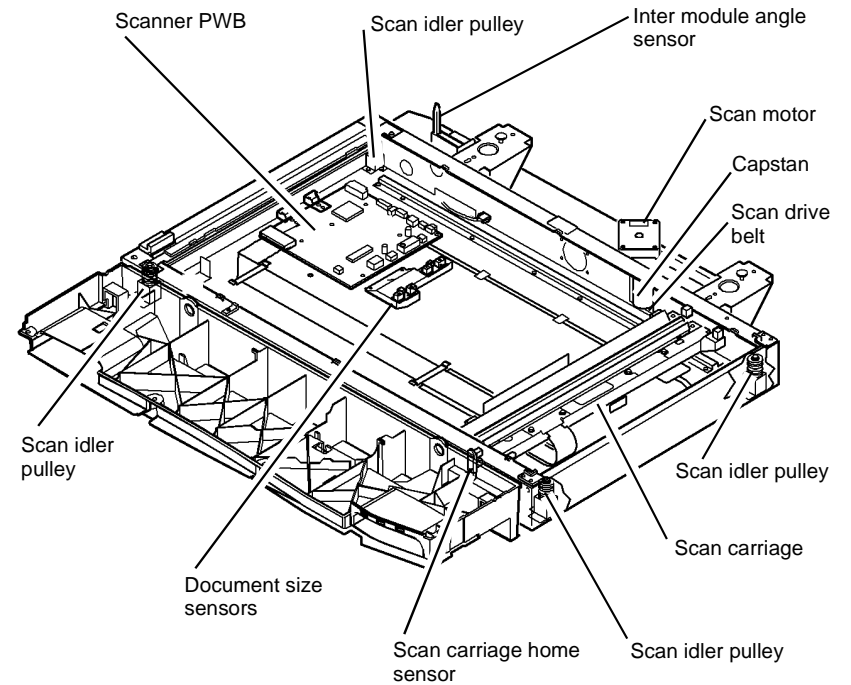

Figure 3 Scanner components

U-5-0038-A

U-5-0039-A

Fax

The L1 common interface Fax (ICF) has an optional 1 or 2 line fax module located in the image processing module draw beneath the scanner.

The fax PWB is fitted with either one or two MultiTech MT9234SMI modems. The PWB supports fax modem reset control, presence indicator, audio volume control and board revision information. The Fax PWB is connected into a fax connector PWB, which in turn is connected by a ribbon cable to the single board controller PWB.

The fax is controlled by the copy and process controller on the single board controller PWB.

Fax functionality is selected and controlled via the main control panel.

Three Tray Module (3TM)

Overview

The three tray module consists of three trays. [Figure 1](#) shows the positions of the trays.

Trays 1 and 2 are adjustable between A5 SEF and 11 x 17 inch SEF. The paper stack is loaded centrally in the tray and the side guides move jointly and an equal distance relative to the centre of the tray. Movement of both the side and end guides are moved individually by the customer using pinch grip / release handles. The slides have detentes at given sizes. In between these standard sizes, the guides will still lock in position via a ratchet / pawl feature to support custom sized media.

Tray 3 is a dedicated size tray, either A4 LEF or 8.5 x 11 inch LEF. The controller will supply an NVM value to distinguish between the two possible sizes. The side guides and trail edge guides in the tray to support the paper stack, are adjustable and lockable between the two sizes. The paper tray is aligned with the centre of the paper path to the IME.

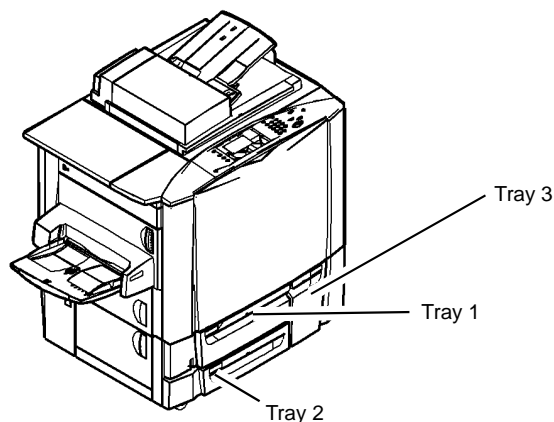

U-5-0059-A

Figure 1 Three tray module

Configuration

The three tray module feeds paper that is centre registered to the IME.

The main features of the three tray module are:

- Tray 1 and 2 each have a capacity of 550 sheets of 80gsm paper.
- Tray 1 and 2 paper sizes are between A5 or 5.5 x 8.5 inch SEF to A3 or 11 x 17 inch SEF.
- Tray 3 has a capacity of 2100 sheets of 80 gsm paper.
- Tray 3 paper sizes are A4 or 8.5 x 11 inch LEF.

- Paper weights from 60 gsm to 216 gsm.
- Paper low warning utilizing the elevate pulses taken to reach a given elevate plate position equivalent to 25% stock remaining in tray 1 and tray 2 and 10% for tray 3.
- Tray 1 and 2 will be used to feed tab stock and labels.
- The 3TM has a PWB without an intelligent controller. This provides the following information to the IME, via PJ950 on the media path driver PWB:
 - The paper path sensors status.
 - Paper present status for each tray, (tray empty sensors).
 - Tray open / closed status for each tray.
 - Approximate paper levels for each tray, (encoder pulse count for tray 3 elevator motor).
 - Tray in use status.
 - Paper size detected by the use of 5 switches for trays 1 and 2.
 - Left hand lower door open / closed status.
 - 3TM horizontal transport open / closed status, (transport closed switch).

Machine Interface

The three tray module PWB receives and sends serial input and output data to and from the Media Path Driver PWB.

Tray and Transport Closed Sensing

For trays 1 and 2, the 3TM PWB detects the tray open if none of the five media size switches at the rear of the drawer is actuated. This is because no paper size switches for that drawer can be actuated while the drawer is open.

Tray 3 has a dedicated tray home sensor, located at the rear of the tray. [Figure 2](#) shows the tray 3 home sensor.

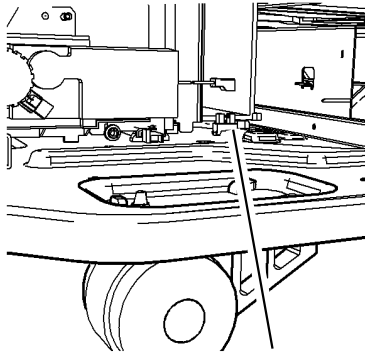

Tray 3 home sensor

U-5-0065-A

Figure 2 Tray 3 home sensor

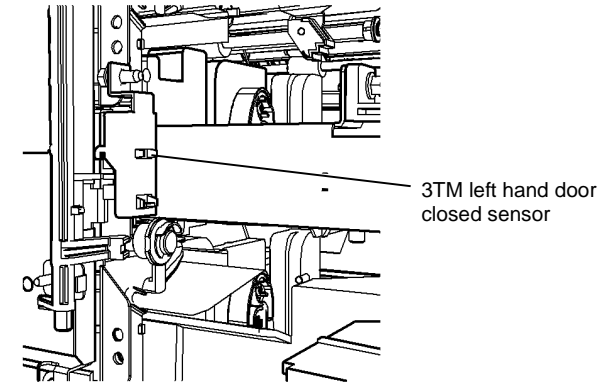

U-5-0066-A

Figure 3 3TM left hand door closed sensor

The 3TM horizontal transport home sensor is the topmost switch on the 3TM PWB, located at the rear of trays 1 and 2.

The 3TM left hand door closed sensor is located at the front of the jam clearance door, behind the lower left door. [Figure 3](#) shows the vertical transport closed sensor.

Paper Size Sensing

Trays 1 and 2 can accommodate various paper sizes which the machine can detect, according to the position of the paper guides. The paper guide positions are detected by five switches at the rear of each drawer, mounted on the 3TM PWB. As the paper guides are adjusted, slotted guide brackets slide to the left or to the right. When the drawer is then closed, the combination of the switches actuated, informs the 3TM PWB which size paper is held in the drawer. [Figure 4](#) shows the components of the trays 1 and 2 paper size sensing function.

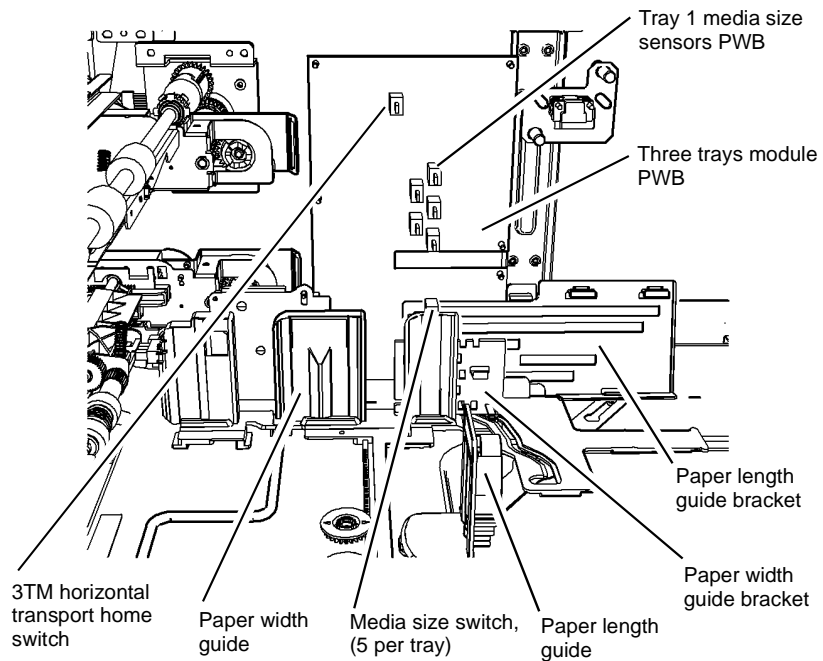

U-5-0064-A

Figure 4 Tray 1 and 2 paper size components

Paper Tray Elevation

Trays 1 and 2 each have an elevate system which lifts the stack. A stack height sensor detects and maintains the top of the paper stack at the correct height. An elevate plate is pivoted at the right hand edge of the tray and the left edge is raised by a lift bar. The method of elevation is achieved by driving the feed motor in reverse through a gear train and a one-way clutch. Figure 5 shows the tray 1 and 2 elevator components.

Tray 3 has a dedicated elevator motor. Stack elevation is achieved with a parallel elevate plate and supporting hoist cables and pulleys. The drive for this system is by a motor with a coupling to a gear box. A stack height sensor detects the correct paper stack height and an over run switch removes the power from the elevator motor if necessary. Figure 6 shows the tray 3 elevator components.

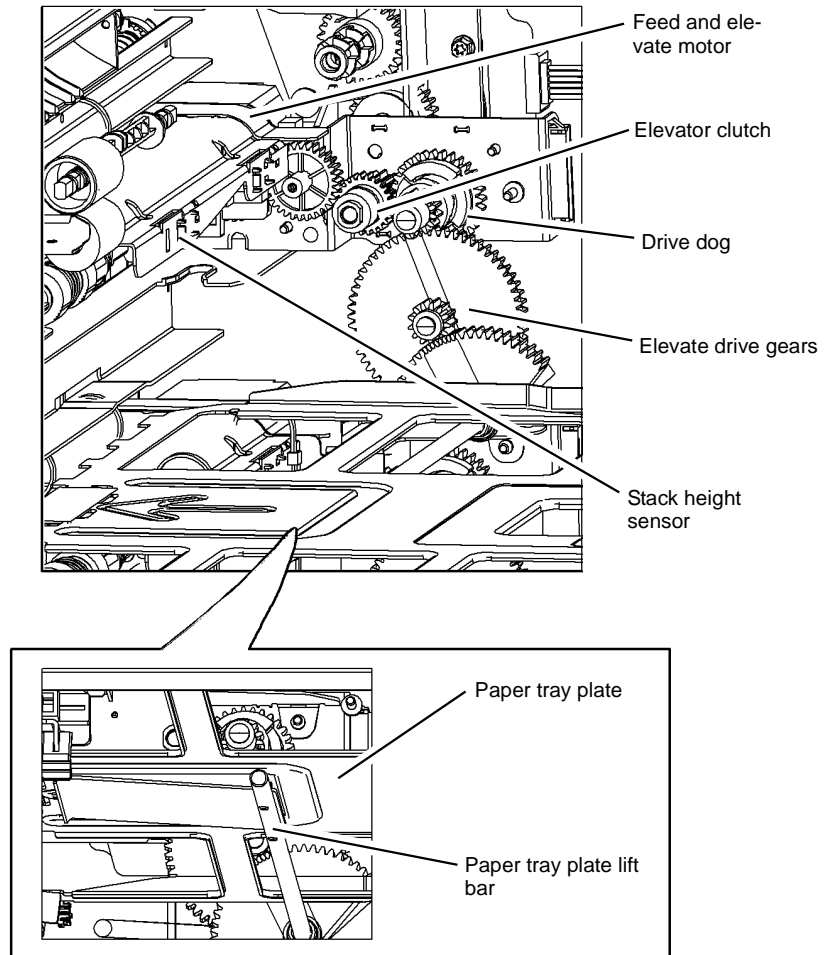

U-5-0060-A

Figure 5 Tray 1 and 2 elevate system

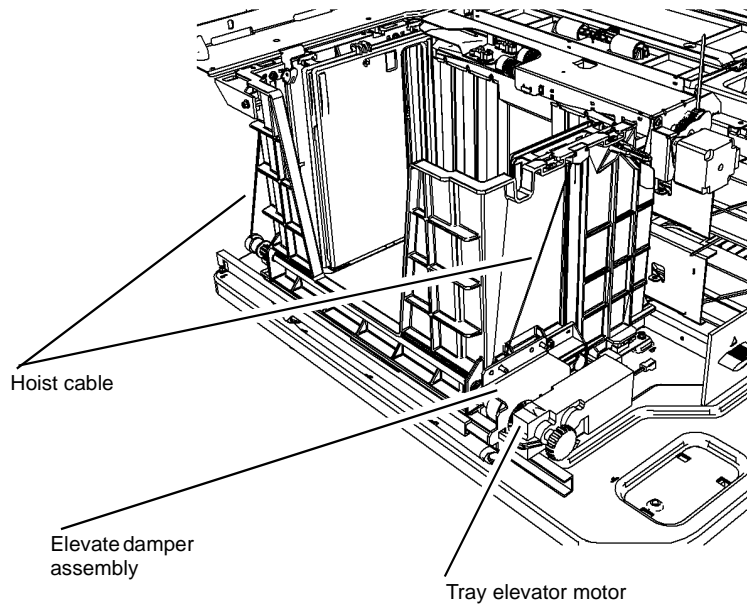

REAR VIEW

U-5-0061-A

Figure 6 Tray 3 elevator system

Paper Feed

Trays 1 and 2 have identical paper feed components. Figure 7 shows the paper feed components for trays 1 and 2. When the tray is closed the nudger roll is released and rests permanently on the top sheet. The force with which rests on the stack is controlled by a spring. The nudger roll is turned by a small belt drive from the feeder roll shaft, which is driven by the elevate / feed motor for the tray.

When the top sheet is fed to the feed roll, a single sheet has sufficient friction to turn the retard roll, and continue being fed. If two sheets are fed, there will not be enough friction between the two sheet to drive the retard roll, and therefore the lower of the two sheets is stalled in the nip and is not fed through the feed nip.

The feed sensor detects the sheet, which is passed to the next nip, located in the 3TM vertical transport. The sheet from tray 1 is passed to take away roll 1 with its associated sensor, TAR 1. The sheet from tray 2 is passed to take away roll 2 with its associated sensor., TAR 2. The nips in the 3TM vertical transport are driven by the 3TM transport motor. This motor also drives the 3TM horizontal transport. Figure 8 shows the 3TM vertical transport.

Note that after the sheet has left the tray 1, 2 or 3 feed sensor, and before it enters take away roll, there is a short wait period. This is to synchronize the leading edge of the sheet with the marking operation. This is the case with all three trays in the module.

When the sheets leave the 3TM vertical transport, they enter the main vertical transport. This is described in the Paper Path section.

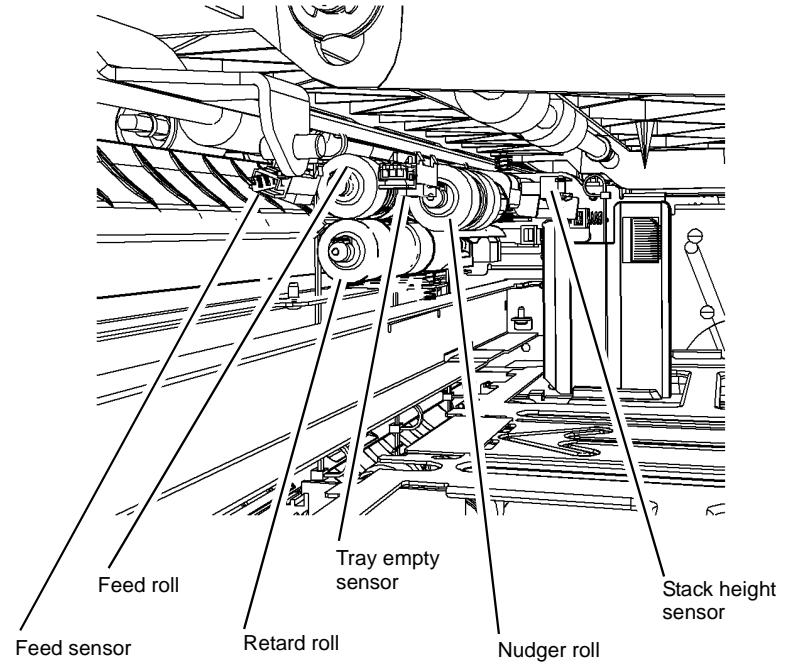

U-5-0070-A

Figure 7 Trays 1 and 2 paper feed

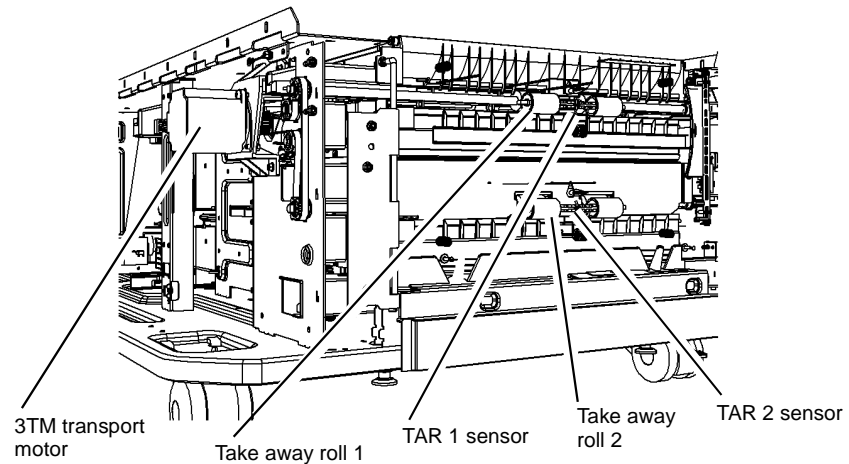

U-5-0071-A

Figure 8 3TM vertical transport drive and nips

The tray 3 feed roll, retard roll and nudger roll are the same as for trays 1 and 2. Tray 3 also has the same feed sensor, tray empty sensor and stack height sensor arrangement. However, tray 3 features an additional switch: the overrun switch described in the paper tray elevation section above. The overrun switch is actuated in the event of tray 3 over running the control of the stack height sensor. When actuated the power is switched off from the tray 3 elevator motor. [Figure 9](#) shows the tray 3 paper feed components.

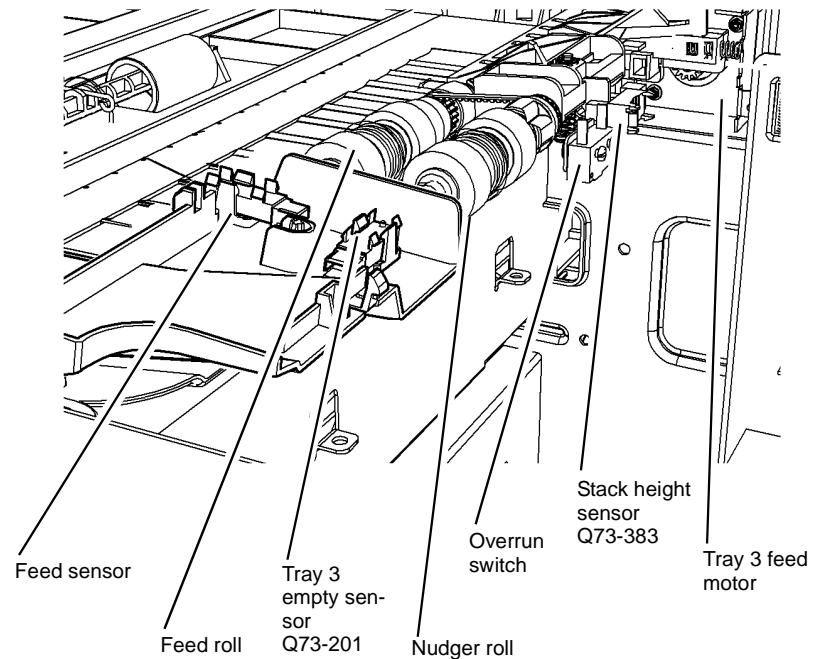

U-5-0067-A

Figure 9 Tray 3 paper feed

When a sheet has been fed from tray 3, it enters take away roll 3, the first nip in the 3TM horizontal transport. This has an associated TAR 3 sensor. The sheet is then fed to nip V and then on past the 3TM horizontal transport jam sensor and into nip U. [Figure 10](#) shows the components of the 3TM horizontal transport. When the sheet leaves the 3TM horizontal transport, it enters the main vertical transport.

When the sheets leave the 3TM horizontal transport, they enter the main vertical transport. This is described in the Paper Path section.

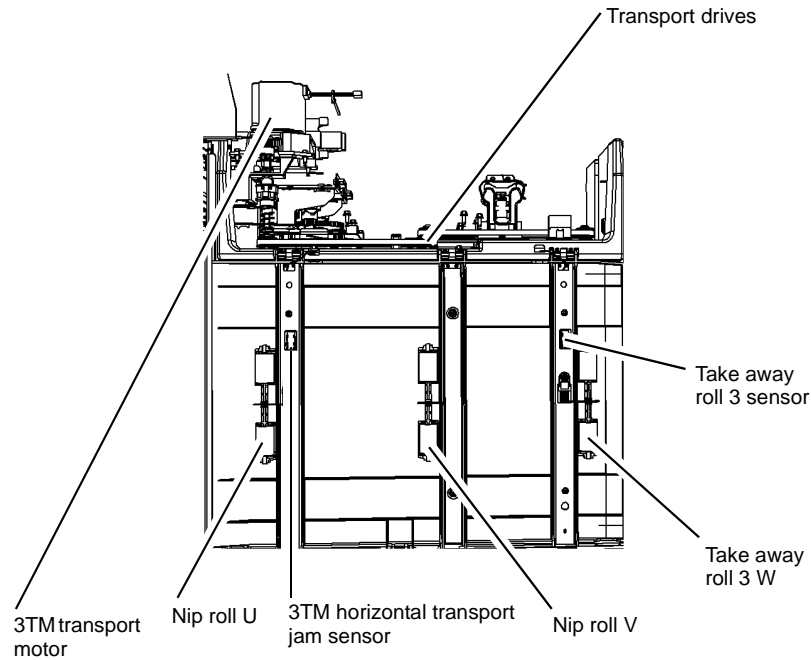

U-5-0068-A

Figure 10 3TM horizontal transport

Bypass tray 4

Overview

The bypass tray 4 is a media feeding device integrated into the IME. The bypass tray can be folded away when not in use.

The main function of the bypass tray is to enable the loading of special material that is either not already in a paper tray, or that cannot be fed from existing trays.

Configuration

The paper tray will accept 100 sheets either A4 or 8.5 x 11 inch of 80 gsm, (20 lb.).

The main features of the bypass are:

- Feeds up to 100 sheet capacity at 80 gsm (20lb).
- Allows feeding of A5 / 5.5 x 8.5 inch SEF.
- Allows feeding of paper size up to 12 x 18 inch / SRA3 SEF.
- Allows feeding of paper weight from 60 to 216 gsm, (US bond weight 16 to 58lb).
- Allows feeding of transparencies, labels, tab stock, cover and envelopes.

The Bypass is controlled directly by software located in the IME.

Machine Interface

The bypass receives and sends serial input and output data to and from the media path driver PWB

Bypass Feeder

The Bypass feeder components are:

- Retard roll and feed roll
- Registration gate
- Feed motor
- Width sensor
- Tray empty sensor
- Media size potentiometer
- Feed sensor
- Nudger home sensor

Media Loading and Registration

The top edge registration of the stack is achieved by the user pushing the synchronously moving media guides against the front and rear edges of the stack.

This de-skews and registers the stack in the cross process direction.

The user must then push the stack forward into the bypass feeder until its lead edge touches the registration gate. The registration gate consists of two pairs of vertical fingers aligned symmetrically around the centre of the paper path.

The inner two fingers are approximately 56 mm apart for registering thinner media fed by the bypass and the outer two fingers are approximately 250 mm apart for registering the wider media fed by the bypass.

The registration gate is positioned such that when the stack is registered:

- the stacks lead edge will be at the base of the ramp between the nudger and the feed nip,
- the nudger will be above the stack ready to lower and feed, and
- the media present sensor flag will be resting on the top of the stack indicating that media is present.

Media Size Detection

The media size detection in the bypass tray is achieved using the width of the stack indicated by the position of the media guides.

The customer is required to set the media guides to the front and rear edges of the stack to enable accurate media width sensing. The user must correctly adjust the guide position, as there is no alternative mechanism for sensing the media width in the bypass tray.

The media guides move synchronously when the customer moves either guide due to a double rack and pinion mechanism. This ensures that the rack connected to the rear guide is always in the same place for any specific media width.

The bypass tray features a potentiometer that has its follower sprung loaded against a ramp profile in the rear rack. As the guides are moved further apart the voltage output from the potentiometer decreases and when the guides are moved closer together the voltage output from the potentiometer increases.

Also housed in the bypass tray is an opto-interrupt sensor called the media width sensor. The activation flag of this sensor is part of the rear rack. The flag in the rack has three sections to it giving a total of 7 regions.

There are 3 regions with a voltage high response and 4 regions with a voltage low response. The combination of the potentiometer output voltage and the state of the media width sensor indicates to the bypass tray software which width region the rear guide is in.

Each region has a defined maximum and minimum stack width that could be in the tray. This information is then passed onto the IME code where the user is required to confirm the media size in the tray.

As the width sensing is market differentiated, the default media size that will be presented to the user for any given width region will depend on the worldwide location of the machine.

Table 1 covers each region's width boundaries, default media by market and other media.

Table 1 Region width boundaries

Width Region	Region width (mm)		US default	EU default	Other media sizes in region
	Min	Max			
Region 1	100	126	ENV US#10 SEF	Env dl SEF	-
Region 2	122	170	Statement SEF	A5 SEF	Env C5 SEF, Env 6 x 9 SEF
Region 3	166	206	Executive	-	-
Region 4	202	256	Letter SEF	A4 SEF	Env C4 SEF, Env 9 x 12 SEF
Region 5	252	290	Letter LEF	-	Tabloid SEF
Region 6	286	314	Tabloid extra SEF	A4 LEF	A3 SEF
Region 7	310	322	-	SRA3 SEF	-

The media size in the cross process direction is detected using the potentiometer and flag sensor, attached to the paper width guides. The user is asked to confirm the detected width size via the UI or to enter a custom size. The size in the process direction is measured when the edge of the paper activates the paper path timing sensor #16.

Nudger and Registration gate Operation

The nudger is lifted and lowered via a cam mechanism that is driven when the stepper motor is reversed. Rotating the motor in reverse does not drive either the feed or the nudger roll due to the one-way clutches on the feed shaft. The cam can only be driven in one direction by virtue of a one way bearing housed in one of the gears in the gear train driving the cam. There are 2 'V' profiles on the cam surface that interact with the nudger follower and an additional spring loaded locking lever. These enable the following functionality;

1. When the nudger follower is in either 'V' it prevents the nudger from lowering onto the stack
2. When the additional locking lever is in a 'V' it prevents the cam rotating and lifting the nudger during feeding, or affecting the nudger load.
3. Enables a large stop position window for all functional positions as the 'Vs' enable the mechanism to self centre when stopped (the self centring also provides positional robustness to any system vibrations should they occur)

The registration gate in its media loading position has its' four fingers vertical in the paper path at the base of the ramp between the nudger and the separation nip. The reg gate hard stop is provided by a sprung loaded locking lever that prevents the rotation of the reg gate at its cam follower. As the cam is rotated it first lifts the locking lever, thus removing the reg gate hard stop, and then rotates the reg gate so its' fingers retreat out of the paper path. The cam is designed so that the nudger is not lowered until the reg gate is completely out of the paper path and the reg gate is not raised until the nudger has been lifted off the stack. The reg gate returns to its hard stopped position using a return spring. The forces have been balanced to ensure that the reg gate spring will always overcome the locking lever spring forces. This ensures that when media is removed from the bypass tray the reg gate will always return to its media load locked position.

There are three functional cam rotational positions;

1. Jam clear position – the nudger is up, the reg gate is held down and the cam rotation is prevented by the nudger follower in the first 'V'.
2. Media load position – the nudger is up, the reg gate is up and locked and the cam rotation is prevented by the nudger follower in the second 'V'.
3. Feed position – the nudger is down, the reg gate is down and the cam is locked by the additional lever in the second 'V'.

The cam includes a sensor vane that runs in an opto-interrupt sensor called the nudger home sensor. The lead edge of this vane indicates the number of steps left to both the jam clear and the media load position. The trail edge of this vane indicates the number of steps left to lower the nudger. The nudger roll can be lowered over the whole stack height negating the need for stack elevation. The mechanism does not continually adjust the nudger position; it allows the nudger to travel over the full stack height under the force of its spring.

Whenever a jam is detected the nudger will be raised to the jam clear position. Once clear, the nudger should be moved to the media load position

Feeding operation

When media has been loaded and its size confirmed by the user, feeding can begin.

The stepper motor is rotated in reverse, lowering the registration gate out of the paper path and then lowering the nudger onto the stack. A wait period is then observed to ensure that the nudger has settled on the stack prior to commencing feeding. The stepper motor is then driven forward, feeding the top sheet into the shingle ramp and then into the separation nip.

If more than one sheet has been fed off the top of the stack then the shingle ramp will shingle them, minimizing the number of cases where more than two sheets enter the separation nip. The separation nip then feeds the top sheet forward, (retarding the second lower sheet if it has entered the nip), until its lead edge is seen at the feed sensor.

The sheet is then be delivered to a specified stage location after the feed nip but before nip E where the sheet waits. This wait period will be adjusted for each sheet to enable the correct delivery time of the sheet to the confirm sensor 16, but will also be of a minimum value to enable the system dynamics to settle prior to an additional move. The sheet is then be fed on to nip E and sensor 16.

Once the sheets lead edge has been seen at the confirm sensor #16 the bypass feed motor stops and nip E drags the sheet out of the bypass tray. This guarantees an inter document gap between consecutive sheets. To minimize the drive force required at nip E to pull a sheet through the bypass tray, the feed roll and nudger roll one-way clutches over-run when the sheet is dragged through. This disengages the motor and gear train from the drag requirement.

Once the sheets trail edge has been seen at the feed sensor, the presence of the next sheet can be confirmed. The next sheet can then be acquired. This is repeated until either the bypass tray runs out of media or all desired sheets have been fed. The stepper motor is then reversed to raise the nudger and return the registration gate to the media load position. Note that the nudger remains down on the stack throughout the full multiple sheet feeding sequence.

Multifeed Prevention Pre-Separation Nip

When nudging sheets to the separation nip, the ideal situation is that only the top sheet is moved each time. To help facilitate this, the bottom of the stack is retarded using a cork pad positioned directly underneath the nudger. The high coefficient of friction of the media to the pad prevents the stack as a whole moving forward, but slug feeds of multiple sheets above the base of the stack can still occur.

The separation nip can feed these slugs one sheet at a time if:

- the slug is 2 sheets in number, or
- the slug is shingled with the top-most sheet further forward and each consecutive lower sheet slightly further behind.

To aid in the shingling of any multiple sheet slug feeds, the bypass tray drives all sheets into a steep sheet metal ramp between the nudger roll and the separation nip. The shingle ramp angle, nudger load and distance between the nudger roll and the ramp have been optimized to minimize miss-feeds whilst maximizing the ability to shingle multiple sheet slug feeds.

Multifeed Prevention at the Separation Nip

When feeding sheets the separation nip performs the following functions:

- If a single sheet enters the nip it will feed the sheet.
- If 2 sheets enter the nip it will feed the top sheet whilst retarding the bottom sheet.

The separation nip consists of a feed roll mounted on a feed shaft. The feed roll is driven by an in-line mechanical one-way clutch only when the feed shaft is rotated in the feed direction. A retard roll is then sprung loaded against the feed roll, with the pivot point a known X and Y distance from the feed roll centre line. The retard roll has an in-line mechanical slip clutch that will rotate when a known torque has been achieved. If a single sheet enters the nip then there is enough drive from the feed roll to overcome the retardation of the slip clutch. Therefore the sheet is fed and the slip clutch rotates. If two sheets enter the separation nip then the drive exerted from the top sheet to the bottom sheet is not enough to overcome the slip clutch torque. Therefore the top sheet is feed over the bottom sheet which is retarded by the stationary retard roll.

'D' Solenoid

The solenoid at the 'D' nip rolls opens and closes the nip. This is to accommodate the trailing edge of the second side prints and to assist the registration / preheat assembly operation.

Figure 1 shows the bypass attached to the machine. Figure 2 shows the rack assembly and media width sensors. Figure 3 shows the media feeding components. Figure 4 shows the nudger home sensor, media present sensor and the feed sensor. Figure 5 shows the 'D' and sensor 16.

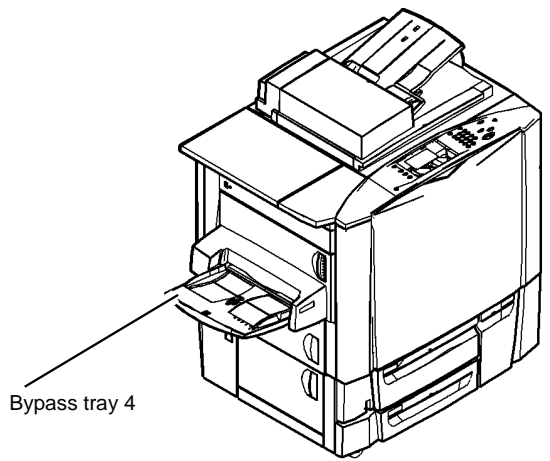

Bypass tray 4

Figure 1 Bypass tray 4 installed on IME

U-5-0054-A

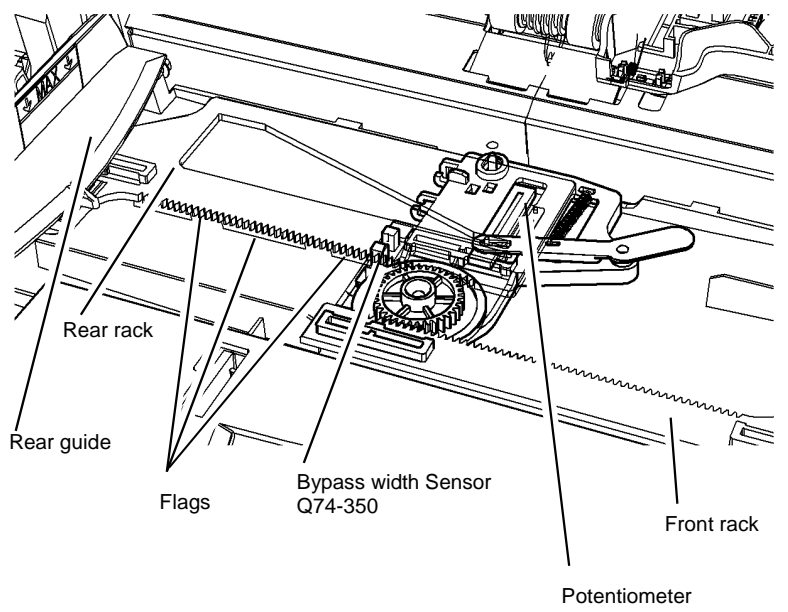

Rear rack

Rear guide

Flags

Bypass width Sensor
Q74-350

Front rack

Potentiometer

U-5-0055-A

Figure 2 Bypass width sensors

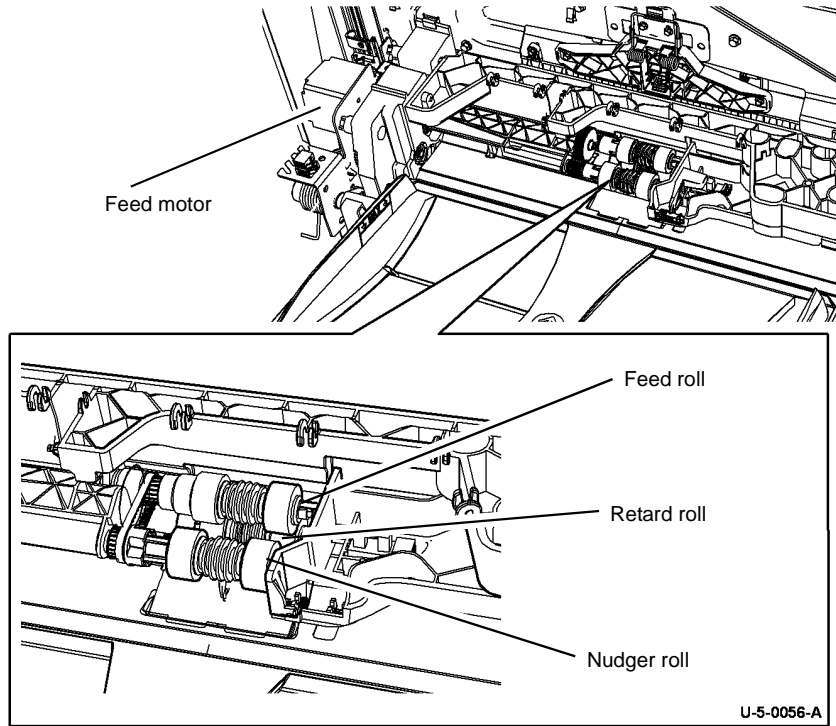

Figure 3 Bypass media feed components

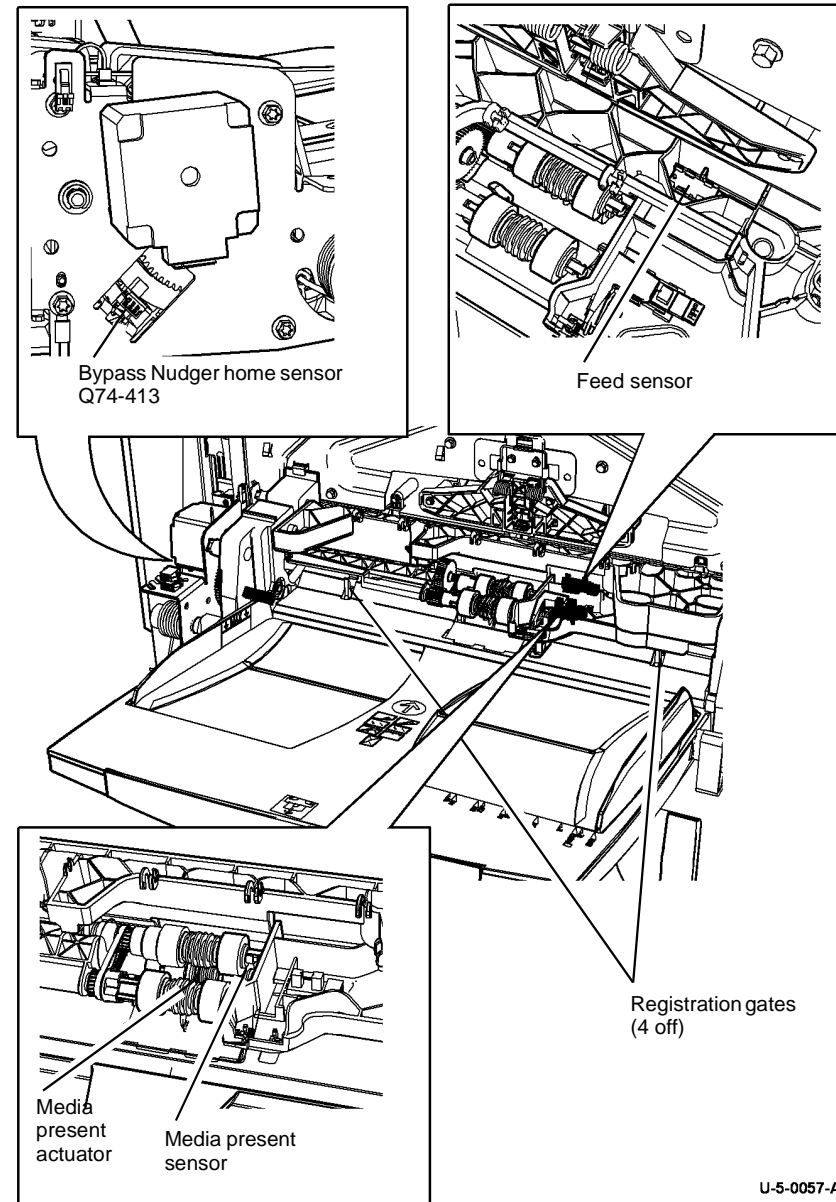
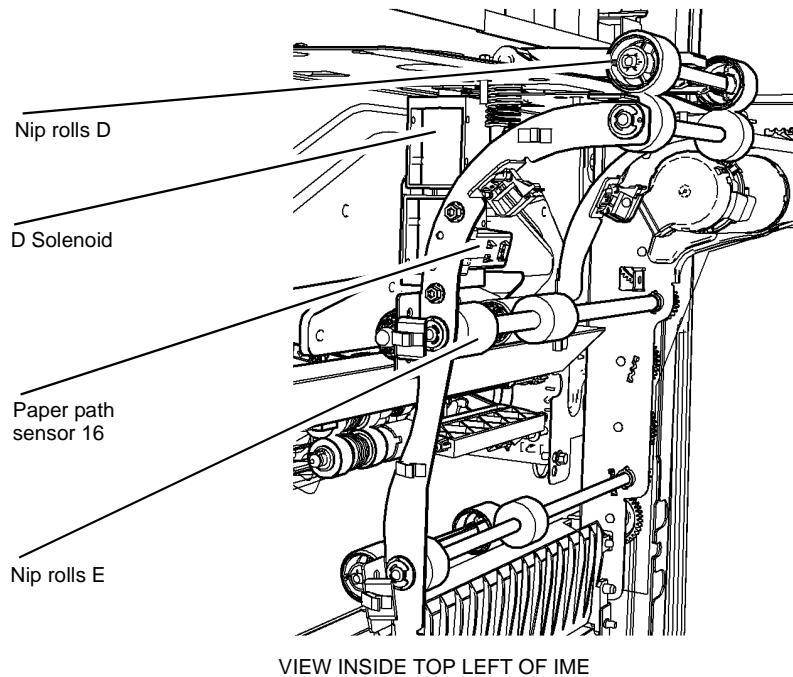

Figure 4 Bypass media feed components



U-5-0058-A

Figure 5 Bypass feed operation

Tray 5 Module

Overview

The tray 5 module is a high capacity paper source that can be used as the primary paper feeder for the system. It provides a single tray with a dedicated paper size setting that can be set to A4 or 8.5 x 11 inch, long edge feed, (LEF). It provides paper at the rate required by the machine to which it is attached.

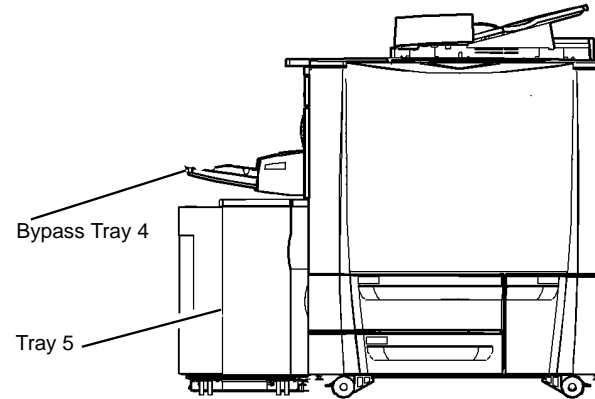

U-5-0004-A

Figure 1 Tray 5

The tray 5 module is positioned to the left of the machine [Figure 1](#). It is attached to the machine by a fixed base. Runners on the base allow the unit to be moved to the left for access to the left hand door, for jam clearance.

Power is derived from the main machine via a combined, communications connector. The tray can be reloaded with paper while other paper sources are in use.

A transport lock mechanism allows the tray 5 module to be moved safely, when not attached to the IME.

Configuration

The paper tray size is a mechanical setting that can be adjusted to accept 4000 sheets either A4 or 8.5 x 11 inch (80 gsm / 20 lb.), long edge feed stock. The paper size is pre-set at the factory and is dependant on the market region. There is no paper size sensing available in tray 5.

Kits are available to convert tray 5 to accept the following media:

- A4, short edge feed
- 8.5 x 11 inch, short edge feed

- 8.5x14 inch, short edge feed
- A3, short edge feed
- 11 x 17 inch, short edge feed

When one of these kits is installed, the door is not present and the door switch is replaced by a manual tray loading switch.

Tray 5 contains the following main elements:

- Paper tray
- Semi-active retard feed head, (SAR)
- Paper transport system
- Tray elevator
- Docking and interlocks
- Component location

Machine Interface

The serial interface is a hi-speed communication interface for transferring low-level data. This is done in the form of sensor data from the tray 5 hardware to the IME and control data from the IME to the tray 5 hardware.

The machine interface comprises of the tray 5 control PWB, the communication cable, a bulk-head connector, a harness and the host controller PWB.

The communication cable also provides +5V and +24V to the tray 5 components.

If any communications data lines become open circuit or short circuit, a communications fault is indicated by the IME.

The software is capable of handling all stock formats, and the GUI setting should match the tray setting. As there is no paper size detection on tray 5, and therefore no size information is fed to the machine, failure to set the GUI size to match the tray 5 stock may result in faults such as: jams, image quality faults, finisher tamping errors, etc.

Interlock

Interlock switches in the tray 5 module interrupt the +24V power when the front door interlock or the docking interlock are opened for jam clearance or service. The interlocks must be closed to enable initialization.

Paper Path

Figure 2 shows the paper path between tray 5 and the IME.

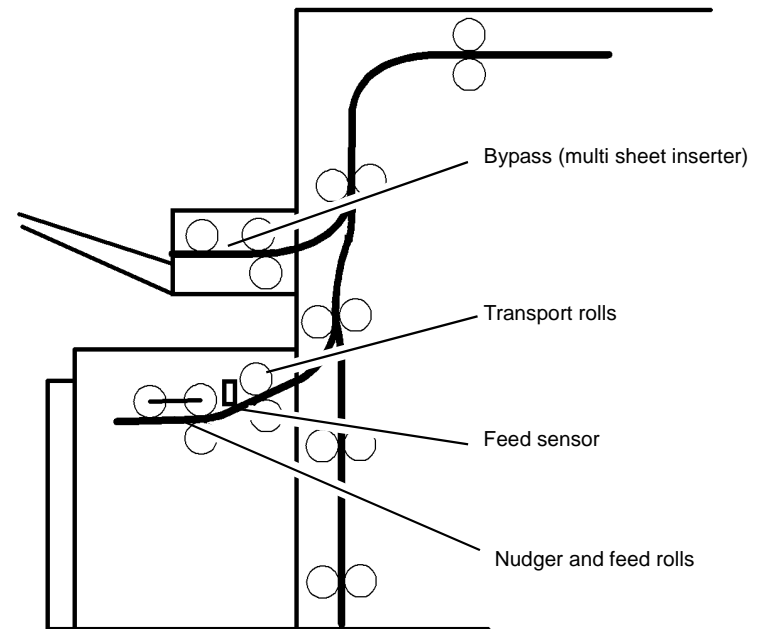

U-5-0005-A

Figure 2 Paper path

The nudge roll and the feed rolls are driven by the tray 5 feed motor, and feed the sheet to the feed rolls, (SAR feeder). The feed rolls transport the sheet past the feed sensor to the tray 5 transport rolls. Because of the inherent slippage in SAR feed heads, the paper does not arrive at a well defined time. The transport rolls, which are not SAR, are driven by the tray 5 transport motor, whose speed is controlled by the software. The time for the sheet to reach the paper feed sensor is measured, and the speed of the transport motor is adjusted to ensure the leading edge of the sheet arrives at the IME at the correct time.

Semi-Active Retard Feed Head (SAR)

This consists of a nudge roll, mounted on a pivoting arm, as shown in Figure 3.

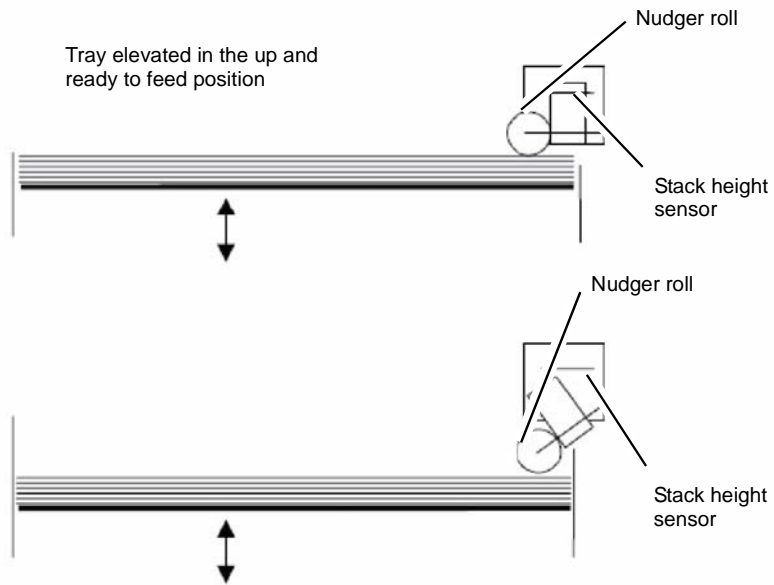

Note: Retard roll and other parts of SAR assembly not shown

U-5-0001-A

Figure 3 SAR Feeders

A separation nip is formed by the nudge roll and a retard roll which is not shown. The nudge roll is sprung and rests on the stack to feed the top sheet. If the stack is not within the feeding position, the stack height sensor triggers the elevator to rise to the feeding position.

The SAR mechanism substantially reduces the incidence of multi-sheet feeding.

Because the speed of the sheet is slightly reduced by the effect of the retard roll, when the leading edge reaches the paper feed sensor, the feeding speed is controlled to ensure the sheet reaches the hand-over point in the IME within the allowable time window.

Paper Feed and Retard Rolls

Tray 5 feed roll / retard rolls are accessible from tray door access and by sliding the tray away from the IME. The host controller monitors their usage, recording the sheet feed count in the NVM, along with their life expectancy, to inform the customer service engineer (CSE) when their end of life occurs.

Paper Present Detection

When the tray is less than 10% full, and the tray is in the up position, the software checks after each sheet feed for an 'out of paper' condition. The tray 5 empty sensor is a reflective type and is situated directly over a hole in the paper tray, normally covered by paper. There will be no reflection when the last sheet has been fed, and an 'out of paper' condition will be declared. The GUI instructs the operator to refill the tray and further paper feeds will be inhibited. In a normal tray 5 module, with A4 or 8.5 x 11 inch LEF stock and a door present, the tray is automatically lowered. If there is no door, and a paper kit is installed, the tray is lowered when the manual push button is pressed and released. The out of paper status is raised to the host controller. The tray will elevate again when the door is closed after refilling the tray.

Tray Height Sensor

The machine keeps track of the tray height, based on the distance travelled from the start of lift. A software height counter is zeroed when the tray starts to rise and the stack down sensor goes low. As the tray rises, the elevator motor encoder sensor increments the height counter for each pulse sensed from the vertical encoder track. When the tray reaches its upper position, and the stack height sensor is actuated by the nudge roll, the value of the height counter is passed to the IME, as a percentage of the tray 5 paper stock left on the tray. The IME holds the stack height value as 0%, 5%, 10% and at 10% intervals up to 100% full, and this is available for display to the remote web UI. The counter value is updated whenever the elevator motor encoder sensor, changes state, and is saved to the NVM each time. If an expected change in state of the height encoder does not occur, when the elevator motor is operating, a fault condition is declared.

Stack Height when Feeding

The stack height sensor maintains the stack height by triggering activity of the elevator motor. When a change in the condition of this sensor is detected, there is a de-bounce delay of 33 milli-seconds to allow the condition to settle, and if the change in the state of the sensor is confirmed, the elevator motor raises the tray, after the paper leading edge has passed the transport rolls. The amount of movement is determined by the current position of the tray. This position is used to read the 'motor-on time' from a look-up table, held within the machine.

Tray Overload

If the stack height sensor indicates the tray is at the feeding position, and at the same time the stack down sensor detects the tray in the fully lowered position, the 'overloaded tray' status is raised. The elevator motor movement is inhibited and an error is raised. This error condition is maintained until the conditions producing it no longer apply.

Elevator Motor Stop

The elevator motor is never stopped by simply removing the power and allowing it to coast to a stop. Whenever the motor is stopped, it is dynamically, actively braked to a stand still.

Elevator Upper and Lower Positions

The commonly used tray control sensors are:

- The stack height sensor
- The stack down sensor
- The paper empty sensor
- The elevator motor encoder sensor.

The safety limit switches are:

- The tray down limit switch
- The tray upper limit switch

The down limit switch breaks the +24V supply to the elevator motor in the down direction only. The upper limit switch breaks the +24V supply to the elevator motor in the up direction only. This allows the tray to recover its position, while preventing damage that would occur through further movement in the wrong direction.

The limit switches are connected to the tray 5 control PWB motor drive circuitry, rather than the sensing circuitry. Therefore, if one of the limit switches is actuated, the elevator movement is stopped, the lack of movement is detected by the software and a fault condition is declared

Component Location

Table 1 lists the active components of tray 5.

Table 1 Active components

Name	Function
Tray 5 feed sensor	Detects the leading edge and trailing edge of the paper
Tray 5 empty sensor	Detects paper present in the tray
Stack height sensor	Detects the tray at the feed position
Stack down sensor	Detects the tray in the fully lowered position
Elevator motor encoder sensor	Detects teeth on the vertical encoder, used to determine stack height
Tray 5 docking switch	Detects tray 5 in the docked position
Tray 5 door closed switch	Detects the tray 5 door open or closed
Tray 5 upper limit switch	Cuts the +24V to stop tray when moving to the up position
Tray 5 down limit switch	Cuts +24V to stop tray when moving in the down direction
Tray 5 transport motor	Stepper motor feeding paper out of tray 5
Tray 5 feed motor	Stepper motor to separate sheets and move the paper to the transport rolls
Tray 5 elevator motor	Moves the tray up and down
Tray 5 control PWB	Controls the operation of tray 5

Refer to Figure 4 for the location of components motors and sensors.

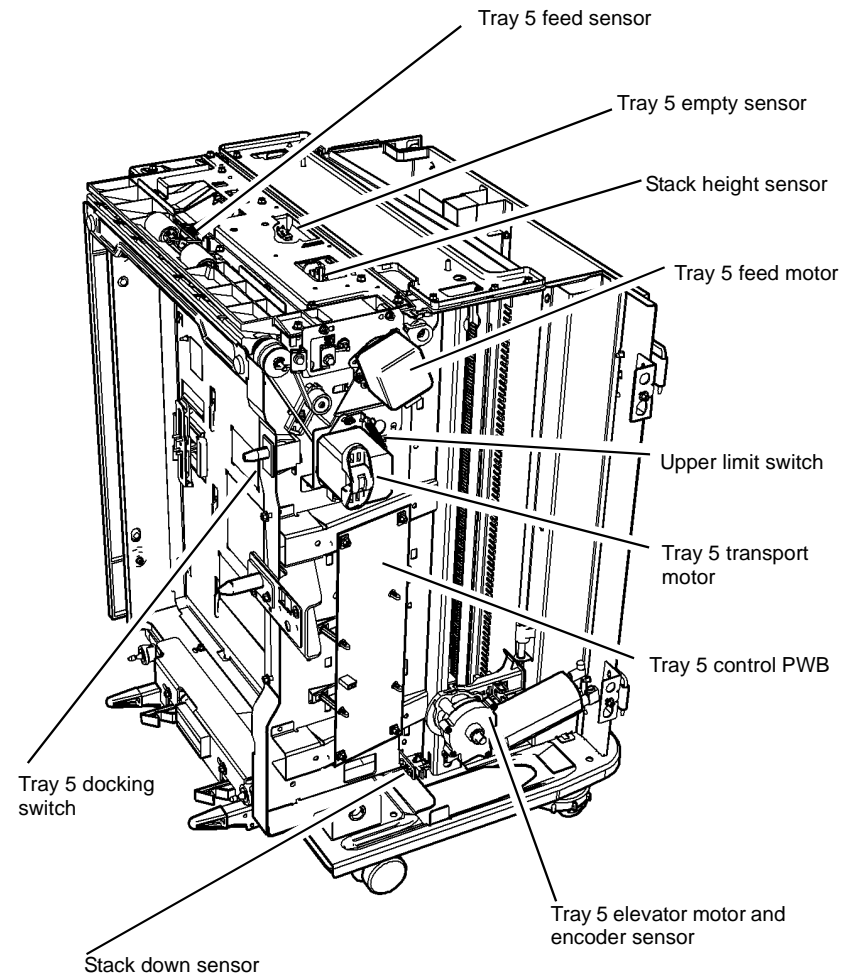

U-5-0002-A

Figure 4 Component location

Figure 5 Transit lock, paper size adjustment door switch and limit switch

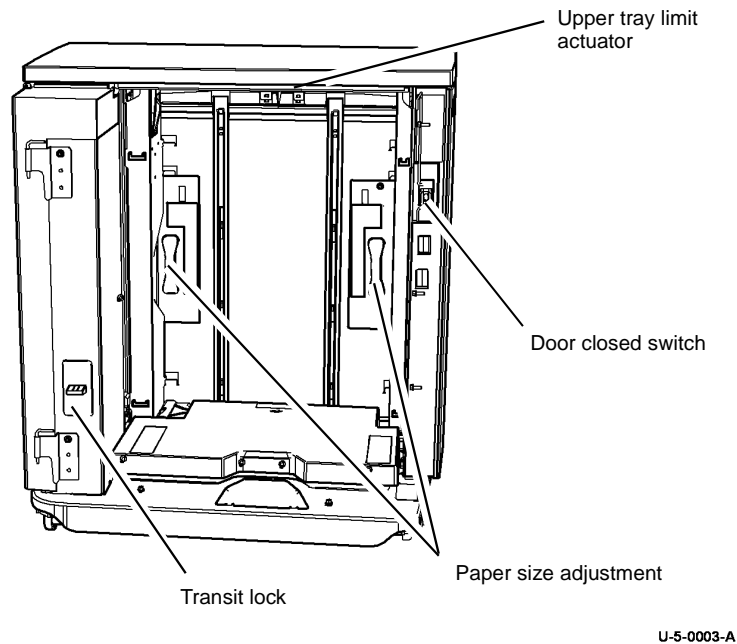

Figure 5 Component location

Adjustment

The following tray 5 adjustment procedures are described in the service manual:

ADJ 75.1, Tray 5 Paper Tray Guide Setting. This is performed to adjust the paper tray guide in tray 5 for A4 / A3, or for 8.5 x 11 inch / 11 x 17 inch paper.

ADJ 75.2, Tray 5 Module to Machine Alignment. This is performed to align the tray 5 module to the IME. This is the first adjustment in achieving correct registration and reliable paper transfer between tray 5 and the IME.

ADJ 75.3, Tray 5 Module Tray Alignment. This is the second adjustment to be performed when aligning tray 5 to the IME. It is performed when top edge registration cannot be achieved, using only the NVM values in Registration Setup Procedure.

Image Marking Engine (IME)

Figure 1. The IME includes these components:

- Vertical transport
- Horizontal transport
- Registration
- Print marking unit and drum assembly

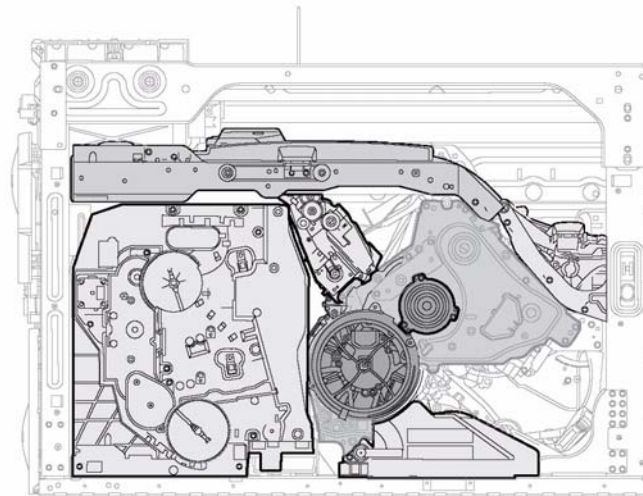

Figure 1 Image marking engine

Vertical Transport

The vertical transport nips takes the sheets from the 3TM, tray 5 or the bypass tray. The components associated with the vertical transport are:

Vertical transport motor, M2 - A servo motor located at the top rear of the transport. The vertical transport motor drives the vertical transport nips via a train of gears and a toothed belt. **Figure 2.**

Nip H - On leaving the 3TM area, the sheets are taken by nip H, the lowest nip in the main vertical transport. Refer to **Figure 2.**

The vertical jam sensor - This checks for the presence of the sheet after nip H and before nip F. Refer to **Figure 2.**

Nip F - This nip accepts sheets from the 3TM area and also takes sheets from tray 5. Refer to **Figure 2.**

Nip E and the confirm sensor - This nip accepts sheet from nip H and it also accepts sheets from the bypass tray. When a sheet arrives from the bypass tray, the leading edge passes through nip E. Once its presence is confirmed by the confirm sensor (#16), the sheet is pulled from the bypass tray by nip E. Refer to [Figure 2](#).

NOTE: after the sheet has left the bypass tray feed sensor, and before it enters nip E, there is a short wait period. This is to synchronize the leading edge of the sheet with the marking operation

Nip D - This is the last set of rolls to be driven by the vertical transport motor. This nip can be opened or closed by the action of the nip D solenoid. It is necessary to open the nip to accommodate duplex sheet feeding. Refer to [Figure 2](#).

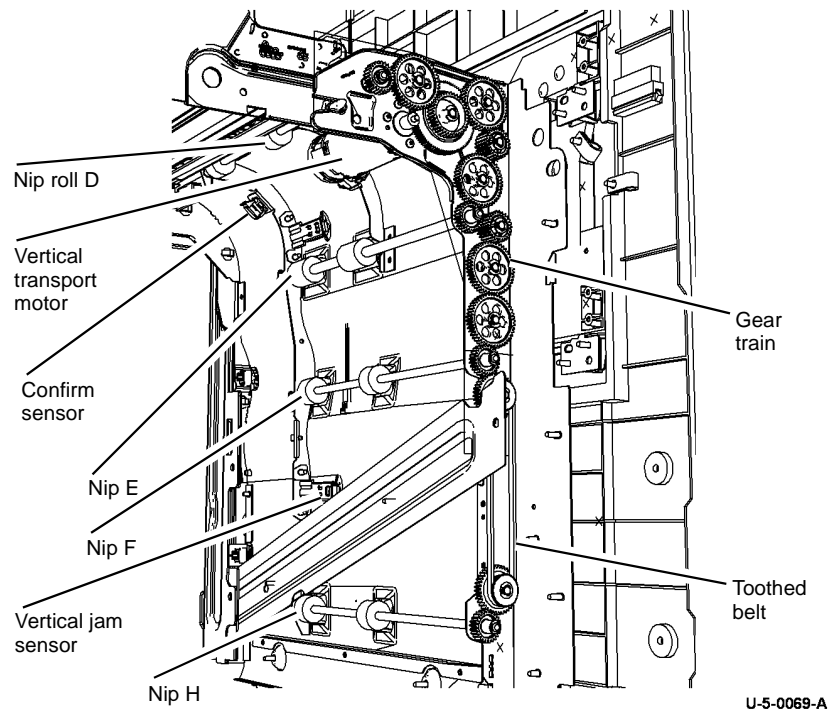

Figure 2 Vertical transport components

Horizontal Transport

The horizontal transport handles sheets being fed to the marking process. Simplex sheets or duplex sheets for first-side marking are fed from the vertical transport. Duplex sheets for second-side marking are fed back into the horizontal transport from the duplex transport. The horizontal transport is also used when performing the final inversion on single-side printed tabs and duplex pre-drilled or pre-printed stock. The components associated with the horizontal transport are:

Horizontal transport motor, M6 - This is a servo motor, located at the rear of the transport. This motor drives nips C, R and Q via a 90-tooth gear and two, 108-tooth drive belts. Refer to [Figure 3](#).

Duplex sensor (#14) - A reflective sensor, located on the top of the horizontal transport. When the sheet is fed from the vertical transport, this sensor detects the leading edge. Nip C rotates in the forward direction to transport the sheet for first-side marking. When the sheet returns via nip C for second-side marking, the duplex sensor detects the sheet leading edge. Nip C rotates in the reverse direction and continues to do so until the sensor detects the sheet trailing edge. Nip C then changes to rotate in the forward direction to feed the second side of the sheet for marking. Refer to [Figure 4](#).

Nip C - Driven by motor M6 and can be opened when necessary, by the nip C solenoid.

Nip C solenoid - A 48V solenoid located on top of the horizontal transport. The nip C solenoid actuates to open nip C. Nip C opens to allow nip A in the registration / preheat assembly module to control the speed and skew of the sheet. Refer to [Figure 4](#).

Diverter solenoid - A 48V solenoid, located on top of the horizontal transport. The diverter solenoid actuates to allow sheets to return from the duplex transport to nip C, rotating in reverse, for second-side marking. It de-actuates to feed sheets to the drum, with nip C rotating forwards. Refer to [Figure 4](#) and [Figure 5](#).

Duplex sensor (#17) - A reflective sensor, located on the top of the horizontal transport. Duplex sensor 17 detects the leading and trailing edges of sheets returning along the horizontal transport for second-side marking. Refer to [Figure 4](#).

Nip roll R and nip roll Q - Fixed nips driven by motor M6. Nips R and Q transport the sheets returning along the horizontal transport, for second-side marking. Refer to [Figure 4](#).

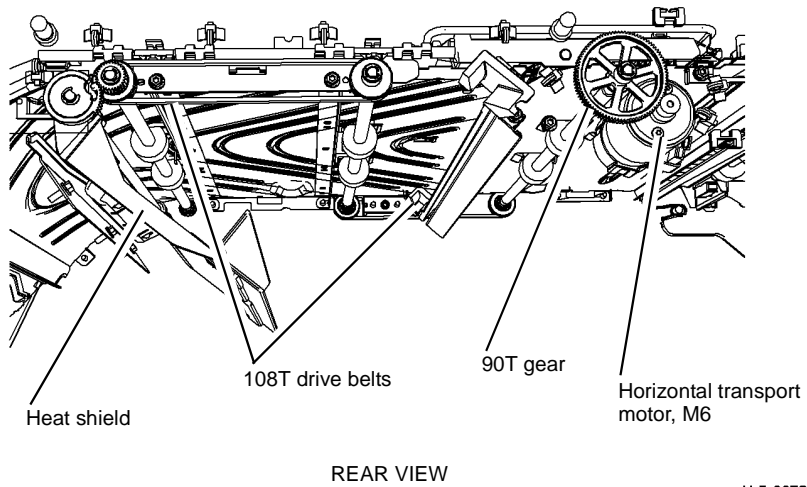

U-5-0072-A

Figure 3 Horizontal transport motor and drives

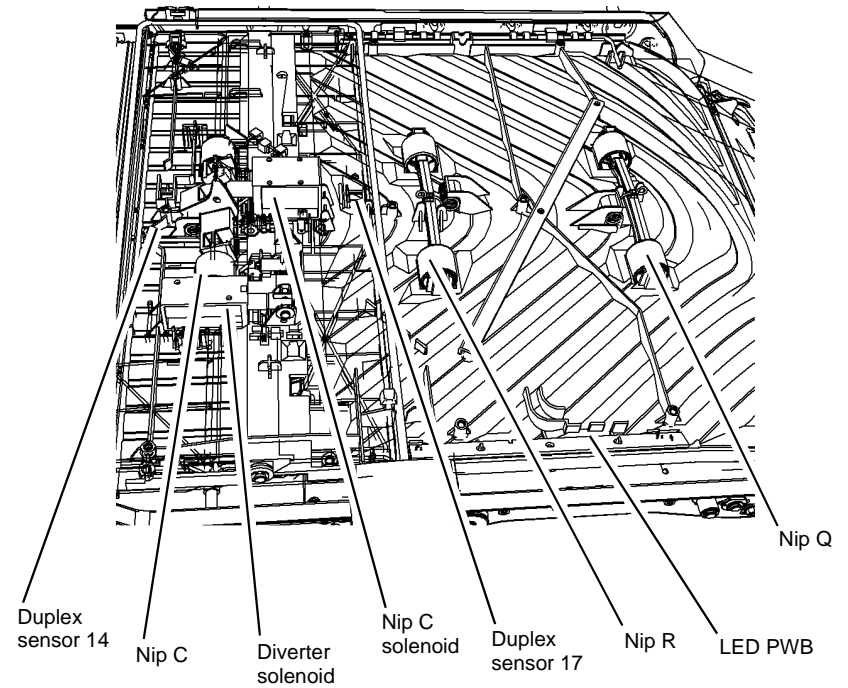

U-5-0073-A

Figure 4 Horizontal transport components

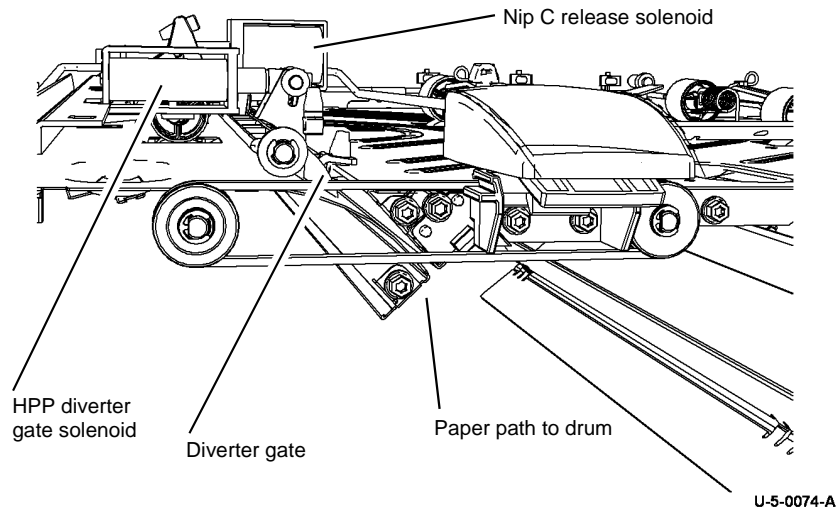

Figure 5 Marker diverter components

Heat shield - A hinged plate, located to the right of nip Q. It protects the rollers from the heat of the registration / preheat module and the drum, and it hinges up when the clamshell on the registration / preheat module is raised. Refer to [Figure 3](#).

Illumination LEDs - Are mounted on PWBs located in the heat shield and in the horizontal transport jam clearance door. The LEDs assist the customer and the service engineer when clearing media jams. Refer to [Figure 6](#).

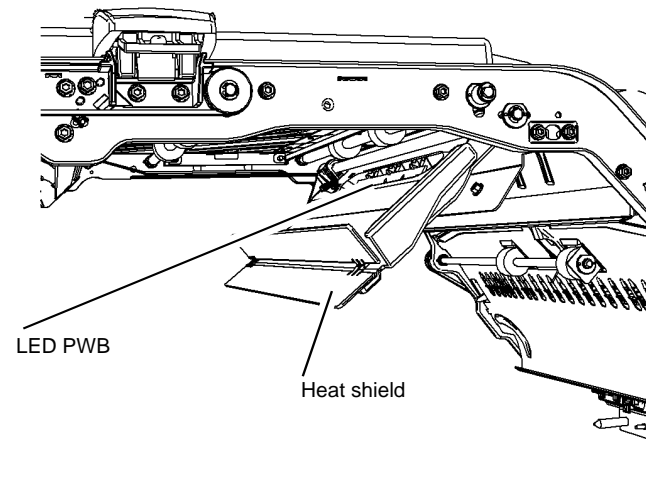
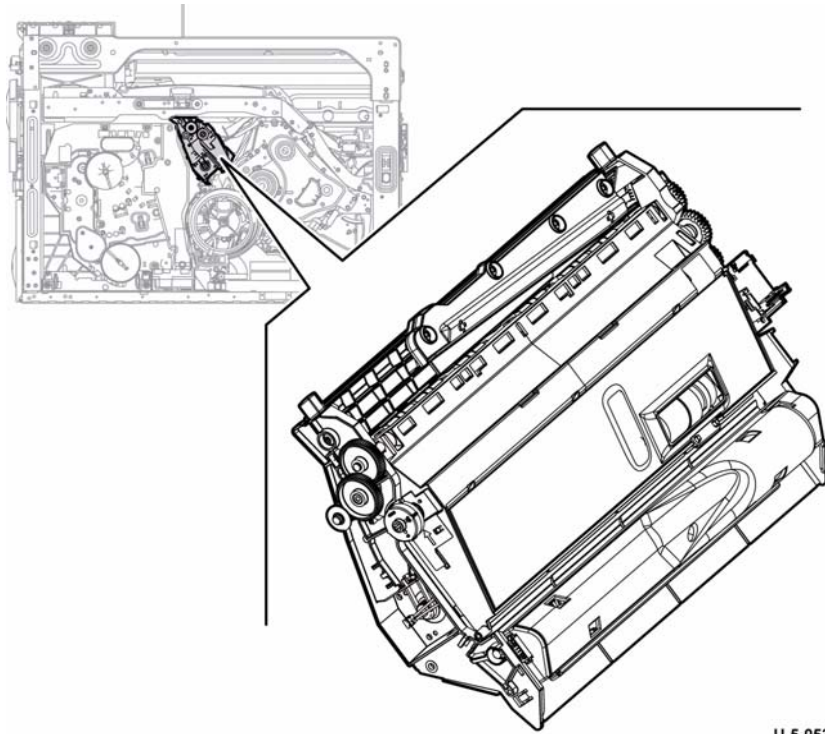

Figure 6 Heat shield LED PWB

Registration / Preheat Assembly

[Figure 7](#) shows the location of the registration / preheat assembly.



U-5-0537-A

Figure 7 Registration/preheat assembly location

The registration / preheat assembly uses a single CIS scan bar to detect the rear lateral edge of the sheet. Based on the location of this edge it can be determined if the sheet is wider or narrower than expected by more than 10 mm. If the rear edge is within 10 mm of the expected position, the lateral location of the sheet is corrected by the registration mechanism. If the rear edge is more than 10 mm from the expected position a jam is declared by the machine. As the CIS scan bar is mounted at an angle relative to the lateral direction, it can also detect sheet skew.

The registration / preheat assembly reads the skew and position of the media and uses this information to determine the amount of de-skew required to orient the media correctly from inboard to outboard. De-skewing is accomplished by intentionally skewing the paper twice. The sum of the two actions causes the media to be both aligned inboard to outboard and the lead edge to be de-skewed. Due to these movements, the motion of the paper through the registration / preheat module is sometimes referred to as 'wag'.

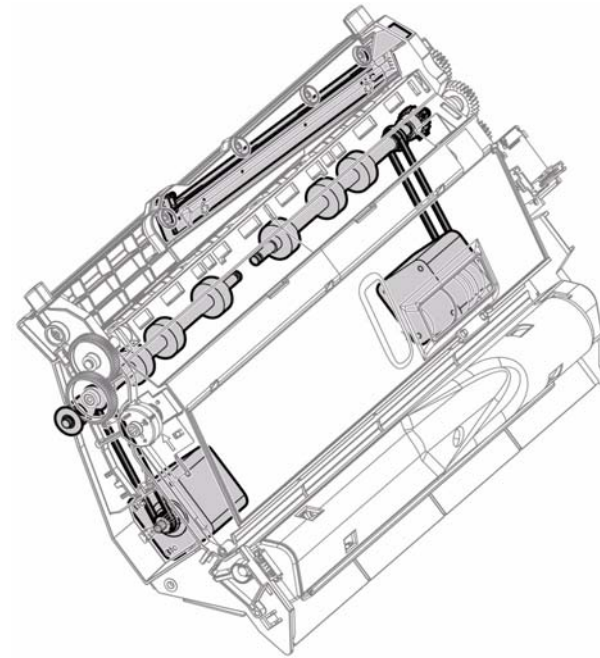

U-5-0100-A

Figure 8 Skew correction drive

Figure 8. The intentional skewing of the paper is accomplished by the steering rolls. The steering roll shafts align with one another but are separate and are driven by separate stepper motors. Depending upon the width of the media, various idlers will be engaged to provide drive to the paper. This is accomplished with the rear drive motor by running in reverse. **Figure 9.**

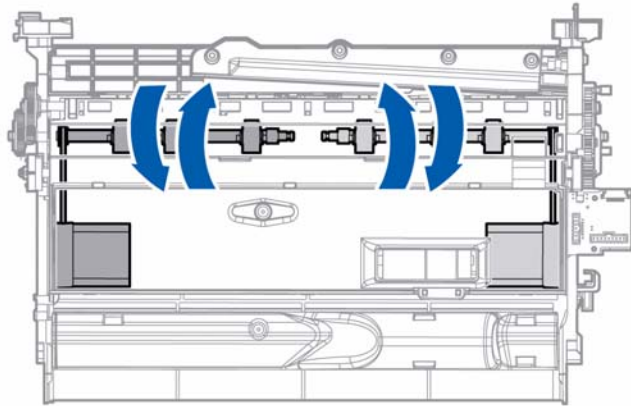

U-5-0560-A

Figure 9 Registration skew drive

The knob on the front of the registration / preheat assembly is marked with dots indicating the current operating position. If there is no dot in alignment with the arrow, the registration / preheat assembly is in the 'ready to open' position.

Position 1 = widest stance = ~ 11 inch (LEF) or B size - Load outer rollers only

Position 2 = narrowest stance = Statement, A5, Smaller Envelopes. Load inner-most rollers only

Position 3 = middle stance = ~8.5 inch Load middle most rollers only. Generally for 8.5 X 11 inch SEF or legal (8.5 X 14 inch)

Position 0 = Open, when set to 0, the registration / preheat assembly can be opened via motor or manually

To assist in making these rapid movements, the registration / preheat assembly employs an air system which reduces friction on the media while helping to hold it in contact with the heated lower plate. Air from two air pumps (connected in parallel) is fed to the center of the eight upper platelets. Four platelets on each end of the registration / preheat module. This air helps to force the media down while 'floating' the platelets, thereby allowing easy movement of the media. Loss of this air system may cause smearing on duplex prints, poor lead edge registration, image quality issues due to poor heating of the media and / or skewing of the media.

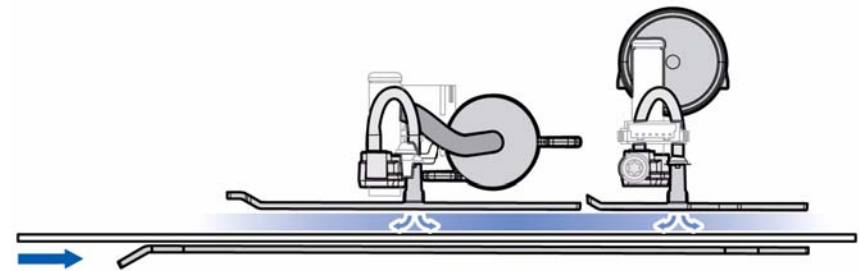

U-5-0562-A

Figure 10 Registration / Preheat airflow

Figure 10. Air pumps are activated just before the paper enters the registration / preheat assembly and deactivated soon after the paper exits the registration / preheat assembly.

Figure 11.

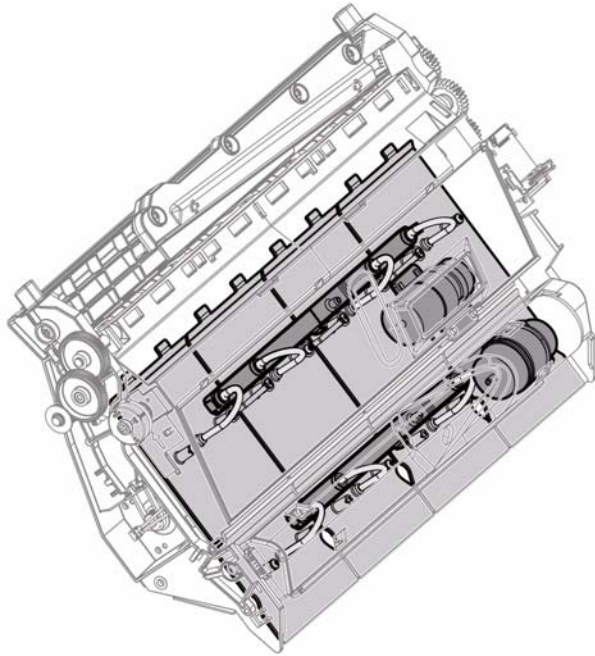

U-5-0503-A

Figure 11 Preheater plates and air supply

Heating of the media

In order to assure a good transfer of image from the drum to the media and to assure a good bond of the ink, the media is pre-heated. This is accomplished by a large heating surface below the lower paper path plate of the registration / preheat assembly. Air pressure forces the paper to contact the heated lower metal plate. A loss of air pressure to the platelets will probably not result in jams but may contribute to lead edge mis-registration. Often the first indication of an air pressure failure is missing pixels on side two of two-sided media. This is mainly caused by insufficient heat since the paper is not being held fully against the heated plate.

Jam Clearance

If the machine jams and media is located in the registration / preheat assembly, the inboard paper path drive motor will run in reverse until the stance sensor (at the rear) is actuated indicating the registration / preheat assembly is in the '0' position. This is the position which will allow the registration / preheat assembly to open. The outboard motor will then run in reverse for a designated amount of time to open the registration / preheat assembly and to position the heat shield (which hangs from the bottom of the horizontal paper path) in the open position. The motor then maintains this open position. Two LEDs on the bottom of the heat shield will be illuminated to help in jam clearance. To close the registration / preheat assembly, the front motor will run very slowly in the forward direction to lower the registration / preheat assembly. Jams may occur in the registration / preheat assembly if the scan bar senses more skew or lateral movement than the registration / preheat assembly can rectify, resulting in a partial image being left on the drum and / or transfix roller.

Drum Thermal Cutout

AC power to the drum heaters run through the thermal cutouts on the registration / preheat assembly thermal cutout PWB. If the drum temperature is higher than the nominal operating range (108 C), the thermal cutouts on the PWB open and interrupt AC power to the drum heaters.

Print Marking Unit and Drum Assembly

Marking Unit

The Marking Unit (MU) is composed of an enclosure (drawer) mounted on rails that allow the MU to be pulled out from the IME for service. A fan and duct cools the electronics. The drawer structure is composed of two injection molded plastic frames connected by sheet metal, which is comprised of the MU frame mid-wall and MU frame floor. A MU Electronics Cover is removable for servicing the MU electronics. Figure 1 illustrates the MU construction.

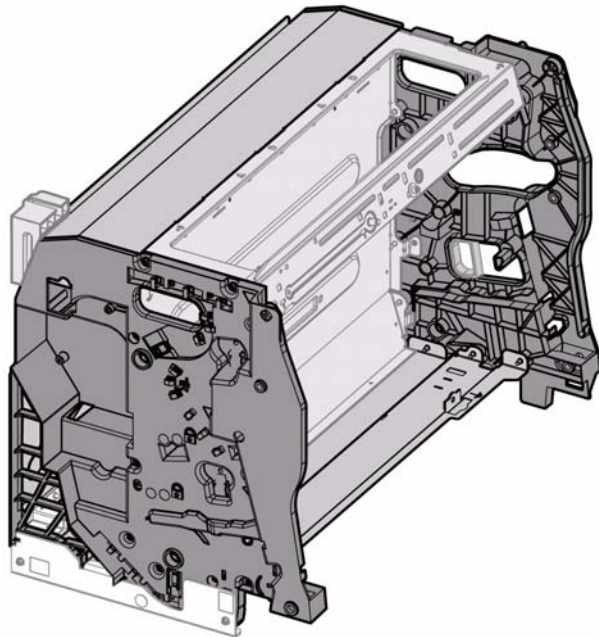

U-5-0521-A

Figure 1 Marking unit drawer

The drawer is mounted on full extension drawer slides, allowing it to be pulled out for service. When the drawer is pushed back into the machine it registers to the chassis at four points, two at the front and two at the back. The connection is made by two cylindrical protrusions moulded into the front and two cylindrical holes moulded into the rear drawer frames that are mated with features (extruded hole and raised pins) in the chassis. Once the drawer is pushed in and registered by the frame pins, fasteners are used to secure the drawer. Two fasteners are installed near the front registration pins.

The MU includes the Staggered Full Width Array (SFWA) carriages that support the printheads which deposit ink on the drum, the electronics to drive them and the Head maintenance system. A series of linkages are employed to move the carriages between functional positions using the drive mechanism on the back of the enclosure. The ink reservoir and valve manifold are also attached to the back of the MU and the heated ink umbilicals run from the reservoir to the carriages. Figure 2. The MU comprises the following components:

- Printheads
- Head Maintenance Wiper
- Waste Tray
- Umbilicals
- Carriages
- Ink Reservoir
- Carriage Drive

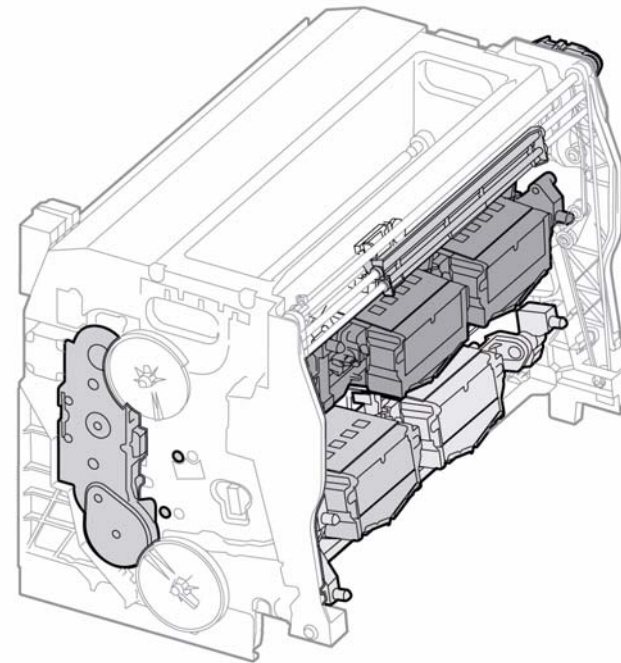

U-5-0519-A

Figure 2 Marking unit components

The carriages register to the drum frame at three points. Three pins on each carriage, two primary pins front and back, are forced into contact with features on the drum frame and a third secondary pin, is forced against an additional contact point to lock the carriage.

Head Maintenance

Figure 3. During head maintenance activities, the carriages are positioned for optimal purge and wiping efficiency. The carriage drive system positions the carriages as required

The printheads are purged with a 4psi pressure purge to correct weak or missing jets. The function of the printhead maintenance system is to wipe the printheads after ink purge to remove waste ink and debris. The wiper moves in a wiper track that guides the vertical motion of the wiper parallel to the printhead face during the jet stack wipe. The two wipers on the wiper carriage wipe two heads at a time; both upper heads or both lower heads. The wiper drive system moves the wiper carriage to the home position, to the upper heads, and to the lower heads. The shuttling gearbox and cable / paddle system move the wipers in the cross-process direction to align with either the upper or lower printheads. Figure 3 shows the location of the printhead maintenance components.

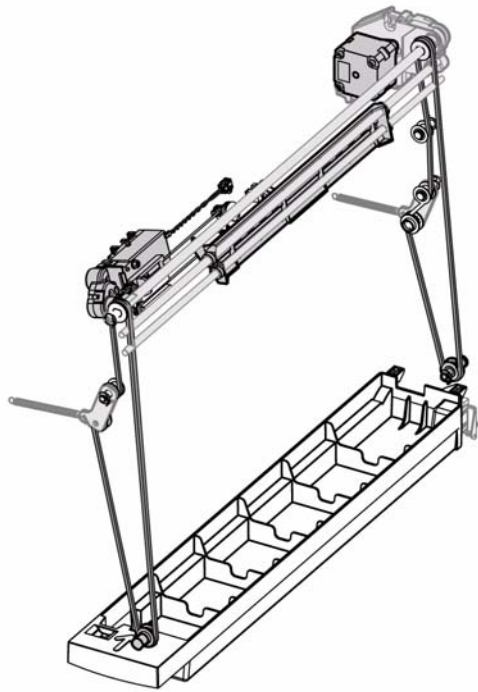

11-5-0531-A

Figure 3 Head maintenance components

Carriage Motion

The carriages are supported by the MU drawer frames by two different methods. The lower carriage is supported on either end by two support pins attached to the carriage end plates. These pins slide along slots in the frames resulting in linear motion between functional positions. The upper carriage is supported by an arm on either end that pivots about a pin on the drawer frames. The carriage drive system for each carriage incorporates a drive shaft connected to crank links at either end of the carriage. This crank link is pinned to another link that is in turn pinned to the carriage. When the drive shaft turns, the carriage is moved left and right as shown in Figure 4.

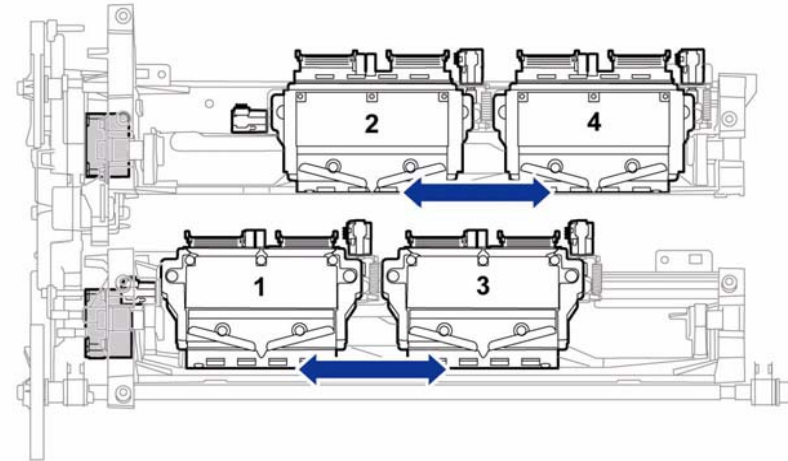

U-5-0514-A

Figure 4 Cross-process (X-axis) carriage motion

Marking Unit Drive

The MU drive employs a two-output gearbox contained in the SFWA carriages. A gearbox that allows active switching between two output shafts is depicted in [Figure 5](#).

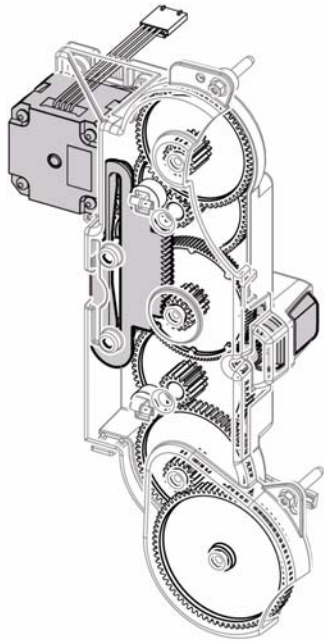

Figure 5 Marking unit drive

U-5-0522-A

A stepper motor operates through an idler gear to drive a pair of cog gears. These gears have square tooth cogs on the top of the gears. On top of these gears are mating pairs of gears with a spring between to keep the gears separated enough that cogs cannot mesh. On top of the cog gear pairs is another spring and selector slide. A small, open loop DC motor, through one reduction stage (compound gear) drives the previously mentioned selector slide. This slide has inclined surfaces, one on either side of the cog gear shafts. [Figure 6](#).

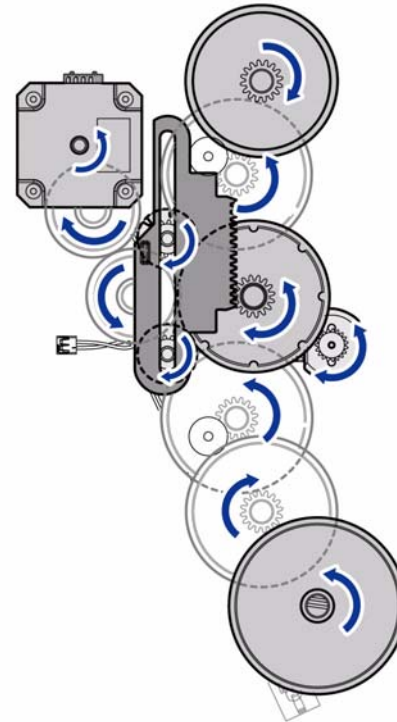

Figure 6 Gear rotation

U-5-0523-A

To select an output (Figure 7 and Figure 8, upper or lower carriage), the DC motor is activated moving the output selection slide completely in one direction until the appropriate feature on the top of the gear runs into a mating surface on the gearbox cover. The inclined slide surface pushes the upper cog spring driving the cog gear down to mesh with its mating cog gear. Each upper cog gear is connected to a reduction section (two compound gears) and through idlers to the output gear that is connected to the carriage drive shafts.

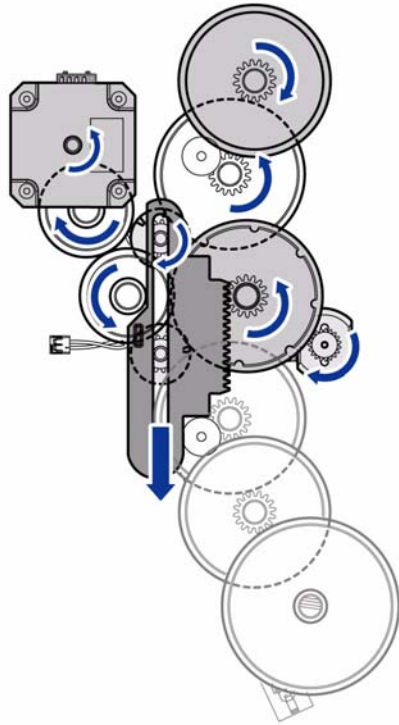

Figure 7 Gear rotation upper carriage

U-5-0525-A

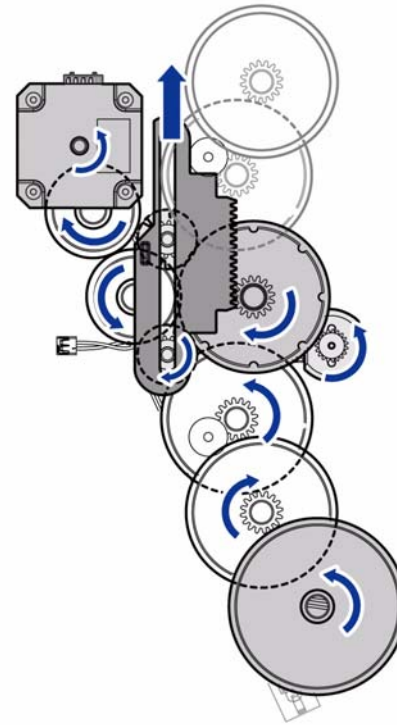

Figure 8 Gear rotation lower carriage

U-5-0524-A

A home sensor is employed to initialize carriage motion. The sensor is located on the front frame of the Marking Unit, and detects home position via a feature molded into the underside of the Upper and Lower Carriage Output Gears.

Upper and Lower Carriages

The SFWA and carriage are known as the SFWA-Carriage when assembled together. SFWA refers to the inner, moving portion, which holds 2 printheads. The SFWA travels along the x-axis while supported by the carriage. The carriage provides a structure that is fixed to the drum frame during printing. The carriage retracts away from the drum to allow printheads to be purged and wiped clean. In addition, there is a carriage position farthest from the drum in which the SFWA is locked to the service drawer frame. This restrains the SFWA-Carriage and x-axis relative to the drawer structure during shipping.

Marking Unit Electrical

The MU electrical components are illustrated in Figure 9.

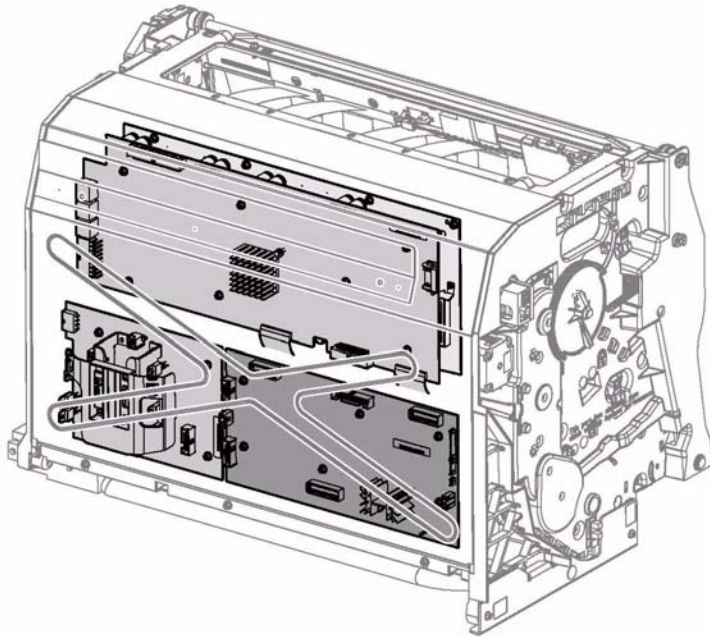

U-5-0528-A

Figure 9 Marking unit electrical

Service Access

Moving the upper carriage to the full forward (print) position allows access to components on the top side of the upper carriage. The Lower Carriage must be moved to the forward (print) position and then disengaged from the compliant link arms. The lower carriage can then be moved even further forward and rotated down with the carriage support pin resting on a service support shelf to allow access to the top of the lower carriage printheads.

Ink Loader

Figure 10. Ink can be added to the ink loader provided that the machine is powered on and sufficient space is available to accommodate additional ink. An ink loader door sensor is actuated when the ink loader door is opened.

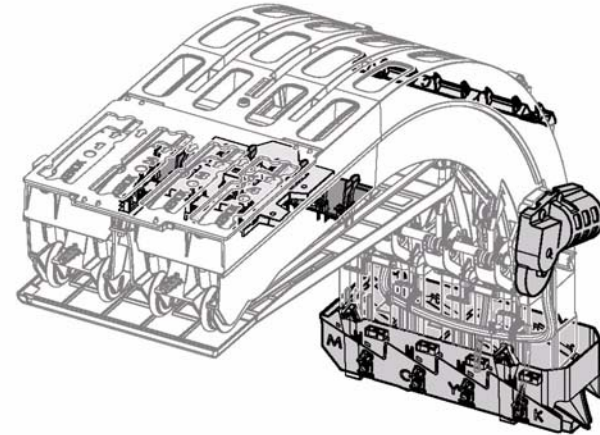

U-5-0532-A

Figure 10 Ink loader components

Key Plate

Figure 11. The key plate moves to a position determined by the configuration.

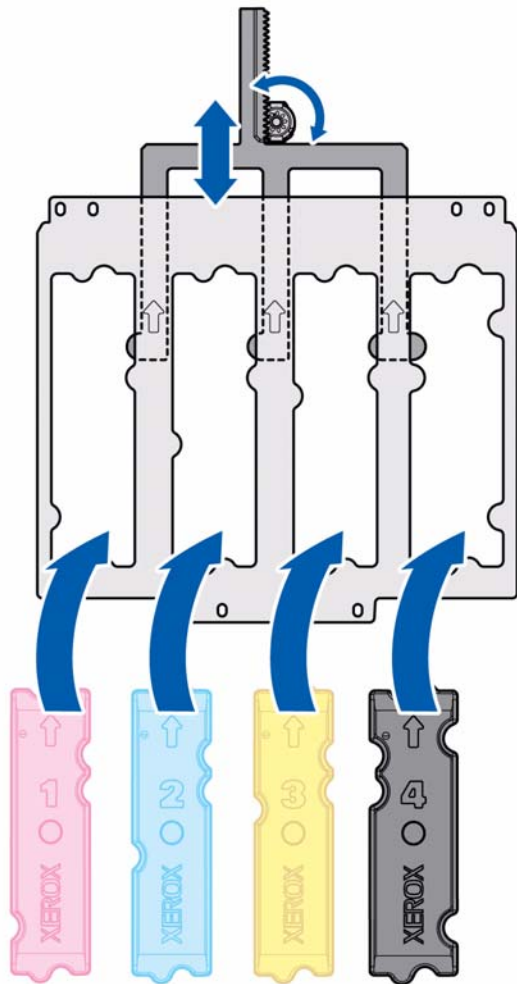

U-5-0559-A

Figure 11 Key plate

Once inserted, the ink stick is advanced by the belt drive approximately 50 mm. Stock Keeping Unit (SKU) sensors in the ink loader check features on the bottom of the ink stick and determine which type of ink is present. One sensor is employed for the CMY sticks, distinguishing between the NA/EU sold sticks and the other 2 SKU's. The black ink loader chute employs 2 SKU sensors which can distinguish all three SKU families.

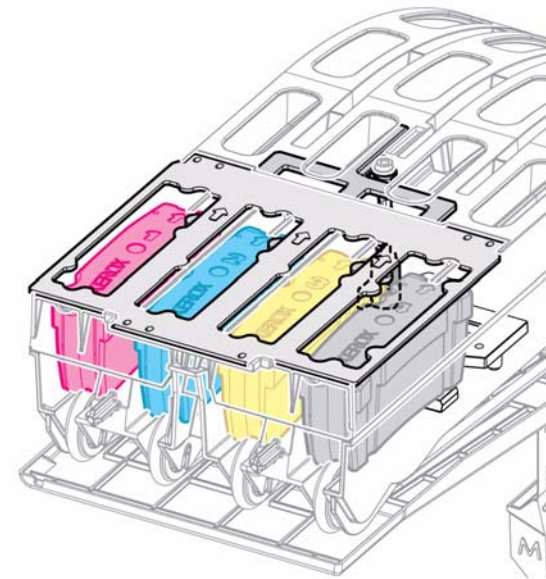

U-5-0558-A

Figure 12 Ink stick loading

If the SKU sensors detect the correct ink stick, then the belts continue to advance the ink into the ink loader, allowing additional sticks to be inserted. If the SKU sensors detect an incorrect ink stick, a user interface message requests that the user remove the stick and a software counter is updated to record that an incorrect ink stick was inserted. It is possible for the user to force the ink stick forward into the ink loader rather than removing the ink stick as requested. If this happens, the printer will continue to operate. Figure 12.

Ink stick transport

If the stick is confirmed as being of an approved shape, the loader then feeds the stick past the SKU sensor shown in Figure 13. The ink stick moves past the ink present sensor and by drive and gravity to the ink low sensor and eventually to the melt plate. The ink block drive belts turn for a sufficient length of time to ensure that the ink block will traverse the entire length of the loader channel if necessary (i.e even if only one ink stick is present in the loader channel).

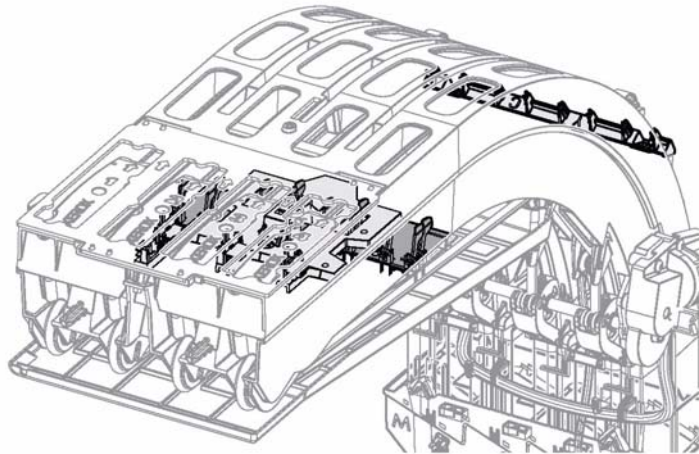

U-5-0536-A

Figure 13 Ink stick detection

Each ink loader chute includes an ink low sensor, which is actuated when about two usable ink sticks remain in the chute. The ink low sensor (reflective) is used to estimate when ink will run out. Once the ink low sensor is no longer actuated, an algorithm determines by average usage in copies and area coverage when it is anticipated to run out of this color ink. An appropriate message is displayed on the user interface in time for the customer to insert additional ink sticks. In order to ensure that the algorithm works consistently if the ink loader is replaced, the NVM counters should be reset and the new ink reservoir should be filled at least to the ink low sensor while power is on.

Printing stops when the ink loader has about one-third ink stick remaining in any chute. Control panel messages indicate time to order ink, ink low, or ink out. True 'ink empty' is detected by monitoring the temperature change rate of the melt plates, when no ink is present the warm up is much quicker and an 'ink empty' message can be displayed on the user interface.

Ink Stick Transport

Figure 14

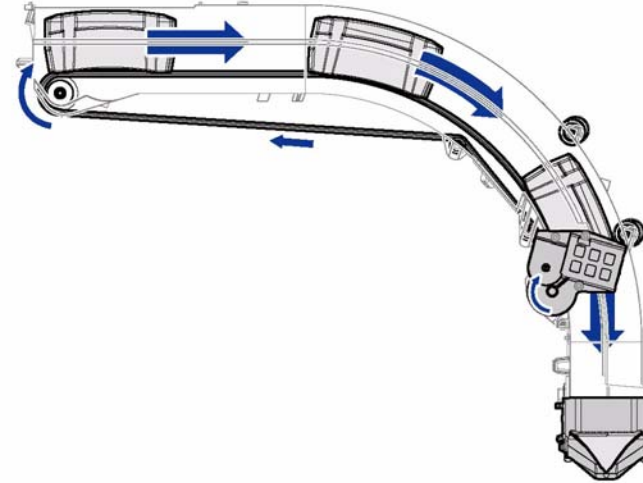

U-5-0511-A

Figure 14 Ink Stick Transport

If the ink loader suspects an ink stick jam, the ink belt drive motor is run in reverse for one second and then forward again to attempt to clear the jam. This may occur if the system does not detect an ink stick via the low ink sensor within an appropriate length of time after detecting it's insertion into the loader.

Ink Melt Heaters

Ink sticks are delivered by the ink loader and held against the ink melt plates by gravity only. The system contains four melt heater / plate assemblies, one for each ink stick colour (cyan, magenta, yellow and black), [Figure 15](#). The ink melt plate is heated using a ceramic Positive Thermal Coefficient (PTC) disk to emphasis safety in the ink melt system; as the temperature of the melt plate rises, the electrical resistance increases reducing the electrical current drawn by the heater. When the melt heater reaches the correct temperature the part of the ink stick that contacts the plate melts and the liquid ink runs into the low pressure ink reservoir below.

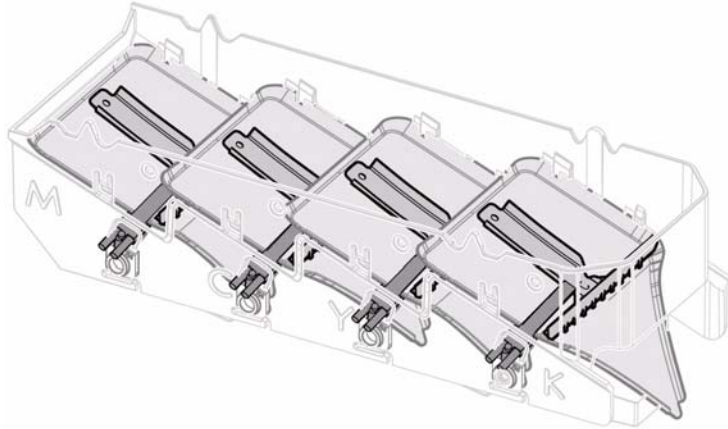

U-5-0510-A

Figure 15 Ink melt heaters

Ink Reservoir

The ink reservoir consists of a low pressure ink reservoir, a high pressure ink reservoir, 16 disk valves, a reservoir heater and manifold plates. Refer to [Figure 16](#).

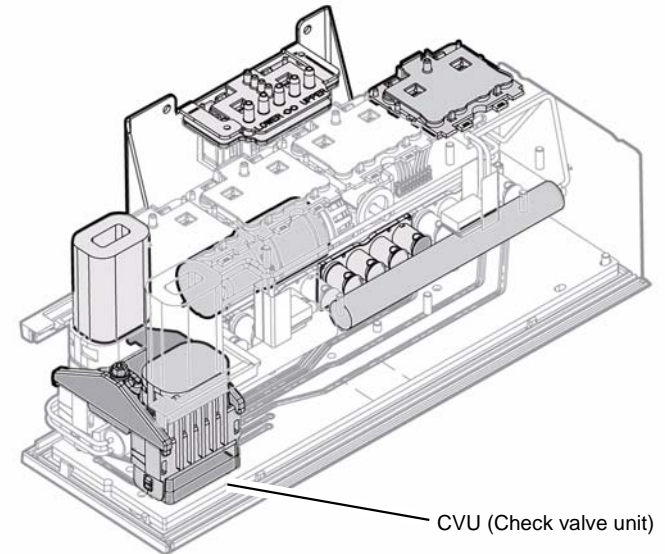

U-5-0554-A

Figure 16 Ink reservoir detail

Melted ink is received on the low pressure side from the ink loader melt plates through holes at the top of each color reservoir. Each color reservoir is divided into four areas (one for each printhead). If the air solenoid for a particular area is not energized, then a mechanical flapper valve between the low and high pressure side opens to allow the ink level in the low and high pressure side to equalize up to the fill limit determined by the ink level sensor. If the air solenoid for the a particular storage area is enabled then the high pressure side will go to ~ 4 lbs. of pressure and this pressure will close the mechanical 'flapper' valve between the high and low pressure sides of the reservoir. The low pressure side may continue to fill but the high pressure side cannot fill until the air solenoid for that storage area is de-energized.

Varying air pressure (purge, fill or low pressure assist) is accomplished by an electrically operated valve on the air pump motor assembly. When energized (open) the pressure drops for low pressure assist which places enough pressure on the jets so that the ink will stick out of the jet and provide lubrication for the cleaning blade but will not run, resulting in increased wastage.

When the solenoid is energized, ink flows from the high pressure side to the ink router plates which comprise the lower portion of the ink reservoir, then to the appropriate umbilical connection and on to the appropriate printhead.

Low Pressure Reservoir

The low pressure reservoir is a thermally conductive part with four chambers, each of which has four outlets at the bottom for a total of sixteen outlets. Ink travels out at the bottom of the chamber, and each outlet orifice also houses a disk valve. A wire mesh filter is placed inside of each low pressure chamber to remove contaminants.

High Pressure Reservoir

The high pressure reservoir is a thermally conductive part with sixteen chambers, four per color. Features in the dividing walls of the chamber act to stop the disk valve in its open position. Upon actuation, pressurized air enters the opening at the top of the chamber, and ink is forced against the disk valve, which causes it to close and directs the ink through an exit path opposite the disk valve.

Normally Open Disk Valve

The normally open disk valve is 7 mm in diameter. The contact seat is an 'O' shaped flat around the outlet orifice of the low pressure ink reservoir. [Figure 17](#).

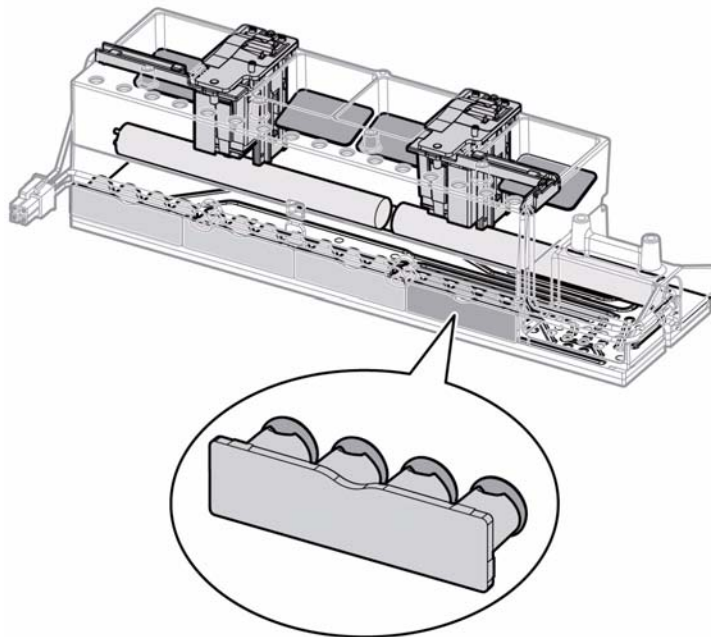
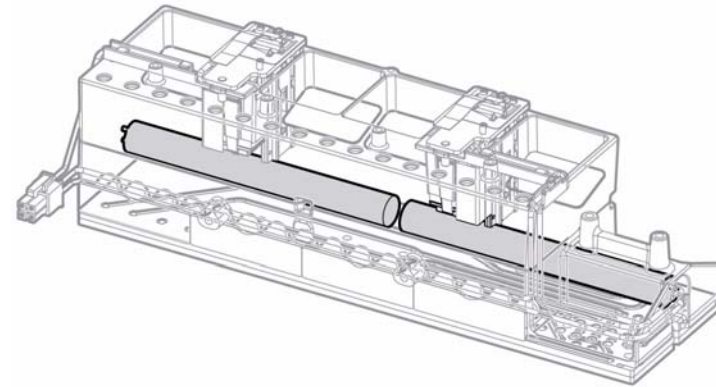

Figure 17 Check valves

U-5-0099-A

Ink Reservoir Heater

[Figure 18](#). Sandwiched between the manifold plate and the high pressure reservoir, the reservoir heater maintains the set point temperature. The ink reservoir is brought to and maintained at temperature by two rod type AC heaters which are thermally protected from overheat.



U-5-0556-A

Figure 18 Ink reservoir heaters

Manifold Plate

The manifold plate routes ink from the 16 high pressure reservoir chamber outlets to the umbilicals. The manifold plate channels the ink into four rows, each row containing CYMK. Each channel has an outlet, which passes through a small boss on the other side of the plate. This boss acts as a seat for a normally-closed check valve.

Umbilical Connector Plate

The connector plate completes ink routing to the umbilicals. The start of each ink channel houses a spring and provides a recess for the normally closed check valve. The outlet of each channel is a through hole where the tube fitting will be pressed in.

Normally Closed Check Valves

The normally closed check valves press against the top of the boss on the manifold using a spring that acts on the metal side. The pressure applied to the high pressure ink reservoir in order to deliver ink will act to overcome the spring force and open the valve.

Ink Level Sense

Ink level detection, [Figure 19](#) is provided by one of two capacitive sensor assemblies. Each assembly has two capacitive sensor probes that sit in the low pressure reservoir and monitor ink level for two colors (1 probe in each ink reservoir). One set monitors the black and yellow while the other set monitors magenta and cyan.

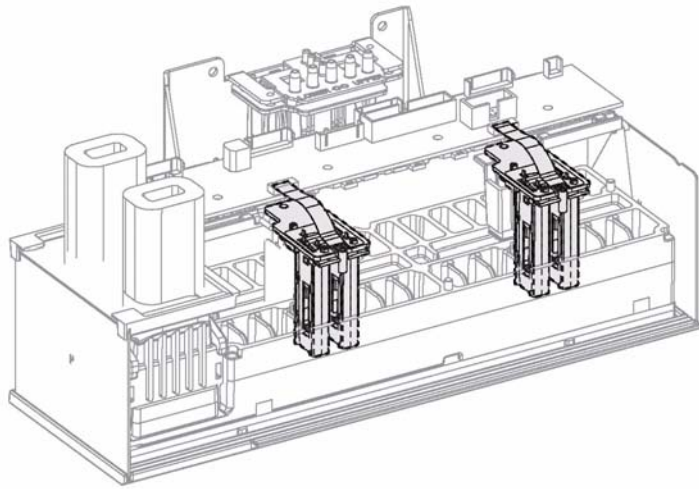

U-5-0555-A

Figure 19 Level detection

Mica Insulation Plates

Mica insulation plates surround the ink reservoir and help to maintain the ink reservoir temperatures. The plates provide excellent thermal qualities at a low cost but are fragile and are therefore spared separately.

Air Pump

A rolling diaphragm air pump provides the air pressure required to:

- Supply ink to the printheads.
- Purge the printheads.
- Following a purge, provide low pressure assist until the printheads have been wiped by the head maintenance (HM) assembly.

A manifold and a series of valves direct the air pressure to perform these functions. The system contains twenty normally-vented three-way valves. Sixteen of the valves are used for ink delivery and four for printhead maintenance. The air pump relies on pulse width modulation (PWM) control to provide the correct flow rate for the varying functions.

The Low Pressure Assist (LPA) valve and the air pump are connected to an accumulator. The LPA valve is a normally-open two way valve that closes when the system is required to increase pressure for ink supply or a printhead purge, and opens, venting system pressure, when ink supply or the purge is complete. To provide LPA, the pump shifts PWM values and the LPA valve opens, dropping system pressure from approximately 4 psi to approximately 0.05 psi. The accumulator is a small plastic tank that houses an air filter and provides additional air volume rendering the purge and ink supply masses more robust to air leakage and system variation.

Service Access

The ink reservoir is attached to the rear frame of the marking unit. It is held in place by two screws and is removed by lifting the reservoir until the two locating pins clear the frame. Remove the ink reservoir with the marking unit drawer fully extended.

Waste Tray

Waste Tray Detect Sensor

Refer to [Figure 20](#).

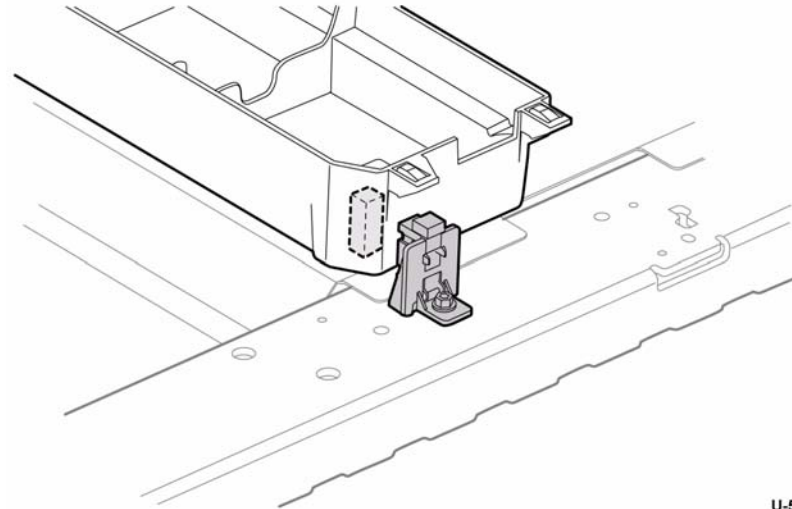

U-5-0518-A

Figure 20 Waste tray detect sensor

Waste Tray Lock Solenoid

Refer to [Figure 21](#).

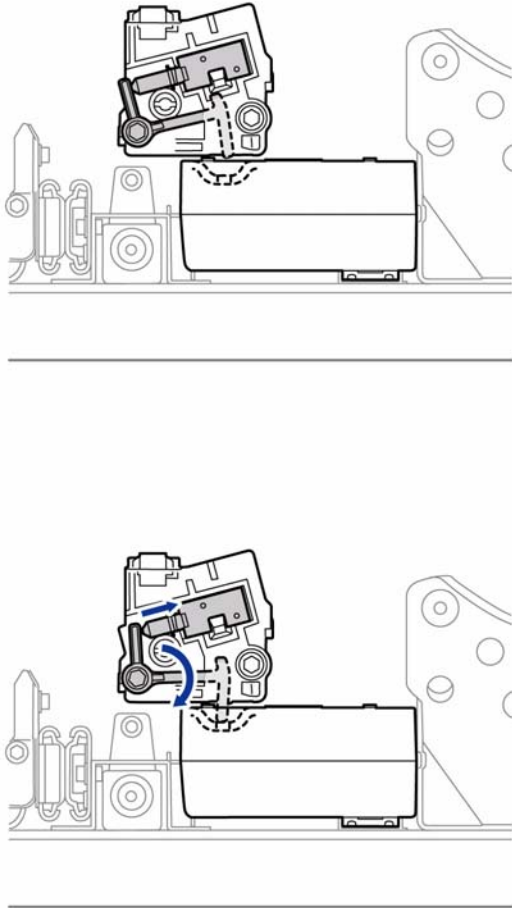
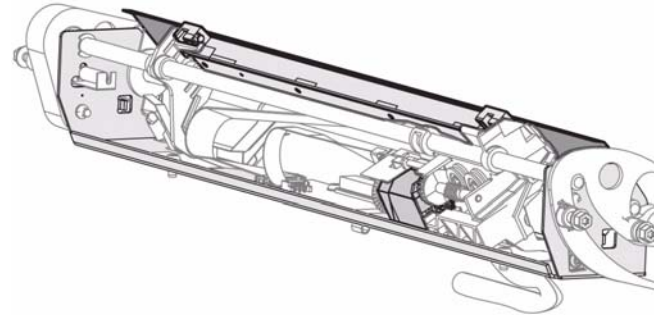

Figure 21 Waste tray lock solenoid

U-5-0517-A

Ink on Drum (IOD) Monitoring

The IME contains a subsystem that periodically monitors the quality of the image being applied to the drum. This system automatically detects and corrects a number of parameters in order to maintain optimum print quality. The IOD is an A size scan bar located at the 6 o'clock position beneath the drum. This is the same type of scan bar used in the registration / preheat assembly for skew measurement. The primary function of the IOD scanbar is to read special test prints on the drum and send this information to the controller to maintain alignment and efficiency of the four printheads.



U-5-0539-A

Figure 22 IOD components

As the scan bar is ~ 8.5 inches long and the drum is ~ 12 inches in length, the IOD is mounted to a rail system that allows movement of the IOD to front and rear positions. This assures the IOD can properly 'see' the transition area between each of the four printheads. [Figure 22](#).

Since the IOD is located beneath the drum, it is possible to contaminate the IOD lens. To help avoid this, the IOD lens is covered by a plastic shield which remains in place except when the IOD is actually reading images on the drum. IOD calibrations occur on a regular basis depending on setting in software, but checks of the printhead alignment are more frequent until the machine is considered thermally stable. This is to reduce misalignment caused by thermal shifts to the Staggered Full Width Arrays (SFWAs) and Image Marking Engine (IME). Presently, when the heads are re-docked, the thermal 'timer' restarts and IOD calibrations will be more frequent until considered thermally stable. There is no post-adjustment IOD validate process; adjustments are made and then assumed to be correct.

The IOD has three color outputs (RGB) that are used to achieve the best contrast for the various colors printed on the drum.

The IOD module enables a variety of system functions on the ColorQube. Its primary function is to align the four printheads to create a seamless image. This is called head-to-head alignment, or H2H alignment. A second function is to adjust the jetting intensity of the heads, again to maintain consistent intensity across the entire image. This is called head-to-head intensity, or H2H intensity. Intensity for the whole printhead is set at once, jets cannot be individually adjusted for intensity. A third function is to detect and correct weak and missing jets by substitution, a process known as jet masking.

IOD Operational Sequence

The IOD sequence is only performed from standby state. The IOD sequence typically occurs every 500 pages. The printer stops and performs an IOD rear scan then waits another 500 pages and performs IOD front scan. Scans continue to alternate between rear and front every 500 pages. Manually activated scans are executed from diagnostics. The technician selects either a front or rear IOD scan.

When an IOD sequence is executed, the following steps are performed:

1. A drum maintenance cycle is performed to prepare the drum for imaging.
2. The scan bar is moved to the rear (or front) position. The unmarked drum surface is read with and without illumination to establish black and white calibration levels. This is done while the drum is rotating, so that an average is achieved. After calibration, the scan bar moves to the park position, which is the approximate center of travel of the IOD assembly.
3. The target image is jetted onto the drum.
4. The scan bar is moved to the rear (or front) position. A snapshot of the image is acquired by the IOD by rotating the drum with the target image across the scan bar. After the IOD has acquired the image, the scan bar is protected and then moved to the park position.
5. The acquired target is analyzed to calculate head position.
6. Appropriate head position corrections are calculated and applied. There are four types of corrections:
 - Each printhead has a small motor to adjust printhead rotation in the radial axis. The IOD correction step immediately moves these motors.
 - Each printhead has a Y-axis offset value from the drum home position that controls jet timing for all jets on that head during imaging. The IOD correction step updates these Y-offset values.
 - Each SFWA has an X-Axis offset value from the SFWA home position that controls the starting position of the SFWAs during imaging. The IOD correction step updates these X-offset values.
 - Each SFWA has a head that is fixed, and a second head with a small motor to adjust X-position relative to the fixed head. The IOD correction step immediately moves these motors.
7. A cleaning unit cycle is performed to scrape the target image from the drum.

IOD Sequence Types

Since the IOD cannot see one of the printheads during a scan, it is unable to correct head alignment for all four heads in one scan sequence. In its present form, the IOD system is only able to correct printhead alignment based on what it sees during that sequence. Also, it does not retain scan data to be interpreted by a subsequent scan sequence to provide a single adjustment covering all printheads.

The IOD has no home sensor. It drives fully in one direction until it stalls and assumes it is fully forward or rearward. Then it counts clock pulses to the central park position.

Table 1 Measurement and corrective Actions for Front and Rear IOD Scans

Table 1 Measurement and Correction Actions for Front and Rear IOD Scans

Head Positions	Front Scan	Rear Scan
Head 1 Roll	Measure and adjust.	Cannot be measured during a rear scan. Adjustment cannot be performed.
Head 2 Roll	Measure. Do not adjust.	Measure and adjust.
Head 3 Roll	Measure. Do not adjust.	Measure and adjust.
Head 4 Roll	Cannot be measured during a front scan. Adjustment cannot be performed.	Measure and adjust.
Head 1 Y-offset	Measure and adjust.	Cannot be measured during a rear scan. Adjust as if stitched to printhead 2.
Head 2 Y-offset	Measure. Do not adjust.	Measure and adjust.
Head 3 Y-offset	Anchor.	Anchor.
Head 4 Y-offset	Cannot be measured during a front scan. Adjustment cannot be performed.	Measure and adjust.
Head 1 X-stitch	Measure and adjust.	Cannot be measured during a rear scan. Adjust as if stitched to printhead 2.
Head 2 X-stitch	Measure. Do not adjust.	Measure and adjust.
Head 3 X-stitch	Anchor.	Anchor.
Head 4 X-stitch	Cannot be measured during a front scan, Adjustment cannot be performed.	Measure and adjust.

IOD reads drum run out at home (from the drum encoder) and at 6 degree intervals. These values are stored and used to set Y axis run out variance of timing of the jets on the printheads. This calibration should be performed whenever the drum encoder is serviced (which may change the home position) or whenever the drum is changed (which will change the run out).

IOD Printhead efficiency maintenance

The efficiency of the printheads is measured by Closed Loop Dropmass (CLD) calibration.

There are two CLD measurement processes, cldBaseline and cldAdjust. The cldBaseline process measures the efficiency of each printhead when it is first installed onto a printer (time zero). The value of the cldBaseline measurement is stored in the machines NVRAM. The cldAdjust process measures the efficiency of each printhead periodically over its life time, and applies incremental head-drive voltage adjustments to maintain the original printhead efficiency captured by the cldBaseline process at time zero.

The cldAdjust and cldBaseline process are similar and include the following steps:

- Calibration of the IOD scanbar sensor.
- Render and print measurement target into the drum surface.
- Scan an image of the drum surface using the IOD scan bar.

- An analysis algorithm identifies the printed pattern kernels scanned from the drum surface and then performs digital signal processing to reduce the raw image data into a set of numerical arrays which quantify the efficiency of the printhead at the time of printing.
- The image is scraped from the drum surface using the drum maintenance subsystem.
- In the case of cldBaseline calibration, the efficiency valuations are stored to the machines NVRAM, and later used for the cldAdjust calibration process.
- In the case of cldAdjust calibration, the efficiency valuations are used to calculate a voltage correction that is applied to the printheads in order to maintain the printhead efficiency captured at the original cldBaseline measurement.

Drum

The Drum and enclosed heaters form the key portion of the system where imaging takes place. The Drum Assembly and transfix system are separate, but interrelated. The front and rear drum frames provide support to the drum and transfix assembly, [Figure 23](#). This section describes the drum assembly. The next section goes into more detail about the transfix system.

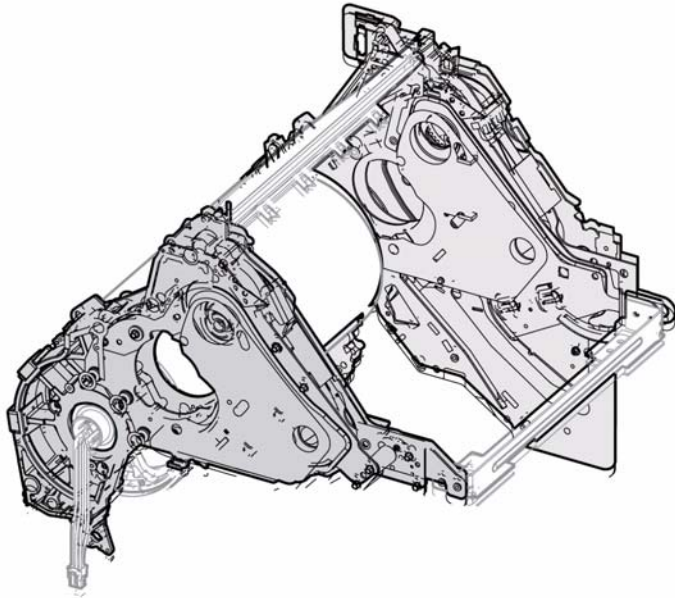
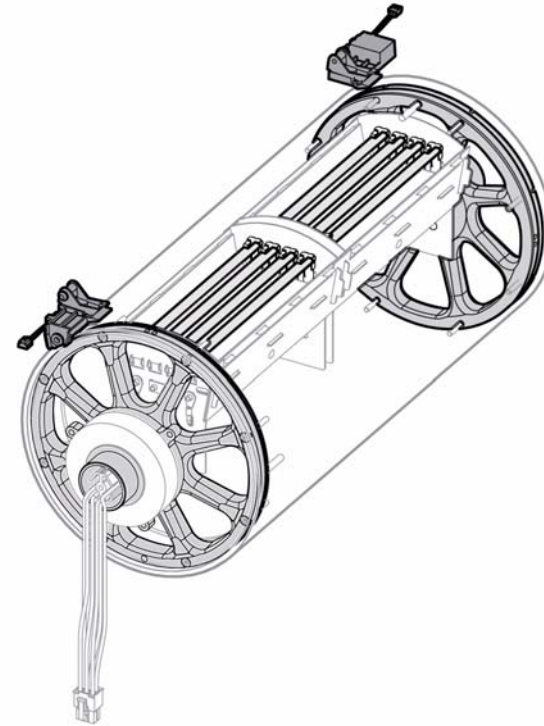

Figure 23 Drum frames

U-5-0567-A

In operation, the image to be printed is formed on the rotating drum. The registration / preheat assembly heats the media to prepare it for image transfer. The heated media is then passed between the drum (now rotating much more slowly) and the transfix roller. Under the pressure between the drum and the transfix roller, the image is transferred. An encoder disk and sensor on the front end of the drum monitors the drum's speed and position.

The drum heater heats the surface of the drum for imaging, [Figure 24](#). The drum heater does not rotate. The heater is located inside the drum and is controlled by the drum driver PWB. The drum heater consists of two resistive heater coils that operate in series for 220V and in parallel for 110V operation. The series / parallel operation is controlled by the drum driver PWB. Two temperature sensors (one front and one rear) in contact with the drum surface monitor the drum temperature. The drum driver PWB interprets the sensor's signal and turns on the drum heater and drum fan to heat the drum, or turns on the drum fan alone to cool the drum.



U-5-0563-A

Figure 24 Drum heaters and temperature sensors

The drum is driven by the drum drive motor through a single reduction belt drive, the motor rotates the drum at a high speed for imaging and a constant low speed for image transfer. The drum drive, [Figure 25](#), uses an active tension system to allow the drum pulley to float while the spring adjusts the belt tension.

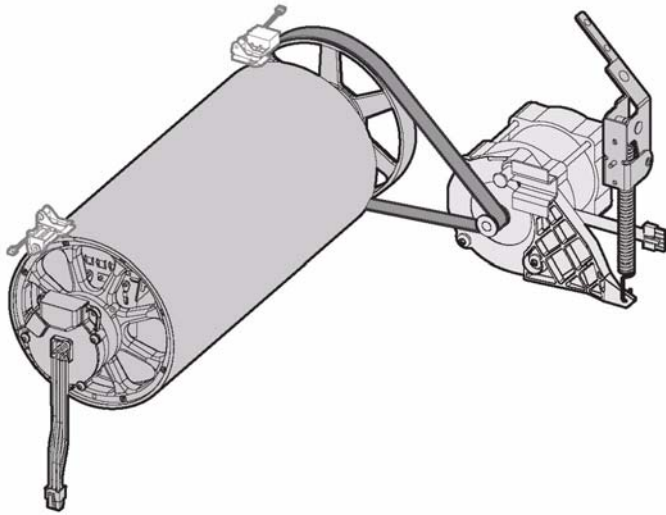

U-5-0538-A

Figure 25 Drum drive

Drum Encoder

Figure 26. The drum encoder provides drum position information.

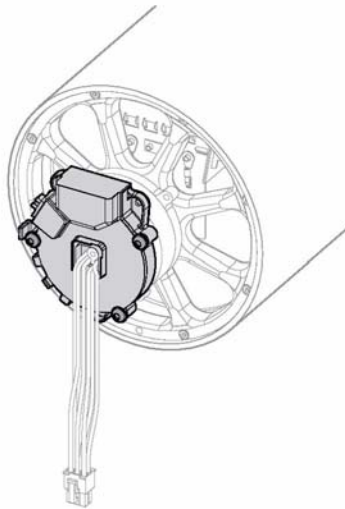

U-5-0096-A

Figure 26 Drum encoder

Cleaning Unit

The function of the cleaning unit is to uniformly apply a thin layer of release agent (silicon oil) onto the drum's surface, while clearing the drum surface of contaminants. Prior to imaging, the drum receives a uniform coating of release agent applied by the cleaning unit roll. The amount of release agent used is bounded by major failure modes and controlled by the oil metering blade. If too little release agent is applied to the drum, the ink will not completely transfer and the print quality will degrade as well as increase the amount of ink that the cleaning unit must clean off the drum before making the next print. In addition, too little release agent will cause stripping failures, as the ink will not release from the drum. If too much release agent is applied, it saturates the paper with release agent and, during duplex printing, prevents complete transfer to the second side of the paper. Once the drum has been coated with release agent, the roller is moved away from the drum surface to enable the written image to be formed.

Figure 27. The cleaning unit utilizes two release agent level sensors; a low sensor consisting of a hall effect switch on a float and an out sensor that detects the pressure difference when pumping air instead of release agent. This can occur when the release agent reservoir is depleted. A software algorithm is used to estimate the amount of release agent remaining in the cleaning unit based on the amount of paper and ink run through the printer. This algorithm in combination with the two level sensors and the knowledge of the release agent in the reservoir in a new cleaning unit, allows an approximate level sensing ability at all release agent levels.

Once the release agent reservoir is depleted, the cleaning unit can support the printing of several thousand additional prints by using the release agent in the cleaning unit roller. All level sense and life information is stored in an EEPROM inside of the cleaning unit allowing a cleaning unit to be moved from machine to machine without loss of information.

The cleaning unit provides approximate 'percentage of life' information until the reservoir is depleted. When the unit can support a further 30,000 A-size prints, the cleaning unit low release agent state is reported. When the reservoir is depleted, the cleaning unit reports a very low release agent state and begins an A-size print remaining countdown, starting from 3000 prints. The cleaning unit reorder message will appear based on a calculated number of days remaining. When the counter reaches zero, the cleaning unit is no longer functional and must be replaced. The average cleaning unit life is 285,000 prints for the average ink coverage of 11% fill on A / A4 size office media. As ink coverage increases, the cleaning unit life will decrease. Coated and smooth media will also use more release agent, which also causes the cleaning unit life to decrease.

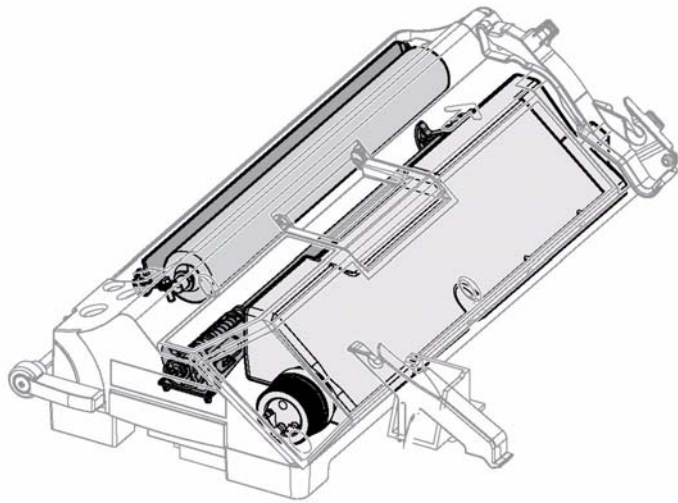

U-5-0540-A

Figure 27 Cleaning unit components

Because the oil metering blade must engage and disengage from the drum a narrow oil bar naturally occurs where disengagement of the oil metering blade occurs. The speed with which the roll and blade are removed from contact with the drum, as well as the timing of the blade and roll movement will determine the size and shape of the oil bar. The amount of gel (oil and ink mixture) in the oil, will also impact the oil bar geometry. If the oil bar is too large, the transfix roll or stripper blade will pass through the oil bar and potentially become contaminated with oil.

NOTE: As the cleaning unit is removed, the cleaning unit latch is moved to the front to lock the mechanism in place. The cams are locked in the down position and the cleaning unit can be re-installed easily. Care should be taken not to run the cams while in diagnostics unless this latch is unlatched (in and down). CRUM corruption may occur if cleaning unit is removed while writing. To avoid this, the cleaning unit latch solenoid waits ~2 seconds after opening the front door interlock before unlocking the cleaning unit.

Cleaning Unit initialization

Figure 28. Cleaning unit presence is determined by attempting to communicate with the CRUM. If the cleaning unit is present, full cleaning unit travel operation is checked during system initialization. During the full travel operation, the cam position required to lift the blade to the blade engage position is determined by monitoring the cleaning unit lift motor following error. The position where the oil metering blade makes contact with the drum will also be determined based on a spike in either the motor drive voltage of the drum (as it is spinning) and/or a spike in the motor drive voltage while lifting the cleaning unit. A cleaning unit operation is performed at the end of mechanical initialization.

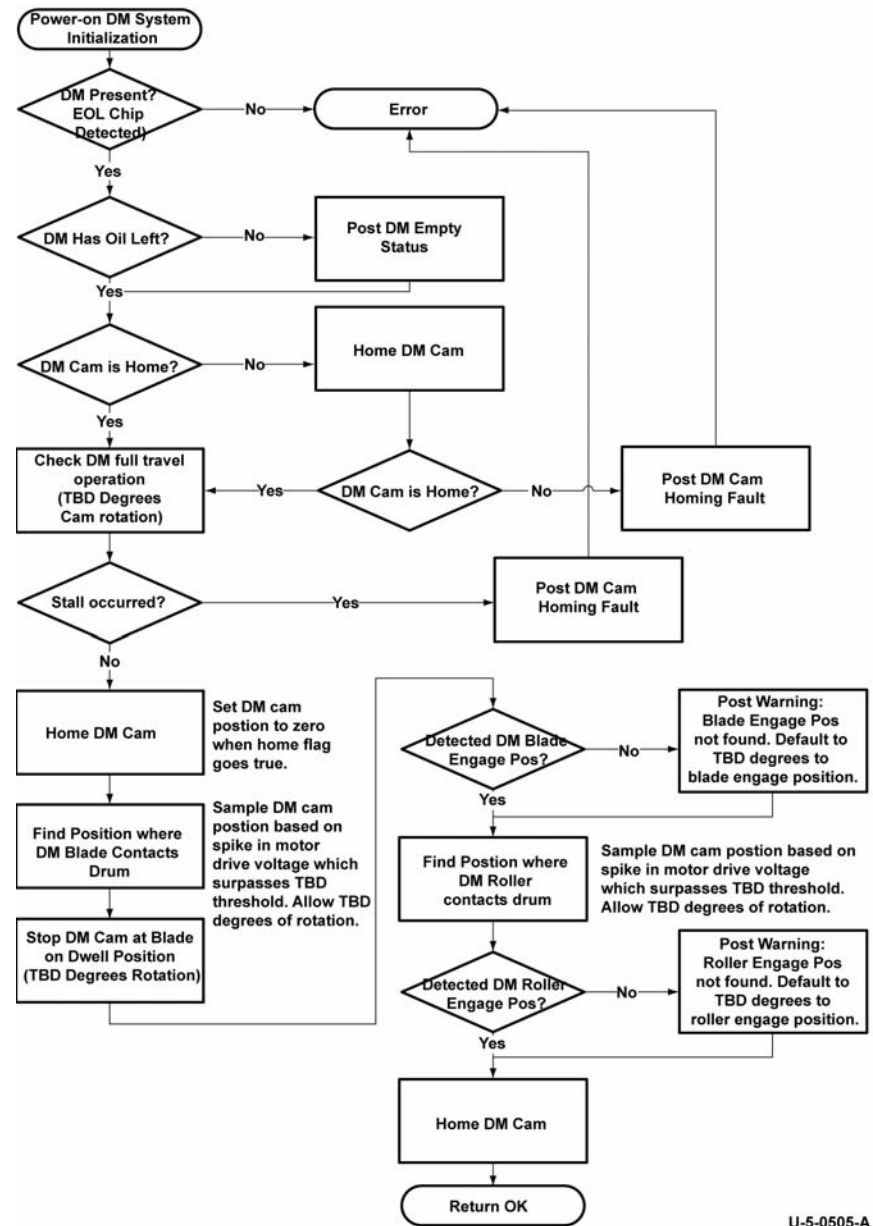

U-5-0505-A

Figure 28 Cleaning unit unitization

Figure 29. Cleaning unit processing

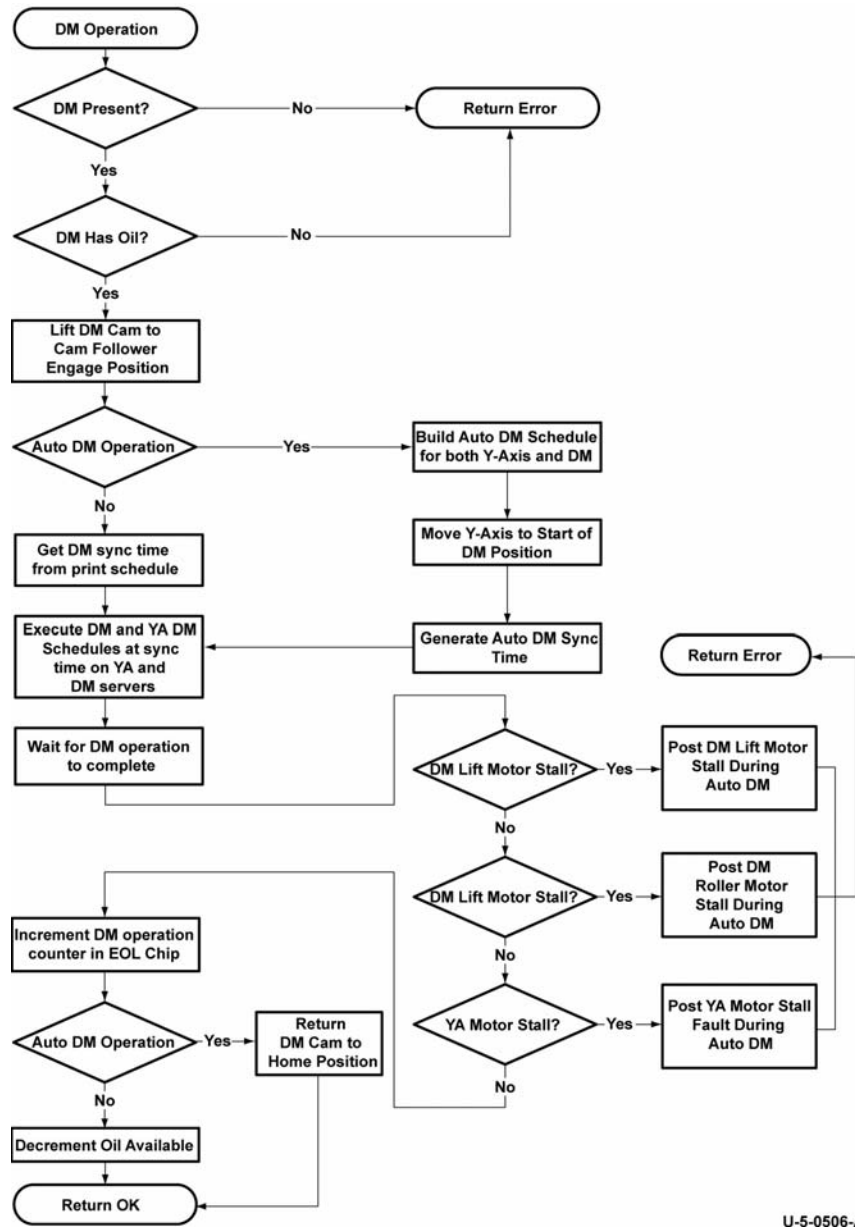

Figure 29 Cleaning unit management

Cleaning unit Components

The cleaning unit comprises the following components:

- Oil roller
- Metering blade
- Cleaning unit drive motor
- Solenoid valve
- Sump pump
- Delivery pump
- Oil return

Oil Roller

The oil supply roller is loaded with oil that is applied to the drum when the roll is moved into contact with the drum surface. It is made from a continuous web wrapped into a roll and then loaded with oil. The amount of oil applied to the drum is dependent on the penetration of the roll into the drum surface and the amount of oil left in the roll. The rate of oil migration through the roll is another factor in determining the oil applied to the drum surface.

Metering Blade

The metering blade meters the oil applied to the drum by the roller. The blade is spring loaded against the drum. The amount of blade force on the drum determines the oil rate. In addition, the roughness of the drum, as well as the edge condition of the blade have an affect on the oil rate. The metering blade is required to clean any ink that has not been transferred to paper off of the drum.

Cleaning Unit Drive

The roll and blade are driven into engagement with the drum via a stepper motor and the cleaning unit camshaft, Figure 31. The camshaft supports two sets of cams for independently actuating the roller and blade assembly. The stepper motor must be able to move fast enough to disengage the cleaning unit in sufficiently short time so as to minimize the size of the oil bar. In addition, the timing between the two sets of cams are such that the roller touches the drum after the blade has been dropped and leaves the drum before the blade has been lifted. This order of disengagement minimizes the size of the oil bar. The motor that drives the cleaning unit engagement is a 1.8 degree stepper motor. This motor is operated at 8 microsteps per natural motor step. The resistance of the motor is 1.8 ohms and the current necessary to drive the motor is 3 amps.

Oil Return

Figure 30. The return oil wick is used to recirculate the oil that is metered off of the drum by the blade back into the roll to be reapplied to the drum. The oil rate through this wick must be greater than the amount of oil metered off the drum by the metering blade. The gel shield prevents the gel (oil and ink mixture) that is removed from the drum by the metering blade from contaminating the oil roller. The shield directs the gel away from the roll and accumulates the gel in the housing. The shield also acts as a spring to hold the wick material against the oil roller.

U-5-0506-A

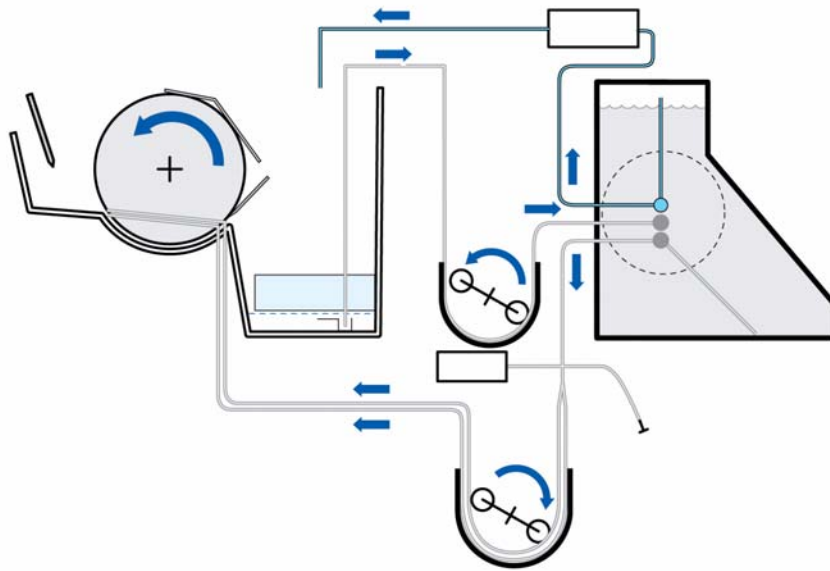

U-5-0512-A

Figure 30 Cleaning unit oil path

Cleaning Unit Operation

For every print cycle, the home, engage, and disengage moves are required. During the normal run mode, the drive motor will first position the cam so that the sensor signal will transition from high to low, refer to [Table 2](#):

Table 2 Motor position

Motor Direction	Home Sensor State
CCW	Low
CW	High

Once the cam has been homed, [Figure 31](#), the cleaning unit drives to an engaged position. There are two variables to the motor profile that will be changed as a function of the cleaning unit supply roll age. These two variables are the penetration of the supply roll into the drum surface and the time between blade landing and supply roll landing. The engage motion profile is initiated by the drum position. When the drum (and the expected location of the lead edge of the image) rotates to the required position, the engage profile described below is commanded. The variable time and penetration will be adjusted based on the age of the supply roll in the machine. As the roll ages, the roll penetration will have to be increased and the time from blade engage and roll touch will be shortened.

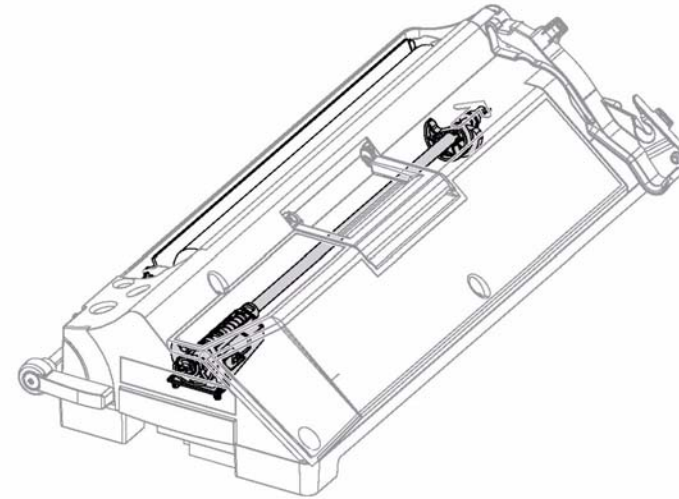

U-5-0570-A

Figure 31 Cleaning unit camshaft

The motor motion profile to disengage the cleaning unit is again initiated by the drum position. The motion profile is the inverse of the engage and must accommodate the total engage motion, which is a function of the cleaning unit roll age.

At ready state the cleaning unit performs an auto cleaning cycle after every IOD cycle to capture dust particles which may collect on the drum. At the end of every cleaning cycle, the CU cam will be returned all the way to the home position. When a print cycle is started, the cleaning unit cam is engaged against the cam followers to minimize noise and wear on the cam and cam followers. During print state, a cleaning cycle is performed after every image transfer cycle. There may be special multi pass prints which do not require a transfix cycle until the vary last pass is completed.

Fault state drives the cleaning unit cam to the cleaning unit removal position so that the cam can be removed by the customer. The cleaning unit is locked if any of the machine doors are open. The cleaning unit cam motor is locked away from the home position if the cleaning unit cartridge is not detected.

Stored Parameters

These cleaning unit parameters are stored locally in the End of Life (EOL) device and mirrored in system NVRAM.

- Cleaning unit operations performed (count)
- Oil consumption
- Initial oil pressure
- First use
- Cleaning unit serial number

Control Signals

The Drum Driver Board provides control signals to the cleaning unit, refer to [Table 3](#).

Table 3 Cleaning Unit Control Signals

Signal	Description	I/O	Type	Comment
MTR1	Motor drive phase A	Input	Analog	Encoder serial data
MTR2	Motor drive phase A	Input	Analog	Encoder serial data
MTR3	Motor drive phase B	Input	Analog	Encoder serial data
MTR3	Motor drive phase B	Input	Analog	Encoder serial data
Home	Home position sensor	Output	TTL level	DM Camshaft Home
GND	Ground	Output		Chassis ground
+ 5 V	Sensor Vcc	Input	TTL level	Sensor supply voltage

NOTE: The cleaning unit makes a ground connection via a feature at the front of the cleaning unit. This mechanical ground makes prior to the rear electrical connector connecting and remains grounded till after the electrical connector at the rear disconnects during cleaning unit removal. Loss of this ground may lead to cleaning unit circuitry failure because very high electrical charges can build with the movement of the oil over cleaning unit components. The ground through the electrical connection is insufficient to fully handle the current discharge to ground.

Transfix/Strip

[Figure 32](#). Transfix assembly comprises the following components:

- Transfix linkage assemblies
- Transfix motors
- Compound transfix gears
- Transfix roller
- Transfix encoders
- Transfix stripper blade assembly

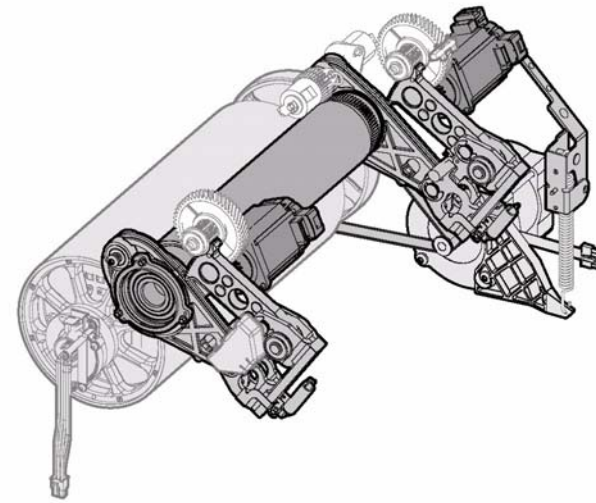

U-5-0504-A

Figure 32 Transfix components

Transfix Linkages

The transfix linkages apply force to the transfix roller to bond the image to the media. [Figure 33](#) illustrates the transfix linkages.

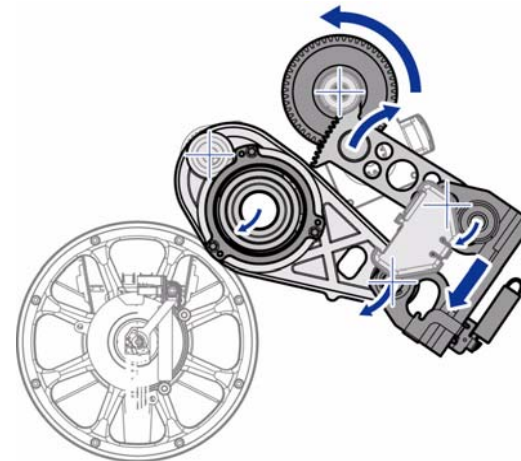

U-5-0526-A

Figure 33 Transfix linkage motion

Transfix Stripper Blade

The transfix stripper blade removes adhered paper from the transfix roller and directs it to the exit portion of the paper path. The stripper blade is attached to an aluminum extrusion using an adhesive strip. These components, along with the adhesive, comprise the transfix stripper assembly. The assembly is constrained in proximity to the transfix roller such that the blade is always in contact with the roller surface.

Post Fix Transport

The post fix transport takes the printed sheets from the drum and delivers them to the output transport. The post fix transport comprises the following components:

Post fix transport motor, M4 - A stepper motor, located at the rear of the post fix transport. The motor turns in the forward direction to power the nips L and J, via a chain of gears. In the reverse direction, this motor turns the eccentric cams that slide home the latching mechanism. Refer to [Figure 34](#).

Post fix sensor (#11) - A reflective sensor, located before nip J. It is the first sensor to detect the marked sheet, freshly stripped from the drum. Refer to [Figure 34](#).

Nip J - Driven by the post fix transport motor, M4. Nip J transports the sheet to the pre-exit sensor, 12 and nip L. Refer to [Figure 34](#).

Pre-exit sensor, (#12) - A reflective sensor, located just before nip L. The sensor detects the sheets fed to nip L, and out to the output transport. Refer to [Figure 34](#).

Nip L - The last nip in the post fix transport. Nip L transfers the sheets to the output transport and is driven by the post fix transport motor, M4. Refer to [Figure 34](#).

Stripper solenoid - A 48V solenoid, driven from the drum driver PWB. Before the solenoid is actuated, a small gap is present between the stripper blade and the drum. When the solenoid is actuated, the gap closes, and the stripper blade contacts the drum momentarily to catch the leading edge of the sheet and strip it from the drum. Refer to [Figure 34](#).

Latch sensor - A flag sensor, located at the front of the post fix transport. The sensor detects the position of the front latch. A flag under the front latch actuates the sensor in the latched position. This sensor is under the control of the drum driver PWB. Refer to [Figure 34](#).

Jam clearance latches - Two latch forks, at the front and rear of the post fix transport, operated by cams, driven by the post fix transport motor, M4. The latches prevent the jam clearance guide opening during normal operation. Refer to [Figure 34](#).

Jam clearance LEDs - An LED PWB is located between nip J and nip L. This PWB holds four LEDs, to illuminate the jam clearance area. Refer to [Figure 34](#).

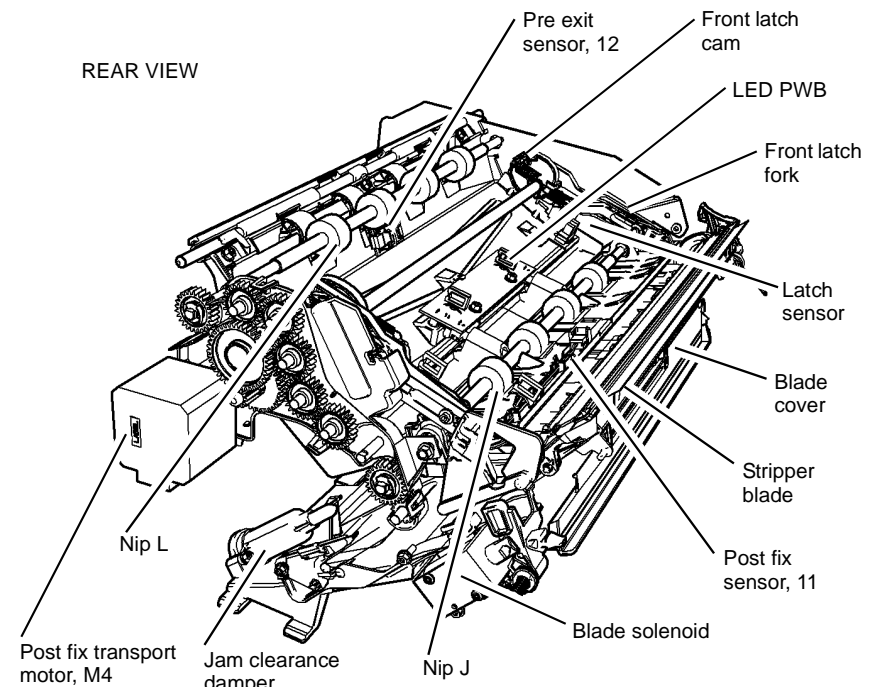

U-5-0076-A

Figure 34 Post fix transport components

Output Transport

Overview

The output transport performs the following functions:

- Delivering printed media to output module, (LCCS, HVF or OCT).
- Returning the duplex media for second-side marking.
- Performing the final inversion on single-side tabs and duplex pre-drilled or pre-printed stock.

The output transport comprises the following components:

Output transport motor, M5 - A stepper motor, located at the rear of the output transport driving nip N and nip P via two gears and two toothed belts. Refer to [Figure 1](#).

Exit sensor, 15 - A reflective sensor, located immediately before nip N. The sensor detects sheets being fed either from nip P or nip L, to nip N. Refer to [Figure 2](#).

Nip N - The exit nip, feeding sheets to the output module. Refer to [Figure 2](#).

Nip P - Used to feed sheets back for second-side marking. Nip P is also used, in conjunction with the output diverters, in performing the final inversion of single-sided tabs and duplex drilled or pre-printed sheets. Refer to [Figure 2](#).

Duplex sensor (#13) - A reflective sensor detecting the sheets going for second-side marking. The sensor also detects the trailing edges of sheets being inverted before being fed to the output module. Refer to [Figure 2](#).

Output diverter solenoid - Before the solenoid is actuated, the diverters are positioned so that sheets arriving from the post fix transport, or from the horizontal transport, are fed to the output nip N. When the solenoid is actuated, the diverters are positioned so that sheets from the post fix transport are fed back to the horizontal transport. Once at the horizontal transport, the sheets either continue for second-side marking or are fed back for final inversion and output. Refer to [Figure 1](#).

Output diverters - A set of two diverters, geared together so they can be controlled by the one output diverter solenoid. Refer to [Figure 1](#).

Jam clearance LEDs - Two LED PWBs, located in the jam clearance door, provide four LEDs to assist in the jam clearance process. Refer to [Figure 2](#).

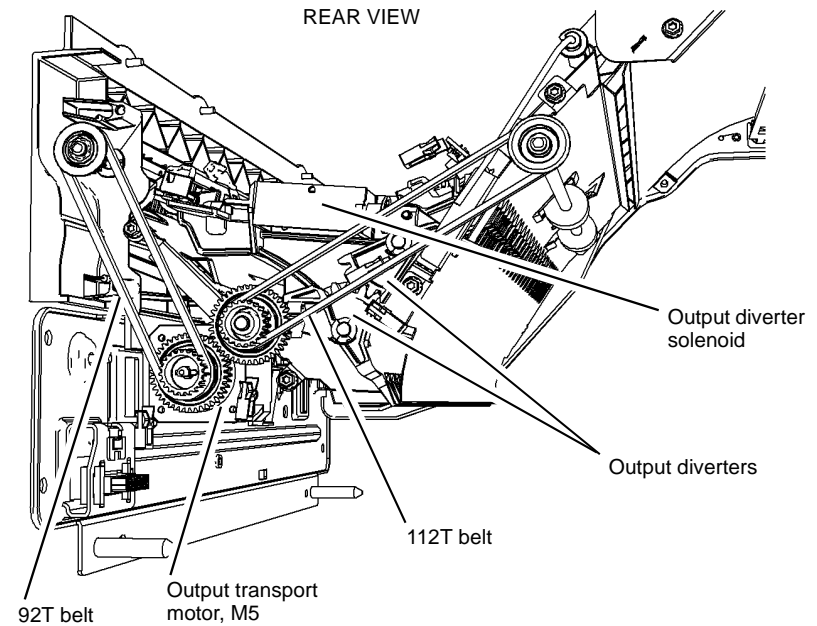

U-5-0077-A

Figure 1 Output transport components 1

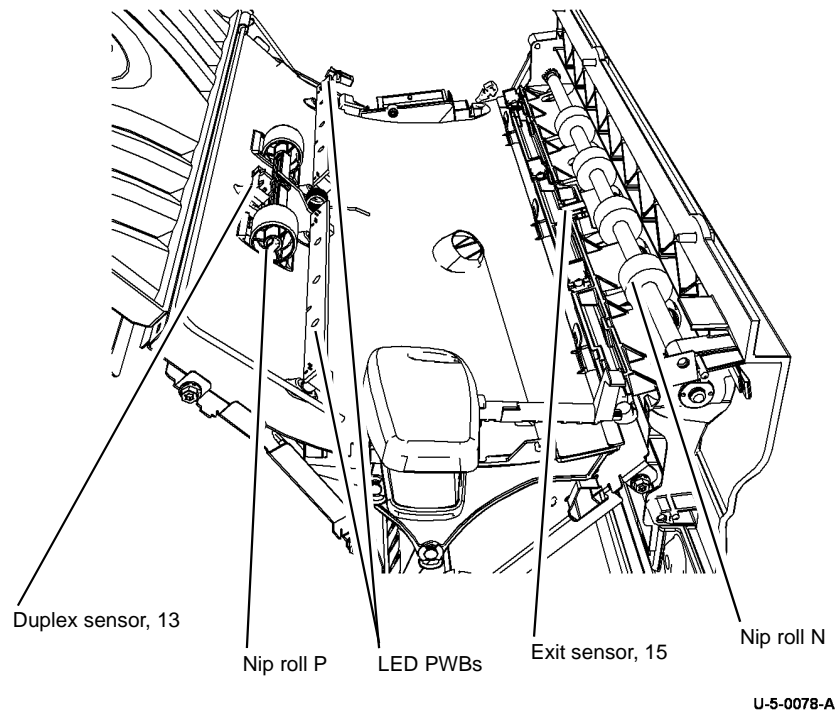

Figure 2 Output transport components 2

Corrugation roller - A spring-loaded, swinging roller at the exit nip gives the sheets a degree of corrugation, increasing stiffness as the sheets leave the exit nip for the output module. Refer to [Figure 3](#).

Anti-static brush - An earthed anti-static brush at the exit removes any static from the sheets that may have been picked up during transportation. This helps to produce even stacking at the output module. Refer to [Figure 3](#).

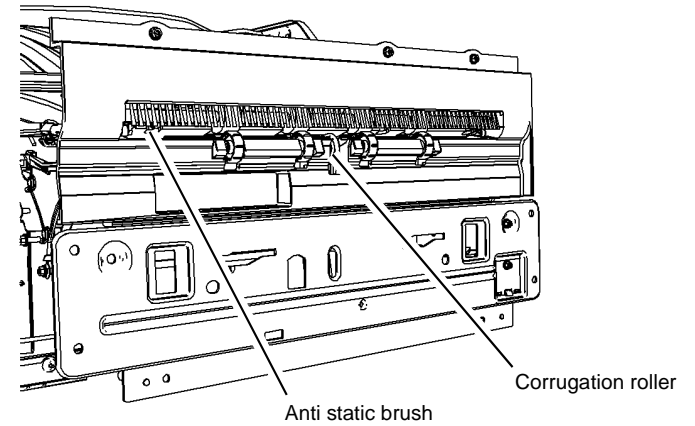

Figure 3 Output transport corrugation and anti-static components

Offsetting Catch Tray (OCT)

The OCT is an optional device, attached to the right hand side of the IME. The output is stacked in 1 to N order, face down or face up in the tray. The user can select to have alternate sets offset to provide set differentiation, including single-sheet sets.

A sensor detects when the tray has reached 90% of its full capacity.

The offset function is controlled on the OCT PWB, initiated by a motor enable signal from the media path driver PWB.

The OCT is controlled from the media path driver PWB. The tray capacity is as follows:

The OCT tray capacity is as follows:

- 500 sheets, A4 80gsm / Letter 75gsm flat output
- 300 sheets, A4 80gsm / Letter 75gsm with 12 mm curl

Up to 50% reduction in capacity will occur for other sizes, weights and environments. With sheets larger than A3 60gsm, there may be a greater reduction in capacity.

Low Capacity Stapler Stacker (LCSS)

Overview

The LCSS provides two selectable destinations bins, a 250 sheet capacity top tray (80 gsm / 20 lb.) and a high capacity 2000 sheet stacker tray (80 gsm / 20 lb.). When the top tray is selected the output will be stacked in an un-tamped manner. When the high capacity stacker tray is selected the output will be compiled and tamped.

The user may choose from the following finishing options when output is directed to the stacker tray.

- Offsetting of sets (25 mm) to create a visible set boundary stacking feature.
- Hole punching of sheets 2, 3 or 4 hole, Swedish 4 and Legal 2 hole configuration.
- Automatic stapling of up to 50 sheets (80gsm) sets, with the user able to select one of the following three positions dependant upon paper size and feed direction:
 - Single front
 - Single rear
 - Dual

Configuration

The LCSS is configured with two output bins: bin 0 and bin 1. The LCSS will carry up to 50 sheets in collating or collating and stapling mode.

Machine Interface

The LCSS receives and sends serial input and output data to and from the IME.

The machine interface comprises of the LCSS PWB, the communication cable, a bulkhead connector, a harness and the IME PWB.

The communication cable is the electrical connection between the IME and the LCSS PWB.

Communications between the IME PWB and the LCSS PWB are provided by the communication cable. If any communications data lines become open circuit or short circuit, a communication s fault is declared by the IME.

Power / Interlock

The LCSS requires a dedicated power cord which is connected to the self adjusting LCSS power supply module located inside the LCSS. The power supply module will accept 90 to 265 volts AC at 50 or 60Hz.

Interlock switches in the LCSS interrupt +24V power when the front door interlock, docking interlock or top tray jam access cover are opened for jam clearance or service.

Entrance Paper Path

The entrance paper path is located in the middle left side of the LCSS. It receives printed sheets from the host machine and moves them into the diverter gate and through the hole punch unit and into the stacker tray.

Entry Sensor

Entry Sensor Q12-077 is located in the LCSS entrance paper path. In addition to supplying the LCSS PWB with jam detection information, the sensor signal is used to time the operation of components in the LCSS. Refer to [Figure 1](#).

Hole Punch Unit

As sheets are received in the LCSS entrance paper path, sets of nip rollers transport the sheets through the hole punch unit.

If hole punching has been requested by the operator, the punch sensor, Q12-078 senses the trail edge of the sheet. The sheet is halted in the correct position by the LCSS PWB controlling transport motor, MOT12-223. Hole punch motor, MOT 12-243 is then energized to punch the sheet, the hole punch motor continues to be driven until the hole punch home sensor, Q12-194 sends a signal to the LCSS PWB, so that the hole punch motor is stopped at the home position.

If hole punching is not requested by the operator, sheets pass straight through the hole punch unit to the vertical transport.

Transport Motor 1

Transport motor 1, MOT12-223, is a stepper motor located on the rear frame. The output shaft of the motor drives a toothed timing belt, that transfers mechanical drive to two sets of nip rolls in the entrance paper path. Refer to [Figure 1](#).

Diverter Gate

Sheets continue up the entrance paper path, by way of two sets of nip rolls, to the diverter gate. The diverter gate is opened by the diverter gate solenoid, SOL 12-225.

If the diverter gate is open, the sheets are diverted to bin 0. If the diverter gate is closed, sheets continue to the vertical paper transport. Refer to [Figure 1](#).

Bin 0

Bin 0 receives all transparency jobs, label jobs and all jobs not selected by the operator to be made into compiled sets or compiled and stapled sets.

Bin 0 Paper Path and Transport Motor 2

Transport motor 2, MOT12-224, is a stepper motor located on the rear frame. The output shaft of the motor drives a toothed timing belt, that transfers mechanical drive to the driven components in the upper paper path. Sheets leaving the vertical transport via the opened upper diverter gate are transported to bin 0 by the upper paper path. Refer to [Figure 1](#).

Bin 0 Operation

Top exit sensor, Q12-107 is used to detect jams in the bin 0 area. When the trail edge clears the top exit sensor it signals the control logic that the sheet has exited the upper paper path.

Sheet edge detection is disabled until just before either edge is expected (approx. 30 mm). This is done to avoid reading false signals caused by sensor bounce.

As the paper is ejected, it drops vertically to the bin 0 surface. Subsequent sheets settle on top of the previous sheets, creating a stack.

Vertical Paper Transport

The vertical paper transport is used to feed the printed sheets to the compiler.

Compiler Carriage

The sheets are transported through the vertical transport by two sets of nip rolls, powered via toothed timing belts from transport motor 1, MOT12-223. Refer to [Figure 1](#).

Sheets arrive at the compiler tray and are reversed against the backstops by the combined action of the angle of the compiler tray and the rotation of the paddle wheel. The paddle wheel is driven by the paddle roll motor, MOT12-237. The paddle wheel position is set by the paddle roll position sensor, Q12-186, adjacent to the motor.

As each sheet is registered against the backstops, it is tamped to ensure a neat set. When the set is complete it is stapled, if required, before being ejected into bin 1.

The eject assembly then ejects the set into the stacker tray.

Compiler Stapler Operation

The purpose of the compiler carriage stapler is to staple the compiled sets in the compiler tray. Up to 50 sheets of (80gsm / 20lb) paper can be stapled. Single or double stapling is available in portrait or landscape mode, corner stapling is also available.

The staple head unit 1 assembly is mounted on the stapler mount and traverse shaft, which moves the stapler to the various stapling positions within the compiler. Drive is provided by the stapling unit traverse motor, MOT 12-249 which drives the stapler mount and traverse shaft assembly, to position the stapler. The stapling unit home sensor, Q12-135 senses when the stapler is at the home position.

Once the signal has been received to staple, the staple head 1 motor, MOT 12-247 (located within the staple head) is energized. The motor remains energized until the cam has made a complete revolution and the staple head home sensor, Q12-135 has been actuated. The one revolution of the cam enables a staple to be driven through the set, clinched, and then return the staple head to the home (open) position for the next staple.

Stapler Unit 1 Home Sensor

The stapling unit (SU1) home sensor, Q12-135 is located at the front of the compiler carriage. All stapler traverse positions are calculated using this home reference.

When the stapler transport is started for the first time the 2K LCSS PWB starts the stapling unit traverse motor, MOT12-249, towards the rear for 200 steps. After this movement, the motor is stopped and driven towards the front until the home sensor is detected. This is the home position, and all traverse values for stapling positions are relative to it.

Stapler Unit Transverse Motor

The stapler transport consists of a linear slide and traverse shaft assembly which is driven by the stapling unit traverse motor, MOT12-249. The transport system positions the stapler at the various positions necessary for the stapling operation.

SH1 Priming Sensor

Priming of the staple head is the pre-forming of the first two staples in the staple stick. If the staple head home sensor is low at machine initialization, the SH1 priming sensor (located within the staple head) is checked for staple head primed (H) (high = primed). If the sensor is high then the initialization is complete. If the staple head primed signal is low, the control logic will cycle the staple head 1 motor until the SH1 priming sensor signal goes high.

SH1 Home Sensor

After the staple has been formed in the compiled set, the staple head cam continues to rotate until it has made one complete revolution and the staple head home sensor, Q12-135 (located within the staple head) has been actuated, sending a (H) signal to the control logic to stop the staple head 1 motor at the home position.

SH Low Staples Sensor

The SH1 low staples sensor (located within the staple head) is used to detect the presence of staples (and therefore a staple cartridge) in the compiler carriage stapler. The sensor signals the control logic when the cartridge is missing or low on staples.

Tamping

The purpose of the tamping function is to align the sheets in the compiler carriage to eliminate skew and offset. Tamping registers all sheets in the correct position, as a set, for correct stapling.

The front tamper arm is driven by the front tamper motor, MOT12-226. The rear tamper arm is driven by the rear tamper motor, MOT12-227. The tamper motors are mounted on the front and rear frames of the compiler carriage and drive their respective tamper arms using a toothed belt driven lead screw for each tamper.

Home Position

The tamper arms are initially at a home position that puts them outside of the paper path. The home positions are detected by the front tamper home sensor, Q12-180 and the rear tamper home sensor, Q12-181, which monitor flags located on the tamper arms. These two sensors are bonded to the compiler carriage frames. If a sensor failure occurs, a new compiler carriage must be installed.

Tamp Position

Upon actuation of the compiler sensor by the first sheet of a set, the tamper arms are moved from the home position to the ready position. The ready position is paper size dependent and the information is obtained from the IME. When each sheet of the set is fully within the compiling area, the tamper arms are moved to the tamp position and then back to the ready position to wait for the next sheet. The tamper arms are moved back to the ready position at a slower speed so that an over tamp buckle is avoided which could move sheets out of the registered position.

Bin 1 Stacking

Bin 1 of the LCSS provides a platform to stack up to 2000 sheets. The bin 1 tray surface or the top of the stack in bin 1, assists in the compiling mode by providing an extended surface to support longer documents, e.g. SEF A4 and A3 (SEF 8.5 x 11 and 11 x 17 inch).

As the paper stack increases in the tray, the bin 1 elevator motor, MOT 12-241 lowers the tray to the appropriate eject height to receive the set.

The bin 1 upper level sensor, Q12-188 measures the height of the stack in bin 1. This signal is used by the LCSS PWB to determine when to lower bin 1 in steps to maintain the correct stack height, with regard to the output from the compiler. The 90% full sensor, Q12-187 is used to signal when bin 1 is 90% full, together with the bin 1 lower limit switch, S12-191 being made. The control logic will allow 10% more set feeds prior to declaring a bin 1 full status to the IME.

Refer to the following:

- [Figure 1](#) LCSS rear view
- [Figure 2](#) LCSS left view
- [Figure 3](#) LCSS paper path
- [Figure 4](#) LCSS Paddle wheel and stapler unit
- [Figure 5](#) LCSS Stapler head
- [Figure 6](#) LCSS tramper unit
- [Figure 7](#) LCSS hole punch unit (rear view)
- [Figure 8](#) LCSS ejector unit
- [Figure 9](#) LCSS stacker unit
- [Figure 10](#) LCSS Manual stapler button

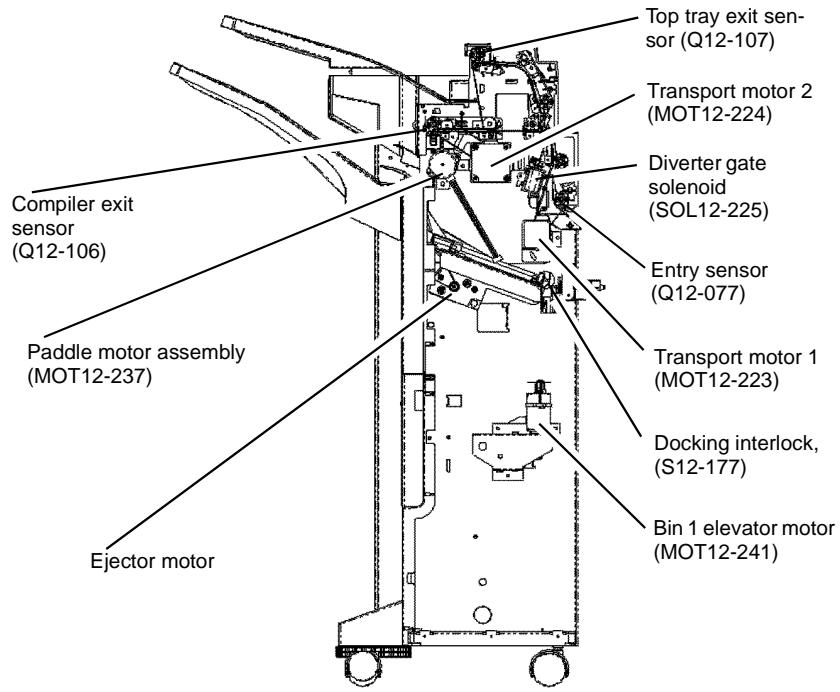

U-5-0006-A

Figure 1 LCSS rear view

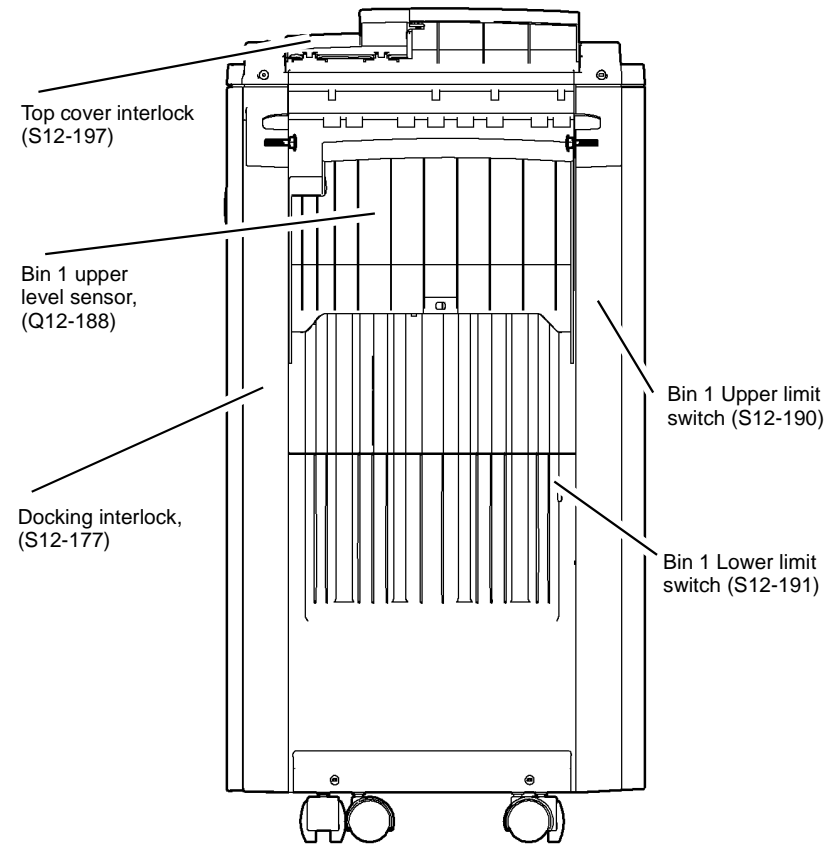

This shows approximate position of components behind the cover

U-5-0007-A

Figure 2 LCSS left view

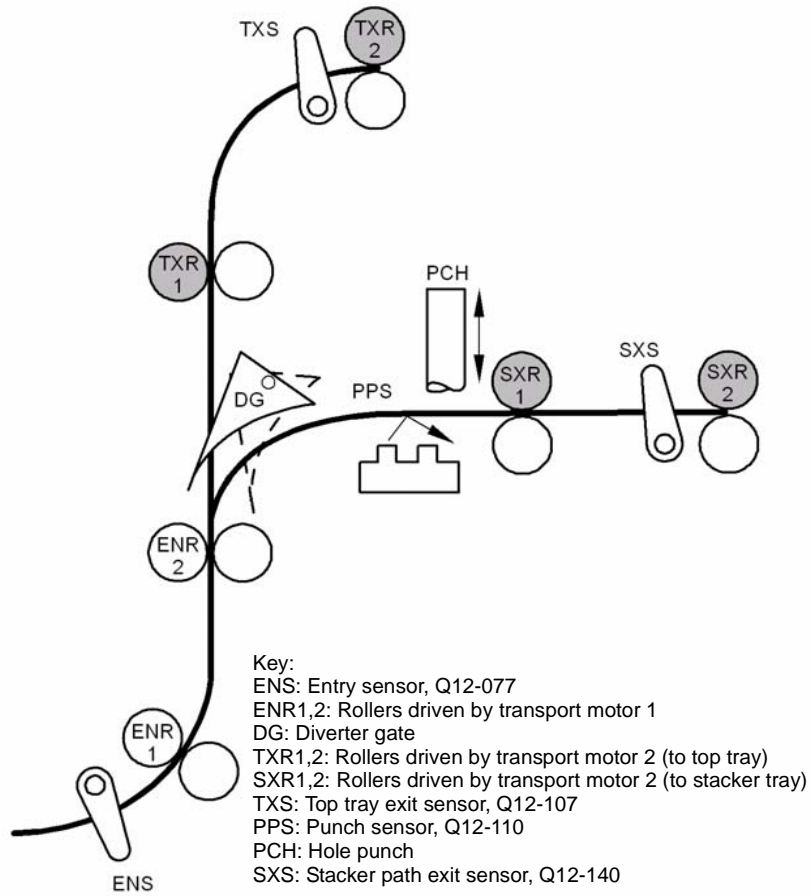

Figure 3 LCSS paper path

U-5-0008-A

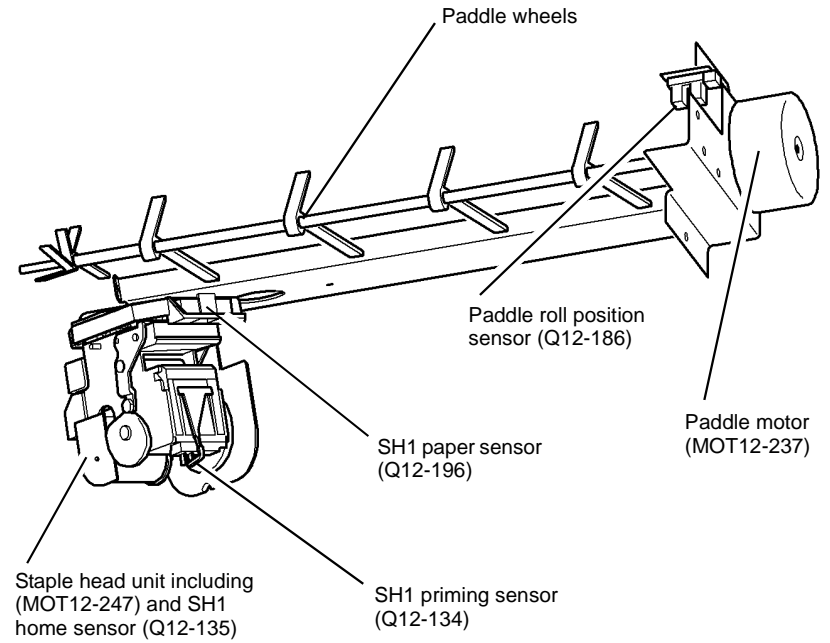
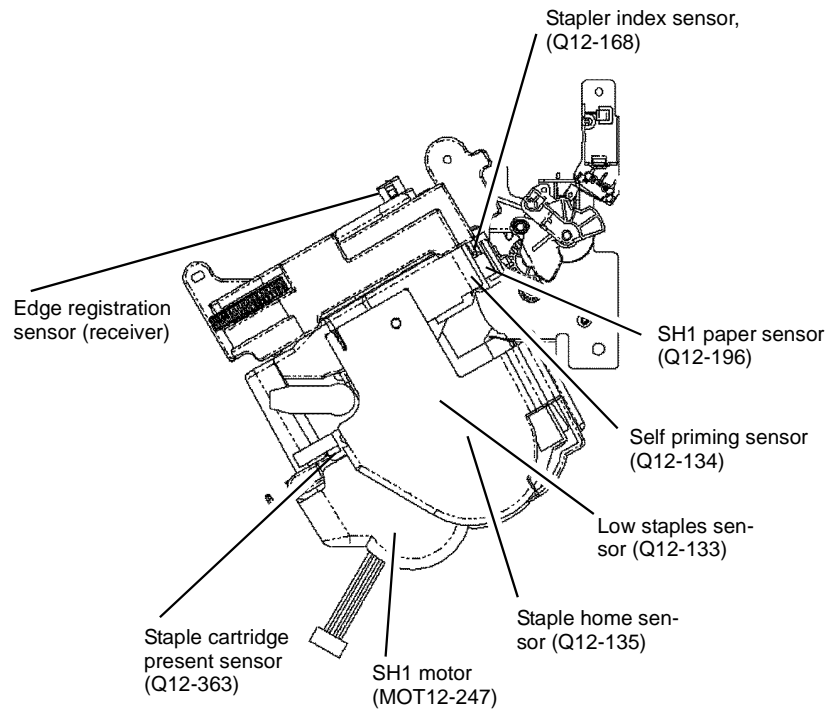

Figure 4 LCSS Paddle wheel and stapler unit

U-5-0009-A



U-5-0010-A

Figure 5 LCSS Stapler head

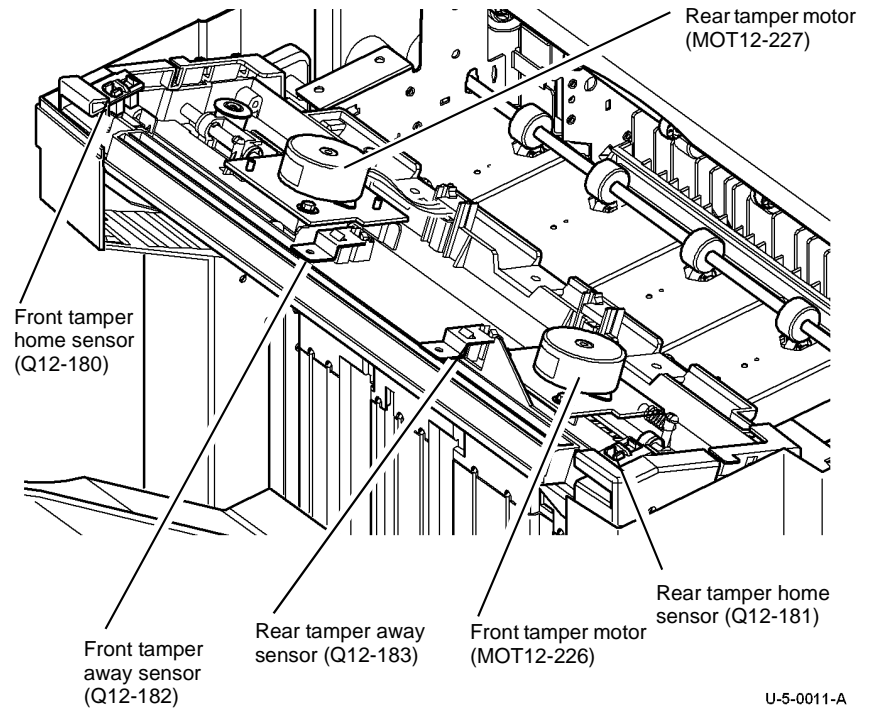

U-5-0011-A

Figure 6 LCSS tamper unit

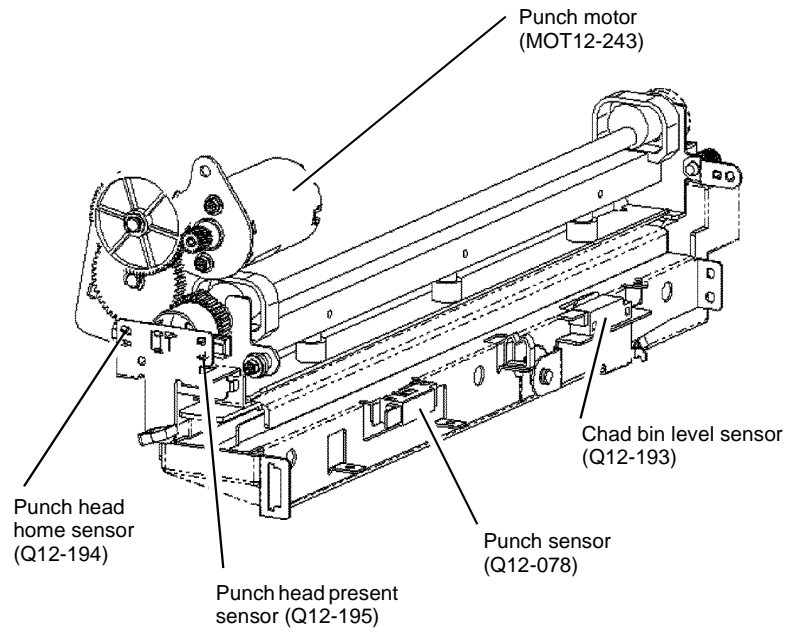

U-5-0012-A

Figure 7 LCSS hole punch unit (rear view)

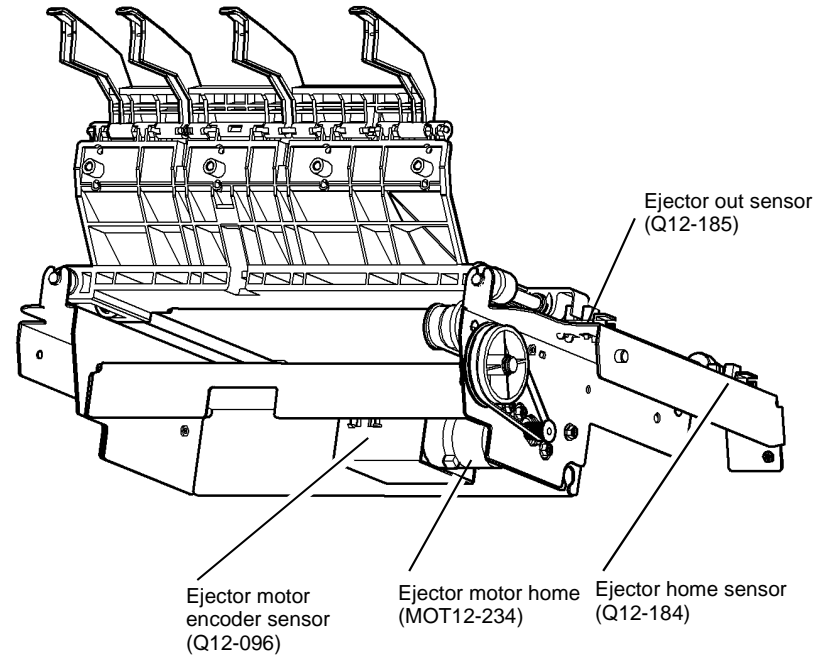

U-5-0013-A

Figure 8 LCSS ejector unit

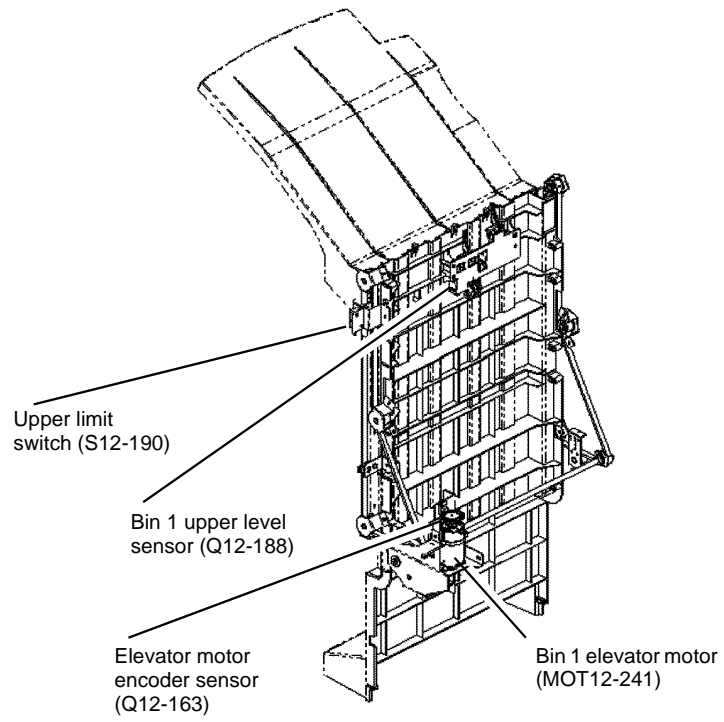

U-5-0014-A

Figure 9 LCSS stacker unit

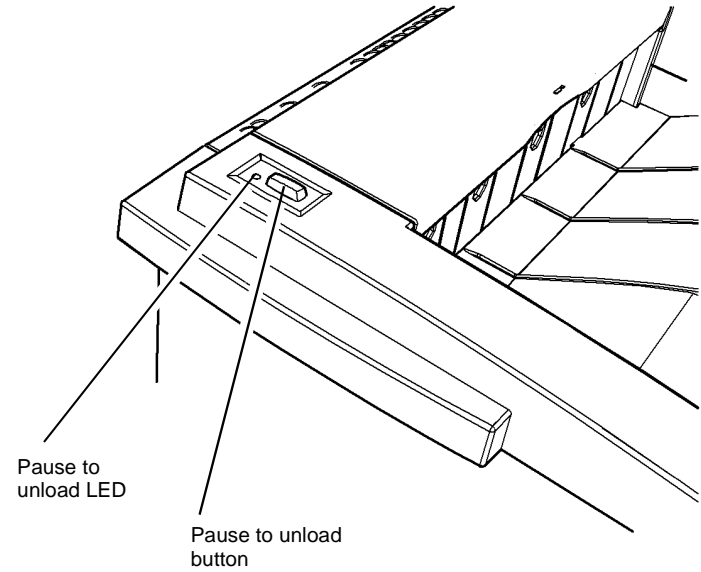

U-5-0015-A

Figure 10 LCSS Manual stapler button

High Volume Finisher (HVF)

Overview

The high volume finisher (HVF) provides the following functions:

- A top tray output for single sheets from the IME module, with a capacity of 250 sheets at 80gsm/20lb.
- A bin 1 output, providing compiled, multiple sheet sets, with a capacity of 3000 sheets at 80gsm/20lb. When a tri-folder module is fitted, the bin 1 capacity is 2000 sheets at 80gsm/20lb.
- A booklet maker with a minimum capacity of 10 sets of 15-sheet, stapled booklets at 80gsm / 20lb.
- A tri-folder, capable of producing Z-folds or C-folds. This has an output bin with a minimum capacity of 50 single-sheet tri-folder jobs at 80 gsm, (20lb). It can fold 60-120gsm, (15-30lb) sheets.
- A HVF stapler with a maximum capacity of 100 sheets at 80gsm/20lb.
- A HVF hole punch
- Inserter, which will allow paper to be inserted at any point into compiled sets.

The range of paper weights handled by the top tray, bin 1, booklet maker and inserter is 60 to 216gsm, 15 to 54lb. The tri-folder paper weight range is 60 to 120gsm, 15 to 30lb.

Configuration

The HVF comprises the following main systems which are described in this document:

- [Machine Interface](#)
- [Power / Interlocks](#)
- [Paper Paths](#)
- [Compiler](#)
- [Stacker](#)
- [Hole Punch](#)
- [Tray 6 Inserter](#)
- [Booklet Maker Module](#)
- [Tri-Folder](#)
- [Booklet Maker Bin 2 Output Tray](#)

Machine Interface

The harness between the rear of the IME, (PJ121), and the HVF PWB carries the communications between the two modules on serial data lines. The IME identifies the type of output device by the voltages on the ID lines in this harness. Communications between the HVF PWB, (PJ133), and the booklet maker PWB are carried on serial data lines. A 'booklet maker present' link is also present in this harness. The inserter module does not have dedicated communications to the HVF PWB. The 'inserter present' information is carried on PJ701 to the HVF PWB. The tri-folder module does not include a dedicated communications lines to the booklet maker PWB. The 'tri-folder present' link is carried in the harness to PJ563 into the booklet maker PWB.

Power / Interlocks

Power to the HVF module is supplied by a dedicated PSU in the base of the HVF. This supplies +5V and +24V. This PSU includes its own power cord.

A harness from the HVF control PWB, (PJ131), to the booklet maker PWB supplies +5V and +24V. The booklet maker PWB, (via PJ553), supplies the tri-folder with +5V and +24V.

The inserter module is powered from the HVF control PWB, through a complex connector at the base of the inserter. This connector has of two lines of terminals, TO55 / TO77, supplying the signals and the +5V, and AO55 / AO77. It also provides one higher current terminal at each corner of the connector body, supplying the +24V, 0V and ground to the inserter, plus the drive line for the inserter electric clutch. The inserter interlocks are described later in this document in the Inserter section, and the tri-folder interlocks are described in the Tri-folder section.

In the HVF module, three interlocks, wired in series, pass +24V to the module. These are:

- Top cover interlock switch, S12-197,
- Front door interlock switch, S12-303.
- Docking interlock switch, S12-177.

When all three interlock switches are closed, the +24V interlock indicator, LED 8 on the HVF control PWB is lit and the +24V supply is available to motors, solenoids and clutches.

Figure 1 shows the LEDs on the HVF PWB. These are:

- LED 1 - red, toggling. The LED changes state every time one of the following events occurs:
 - When the support fingers are fully extended,
 - When the rear wall sensor stops sensing the paper stack rear wall
 - When the stapler mode for the current set is not multiple, dual or rear stapling
- LED 2 - red. Not used.
- LED 3 - red, flashing. The LED indicates CPU function. When flashing at 2Hz, (every 1/2 second), the software is running normally. When flashing at about 1/4Hz, (every 4 seconds), this indicates that the software is encountering a code problem and a possible software upgrade is needed. If this LED is OFF, the CPU does not function and a new HVF control PWB is needed.
- LED 4 - red. Not used.
- LED 5 - red, toggling. The LED changes state whenever the paper is accelerated to 1,300 m/s. It is only used for paper that is longer than 220 mm.
- LED 6 - red, steady. When the LED is illuminated, a paper jam has been detected. It remains illuminated until the HVF successfully initializes. In all other cases this LED is off.
- LED 7 - red. The LED is used during the machine production and is connected with the activity of the stacker nearly full sensor.
- LED 8 - red, steady. The indicates that the HVF top cover, front door and docking interlocks are all closed and +24V is available at the HVF module.
- LED 9 - red, steady. The LED indicates that the +5V supply is present in the HVF module.

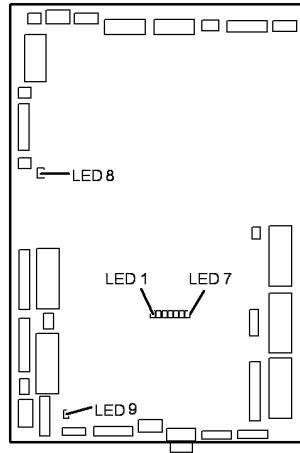

U-5-0026-A

Figure 1 LEDs on the HVF control PWB

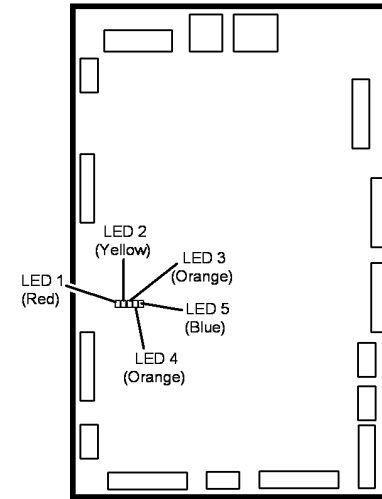

U-5-0027-A

Figure 2 LEDs on the BM control PWB

Figure 2 shows the LEDs on the BM PWB. These are:

- LED 1 - red, steady. The LED indicates a fault or other abnormal status.
- LED 2 - yellow, flashing at about 1Hz. The LED indicates that the software is operating in normal mode. In other modes, e.g., software downloading, the flashing rate is higher.
- LED 3 - orange, steady. The LED indicates either:
 - that the tri-folder front door and top cover interlocks are closed, and +24V is available to the BM module or, if the tri-folder is not installed;
 - that the interlock cheater is present in PJ553 on the BM control PWB the logic cheater is present in PL563 on the BM control PWB.
- LED 4 - orange, steady. The LED indicates that the +24V supply is within voltage and current limits, and that the power limiting circuit has not been active for over a set time limit.
- LED 5 - blue, steady. The LED indicates that the +5V supply is present in the BM module.

Paper Paths

This covers the motors, sensors, solenoids, etc., along the paper paths.

- Entry Sensor, Q12-077 - This is a reflective sensor at the HVF input transport, receiving paper from the IME. Refer to [Figure 3](#).
- Transport motor 1, MOT12-223 - This is a stepper motor, located at the rear of the HVF, and driving a toothed belt. This provides the drive to the input path from the IME. It also drives the vertical paper path from the inserter and takes the paper through to the hole punch. Refer to [Figure 3](#).

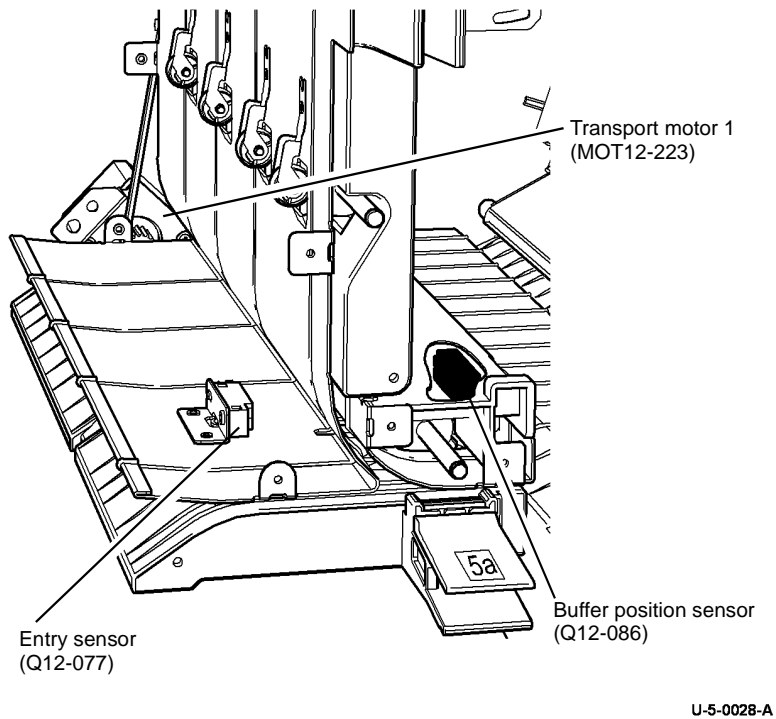

Figure 3 Entry sensor and Entry feed motor

U-5-0028-A

- Buffer position sensor, Q12-086 - A reflective sensor at the end of the input transport. This senses paper fed to the hole punch and beyond, to the buffer transport. Refer to [Figure 3](#).
- Bypass feed motor, MOT12-262 - A stepper motor, located at the rear of the HVF and driving a toothed belt. It takes the paper from the hole punch to the buffer transport or to the booklet maker, depending on the action of the booklet maker diverter solenoid. Refer to [Figure 4](#).
- Set clamp solenoid, SOL12-056 - Actuates during multiple-sheet compiled output jobs. When actuated, it holds the trailing edge of the first sheet in the buffer pocket until the arrival of the second sheet, at which time both sheets are fed to the ejector. The action is as follows:
 - The first sheet is fed vertically up into the buffer transport until it is released by the action of the nip split motor, which moved the idler rolls to the left, away from the paper. At the same time, the buffer feed motor stops.
 - The sheet then drops into the buffer pocket, where it is held by the set clamp solenoid until the second sheet arrives. This action maintains the inter-set gap. Refer to [Figure 4](#).
- Booklet maker diverter solenoid, SOL12-258 - Actuates to pass paper to the booklet maker. In the non-actuated condition, it allows paper to pass to the buffer transport. Refer to [Figure 4](#).

- HVF booklet exit sensor, Q12-087 - A flag sensor, located in the paper guide leading to the booklet maker. It senses paper exiting the HVF for the booklet maker. Refer to [Figure 4](#).
- Buffer motor, MOT12-262 - A stepper motor located at the rear of the HVF. It takes the paper from the booklet maker diverter to the top tray or stacker. Refer to [Figure 5](#).

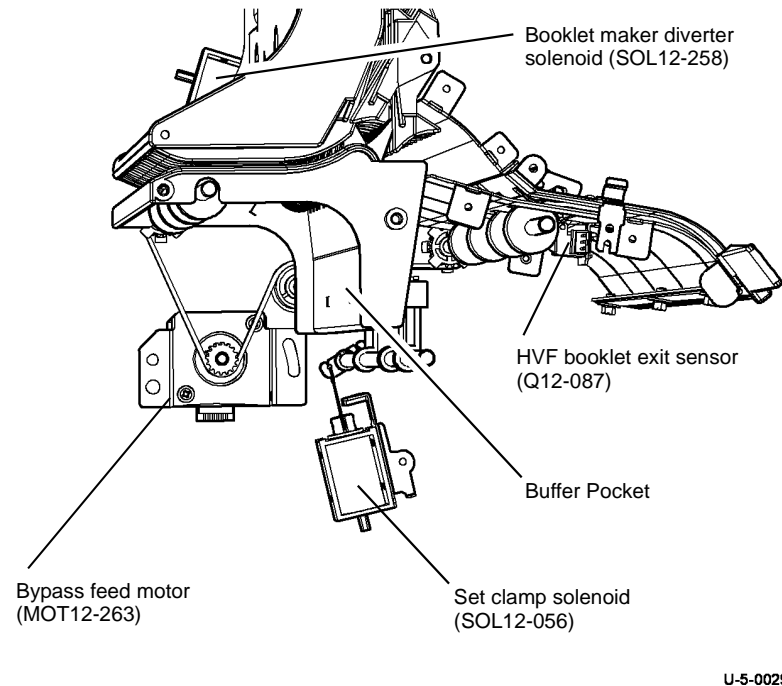
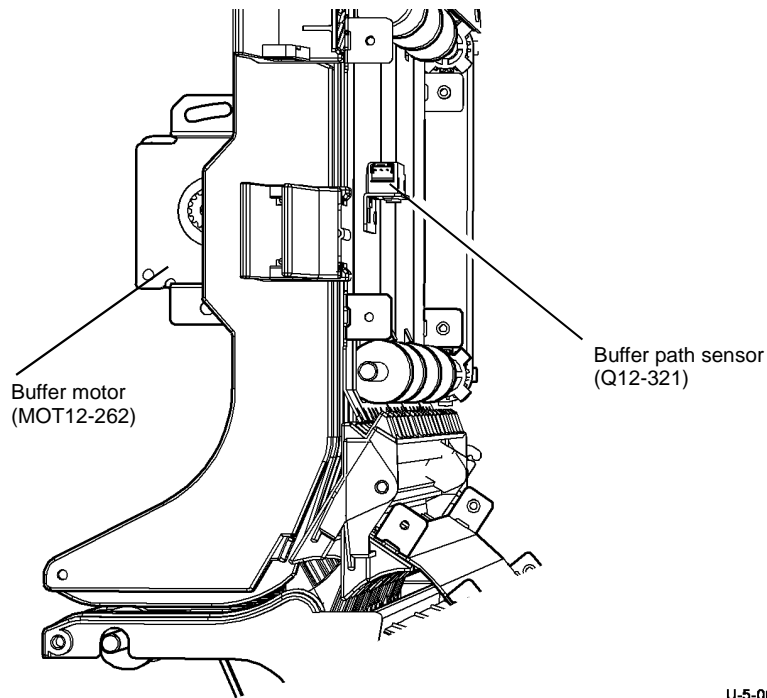

Figure 4 Buffer area components

U-5-0029-A

- Buffer path sensor, Q12-321 - A reflective sensor, located in the buffer transport. It senses paper being fed to the top tray or stacker. Refer to [Figure 5](#).



U-5-0030-A

Figure 5 Buffer feed motor and buffer path sensor

- Nip split motor, MOT12-264 - A DC motor, located in a housing at the rear of the 5b jam clearance guide. It opens the nip in the vertical buffer path by moving the idler rolls to the left, away from the paper. This allows the first sheet of a multi-sheet compiled job, to drop into the buffer pocket, as explained in the 'Buffer clamp solenoid' bulleted item, above. Refer to [Figure 6](#).

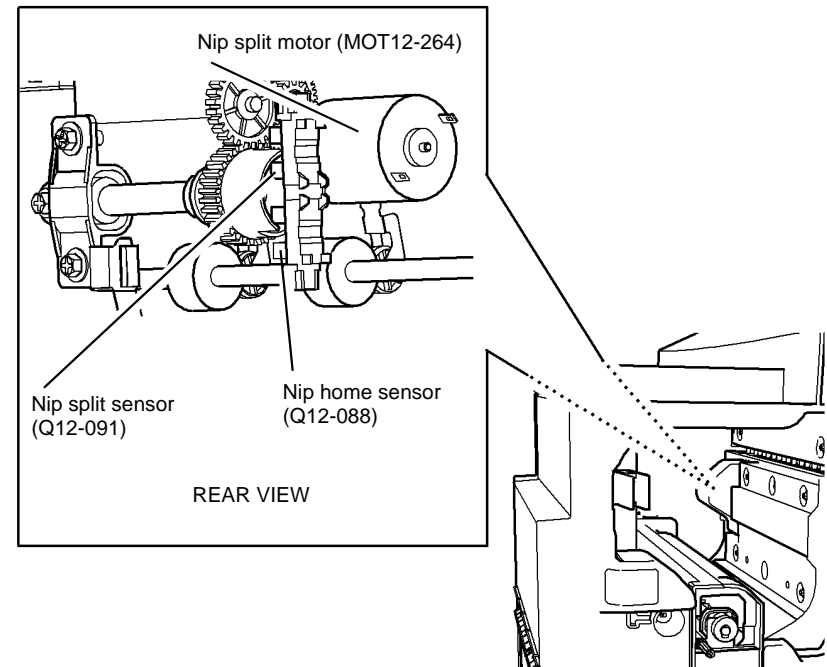

U-5-0031-A

Figure 6 Nip split mechanism

- Nip split sensor, Q12-091 - A flag sensor, operated by a cylindrical flag on the nip split cam shaft. It senses the open position of the nip. Refer to [Figure 6](#).
- Nip home sensor, Q12-088 - A flag sensor, operated by a cylindrical flag on the nip split cam shaft. It senses the closed position of the nip. Refer to [Figure 6](#).
- Transport motor 2, MOT12-224 - A stepper motor, located at the rear of the machine and driving two toothed belts. It takes the paper from the exit diverter and feeds it either to the top tray, via the top exit sensor, or to the stacker, via the stacker exit sensor. Refer to [Figure 7](#).

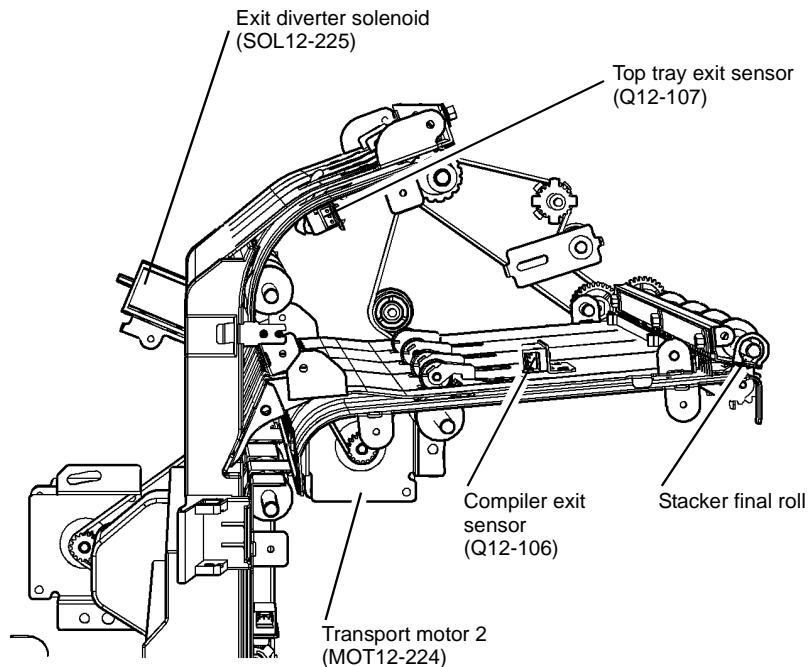

U-5-0032-A

Figure 7 Top tray and stacker components

- Exit diverter solenoid, SOL12-225 - Actuates to divert the paper from the buffer to the top tray. In the non-actuated condition, it allows the paper to pass to the stacker. Refer to [Figure 7](#).
- Top exit sensor, Q12-107 - A flag sensor located in the upper exit paper guide. It senses paper passing out to the top tray. Refer to [Figure 7](#).
- Compiler exit sensor, Q12-106 - A reflective sensor located on the top jam clearance paper guide. It senses paper passing out to the stacker. Refer to [Figure 7](#).

Compiler

This section includes the functions of paper pusher, upper and lower paddles, tamping, stapling, paper ejection, pressing and support.

Paper Pusher: The final roll at the stacker exit, (see [Figure 7](#)), corrugates the paper to give it stiffness. The paper pusher moves down as each sheet leaves the final roll, and pushes the sheet down to the ejector unit. The components associated with the paper pusher are:

- Paper pusher motor, MOT12-265 - A stepper motor located at the inboard end of the compile exit upper guide. The motor drives pinions that engage with racks integral with the pusher. Refer to [Figure 8](#).

- Paper pusher upper sensor, Q12-092 - A flag sensor that detects the pusher in the upper position. Refer to [Figure 8](#).
- Paper pusher lower sensor, Q12-094 - A flag sensor that detects the pusher in the lower position. Refer to [Figure 8](#).
- Stapler gate safety switch, S12-319 - A micro switch located at the inboard left of the paper pusher. This switch disables the +24V supply to the stapler when the paper pusher is away from the lower position. This is to ensure personal safety when it is possible to reach the stapler jaws, under the paper pusher. Refer to [Figure 8](#).

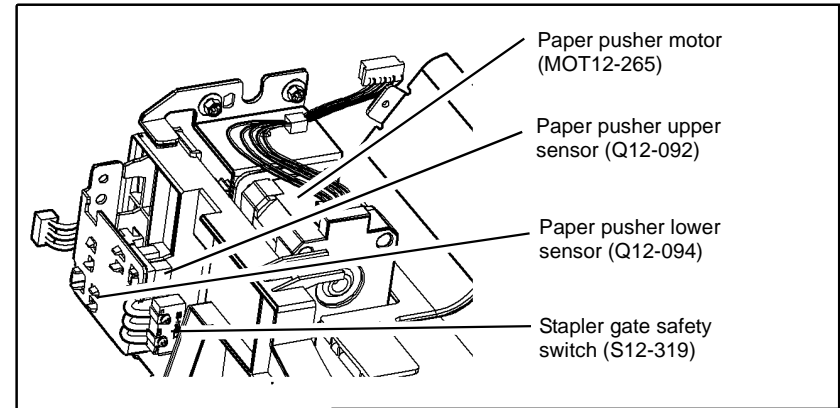

U-5-0016-A

Figure 8 Paper pusher components

Upper Paddle: As the paper pusher moves down with the first sheet, the paddle unit moves to the lower position. As the paper pusher returns to the upper position, ready for the next sheet, the paddles rotate to position the first sheet correctly in the ejector. The sheet is correctly positioned when its trailing edge is in contact with the upright posts in the stapler module.

The number of cycles the paddle rotates depends on the size and orientation of the paper. The paddle unit remains in the lower position and every sheet in the set is positioned in this way. When the final sheet in the set has been positioned by the paddle, the paddle unit returns to the upper position.

The components associated with the paddle unit are:

- Paddle unit motor, MOT12-239 - A stepper motor located on the rear frame. It drives the paddle unit down to the working position and back up at the end of each set. Refer to [Figure 9](#).
- Paddle unit lower sensor, Q12-175 - A flag sensor located on a bracket beside the paddle unit, and sensing the paddle unit in the lower position. Refer to [Figure 9](#).
- Paddle unit upper sensor, Q12-174 - A flag sensor located on a bracket beside the paddle unit, and sensing the paddle unit in the upper position. Refer to [Figure 9](#).

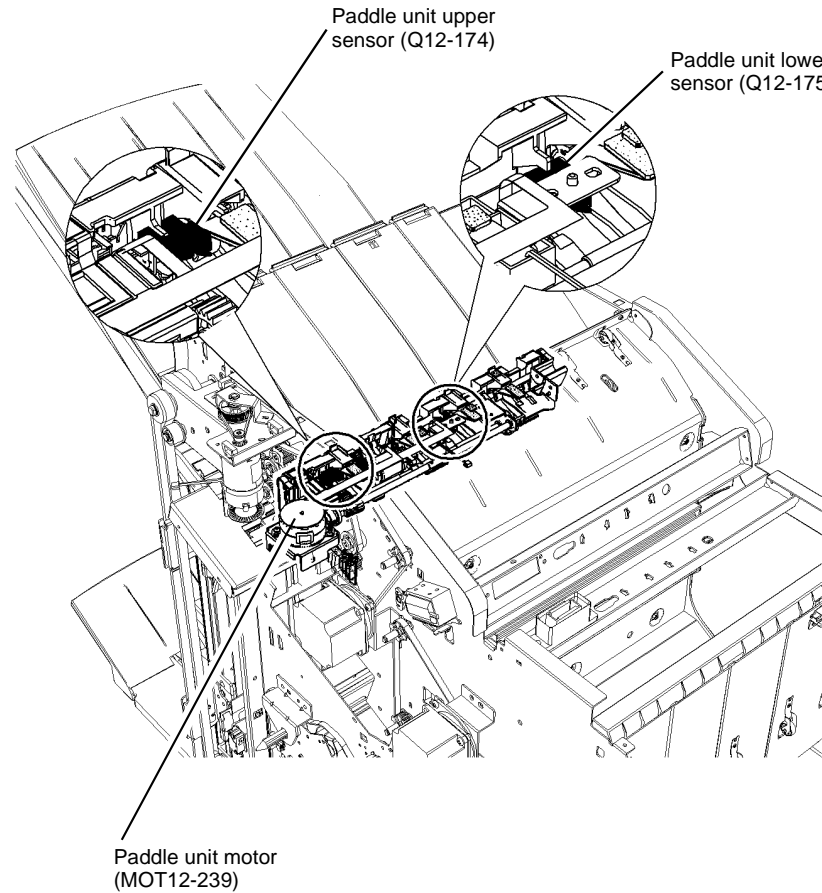

Figure 9 Paddle unit components

U-5-0017-A

- Paddle roller motor, MOT12-238 - A DC motor located in the paddle unit. The paddle is turned one complete revolution. Refer to [Figure 10](#).
- Paddle roller home sensor, Q12-186 - A flag sensor located in the paddle unit, and sensing the paddle roller in the home position. Refer to [Figure 10](#).

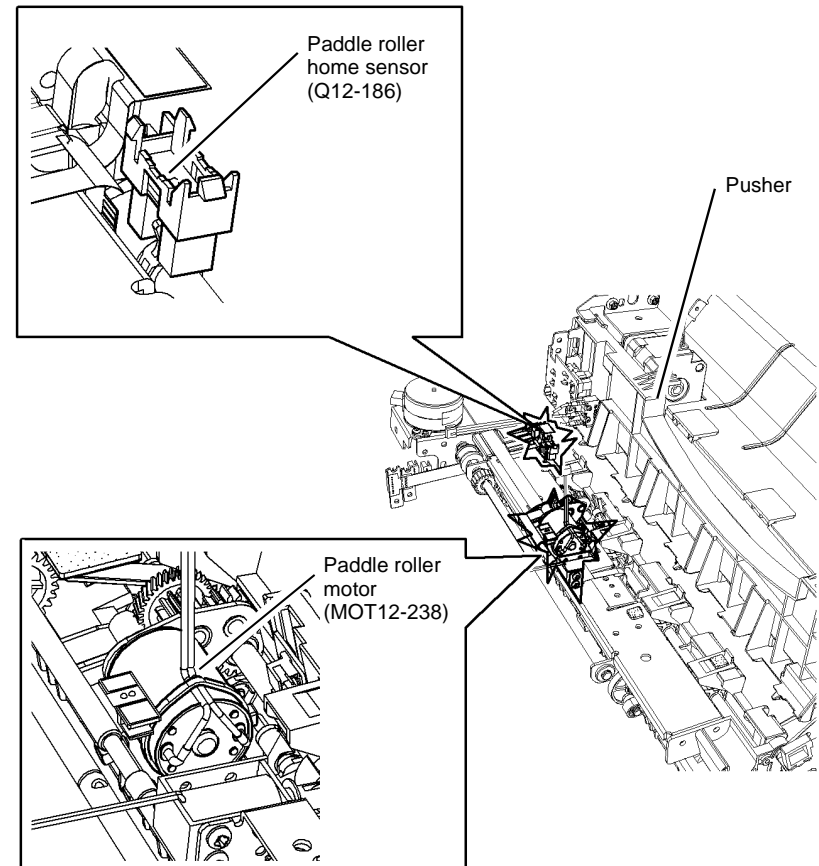
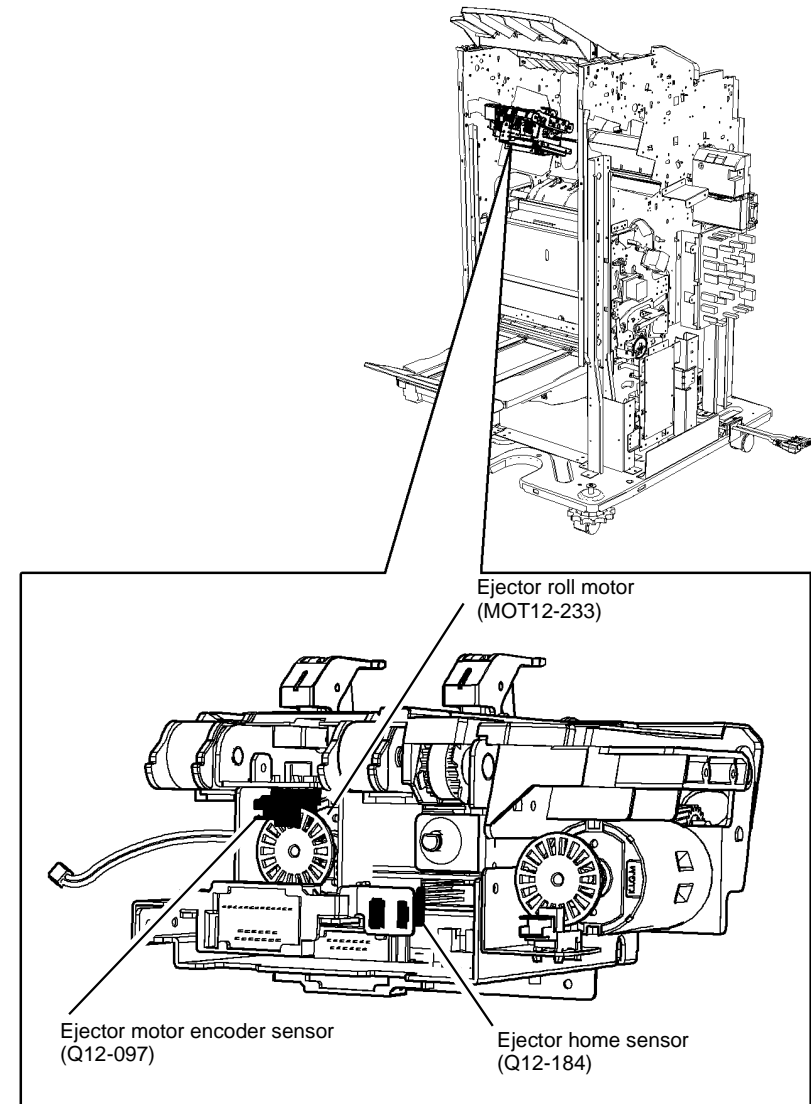

Figure 10 Paddle roller components

U-5-0018-A

Lower Paddle: A single paddle that is integrated into the ejector unit, which operates on the first sheet only in each set. The lower paddle turns at the same time as the upper paddle. It is actuated by the ejector roll motor, turning in the reverse direction. The action of this motor in the forward direction is described later (See: Eject function). The components associated with the lower paddle function are:

- Ejector roll motor, MOT12-233 - A DC motor located at the rear underside of the ejector unit. It runs in the reverse direction to rotate the lower paddle. Refer to [Figure 11](#).
- Ejector roll motor encoder sensor, Q12-097- A normal flag type encoder sensor, sensing the motor rotation. Refer to [Figure 11](#).
- Ejector home sensor, Q12-184 - A normal flag type sensor, sensing the ejector home. Refer to [Figure 11](#).
- Ejector lower paddle home switch, S12-099 - A micro switch located at the front underside of the ejector unit, sensing the home position of the lower paddle. This switch allows the paddle to rotate for one complete cycle. Refer to [Figure 12](#).



U-5-0019-A

Figure 11 Ejector roll motor and encoder sensor

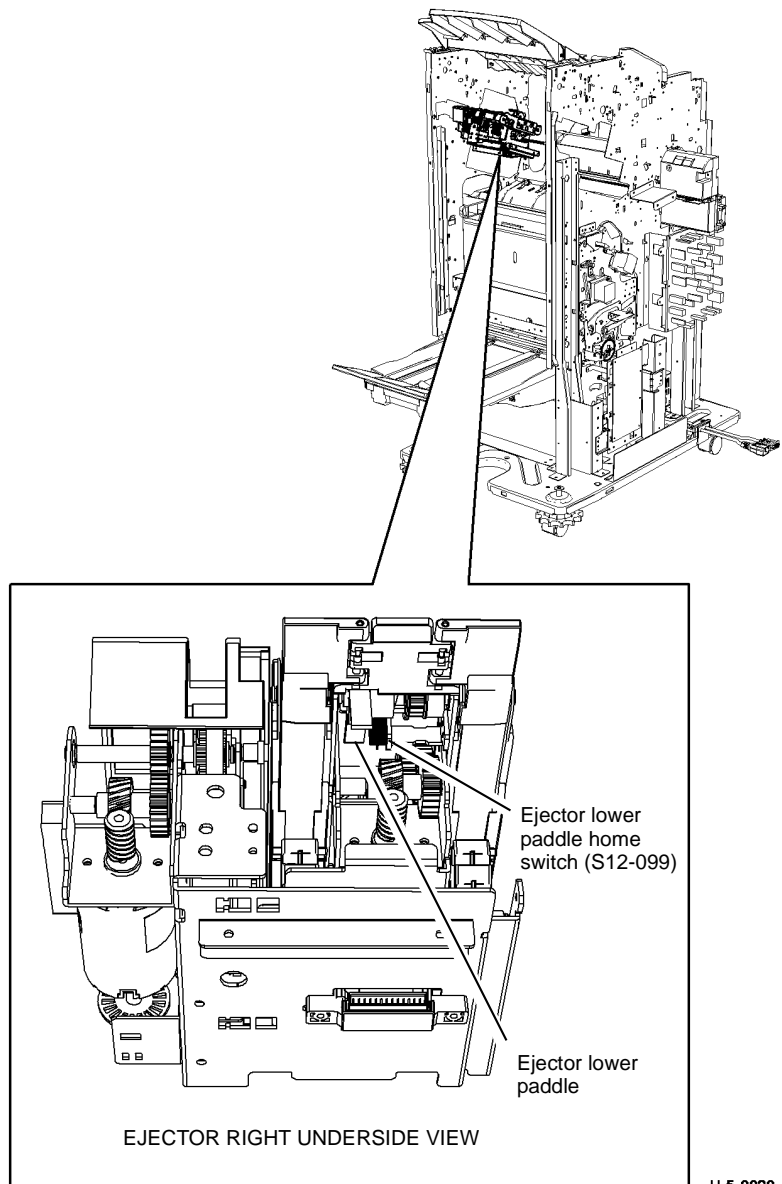

U-5-0020-A

Figure 12 Ejector lower paddle and paddle home switch

Tamping and Offsetting: The operation of offsetting the compiled sets is performed by the front and rear tampers. Offsetting is performed immediately before ejection. If stapling is selected, offsetting is performed after stapling. When a stapling operation is selected, the rear tamper operates before stapling, to ensure that each set is correctly positioned for stapling at its outboard end. After stapling the sets are alternately either left at the outboard end, or offset towards the inboard end by the front tamper. The components associated with the tamping and offset functions are:

- Front tamper motor, MOT12-266 - A DC motor, located above the bracket on the front frame. This motor moves the front tamper to the away and home positions. Refer to [Figure 13](#).
- Front tamper home sensor, Q12-180 - A flag sensor, located under the bracket on the front frame. This sensor detects the front tamper in the home position. Refer to [Figure 13](#).
- Front tamper away sensor, Q12-182 - A flag sensor, located under the bracket on the front frame. This sensor detects the front tamper in the away position. Refer to [Figure 13](#).

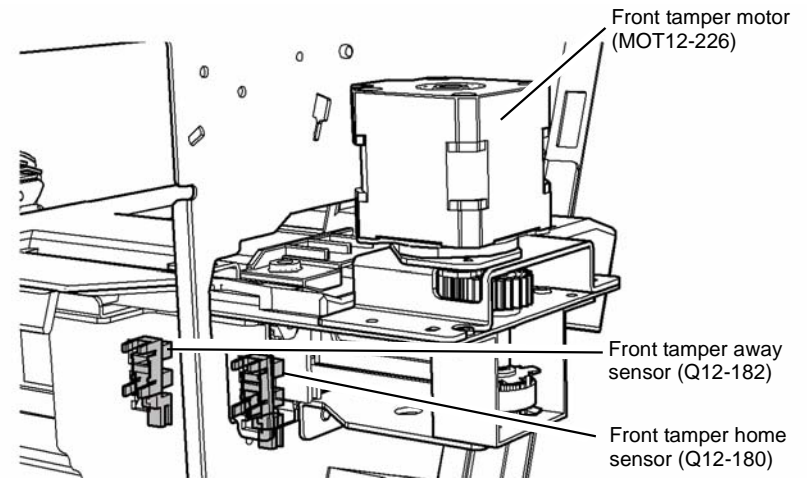

U-5-0034-A

Figure 13 Front tamper components

- Rear tamper motor, MOT12-227 - A stepper motor, located immediately to the rear of the ejector unit. This motor between the rear and home positions. Refer to [Figure 14](#).
- Rear tamper home sensor, Q12-181 - A flag sensor, located to the rear of the rear tamper motor. This sensor detects the rear tamper in the home position. Refer to [Figure 14](#).
- Rear tamper away sensor, Q12-183 - A flag sensor, located to the rear of the rear home sensor. This sensor detects the rear tamper in the away position. Refer to [Figure 14](#).

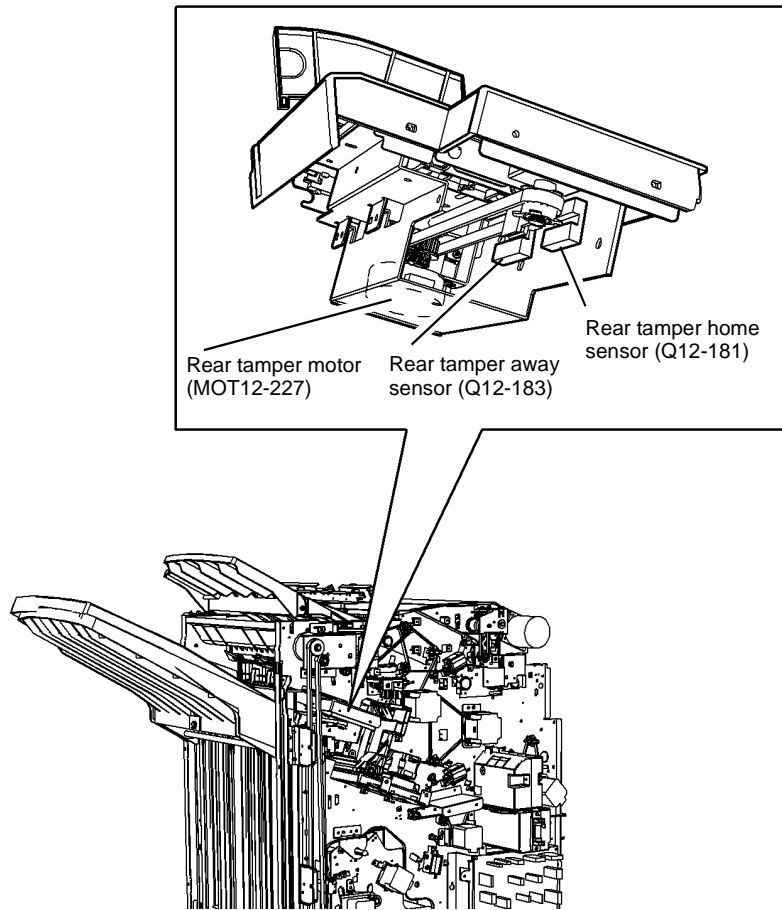

U-5-0035-A

Figure 14 Rear tamper components

Stapling: The stapling functions of the HVF, are distinct from those of the booklet maker and are performed on each set immediately after compiling the last sheet of each set. A single, travelling stapler unit is used. When 'one staple' is selected, the stapler unit remains at the outboard end of its travel, and the corner of each set is stapled. When two or more staples are selected, the stapler unit travels from outboard to inboard between each staple, then travels to the mid home position where it remains during the tamping and ejection functions. The stapler unit then returns to the home position. The components associated with the stapling function are:

- Stapler head motor, MOT12-247 - A DC motor that drives the closing of the stapler jaws and the forming of the staple from a straight bar. The motor is an integral part of the stapler and cannot be serviced. The high current to the stapler necessitates multiple wires between the HVF PWB and the stapler unit.
- Stapler primed sensor, Q12-134 - This is an integral part of the stapler and cannot be serviced. It detects the staples in the correct position, ready for forming and stapling.
- Cartridge sensor, Q12-317 - This is an integral part of the stapler and cannot be serviced. It detects the presence of cartridge, correctly fitted in position.
- Stapler jaw home sensor, Q12-318 - This is an integral part of the stapler and cannot be serviced. It senses that the stapler jaws are correctly positioned, ready for a stapling cycle.
- Low staples sensor, Q12-133 - This is an integral part of the stapler and cannot be serviced. It senses when the staples are running low and warns the user.
- Stapler gate safety switch, S12-319 - This is described also in the paper pusher section, in this document. The stapler gate safety switch is a micro switch located at the inboard left of the paper pusher. This switch disables the +24V supply to the stapler motor drive circuit, when the paper pusher is away from the lower position. This is to ensure personal safety when it is possible to reach the stapler jaws, under the paper pusher. Refer to [Figure 8](#).
- Stapler unit home sensor, Q12-135 - A flag sensor, located at the outboard end of the bed of the stapler unit. It detects the stapler unit in the home position. Refer to [Figure 15](#).
- Stapler unit mid home sensor, Q12-176 - A flag sensor, located towards the inboard end of the bed of the stapler module. It detects the stapler at the inboard end of its travel. Refer to [Figure 15](#).

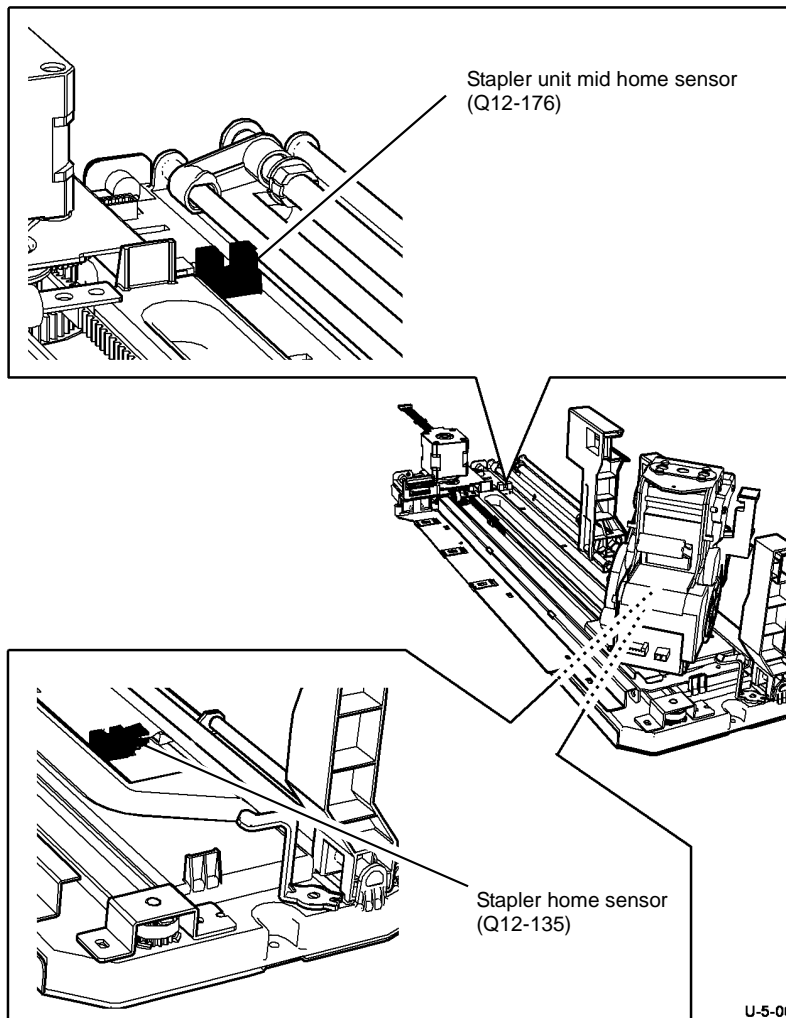
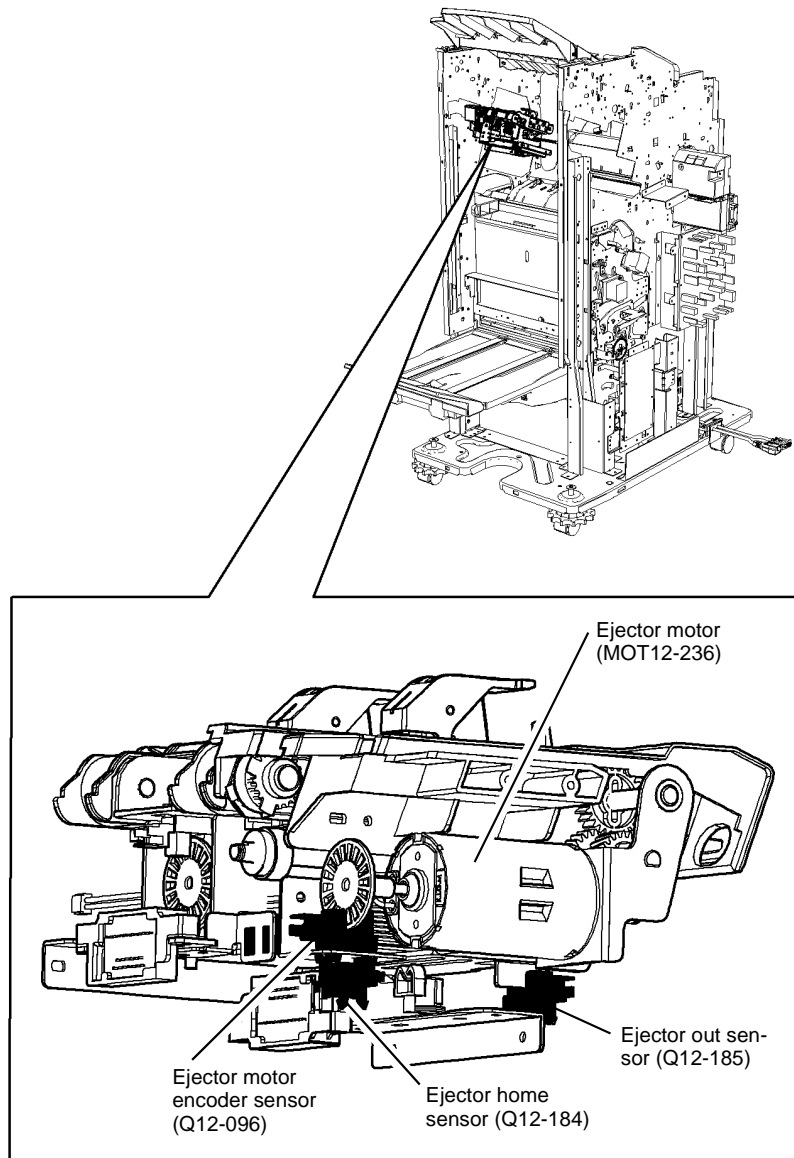

Figure 15 Stapling components

Paper ejection, pressing and support: Includes all actions necessary to transfer the paper sets from the compiler to the stacker. When the set is compiled, and the paper pusher and paddle units have returned to the upper position the ejector unit moves to the out position. The support fingers move out, taking the pressing fingers down to hold the previous set in place on the stacker. The ejector roll motor turns the belts and the ejector fingers push the set out to the stacker. The pressing and support fingers then return to the home position. The ejector fingers are carried round on the belts to their home position as the ejector unit moves back to its home position. The components associated with these functions are:

- Ejector motor, MOT12-236 - A DC motor, located at the front underside of the ejector unit. This motor moves the ejector unit to the 'out' and 'home' positions. Refer to [Figure 16](#).
- Ejector motor encoder sensor, Q12-096 - A standard flag, encoder-disc sensor, sensing the rotation of the ejector unit motor. Refer to [Figure 16](#).
- Ejector out sensor, Q12-185 - A flag sensor that senses the ejector unit in the out position. Refer to [Figure 16](#).
- Ejector home sensor, Q12-184 - A flag sensor that senses the ejector unit in the home position. Refer to [Figure 16](#).

- Ejector roll motor, MOT12-233 - A DC motor, located at the rear underside of the ejector unit. This motor turns in the forward direction to move the belts holding the ejector fingers. Its function in the reverse direction was covered in the 'Lower Paddle' paragraph, earlier in this document. Refer to [Figure 17](#).
- Ejector roll encoder sensor, Q12-097 - A flag sensor located at the rear of the ejector roll motor. This senses the movement of the ejector roll motor.
- Ejector plate home sensor, Q12-184 - A flag sensor, located at the rear of the ejector assembly, under the ejector belt. This detects the eject fingers in the home position.



U-5-0022-A

Figure 16 Ejector unit components

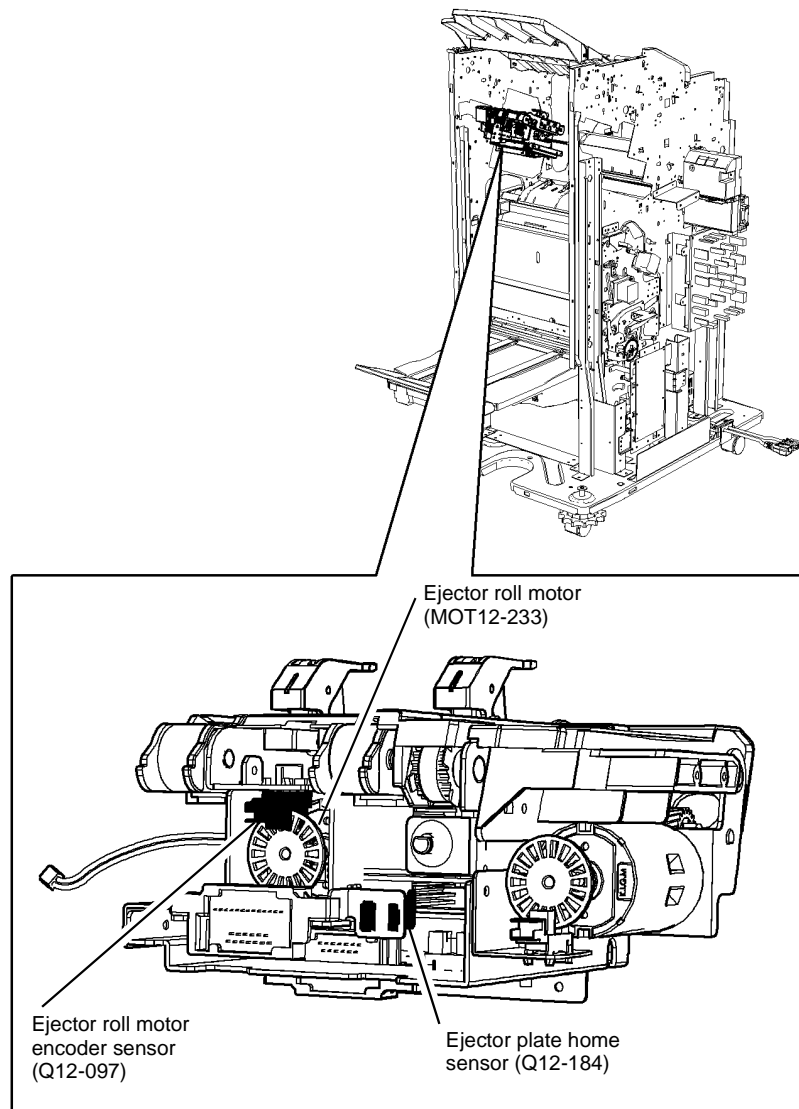

- Pressing and support motor, MOT12-323 - A DC motor, located below the HVF rear tamper. This motor moves the support fingers to the 'out', 'init' and 'home' positions. The pressing fingers are mechanically linked to the support fingers so that as the support fingers leave the home position, the pressing fingers move down to hold the previous set on the stack. Refer to [Figure 18](#).
- Pressing and support encoder sensor, Q12-093 - This is a standard flag, encoder-disc sensor, sensing the rotation of the pressing and support motor. Refer to [Figure 18](#).
- Pressing and support A sensor, Q12-172 - A flag sensor, detecting the support fingers in the 'home' position. Refer to [Figure 18](#).
- Pressing and support B sensor, Q12-171 - A flag sensor, detecting the support fingers in the 'init' position. Refer to [Figure 18](#).
- Pressing and support C sensor, Q12-173 - A flag sensor, detecting the support fingers in the 'out' position. Refer to [Figure 18](#).

U-5-0023-A

Figure 17 Ejector roll components

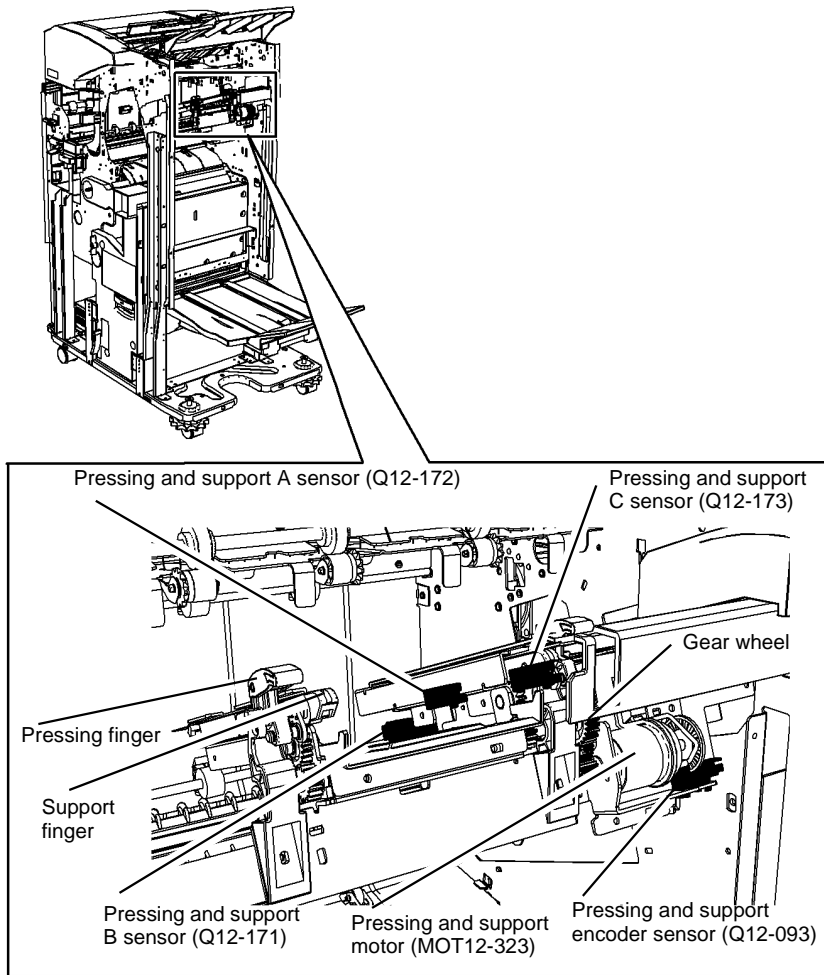

U-5-0024-A

Figure 18 Ejector roll components

Stacker

This section covers bin 1 tray movement and control. As the bin fills, the tray moves down to maintain the top of the stack at the correct level. This is controlled by the bin 1 upper level sensor, which is in two parts, and also by the paper pressing sensor that senses the top edge of the rear wall of the stack of paper. If the paper stack is flat, the paper pressing sensor will control the stack height, and if the paper stack is curved, the bin 1 upper level sensor will detect the top of the stack and control its height. There is a 90% full sensor, used to warn the user that the bin is nearly full, and there are upper and lower limit switches, to keep the tray within its allowable range of movement. The active components comprising the stacker are:

- Bin 1 elevator motor, MOT12-241 - A DC motor, located on the rear frame. This motor lifts and lowers the paper stack via a gear chain, driving two toothed belts. In the forward direction, this motor drives the stack down, and in the reverse direction, the stack is driven up. Refer to [Figure 19](#).
- Bin 1 encoder sensor, Q12-163 - A standard flag, encoder-disc sensor, sensing the rotation of the bin 1 elevator motor. Refer to [Figure 19](#).
- Bin 1 upper level sensor, Q12-188 - Consisting of two sensors, located in the frame at the front and the rear of the tray. The rear sensor is used as the receiving sensor, while the front sensor is used as the transmitter sensor. Refer to [Figure 19](#).
- Paper pressing sensor, Q12-322 - A reflective sensor, located beneath the ejector front cover. This sensor detects the top of the rear wall of the paper stack. Refer to [Figure 19](#).
- Bin 1 90% full sensor, Q12-187 - A flag sensor, located on the rear frame and mounted on the same bracket as the lower limit switch. The bracket has two possible positions; the lower position, used when a tri-folder module is not installed, and the upper position, used when a tri-folder is present. This sensor is actuated by a flag on the bin 1 rear bar lift bracket. Refer to [Figure 19](#).
- Bin 1 upper limit switch, S12-190 - A micro switch, located on the rear frame. This switch is actuated when the tray is above its normal level of operation. When this switch is actuated, the reverse, upwards, direction of the elevator motor is disabled, but the motor is allowed to drive the stack down. Refer to [Figure 19](#).
- Bin 1 lower limit switch, S12-191 - A micro switch, located on the rear frame and mounted on the same bracket as the 90% full sensor. The switch is actuated when the tray is at its lowest allowable limit of operation. When this switch is actuated, the forwards, downwards, direction of the elevator motor is disabled, but the motor is allowed to drive the stack up. Refer to [Figure 19](#).

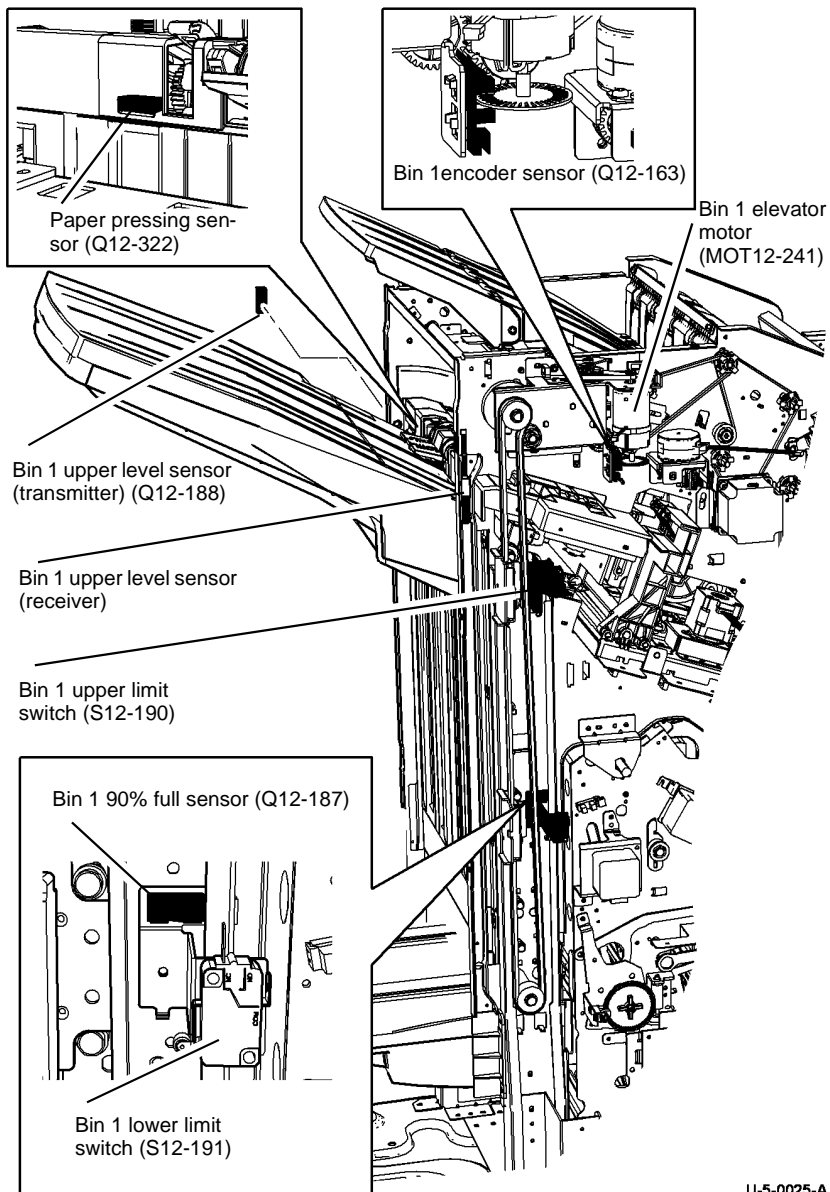

U-5-0025-A

Figure 19 Stacker components

Hole Punch

The hole punch is an optional module, providing 2 or 3 hole options, 4 hole, Swedish 4 hole and Legal 2 hole. Each option is provided as a kit, easily installed, using a knurled thumb screw. When the hole punch module is not installed, a blanking assembly is fitted in its place. When the hole punch is installed, the punch present link is detected at power-on by the HVF PWB, and the hole punch is acknowledged on the GUI. The active components of the hole punch are:

- Punch head motor, MOT12-244 - A DC motor, driving the punch head to operate all punches simultaneously, via eccentric cams. Refer to [Figure 20](#).
- Punch head home sensor, Q12-194 - A flag sensor, detecting the punch head in the home position, via a notched, cylindrical flag at the end of the cam shaft. Refer to [Figure 20](#).
- Punch unit motor, MOT12-245 - A stepper motor, driving the punch unit between the home and 'paper edge detected' positions. Refer to [Figure 20](#).
- Punch unit home sensor, Q12-114 - A flag sensor, detecting the punch unit in the home, (outboard), position. Refer to [Figure 20](#).
- Punch sensor 1, Q12-078 - A reflective sensor, detecting the front, (outboard), edge of 8.5"x11" LE fed paper. The punch unit motor MOT12-245, drives the punch unit forwards until the paper edge is detected. The punch unit is then in the correct position for the punch head to operate. Refer to [Figure 20](#).
- Punch sensor 2, Q12-075 - A reflective sensor, detecting the rear, (inboard), edge of 8.5"x11" SE fed paper. The punch unit motor MOT12-245, drives the punch unit forwards until the paper edge is detected. The punch unit is then in the correct position for the punch head to operate. Refer to [Figure 20](#).
- Punch sensor 3, Q12-076 - A reflective sensor, detecting the rear, (inboard), edge of A4 LE fed paper. The punch unit motor drives the punch unit forwards until the paper edge is detected. The punch unit is then in the correct position for the punch head to operate. Refer to [Figure 20](#).

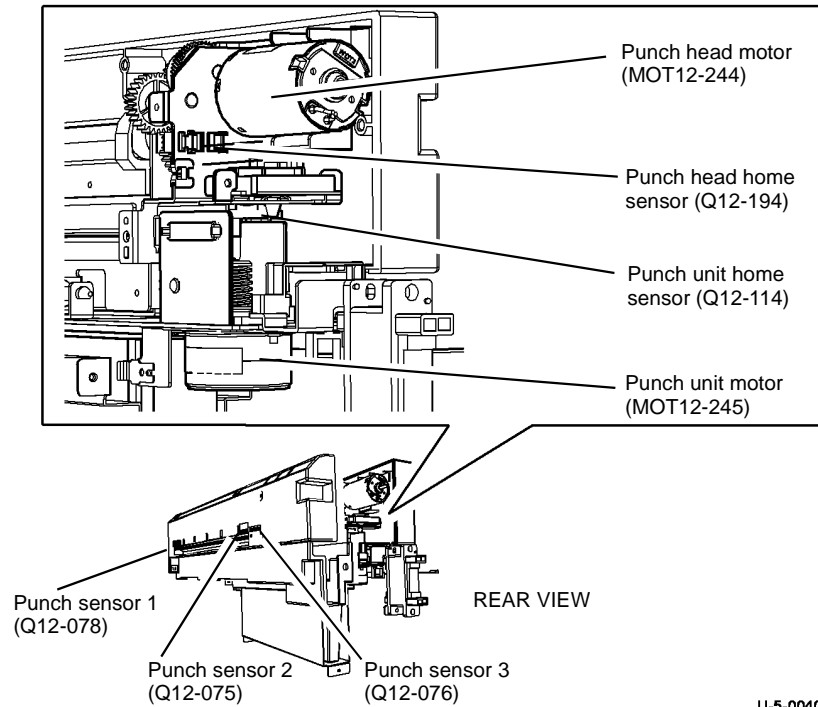

Figure 20 Hole punch components

- Chad bin present sensor, Q12-118 - A flag sensor, detecting the presence of a chad bin, under the hole punch module. Refer to [Figure 21](#).
- Chad bin level sensor, Q12-193 - A reflective sensor, detecting the presence of chad, through a hole, high in the side of the chad bin. Refer to [Figure 21](#).

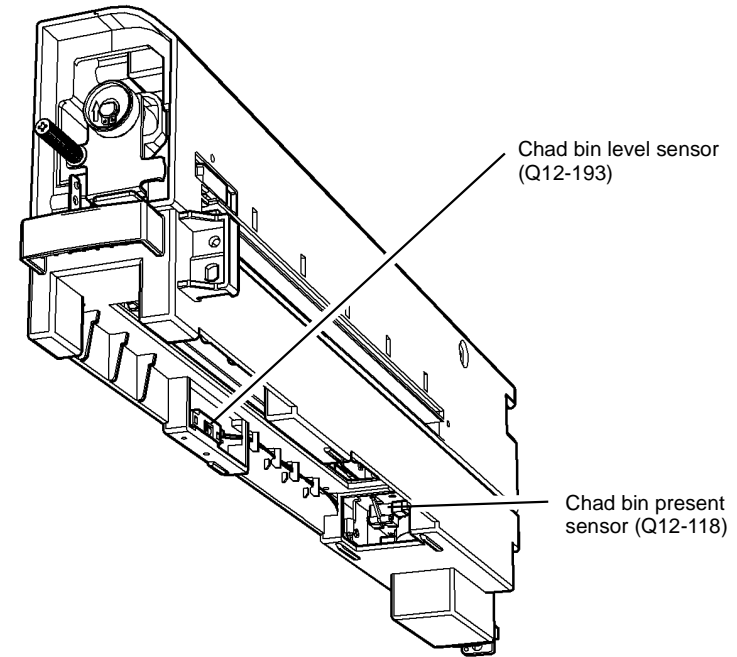

Figure 21 Chad bin components

Tray 6 Inserter

The Inserter, enables the user to insert a sheet at a pre-defined point in a set. For example it may be used to insert cover sheets or separators. The media inserted can be hole-punched, stapled or folded, as required. The active components of the Inserter are:

- Inserter motor, MOT12-261 - A stepper motor, located at the rear of the inserter. This motor runs forward to drive the paper tray up and to feed the paper, and the motor runs in reverse to drive the paper tray down. This is a variable speed motor, under the control of the software. The variable speed is used to synchronize the inserted media with the printed sheets coming from the IME, and compensates for any speed mis-match. In the forward direction, this motor turns the retard roll in the reverse direction, via a torque limiter. The retard roll thus acts as a retard pad, continually renewing its point of contact with the paper, thereby increasing its life and effectiveness. Refer to [Figure 22](#).
- Inserter clutch, CL12-260 - Located at the rear of the inserter, this clutch passes the drive to the feeder roll and nudger roll. Refer to [Figure 22](#).
- Inserter Pickup sensor, Q12-315 - A reflective sensor, located on the underside of the inserter top cover. The pickup sensor controls the electric clutch to start feeding. Refer to [Figure 22](#).

- Inserter TE sensor, Q12-084 - This is a reflective sensor, located mid-module, immediately in front of the feeder roll. The pickup sensor detects the trailing edge of the sheet, to control the electric clutch and is part of the speed compensation system. Refer to [Figure 22](#).
- Inserter LE sensor, Q12-083 - A reflective sensor, located mid-module, immediately after the feeder roll. The paper path sensor detects the leading edge of the sheet, to verify that the sheet was successfully fed. Refer to [Figure 22](#).
- Inserter acceleration sensor, Q12-316 - A reflective sensor, located behind the inserter left hand door. This sensor detects the leading edge of the sheet and operates together with the inserter LE sensor, to determine the speed of the paper. When the speed has been measured, the information is used to control the speed of the inserter motor. Refer to [Figure 22](#).
- Inserter standby sensor, Q12-320 - A reflective sensor, located on the HVF vertical transport, below the inserter. It senses the leading edge of the sheet passing into the HVF from the inserter and provides the final Go / Wait information, for feeding the sheet into the HVF at the correct inter-document gap (IDG). Refer to [Figure 22](#).

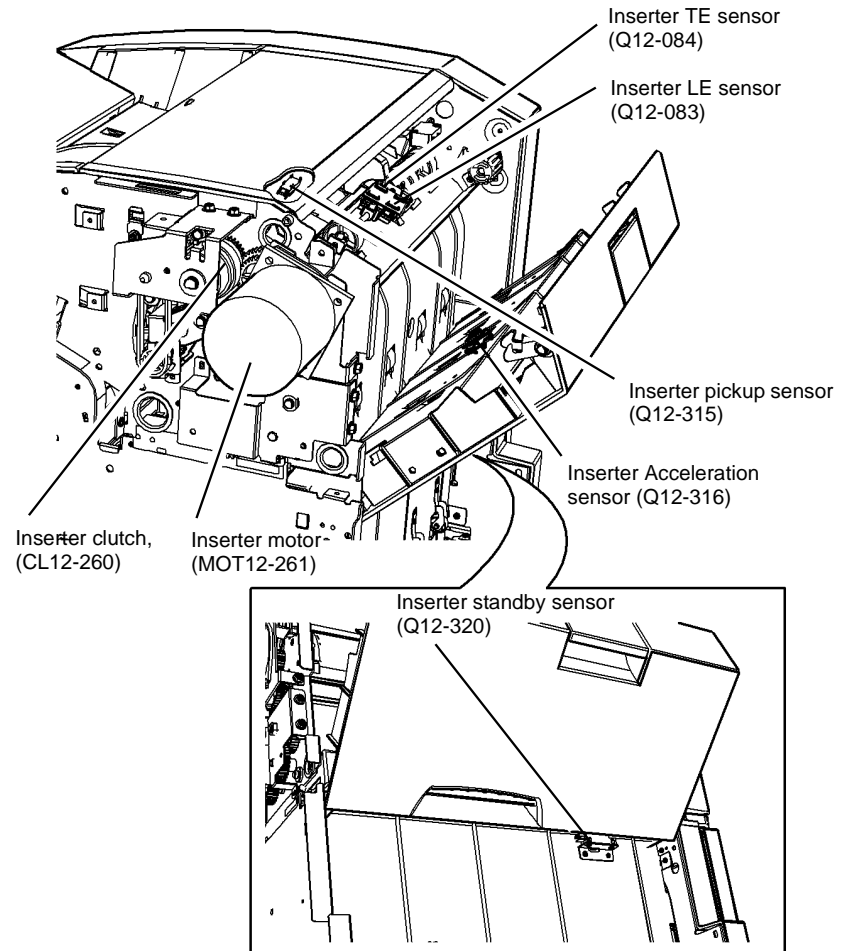

U-5-0042-A

Figure 22 Inserter Paper Path components

- Inserter unit empty sensor, Q12-082 - A reflective sensor, located on the inserter paper tray. This sensor detects the presence of paper in the inserter tray. In normal operation, once this sensor detects no paper in the tray, the tray lowers after about two seconds. Refer to [Figure 23](#).
- Inserter paper length sensor 1, Q12-079 - A reflective sensor, located on the sensor tray. It detects paper longer than 203 x 330 mm (8 x 13 inches). Refer to [Figure 23](#).
- Inserter paper length sensor 2, Q12-080 - A reflective sensor, located on the sensor tray. It detects paper longer than 203 x 280 mm (8 x 11 inches). Refer to [Figure 23](#).

- Inserter paper length sensor 3, Q12-090 - A reflective sensor, located on the sensor tray. It detects paper less than 203 x 280 mm (8 x 11 inches). Refer to [Figure 23](#).
- Inserter paper width sensor 1, Q12-081 - The detector incorporates two width sensors. Width sensor 1 is a flag sensor, actuated by the paper width guide position. The sensor changes state at 285 mm, (11 1/4 inches) and 210 mm, (8 1/4 inches) paper widths. Refer to [Figure 23](#).
- Inserter paper width sensor 2, Q12-169. Width sensor 2 - A flag sensor, actuated by the paper width guide position. The sensor changes state at 273 mm, (10 3/4 inches) paper width. Refer to [Figure 23](#).

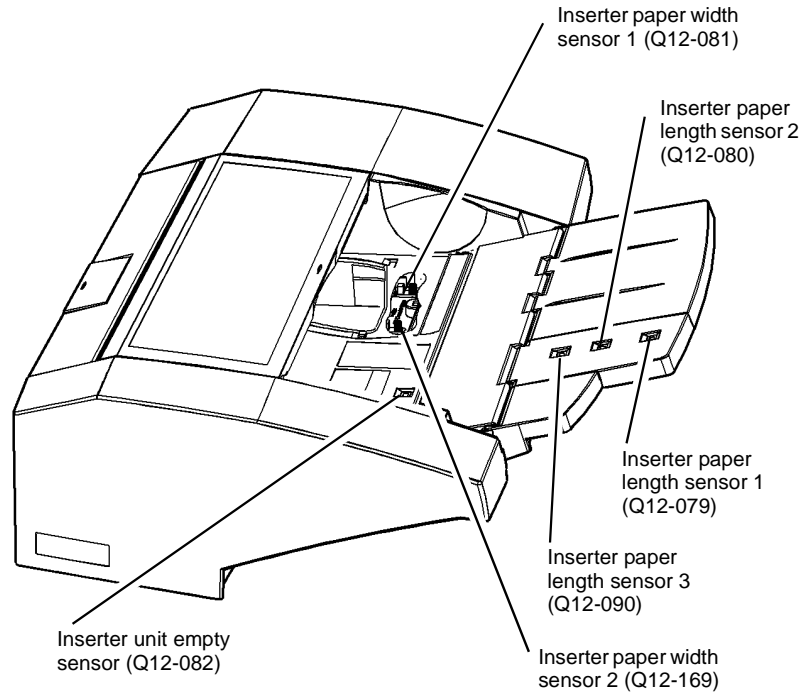

U-5-0043-A

Figure 23 Inserter paper sensors

- Inserter jam cover interlock, S12-179. A micro switch, located behind the top inside cover. This switch is wired in series with the inserter top cover interlock, to supply +24V to the inserter. When both interlocks are closed, the +24V LED on the Inserter PWB is lit. Refer to [Figure 24](#).
- Inserter top cover interlock, S12-178. A micro switch, located behind the front cover. This switch is wired in series with the inserter left hand door interlock, to supply +24V to the inserter. When both interlocks are closed, the +24V LED on the Inserter PWB is lit. Refer to [Figure 24](#).

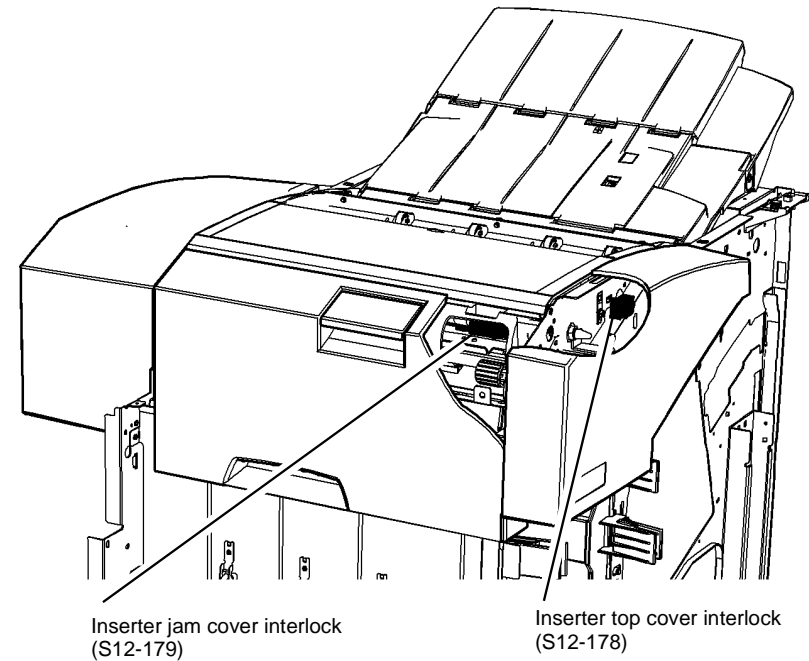

U-5-0044-A

Figure 24 Inserter interlocks

Booklet Maker Module

The booklet maker module receives, compiles, staples, folds and delivers finished booklets to bin 2. Booklets can be up to 15 sheets, including a cover.

Compiling and Tamping

When a booklet maker job is requested, but prior to the first sheet arriving at the booklet maker, the BM backstop motor, MOT 12-255 is energized to move the backstop assembly to a preset receiving position based on the paper size value provided by the media path driver PWB. The positioning of the backstop is measured in stepper motor pulses from the BM backstop guide home sensor, Q12-204.

The booklet maker module receives sheets from the lower diverter gate and through the BM entry roll nips. As each sheet is fed through the entry nip, it is driven downwards until it rests against the backstop.

The BM entry roll has smaller hard rollers and larger soft foam rollers. As the lead edge of each sheet touches the backstop, the trail edge is released by the hard roller nip, but is still held by the soft roller, which pushes the sheet under the roller and against the right side of the booklet compiler tray. This ensures that the trail edge of every compiled sheet is always located on the same side of the following sheet, thus eliminating both stubbing and sheet order errors.

Cross process registration is maintained by using two tampers, which move in opposite directions simultaneously, and are driven by the BM tamper 1 motor, MOT 12-256. Tamping aligns the centre of the sheets with the centre of the booklet compiler tray.

The tamping position is a preset number of motor steps from the BM tamper 1 home sensor, Q12-205 and is based on the paper size of the compiled sheet, provided by the media path driver PWB.

The tampers are moved from the home position to a ready position stored in NVM, when the lead edge of the first sheet in the set is detected at the BM entry sensor, Q12-089.

As each sheet enters the booklet compiler tray, the tampers are moved from the ready position to the tamping position, then returned to the ready position. For the last sheet of the set, the tamping stroke is repeated once more. After the last sheet in a set is compiled and tamped, the tampers are moved to the home position.

The BM flapper is utilized when the tampers start their return stroke from the tamp position to the ready position. The BM flapper motor, MOT12-271 provides mechanical drive to the BM flapper and the position of the flapper is controlled by the flapper home sensor Q12-207. The fingers on the flapper push the sheet into the booklet tray to aid the registration and de-skewing process. The flapper rotates after each sheet is tamped. The flappers are then parked in the home position, so that the fingers on the flapper do not impede the next sheet fed into the booklet compiler tray.

The set is then ready to be moved into position for the next operation of stapling.

Backstop Movement

The BM backstop system consists of a backstop assembly, mounted on a near vertical slide driven by BM backstop motor MOT12-255, via a toothed belt. A flag mounted on the backstop assembly actuates the BM guide home sensor, Q12-204 to signal the home position of the backstop.

After the last sheet of the set has been received and compiled, the BM stack hold solenoids, SOL12-259 are energized to hold the set in place. The BM backstop motor then moves the backstop to the stapling position. The BM motor now performs a short up and then down again to jog the set into place. After stapling, the BM backstop motor moves the backstop to the creasing position.

Booklet Stapling

Two BM staple head assemblies are mounted on a bracket, which can be pivoted open for staple jam clearance. The BM staple head carrier closed sensor, Q12-217 detects the closed position of the stapler bracket assembly.

When the staplers are actuated, two staples are placed in the centre of the compiled stack, spaced 120 mm apart. The maximum capacity for the stapling and folding in the booklet maker is given in [Table 1](#).

Table 1 Booklet maker stapling and folding capacity

Media	Paper weight	Maximum No. of sheets	Maximum No. of booklet pages
Plain paper	60 to 80gsm (16 to 21lb bond)	15	60
Heavyweight	90gsm (24lb bond)	13	52
Heavyweight	120gsm (32lb bond)	10	40
Heavyweight	160gsm (43lb bond)	7	28
Heavyweight	216gsm (58lb bond)	5	20
Plain paper with heavyweight cover	60 to 80gsm (16 to 21lb bond) with 160gsm (43lb bond) cover	14 including 1 cover	56

Each stapler is cam driven by a DC motor and contains a home position switch. Each of the staplers also contain a low staples switch to inform the control logic of a low staples condition. The BM paper present sensor, Q12-170 is mounted on the stapler bracket assembly between the two staplers. This sensor is used to prevent the staplers being energized if there is no paper present in the booklet compiler tray, thereby preventing staple jams.

The stapling sequence operates as follows:

1. The tampers are energized to engage the stack and keep both edges in place.
2. After 50 ms, the front stapler is energized.
3. After a further 80 ms the rear stapler is energized.

This sequence prevents wrinkling of the paper and limits the load imposed on the power supply.

Once the staplers reach the home position, a dynamic brake is applied to prevent overrun. The stapler motor will be reversed if the home switch is not made, after the stapling operation, in an attempt to bring the stapler home and avoid a fault.

Folding and Creasing

The booklet creasing system consists of a crease blade, two pairs of crease rolls, a crease roll gate and the backstop assembly.

The crease roll gate is used to cover the entry nip into the crease rolls. This prevents sheets from coming into contact with the crease rolls during compiling. The crease roll gate is raised to expose the crease rolls, or lowered to cover the opening to the crease rolls, by the crease roll gate motor, MOT12-273. The home position (fully raised) is sensed by the BM crease roll gate home sensor, Q12-222.

After the stapling operation is complete, the backstop raises the stapled set to the fold position, so that the centre line of the set is directly in line with the crease blade. At the same time, the crease roll gate motor moves the crease roll gate up until it actuates the crease roll gate home sensor.

The BM crease roll motor, MOT12-253 is energized when the backstop reaches the fold position, and continues to run until 220 ms after the trail edge of the folded book is detected at the BM exit sensor, Q12-213. An encoder wheel is mounted on the output shaft of the BM crease roll motor. The encoder wheel is read by the BM crease roll motor encoder sensor, Q12-216 to control the roll surface speed.

A stapled set is folded by the combined function of the crease rolls and the crease blade. The crease blade pushes the centre of the set into the crease rolls nip. The crease blade is driven by the BM crease blade motor, MOT12-252. The BM crease blade home sensor, Q12-214 and the BM crease blade motor encoder sensor, Q12-215 are used to monitor the location of the crease blade during the folding process.

During booklet folding, the crease blade moves from home position when the backstop reaches the fold position. The blade stroke is 36 pulses of the crease blade motor encoder sensor from the blade home position.

During banner sheet folding, a delay of 700 ms from the trail edge at the BM entry sensor is used before the crease blade moves from the home position.

The crease blade is held at the fold position by a dynamic brake for 250 ms to allow the banner sheet or stapled set to be drawn into the crease rolls. The BM crease blade motor is then reversed to drive the crease blade back to its home position as the crease rolls crease and feed the booklet. The BM exit sensor, Q12-213, located just after the crease rolls, detects jams. When the BM eject sensor is clear, the crease roll gate motor moves the crease roll gate down to cover the crease rolls.

For a booklet consisting of 10 or more sheets, or when handling 8.5 x 11 in paper, folding is executed four times before ejecting to provide extra creasing.

Bin 2

After a booklet is folded, it is ejected onto the bin 2 by the crease roll nip.

The bin 2 is mounted at the lower right side of the booklet maker, below bin 1. Bin 2 has two bail arms and two parallel conveyor belts over a flat surface. With the tray extension raised, bin 2 has a capacity of 10 booklets of 11-15 sheets, or 20 booklets of 6-10 sheets, or 30 booklets of 1-5 sheets. With the tray extension lowered, the booklets can be allowed to drop into a suitable box on the floor.

The BM eject sensor, located at the exit, provides control logic signals and monitors the paper path for jam detection and timing control for actuation of the BM conveyor belt drive motor.

When a booklet has been compiled, it passes under the BM eject sensor and pushes partially through the bail arm rollers. 200 ms after the lead edge is detected at BM eject sensor, the BM conveyor belt drive motor, MOT12-274, is turned on and drives the two conveyor belts for a preset time dependent on the booklet size.

The BM bin 2 90% full sensor, Q12-206 is an optical sensor located at the right of bin 2 between the conveyor belts.

As the booklets travel along the conveyor belts, they will actuate the BM bin 2 90% full sensor. After 2000 ms, the control logic will declare a 90% tray full condition. At this point a counter is set and the total number of books allowed after that point is determined by the number of books already on the tray. Any additional books allowed to be stacked is based on the number of times the BM eject sensor is actuated and the sizes of the books.

BM Paper Path Transport Motor

The BM compiler motor, MOT12-251 is driven at host speed and provides mechanical drive to the BM entry roll nip.

Component location [Figure 25](#) and [Figure 26](#).

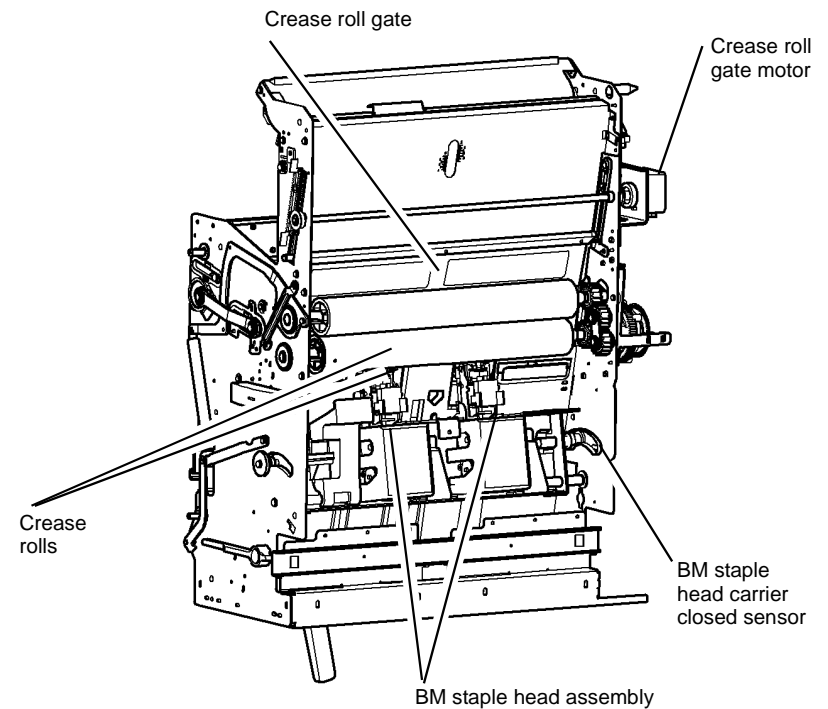

U-5-0092-A

Figure 25 Booklet maker module components (1)

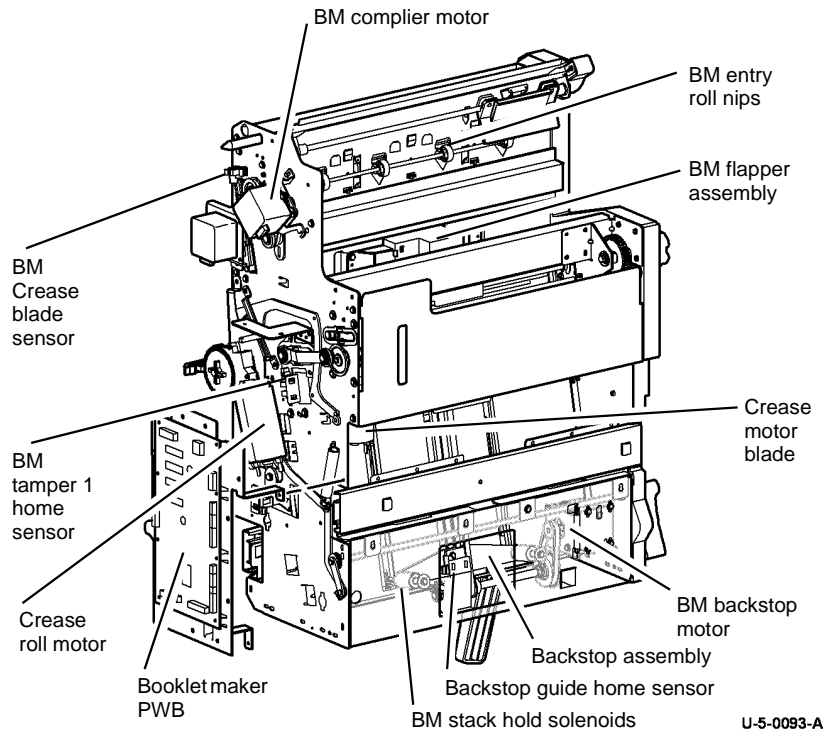

Figure 26 Booklet maker module components (2)

Figure 27 shows how the C-folds and the Z-folds are formed. The difference lies in where the first fold is made in the sheet, by the booklet maker. For a C-fold, the backstop is raised to produce a fold near the leading edge of the sheet. For a Z-fold, the backstop is lowered to produce a fold near the trailing edge of the sheet, effectively inverting the sheet.

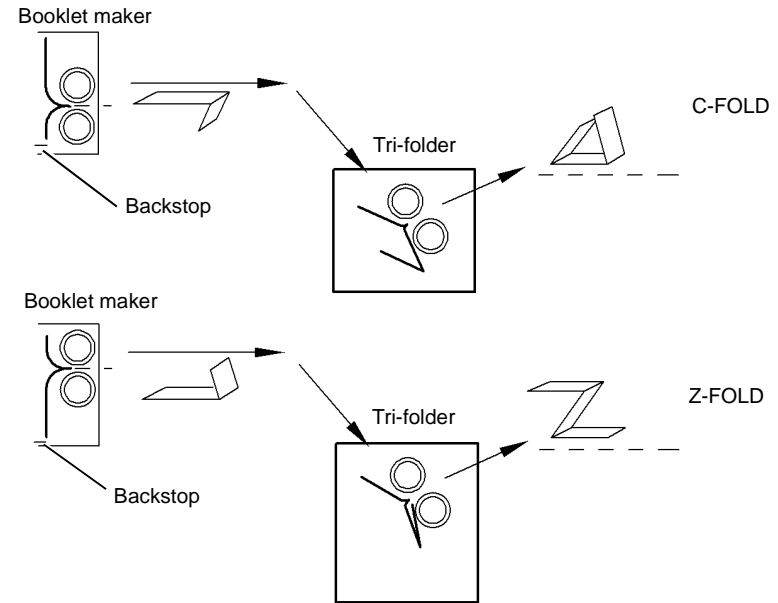

Figure 27 C and Z Folds

U-5-0045-A

Tri-Folder

When the job does not require a tri-fold, the tri-folder becomes a straight-through paper path from the booklet maker to the output tray. When a tri-fold is requested, the tri-folder clutch, diverter solenoid, and for C-folds only, the assist gate solenoid are brought into use.

The tri-folder does not require a dedicated drive motor, but takes its motive power using a toothed belt and drive coupler, from the crease roll motor in the booklet maker. The drive coupler engages when the booklet maker is pushed into the home position. The belt turns as each sheet is folded and stops as each sheet leaves the tri-folder.

When the tri-folder is not installed, a shorting link fitted to PJ553 in the booklet maker PWB, simulates the tri-folder interlocks, to feed +24V to the booklet maker PWB.

The tri-folder works in conjunction with the booklet maker, to produce 'C' or 'Z' folds. The booklet maker makes the first fold, and passes the sheet to the tri-folder to make the second fold. One sheet at a time is folded, and the tri-folder can fold 60-120gsm, (15-30lb) sheets.

The active components of the tri-folder are:

- Tri-folder entry sensor, Q12-164 - A flag sensor, located in the input paper guide. This sensor detects the sheet entering the tri-folder from the booklet maker. Refer to Figure 28.
- Crease roll clutch, CL12-269 - The clutch is located at the rear of the tri-folder, and actuates to drive the tri-folder crease rolls via a toothed belt. Refer to Figure 28.
- Tri-folder diverter solenoid, SOL12-267 - The solenoid is located at the rear of the tri-folder, and diverts single, tri-fold job sheets into the folder mechanism. It is actuated immediately after the drive belt from the BM starts to turn, and de-actuates as each sheet leaves the tri-folder. Refer to Figure 28.
- Tri-folder assist gate sensor, Q12-165 - A flag sensor, located in the roller assembly, and is mounted on the adjustable backstop plate. This sensor detects the sheet entering the roller assembly to be folded. Refer to Figure 28.

- Tri-folder assist gate solenoid, SOL12-268 - The solenoid is located at the rear of the tri-folder. The assist gate solenoid is only actuated during C-folds, to assist the first folded flap into the crease rolls. It actuates as the sheet enters the crease rolls and ensures that the trailing edge of the first fold stays inside the crease of the second fold. Refer to [Figure 28](#).

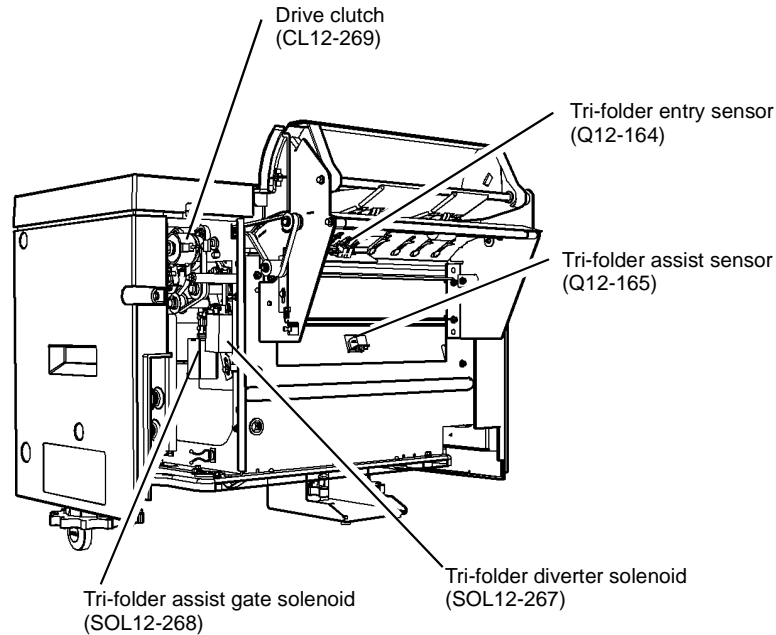

Figure 28 Entry sensor and folding components

U-5-0046-A

- Folder exit sensor, Q12-166 - A flag sensor, located in the exit paper guide. This sensor detects the sheets as they leave the tri-folder. Refer to [Figure 29](#).

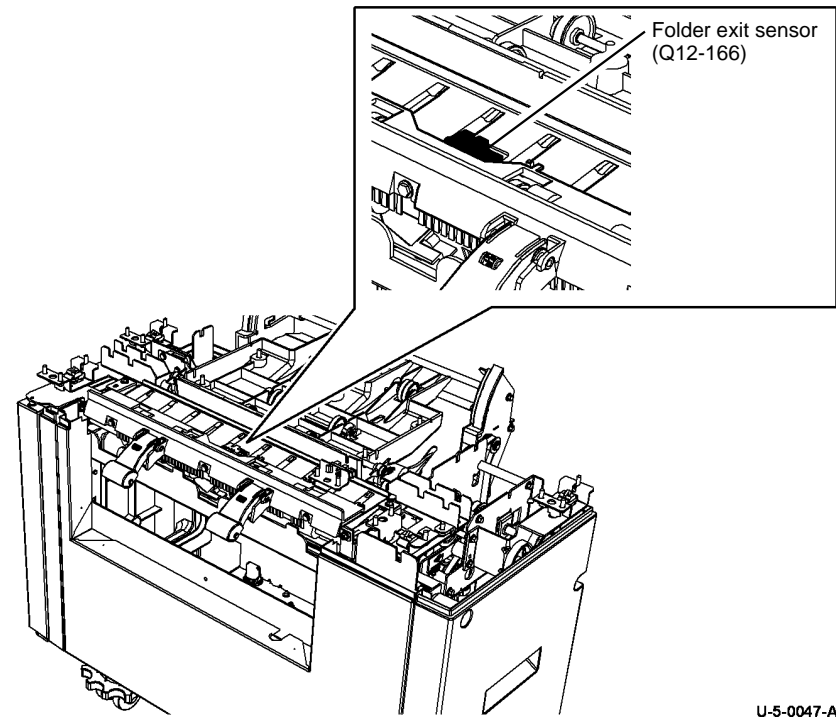

Figure 29 Tri-folder exit sensor

U-5-0047-A

- Tri-folder top cover interlock switch - A single-pole micro switch, located at the front of the tri-folder. This switch is connected in series with the front door interlock switch, S12-209. When both switches are made, the +24V supply is fed to the tri-folder PWB and the BM PWB. The BM PWB has +24V LED indication, as described in the Power / Interlocks section of this document. Refer to [Figure 30](#).
- Top cover interlock sensor, Q12-210 - A flag sensor, located towards the rear of the tri-folder top cover. This sensor detects whether the top cover is open or closed. Refer to [Figure 30](#).
- Front door interlock switch, S12-209 - A double-pole switch, located behind the top of the tri-folder front door. One pole of this switch is connected in series with the TF top cover interlock switch. When both switches are made, the +24V supply is fed to the tri-folder PWB and the BM PWB. The second pole of this switch detects whether the tri-folder front door is open or closed. Refer to [Figure 30](#).

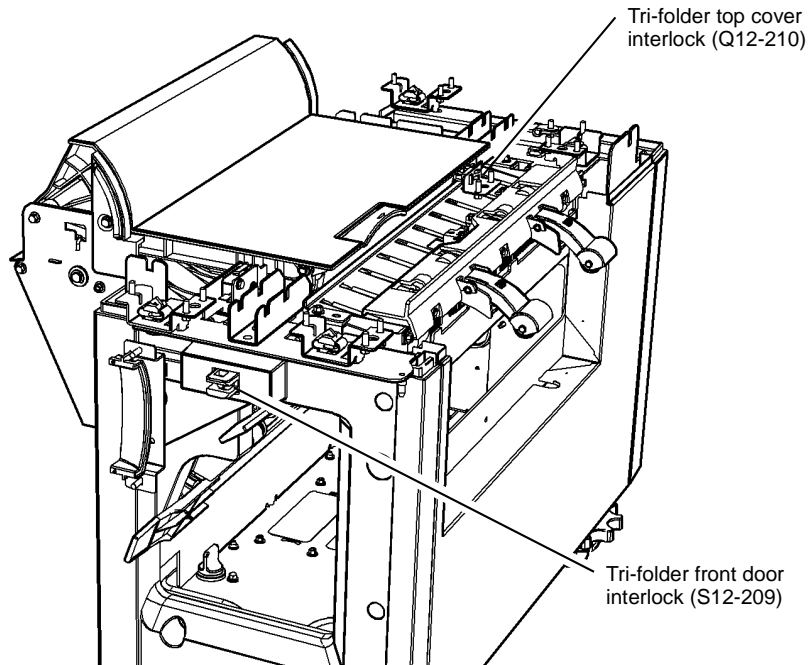

Figure 30 Tri-folder interlock components

U-5-0048-A

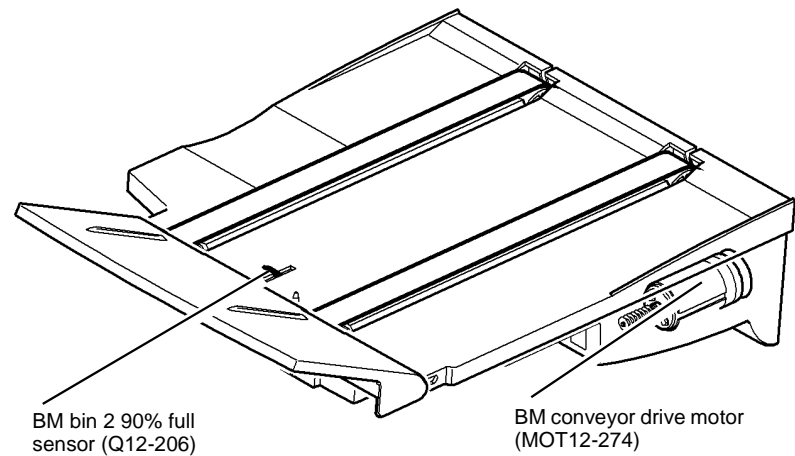

Figure 31 Bin 2 Output tray components

U-5-0080-A

Booklet Maker Bin 2 Output Tray

Bin 2 receives the folded output from the tri-folder, and the booklets from the booklet maker and / or the tri-folder module. The components associated with this tray are:

- BM conveyor drive motor, MOT12-274 - A stepper motor, driving the conveyer belts. Refer to [Figure 31](#).
- Bin 2 90% full sensor, Q12-206. A flag sensor, detecting a nearly-full tray. Refer to [Figure 31](#).



EHS 700 - Health & Safety Incident Report Form for Incidents Involving a Xerox Product

CONFIDENTIAL
(When filled in)

EH&S Office Use ONLY
EH&S Incident Reference Number:

*Date Of Incident (mm / dd / yy):			
Product Description			
*Model No. or Product Name:			
Product Serial Number:	Serial Number(s) of Accessory (ies):		
Installation Date:	Total Copy Meter:		
Date of last service maintenance:			
List damaged and affected part(s) of the machine by description and part number:			
*Description	Part Number		
*Location of product and affected part(s):			
Customer Identification			
*Customer Name:		*Name of Customer Contact Person:	
*Address:	E-mail:	*Telephone:	
		Fax:	
Customer Service Engineer Identification			
*Name (required for Xerox serviced equipment):	Employee:	E-mail:	
Location:	*Phone (required for Xerox serviced equipment):		
Individual Providing Notification			
*Name:	*Title:	*Telephone Number:	
*Organization:	E-Mail:		
Mailing Address:		*Date Report Submitted:	

* Required information is preceded by asterisk, **title shown in red**, turquoise wash background

Details of Incident

*Description Of Incident: (Check all that apply)

Smoke

Describe quantity and duration of smoke:

Fire with open flames seen

Electric shock to operator or service representative

Physical Injury/illness to operator or service representative

Describe:

Other, **Describe:**

MANDATORY DESCRIPTION (above): Provide a detailed description of all valid factors that may have contributed to the incident. Hardware involved in the incident should be preserved and retained for further investigation should investigation be deemed necessary by EH&S.

LIST INCIDENT DESCRIPTIONS AND SUPPORT DIAGRAMS/DATA INCLUDED OR ATTACHED:

*Any damage to customer property? No Yes Describe:

*Did external emergency response provider(s) such as fire department, ambulance, etc. respond?

No Yes Identify: (i.e., source, names of individuals)

Apparent cause of incident (Identify part that is suspect to be responsible for the incident)

*Preliminary actions taken to mitigate incident:

Instructions: E-mail or fax both pages of this completed form to EH&S:

- For incidents in **Xerox Europe and Developing Markets East**
(Middle East, Africa, India, China, and Hong Kong)
Submit to Elaine Grange
e-mail: ehs-europe@xerox.com or fax: +44 (0) 1707 35 3914 [Intelnet 8*668 3914]
- For incidents in **North America and Developing Markets West**
(Brazil, Mexico, Latin America North and Latin America South,
Submit form to Doris Bush
e-mail: usa.xerox.ehs@xerox.com or fax 585-216-8817 [Intelnet 8*219-8817]

* Required information is preceeded by asterisk, **title shown in red**, turquoise wash background

PUBLICATION COMMENT SHEET

Please copy this master sheet and use it to help us to improve this publication. We would like you to tell us about improvements to its accuracy, format and quality.
 Please give specific references, i.e.: page numbers and figure numbers and attach marked up photocopies wherever possible. If you have identified a solution please include your suggestions with your reply.
 Please also answer the customer satisfaction question set.
 When you have completed the PCS, send it by internal mail to the address below. You will receive an acknowledgement and feedback on your comments. Please ensure that your name and CBU/District location code are fully completed.

NAME:		OPERATING COMPANY:	
JOB TITLE:		CBU/DISTRICT LOCATION CODE:	
ENGINEER NUMBER:			
CONTACT TELEPHONE NUMBER:			
DATE:			
PRODUCT AND PUBLICATION TITLE:	PUBLICATION REVISION DATE:	SOFTWARE REVISION LEVEL:	
PAGE NUMBER:	COMMENT		

Please submit a marked-up photocopy of the relevant pages

CUSTOMER SATISFACTION QUESTION SET						
QUESTION	NOT APPLICABLE	VERY SATISFIED	SATISFIED	NEITHER SATISFIED NOR DISSATISFIED	DISSATISFIED	VERY DISSATISFIED
DO YOU FIND THE MANUAL IS TECHNICALLY ACCURATE?						
DO YOU FIND THE FORMAT OF THE MANUAL EASY TO USE?						
WHAT IS YOUR OVERALL SATISFACTION LEVEL WITH THE MANUAL						
FOR OFFICE USE ONLY						
RECEIVED DATE:						
PCS. NUMBER:						
MANAGER:						
DUE DATE:						

Creative and Technical Communications
 Xerox Global Services
 Enterprise Centre
 Bessemer Road
 Welwyn Garden City
 Hertfordshire AL7 1BU
 UK.
 Attention: Niki Dow

