

Version 2.0
January 2022
702P08774

Xerox® C230 Color Printer Service Manual

Publication Information

Product: Xerox® C230 Printer

Title: Xerox® C230 Printer Service Manual

Part Number: 702P08774

Publication Status: First revision

Publication Date: January 2022

Preparation Notes:

Prepared for:

Xerox Corporation

800 Phillips Road

Webster, New York, 14580

Copyright Statement:

© 2022 Xerox Corporation. All Rights Reserved. Xerox®, and Xerox are trademarks of Xerox Corporation in the United States and/or other countries.

Registered Trademarks:

Other company trademarks are also acknowledged.

NOTICE

While every care has been taken in the preparation of this manual, no liability will be accepted by Xerox arising out of any inaccuracies or omissions.

All service documentation is supplied to Xerox external customers for informational purposes only. Xerox service documentation is intended for use by certified, product trained service personnel only. Xerox does not warrant or represent that it will notify or provide to such customer any future change to this documentation. Customer performed service of equipment, or modules, components or parts of such equipment may affect whether Xerox is responsible to fix machine defects under the warranty offered by Xerox with respect to such equipment. You should consult the applicable warranty for its terms regarding customer or third-party provided service.

Table of Contents

1 Notices, Conventions, and Safety Information.....	9
Laser Notice.....	10
Avis Relatif À L'utilisation Du Laser	10
Aviso De Láser	10
Laser-hinweis	11
Avvertenza sui prodotti laser	11
Conventions.....	12
Conventions.....	12
Convenciones.....	12
Konventionen	13
Convenzioni	13
Safety Information	15
Consignes De Sécurité.....	15
Información De Seguridad.....	16
Sicherheitshinweise.....	17
Informazioni sulla sicurezza	18
Health and Safety Incident Reporting	20
2 Change History.....	23
Change History	24
3 General Information	25
Printer Model Configurations	26
Locating the Printer Serial Number.....	27
Selecting Paper	28
Paper Guidelines	28
Paper Characteristics.....	28
Unacceptable Paper.....	29
Storing Paper	29
Selecting Preprinted Forms and Letterhead	30
Supported Paper Sizes.....	30
Supported Paper Types	32
Supported Paper Weights.....	33
Tools Required For Service	34
4 Diagnostics and Troubleshooting.....	35
Troubleshooting Precautions.....	36
Précautions De Dépannage.....	36
Precauciones Durante La Solución De Problemas.....	37

Table of Contents

Vorsichtsmaßnahmen Bei Der Fehlerbehebung	37
Precauzioni per gli interventi di riparazione	38
Troubleshooting Overview	40
Performing The Initial Troubleshooting Check	40
Fixing Print Quality Issues	41
Initial Print Quality Check	41
Supplies Used to Resolve Print Quality Issues	41
Blank or White Pages Check	42
Dark Print Check	47
Ghost Images Check	54
Gray or Colored Background Check	61
Horizontal Dark Lines Check	66
Horizontal White Lines Check	72
Incorrect Margins Check	78
Light Print Check	82
Missing Colors Check	90
Mottled Print and Dots Check	96
Paper Curl Check	102
Print Crooked or Skewed Check	106
Repeating Defects Check	110
Solid Color or Black Images Check	111
Text or Images Cut Off Check	115
Toner Easily Rubs Off Check	121
Uneven Print Density Check	125
Vertical White Lines Check	131
Horizontal Colored Lines or Banding Check	137
Missing One Color Check	144
Vertical Colored Lines or Banding Check	148
Paper Jams	156
Avoiding Jams	156
Identifying Jam Locations	157
200 Paper Jams	159
202 Paper Jams	182
232 Paper Jams	199
241 Paper Jams	211
User Attendance Messages	212
Non-Xerox Supply	212
Metered Supply Installed in Printer Configured For Sold	212
0y User Attendance Errors	215
1y User Attendance Errors	220
2y User Attendance Errors	227
3y User Attendance Errors	229
42–55 User Attendance Errors	236
7y User Attendance Errors	241
8y User Attendance Errors	243
9y User Attendance Errors	257
Printer Hardware Errors	261

100–110 Errors	261
12y Errors	265
142 Errors	273
151 Errors	275
6yy Errors	278
Procedure Before Starting The 9yy Service Checks.....	282
90y Errors	283
912–992 Errors	286
Other Symptoms.....	297
Base Printer Symptoms	297
5 Service Menus.....	305
Understanding The Printer Control Panel.....	306
Using The Control Panel.....	306
Understanding The Status Of The Indicator Light	307
Diagnostics Menu	308
Entering The Diagnostics Menu.....	308
Reports	308
Advanced Print Quality Samples.....	308
Event Log.....	308
Input Tray Quick Print	309
Printer Setup.....	310
Printer Diagnostics and Adjustments.....	312
Config Menu.....	315
Entering The Config Menu	315
Config Menu.....	315
Service Engineer (SE) Menu.....	319
Entering Invalid Engine Mode	319
Entering The SE Menu.....	319
General SE Menu	319
Network SE Menu	319
6 Parts Removal.....	321
Data Security Notice.....	322
Identifying Printer Memory.....	322
Erasing Printer Memory.....	322
Removal Precautions.....	323
Précautions De Retrait.....	323
Precauciones Durante La Extracción.....	324
Vorsichtsmaßnahmen Bei Der Demontage.....	324
Precauzioni per la rimozione.....	325
Handling ESD-sensitive Parts.....	325
Critical Information For Controller Board or Control Panel Replacement	326
Restoring The Printer Configuration After Replacing The Controller Board	326
Restoring Licenses and Configuration Settings	327
Updating The Printer Firmware	328

Table of Contents

Covering The Print Cartridge Tray.....	329
Compatibility Information For Left Cover and Separator Bracket.....	331
Adjustments	333
Registration Adjustment	333
Printhead Characterization	336
Sensor (Waste Toner Bottle) Calibration	337
Removal Procedures.....	339
Left Side Removals.....	340
Left Cover Removal.....	340
Motor (CMY) Removal.....	342
Motor (k/transfer Belt) Removal	343
Wireless Network Card Removal.....	344
Controller Board Shield Removal	345
Controller Board Removal.....	346
Controller Board Bracket Removal	348
Motor (fuser) Removal	349
Staging Clutch Removal.....	349
Gearbox Removal.....	350
Pick Clutch Removal.....	356
Staging Belt, Gear, and Pulley Removal	357
Right Side Removals.....	359
Right Cover Removal.....	359
Sensor (waste Toner Bottle) Removal	361
Exhaust Fan Removal.....	361
HVPS Removal	362
LVPS Removal	364
Front Side Removals.....	369
Print Cartridge Tray Removal.....	369
Control Panel Removal.....	370
Printhead Interlock Switch Removal	371
Front Door Removal.....	372
Inner Front Cover Removal.....	373
Rear Side Removals.....	375
Transfer Module Removal.....	375
Rear Door Removal	380
Sensor (fuser Buckle) Removal.....	382
Fuser Removal	383
Sensor (fuser Exit) Removal.....	388
Sensor (input) Removal.....	389
Top Side Removals	391
Top Cover Removal	391
Printhead Removal.....	394
Sensor (bin/narrow Media) Removal.....	397
Bin Flag Removal	398
Bottom Side Removals	400
Pick Tire Removal.....	400
Sensor (manual Feeder) Removal	400

Separator Bracket Removal	401
Tray Interlock Switch Removal	403
Sensor (tray Near Empty) Removal.....	404
7 Component Locations.....	409
Printer Configurations	410
Xerox C230 Printers	410
Port Locations.....	411
Board Locations.....	412
Motor Locations.....	413
Sensor Locations.....	414
Controller Board Connectors.....	415
8 Maintenance	421
Cleaning The Printer	422
9 Parts Catalog	423
Legend	424
Assembly 1: Covers	425
Assembly 2: Drive Components	427
Assembly 3: EP Components	428
Assembly 4: Paper Feed.....	430
Assembly 5: Sensors.....	431
Assembly 6: Electronics	433
Assembly 7: 250-sheet Tray Options.....	435
10 Printer Specifications	437
Power Consumption	438
Product Power Consumption	438
Sleep Mode.....	438
Hibernate Mode.....	439
Off Mode.....	439
Total Energy Usage.....	439
Selecting A Location For The Printer	440
Noise Emission Levels.....	441
Temperature Information.....	442
11 Theory Of Operation.....	443
Paper Path and Drive Components.....	444
Paper Path Summary	444
Drive Components	445
Duplexing	448
Power Supply Operation.....	449

Table of Contents

Electrophotographic (EP) Process Theory.....	451
EP Process Summary.....	451
EP Process.....	453
12 Part Number Index.....	461
13 Part Name Index.....	463
14 Wiring Diagram (C230).....	465
Wiring Diagram (C230).....	466

Notices, Conventions, and Safety Information

Laser Notice

The printer is certified in the U.S. to conform to the requirements of DHHS 21 CFR, Chapter I, Subchapter J for Class I (1) laser products, and elsewhere is certified as a Class I laser product conforming to the requirements of IEC 60825-1: 2014.

Class I laser products are not considered to be hazardous. The laser system and printer are designed so there is never any human access to laser radiation above a Class I level during normal operation, user maintenance, or prescribed service conditions. The printer has a non-serviceable printhead assembly that contains a laser with the following specifications:

Class: IIIb (3b) AlGaAs

Nominal output power (milliwatts): 8

Wavelength (nanometers): 770–800

Avis Relatif À L'utilisation Du Laser

Cette imprimante est certifiée conforme aux exigences de la réglementation des Etats-Unis relative aux produits laser de classe I (1) (DHHS 21 CFR, Chapitre I, Sous-chapitre J). Pour les autres pays, elle est certifiée conforme aux exigences des normes CEI 60825-1:2014 relatives aux produits laser de classe I.

Les produits laser de classe I ne sont pas considérés comme dangereux. Le système laser ainsi que l'imprimante ont été conçus de manière à ce que personne ne soit jamais exposé à des radiations laser dépassant le niveau de classe I dans le cadre d'un fonctionnement normal, de l'entretien par l'utilisateur ou de la maintenance. L'imprimante dispose d'un ensemble de têtes d'impression non réparable contenant un laser doté des caractéristiques suivantes:

Class: IIIb (3b) AlGaAs

Nominal output power (milliwatts): 8

Wavelength (nanometers): 770–800

Aviso De Láser

Esta impresora se ha certificado en EE.UU. cumpliendo con los requisitos de DHHS 21 CFR, capítulo I, subcapítulo J para los productos láser de Clase I (1) y en otros países está certificada como un producto láser de Clase I de acuerdo con los requisitos de IEC 60825-1: 2014.

Los productos láser de Clase I no se consideran peligrosos. El sistema láser y la impresora se han diseñado para que el ser humano no acceda nunca a las radiaciones láser por encima del nivel de Clase I durante su uso normal, ni en tareas de mantenimiento o intervenciones de servicio técnico prescritas. El conjunto de cabezal de impresión de la impresora no se puede reparar y contiene un láser con las siguientes especificaciones:

Class: IIIb (3b) AlGaAs

Nominal output power (milliwatts): 8

Wavelength (nanometers): 770–800

Laser-hinweis

Der Drucker wurde in den USA zertifiziert und entspricht den Anforderungen der Vorschriften DHHS21CFR KapitelI für Laserprodukte der KlasseI(1), andernorts ist er als Laserprodukt der KlasseI zertifiziert, das den Anforderungen von IEC60825-1 entspricht: 2014.

Laserprodukte der KlasseI werden nicht als gefährlich betrachtet. Das Lasersystem und der Drucker sind so konstruiert, dass unter normalen Betriebsbedingungen, bei der Wartung durch den Benutzer oder bei den vorgeschriebenen Wartungsbedingungen Menschen keiner Laserstrahlung ausgesetzt sind, die die Werte für KlasseI überschreitet. Der Drucker verfügt über eine Druckkopfeinheit, die nicht gewartet werden kann und mit einem Laser mit den folgenden Spezifikationen ausgestattet ist.

Class: IIIb (3b) AlGaAs

Nominal output power (milliwatts): 8

Wavelength (nanometers): 770–800

Avvertenza sui prodotti laser

La stampante è certificata negli Stati Uniti come prodotto conforme ai requisiti DHHS 21 CFR Capitolo I, Sottocapitolo J per i prodotti laser di Classe I (1), mentre in altri paesi è certificata come prodotto laser di Classe I conforme ai requisiti IEC 60825-1: 2014.

I prodotti laser di Classe I non sono considerati pericolosi. Il sistema laser e la stampante sono stati progettati in modo da impedire l'esposizione a radiazioni laser superiori al livello previsto dalla Classe I durante le normali operazioni di stampa, manutenzione o assistenza. La stampante è dotata di un gruppo testina di stampa non riparabile che contiene un laser con le seguenti specifiche:

Classe: IIIb (3b) AlGaAs

Potenza di uscita nominale (milliwatt): 8

Lunghezza d'onda (nanometri): 770-800







Conventions

Note: A *note* identifies information that could help you.

Warning: A *warning* identifies something that could damage the product hardware or software.

CAUTION: A *caution* indicates a potentially hazardous situation that could injure you.

Different types of caution statements include:

-  **CAUTION—POTENTIAL INJURY:** Indicates a risk of injury.
-  **CAUTION—SHOCK HAZARD:** Indicates a risk of electrical shock.
-  **CAUTION—HOT SURFACE:** Indicates a risk of burn if touched.
-  **CAUTION—TIPPING HAZARD:** Indicates a crush hazard.
-  **CAUTION—PINCH HAZARD:** Indicates a risk of being caught between moving parts.
-  **CAUTION—MOVING PARTS:** Indicates a risk of laceration or abrasion injuries from rotating parts.







Conventions

Remarque: Une *Remarque* fournit des informations pouvant vous être utiles.

Avertissement: Un *Avertissement* signale un danger susceptible d'endommager le logiciel ou le matériel.

ATTENTION: La mention *Attention* vous signale un risque de blessure corporelle.

Il existe différentes mises en garde:

-  **ATTENTION ! DOMMAGE POTENTIEL :** Signale un risque de blessure.
-  **ATTENTION ! RISQUE D'ÉLECTROCUTION :** Signale un risque d'électrocution.
-  **ATTENTION ! SURFACE CHAUDE :** Signale un risque de brûlure de contact.
-  **ATTENTION ! RISQUE DE BASCULEMENT :** Signale un risque d'écrasement.
-  **ATTENTION ! RISQUE DE PINCEMENT :** Signale un risque de pincement entre des pièces mobiles.
-  **ATTENTION ! PIÈCES MOBILES :** Signale un risque de coupures ou de frottements à cause des pièces rotatives.







Convenciones

Nota: Las *notas* señalan información que puede serle útil.

Aviso: Las *advertencias* indican algo que podría dañar el software o el hardware del producto.

PRECAUCIÓN: Las *precauciones* indican una situación de posible peligro que puede implicar lesiones para el usuario.

Estos son los tipos de avisos de precaución que existen:

-  **PRECAUCIÓN—RIESGO DE LESIONES:** Indica que existe riesgo de lesiones.
-  **PRECAUCIÓN—RIESGO DE DESCARGA:** Indica que existe riesgo de descarga eléctrica.
-  **PRECAUCIÓN—SUPERFICIE CALIENTE:** Indica que existe riesgo de sufrir quemaduras por contacto.
-  **PRECAUCIÓN—RIESGO DE CAÍDA:** Indica que existe peligro de aplastamiento.
-  **PRECAUCIÓN—RIESGO DE DESCARGA ELÉCTRICA:** Existe riesgo de atrapamiento entre las piezas en movimiento.
-  **PRECAUCIÓN—PARTES MÓVILES:** Indica que existe riesgo de lesiones por laceración o abrasión causadas por piezas giratorias.







Konventionen

Hinweis: Ein *Hinweis* enthält nützliche Informationen.

Warnung: Durch eine *Warnung* werden Sie auf einen Umstand hingewiesen, durch den die Produkthardware oder -software beschädigt werden könnte.

VORSICHT: *Vorsicht* weist auf eine mögliche gefährliche Situation hin, die ein Verletzungsrisiko birgt.

Verschiedene Vorsichtshinweise:

-  **VORSICHT – VERLETZUNGSGEFAHR:** Weist auf ein Verletzungsrisiko hin.
-  **VORSICHT – STROMSCHLAGGEFAHR:** Weist auf das Risiko eines elektrischen Schlags hin.
-  **VORSICHT – HEISS:** Weist auf das Risiko von Verbrennungen bei Berührung hin.
-  **VORSICHT – KIPPGEFAHR:** Weist auf Quetschgefahr hin.
-  **VORSICHT – QUETSCHGEFAHR:** Weist auf das Risiko hin, zwischen beweglichen Komponenten eingequetscht zu werden.
-  **VORSICHT – BEWEGLICHE TEILE:** Weist auf das Risiko von Verletzungen und Abschürfungen durch sich drehende Teile hin.







Convenzioni

Nota: Una *nota* identifica informazioni che potrebbero essere di aiuto.







Avvertenza: Un messaggio di *avvertenza* segnala qualcosa che potrebbe danneggiare l'hardware o il software del prodotto.

ATTENZIONE: Un messaggio di *attenzione* segnala una situazione potenzialmente pericolosa che potrebbe causare lesioni all'utente.

I diversi tipi di messaggi di attenzione sono:

-  **ATTENZIONE – PERICOLO DI LESIONI:** Indica il rischio di ferirsi.
-  **ATTENZIONE – PERICOLO DI SCOSSA ELETTRICA:** Indica il rischio di scosse elettriche.
-  **ATTENZIONE – SUPERFICIE SURRISCALDATA:**Indica il rischio di bruciarsi al contatto.
-  **ATTENZIONE – PERICOLO DI RIBALTAMENTO:** Indica il pericolo di essere schiacciati.
-  **ATTENZIONE – PERICOLO DI SCHIACCIAMENTO:** Indica il rischio di intrappolamento tra parti in movimento.
-  **ATTENZIONE – PARTI MOBILI:** Indica il rischio di lesioni da lacerazione o abrasione dovute a parti rotanti.

Safety Information



- The safety of this product is based on testing and approvals of the original design and specific components. The manufacturer is not responsible for safety in the event of use of unauthorized replacement parts.
 - The maintenance information for this product has been prepared for use by a professional service person and is not intended to be used by others.
 - There may be an increased risk of electrical shock and personal injury during disassembly and servicing of this product. Professional service personnel should understand this risk and take necessary precautions.
-  **CAUTION—SHOCK HAZARD:** When you see this symbol on the product, there is a danger from hazardous voltage in the area of the product where you are working. Unplug the product before you begin, or use caution if the product must receive power in order to perform the task.
-  **CAUTION—POTENTIAL INJURY:** The lithium battery in this product is not intended to be replaced. There is a danger of explosion if a lithium battery is incorrectly replaced. Do not recharge, disassemble, or incinerate a lithium battery. Discard used lithium batteries according to the manufacturer's instructions and local regulations.
-  **CAUTION—POTENTIAL INJURY:** To avoid the risk of fire or electrical shock, connect the power cord to an appropriately rated and properly grounded electrical outlet that is near the product and easily accessible.
-  **CAUTION—POTENTIAL INJURY:** To avoid the risk of fire or electrical shock, use only the power cord provided with this product or the manufacturer's authorized replacement.
-  **CAUTION—POTENTIAL INJURY:** Do not use this product with extension cords, multioutlet power strips, multioutlet extenders, or UPS devices. The power capacity of these types of accessories can be easily overloaded by a laser printer and may result in a risk of fire, property damage, or poor printer performance.
-  **CAUTION—POTENTIAL INJURY:** Only a Xerox Inline Surge Protector that is properly connected between the printer and the power cord provided with the printer may be used with this product. The use of non-Xerox surge protection devices may result in a risk of fire, property damage, or poor printer performance.
-  **CAUTION—POTENTIAL INJURY:** If the printer weight is greater than 20kg (44lb), then it may require two or more people to lift it safely.

Consignes De Sécurité

- La sécurité de ce produit est basée sur des tests et certifications de sa conception d'origine et de ses composants spécifiques. Le fabricant décline toute responsabilité en cas d'utilisation de pièces de rechange non autorisées.
- Les informations de maintenance de ce produit sont destinées à des professionnels qualifiés et ne sont pas conçues pour être utilisées par d'autres personnes.
- Il existe un risque potentiel de choc électrique et de blessures lors du démontage et de la maintenance de ce produit. Le personnel professionnel de maintenance doit comprendre les risques et prendre les précautions nécessaires.





-  **ATTENTION ! RISQUE D'ÉLECTROCUTION :** Ce symbole indique un danger lié à des niveaux de tension dangereux dans la zone du produit à manipuler. Débranchez le produit avant de commencer, ou agissez avec prudence si le produit doit être alimenté pour effectuer l'opération.
-  **ATTENTION ! DOMMAGE POTENTIEL :** La batterie lithium de ce produit n'est pas destinée à être remplacée. Si vous ne respectez pas les instructions de remplacement de la batterie, vous risquez de provoquer une explosion. Ne rechargez pas, ne désassemblez pas et ne brûlez pas la batterie au lithium. Mettez les batteries lithium usagées au rebut selon les instructions du fabricant et les réglementations locales.
-  **ATTENTION ! DOMMAGE POTENTIEL :** Pour éviter tout risque d'électrocution ou d'incendie, branchez le câble d'alimentation directement à une prise électrique répondant aux exigences requises et correctement mise à la terre, proche du produit et facile d'accès.
-  **ATTENTION ! DOMMAGE POTENTIEL :** Pour éviter tout risque d'incendie ou d'électrocution, utilisez uniquement le câble d'alimentation fourni avec ce produit ou un câble de remplacement autorisé par le fabricant.
-  **ATTENTION ! DOMMAGE POTENTIEL :** Ce produit ne doit pas être utilisé avec des rallonges, des barres multiprises, des rallonges multiprises ou des périphériques UPS. La capacité de ces types d'accessoires peut être facilement dépassée par une imprimante laser, d'où un risque de dégâts matériels, d'incendie ou de performances d'impression amoindries.
-  **ATTENTION ! DOMMAGE POTENTIEL :** Utilisez uniquement un parasurtenseur correctement raccordé à l'imprimante et au câble d'alimentation fourni avec la machine. L'utilisation de parasurtenseurs non fabriqués par Xerox comporte un risque d'incendie et de dégâts matériels, et peut amoindrir les performances de l'imprimante.
-  **ATTENTION ! DOMMAGE POTENTIEL :** Si votre imprimante pèse plus de 20kg (44lb), l'intervention d'au moins deux personnes est nécessaire pour la soulever sans risque.



Información De Seguridad

- La seguridad de este producto se basa en las pruebas y comprobaciones del diseño original y los componentes específicos. El fabricante no se hace responsable de la seguridad en caso de uso de piezas de repuesto no autorizadas.
- La información de mantenimiento de este producto se ha preparado para su uso por parte de un profesional de asistencia técnica y no está diseñada para su uso por parte de otros usuarios.
- Es posible que haya un mayor riesgo de descarga eléctrica y daños personales durante el desmontaje y el mantenimiento de este producto. El personal de asistencia profesional debe conocer este riesgo y tomar las precauciones necesarias.
-  **PRECAUCIÓN—RIESGO DE DESCARGA:** Cuando vea este símbolo en el producto, existe peligro de tensiones peligrosas en el área del producto en la que está trabajando. Desconecte el producto antes de empezar o tenga cuidado si el producto debe recibir alimentación a fin de realizar la tarea.
-  **PRECAUCIÓN—RIESGO DE LESIONES:** La batería de litio de este producto no debe reemplazarse. Existe riesgo de explosión si se sustituye incorrectamente una batería de litio. No recargue, desmonte ni incinere una batería de litio. Deseche las baterías de litio usadas según las instrucciones del fabricante y las normativas locales.







-  **PRECAUCIÓN—RIESGO DE LESIONES:** Para evitar el riesgo de incendio o descarga eléctrica, conecte el cable de alimentación a una toma de corriente debidamente conectada a tierra con la potencia adecuada que se encuentre cerca del dispositivo y resulte fácilmente accesible.
-  **PRECAUCIÓN—RIESGO DE LESIONES:** Para evitar el riesgo de incendio o descarga eléctrica, utilice exclusivamente el cable de alimentación que se suministra junto con este producto o el repuesto autorizado por el fabricante.
-  **PRECAUCIÓN—RIESGO DE LESIONES:** No utilice este producto con cables alargadores, regletas de varias tomas, cables alargadores de varias tomas o sistemas de alimentación ininterrumpida. La potencia de este tipo de accesorios puede sobrecargarse fácilmente si se utiliza una impresora láser, lo que puede dar lugar a que el rendimiento de la impresora sea bajo, a daños materiales o a posibles incendios.
-  **PRECAUCIÓN—RIESGO DE LESIONES:** Solo debe usarse con este producto un protector de sobretensión insertable Xerox debidamente conectado entre la impresora y el cable de alimentación que con ella se suministra. El uso de protectores de sobretensión de marcas distintas a Xerox puede dar lugar a que el rendimiento de la impresora sea bajo, a daños materiales o a posibles incendios.
-  **PRECAUCIÓN—RIESGO DE LESIONES:** si el peso de la impresora es superior a 20kg (44lb), pueden ser necesarias dos o más personas para levantarla de forma segura.

Sicherheitshinweise

- Die Sicherheit dieses Produkts basiert auf Tests und Zulassungen des Originaldesigns und der spezifischen Komponenten. Sofern nicht autorisierte Ersatzteile eingesetzt werden, übernimmt der Hersteller keinerlei Verantwortung in Bezug auf die Sicherheit dieses Produkts.
- Die Wartungsinformationen für dieses Produkt wurden für ausgebildete Servicemitarbeiter zusammengestellt und dürfen nicht von anderen verwendet werden.
- Möglicherweise besteht bei der Demontage und Wartung dieses Produkts eine erhöhte Stromschlag- und Verletzungsgefahr. Ausgebildete Servicemitarbeiter sollten sich dieser Gefahr bewusst sein und die notwendigen Vorsichtsmaßnahmen ergreifen.
-  **VORSICHT – STROMSCHLAGGEFAHR:** Wenn Sie dieses Symbol sehen, besteht eine Gefahr durch gefährliche Spannungen in dem Produktbereich, in dem Sie arbeiten. Trennen Sie das Produkt von seiner Stromverbindung, bevor Sie beginnen, oder gehen Sie vorsichtig vor, wenn das Produkt für die Durchführung der Aufgabe mit Strom versorgt werden muss.
-  **VORSICHT – VERLETZUNGSGEFAHR:** Die Lithiumbatterie in diesem Produkt darf nicht ausgetauscht werden. Wird eine Lithiumbatterie nicht ordnungsgemäß ausgetauscht, besteht Explosionsgefahr. Lithiumbatterien dürfen auf keinen Fall wieder aufgeladen, auseinander genommen oder verbrannt werden. Befolgen Sie zum Entsorgen verbrauchter Lithiumbatterien die Anweisungen des Herstellers und die örtlichen Bestimmungen.
-  **VORSICHT – VERLETZUNGSGEFAHR:** Um Feuer- und Stromschlaggefahr zu vermeiden, schließen Sie das Netzkabel direkt an eine ordnungsgemäß geerdete Steckdose an, die sich in der Nähe des Geräts befindet und leicht zugänglich ist.
-  **VORSICHT – VERLETZUNGSGEFAHR:** Um das Risiko eines Feuers oder elektrischen Schlags zu vermeiden, verwenden Sie ausschließlich das diesem Produkt beiliegende Netzkabel bzw. ein durch den Hersteller zugelassenes Ersatzkabel.

-  **VORSICHT – VERLETZUNGSGEFAHR:** Verwenden Sie das Produkt nicht mit Verlängerungskabeln, Mehrfachsteckdosen, Mehrfachverlängerungen oder Geräten für unterbrechungsfreie Stromversorgung. Die Belastbarkeit solcher Zubehörteile kann durch Laserdrucker schnell überschritten werden, was zu Brandgefahr, Beschädigung von Eigentum oder einer eingeschränkten Druckerleistung führen kann.
-  **VORSICHT – VERLETZUNGSGEFAHR:** Mit diesem Produkt darf nur ein Xerox Inline Surge Protector verwendet werden, der vorschriftsgemäß zwischen dem Drucker und dem mitgelieferten Netzkabel angeschlossen ist. Die Verwendung von nicht von Xerox stammenden Überspannungsschutzgeräten kann zu Brandgefahr, Beschädigung von Eigentum oder einer eingeschränkten Druckerleistung führen.
-  **VORSICHT – VERLETZUNGSGEFAHR:** Wenn der Drucker mehr als 20kg wiegt, sind zum sicheren Anheben mindestens zwei Personen notwendig.

Informazioni sulla sicurezza

- La sicurezza di questo prodotto è basata sul collaudo e le approvazioni del progetto tecnico originale e di specifici componenti. Il produttore non è responsabile per la sicurezza in caso di utilizzo di parti di ricambio non autorizzate.
- Le informazioni sulla manutenzione di questo prodotto sono rivolte esclusivamente a personale di manutenzione e assistenza specializzato.
- L'intervento di smontaggio e manutenzione/riparazione di questo dispositivo potrebbe comportare un maggiore rischio di scossa elettrica o lesioni personali. Il personale di assistenza specializzato deve essere consapevole di tale rischio e assumere le necessarie precauzioni.
-  **ATTENZIONE – PERICOLO DI SCOSSA ELETTRICA:** La presenza di questo simbolo sul prodotto significa che è presente tensione pericolosa nell'area del prodotto su cui si sta lavorando. Scollegare il prodotto prima di iniziare, o prestare cautela se l'intervento richiede che il prodotto debba ricevere alimentazione.
-  **ATTENZIONE – PERICOLO DI LESIONI:** La batteria al litio presente nel prodotto non deve essere sostituita. In caso di sostituzione errata della batteria al litio, potrebbe verificarsi un'esplosione. Non ricaricare, smontare o bruciare batterie al litio. Smaltire le batterie al litio usate seguendo le istruzioni del produttore e le norme locali.
-  **ATTENZIONE – PERICOLO DI LESIONI:** Per evitare il rischio di incendio o scosse elettriche, collegare il cavo di alimentazione a una presa elettrica dotata di messa a terra e con le specifiche adeguate, situata in prossimità del prodotto e facilmente accessibile.
-  **ATTENZIONE – PERICOLO DI LESIONI:** Per evitare il rischio di incendi o scosse elettriche, utilizzare solo il cavo di alimentazione fornito con il prodotto o componenti sostitutivi autorizzati dal produttore.
-  **ATTENZIONE – PERICOLO DI LESIONI:** Non utilizzare il prodotto con cavi di prolunga, prese multiple, prolunghe multipresa o gruppi di continuità. La capacità di potenza di questi tipi di accessori può essere facilmente sovraccaricata da una stampante laser e può comportare incendi, danni o scarse prestazioni della stampante.
-  **ATTENZIONE – PERICOLO DI LESIONI:** Con questo prodotto può essere utilizzato solo un protettore di sovratensione in linea Xerox fornito con la stampante, correttamente collegato alla stampante e al cavo di alimentazione. L'utilizzo di protettori di sovratensione non Xerox può comportare il rischio di incendi, danni o scarse prestazioni della stampante.



ATTENZIONE – PERICOLO DI LESIONI: Se la stampante pesa più di 20 kg (44 lb), potrebbe richiedere due o più persone per essere sollevata in modo sicuro.

Health and Safety Incident Reporting

I. Summary

This section defines requirements for notification of health and safety incidents involving Xerox products (equipment and materials) at customer locations.

II. Scope

Xerox Corporation and subsidiaries worldwide.

III. Objective

To enable prompt resolution of health and safety incidents involving Xerox products and to ensure Xerox regulatory compliance.

IV. Definitions

Incident:

An event or condition occurring in a customer account that has resulted in injury, illness or property damage. Examples of incidents include machine fires, smoke generation, physical injury to an operator or service representative. Alleged events and product conditions are included in this definition.

V. Requirements

Initial Report:

1. Xerox organizations shall establish a process for individuals to report product incidents to Xerox Environment Health and Safety within 24 hours of becoming aware of the event.
2. The information to be provided at the time of reporting is contained in Appendix A (Health and Safety Incident Report involving a Xerox product).
3. The initial notification may be made by the method that follows:
 - Email Xerox EH&S at: usa.product.incident@xerox.com.
 - Fax Xerox EH&S at: 585-422-2249.



Note: If sending a fax, please also send the original via internal mail.

Responsibilities for resolution:

1. Business Groups/Product Design Teams responsible for the product involved in the incident shall:
 - a. Manage field bulletins, customer correspondence, product recalls, safety retrofits.
 - b. Fund all field retrofits.
2. Field Service Operations shall:
 - a. Preserve the Xerox product involved and the scene of the incident inclusive of any associated equipment located in the vicinity of the incident.
 - b. Return any affected equipment/part(s) to the location designated by Xerox EH&S and/or the Business Division.
 - c. Implement all safety retrofits.
3. Xerox EH&S shall:
 - a. Manage and report all incident investigation activities.
 - b. Review and approve proposed product corrective actions and retrofits, if necessary.
 - c. Manage all communications and correspondence with government agencies.
 - d. Define actions to correct confirmed incidents.

VI. Appendices

The Health and Safety Incident Report involving a Xerox Product (Form # EH&S-700) is available in the following location:

- [GSN Library 1789](#)

Change History

Change History

Version No.	Month and Year	Description
02	January, 2022	<p>Updated the following topics:</p> <ul style="list-style-type: none">• 31–39 User Attendance Messages• 900-909 Error Messages• Supplies Used to Resolve Print Quality Issues <p>Added the following topics:</p> <ul style="list-style-type: none">• Non-Xerox Supply• Metered Supply Installed In Printer Configured For Sold• Changing The Service Plan (Non-PagePack)• Changing The Service Plan (PagePack)• 900 Error Service Check <p>Removed the following topics:</p> <ul style="list-style-type: none">• System Software Error Service Check
01	July, 2021	This is the launch version of the service manual.

General Information

Printer Model Configurations

The Xerox C230 SFP printer is a color, network-capable, laser printers. All information in this Service Manual pertains to all models unless explicitly noted.

The printer is available in the following models:

Model name	Configuration / description
C230	Network with wireless support, duplex print, 2-line display

Locating the Printer Serial Number

Follow the below steps to locate the serial number of the printer.

1. Open the front door, and then firmly push it down.

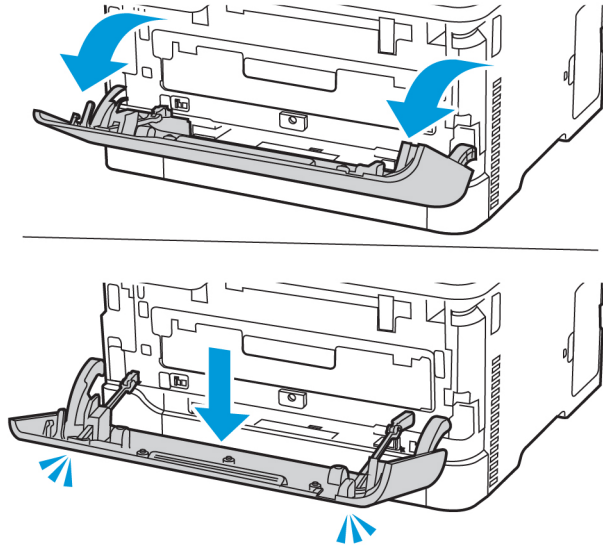

2. Locate the serial number behind the front door.

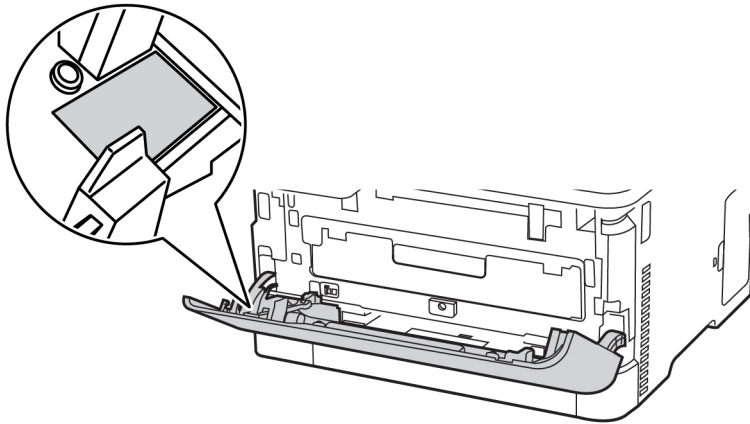

Selecting Paper

Paper Guidelines

Use the appropriate paper to prevent jams and help ensure trouble-free printing.

- Always use new, undamaged paper.
- Before loading paper, know the recommended printable side of the paper. This information is usually indicated on the paper package.
- Do not use paper that has been cut or trimmed by hand.
- Do not mix paper sizes, types, or weights in the same tray; mixing results in jams.
- Do not use coated papers unless they are specifically designed for electrophotographic printing.

Paper Characteristics

The following paper characteristics affect print quality and reliability. Consider these factors before printing on them.

Weight

The trays can feed paper weights from 60 to 176g/m² (16 to 47 lb) grain long paper. Paper lighter than 60g/m² (16lb) may not be stiff enough to feed properly, and may cause jams.

Curl

Curl is the tendency for paper to curl at its edges. Excessive curl can cause paper feeding problems. Curl can occur after the paper passes through the printer, where it is exposed to high temperatures. Storing paper unwrapped in hot, humid, cold, or dry conditions can contribute to paper curling before printing and can cause feeding problems.

Smoothness

Paper smoothness directly affects print quality. If paper is too rough, toner cannot fuse to it properly. If paper is too smooth, it can cause paper feeding or print quality issues. We recommend the use of paper with 50 Sheffield points.

Moisture Content

The amount of moisture in paper affects both print quality and the printer ability to feed the paper correctly. Leave paper in its original wrapper until you use it. Exposure of paper to moisture changes can degrade its performance.

Store paper in its original wrapper in the same environment as the printer for 24 to 48 hours before printing. Extend the time several days if the storage or transportation environment is very different from the printer environment. Thick paper may also require a longer conditioning period.

Grain Direction

Grain refers to the alignment of the paper fibers in a sheet of paper. Grain is either *grain long*, running the length of the paper, or *grain short*, running the width of the paper.

For 60–176g/m²(16–47-lb) paper, grain long paper is recommended.

Fiber Content

Most high-quality xerographic paper is made from 100 percent chemically treated pulped wood. This content provides the paper with a high degree of stability, resulting in fewer paper feeding problems and better print quality. Paper containing fibers such as cotton can negatively affect paper handling.

Unacceptable Paper

The following paper types are not recommended for use with the printer:

- Chemically treated papers used to make copies without carbon paper, also known as carbonless papers, carbonless copy paper (CCP), or no carbon required (NCR) paper
- Preprinted papers with chemicals that may contaminate the printer
- Preprinted papers that can be affected by the temperature in the printer fuser
- Preprinted papers that require a registration (the precise print location on the page) greater than ±2.3 mm (±0.9 in.), such as optical character recognition (OCR) forms

In some cases, registration can be adjusted with a software application to successfully print on these forms.

- Coated papers (erasable bond), synthetic papers, thermal papers
- Rough-edged, rough or heavily textured surface papers, or curled papers
- Recycled papers that fail EN12281:2002 (European)
- Paper weighing less than 60 g/m² (16 lb)
- Multiple-part forms or documents

Storing Paper

Use these paper storage guidelines to help avoid jams and uneven print quality:

- Store paper in its original wrapper in the same environment as the printer for 24 to 48 hours before printing.
- Extend the time several days if the storage or transportation environment is very different from the printer environment. Thick paper may also require a longer conditioning period.
- For best results, store paper where the temperature is 21°C (70°F) and the relative humidity is 40 percent.
- Most label manufacturers recommend printing in a temperature range of 18–24°C (65–75°F) with relative humidity between 40 and 60 percent.
- Store paper in cartons, on a pallet or shelf, rather than on the floor.
- Store individual packages on a flat surface.

General Information

- Do not store anything on top of individual paper packages.
- Take paper out of the carton or wrapper only when you are ready to load it in the printer. The carton and wrapper help keep the paper clean, dry, and flat.

Selecting Preprinted Forms and Letterhead

- Use grain long paper.
- Use only forms and letterhead printed using an offset lithographic or engraved printing process.
- Avoid paper with rough or heavily textured surfaces.
- Use inks that are not affected by the resin in toner. Inks that are oxidation-set or oil-based generally meet these requirements; latex inks might not.
- Print samples on preprinted forms and letterheads considered for use before buying large quantities. This action determines whether the ink in the preprinted form or letterhead affects print quality.
- When in doubt, contact your paper supplier.
- When printing on letterhead, load the paper in the proper orientation for your printer. For more information, see the Paper and Specialty Media Guide.

Supported Paper Sizes

Paper size	Standard 250-sheet tray	Manual feeder	Two-sided printing
A4 210x297mm (8.27x11.7in.)	✓	✓	✓
A5¹ 148x210mm (5.83x8.27in.)	✓	✓	X
A6 105x148mm (4.13x5.83in.)	✓	✓	X
JIS B5 182x257mm (7.17x10.1in.)	✓	✓	X
Oficio (Mexico) 215.9x340.4mm (8.5x13.4in.)	✓	✓	✓
Hagaki 100x148mm (3.94x5.83in.)	✓	✓	X

Paper size	Standard 250-sheet tray	Manual feeder	Two-sided printing
Statement 139.7x215.9mm (5.5x8.5in.)	✓	✓	X
Executive 184.2x266.7mm (7.25x10.5in.)	✓	✓	X
Letter 215.9x279.4mm (8.5x11in.)	✓	✓	✓
Legal 215.9x355.6mm (8.5x14in.)	✓	✓	✓
Folio 215.9x330.2mm (8.5x13in.)	✓	✓	✓
Universal^{2,3} 98.4x148mm (3.86x5.83in.) to 215.9x355.6mm (8.5x14in.)	✓	✓	✓
Universal^{2,3} 25.4x25.4mm (1x1in.) to 215.9x297mm (8.5x11.69in.)	X	X	X
Universal^{2,3} 105x148mm (4.13x5.83in.) to 215.9x355.6mm (8.5x14in.)	X	X	X
73/4 Envelope 98.4x190.5mm (3.875x7.5in.)	✓ ₄	✓	X
9Envelope 98.4x225.4mm (3.875x8.9in.)	✓ ₄	✓	X
10Envelope 104.8x241.3mm (4.12x9.5in.)	✓ ₄	✓	X

Paper size	Standard 250-sheet tray	Manual feeder	Two-sided printing
DLEnvelope 110x220mm (4.33x8.66in.)	✓ ⁴	✓	X
C5Envelope 162x229mm (6.38x9.01in.)	✓ ⁴	✓	X
B5Envelope 176x250mm (6.93x9.84in.)	✓ ⁴	✓	X
Other Envelope 98.4x162mm (3.87x6.38in.) to 176x250mm (6.93x9.84in.)	✓ ⁴	✓	X
<p>¹ The default support is long-edge feed. When running on short-edge feed, A5 is treated as narrow paper.</p> <p>² When Universal is selected, the page is formatted for 215.90x355.60mm (8.5x14in.) unless specified by the software application.</p> <p>³ Load narrow paper with the short edge entering the printer first.</p> <p>⁴ The standard 250-sheet tray supports up to 5 envelopes at a time.</p>			

Supported Paper Types

 **Note:**

- Labels, envelopes, and card stock always print at reduced speed.
- Labels are supported for occasional use and must be tested for acceptability.

Paper type	Standard 250-sheet tray	Manual feeder	Two-sided printing
Plain paper	✓	✓	✓
Card stock	✓	✓	X
Labels	✓	✓	X
Envelopes	✓	✓	X

Supported Paper Weights







Paper type and weight	Standard 250-sheet tray	Manual feeder	Two-sided printing
Light paper 60–74.9g/m ² grain long (16–19.9-lb bond)	✓	✓	✓
Plain paper 75–90.3g/m ² grain long (20–24-lb bond)	✓	✓	✓
Heavy paper 90.3–100g/m ² grain long (24.1–26-lb bond)	✓	✓	✓
Card stock 105.1–162g/m ² grain long (28.1–43-lb bond)	✓	✓	X
Card stock 105.1–200g/m ² grain long (28.1–53-lb bond)	X	✓	X
Paper labels 131g/m ² (35-lb bond)	✓	✓	X
Envelopes 60–90g/m ² (16–24-lb bond)	✓	✓	X

Tools Required For Service





- Flat-blade screwdrivers, various sizes
- #1 Phillips screwdriver, magnetic
- #2 Phillips screwdriver, magnetic
- #2 Phillips screwdriver, magnetic short-blade
- Torx screwdriver (T10 head)
- Needle-nose pliers
- Diagonal side cutters
- Spring hook
- Feeler gauges
- Analog or digital multimeter
- 3-mm ball hex wrench
- Toner vacuum
- Flashlight

Diagnostics and Troubleshooting

Troubleshooting Precautions

-  **CAUTION—SHOCK HAZARD:** When you see this symbol on the product, there is a danger from hazardous voltage in the area of the product where you are working. Unplug the product before you begin, or use caution if the product must receive power in order to perform the task.
-  **CAUTION—SHOCK HAZARD:** This product uses an electronic power switch. It does not physically disconnect the input AC voltage. To avoid the risk of electrical shock, always remove the power cord from the printer when removal of the input AC voltage is required.
-  **CAUTION—SHOCK HAZARD:** To avoid the risk of electrical shock while troubleshooting with covers removed or doors open, do not touch the exposed wires or circuits while the printer is connected to an electrical outlet.
-  **CAUTION—SHOCK HAZARD:** To avoid the risk of electrical shock and to prevent damage to the printer, remove the power cord from the electrical outlet and disconnect all connections to any external devices before you connect or disconnect any cable, electronic board, or assembly.
-  **CAUTION—HOT SURFACE:** The inside of the printer might be hot. To reduce the risk of injury from a hot component, allow the surface to cool before touching it.
-  **CAUTION—PINCH HAZARD:** To avoid the risk of a pinch injury, use caution in areas marked with this label. Pinch injuries may occur around moving parts, such as gears, doors, trays, and covers.
-  **CAUTION—MOVING PARTS:** To avoid the risk of laceration or abrasion injuries, keep hands away from moving parts in areas marked with this label. Injuries from moving parts may occur around gears and other rotating parts.

Précautions De Dépannage

-  **ATTENTION ! RISQUE D'ÉLECTROCUTION :** Ce symbole indique un danger lié à des niveaux de tension dangereux dans la zone du produit à manipuler. Débranchez le produit avant de commencer, ou agissez avec prudence si le produit doit être alimenté pour effectuer l'opération.
-  **ATTENTION ! RISQUE D'ÉLECTROCUTION :** Ce produit utilise un commutateur d'alimentation électronique. Il ne déconnecte pas physiquement la tension d'alimentation CA. Pour éviter tout risque d'électrocution, débranchez toujours le cordon d'alimentation de l'imprimante lorsque vous devez déconnecter la tension d'alimentation CA.
-  **ATTENTION ! RISQUE D'ÉLECTROCUTION :** Pour éviter tout risque d'électrocution lors du dépannage de l'imprimante avec les capots retirés ou les portes ouvertes, prenez garde de ne pas toucher les fils ou circuits dénudés si l'imprimante est connectée à une prise électrique.
-  **ATTENTION ! RISQUE D'ÉLECTROCUTION :** Pour éviter tout risque d'électrocution et éviter d'endommager l'imprimante, débranchez le cordon d'alimentation de la prise électrique et déconnectez toute connexion à tout périphérique externe avant de brancher ou débrancher des câbles ou circuits et assemblages électroniques.
-  **ATTENTION ! SURFACE CHAUDE :** L'intérieur de l'imprimante risque d'être brûlant. pour réduire le risque de brûlure, laissez la surface ou le composant refroidir avant d'y toucher.

 **ATTENTION ! RISQUE DE PINCEMENT :** Pour éviter tout risque de blessure par pincement, agissez avec précaution au niveau des zones signalées par cette étiquette. Les blessures par pincement peuvent se produire autour des pièces mobiles telles que les engrenages, portes, tiroirs et capots.

 **ATTENTION ! PIÈCES MOBILES :** Pour éviter tout risque de coupures ou de frottements, éloignez les mains des pièces en mouvement dans les zones signalées par cette étiquette. Les pièces en mouvement autour des engrenages et autres pièces rotatives peuvent causer des blessures.

Precauciones Durante La Solución De Problemas

 **PRECAUCIÓN—RIESGO DE DESCARGA:** Cuando vea este símbolo en el producto, existe peligro de tensiones peligrosas en el área del producto en la que está trabajando. Desconecte el producto antes de empezar o tenga cuidado si el producto debe recibir alimentación a fin de realizar la tarea.

 **PRECAUCIÓN—RIESGO DE DESCARGA:** Este producto utiliza un interruptor de corriente electrónico. No desconecta físicamente la entrada de voltaje de CA. Para evitar el riesgo de descarga eléctrica, desenchufe siempre el cable de alimentación de la impresora cuando sea necesario retirar la entrada de voltaje de CA.

 **PRECAUCIÓN—RIESGO DE DESCARGA:** Para evitar el riesgo de descarga eléctrica al solucionar problemas sin las cubiertas o con las puertas abiertas, no toque los cables ni los circuitos expuestos mientras la impresora está conectada a una toma de corriente.

 **PRECAUCIÓN—RIESGO DE DESCARGA:** Para evitar el riesgo de descargas eléctricas y daños en la impresora, retire el cable de alimentación de la toma eléctrica y desconecte todas las conexiones a dispositivos externos antes de conectar o desconectar cualquier cable, placa electrónica o conjunto.







 **PRECAUCIÓN—SUPERFICIE CALIENTE:** El interior de la impresora podría estar caliente. Para evitar el riesgo de heridas producidas por el contacto con un componente caliente, deje que la superficie se enfríe antes de tocarlo.

 **PRECAUCIÓN—RIESGO DE DESCARGA ELÉCTRICA:** Para evitar el riesgo de lesión por atrapamiento, preste atención en las áreas marcadas con esta etiqueta. Las lesiones por atrapamiento se pueden producir en torno a partes móviles, tales como engranajes, puertas, bandejas y cubiertas.





 **PRECAUCIÓN—PARTES MÓVILES:** Para evitar el riesgo de lesiones por laceración o abrasión, mantenga las manos lejos de las partes móviles en las zonas marcadas con esta etiqueta. Las lesiones causadas por partes móviles pueden producirse cerca de los engranajes u otras piezas giratorias.

Vorsichtsmaßnahmen Bei Der Fehlerbehebung

 **VORSICHT – STROMSCHLAGEFAHR:** Wenn Sie dieses Symbol sehen, besteht eine Gefahr durch gefährliche Spannungen in dem Produktbereich, in dem Sie arbeiten. Trennen Sie das Produkt von seiner Stromverbindung, bevor Sie beginnen, oder gehen Sie vorsichtig vor, wenn das Produkt für die Durchführung der Aufgabe mit Strom versorgt werden muss.

-  **VORSICHT – STROMSCHLAGGEFAHR:** Dieses Produkt verwendet einen elektronischen Leistungsschalter. Er trennt die Eingangswchselspannung nicht physikalisch. Um das Risiko eines elektrischen Schlags zu vermeiden, ziehen Sie stets das Netzkabel vom Drucker ab, wenn eine Abtrennung der Eingangswchselspannung erforderlich ist.
-  **VORSICHT – STROMSCHLAGGEFAHR:** Um die Gefahr eines Stromschlags während der Fehlerbehebung bei entfernten Abdeckungen oder offenen Klappen zu vermeiden, berühren Sie die freiliegenden Drähte oder Stromkreise nicht, wenn der Drucker an eine Steckdose angeschlossen ist.
-  **VORSICHT – STROMSCHLAGGEFAHR:** Um das Risiko eines elektrischen Schlags und Schäden am Drucker zu vermeiden, ziehen Sie das Netzkabel aus der Steckdose und trennen Sie alle Verbindungen zu jeglichen externen Geräten, bevor Sie Kabel, Elektronikplatinen oder Baugruppen einstecken oder abziehen.
-  **VORSICHT – HEISS:** Das Innere des Druckers kann sehr heiß sein. Vermeiden Sie Verletzungen, indem Sie heiße Komponenten stets abkühlen lassen, bevor Sie ihre Oberfläche berühren.
-  **VORSICHT – QUETSCHGEFAHR:** Um das Risiko einer Quetschung zu vermeiden, gehen Sie in Bereichen, die mit diesem Etikett gekennzeichnet sind, mit Vorsicht vor. Quetschungen können im Bereich von beweglichen Komponenten auftreten, wie z.B. Zahnrädern, Klappen, Fächern und Abdeckungen.
-  **VORSICHT – BEWEGLICHE TEILE:** Um das Risiko von Verletzungen und Abschürfungen zu vermeiden, halten Sie Ihre Hände von sich bewegenden Teilen in Bereichen fern, die mit diesem Hinweis gekennzeichnet sind. Verletzungen durch sich bewegende Teile treten unter Umständen im Bereich von Zahnrädern und anderen sich drehenden Teilen auf.

Precauzioni per gli interventi di riparazione

-  **ATTENZIONE – PERICOLO DI SCOSSA ELETTRICA:** La presenza di questo simbolo sul prodotto significa che è presente tensione pericolosa nell'area del prodotto su cui si sta lavorando. Scollegare il prodotto prima di iniziare, o prestare cautela se l'intervento richiede che il prodotto debba ricevere alimentazione.
-  **ATTENZIONE – PERICOLO DI SCOSSA ELETTRICA:** Questo prodotto utilizza un interruttore di alimentazione elettronico. Tale interruttore non scollega fisicamente la tensione CA in entrata. Per evitare il rischio di scossa elettrica, rimuovere sempre il cavo di alimentazione dalla stampante quando è necessario rimuovere la tensione CA in entrata.
-  **ATTENZIONE – PERICOLO DI SCOSSA ELETTRICA:** Per evitare il rischio di scossa elettrica quando si eseguono interventi sulla macchina con coperture rimosse e sportelli aperti, non toccare cavi o circuiti esposti quando la stampante è collegata a una presa elettrica.
-  **ATTENZIONE – PERICOLO DI SCOSSA ELETTRICA:** Per evitare il rischio di scossa elettrica e per impedire danni alla stampante, rimuovere il cavo di alimentazione dalla presa elettrica e scollegare tutti i collegamenti a eventuali dispositivi esterni prima di collegare o scollegare qualsiasi cavo, scheda elettronica o gruppo.
-  **ATTENZIONE – SUPERFICIE SURRISCALDATA:** L'area interna della stampante potrebbe surriscaldarsi. Per evitare infortuni, lasciare raffreddare la superficie dei componenti prima di toccarla.



ATTENZIONE – PERICOLO DI SCHIACCIAMENTO: Per evitare il rischio di lesioni, prestare la massima cautela quando si accede alle aree contrassegnate con questa etichetta. Potrebbero infatti verificarsi lesioni da schiacciamento in prossimità di parti in movimento, quali ad esempio ingranaggi, porte, vassoi e coperchi.



ATTENZIONE – PARTI MOBILI: Per evitare il rischio di lesioni da lacerazione o abrasione, tenere le mani lontano da parti in movimento nelle aree contrassegnate con questa etichetta. Le lesioni dovute a parti in movimento possono verificarsi intorno a ingranaggi e altre parti rotanti.

Troubleshooting Overview

Performing The Initial Troubleshooting Check

- With the power cord unplugged from the electrical outlet, check if the cord is free from breakage, short circuits, disconnected wires, or incorrect connections.
- Make sure that the printer is properly grounded.
- Make sure that the power supply line voltage is within 10 % of the rated line voltage.
- Make sure that the printer is securely installed on a level surface in a well-ventilated area.
- Make sure that the temperature and relative humidity are within the specifications. See [Temperature Information](#).
- Avoid locations that:
 - Generate ammonia gas
 - Are exposed to direct sunlight
 - Are near open flames
 - Are dusty
- Make sure that the recommended paper for this printer is used.
- Do a test print with paper from a newly opened package, and then check the result.

Fixing Print Quality Issues

Initial Print Quality Check

Before troubleshooting print problems, perform the following:

- Make sure that the printer is located in an area that follows the recommended operating environment and power requirement specifications.
- Check the status of supplies. Replace supplies that are low or empty.
- Load 20-lb plain letter or A4 paper. Make sure that the paper guides are properly set and locked. From the control panel, set the paper size and type to match the paper loaded in the tray.
- Print and keep the Menu settings page. The page will be used to restore the custom settings, if necessary.
- Make sure that the print resolution and toner darkness on the Menu settings page are set to their default values.
- Check the print cartridge for damage, and replace if necessary.
- Print the advanced print quality samples to see if the problem remains. Use tray 1 to test print quality problems. Look for variations in the print from what is expected.
- Make sure that the correct print driver is used to prevent print problems. If the wrong driver is installed, then incorrect characters may print and the copy may not fit the page correctly.

Supplies Used to Resolve Print Quality Issues

For this family of printers, the following supplies are available to resolve print quality issues:

Supply Item	P/N
Standard-Capacity Black Print Cartridge (1.5K) NA/XE Sold	006R04383
Standard-Capacity Cyan Print Cartridge (1.5K) NA/XE Sold	006R04384
Standard-Capacity Magenta Print Cartridge (1.5K) NA/XE Sold	006R04385
Standard-Capacity Yellow Print Cartridge (1.5K) NA/XE Sold	006R04386
Standard-Capacity Black Print Cartridge (1.5K) DMO Sold	006R04387
Standard-Capacity Cyan Print Cartridge (1.5K) DMO Sold	006R04388
Standard-Capacity Magenta Print Cartridge (1.5K) DMO Sold	006R04389
Standard-Capacity Yellow Print Cartridge (1.5K) DMO Sold	006R04390
High-Capacity Black Print Cartridge (3K) NA/XE Sold	006R04391

Supply Item	P/N
High-Capacity Cyan Print Cartridge (2.5K) NA/XE Sold	006R04392
High-Capacity Magenta Print Cartridge (2.5K) NA/XE Sold	006R04393
High-Capacity Yellow Print Cartridge (2.5K) NA/XE Sold	006R04394
High-Capacity Black Print Cartridge (3K) DMO Sold	006R04395
High-Capacity Cyan Print Cartridge (2.5K) DMO Sold	006R04396
High-Capacity Magenta Print Cartridge (2.5K) DMO Sold	006R04397
High-Capacity Yellow Print Cartridge (2.5K) DMO Sold	006R04398
World Wide Metered Black Print Cartridge (3k)	006R04529
World Wide Metered Cyan Print Cartridge (2.5k)	006R04530
World Wide Metered Magenta Print Cartridge (2.5k)	006R04531
World Wide Metered Yellow Print Cartridge (2.5k)	006R04532
Waste Toner Bottle (15K)	008R13326

Blank or White Pages Check



Note: Before performing this print quality check, print the Print Quality Test Pages. From the control panel, navigate to **Settings > Troubleshooting > Print Quality Test Pages**, and then perform the initial print quality check. See [Initial print quality check](#) .

Action	Yes	No
<p>Step 1</p> <p>1 From the control panel, navigate to:</p> <p>Settings > Print > Quality > Advanced Imaging > Color Adjust</p> <p>The Color Adjust calibrates the printer to adjust the color variations in the printed output.</p> <p>2 Do a print test.</p> <p>Does the problem remain?</p>	Go to step 2.	The problem is solved.
<p>Step 2</p> <p>1 Firmly shake the cartridge to redistribute the toner.</p> <p>2 Make sure that the affected cartridge is properly installed.</p> <p>The cartridge must fit and lock properly with the print cartridge tray. No packing material must be left on the cartridge.</p> <p>Does the problem remain?</p>	Go to step 3.	The problem is solved.
<p>Step 3</p> <p>1 Check the cartridge for damage and leaks.</p> <p>2 Check the cartridge smart chip contacts for improper connections.</p> <ul style="list-style-type: none"> • Corrosion and contamination • Loose connection with the HVPS contacts <p>Is the cartridge free of damage, leaks, and contamination?</p>	Go to step 5.	Go to step 4.
<p>Step 4</p> <p>Clean the contaminated contacts or replace the affected cartridge.</p> <p>Does the problem remain?</p>	Go to step 5.	The problem is solved.
<p>Step 5</p> <p>1 Remove the right cover. See Right cover removal.</p> <p>2 Remove the controller board shield. See Controller board shield removal.</p>	Go to step 6.	The problem is solved.

Diagnostics and Troubleshooting

Action	Yes	No
<p>3 Reseat the HVPS flat cables on the HVPS and controller board.</p> <p>Does the problem remain?</p>		
<p>Step 6</p> <p>Check the cables for damage.</p> <p>Are the cables free of damage?</p>	Go to step 8.	Go to step 7.
<p>Step 7</p> <p>Replace the affected cable.</p> <p>Does the problem remain?</p>	Go to step 8.	The problem is solved.
<p>Step 8</p> <p>1 Make sure that the HVPS is properly installed.</p> <p>2 Reseat all the cables on the HVPS.</p> <p>3 Properly align the spring contacts.</p> <p>Does the problem remain?</p>	Go to step 9.	The problem is solved.
<p>Step 9</p> <p>Check the HVPS contacts for contamination and damage.</p> <p>Are the HVPS contacts free of contamination and damage?</p>	Go to step 11.	Go to step 10.
<p>Step 10</p> <p>Clean or replace the HVPS. See HVPS removal.</p> <p>Does the problem remain?</p>	Go to step 11.	The problem is solved.
<p>Step 11</p> <p>1 Enter the Diagnostics menu, and then navigate to:</p> <p>Printer diagnostics and adjustments > Motor tests</p> <p>2 Select K/Transfer belt, and then start the test.</p> <p>Does the transfer belt or transfer roller move?</p>	Go to step 16.	Go to step 12.
<p>Step 12</p> <p>Check the transfer module and its components for improper installation and damage.</p> <ul style="list-style-type: none"> Transfer belt 	Go to step 13.	Go to step 15.

Action	Yes	No
<ul style="list-style-type: none"> • Transfer roller • Coupler gears <p>Is the transfer module properly installed and free of damage?</p>		
<p>Step 13</p> <p>Make sure that the transfer module cable on the HVPS is properly connected.</p> <p>Does the problem remain?</p>	Go to step 14.	The problem is solved.
<p>Step 14</p> <ol style="list-style-type: none"> 1 Remove any toner spills or contamination from the transfer module. 2 Check the transfer belt cleaner and its waste toner nozzle for leaks and damage. <p>If the transfer belt cleaner is defective, then excess toner may build up on the transfer belt. If there are leaks on the waste toner nozzle, then toner spills will occur.</p> <p>Is the transfer belt cleaner free of leaks and damage?</p>	Go to step 16.	Go to step 15.
<p>Step 15</p> <p>Reinstall or replace the transfer module. See Transfer module removal.</p> <p>Does the problem remain?</p>	Go to step 16.	The problem is solved.
<p>Step 16</p> <ol style="list-style-type: none"> 1 Remove the top cover. See Top cover removal. 2 Reseat the flat cables on the printhead. 3 Reseat the printhead cables on the controller board. <p>Does the problem remain?</p>	Go to step 17.	The problem is solved.
<p>Step 17</p> <p>Check the cables for damage.</p> <p>Are the cables free of damage?</p>	Go to step 19.	Go to step 18.
<p>Step 18</p> <p>Replace the affected cable.</p>	Go to step 19.	The problem is solved.

Diagnostics and Troubleshooting

Action	Yes	No
Does the problem remain?		
Step 19 1 Check the printhead and its components for damage. <ul style="list-style-type: none"> • Flat cable • Connector sockets 2 Check the printhead mirrors for contamination. Is the printhead free of damage and contamination?	Go to step 21.	Go to step 20.
Step 20 Clean or replace the printhead. See Printhead removal . Does the problem remain?	Go to step 21.	The problem is solved.
Step 21 Check the firmware version. Is the firmware updated to the latest version?	Go to step 23.	Go to step 22.
Step 22 Update the firmware. Does the problem remain?	Go to step 23.	The problem is solved.
Step 23 Make sure that the controller board is properly installed. Reseat all the cables on the controller board. Does the problem remain?	Go to step 24.	The problem is solved.
Step 24 Check the controller board and its connector pins for damage. Are the controller board and its connectors free of damage?	Contact the next level of support.	Go to step 25.
Step 25 Replace the controller board. See Controller board removal . Does the problem remain?	Contact the next level of support.	The problem is solved.

Dark Print Check

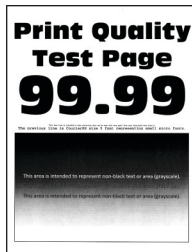

Note: Before performing this print quality check, print the Print Quality Test Pages. From the control panel, navigate to **Settings > Troubleshooting > Print Quality Test Pages**, and then perform the initial print quality check. See [Initial print quality check](#) .

Action	Yes	No
<p>Step 1</p> <ol style="list-style-type: none"> 1 Make sure that the paper is properly loaded in the tray and manual feeder. See Avoiding jams. 2 Make sure that the tray and manual feeder are properly installed. <p>Does the problem remain?</p>	Go to step 2.	The problem is solved.
<p>Step 2</p> <ol style="list-style-type: none"> 1 From the control panel, navigate to: Settings > Paper > Tray Configuration > Paper Size/Type 2 Make sure that the setting matches the paper loaded. <p>Does the problem remain?</p>	Go to step 3.	The problem is solved.
<p>Step 3</p> <ol style="list-style-type: none"> 1 From the control panel, navigate to: Settings > Paper > Media Configuration > Media Types 2 Make sure that the Texture and Weight settings match the paper loaded. <p>Does the problem remain?</p>	Go to step 4.	The problem is solved.
<p>Step 4</p> <p>Make sure that the paper loaded is supported and free of damage and defect.</p>	Go to step 5.	The problem is solved.

Diagnostics and Troubleshooting

Action	Yes	No
To check for paper curl, print on both sides of the paper. Does the problem remain?		
Step 5 Load paper from a fresh package. Paper absorbs moisture due to high humidity. Store paper in its original wrapper until you are ready to use it. Does the problem remain?	Go to step 6.	The problem is solved.
Step 6 1 Remove the print cartridge tray. See Print cartridge tray removal . 2 Enter the Diagnostics menu, and then navigate to: Printer diagnostics and adjustments > Sensor tests > TPS L and R 3 Insert a white sheet of paper between the transfer belt and sensor (TPS), and then check if the sensor values increase to almost 100%. 4 Insert a color-printed sheet of paper between the transfer belt and sensor (TPS), and then check if the sensor values change. Do the sensor values change properly?	Go to step 10.	Go to step 7.
Step 7 1 Remove the controller board shield. See Controller board shield removal . 2 Reseat the TPS sensor cables on the controller board. Does the problem remain?	Go to step 8.	The problem is solved.
Step 8 Check the TPS sensor cables for damage. Are the cables free of damage?	Go to step 37.	Go to step 9.
Step 9	Go to step 37.	The problem is solved.

Action	Yes	No
<p>Replace the affected TPS sensor cable.</p> <p>Does the problem remain?</p>		
<p>Step 10</p> <p>Enter the Diagnostics menu, and then navigate to:</p> <p>Printer diagnostics and adjustments > Weather station</p> <p>Is the weather station detecting properly?</p>	Go to step 11.	Go to step 35.
<p>Step 11</p> <ol style="list-style-type: none"> 1 Firmly shake the cartridge to redistribute the toner. 2 Make sure that the affected cartridge is properly installed. <p>The cartridge must fit and lock properly with the print cartridge tray. No packing material must be left on the cartridge.</p> <p>Does the problem remain?</p>	Go to step 12.	The problem is solved.
<p>Step 12</p> <ol style="list-style-type: none"> 1 Check the cartridge for damage and leaks. 2 Check the cartridge smart chip contacts for improper connections. <ul style="list-style-type: none"> • Corrosion and contamination • Loose connection with the HVPS contacts <p>Is the cartridge free of damage, leaks, and contamination?</p>	Go to step 14.	Go to step 13.
<p>Step 13</p> <p>Clean the contaminated contacts or replace the affected cartridge.</p> <p>Does the problem remain?</p>	Go to step 14.	The problem is solved.
<p>Step 14</p> <ol style="list-style-type: none"> 1 From the control panel, navigate to: <p>Settings > Print > Quality > Toner Darkness</p>	Go to step 15.	The problem is solved.

Diagnostics and Troubleshooting

Action	Yes	No
<p>2 Adjust the values to find the best result.</p> <p>Does the problem remain?</p>		
<p>Step 15</p> <p>1 Enter the Diagnostics menu, and then navigate to:</p> <p>Printer setup > EP setup > Charge adjust > Black & Color (DC bias voltage)</p> <p>2 Find the setting that produces the best result.</p> <p>Does the problem remain?</p>	Go to step 16.	The problem is solved.
<p>Step 16</p> <p>1 Enter the Diagnostics menu, and then navigate to:</p> <p>Printer setup > EP setup > Developer adjust > Black & Color (DC bias voltage)</p> <p>2 Find the setting that produces the best result.</p> <p>Does the problem remain?</p>	Go to step 17.	The problem is solved.
<p>Step 17</p> <p>1 Enter the Diagnostics menu, and then navigate to:</p> <p>Printer setup > EP setup > Transfer adjust > Black & Color (DC bias voltage)</p> <p>2 Find the setting that produces the best result.</p> <p>Does the problem remain?</p>	Go to step 18.	The problem is solved.
<p>Step 18</p> <p>1 From the Diagnostics menu, navigate to:</p> <p>Printer setup > EP setup > Transfer adjust > 2nd transfer roller (DC bias voltage)</p> <p>2 Find the setting that produces the best result.</p> <p>Does the problem remain?</p>	Go to step 19.	The problem is solved.
<p>Step 19</p> <p>1 Remove the right cover. See Right cover removal.</p>	Go to step 20.	The problem is solved.

Action	Yes	No
<p>2 Remove the controller board shield. See Controller board shield removal.</p> <p>3 Reseat the HVPS flat cables on the HVPS and controller board.</p> <p>Does the problem remain?</p>		
<p>Step 20</p> <p>Check the cables for damage.</p> <p>Are the cables free of damage?</p>	Go to step 22.	Go to step 21.
<p>Step 21</p> <p>Replace the affected cable.</p> <p>Does the problem remain?</p>	Go to step 22.	The problem is solved.
<p>Step 22</p> <p>1 Make sure that the HVPS is properly installed.</p> <p>2 Reseat all the cables on the HVPS.</p> <p>3 Properly align the spring contacts.</p> <p>Does the problem remain?</p>	Go to step 23.	The problem is solved.
<p>Step 23</p> <p>Check the HVPS contacts for contamination and damage.</p> <p>Are the HVPS contacts free of contamination and damage?</p>	Go to step 25.	Go to step 24.
<p>Step 24</p> <p>Clean or replace the HVPS. See HVPS removal.</p> <p>Does the problem remain?</p>	Go to step 25.	The problem is solved.
<p>Step 25</p> <p>1 Enter the Diagnostics menu, and then navigate to:</p> <p>Printer diagnostics and adjustments > Motor tests</p> <p>2 Select K/Transfer belt, and then start the test.</p> <p>Does the transfer belt or transfer roller move?</p>	Go to step 30.	Go to step 26.
<p>Step 26</p>	Go to step 27.	Go to step 29.

Diagnostics and Troubleshooting

Action	Yes	No
<p>Check the transfer module and its components for improper installation and damage.</p> <ul style="list-style-type: none"> • Transfer belt • Transfer roller • Coupler gears <p>Is the transfer module properly installed and free of damage?</p>		
<p>Step 27</p> <p>Make sure that the transfer module cable on the HVPS is properly connected.</p> <p>Does the problem remain?</p>	Go to step 28.	The problem is solved.
<p>Step 28</p> <ol style="list-style-type: none"> 1 Remove any toner spills or contamination from the transfer module. 2 Check the transfer belt cleaner and its waste toner nozzle for leaks and damage. <p>If the transfer belt cleaner is defective, then excess toner may build up on the transfer belt. If there are leaks on the waste toner nozzle, then toner spills will occur.</p> <p>Is the transfer belt cleaner free of leaks and damage?</p>	Go to step 30.	Go to step 29.
<p>Step 29</p> <p>Reinstall or replace the transfer module. See Transfer module removal.</p> <p>Does the problem remain?</p>	Go to step 30.	The problem is solved.
<p>Step 30</p> <ol style="list-style-type: none"> 1 Remove the top cover. See Top cover removal. 2 Reseat the flat cables on the printhead. 3 Reseat the printhead cables on the controller board. <p>Does the problem remain?</p>	Go to step 31.	The problem is solved.
<p>Step 31</p> <p>Check the cables for damage.</p>	Go to step 33.	Go to step 32.

Action	Yes	No
Are the cables free of damage?		
Step 32 Replace the affected cable. Does the problem remain?	Go to step 33.	The problem is solved.
Step 33 1 Check the printhead and its components for damage. <ul style="list-style-type: none"> • Flat cable • Connector sockets 2 Check the printhead mirrors for contamination. Is the printhead free of damage and contamination?	Go to step 35.	Go to step 34.
Step 34 Clean or replace the printhead. See Printhead removal . Does the problem remain?	Go to step 35.	The problem is solved.
Step 35 Check the firmware version. Is the firmware updated to the latest version?	Go to step 37.	Go to step 36.
Step 36 Update the firmware. Does the problem remain?	Go to step 37.	The problem is solved.
Step 37 Make sure that the controller board is properly installed. Reseat all the cables on the controller board. Does the problem remain?	Go to step 38.	The problem is solved.

Action	Yes	No
<p>Step 38</p> <p>Check the controller board and its connector pins for damage.</p> <p>Are the controller board and its connectors free of damage?</p>	Contact the next level of support.	Go to step 39.
<p>Step 39</p> <p>Replace the controller board. See Controller board removal.</p> <p>Does the problem remain?</p>	Contact the next level of support.	The problem is solved.

Ghost Images Check

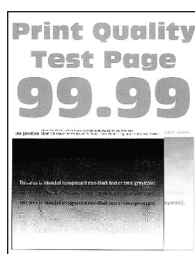

 **Note:** Before performing this print quality check, print the Print Quality Test Pages. From the control panel, navigate to **Settings > Troubleshooting > Print Quality Test Pages**, and then perform the initial print quality check. See [Initial print quality check](#).

Action	Yes	No
<p>Step 1</p> <ol style="list-style-type: none"> 1 Make sure that the paper is properly loaded in the tray and manual feeder. See Avoiding jams. 2 Make sure that the tray and manual feeder are properly installed. <p>Does the problem remain?</p>	Go to step 2.	The problem is solved.
<p>Step 2</p> <ol style="list-style-type: none"> 1 From the control panel, navigate to: Settings > Paper > Tray Configuration > Paper Size/Type 2 Make sure that the setting matches the paper loaded. <p>Does the problem remain?</p>	Go to step 3.	The problem is solved.

Action	Yes	No
<p>Step 3</p> <p>1 From the control panel, navigate to:</p> <p>Settings > Paper > Media Configuration > Media Types</p> <p>2 Make sure that the Texture and Weight settings match the paper loaded.</p> <p>Does the problem remain?</p>	Go to step 4.	The problem is solved.
<p>Step 4</p> <p>Make sure that the paper loaded is supported and free of damage and defect.</p> <p>To check for paper curl, print on both sides of the paper.</p> <p>Does the problem remain?</p>	Go to step 5.	The problem is solved.
<p>Step 5</p> <p>Load paper from a fresh package.</p> <p>Paper absorbs moisture due to high humidity. Store paper in its original wrapper until you are ready to use it.</p> <p>Does the problem remain?</p>	Go to step 6.	The problem is solved.
<p>Step 6</p> <p>1 From the control panel, navigate to:</p> <p>Settings > Print > Quality > Advanced Imaging > Color Adjust</p> <p>The Color Adjust calibrates the printer to adjust the color variations in the printed output.</p> <p>2 Do a print test.</p> <p>Does the problem remain?</p>	Go to step 7.	The problem is solved.
<p>Step 7</p> <p>1 Firmly shake the cartridge to redistribute the toner.</p> <p>2 Make sure that the affected cartridge is properly installed.</p> <p>The cartridge must fit and lock properly with the print</p>	Go to step 8.	The problem is solved.

Diagnostics and Troubleshooting

Action	Yes	No
<p>cartridge tray. No packing material must be left on the cartridge.</p> <p>Does the problem remain?</p>		
<p>Step 8</p> <ol style="list-style-type: none"> 1 Check the cartridge for damage and leaks. 2 Check the cartridge smart chip contacts for improper connections. <ul style="list-style-type: none"> • Corrosion and contamination • Loose connection with the HVPS contacts <p>Is the cartridge free of damage, leaks, and contamination?</p>	Go to step 10.	Go to step 9.
<p>Step 9</p> <p>Clean the contaminated contacts or replace the affected cartridge.</p> <p>Does the problem remain?</p>	Go to step 10.	The problem is solved.
<p>Step 10</p> <ol style="list-style-type: none"> 1 Enter the Diagnostics menu, and then navigate to: Printer setup > EP setup > Charge adjust > Black & Color (DC bias voltage) 2 Find the setting that produces the best result. <p>Does the problem remain?</p>	Go to step 11.	The problem is solved.
<p>Step 11</p> <ol style="list-style-type: none"> 1 Enter the Diagnostics menu, and then navigate to: Printer setup > EP setup > Developer adjust > Black & Color (DC bias voltage) 2 Find the setting that produces the best result. <p>Does the problem remain?</p>	Go to step 12.	The problem is solved.
<p>Step 12</p> <ol style="list-style-type: none"> 1 Enter the Diagnostics menu, and then navigate to: 	Go to step 13.	The problem is solved.

Action	Yes	No
<p>Printer setup > EP setup > Transfer adjust > Black & Color (DC bias voltage)</p> <p>2 Find the setting that produces the best result.</p> <p>Does the problem remain?</p>		
<p>Step 13</p> <p>1 From the Diagnostics menu, navigate to:</p> <p>Printer setup > EP setup > Transfer adjust > 2nd transfer roller (DC bias voltage)</p> <p>2 Find the setting that produces the best result.</p> <p>Does the problem remain?</p>	Go to step 14.	The problem is solved.
<p>Step 14</p> <p>1 Enter the Diagnostics menu, and then navigate to:</p> <p>Printer diagnostics and adjustments > Motor tests</p> <p>2 Select K/Transfer belt, and then start the test.</p> <p>Does the transfer belt or transfer roller move?</p>	Go to step 19.	Go to step 15.
<p>Step 15</p> <p>Check the transfer module and its components for improper installation and damage.</p> <ul style="list-style-type: none"> • Transfer belt • Transfer roller • Coupler gears <p>Is the transfer module properly installed and free of damage?</p>	Go to step 16.	Go to step 18.
<p>Step 16</p> <p>1 Remove the right cover. See Right cover removal.</p> <p>2 Make sure that the transfer module cable on the HVPS is properly connected.</p> <p>Does the problem remain?</p>	Go to step 17.	The problem is solved.
Step 17	Go to step 19.	Go to step 18.

Diagnostics and Troubleshooting

Action	Yes	No
<p>1 Remove any toner spills or contamination from the transfer module.</p> <p>2 Check the transfer belt cleaner and its waste toner nozzle for leaks and damage.</p> <p>If the transfer belt cleaner is defective, then excess toner may build up on the transfer belt. If there are leaks on the waste toner nozzle, then toner spills will occur.</p> <p>Is the transfer belt cleaner free of leaks and damage?</p>		
<p>Step 18</p> <p>Reinstall or replace the transfer module. See Transfer module removal.</p> <p>Does the problem remain?</p>	Go to step 19.	The problem is solved.
<p>Step 19</p> <p>1 Remove the right cover. See Right cover removal.</p> <p>2 Remove the controller board shield. See Controller board shield removal.</p> <p>3 Reseat the HVPS flat cables on the HVPS and controller board.</p> <p>Does the problem remain?</p>	Go to step 20.	The problem is solved.
<p>Step 20</p> <p>Check the cables for damage.</p> <p>Are the cables free of damage?</p>	Go to step 22.	Go to step 21.
<p>Step 21</p> <p>Replace the affected cable.</p> <p>Does the problem remain?</p>	Go to step 22.	The problem is solved.
<p>Step 22</p> <p>1 Make sure that the HVPS is properly installed.</p> <p>2 Reseat all the cables on the HVPS.</p> <p>3 Properly align the spring contacts.</p> <p>Does the problem remain?</p>	Go to step 23.	The problem is solved.

Action	Yes	No
<p>Step 23</p> <p>Check the HVPS contacts for contamination and damage.</p> <p>Are the HVPS contacts free of contamination and damage?</p>	Go to step 25.	Go to step 24.
<p>Step 24</p> <p>Clean or replace the HVPS. See HVPS removal.</p> <p>Does the problem remain?</p>	Go to step 25.	The problem is solved.
<p>Step 25</p> <p>Check if the fuser voltage rating matches the printer and electrical outlet voltage rating.</p> <p>Does the fuser have the correct voltage rating?</p>	Go to step 26.	Go to step 30.
<p>Step 26</p> <p>1 Enter the Diagnostics menu, and then navigate to:</p> <p style="padding-left: 20px;">Printer diagnostics and adjustments > Motor tests</p> <p>2 Select Fuser, and then start the test.</p> <p>Do the fuser rollers and exit rollers turn?</p>	Go to step 29.	Go to step 27.
<p>Step 27</p> <p>1 Make sure that the fuser is properly installed.</p> <p>2 Remove the controller board shield. See Controller board shield removal.</p> <p>3 Remove the right cover. See Right cover removal.</p> <p>4 Reseat the fuser cables from the following components, and then check the cables for damage:</p> <ul style="list-style-type: none"> • HVPS • LVPS • Fuser to controller board connections <p>Are the fuser cables free of damage?</p>	Go to step 29.	Go to step 28.
<p>Step 28</p>	Go to step 29.	The problem is solved.

Diagnostics and Troubleshooting

Action	Yes	No
Replace the affected cable. Does the problem remain?		
Step 29 Check the fuser and its components for damage. <ul style="list-style-type: none"> • Gears • Rollers • Cable • Guides and actuators • Thermistor Is the fuser free of damage?	Go to step 31.	Go to step 30.
Step 30 Replace the fuser. See Fuser removal . Does the problem remain?	Go to step 31.	The problem is solved.
Step 31 1 Remove the top cover. See Top cover removal . 2 Reseat the flat cables on the printhead. 3 Reseat the printhead cables on the controller board. Does the problem remain?	Go to step 32.	The problem is solved.
Step 32 Check the cables for damage. Are the cables free of damage?	Go to step 34.	Go to step 33.
Step 33 Replace the affected cable. Does the problem remain?	Go to step 34.	The problem is solved.
Step 34 1 Check the printhead and its components for damage. <ul style="list-style-type: none"> • Flat cable • Connector sockets 2 Check the printhead mirrors for contamination. Is the printhead free of damage and contamination?	Go to step 36.	Go to step 35.
Step 35	Go to step 36.	The problem is solved.

Action	Yes	No
Clean or replace the printhead. See Printhead removal . Does the problem remain?		
Step 36 Check the firmware version. Is the firmware updated to the latest version?	Go to step 38.	Go to step 37.
Step 37 Update the firmware. Does the problem remain?	Go to step 38.	The problem is solved.
Step 38 Make sure that the controller board is properly installed. Reseat all the cables on the controller board. Does the problem remain?	Go to step 39.	The problem is solved.
Step 39 Check the controller board and its connector pins for damage. Are the controller board and its connectors free of damage?	Contact the next level of support.	Go to step 40.
Step 40 Replace the controller board. See Controller board removal . Does the problem remain?	Contact the next level of support.	The problem is solved.

Gray or Colored Background Check

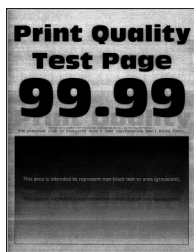

Note: Before performing this print quality check, print the Print Quality Test Pages. From the control panel, navigate to **Settings > Troubleshooting > Print Quality Test Pages**, and then perform the initial print quality check. See [Initial print quality check](#) .

Action	Yes	No
<p>Step 1</p> <p>1 From the control panel, navigate to:</p> <p>Settings > Print > Quality > Advanced Imaging > Color Adjust</p> <p>The Color Adjust calibrates the printer to adjust the color variations in the printed output.</p> <p>2 Do a print test.</p> <p>Does the problem remain?</p>	Go to step 2.	The problem is solved.
<p>Step 2</p> <p>1 Firmly shake the cartridge to redistribute the toner.</p> <p>2 Make sure that the affected cartridge is properly installed.</p> <p>The cartridge must fit and lock properly with the print cartridge tray. No packing material must be left on the cartridge.</p> <p>Does the problem remain?</p>	Go to step 3.	The problem is solved.
<p>Step 3</p> <p>1 Check the cartridge for damage and leaks.</p> <p>2 Check the cartridge smart chip contacts for improper connections.</p> <ul style="list-style-type: none"> • Corrosion and contamination • Loose connection with the HVPS contacts <p>Is the cartridge free of damage, leaks, and contamination?</p>	Go to step 5.	Go to step 4.
<p>Step 4</p> <p>Clean the contaminated contacts or replace the affected cartridge.</p> <p>Does the problem remain?</p>	Go to step 5.	The problem is solved.
<p>Step 5</p> <p>1 Remove the right cover. See Right cover removal.</p> <p>2 Remove the controller board shield. See Controller board shield removal.</p>	Go to step 6.	The problem is solved.

Action	Yes	No
<p>3 Reseat the HVPS flat cables on the HVPS and controller board.</p> <p>Does the problem remain?</p>		
<p>Step 6</p> <p>Check the cables for damage.</p> <p>Are the cables free of damage?</p>	Go to step 8.	Go to step 7.
<p>Step 7</p> <p>Replace the affected cable.</p> <p>Does the problem remain?</p>	Go to step 8.	The problem is solved.
<p>Step 8</p> <p>1 Make sure that the HVPS is properly installed.</p> <p>2 Reseat all the cables on the HVPS.</p> <p>3 Properly align the spring contacts.</p> <p>Does the problem remain?</p>	Go to step 9.	The problem is solved.
<p>Step 9</p> <p>Check the HVPS contacts for contamination and damage.</p> <p>Are the HVPS contacts free of contamination and damage?</p>	Go to step 11.	Go to step 10.
<p>Step 10</p> <p>Clean or replace the HVPS. See HVPS removal.</p> <p>Does the problem remain?</p>	Go to step 11.	The problem is solved.
<p>Step 11</p> <p>1 Enter the Diagnostics menu, and then navigate to:</p> <p>Printer diagnostics and adjustments > Motor tests</p> <p>2 Select K/Transfer belt, and then start the test.</p> <p>Does the transfer belt or transfer roller move?</p>	Go to step 16.	Go to step 12.
<p>Step 12</p> <p>Check the transfer module and its components for improper installation and damage.</p> <ul style="list-style-type: none"> Transfer belt 	Go to step 13.	Go to step 15.

Diagnostics and Troubleshooting

Action	Yes	No
<ul style="list-style-type: none"> • Transfer roller • Coupler gears <p>Is the transfer module properly installed and free of damage?</p>		
<p>Step 13</p> <p>Make sure that the transfer module cable on the HVPS is properly connected.</p> <p>Does the problem remain?</p>	Go to step 14.	The problem is solved.
<p>Step 14</p> <ol style="list-style-type: none"> 1 Remove any toner spills or contamination from the transfer module. 2 Check the transfer belt cleaner and its waste toner nozzle for leaks and damage. <p>If the transfer belt cleaner is defective, then excess toner may build up on the transfer belt. If there are leaks on the waste toner nozzle, then toner spills will occur.</p> <p>Is the transfer belt cleaner free of leaks and damage?</p>	Go to step 16.	Go to step 15.
<p>Step 15</p> <p>Reinstall or replace the transfer module. See Transfer module removal.</p> <p>Does the problem remain?</p>	Go to step 16.	The problem is solved.
<p>Step 16</p> <ol style="list-style-type: none"> 1 Remove the top cover. See Top cover removal. 2 Reseat the flat cables on the printhead. 3 Reseat the printhead cables on the controller board. <p>Does the problem remain?</p>	Go to step 17.	The problem is solved.
<p>Step 17</p> <p>Check the cables for damage.</p> <p>Are the cables free of damage?</p>	Go to step 19.	Go to step 18.
<p>Step 18</p> <p>Replace the affected cable.</p>	Go to step 19.	The problem is solved.

Action	Yes	No
Does the problem remain?		
Step 19 1 Check the printhead and its components for damage. <ul style="list-style-type: none"> • Flat cable • Connector sockets 2 Check the printhead mirrors for contamination. Is the printhead free of damage and contamination?	Go to step 21.	Go to step 20.
Step 20 Clean or replace the printhead. See Printhead removal . Does the problem remain?	Go to step 21.	The problem is solved.
Step 21 Check the firmware version. Is the firmware updated to the latest version?	Go to step 23.	Go to step 22.
Step 22 Update the firmware. Does the problem remain?	Go to step 23.	The problem is solved.
Step 23 Make sure that the controller board is properly installed. Reseat all the cables on the controller board. Does the problem remain?	Go to step 24.	The problem is solved.
Step 24 Check the controller board and its connector pins for damage. Are the controller board and its connectors free of damage?	Contact the next level of support.	Go to step 25.
Step 25 Replace the controller board. See Controller board removal . Does the problem remain?	Contact the next level of support.	The problem is solved.

Horizontal Dark Lines Check



Note: Before performing this print quality check, print the Print Quality Test Pages. From the control panel, navigate to **Settings > Troubleshooting > Print Quality Test Pages**, and then perform the initial print quality check. See [Initial print quality check](#) .

Action	Yes	No
<p>Step 1</p> <ol style="list-style-type: none"> 1 Make sure that the paper is properly loaded in the tray and manual feeder. See Avoiding jams. 2 Make sure that the tray and manual feeder are properly installed. <p>Does the problem remain?</p>	Go to step 2.	The problem is solved.
<p>Step 2</p> <ol style="list-style-type: none"> 1 From the control panel, navigate to: Settings > Paper > Tray Configuration > Paper Size/Type 2 Make sure that the setting matches the paper loaded. <p>Does the problem remain?</p>	Go to step 3.	The problem is solved.
<p>Step 3</p> <ol style="list-style-type: none"> 1 From the control panel, navigate to: Settings > Paper > Media Configuration > Media Types 2 Make sure that the Texture and Weight settings match the paper loaded. <p>Does the problem remain?</p>	Go to step 4.	The problem is solved.
<p>Step 4</p> <p>Make sure that the paper loaded is supported and free of damage and defect.</p>	Go to step 5.	The problem is solved.

Action	Yes	No
To check for paper curl, print on both sides of the paper. Does the problem remain?		
Step 5 Load paper from a fresh package. Paper absorbs moisture due to high humidity. Store paper in its original wrapper until you are ready to use it. Does the problem remain?	Go to step 6.	The problem is solved.
Step 6 1 From the control panel, navigate to: Settings > Print > Quality > Advanced Imaging > Color Adjust The Color Adjust calibrates the printer to adjust the color variations in the printed output. 2 Do a print test. Does the problem remain?	Go to step 7.	The problem is solved.
Step 7 1 Firmly shake the cartridge to redistribute the toner. 2 Make sure that the affected cartridge is properly installed. The cartridge must fit and lock properly with the print cartridge tray. No packing material must be left on the cartridge. Does the problem remain?	Go to step 8.	The problem is solved.
Step 8 1 Check the cartridge for damage and leaks. 2 Check the cartridge smart chip contacts for improper connections. <ul style="list-style-type: none"> • Corrosion and contamination • Loose connection with the HVPS contacts 	Go to step 10.	Go to step 9.

Diagnostics and Troubleshooting

Action	Yes	No
Is the cartridge free of damage, leaks, and contamination?		
Step 9 Clean the contaminated contacts or replace the affected cartridge. Does the problem remain?	Go to step 10.	The problem is solved.
Step 10 1 Pull out the print cartridge tray, and then remove all the print cartridges. 2 Check the cartridge tray for proper movement. Does the cartridge tray open and close properly?	Go to step 12.	Go to step 11.
Step 11 1 Remove any obstructions that hinder the cartridge tray. 2 Reinstall the cartridge tray. Does the problem remain?	Go to step 12.	The problem is solved.
Step 12 Check the cartridge tray and its components for damage. <ul style="list-style-type: none"> • Print cartridge locking mechanisms • Sliding mechanism under the cartridge tray • Latch mechanism Is the cartridge tray free of damage?	Go to step 14.	Go to step 13.
Step 13 Replace the cartridge tray. See Print cartridge tray removal . Does the problem remain?	Go to step 14.	The problem is solved.
Step 14 1 From the control panel, navigate to: Settings > Print > Quality > Toner Darkness 2 Adjust the values to find the best result. Does the problem remain?	Go to step 15.	The problem is solved.

Action	Yes	No
<p>Step 15</p> <p>1 Enter the Diagnostics menu, and then navigate to:</p> <p>Printer setup > EP setup > Charge adjust > Black & Color (DC bias voltage)</p> <p>2 Find the setting that produces the best result.</p> <p>Does the problem remain?</p>	Go to step 16.	The problem is solved.
<p>Step 16</p> <p>1 Enter the Diagnostics menu, and then navigate to:</p> <p>Printer setup > EP setup > Developer adjust > Black & Color (DC bias voltage)</p> <p>2 Find the setting that produces the best result.</p> <p>Does the problem remain?</p>	Go to step 17.	The problem is solved.
<p>Step 17</p> <p>1 Enter the Diagnostics menu, and then navigate to:</p> <p>Printer setup > EP setup > Transfer adjust > Black & Color (DC bias voltage)</p> <p>2 Find the setting that produces the best result.</p> <p>Does the problem remain?</p>	Go to step 18.	The problem is solved.
<p>Step 18</p> <p>1 From the Diagnostics menu, navigate to:</p> <p>Printer setup > EP setup > Transfer adjust > 2nd transfer roller (DC bias voltage)</p> <p>2 Find the setting that produces the best result.</p> <p>Does the problem remain?</p>	Go to step 19.	The problem is solved.
<p>Step 19</p> <p>1 Use the table on the Print Quality Test Pages to match the distance between vertically repeating defects.</p>	Go to step 20.	The problem is solved.

Diagnostics and Troubleshooting

Action	Yes	No
<p>2 Replace the part or supply item that best matches the distance.</p> <p>Does the problem remain?</p>		
<p>Step 20</p> <p>1 Remove the right cover. See Right cover removal.</p> <p>2 Remove the controller board shield. See Controller board shield removal.</p> <p>3 Reseat the HVPS flat cables on the HVPS and controller board.</p> <p>Does the problem remain?</p>	Go to step 21.	The problem is solved.
<p>Step 21</p> <p>Check the cables for damage.</p> <p>Are the cables free of damage?</p>	Go to step 23.	Go to step 22.
<p>Step 22</p> <p>Replace the affected cable.</p> <p>Does the problem remain?</p>	Go to step 23.	The problem is solved.
<p>Step 23</p> <p>1 Make sure that the HVPS is properly installed.</p> <p>2 Reseat all the cables on the HVPS.</p> <p>3 Properly align the spring contacts.</p> <p>Does the problem remain?</p>	Go to step 24.	The problem is solved.
<p>Step 24</p> <p>Check the HVPS contacts for contamination and damage.</p> <p>Are the HVPS contacts free of contamination and damage?</p>	Go to step 26.	Go to step 25.
<p>Step 25</p> <p>Clean or replace the HVPS. See HVPS removal.</p> <p>Does the problem remain?</p>	Go to step 26.	The problem is solved.
<p>Step 26</p> <p>1 Remove the top cover. See Top cover removal.</p> <p>2 Reseat the flat cables on the printhead.</p>	Go to step 27.	The problem is solved.

Action	Yes	No
<p>3 Reseat the printhead cables on the controller board.</p> <p>Does the problem remain?</p>		
<p>Step 27</p> <p>Check the cables for damage.</p> <p>Are the cables free of damage?</p>	Go to step 29.	Go to step 28.
<p>Step 28</p> <p>Replace the affected cable.</p> <p>Does the problem remain?</p>	Go to step 29.	The problem is solved.
<p>Step 29</p> <p>1 Check the printhead and its components for damage.</p> <ul style="list-style-type: none"> • Flat cable • Connector sockets <p>2 Check the printhead mirrors for contamination.</p> <p>Is the printhead free of damage and contamination?</p>	Go to step 31.	Go to step 30.
<p>Step 30</p> <p>Clean or replace the printhead. See Printhead removal.</p> <p>Does the problem remain?</p>	Go to step 31.	The problem is solved.
<p>Step 31</p> <p>Check the firmware version.</p> <p>Is the firmware updated to the latest version?</p>	Go to step 33.	Go to step 32.
<p>Step 32</p> <p>Update the firmware.</p> <p>Does the problem remain?</p>	Go to step 33.	The problem is solved.
<p>Step 33</p> <p>Make sure that the controller board is properly installed. Reseat all the cables on the controller board.</p> <p>Does the problem remain?</p>	Go to step 34.	The problem is solved.

Action	Yes	No
<p>Step 34</p> <p>Check the controller board and its connector pins for damage.</p> <p>Are the controller board and its connectors free of damage?</p>	Contact the next level of support.	Go to step 35.
<p>Step 35</p> <p>Replace the controller board. See Controller board removal.</p> <p>Does the problem remain?</p>	Contact the next level of support.	The problem is solved.

Horizontal White Lines Check



 **Note:** Before performing this print quality check, print the Print Quality Test Pages. From the control panel, navigate to **Settings > Troubleshooting > Print Quality Test Pages**, and then perform the initial print quality check. See [Initial print quality check](#) .

Action	Yes	No
<p>Step 1</p> <ol style="list-style-type: none"> 1 Make sure that the paper is properly loaded in the tray and manual feeder. See Avoiding jams. 2 Make sure that the tray and manual feeder are properly installed. <p>Does the problem remain?</p>	Go to step 2.	The problem is solved.
<p>Step 2</p> <ol style="list-style-type: none"> 1 From the control panel, navigate to: Settings > Paper > Tray Configuration > Paper Size/Type 2 Make sure that the setting matches the paper loaded. <p>Does the problem remain?</p>	Go to step 3.	The problem is solved.

Action	Yes	No
<p>Step 3</p> <p>1 From the control panel, navigate to:</p> <p>Settings > Paper > Media Configuration > Media Types</p> <p>2 Make sure that the Texture and Weight settings match the paper loaded.</p> <p>Does the problem remain?</p>	Go to step 4.	The problem is solved.
<p>Step 4</p> <p>Make sure that the paper loaded is supported and free of damage and defect.</p> <p>To check for paper curl, print on both sides of the paper.</p> <p>Does the problem remain?</p>	Go to step 5.	The problem is solved.
<p>Step 5</p> <p>Load paper from a fresh package.</p> <p>Paper absorbs moisture due to high humidity. Store paper in its original wrapper until you are ready to use it.</p> <p>Does the problem remain?</p>	Go to step 6.	The problem is solved.
<p>Step 6</p> <p>1 From the control panel, navigate to:</p> <p>Settings > Print > Quality > Advanced Imaging > Color Adjust</p> <p>The Color Adjust calibrates the printer to adjust the color variations in the printed output.</p> <p>2 Do a print test.</p> <p>Does the problem remain?</p>	Go to step 7.	The problem is solved.
<p>Step 7</p> <p>1 Firmly shake the cartridge to redistribute the toner.</p> <p>2 Make sure that the affected cartridge is properly installed.</p> <p>The cartridge must fit and lock properly with the print</p>	Go to step 8.	The problem is solved.

Diagnostics and Troubleshooting

Action	Yes	No
<p>cartridge tray. No packing material must be left on the cartridge.</p> <p>Does the problem remain?</p>		
<p>Step 8</p> <ol style="list-style-type: none"> 1 Check the cartridge for damage and leaks. 2 Check the cartridge smart chip contacts for improper connections. <ul style="list-style-type: none"> • Corrosion and contamination • Loose connection with the HVPS contacts <p>Is the cartridge free of damage, leaks, and contamination?</p>	Go to step 10.	Go to step 9.
<p>Step 9</p> <p>Clean the contaminated contacts or replace the affected cartridge.</p> <p>Does the problem remain?</p>	Go to step 10.	The problem is solved.
<p>Step 10</p> <ol style="list-style-type: none"> 1 Pull out the print cartridge tray, and then remove all the print cartridges. 2 Check the cartridge tray for proper movement. <p>Does the cartridge tray open and close properly?</p>	Go to step 12.	Go to step 11.
<p>Step 11</p> <ol style="list-style-type: none"> 1 Remove any obstructions that hinder the cartridge tray. 2 Reinstall the cartridge tray. <p>Does the problem remain?</p>	Go to step 12.	The problem is solved.
<p>Step 12</p> <p>Check the cartridge tray and its components for damage.</p> <ul style="list-style-type: none"> • Print cartridge locking mechanisms • Sliding mechanism under the cartridge tray • Latch mechanism <p>Is the cartridge tray free of damage?</p>	Go to step 14.	Go to step 13.

Action	Yes	No
<p>Step 13</p> <p>Replace the cartridge tray. See Print cartridge tray removal.</p> <p>Does the problem remain?</p>	Go to step 14.	The problem is solved.
<p>Step 14</p> <p>1 From the control panel, navigate to:</p> <p>Settings > Print > Quality > Toner Darkness</p> <p>2 Adjust the values to find the best result.</p> <p>Does the problem remain?</p>	Go to step 15.	The problem is solved.
<p>Step 15</p> <p>1 Enter the Diagnostics menu, and then navigate to:</p> <p>Printer setup > EP setup > Charge adjust > Black & Color (DC bias voltage)</p> <p>2 Find the setting that produces the best result.</p> <p>Does the problem remain?</p>	Go to step 16.	The problem is solved.
<p>Step 16</p> <p>1 Enter the Diagnostics menu, and then navigate to:</p> <p>Printer setup > EP setup > Developer adjust > Black & Color (DC bias voltage)</p> <p>2 Find the setting that produces the best result.</p> <p>Does the problem remain?</p>	Go to step 17.	The problem is solved.
<p>Step 17</p> <p>1 Enter the Diagnostics menu, and then navigate to:</p> <p>Printer setup > EP setup > Transfer adjust > Black & Color (DC bias voltage)</p> <p>2 Find the setting that produces the best result.</p> <p>Does the problem remain?</p>	Go to step 18.	The problem is solved.
<p>Step 18</p>	Go to step 19.	The problem is solved.

Action	Yes	No
<p>1 From the Diagnostics menu, navigate to:</p> <p>Printer setup > EP setup > Transfer adjust > 2nd transfer roller (DC bias voltage)</p> <p>2 Find the setting that produces the best result.</p> <p>Does the problem remain?</p>		
<p>Step 19</p> <p>1 Use the table on the Print Quality Test Pages to match the distance between vertically repeating defects.</p> <p>2 Replace the part or supply item that best matches the distance.</p> <p>Does the problem remain?</p>	Go to step 20.	The problem is solved.
<p>Step 20</p> <p>1 Remove the right cover. See Right cover removal.</p> <p>2 Remove the controller board shield. See Controller board shield removal.</p> <p>3 Reseat the HVPS flat cables on the HVPS and controller board.</p> <p>Does the problem remain?</p>	Go to step 21.	The problem is solved.
<p>Step 21</p> <p>Check the cables for damage.</p> <p>Are the cables free of damage?</p>	Go to step 23.	Go to step 22.
<p>Step 22</p> <p>Replace the affected cable.</p> <p>Does the problem remain?</p>	Go to step 23.	The problem is solved.
<p>Step 23</p> <p>1 Make sure that the HVPS is properly installed.</p> <p>2 Reseat all the cables on the HVPS.</p> <p>3 Properly align the spring contacts.</p> <p>Does the problem remain?</p>	Go to step 24.	The problem is solved.
<p>Step 24</p>	Go to step 26.	Go to step 25.

Action	Yes	No
<p>Check the HVPS contacts for contamination and damage.</p> <p>Are the HVPS contacts free of contamination and damage?</p>		
<p>Step 25</p> <p>Clean or replace the HVPS. See HVPS removal.</p> <p>Does the problem remain?</p>	Go to step 26.	The problem is solved.
<p>Step 26</p> <ol style="list-style-type: none"> 1 Remove the top cover. See Top cover removal. 2 Reseat the flat cables on the printhead. 3 Reseat the printhead cables on the controller board. <p>Does the problem remain?</p>	Go to step 27.	The problem is solved.
<p>Step 27</p> <p>Check the cables for damage.</p> <p>Are the cables free of damage?</p>	Go to step 29.	Go to step 28.
<p>Step 28</p> <p>Replace the affected cable.</p> <p>Does the problem remain?</p>	Go to step 29.	The problem is solved.
<p>Step 29</p> <ol style="list-style-type: none"> 1 Check the printhead and its components for damage. <ul style="list-style-type: none"> • Flat cable • Connector sockets 2 Check the printhead mirrors for contamination. <p>Is the printhead free of damage and contamination?</p>	Go to step 31.	Go to step 30.
<p>Step 30</p> <p>Clean or replace the printhead. See Printhead removal.</p> <p>Does the problem remain?</p>	Go to step 31.	The problem is solved.
<p>Step 31</p> <p>Check the firmware version.</p> <p>Is the firmware updated to the latest version?</p>	Go to step 33.	Go to step 32.

Action	Yes	No
Step 32 Update the firmware. Does the problem remain?	Go to step 33.	The problem is solved.
Step 33 Make sure that the controller board is properly installed. Reseat all the cables on the controller board. Does the problem remain?	Go to step 34.	The problem is solved.
Step 34 Check the controller board and its connector pins for damage. Are the controller board and its connectors free of damage?	Contact the next level of support.	Go to step 35.
Step 35 Replace the controller board. See Controller board removal . Does the problem remain?	Contact the next level of support.	The problem is solved.

Incorrect Margins Check



 **Note:** Before performing this print quality check, print the Print Quality Test Pages. From the control panel, navigate to **Settings > Troubleshooting > Print Quality Test Pages**, and then perform the initial print quality check. See [Initial print quality check](#) .

Action	Yes	No
<p>Step 1</p> <p>1 Make sure that the paper is properly loaded in the tray and manual feeder. See Avoiding jams.</p> <p>2 Make sure that the tray and manual feeder are properly installed.</p> <p>Does the problem remain?</p>	Go to step 2.	The problem is solved.
<p>Step 2</p> <p>1 From the control panel, navigate to:</p> <p>Settings > Paper > Tray Configuration > Paper Size/Type</p> <p>2 Make sure that the setting matches the paper loaded.</p> <p>Does the problem remain?</p>	Go to step 3.	The problem is solved.
<p>Step 3</p> <p>1 From the control panel, navigate to:</p> <p>Settings > Paper > Media Configuration > Media Types</p> <p>2 Make sure that the Texture and Weight settings match the paper loaded.</p> <p>Does the problem remain?</p>	Go to step 4.	The problem is solved.
<p>Step 4</p> <p>Make sure that the paper loaded is supported and free of damage and defect.</p> <p>To check for paper curl, print on both sides of the paper.</p> <p>Does the problem remain?</p>	Go to step 5.	The problem is solved.
<p>Step 5</p> <p>Load paper from a fresh package.</p> <p>Paper absorbs moisture due to high humidity. Store paper in its original wrapper until you are ready to use it.</p> <p>Does the problem remain?</p>	Go to step 6.	The problem is solved.
<p>Step 6</p>	Go to step 7.	Go to step 12.

Diagnostics and Troubleshooting

Action	Yes	No
Did the problem occur while printing from the manual feeder?		
Step 7 1 Make sure that the manual feeder guides are free of obstructions. 2 Check the guides for improper installation and damage. Are the guides properly installed and free of damage?	Go to step 9.	Go to step 8.
Step 8 Replace the manual feeder. Does the problem remain?	Go to step 9.	The problem is solved.
Step 9 Check the manual feeder transport mechanism for damage. Are the components free of damage?	Go to step 10.	Contact the next level of support.
Step 10 Check the manual feeder belts for improper installation and damage. Are the belts properly installed and free of damage?	Go to step 11.	Contact the next level of support.
Step 11 Check the manual feeder rollers for wear, damage, and contamination. Are the rollers free of wear, damage, and contamination?	Go to step 12.	Contact the next level of support.
Step 12 1 Check the tray insert and its guides for damage. 2 Check the tray insert pads for wear and damage. Is the tray insert free of damage?	Go to step 14.	Go to step 13.
Step 13 Replace the tray insert. Does the problem remain?	Go to step 14.	The problem is solved.
Step 14	Go to step 16.	Go to step 15.

Action	Yes	No
<p>Check the pick tires for improper installation, contamination, wear, and damage.</p> <p>Are the pick tires properly installed and free of contamination, wear, and damage?</p>		
<p>Step 15</p> <p>Reinstall, clean, or replace the pick tire. See Pick tire removal.</p> <p>Does the problem remain?</p>	Go to step 16.	The problem is solved.
<p>Step 16</p> <ol style="list-style-type: none"> 1 Clear any obstructions from the rollers along the paper path. 2 Check the rollers for contamination. <p>Are the rollers free of contamination?</p>	Go to step 18.	Go to step 17.
<p>Step 17</p> <p>Clean the rollers.</p> <p>Does the problem remain?</p>	Go to step 18.	The problem is solved.
<p>Step 18</p> <ol style="list-style-type: none"> 1 Enter the Diagnostics menu, and then navigate to: Printer diagnostics and adjustments > Registration adjust 2 Run the appropriate quick test. <ul style="list-style-type: none"> • Quick test • Duplex quick test • Manual feed quick test 3 Perform the registration adjustment. See Registration adjustment. <p>Does the problem remain?</p>	Go to step 19.	The problem is solved.
<p>Step 19</p> <ol style="list-style-type: none"> 1 Remove the top cover. See Top cover removal. 2 Remove the controller board shield. See Controller board shield removal. 3 Reseat the flat cables on the printhead. 	Go to step 20.	The problem is solved.

Action	Yes	No
<p>4 Reseat the printhead cables on the controller board.</p> <p>Does the problem remain?</p>		
<p>Step 20</p> <p>Check the cables for damage.</p> <p>Are the cables free of damage?</p>	Go to step 22.	Go to step 21.
<p>Step 21</p> <p>Replace the affected cable.</p> <p>Does the problem remain?</p>	Go to step 22.	The problem is solved.
<p>Step 22</p> <p>1 Check the printhead and its components for damage.</p> <ul style="list-style-type: none"> • Flat cable • Connector sockets <p>2 Check the printhead mirrors for contamination.</p> <p>Is the printhead free of damage and contamination?</p>	Contact the next level of support.	Go to step 23.
<p>Step 23</p> <p>Clean or replace the printhead. See Printhead removal.</p> <p>Does the problem remain?</p>	Contact the next level of support.	The problem is solved.

Light Print Check

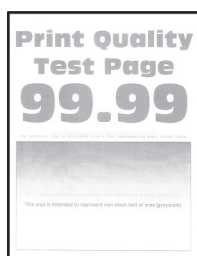

Note: Before performing this print quality check, print the Print Quality Test Pages. From the control panel, navigate to **Settings > Troubleshooting > Print Quality Test Pages**, and then perform the initial print quality check. See [Initial print quality check](#) .

Action	Yes	No
<p>Step 1</p> <p>1 Make sure that the paper is properly loaded in the tray and manual feeder. See Avoiding jams.</p> <p>2 Make sure that the tray and manual feeder are properly installed.</p> <p>Does the problem remain?</p>	Go to step 2.	The problem is solved.
<p>Step 2</p> <p>1 From the control panel, navigate to:</p> <p>Settings > Paper > Tray Configuration > Paper Size/Type</p> <p>2 Make sure that the setting matches the paper loaded.</p> <p>Does the problem remain?</p>	Go to step 3.	The problem is solved.
<p>Step 3</p> <p>1 From the control panel, navigate to:</p> <p>Settings > Paper > Media Configuration > Media Types</p> <p>2 Make sure that the Texture and Weight settings match the paper loaded.</p> <p>Does the problem remain?</p>	Go to step 4.	The problem is solved.
<p>Step 4</p> <p>Make sure that the paper loaded is supported and free of damage and defect.</p> <p>To check for paper curl, print on both sides of the paper.</p> <p>Does the problem remain?</p>	Go to step 5.	The problem is solved.
<p>Step 5</p> <p>Load paper from a fresh package.</p> <p>Paper absorbs moisture due to high humidity. Store paper in its original wrapper until you are ready to use it.</p> <p>Does the problem remain?</p>	Go to step 6.	The problem is solved.
Step 6	Go to step 10.	Go to step 7.

Diagnostics and Troubleshooting

Action	Yes	No
<p>1 Remove the print cartridge tray. See Print cartridge tray removal .</p> <p>2 Enter the Diagnostics menu, and then navigate to:</p> <p>Printer diagnostics and adjustments > Sensor tests > TPS L and R</p> <p>3 Insert a white sheet of paper between the transfer belt and sensor (TPS), and then check if the sensor values increase to almost 100 %.</p> <p>4 Insert a color-printed sheet of paper between the transfer belt and sensor (TPS), and then check if the sensor values change.</p> <p>Do the sensor values change properly?</p>		
<p>Step 7</p> <p>1 Remove the controller board shield. See Controller board shield removal .</p> <p>2 Reseat the TPS sensor cables on the controller board.</p> <p>Does the problem remain?</p>	Go to step 8.	The problem is solved.
<p>Step 8</p> <p>Check the TPS sensor cables for damage.</p> <p>Are the cables free of damage?</p>	Go to step 38.	Go to step 9.
<p>Step 9</p> <p>Replace the affected TPS sensor cable.</p> <p>Does the problem remain?</p>	Go to step 38.	The problem is solved.
<p>Step 10</p> <p>Enter the Diagnostics menu, and then navigate to:</p> <p>Printer diagnostics and adjustments > Weather station</p> <p>Is the weather station detecting properly?</p>	Go to step 11.	Go to step 36.
<p>Step 11</p>	Go to step 12.	The problem is solved.

Action	Yes	No
<p>1 From the control panel, navigate to:</p> <p>Settings > Print > Quality > Advanced Imaging > Color Adjust</p> <p>The Color Adjust calibrates the printer to adjust the color variations in the printed output.</p> <p>2 Do a print test.</p> <p>Does the problem remain?</p>		
<p>Step 12</p> <p>1 Firmly shake the cartridge to redistribute the toner.</p> <p>2 Make sure that the affected cartridge is properly installed.</p> <p>The cartridge must fit and lock properly with the print cartridge tray. No packing material must be left on the cartridge.</p> <p>Does the problem remain?</p>	Go to step 13.	The problem is solved.
<p>Step 13</p> <p>1 Check the cartridge for damage and leaks.</p> <p>2 Check the cartridge smart chip contacts for improper connections.</p> <ul style="list-style-type: none"> • Corrosion and contamination • Loose connection with the HVPS contacts <p>Is the cartridge free of damage, leaks, and contamination?</p>	Go to step 15.	Go to step 14.
<p>Step 14</p> <p>Clean the contaminated contacts or replace the affected cartridge.</p> <p>Does the problem remain?</p>	Go to step 15.	The problem is solved.
<p>Step 15</p> <p>1 From the control panel, navigate to:</p> <p>Settings > Print > Quality > Toner Darkness</p>	Go to step 16.	The problem is solved.

Action	Yes	No
<p>2 Adjust the values to find the best result.</p> <p>Does the problem remain?</p>		
<p>Step 16</p> <p>1 Enter the Diagnostics menu, and then navigate to:</p> <p>Printer setup > EP setup > Charge adjust > Black & Color (DC bias voltage)</p> <p>2 Find the setting that produces the best result.</p> <p>Does the problem remain?</p>	Go to step 17.	The problem is solved.
<p>Step 17</p> <p>1 Enter the Diagnostics menu, and then navigate to:</p> <p>Printer setup > EP setup > Developer adjust > Black & Color (DC bias voltage)</p> <p>2 Find the setting that produces the best result.</p> <p>Does the problem remain?</p>	Go to step 18.	The problem is solved.
<p>Step 18</p> <p>1 Enter the Diagnostics menu, and then navigate to:</p> <p>Printer setup > EP setup > Transfer adjust > Black & Color (DC bias voltage)</p> <p>2 Find the setting that produces the best result.</p> <p>Does the problem remain?</p>	Go to step 19.	The problem is solved.
<p>Step 19</p> <p>1 From the Diagnostics menu, navigate to:</p> <p>Printer setup > EP setup > Transfer adjust > 2nd transfer roller (DC bias voltage)</p> <p>2 Find the setting that produces the best result.</p> <p>Does the problem remain?</p>	Go to step 20.	The problem is solved.
<p>Step 20</p> <p>1 Remove the right cover. See Right cover removal.</p>	Go to step 21.	The problem is solved.

Action	Yes	No
<p>2 Remove the controller board shield. See Controller board shield removal.</p> <p>3 Reseat the HVPS flat cables on the HVPS and controller board.</p> <p>Does the problem remain?</p>		
<p>Step 21</p> <p>Check the cables for damage.</p> <p>Are the cables free of damage?</p>	Go to step 23.	Go to step 22.
<p>Step 22</p> <p>Replace the affected cable.</p> <p>Does the problem remain?</p>	Go to step 23.	The problem is solved.
<p>Step 23</p> <p>1 Make sure that the HVPS is properly installed.</p> <p>2 Reseat all the cables on the HVPS.</p> <p>3 Properly align the spring contacts.</p> <p>Does the problem remain?</p>	Go to step 24.	The problem is solved.
<p>Step 24</p> <p>Check the HVPS contacts for contamination and damage.</p> <p>Are the HVPS contacts free of contamination and damage?</p>	Go to step 26.	Go to step 25.
<p>Step 25</p> <p>Clean or replace the HVPS. See HVPS removal.</p> <p>Does the problem remain?</p>	Go to step 26.	The problem is solved.
<p>Step 26</p> <p>1 Enter the Diagnostics menu, and then navigate to:</p> <p>Printer diagnostics and adjustments > Motor tests</p> <p>2 Select K/Transfer belt, and then start the test.</p> <p>Does the transfer belt or transfer roller move?</p>	Go to step 31.	Go to step 27.
<p>Step 27</p>	Go to step 28.	Go to step 30.

Diagnostics and Troubleshooting

Action	Yes	No
<p>Check the transfer module and its components for improper installation and damage.</p> <ul style="list-style-type: none"> • Transfer belt • Transfer roller • Coupler gears <p>Is the transfer module properly installed and free of damage?</p>		
<p>Step 28</p> <p>Make sure that the transfer module cable on the HVPS is properly connected.</p> <p>Does the problem remain?</p>	Go to step 29.	The problem is solved.
<p>Step 29</p> <ol style="list-style-type: none"> 1 Remove any toner spills or contamination from the transfer module. 2 Check the transfer belt cleaner and its waste toner nozzle for leaks and damage. <p>If the transfer belt cleaner is defective, then excess toner may build up on the transfer belt. If there are leaks on the waste toner nozzle, then toner spills will occur.</p> <p>Is the transfer belt cleaner free of leaks and damage?</p>	Go to step 31.	Go to step 30.
<p>Step 30</p> <p>Reinstall or replace the transfer module. See Transfer module removal.</p> <p>Does the problem remain?</p>	Go to step 31.	The problem is solved.
<p>Step 31</p> <ol style="list-style-type: none"> 1 Remove the top cover. See Top cover removal. 2 Reseat the flat cables on the printhead. 3 Reseat the printhead cables on the controller board. <p>Does the problem remain?</p>	Go to step 32.	The problem is solved.
<p>Step 32</p> <p>Check the cables for damage.</p>	Go to step 34.	Go to step 33.

Action	Yes	No
Are the cables free of damage?		
Step 33 Replace the affected cable. Does the problem remain?	Go to step 34.	The problem is solved.
Step 34 1 Check the printhead and its components for damage. <ul style="list-style-type: none"> • Flat cable • Connector sockets 2 Check the printhead mirrors for contamination. Is the printhead free of damage and contamination?	Go to step 36.	Go to step 35.
Step 35 Clean or replace the printhead. See Printhead removal . Does the problem remain?	Go to step 36.	The problem is solved.
Step 36 Check the firmware version. Is the firmware updated to the latest version?	Go to step 38.	Go to step 37.
Step 37 Update the firmware. Does the problem remain?	Go to step 38.	The problem is solved.
Step 38 Make sure that the controller board is properly installed. Reseat all the cables on the controller board. Does the problem remain?	Go to step 39.	The problem is solved.

Action	Yes	No
<p>Step 39</p> <p>Check the controller board and its connector pins for damage.</p> <p>Are the controller board and its connectors free of damage?</p>	Contact the next level of support.	Go to step 40.
<p>Step 40</p> <p>Replace the controller board. See Controller board removal.</p> <p>Does the problem remain?</p>	Contact the next level of support.	The problem is solved.

Missing Colors Check

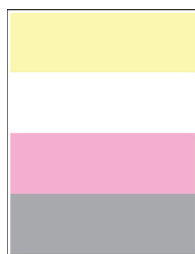

 **Note:** Before performing this print quality check, print the Print Quality Test Pages. From the control panel, navigate to **Settings > Troubleshooting > Print Quality Test Pages**, and then perform the initial print quality check. See [Initial print quality check](#) .

Action	Yes	No
<p>Step 1</p> <p>1 From the control panel, navigate to:</p> <p>Settings > Print > Quality > Advanced Imaging > Color Adjust</p> <p>The Color Adjust calibrates the printer to adjust the color variations in the printed output.</p> <p>2 Do a print test.</p> <p>Does the problem remain?</p>	Go to step 2.	The problem is solved.
<p>Step 2</p> <p>1 Firmly shake the cartridge to redistribute the toner.</p> <p>2 Make sure that the affected cartridge is properly installed.</p>	Go to step 3.	The problem is solved.

Action	Yes	No
<p>The cartridge must fit and lock properly with the print cartridge tray. No packing material must be left on the cartridge.</p> <p>Does the problem remain?</p>		
<p>Step 3</p> <ol style="list-style-type: none"> 1 Check the cartridge for damage and leaks. 2 Check the cartridge smart chip contacts for improper connections. <ul style="list-style-type: none"> • Corrosion and contamination • Loose connection with the HVPS contacts <p>Is the cartridge free of damage, leaks, and contamination?</p>	Go to step 5.	Go to step 4.
<p>Step 4</p> <p>Clean the contaminated contacts or replace the affected cartridge.</p> <p>Does the problem remain?</p>	Go to step 5.	The problem is solved.
<p>Step 5</p> <ol style="list-style-type: none"> 1 Pull out the print cartridge tray, and then remove all the print cartridges. 2 Check the cartridge tray for proper movement. <p>Does the cartridge tray open and close properly?</p>	Go to step 7.	Go to step 6.
<p>Step 6</p> <ol style="list-style-type: none"> 1 Remove any obstructions that hinder the cartridge tray. 2 Reinstall the cartridge tray. <p>Does the problem remain?</p>	Go to step 7.	The problem is solved.
<p>Step 7</p> <p>Check the cartridge tray and its components for damage.</p> <ul style="list-style-type: none"> • Print cartridge locking mechanisms • Sliding mechanism under the cartridge tray • Latch mechanism 	Go to step 9.	Go to step 8.

Diagnostics and Troubleshooting

Action	Yes	No
Is the cartridge tray free of damage?		
Step 8 Replace the cartridge tray. See Print cartridge tray removal . Does the problem remain?	Go to step 9.	The problem is solved.
Step 9 1 Remove the right cover. See Right cover removal . 2 Remove the controller board shield. See Controller board shield removal . 3 Reseat the HVPS flat cables on the HVPS and controller board. Does the problem remain?	Go to step 10.	The problem is solved.
Step 10 Check the cables for damage. Are the cables free of damage?	Go to step 12.	Go to step 11.
Step 11 Replace the affected cable. Does the problem remain?	Go to step 12.	The problem is solved.
Step 12 1 Make sure that the HVPS is properly installed. 2 Reseat all the cables on the HVPS. 3 Properly align the spring contacts. Does the problem remain?	Go to step 13.	The problem is solved.
Step 13 Check the HVPS contacts for contamination and damage. Are the HVPS contacts free of contamination and damage?	Go to step 15.	Go to step 14.
Step 14 Clean or replace the HVPS. See HVPS removal . Does the problem remain?	Go to step 15.	The problem is solved.
Step 15	Go to step 16.	The problem is solved.

Action	Yes	No
1 Remove the top cover. See Top cover removal . 2 Reseat the flat cables on the printhead. 3 Reseat the printhead cables on the controller board. Does the problem remain?		
Step 16 Check the cables for damage. Are the cables free of damage?	Go to step 18.	Go to step 17.
Step 17 Replace the affected cable. Does the problem remain?	Go to step 18.	The problem is solved.
Step 18 1 Check the printhead and its components for damage. <ul style="list-style-type: none"> • Flat cable • Connector sockets 2 Check the printhead mirrors for contamination. Is the printhead free of damage and contamination?	Go to step 20.	Go to step 19.
Step 19 Clean or replace the printhead. See Printhead removal . Does the problem remain?	Go to step 20.	The problem is solved.
Step 20 1 Enter the Diagnostics menu, and then navigate to: Printer diagnostics and adjustments > Motor tests 2 Select K/Transfer belt , and then start the test. Does the transfer belt or transfer roller move?	Go to step 25.	Go to step 21.
Step 21 Check the transfer module and its components for improper installation and damage. <ul style="list-style-type: none"> • Transfer belt • Transfer roller 	Go to step 22.	Go to step 24.

Diagnostics and Troubleshooting

Action	Yes	No
<ul style="list-style-type: none"> Coupler gears <p>Is the transfer module properly installed and free of damage?</p>		
<p>Step 22</p> <p>Make sure that the transfer module cable on the HVPS is properly connected.</p> <p>Does the problem remain?</p>	Go to step 23.	The problem is solved.
<p>Step 23</p> <ol style="list-style-type: none"> Remove any toner spills or contamination from the transfer module. Check the transfer belt cleaner and its waste toner nozzle for leaks and damage. <p>If the transfer belt cleaner is defective, then excess toner may build up on the transfer belt. If there are leaks on the waste toner nozzle, then toner spills will occur.</p> <p>Is the transfer belt cleaner free of leaks and damage?</p>	Go to step 25.	Go to step 24.
<p>Step 24</p> <p>Reinstall or replace the transfer module. See Transfer module removal.</p> <p>Does the problem remain?</p>	Go to step 25.	The problem is solved.
<p>Step 25</p> <ol style="list-style-type: none"> Enter the Diagnostics menu, and then navigate to: Printer diagnostics and adjustments > Motor tests Run the test on the following motors and clutches. In each test, check the gears for lack of movement and unusual noise. <ul style="list-style-type: none"> CMY K/Transfer belt Pick clutch Staging clutch <p>Do the gears move properly without unusual noise?</p>	Go to step 29.	Go to step 26.

Action	Yes	No
<p>Step 26</p> <p>Check the gearbox gears and couplers for wear and damage.</p> <ul style="list-style-type: none"> • Drive gears for all print cartridges and transfer belt • Drive gears that engage with the clutches • Couplers for all print cartridges and the transfer belt <p>Are the gears and couplers free of wear and damage?</p>	Go to step 27.	Go to step 28.
<p>Step 27</p> <ol style="list-style-type: none"> 1 Remove the gearbox. See Gearbox removal. 2 Make sure that the gearbox gears are properly lubricated. 3 Reinstall the gearbox. <p>Does the problem remain?</p>	Go to step 28.	The problem is solved.
<p>Step 28</p> <p>Replace the gearbox. See Gearbox removal.</p> <p>Does the problem remain?</p>	Go to step 29.	The problem is solved.
<p>Step 29</p> <p>Check the firmware version.</p> <p>Is the firmware updated to the latest version?</p>	Go to step 31.	Go to step 30.
<p>Step 30</p> <p>Update the firmware.</p> <p>Does the problem remain?</p>	Go to step 31.	The problem is solved.
<p>Step 31</p> <p>Make sure that the controller board is properly installed. Reseat all the cables on the controller board.</p> <p>Does the problem remain?</p>	Go to step 32.	The problem is solved.

Action	Yes	No
<p>Step 32</p> <p>Check the controller board and its connector pins for damage.</p> <p>Are the controller board and its connectors free of damage?</p>	Contact the next level of support.	Go to step 33.
<p>Step 33</p> <p>Replace the controller board. See Controller board removal.</p> <p>Does the problem remain?</p>	Contact the next level of support.	The problem is solved.

Mottled Print and Dots Check



 **Note:** Before performing this print quality check, print the Print Quality Test Pages. From the control panel, navigate to **Settings > Troubleshooting > Print Quality Test Pages**, and then perform the initial print quality check. See [Initial print quality check](#) .

Action	Yes	No
<p>Step 1</p> <ol style="list-style-type: none"> 1 Make sure that the paper is properly loaded in the tray and manual feeder. See Avoiding jams. 2 Make sure that the tray and manual feeder are properly installed. <p>Does the problem remain?</p>	Go to step 2.	The problem is solved.
<p>Step 2</p> <ol style="list-style-type: none"> 1 From the control panel, navigate to: Settings > Paper > Tray Configuration > Paper Size/Type 2 Make sure that the setting matches the paper loaded. <p>Does the problem remain?</p>	Go to step 3.	The problem is solved.

Action	Yes	No
<p>Step 3</p> <p>1 From the control panel, navigate to:</p> <p>Settings > Paper > Media Configuration > Media Types</p> <p>2 Make sure that the Texture and Weight settings match the paper loaded.</p> <p>Does the problem remain?</p>	Go to step 4.	The problem is solved.
<p>Step 4</p> <p>Make sure that the paper loaded is supported and free of damage and defect.</p> <p>To check for paper curl, print on both sides of the paper.</p> <p>Does the problem remain?</p>	Go to step 5.	The problem is solved.
<p>Step 5</p> <p>Load paper from a fresh package.</p> <p>Paper absorbs moisture due to high humidity. Store paper in its original wrapper until you are ready to use it.</p> <p>Does the problem remain?</p>	Go to step 6.	The problem is solved.
<p>Step 6</p> <p>1 From the control panel, navigate to:</p> <p>Settings > Print > Quality > Advanced Imaging > Color Adjust</p> <p>The Color Adjust calibrates the printer to adjust the color variations in the printed output.</p> <p>2 Do a print test.</p> <p>Does the problem remain?</p>	Go to step 7.	The problem is solved.
<p>Step 7</p> <p>1 Firmly shake the cartridge to redistribute the toner.</p> <p>2 Make sure that the affected cartridge is properly installed.</p> <p>The cartridge must fit and lock properly with the print</p>	Go to step 8.	The problem is solved.

Diagnostics and Troubleshooting

Action	Yes	No
<p>cartridge tray. No packing material must be left on the cartridge.</p> <p>Does the problem remain?</p>		
<p>Step 8</p> <ol style="list-style-type: none"> 1 Check the cartridge for damage and leaks. 2 Check the cartridge smart chip contacts for improper connections. <ul style="list-style-type: none"> • Corrosion and contamination • Loose connection with the HVPS contacts <p>Is the cartridge free of damage, leaks, and contamination?</p>	Go to step 10.	Go to step 9.
<p>Step 9</p> <p>Clean the contaminated contacts or replace the affected cartridge.</p> <p>Does the problem remain?</p>	Go to step 10.	The problem is solved.
<p>Step 10</p> <ol style="list-style-type: none"> 1 Remove the right cover. See Right cover removal. 2 Remove the controller board shield. See Controller board shield removal. 3 Reseat the HVPS flat cables on the HVPS and controller board. <p>Does the problem remain?</p>	Go to step 11.	The problem is solved.
<p>Step 11</p> <p>Check the cables for damage.</p> <p>Are the cables free of damage?</p>	Go to step 13.	Go to step 12.
<p>Step 12</p> <p>Replace the affected cable.</p> <p>Does the problem remain?</p>	Go to step 13.	The problem is solved.
<p>Step 13</p> <ol style="list-style-type: none"> 1 Make sure that the HVPS is properly installed. 2 Reseat all the cables on the HVPS. 3 Properly align the spring contacts. 	Go to step 14.	The problem is solved.

Action	Yes	No
Does the problem remain?		
Step 14 Check the HVPS contacts for contamination and damage. Are the HVPS contacts free of contamination and damage?	Go to step 16.	Go to step 15.
Step 15 Clean or replace the HVPS. See HVPS removal . Does the problem remain?	Go to step 16.	The problem is solved.
Step 16 1 From the control panel, navigate to: Settings > Print > Quality > Toner Darkness 2 Adjust the values to find the best result. Does the problem remain?	Go to step 17.	The problem is solved.
Step 17 1 Enter the Diagnostics menu, and then navigate to: Printer setup > EP setup > Charge adjust > Black & Color (DC bias voltage) 2 Find the setting that produces the best result. Does the problem remain?	Go to step 18.	The problem is solved.
Step 18 1 Enter the Diagnostics menu, and then navigate to: Printer setup > EP setup > Developer adjust > Black & Color (DC bias voltage) 2 Find the setting that produces the best result. Does the problem remain?	Go to step 19.	The problem is solved.
Step 19 1 Enter the Diagnostics menu, and then navigate to:	Go to step 20.	The problem is solved.

Action	Yes	No
<p>Printer setup > EP setup > Transfer adjust > Black & Color (DC bias voltage)</p> <p>2 Find the setting that produces the best result.</p> <p>Does the problem remain?</p>		
<p>Step 20</p> <p>1 From the Diagnostics menu, navigate to:</p> <p>Printer setup > EP setup > Transfer adjust > 2nd transfer roller (DC bias voltage)</p> <p>2 Find the setting that produces the best result.</p> <p>Does the problem remain?</p>	Go to step 21.	The problem is solved.
<p>Step 21</p> <p>1 Enter the Diagnostics menu, and then navigate to:</p> <p>Printer diagnostics and adjustments > Motor tests</p> <p>2 Select K/Transfer belt, and then start the test.</p> <p>Does the transfer belt or transfer roller move?</p>	Go to step 26.	Go to step 22.
<p>Step 22</p> <p>Check the transfer module and its components for improper installation and damage.</p> <ul style="list-style-type: none"> • Transfer belt • Transfer roller • Coupler gears <p>Is the transfer module properly installed and free of damage?</p>	Go to step 23.	Go to step 25.
<p>Step 23</p> <p>Make sure that the transfer module cable on the HVPS is properly connected.</p> <p>Does the problem remain?</p>	Go to step 24.	The problem is solved.
<p>Step 24</p> <p>1 Remove any toner spills or contamination from the transfer module.</p>	Go to step 26.	Go to step 25.

Action	Yes	No
<p>2 Check the transfer belt cleaner and its waste toner nozzle for leaks and damage.</p> <p>If the transfer belt cleaner is defective, then excess toner may build up on the transfer belt. If there are leaks on the waste toner nozzle, then toner spills will occur.</p> <p>Is the transfer belt cleaner free of leaks and damage?</p>		
<p>Step 25</p> <p>Reinstall or replace the transfer module. See Transfer module removal.</p> <p>Does the problem remain?</p>	Go to step 26.	The problem is solved.
<p>Step 26</p> <p>1 Remove the top cover. See Top cover removal.</p> <p>2 Reseat the flat cables on the printhead.</p> <p>3 Reseat the printhead cables on the controller board.</p> <p>Does the problem remain?</p>	Go to step 27.	The problem is solved.
<p>Step 27</p> <p>Check the cables for damage.</p> <p>Are the cables free of damage?</p>	Go to step 29.	Go to step 28.
<p>Step 28</p> <p>Replace the affected cable.</p> <p>Does the problem remain?</p>	Go to step 29.	The problem is solved.
<p>Step 29</p> <p>1 Check the printhead and its components for damage.</p> <ul style="list-style-type: none"> • Flat cable • Connector sockets <p>2 Check the printhead mirrors for contamination.</p> <p>Is the printhead free of damage and contamination?</p>	Go to step 31.	Go to step 30.
<p>Step 30</p> <p>Clean or replace the printhead. See Printhead removal.</p>	Go to step 31.	The problem is solved.

Action	Yes	No
Does the problem remain?		
Step 31 Check the firmware version. Is the firmware updated to the latest version?	Go to step 33.	Go to step 32.
Step 32 Update the firmware. Does the problem remain?	Go to step 33.	The problem is solved.
Step 33 Make sure that the controller board is properly installed. Reseat all the cables on the controller board. Does the problem remain?	Go to step 34.	The problem is solved.
Step 34 Check the controller board and its connector pins for damage. Are the controller board and its connectors free of damage?	Contact the next level of support.	Go to step 35.
Step 35 Replace the controller board. See Controller board removal . Does the problem remain?	Contact the next level of support.	The problem is solved.

Paper Curl Check



 **Note:** Before performing this print quality check, print the Print Quality Test Pages. From the control panel, navigate to **Settings > Troubleshooting > Print Quality Test Pages**, and then perform the initial print quality check. See [Initial print quality check](#) .

Action	Yes	No
<p>Step 1</p> <p>1 Make sure that the paper is properly loaded in the tray and manual feeder. See Avoiding jams.</p> <p>2 Make sure that the tray and manual feeder are properly installed.</p> <p>Does the problem remain?</p>	Go to step 2.	The problem is solved.
<p>Step 2</p> <p>1 From the control panel, navigate to:</p> <p>Settings > Paper > Tray Configuration > Paper Size/Type</p> <p>2 Make sure that the setting matches the paper loaded.</p> <p>Does the problem remain?</p>	Go to step 3.	The problem is solved.
<p>Step 3</p> <p>1 From the control panel, navigate to:</p> <p>Settings > Paper > Media Configuration > Media Types</p> <p>2 Make sure that the Texture and Weight settings match the paper loaded.</p> <p>Does the problem remain?</p>	Go to step 4.	The problem is solved.
<p>Step 4</p> <p>Make sure that the paper loaded is supported and free of damage and defect.</p> <p>To check for paper curl, print on both sides of the paper.</p> <p>Does the problem remain?</p>	Go to step 5.	The problem is solved.
<p>Step 5</p> <p>Load paper from a fresh package.</p> <p>Paper absorbs moisture due to high humidity. Store paper in its original wrapper until you are ready to use it.</p> <p>Does the problem remain?</p>	Go to step 6.	The problem is solved.
Step 6	Go to step 8.	Go to step 7.

Diagnostics and Troubleshooting

Action	Yes	No
<ol style="list-style-type: none"> 1 Check the tray insert and its guides for damage. 2 Check the tray insert pads for wear and damage. <p>Is the tray insert free of damage?</p>		
<p>Step 7</p> <p>Replace the tray insert.</p> <p>Does the problem remain?</p>	Go to step 8.	The problem is solved.
<p>Step 8</p> <ol style="list-style-type: none"> 1 Check the rear door for improper installation, misalignment, and damage. 2 Check the rear door sensor flag for damage. 3 Check the rear door rollers and gears for wear, damage, and contamination. <p>Are the rear door and its components properly installed and free of wear, damage, and contamination?</p>	Go to step 10.	Go to step 9.
<p>Step 9</p> <p>Reinstall, clean, or replace the rear door. See Rear door removal.</p> <p>Does the problem remain?</p>	Go to step 10.	The problem is solved.
<p>Step 10</p> <ol style="list-style-type: none"> 1 Enter the Diagnostics menu, and then navigate to: Printer setup > EP setup > Fuser adjust > Temperature 2 Do a print test using each of the Temperature settings. <ul style="list-style-type: none"> • Normal • High • Low • Lower 3 Select the setting that produces the best result. <p>Does the problem remain?</p>	Go to step 11.	The problem is solved.
<p>Step 11</p> <ol style="list-style-type: none"> 1 Enter the Diagnostics menu, and then navigate to: 	Go to step 15.	Go to step 12.

Action	Yes	No
<p>Printer diagnostics and adjustments > Motor tests</p> <p>2 Select Fuser, and then start the test.</p> <p>The fuser rollers and exit rollers turn when the motor runs.</p> <p>Does the motor run?</p>		
<p>Step 12</p> <p>1 Remove the controller board shield. See Controller board shield removal.</p> <p>2 Reseat the cable on the motor and on the controller board.</p> <p>Does the problem remain?</p>	Go to step 13.	The problem is solved.
<p>Step 13</p> <p>Check the motor for improper installation, wear, and damage.</p> <p>Is the motor properly installed and free of damage?</p>	Go to step 15.	Go to step 14.
<p>Step 14</p> <p>Reinstall or replace the motor. See Motor (fuser) removal.</p> <p>Does the problem remain?</p>	Go to step 15.	The problem is solved.
<p>Step 15</p> <p>Check if the fuser voltage rating matches the printer and electrical outlet voltage rating.</p> <p>Does the fuser have the correct voltage rating?</p>	Go to step 16.	Go to step 20.
<p>Step 16</p> <p>1 Enter the Diagnostics menu, and then navigate to:</p> <p>Printer diagnostics and adjustments > Motor tests</p> <p>2 Select Fuser, and then start the test.</p> <p>Do the fuser rollers and exit rollers turn?</p>	Go to step 19.	Go to step 17.
<p>Step 17</p> <p>1 Make sure that the fuser is properly installed.</p>	Go to step 19.	Go to step 18.

Action	Yes	No
<p>2 Remove the left cover. See Left cover removal.</p> <p>3 Remove the right cover. See Right cover removal.</p> <p>4 Reseat the fuser cables from the following components, and then check the cables for damage:</p> <ul style="list-style-type: none"> • HVPS • LVPS • Fuser to controller board connections <p>Are the fuser cables free of damage?</p>		
<p>Step 18</p> <p>Replace the affected cable.</p> <p>Does the problem remain?</p>	Go to step 19.	The problem is solved.
<p>Step 19</p> <p>Check the fuser and its components for damage.</p> <ul style="list-style-type: none"> • Gears • Rollers • Cable • Guides and actuators • Thermistor <p>Is the fuser free of damage?</p>	Contact the next level of support.	Go to step 20.
<p>Step 20</p> <p>Replace the fuser. See Fuser removal.</p> <p>Does the problem remain?</p>	Contact the next level of support.	The problem is solved.

Print Crooked or Skewed Check



 **Note:** Before performing this print quality check, print the Print Quality Test Pages. From the control panel, navigate to **Settings > Troubleshooting > Print Quality Test Pages**, and then perform the initial print quality check. See [Initial print quality check](#) .

Action	Yes	No
<p>Step 1</p> <p>1 Make sure that the paper is properly loaded in the tray and manual feeder. See Avoiding jams.</p> <p>2 Make sure that the tray and manual feeder are properly installed.</p> <p>Does the problem remain?</p>	Go to step 2.	The problem is solved.
<p>Step 2</p> <p>1 From the control panel, navigate to:</p> <p>Settings > Paper > Tray Configuration > Paper Size/Type</p> <p>2 Make sure that the setting matches the paper loaded.</p> <p>Does the problem remain?</p>	Go to step 3.	The problem is solved.
<p>Step 3</p> <p>1 From the control panel, navigate to:</p> <p>Settings > Paper > Media Configuration > Media Types</p> <p>2 Make sure that the Texture and Weight settings match the paper loaded.</p> <p>Does the problem remain?</p>	Go to step 4.	The problem is solved.
<p>Step 4</p> <p>Make sure that the paper loaded is supported and free of damage and defect.</p> <p>To check for paper curl, print on both sides of the paper.</p> <p>Does the problem remain?</p>	Go to step 5.	The problem is solved.
<p>Step 5</p> <p>Load paper from a fresh package.</p> <p>Paper absorbs moisture due to high humidity. Store paper in its original wrapper until you are ready to use it.</p>	Go to step 6.	The problem is solved.

Diagnostics and Troubleshooting

Action	Yes	No
Does the problem remain?		
Step 6 Did the problem occur while printing from the manual feeder?	Go to step 7.	Go to step 12.
Step 7 1 Make sure that the manual feeder guides are free of obstructions. 2 Check the guides for improper installation and damage. Are the guides properly installed and free of damage?	Go to step 9.	Go to step 8.
Step 8 Replace the manual feeder. Does the problem remain?	Go to step 9.	The problem is solved.
Step 9 Check the manual feeder transport mechanism for damage. Are the components free of damage?	Go to step 10.	Contact the next level of support.
Step 10 Check the manual feeder belts for improper installation and damage. Are the belts properly installed and free of damage?	Go to step 11.	Contact the next level of support.
Step 11 Check the manual feeder rollers for wear, damage, and contamination. Are the rollers free of wear, damage, and contamination?	Go to step 12.	Contact the next level of support.
Step 12 1 Check the tray insert and its guides for damage. 2 Check the tray insert pads for wear and damage. Is the tray insert free of damage?	Go to step 14.	Go to step 13.
Step 13 Replace the tray insert.	Go to step 14.	The problem is solved.

Action	Yes	No
Does the problem remain?		
Step 14 Check the pick tires for improper installation, contamination, wear, and damage. Are the pick tires properly installed and free of contamination, wear, and damage?	Go to step 16.	Go to step 15.
Step 15 Reinstall, clean, or replace the pick tire. See Pick tire removal . Does the problem remain?	Go to step 16.	The problem is solved.
Step 16 1 Clear any obstructions from the rollers along the paper path. 2 Check the rollers for contamination. Are the rollers free of contamination?	Go to step 18.	Go to step 17.
Step 17 Clean the rollers. Does the problem remain?	Go to step 18.	The problem is solved.
Step 18 1 Enter the Diagnostics menu, and then navigate to: Printer diagnostics and adjustments > Registration adjust 2 Run the appropriate quick test. <ul style="list-style-type: none"> • Quick test • Duplex quick test • Manual feed quick test 3 Perform the registration adjustment. See Registration adjustment . Does the problem remain?	Go to step 19.	The problem is solved.
Step 19 1 Remove the top cover. See Top cover removal .	Go to step 20.	The problem is solved.

Action	Yes	No
<p>2 Remove the controller board shield. See Controller board shield removal .</p> <p>3 Reseat the flat cables on the printhead.</p> <p>4 Reseat the printhead cables on the controller board.</p> <p>Does the problem remain?</p>		
<p>Step 20</p> <p>Check the cables for damage.</p> <p>Are the cables free of damage?</p>	Go to step 22.	Go to step 21.
<p>Step 21</p> <p>Replace the affected cable.</p> <p>Does the problem remain?</p>	Go to step 22.	The problem is solved.
<p>Step 22</p> <p>1 Check the printhead and its components for damage.</p> <ul style="list-style-type: none"> • Flat cable • Connector sockets <p>2 Check the printhead mirrors for contamination.</p> <p>Is the printhead free of damage and contamination?</p>	Contact the next level of support.	Go to step 23.
<p>Step 23</p> <p>Clean or replace the printhead. See Printhead removal.</p> <p>Does the problem remain?</p>	Contact the next level of support.	The problem is solved.

Repeating Defects Check



 **Note:** Before performing this print quality check, print the Print Quality Test Pages. From the control panel, navigate to **Settings > Troubleshooting > Print Quality Test Pages**, and then perform the initial print quality check. See [Initial print quality check](#) .

Action	Yes	No
Step 1 Clear the paper path of dust and debris. Does the problem remain?	Go to step 2.	The problem is solved.
Step 2 1 Use the table on the Print Quality Test Pages to match the distance between vertically repeating defects. 2 Replace the part or supply item that best matches the distance. Does the problem remain?	Contact the next level of support.	The problem is solved.

Solid Color or Black Images Check



 **Note:** Before performing this print quality check, print the Print Quality Test Pages. From the control panel, navigate to **Settings > Troubleshooting > Print Quality Test Pages**, and then perform the initial print quality check. See [Initial print quality check](#) .

Action	Yes	No
Step 1 1 From the control panel, navigate to: Settings > Print > Quality > Advanced Imaging > Color Adjust The Color Adjust calibrates the printer to adjust the color variations in the printed output. 2 Do a print test. Does the problem remain?	Go to step 2.	The problem is solved.
Step 2 1 Firmly shake the cartridge to redistribute the toner.	Go to step 3.	The problem is solved.

Diagnostics and Troubleshooting

Action	Yes	No
<p>2 Make sure that the affected cartridge is properly installed.</p> <p>The cartridge must fit and lock properly with the print cartridge tray. No packing material must be left on the cartridge.</p> <p>Does the problem remain?</p>		
<p>Step 3</p> <p>1 Check the cartridge for damage and leaks.</p> <p>2 Check the cartridge smart chip contacts for improper connections.</p> <ul style="list-style-type: none"> • Corrosion and contamination • Loose connection with the HVPS contacts <p>Is the cartridge free of damage, leaks, and contamination?</p>	Go to step 5.	Go to step 4.
<p>Step 4</p> <p>Clean the contaminated contacts or replace the affected cartridge.</p> <p>Does the problem remain?</p>	Go to step 5.	The problem is solved.
<p>Step 5</p> <p>1 Enter the Diagnostics menu, and then navigate to:</p> <p>Printer diagnostics and adjustments > Motor tests</p> <p>2 Select K/Transfer belt, and then start the test.</p> <p>Does the transfer belt or transfer roller move?</p>	Go to step 10.	Go to step 6.
<p>Step 6</p> <p>Check the transfer module and its components for improper installation and damage.</p> <ul style="list-style-type: none"> • Transfer belt • Transfer roller • Coupler gears <p>Is the transfer module properly installed and free of damage?</p>	Go to step 7.	Go to step 9.
<p>Step 7</p>	Go to step 8.	The problem is solved.

Action	Yes	No
<p>1 Remove the right cover. See Right cover removal.</p> <p>2 Make sure that the transfer module cable on the HVPS is properly connected.</p> <p>Does the problem remain?</p>		
<p>Step 8</p> <p>1 Remove any toner spills or contamination from the transfer module.</p> <p>2 Check the transfer belt cleaner and its waste toner nozzle for leaks and damage.</p> <p>If the transfer belt cleaner is defective, then excess toner may build up on the transfer belt. If there are leaks on the waste toner nozzle, then toner spills will occur.</p> <p>Is the transfer belt cleaner free of leaks and damage?</p>	Go to step 10.	Go to step 9.
<p>Step 9</p> <p>Reinstall or replace the transfer module. See Transfer module removal.</p> <p>Does the problem remain?</p>	Go to step 10.	The problem is solved.
<p>Step 10</p> <p>1 Remove the top cover. See Top cover removal.</p> <p>2 Remove the controller board shield. See Controller board shield removal.</p> <p>3 Reseat the flat cables on the printhead.</p> <p>4 Reseat the printhead cables on the controller board.</p> <p>Does the problem remain?</p>	Go to step 11.	The problem is solved.
<p>Step 11</p> <p>Check the cables for damage.</p> <p>Are the cables free of damage?</p>	Go to step 13.	Go to step 12.
<p>Step 12</p> <p>Replace the affected cable.</p> <p>Does the problem remain?</p>	Go to step 13.	The problem is solved.

Diagnostics and Troubleshooting

Action	Yes	No
<p>Step 13</p> <p>1 Check the printhead and its components for damage.</p> <ul style="list-style-type: none"> • Flat cable • Connector sockets <p>2 Check the printhead mirrors for contamination.</p> <p>Is the printhead free of damage and contamination?</p>	Go to step 15.	Go to step 14.
<p>Step 14</p> <p>Clean or replace the printhead. See Printhead removal.</p> <p>Does the problem remain?</p>	Go to step 15.	The problem is solved.
<p>Step 15</p> <p>1 Remove the right cover. See Right cover removal.</p> <p>2 Reseat the HVPS flat cables on the HVPS and controller board.</p> <p>Does the problem remain?</p>	Go to step 16.	The problem is solved.
<p>Step 16</p> <p>Check the cables for damage.</p> <p>Are the cables free of damage?</p>	Go to step 18.	Go to step 17.
<p>Step 17</p> <p>Replace the affected cable.</p> <p>Does the problem remain?</p>	Go to step 18.	The problem is solved.
<p>Step 18</p> <p>1 Make sure that the HVPS is properly installed.</p> <p>2 Reseat all the cables on the HVPS.</p> <p>3 Properly align the spring contacts.</p> <p>Does the problem remain?</p>	Go to step 19.	The problem is solved.
<p>Step 19</p> <p>Check the HVPS contacts for contamination and damage.</p> <p>Are the HVPS contacts free of contamination and damage?</p>	Go to step 21.	Go to step 20.
<p>Step 20</p> <p>Clean or replace the HVPS. See HVPS removal.</p>	Go to step 21.	The problem is solved.

Action	Yes	No
Does the problem remain?		
Step 21 Check the firmware version. Is the firmware updated to the latest version?	Go to step 23.	Go to step 22.
Step 22 Update the firmware. Does the problem remain?	Go to step 23.	The problem is solved.
Step 23 Make sure that the controller board is properly installed. Reseat all the cables on the controller board. Does the problem remain?	Go to step 24.	The problem is solved.
Step 24 Check the controller board and its connector pins for damage. Are the controller board and its connectors free of damage?	Contact the next level of support.	Go to step 25.
Step 25 Replace the controller board. See Controller board removal . Does the problem remain?	Contact the next level of support.	The problem is solved.

Text or Images Cut Off Check



Note: Before performing this print quality check, print the Print Quality Test Pages. From the control panel, navigate to **Settings > Troubleshooting > Print Quality Test Pages**, and then perform the initial print quality check. See [Initial print quality check](#).

Action	Yes	No
<p>Step 1</p> <p>1 From the control panel, navigate to:</p> <p>Settings > Print > Quality > Advanced Imaging > Color Adjust</p> <p>The Color Adjust calibrates the printer to adjust the color variations in the printed output.</p> <p>2 Do a print test.</p> <p>Does the problem remain?</p>	Go to step 2.	The problem is solved.
<p>Step 2</p> <p>1 Firmly shake the cartridge to redistribute the toner.</p> <p>2 Make sure that the affected cartridge is properly installed.</p> <p>The cartridge must fit and lock properly with the print cartridge tray. No packing material must be left on the cartridge.</p> <p>Does the problem remain?</p>	Go to step 3.	The problem is solved.
<p>Step 3</p> <p>1 Check the cartridge for damage and leaks.</p> <p>2 Check the cartridge smart chip contacts for improper connections.</p> <ul style="list-style-type: none"> • Corrosion and contamination • Loose connection with the HVPS contacts <p>Is the cartridge free of damage, leaks, and contamination?</p>	Go to step 5.	Go to step 4.
<p>Step 4</p> <p>Clean the contaminated contacts or replace the affected cartridge.</p> <p>Does the problem remain?</p>	Go to step 5.	The problem is solved.
<p>Step 5</p> <p>1 Pull out the print cartridge tray, and then remove all the print cartridges.</p> <p>2 Check the cartridge tray for proper movement.</p>	Go to step 7.	Go to step 6.

Action	Yes	No
Does the cartridge tray open and close properly?		
Step 6 1 Remove any obstructions that hinder the cartridge tray. 2 Reinstall the cartridge tray. Does the problem remain?	Go to step 7.	The problem is solved.
Step 7 Check the cartridge tray and its components for damage. <ul style="list-style-type: none"> • Print cartridge locking mechanisms • Sliding mechanism under the cartridge tray • Latch mechanism Is the cartridge tray free of damage?	Go to step 9.	Go to step 8.
Step 8 Replace the cartridge tray. See Print cartridge tray removal . Does the problem remain?	Go to step 9.	The problem is solved.
Step 9 1 Remove the right cover. See Right cover removal . 2 Remove the controller board shield. See Controller board shield removal . 3 Reseat the HVPS flat cables on the HVPS and controller board. Does the problem remain?	Go to step 10.	The problem is solved.
Step 10 Check the cables for damage. Are the cables free of damage?	Go to step 12.	Go to step 11.
Step 11 Replace the affected cable. Does the problem remain?	Go to step 12.	The problem is solved.
Step 12 1 Make sure that the HVPS is properly installed.	Go to step 13.	The problem is solved.

Diagnostics and Troubleshooting

Action	Yes	No
<p>2 Reseat all the cables on the HVPS.</p> <p>3 Properly align the spring contacts.</p> <p>Does the problem remain?</p>		
<p>Step 13</p> <p>Check the HVPS contacts for contamination and damage.</p> <p>Are the HVPS contacts free of contamination and damage?</p>	Go to step 15.	Go to step 14.
<p>Step 14</p> <p>Clean or replace the HVPS. See HVPS removal.</p> <p>Does the problem remain?</p>	Go to step 15.	The problem is solved.
<p>Step 15</p> <p>1 Remove the top cover. See Top cover removal.</p> <p>2 Reseat the flat cables on the printhead.</p> <p>3 Reseat the printhead cables on the controller board.</p> <p>Does the problem remain?</p>	Go to step 16.	The problem is solved.
<p>Step 16</p> <p>Check the cables for damage.</p> <p>Are the cables free of damage?</p>	Go to step 18.	Go to step 17.
<p>Step 17</p> <p>Replace the affected cable.</p> <p>Does the problem remain?</p>	Go to step 18.	The problem is solved.
<p>Step 18</p> <p>1 Check the printhead and its components for damage.</p> <ul style="list-style-type: none"> • Flat cable • Connector sockets <p>2 Check the printhead mirrors for contamination.</p> <p>Is the printhead free of damage and contamination?</p>	Go to step 20.	Go to step 19.
<p>Step 19</p> <p>Clean or replace the printhead. See Printhead removal.</p>	Go to step 20.	The problem is solved.

Action	Yes	No
Does the problem remain?		
<p>Step 20</p> <p>1 Enter the Diagnostics menu, and then navigate to:</p> <p style="padding-left: 20px;">Printer diagnostics and adjustments > Motor tests</p> <p>2 Select K/Transfer belt, and then start the test.</p> <p>Does the transfer belt or transfer roller move?</p>	Go to step 25.	Go to step 21.
<p>Step 21</p> <p>Check the transfer module and its components for improper installation and damage.</p> <ul style="list-style-type: none"> • Transfer belt • Transfer roller • Coupler gears <p>Is the transfer module properly installed and free of damage?</p>	Go to step 22.	Go to step 24.
<p>Step 22</p> <p>Make sure that the transfer module cable on the HVPS is properly connected.</p> <p>Does the problem remain?</p>	Go to step 23.	The problem is solved.
<p>Step 23</p> <p>1 Remove any toner spills or contamination from the transfer module.</p> <p>2 Check the transfer belt cleaner and its waste toner nozzle for leaks and damage.</p> <p>If the transfer belt cleaner is defective, then excess toner may build up on the transfer belt. If there are leaks on the waste toner nozzle, then toner spills will occur.</p> <p>Is the transfer belt cleaner free of leaks and damage?</p>	Go to step 25.	Go to step 24.
<p>Step 24</p> <p>Reinstall or replace the transfer module. See Transfer module removal.</p>	Go to step 25.	The problem is solved.

Diagnostics and Troubleshooting

Action	Yes	No
Does the problem remain?		
<p>Step 25</p> <p>1 Enter the Diagnostics menu, and then navigate to:</p> <p>Printer diagnostics and adjustments > Motor tests</p> <p>2 Run the test on the following motors and clutches. In each test, check the gears for lack of movement and unusual noise.</p> <ul style="list-style-type: none"> • CMY • K/Transfer belt • Pick clutch • Staging clutch <p>Do the gears move properly without unusual noise?</p>	Go to step 29.	Go to step 26.
<p>Step 26</p> <p>Check the gearbox gears and couplers for wear and damage.</p> <ul style="list-style-type: none"> • Drive gears for all print cartridges and transfer belt • Drive gears that engage with the clutches • Couplers for all print cartridges and the transfer belt <p>Are the gears and couplers free of wear and damage?</p>	Go to step 27.	Go to step 28.
<p>Step 27</p> <p>1 Remove the gearbox. See Gearbox removal.</p> <p>2 Make sure that the gearbox gears are properly lubricated.</p> <p>3 Reinstall the gearbox.</p> <p>Does the problem remain?</p>	Go to step 28.	The problem is solved.
<p>Step 28</p> <p>Replace the gearbox. See Gearbox removal.</p> <p>Does the problem remain?</p>	Go to step 29.	The problem is solved.
<p>Step 29</p> <p>Check the firmware version.</p> <p>Is the firmware updated to the latest version?</p>	Go to step 31.	Go to step 30.

Action	Yes	No
Step 30 Update the firmware. Does the problem remain?	Go to step 31.	The problem is solved.
Step 31 Make sure that the controller board is properly installed. Reseat all the cables on the controller board. Does the problem remain?	Go to step 32.	The problem is solved.
Step 32 Check the controller board and its connector pins for damage. Are the controller board and its connectors free of damage?	Contact the next level of support.	Go to step 33.
Step 33 Replace the controller board. See Controller board removal . Does the problem remain?	Contact the next level of support.	The problem is solved.

Toner Easily Rubs Off Check



 **Note:** Before performing this print quality check, print the Print Quality Test Pages. From the control panel, navigate to **Settings > Troubleshooting > Print Quality Test Pages**, and then perform the initial print quality check. See [Initial print quality check](#) .

Diagnostics and Troubleshooting

Action	Yes	No
<p>Step 1</p> <ol style="list-style-type: none"> 1 Make sure that the paper is properly loaded in the tray and manual feeder. See Avoiding jams. 2 Make sure that the tray and manual feeder are properly installed. <p>Does the problem remain?</p>	Go to step 2.	The problem is solved.
<p>Step 2</p> <ol style="list-style-type: none"> 1 From the control panel, navigate to: Settings > Paper > Tray Configuration > Paper Size/Type 2 Make sure that the setting matches the paper loaded. <p>Does the problem remain?</p>	Go to step 3.	The problem is solved.
<p>Step 3</p> <ol style="list-style-type: none"> 1 From the control panel, navigate to: Settings > Paper > Media Configuration > Media Types 2 Make sure that the Texture and Weight settings match the paper loaded. <p>Does the problem remain?</p>	Go to step 4.	The problem is solved.
<p>Step 4</p> <p>Make sure that the paper loaded is supported and free of damage and defect.</p> <p>To check for paper curl, print on both sides of the paper.</p> <p>Does the problem remain?</p>	Go to step 5.	The problem is solved.
<p>Step 5</p> <p>Load paper from a fresh package.</p> <p>Paper absorbs moisture due to high humidity. Store paper in its original wrapper until you are ready to use it.</p> <p>Does the problem remain?</p>	Go to step 6.	The problem is solved.
<p>Step 6</p>	Go to step 7.	The problem is solved.

Action	Yes	No
<p>1 Enter the Diagnostics menu, and then navigate to:</p> <p>Printer setup > EP setup > Fuser adjust > Temperature</p> <p>2 Do a print test using each of the Temperature settings.</p> <ul style="list-style-type: none"> • Normal • High • Low • Lower <p>3 Select the setting that produces the best result.</p> <p>Does the problem remain?</p>		
<p>Step 7</p> <p>Check if the fuser voltage rating matches the printer and electrical outlet voltage rating.</p> <p>Does the fuser have the correct voltage rating?</p>	Go to step 8.	Go to step 12.
<p>Step 8</p> <p>1 Enter the Diagnostics menu, and then navigate to:</p> <p>Printer diagnostics and adjustments > Motor tests</p> <p>2 Select Fuser, and then start the test.</p> <p>Do the fuser rollers and exit rollers turn?</p>	Go to step 11.	Go to step 9.
<p>Step 9</p> <p>1 Make sure that the fuser is properly installed.</p> <p>2 Remove the left cover. See Left cover removal.</p> <p>3 Remove the right cover. See Right cover removal.</p> <p>4 Reseat the fuser cables from the following components, and then check the cables for damage:</p> <ul style="list-style-type: none"> • HVPS • LVPS • Fuser to controller board connections <p>Are the fuser cables free of damage?</p>	Go to step 11.	Go to step 10.

Diagnostics and Troubleshooting

Action	Yes	No
Step 10 Replace the affected cable. Does the problem remain?	Go to step 11.	The problem is solved.
Step 11 Check the fuser and its components for damage. <ul style="list-style-type: none"> • Gears • Rollers • Cable • Guides and actuators • Thermistor Is the fuser free of damage?	Go to step 13.	Go to step 12.
Step 12 Replace the fuser. See Fuser removal . Does the problem remain?	Go to step 13.	The problem is solved.
Step 13 1 Enter the Diagnostics menu, and then navigate to: Printer diagnostics and adjustments > Motor tests 2 Select Fuser , and then start the test. The fuser rollers and exit rollers turn when the motor runs. Does the motor run?	Go to step 17.	Go to step 14.
Step 14 1 Remove the controller board shield. See Controller board shield removal . 2 Reseat the cable on the motor and on the controller board. Does the problem remain?	Go to step 15.	The problem is solved.
Step 15 Check the motor for improper installation, wear, and damage. Is the motor properly installed and free of damage?	Go to step 17.	Go to step 16.
Step 16	Go to step 17.	The problem is solved.

Action	Yes	No
Reinstall or replace the motor. See Motor (fuser) removal . Does the problem remain?		
Step 17 Check if the LVPS voltage rating matches the fuser voltage rating. Does the LVPS have the correct voltage rating?	Go to step 18.	Go to step 20.
Step 18 1 Remove the right cover. See Right cover removal . 2 Reseat the LVPS cables. Does the problem remain?	Go to step 19.	The problem is solved.
Step 19 Check the cable from the power inlet to the LVPS board for improper connection and damage. Is the cable properly connected and free of damage?	Contact the next level of support.	Go to step 20.
Step 20 Replace the LVPS. See LVPS removal . Does the problem remain?	Contact the next level of support.	The problem is solved.

Uneven Print Density Check

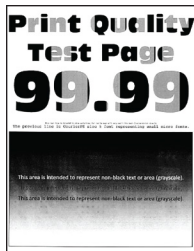

Note: Before performing this print quality check, print the Print Quality Test Pages. From the control panel, navigate to **Settings > Troubleshooting > Print Quality Test Pages**, and then perform the initial print quality check. See [Initial print quality check](#).

Diagnostics and Troubleshooting

Action	Yes	No
<p>Step 1</p> <ol style="list-style-type: none"> 1 Make sure that the paper is properly loaded in the tray and manual feeder. See Avoiding jams. 2 Make sure that the tray and manual feeder are properly installed. <p>Does the problem remain?</p>	Go to step 2.	The problem is solved.
<p>Step 2</p> <ol style="list-style-type: none"> 1 From the control panel, navigate to: Settings > Paper > Tray Configuration > Paper Size/Type 2 Make sure that the setting matches the paper loaded. <p>Does the problem remain?</p>	Go to step 3.	The problem is solved.
<p>Step 3</p> <ol style="list-style-type: none"> 1 From the control panel, navigate to: Settings > Paper > Media Configuration > Media Types 2 Make sure that the Texture and Weight settings match the paper loaded. <p>Does the problem remain?</p>	Go to step 4.	The problem is solved.
<p>Step 4</p> <p>Make sure that the paper loaded is supported and free of damage and defect.</p> <p>To check for paper curl, print on both sides of the paper.</p> <p>Does the problem remain?</p>	Go to step 5.	The problem is solved.
<p>Step 5</p> <p>Load paper from a fresh package.</p> <p>Paper absorbs moisture due to high humidity. Store paper in its original wrapper until you are ready to use it.</p> <p>Does the problem remain?</p>	Go to step 6.	The problem is solved.
<p>Step 6</p>	Go to step 7.	The problem is solved.

Action	Yes	No
<p>1 From the control panel, navigate to:</p> <p>Settings > Print > Quality > Advanced Imaging > Color Adjust</p> <p>The Color Adjust calibrates the printer to adjust the color variations in the printed output.</p> <p>2 Do a print test.</p> <p>Does the problem remain?</p>		
<p>Step 7</p> <p>1 Firmly shake the cartridge to redistribute the toner.</p> <p>2 Make sure that the affected cartridge is properly installed.</p> <p>The cartridge must fit and lock properly with the print cartridge tray. No packing material must be left on the cartridge.</p> <p>Does the problem remain?</p>	Go to step 8.	The problem is solved.
<p>Step 8</p> <p>1 Check the cartridge for damage and leaks.</p> <p>2 Check the cartridge smart chip contacts for improper connections.</p> <ul style="list-style-type: none"> • Corrosion and contamination • Loose connection with the HVPS contacts <p>Is the cartridge free of damage, leaks, and contamination?</p>	Go to step 10.	Go to step 9.
<p>Step 9</p> <p>Clean the contaminated contacts or replace the affected cartridge.</p> <p>Does the problem remain?</p>	Go to step 10.	The problem is solved.
<p>Step 10</p> <p>1 Enter the Diagnostics menu, and then navigate to:</p> <p>Printer diagnostics and adjustments > Motor tests</p>	Go to step 15.	Go to step 11.

Diagnostics and Troubleshooting

Action	Yes	No
<p>2 Select K/Transfer belt, and then start the test.</p> <p>Does the transfer belt or transfer roller move?</p>		
<p>Step 11</p> <p>Check the transfer module and its components for improper installation and damage.</p> <ul style="list-style-type: none"> • Transfer belt • Transfer roller • Coupler gears <p>Is the transfer module properly installed and free of damage?</p>	Go to step 12.	Go to step 14.
<p>Step 12</p> <p>1 Remove the right cover. See Right cover removal.</p> <p>2 Make sure that the transfer module cable on the HVPS is properly connected.</p> <p>Does the problem remain?</p>	Go to step 13.	The problem is solved.
<p>Step 13</p> <p>1 Remove any toner spills or contamination from the transfer module.</p> <p>2 Check the transfer belt cleaner and its waste toner nozzle for leaks and damage.</p> <p>If the transfer belt cleaner is defective, then excess toner may build up on the transfer belt. If there are leaks on the waste toner nozzle, then toner spills will occur.</p> <p>Is the transfer belt cleaner free of leaks and damage?</p>	Go to step 15.	Go to step 14.
<p>Step 14</p> <p>Reinstall or replace the transfer module. See Transfer module removal.</p> <p>Does the problem remain?</p>	Go to step 15.	The problem is solved.
<p>Step 15</p> <p>1 Remove the top cover. See Top cover removal.</p>	Go to step 16.	The problem is solved.

Action	Yes	No
<p>2 Remove the controller board shield. See Controller board shield removal .</p> <p>3 Reseat the flat cables on the printhead.</p> <p>4 Reseat the printhead cables on the controller board.</p> <p>Does the problem remain?</p>		
<p>Step 16</p> <p>Check the cables for damage.</p> <p>Are the cables free of damage?</p>	Go to step 18.	Go to step 17.
<p>Step 17</p> <p>Replace the affected cable.</p> <p>Does the problem remain?</p>	Go to step 18.	The problem is solved.
<p>Step 18</p> <p>1 Check the printhead and its components for damage.</p> <ul style="list-style-type: none"> • Flat cable • Connector sockets <p>2 Check the printhead mirrors for contamination.</p> <p>Is the printhead free of damage and contamination?</p>	Go to step 20.	Go to step 19.
<p>Step 19</p> <p>Clean or replace the printhead. See Printhead removal.</p> <p>Does the problem remain?</p>	Go to step 20.	The problem is solved.
<p>Step 20</p> <p>1 Remove the right cover. See Right cover removal.</p> <p>2 Reseat the HVPS flat cables on the HVPS and controller board.</p> <p>Does the problem remain?</p>	Go to step 21.	The problem is solved.
<p>Step 21</p> <p>Check the cables for damage.</p> <p>Are the cables free of damage?</p>	Go to step 23.	Go to step 22.
<p>Step 22</p> <p>Replace the affected cable.</p> <p>Does the problem remain?</p>	Go to step 23.	The problem is solved.

Diagnostics and Troubleshooting

Action	Yes	No
<p>Step 23</p> <ol style="list-style-type: none"> 1 Make sure that the HVPS is properly installed. 2 Reseat all the cables on the HVPS. 3 Properly align the spring contacts. <p>Does the problem remain?</p>	Go to step 24.	The problem is solved.
<p>Step 24</p> <p>Check the HVPS contacts for contamination and damage.</p> <p>Are the HVPS contacts free of contamination and damage?</p>	Go to step 26.	Go to step 25.
<p>Step 25</p> <p>Clean or replace the HVPS. See HVPS removal.</p> <p>Does the problem remain?</p>	Go to step 26.	The problem is solved.
<p>Step 26</p> <p>Check the firmware version.</p> <p>Is the firmware updated to the latest version?</p>	Go to step 28.	Go to step 27.
<p>Step 27</p> <p>Update the firmware.</p> <p>Does the problem remain?</p>	Go to step 28.	The problem is solved.
<p>Step 28</p> <p>Make sure that the controller board is properly installed. Reseat all the cables on the controller board.</p> <p>Does the problem remain?</p>	Go to step 29.	The problem is solved.
<p>Step 29</p> <p>Check the controller board and its connector pins for damage.</p> <p>Are the controller board and its connectors free of damage?</p>	Contact the next level of support.	Go to step 30.
<p>Step 30</p> <p>Replace the controller board. See Controller board removal.</p> <p>Does the problem remain?</p>	Contact the next level of support.	The problem is solved.

Vertical White Lines Check



 **Note:** Before performing this print quality check, print the Print Quality Test Pages. From the control panel, navigate to **Settings > Troubleshooting > Print Quality Test Pages**, and then perform the initial print quality check. See [Initial print quality check](#) .

Action	Yes	No
<p>Step 1</p> <ol style="list-style-type: none"> 1 Make sure that the paper is properly loaded in the tray and manual feeder. See Avoiding jams. 2 Make sure that the tray and manual feeder are properly installed. <p>Does the problem remain?</p>	Go to step 2.	The problem is solved.
<p>Step 2</p> <ol style="list-style-type: none"> 1 From the control panel, navigate to: Settings > Paper > Tray Configuration > Paper Size/Type 2 Make sure that the setting matches the paper loaded. <p>Does the problem remain?</p>	Go to step 3.	The problem is solved.
<p>Step 3</p> <ol style="list-style-type: none"> 1 From the control panel, navigate to: Settings > Paper > Media Configuration > Media Types 2 Make sure that the Texture and Weight settings match the paper loaded. <p>Does the problem remain?</p>	Go to step 4.	The problem is solved.
<p>Step 4</p> <p>Make sure that the paper loaded is supported and free of damage and defect.</p>	Go to step 5.	The problem is solved.

Diagnostics and Troubleshooting

Action	Yes	No
<p>To check for paper curl, print on both sides of the paper.</p> <p>Does the problem remain?</p>		
<p>Step 5</p> <p>Load paper from a fresh package.</p> <p>Paper absorbs moisture due to high humidity. Store paper in its original wrapper until you are ready to use it.</p> <p>Does the problem remain?</p>	Go to step 6.	The problem is solved.
<p>Step 6</p> <p>1 From the control panel, navigate to:</p> <p>Settings > Print > Quality > Advanced Imaging > Color Adjust</p> <p>The Color Adjust calibrates the printer to adjust the color variations in the printed output.</p> <p>2 Do a print test.</p> <p>Does the problem remain?</p>	Go to step 7.	The problem is solved.
<p>Step 7</p> <p>1 Firmly shake the cartridge to redistribute the toner.</p> <p>2 Make sure that the affected cartridge is properly installed to its corresponding slot.</p> <p>The cartridge must fit and lock properly with the print cartridge tray. No packing material must be left on the cartridge.</p> <p>Does the problem remain?</p>	Go to step 8.	The problem is solved.
<p>Step 8</p> <p>1 Check the cartridge for damage and leaks.</p> <p>2 Check the cartridge smart chip contacts for improper connections.</p> <ul style="list-style-type: none"> • Corrosion and contamination • Loose connection with the HVPS contacts 	Go to step 10.	Go to step 9.

Action	Yes	No
Is the cartridge free of damage, leaks, and contamination?		
<p>Step 9</p> <p>Clean the contaminated contacts or replace the affected cartridge.</p> <p>Does the problem remain?</p>	Go to step 10.	The problem is solved.
<p>Step 10</p> <p>1 From the control panel, navigate to:</p> <p>Settings > Troubleshooting > Print Quality Test Pages</p> <p>2 Check the results and determine the color that has issues.</p> <p>3 Transfer the affected print cartridge to another slot on the print cartridge tray.</p> <p>4 Print, and then check the results of the Print Quality Test Pages.</p> <p>Does the affected cartridge still have issues?</p>	Go to step 11.	Go to step 17.
<p>Step 11</p> <p>Replace the affected cartridge.</p> <p>Return the swapped cartridges to their original slots.</p> <p>Does the problem remain?</p>	Go to step 12.	The problem is solved.
<p>Step 12</p> <p>1 Enter the Diagnostics menu, and then navigate to:</p> <p>Printer diagnostics and adjustments > Motor tests</p> <p>2 Select K/Transfer belt, and then start the test.</p> <p>Does the transfer belt or transfer roller move?</p>	Go to step 17.	Go to step 13.
<p>Step 13</p> <p>Check the transfer module and its components for improper installation and damage.</p> <ul style="list-style-type: none"> • Transfer belt • Transfer roller 	Go to step 14.	Go to step 16.

Diagnostics and Troubleshooting

Action	Yes	No
<ul style="list-style-type: none"> Coupler gears <p>Is the transfer module properly installed and free of damage?</p>		
<p>Step 14</p> <ol style="list-style-type: none"> Remove the right cover. See Right cover removal. Make sure that the transfer module cable on the HVPS is properly connected. <p>Does the problem remain?</p>	Go to step 15.	The problem is solved.
<p>Step 15</p> <ol style="list-style-type: none"> Remove any toner spills or contamination from the transfer module. Check the transfer belt cleaner and its waste toner nozzle for leaks and damage. <p>If the transfer belt cleaner is defective, then excess toner may build up on the transfer belt. If there are leaks on the waste toner nozzle, then toner spills will occur.</p> <p>Is the transfer belt cleaner free of leaks and damage?</p>	Go to step 17.	Go to step 16.
<p>Step 16</p> <p>Reinstall or replace the transfer module. See Transfer module removal.</p> <p>Does the problem remain?</p>	Go to step 17.	The problem is solved.
<p>Step 17</p> <ol style="list-style-type: none"> Check the printhead and its components for damage. <ul style="list-style-type: none"> Flat cable Connector sockets Check the printhead mirrors for contamination. <p>Is the printhead free of damage and contamination?</p>	Go to step 19.	Go to step 18.
<p>Step 18</p> <p>Clean or replace the printhead. See Printhead removal.</p> <p>Does the problem remain?</p>	Go to step 19.	The problem is solved.

Action	Yes	No
<p>Step 19</p> <ol style="list-style-type: none"> 1 Make sure that the HVPS is properly installed. 2 Reseat all the cables on the HVPS. 3 Properly align the spring contacts. <p>Does the problem remain?</p>	Go to step 20.	The problem is solved.
<p>Step 20</p> <p>Check the HVPS contacts for contamination and damage.</p> <p>Are the HVPS contacts free of contamination and damage?</p>	Go to step 22.	Go to step 21.
<p>Step 21</p> <p>Clean or replace the HVPS. See HVPS removal.</p> <p>Does the problem remain?</p>	Go to step 22.	The problem is solved.
<p>Step 22</p> <p>Check if the fuser voltage rating matches the printer and electrical outlet voltage rating.</p> <p>Does the fuser have the correct voltage rating?</p>	Go to step 23.	Go to step 27.
<p>Step 23</p> <ol style="list-style-type: none"> 1 Enter the Diagnostics menu, and then navigate to: Printer diagnostics and adjustments > Motor tests 2 Select Fuser, and then start the test. <p>Do the fuser rollers and exit rollers turn?</p>	Go to step 26.	Go to step 24.
<p>Step 24</p> <ol style="list-style-type: none"> 1 Make sure that the fuser is properly installed. 2 Remove the left cover. See Left cover removal. 3 Remove the right cover. See Right cover removal. 4 Reseat the fuser cables from the following components, and then check the cables for damage: <ul style="list-style-type: none"> • HVPS 	Go to step 26.	Go to step 25.

Diagnostics and Troubleshooting

Action	Yes	No
<ul style="list-style-type: none"> • LVPS • Fuser to controller board connections <p>Are the fuser cables free of damage?</p>		
<p>Step 25</p> <p>Replace the affected cable.</p> <p>Does the problem remain?</p>	Go to step 26.	The problem is solved.
<p>Step 26</p> <p>Check the fuser and its components for damage.</p> <ul style="list-style-type: none"> • Gears • Rollers • Cable • Guides and actuators • Thermistor <p>Is the fuser free of damage?</p>	Go to step 28.	Go to step 27.
<p>Step 27</p> <p>Replace the fuser. See Fuser removal.</p> <p>Does the problem remain?</p>	Go to step 28.	The problem is solved.
<p>Step 28</p> <p>Check the firmware version.</p> <p>Is the firmware updated to the latest version?</p>	Go to step 30.	Go to step 29.
<p>Step 29</p> <p>Update the firmware.</p> <p>Does the problem remain?</p>	Go to step 30.	The problem is solved.
<p>Step 30</p> <p>Make sure that the controller board is properly installed. Reseat all the cables on the controller board.</p> <p>Does the problem remain?</p>	Go to step 31.	The problem is solved.

Action	Yes	No
Step 31 Check the controller board and its connector pins for damage. Are the controller board and its connectors free of damage?	Contact the next level of support.	Go to step 32.
Step 32 Replace the controller board. See Controller board removal . Does the problem remain?	Contact the next level of support.	The problem is solved.

Horizontal Colored Lines or Banding Check



Note: Before performing this print quality check, print the Print Quality Test Pages. From the control panel, navigate to **Settings > Troubleshooting > Print Quality Test Pages**, and then perform the initial print quality check. See [Initial print quality check](#).

Action	Yes	No
Step 1 1 Make sure that the paper is properly loaded in the tray and manual feeder. See Avoiding jams . 2 Make sure that the tray and manual feeder are properly installed. Does the problem remain?	Go to step 2.	The problem is solved.
Step 2 1 From the control panel, navigate to: Settings > Paper > Tray Configuration > Paper Size/Type 2 Make sure that the setting matches the paper loaded. Does the problem remain?	Go to step 3.	The problem is solved.
Step 3 1 From the control panel, navigate to: Settings > Paper > Media Configuration > Media Types 2 Make sure that the Texture and Weight settings match the paper loaded.	Go to step 4.	The problem is solved.

Diagnostics and Troubleshooting

Action	Yes	No
Does the problem remain?		
<p>Step 4</p> <p>Make sure that the paper loaded is supported and free of damage and defect.</p> <p>To check for paper curl, print on both sides of the paper.</p> <p>Does the problem remain?</p>	Go to step 5.	The problem is solved.
<p>Step 5</p> <p>Load paper from a fresh package.</p> <p>Paper absorbs moisture due to high humidity. Store paper in its original wrapper until you are ready to use it.</p> <p>Does the problem remain?</p>	Go to step 6.	The problem is solved.
<p>Step 6</p> <p>1 From the control panel, navigate to:</p> <p>Settings > Print > Quality > Advanced Imaging > Color Adjust</p> <p>The Color Adjust calibrates the printer to adjust the color variations in the printed output.</p> <p>2 Do a print test.</p> <p>Does the problem remain?</p>	Go to step 7.	The problem is solved.
<p>Step 7</p> <p>1 Firmly shake the cartridge to redistribute the toner.</p> <p>2 Make sure that the affected cartridge is properly installed to its corresponding slot.</p> <p>The cartridge must fit and lock properly with the print cartridge tray. No packing material must be left on the cartridge.</p> <p>Does the problem remain?</p>	Go to step 8.	The problem is solved.
<p>Step 8</p> <p>1 Check the cartridge for damage and leaks.</p>	Go to step 10.	Go to step 9.

Action	Yes	No
<p>2 Check the cartridge smart chip contacts for improper connections.</p> <ul style="list-style-type: none"> • Corrosion and contamination • Loose connection with the HVPS contacts <p>Is the cartridge free of damage, leaks, and contamination?</p>		
<p>Step 9</p> <p>Clean the contaminated contacts or replace the affected cartridge.</p> <p>Does the problem remain?</p>	Go to step 10.	The problem is solved.
<p>Step 10</p> <p>1 Pull out the print cartridge tray, and then remove all the print cartridges.</p> <p>2 Check the cartridge tray for proper movement.</p> <p>Does the cartridge tray open and close properly?</p>	Go to step 12.	Go to step 11.
<p>Step 11</p> <p>1 Remove any obstructions that hinder the cartridge tray.</p> <p>2 Reinstall the cartridge tray.</p> <p>Does the problem remain?</p>	Go to step 12.	The problem is solved.
<p>Step 12</p> <p>Check the cartridge tray and its components for damage.</p> <ul style="list-style-type: none"> • Print cartridge locking mechanisms • Sliding mechanism under the cartridge tray • Latch mechanism <p>Is the cartridge tray free of damage?</p>	Go to step 14.	Go to step 13.
<p>Step 13</p> <p>Replace the cartridge tray. See Print cartridge tray removal.</p> <p>Does the problem remain?</p>	Go to step 14.	The problem is solved.
<p>Step 14</p>	Go to step 15.	The problem is solved.

Action	Yes	No
<p>1 From the control panel, navigate to:</p> <p>Settings > Print > Quality > Toner Darkness</p> <p>2 Adjust the values to find the best result.</p> <p>Does the problem remain?</p>		
<p>Step 15</p> <p>1 Enter the Diagnostics menu, and then navigate to:</p> <p>Printer setup > EP setup > Charge adjust > Black & Color (DC bias voltage)</p> <p>2 Find the setting that produces the best result.</p> <p>Does the problem remain?</p>	Go to step 16.	The problem is solved.
<p>Step 16</p> <p>1 Enter the Diagnostics menu, and then navigate to:</p> <p>Printer setup > EP setup > Developer adjust > Black & Color (DC bias voltage)</p> <p>2 Find the setting that produces the best result.</p> <p>Does the problem remain?</p>	Go to step 17.	The problem is solved.
<p>Step 17</p> <p>1 Enter the Diagnostics menu, and then navigate to:</p> <p>Printer setup > EP setup > Transfer adjust > Black & Color (DC bias voltage)</p> <p>2 Find the setting that produces the best result.</p> <p>Does the problem remain?</p>	Go to step 18.	The problem is solved.
<p>Step 18</p> <p>1 From the Diagnostics menu, navigate to:</p> <p>Printer setup > EP setup > Transfer adjust > 2nd transfer roller (DC bias voltage)</p> <p>2 Find the setting that produces the best result.</p>	Go to step 19.	The problem is solved.

Action	Yes	No
Does the problem remain?		
<p>Step 19</p> <p>1 Enter the Diagnostics menu, and then navigate to:</p> <p style="padding-left: 20px;">Printer diagnostics and adjustments > Motor tests</p> <p>2 Select K/Transfer belt, and then start the test.</p> <p>Does the transfer belt or transfer roller move?</p>	Go to step 24.	Go to step 20.
<p>Step 20</p> <p>Check the transfer module and its components for improper installation and damage.</p> <ul style="list-style-type: none"> • Transfer belt • Transfer roller • Coupler gears <p>Is the transfer module properly installed and free of damage?</p>	Go to step 21.	Go to step 23.
<p>Step 21</p> <p>1 Remove the right cover. See Right cover removal.</p> <p>2 Make sure that the transfer module cable on the HVPS is properly connected.</p> <p>Does the problem remain?</p>	Go to step 22.	The problem is solved.
<p>Step 22</p> <p>1 Remove any toner spills or contamination from the transfer module.</p> <p>2 Check the transfer belt cleaner and its waste toner nozzle for leaks and damage.</p> <p>If the transfer belt cleaner is defective, then excess toner may build up on the transfer belt. If there are leaks on the waste toner nozzle, then toner spills will occur.</p> <p>Is the transfer belt cleaner free of leaks and damage?</p>	Go to step 24.	Go to step 23.
Step 23	Go to step 24.	The problem is solved.

Action	Yes	No
<p>Reinstall or replace the transfer module. See Transfer module removal.</p> <p>Does the problem remain?</p>		
<p>Step 24</p> <ol style="list-style-type: none"> 1 Make sure that the HVPS is properly installed. 2 Reseat all the cables on the HVPS. 3 Properly align the spring contacts. <p>Does the problem remain?</p>	Go to step 25.	The problem is solved.
<p>Step 25</p> <p>Check the HVPS contacts for contamination and damage.</p> <p>Are the HVPS contacts free of contamination and damage?</p>	Go to step 27.	Go to step 26.
<p>Step 26</p> <p>Clean or replace the HVPS. See HVPS removal.</p> <p>Does the problem remain?</p>	Go to step 27.	The problem is solved.
<p>Step 27</p> <p>Check if the fuser voltage rating matches the printer and electrical outlet voltage rating.</p> <p>Does the fuser have the correct voltage rating?</p>	Go to step 28.	Go to step 32.
<p>Step 28</p> <ol style="list-style-type: none"> 1 Enter the Diagnostics menu, and then navigate to: Printer diagnostics and adjustments > Motor tests 2 Select Fuser, and then start the test. <p>Do the fuser rollers and exit rollers turn?</p>	Go to step 31.	Go to step 29.
<p>Step 29</p> <ol style="list-style-type: none"> 1 Make sure that the fuser is properly installed. 2 Remove the left cover. See Left cover removal. 	Go to step 31.	Go to step 30.

Action	Yes	No
<p>3 Remove the right cover. See Right cover removal.</p> <p>4 Reseat the fuser cables from the following components, and then check the cables for damage:</p> <ul style="list-style-type: none"> • HVPS • LVPS • Fuser to controller board connections <p>Are the fuser cables free of damage?</p>		
<p>Step 30</p> <p>Replace the affected cable.</p> <p>Does the problem remain?</p>	Go to step 31.	The problem is solved.
<p>Step 31</p> <p>Check the fuser and its components for damage.</p> <ul style="list-style-type: none"> • Gears • Rollers • Cable • Guides and actuators • Thermistor <p>Is the fuser free of damage?</p>	Go to step 33.	Go to step 32.
<p>Step 32</p> <p>Replace the fuser. See Fuser removal.</p> <p>Does the problem remain?</p>	Go to step 33.	The problem is solved.
<p>Step 33</p> <p>Check the firmware version.</p> <p>Is the firmware updated to the latest version?</p>	Go to step 35.	Go to step 34.
<p>Step 34</p> <p>Update the firmware.</p> <p>Does the problem remain?</p>	Go to step 35.	The problem is solved.
<p>Step 35</p> <p>Make sure that the controller board is properly installed. Reseat all the cables on the controller board.</p>	Go to step 36.	The problem is solved.

Action	Yes	No
Does the problem remain?		
Step 36 Check the controller board and its connector pins for damage. Are the controller board and its connectors free of damage?	Contact the next level of support.	Go to step 37.
Step 37 Replace the controller board. See Controller board removal . Does the problem remain?	Contact the next level of support.	The problem is solved.

Missing One Color Check

 **Note:** Before performing this print quality check, print the Print Quality Test Pages. From the control panel, navigate to **Settings > Troubleshooting > Print Quality Test Pages**, and then perform the initial print quality check. See [Initial print quality check](#).

Action	Yes	No
Step 1 1 From the control panel, navigate to: Settings > Print > Quality > Advanced Imaging > Color Adjust The Color Adjust calibrates the printer to adjust the color variations in the printed output. 2 Do a print test. Does the problem remain?	Go to step 2.	The problem is solved.
Step 2 1 Firmly shake the cartridge to redistribute the toner. 2 Make sure that the affected cartridge is properly installed. The cartridge must fit and lock properly with the print cartridge tray. No packing material must be left on the cartridge. Does the problem remain?	Go to step 3.	The problem is solved.

Action	Yes	No
<p>Step 3</p> <ol style="list-style-type: none"> 1 Check the cartridge for damage and leaks. 2 Check the cartridge smart chip contacts for improper connections. <ul style="list-style-type: none"> • Corrosion and contamination • Loose connection with the HVPS contacts <p>Is the cartridge free of damage, leaks, and contamination?</p>	Go to step 5.	Go to step 4.
<p>Step 4</p> <p>Clean the contaminated contacts or replace the affected cartridge.</p> <p>Does the problem remain?</p>	Go to step 5.	The problem is solved.
<p>Step 5</p> <ol style="list-style-type: none"> 1 Remove the right cover. See Right cover removal. 2 Remove the controller board shield. See Controller board shield removal. 3 Reseat the HVPS flat cables on the HVPS and controller board. <p>Does the problem remain?</p>	Go to step 6.	The problem is solved.
<p>Step 6</p> <p>Check the cables for damage.</p> <p>Are the cables free of damage?</p>	Go to step 8.	Go to step 7.
<p>Step 7</p> <p>Replace the affected cable.</p> <p>Does the problem remain?</p>	Go to step 8.	The problem is solved.
<p>Step 8</p> <ol style="list-style-type: none"> 1 Make sure that the HVPS is properly installed. 2 Reseat all the cables on the HVPS. 3 Properly align the spring contacts. <p>Does the problem remain?</p>	Go to step 9.	The problem is solved.
<p>Step 9</p> <p>Check the HVPS contacts for contamination and damage.</p>	Go to step 11.	Go to step 10.

Action	Yes	No
Are the HVPS contacts free of contamination and damage?		
<p>Step 10</p> <p>Clean or replace the HVPS. See HVPS removal.</p> <p>Does the problem remain?</p>	Go to step 11.	The problem is solved.
<p>Step 11</p> <p>1 Enter the Diagnostics menu, and then navigate to:</p> <p style="padding-left: 20px;">Printer diagnostics and adjustments > Motor tests</p> <p>2 Select K/Transfer belt, and then start the test.</p> <p>Does the transfer belt or transfer roller move?</p>	Go to step 16.	Go to step 12.
<p>Step 12</p> <p>Check the transfer module and its components for improper installation and damage.</p> <ul style="list-style-type: none"> • Transfer belt • Transfer roller • Coupler gears <p>Is the transfer module properly installed and free of damage?</p>	Go to step 13.	Go to step 15.
<p>Step 13</p> <p>Make sure that the transfer module cable on the HVPS is properly connected.</p> <p>Does the problem remain?</p>	Go to step 14.	The problem is solved.
<p>Step 14</p> <p>1 Remove any toner spills or contamination from the transfer module.</p> <p>2 Check the transfer belt cleaner and its waste toner nozzle for leaks and damage.</p> <p>If the transfer belt cleaner is defective, then excess toner may build up on the transfer belt. If there are leaks on the waste toner nozzle, then toner spills will occur.</p>	Go to step 16.	Go to step 15.

Action	Yes	No
Is the transfer belt cleaner free of leaks and damage?		
Step 15 Reinstall or replace the transfer module. See Transfer module removal . Does the problem remain?	Go to step 16.	The problem is solved.
Step 16 1 Remove the top cover. See Top cover removal . 2 Reseat the flat cables on the printhead. 3 Reseat the printhead cables on the controller board. Does the problem remain?	Go to step 17.	The problem is solved.
Step 17 Check the cables for damage. Are the cables free of damage?	Go to step 19.	Go to step 18.
Step 18 Replace the affected cable. Does the problem remain?	Go to step 19.	The problem is solved.
Step 19 1 Check the printhead and its components for damage. <ul style="list-style-type: none"> • Flat cable • Connector sockets 2 Check the printhead mirrors for contamination. Is the printhead free of damage and contamination?	Go to step 21.	Go to step 20.
Step 20 Clean or replace the printhead. See Printhead removal . Does the problem remain?	Go to step 21.	The problem is solved.
Step 21 Check the firmware version. Is the firmware updated to the latest version?	Go to step 23.	Go to step 22.
Step 22	Go to step 23.	The problem is solved.

Action	Yes	No
Update the firmware. Does the problem remain?		
Step 23 Make sure that the controller board is properly installed. Reseat all the cables on the controller board. Does the problem remain?	Go to step 24.	The problem is solved.
Step 24 Check the controller board and its connector pins for damage. Are the controller board and its connectors free of damage?	Contact the next level of support.	Go to step 25.
Step 25 Replace the controller board. See Controller board removal . Does the problem remain?	Contact the next level of support.	The problem is solved.

Vertical Colored Lines or Banding Check



Note: Before performing this print quality check, print the Print Quality Test Pages. From the control panel, navigate to **Settings > Troubleshooting > Print Quality Test Pages**, and then perform the initial print quality check. See [Initial print quality check](#).

Action	Yes	No
Step 1 1 Make sure that the paper is properly loaded in the tray and manual feeder. See Avoiding jams . 2 Make sure that the tray and manual feeder are properly installed. Does the problem remain?	Go to step 2.	The problem is solved.
Step 2 1 From the control panel, navigate to: Settings > Paper > Tray Configuration > Paper Size/Type 2 Make sure that the setting matches the paper loaded.	Go to step 3.	The problem is solved.

Action	Yes	No
Does the problem remain?		
<p>Step 3</p> <p>1 From the control panel, navigate to:</p> <p>Settings > Paper > Media Configuration > Media Types</p> <p>2 Make sure that the Texture and Weight settings match the paper loaded.</p> <p>Does the problem remain?</p>	Go to step 4.	The problem is solved.
<p>Step 4</p> <p>Make sure that the paper loaded is supported and free of damage and defect.</p> <p>To check for paper curl, print on both sides of the paper.</p> <p>Does the problem remain?</p>	Go to step 5.	The problem is solved.
<p>Step 5</p> <p>Load paper from a fresh package.</p> <p>Paper absorbs moisture due to high humidity. Store paper in its original wrapper until you are ready to use it.</p> <p>Does the problem remain?</p>	Go to step 6.	The problem is solved.
<p>Step 6</p> <p>1 From the control panel, navigate to:</p> <p>Settings > Print > Quality > Advanced Imaging > Color Adjust</p> <p>The Color Adjust calibrates the printer to adjust the color variations in the printed output.</p> <p>2 Do a print test.</p> <p>Does the problem remain?</p>	Go to step 7.	The problem is solved.
<p>Step 7</p> <p>1 Firmly shake the cartridge to redistribute the toner.</p> <p>2 Make sure that the affected cartridge is properly installed.</p>	Go to step 8.	The problem is solved.

Diagnostics and Troubleshooting

Action	Yes	No
<p>The cartridge must fit and lock properly with the print cartridge tray. No packing material must be left on the cartridge.</p> <p>Does the problem remain?</p>		
<p>Step 8</p> <ol style="list-style-type: none"> 1 Check the cartridge for damage and leaks. 2 Check the cartridge smart chip contacts for improper connections. <ul style="list-style-type: none"> • Corrosion and contamination • Loose connection with the HVPS contacts <p>Is the cartridge free of damage, leaks, and contamination?</p>	Go to step 10.	Go to step 9.
<p>Step 9</p> <p>Clean the contaminated contacts or replace the affected cartridge.</p> <p>Does the problem remain?</p>	Go to step 10.	The problem is solved.
<p>Step 10</p> <ol style="list-style-type: none"> 1 From the control panel, navigate to: Settings > Troubleshooting > Print Quality Test Pages 2 Check the results and determine the color that has issues. 3 Transfer the affected print cartridge to another slot on the print cartridge tray. 4 Print, and then check the results of the Print Quality Test Pages. <p>Does the affected cartridge still have issues?</p>	Go to step 11.	Go to step 15.
<p>Step 11</p> <p>Replace the affected cartridge.</p> <p>Return the swapped cartridges to their original slots.</p> <p>Does the problem remain?</p>	Go to step 12.	The problem is solved.

Action	Yes	No
<p>Step 12</p> <ol style="list-style-type: none"> 1 Remove the top cover. See Top cover removal. 2 Remove the controller board shield. See Controller board shield removal. 3 Reseat the flat cables on the printhead. 4 Reseat the printhead cables on the controller board. <p>Does the problem remain?</p>	Go to step 13.	The problem is solved.
<p>Step 13</p> <p>Check the cables for damage.</p> <p>Are the cables free of damage?</p>	Go to step 15.	Go to step 14.
<p>Step 14</p> <p>Replace the affected cable.</p> <p>Does the problem remain?</p>	Go to step 15.	The problem is solved.
<p>Step 15</p> <ol style="list-style-type: none"> 1 Check the printhead and its components for damage. <ul style="list-style-type: none"> • Flat cable • Connector sockets 2 Check the printhead mirrors for contamination. <p>Is the printhead free of damage and contamination?</p>	Go to step 17.	Go to step 16.
<p>Step 16</p> <p>Clean or replace the printhead. See Printhead removal.</p> <p>Does the problem remain?</p>	Go to step 17.	The problem is solved.
<p>Step 17</p> <ol style="list-style-type: none"> 1 Enter the Diagnostics menu, and then navigate to: <p>Printer diagnostics and adjustments > Motor tests</p> 2 Select K/Transfer belt, and then start the test. <p>Does the transfer belt or transfer roller move?</p>	Go to step 22.	Go to step 18.
<p>Step 18</p>	Go to step 19.	Go to step 21.

Diagnostics and Troubleshooting

Action	Yes	No
<p>Check the transfer module and its components for improper installation and damage.</p> <ul style="list-style-type: none"> • Transfer belt • Transfer roller • Coupler gears <p>Is the transfer module properly installed and free of damage?</p>		
<p>Step 19</p> <ol style="list-style-type: none"> 1 Remove the right cover. See Right cover removal. 2 Make sure that the transfer module cable on the HVPS is properly connected. <p>Does the problem remain?</p>	Go to step 20.	The problem is solved.
<p>Step 20</p> <ol style="list-style-type: none"> 1 Remove any toner spills or contamination from the transfer module. 2 Check the transfer belt cleaner and its waste toner nozzle for leaks and damage. <p>If the transfer belt cleaner is defective, then excess toner may build up on the transfer belt. If there are leaks on the waste toner nozzle, then toner spills will occur.</p> <p>Is the transfer belt cleaner free of leaks and damage?</p>	Go to step 22.	Go to step 21.
<p>Step 21</p> <p>Reinstall or replace the transfer module. See Transfer module removal.</p> <p>Does the problem remain?</p>	Go to step 22.	The problem is solved.
<p>Step 22</p> <ol style="list-style-type: none"> 1 Remove the right cover. See Right cover removal. 2 Remove the controller board shield. See Controller board shield removal. 3 Reseat the HVPS flat cables on the HVPS and controller board. <p>Does the problem remain?</p>	Go to step 23.	The problem is solved.

Action	Yes	No
Step 23 Check the cables for damage. Are the cables free of damage?	Go to step 25.	Go to step 24.
Step 24 Replace the affected cable. Does the problem remain?	Go to step 25.	The problem is solved.
Step 25 1 Make sure that the HVPS is properly installed. 2 Reseat all the cables on the HVPS. 3 Properly align the spring contacts. Does the problem remain?	Go to step 26.	The problem is solved.
Step 26 Check the HVPS contacts for contamination and damage. Are the HVPS contacts free of contamination and damage?	Go to step 28.	Go to step 27.
Step 27 Clean or replace the HVPS. See HVPS removal . Does the problem remain?	Go to step 28.	The problem is solved.
Step 28 Check if the fuser voltage rating matches the printer and electrical outlet voltage rating. Does the fuser have the correct voltage rating?	Go to step 29.	Go to step 33.
Step 29 1 Enter the Diagnostics menu, and then navigate to: Printer diagnostics and adjustments > Motor tests 2 Select Fuser , and then start the test. Do the fuser rollers and exit rollers turn?	Go to step 32.	Go to step 30.
Step 30	Go to step 32.	Go to step 31.

Diagnostics and Troubleshooting

Action	Yes	No
<p>1 Make sure that the fuser is properly installed.</p> <p>2 Remove the controller board shield. See Controller board shield removal .</p> <p>3 Remove the right cover. See Right cover removal.</p> <p>4 Reseat the fuser cables from the following components, and then check the cables for damage:</p> <ul style="list-style-type: none"> • HVPS • LVPS • Fuser to controller board connections <p>Are the fuser cables free of damage?</p>		
<p>Step 31</p> <p>Replace the affected cable.</p> <p>Does the problem remain?</p>	Go to step 32.	The problem is solved.
<p>Step 32</p> <p>Check the fuser and its components for damage.</p> <ul style="list-style-type: none"> • Gears • Rollers • Cable • Guides and actuators • Thermistor <p>Is the fuser free of damage?</p>	Go to step 34.	Go to step 33.
<p>Step 33</p> <p>Replace the fuser. See Fuser removal.</p> <p>Does the problem remain?</p>	Go to step 34.	The problem is solved.
<p>Step 34</p> <p>Check the firmware version.</p> <p>Is the firmware updated to the latest version?</p>	Go to step 36.	Go to step 35.
<p>Step 35</p> <p>Update the firmware.</p> <p>Does the problem remain?</p>	Go to step 36.	The problem is solved.

Action	Yes	No
<p>Step 36</p> <p>Make sure that the controller board is properly installed. Reseat all the cables on the controller board.</p> <p>Does the problem remain?</p>	Go to step 37.	The problem is solved.
<p>Step 37</p> <p>Check the controller board and its connector pins for damage.</p> <p>Are the controller board and its connectors free of damage?</p>	Contact the next level of support.	Go to step 38.
<p>Step 38</p> <p>Replace the controller board. See Controller board removal.</p> <p>Does the problem remain?</p>	Contact the next level of support.	The problem is solved.

Paper Jams

Avoiding Jams

Load Paper Properly

- Make sure that the paper lies flat in the tray.



- Do not load or remove a tray while the printer is printing.
- Do not load too much paper. Make sure that the stack height is below the maximum paper fill indicator.
- Do not slide paper into the tray. Load paper as shown in the illustration.



- Make sure that the paper guides are positioned correctly and are not pressing tightly against the paper or envelopes.
- Push the tray firmly into the printer after loading paper.

Use Recommended Paper

- Use only recommended paper or specialty media.
- Do not load paper that is wrinkled, creased, damp, bent, or curled.

- Flex, fan, and align the paper edges before loading.



- Do not use paper that has been cut or trimmed by hand.
- Do not mix paper sizes, weights, or types in the same tray.
- Make sure that the paper size and type are set correctly on the computer or printer control panel.
- Store paper according to manufacturer recommendations.

Identifying Jam Locations

 **Note:**

- When Jam Assist is set to On, the printer might attempt to flush blank pages or pages with partial prints after a jammed page has been cleared. Check your printed output for blank pages.
- When Jam Recovery is set to On or Auto, the printer reprints jammed pages.

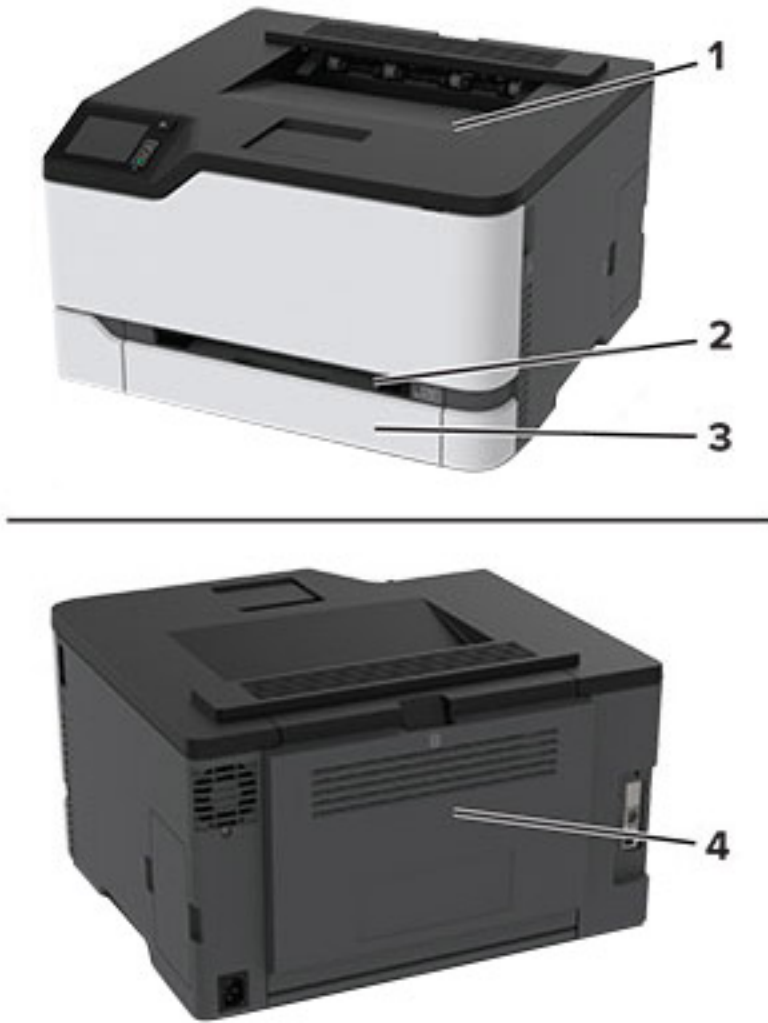

	Jam locations
1	Standard bin
2	Manual feeder
3	Trays
4	Door B
5	Door E

200 Paper Jams

200 Paper Jam Messages

Error code	Description	Action
200.05	Paper fed from the manual feeder never cleared the sensor (input).	See Sensor (input) late-leaving jam service check .
200.06	Paper fed from the manual feeder was picked but it never reached the sensor (input).	See Manual feeder pick jam service check .
200.15	Paper fed from tray 1 never cleared the sensor (input).	See Tray 1 to sensor (input) late-leaving jam service check .
200.16	Paper fed from tray 1 was picked but it never reached the sensor (input).	See Tray 1 pick failure service check .
200.91	Paper remains detected at the sensor (input) after the printer is turned on.	See Sensor (input) static jam service check .
200.99	The sensor (TPS) detected a lack or an excess of toner patches on the printed image. TPS stands for toner patch sensing.	See Toner patch sensing error service check .

Sensor (Input) Late-leaving Jam Service Check

Action	Yes	No
Step 1 1 Open all printer doors, and then remove the manual feeder and tray. 2 Check the paper path, tray, and bin for paper fragments and partially fed paper. Are the paper path, bin, and tray free of paper fragments and partially fed paper?	Go to step 3.	Go to step 2.
Step 2 Remove the paper fragments and partially fed paper. Does the problem remain?	Go to step 3.	The problem is solved.
Step 3	Go to step 7.	Go to step 4.

Diagnostics and Troubleshooting

Action	Yes	No
<p>1 Enter the Diagnostics menu, and then navigate to:</p> <p>Printer diagnostics and adjustments > Sensor tests</p> <p>2 Find the sensor (Input).</p> <p>Does the sensor status change while toggling the sensor?</p>		
<p>Step 4</p> <p>1 Remove the controller board shield. See Controller board shield removal.</p> <p>2 Reseat the cable of the sensor on the controller board.</p> <p>Does the problem remain?</p>	Go to step 5.	The problem is solved.
<p>Step 5</p> <p>Check the sensor and its flag for improper installation and damage.</p> <p>Is the sensor properly installed and free of damage?</p>	Go to step 7.	Go to step 6.
<p>Step 6</p> <p>Reinstall or replace the sensor. See Sensor (input) removal.</p> <p>Does the problem remain?</p>	Go to step 7.	The problem is solved.
<p>Step 7</p> <p>1 Enter the Diagnostics menu, and then navigate to:</p> <p>Printer diagnostics and adjustments > Motor tests > Staging clutch</p> <p>2 Find the staging clutch, and then start the test.</p> <p>Does the clutch operate?</p>	Go to step 11.	Go to step 8.
<p>Step 8</p> <p>1 Remove the controller board shield. See Controller board shield removal.</p> <p>2 Reseat the clutch cable.</p> <p>Does the problem remain?</p>	Go to step 9.	The problem is solved.
<p>Step 9</p> <p>Check the clutch for improper installation and damage.</p>	Go to step 11.	Go to step 10.

Action	Yes	No
Is the clutch properly installed and free of damage?		
Step 10 Reinstall or replace the clutch. See Staging clutch removal . Does the problem remain?	Go to step 11.	The problem is solved.
Step 11 1 Enter the Diagnostics menu, and then navigate to: Printer diagnostics and adjustments > Motor tests 2 Select K/Transfer belt , and then start the test. Does the motor run?	Go to step 15.	Go to step 12.
Step 12 1 Remove the controller board shield. See Controller board shield removal . 2 Reseat the cable on the motor and on the controller board. Does the problem remain?	Go to step 13.	The problem is solved.
Step 13 Check the motor for improper installation, wear, and damage. Is the motor properly installed and free of wear and damage?	Go to step 15.	Go to step 14.
Step 14 Reinstall or replace the motor. See Motor (K/transfer belt) removal . Does the problem remain?	Go to step 15.	The problem is solved.
Step 15 1 Enter the Diagnostics menu, and then navigate to: Printer diagnostics and adjustments > Motor tests 2 Select K/Transfer belt , and then start the test. Does the transfer belt or transfer roller move?	Go to step 18.	Go to step 16.
Step 16	Go to step 18.	Go to step 17.

Diagnostics and Troubleshooting

Action	Yes	No
<p>Check the transfer module and its components for improper installation and damage.</p> <ul style="list-style-type: none"> • Transfer belt • Transfer roller • Coupler gears <p>Is the transfer module properly installed and free of damage?</p>		
<p>Step 17</p> <p>Reinstall or replace the transfer module. See Transfer module removal.</p> <p>Does the problem remain?</p>	Go to step 18.	The problem is solved.
<p>Step 18</p> <p>1 Enter the Diagnostics menu, and then navigate to:</p> <p>Printer diagnostics and adjustments > Motor tests</p> <p>2 Select Fuser, and then start the test.</p> <p>The fuser rollers and exit rollers turn when the motor runs.</p> <p>Does the motor run?</p>	Go to step 22.	Go to step 19.
<p>Step 19</p> <p>1 Remove the controller board shield. See Controller board shield removal.</p> <p>2 Reseat the cable on the motor and on the controller board.</p> <p>Does the problem remain?</p>	Go to step 20.	The problem is solved.
<p>Step 20</p> <p>Check the motor for improper installation, wear, and damage.</p> <p>Is the motor properly installed and free of damage?</p>	Go to step 22.	Go to step 21.
<p>Step 21</p> <p>Reinstall or replace the motor. See Motor (fuser) removal.</p> <p>Does the problem remain?</p>	Go to step 22.	The problem is solved.
<p>Step 22</p>	Go to step 26.	Go to step 23.

Action	Yes	No
<p>1 Enter the Diagnostics menu, and then navigate to:</p> <p>Printer diagnostics and adjustments > Motor tests</p> <p>2 Select Fuser, and then start the test.</p> <p>Do the fuser rollers and exit rollers turn?</p>		
<p>Step 23</p> <p>1 Make sure that the fuser is properly installed.</p> <p>2 Remove the left cover. See Left cover removal.</p> <p>3 Remove the right cover. See Right cover removal.</p> <p>4 Reseat the fuser cables from the following components:</p> <ul style="list-style-type: none"> • HVPS • LVPS • Fuser to controller board connections <p>Does the problem remain?</p>	Go to step 24.	The problem is solved.
<p>Step 24</p> <p>Check the fuser and its components for damage.</p> <ul style="list-style-type: none"> • Gears • Rollers • Cable • Guides and actuators <p>Is the fuser free of damage?</p>	Go to step 26.	Go to step 25.
<p>Step 25</p> <p>Replace the fuser. See Fuser removal.</p> <p>Does the problem remain?</p>	Go to step 26.	The problem is solved.
<p>Step 26</p> <p>1 Check the rear door for improper installation, misalignment, and damage.</p> <p>2 Check the rear door sensor flag for damage.</p> <p>3 Check the rear door rollers and gears for wear, damage, and contamination.</p>	Go to step 28.	Go to step 27.

Action	Yes	No
Are the rear door and its components properly installed and free of wear, damage, and contamination?		
Step 27 Reinstall, clean, or replace the rear door. See Rear door removal . Does the problem remain?	Go to step 28.	The problem is solved.
Step 28 Make sure that the controller board is properly installed. Reseat all the cables on the controller board. Does the problem remain?	Go to step 29.	The problem is solved.
Step 29 Check the controller board and its connector pins for damage. Are the controller board and its connectors free of damage?	Contact the next level of support.	Go to step 30.
Step 30 Replace the controller board. See Controller board removal . Does the problem remain?	Contact the next level of support.	The problem is solved.

Manual Feeder Pick Jam Service Check

Action	Yes	No
Step 1 1 Open all printer doors, and then remove the manual feeder and tray. 2 Check the paper path, tray, and bin for paper fragments and partially fed paper. Are the paper path, bin, and tray free of paper fragments and partially fed paper?	Go to step 3.	Go to step 2.
Step 2 Remove the paper fragments and partially fed paper. Does the problem remain?	Go to step 3.	The problem is solved.

Action	Yes	No
<p>Step 3</p> <p>1 Enter the Diagnostics menu, and then navigate to:</p> <p>Printer diagnostics and adjustments > Sensor tests</p> <p>2 Find the sensor (Input).</p> <p>Does the sensor status change while toggling the sensor?</p>	Go to step 7.	Go to step 4.
<p>Step 4</p> <p>1 Remove the controller board shield. See Controller board shield removal.</p> <p>2 Reseat the cable of the sensor on the controller board.</p> <p>Does the problem remain?</p>	Go to step 5.	The problem is solved.
<p>Step 5</p> <p>Check the sensor and its flag for improper installation and damage.</p> <p>Is the sensor properly installed and free of damage?</p>	Go to step 7.	Go to step 6.
<p>Step 6</p> <p>Reinstall or replace the sensor. See Sensor (input) removal.</p> <p>Does the problem remain?</p>	Go to step 7.	The problem is solved.
<p>Step 7</p> <p>1 Enter the Diagnostics menu, and then navigate to:</p> <p>Printer diagnostics and adjustments > Sensor tests</p> <p>2 Find the sensor (Manual feeder).</p> <p>Does the sensor status change while toggling the sensor?</p>	Go to step 11.	Go to step 8.
<p>Step 8</p> <p>1 Remove the controller board shield. See Controller board shield removal.</p> <p>2 Reseat the cable of the sensor on the controller board.</p> <p>Does the problem remain?</p>	Go to step 9.	The problem is solved.
<p>Step 9</p>	Go to step 11.	Go to step 10.

Diagnostics and Troubleshooting

Action	Yes	No
<p>Check the sensor and its flag for improper installation and damage.</p> <p>Is the sensor properly installed and free of damage?</p>		
<p>Step 10</p> <p>Reinstall or replace the sensor. See Sensor (manual feeder) removal.</p> <p>Does the problem remain?</p>	Go to step 11.	The problem is solved.
<p>Step 11</p> <ol style="list-style-type: none"> 1 Make sure that the manual feeder guides are free of obstructions. 2 Check the guides for improper installation and damage. <p>Are the guides properly installed and free of damage?</p>	Go to step 13.	Go to step 12.
<p>Step 12</p> <p>Replace the manual feeder.</p> <p>Does the problem remain?</p>	Go to step 13.	The problem is solved.
<p>Step 13</p> <p>Check the manual feeder transport mechanism for damage.</p> <p>Are the components free of damage?</p>	Go to step 14.	Contact the next level of support.
<p>Step 14</p> <p>Check the manual feeder belts for improper installation and damage.</p> <p>Are the belts properly installed and free of damage?</p>	Go to step 15.	Contact the next level of support.
<p>Step 15</p> <p>Check the manual feeder rollers for wear, damage, and contamination.</p> <p>Are the rollers free of wear, damage, and contamination?</p>	Go to step 16.	Contact the next level of support.
<p>Step 16</p> <ol style="list-style-type: none"> 1 Enter the Diagnostics menu, and then navigate to: 	Go to step 20.	Go to step 17.

Action	Yes	No
<p>Printer diagnostics and adjustments > Motor tests > Staging clutch</p> <p>2 Find the staging clutch, and then start the test.</p> <p>Does the clutch operate?</p>		
<p>Step 17</p> <p>1 Remove the controller board shield. See Controller board shield removal.</p> <p>2 Reseat the clutch cable.</p> <p>Does the problem remain?</p>	Go to step 18.	The problem is solved.
<p>Step 18</p> <p>Check the clutch for improper installation and damage.</p> <p>Is the clutch properly installed and free of damage?</p>	Go to step 20.	Go to step 19.
<p>Step 19</p> <p>Reinstall or replace the clutch. See Staging clutch removal.</p> <p>Does the problem remain?</p>	Go to step 20.	The problem is solved.
<p>Step 20</p> <p>Check the staging drive components for improper installation, wear, and damage.</p> <ul style="list-style-type: none"> • Belt • Gear • Pulley <p>Are the staging drive components properly installed and free of wear and damage?</p>	Go to step 22.	Go to step 21.
<p>Step 21</p> <p>Reinstall or replace the affected staging belt, gear, or pulley. See Staging belt, gear, and pulley removal.</p> <p>Does the problem remain?</p>	Go to step 22.	The problem is solved.
<p>Step 22</p> <p>1 Check the rear door for improper installation, misalignment, and damage.</p>	Go to step 24.	Go to step 23.

Diagnostics and Troubleshooting

Action	Yes	No
<p>2 Check the rear door sensor flag for damage.</p> <p>3 Check the rear door rollers and gears for wear, damage, and contamination.</p> <p>Are the rear door and its components properly installed and free of wear, damage, and contamination?</p>		
<p>Step 23</p> <p>Reinstall, clean, or replace the rear door. See Rear door removal.</p> <p>Does the problem remain?</p>	Go to step 24.	The problem is solved.
<p>Step 24</p> <p>Make sure that the controller board is properly installed. Reseat all the cables on the controller board.</p> <p>Does the problem remain?</p>	Go to step 25.	The problem is solved.
<p>Step 25</p> <p>Check the controller board and its connector pins for damage.</p> <p>Are the controller board and its connectors free of damage?</p>	Contact the next level of support.	Go to step 26.
<p>Step 26</p> <p>Replace the controller board. See Controller board removal.</p> <p>Does the problem remain?</p>	Contact the next level of support.	The problem is solved.

Tray 1 To Sensor (Input) Late-leaving Jam Service Check

Action	Yes	No
<p>Step 1</p> <ol style="list-style-type: none"> 1 Open all printer doors, and then remove the manual feeder and tray. 2 Check the paper path, tray, and bin for paper fragments and partially fed paper. <p>Are the paper path, bin, and tray free of paper fragments and partially fed paper?</p>	Go to step 3.	Go to step 2.
<p>Step 2</p> <p>Remove the paper fragments and partially fed paper.</p> <p>Does the problem remain?</p>	Go to step 3.	The problem is solved.
<p>Step 3</p> <ol style="list-style-type: none"> 1 Make sure that the paper is properly loaded in the tray and manual feeder. See Avoiding jams. 2 Make sure that the tray and manual feeder are properly installed. <p>Does the problem remain?</p>	Go to step 4.	The problem is solved.
<p>Step 4</p> <ol style="list-style-type: none"> 1 From the control panel, navigate to: Settings > Paper > Tray Configuration > Paper Size/Type 2 Make sure that the setting matches the paper loaded. <p>Does the problem remain?</p>	Go to step 5.	The problem is solved.
<p>Step 5</p> <ol style="list-style-type: none"> 1 Enter the Diagnostics menu, and then navigate to: Printer diagnostics and adjustments > Sensor tests 2 Find the sensor (Input). <p>Does the sensor status change while toggling the sensor?</p>	Go to step 9.	Go to step 6.
<p>Step 6</p>	Go to step 7.	The problem is solved.

Diagnostics and Troubleshooting

Action	Yes	No
<p>1 Remove the controller board shield. See Controller board shield removal .</p> <p>2 Reseat the cable of the sensor on the controller board.</p> <p>Does the problem remain?</p>		
<p>Step 7</p> <p>Check the sensor and its flag for improper installation and damage.</p> <p>Is the sensor properly installed and free of damage?</p>	Go to step 9.	Go to step 8.
<p>Step 8</p> <p>Reinstall or replace the sensor. See Sensor (input) removal.</p> <p>Does the problem remain?</p>	Go to step 9.	The problem is solved.
<p>Step 9</p> <p>1 Enter the Diagnostics menu, and then navigate to:</p> <p style="padding-left: 20px;">Printer diagnostics and adjustments > Motor tests</p> <p>2 Select K/Transfer belt, and then start the test.</p> <p>Does the transfer belt or transfer roller move?</p>	Go to step 12.	Go to step 10.
<p>Step 10</p> <p>Check the transfer module and its components for improper installation and damage.</p> <ul style="list-style-type: none"> • Transfer belt • Transfer roller • Coupler gears <p>Is the transfer module properly installed and free of damage?</p>	Go to step 12.	Go to step 11.
<p>Step 11</p> <p>Reinstall or replace the transfer module. See Transfer module removal.</p> <p>Does the problem remain?</p>	Go to step 12.	The problem is solved.
<p>Step 12</p> <p>1 Enter the Diagnostics menu, and then navigate to:</p>	Go to step 16.	Go to step 13.

Action	Yes	No
<p>Printer diagnostics and adjustments > Motor tests</p> <p>2 Select K/Transfer belt, and then start the test.</p> <p>Does the motor run?</p>		
<p>Step 13</p> <p>1 Remove the controller board shield. See Controller board shield removal.</p> <p>2 Reseat the cable on the motor and on the controller board.</p> <p>Does the problem remain?</p>	Go to step 14.	The problem is solved.
<p>Step 14</p> <p>Check the motor for improper installation, wear, and damage.</p> <p>Is the motor properly installed and free of wear and damage?</p>	Go to step 16.	Go to step 15.
<p>Step 15</p> <p>Reinstall or replace the motor. See Motor (K/transfer belt) removal.</p> <p>Does the problem remain?</p>	Go to step 16.	The problem is solved.
<p>Step 16</p> <p>1 Enter the Diagnostics menu, and then navigate to:</p> <p>Printer diagnostics and adjustments > Motor tests > Staging clutch</p> <p>2 Find the staging clutch, and then start the test.</p> <p>Does the clutch operate?</p>	Go to step 20.	Go to step 17.
<p>Step 17</p> <p>1 Remove the controller board shield. See Controller board shield removal.</p> <p>2 Reseat the clutch cable.</p> <p>Does the problem remain?</p>	Go to step 18.	The problem is solved.
<p>Step 18</p> <p>Check the clutch for improper installation and damage.</p> <p>Is the clutch properly installed and free of damage?</p>	Go to step 20.	Go to step 19.

Diagnostics and Troubleshooting

Action	Yes	No
<p>Step 19</p> <p>Reinstall or replace the clutch. See Staging clutch removal.</p> <p>Does the problem remain?</p>	Go to step 20.	The problem is solved.
<p>Step 20</p> <p>Check the staging drive components for improper installation, wear, and damage.</p> <ul style="list-style-type: none"> • Belt • Gear • Pulley <p>Are the staging drive components properly installed and free of wear and damage?</p>	Go to step 22.	Go to step 21.
<p>Step 21</p> <p>Reinstall or replace the affected staging belt, gear, or pulley. See Staging belt, gear, and pulley removal.</p> <p>Does the problem remain?</p>	Go to step 22.	The problem is solved.
<p>Step 22</p> <p>1 Enter the Diagnostics menu, and then navigate to:</p> <p>Printer diagnostics and adjustments > Motor tests</p> <p>2 Select Fuser, and then start the test.</p> <p>The fuser rollers and exit rollers turn when the motor runs.</p> <p>Does the motor run?</p>	Go to step 26.	Go to step 23.
<p>Step 23</p> <p>1 Remove the controller board shield. See Controller board shield removal.</p> <p>2 Reseat the cable on the motor and on the controller board.</p> <p>Does the problem remain?</p>	Go to step 24.	The problem is solved.
<p>Step 24</p> <p>Check the motor for improper installation, wear, and damage.</p> <p>Is the motor properly installed and free of damage?</p>	Go to step 26.	Go to step 25.

Action	Yes	No
<p>Step 25</p> <p>Reinstall or replace the motor. See Motor (fuser) removal.</p> <p>Does the problem remain?</p>	Go to step 26.	The problem is solved.
<p>Step 26</p> <ol style="list-style-type: none"> 1 Check the rear door for improper installation, misalignment, and damage. 2 Check the rear door sensor flag for damage. 3 Check the rear door rollers and gears for wear, damage, and contamination. <p>Are the rear door and its components properly installed and free of wear, damage, and contamination?</p>	Go to step 28.	Go to step 27.
<p>Step 27</p> <p>Reinstall, clean, or replace the rear door. See Rear door removal.</p> <p>Does the problem remain?</p>	Go to step 28.	The problem is solved.
<p>Step 28</p> <ol style="list-style-type: none"> 1 Enter the Diagnostics menu, and then navigate to: <p>Printer diagnostics and adjustments > Motor tests</p> 2 Run the test on the following motors and clutches. In each test, check the gears for lack of movement and unusual noise. <ul style="list-style-type: none"> • CMY • K/Transfer belt • Pick clutch • Staging clutch <p>Do the gears move properly without unusual noise?</p>	Go to step 32.	Go to step 29.
<p>Step 29</p> <p>Check the gearbox gears and couplers for wear and damage.</p> <ul style="list-style-type: none"> • Drive gears for all print cartridges and transfer belt • Drive gears that engage with the clutches 	Go to step 30.	Go to step 31.

Diagnostics and Troubleshooting

Action	Yes	No
<ul style="list-style-type: none"> Couplers for all print cartridges and the transfer belt <p>Are the gears and couplers free of wear and damage?</p>		
<p>Step 30</p> <ol style="list-style-type: none"> Remove the gearbox. See Gearbox removal. Make sure that the gearbox gears are properly lubricated. Reinstall the gearbox. <p>Does the problem remain?</p>	Go to step 31.	The problem is solved.
<p>Step 31</p> <p>Replace the gearbox. See Gearbox removal.</p> <p>Does the problem remain?</p>	Go to step 32.	The problem is solved.
<p>Step 32</p> <p>Make sure that the controller board is properly installed. Reseat all the cables on the controller board.</p> <p>Does the problem remain?</p>	Go to step 33.	The problem is solved.
<p>Step 33</p> <p>Check the controller board and its connector pins for damage.</p> <p>Are the controller board and its connectors free of damage?</p>	Contact the next level of support.	Go to step 34.
<p>Step 34</p> <p>Replace the controller board. See Controller board removal.</p> <p>Does the problem remain?</p>	Contact the next level of support.	The problem is solved.

Tray 1 Pick Failure Service Check

Action	Yes	No
<p>Step 1</p> <ol style="list-style-type: none"> 1 Open all printer doors, and then remove the manual feeder and tray. 2 Check the paper path, tray, and bin for paper fragments and partially fed paper. <p>Are the paper path, bin, and tray free of paper fragments and partially fed paper?</p>	Go to step 3.	Go to step 2.
<p>Step 2</p> <p>Remove the paper fragments and partially fed paper.</p> <p>Does the problem remain?</p>	Go to step 3.	The problem is solved.
<p>Step 3</p> <ol style="list-style-type: none"> 1 Make sure that the paper is properly loaded in the tray and manual feeder. See Avoiding jams. 2 Make sure that the tray and manual feeder are properly installed. <p>Does the problem remain?</p>	Go to step 4.	The problem is solved.
<p>Step 4</p> <ol style="list-style-type: none"> 1 From the control panel, navigate to: Settings > Paper > Tray Configuration > Paper Size/Type 2 Make sure that the setting matches the paper loaded. <p>Does the problem remain?</p>	Contact the next level of support.	The problem is solved.
<p>Step 5</p> <ol style="list-style-type: none"> 1 Enter the Diagnostics menu, and then navigate to: Printer diagnostics and adjustments > Sensor tests 2 Find the sensor (Input). <p>Does the sensor status change while toggling the sensor?</p>	Go to step 9.	Go to step 6.
<p>Step 6</p>	Go to step 7.	The problem is solved.

Diagnostics and Troubleshooting

Action	Yes	No
<p>1 Remove the controller board shield. See Controller board shield removal .</p> <p>2 Reseat the cable of the sensor on the controller board.</p> <p>Does the problem remain?</p>		
<p>Step 7</p> <p>Check the sensor and its flag for improper installation and damage.</p> <p>Is the sensor properly installed and free of damage?</p>	Go to step 9.	Go to step 8.
<p>Step 8</p> <p>Reinstall or replace the sensor. See Sensor (input) removal.</p> <p>Does the problem remain?</p>	Go to step 9.	The problem is solved.
<p>Step 9</p> <p>1 Enter the Diagnostics menu, and then navigate to:</p> <p style="padding-left: 20px;">Printer diagnostics and adjustments > Motor tests</p> <p>2 Select K/Transfer belt, and then start the test.</p> <p>Does the motor run?</p>	Go to step 13.	Go to step 10.
<p>Step 10</p> <p>1 Remove the controller board shield. See Controller board shield removal .</p> <p>2 Reseat the cable on the motor and on the controller board.</p> <p>Does the problem remain?</p>	Go to step 11.	The problem is solved.
<p>Step 11</p> <p>Check the motor for improper installation, wear, and damage.</p> <p>Is the motor properly installed and free of wear and damage?</p>	Go to step 13.	Go to step 12.
<p>Step 12</p> <p>Reinstall or replace the motor. See Motor (K/transfer belt) removal .</p> <p>Does the problem remain?</p>	Go to step 13.	The problem is solved.
<p>Step 13</p>	Go to step 14.	Contact the next level of support.

Action	Yes	No
<p>1 Check the pick roller for improper mechanism.</p> <p>After the pick roller is lowered, it must move automatically to its original position.</p> <p>2 Check the pick roller for damage.</p> <p>Is the pick roller functional and free of damage?</p>		
<p>Step 14</p> <p>Check the pick tires for improper installation, contamination, wear, and damage.</p> <p>Are the pick tires properly installed and free of contamination, wear, and damage?</p>	Go to step 16.	Go to step 15.
<p>Step 15</p> <p>Reinstall, clean, or replace the pick tire. See Pick tire removal.</p> <p>Does the problem remain?</p>	Go to step 16.	The problem is solved.
<p>Step 16</p> <p>1 Enter the Diagnostics menu, and then navigate to:</p> <p>Printer diagnostics and adjustments > Motor tests > Staging clutch</p> <p>2 Find the staging clutch, and then start the test.</p> <p>Does the clutch operate?</p>	Go to step 20.	Go to step 17.
<p>Step 17</p> <p>1 Remove the controller board shield. See Controller board shield removal.</p> <p>2 Reseat the clutch cable.</p> <p>Does the problem remain?</p>	Go to step 18.	The problem is solved.
<p>Step 18</p> <p>Check the clutch for improper installation and damage.</p> <p>Is the clutch properly installed and free of damage?</p>	Go to step 20.	Go to step 19.
<p>Step 19</p>	Go to step 20.	The problem is solved.

Diagnostics and Troubleshooting

Action	Yes	No
<p>Reinstall or replace the clutch. See Staging clutch removal.</p> <p>Does the problem remain?</p>		
<p>Step 20</p> <p>Check the staging drive components for improper installation, wear, and damage.</p> <ul style="list-style-type: none"> • Belt • Gear • Pulley <p>Are the staging drive components properly installed and free of wear and damage?</p>	Go to step 22.	Go to step 21.
<p>Step 21</p> <p>Reinstall or replace the affected staging belt, gear, or pulley. See Staging belt, gear, and pulley removal.</p> <p>Does the problem remain?</p>	Go to step 22.	The problem is solved.
<p>Step 22</p> <ol style="list-style-type: none"> 1 Enter the Diagnostics menu, and then navigate to: Printer diagnostics and adjustments > Motor tests 2 Select Fuser, and then start the test. The fuser rollers and exit rollers turn when the motor runs. <p>Does the motor run?</p>	Go to step 26.	Go to step 23.
<p>Step 23</p> <ol style="list-style-type: none"> 1 Remove the controller board shield. See Controller board shield removal. 2 Reseat the cable on the motor and on the controller board. <p>Does the problem remain?</p>	Go to step 24.	The problem is solved.
<p>Step 24</p> <p>Check the motor for improper installation, wear, and damage.</p> <p>Is the motor properly installed and free of damage?</p>	Go to step 26.	Go to step 25.

Action	Yes	No
<p>Step 25</p> <p>Reinstall or replace the motor. See Motor (fuser) removal.</p> <p>Does the problem remain?</p>	Go to step 26.	The problem is solved.
<p>Step 26</p> <ol style="list-style-type: none"> 1 Check the rear door for improper installation, misalignment, and damage. 2 Check the rear door sensor flag for damage. 3 Check the rear door rollers and gears for wear, damage, and contamination. <p>Are the rear door and its components properly installed and free of wear, damage, and contamination?</p>	Go to step 28.	Go to step 27.
<p>Step 27</p> <p>Reinstall, clean, or replace the rear door. See Rear door removal.</p> <p>Does the problem remain?</p>	Go to step 28.	The problem is solved.
<p>Step 28</p> <ol style="list-style-type: none"> 1 Enter the Diagnostics menu, and then navigate to: Printer diagnostics and adjustments > Motor tests 2 Run the test on the following motors and clutches. In each test, check the gears for lack of movement and unusual noise. <ul style="list-style-type: none"> • CMY • K/Transfer belt • Pick clutch • Staging clutch <p>Do the gears move properly without unusual noise?</p>	Go to step 32.	Go to step 29.
<p>Step 29</p> <p>Check the gearbox gears and couplers for wear and damage.</p> <ul style="list-style-type: none"> • Drive gears for all print cartridges and transfer belt • Drive gears that engage with the clutches 	Go to step 30.	Go to step 31.

Diagnostics and Troubleshooting

Action	Yes	No
<ul style="list-style-type: none"> Couplers for all print cartridges and the transfer belt <p>Are the gears and couplers free of wear and damage?</p>		
<p>Step 30</p> <ol style="list-style-type: none"> Remove the gearbox. See Gearbox removal. Make sure that the gearbox gears are properly lubricated. Reinstall the gearbox. <p>Does the problem remain?</p>	Go to step 31.	The problem is solved.
<p>Step 31</p> <p>Replace the gearbox. See Gearbox removal.</p> <p>Does the problem remain?</p>	Go to step 32.	The problem is solved.
<p>Step 32</p> <p>Make sure that the controller board is properly installed. Reseat all the cables on the controller board.</p> <p>Does the problem remain?</p>	Go to step 33.	The problem is solved.
<p>Step 33</p> <p>Check the controller board and its connector pins for damage.</p> <p>Are the controller board and its connectors free of damage?</p>	Contact the next level of support.	Go to step 34.
<p>Step 34</p> <p>Replace the controller board. See Controller board removal.</p> <p>Does the problem remain?</p>	Contact the next level of support.	The problem is solved.

Sensor (Input) Static Jam Service Check

Action	Yes	No
<p>Step 1</p> <p>1 Open all printer doors, and then remove the manual feeder and tray.</p> <p>2 Check the paper path, tray, and bin for paper fragments and partially fed paper.</p> <p>Are the paper path, bin, and tray free of paper fragments and partially fed paper?</p>	Go to step 3.	Go to step 2.
<p>Step 2</p> <p>Remove the paper fragments and partially fed paper.</p> <p>Does the problem remain?</p>	Go to step 3.	The problem is solved.
<p>Step 3</p> <p>1 Enter the Diagnostics menu, and then navigate to:</p> <p>Printer diagnostics and adjustments > Sensor tests</p> <p>2 Find the sensor (Input).</p> <p>Does the sensor status change while toggling the sensor?</p>	Go to step 7.	Go to step 4.
<p>Step 4</p> <p>1 Remove the controller board shield. See Controller board shield removal.</p> <p>2 Reseat the cable of the sensor on the controller board.</p> <p>Does the problem remain?</p>	Go to step 5.	The problem is solved.
<p>Step 5</p> <p>Check the sensor and its flag for improper installation and damage.</p> <p>Is the sensor properly installed and free of damage?</p>	Go to step 7.	Go to step 6.
<p>Step 6</p> <p>Reinstall or replace the sensor. See Sensor (input) removal.</p> <p>Does the problem remain?</p>	Go to step 7.	The problem is solved.
<p>Step 7</p>	Go to step 8.	The problem is solved.

Action	Yes	No
Make sure that the controller board is properly installed. Reseat all the cables on the controller board. Does the problem remain?		
Step 8 Check the controller board and its connector pins for damage. Are the controller board and its connectors free of damage?	Contact the next level of support.	Go to step 9.
Step 9 Replace the controller board. See Controller board removal . Does the problem remain?	Contact the next level of support.	The problem is solved.

202 Paper Jams

202 Paper Jam Messages

Error code	Description	Action
202.03	Paper fed from the manual feeder never reached the sensor (fuser exit).	See Sensor (fuser exit) late-arriving jam service check .
202.04	Paper fed from the manual feeder cleared the sensor (fuser exit) earlier than expected.	See Sensor (fuser exit) early-leaving jam service check .
202.05	Paper fed from the manual feeder never cleared the sensor (fuser exit).	See Sensor (fuser exit) late-leaving jam service check .
202.13	Paper fed from tray 1 never reached the sensor (fuser exit).	See Sensor (fuser exit) late-arriving jam service check .
202.14	Paper fed from tray 1 cleared the sensor (fuser exit) earlier than expected.	See Sensor (fuser exit) early-leaving jam service check .
202.15	Paper fed from tray 1 never cleared the sensor (fuser exit).	See Sensor (fuser exit) late-leaving jam service check .
202.91	Paper remains detected at the sensor (fuser exit) after the printer is turned on.	See Sensor (fuser exit) static jam service check .

Sensor (Fuser Exit) Late-arriving Jam Service Check

Action	Yes	No
<p>Step 1</p> <ol style="list-style-type: none"> 1 Open all printer doors, and then remove the manual feeder and tray. 2 Check the paper path, tray, and bin for paper fragments and partially fed paper. <p>Are the paper path, bin, and tray free of paper fragments and partially fed paper?</p>	Go to step 3.	Go to step 2.
<p>Step 2</p> <p>Remove the paper fragments and partially fed paper.</p> <p>Does the problem remain?</p>	Go to step 3.	The problem is solved.
<p>Step 3</p> <ol style="list-style-type: none"> 1 Enter the Diagnostics menu, and then navigate to: Printer diagnostics and adjustments > Sensor tests 2 Find the sensor (Fuser exit). <p>Does the sensor status change while toggling the sensor?</p>	Go to step 7.	Go to step 4.
<p>Step 4</p> <ol style="list-style-type: none"> 1 Remove the controller board shield. See Controller board shield removal. 2 Reseat the cable of the sensor on the controller board. <p>Does the problem remain?</p>	Go to step 5.	The problem is solved.
<p>Step 5</p> <p>Check the sensor for improper installation and damage.</p> <p>Is the sensor properly installed and free of damage?</p>	Go to step 7.	Go to step 6.
<p>Step 6</p> <p>Reinstall or replace the sensor. See Sensor (fuser exit) removal.</p> <p>Does the problem remain?</p>	Go to step 7.	The problem is solved.
<p>Step 7</p>	Go to step 11.	Go to step 8.

Diagnostics and Troubleshooting

Action	Yes	No
<p>1 Enter the Diagnostics menu, and then navigate to:</p> <p>Printer diagnostics and adjustments > Motor tests</p> <p>2 Select Fuser, and then start the test.</p> <p>The fuser rollers and exit rollers turn when the motor runs.</p> <p>Does the motor run?</p>		
<p>Step 8</p> <p>1 Remove the controller board shield. See Controller board shield removal.</p> <p>2 Reseat the cable on the motor and on the controller board.</p> <p>Does the problem remain?</p>	Go to step 9.	The problem is solved.
<p>Step 9</p> <p>Check the motor for improper installation, wear, and damage.</p> <p>Is the motor properly installed and free of damage?</p>	Go to step 11.	Go to step 10.
<p>Step 10</p> <p>Reinstall or replace the motor. See Motor (fuser) removal.</p> <p>Does the problem remain?</p>	Go to step 11.	The problem is solved.
<p>Step 11</p> <p>1 Enter the Diagnostics menu, and then navigate to:</p> <p>Printer diagnostics and adjustments > Motor tests</p> <p>2 Select Fuser, and then start the test.</p> <p>Do the fuser rollers and exit rollers turn?</p>	Go to step 16.	Go to step 12.
<p>Step 12</p> <p>1 Make sure that the fuser is properly installed.</p> <p>2 Remove the left cover. See Left cover removal.</p> <p>3 Remove the right cover. See Right cover removal.</p>	Go to step 14.	Go to step 13.

Action	Yes	No
<p>4 Reseat the fuser cables from the following components, and then check the cables for damage:</p> <ul style="list-style-type: none"> • HVPS • LVPS • Fuser to controller board connections <p>Are the fuser cables free of damage?</p>		
<p>Step 13</p> <p>Replace the affected cable.</p> <p>Does the problem remain?</p>	Go to step 14.	The problem is solved.
<p>Step 14</p> <p>Check the fuser and its components for damage.</p> <ul style="list-style-type: none"> • Gears • Rollers • Cable • Guides and actuators <p>Is the fuser free of damage?</p>	Go to step 16.	Go to step 15.
<p>Step 15</p> <p>Replace the fuser. See Fuser removal.</p> <p>Does the problem remain?</p>	Go to step 16.	The problem is solved.
<p>Step 16</p> <p>Reseat the HVPS flat cables.</p> <p>Does the problem remain?</p>	Go to step 17.	The problem is solved.
<p>Step 17</p> <p>Check the cables for damage.</p> <p>Are the cables free of damage?</p>	Go to step 19.	Go to step 18.
<p>Step 18</p> <p>Replace the affected cable.</p> <p>Does the problem remain?</p>	Go to step 19.	The problem is solved.
<p>Step 19</p> <p>1 Enter the Diagnostics menu, and then navigate to:</p>	Go to step 23.	Go to step 20.

Action	Yes	No
<p>Printer diagnostics and adjustments > Motor tests > Staging clutch</p> <p>2 Find the staging clutch, and then start the test.</p> <p>Does the clutch operate?</p>		
<p>Step 20</p> <p>1 Remove the controller board shield. See Controller board shield removal.</p> <p>2 Reseat the clutch cable.</p> <p>Does the problem remain?</p>	Go to step 21.	The problem is solved.
<p>Step 21</p> <p>Check the clutch for improper installation and damage.</p> <p>Is the clutch properly installed and free of damage?</p>	Go to step 23.	Go to step 22.
<p>Step 22</p> <p>Reinstall or replace the clutch. See Staging clutch removal.</p> <p>Does the problem remain?</p>	Go to step 23.	The problem is solved.
<p>Step 23</p> <p>Check the staging drive components for improper installation, wear, and damage.</p> <ul style="list-style-type: none"> • Belt • Gear • Pulley <p>Are the staging drive components properly installed and free of wear and damage?</p>	Go to step 25.	Go to step 24.
<p>Step 24</p> <p>Reinstall or replace the affected staging belt, gear, or pulley. See Staging belt, gear, and pulley removal.</p> <p>Does the problem remain?</p>	Go to step 25.	The problem is solved.
<p>Step 25</p> <p>1 Enter the Diagnostics menu, and then navigate to:</p>	Go to step 28.	Go to step 26.

Action	Yes	No
<p>Printer diagnostics and adjustments > Motor tests</p> <p>2 Select K/Transfer belt, and then start the test.</p> <p>Does the transfer belt or transfer roller move?</p>		
<p>Step 26</p> <p>Check the transfer module and its components for improper installation and damage.</p> <ul style="list-style-type: none"> • Transfer belt • Transfer roller • Coupler gears <p>Is the transfer module properly installed and free of damage?</p>	Go to step 28.	Go to step 27.
<p>Step 27</p> <p>Reinstall or replace the transfer module. See Transfer module removal.</p> <p>Does the problem remain?</p>	Go to step 28.	The problem is solved.
<p>Step 28</p> <p>1 Enter the Diagnostics menu, and then navigate to:</p> <p>Printer diagnostics and adjustments > Motor tests</p> <p>2 Select K/Transfer belt, and then start the test.</p> <p>Does the motor run?</p>	Go to step 32.	Go to step 29.
<p>Step 29</p> <p>1 Remove the controller board shield. See Controller board shield removal.</p> <p>2 Reseat the cable on the motor and on the controller board.</p> <p>Does the problem remain?</p>	Go to step 30.	The problem is solved.
<p>Step 30</p> <p>Check the motor for improper installation, wear, and damage.</p> <p>Is the motor properly installed and free of wear and damage?</p>	Go to step 32.	Go to step 31.
<p>Step 31</p>	Go to step 32.	The problem is solved.

Diagnostics and Troubleshooting

Action	Yes	No
<p>Reinstall or replace the motor. See Motor (K/transfer belt) removal .</p> <p>Does the problem remain?</p>		
<p>Step 32</p> <p>1 Enter the Diagnostics menu, and then navigate to:</p> <p>Printer diagnostics and adjustments > Motor tests</p> <p>2 Run the test on the following motors and clutches. In each test, check the gears for lack of movement and unusual noise.</p> <ul style="list-style-type: none"> • CMY • K/Transfer belt • Pick clutch • Staging clutch <p>Do the gears move properly without unusual noise?</p>	Go to step 36.	Go to step 33.
<p>Step 33</p> <p>Check the gearbox gears and couplers for wear and damage.</p> <ul style="list-style-type: none"> • Drive gears for all print cartridges and transfer belt • Drive gears that engage with the clutches • Couplers for all print cartridges and the transfer belt <p>Are the gears and couplers free of wear and damage?</p>	Go to step 34.	Go to step 35.
<p>Step 34</p> <p>1 Remove the gearbox. See Gearbox removal.</p> <p>2 Make sure that the gearbox gears are properly lubricated.</p> <p>3 Reinstall the gearbox.</p> <p>Does the problem remain?</p>	Go to step 35.	The problem is solved.
<p>Step 35</p> <p>Replace the gearbox. See Gearbox removal.</p> <p>Does the problem remain?</p>	Go to step 36.	The problem is solved.
<p>Step 36</p>	Go to step 37.	The problem is solved.

Action	Yes	No
<p>Make sure that the controller board is properly installed. Reseat all the cables on the controller board.</p> <p>Does the problem remain?</p>		
<p>Step 37</p> <p>Check the controller board and its connector pins for damage.</p> <p>Are the controller board and its connectors free of damage?</p>	Contact the next level of support.	Go to step 38.
<p>Step 38</p> <p>Replace the controller board. See Controller board removal.</p> <p>Does the problem remain?</p>	Contact the next level of support.	The problem is solved.

Sensor (Fuser Exit) Early-leaving Jam Service Check

Action	Yes	No
<p>Step 1</p> <ol style="list-style-type: none"> 1 Open all printer doors, and then remove the manual feeder and tray. 2 Check the paper path, tray, and bin for paper fragments and partially fed paper. <p>Are the paper path, bin, and tray free of paper fragments and partially fed paper?</p>	Go to step 3.	Go to step 2.
<p>Step 2</p> <p>Remove the paper fragments and partially fed paper.</p> <p>Does the problem remain?</p>	Go to step 3.	The problem is solved.
<p>Step 3</p> <ol style="list-style-type: none"> 1 Enter the Diagnostics menu, and then navigate to: Printer diagnostics and adjustments > Sensor tests 2 Find the sensor (Fuser exit). <p>Does the sensor status change while toggling the sensor?</p>	Go to step 7.	Go to step 4.

Diagnostics and Troubleshooting

Action	Yes	No
<p>Step 4</p> <p>1 Remove the controller board shield. See Controller board shield removal .</p> <p>2 Reseat the cable of the sensor on the controller board.</p> <p>Does the problem remain?</p>	Go to step 5.	The problem is solved.
<p>Step 5</p> <p>Check the sensor for improper installation and damage.</p> <p>Is the sensor properly installed and free of damage?</p>	Go to step 7.	Go to step 6.
<p>Step 6</p> <p>Reinstall or replace the sensor. See Sensor (fuser exit) removal .</p> <p>Does the problem remain?</p>	Go to step 7.	The problem is solved.
<p>Step 7</p> <p>1 Enter the Diagnostics menu, and then navigate to:</p> <p>Printer diagnostics and adjustments > Motor tests</p> <p>2 Select Fuser, and then start the test.</p> <p>The fuser rollers and exit rollers turn when the motor runs.</p> <p>Does the motor run?</p>	Go to step 11.	Go to step 8.
<p>Step 8</p> <p>1 Remove the controller board shield. See Controller board shield removal .</p> <p>2 Reseat the cable on the motor and on the controller board.</p> <p>Does the problem remain?</p>	Go to step 9.	The problem is solved.
<p>Step 9</p> <p>Check the motor for improper installation, wear, and damage.</p> <p>Is the motor properly installed and free of damage?</p>	Go to step 11.	Go to step 10.
<p>Step 10</p> <p>Reinstall or replace the motor. See Motor (fuser) removal.</p>	Go to step 11.	The problem is solved.

Action	Yes	No
Does the problem remain?		
<p>Step 11</p> <p>1 Enter the Diagnostics menu, and then navigate to:</p> <p style="padding-left: 20px;">Printer diagnostics and adjustments > Motor tests</p> <p>2 Select Fuser, and then start the test.</p> <p>Do the fuser rollers and exit rollers turn?</p>	Go to step 16.	Go to step 12.
<p>Step 12</p> <p>1 Make sure that the fuser is properly installed.</p> <p>2 Remove the left cover. See Left cover removal.</p> <p>3 Remove the right cover. See Right cover removal.</p> <p>4 Reseat the fuser cables from the following components, and then check the cables for damage:</p> <ul style="list-style-type: none"> • HVPS • LVPS • Fuser to controller board connections <p>Are the fuser cables free of damage?</p>	Go to step 14.	Go to step 13.
<p>Step 13</p> <p>Replace the affected cable.</p> <p>Does the problem remain?</p>	Go to step 14.	The problem is solved.
<p>Step 14</p> <p>Check the fuser and its components for damage.</p> <ul style="list-style-type: none"> • Gears • Rollers • Cable • Guides and actuators <p>Is the fuser free of damage?</p>	Go to step 16.	Go to step 15.
<p>Step 15</p> <p>Replace the fuser. See Fuser removal.</p> <p>Does the problem remain?</p>	Go to step 16.	The problem is solved.

Diagnostics and Troubleshooting

Action	Yes	No
Step 16 Reseat the HVPS flat cables. Does the problem remain?	Go to step 17.	The problem is solved.
Step 17 Check the cables for damage. Are the cables free of damage?	Go to step 19.	Go to step 18.
Step 18 Replace the affected cable. Does the problem remain?	Go to step 19.	The problem is solved.
Step 19 Make sure that the controller board is properly installed. Reseat all the cables on the controller board. Does the problem remain?	Go to step 20.	The problem is solved.
Step 20 Check the controller board and its connector pins for damage. Are the controller board and its connectors free of damage?	Contact the next level of support.	Go to step 21.
Step 21 Replace the controller board. See Controller board removal . Does the problem remain?	Contact the next level of support.	The problem is solved.

Sensor (Fuser Exit) Late-leaving Jam Service Check

Action	Yes	No
<p>Step 1</p> <p>1 Open all printer doors, and then remove the manual feeder and tray.</p> <p>2 Check the paper path, tray, and bin for paper fragments and partially fed paper.</p> <p>Are the paper path, bin, and tray free of paper fragments and partially fed paper?</p>	Go to step 3.	Go to step 2.
<p>Step 2</p> <p>Remove the paper fragments and partially fed paper.</p> <p>Does the problem remain?</p>	Go to step 3.	The problem is solved.
<p>Step 3</p> <p>1 Enter the Diagnostics menu, and then navigate to:</p> <p>Printer diagnostics and adjustments > Sensor tests</p> <p>2 Find the sensor (Fuser exit).</p> <p>Does the sensor status change while toggling the sensor?</p>	Go to step 7.	Go to step 4.
<p>Step 4</p> <p>1 Remove the controller board shield. See Controller board shield removal.</p> <p>2 Reseat the cable of the sensor on the controller board.</p> <p>Does the problem remain?</p>	Go to step 5.	The problem is solved.
<p>Step 5</p> <p>Check the sensor for improper installation and damage.</p> <p>Is the sensor properly installed and free of damage?</p>	Go to step 7.	Go to step 6.
<p>Step 6</p> <p>Reinstall or replace the sensor. See Sensor (fuser exit) removal.</p> <p>Does the problem remain?</p>	Go to step 7.	The problem is solved.
<p>Step 7</p>	Go to step 11.	Go to step 8.

Diagnostics and Troubleshooting

Action	Yes	No
<p>1 Enter the Diagnostics menu, and then navigate to:</p> <p>Printer diagnostics and adjustments > Motor tests</p> <p>2 Select Fuser, and then start the test.</p> <p>The fuser rollers and exit rollers turn when the motor runs.</p> <p>Does the motor run?</p>		
<p>Step 8</p> <p>1 Remove the controller board shield. See Controller board shield removal.</p> <p>2 Reseat the cable on the motor and on the controller board.</p> <p>Does the problem remain?</p>	Go to step 9.	The problem is solved.
<p>Step 9</p> <p>Check the motor for improper installation, wear, and damage.</p> <p>Is the motor properly installed and free of damage?</p>	Go to step 11.	Go to step 10.
<p>Step 10</p> <p>Reinstall or replace the motor. See Motor (fuser) removal.</p> <p>Does the problem remain?</p>	Go to step 11.	The problem is solved.
<p>Step 11</p> <p>Check the top cover for improper installation and damage.</p> <p>Is the top cover properly installed and free of damage?</p>	Go to step 13.	Go to step 12.
<p>Step 12</p> <p>Replace the top cover. See Top cover removal.</p> <p>Does the problem remain?</p>	Go to step 13.	The problem is solved.
<p>Step 13</p> <p>1 Enter the Diagnostics menu, and then navigate to:</p> <p>Printer diagnostics and adjustments > Motor tests</p>	Go to step 18.	Go to step 14.

Action	Yes	No
<p>2 Select Fuser, and then start the test.</p> <p>Do the fuser rollers and exit rollers turn?</p>		
<p>Step 14</p> <p>1 Make sure that the fuser is properly installed.</p> <p>2 Remove the left cover. See Left cover removal.</p> <p>3 Remove the right cover. See Right cover removal.</p> <p>4 Reseat the fuser cables from the following components, and then check the cables for damage:</p> <ul style="list-style-type: none"> • HVPS • LVPS • Fuser to controller board connections <p>Are the fuser cables free of damage?</p>	Go to step 16.	Go to step 15.
<p>Step 15</p> <p>Replace the affected cable.</p> <p>Does the problem remain?</p>	Go to step 16.	The problem is solved.
<p>Step 16</p> <p>Check the fuser and its components for damage.</p> <ul style="list-style-type: none"> • Gears • Rollers • Cable • Guides and actuators <p>Is the fuser free of damage?</p>	Go to step 18.	Go to step 17.
<p>Step 17</p> <p>Replace the fuser. See Fuser removal.</p> <p>Does the problem remain?</p>	Go to step 18.	The problem is solved.
<p>Step 18</p> <p>Reseat the HVPS flat cables.</p> <p>Does the problem remain?</p>	Go to step 19.	The problem is solved.
<p>Step 19</p> <p>Check the cables for damage.</p>	Go to step 21.	Go to step 20.

Action	Yes	No
Are the cables free of damage?		
Step 20 Replace the affected cable. Does the problem remain?	Go to step 21.	The problem is solved.
Step 21 Make sure that the controller board is properly installed. Reseat all the cables on the controller board. Does the problem remain?	Go to step 22.	The problem is solved.
Step 22 Check the controller board and its connector pins for damage. Are the controller board and its connectors free of damage?	Contact the next level of support.	Go to step 23.
Step 23 Replace the controller board. See Controller board removal . Does the problem remain?	Contact the next level of support.	The problem is solved.

Sensor (Fuser Exit) Static Jam Service Check

Action	Yes	No
Step 1 1 Open all printer doors, and then remove the manual feeder and tray. 2 Check the paper path, tray, and bin for paper fragments and partially fed paper. Are the paper path, bin, and tray free of paper fragments and partially fed paper?	Go to step 3.	Go to step 2.
Step 2 Remove the paper fragments and partially fed paper. Does the problem remain?	Go to step 3.	The problem is solved.
Step 3	Go to step 7.	Go to step 4.

Action	Yes	No
<p>1 Enter the Diagnostics menu, and then navigate to:</p> <p>Printer diagnostics and adjustments > Sensor tests</p> <p>2 Find the sensor (Fuser exit).</p> <p>Does the sensor status change while toggling the sensor?</p>		
<p>Step 4</p> <p>1 Remove the controller board shield. See Controller board shield removal.</p> <p>2 Reseat the cable of the sensor on the controller board.</p> <p>Does the problem remain?</p>	Go to step 5.	The problem is solved.
<p>Step 5</p> <p>Check the sensor for improper installation and damage.</p> <p>Is the sensor properly installed and free of damage?</p>	Go to step 7.	Go to step 6.
<p>Step 6</p> <p>Reinstall or replace the sensor. See Sensor (fuser exit) removal.</p> <p>Does the problem remain?</p>	Go to step 7.	The problem is solved.
<p>Step 7</p> <p>1 Enter the Diagnostics menu, and then navigate to:</p> <p>Printer diagnostics and adjustments > Motor tests</p> <p>2 Select Fuser, and then start the test.</p> <p>Do the fuser rollers and exit rollers turn?</p>	Go to step 12.	Go to step 8.
<p>Step 8</p> <p>1 Make sure that the fuser is properly installed.</p> <p>2 Remove the left cover. See Left cover removal.</p> <p>3 Remove the right cover. See Right cover removal.</p> <p>4 Reseat the fuser cables from the following components, and then check the cables for damage:</p>	Go to step 10.	Go to step 9.

Diagnostics and Troubleshooting

Action	Yes	No
<ul style="list-style-type: none"> • HVPS • LVPS • Fuser to controller board connections <p>Are the fuser cables free of damage?</p>		
<p>Step 9</p> <p>Replace the affected cable.</p> <p>Does the problem remain?</p>	Go to step 10.	The problem is solved.
<p>Step 10</p> <p>Check the fuser and its components for damage.</p> <ul style="list-style-type: none"> • Gears • Rollers • Cable • Guides and actuators <p>Is the fuser free of damage?</p>	Go to step 12.	Go to step 11.
<p>Step 11</p> <p>Replace the fuser. See Fuser removal.</p> <p>Does the problem remain?</p>	Go to step 12.	The problem is solved.
<p>Step 12</p> <p>Reseat the HVPS flat cables.</p> <p>Does the problem remain?</p>	Go to step 13.	The problem is solved.
<p>Step 13</p> <p>Check the cables for damage.</p> <p>Are the cables free of damage?</p>	Go to step 15.	Go to step 14.
<p>Step 14</p> <p>Replace the affected cable.</p> <p>Does the problem remain?</p>	Go to step 15.	The problem is solved.
<p>Step 15</p> <p>Make sure that the controller board is properly installed. Reseat all the cables on the controller board.</p> <p>Does the problem remain?</p>	Go to step 16.	The problem is solved.

Action	Yes	No
Step 16 Check the controller board and its connector pins for damage. Are the controller board and its connectors free of damage?	Contact the next level of support.	Go to step 17.
Step 17 Replace the controller board. See Controller board removal . Does the problem remain?	Contact the next level of support.	The problem is solved.

232 Paper Jams

232 Paper Jam Messages

Error code	Description	Action
232.03	During a duplex print job, paper fed from the manual feeder never reached the sensor (input).	See Sensor (input) late-arriving jam (during duplex print) service check .
232.05	During a duplex print job, paper fed from the manual feeder never cleared the sensor (input).	See Sensor (input) late-leaving jam (during duplex print) service check .
232.13	During a duplex print job, paper fed from tray 1 never reached the sensor (input).	See Sensor (input) late-arriving jam (during duplex print) service check .
232.15	During a duplex print job, paper fed from tray 1 never cleared the sensor (input).	See Sensor (input) late-leaving jam (during duplex print) service check .
232.93	During a duplex print job, paper never reached the sensor (input). Paper source is undetermined.	See Sensor (input) late-leaving jam (during duplex print) service check .
232.95	During a duplex print job, paper never cleared the sensor (input). Paper source is undetermined.	

Sensor (Input) Late-arriving Jam (During Duplex Print) Service Check

Action	Yes	No
<p>Step 1</p> <p>1 Open all printer doors, and then remove the manual feeder and tray.</p> <p>2 Check the paper path, tray, and bin for paper fragments and partially fed paper.</p> <p>Are the paper path, bin, and tray free of paper fragments and partially fed paper?</p>	Go to step 3.	Go to step 2.
<p>Step 2</p> <p>Remove the paper fragments and partially fed paper.</p> <p>Does the problem remain?</p>	Go to step 3.	The problem is solved.
<p>Step 3</p> <p>1 Enter the Diagnostics menu, and then navigate to:</p> <p>Printer diagnostics and adjustments > Sensor tests</p> <p>2 Find the sensor (Input).</p> <p>Does the sensor status change while toggling the sensor?</p>	Go to step 7.	Go to step 4.
<p>Step 4</p> <p>1 Remove the controller board shield. See Controller board shield removal.</p> <p>2 Reseat the cable of the sensor on the controller board.</p> <p>Does the problem remain?</p>	Go to step 5.	The problem is solved.
<p>Step 5</p> <p>Check the sensor and its flag for improper installation and damage.</p> <p>Is the sensor properly installed and free of damage?</p>	Go to step 7.	Go to step 6.
<p>Step 6</p> <p>Reinstall or replace the sensor. See Sensor (input) removal.</p> <p>Does the problem remain?</p>	Go to step 7.	The problem is solved.

Action	Yes	No
<p>Step 7</p> <ol style="list-style-type: none"> 1 Check the rear door for improper installation, misalignment, and damage. 2 Check the rear door sensor flag for damage. 3 Check the rear door rollers and gears for wear, damage, and contamination. <p>Are the rear door and its components properly installed and free of wear, damage, and contamination?</p>	Go to step 9.	Go to step 8.
<p>Step 8</p> <p>Reinstall, clean, or replace the rear door. See Rear door removal.</p> <p>Does the problem remain?</p>	Go to step 9.	The problem is solved.
<p>Step 9</p> <ol style="list-style-type: none"> 1 Enter the Diagnostics menu, and then navigate to: Printer diagnostics and adjustments > Motor tests 2 Select Fuser, and then start the test. The fuser rollers and exit rollers turn when the motor runs. <p>Does the motor run?</p>	Go to step 13.	Go to step 10.
<p>Step 10</p> <ol style="list-style-type: none"> 1 Remove the controller board shield. See Controller board shield removal. 2 Reseat the cable on the motor and on the controller board. <p>Does the problem remain?</p>	Go to step 11.	The problem is solved.
<p>Step 11</p> <p>Check the motor for improper installation, wear, and damage.</p> <p>Is the motor properly installed and free of damage?</p>	Go to step 13.	Go to step 12.
<p>Step 12</p> <p>Reinstall or replace the motor. See Motor (fuser) removal.</p> <p>Does the problem remain?</p>	Go to step 13.	The problem is solved.

Diagnostics and Troubleshooting

Action	Yes	No
<p>Step 13</p> <p>1 Enter the Diagnostics menu, and then navigate to:</p> <p>Printer diagnostics and adjustments > Motor tests > Staging clutch</p> <p>2 Find the staging clutch, and then start the test.</p> <p>Does the clutch operate?</p>	Go to step 17.	Go to step 14.
<p>Step 14</p> <p>1 Remove the controller board shield. See Controller board shield removal.</p> <p>2 Reseat the clutch cable.</p> <p>Does the problem remain?</p>	Go to step 15.	The problem is solved.
<p>Step 15</p> <p>Check the clutch for improper installation and damage.</p> <p>Is the clutch properly installed and free of damage?</p>	Go to step 17.	Go to step 16.
<p>Step 16</p> <p>Reinstall or replace the clutch. See Staging clutch removal.</p> <p>Does the problem remain?</p>	Go to step 17.	The problem is solved.
<p>Step 17</p> <p>Check the staging drive components for improper installation, wear, and damage.</p> <ul style="list-style-type: none"> • Belt • Gear • Pulley <p>Are the staging drive components properly installed and free of wear and damage?</p>	Go to step 19.	Go to step 18.
<p>Step 18</p> <p>Reinstall or replace the affected staging belt, gear, or pulley. See Staging belt, gear, and pulley removal.</p> <p>Does the problem remain?</p>	Go to step 19.	The problem is solved.
<p>Step 19</p>	Go to step 23.	Go to step 20.

Action	Yes	No
<p>1 Enter the Diagnostics menu, and then navigate to:</p> <p>Printer diagnostics and adjustments > Motor tests</p> <p>2 Select K/Transfer belt, and then start the test.</p> <p>Does the motor run?</p>		
<p>Step 20</p> <p>1 Remove the controller board shield. See Controller board shield removal.</p> <p>2 Reseat the cable on the motor and on the controller board.</p> <p>Does the problem remain?</p>	Go to step 21.	The problem is solved.
<p>Step 21</p> <p>Check the motor for improper installation, wear, and damage.</p> <p>Is the motor properly installed and free of wear and damage?</p>	Go to step 23.	Go to step 22.
<p>Step 22</p> <p>Reinstall or replace the motor. See Motor (K/transfer belt) removal.</p> <p>Does the problem remain?</p>	Go to step 23.	The problem is solved.
<p>Step 23</p> <p>1 Enter the Diagnostics menu, and then navigate to:</p> <p>Printer diagnostics and adjustments > Motor tests</p> <p>2 Run the test on the following motors and clutches. In each test, check the gears for lack of movement and unusual noise.</p> <ul style="list-style-type: none"> • CMY • K/Transfer belt • Pick clutch • Staging clutch <p>Do the gears move properly without unusual noise?</p>	Go to step 27.	Go to step 24.
<p>Step 24</p> <p>Check the gearbox gears and couplers for wear and damage.</p>	Go to step 25.	Go to step 26.

Diagnostics and Troubleshooting

Action	Yes	No
<ul style="list-style-type: none"> • Drive gears for all print cartridges and transfer belt • Drive gears that engage with the clutches • Couplers for all print cartridges and the transfer belt <p>Are the gears and couplers free of wear and damage?</p>		
<p>Step 25</p> <ol style="list-style-type: none"> 1 Remove the gearbox. See Gearbox removal. 2 Make sure that the gearbox gears are properly lubricated. 3 Reinstall the gearbox. <p>Does the problem remain?</p>	Go to step 26.	The problem is solved.
<p>Step 26</p> <p>Replace the gearbox. See Gearbox removal.</p> <p>Does the problem remain?</p>	Go to step 27.	The problem is solved.
<p>Step 27</p> <p>Make sure that the controller board is properly installed. Reseat all the cables on the controller board.</p> <p>Does the problem remain?</p>	Go to step 28.	The problem is solved.
<p>Step 28</p> <p>Check the controller board and its connector pins for damage.</p> <p>Are the controller board and its connectors free of damage?</p>	Contact the next level of support.	Go to step 29.
<p>Step 29</p> <p>Replace the controller board. See Controller board removal.</p> <p>Does the problem remain?</p>	Contact the next level of support.	The problem is solved.

Sensor (Input) Late-leaving Jam (During Duplex Print) Service Check

Action	Yes	No
<p>Step 1</p> <p>1 Open all printer doors, and then remove the manual feeder and tray.</p> <p>2 Check the paper path, tray, and bin for paper fragments and partially fed paper.</p> <p>Are the paper path, bin, and tray free of paper fragments and partially fed paper?</p>	Go to step 3.	Go to step 2.
<p>Step 2</p> <p>Remove the paper fragments and partially fed paper.</p> <p>Does the problem remain?</p>	Go to step 3.	The problem is solved.
<p>Step 3</p> <p>1 Enter the Diagnostics menu, and then navigate to:</p> <p>Printer diagnostics and adjustments > Sensor tests</p> <p>2 Find the sensor (Input).</p> <p>Does the sensor status change while toggling the sensor?</p>	Go to step 7.	Go to step 4.
<p>Step 4</p> <p>1 Remove the controller board shield. See Controller board shield removal.</p> <p>2 Reseat the cable of the sensor on the controller board.</p> <p>Does the problem remain?</p>	Go to step 5.	The problem is solved.
<p>Step 5</p> <p>Check the sensor and its flag for improper installation and damage.</p> <p>Is the sensor properly installed and free of damage?</p>	Go to step 7.	Go to step 6.
<p>Step 6</p> <p>Reinstall or replace the sensor. See Sensor (input) removal.</p> <p>Does the problem remain?</p>	Go to step 7.	The problem is solved.

Diagnostics and Troubleshooting

Action	Yes	No
<p>Step 7</p> <ol style="list-style-type: none"> 1 Check the rear door for improper installation, misalignment, and damage. 2 Check the rear door sensor flag for damage. 3 Check the rear door rollers and gears for wear, damage, and contamination. <p>Are the rear door and its components properly installed and free of wear, damage, and contamination?</p>	Go to step 9.	Go to step 8.
<p>Step 8</p> <p>Reinstall, clean, or replace the rear door. See Rear door removal.</p> <p>Does the problem remain?</p>	Go to step 9.	The problem is solved.
<p>Step 9</p> <ol style="list-style-type: none"> 1 Enter the Diagnostics menu, and then navigate to: Printer diagnostics and adjustments > Motor tests > Staging clutch 2 Find the staging clutch, and then start the test. <p>Does the clutch operate?</p>	Go to step 13.	Go to step 10.
<p>Step 10</p> <ol style="list-style-type: none"> 1 Remove the controller board shield. See Controller board shield removal. 2 Reseat the clutch cable. <p>Does the problem remain?</p>	Go to step 11.	The problem is solved.
<p>Step 11</p> <p>Check the clutch for improper installation and damage.</p> <p>Is the clutch properly installed and free of damage?</p>	Go to step 13.	Go to step 12.
<p>Step 12</p> <p>Reinstall or replace the clutch. See Staging clutch removal.</p> <p>Does the problem remain?</p>	Go to step 13.	The problem is solved.
<p>Step 13</p>	Go to step 15.	Go to step 14.

Action	Yes	No
<p>Check the staging drive components for improper installation, wear, and damage.</p> <ul style="list-style-type: none"> • Belt • Gear • Pulley <p>Are the staging drive components properly installed and free of wear and damage?</p>		
<p>Step 14</p> <p>Reinstall or replace the affected staging belt, gear, or pulley. See Staging belt, gear, and pulley removal .</p> <p>Does the problem remain?</p>	Go to step 15.	The problem is solved.
<p>Step 15</p> <p>1 Enter the Diagnostics menu, and then navigate to:</p> <p>Printer diagnostics and adjustments > Motor tests</p> <p>2 Select K/Transfer belt, and then start the test.</p> <p>Does the motor run?</p>	Go to step 19.	Go to step 16.
<p>Step 16</p> <p>1 Remove the controller board shield. See Controller board shield removal .</p> <p>2 Reseat the cable on the motor and on the controller board.</p> <p>Does the problem remain?</p>	Go to step 17.	The problem is solved.
<p>Step 17</p> <p>Check the motor for improper installation, wear, and damage.</p> <p>Is the motor properly installed and free of wear and damage?</p>	Go to step 19.	Go to step 18.
<p>Step 18</p> <p>Reinstall or replace the motor. See Motor (K/transfer belt) removal .</p> <p>Does the problem remain?</p>	Go to step 19.	The problem is solved.
<p>Step 19</p>	Go to step 22.	Go to step 20.

Diagnostics and Troubleshooting

Action	Yes	No
<p>1 Enter the Diagnostics menu, and then navigate to:</p> <p>Printer diagnostics and adjustments > Motor tests</p> <p>2 Select K/Transfer belt, and then start the test.</p> <p>Does the transfer belt or transfer roller move?</p>		
<p>Step 20</p> <p>Check the transfer module and its components for improper installation and damage.</p> <ul style="list-style-type: none"> • Transfer belt • Transfer roller • Coupler gears <p>Is the transfer module properly installed and free of damage?</p>	Go to step 22.	Go to step 21.
<p>Step 21</p> <p>Reinstall or replace the transfer module. See Transfer module removal.</p> <p>Does the problem remain?</p>	Go to step 22.	The problem is solved.
<p>Step 22</p> <p>1 Enter the Diagnostics menu, and then navigate to:</p> <p>Printer diagnostics and adjustments > Motor tests</p> <p>2 Select Fuser, and then start the test.</p> <p>The fuser rollers and exit rollers turn when the motor runs.</p> <p>Does the motor run?</p>	Go to step 26.	Go to step 23.
<p>Step 23</p> <p>1 Remove the controller board shield. See Controller board shield removal.</p> <p>2 Reseat the cable on the motor and on the controller board.</p> <p>Does the problem remain?</p>	Go to step 24.	The problem is solved.
<p>Step 24</p> <p>Check the motor for improper installation, wear, and damage.</p>	Go to step 26.	Go to step 25.

Action	Yes	No
Is the motor properly installed and free of damage?		
Step 25 Reinstall or replace the motor. See Motor (fuser) removal . Does the problem remain?	Go to step 26.	The problem is solved.
Step 26 1 Enter the Diagnostics menu, and then navigate to: Printer diagnostics and adjustments > Motor tests 2 Select Fuser , and then start the test. Do the fuser rollers and exit rollers turn?	Go to step 30.	Go to step 27.
Step 27 1 Make sure that the fuser is properly installed. 2 Remove the left cover. See Left cover removal . 3 Remove the right cover. See Right cover removal . 4 Reseat the fuser cables from the following components: <ul style="list-style-type: none"> • HVPS • LVPS • Fuser to controller board connections Does the problem remain?	Go to step 28.	The problem is solved.
Step 28 Check the fuser and its components for damage. <ul style="list-style-type: none"> • Gears • Rollers • Cable • Guides and actuators Is the fuser free of damage?	Go to step 30.	Go to step 29.
Step 29 Replace the fuser. See Fuser removal . Does the problem remain?	Go to step 30.	The problem is solved.

Action	Yes	No
<p>Step 30</p> <p>1 Enter the Diagnostics menu, and then navigate to:</p> <p>Printer diagnostics and adjustments > Motor tests</p> <p>2 Run the test on the following motors and clutches. In each test, check the gears for lack of movement and unusual noise.</p> <ul style="list-style-type: none"> • CMY • K/Transfer belt • Pick clutch • Staging clutch <p>Do the gears move properly without unusual noise?</p>	Go to step 34.	Go to step 31.
<p>Step 31</p> <p>Check the gearbox gears and couplers for wear and damage.</p> <ul style="list-style-type: none"> • Drive gears for all print cartridges and transfer belt • Drive gears that engage with the clutches • Couplers for all print cartridges and the transfer belt <p>Are the gears and couplers free of wear and damage?</p>	Go to step 32.	Go to step 33.
<p>Step 32</p> <p>1 Remove the gearbox. See Gearbox removal.</p> <p>2 Make sure that the gearbox gears are properly lubricated.</p> <p>3 Reinstall the gearbox.</p> <p>Does the problem remain?</p>	Go to step 33.	The problem is solved.
<p>Step 33</p> <p>Replace the gearbox. See Gearbox removal.</p> <p>Does the problem remain?</p>	Go to step 34.	The problem is solved.
<p>Step 34</p> <p>Make sure that the controller board is properly installed. Reseat all the cables on the controller board.</p> <p>Does the problem remain?</p>	Go to step 35.	The problem is solved.

Action	Yes	No
Step 35 Check the controller board and its connector pins for damage. Are the controller board and its connectors free of damage?	Contact the next level of support.	Go to step 36.
Step 36 Replace the controller board. See Controller board removal . Does the problem remain?	Contact the next level of support.	The problem is solved.

241 Paper Jams

241 Paper Jam Messages

Error code	Description	Action
241.05	Paper fed from the manual feeder cleared the sensor (input) later than expected.	See Sensor (input) late-leaving jam service check .
241.91	Paper remains detected at the sensor (input) after the printer is turned on.	See Sensor (input) static jam service check .

User Attendance Messages

Non-Xerox Supply

The printer has detected a non-Xerox supply or part installed in the printer.

The Xerox printer is designed to function best with genuine Xerox supplies and parts. Use of third-party supplies or parts may affect the performance, reliability, or life of the printer and its imaging components.

All life indicators are designed to function with Xerox supplies and parts and may deliver unpredictable results if third-party supplies or parts are used. Imaging component usage beyond the intended life may damage the Xerox printer or associated components.

 **Warning:** Use of third-party supplies or parts can affect warranty coverage. Damage caused by the use of third-party supplies or parts may not be covered by the warranty.

If a customer accepts any and all of these risks and proceeds with the use of non-genuine supplies or parts in the printer, then instruct the customer to press and hold **X** and **#** simultaneously from the control panel for 15 seconds. Do not perform this action yourself.

If a customer does not want to accept these risks, then remove the third-party supply or part from the printer and install a genuine Xerox supply or part.

If the printer does not print after pressing and holding **X** and **#** simultaneously for 15 seconds, then instruct the customer to reset the supply usage counter.

1. From the control panel, navigate to:
Settings > Device > Maintenance > Configuration Menu > Supply Usage And Counters
2. Select the part or supply to reset, and then select **Start**.
3. Read the warning message, and then select **Continue**.
4. Press and hold **X** and **#** simultaneously for 15 seconds to clear the message.

 **Note:** If the customer is unable to reset the supply usage counters, then the customer should return the item to the place of purchase.

Metered Supply Installed in Printer Configured For Sold

The printer has detected a metered supply installed in the printer configured to use sold supply.

The printers ship with worldwide neutral toner cartridges. Initial installation of these cartridges sets the printer to worldwide neutral configuration. The first toner cartridge replacement sets the geographic differentiation code and toner cartridge type in NVM to that of the replacement cartridge. To change these NVM, a supplies plan conversion code (non-PagePack) or activation code (PagePack) code is required.

See [Supplies Used to Resolve Print Quality Issues](#) for part numbers.

If an incorrect type of toner cartridge is installed, an error code is generated indicating toner incompatibility.

Changing The Service Plan (Non-PagePack)

Contact the relevant OpCo to obtain a conversion code:

- **US:** Provide the printer Serial Number and Total Meter Read using the email template provided in Eureka Tip 1465825. A conversion PIN code is provided within 10 minutes. For any service plan conversion issues or special requests, phone Xerox Corporate Licensing Systems (XDSS), 1-800-890-3260.
- **Xerox Business Solutions (XBS):** All requests for service plan conversions must be approved by the XBS VP of Service. Request your field service manager to contact your XBS company VP of Service for direction. The XBS Core Company VP of Service will require authorization to convert the printer from sold to metered, and will provide a status of your request. Do not phone Field Engineering to request a conversion code.
- **US Authorized Service Provider (ASP):** Provide the printer Serial Number and Total Meter Read using the email template provided in Eureka Tip 1465825. A conversion PIN code is provided within 10 minutes. For any service plan conversion issues or special requests, phone Xerox Corporate Licensing Systems (XDSS), 1-800-890-3260.
- **Canada:** Provide the printer Serial Number and Total Meter Read using the email template provided in Eureka Tip 1465825. A conversion PIN code is provided within 10 minutes. For any service plan conversion issues or special requests, phone Customer Delivery Organization (CDO) field support, 1-800-647-1331.



Note: The service plan conversion code must be entered within 500 Total Impression counts. If this count is exceeded, a new code is required.

Using The Control Panel

1. From the control panel, navigate to **Settings > Supplies Plan > Plan Conversion**.
2. Record the **Total Impressions** and **Device Serial Number**.
3. Contact the relevant OpCo to obtain the conversion code.
4. After receiving the conversion code, on the control panel, navigate to **Supplies Plan > Plan Conversion > Conversion Code**.
5. Enter the conversion code provided, then select **Convert Plan**.
6. Navigate to **Supplies Plan > Plan Conversion > Current Plan** to confirm the conversion is successful.

Using The Embedded Web Server

1. Open a web browser, and then type the printer IP address. If necessary, ask the customer to enter the Admin password.
2. From the home page, navigate to **Settings > Supplies Plan > Plan Conversion**.
3. Record the **Total Impressions** and **Device Serial Number**.
4. Contact the relevant OpCo to obtain the conversion code.
5. After receiving the conversion code, on the embedded web server, navigate to **Settings > Supplies Plan > Plan Conversion > Conversion Code**.

6. Enter the conversion code provided, then click **Convert Plan**.
7. Check the **Current Plan** status to confirm the conversion is successful.

Changing The Service Plan (PagePack)

Contact the relevant OpCo to obtain an activation code. Provide the Sequence Number and Device Serial Number.

- **EMEA (XE):** Email office.europe.page.pack.pin@xerox.com
- **EMEA (DMO-E):** Follow your local process.
- **LATAM (Latin America):** Follow your local process.



Note: The service plan activation code must be entered within 1000 Total Impression counts. If this count is exceeded, a new code is required.

Using The Control Panel

1. From the control panel, navigate to **Supplies Plan > Plan Activation**.
2. Record the **Sequence Number** and **Device Serial Number**.
3. Contact the relevant OpCo to obtain the activation code.
4. After receiving the activation code, on the control panel, navigate to **Settings > Supplies Plan > Plan Activation > Activation Code**.
5. Enter the activation code provided, then select **Activate Plan**.

Using The Embedded Web Server

1. Open a web browser, and then type the printer IP address. If necessary, ask the customer to enter the Admin password.
2. From the home page, navigate to **Settings > Supplies Plan > Plan Activation**.
3. Record the **Sequence Number** and **Device Serial Number**.
4. Contact the relevant OpCo to obtain the activation code.
5. After receiving the activation code, on the embedded web server, navigate to **Settings > Supplies Plan > Plan Activation > Activation Code**.
6. Enter the activation code provided, then click **Activate Plan**.

0y User Attendance Errors

8–9 User Attendance Messages

Error code	Description	Action
8.01	Door A was detected as open.	See Undetected door A service check .
8.02	Door B was detected as open.	See Undetected door B service check .
9.00	A problem caused the printer to restart automatically.	See Auto reboot error service check .

Undetected Door A Service Check

Action	Yes	No
<p>Step 1</p> <ol style="list-style-type: none"> 1 Open all printer doors, and then clear any obstructions. 2 Close the doors properly. Make sure that there is no gap between the door and the printer. <p>Does the problem remain?</p>	Go to step 2.	The problem is solved.
<p>Step 2</p> <ol style="list-style-type: none"> 1 Check the front door and its components for improper installation. Make sure that the door links and hinges are properly engaged. 2 Check the front door and its interlock actuator for damage. <p>Are the front door and its components properly installed and free of damage?</p>	Go to step 4.	Go to step 3.
<p>Step 3</p> <p>Reinstall or replace the front door. See Front door removal.</p> <p>Does the problem remain?</p>	Go to step 4.	The problem is solved.
<p>Step 4</p> <ol style="list-style-type: none"> 1 Enter the Diagnostics menu, and then navigate to: Printer diagnostics and adjustments > Sensor tests 	Go to step 6.	Go to step 5.

Diagnostics and Troubleshooting

Action	Yes	No
<p>2 Find the front door interlock switch.</p> <p>Does the switch status change while toggling the switch?</p>		
<p>Step 5</p> <p>Check the switch for damage.</p> <p>Is the switch free of damage?</p>	Go to step 6.	Go to step 11.
<p>Step 6</p> <p>Reseat the HVPS flat cables.</p> <p>Does the problem remain?</p>	Go to step 7.	The problem is solved.
<p>Step 7</p> <p>Check the cables for damage.</p> <p>Are the cables free of damage?</p>	Go to step 9.	Go to step 8.
<p>Step 8</p> <p>Replace the affected cable.</p> <p>Does the problem remain?</p>	Go to step 9.	The problem is solved.
<p>Step 9</p> <p>1 Make sure that the HVPS is properly installed.</p> <p>2 Reseat all the cables on the HVPS.</p> <p>3 Properly align the spring contacts.</p> <p>Does the problem remain?</p>	Go to step 10.	The problem is solved.
<p>Step 10</p> <p>Check the HVPS contacts for contamination and damage.</p> <p>Are the HVPS contacts free of contamination and damage?</p>	Go to step 12.	Go to step 11.
<p>Step 11</p> <p>Clean or replace the HVPS. See HVPS removal.</p> <p>Does the problem remain?</p>	Go to step 12.	The problem is solved.
<p>Step 12</p> <p>Make sure that the controller board is properly installed. Reseat all the cables on the controller board.</p>	Go to step 13.	The problem is solved.

Action	Yes	No
Does the problem remain?		
Step 13 Check the controller board and its connector pins for damage. Are the controller board and its connectors free of damage?	Contact the next level of support.	Go to step 14.
Step 14 Replace the controller board. See Controller board removal . Does the problem remain?	Contact the next level of support.	The problem is solved.

Undetected Door B Service Check

Action	Yes	No
Step 1 1 Check the rear door for improper installation, misalignment, and damage. 2 Check the rear door sensor flag for damage. 3 Check the rear door rollers and gears for wear, damage, and contamination. Are the rear door and its components properly installed and free of wear, damage, and contamination?	Go to step 3.	Go to step 2.
Step 2 Reinstall, clean, or replace the rear door. See Rear door removal . Does the problem remain?	Go to step 3.	The problem is solved.
Step 3 1 Enter the Diagnostics menu, and then navigate to: Printer diagnostics and adjustments > Sensor tests 2 Find the sensor (Fuser buckle). Does the sensor status change while toggling the sensor?	Go to step 7.	Go to step 4.
Step 4	Go to step 5.	The problem is solved.

Diagnostics and Troubleshooting

Action	Yes	No
<p>1 Remove the controller board shield. See Controller board shield removal .</p> <p>2 Reseat the cable of the sensor on the controller board.</p> <p>Does the problem remain?</p>		
<p>Step 5</p> <p>Check the sensor and its flag for improper installation and damage.</p> <p>Is the sensor properly installed and free of damage?</p>	Go to step 7.	Go to step 6.
<p>Step 6</p> <p>Reinstall or replace the sensor. See Sensor (fuser buckle) removal .</p> <p>Does the problem remain?</p>	Go to step 7.	The problem is solved.
<p>Step 7</p> <p>1 Remove the left cover. See Left cover removal.</p> <p>2 Remove the right cover. See Right cover removal.</p> <p>3 Reseat the fuser cables from the following components, and then check the cables for damage:</p> <ul style="list-style-type: none"> • HVPS • LVPS • Fuser to controller board connections <p>Are the fuser cables free of damage?</p>	Go to step 9.	Go to step 8.
<p>Step 8</p> <p>Replace the affected cable.</p> <p>Does the problem remain?</p>	Go to step 9.	The problem is solved.
<p>Step 9</p> <p>Reseat the HVPS flat cables.</p> <p>Does the problem remain?</p>	Go to step 10.	The problem is solved.
<p>Step 10</p> <p>Check the cables for damage.</p> <p>Are the cables free of damage?</p>	Go to step 12.	Go to step 11.
<p>Step 11</p>	Go to step 12.	The problem is solved.

Action	Yes	No
Replace the affected cable. Does the problem remain?		
Step 12 Make sure that the controller board is properly installed. Reseat all the cables on the controller board. Does the problem remain?	Go to step 13.	The problem is solved.
Step 13 Check the controller board and its connector pins for damage. Are the controller board and its connectors free of damage?	Contact the next level of support.	Go to step 14.
Step 14 Replace the controller board. See Controller board removal . Does the problem remain?	Contact the next level of support.	The problem is solved.

Auto Reboot Error Service Check

Action	Yes	No
Step 1 Turn off the printer, wait for about 10 seconds, and then turn on the printer. Does the problem remain?	Go to step 2.	The problem is solved.
Step 2 1 Turn off the printer. 2 Turn on the printer and enter the Diagnostics menu. 3 Do a print test. 4 Restart the printer. Does the problem remain?	Go to step 3.	The problem is solved.
Step 3 Make sure that the controller board is properly installed. Reseat all the cables on the controller board. Does the problem remain?	Go to step 4.	The problem is solved.

Action	Yes	No
Step 4 Check the controller board cables for damage. Are the cables free of damage?	Go to step 6.	Go to step 5.
Step 5 Replace the affected cables. Does the problem remain?	Go to step 6.	The problem is solved.
Step 6 Check the firmware version. Is the firmware updated to the latest version?	Go to step 8.	Go to step 7.
Step 7 Update the firmware. Does the problem remain?	Go to step 8.	The problem is solved.
Step 8 Check the controller board and its connector pins for damage. Are the controller board and its connectors free of damage?	Contact the next level of support.	Go to step 9.
Step 9 Replace the controller board. See Controller board removal . Does the problem remain?	Contact the next level of support.	The problem is solved.

1y User Attendance Errors

11–12 User Attendance Messages

Error code	Description	Action
11.11	A wrong paper type or size was detected on tray 1.	See Paper loading error service check .
11.12	A wrong paper type, size, or orientation was detected on tray 1.	
11.81	A wrong paper type or size was detected on the manual feeder.	See Paper loading error service check .

Error code	Description	Action
11.82	A wrong paper type, size, or orientation was detected on the manual feeder.	
12.11	A wrong setting for paper type or size was detected on tray 1.	
12.12	A wrong setting for paper type, size, or orientation was detected on tray 1.	
12.81	A wrong setting for paper type or size was detected on the manual feeder.	
12.82	A wrong setting for paper type, size, or orientation was detected on the manual feeder.	

Paper Loading Error Service Check

Action	Yes	No
<p>Step 1</p> <ol style="list-style-type: none"> 1 Open all printer doors, and then remove the manual feeder and tray. 2 Check the paper path, tray, and bin for paper fragments and partially fed paper. <p>Are the paper path, bin, and tray free of paper fragments and partially fed paper?</p>	Go to step 3.	Go to step 2.
<p>Step 2</p> <p>Remove the paper fragments and partially fed paper.</p> <p>Does the problem remain?</p>	Go to step 3.	The problem is solved.
<p>Step 3</p> <ol style="list-style-type: none"> 1 Make sure that the paper is properly loaded in the tray and manual feeder. See Avoiding jams. 2 Make sure that the tray and manual feeder are properly installed. <p>Does the problem remain?</p>	Go to step 4.	The problem is solved.
<p>Step 4</p> <ol style="list-style-type: none"> 1 From the control panel, navigate to: 	Go to step 5.	The problem is solved.

Diagnostics and Troubleshooting

Action	Yes	No
<p>Settings > Paper > Tray Configuration > Paper Size/Type</p> <p>2 Make sure that the setting matches the paper loaded.</p> <p>Does the problem remain?</p>		
<p>Step 5</p> <p>1 Check the tray insert and its guides for damage.</p> <p>2 Check the tray insert pads for wear and damage.</p> <p>Is the tray insert free of damage?</p>	Go to step 7.	Go to step 6.
<p>Step 6</p> <p>Replace the tray insert.</p> <p>Does the problem remain?</p>	Go to step 7.	The problem is solved.
<p>Step 7</p> <p>Check the pick tires for improper installation, contamination, wear, and damage.</p> <p>Are the pick tires properly installed and free of contamination, wear, and damage?</p>	Go to step 9.	Go to step 8.
<p>Step 8</p> <p>Reinstall, clean, or replace the pick tire. See Pick tire removal.</p> <p>Does the problem remain?</p>	Go to step 9.	The problem is solved.
<p>Step 9</p> <p>1 Check the pick roller for improper mechanism.</p> <p>After the pick roller is lowered, it must move automatically to its original position.</p> <p>2 Check the pick roller for damage.</p> <p>Is the pick roller functional and free of damage?</p>	Go to step 10.	Contact the next level of support.
<p>Step 10</p> <p>1 Enter the Diagnostics menu, and then navigate to:</p> <p>Printer diagnostics and adjustments > Sensor tests</p>	Go to step 14.	Go to step 11.

Action	Yes	No
<p>2 Find the sensor (Input).</p> <p>Does the sensor status change while toggling the sensor?</p>		
<p>Step 11</p> <p>1 Remove the controller board shield. See Controller board shield removal.</p> <p>2 Reseat the cable of the sensor on the controller board.</p> <p>Does the problem remain?</p>	Go to step 12.	The problem is solved.
<p>Step 12</p> <p>Check the sensor and its flag for improper installation and damage.</p> <p>Is the sensor properly installed and free of damage?</p>	Go to step 14.	Go to step 13.
<p>Step 13</p> <p>Reinstall or replace the sensor. See Sensor (input) removal.</p> <p>Does the problem remain?</p>	Go to step 14.	The problem is solved.
<p>Step 14</p> <p>1 Enter the Diagnostics menu, and then navigate to:</p> <p>Printer diagnostics and adjustments > Motor tests</p> <p>2 Select K/Transfer belt, and then start the test.</p> <p>Does the motor run?</p>	Go to step 18.	Go to step 15.
<p>Step 15</p> <p>1 Remove the controller board shield. See Controller board shield removal.</p> <p>2 Reseat the cable on the motor and on the controller board.</p> <p>Does the problem remain?</p>	Go to step 16.	The problem is solved.
<p>Step 16</p> <p>Check the motor for improper installation, wear, and damage.</p> <p>Is the motor properly installed and free of wear and damage?</p>	Go to step 18.	Go to step 17.
<p>Step 17</p>	Go to step 18.	The problem is solved.

Action	Yes	No
<p>Reinstall or replace the motor. See Motor (K/transfer belt) removal .</p> <p>Does the problem remain?</p>		
<p>Step 18</p> <p>1 Enter the Diagnostics menu, and then navigate to:</p> <p>Printer diagnostics and adjustments > Motor tests > Pick clutch (Tray 1 or Manual Feed)</p> <p>2 Find the pick clutch, and then start the test.</p> <p>Does the clutch operate?</p>	Go to step 22.	Go to step 19.
<p>Step 19</p> <p>1 Remove the controller board shield. See Controller board shield removal .</p> <p>2 Reseat the clutch cable.</p> <p>Does the problem remain?</p>	Go to step 20.	The problem is solved.
<p>Step 20</p> <p>Check the clutch for improper installation and damage.</p> <p>Is the clutch properly installed and free of damage?</p>	Go to step 22.	Go to step 21.
<p>Step 21</p> <p>Reinstall or replace the clutch. See Pick clutch removal.</p> <p>Does the problem remain?</p>	Go to step 22.	The problem is solved.
<p>Step 22</p> <p>1 Enter the Diagnostics menu, and then navigate to:</p> <p>Printer diagnostics and adjustments > Motor tests > Staging clutch</p> <p>2 Find the staging clutch, and then start the test.</p> <p>Does the clutch operate?</p>	Go to step 26.	Go to step 23.
<p>Step 23</p> <p>1 Remove the controller board shield. See Controller board shield removal .</p>	Go to step 24.	The problem is solved.

Action	Yes	No
2 Reseat the clutch cable. Does the problem remain?		
Step 24 Check the clutch for improper installation and damage. Is the clutch properly installed and free of damage?	Go to step 26.	Go to step 25.
Step 25 Reinstall or replace the clutch. See Staging clutch removal . Does the problem remain?	Go to step 26.	The problem is solved.
Step 26 Check the staging drive components for improper installation, wear, and damage. <ul style="list-style-type: none"> • Belt • Gear • Pulley Are the staging drive components properly installed and free of wear and damage?	Go to step 28.	Go to step 27.
Step 27 Reinstall or replace the affected staging belt, gear, or pulley. See Staging belt, gear, and pulley removal . Does the problem remain?	Go to step 28.	The problem is solved.
Step 28 1 Enter the Diagnostics menu, and then navigate to: Printer diagnostics and adjustments > Motor tests 2 Run the test on the following motors and clutches. In each test, check the gears for lack of movement and unusual noise. <ul style="list-style-type: none"> • CMY • K/Transfer belt • Pick clutch • Staging clutch Do the gears move properly without unusual noise?	Go to step 32.	Go to step 29.

Diagnostics and Troubleshooting

Action	Yes	No
<p>Step 29</p> <p>Check the gearbox gears and couplers for wear and damage.</p> <ul style="list-style-type: none"> • Drive gears for all print cartridges and transfer belt • Drive gears that engage with the clutches • Couplers for all print cartridges and the transfer belt <p>Are the gears and couplers free of wear and damage?</p>	Go to step 30.	Go to step 31.
<p>Step 30</p> <ol style="list-style-type: none"> 1 Remove the gearbox. See Gearbox removal. 2 Make sure that the gearbox gears are properly lubricated. 3 Reinstall the gearbox. <p>Does the problem remain?</p>	Go to step 31.	The problem is solved.
<p>Step 31</p> <p>Replace the gearbox. See Gearbox removal.</p> <p>Does the problem remain?</p>	Go to step 32.	The problem is solved.
<p>Step 32</p> <p>Make sure that the controller board is properly installed. Reseat all the cables on the controller board.</p> <p>Does the problem remain?</p>	Go to step 33.	The problem is solved.
<p>Step 33</p> <p>Check the controller board and its connector pins for damage.</p> <p>Are the controller board and its connectors free of damage?</p>	Contact the next level of support.	Go to step 34.
<p>Step 34</p> <p>Replace the controller board. See Controller board removal.</p> <p>Does the problem remain?</p>	Contact the next level of support.	The problem is solved.

2y User Attendance Errors

24–29 User Attendance Messages

Error code	Description	Action
24.04	During a duplex print job, a mismatch between the actual paper size and paper size setting was detected.	See Paper size mismatch (duplex print) service check .
29.40	A disconnection was detected on the black print cartridge.	See Engine, supplies, and system errors service check .
29.41	A disconnection was detected on the cyan print cartridge.	
29.42	A disconnection was detected on the magenta print cartridge.	
29.43	A disconnection was detected on the yellow print cartridge.	
29.49	Disconnections were detected on multiple print cartridges.	

Paper Size Mismatch (Duplex Print) Service Check

Action	Yes	No
<p>Step 1</p> <p>1 Make sure that the paper is properly loaded in the tray and manual feeder. See Avoiding jams.</p> <p>2 Make sure that the tray and manual feeder are properly installed.</p> <p>Does the problem remain?</p>	Go to step 2.	The problem is solved.
<p>Step 2</p> <p>1 From the control panel, navigate to:</p> <p>Settings > Paper > Tray Configuration > Paper Size/Type</p> <p>2 Make sure that the setting matches the paper loaded.</p> <p>Does the problem remain?</p>	Go to step 3.	The problem is solved.
<p>Step 3</p>	Go to step 4.	The problem is solved.

Diagnostics and Troubleshooting

Action	Yes	No
<p>1 From the control panel, navigate to:</p> <p>Settings > Paper > Media Configuration > Media Types</p> <p>2 Make sure that the Texture and Weight settings match the paper loaded.</p> <p>Does the problem remain?</p>		
<p>Step 4</p> <p>Make sure that the paper loaded is supported and free of damage and defect.</p> <p>To check for paper curl, print on both sides of the paper.</p> <p>Does the problem remain?</p>	Go to step 5.	The problem is solved.
<p>Step 5</p> <p>Load paper from a fresh package.</p> <p>Paper absorbs moisture due to high humidity. Store paper in its original wrapper until you are ready to use it.</p> <p>Does the problem remain?</p>	Go to step 6.	The problem is solved.
<p>Step 6</p> <p>1 Enter the Diagnostics menu, and then navigate to:</p> <p>Printer diagnostics and adjustments > Sensor tests</p> <p>2 Find the sensor (Bin/Narrow media).</p> <p>Does the sensor status change while toggling the sensor?</p>	Go to step 10.	Go to step 7.
<p>Step 7</p> <p>1 Remove the controller board shield. See Controller board shield removal .</p> <p>2 Reseat the cable of the sensor on the controller board.</p> <p>Does the problem remain?</p>	Go to step 8.	The problem is solved.
<p>Step 8</p> <p>Check the sensor and its flag for improper installation and damage.</p>	Go to step 10.	Go to step 9.

Action	Yes	No
Is the sensor properly installed and free of damage?		
Step 9 Reinstall or replace the sensor. See Sensor (bin/narrow media) removal . Does the problem remain?	Go to step 10.	The problem is solved.
Step 10 1 Check the rear door for improper installation, misalignment, and damage. 2 Check the rear door sensor flag for damage. 3 Check the rear door rollers and gears for wear, damage, and contamination. Are the rear door and its components properly installed and free of wear, damage, and contamination?	Contact the next level of support.	Go to step 11.
Step 11 Reinstall, clean, or replace the rear door. See Rear door removal . Does the problem remain?	Contact the next level of support.	The problem is solved.

3y User Attendance Errors

31–39 User Attendance Messages

Error code	Description	Action
31.00	An MICR print cartridge is required.	See Engine, supplies, and system errors service check .
31.35	A waste toner bottle smart chip or sensor communication error was detected.	
31.40	A black print cartridge smart chip or sensor communication error was detected.	
31.41	A cyan print cartridge smart chip or sensor communication error was detected.	

Error code	Description	Action
31.42	A magenta print cartridge smart chip or sensor communication error was detected.	
31.43	A yellow print cartridge smart chip or sensor communication error was detected.	
32.40A	Black print cartridge is unsupported—Unsupported memory map version in the smart chip.	See Engine, supplies, and system errors service check .
32.40B	Black print cartridge is unsupported—Failed capacity class/model compatibility check.	
32.40C	Black print cartridge is unsupported—Failed OEM check.	
32.40D	Black print cartridge is incorrect or unsupported—Failed SWE marriage check.	See Unsupported Print Cartridge Service Check .
32.40E	Black print cartridge is unsupported—The supply is on the revoked list.	See Engine, supplies, and system errors service check .
32.40F	Black print cartridge is unsupported—The print cartridge is MICR, and the firmware release does not support MICR.	
32.40J	Metered toner black print cartridge installed in printer configured for Sold.	See Metered supply installed in printer configured for sold .
32.41A	Cyan print cartridge is unsupported—Unsupported memory map version in the smart chip.	See Engine, supplies, and system errors service check .
32.41B	Cyan print cartridge is unsupported—Failed capacity class/model compatibility check.	
32.41C	Cyan print cartridge is unsupported—Failed OEM check.	
32.41D	Cyan print cartridge is incorrect or unsupported—Failed SWE marriage check.	See Unsupported Print Cartridge Service Check .
32.41E	Cyan print cartridge is unsupported—The supply is on the revoked list.	See Engine, supplies, and system errors service check .

Error code	Description	Action
32.41F	Cyan print cartridge is unsupported—The print cartridge is MICR, and the firmware release does not support MICR.	
32.41J	Metered toner cyan print cartridge installed in printer configured for Sold.	See Metered supply installed in printer configured for sold .
32.42A	Magenta print cartridge is unsupported—Unsupported memory map version in the smart chip.	See Engine, supplies, and system errors service check .
32.42B	Magenta print cartridge is unsupported—Failed capacity class/model compatibility check.	
32.42C	Magenta print cartridge is unsupported—Failed OEM check.	
32.42D	Magenta print cartridge is incorrect or unsupported—Failed SWE marriage check.	See Unsupported Print Cartridge Service Check .
32.42E	Magenta print cartridge is unsupported—The supply is on the revoked list.	See Engine, supplies, and system errors service check .
32.42F	Magenta print cartridge is unsupported—The print cartridge is MICR, and the firmware release does not support MICR.	
32.42J	Metered toner magenta print cartridge installed in printer configured for Sold.	See Metered supply installed in printer configured for sold .
32.43A	Yellow print cartridge is unsupported—Unsupported memory map version in the smart chip.	See Engine, supplies, and system errors service check .
32.43B	Yellow print cartridge is unsupported—Failed capacity class/model compatibility check.	
32.43C	Yellow print cartridge is unsupported—Failed OEM check.	
32.43D	Yellow print cartridge is incorrect or unsupported—Failed SWE marriage check.	See Unsupported Print Cartridge Service Check .
32.43E	Yellow print cartridge is unsupported—The supply is on the revoked list.	See Engine, supplies, and system errors service check .

Error code	Description	Action
32.43F	Yellow print cartridge is unsupported—The print cartridge is MICR, and the firmware release does not support MICR.	
32.43J	Metered toner yellow print cartridge installed in printer configured for Sold.	See Metered supply installed in printer configured for sold .
33.40	A non-Xerox black print cartridge was detected.	See Engine, supplies, and system errors service check .
33.41	A non-Xerox cyan print cartridge was detected.	
33.42	A non-Xerox magenta print cartridge was detected.	
33.43	A non-Xerox yellow print cartridge was detected.	
34	The print area is too large for the paper.	See Insufficient Paper Size For Print Service Check .
37.03	The memory is insufficient for the job. Some held jobs had to be removed.	See Insufficient Memory Service Check
37.1	The document is too large to be collated.	
38.01	The memory is full.	
39.01	The page is too complex. The printer memory is not enough for the details on the page.	
39.02	The page is too complex. The printer memory is not enough for the details on the page.	

Insufficient Paper Size For Print Service Check

Action	Yes	No
<p>Step 1</p> <ol style="list-style-type: none"> 1 Open all printer doors, and then remove the manual feeder and tray. 2 Check the paper path, tray, and bin for paper fragments and partially fed paper. <p>Are the paper path, bin, and tray free of paper fragments and partially fed paper?</p>	Go to step 3.	Go to step 2.
<p>Step 2</p> <p>Remove the paper fragments and partially fed paper.</p> <p>Does the problem remain?</p>	Go to step 3.	The problem is solved.
<p>Step 3</p> <p>Do a print test.</p> <p>Does the problem remain?</p>	Go to step 4.	The problem is solved.
<p>Step 4</p> <ol style="list-style-type: none"> 1 Make sure that the paper is properly loaded in the tray and manual feeder. See Avoiding jams. 2 Make sure that the tray and manual feeder are properly installed. <p>Does the problem remain?</p>	Go to step 5.	The problem is solved.
<p>Step 5</p> <ol style="list-style-type: none"> 1 From the control panel, navigate to: Settings > Paper > Tray Configuration > Paper Size/Type 2 Make sure that the setting matches the paper loaded. <p>Does the problem remain?</p>	Go to step 6.	The problem is solved.
<p>Step 6</p> <ol style="list-style-type: none"> 1 From the control panel, navigate to: Settings > Paper > Media Configuration > Media Types 	Go to step 7.	The problem is solved.

Diagnostics and Troubleshooting

Action	Yes	No
<p>2 Make sure that the Texture and Weight settings match the paper loaded.</p> <p>Does the problem remain?</p>		
<p>Step 7</p> <p>Make sure that the paper loaded is supported and free of damage and defect.</p> <p>To check for paper curl, print on both sides of the paper.</p> <p>Does the problem remain?</p>	Go to step 8.	The problem is solved.
<p>Step 8</p> <p>Load paper from a fresh package.</p> <p>Paper absorbs moisture due to high humidity. Store paper in its original wrapper until you are ready to use it.</p> <p>Does the problem remain?</p>	Go to step 9.	The problem is solved.
<p>Step 9</p> <p>1 Check the tray insert and its guides for damage.</p> <p>2 Check the tray insert pads for wear and damage.</p> <p>Is the tray insert free of damage?</p>	Contact the next level of support.	Go to step 10.
<p>Step 10</p> <p>Replace the tray insert.</p> <p>Does the problem remain?</p>	Contact the next level of support.	The problem is solved.

Insufficient Memory Service Check

Action	Yes	No
<p>Step 1</p> <p>1 Delete the held jobs to free up printer memory.</p> <p>2 Turn off the printer, wait for about 10 seconds, and then turn on the printer.</p> <p>3 Resend the print job or scan job.</p> <p>Does the problem remain?</p>	Go to step 2.	The problem is solved.
<p>Step 2</p> <p>Do a print test.</p> <p>Does the problem remain?</p>	Go to step 3.	The problem is solved.
<p>Step 3</p> <p>Check the firmware version.</p> <p>Is the firmware updated to the latest version?</p>	Go to step 5.	Go to step 4.
<p>Step 4</p> <p>Update the firmware.</p> <p>Does the problem remain?</p>	Go to step 5.	The problem is solved.
<p>Step 5</p> <p>Make sure that the controller board is properly installed. Reseat all the cables on the controller board.</p> <p>Does the problem remain?</p>	Go to step 6.	The problem is solved.
<p>Step 6</p> <p>Check the controller board and its connector pins for damage.</p> <p>Are the controller board and its connectors free of damage?</p>	Contact the next level of support.	Go to step 7.
<p>Step 7</p> <p>Replace the controller board. See Controller board removal.</p> <p>Does the problem remain?</p>	Contact the next level of support.	The problem is solved.

Unsupported Print Cartridge Service Check

Action	Yes	No
<p>Step 1</p> <p>Check whether the correct print cartridge is used.</p> <p> Note:</p> <ul style="list-style-type: none"> The original or first print cartridge used is called an SWE print cartridge. SWE stands for <i>shipped with equipment</i>. The SWE print cartridge cannot be installed to another printer. If the SWE print cartridge is used by another printer, then a 32.40D, 32.41D, 32.42D, or 32.43D error occurs. <p>Is the printer using the incorrect print cartridge?</p>	Go to step 2.	Contact the next level of support.
<p>Step 2</p> <p>Do either of the following:</p> <ul style="list-style-type: none"> Find the SWE print cartridge, and then reinstall it. Replace the cartridge with the correct and genuine Xerox part. <p>Does the problem remain?</p>	Contact the next level of support.	The problem is solved.

42–55 User Attendance Errors

42–55 User Attendance Messages

Error code	Description	Action
42.01	The print cartridge and printer regions are mismatched.	See Print cartridge region mismatch service check .
42.02	The print cartridge and printer regions are mismatched.	
42.03	The print cartridge and printer regions are mismatched.	
42.04	The print cartridge and printer regions are mismatched.	
42.05	The print cartridge and printer regions are mismatched.	

Error code	Description	Action
42.09	The print cartridge and printer regions are mismatched.	
42.10	The print cartridge and printer regions are mismatched.	See Print cartridge region mismatch service check .
42.12	The print cartridge and printer regions are mismatched.	
42.13	The print cartridge and printer regions are mismatched.	
42.14	The print cartridge and printer regions are mismatched.	
42.15	The print cartridge and printer regions are mismatched.	
42.19	The print cartridge and printer regions are mismatched.	
42.20	The print cartridge and printer regions are mismatched.	See Print cartridge region mismatch service check .
42.21	The print cartridge and printer regions are mismatched.	
42.23	The print cartridge and printer regions are mismatched.	
42.24	The print cartridge and printer regions are mismatched.	
42.25	The print cartridge and printer regions are mismatched.	
42.29	The print cartridge and printer regions are mismatched.	
42.30	The print cartridge and printer regions are mismatched.	See Print cartridge region mismatch service check .
42.31	The print cartridge and printer regions are mismatched.	
42.32	The print cartridge and printer regions are mismatched.	
42.34	The print cartridge and printer regions are mismatched.	
42.35	The print cartridge and printer regions are mismatched.	
42.39	The print cartridge and printer regions are mismatched.	

Diagnostics and Troubleshooting

Error code	Description	Action
42.40	The print cartridge and printer regions are mismatched.	See Print cartridge region mismatch service check .
42.41	The print cartridge and printer regions are mismatched.	
42.42	The print cartridge and printer regions are mismatched.	
42.43	The print cartridge and printer regions are mismatched.	
42.45	The print cartridge and printer regions are mismatched.	
42.49	The print cartridge and printer regions are mismatched.	
42.50	The print cartridge and printer regions are mismatched.	See Print cartridge region mismatch service check .
42.51	The print cartridge and printer regions are mismatched.	
42.52	The print cartridge and printer regions are mismatched.	
42.53	The print cartridge and printer regions are mismatched.	
42.54	The print cartridge and printer regions are mismatched.	
42.59	The print cartridge and printer regions are mismatched.	
42.90	The print cartridge and printer regions are mismatched.	See Print cartridge region mismatch service check .
42.91	The print cartridge and printer regions are mismatched.	
42.92	The print cartridge and printer regions are mismatched.	
42.93	The print cartridge and printer regions are mismatched.	
42.94	The print cartridge and printer regions are mismatched.	
42.95	The print cartridge and printer regions are mismatched.	
55.1	The USB device is unsupported.	See Unsupported USB device or hub service check .
55.2	The USB hub is unsupported.	

Print Cartridge Region Mismatch Service Check

Action	Yes	No
<p>Step 1</p> <ol style="list-style-type: none"> 1 Make sure that the cartridge is a genuine and supported Xerox supply. 2 Make sure that the cartridge region matches the printer region. <p>The worldwide region is compatible with all printer regions.</p> <p>Does the problem remain?</p>	Go to step 2.	The problem is solved.
<p>Step 2</p> <ol style="list-style-type: none"> 1 Firmly shake the cartridge to redistribute the toner. 2 Make sure that the affected cartridge is properly installed. <p>The cartridge must fit and lock properly with the print cartridge tray. No packing material must be left on the cartridge.</p> <p>Does the problem remain?</p>	Go to step 3.	The problem is solved.
<p>Step 3</p> <ol style="list-style-type: none"> 1 Check the cartridge for damage and leaks. 2 Check the cartridge smart chip contacts for improper connections. <ul style="list-style-type: none"> • Corrosion and contamination • Loose connection with the HVPS contacts <p>Is the cartridge free of damage, leaks, and contamination?</p>	Go to step 5.	Go to step 4.
<p>Step 4</p> <p>Clean the contaminated contacts or replace the affected cartridge.</p> <p>Does the problem remain?</p>	Go to step 5.	The problem is solved.
<p>Step 5</p> <ol style="list-style-type: none"> 1 Remove the print cartridge tray. See Print cartridge tray removal. 2 Inside the printer on the right side, check the HVPS contacts 	Go to step 6.	Contact the next level of support.

Action	Yes	No
<p>that connect with the cartridges for damage.</p> <p>Are the contacts free of damage?</p>		
<p>Step 6</p> <ol style="list-style-type: none"> 1 Pull out the print cartridge tray, and then remove all the cartridges. 2 Check the cartridge tray for proper movement. <p>Does the cartridge tray open and close properly?</p>	Go to step 8.	Go to step 7.
<p>Step 7</p> <ol style="list-style-type: none"> 1 Remove any obstructions that hinder the cartridge tray. 2 Reinstall the cartridge tray. <p>Does the problem remain?</p>	Go to step 8.	The problem is solved.
<p>Step 8</p> <p>Check the cartridge tray and its components for damage.</p> <ul style="list-style-type: none"> • Cartridge locking mechanisms • Sliding mechanism under the cartridge tray • Latch mechanism <p>Is the cartridge tray free of damage?</p>	Contact the next level of support.	Go to step 9.
<p>Step 9</p> <p>Replace the cartridge tray. See Print cartridge tray removal.</p> <p>Does the problem remain?</p>	Contact the next level of support.	The problem is solved.

Unsupported USB Device or Hub Service Check

Action	Yes	No
<p>Step 1</p> <p>Make sure that the flash drive supports the File Allocation Table (FAT) system.</p> <p>Does the problem remain?</p>	Go to step 2.	The problem is solved.
<p>Step 2</p> <p>Try another flash drive.</p>	Go to step 3.	The problem is not with the printer. Replace the unsupported or defective flash drive.

Action	Yes	No
Does the problem remain?		
Step 3 Check the firmware version. Is the firmware updated to the latest version?	Go to step 5.	Go to step 4.
Step 4 Update the firmware. Does the problem remain?	Go to step 5.	The problem is solved.
Step 5 Make sure that the controller board is properly installed. Reseat all the cables on the controller board. Does the problem remain?	Go to step 6.	The problem is solved.
Step 6 Check the controller board and its connector pins for damage. Are the controller board and its connectors free of damage?	Contact the next level of support.	Go to step 7.
Step 7 Replace the controller board. See Controller board removal . Does the problem remain?	Contact the next level of support.	The problem is solved.

7y User Attendance Errors

71–72 User Attendance Messages

Error code	Description	Action
71.4	The printer time is wrong.	See Incorrect Time Service Check .
72.1	The SMTP server is not set up.	See Server error service check .
72.2	The Weblink server is not set up.	

Incorrect Time Service Check

Action	Yes	No
<p>Step 1</p> <p>1 From the control panel, navigate to:</p> <p>Settings > Device > Preferences > Date and Time</p> <p>2 Set the correct date and time.</p> <p>Does the problem remain?</p>	Go to step 2.	The problem is solved.
<p>Step 2</p> <p>Check the firmware version.</p> <p>Is the firmware updated to the latest version?</p>	Go to step 4.	Go to step 3.
<p>Step 3</p> <p>Update the firmware.</p> <p>Does the problem remain?</p>	Go to step 4.	The problem is solved.
<p>Step 4</p> <p>Make sure that the controller board is properly installed. Reseat all the cables on the controller board.</p> <p>Does the problem remain?</p>	Go to step 5.	The problem is solved.
<p>Step 5</p> <p>Check the controller board and its connector pins for damage.</p> <p>Are the controller board and its connectors free of damage?</p>	Contact the next level of support.	Go to step 6.
<p>Step 6</p> <p>Replace the controller board. See Controller board removal.</p> <p>Does the problem remain?</p>	Contact the next level of support.	The problem is solved.

Server Error Service Check

Action	Yes	No
Step 1 Turn off the printer, wait for about 10 seconds, and then turn on the printer. Does the problem remain?	Go to step 2.	The problem is solved.
Step 2 Make sure that the network connection is working. Contact the administrator if necessary. Does the problem remain?	Contact the next level of support.	The problem is solved.

8y User Attendance Errors

82–88 User Attendance Messages

Error code	Description	Action
80.06	A fuser memory error occurred.	See Fuser temperature error service check .
80.16	A fuser memory error occurred.	
80.26	A fuser memory error occurred.	
82.00	The waste toner bottle is nearly low.	See Waste toner bottle error service check .
82.02	The waste toner bottle is nearly low. The limit is based on waste toner counter set point.	
82.09	The waste toner bottle is nearly low. The limit is based on user-selected EWS set point.	
82.12	The waste toner bottle is low. The limit is based on waste toner counter set point.	
82.13	The waste toner bottle is low.	
82.19	The waste toner bottle is low. The limit is based on user-selected EWS set point.	

Error code	Description	Action
82.20	The waste toner bottle is very low.	
82.22	The waste toner bottle is very low. The limit is based on waste toner counter set point.	
82.23	The waste toner bottle is very low.	
82.29	The waste toner bottle is very low. The limit is based on user-selected EWS set point.	
82.30	The waste toner bottle is empty.	See Waste toner bottle error service check .
82.32	The waste toner bottle is empty. The limit is based on waste toner counter set point.	
82.33	The waste toner bottle is empty.	
82.39	The waste toner bottle is empty. The limit is based on user-selected EWS set point.	
82.40	The waste toner bottle life has ended.	
82.42	The waste toner bottle life has ended. The limit is based on waste toner counter set point.	
82.49	The waste toner bottle life has ended. The limit is based on user-selected EWS set point.	
84.03C	The colored print cartridge is nearly low. The limit is based on a side count.	See Low or empty print cartridge service check .
84.03K	The black print cartridge is nearly low. The limit is based on a side count.	
84.13C	The colored print cartridge is low. The limit is based on a side count.	
84.13K	The black print cartridge is low. The limit is based on a side count.	

Error code	Description	Action	
88.00C	The cyan print cartridge is nearly low. The limit is based on default set point.	See Low or empty print cartridge service check .	
88.00M	The magenta print cartridge is nearly low. The limit is based on default set point.		
88.00Y	The yellow print cartridge is nearly low. The limit is based on default set point.		
88.00K	The black print cartridge is nearly low. The limit is based on default set point.		
88.01C	The cyan print cartridge is nearly low.		
88.01M	The magenta print cartridge is nearly low.		
88.01Y	The yellow print cartridge is nearly low.		
88.01K	The black print cartridge is nearly low.		
88.02C	The cyan print cartridge is nearly low.		
88.02M	The magenta print cartridge is nearly low.		
88.02Y	The yellow print cartridge is nearly low.		
88.02K	The black print cartridge is nearly low.		
88.08C	A cyan print cartridge quanta error occurred.		See Low or empty print cartridge service check .
88.08M	A magenta print cartridge quanta error occurred.		
88.08Y	A yellow print cartridge quanta error occurred.		
88.08K	A black print cartridge quanta error occurred.		

Error code	Description	Action
88.09C	<p>The cyan print cartridge is nearly low.</p> <p>The limit is based on user-selected EWS set point.</p>	
88.09M	<p>The magenta print cartridge is nearly low.</p> <p>The limit is based on user-selected EWS set point.</p>	
88.09Y	<p>The yellow print cartridge is nearly low.</p> <p>The limit is based on user-selected EWS set point.</p>	
88.09K	<p>The black print cartridge is nearly low.</p> <p>The limit is based on user-selected EWS set point.</p>	
88.10C	<p>The cyan print cartridge is low.</p> <p>The limit is based on default set point.</p>	See Low or empty print cartridge service check .
88.10M	<p>The magenta print cartridge is low.</p> <p>The limit is based on default set point.</p>	
88.10Y	<p>The yellow print cartridge is low.</p> <p>The limit is based on default set point.</p>	
88.10K	<p>The black print cartridge is low.</p> <p>The limit is based on default set point.</p>	
88.11C	<p>The cyan print cartridge is low.</p>	
88.11M	<p>The magenta print cartridge is low.</p>	
88.11Y	<p>The yellow print cartridge is low.</p>	
88.11K	<p>The black print cartridge is low.</p>	
88.12C	<p>The cyan print cartridge is low.</p>	
88.12M	<p>The magenta print cartridge is low.</p>	
88.12Y	<p>The yellow print cartridge is low.</p>	

Error code	Description	Action
88.12K	The black print cartridge is low.	
88.13C	The cyan print cartridge is low. The limit is based on a side count.	See Low or empty print cartridge service check .
88.13M	The magenta print cartridge is low. The limit is based on a side count.	
88.13Y	The yellow print cartridge is low. The limit is based on a side count.	
88.13K	The black print cartridge is low. The limit is based on a side count.	
88.18C	A cyan print cartridge quanta error occurred.	
88.18M	A magenta print cartridge quanta error occurred.	
88.18Y	A yellow print cartridge quanta error occurred.	
88.18K	A black print cartridge quanta error occurred.	
88.19C	The cyan print cartridge is low. The limit is based on user-selected EWS set point.	See Low or empty print cartridge service check .
88.19M	The magenta print cartridge is low. The limit is based on user-selected EWS set point.	
88.19Y	The yellow print cartridge is low. The limit is based on user-selected EWS set point.	
88.19K	The black print cartridge is low. The limit is based on user-selected EWS set point.	
88.20C	The cyan print cartridge is very low. The limit is based on default set point.	See Low or empty print cartridge service check .
88.20M	The magenta print cartridge is very low.	

Error code	Description	Action	
	The limit is based on default set point.		
88.20Y	The yellow print cartridge is very low. The limit is based on default set point.		
88.20K	The black print cartridge is very low. The limit is based on default set point.		
88.21C	The cyan print cartridge is very low.	See Low or empty print cartridge service check .	
88.21M	The magenta print cartridge is very low.		
88.21Y	The yellow print cartridge is very low.		
88.21K	The black print cartridge is very low.		
88.22C	The cyan print cartridge is very low.		
88.22M	The magenta print cartridge is very low.		
88.22Y	The yellow print cartridge is very low.		
88.22K	The black print cartridge is very low.		
88.23C	The cyan print cartridge is very low. The limit is based on a side count.		See Low or empty print cartridge service check .
88.23M	The magenta print cartridge is very low. The limit is based on a side count.		
88.23Y	The yellow print cartridge is very low. The limit is based on a side count.		
88.23K	The black print cartridge is very low. The limit is based on a side count.		
88.28C	A cyan print cartridge quanta error occurred.		

Error code	Description	Action
88.28M	A magenta print cartridge quanta error occurred.	
88.28Y	A yellow print cartridge quanta error occurred.	
88.28K	A black print cartridge quanta error occurred.	
88.29C	The cyan print cartridge is very low. The limit is based on user-selected EWS set point.	See Low or empty print cartridge service check .
88.29M	The magenta print cartridge is very low. The limit is based on user-selected EWS set point.	
88.29Y	The yellow print cartridge is very low. The limit is based on user-selected EWS set point.	
88.29K	The black print cartridge is very low. The limit is based on user-selected EWS set point.	
88.30C	The cyan print cartridge is empty.	
88.30M	The magenta print cartridge is empty.	
88.30Y	The yellow print cartridge is empty.	
88.30K	The black print cartridge is empty.	See Low or empty print cartridge service check .
88.31C	The cyan print cartridge is empty.	
88.31M	The magenta print cartridge is empty.	
88.31Y	The yellow print cartridge is empty.	
88.31K	The black print cartridge is empty.	
88.32C	The cyan print cartridge is empty.	
88.32M	The magenta print cartridge is empty.	
88.32Y	The yellow print cartridge is empty.	

Diagnostics and Troubleshooting

Error code	Description	Action
88.32K	The black print cartridge is empty.	
88.33C	The cyan print cartridge is empty. The limit is based on a side count.	See Low or empty print cartridge service check .
88.33M	The magenta print cartridge is empty. The limit is based on a side count.	
88.33Y	The yellow print cartridge is empty. The limit is based on a side count.	
88.33K	The black print cartridge is empty. The limit is based on a side count.	
88.38C	A cyan print cartridge quanta error occurred.	
88.38M	A magenta print cartridge quanta error occurred.	
88.38Y	A yellow print cartridge quanta error occurred.	
88.38K	A black print cartridge quanta error occurred.	
88.40C	The cyan print cartridge is empty. The printer forces a hard stop on the cartridge.	See Low or empty print cartridge service check .
88.40M	The magenta print cartridge is empty. The printer forces a hard stop on the cartridge.	
88.40Y	The yellow print cartridge is empty. The printer forces a hard stop on the cartridge.	
88.40K	The black print cartridge is empty. The printer forces a hard stop on the cartridge.	
88.41C	The cyan print cartridge is empty. The printer forces a hard stop on the cartridge.	
88.41M	The magenta print cartridge is empty. The printer forces a hard stop on the cartridge.	
88.41Y	The yellow print cartridge is empty. The printer forces a hard stop on the cartridge.	

Error code	Description	Action
88.41K	The black print cartridge is empty. The printer forces a hard stop on the cartridge.	
88.42C	The cyan print cartridge is empty. The printer forces a hard stop on the cartridge.	See Low or empty print cartridge service check .
88.42M	The magenta print cartridge is empty. The printer forces a hard stop on the cartridge.	
88.42Y	The yellow print cartridge is empty. The printer forces a hard stop on the cartridge.	
88.42K	The black print cartridge is empty. The printer forces a hard stop on the cartridge.	
88.43C	The cyan print cartridge is empty. The printer forces a hard stop on the cartridge. The limit is based on a side count.	
88.43M	The magenta print cartridge is empty. The printer forces a hard stop on the cartridge. The limit is based on a side count.	
88.43Y	The yellow print cartridge is empty. The printer forces a hard stop on the cartridge. The limit is based on a side count.	
88.43K	The black print cartridge is empty. The printer forces a hard stop on the cartridge. The limit is based on a side count.	
88.48C	The cyan print cartridge is empty. The printer forces a hard stop on the cartridge.	
88.48M	The magenta print cartridge is empty. The printer forces a hard stop on the cartridge.	
88.48Y	The yellow print cartridge is empty. The printer forces a hard stop on the cartridge.	
88.48K	The black print cartridge is empty. The printer forces a hard stop on the cartridge.	

Waste Toner Bottle Error Service Check

Action	Yes	No
<p>Step 1</p> <p>Reinstall the waste toner bottle.</p> <p>Make sure that the waste toner bottle is upright. If it is tilted, then the sensor may get a false reading on the amount of toner.</p> <p>Does the problem remain?</p>	Go to step 2.	The problem is solved.
<p>Step 2</p> <p>1 Tap the waste toner bottle to dislodge the toner particles from its walls.</p> <p>2 Check if the waste toner bottle is full.</p> <p>If the level of the waste toner reaches the sensor detection area, then the waste toner bottle is already full.</p> <p>3 Check the waste toner bottle for damage.</p> <p>Is the waste toner bottle full or damaged?</p>	Go to step 3.	Go to step 4.
<p>Step 3</p> <p>Replace the waste toner bottle.</p> <p>Does the problem remain?</p>	Go to step 4.	The problem is solved.
<p>Step 4</p> <p>1 Enter the Diagnostics menu, and then navigate to:</p> <p>Printer diagnostics and adjustments > Sensor tests</p> <p>2 Find the sensor (Waste toner bottle).</p> <p>Does the sensor status change while toggling the sensor?</p>	Go to step 10.	Go to step 5.
<p>Step 5</p> <p>1 Remove the right cover. See Right cover removal.</p> <p>2 Reseat the cable of the sensor on the HVPS.</p> <p>Does the problem remain?</p>	Go to step 6.	The problem is solved.
Step 6	Go to step 8.	Go to step 7.

Action	Yes	No
Check the cable for damage. Is the cable free of damage?		
Step 7 Replace the cable. Does the problem remain?	Go to step 8.	The problem is solved.
Step 8 Check the sensor and its flag for improper installation, contamination, and damage. Is the sensor properly installed and free of contamination and damage?	Go to step 10.	Go to step 9.
Step 9 Reinstall, clean, or replace the sensor. See Sensor (waste toner bottle) removal . Does the problem remain?	Go to step 10.	The problem is solved.
Step 10 Perform the sensor (waste toner bottle) calibration. See Sensor (waste toner bottle) calibration . Does the problem remain?	Go to step 11.	The problem is solved.
Step 11 Reseat the HVPS flat cables. Does the problem remain?	Go to step 12.	The problem is solved.
Step 12 Check the cables for damage. Are the cables free of damage?	Go to step 14.	Go to step 13.
Step 13 Replace the affected cable. Does the problem remain?	Go to step 14.	The problem is solved.
Step 14 1 Make sure that the HVPS is properly installed. 2 Reseat all the cables on the HVPS. 3 Properly align the spring contacts.	Go to step 15.	The problem is solved.

Action	Yes	No
Does the problem remain?		
Step 15 Check the HVPS contacts for contamination and damage. Are the HVPS contacts free of contamination and damage?	Go to step 17.	Go to step 16.
Step 16 Clean or replace the HVPS. See HVPS removal . Does the problem remain?	Go to step 17.	The problem is solved.
Step 17 Make sure that the controller board is properly installed. Reseat all the cables on the controller board. Does the problem remain?	Go to step 18.	The problem is solved.
Step 18 Check the controller board and its connector pins for damage. Are the controller board and its connectors free of damage?	Contact the next level of support.	Go to step 19.
Step 19 Replace the controller board. See Controller board removal . Does the problem remain?	Contact the next level of support.	The problem is solved.

Low or Empty Print Cartridge Service Check

Action	Yes	No
Step 1 1 Access the Embedded Web Server. 2 Disable the Custom Supply Levels setting. Does the problem remain?	Go to step 2.	The problem is solved.
Step 2 1 Firmly shake the cartridge to redistribute the toner.	Go to step 3.	The problem is solved.

Action	Yes	No
<p>2 Make sure that the affected cartridge is properly installed.</p> <p>The cartridge must fit and lock properly with the print cartridge tray. No packing material must be left on the cartridge.</p> <p>Does the problem remain?</p>		
<p>Step 3</p> <p>1 Check the cartridge for damage and leaks.</p> <p>2 Check the cartridge smart chip contacts for improper connections.</p> <ul style="list-style-type: none"> • Corrosion and contamination • Loose connection with the HVPS contacts <p>Is the cartridge free of damage, leaks, and contamination?</p>	Go to step 5.	Go to step 4.
<p>Step 4</p> <p>Clean the contaminated contacts or replace the affected cartridge.</p> <p>Does the problem remain?</p>	Go to step 5.	The problem is solved.
<p>Step 5</p> <p>1 Pull out the print cartridge tray, and then remove all the cartridges.</p> <p>2 Check the cartridge tray for proper movement.</p> <p>Does the cartridge tray open and close properly?</p>	Go to step 7.	Go to step 6.
<p>Step 6</p> <p>1 Remove any obstructions that hinder the cartridge tray.</p> <p>2 Reinstall the cartridge tray.</p> <p>Does the problem remain?</p>	Go to step 7.	The problem is solved.
<p>Step 7</p> <p>Check the cartridge tray and its components for damage.</p> <ul style="list-style-type: none"> • Cartridge locking mechanisms • Sliding mechanism under the cartridge tray • Latch mechanism 	Go to step 9.	Go to step 8.

Diagnostics and Troubleshooting

Action	Yes	No
Is the cartridge tray free of damage?		
Step 8 Replace the cartridge tray. See Print cartridge tray removal . Does the problem remain?	Go to step 9.	The problem is solved.
Step 9 1 Make sure that the HVPS is properly installed. 2 Reseat all the cables on the HVPS. 3 Properly align the spring contacts. Does the problem remain?	Go to step 10.	The problem is solved.
Step 10 Check the HVPS contacts for contamination and damage. Are the HVPS contacts free of contamination and damage?	Go to step 12.	Go to step 11.
Step 11 Clean or replace the HVPS. See HVPS removal . Does the problem remain?	Go to step 12.	The problem is solved.
Step 12 Reseat the HVPS flat cables. Does the problem remain?	Go to step 13.	The problem is solved.
Step 13 Check the cables for damage. Are the cables free of damage?	Go to step 15.	Go to step 14.
Step 14 Replace the affected cable. Does the problem remain?	Go to step 15.	The problem is solved.
Step 15 Check the firmware version. Is the firmware updated to the latest version?	Go to step 17.	Go to step 16.
Step 16	Go to step 17.	The problem is solved.

Action	Yes	No
Update the firmware. Does the problem remain?		
Step 17 Make sure that the controller board is properly installed. Reseat all the cables on the controller board. Does the problem remain?	Go to step 18.	The problem is solved.
Step 18 Check the controller board and its connector pins for damage. Are the controller board and its connectors free of damage?	Contact the next level of support.	Go to step 19.
Step 19 Replace the controller board. See Controller board removal . Does the problem remain?	Contact the next level of support.	The problem is solved.

9y User Attendance Errors

96–99 User Attendance Messages

Error code	Description	Action
96.xx	A firmware error (invalid option code) was detected.	See Firmware code error service check .
97.xx	A firmware error (printhead code CRC failure) was detected.	See Printhead code error service check .
98.xx	A firmware error (engine code CRC failure) was detected.	See Firmware code error service check .
99.xx	A firmware error (invalid RIP code) was detected.	

Firmware Code Error Service Check

Action	Yes	No
Step 1 Turn off the printer, wait for about 10 seconds, and then turn on the printer. Does the problem remain?	Go to step 2.	The problem is solved.
Step 2 1 Turn off the printer. 2 Turn on the printer and enter the Diagnostics menu. 3 Do a print test. 4 Restart the printer. Does the problem remain?	Go to step 3.	The problem is solved.
Step 3 Make sure that the controller board is properly installed. Reseat all the cables on the controller board. Does the problem remain?	Go to step 4.	The problem is solved.
Step 4 Check the controller board cables for damage. Are the cables free of damage?	Go to step 6.	Go to step 5.
Step 5 Replace the affected cables. Does the problem remain?	Go to step 6.	The problem is solved.
Step 6 Check the firmware version. Is the firmware updated to the latest version?	Go to step 8.	Go to step 7.
Step 7 Update the firmware. Does the problem remain?	Go to step 8.	The problem is solved.

Action	Yes	No
Step 8 Check the controller board and its connector pins for damage. Are the controller board and its connectors free of damage?	Contact the next level of support.	Go to step 9.
Step 9 Replace the controller board. See Controller board removal . Does the problem remain?	Contact the next level of support.	The problem is solved.

Printhead Code Error Service Check

Action	Yes	No
Step 1 Turn off the printer, wait for about 10 seconds, and then turn on the printer. Does the problem remain?	Go to step 2.	The problem is solved.
Step 2 1 Check the printhead and its components for damage. <ul style="list-style-type: none"> • Flat cable • Connector sockets 2 Check the printhead mirrors for contamination. Is the printhead free of damage and contamination?	Go to step 4.	Go to step 3.
Step 3 Clean or replace the printhead. See Printhead removal . Does the problem remain?	Go to step 4.	The problem is solved.
Step 4 1 Reseat the flat cables on the printhead. 2 Reseat the printhead cables on the controller board. Does the problem remain?	Go to step 5.	The problem is solved.
Step 5 Check the cables for damage. Are the cables free of damage?	Go to step 7.	Go to step 6.

Diagnostics and Troubleshooting

Action	Yes	No
Step 6 Replace the affected cable. Does the problem remain?	Go to step 7.	The problem is solved.
Step 7 Check the firmware version. Is the firmware updated to the latest version?	Go to step 9.	Go to step 8.
Step 8 Update the firmware. Does the problem remain?	Go to step 9.	The problem is solved.
Step 9 Make sure that the controller board is properly installed. Reseat all the cables on the controller board. Does the problem remain?	Go to step 10.	The problem is solved.
Step 10 Check the controller board and its connector pins for damage. Are the controller board and its connectors free of damage?	Contact the next level of support.	Go to step 11.
Step 11 Replace the controller board. See Controller board removal . Does the problem remain?	Contact the next level of support.	The problem is solved.

Printer Hardware Errors

100–110 Errors

100 Error Messages

Error code	Description	Action
100.04	The printhead temperature is out of range.	See Printhead temperature error service check .
100.25	The TPS temperature is out of range. TPS stands for toner patch sensing.	See Toner patch sensing error service check .

110 Error Messages

Error code	Description	Action
110.20	Printhead error (mirror motor lock) was detected before the motor was turned on.	See Printhead temperature error service check .
110.21	No printhead power (+5V) when the laser servo started.	
110.31	Printhead error (no first HSYNC) was detected.	
110.32	Printhead error (lost HSYNC) was detected.	
110.33	Printhead error (lost HSYNC) was detected during servo.	
110.34	Printhead error (mirror motor lost lock) was detected.	
110.35	Printhead error (mirror motor never got first lock) was detected.	
110.36	Printhead error (mirror motor lock never stabilized) was detected.	
110.37	Printhead error (undetermined printhead type) was detected.	
110.41	Printhead NVRAM read failure occurred.	See Printhead temperature error service check .
110.70	Printhead NVRAM contents are incorrect.	

Error code	Description	Action
110.71	Printhead error (bad facet time measurement) was detected.	
110.91	Printhead error (bad facet time reading) was detected.	
110.92	Printhead error (NVRAM checksum mismatch) was detected.	

Printhead Temperature Error Service Check

Action	Yes	No
Step 1 1 Reseat the flat cables on the printhead. 2 Reseat the printhead cables on the controller board. Does the problem remain?	Go to step 2.	The problem is solved.
Step 2 Check the cables for damage. Are the cables free of damage?	Go to step 4.	Go to step 3.
Step 3 Replace the affected cable. Does the problem remain?	Go to step 4.	The problem is solved.
Step 4 1 Make sure that the printhead interlock switch is properly installed. Reseat the printhead interlock switch cable. 2 Check the printhead interlock switch for damage. Is the printhead interlock switch free of damage?	Go to step 6.	Go to step 5.
Step 5 Replace the printhead interlock switch. See Printhead interlock switch removal . Does the problem remain?	Go to step 6.	The problem is solved.
Step 6 Check the firmware version. Is the firmware updated to the latest version?	Go to step 8.	Go to step 7.

Action	Yes	No
Step 7 Update the firmware. Does the problem remain?	Go to step 8.	The problem is solved.
Step 8 1 Check the printhead and its components for damage. <ul style="list-style-type: none"> • Flat cable • Connector sockets 2 Check the printhead mirrors for contamination. Is the printhead free of damage and contamination?	Go to step 10.	Go to step 9.
Step 9 Clean or replace the printhead. See Printhead removal . Does the problem remain?	Go to step 10.	The problem is solved.
Step 10 Make sure that the controller board is properly installed. Reseat all the cables on the controller board. Does the problem remain?	Go to step 11.	The problem is solved.
Step 11 Check the controller board and its connector pins for damage. Are the controller board and its connectors free of damage?	Contact the next level of support.	Go to step 12.
Step 12 Replace the controller board. See Controller board removal . Does the problem remain?	Contact the next level of support.	The problem is solved.

Toner Patch Sensing Error Service Check

Action	Yes	No
<p>Step 1</p> <p>1 Enter the Diagnostics menu, and then navigate to:</p> <p>Printer diagnostics and adjustments > Sensor tests > TPS L and R</p> <p>2 Insert a sheet of paper between the transfer belt and sensor (TPS).</p> <p>Do the sensor values change?</p>	Go to step 5.	Go to step 2.
<p>Step 2</p> <p>1 Remove the controller board shield. See Controller board shield removal.</p> <p>2 Reseat the TPS sensor cables on the controller board.</p> <p>Does the problem remain?</p>	Go to step 3.	The problem is solved.
<p>Step 3</p> <p>Check the TPS sensor cables for damage.</p> <p>Are the cables free of damage?</p>	Go to step 5.	Go to step 4.
<p>Step 4</p> <p>Replace the affected TPS sensor cable.</p> <p>Does the problem remain?</p>	Go to step 5.	The problem is solved.
<p>Step 5</p> <p>Make sure that the controller board is properly installed. Reseat all the cables on the controller board.</p> <p>Does the problem remain?</p>	Go to step 6.	The problem is solved.

Action	Yes	No
Step 6 Check the controller board and its connector pins for damage. Are the controller board and its connectors free of damage?	Contact the next level of support.	Go to step 7.
Step 7 Replace the controller board. See Controller board removal . Does the problem remain?	Contact the next level of support.	The problem is solved.

12y Errors

121 Error Messages

Error code	Description	Action
121.00	Fuser did not reach the required temperature (during warm-up).	See Fuser temperature error service check .
121.01	During an attempt to heat up, the fuser was not detected.	
121.02	Fuser went over the required temperature (during EWC/line voltage detection).	
121.03	Fuser hardware and driver are mismatched.	
121.04	During an attempt to heat up, the fuser relay was open and the microcontroller was not reporting an error.	
121.09	Fuser fell below the required temperature for motors. The error is not applicable to standby mode.	
121.10	Fuser did not reach the required temperature (during start of EWC/line voltage detection).	
121.11	Fuser reached the required temperature (during final EWC/line voltage detection) too late.	
121.12	Fuser did not reach the required temperature (during final EWC/line voltage detection).	

Diagnostics and Troubleshooting

Error code	Description	Action
121.13	Fuser reached the required temperature (during final EWC/ line voltage detection) too fast.	
121.14	Fuser is heating too fast (triac has latched on).	
121.22	Open fuser relay was detected.	
121.23	Open fuser relay was detected by the engine code, though the fuser relay was turned off.	
121.24	Fuser did not reach the required temperature (during final EWC/ line voltage detection).	
121.32	Fuser did not reach the required temperature (at 100 % power).	
121.33	Fuser did not reach the required temperature (while page is in the fuser).	
121.34	Fuser did not reach the required temperature (during steady state control).	
121.36	Open fuser relay was detected with very cold or unknown ambient temperature.	
121.50	Fuser went over the required temperature (during global overtemp check).	
121.52	Main thermistor temperature is out of range.	
121.53	Main thermistor temperature change rate is out of range.	
121.71	Open fuser main heater thermistor was detected.	
121.81	Open fuser backup roll thermistor was detected.	
121.86	Backup thermistor temperature is out of range.	
121.87	Backup thermistor temperature change rate is out of range.	

126 Error Messages

Error code	Description	Action
126.05	The LVPS switched power output dropped but the printer was not in Sleep mode.	See LVPS failure service check .
126.06	LVPS 25V output was not up on time after power-on.	
126.07	Sensor rail was down during power-on.	
126.10	No line frequency was detected.	
126.11	Line frequency has gone outside the operating range.	
126.14	LVPS relay is closed, but stuck.	

Fuser Temperature Error Service Check

Action	Yes	No
<p>Step 1</p> <p>1 Make sure that the power cord is properly connected to the printer and electrical outlet.</p> <p>2 Make sure that the electrical outlet supplies the correct voltage.</p> <p>Does the problem remain?</p>	Go to step 2.	The problem is solved.
<p>Step 2</p> <p>Check if the fuser voltage rating matches the printer and electrical outlet voltage rating.</p> <p>Does the fuser have the correct voltage rating?</p>	Go to step 3.	Go to step 7.
<p>Step 3</p> <p>1 Enter the Diagnostics menu, and then navigate to:</p> <p style="padding-left: 20px;">Printer diagnostics and adjustments > Motor tests</p> <p>2 Select Fuser, and then start the test.</p> <p>Do the fuser rollers and exit rollers turn?</p>	Go to step 6.	Go to step 4.
Step 4	Go to step 6.	Go to step 5.

Diagnostics and Troubleshooting

Action	Yes	No
<p>1 Make sure that the fuser is properly installed.</p> <p>2 Remove the left cover. See Left cover removal.</p> <p>3 Remove the right cover. See Right cover removal.</p> <p>4 Reseat the fuser cables from the following components, and then check the cables for damage:</p> <ul style="list-style-type: none"> • HVPS • LVPS • Fuser to controller board connections <p>Are the fuser cables free of damage?</p>		
<p>Step 5</p> <p>Replace the affected cable.</p> <p>Does the problem remain?</p>	Go to step 6.	The problem is solved.
<p>Step 6</p> <p>Check the fuser and its components for damage.</p> <ul style="list-style-type: none"> • Gears • Rollers • Cable • Guides and actuators • Thermistor <p>Is the fuser free of damage?</p>	Go to step 8.	Go to step 7.
<p>Step 7</p> <p>Replace the fuser. See Fuser removal.</p> <p>Does the problem remain?</p>	Go to step 8.	The problem is solved.
<p>Step 8</p> <p>Reseat the HVPS flat cables.</p> <p>Does the problem remain?</p>	Go to step 9.	The problem is solved.
<p>Step 9</p> <p>Check the cables for damage.</p> <p>Are the cables free of damage?</p>	Go to step 11.	Go to step 10.
<p>Step 10</p> <p>Replace the affected cable.</p>	Go to step 11.	The problem is solved.

Action	Yes	No
Does the problem remain?		
Step 11 1 Make sure that the HVPS is properly installed. 2 Reseat all the cables on the HVPS. 3 Properly align the spring contacts. Does the problem remain?	Go to step 12.	The problem is solved.
Step 12 Check the HVPS contacts for contamination and damage. Are the HVPS contacts free of contamination and damage?	Go to step 14.	Go to step 13.
Step 13 Clean or replace the HVPS. See HVPS removal . Does the problem remain?	Go to step 14.	The problem is solved.
Step 14 Check if the LVPS voltage rating matches the fuser voltage rating. Does the LVPS have the correct voltage rating?	Go to step 15.	Go to step 17.
Step 15 1 Remove the right cover. See Right cover removal . 2 Reseat the LVPS cables. Does the problem remain?	Go to step 16.	The problem is solved.
Step 16 Check the cable from the power inlet to the LVPS board for improper connection and damage. Is the cable properly connected and free of damage?	Go to step 18.	Go to step 17.
Step 17 Replace the LVPS. See LVPS removal . Does the problem remain?	Go to step 18.	The problem is solved.
Step 18	Go to step 19.	The problem is solved.

Action	Yes	No
<p>Make sure that the controller board is properly installed. Reseat all the cables on the controller board.</p> <p>Does the problem remain?</p>		
<p>Step 19</p> <p>Check the controller board and its connector pins for damage.</p> <p>Are the controller board and its connectors free of damage?</p>	Contact the next level of support.	Go to step 20.
<p>Step 20</p> <p>Replace the controller board. See Controller board removal.</p> <p>Does the problem remain?</p>	Contact the next level of support.	The problem is solved.

LVPS Failure Service Check

Action	Yes	No
<p>Step 1</p> <ol style="list-style-type: none"> 1 Make sure that the power cord is properly connected to the printer and electrical outlet. 2 Make sure that the electrical outlet supplies the correct voltage. <p>Does the problem remain?</p>	Go to step 2.	The problem is solved.
<p>Step 2</p> <ol style="list-style-type: none"> 1 Open the rear door, and then reseat the fuser cable. 2 Reseat the cable J THERM1 on the controller board. <p>Does the problem remain?</p>	Go to step 3.	The problem is solved.
<p>Step 3</p> <p>Check if the LVPS voltage rating matches the fuser voltage rating.</p> <p>Does the LVPS have the correct voltage rating?</p>	Go to step 4.	Go to step 6.
<p>Step 4</p> <ol style="list-style-type: none"> 1 Remove the right cover. See Right cover removal. 2 Reseat the LVPS cables. 	Go to step 5.	The problem is solved.

Action	Yes	No
Does the problem remain?		
<p>Step 5</p> <p>Check the cable from the power inlet to the LVPS board for improper connection and damage.</p> <p>Is the cable properly connected and free of damage?</p>	Go to step 7.	Go to step 6.
<p>Step 6</p> <p>Replace the LVPS. See LVPS removal.</p> <p>Does the problem remain?</p>	Go to step 7.	The problem is solved.
<p>Step 7</p> <p>Check if the fuser voltage rating matches the printer and electrical outlet voltage rating.</p> <p>Does the fuser have the correct voltage rating?</p>	Go to step 8.	Go to step 12.
<p>Step 8</p> <p>1 Enter the Diagnostics menu, and then navigate to:</p> <p style="padding-left: 20px;">Printer diagnostics and adjustments > Motor tests</p> <p>2 Select Fuser, and then start the test.</p> <p>Do the fuser rollers and exit rollers turn?</p>	Go to step 11.	Go to step 9.
<p>Step 9</p> <p>1 Make sure that the fuser is properly installed.</p> <p>2 Remove the left cover. See Left cover removal.</p> <p>3 Remove the right cover. See Right cover removal.</p> <p>4 Reseat the fuser cables from the following components, and then check the cables for damage:</p> <ul style="list-style-type: none"> • HVPS • LVPS • Fuser to controller board connections <p>Are the fuser cables free of damage?</p>	Go to step 11.	Go to step 10.

Diagnostics and Troubleshooting

Action	Yes	No
<p>Step 10</p> <p>Replace the affected cable.</p> <p>Does the problem remain?</p>	Go to step 11.	The problem is solved.
<p>Step 11</p> <p>Check the fuser and its components for damage.</p> <ul style="list-style-type: none"> • Gears • Rollers • Cable • Guides and actuators • Thermistor <p>Is the fuser free of damage?</p>	Go to step 13.	Go to step 12.
<p>Step 12</p> <p>Replace the fuser. See Fuser removal.</p> <p>Does the problem remain?</p>	Go to step 13.	The problem is solved.
<p>Step 13</p> <p>Make sure that the controller board is properly installed. Reseat all the cables on the controller board.</p> <p>Does the problem remain?</p>	Go to step 14.	The problem is solved.
<p>Step 14</p> <p>Check the controller board and its connector pins for damage.</p> <p>Are the controller board and its connectors free of damage?</p>	Contact the next level of support.	Go to step 15.
<p>Step 15</p> <p>Replace the controller board. See Controller board removal.</p> <p>Does the problem remain?</p>	Contact the next level of support.	The problem is solved.

142 Errors

142 Error Messages

Error code	Description	Action
142.80	Motor (CMY) does not turn on.	See Motor (CMY) drive failure service check .
142.81	Motor (CMY) does not turn off.	
142.82	Motor (CMY) speed did not ramp up to the required level.	
142.83	Motor (CMY) stalled.	
142.84	Motor (CMY) ran too slow.	
142.85	Motor (CMY) ran too fast.	
142.86	Motor (CMY) moved too long.	

Motor (CMY) Drive Failure Service Check

Action	Yes	No
<p>Step 1</p> <p>1 Enter the Diagnostics menu, and then navigate to:</p> <p>Printer diagnostics and adjustments > Motor tests</p> <p>2 Select CMY, and then start the test.</p> <p>Does the motor run?</p>	Go to step 7.	Go to step 2.
<p>Step 2</p> <p>1 Remove the controller board shield. See Controller board shield removal .</p> <p>2 Reseat the cable on the motor and on the controller board.</p> <p>Does the problem remain?</p>	Go to step 3.	The problem is solved.
<p>Step 3</p> <p>Check the cable for damage.</p> <p>Is the cable free of damage?</p>	Go to step 5.	Go to step 4.
<p>Step 4</p> <p>Replace the cable.</p> <p>Does the problem remain?</p>	Go to step 5.	The problem is solved.

Diagnostics and Troubleshooting

Action	Yes	No
<p>Step 5</p> <p>Check the motor for improper installation, wear, and damage.</p> <p>Is the motor properly installed and free of wear and damage?</p>	Go to step 7.	Go to step 6.
<p>Step 6</p> <p>Reinstall or replace the motor. See Motor (CMY) removal.</p> <p>Does the problem remain?</p>	Go to step 7.	The problem is solved.
<p>Step 7</p> <p>1 Enter the Diagnostics menu, and then navigate to:</p> <p>Printer diagnostics and adjustments > Motor tests</p> <p>2 Run the test on the following motors and clutches. In each test, check the gears for lack of movement and unusual noise.</p> <ul style="list-style-type: none"> • CMY • K/Transfer belt • Pick clutch • Staging clutch <p>Do the gears move properly without unusual noise?</p>	Go to step 11.	Go to step 8.
<p>Step 8</p> <p>Check the gearbox gears and couplers for wear and damage.</p> <ul style="list-style-type: none"> • Drive gears for all print cartridges and transfer belt • Drive gears that engage with the clutches • Couplers for all print cartridges and the transfer belt <p>Are the gears and couplers free of wear and damage?</p>	Go to step 9.	Go to step 10.
<p>Step 9</p> <p>1 Remove the gearbox. See Gearbox removal.</p> <p>2 Make sure that the gearbox gears are properly lubricated.</p> <p>3 Reinstall the gearbox.</p> <p>Does the problem remain?</p>	Go to step 10.	The problem is solved.

Action	Yes	No
Step 10 Replace the gearbox. See Gearbox removal . Does the problem remain?	Go to step 11.	The problem is solved.
Step 11 Make sure that the controller board is properly installed. Reseat all the cables on the controller board. Does the problem remain?	Go to step 12.	The problem is solved.
Step 12 Check the controller board and its connector pins for damage. Are the controller board and its connectors free of damage?	Contact the next level of support.	Go to step 13.
Step 13 Replace the controller board. See Controller board removal . Does the problem remain?	Contact the next level of support.	The problem is solved.

151 Errors

151 Error Messages

Error code	Description	Action
151.80	Motor (K) does not turn on.	See Motor (K) drive failure service check .
151.81	Motor (K) does not turn off.	
151.82	Motor (K) speed did not ramp up to the required level.	
151.83	Motor (K) stalled.	
151.84	Motor (K) ran too slow.	
151.85	Motor (K) ran too fast.	
151.86	Motor (K) moved too long.	

Motor (K) Drive Failure Service Check

Action	Yes	No
<p>Step 1</p> <p>1 Enter the Diagnostics menu, and then navigate to:</p> <p>Printer diagnostics and adjustments > Motor tests</p> <p>2 Select K/Transfer belt, and then start the test.</p> <p>Does the motor run?</p>	Go to step 7.	Go to step 2.
<p>Step 2</p> <p>1 Remove the controller board shield. See Controller board shield removal .</p> <p>2 Reseat the cable on the motor and on the controller board.</p> <p>Does the problem remain?</p>	Go to step 3.	The problem is solved.
<p>Step 3</p> <p>Check the cable for damage.</p> <p>Is the cable free of damage?</p>	Go to step 5.	Go to step 4.
<p>Step 4</p> <p>Replace the cable.</p> <p>Does the problem remain?</p>	Go to step 5.	The problem is solved.
<p>Step 5</p> <p>Check the motor for improper installation, wear, and damage.</p> <p>Is the motor properly installed and free of wear and damage?</p>	Go to step 7.	Go to step 6.
<p>Step 6</p> <p>Reinstall or replace the motor. See Motor (K/transfer belt) removal .</p> <p>Does the problem remain?</p>	Go to step 7.	The problem is solved.
<p>Step 7</p> <p>1 Enter the Diagnostics menu, and then navigate to:</p> <p>Printer diagnostics and adjustments > Motor tests</p> <p>2 Run the test on the following motors and clutches. In each test, check the gears for lack of movement and unusual noise.</p>	Go to step 11.	Go to step 8.

Action	Yes	No
<ul style="list-style-type: none"> • CMY • K/Transfer belt • Pick clutch • Staging clutch <p>Do the gears move properly without unusual noise?</p>		
<p>Step 8</p> <p>Check the gearbox gears and couplers for wear and damage.</p> <ul style="list-style-type: none"> • Drive gears for all print cartridges and transfer belt • Drive gears that engage with the clutches • Couplers for all print cartridges and the transfer belt <p>Are the gears and couplers free of wear and damage?</p>	Go to step 9.	Go to step 10.
<p>Step 9</p> <ol style="list-style-type: none"> 1 Remove the gearbox. See Gearbox removal. 2 Make sure that the gearbox gears are properly lubricated. 3 Reinstall the gearbox. <p>Does the problem remain?</p>	Go to step 10.	The problem is solved.
<p>Step 10</p> <p>Replace the gearbox. See Gearbox removal.</p> <p>Does the problem remain?</p>	Go to step 11.	The problem is solved.
<p>Step 11</p> <p>Make sure that the controller board is properly installed. Reseat all the cables on the controller board.</p> <p>Does the problem remain?</p>	Go to step 12.	The problem is solved.

Action	Yes	No
Step 12 Check the controller board and its connector pins for damage. Are the controller board and its connectors free of damage?	Contact the next level of support.	Go to step 13.
Step 13 Replace the controller board. See Controller board removal . Does the problem remain?	Contact the next level of support.	The problem is solved.

6yy Errors

600–621 Error Messages

Error code	Description	Action
600.95	RIP intentionally declared a jam error, usually to prevent a kiosk user from printing free pages.	See RIP Error Service Check .
611.32	Lost HSYNC errors were detected. Laser safety interlock system may be the cause.	See Printhead Communication Error Service Check .
611.34	A mirror motor lock error was detected.	
611.72	A facet map failure error occurred.	See Printhead temperature error service check .
621.01	The fuser heater was not hot enough when the paper entered the fuser nip.	See Fuser temperature error service check .

RIP Error Service Check

Action	Yes	No
<p>Step 1</p> <p>1 Open all printer doors, and then remove the manual feeder and tray.</p> <p>2 Check the paper path, tray, and bin for paper fragments and partially fed paper.</p> <p>Are the paper path, bin, and tray free of paper fragments and partially fed paper?</p>	Go to step 3.	Go to step 2.
<p>Step 2</p> <p>Remove the paper fragments and partially fed paper.</p> <p>Does the problem remain?</p>	Go to step 3.	The problem is solved.
<p>Step 3</p> <p>Reseat the HVPS flat cables.</p> <p>Does the problem remain?</p>	Go to step 4.	The problem is solved.
<p>Step 4</p> <p>Check the cables for damage.</p> <p>Are the cables free of damage?</p>	Go to step 6.	Go to step 5.
<p>Step 5</p> <p>Replace the affected cable.</p> <p>Does the problem remain?</p>	Go to step 6.	The problem is solved.
<p>Step 6</p> <p>Make sure that the controller board is properly installed. Reseat all the cables on the controller board.</p> <p>Does the problem remain?</p>	Go to step 7.	The problem is solved.
<p>Step 7</p> <p>Check the controller board and its connector pins for damage.</p> <p>Are the controller board and its connectors free of damage?</p>	Contact the next level of support.	Go to step 8.
<p>Step 8</p> <p>Replace the controller board. See Controller board removal.</p> <p>Does the problem remain?</p>	Contact the next level of support.	The problem is solved.

Printhead Communication Error Service Check

Action	Yes	No
<p>Step 1</p> <ol style="list-style-type: none"> 1 Open all printer doors, and then clear any obstructions. 2 Close the doors properly. Make sure that there is no gap between the door and the printer. <p>Does the problem remain?</p>	Go to step 2.	The problem is solved.
<p>Step 2</p> <ol style="list-style-type: none"> 1 Check the front door and its components for improper installation. Make sure that the door links and hinges are properly engaged. 2 Check the front door and its interlock actuator for damage. <p>Are the front door and its components properly installed and free of damage?</p>	Go to step 4.	Go to step 3.
<p>Step 3</p> <p>Reinstall or replace the front door. See Front door removal.</p> <p>Does the problem remain?</p>	Go to step 4.	The problem is solved.
<p>Step 4</p> <ol style="list-style-type: none"> 1 Make sure that the printhead interlock switch is properly installed. Reseat the printhead interlock switch cable. 2 Check the printhead interlock switch for damage. <p>Is the printhead interlock switch free of damage?</p>	Go to step 6.	Go to step 5.
<p>Step 5</p> <p>Replace the printhead interlock switch. See Printhead interlock switch removal.</p> <p>Does the problem remain?</p>	Go to step 6.	The problem is solved.
<p>Step 6</p> <ol style="list-style-type: none"> 1 Check the printhead and its components for damage. <ul style="list-style-type: none"> • Flat cable • Connector sockets 	Go to step 8.	Go to step 7.

Action	Yes	No
<p>2 Check the printhead mirrors for contamination.</p> <p>Is the printhead free of damage and contamination?</p>		
<p>Step 7</p> <p>Clean or replace the printhead. See Printhead removal.</p> <p>Does the problem remain?</p>	Go to step 8.	The problem is solved.
<p>Step 8</p> <p>1 Reseat the flat cables on the printhead.</p> <p>2 Reseat the printhead cables on the controller board.</p> <p>Does the problem remain?</p>	Go to step 9.	The problem is solved.
<p>Step 9</p> <p>Check the cables for damage.</p> <p>Are the cables free of damage?</p>	Go to step 11.	Go to step 10.
<p>Step 10</p> <p>Replace the affected cable.</p> <p>Does the problem remain?</p>	Go to step 11.	The problem is solved.
<p>Step 11</p> <p>Make sure that the controller board is properly installed. Reseat all the cables on the controller board.</p> <p>Does the problem remain?</p>	Go to step 12.	The problem is solved.
<p>Step 12</p> <p>Check the controller board and its connector pins for damage.</p> <p>Are the controller board and its connectors free of damage?</p>	Contact the next level of support.	Go to step 13.
<p>Step 13</p> <p>Replace the controller board. See Controller board removal.</p> <p>Does the problem remain?</p>	Contact the next level of support.	The problem is solved.

Procedure Before Starting The 9yy Service Checks

Retrieve certain information that helps your next level of support in diagnosing the problem before replacing the controller board.

 **Warning:** Do not replace the controller board unless instructed by your next level of support.

1. Collect the history information and firmware logs (Fwdebug and logs.tar.gz) from the SE menu.
2. Collect the settings from the Menu Settings Page.
3. Collect information from the user.

 **Note:** Not all of the items are retrievable from the printer that you are working on.

A. Collecting The History Information From The SE Menu

 **Note:** Make sure that your printer is connected to a network or to a print server.

1. Open a web browser, type `http://printer_IP_address/se`, and then press **Enter**.

 **Note:**

- `printer_IP_address` is the TCP/IP address of the printer.
 - `se` is required to access the printer diagnostic information.
2. Click **History Information**, copy all information, and then save it as a text file.
 3. E-mail the text file to your next level of support.

B. Collecting The Firmware Logs (fwdebug and Logs.tar.gz) From The SE Menu

 **Note:**

- Make sure that your printer is connected to a network or to a print server.
 - Some printers are designed to restart automatically after a 9yy error. On these printers, you can retrieve the secondary crash code information using the SE menu.
1. Open a web browser, type `http://printer_IP_address/se`, and then press **Enter**.
 2. Click **Logs Gzip Compressed**.

 **Note:** A logs.tar.gz file is saved to the Downloads folder. The file may take several minutes to save. You may rename the file if a logs.tar.gz already exists in the Downloads folder.

3. E-mail the logs to your next level of support.

 **Note:** To download the FWdebug log to a flash drive, see [General SE Menu](#).

C. Collecting The Settings From The Menu Settings Page

 **Note:** The Menu Settings Page is different for each printer. For more information, see the printer User's Guide. Your next level of support will tell you which page they want to see.

D. Collecting Information From The User

Ask the user for information about the following:

- Print job being run
- Operating system being used
- Print driver being used
- Other information on what was happening when the 9yy error occurred

90y Errors

900-909 Error Messages

Error code	Description	Action
900-909.xx	RIP firmware errors	See Error Service Check

900 Error Service Check

Action	Yes	No
Step 1 <ul style="list-style-type: none"> • Perform a POR. • Check if a 900.xx error code appears on the display. Does a 900.xx error code appear?	Go to step 4.	Go to step 2.
Step 2 Check if another type of error code appears instead of the 900.xx error code. Does a different error code appear?	Go to step 3.	Go to step 4.
Step 3 See the error code and its service instructions in the printer service manual. Does the problem remain?	Go to step 4.	The problem is solved.
Step 4 <ul style="list-style-type: none"> • Turn off the printer. • At the rear of the printer, disconnect the network cable, USB cable, and the fax line. • Turn on the printer. Does the problem remain?	Go to step 12.	Go to step 5.
Step 5 <ul style="list-style-type: none"> • From the control panel, navigate to the Reports menu. 	Go to step 12.	Go to step 6.

Diagnostics and Troubleshooting

Action	Yes	No
<ul style="list-style-type: none"> Select Device Statistics and Device Settings. <p>Does the problem remain?</p>		
<p>Step 6</p> <p>Check if the printer has a scanner.</p> <p>Does the printer have a scanner?</p>	Go to step 7.	Go to step 8.
<p>Step 7</p> <p>Using the scanner, perform a one-page copy job in color.</p> <p>Does the problem remain?</p>	Go to step 12.	Go to step 8.
<p>Step 8</p> <ul style="list-style-type: none"> Turn off the printer. At the rear of the printer, connect the network cable, USB cable, and the fax line. Turn on the printer. <p>Does the problem remain?</p>	Go to step 9.	Go to step 10.
<p>Step 9</p> <ul style="list-style-type: none"> Start the printer in Invalid engine mode. See [Either the href or the keyref attribute should be set on xref elements] Check if an Invalid Engine Code message appears. <p>Does the Invalid Engine Code message appear?</p>	Go to step 10.	Contact the next level of support.
<p>Step 10</p> <p>Using the Device Settings report that is printed in step 5, check if the firmware level is older than the latest available version.</p> <p>Is the firmware version older, and does the customer agree to update the firmware?</p>	Go to step 11.	Contact the next level of support.
<p>Step 11</p> <p>Update the firmware to the latest version.</p> <p>Does the problem remain?</p>	Go to step 12.	The problem is solved.
<p>Step 12</p> <ul style="list-style-type: none"> Turn off the printer. Make sure that all the cables on the controller board and scanner are properly connected. Turn on the printer. From the control panel, navigate to the Reports menu, and then select Device Statistics and Device Settings. For MFPs, perform a one-page copy and scan job in color. 	Go to step 13.	The problem is solved.

Action	Yes	No
Does the problem remain?		
<p>Step 13</p> <p>Check if the printer has any of the following components installed:</p> <ul style="list-style-type: none"> • Memory options • Fax card • Modem • Wireless and network option cards <p>Is any of the components installed?</p>	Go to step 14.	Go to step 17.
<p>Step 14</p> <ul style="list-style-type: none"> • Turn off the printer. • Remove all the installed components. • Turn on the printer. <p>Does the problem remain?</p>	Go to step 17.	Go to step 15.
<p>Step 15</p> <ul style="list-style-type: none"> • Turn off the printer. • Install the following components one at a time: <ul style="list-style-type: none"> – Memory options – Fax card – Modem – Wireless and network option cards <p> Note: Make sure to perform a POR after installing each component.</p> <p>Does the problem remain?</p>	Go to step 16.	The problem is solved.
<p>Step 16</p> <ul style="list-style-type: none"> • Turn off the printer. • Replace the components that caused the error. • Turn on the printer. <p>Does the problem remain?</p>	Go to step 17.	The problem is solved.
<p>Step 17</p> <p>Replace the controller board. See Controller board removal</p> <p>Does the problem remain?</p>	Contact the next level of support.	The problem is solved.

912–992 Errors

912–992 Error Messages

Error code	Description	Action
912.05	An engine error occurred.	See Engine, supplies, and system errors service check .
912.15	An engine error occurred.	
912.16	An engine error occurred.	
912.17	An engine error occurred.	
912.19	An engine error occurred.	
912.28	An engine error occurred.	
912.32	An engine error occurred.	See Printhead temperature error service check .
912.33	An engine error occurred.	See LVPS failure service check .
912.34	An engine error occurred.	See Engine, supplies, and system errors service check .
912.35	An engine error occurred.	
912.39	An engine error occurred.	See Engine, supplies, and system errors service check .
912.40	An engine error occurred.	
912.42	An engine error occurred.	
912.44	An engine error occurred.	
912.45	An engine error occurred.	
912.46	An engine error occurred.	
912.48	An engine error occurred.	
912.49	An engine error occurred.	
912.52	An engine error occurred.	
912.57	An engine error occurred.	
912.58	An engine error occurred.	
912.60	An engine error occurred.	See Printhead temperature error service check .
912.61	An engine error occurred.	See Engine, supplies, and system errors service check .
912.64	An engine error occurred.	
912.65	An engine error occurred.	
912.66	An engine error occurred.	

Error code	Description	Action
912.69	An engine error occurred.	
912.70	An engine error occurred.	
912.72	An engine error occurred.	
912.74	An engine error occurred.	
912.76	An engine error occurred.	
912.77	An engine error occurred.	
912.79	An engine error occurred.	
912.80	An engine error occurred.	
912.82	An engine error occurred.	See Fuser software error service check .
912.86	An engine error occurred.	See Engine, supplies, and system errors service check .
938.04	Supplies security is not enabled.	
950.10	An NVRAM mismatch error occurred.	See NVRAM mismatch failure service check .
952	A recoverable NVRAM Cyclic Redundancy Check (CRC) error occurred.	See Controller board NAND or NVRAM failure service check .
953.99	A control panel NVRAM error occurred.	See NVRAM mismatch failure service check .
954	A controller board NVRAM error occurred.	
958.99	A controller board NAND error occurred.	See Controller board NAND or NVRAM failure service check .

Engine, Supplies, and System Errors Service Check

Action	Yes	No
<p>Step 1</p> <p>Remove any packing material that is left on the affected print cartridge.</p> <p>Does the problem remain?</p>	Go to step 2.	The problem is solved.
<p>Step 2</p> <p>1 Make sure that the cartridge is a genuine and supported Xerox supply.</p>	Go to step 3.	The problem is solved.

Diagnostics and Troubleshooting

Action	Yes	No
<p>2 Make sure that the cartridge region matches the printer region.</p> <p>The worldwide region is compatible with all printer regions.</p> <p>3 Firmly shake the cartridge to redistribute the toner.</p> <p>Does the problem remain?</p>		
<p>Step 3</p> <p>Is the affected cartridge near end of life?</p>	Go to step 6.	Go to step 4.
<p>Step 4</p> <p>Make sure that the affected cartridge is properly installed.</p> <p>The cartridge must fit and lock properly with the print cartridge tray.</p> <p>Does the problem remain?</p>	Go to step 5.	The problem is solved.
<p>Step 5</p> <p>Check the cartridge smart chip contacts for corrosion and contamination.</p> <p>Is the cartridge free of damage and contamination?</p>	Go to step 7.	Go to step 6.
<p>Step 6</p> <p>Clean the contacts or replace the cartridge.</p> <p>Does the problem remain?</p>	Go to step 7.	The problem is solved.
<p>Step 7</p> <p>1 Pull out the print cartridge tray, and then remove all the cartridges.</p> <p>2 Check the cartridge tray for proper movement.</p> <p>Does the cartridge tray open and close properly?</p>	Go to step 9.	Go to step 8.
<p>Step 8</p> <p>1 Remove any obstructions that hinder the cartridge tray.</p> <p>2 Reinstall the cartridge tray.</p> <p>Does the problem remain?</p>	Go to step 9.	The problem is solved.

Action	Yes	No
<p>Step 9</p> <p>Check the cartridge tray and its components for damage.</p> <ul style="list-style-type: none"> • Cartridge locking mechanisms • Sliding mechanism under the cartridge tray • Latch mechanism <p>Is the cartridge tray free of damage?</p>	Go to step 11.	Go to step 10.
<p>Step 10</p> <p>Replace the cartridge tray. See Print cartridge tray removal.</p> <p>Does the problem remain?</p>	Go to step 11.	The problem is solved.
<p>Step 11</p> <p>Reseat the HVPS flat cables.</p> <p>Does the problem remain?</p>	Go to step 12.	The problem is solved.
<p>Step 12</p> <p>Check the cables for damage.</p> <p>Are the cables free of damage?</p>	Go to step 14.	Go to step 13.
<p>Step 13</p> <p>Replace the affected cable.</p> <p>Does the problem remain?</p>	Go to step 14.	The problem is solved.
<p>Step 14</p> <ol style="list-style-type: none"> 1 Make sure that the HVPS is properly installed. 2 Reseat all the cables on the HVPS. 3 Properly align the spring contacts. <p>Does the problem remain?</p>	Go to step 15.	The problem is solved.
<p>Step 15</p> <p>Check the HVPS contacts for contamination and damage.</p> <p>Are the HVPS contacts free of contamination and damage?</p>	Go to step 17.	Go to step 16.
<p>Step 16</p> <p>Clean or replace the HVPS. See HVPS removal.</p>	Go to step 17.	The problem is solved.

Action	Yes	No
Does the problem remain?		
Step 17 Make sure that the controller board is properly installed. Reseat all the cables on the controller board. Does the problem remain?	Go to step 18.	The problem is solved.
Step 18 Check the controller board and its connector pins for damage. Are the controller board and its connectors free of damage?	Contact the next level of support.	Go to step 19.
Step 19 Replace the controller board. See Controller board removal . Does the problem remain?	Contact the next level of support.	The problem is solved.

Fuser Software Error Service Check

Action	Yes	No
Step 1 Turn off the printer, wait for about 10 seconds, and then turn on the printer. Does the problem remain?	Go to step 2.	The problem is solved.
Step 2 1 Make sure that the power cord is properly connected to the printer and electrical outlet. 2 Make sure that the electrical outlet supplies the correct voltage. Does the problem remain?	Go to step 3.	The problem is solved.
Step 3 1 Open the rear door, and then reseat the fuser cable. 2 Reseat the cable J THERM1 on the controller board. Does the problem remain?	Go to step 4.	The problem is solved.
Step 4	Go to step 5.	Go to step 9.

Action	Yes	No
<p>Check if the fuser voltage rating matches the printer and electrical outlet voltage rating.</p> <p>Does the fuser have the correct voltage rating?</p>		
<p>Step 5</p> <p>1 Enter the Diagnostics menu, and then navigate to:</p> <p>Printer diagnostics and adjustments > Motor tests</p> <p>2 Select Fuser, and then start the test.</p> <p>Do the fuser rollers and exit rollers turn?</p>	Go to step 8.	Go to step 6.
<p>Step 6</p> <p>1 Make sure that the fuser is properly installed.</p> <p>2 Remove the left cover. See Left cover removal.</p> <p>3 Remove the right cover. See Right cover removal.</p> <p>4 Reseat the fuser cables from the following components, and then check the cables for damage:</p> <ul style="list-style-type: none"> • HVPS • LVPS • Fuser to controller board connections <p>Are the fuser cables free of damage?</p>	Go to step 8.	Go to step 7.
<p>Step 7</p> <p>Replace the affected cable.</p> <p>Does the problem remain?</p>	Go to step 8.	The problem is solved.
<p>Step 8</p> <p>Check the fuser and its components for damage.</p> <ul style="list-style-type: none"> • Gears • Rollers • Cable • Guides and actuators • Thermistor <p>Is the fuser free of damage?</p>	Go to step 10.	Go to step 9.

Diagnostics and Troubleshooting

Action	Yes	No
<p>Step 9</p> <p>Replace the fuser. See Fuser removal.</p> <p>Does the problem remain?</p>	Go to step 10.	The problem is solved.
<p>Step 10</p> <p>1 Enter the Diagnostics menu, and then navigate to:</p> <p>Printer diagnostics and adjustments > Motor tests</p> <p>2 Select Fuser, and then start the test.</p> <p>The fuser rollers and exit rollers turn when the motor runs.</p> <p>Does the motor run?</p>	Go to step 14.	Go to step 11.
<p>Step 11</p> <p>1 Remove the controller board shield. See Controller board shield removal.</p> <p>2 Reseat the cable on the motor and on the controller board.</p> <p>Does the problem remain?</p>	Go to step 12.	The problem is solved.
<p>Step 12</p> <p>Check the motor for improper installation, wear, and damage.</p> <p>Is the motor properly installed and free of damage?</p>	Go to step 14.	Go to step 13.
<p>Step 13</p> <p>Reinstall or replace the motor. See Motor (fuser) removal.</p> <p>Does the problem remain?</p>	Go to step 14.	The problem is solved.
<p>Step 14</p> <p>Check if the LVPS voltage rating matches the fuser voltage rating.</p> <p>Does the LVPS have the correct voltage rating?</p>	Go to step 15.	Go to step 17.
<p>Step 15</p> <p>1 Remove the right cover. See Right cover removal.</p> <p>2 Reseat the LVPS cables.</p> <p>Does the problem remain?</p>	Go to step 16.	The problem is solved.

Action	Yes	No
Step 16 Check the cable from the power inlet to the LVPS board for improper connection and damage. Is the cable properly connected and free of damage?	Go to step 18.	Go to step 17.
Step 17 Replace the LVPS. See LVPS removal . Does the problem remain?	Go to step 18.	The problem is solved.
Step 18 Check the firmware version. Is the firmware updated to the latest version?	Go to step 20.	Go to step 19.
Step 19 Update the firmware. Does the problem remain?	Go to step 20.	The problem is solved.
Step 20 Make sure that the controller board is properly installed. Reseat all the cables on the controller board. Does the problem remain?	Go to step 21.	The problem is solved.
Step 21 Check the controller board and its connector pins for damage. Are the controller board and its connectors free of damage?	Contact the next level of support.	Go to step 22.
Step 22 Replace the controller board. See Controller board removal . Does the problem remain?	Contact the next level of support.	The problem is solved.

NVRAM Mismatch Failure Service Check

 **Warning:** To avoid NVRAM mismatch issues, replace only one of the following components at a time:

- Control panel
- Controller board

To replace a component and to test whether the problem is resolved:

1. Replace the affected component.

 **Warning:** Do not perform a Power-On Reset (POR) until the problem is resolved. If a POR is performed at this point, then the replacement part can no longer be used in another printer and must be returned to the manufacturer.

2. Enter the Diagnostics menu. The Diagnostics menu allows you to use temporarily the replacement part.

 **Warning:** Some printers perform automatically a POR if the Diagnostics menu is not opened within five seconds. If a POR is performed at this point, then the replacement part can no longer be used in another printer and must be returned to the manufacturer.

3. Use the Diagnostics menu to test the replacement part. Perform a feed test to check if the problem is resolved.
 - If the problem is not resolved—Turn off the printer, and then install the old part.
 - If the problem is resolved—Perform a POR.

Action	Yes	No
Step 1 Check if the control panel was recently replaced. Was the control panel recently replaced?	Go to step 2.	Go to step 4.
Step 2 Replace the current control panel with the original control panel. See Control panel removal . Does the problem remain?	Go to step 3.	The problem is solved.
Step 3 Replace the original control panel with a new control panel. Make sure that the new control panel is not previously installed from another printer. Does the problem remain?	Contact the next level of support.	The problem is solved.
Step 4	Go to step 5.	Contact the next level of support.

Action	Yes	No
<p>Check if the controller board was recently replaced.</p> <p>Was the controller board recently replaced?</p>		
<p>Step 5</p> <p>Replace the current controller board with the original controller board. See Controller board removal.</p> <p>Does the problem remain?</p>	Go to step 6.	The problem is solved.
<p>Step 6</p> <p>Replace the original controller board with a new controller board.</p> <p>Make sure that the new controller board is not previously installed from another printer.</p> <p>Does the problem remain?</p>	Contact the next level of support.	The problem is solved.

Controller Board NAND or NVRAM Failure Service Check

Action	Yes	No
<p>Step 1</p> <p>Turn off the printer, wait for about 10 seconds, and then turn on the printer.</p> <p>Does the problem remain?</p>	Go to step 2.	The problem is solved.
<p>Step 2</p> <p>Make sure that the controller board is properly installed. Reseat all the cables on the controller board.</p> <p>Does the problem remain?</p>	Go to step 3.	The problem is solved.
<p>Step 3</p> <p>Check the controller board cables for damage.</p> <p>Are the cables free of damage?</p>	Go to step 5.	Go to step 4.
<p>Step 4</p> <p>Replace the damaged cables.</p> <p>Does the problem remain?</p>	Go to step 5.	The problem is solved.

Diagnostics and Troubleshooting

Action	Yes	No
Step 5 Check the controller board and its connector pins for damage. Are the controller board and its connectors free of damage?	Contact the next level of support.	Go to step 6.
Step 6 Replace the controller board. See Controller board removal . Does the problem remain?	Contact the next level of support.	The problem is solved.

Other Symptoms

Base Printer Symptoms

Base Printer Symptoms

Symptom	Action
Tray 1 is undetected when inserted or removed.	See Tray Present Error Service Check .
The control panel has no power.	See Blank Control Panel Display Service Check .
A false tray media low message prompts.	See Tray Near Empty Service Check .
A false reading on the amount of paper in Tray 1 occurs.	

Tray Present Error Service Check

Action	Yes	No
<p>Step 1</p> <ol style="list-style-type: none"> 1 Make sure that the paper is properly loaded in the tray and manual feeder. See Avoiding jams. 2 Make sure that the tray and manual feeder are properly installed. <p>Does the problem remain?</p>	Go to step 2.	The problem is solved.
<p>Step 2</p> <ol style="list-style-type: none"> 1 From the control panel, navigate to: Settings > Paper > Tray Configuration > Paper Size/Type 2 Make sure that the setting matches the paper loaded. <p>Does the problem remain?</p>	Go to step 3.	The problem is solved.
<p>Step 3</p> <ol style="list-style-type: none"> 1 Check the tray insert and its guides for damage. 2 Check the tray insert pads for wear and damage. <p>Is the tray insert free of damage?</p>	Go to step 5.	Go to step 4.
Step 4	Go to step 5.	The problem is solved.

Diagnostics and Troubleshooting

Action	Yes	No
<p>Replace the tray insert.</p> <p>Does the problem remain?</p>		
<p>Step 5</p> <p>1 Enter the Diagnostics menu, and then navigate to:</p> <p>Printer diagnostics and adjustments > Sensor tests</p> <p>2 Find the sensor (Tray present).</p> <p>3 Remove or insert the tray to toggle the tray interlock switch.</p> <p>Does the sensor status change while toggling the switch?</p>	Go to step 9.	Go to step 6.
<p>Step 6</p> <p>1 Remove the controller board shield. See Controller board shield removal .</p> <p>2 Reseat the cable of the switch on the controller board.</p> <p>Does the problem remain?</p>	Go to step 7.	The problem is solved.
<p>Step 7</p> <p>Check the switch for improper installation and damage.</p> <p>Is the switch properly installed and free of damage?</p>	Go to step 9.	Go to step 8.
<p>Step 8</p> <p>Reinstall or replace the switch. See Tray interlock switch removal .</p> <p>Does the problem remain?</p>	Go to step 9.	The problem is solved.
<p>Step 9</p> <p>Make sure that the controller board is properly installed. Reseat all the cables on the controller board.</p> <p>Does the problem remain?</p>	Go to step 10.	The problem is solved.

Action	Yes	No
Step 10 Check the controller board and its connector pins for damage. Are the controller board and its connectors free of damage?	Contact the next level of support.	Go to step 11.
Step 11 Replace the controller board. See Controller board removal . Does the problem remain?	Contact the next level of support.	The problem is solved.

Blank Control Panel Display Service Check

Action	Yes	No
Step 1 1 Make sure that the power cord is properly connected to the printer and electrical outlet. 2 Make sure that the electrical outlet supplies the correct voltage. Does the problem remain?	Go to step 2.	The problem is solved.
Step 2 Check if the LVPS voltage rating matches the fuser voltage rating. Does the LVPS have the correct voltage rating?	Go to step 3.	Go to step 5.
Step 3 1 Remove the right cover. See Right cover removal . 2 Reseat the LVPS cables. Does the problem remain?	Go to step 4.	The problem is solved.
Step 4 Check the cable from the power inlet to the LVPS board for improper connection and damage. Is the cable properly connected and free of damage?	Go to step 6.	Go to step 5.
Step 5 Replace the LVPS. See LVPS removal .	Go to step 6.	The problem is solved.

Diagnostics and Troubleshooting

Action	Yes	No
Does the problem remain?		
Step 6 Check the control panel for damage. Is the control panel free of damage?	Go to step 7.	Go to step 10.
Step 7 1 Remove the controller board shield. See Controller board shield removal . 2 Remove the top cover. See Top cover removal . 3 Reseat the cable on the control panel and controller board. Does the problem remain?	Go to step 8.	The problem is solved.
Step 8 Check the control panel flat cable for damage. Is the flat cable free of damage?	Go to step 10.	Go to step 9.
Step 9 Replace the cable. Does the problem remain?	Go to step 10.	The problem is solved.
Step 10 Replace the control panel. See Control panel removal . Does the problem remain?	Go to step 11.	The problem is solved.
Step 11 Make sure that the controller board is properly installed. Reseat all the cables on the controller board. Does the problem remain?	Go to step 12.	The problem is solved.

Action	Yes	No
Step 12 Check the controller board and its connector pins for damage. Are the controller board and its connectors free of damage?	Contact the next level of support.	Go to step 13.
Step 13 Replace the controller board. See Controller board removal . Does the problem remain?	Contact the next level of support.	The problem is solved.

Tray Near Empty Service Check

Action	Yes	No
Step 1 1 Make sure that the paper is properly loaded in the tray and manual feeder. See Avoiding jams . 2 Make sure that the tray and manual feeder are properly installed. Does the problem remain?	Go to step 2.	The problem is solved.
Step 2 1 From the control panel, navigate to: Settings > Paper > Tray Configuration > Paper Size/Type 2 Make sure that the setting matches the paper loaded. Does the problem remain?	Go to step 3.	The problem is solved.
Step 3 1 Check the tray insert and its guides for damage. 2 Check the tray insert pads for wear and damage. Is the tray insert free of damage?	Go to step 5.	Go to step 4.
Step 4 Replace the tray insert. Does the problem remain?	Go to step 5.	The problem is solved.

Action	Yes	No
<p>Step 5</p> <p>1 Enter the Diagnostics menu, and then navigate to:</p> <p>Printer diagnostics and adjustments > Sensor tests</p> <p>2 Find the sensor (Media low).</p> <p>Does the sensor status change while toggling the sensor?</p>	Go to step 9.	Go to step 6.
<p>Step 6</p> <p>1 Remove the controller board shield. See Controller board shield removal.</p> <p>2 Reseat the cable of the sensor (tray near empty) on the controller board.</p> <p>Does the problem remain?</p>	Go to step 7.	The problem is solved.
<p>Step 7</p> <p>Check the sensor and its flag for improper installation and damage.</p> <p>Is the sensor properly installed and free of damage?</p>	Go to step 9.	Go to step 8.
<p>Step 8</p> <p>Reinstall or replace the sensor. See Sensor (tray Near Empty) Removal.</p> <p>Does the problem remain?</p>	Go to step 9.	The problem is solved.
<p>Step 9</p> <p>1 Check the pick roller for improper mechanism.</p> <p>After the pick roller is lowered, it must move automatically to its original position.</p> <p>2 Check the pick roller for damage.</p> <p>Is the pick roller functional and free of damage?</p>	Go to step 10.	Contact the next level of support.
<p>Step 10</p> <p>Make sure that the controller board is properly installed. Reseat all the cables on the controller board.</p> <p>Does the problem remain?</p>	Go to step 11.	The problem is solved.

Action	Yes	No
Step 11 Check the controller board cables for damage. Are the cables free of damage?	Go to step 13.	Go to step 12.
Step 12 Replace the damaged cables. Does the problem remain?	Go to step 13.	The problem is solved.
Step 13 Check the controller board and its connector pins for damage. Are the controller board and its connectors free of damage?	Contact the next level of support.	Go to step 14.
Step 14 Replace the controller board. See Controller board removal . Does the problem remain?	Contact the next level of support.	The problem is solved.

Service Menus

Understanding The Printer Control Panel

Using The Control Panel

Xerox C230 Printers

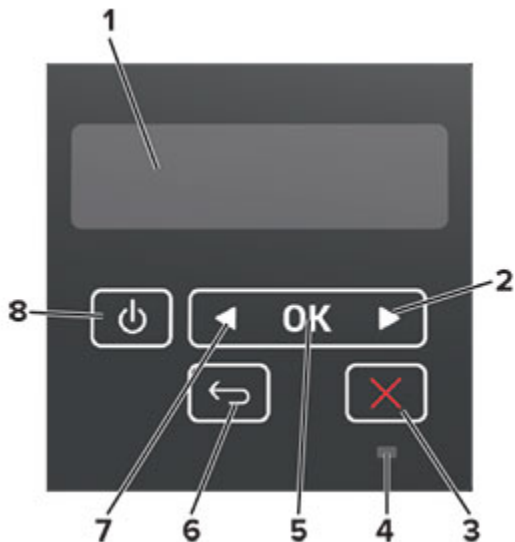

	Control panel part	Function
1	Display	<ul style="list-style-type: none"> View printer messages and supply status. Set up and operate the printer.
2	Right arrow button	<ul style="list-style-type: none"> Scroll through menus or move between screens and menu options. Increase the numeric value of a setting.
3	Stop or Cancel button	Stop the current job.
4	Indicator light	Check the status of the printer.
5	Select button	<ul style="list-style-type: none"> Select a menu option. Save the changes in a setting.
6	Back button	Return to the previous screen.

	Control panel part	Function
7	Left arrow button	<ul style="list-style-type: none"> • Scroll through menus or move between screens and menu options. • Decrease the numeric value of a setting.
8	Power button	<p>Turn on or turn off the printer.</p> <p>To turn off the printer, press and hold the power button for five seconds.</p>

Understanding The Status Of The Indicator Light

Indicator light	Printer status
Off	The printer is off.
Blue	The printer is on or ready.
Blinking blue	The printer is processing data.
Blinking red	The printer requires user intervention.
Amber	The printer is in Sleep mode.

Diagnostics Menu

Entering The Diagnostics Menu

The Diagnostics menu contains tests that are used to help isolate issues with the printer.

Diagnostics Menu

- To access the menu from POST, on the control panel, press and hold the **Left arrow** and **OK** buttons.
- To access the menu from the home screen, on the control panel, press the following buttons in this sequence: **Back, Right arrow, Back, Right arrow**.

Reports

Device Settings

This report lists all the current printer settings.

Enter the Diagnostics menu, and then navigate to:

Reports > Device > Device Settings

For non-touch-screen printer models, press  to navigate through the settings.

Installed Licenses

This setting lists all the installed licenses and their feature data.

Enter the Diagnostics menu, and then navigate to:

Reports > Licenses > Installed Licenses

For non-touch-screen printer models, press  to navigate through the settings.

Advanced Print Quality Samples

This setting prints the Print Quality Test Pages.

Enter the Diagnostics menu, and then select **Advanced Print Quality Samples**.

Event Log

Display Log

This setting shows a history of printer events.

Enter the Diagnostics menu, and then navigate to:

Event Log > Display Log

For non-touch-screen printer models, press  to navigate through the settings.

Print Log

This setting shows additional information about the printer events.

Enter the Diagnostics menu, and then navigate to:

Event Log > Print Log

For non-touch-screen printer models, press  to navigate through the settings.



Note: The events that appear in the report vary depending on the operational history of the printer.

Print Log Summary

This setting lists a brief summary of the various printer events.

Enter the Diagnostics menu, and then navigate to:

Event Log > Print Log Summary

For non-touch-screen printer models, press  to navigate through the settings.



Note: The events that appear in the report vary depending on the operational history of the printer.

Mark Log

This setting allows you to create a service, maintenance, or custom log entry. Each log entry is added in the printer event log.

1. Enter the Diagnostics menu, and then navigate to:

Event Log > Mark Log

For non-touch-screen printer models, press  to navigate through the settings.

2. Select a log that you want to create.

Input Tray Quick Print

This setting lets you print a single or continuous Quick Test page in either duplex or simplex mode.

1. Enter the Diagnostics menu, and then select **Input tray quick print**.
2. Select a paper source.
3. Select whether to print a single or continuous test page.

Printer Setup

Printed Page Count (mono)

This setting displays the amount of pages printed in mono.

1. Enter the Diagnostics menu, and then select **Printer Setup**.
2. View the printed page count for mono.

Printed Page Count (color)

This setting displays the amount of pages printed in color.

1. Enter the Diagnostics menu, and then select **Printer Setup**.
2. View the printed page count for color.

Permanent Page Count

This setting displays the total number of pages printed in mono and color. After all the print tests are completed, this value resets to zero.

1. Enter the Diagnostics menu, and then select **Printer Setup**.
2. View the permanent page count.

Processor ID

This setting indicates the ID of the processor on the controller board.

1. Enter the Diagnostics menu, and then select **Printer Setup**.
2. View the processor ID.

Serial Number

This setting shows the printer serial number.

1. Enter the Diagnostics menu, and then navigate to:

Printer Setup > Serial number

For non-touch-screen printer models, press  to navigate through the settings.

2. View the serial number.

Model Name

This setting shows the model name of the printer.

1. Enter the Diagnostics menu, and then navigate to:

Printer Setup > Model name

For non-touch-screen printer models, press  to navigate through the settings.

2. View the model name.

Engine Setting [x]

 **Warning:** Do not change this setting without specific instructions from the next level of support.

This setting allows you to select a printer engine setting. Possible values are 0–255. The default value is 0.

For non-touch-screen printer models, press  to navigate through the settings.

1. Enter the Diagnostics menu, and then navigate to:

Printer Setup > Engine setting [x]

2. Select a setting, and then enter a value.

EP Setup

 **Warning:** Do not change this setting without specific instructions from the next level of support.

This setting allows you to adjust the EP setup of the printer.

For non-touch-screen printer models, press  to navigate through the settings.

1. Enter the Diagnostics menu, and then navigate to:

Printer Setup > EP setup

2. Select a setting.

Waste Toner Sensor Calibration

To ensure the accuracy of the waste toner level detection, calibrate the sensor (waste toner bottle).

1. Enter the Diagnostics menu, and then navigate to:

Printer setup > Waste toner sensor calibration

For non-touch-screen printer models, press  to navigate through the settings.

2. Remove the waste toner bottle.
3. Select **Start calibration**.

If the calibration is successful, then a Test passed message appears on the display.

4. Insert the waste toner bottle, and then restart the printer.

If problems occur during calibration, then see [Waste toner bottle error service check](#).

Printer Diagnostics and Adjustments

Sensor Tests

1. Enter the Diagnostics menu, and then navigate to:
Printer diagnostics and adjustments > Sensor tests

For non-touch-screen printer models, press  to navigate through the settings.

A list of sensor tests appears.

2. Find, and then manually toggle the sensor.

 **Note:**

- The sensor status on the screen toggles between **1** and **0** when the sensor is properly working.
- If a sensor test fails, the test failure may not indicate a failed sensor. Further troubleshooting may be required. Check the boards and cables for possible issues.

List Of Sensor Tests

Input
Manual Feeder
Bin/Narrow media
Fuser buckle
Fuser exit
Door interlock
Media low
Tray present
TPS L and R
Waste Toner Bottle

Motor Tests

1. Enter the Diagnostics menu, and then navigate to:
Printer diagnostics and adjustments > Motor tests

For non-touch-screen printer models, press  to navigate through the settings.

2. Select a motor.

 **Note:**

- If the motor is activated, then it is properly working.
- Some motors require automatic deactivation to avoid secondary issues such as possible damage and contamination.
- Some tests require a special action to activate a motor such as removing a major component.
- If the motor fails, the test failure may not indicate a failed motor. Further troubleshooting may be required. Check the boards and cables for possible issues.
- To stop a running motor in non-touch-screen printer models, press .

List Of Motor Tests

Pick clutch (Tray 1 or Manual Feed)
Staging clutch
Fuser
CMY
K/Transfer belt
Fan (main)

Registration Adjust

This setting lets you adjust the skew and margins or print a Quick Test page.

For non-touch-screen printer models, press  to navigate through the settings.

1. Enter the Diagnostics menu, and then navigate to:
Printer diagnostics and adjustments > Registration adjust
2. Select a setting to adjust.

Color Alignment Adjust

This setting allows you to adjust the color alignments and to print or reset the default settings.

For non-touch-screen printer models, press  to navigate through the settings.

1. Enter the Diagnostics menu, and then navigate to:
Printer diagnostics and adjustments > Color alignment adjust
2. Select a setting.

Supply Reset

The setting resets the fuser and transfer module counter values to zero.

For non-touch-screen printer models, press  to navigate through the settings.

Service Menus

1. Enter the Diagnostics menu, and then navigate to:
Printer diagnostics and adjustments > Supply reset
2. Select a setting.

Weather Station

This setting lets you view the temperature and humidity that is reported by the weather station.

Enter the Diagnostics menu, and then navigate to:

Printer diagnostics and adjustments > Weather station

For non-touch-screen printer models, press  to navigate through the settings.

Universal Override

This setting allows the user to load custom paper sizes into a paper source.

For non-touch-screen printer models, press  to navigate through the settings.

1. Enter the Diagnostics menu, and then navigate to:
Printer diagnostics and adjustments > Universal Override
2. Select a setting to adjust.

Config Menu

Entering The Config Menu

From the control panel, navigate to:

Settings > Device > Maintenance > Config Menu

For non-touch-screen printer models, press  to navigate through the settings.

Config Menu

Menu item	Description
USB Configuration USB PnP 1* 2	Change the USB driver mode of the printer to improve its compatibility with a personal computer.
USB Configuration USB Speed Full Auto*	Set the USB port to run at full speed and disable its high-speed capabilities.
Tray Configuration Tray Linking Automatic* Off	Set the printer to link the trays that have the same paper type and paper size settings. This menu item is available only in some printer models.
Tray Configuration Show Tray Insert Message Off Only for unknown sizes* Always	Display a message to select paper size and type after inserting the tray.
Tray Configuration A5 Loading Short Edge Long Edge*	Specify the page orientation when loading A5 paper size.
Tray Configuration Paper Prompts Auto*	Set the paper source that the user fills when a prompt to load paper appears.

Service Menus

Menu item	Description
Manual Paper	
Tray Configuration Envelope Prompts Auto* Manual Envelope	Set the paper source that the user fills when a prompt to load envelope appears.
Tray Configuration Action for Prompts Prompt user* Continue Use current	Set the printer to resolve paper- or envelope-related change prompts.
Reports Menu Settings Page Event Log Event Log Summary	Print reports about printer menu settings, status, and event logs.
Supply Usage And Counters Clear Supply Usage History	Reset the supply usage history, such as number of pages and days remaining, to the factory shipped level.
Supply Usage And Counters Fuser Reset ITM Reset	Reset the counter after installing a new supply.
Printer Emulations PS Emulation On* Off	Set the printer to recognize and use the PS data stream.
Printer Emulations Emulator Security Page Timeout 0–60 (60*)	Set the page timeout during emulation.
Printer Emulations Emulator Security Reset Emulator After Job Off* On	Reset the emulator after a print job.

Menu item	Description
Printer Emulations Emulator Security Disable Printer Message Access On* Off	Disable access to printer message during emulation.
Print Configuration Black Only Mode Off* On	Print color content in grayscale.
Print Configuration Color Trapping Off 1 2* 3 4 5	Enhance the printed output to compensate for misregistration in the printer.
Print Configuration Font Sharpening 0–150 (24*)	Set a text point-size value below which the high-frequency screens are used when printing font data. For example, if the value is 24, then all fonts sized 24 points or less use the high-frequency screens.
Device Operations Quiet Mode Off* On	Set the printer to operate in Quiet Mode. Enabling this setting slows down the printer performance.
Device Operations Safe Mode Off* On	Set the printer to operate in a mode in which it attempts to continue offering as much functionality as possible, despite known issues. For example, when set to On, and the duplex motor is nonfunctional, the printer performs one-sided printing of the documents even if the job is two-sided printing. This menu item is available only in some printer models.
Device Operations Clear Custom Status	Erase user-defined strings for the Default or Alternate custom messages.
Device Operations	Erase messages that were remotely installed.

Service Menus

Menu item	Description
Clear all remotely-installed messages	This menu item is available only in some printer models.
Device Operations Automatically Display Error Screens On* Off	Show existing error messages on the display after the printer remains inactive on the home screen for a length of time equal to the Screen Timeout setting. This menu item is available only in some printer models.
Toner patch sensor setup Calibration frequency preference Disabled Fewest color adjustments Fewer color adjustments Normal* Better color accuracy Best color accuracy	Set the default calibration frequency.
Toner patch sensor setup Full calibration	Run the full color calibration.
Toner patch sensor setup Print TPS information page	Print a diagnostic page that contains toner patch sensor calibration.
An asterisk (*) next to a value indicates the factory default setting.	

Service Engineer (SE) Menu

Entering Invalid Engine Mode

This mode allows the printer to load the correct firmware code.

1. Unplug the power cord from the electrical outlet.
2. Open tray 1.
3. Connect the power cord to the electrical outlet.

When the display shows the following icon, close tray 1.

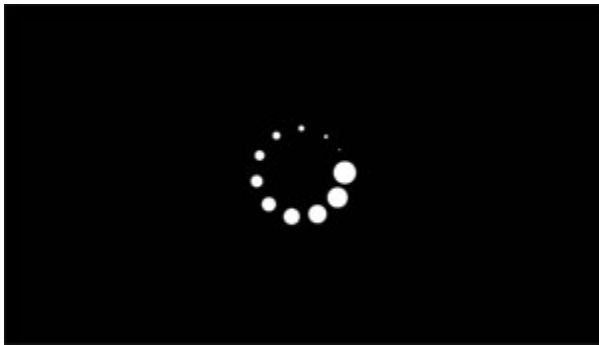

4. Touch -> to navigate the menu that appears on the display, and then select **ENGINE_FLASH**.

 **Note:** For non-touch-screen printer models, press the arrow buttons to navigate the menu.

Entering The SE Menu

- To access the menu from the home screen on a 2-line display control panel, press the following buttons in this sequence: **Back, Left arrow, Back, Left arrow**
- To access the menu from the home screen on a touch-screen display control panel, press the following buttons in this sequence:

Back, Back, Home, Home

General SE Menu

- Capture Logs to USB Drive

 **Note:** This setting allows you to save a log file to a USB drive.

- Code Versions
- Debug Level

Network SE Menu

Enter the SE menu, and then select **Network SE Menu**.

Service Menus

 **Note:** Use these settings as directed by the next level of support.

Top-level menu	Intermediate menu
HISTORY	<ul style="list-style-type: none"> • Print History • Mark History
MAC	<ul style="list-style-type: none"> • Set Card Speed • LAA • Keep Alive
NPAP	Print Alerts
TCP/IP	<ul style="list-style-type: none"> • DHCP Request Options • netstat • arp • Allow SNMP Set • MTU • Mediatech Mode • RAW LPR Mode • Garp Interval
Wireless Settings	Wireless Performance Enhancement
	Unset Wireless Region
Ping Test	<ul style="list-style-type: none"> • Ping Address • Attempts • Packet Size • Ping
Other Actions	<ul style="list-style-type: none"> • ifconfig • IPtables [Firewall Dump] • IP6tables [Firewall Dump] • IPsec Dump
Enable/Disable USB Auto Suspend	N/A
Enable DHCPCD Debugging	N/A
Enable WPA-suplicant Debugging	N/A
Enable Ethernet Gigabit	N/A

Parts Removal

Data Security Notice

Identifying Printer Memory

- **Volatile memory**—The printer uses standard random access memory (RAM) to buffer user data temporarily during simple print and copy jobs.
- **Nonvolatile memory**—The printer may use two forms of nonvolatile memory: EEPROM and NAND (flash memory). Both types are used to store the operating system, printer settings, network information, scanner and bookmark settings, and embedded solutions.

The following parts can store memory:

- Printer control panel
- User interface controller card (UICC)
- Controller board



Note: The printer control panel and controller board contain NVRAM.

Erasing Printer Memory

To erase volatile memory or buffered data, turn off the printer.

To erase non-volatile memory or individual settings, device and network settings, security settings, and embedded solutions, do the following:





1. From the control panel, navigate to:

Settings > Device > Maintenance > Out of Service Erase > Sanitize all information on nonvolatile memory





For non-touch-screen printer models, press  to navigate through the settings.

2. Select either **Start initial setup** or **Leave printer offline**.





Removal Precautions

-  **CAUTION—SHOCK HAZARD:** The low-voltage power supply (LVPS) and the high-voltage power supply (HVPS) may have residual voltage present. To avoid the risk of electrical shock, do not touch their circuit components or the solder side of the board. Only handle them by their outer edges or metal housing.
-  **CAUTION—SHOCK HAZARD:** This product uses an electronic power switch. It does not physically disconnect the input AC voltage. To avoid the risk of electrical shock, always remove the power cord from the printer when removal of the input AC voltage is required.
-  **CAUTION—SHOCK HAZARD:** To avoid the risk of electrical shock and to prevent damage to the printer, remove the power cord from the electrical outlet and disconnect all connections to any external devices before you connect or disconnect any cable, electronic board, or assembly.
-  **CAUTION—HOT SURFACE:** The inside of the printer might be hot. To reduce the risk of injury from a hot component, allow the surface to cool before touching it.
-  **CAUTION—PINCH HAZARD:** To avoid the risk of a pinch injury, use caution in areas marked with this label. Pinch injuries may occur around moving parts, such as gears, doors, trays, and covers.





Précautions De Retrait

-  **ATTENTION ! RISQUE D'ÉLECTROCUTION :** Une tension résiduelle peut être présente dans le bloc d'alimentation basse tension (LVPS) et le bloc d'alimentation haute tension (HVPS). Pour éviter tout risque d'électrocution, ne touchez pas les composants du circuit ou le côté soudure de la carte. Tenez-les uniquement par leurs extrémités ou le boîtier en métal.
-  **ATTENTION ! RISQUE D'ÉLECTROCUTION :** Ce produit utilise un commutateur d'alimentation électronique. Il ne déconnecte pas physiquement la tension d'alimentation CA. Pour éviter tout risque d'électrocution, débranchez toujours le cordon d'alimentation de l'imprimante lorsque vous devez déconnecter la tension d'alimentation CA.
-  **ATTENTION ! RISQUE D'ÉLECTROCUTION :** Pour éviter tout risque d'électrocution et éviter d'endommager l'imprimante, débranchez le cordon d'alimentation de la prise électrique et déconnectez toute connexion à tout périphérique externe avant de brancher ou débrancher des câbles ou circuits et assemblages électroniques.
-  **ATTENTION ! SURFACE CHAUDE :** L'intérieur de l'imprimante risque d'être brûlant. pour réduire le risque de brûlure, laissez la surface ou le composant refroidir avant d'y toucher.
-  **ATTENTION ! RISQUE DE PINCEMENT :** Pour éviter tout risque de blessure par pincement, agissez avec précaution au niveau des zones signalées par cette étiquette. Les blessures par pincement peuvent se produire autour des pièces mobiles telles que les engrenages, portes, tiroirs et capots.





Precauciones Durante La Extracción

-  **PRECAUCIÓN—RIESGO DE DESCARGA:** La fuente de alimentación de bajo voltaje (LVPS) y la fuente de alimentación de alto voltaje (HVPS) pueden presentar voltaje residual. Para evitar el riesgo de descarga eléctrica, no toque los componentes del circuito ni el lateral soldado de la placa. Manipule solo los bordes exteriores o la carcasa metálica.
-  **PRECAUCIÓN—RIESGO DE DESCARGA:** Este producto utiliza un interruptor de corriente electrónico. No desconecta físicamente la entrada de voltaje de CA. Para evitar el riesgo de descarga eléctrica, desenchufe siempre el cable de alimentación de la impresora cuando sea necesario retirar la entrada de voltaje de CA.
-  **PRECAUCIÓN—RIESGO DE DESCARGA:** Para evitar el riesgo de descargas eléctricas y daños en la impresora, retire el cable de alimentación de la toma eléctrica y desconecte todas las conexiones a dispositivos externos antes de conectar o desconectar cualquier cable, placa electrónica o conjunto.
-  **PRECAUCIÓN—SUPERFICIE CALIENTE:** El interior de la impresora podría estar caliente. Para evitar el riesgo de heridas producidas por el contacto con un componente caliente, deje que la superficie se enfríe antes de tocarlo.
-  **PRECAUCIÓN—RIESGO DE DESCARGA ELÉCTRICA:** Para evitar el riesgo de lesión por atrapamiento, preste atención en las áreas marcadas con esta etiqueta. Las lesiones por atrapamiento se pueden producir en torno a partes móviles, tales como engranajes, puertas, bandejas y cubiertas.

Vorsichtsmaßnahmen Bei Der Demontage

-  **VORSICHT – STROMSCHLAGGEFAHR:** Im Niederspannungsnetzteil (LVPS) und Hochspannungsnetzteil (HVPS) liegt unter Umständen Restspannung vor. Um das Risiko eines elektrischen Schlags zu vermeiden, berühren Sie keine umliegenden Bauteile oder die Lötseite der Platine. Fassen Sie sie nur an den Außenkanten oder am Metallgehäuse an.
-  **VORSICHT – STROMSCHLAGGEFAHR:** Dieses Produkt verwendet einen elektronischen Leistungsschalter. Er trennt die Eingangswchselspannung nicht physikalisch. Um das Risiko eines elektrischen Schlags zu vermeiden, ziehen Sie stets das Netzkabel vom Drucker ab, wenn eine Abtrennung der Eingangswchselspannung erforderlich ist.
-  **VORSICHT – STROMSCHLAGGEFAHR:** Um das Risiko eines elektrischen Schlags und Schäden am Drucker zu vermeiden, ziehen Sie das Netzkabel aus der Steckdose und trennen Sie alle Verbindungen zu jeglichen externen Geräten, bevor Sie Kabel, Elektronikplatinen oder Baugruppen einstecken oder abziehen.
-  **VORSICHT – HEISS:** Das Innere des Druckers kann sehr heiß sein. Vermeiden Sie Verletzungen, indem Sie heiße Komponenten stets abkühlen lassen, bevor Sie ihre Oberfläche berühren.
-  **VORSICHT – QUETSCHGEFAHR:** Um das Risiko einer Quetschung zu vermeiden, gehen Sie in Bereichen, die mit diesem Etikett gekennzeichnet sind, mit Vorsicht vor. Quetschungen können im Bereich von beweglichen Komponenten auftreten, wie z.B. Zahnrädern, Klappen, Fächern und Abdeckungen.

Precauzioni per la rimozione

-  **ATTENZIONE – PERICOLO DI SCOSSA ELETTRICA:** Sull'alimentatore a bassa tensione (LVPS) e l'alimentatore ad alta tensione (HVPS) può essere presente tensione residua. Per evitare il rischio di scossa elettrica, non toccare i loro componenti elettrici o il lato saldatura della scheda. Toccarli soltanto dai bordi esterni o dall'alloggiamento in metallo.
-  **ATTENZIONE – PERICOLO DI SCOSSA ELETTRICA:** Questo prodotto utilizza un interruttore di alimentazione elettronico. Tale interruttore non scollega fisicamente la tensione CA in entrata. Per evitare il rischio di scossa elettrica, rimuovere sempre il cavo di alimentazione dalla stampante quando è necessario rimuovere la tensione CA in entrata.
-  **ATTENZIONE – PERICOLO DI SCOSSA ELETTRICA:** Per evitare il rischio di scossa elettrica e per impedire danni alla stampante, rimuovere il cavo di alimentazione dalla presa elettrica e scollegare tutti i collegamenti a eventuali dispositivi esterni prima di collegare o scollegare qualsiasi cavo, scheda elettronica o gruppo.
-  **ATTENZIONE – SUPERFICIE SURRISCALDATA:** L'area interna della stampante potrebbe surriscaldarsi. Per evitare infortuni, lasciare raffreddare la superficie dei componenti prima di toccarla.
-  **ATTENZIONE – PERICOLO DI SCHIACCIAMENTO:** Per evitare il rischio di lesioni, prestare la massima cautela quando si accede alle aree contrassegnate con questa etichetta. Potrebbero infatti verificarsi lesioni da schiacciamento in prossimità di parti in movimento, quali ad esempio ingranaggi, porte, vassoi e coperchi.

Handling ESD-sensitive Parts

To prevent damage to the electrostatic discharge (ESD)-sensitive parts in the printer, do the following:

- Turn off the printer before removing logic boards.
- Keep the parts in their original packing material until you are ready to install them into the printer.
- Make the least-possible movements with your body to prevent an increase of static electricity from clothing fibers, carpets, and furniture.
- Use the ESD wrist strap. Connect the wrist band to the system ground point. This action discharges any static electricity in your body to the printer.
- Hold the parts by their edge connector shroud. Do not touch its pins. If you are removing a pluggable module, then use the correct tool.
- If possible, keep all parts in a grounded metal cabinet.
- Do not place the parts on the printer cover or on a metal table. If you need to put down the parts, then put them in their packing material.
- Prevent parts from being accidentally touched by other personnel. Cover the printer when you are not working on it.
- Be careful while working with the parts when cold-weather heating is used. Low humidity increases static electricity.

Critical Information For Controller Board or Control Panel Replacement

 **Warning:** Observe all precautions when handling ESD sensitive parts. See [Handling ESD-sensitive Parts](#).

 **Warning:** Carefully remove cables and connectors. Make sure that they are not damaged.

 **Warning:** To avoid damaging the part or experience NVRAM mismatch issues, replace only one of the following components at a time:

- Control panel
- Controller board

To replace a component and to test whether the problem is resolved:

1. Replace the affected component.

 **Warning:** Do not perform a Power-On Reset (POR) until the problem is resolved. If a POR is performed at this point, then the replacement part can no longer be used in another printer and must be returned to the manufacturer.

2. Enter the Diagnostics menu. The menu allows you to temporarily use the replacement part.

 **Warning:** Some printers perform a POR automatically if the Diagnostics menu is not opened within five seconds. If a POR is performed at this point, then the replacement part can no longer be used in another printer and must be returned to the manufacturer.

3. Use the Diagnostics menu to test the replacement part. Do a feed test to check if the problem is resolved.

- If the problem is not resolved—Turn off the printer, and then install the old part.
- If the problem is resolved—Perform a POR.

4. To replace the controller board and the control panel simultaneously on the machine, follow the below procedure to avoid losing the printer's NVRAM settings and damaging the printer.

- a. Replace either the controller board or the control panel on the machine. Do not replace both the parts at the same time.
- b. Power on the printer and perform a POR.
- c. After the printer has completed startup (printer will be either READY or post an error), power off the printer and replace the second part.

 **Note:** If the control panel display has failed, the printers' startup cycle is complete after the driver motor and fans shut down and the machine is quiet.

- d. Power on the printer and allow the printer to go through a complete startup cycle and the display changes to READY.

Restoring The Printer Configuration After Replacing The Controller Board

Restore the printer to its correct configuration. Contact your Hardware Support Line to obtain the applicable zip file. Flash the printer settings and embedded solutions..

-  **Note:** The software bundle contains the latest version of the firmware, applications, and software licenses from the Lexmark Virtual Solutions Center (VSC). The printer firmware may be at a different level from what was used before replacing the controller board.

Extract the contents of the zip file.

- Perform the install instructions on the Readme file in the exact order shown. Restart the printer only if the file says so.
- For more information on how to flash the downloaded files, see [Updating The Printer Firmware](#).
- To load the zip file, see [Restoring Licenses and Configuration Settings](#).

After performing the installation instructions in the Readme file, confirm that the printer is restored.

- If you are unable to access the administrative menus to verify that the printer is restored, then ask the customer for access rights.
- If a 10.00 error appears after you restart the printer, then contact the next level of support.

Restoring Licenses and Configuration Settings

To load the zip files that you received from Hardware Support, do the following:

1. Open a web browser, and then type the printer IP address.

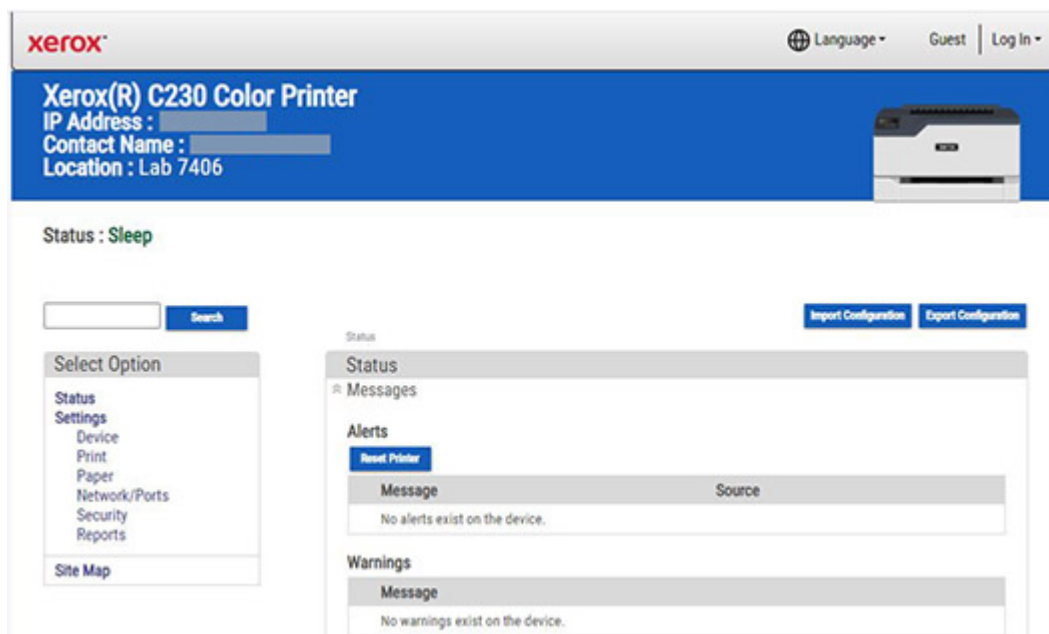

2. Click **Import Configuration**, and then click **Browse**.

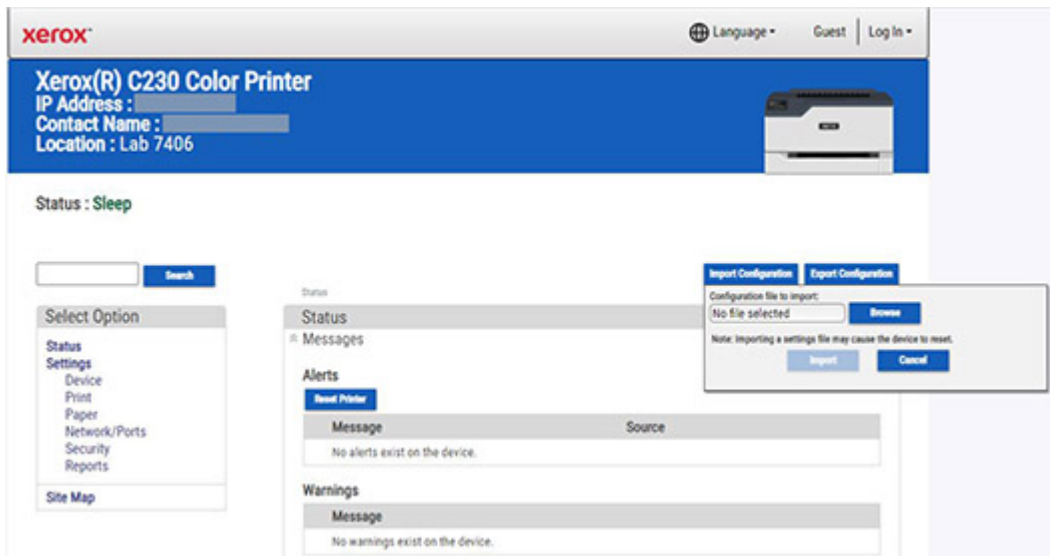

3. Navigate to the folder where the zip files are extracted.

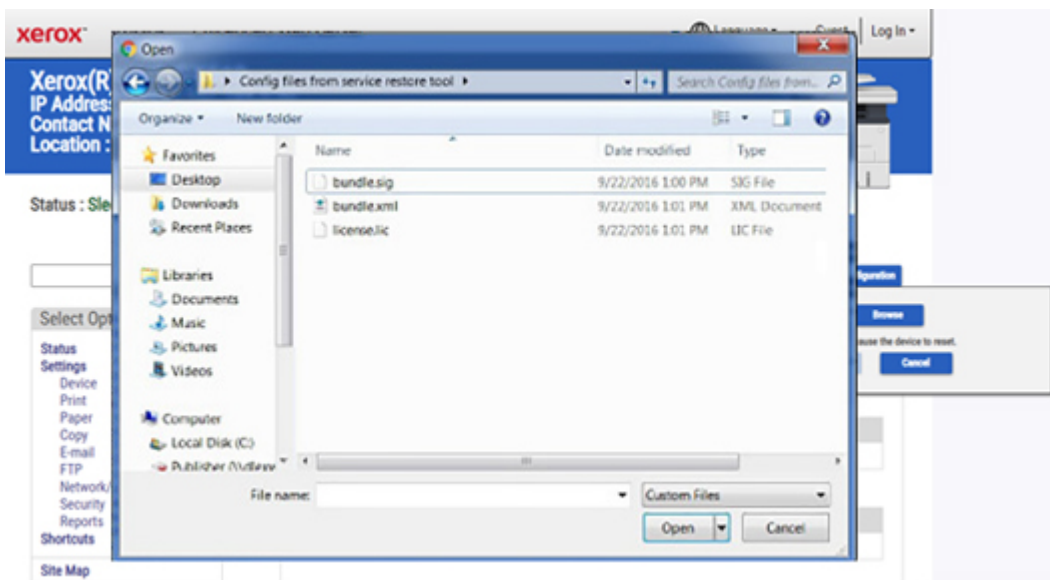

4. Select the file to import, and then click **Import**.
5. Repeat step 2 through step 4 for the other files that are included in the extracted zip file.

Updating The Printer Firmware

Warning: Before updating the printer firmware, ask the next level of support for the correct code. Using an incorrect code level may damage the printer.

The printer must be in ready state to update the firmware.

Using A Flash Drive

This procedure applies only to printer models with front USB support.

1. Insert the flash drive.

The display shows the files on the flash drive.

2. Select the file that you need to flash.

 **Note:** Do not turn off the printer while the update is going on.

Using A Network Computer

Using the File Transfer Protocol (FTP)

Make sure that the printer is in ready state before flashing.

1. Turn on the printer.
2. Obtain the IP address:
 - From the home screen
 - From the Network Overview section of the Network/Ports menu
3. From the command prompt of a network computer, open an FTP session to the printer IP address.
4. Use a PUT command to place the firmware file on the printer.

The printer performs a POR sequence and terminates the FTP session.
5. Repeat step 2 through step 4 for the other files.

Using the Embedded Web Server

Make sure that the printer is in ready state before flashing.

1. Open a web browser, and then type the printer IP address.
2. From the home page, navigate to **Settings > Device > Update Firmware**.
3. Select the file to use.

The printer performs a POR sequence.
4. Repeat step 2 through step 4 for the other files.

Covering The Print Cartridge Tray

 **Warning:** If the printer is laid on its side, then toner contamination may occur. To minimize contamination, cover the print cartridge tray.

Parts Removal

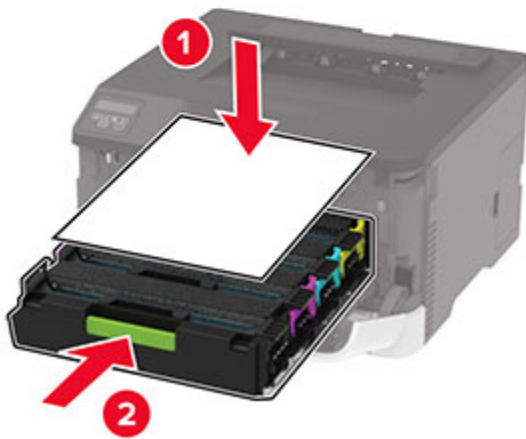

 **Note:** To avoid a false reading on the amount of waste toner, tap the waste toner bottle to dislodge the toner particles from its walls.

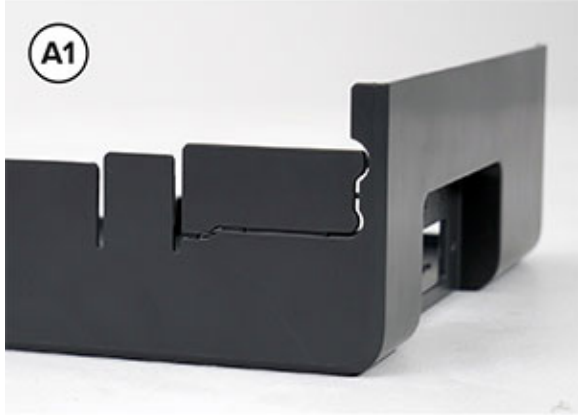
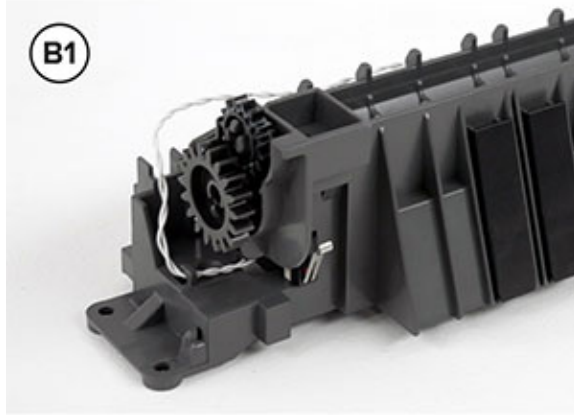
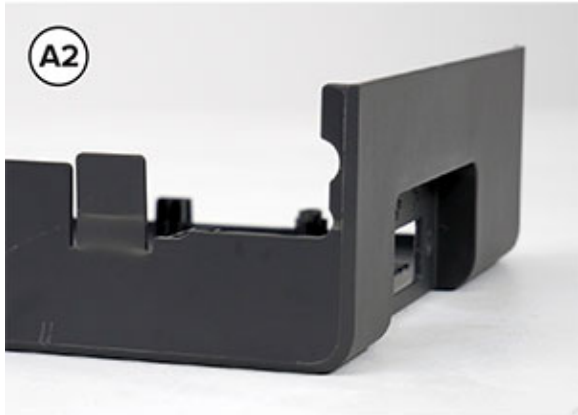
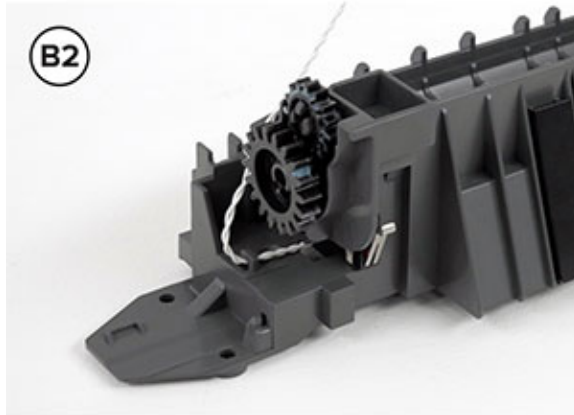

Compatibility Information For Left Cover and Separator Bracket

1. Use the following table to determine the variant of the left cover and separator bracket.

Left cover variants	Separator bracket variants
 <p>A1</p> <p>Image A1 shows a dark grey plastic left cover variant. It features a vertical back flange on the right side, a horizontal top edge, and a complex front profile with several raised sections and a central rectangular cutout. A small circular mark is visible on the bottom left corner.</p>	 <p>B1</p> <p>Image B1 shows a dark grey plastic separator bracket variant. It is a long, narrow component with a series of vertical dividers along its length. On the left side, there is a gear mechanism with a white wire attached. The bottom edge has a small protrusion and a hole.</p>
 <p>A2</p> <p>Image A2 shows a dark grey plastic left cover variant, similar to A1 but with a different front profile. It has a vertical back flange on the right and a horizontal top edge. The front profile is simpler than A1, with fewer raised sections. A small circular mark is visible on the bottom left corner.</p>	 <p>B2</p> <p>Image B2 shows a dark grey plastic separator bracket variant, similar to B1 but with a different front profile. It has a gear mechanism on the left side with a white wire attached. The bottom edge has a different protrusion and hole configuration compared to B1.</p>

Parts Removal

2. Use the following table to perform additional actions depending on the part combination.

Part combination	Action
A1 and B1	None
A1 and B2	<p>Break off the port cover from the left cover.</p>  A close-up photograph showing a person's hand using their thumb to pry a dark grey plastic port cover away from the left side of a printer's frame. The cover is being lifted and separated from the underlying structure.
A2 and B1	<p>Stick the strip over the port.</p> <p>Align the strip along the edges of the frame and separator bracket.</p>  A photograph showing a hand placing a white strip over a port on the printer's frame. To the left of the photo is a small 3D directional diagram with 'LEFT' on the top face, 'REAR' on the left face, and 'BOTTOM' on the bottom face. A red arrow points from the strip towards the port area. The strip is being aligned with the edges of the frame and separator bracket.
A2 and B2	None

Adjustments

Registration Adjustment

Image misalignments can occur after printhead replacement. Perform this procedure to correct the position of the image relative to the paper edges.

 **Note:** You cannot perform mechanical registration or skew adjustments on this printhead.

Before performing the procedure, make sure that the paper guides are properly set and the paper settings on the printer match the paper size loaded in the tray.

Adjusting The Skew

The skew adjustment changes the angle of the horizontal lines so that the lines can be aligned with the leading edge of the page. As the skew setting is changed, the top line on the test page stays in place at the left end, while its right end tilts up or down. All horizontal lines on the page tilt at that same angle while the vertical lines remain vertical. Changing the skew setting moves the right edge of the page up and down, and changes the angle of the top and bottom lines. If the skew is properly adjusted, then the horizontal lines at the top of the page are parallel to the leading edge of the page.

To check for skew:

1. Enter the Diagnostics menu, and then navigate to:

Printer diagnostics and adjustments > Registration adjust

For non-touch-screen printer models, press  to navigate through the settings.

Parts Removal

2. Select **Quick Test**.

The printer prints a test page.

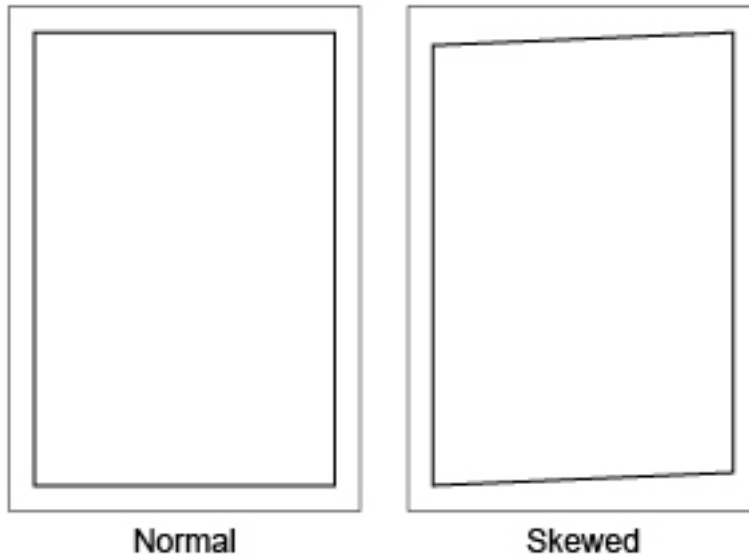

 **Note:** If there is no skew on the page, then go to Adjusting the margins topic. See [Registration adjustment](#).

To adjust the skew:

1. Enter the Diagnostics menu, and then navigate to:
Printer diagnostics and adjustments > Registration adjust > Top Skew
2. Adjust the value.

 **Note:**

- For non-touch-screen printer models, use the left or right arrow button to increase or decrease the value.
 - Increasing the value of the skew rotates the horizontal lines clockwise. The left end of the line remains in the same place and the right end moves downward.
 - Decreasing the value of the skew rotates the horizontal lines counterclockwise. The left end of the line remains in the same place and the right end moves upward.
3. Print a Quick Test page to verify the change.
 4. Repeat step 1 through step 3 until the horizontal line is properly aligned with the leading edge of the page.
 5. Check for proper margin alignment. See [Registration adjustment](#).

Adjusting The Margins

To check for proper margin alignment:

1. Enter the Diagnostics menu, and then navigate to:

Printer diagnostics and adjustments > Registration adjust

For non-touch-screen printer models, press  to navigate through the settings.

2. Select **Quick Test**.

The printer prints a test page.

3. Check the top and bottom margins of the test page for proper alignment.

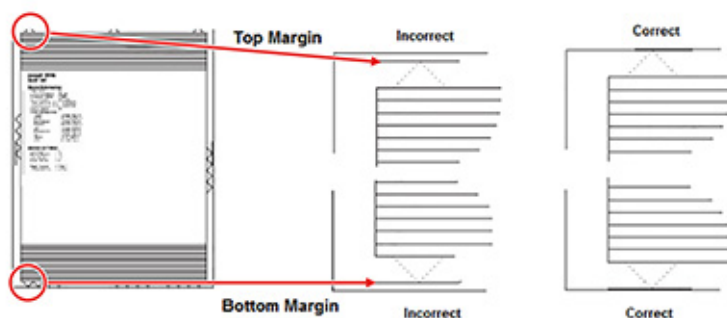

To adjust the margins:

1. Refer to the test page, and then check the arrows along the margins.

 **Note:**

- The arrows must be completely visible along the edges.
- The tip of the arrows must point to the edges of the paper.

2. Enter the Diagnostics menu, and then navigate to:

Printer diagnostics and adjustments > Registration adjust

3. Select the margin to adjust.
4. Adjust the value.

 **Note:**

- For non-touch-screens, use the left or right arrow buttons to increase or decrease the value.
- Increasing the value of the top margin setting pushes the top edge of the image downward.
- Increasing the value of the bottom margin setting pushes the bottom edge of the image upward.
- Increasing the value of the left margin setting pushes the left margin to the right.
- Increasing the value of the right margin setting pushes the right margin to the left.

5. Print a Quick Test page to verify the change.

6. Repeat step 3 through step 5 until the margins are correct.
7. Check for proper color alignment. See [Registration adjustment](#).

Adjusting The Color Alignment

For non-touch-screen printer models, press  to navigate through the settings.

1. Enter the Diagnostics menu, and then navigate to:

Printer diagnostics and adjustments > Color alignment adjust > AA Adjustment

 **Note:** The procedure is performed on the cyan, magenta, and yellow colors.

2. Enter the Diagnostics menu, and then navigate to:

Printer diagnostics and adjustments > Color alignment adjust > Cyan > Quick Test

Check the alignment markings on the test page. Follow the instructions on the test page to correct the color misalignment.

3. Enter the Diagnostics menu, and then navigate to:

Printer diagnostics and adjustments > Color alignment adjust > Yellow > Quick Test

Check the alignment markings on the test page. Follow the instructions on the test page to correct the color misalignment.

4. Enter the Diagnostics menu, and then navigate to:

Printer diagnostics and adjustments > Color alignment adjust > Magenta > Quick Test

Check the alignment markings on the test page. Follow the instructions on the test page to correct the color misalignment.

5. If color misalignment still occurs, then repeat step 1 through step 4.

Printhead Characterization

 **Note:** For a video demonstration, see [Printhead characterization](#).

 **Note:**

- A new printhead includes a flash drive that contains the characterization data.
- After installing a new printhead, enter the characterization data using any of the following procedures.
- The characterization data cannot be used on another printhead. Erase the files from the flash drive after entering the characterization data.

Entering Characterization Data From The Flash Drive

 **Note:** This procedure applies only to printer models with front USB support.

1. Insert the flash drive into the USB port.

 **Note:** The printer copies automatically the required data from the flash drive. The printer restarts after copying the data.

2. While the printer is restarting, remove the flash drive.
3. Perform the printhead adjustment. See [Registration adjustment](#).

Entering Characterization Data Using Winblast

1. On your laptop, create a folder and name it *Printhead data*.
2. Copy the flash drive contents to the folder.
3. Connect the laptop to the printer using a USB cable.
4. In the Printhead data folder, run the WinBlast application.
5. Select the printer.
6. Click ..., access the Printhead data folder, and then select the *.npa* file.
7. Click **Send**. On the control panel, the printer shows its status while processing the files. After the update, restart the printer.
8. Perform the printhead adjustment. See [Registration adjustment](#).

Entering Characterization Data On A Network

 **Note:** Request permission from the customer to use the network.

1. On your Windows laptop, create a folder and name it *Printhead data*.
2. Copy the flash drive contents to the folder. Take note of the *.npa* filename.
3. Obtain the IP address of the printer.
4. On the laptop, use the command prompt to enter the Printhead data folder.
5. Type the following:

```
tcpipblast.exe <printer IP address> <.npa filename>
```

For example:



```
D:\>Printhead data>tcpipblast.exe 10.194.21.01 40N110012LPTB90180038__2019_01_22__17_34_14__LSUimage.npa
```

Printhead data folder location Printer IP address .npa filename

6. Press **Enter**. On the control panel, the printer shows its status while processing the files. After the update, restart the printer.
7. Perform the printhead adjustment. See [Registration adjustment](#).

Sensor (Waste Toner Bottle) Calibration

To ensure the accuracy of the waste toner level detection, calibrate the sensor (waste toner bottle).

Parts Removal

1. Enter the Diagnostics menu, and then navigate to:

Printer setup > Waste toner sensor calibration

For non-touch-screen printer models, press  to navigate through the settings.

2. Remove the waste toner bottle.
3. Select **Start calibration**.

If the calibration is successful, then a Test passed message appears on the display.

4. Install the waste toner bottle, and then restart the printer.

Removal Procedures

Keep the following tips in mind as you replace parts:

- Some removal procedures require removing cable ties. Do not forget to install these cable ties during reassembly to avoid pinching wires, obstructing the paper path, or restricting mechanical movement.
- Remove the print cartridges before removing other printer parts. Carefully set the cartridges on a clean, smooth, and flat surface. Protect the cartridges from light while out of the printer.
- Disconnect all external cables from the printer to prevent possible damage during service.
- Unless otherwise stated, install the parts in reverse order of removal.
- When installing a part held with several screws, start all screws before the final tightening.
- For printers that have an electronic power switch, make sure to unplug the power cord after powering off.

Left Side Removals

Left Cover Removal

1. Remove the tray and manual feeder.
2. Remove the lower front cover.

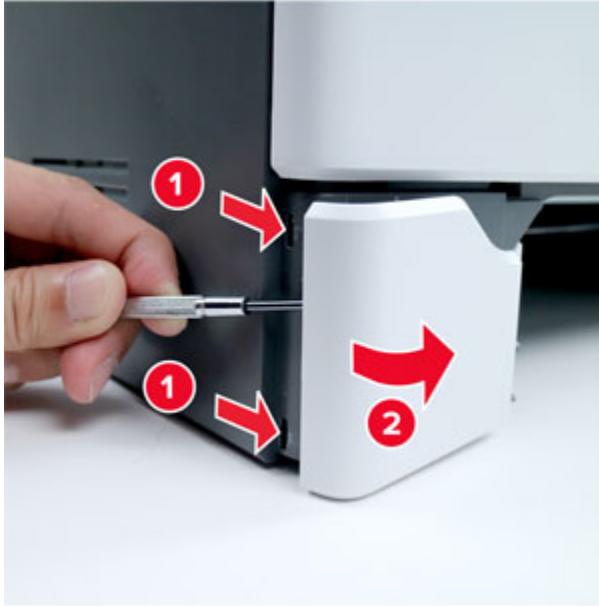

3. Remove the two screws.



4. Open the front and rear doors.

5. Position the printer as shown, and then release the rear latch.



6. Release the rear latch.



Parts Removal

7. Release the front latch.



8. Remove the cover.



Installation warning: To avoid compatibility issues, see [Compatibility information for left cover and separator bracket](#) before installing the replacement part.

Motor (CMY) Removal

1. Remove the left cover. See [Left cover removal](#).

2. Remove the cover.

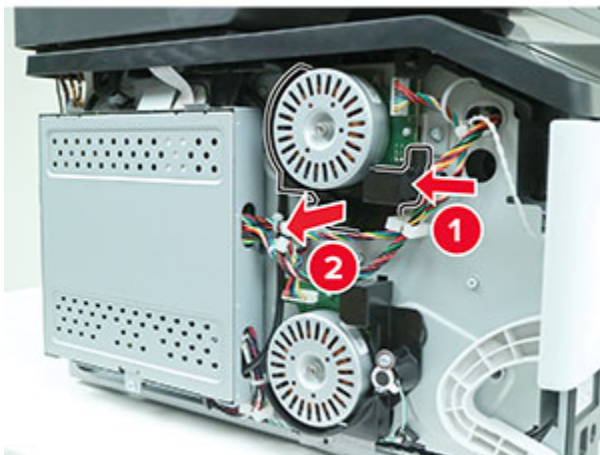

3. Disconnect the cable, and then remove the three screws.

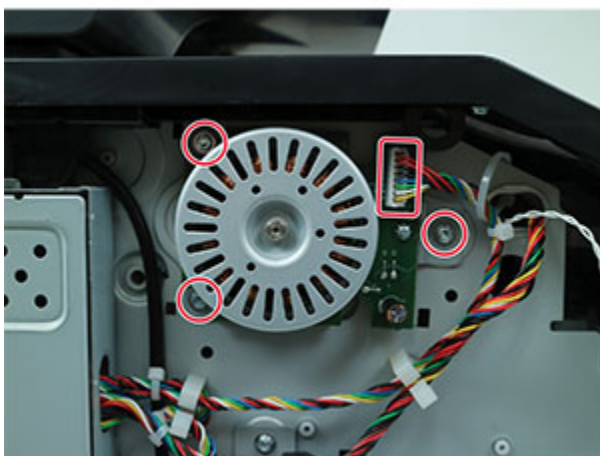

4. Remove the motor.

Motor (k/transfer Belt) Removal

1. Remove the left cover. See [Left cover removal](#).

Parts Removal

2. Remove the cover.

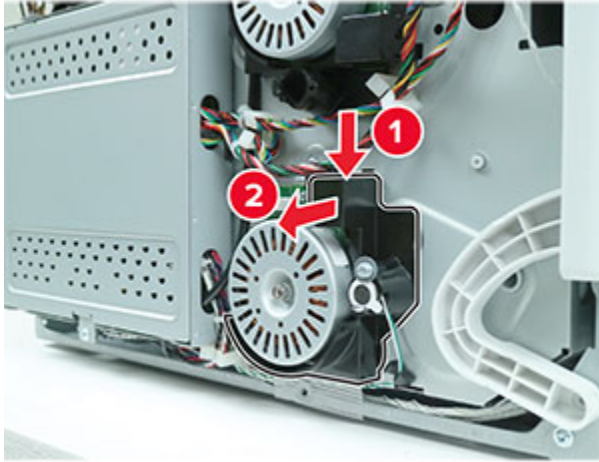

3. Disconnect the cable, and then remove the three screws.

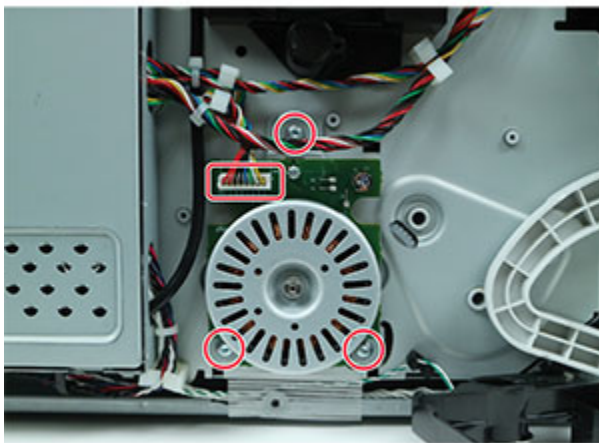

4. Remove the motor.

Wireless Network Card Removal

 **Note:** Not all printer models have a detachable wireless network card.

1. Remove the left cover. See [Left cover removal](#).

2. Disconnect the cable (A), and then release the latch (B).

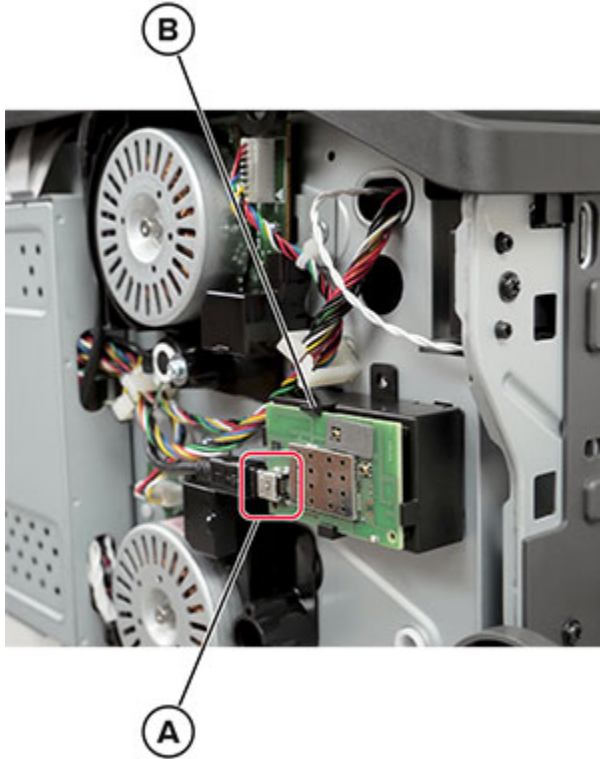

3. Remove the card.

Controller Board Shield Removal

1. Remove the left cover. See [Left cover removal](#).
2. Remove screw, and then remove the shield.

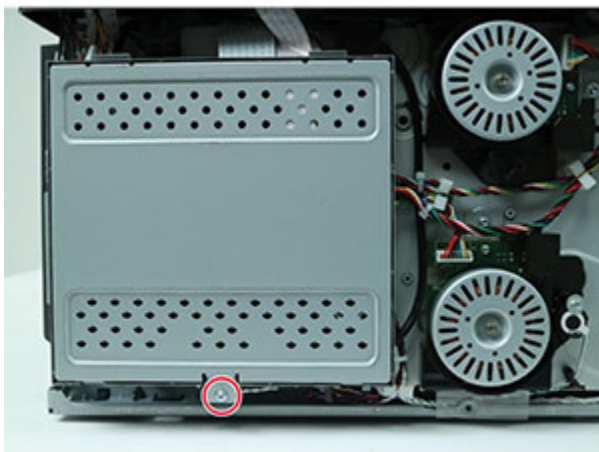

Controller Board Removal

Critical Information For Controller Board or Control Panel Replacement

 **Warning:** To avoid NVRAM mismatch issues, replace only one of the following components at a time:

- Control panel
- Controller board

To replace a component and to test whether the problem is resolved:

1. Replace the affected component.

 **Warning:** Do not perform a Power-On Reset (POR) until the problem is resolved. If a POR is performed at this point, then the replacement part can no longer be used in another printer and must be returned to the manufacturer.

2. Enter the Diagnostics Menu. The Diagnostics Menu allows you to temporarily use the replacement part.

 **Warning:** Some printers will automatically perform a POR if the Diagnostics Menu is not opened within five seconds. If a POR is performed at this point, then the replacement part can no longer be used in another printer and must be returned to the manufacturer.

3. Use the Diagnostics Menu to test the replacement part. Perform a feed test to check if the problem is resolved.
 - If the problem is not resolved—Turn off the printer, and then reinstall the old part.
 - If the problem is resolved—Perform a POR.
4. To replace the controller board and the control panel simultaneously on the machine, follow the below procedure to avoid losing the printer's NVRAM settings and damaging the printer.
 - a. Replace either the controller board or the control panel on the machine. Do not replace both the parts at the same time.
 - b. Power on the printer and perform a POR.
 - c. After the printer has completed startup (printer will be either READY or post an error), power off the printer and replace the second part.

 **Note:** If the control panel display has failed, the printers' startup cycle is complete after the driver motor and fans shut down and the machine is quiet.

- d. Power on the printer and allow the printer to go through a complete startup cycle and the display changes to READY.

C230 Controller Board

1. Remove the left cover. See [Left cover removal](#).
2. Remove the controller board shield. See [Controller board shield removal](#).

3. Disconnect all the board cables.



4. Release the antenna card from its bracket, and then release it from the controller board frame.

 **Warning:** The antenna card cable is soldered to the board. Be careful not to damage the antenna card and its connections.

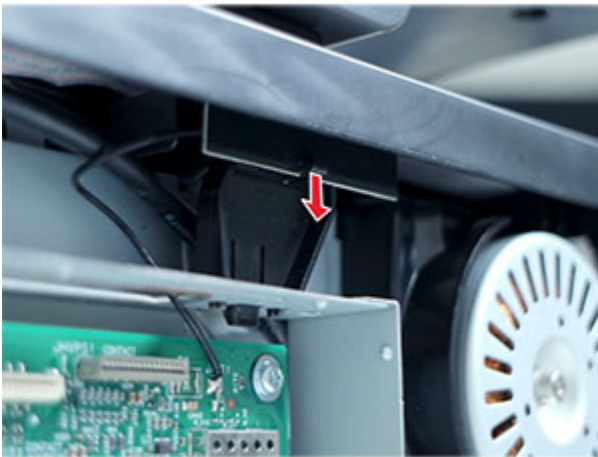

Parts Removal

5. Remove the five screws.

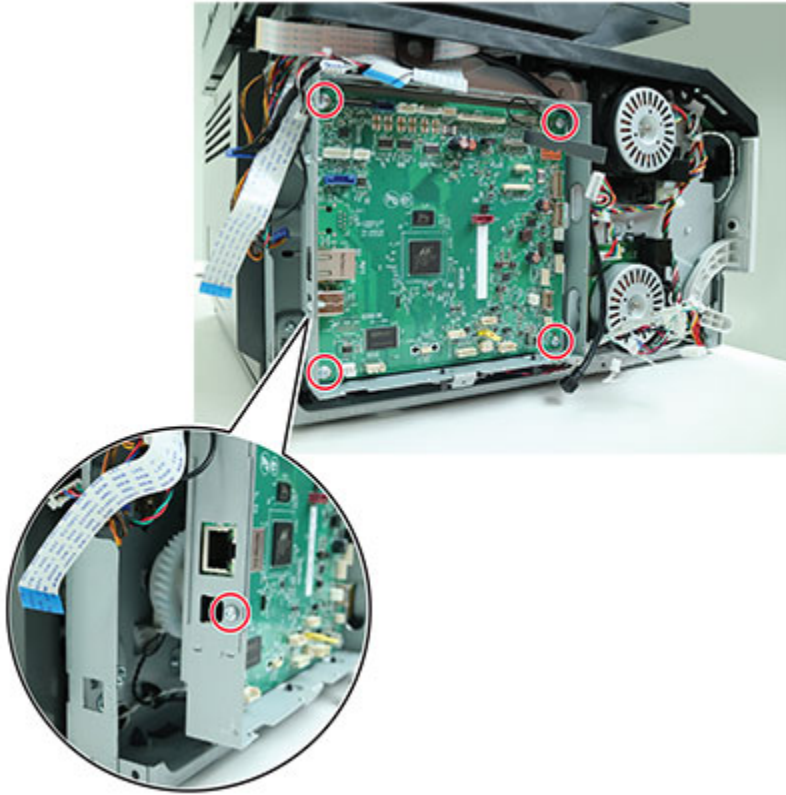

6. Remove the board.

 **Note:** Installation note:After installing the new board, perform the sensor (waste toner bottle) calibration. See [Sensor \(waste toner bottle\) calibration](#).

Controller Board Bracket Removal

1. Remove the left cover. See [Left cover removal](#).
2. Remove the controller board shield. See [Controller board shield removal](#).
3. Remove the controller board. See [Controller board removal](#).

4. Remove the four screws.

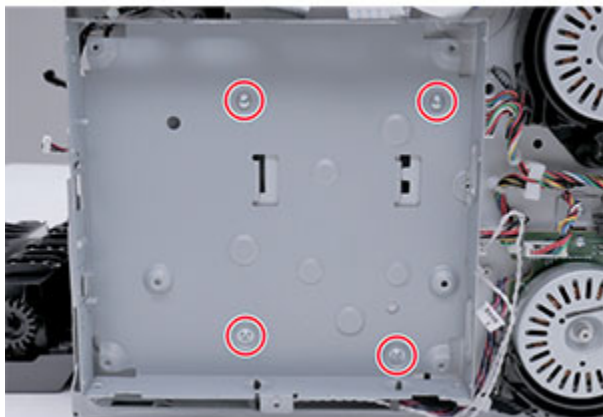

5. Remove the bracket.

Motor (fuser) Removal

1. Remove the left cover. See [Left cover removal](#).
2. Remove the controller board shield. See [Controller board shield removal](#).
3. Remove the controller board. See [Controller board removal](#).
4. Remove the controller board bracket. See [Controller board bracket removal](#).
5. Disconnect the cable, and then remove the two screws.

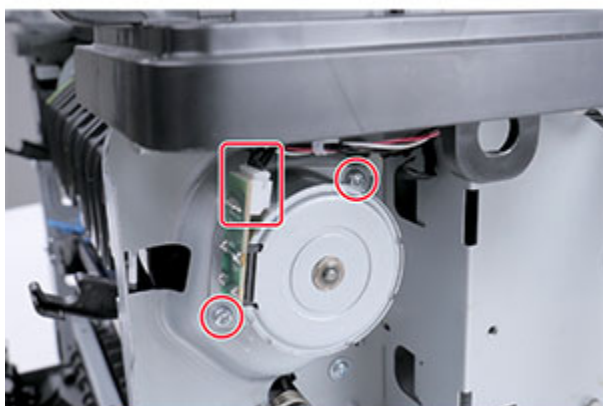

6. Remove the motor.

Staging Clutch Removal

1. Remove the left cover. See [Left cover removal](#).
2. Remove the controller board shield. See [Controller board shield removal](#).
3. Remove the controller board. See [Controller board removal](#).

Parts Removal

4. Remove the controller board bracket. See [Controller board bracket removal](#).
5. Remove the E-clip (A), and then remove the staging clutch gear.

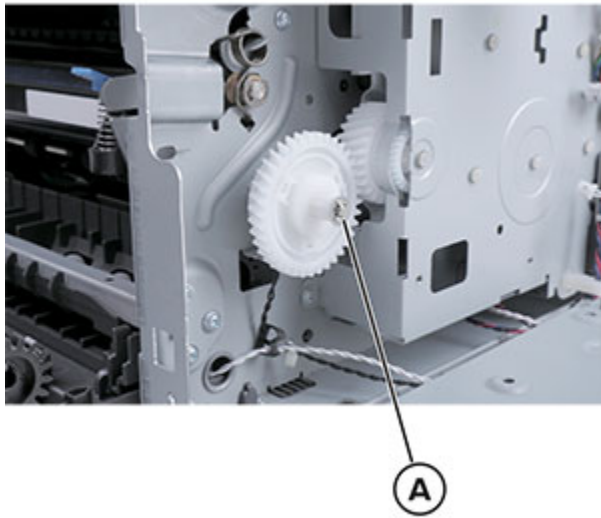

6. Disconnect the cable, and then remove the clutch.

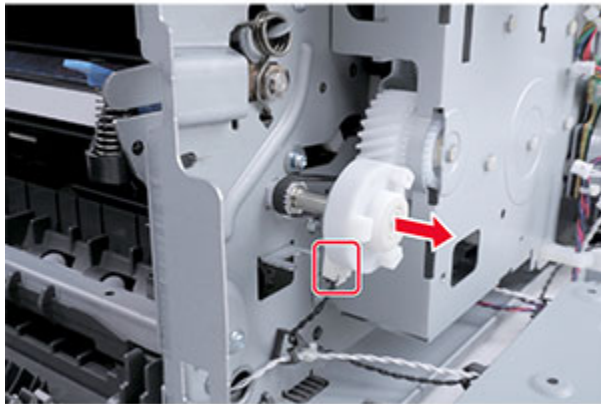

Gearbox Removal

 **Note:** For a video demonstration, see [Gearbox removal](#).

1. Remove the left cover. See [Left cover removal](#).
2. Remove the print cartridge tray. See [Print cartridge tray removal](#).
3. Remove the controller board shield. See [Controller board shield removal](#).
4. Remove the controller board. See [Controller board removal](#).

5. Release the cable guides from the bracket.

 **Note:** Using a pair of pliers, pinch the cable guide latches to make them fit their holes.

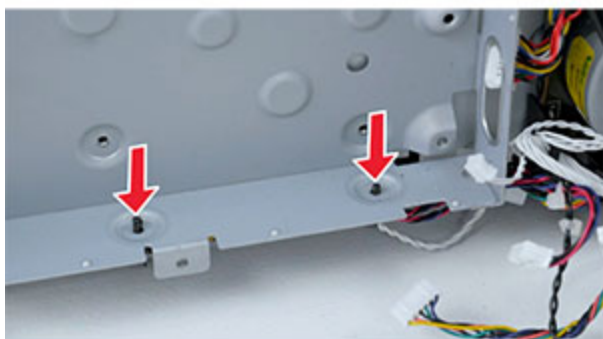

6. Remove the controller board bracket. See [Controller board bracket removal](#).
7. Remove the screw, and then release the printhead interlock switch from the frame.

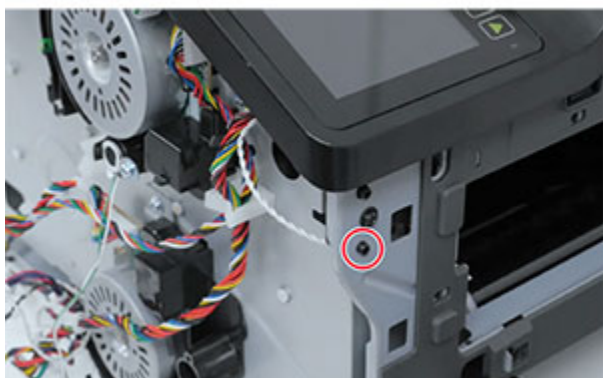

8. Remove the screw, and then release the switch from its bracket.

 **Note:** Installation note: Be careful not to disconnect the switch cable from the printhead.



Parts Removal

9. Slightly push the door as shown, and then press the latches to lock.

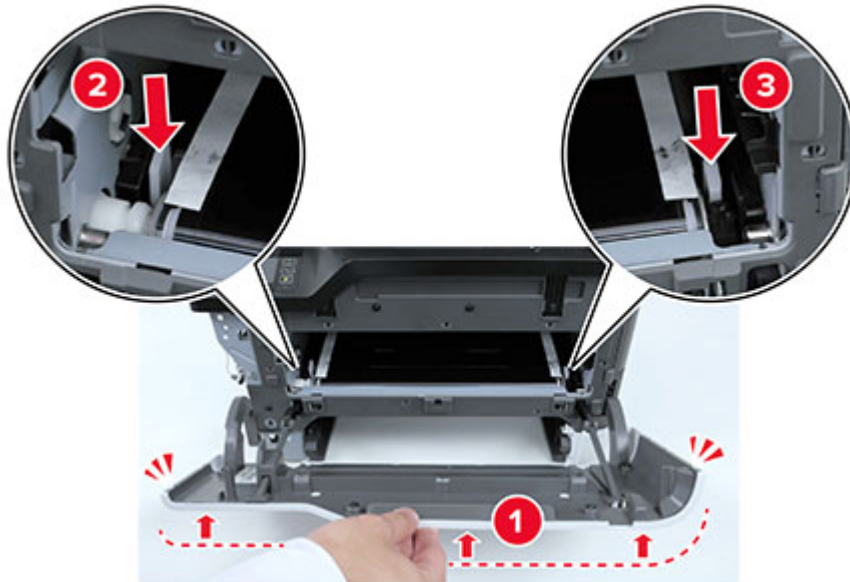

10. Release, and then move the door hinge out of the way.



11. Release the cables from their guides (A).

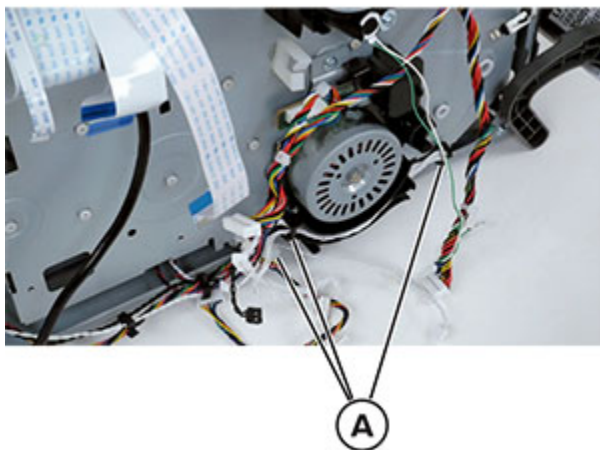

12. Remove the screw, and then remove the speaker.

 **Note:** Not all printer models have a speaker.



13. Disconnect, and then release the cables.

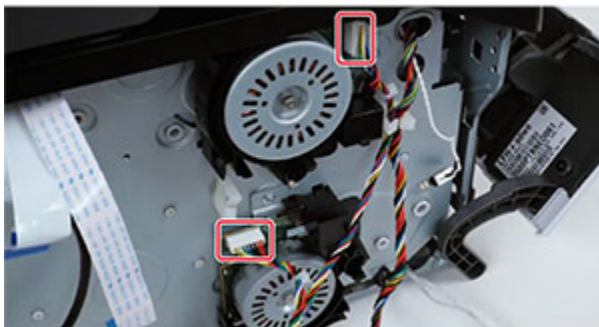

14. Remove the six screws.

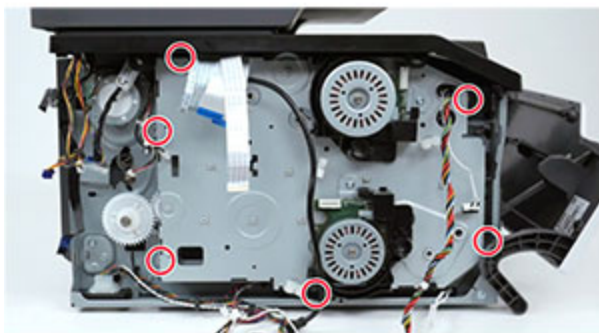

Parts Removal

15. Remove the gearbox.

 **Note:** Be careful not to disconnect the cable (B) from the printhead.

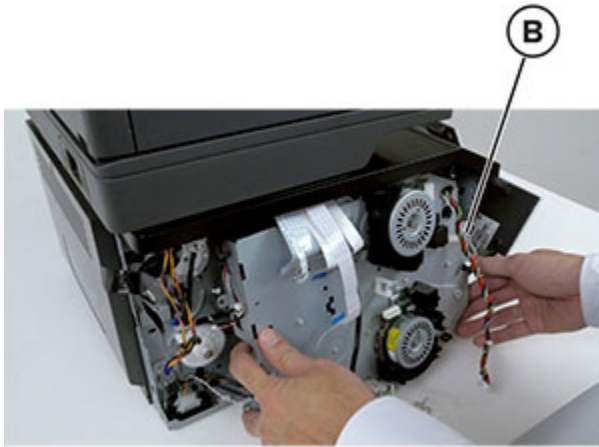

Installation notes:

- Make sure that the coupler and spring are properly installed.

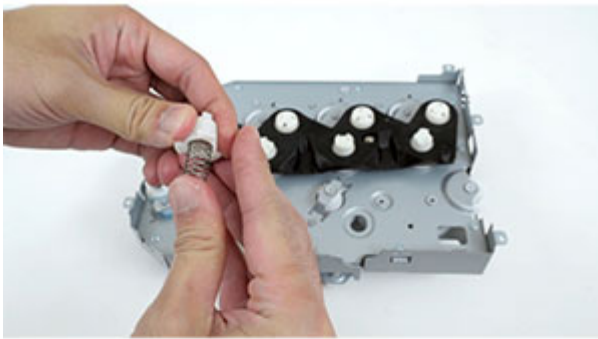

- Align the locating tabs to their slots.

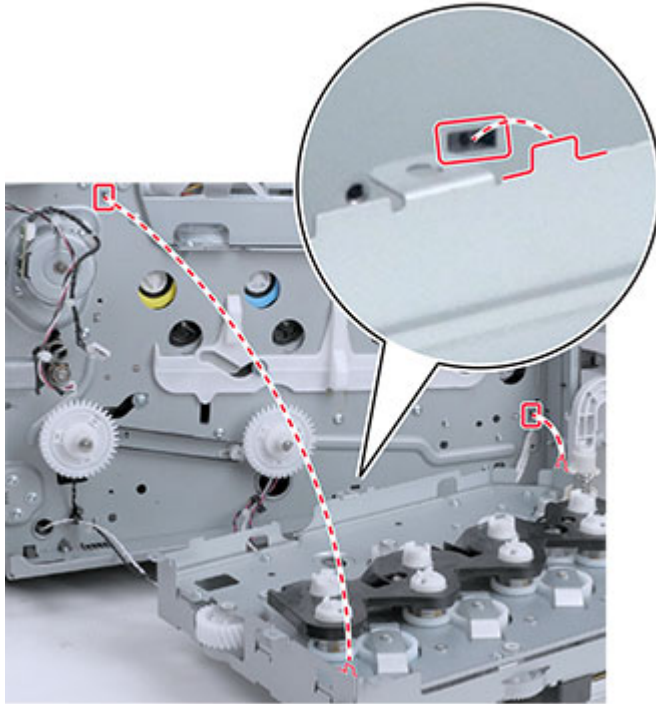

- Thread the cables to their slots. Be careful not to disconnect the switch cable from the printhead.

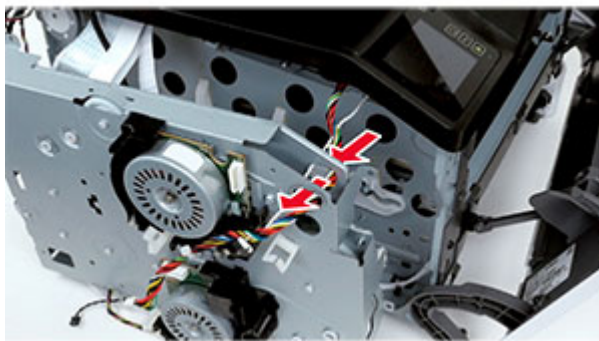

- Make sure that the coupler and spring are not detached.

Parts Removal



- Make sure that the couplers (A) are properly engaged.

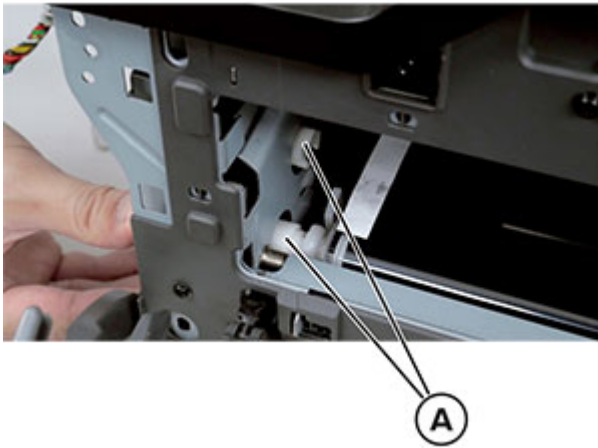

- Turn the motors to verify if the couplers move.



Pick Clutch Removal

1. Remove the left cover. See [Left cover removal](#).
2. Remove the print cartridge tray. See [Print cartridge tray removal](#).
3. Remove the controller board shield. See [Controller board shield removal](#).

4. Remove the controller board. See [Controller board removal](#).
5. Remove the controller board bracket. See [Controller board bracket removal](#).
6. Remove the gearbox. See [Gearbox removal](#).
7. Remove the E-clip (A), and then remove the pick clutch gear.

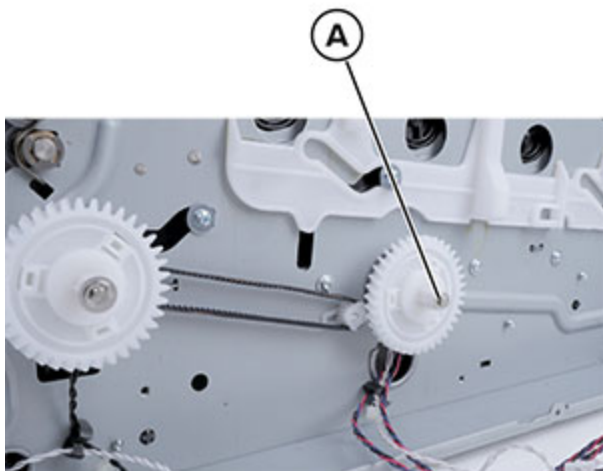

8. Disconnect the cable, and then remove the clutch.

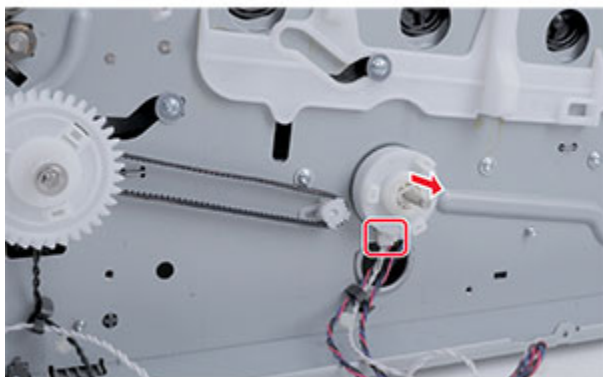

Staging Belt, Gear, and Pulley Removal

1. Remove the left cover. See [Left cover removal](#).
2. Remove the print cartridge tray. See [Print cartridge tray removal](#).
3. Remove the controller board shield. See [Controller board shield removal](#).
4. Remove the controller board. See [Controller board removal](#).
5. Remove the controller board bracket. See [Controller board bracket removal](#).
6. Remove the gearbox. See [Gearbox removal](#).

Parts Removal

7. Remove the pulley.

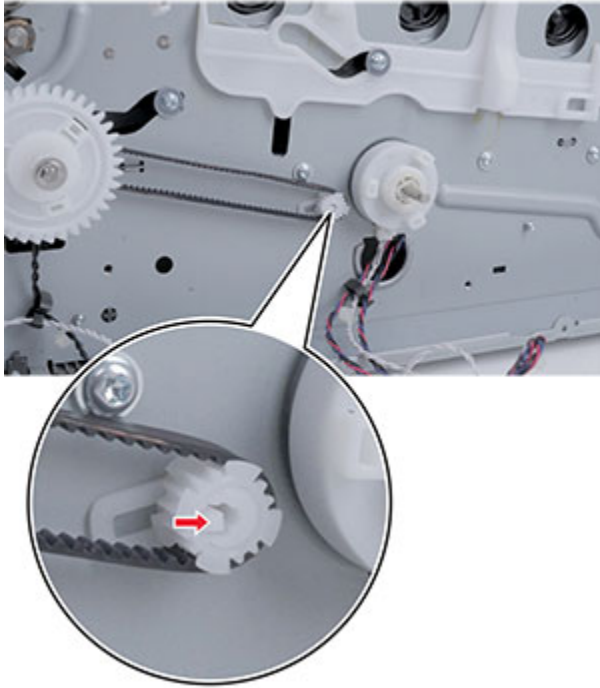

8. Remove the belt.

Right Side Removals

Right Cover Removal

1. Remove the tray and manual feeder.
2. Remove the lower front cover.



3. Open the front and rear doors.
4. Remove the two screws.



Parts Removal

5. Position the printer as shown, and then release the rear latches.

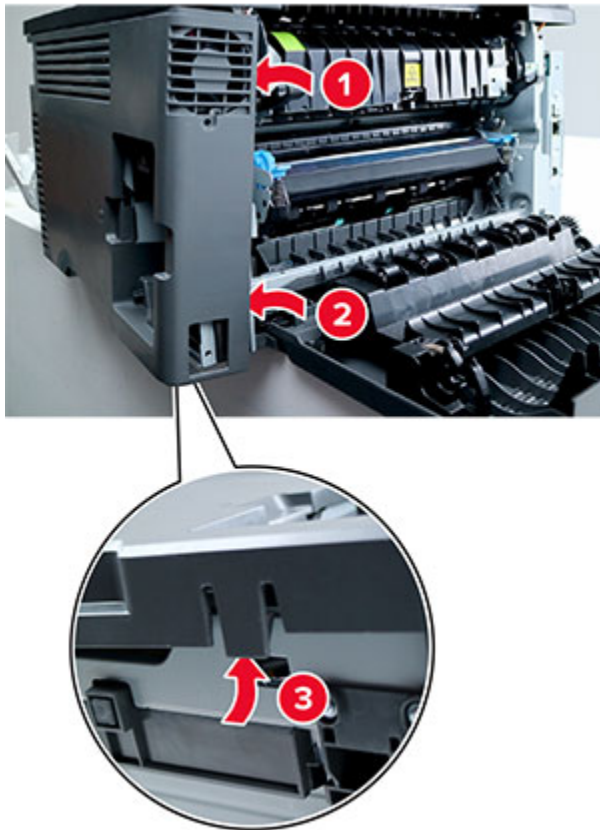

6. Release the front latch.



7. Remove the cover.



Sensor (waste Toner Bottle) Removal

 **Note:** For a video demonstration, see [Sensor \(waste toner bottle\) removal](#).

1. Remove the right cover. See [Right cover removal](#).
2. Disconnect the cable, and then remove the screw.

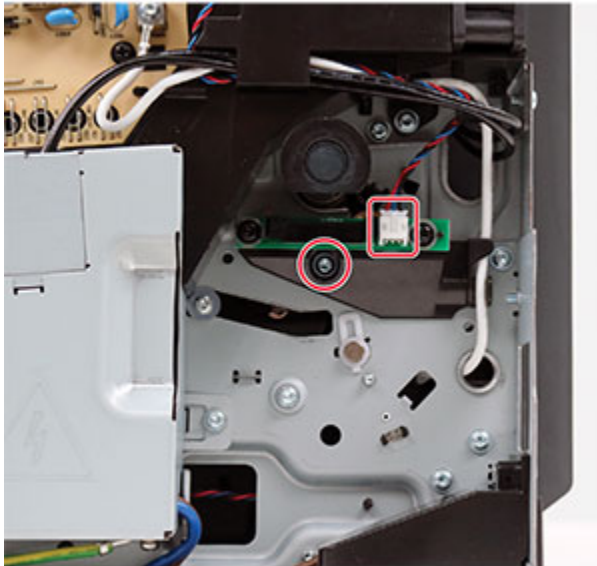

3. Remove the sensor.

 **Note:** Installation note: Perform the sensor (waste toner bottle) calibration. See [Sensor \(waste toner bottle\) calibration](#).

Exhaust Fan Removal

 **Note:** For a video demonstration, see [Exhaust fan removal](#).

Parts Removal

1. Remove the right cover. See [Right cover removal](#).
2. Disconnect the cable, and then remove the fan.

 **Note:** Installation note: Pay attention to the orientation of the fan.



 **Note:** Installation note: Stick the pad to the fan on the area shown.



HVPS Removal

 **Note:** For a video demonstration, see [HVPS removal](#).

1. Remove the right cover. See [Right cover removal](#).

2. Remove the cover.



3. Disconnect all the cables, and then remove the cable screw.

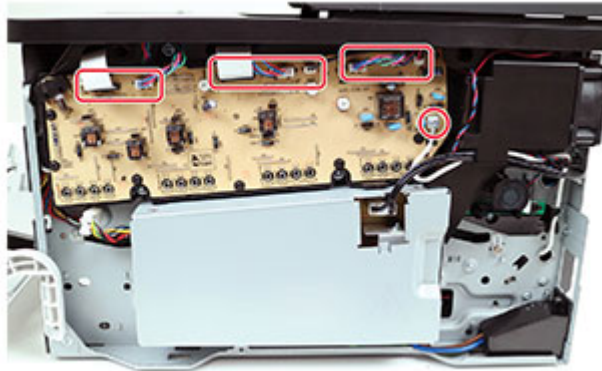

Parts Removal

4. Cut the cable tie, and then remove the four screws.

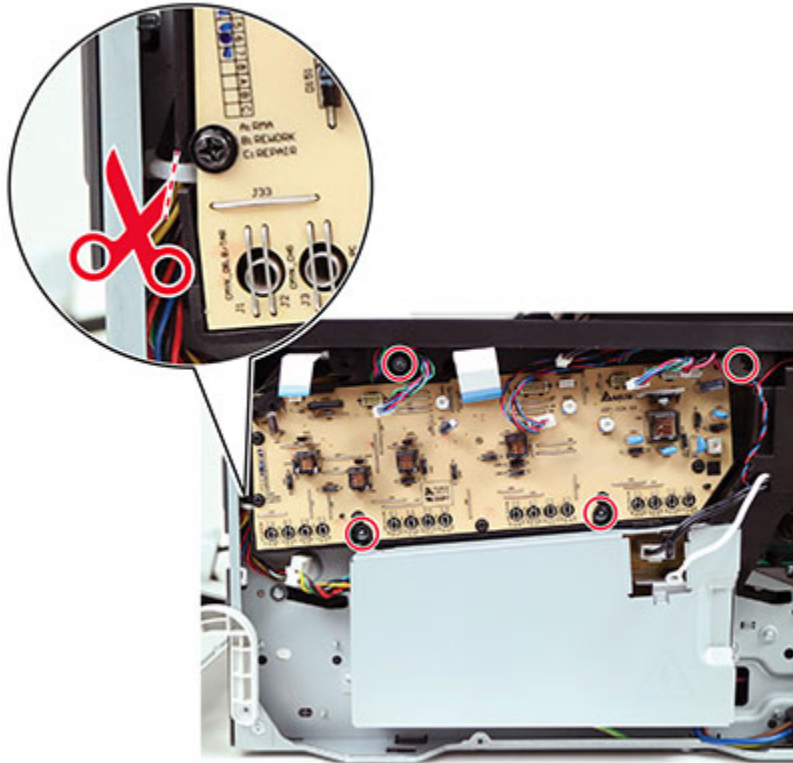

5. Remove the HVPS.

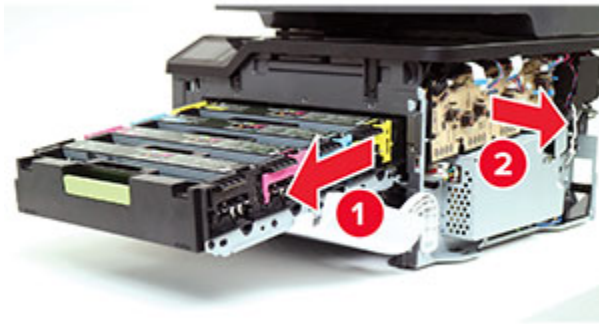

Warning: Extended exposure of the cartridge to light may cause print quality problems.

LVPS Removal

Note: For a video demonstration, see [LVPS removal](#).

1. Remove the right cover. See [Right cover removal](#).

2. Remove the screw, and then remove the cover.

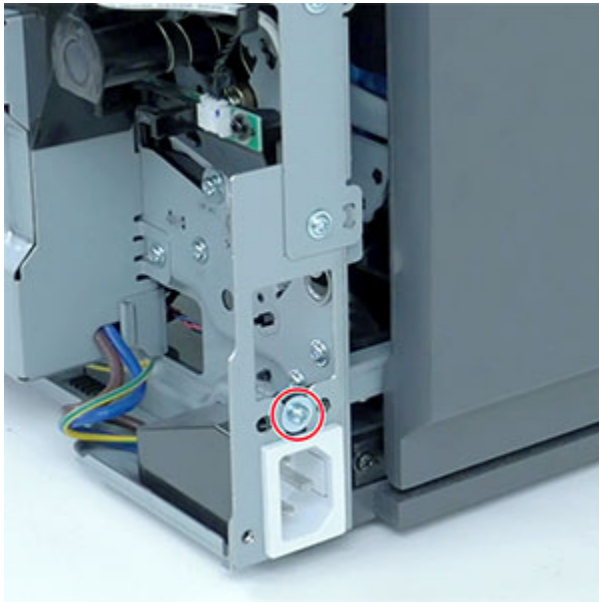

3. To minimize toner contamination, cover the print cartridge tray. See [Covering the print cartridge tray](#).
4. Under the printer, remove the four screws.

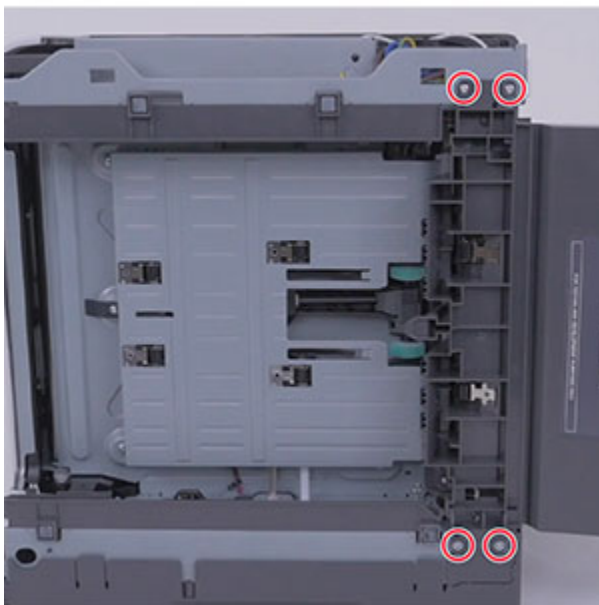

Parts Removal

5. Release the connector latches.

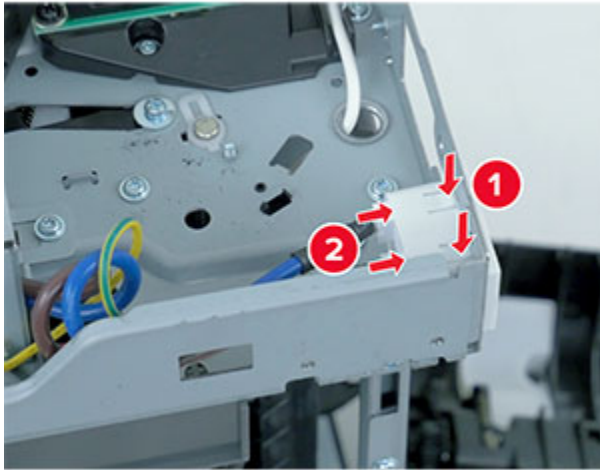

6. Using a prying tool, release the connector from the frame.

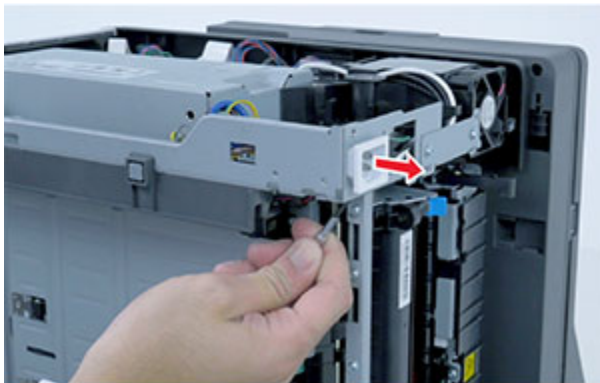
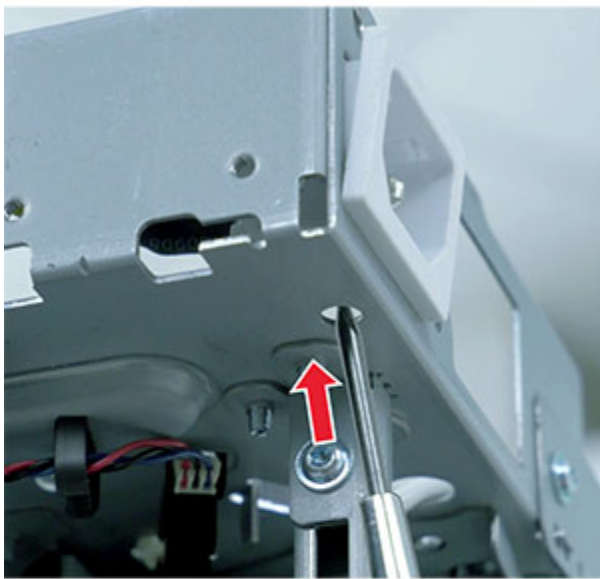

7. On the right side, remove the cover.



8. Disconnect the cables.



9. Remove the two screws.

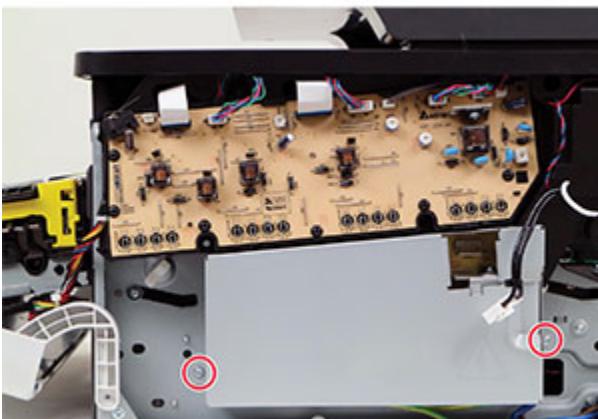

Parts Removal

10. Remove the LVPS.

Front Side Removals

Print Cartridge Tray Removal

1. Open the front door, and then pull out the print cartridge tray.
2. Unlock the print cartridge tray.

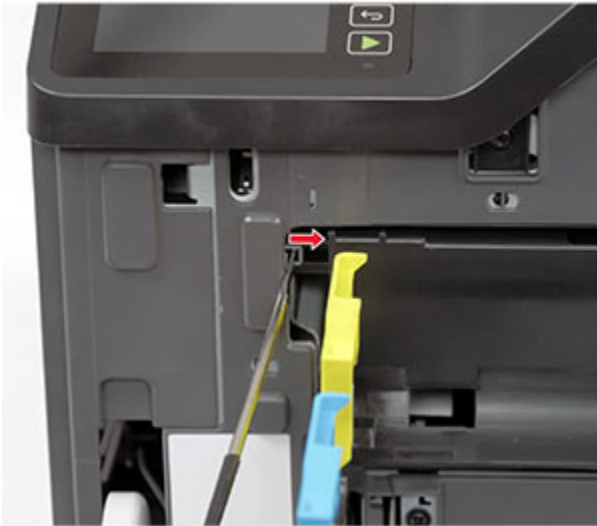

3. Remove the print cartridge tray.

 **Note:** Installation note: Make sure that the front door is pushed all the way down before inserting the print cartridge tray.

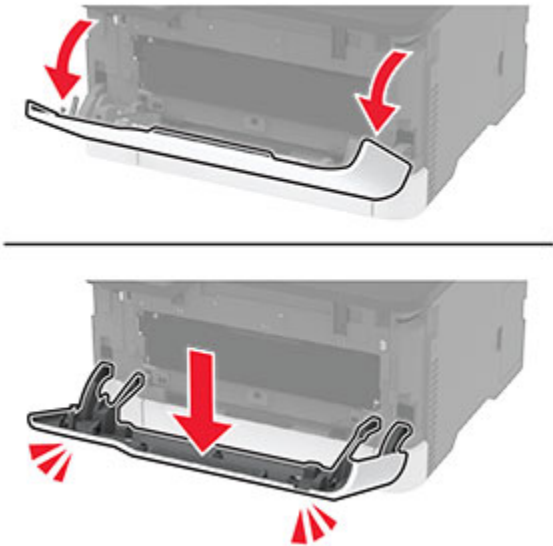

Control Panel Removal

Critical Information For Controller Board or Control Panel Replacement

 **Warning:** To avoid NVRAM mismatch issues, replace only one of the following components at a time:

- Control panel
- Controller board

To replace a component and to test whether the problem is resolved:

1. Replace the affected component.

 **Warning:** Do not perform a Power-On Reset (POR) until the problem is resolved. If a POR is performed at this point, then the replacement part can no longer be used in another printer and must be returned to the manufacturer.

2. Enter the Diagnostics Menu. The Diagnostics Menu allows you to temporarily use the replacement part.

 **Warning:** Some printers will perform automatically a POR if the Diagnostics Menu is not opened within five seconds. If a POR is performed at this point, then the replacement part can no longer be used in another printer and must be returned to the manufacturer.

3. Use the Diagnostics Menu to test the replacement part. Do a feed test to check if the problem is resolved.

- If the problem is not resolved—Turn off the printer, and then reinstall the old part.
- If the problem is resolved—Perform a POR.

4. To replace the controller board and the control panel simultaneously on the machine, follow the below procedure to avoid losing the printer's NVRAM settings and damaging the printer.

- a. Replace either the controller board or the control panel on the machine. Do not replace both the parts at the same time.
- b. Power on the printer and perform a POR.
- c. After the printer has completed startup (printer will be either READY or post an error), power off the printer and replace the second part.

 **Note:** If the control panel display has failed, the printers' startup cycle is complete after the driver motor and fans shut down and the machine is quiet.

- d. Power on the printer and allow the printer to go through a complete startup cycle and the display changes to READY.

2-line Display Control Panel

1. Remove the left cover. See [Left cover removal](#).
2. Remove the right cover. See [Right cover removal](#).
3. Remove the controller board shield. See [Controller board shield removal](#).

4. Remove the top cover. See [Top cover removal](#).
5. Disconnect the cable under the top cover, and then remove the two screws.

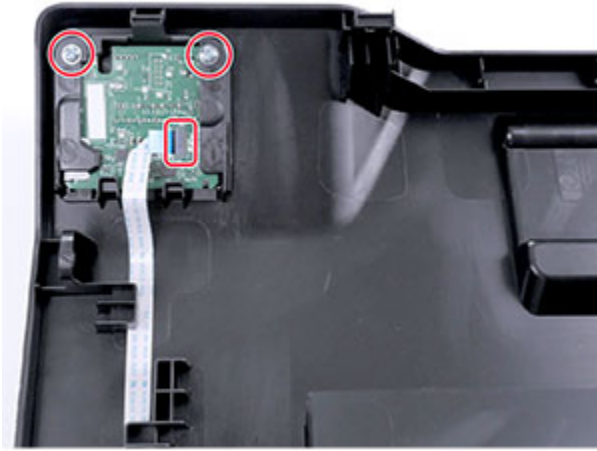

6. Remove the control panel.

Printhead Interlock Switch Removal

1. Remove the left cover. See [Left cover removal](#).
2. Remove the right cover. See [Right cover removal](#).
3. Remove the controller board shield. See [Controller board shield removal](#).
4. Remove the top cover. See [Top cover removal](#).
5. Disconnect the cable, and then remove the screw.

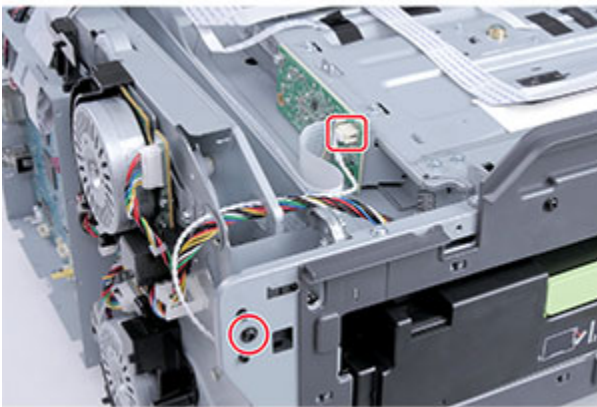

6. Remove the switch bracket.

Parts Removal

7. Remove the screw.



8. Remove the switch.

Front Door Removal

1. Remove the left cover. See [Left cover removal](#).
2. Remove the right cover. See [Right cover removal](#).
3. Remove the hinge pins.

 **Warning:** Do not lose the pins.

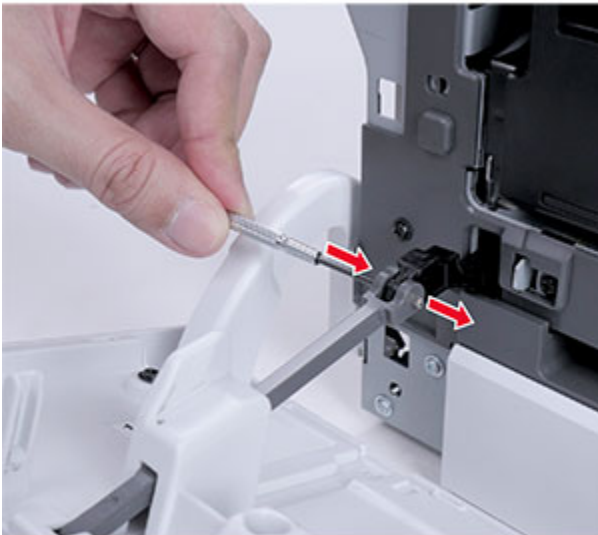

4. Release the door links.



5. Remove the door.

Inner Front Cover Removal

1. Remove the left cover. See [Left cover removal](#).
2. Remove the right cover. See [Right cover removal](#).
3. Remove the front door. See [Front door removal](#).
4. Remove the five screws.



Parts Removal

5. Remove the inner front cover.



Rear Side Removals

Transfer Module Removal

 **Note:** For a video demonstration, see [Transfer module removal](#).

1. Remove the right cover. See [Right cover removal](#).
2. Remove the left cover. See [Left cover removal](#).
3. Remove the print cartridge tray. See [Print cartridge tray removal](#).
4. Release the left spring (A).

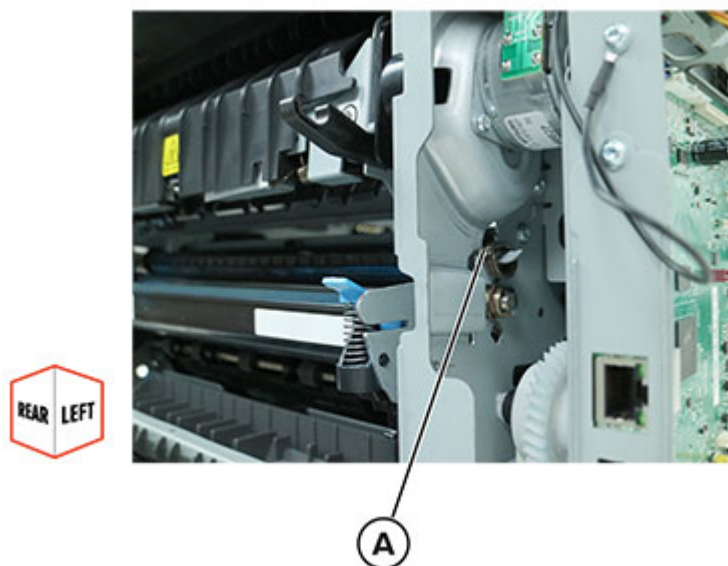

Parts Removal

5. Release the right spring (B).

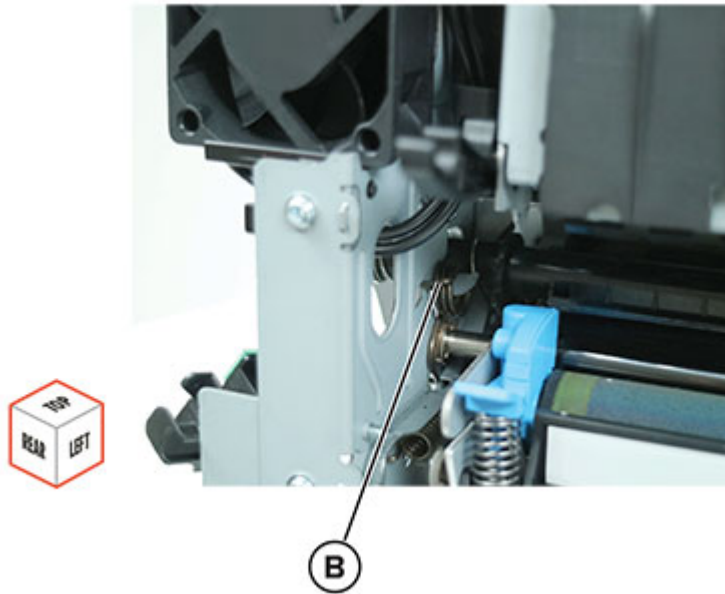

6. Remove the cover.



7. Disconnect and release the cables (C), and then remove the two screws.

 **Note:** Installation note: Pay attention to the cable routes.

 **Warning:** To avoid damaging the transfer module nozzle, move the sensor (waste toner bottle) out of the way.

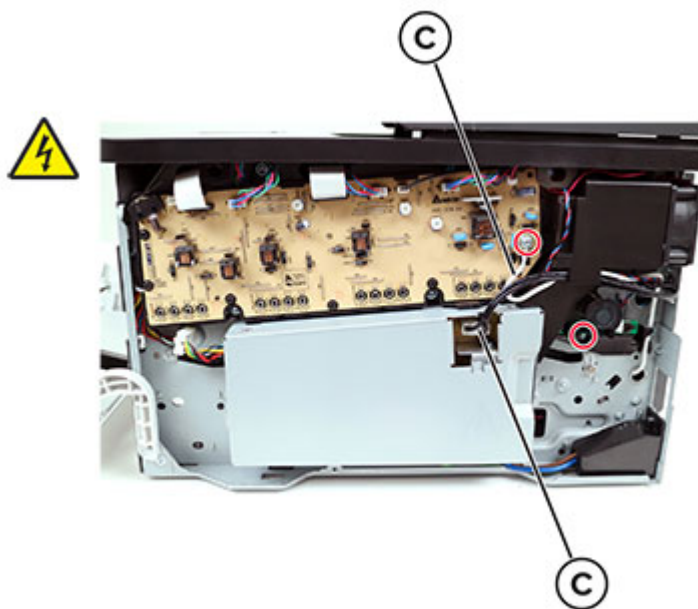

8. Remove the four screws.

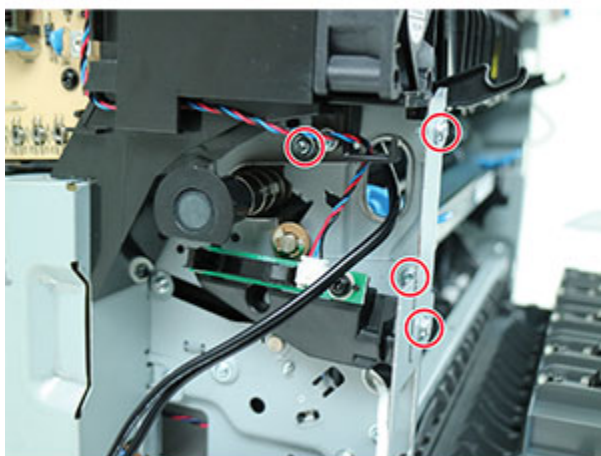

Parts Removal

9. Release the bracket, and then move it out of the way.



10. Press the latch. Lock the latch position using a prying tool or screwdriver.

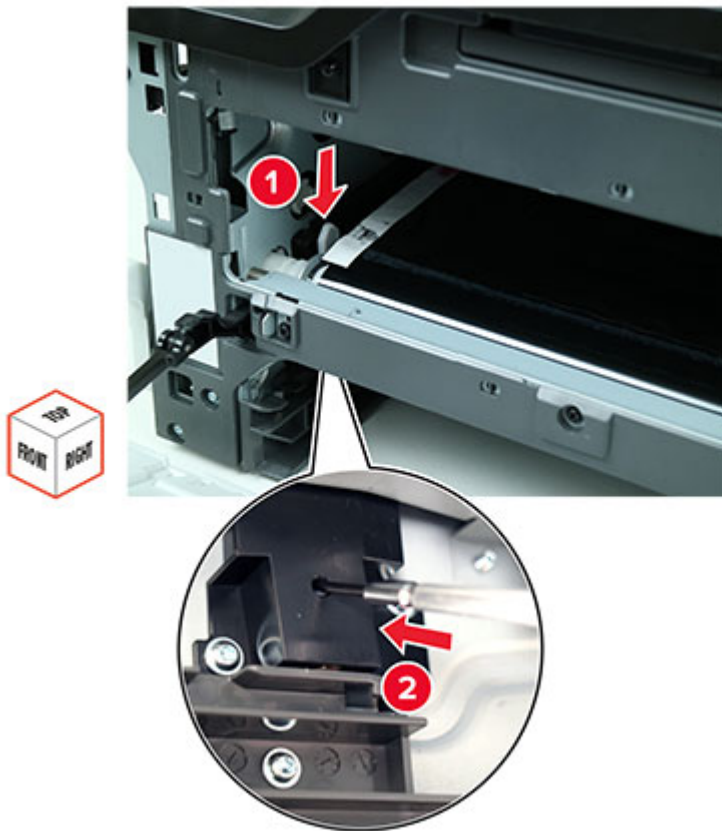

11. Move the coupler to release the transfer module.

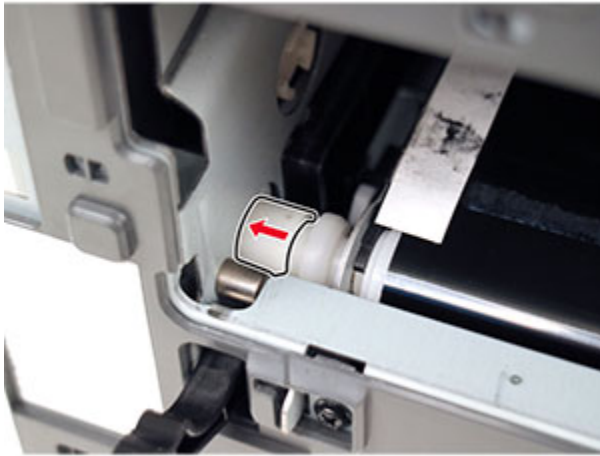

12. Remove the transfer module.

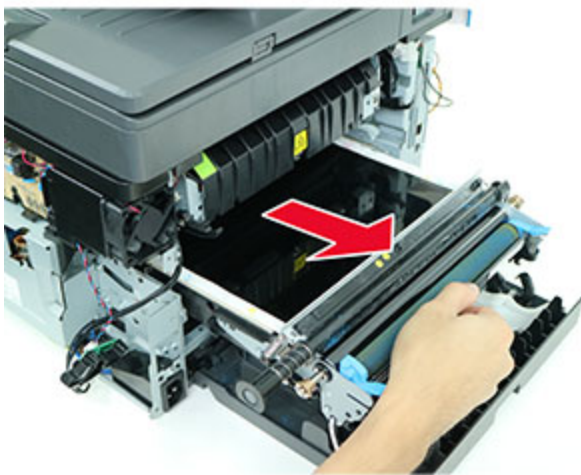

Installation warning: To avoid print quality issues, do not touch or scratch the transfer belt and transfer roller surface.



Installation notes:

- a. Perform the supply reset on the transfer module. See [Supply reset](#).
- b. Perform the registration adjustment. See [Registration adjustment](#).

Rear Door Removal

1. Remove the two screws.



2. Slightly move the cover to remove the screw behind it.

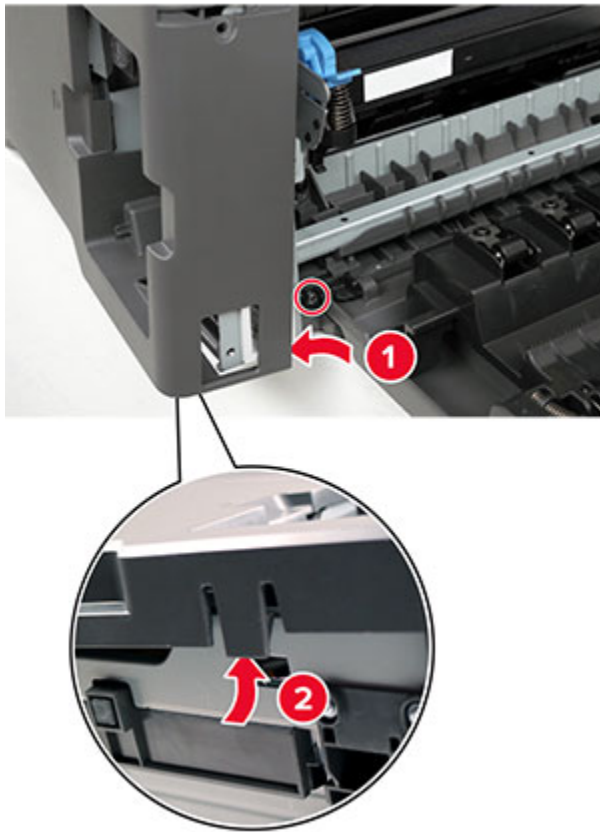

Parts Removal

3. Remove the door, and then remove the hinge pin (A).



Sensor (fuser Buckle) Removal

1. Open the rear door.
2. Remove the screw.



3. Disconnect the cable.



4. Remove the sensor.

Fuser Removal

 **Note:** For a video demonstration, see [Fuser Removal](#).

1. Remove the left cover. See [Left cover removal](#).
2. Remove the right cover. See [Right cover removal](#).
3. Remove the controller board shield. See [Controller board shield removal](#).
4. Remove the top cover. See [Top cover removal](#).
5. Remove the bin flag. See [Bin Flag Removal](#).
6. Disconnect the cable.

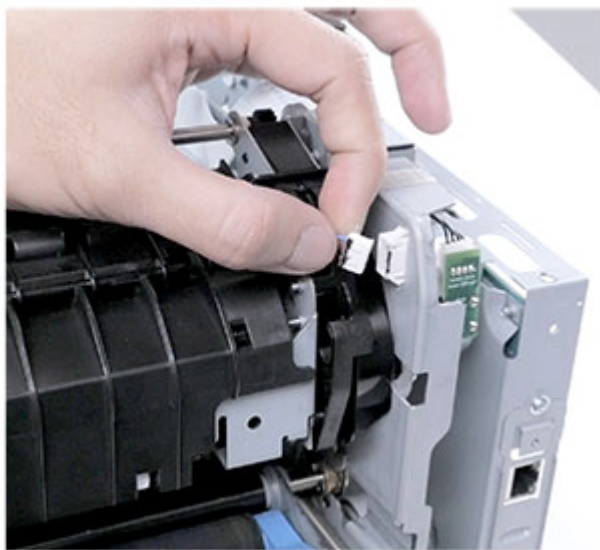

Parts Removal

7. Disconnect, and then release the cables.

 **Note:** Installation note: Pay attention to the cable routes.

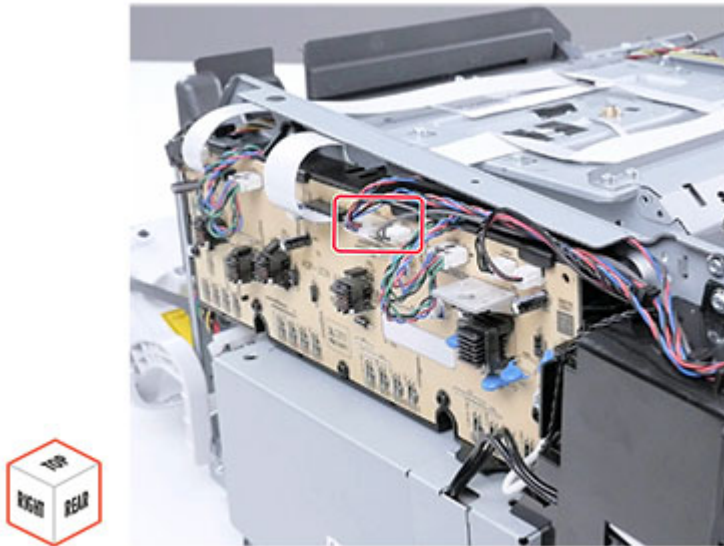

8. Thread the cables through the hole.



9. Remove the cover.



10. Disconnect the cable.

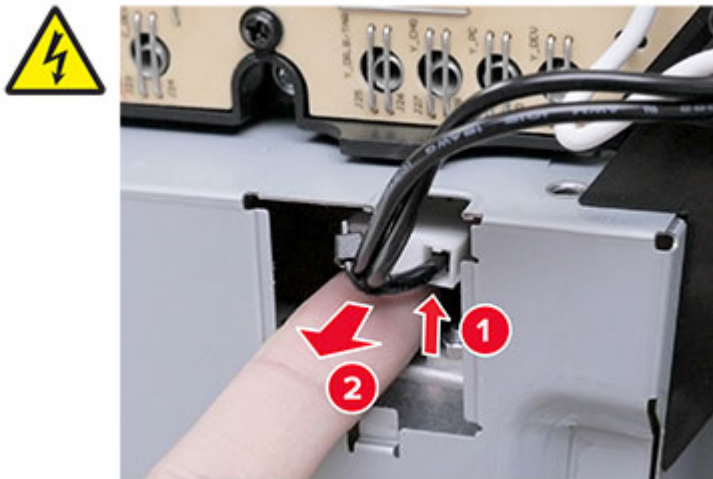

Parts Removal

11. Thread the cable through the hole.

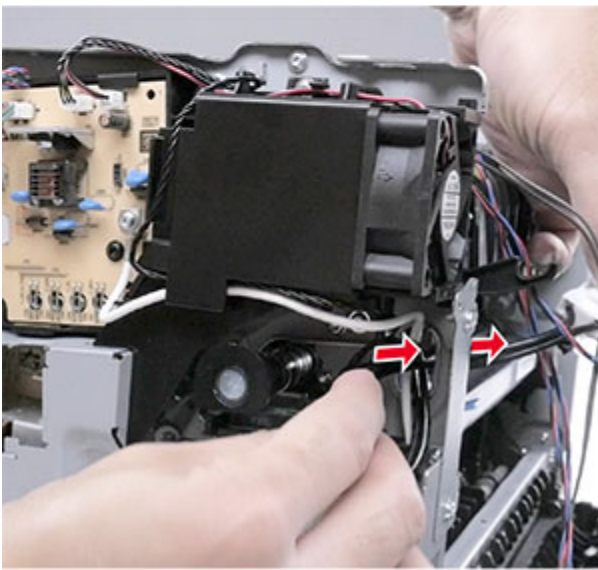
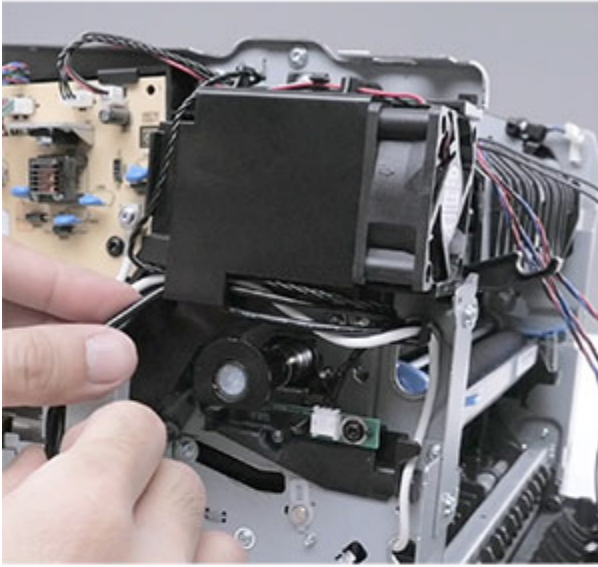

12. Loosen the two screws until the fuser is released.

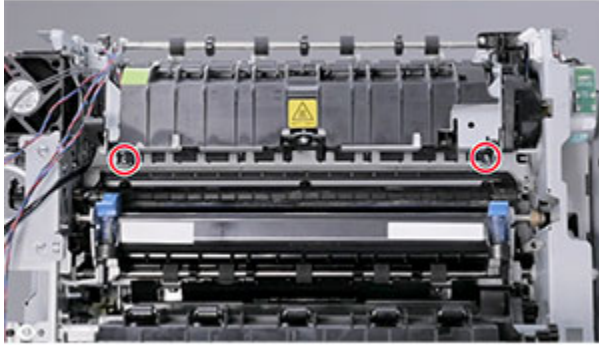

13. Remove the fuser.

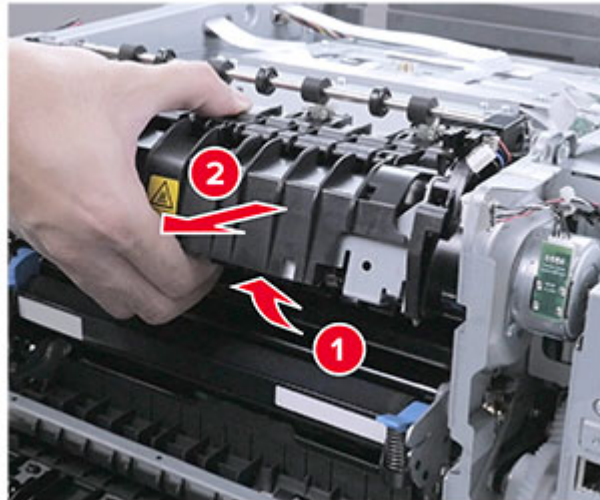

Installation notes:

- Align the locating tabs to their slots.

Parts Removal

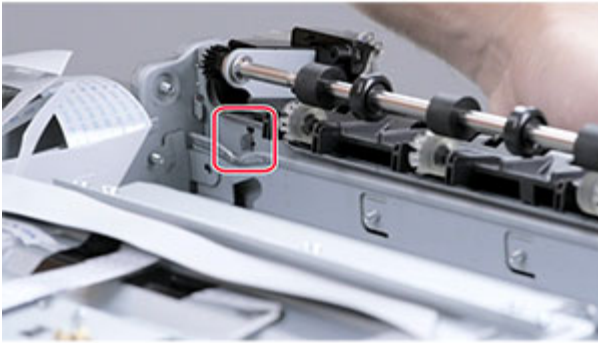
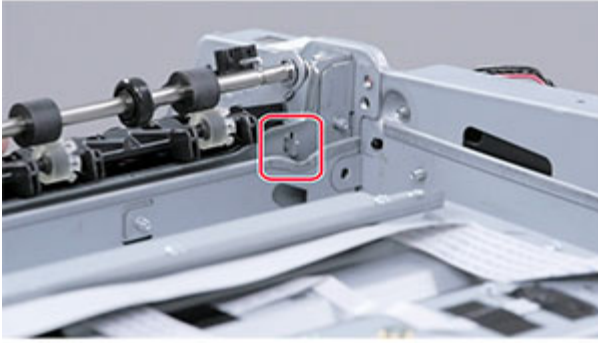

- Perform the supply reset on the fuser. See [Supply reset](#).

Sensor (fuser Exit) Removal

1. Open the rear door.
2. Remove the screw.

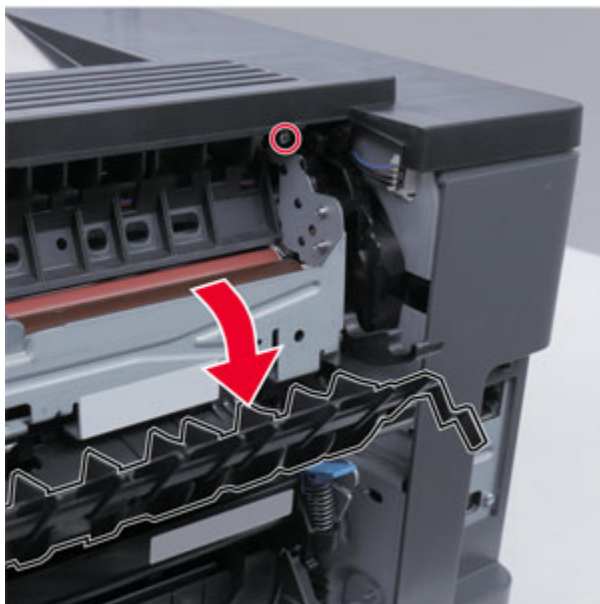

3. Disconnect the cable.



4. Remove the sensor.

Sensor (input) Removal

Warning: If the printer is laid on its side, then toner contamination may occur. To minimize contamination, cover the print cartridge tray. See [Covering the print cartridge tray](#).

1. Under the printer, remove the four screws.



Parts Removal

2. Disconnect the cable, and then remove the screw.

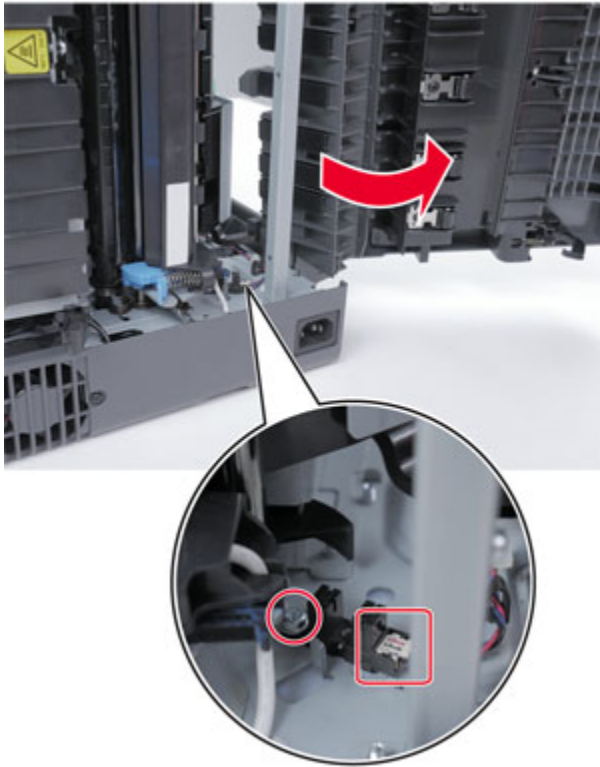

3. Remove the sensor.

Top Side Removals

Top Cover Removal

Critical Information For Controller Board or Control Panel Replacement

 **Warning:** To avoid NVRAM mismatch issues, replace only one of the following components at a time:

- Top cover with control panel
- Controller board

To replace a component and to test whether the problem is resolved:

1. Replace the affected component.

 **Warning:** Do not perform a Power-On Reset (POR) until the problem is resolved. If a POR is performed at this point, then the replacement part can no longer be used in another printer and must be returned to the manufacturer.

2. Enter the Diagnostics Menu. The Diagnostics Menu allows you to temporarily use the replacement part.

 **Warning:** Some printers will perform automatically a POR if the Diagnostics Menu is not opened within five seconds. If a POR is performed at this point, then the replacement part can no longer be used in another printer and must be returned to the manufacturer.

3. Use the Diagnostics Menu to test the replacement part. Do a feed test to check if the problem is resolved.
 - If the problem is not resolved—Turn off the printer, and then reinstall the old part.
 - If the problem is resolved—Perform a POR.
4. To replace the controller board and the control panel simultaneously on the machine, follow the below procedure to avoid losing the printer's NVRAM settings and damaging the printer.
 - a. Replace either the controller board or the control panel on the machine. Do not replace both the parts at the same time.
 - b. Power on the printer and perform a POR.
 - c. After the printer has completed startup (printer will be either READY or post an error), power off the printer and replace the second part.

 **Note:** If the control panel display has failed, the printers' startup cycle is complete after the driver motor and fans shut down and the machine is quiet.

- d. Power on the printer and allow the printer to go through a complete startup cycle and the display changes to READY.

Removal Procedure

1. Remove the left cover. See [Left cover removal](#).

Parts Removal

2. Remove the right cover. See [Right cover removal](#).
3. Remove the controller board shield. See [Controller board shield removal](#).
4. Disconnect the cable.



5. Remove the two screws.



6. Release the latches.



7. Release the latch.

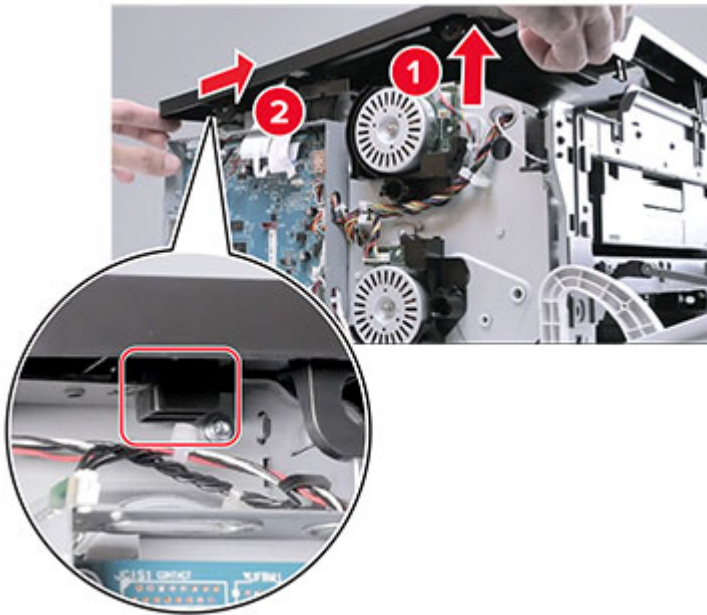

Parts Removal

8. Release the latch.

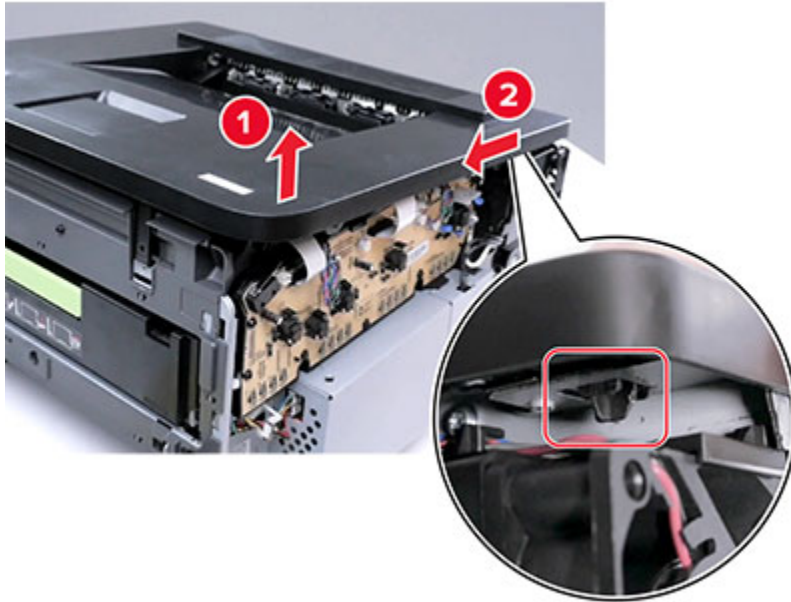

9. Remove the cover.

Printhead Removal

 **Note:** For a video demonstration, see [Printhead Removal](#) and [Printhead Characterization](#).

1. Remove the left cover. See [Left cover removal](#).
2. Remove the right cover. See [Right cover removal](#).
3. Remove the controller board shield. See [Controller board shield removal](#).
4. Remove the top cover. See [Top cover removal](#).
5. Disconnect the cables.

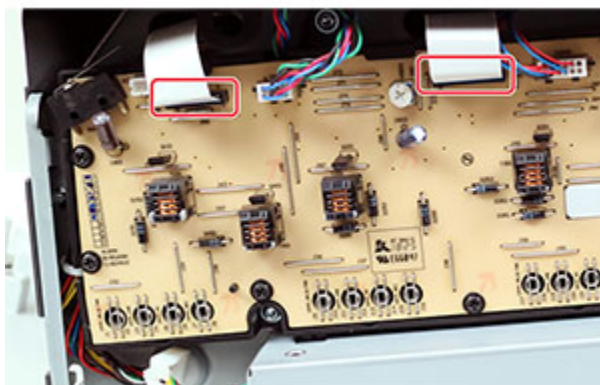

6. Disconnect the cables.



7. Disconnect the cables, and then release the spring (A).

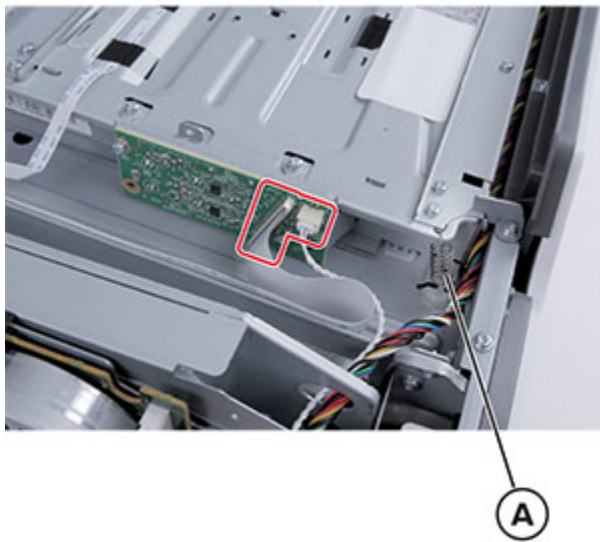

Parts Removal

8. Release the cables from the printhead.

 **Note:** Installation note: Pay attention to the cable routes.

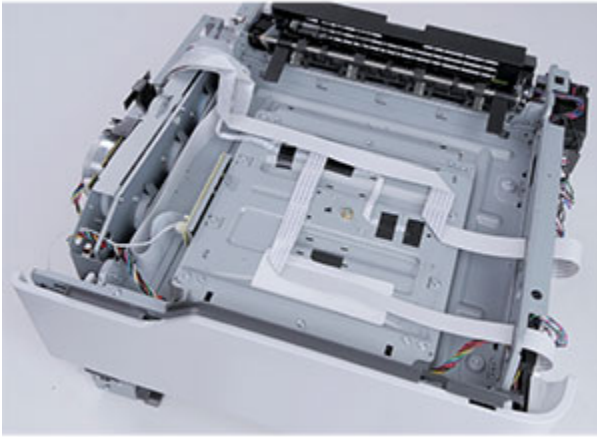

9. Remove the four screws.

 **Warning:** Do not lose the bracket (B).

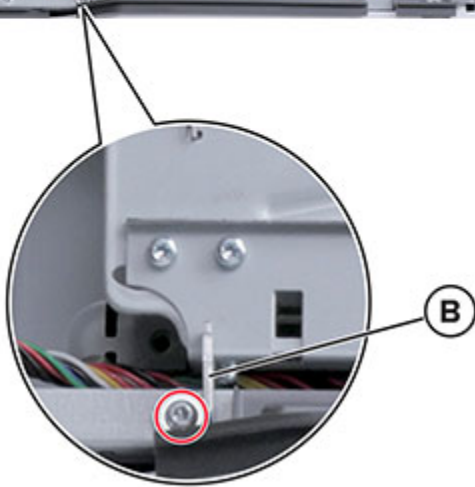
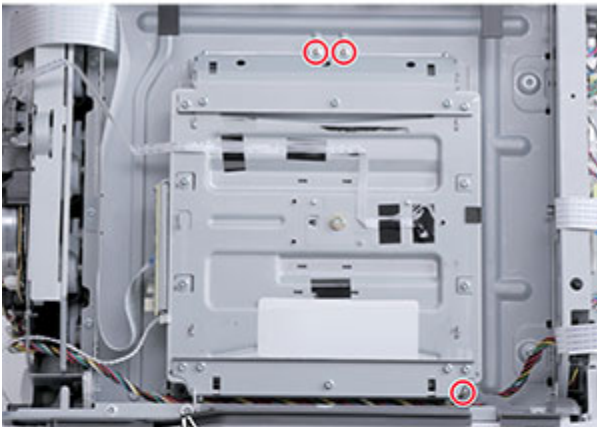

10. Remove the printhead. Installation warning: Do not touch the mirrors under the printhead.

**Installation notes:**

1. Perform the registration adjustment and color alignment adjustment. See [Registration adjustment](#).
2. Perform the printhead characterization procedure. See [Printhead Characterization](#).

Sensor (bin/narrow Media) Removal

1. Remove the left cover. See [Left cover removal](#).
2. Remove the right cover. See [Right cover removal](#).
3. Remove the controller board shield. See [Controller board shield removal](#).
4. Remove the top cover. See [Top cover removal](#).
5. Disconnect the cable, and then remove the screw.

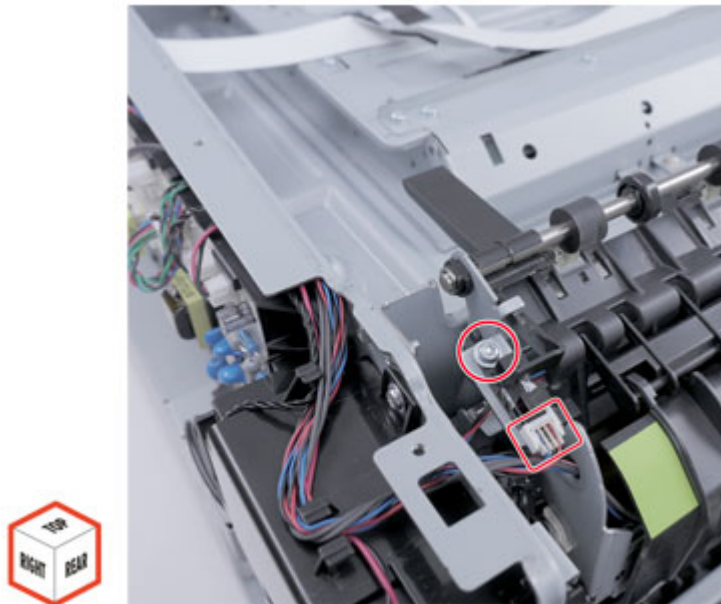

Parts Removal

6. Remove the sensor.

Bin Flag Removal

1. Remove the left bin flag.

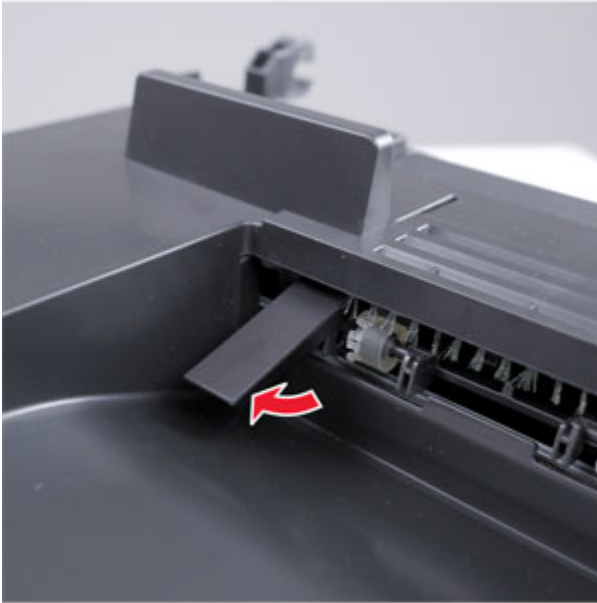

2. Remove the right bin flag.



 **Note:** Installation note: Move the flag up and down. Check if the flag (A) toggles the sensor. Check if the bin flag drops down freely to its default lower position.

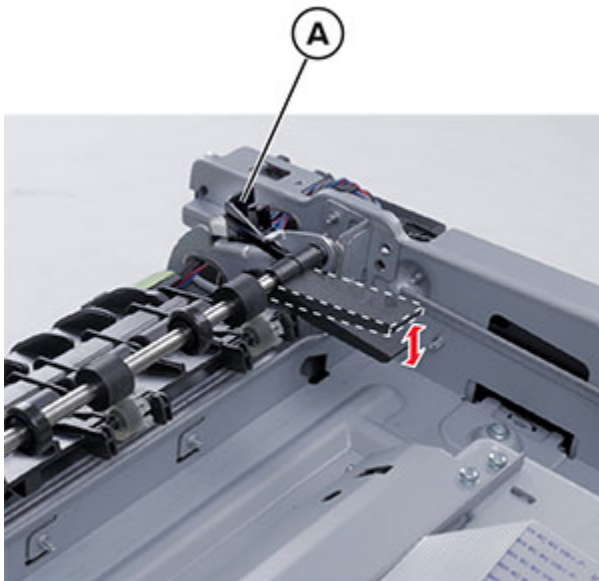

Bottom Side Removals

Pick Tire Removal

 **Warning:** If the printer is laid on its side, then toner contamination may occur. To minimize contamination, cover the print cartridge tray. See [Covering the print cartridge tray](#) .

Position the printer as shown, and then remove the pick tire.



Sensor (manual Feeder) Removal

 **Warning:** If the printer is laid on its side, then toner contamination may occur. To minimize contamination, cover the print cartridge tray. See [Covering the print cartridge tray](#) .

1. Remove the four screws under the printer, and then remove the cover.

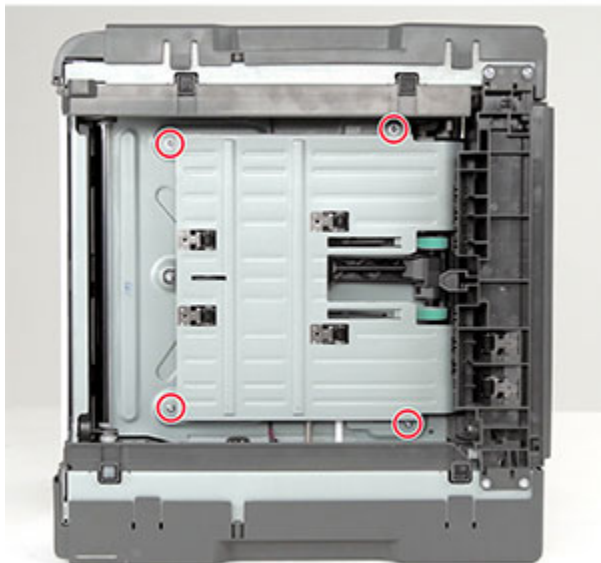

2. Disconnect the cable, and then remove the screw.



3. Remove the sensor.

Separator Bracket Removal

Warning: If the printer is laid on its side, then toner contamination may occur. To minimize contamination, cover the print cartridge tray. See [Covering the print cartridge tray](#) .

1. Remove the left cover. See [Left cover removal](#) .
2. Remove the controller board shield. See [Controller board shield removal](#) .

Parts Removal

3. Disconnect the cable.



4. Remove the four screws, and then remove the door.

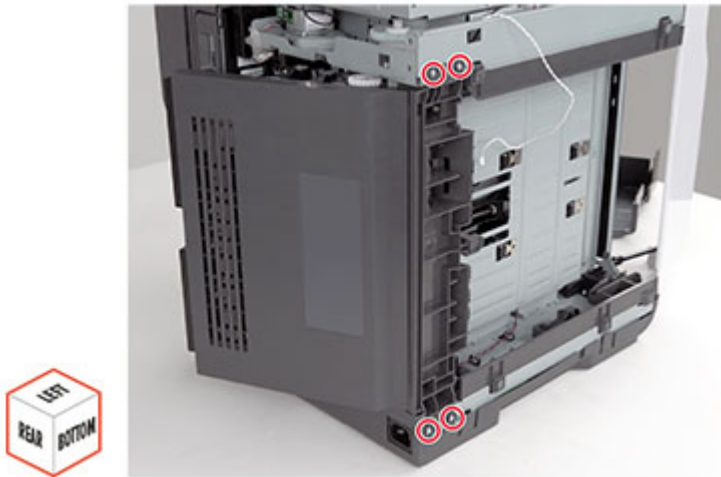

5. Remove the screw.

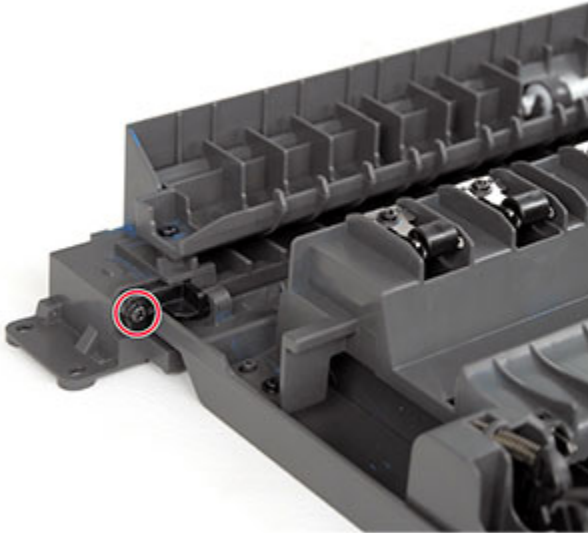

6. Remove the separator bracket. Installation warning: To avoid compatibility issues, see [Compatibility information for left cover and separator bracket](#) before installing the replacement part. Installation warning: When unpacking the replacement separator bracket, be careful not to contaminate the rollers and pad with the grease from the gears.

Tray Interlock Switch Removal

1. Remove the left cover. See [Left cover removal](#).
2. Remove the controller board shield. See [Controller board shield removal](#).
3. Remove the separator bracket. See [Separator bracket removal](#).
4. Remove the two screws.

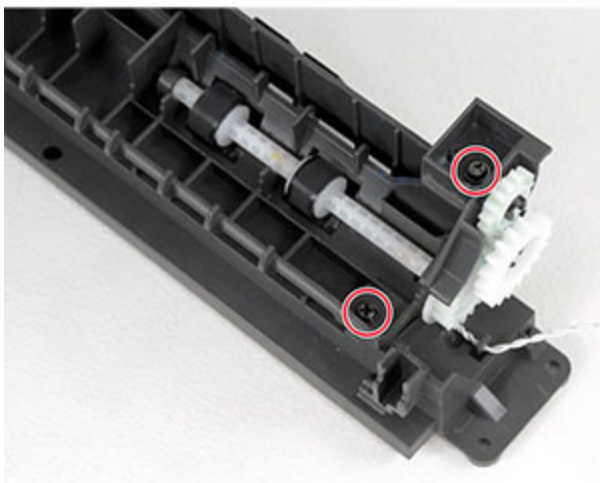

Parts Removal

5. Remove the switch.

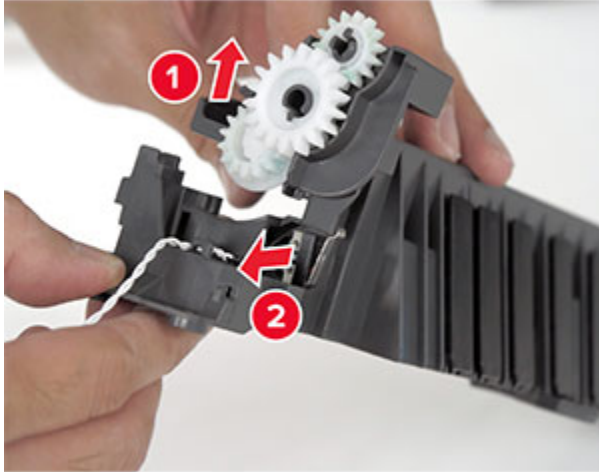

Sensor (tray Near Empty) Removal

 **Warning:** If the printer is laid on its side, then toner contamination may occur. To minimize contamination, cover the print cartridge tray. See [Covering the print cartridge tray](#).

1. Remove the four screws under the printer, and then remove the plate.



2. Release the cable from its guide (A), and then remove the six screws (B).

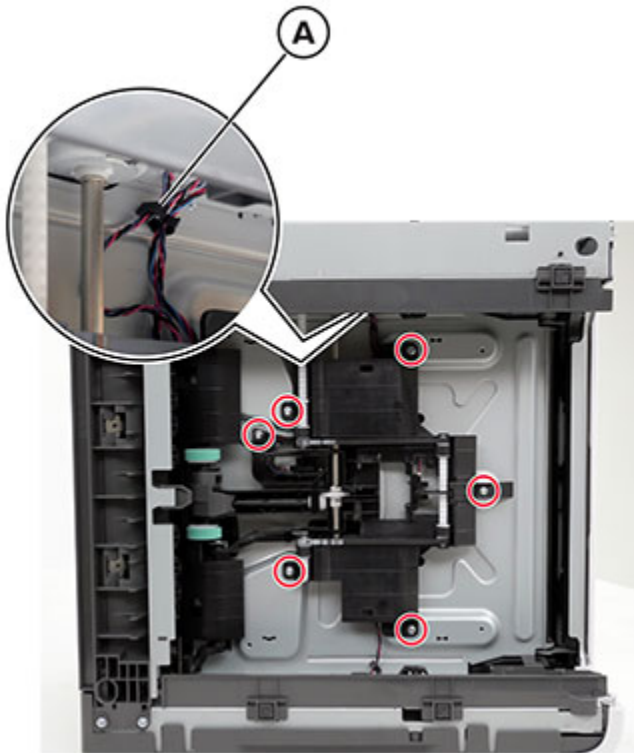

3. Behind the feeder, remove the screw (C).

 **Note:** Make sure that the top end of the feeder shaft (D) is not dislodged.

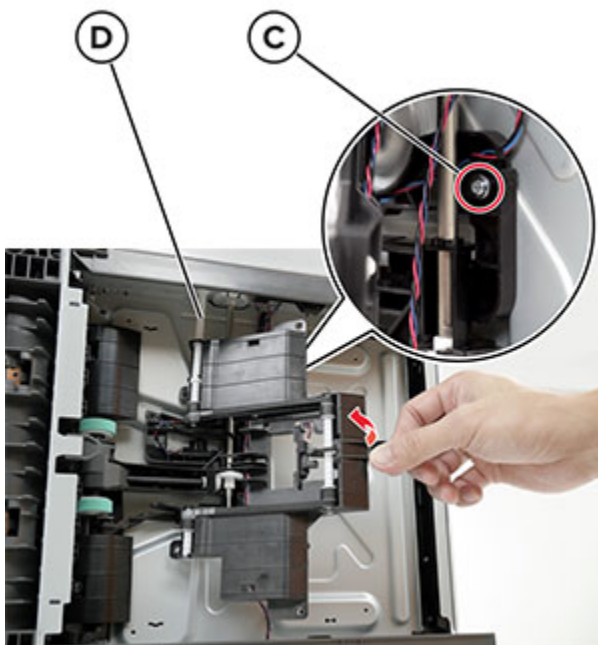

Parts Removal

4. Release the retainer, and then release the bottom end of the pick roller shaft.

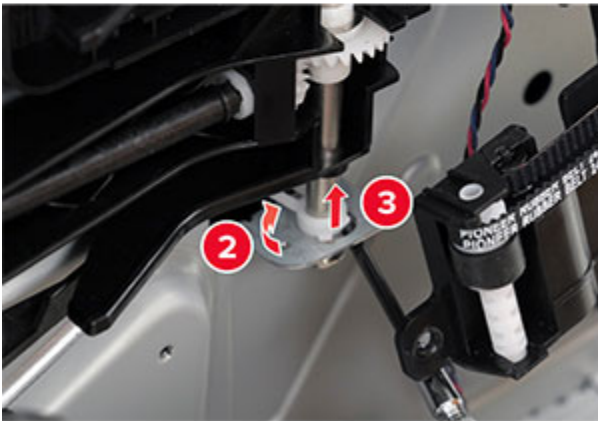

5. Slightly pull the feeder, lower the pick roller, and then release the sensor bracket.

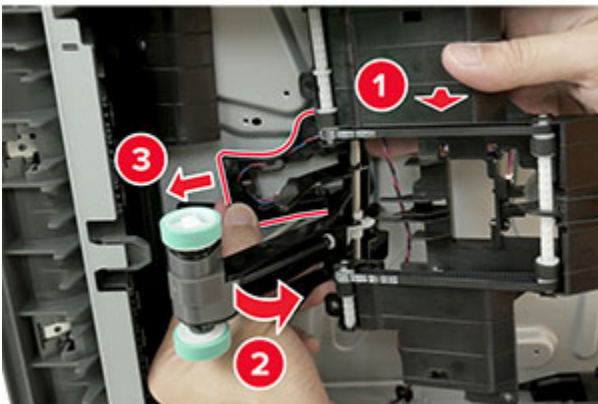

6. Disconnect the cable (E), and then remove the screw (F).

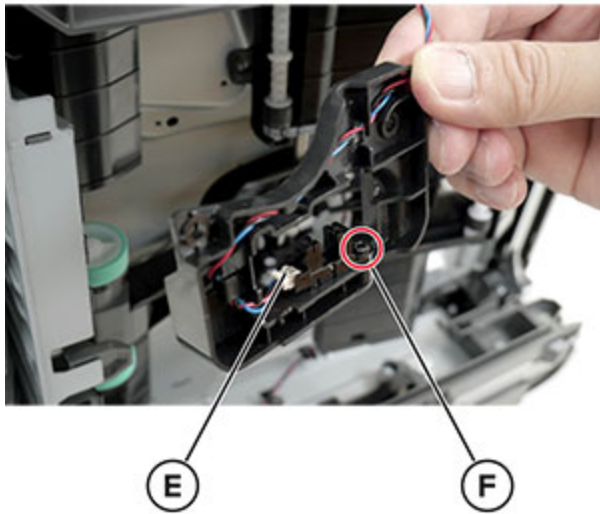

7. Remove the sensor.

Installation notes:

- Make sure that the sensor (A) and its actuator are properly engaged.
- Make sure that the finger (B) is positioned as shown.

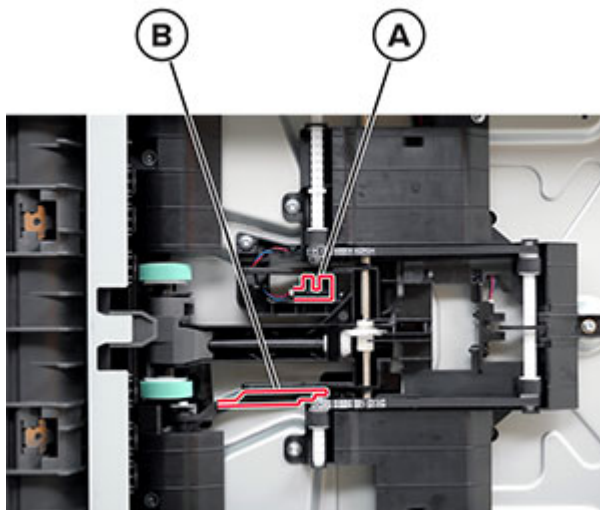

- Make sure that the pick roller spring is not dislodged.

Component Locations

Printer Configurations

Xerox C230 Printers



1	Control panel
2	Standard bin
3	Manual feeder
4	250-sheet tray

Port Locations



	Printer port	Function
1	Ethernet port	Connect the printer to a network.
2	USB printer port	Connect the printer to a computer.
3	Power cord socket	Connect the printer to an electrical outlet.

Board Locations

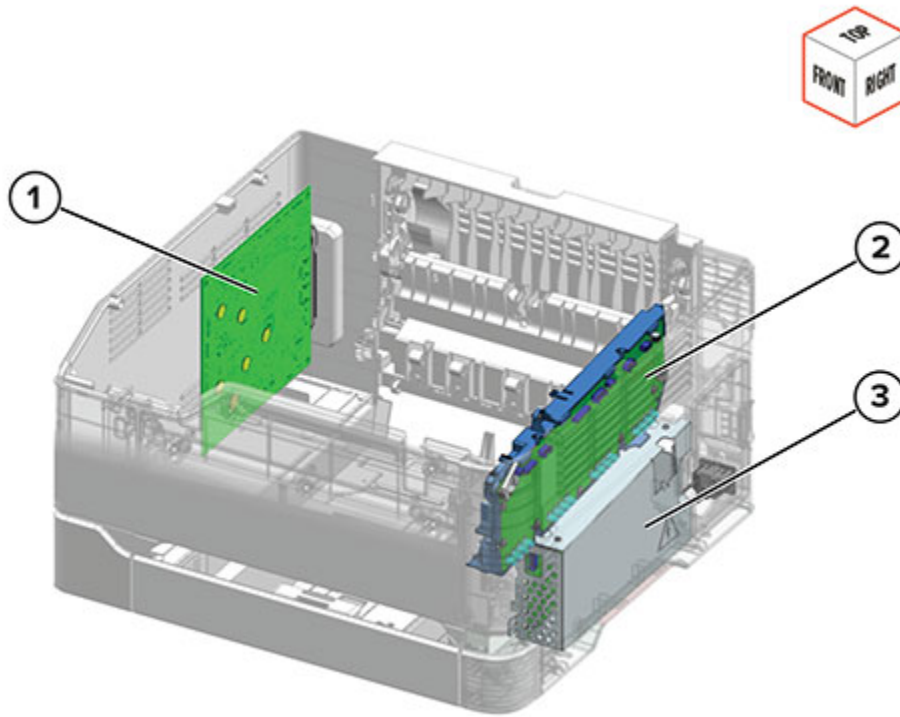

Part	Description
1	Controller board
2	HVPS
3	LVPS

Motor Locations

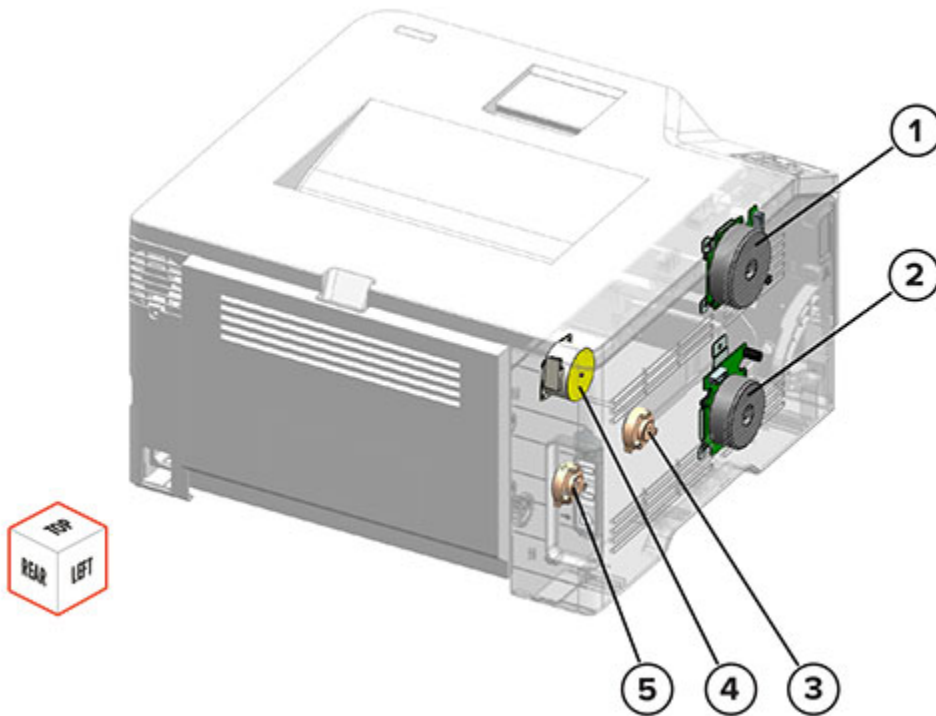

Part	Description
1	Motor (CMY)
2	Motor (K/transfer belt)
3	Pick clutch
4	Motor (fuser)
5	Staging clutch

Sensor Locations

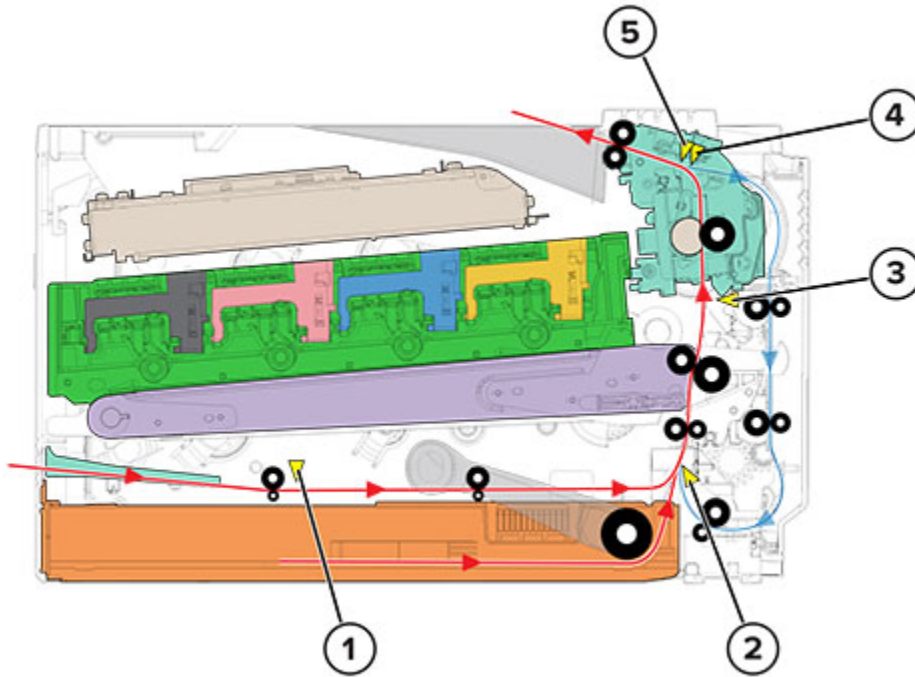

Part	Description
1	Sensor (manual feeder)
2	Sensor (input)
3	Sensor (fuser buckle)
4	Sensor (fuser exit)
5	Sensor (bin/narrow media)

Controller Board Connectors

Connector	Connects to	Pin number	Signal
JBLDC1	Motor (CMY) and motor (K/transfer belt)	1	25V_F_CMY_DRV
		2	GND
		3	CMY_BLDC_BRAKE
		4	CMY_BLDC_PWM
		5	CMY_BLDC_DIR
		6	CMY_BLDC_FG
		7	25V_F_CMY_DRV
		8	GND
		9	25V_F_DRV
		10	GND
		11	K_BLDC_BRAKE
		12	K_BLDC_PWM
		13	K_BLDC_DIR
		14	K_BLDC_FG
		15	25V_F_DRV
		16	GND
JCLUTCH1	Pick clutch	1	PICKDRV+(25V_F_DRV)
		2	PICKDRV-
JCLUTCH2	Staging clutch	1	STAGEDRV+(25V_F_DRV)
		2	STAGEDRV-
JFDRIV1	Motor (fuser)	1	MOT1_A
		2	MOT1_B
		3	MOT2_A
		4	MOT2_B
JFTHERM1	Fuser	1	FUSER_THERM_ADC
		2	GND
		3	TCO-
		4	TCO+
JHVPS1	HVPS	1	24V_SAFETY
		2	GND

Component Locations

Connector	Connects to	Pin number	Signal		
		3	GND		
		4	GND		
		5	25V_F_HVPS		
		6	25V_F_HVPS		
		7	K_CHARGE_PWM		
		8	CMY_CHARGE_PWM		
		9	K_DEV_PWM		
		10	CMY_DEV_PWM		
		11	SEC_XFER_PWM		
		12	CMYK_CORE_PWM		
		13	GND		
		14	SEC_XFER_SERVO_ADC		
		15	GND		
		JHVPS2	HVPS	1	3.3V_SCHIP
				2	I2C_DATA
3	GND				
4	I2C_CLK				
5	GND				
6	5V_SW				
7	BUBBLE_SENS				
8	FUSER_EXIT_SENS				
9	SPARE_UPP_SENS				
10	A_BUR_THERM				
11	MAIN_FAN_ON				
12	WASTE_LEVEL_SNS_DRV				
13	GND				
14	25V_F_FAN				
15	5V_SW				
16	WASTE_PWM				
17	GND				
18	WASTE_ADC				

Connector	Connects to	Pin number	Signal
		19	GND
JLVPS1	LVPS	1	Zero_cross
		2	Relay_on
		3	GND
		4	Heat_on
		5	GND
		6	25V_ON
		7	GND
		8	25V_CONT
		9	GND
		10	25V_SW
		11	GND
		12	25V_SW
		13	GND
		14	25V_SW
JMIRR1	Printhead	1	25V_F_MIR
		2	GND
		3	MM_START
		4	MM_LOCK
		5	MM_REF_CLK
JPH1	Printhead	1	GND
		2	vy1+
		3	vy1-
		4	GND
		5	vk1+
		6	vk1-
		7	GND
		8	LPOWY
		9	lenak
		10	LPOWK
		11	adjy
		12	ADJK

Component Locations

Connector	Connects to	Pin number	Signal
		13	Boost
		14	GND
		15	vc1+
		16	vc1-
		17	GND
		18	vm1+
		19	vm1-
		20	3.3V_ENG
		21	LenaCMY
		22	hsync
		23	LSU_THERM
		24	LPOWC
		25	LPOWM
		26	ADJC
		27	ADJM
28	3.3V_ENG(Spare)		
JSENS1	Sensor (input) and sensor (manual feeder)	1	5V_SW
		2	MAN_FD_DET
		3	GND
		4	5V_SW
		5	SPARE_LPP_SENSOR
		6	GND
		7	5V_SW
		8	STAGE_DET
		9	GND
		10	N/C
JTSP1	Sensor (TPS)	1	TPS1_SPEC
		2	TPS1_SPEC_PWM
		3	GND
		4	TPS1_THERM
		5	TPS1_LED_PWM
		6	5V_SW





Connector	Connects to	Pin number	Signal
		7	TPS1_DIFF
JTPS2	Sensor (TPS)	1	TPS2_SPEC
		2	TPS2_SPEC_PWM
		3	GND
		4	TPS2_LED_PWM
		5	5V_SW
		6	TPS2_DIFF
JTRAY1	Tray interlock switch	1	5V_FUSED
		2	TRAY_PRES_DET
JUICC2L1	Control panel (2-line display)	1	opp_led_drv
		2	5V_CONT_UI
		3	mir_spi_txd
		4	mir_spi_cs-
		5	opp_pwr_btn
		6	gnd
		7	mir_spi_rxd
		8	5V_UI
		9	mir_spi_clk
		10	gnd
		11	i2c_data_ui
		12	i2c_clk_ui
		13	3.3V
		14	opp_reset-
		15	opp_irq-
		16	3.3V_FUSED
JUICC24	Control panel (2.8-inch display)	1	opp_led_drv
		2	5V_CONT_UI
		3	mir_spi_txd
		4	mir_spi_cs-
		5	opp_pwr_btn
		6	LCD_RS

Component Locations

Connector	Connects to	Pin number	Signal
		7	LCD_TE
		8	mir_spi_rxd
		9	N/C
		10	mir_spi_clk
		11	GND
		12	i2c_data_ui
		13	i2c_clk_ui
		14	N/C
		15	opp_reset-
		16	opp_irq-
		17	GND
		18	LCD_WR
		19	LCD_RD
		20	5V_UI
		21	LCD_D0
		22	LCD_D1
		23	GND
		24	LCD_D2
		25	LCD_D3
		26	5V_UI
		27	LCD_D4
		28	LCD_D5
		29	GND
		30	LCD_D6
		31	LCD_D7
		32	5V_UI

Maintenance

Cleaning The Printer

-  **CAUTION—SHOCK HAZARD:** To avoid the risk of electrical shock when cleaning the exterior of the printer, unplug the power cord from the electrical outlet and disconnect all cables from the printer before proceeding.
-  **ATTENTION ! RISQUE D'ÉLECTROCUTION :** pour éviter tout risque d'électrocution lors du nettoyage de l'extérieur de l'imprimante, débranchez le cordon d'alimentation électrique de la prise et déconnectez tous les câbles de l'imprimante avant de continuer.
-  **PRECAUCIÓN—RIESGO DE DESCARGA:** Para evitar el riesgo de descarga eléctrica al limpiar el exterior de la impresora, desconecte el cable de alimentación de la toma eléctrica y desconecte todos los cables de la impresora antes de realizar la operación.
-  **VORSICHT – STROMSCHLAGGEFAHR:** Um das Risiko eines elektrischen Schlags beim Reinigen des Druckergehäuses zu vermeiden, ziehen Sie das Netzkabel aus der Steckdose, und ziehen Sie alle Kabel vom Drucker ab, bevor Sie fortfahren.
-  **ATTENZIONE – PERICOLO DI SCOSSA ELETTRICA:** Per evitare il rischio di scosse elettriche quando si pulisce la parte esterna della stampante, scollegare il cavo di alimentazione dalla presa a muro e scollegare tutti i cavi della stampante prima di procedere.

 **Note:**

- Perform this task after every few months.
 - Damage to the printer caused by improper handling is not covered by the printer warranty.
1. Turn off the printer, and then unplug the power cord from the electrical outlet.
 2. Remove paper from the standard bin and manual feeder.
 3. Remove any dust, lint, and pieces of paper around the printer using a soft brush or vacuum.
 4. Wipe the outside of the printer with a damp, soft, lint-free cloth.

 **Note:**

- Do not use household cleaners or detergents, as they may damage the finish of the printer.
 - Make sure that all areas of the printer are dry after cleaning.
5. Connect the power cord to the electrical outlet, and then turn on the printer.

Parts Catalog

Legend

- The following column headings are used in the parts catalog:
- **Asm-index**—Identifies the item in the illustration
- **P/N**—Identifies the part number of a FRU
- **Units/mach**—Refers to the number of units in a printer
- **Units/opt**—Refers to the number of units in an option
- **Units/FRU**—Refers to the number of units in a FRU
- **Description**—A brief description of the part

The following abbreviations are used in the parts catalog:

- **NS** (not shown) in the Asm-index column indicates that the part is procurable but is not shown in the illustration.
- **PP** (parts packet) in the Description or P/N column indicates that the part is contained in a parts packet.

Assembly 1: Covers

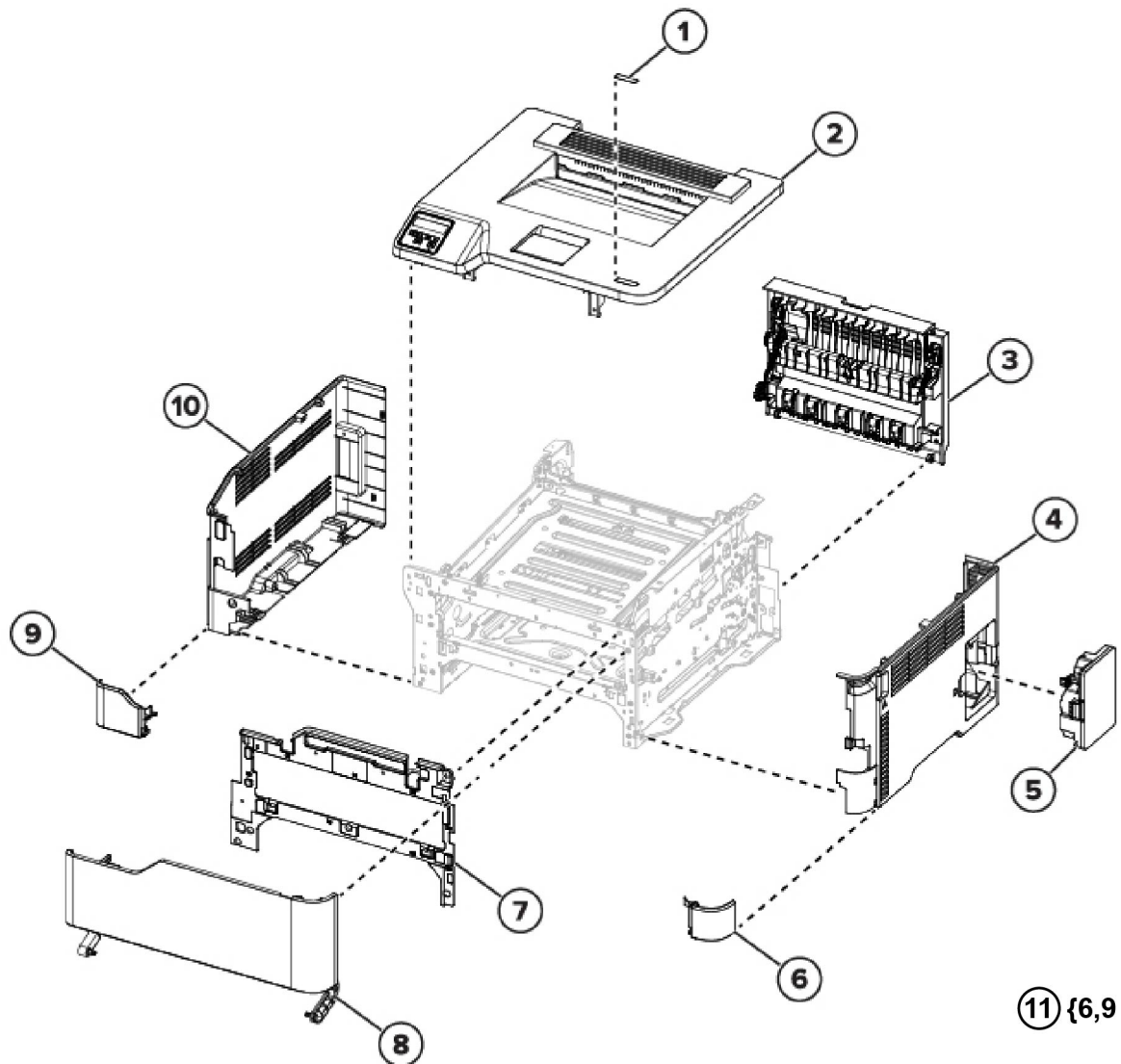

Asm-index	P/N	Units/mach	Units/FRU	Description	Removal procedure
1	056N00218	1	1	Bezel	–
2	002N03404	1	1	Top cover	Top cover removal
3	002N03425	1	1	Rear door	Rear door removal
4	002N03408	1	1	Right cover	Right cover removal

Parts Catalog

Asm-index	P/N	Units/mach	Units/FRU	Description	Removal procedure
5	008R13326	1	1	Waste toner bottle	–
6	PP item 11	1	1	Lower right front cover	Right cover removal
7	002N03387	1	1	Inner front cover	Inner Front Cover Removal
8	002N03406	1	1	Front door	Front door removal
9	PP item 11	1	1	Lower left front cover	Left cover removal
10	002N03407	1	1	Left cover	Left cover removal
11	002N03398	1	1	Lower front cover kit	Left cover removal, Right cover removal
NS	017N00312	4	4	Rubber feet	–

Assembly 2: Drive Components

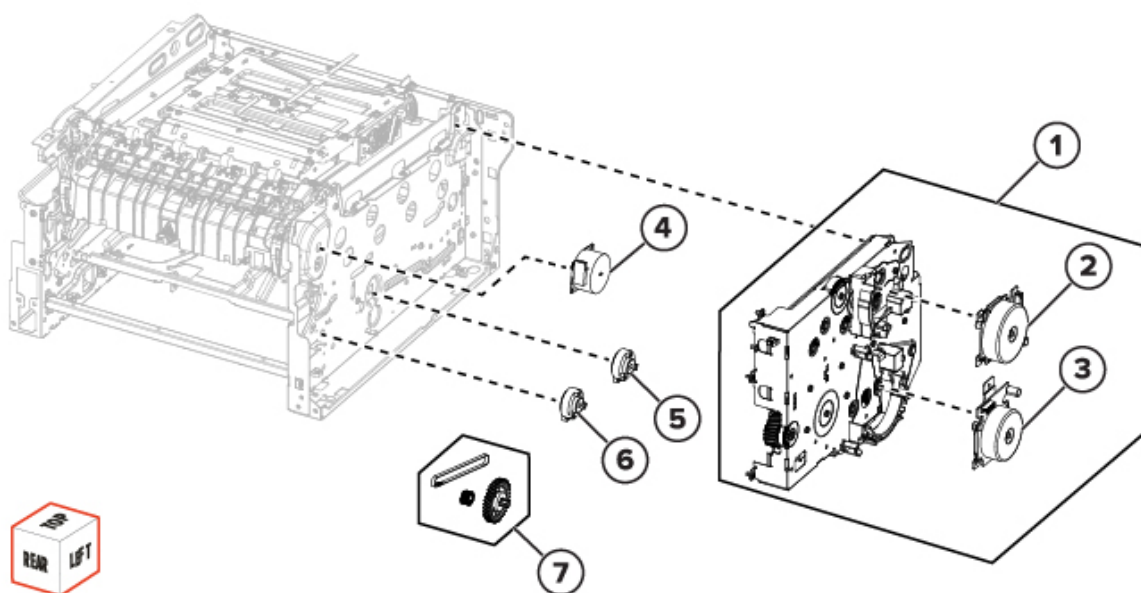

Asm-index	P/N	Units/mach	Units/FRU	Description	Removal procedure
1	007N01853	1	1	Gearbox	Gearbox removal
2	127N07964	1	1	Motor (CMY)	Motor (CMY) removal
3	127N07962	1	1	Motor (K)	Motor (K/ transfer belt) removal
4	127N07963	1	1	Motor (fuser)	Motor (fuser) removal
5	005N01213	1	1	Pick clutch	Pick clutch removal
6	005N01213	1	1	Staging clutch	Staging clutch removal
7	023N01404	1	1	Staging belt, gear, and pulley	Staging belt, gear, and pulley removal

Assembly 3: EP Components

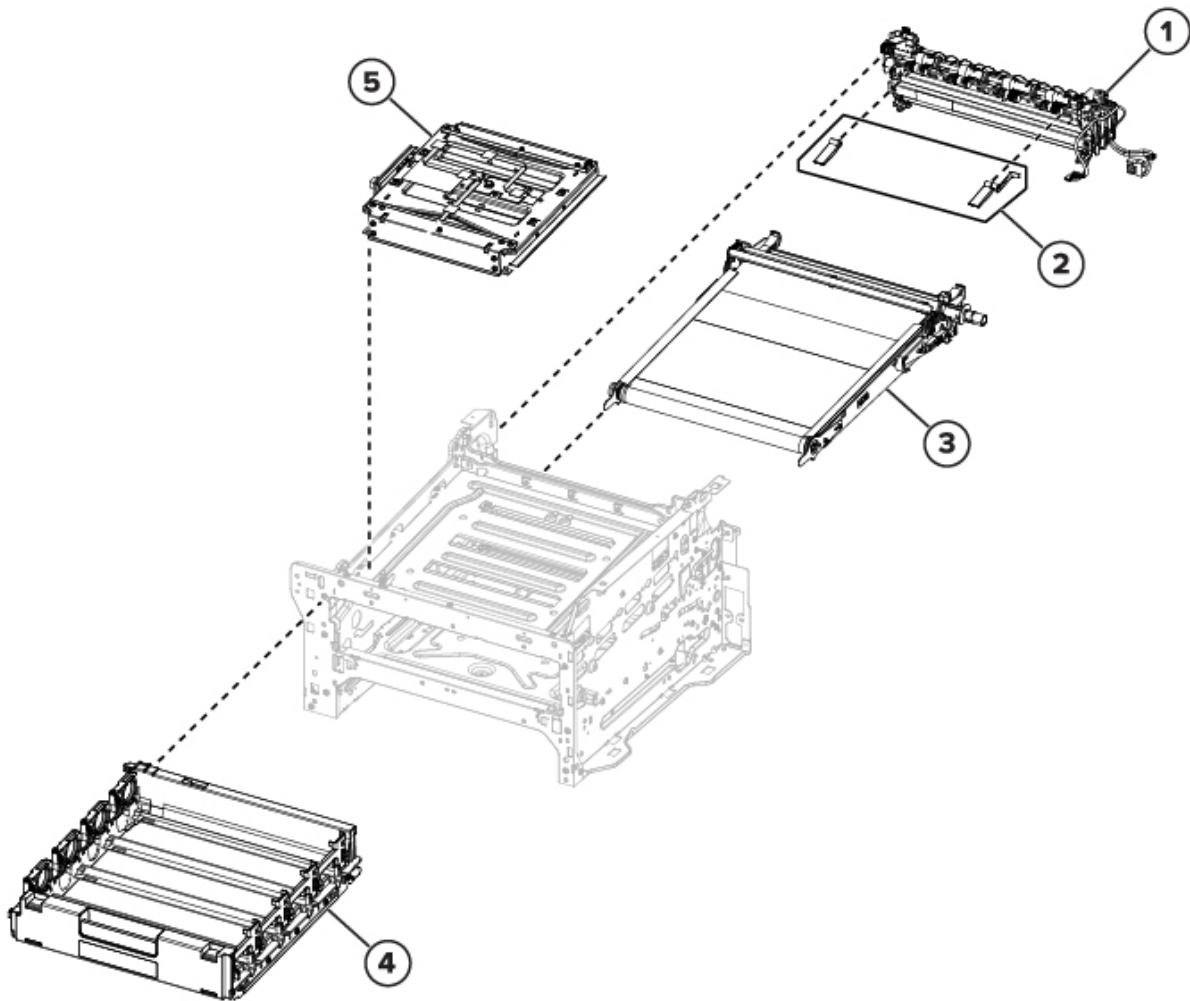

Asm-index	P/N	Units/mach	Units/FRU	Description	Removal procedure
1	126N00452	1	1	Fuser, 110 V	Fuser removal
1	126N00453	1	1	Fuser, 220 V	Fuser removal
2	120N00572	1	1	Bin flag	Bin Flag Removal
3	133N23276	1	1	Transfer module	Transfer module removal
4	050N00712	1	1	Print cartridge tray	Print cartridge tray removal

Asm-index	P/N	Units/mach	Units/FRU	Description	Removal procedure
5	046N00242	1	1	Printhead	Printhead removal
NS	009N01757	1	1	Spring parts pack <ul style="list-style-type: none">• Transfer module springs (2)• Printhead spring• Printhead bracket	–

Assembly 4: Paper Feed

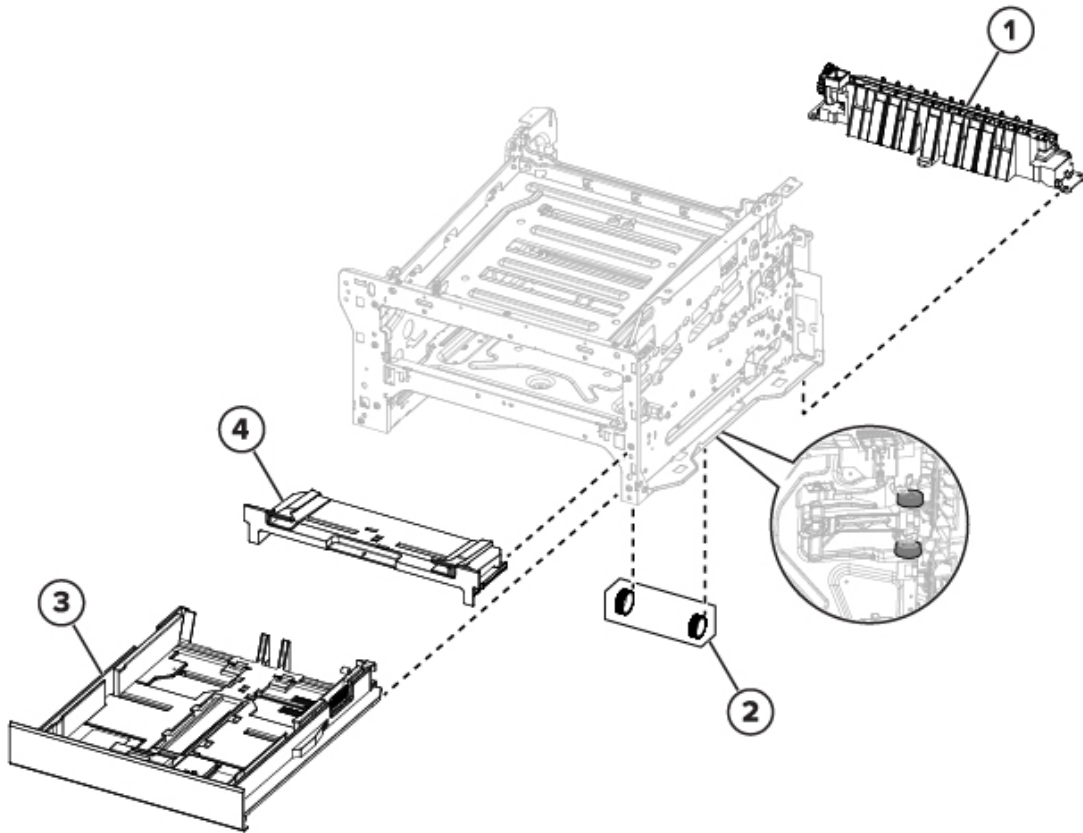

Asm-index	P/N	Units/mach	Units/FRU	Description	Removal procedure
1	030N00828	1	1	Separator bracket	Separator bracket removal
2	022N02905	2	2	Pick tires	Pick tire removal
3	050N00710	1	1	Tray insert	–
4	022N02899	1	1	Manual feeder	–

Assembly 5: Sensors

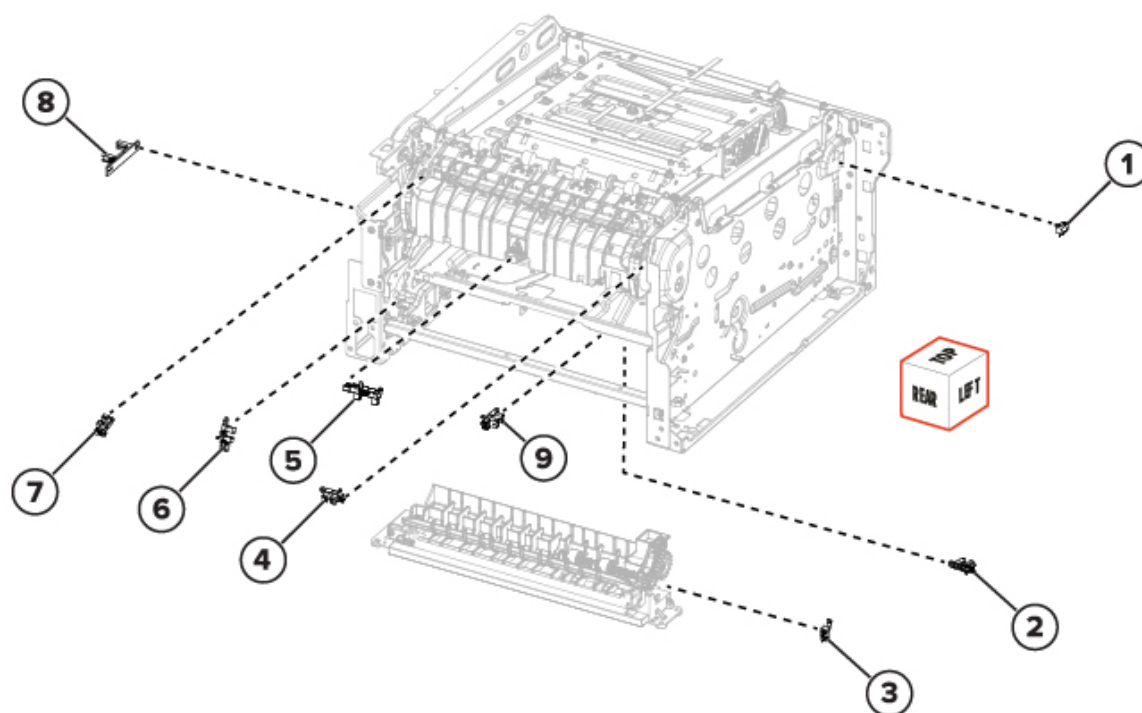

Asm-index	P/N	Units/mach	Units/FRU	Description	Removal procedure
1	110N01560	1	1	Printhead interlock switch	Printhead interlock switch removal
2	130N01897	1	1	Sensor (manual feeder)	Sensor (manual feeder) removal
3	110N01561	1	1	Tray interlock switch	Tray interlock switch removal
4	130N01897	1	1	Sensor (fuser exit)	Sensor (fuser exit) removal
5	130N01895	1	1	Sensor (fuser buckle)	Sensor (fuser buckle) removal
6	130N01897	1	1	Sensor (input)	Sensor (input) removal
7	130N01897	1	1	Sensor (bin/narrow media)	Sensor (bin/narrow media) removal

Parts Catalog

Asm-index	P/N	Units/mach	Units/FRU	Description	Removal procedure
8	130N01904	1	1	Sensor (waste toner bottle)	Sensor (waste toner bottle) removal
9	130N01897	1	1	Sensor (tray near empty)	Sensor (tray Near Empty) Removal

Assembly 6: Electronics

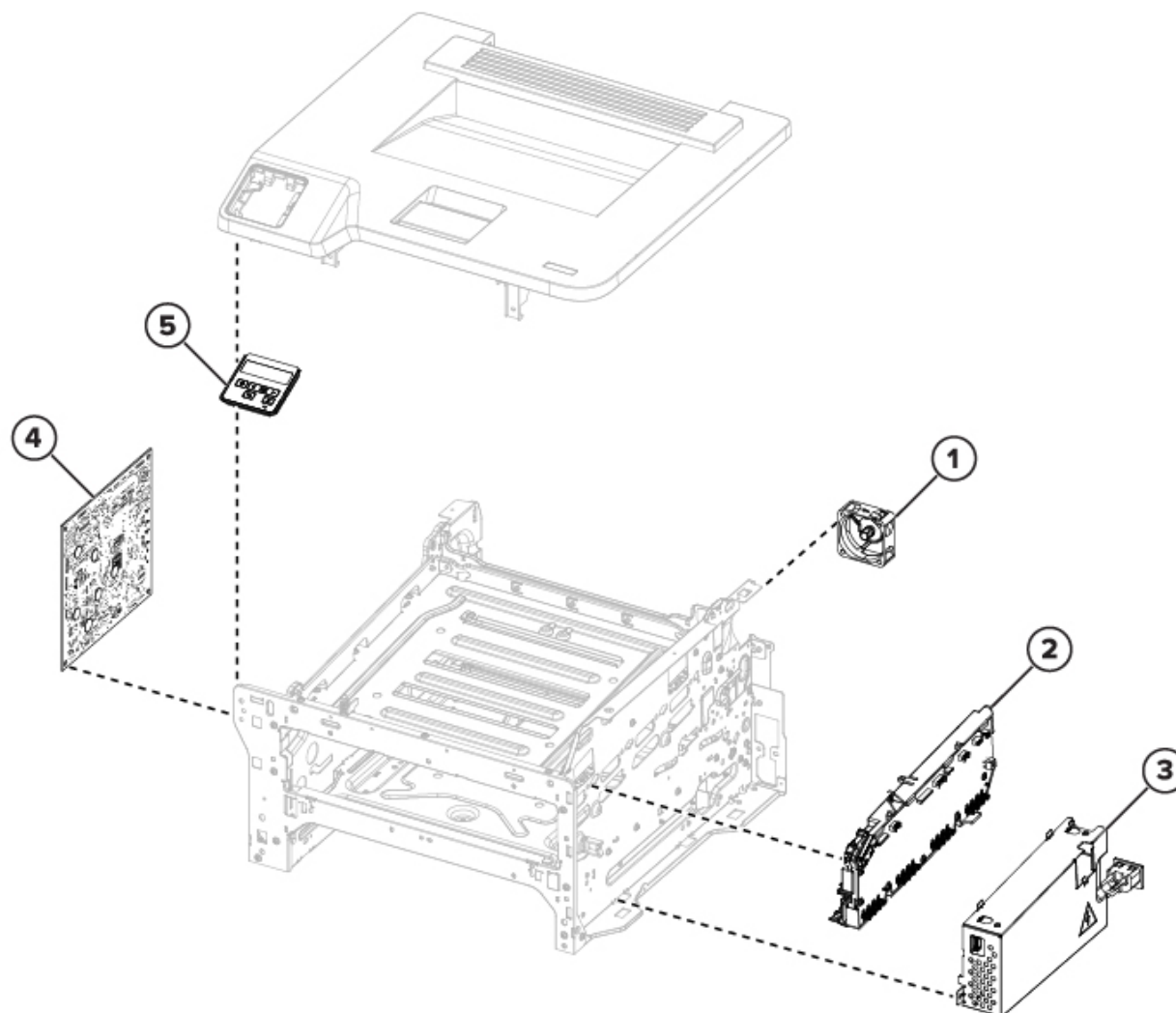

Asm-index	P/N	Units/mach	Units/FRU	Description	Removal procedure
1	127N07967	1	1	Exhaust fan	Exhaust Fan Removal
2	112N00259	1	1	HVPS	HVPS removal
3	112N00260	1	1	LVPS, 220 V	LVPS removal
3	112N00261	1	1	LVPS, 110 V	LVPS removal
4	109N00865	1	1	Controller board	Controller board removal
5	123N00292	1	1	Control panel (2-line display)	Control panel removal

Parts Catalog

Asm-index	P/N	Units/mach	Units/FRU	Description	Removal procedure
NS	117N02195	1	1	Flat cables	–
NS	117N02194	1	1	Cable parts pack <ul style="list-style-type: none"> • Cable harness • Motor cable • USB cable • Pick clutch cable • Staging clutch cable • TPS cable • Fuser motor cable • Fuser thermistor cable • Waste toner bottle sensor cable • LVPS cable • Speaker 	–

Assembly 7: 250-sheet Tray Options

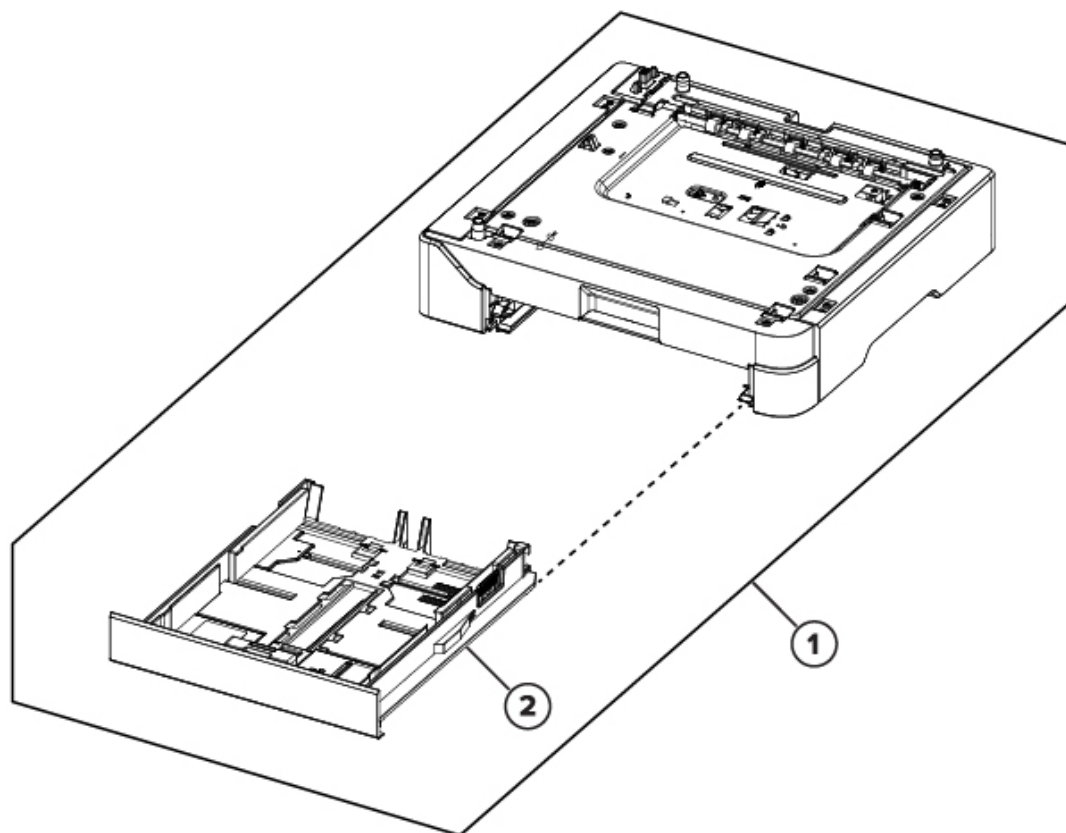

Asm-index	P/N	Units/mach	Units/FRU	Description	Removal procedure
1	—	1	1	Optional 250-sheet tray	Optional 250-sheet tray removal
2	050N00710	1	1	250-sheet tray insert	-

Printer Specifications

Power Consumption

Product Power Consumption

The following table documents the power consumption characteristics of the product.

 **Note:** Some modes may not apply to your product.

Mode	Description	Power consumption (Watts)
Printing	The product is generating hard-copy output from electronic inputs.	One-sided: 385 Two-sided: 260
Copy	The product is generating hard-copy output from hard-copy original documents.	N/A
Scan	The product is scanning hard-copy documents.	N/A
Ready	The product is waiting for a print job.	15.5
Sleep Mode	The product is in a high-level energy-saving mode.	0.86
Hibernate	The product is in a low-level energy-saving mode.	N/A
Off	The product is plugged into an electrical outlet, but the power switch is turned off.	0.1

The power consumption levels listed in the previous table represent time-averaged measurements. Instantaneous power draws may be substantially higher than the average.

Values are subject to change. See <https://www.xerox.com> for current values.

Sleep Mode

This product is designed with an energy-saving mode called *Sleep Mode*. The Sleep Mode saves energy by lowering power consumption during extended periods of inactivity. The Sleep Mode is automatically engaged after this product is not used for a specified period of time, called the *Sleep Mode Timeout*.

Factory default Sleep Mode Timeout for this product (in minutes):	15
-------------------------------------------------------------------	----

By using the configuration menus, the Sleep Mode Timeout can be modified between 1 minute and 120 minutes. If the A4 print speed is less than or equal to 30 pages per minute, then you can set the timeout only up to 60 minutes. Setting the Sleep Mode Timeout to a low value reduces energy consumption, but may increase the response time of the product. Setting the Sleep Mode Timeout to a high value maintains a fast response, but uses more energy.

Hibernate Mode

This product is designed with an ultra-low power operating mode called *Hibernate mode*. When operating in Hibernate Mode, all other systems and devices are powered down safely.

The Hibernate mode can be entered in any of the following methods:

- Using the Hibernate Timeout
- Using the Schedule Power modes

Factory default Hibernate Timeout for this product in all countries or regions	3 days
--------------------------------------------------------------------------------	--------

The amount of time the printer waits after a job is printed before it enters Hibernate mode can be modified between one hour and one month.

Off Mode

If this product has an off mode which still consumes a small amount of power, then to completely stop product power consumption, disconnect the power supply cord from the electrical outlet.

Total Energy Usage

It is sometimes helpful to estimate the total product energy usage. Since power consumption claims are provided in power units of Watts, the power consumption should be multiplied by the time the product spends in each mode in order to calculate energy usage. The total product energy usage is the sum of each mode's energy usage.

Selecting A Location For The Printer

- Leave enough room to open trays, covers, and doors and to install hardware options.
- Make sure that airflow in the room meets the latest revision of theASHRAE 62 standard or the CEN Technical Committee 156 standard.
- Provide a flat, sturdy, and stable surface.
- Keep the printer:
 - Clean, dry, and free of dust
 - Away from stray staples and paper clips
 - Away from the direct airflow of air conditioners, heaters, or ventilators
 - Free from direct sunlight and humidity extremes
- Observe the temperature range.

Operating temperature	10 to 32.2°C (50 to 90°F)
-----------------------	---------------------------

- Allow the following recommended amount of space around the printer for proper ventilation:

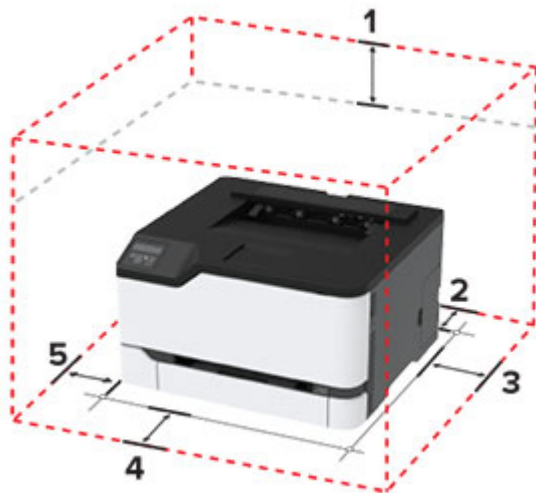

1	Top	101 mm (4 in.)
2	Rear	102 mm (4 in.)
3	Right side	76 mm (3 in.)
4	Front	76 mm (3 in.)
5	Left side	76 mm (3 in.)

Noise Emission Levels

The following measurements were made in accordance with ISO 7779 and reported in conformance with ISO 9296.

 **Note:** Some modes may not apply to your product.

1-meter average sound pressure, dBA	
Printing	One-sided: 52 Two-sided: 50
Ready	14

Values are subject to change. See <https://www.xerox.com> for current values.

Temperature Information

Operating temperature and relative humidity	10° to 32.2° C (50° to 90° F) and 15 to 80 % RH 15.6° to 32.2° C (60° to 90° F) and 8 to 80 % RH Maximum wet-bulb temperature ² : 22.8° C (73° F) Non-condensing environment
Printer / cartridge / imaging unit long-term storage ¹	15.6° to 32.2° C (60° to 90° F) and 8 to 80 % RH Maximum wet-bulb temperature ² : 22.8° C (73° F)
Printer / cartridge / imaging unit short-term shipping	-40° to 40° C (-40° to 104° F)
<p>¹ Supplies shelf life is approximately 2 years. This is based on storage in a standard office environment at 22° C (72° F) and 45 % humidity.</p> <p>² Wet-bulb temperature is determined by the air temperature and the relative humidity.</p>	

Theory Of Operation

Paper Path and Drive Components

Paper Path Summary

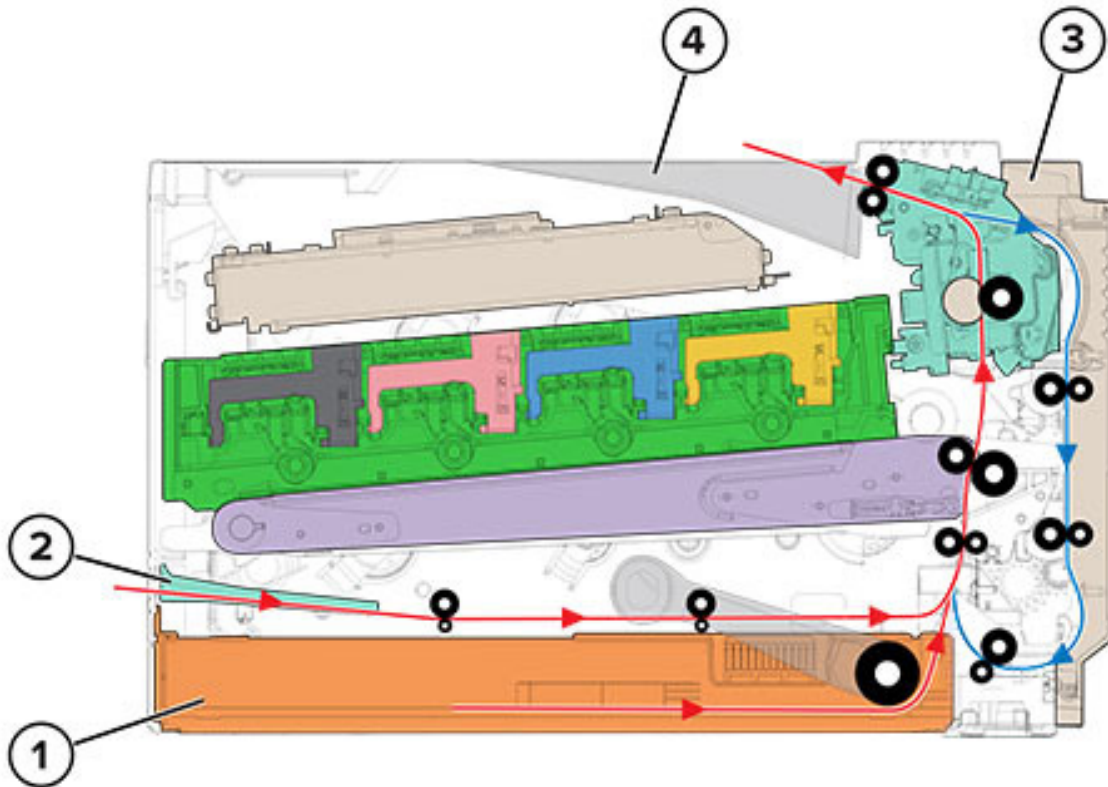

1	Tray
2	Manual feeder
3	Rear door
4	Bin

The printer has a C-shaped paper path. The standard paper path is shown in red.

Paper is fed from the front of the printer and transported upward through the rear of the printer.

The duplex unit is built into the rear door. The duplex paper path is shown in blue.

The manual feeder is above the tray at the front of the printer. The paper path is also shown in red.

Drive Components

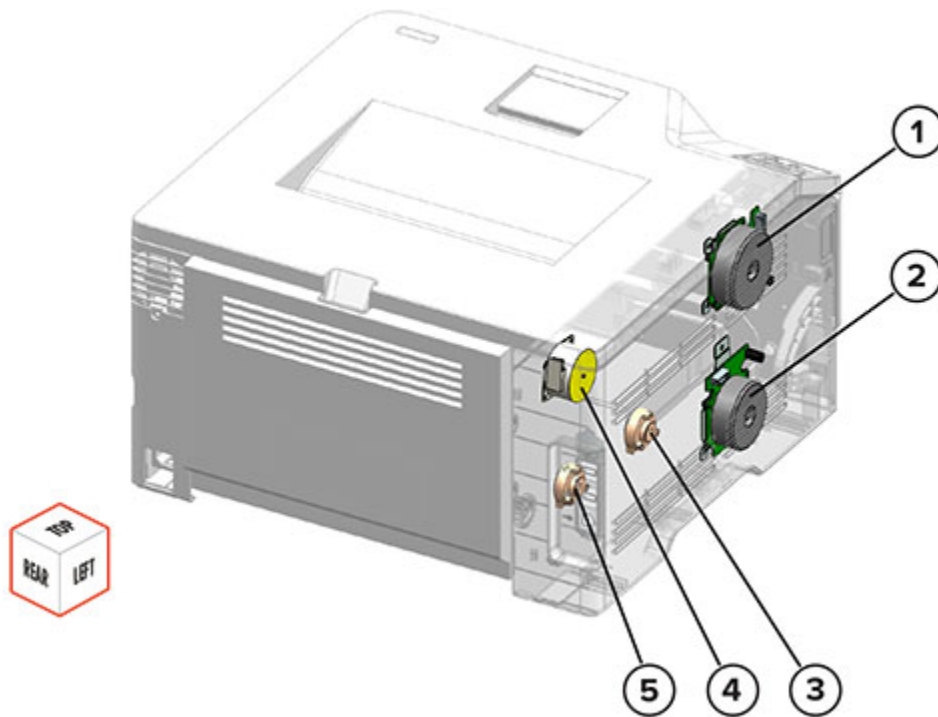

1	Motor (CMY)
2	Motor (K/transfer belt)
3	Pick clutch
4	Motor (fuser)
5	Staging clutch

When a print job is sent to the printer, the printhead motor initiates and the fuser starts to heat. After the printhead motor reaches speed, the CMY and K motors begin turning to start the EP process. For more information, see [EP process](#).

Paper Staging

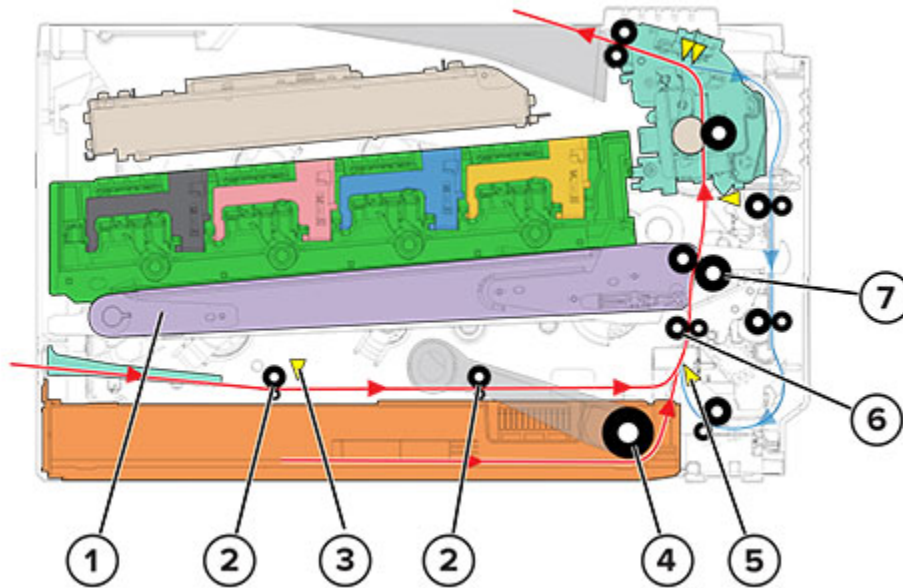

1	Transfer belt
2	Manual feeder rollers
3	Sensor (manual feeder)
4	Pick roller
5	Sensor (input)
6	Input roller
7	Second transfer roller

After the image is placed on the transfer belt, the image moves toward the second transfer roller. The leading-edge position of the image is tracked. When the leading edge of the image reaches a predetermined point, the pick clutch is energized and a sheet of paper is picked. The staging clutch is energized next, and then the paper moves to meet the image. When the paper reaches the sensor (input), the print engine calculates the image position on the belt relative to the paper position. If the paper is early, then the staging clutch is turned off until the image is in the correct position. When the image and paper are aligned, the staging clutch is energized and the input rollers move the paper to the second transfer roller nip to do the second transfer.

Fuser and Exit

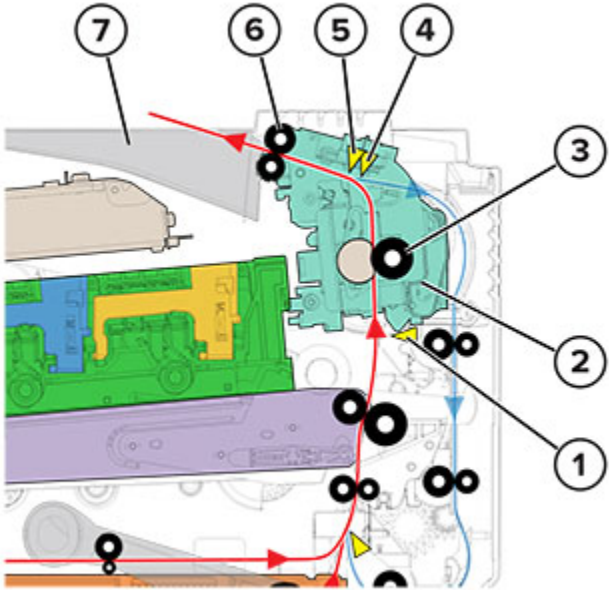

1	Sensor (fuser buckle)
2	Fuser
3	Fuser roller
4	Sensor (fuser exit)
5	Sensor (bin/narrow media)
6	Exit roller
7	Bin

After the second transfer, the paper is fed to the fuser. When the paper hits the fuser rollers, it buckles before passing through. The sensor (fuser buckle) detects the buckle. If the buckle is too great, then the motor (fuser) speeds up to avoid causing a paper jam. If the buckle is too small, then the motor slows to avoid smearing the image. After the image is fused, the paper passes through the sensor (fuser exit) and exits. Before the paper reaches the bin, it triggers the sensor (bin/narrow media). If narrow media is being run, then the printer may slow down after several sheets to avoid damaging the fuser. If narrow media is being run but the printer is set for wide media, then the printer may stop and post a paper size mismatch message. If the bin is overfilled when running narrow media, then paper jams may occur.

Duplexing

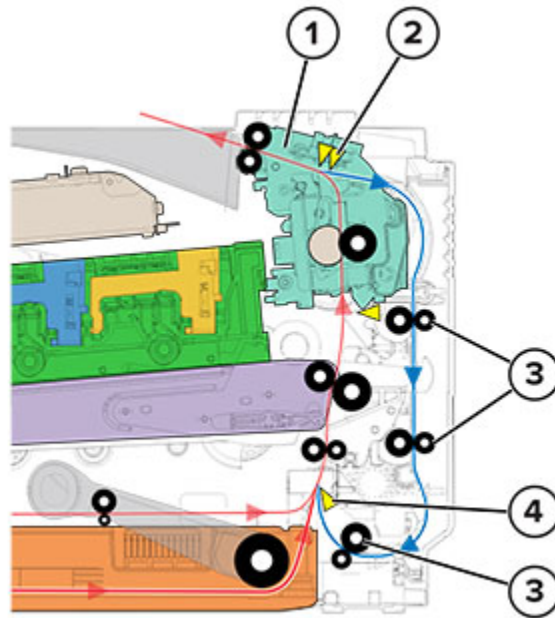

1	Fuser
2	Sensor (fuser exit)
3	Duplex rollers
4	Sensor (input)

Printers with duplex support use a secondary paper path, shown in blue, to print on the second side of a sheet of paper. The duplexing process is summarized as follows:

1. After the first side of the paper is printed and the trailing edge of the paper clears the sensor (fuser exit), the motor (fuser) reverses direction to feed the paper into the duplex unit.

 **Note:** While the sheet is being transported through the duplex unit, it is the only sheet of paper processed by the print engine. Inserting a sheet of paper into the manual feeder while a duplex job is processed causes a paper jam.

2. When the trailing edge of the paper clears the fuser, the motor (fuser) rotates forward to prepare the fuser for the page traveling from the duplex unit.
3. The duplex rollers transport the paper along the duplex unit. The staging clutch drives the rollers.
4. When the paper reaches the sensor (input), it follows the standard paper path again to print on the second side.

Power Supply Operation

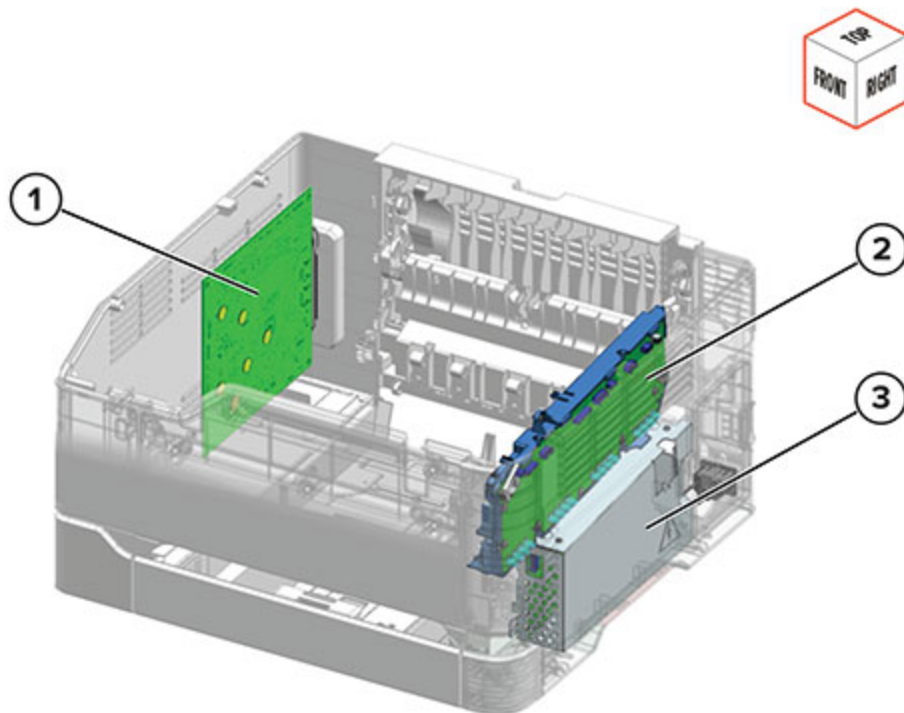

1	Controller board
2	HVPS
3	LVPS

The LVPS (low voltage power supply) powers the printer. It converts the power from the AC outlet to controlled AC and DC outputs.

LVPS outputs	Description
AC output	Powers the fuser heater.
25 V / 7 V DC output	Powers the logic type loads. <ul style="list-style-type: none"> • During Idle/Ready and Print modes, the output is 25V. • During Sleep and Hibernate modes, the output is about 7.5V.
25 V_SW DC output	Powers the electromechanical loads like the motors and the HVPS. <ul style="list-style-type: none"> • During Idle/Ready and Print modes, the output is 25V. • During Sleep and Hibernate modes, the output is 0V.

The HVPS (high voltage power supply) converts the DC output from the LVPS to controlled outputs

Theory Of Operation

used during the EP process.

Electrophotographic (EP) Process Theory

EP Process Summary

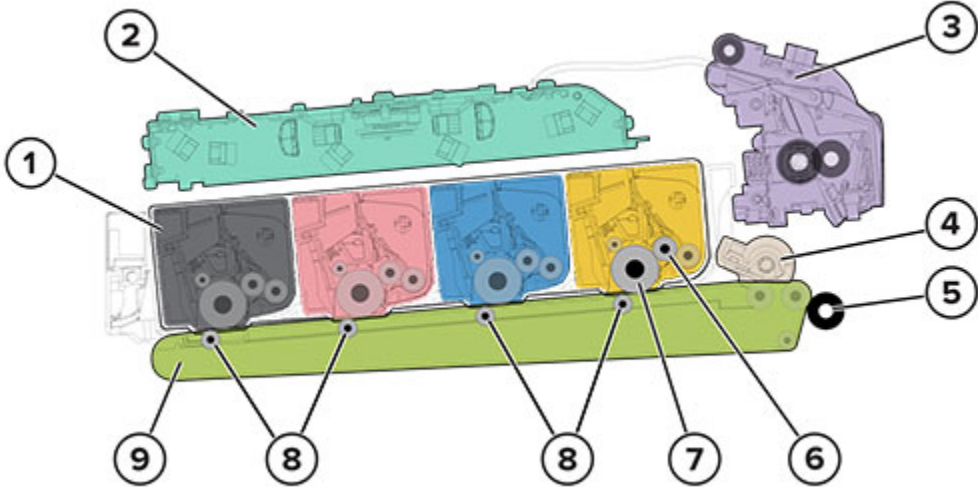

1	Print cartridge
2	Printhead
3	Fuser
4	Cleaner
5	Second transfer roller
6	Developer roller
7	Photoconductor drum
8	First transfer rollers
9	Transfer belt

This single-laser printer uses four print cartridges (cyan, yellow, magenta, and black) to create text and images on paper.

The photoconductor drums, developer rollers, and toner supplies are built into the print cartridges.

The transfer belt passes under the four photoconductor drums to produce and transfer the four-color image to the paper in one pass.

 **Note:** The transfer belt and second transfer roller are parts of the transfer module.

During the printing process, the printer follows the six basic steps of the EP process to create its output to the page.

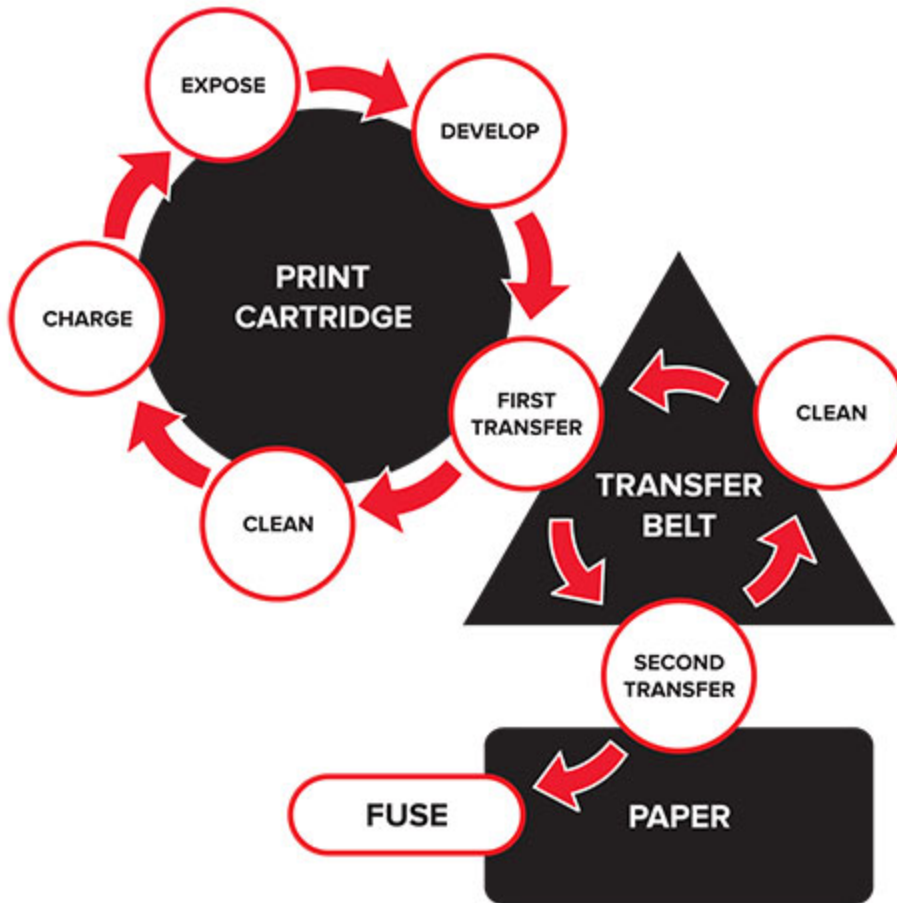

1. Charge the photoconductor drums.
2. Expose the photoconductor drums with the laser.
3. Develop toner on the photoconductor drums.
4. Do the *First transfer* to the transfer belt, and the *Second transfer* to the paper.
5. Fuse the toner to the paper.
6. Clean/Erase the photoconductor drums and the transfer belt.

The printer controller board receives the print data and print command. The controller board then initiates the print process. The controller board is the command center for the EP process and it coordinates the various motors and signals. The HVPS sends voltage to various components in the EP process. A laser contacts each photoconductor drum and alters the surface charge relative to the image. Each photoconductor drum rotates past its respective developer roller, and toner is developed

on its surface. The four separate color images are then transferred to the transfer belt. After the image is transferred to the transfer belt, the photoconductor drums are cleaned and recharged. The transfer belt carries the four-colored image toward the second transfer roller. The timing of the paper pick is determined by the position of the leading edge of the image on the transfer belt. For more information, see the Paper staging section on [Drive components](#).

Paper is carried to the fuser rollers where heat and pressure are applied to the page to bond permanently the toner to the page. The fuser exit roller driven by the motor (fuser) pushes the paper into the bin. The transfer belt is cleaned and the process begins again for the next page.

EP Process

Charge

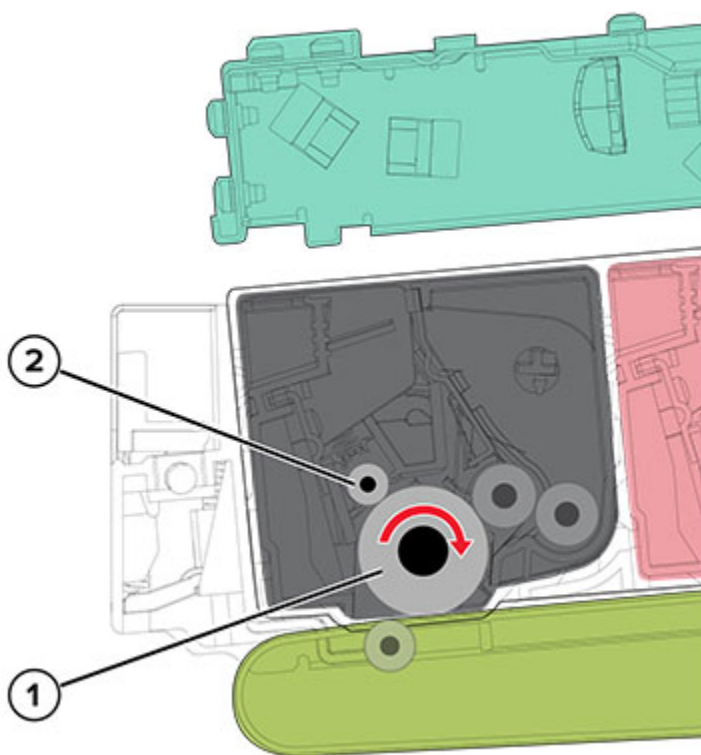

1	Photoconductor drum
2	Charge roller

During the charge step, voltage is sent from the HVPS to the charge roller on each of the four photoconductor drums. In this printer, the charge roller is part of the print cartridge.

The charge roller puts a uniform negative charge over the entire surface of the photoconductor drum to prepare it for the laser beam.

Expose

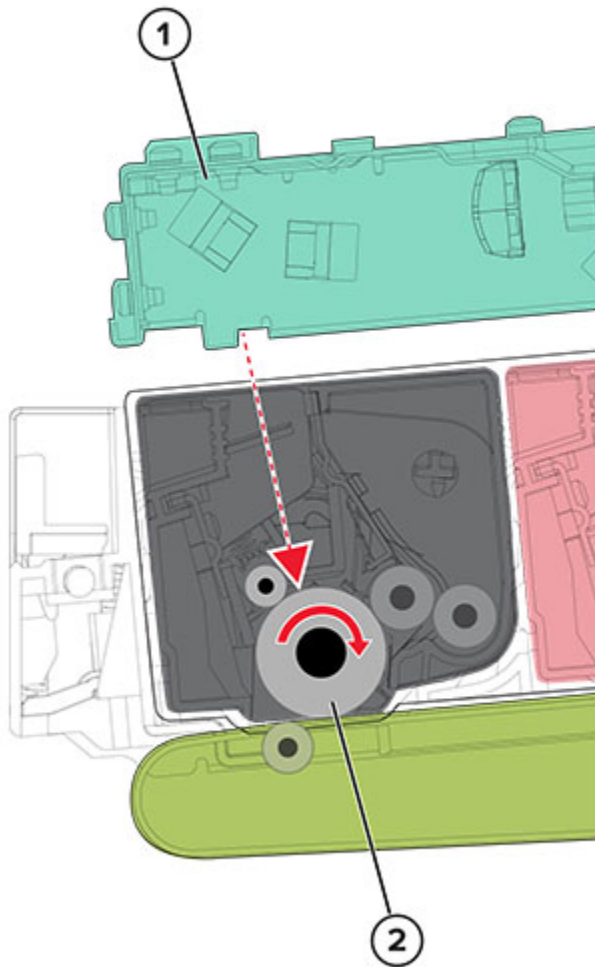

1	Printhead
2	Photoconductor drum

During the expose step, the printhead laser fires a focused beam of light at the surface of each photoconductor drum and writes an invisible image. The image formed for each color is called a latent image or electrostatic image.

The laser beam discharges only the surface where the beam hits the photoconductor drum. This discharge creates a difference in charge potential between the exposed area and the rest of the photoconductor drum surface.

Develop

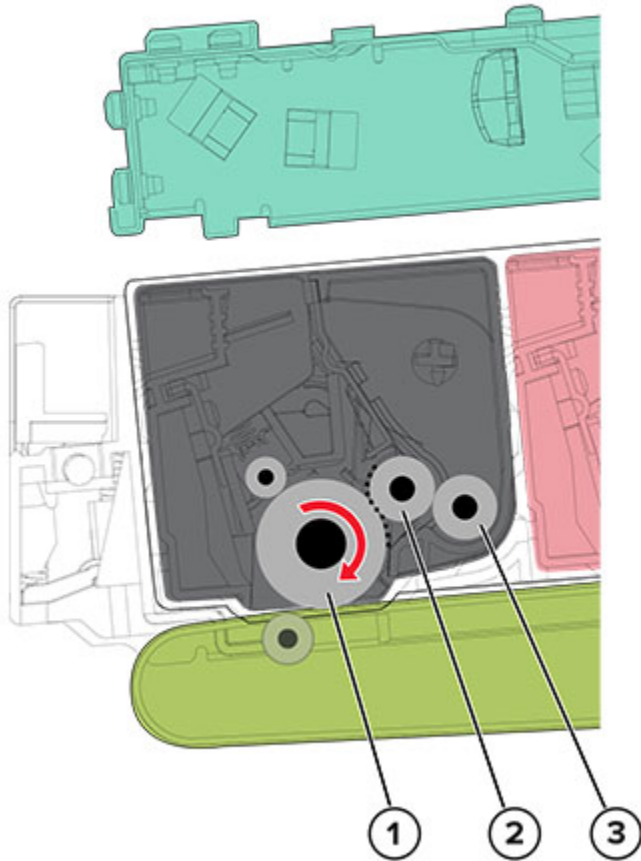

1	Photoconductor drum
2	Developer roller
3	Toner add roller

When the laser exposes the photoconductor drum in the print cartridge, the HVPS sends charge to the developer roller. For each color, the print cartridge engages the photoconductor drum so it is in contact with the developer roller. Because of the charge difference, the toner is attracted to areas of the photoconductor drum surface exposed by the laser.

This process is similar to using glue to write on a can, and then rolling the can over glitter. The glitter sticks to the glue but does not stick to the rest of the can.

First Transfer

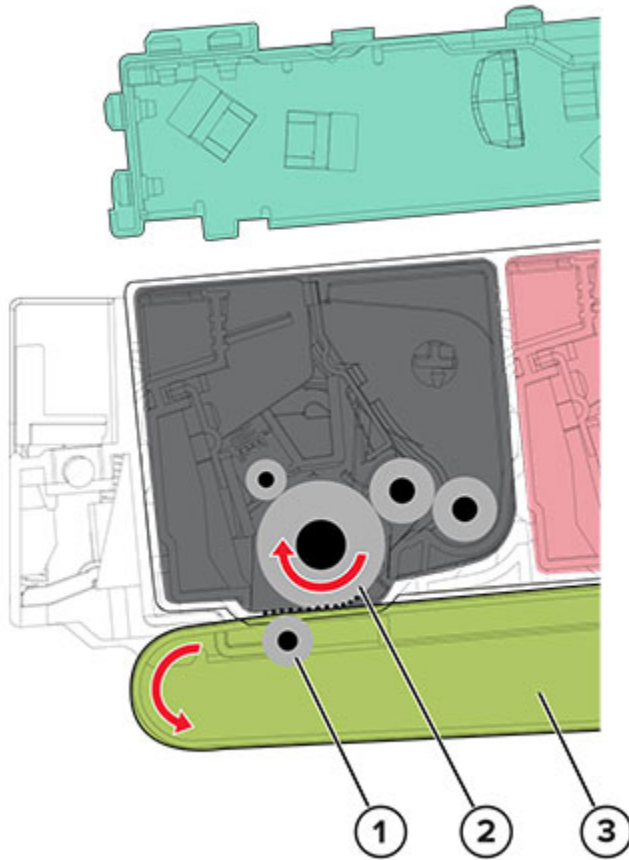

1	First transfer roller
2	Photoconductor drum
3	Transfer belt

When the latent images are developed on each photoconductor drum, the HVPS sends voltage to the first transfer rollers inside the transfer belt.

For each color, the charge difference between the developed toner image on the photoconductor drum surface and the first transfer roller causes the images to transfer to the surface of the transfer belt. This transfer occurs during a direct surface-to-surface contact between the photoconductor drum and the transfer belt.

Second Transfer

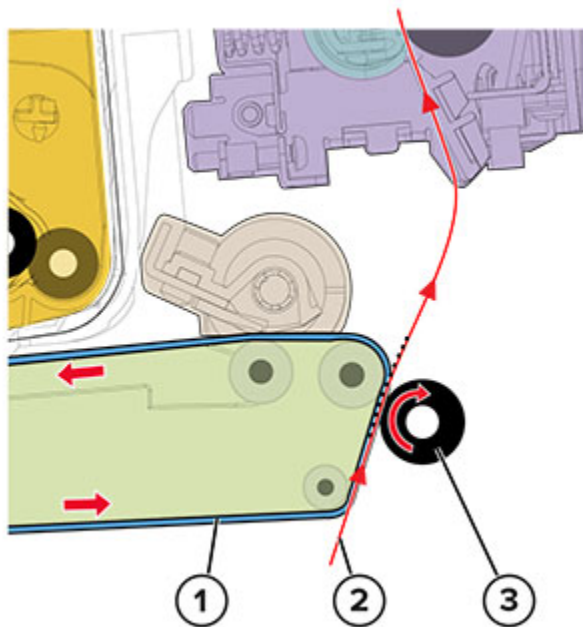

1	Transfer belt
2	Paper
3	Second transfer roller

On the transfer belt, the four-color image is carried toward the second transfer roller. When the image on the transfer belt reaches a predetermined point, the paper pick is timed so that the paper is at the exact position between the transfer belt and second transfer roller. For more information, see the Paper staging section on [Drive components](#).

The HVPS sends voltage to the second transfer roller to create a positive charge. When the image on the transfer belt reaches the second transfer roller, the negatively charged toner clings to the paper. The entire image is then transferred from the transfer belt to the paper.

Fuse

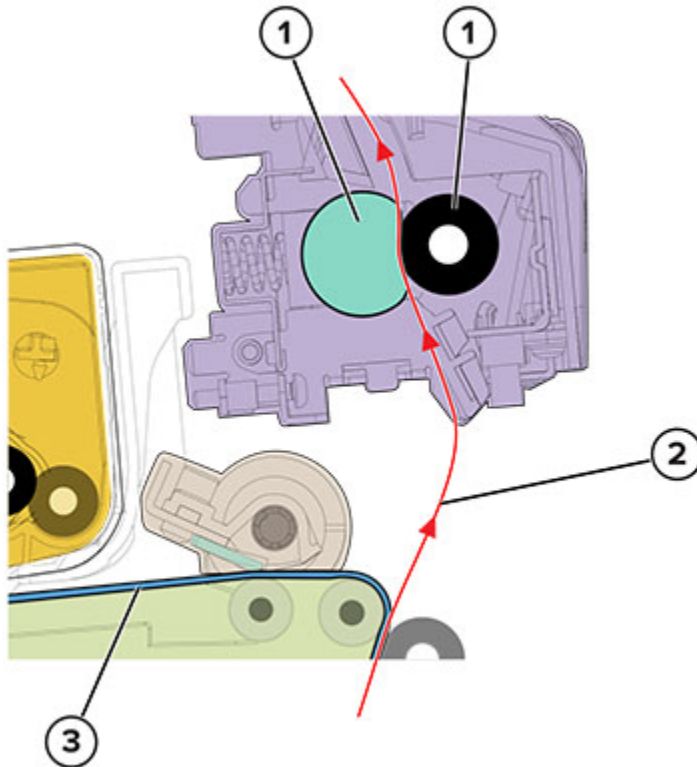

1	Fuser rollers
2	Paper
3	Transfer belt

With the help of the transfer roller, the paper with the image moves into the fuser area.

The fuser applies heat and pressure to the page to melt the toner particles and bond them permanently to the paper. The fuser moves the paper to the exit rollers which move the paper to the bin.

Clean/erase

Two cleaning processes take place during the EP process. Both processes remove the residual toner from the system.

Transfer belt clean

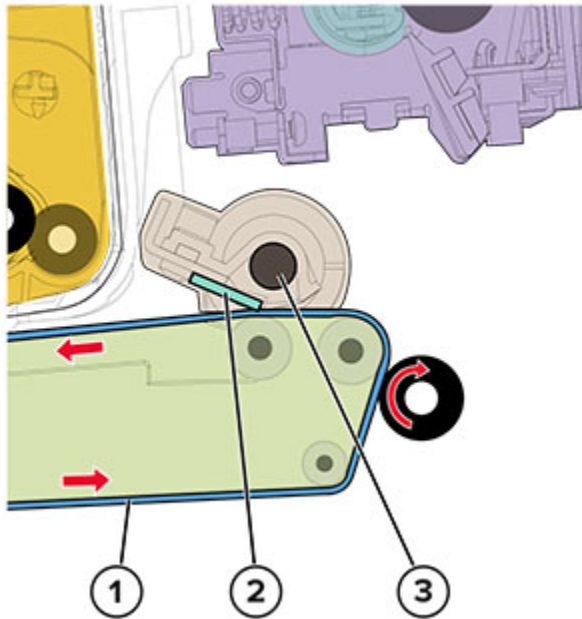

1	Transfer belt
2	Cleaning blade
3	Auger

When the toner image on the transfer belt is transferred to the page, the transfer belt rotates and gets cleaned by the cleaning blade. The cleaning occurs for every page that is printed.

The removed toner is moved to the waste toner bottle using a rotating auger.

Photoconductor drum clean/erase

Theory Of Operation

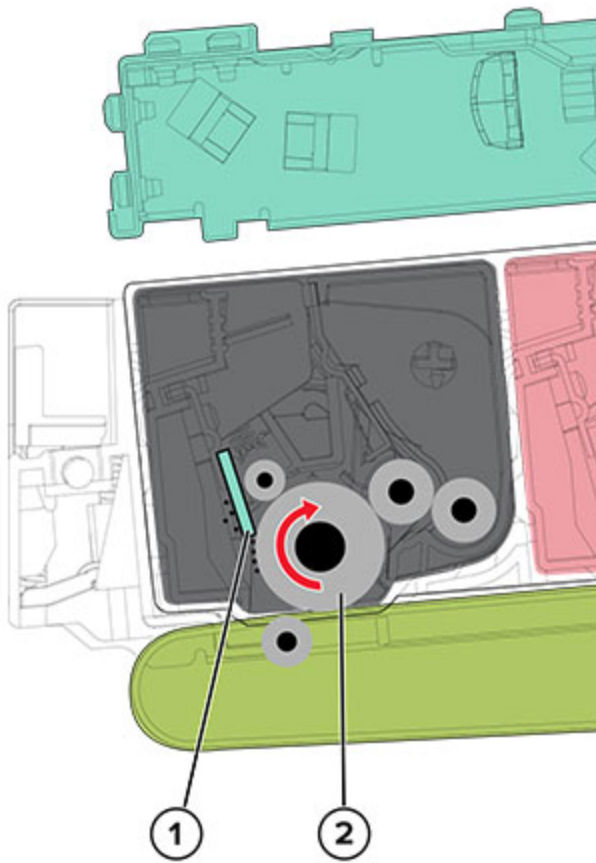

1	Cleaning blade
2	Photoconductor drum

After each plane of color is transferred to the transfer belt from the photoconductor drums, a cleaning blade scrapes the remaining toner from the surface of each photoconductor drum.

The photoconductor drum surface is prepared to restart the EP process. This cleaning/erasing cycle happens after each plane of color is transferred to the transfer belt.

Part Number Index

P/N	Part name
002N03387	Inner front cover
002N03398	Lower front cover kit
002N03404	Top cover
002N03406	Front door
002N03407	Left cover
002N03408	Right cover
002N03425	Rear door
005N01213	Pick clutch
005N01213	Staging clutch
007N01853	Gearbox
008R13326	Waste toner bottle
009N01757	Spring parts pack
017N00312	Rubber feet
022N02899	Manual feeder
022N02905	Pick tires
023N01404	Staging belt, gear, and pulley
030N00828	Separator bracket
046N00242	Printhead
050N00710	Tray insert
050N00710	250-sheet tray insert
050N00712	Print cartridge tray
056N00218	Bezel
109N00865	Controller board
110N01560	Printhead interlock switch
110N01561	Tray interlock switch
112N00259	HVPS
112N00260	LVPS, 220 V
112N00261	LVPS, 110 V

Part Number Index

P/N	Part name
117N02194	Cable parts pack
117N02195	Flat cables
120N00572	Bin flag
123N00292	Control panel (2-line display)
126N00452	Fuser, 110 V
126N00453	Fuser, 220 V
127N07962	Motor (K)
127N07963	Motor (fuser)
127N07964	Motor (CMY)
127N07967	Exhaust fan
130N01895	Sensor (fuser buckle)
130N01897	Sensor (manual feeder)
130N01897	Sensor (fuser exit)
130N01897	Sensor (input)
130N01897	Sensor (bin/narrow media)
130N01897	Sensor (tray near empty)
130N01904	Sensor (waste toner bottle)
133N23276	Transfer module

Part Name Index

P/N	Part name
050N00710	250-sheet tray insert
056N00218	Bezel
120N00572	Bin flag
117N02194	Cable parts pack
123N00292	Control panel (2-line display)
109N00865	Controller board
127N07967	Exhaust fan
117N02195	Flat cables
002N03406	Front door
126N00452	Fuser, 110 V
126N00453	Fuser, 220 V
007N01853	Gearbox
112N00259	HVPS
002N03387	Inner front cover
002N03407	Left cover
002N03398	Lower front cover kit
112N00261	LVPS, 110 V
112N00260	LVPS, 220 V
022N02899	Manual feeder
127N07964	Motor (CMY)
127N07963	Motor (fuser)
127N07962	Motor (K)
005N01213	Pick clutch
022N02905	Pick tires
050N00712	Print cartridge tray
046N00242	Printhead
110N01560	Printhead interlock switch
002N03425	Rear door

Part Name Index

P/N	Part name
002N03408	Right cover
017N00312	Rubber feet
130N01897	Sensor (bin/narrow media)
130N01895	Sensor (fuser buckle)
130N01897	Sensor (fuser exit)
130N01897	Sensor (input)
130N01897	Sensor (manual feeder)
130N01897	Sensor (tray near empty)
130N01904	Sensor (waste toner bottle)
030N00828	Separator bracket
009N01757	Spring parts pack
023N01404	Staging belt, gear, and pulley
005N01213	Staging clutch
002N03404	Top cover
133N23276	Transfer module
050N00710	Tray insert
110N01561	Tray interlock switch
130N01897	Tray near empty sensor cable
008R13326	Waste toner bottle

Wiring Diagram (C230)

Wiring Diagram (C230)

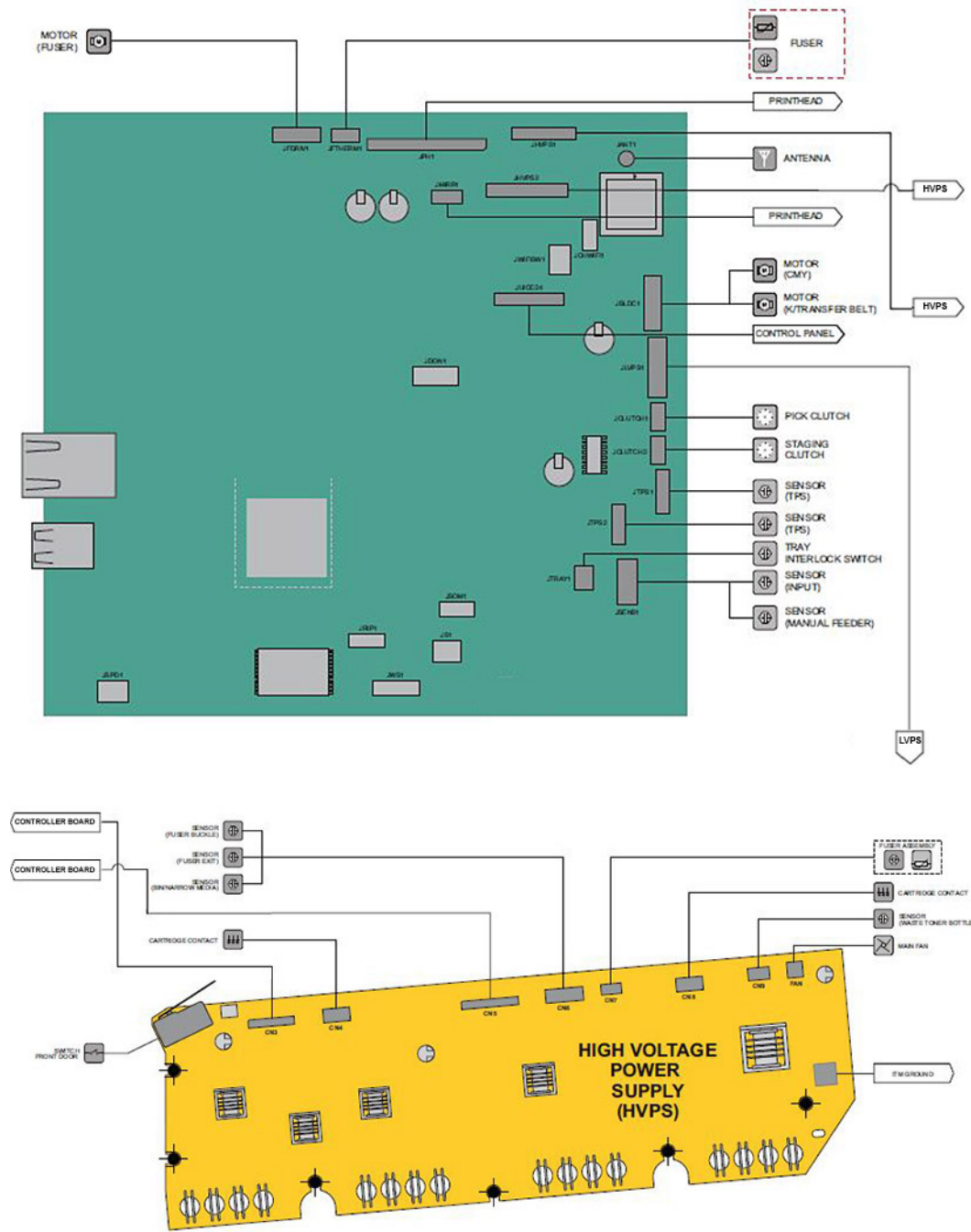

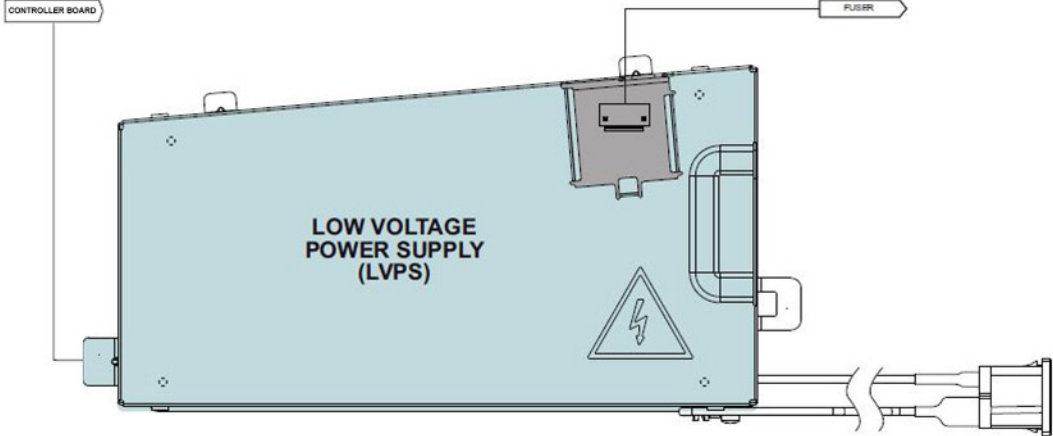

Wiring Diagram (C230)

