

3000-Sheet High-Capacity Feeder Service Manual

Initial Issue

Dynamic Rules

Dynamic Rules

Book Configuration

Book Configuration..... ii

Book Configuration

PURPOSE

This procedure can be utilized to set certain browser variables. These variables are used in the EDOC to display pertinent information or hide information not applicable to the present configuration.

Languages

Select a language or languages in which to display **Warnings**

Choices

- ◆ English
- ◆ Français (French)
- ◆ Italiano (Italian)
- ◆ Deutsch (German)
- ◆ Español (Spanish)

Results



WARNING: English Warnings will be displayed.

Les avis de DANGER sont affichés en français.

I messaggi di pericolo verranno visualizzati in italiano.

Es werden Warnhinweise in Deutsch angezeigt.

Se mostrarán avisos en Español.

3000-Sheet High-Capacity Feeder

Service Documentation

3000-Sheet High-Capacity Feeder Service Manual

705P01443

Initial Issue

March 2020

Prepared For:

Xerox Corporation

800 Phillips Road

Webster, New York, 14580

©2020 Xerox Corporation. All rights reserved. Xerox®, Xerox®, and Design are trademarks of Xerox Corporation in the United States and/or other countries.

NOTICE

All service documentation is supplied to Xerox external customers for informational purposes only. Xerox service documentation is intended for use by certified, product trained service personnel only. Xerox does not warrant or represent that it will notify or provide to such customer any future change to this documentation. Customer performed service of equipment, or modules, components or parts of such equipment may affect whether Xerox is responsible to fix machine defects under the warranty offered by Xerox with respect to such equipment. You should consult the applicable warranty for its terms regarding customer or third-party provided service.

While every care has been taken in the preparation of this manual, no liability will be accepted by Xerox arising out of any inaccuracies or omissions.

Other company trademarks are also acknowledged.

About This Manual	ii
How to Use this Documentation.....	ii
Safety Informationiii
Health and Safety Incident Reporting.....	v
Translated Warningsvi

About This Manual

This Service Manual is part of the multinational documentation system for this copier/printer accessory. The Service Documentation is used in order to diagnose machine malfunctions, adjust components and has information which is used to maintain the product in superior operating condition. It is the controlling publication for a service call. Information on its use is found in the Introduction of the Service Documentation.

Service Manual Revision

The Service Manual will be updated as the machine changes or as problem areas are identified.

Organization

The titles of the sections and a description of the information contained in each section are contained in the following paragraphs:

Section 1 Service Call Procedures

This section is used to start and complete a service call. The procedures in this section will either direct you to a Repair Analysis Procedure (RAP), or identify a faulty component or subassembly. For this accessory manual, the strategy is to utilize the Service Call Procedures in the IOT manual.

Section 2 Status Indicator Repair Analysis Procedures

This section contains the Repair Analysis Procedures (RAPs) and checkouts necessary to diagnose, isolate and repair faults other than image quality faults.

Section 3 Image Quality

The Service Documentation for this accessory does not include an Image Quality section.

Section 4 Repairs/Adjustments

This section contains the instructions for removal, replacement, and adjustment of parts within the machine.

Section 5 Parts List

This section contains the detailed and illustrated spare parts list. Any part that is spared or that must be removed to access a spared part is illustrated.

Section 6 General Procedures/Information

This section contains all other procedures, product specifications and general information. It also contains Tag/MOD information.

Section 7 Wiring Data

This section contains drawings, lists of plug/jack locations, and diagrams of the power distribution wire networks in the machine. This section also contains the Block Schematic Diagrams.

How to Use this Documentation

The Service Call Procedures in Section 1 of the IOT manual describe the sequence of activities used during the service call. The call **must** be entered using these procedures.

Fault Codes in Section 2, Status Indicator RAPs, use a leading **0** to indicate if the IOT has a DMP controller or **3** if the IOT has a ConnectKey Controller. This manual defaults to a leading **0**, for example, 012–283.

Warnings, Cautions, and Notes



WARNING: A Warning is used whenever an operating or maintenance procedure, a practice, condition, or statement, if not strictly observed, could result in personal injury.

Une note Danger est utilisée chaque fois qu'une procédure d'utilisation ou de maintenance peut être cause de blessure si elle n'est pas strictement respectée.

Un segnale di avvertenza è utilizzato ogni volta che una procedura operativa o di manutenzione, una pratica, una condizione o un'istruzione, se non strettamente osservata, potrebbe causare lesioni personali.

Weist darauf hin, dass ein Abweichen von den angeführten Arbeits- und Wartungsanweisungen gesundheitliche Schäden, möglicherweise sogar schwere Verletzungen zur Folge haben kann.

Un aviso se utiliza siempre que un procedimiento de operación o mantenimiento, práctica o condición puede causar daños personales si no se respetan estrictamente.



CAUTION: A caution is used whenever an operation or maintenance procedure, practice, condition or statement, if not strictly observed, could result in damage to the equipment.

Note: A note is used where it is essential to highlight a procedure, practice, condition or statement.

Use of the Block Schematic Diagrams

Block Schematic Diagrams (BSDs) are included in Section 7 (Wiring Data) of the Service Manual. The BSDs show the functional relationship of the electrical circuitry to any mechanical, or non-mechanical, inputs or outputs throughout the machine. Inputs and outputs such as motor drive, mechanical linkages, operator actions, and air flow are shown. The BSDs provide an overall view of how the entire subsystem works.

Electrostatic Discharge (ESD) Field Service Kit



The purpose of the ESD Protection Program is to preserve the inherent reliability and quality of electronic components that are handled by the Field Service Personnel. This program is implemented as a direct result of advances in microcircuitry technology, as well as a new acknowledgment of the magnitude of the ESD problem in the electronics industry today.

This program will reduce Field Service costs that are charged to PWB failures. Ninety percent of all PWB failures that are ESD related do not occur immediately. Using the ESD Field Service Kit will eliminate these delayed failures and intermittent problems caused by ESD. This will improve product reliability and reduce callbacks.

The ESD Field Service Kit should be used whenever Printed Wiring Boards or ESD sensitive components are being handled. This includes activities such as replacing or reseating of circuit boards or connectors. The kit should also be used to prevent additional damage when circuit boards are returned for repair.

The instructions for using the ESD Field Service Kit can be found in the ESD Field Service Kit Usage in the General Procedures section of the Service Documentation.

Safety Information

The WARNING that follows is for general guidance when live working.



WARNING: Do not work in a confined space. 1 m (39 inches) space is needed for safe working.

Ne pas travailler dans un espace restreint. 1 mètre d'espace est nécessaire pour un dépannage en toute sécurité.

Non lavorare in uno spazio limitato; è necessario uno spazio di almeno un metro attorno alla macchina per la sicurezza dell'operatore.

Nur mit ausreichendem Bewegungsspielraum (1 m) arbeiten.

No trabaje en un espacio reducido. Se necesita 1 metro de espacio para trabajar con seguridad.

Safety Icons

The safety icons that follow are displayed on the machine:

ESD Caution Symbol



CAUTION: Certain components in this product are susceptible to damage from electrostatic discharge. Observe all ESD procedures to avoid component damage.

Location Arrow Symbol

The location arrow symbol points to the location to install, to gain access to, or to release an object.



Hot Surface Symbol

This symbol indicates hot surfaces. Take care when servicing the machine.



Lethal Voltage Symbol

This symbol indicates potentially lethal voltages. Take care when servicing the machine when the power cord is connected.



Toner Cartridge

The product contains a toner cartridge that is recyclable. Under various state and local laws, it may be illegal to dispose of the cartridge into the municipal waste. Check with the local waste officials for details on recycling options or the proper disposal procedures.

Fuses



WARNING: Do not install a fuse of a different type or rating. Installing the wrong type or rating of fuse can cause overheating and a risk of fire.

Ne pas installer de fusible de type ou de calibre différent. Il existe un risque de surchauffe voire d'incendie.

Per evitare rischi di surriscaldamento o d'incendio, non installare un fusibile di tipo o carica diversi da quelli esistenti.

Keine Sicherungen anderer Art oder anderer Leistung auf dem IOT-PWB installieren - Überhitzungs- und Brandgefahr.

No instale un fusible de potencia o tipo distinto. Un fusible de potencia o tipo distinto puede producir sobrecalentamiento y el riesgo de incendio.

Part Replacement

Only use genuine Xerox approved spare parts or components to maintain compliance with legislation and safety certification. Also refer to Restriction of Hazardous Substances (RoHS) in the IOT manual.

Disassembly Precautions

Do not leave the machine with any covers removed at a customer location.

Reassembly Precautions

Use extreme care during assembly. Check all harnesses to ensure they do not contact moving parts and do not get trapped between components.

General Procedures

Observe all warnings displayed on the machine and written in the service procedures. Do not attempt to perform any task that is not specified in the service procedures.

Health and Safety Incident Reporting

I. Summary

This section defines requirements for notification of health and safety incidents involving Xerox products (equipment and materials) at customer locations.

II. Scope

Xerox Corporation and subsidiaries worldwide.

III. Objective

To enable prompt resolution of health and safety incidents involving Xerox products and to ensure Xerox regulatory compliance.

IV. Definitions

Incident:

An event or condition occurring in a customer account that has resulted in injury, illness or property damage. Examples of incidents include machine fires, smoke generation, physical injury to an operator or service representative. Alleged events and product conditions are included in this definition.

V. Requirements

Initial Report:

1. Xerox organizations shall establish a process for individuals to report product incidents to Xerox Environment Health and Safety within 24 hours of becoming aware of the event.
2. The information to be provided at the time of reporting is contained in Appendix A (Health and Safety Incident Report involving a Xerox product).
3. The initial notification may be made by the method that follows:
 - Email Xerox EH&S at: usa.product.incident@xerox.com.
 - Fax Xerox EH&S at: 1-585-422-8217 (intelnet 8*222-8217).

Note: If sending a fax, please also send the original via internal mail.

Responsibilities for resolution:

1. Business Groups/Product Design Teams responsible for the product involved in the incident shall:
 - a. Manage field bulletins, customer correspondence, product recalls, safety retrofits.
 - b. Fund all field retrofits.
2. Field Service Operations shall:

- a. Preserve the Xerox product involved and the scene of the incident inclusive of any associated equipment located in the vicinity of the incident.
 - b. Return any affected equipment/part(s) to the location designated by Xerox EH&S and/or the Business Division.
 - c. Implement all safety retrofits.
3. Xerox EH&S shall:
 - a. Manage and report all incident investigation activities.
 - b. Review and approve proposed product corrective actions and retrofits, if necessary.
 - c. Manage all communications and correspondence with government agencies.
 - d. Define actions to correct confirmed incidents.

VI. Appendices

The Health and Safety Incident Report involving a Xerox Product (Form # EH&S-700) is available in the locations that follow:

- On electronic documentation (EDOC), located in the Library.
- In the hardcopy, located at the end of the manual.

Translated Warnings

All translated warnings for this book are located at point of need within the documentation.

1 Service Call Procedures

Service Call Procedures 8

Service Call Procedures

Service Strategy

The service strategy for this accessory, is to use the Service Call Procedures for the IOT.

Procedure

Go to the Service Call Procedures (SCP) for the IOT.

2 Status Indicator RAPs

Chain 78	10
078-103, 078-904 HCF Exit Sensor Jam	10
078-104, 078-151, 078-901 HCF Feed Out Sensor Jam	11
078-216 HCF Logic Fail	12
078-219 HCF PF2 Soft Download Fail	12
078-250 HCF1 Tray Lift Up Fail	13
078-300 HCF1 Transport Interlock	13
078-301 HCF1 Side Out Interlock	14
078A False HCF Tray Empty	14

078–103, 078–904 HCF Exit Sensor Jam

BSD-ON: [BSD 78.6](#)

- 078–103: Exit Sensor does not turn ON within the specified time.
- 078–904: Exit sensor does not turn OFF within the specified time.

Initial Actions

- Check the HCF paper path for obstructions.
- Check for obstructions between the HCF and the IOT.
- Check the condition and specification of the paper.
- Check the following components for wear and damage:
 - Springs ([PL 78.4](#))
 - Bearings ([PL 78.4](#))
 - Pinch roll assembly ([PL 78.4](#))
 - Upper chute assembly ([PL 78.4](#))
 - Lower chute assembly ([PL 78.4](#))
 - Bearings ([PL 78.4](#))
 - Takeaway roll assembly ([PL 78.4](#))
 - Roller assembly ([PL 78.4](#))

Procedure

Check the HCF Exit Sensor (DC330 [078–102]) for operational failure. ([GP 1](#))

The HCF Exit Sensor functions correctly.

Y N

Switch OFF the power and check the connection between the HCF PWB and the HCF Exit Sensor. If the problem persists, replace the HCF Exit Sensor. ([PL 78.4](#))

Check the HCF Takeaway Motor (DC330 [078–006]) for operational failure. ([GP 4](#))

The HCF Takeaway Motor functions correctly.

Y N

Switch OFF the power and check the connection between the HCF PWB and the HCF Takeaway Motor. If the problem persists, replace the HCF Takeaway Motor. ([PL 78.4](#))

Replace the HCF PWB. ([PL 78.8](#))

078–104, 078–151, 078–901 HCF Feed Out Sensor Jam

Replace the HCF PWB. (PL 78.8)

BSD-ON: [BSD 78.6](#)

- 078–104: Feed Out Sensor does not turn ON within the specified time from Feed start.
- 078–151: Feed Out Sensor does not turn ON within the specified time in transport of paper inside HCF1.
- 078–901: Paper still remains inside HCF1 when Cover of each type has been closed or when Printing has been completed.

Initial Actions

- Check the HCF paper path for obstructions.
- Check for obstructions between the HCF and the IOT.
- Check the condition and specification of the paper.
- Check the following components for wear and damage:
 - Springs ([PL 78.4](#))
 - Bearings ([PL 78.4](#))
 - Pinch roll assembly ([PL 78.4](#))
 - Upper chute assembly ([PL 78.4](#))
 - Lower chute assembly ([PL 78.4](#))
 - Bearings ([PL 78.4](#))
 - Takeaway roll assembly ([PL 78.4](#))
 - Roller assembly ([PL 78.4](#))
 - Feed head assembly ([PL 78.5](#), [PL 78.6](#), [PL 78.7](#))
 - ◆ Shaft
 - ◆ Gears
 - ◆ Drive gear assembly
 - ◆ Ball bearings
 - ◆ Upper feeder assembly
 - ◆ Feed shaft assembly
 - ◆ Feed gear
 - ◆ Feed roll kit
 - ◆ Lower feeder assembly
 - ◆ Retard shaft assembly

Procedure

Check the HCF Feed Out Sensor (DC330 [078–101]) for operational failure. ([GP 1](#))

The HCF Feed Out Sensor functions correctly.

Y N

Switch OFF the power and check the connection between the HCF PWB and the HCF Feed Out Sensor. If the problem persists, replace the HCF Feed Out Sensor. ([PL 78.4](#))

Check the HCF Takeaway Motor (DC330 [078–006]) for operational failure. ([GP 4](#))

The HCF Takeaway Motor functions correctly.

Y N

Switch OFF the power and check the connection between the HCF PWB and the HCF Takeaway Motor. If the problem persists, replace the HCF Takeaway Motor. ([PL 78.4](#))

078–216 HCF Logic Fail

BSD-ON: [BSD 78.2](#)

Fatal error detected with HCF.

Initial Actions

- Check the HCF is plugged in.
- Check the condition and the connection quality of the IOT connector. ([Rear Connectors](#))

Procedure

Replace the HCF PWB. ([PL 78.8](#))

078–219 HCF PF2 Soft Download Fail

BSD-ON: [BSD 78.2](#)

PF2 HCF SW download failed.

Initial Actions

- Check the HCF is plugged in.
- Check the condition and the connection quality of the IOT connector. ([Rear Connectors](#))

Procedure

Replace the HCF PWB. ([PL 78.8](#))

If the problem persists, refer to the IOT service manual.

078–250 HCF1 Tray Lift Up Fail

BSD-ON: [BSD 78.4](#)

Level Sensor does not turn ON within the specified time at HCF1 Lift Up.

Initial Actions

- Check the HCF paper path for obstructions.
- Check the condition and specification of the paper.
- Check the paper is loaded correctly in the tray.
- Check the condition and functionality of the HCF Cables. ([PL 78.4](#))
- Check the following components for wear and damage:
 - Front cover assembly ([PL 78.2](#))
 - Pulleys([PL 78.3](#))
 - Cables ([PL 78.3](#))
 - Gears ([PL 78.3](#))
 - Lift gear ([PL 78.3](#))
 - Gear bracket assembly([PL 78.3](#))

Procedure

Check the HCF level sensor (DC330 [078–201]) for operational failure.

The HCF Level Sensor functions correctly.

Y N

| Switch OFF the power and check the connection between the HCF PWB and the HCF level sensor. If the problem persists, replace the HCF level sensor. ([PL 78.4](#))

Check the HCF feed motor lift up function (DC330 [078–004]) for operational failure.

The HCF Feed Motor functions correctly.

Y N

| Switch OFF the power and check the connection between the HCF PWB and the HCF Feed Motor. If the problem persists, replace the HCF Feed Motor. ([PL 78.4](#))

Replace the HCF PWB. ([PL 78.8](#))

078–300 HCF1 Transport Interlock

BSD-ON: [BSD 78.1](#)

HCF1 Transport Cover has been opened.

Initial Actions

- Check the HCF top chute cover is closed fully. ([PL 78.4](#))
- Check the HCF top chute cover for obstructions.
- Check the following components for wear and damage:
 - Rear latch ([PL 78.4](#))
 - Front latch ([PL 78.4](#))
 - Shaft ([PL 78.4](#))

Procedure

Check the HCF interlock switch (DC330 [078–300]) for operational failure.

The HCF Interlock Switch functions correctly.

Y N

| Switch OFF the power and check the connection between the HCF PWB and the HCF interlock switch. If the problem persists, replace the HCF interlock switch. ([PL 78.4](#))

Replace the HCF PWB. ([PL 78.8](#))

078–301 HCF1 Side Out Interlock

BSD-ON: [BSD 78.1](#)

HCF1 has been disconnected from IOT.

Initial Actions

- Check the HCF is docked correctly to the IOT.

Procedure

Check the HCF side out switch (DC330 [078–301]) for operational failure.

The HCF Side Out Switch functions correctly.

Y N

| Switch OFF the power and check the connection between the HCF PWB and the HCF side out switch. If the problem persists, replace the HCF side out switch. ([PL 78.8](#))

Replace the HCF PWB. ([PL 78.8](#))

078A False HCF Tray Empty

BSD-ON: [BSD 78.4](#)

Initial Actions

- Check the condition and specification of the paper.
- Check the paper is loaded correctly in the tray.
- Check the condition and functionality of the HCF Cables. ([PL 78.4](#))
- Check the following components for wear and damage:
 - Front cover assembly ([PL 78.2](#))
 - Pulleys([PL 78.3](#))
 - Cables ([PL 78.3](#))
 - Gears ([PL 78.3](#))
 - Lift gear ([PL 78.3](#))
 - Gear bracket assembly([PL 78.3](#))

Procedure

Check the HCF no paper sensor (DC330 [078–200]) for operational failure.

The HCF No Paper Sensor functions correctly.

Y N

| Switch OFF the power and check the connection between the HCF PWB and the HCF no paper sensor. If the problem persists, replace the HCF Exit Sensor. ([PL 78.4](#))

Check the HCF level sensor (DC330 [078–201]) for operational failure.

The HCF Level Sensor functions correctly.

Y N

| Switch OFF the power and check the connection between the HCF PWB and the HCF level sensor. If the problem persists, replace the HCF level sensor. ([PL 78.4](#))

Check the HCF feed motor lift up function (DC330 [078–004]) for operational failure.

The HCF Feed Motor functions correctly.

Y N

| Switch OFF the power and check the connection between the HCF PWB and the HCF Feed Motor. If the problem persists, replace the HCF Feed Motor. ([PL 78.4](#))

Replace the HCF PWB. ([PL 78.8](#))

4 Repairs and Adjustments

REP 78.1 Tray Rail (Lower)	16
REP 78.2 Tray Rail (Upper)	17
REP 78.3 HCF Tray Assembly	18
REP 78.4 HCF Feed Head	19
REP 78.5 Front Cover Assembly	22
REP 78.6 End Guide Assembly	23
REP 78.7 Bottom Plate Assembly	24
REP 78.8 Cables	25
REP 78.9 Gear Bracket Assembly	28
REP 78.10 Sensor	29
REP 78.11 Lower Chute Cover Assembly	31
REP 78.12 Takeaway Roll Assembly	32
REP 78.13 Top Chute Cover	34
REP 78.14 Shaft	36
REP 78.15 Gear	37
REP 78.16 Gear	38
REP 78.17 Ball Bearing	39
REP 78.18 Drive Gear Assembly	40
REP 78.19 Upper Feeder Assembly	41
REP 78.20 Feed Shaft Assembly	43
REP 78.21 Ball Bearing	44
REP 78.22 Feed Gear	45
REP 78.23 Level Sensor	46
REP 78.24 No Paper Sensor	48
REP 78.25 Pre Feed Sensor	50
REP 78.26 Lower Feeder Assembly	51
REP 78.27 Retard Shaft Assembly	52
REP 78.28 Casters and Adjuster Feet	53
REP 78.29 Rail Assembly	54
REP 78.30 Gear Rack	56
REP 78.31 Drive Assembly	58
REP 78.32 Paper Size Sensors and Tray In Sensor	59
REP 78.33 Cable Assembly	62
REP 78.34 HCF PWB	64
REP 78.35 Pinion and Damper	66

REP 78.1 Tray Rail (Lower)Parts List on [PL 78.1](#)**Removal**

WARNING: Do not perform repair activities with the power on or electrical power supplied to the machine. The machine could activate and cause serious personal injury when the power is on or electrical power is supplied.

Ne pas effectuer de dépannage avec le contact principal activé ou avec l'alimentation électrique appliquée à la machine: celle-ci pourrait démarrer et causer de graves blessures.

Non effettuare alcuna riparazione con la macchina accesa o con l'alimentazione elettrica inserita. La macchina potrebbe avviarsi all'improvviso e causare gravi ferite.

Es dürfen keine Reparaturarbeiten durchgeführt werden, solange das Gerät eingeschaltet oder mit der Stromquelle verbunden ist. Das Gerät kann u.U. in den Aktiv-Zustand übergehen und somit erhebliche körperliche Schäden verursachen

No realice reparaciones con la máquina encendida o conectada a la corriente. La máquina podría activarse y ocasionar daños personales graves.

1. To remove the left cover, remove 3 screws (Figure 1).



Q-1-0157-A

Figure 1 Removal of the Left Cover

2. Remove the HCF tray assembly. ([REP 78.3](#))

3. Lift the handle on the top cover, and pull the HCF fully to the left.
4. Remove 3 screws securing the rail to the HCF frame (Figure 2).

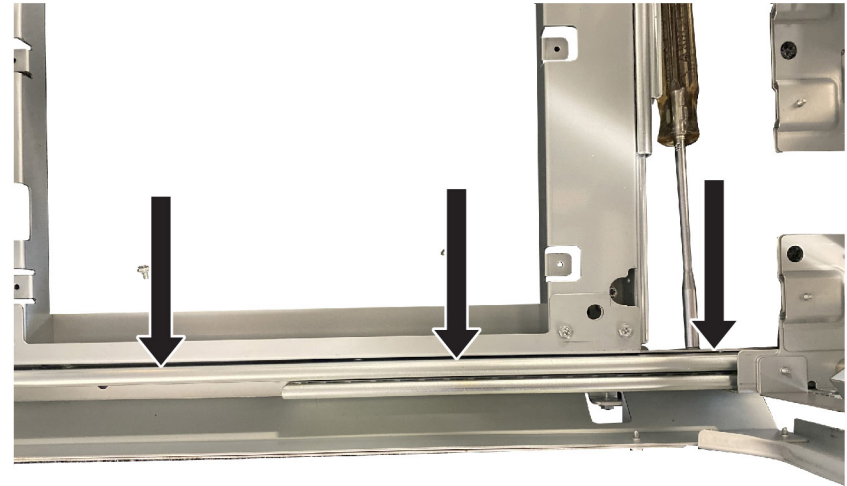

Q-1-0158-A

Figure 2 Removal of the Tray Rail (Lower)**Replacement**

1. The replacement is the reverse of the removal procedure.

REP 78.2 Tray Rail (Upper)

Parts List on [PL 78.1](#)

Removal



WARNING: Do not perform repair activities with the power on or electrical power supplied to the machine. The machine could activate and cause serious personal injury when the power is on or electrical power is supplied.

Ne pas effectuer de dépannage avec le contact principal activé ou avec l'alimentation électrique appliquée à la machine: celle-ci pourrait démarrer et causer de graves blessures.

Non effettuare alcuna riparazione con la macchina accesa o con l'alimentazione elettrica inserita. La macchina potrebbe avviarsi all'improvviso e causare gravi ferite.

Es dürfen keine Reparaturarbeiten durchgeführt werden, solange das Gerät eingeschaltet oder mit der Stromquelle verbunden ist. Das Gerät kann u.U in den Aktiv-Zustand übergehen und somit erhebliche körperliche Schäden verursachen

No realice reparaciones con la máquina encendida o conectada a la corriente. La máquina podría activarse y ocasionar daños personales graves.

1. Remove the HCF tray assembly. ([REP 78.3](#))
2. To remove the right cover, remove 6 screws ([Figure 1](#)).



Q-1-0159-A

Figure 1 Removal of the Right Cover

3. Remove the lower chute assembly. ([REP 78.11](#)).
4. Remove 3 screws securing the rail to the HCF frame ([Figure 2](#)).

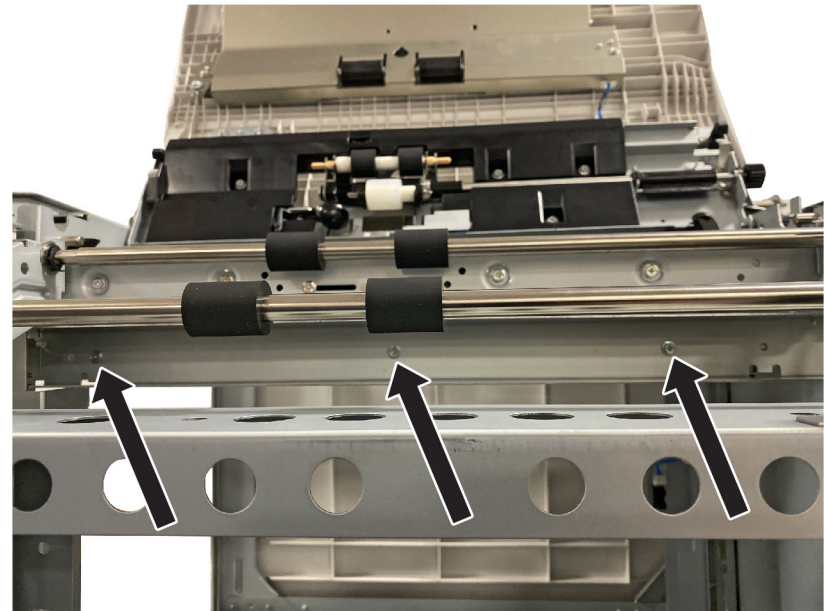

Q-1-0160-A

Figure 2 Removal of the Tray Rail (Upper)

Replacement

1. The replacement is the reverse of the removal procedure.

REP 78.3 HCF Tray Assembly

Parts List on [PL 78.1](#)

Removal



WARNING: Do not perform repair activities with the power on or electrical power supplied to the machine. The machine could activate and cause serious personal injury when the power is on or electrical power is supplied.

Ne pas effectuer de dépannage avec le contact principal activé ou avec l'alimentation électrique appliquée à la machine: celle-ci pourrait démarrer et causer de graves blessures.

Non effettuare alcuna riparazione con la macchina accesa o con l'alimentazione elettrica inserita. La macchina potrebbe avviarsi all'improvviso e causare gravi ferite.

Es dürfen keine Reparaturarbeiten durchgeführt werden, solange das Gerät eingeschaltet oder mit der Stromquelle verbunden ist. Das Gerät kann u.U in den Aktiv-Zustand übergehen und somit erhebliche körperliche Schäden verursachen

No realice reparaciones con la máquina encendida o conectada a la corriente. La máquina podría activarse y ocasionar daños personales graves.

1. Open the HCF paper tray by pulling the tray toward the front of the HCF.
2. Remove all paper from the tray.
3. Remove 4 screws ([Figure 1](#)).
 - a. Remove 2 screws [1] from the top right side of the tray.
 - b. Remove 2 screws [2] from the bottom left side of the tray.

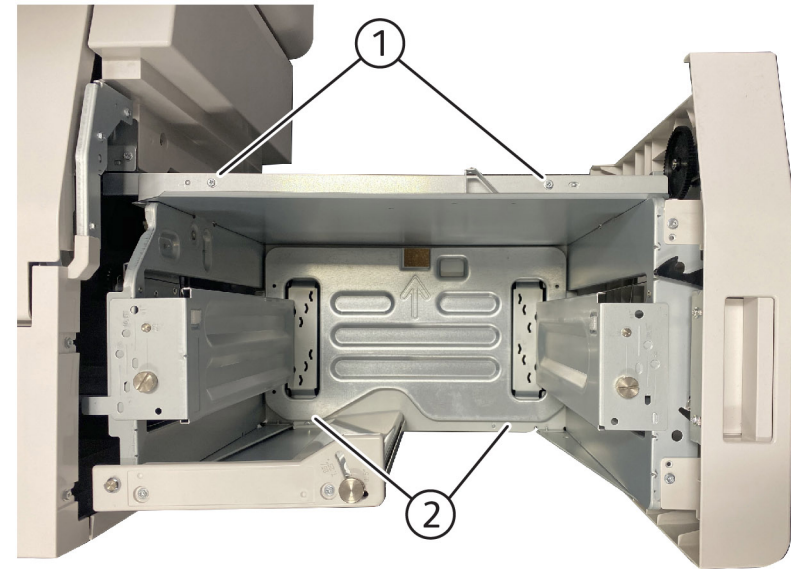

Q-1-0161-A

Figure 1 Removal of 4 Screws from the Tray Assembly

4. Remove 1 screw from the rear left side of the tray ([Figure 2](#)).



Q-1-0162-A

Figure 2 Removal of 1 Screw from the Tray Assembly

5. Lift the tray off the rails.

Replacement

Note: Before replacing the HCF tray assembly, ensure that the tray rails are fully extended.

1. The replacement is the reverse of the removal procedure.

REP 78.4 HCF Feed Head

Parts List on [PL 78.1](#)

Removal

WARNING: Do not perform repair activities with the power on or electrical power supplied to the machine. The machine could activate and cause serious personal injury when the power is on or electrical power is supplied.

Ne pas effectuer de dépannage avec le contact principal activé ou avec l'alimentation électrique appliquée à la machine: celle-ci pourrait démarrer et causer de graves blessures.

Non effettuare alcuna riparazione con la macchina accesa o con l'alimentazione elettrica inserita. La macchina potrebbe avviarsi all'improvviso e causare gravi ferite.

Es dürfen keine Reparaturarbeiten durchgeführt werden, solange das Gerät eingeschaltet oder mit der Stromquelle verbunden ist. Das Gerät kann u.U in den Aktiv-Zustand übergehen und somit erhebliche körperliche Schäden verursachen

No realice reparaciones con la máquina encendida o conectada a la corriente. La máquina podría activarse y ocasionar daños personales graves.

1. To remove the upper rear cover, remove 2 screws([Figure 1](#)).



Q-1-0163-A

Figure 1 Removal of the Upper Rear Cover

2. Raise the top chute cover. ([PL 78.4](#))

4 Repairs and Adjustments

3. Open the HCF paper tray by pulling the tray toward the front of the HCF.
4. Remove 2 P/J connectors (Figure 2).
 - a. Disconnect PJ 7410 and PJ 7412 [1] from the PWB.
 - b. Unclip the harness [2] from the frame.

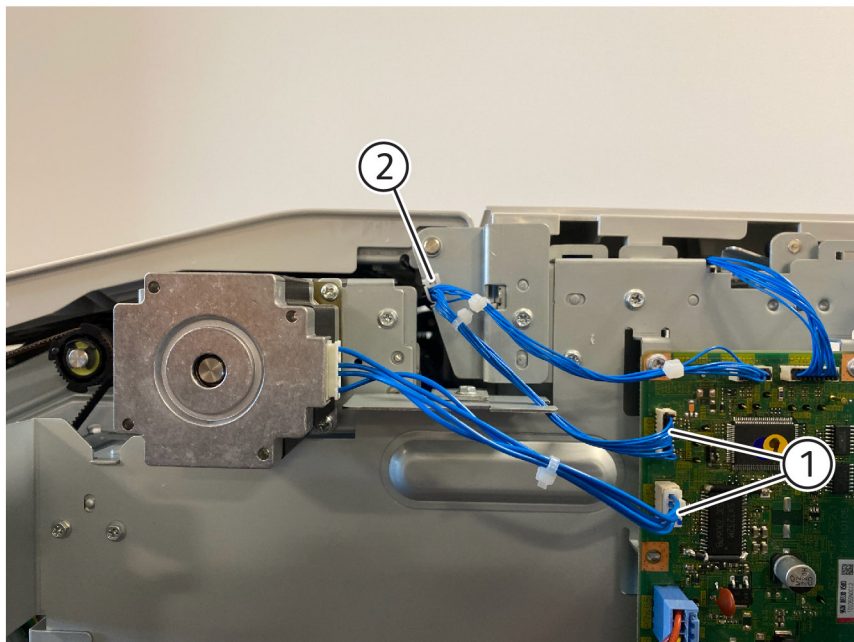

Q-1-0164-A

Figure 2 Removal of PJ 7410 and PJ 7412

5. Remove the plastic strap and 2 screws (Figure 3).
 - a. To release the plastic strap from the feed head frame, rotate the strap 90 degrees counter-clockwise.
 - b. Remove 2 screws [2] at the front of the feed head.

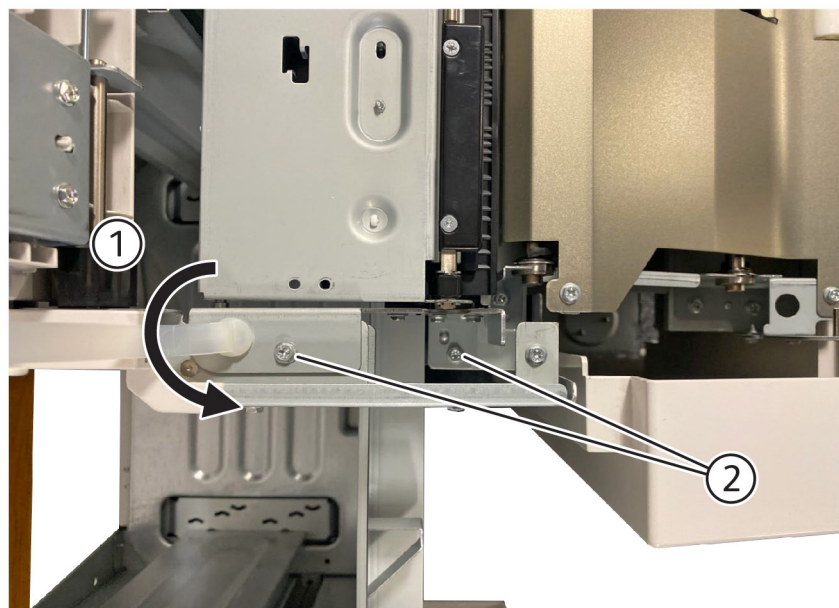

Q-1-0165-A

Figure 3 Release of the Plastic Strap and Removal of 2 Screws from the HCF Feed Head

6. Remove 2 screws at the rear of the feed head (Figure 4).

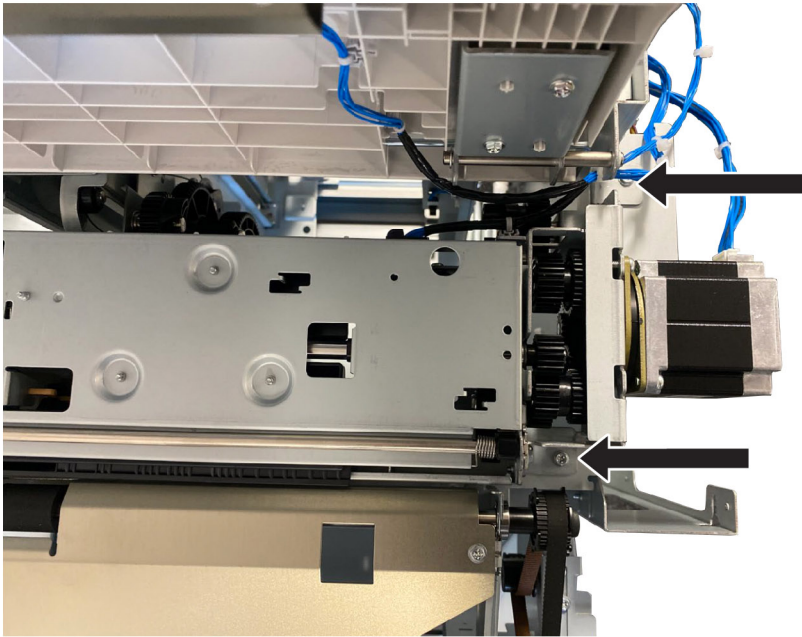

Q-1-0166-A

Figure 4 Removal of 2 Screws from the HCF Feed Head

7. Prepare to remove the feedhead assembly (Figure 5).
 - a. To de-tension the takeaway rolls belt, loosen 2 screws [1].
 - b. To provide adequate clearance for removal of the feed head, remove the KL-clip [2] from the upper takeaway roll, then remove the pulley.

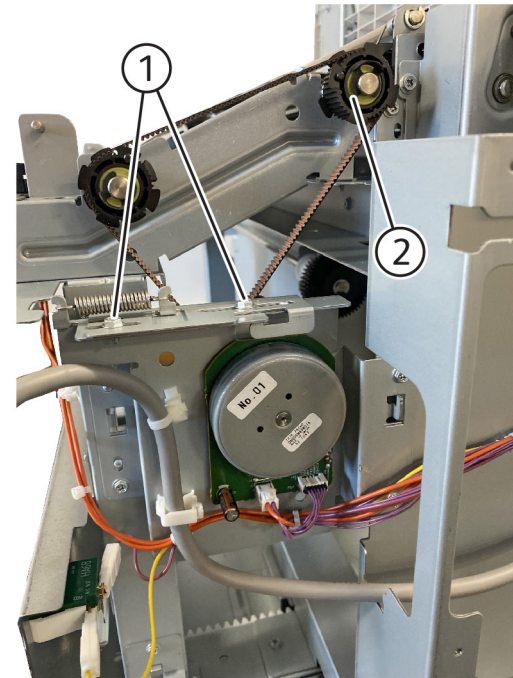

Q-1-0167-A

Figure 5 Removal of the KL-Clip and the Pulley from the Takeaway Roll

8. Remove the feed head assembly.
 - a. Lift the front of the assembly.
 - b. To release the rear of the assembly, rotate the assembly up slightly at the right and lift it out of the HCF.

Replacement

1. The replacement is the reverse of the removal procedure.

REP 78.5 Front Cover Assembly

Parts List on [PL 78.2](#)

Removal



WARNING: Do not perform repair activities with the power on or electrical power supplied to the machine. The machine could activate and cause serious personal injury when the power is on or electrical power is supplied.

Ne pas effectuer de dépannage avec le contact principal activé ou avec l'alimentation électrique appliquée à la machine: celle-ci pourrait démarrer et causer de graves blessures.

Non effettuare alcuna riparazione con la macchina accesa o con l'alimentazione elettrica inserita. La macchina potrebbe avviarsi all'improvviso e causare gravi ferite.

Es dürfen keine Reparaturarbeiten durchgeführt werden, solange das Gerät eingeschaltet oder mit der Stromquelle verbunden ist. Das Gerät kann u.U. in den Aktiv-Zustand übergehen und somit erhebliche körperliche Schäden verursachen

No realice reparaciones con la máquina encendida o conectada a la corriente. La máquina podría activarse y ocasionar daños personales graves.

1. Open the HCF paper tray by pulling the tray toward the front of the HCF.
2. Remove 2 screws from the top side of the cover ([Figure 1](#)).

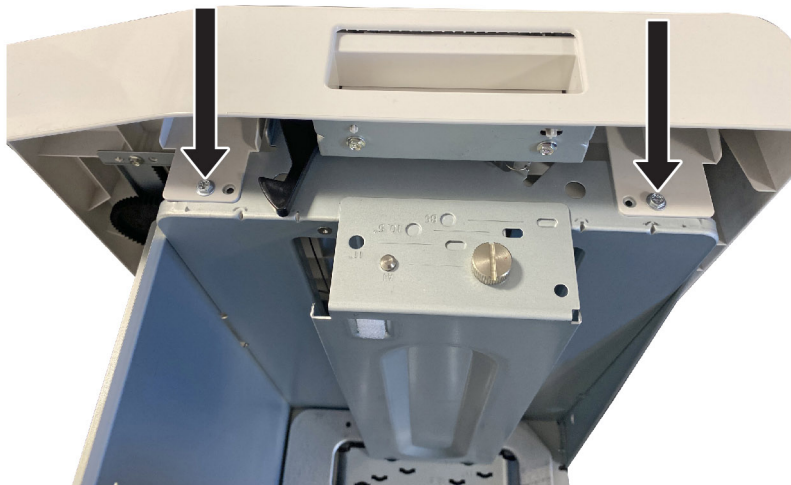

Q-1-0168-A

Figure 1 Removal of 2 Screws from the Top Side of the Front Cover Assembly

3. Remove 2 screws from the left side of the cover ([Figure 2](#)).



Q-1-0169-A

Figure 2 Removal of 2 Screws from the Left Side of the Front Cover Assembly

4. Remove 2 screws from the right side of the cover ([Figure 3](#)).

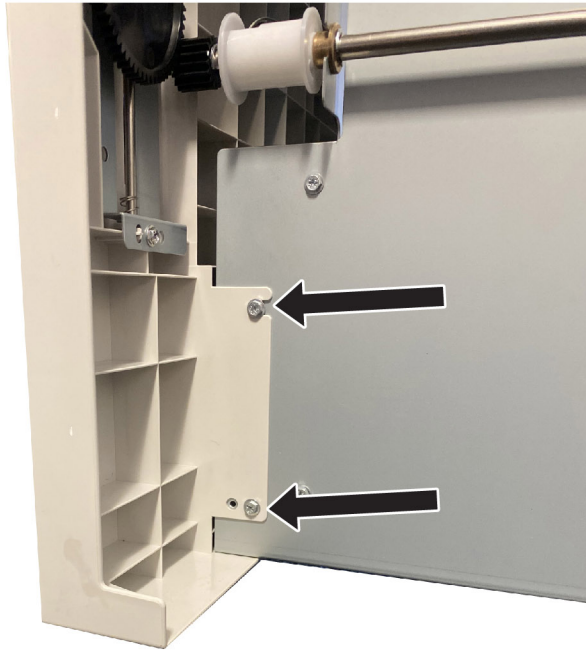

Q-1-0170-A

Figure 3 Removal of 2 Screws from the Right Side of the Front Cover Assembly

5. Remove the cover, taking care to ensure that the latch spring at the top of the cover remains in place.

Replacement

Note: To avoid damage to the HCF and the IOT, when replacing the front cover assembly, ensure that the black gear and paper level indicator on the rear side of the cover are set in the low position.

1. The replacement is the reverse of the removal procedure.

REP 78.6 End Guide Assembly

Parts List on [PL 78.2](#)

Removal



WARNING: Do not perform repair activities with the power on or electrical power supplied to the machine. The machine could activate and cause serious personal injury when the power is on or electrical power is supplied.

Ne pas effectuer de dépannage avec le contact principal activé ou avec l'alimentation électrique appliquée à la machine: celle-ci pourrait démarrer et causer de graves blessures.

Non effettuare alcuna riparazione con la macchina accesa o con l'alimentazione elettrica inserita. La macchina potrebbe avviarsi all'improvviso e causare gravi ferite.

Es dürfen keine Reparaturarbeiten durchgeführt werden, solange das Gerät eingeschalten oder mit der Stromquelle verbunden ist. Das Gerät kann u.U in den Aktiv-Zustand übergehen und somit erhebliche körperliche Schäden verursachen

No realice reparaciones con la máquina encendida o conectada a la corriente. La máquina podría activarse y ocasionar daños personales graves.

1. Open the HCF paper tray by pulling the tray toward the front of the HCF.
2. Remove the c-clip from the top of the shaft ([Figure 1](#)).

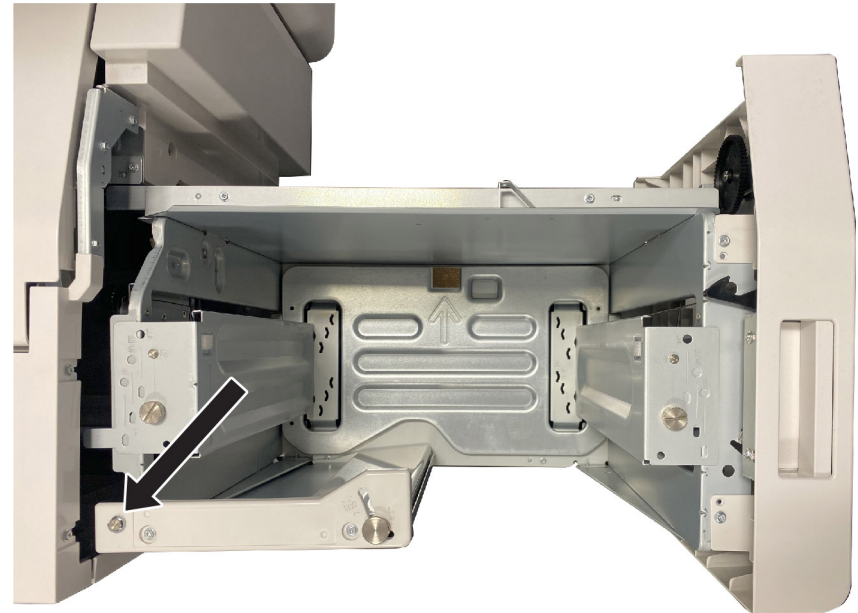

Q-1-0171-A

Figure 1 Removal of the C-Clip from the Top of the Shaft.

3. Lift the end guide assembly up out of the paper tray.

Replacement

1. The replacement is the reverse of the removal procedure.

REP 78.7 Bottom Plate Assembly

Parts List on [PL 78.3](#)

Removal



WARNING: Do not perform repair activities with the power on or electrical power supplied to the machine. The machine could activate and cause serious personal injury when the power is on or electrical power is supplied.

Ne pas effectuer de dépannage avec le contact principal activé ou avec l'alimentation électrique appliquée à la machine: celle-ci pourrait démarrer et causer de graves blessures.

Non effettuare alcuna riparazione con la macchina accesa o con l'alimentazione elettrica inserita. La macchina potrebbe avviarsi all'improvviso e causare gravi ferite.

Es dürfen keine Reparaturarbeiten durchgeführt werden, solange das Gerät eingeschalten oder mit der Stromquelle verbunden ist. Das Gerät kann u.U in den Aktiv-Zustand übergehen und somit erhebliche körperliche Schäden verursachen

No realice reparaciones con la máquina encendida o conectada a la corriente. La máquina podría activarse y ocasionar daños personales graves.

1. Open the HCF paper tray by pulling the tray toward the front of the HCF.
2. Remove 2 size guide thumb screws ([Figure 1](#)).
 - a. Remove the front size guide thumb screw [1], then lift the guide out of the tray.
 - b. Remove the rear size guide thumb screw [2], then lift the guide out of the tray.

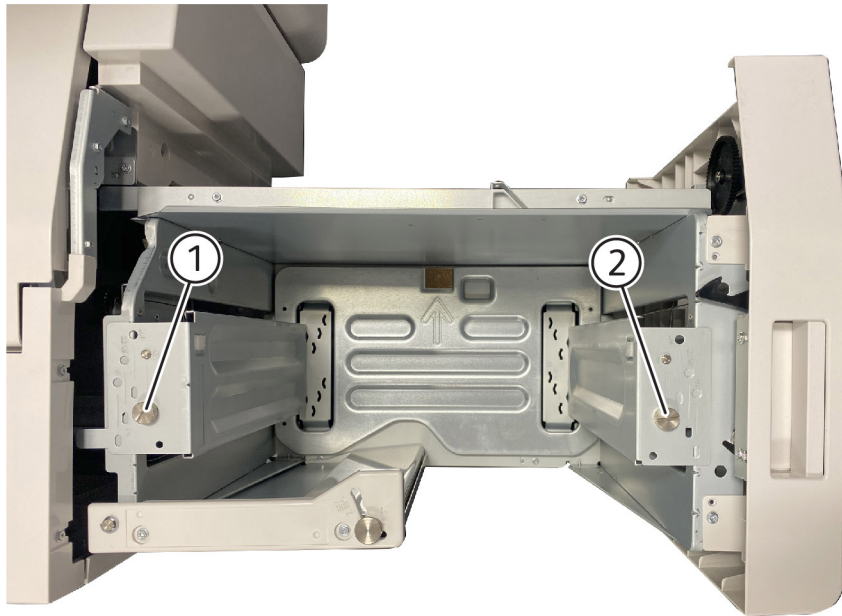

Q-1-0172-A

Figure 1 Removal of 2 Size Guide Thumb Screws and 2 Guides from the Paper Tray

3. Remove the front cover assembly. (REP 78.5)
4. Remove the cables. (REP 78.8)
5. Lift the bottom plate assembly out of the paper tray.

Replacement

1. The replacement is the reverse of the removal procedure.

REP 78.8 CablesParts List on [PL 78.3](#)**Removal**

WARNING: Do not perform repair activities with the power on or electrical power supplied to the machine. The machine could activate and cause serious personal injury when the power is on or electrical power is supplied.

Ne pas effectuer de dépannage avec le contact principal activé ou avec l'alimentation électrique appliquée à la machine: celle-ci pourrait démarrer et causer de graves blessures.

Non effettuare alcuna riparazione con la macchina accesa o con l'alimentazione elettrica inserita. La macchina potrebbe avviarsi all'improvviso e causare gravi ferite.

Es dürfen keine Reparaturarbeiten durchgeführt werden, solange das Gerät eingeschaltet oder mit der Stromquelle verbunden ist. Das Gerät kann u.U in den Aktiv-Zustand übergehen und somit erhebliche körperliche Schäden verursachen

No realice reparaciones con la máquina encendida o conectada a la corriente. La máquina podría activarse y ocasionar daños personales graves.

1. Remove the HCF tray assembly. (REP 78.3)
2. Remove the front cover assembly. (REP 78.5)
3. Place the HCF tray assembly on a flat surface with the front of the assembly facing toward you.
4. Remove the front lift cables from the HCF tray assembly.
 - a. Remove the C-clip from the end of the pulley shaft, then remove the gear (Figure 1).

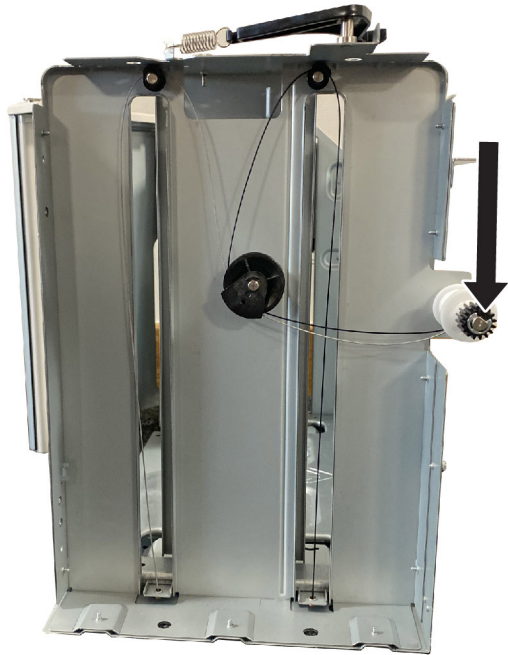

Q-1-0173-A

Figure 1 Removal of the C-Clip and the Gear from the Pulley Shaft

- b. Release the cable ends from the pulley shaft (Figure 2).
 - i. Remove 2 C-clips [1] from the pulley shaft.
 - ii. Turn the pulley so that the slot [2] on the pulley aligns with the retaining slot on the shaft.
 - iii. To release the cable ends, slide the pulley forward a few millimetres [3], then pull the cable ends out of the retaining slot.

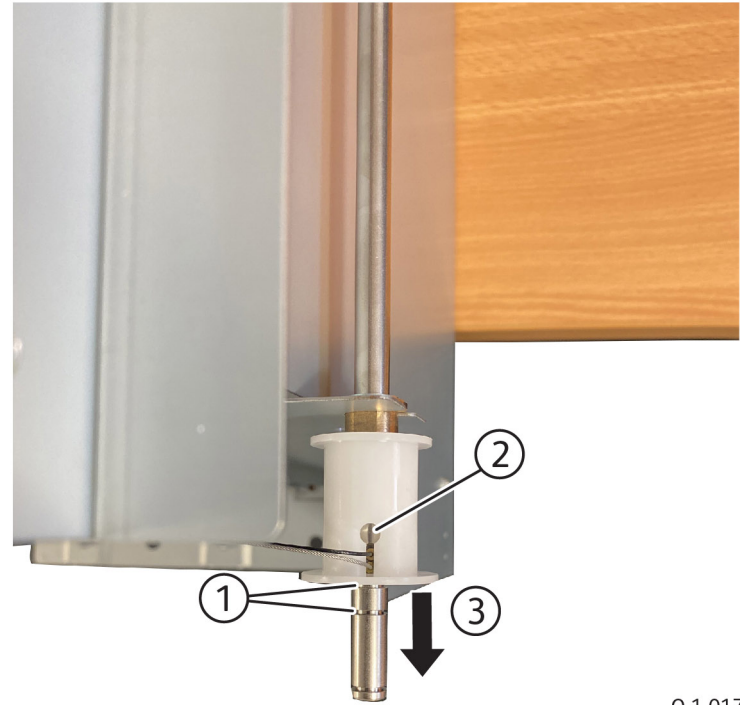

Q-1-0174-A

Figure 2 Removal of the Front Cables

- c. Take note of the routing for both cables, then remove each cable in turn (Figure 3).

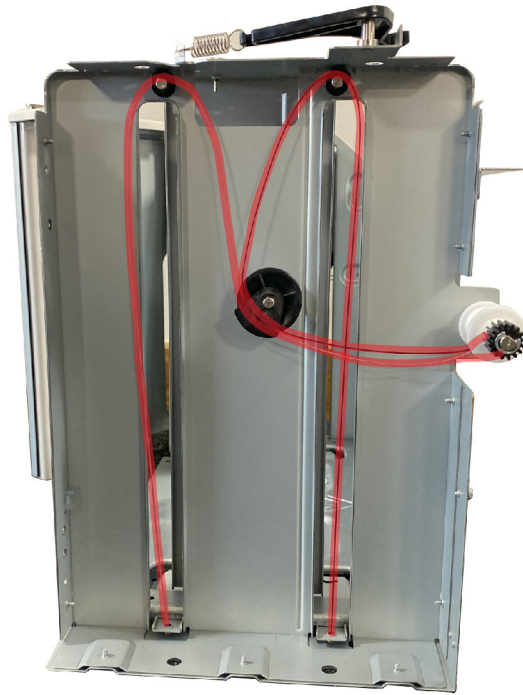

Q-1-0175-A

Figure 3 Cable Routing for the Front Cables

5. Remove the rear lift cables from the HCF tray assembly.
 - a. Remove 2 C-clips, the plastic plate, and the gear (Figure 4).
 - i. Remove the C-clip from the pulley shaft [1].
 - ii. Remove the C-clip from the gear shaft [2].
 - iii. Remove the plastic plate [3].
 - iv. Remove the gear from the pulley shaft [4].

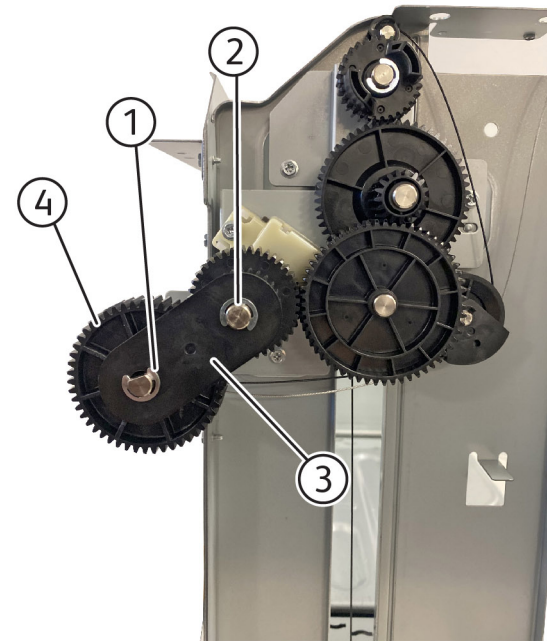

Q-1-0176-A

Figure 4 Removal of 2 C-Clips, the Plastic Plate, and the Gear

- b. Remove the pin and the C-clip (Figure 5).
 - i. Remove the pin [1] from the pulley shaft.
 - ii. Remove the C-clip [2].

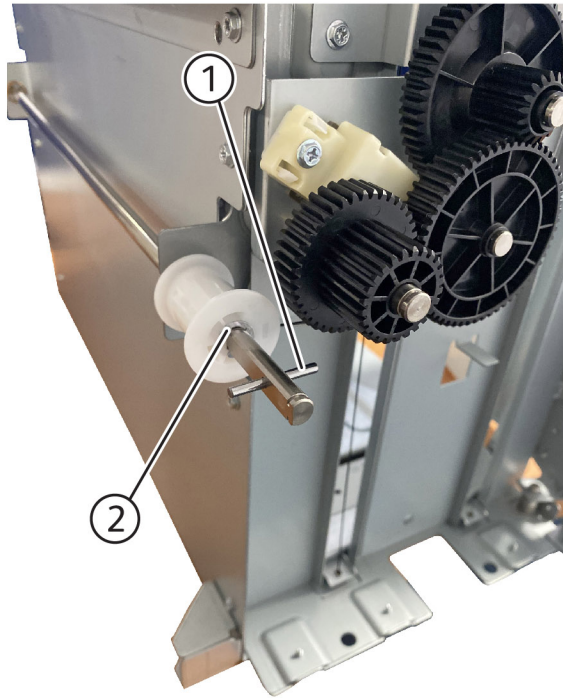

Q-1-0177-A

Figure 5 Removal of the C-Clip and the Gear from the Pulley Shaft

- c. Turn the pulley so that the slot on the pulley aligns with the retaining slot on the shaft.
- d. To release the cable ends, slide the pulley forward a few millimetres, then pull the cable ends out of the retaining slot.
- e. Take note of the routing for both cables, then remove each cable in turn.

Note: The routing for the rear cables is the same as the routing for the front cables.

Replacement

1. The replacement is the reverse of the removal procedure.

Note: After replacing the tray lift cables, manually wind the pulley shaft to ensure the following:

- The cables wind correctly onto the pulleys.
- The assembly moves freely.
- The tray base raises parallel to the tray frame.

REP 78.9 Gear Bracket Assembly

Parts List on [PL 78.3](#)

Removal



WARNING: Do not perform repair activities with the power on or electrical power supplied to the machine. The machine could activate and cause serious personal injury when the power is on or electrical power is supplied.

Ne pas effectuer de dépannage avec le contact principal activé ou avec l'alimentation électrique appliquée à la machine: celle-ci pourrait démarrer et causer de graves blessures.

Non effettuare alcuna riparazione con la macchina accesa o con l'alimentazione elettrica inserita. La macchina potrebbe avviarsi all'improvviso e causare gravi ferite.

Es dürfen keine Reparaturarbeiten durchgeführt werden, solange das Gerät eingeschaltet oder mit der Stromquelle verbunden ist. Das Gerät kann u.U in den Aktiv-Zustand übergehen und somit erhebliche körperliche Schäden verursachen

No realice reparaciones con la máquina encendida o conectada a la corriente. La máquina podría activarse y ocasionar daños personales graves.

1. Remove the HCF tray assembly. ([REP 78.3](#))
2. Prepare to remove the gear bracket assembly ([Figure 1](#)).
 - a. Remove the c-clip [1] from the pulley shaft.
 - b. Remove the c-clip [2] from the gear shaft.
 - c. Remove the plastic plate [3].
 - d. Remove the gear [4].

Note: Take care not to dislodge the pin from the pulley shaft.

- e. Remove 3 screws [5].

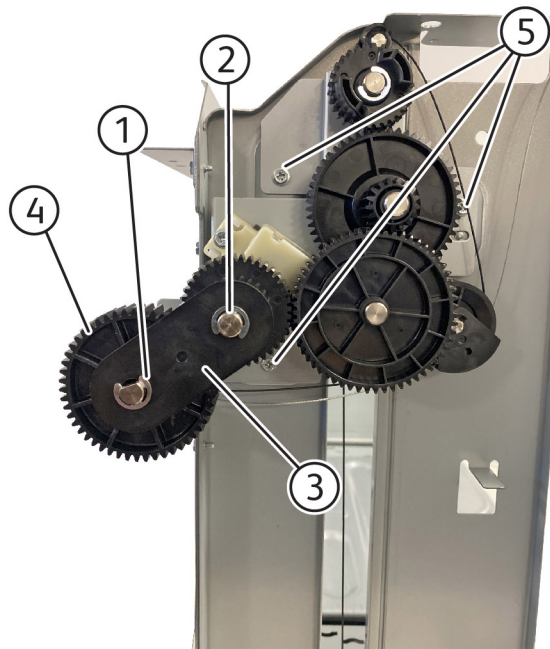

Figure 1 Removal of the Gear Bracket Assembly

3. Remove the gear bracket assembly.

Replacement

1. The replacement is the reverse of the removal procedure.

REP 78.10 Sensor

Parts List on [PL 78.4](#)

Removal



WARNING: Do not perform repair activities with the power on or electrical power supplied to the machine. The machine could activate and cause serious personal injury when the power is on or electrical power is supplied.

Ne pas effectuer de dépannage avec le contact principal activé ou avec l'alimentation électrique appliquée à la machine: celle-ci pourrait démarrer et causer de graves blessures.

Non effettuare alcuna riparazione con la macchina accesa o con l'alimentazione elettrica inserita. La macchina potrebbe avviarsi all'improvviso e causare gravi ferite.

Es dürfen keine Reparaturarbeiten durchgeführt werden, solange das Gerät eingeschaltet oder mit der Stromquelle verbunden ist. Das Gerät kann u.U in den Aktiv-Zustand übergehen und somit erhebliche körperliche Schäden verursachen

No realice reparaciones con la máquina encendida o conectada a la corriente. La máquina podría activarse y ocasionar daños personales graves.

1. Open the HCF top chute cover.([PL 78.4](#))
2. Remove the upper chute assembly ([Figure 1](#)).
 - a. Remove 4 screws [1].
 - b. Remove the upper chute assembly [2].

Q-1-0178-A

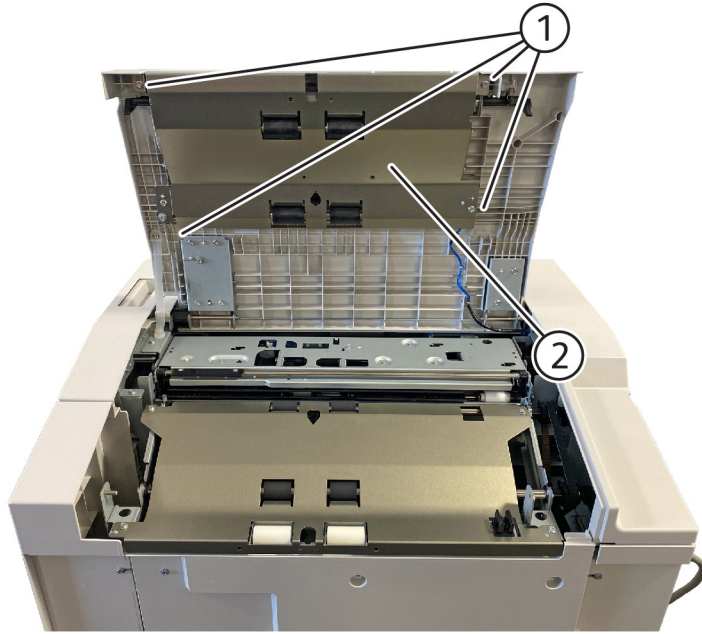

Q-1-0179-A

Figure 1 Removal of the Upper Chute Assembly

3. Remove the sensor (Figure 2).
 - a. Unplug the sensor [1].
 - b. To remove the sensor bracket, remove 1 screw [2].
 - c. To remove the sensor, remove 1 screw [3].

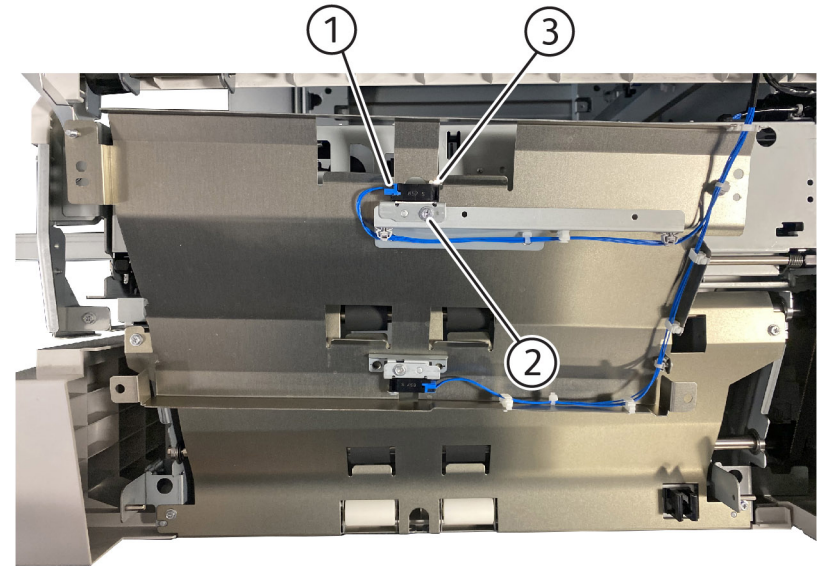

Q-1-0180-A

Figure 2 Removal of the Sensor

Replacement

1. The replacement is the reverse of the removal procedure.

REP 78.11 Lower Chute Cover Assembly

Parts List on [PL 78.4](#)

Removal



WARNING: Do not perform repair activities with the power on or electrical power supplied to the machine. The machine could activate and cause serious personal injury when the power is on or electrical power is supplied.

Ne pas effectuer de dépannage avec le contact principal activé ou avec l'alimentation électrique appliquée à la machine: celle-ci pourrait démarrer et causer de graves blessures.

Non effettuare alcuna riparazione con la macchina accesa o con l'alimentazione elettrica inserita. La macchina potrebbe avviarsi all'improvviso e causare gravi ferite.

Es dürfen keine Reparaturarbeiten durchgeführt werden, solange das Gerät eingeschaltet oder mit der Stromquelle verbunden ist. Das Gerät kann u.U in den Aktiv-Zustand übergehen und somit erhebliche körperliche Schäden verursachen

No realice reparaciones con la máquina encendida o conectada a la corriente. La máquina podría activarse y ocasionar daños personales graves.

1. Lift the top chute cover. ([PL 78.4](#))
2. Remove 4 screws ([Figure 1](#)).

3. Remove the lower chute cover assembly.

Replacement

1. The replacement is the reverse of the removal procedure.

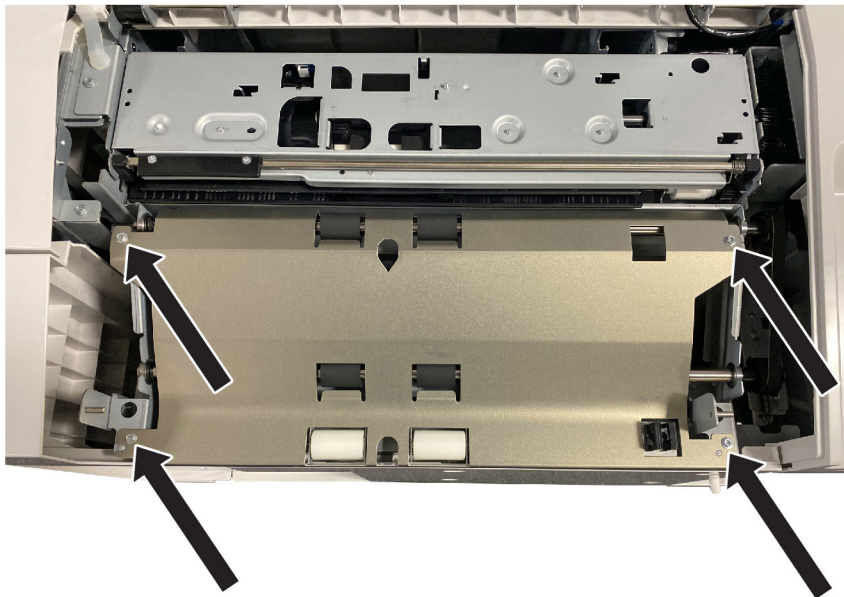

Q-1-0181-A

Figure 1 Removal of 4 Screws from the Lower Chute Cover Assembly

REP 78.12 Takeaway Roll Assembly

Parts List on [PL 78.4](#)

Removal



WARNING: Do not perform repair activities with the power on or electrical power supplied to the machine. The machine could activate and cause serious personal injury when the power is on or electrical power is supplied.

Ne pas effectuer de dépannage avec le contact principal activé ou avec l'alimentation électrique appliquée à la machine: celle-ci pourrait démarrer et causer de graves blessures.

Non effettuare alcuna riparazione con la macchina accesa o con l'alimentazione elettrica inserita. La macchina potrebbe avviarsi all'improvviso e causare gravi ferite.

Es dürfen keine Reparaturarbeiten durchgeführt werden, solange das Gerät eingeschaltet oder mit der Stromquelle verbunden ist. Das Gerät kann u.U in den Aktiv-Zustand übergehen und somit erhebliche körperliche Schäden verursachen

No realice reparaciones con la máquina encendida o conectada a la corriente. La máquina podría activarse y ocasionar daños personales graves.

1. Remove the lower chute cover assembly. ([REP 78.11](#))
2. Remove the takeaway rolls belt, the KL-clips, and the pulleys ([Figure 1](#)).
 - a. To de-tension the takeaway rolls belt, loosen 2 screws [1].
 - b. Remove the takeaway rolls belt [2].
 - c. Remove the KL-clips at the rear of the takeaway rolls [3].
 - d. Remove the pulleys [4].

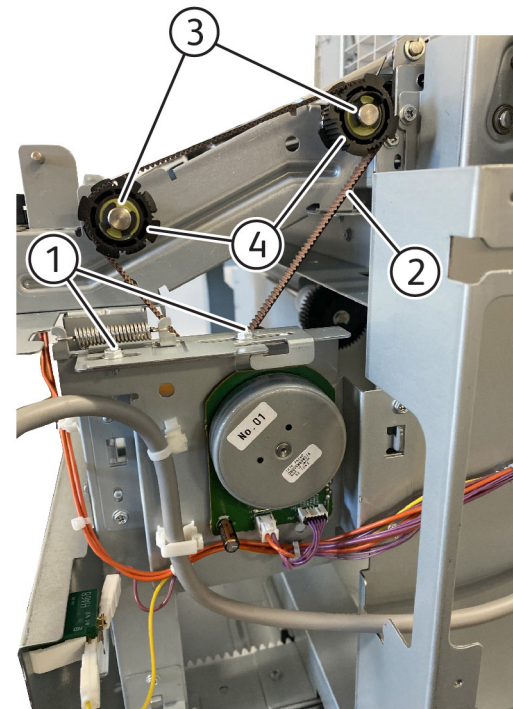

Q-1-0182-A

Figure 1 Removal of the Takeaway Rolls Belt, the KL-Clips, and the Pulleys

3. Remove the KL-clips at the front of the takeaway rolls ([Figure 2](#)).

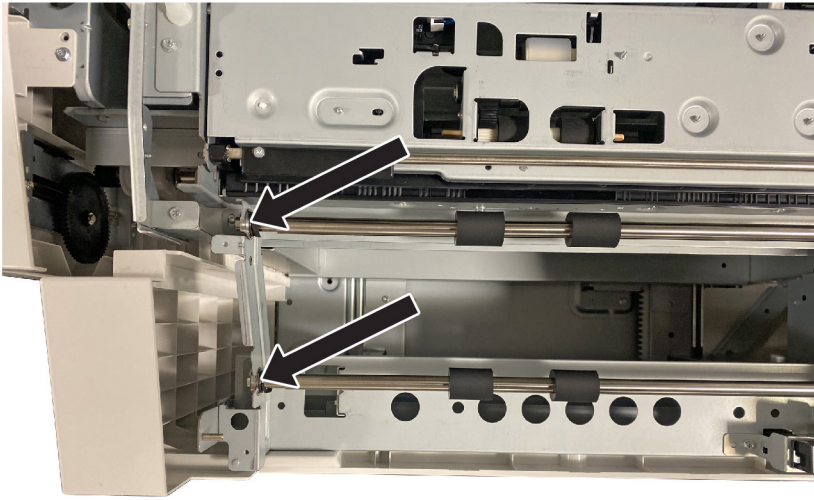

Q-1-0183-A

Figure 2 Removal of the KL-Clips

- Slide the front and rear bearings out of the frame (Figure 3).

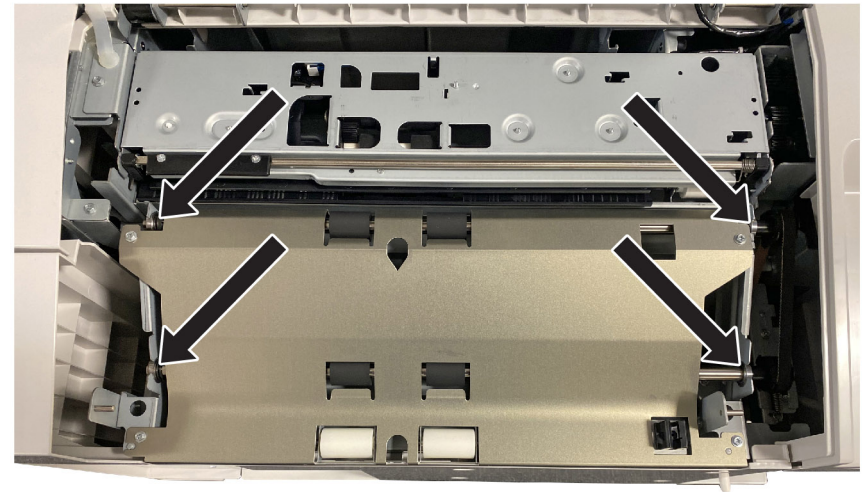

Q-1-0184-A

Figure 3 Removal of the Front and Rear Bearings

- Lift the takeaway rolls out of the frame.

Replacement

- The replacement is the reverse of the removal procedure.

REP 78.13 Top Chute Cover

Parts List on [PL 78.4](#)

Removal



WARNING: Do not perform repair activities with the power on or electrical power supplied to the machine. The machine could activate and cause serious personal injury when the power is on or electrical power is supplied.

Ne pas effectuer de dépannage avec le contact principal activé ou avec l'alimentation électrique appliquée à la machine: celle-ci pourrait démarrer et causer de graves blessures.

Non effettuare alcuna riparazione con la macchina accesa o con l'alimentazione elettrica inserita. La macchina potrebbe avviarsi all'improvviso e causare gravi ferite.

Es dürfen keine Reparaturarbeiten durchgeführt werden, solange das Gerät eingeschaltet oder mit der Stromquelle verbunden ist. Das Gerät kann u.U in den Aktiv-Zustand übergehen und somit erhebliche körperliche Schäden verursachen

No realice reparaciones con la máquina encendida o conectada a la corriente. La máquina podría activarse y ocasionar daños personales graves.

1. To remove the upper rear cover, remove 2 screws (Figure 1).



Q-1-0185-A

Figure 1 Removal of the Upper Rear Cover

2. Open the top chute cover. ([PL 78.4](#))

3. Remove the P/J connector (Figure 2).
 - a. Remove PJ7409 [1] from the PWB.
 - b. Unclip the harness [2] from the frame.

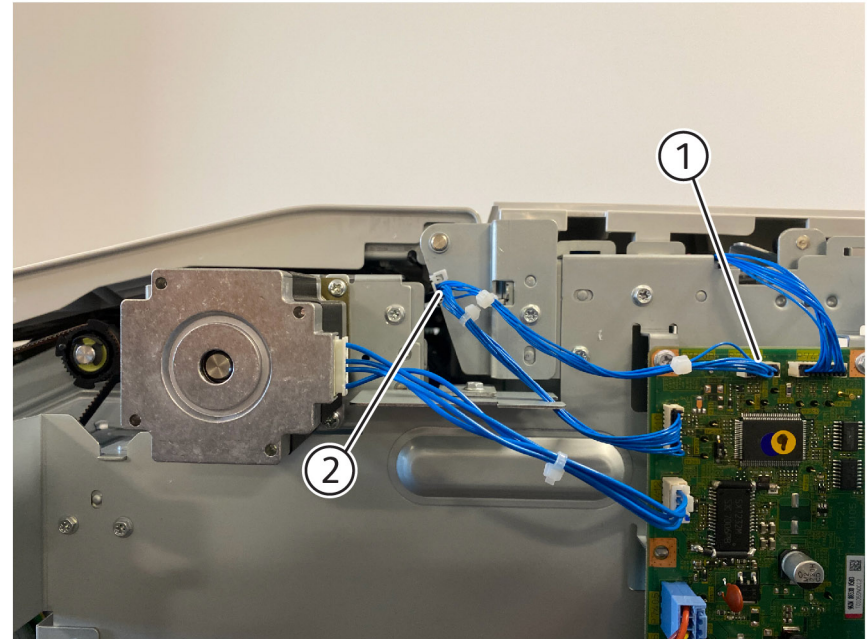

Q-1-0186-A

Figure 2 Removal of PJ 7409 from the PWB

4. To release the plastic strap from the feed head frame, rotate the strap 90 degrees counter-clockwise (Figure 3).

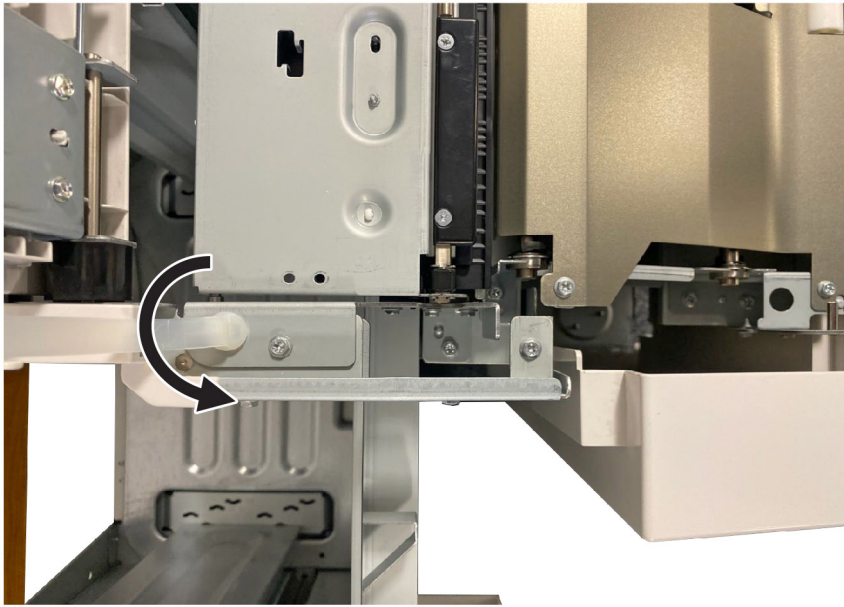

Q-1-0187-A

Figure 3 Removal of the Plastic Strap from the Feed Head Frame

5. Remove the C-clip and the hinge pin (Figure 4).
 - a. Remove the C-clip [1] from the rear hinge pin.
 - b. Slide the hinge pin [2] out of the frame, toward the rear of the HCF.

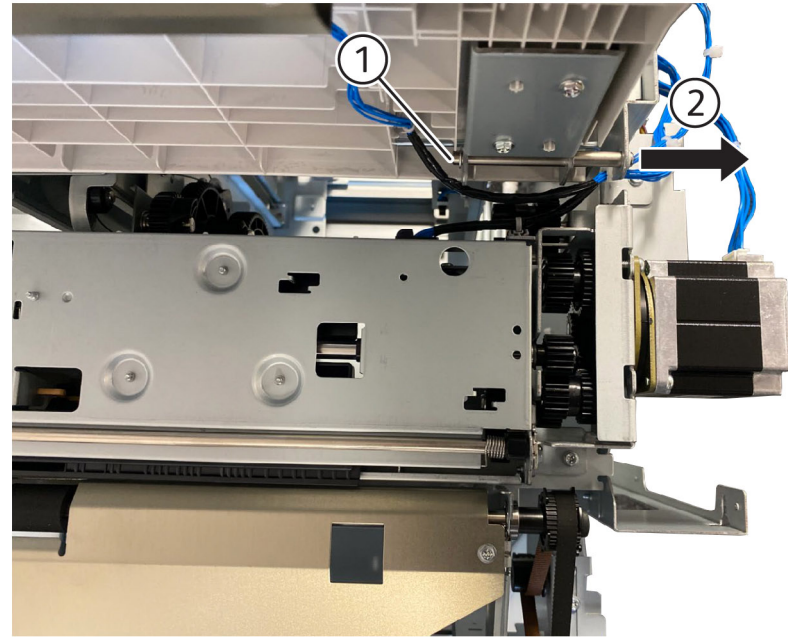

Q-1-0188-A

Figure 4 Removal of the C-Clip and the Hinge Pin

6. To release the top chute cover from the front hinge pin, lift the cover and slide it toward the rear of the HCF (Figure 5).

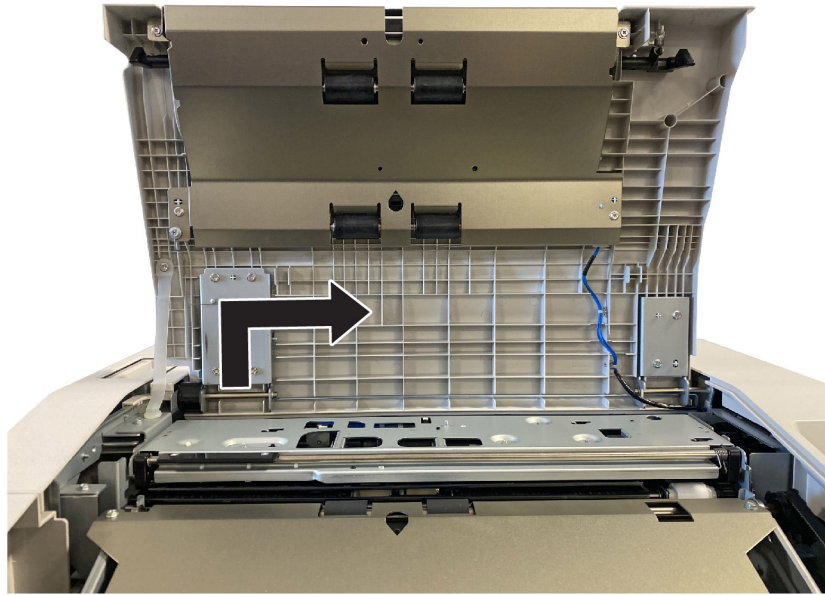

Q-1-0189-A

Figure 5 Removal of the Top Chute Cover

Replacement

1. The replacement is the reverse of the removal procedure.

REP 78.14 Shaft

Parts List on [PL 78.5](#)

Removal



WARNING: Do not perform repair activities with the power on or electrical power supplied to the machine. The machine could activate and cause serious personal injury when the power is on or electrical power is supplied.

Ne pas effectuer de dépannage avec le contact principal activé ou avec l'alimentation électrique appliquée à la machine: celle-ci pourrait démarrer et causer de graves blessures.

Non effettuare alcuna riparazione con la macchina accesa o con l'alimentazione elettrica inserita. La macchina potrebbe avviarsi all'improvviso e causare gravi ferite.

Es dürfen keine Reparaturarbeiten durchgeführt werden, solange das Gerät eingeschaltet oder mit der Stromquelle verbunden ist. Das Gerät kann u.U in den Aktiv-Zustand übergehen und somit erhebliche körperliche Schäden verursachen

No realice reparaciones con la máquina encendida o conectada a la corriente. La máquina podría activarse y ocasionar daños personales graves.

1. Remove the feed head assembly. ([REP 78.4](#))
2. Remove the drive gear assembly. ([REP 78.18](#))
3. Remove the shaft ([Figure 1](#)).

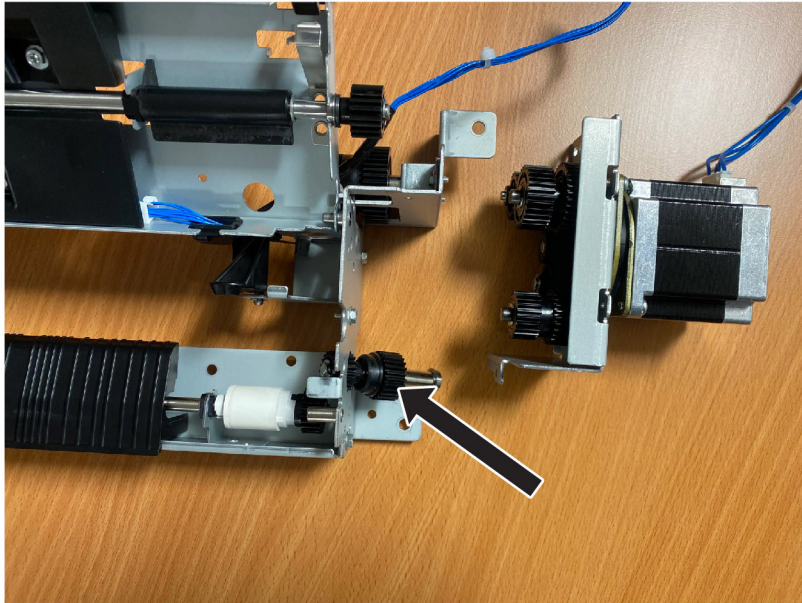

Q-1-0190-A

Figure 1 Removal of the Shaft

4. Remove the bearing from the rear end of the shaft.
5. Remove the C-clip from the front end of the shaft.
6. Remove the gear (19T), bearing, and gear (25T).

Replacement

1. The replacement is the reverse of the removal procedure.

REP 78.15 Gear

Parts List on [PL 78.5](#)

Removal



WARNING: Do not perform repair activities with the power on or electrical power supplied to the machine. The machine could activate and cause serious personal injury when the power is on or electrical power is supplied.

Ne pas effectuer de dépannage avec le contact principal activé ou avec l'alimentation électrique appliquée à la machine: celle-ci pourrait démarrer et causer de graves blessures.

Non effettuare alcuna riparazione con la macchina accesa o con l'alimentazione elettrica inserita. La macchina potrebbe avviarsi all'improvviso e causare gravi ferite.

Es dürfen keine Reparaturarbeiten durchgeführt werden, solange das Gerät eingeschaltet oder mit der Stromquelle verbunden ist. Das Gerät kann u.U in den Aktiv-Zustand übergehen und somit erhebliche körperliche Schäden verursachen

No realice reparaciones con la máquina encendida o conectada a la corriente. La máquina podría activarse y ocasionar daños personales graves.

1. Remove the drive gear assembly. ([REP 78.18](#))
2. To release the gear from the drive gear assembly, remove the C-clip then slide the gear off the shaft ([Figure 1](#)).

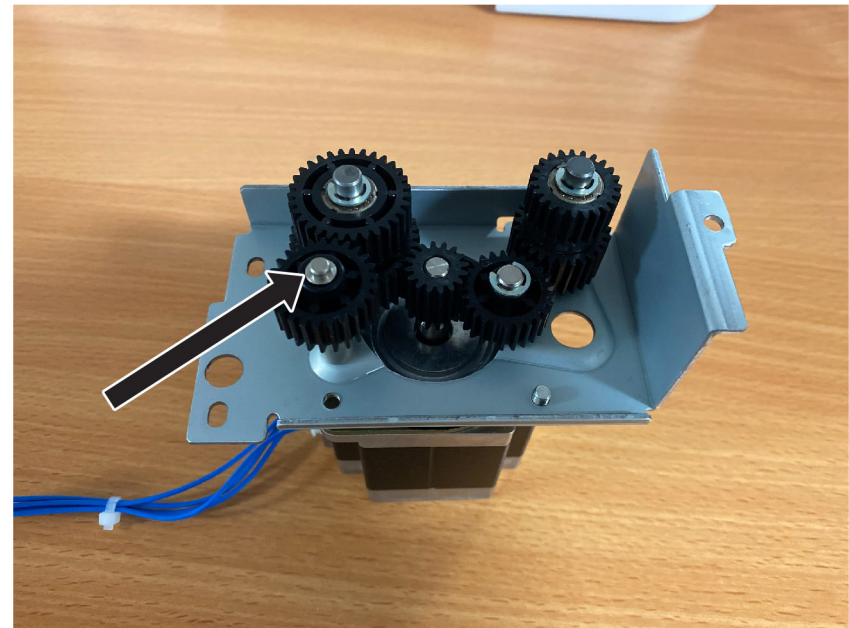

Q-1-0191-A

Figure 1 Removal of the Gear from the Drive Gear Assembly Replacement

1. The replacement is the reverse of the removal procedure.

REP 78.16 Gear

Parts List on [PL 78.5](#)

Removal



WARNING: Do not perform repair activities with the power on or electrical power supplied to the machine. The machine could activate and cause serious personal injury when the power is on or electrical power is supplied.

Ne pas effectuer de dépannage avec le contact principal activé ou avec l'alimentation électrique appliquée à la machine: celle-ci pourrait démarrer et causer de graves blessures.

Non effettuare alcuna riparazione con la macchina accesa o con l'alimentazione elettrica inserita. La macchina potrebbe avviarsi all'improvviso e causare gravi ferite.

Es dürfen keine Reparaturarbeiten durchgeführt werden, solange das Gerät eingeschalten oder mit der Stromquelle verbunden ist. Das Gerät kann u.U in den Aktiv-Zustand übergehen und somit erhebliche körperliche Schäden verursachen

No realice reparaciones con la máquina encendida o conectada a la corriente. La máquina podría activarse y ocasionar daños personales graves.

1. Remove the drive gear assembly. ([REP 78.18](#))
2. To release the gear from the feed head assembly, remove the C-clip then slide the gear off the shaft ([Figure 1](#)).

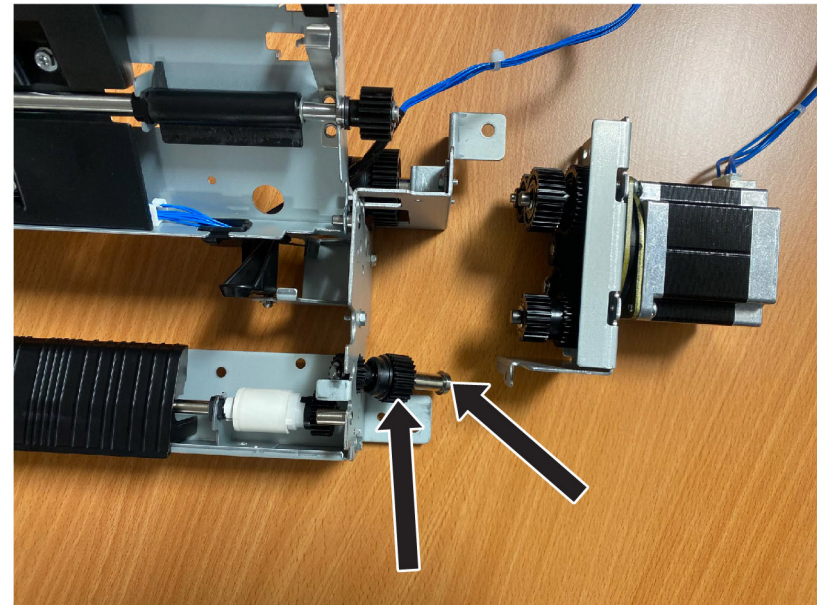

Q-1-0192-A

Figure 1 Removal of the Gear from the Feed Head Assembly Replacement

1. The replacement is the reverse of the removal procedure.

REP 78.17 Ball Bearing

Parts List on [PL 78.5](#)

Removal



WARNING: Do not perform repair activities with the power on or electrical power supplied to the machine. The machine could activate and cause serious personal injury when the power is on or electrical power is supplied.

Ne pas effectuer de dépannage avec le contact principal activé ou avec l'alimentation électrique appliquée à la machine: celle-ci pourrait démarrer et causer de graves blessures.

Non effettuare alcuna riparazione con la macchina accesa o con l'alimentazione elettrica inserita. La macchina potrebbe avviarsi all'improvviso e causare gravi ferite.

Es dürfen keine Reparaturarbeiten durchgeführt werden, solange das Gerät eingeschaltet oder mit der Stromquelle verbunden ist. Das Gerät kann u.U in den Aktiv-Zustand übergehen und somit erhebliche körperliche Schäden verursachen

No realice reparaciones con la máquina encendida o conectada a la corriente. La máquina podría activarse y ocasionar daños personales graves.

1. Remove the drive gear assembly. ([REP 78.18](#))
2. To release the ball bearing from the feed head assembly, remove the C-clip then slide the ball bearing off the shaft ([Figure 1](#)).

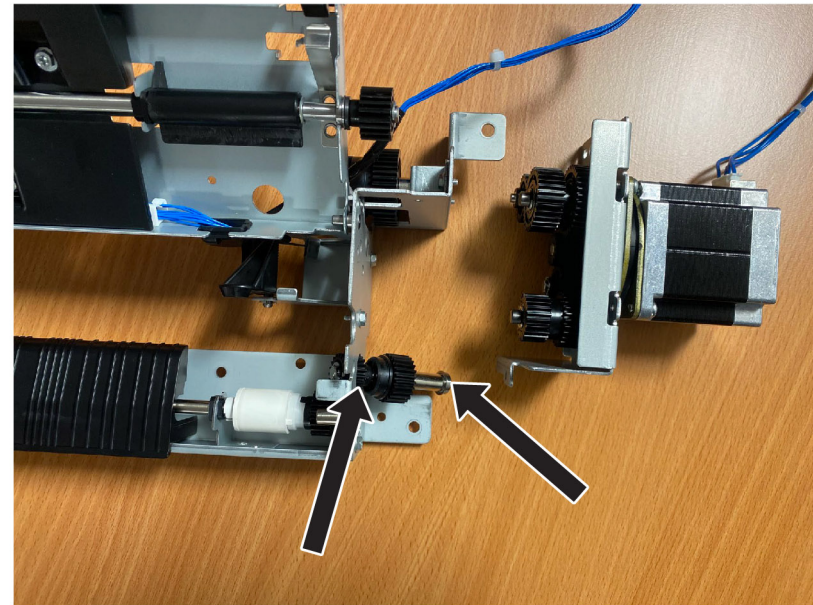

Q-1-0193-A

Figure 1 Removal of the Ball Bearing from the Feed Head Assembly**Replacement**

1. The replacement is the reverse of the removal procedure.

REP 78.18 Drive Gear AssemblyParts List on [PL 78.5](#)**Removal**

WARNING: Do not perform repair activities with the power on or electrical power supplied to the machine. The machine could activate and cause serious personal injury when the power is on or electrical power is supplied.

Ne pas effectuer de dépannage avec le contact principal activé ou avec l'alimentation électrique appliquée à la machine: celle-ci pourrait démarrer et causer de graves blessures.

Non effettuare alcuna riparazione con la macchina accesa o con l'alimentazione elettrica inserita. La macchina potrebbe avviarsi all'improvviso e causare gravi ferite.

Es dürfen keine Reparaturarbeiten durchgeführt werden, solange das Gerät eingeschaltet oder mit der Stromquelle verbunden ist. Das Gerät kann u.U in den Aktiv-Zustand übergehen und somit erhebliche körperliche Schäden verursachen

No realice reparaciones con la máquina encendida o conectada a la corriente. La máquina podría activarse y ocasionar daños personales graves.

1. Remove the feed head assembly. ([REP 78.4](#))
2. To remove the drive gear assembly, remove 3 screws ([Figure 1](#)).

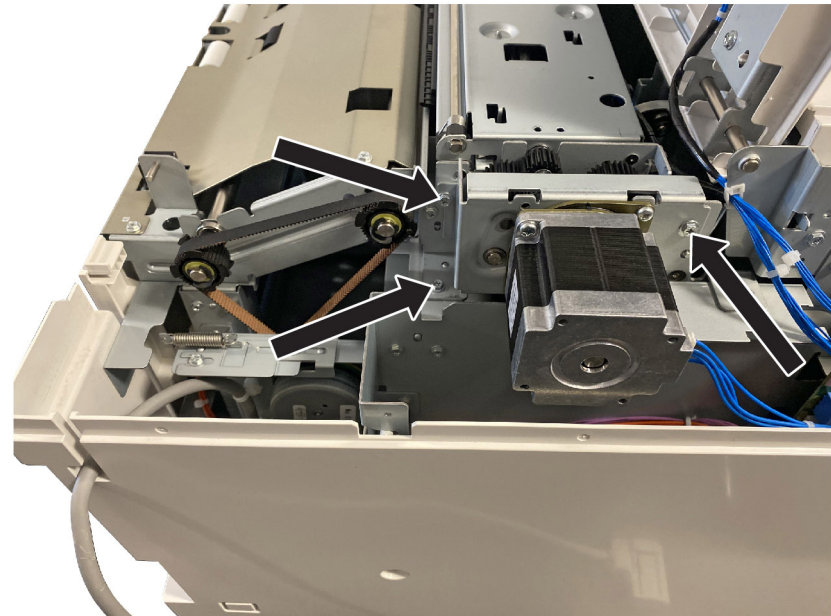

Q-1-0194-A

Figure 1 Removal of the Drive Gear Assembly

Replacement

1. The replacement is the reverse of the removal procedure.

REP 78.19 Upper Feeder Assembly

Parts List on [PL 78.6](#)

Removal



WARNING: Do not perform repair activities with the power on or electrical power supplied to the machine. The machine could activate and cause serious personal injury when the power is on or electrical power is supplied.

Ne pas effectuer de dépannage avec le contact principal activé ou avec l'alimentation électrique appliquée à la machine: celle-ci pourrait démarrer et causer de graves blessures.

Non effettuare alcuna riparazione con la macchina accesa o con l'alimentazione elettrica inserita. La macchina potrebbe avviarsi all'improvviso e causare gravi ferite.

Es dürfen keine Reparaturarbeiten durchgeführt werden, solange das Gerät eingeschalten oder mit der Stromquelle verbunden ist. Das Gerät kann u.U in den Aktiv-Zustand übergehen und somit erhebliche körperliche Schäden verursachen

No realice reparaciones con la máquina encendida o conectada a la corriente. La máquina podría activarse y ocasionar daños personales graves.

1. Remove the feed head assembly. ([REP 78.4](#))
2. Raise the upper feeder assembly.
3. Remove the cable clamp from the frame ([Figure 1](#)).

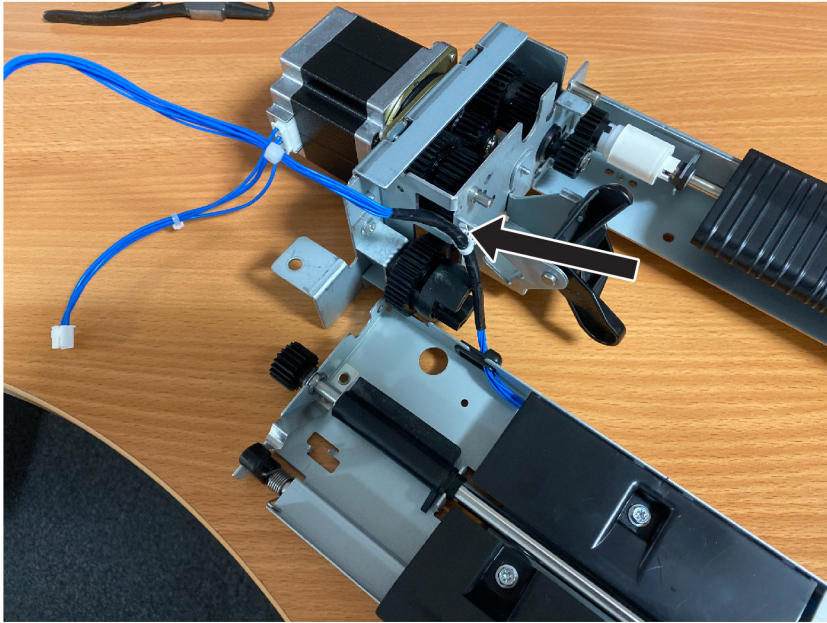

Q-1-0195-A

Figure 1 Removal of the Cable Clamp from the Frame

4. Prepare to remove the upper feeder assembly (Figure 2).
 - a. Remove the C-clip [1] from the front hinge pin.
 - b. To release the front hinge, gently flex [2] the front of the feed head frame.

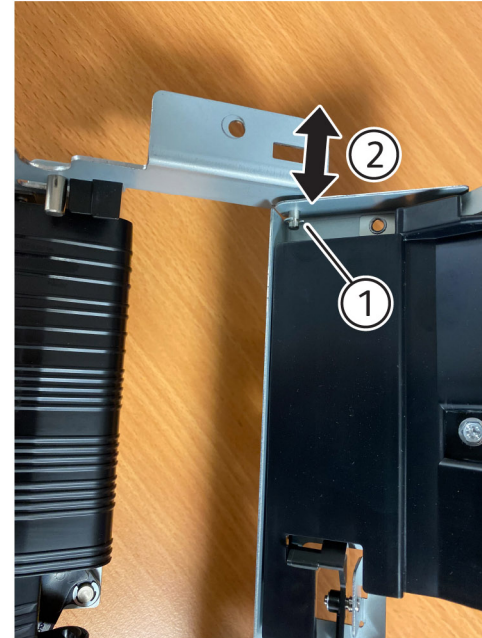

Q-1-0196-A

Figure 2 Removal of the Upper Feeder Assembly

5. To release the rear hinge, slide the upper feeder assembly off the rear hinge pin.

Replacement

1. The replacement is the reverse of the removal procedure.

REP 78.20 Feed Shaft Assembly

Parts List on [PL 78.6](#)

Removal



WARNING: Do not perform repair activities with the power on or electrical power supplied to the machine. The machine could activate and cause serious personal injury when the power is on or electrical power is supplied.

Ne pas effectuer de dépannage avec le contact principal activé ou avec l'alimentation électrique appliquée à la machine: celle-ci pourrait démarrer et causer de graves blessures.

Non effettuare alcuna riparazione con la macchina accesa o con l'alimentazione elettrica inserita. La macchina potrebbe avviarsi all'improvviso e causare gravi ferite.

Es dürfen keine Reparaturarbeiten durchgeführt werden, solange das Gerät eingeschaltet oder mit der Stromquelle verbunden ist. Das Gerät kann u.U in den Aktiv-Zustand übergehen und somit erhebliche körperliche Schäden verursachen

No realice reparaciones con la máquina encendida o conectada a la corriente. La máquina podría activarse y ocasionar daños personales graves.

1. Raise the top chute cover.
2. Raise the upper feeder assembly.
3. Prepare to remove the feed shaft assembly (Figure 1).
 - a. Remove the feed roller [1].
 - b. Remove the C-clip [2] from the front of the shaft.
 - c. Remove the bearing [3] from the front of the shaft.
 - d. Slide the shaft [4] out of the frame toward the rear of the HCF.

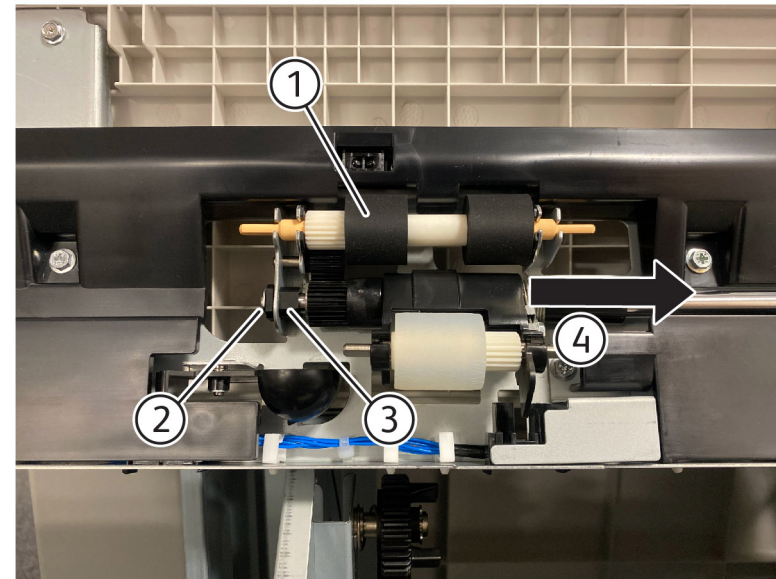

Q-1-0197-A

Figure 1 Removal of the Feed Shaft Assembly

4. Remove the feed shaft assembly.

Note: For the replacement procedure, observe the alignment of the spring and the lever.

Replacement

1. The replacement is the reverse of the removal procedure.

REP 78.21 Ball Bearing

Parts List on [PL 78.6](#)

Removal



WARNING: Do not perform repair activities with the power on or electrical power supplied to the machine. The machine could activate and cause serious personal injury when the power is on or electrical power is supplied.

Ne pas effectuer de dépannage avec le contact principal activé ou avec l'alimentation électrique appliquée à la machine: celle-ci pourrait démarrer et causer de graves blessures.

Non effettuare alcuna riparazione con la macchina accesa o con l'alimentazione elettrica inserita. La macchina potrebbe avviarsi all'improvviso e causare gravi ferite.

Es dürfen keine Reparaturarbeiten durchgeführt werden, solange das Gerät eingeschaltet oder mit der Stromquelle verbunden ist. Das Gerät kann u.U in den Aktiv-Zustand übergehen und somit erhebliche körperliche Schäden verursachen

No realice reparaciones con la máquina encendida o conectada a la corriente. La máquina podría activarse y ocasionar daños personales graves.

1. Remove the feed shaft assembly. ([REP 78.20](#))
2. Remove the C-clip from the rear of the shaft ([Figure 1](#)).

3. Slide the gear off the feed shaft.
4. Slide the ball bearing off the feed shaft.

Replacement

1. The replacement is the reverse of the removal procedure.

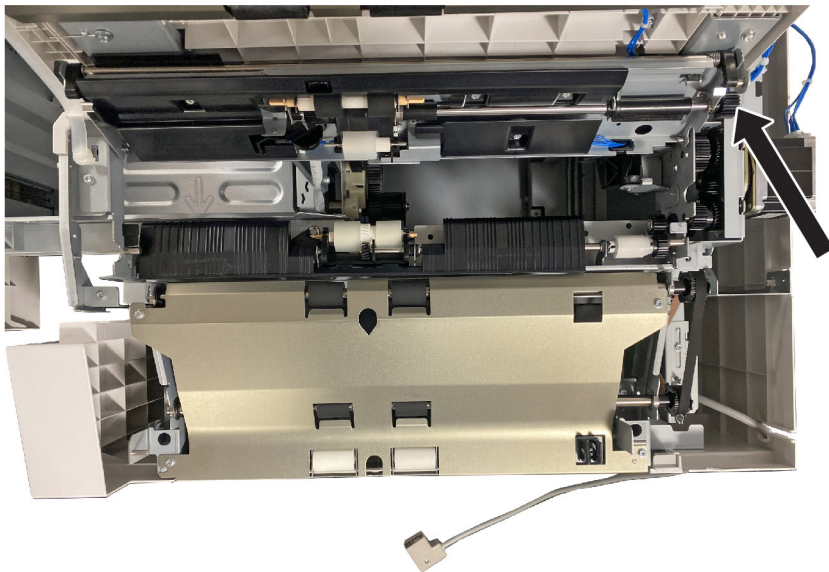

Q-1-0198-A

Figure 1 Removal of the C-Clip from the Feed Shaft Assembly

REP 78.22 Feed Gear

Parts List on [PL 78.6](#)

Removal



WARNING: Do not perform repair activities with the power on or electrical power supplied to the machine. The machine could activate and cause serious personal injury when the power is on or electrical power is supplied.

Ne pas effectuer de dépannage avec le contact principal activé ou avec l'alimentation électrique appliquée à la machine: celle-ci pourrait démarrer et causer de graves blessures.

Non effettuare alcuna riparazione con la macchina accesa o con l'alimentazione elettrica inserita. La macchina potrebbe avviarsi all'improvviso e causare gravi ferite.

Es dürfen keine Reparaturarbeiten durchgeführt werden, solange das Gerät eingeschaltet oder mit der Stromquelle verbunden ist. Das Gerät kann u.U in den Aktiv-Zustand übergehen und somit erhebliche körperliche Schäden verursachen

No realice reparaciones con la máquina encendida o conectada a la corriente. La máquina podría activarse y ocasionar daños personales graves.

1. Open the top chute cover.
2. Raise the upper feeder assembly.
3. Remove the feed roll ([Figure 1](#)).

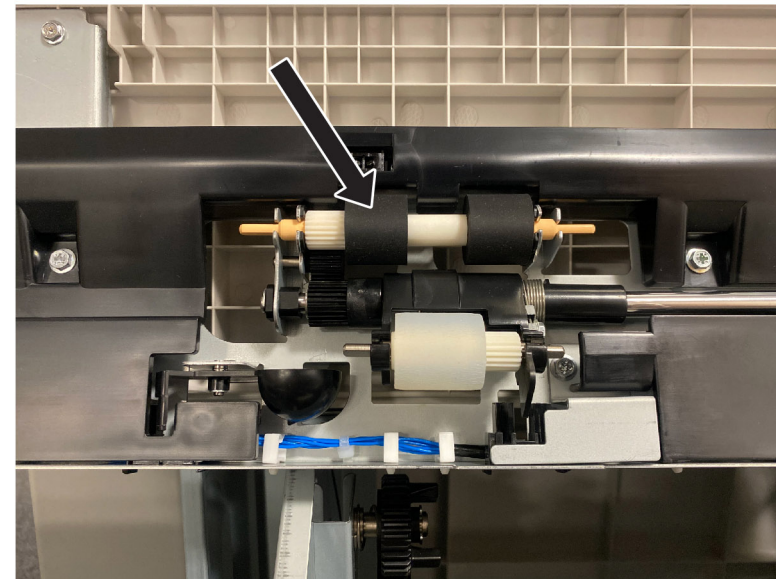

Q-1-0199-A

Figure 1 Removal of the Feed Roll

4. Lower the upper feeder assembly.
5. Remove the C-clip and the shaft ([Figure 2](#)).
 - a. Remove the small C-clip [1] from the shaft.
 - b. Slide the shaft [2] out of the frame toward the rear of the HCF.

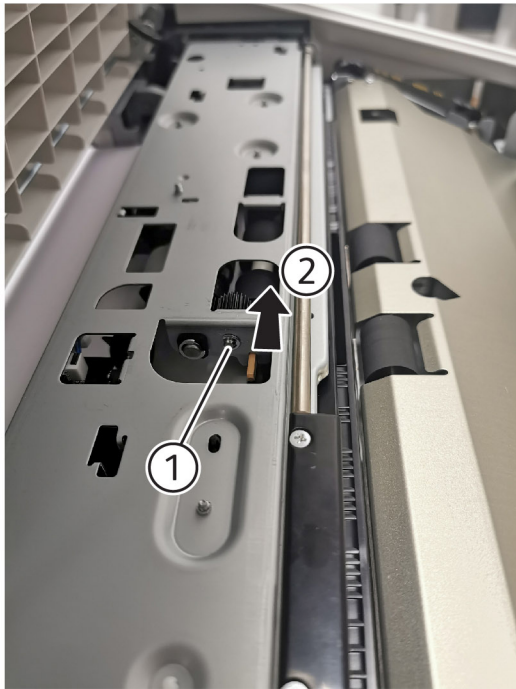

Figure 2 Removal of the C-Clip and the Shaft

6. Slide the feed gear off the shaft.

Replacement

1. The replacement is the reverse of the removal procedure.

REP 78.23 Level Sensor

Parts List on [PL 78.6](#)

Removal



WARNING: Do not perform repair activities with the power on or electrical power supplied to the machine. The machine could activate and cause serious personal injury when the power is on or electrical power is supplied.

Ne pas effectuer de dépannage avec le contact principal activé ou avec l'alimentation électrique appliquée à la machine: celle-ci pourrait démarrer et causer de graves blessures.

Non effettuare alcuna riparazione con la macchina accesa o con l'alimentazione elettrica inserita. La macchina potrebbe avviarsi all'improvviso e causare gravi ferite.

Es dürfen keine Reparaturarbeiten durchgeführt werden, solange das Gerät eingeschaltet oder mit der Stromquelle verbunden ist. Das Gerät kann u.U in den Aktiv-Zustand übergehen und somit erhebliche körperliche Schäden verursachen

No realice reparaciones con la máquina encendida o conectada a la corriente. La máquina podría activarse y ocasionar daños personales graves.

1. Open the top chute cover.
2. Raise the upper feeder assembly.
3. To remove the rear upper chute, remove 1 screw ([Figure 1](#)).

Q-1-0200-A

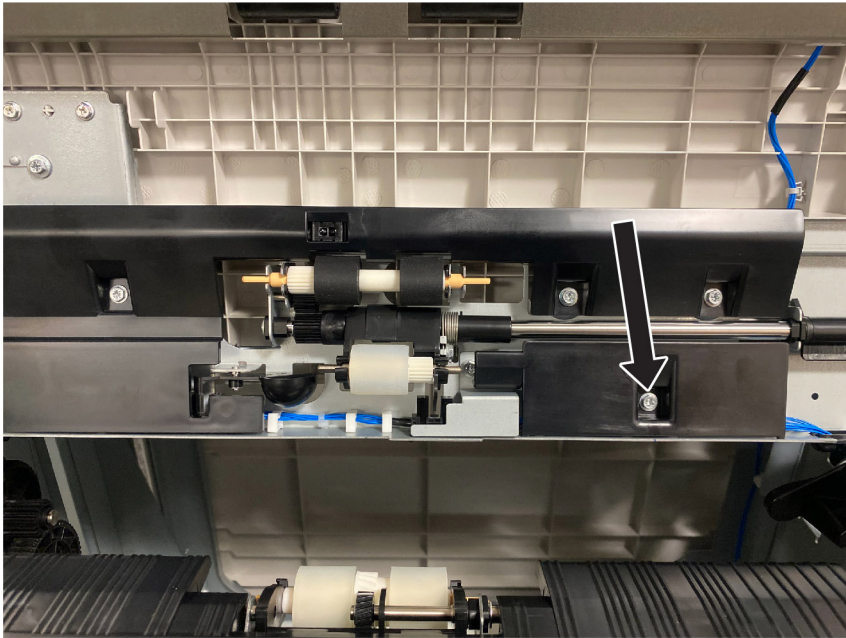

Q-1-0201-A

Figure 1 Removal of the Rear Upper Chute

4. To remove the metal bracket, remove 1 screw (Figure 2).



Q-1-0202-A

Figure 2 Removal of the Metal Bracket

5. Remove the level sensor (Figure 3).
 - a. Unplug the sensor [1].
 - b. Unclip the sensor [2] from the frame.

REP 78.24 No Paper Sensor

Parts List on [PL 78.6](#)

Removal



WARNING: Do not perform repair activities with the power on or electrical power supplied to the machine. The machine could activate and cause serious personal injury when the power is on or electrical power is supplied.

Ne pas effectuer de dépannage avec le contact principal activé ou avec l'alimentation électrique appliquée à la machine: celle-ci pourrait démarrer et causer de graves blessures.

Non effettuare alcuna riparazione con la macchina accesa o con l'alimentazione elettrica inserita. La macchina potrebbe avviarsi all'improvviso e causare gravi ferite.

Es dürfen keine Reparaturarbeiten durchgeführt werden, solange das Gerät eingeschaltet oder mit der Stromquelle verbunden ist. Das Gerät kann u.U in den Aktiv-Zustand übergehen und somit erhebliche körperliche Schäden verursachen

No realice reparaciones con la máquina encendida o conectada a la corriente. La máquina podría activarse y ocasionar daños personales graves.

1. Open the top chute cover.
2. Raise the upper feeder assembly.
3. To remove the upper chute, remove 3 screws ([Figure 1](#)).

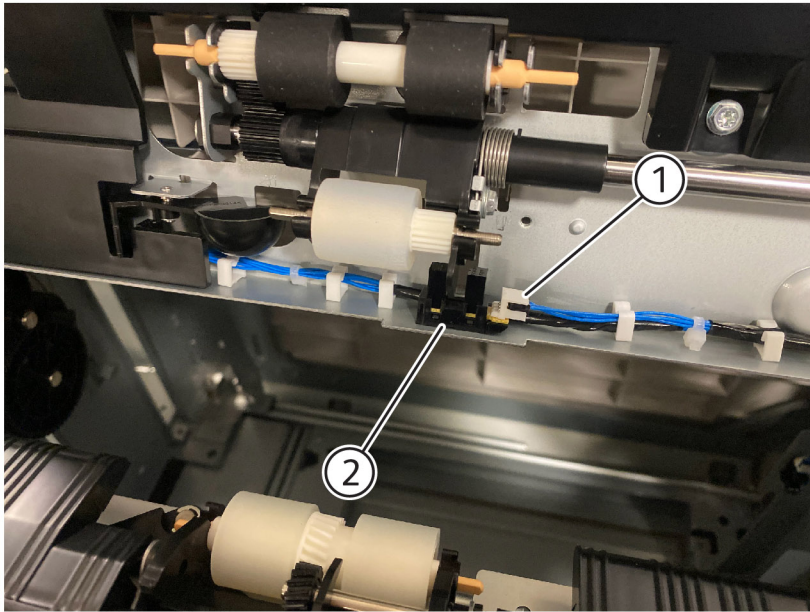

Q-1-0203-A

Figure 3 Removal of the Level Sensor

Replacement

1. The replacement is the reverse of the removal procedure.

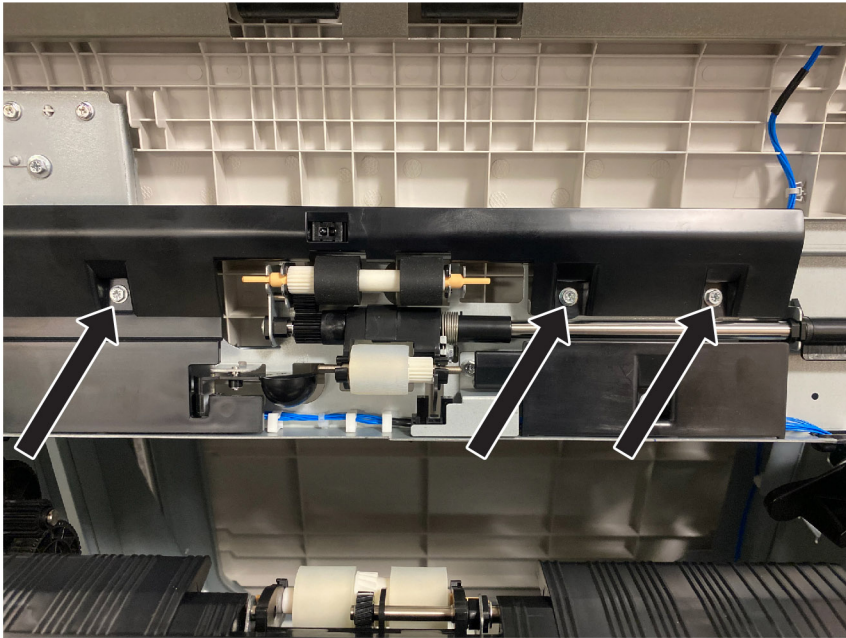

Q-1-0204-A

Figure 1 Removal of the Upper Chute

4. Remove the no paper sensor (Figure 2).
 - a. Unplug the sensor [1].
 - b. Unclip the sensor [2] from the frame.

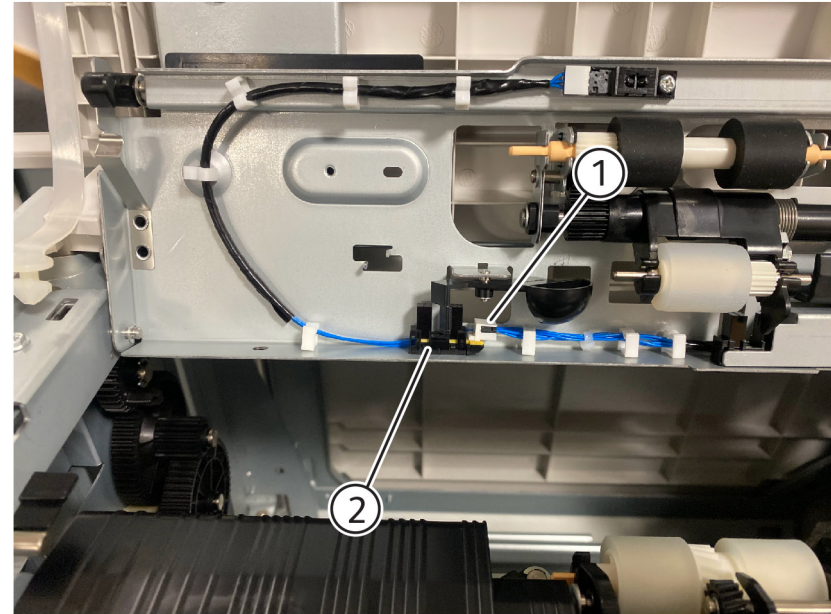

Q-1-0205-A

Figure 2 Removal of the No Paper Sensor**Replacement**

1. The replacement is the reverse of the removal procedure.

REP 78.25 Pre Feed Sensor

Parts List on [PL 78.6](#)

Removal



WARNING: Do not perform repair activities with the power on or electrical power supplied to the machine. The machine could activate and cause serious personal injury when the power is on or electrical power is supplied.

Ne pas effectuer de dépannage avec le contact principal activé ou avec l'alimentation électrique appliquée à la machine: celle-ci pourrait démarrer et causer de graves blessures.

Non effettuare alcuna riparazione con la macchina accesa o con l'alimentazione elettrica inserita. La macchina potrebbe avviarsi all'improvviso e causare gravi ferite.

Es dürfen keine Reparaturarbeiten durchgeführt werden, solange das Gerät eingeschaltet oder mit der Stromquelle verbunden ist. Das Gerät kann u.U in den Aktiv-Zustand übergehen und somit erhebliche körperliche Schäden verursachen

No realice reparaciones con la máquina encendida o conectada a la corriente. La máquina podría activarse y ocasionar daños personales graves.

1. Open the top chute cover.
2. Raise the upper feeder assembly.
3. To remove the upper chute, remove 3 screws (Figure 1).

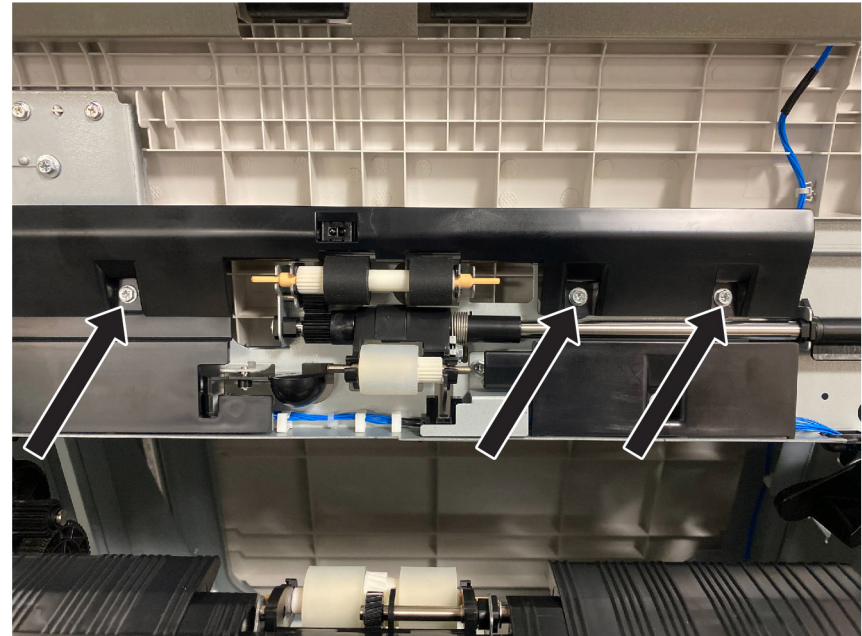

Q-1-0204-A

Figure 1 Removal of the Upper Chute

4. Remove the pre feed sensor (Figure 2).
 - a. Unplug the sensor [1].
 - b. To remove the sensor from the frame, remove 1 screw [2].

REP 78.26 Lower Feeder Assembly

Parts List on [PL 78.7](#)

Removal



WARNING: Do not perform repair activities with the power on or electrical power supplied to the machine. The machine could activate and cause serious personal injury when the power is on or electrical power is supplied.

Ne pas effectuer de dépannage avec le contact principal activé ou avec l'alimentation électrique appliquée à la machine: celle-ci pourrait démarrer et causer de graves blessures.

Non effettuare alcuna riparazione con la macchina accesa o con l'alimentazione elettrica inserita. La macchina potrebbe avviarsi all'improvviso e causare gravi ferite.

Es dürfen keine Reparaturarbeiten durchgeführt werden, solange das Gerät eingeschalten oder mit der Stromquelle verbunden ist. Das Gerät kann u.U in den Aktiv-Zustand übergehen und somit erhebliche körperliche Schäden verursachen

No realice reparaciones con la máquina encendida o conectada a la corriente. La máquina podría activarse y ocasionar daños personales graves.

1. Remove the feed head. ([REP 78.4](#))
2. Remove the upper feeder assembly. ([REP 78.19](#))
3. To release the lower feeder assembly, remove the drive gear assembly. ([REP 78.18](#))

Replacement

1. The replacement is the reverse of the removal procedure.

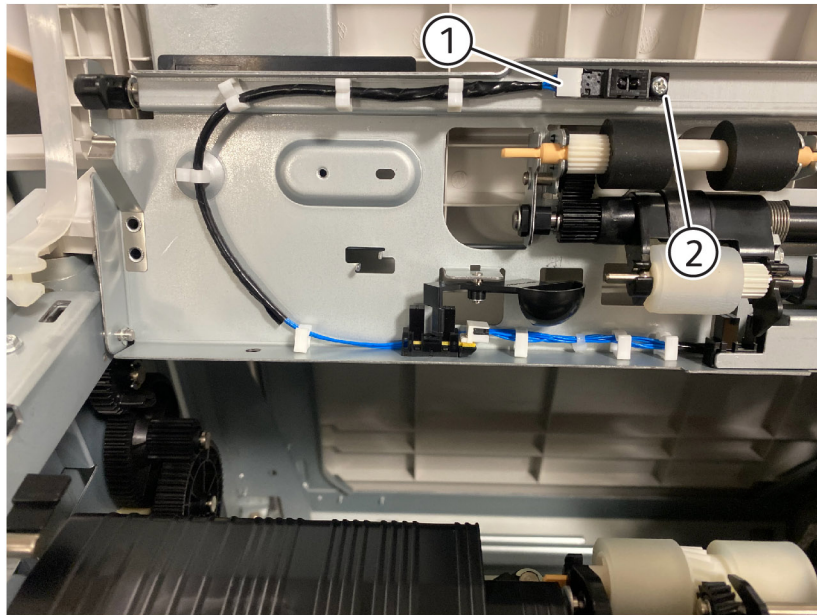

Q-1-0206-A

Figure 2 Removal of the Pre Feed Sensor

Replacement

1. The replacement is the reverse of the removal procedure.

REP 78.27 Retard Shaft Assembly

Parts List on [PL 78.7](#)

Removal



WARNING: Do not perform repair activities with the power on or electrical power supplied to the machine. The machine could activate and cause serious personal injury when the power is on or electrical power is supplied.

Ne pas effectuer de dépannage avec le contact principal activé ou avec l'alimentation électrique appliquée à la machine: celle-ci pourrait démarrer et causer de graves blessures.

Non effettuare alcuna riparazione con la macchina accesa o con l'alimentazione elettrica inserita. La macchina potrebbe avviarsi all'improvviso e causare gravi ferite.

Es dürfen keine Reparaturarbeiten durchgeführt werden, solange das Gerät eingeschaltet oder mit der Stromquelle verbunden ist. Das Gerät kann u.U in den Aktiv-Zustand übergehen und somit erhebliche körperliche Schäden verursachen

No realice reparaciones con la máquina encendida o conectada a la corriente. La máquina podría activarse y ocasionar daños personales graves.

1. Remove the feed head. ([REP 78.4](#))
2. Raise the upper feeder assembly.
3. Remove the drive gear assembly. ([REP 78.18](#))
4. To remove the lower chute, remove 4 screws from the right side of the feed head ([Figure 1](#)).

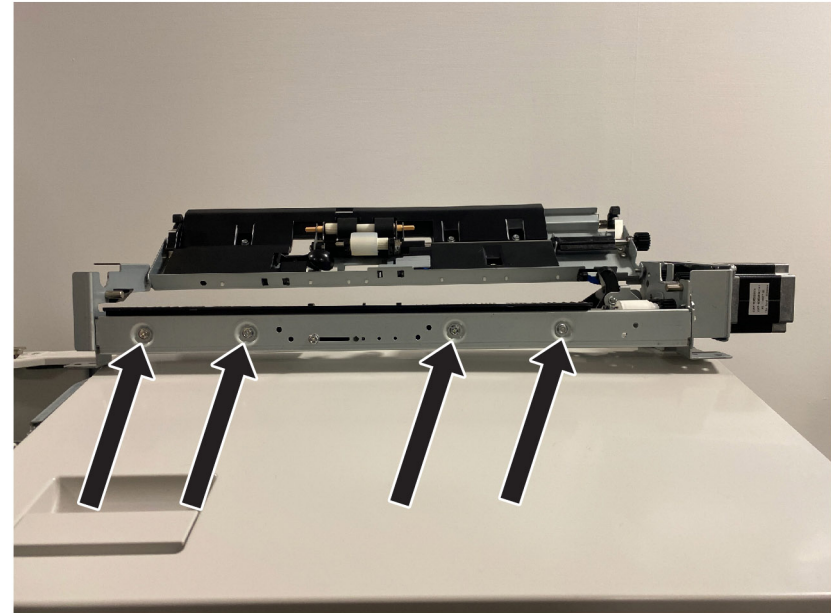

Q-1-0207-A

Figure 1 Removal of the Lower Chute

5. Remove 2 C-clips from the rear of the shaft ([Figure 2](#)).

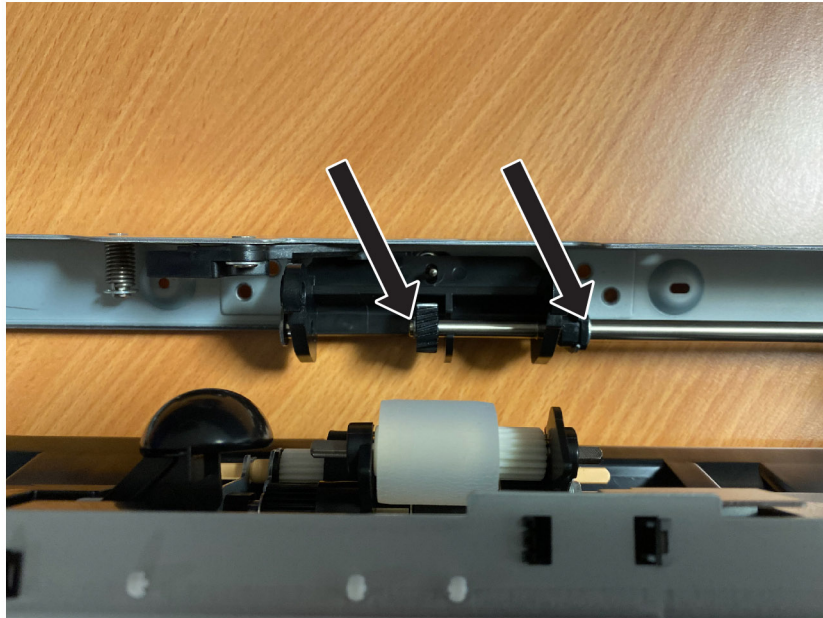

Q-1-0208-A

Figure 2 Removal of the C-Clips from the Rear of the Shaft

6. Slide the bearings off the shaft.
7. Remove the retard shaft assembly from the frame.

Note: For the replacement procedure, observe the alignment of the spring and the lever.

Replacement

1. The replacement is the reverse of the removal procedure.

REP 78.28 Casters and Adjuster Feet

Parts List on [PL 78.8](#)

Removal



WARNING: Do not perform repair activities with the power on or electrical power supplied to the machine. The machine could activate and cause serious personal injury when the power is on or electrical power is supplied.

Ne pas effectuer de dépannage avec le contact principal activé ou avec l'alimentation électrique appliquée à la machine: celle-ci pourrait démarrer et causer de graves blessures.

Non effettuare alcuna riparazione con la macchina accesa o con l'alimentazione elettrica inserita. La macchina potrebbe avviarsi all'improvviso e causare gravi ferite.

Es dürfen keine Reparaturarbeiten durchgeführt werden, solange das Gerät eingeschaltet oder mit der Stromquelle verbunden ist. Das Gerät kann u.U in den Aktiv-Zustand übergehen und somit erhebliche körperliche Schäden verursachen

No realice reparaciones con la máquina encendida o conectada a la corriente. La máquina podría activarse y ocasionar daños personales graves.

1. Undock the HCF from the IOT.
2. Remove the HCF tray assembly. ([REP 78.3](#))
3. To expose the casters and adjuster feet, place the HCF on a flat surface with the right side face up.
4. Remove the casters and adjuster feed ([Figure 1](#)).
 - a. To remove the casters [1], remove 3 screws per caster.
 - b. To remove the adjuster feet, unscrew each foot [2] from the frame.

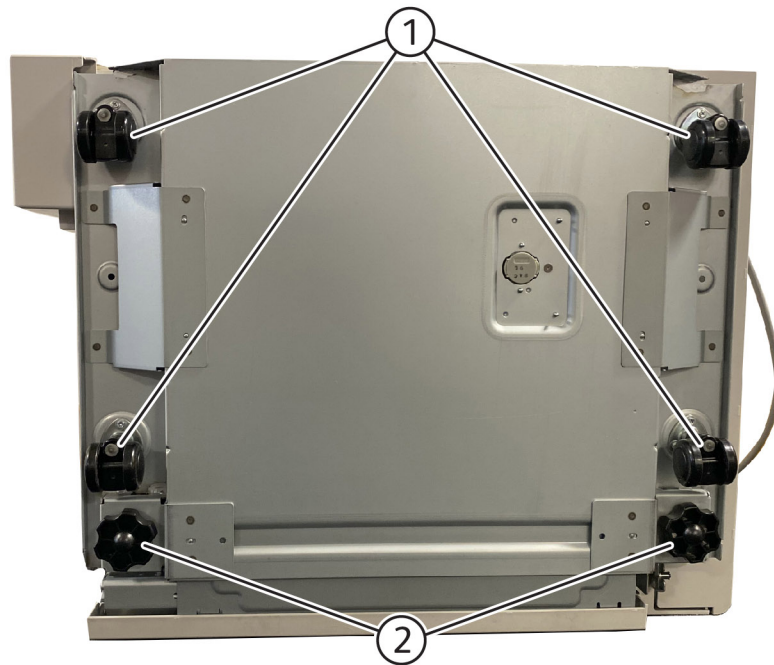

Q-1-0209-A

Figure 1 Removal of the Casters and Adjuster Feet**Replacement**

1. The replacement is the reverse of the removal procedure.

REP 78.29 Rail AssemblyParts List on [PL 78.8](#)**Removal**

WARNING: Do not perform repair activities with the power on or electrical power supplied to the machine. The machine could activate and cause serious personal injury when the power is on or electrical power is supplied.

Ne pas effectuer de dépannage avec le contact principal activé ou avec l'alimentation électrique appliquée à la machine: celle-ci pourrait démarrer et causer de graves blessures.

Non effettuare alcuna riparazione con la macchina accesa o con l'alimentazione elettrica inserita. La macchina potrebbe avviarsi all'improvviso e causare gravi ferite.

Es dürfen keine Reparaturarbeiten durchgeführt werden, solange das Gerät eingeschaltet oder mit der Stromquelle verbunden ist. Das Gerät kann u.U in den Aktiv-Zustand übergehen und somit erhebliche körperliche Schäden verursachen

No realice reparaciones con la máquina encendida o conectada a la corriente. La máquina podría activarse y ocasionar daños personales graves.

1. Undock the HCF from the IOT.
2. Remove the HCF tray assembly. ([REP 78.3](#))
3. To expose the base, place the HCF on a flat surface with the underside face up.
4. Expose the rail assembly ([Figure 1](#)).
 - a. To allow the base to slide freely, push down on the latch bar [1].
 - b. Slide the base [2] fully toward the right side of the HCF.

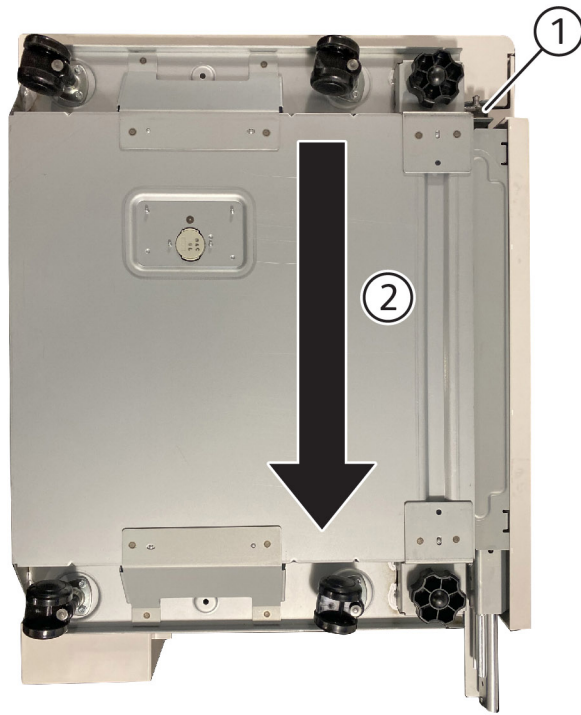

Q-1-0210-A

Figure 1 Exposure of the Rail Assembly

5. Remove the base (Figure 2).
 - a. Using a small screwdriver or other small, blunt instrument, press the catch to release the stopper on each rail [1].
 - b. To release the base from the HCF frame, slide the base off the rail guides [2].

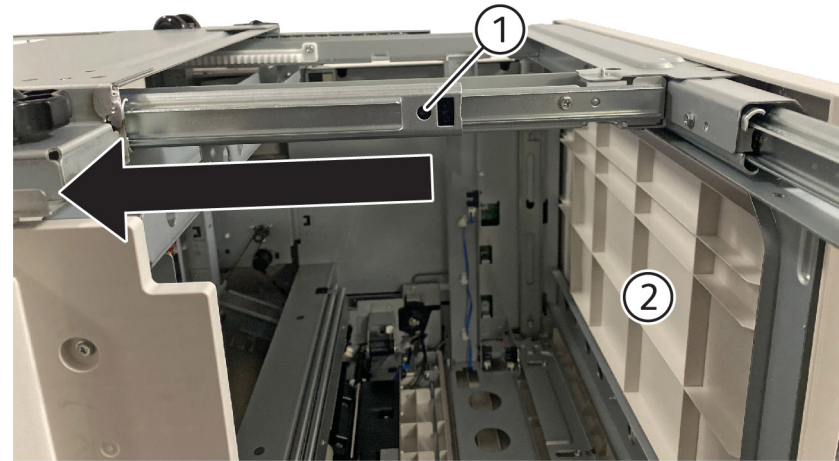

Q-1-0211-A

Figure 2 Removal of the Base

6. To release each rail from the base, remove 3 screws per rail (Figure 3).

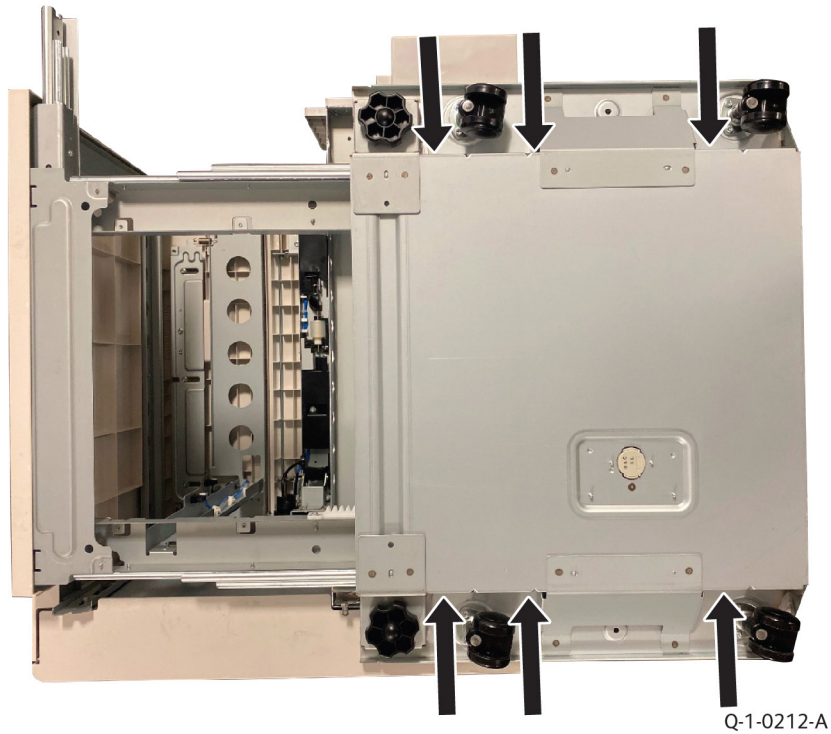

Figure 3 Removal of the Rail Assembly (x2)

Replacement

1. The replacement is the reverse of the removal procedure.

REP 78.30 Gear Rack

Parts List on [PL 78.8](#)

Removal



WARNING: Do not perform repair activities with the power on or electrical power supplied to the machine. The machine could activate and cause serious personal injury when the power is on or electrical power is supplied.

Ne pas effectuer de dépannage avec le contact principal activé ou avec l'alimentation électrique appliquée à la machine: celle-ci pourrait démarrer et causer de graves blessures.

Non effettuare alcuna riparazione con la macchina accesa o con l'alimentazione elettrica inserita. La macchina potrebbe avviarsi all'improvviso e causare gravi ferite.

Es dürfen keine Reparaturarbeiten durchgeführt werden, solange das Gerät eingeschaltet oder mit der Stromquelle verbunden ist. Das Gerät kann u.U in den Aktiv-Zustand übergehen und somit erhebliche körperliche Schäden verursachen

No realice reparaciones con la máquina encendida o conectada a la corriente. La máquina podría activarse y ocasionar daños personales graves.

1. To remove the left cover, remove 3 screws (Figure 1).



Q-1-0213-A

Figure 1 Removal of the Left Cover

2. Open the HCF paper tray fully.

3. Remove 1 screw from the left side of the gear rack (Figure 2).



Q-1-0214-A

Figure 2 Removal of 1 Screw from the Left Side of the Gear Rack

4. Lift the handle on the top left side of the HCF, then pull the HCF fully to the left.
5. Remove 1 screw from the right side of the gear rack (Figure 3).

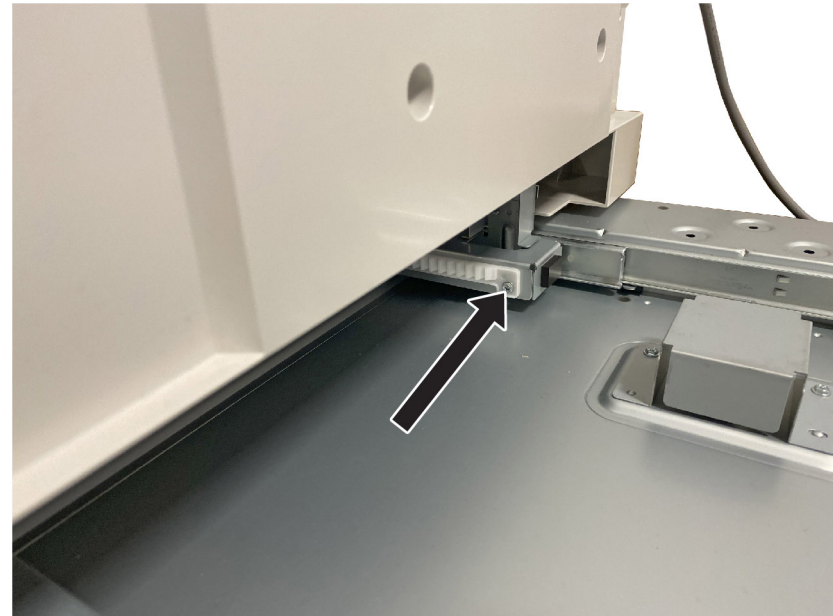

Q-1-0215-A

Figure 3 Removal of 1 Screw from the Right Side of the Gear Rack

6. Remove the gear rack.

Replacement

1. The replacement is the reverse of the removal procedure.

REP 78.31 Drive Assembly

Parts List on [PL 78.8](#)

Removal



WARNING: Do not perform repair activities with the power on or electrical power supplied to the machine. The machine could activate and cause serious personal injury when the power is on or electrical power is supplied.

Ne pas effectuer de dépannage avec le contact principal activé ou avec l'alimentation électrique appliquée à la machine: celle-ci pourrait démarrer et causer de graves blessures.

Non effettuare alcuna riparazione con la macchina accesa o con l'alimentazione elettrica inserita. La macchina potrebbe avviarsi all'improvviso e causare gravi ferite.

Es dürfen keine Reparaturarbeiten durchgeführt werden, solange das Gerät eingeschaltet oder mit der Stromquelle verbunden ist. Das Gerät kann u.U in den Aktiv-Zustand übergehen und somit erhebliche körperliche Schäden verursachen

No realice reparaciones con la máquina encendida o conectada a la corriente. La máquina podría activarse y ocasionar daños personales graves.

1. Lift the handle on the top left side of the HCF, then pull the HCF fully to the left.
2. Loosen 2 screws on the right side of the HCF ([Figure 1](#)).

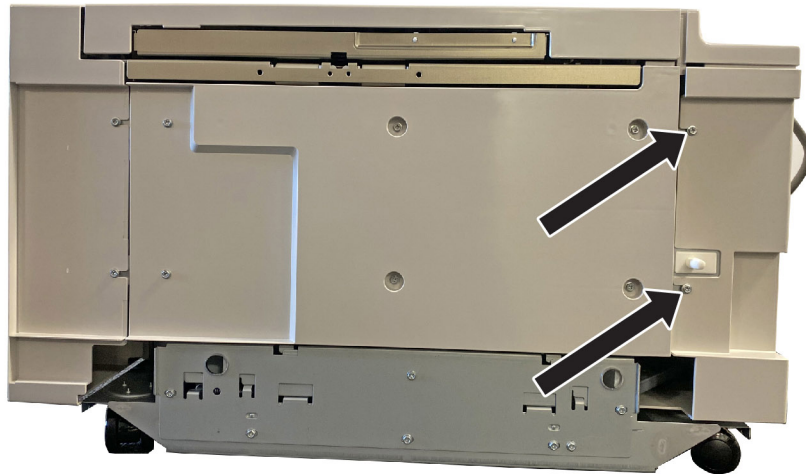

Q-1-0216-A

Figure 1 Loosening of 2 screws on the right side of the HCF

3. Remove the upper and lower rear covers ([Figure 2](#)).
 - a. To remove the upper rear cover, remove 2 screws [1].
 - b. To remove the lower rear cover, remove 3 screws [2].

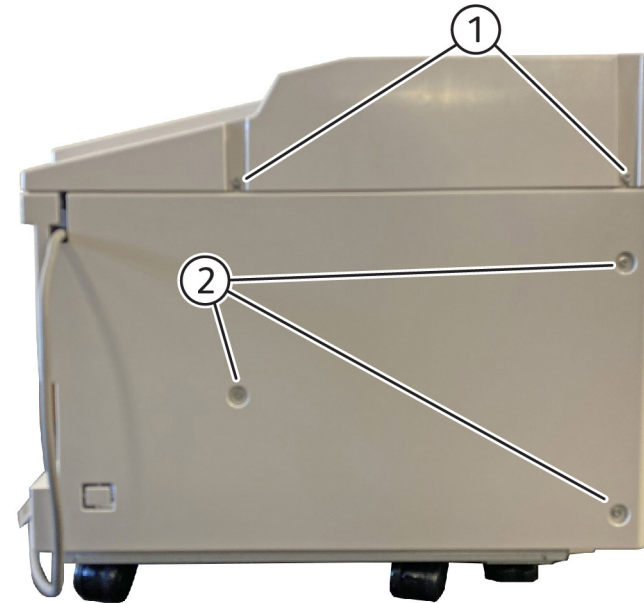

Q-1-0217-A

Figure 2 Removal of the Upper Rear Cover and the Lower Rear Cover

4. Remove the drive assembly ([Figure 3](#)).
 - a. To detension the takeaway rolls belt, loosen 2 screws [1].
 - b. Remove 2 PJ connectors [2] from the motor PWB.
 - c. To remove the cable harness, remove 2 cable clips [3] from the drive assembly.
 - d. To remove the comms cable, remove 2 cable clips [4] from the drive assembly.
 - e. To remove the drive assembly, remove 4 screws [5].

REP 78.32 Paper Size Sensors and Tray In Sensor

Parts List on [PL 78.8](#)

Removal



WARNING: Do not perform repair activities with the power on or electrical power supplied to the machine. The machine could activate and cause serious personal injury when the power is on or electrical power is supplied.

Ne pas effectuer de dépannage avec le contact principal activé ou avec l'alimentation électrique appliquée à la machine: celle-ci pourrait démarrer et causer de graves blessures.

Non effettuare alcuna riparazione con la macchina accesa o con l'alimentazione elettrica inserita. La macchina potrebbe avviarsi all'improvviso e causare gravi ferite.

Es dürfen keine Reparaturarbeiten durchgeführt werden, solange das Gerät eingeschaltet oder mit der Stromquelle verbunden ist. Das Gerät kann u.U in den Aktiv-Zustand übergehen und somit erhebliche körperliche Schäden verursachen

No realice reparaciones con la máquina encendida o conectada a la corriente. La máquina podría activarse y ocasionar daños personales graves.

1. Remove the top over assembly ([Figure 1](#)).
 - a. Open the HCF paper tray [1].
 - b. To remove the top cover assembly, remove 2 screws [2].

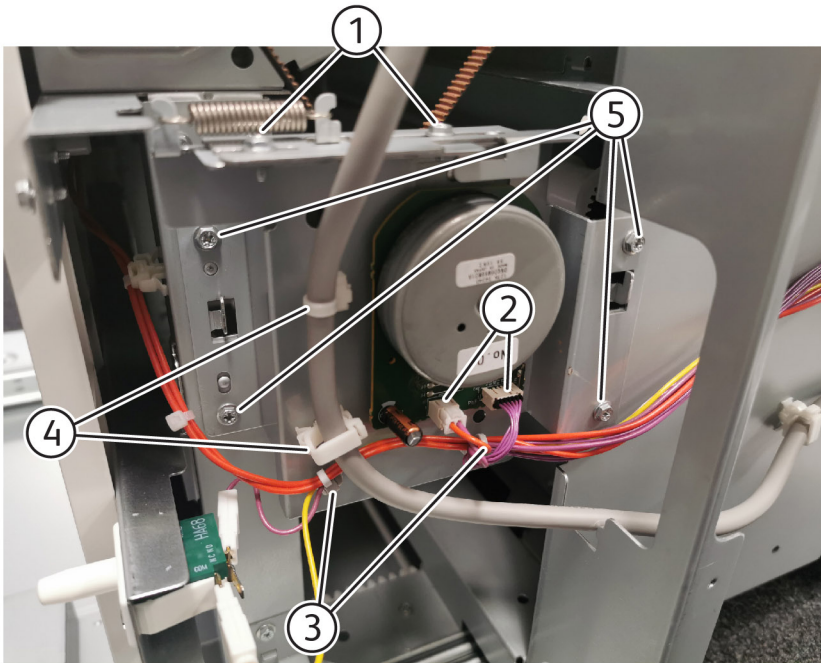

Q-1-0218-A

Figure 3 Removal of the Drive Assembly

Replacement

1. The replacement is the reverse of the removal procedure.

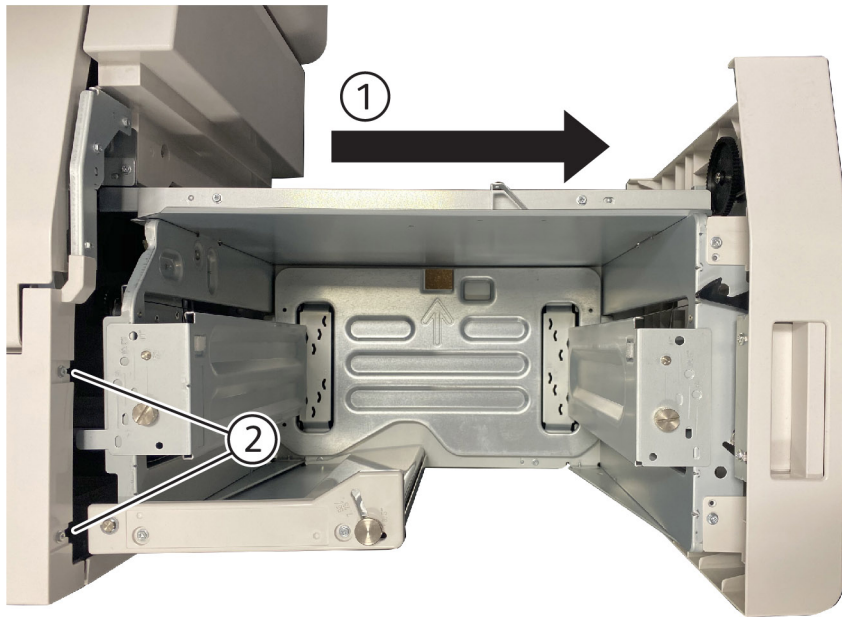

Q-1-0219-A

Figure 1 Removal of the Top Cover Assembly

2. Remove 2 paper size sensors (Figure 2).
 - a. Unplug each paper size sensor [1].
 - b. Unclip each paper size sensor [2] from the frame.

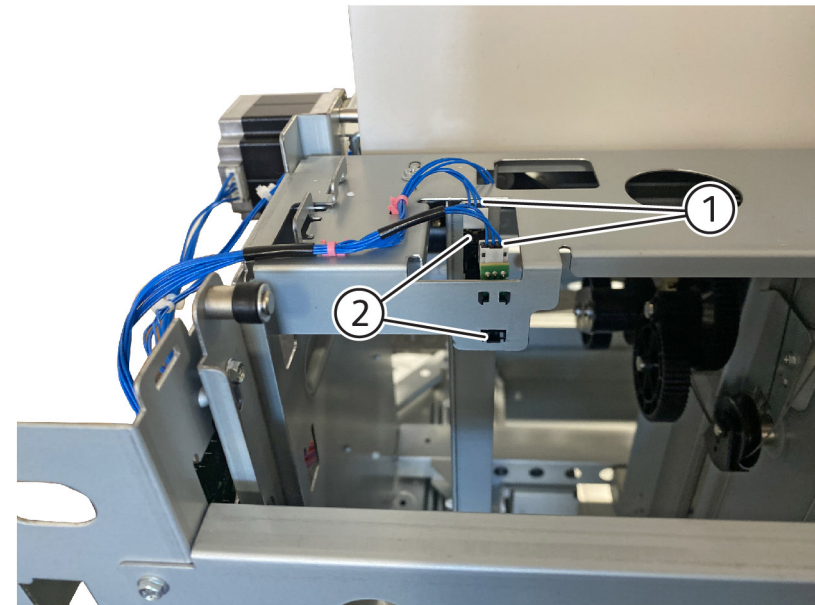

Q-1-0220-A

Figure 2 Removal of the Paper Size Sensors (x2)

3. To remove the left cover, remove 3 screws (Figure 3).

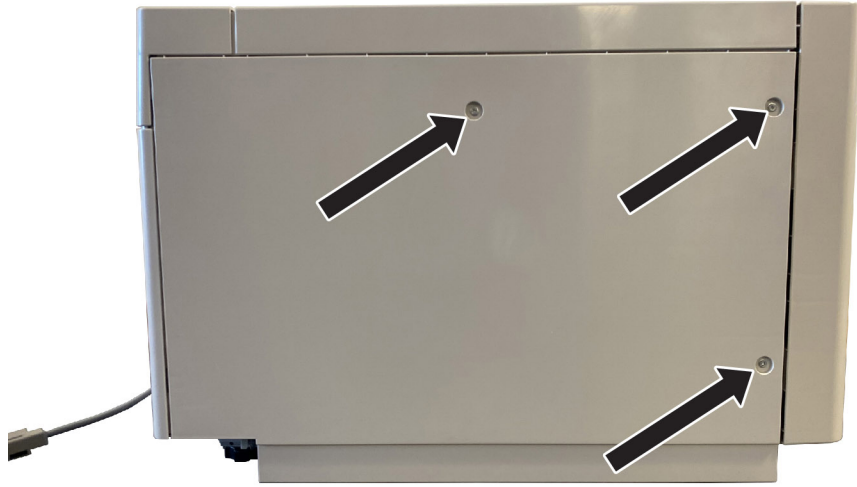

Q-1-0221-A

Figure 3 Removal of the Left Cover

4. Remove the tray in sensor (Figure 4).
 - a. Unplug the tray in sensor [1].
 - b. Unclip the tray in sensor [2] from the frame.

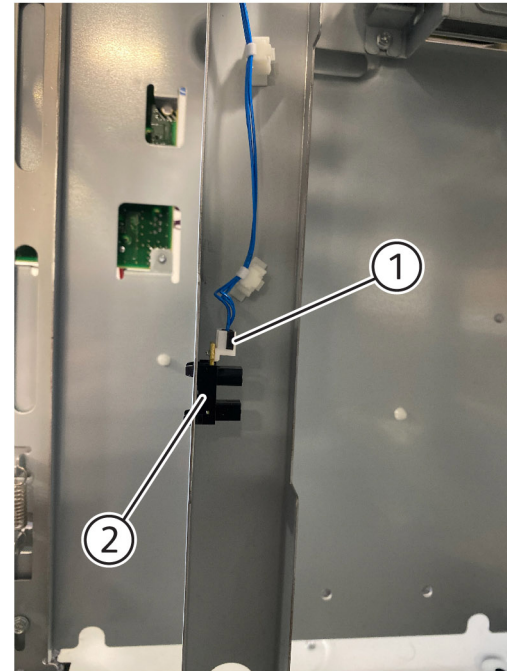

Q-1-0222-A

Figure 4 Removal of the Tray In Sensor**Replacement**

1. The replacement is the reverse of the removal procedure.

REP 78.33 Cable Assembly

Parts List on [PL 78.8](#)

Removal



WARNING: Do not perform repair activities with the power on or electrical power supplied to the machine. The machine could activate and cause serious personal injury when the power is on or electrical power is supplied.

Ne pas effectuer de dépannage avec le contact principal activé ou avec l'alimentation électrique appliquée à la machine: celle-ci pourrait démarrer et causer de graves blessures.

Non effettuare alcuna riparazione con la macchina accesa o con l'alimentazione elettrica inserita. La macchina potrebbe avviarsi all'improvviso e causare gravi ferite.

Es dürfen keine Reparaturarbeiten durchgeführt werden, solange das Gerät eingeschaltet oder mit der Stromquelle verbunden ist. Das Gerät kann u.U in den Aktiv-Zustand übergehen und somit erhebliche körperliche Schäden verursachen

No realice reparaciones con la máquina encendida o conectada a la corriente. La máquina podría activarse y ocasionar daños personales graves.

1. Lift the handle on the top left side of the HCF, then pull the HCF fully to the left.
2. Loosen 2 screws on the right side of the HCF ([Figure 1](#)).

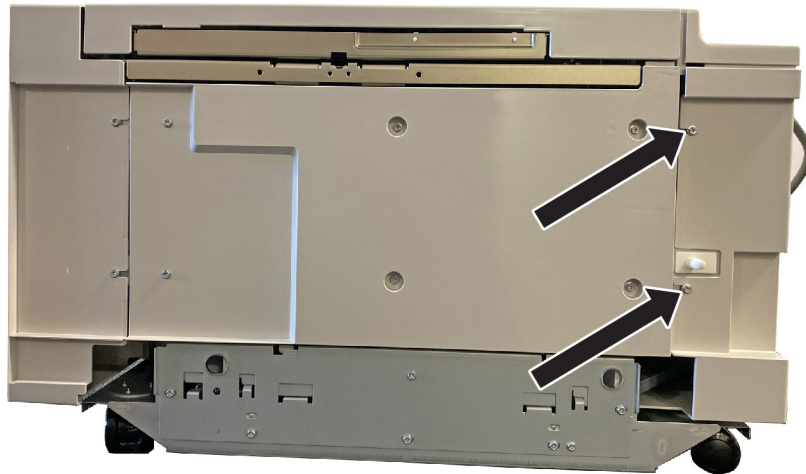

Q-1-0223-A

Figure 1 Loosening of 2 Screws on the Right Side fo the HCF

3. Remove the upper and lower rear covers ([Figure 2](#)).
 - a. To remove the upper rear cover, remove 2 screws [1].
 - b. To remove the lower rear cover, remove 3 screws [2].

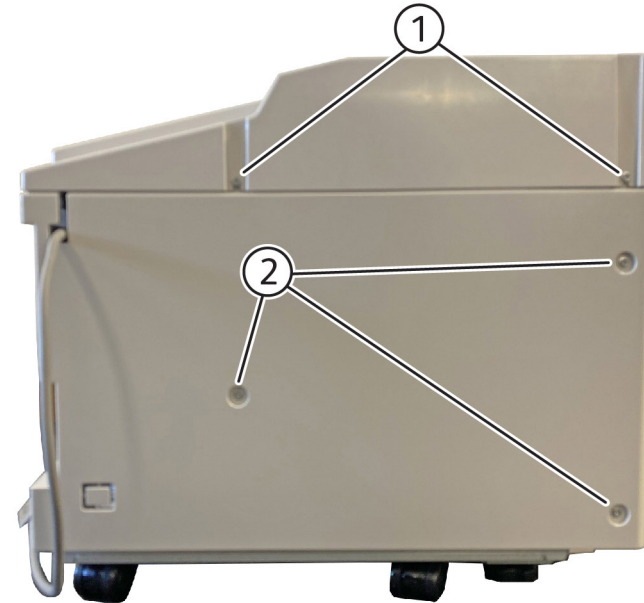

Q-1-0224-A

Figure 2 Removal of the Upper Rear Cover and the Lower Rear Cover

4. Remove 3 P/J connectors ([Figure 3](#)).
 - a. Remove PJ7405, PJ7406, and PJ7407 [1] from the PWB.
 - b. Remove 2 cable clips [2] from the rear frame.

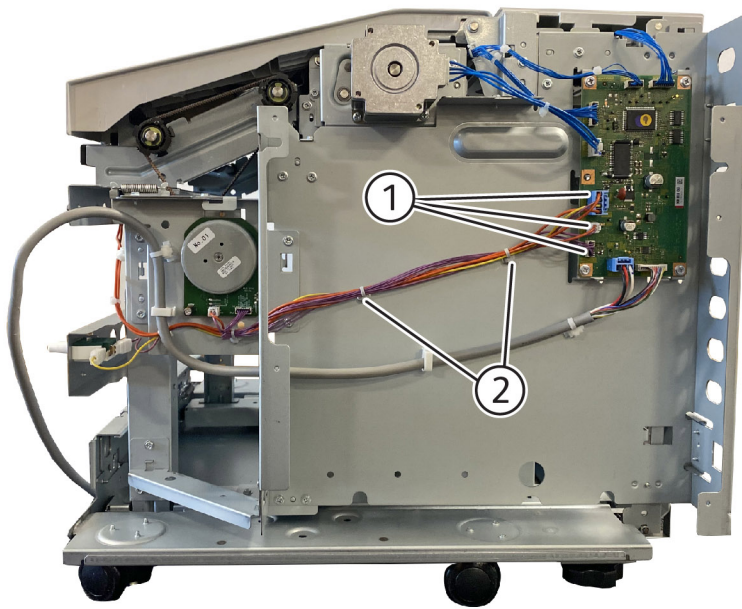

Q-1-0225-A

Figure 3 Removal of 3 PJs from the PWB.

5. Remove 2 P/J connectors (Figure 4).
 - a. Remove 2 P/J connectors [1] from the drive PWB.
 - b. Remove 2 connectors [2] from the docking switch.
 - c. Remove 2 cable clips [3] from the drive assembly.

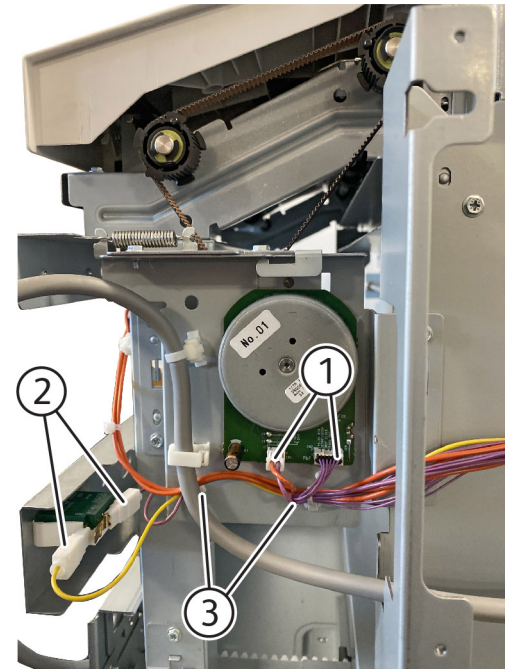

Q-1-0226-A

Figure 4 Removal of 2 PJs from the Drive PWB and 2 Connectors from the Docking Switch

6. Remove the interlock switch connector (Figure 5).
 - a. Remove 1 cable clip [1] from the frame.
 - b. Remove the interlock switch connector [2] from the interlock switch.

REP 78.34 HCF PWB

Parts List on [PL 78.8](#)

Removal



WARNING: Do not perform repair activities with the power on or electrical power supplied to the machine. The machine could activate and cause serious personal injury when the power is on or electrical power is supplied.

Ne pas effectuer de dépannage avec le contact principal activé ou avec l'alimentation électrique appliquée à la machine: celle-ci pourrait démarrer et causer de graves blessures.

Non effettuare alcuna riparazione con la macchina accesa o con l'alimentazione elettrica inserita. La macchina potrebbe avviarsi all'improvviso e causare gravi ferite.

Es dürfen keine Reparaturarbeiten durchgeführt werden, solange das Gerät eingeschaltet oder mit der Stromquelle verbunden ist. Das Gerät kann u.U in den Aktiv-Zustand übergehen und somit erhebliche körperliche Schäden verursachen

No realice reparaciones con la máquina encendida o conectada a la corriente. La máquina podría activarse y ocasionar daños personales graves.

1. Lift the handle on the top left side of the HCF, then pull the HCF fully to the left.
2. Loosen 2 screws on the right side of the HCF ([Figure 1](#)).

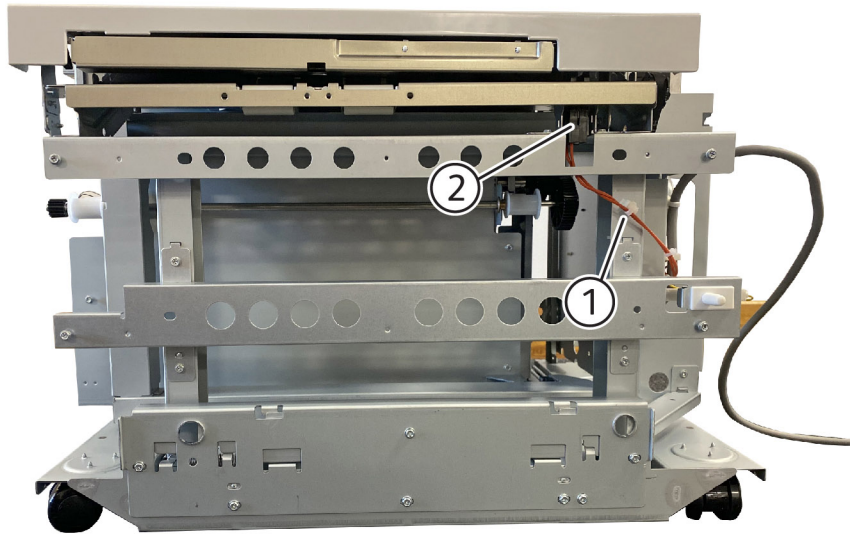

Q-1-0227-A

Figure 5 Removal of 1 Cable Clip and 1 Connector

Replacement

1. The replacement is the reverse of the removal procedure.

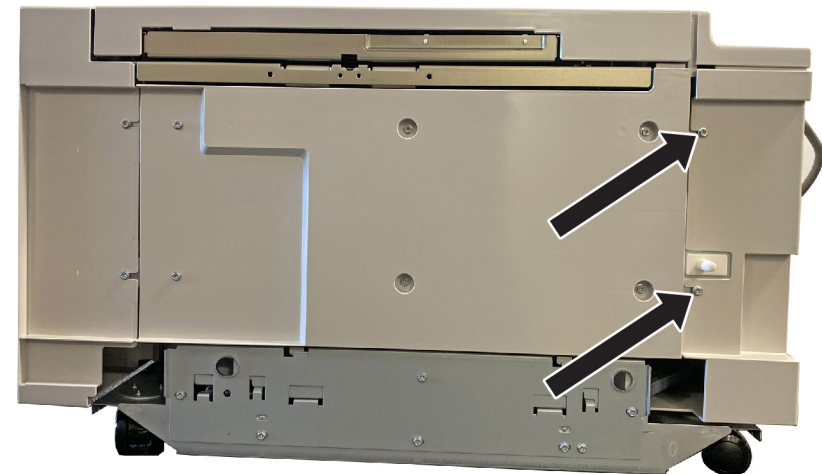

Q-1-0228-A

Figure 1 Loosening of 2 Screws on the Right Side of the HCF

3. Remove the upper and lower rear covers (Figure 2).
 - a. To remove the upper rear cover, remove 2 screws [1].
 - b. To remove the lower rear cover, remove 3 screws [2].

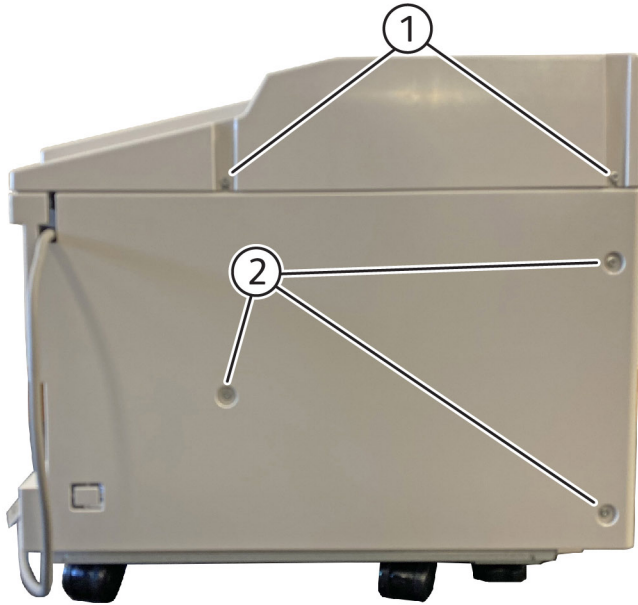
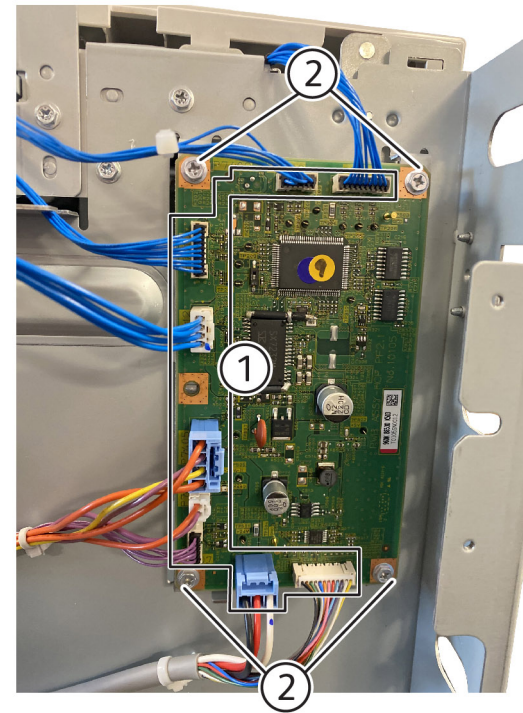

Figure 2 Removal of the Upper Rear Cover and the Lower Rear Cover

4. Remove the HCF PWB (Figure 3).
 - a. Remove all PJ connectors [1] from the PWB.
 - b. Remove 4 screws [2].

Q-1-0229-A



Q-1-0230-A

Figure 3 Removal of the HCF PWB.

Replacement

1. The replacement is the reverse of the removal procedure.

REP 78.35 Pinion and Damper

Parts List on [PL 78.8](#)

Removal



WARNING: Do not perform repair activities with the power on or electrical power supplied to the machine. The machine could activate and cause serious personal injury when the power is on or electrical power is supplied.

Ne pas effectuer de dépannage avec le contact principal activé ou avec l'alimentation électrique appliquée à la machine: celle-ci pourrait démarrer et causer de graves blessures.

Non effettuare alcuna riparazione con la macchina accesa o con l'alimentazione elettrica inserita. La macchina potrebbe avviarsi all'improvviso e causare gravi ferite.

Es dürfen keine Reparaturarbeiten durchgeführt werden, solange das Gerät eingeschaltet oder mit der Stromquelle verbunden ist. Das Gerät kann u.U. in den Aktiv-Zustand übergehen und somit erhebliche körperliche Schäden verursachen

No realice reparaciones con la máquina encendida o conectada a la corriente. La máquina podría activarse y ocasionar daños personales graves.

1. Lift the handle on the top cover, and pull the HCF fully to the left.
2. To remove the metal cover, remove 2 screws (Figure 1).



Q-1-0231-A

Figure 1 Removal of the Metal Cover

3. Remove the pinion and the damper (Figure 2).
 - a. To remove the pinion, remove the C-clip [1], then slide the pinion off the shaft.
 - b. To remove the damper, remove 2 screws [2].

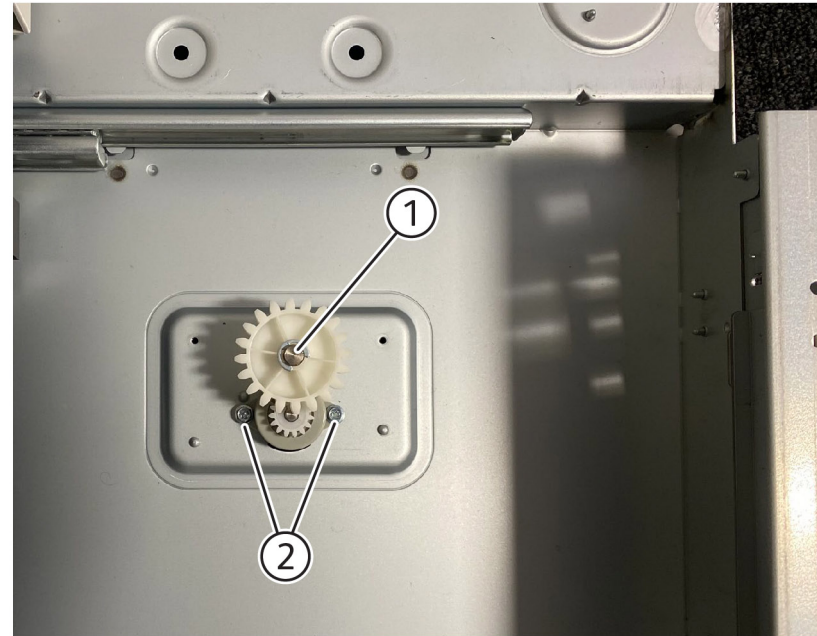

Q-1-0232-A

Figure 2 Removal of the Pinion and the Damper
Replacement

1. The replacement is the reverse of the removal procedure.

5 Parts List

3000-Sheet High-Capacity Feeder	68
PL 78.1 HCF Unit	69
PL 78.2 HCF Tray 6 (1 of 2)	70
PL 78.3 HCF Tray 6 (2 of 2)	71
PL 78.4 HCF Top Chute Cover	72
PL 78.5 HCF Feeder (1 of 3)	73
PL 78.6 HCF Feeder (2 of 3)	74
PL 78.7 HCF Feeder (3 of 3)	75
PL 78.8 HCF Electrical and Rail	76

PL 78.1 HCF Unit

Item	Part	Description
1	815K17621	Docking plate
2	—	Knob (Not Spared)
3	—	Frame assembly (Not Spared)
4	801K68380	Tray rail (REP 78.1, REP 78.2)
5	050K75051	HCF tray assembly (REP 78.3)
6	948K01900	Top cover assembly
7	—	Right cover (Not Spared)
8	—	Front right cover (Not Spared)
9	—	Left cover (Not Spared)
10	—	Lower rear cover (Not Spared)
11	—	Upper rear cover
12	859K02872	HCF feed head (REP 78.4)
13	890E86280	Label (Tray No.)
14	890E86291	Label (End top)
15	890E92600	Label (Max)

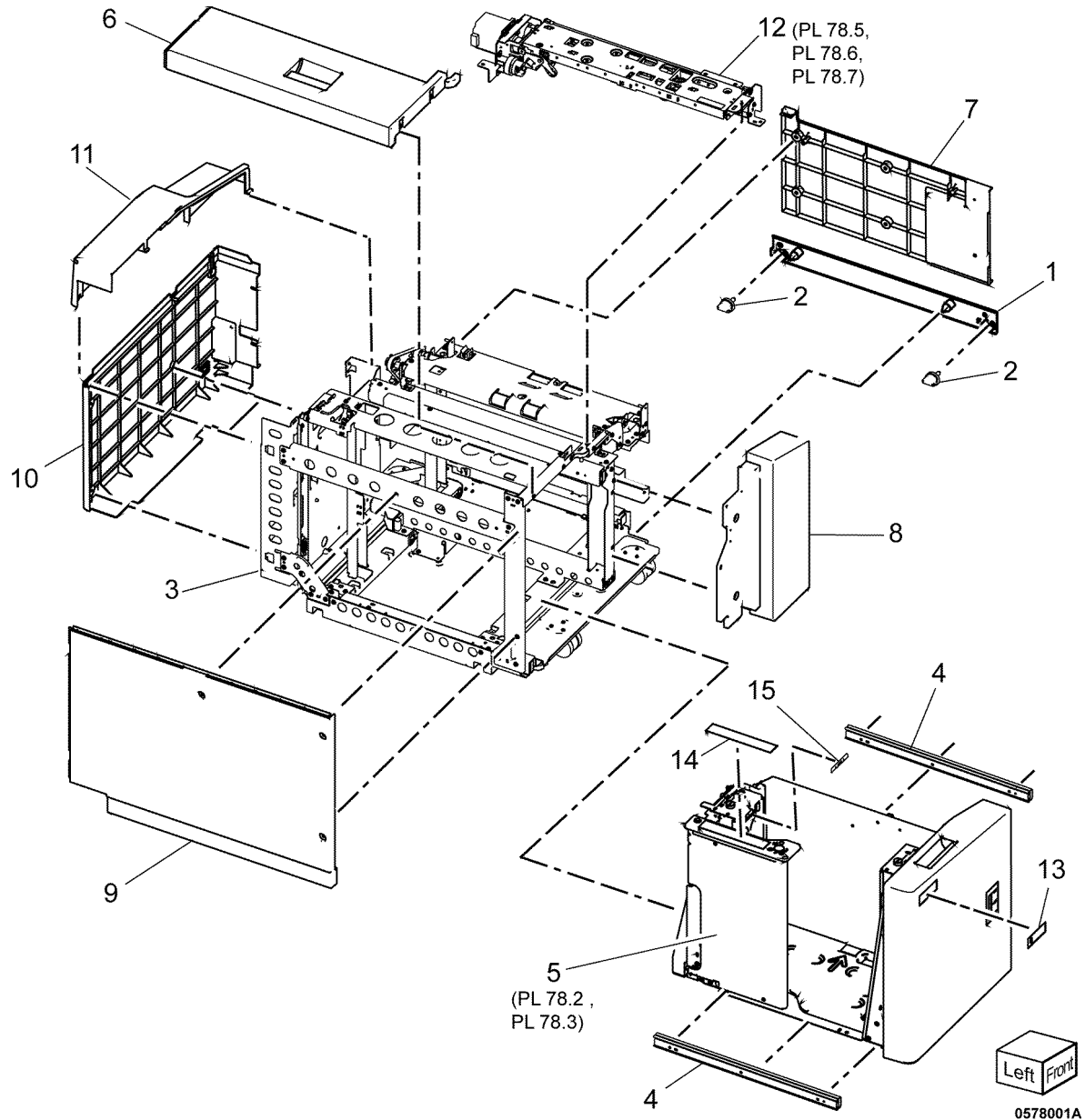

PL 78.2 HCF Tray 6 (1 of 2)

Item	Part	Description
1	—	Tray handle assembly (P/O PL 78.2 Item 6)
2	—	Bracket (P/O PL 78.2 Item 6)
3	899E14080	Spring
4	803E25850	Latch lever
5	—	Tray frame assembly (Not Spared)
6	948K01860	Front cover assembly (REP 78.5)
7	—	Front cover (P/O PL 78.2 Item 6)
8	—	Gear bracket (P/O PL 78.2 Item 6)
9	—	Label (Gauge) (P/O PL 78.2 Item 6)
10	032K09310	End guide assembly (REP 78.6)
11	—	End guide (P/O PL 78.2 Item 10)
12	—	End guide bracket (P/O PL 78.2 Item 10)
13	—	Pin (P/O PL 78.2 Item 10)
14	—	Spring (P/O PL 78.2 Item 10)
15	—	End guide support (P/O PL 78.2 Item 10)
16	028E93800	Wave washer
17	—	Spring (P/O PL 78.2 Item 6)

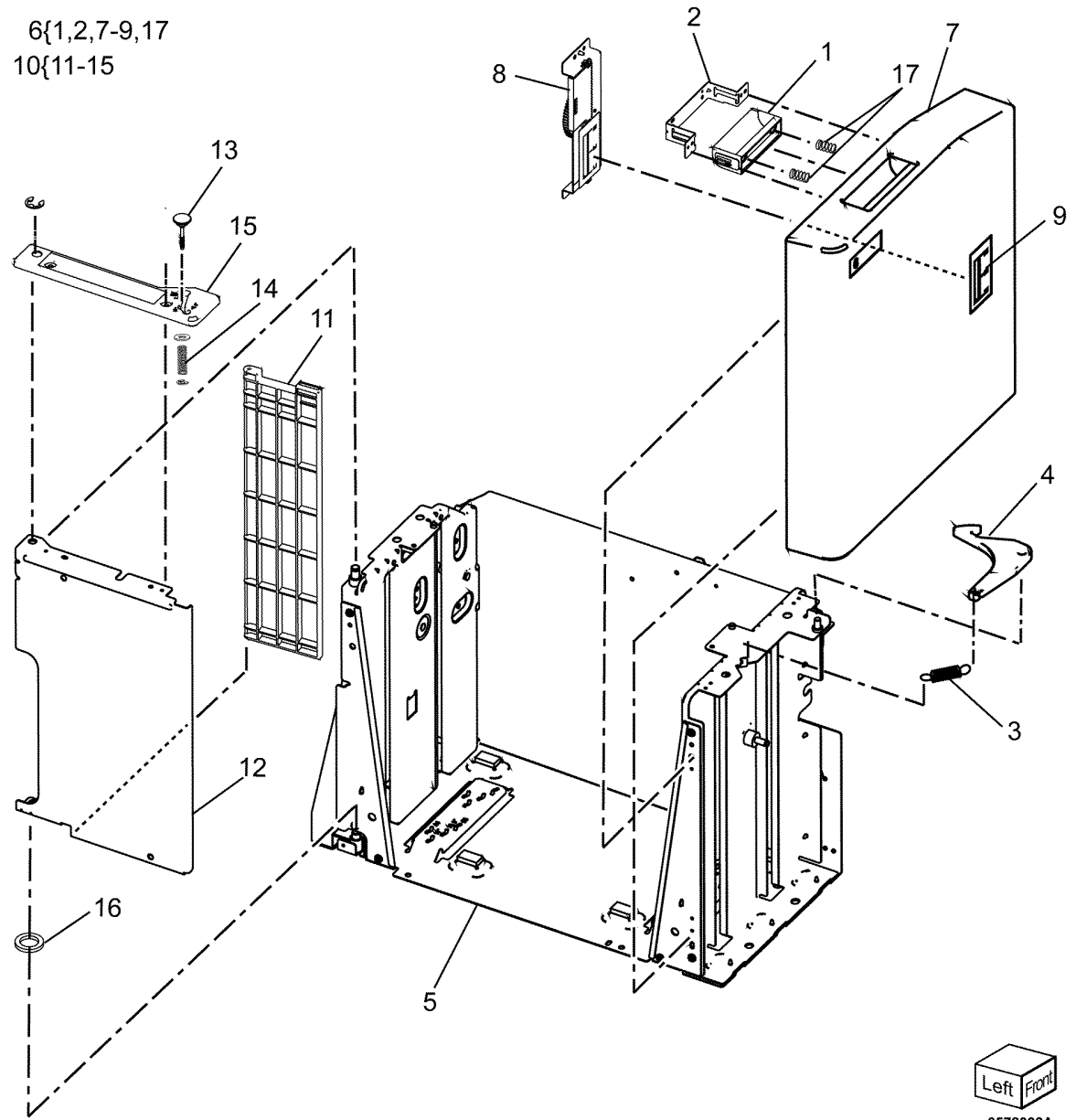

PL 78.3 HCF Tray 6 (2 of 2)

Item	Part	Description
1	—	Lift shaft
2	—	Bearing
3	020E51830	Pulley
4	—	Gear (Not Spared)
5	815K17410	Bottom plate assembly (REP 78.7)
6	—	Bottom plate (P/O PL 78.3 Item 5)
7	—	Pad (P/O PL 78.3 Item 5)
8	032K09320	Front side guide
9	032K09330	Rear side guide
10	012E20120	Cable (REP 78.8)
—	012E20620	Cable (Black) (REP 78.8)
11	—	Long wire guide (Not Spared)
12	—	Pulley (Not Spared)
13	—	Short wire guide (Not Spared)
14	020E36830	Pulley
15	—	Screw (Not Spared)
16	049K33260	Gear bracket assembly (REP 78.9)
17	—	Gear bracket (P/O PL 78.3 Item 16)
18	—	Contact gear (P/O PL 78.3 Item 16)
19	—	Gear (P/O PL 78.3 Item 16)
20	—	Gear (P/O PL 78.3 Item 16)
21	—	Brake (P/O PL 78.3 Item 16)
22	—	Spring (P/O PL 78.3 Item 16)
23	807E52710	Gear
24	807E52730	Lift gear
25	—	Plate (Not Spared)

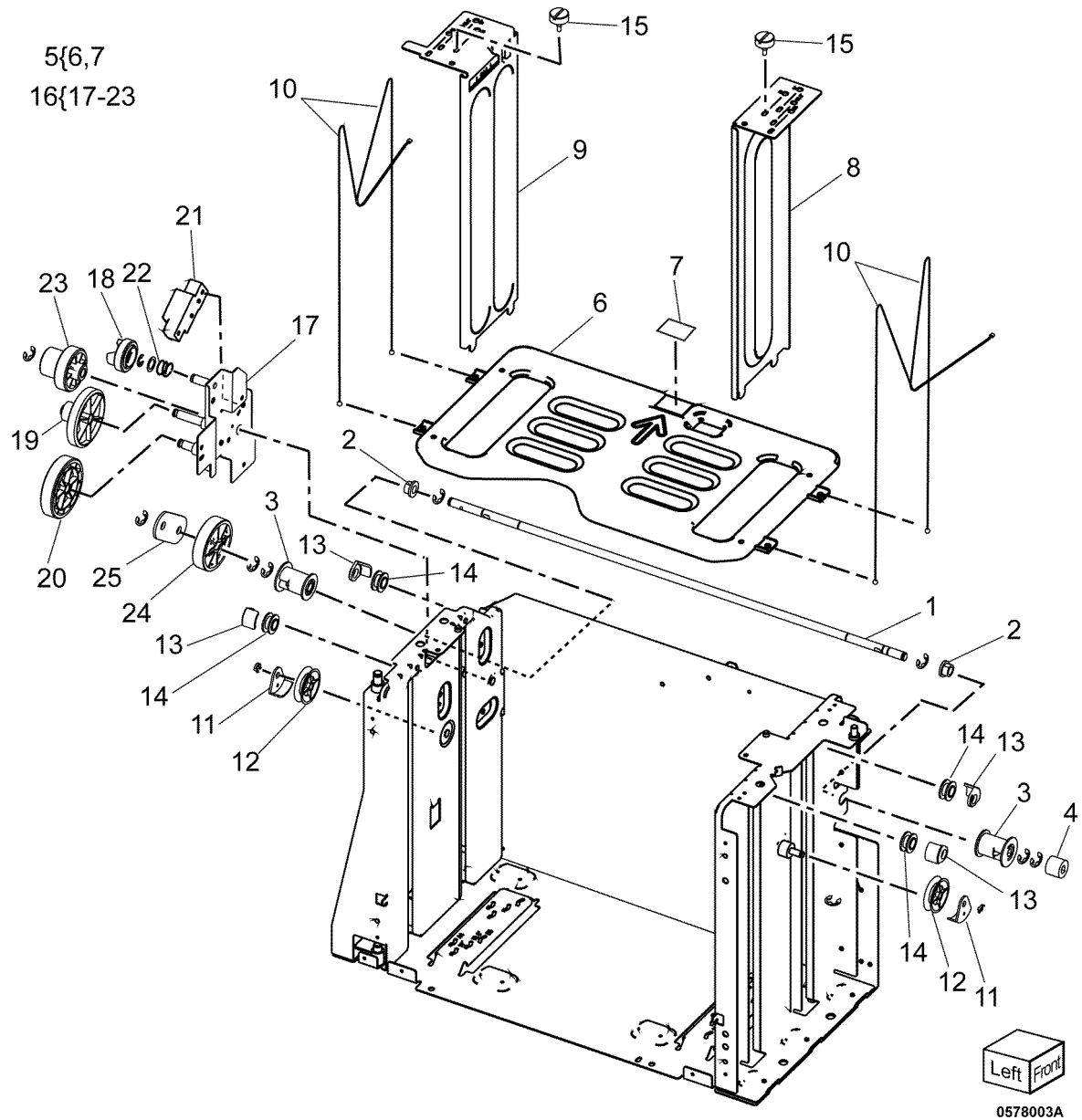

PL 78.4 HCF Top Chute Cover

Item	Part	Description
1	—	Top chute cover (P/O PL 78.4 Item 17)
2	—	Rear latch (P/O PL 78.4 Item 17)
3	—	Shaft (P/O PL 78.4 Item 17)
4	—	Handle (P/O PL 78.4 Item 17)
5	—	Front latch (P/O PL 78.4 Item 17)
6	—	Spring (P/O PL 78.4 Item 17)
7	—	Bearing (P/O PL 78.4 Item 17)
8	—	Pinch roll assembly (P/O PL 78.4 Item 17)
9	—	Upper chute assembly (P/O PL 78.4 Item 17)
10	130E89381	Sensor (REP 78.10)
11	054K55270	Lower chute assembly (REP 78.11)
12	413W08350	Bearing
—	413W82370	Bearing (alternative)
13	859K02890	Takeaway roll assembly (REP 78.12)
14	—	Interlock switch
15	—	Roller assembly (P/O PL 78.4 Item 17)
16	674E05980	Bracket
17	948K01851	Top chute cover assembly (REP 78.13)
18	—	Strap (P/O PL 78.4 Item 17)

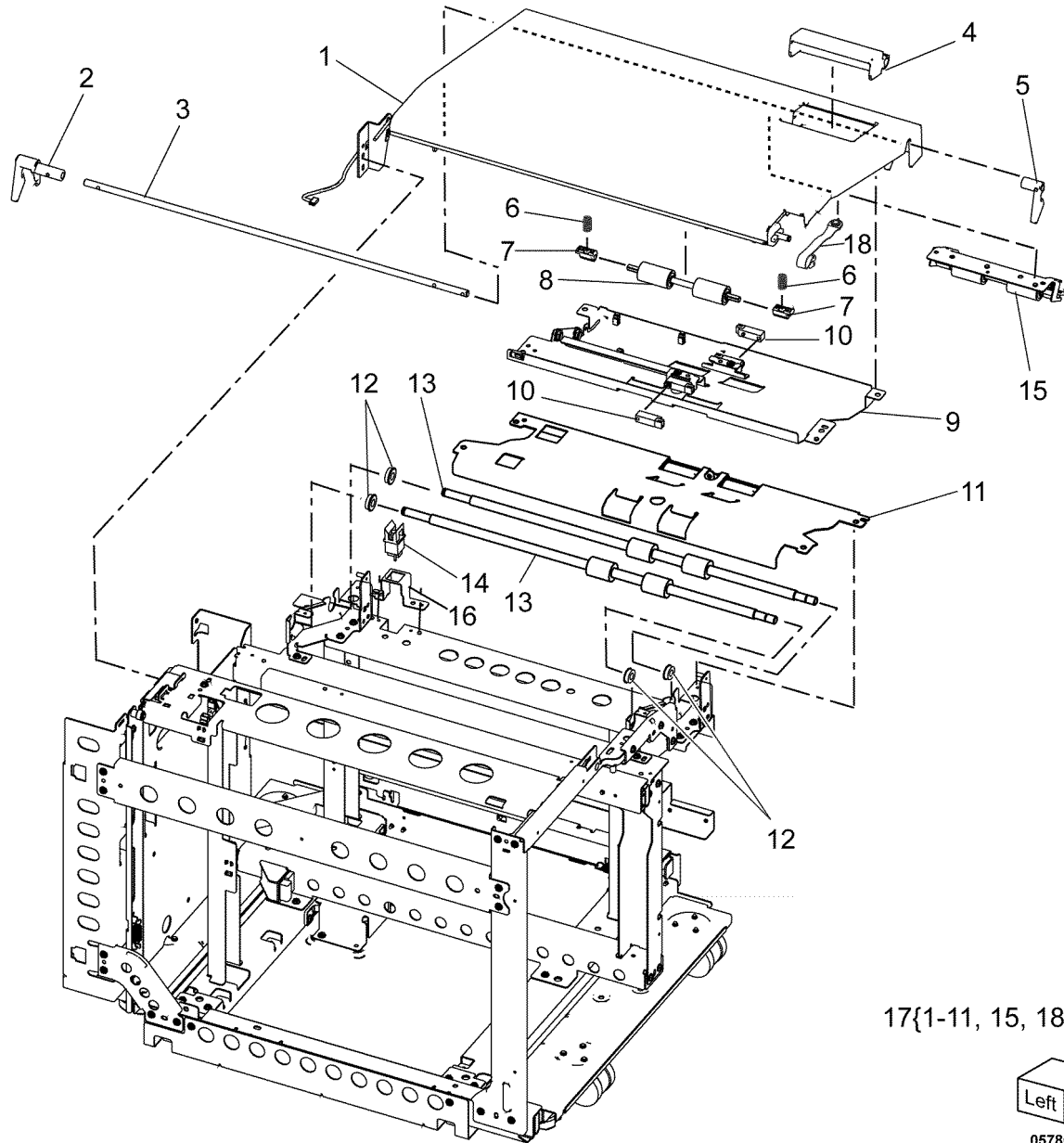

17{1-11, 15, 18



0578004A

PL 78.5 HCF Feeder (1 of 3)

Item	Part	Description
1	006K23112	Shaft (REP 78.14)
2	—	Gear (19T)
3	007E78770	Gear (25T) (REP 78.15)
4	007E78780	Gear (25T) (REP 78.16)
5	—	Gear (40T) (P/O PL 78.1 Item 12)
6	—	Bearing (P/O PL 78.1 Item 12)
7	—	Block (P/O PL 78.1 Item 12)
8	—	Spacer (P/O PL 78.1 Item 12)
9	—	Motor frame (P/O PL 78.5 Item 19)
10	—	Upper feeder assembly (REF: PL 78.6)
11	—	Lower feeder assembly (REF: PL 78.7)
12	413W66250	Ball bearing (REP 78.17)
13	—	Front feeder frame assembly (P/O PL 78.1 Item 12)
14	—	Rear frame assembly (P/O PL 78.1 Item 12)
15	—	Link assembly (P/O PL 78.5 Item 14)
16	—	Rear frame (P/O PL 78.5 Item 14)
17	—	Spring (P/O PL 78.1 Item 12)
18	—	Bracket (P/O PL 78.1 Item 12)
19	801K70190	Drive gear assembly (REP 78.18)
20	—	Gear (23T/27T) (P/O PL 78.5 Item 19)
21	—	Gear (31T/36T) (P/O PL 78.5 Item 19)
22	—	HCF feed lift motor (MOT78-003) (P/O PL 78.5 Item 19)

14{15,16
19{3,9,20-22

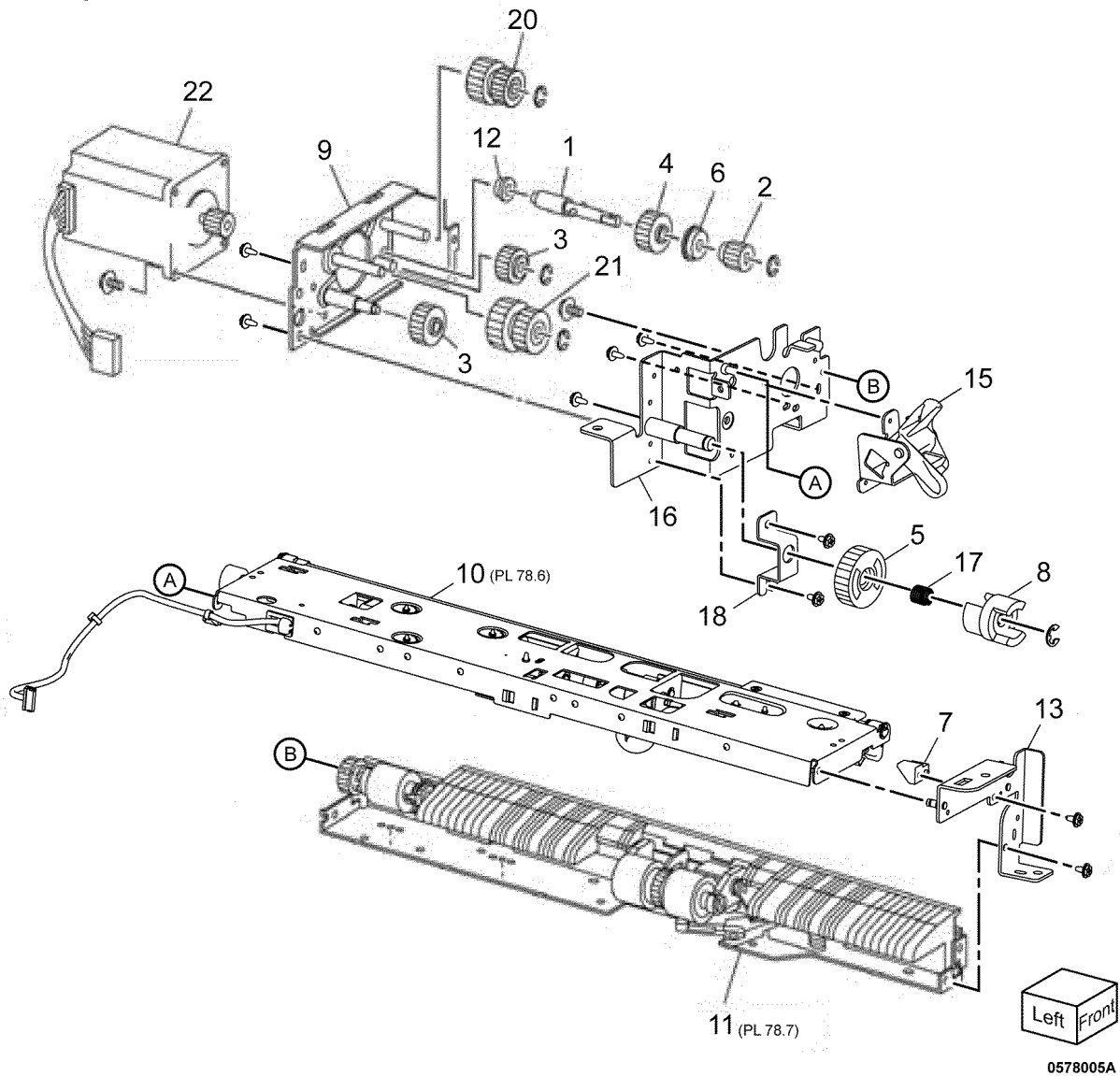

PL 78.6 HCF Feeder (2 of 3)

Item	Part	Description
1	859K05270	Upper feeder assembly (REP 78.19)
2	—	Latch (P/O PL 78.6 Item 1)
3	—	Shaft latch (P/O PL 78.6 Item 1)
4	006K23124	Feed shaft assembly (REP 78.20)
5	—	Feed shaft (P/O PL 78.6 Item 4)
6	413W66250	Ball bearing (REP 78.21)
7	—	Gear (20T) (P/O PL 78.6 Item 4)
8	007E78180	Feed gear (25T) (REP 78.22)
9	—	Lever (P/O PL 78.6 Item 1)
10	—	Bearing (P/O PL 78.6 Item 1)
11	—	Spacer (P/O PL 78.6 Item 1)
12	—	Pin drive (P/O PL 78.6 Item 1)
13	—	Guide (P/O PL 78.6 Item 1)
14	—	Rear upper chute (P/O PL 78.6 Item 1)
15	—	Upper chute (P/O PL 78.6 Item 1)
16	—	Actuator
17	—	Upper Frame (P/O PL 78.6 Item 1)
18	—	Spring (P/O PL 78.6 Item 1)
19	930W00112	HCF level sensor (REP 78.23)/ HCF no paper sensor (REP 78.24)
20	930W00211	HCF pre feed sensor (REP 78.25)
21	—	Wire harness (P/O PL 78.6 Item 1)
22	—	Feed roll (P/O PL 78.6 Item 24)
23	—	Nudger roll (P/O PL 78.6 Item 24)
24	604K23660	Feed roll kit
25	—	Sensor bracket (P/O PL 78.6 Item 1)

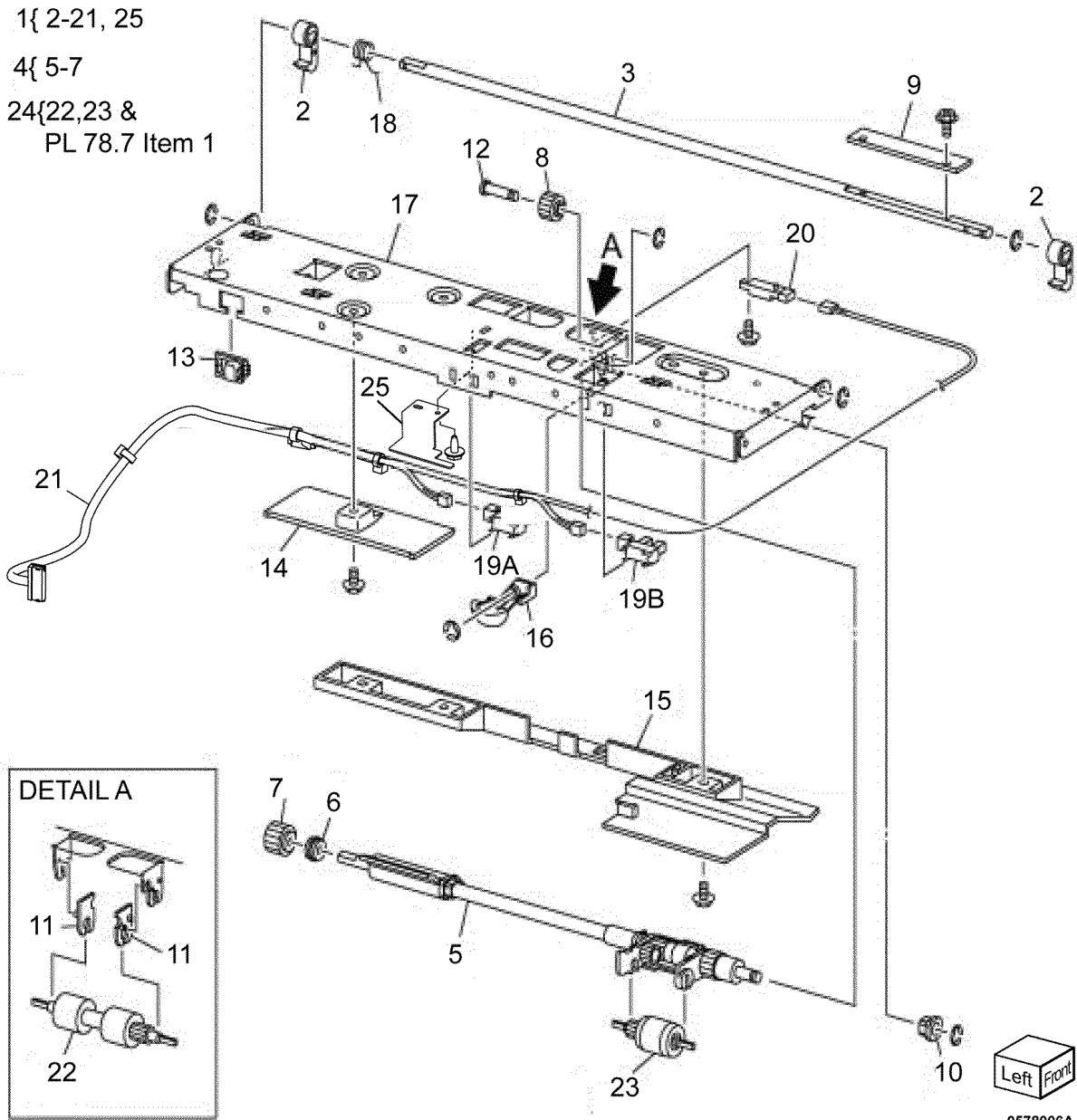

PL 78.7 HCF Feeder (3 of 3)

Item	Part	Description
1	—	Retard roll (P/O PL 78.7 Item 18)
2	059K26687	Lower feeder assembly (REP 78.26)
3	006K23135	Retard shaft assembly (REP 78.27)
4	—	Collar (P/O PL 78.7 Item 3)
5	005K06701	Friction clutch
6	—	Shaft (P/O PL 78.7 Item 3)
7	007E78170	Gear (15T)
8	007E89760	Gear (22T)
9	—	Bearing
10	—	Bearing
11	—	Retard bracket (P/O PL 78.7 Item 3)
12	—	Slide (P/O PL 78.7 Item 2)
13	—	Lever (P/O PL 78.7 Item 2)
14	—	Lower chute (P/O PL 78.7 Item 2)
15	—	Lower frame (P/O PL 78.7 Item 2)
16	—	Spring (P/O PL 78.7 Item 2)
17	—	Spring (P/O PL 78.7 Item 2)
18	604K23660	Feed roll kit

2 { 3-17
 3 { 4-11
 18 { 1 & PL 78.6
 Items 22, 23

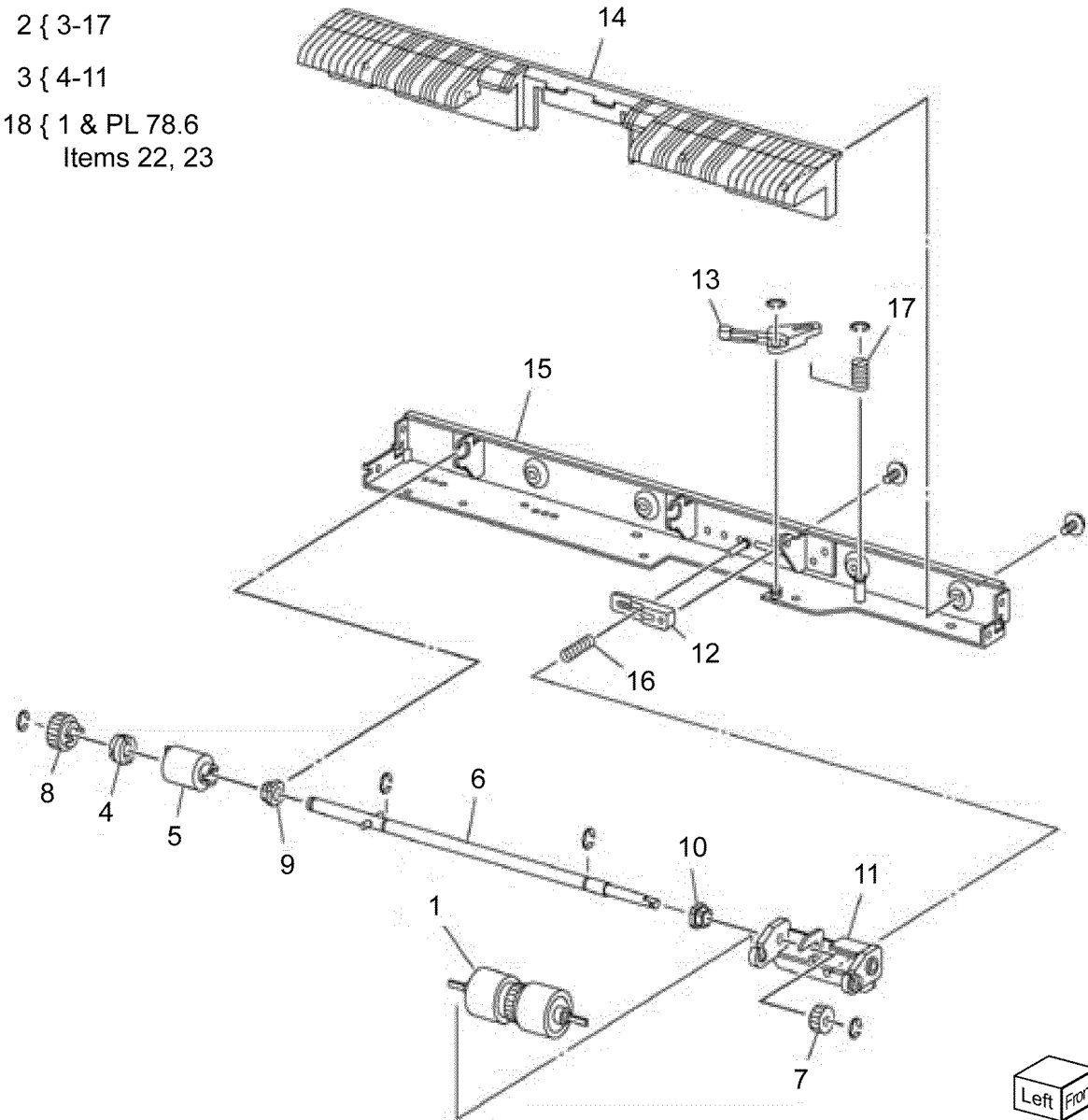

0578007A

PL 78.8 HCF Electrical and Rail

Item	Part	Description
1	—	Plate (Not Spared)
2	017E92820	Rack caster (REP 78.28)
3	017E14140	Adjuster foot (REP 78.28)
4	801K67280	Rail assembly (REP 78.29)
5	—	Bracket (Not Spared)
6	807E53510	Gear rack (REP 78.30)
7	007K21610	Drive assembly (REP 78.31)
8	—	Docking switch
9	930W00111	HCF paper size sensor (Letter) (Q78-202) / HCF paper size sensor (A4) (Q78-203)/HCF In sensor (Q78-xxx) (REP 78.32)
10	117K49400	Cable assembly (REP 78.33)
11	960K86530	HCF PWB (REP 78.34)
12	—	Latch Plate (Not Spared)
13	807E55980	Pinion (REP 78.35)
14	004E24810	Damper (REP 78.35)
15	—	Latch Spring (Not Spared)

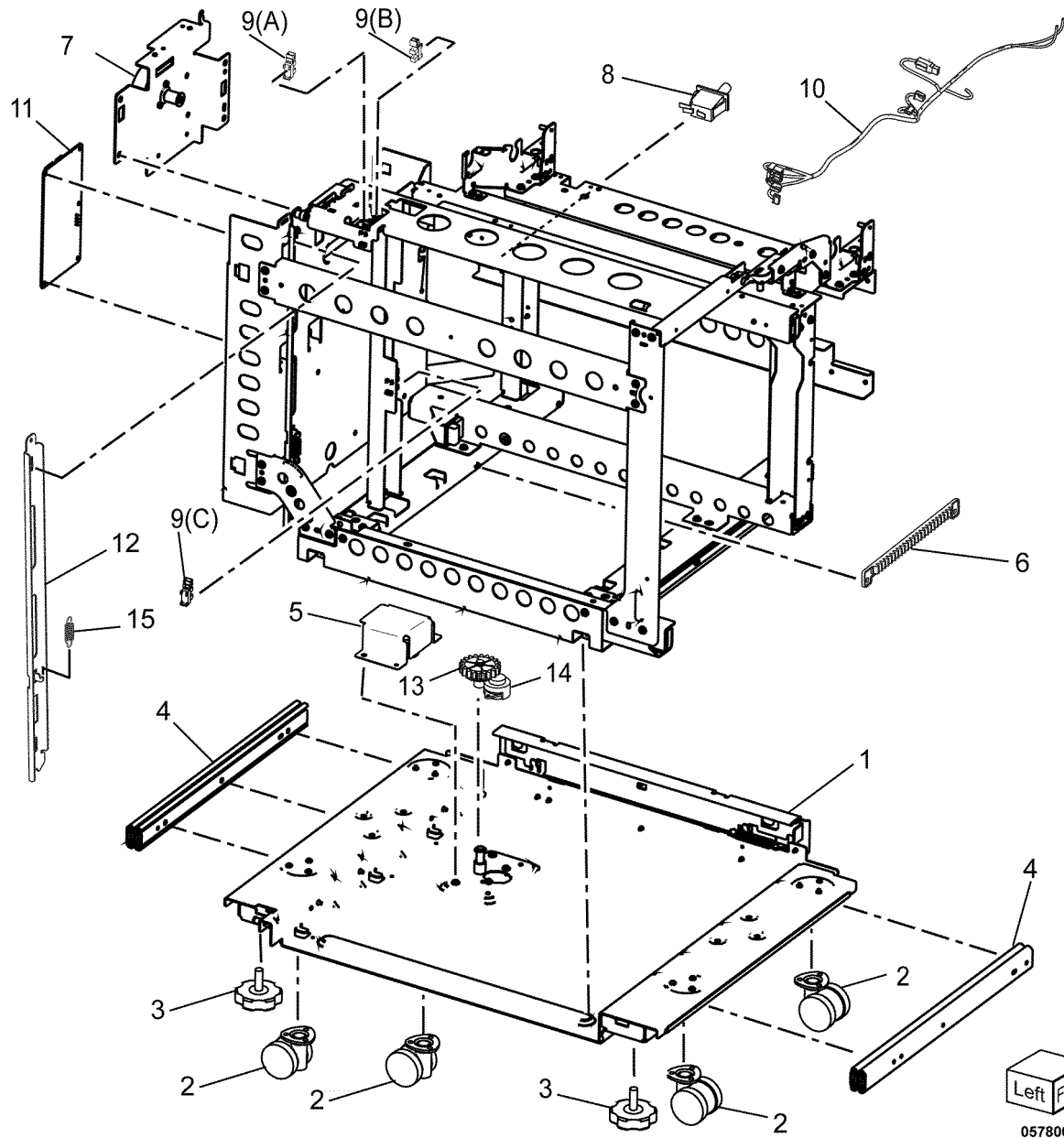

6 General Procedures

GP 1 How to Check a Reflective Sensor	78
GP 2 How to Check a Transmissive Sensor	79
GP 3 How to Check a Switch	80
GP 4 How to Check a Multiple Wire Motor	80
Machine Dimensions	81
Weight	81
Electrical Specification	82
Product Codes	82
Change Tags	83
DC330 Input Component Check List	83
DC330 Output Component Check List	85

GP 1 How to Check a Reflective Sensor

Sensors consist of a light-emitting diode and a photo transistor. When energized, the light from the LED causes the photo transistor to conduct, drawing current through a pull-up resistor. The voltage drop across the resistor causes the input signal to the control logic to change from a high to a low.

Reflective sensors operate by light from the LED being reflected off the paper to the photo transistor, causing the output of the sensor to go to the low (L) state.

Initial Actions

Ensure that the sensor is not actuated.

Note: To power down the machine, press the UI Power Button and then respond to the on-screen prompts. Wait until the Power Button LED turns off, then switch off the Main Power Switch (GP 4).

Procedure

Enter the component control code indicated in the specific RAP and/or Circuit Diagnostic. Block and unblock the sensor.

The display changes with each actuation.

Y N
Clean the sensor and then block and unblock it.

The display changes with each actuation.

Y N
Access to some sensors in this machine is difficult. Follow the Y leg if you can access the sensor connector. Follow the N leg if access is not possible.

The sensor connector is accessible.

Y N
Check the voltage at the output of the PWB or power supply (refer to the Circuit Diagnostic). In the example for this generic procedure, voltage is provided from J533 on the I/F (MDD) PWB. Check for pull-up voltage for the output signal. This voltage will be either +5 VDC or +3.3 VDC depending on the circuit (refer to the Circuit Diagnostic for the correct voltage).

The voltage corresponds with the voltage shown in the Circuit Diagnostic.

Y N
Check for short circuit(s) that may be loading down the line. Check the power input to the PWB(s). If this does not resolve the problem, replace the PWB.

Refer to the Circuit Diagnostic. Check the wires from the PWB to the sensor for opens, shorts, or loose contacts. If the wires are OK, replace the sensor. If this does not resolve the problem, replace the PWB

The display indicates a constant L.

Y N
Check for +5VDC to the sensor (typically pins 1 and 3 on a 3 pin connector). +5 VDC is present.

Y N
Use the circuit diagram and/or the wirenets in Section 7 to trace the problem.

Disconnect the sensor. Use a jumper wire to connect the output wire from the sensor (typically pin 2 on a 3 pin connector) to DC COM or GND.

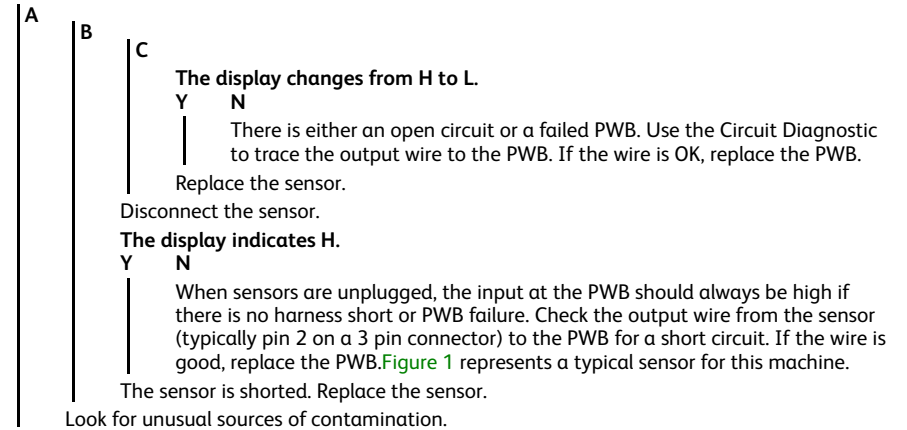

The sensor and the circuit appear to operate normally. Check the adjustment of the sensor. Clean the sensor. Check for intermittent connections, shorted, or open wires. If the problem continues, replace the sensor.

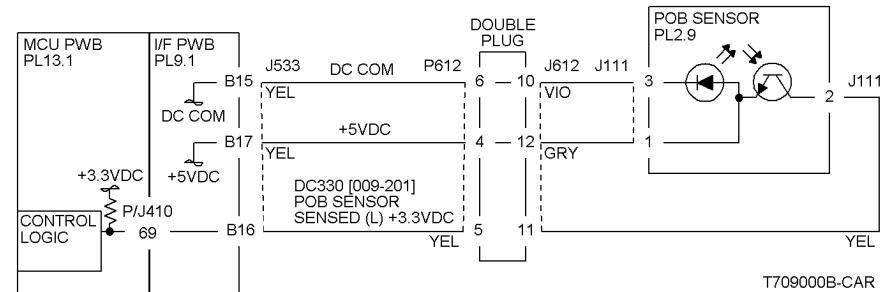

Figure 1 Typical Reflective Sensor Circuit Diagnostic

GP 2 How to Check a Transmissive Sensor

Sensors consist of a light-emitting diode and a photo transistor. When energized, the light from the LED causes the photo transistor to conduct, drawing current through a pull-up resistor. The voltage drop across the resistor causes the input signal to the control logic to change from a high to a low.

Transmissive sensors have a flag or actuator that is pushed into the space between the LED and transistor, blocking the light beam and causing the output of the sensor to go to the high (H) state. This actuation may be caused by a sheet of paper striking a pivoting flag, or a rotating actuator on a shaft or roll.

Some sensors have built-in inverters and the outputs will go to the low (L) state when the sensors are blocked. In other situations, the processing of the signal in control logic may cause the logic level displayed on the UI or the PWS to be the opposite of the actual voltage output by the sensor. The specific RAP and/or Circuit Diagnostic will indicate if this is the case. **Figure 1** is an example of a typical sensor circuit for this machine

Procedure

Enter the component control code indicated in the specific RAP and/or Circuit Diagnostic. Block and unblock the sensor.

The display changes with each actuation.

Y N
Clean the sensor and then block and unblock it.

The display changes with each actuation.

Y N
Access to some sensors in this machine is difficult. Follow the **Y** leg if you can access the sensor connector. Follow the **N** leg if access is not possible.

The sensor connector is accessible.

Y N
Check for +5VDC at the output of the PWB or power supply. Refer to the Circuit Diagnostic. In the example for this generic procedure, voltage is provided from J533 on the I/F (MDD) PWB. Check for pull-up voltage for the output signal. This voltage will be either +5 VDC or +3.3 VDC, depending on the circuit. Refer to the circuit diagram for the correct voltage.

Y N
Check for short circuit(s) that may be loading down the line. Check the power input to the PWB(s). If this does not resolve the problem, replace the PWB.

Refer to the Circuit Diagnostic. Check the wires from the PWB to the sensor for opens, shorts, or loose contacts. If the wires are OK, replace the sensor. If this does not resolve the problem, replace the PWB

The display indicates a constant L

Y N
Check for +5VDC to the sensor (typically pins 1 and 3 on a 3 pin connector). +5 VDC is present.

Y N
Use the circuit diagram and /or the wirenets in Section 7 to trace the problem.

Disconnect the sensor. Use a jumper wire to connect the output wire from the sensor (typically pin 2 on a 3 pin connector) to DC COM or GND.

A | **B** | **C**
The display changes from H to L.
Y N
There is either an open circuit or a failed PWB. Use the Circuit Diagnostic to trace the output wire to the PWB. If the wire is OK, replace the PWB.
Replace the sensor.
Disconnect the sensor.
The display indicates H.
Y N
When sensors are unplugged, the input at the PWB should always be high if there is no harness short or PWB failure. Check the output wire from the sensor (typically pin 2 on a 3 pin connector) to the PWB for a short circuit. If the wire is good, replace the PWB. **Figure 1** represents a typical sensor for this machine
The sensor is shorted. Replace the sensor.
Look for unusual sources of contamination.

The sensor and the circuit appear to operate normally. Check the adjustment of the sensor. Clean the sensor. Check the sensor actuator/flag for proper operation. Check for intermittent connections, shorted, or open wires. If the problem continues, replace the sensor.

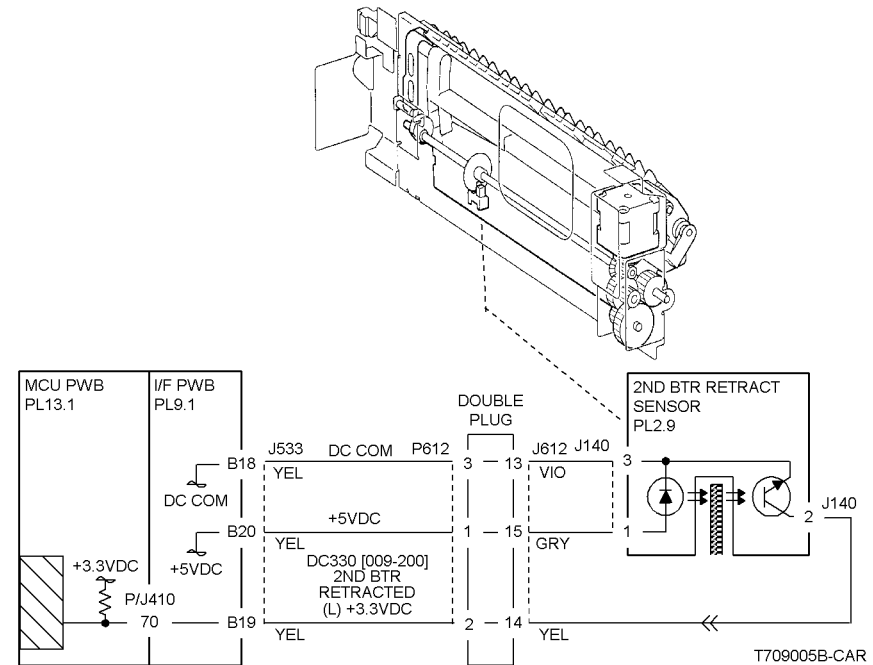

Figure 1 Typical Transmissive Sensor Circuit Diagnostic

GP 3 How to Check a Switch

Procedure

Enter the component control code indicated in the specific RAP and/or Circuit Diagnostic. Actuate the switch.

The display changed.

Y N
 | There is +3.5 / 5VDC measured between Pin 2(+) of the Switch and GND(-).
 Y N
 | Check the wire between the switch Pin 2 and the PWB Pin 3 for an open circuit and poor contact. If the check is OK, replace the PWB.
 There is +3.5 / 5VDC measured between Pin 1(+) of the Switch and GND(-), **Figure 1**.
 Y N
 | Replace the switch.
 Check the wire between the PWB Pin 4 and the switch Pin 1 for an open circuit and poor contact. If the check is OK, replace the PWB.

De-actuate the switch.

The display changed.

Y N
 | Disconnect the connector on the switch.
The display changed.
 Y N
 | Check for a short between the switch Pin 2 and the PWB Pin 3. If the check is OK, replace the PWB.
 Replace the switch.

Replace the switch.

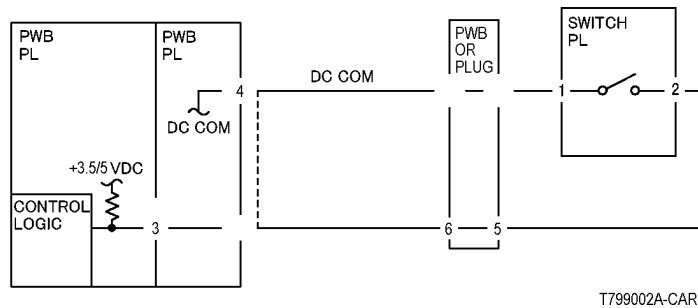

Figure 1 2003

GP 4 How to Check a Multiple Wire Motor

For use on DC motors that:

- have 1 or 2 DC power inputs
- are controlled by 2 or more drivers
- have no DC COM connections for return power
- have no specific feedback circuits

Procedure

Connect black meter lead to ground. Measure voltage at each pin of J2 (example only, refer to the actual Circuit Diagnostic for the correct voltage and connector designation).

+24 VDC is measured at each pin.

Y N
 | Disconnect J2. Measure voltage at P2-1 and P2-6.
+24 VDC is measured.
 Y N
 | Switch machine off then on. Measure voltage at P2-1 and P2-6.
+24 VDC is measured.
 Y N
 | If an interlock circuit is present, check the interlock circuit. Repair as required. If the interlock circuit is good, replace the PWB.
 Check the motor wires for a short circuit. If the wires are good, replace the Motor.
 Check the motor wires for obvious damage. If the wires are good, replace the Motor.

Replace the PWB.

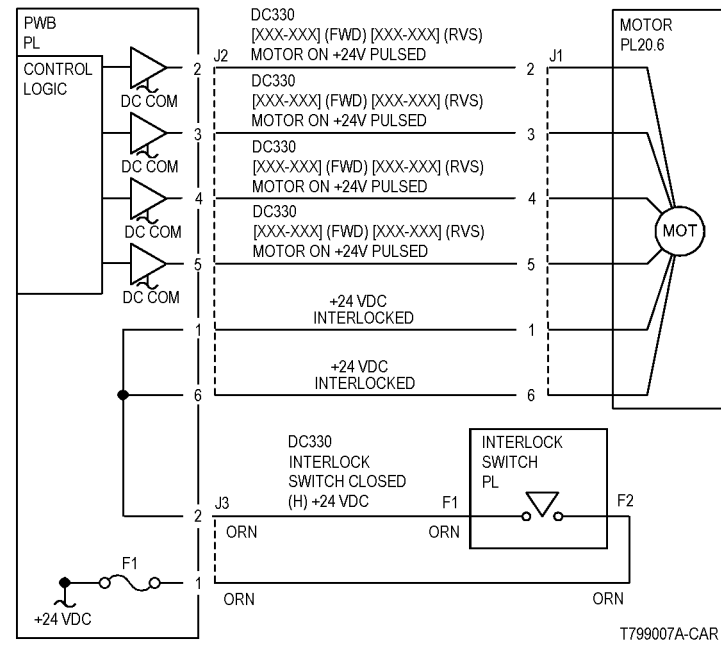

Figure 1 Motor CD

Machine Dimensions

Table 1 Feeder Standalone Dimensions

	Height	Width	Depth
Base Dimensions	433mm	476mm	618mm
Dimensions When Paper Tray is Open	433mm	476mm	1055mm
Dimensions When HCF Slide is Open	433mm	726mm	618mm
Dimensions When Paper Tray is Open and HCF Slide is Open	433mm	726mm	1055mm

Weight

31kg or less (Standalone Unit Weight)

Electrical Specification

Supplied from IOT Main Unit.

1. Voltage: 24V DC
2. Electric Current: 1.9A [55PPM machines (converted to 24.5V) Power: 46.6Wdc]

Product Codes

Table 1 Product Codes

Item	Code
3000-Sheet High-Capacity Feeder	EZL

Change Tags

Change Tags Introduction

Important modifications to the copier are identified by a tag number which is recorded on a tag matrix:

- The tag matrix for the IOT is molded into the inside of the Front Door.
- The tag matrix for the Finisher is a label affixed to the inside of the Finisher Front Door.

Classification Codes

A tag number can be required to identify differences between parts that cannot be interchanged, or differences in diagnostic, repair, installation, or adjustment procedures.

A tag number can also be required to identify the presence of optional hardware, special non-volatile memory programming, or whether mandatory modifications have been installed. Each tag number is given a classification code to identify the type of change that the tag has made. The classification codes and their descriptions are listed in Table 1.

Table 1 Classification Codes

Classification Code	Description
M	Mandatory tag.
N	Tag not installed in the field.
O	Optional tag.
R	Repair tag.

DC330 Input Component Check List

The purpose of Component Control is to display the logic state of input signals, from Sensors and Switches, and to energize output components, such as Motors and Solenoids. These functions are accessed from the IOT control panel.

For details on accessing Component Control, refer to Section 6, General Procedures, of the IOT Service Manual.

Table 1 DC330 Input Component Check List

Chain-Link	Component Name	Description	Display
078-100	HCF Pre Feed Sensor	HCF pre feed sensor (PL 78.6)	High/Low
078-101	HCF Feed Out Sensor	First sensor in HCF transport (PL 78.4)	High/Low
078-102	HCF 2.1 Exit Sensor	Second sensor in HCF transport (PL 78.4)	High/Low
078-200	HCF No Paper Sensor	Tray empty sensor (PL 78.6)	High/Low
078-201	HCF Level Sensor	Paper level sensor (PL 78.6)	High/Low
078-202	HCF Size Sensor A	Letter size sensor (PL 78.8)	High/Low
078-203	HCF Size Sensor B	A4 size sensor (PL 78.8)	High/Low
078-204	HCF Tray In Sensor	HCF Paper tray closed sensor (PL 78.8)	High/Low
078-300	HCF Transport Interlock	HCF transport jam clearance cover interlock (PL 78.4)	High/Low
078-301	HCF Side Out Switch	HCF docking switch (PL 78.8)	High/Low

DC330 Output Component Check List

The purpose of Component Control is to display the logic state of input signals, from Sensors and Switches, and to energize output components, such as Motors and Solenoids. These functions are accessed from the IOT control panel.

For details on accessing Component Control, refer to the Section 6, General Procedures, of the IOT Service Manual.

Table 1 DC330 Output Component Check List

Chain-Link	Component Name	Description	Simultaneous Execution Prohibited Chain-Link	Display
078-003	HCF Feed Motor-Feed	Runs the feed motor in the feed direction	078-004	On/Off
078-004	HCF Feed Motor- Lift Up	Runs the feed motor to elevate the paper tray	078-003	On/Off
078-006	HCF1 T/A Motor (500 mm/s)	Runs the takeaway (transport) motor at 500 mm/s	078-007, 078-008	On/Off
078-007	HCF1 T/A Motor (640 mm/s)	Runs the takeaway (transport) motor at 640 mm/s	078-006, 078-008	On/Off
078-008	HCF1 T/A Motor (364 mm/s)	Runs the takeaway (transport) motor at 364 mm/s	078-006, 078-007	On/Off

7 Wiring Data

Plug/Jack Locations88
Plug/Jack Locations88
Feeder Plug/Jack List88
Feeder Plug/Jack Locations89
Block Schematic Diagram (BSD)91
Block Schematic Diagram (BSD).....91

Plug/Jack Locations

Purpose

Wiring diagrams are an aid to trace wiring faults. Wiring diagrams are used to complement the circuit diagram in the relevant RAP.

How to Use the Finisher Plug/Jack Location List

- To find which position to install specific connectors, refer to [Feeder Plug/Jack List](#). To see an illustration for your specific P/J number, refer to the specific figure number, then locate the item number callout.
- The Finisher Plug/Jack Location List is expressed in the four ways below, [Figure 1](#):
 - J250 represents Jack 250.
 - P250 represents Plug 250.
 - CN1 represents Connector 1.
 - FS1 represents Faston Terminal 1.

Example:

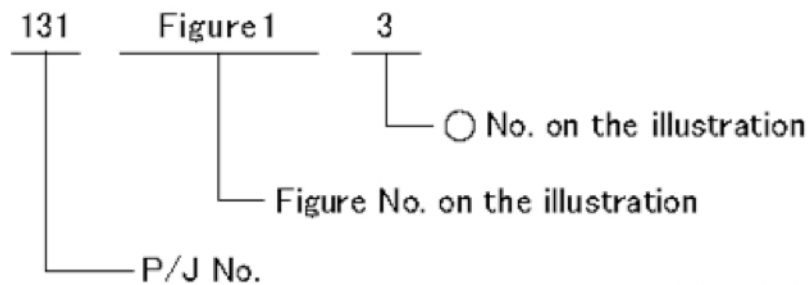

F-1-0126-A

Figure 1 Plug/Jack Location List

Feeder Plug/Jack List

Table 1 Feeder Plug/Jack List

P/J No.	Figure No.	Item No.	Remarks
P/J7403	1	3	HCF PWB
P/J7404	1	4	HCF PWB
P/J7405	1	7	HCF PWB
P/J7406	1	6	HCF PWB
P/J7407	1	5	HCF PWB
P/J7409	1	1	HCF PWB
P/J7410	1	9	HCF PWB
P/J7411	1	2	HCF PWB
P/J7412	1	8	HCF PWB
IOT Connector	2	1	IOT to HCF power and comms
Side Set Sensor	2	3	
CN1	2	4	Takeaway motor power
P/J26	2	5	Takeaway motor control
Lift/Drive Motor	2	6	
11 Inch Size Motor	2	7	
A4 Size Sensor	2	8	
Exit Sensor	3	1	
Feed Out Sensor	3	2	
Top Cover Interlock	3	3	

P/J No.	Figure No.	Item No.	Remarks
No Paper Sensor	3	4	
Tray Level Sensor	3	5	Paper stack height sensor
Pre-Feed Sensor	3	6	
Tray In Sensor	4	1	

Feeder Plug/Jack Locations

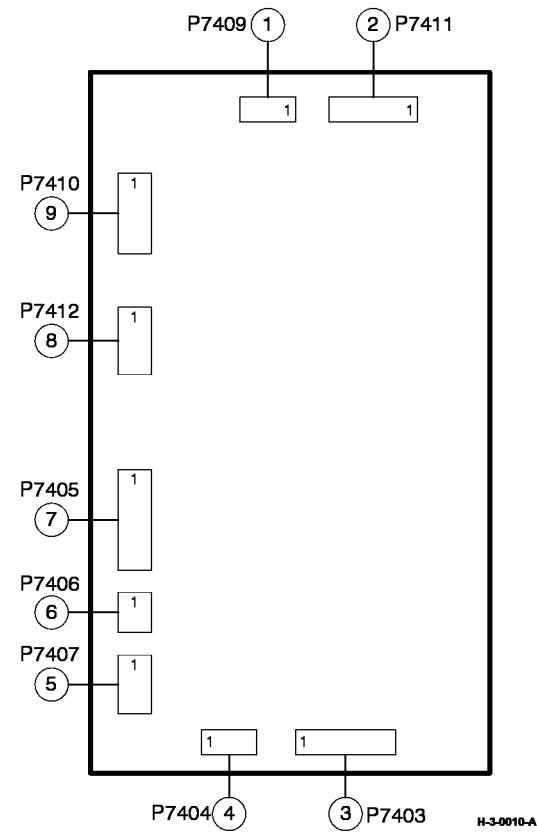
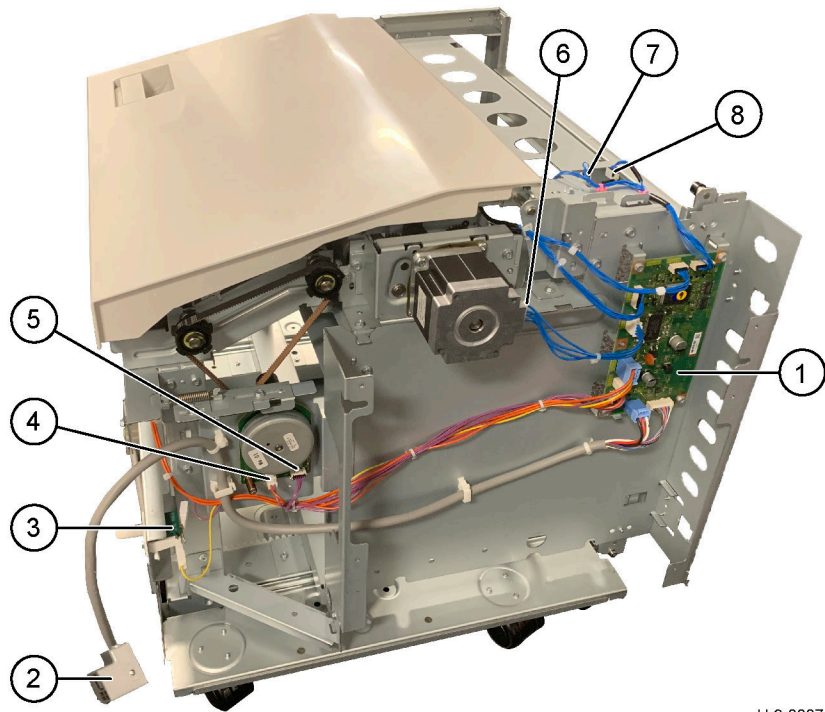
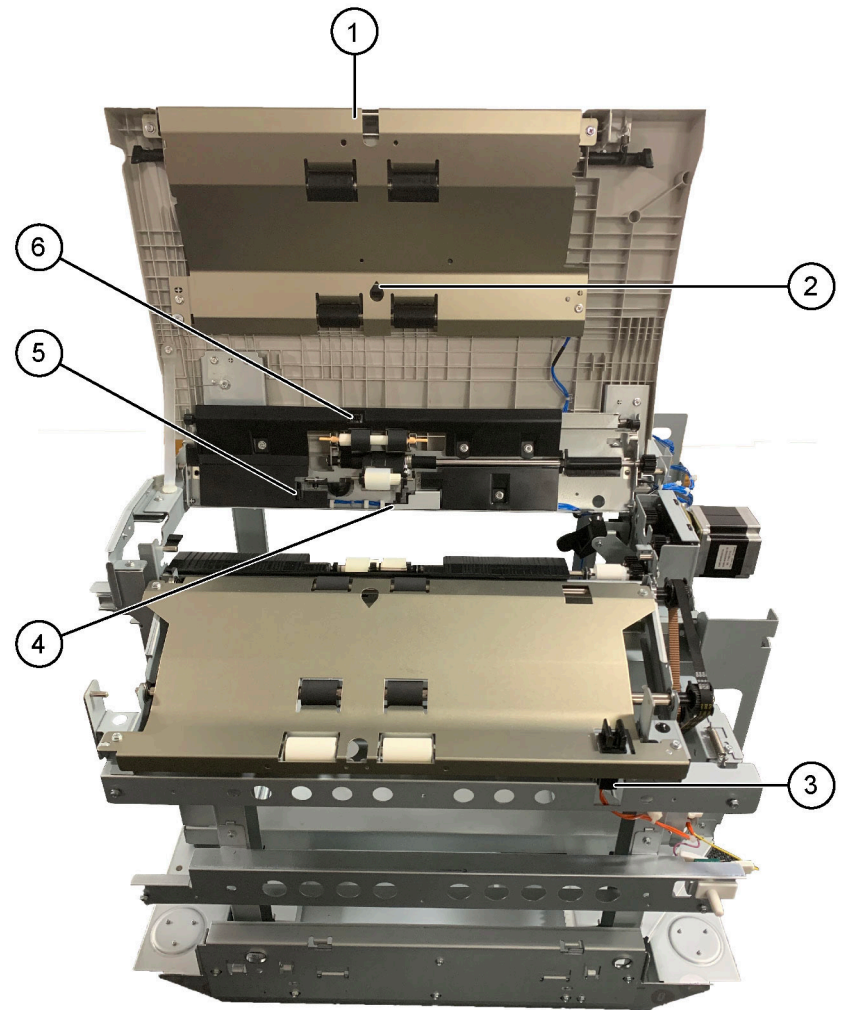

Figure 1 HCF PWB



H-3-0007-A

Figure 2 Rear Connectors



H-3-0008-A

Figure 3 Top Connectors

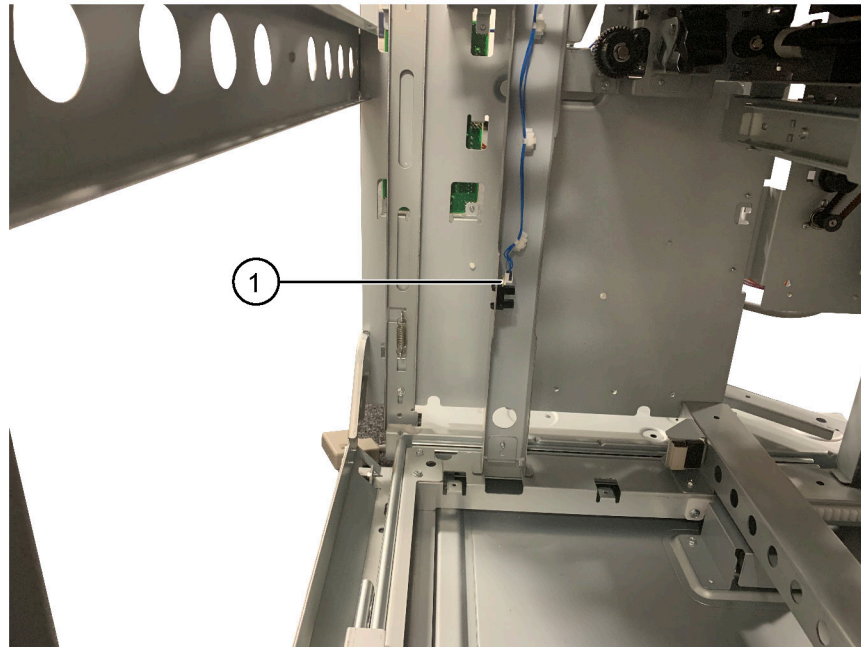

H-3-0009-A

Figure 4 Internal Connectors

Block Schematic Diagram (BSD)

Preface

How to Use the BSDs

1. Enter the Chain specified in the Troubleshooting chapter.
2. Or enter the appropriate Chain, referring to the Contents.
3. Perform failure analysis in the Chain, using test data and the general procedures in the General chapter.



WARNING: Do not perform repair activities with the power on or electrical power supplied to the machine. The machine could activate and cause serious personal injury when the power is on or electrical power is supplied.

Ne pas effectuer de dépannage avec le contact principal activé ou avec l'alimentation électrique appliquée à la machine: celle-ci pourrait démarrer et causer de graves blessures.

Non effettuare alcuna riparazione con la macchina accesa o con l'alimentazione elettrica inserita. La macchina potrebbe avviarsi all'improvviso e causare gravi ferite.

Es dürfen keine Reparaturarbeiten durchgeführt werden, solange das Gerät eingeschaltet oder mit der Stromquelle verbunden ist. Das Gerät kann u.U in den Aktiv-Zustand übergehen und somit erhebliche körperliche Schäden verursachen













No realice reparaciones con la máquina encendida o conectada a la corriente. La máquina podría activarse y ocasionar daños personales graves.









Once you have located the failure, go to the Parts List No. and/or Adjustment No. indicated for reference on the BSD.







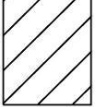
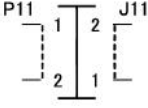
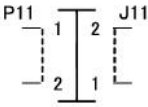
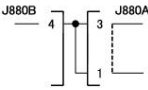

Explanation of Symbols

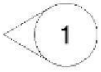
Table 1 Explanation of Symbols

Symbol	Description
	Explanation of Symbols
	Refers to test data that is usually on the same page when the voltage value shown on the BSD is different from the measured value.
PL 7.7	Refers to the Parts List No. PL stands for Parts List. 7.7 refers to the Plate No. PL No. indicates that the part is listed

Symbol	Description
	on the specified plate. PL No. is shown for all the replaceable parts on the BSDs.
 7.7.1	Refers to the adjustment item(s) in the Disassembly, Assembly, and Adjustment chapter. 7.7.1 indicates that the adjustment procedure is described under the 7.7.1 section in the Disassembly, Assembly, and Adjustment chapter.
 VR3	Indicates a variable register that is adjustable in the field.
 TP1	Indicates a signal test point.
 1.3	Indicates where the input to a function originates. The example indicates that the input originates from group function 3 of Chain 1
 6.1	Indicates where the output from a function goes. The example indicates that the output goes to group function 1 of chain 6.
	Indicates that the signal line continues vertically.
	Indicates that the signal line continues horizontally.
 ZONE E3	Indicates that the signal line goes to another zone in the same function. The example refers to zone E3.
 ZONE A4	Indicates that the signal line goes back to another zone in the same function. The example refers to zone A4
 CH8.5 ZN A2	Indicates that the signal line goes to a zone in another sheet. The example refers to zone A2, CH8.5.
 CH8.5 ZN H4	Indicates that the signal line goes back to a zone in another sheet. The example refers to zone H4, CH8.5.
 +5VDC (1.2 J2)	Indicates a power line output from Chain 1.

Symbol	Description
	Indicates frame ground.
	Indicates a twisted pair of wires.
	Indicates that the signal goes from right to left, in the opposite direction to the normal direction.
	Indicates a feedback signal.
	Indicates a mechanical connection to a part.
	Indicates that a mechanical drive signal goes in the direction indicated.
	Indicates Control Logic.
	Indicates a double plug connector.
	Indicates a double plug connector.
	Indicates a shorting plug connector.
	Indicates that the fasten is used for connection.
	Indicates that an electrically conductive material such as a leaf spring and a plate is used for connection.

Symbol	Description
	Indicates that the symbol-pointed-to section has been modified to code 1V.
	Indicates the symbol-pointed-to section has not been modified to code 1V.
	Indicates that the whole figure or the framed illustration has information with 1V installed.
	Indicates that the whole figure or the framed illustration has information without 1V installed.
	Indicates direction the air flows.
	Indicates switch and is also used as Interlock Switch.
	Indicates the Cheater type of Interlock Switch.
	Indicates the Chip Fuse.

Signal Name Structure

The example indicates that when paper is sensed, this signal level is (L), otherwise the signal level is (H) with the voltage +5VDC:

Table 2 Input Component

Signal	Description
PAPER SENSED	Operation state
(L)	Logical Value
+5VDC	Voltage with signal (H)

The example indicates that when the part is ON, the signal level is (L) and that when it is OFF, the signal level is (H) with the voltage +24VDC:

Table 3 Input Component

Signal	Description
ON	Operation state
(L)	Logical Value
+24VDC	Voltage with signal (H)

DC Voltage

A measurement of DC voltage is made between the particular test point and the frame unless otherwise specified by note and test data. The measured DC voltage is in the range below:

Voltage	Level	Range
—	-	-

Other Descriptions

DC330 Input Component Voltage Level

The voltage levels (H/L) shown on the BSDs are the levels that are measured by the tester. Some of them are therefore different from H/L displayed on the UI panel.

1. Wiring Color

- Wires are distinguished by color in part of the BSDs for this model. The colors of wires are shown below the signal lines in their respective abbreviations listed below:

Abbreviation	Color
BRN	BROWN
RED	RED
ORN	ORANGE
YEL	YELLOW
GRN	GREEN
BLU	BLUE
VIO	VIOLET
GRY	GRAY
WHT	WHITE
BLK	BLACK

Abbreviation	Color
GRN/YEL	GREEN/YELLOW
PNK	PINK
SKY	SKY

2. On this model, the color of power supply line depends on the voltage. The relations between voltages and wire colors are as follows: The colors of actual wires may sometimes differ from the colors of power supply lines on BSD.

Voltage	Color
ACH	BROWN
ACN	BLUE
+3.3VDC	YELLOW GREEN
+5VDC	GRAY
+24VDC	ORANGE
DC COM	VIOLET

Figures on the BSDs

The grayed-out portion of the figure shows the path from Motor or Solenoid to parts to drive.

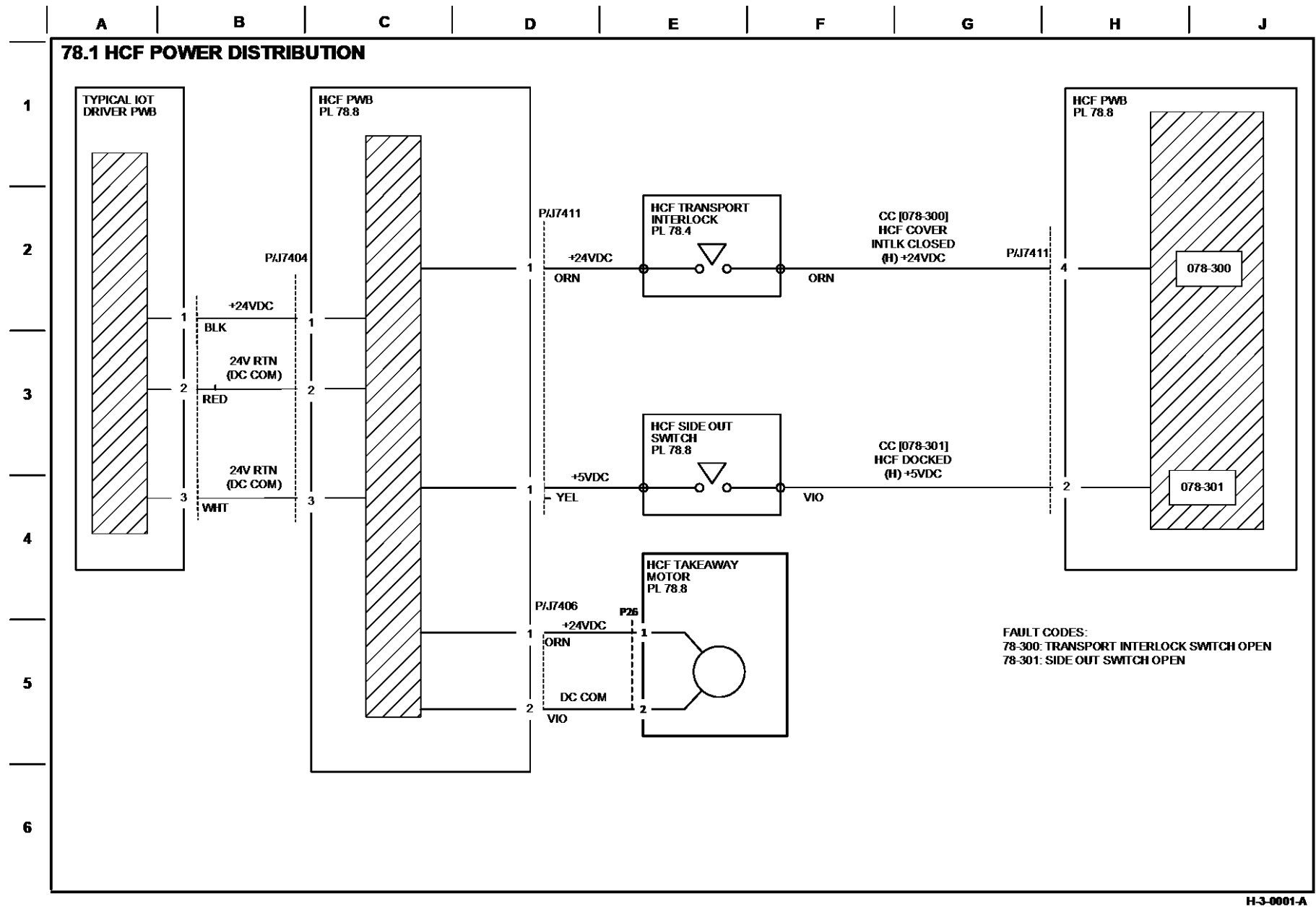

H-3-0001-A

Figure 1 BSD 78.1 HCF Power Distribution

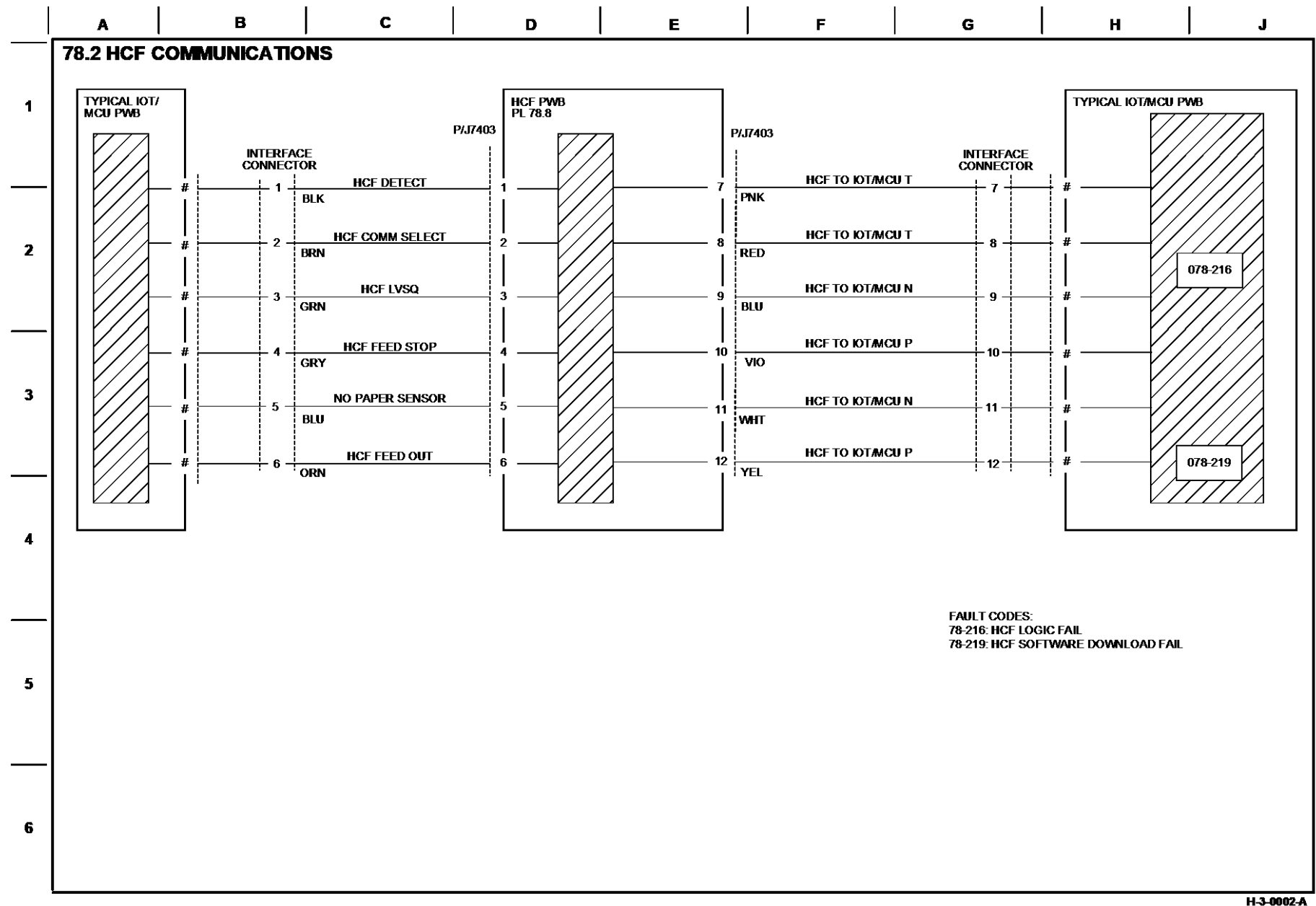

H-3-0002-A

Figure 2 BSD 78.2 HCF Communications

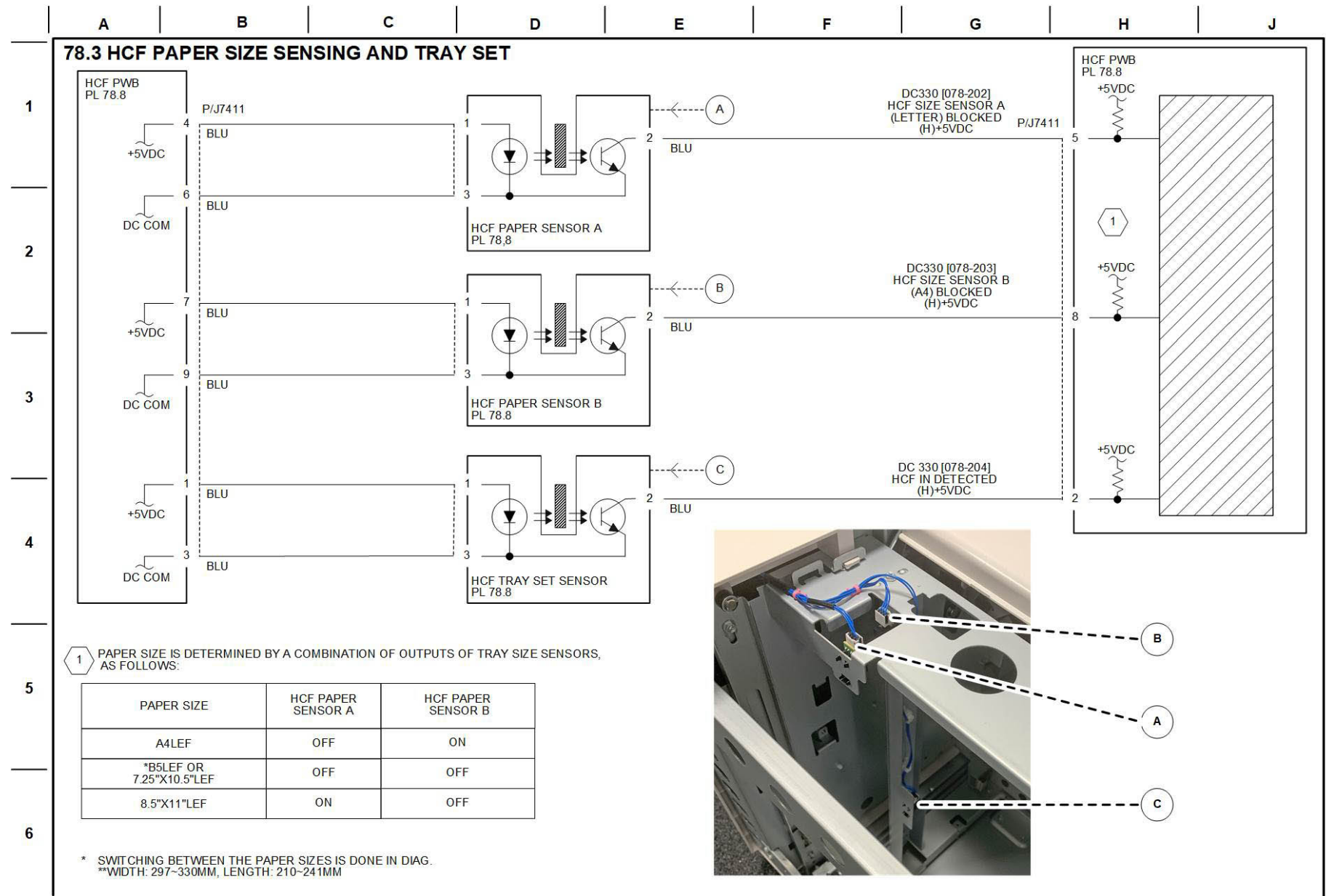
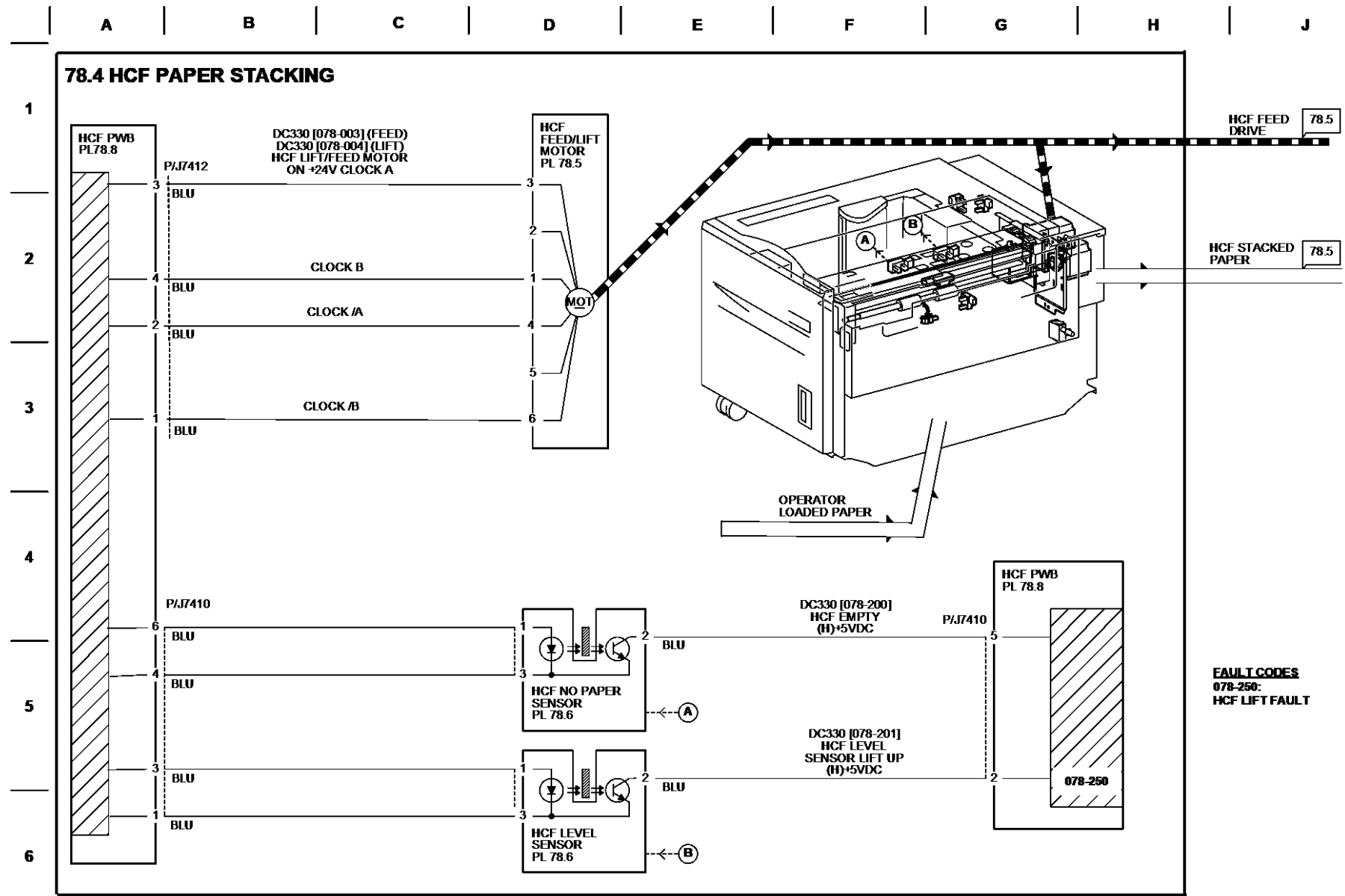
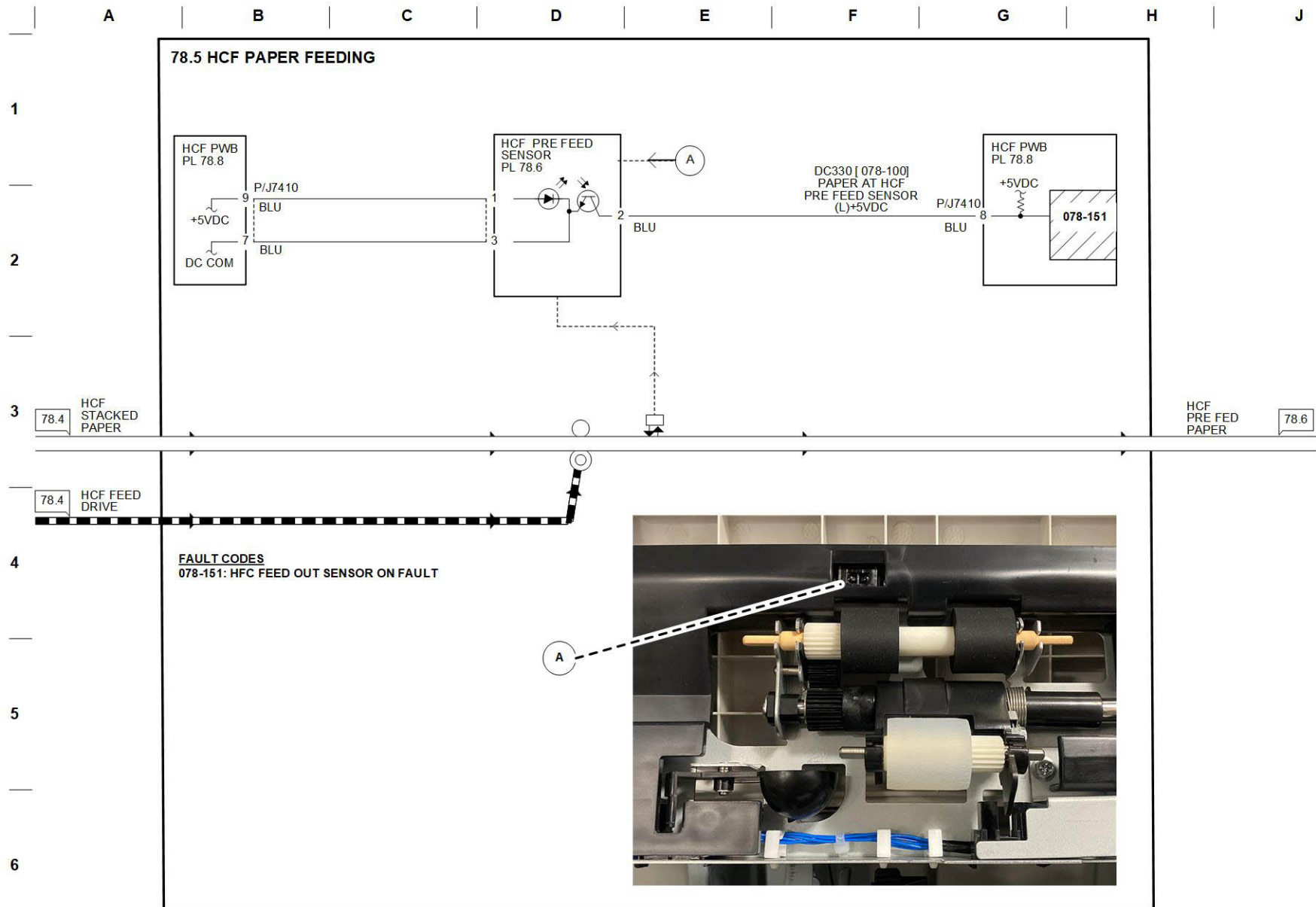

Figure 3 BSD 78.3 HCF Size Sensing and Tray Set



H-3-0004-A

Figure 4 BSD 78.4 HCF Paper Stacking



H-3-0005-A

Figure 5 BSD 78.5 HCF Paper Feeding

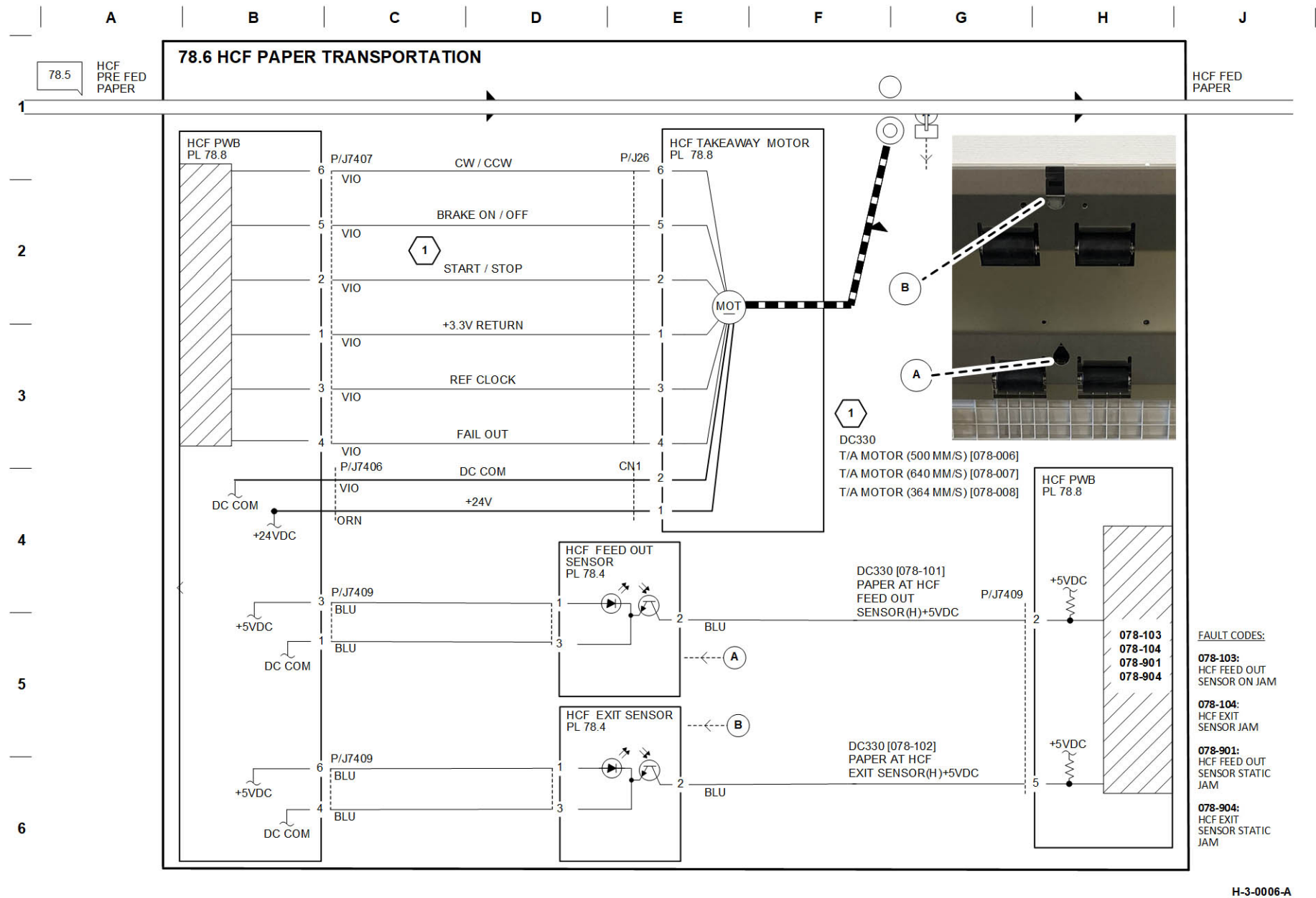

Figure 6 BSD 78.6 HCF Paper Transport

