

TOSHIBA

SERVICE MANUAL

DUAL SCAN DOCUMENT FEEDER

MR-4010/4020

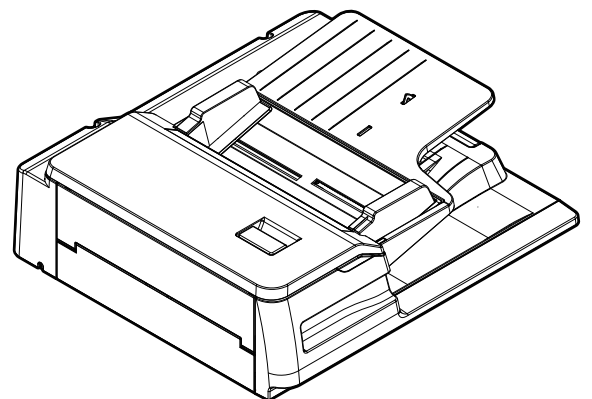

Model: MR-4010/4020
Publish Date: December, 2021
File No. SME21001700
R210221X2100-TTEC
Ver00 F1 2022-03

Trademarks

- MOLYKOTE® is a trademark of DDP SPECIALTY ELECTRONIC MATERIALS US, INC..
- The company and product names described in this manual are trademarks or registered trademarks of their respective companies.

© 2021, 2022 Toshiba Tec Corporation All rights reserved

Under the copyright laws, this manual cannot be reproduced in any form without the prior written permission of Toshiba Tec Corporation.

General Precautions for Installation, Servicing and Maintenance for this Option

The installation and service shall be done by a qualified service technician.

1. When installing this option to the MFP, be sure to follow the instructions described in the “Unpacking/Set-Up Procedure for the Equipment” booklet which comes with this option.
2. This option shall be installed by an authorized or qualified person.
3. Before starting installation, servicing or maintenance work, be sure unplug the power cable of the MFP first.
4. The MFP with this option connected shall be installed near the socket outlet and shall be easily accessible.
5. Be sure to fix and plug in the power cable securely after the installation so that no one trips over it.
6. When servicing or maintaining the MFP with this option connected, be careful about the rotating or operating sections such as gears, pulleys, sprockets, cams, belts, etc.
7. When the parts of this option are disassembled, reassembly is the reverse of disassembly unless otherwise noted in this manual or other related documents. Be careful not to install small parts such as screws, washers, pins, E-rings, star washers, harnesses in the wrong places.
8. Basically, the MFP with this option connected should not be operated with any parts removed or disassembled.
9. When servicing the MFP with this option connected while the power is turned ON, be sure not to touch live sections and rotating/operating sections.
10. Delicate parts for preventing safety hazard problems (such as fuses, thermofuses, door switches, sensors, etc. if any) should be handled, installed and adjusted correctly.
11. Tools and instruments
 - Use designated jigs and tools.
 - Use recommended measuring instruments or equivalents.
12. During servicing or maintenance work, be sure to check the nameplate and other cautionary labels (if any) to see if they are clean and firmly stuck. If not, take appropriate actions.
13. The ICs on the PC boards tend to be damaged by static electricity. Therefore, the PC boards must be stored in an anti-electrostatic bag and handled carefully using a wristband. Before using the antistatic wrist strap, unplug the power cable of the MFP and make sure that there are no charged objects which are not insulated in the vicinity.
14. Regarding the recovery and disposal of the MFP with this option connected, supplies, packing materials, follow the relevant local regulations or rules.
15. There is a risk of an electric shock or fire resulting from the damage to the harness covering or conduction blockage. To avoid this, be sure to wire the harness in the same way as that before disassembling when the MFP is assembled and disassembled.
16. Return the MFP with this option connected to the original state and check the operation when the service is finished.

17. Unplug the power cable and clean the area around the prongs of the plug and socket outlet once a year or more. A fire may occur when dust lies on this area.
18. Check the procedures and perform them as described in the Service Manual.
19. Make sure you do not lose your balance.
20. Avoid exposure to your skin and wear protective gloves as needed.
21. Do not leave plastic bags where children can get at them. This may cause an accident such as suffocation if a child puts his/her head into a bag. Plastic bags of options or service parts must be brought back.
22. After the power cable is disconnected, an electric charge may remain in the boards of the MFP. Therefore, be sure to disconnect or connect the connectors when about 1 minute (e.g.: the time for taking off the rear cover) has passed after the power cable is disconnected.
23. The DSDF equips the function to transmit its adjustment values to the MFP only at the first normal startup (power OFF/ON) once the DSDF has been installed.
This function will not work when the MFP is started in the self-diagnosis mode by means of pressing buttons on the control panel or at the easy set-up mode during unpacking. Therefore, even if various adjustments of the DSDF are carried out in the self-diagnostic mode at the first startup of the MFP once the DSDF has been installed, the values set in the adjustment are overwritten by the adjustment values of the DSDF when the normal startup (power OFF/ON) is performed since they are transmitted at this timing.

In addition, this function will not work when a DSDF, which was already installed in another MFP, is installed in other one. In such a case, perform FS-05-3240 and FS-05-3400 in order to transmit the adjustment values of the DSDF to the MFP. (When they are performed, the adjustment values of the DSDF or RADF which was previously installed will be changed.) In the similar way, when the DSDF is replaced with the RADF, perform FS-05-3401. (When this is performed, the adjustment values of the DSDF which was previously installed will be changed.)

CONTENTS

1. SPECIFICATIONS	1-1
2. OVERVIEW	2-1
2.1 Main Components	2-1
2.2 Sectional View	2-3
2.3 Electric Parts Layout	2-5
2.4 Symbols and Functions of Various Components	2-8
2.4.1 Motor	2-8
2.4.2 Clutch	2-8
2.4.3 Sensor and switch	2-8
2.4.4 PC Board	2-10
2.4.5 Others	2-10
2.5 Signal Block Diagram	2-11
2.6 Interface Signals	2-12
3. OPERATION DESCRIPTION	3-1
3.1 Overview	3-1
3.1.1 Original transport path	3-1
3.2 Drive Section	3-2
3.2.1 Motor	3-2
3.2.2 DSDF original feed motor	3-2
3.2.3 DSDF separation motor	3-3
3.2.4 DSDF registration motor	3-4
3.2.5 DSDF read motor	3-5
3.2.6 DSDF original exit motor	3-6
3.3 Original Size Detection	3-7
3.3.1 DSDF tray original width sensor, DSDF tray original length sensor-1 and -2	3-8
3.3.2 DSDF original width detection sensor-1 and -2, DSDF registration sensor	3-9
3.4 Multiple Feeding Detection (MR-4020 only)	3-12
4. DISASSEMBLY AND REASSEMBLY	4-1
4.1 PM Parts	4-1
4.1.1 DSDF pickup unit	4-1
4.1.2 DSDF separation roller	4-3
4.1.3 DSDF pickup roller	4-6
4.1.4 DSDF original feed roller	4-7
4.2 Cover	4-9
4.2.1 DSDF rear cover	4-9
4.2.2 DSDF front cover	4-10
4.2.3 Original jam access cover	4-11
4.2.4 DSDF left cover	4-12
4.3 PC Board	4-13
4.3.1 DSDF-LED PC board (LEDD)	4-13
4.3.2 DSDF control PC board (DLGD)	4-13
4.3.3 DSDF relay PC board (DFRLY)	4-14
4.3.4 DSDF multiple feeding detection relay PC board (DLGRLY)	4-15
4.4 Original Tray Section	4-16
4.4.1 Original tray	4-16
4.4.2 DSDF tray original length sensor-1 (SD1), DSDF tray original length sensor-2 (SD2)	4-17
4.4.3 DSDF tray original width sensor (SD3)	4-18
4.4.4 DSDF original empty sensor (SD4)	4-20
4.5 Original Feeding Section	4-21
4.5.1 DSDF original feed sensor (SD5), DSDF tray lift upper limit sensor (SD9)	4-21
4.5.2 DSDF original width detection sensor-1 (SD7), DSDF original width detection sensor-2 (SD8)	4-23

4.5.3	DSDF registration sensor (SD6)	4-24
4.6	Driving Section	4-27
4.6.1	DSDF cooling fan motor (FD1)	4-27
4.6.2	DSDF upper cover interlock switch (SWD2)	4-28
4.6.3	DSDF upper cover opening/closing detection sensor (SD16)	4-28
4.6.4	DSDF registration motor (MD3)	4-30
4.6.5	DSDF read motor (MD4)	4-32
4.6.6	DSDF original exit motor (MD5)	4-34
4.6.7	DSDF lower cover interlock switch (SWD1)	4-36
4.6.8	DSDF original feed motor (MD1)	4-37
4.6.9	DSDF separation motor (MD2)	4-37
4.7	Original Transport Section	4-38
4.7.1	Intermediate transport unit	4-38
4.7.2	DSDF read-in sensor-1 (SD11), DSDF read-in sensor-2 (SD12)	4-40
4.7.3	DSDF original exit sensor (SD13), DSDF tray lift lower limit sensor (SD10) ..	4-41
4.7.4	Lower transport unit	4-42
4.7.5	DSDF shading sheet HP sensor (SD14)	4-43
4.7.6	DSDF lower cover opening/closing detection sensor (SD15)	4-44
4.7.7	Multiple feeding detection sensor (reception side) (SD18)	4-45
4.7.8	Multiple feeding detection sensor (transmission side) (SD17)	4-46
4.8	Original Scanning Section	4-47
4.8.1	DSDF-CCD module (CCDD)	4-47
4.9	Film Attachment Reference	4-49
4.9.1	Registration films (F), (R)	4-49
4.9.2	Films with a spacer	4-50
5.	ADJUSTMENT	5-1
5.1	Position Adjustment	5-1
5.1.1	Checking	5-1
5.1.2	Adjustment	5-2
5.2	Height Adjustment	5-5
5.2.1	Checking	5-5
5.2.2	Adjustment	5-6
5.3	Skew adjustment	5-7
5.3.1	Checking	5-7
5.3.2	Adjustment	5-8
5.4	Leading Edge Position Adjustment	5-11
5.4.1	Checking	5-11
5.4.2	Adjustment	5-12
5.5	Horizontal Position Adjustment	5-13
5.5.1	Front side	5-13
5.5.2	Back side	5-14
5.6	Copy Ratio Adjustment	5-15
5.6.1	Checking	5-15
5.6.2	Adjustment	5-15
5.7	DSDF Read-in Sensor-1 Adjustment	5-16
5.7.1	DSDF read-in sensor-1 automatic adjustment	5-16
5.7.2	DSDF read-in sensor-1 manual adjustment	5-16
5.8	Platen Sheet	5-18
5.9	DSDF Separation Roller Pressure Force Adjustment	5-19
6.	TROUBLESHOOTING	6-1
6.1	Other Errors	6-1
7.	MAINTENANCE	7-1
7.1	Maintenance and Inspection Points	7-1
7.2	Maintenance Part List	7-2
7.2.1	How to attach the stopper jig	7-2
7.3	Firmware Updating	7-3

8. Harness Diagram 8-1
REVISION RECORD..... 1

1. SPECIFICATIONS

Item	Contents
Maximum number of originals on the original feeding tray	Up to 300 sheets or 38 mm in height * 35 g/m ² to 80 g/m ² (9.3 lb. Bond to 21.3 lb. Bond)
Acceptable paper size	A5-R, A4, A4-R, B5, B5-R, B4, A3, FOLIO, ST-R, LT, LT-R, LG, LD, COMPUTER
Acceptable paper weight	35 g/m ² to 209 g/m ² (9.3 lb. Bond to 41.8 lb. Bond, 77.3 lb. Cover)
Acceptable paper type	Plain, Recycled paper
Scanner	3-line CCD (RGB) 7450 pix.
Scanning speed	Black, Gray Scale, Color (A4, LT) • Simplex: 120 spm, Duplex: 240 spm (200 dpi, 300 dpi) • Simplex: 70 spm, Duplex: 140 spm (600 dpi)
Multiple feeding detection function	MR-4010: Not available MR-4020: Available
Dimensions	575 (W) x 531 (D) x 180 (H) mm * Excluding the original tray and hinge space
Weight	Approx. 14 kg (30 lb.)
Power consumption	Approx. 60 W
Power supply	DC 24 V, DC 5V * Supplied from the MFP
Accessories	Unpacking/Setup Instructions (1 set) Chart (A4 and LT: 1 sheet each) Fixing screw (6 pcs.) Stopper bracket (2 pcs.) Stopper bracket fixing screw (4 pcs.) DSDF I/F board (1 pc.) DSDF I/F board fixing screw (2 pcs.) Locking support (1 pc.) Hinge cover (1 pc.) Positioning pin (2 pcs.) Washer (2 pcs.) Label (1 pc.)

2. OVERVIEW

2.1 Main Components

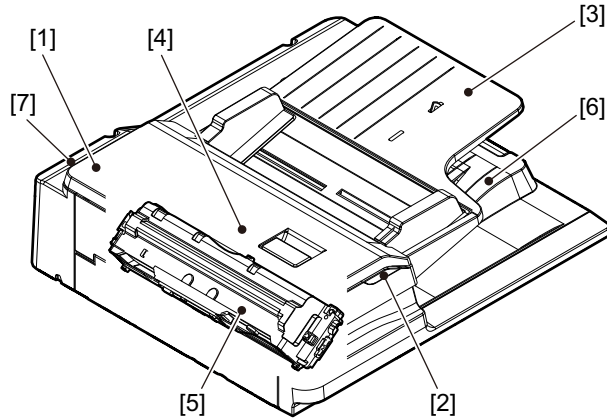

Fig. 2-1

Sym bol	Location	Components		
1	Original jam access cover			
2	LED	LEDD	DSDF-LED PC board	
3	Original tray	SD1	DSDF tray original length sensor-1	Original tray
		SD2	DSDF tray original length sensor-2	Original tray lift
		SD3	DSDF tray original width sensor	
		SD4	DSDF original empty sensor	
4	Paper feeding and transporting	SD5	DSDF original feed sensor	DSDF pickup roller
		SD6	DSDF registration sensor	DSDF separation roller
		SD7	DSDF original width detection sensor-1	DSDF original feed roller
		SD8	DSDF original width detection sensor-2	DSDF registration roller
		SD9	DSDF tray lift upper limit sensor	Pre-read roller-1
		SD10	DSDF tray lift lower limit sensor	Post-read roller-1
		SD11	DSDF read-in sensor-1	Pre-read roller-2
		SD12	DSDF read-in sensor-2	Post-read roller-2
		SD13	DSDF original exit sensor	DSDF original exit roller
		SD15	DSDF lower cover opening/closing detection sensor	
		SD16	DSDF upper cover opening/closing detection sensor	
		SD17	Multiple feeding detection sensor (transmission side)	
		SD18	Multiple feeding detection sensor (reception side)	
		SWD1	DSDF lower cover interlock switch	
		SWD2	DSDF upper cover interlock switch	
5	Original scanning	CCDD	DSDF-CCD module	DSDF shading sheet
		SD14	DSDF shading sheet HP sensor	
6	Original exit tray			

Sym bol	Location	Components	
7	Driving and controlling	MD1	DSDF original feed motor
		MD2	DSDF separation motor
		MD3	DSDF registration motor
		MD4	DSDF read motor
		MD5	DSDF original exit motor
		FD1	DSDF cooling fan motor
		CLD	DSDF tray-up clutch
		DLGD	DSDF control PC board
		DLGRLY	DSDF multiple feeding detection relay PC board

2.2 Sectional View

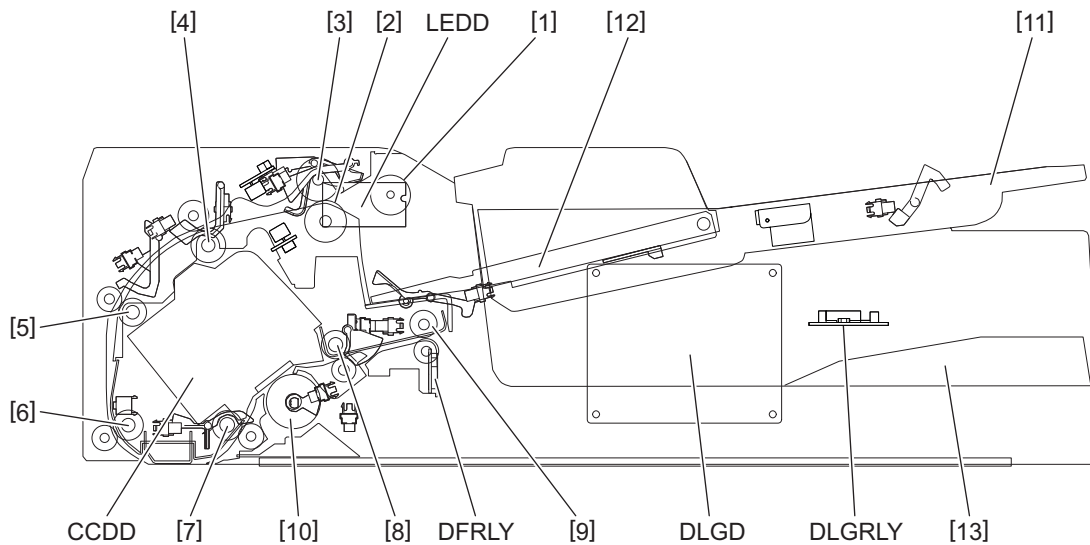

Fig. 2-2

Symbol	Name	Symbol	Name
LEDD	DSDF-LED PC board	7	Pre-read roller-2
CCDD	DSDF-CCD module	8	Post-read roller-2
DLGD	DSDF control PC board	9	DSDF original exit roller
1	DSDF pickup roller	10	DSDF shading sheet
2	DSDF separation roller	11	Original tray
3	DSDF original feed roller	12	Original tray lift
4	DSDF registration roller	13	Original exit tray
5	Pre-read roller-1	DFRLY	DSDF relay PC board
6	Post-read roller-1	DLGRLY	DSDF multiple feeding detection relay PC board (MR-4020 only)

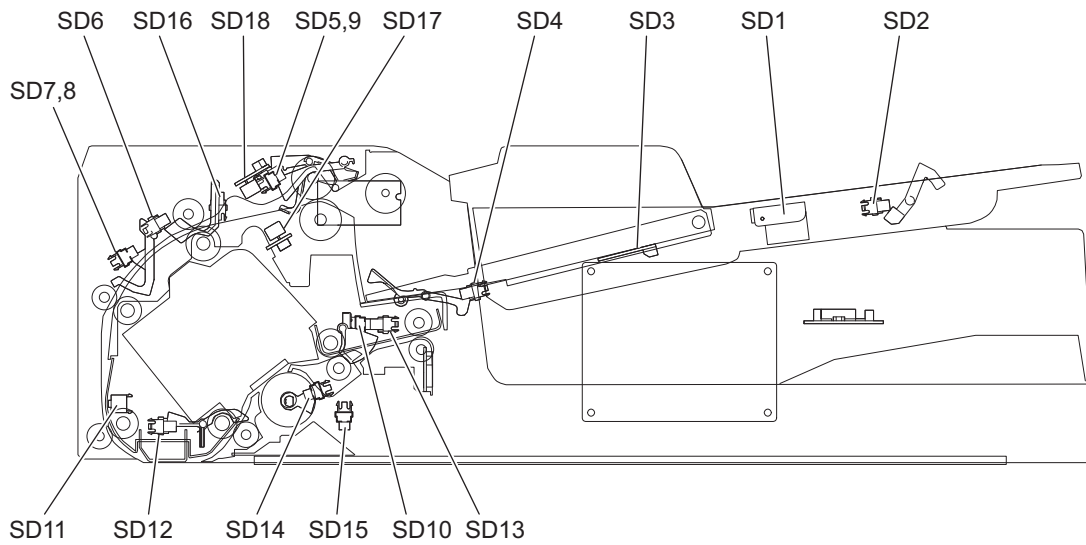

Fig. 2-3

Symb ol	Name	Symb ol	Name
SD1	DSDF tray original length sensor-1	SD10	DSDF tray lift lower limit sensor
SD2	DSDF tray original length sensor-2	SD11	DSDF read-in sensor-1
SD3	DSDF tray original width sensor	SD12	DSDF read-in sensor-2
SD4	DSDF original empty sensor	SD13	DSDF original exit sensor
SD5	DSDF original feed sensor	SD14	DSDF shading sheet HP sensor
SD6	DSDF registration sensor	SD15	DSDF lower cover opening/closing detection sensor
SD7	DSDF original width detection sensor-1	SD16	DSDF upper cover opening/closing detection sensor
SD8	DSDF original width detection sensor-2	SD17	Multiple feeding detection sensor (transmission side) (MR-4020 only)
SD9	DSDF tray lift upper limit sensor	SD18	Multiple feeding detection sensor (reception side) (MR-4020 only)

2.3 Electric Parts Layout

[A] Motor layout

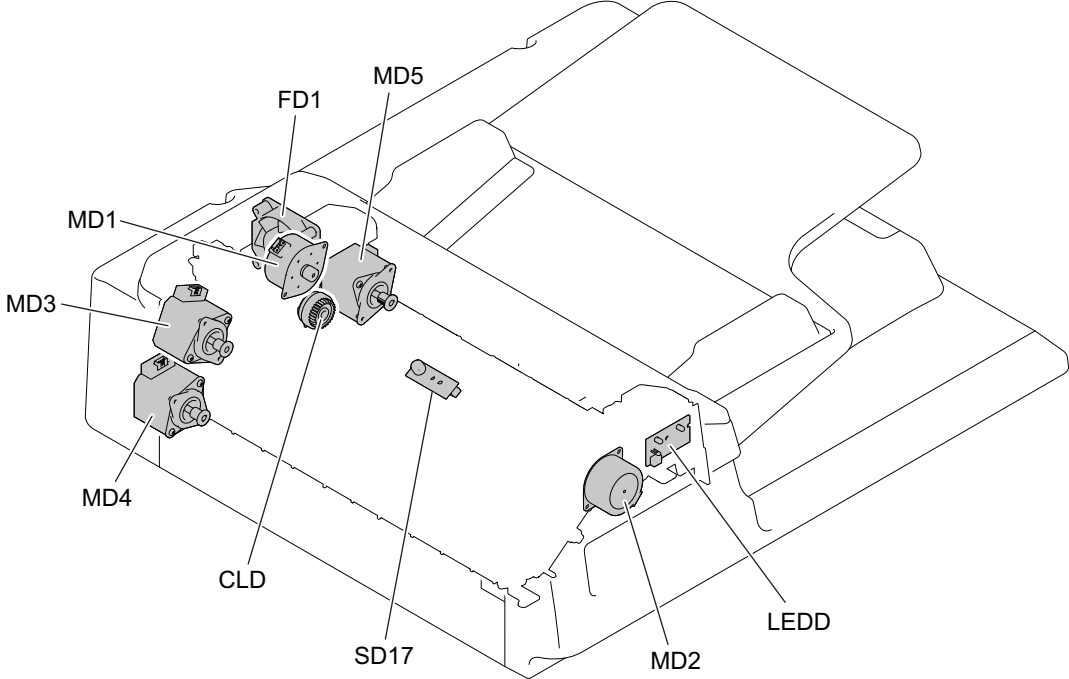

Fig. 2-4

[B] Original sensor layout 1

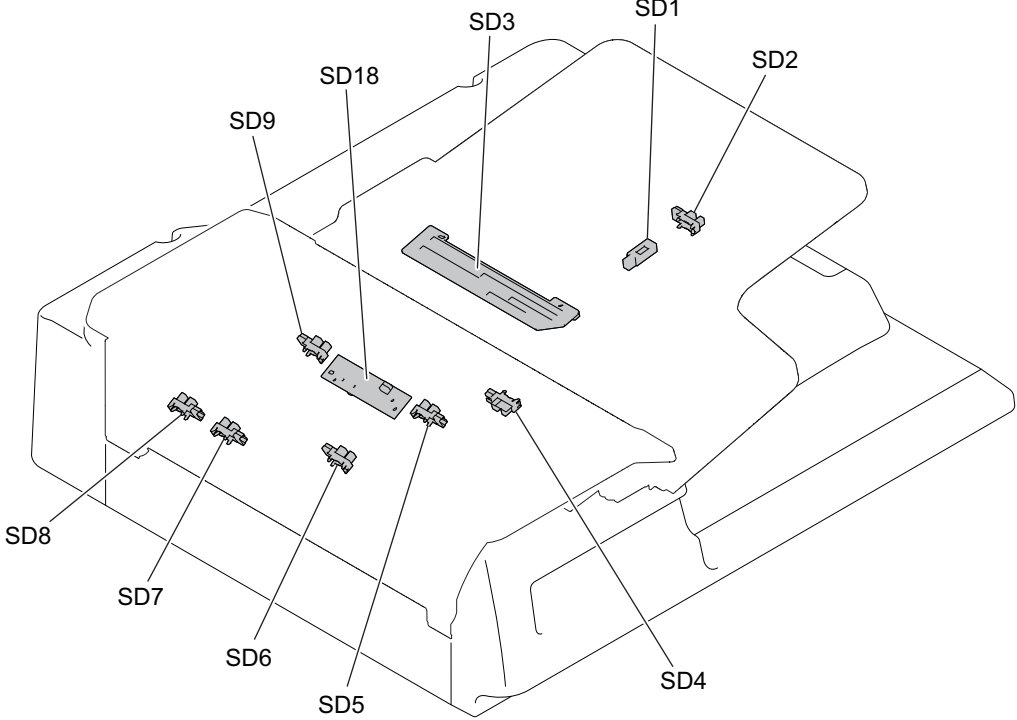

Fig. 2-5

[C] Original sensor layout 2

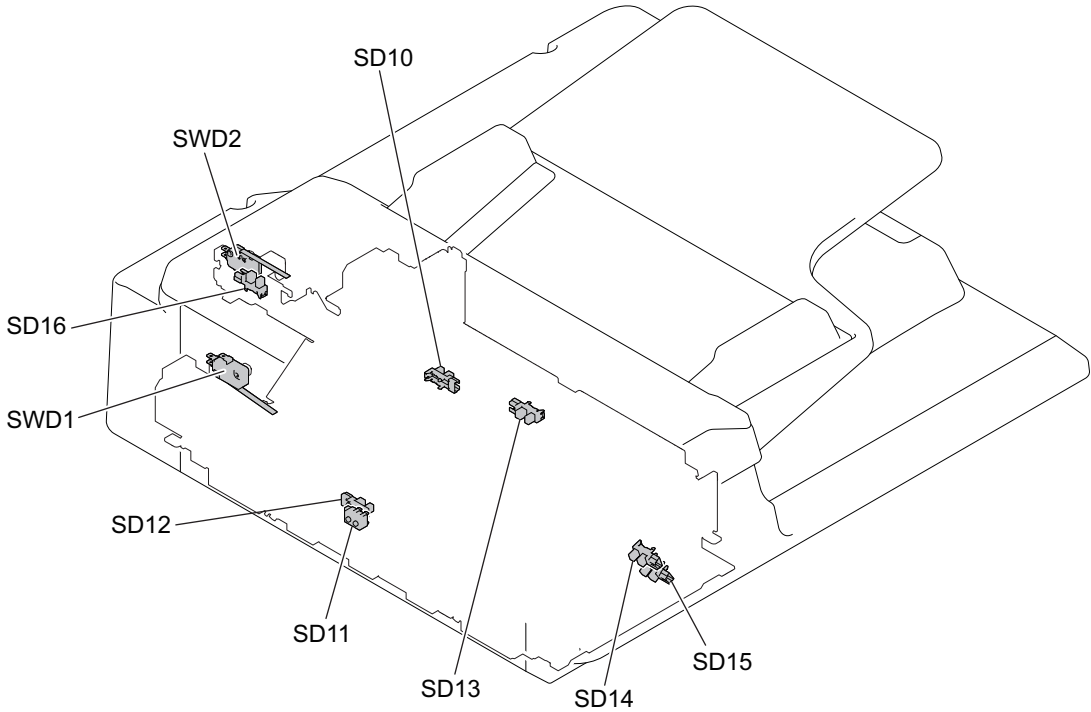

Fig. 2-6

[D] PC board layout

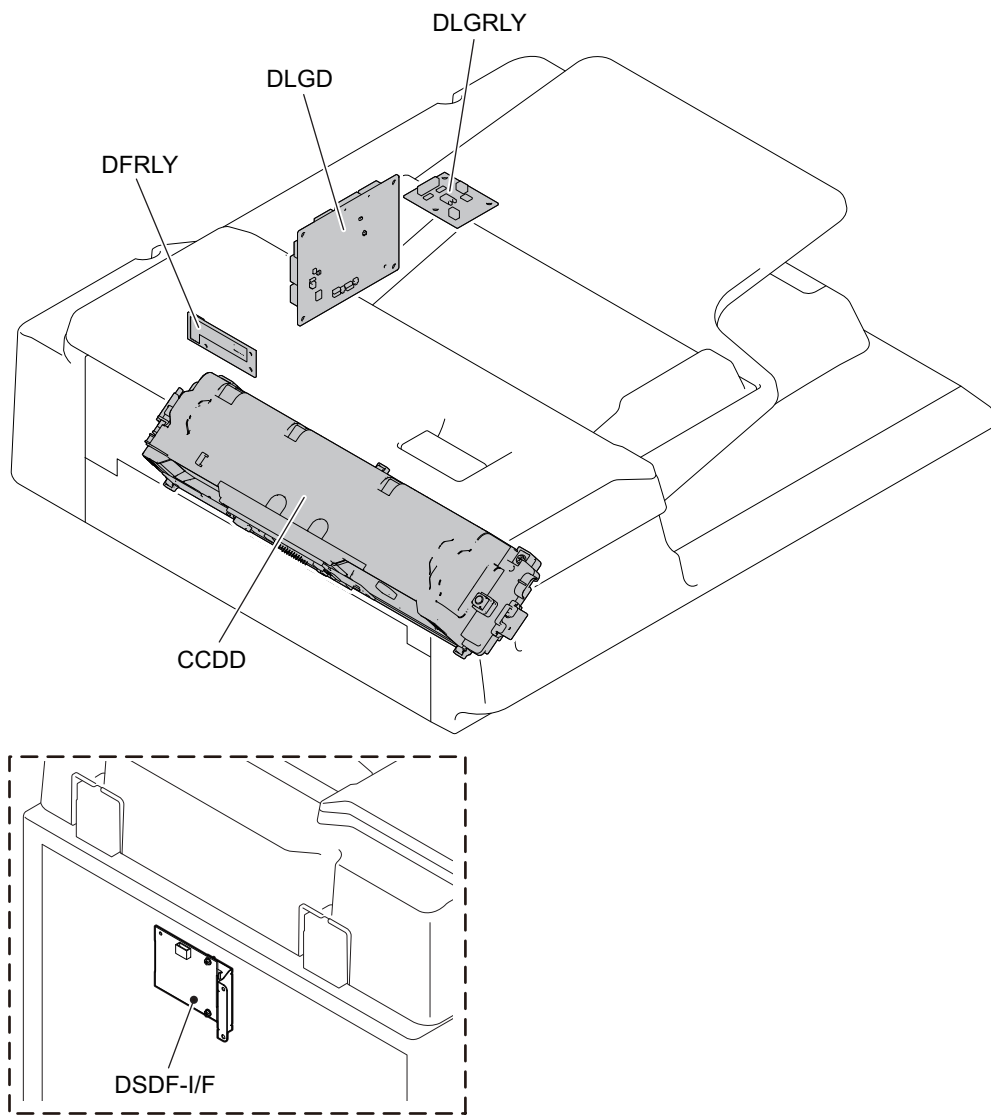

Fig. 2-7

2.4 Symbols and Functions of Various Components

Notes:

The column "P-I" shows the page and item number in the parts list.

2.4.1 Motor

Symbol	Name	Function	Remarks	P-I
MD1	DSDf original feed motor	Drives the DSDf pickup roller and the DSDf original feed roller.	☰ P. 2-5 "[A] Motor layout"	Fig. 2-4 6-8
MD2	DSDf separation motor	Drives the DSDf separation roller in reverse and moves the original tray lift upward and downward.	☰ P. 2-5 "[A] Motor layout"	Fig. 2-4 5-10
MD3	DSDf registration motor	Drives the DSDf registration roller.	☰ P. 2-5 "[A] Motor layout"	Fig. 2-4 6-4
MD4	DSDf read motor	Drives the pre-read roller-1, post-read roller-1, pre-read roller-2 and post-read roller-2.	☰ P. 2-5 "[A] Motor layout"	Fig. 2-4 10-5
MD5	DSDf original exit motor	Drives the DSDf original exit roller and rotates the DSDf shading sheet.	☰ P. 2-5 "[A] Motor layout"	Fig. 2-4 10-5
FD1	DSDf cooling fan motor	Cools down inside of the DSDf.	☰ P. 2-5 "[A] Motor layout"	Fig. 2-4 5-1

2.4.2 Clutch





Symbol	Name	Function	Remarks	P-I
CLD	DSDf tray-up clutch	Transmits the driving force to move the original tray upward and downward.	☰ P. 2-5 "[A] Motor layout"	Fig. 2-4 8-13

2.4.3 Sensor and switch

Symbol	Name	Function	Remarks	P-I
SD1	DSDf tray original length sensor-1	Detects the length of the original on the original tray.	☰ P. 2-5 "[B] Original sensor layout 1"	Fig. 2-5 2-4
SD2	DSDf tray original length sensor-2	Detects the length of the original on the original tray.	☰ P. 2-5 "[B] Original sensor layout 1"	Fig. 2-5 2-4
SD3	DSDf tray original width sensor	Detects the width of the original on the original tray.	☰ P. 2-5 "[B] Original sensor layout 1"	Fig. 2-5 2-12
SD4	DSDf original empty sensor	Detects whether there is an original on the original tray or not.	☰ P. 2-5 "[B] Original sensor layout 1"	Fig. 2-5 2-4
SD5	DSDf original feed sensor	Detects the original in the original feeding section.	☰ P. 2-5 "[B] Original sensor layout 1"	Fig. 2-5 4-7
SD6	DSDf registration sensor	Detects the original transportation in the DSDf registration roller. Detects the length of the original.	☰ P. 2-5 "[B] Original sensor layout 1"	Fig. 2-5 4-7
SD7	DSDf original width detection sensor-1	Detects the width of the original.	☰ P. 2-5 "[B] Original sensor layout 1"	Fig. 2-5 3-11

Symbol	Name	Function	Remarks	P-I
SD8	DSDF original width detection sensor-2	Detects the width of the original.	☞ P. 2-5 "[B] Original sensor layout 1"	Fig. 2-5 3-11
SD9	DSDF tray lift upper limit sensor	Detects the upper limit position of the original tray lift.	☞ P. 2-5 "[B] Original sensor layout 1"	Fig. 2-5 4-7
SD10	DSDF tray lift lower limit sensor	Detects the lower limit position of the original tray lift.	☞ P. 2-6 "[C] Original sensor layout 2"	Fig. 2-6 11-5
SD11	DSDF read-in sensor-1	Detects the leading edge position of the original at the original scanning section of the MFP.	☞ P. 2-6 "[C] Original sensor layout 2"	Fig. 2-6 14-14
SD12	DSDF read-in sensor-2	Detects the leading edge position of the original at the CCD module original scanning section of the DSDF.	☞ P. 2-6 "[C] Original sensor layout 2"	Fig. 2-6 14-15
SD13	DSDF original exit sensor	Detects the original in the original exit section.	☞ P. 2-6 "[C] Original sensor layout 2"	Fig. 2-6 11-5
SD14	DSDF shading sheet HP sensor	Detects the home position of the DSDF shading sheet.	☞ P. 2-6 "[C] Original sensor layout 2"	Fig. 2-6 15-8
SD15	DSDF lower cover opening/closing detection sensor	Detects the opening and closing status of the top DSDF lower cover.	☞ P. 2-6 "[C] Original sensor layout 2"	Fig. 2-6 15-8
SD16	DSDF upper cover opening/closing detection sensor	Detects the opening and closing status of the top DSDF upper cover.	☞ P. 2-6 "[C] Original sensor layout 2"	Fig. 2-6 6-22
SD17	Multiple feeding detection sensor (transmission side)	Detects that the multiple sheets of the original have been transported together. This will be made to function by the combination with the transmission and reception side sensors. (MR-4020 only)	☞ P. 2-5 "[A] Motor layout"	Fig. 2-4 17-1
SD18	Multiple feeding detection sensor (reception side)	Detects that the multiple sheets of the original have been transported together. This will function by the combination with the transmission and reception side sensors. (MR-4020 only)	☞ P. 2-5 "[B] Original sensor layout 1"	Fig. 2-5 17-1
SWD1	DSDF lower cover interlock switch	Shuts down the 24 V voltage when the DSDF lower cover is opened.	☞ P. 2-6 "[C] Original sensor layout 2"	Fig. 2-6 16-5
SWD2	DSDF upper cover interlock switch	Shuts down the 24 V voltage when the DSDF upper cover is opened.	☞ P. 2-6 "[C] Original sensor layout 2"	Fig. 2-6 6-19

2.4.4 PC Board

Symbol	Name	Function	Remarks	P-I
LEDD	DSDf-LED PC board	Lights the LED when an original is set or an abnormality occurs.	 P. 2-5 “[A] Motor layout”	Fig. 2-4 5-9
DLGD	DSDf control PC board	Controls the DSDf.	 P. 2-7 “[D] PC board layout”	Fig. 2-7 16-1
DSDf-I/F	DSDf-I/F PC board	Transmits the signal among the DSDf-CCD module and the system control PC board.	 P. 2-7 “[D] PC board layout”	Fig. 2-7 20-5
DFRLY	DSDf relay PC board	Transmits the signal among the DSDf-CCD module and the DSDf-I/F PC board.	 P. 2-7 “[D] PC board layout”	Fig. 2-7 16-28
DLGRLY	DSDf multiple feeding detection relay PC board	Transmits the signal among the Multiple feeding detection sensors and DSDf control PC board. (MR-4020 only)	 P. 2-7 “[D] PC board layout”	Fig. 2-7 17-1

2.4.5 Others

Symbol	Name	Function	Remarks	P-I
CCDD	DSDf-CCD module	Scans the back side of the original in the DSDf.	 P. 2-7 “[D] PC board layout”	Fig. 2-7 5-22

2.5 Signal Block Diagram

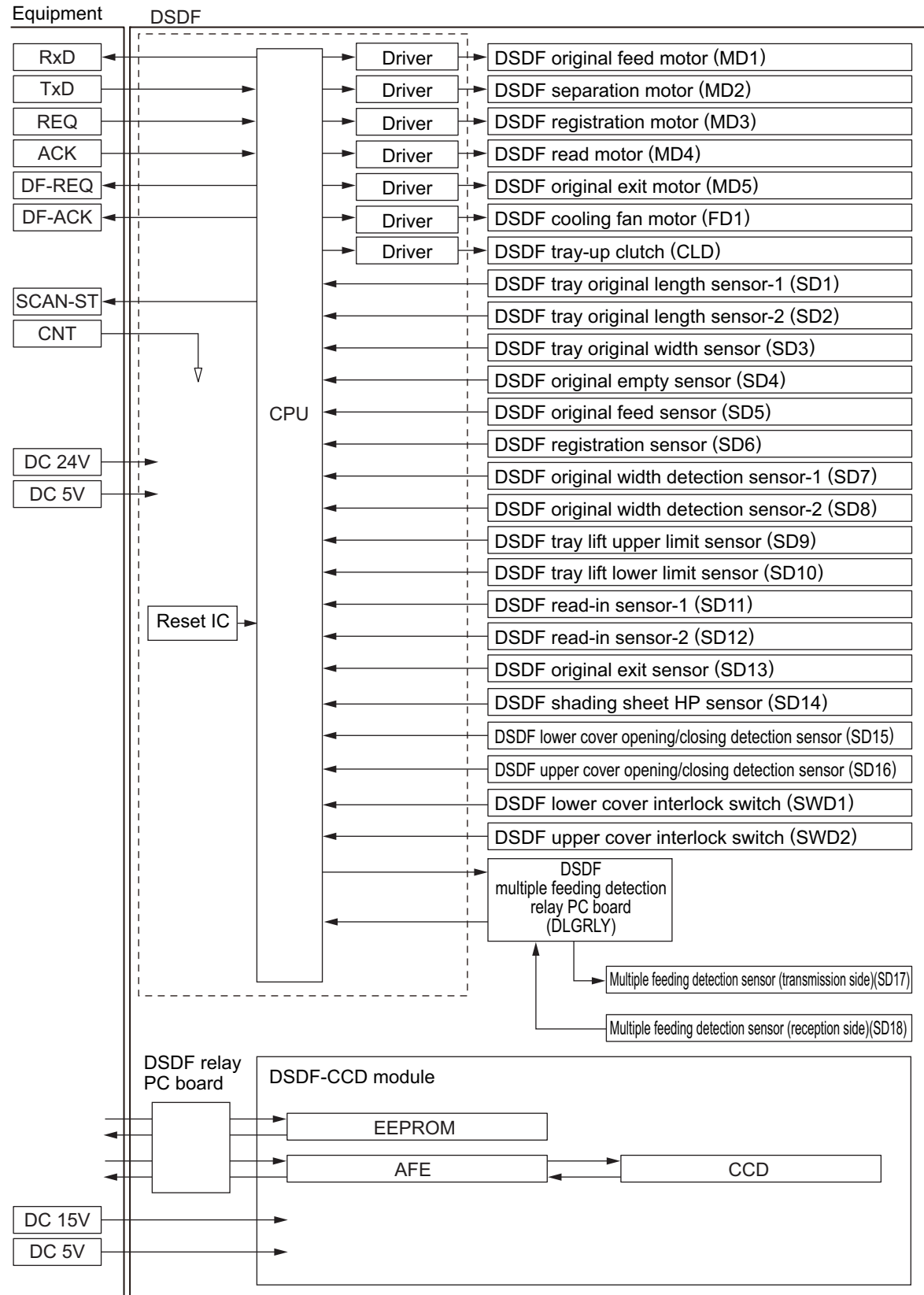

Fig. 2-8

2.6 Interface Signals

The following 6 lines are used to transmit and receive signals between the MFP and the DSDF.

- 1. REQ: Communication request signal (from the MFP to the DSDF)
- 2. DF-REQ: Communication request signal (from the DSDF to the MFP)
- 3. DF-ACK: Communication request acknowledging signal (from the DSDF to the MFP)
- 4. ACK: Communication request acknowledging signal (from the MFP to the DSDF)
- 5. TxD: Data transmitted from the MFP to the DSDF
- 6. RxD: Data transmitted from the DSDF to the MFP

Since the serial communication system has been adopted for data communication (RxD and TxD) between the scanner and the DSDF, whether the signals are transmitted or received properly cannot be checked using testing devices in the field.

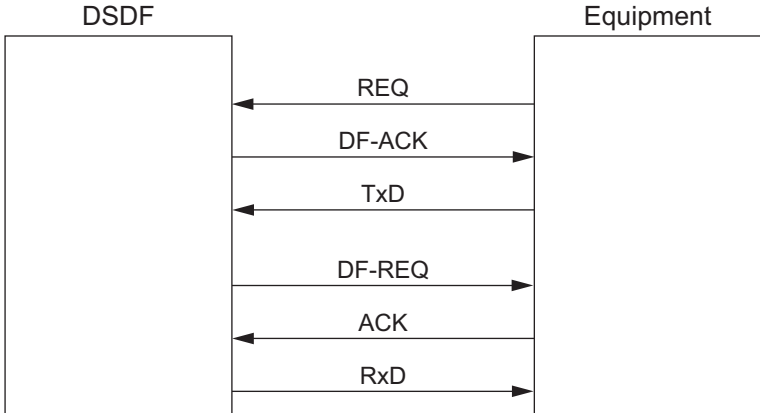

Fig. 2-9

3. OPERATION DESCRIPTION

3.1 Overview

3.1.1 Original transport path

An original is transported by each transport roller via the path shown in the figure. The front side of the original is scanned by the CCD (DF original glass section) of the MFP and the back side is scanned by the DSDF-CCD module embedded in the DSDF.

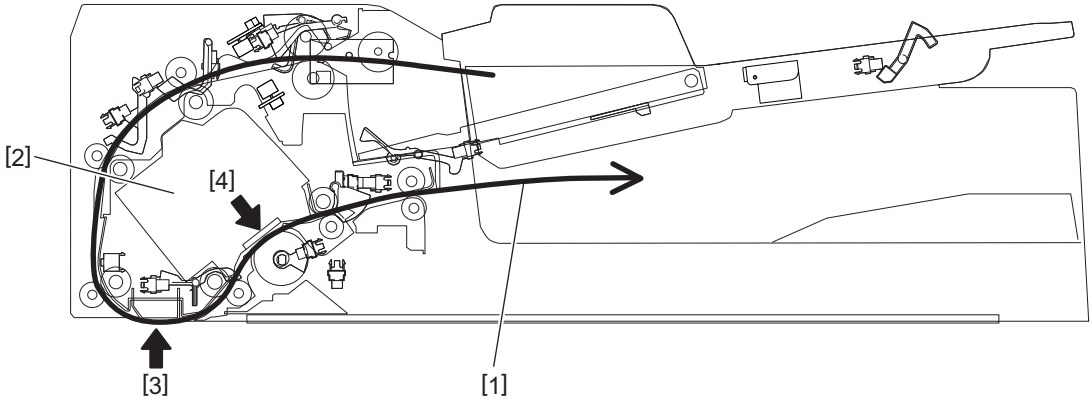

Fig. 3-1

Symbol	Name
1	Transport path
2	DSDF-CCD module
3	Front side scanning section (DF original glass section)
4	Back side scanning section (DSDF-CCD module scanning section)

3.2 Drive Section

3.2.1 Motor

Transportation of originals is operated by the DSDF original feed motor, DSDF read motor and DSDF original exit/reverse motor.

The role for each motor is as below.

Motor	Rotation direction	Function
DSDF original feed motor	Clockwise	Drives the DSDF pickup roller and the DSDF original feed roller.
DSDF separation motor	Clockwise	Moves the original tray lift downward.
	Counterclockwise	Drives the DSDF separation roller in reverse and moves the original tray lift upward.
DSDF registration motor	Counterclockwise	Drives the DSDF registration roller.
DSDF read motor	Counterclockwise	Drives the pre-read roller-1, post-read roller-1, pre-read roller-2 and post-read roller-2.
DSDF original exit motor	Clockwise	Rotates the DSDF shading sheet.
	Counterclockwise	Drives the DSDF original exit roller.

3.2.2 DSDF original feed motor

When the feed signal from the MFP is received, feeding and transporting of an original will start.

The DSDF original feed motor starts rotating to drive the DSDF pickup roller and the DSDF original feed roller to transport the original to the registration roller.

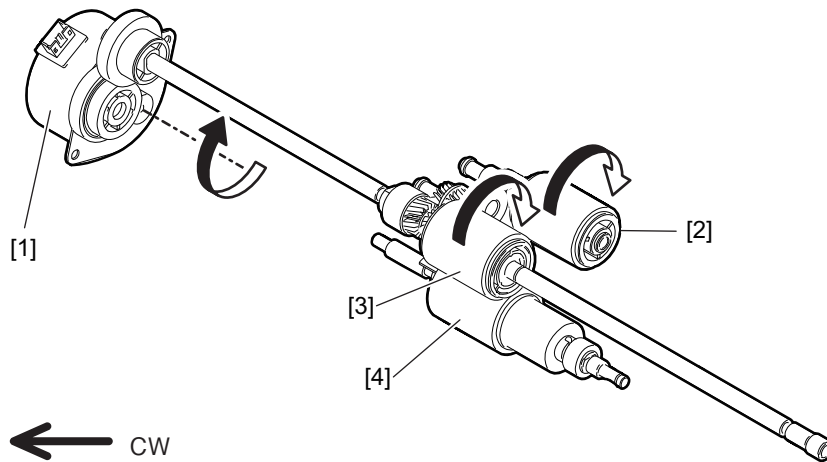

Fig. 3-2

Symbol	Name
1	DSDF original feed motor
2	DSDF pickup roller
3	DSDF original feed roller
4	DSDF separation roller

3.2.3 DSDF separation motor

The DSDF separation motor performs the reverse operation of the DSDF separation roller and moves the original tray lift upward and downward.

When original feeding starts, the DSDF separation motor rotates clockwise to perform the reverse operation of the DSDF separation roller.

This will prevent multiple feeding of the originals.

Moreover, when the DSDF original empty sensor is turned ON, the DSDF separation motor rotates counterclockwise, resulting in the original tray lift ascending.

When the DSDF original empty sensor is turned OFF, the DSDF separation motor rotates clockwise, resulting in the original tray lift descending.

Transmitting the driving force from the DSDF separation motor to the original tray lift is controlled by the DSDF tray-up clutch.

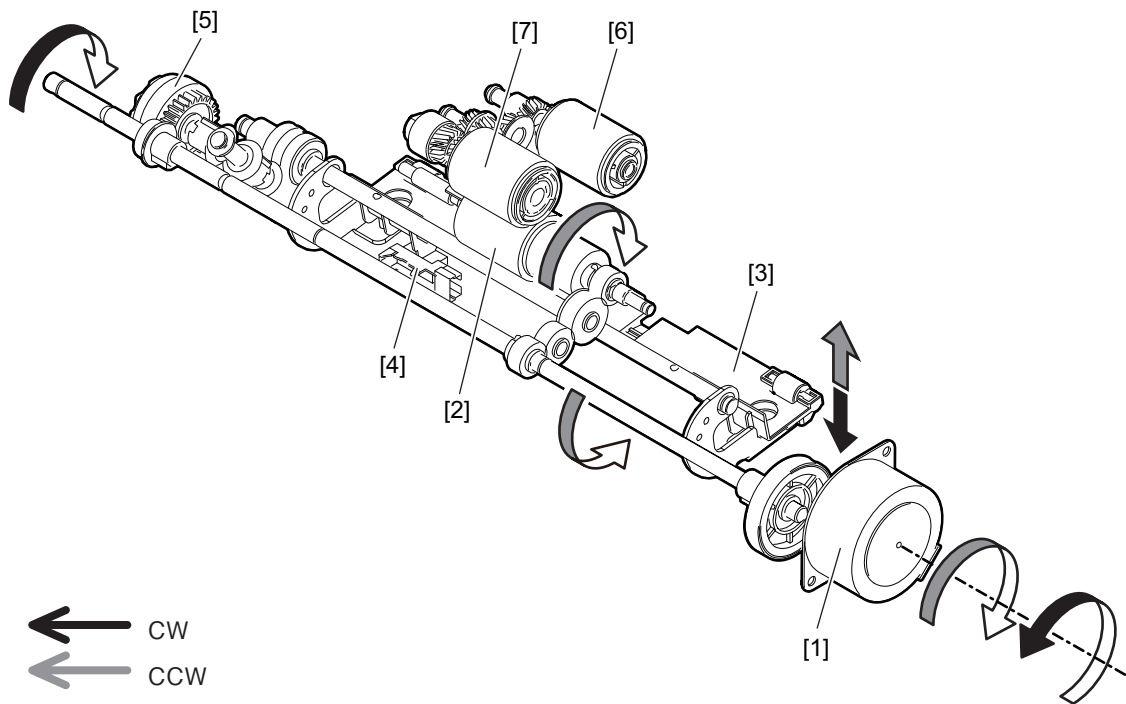

Fig. 3-3

Symbol	Name	Symbol	Name
1	DSDF separation motor	5	DSDF tray-up clutch
2	DSDF separation roller	6	DSDF pickup roller
3	Original tray lift	7	DSDF original feed roller
4	DSDF tray lift lower limit sensor		

3.2.4 DSDF registration motor

The DSDF registration motor rotates the DSDF registration roller.
 The DSDF registration roller aligns the paper and transports it to the pre-read roller-1.

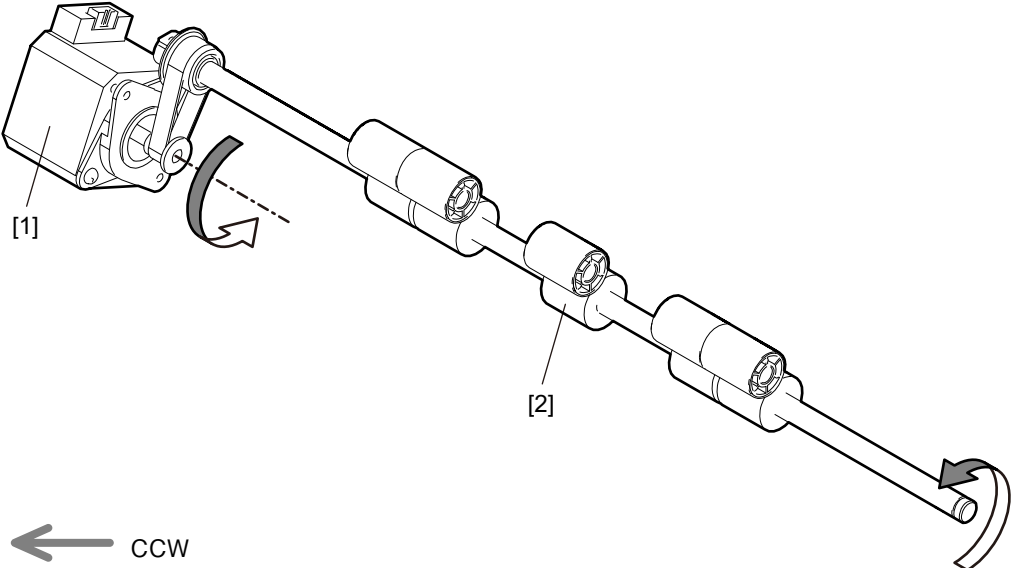

Fig. 3-4

Symbol	Name
1	DSDF registration motor
2	DSDF registration roller

3.2.5 DSDF read motor

The DSDF read motor drives four rollers; the pre-read roller-1, post-read roller-1, pre-read roller-2 and post-read roller-2, by means of the timing belt. The pre-read roller-1 and the post-read roller-1 perform original transporting at the scanning section of the ADF original glass. The pre-read roller-2 and the post-read roller-2 perform original transporting at the scanning section of the DSDF-CCD module.

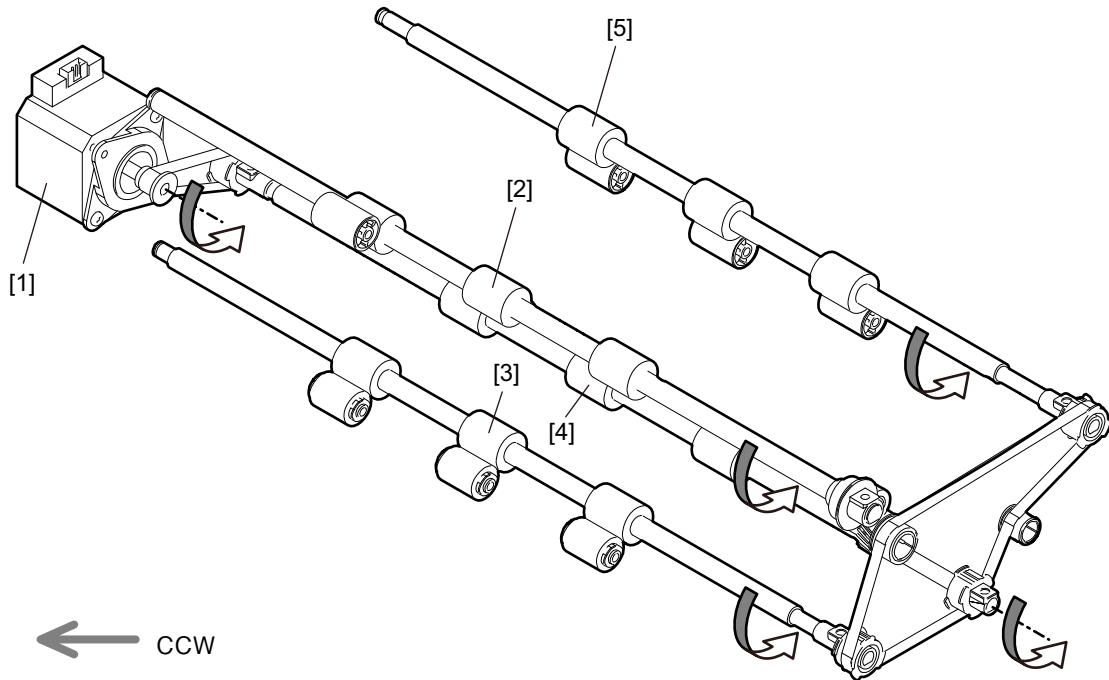

Fig. 3-5

Symbol	Name	Symbol	Name
1	DSDF read motor	4	Pre-read roller-2
2	Pre-read roller-1	5	Post-read roller-2
3	Post-read roller-1		

3.2.6 DSDF original exit motor

When the DSDF original exit motor rotates counterclockwise, the DSDF original exit roller starts rotating to make the original exit.

When the DSDF original exit motor rotates clockwise, the guide covering the DSDF shading sheet starts rotating and then it appears.

The home position of the guide covering the DSDF shading sheet is detected by the DSDF shading sheet HP sensor.

The DSDF shading sheet is used to correct the values of the background peak of the DSDF-CCD module.

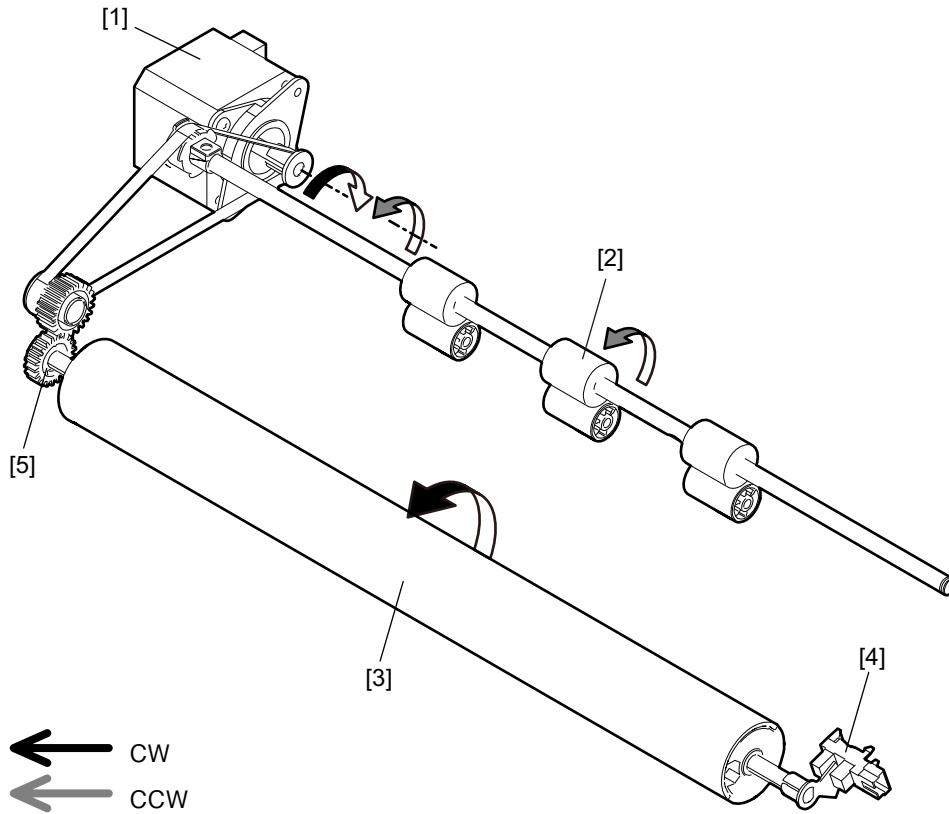

Fig. 3-6

Symbol	Name	Symbol	Name
1	DSDF original exit motor	4	DSDF shading sheet HP sensor
2	DSDF original exit roller	5	One-way clutch
3	DSDF shading sheet		

3.3 Original Size Detection

The size of the original on the original tray is detected by a combination of the DSDF tray original width sensor, DSDF tray original length sensor-1 and -2. Moreover, in the mixed size mode, after an original on the original tray has been fed and transported, the original size is detected again by a combination of the DSDF original width detection sensor-1 and -2 and the DSDF registration sensor to determine the paper size.

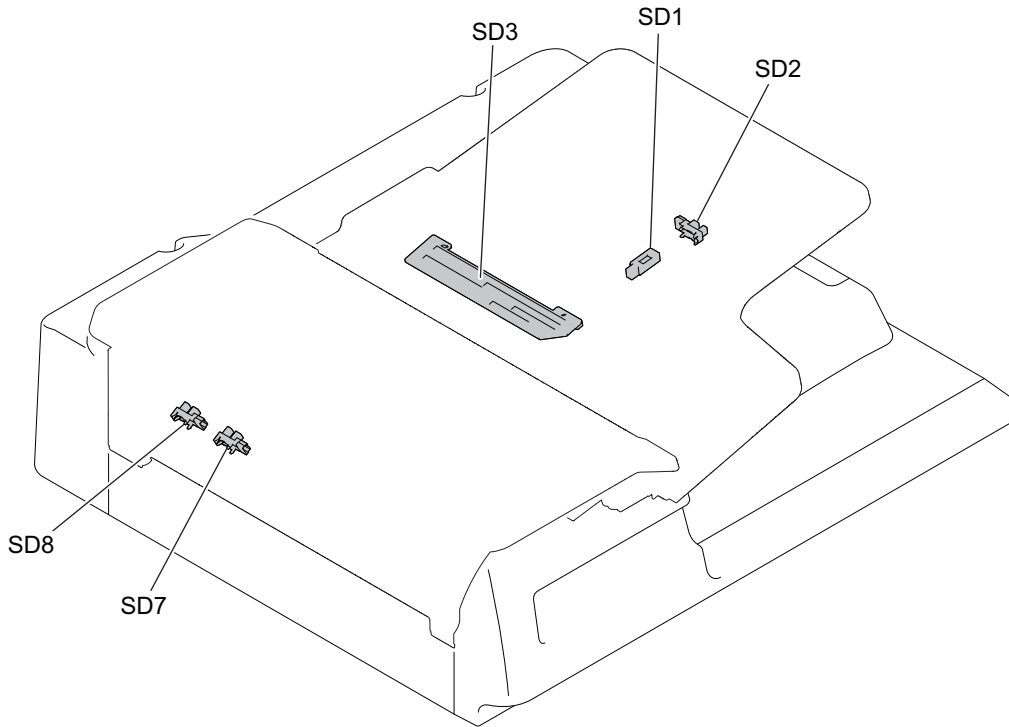

Fig. 3-7

Symbol	Name	Symbol	Name
SD1	DSDF tray original length sensor-1	SD7	DSDF original width detection sensor-1
SD2	DSDF tray original length sensor-2	SD8	DSDF original width detection sensor-2
SD3	DSDF tray original width sensor		

3.3.1 DSDF tray original width sensor, DSDF tray original length sensor-1 and -2

The DSDF tray original width sensor, DSDF tray original length sensor-1 and -2 detect the size of an original placed on the original tray.

It is detected by the brush attached to the rack moving on the tray original width sensor, which is a board with the different length of the patterns written. This brush is moved as the original width guide is moved. Signals (TWID0S, TWID1S, TWID2S) are opened and shorted to SG by this movement. The combination of these short (= low level) and open (= high level) can determine the width of the original. The size of the original is determined by a combination of the ON/OFF status of the DSDF tray original width sensor, DSDF tray original length sensor-1 and -2. Therefore, if the sensors cannot detect the size of the original properly due to its being folded or bent, an incorrect size may be detected.

Sizes detectable in combinations of the opening and shortening of the signals are as follows:

DSDF tray original width sensor			DSDF tray original length sensor-1	DSDF tray original length sensor-2	Original width detection (A series)	Original width detection (LT series)
TWID2S	TWID1S	TWID0S				
L	L	H	*1	*1	Business card	Business card
H	H	L	*1	*1	B5-R	-
H	L	H	*1	*1	A5-R	ST-R
H	L	L	OFF	OFF	A4	LT
			*1	ON	A3	LD
L	H	L	OFF	OFF	A4-R	8.5" x 8.5"
			ON	OFF		LT-R
			*1	ON	FOLIO	LG
L	L	L	OFF	OFF	B5	COMPUTER
			*1	ON	B4	

H (= high level): Open

L (= low level): Short

*1 Not related to the ON/OFF status

3.3.2 DSDF original width detection sensor-1 and -2, DSDF registration sensor

In the mixed size mode, the size of the original is determined by the size which is detected by the DSDF tray original width sensor, DSDF tray original length sensor-1 and -2 located on the original tray by adding the result of the redetection during its transportation.

Redetection is performed by the ON/OFF status of the DSDF tray original width sensor-1 and -2 and by the period in which the DSDF registration is ON (transportation period) to determine the original size.

Sizes detectable in combinations of these sensors are as follows:

A4 series

Original size on the tray	DSDF original width detection sensor-1	DSDF original width detection sensor-2	ON period of the DSDF registration sensor	Determined size
A3	*1	ON	A4 size paper transportation period or longer	A3
			Less than A4 size paper transportation period	A4
	ON	OFF	A4 size paper transportation period or longer	B4
			Less than A4 size paper transportation period	B5
	OFF	OFF	A4-R size paper transportation period or longer	FOLIO
			B5-R size paper transportation period or longer Less than A4-R size paper transportation period	A4-R
Less than B5-R size paper transportation period			B5-R	
A4	*1	ON	*2	A4
	ON	OFF	A4 size paper transportation period or longer	A4
			Less than A4 size paper transportation period	B5
OFF	OFF	*2	A4	
B4	ON	*1	A4 size paper transportation period or longer	B4
			Less than A4 size paper transportation period	B5
	OFF	OFF	A4-R size paper transportation period or longer	FOLIO
			B5-R size paper transportation period or longer Less than A4-R size paper transportation period	A4-R
			A4 size paper transportation period or longer Less than B5-R size paper transportation period	B5-R
Less than A4 size paper transportation period	A5-R			
B5	*1	*1	*2	B5

Original size on the tray	DSDF original width detection sensor-1	DSDF original width detection sensor-2	ON period of the DSDF registration sensor	Determined size
FOLIO	ON	*1	A4-R size paper transportation period or longer	FOLIO
			Less than A4-R size paper transportation period	A4-R
	OFF	OFF	A4 size paper transportation period or longer	B5-R
			Less than A4 size paper transportation period	A5-R
A4-R	ON	*1	*2	A4-R
	OFF	OFF	A4 size paper transportation period or longer	B5-R
			Less than A4 size paper transportation period	A5-R
B5-R	*1	*1	A4 size paper transportation period or longer	B5-R
			Less than A4 size paper transportation period	A5-R
A5-R	*1	*1	*2	A5-R

*1 Not related to the ON/OFF status

*2 Not related to the transportation period

LT series

Original size on the tray	DSDF original width detection sensor-1	DSDF original width detection sensor-2	ON period of the DSDF registration sensor	Determined size
LD	*1	ON	LT size paper transportation period or longer	LD
			Less than LT size paper transportation period	LT
	OFF	OFF	13"LG size paper transportation period or longer	LG
			LT-R size paper transportation period or longer Less than 13"LG size paper transportation period	13"LG
			LT size paper transportation period or longer Less than LT-R size paper transportation period	LT-R
			Less than LT size paper transportation period	8.5"SQ
LT	*1	ON	*2	LT
	OFF	OFF	LT size paper transportation period or longer	LT
			Less than LT size paper transportation period	8.5"SQ

Original size on the tray	DSDF original width detection sensor-1	DSDF original width detection sensor-2	ON period of the DSDF registration sensor	Determined size
COMP	ON	*1	*2	COMP
	OFF	OFF	13"LG size paper transportation period or longer	LG
			LT-R size paper transportation period or longer Less than 13"LG size paper transportation period	13"LG
			LT size paper transportation period or longer Less than LT-R size paper transportation period	LT-R
			Less than LT size paper transportation period	8.5"SQ
LG	ON	*1	13"LG size paper transportation period or longer	LG
			LT-R size paper transportation period or longer Less than 13"LG size paper transportation period	13"LG
			LT size paper transportation period or longer Less than LT-R size paper transportation period	LT-R
			Less than LT size paper transportation period	8.5"SQ
	OFF	OFF	*2	ST-R
LT-R	ON	*1	LT size paper transportation period or longer	LT-R
			Less than LT size paper transportation period	8.5"SQ
	OFF	OFF	*2	ST-R
ST-R	OFF	OFF	*2	ST-R

*1 Not related to the ON/OFF status

*2 Not related to the transportation period

3.4 Multiple Feeding Detection (MR-4020 only)

A transmissive ultrasonic sensor is installed in MR-4020 to detect multiple original feeding. When more than one original sheet is fed together, this sensor detects multiple feeding and generates an alert to stop the operation.

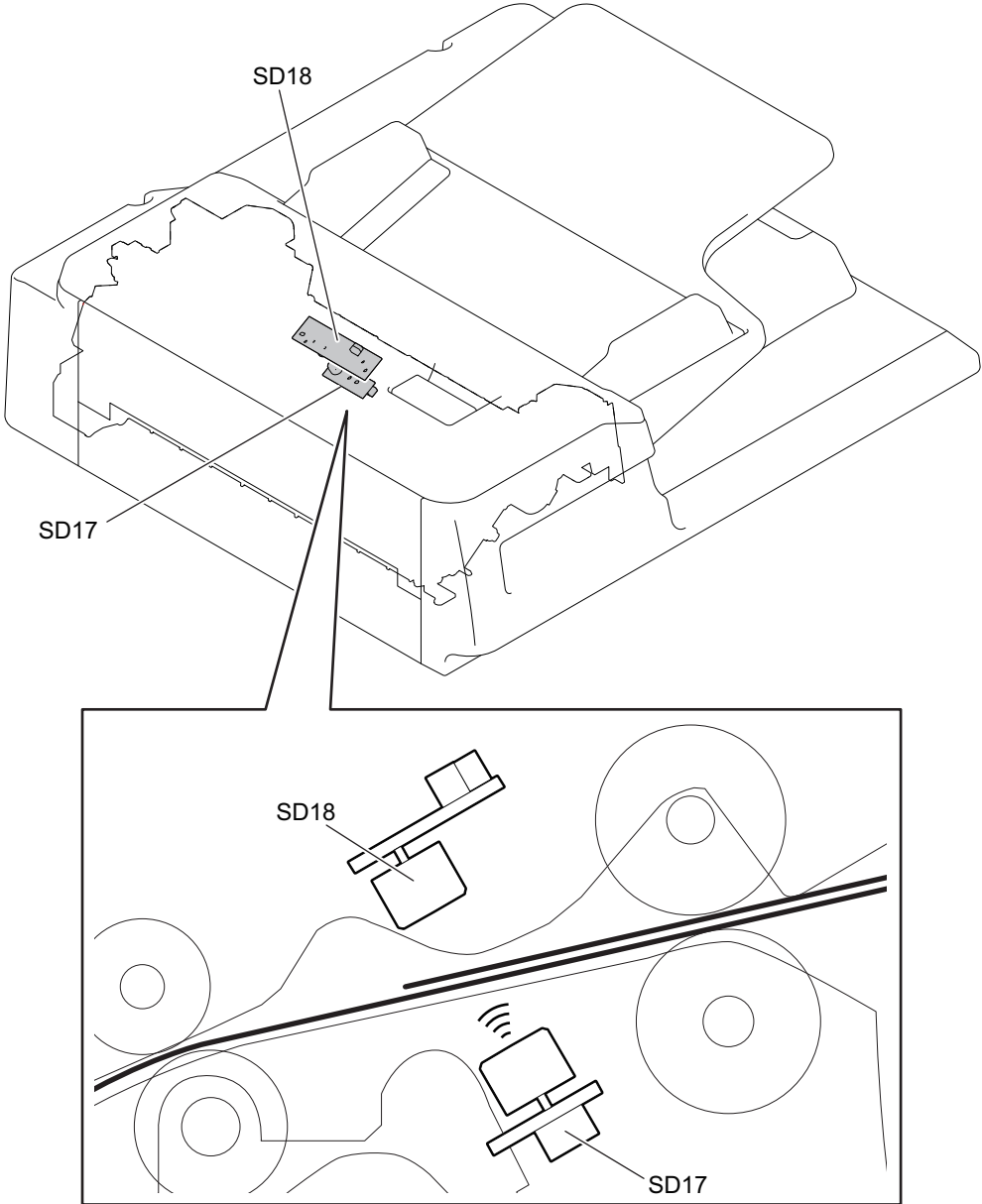

Fig. 3-8

Symbol	Name
SD17	Multiple feeding detection sensor (transmission side)
SD18	Multiple feeding detection sensor (reception side)

4. DISASSEMBLY AND REASSEMBLY

Notes:

☞ P. 4-38 “4.7 Original Transport Section”

Be sure to attach the stopper jig or remove the DSDF from the MFP before starting the above reference and later operations. If the unit is removed from the DSDF while it is still installed in the MFP, the DSDF will be pulled upwards since its weight becomes lighter, resulting in a dangerous situation.

4.1 PM Parts

4.1.1 DSDF pickup unit

- (1) Open the original jam access cover [1].

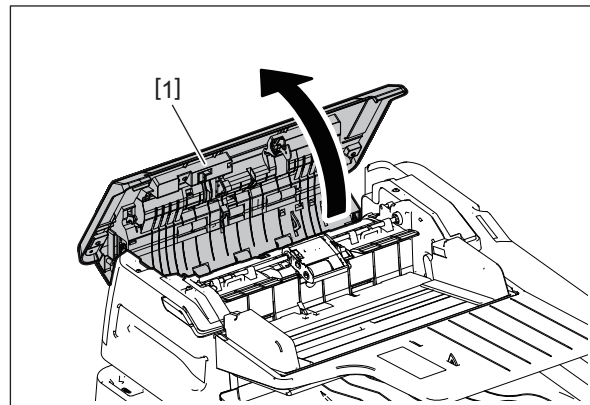

Fig. 4-1

- (2) Turn the lever [2] and take off the DSDF pickup unit [3].

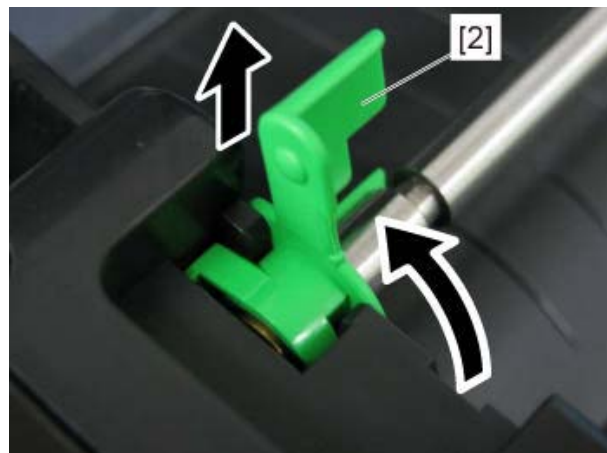

Fig. 4-2

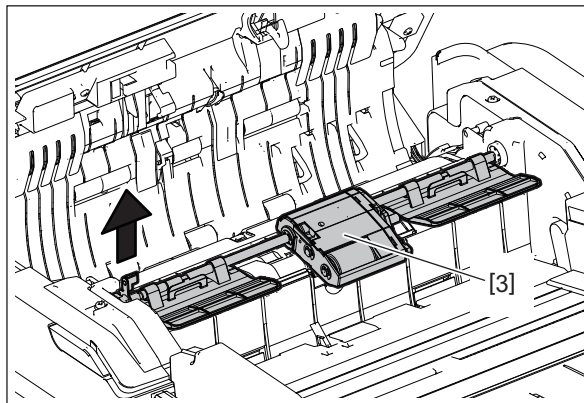

Fig. 4-3

DSDF pickup unit

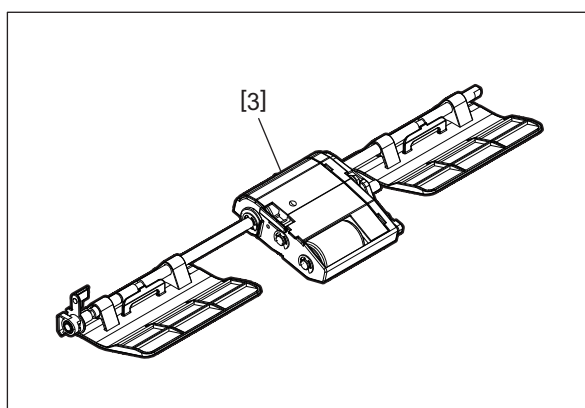

Fig. 4-4

4.1.2 DSDF separation roller^{RM}

- (1) Take off the DSDF pickup unit.
P. 4-1 "4.1.1 DSDF pickup unit"
- (2) Open the DSDF separation roller cover [4].



Fig. 4-5



Fig. 4-6

- (3) Turn the arm [5] to release the lock.



Fig. 4-7

(4) Turn the lever [6] of the front side to align the protrusion to the groove.



Fig. 4-8



Fig. 4-9

(5) Turn the lever [7] of the rear side to align the protrusion to the groove.



Fig. 4-10

- (6) Slide the DSDF separation roller unit [8] to the front side to take it off.

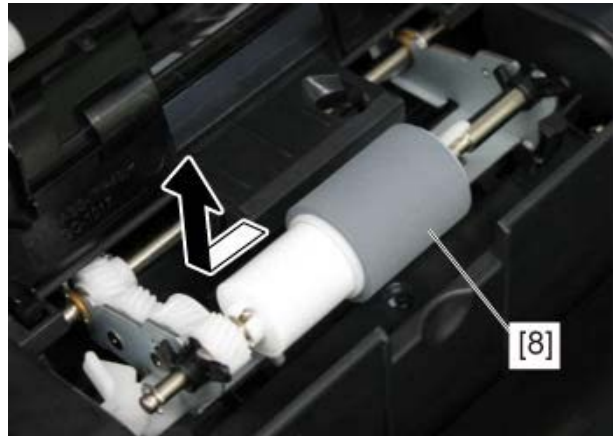

Fig. 4-11

DSDF separation roller unit



Fig. 4-12

- (7) Remove the lever [7] of the rear side from the DSDF separation roller unit [8].
(8) Release the latch and take off the DSDF separation roller [9].

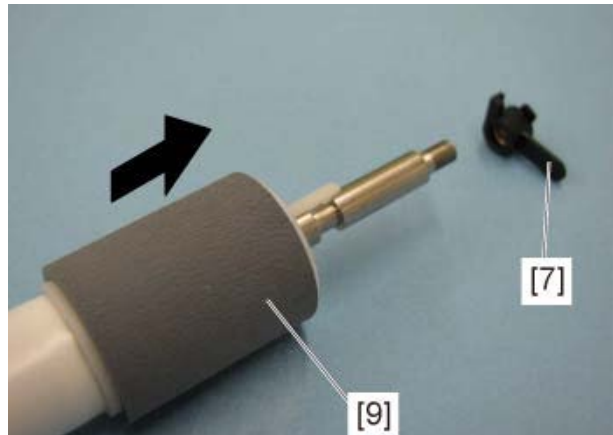

Fig. 4-13

DSDF separation roller



Fig. 4-14

4.1.3 DSDF pickup roller

- (1) Take off the DSDF pickup unit.
P. 4-1 "4.1.1 DSDF pickup unit"
- (2) Remove the paper guide [1].

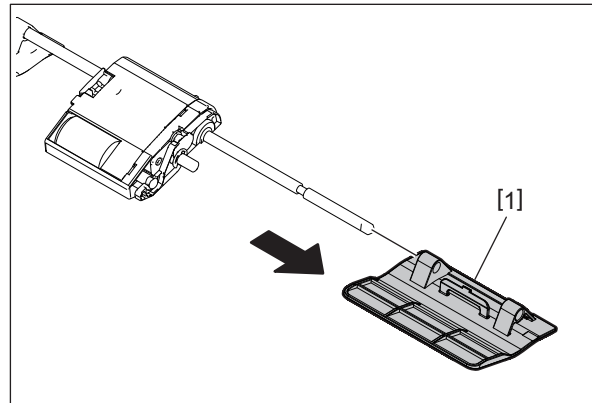

Fig. 4-15

- (3) Take off the holder cover [2].
- (4) Release the stopper [3].

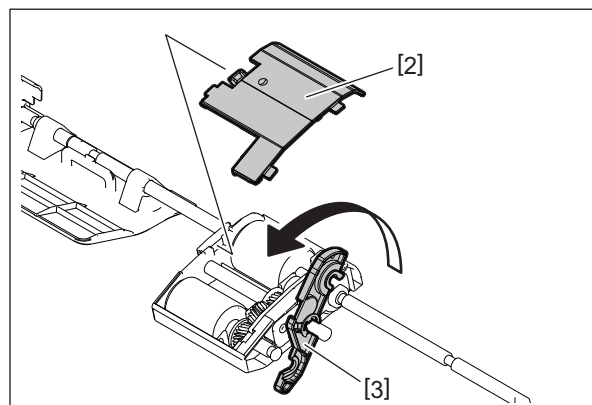

Fig. 4-16

- (5) Pull out the shaft [4] and take off the pickup roller [5].

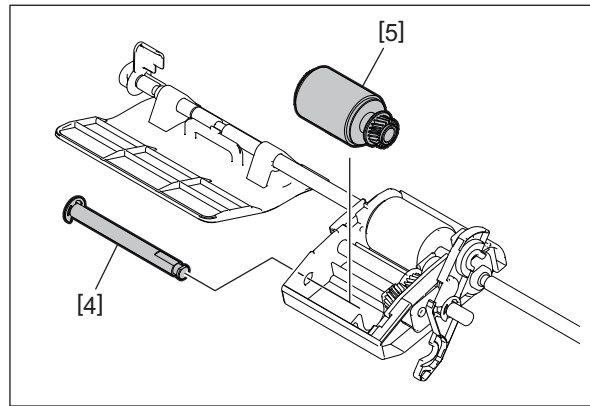

Fig. 4-17

4.1.4 DSDF original feed roller^{RM}

- (1) Take off the DSDF pickup unit.
P. 4-1 “4.1.1 DSDF pickup unit”
- (2) Take off the holder cover and release the stopper.
P. 4-6 “4.1.3 DSDF pickup roller”
- (3) Pull out the shaft [1].

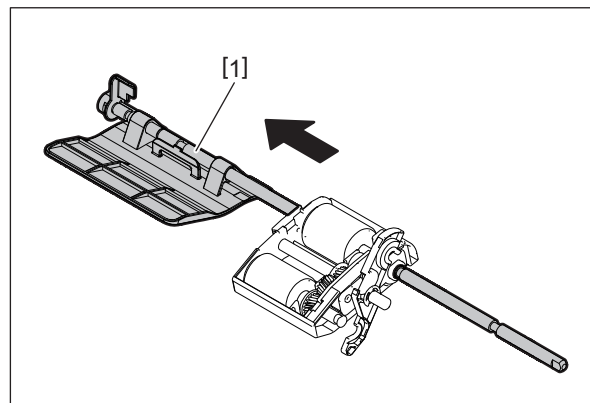

Fig. 4-18

- (4) Take off the DSDF original feed roller [2].

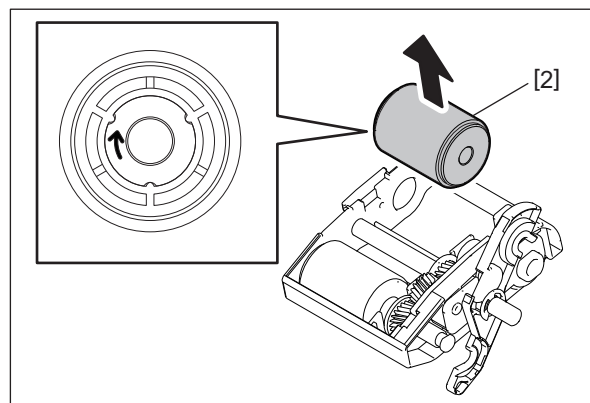

Fig. 4-19

DSDF original feed roller

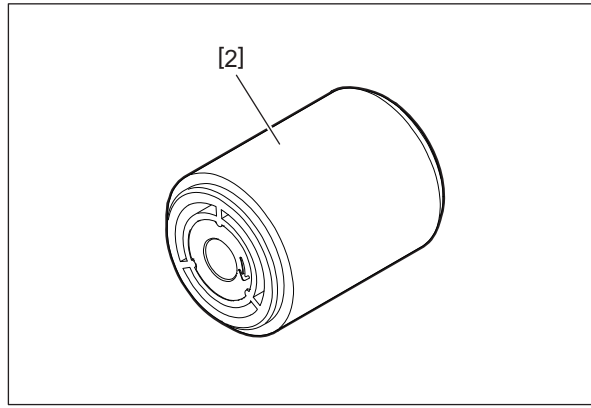

Fig. 4-20

4.2 Cover

4.2.1 DSDF rear cover

- (1) Remove 3 screws.

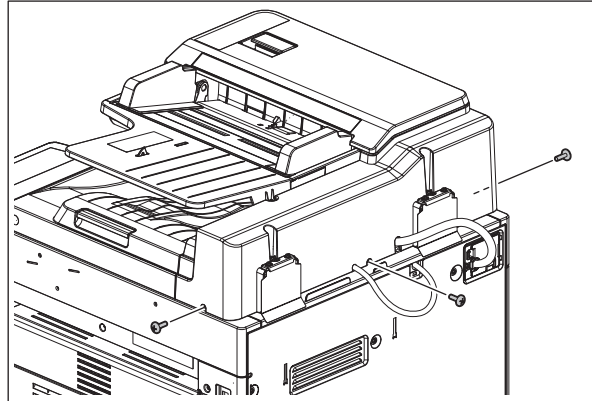

Fig. 4-21

- (2) Open the original jam access cover and remove 2 screws [1][2].

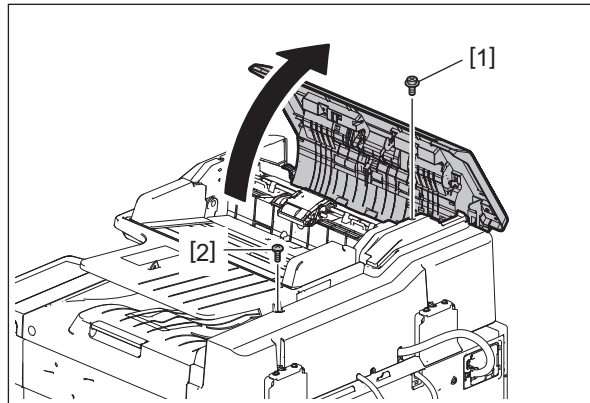

Fig. 4-22

Remarks:

[1] Screw for the metal part: Original feed side

[2] Screw for the plastic part: Original exit side

- (3) While lifting up the original tray [3], take off the DSDF rear cover [4].

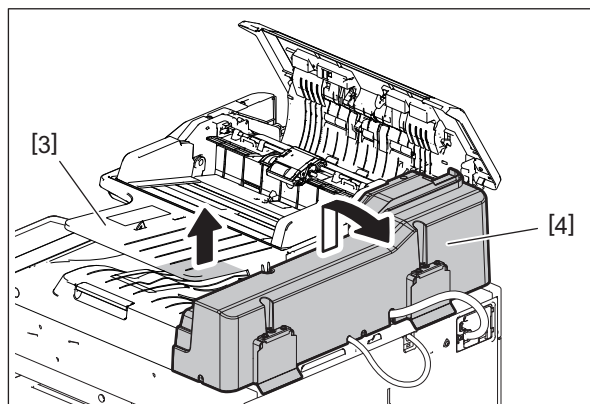

Fig. 4-23

4.2.2 DSDF front cover

- (1) Open the DSDF.
- (2) Remove 2 screws [1] for the plastic part and another 2 screws [2] for the metal part.



Fig. 4-24

Remarks:

- [1] Screw for the metal part: Original feed side
 - [2] Screw for the plastic part: Original exit side
- (3) Remove 1 screw and take off the DSDF front cover [5].

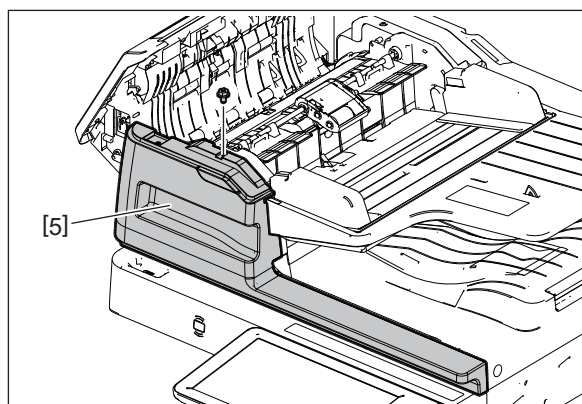

Fig. 4-25

4.2.3 Original jam access cover

- (1) Take off the DSDF rear cover.
📖 P. 4-9 "4.2.1 DSDF rear cover"
- (2) Take off the DSDF front cover.
📖 P. 4-10 "4.2.2 DSDF front cover"
- (3) Disconnect 2 connectors.

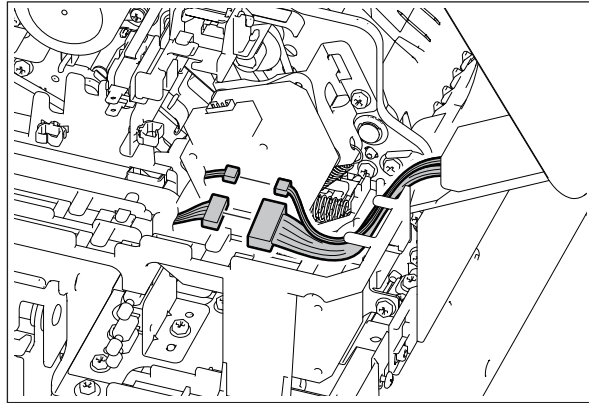

Fig. 4-26

- (4) Remove 1 screw and take off the hinge pin [6] of the rear side.

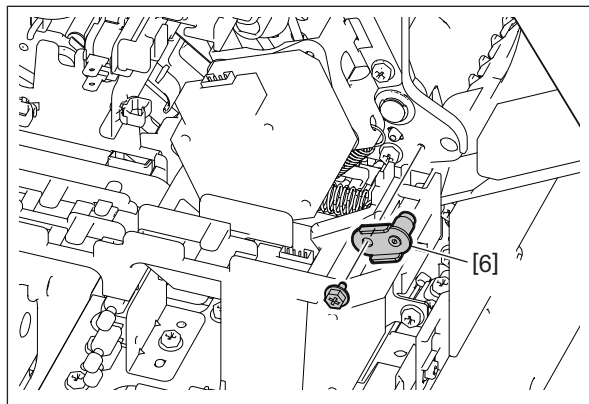

Fig. 4-27

- (5) Remove 1 screw and take off the hinge pin [7] of the front side.
- (6) Remove 1 screw and release the original jam access cover stopper [8].

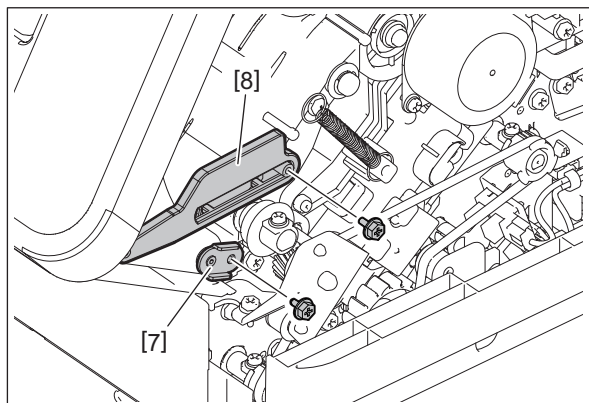

Fig. 4-28

- (7) Take off the original jam access cover [9].

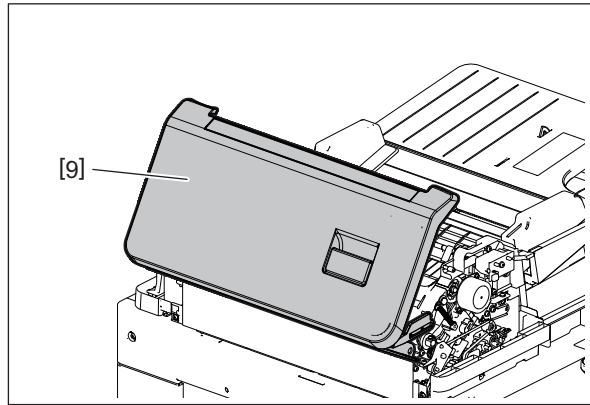

Fig. 4-29

Notes:

When installing and taking off the original jam access cover, be careful not to damage it or the transport guide of the DSDF left cover.

4.2.4 DSDF left cover

- (1) Take off the original jam access cover.
📖 P. 4-11 “4.2.3 Original jam access cover”
- (2) Remove 1 screw [1] for the plastic part and 1 screw [2] for the metal part.

Remarks:

- [1] Screw for the metal part: Front side
- [2] Screw for the plastic part: Rear side

- (3) Take off the DSDF left cover [9] upward.

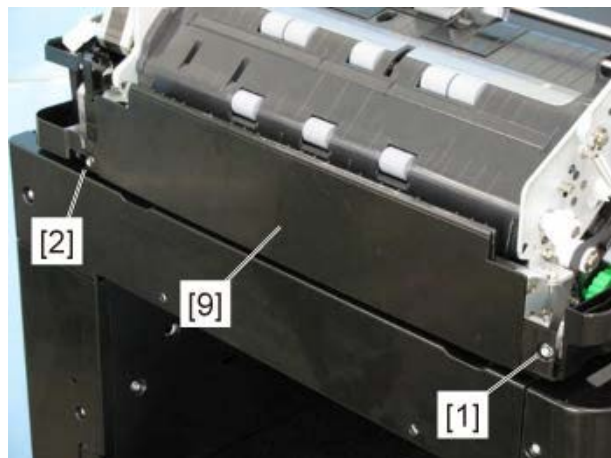



Fig. 4-30

4.3 PC Board

4.3.1 DSDF-LED PC board (LEDD)

- (1) Take off the DSDF front cover.
 P. 4-10 “4.2.2 DSDF front cover”
- (2) Disconnect 1 connector.
Remove 1 screw and take off the DSDF-LED PC board (LEDD) [12].

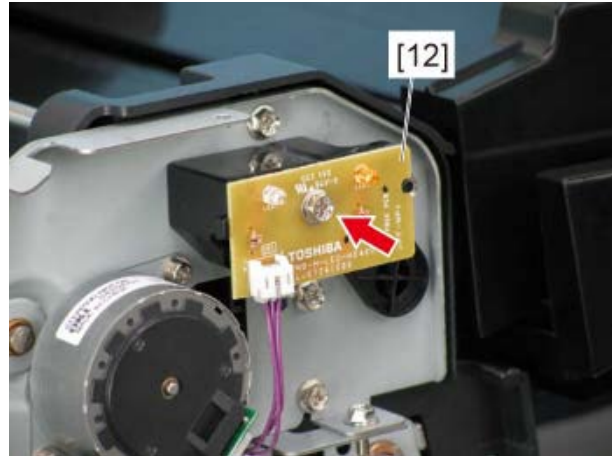



Fig. 4-31

4.3.2 DSDF control PC board (DLGD)

- (1) Take off the DSDF rear cover.
 P. 4-9 “4.2.1 DSDF rear cover”
- (2) Disconnect 13 connectors.
- (3) Remove 2 screws and take off the DSD control PC board [13].

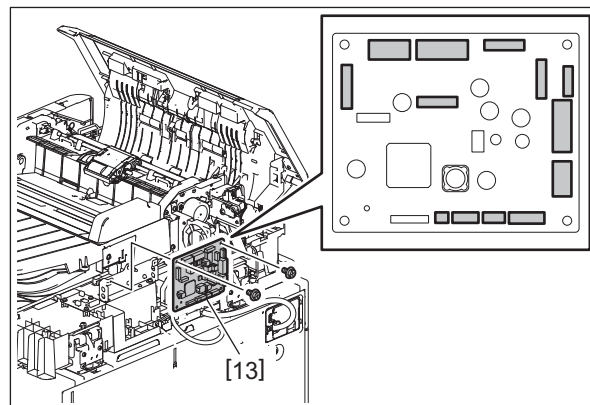



Fig. 4-32

Notes:

When the DSDF control PC board is replaced, be sure to perform the DSDF read-in sensor-1 adjustment.

 P. 5-16 “5.7 DSDF Read-in Sensor-1 Adjustment”

4.3.3 DSDF relay PC board (DFRLY)

- (1) Take off the DSDF rear cover.
P. 4-9 "4.2.1 DSDF rear cover"
- (2) Take off the DSDF cooling fan motor (FD1).
P. 4-27 "4.6.1 DSDF cooling fan motor (FD1)"
- (3) Disconnect 1 HDMI cable. Release the lock and disconnect 1 flat cable.

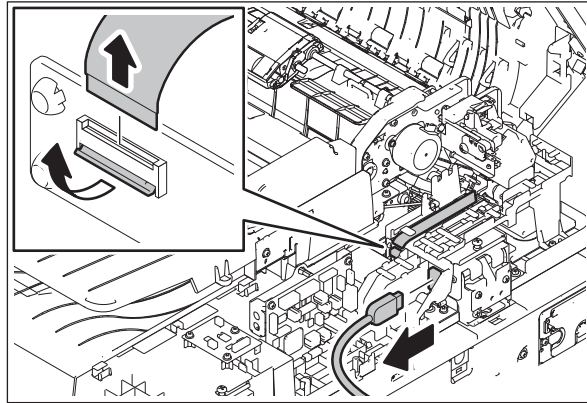

Fig. 4-33

Notes:

- When installing the flat cable, do not push it in strongly.
 - When installing the flat cable, be careful not to insert it at an angle.
 - Do not apply pressure to or damage the edge of the flat cable.
 - Install the flat cable with its conductor side up.
- (4) Release the harnesses [6] from the harness guide [5].
Disconnect the connectors [7] of the DSDF upper cover interlock switch and DSDF lower cover interlock switch.
Remove 2 screws and take off the harness guide [5].

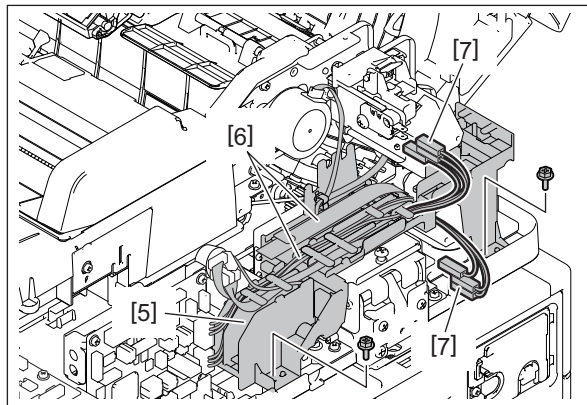

Fig. 4-34

Notes:

Be sure to release the harness from the clamp of the harness guide [5].

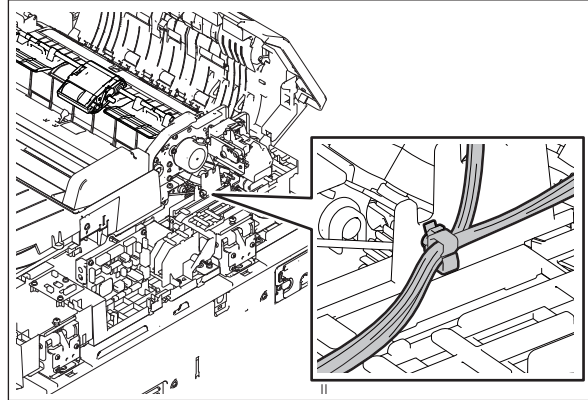

Fig. 4-35

- (5) Take off the DSDF relay PC board [14] from the harness guide.

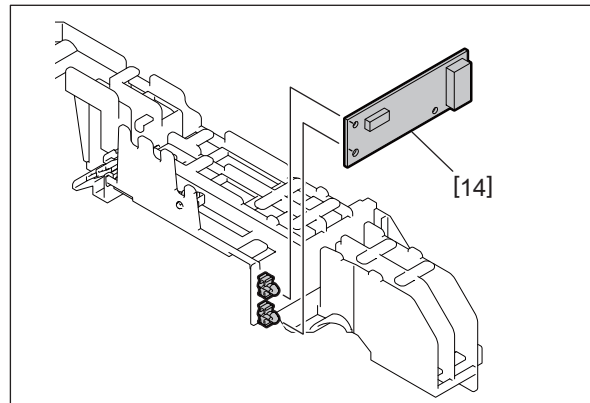

Fig. 4-36

4.3.4 DSDF multiple feeding detection relay PC board (DLGRLY)

- (1) Take off the DSDF rear cover.
P. 4-9 "4.2.1 DSDF rear cover"
- (2) Disconnect 3 connectors from the DSDF multiple feeding detection relay PC board.
- (3) Remove 3 screws [1] and take off the DSDF multiple feeding detection relay PC board (DLGRLY) [2].

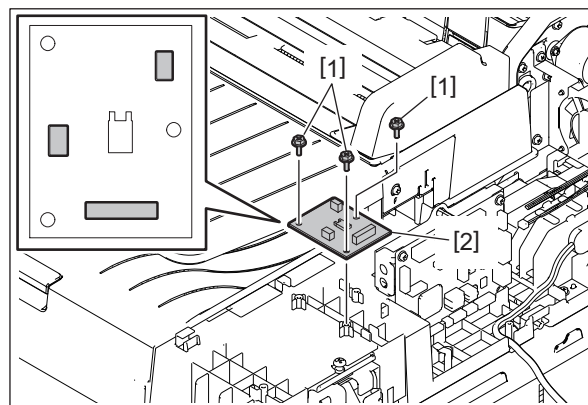



Fig. 4-37

4.4 Original Tray Section

4.4.1 Original tray

- (1) Take off the DSDF rear cover.
 P. 4-9 “4.2.1 DSDF rear cover”
- (2) Take off the DSDF front cover.
 P. 4-10 “4.2.2 DSDF front cover”
- (3) Disconnect 2 connectors from the DSDF control PC board. (CN73, CN76)

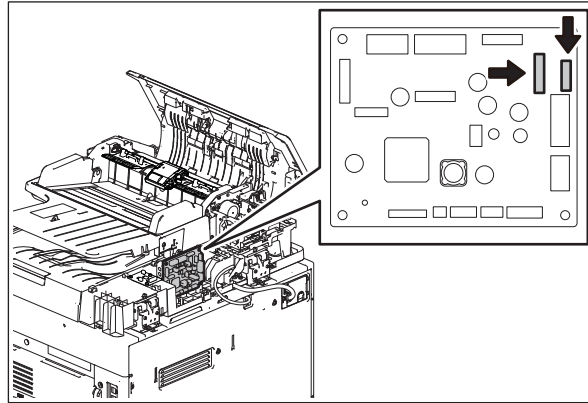

Fig. 4-38

- (4) Take off the bracket cover [1].
- (5) Remove 1 screw, take off the original tray bracket [2] and the original tray holder [3].

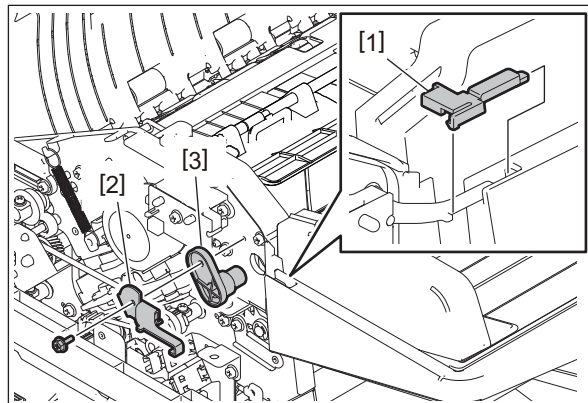

Fig. 4-39

- (6) Take off the original tray [4].

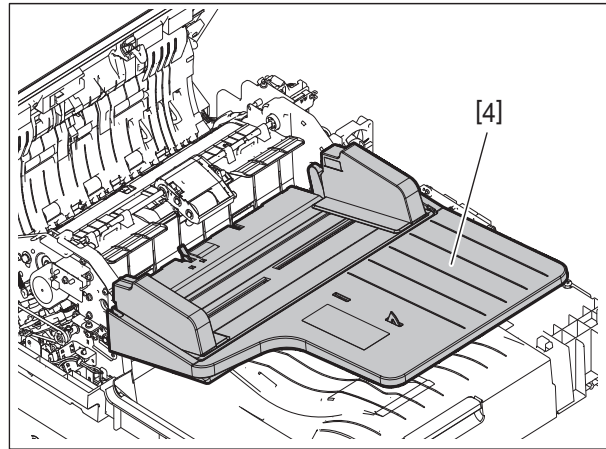

Fig. 4-40

4.4.2 DSDF tray original length sensor-1 (SD1), DSDF tray original length sensor-2 (SD2)

- (1) Take off the original tray.
P. 4-16 "4.4.1 Original tray"
- (2) Remove 1 screw and take off the sensor cover [14].



Fig. 4-41

- (3) Disconnect 1 connector respectively from the DSDF tray original length sensor-1 [15] and the DSDF tray original length sensor-2 [16].

- (4) Release the latch from each sensor. Take off the DSDF tray original length sensor-1 [15] and the DSDF tray original length sensor-2 [16].

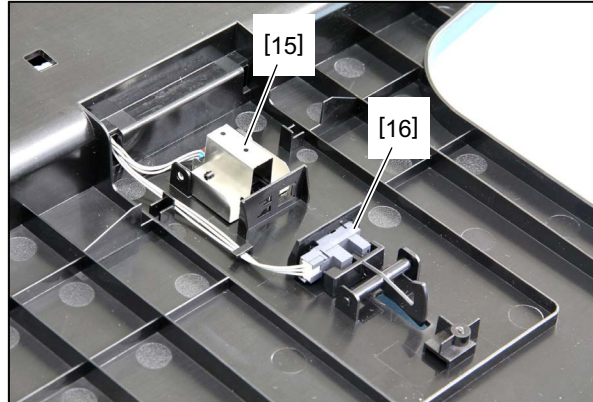

Fig. 4-42

4.4.3 DSDF tray original width sensor (SD3)

- (1) Take off the original tray.
P. 4-16 "4.4.1 Original tray"
- (2) Remove 1 screw and take off the tray holder [17].
Take off the movable tray [18].

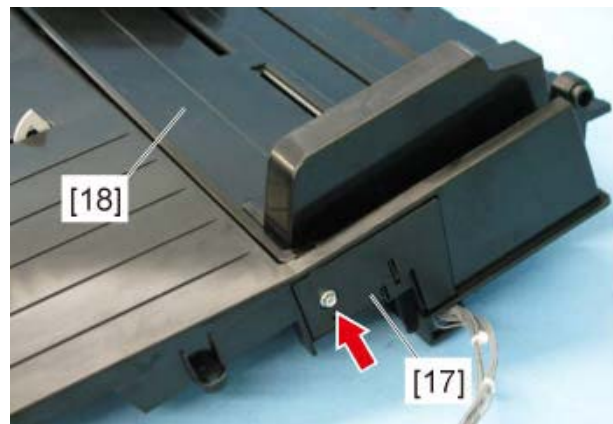

Fig. 4-43

Notes:

When installing the tray holder, be careful not to let the harness get caught in it.

- (3) Remove 1 screw and take off the original width sensor cover [19].

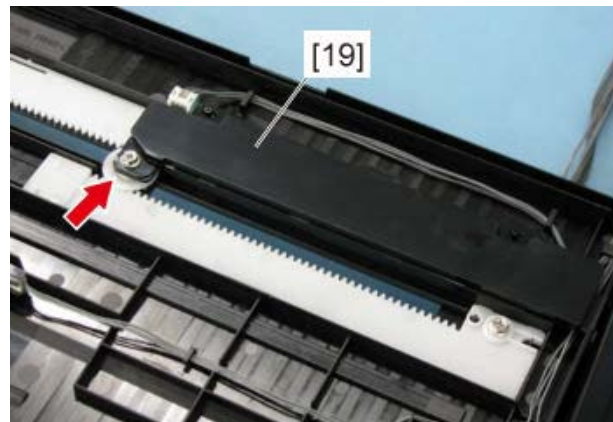

Fig. 4-44

Notes:

Pay attention not to remove the washer and the wave washer of the pinion.

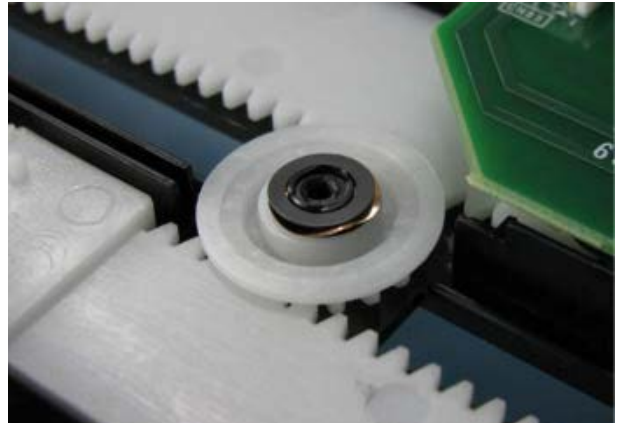

Fig. 4-45

- (4) Disconnect 1 connector and take off the DSDF tray original width sensor [20].

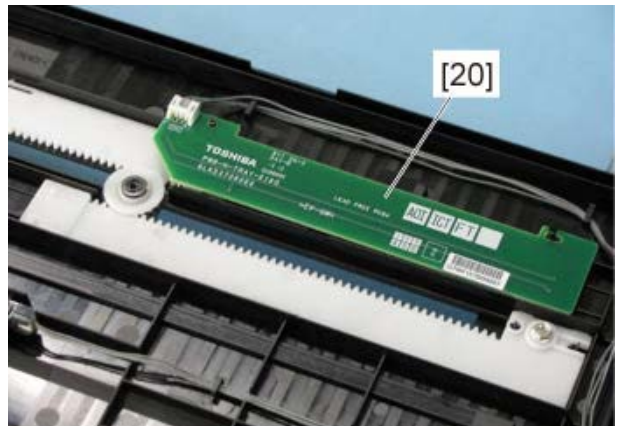

Fig. 4-46

4.4.4 DSDF original empty sensor (SD4)

- (1) Take off the original tray.
P. 4-16 "4.4.1 Original tray"
- (2) Remove 1 screw and take off the tray holder [17].
Take off the movable tray [18].

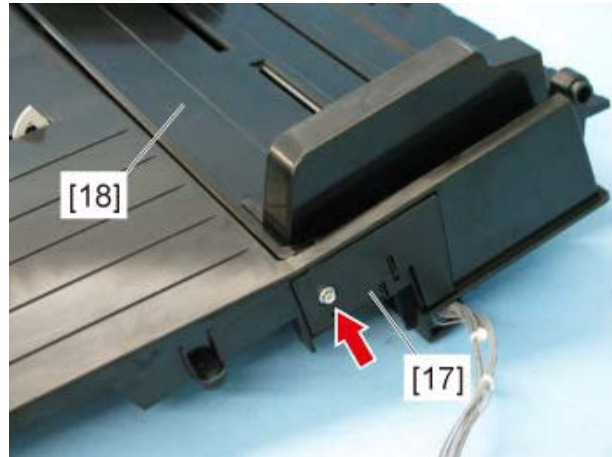

Fig. 4-47

Notes:

When installing the tray holder, be careful not to let the harness get caught in it.

- (3) Disconnect 1 connector. Release the latch and take off the DSDF original empty sensor [21].

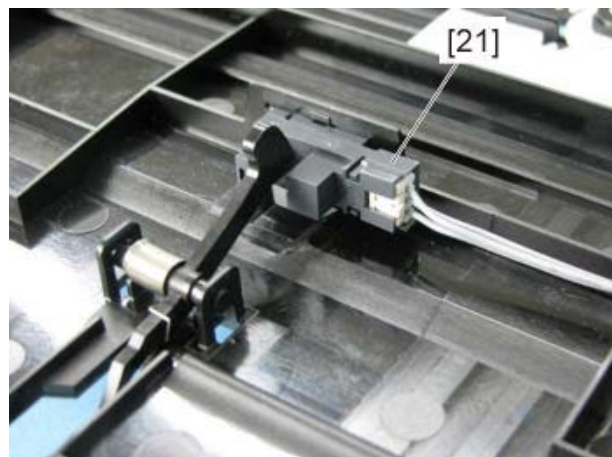

Fig. 4-48

4.5 Original Feeding Section

4.5.1 DSDF original feed sensor (SD5), DSDF tray lift upper limit sensor (SD9)

- (1) Take off the original jam access cover.
☞ P. 4-11 “4.2.3 Original jam access cover”
- (2) Remove 4 screws.

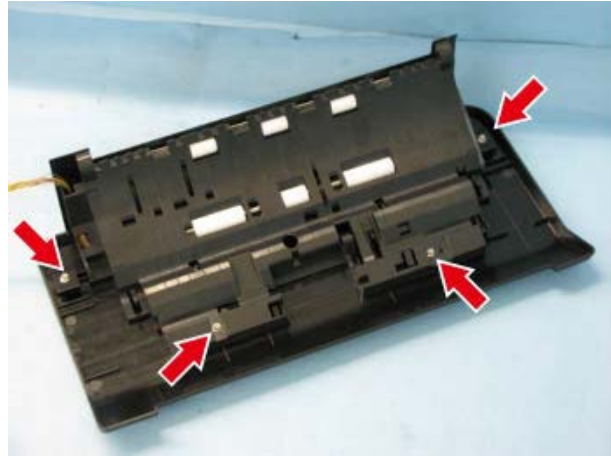

Fig. 4-49

- (3) While pulling the lever, take off the top cover [1].

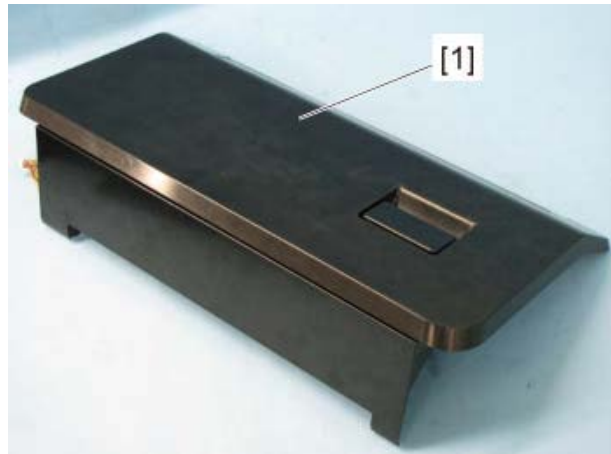

Fig. 4-50

- (4) Release the springs [2] and remove the lever [3].

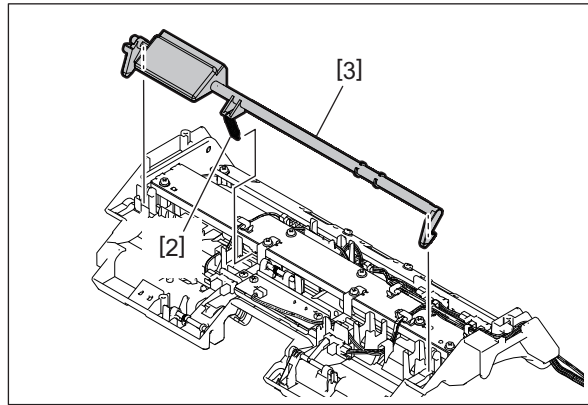

Fig. 4-51

- (5) Disconnect 1 connector [4]. Release the latch and remove the DSDF original feed sensor (SD5) [5].

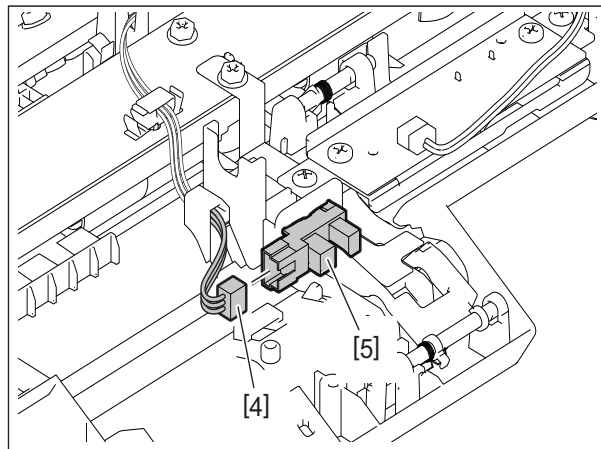

Fig. 4-52

- (6) Disconnect 1 connector [6]. Release the latch and take off the DSDF tray lift upper limit sensor (SD9) [7].

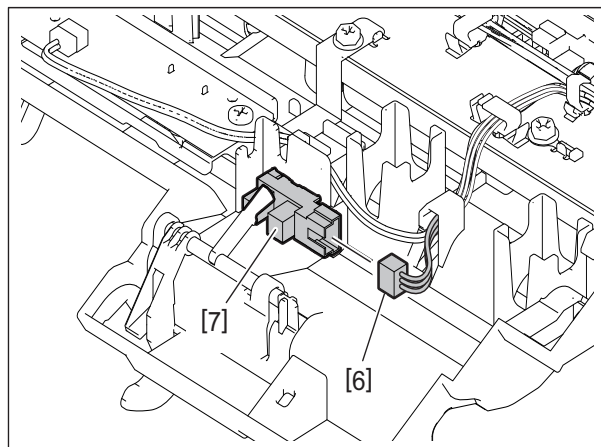

Fig. 4-53

4.5.2 DSDF original width detection sensor-1 (SD7), DSDF original width detection sensor-2 (SD8)

- (1) Take off the original jam access cover.
📖 P. 4-11 “4.2.3 Original jam access cover”
- (2) Remove 4 screws.

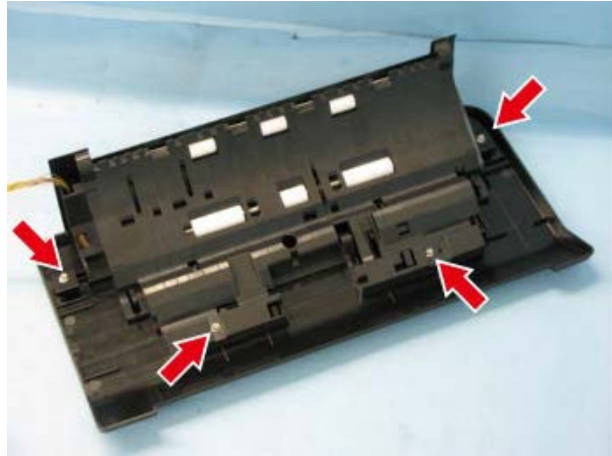

Fig. 4-54

- (3) While pulling the lever, take off the top cover [1].

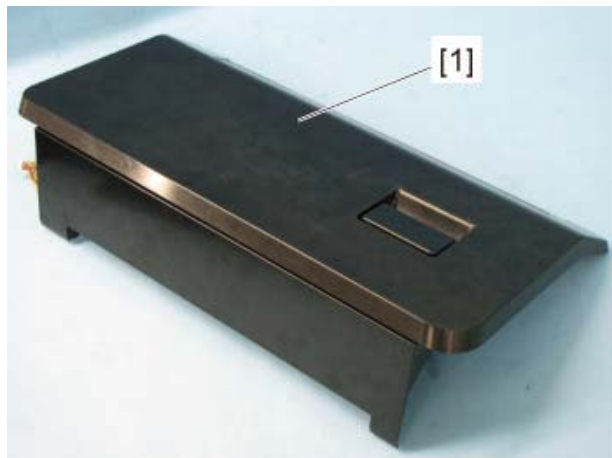

Fig. 4-55

- (4) Remove 2 screws and take off the left top cover [4].

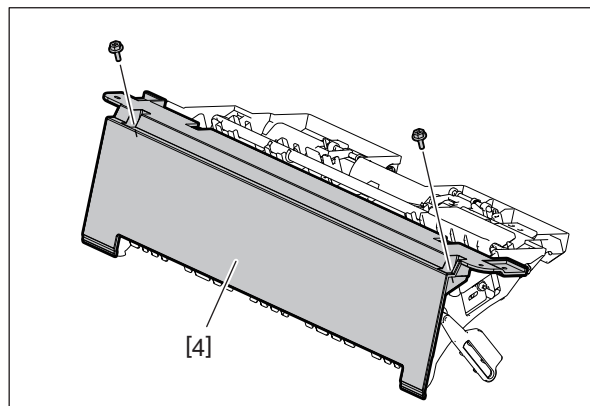

Fig. 4-56

- (5) Disconnect 1 connector. Release the latch and remove the DSDF original width detection sensor-1 (SD7) [5].
- (6) Disconnect 1 connector. Release the latch and remove the DSDF original width detection sensor-2 (SD8) [6].

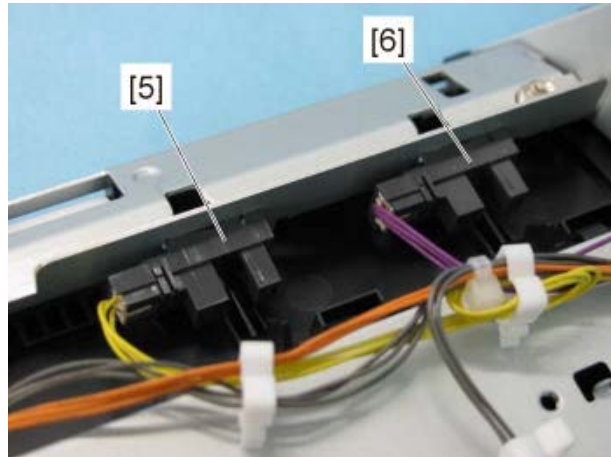



Fig. 4-57

4.5.3 DSDF registration sensor (SD6)

- (1) Take off the original jam access cover.
 P. 4-11 "4.2.3 Original jam access cover"
- (2) Remove 4 screws.

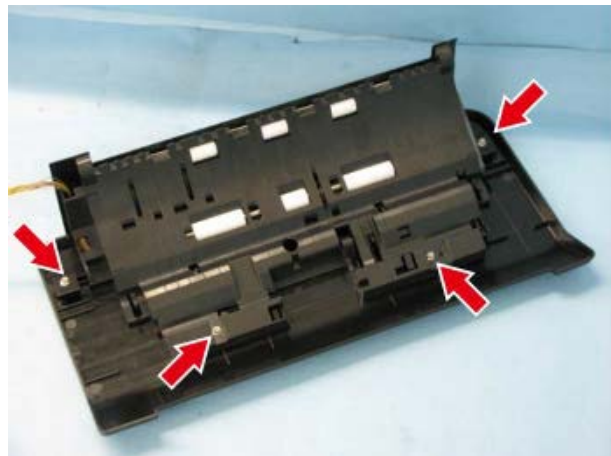

Fig. 4-58

- (3) While pulling the lever, take off the top cover [1].

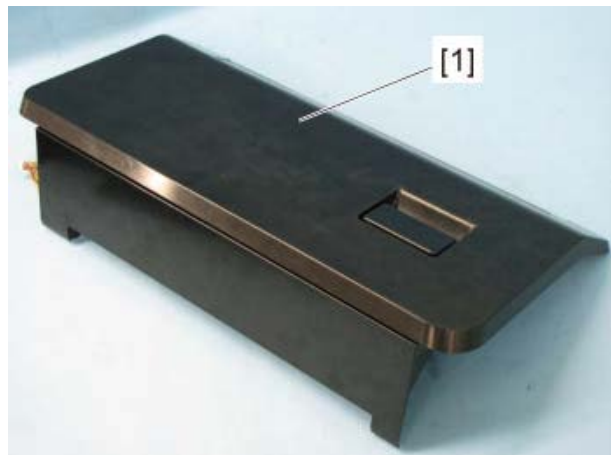

Fig. 4-59

- (4) Remove 2 screws and take off the left top cover [4].

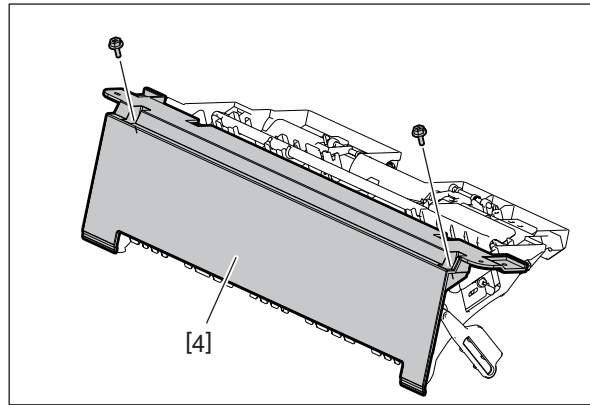

Fig. 4-60

- (5) Disconnect 2 connectors [5].
(6) Remove 8 screws [6] and take off the stay [7].

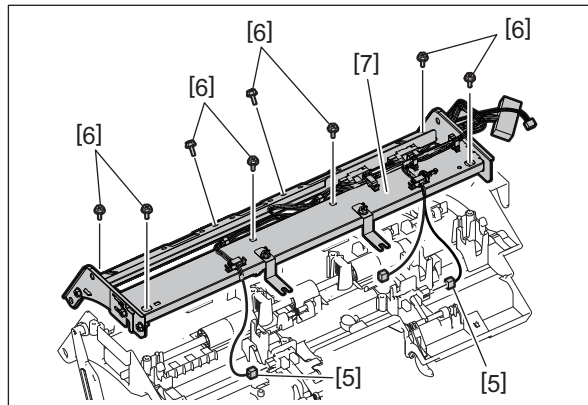

Fig. 4-61

Notes:

Be careful not to drop any of the 6 springs.

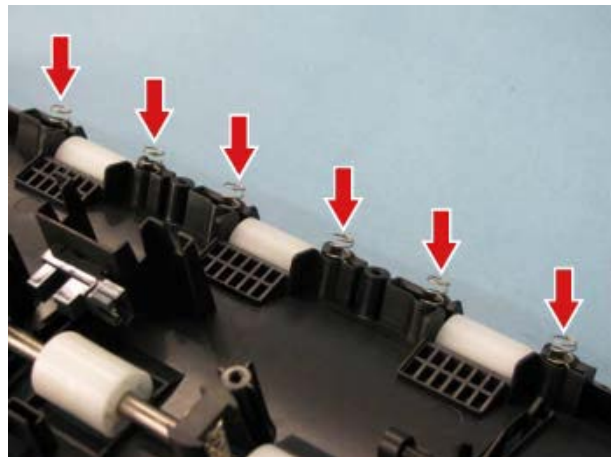

Fig. 4-62

(7) Disconnect 1 connector [9] and take off the DSDF registration sensor (SD6) [8].

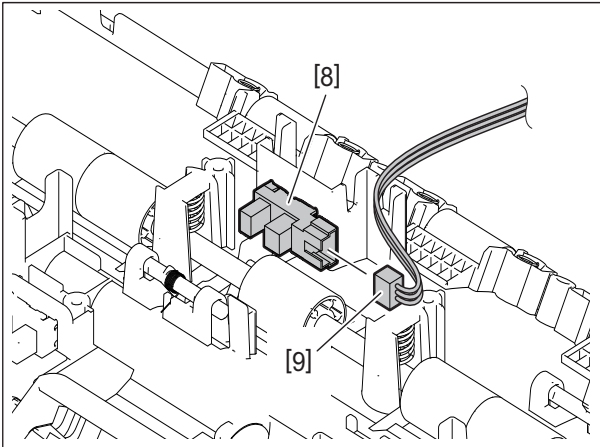



Fig. 4-63

4.6 Driving Section

4.6.1 DSDF cooling fan motor (FD1)

- (1) Take off the DSDF rear cover.
 P. 4-9 “4.2.1 DSDF rear cover”
- (2) Disconnect 1 connector [1]. Remove 2 screws and take off the DSDF cooling fan motor bracket [2].

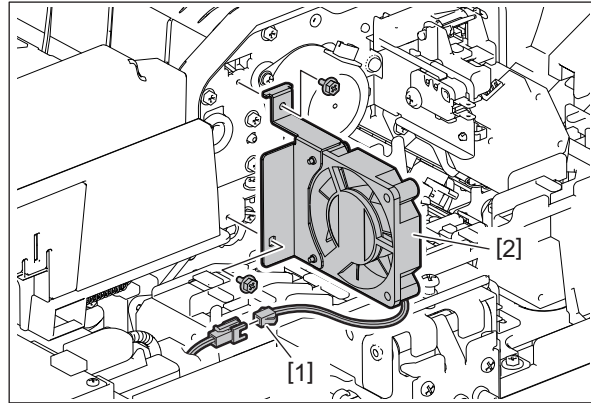

Fig. 4-64

- (3) Remove 2 screws and take off the DSDF cooling fan motor [3] from the bracket.

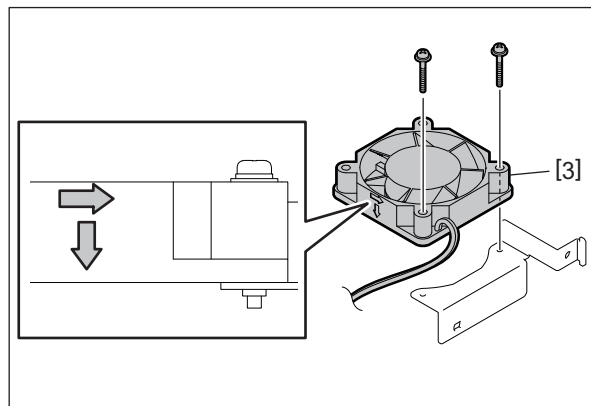

Fig. 4-65

4.6.2 DSDF upper cover interlock switch (SWD2)

Notes:

If the interlock switch is not installed appropriately when it is replaced or installed, it may not work normally. If you carry out the maintenance in such a situation, you could get an electric shock by touching live sections or be injured by touching moving sections. Therefore, to avoid this, be sure to perform correct handling and installation.

- (1) Take off the DSDF cooling fan motor bracket.
P. 4-27 “4.6.1 DSDF cooling fan motor (FD1)”
- (2) Disconnect 3 connectors. Remove 1 screw and take off the DSDF upper cover interlock switch [4].

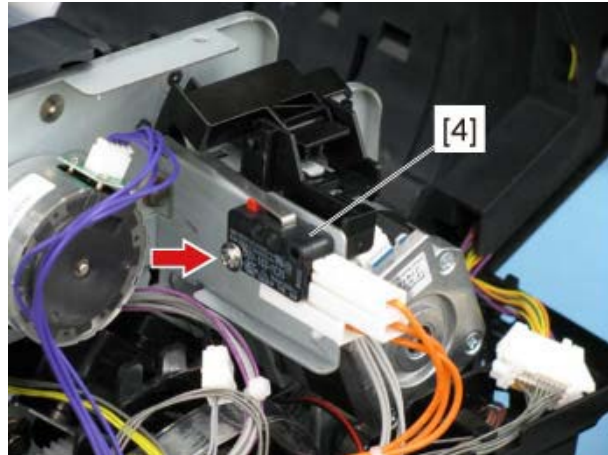

Fig. 4-66

Notes:

Color of all 3 harnesses for the DSDF upper cover interlock switch: Orange

4.6.3 DSDF upper cover opening/closing detection sensor (SD16)

Notes:

If the interlock switch is not installed appropriately when it is replaced or installed, it may not work normally. If you carry out the maintenance in such a situation, you could get an electric shock by touching live sections or be injured by touching moving sections. Therefore, to avoid this, be sure to perform correct handling and installation.

- (1) Take off the DSDF rear cover.
P. 4-9 “4.2.1 DSDF rear cover”
- (2) Remove 2 screws and take off the sensor bracket [1].

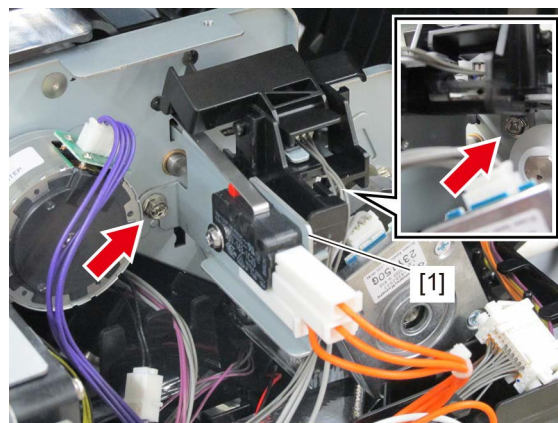

Fig. 4-67

- (3) Release the harness [4] from the clamp [2] and the actuator [3]. Release 2 hooks [5] of the actuator [3] and take it off.

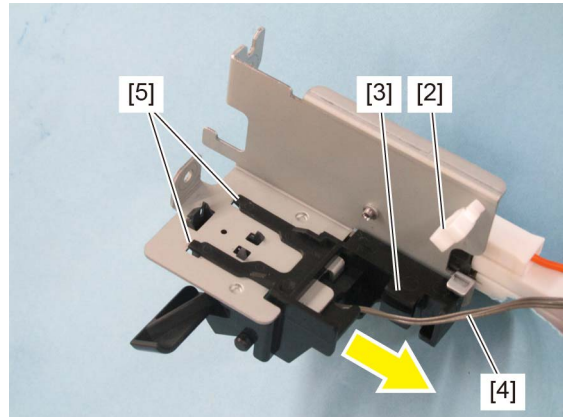

Fig. 4-68

- (4) Release 3 latches [6].

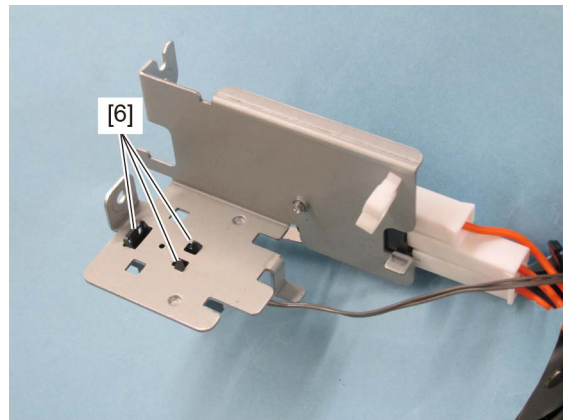

Fig. 4-69

- (5) Disconnect 1 connector [7] and then take off the DSDF upper cover opening/closing detection sensor (SD16) [8].

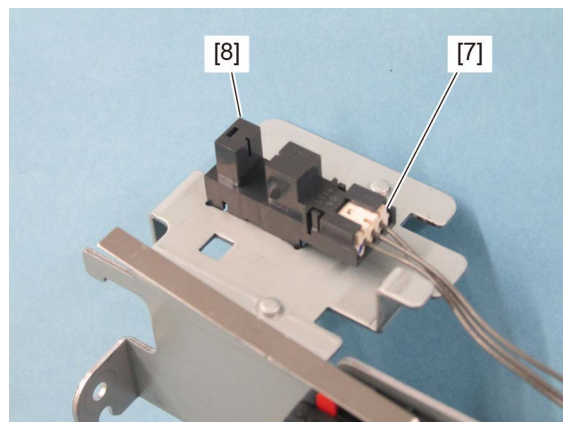

Fig. 4-70

4.6.4 DSDF registration motor (MD3)

- (1) Take off the DSDF rear cover.
📖 P. 4-9 “4.2.1 DSDF rear cover”
- (2) Take off the DSDF cooling fan motor (FD1).
📖 P. 4-27 “4.6.1 DSDF cooling fan motor (FD1)”
- (3) Disconnect 1 HDMI cable. Release the lock and disconnect 1 flat cable.

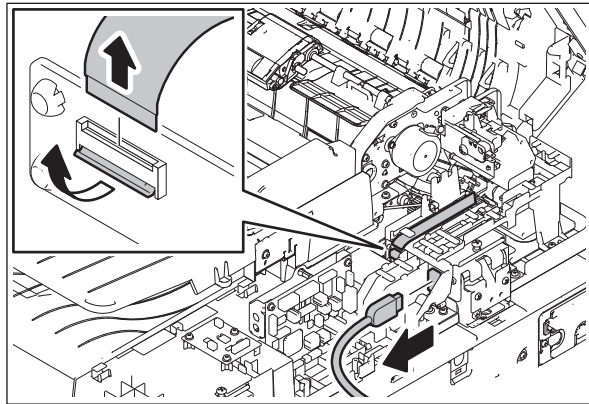

Fig. 4-71

Notes:

- When installing the flat cable, do not push it in strongly.
 - When installing the flat cable, be careful not to insert it at an angle.
 - Do not apply pressure to or damage the edge of the flat cable.
 - Install the flat cable with its conductor side up.
- (4) Release the harness [6] from the harness guide [5].
Disconnect the connectors [7] of the DSDF upper cover interlock switch and DSDF lower cover interlock switch.
Remove 2 screws and take off the harness guide [5].

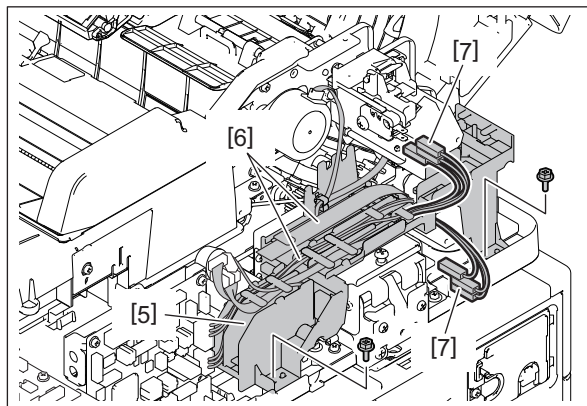

Fig. 4-72

Notes:

Be sure to release the harness from the clamp of the harness guide [5].

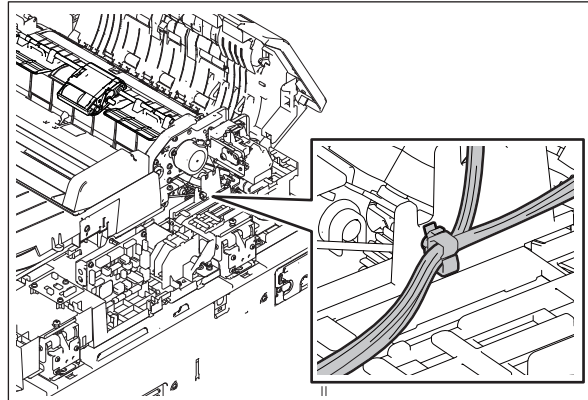

Fig. 4-73

- (5) Disconnect 1 connector [9] from the DSDF registration motor.
Remove 2 screws and take off the DSDF registration motor bracket [10].

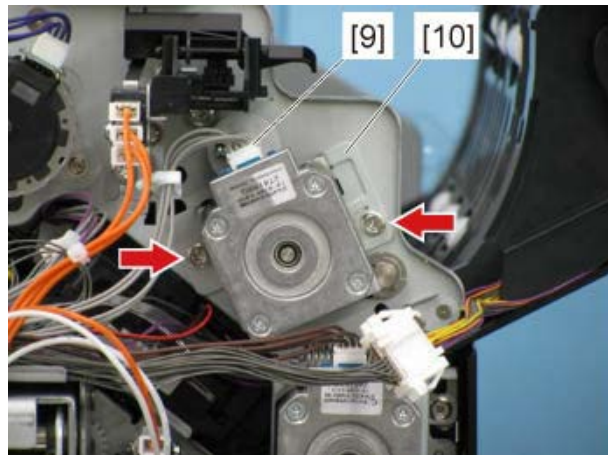

Fig. 4-74

Notes:

- When installing the DSDF registration motor bracket, be sure to hook the pulley to the timing belt.
- The harness color of the DSDF registration motor is gray, be sure to check the harness color at installing.

- (6) Remove 2 screws and take off the DSDF registration motor [11] from the DSDF registration motor bracket [10].

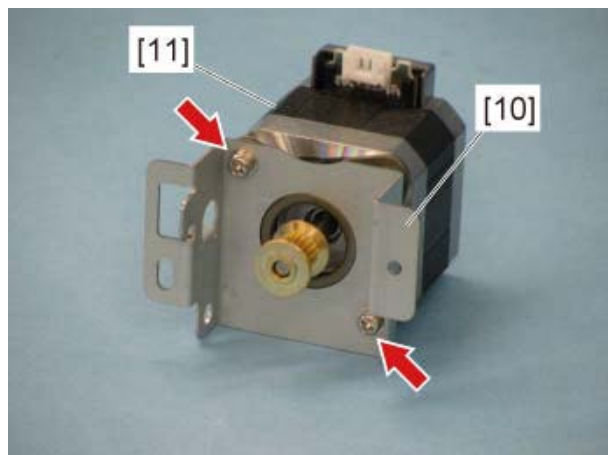

Fig. 4-75

4.6.5 DSDF read motor (MD4)

- (1) Take off the DSDF rear cover.
P. 4-9 "4.2.1 DSDF rear cover"
- (2) Take off the DSDF cooling fan motor (FD1).
P. 4-27 "4.6.1 DSDF cooling fan motor (FD1)"
- (3) Disconnect 1 HDMI cable. Release the lock and disconnect 1 flat cable.

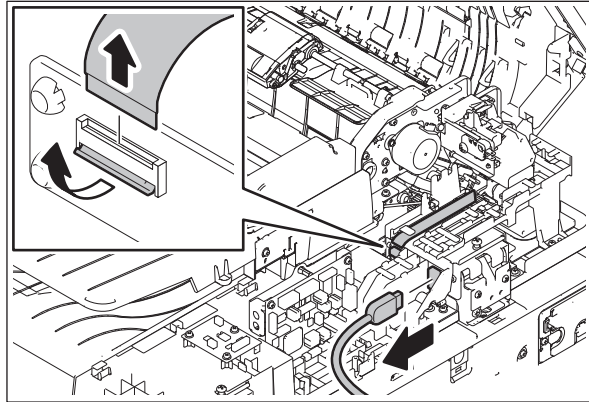

Fig. 4-76

Notes:

- When installing the flat cable, do not push it in strongly.
 - When installing the flat cable, be careful not to insert it at an angle.
 - Do not apply pressure to or damage the edge of the flat cable.
 - Install the flat cable with its conductor side up.
- (4) Release the harness [6] from the harness guide [5].
Disconnect the connectors [7] of the DSDF upper cover interlock switch and DSDF lower cover interlock switch.
Remove 2 screws and take off the harness guide [5].

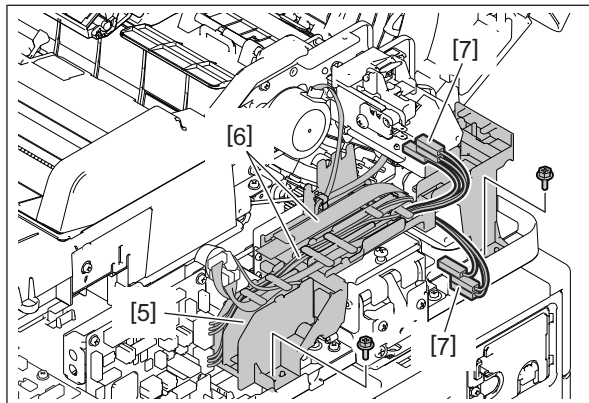

Fig. 4-77

Notes:

Be sure to release the harness from the clamp of the harness guide [5].

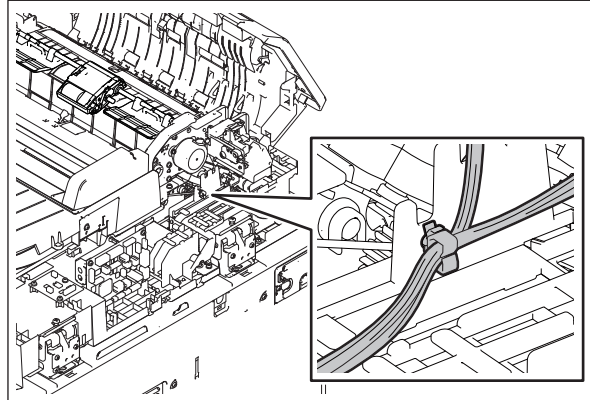

Fig. 4-78

- (5) Disconnect 1 connector [12] from the DSDF read motor.
- (6) Remove the tension spring [13].
Remove 2 screws and take off the DSDF read motor bracket [14].

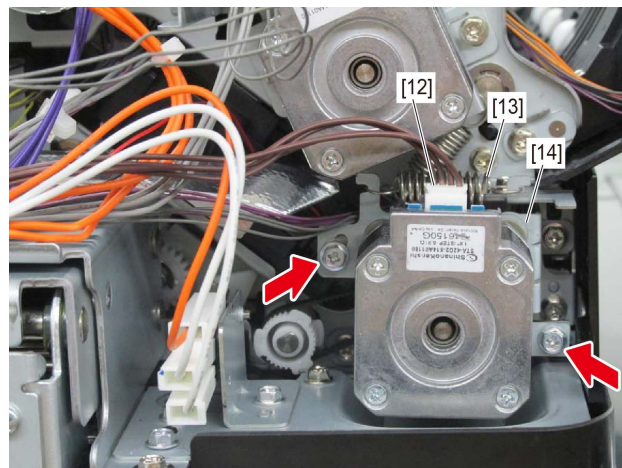

Fig. 4-79

Notes:

- When installing the DSDF read motor bracket, be sure to hook the pulley to the timing belt.
- When installing, temporarily tighten 2 screws, hook the tension spring and then securely tighten them.

- (7) Remove 2 screws and take off the DSDF read motor [25] from the DSDF read motor bracket [24].

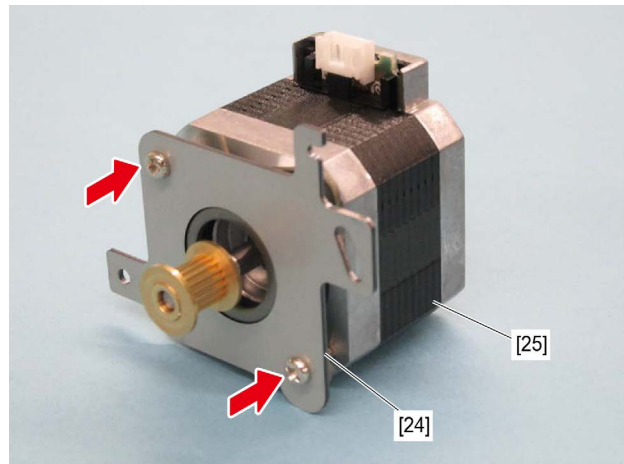

Fig. 4-80

4.6.6 DSDF original exit motor (MD5)

- (1) Take off the DSDF rear cover.
P. 4-9 “4.2.1 DSDF rear cover”
- (2) Take off the DSDF cooling fan motor (FD1).
P. 4-27 “4.6.1 DSDF cooling fan motor (FD1)”
- (3) Disconnect 1 HDMI cable. Release the lock and disconnect 1 flat cable.

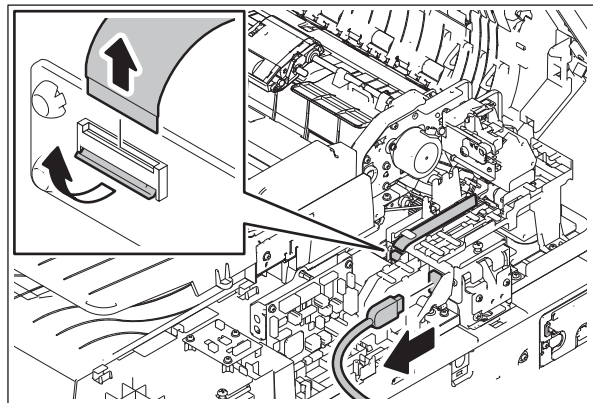

Fig. 4-81

Notes:

- When installing the flat cable, do not push it in strongly.
- When installing the flat cable, be careful not to insert it at an angle.
- Do not apply pressure to or damage the edge of the flat cable.
- Install the flat cable with its conductor side up.

- (4) Release the harness [6] from the harness guide [5].
Disconnect the connectors [7] of the DSDF upper cover interlock switch and DSDF lower cover interlock switch.
Remove 2 screws and take off the harness guide [5].

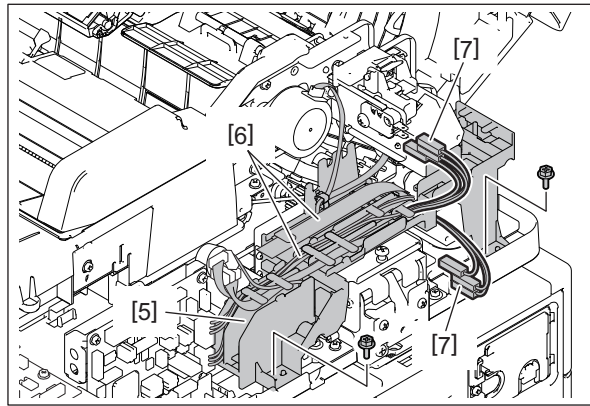

Fig. 4-82

Notes:

Be sure to release the harness from the clamp of the harness guide [5].

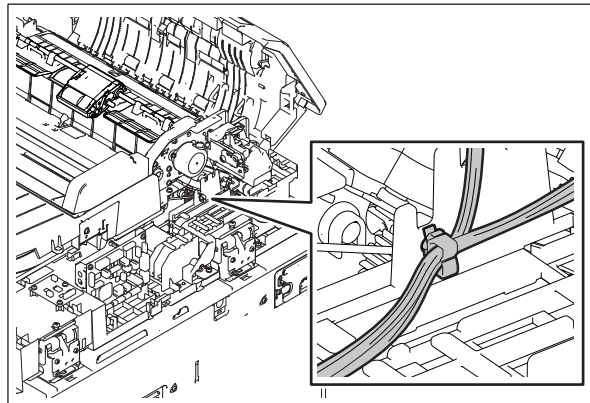

Fig. 4-83

- (5) Disconnect 1 connector [15] from the DSDF original exit motor.
- (6) Remove the tension spring [16].
- (7) Remove 2 screws and take off the DSDF original exit motor bracket [17].

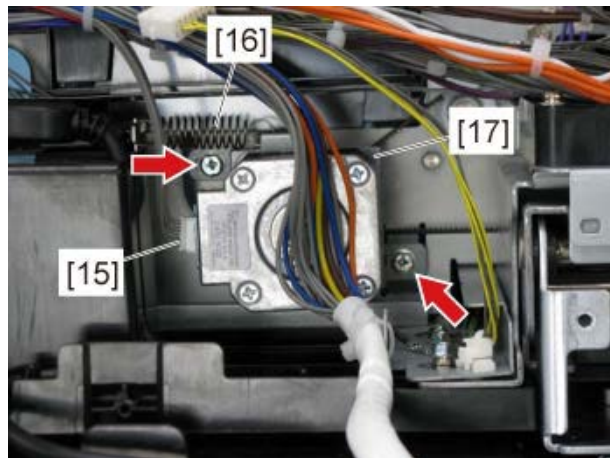

Fig. 4-84

Notes:

- When installing the DSDF original exit motor bracket, be sure to hook the pulley to the timing belt.
- When installing, temporarily tighten 2 screws, hook the tension spring and then securely tighten them.

- (8) Remove 2 screws and take off the DSDF original exit motor [18] from the DSDF original exit motor bracket [17].

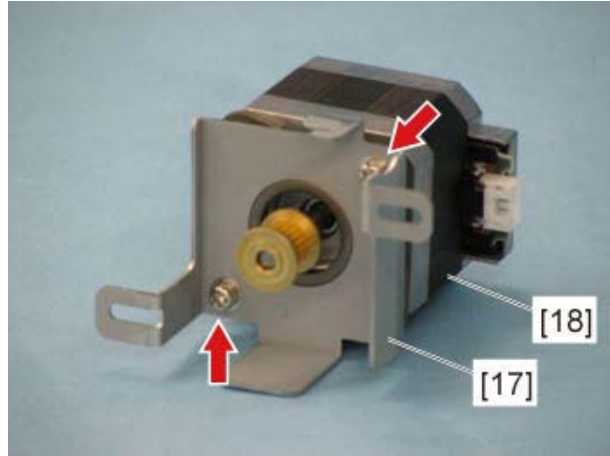

Fig. 4-85

4.6.7 DSDF lower cover interlock switch (SWD1)

Notes:

If the interlock switch is not installed appropriately when it is replaced or installed, it may not work normally. If you carry out the maintenance in such a situation, you could get an electric shock by touching live sections or be injured by touching moving sections. Therefore, to avoid this, be sure to perform correct handling and installation.

- (1) Take off the DSDF read motor.
P. 4-32 "4.6.5 DSDF read motor (MD4)"
- (2) Disconnect 3 connectors. Remove 1 screw and take off the DSDF lower cover interlock switch [19].

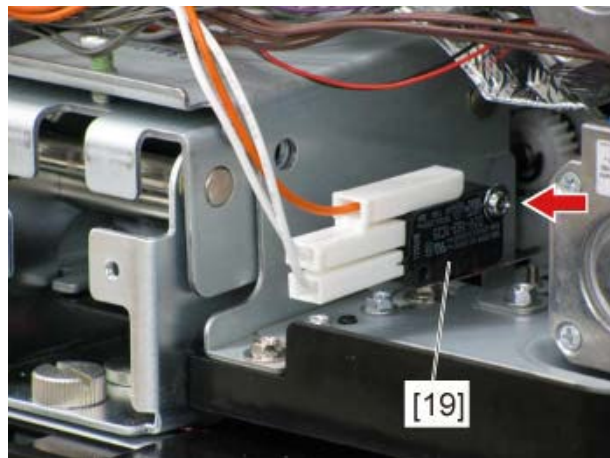

Fig. 4-86

Notes:

Color of 3 harnesses for the DSDF lower cover interlock switch: Orange (1) and white (2)

4.6.8 DSDF original feed motor (MD1)

- (1) Take off the DSDF rear cover.
P. 4-9 “4.2.1 DSDF rear cover”
- (2) Disconnect 1 connectors [20]. Remove 2 screws. Slide the DSDF original feed motor [21] to the upper left to take it off.

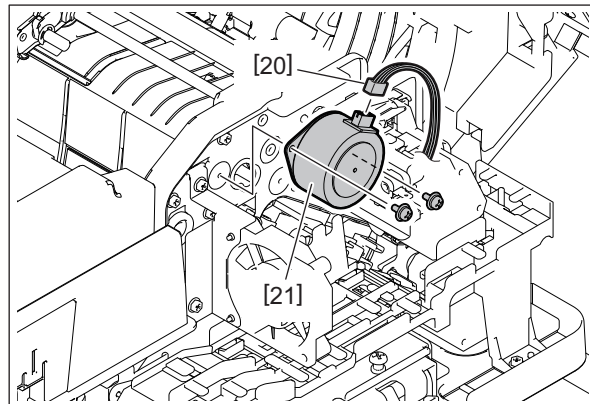

Fig. 4-87

Notes:

The harness color of the DSDF original feed motor is purple, be sure to check the harness color at installing.

4.6.9 DSDF separation motor (MD2)

- (1) Take off the DSDF-LED PC board.
P. 4-13 “4.3.1 DSDF-LED PC board (LEDD)”
- (2) Disconnect 1 connector [22]. Remove 2 screws. Turn the DSDF separation motor [23] clockwise and slide it to the upper right to take it off.

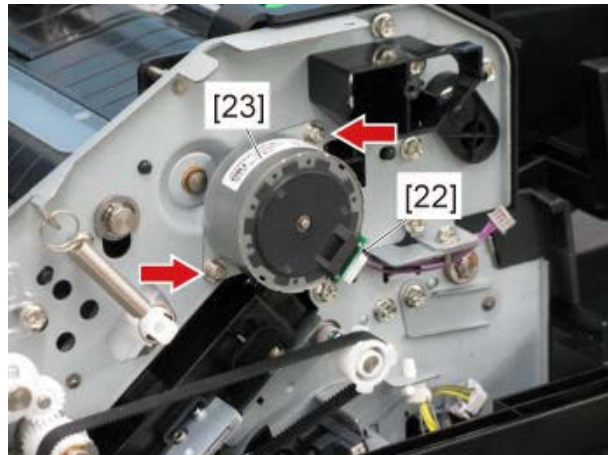

Fig. 4-88

4.7 Original Transport Section

Notes:

- Be sure to attach the stopper jig or to take off the DSDF from the MFP. If the unit is taken off from the DSDF while it is installed in the MFP, the DSDF will be pulled up as its weight becomes lighter, resulting in danger.
- When taking the DSDF from the MFP to disassemble it, be sure to put it on an even workspace.
- Take off the platen sheet before maintenance to prevent it from being damaged or dirtied.

4.7.1 Intermediate transport unit

- (1) Take off the original jam access cover.
📖 P. 4-11 “4.2.3 Original jam access cover”
- (2) Take off the original tray.
📖 P. 4-16 “4.4.1 Original tray”
- (3) Take off the DSDF cooling fan motor (FD1).
📖 P. 4-27 “4.6.1 DSDF cooling fan motor (FD1)”
- (4) Disconnect 5 connectors.

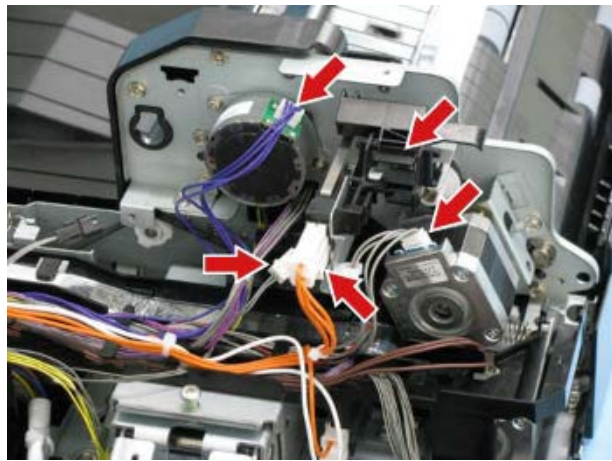

Fig. 4-89

- (5) Disconnect 3 connectors.

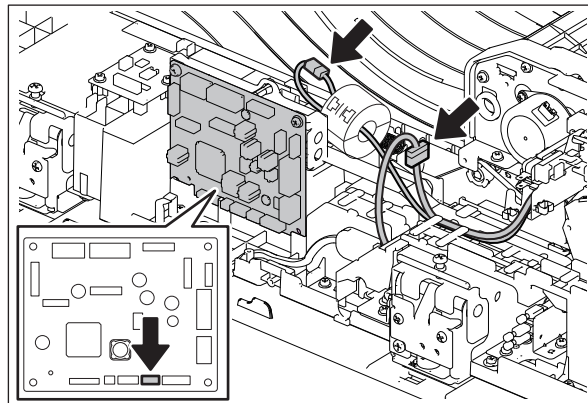

Fig. 4-90

- (6) Remove 1 screw and take off the pulley bracket [14] toward the front side.
- (7) Remove 1 screw.

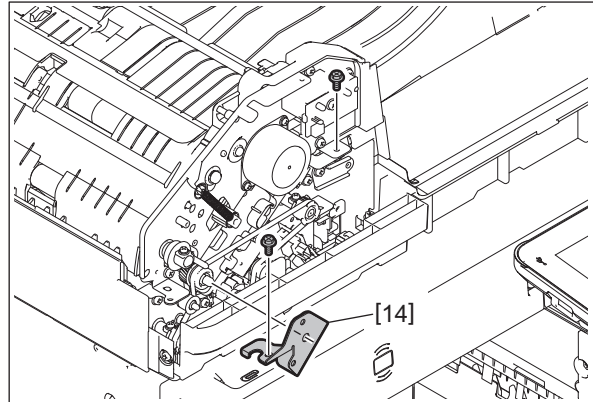

Fig. 4-91

- (8) Remove 2 screws.

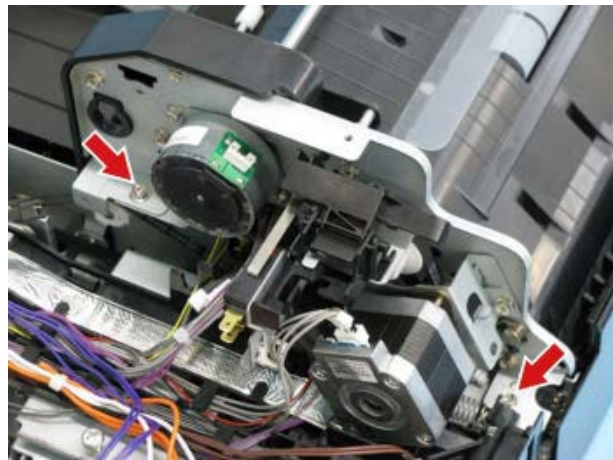

Fig. 4-92

- (9) Take off the intermediate transport unit [1].

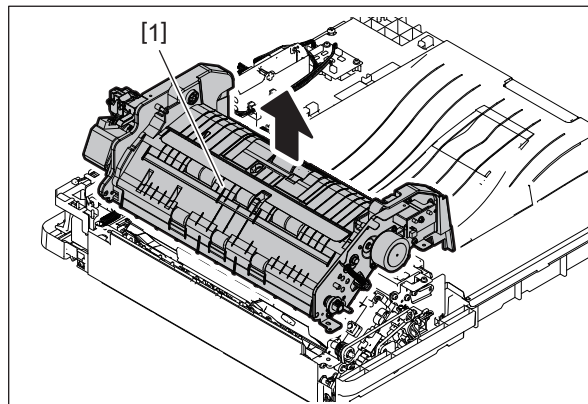



Fig. 4-93

4.7.2 DSDF read-in sensor-1 (SD11), DSDF read-in sensor-2 (SD12)

- (1) Take off the DSDF-CCD module.
 P. 4-47 “4.8.1 DSDF-CCD module (CCDD)”
- (2) Disconnect 2 connectors and remove 1 screw. Then take off the sensor bracket [2].

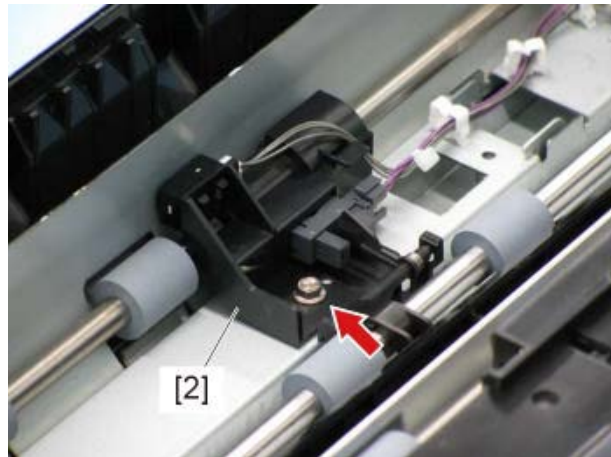

Fig. 4-94

- (3) Release the latch and take off the DSDF read-in sensor-1 [3] from the sensor bracket.
- (4) Release the latch and take off the DSDF read-in sensor-2 [4] from the sensor bracket.

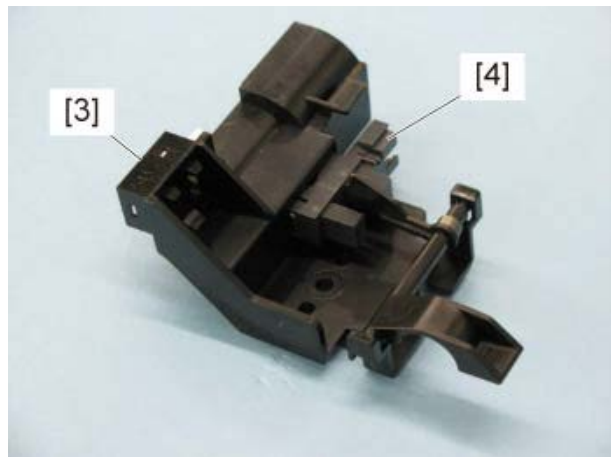



Fig. 4-95

Notes:

When the DSDF read-in sensor-1 is replaced, be sure to perform the DSDF read-in sensor-1 adjustment.

 P. 5-16 “5.7.1 DSDF read-in sensor-1 automatic adjustment”

4.7.3 DSDF original exit sensor (SD13), DSDF tray lift lower limit sensor (SD10)

- (1) Take off the intermediate transport unit.
📖 P. 4-38 “4.7.1 Intermediate transport unit”
- (2) Disconnect 1 connector [10].

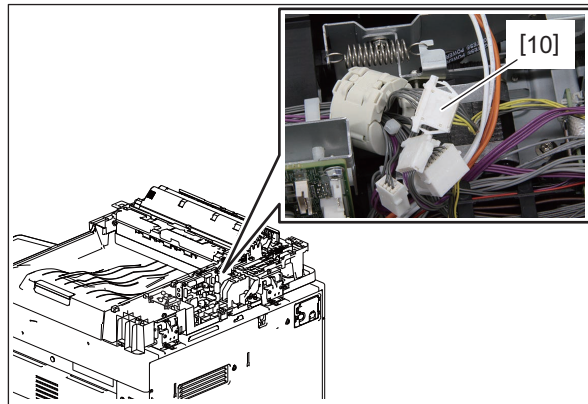

Fig. 4-96

- (3) Remove 1 screw. Remove the pin [6] at the front of the sensor stay [5] and release the latch [7] at the center. Then take off the sensor stay.

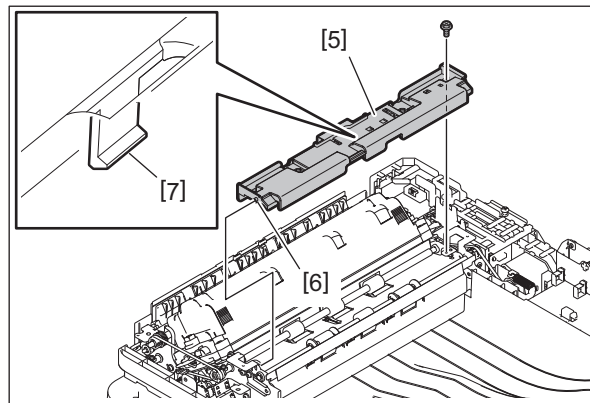

Fig. 4-97

- (4) Disconnect 1 connector. Release the latch and take off the DSDF original exit sensor [8].

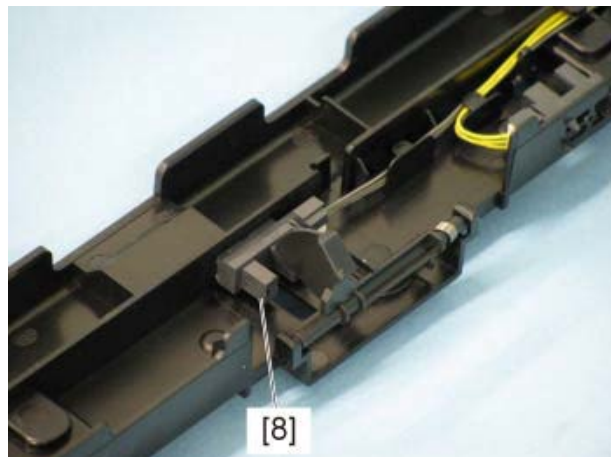

Fig. 4-98

- (5) Disconnect 1 connector. Release the latch and take off the DSDF tray lift lower limit sensor [9].

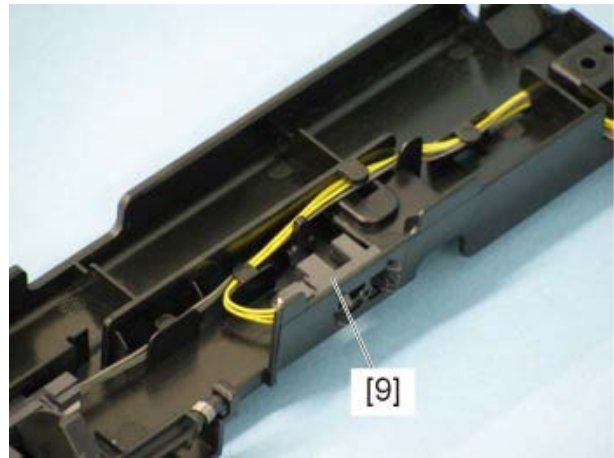

Fig. 4-99

4.7.4 Lower transport unit

- (1) Take off the DSDF-CCD module.
📖 P. 4-47 “4.8.1 DSDF-CCD module (CCDD)”
- (2) Take off the DSDF left cover.
📖 P. 4-12 “4.2.4 DSDF left cover”
- (3) Remove 8 screws and take off the lower transport unit [10].

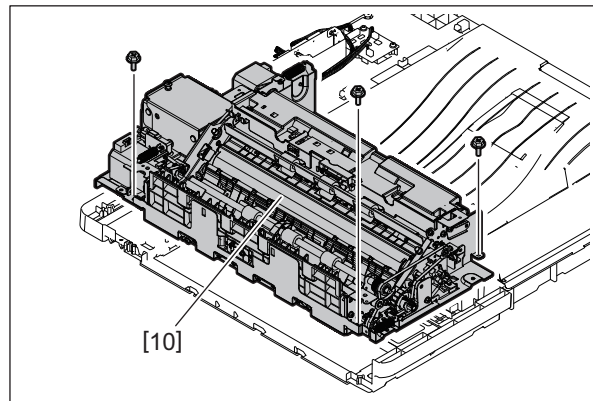

Fig. 4-100

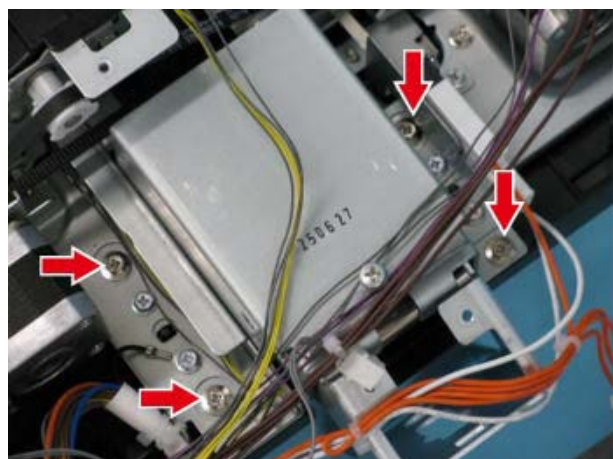

Fig. 4-101

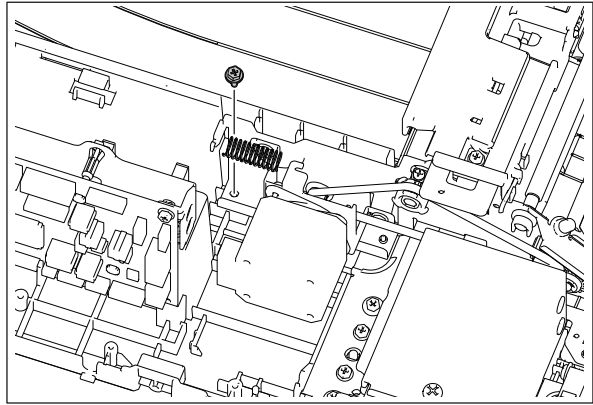

Fig. 4-102

Lower transport unit

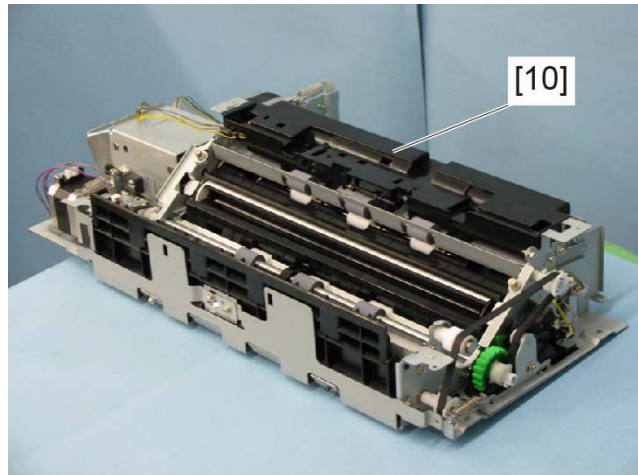

Fig. 4-103

4.7.5 DSDF shading sheet HP sensor (SD14)

- (1) Take off the lower transport unit.
 ⓘ P. 4-42 "4.7.4 Lower transport unit"
- (2) Turn the roller [1].

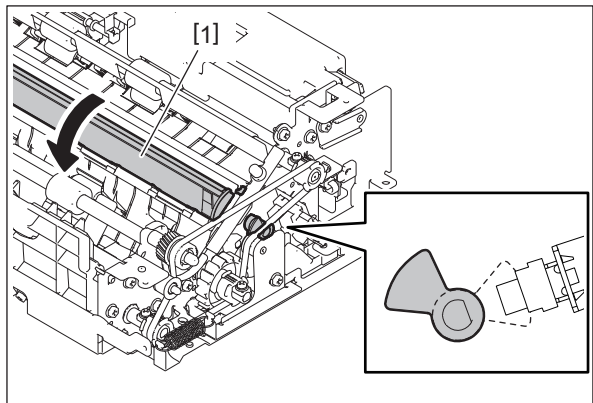

Fig. 4-104

- (3) Disconnect the connector [2] and take off the DSDF shading sheet HP sensor (SD14) [3].

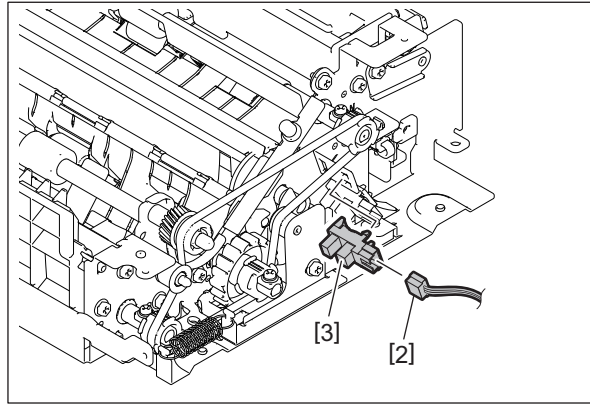

Fig. 4-105

4.7.6 DSDF lower cover opening/closing detection sensor (SD15)

- (1) Take off the lower transport unit.
P. 4-42 “4.7.4 Lower transport unit”
- (2) Remove 2 screws [1] and take off the original exit cover [2].

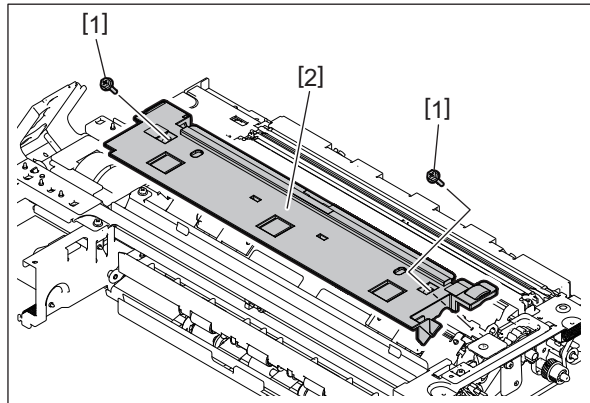

Fig. 4-106

- (3) Disconnect the connector [3] and take off the DSDF lower cover opening/closing detection sensor (SD15) [4].

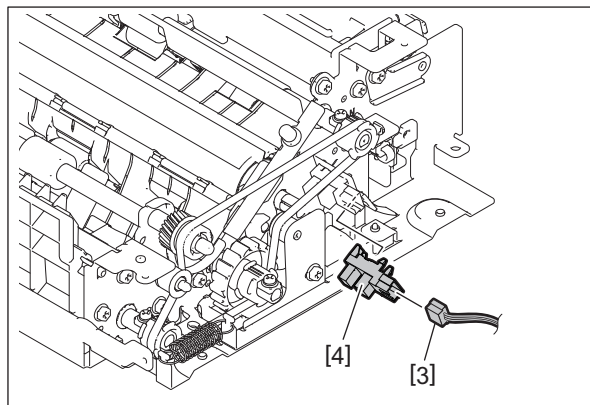

Fig. 4-107

4.7.7 Multiple feeding detection sensor (reception side) (SD18)

- (1) Remove the lever.
☞ P. 4-21 "4.5.1 DSDF original feed sensor (SD5), DSDF tray lift upper limit sensor (SD9)"
- (2) Disconnect the connector [1].
- (3) Remove 2 screws [2] and take off the multiple feeding detection sensor unit [3].

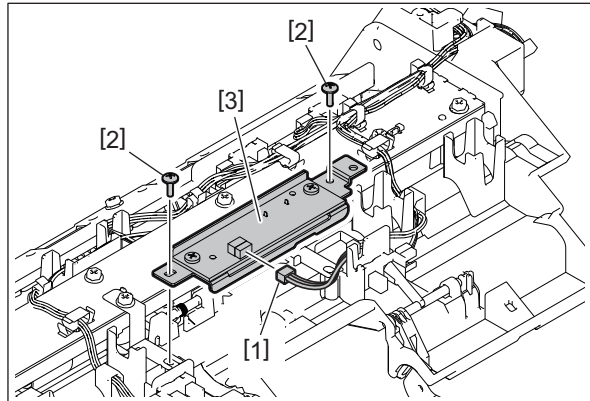

Fig. 4-108

- (4) Remove 2 screws [4] and take off multiple feeding detection sensor (reception side) (SD18) [5].

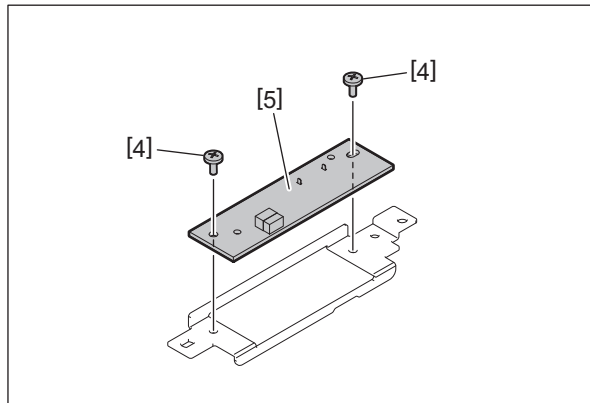

Fig. 4-109

4.7.8 Multiple feeding detection sensor (transmission side) (SD17)

- (1) Take off the original jam access cover.
📖 P. 4-11 “4.2.3 Original jam access cover”
- (2) Take off the DSDF pickup unit.
📖 P. 4-1 “4.1.1 DSDF pickup unit”
- (3) Take off the intermediate transport unit.
📖 P. 4-38 “4.7.1 Intermediate transport unit”
- (4) Remove 2 screws [1]. Take off the multiple feeding detection sensor unit [2] and disconnect the connector [3].

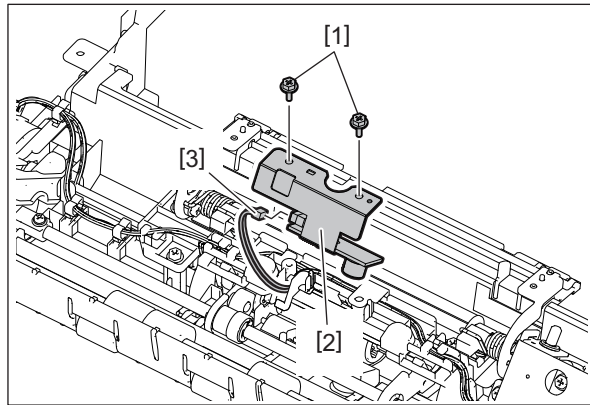

Fig. 4-110

- (5) Remove 1 screw [4] and take off multiple feeding detection sensor (transmission side) [5].

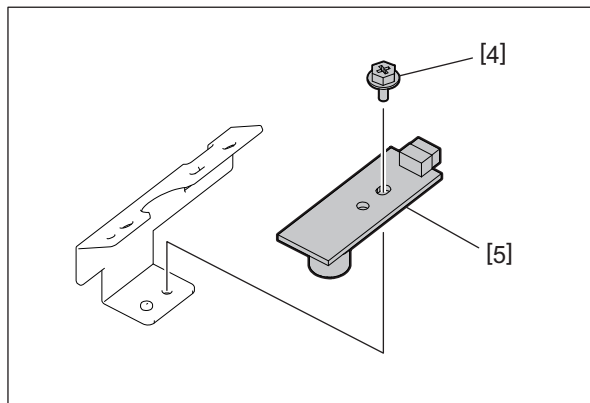

Fig. 4-111

4.8 Original Scanning Section

4.8.1 DSDF-CCD module (CCDD)

Notes:

- Be sure to attach the stopper jig or to take off the DSDF from the MFP. If the unit is taken off from the DSDF while it is installed in the MFP, the DSDF will be pulled up as its weight becomes lighter, resulting in danger.
 - A characteristic value for image process is embedded in this DSDF-CCD module. When the DSDF or DSDF-CCD module has been replaced, be sure to perform FS-05-3240 (Data acquisition of characteristic value of the scanner).
- (1) Take off the intermediate transport unit.
P. 4-38 "4.7.1 Intermediate transport unit"
 - (2) Disconnect 1 connector and 1 flat harness.

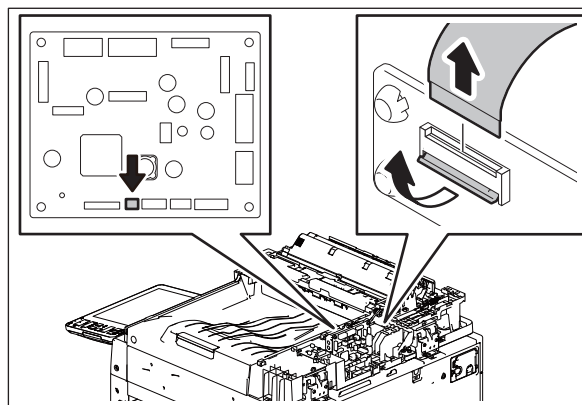

Fig. 4-112

- (3) Take off the DSDF-CCD module [1].

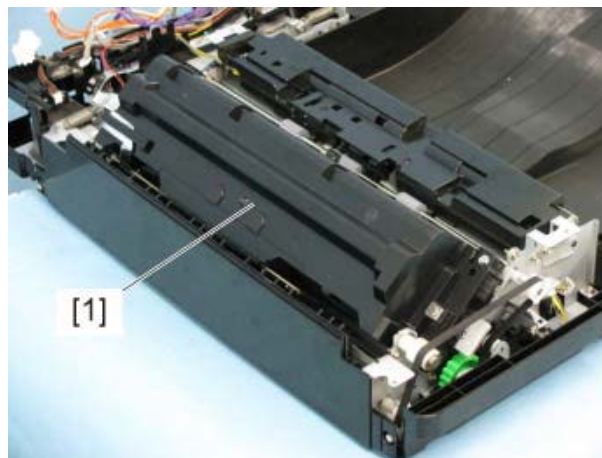

Fig. 4-113

DSDF-CCD module

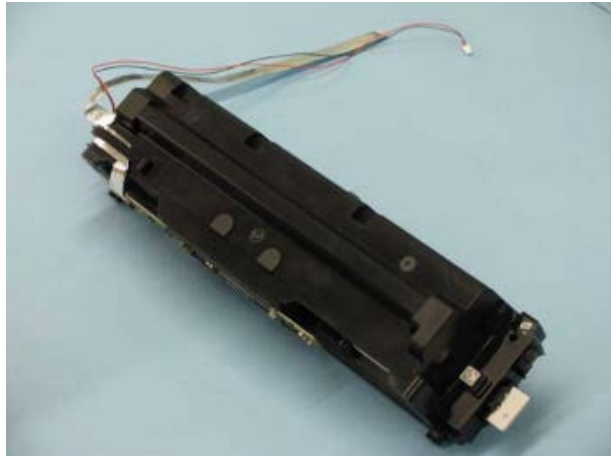

Fig. 4-114

Notes:

- Do not leave fingerprints or stains on the slit glass of the DSDF-CCD module [2].
- Pay close attention not to make an impact or vibration on the DSDF-CCD module because it is a precise apparatus.

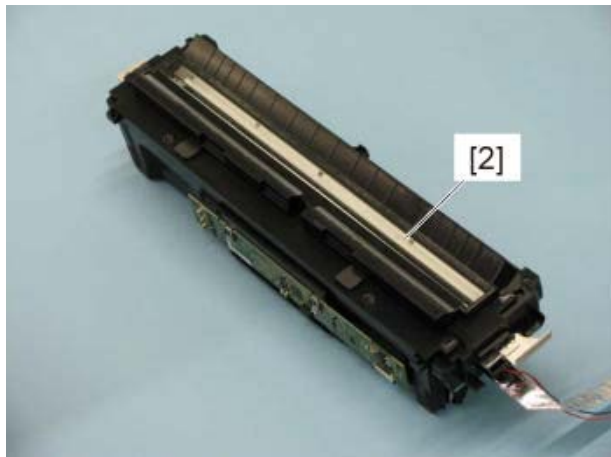

Fig. 4-115

4.9 Film Attachment Reference

4.9.1 Registration films (F), (R)

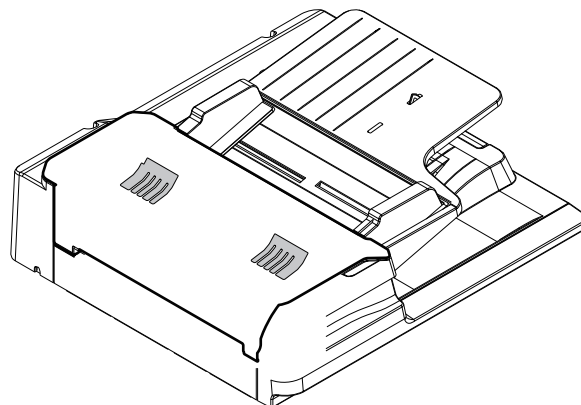

Fig. 4-116

Attach them as shown in the figure below.

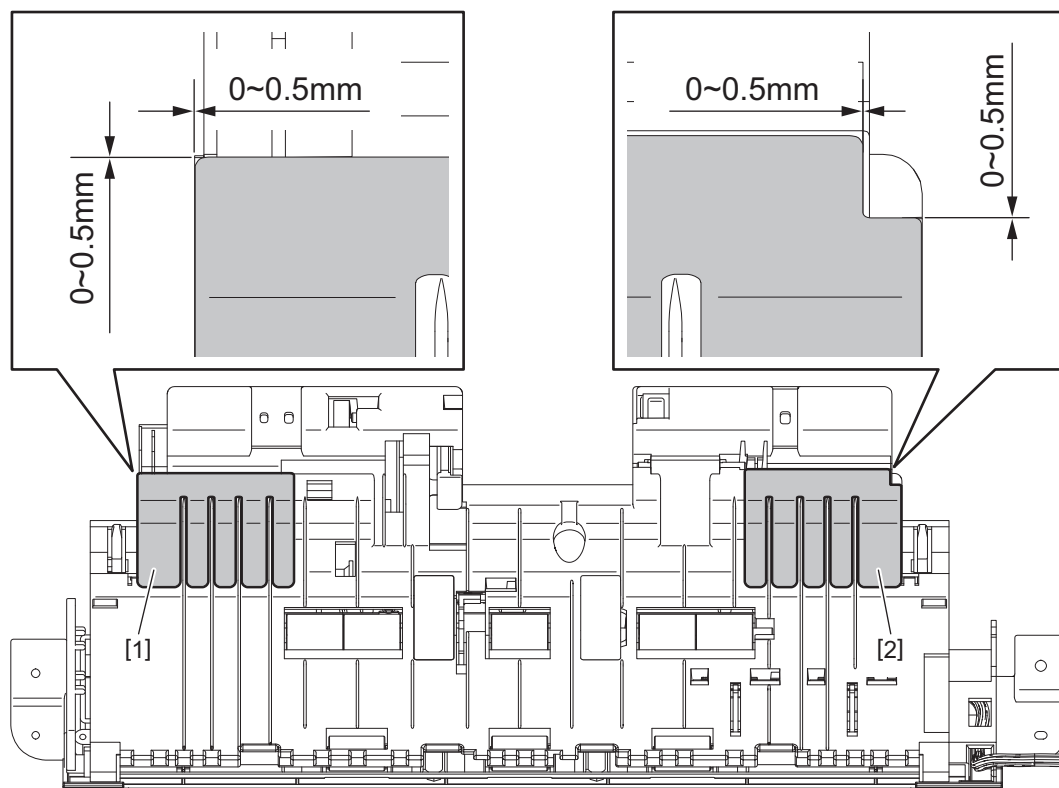

Fig. 4-117

- [1] Registration film (R)
- [2] Registration film (F)

4.9.2 Films with a spacer

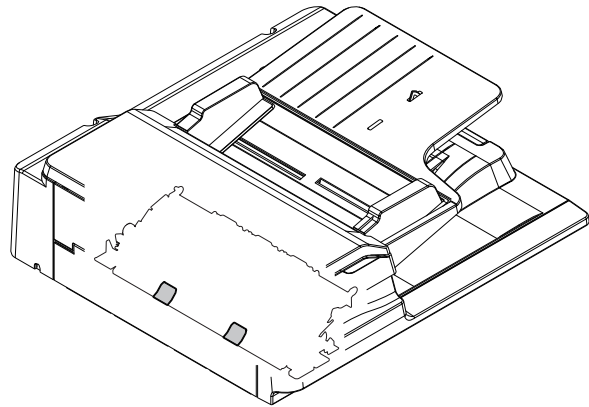

Fig. 4-118

Attach them as shown in the figure below.

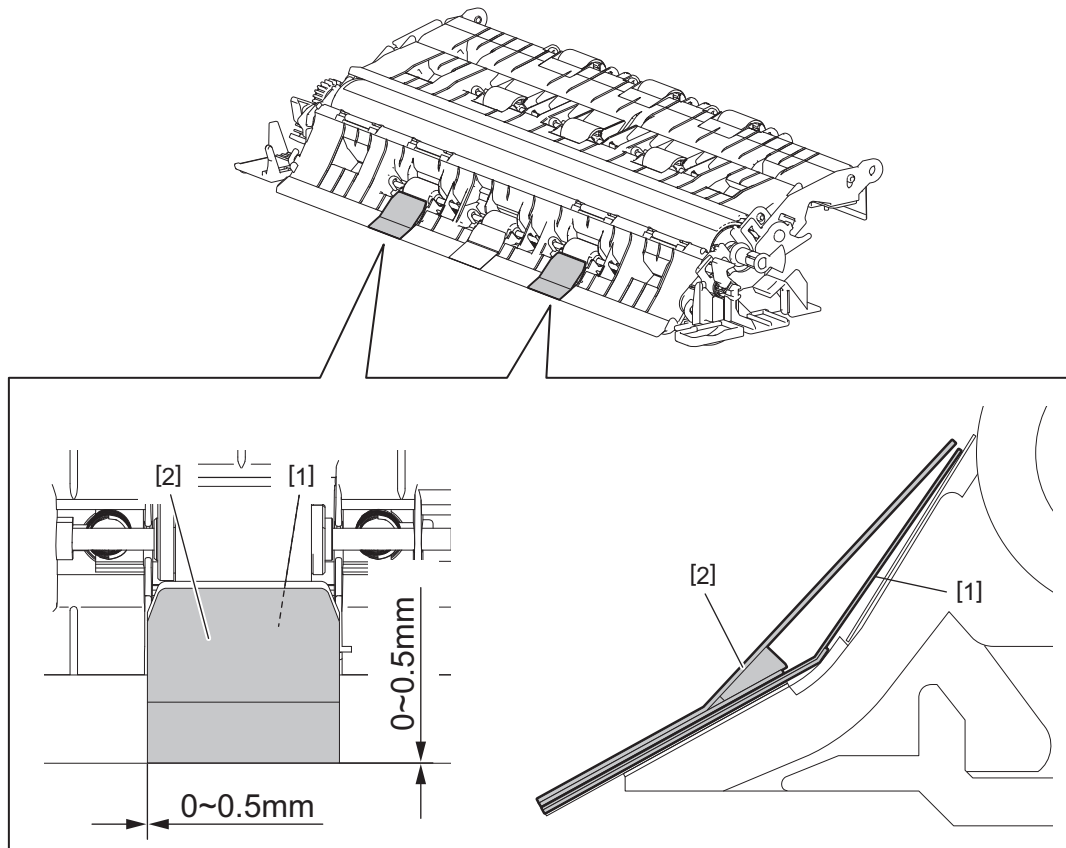

Fig. 4-119

- [1] Film
- [2] Film with a spacer

5. ADJUSTMENT

5.1 Position Adjustment

Perform this adjustment when the DSDF is not installed in the correct position.

Notes:

Check if the image adjustment for the MFP is performed properly before this adjustment of the DSDF.

(See the Service Manual of the applicable MFP.)

5.1.1 Checking

- (1) Open the DSDF and install 2 positioning pins.

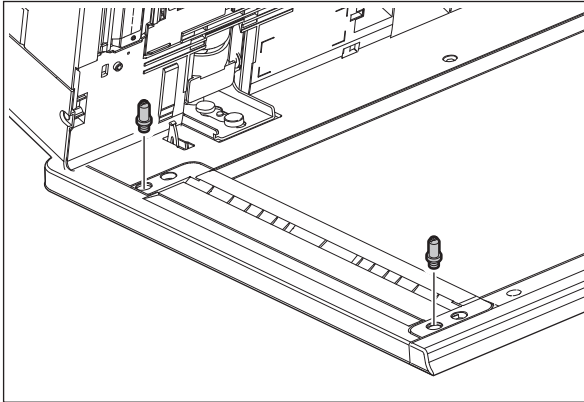

Fig.5-1

- (2) Remove the platen sheet.

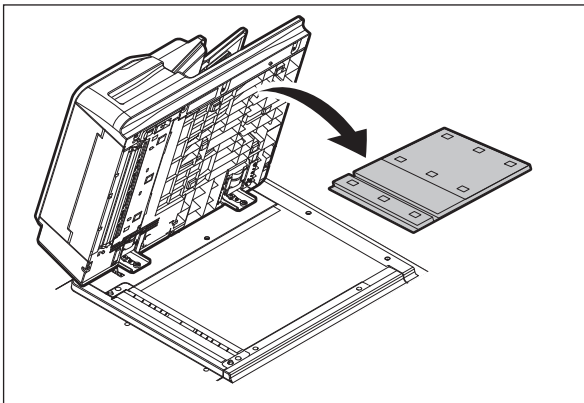

Fig.5-2

- (3) Close the DSDF. Then check if the positioning pins fit the holes on the DSDF.

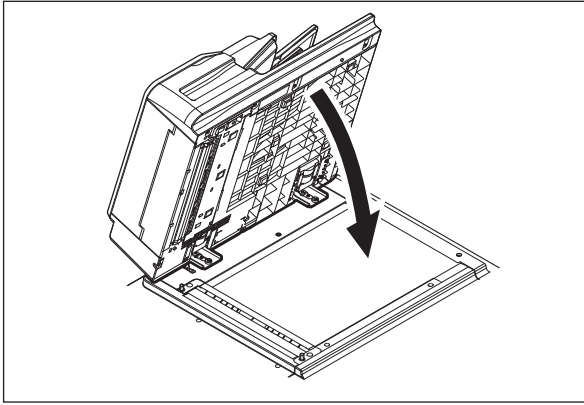

Fig.5-3

Notes:

If the positioning pins cannot be fitted into the holes on the DSDF properly, adjust the position of the DSDF before installing.

📖 P. 5-2 “5.1.2 Adjustment”

- (4) Place the platen sheet on the original glass and align it to the top left corner. Close the DSDF gently and open it to check if the platen sheet is attached properly.

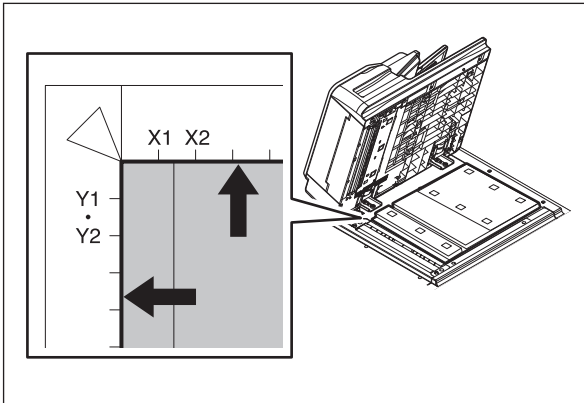

Fig.5-4

5.1.2 Adjustment

If the pins cannot be fitted into the holes, perform the adjustment according to the following procedure.

- (1) Remove the brackets on the hinges.

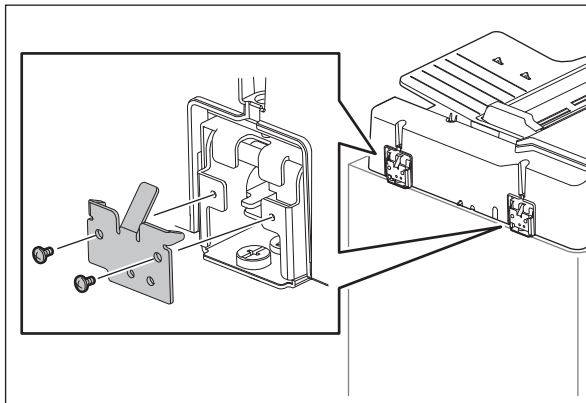

Fig.5-5

- (2) Loosen the fixing screws.

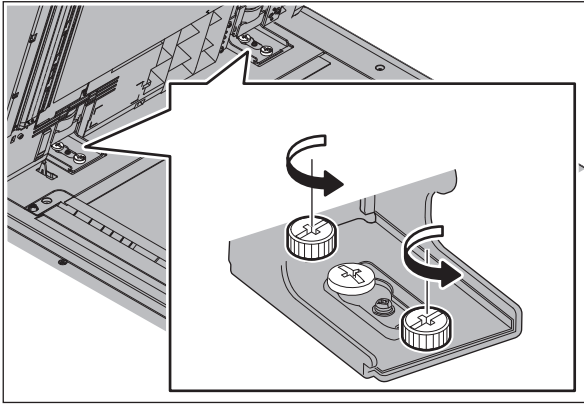

Fig.5-6

- (3) Position the pins with the holes on the DSDF by moving it so that the pins fit into the holes when the DSDF is closed.

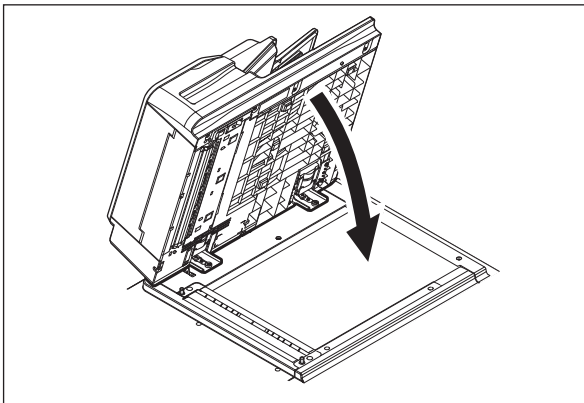

Fig.5-7

- (4) Tighten the fixing screws of the rear side.

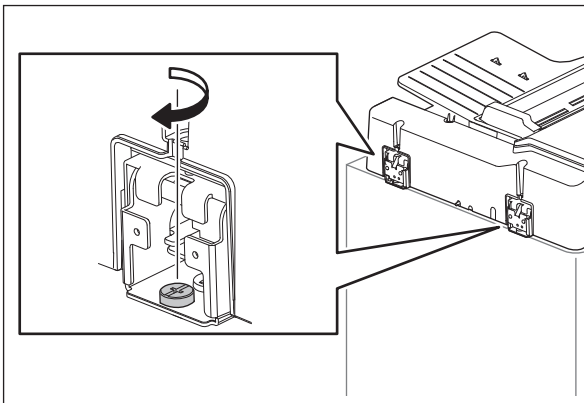

Fig.5-8

- (5) Tighten the fixing screws of the front side.

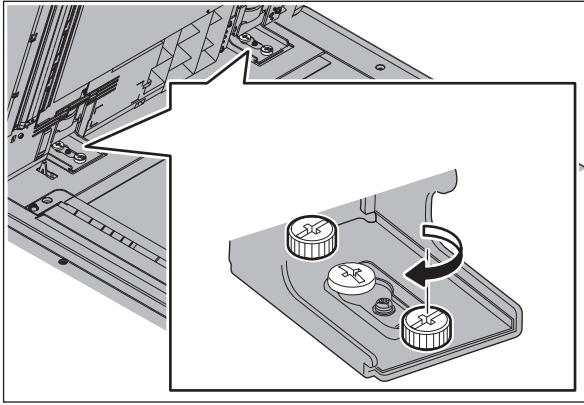

Fig.5-9

- (6) Install the brackets on the hinges.

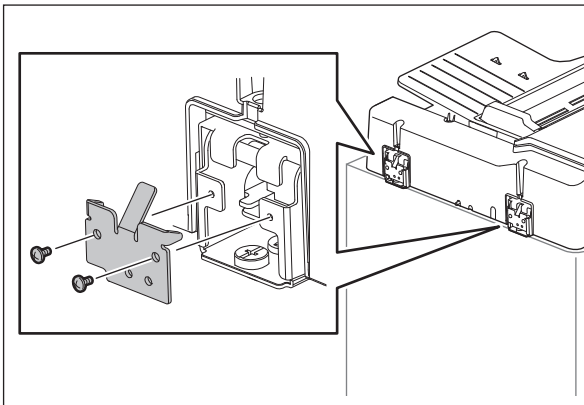

Fig.5-10

- (7) Place the platen sheet on the original glass and align it to the top left corner. Close the DSDF gently and open it to check if the platen sheet is attached properly.

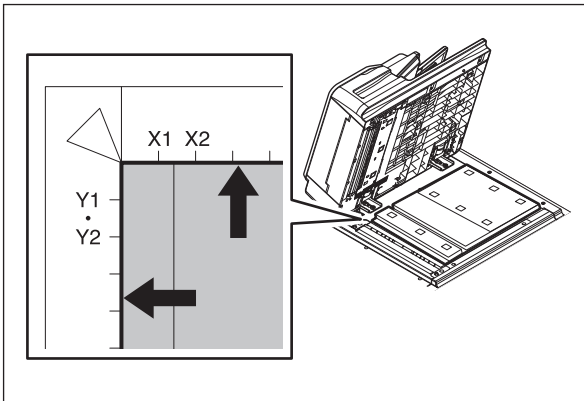

Fig.5-11

5.2 Height Adjustment

Notes:

Check if the image adjustment for the MFP is performed properly before this adjustment of the DSDF.

(See the Service Manual of the applicable MFP.)

5.2.1 Checking

- (1) Close the DSDF.
- (2) Turn on the exposure lamp.
 - Perform FS-03-267.
- (3) Visually check the gap between platen guide holder "A" and upper surface of the cover "B" from the left hand side of the MFP. If the value is not within the tolerance, perform the adjustment according to the following procedure.

[Tolerance of the gap]
Rear side: 0 to 0.5 mm
Front side: 0 mm

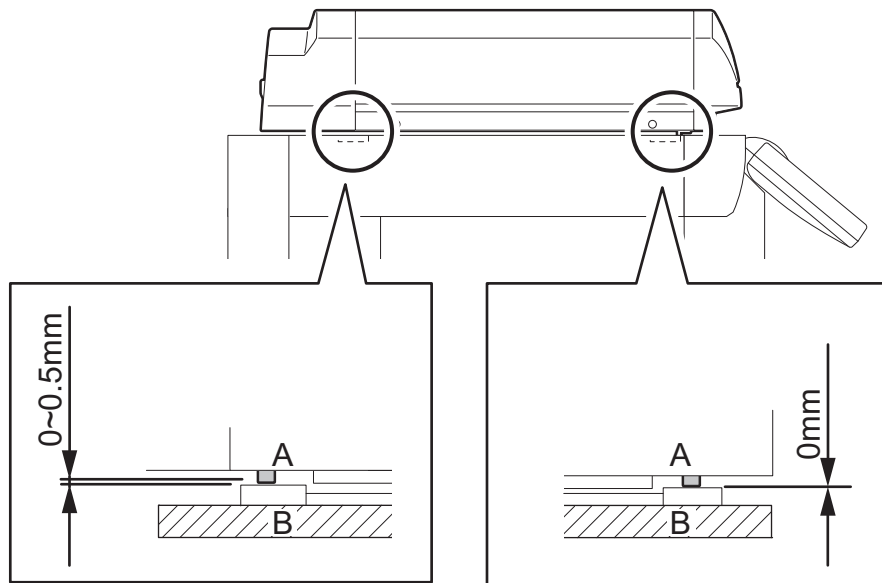

Fig.5-12

5.2.2 Adjustment

- (1) Close the DSDF.
- (2) Adjust it by turning the adjustment screws on the hinges.
 - Adjust the height on the rear side by means of the screw on the hinge on the original feed side of the DSDF.
Turn it clockwise: Heightened
Turn it counterclockwise: Lowered

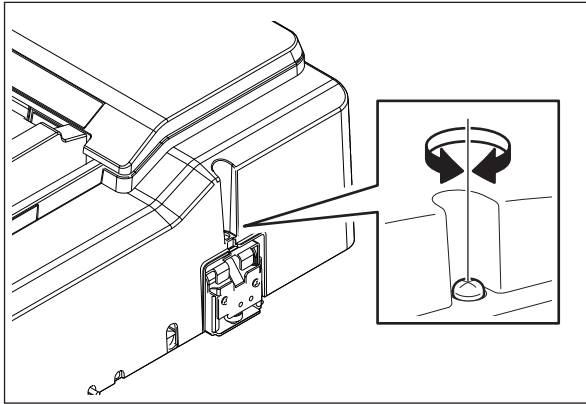

Fig.5-13

- Adjust the gap on the front side by means of the screw on the hinge on the original exit side of the DSDF.
Turn it clockwise: Lowered
Turn it counterclockwise: Heightened

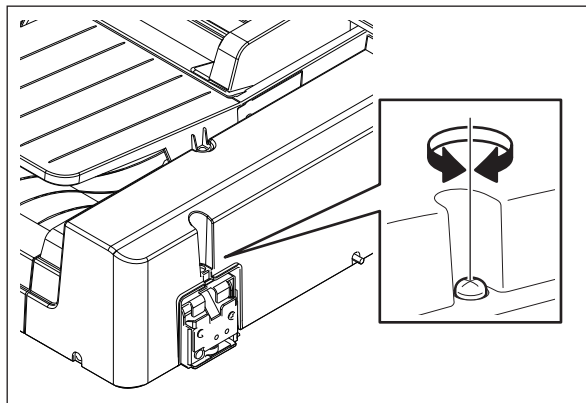

Fig.5-14

5.3 Skew adjustment

Notes:

- Check if the image adjustment for the MFP is performed properly before this adjustment of the DSDF. (See the Service Manual of the applicable MFP.)
- The DSDF position adjustment shall be adjusted properly.

5.3.1 Checking

Check the image using the chart (original) with vertical and horizontal lines in the following procedure.

[1] Simplex (front side) copying

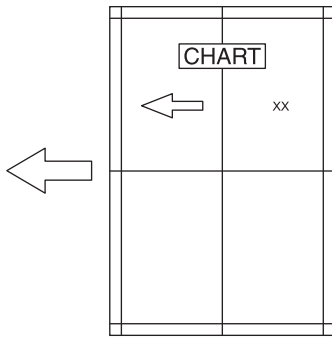

Fig.5-15

- (1) Place the chart provided as an original with its face up on the original tray of the DSDF, select [Sort mode] and [1 Sided > 1 Sided] and then press the [START] button.
- (2) Superimpose the chart on the copy and check the inclination of the copy image.

[2] Duplex (back side) copying

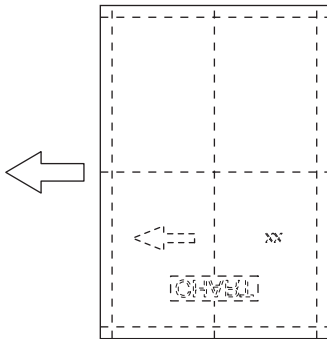

Fig.5-16

- (1) Place the chart provided as an original with its face down on the original tray of the DSDF, select [Sort mode] and [2 Sided > 2 Sided] and then press the [START] button.
- (2) Superimpose the chart on the copy and check the inclination of the copy image.

5.3.2 Adjustment

[1] Simplex (front side) copying

- (1) Change the fixing screws of the front side to the shoulder head screw (service parts).

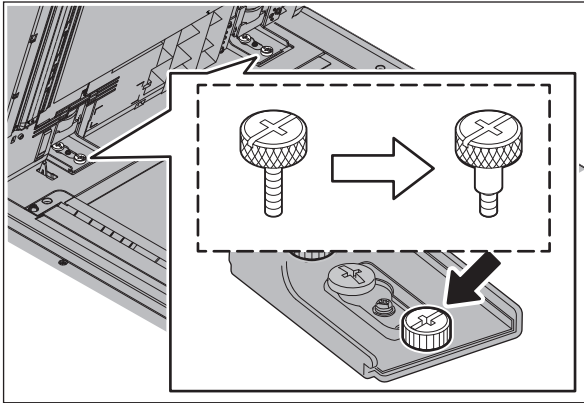

Fig.5-17

- (2) Turn the adjustment screw while checking the scale of the hinge.

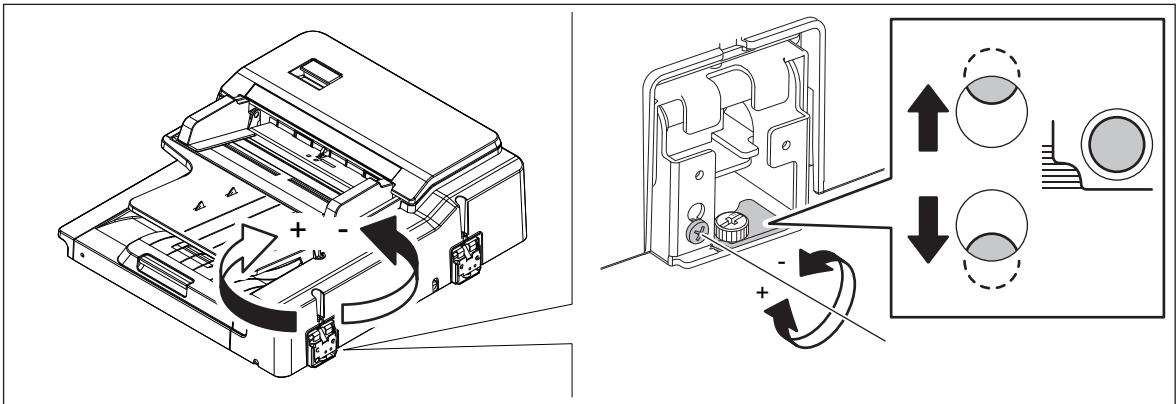

Fig.5-18

- (3) If the image skew is "C" as shown in the figure below, shift the aligning plate in the direction of "-", and if "D", shift it to "+".

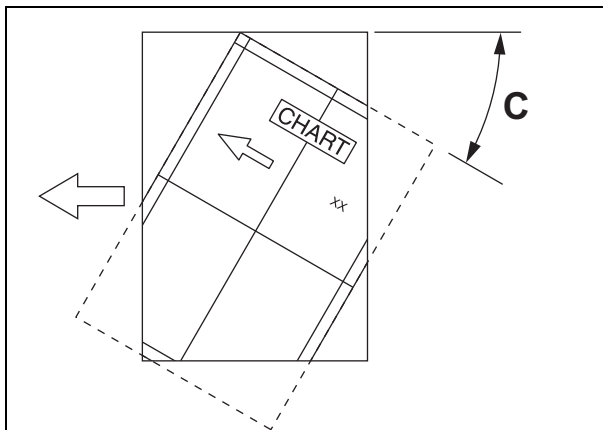

Fig.5-19

Shift the aligning plate in the direction of "-".

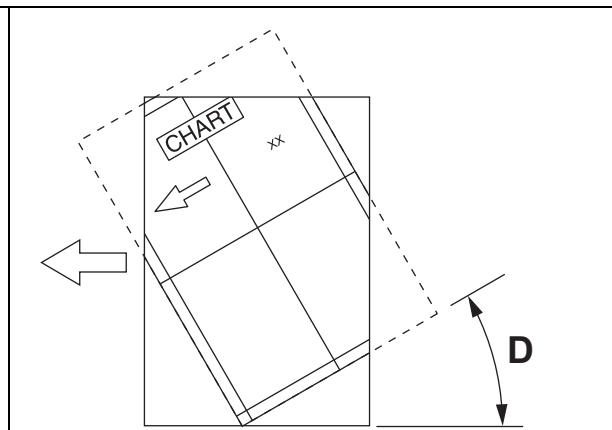

Fig.5-20

Shift the aligning plate in the direction of "+".

- (4) Check the skew of the copy image by using a chart.

[2] Duplex (back side) copying

- (1) Take off the DSDF front cover.
📖 P. 4-10 “4.2.2 DSDF front cover”
- (2) Clarify the attachment position of the plate by drawing a marking-off line.

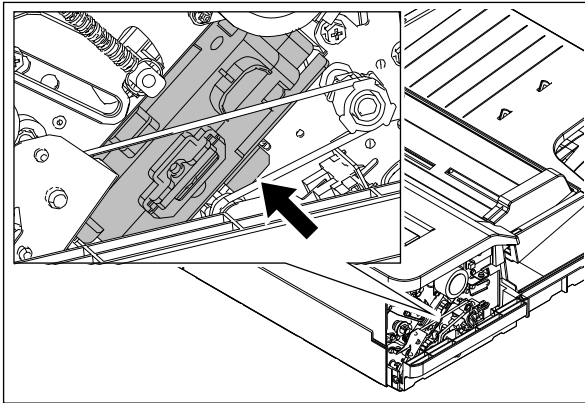

Fig.5-21

- (3) Loosen the screw.

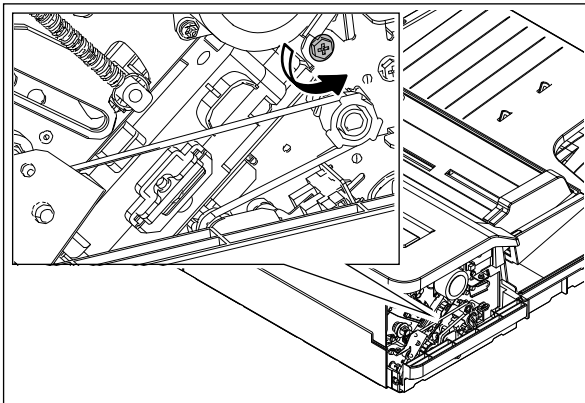
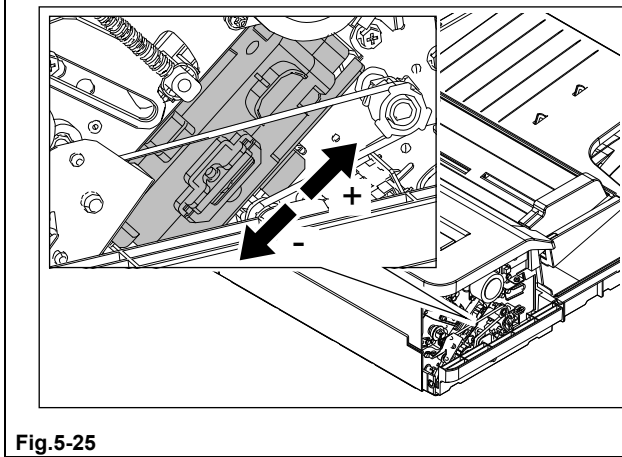
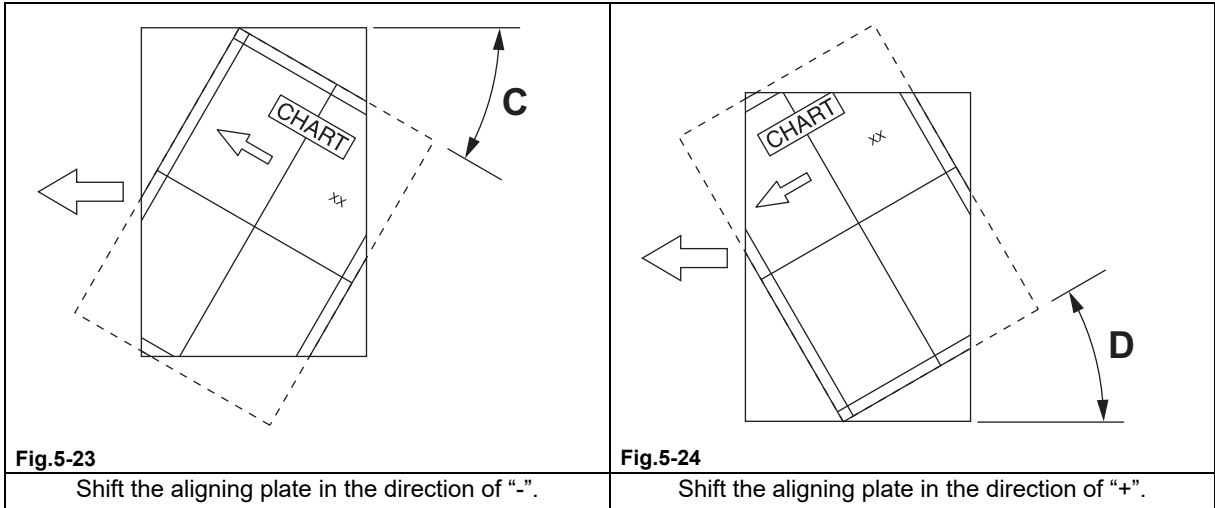

Fig.5-22

- (4) If the image skew is "C" as shown in the figure below, shift the aligning plate in the direction of "-", and if "D", shift it to "+".



- (5) Tighten the screw loosened in step (3). Check the skew of the copy image by using a chart.
 (6) Install the DSDF front cover.

5.4 Leading Edge Position Adjustment

Notes:

Check if the image adjustment for the MFP is performed properly before this adjustment of the DSDF.

(See the Service Manual of the applicable MFP.)

Also, the DSDF position and height shall be adjusted properly.

5.4.1 Checking

Check the image using the chart (original) with vertical and horizontal lines in the following procedure.

[A] Simplex (front side) copying

- (1) Place the chart provided as an original with its face up on the original tray of the DSDF, select [Sort mode] and [1 Sided > 1 Sided] and then press the [START] button.
- (2) Superimpose the chart on the copy and check the leading edge E of the chart and F of the copy.

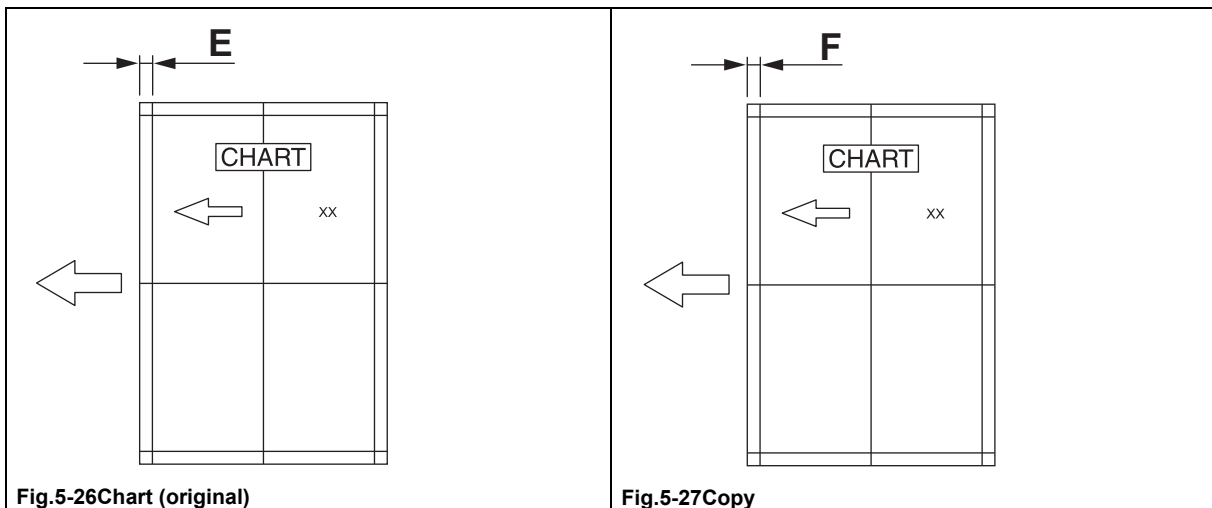

[B] Duplex (back side) copying

- (1) Place the chart provided as an original with its face down on the original tray of the DSDF, select [Sort mode] and [2 Sided > 2 Sided] and then press the [START] button.
- (2) Superimpose the chart on the copy and check the leading edge E of the chart and F of the copy.

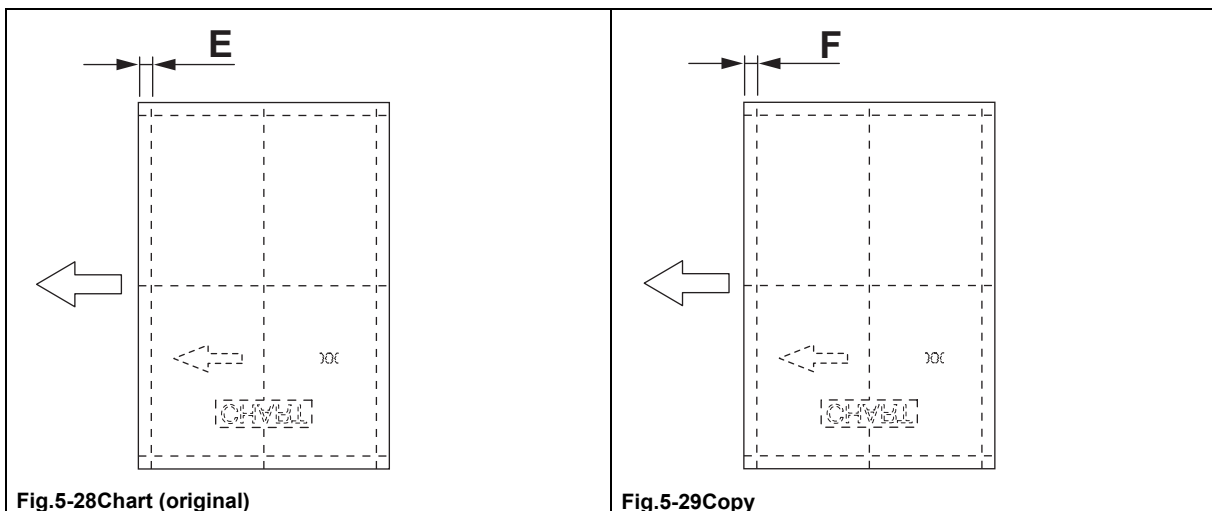

5.4.2 Adjustment

[A] Simplex (front side) copying

- (1) Perform FS-05-3044.
- (2) Enter the value.
 - If the leading edge (F) margin of the copy image is larger than the (E) margin of the chart, enter a value smaller than the current one.
 - If the leading edge (F) margin of the copy image is smaller than the (E) margin of the chart, enter a value larger than the current one.

Notes:

Changing one value shifts the copy image by 0.1 mm.

- (3) Press [OK].

[B] Duplex (back side) copying

- (1) Perform FS-05-3045.
- (2) Enter the value.
 - If the leading edge (F) margin of the copy image is larger than the (E) margin of the chart, enter a value smaller than the current one.
 - If the leading edge (F) margin of the copy image is smaller than the (E) margin of the chart, enter a value larger than the current one.

Notes:

Changing one value shifts the copy image by 0.1 mm.

- (3) Press [OK].

5.5 Horizontal Position Adjustment

Notes:

Check if the image adjustment for the MFP is performed properly before this adjustment of the DSDF.

(See the Service Manual of the applicable MFP.)

Also, the DSDF position and height shall be adjusted properly.

5.5.1 Front side

[A] Checking (front side)

Check the image using the chart (original) with a center line in the following procedure.

- (1) Place the chart provided as an original with its face up on the original tray of the DSDF.
- (2) Select the [Sort mode] and press the [START] button.
- (3) Fold the copy in half and check if the center line is misaligned.

[B] Adjustment (front side)

- (1) Perform FS-05-3043.
 - If the center line of the copy image is shifted to the front side of the MFP
Enter a value larger than the current one.

Notes:

Changing one value shifts the copy image by 0.0423 mm.

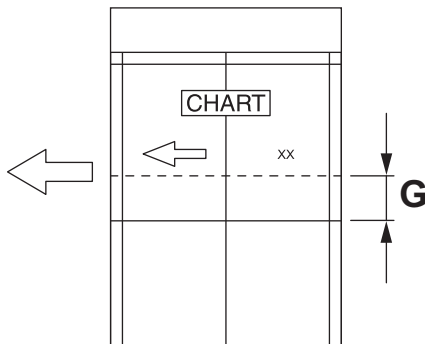

Fig.5-30

- If the center line of the copy image is shifted to the rear side of the MFP
Enter a value smaller than the current one.

Notes:

Changing one value shifts the copy image by 0.0423 mm.

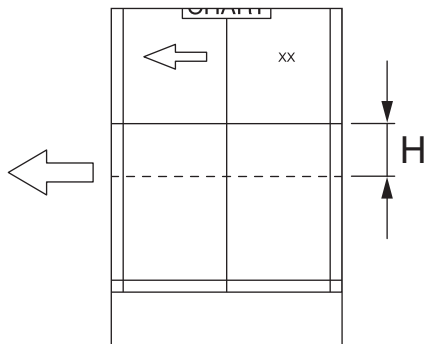

Fig.5-31

- (2) Press [OK].

5.5.2 Back side

[A] Checking (back side)

Check the image using the chart (original) with a center line in the following procedure.

- (1) Place the chart provided as an original with its face down on the original tray of the DSCF.

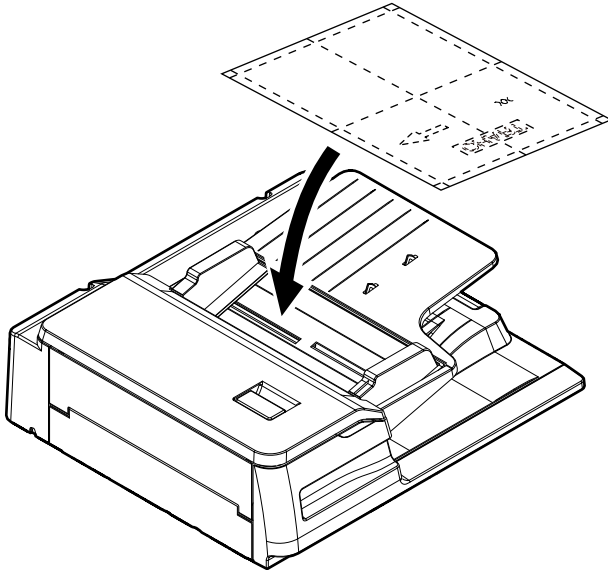

Fig.5-32

- (2) Select [2 Sided > 1 Sided] and press the [START] button.
- (3) Fold the copy in half and check if the center line is misaligned.

[B] Adjustment (back side)

- (1) Perform FS-05-3049.

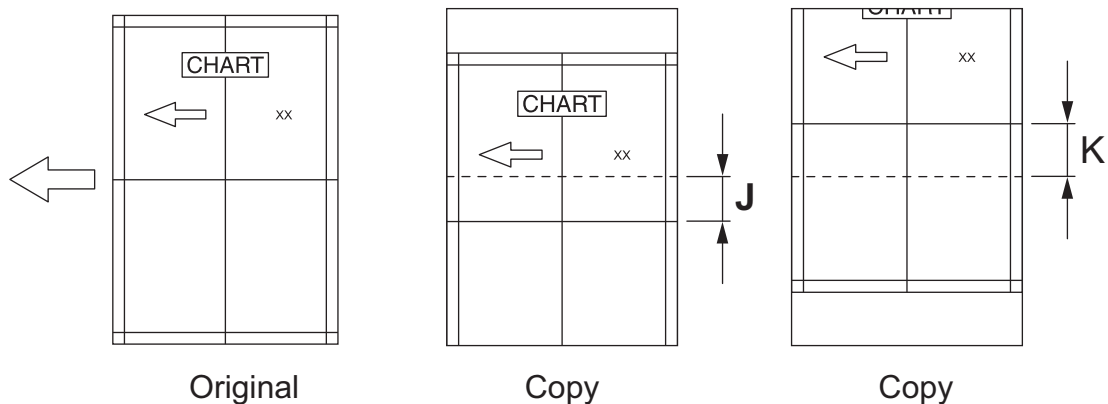

Fig.5-33

- If the center line of the copy image is shifted to the right side to the feeding direction: (J)
Enter a value larger than the current one.
- If the center line of the copy image is shifted to the left side to the feeding direction: (K)
Enter a value smaller than the current one.

Notes:

Changing one value shifts the copy image by 0.0423mm.

- (2) Press [OK].

5.6 Copy Ratio Adjustment

Notes:

Check if the image adjustment for the MFP is performed properly before this adjustment of the DSDF.

(See the Service Manual of the applicable MFP.)

Also, the DSDF position and height shall be adjusted properly.

5.6.1 Checking

Check the image using the chart (original) with vertical and horizontal lines in the following procedure.

- (1) Place the chart provided as an original with its face up on the original tray of the DSDF.
- (2) Select the [Sort mode] and press the [START] button.
- (3) Superimpose the chart on the copy and check the image dimension "l".

5.6.2 Adjustment

- (1) Perform FS-05-3042.
 - If the copy image dimension "l" is larger than the chart dimension, enter a value smaller than the current one.
 - If the copy image dimension "l" is smaller than the chart dimension, enter a value larger than the current one.

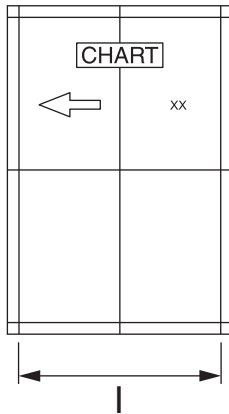

Fig.5-34

- (2) Press [OK].

5.7 DSDF Read-in Sensor-1 Adjustment

5.7.1 DSDF read-in sensor-1 automatic adjustment

Notes:

When the DSDF control PC board or the DSDF read-in sensor-1 is replaced, be sure to perform this adjustment.

- (1) Perform FS-05-3210.

Notes:

- Be sure to close all of the DSDF cover before the adjustment is performed.
- Check that there is no paper on the DSDF read-in sensor-1 so that the light is not shielded.

5.7.2 DSDF read-in sensor-1 manual adjustment

Notes:

When the DSDF read-in sensor-1 is replaced or re-installed, perform this manual adjustment.

- (1) Take off the DSDF left cover.
P. 4-12 “4.2.4 DSDF left cover”
- (2) Install the original jam access cover.
- (3) Close the original jam access cover and the DSDF.
- (4) Perform FS-05-3221.

Notes:

Do not open the original jam access cover and the DSDF until step (7) is finished. If you do so, the adjustment value will be reset. In this case, repeat the adjustment from step (3).

- (5) Loosen 1 prism adjustment screw.

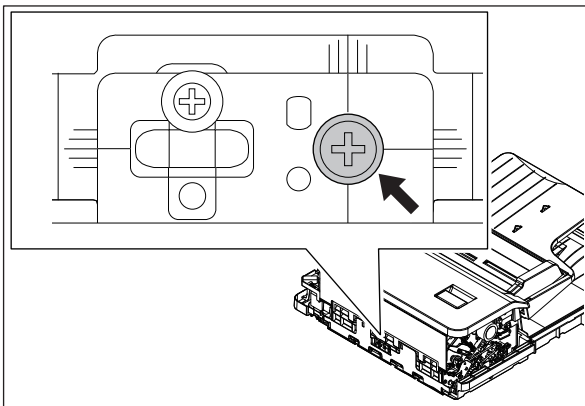

Fig.5-35

- (6) Slide the prism vertically. When the prism comes to the proper adjustment position, LED1 on the DSDF control PC board lights. At this position, tighten 1 prism adjustment screw.

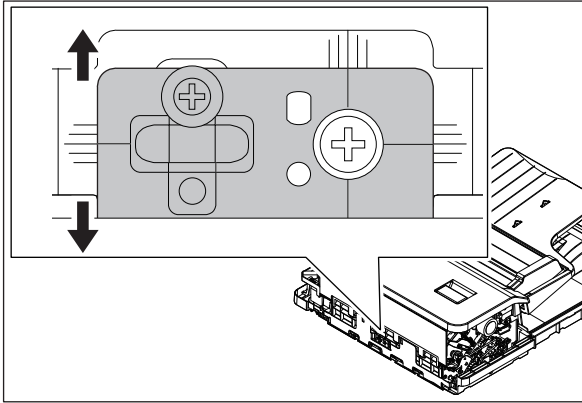

Fig.5-36

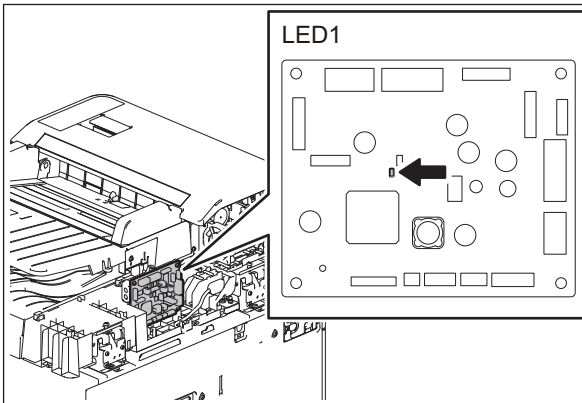

Fig.5-37

- (7) Perform FS-05-3210 (automatic adjustment).

Notes:

After the manual adjustment is performed, be sure to do the automatic one.

- (8) Turn the power OFF and install the cover.

5.8 Platen Sheet

If a shadow-like dark area appears on the edge of the image, reset the platen sheet.

- (1) Remove the platen sheet.

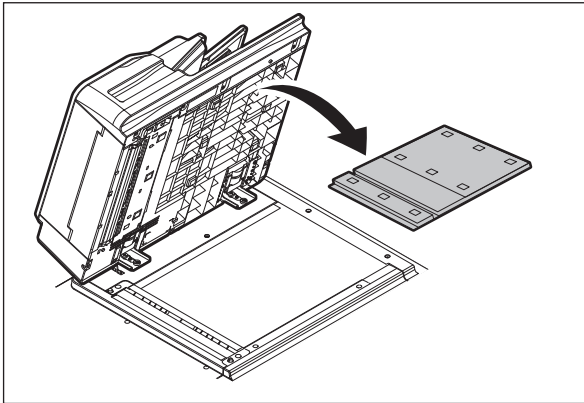

Fig.5-38

- (2) Place the platen sheet on the original glass and align it to the top left corner. Close the DSDF gently and open it to check if the platen sheet is attached properly.

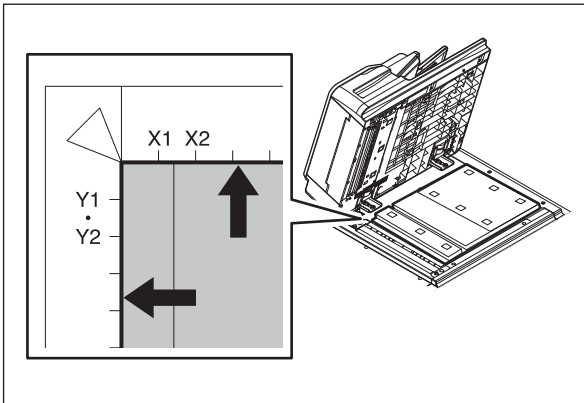

Fig.5-39

5.9 DSDF Separation Roller Pressure Force Adjustment

In cases, the life of the separation roller may be shortened or paper misfeeding (E712, E721) and multiple feeding (E724) may occur regardless of the operation frequency of the MFP. This comes from the weight or edge status of paper used and the amount of paper dust.

Generally, paper jams and multiple feeding often occur around the life end of the roller. However, if they often occur even though its life has not yet reached its replacement timing, or if the life end comes much earlier than the scheduled replacement timing, paper jams and multiple feeding can be suppressed by adjusting the pressure force of the separation roller.

In this method; however, when the roller life becomes longer, paper jams and multiple feeding may occur frequently and when they are suppressed, the roller life may become shorter. Therefore, perform this adjustment while checking the status carefully, and if necessary, give a sufficient explanation to the users. If necessary, give sufficient explanation to the users.

- (1) Take off the DSDF pickup unit.
📖 P. 4-1 “4.1.1 DSDF pickup unit”
- (2) Open the DSDF separation roller cover [1].

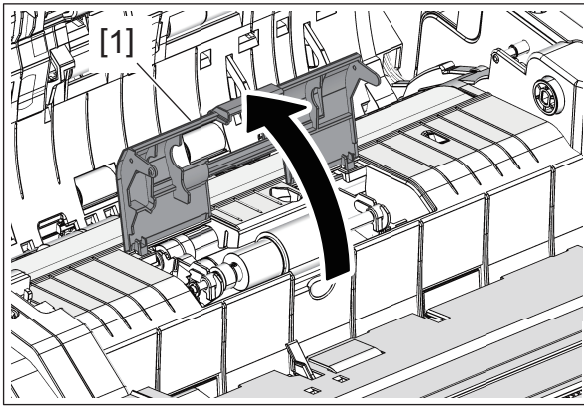

Fig.5-40

- (3) Turn the arm [2] to release the lock.

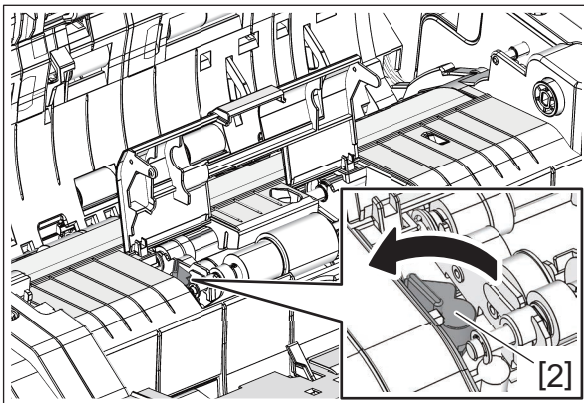

Fig.5-41

- (4) Lift up the DSDF separation roller unit [3].

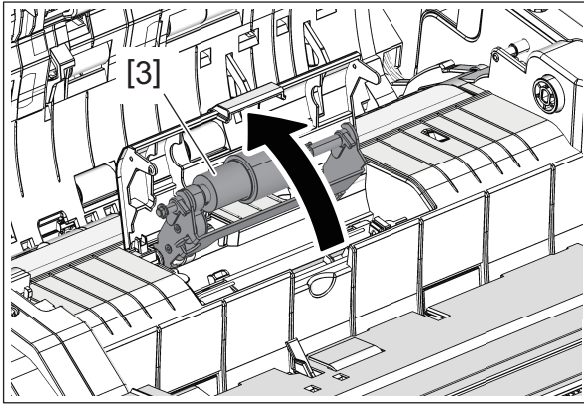

Fig.5-42

- (5) Move the adjustment plate [4] in the direction of F or R by 1 scale.
- Move to the direction F: Paper jams (E712, E721) will be suppressed. The roller life will become longer (but multiple feeding may occur frequently).
 - Move to the direction R: Multiple feeding will be suppressed (but the roller life may become shorter).

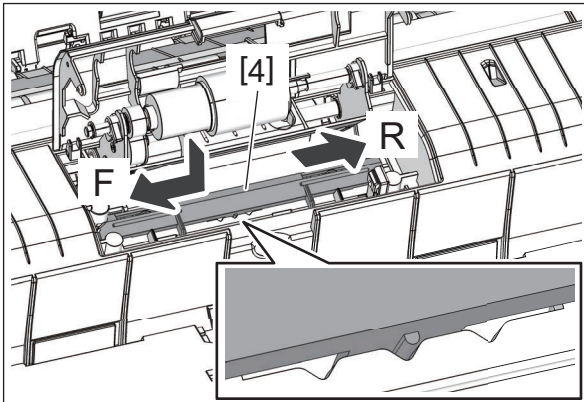

Fig.5-43



6. TROUBLESHOOTING

For details about the troubleshooting for the option, refer to “ERROR CODE AND TROUBLESHOOTING” in the Service Manual for the MFP.

6.1 Other Errors

1. Multiple originals are transported simultaneously

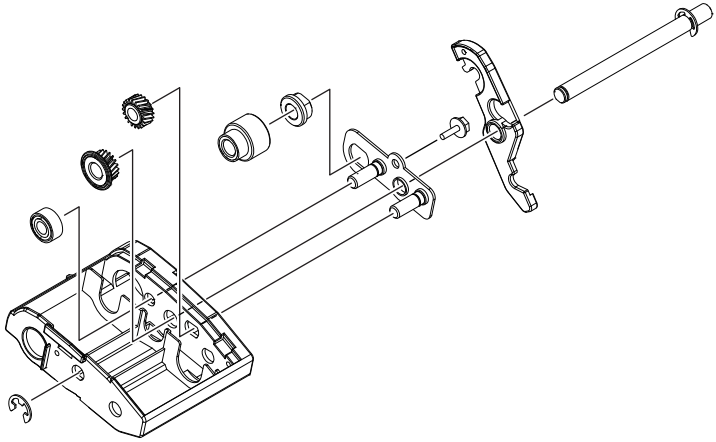
Check item	Measures
Original	Flatten and reload an original if it is curled abnormally or is folded.
	When an original beyond the specifications is copied or scanned, place it on the original glass.
DSDF separation roller	If the DSDF separation roller is dirty, clean it with alcohol.
	Replace the DSDF separation roller.

Check item	Measures
Metal shaft, Gears	<ul style="list-style-type: none"> • Take off the holder cover, DSDF original feed roller and DSDF pickup roller. • Remove the stopper, bracket, bushing and 4 gears.  <p>Fig.6-1</p> <ul style="list-style-type: none"> • Clean the holes in the gears and the metal shaft to remove paper dust.  <p>Fig.6-2</p> <p>Remarks: Disassembly procedure</p> <ol style="list-style-type: none"> (1) Remove the paper guide. (2) Take off the holder cover. (3) Release the stopper. Pull out the shaft and take off the pickup roller. (4) Release the stopper. Pull out the shaft and remove the bushing and one-way clutch. Take off the original feed roller. (5) Remove the screw and take off the bracket. (6) Remove 3 gears. <ul style="list-style-type: none"> • After they are cleaned, apply white grease (Molykote EM-30L) to the gear holes (indicated in the figure). <p>Notes: Pay attention not to apply grease to the tooth surface of the gears.</p>  <p>Fig.6-3</p>

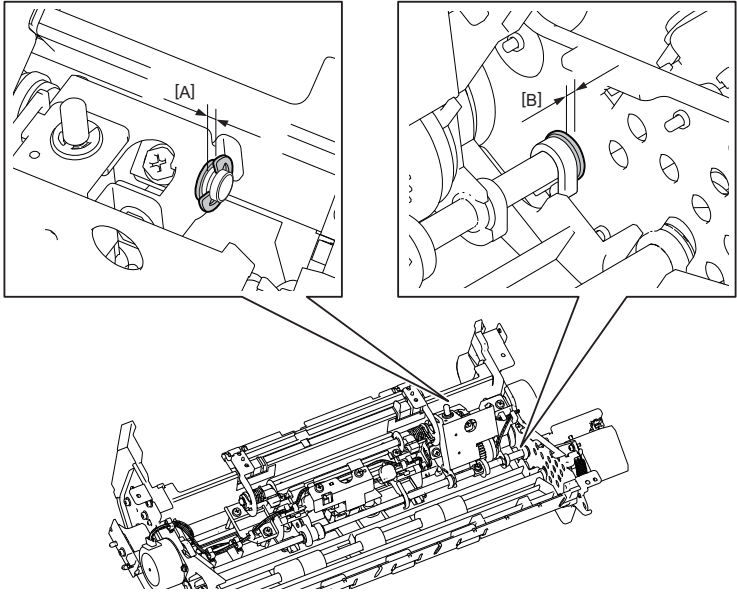
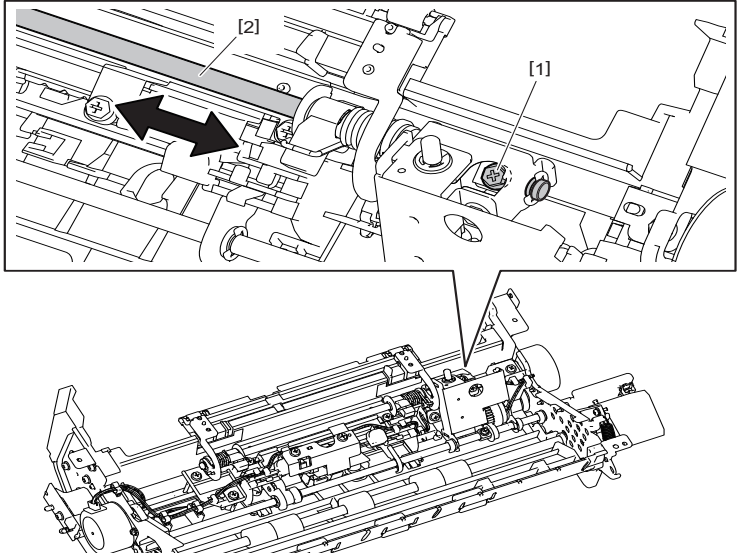
Check item	Measures
<p>Dimension of each shaft of the intermediate transport guide</p>	<p>Take off the intermediate transport guide to check the following dimensions.</p> <ul style="list-style-type: none"> • Elevator shaft: Dimension A between the E-ring and the bushing is 1 mm or more. • DSDF separation roller drive shaft: Dimension B between the bushing and the frame is 0.3 mm or more.  <p>Fig.6-4</p> <p>If the dimensions are less than the above ones, perform the adjustment according to the following procedure.</p> <ul style="list-style-type: none"> • Arrange the dimension A between the E-ring and the bushing on the elevator shaft so that it becomes 1 mm or more. <ol style="list-style-type: none"> (1) Loosen the screw [1] and move the elevator shaft [2]. (2) Tighten the screw [1].  <p>Fig.6-5</p>

Check item	Measures
Dimension of each shaft of the intermediate transport guide	<ul style="list-style-type: none"> Arrange the dimension B between the bushing and the frame on the DSDF separation roller drive shaft so that it becomes 0.3 mm or more. (1) Loosen the screw [3] and move the DSDF separation drive shaft [4]. (2) Tighten the screw [3]. 

Fig.6-6

2. Original is not transported to registration roller

Check item	Measures
Original	<p>Flatten and reload an original if it is curled abnormally or is folded.</p> <p>When an original beyond the specifications is copied or scanned, place it on the original glass.</p>
DSDF pickup roller	<p>If the DSDF pickup roller is dirty, clean it with alcohol.</p> <p>Replace the DSDF pickup roller.</p>
DSDF original feed roller	<p>If the DSDF original feed roller is dirty, clean it with alcohol.</p> <p>Replace the DSDF original feed roller.</p>
DSDF control PC board	<p>Check if the connector (CN79) is connected properly.</p> <p>Check if there is any abnormality in the DSDF control PC board. If there is any abnormality, replace it.</p>
Motor	<p>Check if the harness (purple) for the DSDF original feed motor and the harness (gray) for the DSDF registration motor are connected in reverse. If so, connect the harnesses correctly.</p>

3. Leading edge of original is skewed

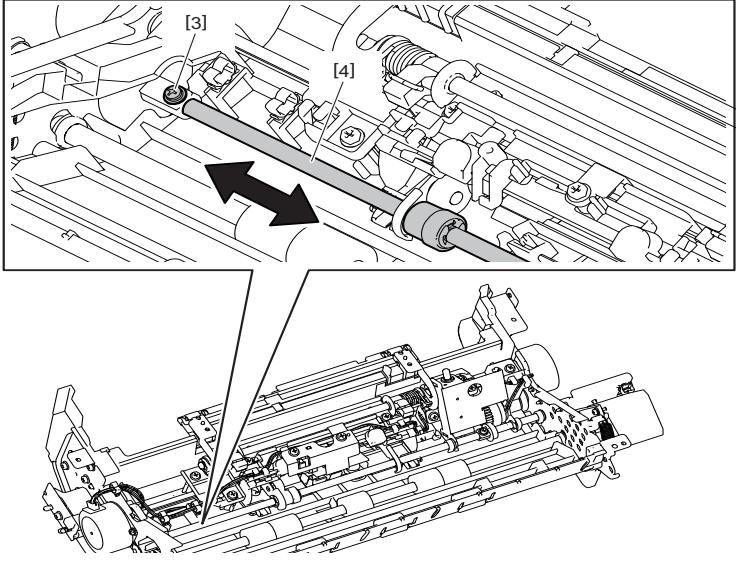
Check item	Measures
Transport roller	<p>If the DSDF transport roller is dirty, clean it with alcohol.</p>
Left hinge	<p>Check that the protrusions at the front and rear sides of the bottom face of the DSDF contact the glass surface.</p> <p>If not, adjust the height of the left hinge so that the protrusions at the front and rear sides contact the glass surface.</p>
Right hinge	<p>Check that the position of the right hinge is aligned properly. If not, adjust it.</p>
Pinch roller	<p>Check if the springs of the pinch rollers facing each transport roller have come off. Check the installation of the pinch roller. If it is not installed properly, correct this.</p>
Transport guide	<p>Check the transport guide. If it has been stained or there is any foreign matter, clean it.</p> <p>Check the film attached to the transport guide. If it is deformed, damaged or has peeled off, replace it</p>

4. Edges of original and copied image are not aligned

Check item	Measures
Side guides of the original tray	<p>Set the side guides of the original tray by aligning them with the original width.</p>
Original scanning section	<p>Adjust the original scanning section of the MFP.</p>

5. Black streaks appear on copied image

Check item		Measures
Front side	ADF original glass of the MFP	Wipe the ADF original glass of the MFP with a dry cloth or clean it with a well-squeezed cloth.
	Original scanning section	Check if there is no abnormality in the original scanning section of the MFP.
Back side	DSDF-CCD module	Wipe the slit glass of the DSDF-CCD module with a dry cloth or clean it with a well-squeezed cloth.
		Check if there is no abnormality in the DSDF-CCD module.

6. "Place Doc. Feeder in the down position" is displayed.

When "Place Doc. Feeder in the down position" is displayed even if the DSDF or its cover is closed appropriately, take the following measures.

Check item	Measures
DSDF lower cover	Check if the DSDF lower cover is closed appropriately.
DSDF original exit motor	Check if the DSDF original exit motor is rotating properly. If not, check the following items. <ul style="list-style-type: none"> - Check if the connector of the DSDF original exit motor is disconnected or the harnesses are open circuited. - Check if the connector of the DSDF control PC board is disconnected or the harnesses are open circuited. - Replace the DSDF original exit motor.
DSDF shading sheet	Check if the DSDF shading sheet is working. Check the timing belt driving the DSDF shading sheet. If the belt has come off or its tension is loosened, correct this.
DSDF shading sheet HP sensor	<ul style="list-style-type: none"> - Check if the DSDF shading sheet HP sensor is working properly. (Input check: FS-03-[F2]ON/[6]/[A]) - Check if the connector of the DSDF shading sheet HP sensor is disconnected or the harnesses are open circuited. - Replace the DSDF shading sheet HP sensor.
DSDF control PC board	<ul style="list-style-type: none"> - Check if the connector of the DSDF control PC board is disconnected or the harnesses are open circuited. - Replace the DSDF control PC board.
DSDF lower cover opening/closing detection sensor	<ul style="list-style-type: none"> - Check if the connectors (J980, J953 and CN75) on the DSDF control PC board are disconnected from the DSDF lower cover opening/closing detection sensor or the harnesses are open circuited. Correct if any. - Check if the DSDF lower cover opening/closing detection sensor is working properly. (Input check: FS-03-[F2]ON/[6]/[C]) - Replace the DSDF lower cover opening/closing detection sensor.
DSDF lower cover interlock switch	<ul style="list-style-type: none"> - Check if the DSDF lower cover interlock switch is working properly. - Replace the DSDF lower cover interlock switch.
DSDF upper cover opening/closing detection sensor	<ul style="list-style-type: none"> - Check if the connectors (J981, J954 and CN75) on the DSDF control PC board are disconnected from the DSDF upper cover opening/closing detection sensor or the harnesses are open circuited. Correct if any. - Check if the DSDF upper cover opening/closing detection sensor is working properly. (Input check: FS-03-[F2]ON/[7]/[C]) - Replace the DSDF upper cover opening/closing detection sensor.
DSDF upper cover interlock switch	<ul style="list-style-type: none"> - Check if the DSDF upper cover interlock switch is working properly. - Replace the DSDF upper cover interlock switch.
Platen sensor-1	<ul style="list-style-type: none"> - Check that the platen sensor-1 works properly. The platen sensor-1 works properly if the exposure lamp is lit when the DSDF is opened by 25 degrees. <p>Check the connector. If it is not connected properly, reconnect it.</p> <ul style="list-style-type: none"> - Replace the platen sensor-1. <p>(See the Service Manual of the applicable MFP.)</p>
Platen sensor-2	<ul style="list-style-type: none"> - Check that the platen sensor-2 works properly. (Input check: FS-03-[F2]ON/[5]/[G]) <p>Check the connector. If it is not connected properly, reconnect it.</p> <ul style="list-style-type: none"> - Replace the platen sensor-2. <p>(See the Service Manual of the applicable MFP.)</p>

Parts to be replaced	Remarks
DSDF original exit motor	
DSDF shading sheet HP sensor	
DSDF control PC board	
DSDF lower cover opening/closing detection sensor	
DSDF lower cover interlock switch	
DSDF upper cover opening/closing detection sensor	
DSDF upper cover interlock switch	
Platen sensor-1	
Platen sensor-2	

7. Image distortion (dogleg image)

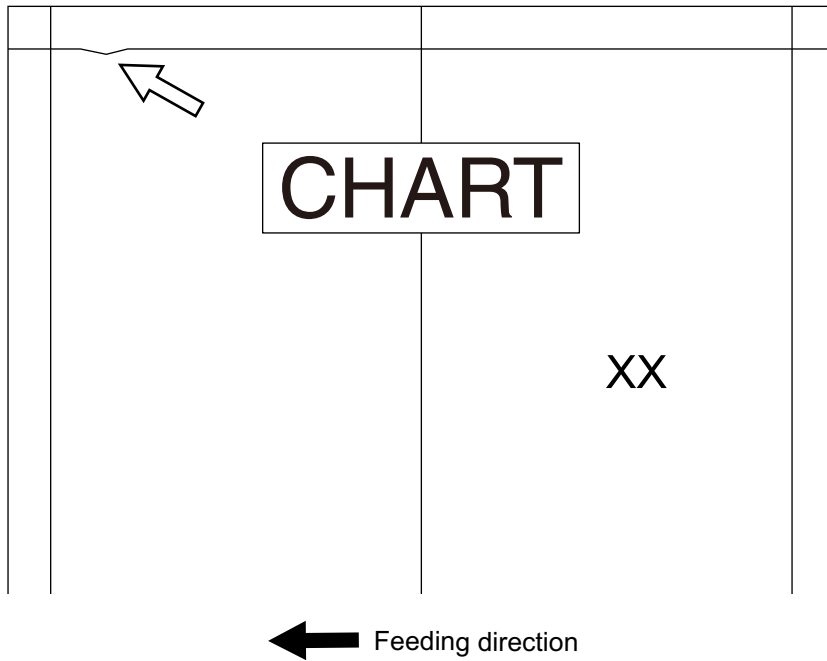

Fig.6-7

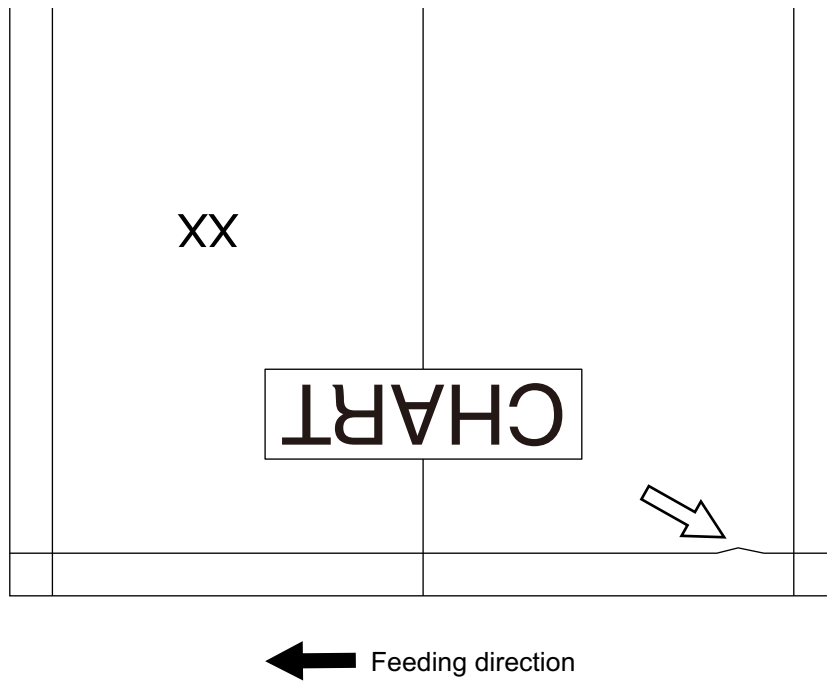
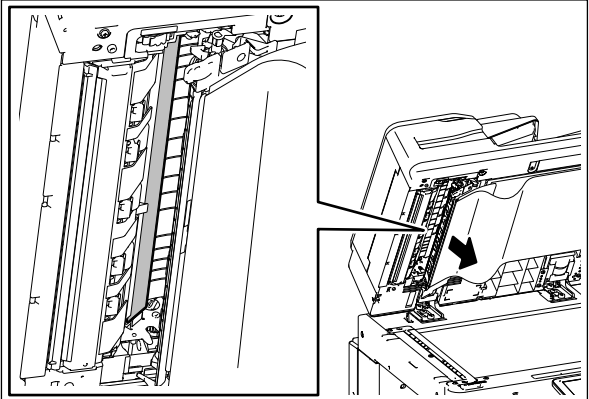

Fig.6-8

The image distortion (dogleg image) shown upper will occur on the leading or trailing edge at the back side of the copied or scanned paper while the DSDF is used.

Cause/Section	Step	Check item	Measures
DSDF	1	Position adjustment, Height adjustment	Check the installation condition of the DSDF and confirm that there are no abnormalities in the adjustment for its position and height. ☞ P. 5-1 "5.1 Position Adjustment" ☞ P. 5-5 "5.2 Height Adjustment"
	2	Skew adjustment	Perform the adjustment of image tilting at the back side. ☞ P. 5-7 "5.3 Skew adjustment" Remarks: The phenomenon tends to be reduced if the CCD module is moved in the "+" direction. Perform the adjustment of image tilting at the front side corresponding to the tilted amount of the back side. Notes: <ul style="list-style-type: none"> • When this adjustment is performed, an entire image may be tilted. • Even if this adjustment is performed, a dogleg image will not be resolved completely.

8. White streaks appear on the back side copied image

Check item	Measures
Slit glass of the DSDF-CCD module	Wipe the slit glass of the DSDF-CCD module with a dry cloth or clean it with a well-squeezed cloth. 

Check item	Measures
DSDF shading sheet	<ol style="list-style-type: none"> 1. Perform FS-03-274 in order to move the DSDF shading sheet to its cleaning position. 2. Check if there are any stains on the DSDF shading sheet. If there is any foreign matter or if dust has adhered, wipe it off with a dry cloth. <div data-bbox="550 257 1137 659" style="text-align: center;"> </div> <p data-bbox="539 668 624 695">Fig.6-10</p> <ol style="list-style-type: none"> 3. If stains cannot be removed completely, replace the DSDF shading sheet.
DSDF-CCD module	Check if there is no abnormality in the DSDF-CCD module.

7. MAINTENANCE

7.1 Maintenance and Inspection Points

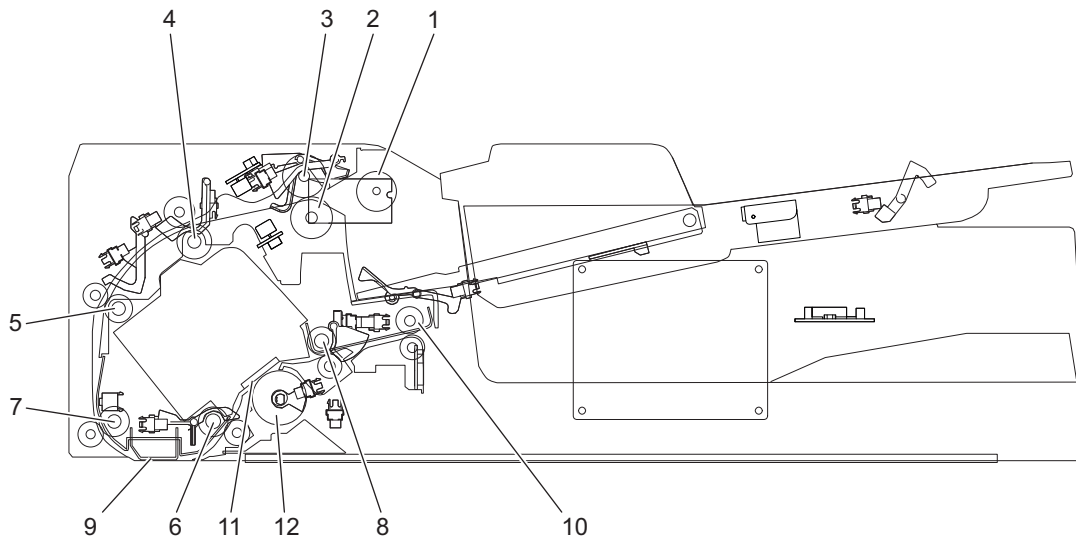

Fig. 7-1

Symbols used in the checklist

Cleaning	Lubrication/Coating	Replacement	Operation check
A: Clean with alcohol B: Clean with a soft pad, cloth or vacuum cleaner	W: White grease (Molykote EM-30L)	Value: Replacement cycle (x 1,000) R1: Replacement R3: Replace if deformed or damaged	O: After cleaning or replacement, confirm there is no problem.

Preventive Maintenance Checklist

Items to check	Cleaning *1	Lubrication/Coating *1	Replacement (X 1,000)	Operation check	Parts list (P-I)	Remarks
1 DSDF pickup roller	A		R1 120		1-18	
2 DSDF separation roller	A		R1 120		5-21	
3 DSDF original feed roller	A		R1 120		1-14	
4 DSDF registration roller	A				7-14	
5 Pre-read roller-1	A				7-13	
6 Pre-read roller-2	A				7-21	
7 Post-read roller-1	A				14-12	
8 Post-read roller-2	A				11-15	
9 Reading guide	A				15-3	
10 DSDF original exit roller	A				11-12	
11 DSDF-CCD original glass	B				5-22	
12 DSDF shading sheet	B				12-14	

*1 Perform cleaning/lubrication for the DSDF at the same interval as for the main MFP to which the DSDF is connected.

Remarks:

The column "Parts List (P-I)" shows the page and item number in the parts list.

7.2 Maintenance Part List

The parts used for the maintenance of this DSDF is as follow.

No.	Name	Purpose	P-I
1	Stopper jig	Use this to press the DSDF to prevent it from becoming open.	-

7.2.1 How to attach the stopper jig

- (1) Take off the DSDF front cover.
📖 P. 4-10 "4.2.2 DSDF front cover"
- (2) Take off the front cover of the scanner section in the MFP.
- (3) Attach the stopper jig.

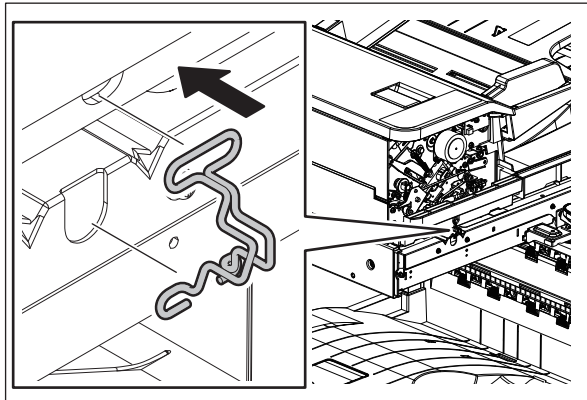

Fig. 7-2

Remarks:

1. Insert the upper side of the stopper jig into the hole of the DSDF.

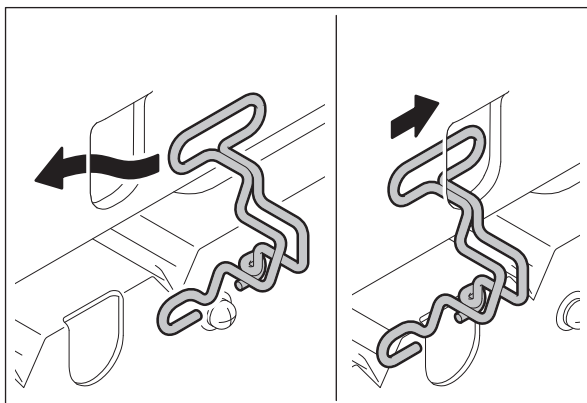

Fig. 7-3

2. Hold the stopper jig and insert its lower side into the hole on the frame of the MFP.

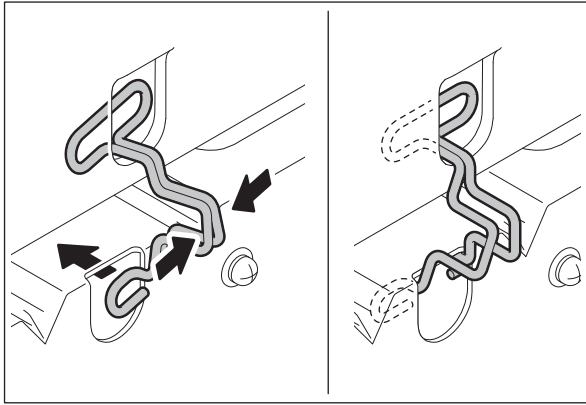

Fig. 7-4

7.3 Firmware Updating

For updating firmware, refer to “FIRMWARE UPDATING” in the Service Manual for the MFP.

8. Harness Diagram

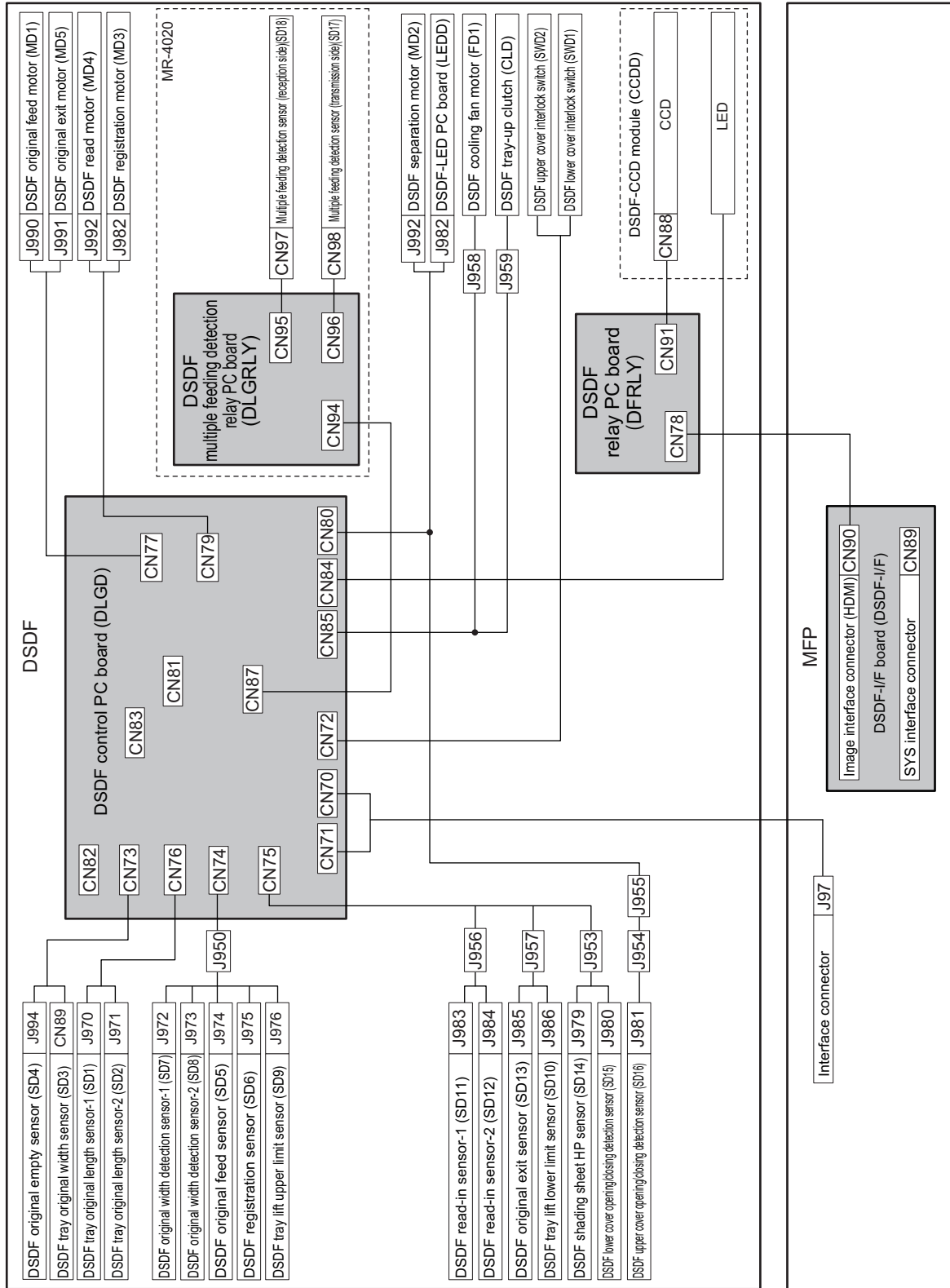

Fig.8-1

REVISION RECORD

Ver00a

Ver00a <2023.07.05>	
Page	Contents
6-4, 6-5	Added content to items 2., 3., and 6.

Ver00

Ver00 <2021.12.27>	
Page	Contents
	Initial release

TOSHIBA

Toshiba Tec Corporation

1-11-1, OSAKI, SHINAGAWA-KU, TOKYO, 141-8562, JAPAN