

TOSHIBA

SERVICE MANUAL

REVERSING AUTOMATIC DOCUMENT FEEDER

MR-3033

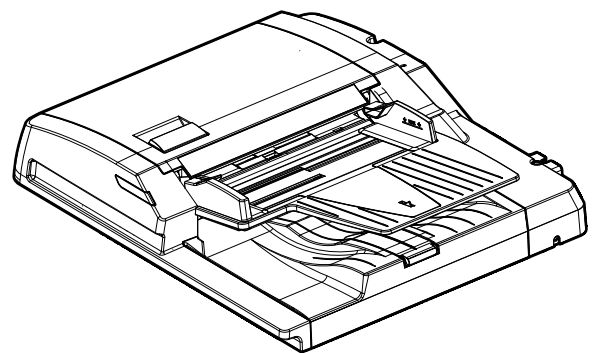

Model: MR-3033
Publish Date: December, 2021
File No. SME21001500
R210221X1900-TTEC
Ver00 F1 2022-03

Trademarks

- MOLYKOTE® is a trademark of DDP SPECIALTY ELECTRONIC MATERIALS US, INC..
- The company and product names described in this manual are trademarks or registered trademarks of their respective companies.

© 2021, 2022 Toshiba Tec Corporation All rights reserved

Under the copyright laws, this manual cannot be reproduced in any form without the prior written permission of Toshiba Tec Corporation.

General Precautions for Installation, Servicing and Maintenance for this Option

The installation and service shall be done by a qualified service technician.

1. When installing this option to the MFP, be sure to follow the instructions described in the "Unpacking/Set-Up Procedure for the Equipment" booklet which comes with this option.
2. This option shall be installed by an authorized or qualified person.
3. Before starting installation, servicing or maintenance work, be sure unplug the power cable of the MFP first.
4. The MFP with this option connected shall be installed near the socket outlet and shall be easily accessible.
5. Be sure to fix and plug in the power cable securely after the installation so that no one trips over it.
6. Unplug the power cable and clean the area around the prongs of the plug and socket outlet once a year or more. A fire may occur when dust lies on this area.
7. This option shall be grounded to the specified positions on the MFP frame.
8. When servicing or maintaining the MFP with this option connected, be careful about the rotating or operating sections such as gears, pulleys, sprockets, cams, belts, etc.
9. When the parts of this option are disassembled, reassembly is the reverse of disassembly unless otherwise noted in this manual or other related documents. Be careful not to install small parts such as screws, washers, pins, E-rings, star washers, harnesses in the wrong places.
10. Basically, the MFP with this option connected should not be operated with any parts removed or disassembled.
11. When servicing the MFP with this option connected while the power is turned ON, be sure not to touch live sections and rotating/operating sections.
12. Delicate parts for preventing safety hazard problems (such as fuses, thermofuses, door switches, sensors, etc. if any) should be handled, installed and adjusted correctly.
13. Tools and instruments
 - Use designated jigs and tools.
 - Use recommended measuring instruments or equivalents.
14. During servicing or maintenance work, be sure to check the nameplate and other cautionary labels (if any) to see if they are clean and firmly stuck. If not, take appropriate actions.
15. The ICs on the PC boards tend to be damaged by static electricity. Therefore, the PC boards must be stored in an anti-electrostatic bag and handled carefully using a wristband. Before using the antistatic wrist strap, unplug the power cable of the MFP and make sure that there are no charged objects which are not insulated in the vicinity.
16. Regarding the recovery and disposal of the MFP with this option connected, supplies, packing materials, follow the relevant local regulations or rules.
17. Return the MFP with this option connected to the original state and check the operation when the service is finished.

18. Check the procedures and perform them as described in the Service Manual.

19. Make sure you do not lose your balance.

20. Avoid exposure to your skin and wear protective gloves as needed.

21. Do not leave plastic bags where children can get at them. This may cause an accident such as suffocation if a child puts his/her head into a bag. Plastic bags of options or service parts must be brought back.

CONTENTS

1. SPECIFICATIONS	1-1
2. OVERVIEW	2-1
2.1 Main Components	2-1
2.2 Sectional View	2-2
2.3 Electric Parts Layout	2-3
2.4 Symbols and Functions of Various Components	2-5
2.5 Signal Block Diagram	2-6
2.6 Interface Signals	2-7
3. OPERATION DESCRIPTION	3-1
3.1 Driving Section	3-1
3.1.1 Overview	3-1
3.1.2 RADF original feed motor driving section	3-2
3.1.3 RADF read motor driving section	3-3
3.1.4 RADF original exit/reverse motor driving section	3-4
3.2 Original Size Detection	3-5
3.2.1 Overview	3-5
3.2.2 RADF tray original width sensor	3-6
3.2.3 RADF original width detection sensors-1 and -2, RADF original length detection sensor	3-7
4. DISASSEMBLY AND REASSEMBLY	4-1
4.1 Cover	4-1
4.1.1 Front cover	4-1
4.1.2 Rear cover	4-2
4.1.3 RADF jam access cover	4-3
4.1.4 Left cover	4-4
4.1.5 Original tray	4-4
4.1.6 Original feed upper guide	4-6
4.1.7 Harness guide	4-6
4.2 Roller	4-7
4.2.1 RADF original feed unit	4-7
4.2.2 RADF pickup roller, RADF original feed roller	4-8
4.2.3 RADF separation roller	4-9
4.2.4 Original feed lower guide	4-10
4.2.5 RADF registration roller	4-11
4.2.6 RADF original exit/reverse roller	4-12
4.2.7 Pre-read guide	4-14
4.2.8 RADF intermediate transport roller	4-15
4.2.9 RADF pre-read roller	4-16
4.2.10 RADF post-read roller	4-17
4.2.11 RADF reverse registration roller	4-19
4.3 Motor, Motor Driving Section	4-20
4.3.1 RADF fan motor (M4)	4-20
4.3.2 RADF read motor (M2)	4-21
4.3.3 RADF read motor driving section	4-21
4.3.4 RADF original feed motor (M1)	4-24
4.3.5 RADF original feed motor driving section	4-24
4.3.6 RADF original exit/reverse motor (M3)	4-27
4.4 Solenoid	4-28
4.4.1 RADF original pickup solenoid (SOL1)	4-28
4.5 Sensor and Switch	4-29
4.5.1 RADF tray original width sensor (S2)	4-29
4.5.2 RADF tray original length sensor (S1)	4-30
4.5.3 RADF jam access cover sensor (S11)	4-31

4.5.4	RADF original empty sensor (S3)	4-32
4.5.5	RADF original length detection sensor (S4)	4-32
4.5.6	RADF original registration sensor (S5)	4-33
4.5.7	RADF original width detection sensor-1 (S6)	4-33
4.5.8	RADF original width detection sensor-1 (S7)	4-34
4.5.9	RADF read sensor (S9)	4-34
4.5.10	RADF original intermediate transport sensor (S8)	4-35
4.5.11	RADF original exit/reverse sensor (S10)	4-35
4.5.12	RADF jam access cover opening/closing switch (SW1)	4-36
4.6	PC Board	4-37
4.6.1	RADF control PC board (RADF board)	4-37
4.6.2	LED board (LED)	4-38
4.7	Others	4-39
4.7.1	Hinge stopper	4-39
4.7.2	RADF registration roller front sheet	4-40
5.	ADJUSTMENT	5-1
5.1	Position Adjustment	5-1
5.1.1	Checking	5-1
5.1.2	Adjustment	5-2
5.2	Height Adjustment	5-6
5.2.1	Checking	5-6
5.2.2	Adjustment	5-7
5.3	Skew adjustment	5-8
5.3.1	Checking	5-8
5.3.2	Adjustment	5-9
5.4	Leading Edge Position Adjustment	5-11
5.4.1	Checking	5-11
5.4.2	Adjustment	5-12
5.5	Horizontal Position Adjustment	5-13
5.5.1	Checking	5-13
5.5.2	Adjustment	5-13
5.6	Copy Ratio Adjustment	5-14
5.6.1	Checking	5-14
5.6.2	Adjustment	5-14
5.7	RADF Separation Roller Pressure Force Adjustment	5-15
5.7.1	Adjustment procedure	5-15
5.8	Platen Sheet	5-16
6.	TROUBLESHOOTING	6-1
6.1	Troubleshooting for Mechanical Errors	6-1
6.2	Troubleshooting for Electrical Errors	6-2
6.3	Paper Misfeeding	6-3
7.	MAINTENANCE AND ROM REWRITING	7-1
7.1	Maintenance and Inspection Points	7-1
7.2	ROM Rewriting (Firmware Updating)	7-3
8.	HARNESS DIAGRAM	8-1
8.1	Harness Diagram	8-1
	REVISION RECORD	1

1. SPECIFICATIONS

Item	Contents
Maximum number of originals on the original feeding tray	Up to 100 sheets or 16 mm in height * 35 g/m ² to 80 g/m ² (9.3 lb. Bond to 21.3 lb. Bond)
Acceptable paper size	A5-R, A4, A4-R, B5, B5-R, B4, A3, FOLIO, ST-R, LT, LT-R, LG, LD, COMPUTER
Acceptable paper weight	1-sided: 35 g/m ² to 157 g/m ² (9.3 lb. Bond to 58 lb. Cover) 2-sided: 50 g/m ² to 157 g/m ² (13.3 lb. Bond to 58 lb. Cover)
Dimensions	575 (W) x 531 (D) x 144 (H) mm * Excluding the original tray
Weight	11 kg
Power consumption	Approx. 49.5 W
Power supply	DC 5 V, DC 24 V * Supplied from the MFP
Accessories	Unpacking/Setup Instructions (1 set) Chart (A4 and LT: 1 sheet each) Fixing screw (6 pcs.) Positioning pin (2 pcs.) Washer (1 pc.) Stopper bracket (1 pc.) Stopper bracket fixing screw (2 pcs.) Hinge cover (1 pc.)
Appearance color	Jet black

2. OVERVIEW

2.1 Main Components

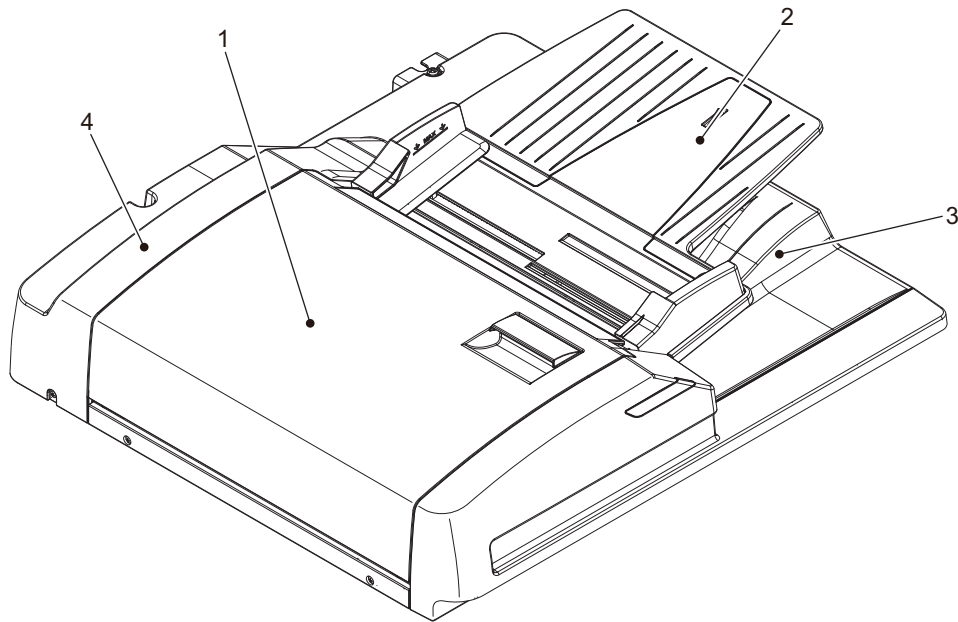

Fig. 2-1

Location		Components	
1	Original feeding and transporting section	RADF pickup roller RADF original feed roller RADF separation roller RADF registration roller RADF intermediate transport roller RADF pre-read roller RADF post-read roller RADF original exit/reverse roller RADF reverse registration roller	RADF original empty sensor (S3) RADF original length detection sensor (S4) RADF original registration sensor (S5) RADF original width detection sensor-1 (S6) RADF original width detection sensor-2 (S7) RADF original intermediate transport sensor (S8) RADF read sensor (S9) RADF original exit/reverse sensor (S10) RADF jam access cover sensor (S11)
2	Original tray section	Original width guide Original tray Original reverse tray	RADF tray original length sensor (S1) RADF tray original width sensor (S2)
3	Original exit tray section	Original exit tray	
4	Driving and controlling section		RADF original feed motor (M1) RADF read motor (M2) RADF original exit/reverse motor (M3) RADF fan motor (M4) RADF original pickup solenoid (SOL1) RADF jam access cover opening/closing switch (SW1) RADF control PC board (RADF)

2.2 Sectional View

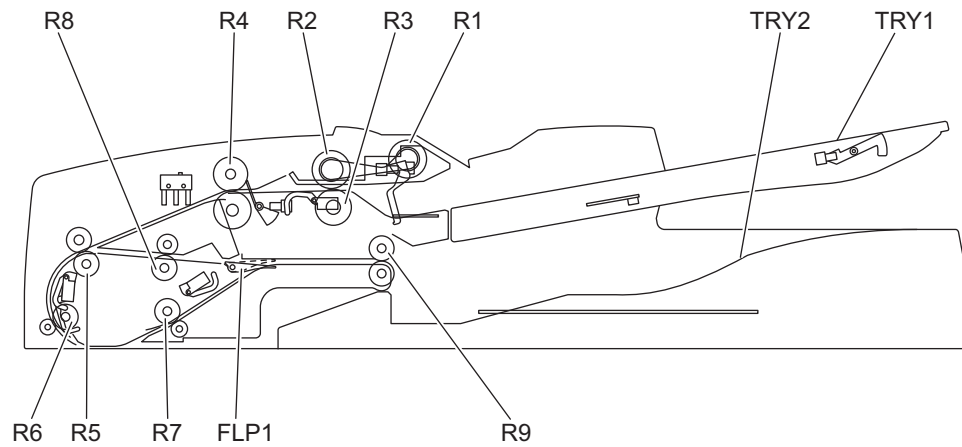

Fig. 2-2

TRY1	Original tray	R4	RADF registration roller
TRY2	Original exit tray	R5	RADF intermediate transport roller
FLP1	Original exit gate	R6	RADF pre-read roller
R1	RADF pickup roller	R7	RADF post-read roller
R2	RADF original feed roller	R8	RADF reverse registration roller
R3	RADF separation roller	R9	RADF original exit/reverse roller

2.3 Electric Parts Layout

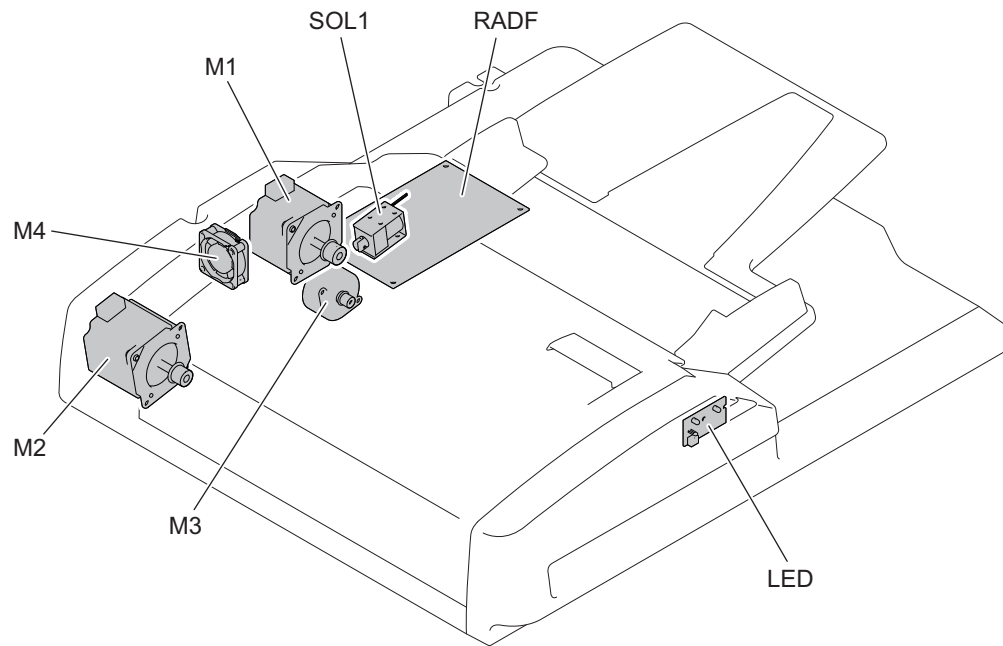

Fig. 2-3

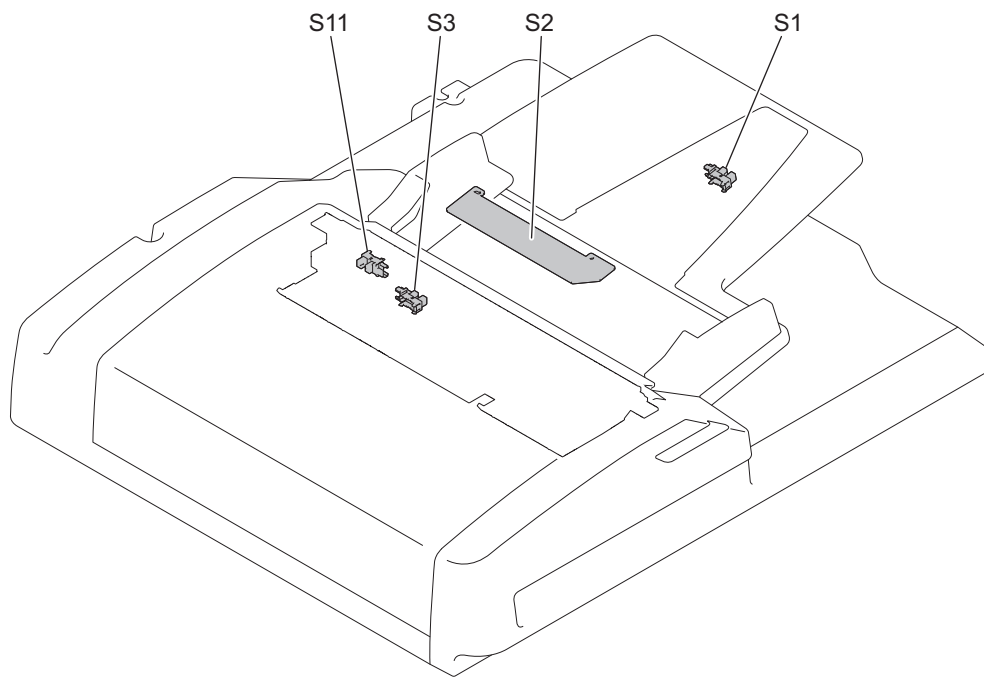

Fig. 2-4

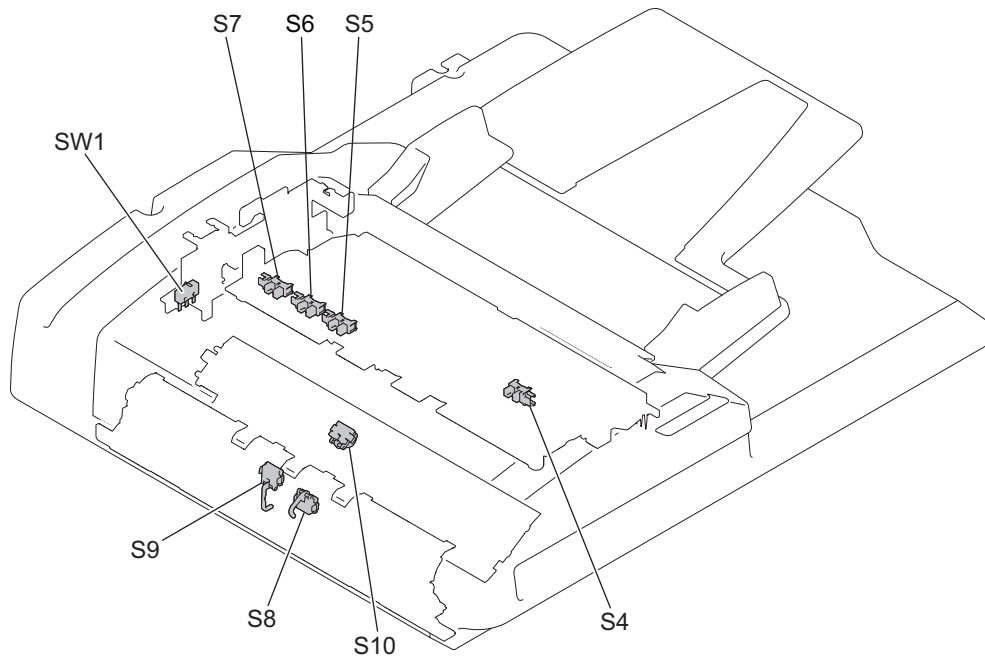

Fig. 2-5

2.4 Symbols and Functions of Various Components

1. Motor

Symbol	Name	Function	P-I
M1	RADF original feed motor	Drives the RADF original feed roller, RADF pickup roller and RADF registration roller.	6-11
M2	RADF read motor	Transports originals by driving the RADF intermediate transport roller, RADF pre-read roller, RADF post-read and RADF reverse registration roller.	6-14
M3	RADF original exit/reverse motor	Drives the RADF original exit/reverse roller.	6-16
M4	RADF fan motor	Cools down the RADF driving section and the RADF control PC board.	7-61

2. Sensor and switch

Symbol	Name	Function	P-I
S1	RADF tray original length sensor	Detects the length of the original placed on the original tray.	1-101
S2	RADF tray original width sensor	Detects the width of the original placed on the original tray.	1-13
S3	RADF original empty sensor	Detects the original loading level placed on the original tray.	5-3
S4	RADF original length detection sensor	Detects the length of the original.	4-102
S5	RADF original registration sensor	Detects the original transportation at the RADF registration roller section.	4-102
S6	RADF original width detection sensor-1	Detects the width of the original.	4-102
S7	RADF original width detection sensor-2	Detects the width of the original.	4-102
S8	RADF original intermediate transport sensor	Detects the original transportation to the pre-scanning position.	2-28
S9	RADF read sensor	Detects the leading edge of the original at the original scanning section.	2-29
S10	RADF original exit/reverse sensor	Detects the exit (transit) of an original and the stop reference position for an original when in reverse.	3-25
S11	RADF jam access cover sensor	Detects the opening and closing status of the RADF jam access cover.	5-3
SW1	RADF jam access cover opening/closing switch	Switches between cutoff and supply state of the 24 V power by opening or closing of the RADF jam access cover. (Cover open: Cutoff)	6-4

3. Solenoid

Symbol	Name	Function	P-I
SOL1	RADF original pickup solenoid	Moves the RADF original pickup roller upward and downward.	7-1

4. PC board

Symbol	Name	Function	P-I
RADF	RADF control PC board (RADF board)	Controls the Reversing Automatic Document Feeder.	7-8
LED	LED board	Controls the lighting of the LED.	1-106

2.5 Signal Block Diagram

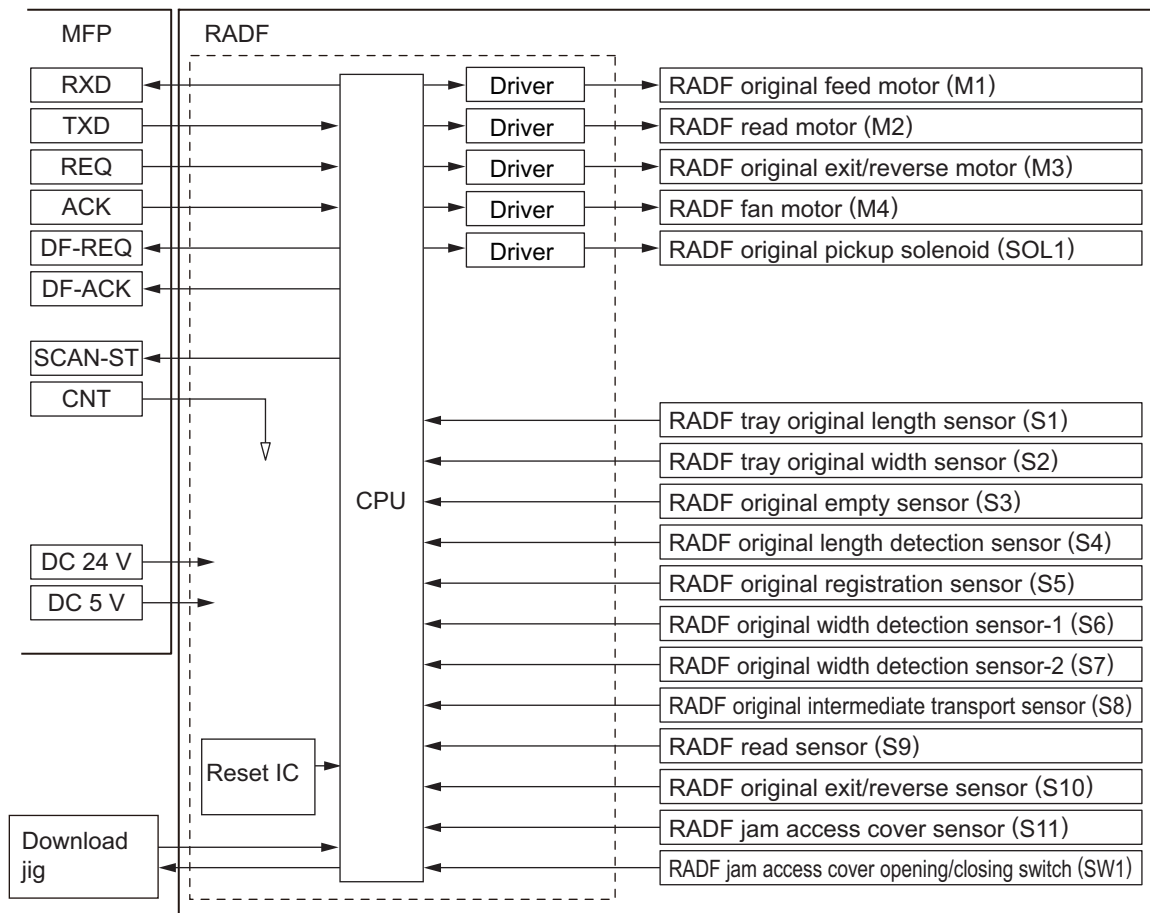

Fig. 2-6

2.6 Interface Signals

The following 6 lines are used to transmit and receive signals between the MFP and the RADF.

- REQ: Communication request signal (from the MFP to the RADF)
- DF-REQ: Communication request signal (from the RADF to the MFP)
- DF-ACK: Communication request acknowledging signal (from the RADF to the MFP)
- ACK: Communication request acknowledging signal (from the MFP to the RADF)
- TXD: Data transmitted from the MFP to the RADF
- RXD: Data transmitted from the RADF to the MFP

Since the serial communication system has been adopted for data communication (RXD and TXD) between the scanner and the RADF, whether the signals are transmitted or received properly cannot be checked using testing devices in the field.

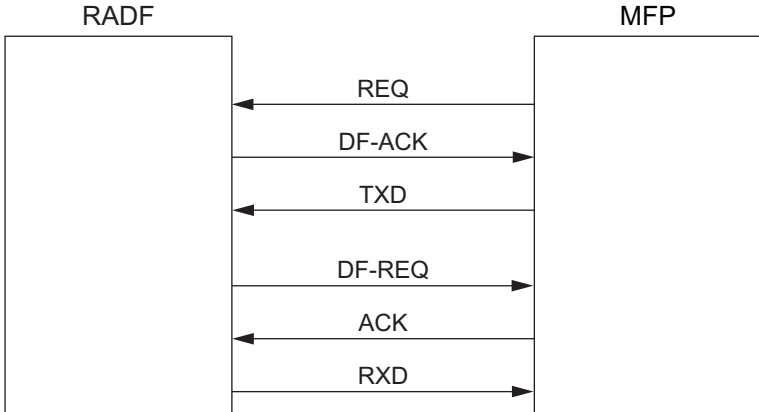

Fig. 2-7

3. OPERATION DESCRIPTION

3.1 Driving Section

3.1.1 Overview

Transportation of originals is operated by the RADF original feed motor, RADF read motor and RADF original exit/reverse motor.

The role for each motor is as below.

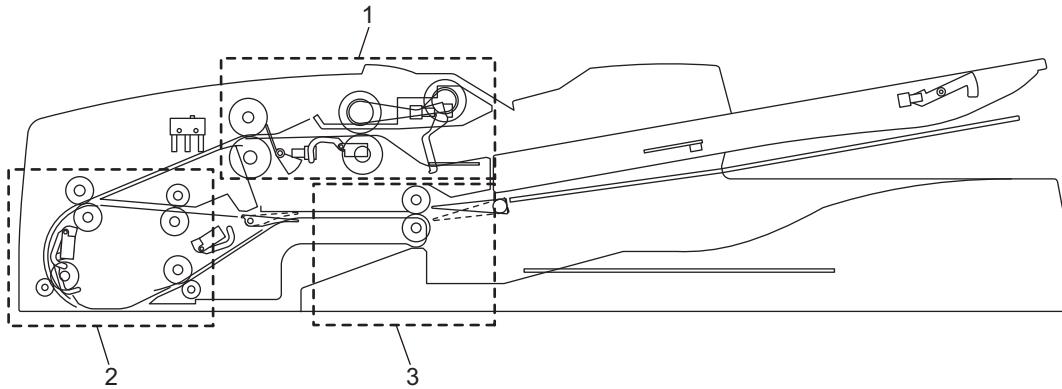

Fig. 3-1

1	RADF original feed motor driving section	Picks up originals and drives the RADF registration roller.
2	RADF read motor driving section	Transports originals and drives the RADF pre-read roller.
3	RADF original exit/reverse motor driving section	Exits and reverses originals and drives the RADF original exit/reverse roller.

The RADF original feed motor rotates in reverse when the originals are being transported at the RADF registration roller, compared to its rotational direction when they are being picked up.

The RADF original exit/reverse motor also rotates in reverse when the originals are being reversed and transported, compared to its rotational direction when they are exiting.

The RADF read motor always rotates in a constant direction.

3.1.2 RADF original feed motor driving section

When an original is placed on the original tray and the RADF receives a feed request signal from the MFP, the feeding of the original is started.

The RADF original empty sensor (S3) detects the presence of the original and then the RADF pickup roller is lowered by the drive from the RADF original pickup solenoid (SOL1).

The RADF original feed motor (M1) rotates, and the RADF pickup roller and the RADF original feed roller then rotate in a normal direction (A) to guide the original into the transport path. Then the original is transported to the RADF registration roller to be aligned.

The original aligned with the RADF registration roller is then transported by the reverse rotation of the RADF original feed motor (M1) (B).

A one-way clutch is installed inside of each gear of the RADF original feed roller and the RADF registration roller, so these gears will not be driven in a reverse rotation.

When the RADF original empty sensor (S3) detects that there is no original on the original tray, the RADF original pickup solenoid (SOL1) is turned OFF and the RADF pickup roller is raised.

The RADF original pickup solenoid (SOL1) is the one can operate both suction and recovery.

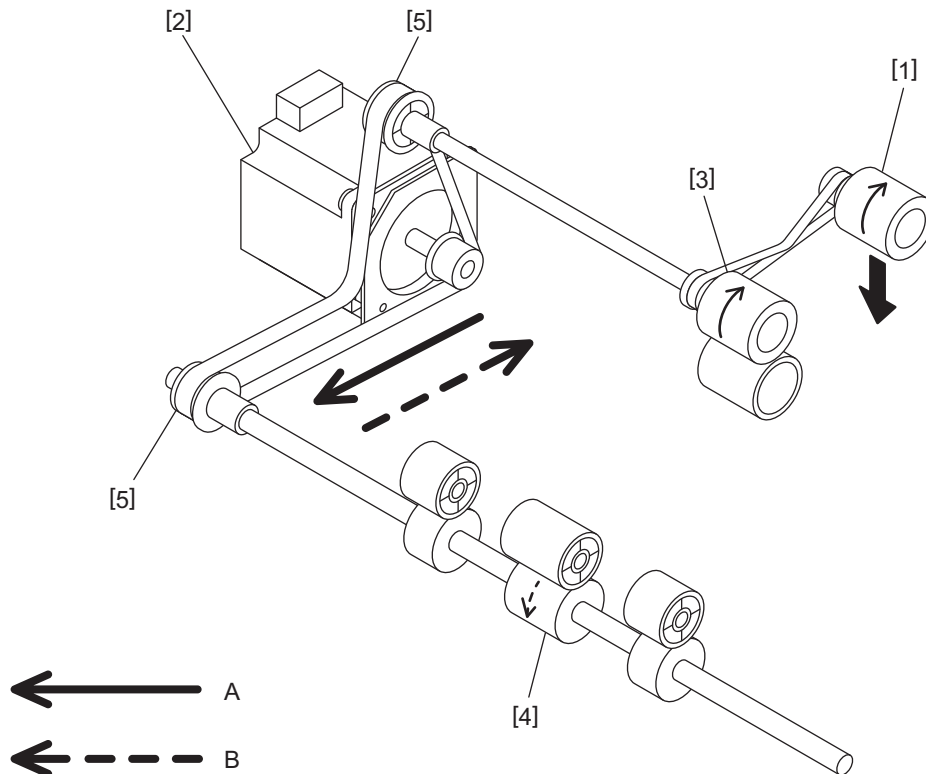

Fig. 3-2

- [A] Original feeding
- [B] Original picking
- [1] RADF pickup roller
- [2] RADF original feed motor
- [3] RADF original feed roller
- [4] RADF registration roller
- [5] One-way clutch

3.1.3 RADF read motor driving section

The transported original is driven by the RADF read motor (M2).

Then the original is transported to a scanning start position by the RADF intermediate transfer roller and RADF pre-read roller.

The original transported to the scanning start position is then scanned in the scanner function of the MFP.

When the data of the original have been scanned, the original is then transported to the original exit tray side by the RADF post-read roller.

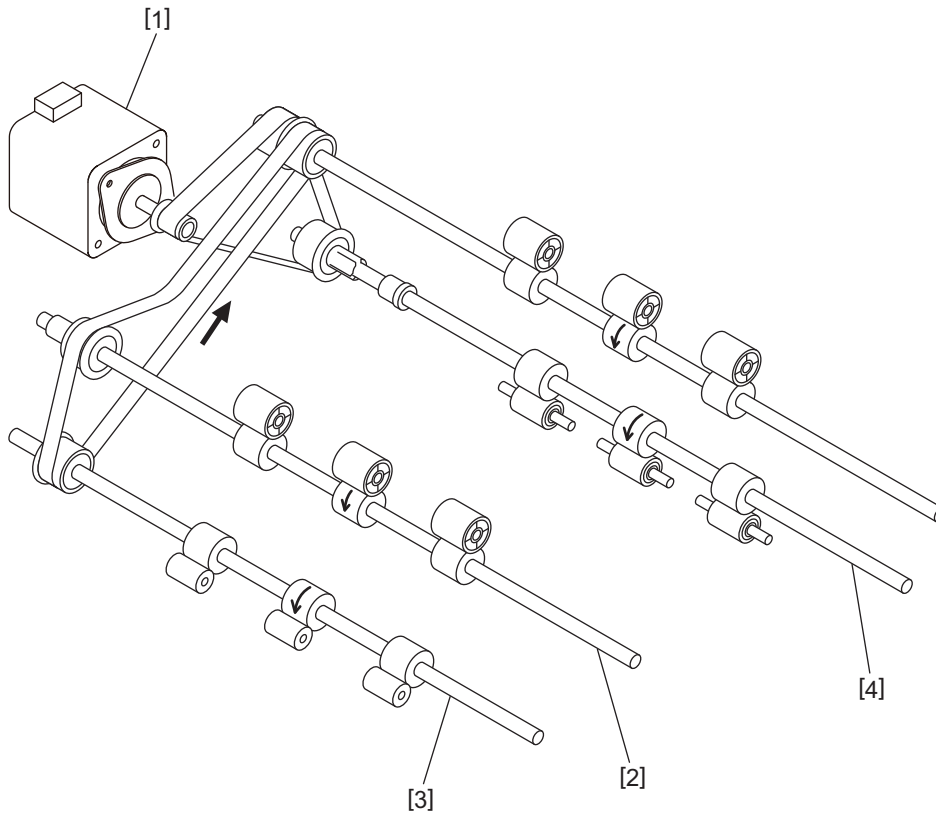

Fig. 3-3

- [1] RADF read motor
- [2] RADF intermediate transport roller
- [3] RADF pre-read roller
- [4] RADF post-read roller

3.1.4 RADF original exit/reverse motor driving section

When the data of the original have been scanned, the original is made to exit to the original exit tray by the RADF original exit/reverse roller driven by the RADF original exit/reverse motor (M3). (A)
In the duplex scanning mode, the original is temporarily transported to the reverse tray, and then the RADF original exit/reverse motor (M3) rotates reversely to return the original to the transport path switched for reverse operation. (B)
The reversed original is aligned with the RADF reverse registration roller, and then the other side of the original is scanned. When the scanning is completed, the original exits to the original exit tray.

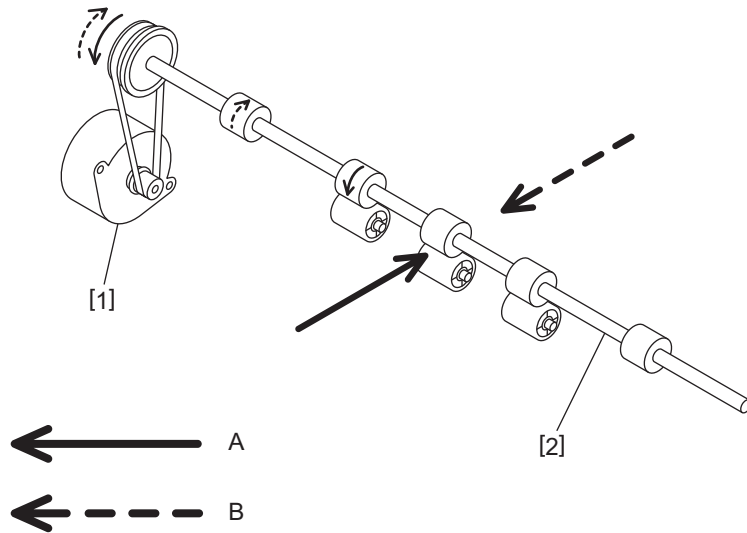

Fig. 3-4

- [A] Original exiting
- [B] Original reversing
- [1] RADF original exit/reverse motor
- [2] RADF original exit/reverse roller

3.2 Original Size Detection

3.2.1 Overview

The RADF original tray width sensor (S2), RADF original length detection sensor (S4), and RADF original width detection sensors-1 and -2 (S6, S7) work in combination to detect the size of the originals.

When an original is placed on the original tray, its width is detected by the positions of the original width guides.

Then the RADF original width sensors-1 and -2 (S6, S7) and the RADF original length detection sensor (S4) detect the size of the original being transported. Based on the detection result of these sensors, the size of the original is finally determined.

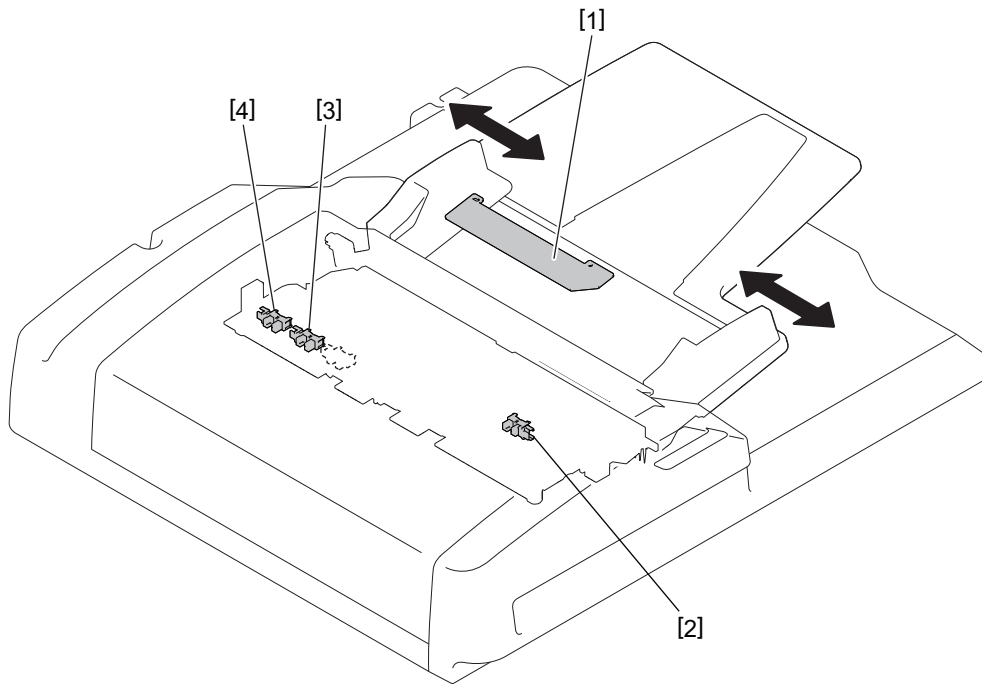

Fig. 3-5

- [1] RADF tray original width sensor
- [2] RADF original length detection sensor
- [3] RADF original size width detection sensor-1
- [4] RADF original size width detection sensor-2

3.2.2 RADF tray original width sensor

The RADF original tray width sensor (S2) detects the width of an original placed on the original tray. It is detected by the brush attached to the rack moving on the RADF original tray width sensor (S2), which is a board with the different length of the patterns written.

This brush is moved as the original width guide is moved. Signals (TWID0S, TWID1S, TWID2S) are opened and shorted to SG by this movement.

The combination of these short (= low level) and open (= high level) can determine the width of the original.

Sizes detectable in combinations of the opening and shortening of the signals are as follows:

TWID2S	TWID1S	TWID0S	Original width size (LT series)	Original width size (A series)
H	H	L	-	B5-R
H	L	H	ST-R	A5-R
H	L	L	LD, LT	A3, A4
L	H	L	8.5 × 8.5, LT-R, LG, 13"LG	A4-R, FOLIO
L	L	L	COMPUTER	B4, B5

H (= high level): Open, L (= low level): Short

3.2.3 RADF original width detection sensors-1 and -2, RADF original length detection sensor

The size of the original is determined by the detection performed in combination of the RADF original width detection sensors-1 and -2 (S6, S7) and the RADF original length detection sensor (S4), as well as the detection performed by the RADF original tray width sensor (S2).
 Sizes detectable in combinations of these sensors are as follows:

A4 series (ORG-SRS: 1)

RADF original length detection sensor	RADF original width detection sensor-1	RADF original width detection sensor-2	Determined size	Original tray width
OFF	OFF	OFF	A5-R	-
	ON	OFF	B5	-
	ON	ON	A4	-
ON	OFF	OFF	B5-R	-
	ON	OFF	A4-R, FOLIO	Determined by a gap between the guides
			B4	
ON	ON	A3	-	

A4 series (width sizes mixed at A3, A4 standard)

RADF original length detection sensor	RADF original width detection sensor-1	RADF original width detection sensor-2	Determined size	Original tray width
ON	ON	ON	A3	A3, A4
	OFF	OFF	A4-R, FOLIO	
	ON	OFF	B4	
OFF	ON	OFF	B5	
	ON	ON	A4	

A4 series (width sizes mixed at B4, B5 standard)

RADF original length detection sensor	RADF original width detection sensor-1	RADF original width detection sensor-2	Determined size	Original tray width
ON	OFF	OFF	A4-R, FOLIO	B4, B5
	ON	OFF	B4	
OFF	ON	OFF	B5	
	OFF	OFF	A5-R	

A4 series (width sizes mixed at A4-R standard)

RADF original length detection sensor	RADF original width detection sensor-1	RADF original width detection sensor-2	Determined size	Original tray width
ON	OFF	OFF	B5-R	A4-R
	ON	OFF	A4-R, FOLIO	
OFF	OFF	OFF	A5-R	

A4 series (width sizes mixed at B5-R standard)

RADF original length detection sensor	RADF original width detection sensor-1	RADF original width detection sensor-2	Determined size	Original tray width
ON	OFF	OFF	B5-R	B5-R
OFF	OFF	OFF	A5-R	

LT series (ORG-SRS: 0)

RADF original length detection sensor	RADF original width detection sensor-1	RADF original width detection sensor-2	Determined size	Original tray width
OFF	OFF	OFF	ST-R	-
	ON	OFF	8.5 x 8.5	-
	ON	ON	LT	-
ON	ON	OFF	LT-R, LG, COMP, 13"LG	-
	ON	ON	LD	-

LT series (width sizes mixed at LD, LT standard)

RADF original length detection sensor	RADF original width detection sensor-1	RADF original width detection sensor-2	Determined size	Original tray width
ON	ON	ON	LD	LD, LT
	ON	OFF	COMP	
	OFF	OFF	LT-R, LG, 8.5x8.5, 13"LG	
OFF	ON	ON	LT	

LT series (width sizes mixed at LG, LT-R standard)

RADF original length detection sensor	RADF original width detection sensor-1	RADF original width detection sensor-2	Determined size	Original tray width
ON	ON	OFF	LT-R, LG, 8.5x8.5, 13"LG	LD, LT
OFF	OFF	OFF	ST-R	

4. DISASSEMBLY AND REASSEMBLY

4.1 Cover

4.1.1 Front cover

- (1) Open the RADF and remove the 2 screws [1] and 1 screw [2].

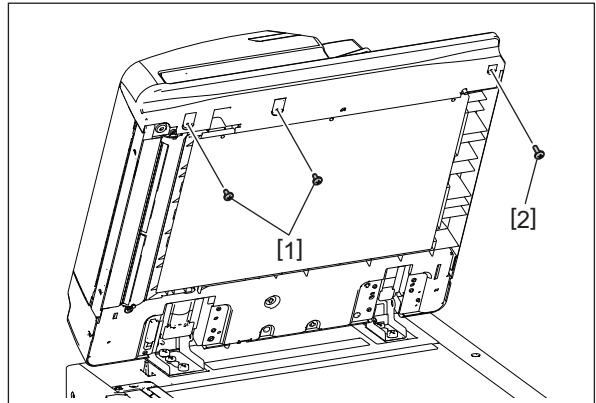

Fig. 4-1

- (2) Close the RADF.
- (3) Open the RADF original jam access cover and remove 2 screws [1].

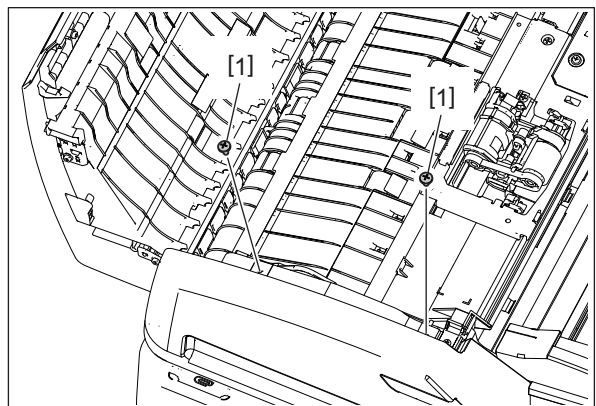

Fig. 4-2

- (4) Take off the front cover [3] toward you. Then disconnect 1 connector [4].

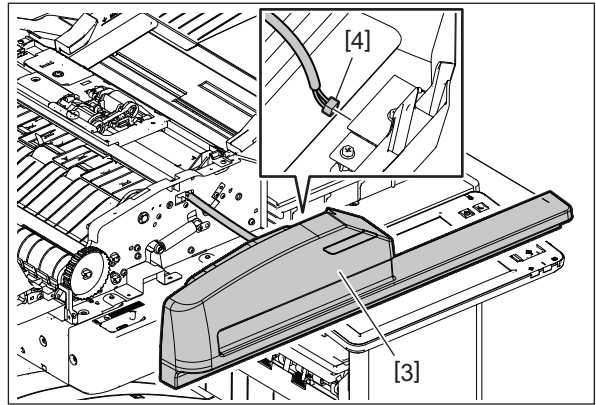

Fig. 4-3

Notes:

Be careful not to pull the harness in strongly.

4.1.2 Rear cover

- (1) Open the RADF original jam access cover and remove 4 screws [1].

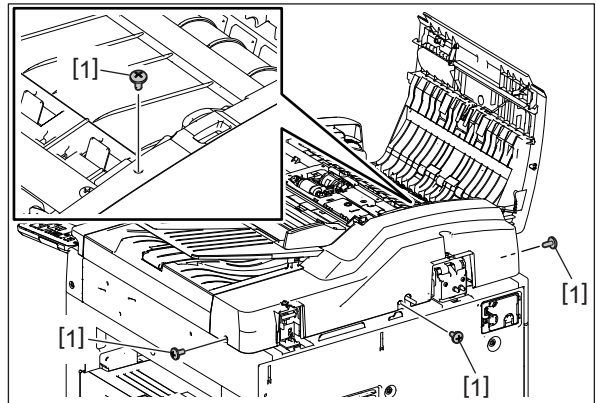

Fig. 4-4

- (2) Raise the original tray [2] and take off the rear cover [3] upward.

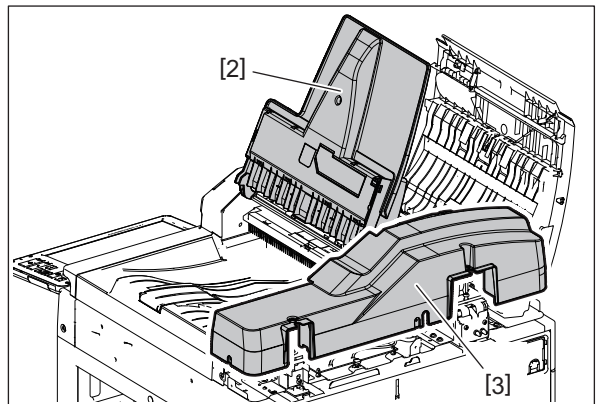

Fig. 4-5

4.1.3 RADF jam access cover

- (1) Take off the front cover.
P. 4-1 "4.1.1 Front cover"
- (2) Remove 1 clip [1], 1 dial [2] and 1 pin [3].

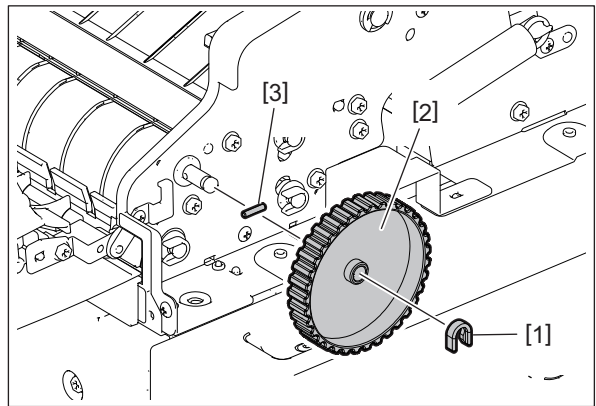

Fig. 4-6

- (3) Remove 1 screw [4] and 1 hinge pin [5].

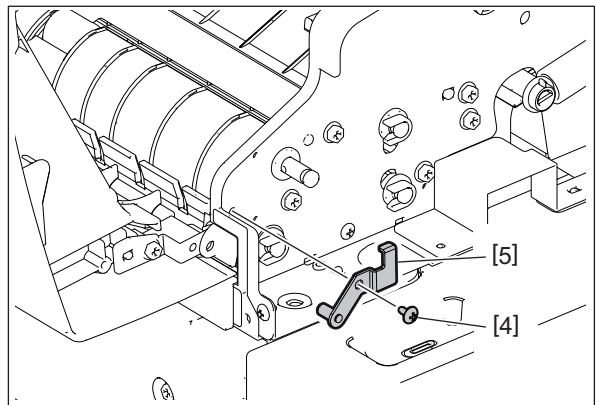

Fig. 4-7

- (4) Slide the RADF jam access cover [6] and take it off.

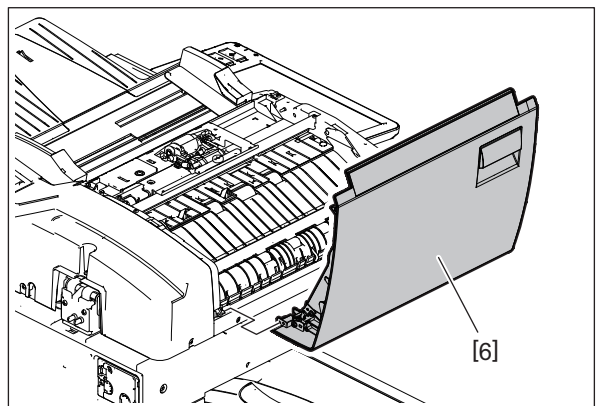

Fig. 4-8

4.1.4 Left cover

- (1) Remove 2 screws [1] and take off the left cover [2].

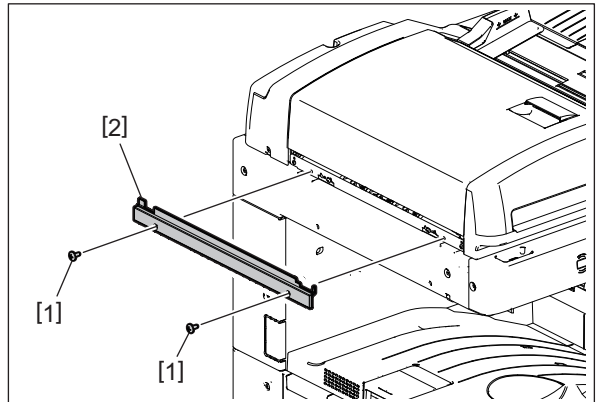

Fig. 4-9

4.1.5 Original tray

- (1) Take off the front cover.
P. 4-1 "4.1.1 Front cover"
- (2) Take off the rear cover.
P. 4-2 "4.1.2 Rear cover"
- (3) Take off the RADF original feed unit.
P. 4-7 "4.2.1 RADF original feed unit"
- (4) Disconnect 1 relay connector [2] of the original feed upper guide [1].

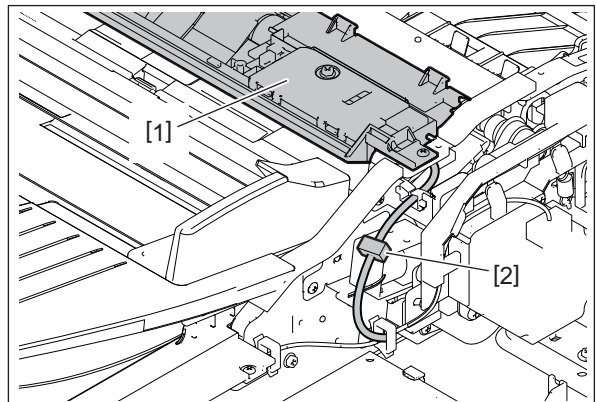

Fig. 4-10

- (5) Remove 2 screws [3]. Release 3 hooks of the original feed upper guide [1] and lift it up.

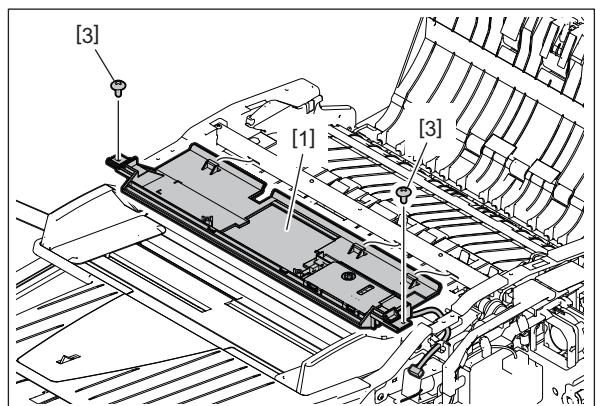

Fig. 4-11

- (6) Slide the original feed upper guide [1] to the rear side.

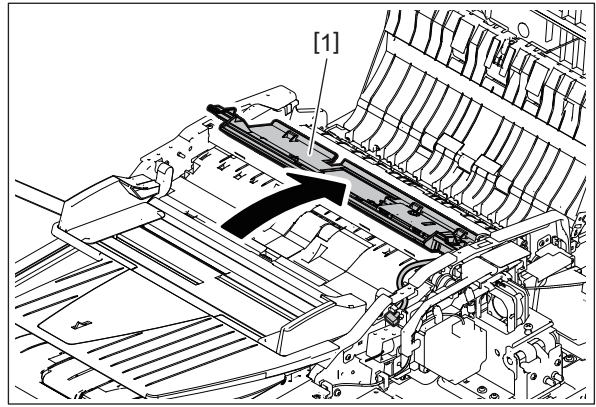

Fig. 4-12

Notes:

Be careful not to pull the harness in strongly.

- (7) Disconnect 1 connector from the RADF control PC board.
(8) Release the harness from 2 harness clamps [4].

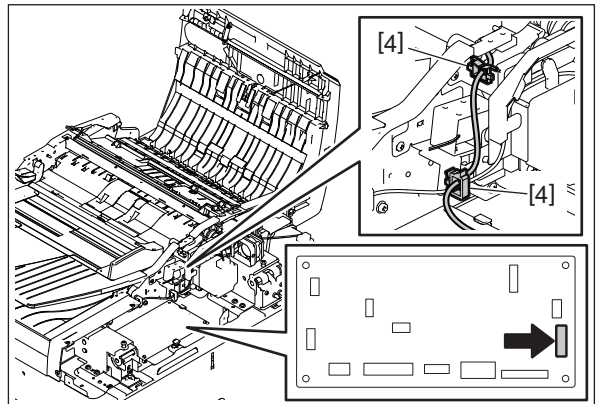

Fig. 4-13

- (9) Remove 1 screw [5] and the bearing [6].
(10) Take off the original tray [7].

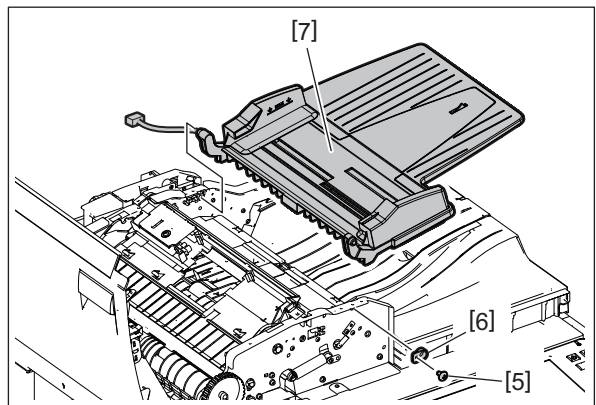

Fig. 4-14

4.1.6 Original feed upper guide

- (1) Take off the original tray.
☞ P. 4-4 "4.1.5 Original tray"
- (2) Release the harness of the original feed upper guide [1] from the harness clamp [2]. Slide the gap of the frame and move the harness to the position indicated in the figure.
- (3) Release the harness from the frame and take off the original feed upper guide [1].

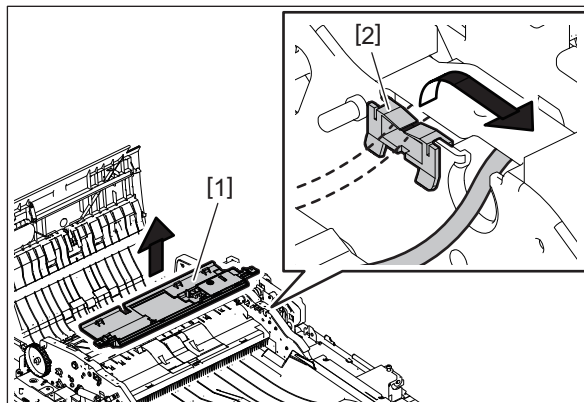

Fig. 4-15

4.1.7 Harness guide

- (1) Take off the rear cover.
☞ P. 4-2 "4.1.2 Rear cover"
- (2) Disconnect 1 connector [1] from the fan motor. Disconnect 5 connectors from the RADF control PC board and release the harness from 2 harness clamps [2].

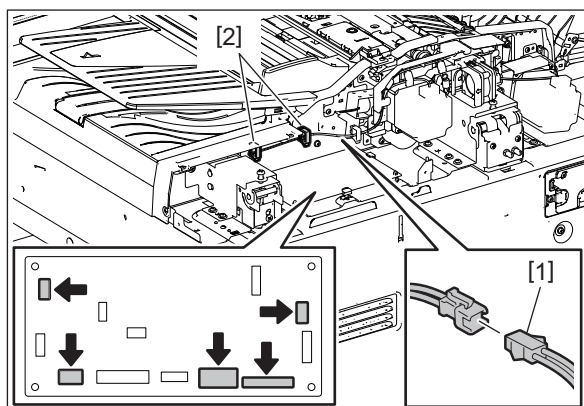

Fig. 4-16

4.2 Roller

4.2.1 RADF original feed unit

- (1) Open the RADF jam access cover.
- (2) Remove 1 screw and take off the bracket [1].

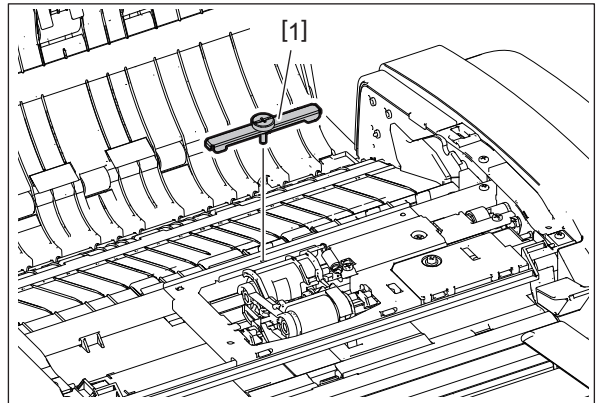

Fig. 4-17

- (3) Slide the RADF original feed unit [3] to take it off.

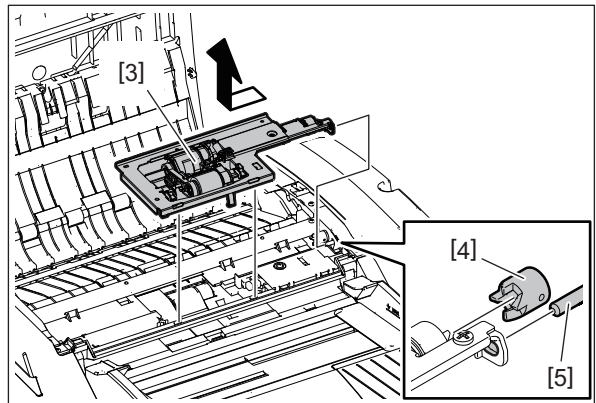

Fig. 4-18

Notes:

When installing, attach the coupling [4] and stud [5].

4.2.2 RADF pickup roller^{PM} , RADF original feed roller^{PM}

- (1) Take off the RADF original feed unit.
P. 4-7 “4.2.1 RADF original feed unit”
- (2) Move the roller holder [1] to the direction indicated by the arrow (A) to release the lock and then turn it by 90 degrees counterclockwise (B).

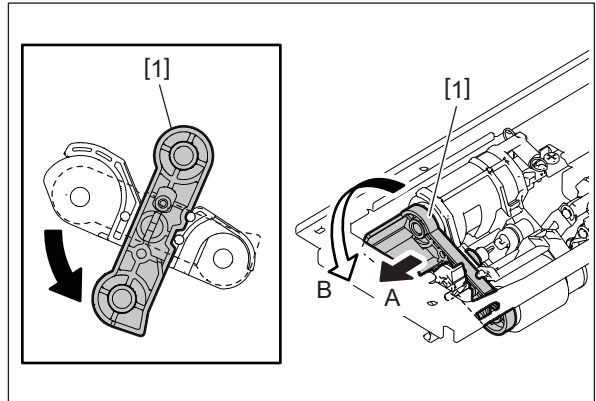

Fig. 4-19

- (3) Remove the RADF pickup roller [2] or RADF original feed roller [3] from the shaft and take it off.

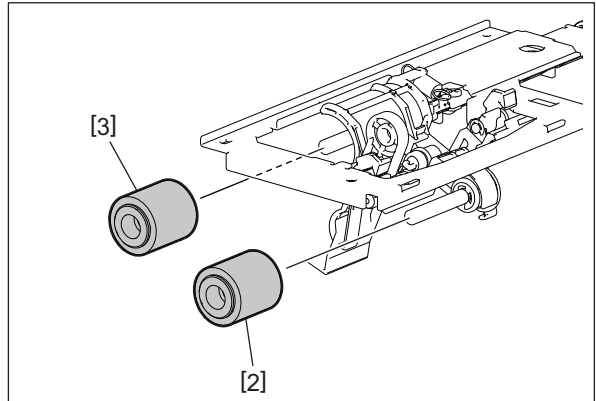

Fig. 4-20

4.2.3 RADF separation roller

- (1) Take off the RADF original feed unit.
P. 4-7 “4.2.1 RADF original feed unit”
- (2) Remove the original feed upper guide.
P. 4-6 “4.1.6 Original feed upper guide”
- (3) Release the hook [1] and take off the RADF separation roller holder [2].

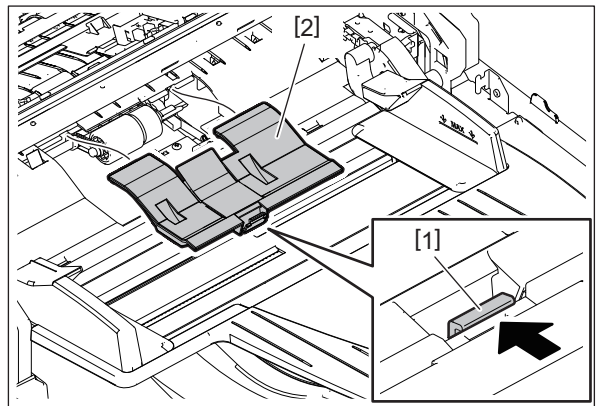

Fig. 4-21

- (4) Release the latch [3] and pull out the shaft [4].
- (5) Take off the RADF separation roller [5] and collar [6].

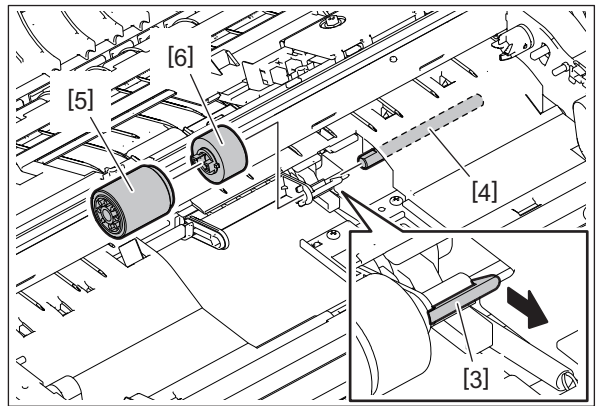

Fig. 4-22

Notes:

When installing, assemble the RADF separation roller [5] and the collar [6] first. Then install it while aligning the groove [7] of the collar [6].

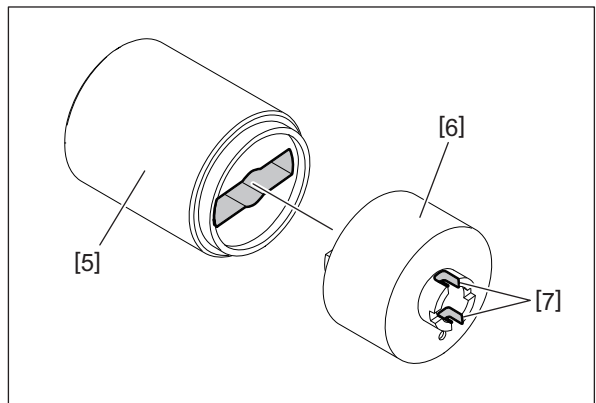

Fig. 4-23

4.2.4 Original feed lower guide

- (1) Remove the original feed upper guide.
📖 P. 4-6 “4.1.6 Original feed upper guide”
- (2) Remove the harness guide.
📖 P. 4-6 “4.1.7 Harness guide”
- (3) Remove 2 screws [1] and take off the stay [2].

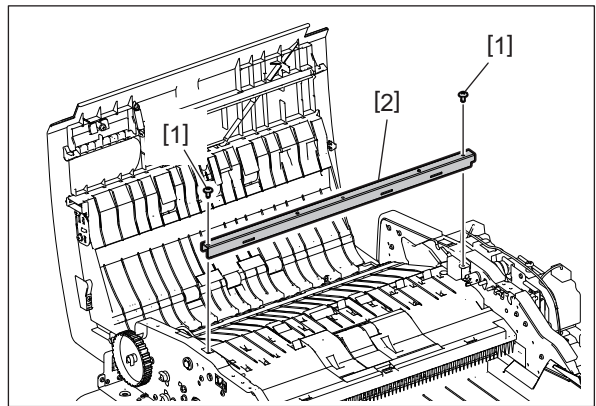

Fig. 4-24

- (4) Remove the RADF jam access guide [3].

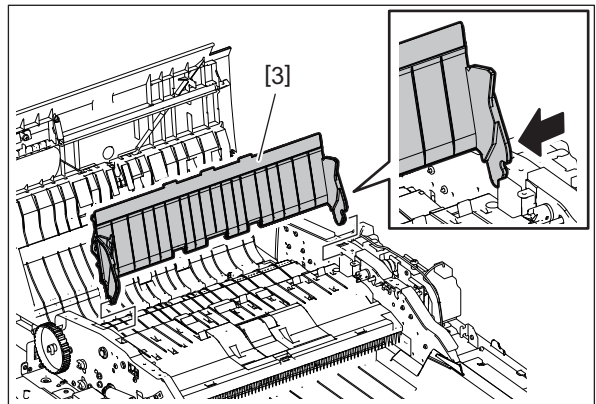

Fig. 4-25

- (5) Remove the clamp [4] from the frame and release the harness [6] from the harness clamp [5].

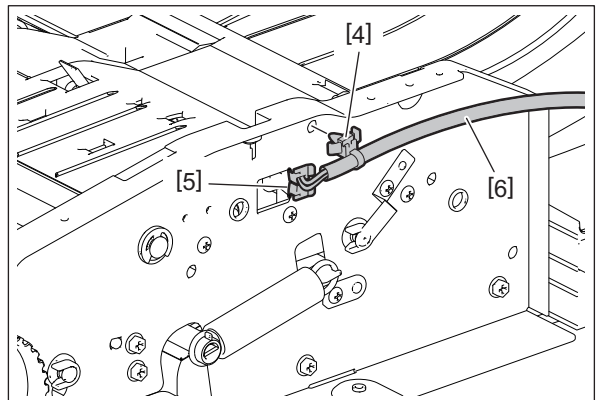

Fig. 4-26

- (6) Remove 4 screws [7] and take off the original feed lower guide [8].

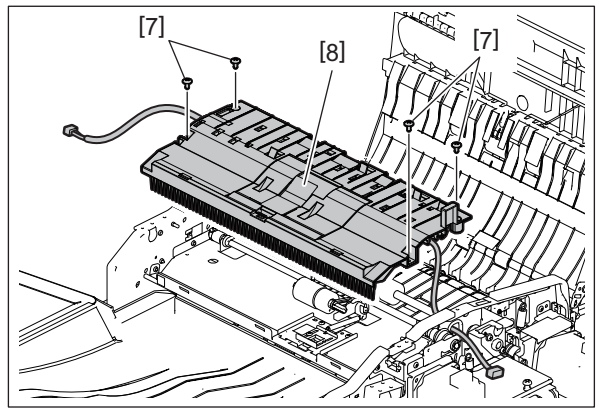

Fig. 4-27

Notes:

While paying attention to the harness, remove the original feed lower guide [8].

4.2.5 RADF registration roller

- (1) Remove the original feed lower guide.
📖 P. 4-10 “4.2.4 Original feed lower guide”
- (2) Remove the RADF original feed motor driving section.
📖 P. 4-24 “4.3.5 RADF original feed motor driving section”
- (3) Remove 1 E-ring [1] and 1 bushing [2] at the front side.
Remove 1 E-ring [1] and 1 bushing [2] at the rear side and take off the RADF registration roller [3].

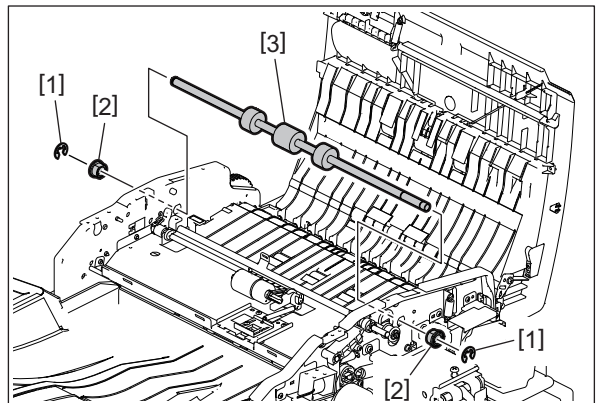

Fig. 4-28

4.2.6 RADF original exit/reverse roller

- (1) Take off the front cover.
 P. 4-1 “4.1.1 Front cover”
- (2) Remove the RADF original exit/reverse motor.
 P. 4-27 “4.3.6 RADF original exit/reverse motor (M3)”
- (3) Remove 1 clip [1], 1 pulley [2], 1 pin [3] and 1 bushing [4] at the rear side.

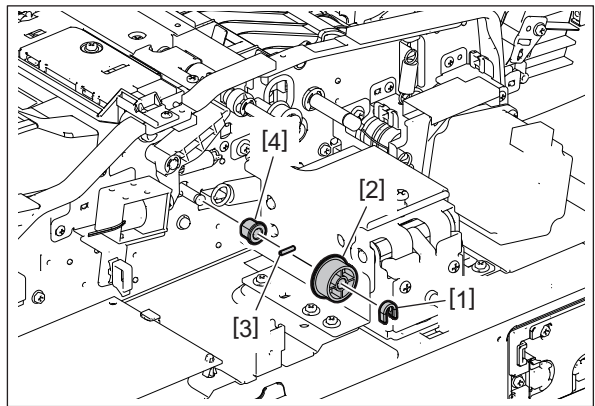

Fig. 4-29

- (4) Remove 1 screw [5] and take off the leaf spring [6].
- (5) Remove 1 clip [7] and 1 bushing [8] at the front side.

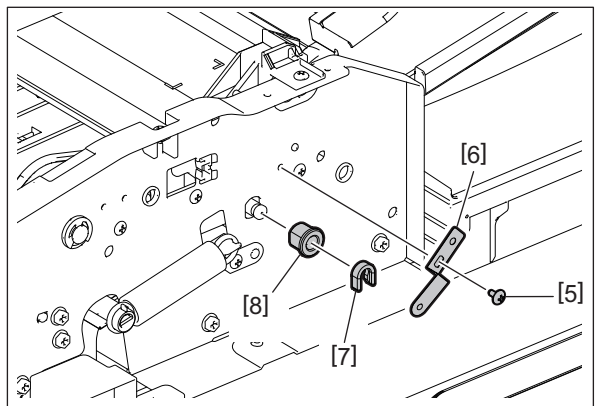

Fig. 4-30

- (6) Remove the RADF jam access guide [9].

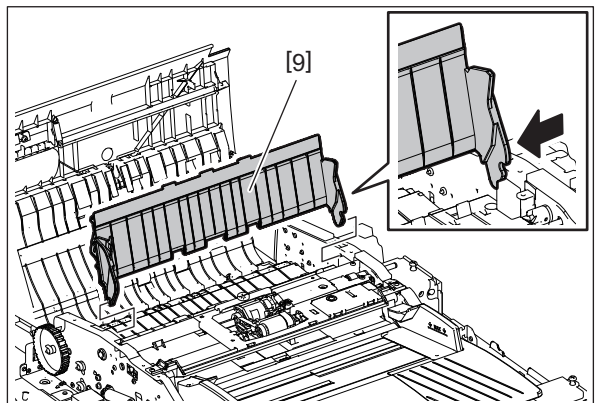

Fig. 4-31

(7) Remove the original exit guide [10].

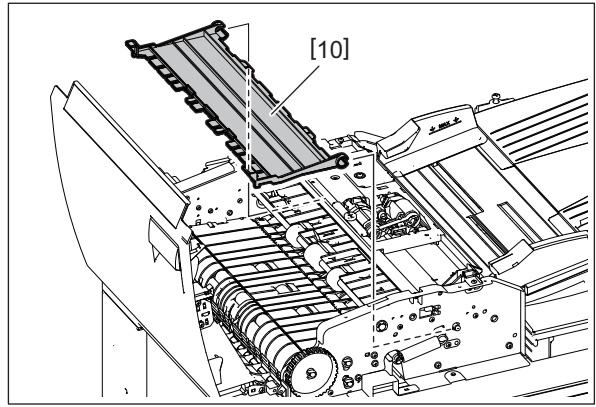

Fig. 4-32

(8) Take off the RADF original exit/reverse roller [11].

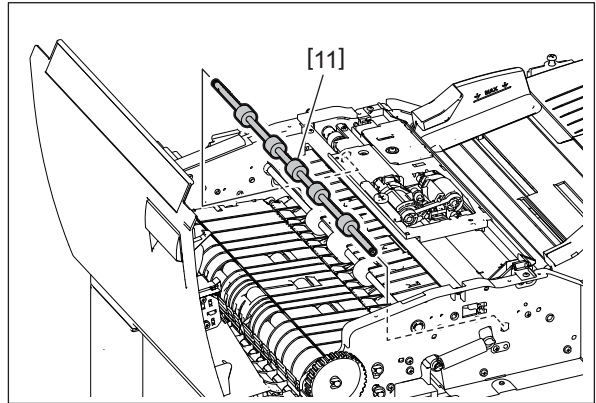

Fig. 4-33

4.2.7 Pre-read guide

- (1) Take off the front cover.
☞ P. 4-1 “4.1.1 Front cover”
- (2) Take off the rear cover.
☞ P. 4-2 “4.1.2 Rear cover”
- (3) Take off the RADF jam access cover.
☞ P. 4-3 “4.1.3 RADF jam access cover”
- (4) Take off the left cover.
☞ P. 4-4 “4.1.4 Left cover”
- (5) Remove 1 screw [1] and 1 hinge pin [2].

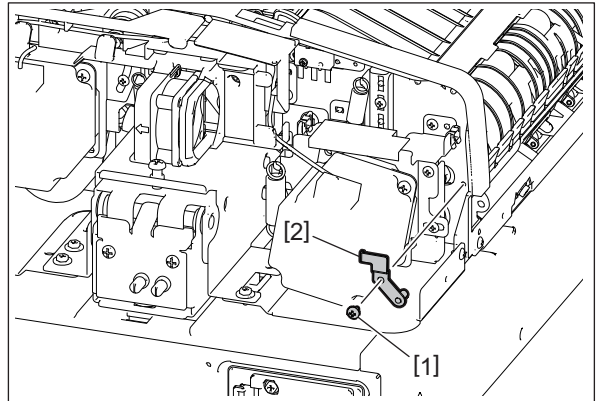

Fig. 4-34

- (6) Disconnect 2 connectors [3] and release them from the clamp [4].
Remove 2 screws [5] and take off the pre-read guide [6].

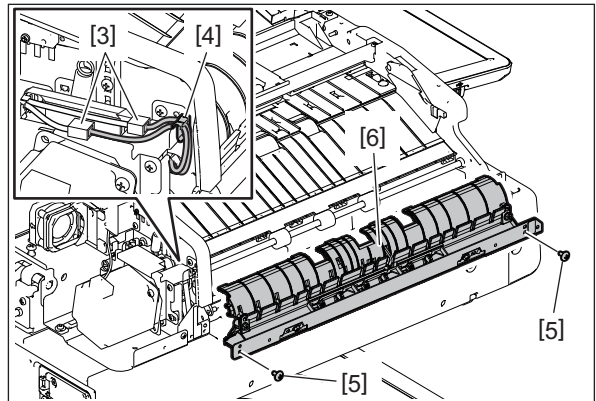

Fig. 4-35

4.2.8 RADF intermediate transport roller

- (1) Take off the pre-read guide.
☞ P. 4-14 “4.2.7 Pre-read guide”
- (2) Remove the RADF read motor driving section.
☞ P. 4-21 “4.3.3 RADF read motor driving section”
- (3) Remove 1 screw [1], 1 pulley [2], and 1 bushing [3] at the rear side.

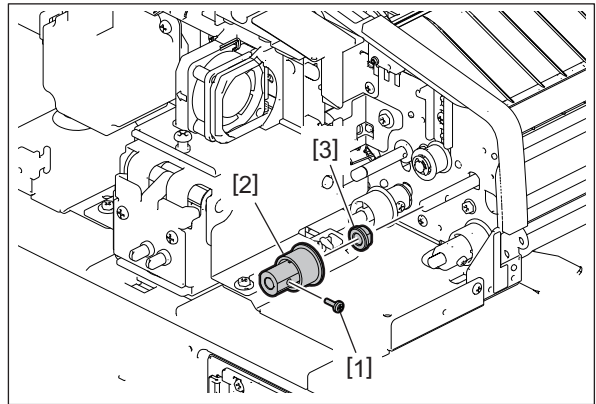

Fig. 4-36

- (4) Remove 1 bushing [4] at the front side and take off the RADF intermediate transport roller [5].

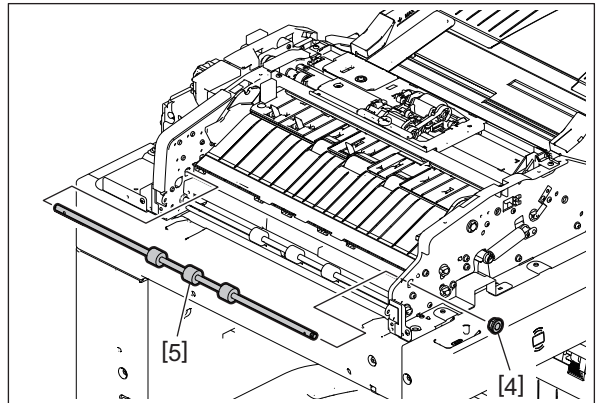

Fig. 4-37

4.2.9 RADF pre-read roller

- (1) Take off the pre-read guide.
☞ P. 4-14 “4.2.7 Pre-read guide”
- (2) Remove the RADF read motor driving section.
☞ P. 4-21 “4.3.3 RADF read motor driving section”
- (3) Remove 1 screw [1], 1 pulley [2] and 1 bearing [3] at the rear side.

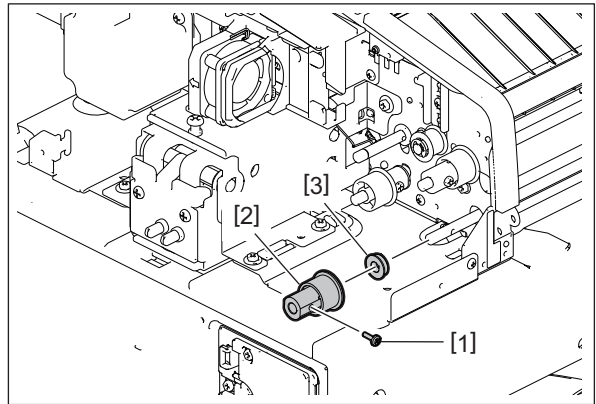

Fig. 4-38

- (4) Remove 1 clip [4] and 1 bushing [5] at the front side and take off the RADF pre-read roller [6].

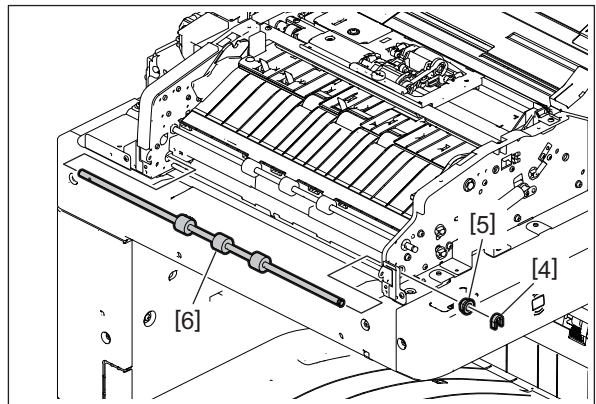



Fig. 4-39

4.2.10 RADF post-read roller

- (1) Take off the pre-read guide.
 P. 4-14 “4.2.7 Pre-read guide”
- (2) Disconnect 1 connector [1].

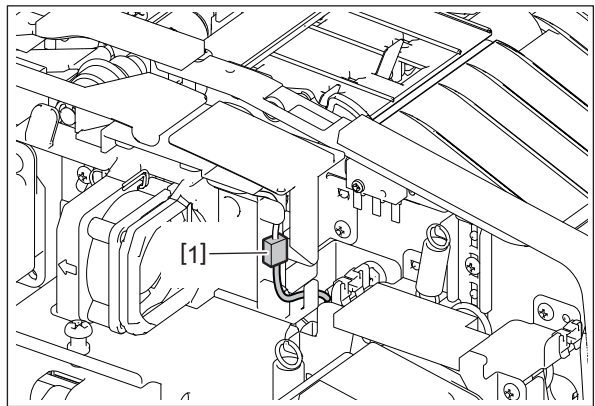



Fig. 4-40

- (3) Remove the RADF read motor driving section.
 P. 4-21 “4.3.3 RADF read motor driving section”
- (4) Remove 1 screw [2], 1 pulley [3] and 1 bearing [4] at the rear side.

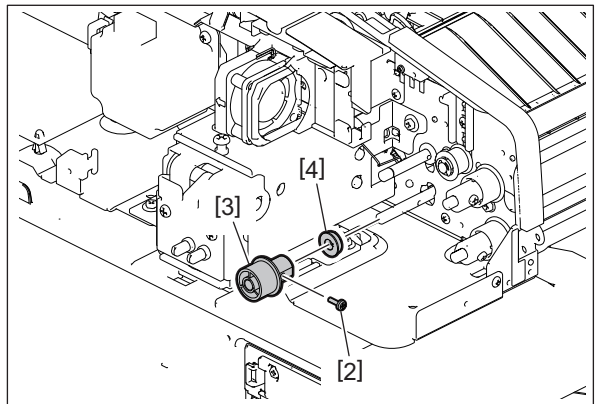

Fig. 4-41

- (5) Remove 1 clip [5] and 1 bushing [6] at the front side.

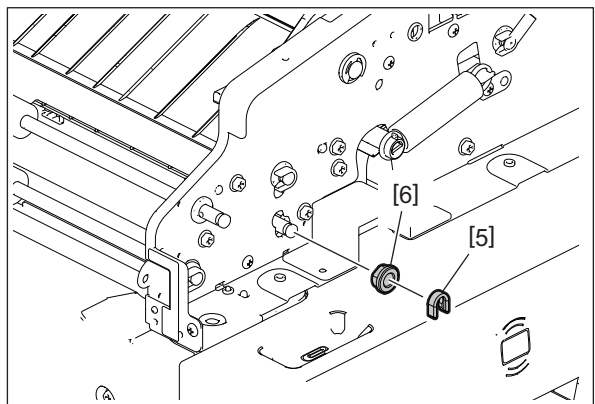

Fig. 4-42

- (6) Open the RADF. Remove 4 screws [7] and take off 2 holders [8] and the platen guide [9].

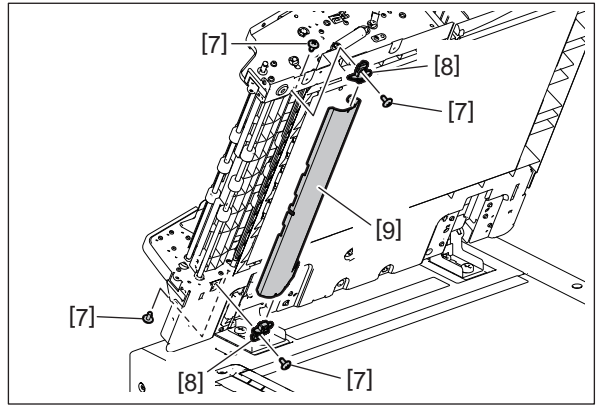

Fig. 4-43

- (7) Remove 2 screws [10]. Open the RADF post-read lower guide [11] and remove the RADF post-read upper guide [12].

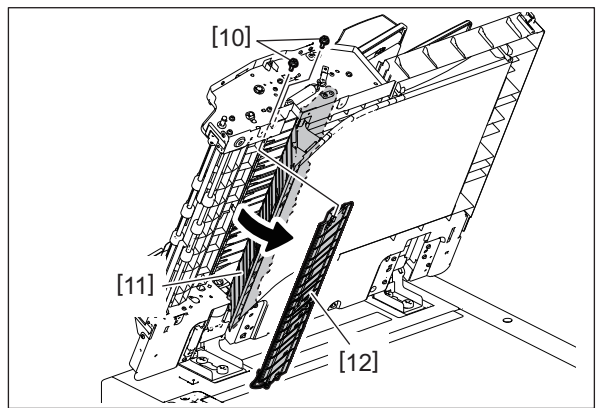

Fig. 4-44

- (8) Remove the RADF post-read roller [13].

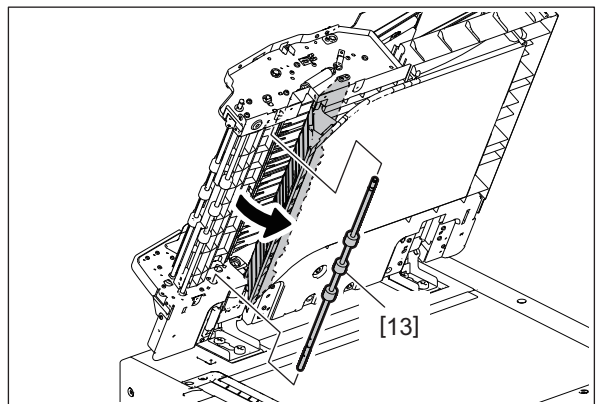



Fig. 4-45

4.2.11 RADF reverse registration roller

- (1) Remove the RADF post-read roller.
 P. 4-17 "4.2.10 RADF post-read roller"
- (2) Remove 1 bushing [1] at the rear side.

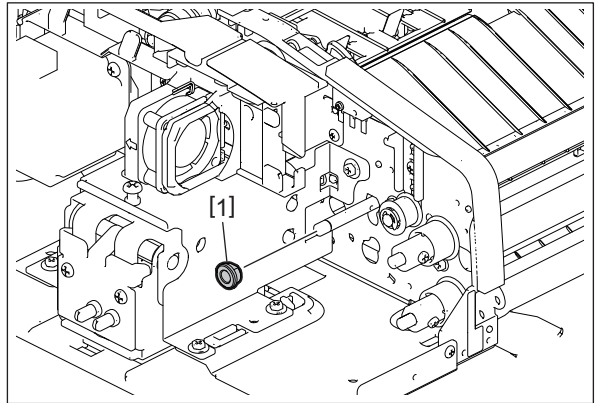

Fig. 4-46

- (3) Remove 1 clip [2] and 1 bushing [3] at the front side.

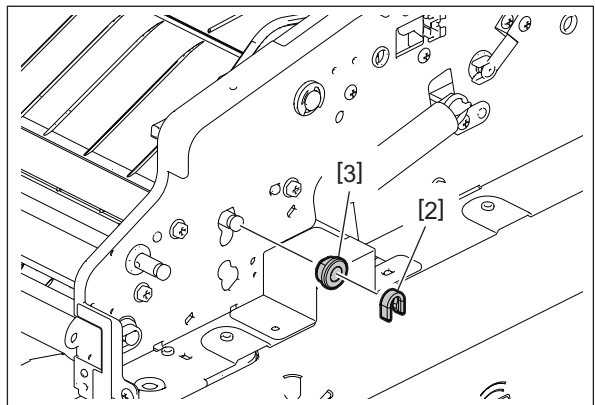

Fig. 4-47

- (4) Open the RADF. Remove the RADF reverse registration roller [4].

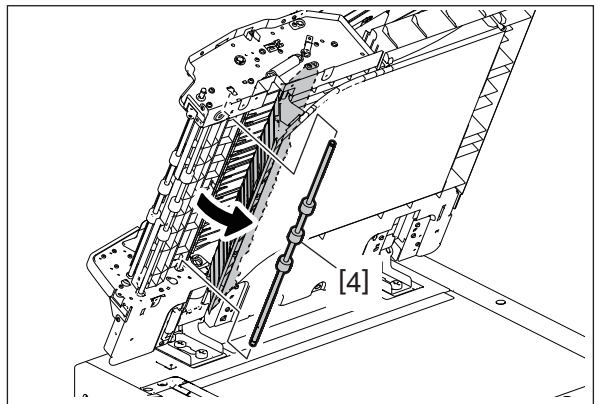

Fig. 4-48

4.3 Motor, Motor Driving Section

4.3.1 RADF fan motor (M4)

- (1) Take off the rear cover.
P. 4-2 "4.1.2 Rear cover"
- (2) Disconnect 1 connector [1] and release it from the harness clamp [2] and harness guide.

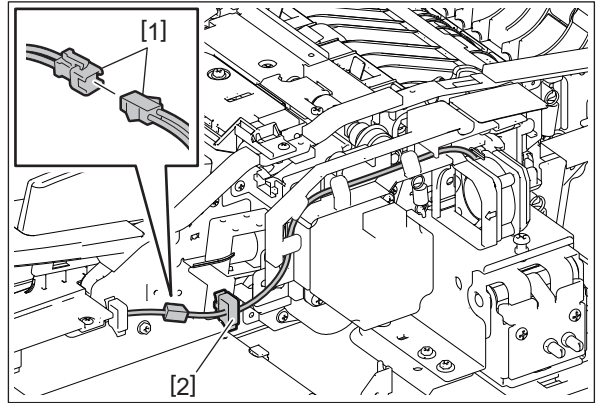

Fig. 4-49

- (3) Push the harness guide out. Release the stud and take off the RADF fan motor [3].

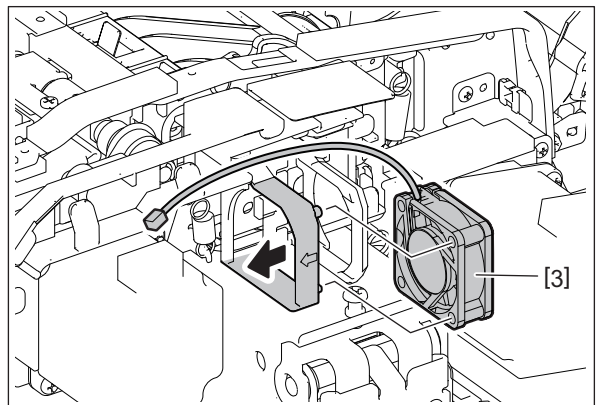

Fig. 4-50

4.3.2 RADF read motor (M2)

- (1) Take off the RADF read motor unit.
📖 P. 4-21 "4.3.3 RADF read motor driving section"
- (2) Remove 2 screws [1] and take off the RADF read motor [2].

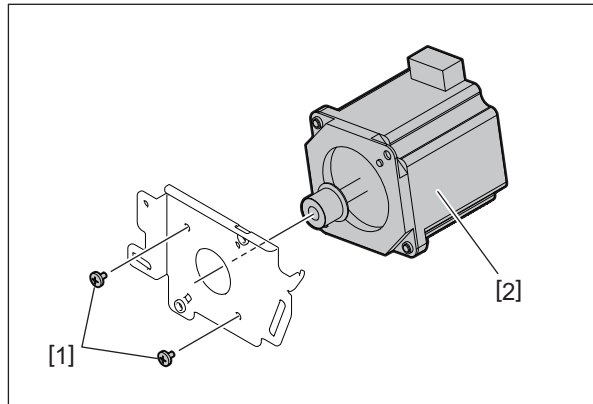

Fig. 4-51

4.3.3 RADF read motor driving section

- (1) Take off the rear cover.
📖 P. 4-2 "4.1.2 Rear cover"
- (2) Disconnect 1 connector [1]. Remove 1 spring [2]. (Outside diameter of coil: $\varnothing 10.2$ mm, Active coils: 12.5)

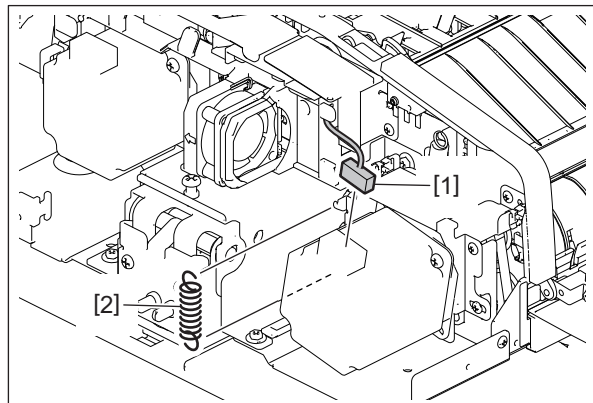

Fig. 4-52

- (3) Remove 3 screws and take off the RADF read motor unit [4].

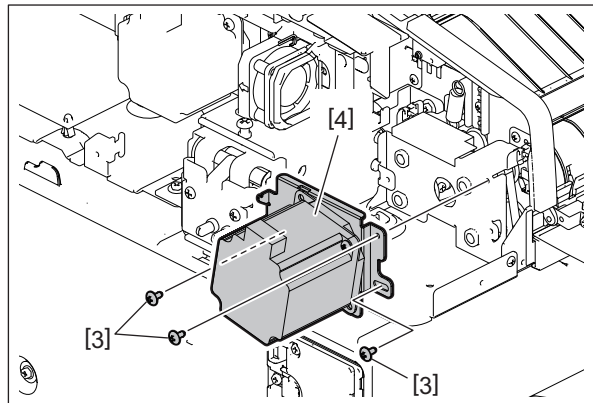

Fig. 4-53

Notes:

When installing, tighten the screws removed in step (3) temporarily and attach the spring detached in step (2). Then tighten the screws securely.

- (4) Remove 1 spring [5]. (Outside diameter of coil: $\varnothing 8.8$ mm, Active coils: 12.5)
- (5) Release the harness from 2 harness clamps [6].

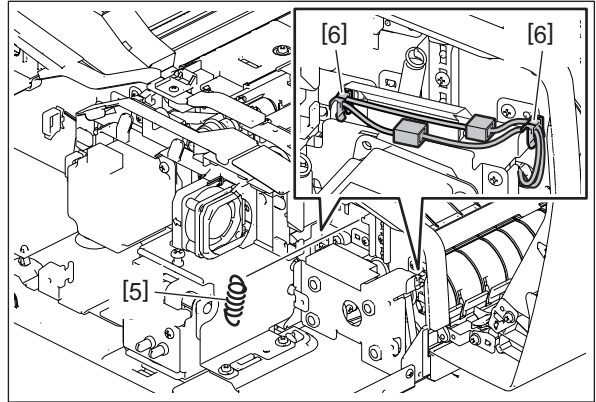

Fig. 4-54

- (6) Remove 3 screws [7] and take off the bracket [8].

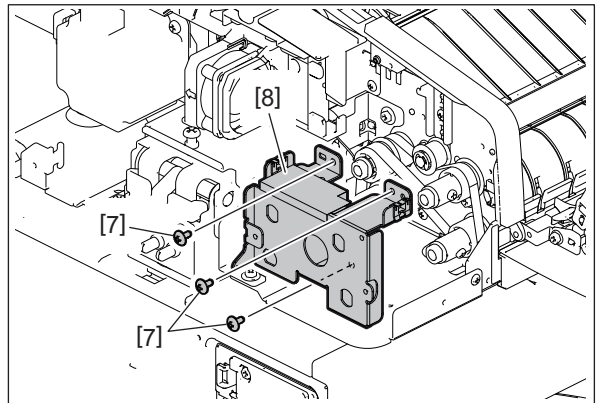

Fig. 4-55

- (7) Remove 1 timing belt [9] and 4 bushings [10].

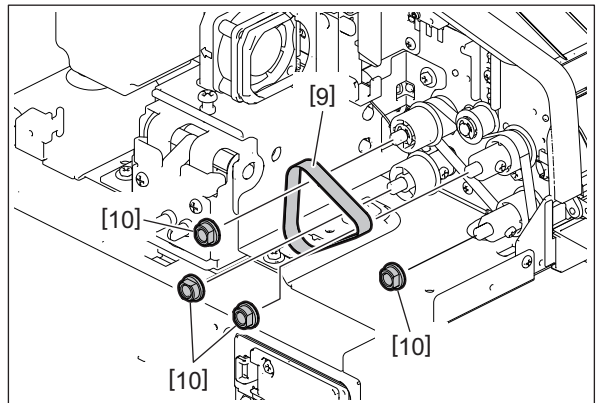

Fig. 4-56

- (8) Loosen 1 screw [12] of the tensioner [11].
- (9) Remove 1 E-ring [13], the pulley [14], pin [15] and timing belt [16].

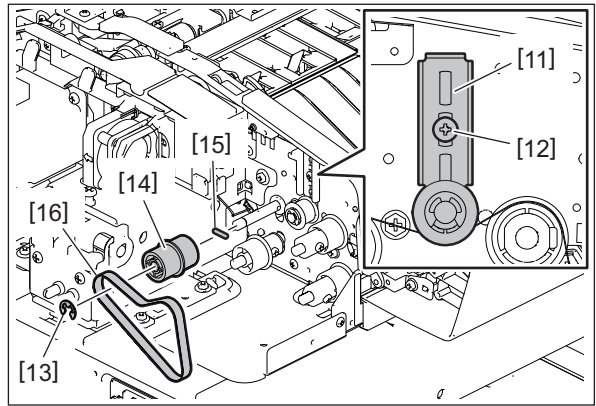

Fig. 4-57

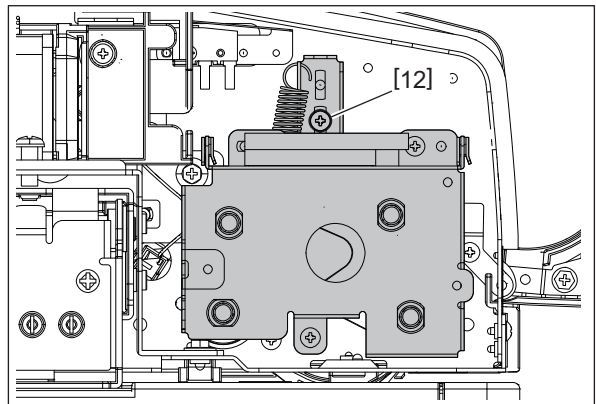

Fig. 4-58

Notes:

When installing, attach the parts removed in steps (5), (6), (7) and (9) and then the spring detached in step (4). Then securely tighten the screw loosened in step (8).

4.3.4 RADF original feed motor (M1)

- (1) Remove the RADF original feed motor unit.
📖 P. 4-24 “4.3.5 RADF original feed motor driving section”
- (2) Remove 2 screws [1] and take off the RADF original feed motor [2].

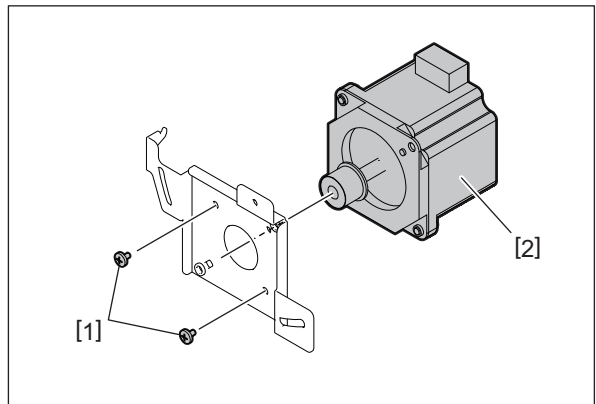

Fig. 4-59

4.3.5 RADF original feed motor driving section

- (1) Take off the rear cover.
📖 P. 4-2 “4.1.2 Rear cover”
- (2) Remove the harness guide.
📖 P. 4-6 “4.1.7 Harness guide”
- (3) Disconnect 1 connector [1]. Remove 1 spring [2].

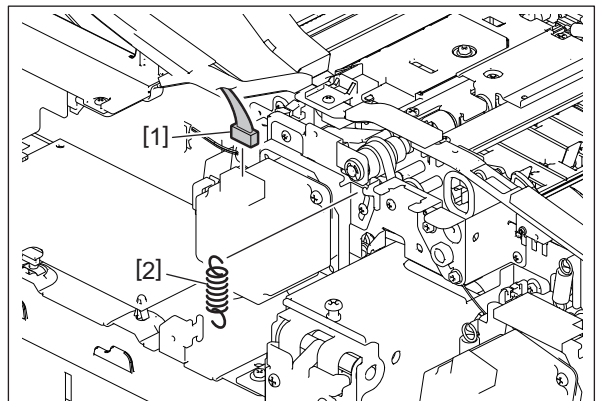

Fig. 4-60

Notes:

Spring color and shape

Black, Outside diameter of coil: $\varnothing 8$ mm, Active coils: 12.5

- (4) Remove 3 screws [3] and take off the RADF original feed motor unit [4].

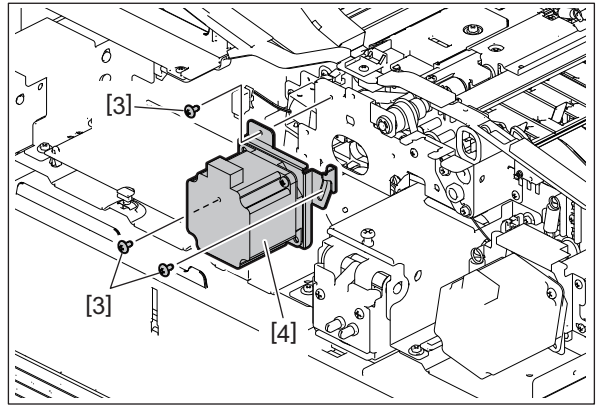

Fig. 4-61

Notes:

When installing, tighten the screws removed in step (4) temporarily and attach the spring detached in step (3). Then tighten the screws securely.

- (5) Remove 1 E-ring [5] and 1 bushing [6].
(6) Remove 2 screws [7] and take off the sub bracket [8].

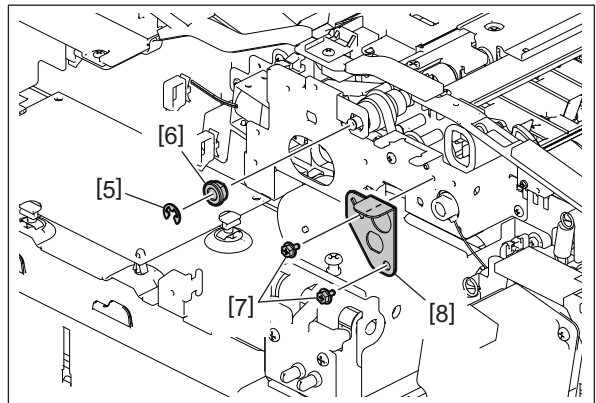

Fig. 4-62

Notes:

When installing, follow the steps below.

1. Loosen 2 screws [7] of the sub bracket [8].
2. Tighten the screws [3] of the RADF original feed motor unit [4] temporarily and attach the spring [2]. Then tighten the screws [3] securely.
3. Tighten 2 screws [7] of the sub bracket.

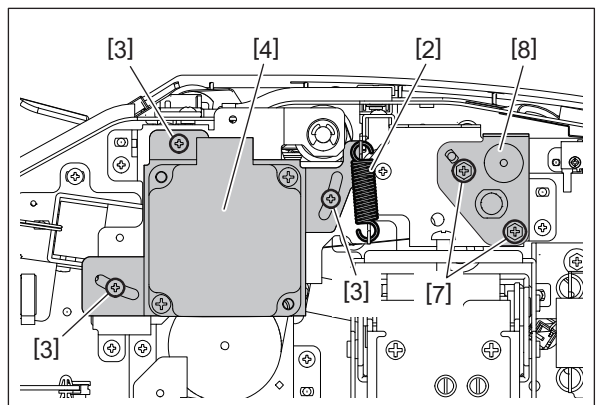

Fig. 4-63

- (7) Release the harness from the harness clamp [9].
- (8) Remove 4 screws [10] and take off the bracket [11].
- (9) Pull out 3 switch terminals.

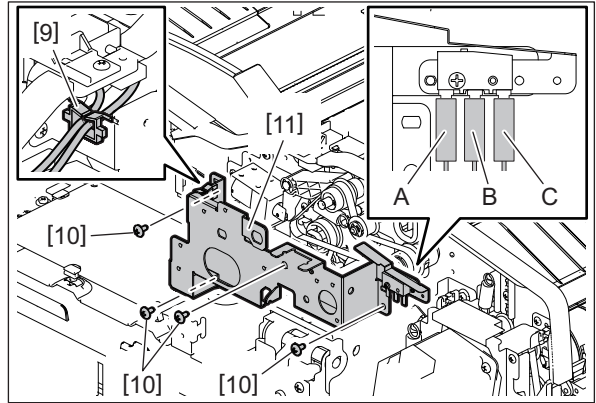

Fig. 4-64

Notes:

When installing them, be sure to check the harness color.

- A: White
- B: Red
- C: Black

- (10) Remove the timing belt [12], 1 bushing [13], 1 E-ring [14], pulley-1 [15], pulley-2 [16] and clutch [17].

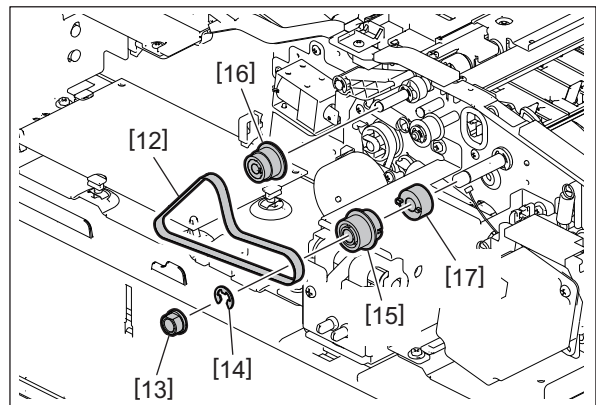

Fig. 4-65

4.3.6 RADF original exit/reverse motor (M3)

- (1) Remove the RADF original feed motor driving section.
P. 4-24 “4.3.5 RADF original feed motor driving section”
- (2) Disconnect 1 connector from the RADF control PC board.

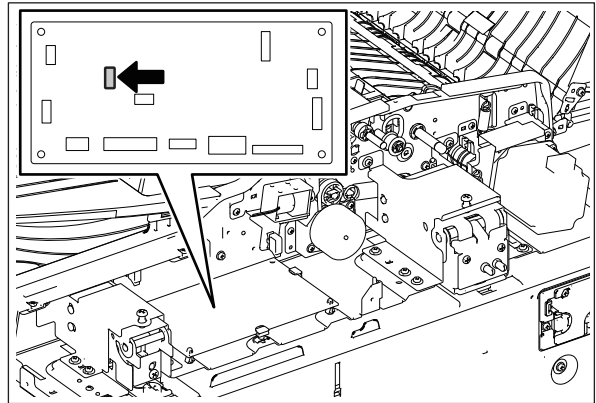

Fig. 4-66

- (3) Remove 2 screws [1] and take off the RADF original exit/reverse motor unit [2] and belt [3].

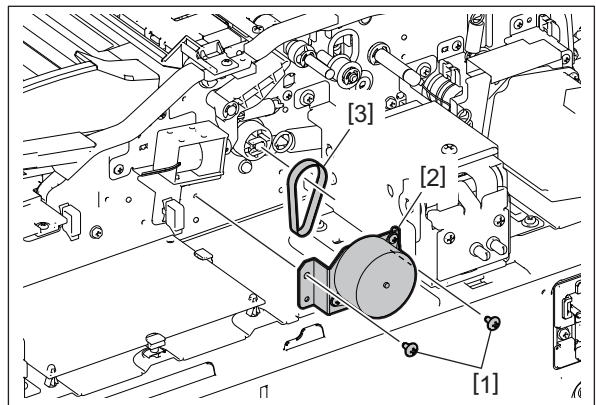

Fig. 4-67

- (4) Remove 2 screws [4] and slide the RADF original exit/reverse motor [5] and take it off from the bracket.

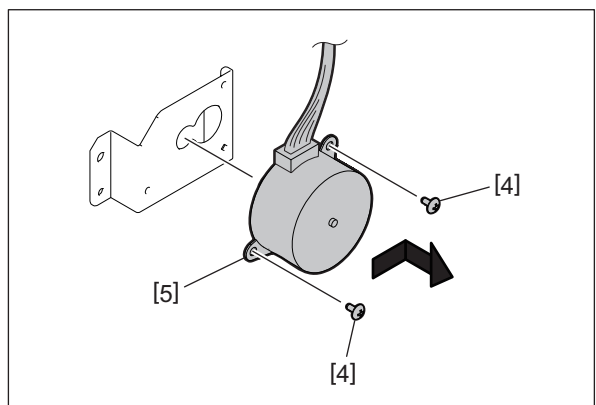

Fig. 4-68

4.4 Solenoid

4.4.1 RADF original pickup solenoid (SOL1)

- (1) Remove the RADF original feed motor driving section.
P. 4-24 “4.3.5 RADF original feed motor driving section”
- (2) Release the harness from the harness clamp [1] and disconnect 1 connector [2].
- (3) Remove 2 screws [3] and take off the RADF original pickup solenoid unit [4].

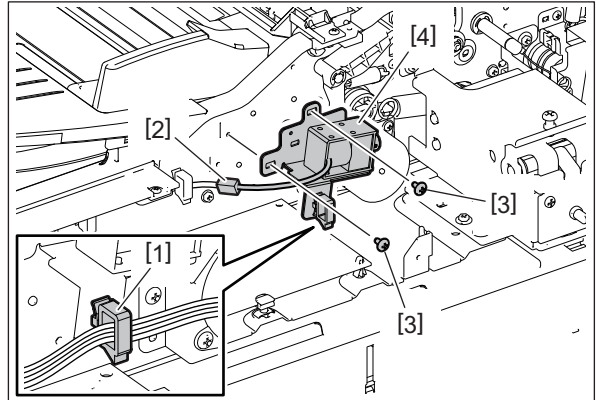

Fig. 4-69

- (4) Remove 2 screws [5] and take off the RADF original pickup solenoid [6].

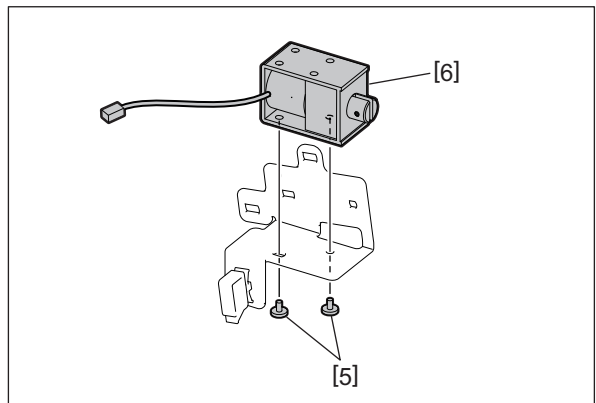

Fig. 4-70

Notes:

When installing, be sure to align the edge of the bracket to the mark-off line [7] on the frame and then tighten it.

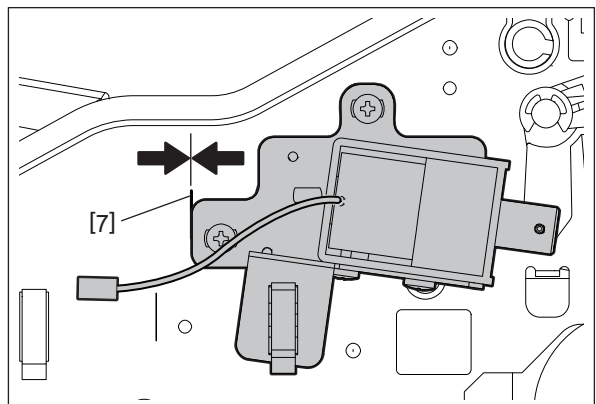



Fig. 4-71

4.5 Sensor and Switch

4.5.1 RADF tray original width sensor (S2)

- (1) Take off the original tray.
 P. 4-4 "4.1.5 Original tray"
- (2) Remove 3 screws. Release 8 latches and separate the original tray into 2 parts.

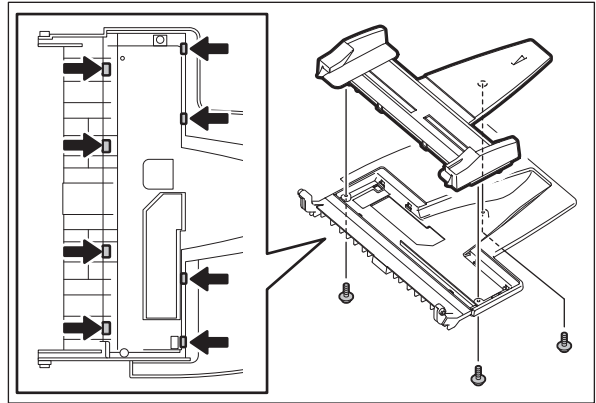

Fig. 4-72

- (3) Remove 1 screw and take off the cover [1].
- (4) Disconnect 1 connector [2] and remove the RADF tray original width sensor [3].

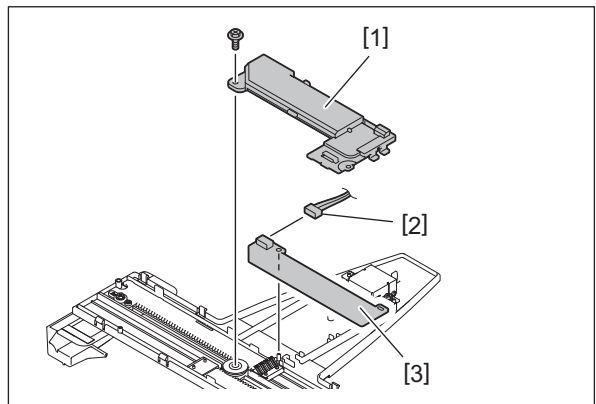

Fig. 4-73

Notes:

If the washers [4] (black: $t=0.25$), [5] (gold) and [6] (black: $t=0.13$) and a pinion [7] come off, assemble them in the order as shown in the figure.

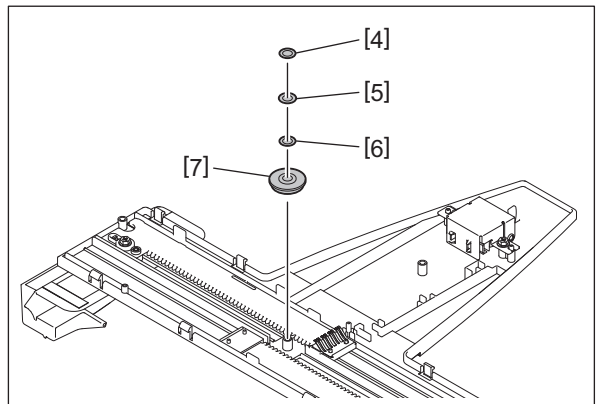

Fig. 4-74

4.5.2 RADF tray original length sensor (S1)

- (1) Take off the original tray.
P. 4-4 "4.1.5 Original tray"
- (2) Remove 3 screws. Release 8 latches and separate the original tray into 2 parts.

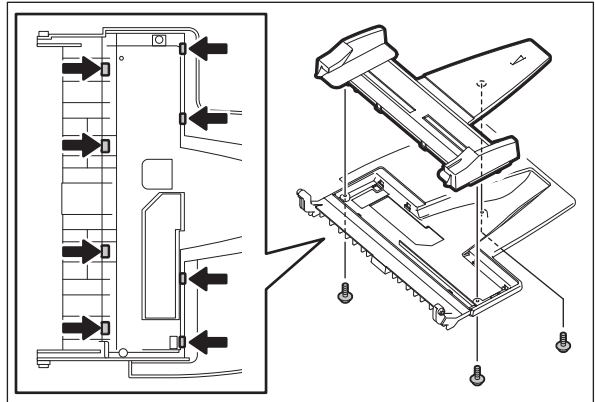

Fig. 4-75

- (3) Remove 2 screws and take off the holder [1].

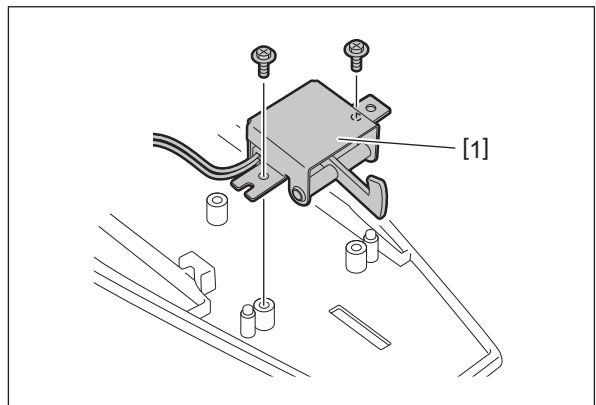

Fig. 4-76

- (4) Release 2 latches and remove the RADF tray original length sensor [2].

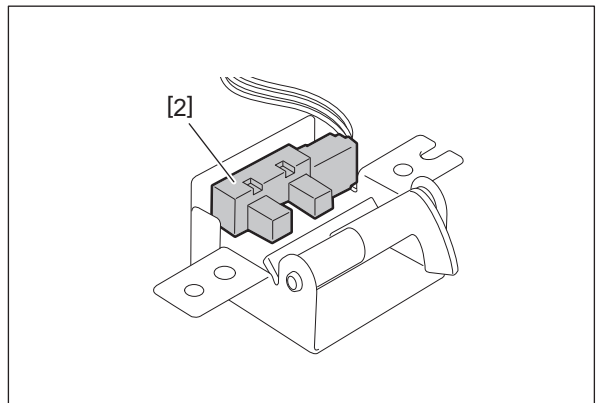

Fig. 4-77

4.5.3 RADF jam access cover sensor (S11)

- (1) Open the RADF jam access cover [1].
- (2) Remove 1 screw [1] and take off the cover [2].

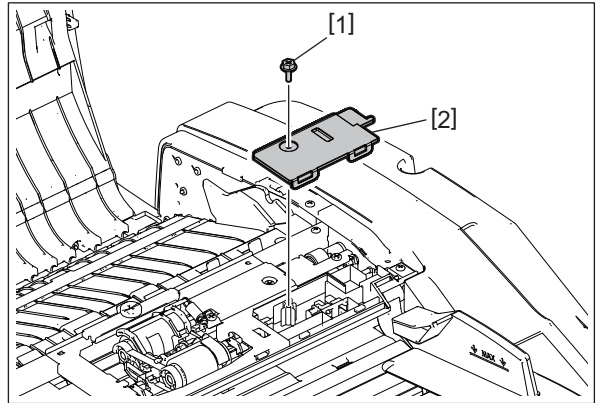

Fig. 4-78

- (3) Disconnect 1 connector [3]. Release 2 latches and take off the RADF jam access cover sensor [4].

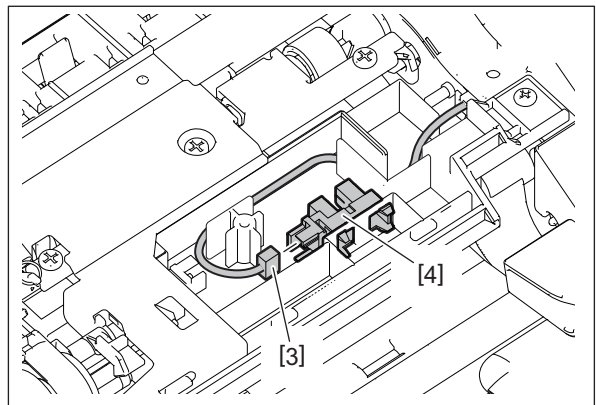

Fig. 4-79

4.5.4 RADF original empty sensor (S3)

- (1) Take off the cover.
☞ P. 4-31 “4.5.3 RADF jam access cover sensor (S11)”
- (2) Take off the RADF original feed unit.
☞ P. 4-7 “4.2.1 RADF original feed unit”
- (3) Disconnect 1 connector [1]. Release 2 latches and take off the RADF original empty sensor [2].

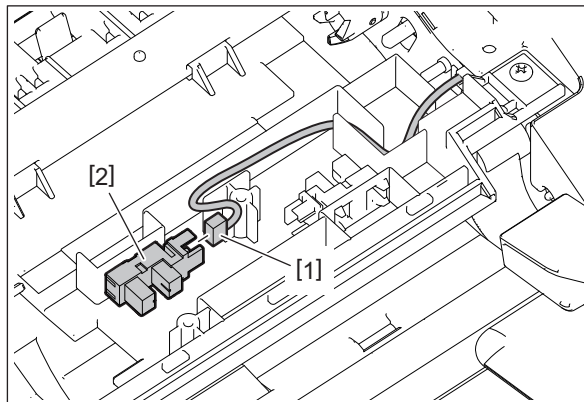

Fig. 4-80

4.5.5 RADF original length detection sensor (S4)

- (1) Remove the original feed lower guide.
☞ P. 4-10 “4.2.4 Original feed lower guide”
- (2) Remove the actuator [1] and spring [2].
- (3) Remove the RADF original length detection sensor [3] and disconnect 1 connector [4].

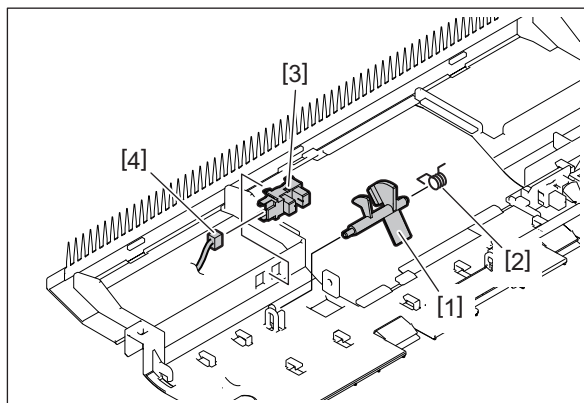

Fig. 4-81

4.5.6 RADF original registration sensor (S5)

- (1) Remove the original feed lower guide.
P. 4-10 “4.2.4 Original feed lower guide”
- (2) Remove the actuator [1] and spring [2].
- (3) Remove the RADF original registration sensor [3] and disconnect 1 connector [4].

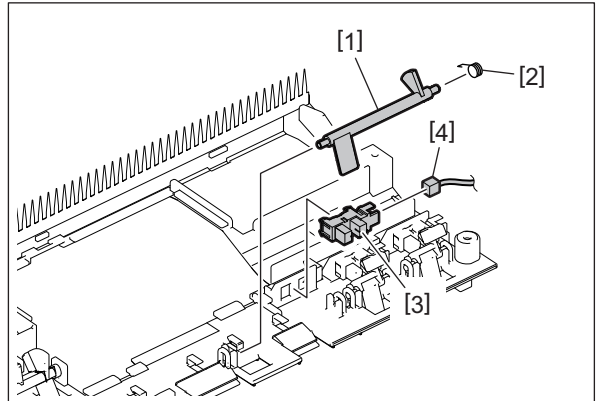

Fig. 4-82

4.5.7 RADF original width detection sensor-1 (S6)

- (1) Remove the original feed lower guide.
P. 4-10 “4.2.4 Original feed lower guide”
- (2) Remove the actuator [1].
- (3) Remove the RADF original width detection sensor-1 [2] and disconnect 1 connector [3].

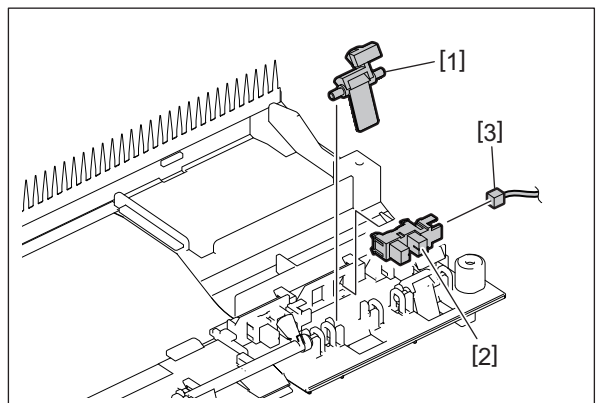

Fig. 4-83

4.5.8 RADF original width detection sensor-1 (S7)

- (1) Remove the original feed lower guide.
P. 4-10 “4.2.4 Original feed lower guide”
- (2) Remove the actuator [1].
- (3) Remove the RADF original width detection sensor-2 [2] and disconnect 1 connector [3].

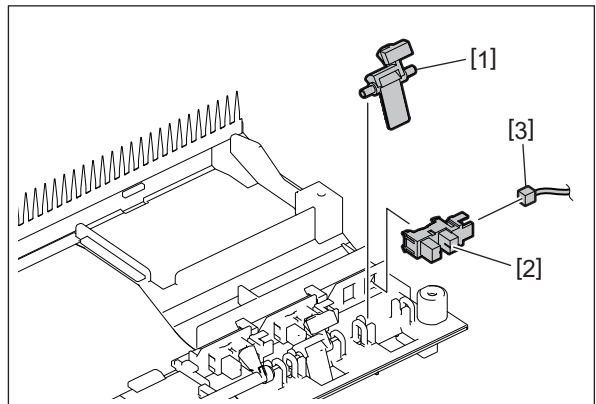

Fig. 4-84

4.5.9 RADF read sensor (S9)

- (1) Take off the pre-read guide.
P. 4-14 “4.2.7 Pre-read guide”
- (2) Remove 2 screws [1] and take off the pre-read upper guide [2].

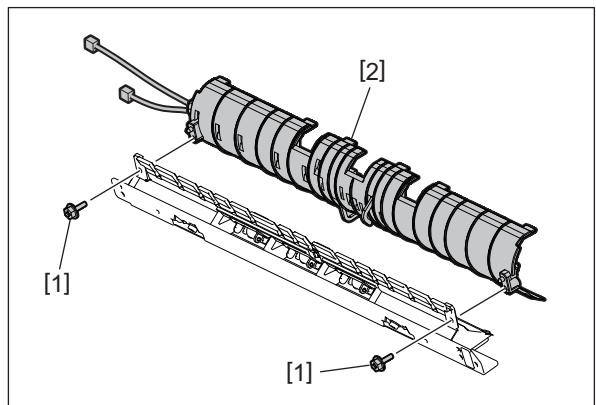

Fig. 4-85

- (3) Release the latch and remove the RADF read sensor [3].

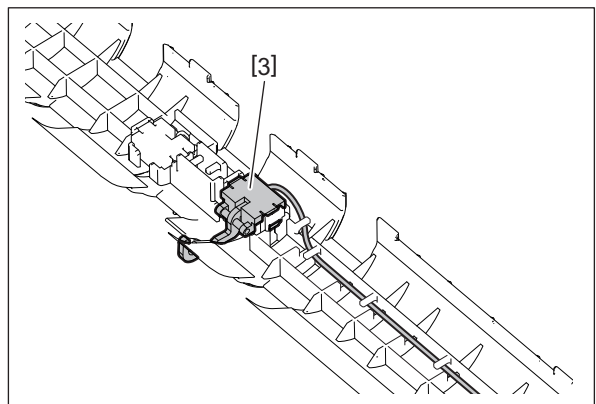

Fig. 4-86

4.5.10 RADF original intermediate transport sensor (S8)

- (1) Take off the pre-read upper guide.
📖 P. 4-34 “4.5.9 RADF read sensor (S9)”
- (2) Release the latch and remove the RADF original intermediate transport sensor [1].

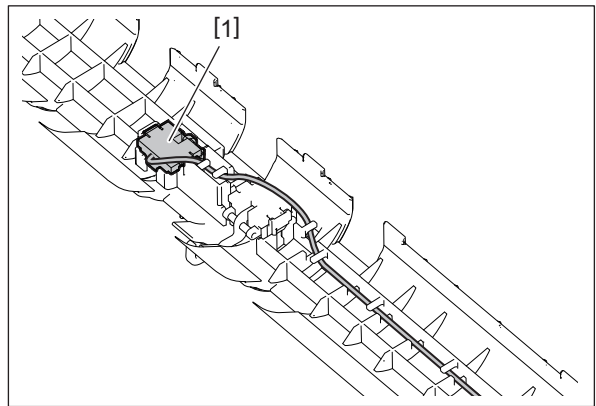

Fig. 4-87

4.5.11 RADF original exit/reverse sensor (S10)

- (1) Take off the post-read lower guide.
📖 P. 4-17 “4.2.10 RADF post-read roller”
- (2) Release the latch and take off the RADF original exit/reverse sensor [1].

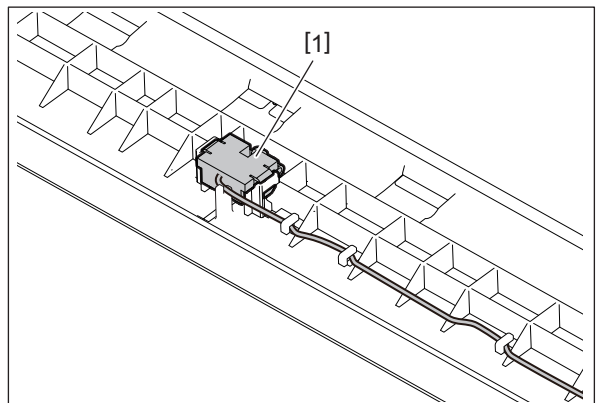

Fig. 4-88

4.5.12 RADF jam access cover opening/closing switch (SW1)

- (1) Remove the bracket of the RADF original feed motor driving section.
📖 P. 4-24 “4.3.5 RADF original feed motor driving section”
- (2) Remove 1 screw [1] and take off the RADF jam access cover opening/closing switch [2] and plate [3].

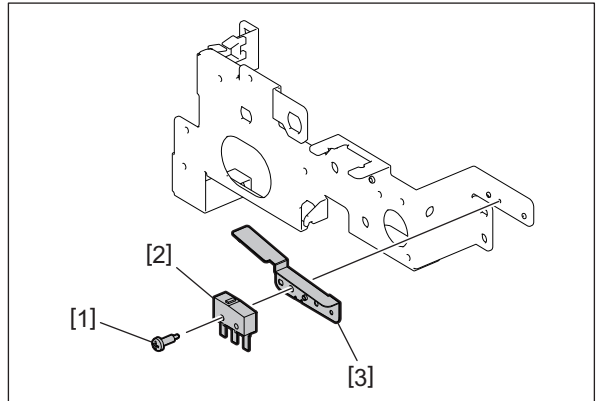

Fig. 4-89

4.6 PC Board

4.6.1 RADF control PC board (RADF board)

- (1) Take off the rear cover.
 P. 4-2 "4.1.2 Rear cover"
- (2) Disconnect all connectors connected to the RADF control PC board [1].

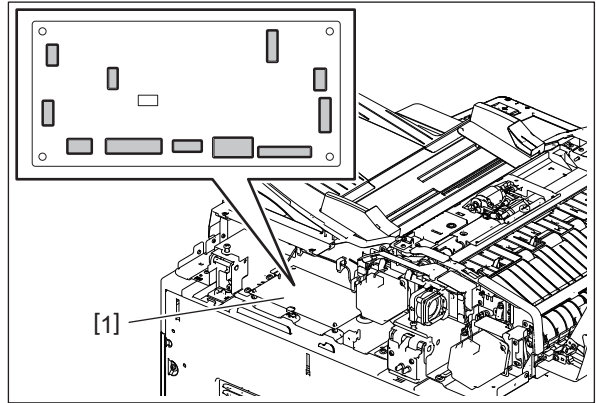

Fig. 4-90

- (3) Remove 2 locking supports [2], 3 edge spacers [3] and take off the RADF control PC board [1].

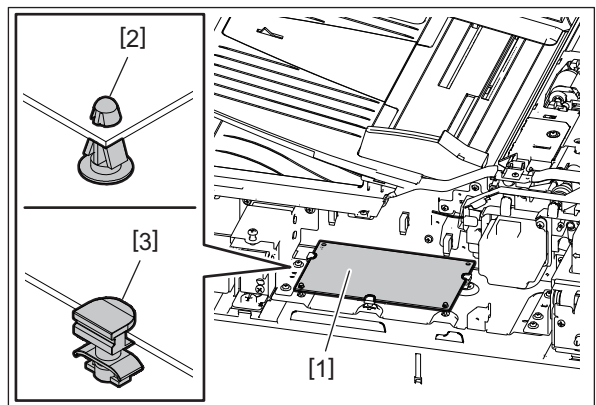

Fig. 4-91

4.6.2 LED board (LED)

- (1) Take off the front cover.
📖 P. 4-1 “4.1.1 Front cover”
- (2) Remove 1 screw [1] and take off the LED board [2].

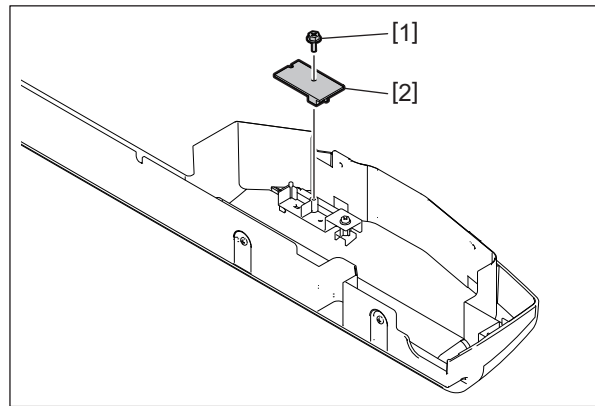

Fig. 4-92

4.7 Others

4.7.1 Hinge stopper

- (1) Remove 2 screws and take off the hinge stopper.

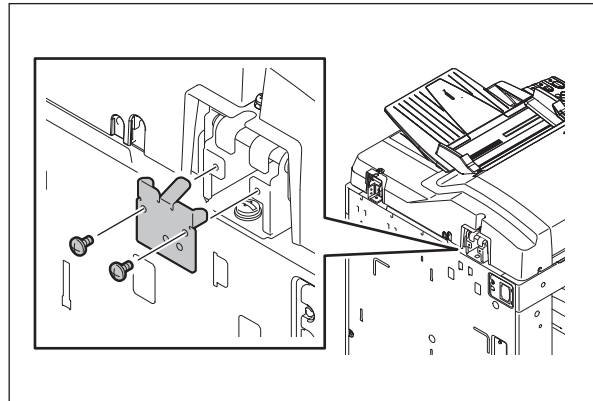

Fig. 4-93

Notes:

When the hinge stopper is taken off, the opening angle for the RADF becomes approx. 90 degrees. Take off the hinge stopper only when it is needed for installation, maintenance service, etc.

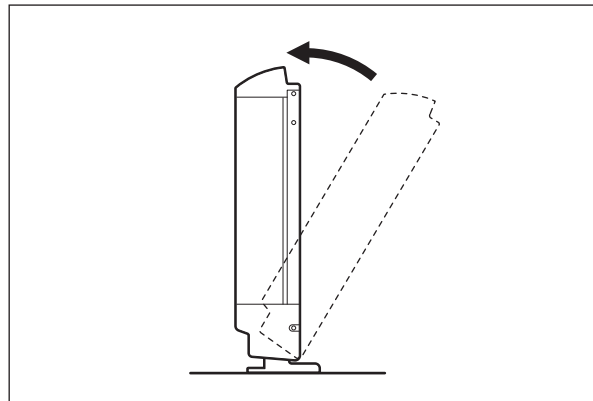

Fig. 4-94

4.7.2 RADF registration roller front sheet

- (1) Open the RADF jam access cover.
- (2) Peel off 2 RADF registration roller front sheets [1] and another 1 [2].

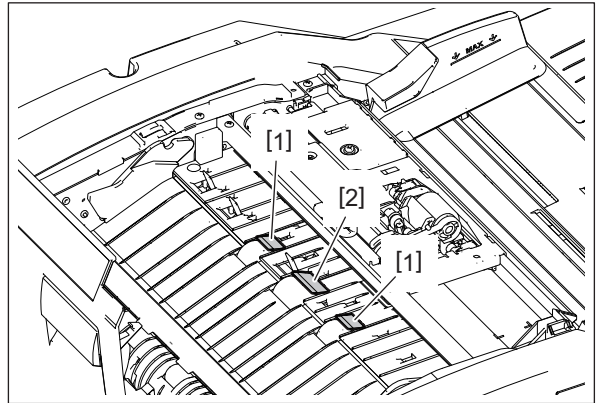

Fig. 4-95

Notes:

When installing, attach the RADF registration roller front sheets [1] [2] to the position indicated in the figure.

Before attaching the RADF registration roller front sheets [1], be sure to clean the attachment surface with alcohol. Attach them securely and check that they do not lift up or become unstuck.

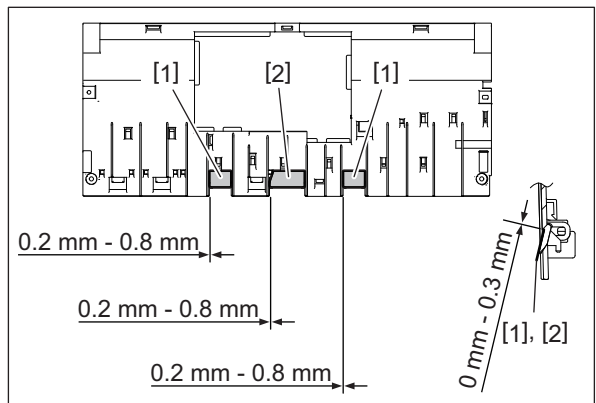

Fig. 4-96

5. ADJUSTMENT

5.1 Position Adjustment

Perform this adjustment when the RADF is not installed in the correct position.

Notes:

Check if the image adjustment for the MFP is performed properly before this adjustment of the RADF.

(See the Service Manual of the applicable MFP.)

5.1.1 Checking

- (1) Open the RADF and install 2 positioning pins. (The positioning pins are installed in the back side of the hinge which is on the left side of the RADF).

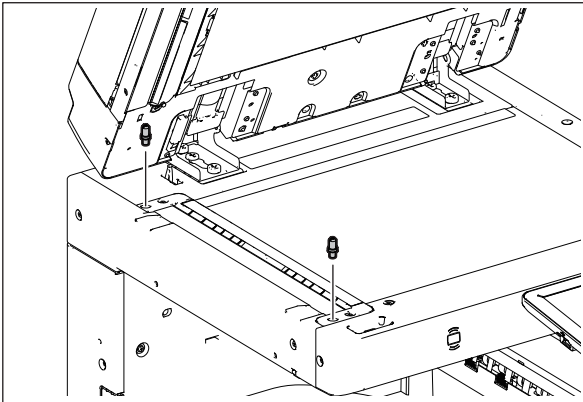

Fig.5-1

- (2) Remove the platen sheet.

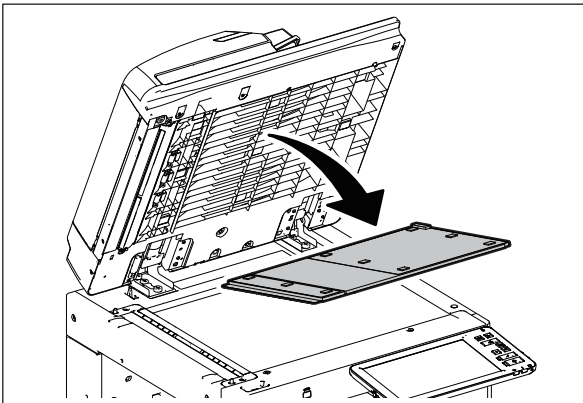

Fig.5-2

- (3) Close the RADF. Then check if the positioning pins fit the holes on the RADF.

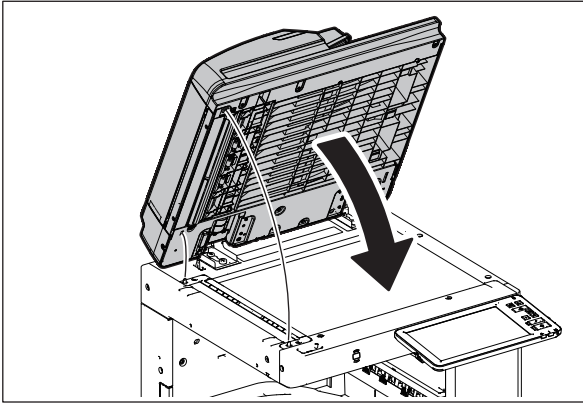

Fig.5-3

5.1.2 Adjustment

If the pins cannot be fitted into the holes, perform the adjustment according to the following procedure.

- (1) Remove the right-hand hinge screw at the rear side.

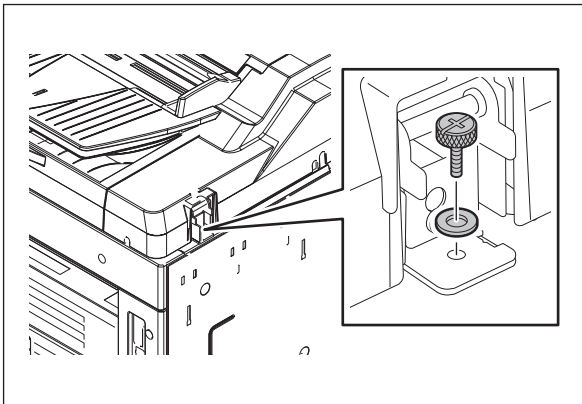

Fig.5-4

- (2) Remove the bracket on the left-hand hinge.

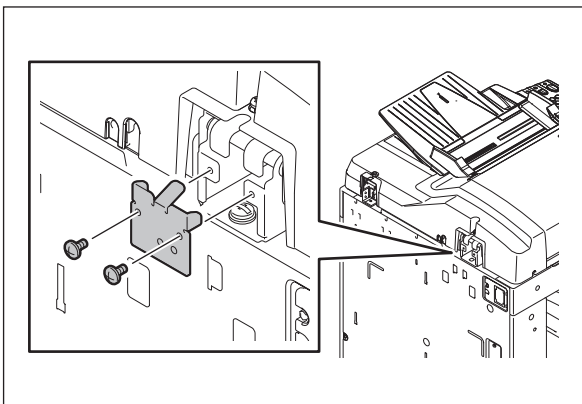

Fig.5-5

- (3) Loosen the left-hand hinge screw at the rear side.

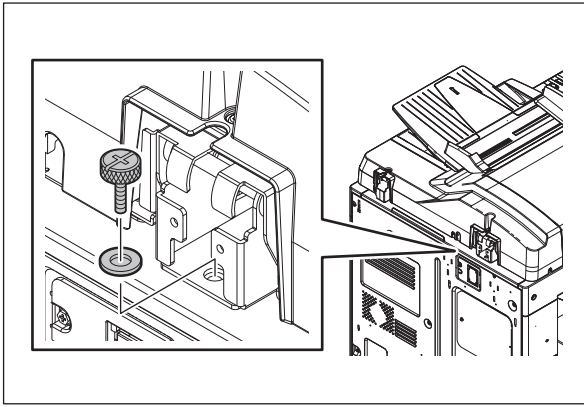

Fig.5-6

- (4) Loosen the hinge screw at the front side.

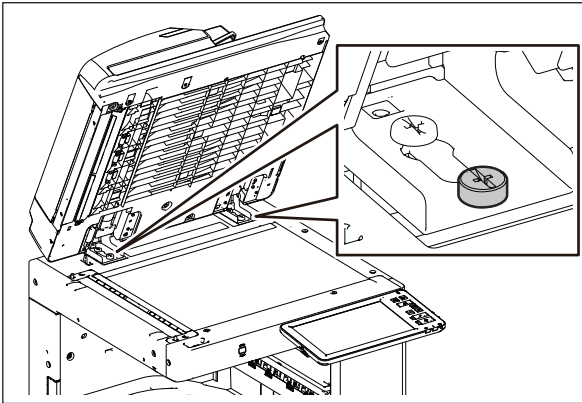

Fig.5-7

- (5) Position the pins with the holes on the RADF by moving it so that the pins fit into the holes when the RADF is closed.

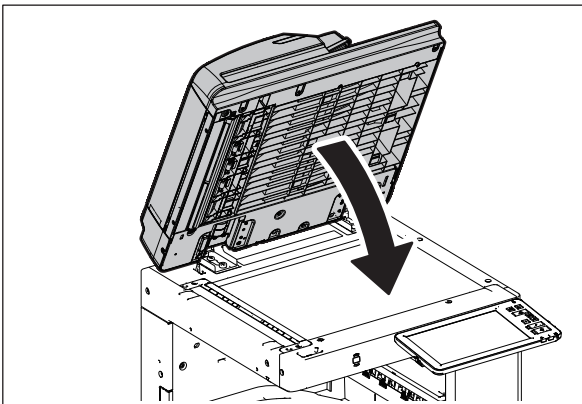

Fig.5-8

- (6) Tighten the left-hand hinge screw at the rear side.

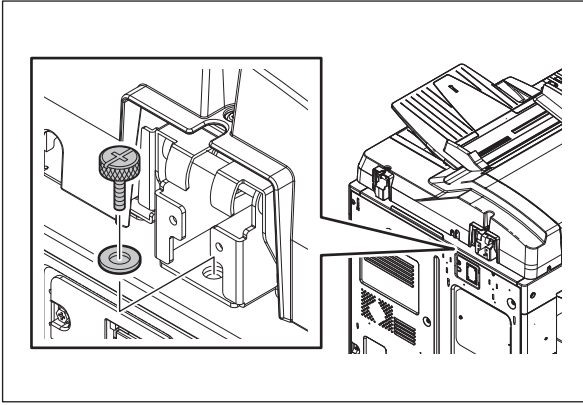

Fig.5-9

- (7) Match the screw hole position.
Turn it clockwise: Moves toward the rear side.
Turn it counterclockwise: Moves toward the front side.

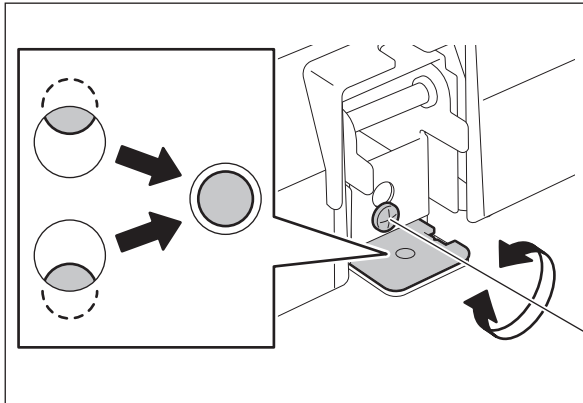

Fig.5-10

- (8) Install the right-hand hinge screw at the rear side.

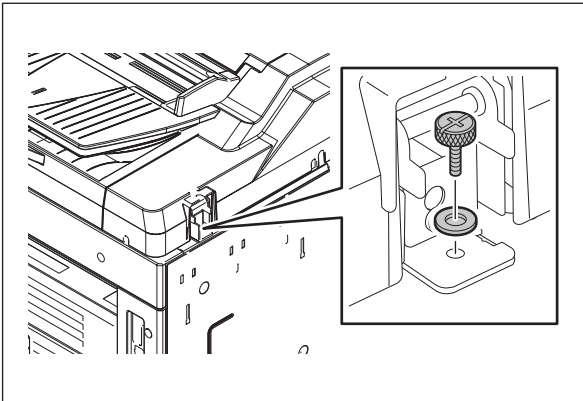

Fig.5-11

- (9) Install the bracket on the left-hand hinge.

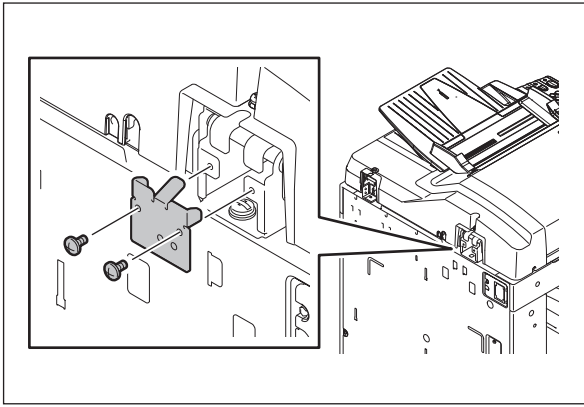

Fig.5-12

- (10) Loosen the hinge screws at the front side.

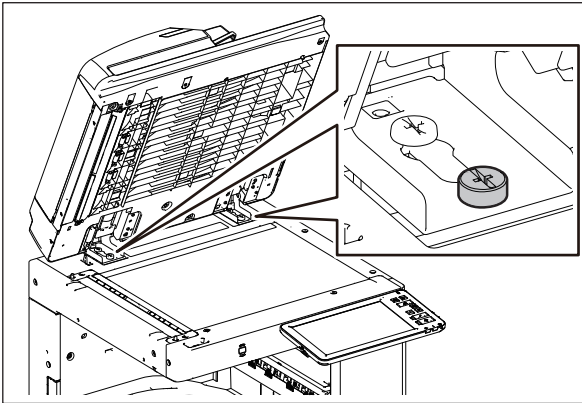

Fig.5-13

- (11) Place the platen sheet on the original glass and align it to the top left corner. Close the RADF gently and open it to check if the platen sheet is attached properly.

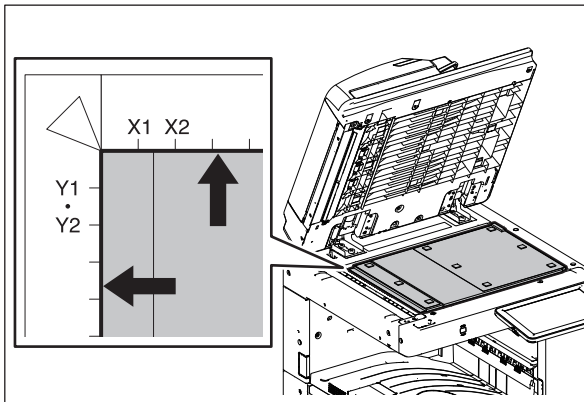

Fig.5-14

5.2 Height Adjustment

Notes:

Check if the image adjustment for the MFP is performed properly before this adjustment of the RADF.

(See the Service Manual of the applicable MFP.)

5.2.1 Checking

- (1) Close the RADF.
- (2) Turn on the exposure lamp.
By performing FS-03-267, the exposure lamp will light for a certain period.
- (3) Visually check the gap between platen guide holder "A" and upper surface of the original glass "B" from the left hand side of the MFP.

If the value is not within the tolerance, perform the adjustment according to the following procedure.

 P. 5-7 "5.2.2 Adjustment"

[Tolerance of the gap]

Rear side: 0 to 0.5 mm

Front side: 0 mm

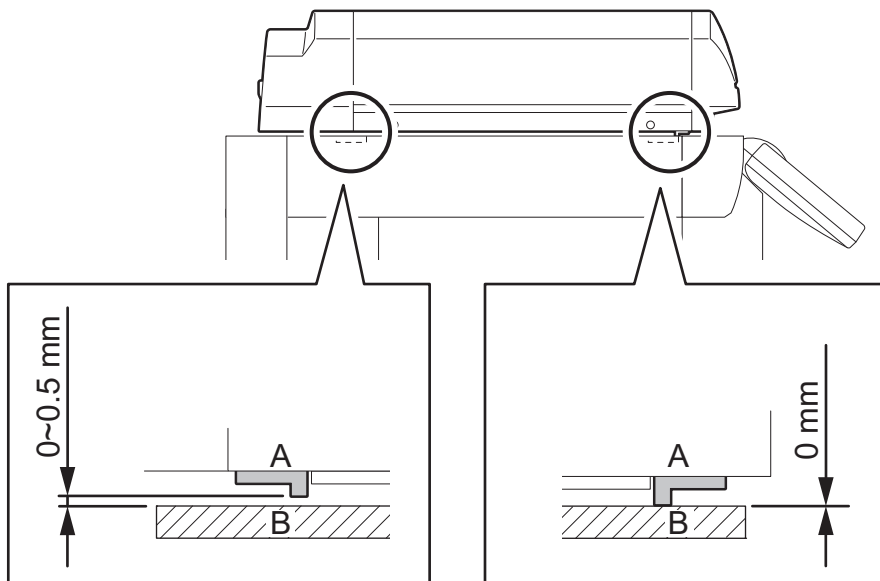

Fig.5-15

5.2.2 Adjustment

- (1) Close the RADF.
- (2) Adjust it by turning the adjustment screws on the hinges.
Adjust the height on the rear side by means of the screw on the hinge on the original feed side of the RADF.
Turn it clockwise: Heightened
Turn it counterclockwise: Lowered

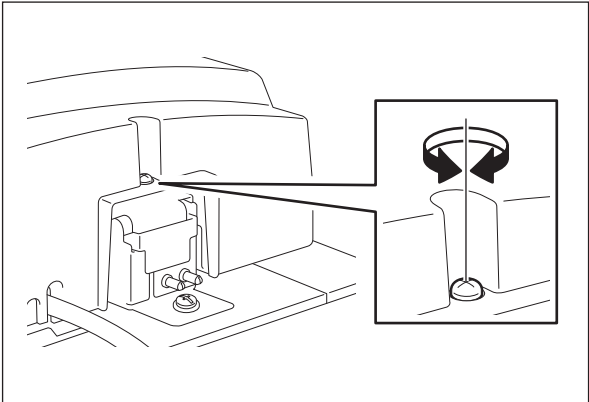

Fig.5-16

- Adjust the gap on the front side by means of the screw on the hinge on the original exit side of the RADF.
Turn it clockwise: Lowered
Turn it counterclockwise: Heightened

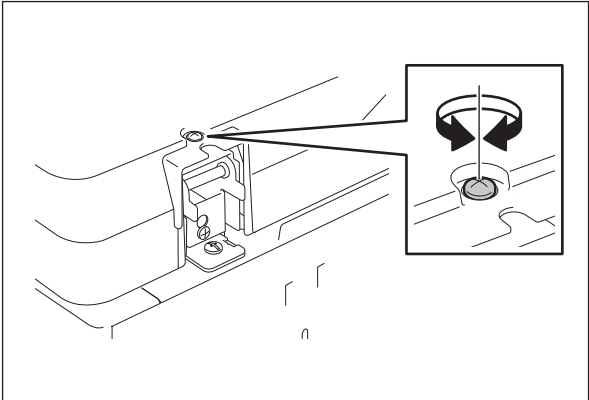

Fig.5-17

5.3 Skew adjustment

Notes:

Check if the image adjustment for the MFP is performed properly before this adjustment of the RADF.

(See the Service Manual of the applicable MFP.)

Also, the RADF position and height shall be adjusted properly.

5.3.1 Checking

Check the image using the chart (original) with vertical and horizontal lines in the following procedure.

Chart (original)

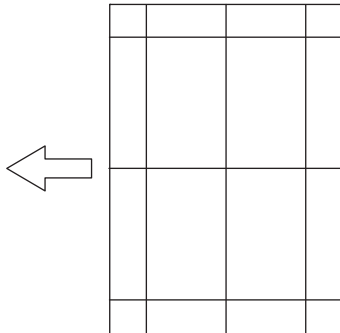

Fig.5-18

Simplex copying:

- (1) Place the chart provided as an original with its face up on the original tray of the RADF, select [Sort] and [1->1 Simplex] and then press the [START] button.
- (2) Superimpose the chart on the copy and check the inclination of the copy image.

Duplex copying:

- (1) Place the chart provided as an original with its face up on the original tray of the RADF, select [Sort] and [2 -> 2 Duplex] and then press the [START] button.
- (2) Superimpose the chart on the copy and check the inclination of the copy image.

5.3.2 Adjustment

Simplex copying:

- (1) Shift the aligning plate with the scale as the guide shown in the figure below to adjust the skew.

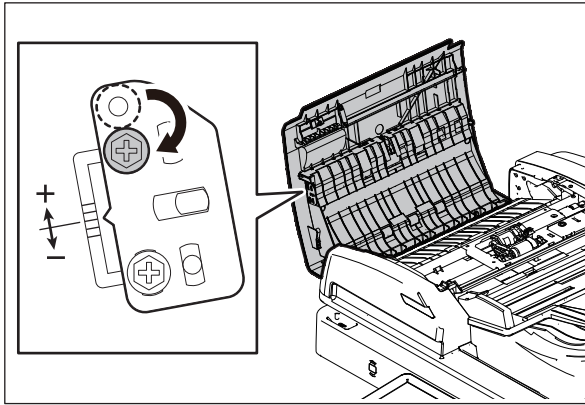

Fig.5-19

- (2) If the image skew is "C" as shown in the figure below, shift the aligning plate in the direction of "+", and if "D", shift it to "-".

Shift the aligning plate in the direction of "+".

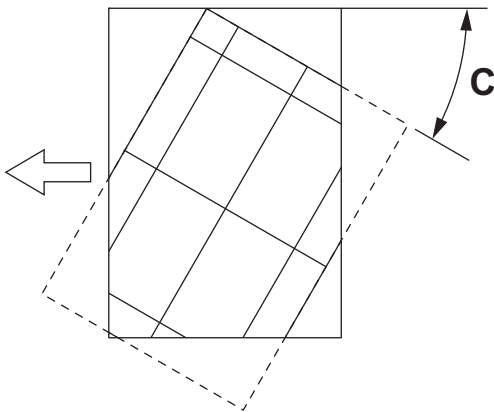

Fig.5-20

Shift the aligning plate in the direction of "-".

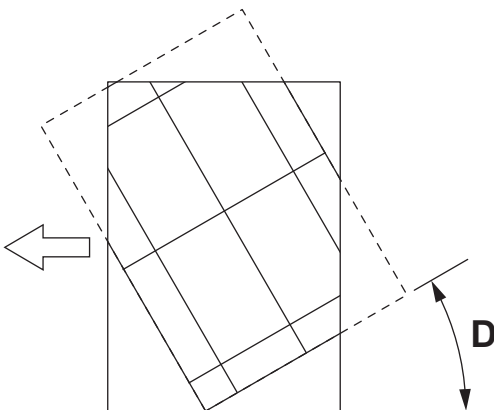

Fig.5-21

Duplex copying:

- (1) Shift the aligning plate with the scale as the guide shown in the figure below to adjust the skew.

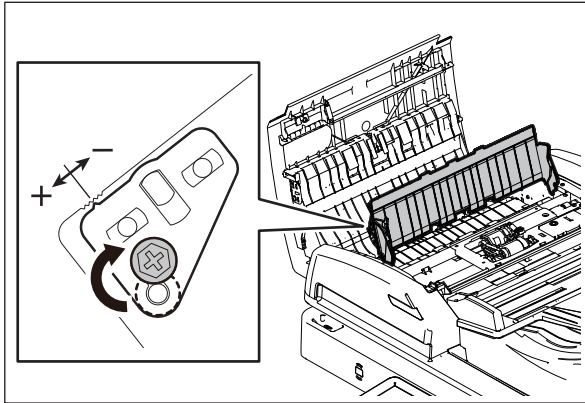

Fig.5-22

- (2) If the image skew is "C" as shown in the figure below, shift the aligning plate in the direction of "-", and if "D", shift it to "+".

Shift the aligning plate in the direction of "-".

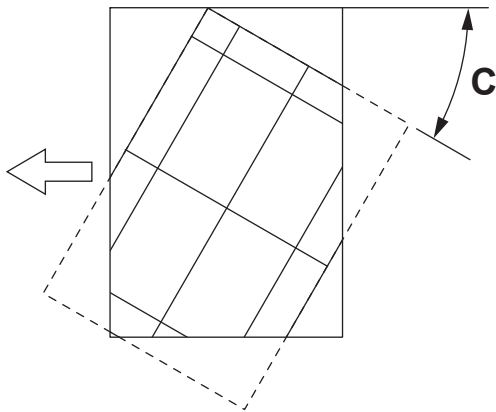

Fig.5-23

Shift the aligning plate in the direction of "+".

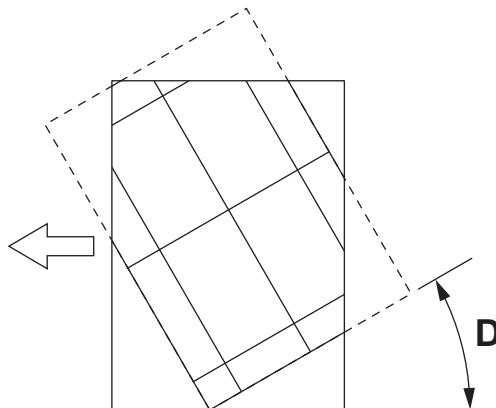

Fig.5-24

5.4 Leading Edge Position Adjustment

Notes:

Check if the image adjustment for the MFP is performed properly before this adjustment of the RADF.

(See the Service Manual of the applicable MFP.)

Also, the RADF position and height shall be adjusted properly.

5.4.1 Checking

Check the image using the chart (original) with vertical and horizontal lines in the following procedure.

Simplex copying:

- (1) Place the chart provided as an original with its face up on the original tray of the RADF, select [Sort] and [1->1 Simplex] and then press the [START] button.
- (2) Superimpose the chart on the copy and check the leading edge E of the chart and F of the copy.

Duplex copying:

- (1) Place the chart provided as an original with its face up on the original tray of the RADF, select [Sort] and [2 -> 2 Duplex] and then press the [START] button.
- (2) Superimpose the chart on the copy and check the leading edge E of the chart and F of the copy.

Chart (original)

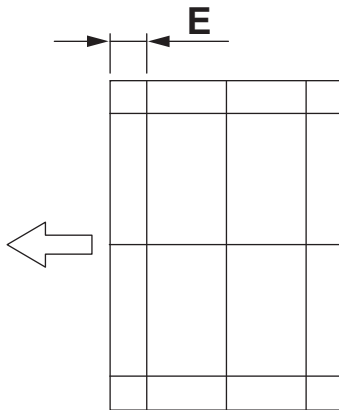

Fig.5-25

Copy

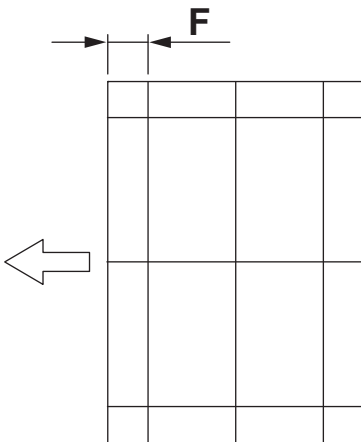

Fig.5-26

5.4.2 Adjustment

Simplex copying:

- (1) Perform FS-05-3044.
- (2) Enter the value.

If the leading edge (F) margin of the copy image is larger than the (E) margin of the chart:
Enter a value smaller than the current one.

If the leading edge (F) margin of the copy image is smaller than the (E) margin of the chart:
Enter a value larger than the current one.

Remarks:

Changing one value shifts the copy image by 0.1 mm.

- (3) Press the [OK] button.

Duplex copying:

- (1) Perform FS-05-3045.
- (2) Enter the value.

If the leading edge (F) margin of the copy image is larger than the (E) margin of the chart:
Enter a value smaller than the current one.

If the leading edge (F) margin of the copy image is smaller than the (E) margin of the chart:
Enter a value larger than the current one.

Remarks:

Changing one value shifts the copy image by 0.1 mm.

- (3) Press the [OK] button.

5.5 Horizontal Position Adjustment

Notes:

Check if the image adjustment for the MFP is performed properly before this adjustment of the RADF.

(See the Service Manual of the applicable MFP.)

Also, the RADF position and height shall be adjusted properly.

5.5.1 Checking

Check the image using the chart (original) with a center line in the following procedure.

- (1) Place the chart provided as an original with its face up on the original tray of the RADF.
- (2) Select [Sort] and press the [START] button.
- (3) Fold the copy in half and check if the center line is misaligned.

5.5.2 Adjustment

- (1) Perform FS-05-3043.

If the center line of the copy image is shifted to the front side of the MFP:
Enter a value larger than the current one.

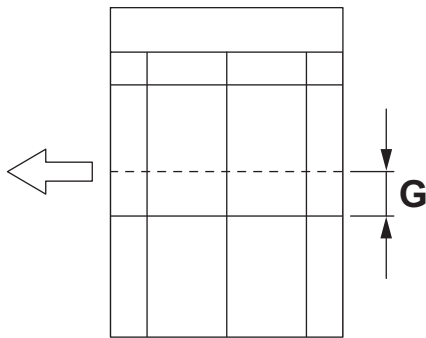

Fig.5-27

If the center line of the copy image is shifted to the rear side of the MFP:
Enter a value smaller than the current one.

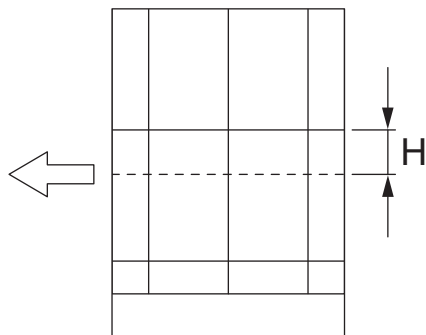

Fig.5-28

Remarks:

Changing one value shifts the copy image by 0.042 mm.

- (2) Press the [OK] button.

5.6 Copy Ratio Adjustment

Notes:

Check if the image adjustment for the MFP is performed properly before this adjustment of the RADF.

(See the Service Manual of the applicable MFP.)

Also, the RADF position and height shall be adjusted properly.

5.6.1 Checking

Check the image using the chart (original) with vertical and horizontal lines in the following procedure.

- (1) Place the chart provided as an original with its face up on the original tray of the RADF.
- (2) Select [Sort] and press the [START] button.
- (3) Superimpose the chart on the copy and check the image dimension "I".

5.6.2 Adjustment

- (1) Perform FS-05-3042.

If the copy image dimension "I" is larger than the chart dimension:

Enter a value smaller than the current one.

If the copy image dimension "I" is smaller than the chart dimension:

Enter a value larger than the current one.

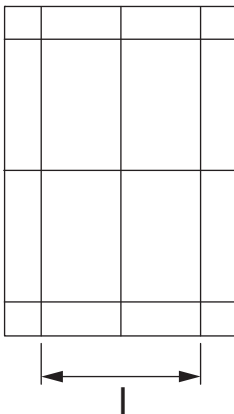

Fig.5-29

Remarks:

When the value increases by "1", the reproduction ratio of the secondary scanning direction when using the RADF increases by approx. 0.1%.

- (2) Press the [OK] button.

5.7 RADF Separation Roller Pressure Force Adjustment

In cases, the life of the separation roller may be shortened or paper misfeeding (E712, E721) and multiple feeding (E724) may occur regardless of the operation frequency of the Reversing Automatic Document Feeder (RADF). This comes from the weight or edge status of paper used and the amount of paper dust.

Generally, paper misfeeding and multiple feeding often occur around the life end of the roller. However, if they often occur even though its life has not yet reached its replacement timing, or if the life end comes much earlier than the scheduled replacement timing, paper misfeeding and multiple feeding can be suppressed by adjusting the pressure force of the separation roller.

In this method; however, when the roller life becomes longer, paper misfeeding and multiple feeding may occur frequently and when they are suppressed, the roller life may become shorter. Therefore, perform this adjustment while checking the status carefully, and if necessary, give a sufficient explanation to the users.

5.7.1 Adjustment procedure

- (1) Take off the RADF separation roller holder.
 P. 4-9 "4.2.3 RADF separation roller"
- (2) While holding the bracket [1] with your hand firmly, remove the screw [2].

Notes:

When taking off the bracket [1], keep it setting up because it is tensed with a spring to L direction.

- (3) Move the bracket [1].
 - Move to the direction R: Paper misfeeding (E712, E721) will be suppressed. The roller life will become longer (but multiple feeding may occur frequently).
 - Move to the direction L: Multiple feeding will be suppressed (but the roller life may become shorter).
 - The upper limit of the movement of the bracket for the adjustment is 1 scale. If the bracket is moved by 2 scales, deterioration of the pressure spring may occur.
- (4) Tighten the screw [2].

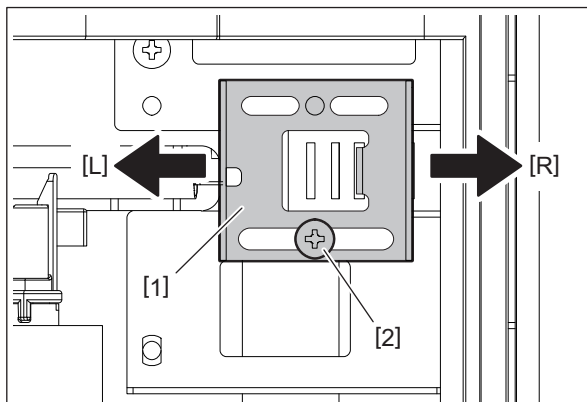

Fig.5-30

5.8 Platen Sheet

If a shadow-like dark area appears on the edge of the image, reset the platen sheet.

- (1) Open the RADF and remove the platen sheet.

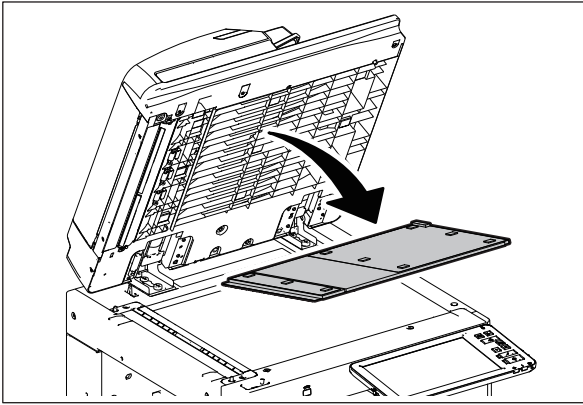

Fig.5-31

- (2) Place the platen sheet on the original glass and align it to the top left corner. Close the RADF gently and open it to check if the platen sheet is attached properly.

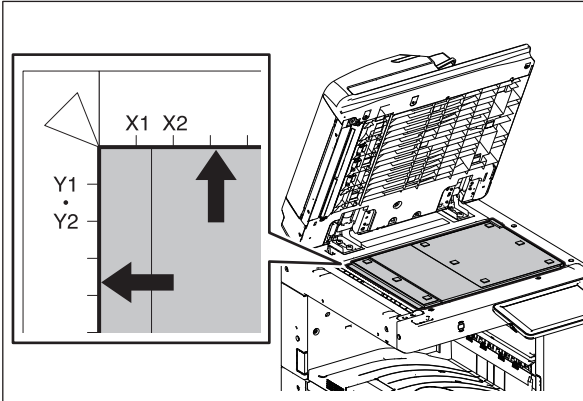

Fig.5-32

6. TROUBLESHOOTING

6.1 Troubleshooting for Mechanical Errors

1. Multiple originals are transported simultaneously.

Step	Check item	Result	Measures
1	An original is abnormally curled or folded.	Yes	Flatten the original and set it again
		No	Go to step 2.
2	The RADF separation roller is dirty.	Yes	Clean it with alcohol.
		No	Replace the RADF separation roller.

2. An original is not transported to the RADF registration roller.

Step	Check item	Result	Measures
1	An original outside the specifications is used.	Yes	Only the original within the specifications can be used. For an original outside the specifications, place it on the original glass to make a copy manually.
		No	Go to step 2.
2	The RADF pickup roller and RADF original feed roller are dirty.	Yes	Clean it with alcohol.
		No	Go to step 3.
3	The transport power of the RADF pickup roller and RADF original feed roller is weak.	Yes	Replace the RADF pickup roller and the RADF original feed roller.
		No	Go to step 4.
4	Timing belt	Yes	Check the timing belt of each transport roller. If the belt has come off or its tension is loosened, correct this.
		No	Go to step 5.
5	RADF board	Yes	Check if there is any abnormality in the RADF board. If there is any abnormality, replace it.

3. Size detection error

Step	Check item	Result	Measures
1	The RADF tray original length sensor is turned on when there is paper.	Yes	Go to step 2.
		No	- Check the RADF tray original length sensor. If there is an abnormality, replace it. - Replace the harness.
2	The RADF registration roller does not catch the original.	Yes	- Clean it with alcohol. - Replace the RADF registration roller.
		No	Go to step 3.
3	The RADF original width detection sensor-1 is turned on when there is paper.	Yes	Go to step 4.
		No	- Check the RADF original width detection sensor-1. If there is an abnormality, replace it. - Replace the harness.
4	The RADF original width detection sensor-2 is turned on when there is paper.	Yes	Check the RADF control PC board. If there is an abnormality, replace it.
		No	- Check the RADF original width detection sensor-2. If there is an abnormality, replace it. - Replace the harness.
5	RADF tray original width sensor	-	- Check if there is any foreign matter or abnormality in the RADF tray original width sensor. If there is any foreign matter, clean it. If there is any abnormality, replace it. - Apply contact grease to the RADF tray original width sensor. (*1) - Check if there is no abnormality in the leaf spring. If there is any abnormality, replace it.

*1: When the rack or the RADF tray original width sensor is replaced, apply an appropriate amount (approx. 0.003 cc) of contact grease (G-347CA) to the terminals of the rack.

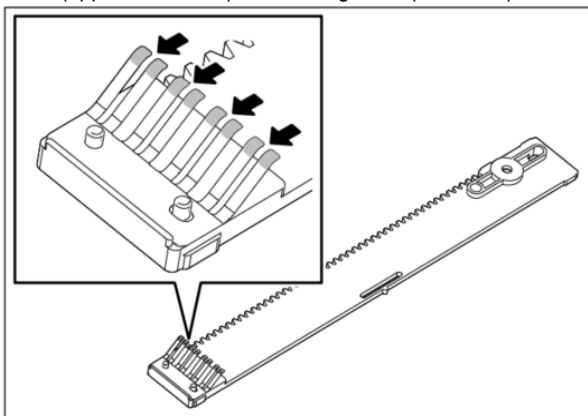

6.2 Troubleshooting for Electrical Errors

1. The RADF does not work. (Except in the case of a paper misfeeding or when the cover is open)

Step	Check item	Result	Measures
1	The interface harness is connected to the MFP properly.	Yes	Go to step 2.
		No	Reconnect the interface harness properly or replace it.
2	The DC +5 V is supplied to the connectors CN70-2-pin and 3-pin.	Yes	Go to step 3.
		No	Reconnect the connectors properly or replace the harness.
3	The DC +24 V is supplied to the connectors CN70-6-pin and 7-pin.	Yes	Go to step 4.
		No	Reconnect the connectors properly or replace the harness.
4	The DC +24 V is supplied to the connector CN70-4-pin.	Yes	Go to step 5.
		No	Check the RADF jam access cover opening/closing switch. If there is an abnormality, replace the connector.
5	The RADF original empty sensor is turned on when there is paper.	Yes	Check the RADF control PC board. If there is an abnormality, replace it.
		No	Check the RADF original empty sensor. If there is an abnormality, replace it.

2. Communication error

Step	Check item	Result	Measures
1	The interface harness is normal.	Yes	<ul style="list-style-type: none"> Check the RADF control PC board. If there is an abnormality, replace it. Check the MFP.
		No	Replace the interface harness.

3. Size detection error

Step	Check item	Result	Measures
1	The RADF tray original length sensor is turned on when there is paper.	Yes	Go to step 2.
		No	<ul style="list-style-type: none"> Check the RADF tray original length sensor. If there is an abnormality, replace it. Replace the harness.
2	The RADF registration roller does not catch the original.	Yes	<ul style="list-style-type: none"> Clean it with alcohol. Replace the RADF registration roller.
		No	Go to step 3.
3	The RADF original width detection sensor-1 is turned on when there is paper.	Yes	Go to step 4.
		No	<ul style="list-style-type: none"> Check the RADF original width detection sensor-1. If there is an abnormality, replace it. Replace the harness.
4	The RADF original width detection sensor-2 is turned on when there is paper.	Yes	Check the RADF control PC board. If there is an abnormality, replace it.
		No	<ul style="list-style-type: none"> Check the RADF original width detection sensor-2. If there is an abnormality, replace it. Replace the harness.

6.3 Paper Misfeeding

Original not reaching the RADF original registration sensor jam

1. If the RADF pickup roller, RADF original feed roller and RADF separation roller are dirty, clean them.
2. If an original is curled abnormally or is folded, flatten and reload it.
3. Check if the RADF original registration sensor is working. (Perform the input check.)
 - * If it is working properly, go to step 7. If not, check steps 4 to 6.
4. Check if the connector CN74 on the RADF control PC board is disconnected from the RADF original registration sensor or the harnesses are open circuited. Correct if any.
5. Replace the RADF original registration sensor.
6. Replace the RADF control PC board.
7. Check if the RADF original pickup solenoid is working properly.
 - * If it is working properly, go to step 12. If not, check steps 8 to 11.
8. Check if the RADF original pickup solenoid is installed at the center of the scale. (The scale is longer in the center.)
9. If it is not, correct the position, aligning with the center of the scale.
10. Check if the connector CN79 on the RADF control PC board is disconnected from the RADF original pickup solenoid or the harnesses are open circuited. Correct if any.
11. Replace the RADF original pickup solenoid.
12. Replace the RADF control PC board.
13. If the RADF pickup roller, RADF original feed roller and RADF separation roller are worn out, replace them.

Original feed signal reception jam

1. Check if the RADF original empty sensor is working. (Perform the input check.)
2. Check if the lever of the RADF original empty sensor is working normally.
3. Check if the connector CN75 on the RADF control PC board is disconnected from the RADF original empty sensor or the harnesses are open circuited. Correct if any.
4. Replace the RADF original empty sensor.

Original not reaching the RADF read sensor jam

1. If the RADF registration roller and RADF read roller are dirty, clean them.
2. Check if the RADF read sensor is working. (Perform the input check.)
 - * If it is working properly, go to step 6. If not, check steps 3 to 5.
3. Check if the connector CN75 on the RADF control PC board is disconnected from the RADF read sensor or the harnesses are open circuited. Correct if any.
4. Replace the RADF read sensor.
5. Replace the RADF control PC board.
6. If the RADF registration roller and RADF read roller are worn out, replace them.

Original not reaching the RADF original exit/reverse sensor jam (during scanning)

1. If the RADF read roller is dirty, clean it.
2. Check if the RADF original exit/reverse sensor is working. (Perform the input check.)
 - * If it is working properly, go to step 6. If not, check steps 3 to 5.
3. Check if the connector CN75 on the RADF control PC board is disconnected from the RADF original exit/reverse sensor or the harnesses are open circuited. Correct if any.
4. Replace the RADF original exit/reverse sensor.
5. Replace the RADF control PC board.
6. If the RADF read roller is worn out, replace it.

Original stopping jam at the RADF original registration sensor

1. If the RADF registration roller is dirty, clean it.
2. Check if the RADF original registration sensor, RADF original width detection sensor-1, RADF original width detection sensor-2 and RADF original length detection sensor are working. (Perform the input check.)
 - * If it is working properly, go to step 9. If not, check steps 3 to 8.
3. Check if the connector CN74 on the RADF control PC board is disconnected from the RADF original registration sensor or the harnesses are open circuited. Correct if any.
4. Check if the connector CN74 on the RADF control PC board is disconnected from the RADF original width detection sensor-1 or the harnesses are open circuited. Correct if any.
5. Check if the connector CN74 on the RADF control PC board is disconnected from the RADF original width detection sensor-2 or the harnesses are open circuited. Correct if any.
6. Check if the connector CN74 on the RADF control PC board is disconnected from the RADF original length detection sensor or the harnesses are open circuited. Correct if any.
7. Replace the RADF original registration sensor.
8. Replace the RADF original width detection sensor-1.
9. Replace the RADF original width detection sensor-2.
10. Replace the RADF original length detection sensor.
11. Replace the RADF control PC board.
12. If the RADF registration roller is worn out, replace it.

Original stopping jam at the RADF read sensor

1. If the RADF read roller is dirty, clean it.
2. Check if the RADF read sensor and RADF original intermediate transport sensor are working. (Perform the input check.)
 - * If it is working properly, go to step 8. If not, check steps 3 to 7.
3. Check if the connector CN75 on the RADF control PC board is disconnected from the RADF read sensor or the harnesses are open circuited. Correct if any.
4. Check if the connector CN75 on the RADF control PC board is disconnected from the RADF original intermediate transport sensor or the harnesses are open circuited. Correct if any.
5. Replace the RADF read sensor.
6. Replace the RADF original intermediate transport sensor.
7. Replace the RADF control PC board.
8. If the RADF read roller is worn out, replace it.

Original stopping jam at the RADF original exit/reverse sensor

1. If the RADF original exit roller is dirty, clean it.
2. Check if the RADF original exit/reverse sensor is working. (Perform the input check.)
 - * If it is working properly, go to step 6. If not, check steps 3 to 5.
3. Check if the connector CN75 on the RADF control PC board is disconnected from the RADF original exit/reverse sensor or the harnesses are open circuited. Correct if any.
4. Replace the RADF original exit/reverse sensor.
5. Replace the RADF control PC board.
6. If the RADF original exit roller is worn out, replace it.

RADF jam access cover open jam

1. If the RADF jam access cover is opened, close it. If there is any original, remove it.
2. Check if the RADF jam access cover opening/closing switch is working. (Perform the input check.)
3. Check if the connector CN72 on the RADF control PC board is disconnected from the RADF jam access cover opening/closing switch or the harnesses are open circuited. Correct if any.
4. Replace the RADF jam access cover opening/closing switch.
5. Replace the RADF control PC board.

RADF open jam

1. If the RADF is opened, close it. If there is any original, remove it.
2. Check if the platen sensor-1 and platen sensor-2 in the MFP are working. (Perform the input check.)
3. Check if the connector CN121 on the SYS board is disconnected from the platen sensor-1 and platen sensor-2 in the MFP or the harnesses are open circuited. Correct if any.
4. Replace the platen sensor-1 and platen sensor-2 in the MFP.
5. Replace the SYS board in the MFP.

Cover open jam in the scanning ready status

1. If the RADF jam access cover or the front cover of the MFP is opened in the scanning ready status, close it.
2. Check if the RADF jam access cover sensor is working. (Perform the input check.)
3. Check if the connector CN75 on the RADF control PC board is disconnected from the RADF jam access cover sensor or the harnesses are open circuited. Correct if any.
4. Replace the RADF jam access cover sensor.
5. Replace the RADF control PC board.

7. MAINTENANCE AND ROM REWRITING

7.1 Maintenance and Inspection Points

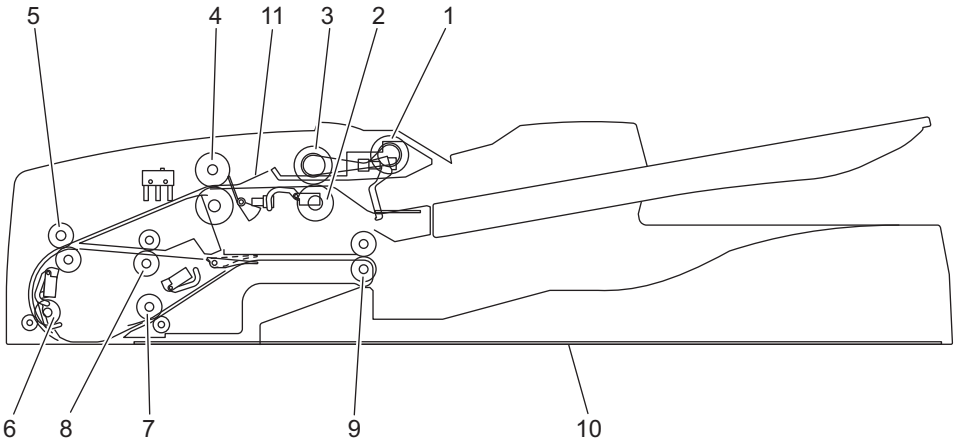

Fig. 7-1

Symbols used in the checklist

Cleaning	Lubrication/Coating	Replacement	Operation check
A: Clean with alcohol B: Clean with a soft pad, cloth or vacuum cleaner	L: Launa 40 Sl: Silicon oil W1: White grease (Molykote EM-30L)	Value: Replacement cycle R1: Replacement R.: Replace if deformed or damaged	O: After cleaning or replacement, confirm there is no problem.

Preventive Maintenance Checklist

Notes:

- The column “Parts List (P-I)” shows the page and item number in the parts list.
- Make sure properly to remove any dirt adhering to the convex-concave on the roller surface while cleaning it.
(See the below figure: e.g. cleaned roller)

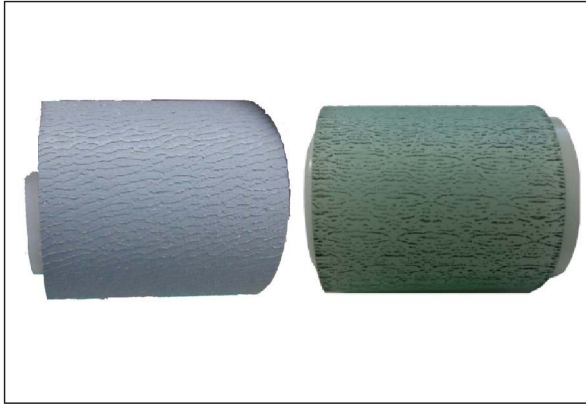

Fig. 7-2

	Items to check	Cleaning (30K)	Lubrication/ Coating	Replacement (X 1,000)	Operation check	Parts list (P-I)	Remarks
1	RADF pickup roller	A		R1 120		5-13	
2	RADF separation roller	A		R1 120		4-10	
3	RADF original feed roller	A		R1 120		5-13	
4	RADF registration roller	A				4-13	
5	RADF intermediate transport roller	A				2-5	
6	RADF pre-read roller	A				3-14	
7	RADF post-read roller	A				3-1	
8	RADF reverse registration roller	A				3-10	
9	RADF original exit/ reverse roller	A				3-21, 3-32	
10	Platen sheet	B or A				1-25	
11	RADF registration roller front sheet			R1 120			Original feed lower guide

7.2 ROM Rewriting (Firmware Updating)

For updating firmware, refer to “FIRMWARE UPDATING” in the Service Manual for the MFP.

8. HARNESS DIAGRAM

8.1 Harness Diagram

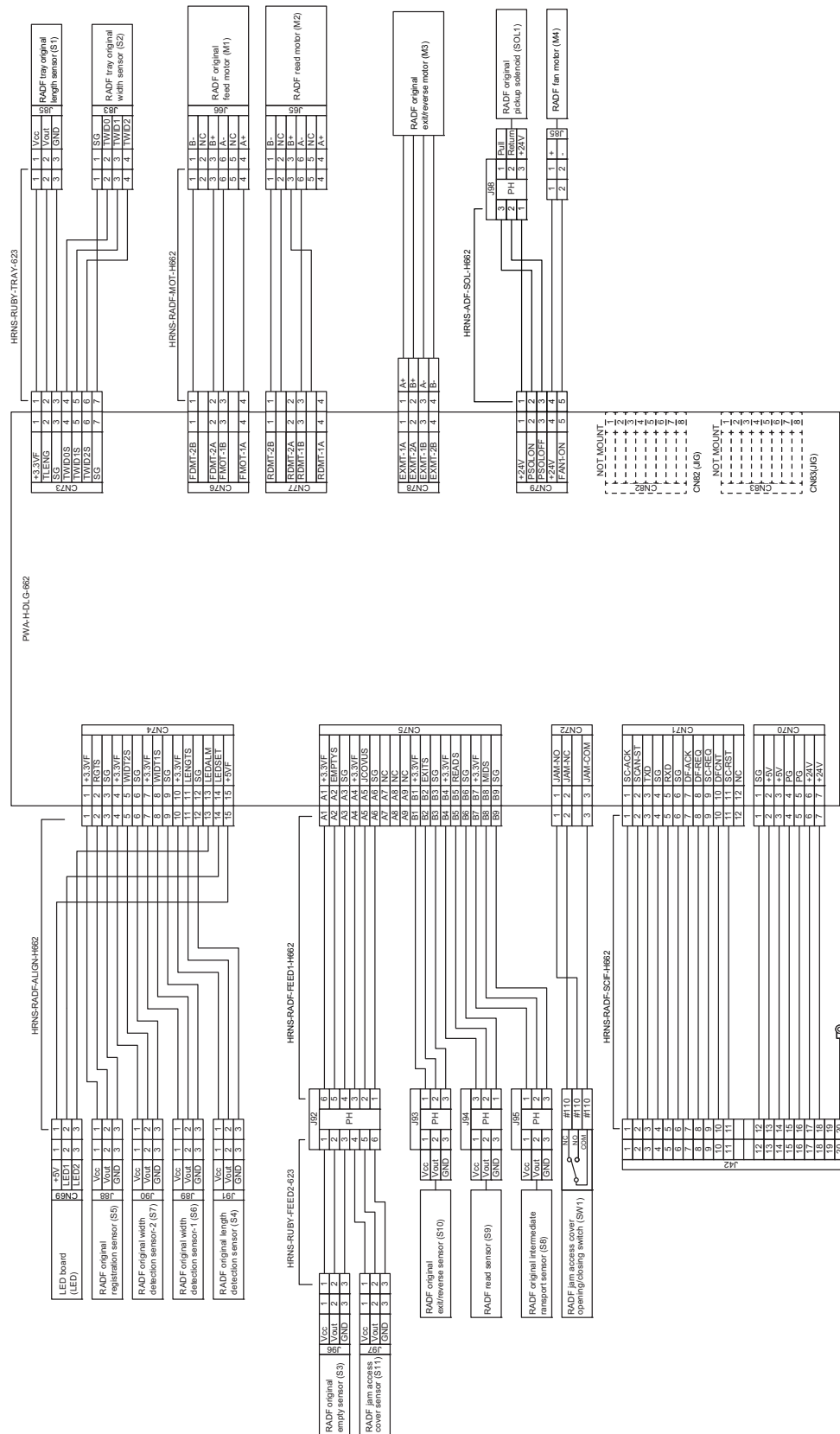

Fig.8-1

REVISION RECORD

Ver00a

Ver00a <2023/06/29>	
Page	Contents
6-1	Added content to Section 6.1 Troubleshooting for Mechanical Errors

Ver00

Ver00 <2021/12/22>	
Page	Contents
	Initial release

TOSHIBA

Toshiba Tec Corporation

1-11-1, OSAKI, SHINAGAWA-KU, TOKYO, 141-8562, JAPAN