

**TOSHIBA**  
Leading Innovation >>>

# **SERVICE MANUAL**

## **FINISHER**

# **MJ-1027/1028**

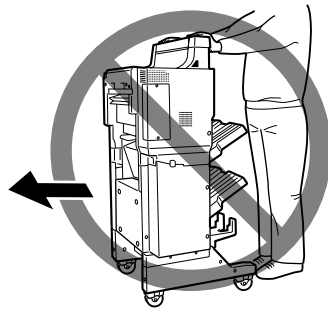


## **General Precautions for Installation/Service/Maintenance for the Finisher MJ-1027/1028**

The installation and service should be done by a qualified service technician.

1. When installing the Finisher MJ-1027/1028 to the equipment, be sure to follow the instructions described in the “Unpacking/Set-Up Procedure for the MJ-1027/1028” booklet which comes with each unit of the MJ-1027/1028.
2. The MJ-1027/1028 should be installed by an authorized/qualified person.
3. Before starting installation, servicing or maintenance work, be sure to turn off and unplug the equipment first.
4. When servicing the machines with the power turned ON, be sure not touch live sections and rotating/operating sections.
5. When selecting the installation site, avoid placing the MJ-1027/1028 and copier on different levels or inclined floors.
6. When servicing or maintaining the MJ-1027/1028, be careful about the rotating or operation sections such as gears, pulleys, sprockets, cams, belts, etc.
7. When parts are disassembled, reassembly is basically the reverse of disassembly unless otherwise noted in this manual or other related materials. Be careful not to reassemble small parts such as screws, washers, pins, E-rings, toothed washers to the wrong places.
8. Basically, the machine should not be operated with any parts removed or disassembled.
9. Delicate parts for preventing safety hazard problems (such as breakers, thermofuses, fuses, door switches, sensors, etc. if any) should be handled/installed/adjusted correctly.
10. Use suitable measuring instruments and tools.
11. During servicing or maintenance work, be sure to check the serial No. plate and other cautionary labels (if any) to see if they are clean and firmly fixed. If not, take appropriate actions.
12. The PC board must be stored in an anti-electrostatic bag and handled carefully using a wristband, because the ICs on it may be damaged due to static electricity. Before using the wrist band, pull out the power cord plug of the copier and make sure that there is no uninsulated charged objects in the vicinity.
13. For the recovery and disposal of used MJ-1027/1028s, consumable parts, packing materials, used batteries, and RAM-ICs including lithium batteries, follow the relevant local regulations/rules.
14. After completing installation, servicing and maintenance of the MJ-1027/1028, return the MJ-1027/1028 to its original state, and check operation.

15. When you move the finisher, do not move it in the direction of the arrow as shown in the figure below otherwise it might fall down.



# INTRODUCTION

This Service Manual contains basic data and figures for the Finisher (MJ-1027)/Saddle Stitch Finisher (MJ-1028) needed to service the machine in the field.

This manual comprises the following chapters:

- Chapter 1 “General Description” introduces the finisher’s features, specifications, and names of parts, and shows how to operate the finisher.
- Chapter 2 “Finisher Unit Basic Operation” discusses the principles of operation used for the finisher mechanical and electrical systems. It also explains the timing at which these systems are operated.
- Chapter 3 “Saddle Stitch Finisher Unit Basic Operation” discusses the principles of operation used for the saddle stitcher unit’s mechanical and electrical systems. It also explains the timing at which these systems are operated.
- Chapter 4 “Mechanical System” discusses how the finisher is constructed mechanically, and shows how it may be disassembled/assembled and adjusted.
- Chapter 5 “Maintenance and Inspection” provides tables of periodically replaced parts and consumables and durables, together with a scheduled servicing chart.
- Chapter 6 “Troubleshooting” shows how to troubleshoot possible faults and gives electrical parts arrangement diagrams, LED/check pin diagrams by PCB, and self diagnosis tables.

“Appendix” contains diagrams showing tables of signals, overall circuit diagrams and tables of solvents/oils.

Descriptions regarding installation are not mentioned in this Service Manual as the Finisher (MJ-1027)/Saddle Stitich Finisher (MJ-1028)’s packing boxes contain Installation Procedures.

The descriptions in this Service Manual are subject to change without notice for product improvement or other purposes, and major changes will be communicated in the form of Service Information bulletins.

All service persons are expected to have a good understanding of the contents of this Service Manual and all relevant Service Information bulletins, and be able to identify and isolate faults in the machine.



# CONTENTS

---

## CHAPTER 1 GENERAL DESCRIPTION

---

I. FEATURES .....	1-1	E. Supplying the Saddle Stitcher Unit with Staples (Saddle Stitch Finisher) .....	1-15
II. SPECIFICATIONS .....	1-2	F. Removing Staple Jams from the Saddle Stitcher Unit (Saddle Stitch Finisher) .....	1-16
A. Specifications .....	1-2	IV. MAINTENANCE BY THE USER .....	1-18
B. Cross Section .....	1-7	A. Maintenance by the User .....	1-18
III. Using the Machine .....	1-9		
A. Removing Paper Jams from the Finisher Unit .....	1-9		
B. Supplying the Finisher Unit with Staples .....	1-10		
C. Removing Staple Jams from the Finisher Unit .....	1-12		
D. Removing Paper Jams from the Saddle Stitcher Unit (Saddle Stitch Finisher) .....	1-13		

---

## CHAPTER 2 FINISHER UNIT BASIC OPERATION

---

I. BASIC OPERATION .....	2-1	E. Staple Operation .....	2-24
A. Outline .....	2-1	F. Stapler Unit .....	2-32
B. Outline of Electrical Circuitry .....	2-2	G. Tray Operation .....	2-38
C. Inputs to and Outputs from the Finisher Controller PCB .....	2-4	H. Detecting the Height of Stack on the Tray .....	2-40
II. FEED/DRIVE SYSTEM .....	2-10	I. Shutter Operation .....	2-42
A. Outline .....	2-10	J. Buffer Path Operation .....	2-46
B. Type of Delivery Paths .....	2-15	K. Detecting Jams .....	2-51
C. Feeding and Delivering .....	2-18	III. POWER SUPPLY SYSTEM .....	2-56
D. Job Offset .....	2-21		

---

## **CHAPTER 3 SADDLE STITCHER UNIT BASIC OPERATION**

---

I. BASIC OPERATION .....	3-1	C. Controlling the Movement of Sheets .....	3-21
A. Outline .....	3-1	D. Aligning the Sheets .....	3-23
B. Electrical Circuitry .....	3-2	E. Controlling the Phase of the Crescent Roller .....	3-26
C. Inputs to and Outputs from the Saddle Stitcher Controller PCB .....	3-3	IV. STITCHING SYSTEM .....	3-28
II. FEEDING/DRIVE SYSTEM .....	3-8	V. FOLDING/DELIVERY SYSTEM .....	3-31
A. Outline .....	3-8	VI. CHECKING FOR A JAM .....	3-38
III. PAPER OUTPUT MECHANISM .....	3-14	VII. POWER SUPPLY .....	3-43
A. Outline .....	3-14		
B. Controlling the Inlet Flappers .....	3-17		

---

## **CHAPTER 4 MECHANICAL CONSTRUCTION**

---

I. FINISHER UNIT .....	4-1	A. Externals and Controls .....	4-14
A. Externals and Controls .....	4-1	B. SADDLE STITCHER UNIT ....	4-17
B. FEEDING SYSTEM .....	4-9	C. PCBs .....	4-27
C. PCBs .....	4-13	D. Accessory .....	4-28
II. SADDLE STITCHER UNIT .....	4-14		

---

## **CHAPTER 5 MAINTENANCE AND INSPECTION**

---

I. PERIODICALLY REPLACED PARTS .....	5-1	A. Finisher Unit .....	5-2
A. Finisher Unit .....	5-1	B. Saddle Stitcher Unit .....	5-2
B. Saddle Stitcher Unit .....	5-1	III. PERIODICAL SERVICING .....	5-2
II. CONSUMABLES AND DURABLES .....	5-2	IV. FIRMWARE UPDATING .....	5-3
		A. Finisher Unit .....	5-3
		B. Saddle Stitcher Unit .....	5-5

---

## CHAPTER 6 TROUBLESHOOTING

---

I. ADJUSTMENTS .....	6-1	A. Finisher Unit .....	6-7
A. Electrical System (finisher unit) .....	6-1	B. Saddle Stitcher Unit .....	6-14
B. Electrical System (saddle stitcher unit) .....	6-5	C. Light-Emitting Diodes (LED) and Check Pins by PCB .....	6-20
II. ARRANGEMENT OF ELECTRICAL PARTS .....	6-7	III. TROUBLESHOOTING .....	6-22
		A. Finisher Unit .....	6-22
		B. Saddle Stitcher Unit .....	6-32

---

## APPENDIX

---

A. FINISHER UNIT GENERAL TIMING CHART .....	A-1	D. FINISHER UNIT CIRCUIT DIAGRAM .....	A-4
B. SADDLE STITCHER UNIT GENERAL TIMING CHART .....	A-2	E. SADDLE STITCHER UNIT CIRCUIT DIAGRAM .....	A-18
C. SIGNAL AND ABBREVIATIONS .....	A-3		





---

# CHAPTER 1

---

## GENERAL DESCRIPTION

---

I. FEATURES .....	1-1	E. Supplying the Saddle Stitcher Unit with Staples (Saddle Stitch Finisher) .....	1-15
II. SPECIFICATIONS .....	1-2	F. Removing Staple Jams from the Saddle Stitcher Unit (Saddle Stitch Finisher) .....	1-16
A. Specifications .....	1-2	IV. MAINTENANCE BY THE USER .....	1-18
B. Cross Section .....	1-7	A. Maintenance by the User .....	1-18
III. Using the Machine .....	1-9		
A. Removing Paper Jams from the Finisher Unit.....	1-9		
B. Supplying the Finisher Unit with Staples .....	1-10		
C. Removing Staple Jams from the Finisher Unit.....	1-12		
D. Removing Paper Jams from the Saddle Stitcher Unit (Saddle Stitch Finisher) .....	1-13		

## I. FEATURES

### 1. Accommodates large quantities of sheets

- Normally, the finisher holds a stack of sheets 250 mm in height in its two bins (small-size paper: equivalent to 2000 sheets)/140 mm in height (large-size paper: equivalent to 1000 sheets)

### 2. Has high paper transportation performance

- The finisher is capable of handling papers between 60 and 256 g/m<sup>2</sup>.

### 3. Offers a job offset function

- The finisher has a job offset function for sorting non-stapled stacks of copies.

### 4. Offers four types of auto stapling

- The finisher offers a choice of four stapling modes (1-point stapling at rear, diagonal stapling at front, diagonal stapling at rear, 2-point stapling).

### 5. Uses a buffer roller

- The use of a buffer roller enables the finisher to accept copies without interruption from the host machine even during stapling or offset operation.

### 6. Has a saddle stitch function (Saddle Stitch Finisher MJ-1028)

- The finisher can staple along the center of paper and fold it in two (up to 15 sheets).

### 7. Offers a punch function (option)

- The use of the puncher unit enables the finisher to punch sheets for binders before they are output. (The puncher unit is capable of handling papers between 60 g/m<sup>2</sup> (16 lb. Bond) and 256 g/m<sup>2</sup> (141.4 lb. Index). It cannot handle special paper, postcards and transparencies.)

### 8. Insert function (option)

- Enable the use of special type of paper and printed paper in addition to the staple sorting or the hole punching mode (Available when the optional staple sorting and the hole punching mode units are installed.) This paper is not run through fuser (heat).

## II. SPECIFICATIONS

### A. Specifications

#### 1. Finisher Unit

Item	Description		
Stacking method	Tray-1 and -2: by lifting tray		
Stacking orientation	Face-down		
Stacking size	AB: A3, A4, A4-R, A5-R, B4, B5, B5-R, FOLIO Inch: LD, LG, LT, LT-R, ST-R, COMPUTER		
Paper weight	60 to 256 g/m <sup>2</sup> (16 lb. Bond to 141.4 lb. Index)		
Bins	Tray-1 and -2		
Modes	Non-sort: tray-1 and -2 Sort: tray-1 and -2 Staple sort: tray-1 and -2		
Stacking capacity	Non sort	A4, B5, LT	250 mm (2000 sheets) <sup>(Note 1, 2)</sup>
	Non staple sort	A3, A4-R, A5-R, B4, B5-R, LD, LG, LT-R, ST-R, FOLIO, COMPUTER	140 mm (1000 sheets) <sup>(Note 1, 2)</sup>
		Staple sort	A4, B5, LT
		A3, A4-R, B4, LD, LG, LT-R, FOLIO, COMPUTER	74 mm/50 sets (500 sheets) <sup>(Note 1)</sup>
Size mixing	Size mixing: 74 mm or less (500 sheets) <sup>(Note 1)</sup> Staple mixing: 74 mm/50 sets or less (500 sheets) <sup>(Note 1)</sup>		
Stacking mixing	Face-down		

Notes:

1. Approximate when computed with reference to 80 g/m<sup>2</sup> (21.3 lb. Bond) paper.
2. Alignment may not be correct if 750 or more small-size sheets are stacked.
3. The accuracy of the stack height is ± 7 mm/0.28 in.

**Table 1-201**

Item	Description			
Stapling	By rotating cam			
Stapling position	See Figure 1-201.			
Stapling capacity (Note1)	Small-size	50 sheets (60 ~ 80 g/m <sup>2</sup> (16 ~ 21.3 lb. Bond))	30 sheets (90 g/m <sup>2</sup> (24 lb. Bond))	30 sheets (105 g/m <sup>2</sup> (28 lb. Bond))
	Large-size	30 sheets (60 ~ 80 g/m <sup>2</sup> (16 ~ 21.3 lb. Bond))	15 sheets (90 g/m <sup>2</sup> (24 lb. Bond))	15 sheets (105 g/m <sup>2</sup> (28 lb. Bond))
Staple supply	Special staple cartridge (5000 staples)			
Staples	Special (STAPLE-700: 3 cartridges of 5000 staples in a package)			
Staple detection	Provided			
Manual stapling	Not provided			
Stapling size	1-point diagonal stapling (diagonal)	Front	A3, B4, A4, A4-R, B5, LD, LG, LT, LT-R, FOLIO, COMPUTER	
		Rear	A3, B4, A4, B5, LD, LT, COMPUTER	
	1-point	Rear	A4-R, LT-R, LG, FOLIO	
	2-point	A3, B4, A4, B5, A4-R, LD, LG, LT, LT-R, FOLIO, COMPUTER		
Available paper weight for stapling	60 to 105 g/m <sup>2</sup> (16 lb. Bond to 28 lb. Bond)			
Paper detection	Provided			
Control panel	Not provided			
Display	Not provided			
Dimensions (W × D × H)	616 × 630 × 1023 mm/24.25 × 24.88 × 40.38 in 740 × 630 × 1023 mm/29.25 × 24.88 × 40.38 in (sub-tray extended)			
Weight	Finisher (MJ-1027): 43 kg/94.80 lb Saddle stitch finisher (MJ-1028): 63 kg/138.89 lb			
Power supply	From host machine (DC 24V ± 10%, 5 VDC)			
Maximum power consumption	170 W or less			

Note1: Including two sheets of thick stock or cover (200 ~ 256 g/m<sup>2</sup> (73.9 lb. Cover to 141.4 lb. Index)).

**Table 1-202**

**Reference:**

The term “small-size” stands for A4, A5-R, B5, LT, ST-R, while the term “large-size” stands for A3, B4, A4-R, B5-R, LT-R, LD, LG, FOLIO, COMPUTER.

Stapling Positions (finisher unit)

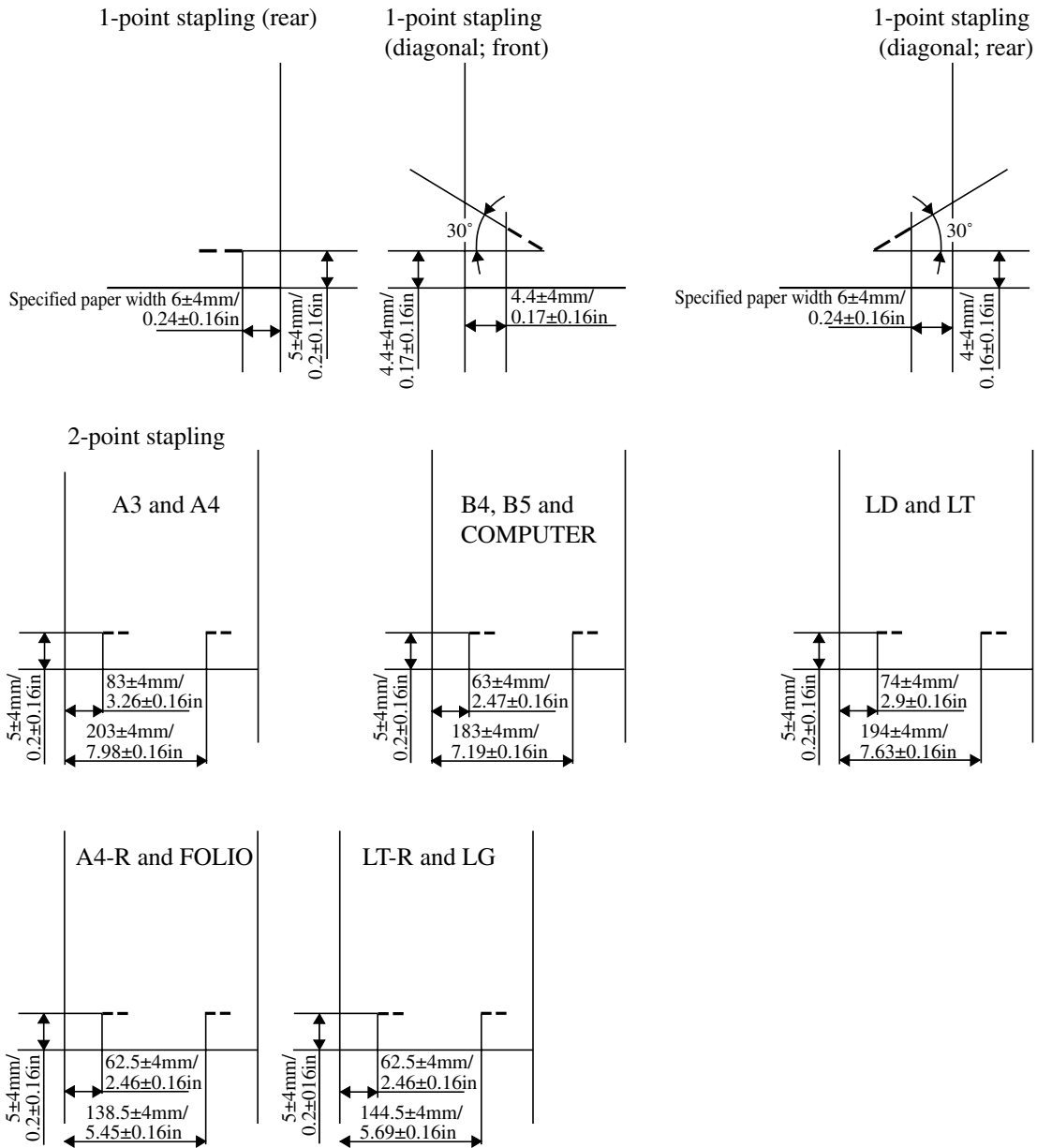


Figure 1-201

## 2. Saddle Stitcher Unit

Item	Description		
Stapling method	Center binding (double folding)		
Folding position	See Figure 1-202.		
Paper size	A3, B4, A4-R, LD, LT-R, LG		
Capacity	With binding: 1 sheet Without binding (including single cover page) : 2 to 15 sheets (60 ~ 80 g/m <sup>2</sup> / 16~21.3 lb. Bond) : 2 to 10 sheets (81 ~ 105 g/m <sup>2</sup> / 21.4~28 lb. Bond)		
Paper weight	60 to 105 g/m <sup>2</sup> (cover page up to 256 g/m <sup>2</sup> ) <sup>(Note 1)</sup>		
Stacking capacity (Note 2)	A3	60 ~ 80g/m <sup>2</sup>	25 (25) sets: stack of 5 sheets or less
	B4	(16 ~ 21.3 lb. Bond)	20 (20) sets: stack of 6 to 10 sheets
	A4-R		10 (10) sets: stack of 11 to 15 sheets
	LD	81 ~ 105 g/m <sup>2</sup>	25 (5) sets: stack of 5 sheets or less
	LT-R	(21.4 ~ 28 lb. Bond)	15 (5) sets: stack of 6 to 10 sheets
	LG	60 ~ 80g/m <sup>2</sup>	20 (20) sets: stack of 5 sheets or less
		(16 ~ 21.3 lb. Bond)	10 (10) sets: stack of 6 to 10 sheets
			10 (10) sets: stack of 11 to 15 sheets
		81 ~ 105 g/m <sup>2</sup>	20 (5) sets: stack of 5 sheets or less
		(21.4 ~ 28 lb. Bond)	10 (5) sets: stack of 6 to 10 sheets
Stapling	Stapling position		2 points (center distribution; fixed interval)
	Staple accommodation		2000 staples
	Staple supply		Special cartridge
	Staples		Special staples (STAPLE-600: 3 cartridges of 2000 staples in a package)
	Staple detection		Provided
	Manual stapling		Not provided
Folding	Folding method		Roller contact
	Folding mode		Double folding
	Folding position		Paper center
	Position adjustment		Provided
Power supply	From finisher unit DC24V, DC5V		

Note1: Special paper, postcards, transparencies, reproducibles, label paper and hole-punched paper cannot be handled.

Note2: The values in ( ) include a sheet of cover page (200 to 256 g/m<sup>2</sup> (73.9 lb. Cover to 141.4 lb. Index)).

**Table 1-203**

Staple and Folding Position (saddle stitcher unit)

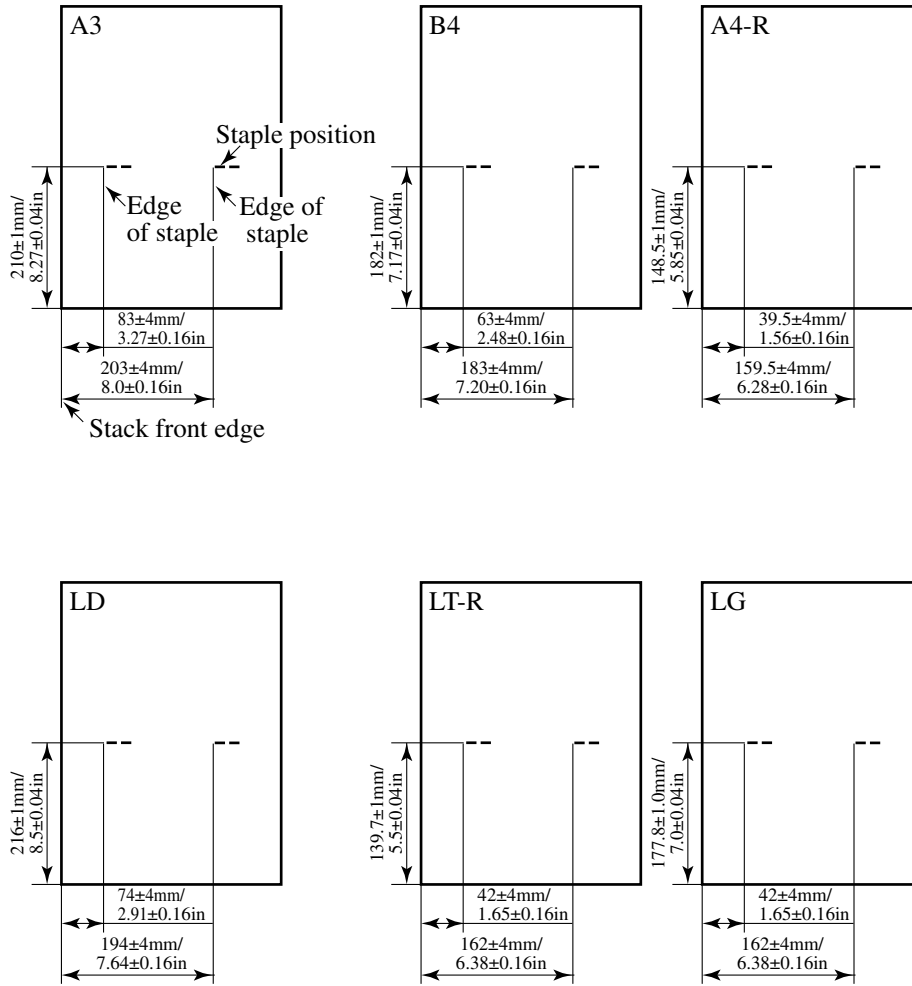
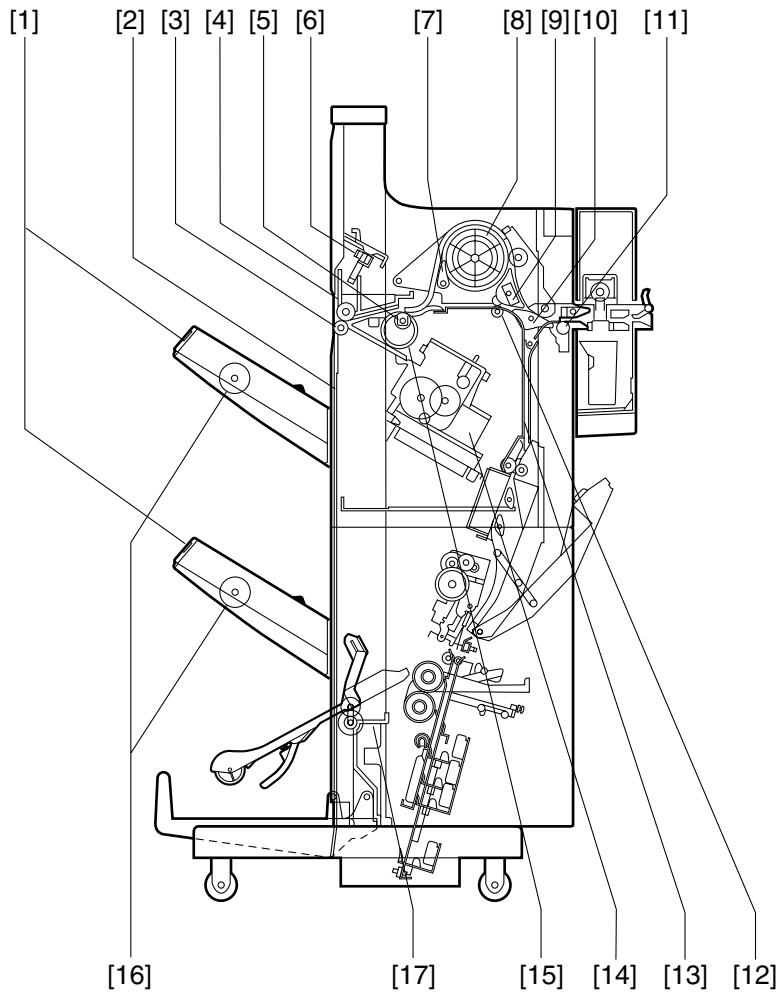


Figure 1-202



## B. Cross Section

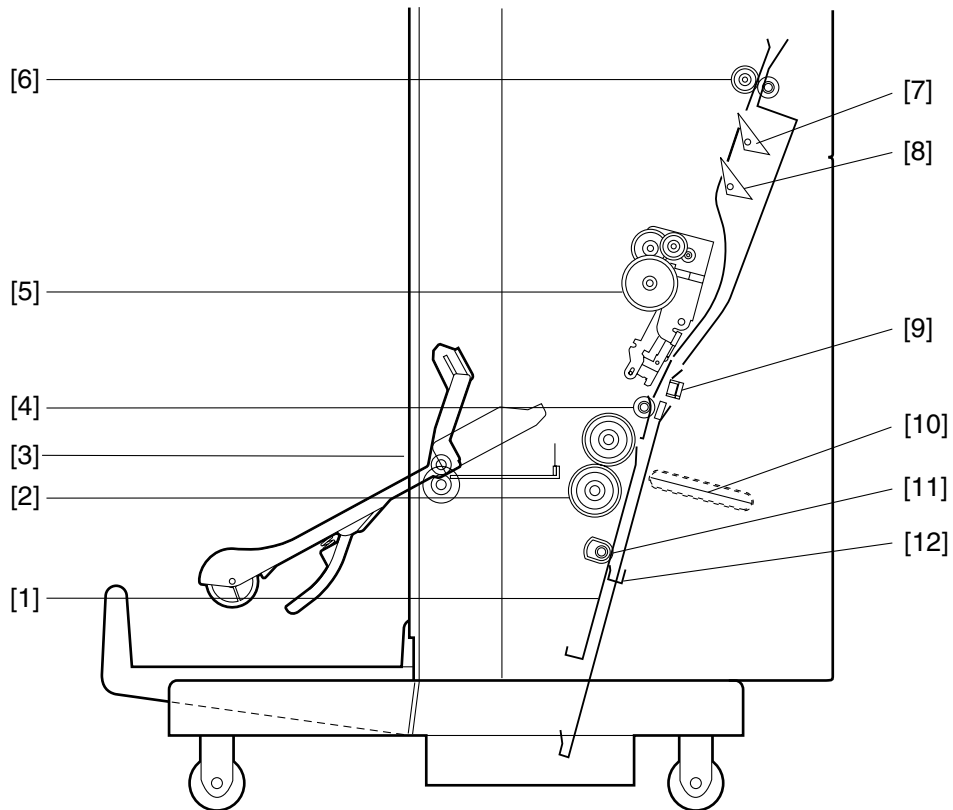
### 1. Finisher Unit



- |                          |                                  |
|--------------------------|----------------------------------|
| [1] Tray -1/-2           | [10] Saddle stitcher flapper     |
| [2] Shutter              | [11] Inlet feed roller           |
| [3] Delivery roller      | [12] Feed roller 1               |
| [4] Swing guide          | [13] Vertical path               |
| [5] Feed roller 2        | [14] Stapler                     |
| [6] Height sensor        | [15] Feed belt                   |
| [7] Wrap flapper         | [16] Tray lift motor             |
| [8] Buffer roller        | [17] Saddle stitcher unit        |
| [9] Buffer inlet flapper | (saddle stitch finisher MJ-1028) |

**Figure 1-203**

2. Saddle Stitcher Unit



- |                            |                              |
|----------------------------|------------------------------|
| [1] Guide plate            | [7] No.1 flapper             |
| [2] Paper folding roller   | [8] No. 2 flapper            |
| [3] Delivery guide plate   | [9] Stitcher mount           |
| [4] Holding roller         | [10] Paper pushing plate     |
| [5] Stitcher (front, rear) | [11] Crescent roller         |
| [6] Inlet roller           | [12] Paper positioning plate |

Figure 1-204

### III. Using the Machine

#### A. Removing Paper Jams from the Finisher Unit

If the host machine indicates the finisher paper jam message, perform the following to remove the jam.

- 1) Pressing the release button of the finisher, move the finisher carefully away from the host machine.

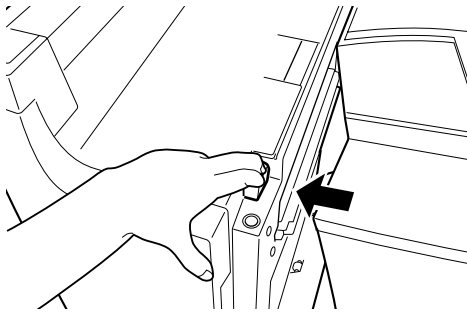


Figure 1-301

- 2) Remove any jam visible from the outside.

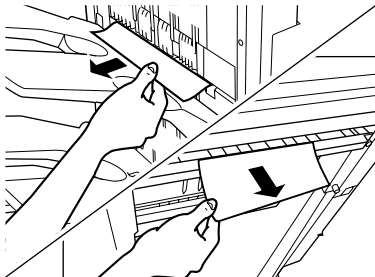


Figure 1-302

- 3) Open the upper cover, and check the inside of the finisher.

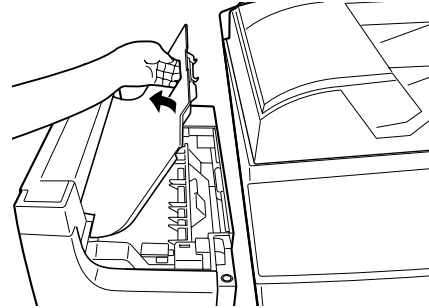


Figure 1-303

- 4) Lift the buffer roller cover, and remove the jam.

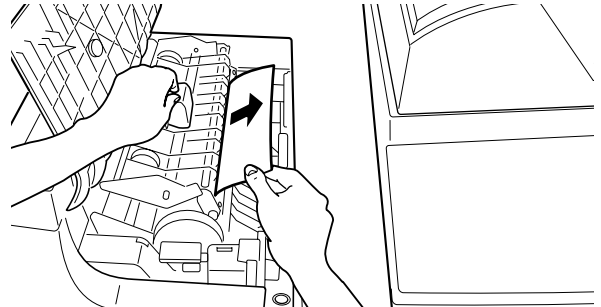


Figure 1-304

- 5) Lift the buffer roller, and remove the jam.

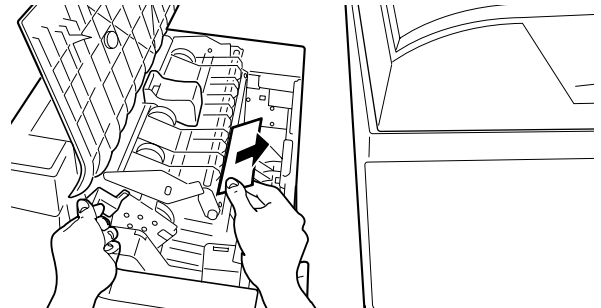
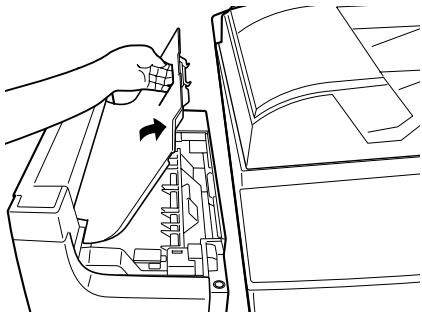


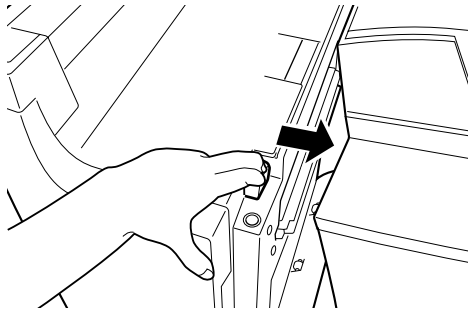
Figure 1-305

- 6) Return the buffer roller and the buffer roller cover to their original positions, and close the upper cover.



**Figure 1-306**

- 7) Connect the finisher to the host machine.



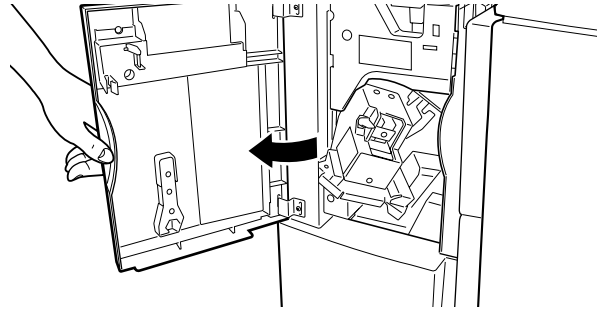
**Figure 1-307**

- 8) Operate as instructed on the display.

## B. Supplying the Finisher Unit with Staples

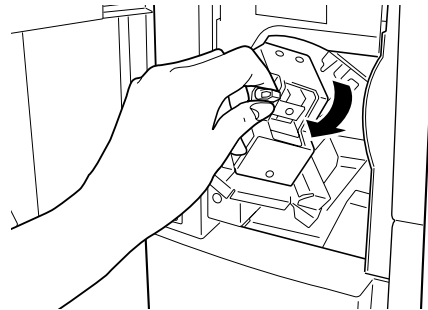
If the host machine indicates the finisher unit staple supply message, perform the following to supply it with staples.

- 1) Open the front cover.



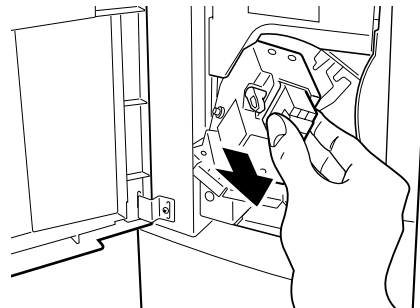
**Figure 1-308**

- 2) Shift down the green lever.



**Figure 1-309**

- 3) When the staple cartridge has slightly slid out, hold and pull it out.



**Figure 1-310**

- 4) Hold the empty staple case on its sides, and slide it out.

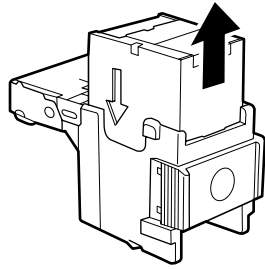


Figure 1-311

- 6) Pull the length of tape (used to hold the staples in place) straight out.

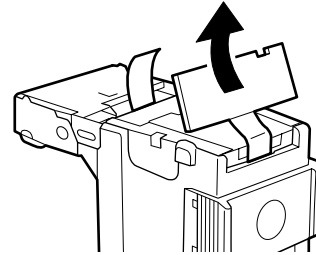


Figure 1-313

- 5) Set a new staple case.

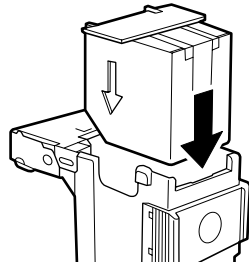


Figure 1-312

- 7) Push in the stapler unit until the green lever returns to its original position.

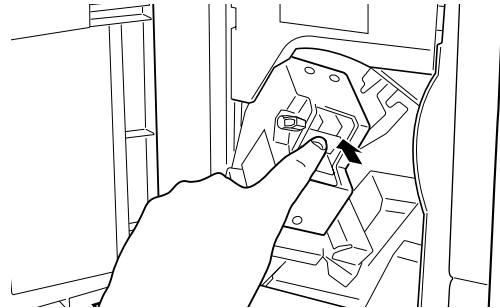


Figure 1-314

**Reference:**

You may set no more than one staple cartridge at a time.  
 Make sure that the new cartridge is one specifically designed for the finisher unit.

- 8) Check to make sure that the stapler has been locked in place, and close the front cover.

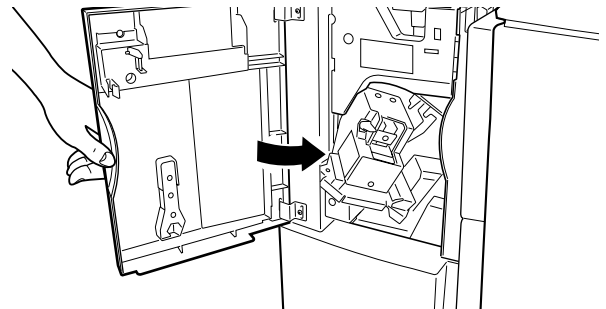
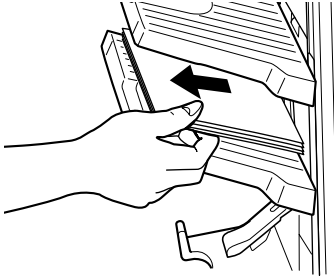


Figure 1-315

## C. Removing Staple Jams from the Finisher Unit

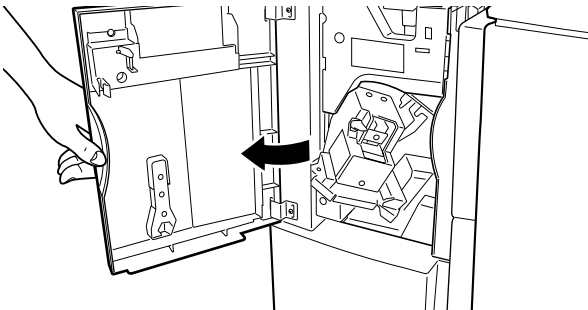
If the host machine indicates the finisher unit staple jam message, perform the following to remove the jam.

- 1) Remove the stack waiting to be stapled from the delivery tray.



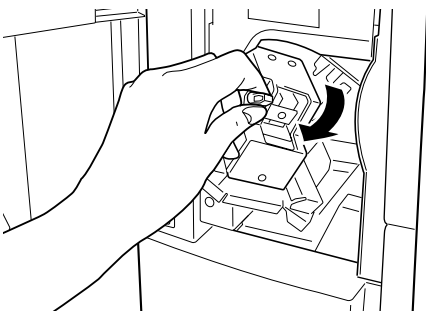
**Figure 1-316**

- 2) Open the front cover.



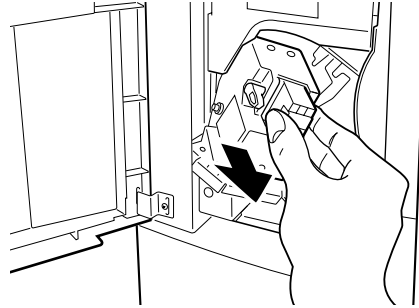
**Figure 1-317**

- 3) Shift down the green lever.



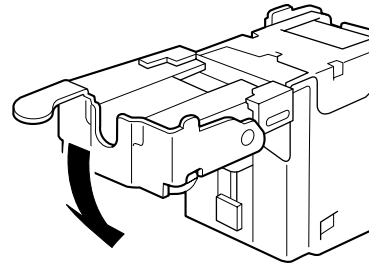
**Figure 1-318**

- 4) When the staple cartridge has slightly slid out, hold and pull it out.



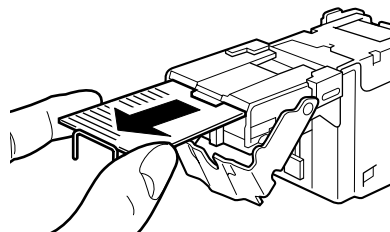
**Figure 1-319**

- 5) Shift down the tab on the staple cartridge.



**Figure 1-320**

- 6) Remove all staples that have slid out of the staple case.



**Figure 1-321**

- 7) Return the tab on the staple cartridge to its original position.
- 8) Return the staple cartridge to its original position, and close the front cover.

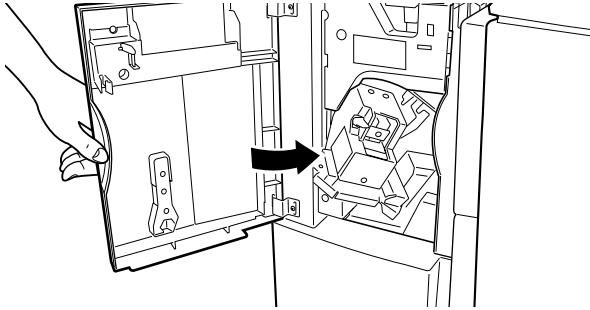


Figure 1-322

**Reference**

When the cover has been closed, the stapler unit will automatically execute idle punching several times to advance the staples.

## D. Removing Paper Jams from the Saddle Stitcher Unit (Saddle Stitch Finisher)

If the host machine indicates the saddle stitcher unit paper jam message, perform the following to remove the jam.

- 1) Pressing the release button of the finisher, move the finisher carefully away from the host machine.

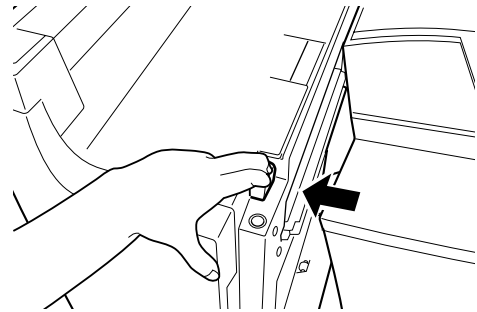


Figure 1-323

- 2) Open the front lower cover.

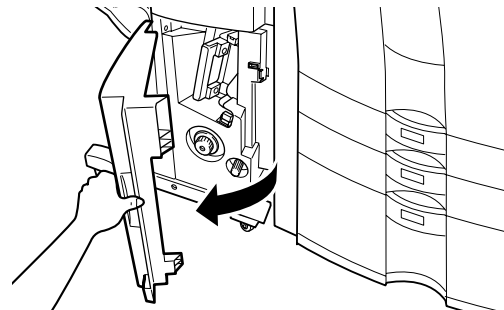


Figure 1-324

- 3) Turn the knob on the left side.

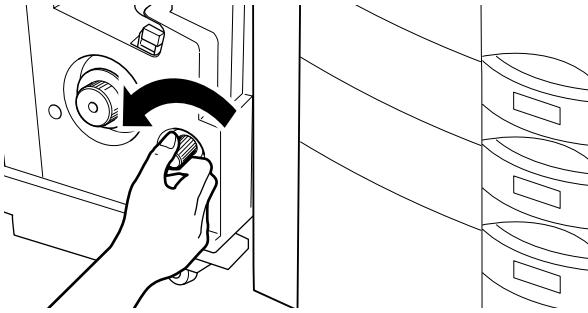


Figure 1-325

- 6) Open the inlet cover, and remove the jam.

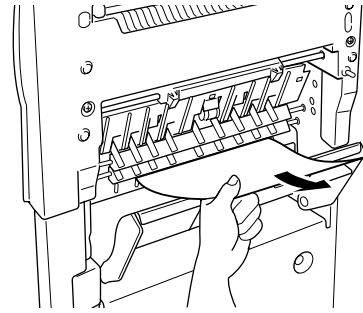


Figure 1-328

- 4) Turn the knob on the right side while pushing it in.

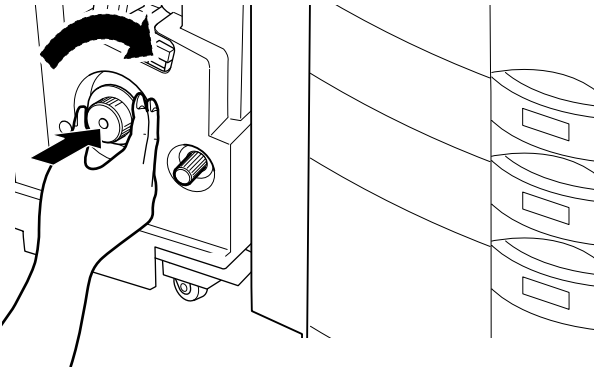


Figure 1-326

- 7) Close the front lower cover.

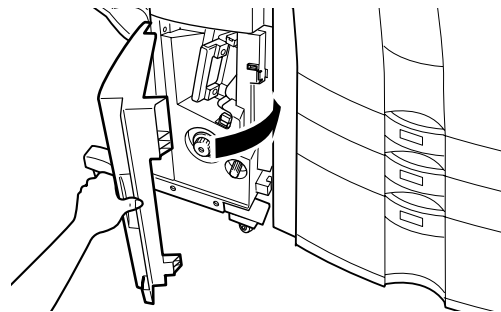


Figure 1-329

- 5) Remove the jam.

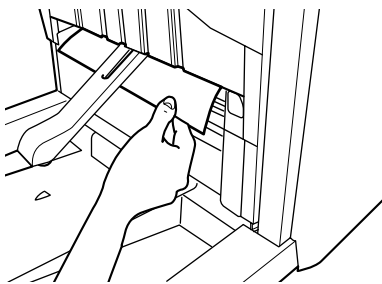


Figure 1-327

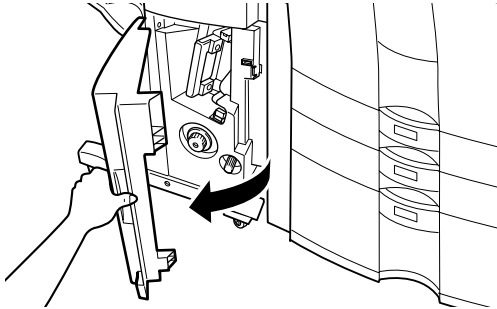
- 8) Connect the finisher unit.  
9) Operate as instructed on the display.



## E. Supplying the Saddle Stitcher Unit with Staples (Saddle Stitch Finisher)

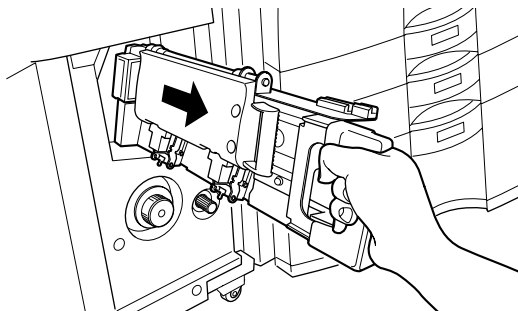
If the host machine indicates the saddle stitcher unit staple supply message, perform the following to supply it with staples.

- 1) Open the front lower cover.



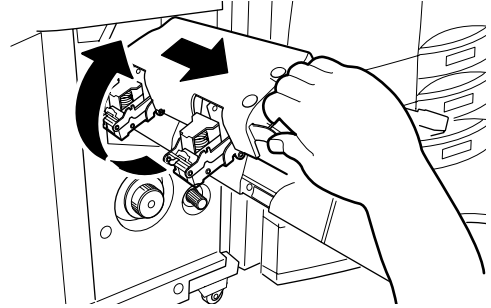
**Figure 1-330**

- 2) Slide out the stitcher unit.



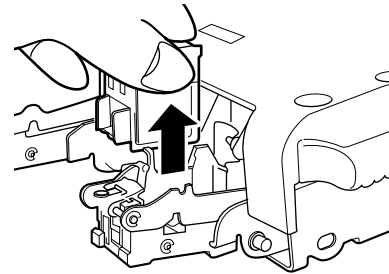
**Figure 1-331**

- 3) Pull the stitcher unit to the front once, and then shift it up.



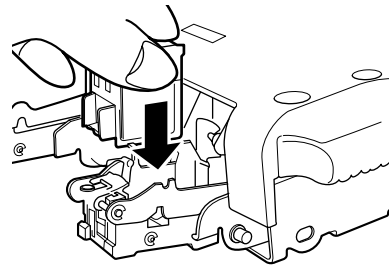
**Figure 1-332**

- 4) Hold the empty cartridge on its sides, and remove it.



**Figure 1-333**

- 5) Set a new cartridge.

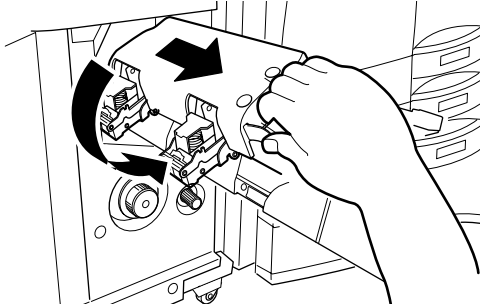


**Figure 1-334**

### Reference

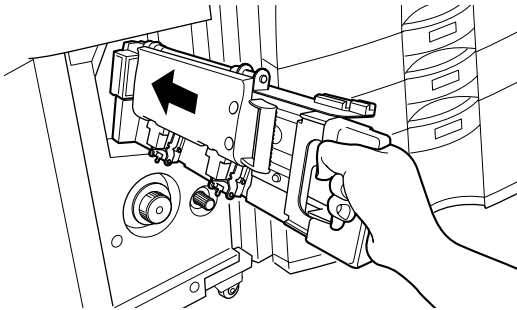
You must always replace both cartridges at the same time.

- 6) Pull the sticher to the front once, and then return it to its original position.



**Figure 1-335**

- 7) Push in the sticher unit, and close the front cover.

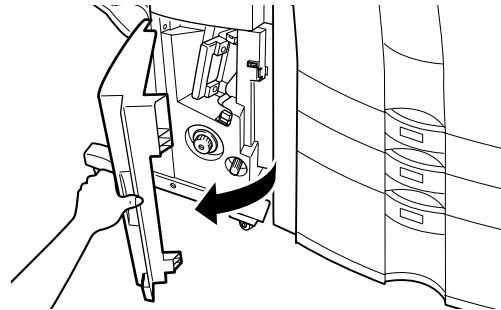


**Figure 1-336**

## F. Removing Staple Jams from the Saddle Sticher Unit (Saddle Sticher Finisher)

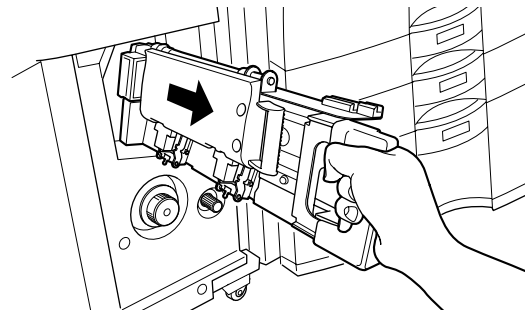
If the host machine indicates the saddle sticher unit staple jam message, perform the following to remove the jam.

- 1) Open the front lower cover.



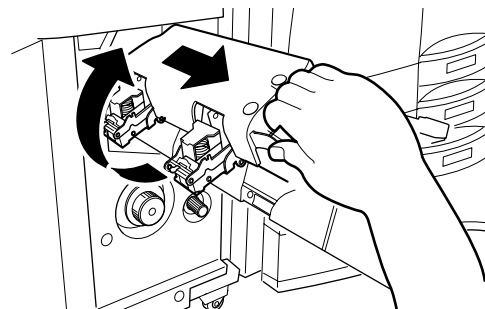
**Figure 1-337**

- 2) Slide out the sticher unit.



**Figure 1-338**

- 3) Pull the stapler of the sticher unit to the front once, and then shift it up.



**Figure 1-339**

- 4) Hold the cartridge on its sides, and remove it.

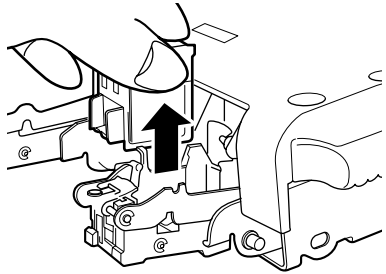


Figure 1-340

- 5) Push down on the area identified as A, and pull up the tab identified as B.

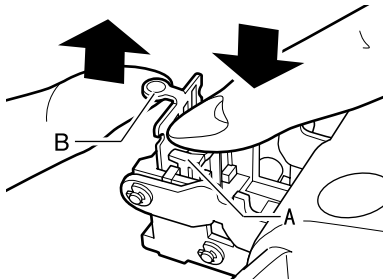


Figure 1-341

- 6) Remove the staple jam, and return the tab B to its original position.

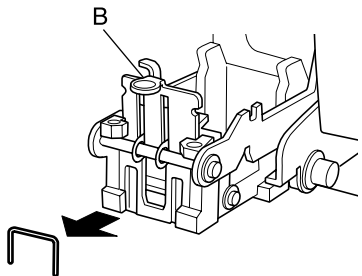


Figure 1-342

- 7) Return the cartridge to its original position.

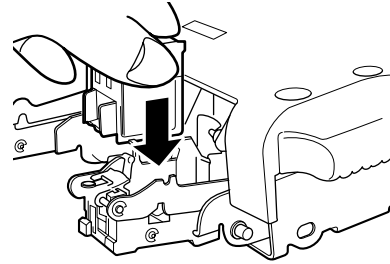


Figure 1-343

- 8) Pull the stitcher of the stitcher unit to the front once, and then return it to its original position.

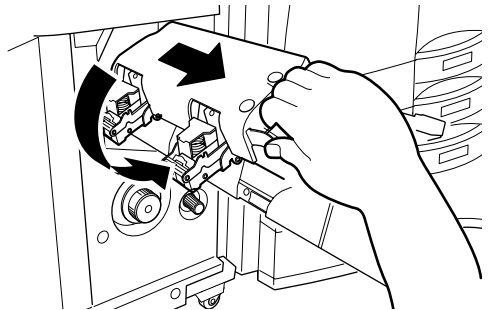


Figure 1-344

- 9) Push the stitcher unit back to its original position, and close the front lower cover.

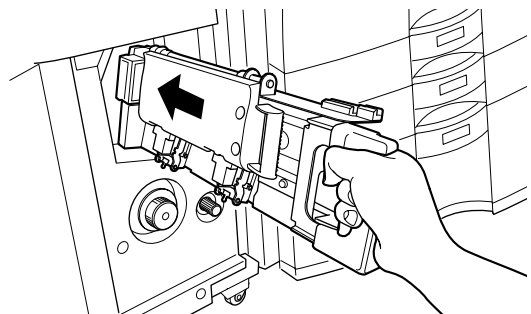


Figure 1-345

**Reference**

Whenever you have removed a staple jam, be sure to execute staple edging.

## IV. MAINTENANCE BY THE USER

### A. Maintenance by the User

No.	Item	Timing
1	Replacing the staple cartridge (finisher unit)	When the appropriate indication is made on the host machine's display.
2	Replacing the staple cartridge (saddle stitcher unit)	

**Caution:**

The finisher unit and the saddle stitcher unit use different cartridge types. Be sure that the appropriate type is used for each.

**Table 1-401**


---

# CHAPTER 2

---

## FINISHER UNIT BASIC OPERATION

---

1. This chapter discusses the purpose and role of each of the finisher's functions, and the principles of operation used for the finisher mechanical and electrical systems. It also explains the timing at which these systems are operated. The  symbol in drawings indicates transmission of mechanical drive, and signals marked by  $\longrightarrow$  together with the signal name indicates the flow of electrical signals.
2. In descriptions of digital circuits on the finisher, "1" indicates a high signal voltage level, while "0" indicates a low signal voltage level. Voltage values differ according to circuit.

A microprocessor is used on the finisher. A description of microprocessor operation is omitted in this chapter as it is practically impossible to check internal operation of the microprocessor.

Descriptions in this chapter also assume that PCBs will not be repaired at user sites. For this reason, descriptions of circuits on PCBs is limited to block diagrams. Two types of block diagrams are provided for separate functions: diagrams indicating details from sensors up to input sections of major PCBs, and diagrams indicating details from the output sections of major PCBs up the loads.

I. BASIC OPERATION .....	2-1	E. Staple Operation .....	2-24
A. Outline .....	2-1	F. Stapler Unit .....	2-32
B. Outline of Electrical Circuitry .....	2-2	G. Tray Operation .....	2-38
C. Inputs to and Outputs from the Finisher Controller PCB .....	2-4	H. Detecting the Height of Stack on the Tray .....	2-40
II. FEED/DRIVE SYSTEM .....	2-10	I. Shutter Operation .....	2-42
A. Outline .....	2-10	J. Buffer Path Operation .....	2-46
B. Type of Delivery Paths .....	2-15	K. Detecting Jams .....	2-51
C. Feeding and Delivering .....	2-18	III. POWER SUPPLY SYSTEM .....	2-56
D. Job Offset .....	2-21		

# I. BASIC OPERATION

## A. Outline

The finisher is designed to deliver copies arriving from its host machine, and its modes of delivery include simple stacking, job offset<sup>(Note)</sup>, and staple.

All operations involved in these modes are controlled by the finisher controller PCB, according to the appropriate commands from the host machine.

In the case of the Saddle Stitch Finisher, copies from the host machine may be routed to the saddle stitcher unit.

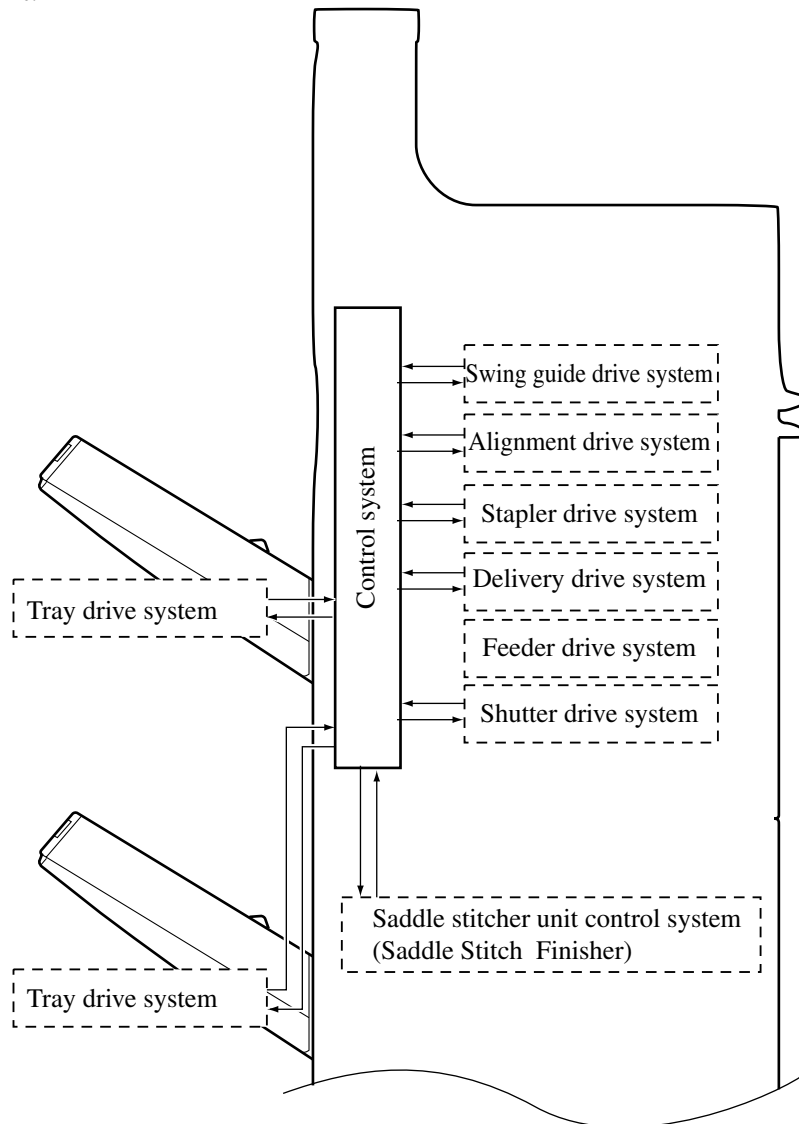


Figure 2-101

**Note:**

The term job offset refers to shifting each sorting job, separating a single stack into several stacks.

## B. Outline of Electrical Circuitry

The finisher's sequence of operation is controlled by the finisher controller PCB. The finisher controller PCB is a 16-bit microprocessor (CPU), and is used for communication with the host machine (serial) in addition to controlling the finisher's sequence of operations.

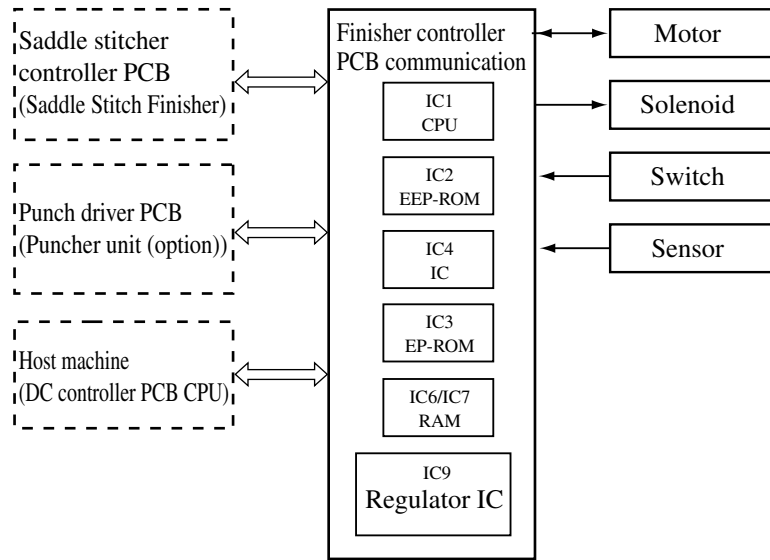
The finisher controller PCB responds to the various commands coming from the host machine through a serial communications line to drive solenoids, motors, and other loads. In addition, it communicates the finisher's various states (information on sensors and switches) to the host machine through a serial communications circuit.

In the case of the Saddle Stitch Finisher, the finisher controller PCB not only communicates with the saddle stitcher controller PCB but also communicates the saddle stitcher unit's various states (information on sensors and switches) to the host machine.

The ICs used on the finisher controller PCB are designed for the following:

- IC1 (CPU)  
Controls sequence of operations.
- IC2 (EP-ROM)  
Backs up adjustment values.
- IC3  
Contains sequence programs.
- IC6/IC7 (RAM)  
Backs up initial setting data.
- IC4 (communications IC)  
Communicates with the host machine and the saddle stitcher unit.
- IC9 (regulator IC)  
Generates PWM.

Figure 2-102 shows the flow of signals between the finisher and the options controller.



Connecting with inserter

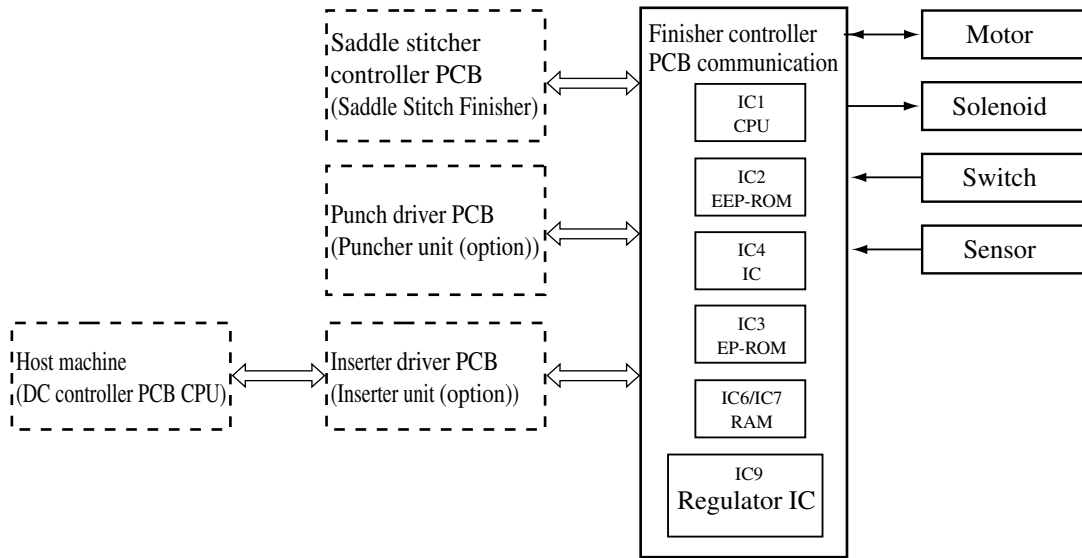


Figure 2-102



## C. Inputs to and Outputs from the Finisher Controller PCB

### 1. Inputs to the Finisher Controller PCB

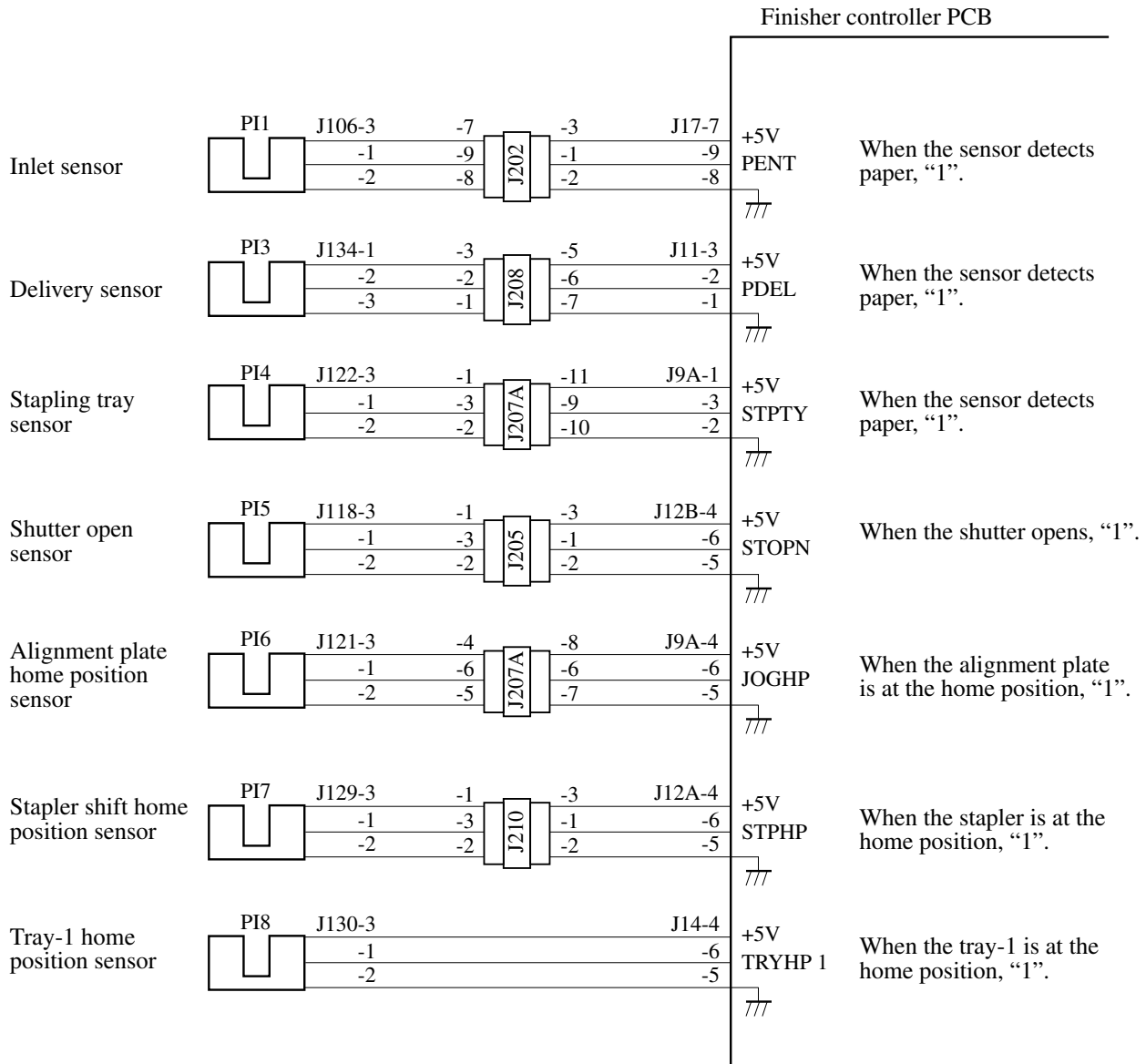


Figure 2-103

## 2. Inputs to the Finisher Controller PCB

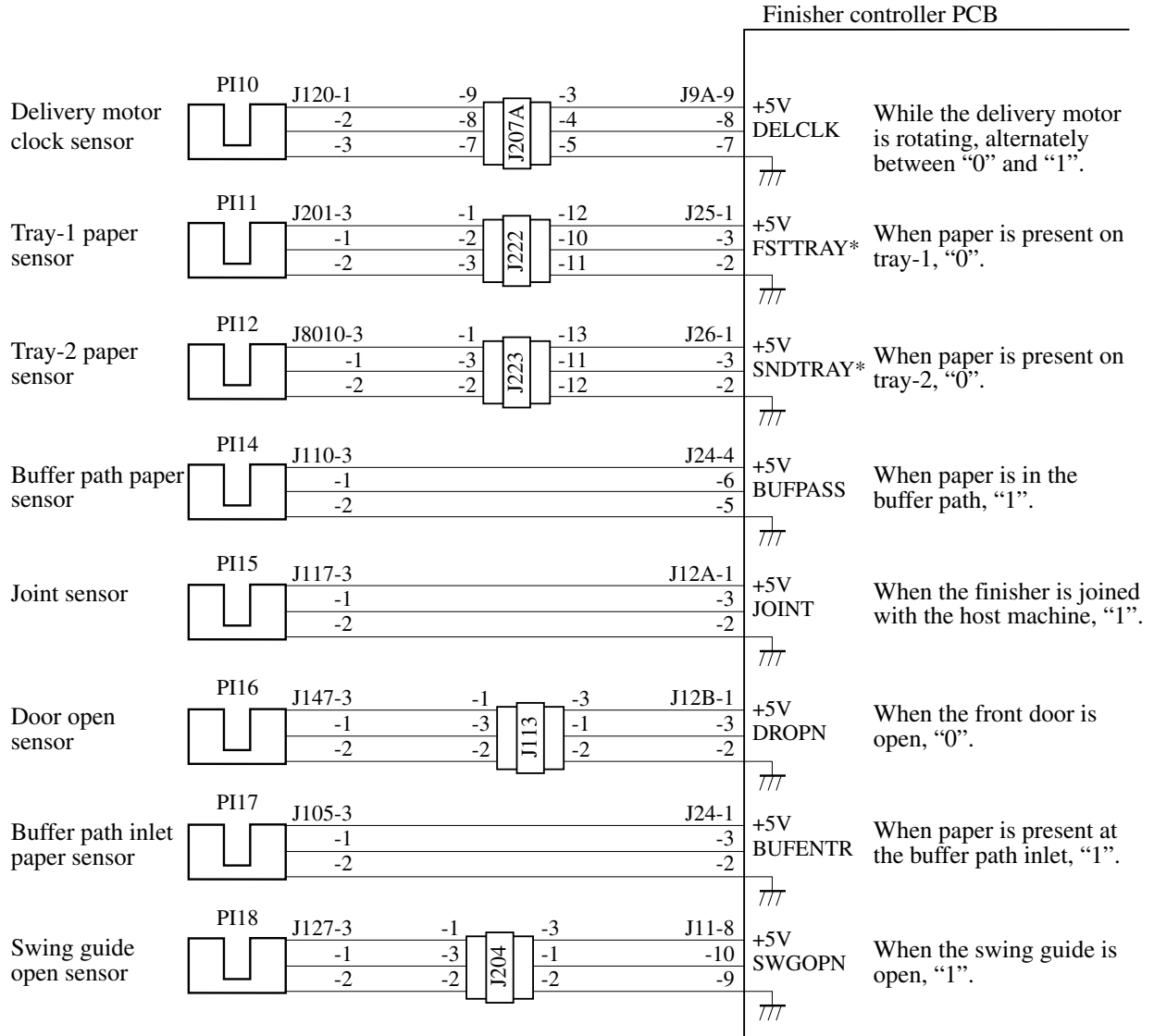


Figure 2-104

3. Inputs to the Finisher Controller PCB

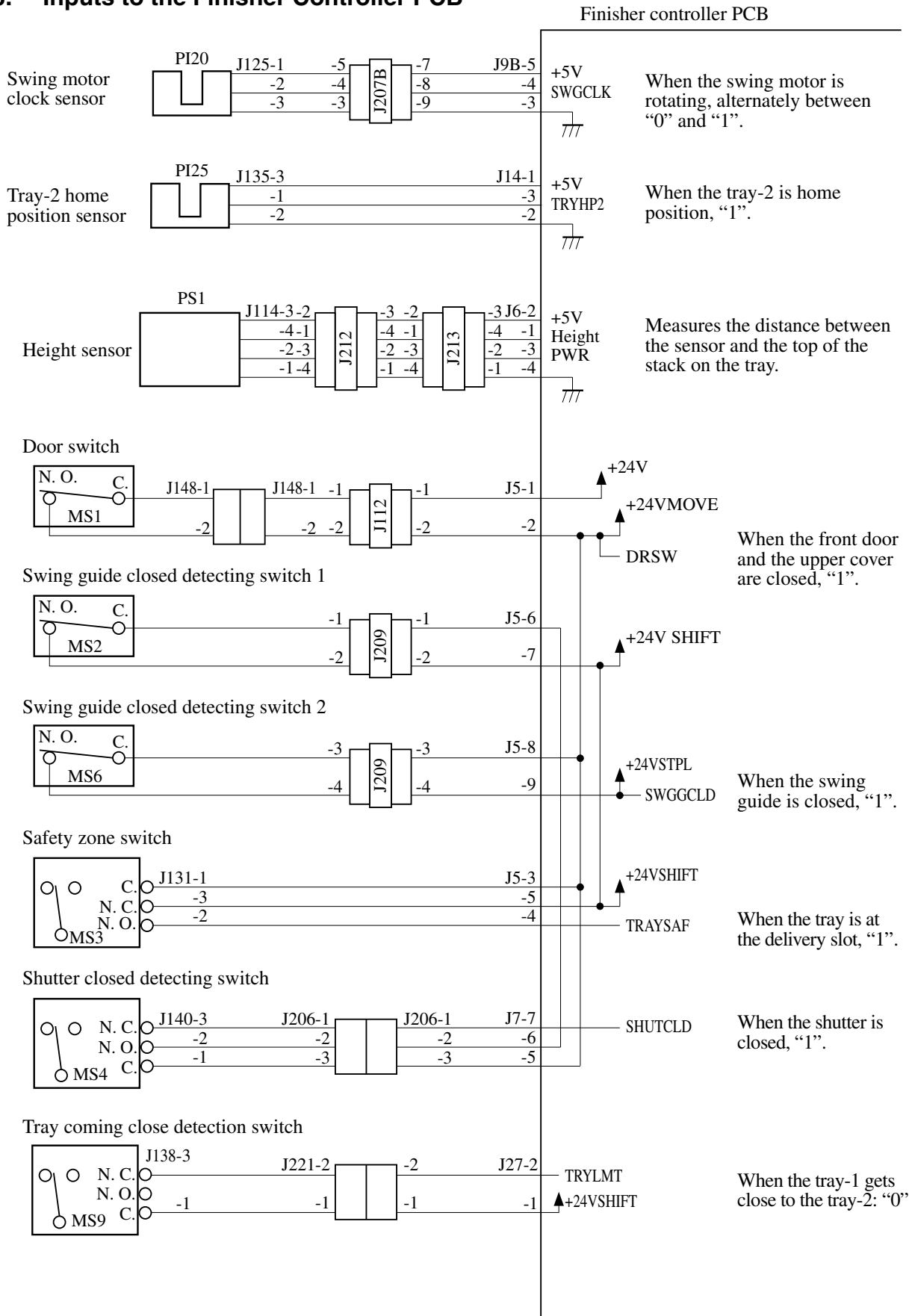


Figure 2-105

### 4. Inputs to and Outputs from the Finisher Controller PCB

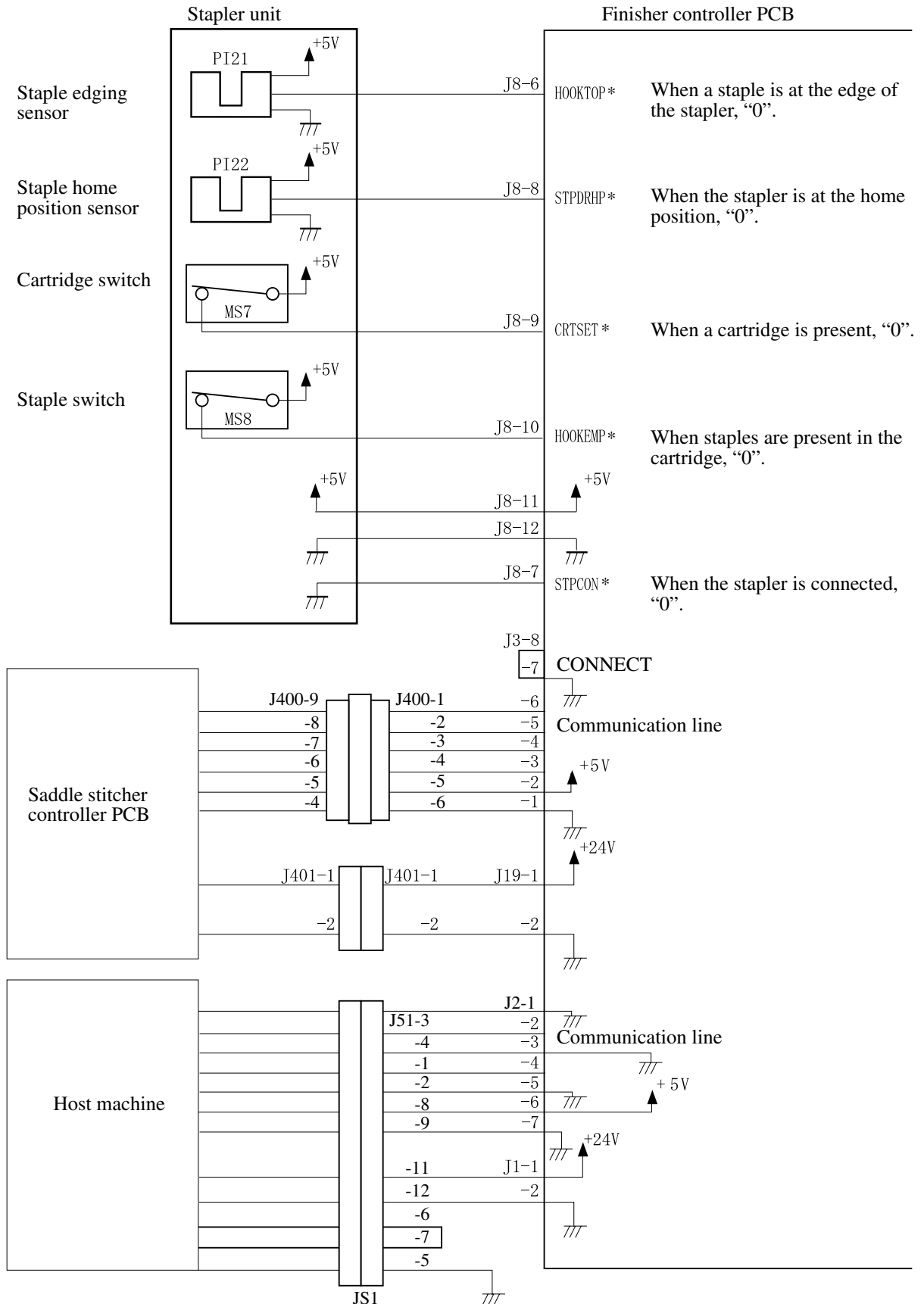


Figure 2-106

### 5. Outputs from the Finisher Controller PCB

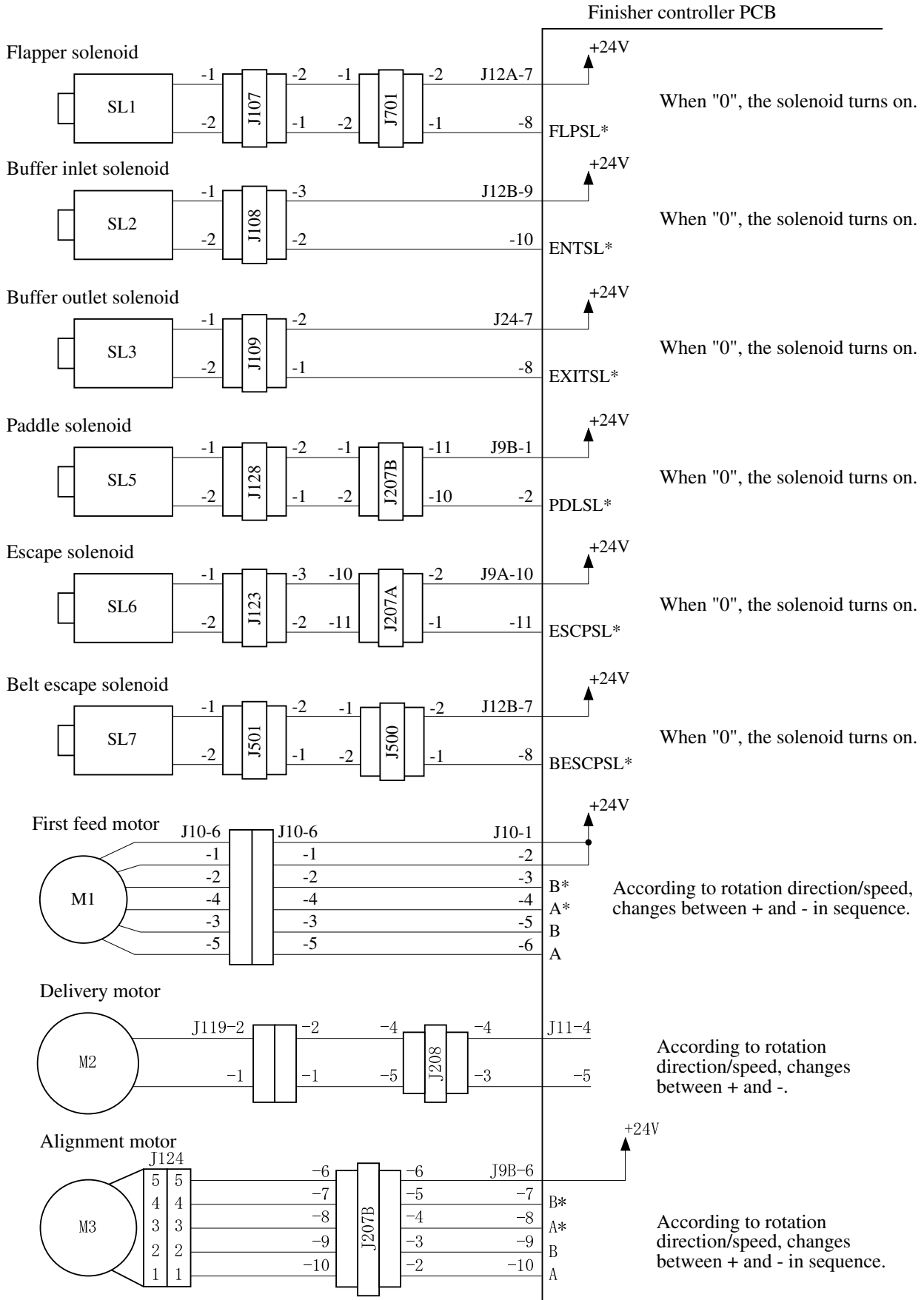


Figure 2-107

6. Outputs from the Finisher Controller PCB

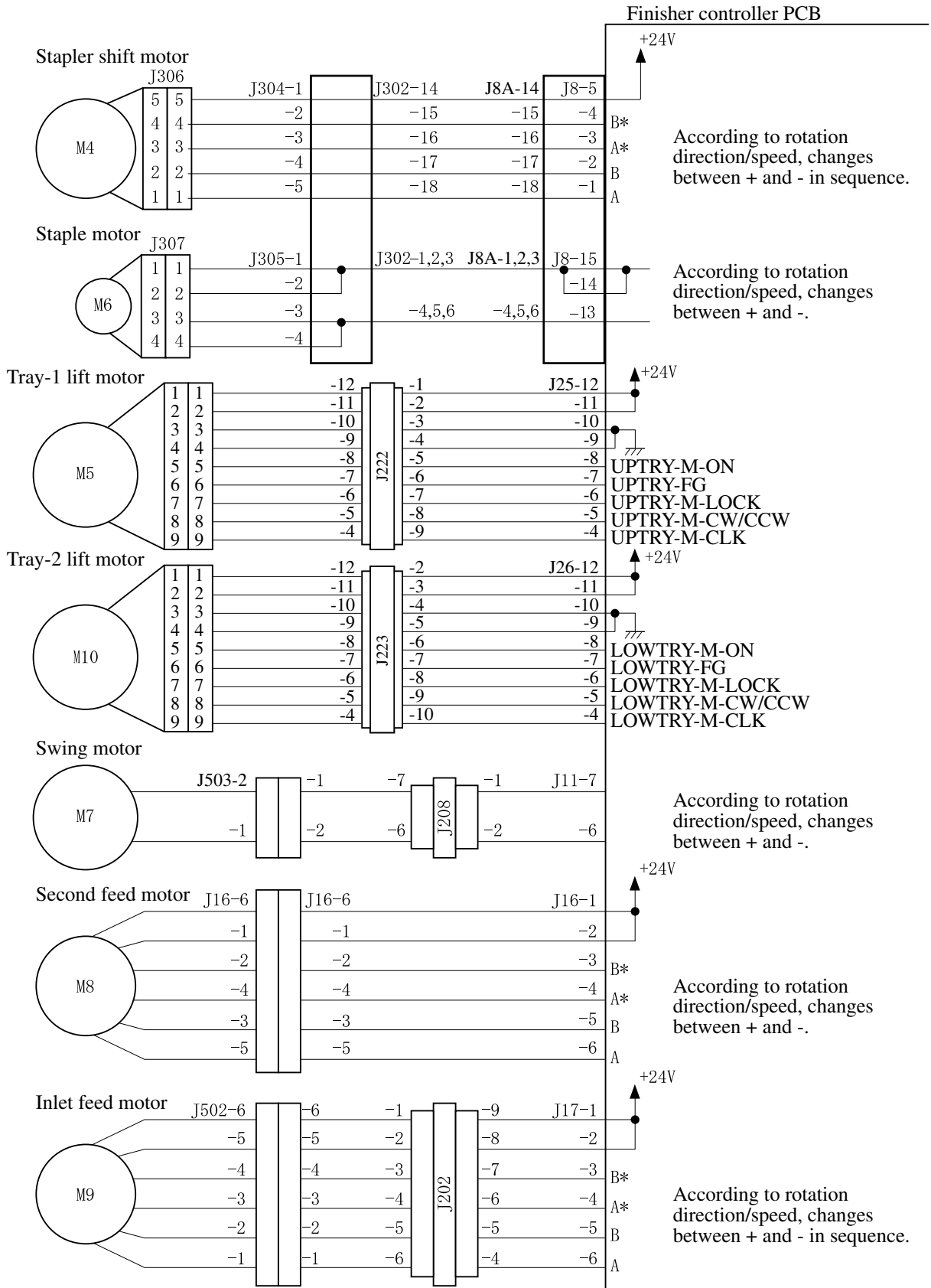


Figure 2-108

## II. FEED/DRIVE SYSTEM

### A. Outline

The finisher is designed to operate according to the commands from its host machine to deliver arriving copies to trays in the appropriate mode: simple stacking, job offset, stapling.

See Figure 2-201 for a diagram of the three modes of delivery (four for the Saddle Stitch Finisher).

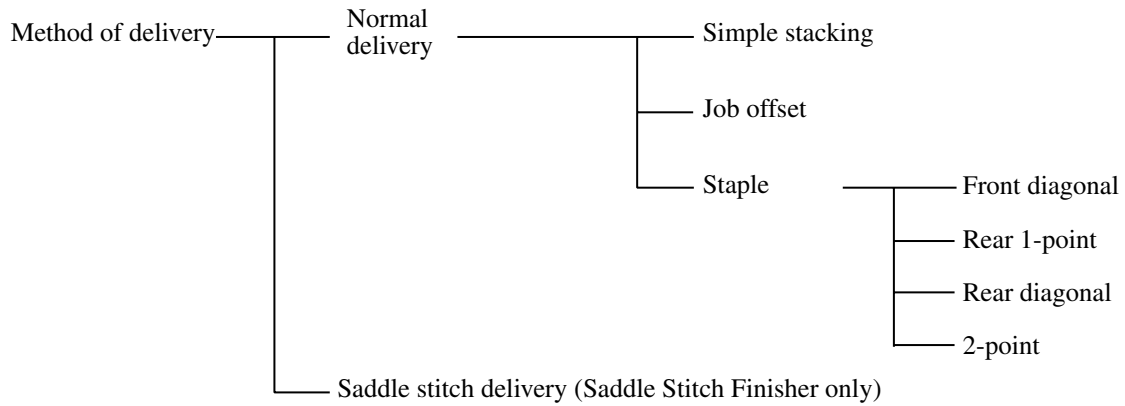


Figure 2-201

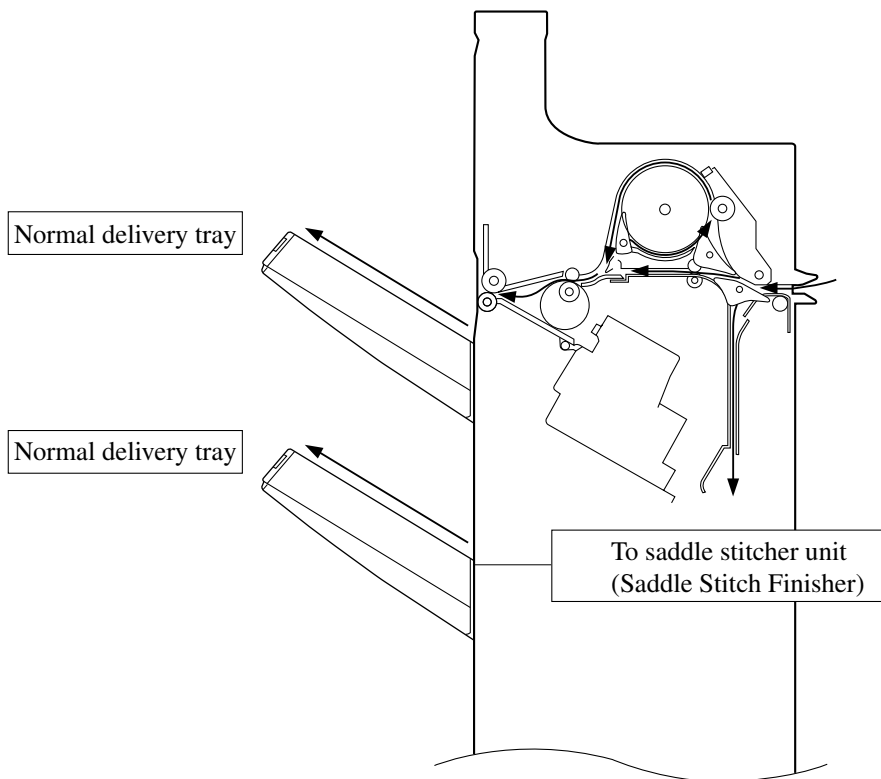
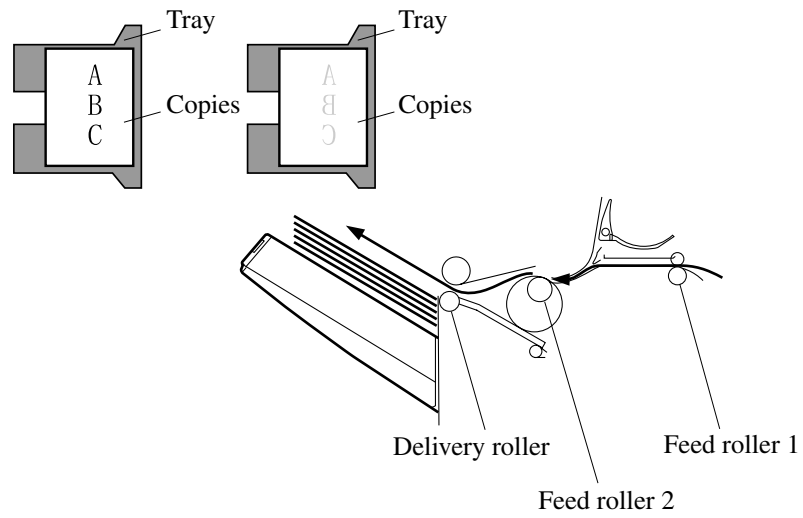


Figure 2-202

**1. Normal Delivery****a. Simple Stacking**

The finisher delivers copies directly to the tray.

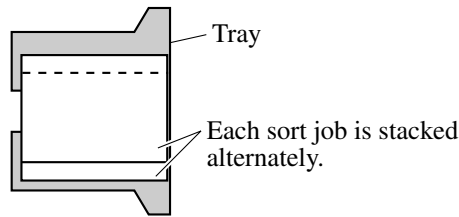


**Figure 2-203**

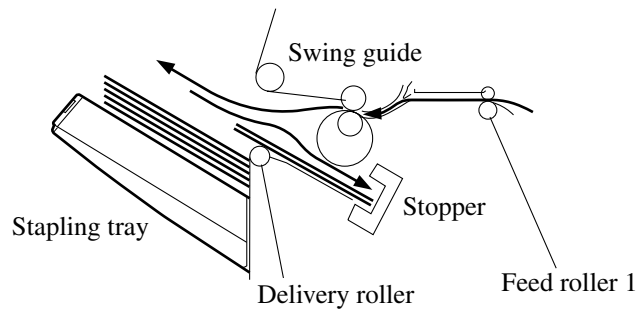


b. Job Offset

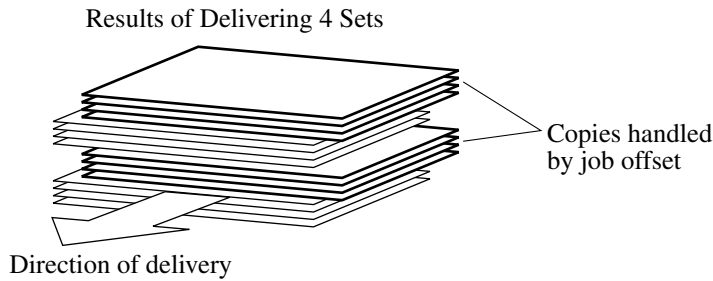
The finisher forwards all copies of each sort job to the stapling tray. The first sort job on the stapling tray is delivered with a shift to the front of about 30 mm, and the second sort job is delivered without being shifted. Whether the first copy or the last copy of a sort job should be shifted is determined by the host machine.



**Figure 2-204**



**Figure 2-205**



**Figure 2-206**

c. Stapling

The finisher stacks copies arriving from its host machine on the stapling tray. Then, it staples and delivers the copies to the appropriate tray.

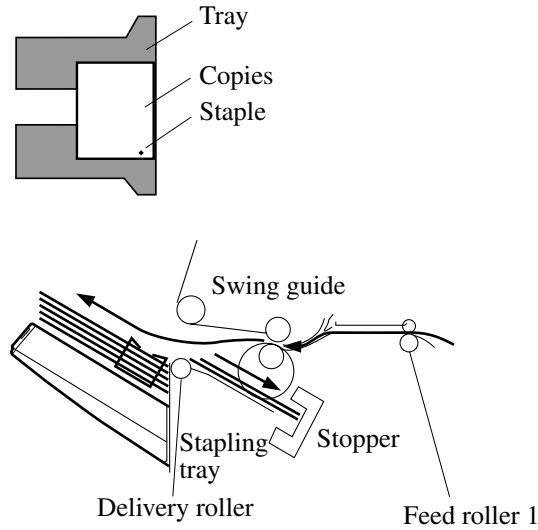


Figure 2-207

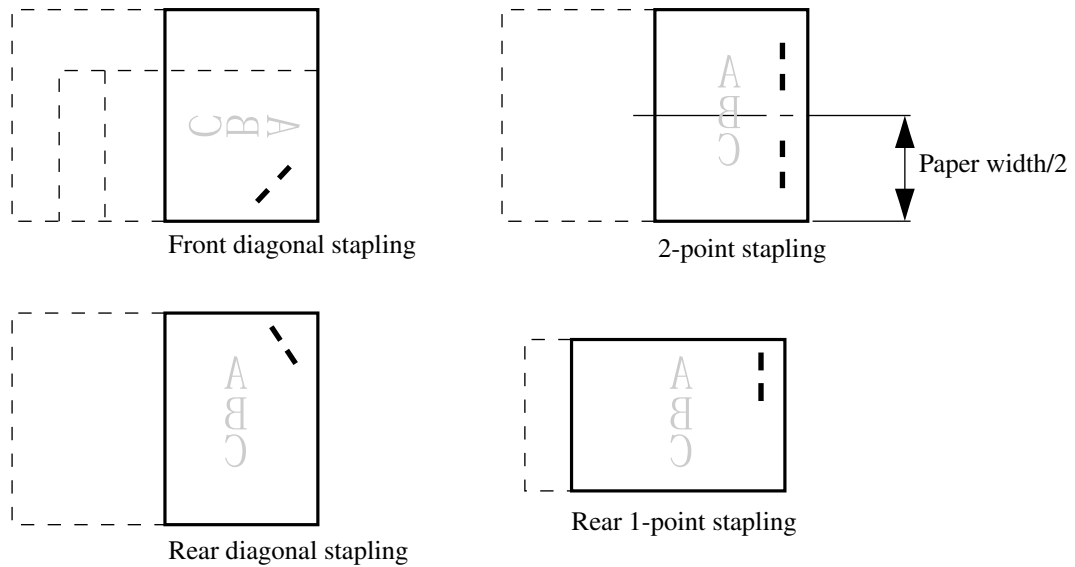
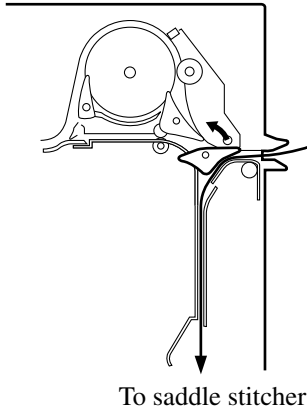


Figure 2-208

## 2. Saddle Stitch Delivery (Saddle Stitch Finisher)

A copy arriving in the finisher from the host machine is routed to the saddle stitcher by the paper deflecting plate. The saddle stitcher executes stitching and saddling operations on the copy and then delivers it to the saddle stitcher tray.

For discussions of stacks in the saddle stitcher, see Chapter 3.



**Figure 2-209**

## B. Type of Delivery Paths

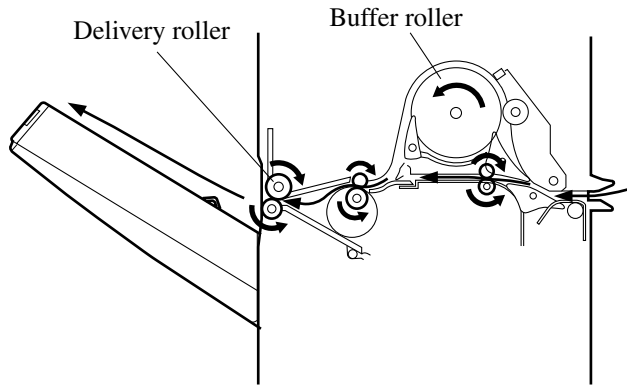
The finisher has three different paper paths for delivery, each selected to suit paper size and delivery mode.

### 1. Straight Path

When stacking copies shown in Table 2-201, the copies pass under the buffer roller.

Copy size	Length or width 182 mm or less
Typical copy examples	A5-R, ST-R, thick paper

**Table 2-201**



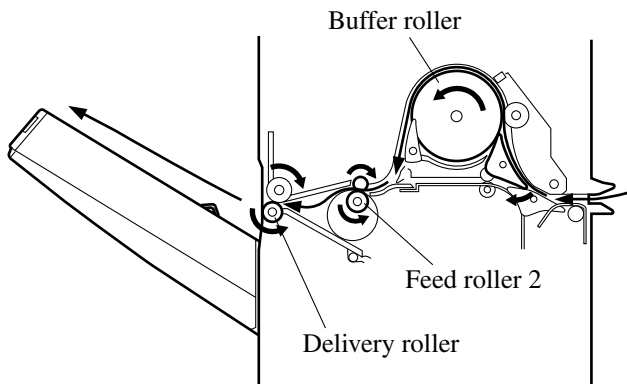
**Figure 2-210**

### 2. Buffer Paper Path 1

When stacking copies shown in Table 2-202, the copies pass over the buffer roller, increasing the distance between copies.

Copy size	Length and width 182 mm or more
Typical copy examples	A3, B4, A4, A4-R, B5, B5-R, LD, LG, LT, LT-R, (excluding transparencies and thick stock)

**Table 2-202**



**Figure 2-211**

### 3. Buffer Paper Path 2

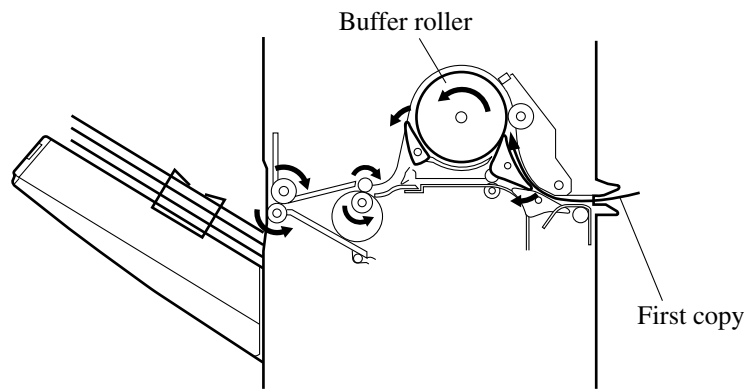
This is the paper path when copy sizes shown in Table 2-203 are stacked. A maximum of three copies (three originals or more in the staple mode) are wrapped round the buffer roller, during which job offset and stapling are performed on the stapling tray.

Copy size	Length 182 to 232mm, and width 182 to 297mm
Typical copy examples	A4, B5, LT, (excluding transparencies and thick stock)

**Table 2-203**

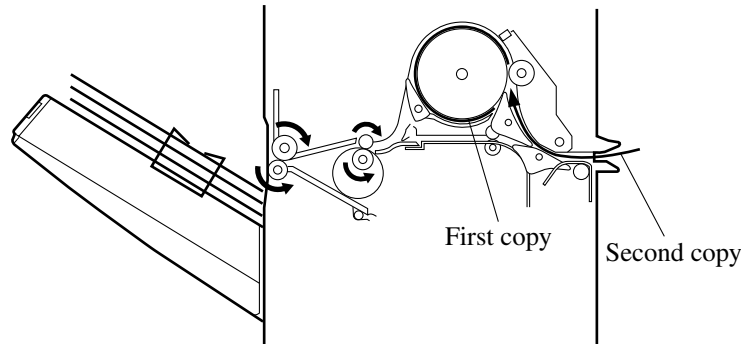
The following shows paper delivery operation in the case of three originals in the staple mode.

- 1) The first copy is moved in the direction of the buffer roller.



**Figure 2-212**

- 2) The first copy wraps around the buffer roller and, at the same time, the second copy arrives from the host machine.



**Figure 2-213**

- 3) The second copy is laid over the first copy and, at the same time, the third copy arrives from the host machine.

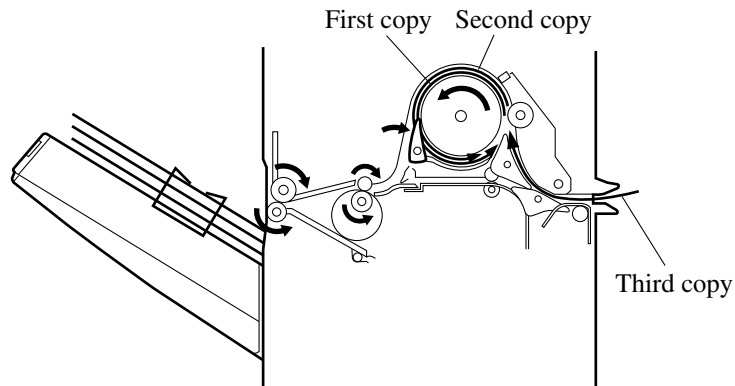


Figure 2-214

- 4) The first, second and third copies are simultaneously pulled into the stapling tray.

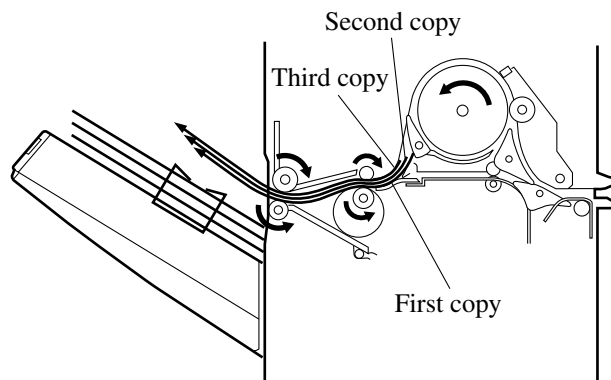


Figure 2-215

**Caution:**

The third copy as explained here is moved through buffer paper path 1. This fact is omitted from the discussion to avoid interrupting the sequence of operations.

## C. Feeding and Delivering

### 1. Outline

The finisher moves copies arriving from the host machine to the delivery tray, stapling tray, or the saddle stitcher unit (Saddle Stitch Finisher) according to the mode of delivery. On the stapling tray, the copies are subjected to job offset or stapling as instructed by the host machine.

The first feed motor (M1), second feed motor (M8) and inlet feed motor (M9) are stepping motors, and delivery motor (M2) is a DC motor. These motors are controlled by the microprocessor (CPU) on the finisher controller PCB, and rotate either clockwise or counterclockwise.

The paper paths are equipped with the following four sensors for detection of paper (arrival, passage):

- Inlet sensor (PI1)
- Delivery sensor (PI3)
- Stapling tray sensor (PI4)
- Buffer path paper sensor (PI14)

In addition, each delivery tray is equipped with a sensor designed to detect the presence/absence of paper on it.

- Tray-1 paper sensor (PI11)
- Tray-2 tray paper sensor (PI12)

If a copy fails to reach or move past each sensor within a specific period of time, the finisher controller PCB identifies the condition as a jam, and stops the ongoing operation, and at the same time, informs the host machine of the condition. When all doors are closed after the paper jam is removed, the buffer path inlet paper sensor (PI17) checks whether or not copies are being detected in addition to the above four sensors (inlet sensor, delivery sensor, stapling tray sensor and buffer path paper sensor). If the sensors detect a copy, the finisher unit judges that paper jams have not completely been removed, and sends the paper jam removal signal to the host machine again.

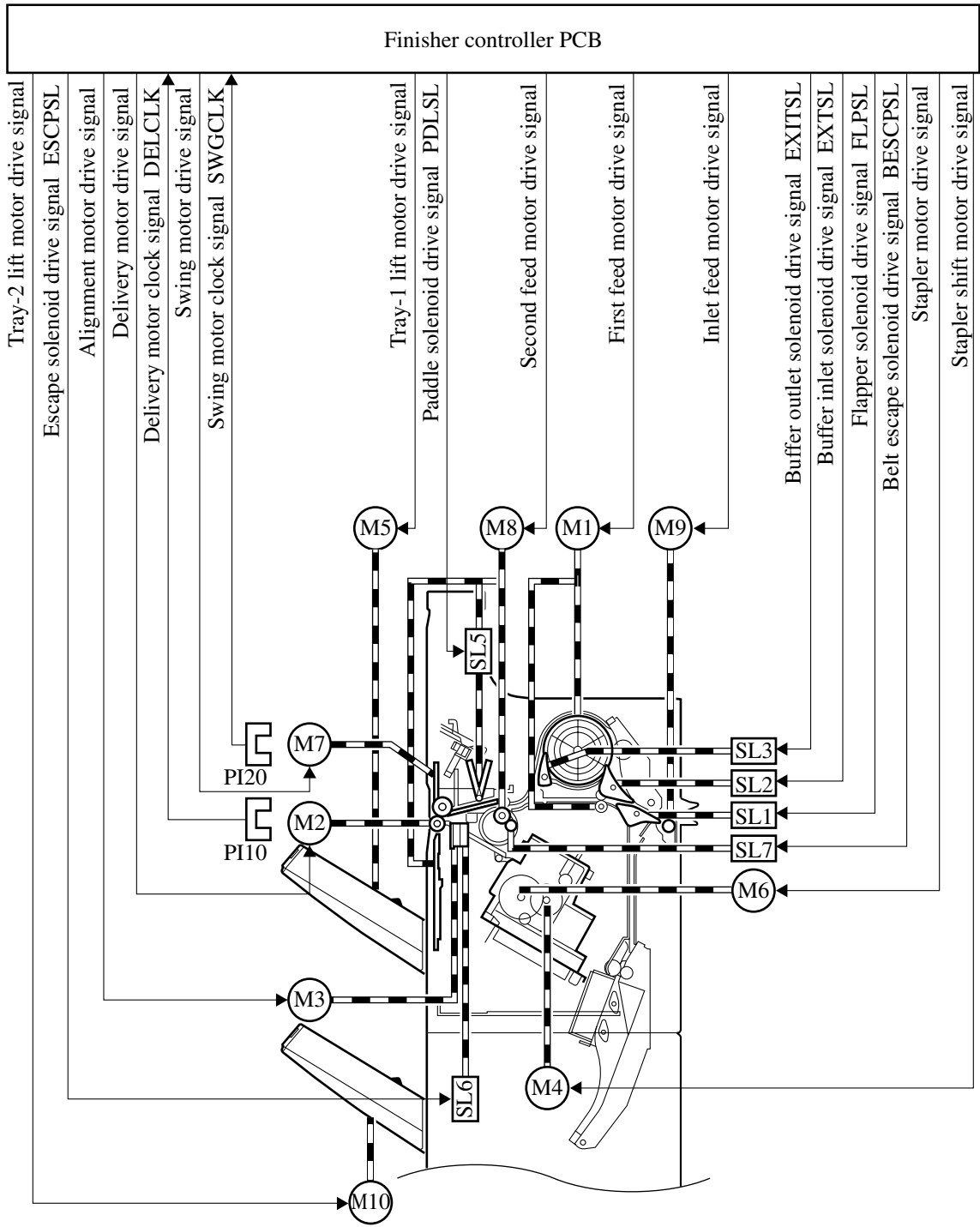


Figure 2-216



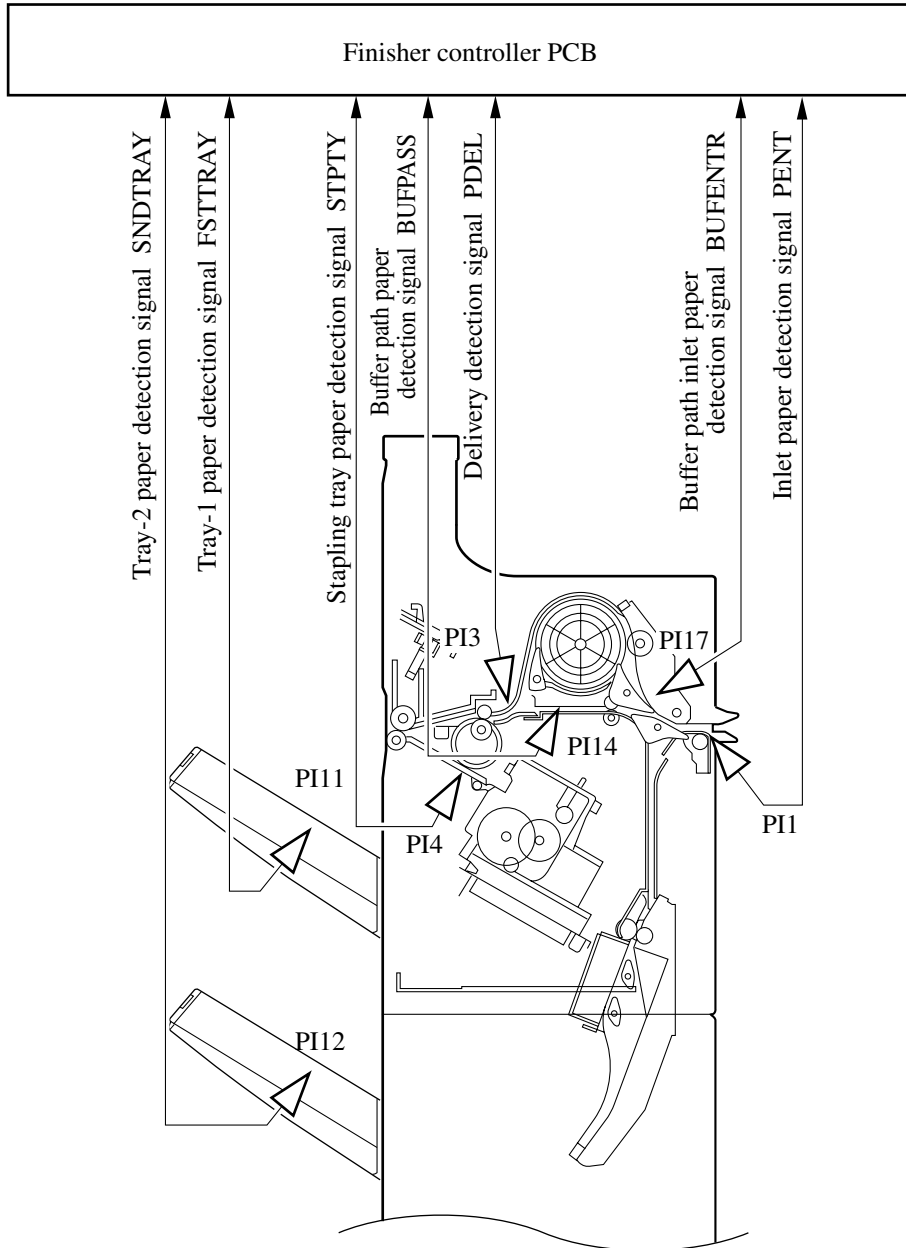


Figure 2-217

## D. Job Offset

### 1. Outline

In the job offset mode, sort jobs and entire copy groups are shifted to the front for delivery to the tray, and other copies are delivered to the tray without a shift.

The copies are shifted by the alignment plate. The alignment plate is checked by the alignment plate home position sensor (PI6) to find out whether it is at the home position.

The finisher controller PCB drives the alignment motor (M3) at power-on to return the alignment plate to its home position.

The finisher controller PCB stops the delivery motor (M2) when the trailing edge of the copy has moved past the feed roller 2. Then, the finisher controller PCB rotates the delivery motor counterclockwise, and drives the swing motor (M7). As a result, the drive of the delivery motor is transmitted to the swing guide to move up the guide. When the swing guide open sensor (PI18) detects the swing guide, the delivery motor stops, and the swing guide is held at the up position.

When the swing guide has moved up, the feed belts attached to the feed roller 2 move the copy to the stapling tray. The presence of paper on the stapling tray is monitored by the stapling tray sensor (PI4). (The first sheet is fed to the stapling tray while the swing guide is moving up.)

The finisher controller PCB drives the alignment motor (M3) in advance, and keeps the alignment plate in wait at a point 10 mm behind the trailing edge of a sheet. Whenever one sheet is moved to the stapling tray, each sheet is aligned, and when the fifth or last sheet in a sort job/group is fed to the stapling tray, the escape solenoid (SL6) moves the guide plate away and under the stapling tray. From then on, the alignment motor shifts the sheets to the front by 30 mm.

When the copy has been shifted, the finisher controller PCB rotates the alignment motor counterclockwise to move the alignment plate to a point 10 mm behind the trailing edge of the sheet. This alignment operation is repeated until alignment of the fifth or last sheet in a sort job is completed. At this time, the swing guide is moved down and is closed, and the delivery motor rotates clockwise to deliver the sheet.

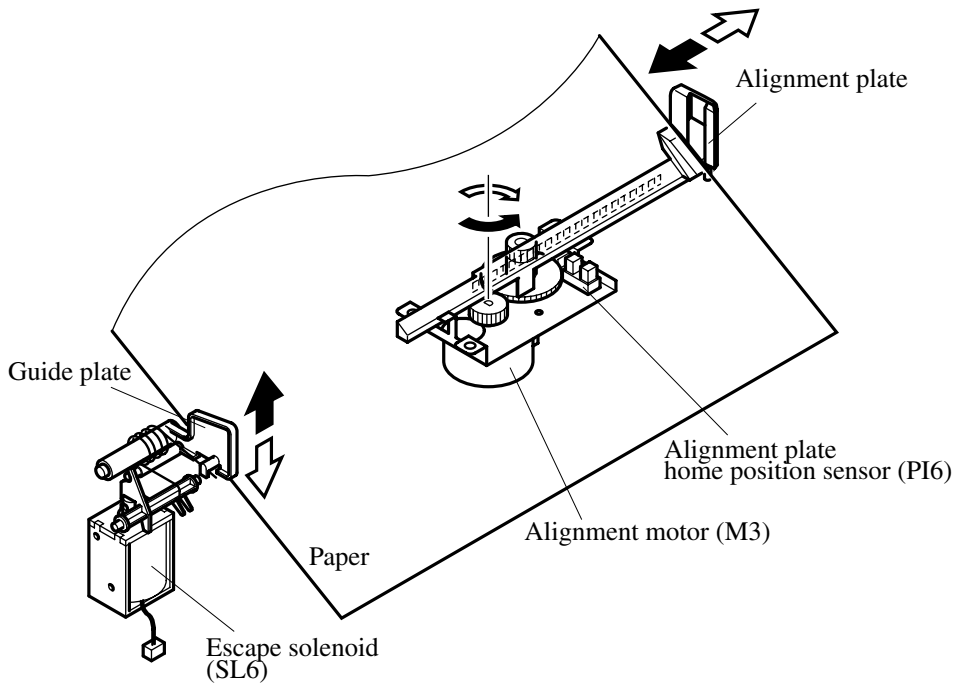


Figure 2-218

Sequence of Operation (job offset)

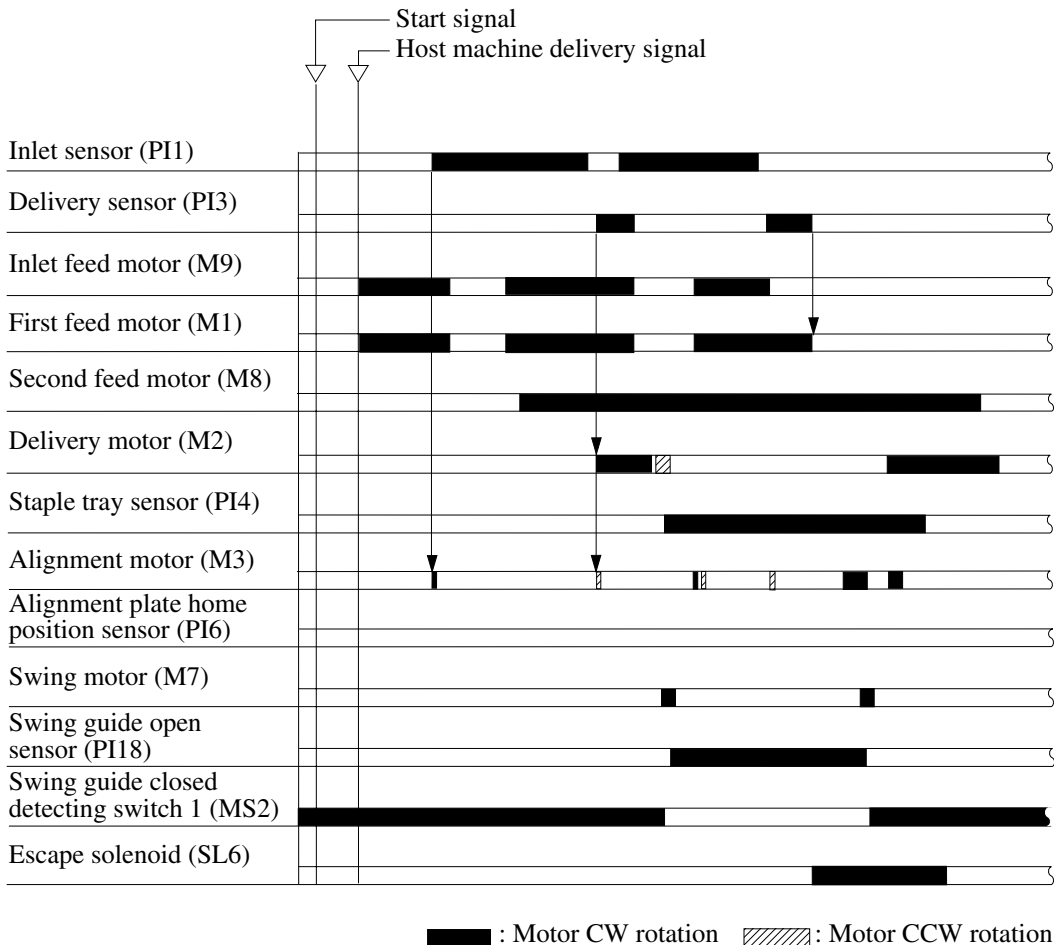
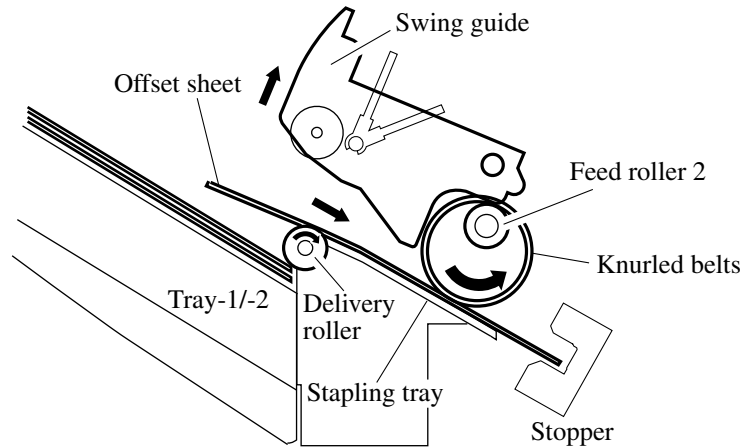


Figure 2-219

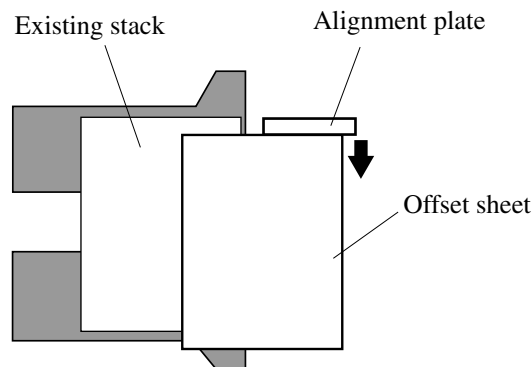
## 2. Flow of Job Offset Operations

- 1) The swing guide moves up and, at the same time, the feed belts move the sheet to the stapling tray.



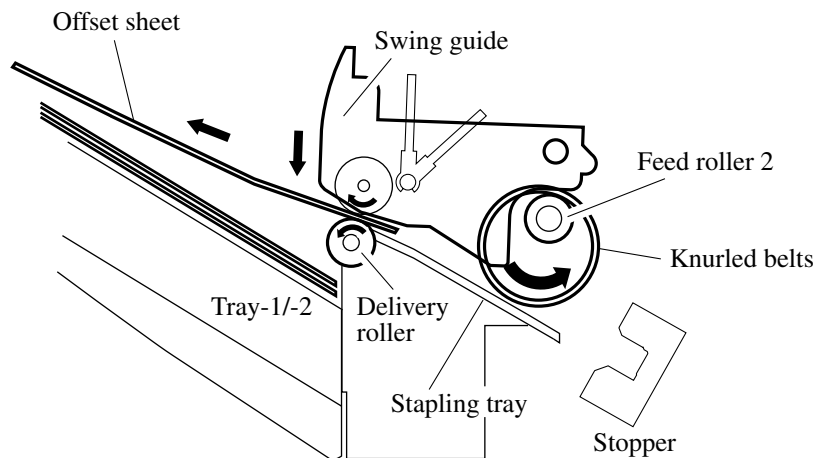
**Figure 2-220**

- 2) The alignment plate shifts the sheet to the front.



**Figure 2-221**

- 3) The swing guide moves down and, at the same time, the delivery roller delivers the sheet.



**Figure 2-222**

## E. Staple Operation

### 1. Outline

The stapler unit staples a stack of as many sheets as specified.

The stapling position differs according to the selected staple mode and paper size.

The stapler unit is checked by the stapler shift home position sensor (PI7) to find out whether it is at the home position.

When starting operation after power-on, the finisher controller PCB drives the stapler shift motor (M4) to return the stapler unit to the home position. If the stapler is already at the home position, it is kept as it is in wait.

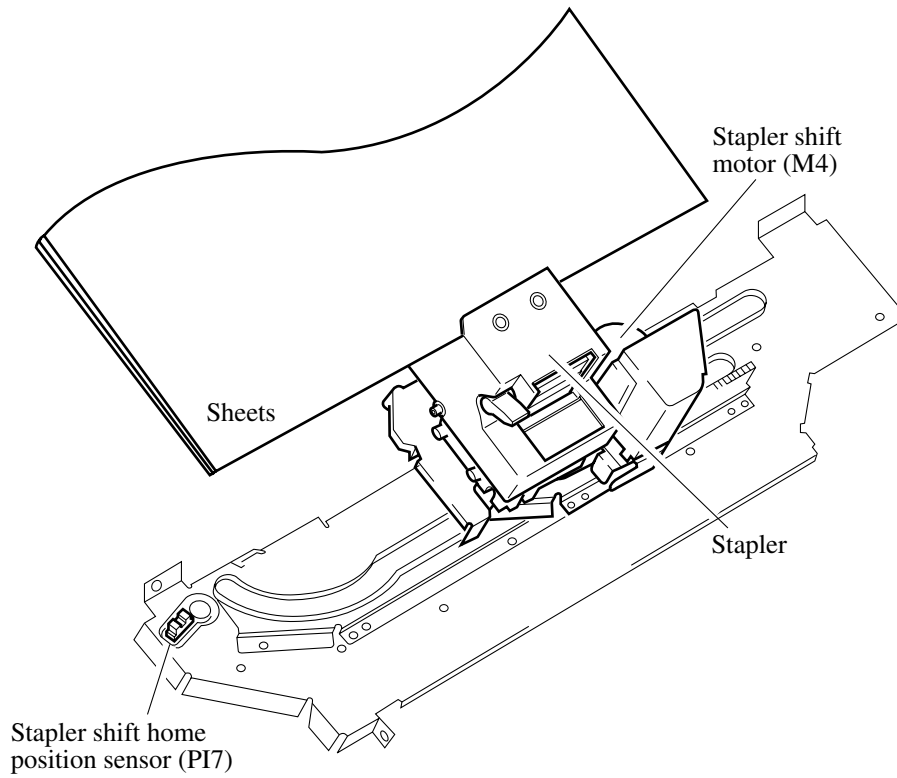


Figure 2-223

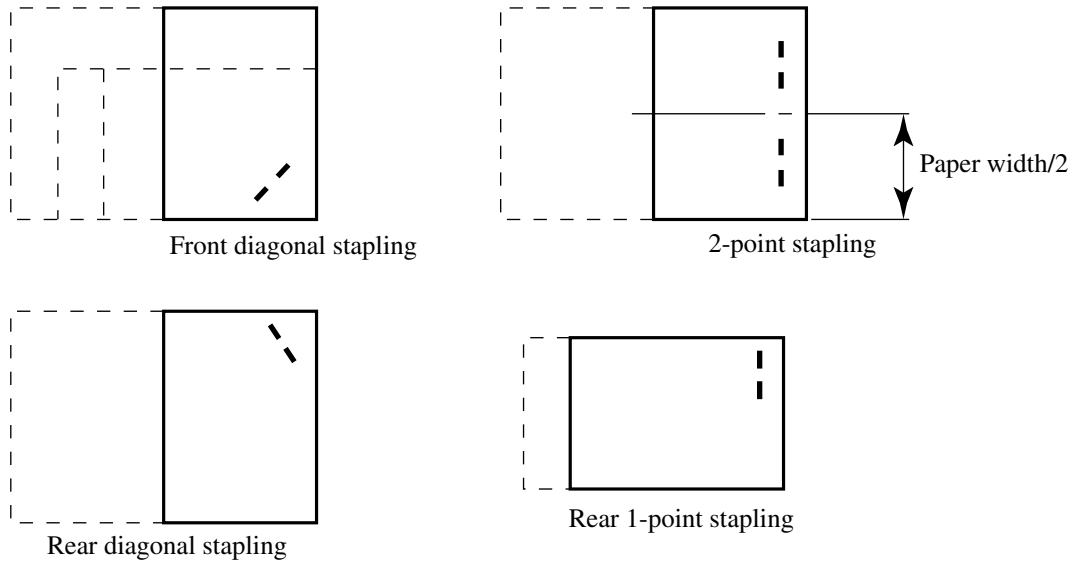


Figure 2-224

## 2. First Sheet

The finisher controller PCB stops the delivery motor (M2) as soon as the trailing edge of the first sheet has moved past the feed roller 2. Then, it rotates the delivery motor clockwise to switch the gear drive to the swing motor (M7), causing the swing guide to move up. When the swing guide open sensor (PI18) finds the swing guide at the up position, the swing motor stops, maintaining the swing guide at the up position.

When the swing guide has moved up, the knurled belts of the feed roller 2 move the sheet to the stapling tray. (The first sheet is fed to the stapling tray while the swing guide is moving up.) The presence of paper on the stapling tray is detected by the stapling tray sensor (PI4).

The finisher controller PCB drives the alignment motor (M3) when the stapling tray paper sensor has detected paper to put sheets in order. The alignment plate is kept in wait in advance at a point 10 mm behind the trailing edge of the paper.

The swing guide is kept in wait at the up position until the last sheet is output onto the stapling tray.

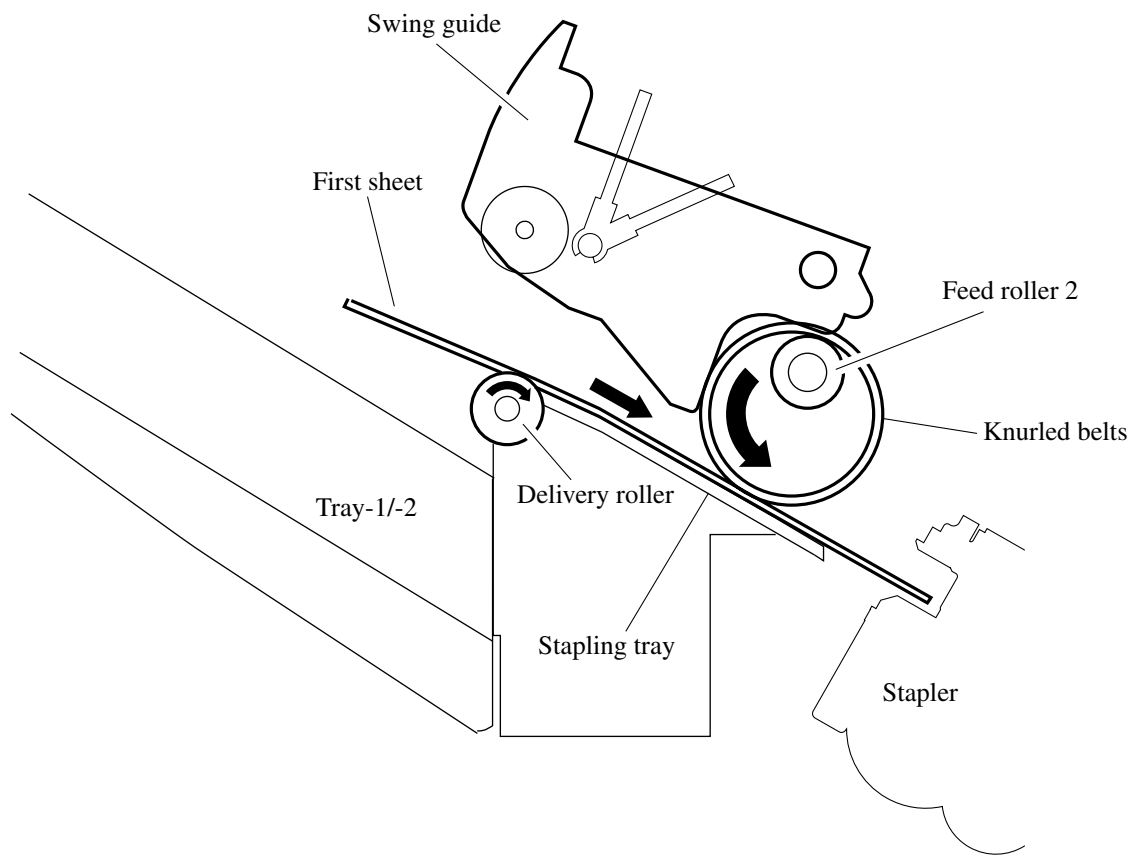


Figure 2-225

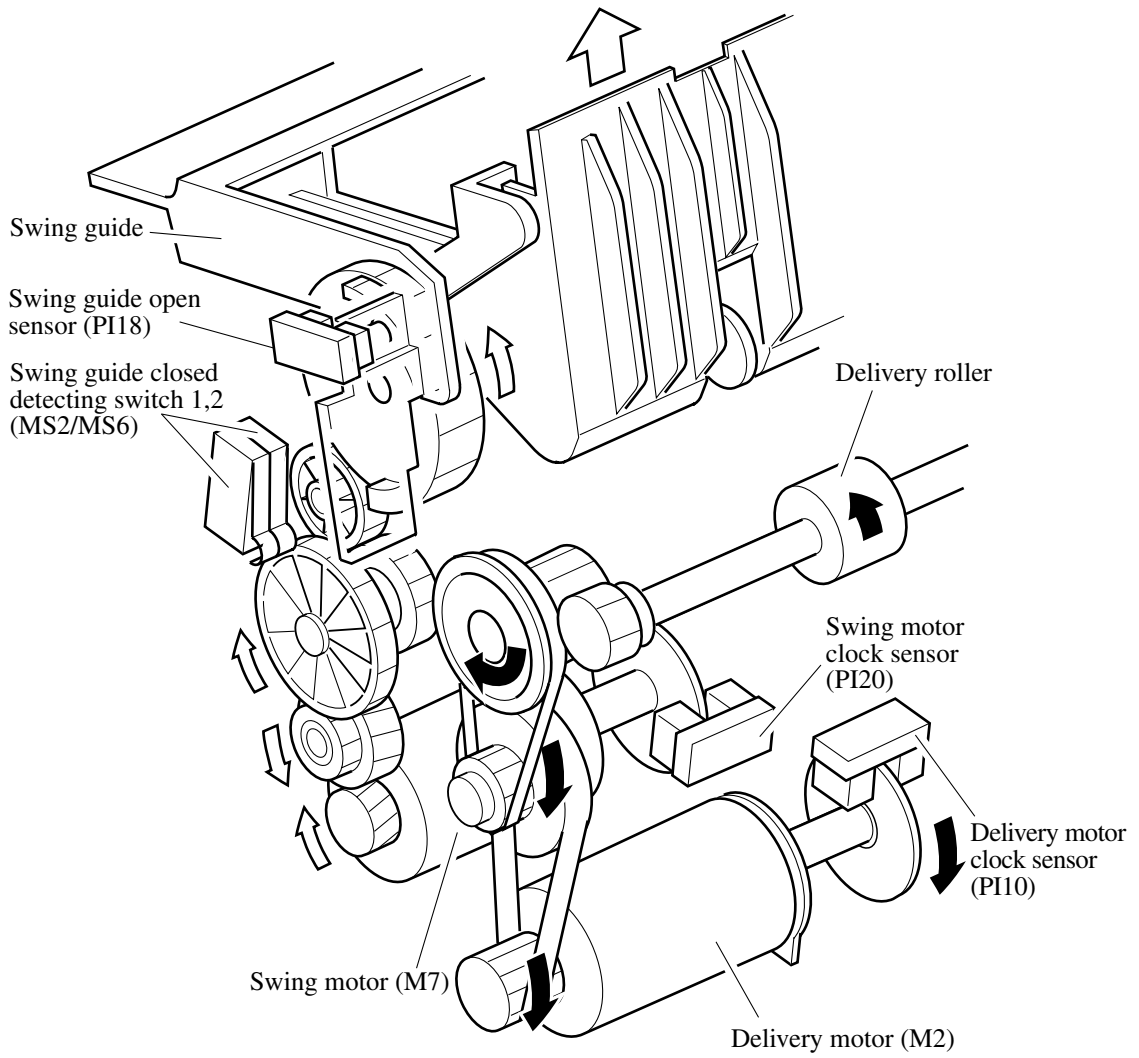


Figure 2-226



### 3. Second and Subsequent Sheets

The finisher controller PCB turns on the belt escape solenoid (SL7) before the trailing edge of the second and subsequent sheets have moved past the feed roller 2 to make the knurled belt escape. This operation is performed to reduce the time it takes for the trailing edge of the paper to fall on the stapling tray, and to improve the product duty. The finisher controller PCB turns on the paddle solenoid (SL5) as soon as the trailing edge of the second and subsequent sheets have moved past the feed roller 2, causing the drive of the second feed motor (M8) to rotate the paddle. The sheets are pushed by the paddle and moved to the stapling tray. Almost simultaneously with the trailing edge of the sheet falling into the stapling tray, the belt escape solenoid turns off to return the knurled belts that were in the escape position to its original position, and feed the sheet onto the stapling tray. When the sheet has been output onto the the stapling tray, the finisher controller PCB rotates the alignment motor (M3) to put the sheets in order.

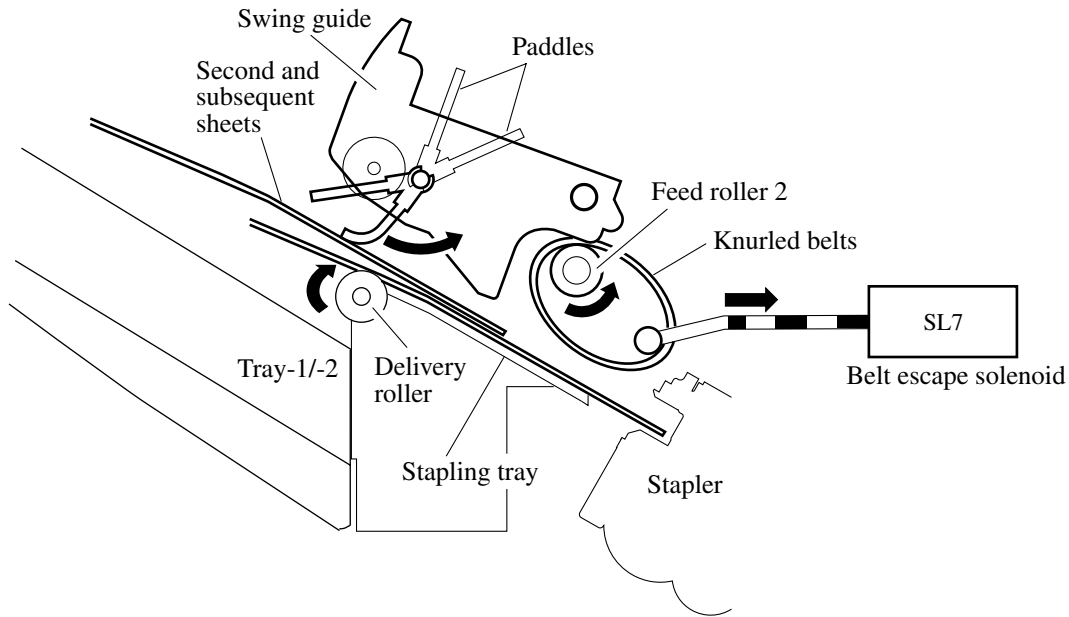


Figure 2-227

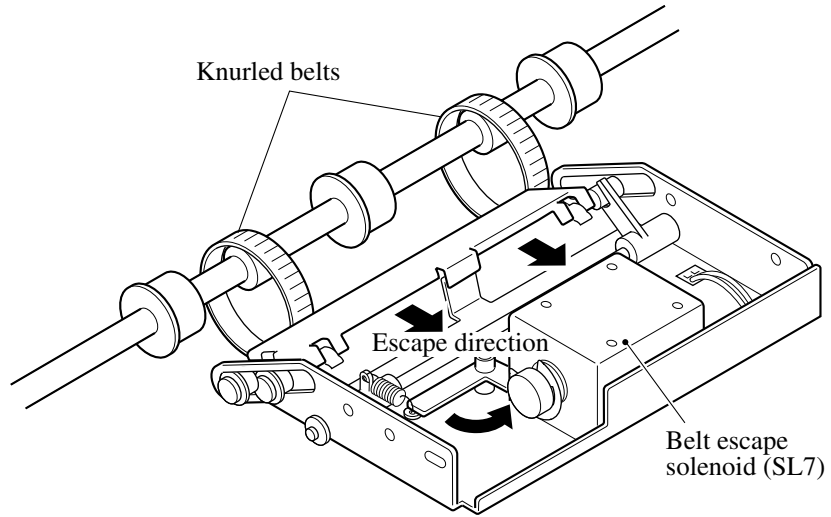


Figure 2-228

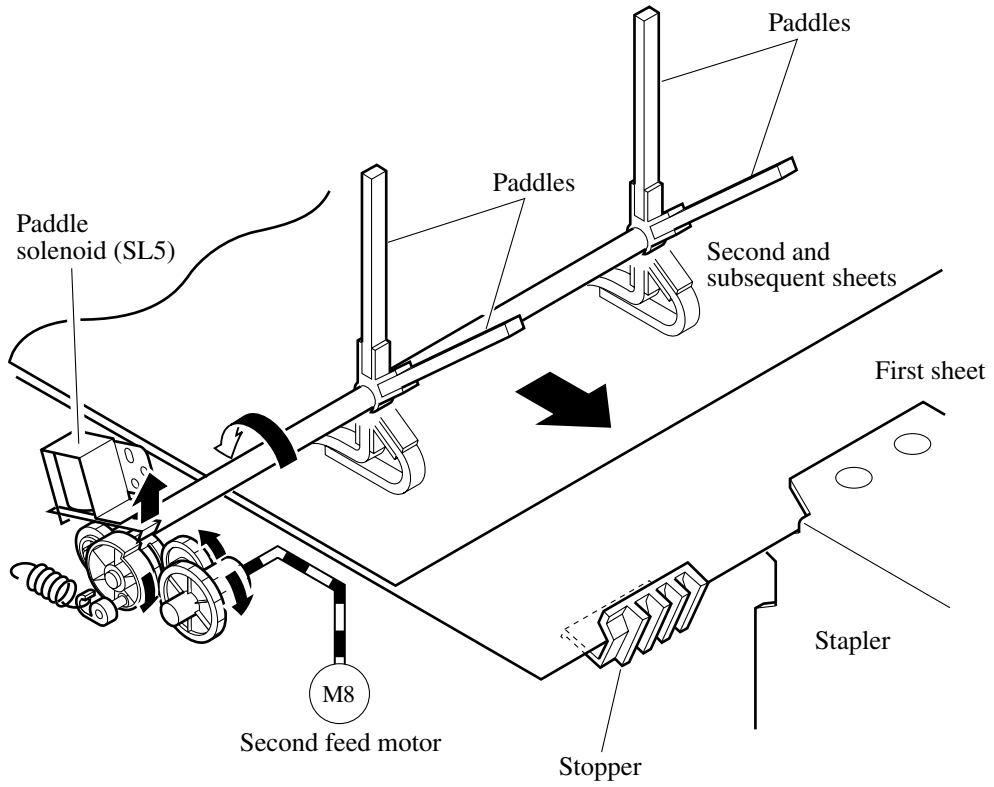


Figure 2-229

#### 4. Last Sheet

When the last sheet has been put in order, the finisher controller PCB turns on the alignment motor (M3) to move the alignment plate to the alignment position (to butt the plate against the stack). Then, the finisher controller PCB rotates the swing motor (M7) counterclockwise to move down the swing guide.

The finisher controller PCB moves the stapler according to the staple mode for stapling. From then on, it rotates the delivery motor (M2) clockwise to deliver the stack to the tray.

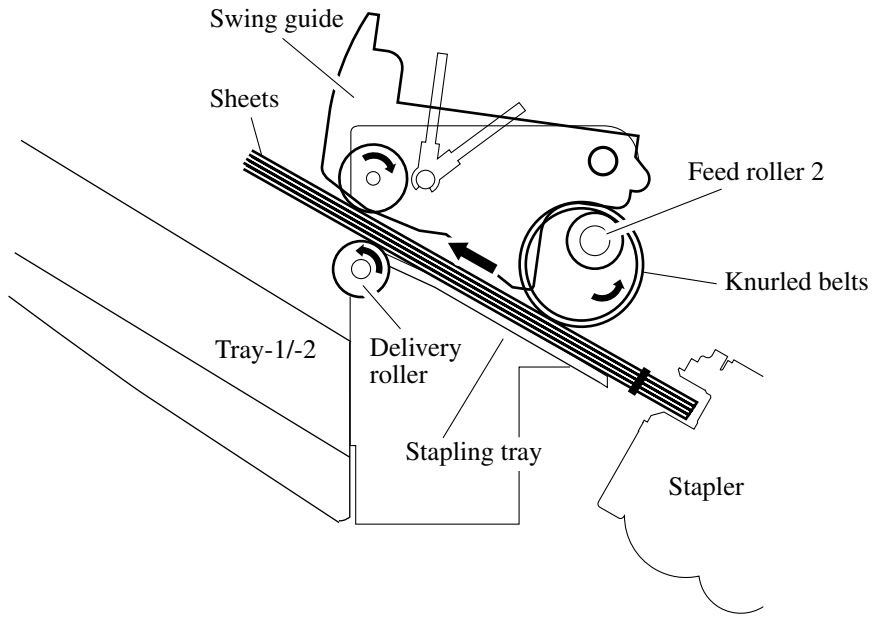


Figure 2-230

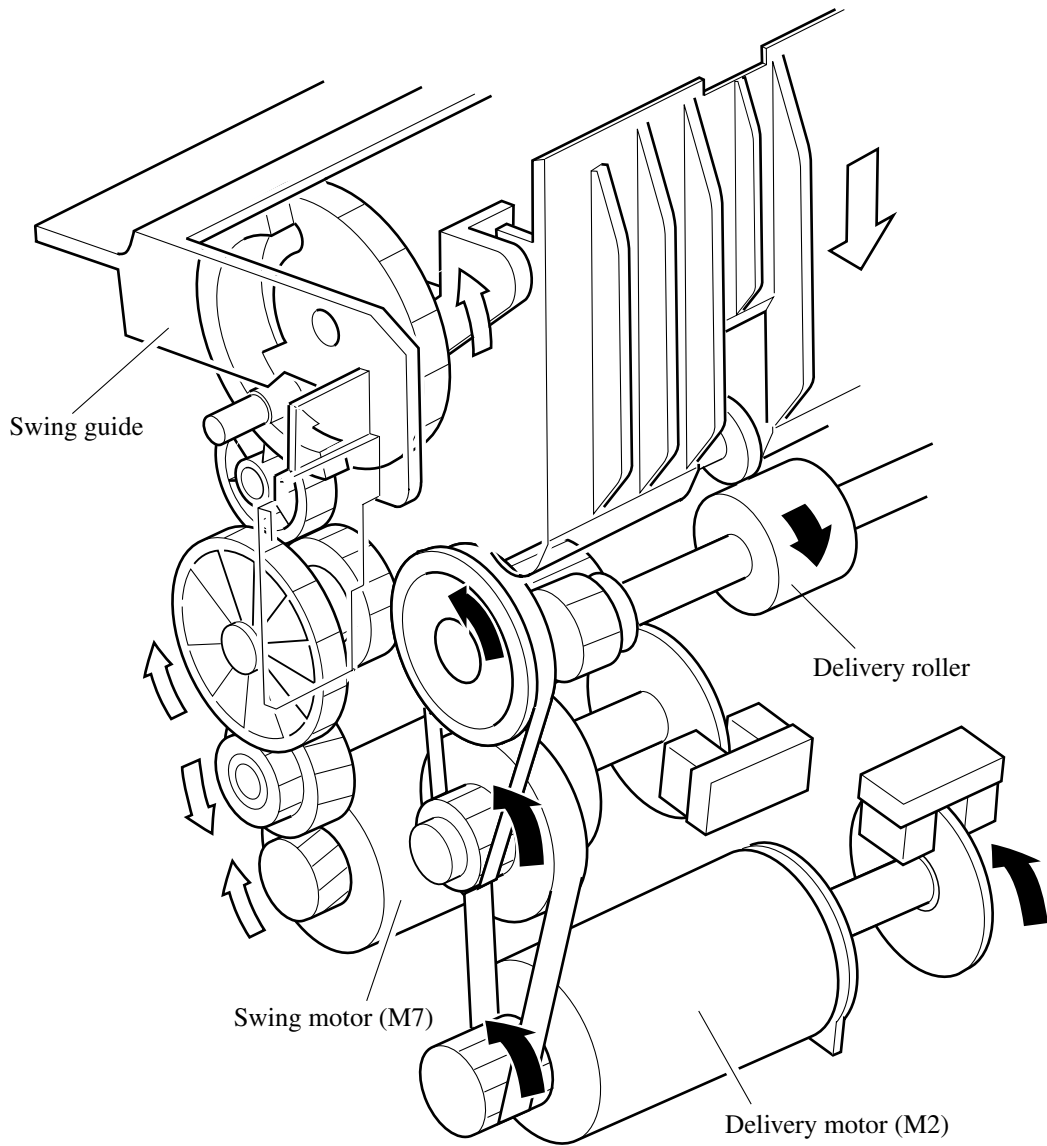


Figure 2-231

## F. Stapler Unit

Stapling is executed by the staple motor (M6). A single rotation of the cam by the motor results in one stapling operation.

The cam is checked by the staple home position sensor (PI22) to find out whether it is at the home position.

The stapler motor is controlled by the microprocessor (IC1) on the finisher controller so that it is rotated clockwise or counterclockwise.

When the stapling home position sensor is off, the finisher controller PCB rotates the stapler motor clockwise until the sensor turns on so as to return the stapling cam to its initial state.

The presence/absence of the staple cartridge is detected by the staple switch (MS8). The presence/absence of staples inside the staple cartridge is detected by the staple detecting switch (MS9). The staple edge sensor (PI21) is used to find out whether a staple has been edged out to the end of the cartridge.

The finisher controller PCB does not drive the staple motor (M6) unless the swing guide closed detecting switch 2 (MS6) is on (i.e., the swing guide is closed). This is to protect against injuries that could occur when a finger is stuck inside the stapler.

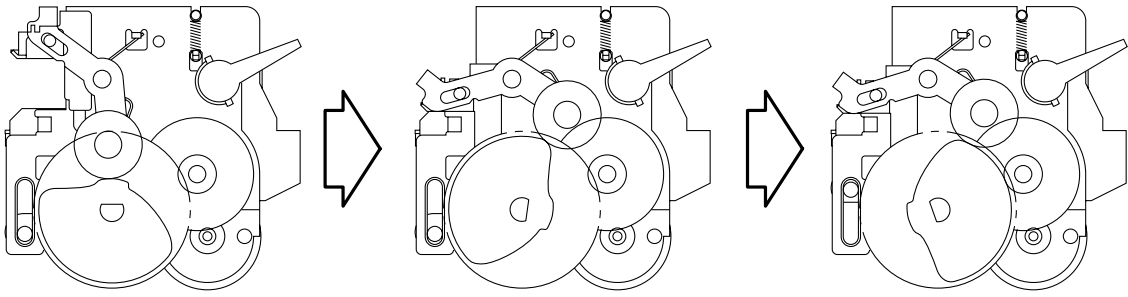


Figure 2-232

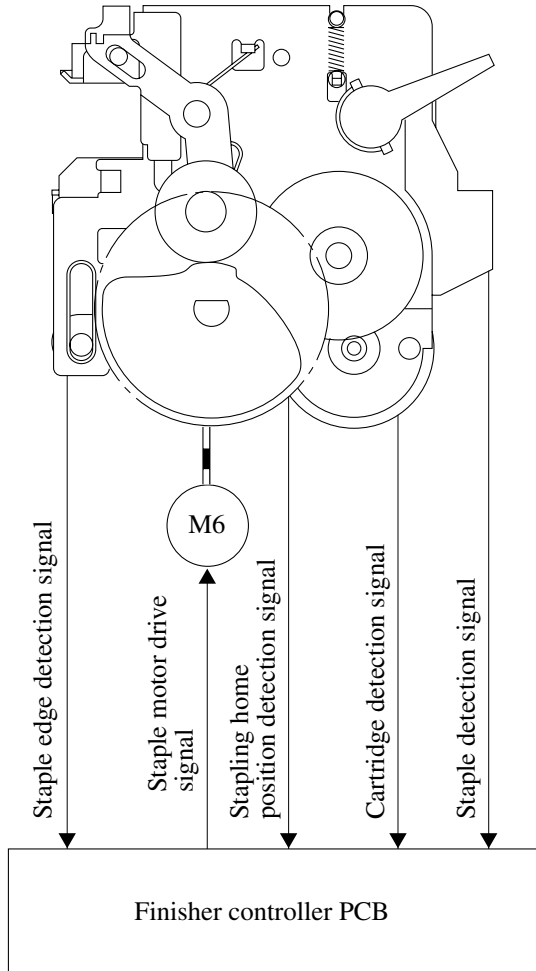


Figure 2-233

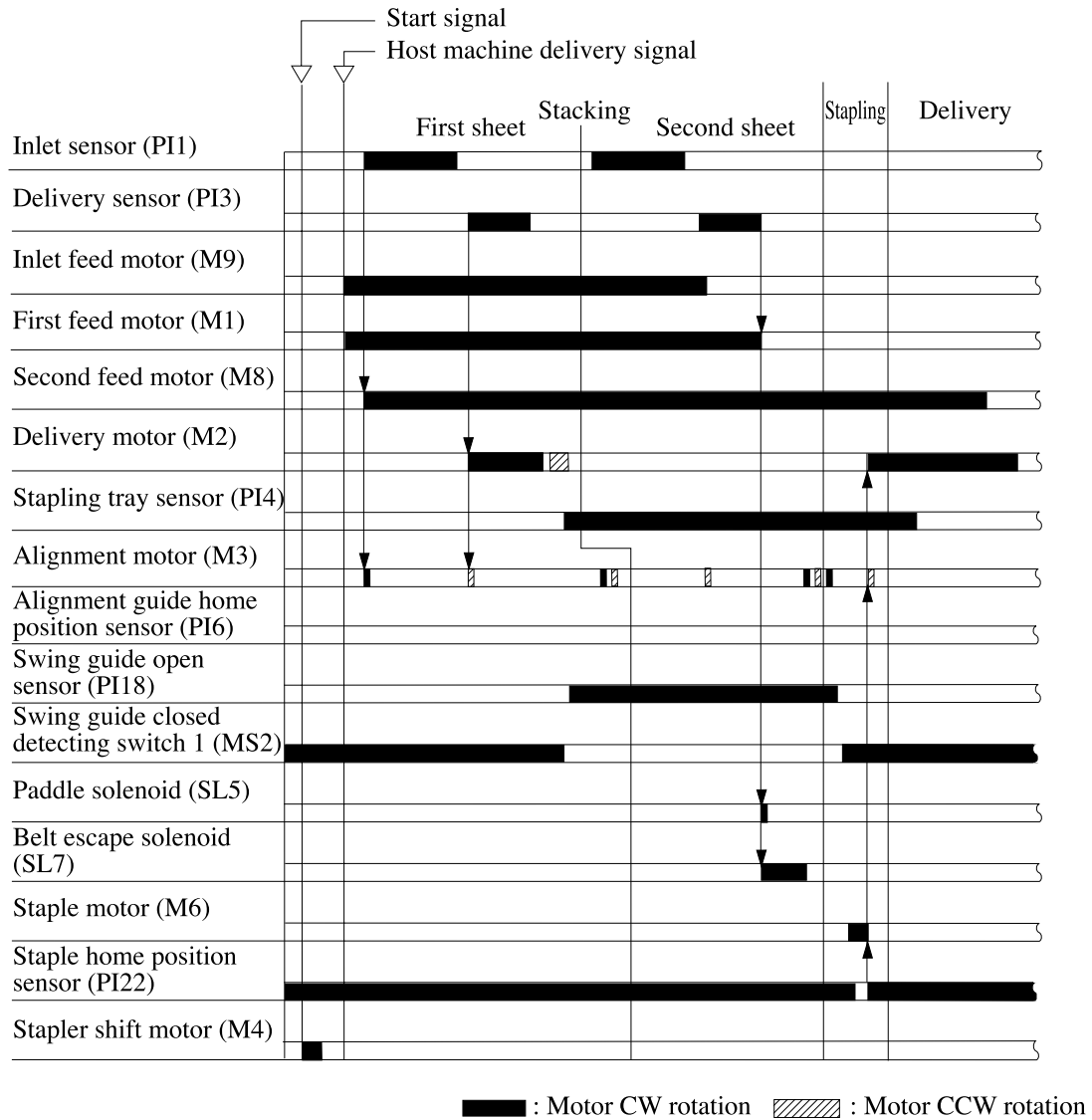


Figure 2-234

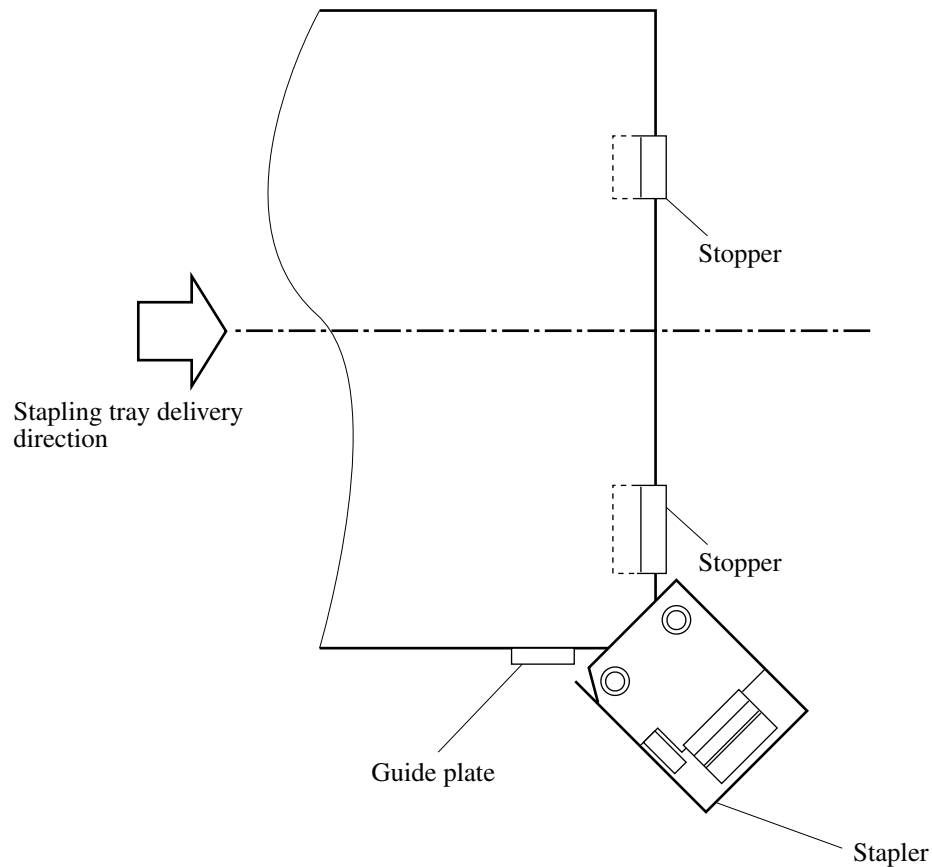
## 5. Shifting the Stapler Unit

The stapler unit is moved by the stapler shift motor (M4). Its home position is detected by the stapler shift home position sensor (PI7). When the start signal arrives from the host machine, the stapler moves to the center of its movement range. This movement occurs regardless of the selected mode of delivery, as no specific mode is recognized at this point in time. When the command for stapling arrives from the host machine after the first sheet has reached the host machine pre-registration sensor, the stapler moves to the staple wait position to suit the appropriate stapling position and paper size.

See Figures 2-235 and later for an idea of the wait position according to the stapling mode.

### a. Front Diagonal Stapling

The position is the same as the stapling position.



**Figure 2-235**



b. Rear 1-Point Stapling

The stapler is kept in wait at the center position. The stapler is moved to and from the stapling position for each stapling operation.

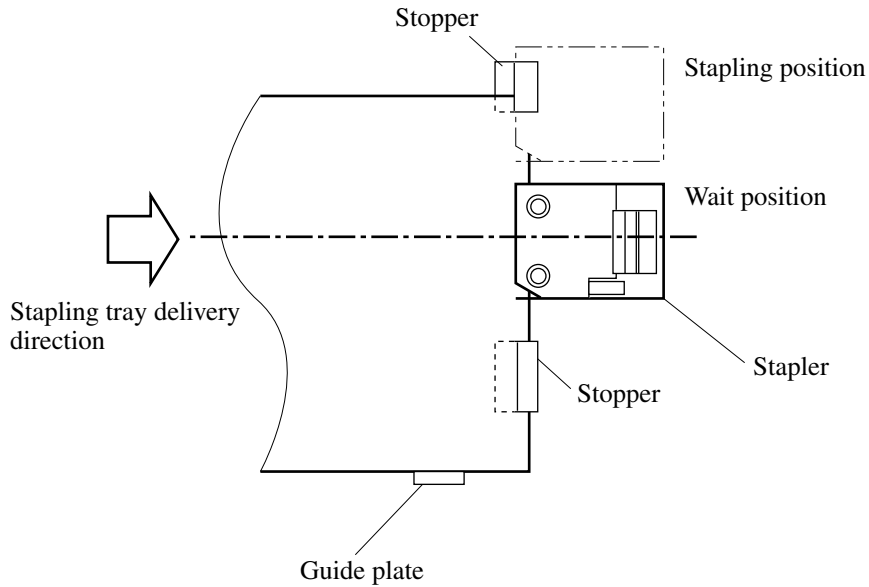


Figure 2-236

c. Rear Diagonal Stapling

For A4, LT and B5 sizes, the stapler is kept in wait toward the rear away from the stapling position. The stapler is moved to and from the stapling position for each stapling operation.

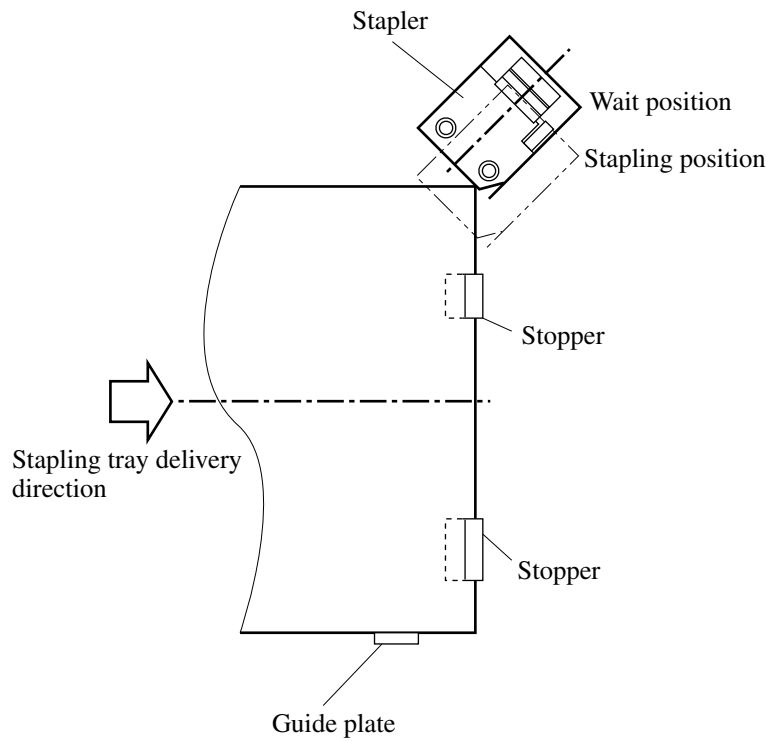


Figure 2-237

d. 2-Point Stapling

The stapler is kept in wait at the center of the paper. Stapling occurs at two points, first at the rear and then at the front.

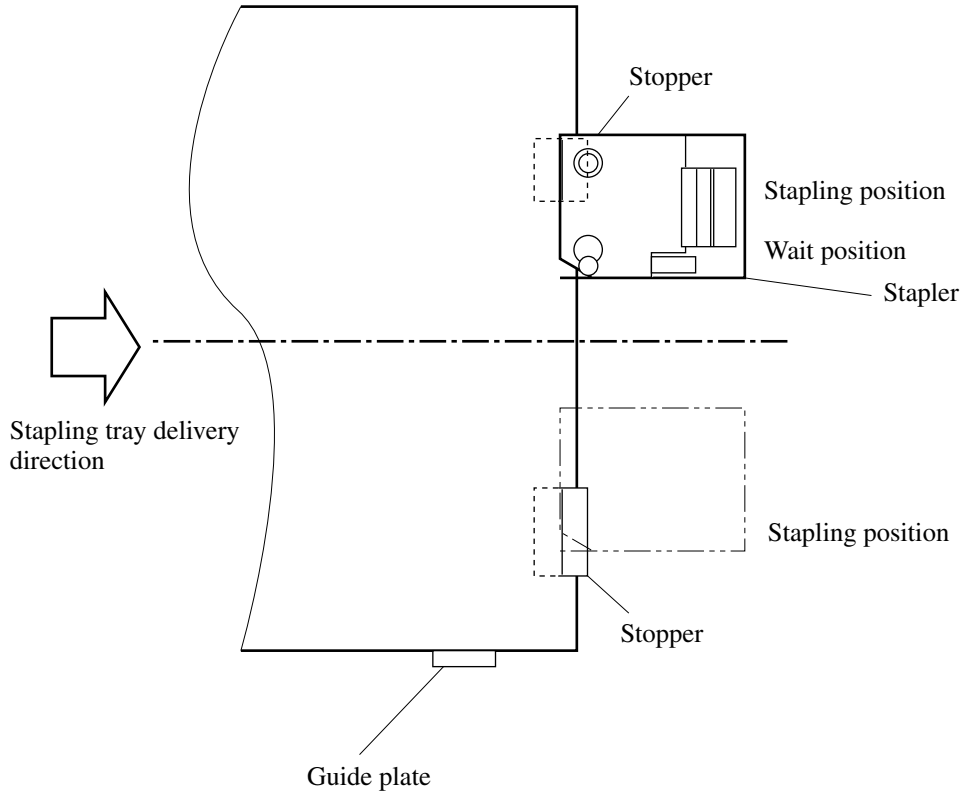


Figure 2-238

## G. Tray Operation

The finisher has two delivery trays. The upper tray is called tray-1 and lower tray is called tray-2. The tray-1 and tray-2 move up and down independently.

Tray-1 is moved up and down by the tray-1 lift motor (M5), and tray-2 by the tray-2 lift motor (M10).

The finisher controller PCB switches the motor driving direction of the tray lift motors (the motor driver PCB embedded) to control the vertical movement of the trays. When the power is turned ON, the finisher controller PCB drives the tray lift motors (M5/M10) to return the trays to their home positions. If the tray is already at the home position, it is moved away from the home position once, and then returned to that position. If both tray-1 and tray-2 are at the home position, the above operation is performed for the tray-1 and -2 in this order.

The tray position is detected by the following operation:

The finisher controller PCB counts the clock signal outputted from the tray lift motor (the motor driver PCB embedded) as soon as the tray starts to move. The finisher controller PCB moves up and down the tray selected by the host machine so that it is positioned at the delivery slot.

The lower limit of the tray-1 is detected by the tray coming close detecting switch (MS 9). The finisher controller PCB stops the drive (down) of the tray-1 lift motor (M5) as soon as the tray coming close detection switch (MS9) turns on.

The height of the stack on the tray is identified by the height sensor (PS1), which measures its distance from the top of the stack. The tray is moved down when the distance between the top of the stack on the tray and the sensor becomes less than the specific measurement.

The finisher controller PCB cuts off the +24V power of the tray lift motors (M5/M10) as soon as the safety zone switch (MS3) turns ON while the shutter and the swing guide are open, stopping the operation of the finisher.

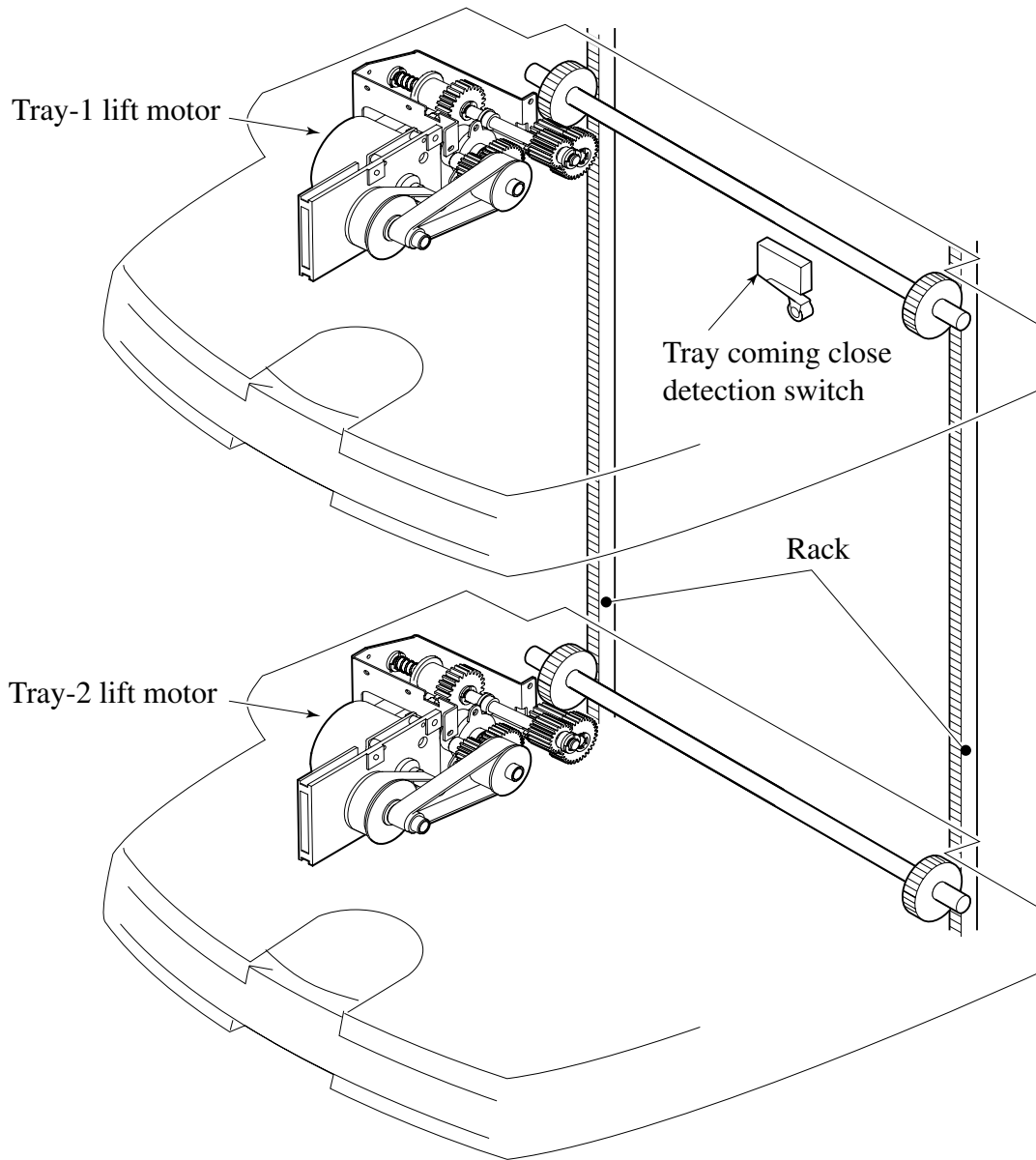


Figure 2-239

## H. Detecting the Height of Stack on the Tray

### 1. Outline

The number of sheets delivered to the tray and the number of sets (number of stapling operations) are stored in memory by the finisher controller PCB. The height of the stack is checked by the height sensor (PS1). See Table 2-204 for the maximum loading capacity of each tray.

The finisher controller PCB stops operation when the conditions in Table 2-204 occur, informing the host machine that the tray is full.

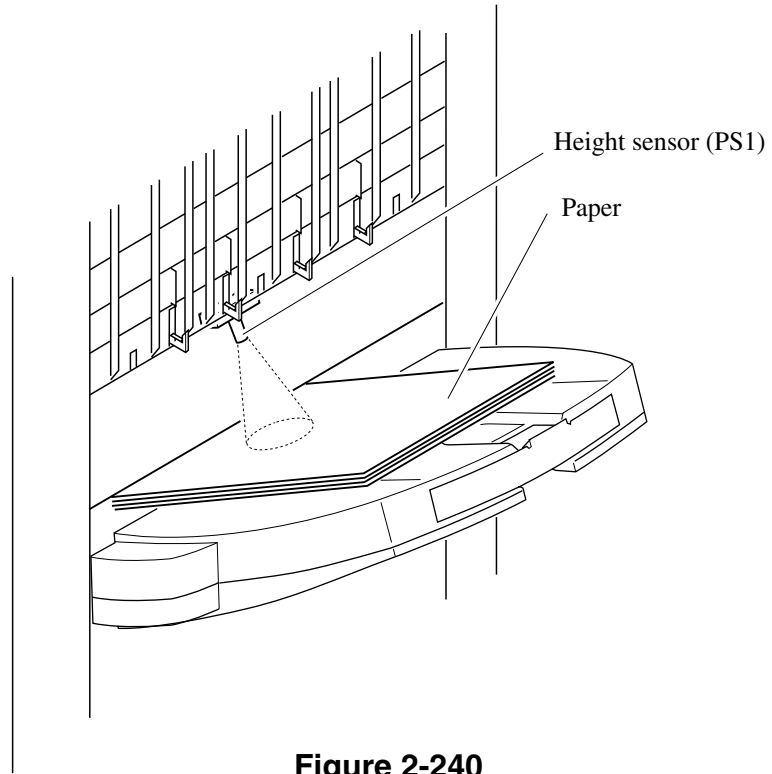
Stacking mode	Non-staple sort			Staple sort		
	Small-size	Large-size	Mixed sizes	Small-size	Large-size	Mixed sizes
Height	250 mm high (2000 sheets)	140 mm high (1000 sheets)	74 mm high (500 sheets)	110 mm high (750 sheets/ 100 sets)	74 mm high (500 sheets/ 50 sets)	22 mm high (500 sheets/ 50 sets)

- Notes:
1. The capacity for the non-staple sort mode is approximate and computed based on 80 g/m<sup>2</sup> (21.3 lb. Bond) paper.
  2. Alignment for stacks containing 750 sheets or more is not guaranteed.
  3. Stacking height precision is ±7 mm.

**Table 2-204**

**Caution:**

1. The term “small-size” stands for A4, LT, B5, A5-R and ST-R.
2. The term “large-size” stands for A3, A4-R, B4, B5-R, LG, LD, LT-R, FOLIO and COMUTER.



**Figure 2-240**

## I. Shutter Operation

When the tray-1 passes the delivery slot, the finisher controller PCB closes the shutter mounted on the delivery slot before moving the tray, preventing the existing stack on the tray by the delivery slot and intrusion of the hands.

The shutter moves up (to close) when the second feed motor (M8) rotates counterclockwise, and is held in position when the motor stops. When the second feed motor rotates counterclockwise once again, it moves down (to open) to enable delivery.

When the shutter is held at the up position, claws slide out of the swing guide to engage the back of the shutter. This way, the existing slack and the swing guide engage while the tray is moved, preventing the guide from opening. The claws slide in when the shutter is moved down to release the engagement.

The upward movement of the shutter is monitored by the shutter closed detecting switch (MS4), and the downward movement is monitored by the shutter open sensor (PI5).

See the following diagrams for how these operations take place.

- 1) The second feed motor rotates counterclockwise to move the shutter up.

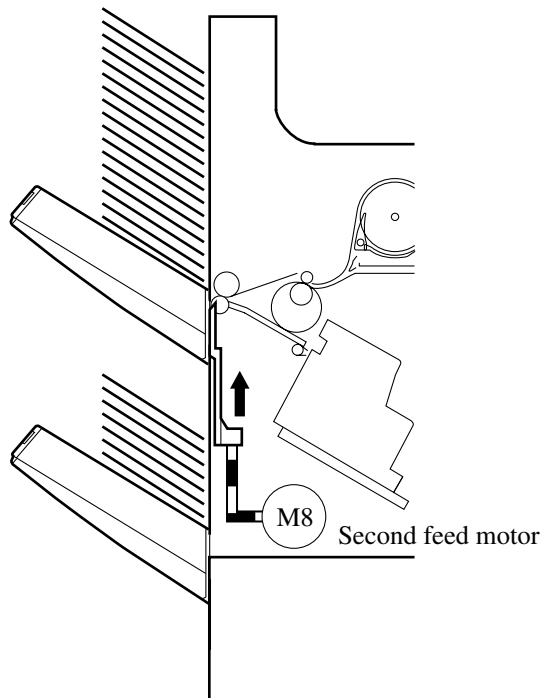


Figure 2-241

- 2) The tray-1,-2 lift motor rotates, and the new tray moves to the stacking lower limit. The distance of movement is detected by the tray-1 lift motor clock sensor 1/2 (PI9/PI9) or tray-2 lift motor clock sensor 1/2 (PI22/PI24).

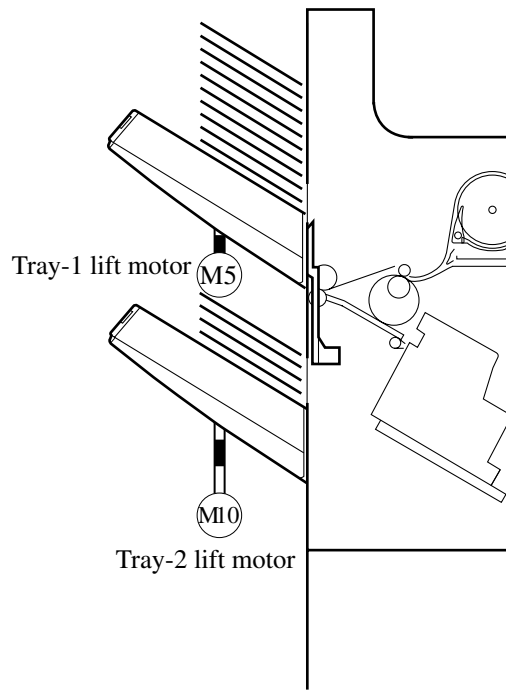


Figure 2-242

- 3) The second feed motor rotates counterclockwise, and the shutter moves down.

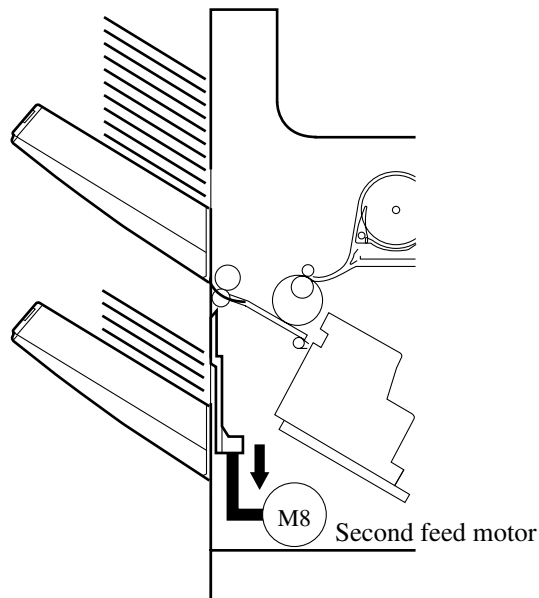


Figure 2-243



- 4) The tray lift motor rotates, and the tray moves to suit the height of the stack. The appropriate height in relation to the existing stack is checked by the height sensor (PS1).

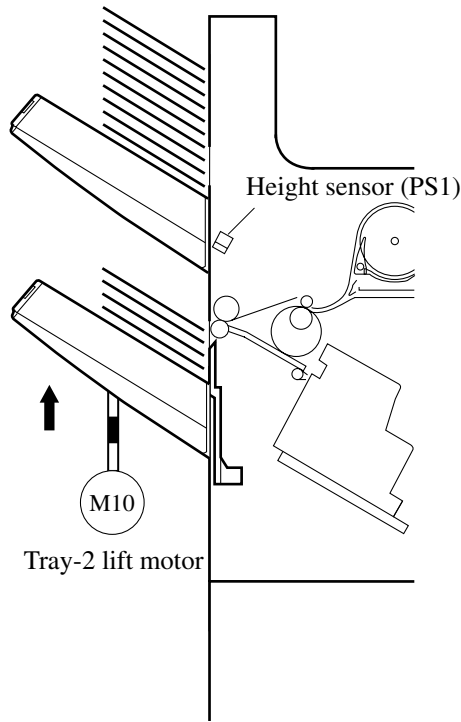


Figure 2-244

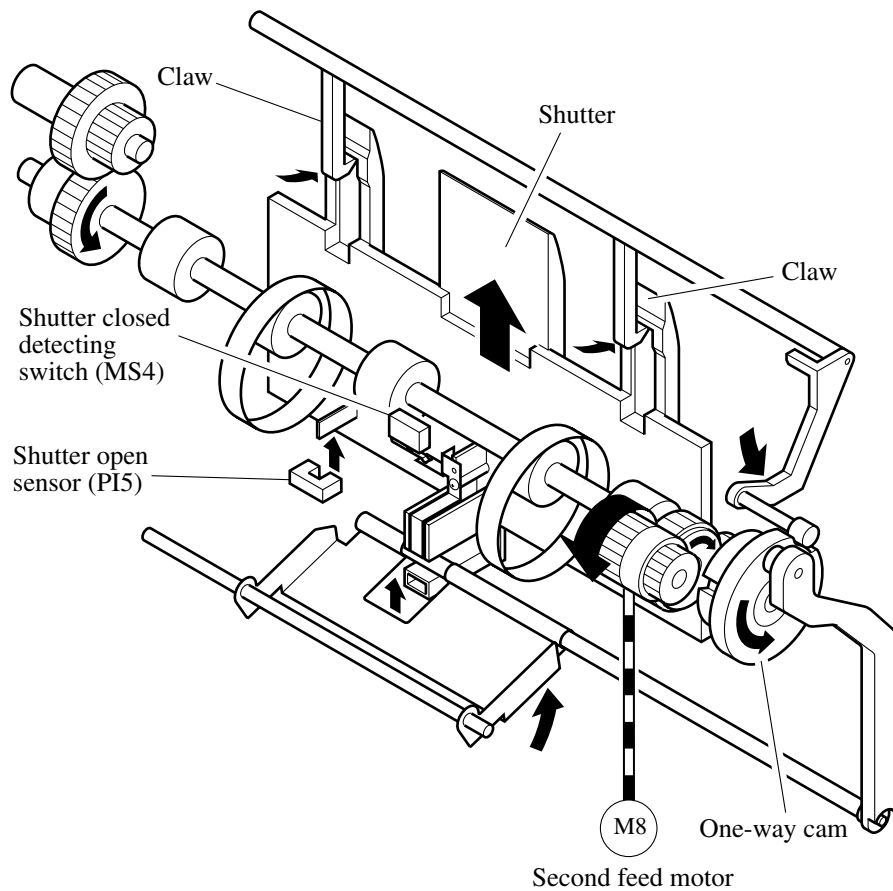


Figure 2-245

Sequence Operations (shutter drive)  
Move from Tray-1 to Tray-2

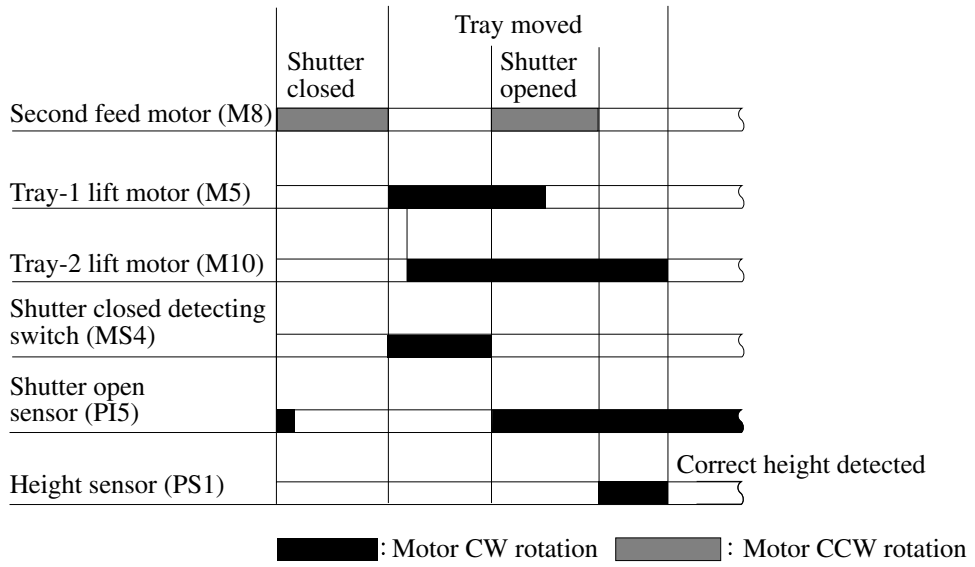


Figure 2-246

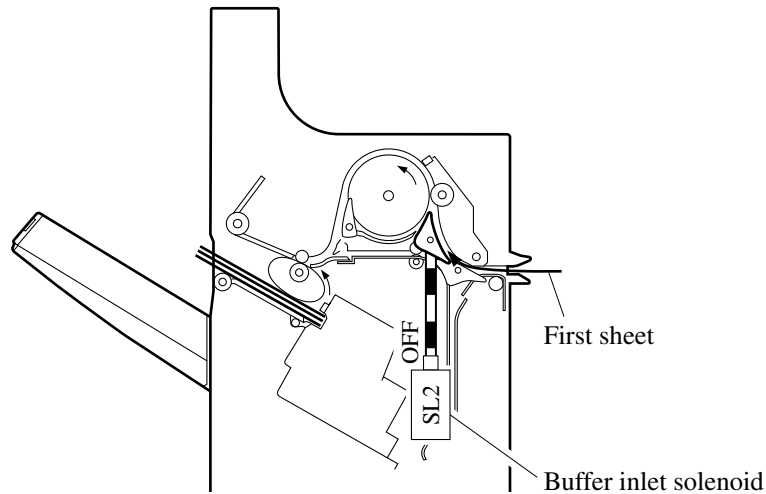
## J. Buffer Path Operation

### 1. Outline

This machine is provided with a buffer paper path for continuously receiving paper from the host machine during stapling and job offset operation on the stapling tray. A maximum of three copies (three originals or more in the staple mode) are wrapped around the buffer roller. During this time, job offset and stapling are performed on the stapling tray.

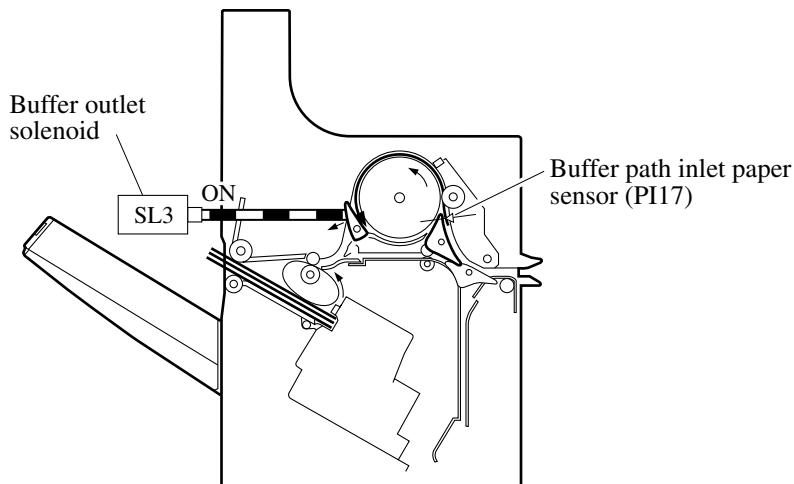
The following shows operation on the buffer paper path.

- 1) When the first sheet arrives, the buffer inlet solenoid (SL2) remains off. The first sheet enters the buffer path.



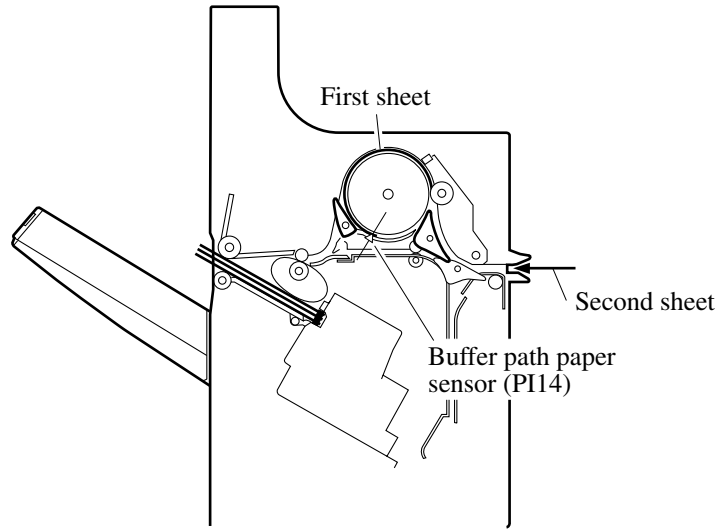
**Figure 2-247**

- 2) When the leading edge of the sheet has moved past the buffer path inlet paper sensor (PI17), the buffer outlet solenoid (SL3) turns on so as to cause the sheet to wrap around the buffer roller.



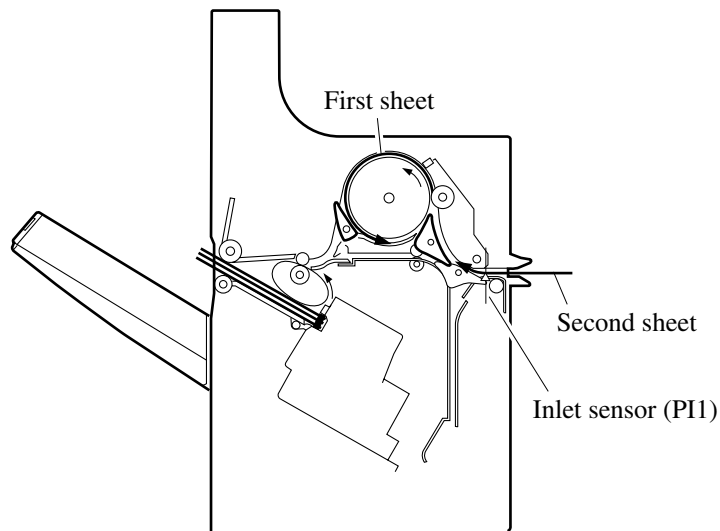
**Figure 2-248**

- 3) When the leading edge of the sheet has moved past the buffer path paper sensor (PI14), the buffer roller stops and waits for the second sheet.



**Figure 2-249**

- 4) When the second sheet arrives and its leading edge reaches the inlet sensor (PI1), the buffer roller starts to operate once again.



**Figure 2-250**

- 5) The buffer roller continues to rotate, and the second sheet overlaps the first sheet.

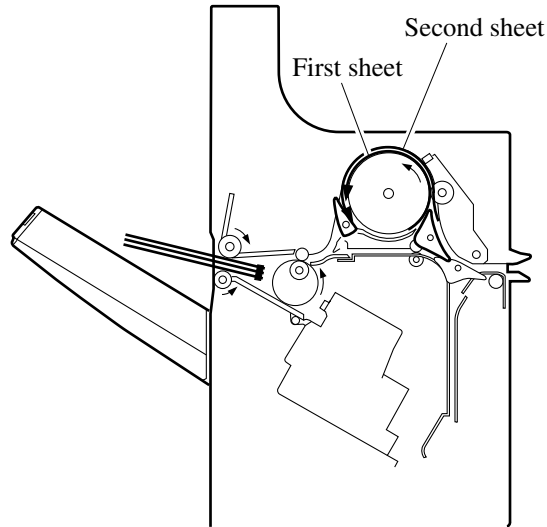


Figure 2-251

- 6) When the trailing edge of the second sheet has moved past the buffer path paper sensor (PI14), the buffer roller stops and waits for the third sheet.

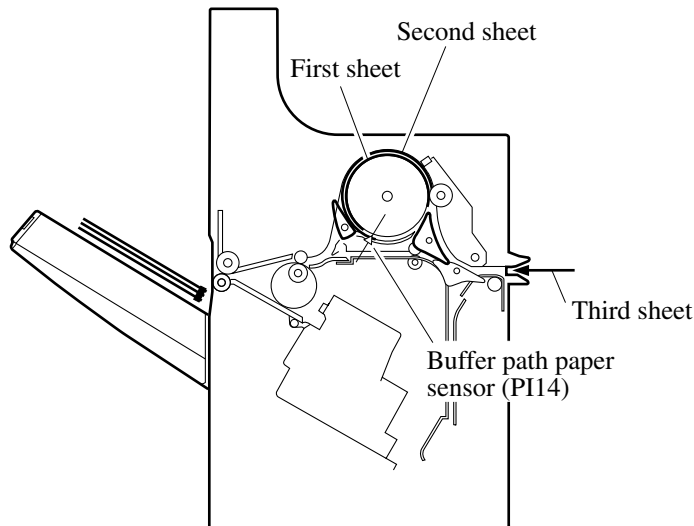
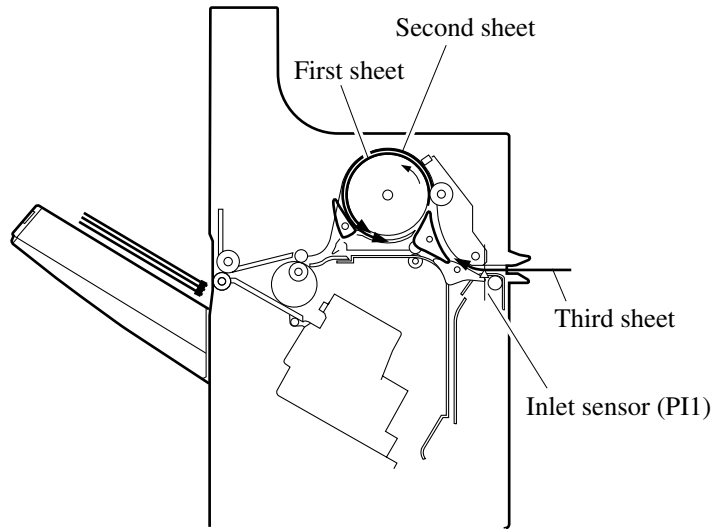


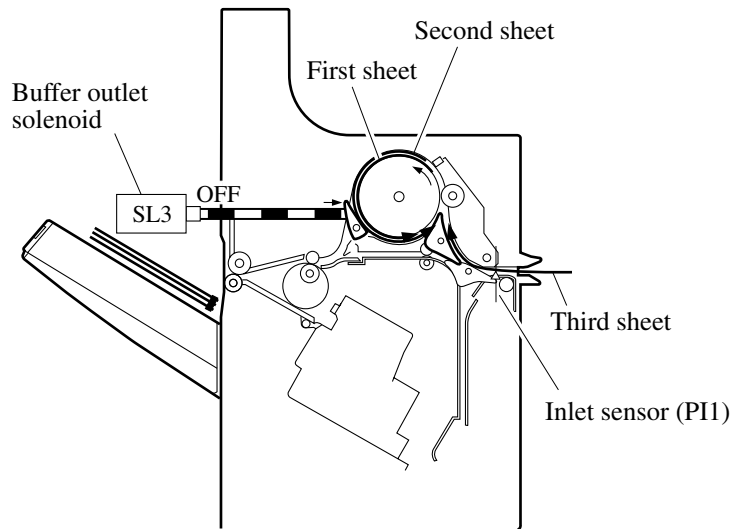
Figure 2-252

- 7) When the third sheet arrives and its leading edge reaches the inlet sensor (PI1), the buffer roller starts to operate once again.



**Figure 2-253**

- 8) When the leading edge of the third sheet reaches the inlet sensor (PI1), the buffer outlet solenoid (SL3) turns off so that the path is directed in the direction of delivery. (The actual switch-over will occur after the trailing edge of the first sheet has moved past the flapper.)



**Figure 2-254**

- 9) The buffer roller continues to rotate, the third sheet overlaps the first and second sheets, and the three sheets are fed together towards the delivery roller.

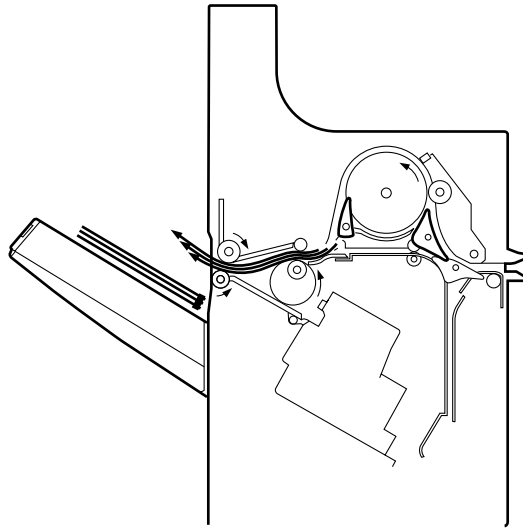


Figure 2-255

## K. Detecting Jams

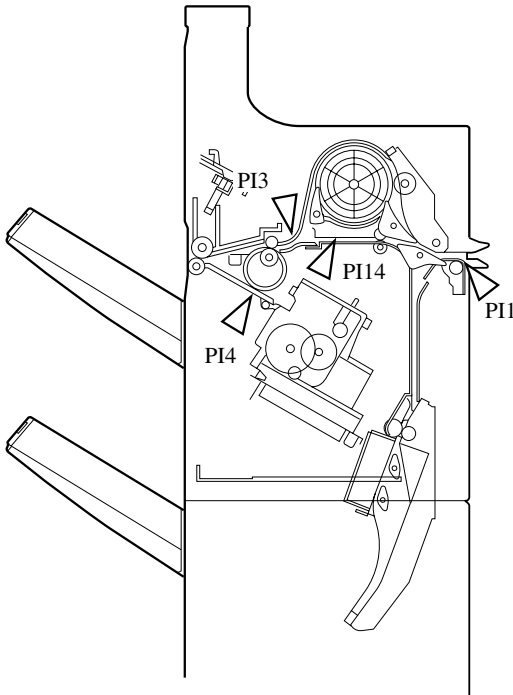
The following sensors are used to detect the presence/absence of paper and to make sure that sheets are moved properly:

- Inlet sensor (PI1)
- Delivery sensor (PI3)
- Stapling tray sensor (PI4)
- Buffer path paper sensor (PI14)

A jam is identified with reference to the presence/absence of paper at each specific sensor at the times programmed in the memory of the microprocessor (CPU) on the finisher controller PCB.

When the CPU identifies a jam, it suspends the finisher's delivery operation and informs the host machine DC controller of the presence of a jam. After the paper jam is removed, the buffer path inlet paper sensor (PI17) checks whether or not copies are being detected in addition to the above four sensors (inlet sensor, delivery sensor, stapling tray sensor and buffer path paper sensor). If the sensors detect a copy when all doors are closed, the finisher unit judges that paper jams have not completely been removed, and sends the paper jam removal signal to the host machine again.

The tray-1 paper sensor (PI11) and tray-2 paper sensor (PI12) are not used to detect jams.



**Figure 2-256**

No.	Sensor names
PI1	Inlet sensor
PI3	Delivery sensor
PI4	Stapling tray sensor
PI14	Buffer path paper sensor

**Table 2-205**



### 1. Inlet Sensor Delay Jam

The inlet sensor does not detect paper when feeding an equivalent of 400 mm from when the host machine delivery signal has been issued.

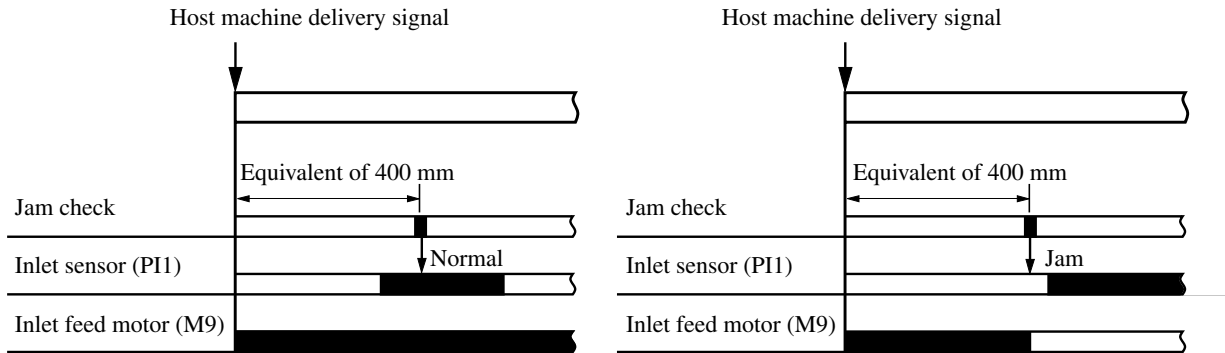


Figure 2-257

### 2. Inlet Sensor Stationary Jam

The sheet does not move past the inlet sensor when an equivalent of twice the feeding length of the sheet has been fed after the sensor turned on.

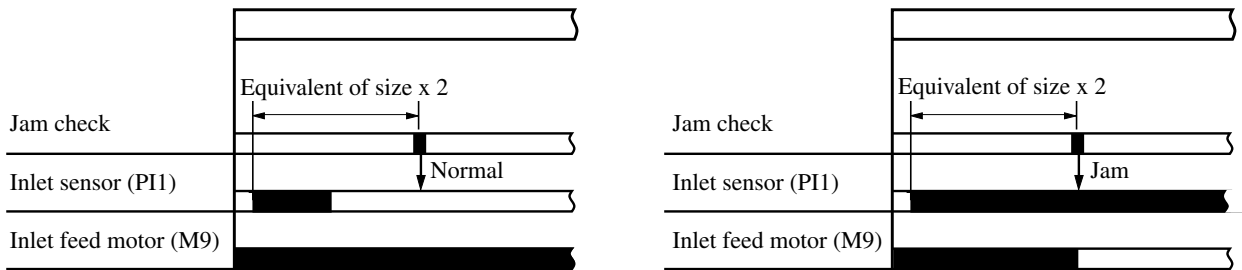


Figure 2-258

### 3. Buffer Path Paper Sensor Delay Jam

The buffer inlet sensor does not detect paper when an equivalent of 550 mm has been fed after the inlet sensor turned on.

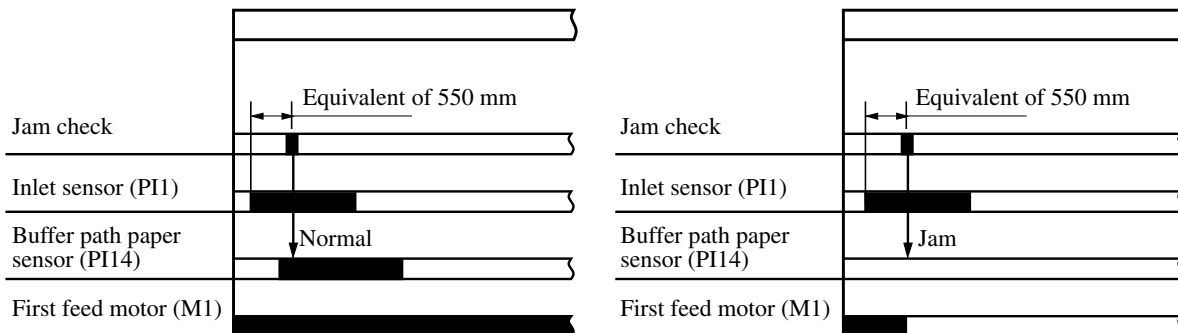


Figure 2-259

#### 4. Buffer Path Paper Sensor Stationary Jam

The sheet does not move past the buffer inlet sensor when an equivalent of twice the feeding length of the sheet has been fed after the sensor turned on.

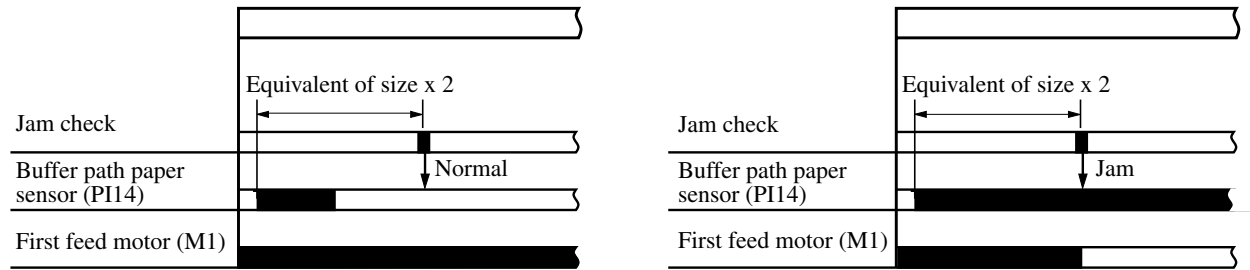


Figure 2-260

#### 5. Delivery Sensor Delay Jam

##### a. Straight Path

The delivery sensor does not detect paper when an equivalent of 476 mm has been fed after the inlet sensor turned on.

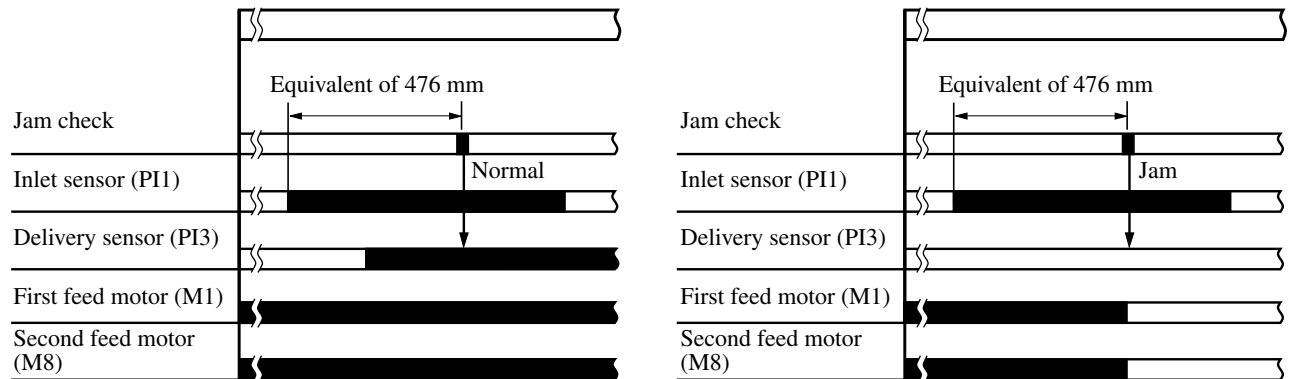


Figure 2-261

b. Buffer Path

The delivery sensor does not detect paper when an equivalent of 772 mm has been fed after the inlet sensor turned on.

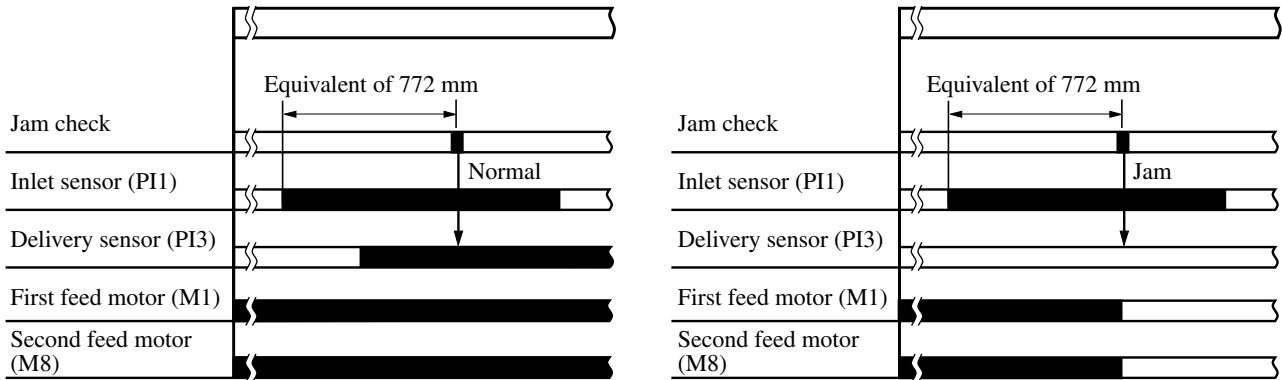


Figure 2-262

6. Delivery Sensor Stationary Jam

The sheet does not move past the delivery sensor when an equivalent of twice the feeding length of the sheet has been fed after the delivery sensor turned on.

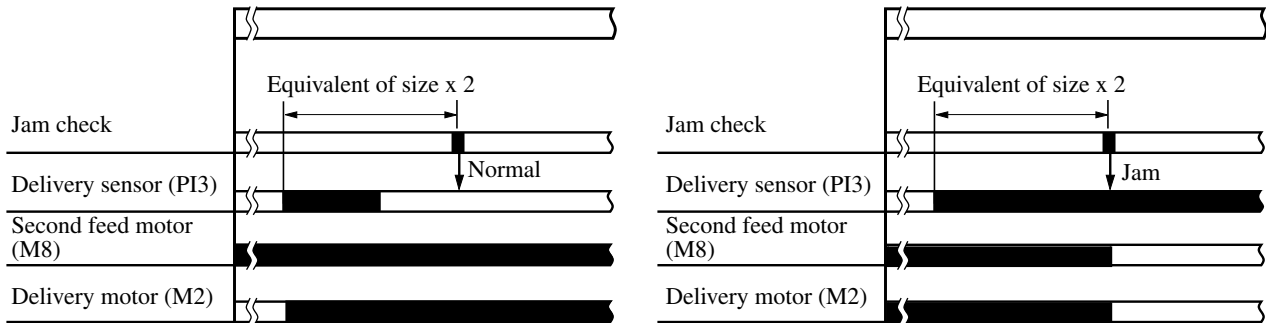


Figure 2-263

## 7. Stapling Tray Sensor Stationary Jam

The sheet does not move past the stapling tray sensor 1 sec after the delivery motor (M2) turned on.

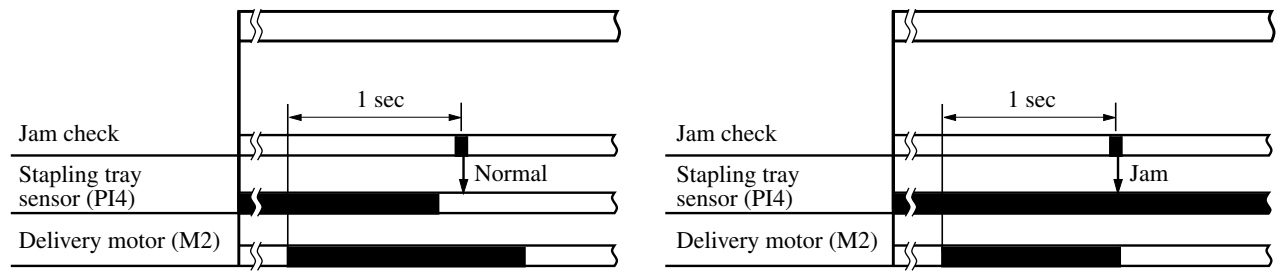


Figure 2-264

## 8. Timing Jam

The inlet sensor (PI1) detects a sheet before the delivery signal is received from the host machine.

## 9. Staple Jam

When the staple motor (M6) is rotating clockwise, the staple home position sensor (PI22) does not turn on within 0.5 sec. after it has turned off. However, the sensor turns on within 0.5 sec. after the motor has been rotated counterclockwise.

## 10. Power-On Jam

One of the inlet sensor (PI1), delivery sensor (PI3), buffer path paper sensor (PI4) or buffer path inlet paper sensor (PI17) detects paper at power-on.

## 11. Door Open Jam

One of the joint sensor (PI15), door open sensor (PI16) or door switches (MS1) detects the cover open during operation (including front door switch (MS2P) when the optional puncher unit is mounted).

## 12. Punch Jam (with the use of Hole Punch Unit)

The punch home sensor (PI3P) does not turn on again within 200 msec after turning off.

## 13. Stay Jam Caused By Finisher Start Signal OFF

The finisher start signal is turned OFF in the host machine while paper is being fed in the finisher.

### III. POWER SUPPLY SYSTEM

#### 1. Outline

The finisher controller PCB is supplied with 24 VDC power (and 5 VDC power) when the host machine is turned on. 24 VDC one is used to drive the motor solenoids, while 5 VDC is used for sensors and ICs on PCBs. Both lines are also used to feed power from the finisher controller PCB to the saddle stitcher controller PCB. Power is also supplied to the punch driver PCB when the optional puncher unit is mounted.

Some of the 24 VDC power used to drive motors is cut off when the door switch (MS1) is open. The power to the saddle stitcher controller PCB, however, will not be cut off.

Figure 2-301 is a block diagram showing the power supply system.

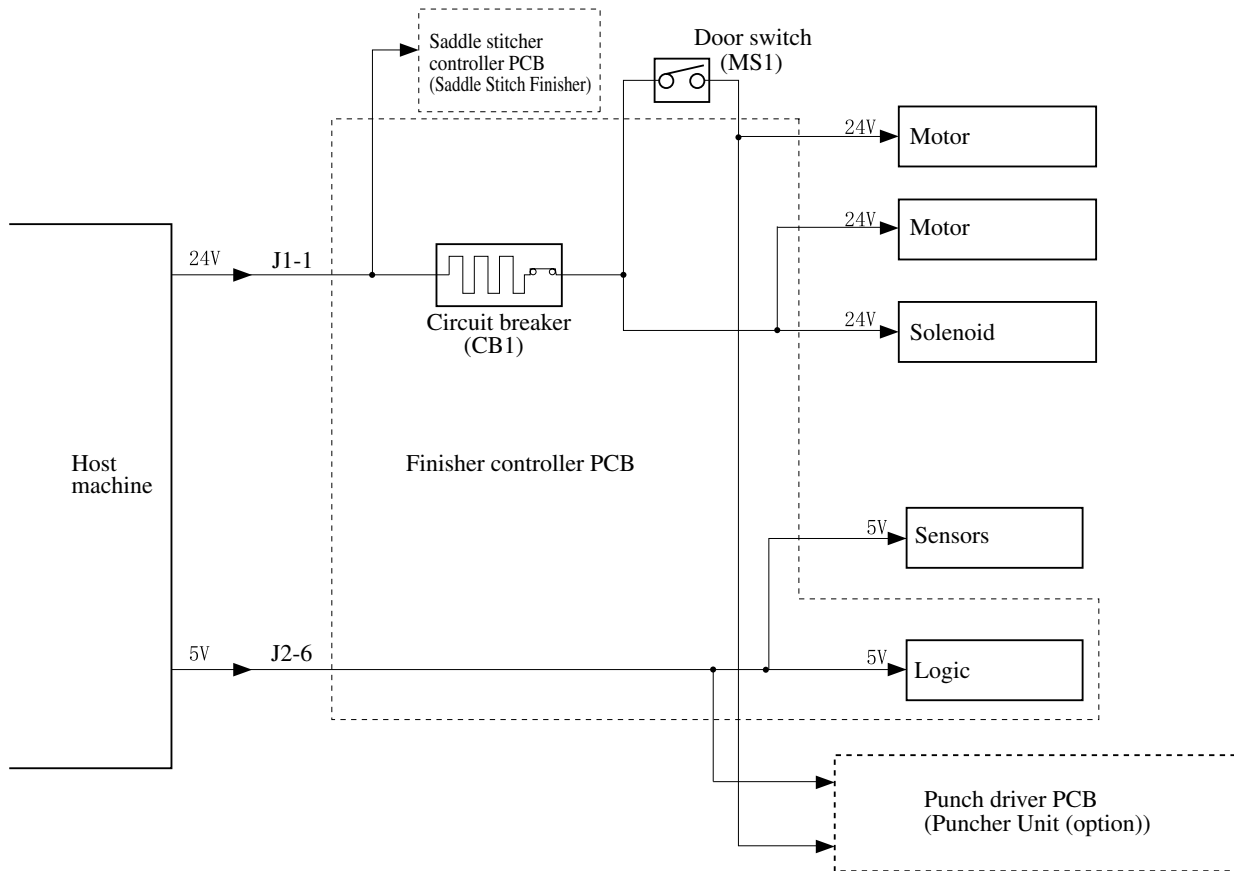


Figure 2-301

#### 2. Protection Functions

The 24 VDC power line used to drive motors and solenoids is equipped with a circuit breaker (CB1) for protection against overcurrent. The 24 V line used to drive the first feed motor (M1), alignment motor (M3), and stapler shift motor (M4) are equipped with a fuse, which is designed to blow when an overcurrent occurs.

---



# CHAPTER 3

---

## SADDLE STITCHER UNIT BASIC OPERATION

---

1. This chapter discusses the purpose and role of each of the stitcher's functions, and the principles of operation used for the stitcher mechanical and electrical systems. It also explains the timing at which these systems are operated.

The  symbol in drawings indicates transmission of mechanical drive, and signals marked by  together with the signal name indicates the flow of electrical signals.

2. In descriptions of digital circuits on the stitcher, "1" indicates a high signal voltage level, while "0" indicates a low signal voltage level. Voltage values differ according to circuit.

A microprocessor is used on the stitcher. A description of microprocessor operation is omitted in this chapter as it is practically impossible to check internal operation of the microprocessor.

Descriptions in this chapter also assume that PCBs will not be repaired at user sites. For this reason, descriptions of circuits on PCBs is limited to block diagrams. Two types of block diagrams are provided for separate functions: diagrams indicating details from sensors up to input sections of major PCBs, and diagrams indicating details from the output sections of major PCBs up the loads.

I. BASIC OPERATION .....	3-1	C. Controlling the Movement of	
A. Outline .....	3-1	Sheets .....	3-21
B. Electrical Circuitry .....	3-2	D. Aligning the Sheets .....	3-23
C. Inputs to and Outputs from the		E. Controlling the Phase of the	
Saddle Stitcher Controller		Crescent Roller .....	3-26
PCB .....	3-3	IV. STITCHING SYSTEM .....	3-28
II. FEEDING/DRIVE SYSTEM .....	3-8	V. FOLDING/DELIVERY	
A. Outline .....	3-8	SYSTEM .....	3-31
III. PAPER OUTPUT		VI. CHECKING FOR A JAM .....	3-38
MECHANISM .....	3-14	VII. POWER SUPPLY .....	3-43
A. Outline .....	3-14		
B. Controlling the Inlet			
Flappers .....	3-17		

# I. BASIC OPERATION

## A. Outline

The unit “stitches” (2 points) a stack of sheets delivered by the finisher unit and folds it in two for delivery. All these operations are controlled by the saddle stitcher controller PCB in response to commands from the host machine via the finisher unit.

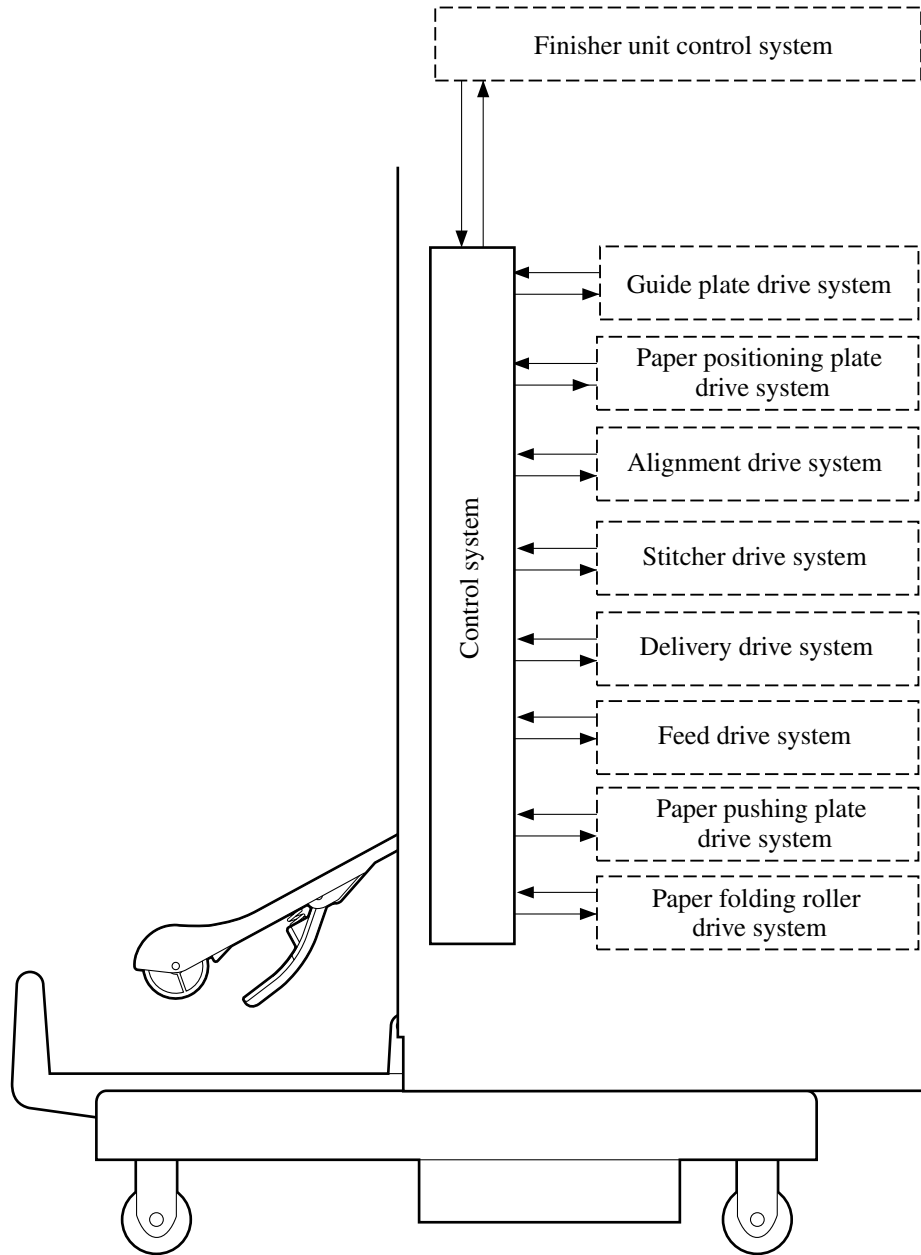


Figure 3-101

## B. Electrical Circuitry

The sequence of operations used for the saddle stitcher is controlled by the saddle stitcher controller PCB. The saddle stitcher controller PCB has a microprocessor. This microprocessor is used to control the sequence of operations and to handle serial communications with the finisher controller PCB, driving solenoids and motors in response to the various commands from the finisher controller PCB.

The saddle stitcher controller PCB is also used to communicate the state of various sensors and switches to the finisher controller PCB in serial.

The functions of the major ICs mounted on the saddle stitcher controller PCB are as follows:

- Q1  
Controls the sequence of operations.
- Q2  
Contains the sequence program.
- Q3  
Controls the sequence of operations.
- Q4  
Handles IPC communications.

Electrical circuitry block diagram

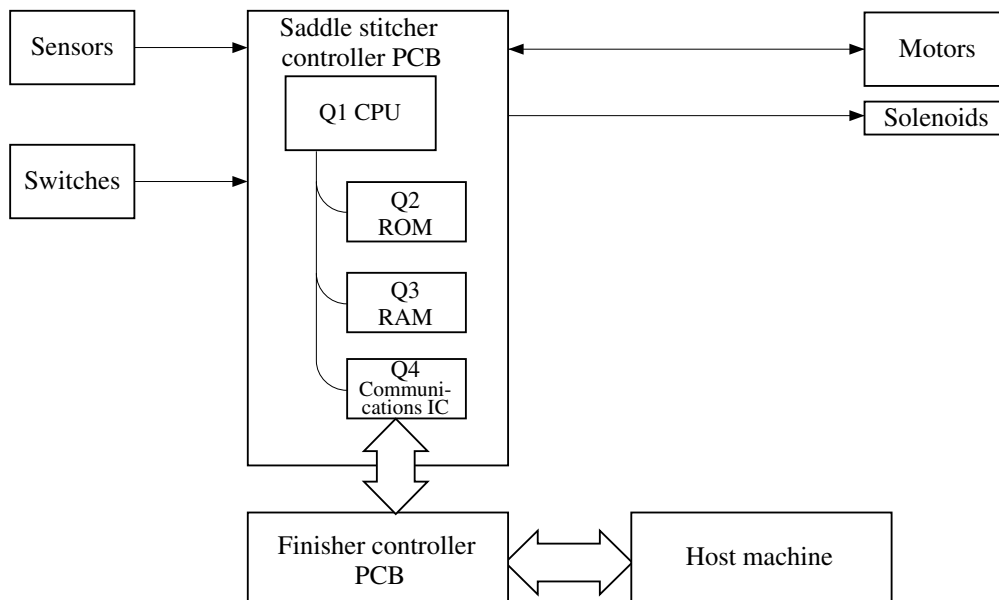


Figure 3-102



### C. Inputs to and Outputs from the Saddle Stitcher Controller PCB

#### 1. Inputs to the Saddle Stitcher Controller PCB

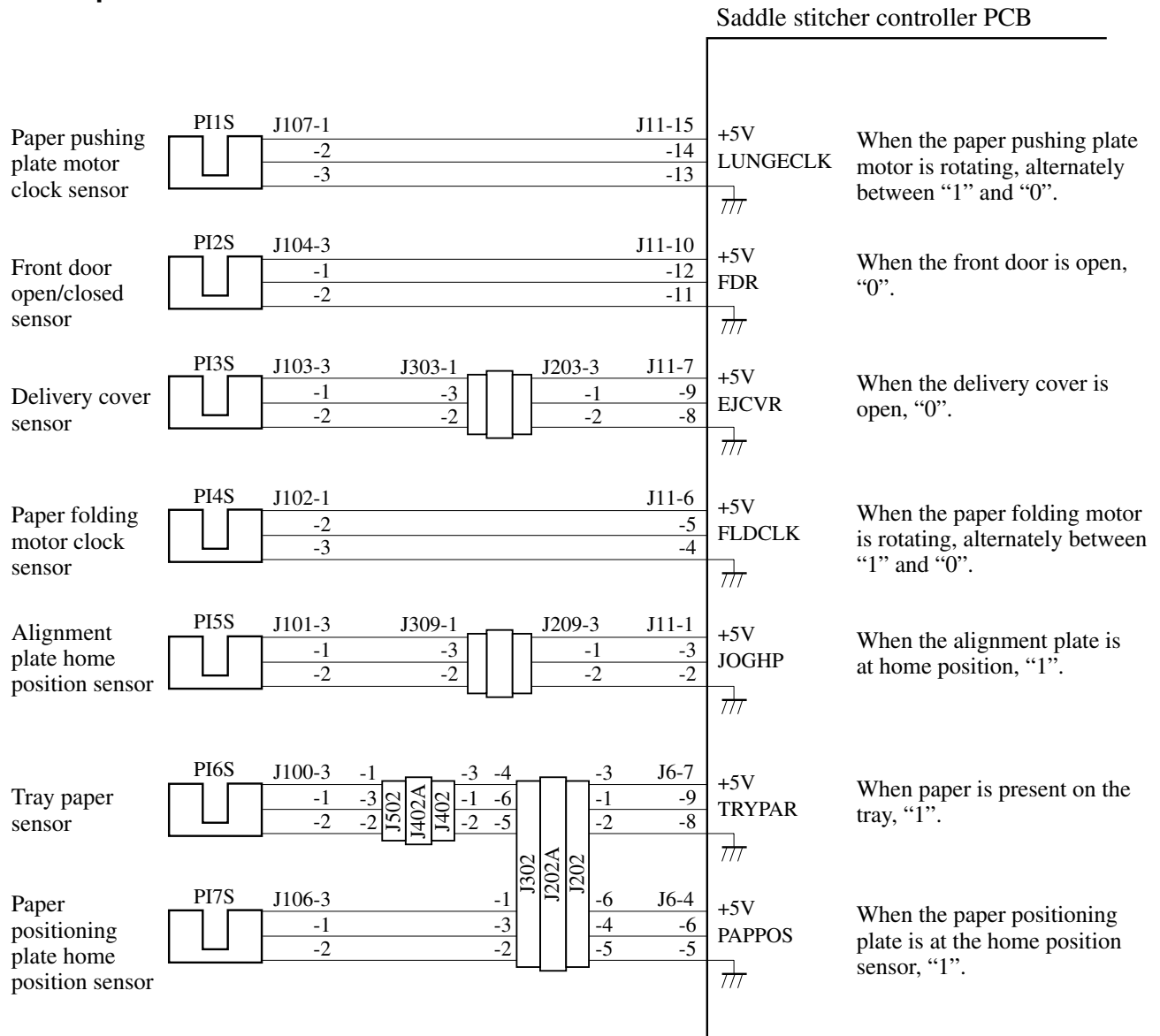


Figure 3-103

2. Inputs to the Saddle Stitcher Controller PCB

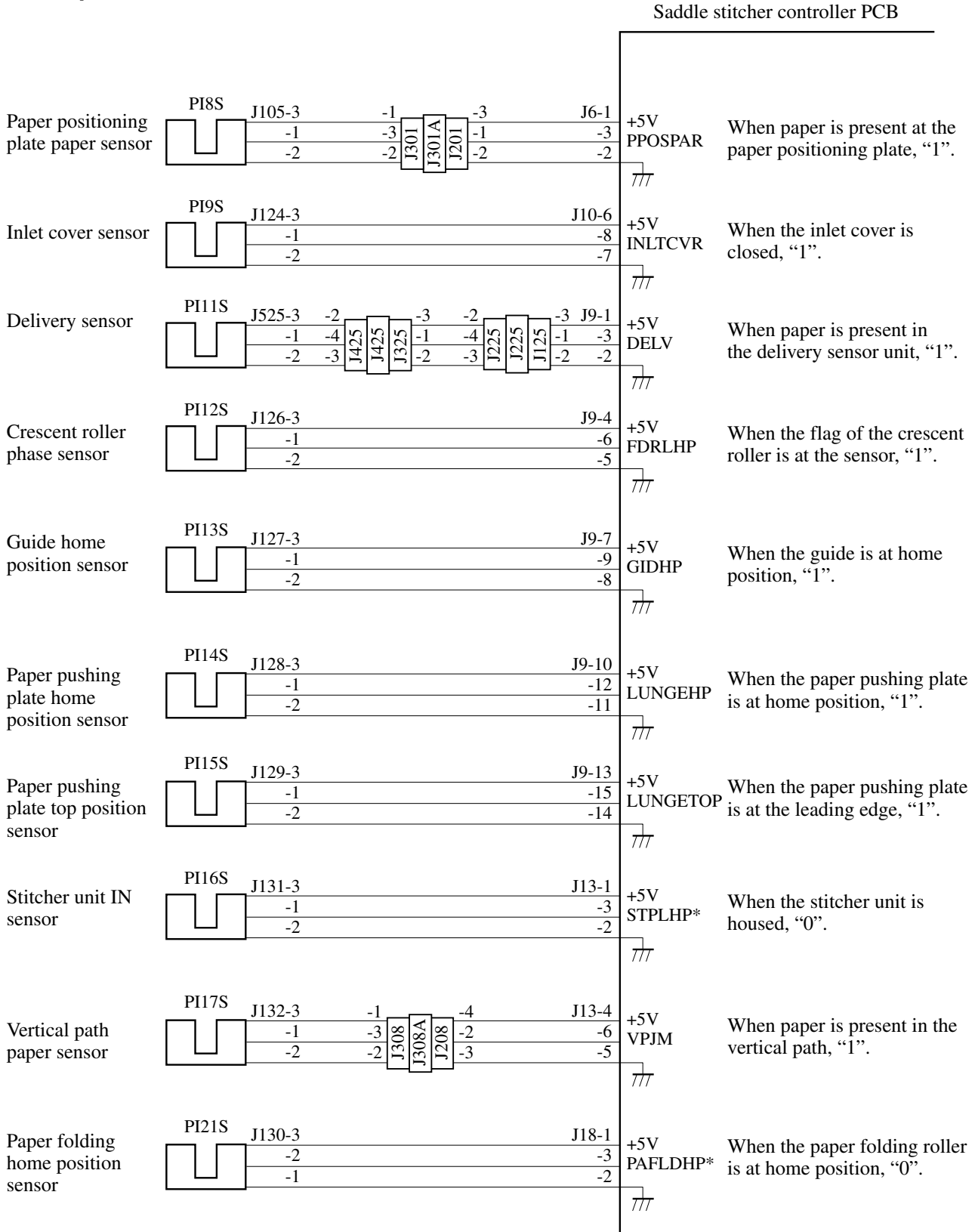


Figure 3-104

### 3. Inputs to the Saddle Stitcher Controller PCB

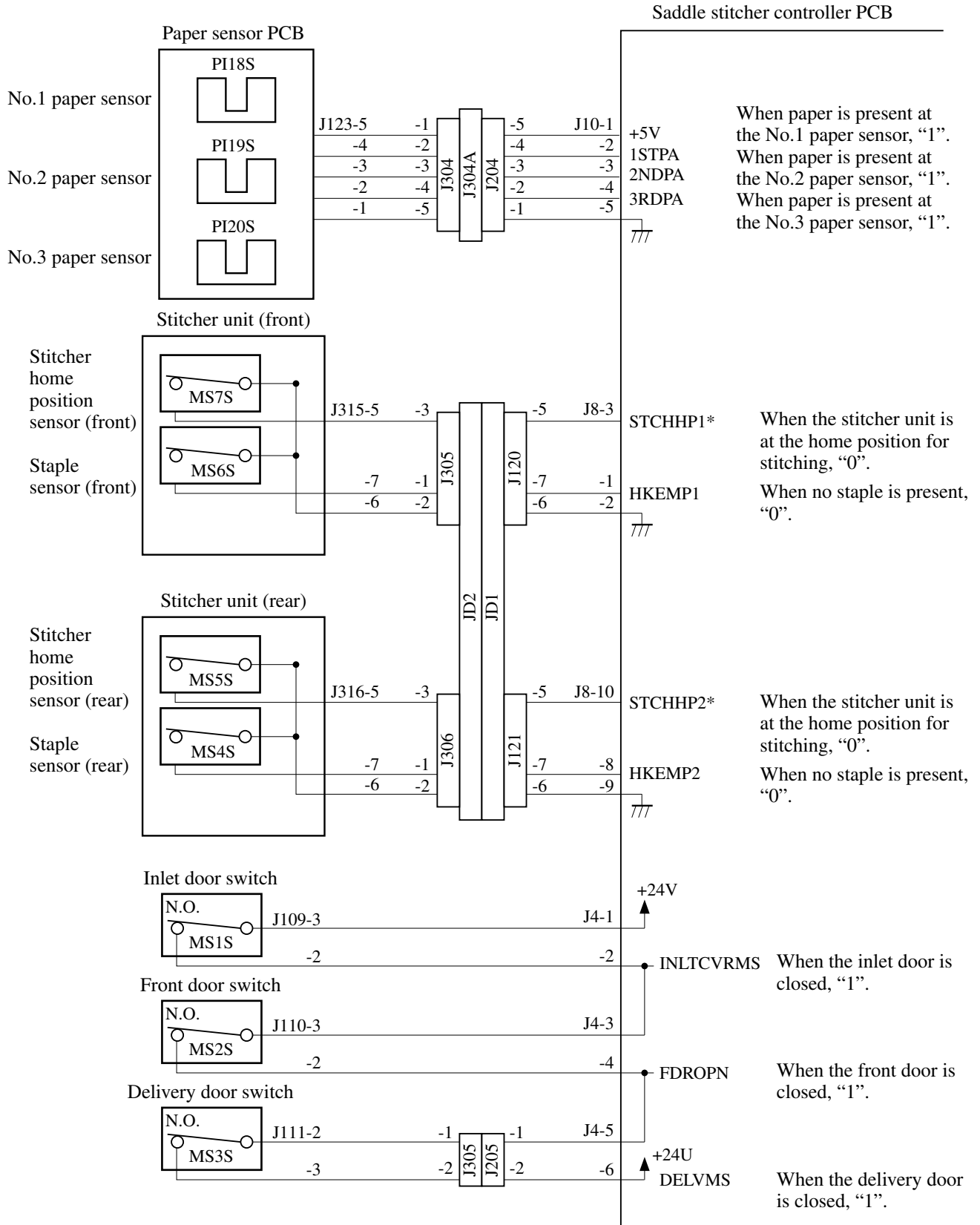


Figure 3-105

### 4. Outputs from the Saddle Stitcher Controller PCB

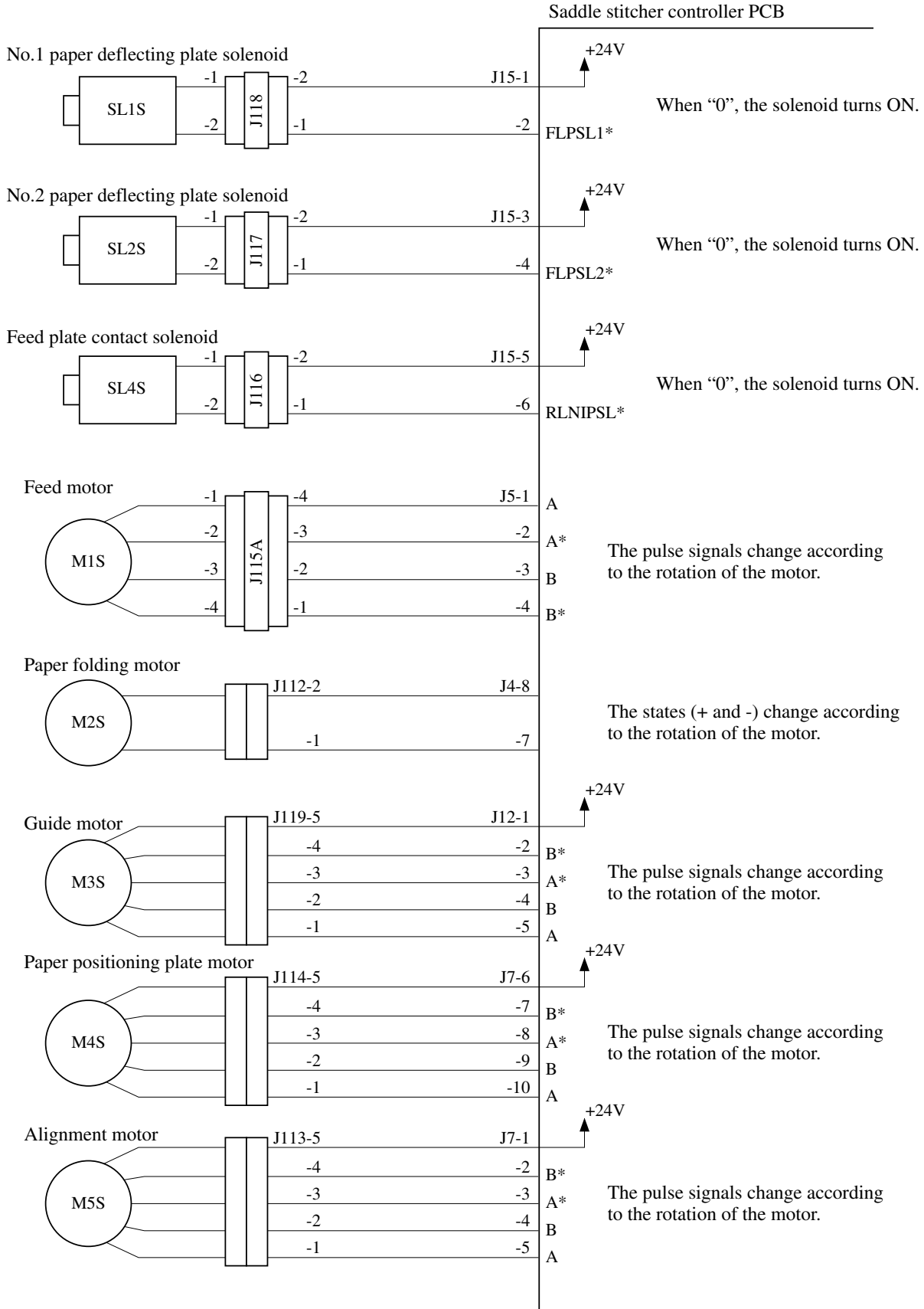


Figure 3-106

5. Outputs from the Saddle Stitcher Controller PCB

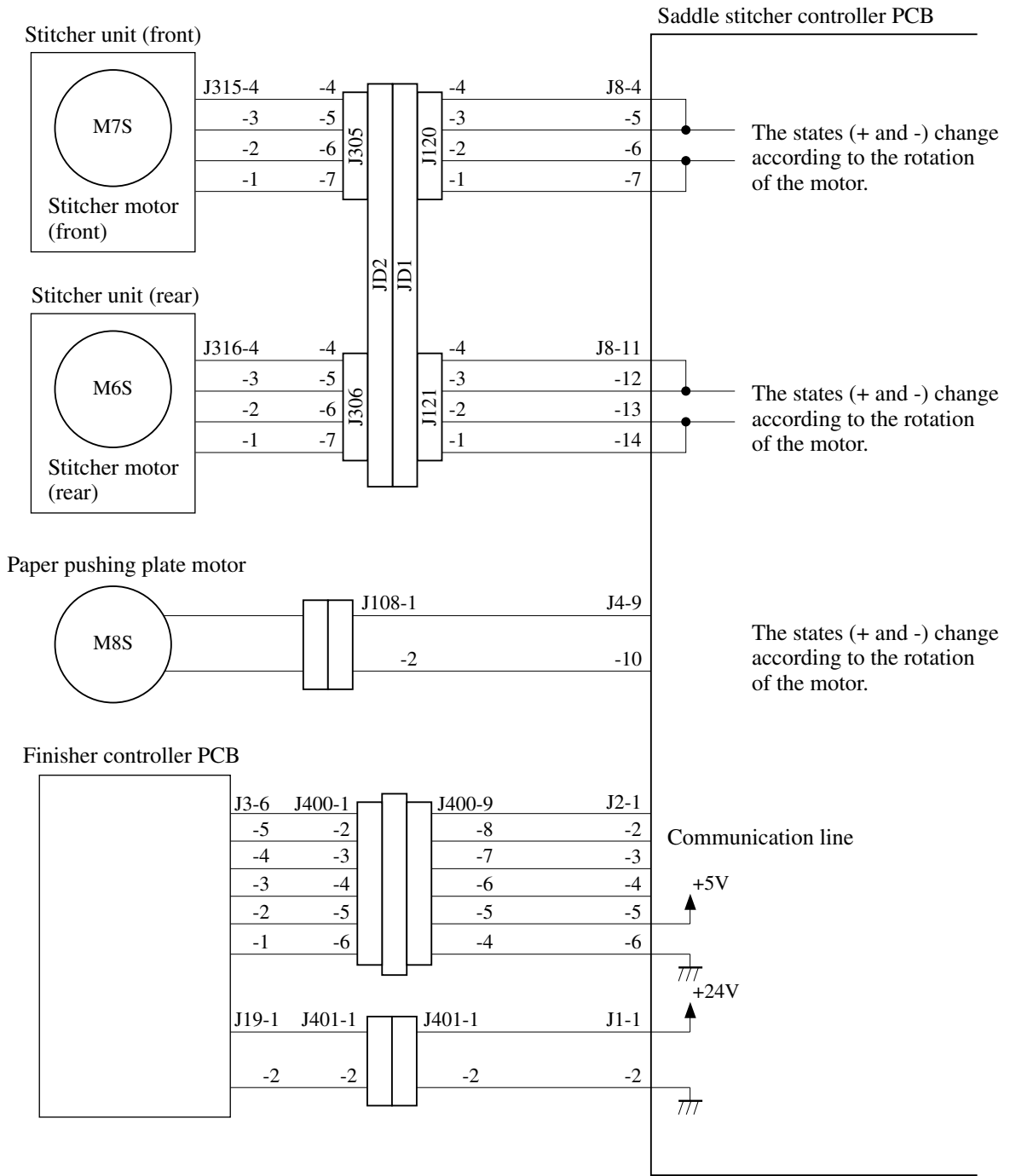


Figure 3-107

## II. FEEDING/DRIVE SYSTEM

### A. Outline

The stitcher unit aligns the sheets coming from the finisher unit and stitches the resulting stack for delivery to the delivery tray according to the commands coming from the finisher controller PCB.

The machine's operation consists of the following:

1. Receive sheets.
2. Aligns the sheets
3. Stitches the stack.
4. Feeds the stack.
5. Folds and delivers the stack.

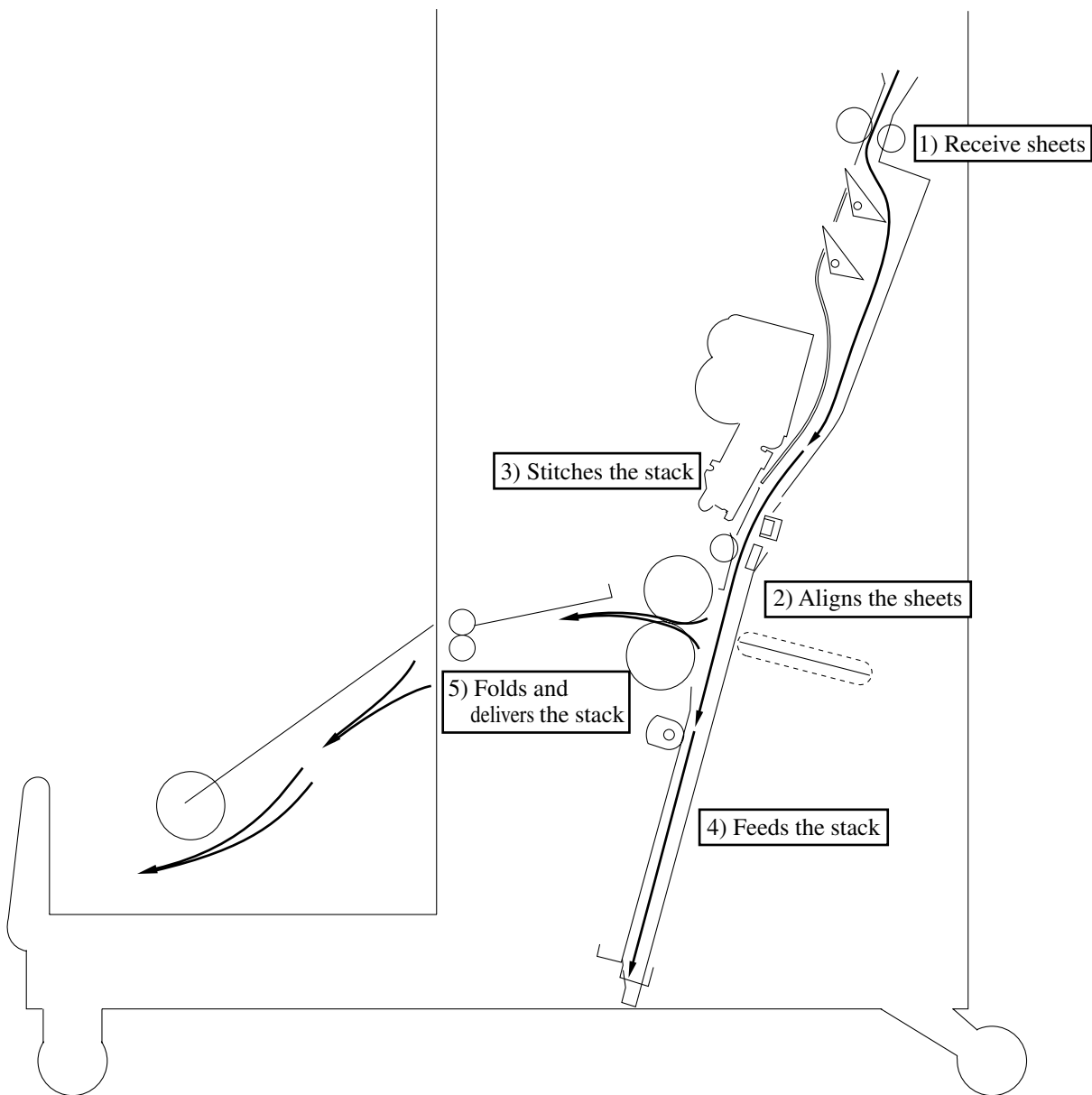


Figure 3-201

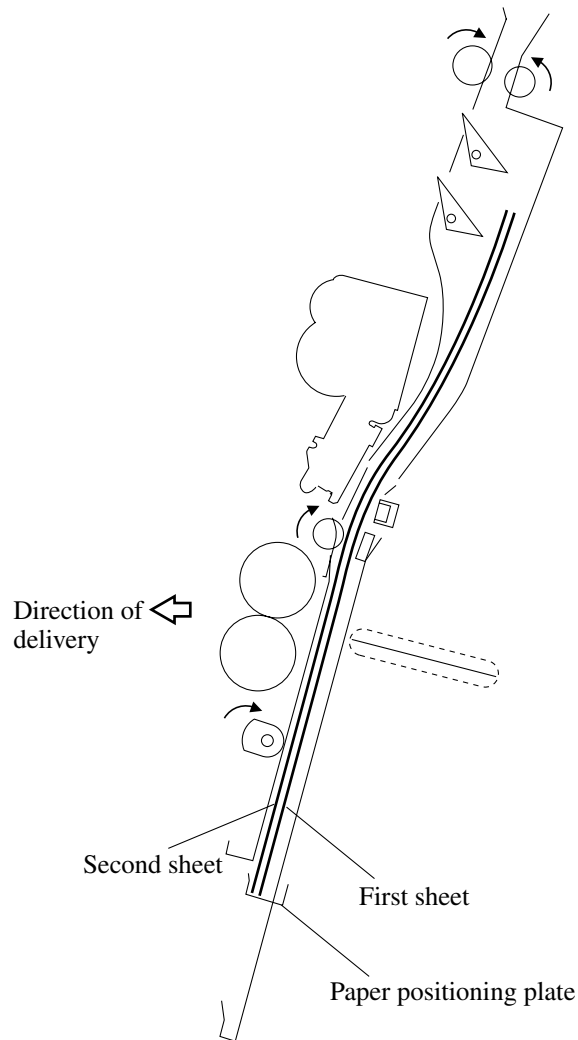
**1. Receiving Sheets**

The stitcher unit receives sheets from the finisher unit and outputs them inside the vertical path in vertical orientation.

The vertical path, while sheets are being output, is configured by two paper deflecting plates.

The position of the sheets being output is set by the paper positioning plate so that the center of the stack matches the stapling/folding position.

Sheets coming later are output closer to the delivery slot.

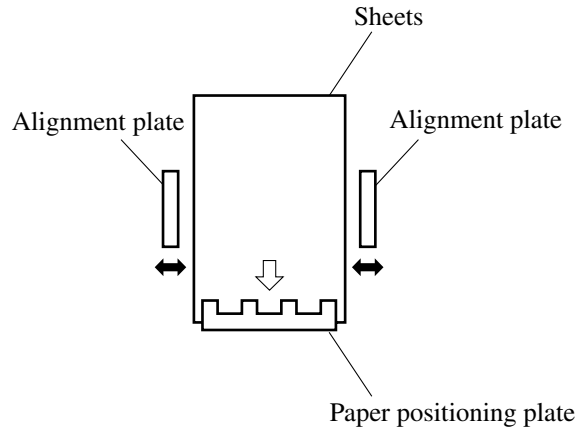


**Figure 3-202**

## 2. Aligning the Sheets

The alignment plates operate to put the sheets in order each time a sheet of paper is output to the vertical path assembly. The alignment plates are mounted at the edge of the vertical path assembly.

The alignment plates also operate after stapling to prepare the stack for delivery.



**Figure 3-203**



### 3. Stitching

When all sheets have been output, the two stitchers stitch the stack. The stitchers are positioned so that they face the center of a stack.

The two stitchers are not operated simultaneously so as to prevent the paper from wrinkling between two staples and to limit the load on the power supply.

If only one sheet of paper arrives from the host machine, stitching does not take place and the sequence goes to the next operation (stack feeding).

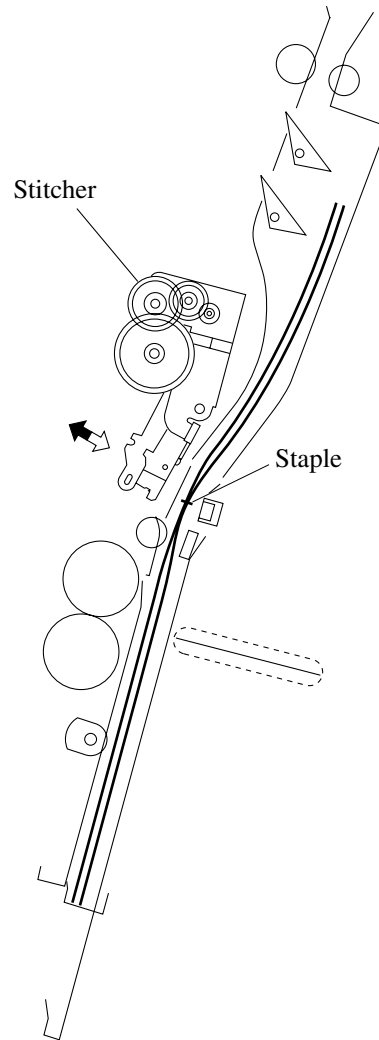


Figure 3-204

#### 4. Feeding the Stack

The unit folds the stitched stack of sheets, and then feeds it to the point of delivery. This point is where the center of the stack, i.e., stapling position, matches the height of the paper pushing plate and the paper folding roller nip.

The stack is moved forward by operating the paper positioning plate. When the plate is operated, the guide plate which has been covering the paper folding rollers, also moves down so that the paper folding rollers directly face the stack.

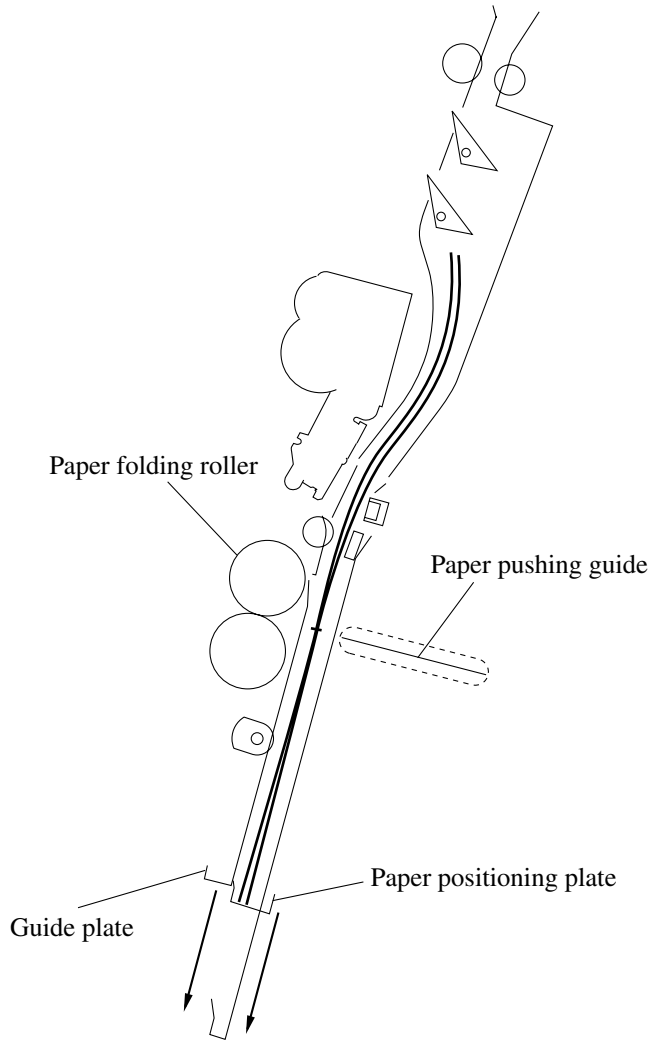
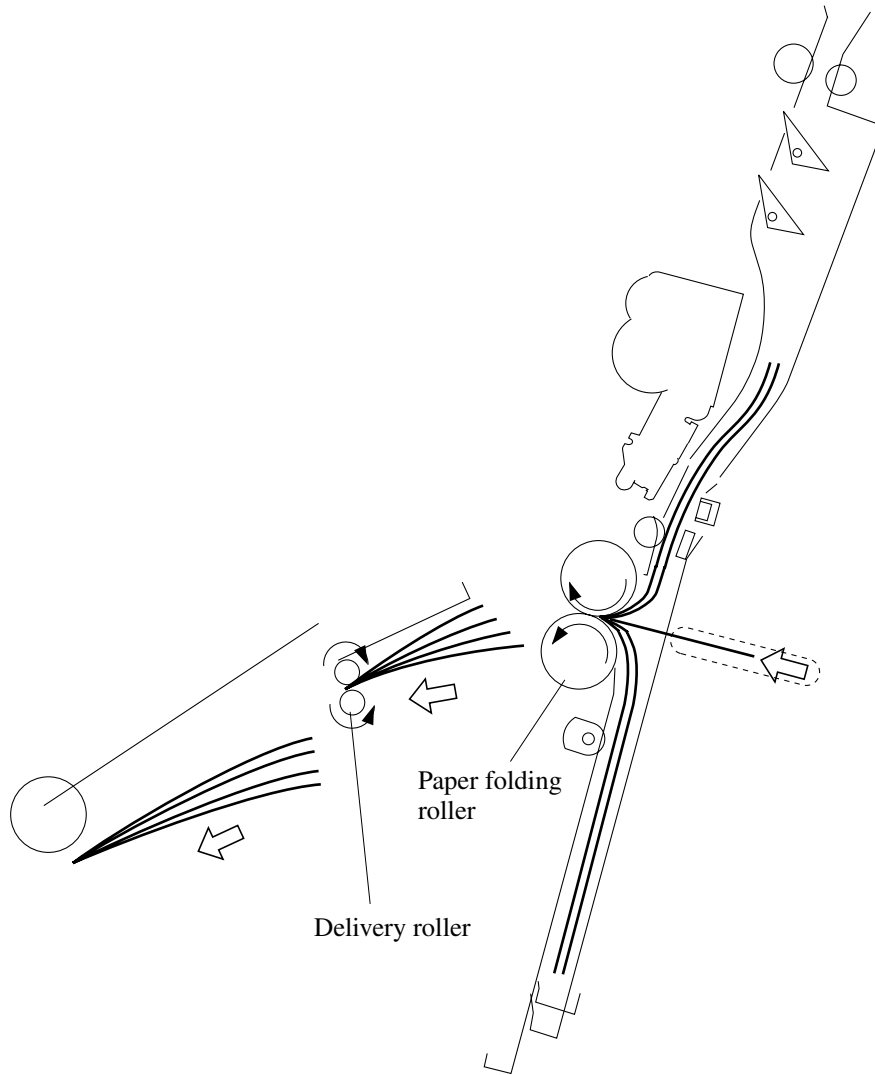


Figure 3-205

**5. Folding/Delivering the Stack**

The paper pushing plate pushes against the center of the stack to move it in the direction of the paper folding rollers. In response, the paper folding rollers pick the stack along its center and fold it in two. The paper folding rollers together with the delivery roller then move the stack along to output it on the delivery tray.



**Figure 3-206**

### III. PAPER OUTPUT MECHANISM

#### A. Outline

The paper output mechanism serves to keep a stack of sheets coming from the finisher in place for the next steps (stapling, folding).

The paper inlet is equipped with the No.1 flapper and the No.2 flapper, which operate to configure the paper path to suit the size of paper. The paper positioning plate is kept in wait at a predetermined location to suit the size of paper. The paper positioning plate is driven by the paper positioning plate motor (M4S), and the position of the plate is identified in reference to the number of motor pulses coming from the paper positioning plate home position sensor (PI7S). A sheet moved by the inlet roller is handled by the feed rollers and the crescent roller and held in a predetermined position. The feed plate serve to move sheets by coming into contact with or moving away from sheets as needed.

The alignment plates put the stack into order each time a sheet is output. The alignment plates are driven by the alignment motor (M5S), whose position is identified in reference to the number of motor pulses coming from the alignment plate home position sensor (PI5S).

To prevent interference between paper and the paper folding rollers when the paper is being output, the folding rollers are designed to be covered by a guide plate. The guide plate moves down before paper is folded so as to expose the paper folding rollers.

The inlet is equipped with the No.1, No.2 and No.3 paper sensors (PI18S, PI19S, PI20S) each suited to a specific paper size, and the paper positioning plate is equipped with a paper positioning plate paper sensor (PI8S).

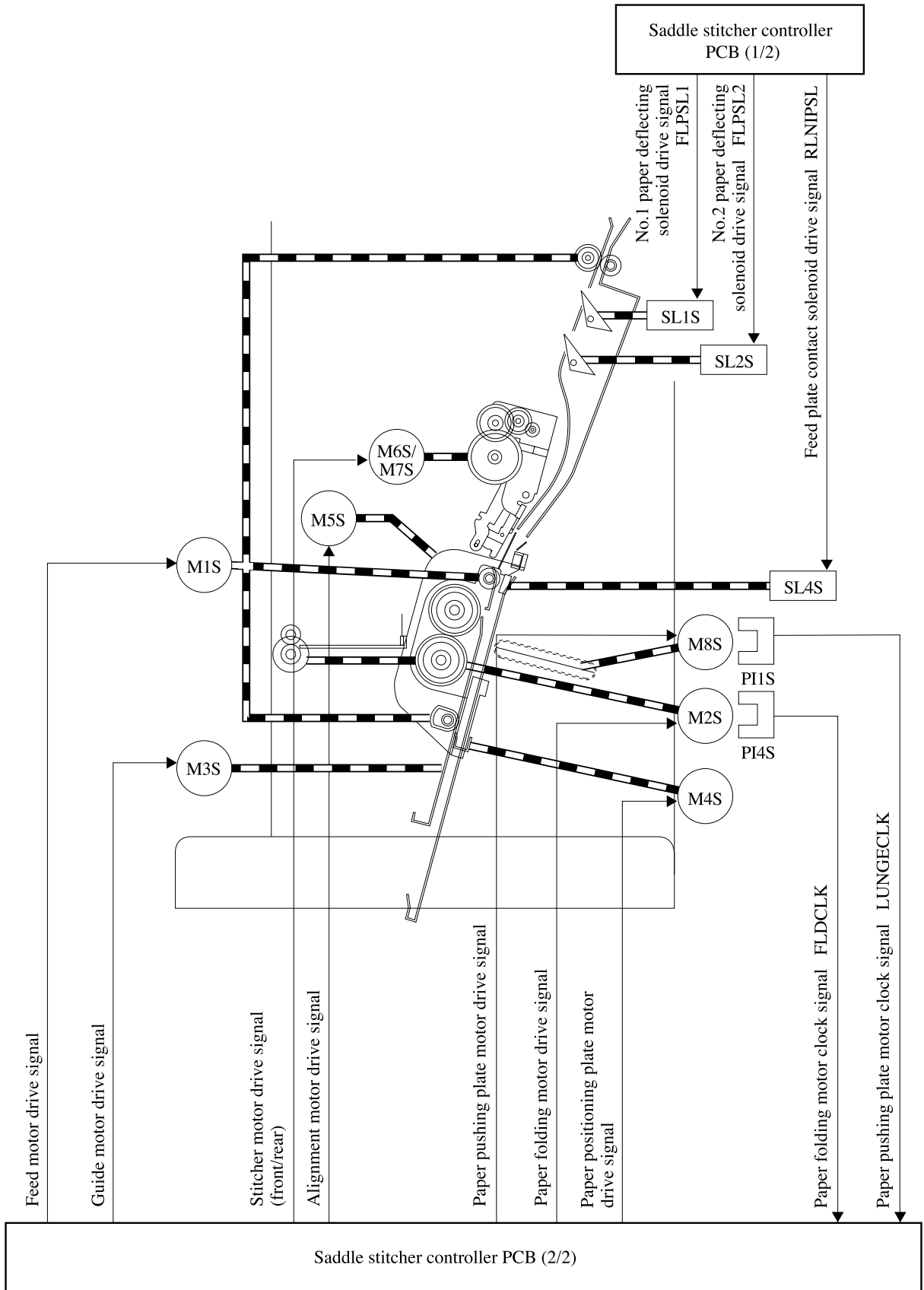


Figure 3-301

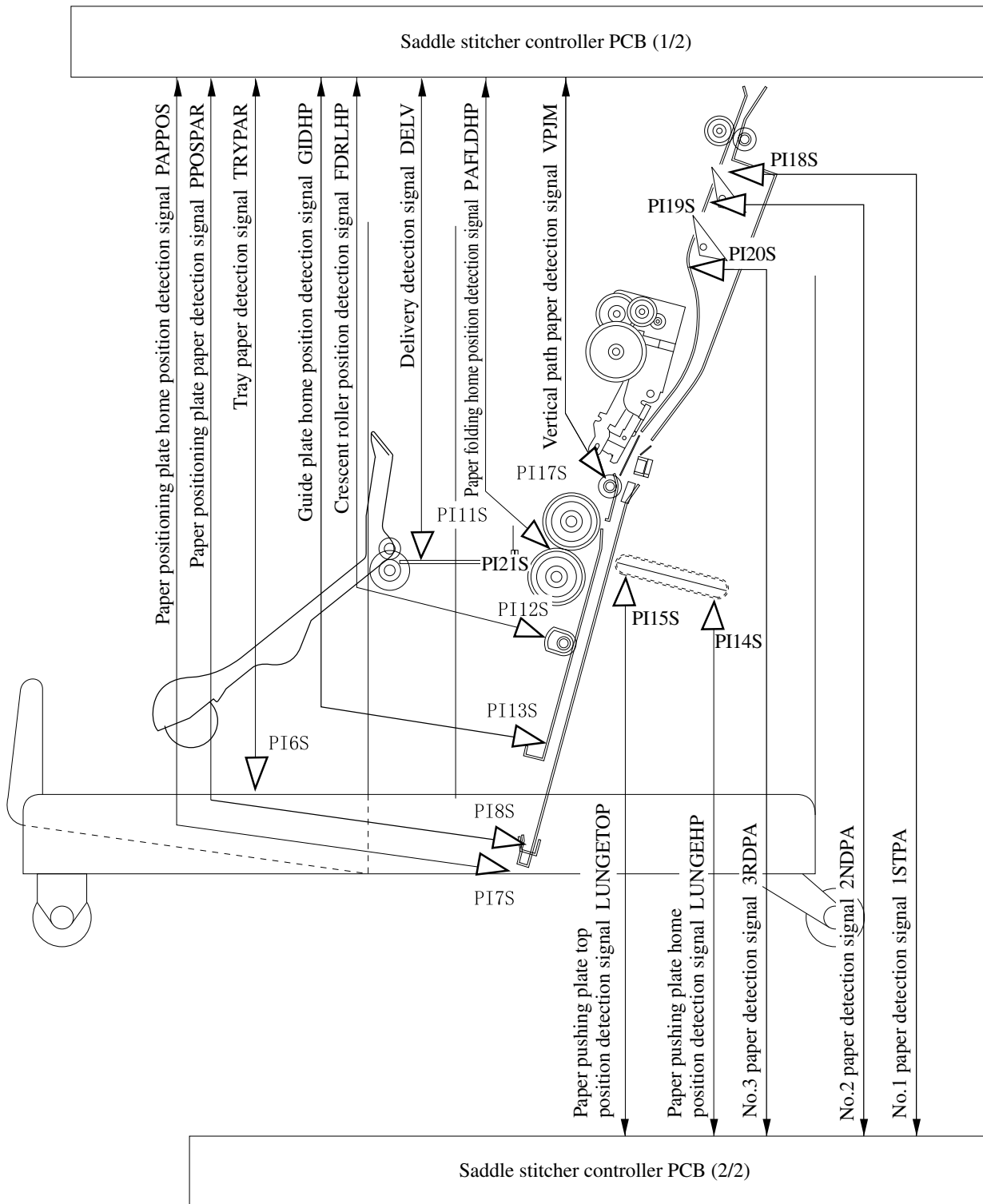


Figure 3-302

## B. Controlling the Inlet Flappers

### 1. Outline

The two flappers mounted at the paper inlet are operated to configure the feed path according to the size of paper. The flappers are used to enable the following:

1. To detect the passage of the trailing edge of the paper being moved by an appropriate sensor.
2. To prevent the following sheet from butting against the top of the existing stack,

Table 3-301 shows the relationship between sensors and paper sizes.

Sensor	A3/LD	B4/LG	A4-R/LT-R
No.1 paper sensor (PI18S)	Used	Used	Used
No.2 paper sensor (PI19S)	Not used	Used	Used
No.3 paper sensor (PI20S)	Not used	Not used	Used

**Table 3-301**

Each flapper is driven by its own solenoid.

Table 3-302 shows the relationship between solenoids and paper sizes.

Solenoid	A3/LD	B4/LG	A4-R/LT-R
No.1 paper deflecting plate solenoid (SL1S)	OFF	ON	ON
No.2 paper deflecting plate solenoid (SL2S)	OFF	OFF	ON

**Table 3-302**

2. A3/LD Paper Path (3 sheets)

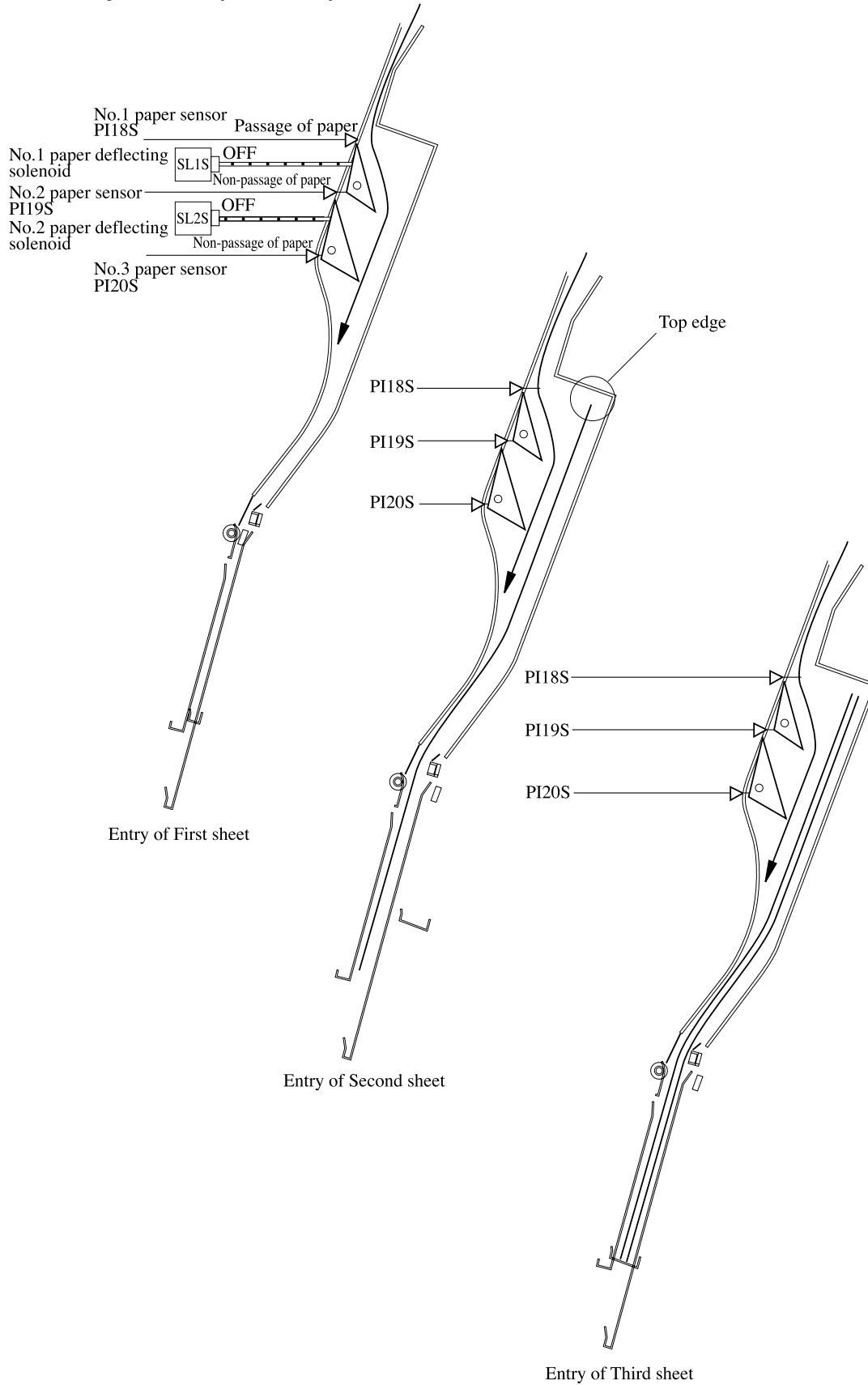


Figure 3-303



3. B4/LG Paper Path (3 sheets)

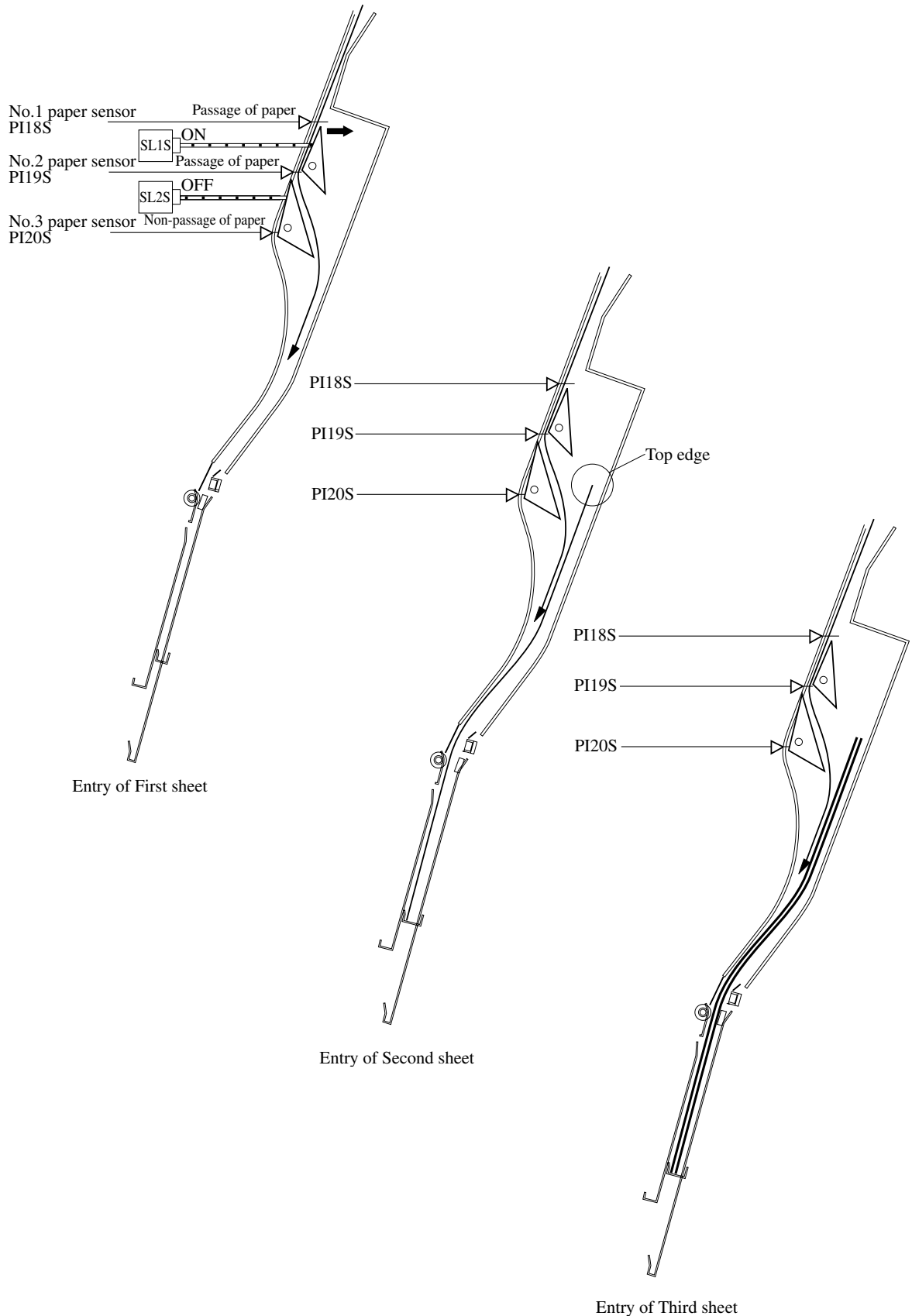


Figure 3-304

4. A4-R/LT-R Paper Path (3 sheets)

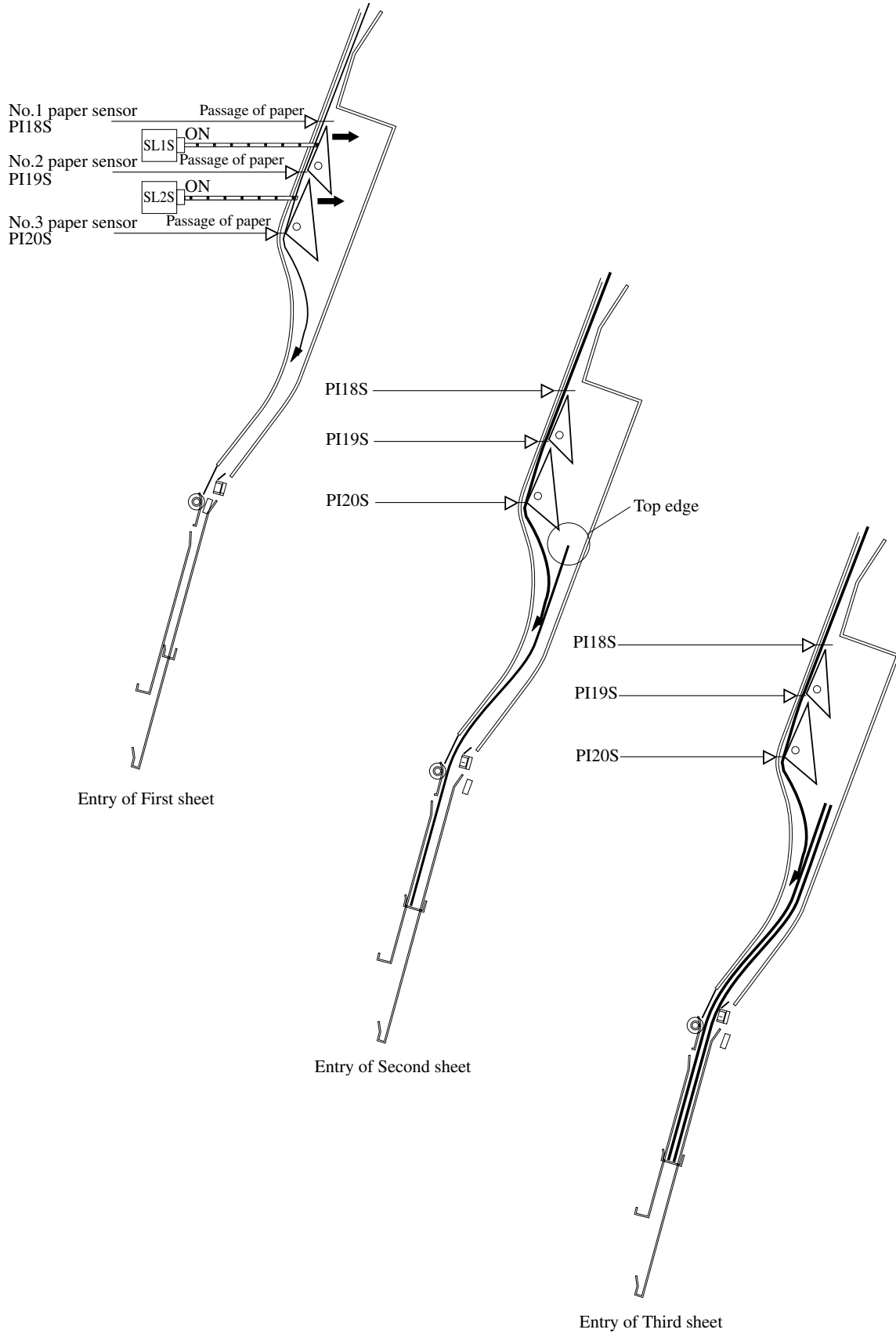


Figure 3-305

## C. Controlling the Movement of Sheets

When the leading edge of a sheet has moved past the inlet flapper, the intermediate feed roller and the crescent roller start to move the sheet forward.

The intermediate feed roller is normally not in contact with the path bed. When the leading edge of a sheet reaches the intermediate feed roller contact section, the feed plate contact solenoid (SL4S) causes the roller to come into contact with the path bed so as to move the sheet. The contact is broken as soon as the leading edge of the sheet reaches the paper positioning plate. This series of operations is executed each time a sheet arrives.

When the leading edge of the first sheet reaches the paper positioning plate, the paper positioning plate paper sensor (PI8S) turns ON. The arrival of the second and subsequent sheets will not be checked since the first sheet will still be over the sensor.

The crescent roller keeps rotating while sheets are being output, butting the leading edge of each sheet against the paper positioning plate, and ultimately, keeping the leading edge of the stack in order.

The alignment plate motor (M5S) drives the alignment plates for each sheet so as to put both left and right edges of the sheet in order.

- 1) The solenoid turns ON while paper is being moved so that the feed plate comes into contact.

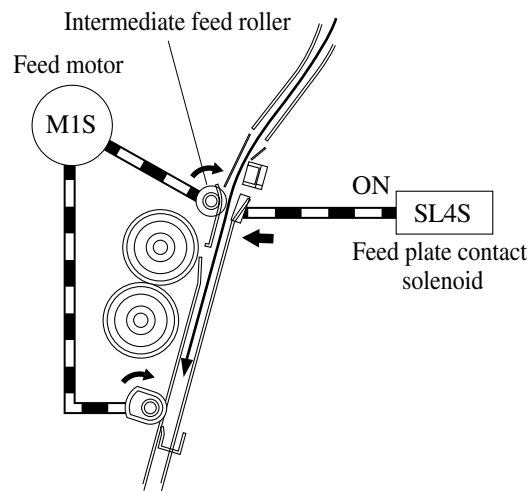


Figure 3-306

- 2) The solenoid turn OFF when the paper butts against the paper positioning plate. The feed motor continues to rotate.

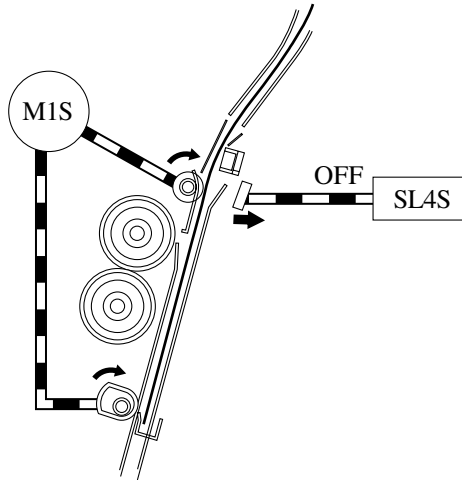


Figure 3-307

- 3) The solenoid turns ON when the next sheet arrives, and the feed plate comes into contact.

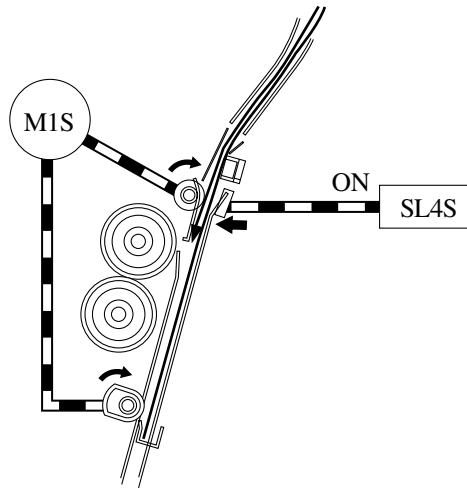


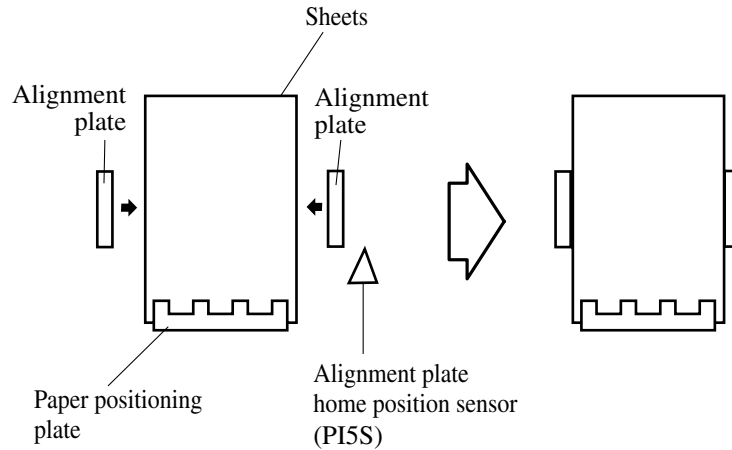
Figure 3-308

## D. Aligning the Sheets

The alignment motor (M5S) drives the alignment plates each time a sheet is output, putting both left and right edges of the sheet in order. The alignment plate motor is a 4-phase stepping motor. The position of the alignment plate is identified in reference to the number of motor pulses from the alignment plate home position sensor (PI5S).

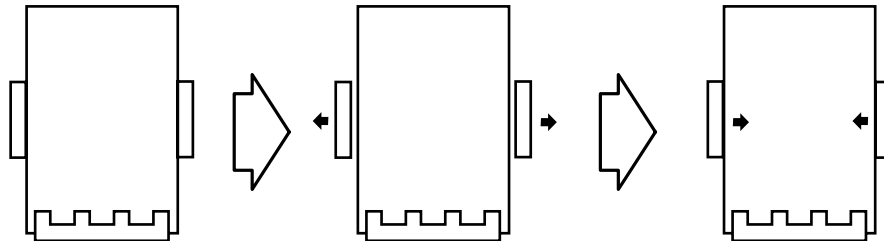
The following briefly describes what takes place when the saddle stitching mechanism operates on two sheets.

- 1) When the first sheet has been output, the alignment plates butt against the left and right edges of the stack (first alignment). The alignment plates leave the home position in advance and remain in wait at points 10 mm from the edges of the stack.



**Figure 3-309**

- 2) The alignment plates move away from the edges of the stack over a short distance and then butt against the edges once again (Second alignment).



**Figure 3-310**

- 3) The alignment plates escape to points 10 mm from the edge of the stack.

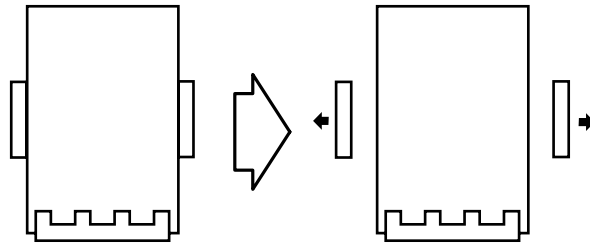


Figure 3-311

- 4) When the following stack arrives, steps 1 through 3 above are repeated.  
 5) The alignment plates butt against the stack once again, during which stitching takes place.

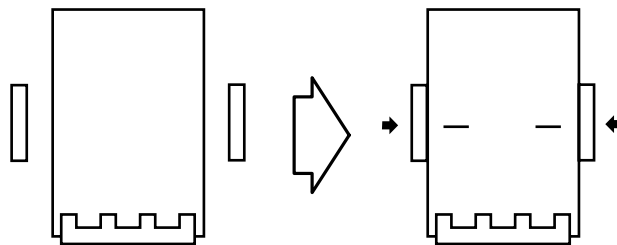


Figure 3-312

- 6) The alignment plates escape to points 10 mm from the edges of the stack, after which folding and delivery take place.

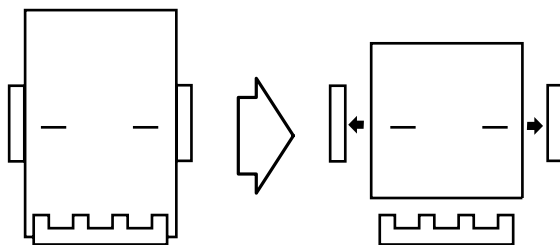


Figure 3-313

- 7) When the first sheet of the following stack reaches the No.1 paper sensor, the guide moves to a point 10 mm from the edge of the stack to be ready for the next alignment operation.

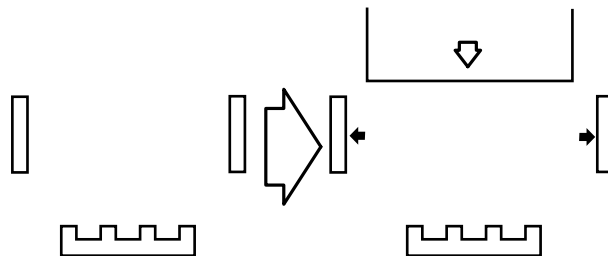
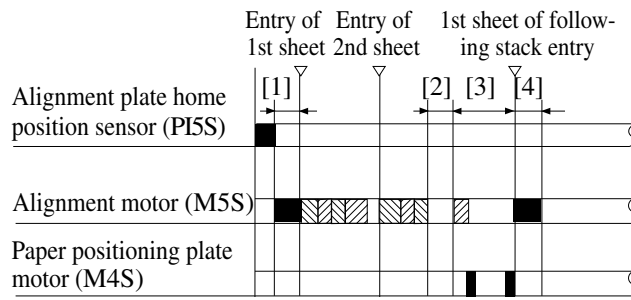


Figure 3-314

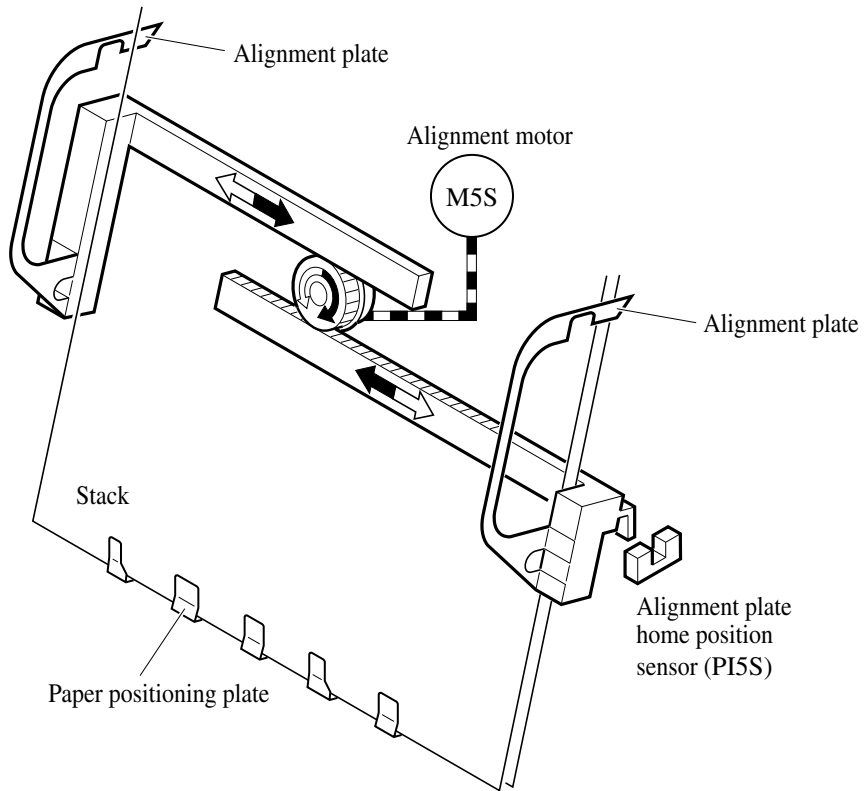
In case of 2 sheets:



▨ : Alignment    ▩ : Escape

- [1]: Move to wait position
- [2]: Stapling period
- [3]: Paper folding/delivery period
- [4]: Move to following stack size wait position

**Figure 3-315**



**Figure 3-316**

## E. Controlling the Phase of the Crescent Roller

### 1. Outline

If alignment was executed with the crescent roller in contact with the stack of sheets, the resulting friction against the roller causes the stack to move inappropriately (Figure 3-317). To prevent this problem, the phase of the roller is identified and used to determine the timing of alignment.

The phase of the crescent roller is identified by the crescent roller phase sensor (PI12S). The flag for the crescent roller phase sensor is mounted to the crescent roller shaft. The flag will leave the sensor while the roller shaft rotates, turning the sensor ON or OFF, enabling the assumption that the crescent roller is positioned at the opposite side of the stack (Figure 3-319). The alignment plates are operated to correspond with this change in the state of the sensor.

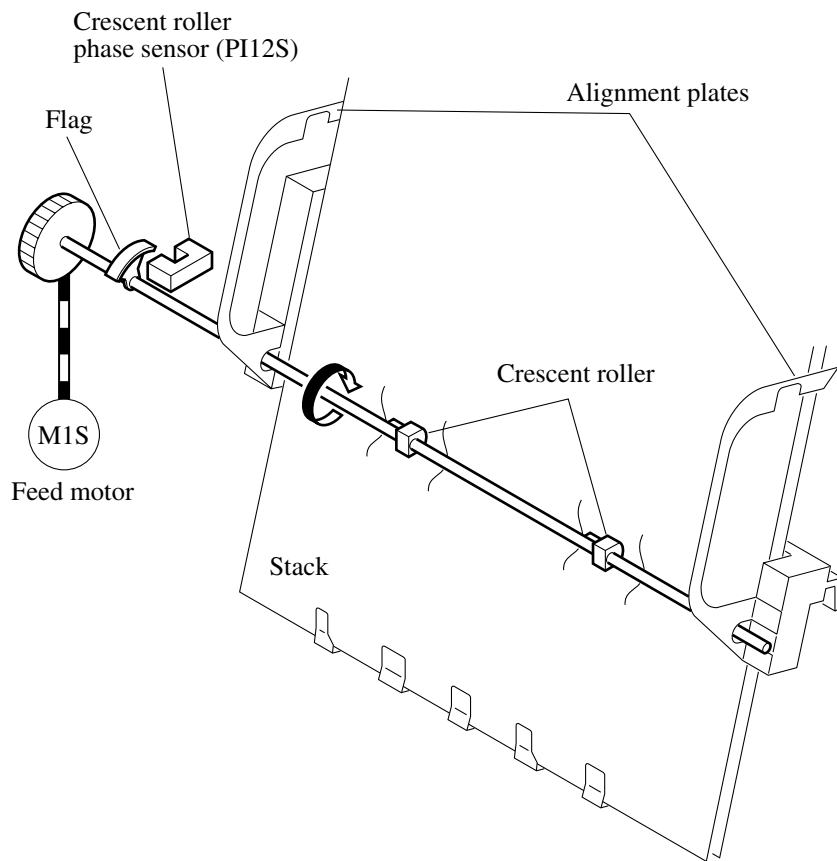


Figure 3-317



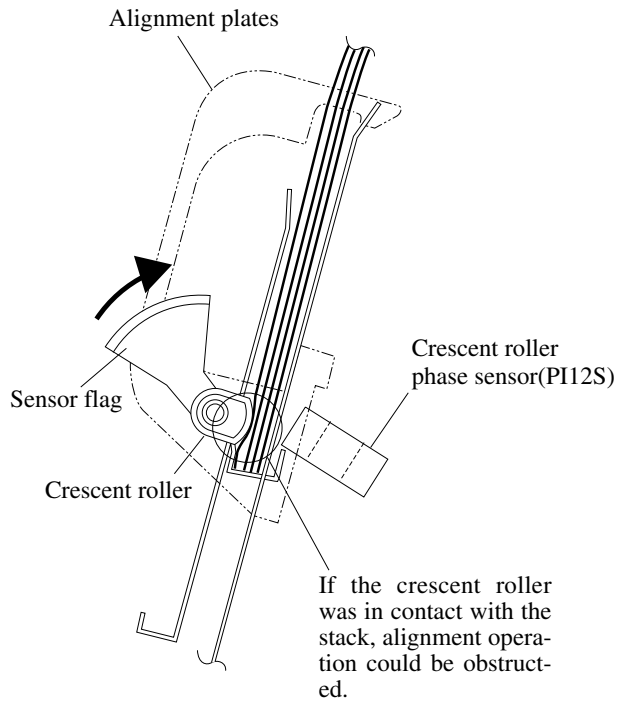


Figure 3-318

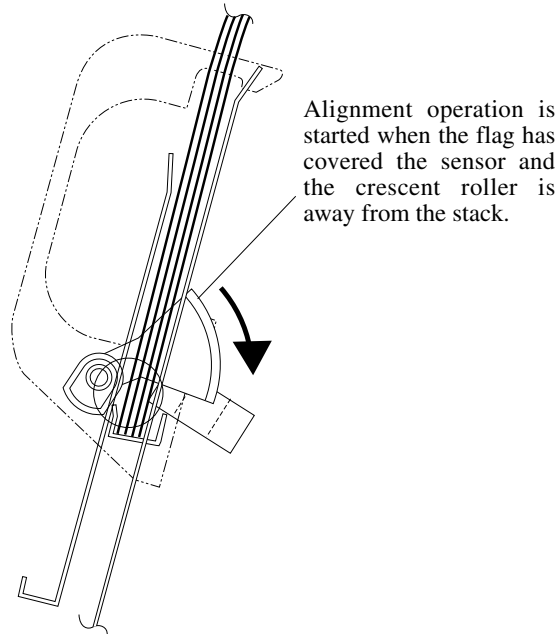


Figure 3-319

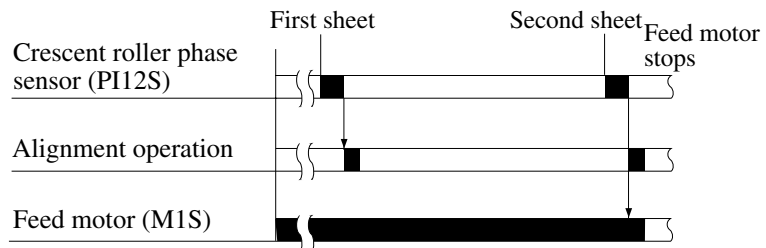


Figure 3-320

## IV. STITCHING SYSTEM

### 1. Outline

The stitching system “stitches” the center of an output stack with staples.

To enable stitching at two locations on a stack, two sticher units (front, rear) are used. Each sticher unit is equipped with a sticher motor (M7S, M6S) for drive, a sticher home position sensor (MS7S, MS5S) for detection of position and a staple sensor (MS6S, MS4S) for detection of the presence/absence of staples.

The sticher base is designed so that it may be drawn out to the front from the saddle sticher for replacement of the staple cartridge or removal of a staple jam. The sticher unit in sensor (PI16S) is used to make sure that the sticher base is properly fitted to the saddle sticher.

Safety switches are not mounted for the sticher unit (front, rear), as the location does not allow access by the user.

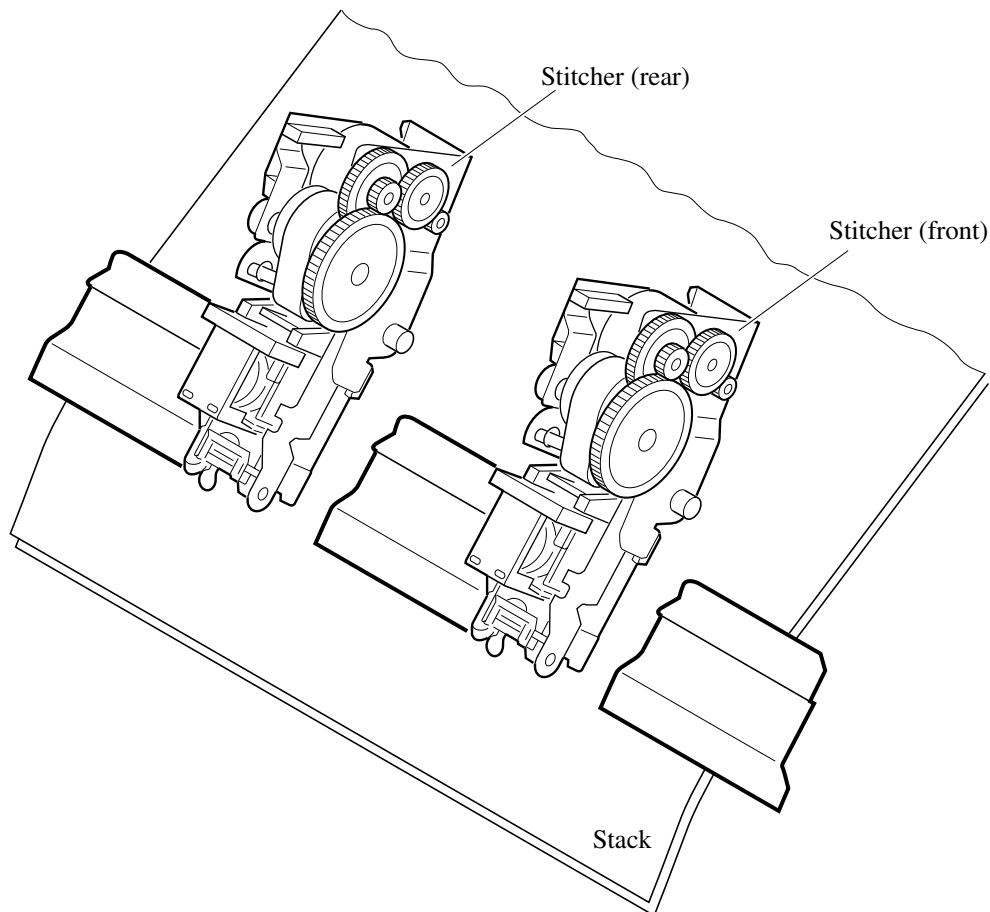


Figure 3-401

## 2. Stitcher Unit Operation

The stitcher base unit consists of two stitchers and stitcher bases. The stitchers are fixed in position, and are not designed to slide or swing.

Stitching is executed by driving the rotary cam by the stitcher motor (M7S, M6S). The front and rear stitcher units are operated with a time delay so as to prevent wrinkling of paper and to limit the load applied to the power supply. (A time delay for initiating the stitcher motor startup current helps decrease the load on the power supply.)

The stitcher home position sensor (MS7S, MS5S) is used to monitor the movement of the rotary cam, enabling identification of individual stitcher operations. The presence/absence of staples inside the staple cartridge fitted to the stitcher is detected by the staple sensor (MS6S, MS4S).

The alignment plates keep both edges of the stack in place while stitching takes place.

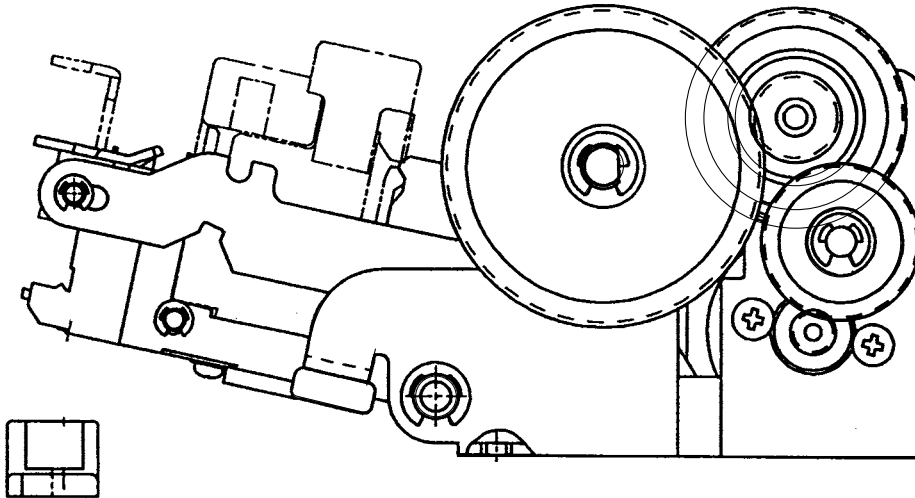


Figure 3-402

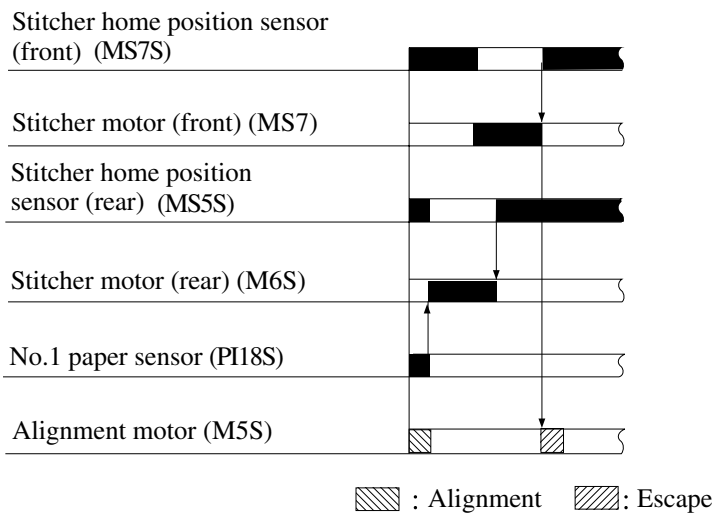


Figure 3-403

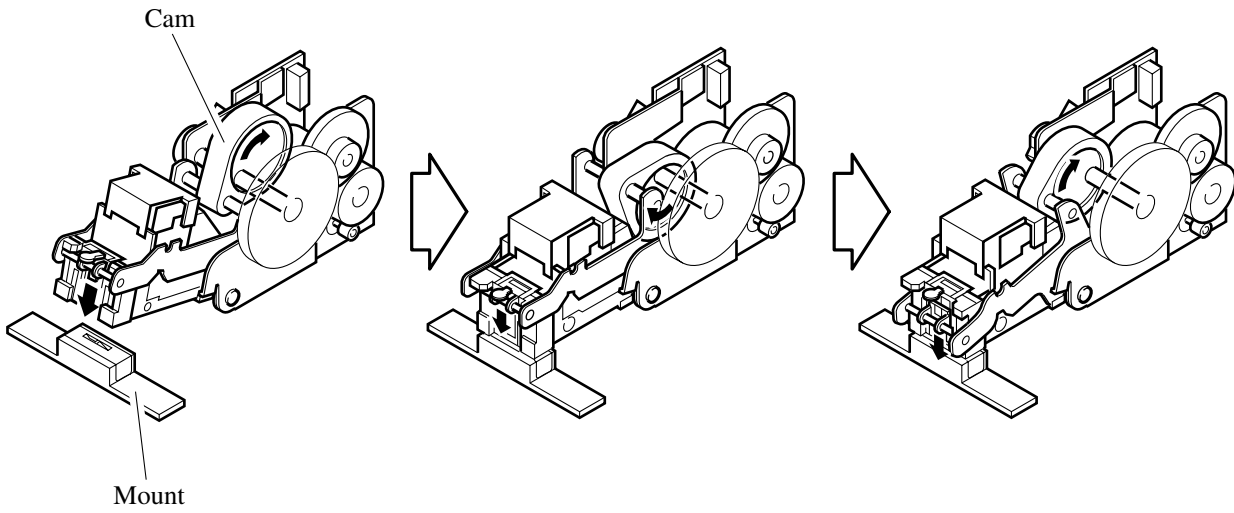


Figure 3-404

## V. FOLDING/DELIVERY SYSTEM

### 1. Outline

The paper folding mechanism consists of a guide plate, paper folding rollers, paper pushing plate, and paper positioning plate.

The guide plate is used to cover the folding rollers while sheets are output so as to prevent sheets from coming into contact with the folding rollers during output. Before the stack is folded, the guide plate moves down to enable the folding rollers to operate.

The folding rollers are driven by the paper folding motor (M2S), and the drive of the motor is monitored by the paper folding motor clock sensor (PI4S). The mechanism is also equipped with a paper folding home position sensor (PI21S) for detecting the position of the paper folding rollers.

The paper pushing plate is driven by the paper pushing plate motor (M8S), and the drive of the paper pushing plate motor is monitored by the paper pushing plate motor clock sensor (PI1S). The paper pushing plate home position sensor (PI14S) and the paper pushing plate top position sensor (PI15S) are used to detect the position of the paper pushing plate.

After being folded into two by the paper folding rollers, a stack is moved ahead by the delivery roller for delivery. The delivery roller is driven by the paper folding motor. The delivery sensor (PI11S) is mounted to the delivery assembly to detect delivery of paper. The tray paper sensor (PI6S) is used to detect the presence/absence of paper on the tray, but does not detect jams. The vertical path paper sensor (PI17S) serves to detect the presence of paper after jam removal.

## 2. Controlling the Movement of Stacks

When a stack has been stitched (2 points), the paper positioning plate lowers so that the stack will move to where the paper folding rollers come into contact with the stack and where the paper pushing plate is located. The position of the paper positioning plate is controlled in reference to the number of motor pulses coming from the paper positioning home position sensor (PI7S).

At the same time as the paper positioning plate operates, the guide plate lowers so that folding may take place.

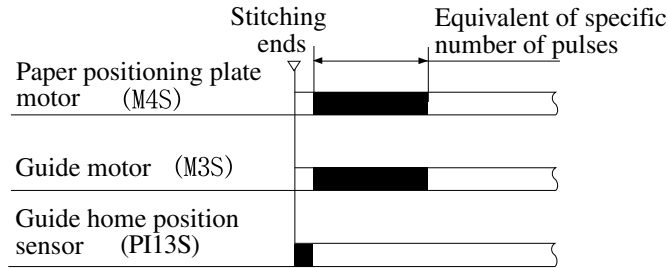


Figure 3-501

### 3. Folding a Stack

A stack is folded by the action of the paper folding rollers and the paper pushing plate.

The paper pushing plate pushes against the center of a stack toward the roller contact section. The paper pushing plate starts at its home position and waits at the leading edge position until the stack has been drawn to the paper folding roller and is gripped for a length of 10 mm. When the paper folding roller has gripped the stack for a length of about 10 mm, the paper pushing plate motor starts to rotate once again, and the paper pushing plate returns to its home position. The stack gripped in this way by the paper folding roller is drawn further by the paper folding roller and then is moved by the delivery roller to the paper tray.

Half of the peripheral area of the paper folding rollers excluding the center part is punched out. This punched out area only feeds the paper as the paper feeding roller (lower) contacts the paper feeding roller (upper) only at the center of the roller to prevent the paper from wrinkling. As the paper feeding roller (lower) contacts the paper feeding roller (upper) at their entire surfaces on the remaining half of the peripheral area, paper folding starts from this half of the peripheral area, and paper is fed while it is being folded. The stop position of the paper folding rollers is in this half of the peripheral area.

The paper folding start and stop positions on the paper folding rollers is controlled according to the motor clock signals from the paper folding home position sensor (PI21S).

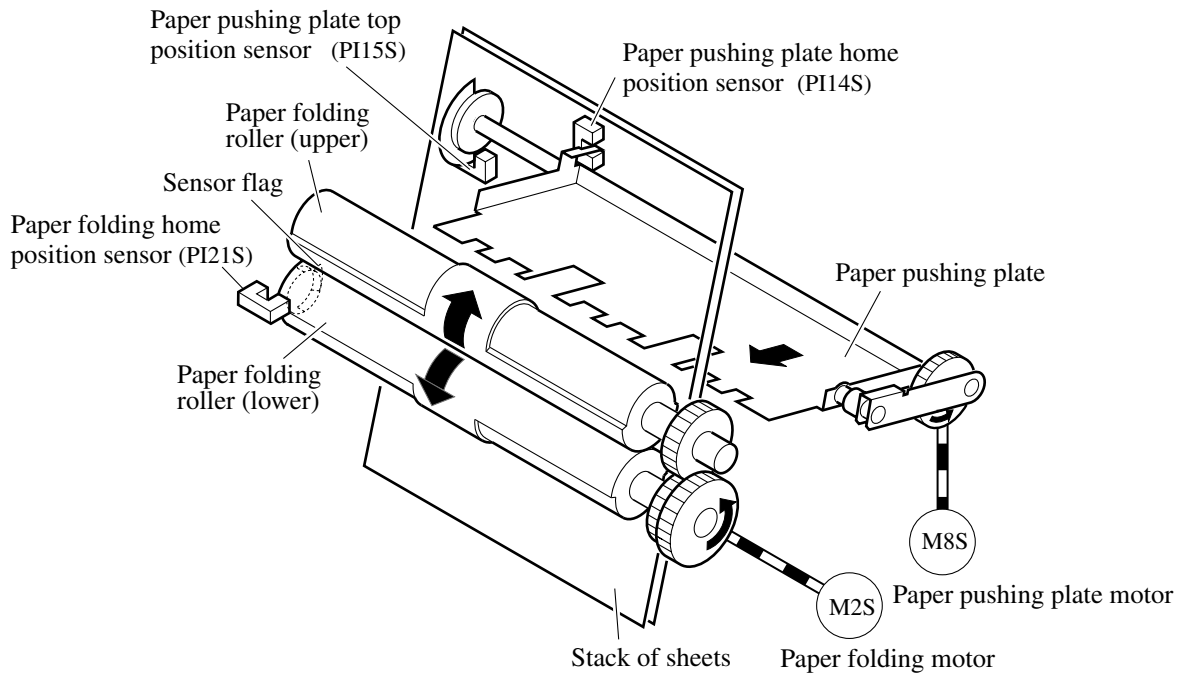


Figure 3-502

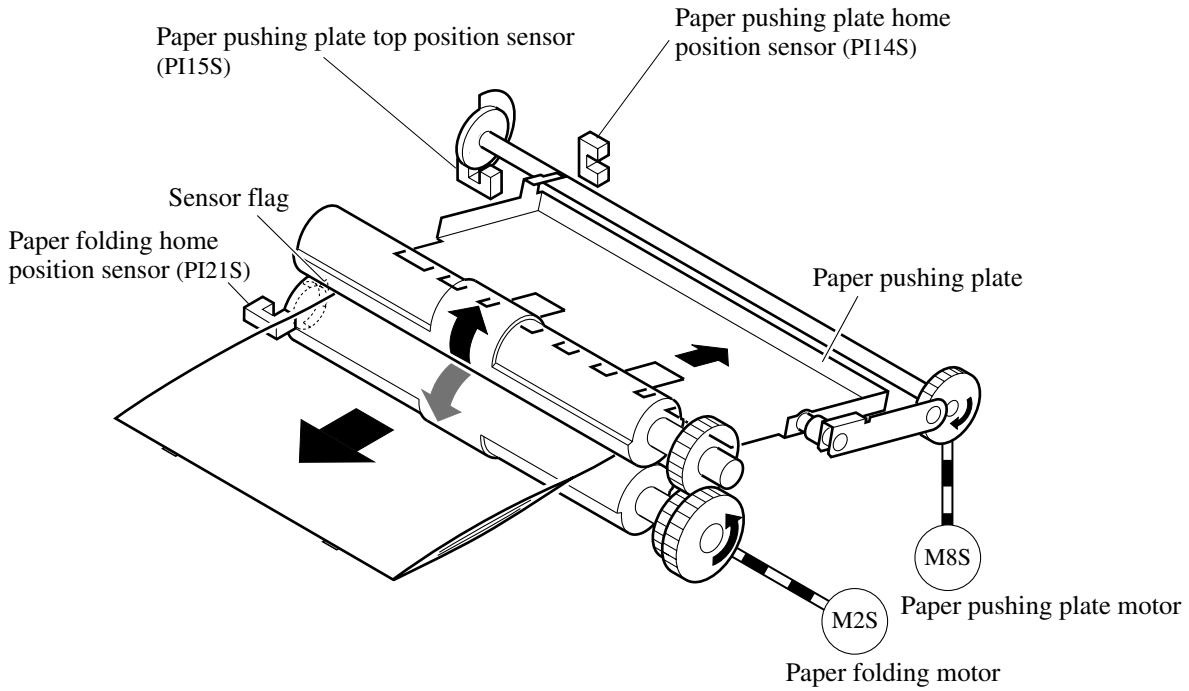


Figure 3-503

[Paper folding start position]

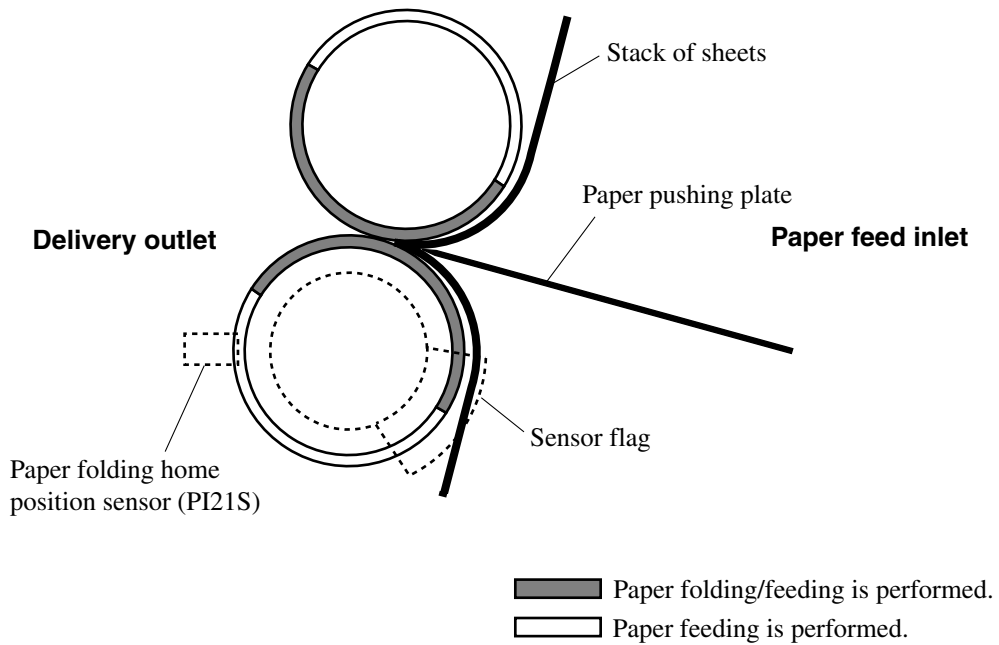


Figure 3-504



[Paper folding roller stop position]

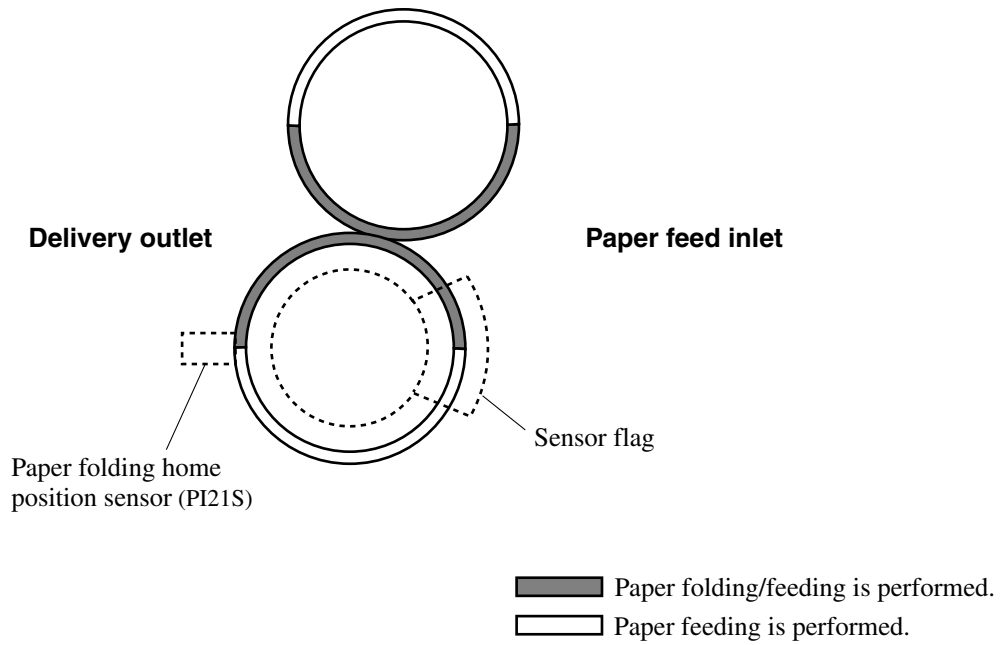


Figure 3-505

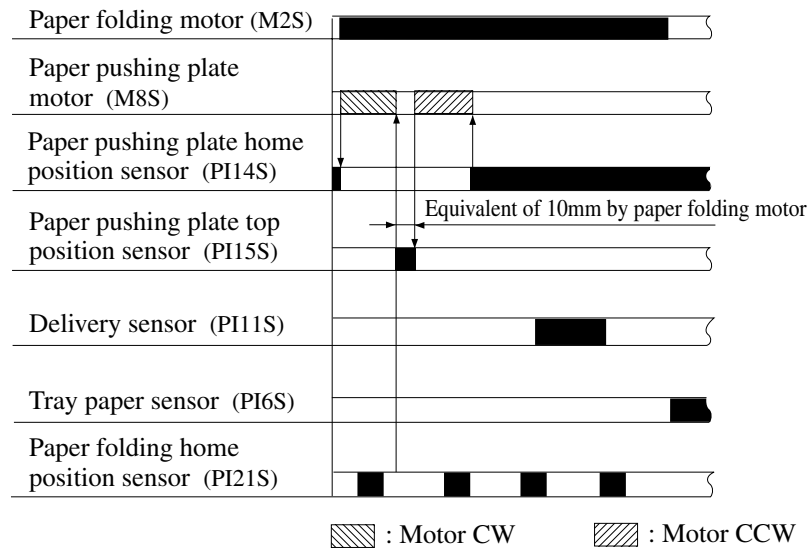


Figure 3-506

#### 4. Double Folding a Stack

To fold a stack consisting of 10 or more A4-R or LT-R sheets, folding is executed twice for the same sheet.

The paper folding rollers rotate in reverse for an equivalent of 20 mm after gripping the stack for a length of 20 mm, enabling the paper folding rollers to apply an increased degree of pressure along the crease on the stack. Then, the paper folding rollers rotate normally, and the paper pushing plate returns to its home position while the stack is being delivered.

This way, a stack requiring a large force may properly be folded with less pressure.

- 1) The paper pushing plate pushes the stack in the direction of the paper folding rollers.

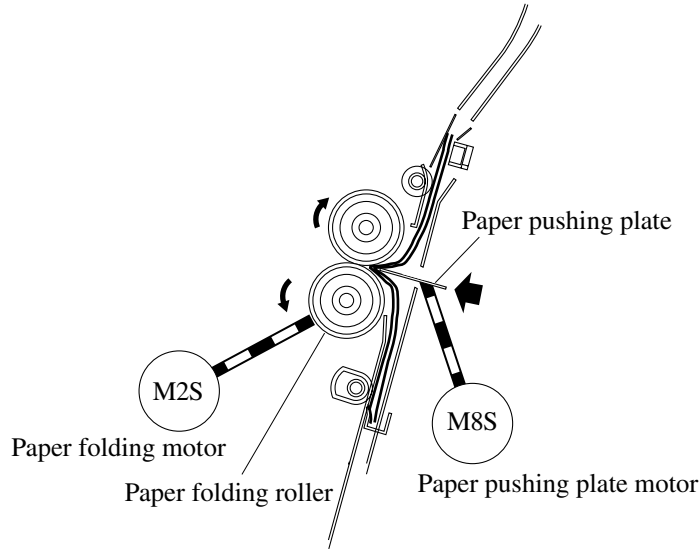


Figure 3-507

- 2) The paper folding rollers grip the stack for a length of about 20 mm.

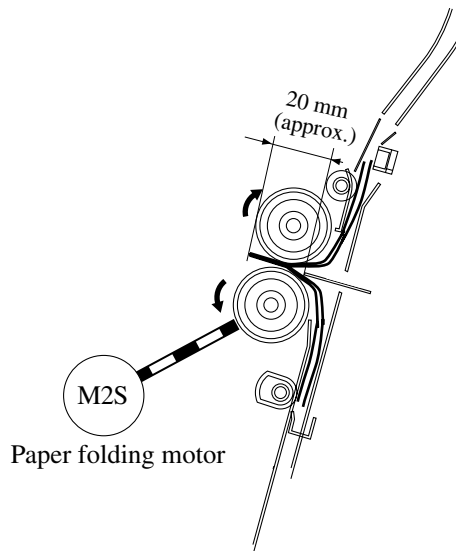


Figure 3-508

- 3) The paper folding rollers rotate in reverse, pushing back the stack for a length of about 20 mm (reverse feeding).

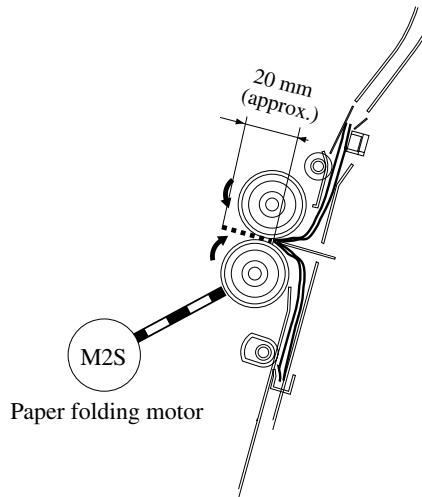


Figure 3-509

- 4) The paper folding rollers rotate again, feeding out the stack. The paper pushing plate returns to its home position.

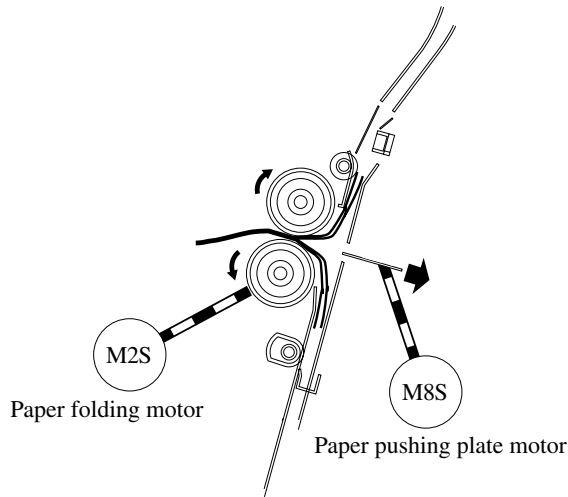


Figure 3-510

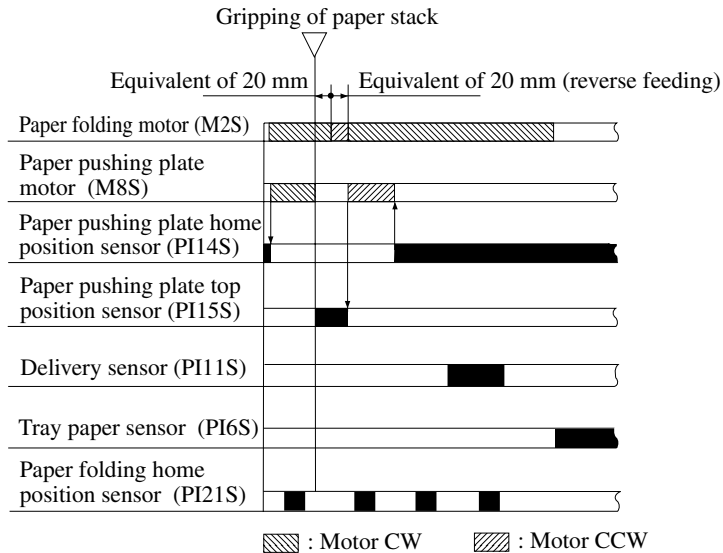


Figure 3-511

## VI. CHECKING FOR A JAM

### 1. Checking for a Jam

The saddle stitcher unit identifies any of the following conditions as a jam, and sends the jam signal to the host machine. In response, the host machine may stop copying operation and indicate the presence of a jam on its control panel.

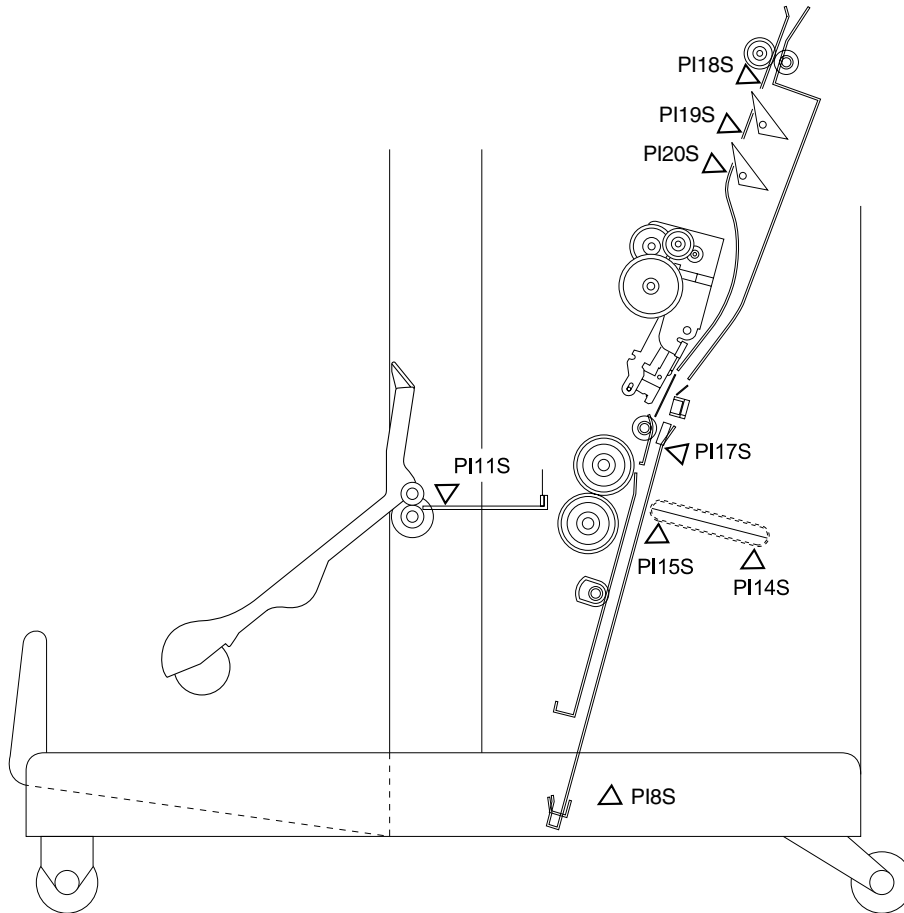


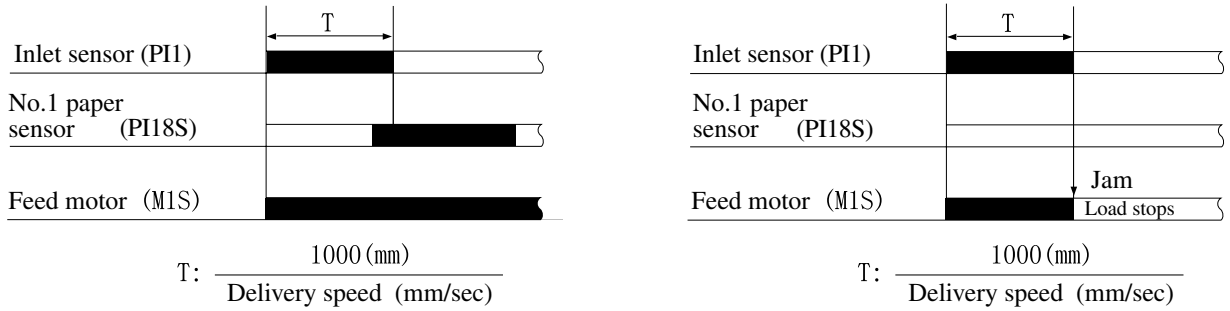
Figure 3-601

No.	Sensor
PI8S	Paper positioning plate paper detection sensor
PI11S	Delivery sensor
PI14S	Paper pushing plate home position sensor
PI15S	Paper pushing plate top position sensor
PI17S	Vertical path paper sensor
PI18S	No.1 paper sensor
PI19S	No.2 paper sensor
PI20S	No.3 paper sensor

Table 3-601

**2. Inlet Delay Jam**

The No.1 paper sensor (PI18S) on the paper sensor PCB does not turn ON for a specific period of time after the inlet sensor (PI1) of the finisher turned ON.

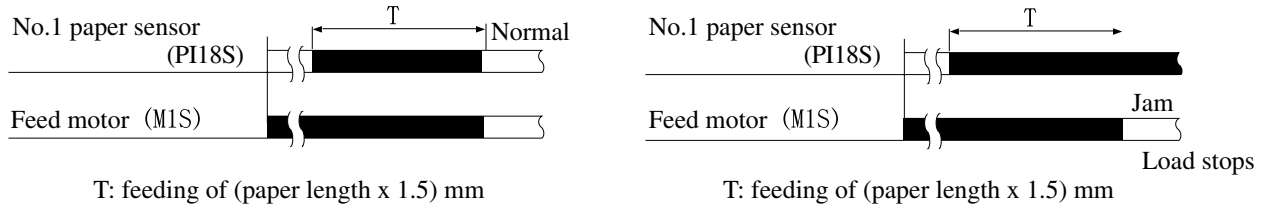


**Figure 3-602**

**3. Inlet Stationary Jam**

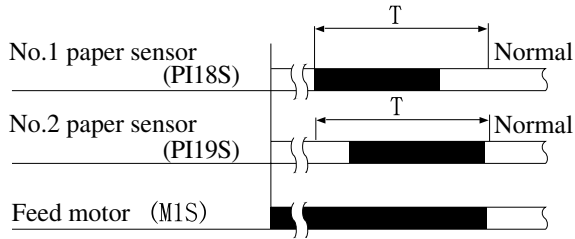
The No.1 paper sensor (PI18S), No.2 paper sensor (PI19S), and No.3 paper sensor (PI20S) on the paper sensor PCB do not turn OFF when the stack has been fed for a specific period after the No.1 paper sensor (PI18S) turns ON. The paper sensor used varies according to the paper size.

**a. A3/LD Stack**

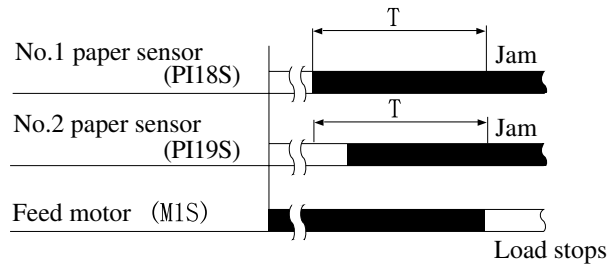


**Figure 3-603**

b. B4/LG Stack



T: feeding of (paper length x 1.5) mm

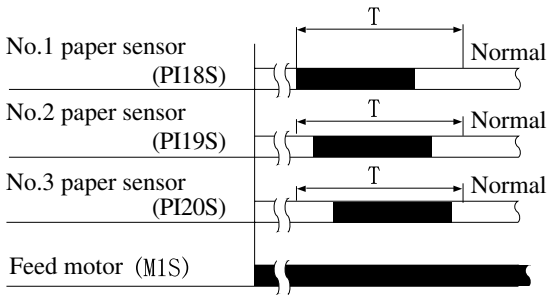


T: feeding of (paper length x 1.5) mm

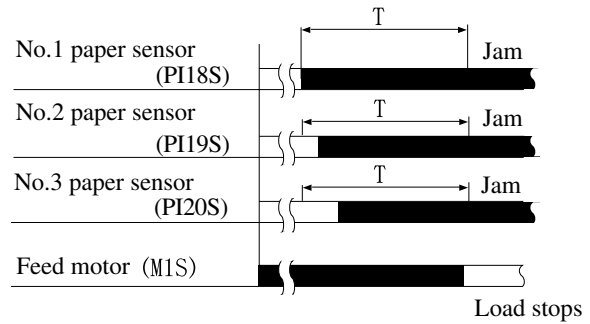
Note: The diagram shows two sensors checking for jams. Single detection, however, uses only one sensor.

Figure 3-604

c. A4-R/LT-R Stack



T: feeding of (paper length x 1.5) mm



T: feeding of (paper length x 1.5) mm

Note: The diagram shows three sensors checking for jams. Single detection, however, uses only one sensor.

Figure 3-605

#### 4. Delivery Delay Jam

##### a. By delivery sensor

The delivery sensor (PI11S) does not turn ON within a specific period of time after the paper pushing plate top position sensor has turned ON.

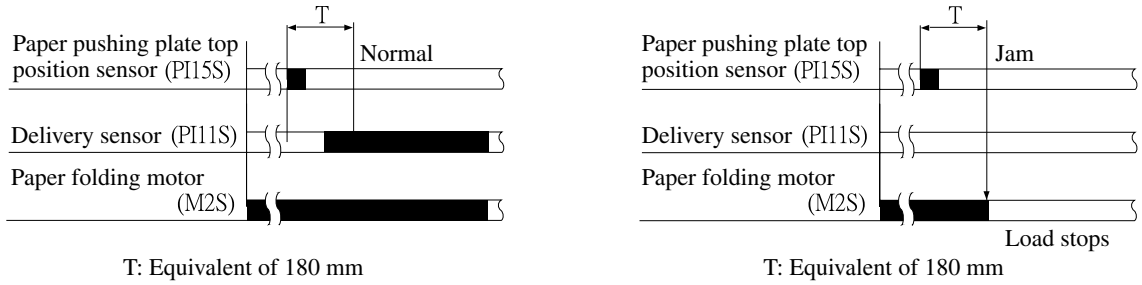
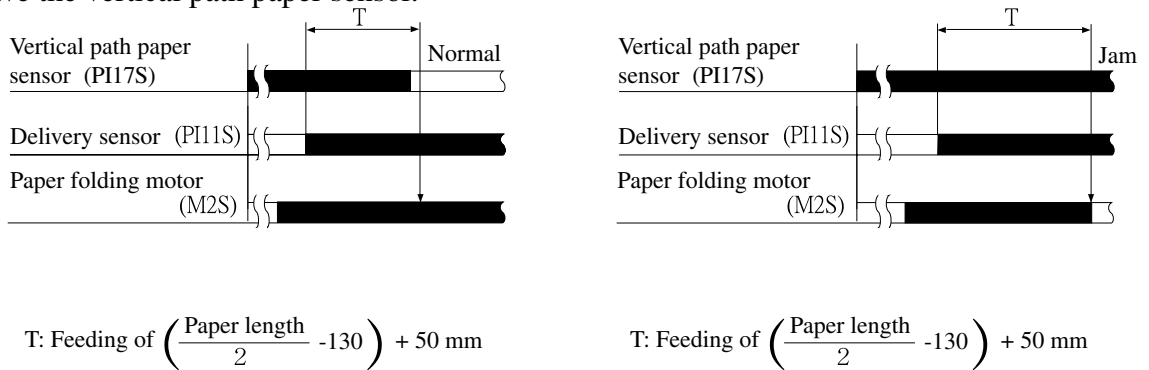


Figure 3-606

#### 5. Delivery Stationary Jam

##### a. By vertical path paper sensor

The vertical path paper sensor (PI17S) does not turn OFF within a specific period of time (feeding) after the delivery sensor (PI11S) has turned ON, i.e., the trailing edge of the stack does not leave the vertical path paper sensor.



Note: The length 130 mm is the length of the feeding path from the vertical path paper sensor to the delivery paper sensor, while the length 50 mm is a margin.

Figure 3-607

b. By delivery sensor

The delivery sensor (PI11S) does not turn OFF within a specific period of time (feeding) after it has turned ON.

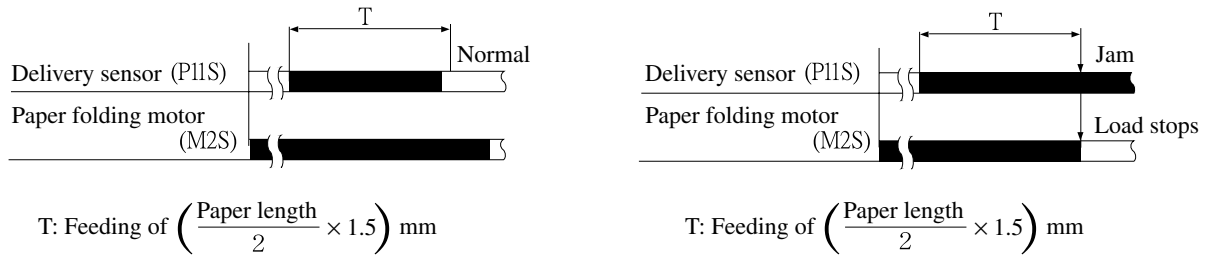


Figure 3-608

6. Power-ON Jam

Any of the No.1 paper sensor (PI18S), No.2 paper sensor (PI19S), No.3 paper sensor (PI20S), Vertical path paper sensor (PI17S) or delivery sensor (PI11S) on the paper sensor PCB detects paper at power-ON.

7. Door Open Jam

The front door open/closed sensor (PI2S), outlet cover sensor (PI3S), or inlet cover sensor (PI9S) finds that the respective cover is open during operation.

8. Stitcher Staple Jam

When the stitcher motor (M7S/M6S) is rotating clockwise, the stitcher home position sensor (MS7S/MS5S) does not turn ON within 0.5 secs after it has turned OFF. In addition, the sensor turns ON within 0.5 secs after the motor has been rotated counterclockwise.

9. Saddle Stitcher Feeding Delay Jam (by the paper sensor for the paper positioning plate)

The paper sensor for the paper positioning plate is not turned ON at the start of the push (folding) operation.

**Reference:**

When all doors are closed after the user has removed the jam, the saddle stitcher unit checks whether the vertical path paper sensor (PI17S) has detected the presence of paper. If the sensor has detected paper, the unit will identify the condition as being faulty jam removal and send the jam signal to the host machine once again.



## VII. POWER SUPPLY

### 1. Outline

When the host machine power switch is turned ON, 24V and 5V power lines are supplied by the finisher controller PCB.

The 24V power is used to drive solenoids. The 24V power from the finisher controller PCB to solenoids does not pass through any protective mechanisms (microswitches, or the like).

The 24V power to motors, on the other hand, will not be supplied if any of the three door switches is open.

The 5V power is used to drive sensors and ICs.

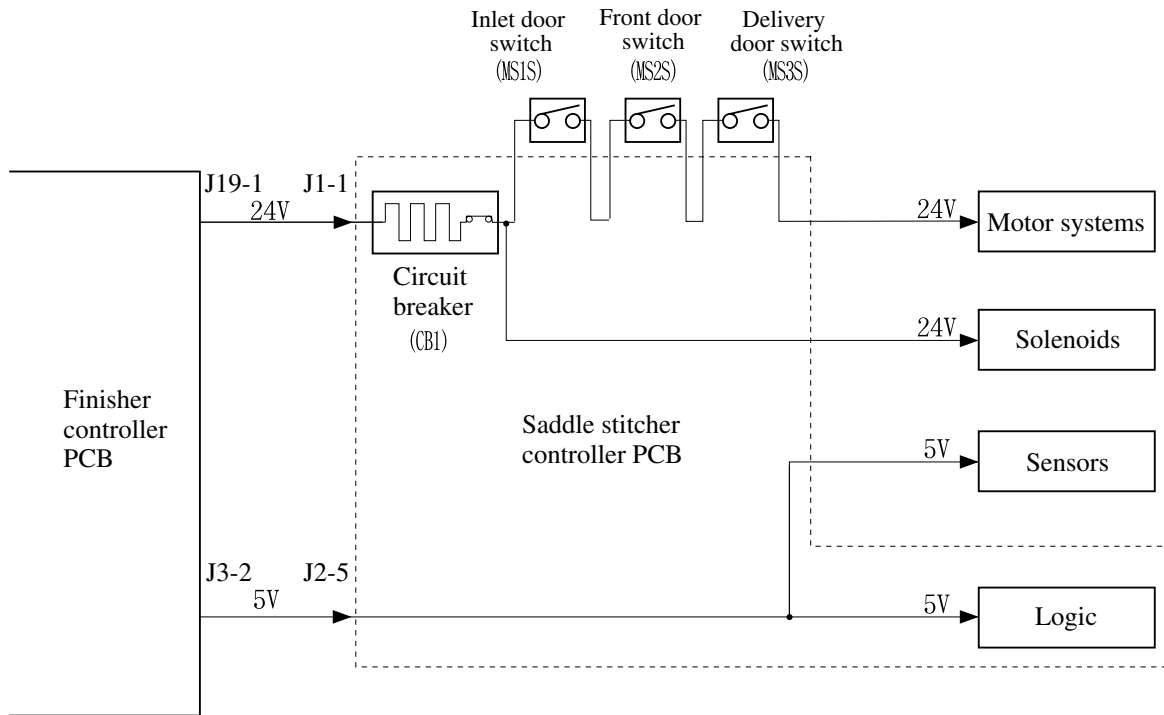


Figure 3-701

### 2. Protective Mechanisms

The 24 VDC power supply used for motors and solenoids is equipped with a circuit breaker (CB1). The 24V power supply used to drive the feed motor (M1S), alignment motor (M5S), and the paper positioning plate motor (M4S) is equipped with a fuse designed to blow when an overcurrent flows.

---

# CHAPTER 4

---

## MECHANICAL CONSTRUCTION

---

This chapter describes the mechanical features and operations, and disassembly and assembly procedures.

Be sure to observe the following points when disassembling and assembling the machine:

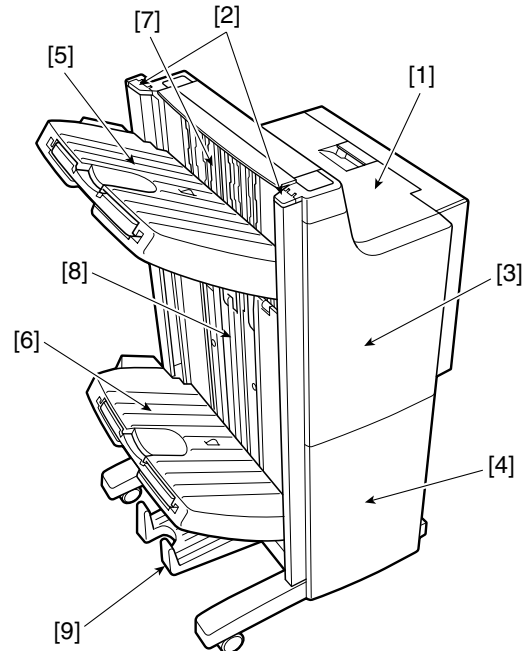
1. **▲** Before performing disassembly and assembly, be sure to unplug the power plug for safety's sake.
2. Assemble parts by following the disassembly procedure in reverse unless otherwise mentioned.
3. Assemble screws, etc., making sure that their type (length and diameter) and location of use are correct.
4. In principle, do not operate the machine with any parts removed.

I. FINISHER UNIT .....	4-1	A. Externals and Controls .....	4-14
A. Externals and Controls .....	4-1	B. SADDLE STITCHER UNIT .....	4-17
B. FEEDING SYSTEM .....	4-9	C. PCBs.....	4-27
C. PCBs.....	4-13	D. Accessory .....	4-28
II. SADDLE STITCHER UNIT .....	4-14		

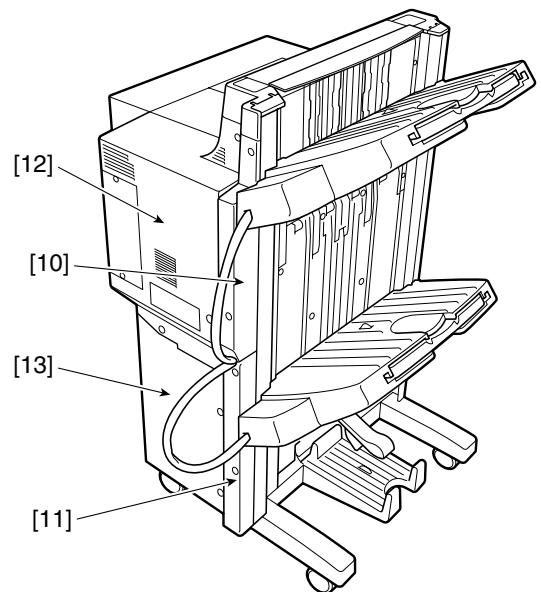
# I. FINISHER UNIT

## A. Externals and Controls

- [1] Upper door
  - [2] End cap
  - [3] Front door
  - [4] Front lower door
  - [5] Tray-1
  - [6] Tray-2
  - [7] Grate-shaped upper guide (6)
  - [8] Grate-shaped lower guide (6)
  - [9] Saddle Stitcher delivery tray
  - [10] Sub-support upper cover (2)
  - [11] Sub-support lower cover (2)
  - [12] Rear cover (3)
  - [13] Rear lower cover (4)
- Figures in parentheses ( ) indicate the number of mounting screws.



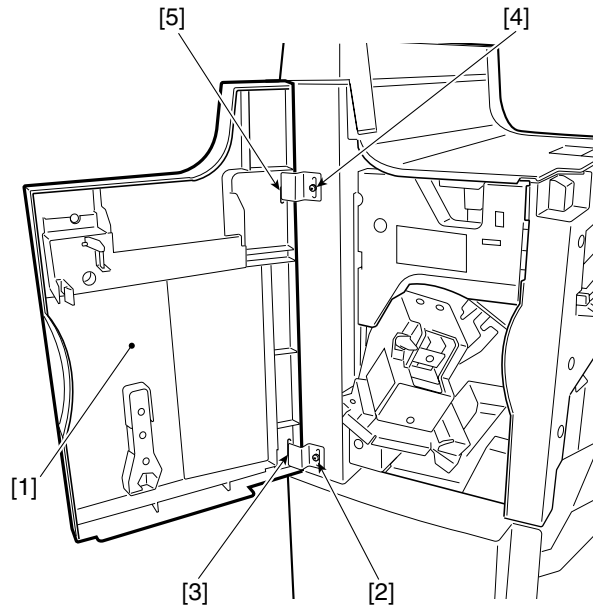
**Figure 4-101**



**Figure 4-102**

**1. Removing the Front Door Assembly**

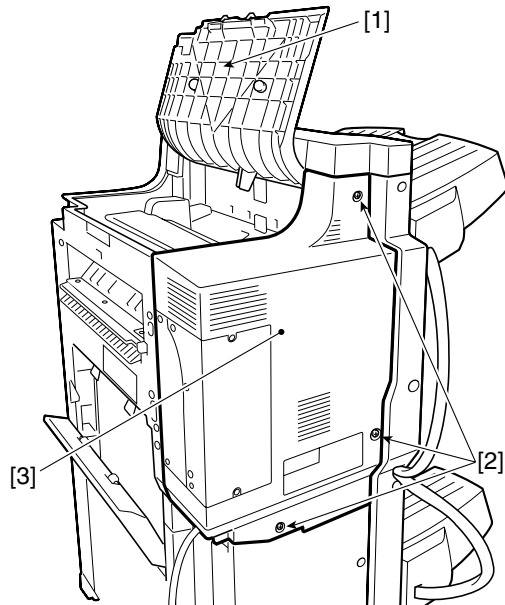
- 1) Open the front door assembly [1].
- 2) Remove the screw [2], and remove the bushing [3] (center).
- 3) Remove the screw [4], and remove the bushing (top) [5]. Then, remove the front door assembly.



**Figure 4-103**

**2. Removing the Rear Cover**

- 1) Open the upper door assembly [1].
- 2) Remove the three screws [2], and lift the rear cover [3] to remove.

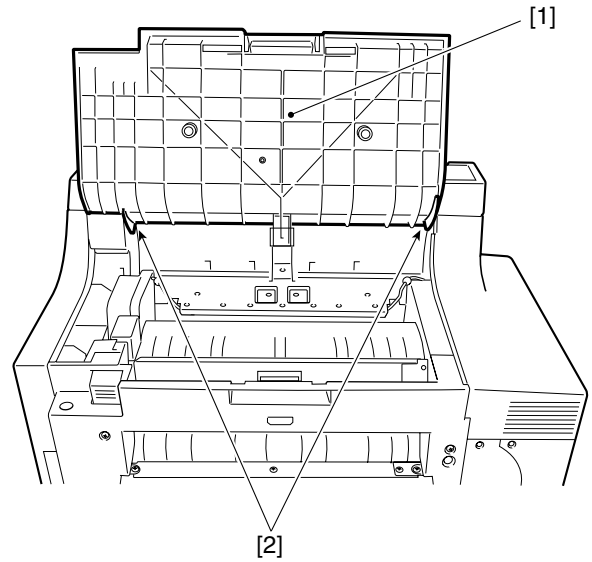


- [1] Upper door assembly
- [2] Screws
- [3] Rear cover

**Figure 4-104**

**3. Removing the Upper Door Assembly**

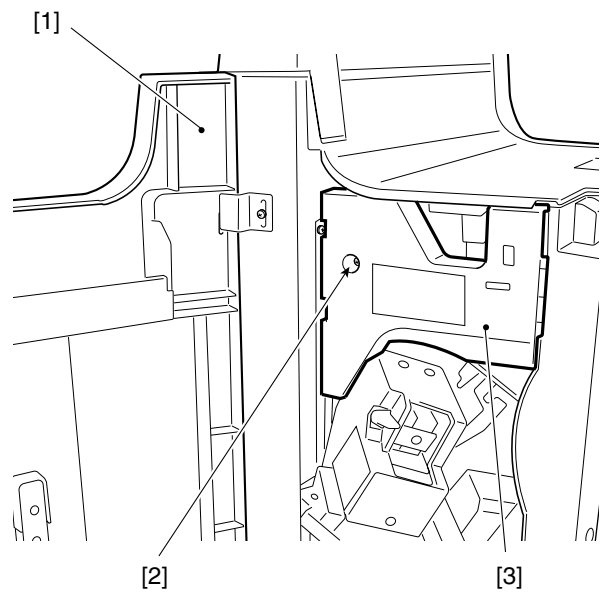
- 1) Open the upper door assembly [1].
- 2) Remove the two claws [2], and remove the upper door assembly.



**Figure 4-105**

**4. Removing the Front Cover**

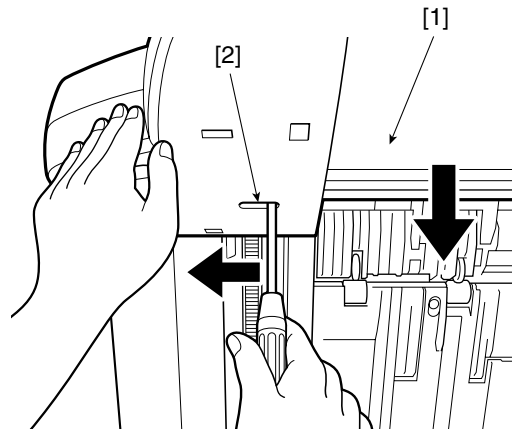
- 1) Open the front door assembly [1].
- 2) Remove the screw [2], and remove the front cover [3].



**Figure 4-106**

**5. How to Lower the Tray -1/-2 Unit**

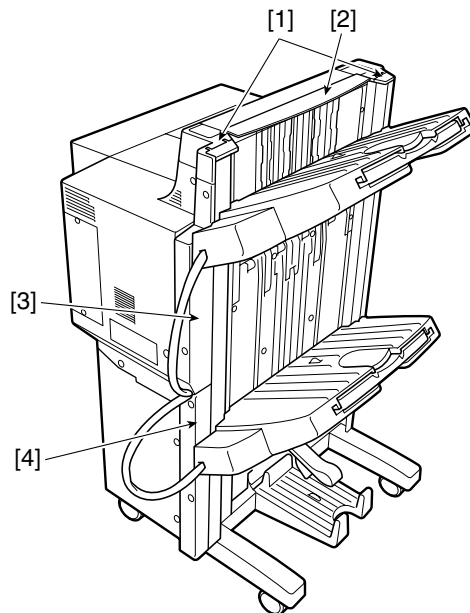
- 1) Insert a screwdriver or similar object into the hole [2] while supporting the tray assembly [1].
- 2) Release the tray lift motor one-way gear, and lower the tray -1/-2 unit.



**Figure 4-107**

**6. Removing the Tray-1 Unit**

- 1) Open the upper cover, and then remove the end caps [1] and the slide guide [2].
- 2) Remove the prop upper cover [3] and the prop lower cover [4].

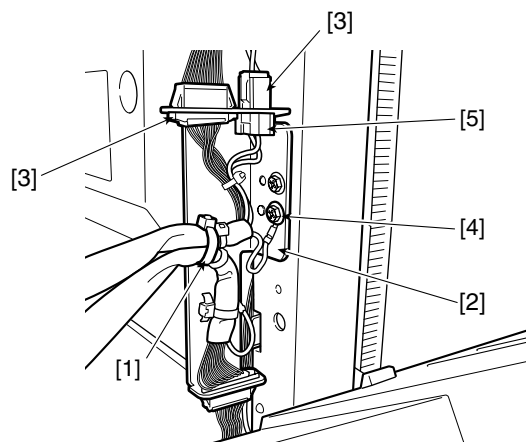


**Figure 4-108**

- 3) Remove the harness band [1] of the tray-1 and -2 from the bracket [2]. Cut the harness band [1] to separate the harnesses of the tray-1 and -2.

**Caution:**  
Replace the cut harness band with the new one when assembling.

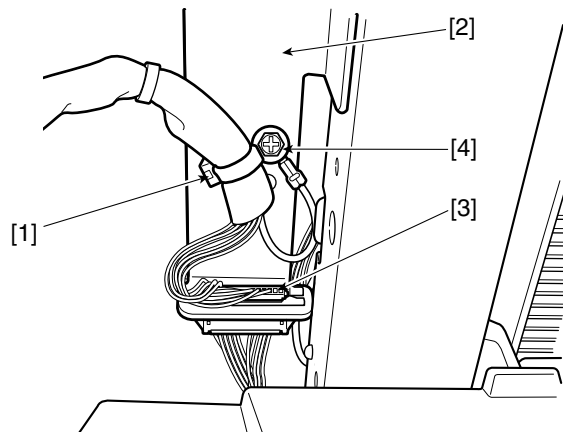
- 4) Disconnect 2 connectors [3] and remove 1 screw [4].
- 5) Disconnect 1 connector [5] from the bracket [2].
- 6) Lift the tray-1 unit to remove.



**Figure 4-109**

**7. Removing the Tray-2 Unit**

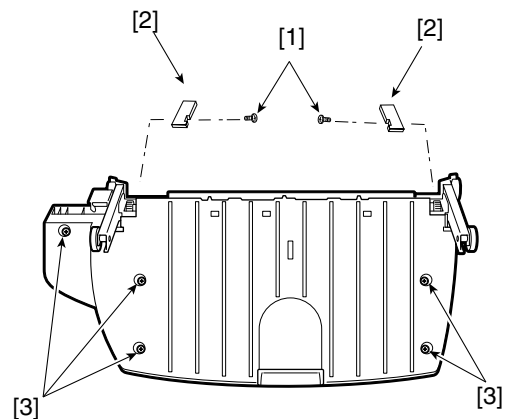
- 1) Remove the tray-1 unit.
- 2) Disconnect the harness band [1] of the tray-2 from the bracket [2].
- 3) Disconnect 1 connector [3] and remove 1 screw [4].
- 4) Lift the tray-2 unit to remove.



**Figure 4-110**

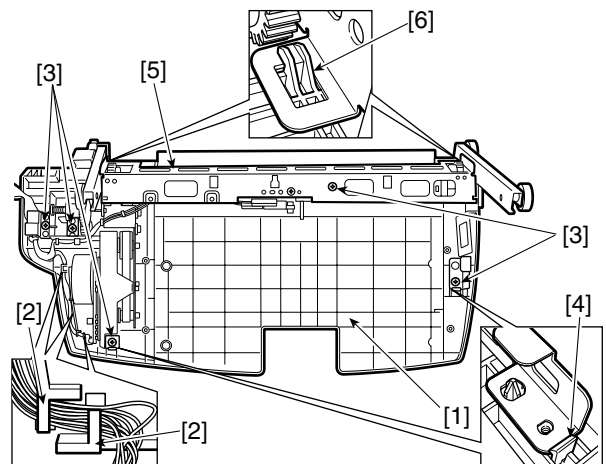
**8. Removing the Tray-1 and -2 Lift Motor**

- 1) Remove the tray -1/-2.
- 2) Remove two screws [1], and two lift blocks [2].
- 3) Remove the five screws [3], and remove the tray from the tray unit.



**Figure 4-111**

- 4) Remove the cable from 4 cable hooks of the tray lower cover [1], and then remove 5 screws [3].
- 5) Release 2 hooks [4] to remove the tray frame [5] from 2 hooks [6] the tray lower cover.



**Figure 4-112**

- 6) Disconnect the connector [1] and remove 4 screws [2] to take off the tray-1 and -2 lift motor [3].

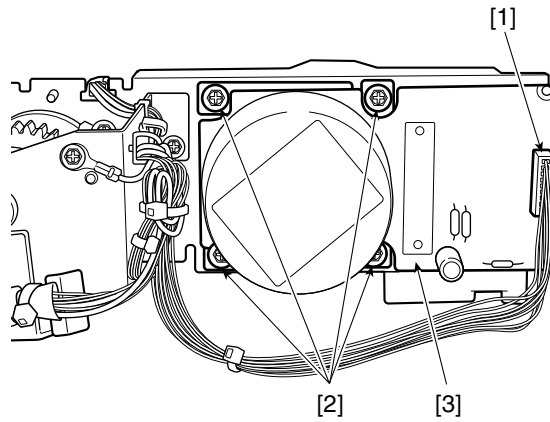


Figure 4-113

**9. Removing the Grate-Shaped Upper Guide**

- 1) Remove the slide guide [1] and end caps [2].
- 2) Release the tray lift motor gear clutch [6] with a screwdriver or similar object while supporting the tray assembly, and gently lower the tray assembly down to its lowest position.
- 3) Remove the five screws [3] (M4).
- 4) Remove the screw [4] (M3), and remove the grate-shaped upper guide [5].

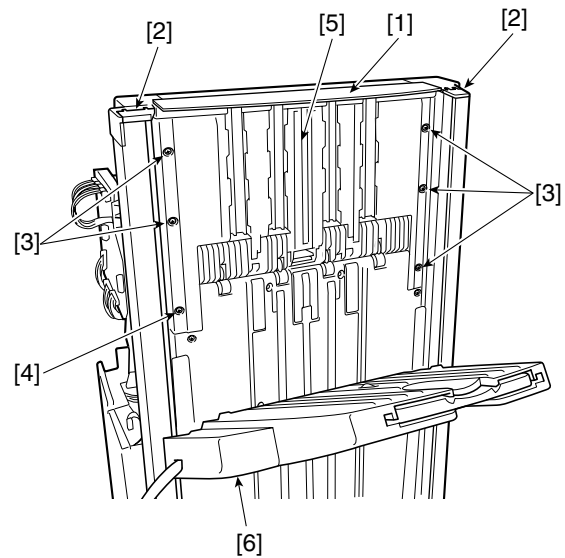


Figure 4-114



## 10. Removing the Grate-Shaped Lower Guide

- 1) Remove the tray assembly.
- 2) Remove the five screws [1] (M4), and remove the front sub-support [2].
- 3) Remove the three screws [3] (M4).
- 4) Remove the three screws [4] (M3), and open the grate-shaped lower guide [5] to the front.

### Caution:

To remove a sub-support, remove the front sub-support [2]. The rear sub-support [6] is adjustable. If the rear sub-support [6] has been removed, be sure to adjust the rear sub-support screw to the marking at which it was set prior to the removal, or adjust parallelism referring to "11. Installing the Rear Sub-Support."

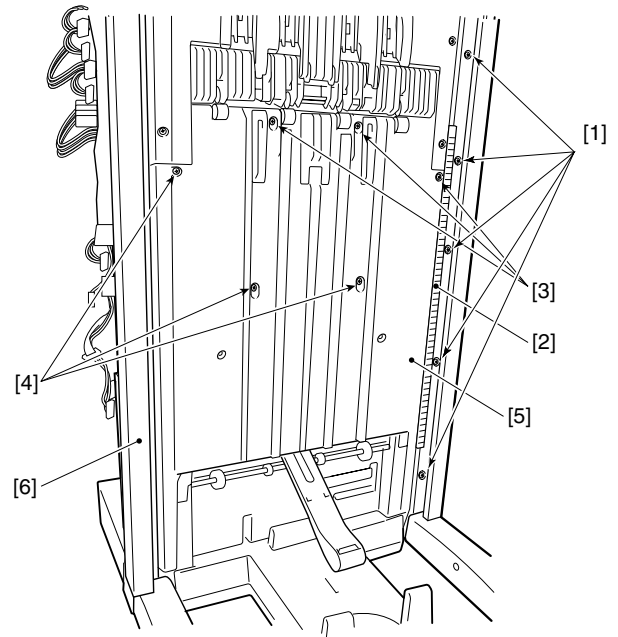


Figure 4-115

- 4) Free the harness [9] from the harness stop [8].
- 5) Disconnect the two connectors [10], and remove the grate-shaped lower guide [7].

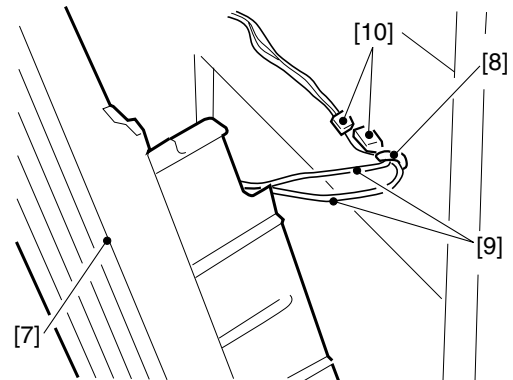
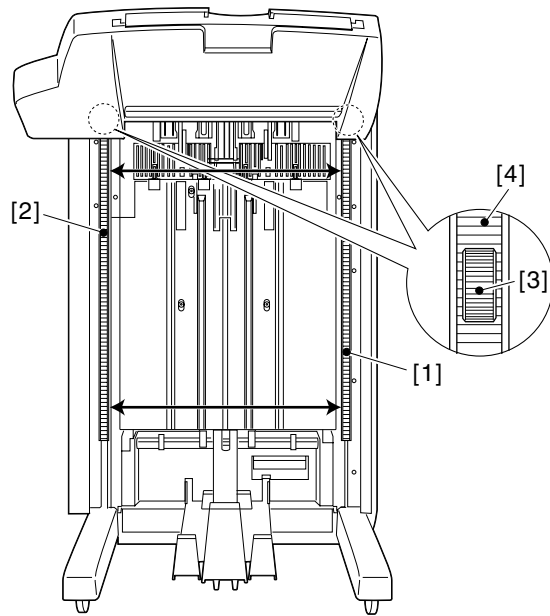


Figure 4-116

**11. Installing the Rear Sub-Support**

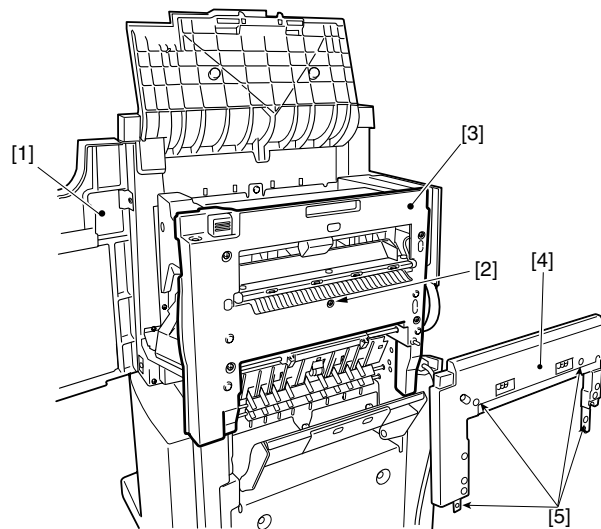
- 1) Install the front sub-support [1]. Loosely fasten the rear sub-support [2].
- 2) Install tray-2. Fasten the rear sub-support so that the tray drive gear [3] is placed at the center of the rack gear [4] of the rear sub-support when tray-2 is at the upper limit position and the lower limit position.
- 3) Move tray-2 by hand and check that it moves smoothly.



**Figure 4-117**

**12. Removing the Right Guide Assembly**

- 1) Remove the four screws [5] to take out the latch unit [4]
- 2) Remove the rear cover (see I-A-2).
- 3) Open the front door assembly [1].
- 4) Remove the one screw [2], and remove the right guide assembly [3].

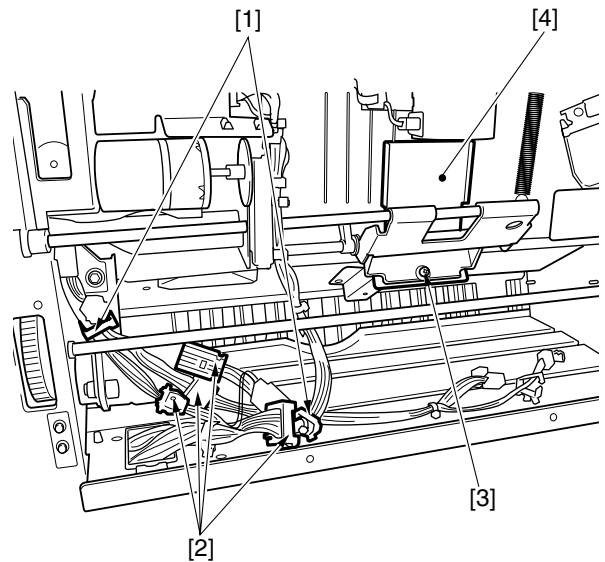


**Figure 4-118**

## B. FEEDING SYSTEM

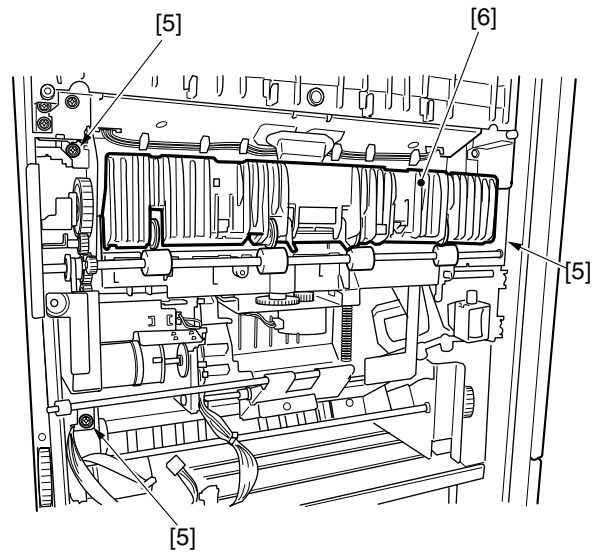
### 1. Removing the Swing Unit

- 1) Remove the tray assembly (see I-A-5).
- 2) Remove the grate-shaped upper guide (see I-A-6).
- 3) Remove the grate-shaped lower guide (see I-A-7).
- 4) Remove the harness from the two harness stops [1], and disconnect the four connectors [2].
- 5) Remove the screw [3], and remove the stapler stay holder [4].



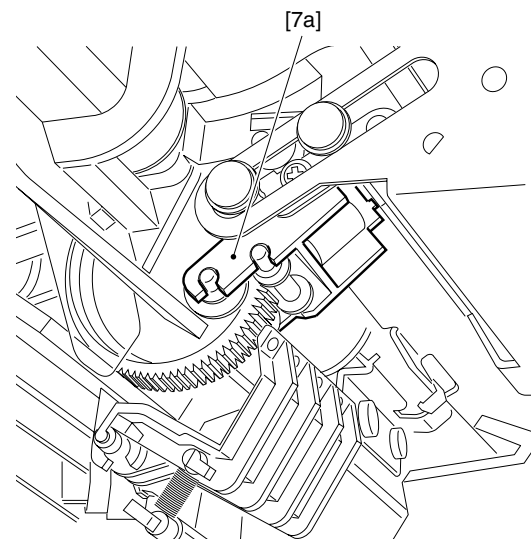
**Figure 4-119**

- 6) Remove the three screws [5], and slide out the swing unit [6] towards you.



**Figure 4-120**

- 7) Remove the claws of the two knurled belt holders (front [7a], rear [7b]) and remove the swing unit.



**Figure 4-121a**

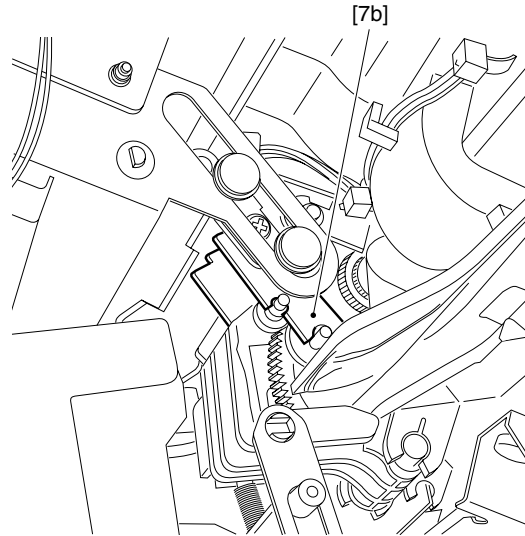


Figure 4-121b

**2. Removing the Feed Drive Unit**

- 1) Remove the finisher controller PCB (see I-C-1).
- 2) Remove the ground lead [1] and the three screws [2], and pull down PCB base [3] towards you.

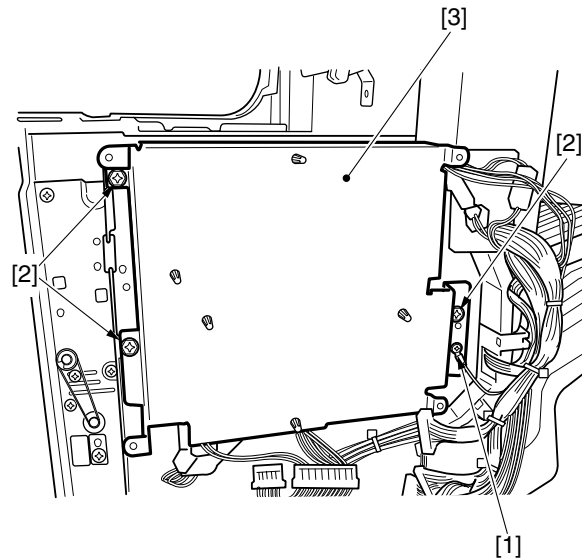


Figure 4-122

- 3) Remove the harness leads [5] from the two edge saddles [4], and remove the PCB base.

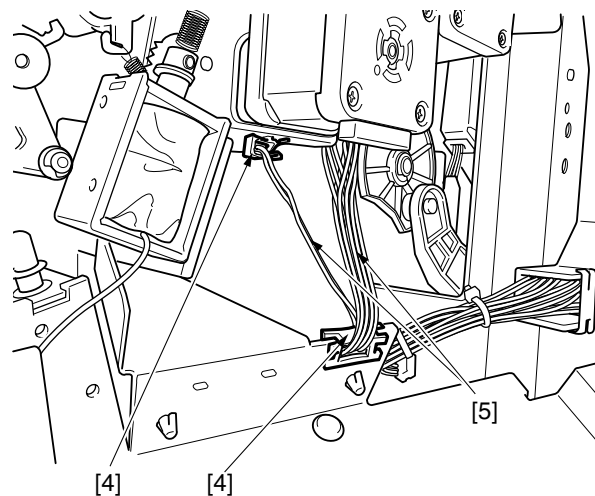


Figure 4-123

- 4) Remove the three screws [6], and remove the feed drive unit [7].

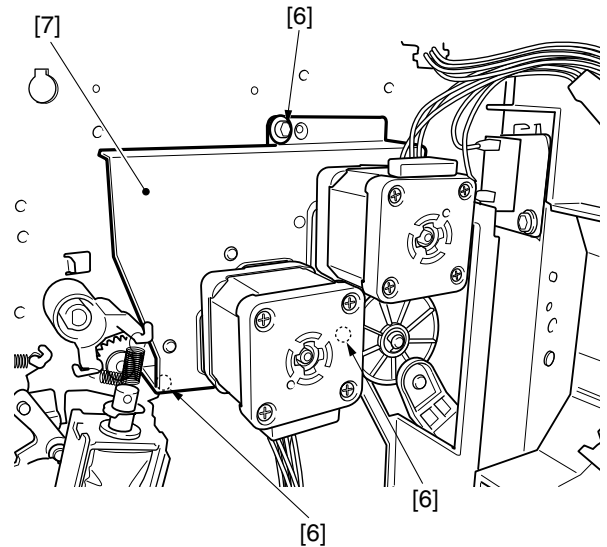


Figure 4-124

**Caution:**

Before re-attaching the removed feed drive unit back on the finisher unit, loosen the move gear stop screw [8] to relieve the tension, and then fasten the screw after attaching the feed drive unit.

The move gear attachment must be adjusted also when removing and attaching the swing unit.

If you forget to fasten the screw, the gear teeth may disengage, resulting in defective feed.

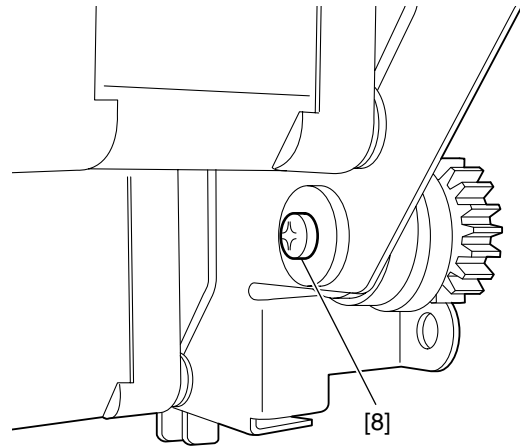


Figure 4-125

**3. Removing the Buffer Roller Assembly**

- 1) Remove the finisher controller PCB (see I-C-1).
- 2) Remove the feed drive unit (see I-B-2).
- 3) Remove the screw [1], and remove the guide support plate assembly [2] to slide out the harness leads [3] towards the buffer roller assembly side.

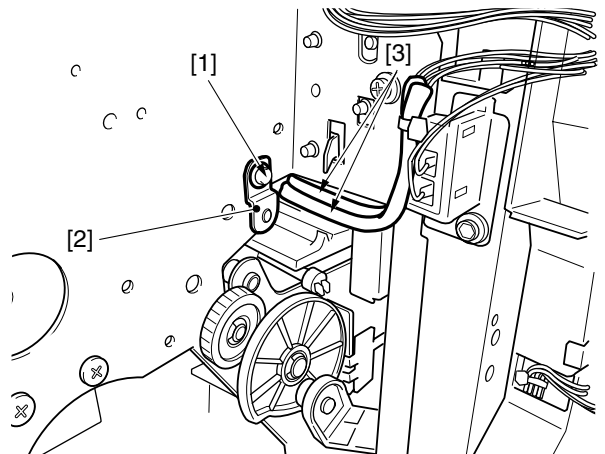


Figure 4-126

- 4) Remove the front cover (see I-A-4).
- 5) Remove the screw [4], and remove the guide support plate assembly [5]. Then, remove the buffer roller assembly [6].

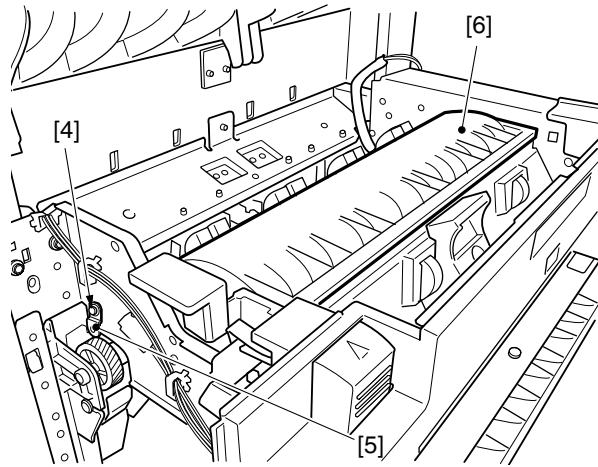


Figure 4-127

**4. Removing the Stapler**

- 1) Open the front cover, and move the stapler assembly to the front.
- 2) Remove the screw [1], and slide out the stapler assembly [2].

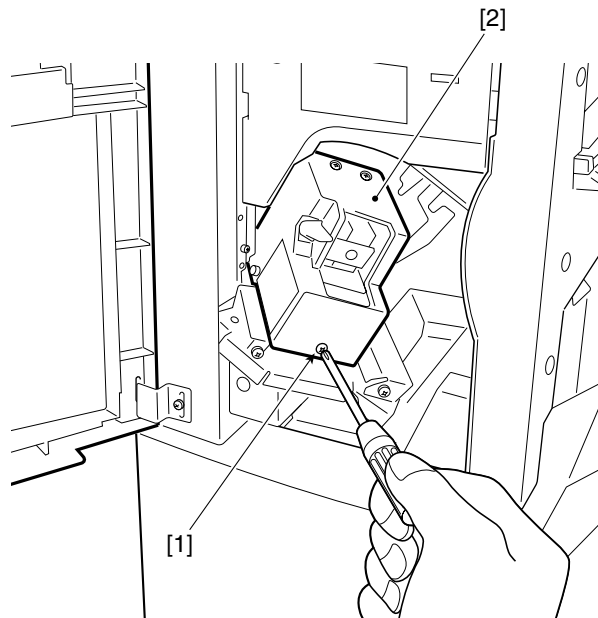


Figure 4-128

- 3) Disconnect the connector [4] of the stapler assembly [3].

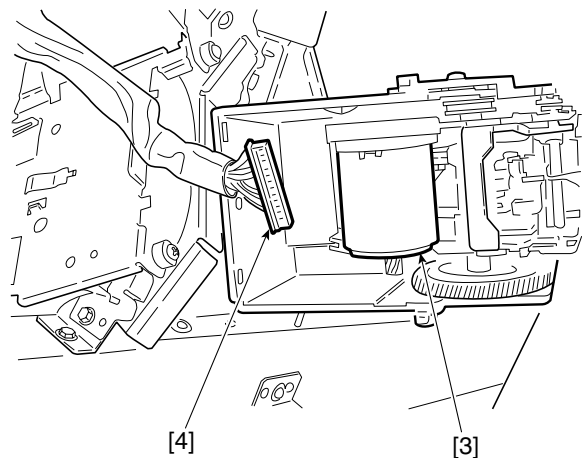


Figure 4-129

- 4) Remove the two screws [6] from the stapler cover [5], and remove the stapler.

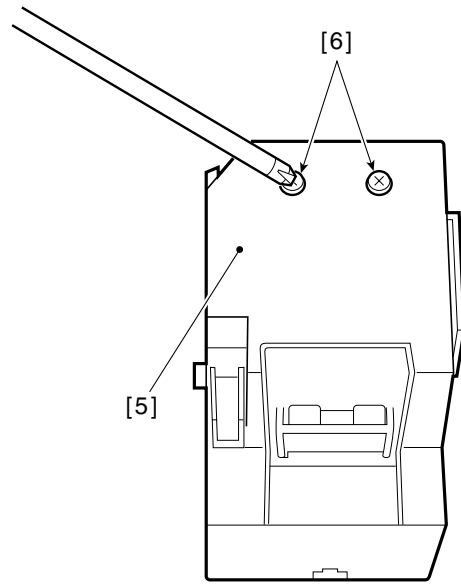


Figure 4-130

## C. PCBs

### 1. Removing the Finisher Controller PCB

- 1) Remove the rear cover.
- 2) Disconnect the 17 connectors [1].
- 3) Remove the four screws [2], and remove the finisher controller PCB [3].

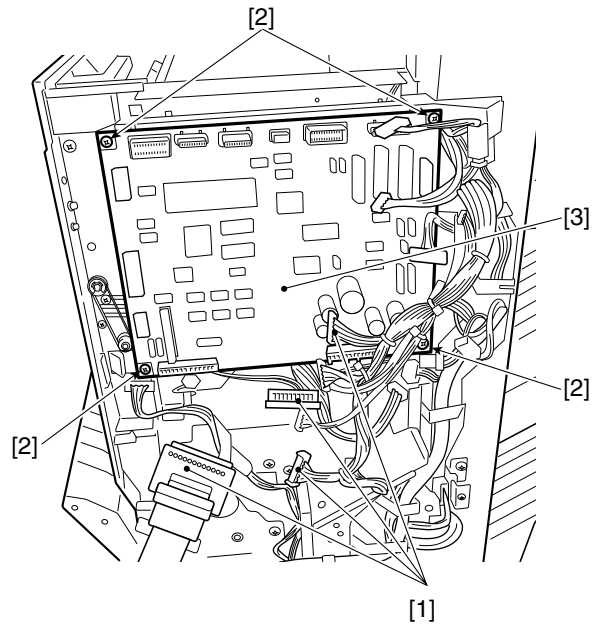


Figure 4-131

## II. SADDLE STITCHER UNIT

### A. Externals and Controls

#### 1. Removing the Front Lower Door Assembly

- 1) Open the front lower door assembly [1].
- 2) Remove the screw [2] and remove the bushing [3], and then remove the front lower door assembly.

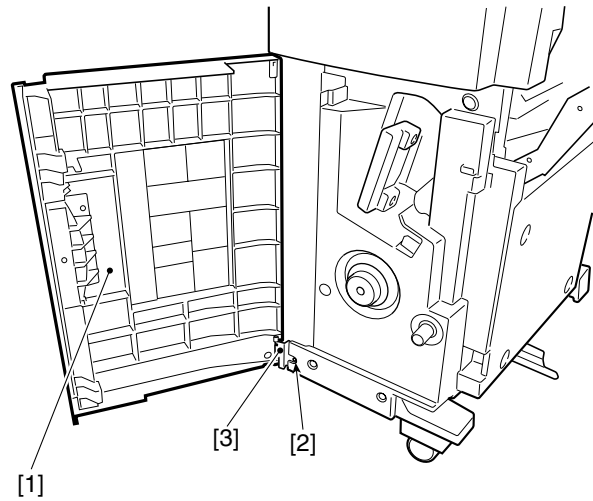


Figure 4-201

#### 2. Removing the Rear Lower Cover

- 1) Remove the four screws [1], and remove the rear lower cover [2].

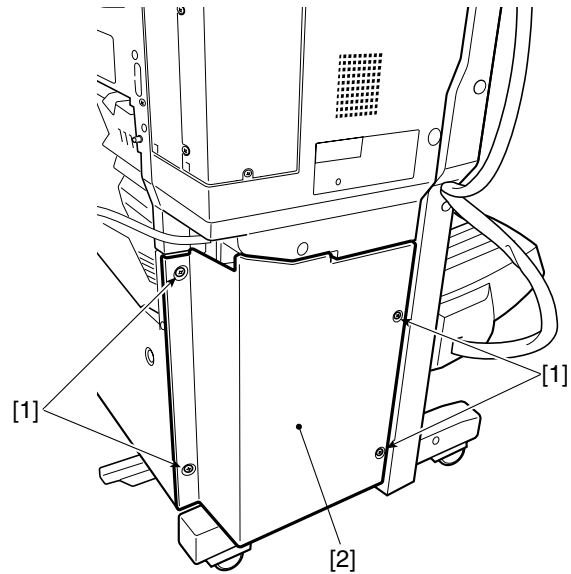
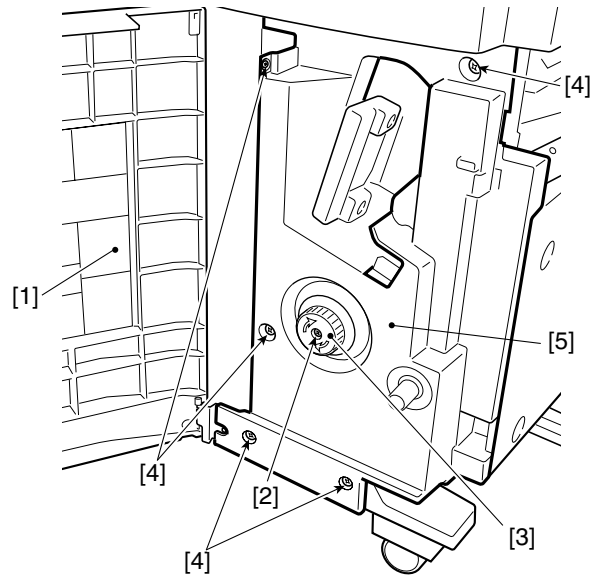


Figure 4-202



### 3. Removing the Front Inside Cover

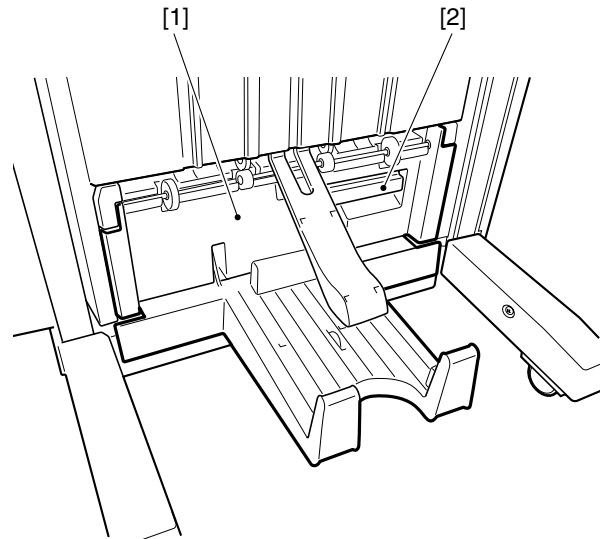
- 1) Open the front lower door assembly [1].
- 2) Remove the screw [2], and remove the folding roller knob [3].
- 3) Remove the five screws [4], and remove the front inside cover [5].



**Figure 4-203**

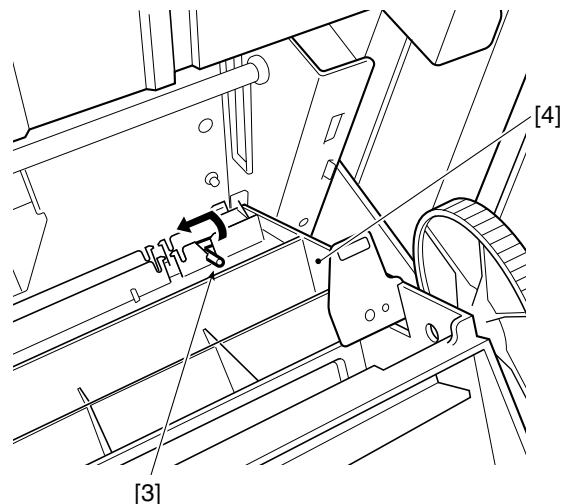
### 4. Removing the Saddle Stitcher Delivery Tray Assembly

- 1) Lift up the open/close lever [2] of the saddle stitcher delivery tray assembly [1], and open the saddle stitcher delivery tray assembly.



**Figure 4-204**

- 2) Remove the door shaft [3] in the direction of the arrow, and slide out towards the front of the saddle stitcher delivery tray assembly [4].



**Figure 4-205**

- 3) Remove the harness leads from the harness stop [5] and edge saddle [6].
- 4) Disconnect the two connectors [7], and remove the saddle stitcher delivery tray assembly [8].

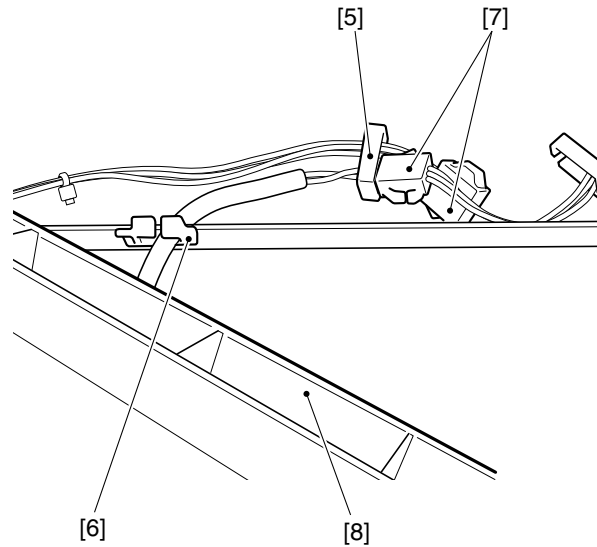


Figure 4-206

**5. Removing Upper Delivery Guide Assembly**

- 1) Remove the grate-shaped lower guide (see I-A-10).
- 2) Remove the two screws [1] and ground lead [2], and remove the upper delivery guide assembly [3].

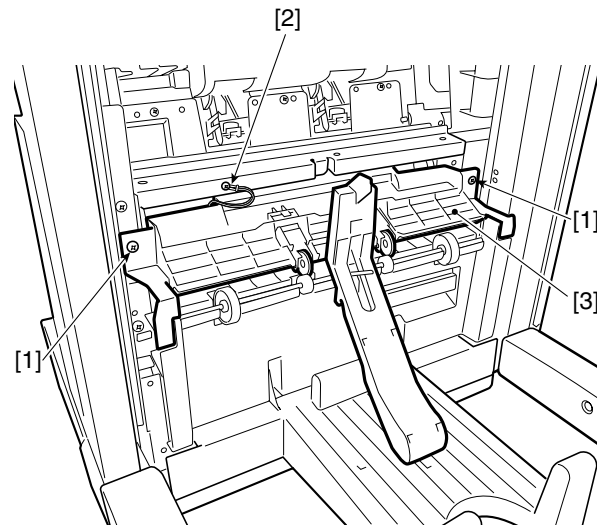


Figure 4-207

**6. Removing the PCB Cover**

- 1) Remove the four screws [1], and remove the PCB cover [2].

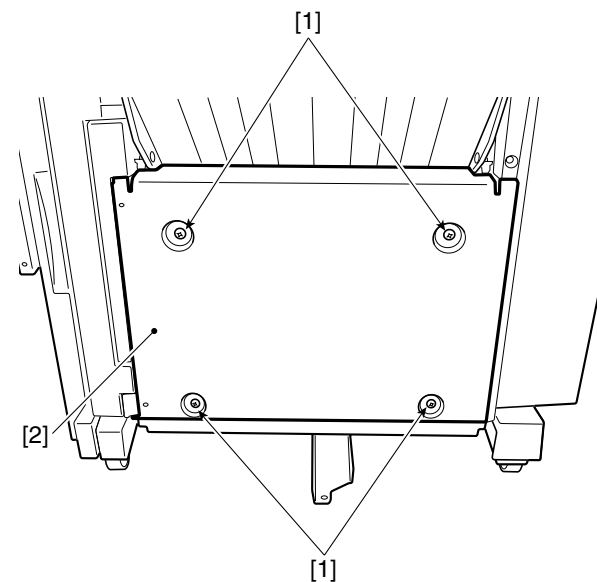


Figure 4-208

## B. SADDLE STITCHER UNIT

### 1. Removing the Saddle Stitcher Unit

- 1) Remove the grate-shaped lower guide (see I-A-7).
- 2) Remove the right guide assembly (see I-A-8).
- 3) Remove the front lower door assembly (see II-A-1).
- 4) Remove the rear lower cover (see II-A-2).
- 5) Remove the front inside cover (see II-A-3).
- 6) Remove the saddle stitcher delivery tray assembly (see II-A-4).

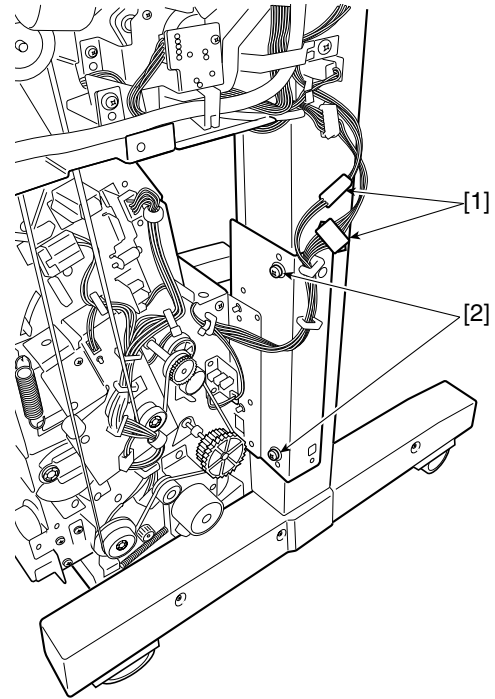


Figure 4-209

- 7) Remove harness stop [3] and harness lead [4].
- 8) Remove the upper delivery guide (see II-A-5).
- 9) Remove the PCB cover (see II-A-6).
- 10) Disconnect two connectors [1] and remove the two screws [2].

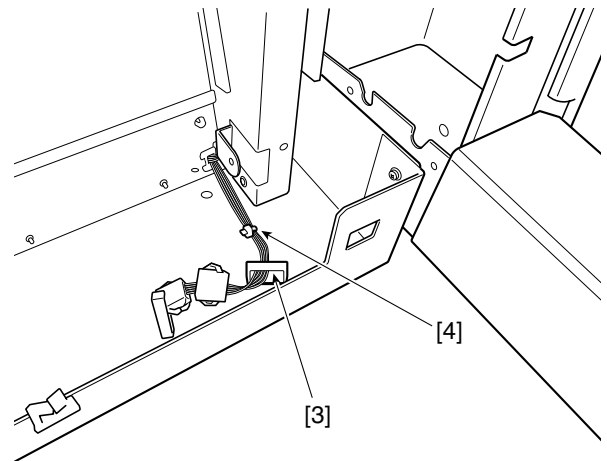


Figure 4-210

11) Remove the screw [5].

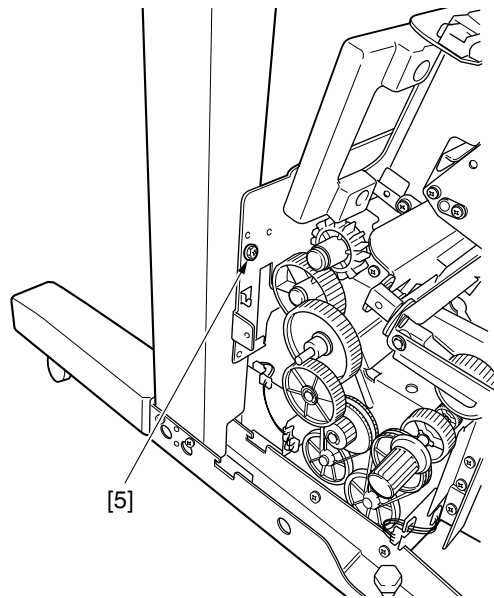


Figure 4-21

12) Remove the two screws [6], and remove the saddle stitcher unit [7] by moving it in the pick-up direction.

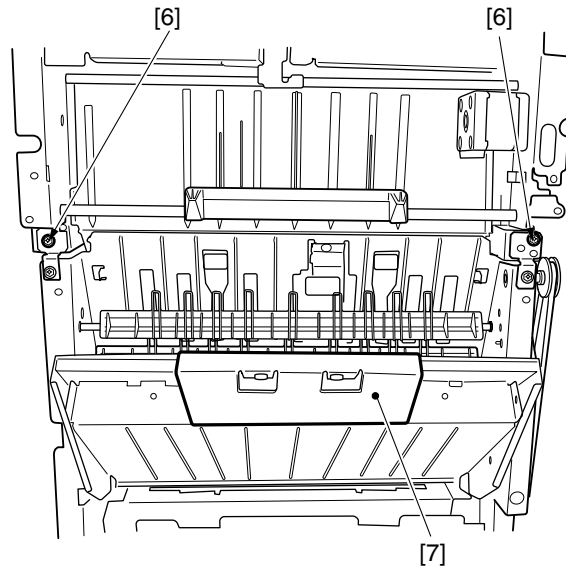


Figure 4-212

**Caution:**

When removing the saddle stitcher unit from the finisher unit body, prevent the timing belt [8] from catching on the communications cable bracket [9].

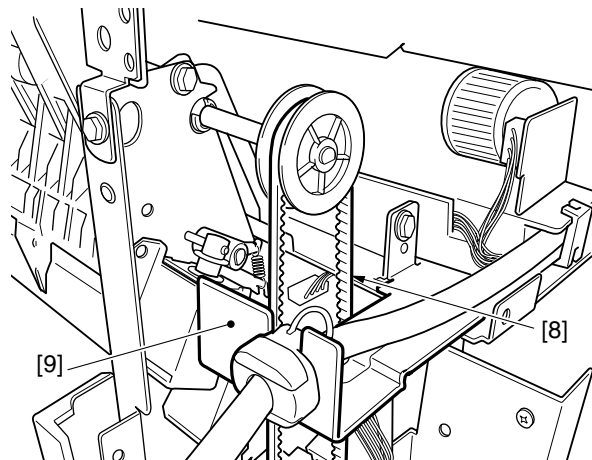
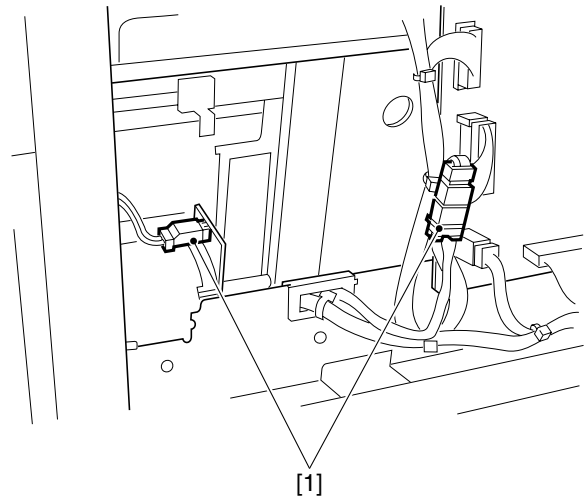


Figure 4-213

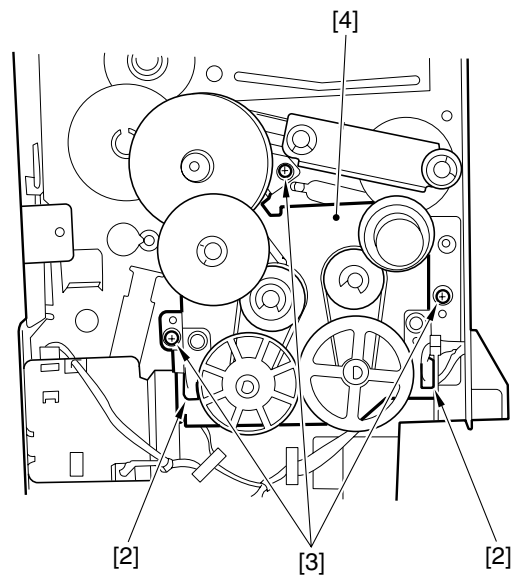
## 2. Removing the Paper Folding Roller

- 1) Remove the front lower door assembly (see II-A-1).
- 2) Remove the front inside cover (see II-A-3).
- 3) Remove the upper delivery guide (see II-A-5).
- 4) Remove the PCB cover (see II-A-6).
- 5) Disconnect the two connectors [1].



**Figure 4-214**

- 6) Disconnect two connectors [2], remove the three screws [3], and remove the paper pushing motor mount [4].



**Figure 4-215**

- 7) Remove the tension springs (front [5], rear [6]).

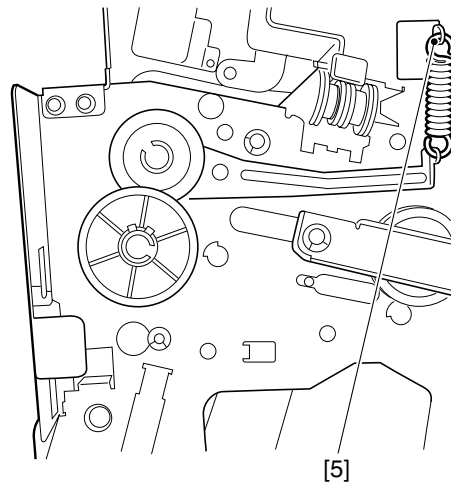


Figure 4-216

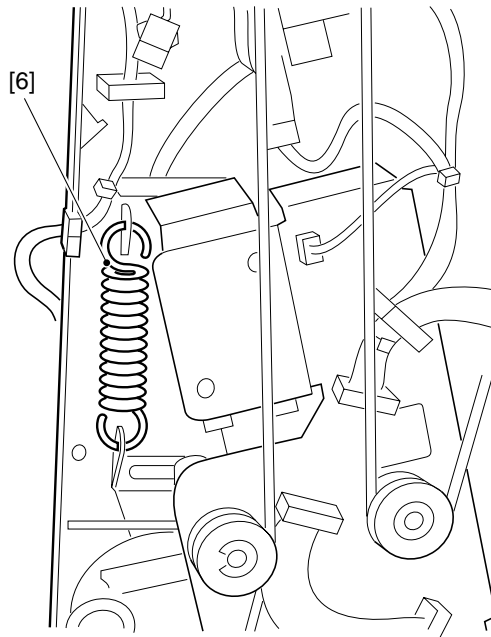
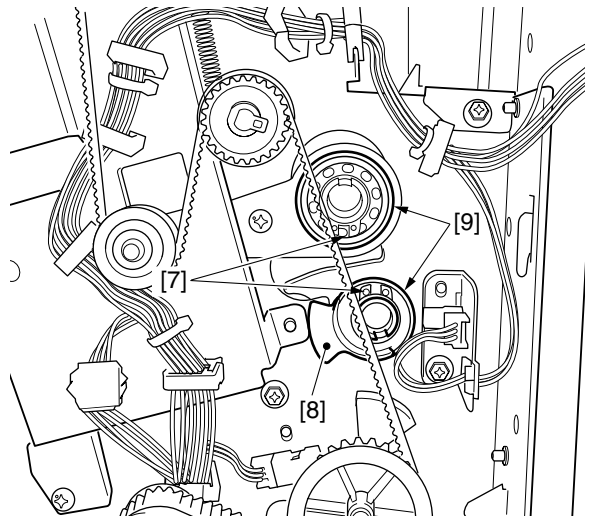


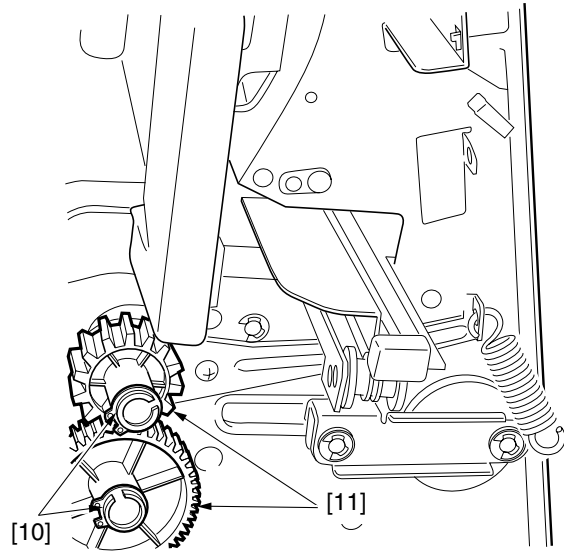
Figure 4-217

- 8) Remove the two C-rings [7], and remove the sensor flag [8] and two bearings [9] at the rear.



**Figure 4-218**

- 9) Remove the two C-rings [10], and remove the two gears [11] at the front.



**Figure 4-219**

10) Remove the two bearings [12].

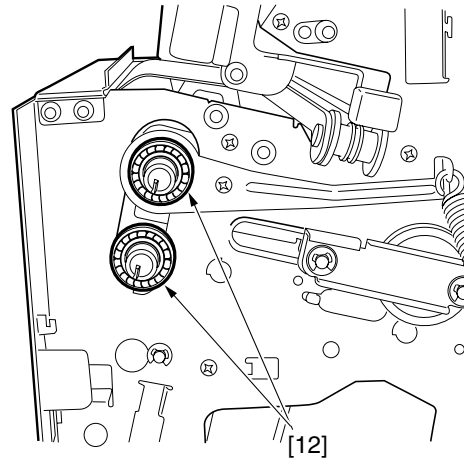


Figure 4-220

- 11) Open the saddle stitcher delivery tray assembly [13].
- 12) Remove the two screws [14], and remove the two alignment plates [15].
- 13) Slide the paper folding roller [16] to the front, and pull it out in the delivery direction.

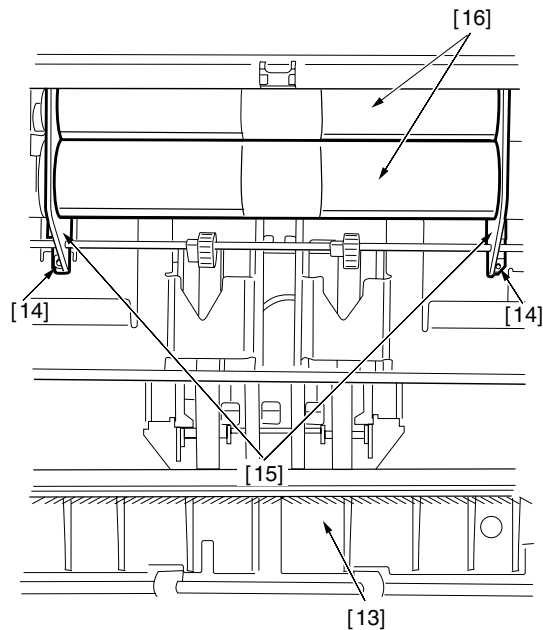


Figure 4-221

### 3. Installing the Paper Folding Roller

- 1) Attach the gear [2] so that the grooved section [1] on the gear is facing the grooved section [1] on the paper folding roller to align the phases.

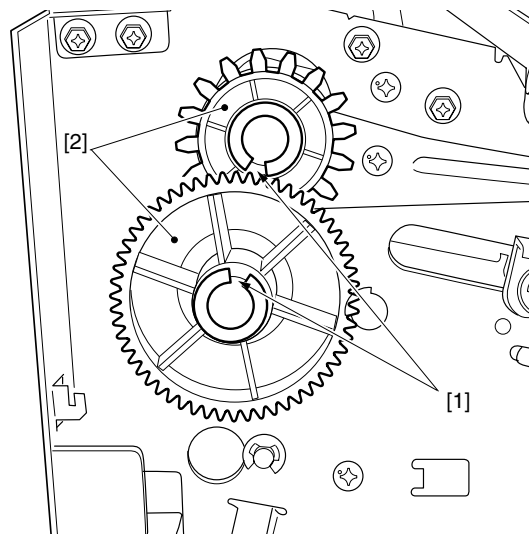


Figure 4-222



#### 4. Removing the Stitcher Mount Unit

- 1) Remove the front inside cover (see II-A-3).
- 2) Remove the E-ring [1], and remove the roll [2] and the shaft [3].

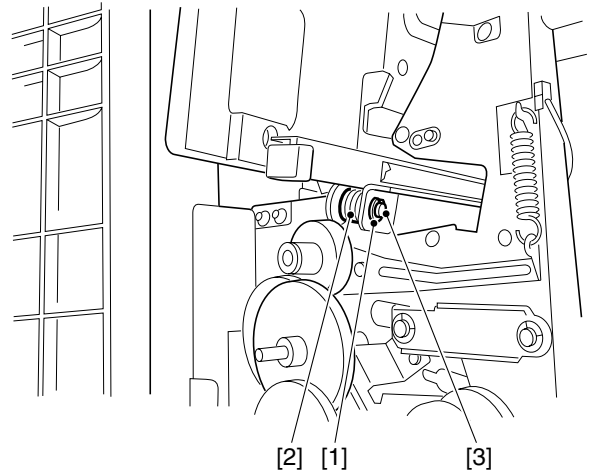


Figure 4-223

- 3) Pull out the stitcher mount unit [4] to the front.

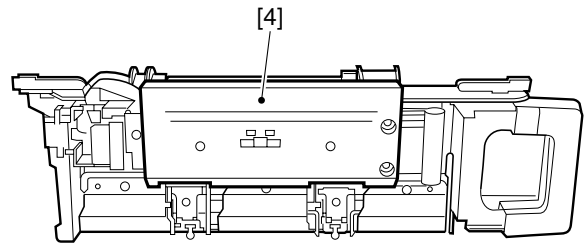


Figure 4-224

#### 5. Adjusting the Stitcher Position

- 1) Remove the front lower door (see II-A-1).
- 2) Remove the front inside cover (see II-A-3).
- 3) Open the front door assembly.
- 4) Pull out the stitcher mount unit to the front, then pull out the stitcher towards you and then pull the stitcher down.
- 5) Remove the three screws [1], and remove the stitcher mount unit cover [2].

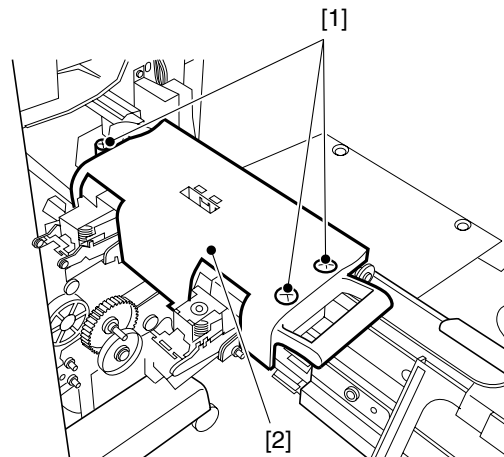


Figure 4-225

- 6) Remove the stitcher positioning tool [3] from the back of the cover.

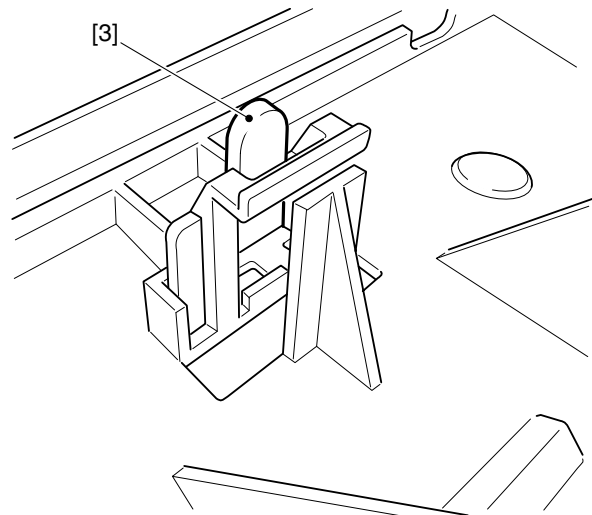


Figure 4-226

- 7) If you must adjust the front stitcher, remove the center guide plate [5] and front guide plate [4] (one screw each). If you must adjust the rear stitcher, remove the center guide plate [5] and the rear guide plate [6] (one screw each).

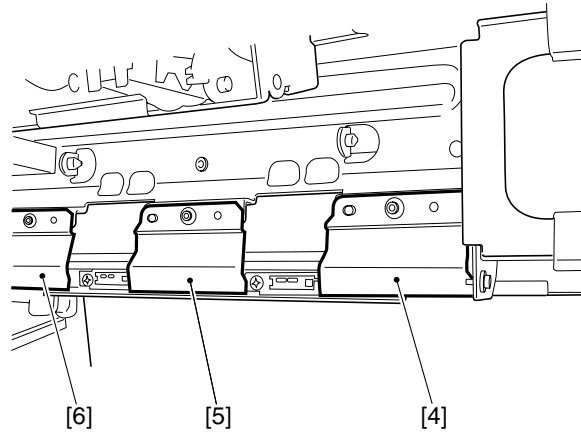


Figure 4-227

- 8) If you must adjust the front stitcher, loosen the two screws [8] on the stitcher mount [7]. If you must adjust the rear stitcher, loosen the two screws [9].

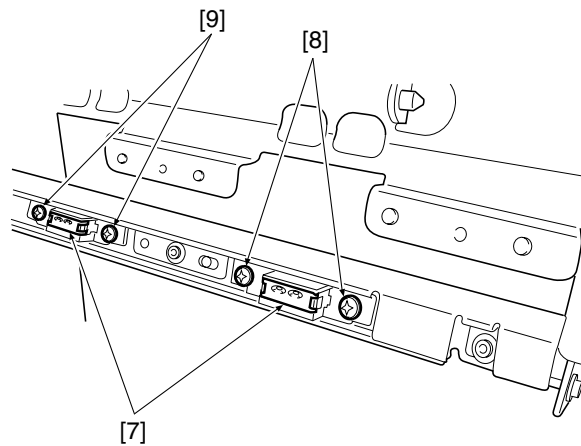


Figure 4-228

- 9) Insert the tool [10] into the staple slot of the stitcher [9].

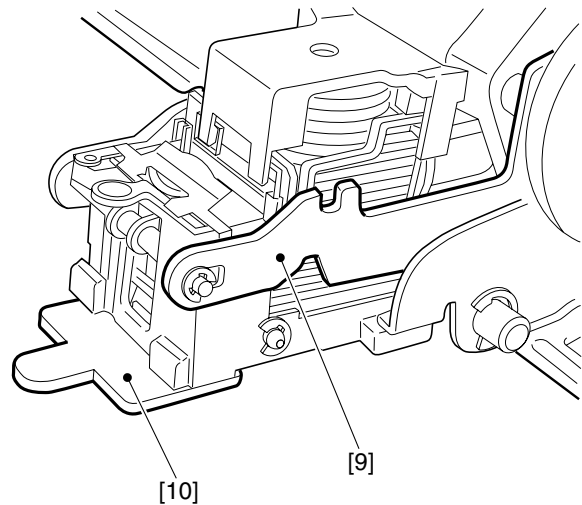


Figure 4-229

- 10) Shift down the stitcher, and turn the stitcher gear so that the boss on the tool [11] and the recess of the mount match. Then, tighten the screws [12] on the mount to fix the two in place.

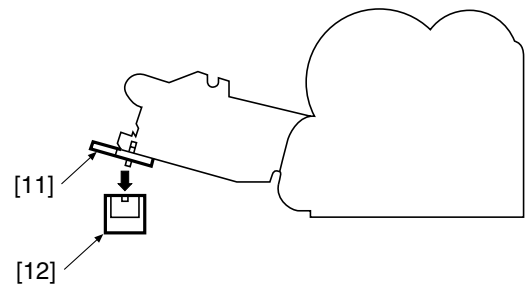


Figure 4-230

## 6. Removing the Positioning Plate Unit

- 1) Remove the saddle stitcher controller PCB (see II-C-1).
- 2) Disconnect the two connectors [1], remove the three harness stops [2], and remove the harness leads [3] from the two edge saddles [4].
- 3) Remove the two screws [5], slide the positioning plate unit [6] once towards the front and remove from the rear side.

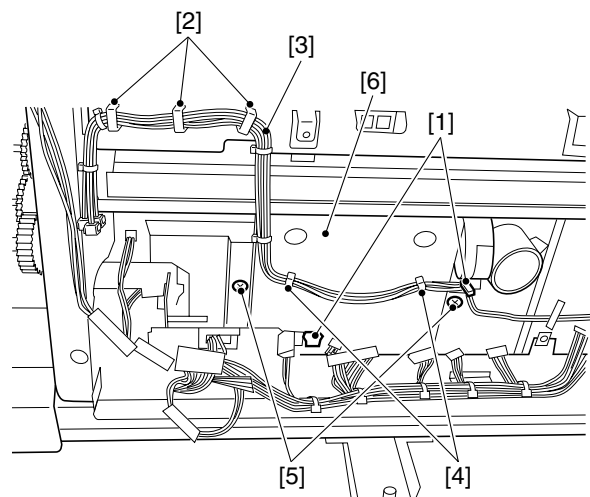
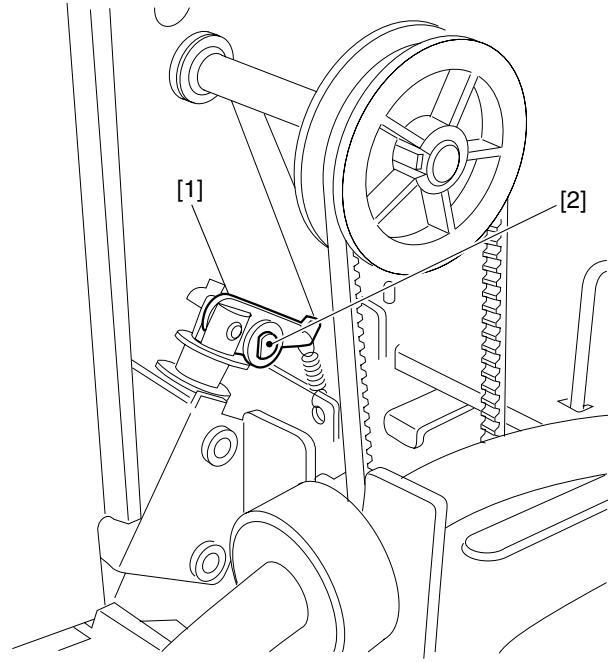


Figure 4-231

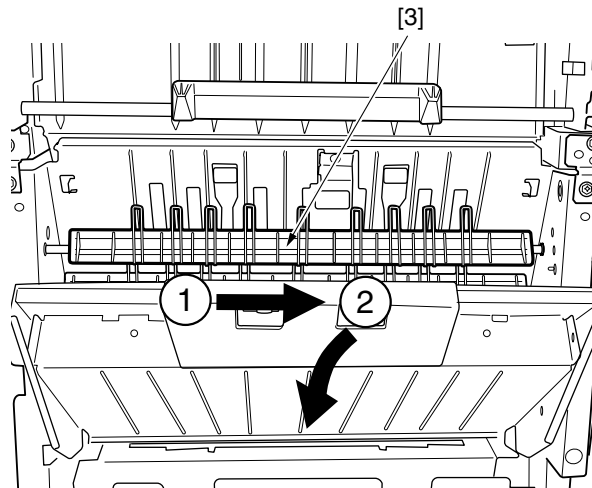
**7. Removing the No.1 and No.2 Paper Deflecting Plates**

- 1) Remove the rear cover (see I-A-2).
- 2) Remove the lower rear cover (see II-A-2).
- 3) Remove the claw [1] of the No.1 deflecting plate bushing, and pull out the No.1 deflecting plate shaft [2] toward the rear. (The procedure is the same for the No.2 paper deflecting plate.)



**Figure 4-232**

- 4) After detaching the front shaft of the No.1 paper deflecting plate [3] from the front side plate, remove the No.1 paper deflecting plate.



**Figure 4-233**

## C. PCBs

### 1. Removing the Saddle Stitcher Controller PCB

- 1) Remove the PCB cover (see II-A-6).
- 2) Remove the four screws [1] and 14 connectors [2], and remove the saddle stitcher controller PCB [3].

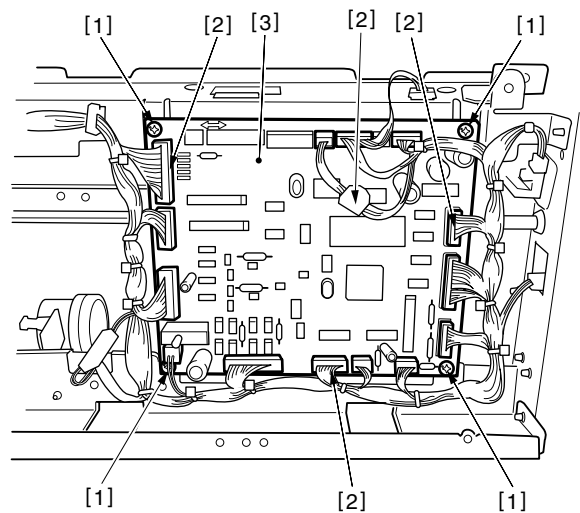


Figure 4-234

## D. Accessory

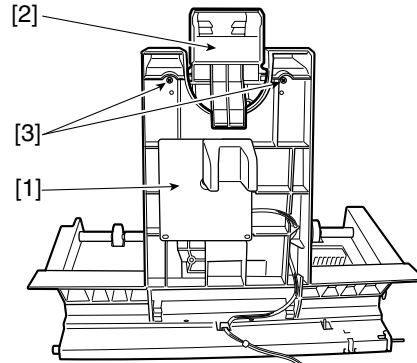
### 1. Support tray

Install the support tray (accessory) to the saddle delivery tray when the paper stacking on the saddle stitcher delivery tray is significantly deteriorated, causing paper to drop, etc.

\* 2 screws are needed to install the support tray.

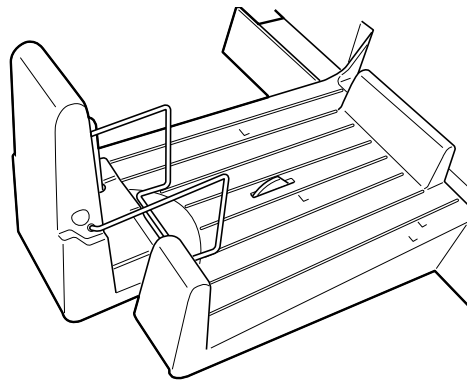
\* Refer to the parts list for the parts numbers and so on.

- 1) Take off the saddle delivery tray (see II-A-4).
- 2) Install the support tray [2] to the saddle stitcher delivery tray [1] with 2 screws.



**Figure 4-235**

- 3) Install the saddle stitcher delivery tray.



**Figure 4-236**

---

# CHAPTER 5

---

## MAINTENANCE AND INSPECTION

---

I. PERIODICALLY REPLACED PARTS .....	5-1	A. Finisher Unit .....	5-2
A. Finisher Unit .....	5-1	B. Saddle Stitcher Unit .....	5-2
B. Saddle Stitcher Unit .....	5-1	III. PERIODICAL SERVICING .....	5-2
II. CONSUMABLES AND DURABLES .....	5-2	IV. FIRMWARE UPDATING .....	5-3
		A. Finisher Unit .....	5-3
		B. Saddle Stitcher Unit .....	5-5

## **I. PERIODICALLY REPLACED PARTS**

### **A. Finisher Unit**

The finisher unit does not have parts that must be replaced on a periodical basis.

### **B. Saddle Stitcher Unit**

The saddle stitcher unit does not have parts that must be replaced on a periodical basis.



## II. CONSUMABLES AND DURABLES

Some of the parts of the machine may need to be replaced one or more times because of wear or tear during the machine's warranty period. Replace them as necessary.

### A. Finisher Unit

No.	Name	Q'ty	Estimated Life	Remarks
1	Stapler	1	500,000 operations	5,000 operations/cartridge
2	Feed belt	2	1,000,000 copies	
3	Paddle	2	1,000,000 copies	Paddle unit
		4		Paddle rubber only

### B. Saddle Stitcher Unit

No.	Name	Q'ty	Estimated Life	Remarks
1	Stitcher	2	200,000 operations	2,000 operations/cartridge

## III. PERIODICAL SERVICING

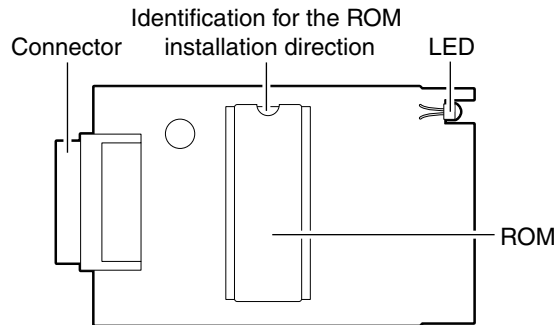
Item	Interval	Work	Remarks
Feed belt	Host machine minimum servicing interval	Cleaning	Use moist cloth
Paddle			

## IV. FIRMWARE UPDATING

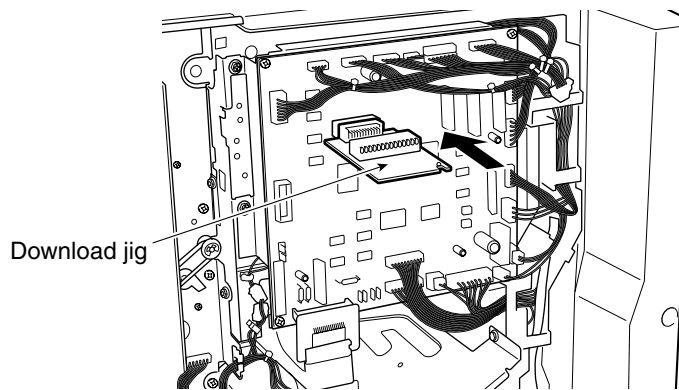
### A. Finisher Unit

- (1) Install the ROM to the download jig.  
Make sure the direction and the type of ROM are correct.

[Download jig: K-PWA-DLM-320]



- (2) Turn OFF the power of the equipment.
- (3) Connect the finisher to the equipment after the finisher rear cover is removed.  
(See chapter 4 I-A-2 for removing the rear cover.)
- (4) Connect the download jig to the jig connector on the finisher controller PCB.

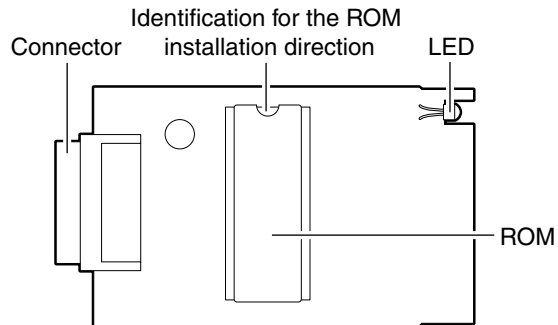


- (5) Turn ON the power while pressing [0] and [8] simultaneously.  
The update starts automatically and LED on the download jig lights.
- (6) After the update is completed properly, the LED on the download jig blinks slowly.  
The LED starts blinking in approx. 20 sec. after the update starts. It is assumed that the update fails if the LED does not start blinking even though 1 min. has passed or it blinks fast. In this case, turn OFF the power and check the following items. Then, clear the problem and restart updating from the beginning.
  - Is the download jig connected properly?
  - Is the ROM installed to the download jig properly?
  - Is the updating data written on the ROM of the download jig correctly?
  - Are the download jig and the equipment not damaged?
- (7) Turn OFF the power, remove the download jig and install the finisher rear cover.

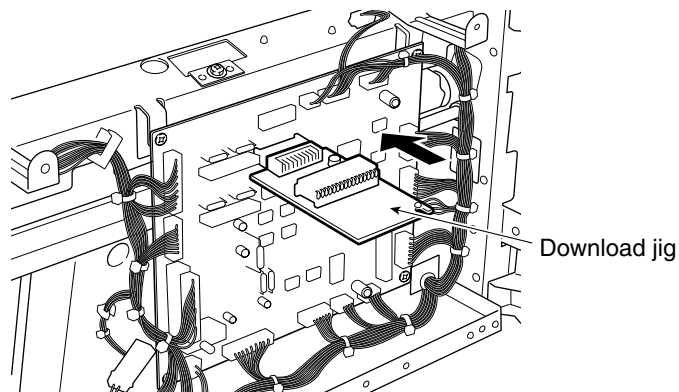
## B. Saddle Stitcher Unit

- (1) Install the ROM to the download jig.  
Make sure the direction and the type of ROM are correct.

[Download jig: K-PWA-DLM-320]



- (2) Turn OFF the power of the equipment.
- (3) Remove the PCB cover on the saddle stitcher.  
(See chapter 4 II-A-6 for removing the PCB cover.)
- (4) Connect the download jig to the jig connector on the saddle stitcher controller PCB to connect the finisher with the equipment.



- (5) Turn ON the power while pressing [0] and [8] simultaneously.  
Updating starts automatically and the LED on the download jig lights.
- (6) After the update is completed properly, the LED on the download jig blinks slowly.  
The LED starts blinking in approx. 20 sec. after the update starts. It is assumed that the update fails if the LED does not start blinking even though 1 min. has passed or it blinks fast. In this case, turn OFF the power and check the following items. Then, clear the problem and restart updating from the beginning.
  - Is the download jig connected properly?
  - Is the ROM installed to the download jig properly?
  - Is the updating data written on the ROM of the download jig correctly?
  - Are the download jig and the equipment not damaged?
- (7) Turn OFF the power, remove the download jig and install the PCB cover on the saddle stitcher.

---

# CHAPTER 6

---

## TROUBLESHOOTING

---

I. ADJUSTMENTS .....	6-1	A. Finisher Unit .....	6-7
A. Electrical System (finisher unit) .....	6-1	B. Saddle Stitcher Unit .....	6-14
B. Electrical System (saddle stitcher unit) .....	6-5	C. Light-Emitting Diodes (LED) and Check Pins by PCB .....	6-20
II. ARRANGEMENT OF ELECTRICAL PARTS .....	6-7	III. TROUBLESHOOTING .....	6-22
		A. Finisher Unit .....	6-22
		B. Saddle Stitcher Unit .....	6-32

## I. ADJUSTMENTS

### Note

Before performing each adjustment, make sure that all covers (incl. those of the finisher and host machine) are closed. Otherwise, the power is not supplied to the finisher and the adjustment may not be performed properly.

### A. Electrical System (finisher unit)

#### 1. Adjusting the Height Sensor (PS1)

Perform the following adjustments whenever you have replaced the finisher controller PCB or the height sensor (PS1).

- 1) Turn the host machine OFF.
- 2) Set SW3 on the finisher controller PCB as indicated.

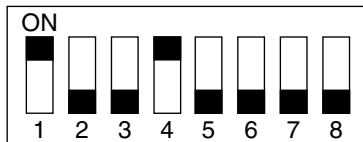


Figure 6-101

- 3) Turn the host machine ON while [0] button and [8] button are pressed simultaneously.
- 4) Place a paper on the tray.
- 5) Press SW1 on the finisher controller PCB. This causes the finisher to execute automatic adjustment, in which the tray unit will shift.
  - At the end of adjustment, trays will return to their home positions.
  - During adjustment, LED1 flashes. At the end of adjustment, LED1 turns and remains ON.
  - If automatic adjustment fails, the mechanism stops while the tray in question is being adjusted (at the same time, LED1 turns OFF).
- 6) Shift all bits on SW3 to OFF, and turn OFF the host machine once.

#### 2. Adjusting the Alignment Position

If you have replaced the finisher controller PCB or if an alignment fault occurs, adjust as follows. Performing the steps will affect all paper sizes.

- 1) Turn the host machine OFF.
- 2) Remove the rear cover of the finisher unit.
- 3) Set SW3 of the finisher controller PCB as indicated.

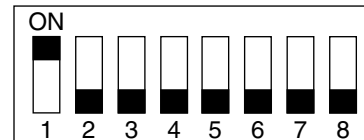


Figure 6-102

- 4) Turn the host machine ON while [0] button and [8] button are pressed simultaneously.
- 5) If you are using A4 paper, press SW1 on the finisher controller PCB. If you are using LT paper, press SW2 on the finisher controller PCB.
  - Pressing SW1/2 will open the swing guide and cause the alignment plate to move to A4/LT positions.
- 6) Place 10 sheets of A4/LT paper between the alignment plate and the guide plate, butting them against the stoppers.
- 7) Press SW1 or SW2 on the finisher controller PCB, and butt the alignment plate against the sheets.
  - Pressing SW1 will shift the alignment plate to the front in 0.35 mm increments.
  - Pressing SW2 will shift the alignment plate to the rear in 0.35 mm increments.

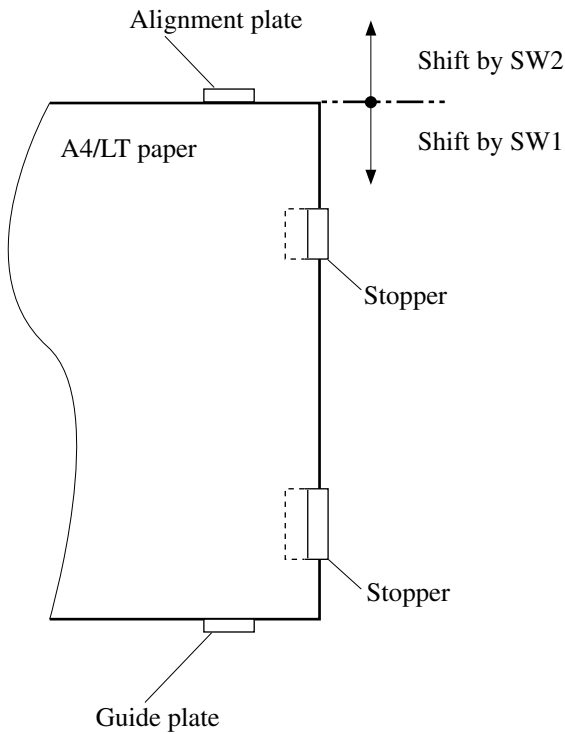


Figure 6-103

- 8) Press SW1 and SW2 simultaneously to store the adjustment value (this will lower the swinging guide).
- 9) Shift all bits of SW3 to OFF, and install the rear cover of the finisher unit.

**3. Adjusting the Staple Position (stapler movement range)**

Adjust as follows if you have replaced the finisher controller PCB. Performing the steps will affect all paper sizes and all stapling positions.

- 1) Turn the host machine OFF.
- 2) Remove the rear cover from the finisher unit.
- 3) Set SW3 on the finisher controller PCB as indicated.

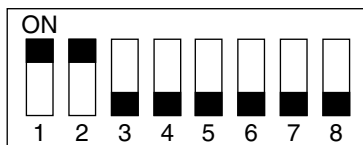


Figure 6-104

- 4) Turn the host machine ON while [0] button and [8] button are pressed simultaneously.
- 5) If you are using A4 paper, press SW1 on the finisher controller PCB. If you are using LT paper, press SW2 on the finisher controller PCB.
  - Pressing SW1/2 will open the swing guide and cause the feed belt to rotate.
- 6) Within 5 secs after pressing the switch, place one sheet of A4/LT paper between the alignment plate and the guide plate, butting it against the stoppers.
  - When the finisher detects the paper, it will lower the swing guide and execute stapling (rear, 1-position). Take out the stapled paper manually as delivery will not be executed.

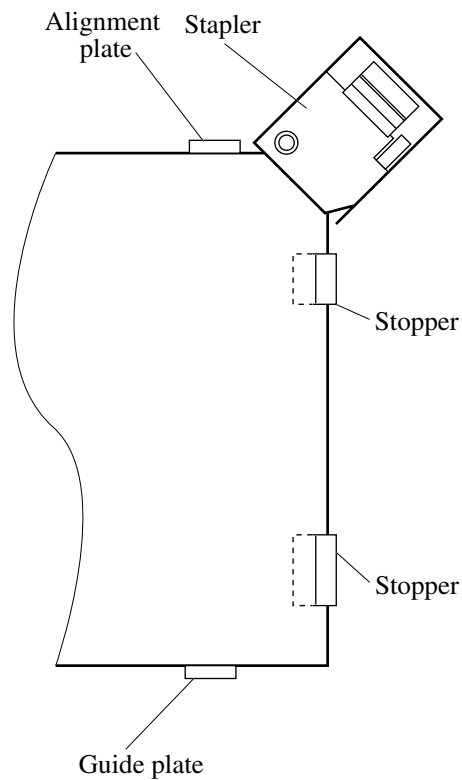
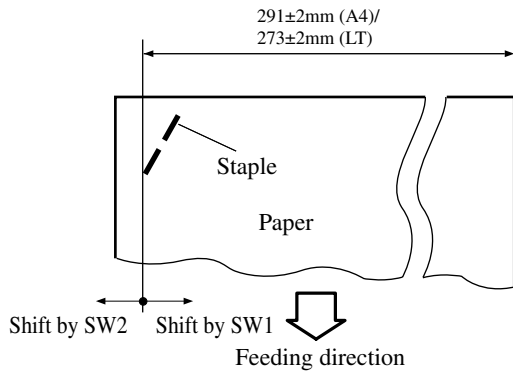


Figure 6-105



- 7) If the stapling position is correct, set all bits on SW3 to OFF to end the adjustments. If you need to change the stapling position, on the other hand, go to the next step.
- 8) To suit the position of the staple on the paper, press SW1 or SW2 on the finisher controller PCB as many times as necessary.
  - Pressing SW1 will shift the stapling position to the front in 0.3 mm increments.
  - Pressing SW2 will shift the stapling position to the rear in 0.3 mm increments.



**Figure 6-106**

- 9) Press SW1 and SW2 simultaneously.
  - This will open the swing guide, and cause the feed belt to rotate. Placement of one sheet of A4/LT paper will cause the finisher to start stapling.
- 10) Check the stapling position. If good, set all bits of SW3 to OFF. If re-adjustments are necessary, go back to Step 8.

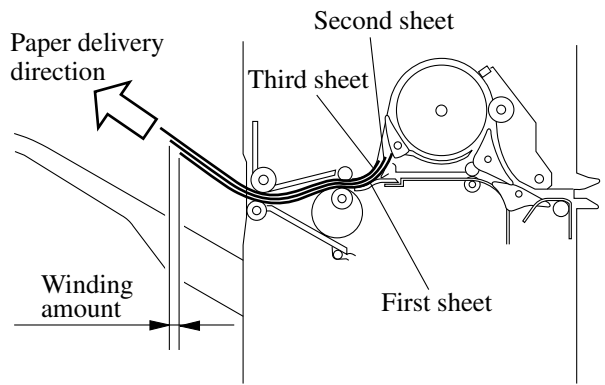
**Caution:**

The settings held by the finisher controller PCB are changed as soon as SW1 or SW2 is pressed. As such, to recover the previous settings after the press, you must press the other of the two switches as many times as you pressed previously.

**4. Adjusting the Buffer Roller Winding Amount**

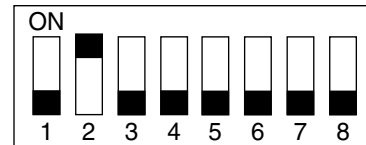
Perform this adjustment in the following instances:

- a. When the finisher controller PCB or the EEPROM (Q2) on the finisher controller PCB has been replaced
  - b. When something causes the winding amount to fluctuate
- The "winding amount" is the amount of difference between the First and Second sheets wound onto the buffer roller device in the feed direction.



**Figure 6-107**

- 1) Turn the host machine OFF.
- 2) Set SW3 on the finisher controller PCB as indicated.



**Figure 6-108**

- 3) Turn the host machine ON while [0] button and [8] button are pressed simultaneously.
- 4) Set the mode setting on the host machine to "1" and the number of originals (A4 or LT) to "3" in the staple mode.
- 5) Press the copy start key.
  - Copying starts, three sheets for the first copy are output as a stack on the staple tray, and copying stops with the copies held at the delivery roller.
- 6) Remove the stack of sheets from the finisher delivery taking care to prevent the offset of the output sheets from changing.

- 7) Measure the winding amount (shift) of the stack of sheets, and compare this amount with the standard amounts.
  - This amount should be measured at the center of the paper leading edge.

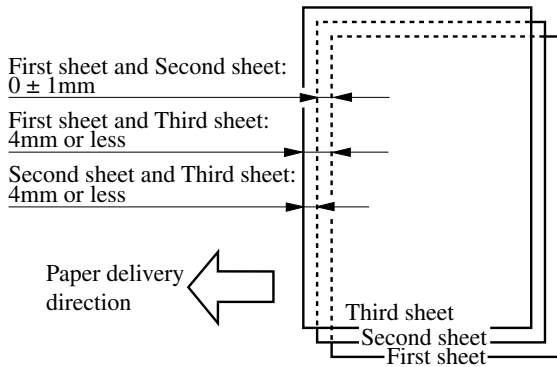


Figure 6-109

- 8) If the amount is within the standard, turn the host machine OFF, and then set all bits of SW3 to OFF. If the amount is outside the standard, perform the following.
- 9) Turn the host machine OFF, and set SW3 on the finisher controller PCB as indicated. If EEPROM (Q2) on the finisher controller PCB has been replaced, proceed to step 12).

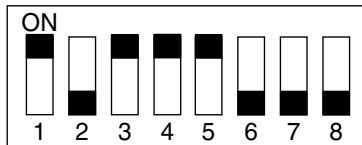


Figure 6-110

- 10) Turn the host machine ON while [0] button and [8] button are pressed simultaneously.
- 11) Press SW2 on the finisher controller PCB.
  - The current setting values are displayed at LED1.

Adjustment value 0	Lights for 1 second (once)
Adjustment value +N	Blinks (lights for 0.2 second) for N times.
Adjustment value -N	Lights for 1 second (once), and blinks (lights for 0.2 second) for N times.

The adjustment width is 0.72mm for each N=1.

Table 6-101

- 12) Turn the host machine OFF, and then set SW3 on the finisher controller PCB as indicated.

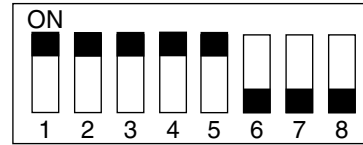


Figure 6-111

- 13) Turn the host machine ON while [0] button and [8] button are pressed simultaneously.
- 14) Press SW1 or SW2 on the finisher controller PCB as necessary.
  - Each press of SW1 increments the winding amount in 0.72mm increments.
  - Each press of SW2 decrements the winding amount in 0.72mm increments.

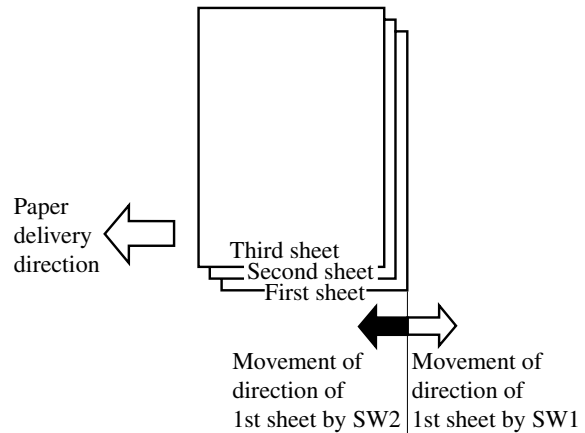


Figure 6-112

- 15) Repeat steps 1) through 7) twice. Check that the winding amount is within the standard in both times.
- 16) Turn the host machine OFF, and set all bits of SW3 to OFF. This completes the adjustment.

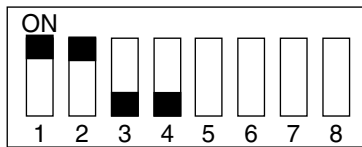
## B. Electrical System (saddle stitcher unit)

### 1. Adjusting the Folding Position

The folding position is adjusted by changing the settings of bits 6 through 8 of DIPSW1 on the saddle stitcher controller PCB to match the stitching position (i.e., adjusting the distance over which the paper positioning plate is moved to the folding position from the stitching position.)

If you have replaced the saddle stitcher controller PCB, be sure to set the new DIP-SW1 so that the settings will be the same as those on the old DIPSW1. If, for any reason, you must change the following position, perform the following steps:

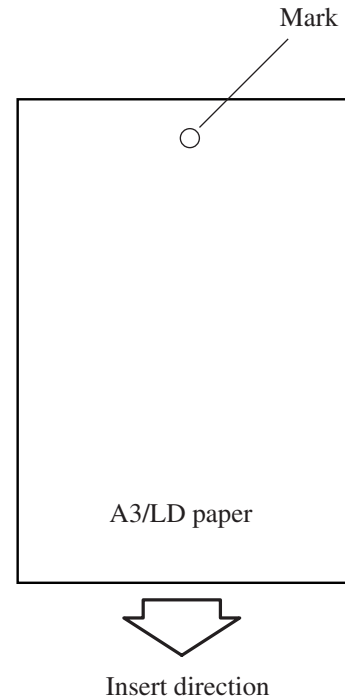
- 1) Turn the host machine OFF.
- 2) Remove the PCB cover, and set bits 1 through 4 of DIPSW1 on the saddle stitcher controller PCB as indicated.



Do not change bits 5 through 8.

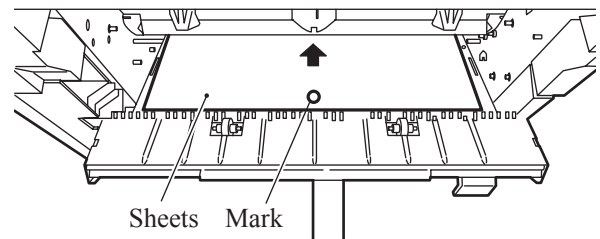
**Figure 6-113**

- 3) Turn the host machine ON while [0] button and [8] button are pressed simultaneously.
- 4) Remove the rear cover of the saddle stitcher unit, and tape the actuator of the inlet cover sensor (PI9S) and the inlet door switch (MS1S) of the saddle stitcher unit in place.
- 5) Before inserting the paper, mark the top of the paper (you will be using two sheets of A3 or LD paper).



**Figure 6-114**

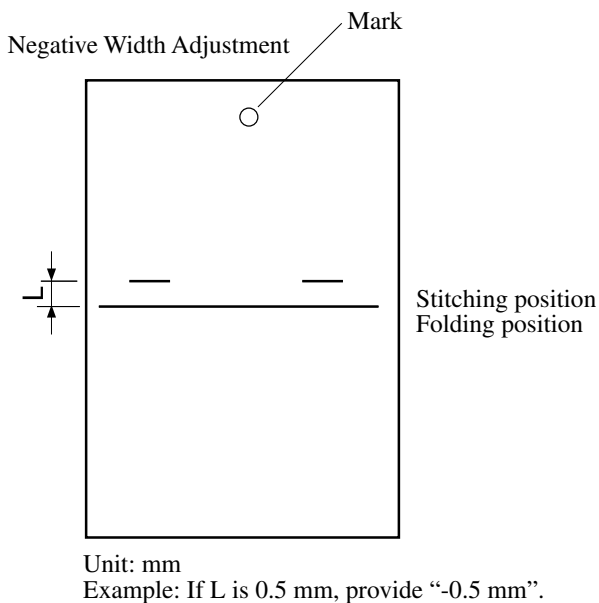
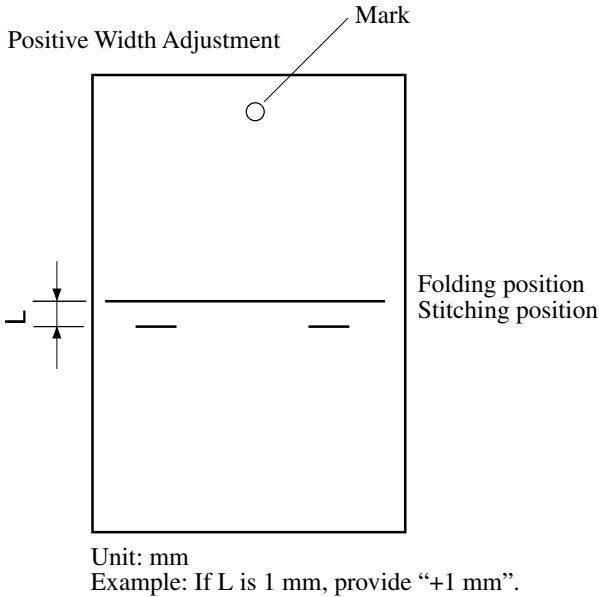
- 6) Press SW2 on the saddle stitcher controller PCB so that the feed motor (M1S) starts to rotate. (Press SW2 three seconds or more if LD paper is used).
- 7) Open the inlet cover, and insert two sheets of paper (push them in by hand until the leading edge of the sheets butts against the paper positioning plate).



**Figure 6-115**

- 8) Close the inlet door while holding it down with your hand.
- 9) Press SW2 on the saddle stitcher controller PCB.
  - The saddle stitcher unit will “stitch” the sheets, and fold and deliver the stack automatically.

- 10) Measure the distance (L) between the stitching position and the folding position. Then, perform “positive width adjustment” or “negative width adjustment” to suit the relationship between the stitching position and the folding position.
- If the stitching position is below the folding position, perform “positive width adjustment.”
  - If the stitching position is above the folding position, perform “negative width adjustment.”



- 11) Change the settings of bits 6 through 8 on DIPSW1 referring to Table 8-102 below.
- If the width adjustment is “0”,  
The stitching position and the folding position match, requiring no change.
  - If for “positive width adjustment,”  
Set DIPSW1 so that the difference resulting from subtraction of the interval from the appropriate setting in Table 8-102 is provided.  
For instance, if the DIPSW1 is currently set to +2 and the interval is +1 mm, set DIPSW1 to reflect -2.
  - If for “negative width adjustment”  
Set DIPSW1 so that the sum resulting from addition of the interval from the appropriate setting is provided.  
For instance, if the DIPSW1 is currently set to -1 and the interval is +0.5 mm, set DIPSW1 to reflect +1.

DIPSW1 bit settings			Settings (in units of 0.5 mm)
bit 6	bit 7	bit 8	
OFF	ON	ON	+3
OFF	ON	OFF	+2
OFF	OFF	ON	+1
OFF	OFF	OFF	0
ON	OFF	ON	-1
ON	ON	OFF	-2
ON	ON	ON	-3

Do not touch the following:

bit 6	bit 7	bit 8
ON	OFF	OFF

**Table 6-102**

- 12) Set bits 1 through 4 on DIPSW1 to OFF.
- 2. Stitching Position (adjusting center stitching)**
- Use the host machine adjustment mode to perform the following:

**Figure 6-116**

## **II. ARRANGEMENT OF ELECTRICAL PARTS**

### **A. Finisher Unit**

1. Sensors

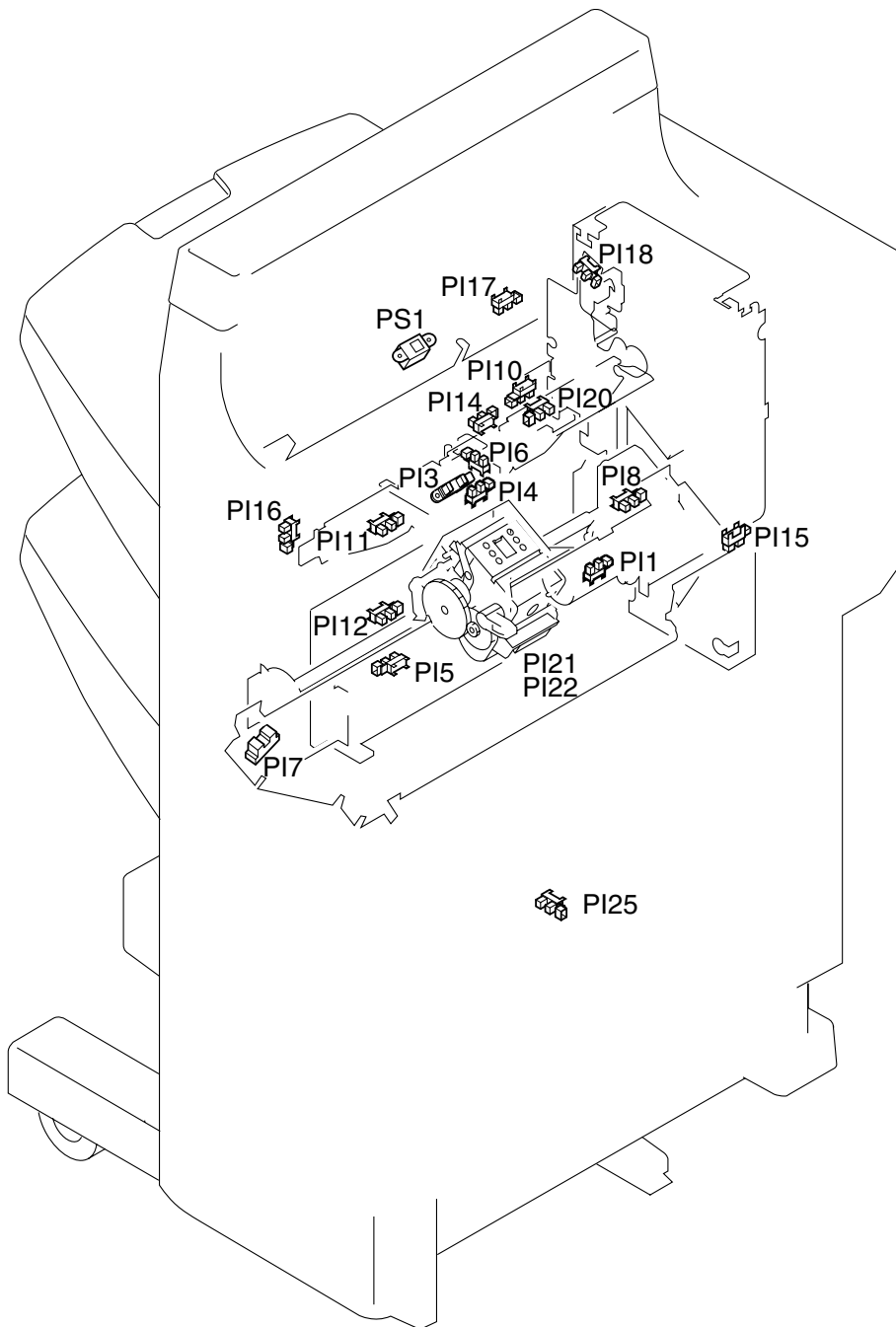


Figure 6-201

Name	Notation	Function
Photointerrupter	PI1	Detects paper in the inlet area
	PI3	Detects paper in the delivery area
	PI4	Detects paper on the stapling tray
	PI5	Detects the state (open) of the shutter
	PI6	Detects alignment plate at home position
	PI7	Detects the stapler at home position
	PI8	Detects the tray at home position
	PI10	Detects delivery motor clock pulses
	PI11	Detects paper on tray-1
	PI12	Detects paper on tray-2
	PI14	Detects paper in the buffer path
	PI15	Detects the finisher joint
	PI16	Detects the state (open) of the door
	PI17	Detects paper at the inlet to the buffer path
	PI18	Detects the state (open) of the swing guide
	PI20	Detects swing guide clock
	PI21	Detects edging of staples (inside stapler)
PI22	Detects staple drive home position (inside stapler)	
PI25	Detects tray home position	
Height sensor	PS1	Detects the height of the stack on the tray

Table 6-201

2. Microswitches

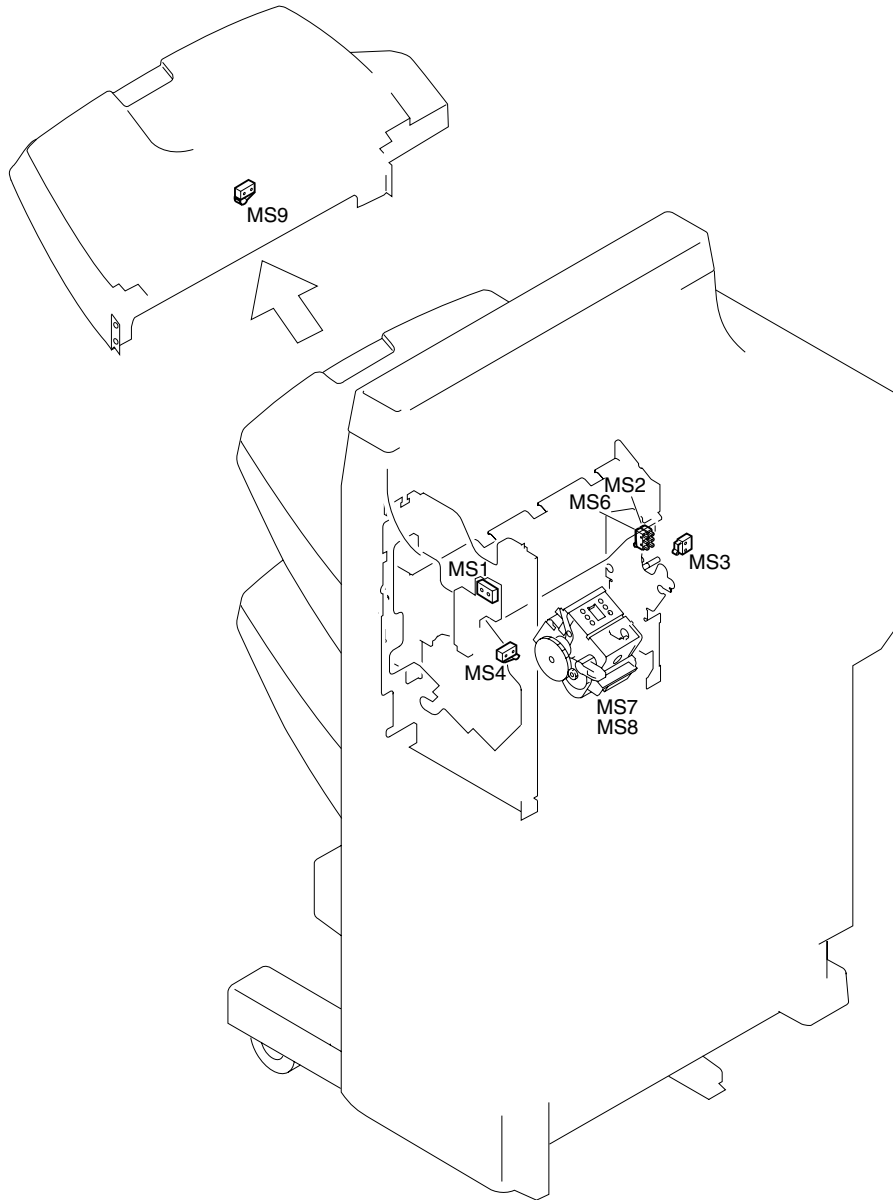


Figure 6-202

Name	Notation	Function
Microswitches	MS1	Detects the state (open) of the front door and the upper door
	MS2	Detects the state (closed) of the swing guide 1
	MS3	Detects the safety range
	MS4	Detects the state (closed) of the shutter
	MS6	Detects the state (closed) of the swing guide 2
	MS7	Detects the cartridge (inside stapler)
	MS8	Detects the presence/absence of staples (inside stapler)
	MS9	Detects the tray coming close

Table 6-202



3. Motors

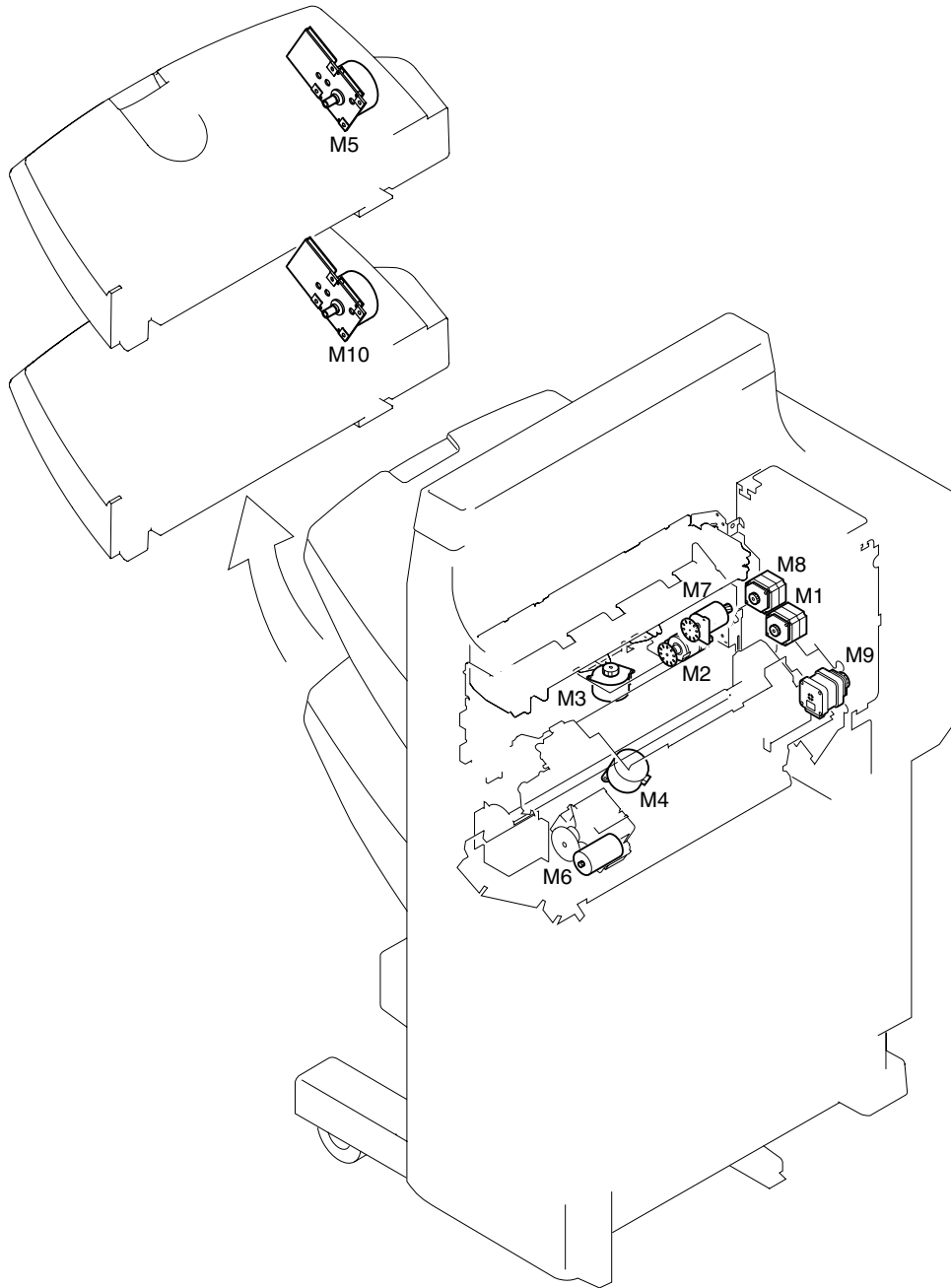


Figure 6-203

Name	Notation	Function
Motor	M1	First Feed motor
	M2	Delivery motor
	M3	Alignment motor
	M4	Stapler shift motor
	M5	Tray-1 lift motor
	M6	Staple motor
	M7	Swing motor
	M8	Second feed motor
	M9	Inlet feed motor
	M10	Tray-2 lift motor

Table 6-203

4. Solenoids

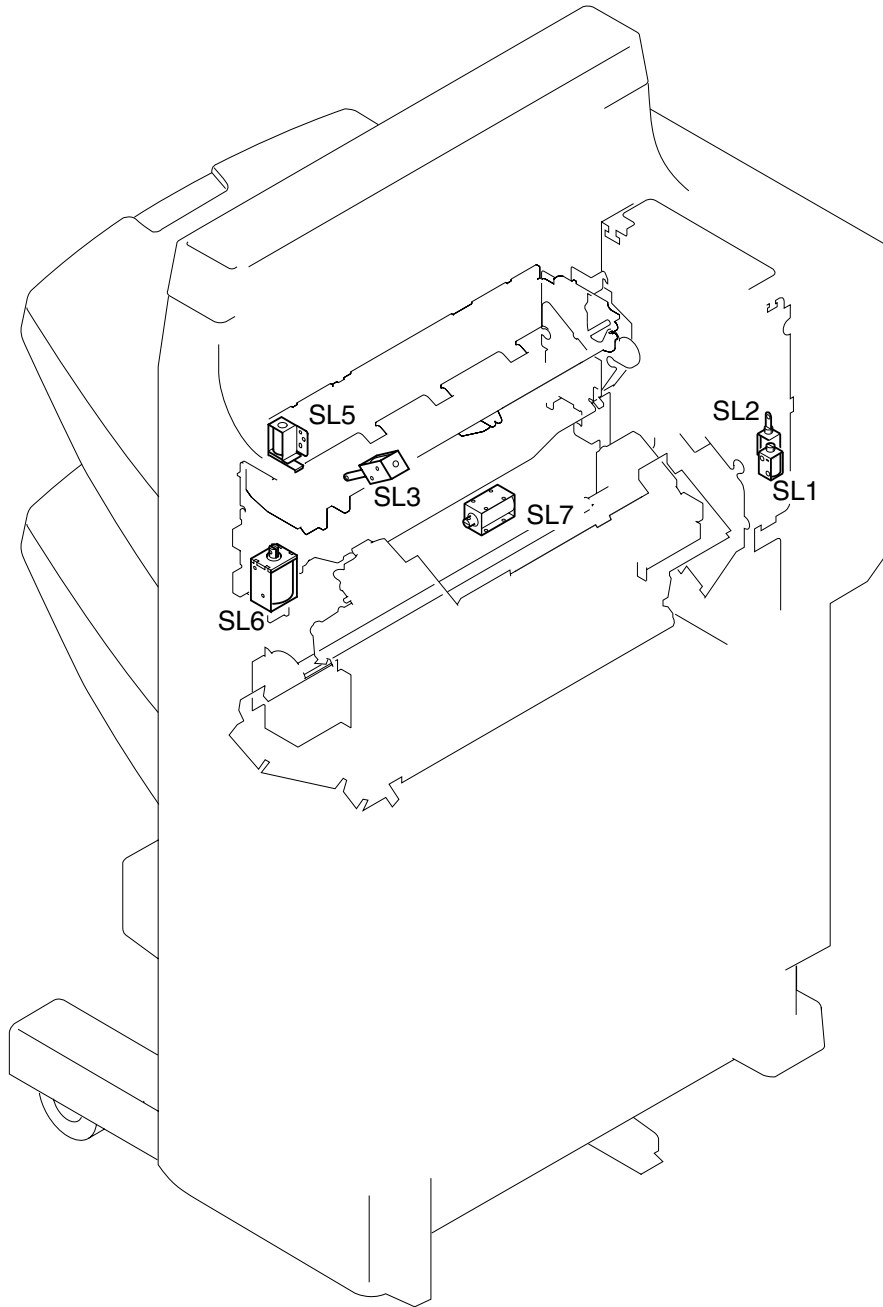


Figure 6-204

Name	Notation	Function
Solenoid	SL1	Flapper solenoid
	SL2	Buffer inlet solenoid
	SL3	Buffer outlet solenoid
	SL5	Paddle solenoid
	SL6	Escape solenoid
	SL7	Belt escape solenoid

Table 6-204

5. PCBs

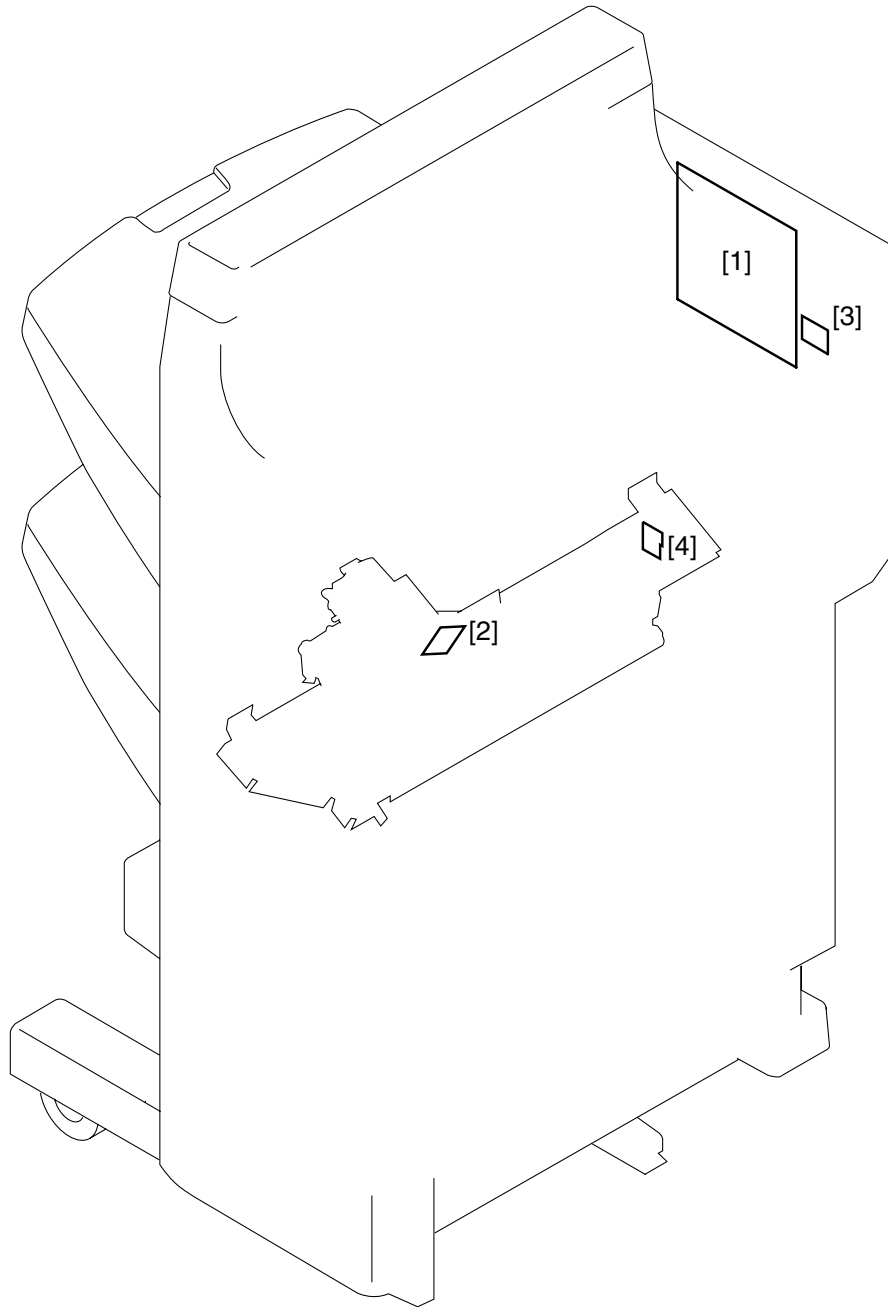


Figure 6-205

Reference	Name
[1]	Finisher controller PCB
[2]	Relay PCB 4
[3]	Relay PCB 3

Table 6-205

## B. Saddle Stitcher Unit

### 1. Photointerrupters

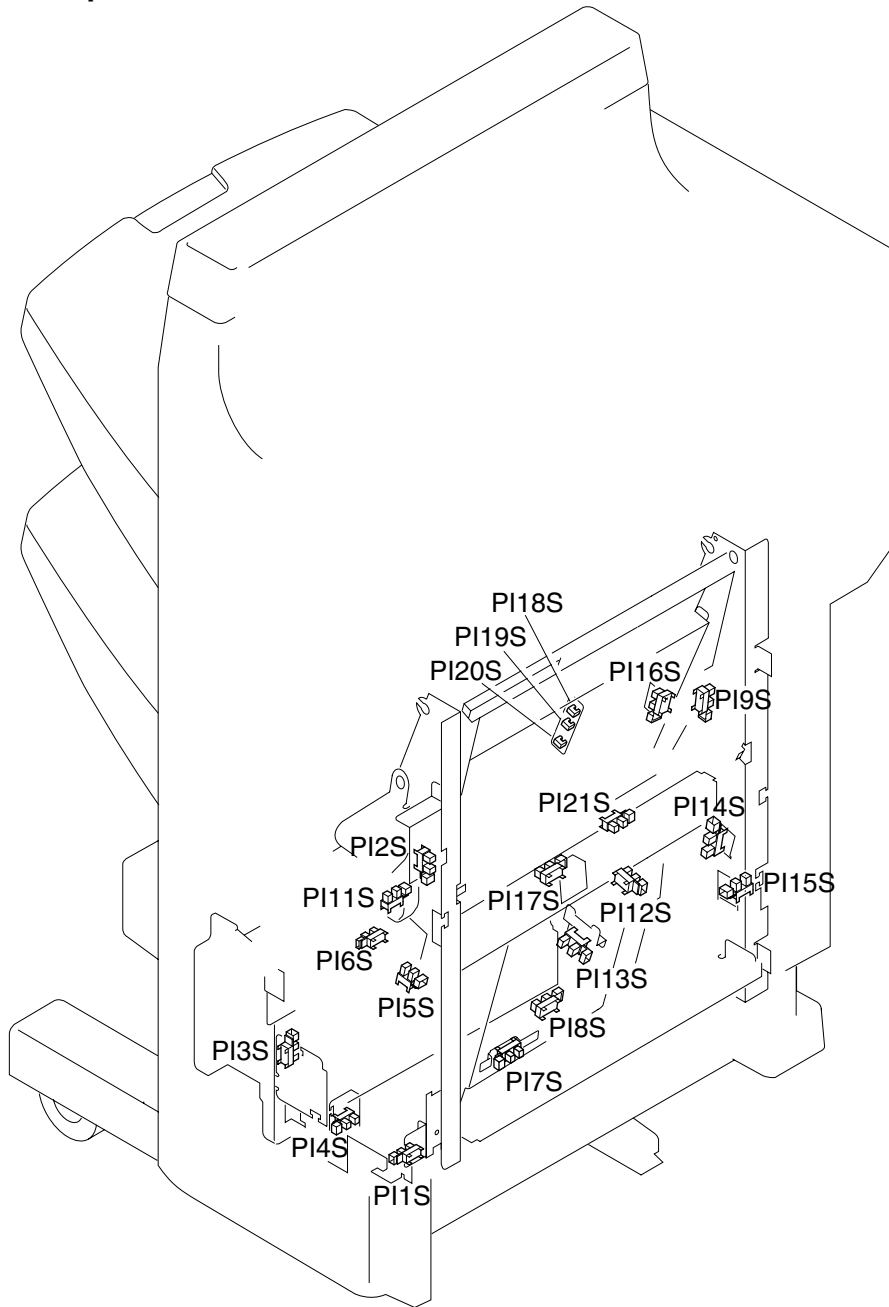


Figure 6-206

Name	Notation	Function
Photointerrupter	PI1S	Detects clock pulses from the paper pushing plate motor
	PI2S	Detects the state (open) of the front door
	PI3S	Detects the state (open) of the delivery cover
	PI4S	Detects clock pulses from the paper folding motor
	PI5S	Detects the alignment plates at home position
	PI6S	Detects paper on the tray
	PI7S	Detects paper positioning plate at home position
	PI8S	Detects paper on the paper positioning plate
	PI9S	Detects the state (open) of the inlet cover
	PI11S	Detects paper in the delivery area
	PI12S	Detects the phase of the crescent roller
	PI13S	Detects the guide at home position
	PI14S	Detects the paper pushing plate at home position
	PI15S	Detects the paper pushing plate at top position
	PI16S	Detects the state (in) of the stitcher unit
	PI17S	Detects paper in the vertical path
	PI18S	Detects paper (No. 1; on paper sensor PCB)
	PI19S	Detects paper (No. 2; on paper sensor PCB)
	PI20S	Detects paper (No. 3; on paper sensor PCB)
	PI21S	Detects the paper folding at home position

Table 6-206

2. Microswitches

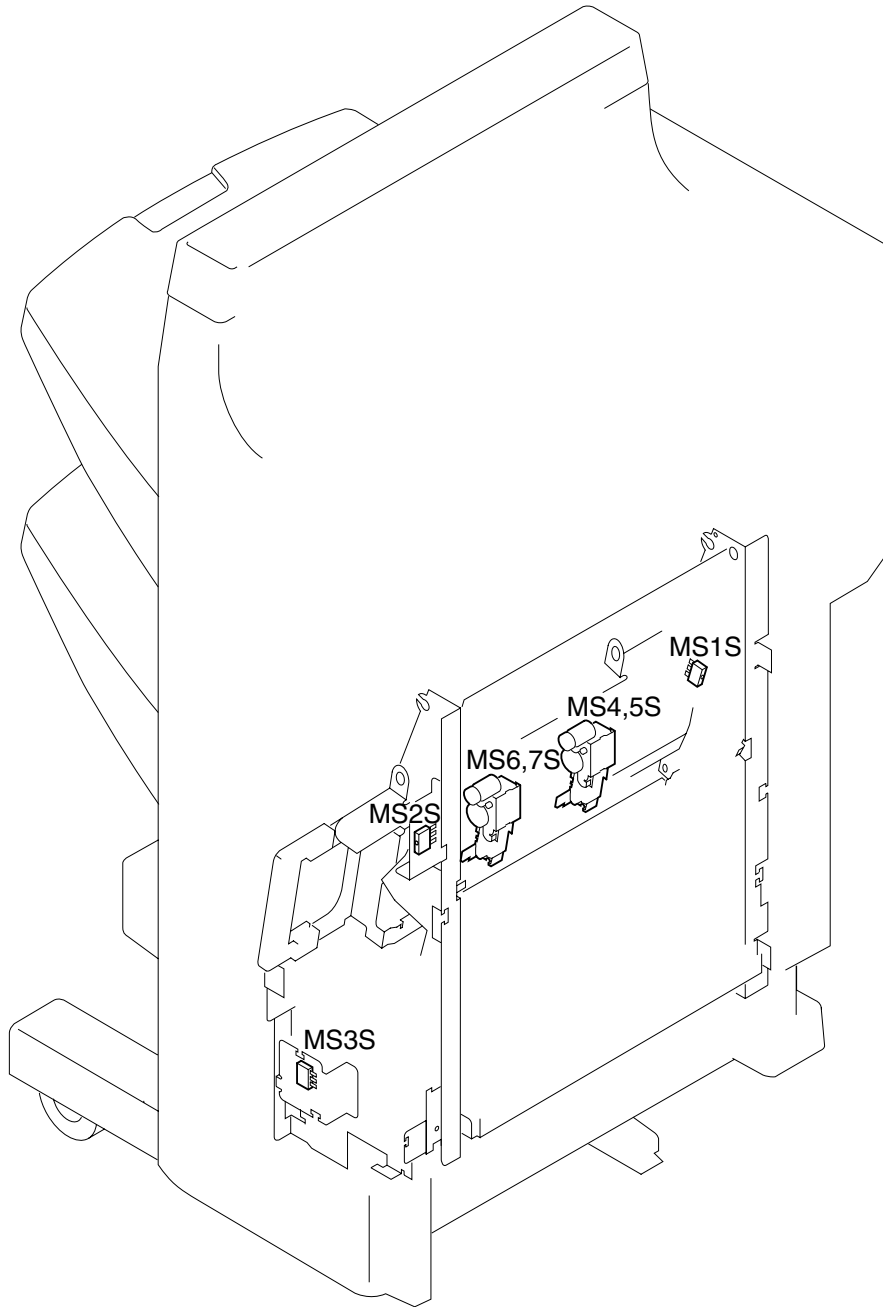


Figure 6-207

Name	Notation	Function
Microswitches	MS1S	Detects the state (open) of the inlet door
	MS2S	Detects the state (open) of the front door
	MS3S	Detects the state (open) of the delivery door
	MS4S	Detects the presence of staples (rear)
	MS5S	Detects stitching home position (rear)
	MS6S	Detects the presence of staples (front)
	MS7S	Detects stitching home position (front)

Table 6-207

3. Motors

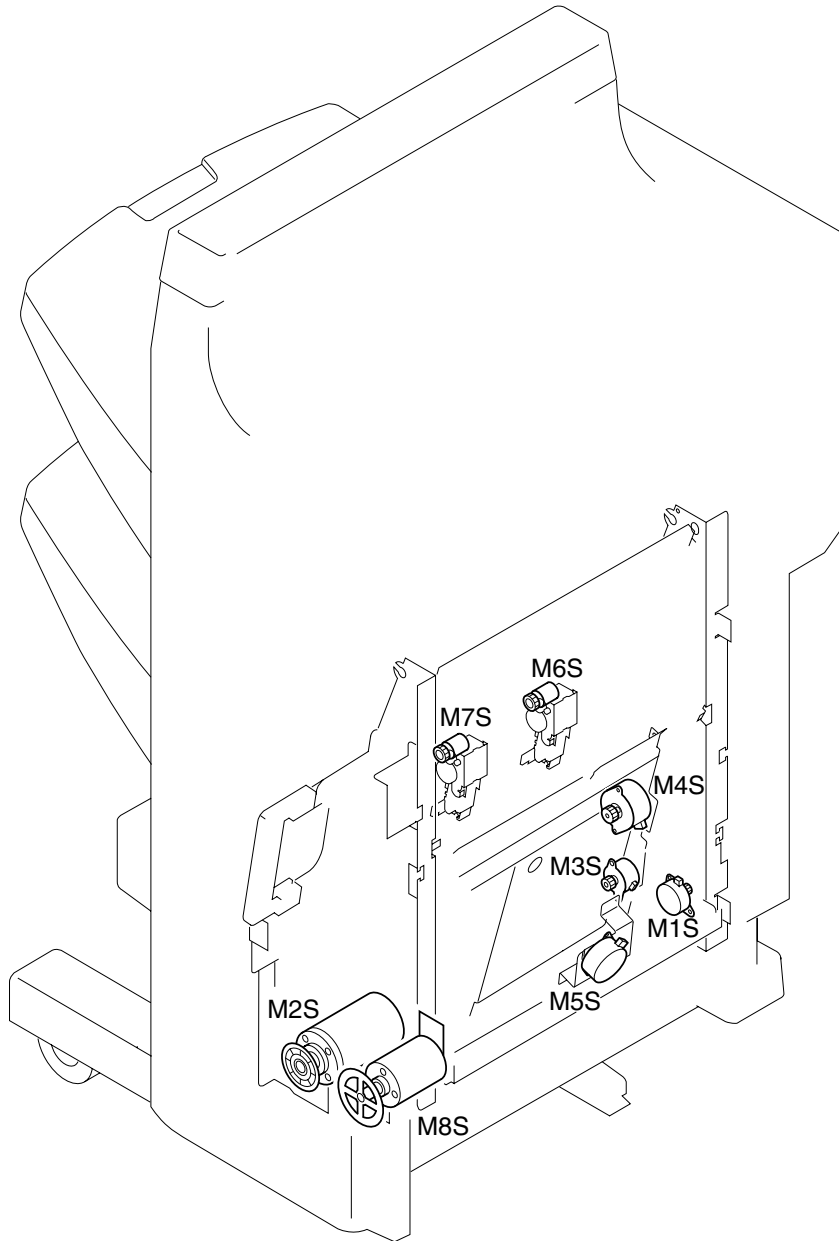


Figure 6-208

Name	Notation	Function
Motor	M1S	Feed motor
	M2S	Paper folding motor
	M3S	Guide motor
	M4S	Paper positioning plate motor
	M5S	Alignment motor
	M6S	Stitcher motor (rear)
	M7S	Stitcher motor (front)
	M8S	Paper pushing plate motor

Table 6-208

4. Solenoids

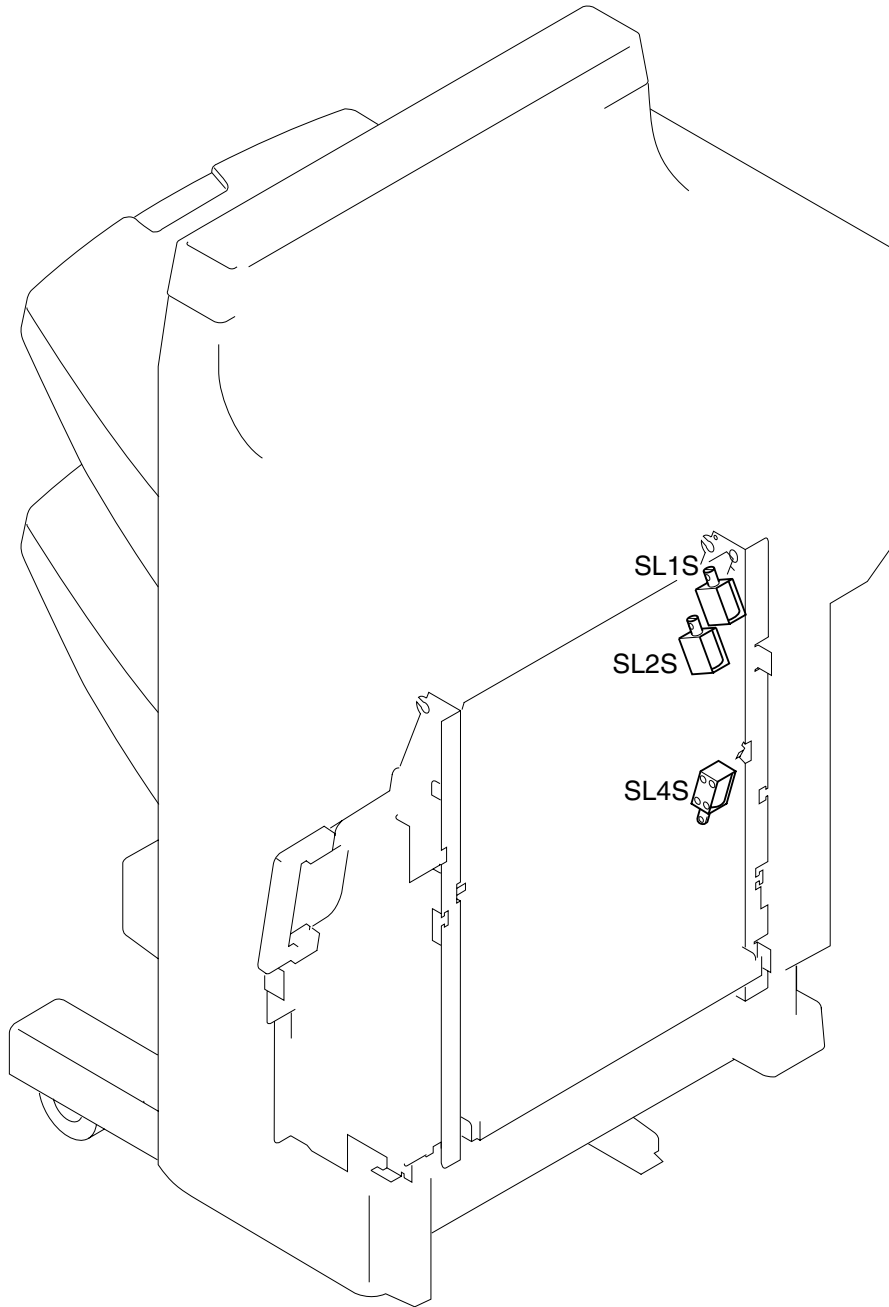


Figure 6-209

Name	Notation	Function
Solenoid	SL1S	No. 1 paper deflecting plate solenoid
	SL2S	No. 2 paper deflecting plate solenoid
	SL4S	Feed plate contact solenoid

Table 6-209



5. PCBs

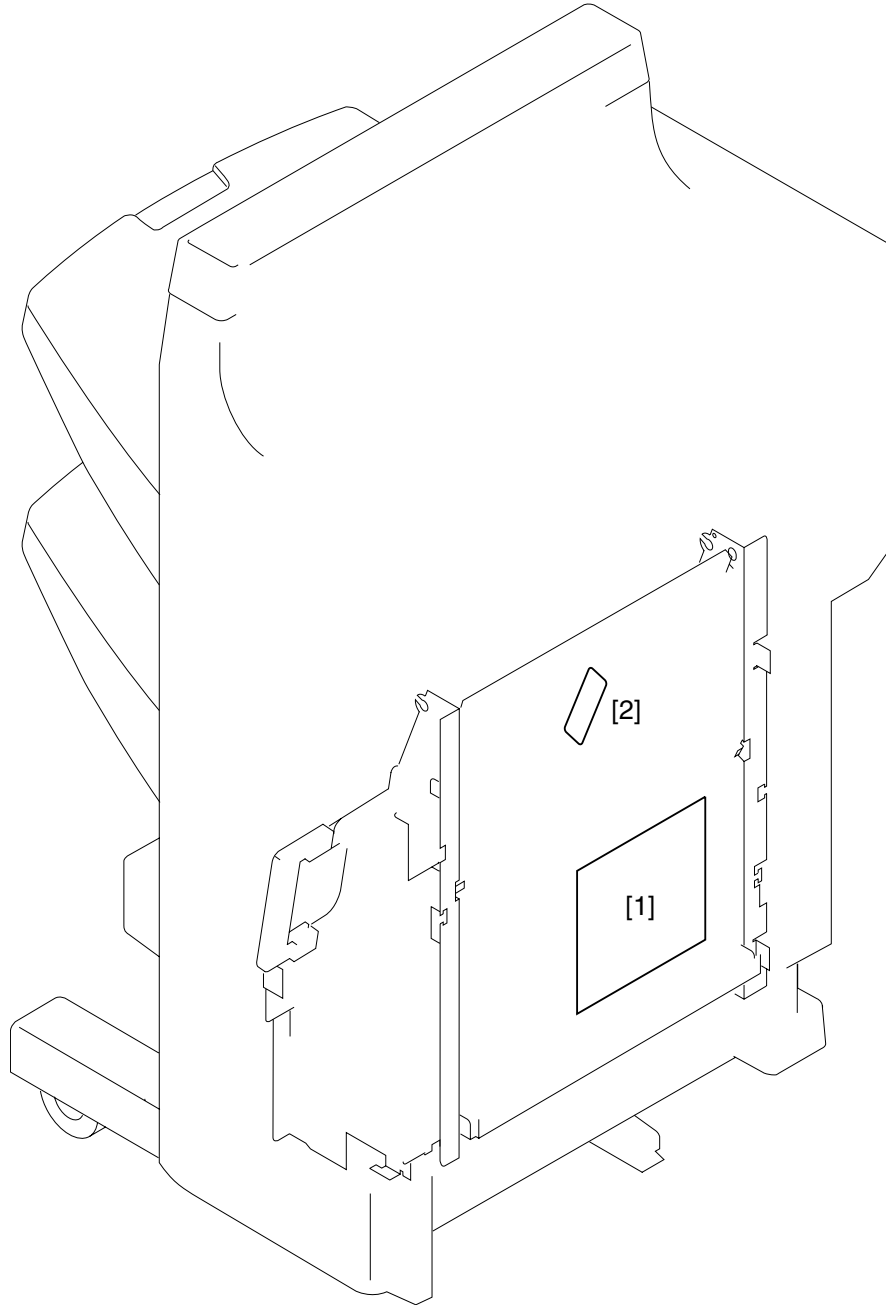


Figure 6-210

Reference	Name
[1]	Saddle stitcher controller PCB
[2]	Paper sensor PCB

Table 6-210

### C. Light-Emitting Diodes (LED) and Check Pins by PCB

This section discusses the LED s and check pins used in the machine that are needed in the field.

**Caution:** The VRs and check pins not discussed in this section are for factory use only. Making adjustments and checks using these will require special tools and instruments and adjustments must be to high accuracy. Do not touch them in the field.

#### 1. Finisher Controller PCB

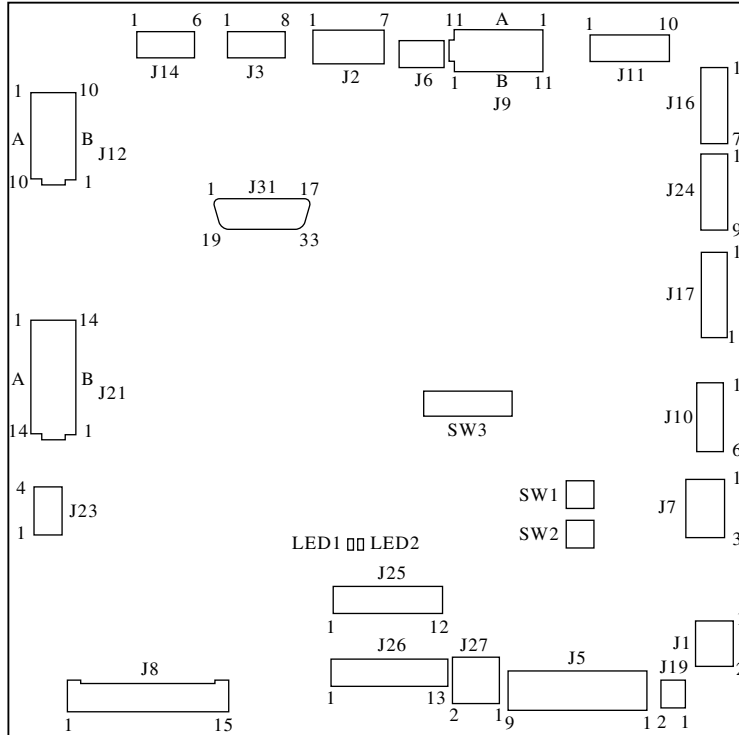


Figure 6-215

Switch	Function
SW1	Adjust the height sensor/alignment plate position/stapling position and move the trays up, etc.
SW2	Adjust the alignment plate position/staple position and move the trays down, etc.
SW3	Adjust the height sensor/alignment plate position and stapling position, etc.

Table 6-215

2. Saddle Stitcher Controller PCB

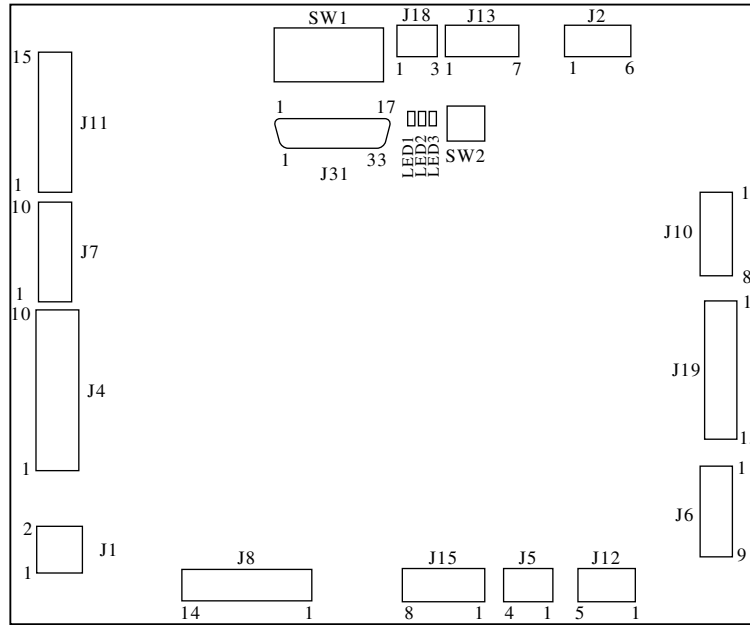


Figure 6-216

Switch	Function
DIPSW1 (bits 1-2)	Starts correction of discrepancy between stitching position and folding position.
DIPSW1 (bits 6-8)	Stores corrected settings for stapling position and folding position.
SW2	Starts correction of discrepancy between stitching position and folding position.

Table 6-216

### III. TROUBLESHOOTING

#### A. Finisher Unit

##### 1. Fault in communication with host machine

Cause	Step	Checks	Yes/No	Action
Finisher controller PCB, Host machine DC controller PCB	1	Turn the host machine OFF then ON. Is the problem corrected?	Yes	End.
Wiring	2	Is the wiring between the finisher controller PCB and the host machine controller PCB normal?	No	Correct it.
Finisher controller PCB, Host machine DC controller PCB	3	Replace the finisher controller PCB and the host machine DC controller PCB. Is the problem corrected?	Yes	End.
			No	Multifunction of the host machine.

##### 2. Fault in communication with saddle stitcher unit

Cause	Step	Checks	Yes/No	Action
Finisher controller PCB, Saddle stitcher controller PCB	1	Turn the host machine OFF then ON. Is the problem corrected?	Yes	End.
Wiring	2	Is the wiring between the finisher controller PCB and the saddle stitcher controller PCB normal?	No	Correct it.
Power supply	3	Measure the voltage between J19-1 (+) and J19-2 (-) on the finisher controller PCB. Is it 24 VDC?	No	Replace the finisher controller PCB.
Saddle stitcher controller PCB			Yes	Replace the saddle stitcher controller PCB.

### 3. Faulty height sensor (communication)

Cause	Step	Checks	Yes/No	Action
Finisher controller PCB	1	Turn the host machine OFF then ON. Is the problem corrected?	Yes	End.
Wiring	2	Is the wiring between the finisher controller PCB and the sensors normal?	No	Correct the wiring.
Power supply	3	Measure the voltage between J6-2 (+) and J6-4 (-) on the finisher controller PCB. Is it 5 VDC?	No	Replace the finisher controller PCB.
Height sensor (PS1)			Yes	Adjust the height sensor once again. If an error occurs again, replace the height sensor.

### 4. Faulty height sensor (disconnection)

Cause	Step	Checks	Yes/No	Action
Connector	1	Is J6 on the finisher controller PCB, J114 on the height sensor, or the relay connector J212 or J213 disconnected?	Yes	Connect the connector.
Power supply	2	Measure the voltage between J6-2 (+) and J6-4 (-) on the finisher controller PCB. Is it 5 VDC?	No	Replace the finisher controller PCB.
Height sensor (PS1)	3	Is the wiring between the finisher controller PCB and sensors normal?	Yes	Replace the height sensor.
Wiring			No	Correct the wiring.

**5. Faulty height sensor (adjustment)**

Cause	Step	Checks	Yes/No	Action
Adjustment	1	Try making adjustments using the DIP switch once again. Is the problem corrected?	Yes	End.
Wiring	2	Is the wiring between the finisher controller PCB and sensors normal?	No	Correct the wiring.
Power supply	3	Measure the voltage between J6-2 (+) and J6-4 (-) on the finisher controller PCB. Is it 5 VDC?	No	Replace the finisher controller PCB.
Height sensor (PS1)			Yes	Replace the height sensor.

**6. Faulty back-up RAM**

Cause	Step	Checks	Yes/No	Action
Finisher controller PCB, punch drive PCB	1	Turn the host machine OFF then ON. Is the problem corrected?	Yes	End.
	2	Replace the finisher controller PCB and punch driver PCB. Is the problem corrected?	Yes	End.

**7. Faulty delivery motor**

Cause	Step	Checks	Yes/No	Action
Deliver roller	1	Turn the delivery roller by hand. Does it turn smoothly?	No	Correct mechanical operation.
Delivery motor clock sensor (PI10)	2	Check the delivery motor clock sensor. Is the sensor normal?	No	Replace the sensor.
Finisher controller PCB	3	Does the voltage between J11-4 and J11-5 on the finisher controller PCB change to 24 VDC as soon as the delivery motor starts to rotate?	No	Replace the finisher controller PCB.
			Yes	Check the wiring from the motor to the controller PCB. If normal, replace the motor.

**8. Faulty alignment motor**

Cause	Step	Checks	Yes/No	Action
Alignment plate home position sensor (PI6)	1	Check the alignment plate home position sensor. Is it normal?	No	Replace the sensor.
Wiring	2	Is the wiring between the finisher controller PCB and the alignment plate motor normal?	No	Correct the wiring.
Alignment plate	3	Is there any mechanical obstacle in the path of the alignment plate?	Yes	Remove the mechanical obstacle.
Alignment motor (M3)	4	Replace the alignment motor. Is the problem corrected?	Yes	End.
Finisher controller PCB			No	Replace the finisher controller PCB.

**9. Faulty staple motor**

Cause	Step	Checks	Yes/No	Action
Wiring	1	Is the wiring between the stapler and the finisher controller PCB normal?	No	Correct the wiring.
Stapler	2	Replace the stapler. Is the problem corrected?	Yes	End.
Finisher controller PCB			No	Replace the finisher controller PCB.

**10. Faulty stapler shift motor**

Cause	Step	Checks	Yes/No	Action
Stapler shift home position sensor (PI7)	1	Check the stapler shift home position sensor. Is the sensor normal?	No	Replace the sensor.
Wiring	2	Is the wiring between the finisher controller PCB and the stapler shift motor normal?	No	Correct the wiring.
Stapler shift base	3	Is there any mechanical obstacle in the path of the stapler shift base?	Yes	Remove the mechanical obstacles.
Stapler shift motor (M4)	4	Replace the stapler motor. Is the problem corrected?	Yes	End
Finisher controller PCB			No	Replace the finisher controller PCB.

**11. Faulty swing motor (related to MS6)**

Cause	Step	Checks	Yes/No	Action
Swinging mechanism	1	Turn the swing motor in reverse by hand. Does the swing guide move up and down?	No	Correct the swing mechanism.
Swing guide closed detection switch 2 (MS6)	2	Is the swing guide closed detection switch 2 normal?	No	Replace the microswitch.
Swing motor (M7)	3	Does the swing motor rotate in reverse at a specific timing?	No	Replace the motor.
Finisher controller PCB			Yes	Replace the finisher controller PCB.



**12. Faulty swing motor (related to PI18)**

Cause	Step	Checks	Yes/No	Action
Swinging mechanism	1	Turn the delivery motor in reverse by hand. Does the swing guide move up and down?	No	Correct the swinging mechanism.
Swing guide open sensor (PI18)	2	Is the swing guide open sensor normal?	No	Replace the sensor.
Swing motor (M7)	3	Does the swing motor rotate in reverse at a specific timing?	No	Replace the motor.
Finisher controller PCB			Yes	Replace the finisher controller PCB.

**13. Faulty swing motor (related to MS3)**

Cause	Step	Checks	Yes/No	Action
Safety range switch (MS3)	1	Check the safety range switch. Is the switch normal?	No	Replace the switch.
	2	Is the safety range detection switch pressed correctly?	No	Correct mechanical operation.
Swing guide closed detection switch 2 (MS6)	3	Check the swing guide closed detection switch 2. Is the switch normal?	No	Replace the switch.
	4	Is the swing guide closed detection switch 2 pressed correctly?	No	Correct mechanical operation.
Finisher controller PCB			Yes	Replace the finisher controller PCB.

**14. Faulty swing motor (related to PI20)**

Cause	Step	Checks	Yes/No	Action
Swing motor clock sensor (PI20)	1	Check the swing motor clock sensor. Is the sensor normal?	No	Replace the sensor.
Finisher controller PCB	2	Does the voltage of the swing motor between J11-6 and -7 on the finisher controller PCB reach 24 V at a specific rotation timing?	No	Replace the finisher controller PCB.
			Yes	Check the wiring from the motor to the finisher controller PCB. If normal, replace the motor.

**15. Faulty tray-1 lift motor (related to PI8)**

Cause	Step	Checks	Yes/No	Action
Tray-1 home position sensor (PI8)	1	Check the tray-1 home position sensor. Is it normal?	No	Replace the sensor.
Tray-1 lift mechanism	2	Check the tray-1 lift mechanism. Is the mechanism normal?	No	Correct the mechanism.
Finisher controller PCB	3	Is the tray-1 lift motor supplied with 24 VDC by the finisher controller PCB as soon as the tray is driven?	No	Replace the finisher controller PCB.
Wiring	4	Check the wiring from the finisher controller PCB to the tray-1 lift motor. Is the wiring normal?	No	Correct the wiring.
Tray-1 lift motor (M5)			Yes	Replace the tray-1 lift motor.

**16. Faulty tray-2 lift motor (related to PI25)**

Cause	Step	Checks	Yes/No	Action
Tray-2 lift mechanism (PI25)	1	Check the tray-2 lift mechanism. Is the mechanism normal?	No	Correct the mechanism.
Finisher controller PCB	2	Is the tray-2 lift motor supplied with 24 VDC by the finisher controller PCB as soon as the tray is driven?	No	Replace the finisher controller PCB.
Wiring	3	Check the wiring from the finisher controller PCB to the tray-2 lift motor. Is the wiring normal?	No	Correct the wiring.
Tray-2 lift motor (M10)			Yes	Replace the tray-2 lift motor.

Note :

If the tray cannot be lowered because it makes contact with something under the Finisher, this error occurs. Therefore, tell the users not to place anything under the tray.

**17. Faulty tray-1 motor (related to M5)**

Cause	Step	Checks	Yes/No	Action
—	1	Does the tray-1 move up/down?	No	Go to step 2.
			Yes	Go to step 4.
Finisher controller PCB	2	Is the motor supplied with power by the finisher controller PCB as soon as the tray-1 moves up/down?	Yes	Go to step 3.
			No	Replace the finisher controller PCB.
Tray-1 lift mechanism	3	Is there a fault in the tray-1 lift mechanism?	Yes	Correct the tray-1 lift mechanism.
Wiring	4	Check the wiring from the finisher controller PCB to the tray-1 lift motor. Is the wiring normal?	No	Correct the wiring.
Tray-1 lift motor (M5)			Yes	Replace the tray-1 lift motor

**18. Faulty tray-2 motor (related to M10)**

Cause	Step	Checks	Yes/No	Action
—	1	Does the tray-2 move up/down?	No	Go to step 2.
			Yes	Go to step 4.
Finisher controller PCB	2	Is the motor supplied with power by the finisher controller PCB as soon as the tray-2 moves up/down?	Yes	Go to step 3.
			No	Replace the finisher controller PCB.
Tray-2 lift mechanism	3	Is there a fault in the tray-2 lift mechanism?	Yes	Correct the tray-2 lift mechanism
Wiring	4	Check the wiring from the finisher controller PCB to the tray-2 lift motor. Is the wiring normal?	No	Correct the wiring.
Tray-2 lift motor (M10)			Yes	Replace the tray-2 lift motor

**19. Faulty tray coming close detection switch (related to MS9)**

Cause	Step	Checks	Yes/No	Action
Tray lift mechanism	1	Check the tray lift mechanism. Is the mechanism normal?	No	Correct the mechanism
Tray coming close detection switch (MS9)	2	Check the tray coming close detection switch. Is the switch is normal?	No	Replace the switch
Finisher controller PCB			Yes	Replace the finisher controller PCB.

**20. Faulty second feed motor (related to PI5)**

Cause	Step	Checks	Yes/No	Action
Second feed motor (M8)	1	Does the second feed motor in reverse at a specific timing?	No	Replace the second feed motor or the finisher controller PCB.
Shutter mechanism	2	Are the shutter and the shutter upper/lower bar engaged correctly?	No	Engage them correctly.
	3	Turn the feed roller 2 in reverse by hand. Does the shutter upper/lower bar move up/down?	No	Correct mechanism from the shutter upper/lower bar to the gear of the feed roller 2.
Shutter open detection sensor (PI5)	4	Is the shutter open detection sensor normal?	No	Replace the sensor.
Finisher controller PCB			Yes	Replace the finisher controller PCB.

**21. Faulty second feed motor (related to MS4)**

Cause	Step	Checks	Yes/No	Action
Second feed motor (M8)	1	Does the second feed motor rotate in reverse at a specific timing?	No	Replace the second feed motor or the finisher controller PCB.
Shutter mechanism	2	Are the shutter and the shutter upper/lower bar engaged correctly?	No	Engage them correctly.
	3	Turn the feed roller 2 in reverse by hand. Does the shutter upper/lower bar move up/down?	No	Correct the mechanism from the shutter upper/lower bar to the gear of the feed roller 2.
Shutter closed detection switch (MS4)	4	Is the shutter closed detection switch normal?	No	Replace the switch.
Finisher controller PCB			Yes	Replace the finisher controller PCB.

**22. Faulty second feed motor (related to MS3)**

Cause	Step	Checks	Yes/No	Action
Safety range switch (MS3)	1	Check the safety range switch. Is the switch normal?	No	Replace the switch.
	2	Is the safety range detection switch passed correctly?	No	Correct mechanical operation.
Shutter closed detection switch (MS4)	3	Check the shutter closed detection switch. Is the switch normal?	No	Replace the switch.
	4	Is the shutter closed detection switch pressed correctly?	No	Correct the mechanism.
Yes			Replace the finisher controller PCB.	
Finisher controller PCB				

## B. Saddle Stitcher Unit

### 1. Faulty paper positioning plate

Cause	Step	Checks	Yes/No	Action
Paper positioning plate home position sensor (PI7S)	1	Check the paper positioning plate home position sensor. Is the sensor normal?	No	Replace the sensor.
Saddle stitcher controller PCB	2	Do the paper positioning plates operate at a specific timing?	Yes	Replace the saddle stitcher controller PCB.
Paper positioning plate motor (M4S)			No	Check the positioning plate drive mechanism. If a fault is found, correct it. Otherwise, go to step 3.
Saddle stitcher controller PCB	3	Replace the paper positioning plate motor. Is the problem corrected?	Yes	End.
			No	Replace the saddle stitcher controller PCB.

### 2. Faulty paper folding motor

Cause	Step	Checks	Yes/No	Action
Paper folding motor clock sensor (PI4S)	1	Check the paper folding motor clock sensor. Is the sensor normal?	No	Replace the sensor.
Paper folding home position sensor (PI21S)	2	Check the paper folding home position sensor. Is the sensor normal?	No	Replace the sensor.
Saddle stitcher controller PCB	3	Does the paper folding motor operate at a specific timing?	Yes	Replace the saddle stitcher controller PCB.
Paper folding motor (M2S)			No	Check the paper folding roller drive mechanism. If a fault is found, correct it. Otherwise, go to step 4.
Saddle stitcher controller PCB	4	Replace the paper folding motor. Is the problem corrected?	Yes	End.
			No	Replace the saddle stitcher controller PCB.

### 3. Faulty guide motor

Cause	Step	Checks	Yes/No	Action
Guide home position sensor (PI13S)	1	Check the guide home position sensor. Is the sensor normal?	No	Replace the sensor.
Saddle stitcher controller PCB	2	Does the guide motor operate at a specific timing?	Yes	Replace the saddle stitcher controller PCB.
Guide motor (M3S)			No	Check the guide plate drive mechanism. If a fault is found, correct it. Otherwise, go to step 3.
Saddle stitcher controller PCB	3	Replace the guide motor. Is the problem corrected?	Yes	End.
			No	Replace the saddle stitcher controller PCB.

### 4. Faulty alignment motor

Cause	Step	Checks	Yes/No	Action
Alignment plate home position sensor (PI5S)	1	Check the alignment plate home position sensor. Is the sensor normal?	No	Replace the sensor.
Saddle stitcher controller PCB	2	Does the alignment motor operate at a specific timing?	Yes	Replace the saddle stitcher controller PCB.
Alignment motor (M5S)			No	Check the alignment plate drive mechanism. If a fault is found, correct it. Otherwise, go to step 3.
Saddle stitcher controller PCB	3	Replace the alignment motor. Is the problem corrected?	Yes	End.
			No	Replace the saddle stitcher controller PCB.

**5. Faulty stitcher**

Cause	Step	Checks	Yes/No	Action
Stitcher (installation)	1	Are the front and rear stitchers and bases installed correctly?	No	Install them correctly.
Stitching home position switch (MS7S/MS5S)	2	Is the stitching home position switch of the front and the rear stitchers normal?	No	Replace the front or rear stitcher.
Saddle stitcher controller PCB	3	Do the front and the rear stitchers operate at a specific timing?	Yes	Check the wiring between the stitcher and the saddle stitcher controller PCB. If normal, replace the controller PCB.
Stitcher motor (M7S/M6S)			No	Replace the front or the rear stitcher.

**6. Faulty paper pushing plate motor (related to PI14S)**

Cause	Step	Checks	Yes/No	Action
Paper pushing plate home position sensor (PI14S)	1	Check the paper pushing plate home position sensor. Is the sensor normal?	No	Replace the sensor.
Paper pushing top position sensor (PI15S)	2	Check the paper pushing plate top position sensor. Is the sensor normal?	No	Replace the sensor.
Saddle stitcher controller PCB	3	Does the paper pushing plate motor operate at a specific timing?	Yes	Replace the saddle stitcher controller PCB
Paper pushing plate motor (M8S)			No	Check the paper pushing plate drive mechanisms. If a fault is found, correct it. Otherwise, go to step 3.
			4	Replace the paper pushing plate motor. Is the problem corrected?
Saddle stitcher controller PCB			No	Replace the saddle stitcher controller PCB.



**7. Faulty paper pushing plate motor (related to PI15S)**

Cause	Step	Checks	Yes/No	Action
Paper pushing top position sensor (PI15S)	1	Check the paper pushing plate top position sensor. Is the sensor normal?	No	Replace the sensor.
Saddle stitcher controller PCB	2	Does the paper pushing plate motor operate at a specific timing?	Yes	Replace the saddle stitcher controller PCB.
Paper pushing plate motor (M8S)			No	Check the paper pushing plate drive mechanism. If a fault is found, correct it. Otherwise, go to step 3.
Saddle stitcher controller PCB	3	Replace the paper pushing plate motor. Is the problem corrected?	Yes	End.
			No	Replace the saddle stitcher controller PCB.

**8. Faulty paper pushing plate motor (related to PI1S)**

Cause	Step	Checks	Yes/No	Action
Paper pushing plate motor clock sensor (PI1S)	1	Check the paper pushing plate motor clock sensor. Is the sensor normal?	No	Replace the sensor.
Saddle stitcher controller PCB	2	Does the paper pushing plate motor operate at a specific timing?	Yes	Replace the saddle stitcher controller PCB.
Paper pushing plate motor (M8S)			No	Check the paper pushing plate drive mechanism. If a fault is found, correct it. Otherwise, go to step 3.
Saddle stitcher controller PCB	3	Replace the paper pushing plate motor. Is the problem corrected?	Yes	End.
			No	Replace the saddle stitcher controller PCB.

**9. Disconnected sensor connector (related to PI13S)**

Cause	Step	Checks	Yes/No	Action	
Guide home position sensor (PI13S; disconnected)	1	Are the connectors of the guide home position sensor and the saddle stitcher controller PCB connected correctly?	No	Replace the saddle stitcher controller PCB.	
Wiring	2	Is the wiring between the sensor and the saddle stitcher broken?	Yes		Correct the wiring.
Power supply	3	Is 5 VDC present at J9-7 on the saddle stitcher controller PCB?	No		
Ground	4	Is J9-8 on the saddle stitcher controller PCB grounded correctly?	No		

**10. Disconnected sensor connector (related to PI14S)**

Cause	Step	Checks	Yes/No	Action	
Paper pushing plate home position sensor (PI14S; disconnected)	1	Are the connectors of the paper pushing plate home position sensor and the saddle stitcher controller PCB connected correctly?	No	Replace the saddle stitcher controller PCB.	
Wiring	2	Is the wiring between the sensor and the saddle stitcher broken?	Yes		Correct the wiring.
Power supply	3	Is 5 VDC present at J9-10 on the saddle stitcher controller PCB?	No		
Ground	4	Is J9-11 on the saddle stitcher controller PCB grounded correctly?	No		

**11. Disconnected sensor connector (PI15S)**

Cause	Step	Checks	Yes/No	Action
Paper pushing plate home position top position sensor (PI15S; disconnected)	1	Are the connectors of the paper pushing plate top position sensor and the saddle stitcher controller PCB connected correctly?	No	Connect the connectors.
Wiring	2	Is the wiring between the sensor and the saddle stitcher broken?	Yes	Correct the wiring.
Power supply	3	Is 5 VDC present at J9-13 on the saddle stitcher controller PCB?	No	Replace the saddle stitcher controller PCB.
Ground	4	Is J9-14 on the saddle stitcher controller PCB grounded correctly?	No	

**12. Faulty microswitch**

Cause	Step	Checks	Yes/No	Action
Switch actuator	1	Check the switch actuator of the inlet door. Do the switch and the sensor operate correctly?	No	Correct the mechanism.
Inlet door switch (MS1S)	2	Check the inlet door switch. Is the switch normal?	No	Replace the switch.
Inlet cover sensor (PI9S)	3	Measure the voltage at J10-8 on the saddle stitcher controller PCB with the inlet cover open. Is it 5 V?	Yes	The sensor is faulty. Replace the sensor.
Power supply, wiring	4	Measure the voltage between J19-1 (+) and J19-2 (–) on the finisher controller PCB. Is it 24 V?	No	Replace the finisher controller PCB.
			Yes	Check the wiring between J19 on the finisher controller PCB and J1 on the saddle stitcher controller PCB. If a fault is found, correct it. Otherwise, replace the saddle stitcher controller PCB.

**13. Faulty microswitch (related to MS2S)**

Cause	Step	Checks	Yes/No	Action
Switch actuator	1	Check the switch actuator of the front door. Do the switch and the sensor operate correctly?	No	Correct the mechanism.
Front door switch (MS2S)	2	Check the front door switch. Is the switch normal?	No	Replace the switch.
Front door open/closed sensor (PI12S)	3	Measure the voltage at J11-12 on the saddle stitcher controller PCB with the front door open. Is it 5 V?	Yes	The sensor is faulty. Replace the sensor.
			No	Replace the saddle stitcher controller PCB.

**14. Faulty microswitch (related to MS3S)**

Cause	Step	Checks	Yes/No	Action
Switch actuator	1	Check the delivery door switch actuator. Do the switch and the sensor operate correctly?	No	Correct the mechanism.
Delivery switch (MS3S)	2	Check the delivery door switch. Is the switch normal?	No	Replace the switch.
Delivery cover sensor (PI3S)	3	Measure the voltage at J11-9 on the saddle stitcher controller PCB with the delivery door open. Is it 5 V?	Yes	The sensor is faulty. Replace the sensor.
			No	Replace the saddle stitcher controller PCB.

---

---

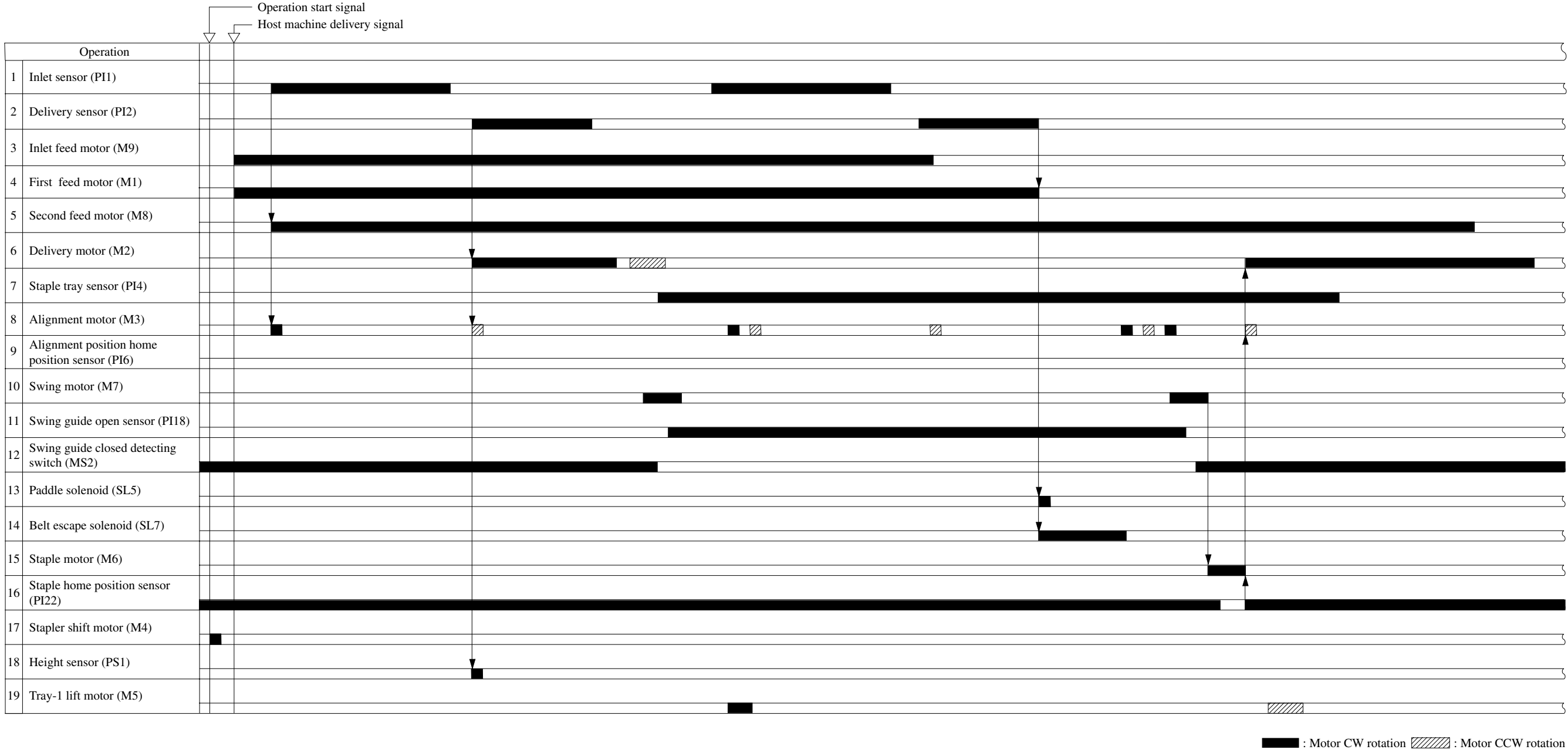
# APPENDIX

---

A.	FINISHER UNIT GENERAL TIMING CHART .....	A-1	D.	FINISHER UNIT CIRCUIT DIAGRAM .....	A-14
B.	SADDLE STITCHER UNIT GENERAL TIMING CHART .....	A-2	E.	SADDLE STITCHER UNIT CIRCUIT DIAGRAM .....	A-18
C.	SIGNAL AND ABBREVIATIONS .....	A-3			

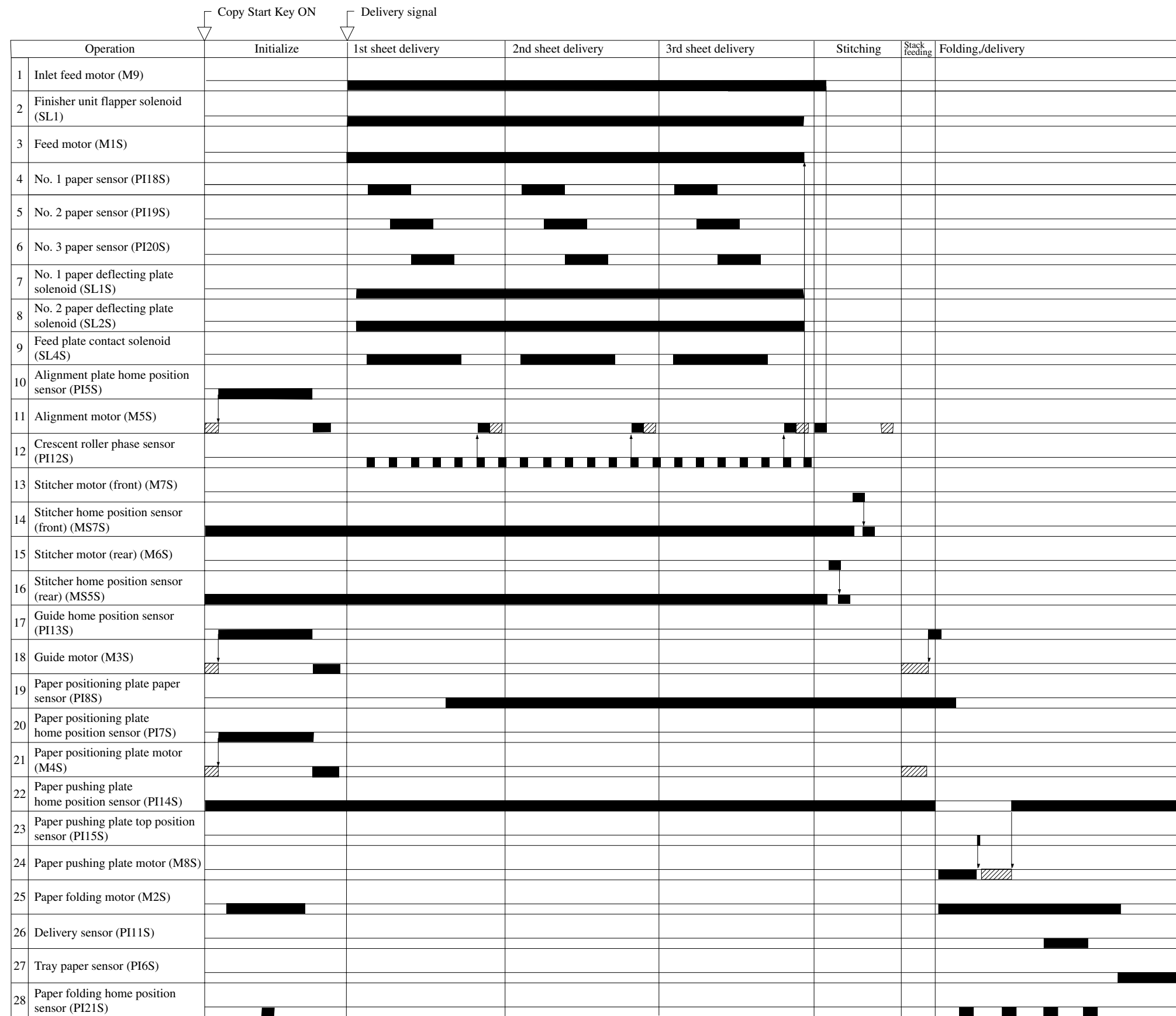
# A. FINISHER UNIT GENERAL TIMING CHART

A4, 2 Sheets, 1-Point Stapling (rear), 1 Set



# B. SADDLE STITCHER UNIT GENERAL TIMING CHART

A4R, 3 Sheets, Stitching, 1 Set



█ : Motor CW rotation █ : Motor CCW rotation

## C. SIGNAL AND ABBREVIATIONS

The following presents the abbreviations of signals used in this manual and in drawings, and the meanings of each signal.

### Reference:

Signals enclosed by brackets [ ] are electrical signals. However, the state “1” or “0” of these analog signals cannot be indicated. Otherwise, the state of digital signals “1” or “0” can be indicated.

#### Finisher unit

BESCPSL	BELT ESCAPE SOLENOID DRIVE Signal
BUFENTR	BUFFER PATH INLET PAPER DETECT Signal
BUFPASS	BUFFER PATH PAPER DETECT Signal
CRTSET	CARTRIDGE DETECT Signal
DELCLK	DELIVERY MOTOR CLOCK DETECT Signal
DROPN	DOOR OPEN DETECT Signal
DRSW	DOOR SWITCH Signal
ENTSL	BUFFER INLET SOLENOID DRIVE Signal
ESCP SL	ESCAPE SOLENOID DRIVE Signal
EXITSL	BUFFER OUTLET SOLENOID DRIVE Signal
FLPSL	FLAPPER SOLENOID DRIVE Signal
FSTTRAY	TRAY-1 PAPER DETECT Signal
HOOKEMP	HOOK EMPTY DETECT Signal
HOOKTOP	HOOK STOP POSITION DETECT Signal
JOGHP	ALIGNMENT PLATE HP DETECT Signal
JOINT	JOINT DETECT Signal
PDEL	DELIVERY DETECT Signal
PDLSL	PADDLE SOLENOID DRIVE Signal
PENT	INLET PAPER DETECT Signal
SHUTCLD	SHUTTER CLOSED DETECT SWITCH Signal
SNDTRAY	TRAY-2 PAPER DETECT Signal
STOPN	SHUTTER OPEN DETECT Signal
STPCON	STAPLER CONNECT DETECT Signal
STPDRHP	STAPLER DRIVE HP DETECT Signal
STPHP	STAPLER HP DETECT Signal
STPTY	STAPLE TRAY PAPER DETECT Signal
SWGCLK	SWING GUIDE CLOCK DETECT Signal
SWGGLD	SWING GUIDE CLOSED DETECT SWITCH Signal
SWGOPN	SWING GUIDE OPEN DETECT Signal
TRAYSAF	TRAY SAFETY SWITCH Signal
TRYHP1, TRYHP2	TRAY HOME POSITION DETECT Signal
TRYLMT	TRAY UPPER LIMIT DETECTING SWITCH Signal

#### Saddle stitcher unit

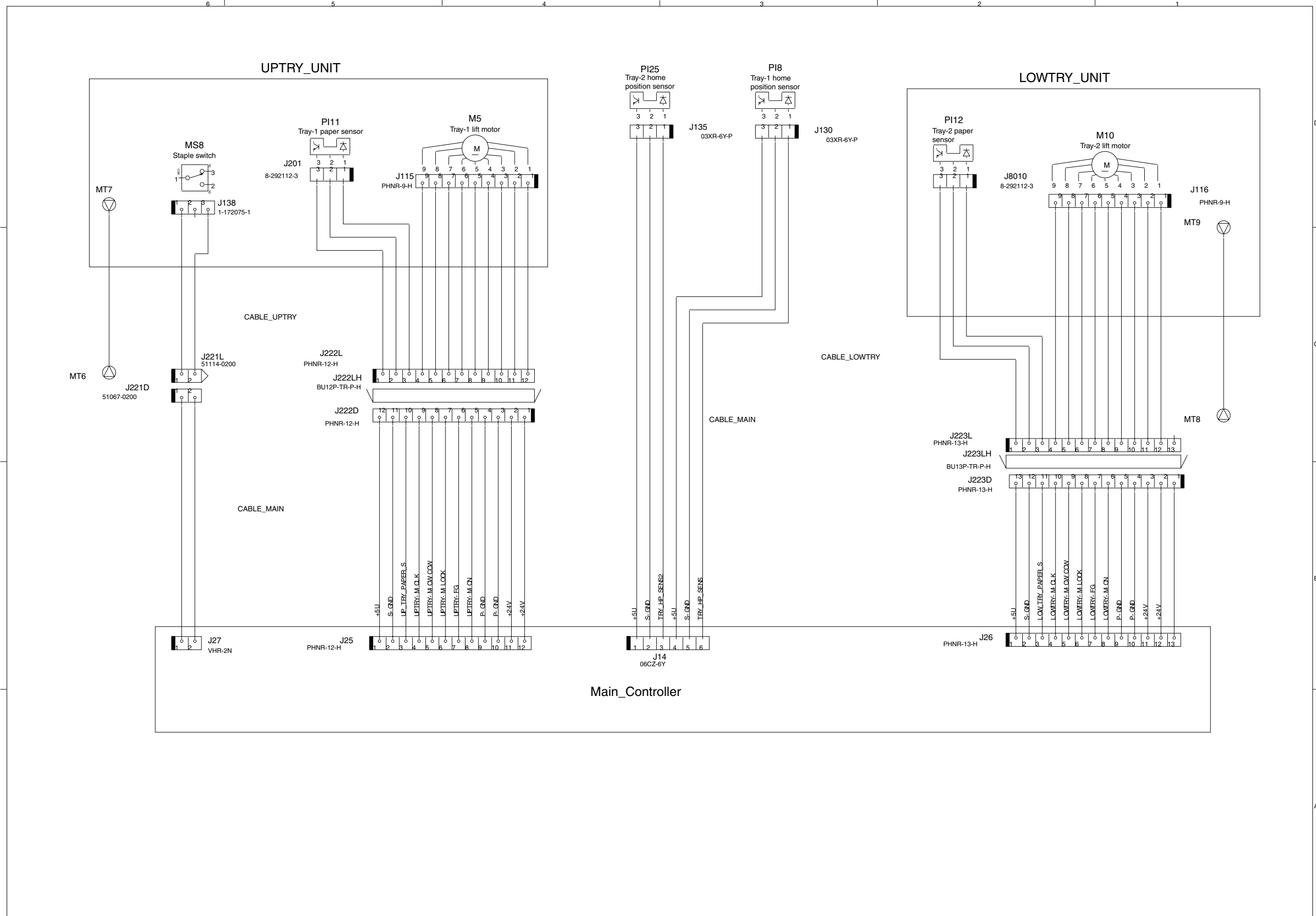
1STPA	No.1 PAPER SENSOR DETECT Signal
2NDPA	No.2 PAPER SENSOR DETECT Signal
3RDDPA	No.3 PAPER SENSOR DETECT Signal
DELV	DELIVERY DETECT Signal
DELVMS	DELIVERY DOOR OPEN DETECT SWITCH Signal
EJCVR	DELIVERY DOOR OPEN DETECT Signal
FDR	FRONT DOOR OPEN DETECT Signal
FDRLHP	CRESCENT ROLLER PHASE DETECT Signal

FDROPN	FRONT DOOR OPEN DETECT SWITCH Signal
FLDCLK	FOLD MOTOR CLOCK Signal
FLPSL1	FLAPPER DRIVE Signal 1
FSPSL2	FLAPPER DRIVE Signal 2
GIDHP	PAPER GUIDE HOME POSITION DETECT Signal
HKEMP1	HOOK EMPTY DETECT Signal 1
HKEMP2	HOOK EMPTY DETECT Signal 2
INLTCVR	INLET COVER OPEN DETECT Signal
INLTCVRMS	INLET COVER OPEN SWITCH Signal
JOGHP	ALIGNMENT HP DETECT Signal
LUNGECLK	LUNGE MOTOR CLOCK Signal
LUNGEHP	LUNGE HOME POSITION DETECT Signal
LUNGETOP	LUNGE TOP POSITION DETECT Signal
PAFLDHP	PAPER FOLD HOME POSITION DETECT Signal
PAPPOS	PAPER POSITION PLATE HP DETECT Signal
PPOSPAR	PAPER POSITIONING GUIDE PAPER DETECT Signal
RLNIPSL	FEED PLATE CONTACT SOLENOID DRIVE Signal
STCHHP1	STITCHING HP DETECT Signal 1
STCHHP2	STITCHING HP DETECT Signal 2
STPLHP	STITCHER IN DETECT Signal
TRYPAR	TRAY PAPER DETECT Signal
VPJM	VERTICAL PATH PAPER DETECT Signal

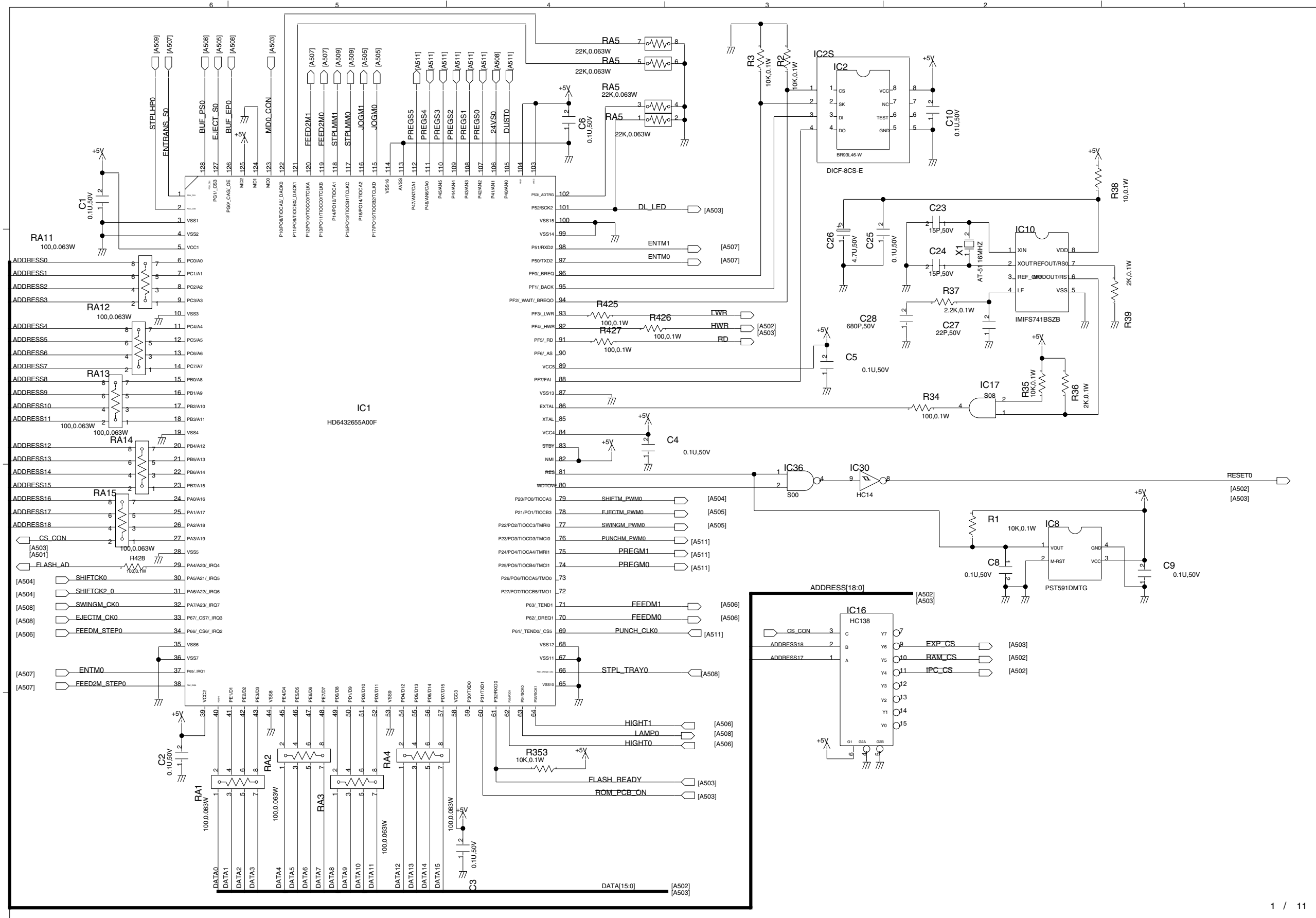




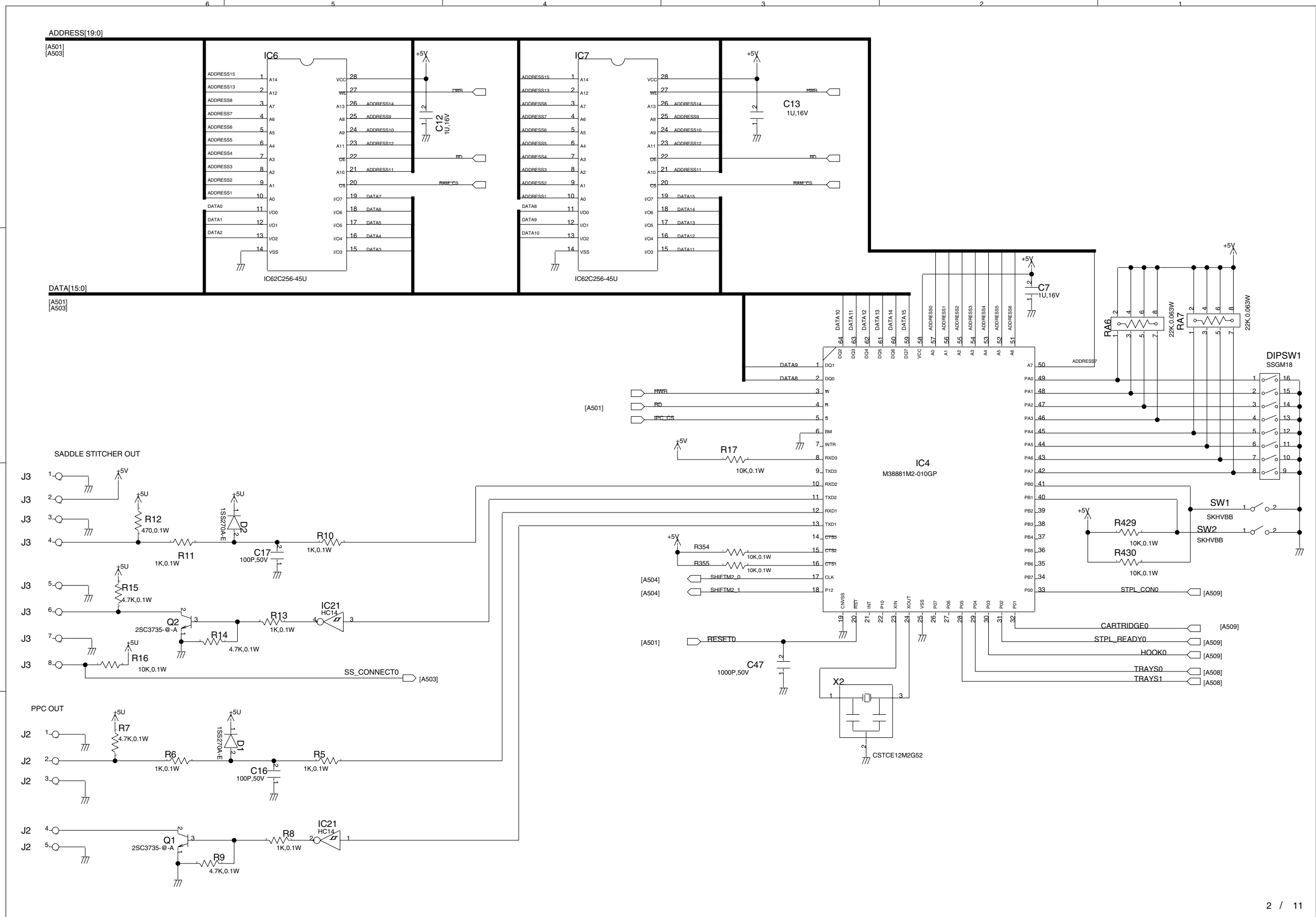




# 1. Finisher Controller PCB (A501)

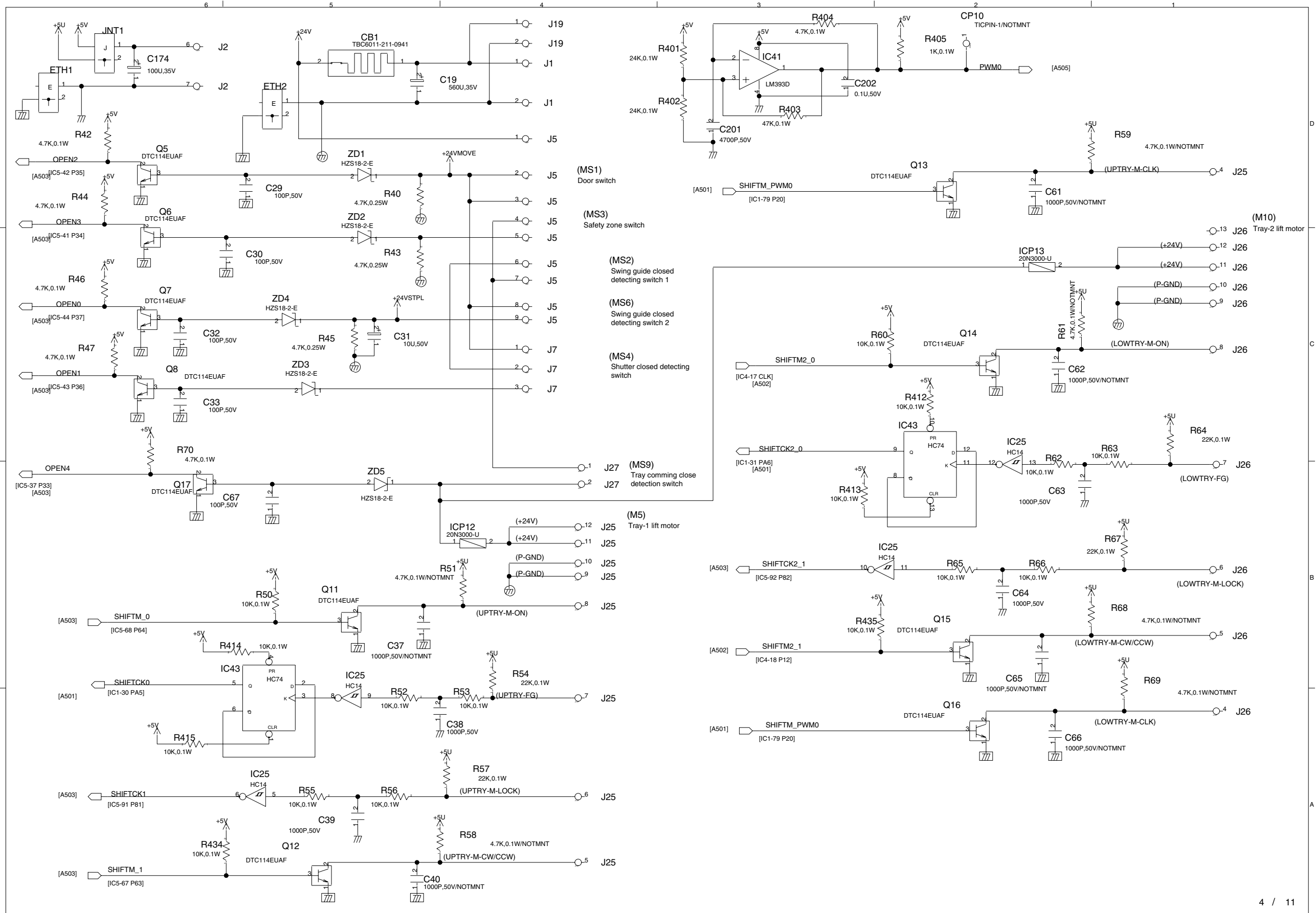


# 1. Finisher Controller PCB (A502)

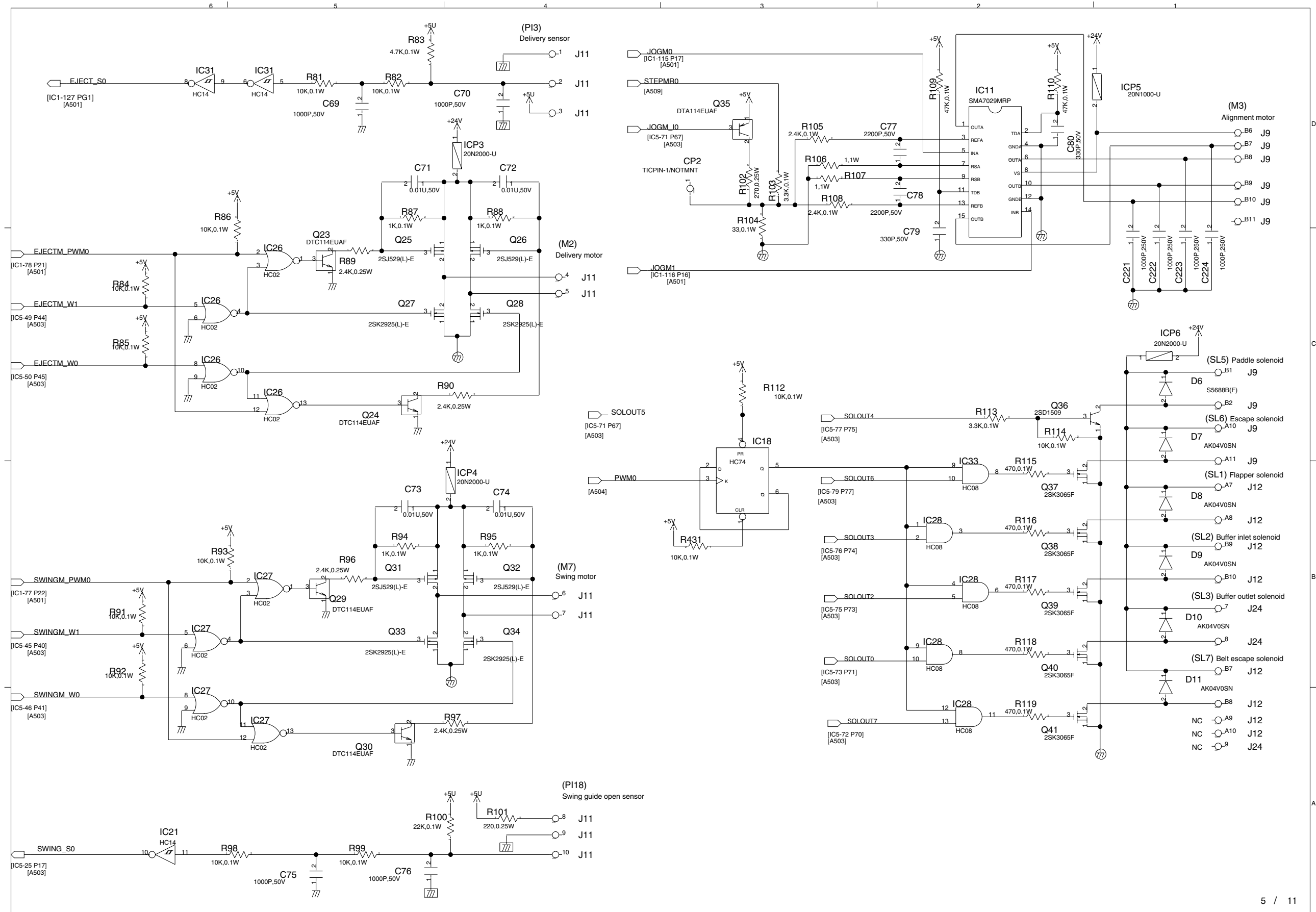




# 1. Finisher Controller PCB (A504)

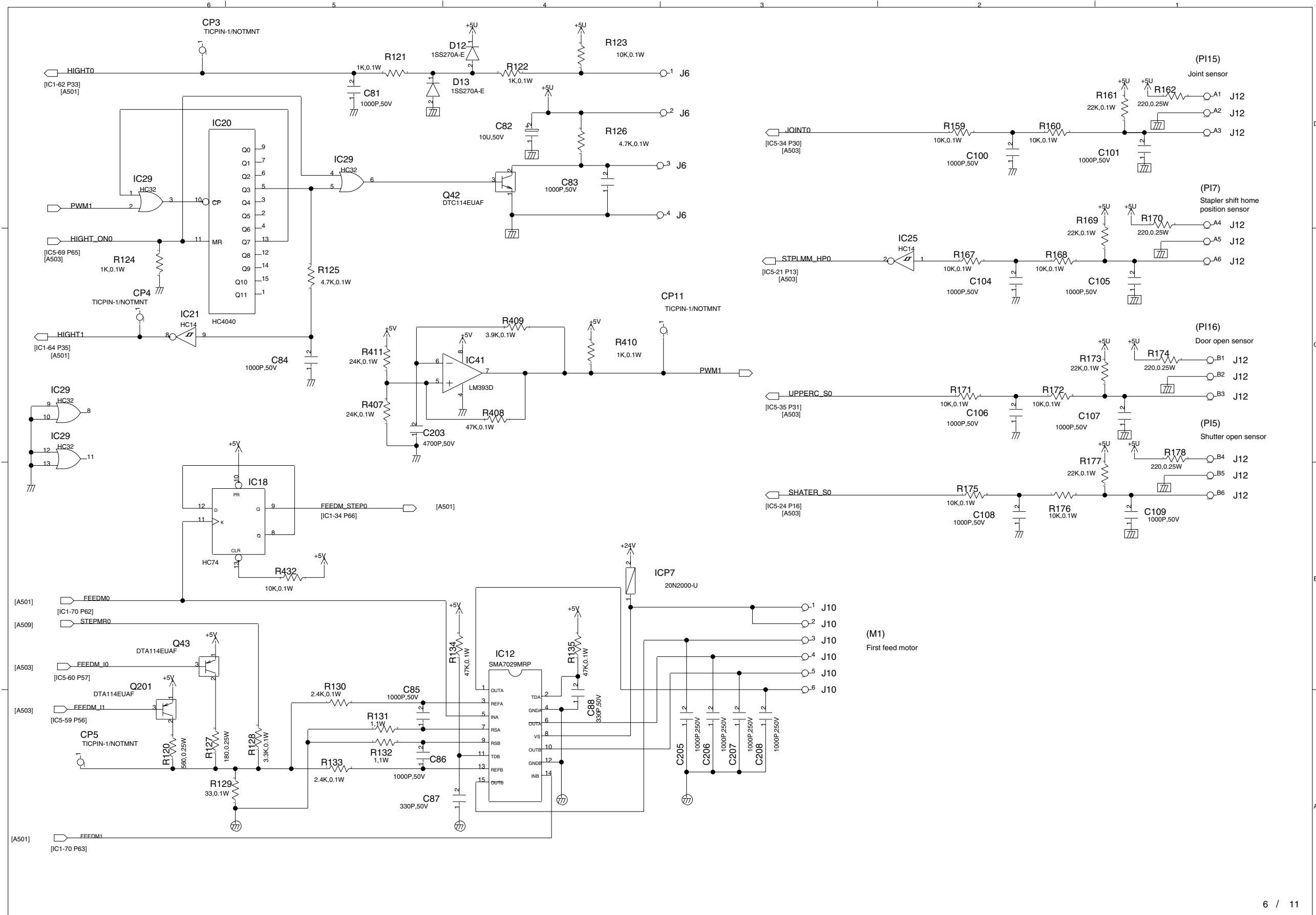


# 1. Finisher Controller PCB (A505)

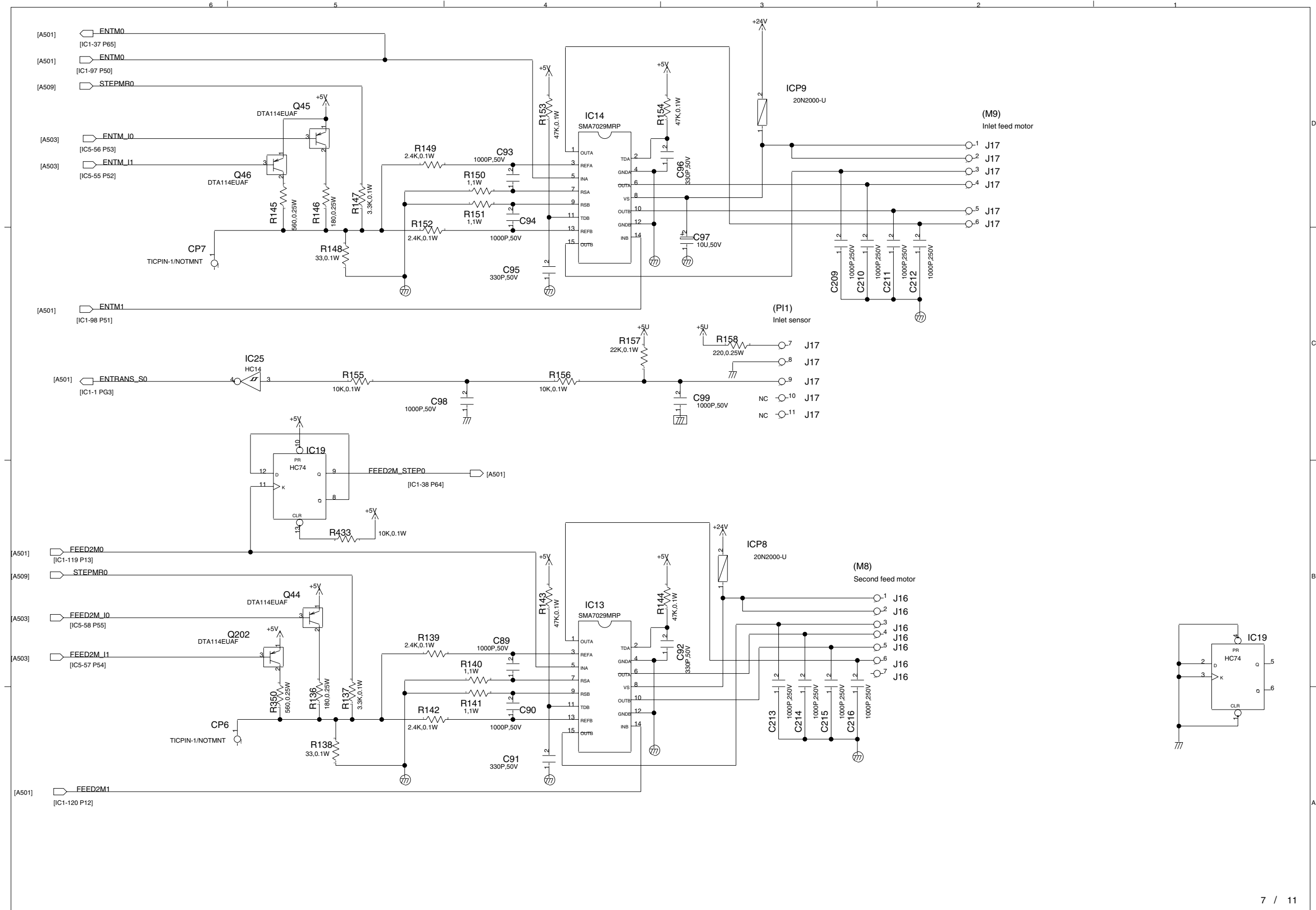




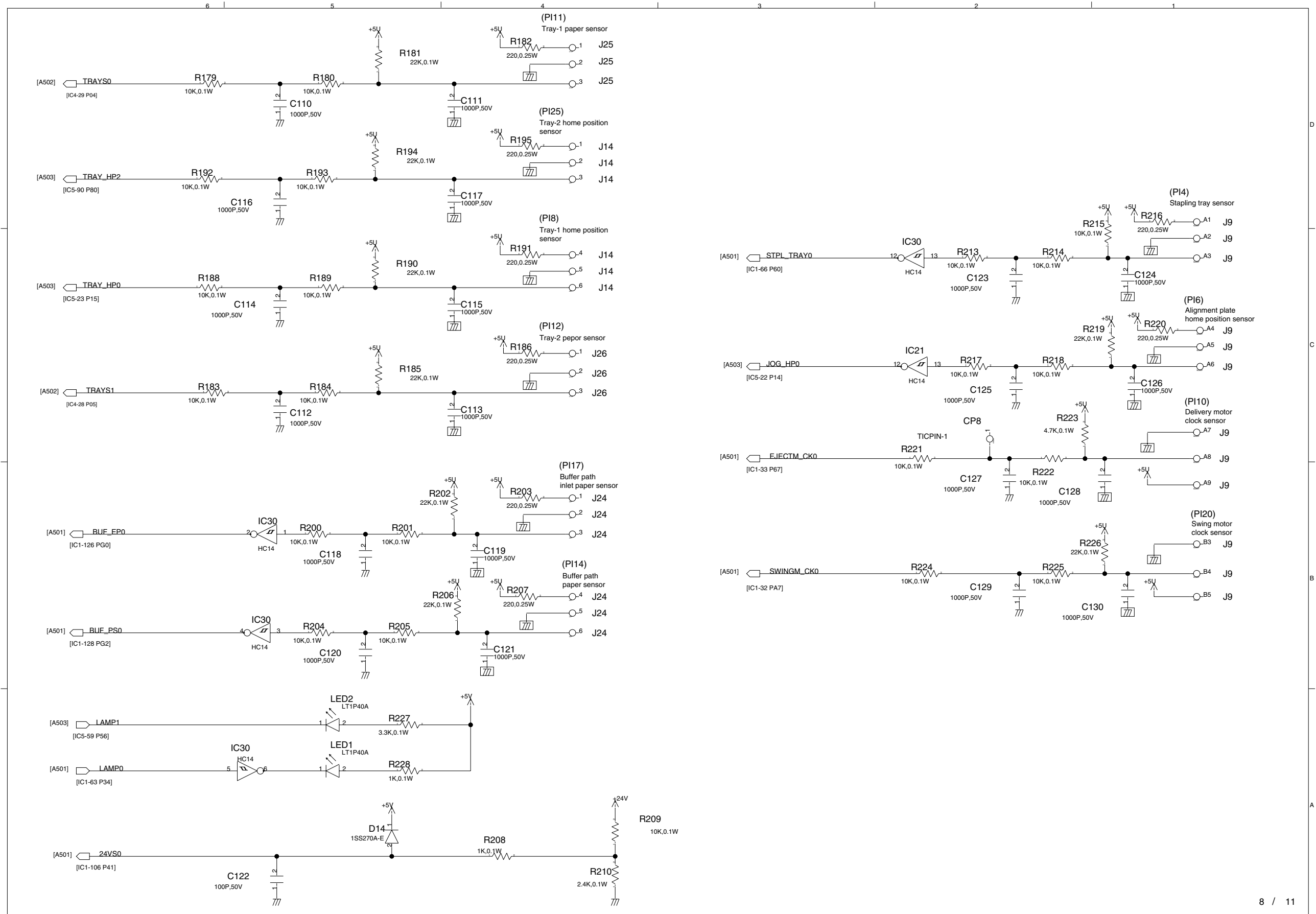
# 1. Finisher Controller PCB (A506)



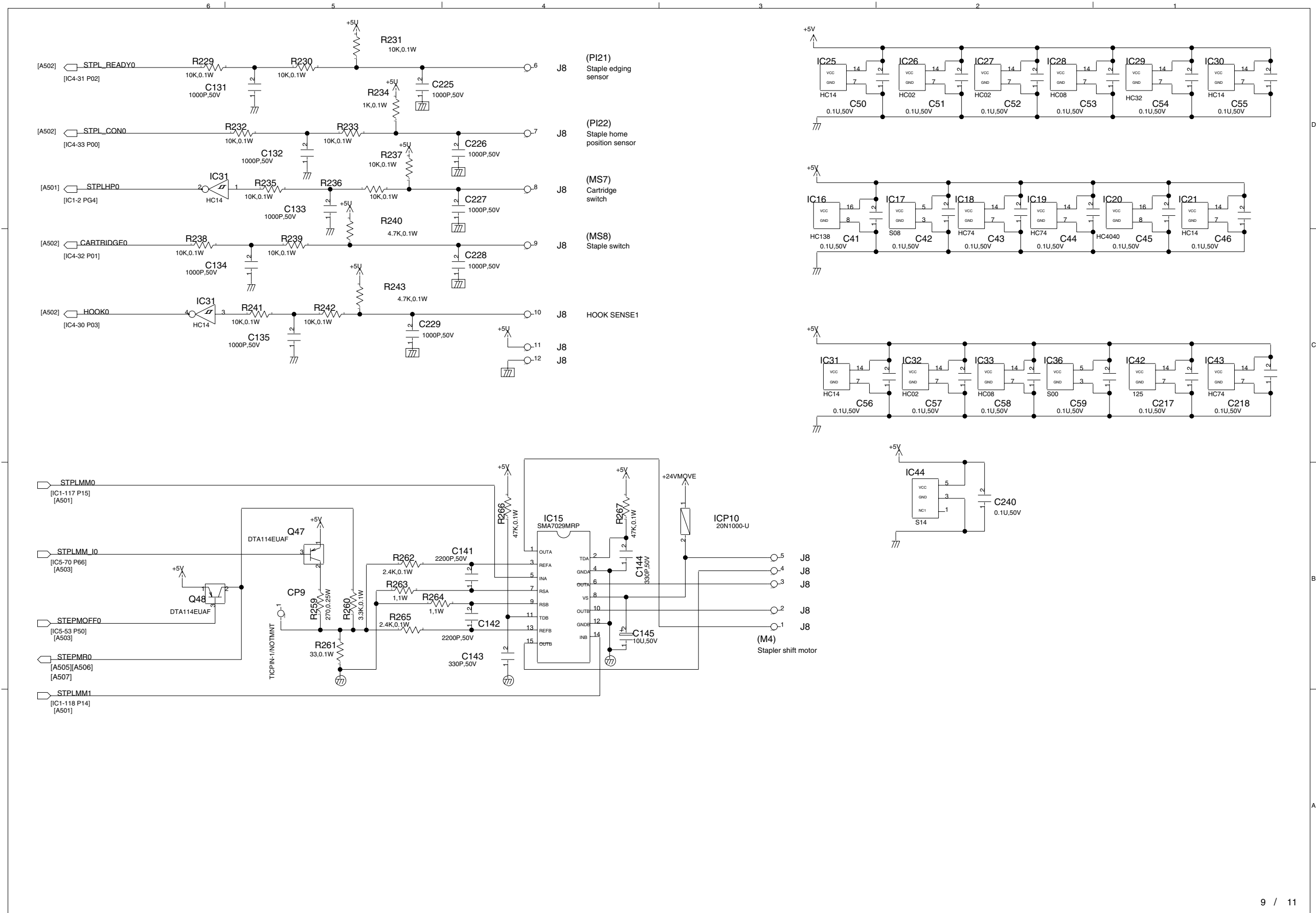
# 1. Finisher Controller PCB (A507)



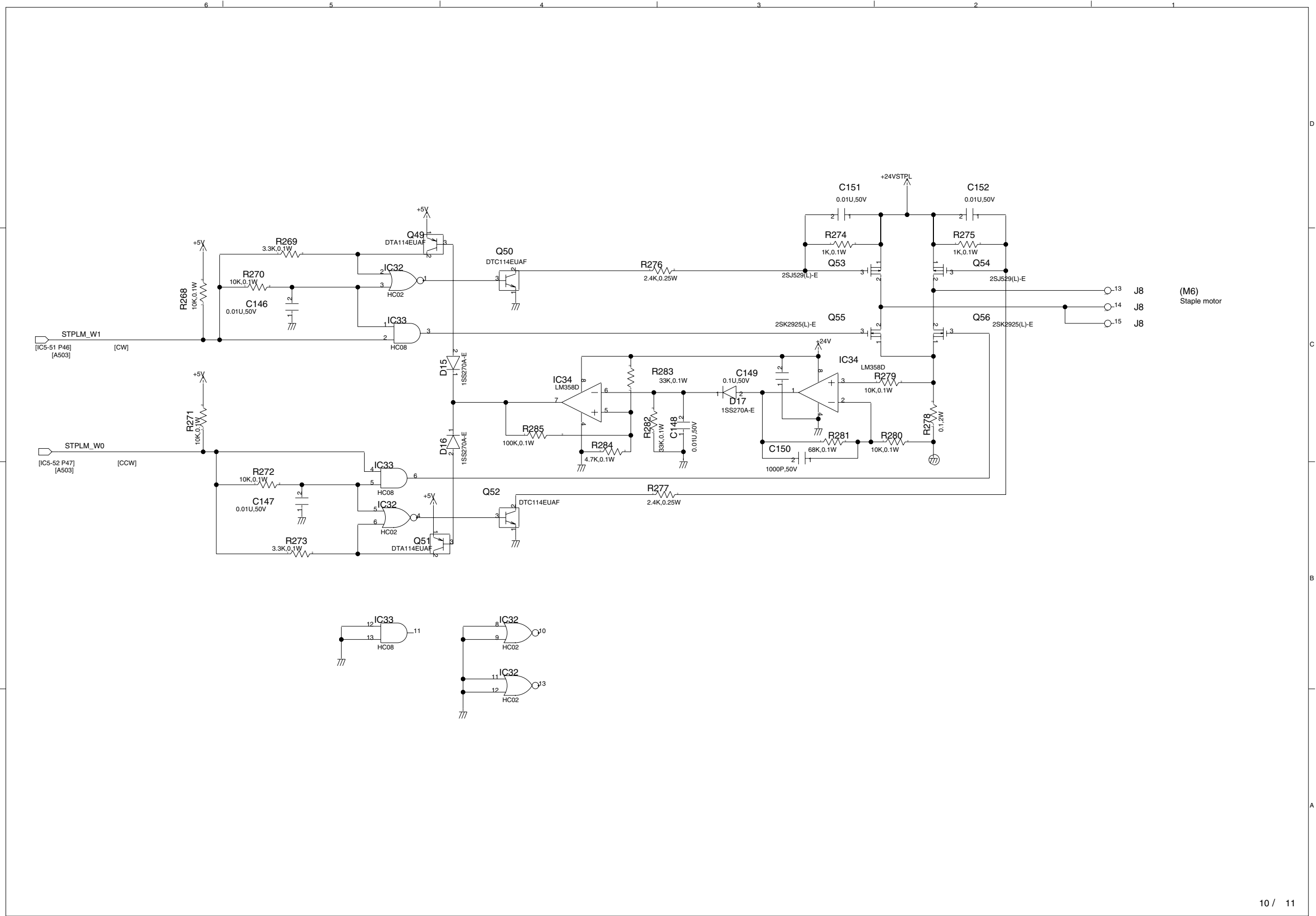
# 1. Finisher Controller PCB (A508)



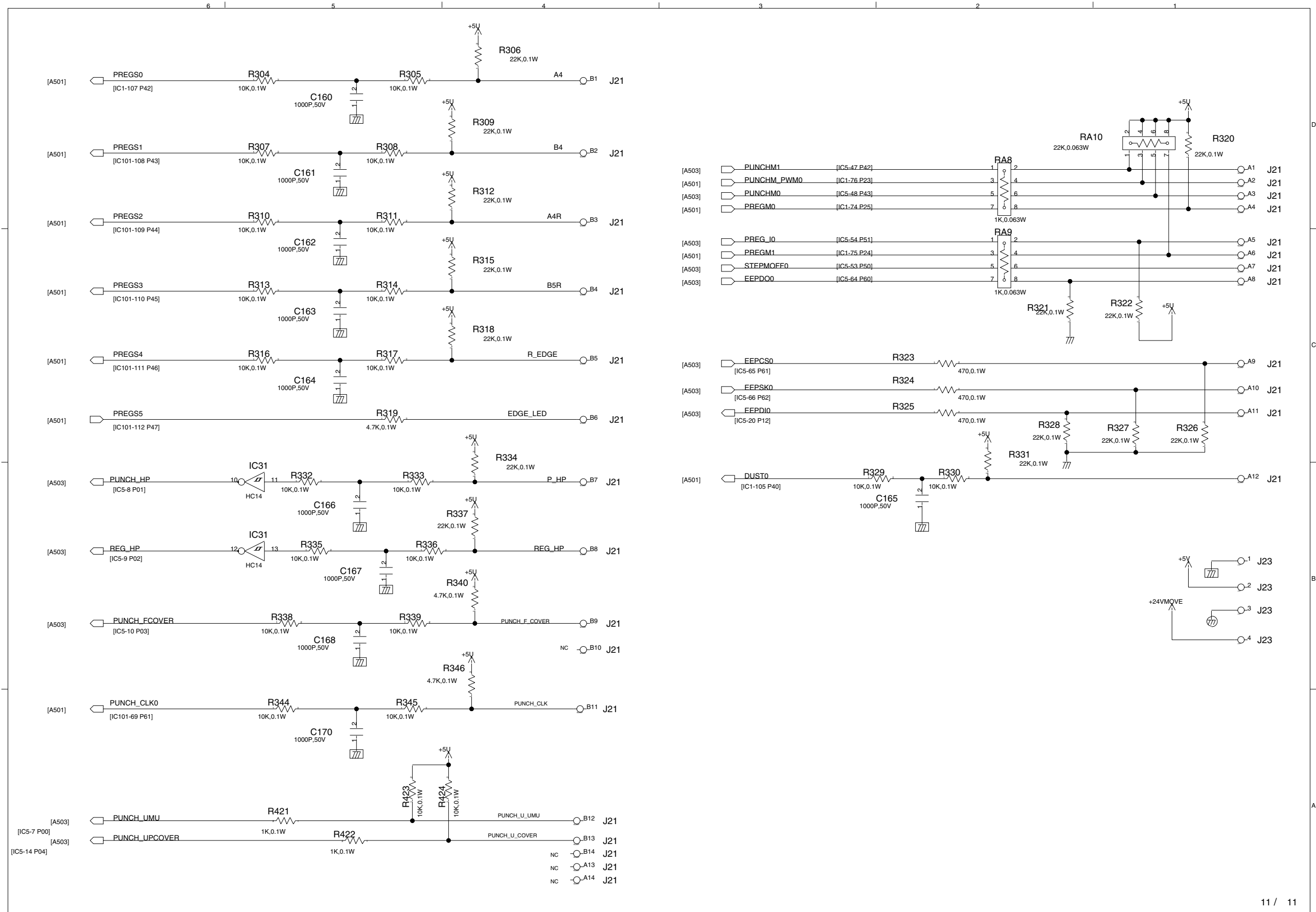
# 1. Finisher Controller PCB (A509)



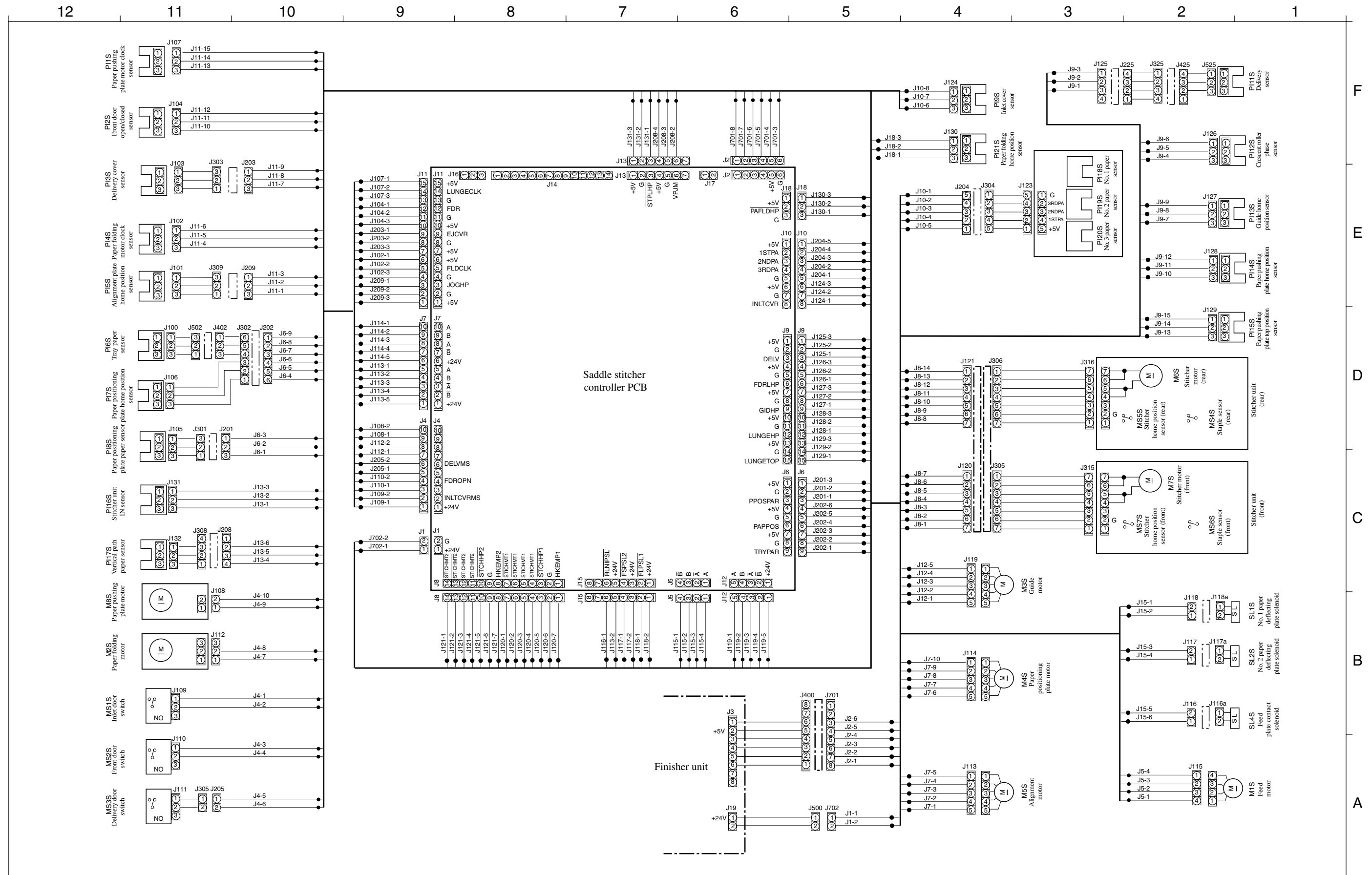
# 1. Finisher Controller PCB (A510)



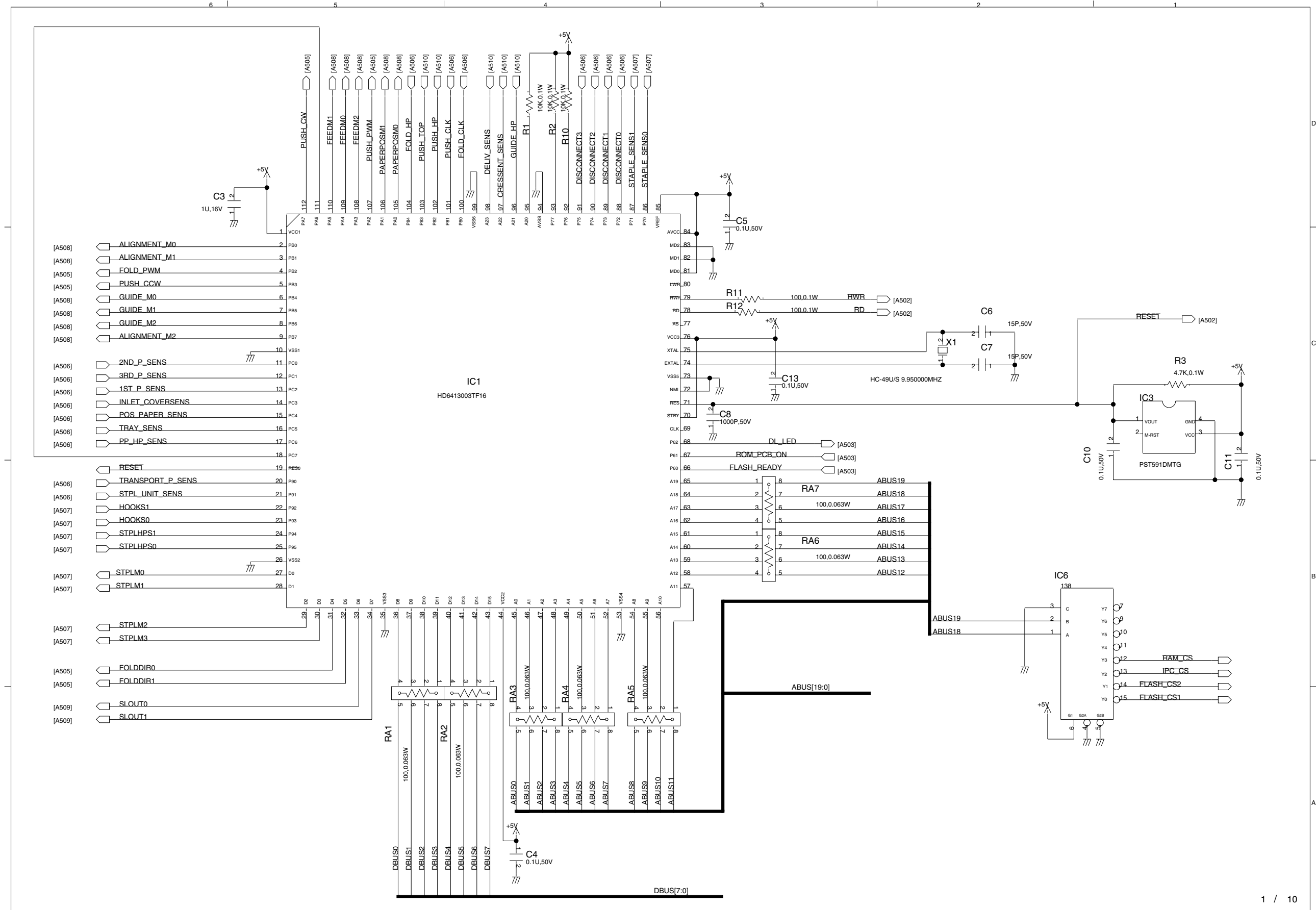
# 1. Finisher Controller PCB (A511)



# E. SADDLE STITCHER UNIT CIRCUIT DIAGRAM



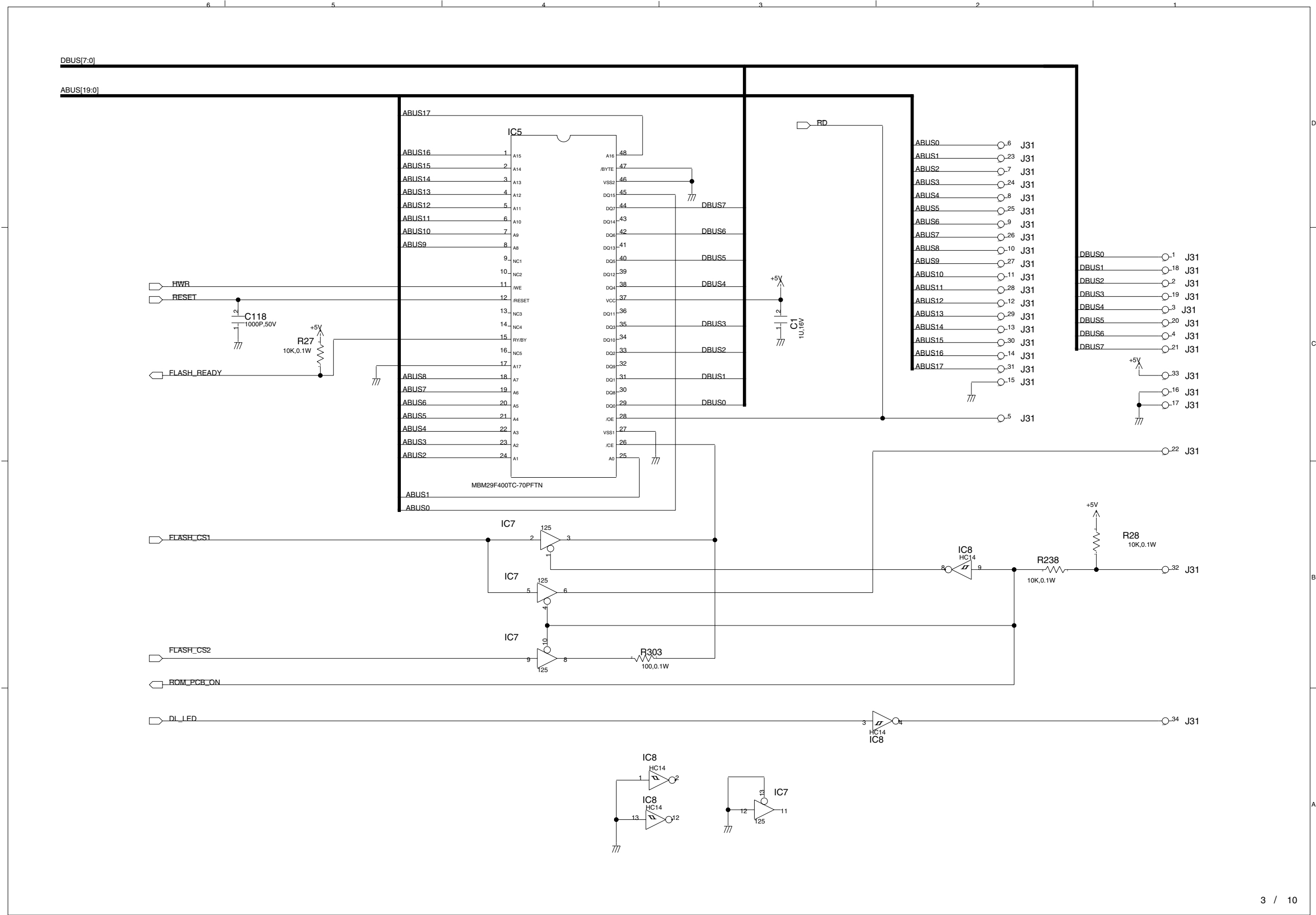
# 1. Saddle Stitcher Unit PCB (A501)



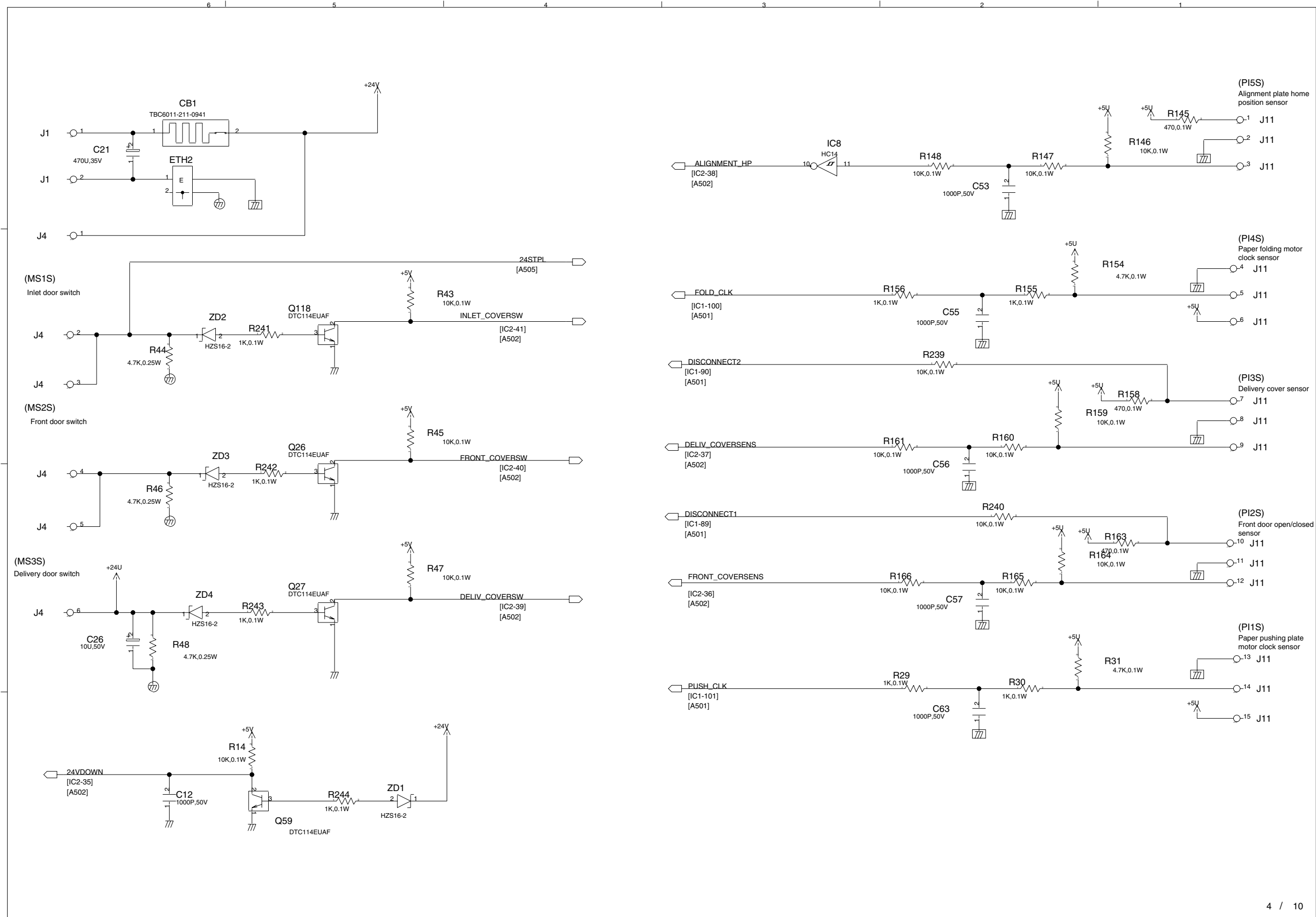




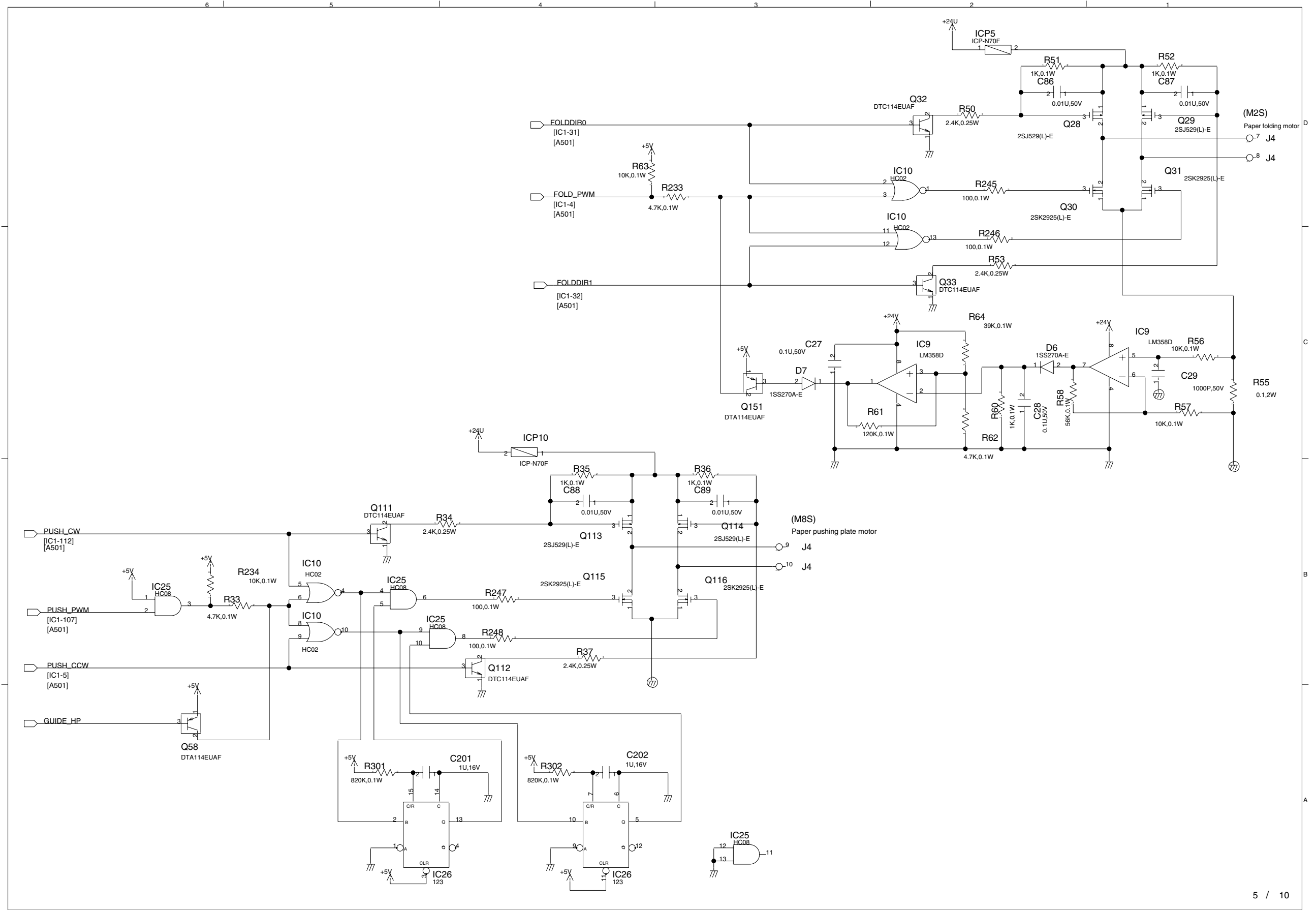
# 1. Saddle Stitcher Unit PCB (A503)



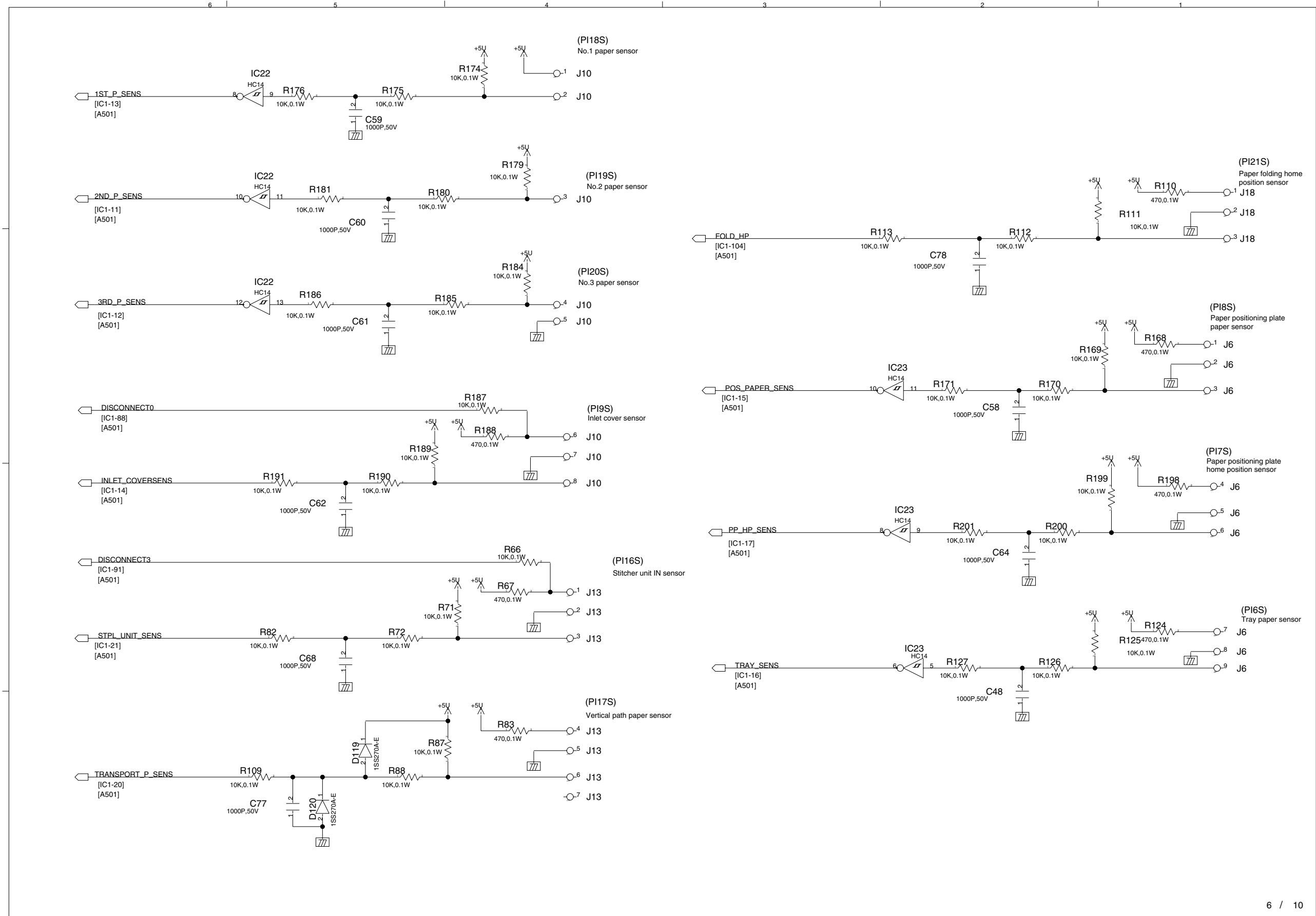
# 1. Saddle Stitcher Unit PCB (A504)



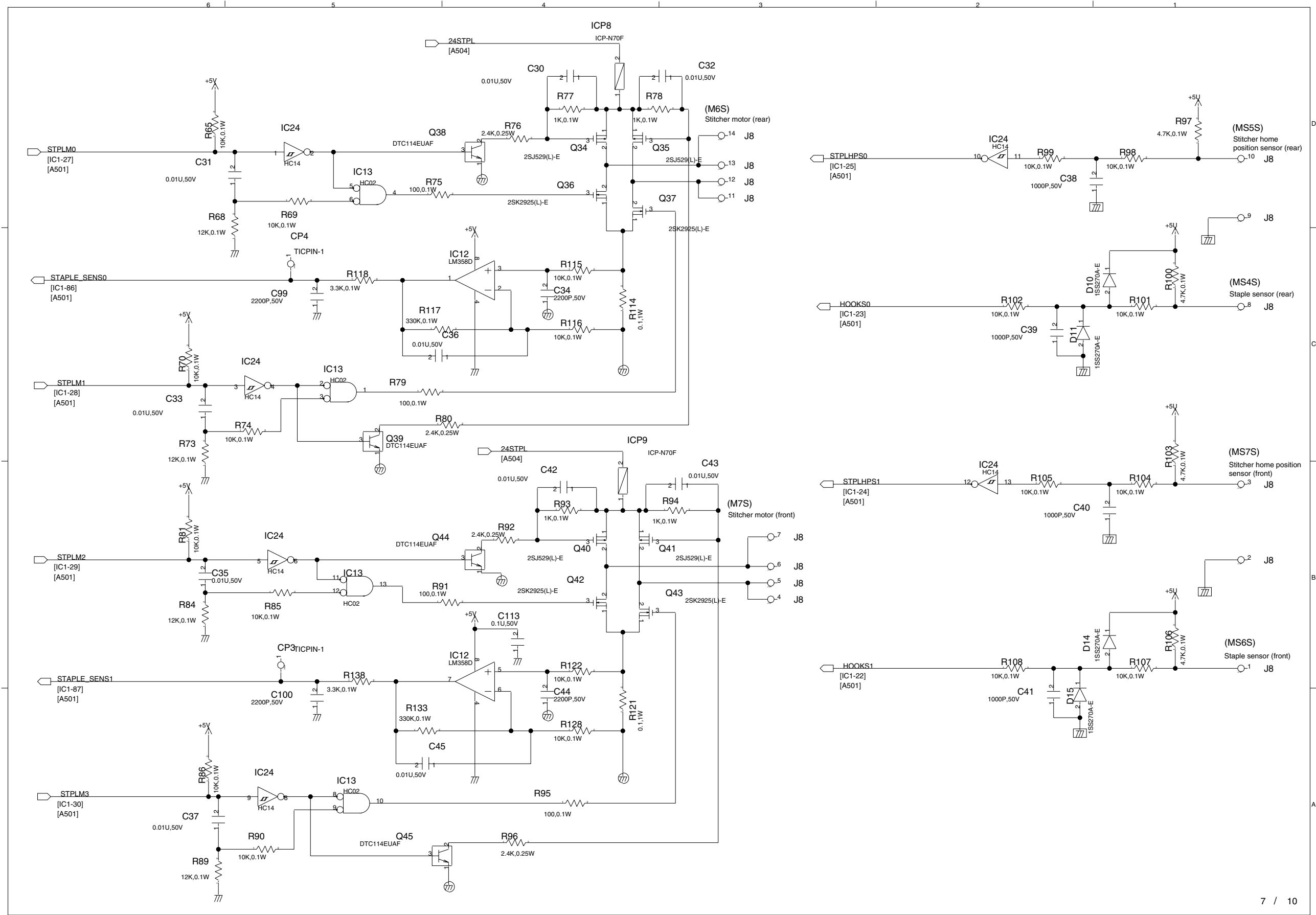
# 1. Saddle Stitcher Unit PCB (A505)



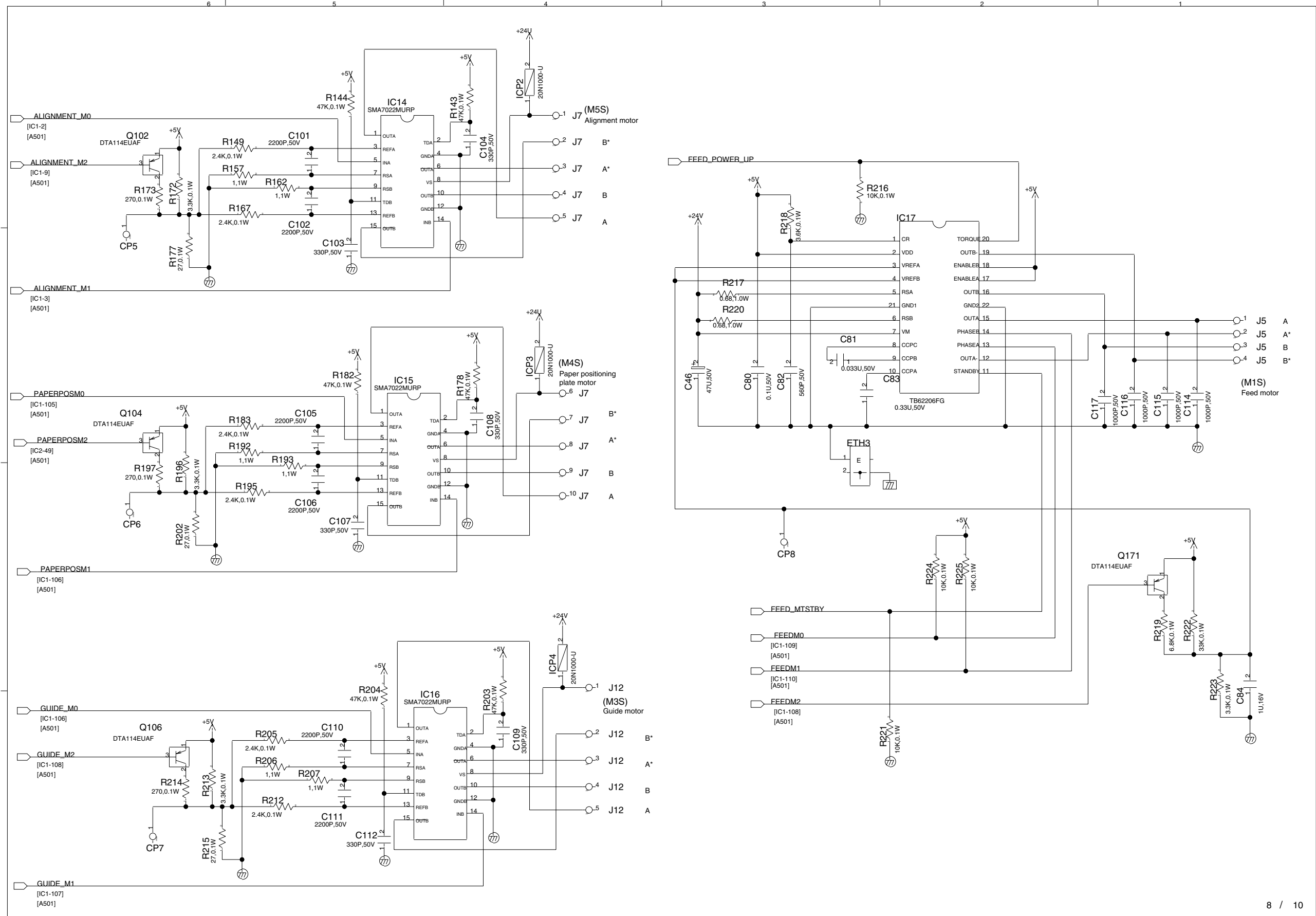
# 1. Saddle Stitcher Unit PCB (A506)



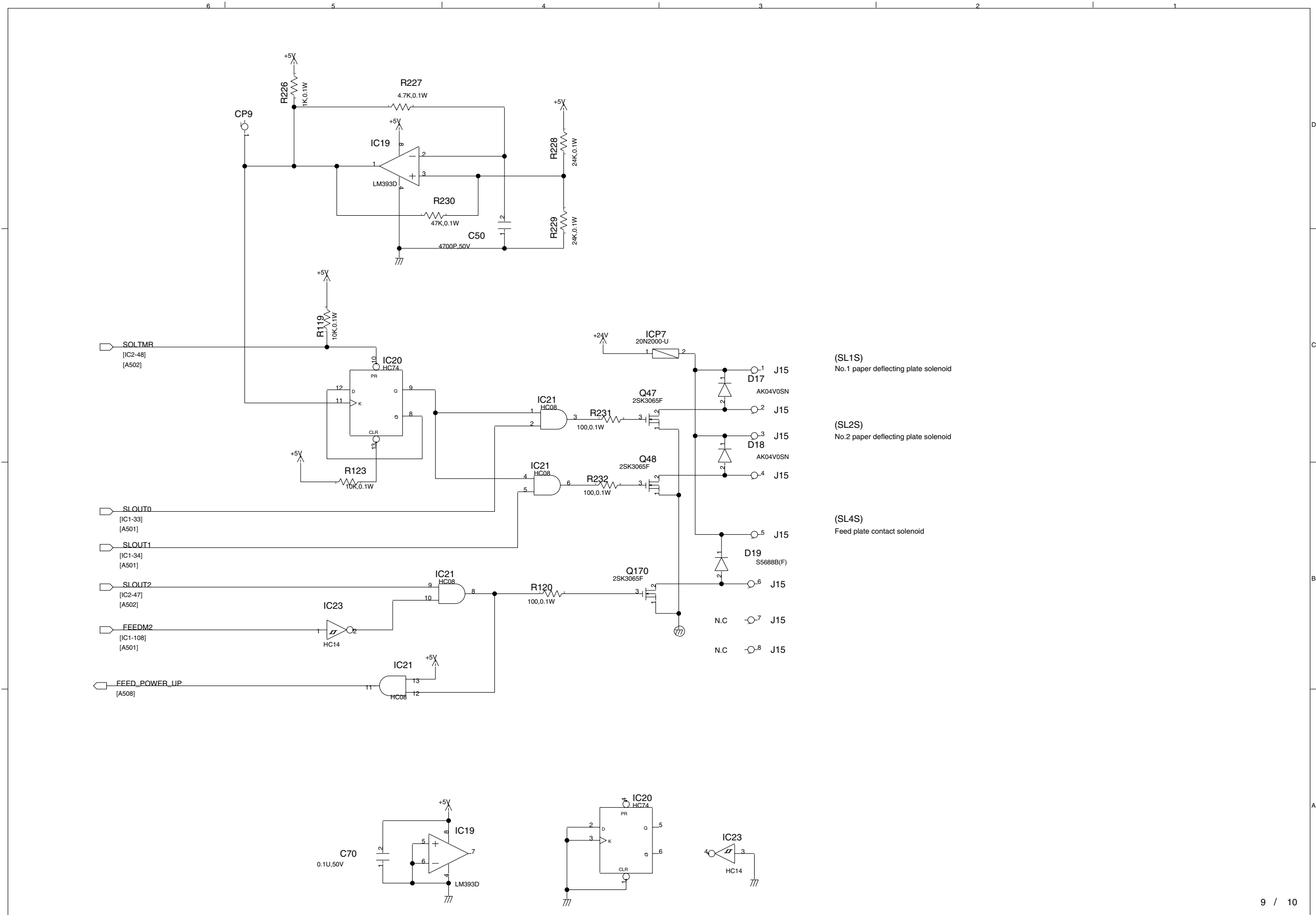
# 1. Saddle Stitcher Unit PCB (A507)



# 1. Saddle Stitcher Unit PCB (A508)

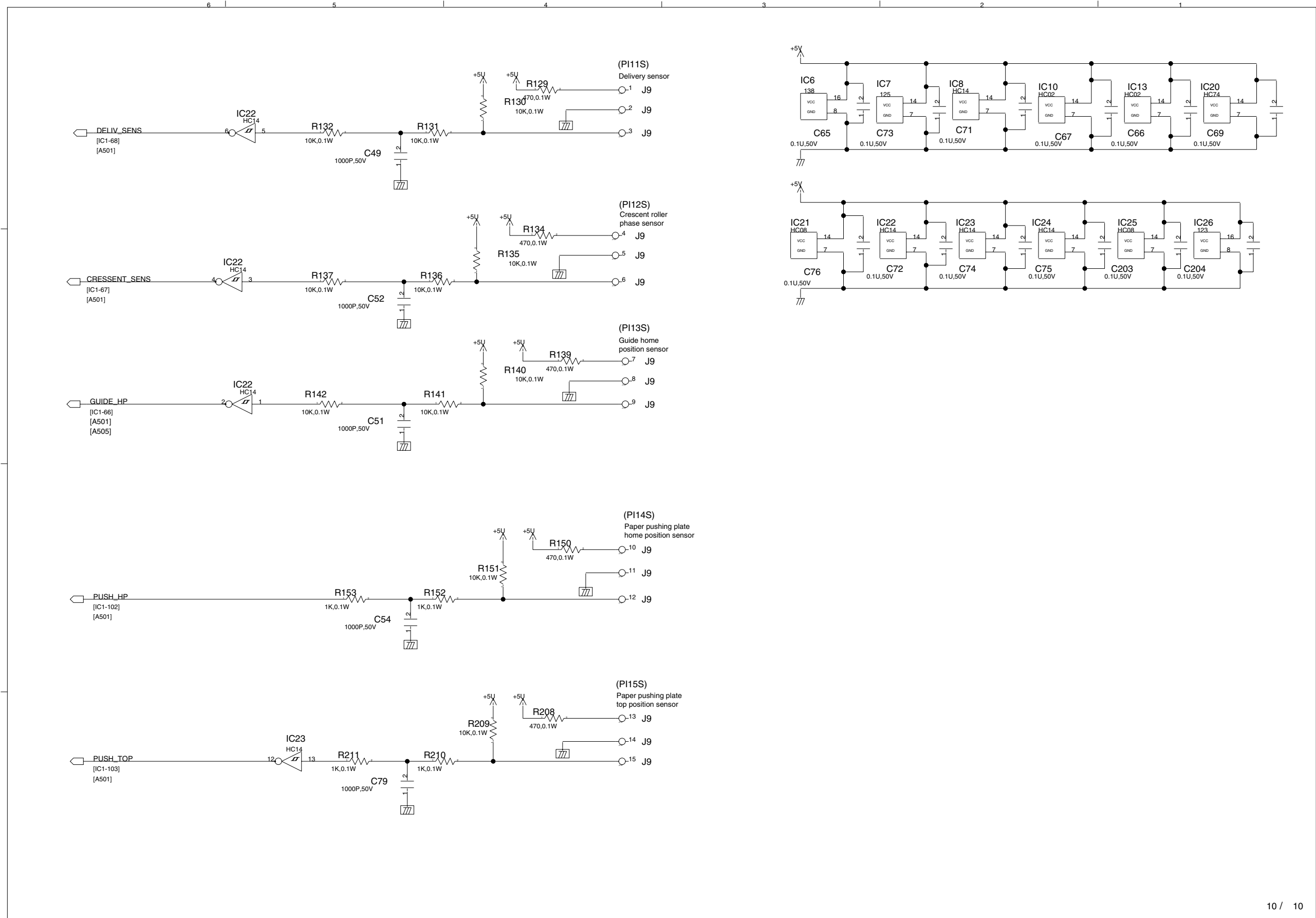


# 1. Saddle Stitcher Unit PCB (A509)





# 1. Saddle Stitcher Unit PCB (A510)



## F. SOLVENTS AND OILS

No.	Name	Description	Composition	Remarks
1	Cleaner	Cleaning: e.g., glass, plastic, rubber parts, external covers	Hydrocarbon (fluorine family) Alcohol Surface activating agent Water	<ul style="list-style-type: none"><li>· Do not bring near fire.</li><li>· Procure locally.</li><li>· Isopropyl alcohol may be substituted.</li></ul>
2	Lubricant	Drive, friction parts, lead cam	Silicone oil	

**TOSHIBA**

**TOSHIBA TEC CORPORATION**

2-17-2, HIGASHIGOTANDA, SHINAGAWA-KU, TOKYO, 141-8664, JAPAN