

# TOSHIBA

# SERVICE MANUAL

Bridge Kit

# KN-2520/2550/5005



Model: KN-2520/2550/5005  
Publish Date: April 2009  
File No. SME090009B0  
R090121H3201-TTEC  
Ver02 F\_2016-03

## Trademarks

- MOLYKOTE® is a registered trademark of Dow Corning Corporation.
- Other company names and product names in this manual are the trademarks of their respective companies.

© 2009 - 2016 TOSHIBA TEC CORPORATION All rights reserved

Under the copyright laws, this manual cannot be reproduced in any form without prior written permission of TOSHIBA TEC CORPORATION.

# General Precautions for Installation/Service/Maintenance for the equipment

The installation and service should be done by a qualified service technician.

1. When installing the equipment to the MFP, be sure to follow the instructions described in the "Unpacking/Set-Up Procedure for the equipment" booklet which comes with each unit of the equipment.
2. The equipment should be installed by an authorized/qualified person.
3. The equipment weights approximately 4 kg (8.8 lb), therefore pay full attention when handling it.
4. The equipment must be grounded for safety.
5. Before starting installation, servicing or maintenance work, be sure to turn off and unplug the equipment first.
6. The equipment shall be installed near the socket outlet and shall be easily accessible.
7. Be sure to fix and plug in the power cable securely after the installation so that no one trips over it.
8. Unplug the power cable and clean the area around the prongs of the plug and socket outlet once a year or more. A fire may occur when dust lies on this area.
9. The equipment should be grounded to the specified position on the machine frame.
10. When servicing or maintaining the equipment, be careful about the rotating or operating sections such as gears, pulleys, sprockets, cams, belts, etc.
11. When parts are disassembled, reassembly is basically the reverse of disassembly unless otherwise noted in this manual or other related materials.  
Be careful not to reassemble small parts such as screws, washers, pins, E-rings, toothed washers to the wrong places.
12. When selecting the installation site, avoid placing the finisher/hole punch unit and equipment on different levels or inclined floors.  
If the heights of the finisher/hole punch unit and the equipment differ, adjust them before the installation.
13. Basically, the machine should not be operated with any parts removed or disassembled.
14. When servicing the machines with the power turned ON, be sure not to touch live sections and rotating/operating sections.
15. Delicate parts for preventing safety hazard problems (such as switches, sensors, etc. if any) should be handled/installed/adjusted correctly.
16. Use suitable measuring instruments and tools.
17. During servicing or maintenance work, be sure to check the nameplate and other cautionary labels (if any) to see if they are clean and firmly stuck. If not, take appropriate actions.

18. The PC board must be stored in an anti-electrostatic bag and handled carefully using a wristband, because the ICs on it may be damaged due to static electricity. Before using the wrist band, pull out the power cord plug of the equipment and make sure that there is no uninsulated charged objects in the vicinity.
19. For the recovery and disposal of used equipment, consumable parts and packing materials, follow the relevant local regulations/rules.
20. After completing installation, servicing and maintenance of the equipment, return the equipment to its original state, and check operation.
21. Check the procedures and perform them as described in the Service Manual.
22. Make sure you do not lose your balance.
23. Avoid exposure to your skin and wear protective gloves as needed.
24. Do not leave plastic bags where children can get at them. This may cause an accident such as suffocation if a child puts his/her head into a bag. Plastic bags of options or service parts must be brought back.

# CONTENTS

<b>1. SPECIFICATIONS</b> .....	<b>1-1</b>
<b>2. GENERAL DESCRIPTION</b> .....	<b>2-1</b>
2.1 Sectional View.....	2-1
2.2 Electric Parts Layout.....	2-2
2.3 Symbols and Functions of Various Components.....	2-2
<b>3. DESCRIPTION OF OPERATIONS</b> .....	<b>3-1</b>
3.1 General Description .....	3-1
3.2 Driving System.....	3-2
<b>4. DISASSEMBLY AND ASSEMBLY</b> .....	<b>4-1</b>
4.1 Disassembly Procedure .....	4-1
4.2 Lubrication.....	4-5
<b>5. ELECTRIC CIRCUIT</b> .....	<b>5-1</b>
5.1 Harness Connection Diagram .....	5-1



# 1. SPECIFICATIONS

Item	KN-2520	KN-2550	KN-5005	Remarks
Paper size	A3, A4, A4-R, A5-R, B4, B5, B5-R, FOLIO, LD, LG, LT, LT-R, ST-R, COMPUTER, 13"LG, 8.5"x8.5", 8K, 16K, 16K-R	A3, A3 wide*, SR-A3*, A4, A4-R, A5-R, B4, B5, B5-R, A6-R, FOLIO, LD, LG, LT, LT-R, ST-R, COMPUTER, 13"LG, 8.5"x8.5", 8K, 16K, 16K-R		* Follow the paper size specifications for the equipment.
Paper weight	52 g/m <sup>2</sup> to 209 g/m <sup>2</sup> (14 lb. Bond to 110 lb. Cover)	52 g/m <sup>2</sup> to 280 g/m <sup>2</sup> (14 lb. Bond to 110 lb. Cover)		
Special paper	Labels, Transparencies, Tab paper, Postcard	Labels, Transparencies, Tab paper, Postcard, Envelope		Special paper recommended by Toshiba TEC
Dimensions	424 (W) × 235 (H) × 419 (D) mm 16.69 (W) × 9.25 (D) × 16.50 (H) (H) inch	430.2(W) × 217(H) × 435.2(D) mm 16.94(W) × 8.54(H) × 17.13(D) inch		
Weight	Approx. 3.9 kg (8.58lb.)	Approx. 3.76 kg (8.27lb.)		
Appearance color	Fair white		Jet black	
Bundled	Front cover (1 pc.) Harness cover (1 pc.) Ferritic core (1 pc.) Screws M3×6 (2 pcs.) Screw M3×8 (1 pc.) Screws M4×8 (2 pcs.)	Front cover (1 pc.) Screws M3×6 (2 pcs.) Screws M4×8 (2 pcs.)	Front cover (1 pc.) Screws M3×6 (2 pcs.) Screws M4×8 (2 pcs.)	
Preventive maintenance parts	None	None	None	





## 2. GENERAL DESCRIPTION

### 2.1 Sectional View

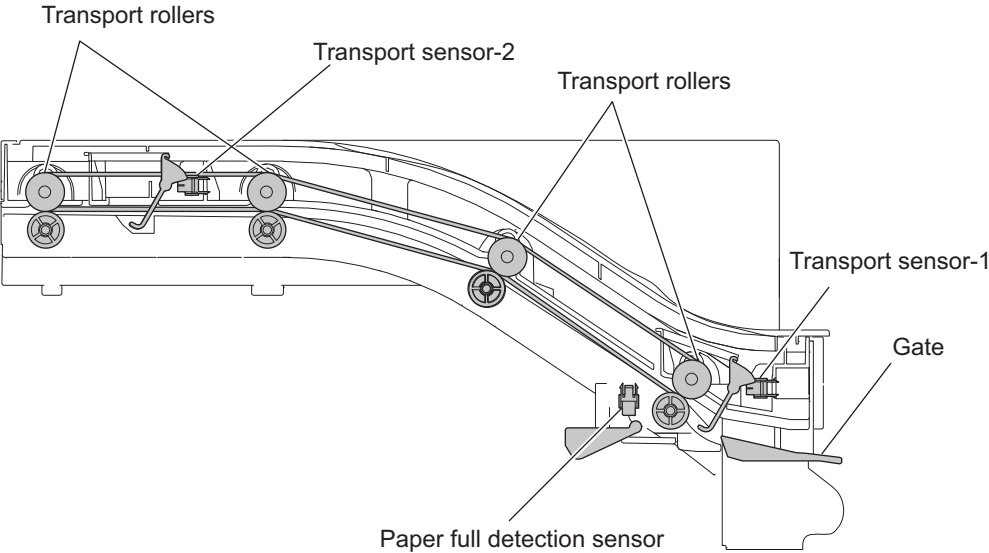

Fig. 2-1

## 2.2 Electric Parts Layout

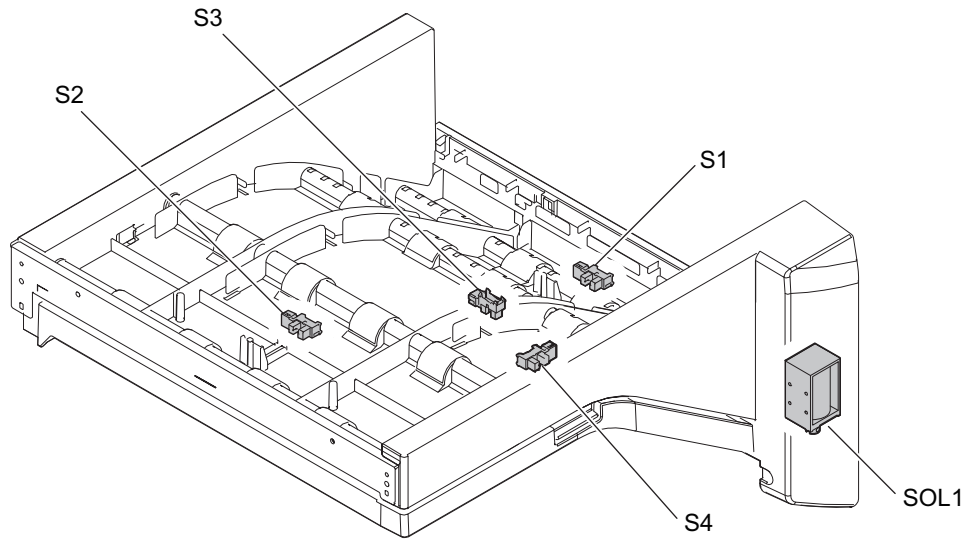

Fig. 2-2

## 2.3 Symbols and Functions of Various Components

Symbol	Name	Function	P-I	Remarks
S1	Transport sensor-1	Detects paper on the transport path (entrance side)		
S2	Transport sensor-2	Detects paper on the transport path (exit side)		
S3	Paper full detection sensor	Detects paper full on the inner tray		
S4	Open/close detection sensor	Detects the open/close state of the bridge unit jam access cover		
SOL1	Gate solenoid	Switches the paper transport path		

# 3. DESCRIPTION OF OPERATIONS

## 3.1 General Description

This unit transports paper from the exit section of the equipment to the finisher. The transport rollers which comprise the bridge unit are rotated by the drive from the host machine. This unit has a switching gate on its entrance section which decides whether the transported paper from the exit roller of the host machine is transported to the finisher or to the inner tray. The gate operates with ON/OFF of the gate solenoid. This unit is also equipped with a sensor which detects paper full for the inner tray.

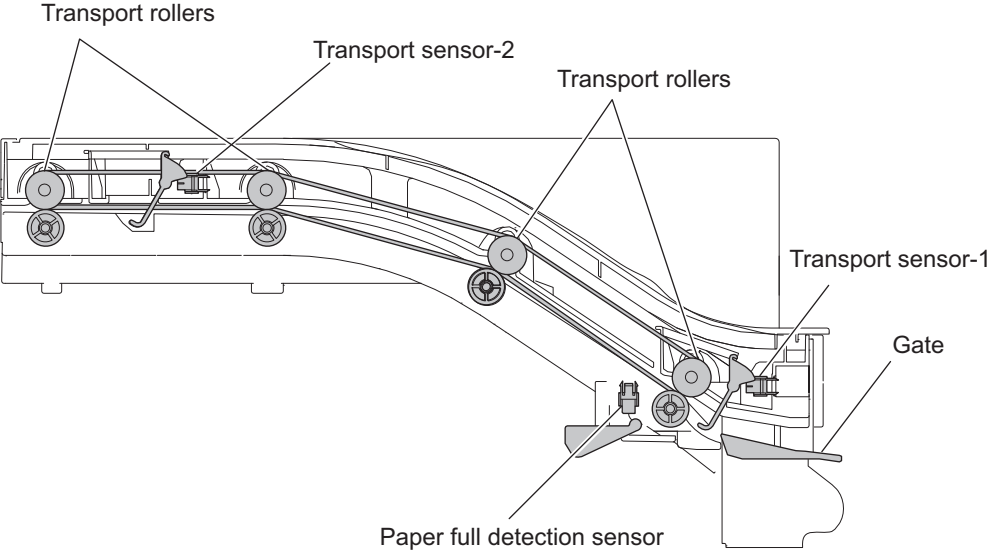

Fig. 3-1

### 3.2 Driving System

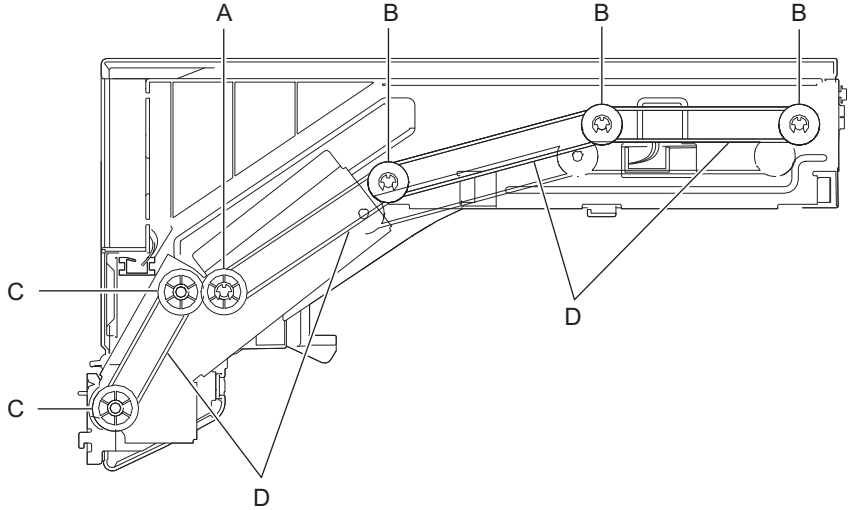

Fig. 3-2

Symbol	Function
A	Drive gear (G24/P20) + one-way pulley (P20)
B	Pulley (P20) + one-way pulley (P20)
C	Drive gear (G24/P20) + pulley (P20)
D	Timing belt

## 4. DISASSEMBLY AND ASSEMBLY

### Note:

The covers of actual equipment and a picture differs in color.

### 4.1 Disassembly Procedure

#### [A] Reverse guide

- (1) Take off the bridge unit.
- (2) Remove 2 screws and take off the reverse guide.

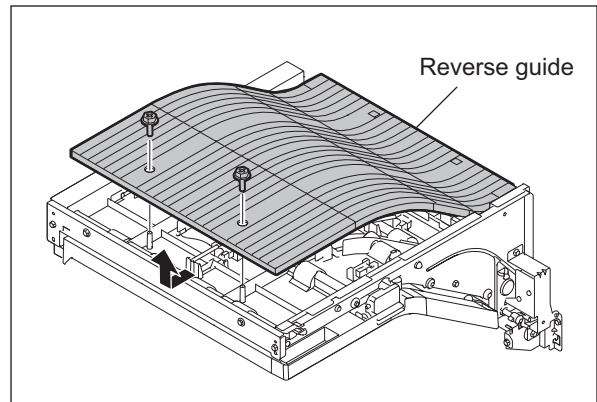

Fig. 4-1

#### [B] Transport sensor-1 (S1)

- (1) Take off the bridge unit.
- (2) Take off the reverse guide.  
P.4-1 "[A] Reverse guide"
- (3) Remove 2 screws and take off the cover.
- (4) Remove 2 screws and take off the stay.

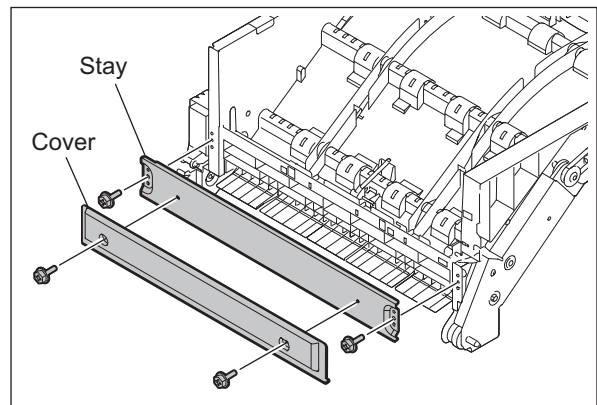

Fig. 4-2

- (5) Remove the spring [1] and take off the actuator [2].
- (6) Disconnect 1 connector [3] and release the latches to remove the transport sensor-1 (S1) [4].

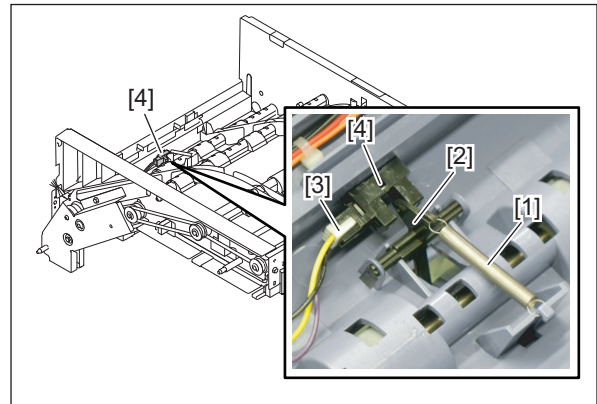



Fig. 4-3

**[C] Transport sensor-2 (S2) [KN-2520]**

- (1) Take off the bridge unit.
- (2) Take off the reverse guide.  
 P.4-1 "[A] Reverse guide"
- (3) Take off the actuator [1].
- (4) Disconnect 1 connector [2] and release the latches to remove the transport sensor-2 (S2) [3].

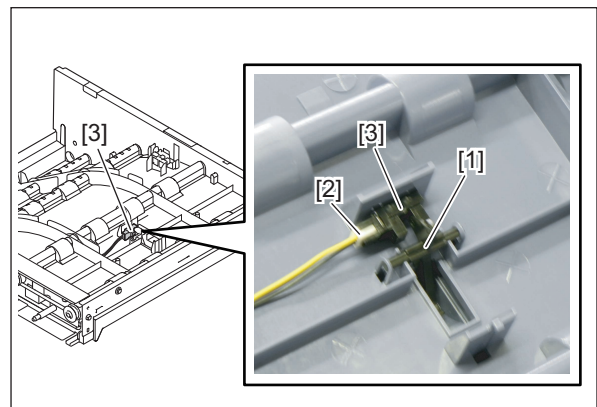



Fig. 4-4

**[D] Transport sensor-2 (S2) [KN-2550][KN-5005]**

- (1) Take off the bridge unit.
- (2) Take off the reverse guide.  
 P.4-1 "[A] Reverse guide"
- (3) Remove the spring [1] and take off the actuator [2].
- (4) Disconnect 1 connector [3] and release the latches to remove the transport sensor-2 (S2) [4].

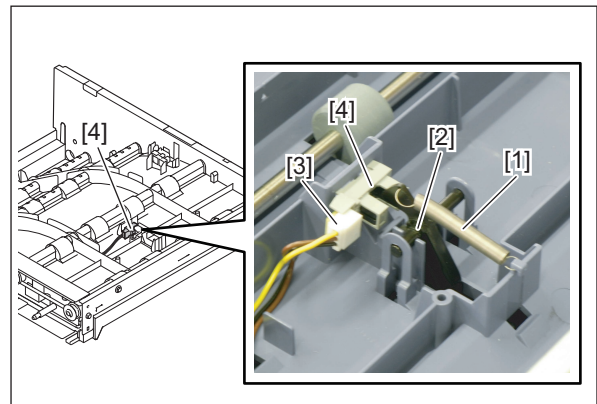

Fig. 4-5

### [E] Open/close detection sensor (S4)

- (1) Take off the bridge unit.
- (2) Take off the reverse guide.  
P.4-1 "[A] Reverse guide"
- (3) Take off the actuator [1].
- (4) Disconnect 1 connector [2] and release the latches to remove the open/close detection sensor (S4) [3].

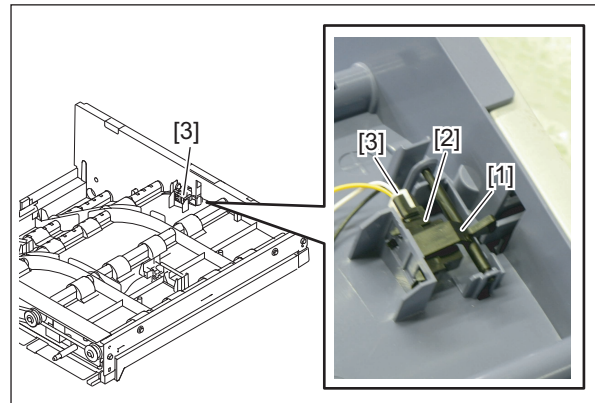

Fig. 4-6

### [F] Paper full detection sensor (S3)

- (1) Take off the bridge unit.
- (2) Remove 1 screw, and take off the sensor cover.

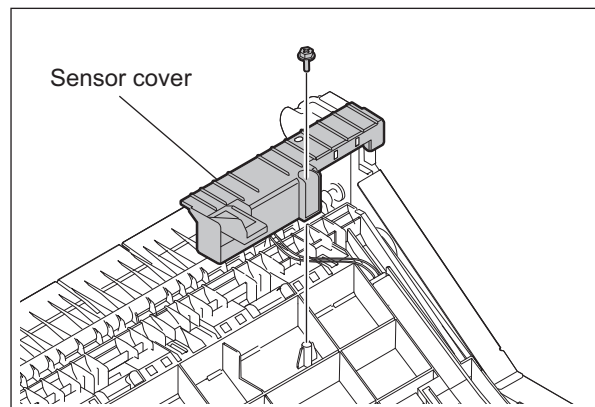

Fig. 4-7

- (3) Take off the actuator [1].
- (4) Disconnect 1 connector [2] and release the latches to remove the paper full detection sensor (S3) [3].

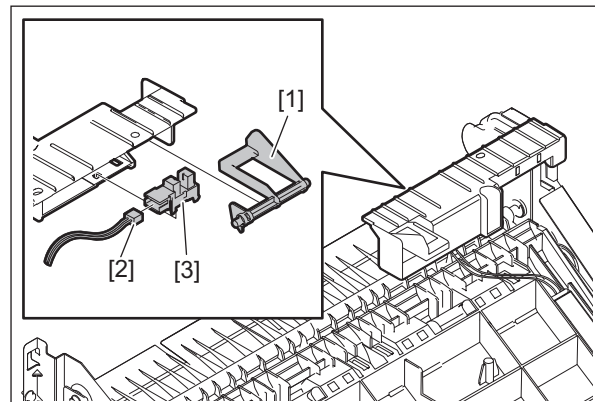

Fig. 4-8

## [G] Gate solenoid

- (1) Take off the bridge unit.
- (2) Remove 2 screws and take off the gate solenoid along with the bracket.
- (3) Disconnect 1 connector.

**Note:**

Match the protruding portion of the plunger with the position shown in the figure for assembling. Also, be sure to install the bracket while pressing it against to the A direction. Incorrect installation could narrow the operating range of the gate, resulting in a paper jam.

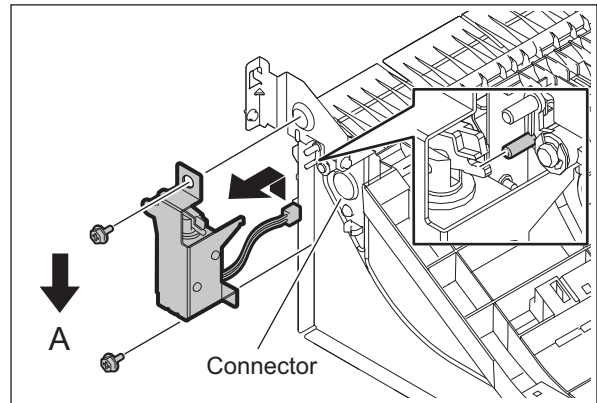

**Fig. 4-9**

- (4) Remove 2 screws, and take off the gate solenoid and plunger from the bracket.

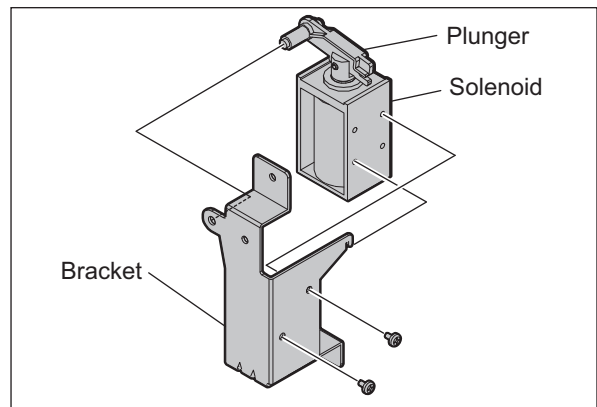

**Fig. 4-10**



## 4.2 Lubrication

Items to check		Lubrication/Coating	Applicable Models
A	Pulley rotating part of the stud	W1: White grease (Molykote EM-30L)	KN-2550 KN-5005
B	Gear rotating part of the stud	W1: White grease (Molykote EM-30L)	KN-2550 KN-5005
C	Pinch roller shaft	W1: White grease (Molykote EM-30L)	KN-2550 KN-5005
D	Bushing part of the transport roller shaft (front)	W1: White grease (Molykote EM-30L)	KN-2550 KN-5005

### [A] Pulley rotating part of the stud

- (1) While removing the gear, pulley and belt, evenly apply approx. 0.05 cc of white grease (Molykote EM-30L) to the whole of the pulley rotating part [1].

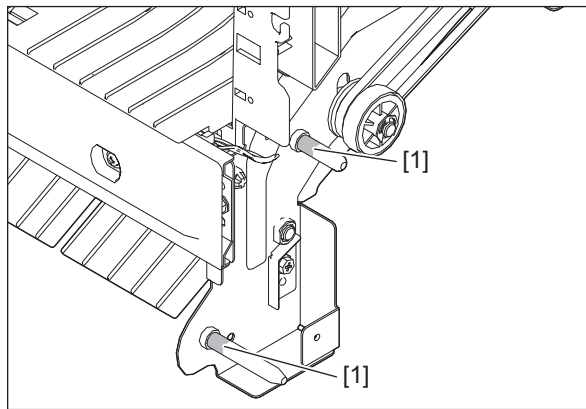

Fig. 4-11

### [B] Gear rotating part of the stud

- (1) Evenly apply approx. 0.05 cc of white grease (Molykote EM-30L) to the whole of the gear rotating part [1] while the belt and pulley are installed in the stud.

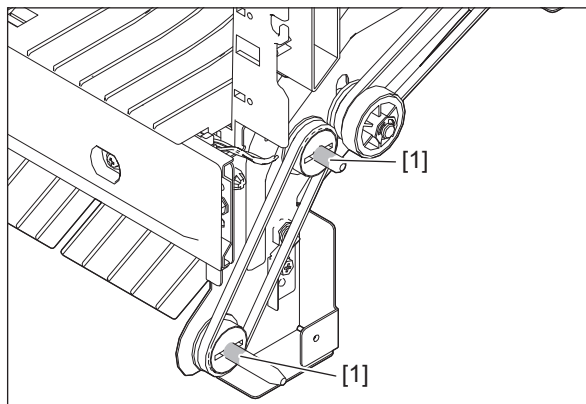

Fig. 4-12

### [C] Pinch roller shaft

- (1) Apply some white grease (Molykote EM-30L) to the roller pinch roller rotating part of the pinch roller shaft, and then install the pinch roller.
- (2) Wipe off the grease which comes out of the rotating part, and then install the lower guide [2].

#### Notes:

- Be careful not to get any grease on the lower guide [2].
- Be careful not to get any grease on the surface at the paper transport side of the pinch roller.

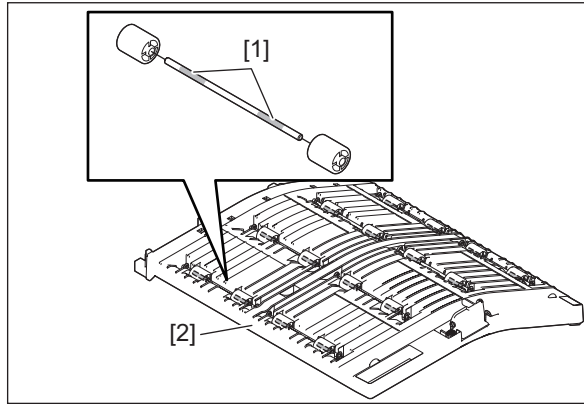

Fig. 4-13

### [D] Bushing part of the transport roller shaft (front)

- (1) While removing the E-ring and bushing from the transport roller shaft (front), apply approx. 0.025 cc of white grease (Molykote EM-30L) to its bushing contacting part [1].

#### Note:

Be careful not to get any grease on the frame and surface at the paper transport side of the transport roller shaft.

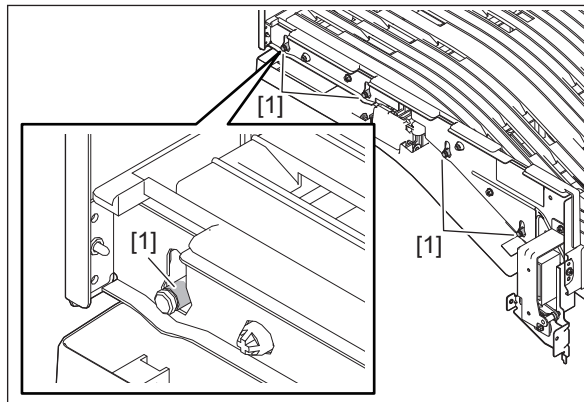

Fig. 4-14

# 5. ELECTRIC CIRCUIT

## 5.1 Harness Connection Diagram

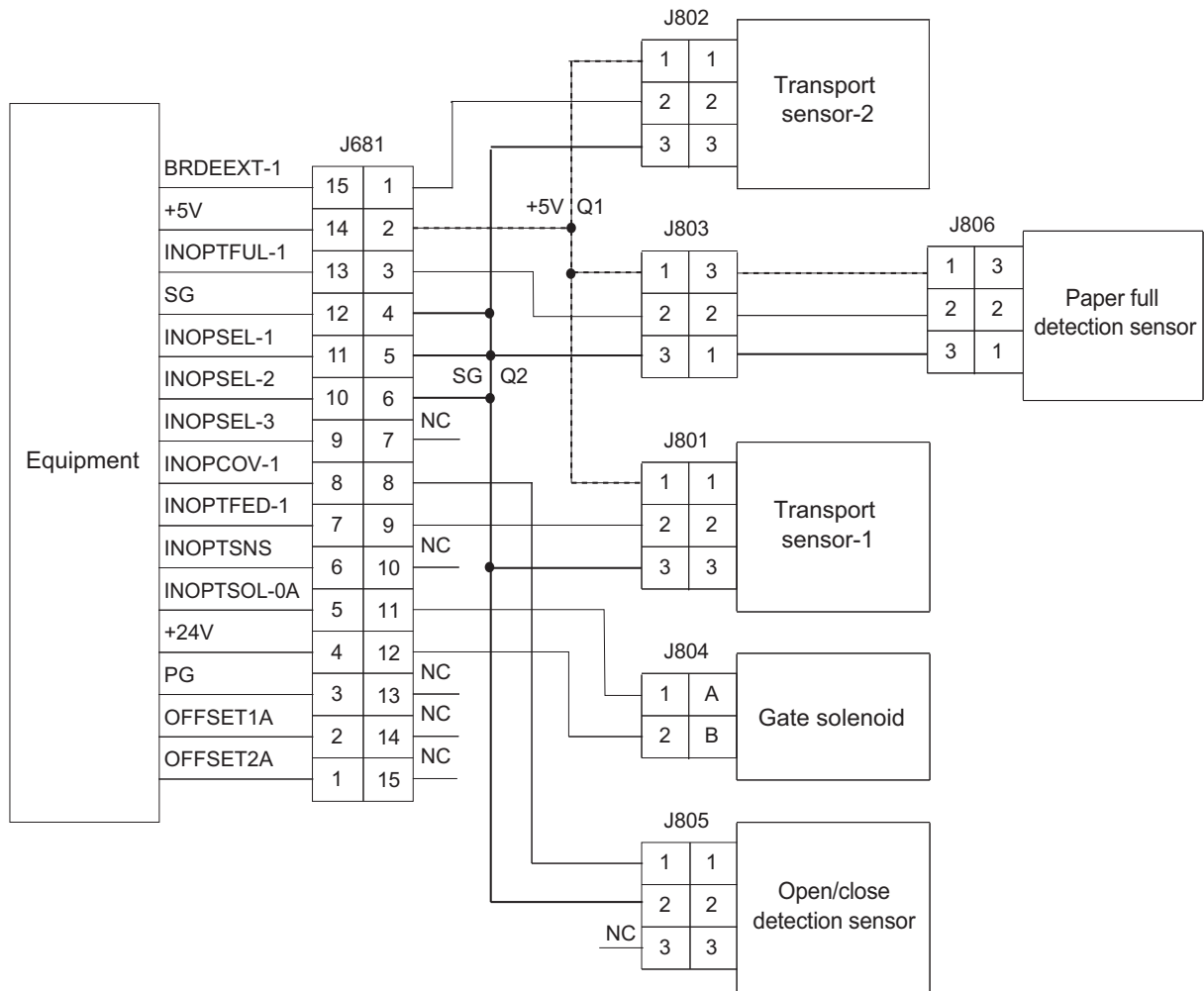

Fig. 5-1



# REVISION RECORD

## Ver.02

Ver.02 <2016.03.11>	
Page	Contents
Cover	KN-5005 has been added.
General Precautions	The notes have been added.
1-1	KN-5005 has been added.
4-1	The notes have been added.
4-2	KN-5005 has been added.
4-5	KN-5005 has been added.

## Ver.01

Ver.01 <2012.09>	
Page	Contents
Cover	KN-2550 has been added.
-	A note has been added.
1-1	KN-2550 has been added.
4-1	The contents of KN-2520 have been changed due to addition of KN-2550.
4-2	KN-2550 has been added. The contents of KN-2520 have been changed due to addition of KN-2550.
4-3	A description has been added to "Note". The contents of KN-2520 have been changed due to addition of KN-2550.
4-5	The lubrication instructions have been added.





**TOSHIBA**

**TOSHIBA TEC CORPORATION**

1-11-1, OSAKI, SHINAGAWA-KU, TOKYO, 141-8562, JAPAN