

TOSHIBA

SERVICE MANUAL

Paper Feed Pedestal

KD-2019/KD-1072

KD-2019

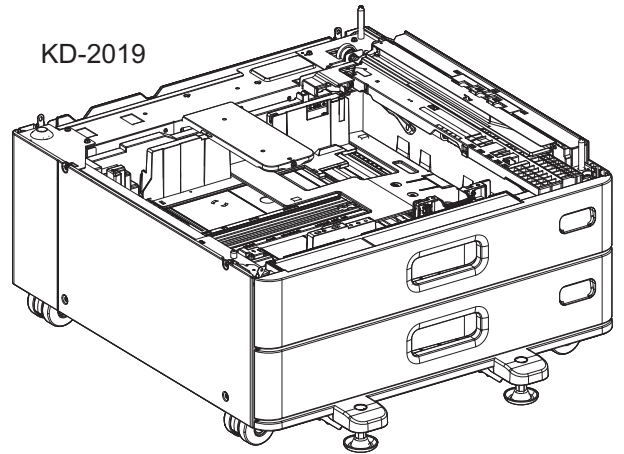

KD-1072

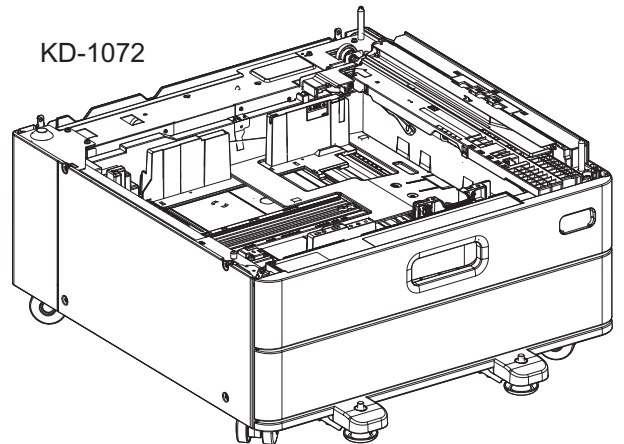

Trademarks

- MOLYKOTE® is a trademark of DDP SPECIALTY ELECTRONIC MATERIALS US, INC..
- The company and product names described in this manual are trademarks or registered trademarks of their respective companies.

© 2021, 2022 Toshiba Tec Corporation All rights reserved

Under the copyright laws, this manual cannot be reproduced in any form without prior written permission of Toshiba Tec Corporation.

General Precautions for Installation, Servicing and Maintenance for this Option

The installation and service shall be done by a qualified service technician.

1. When installing this option to the MFP, be sure to follow the instructions described in the “Unpacking/Set-Up Procedure for the Equipment” booklet which comes with this option.
2. This option shall be installed by an authorized or qualified person.
3. When transporting or installing this option, employ two persons and be sure to use the positions as indicated below.
The weight of KD-2019 is approx. 21.5 kg (47.4 lbs.) and KD-1072 is approx. 18 kg (39.7 lbs.), therefore pay full attention when handling them.

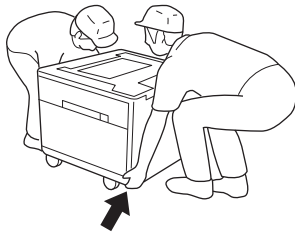

4. Both the Paper Feed Pedestal and the Large Capacity Feeder have 4 adjusters (antiskid devices) underneath. After the MFP with this option connected has been moved and installed, be sure to turn and lower those adjusters to fix it, since the drawers may not be opened or closed smoothly depending on the floor condition.
5. This option must be grounded for safety.
6. Before starting installation, servicing or maintenance work, be sure unplug the power cable of the MFP first.
7. The MFP with this option connected shall be installed near the socket outlet and shall be easily accessible
8. Be sure to fix and plug in the power cable securely after the installation so that no one trips over it.
9. Unplug the power cable and clean the area around the prongs of the plug and socket outlet once a year or more. A fire may occur when dust lies on this area.
10. Power for this option is supplied through the MFP.
11. This option should be grounded to the specified positions on the MFP frame.
12. When servicing or maintaining the MFP with this option connected, be careful about the rotating or operating sections such as gears, pulleys, sprockets, cams, belts, etc.
13. When the parts of this option are disassembled, reassembly is the reverse of disassembly unless otherwise noted in this manual or other related documents.
Be careful not to install small parts such as screws, washers, pins, E-rings, star washers, harnesses in the wrong places.
14. Basically, the MFP with this option connected should not be operated with any parts removed or disassembled.

15. When servicing the MFP with this option connected while the power is turned ON, be sure not to touch live sections and rotating/operating sections.
16. Delicate parts for preventing safety hazard problems (such as fuses, thermofuses, door switches, sensors, etc. if any) should be handled, installed and adjusted correctly.
17. Tools and instruments
 - Use designated jigs and tools.
 - Use recommended measuring instruments or equivalents.
18. During servicing or maintenance work, be sure to check the nameplate and other cautionary labels (if any) to see if they are clean and firmly stuck. If not, take appropriate actions.
19. The ICs on the PC boards tend to be damaged by static electricity. Therefore, the PC boards must be stored in an anti-electrostatic bag and handled carefully using a wristband
Before using the antistatic wrist strap, unplug the power cable of the MFP and make sure that there are no charged objects which are not insulated in the vicinity.
20. Regarding the recovery and disposal of the MFP with this option connected, supplies, packing materials, follow the relevant local regulations or rules.
21. Return the MFP with this option connected to the original state and check the operation when the service is finished.
22. Check the procedures and perform them as described in the Service Manual.
23. Make sure you do not lose your balance.
24. Avoid exposure to your skin and wear protective gloves as needed.
25. Do not leave plastic bags where children can get at them. This may cause an accident such as suffocation if a child puts his/her head into a bag. Plastic bags of options or service parts must be brought back.

CONTENTS

1. SPECIFICATIONS	1-1
2. OVERVIEW	2-1
2.1 Front Sectional View	2-1
2.2 Electric Parts Layout	2-2
2.3 Electric Parts	2-4
3. GENERAL OPERATION	3-1
3.1 Driving and Paper Feeding Operations	3-1
3.2 Operation description	3-2
3.3 Error Detection	3-3
4. DISASSEMBLY AND REASSEMBLY	4-1
4.1 Cover	4-1
4.1.1 Stabilizer cover	4-1
4.1.2 Rear cover	4-2
4.1.3 Right front cover	4-3
4.1.4 Paper feed cover	4-3
4.1.5 Right rear cover	4-4
4.1.6 Side cover	4-5
4.1.7 Front cover (KD-1072 only)	4-6
4.2 PFP PC board (PWB)	4-6
4.3 Upper Transport Roller, Lower Transport Roller	4-7
4.3.1 Upper transport roller	4-7
4.3.2 Lower transport roller	4-8
4.4 Belt	4-11
4.5 Paper Feed Clutch	4-12
4.6 Motor	4-15
4.6.1 3rd drawer tray-up motor (M2), 4th drawer tray-up motor (M3)	4-15
4.6.2 PFP motor	4-17
4.7 Paper Feed Roller, Separation Roller, Pickup Roller	4-18
4.7.1 Drawer Paper Feed Unit	4-18
4.7.2 Paper feed roller, Separation roller, Pickup roller	4-19
4.8 Switch and Sensor	4-20
4.8.1 Tray-up sensor (S3, S4), Paper empty sensor (S5, S6)	4-20
4.8.2 3rd drawer paper remaining detection sensor (S7), 4th drawer paper remaining detection sensor (S8)	4-21
4.8.3 Guide	4-21
4.8.4 3rd drawer paper feed sensor (S1)	4-22
4.8.5 4th drawer paper feed sensor (S2)	4-23
4.8.6 Side cover opening/closing switch (SW1)	4-24
4.8.7 3rd drawer detection switch (SW6), 4th drawer detection switch (SW7)	4-24
4.8.8 3rd drawer paper width detection switch (SW2), 3rd drawer paper length detection switch (SW3)	4-25
4.8.9 4th drawer paper width detection switch (SW4), 4th drawer paper length detection switch (SW5)	4-26
4.9 Soft-close Unit (KD-2019 only)	4-27
4.9.1 Soft-close Unit	4-27
4.9.2 Operation when replacing the soft-close unit for the first time (KD-2019 only)	4-27
4.10 3rd drawer damp heater (DH1), 4th drawer damp heater (DH2) (KD-2019 only)	4-28
5. ELECTRIC CIRCUIT	5-1
5.1 Harness Diagram	5-1
6. ADJUSTMENT	6-1
6.1 Adjustment of the clearance of the paper and side guide	6-1

6.2	Drawer separation roller pressure force adjustment	6-2
7.	PERIODIC MAINTENANCE	7-1
	REVISION RECORD.....	1

1. SPECIFICATIONS

Item	KD-2019 (JPD)	KD-1072 (other than JPD)
Paper feeding method	Automatic paper feeding: double drawer front loading	Automatic paper feeding: single drawer front loading
Paper	Size: A3, B4, A4, A4-R, B5, B5-R, A5-R, 320 mm × 460 mm, SRA3 (320 mm x 450 mm), A3 wide (305 mm x 357 mm), COMPUTER, LD, LG, LT, LT-R, STR, 13"LG, 8.5" x 8.5" Thickness: 60 g/m ² to 300 g/m ² (16 lb. Bond to 150 lb. Index)	
Capacity	Stack height for Plain, Thick: 60.5 mm (Approx. 550 sheets: 80 g/m ² (22 lb. Bond)) Stack height for Reused paper: 52.0 mm (Approx. 400 sheets: 80 g/m ² (22 lb. Bond))	
Dimensions	575 (W) x 583 (D) x 292 (H) mm (Height: From the floor to the top of the front cover of the drawer) 668 (W) x 701 (D) x 292 (H) mm (including the stabilizer covers)	
Weight	Approx. 21.5 kg (47.4 lbs.)	Approx. 18 kg (39.7 lbs.)
Power source	3.3 V, 5 V, 24 V, 100 V (supplied from an MFP)	
Accessories	Unpacking/Setup Instructions (1 pc.) Connecting plate (4 pcs.) M3x6 screw for the connecting plates (6 pcs.) M3x6 screw fixing for the ground wire (1 pc.) Paper size indicator sheet (2 pcs.) Stabilizer bracket (4 pcs.) Stabilizer foot for the paper feeding side (1 pc.) M3x14 screw for the stabilizer foot for the paper feeding side (1 pc.) Stabilizer cover for the rear side (2 pcs.) Stabilizer cover for the front side (1 pc.) M3x6 screw for the stabilizer (5 pcs.)	
Appearance color	Jet black	

2. OVERVIEW

Remarks:

For KD-1072, the overview is described when 2 drawers have been installed in it.

2.1 Front Sectional View

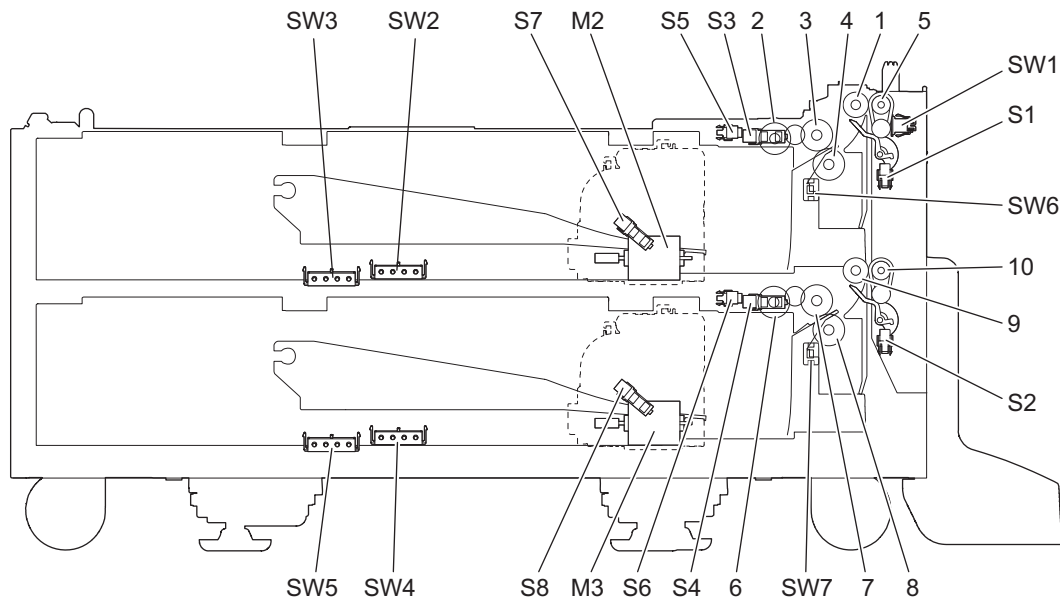

Fig. 2-1

Symbol	Name	Symbol	Name
1	Upper transport roller	S3	3rd drawer tray-up sensor
2	3rd drawer pickup roller	S4	4th drawer tray-up sensor
3	3rd drawer paper feed roller	S5	3rd drawer paper empty sensor
4	3rd drawer separation roller	S6	4th drawer paper empty sensor
5	Upper idling roller	S7	3rd drawer paper remaining detection sensor
6	4th drawer pickup roller	S8	4th drawer paper remaining detection sensor
7	4th drawer paper feed roller	SW1	Side cover opening/closing switch
8	4th drawer separation roller	SW2	3rd drawer paper width detection switch
9	Lower transport roller	SW3	3rd drawer paper length detection switch
10	Lower idling roller	SW4	4th drawer paper width detection switch
M2	3rd drawer tray-up motor	SW5	4th drawer paper length detection switch
M3	4th drawer tray-up motor	SW6	3rd drawer detection switch
S1	3rd drawer paper feed sensor	SW7	4th drawer detection switch
S2	4th drawer paper feed sensor		

2.2 Electric Parts Layout

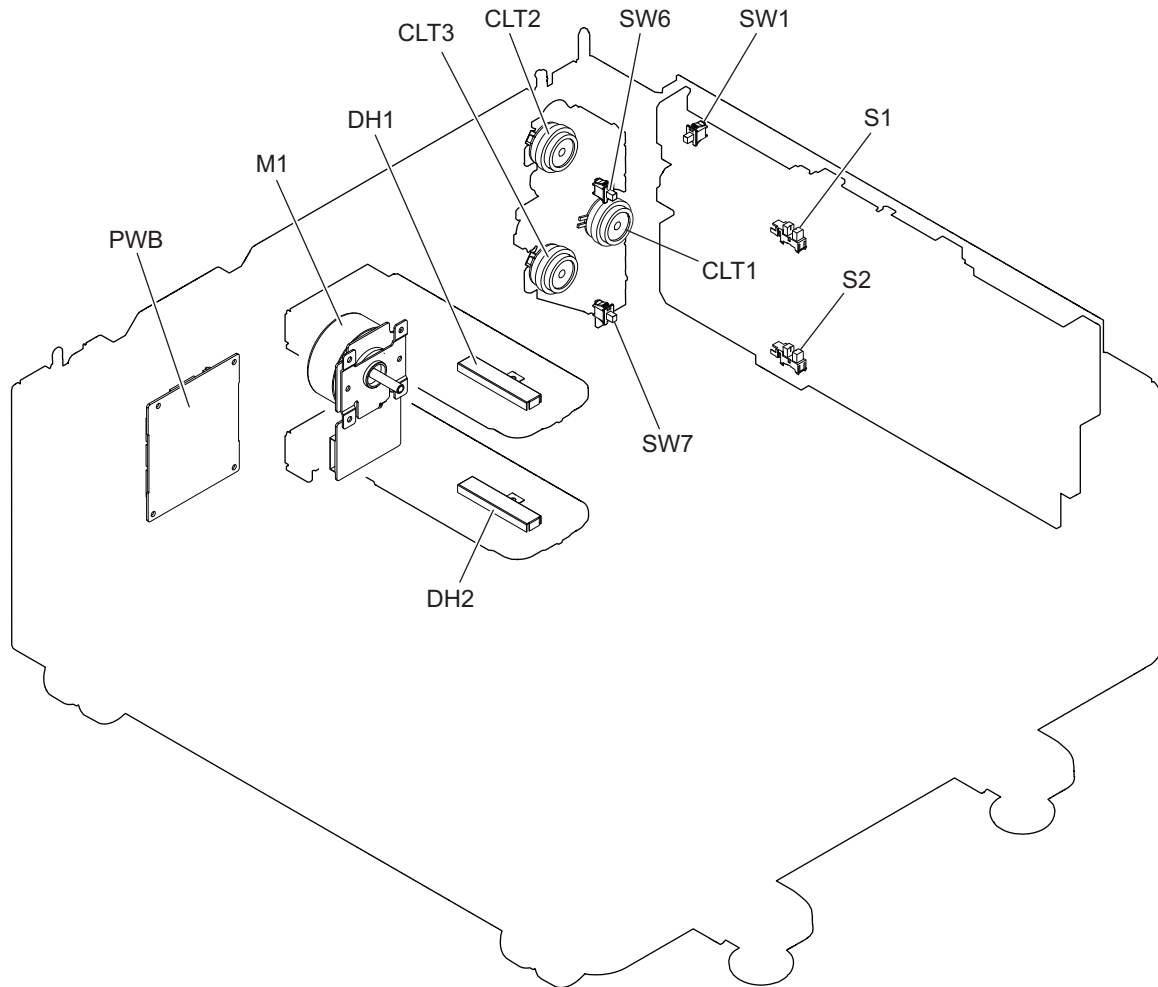

Fig. 2-2

Symbol	Name
M1	PFP motor
CLT1	Transport clutch
CLT2	3rd drawer paper feed clutch
CLT3	4th drawer paper feed clutch
SW1	Side cover opening/closing switch
SW6	3rd drawer detection switch
SW7	4th drawer detection switch
S1	3rd drawer paper feed sensor
S2	4th drawer paper feed sensor
PWB	PFP board
DH1	3rd drawer damp heater (KD-2019 only)
DH2	4th drawer damp heater (KD-2019 only)

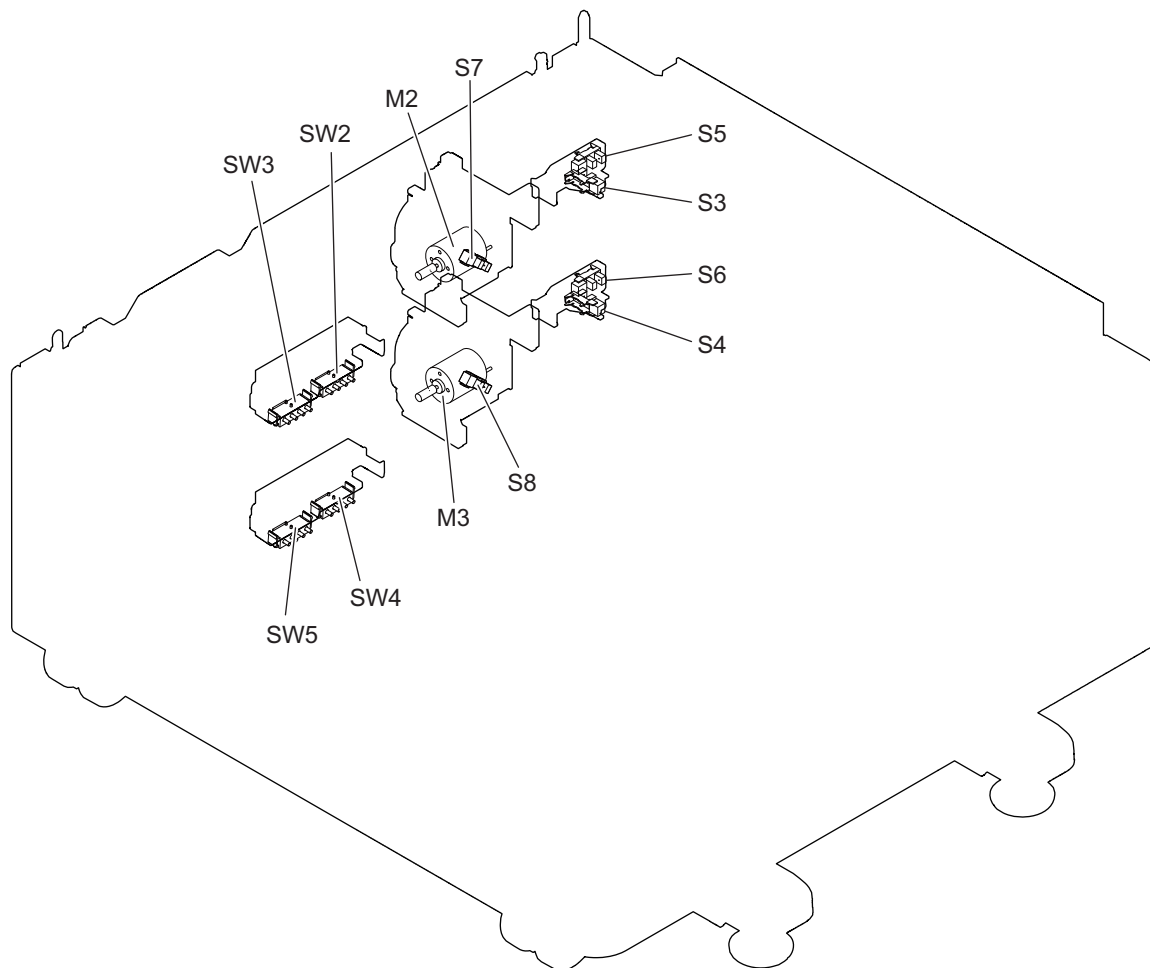

Fig. 2-3

Symbol	Name
M2	3rd drawer tray-up motor
M3	4th drawer tray-up motor
SW2	3rd drawer paper width detection switch
SW3	3rd drawer paper length detection switch
SW4	4th drawer paper width detection switch
SW5	4th drawer paper length detection switch
S3	3rd drawer tray-up sensor
S4	4th drawer tray-up sensor
S5	3rd drawer paper empty sensor
S6	4th drawer paper empty sensor
S7	3rd drawer paper remaining detection sensor
S8	4th drawer paper remaining detection sensor

2.3 Electric Parts

1. Motor

Symbol	Name	Function	<P-I>
M1	PFP motor	Drives paper feeding and transportation.	3-38
M2	3rd drawer tray-up motor	Lifts up the tray in the 3rd drawer.	3-5
M3	4th drawer tray-up motor	Lifts up the tray in the 4th drawer.	3-5

2. Electromagnetic clutch

Symbol	Name	Function	<P-I>
CLT1	Transport clutch	Drives the transport clutch.	3-20
CLT2	3rd drawer paper feed clutch	Feeds paper in the 3rd drawer.	3-20
CLT3	4th drawer paper feed clutch	Feeds paper in the 4th drawer.	3-20

3. Switch and sensor

Symbol	Name	Function	<P-I>
SW1	Side cover opening/closing switch	Detects the opening and closing status of the side cover.	4-18
SW2	3rd drawer paper width detection switch	Detects the paper width of the 3rd drawer.	2-10
SW3	3rd drawer paper length detection switch	Detects the paper length of the 3rd drawer.	2-10
SW4	4th drawer paper width detection switch	Detects the paper width of the 4th drawer.	2-10
SW5	4th drawer paper length detection switch	Detects the paper length of the 4th drawer.	2-10
SW6	3rd drawer detection switch	Detects the 3rd drawer.	2-29
SW7	4th drawer detection switch	Detects the 4th drawer.	2-29
S1	3rd drawer paper feed sensor	Detects the paper transport timing and misfeeding.	4-17
S2	4th drawer paper feed sensor	Detects the paper transport timing and misfeeding.	4-17
S3	3rd drawer tray-up sensor	Detects the lifting up of the tray in the 3rd drawer.	2-43
S4	4th drawer tray-up sensor	Detects the lifting up of the tray in the 4th drawer.	2-43
S5	3rd drawer paper empty sensor	Detects the paper loading level in the 3rd drawer.	2-43
S6	4th drawer paper empty sensor	Detects the paper loading level in the 4th drawer.	2-43
S7	3rd drawer paper remaining detection sensor	Detects the paper remaining level in the 3rd drawer.	3-12
S8	4th drawer paper remaining detection sensor	Detects the paper remaining level in the 4th drawer.	3-12

4. PC Board

Symbol	Name	Function	<P-I>
PWB	PFP board	Controls the PFP driving.	2-11

5. Damp heater (KD-2019 only)

Symbol	Name	Function	<P-I>
DH1	3rd drawer damp heater	Keeps the temperature and dehumidifies the 3rd drawer. (KD-2019 only)	-
DH2	4th drawer damp heater	Keeps the temperature and dehumidifies the 4th drawer. (KD-2019 only)	-

3. GENERAL OPERATION

Remarks:

For KD-1072, the overview is described when 2 drawers have been installed in it.

3.1 Driving and Paper Feeding Operations

The Paper Feed Pedestal (PFP) mainly consists of the drawer, pickup roller, paper feed roller, separation roller, transport roller and drive systems for those components.

- Paper feeding and transporting system
The PFP motor drives the pickup roller, paper feed roller and transport roller in the paper feeding section of the PFP drawer.
- Drawer tray system
The tray-up motor lifts up the tray.

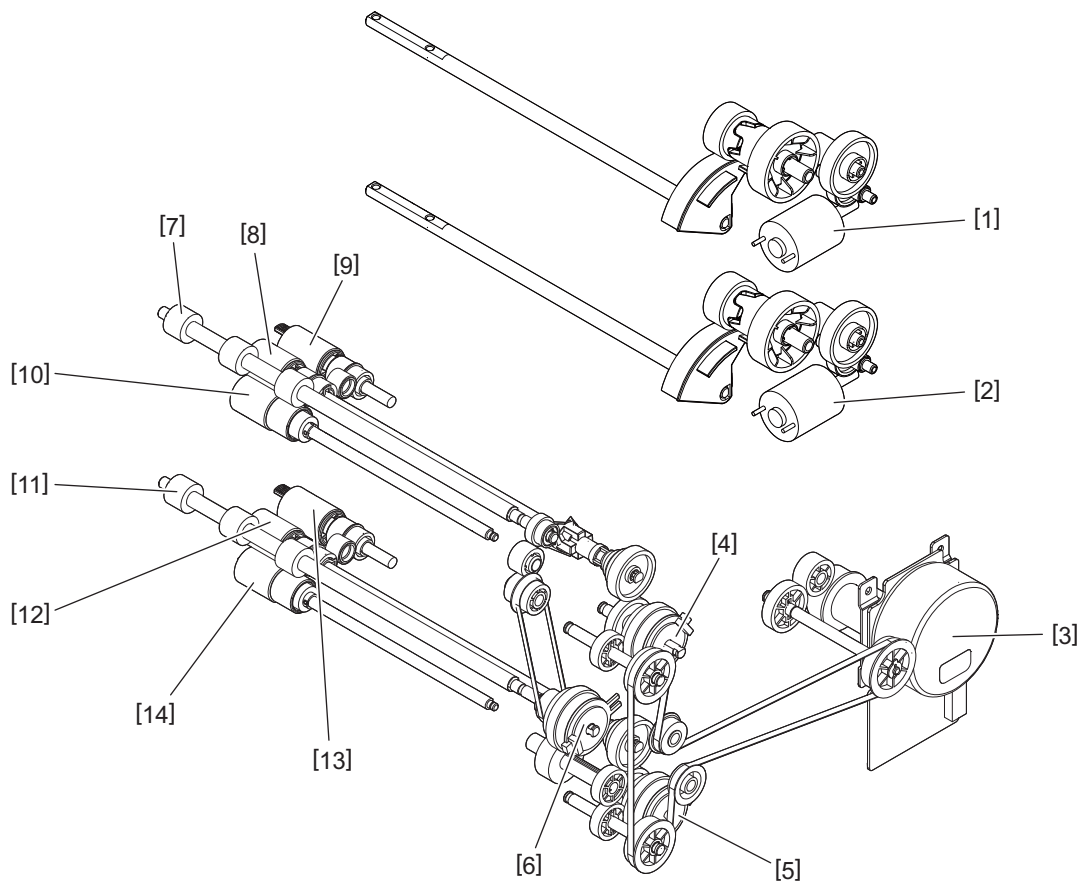

Fig. 3-1

[1]	3rd drawer tray-up motor (M2)	[8]	3rd drawer paper feed roller
[2]	4th drawer tray-up motor (M3)	[9]	3rd drawer pickup roller
[3]	PFP motor (M1)	[10]	3rd drawer separation roller
[4]	3rd drawer paper feed clutch (CLT2)	[11]	Lower transport roller
[5]	4th drawer paper feed clutch (CLT3)	[12]	4th drawer paper feed roller
[6]	Transport clutch (CLT1)	[13]	4th drawer pickup roller
[7]	Upper transport roller	[14]	4th drawer separation roller

3.2 Operation description

[A] From power-ON to the ready status

- (1) When the MFP is turned ON, the power is also supplied to the PFP. Once the power has been supplied, the PFP detects and judges the signal output from the board on the MFP and controls the transport speed of the PFP.
- (2) After that, the tray-up motors (M2, M3) are turned ON to lift up the tray in each drawer. When the tray-up sensors (S3, S4) are turned ON correspondingly, the tray-up motors (M2, M3) are turned OFF and stop the lifting up of the tray. If the 3rd drawer paper empty sensor (S5) and the 4th drawer paper empty sensor (S6) are turned OFF (H) at this time, it is judged that there is no paper in the drawers. If those sensors are turned OFF (L), it is judged that there is paper in the drawers and the trays stay this position until the drawer is removed.
- (3) If a drawer has been pulled out when the power is turned ON, the corresponding tray-up motor is not turned ON. The tray is lifted up as soon as the drawer is installed and whether there is paper or not in the drawer is detected.
- (4) If either of the drawer paper feed sensor (S1) or (S2) is turned ON (there is paper in the transport path) when the power is turned ON, that means paper misfeeding has occurred and the operation is disabled until the misfed paper is removed.
 - When a drawer is installed, the paper size is automatically determined by the drawer paper size detection switch.

[B] Ready status

- (1) By means of the above operation, whether there is paper or not is checked and the MFP goes into the ready status.
- (2) The tray goes down automatically when the drawer is removed and it is lifted up as soon as the drawer is installed again and checks if there is paper in the drawer.

[C] From the start to the end of copying

- (1) When the [START] button is pressed, the MFP turns ON each motor in it as well as the PFP motor (M1).
- (2) When the MFP judges that the PFP is ready for feeding paper, the paper feed clutch (CLT2) or (CLT3) of the selected drawer is turned ON. This clutch drives the pickup roller and the paper feed roller to feed paper from the tray.
- (3) When the drawer paper feed sensor (S1) or (S2) comes ON, the transport clutch (CLT1) is turned ON to drive the PFP transport roller.
- (4) When a certain time has passed after the drawer paper feed sensor (S1) or (S2) comes ON, the paper feed clutch (CLT2) or (CLT3) is turned OFF and paper feeding from the drawer is completed.
- (5) The paper is then transported to the MFP by the PFP transport roller. When a certain time has passed after the leading edge of the paper reaches the drawer paper sensor (S1) and if the trailing edge of the paper previously sent still remains at the drawer paper feed sensor of the MFP, the transport clutch (CLT1) is turned OFF to stop the transportation of the paper.
- (6) When a certain time has passed after the registration clutch was driven, the PFP becomes ready for feeding the next sheet of paper and the procedures (1) to (5) are repeated.
- (7) When the copying operation is completed, each motor in the MFP, the PFP motor (M1) and the transport clutch (CLT1) are turned OFF and the transport roller is stopped.

3.3 Error Detection

[A] Paper misfeeding detection

- (1) Paper misfeeding errors such as E150, E160 and E300 to E360 occur in the following cases.
 - The drawer paper feed sensor (S1) or (S2) is not turned ON within a specified period of time after the paper feeding is started.
 - The leading edge of the paper does not pass each drawer paper feed sensor in the transport path within a specified period of time.
- (2) The paper misfeeding status can be cleared when the side cover of the PFP is opened, all the paper remaining on the transport path is removed and then the side cover is closed. If either of the drawer paper feed sensor (S1) or (S2) is still ON when the side cover is closed, it is determined that there is still paper on the transport path and the paper misfeeding status is not cleared.
- (3) When paper misfeeding occurs in the PFP during continuous copying, the sheet of paper that was fed before the paper misfeeding is copied normally.

[B] Service call

- (1) The tray is lifted up when the power is turned ON or the drawer is installed or removed. If the tray-up sensor (S3) or (S4) is not turned ON within a specified period of time after the tray has started to be lifted up, a message that the selected drawer cannot be used appears on the control panel display.
- (2) The state (1) is cleared by removing the drawer to solve the problem.

4. DISASSEMBLY AND REASSEMBLY

Notes:

The covers of the actual PFP and pictures differ in the color.

4.1 Cover

4.1.1 Stabilizer cover

- (1) Pull out the 3rd and 4th drawers.
- (2) Release 2 latches [3] and take off the stabilizer cover for the front side [1].

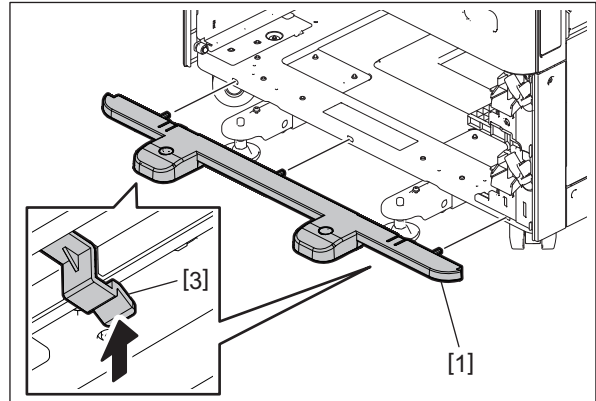

Fig. 4-1

- (3) Remove 1 screw [4] and take off the right stabilizer foot [2].

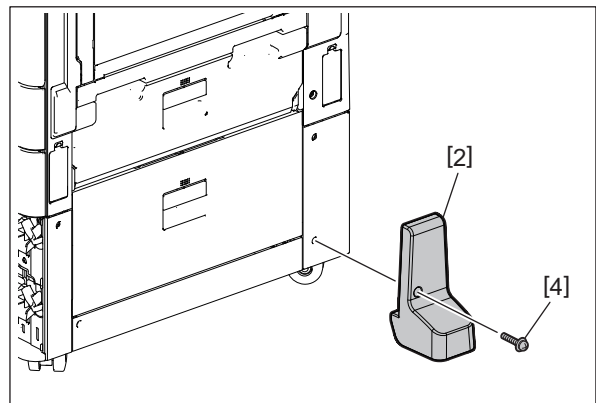

Fig. 4-2

- (4) Remove 2 screws [5] and take off the stabilizer covers for the rear side [6].

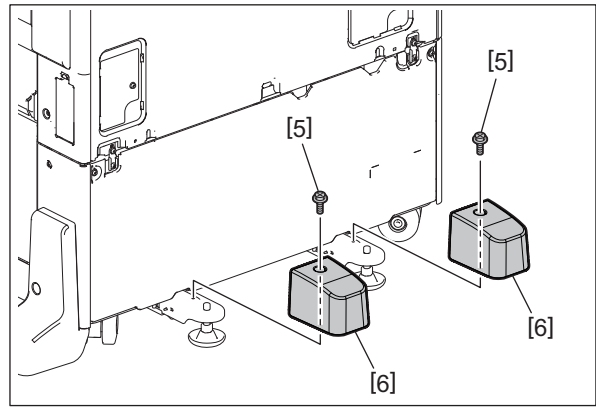

Fig. 4-3

4.1.2 Rear cover

- (1) Take off the stabilizer covers for the rear side.
📖 P. 4-1 “4.1.1 Stabilizer cover”
- (2) Remove 2 screws [2] of the rear cover.
- (3) Take off the rear cover [1].

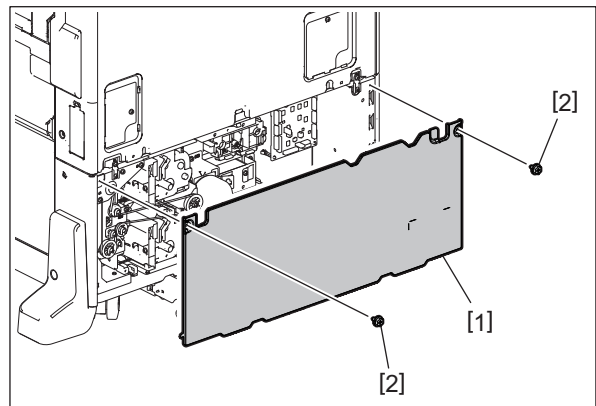

Fig. 4-4

4.1.3 Right front cover

- (1) Pull out the drawer.
- (2) Remove 1 screw [2] and take off the right front cover [1].

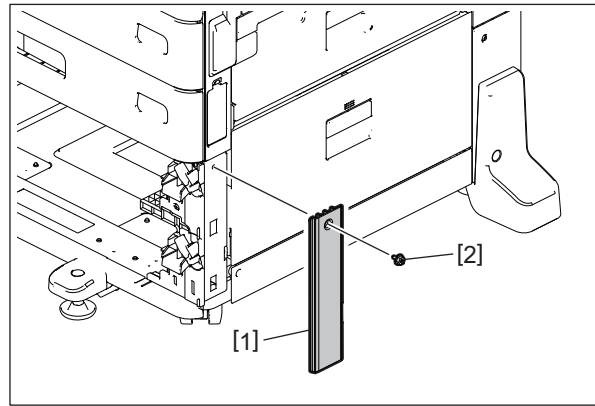

Fig. 4-5

4.1.4 Paper feed cover

- (1) Take off the right front cover.
P. 4-3 "4.1.3 Right front cover"
- (2) Take off the drawer paper feed unit.
P. 4-18 "4.7.1 Drawer Paper Feed Unit"
- (3) Take off the front cover.
P. 4-6 "4.1.7 Front cover (KD-1072 only)"
- (4) Turn the lever counterclockwise. Remove the 3rd drawer lever [1] and the 4th drawer lever [2].

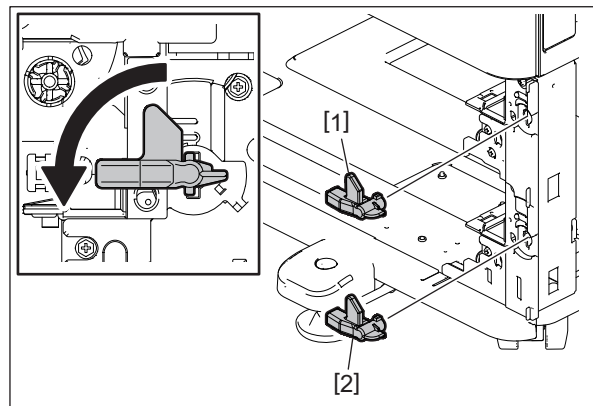

Fig. 4-6

- (5) Remove 1 screw and take off the cover [3].

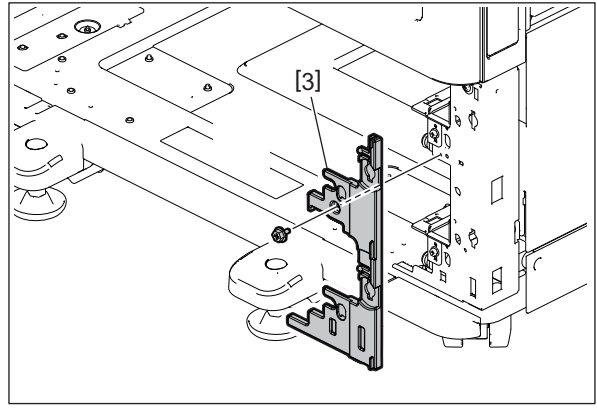

Fig. 4-7

4.1.5 Right rear cover

- (1) Take off the right stabilizer foot.
P. 4-1 "4.1.1 Stabilizer cover"
- (2) Open the side cover [1].
- (3) Remove 1 screw [3] and take off the right rear cover [2].

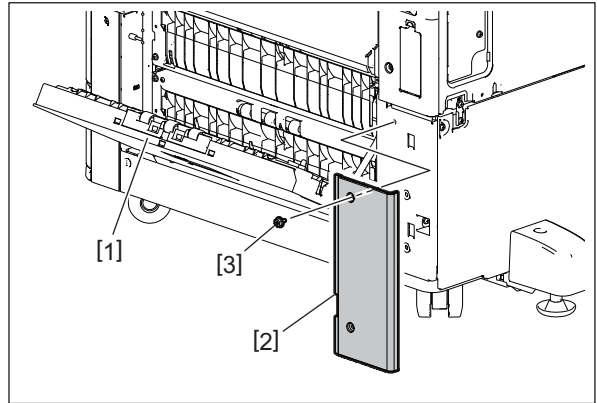

Fig. 4-8

4.1.6 Side cover

- (1) Open the side cover. Remove 1 screw [5] and the band [2].

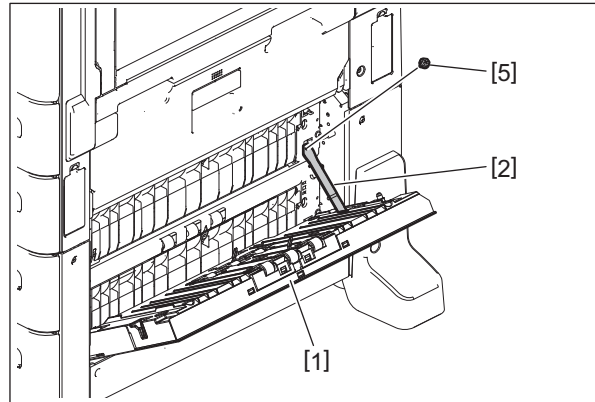

Fig. 4-9

- (2) While pushing the latch on the slit section, remove the block [3].

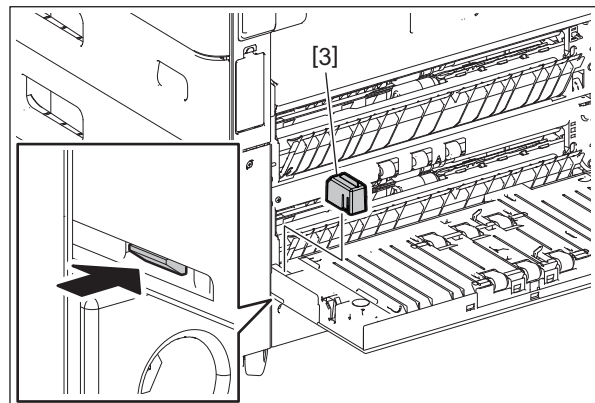

Fig. 4-10

- (3) Push the plate inward to release the stud and take off the side cover [1].
- (4) Disconnect 1 connector [4].

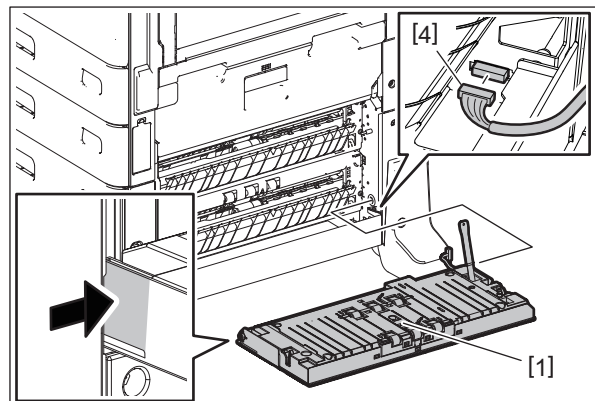

Fig. 4-11

4.1.7 Front cover (KD-1072 only)

- (1) Pull out the 3rd and 4th drawers.
- (2) Remove 2 screws [1] and take off the front cover [2].

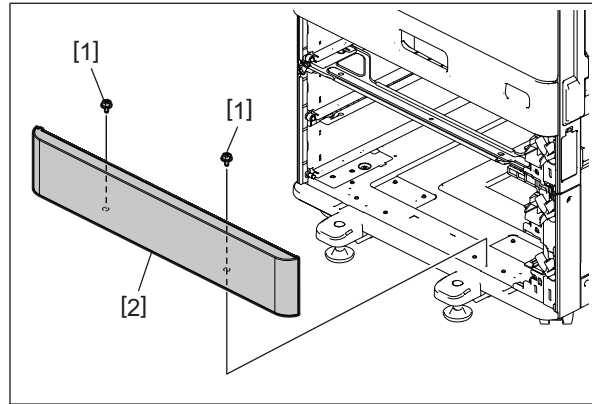

Fig. 4-12

4.2 PFP PC board (PWB)

- (1) Take off the rear cover.
P. 4-2 "4.1.2 Rear cover"
- (2) Disconnect all connectors from the PFP PC board [5] and remove 1 screw [1] and 1 ground wire [2].
Remove 2 screws [3] and release 2 locking supports [4]. Take off the PFP PC board [5].

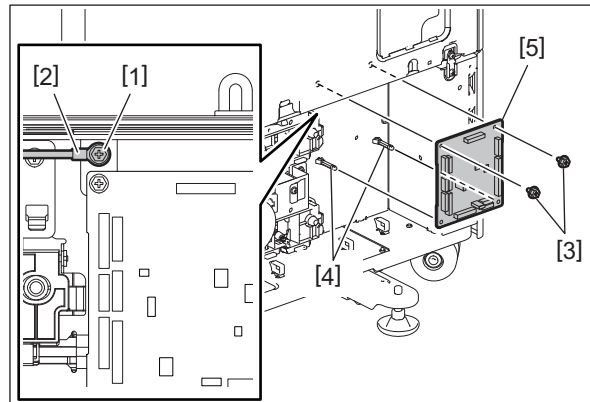

Fig. 4-13

4.3 Upper Transport Roller, Lower Transport Roller

4.3.1 Upper transport roller

- (1) Take off the 3rd drawer paper feed unit.
P. 4-18 "4.7.1 Drawer Paper Feed Unit"
- (2) Open the side cover. Remove 1 screw [1] and release the stopper [2].
- (3) Remove 3 screws [4] and take off the transport roller unit [3].

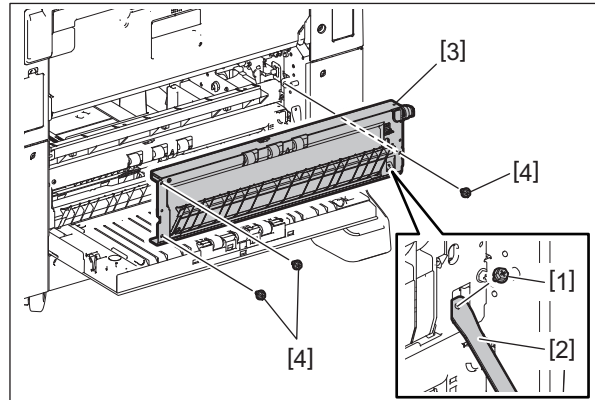

Fig. 4-14

- (4) Remove 2 screws [5] from the transport roller unit [3]. Take off the stay [6] by sliding it.

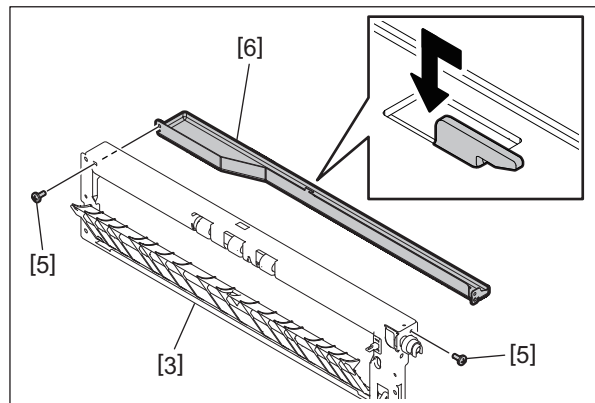

Fig. 4-15

- (5) Remove 1 clip [7], 1 gear [8] and 1 collar [9].

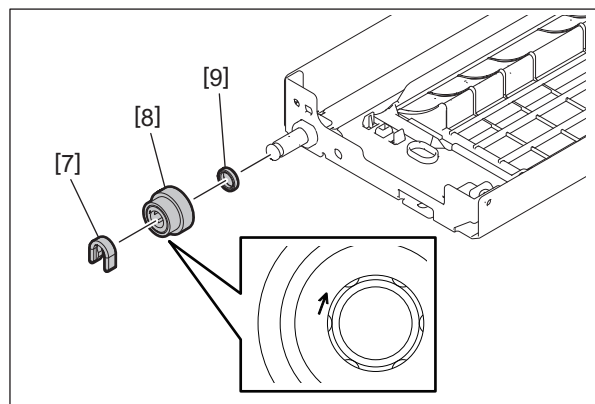

Fig. 4-16

Notes:

Attach the gear so that its arrow can be seen.

- (6) Remove 1 clip [10]. Slide 2 bushings [11] and take off the upper transport roller [12].

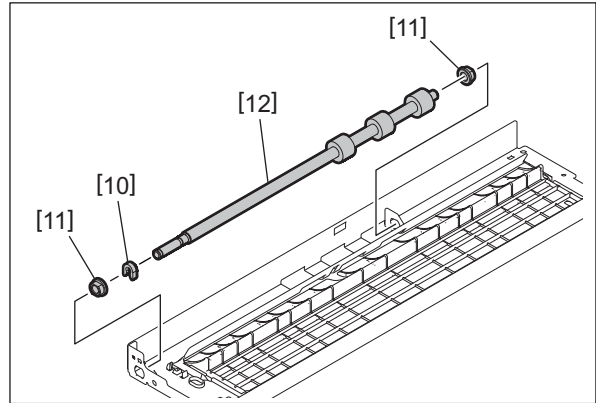

Fig. 4-17

4.3.2 Lower transport roller

- (1) Take off the 4th drawer paper feed unit.
📖 P. 4-18 “4.7.1 Drawer Paper Feed Unit”
- (2) Take off the bracket of the paper feed gear.
📖 P. 4-12 “4.5 Paper Feed Clutch”
- (3) Remove the belt.
- (4) Remove 1 clip [1], take off the transport clutch [2] and disconnect 1 connector [3].
- (5) Remove the gears [4] and [5].

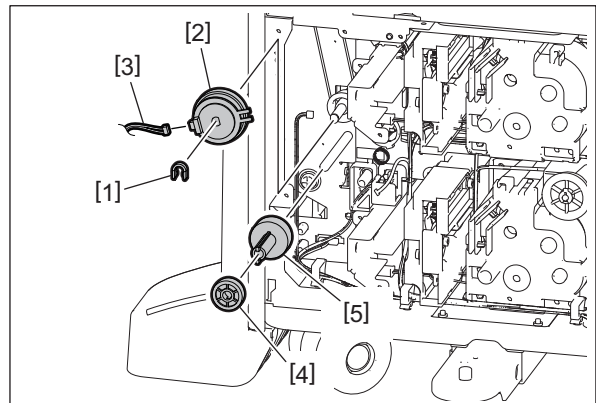

Fig. 4-18

- (6) Remove 1 pulley [6] and 1 belt [7].

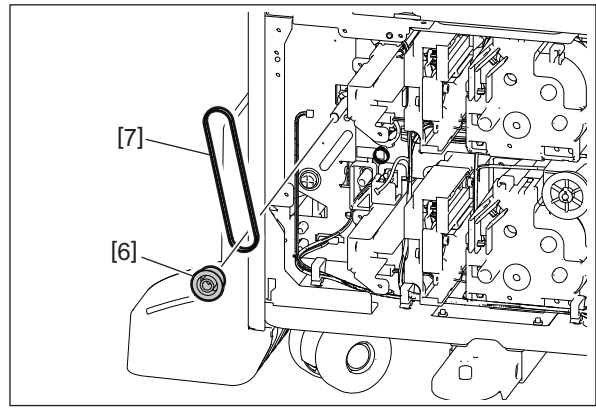

Fig. 4-19

- (7) Take off the side cover.
P. 4-5 "4.1.6 Side cover"

- (8) Remove 3 screws [9] and take off the transport roller unit [8].

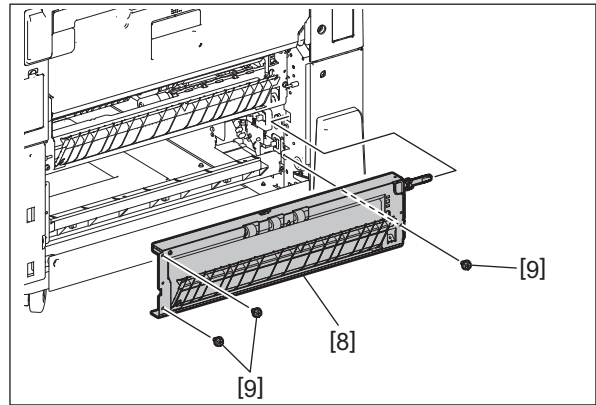

Fig. 4-20

- (9) Remove 2 screws [10] from the transport roller unit [8]. Take off the stay [11] by sliding it.

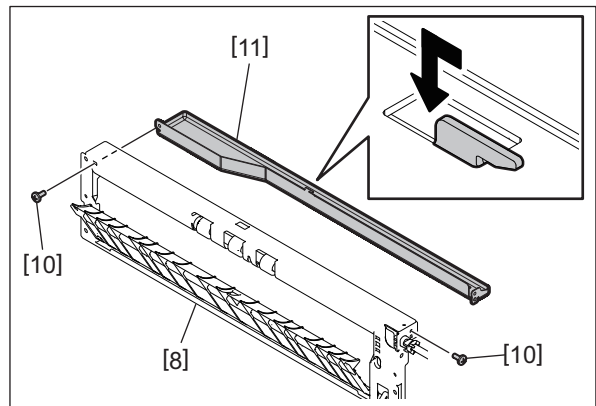

Fig. 4-21

(10) Remove 1 clip [13], 1 pin [12] and 1 coupling [14].

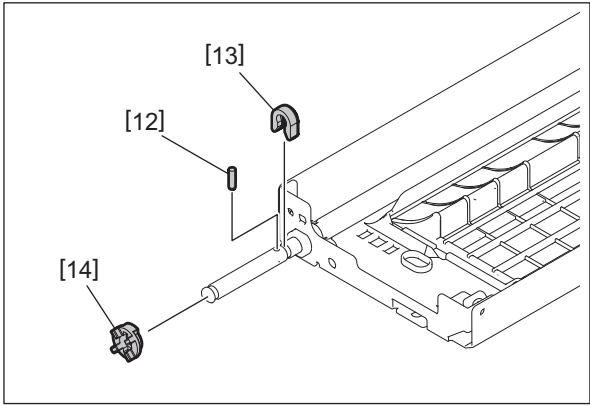

Fig. 4-22

(11) Remove 1 clip [17]. Slide 2 bushings [15] and take off the upper transport roller [16].

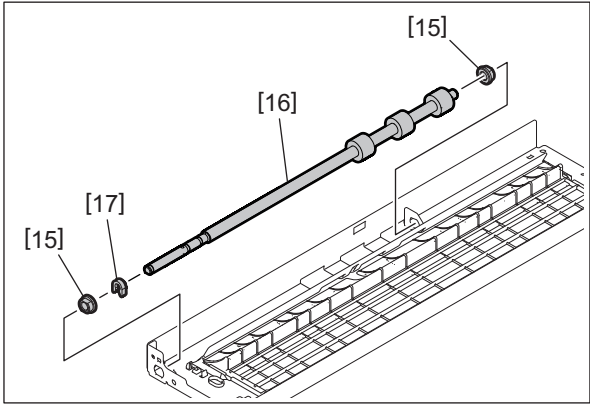

Fig. 4-23

4.4 Belt

- (1) Take off the rear cover.
P. 4-2 "4.1.2 Rear cover"
- (2) Remove 1 screw [1]. Remove 3 screws [2] and take off the plate [3].

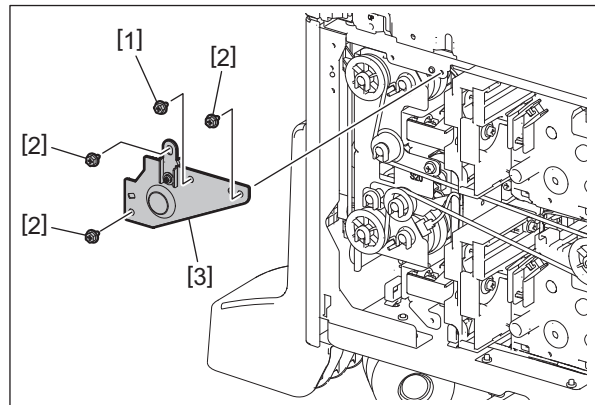

Fig. 4-24

- (3) Lower the auto tensioner roller [4] and remove the belt [5].

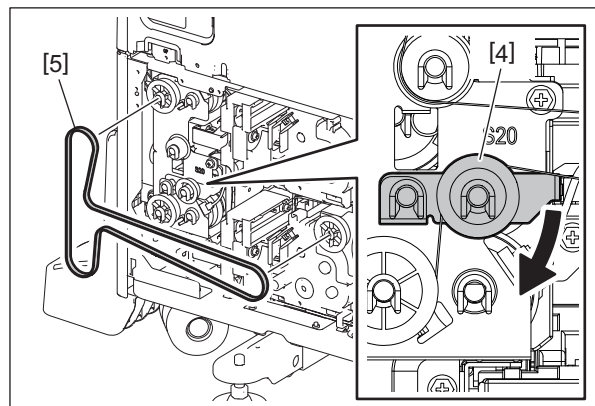

Fig. 4-25

4.5 Paper Feed Clutch

- (1) Remove the belt.
☞ P. 4-11 "4.4 Belt"
- (2) Disconnect 2 connectors [1] of the paper feed clutch.
Remove 5 screws [2] and take off the paper feed gear bracket [3]. Remove the collar [4].

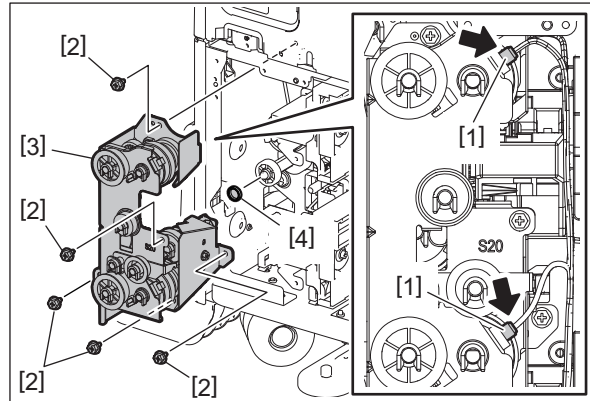

Fig. 4-26

- (3) Remove 1 screw [5] and take off the plate [6].

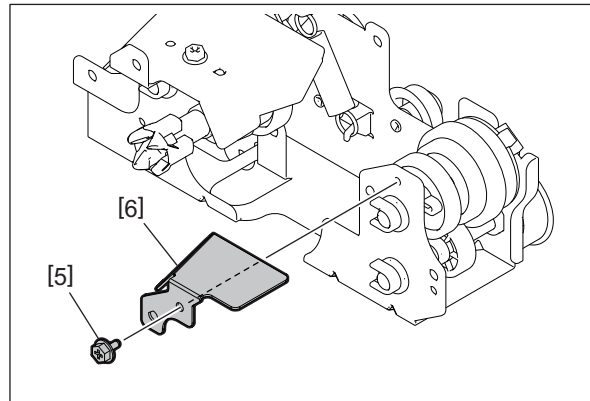

Fig. 4-27

- (4) Remove 3 clips [7], 2 bushings [8], 1 shaft [9], 1 pin [10], 1 gear [11] and take off the 3rd drawer paper feed clutch [12].

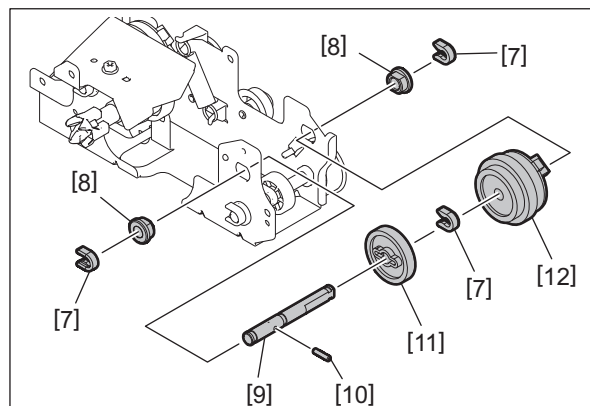

Fig. 4-28

Notes:

When installing the 3rd drawer paper feed clutch [12], firmly engage the stopper on it to the protrusion on the frame.

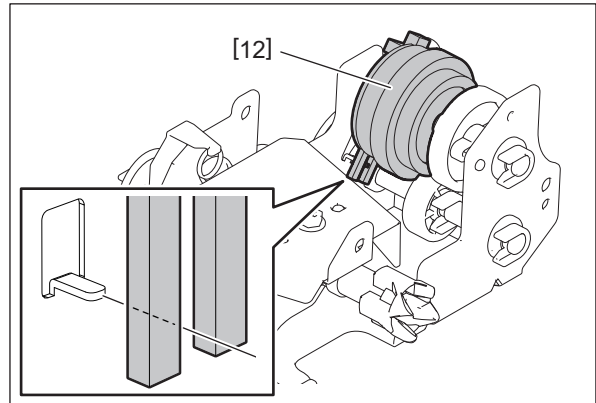

Fig. 4-29

- (5) Remove 1 screw [13] and take off the plate [14].

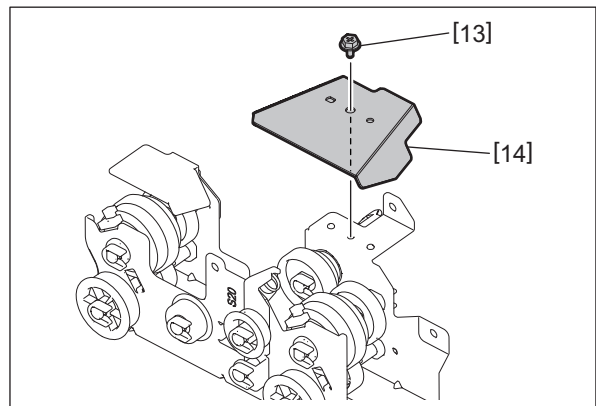

Fig. 4-30

- (6) Remove 3 clips [15], 2 bushings [16], 1 shaft [17], 1 pin [18], 1 gear [19] and take off the 4th drawer paper feed clutch [20].

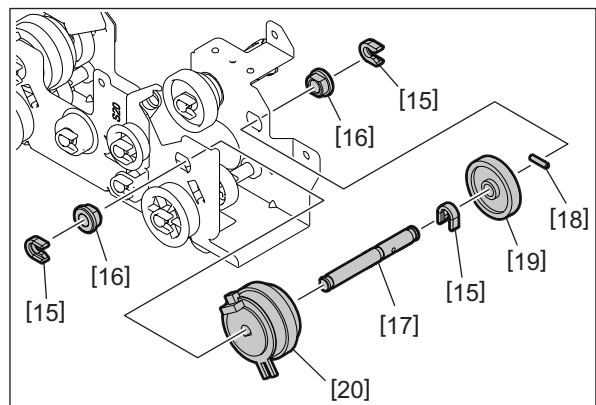

Fig. 4-31

Notes:

When installing the 4th drawer paper feed clutch [20], firmly engage the stopper on it to the protrusion on the frame.

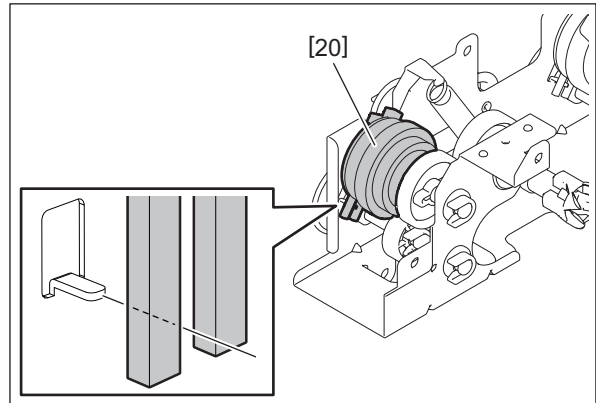



Fig. 4-32

4.6 Motor

4.6.1 3rd drawer tray-up motor (M2), 4th drawer tray-up motor (M3)

- (1) Take off the rear cover.
 P. 4-2 "4.1.2 Rear cover"
- (2) Remove the belt.
 P. 4-11 "4.4 Belt"
- (3) Release 3 harness clamps [1].
- (4) Remove 2 harness clamps [2].

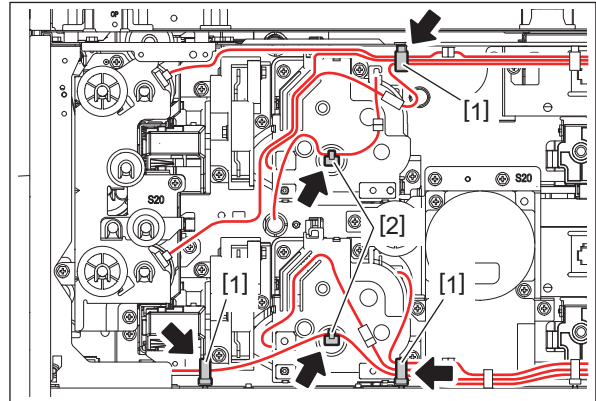

Fig. 4-33

- (5) Disconnect 5 connectors [3].

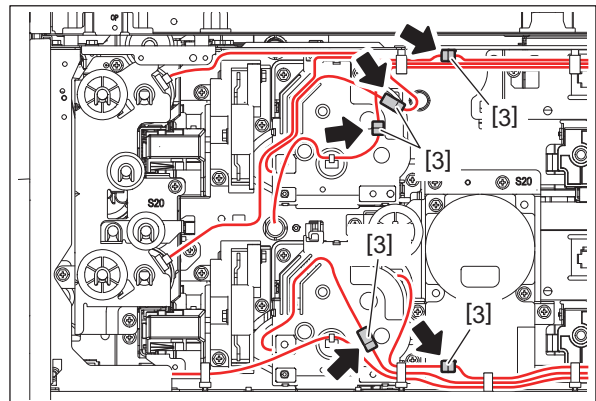

Fig. 4-34

- (6) Remove 3 screws [4] and take off the 3rd drawer tray-up motor unit [5]. Remove 3 screws [4] and take off the 4th drawer tray-up motor unit [6].

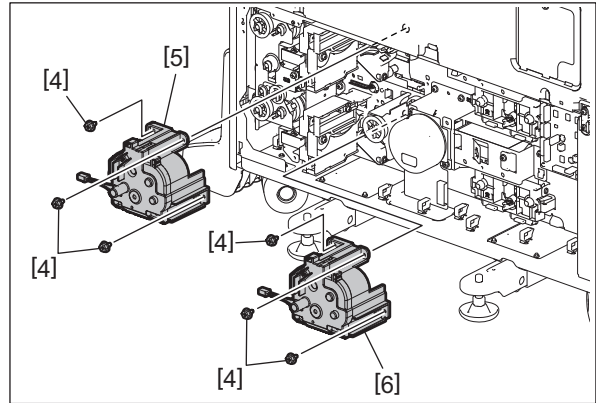

Fig. 4-35

- (7) Take off the tray-up motor from the tray-up motor unit.
(The way of removing the 3rd drawer tray-up motor and the 4th drawer tray-up motor is the same.)
1. Release the harness [7] of the tray-up motor. Release 4 latches [8] and take off the cover [9].

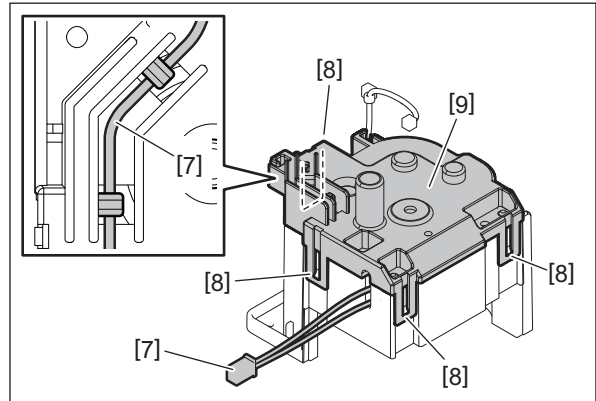

Fig. 4-36

2. Take off the tray-up motor [10].

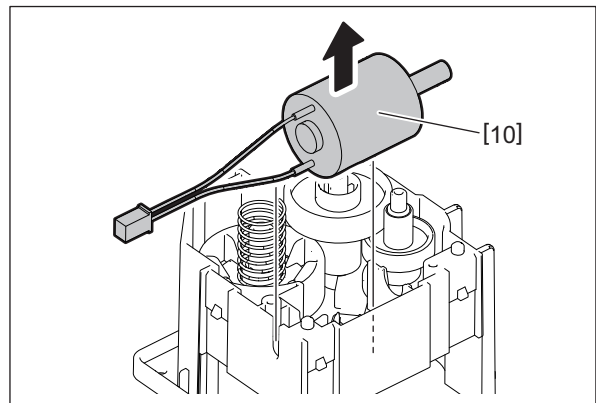

Fig. 4-37

4.6.2 PFP motor

- (1) Take off the rear cover.
☞ P. 4-2 “4.1.2 Rear cover”
- (2) Disconnect 1 connector [1] of the PFP motor.
- (3) Remove 2 screws [3] and take off the PFP motor [2].

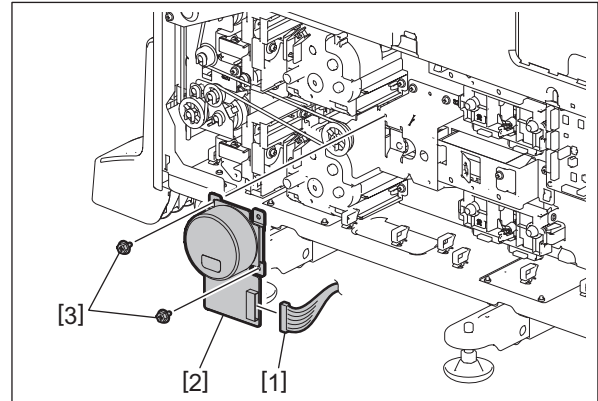

Fig. 4-38

4.7 Paper Feed Roller, Separation Roller, Pickup Roller

4.7.1 Drawer Paper Feed Unit

- (1) Pull out the drawer from which the drawer paper feed unit will be removed, and the drawer immediately above it.
- (2) Turn the locking lever [1] clockwise and take off the drawer paper feed unit [2].

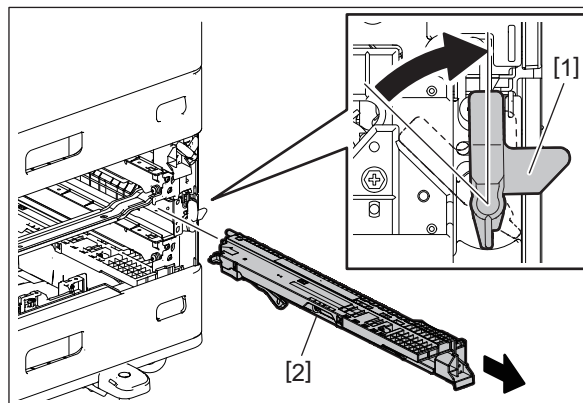

Fig. 4-39

Notes:

When installing, insert the drawer paper feed unit [2] by aligning it to the guide [3].

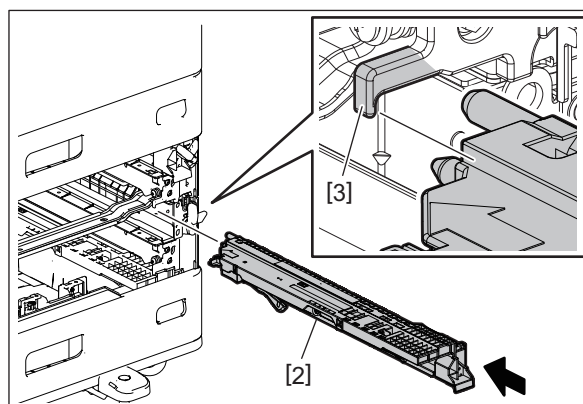

Fig. 4-40

4.7.2 Paper feed roller, Separation roller, Pickup roller **PM**

- (1) Take off the drawer paper feed unit.
📖 P. 4-18 “4.7.1 Drawer Paper Feed Unit”
- (2) Remove 1 clip [1] and take off the separation roller [2]. Remove 1 clip [3] and take off the paper feed roller [4]. Release the latch and take off the pickup roller [5].

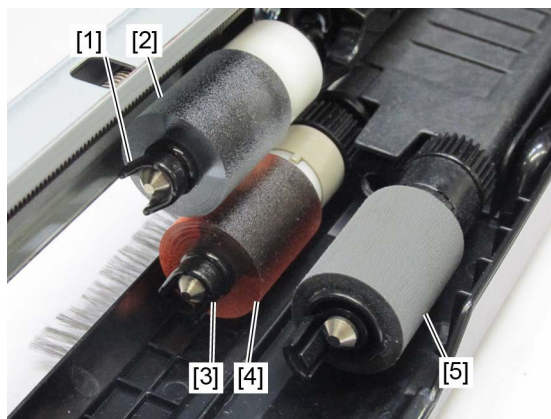

Fig. 4-41

4.8 Switch and Sensor

4.8.1 Tray-up sensor (S3, S4), Paper empty sensor (S5, S6)

- (1) Take off the drawer paper feed unit.
P. 4-18 “4.7.1 Drawer Paper Feed Unit”
- (2) Take off the tray-up motor unit for the drawer whose sensor is removed.
P. 4-15 “4.6.1 3rd drawer tray-up motor (M2), 4th drawer tray-up motor (M3)”
- (3) Release 1 latch [3] and take off the sensor holder [4] from the front side.

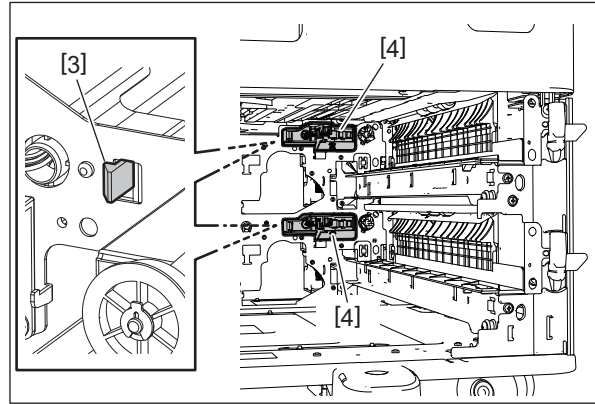

Fig. 4-42

- (4) Disconnect the connector. Release the latch and take off the tray-up sensor [1].
- (5) Disconnect the connector. Release the latch and take off the paper empty sensor [2].

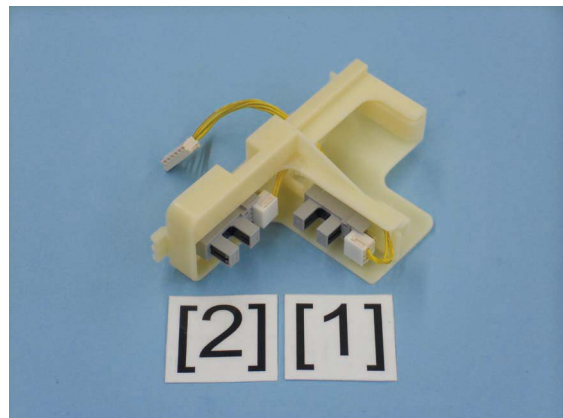

Fig. 4-43

4.8.2 3rd drawer paper remaining detection sensor (S7), 4th drawer paper remaining detection sensor (S8)

- (1) Take off the tray-up motor unit for the drawer whose sensor is removed.
📖 P. 4-15 “4.6.1 3rd drawer tray-up motor (M2), 4th drawer tray-up motor (M3)”
- (2) Disconnect 1 connector. Release the latch and take off the paper remaining detection sensor [1].

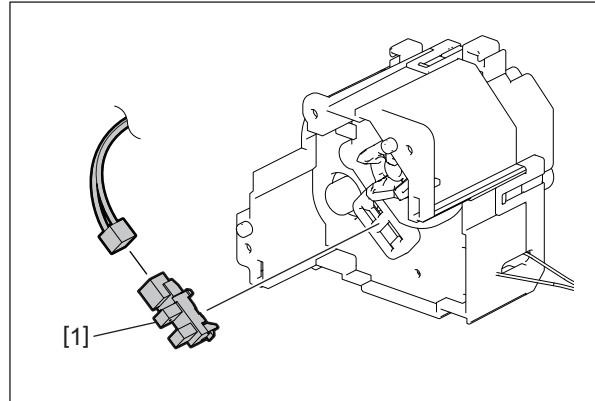

Fig. 4-44

4.8.3 Guide

- (1) Take off the side cover.
📖 P. 4-5 “4.1.6 Side cover”
- (2) Remove 5 screws [2] and take off the guide [1].

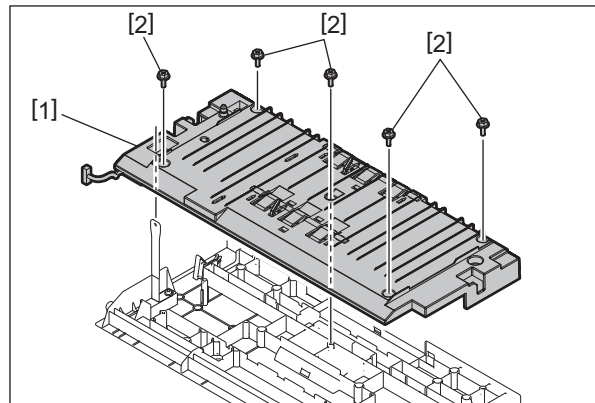

Fig. 4-45

4.8.4 3rd drawer paper feed sensor (S1)

- (1) Take off the guide.
P. 4-21 "4.8.3 Guide"
- (2) Remove 3 screws [3] and release 2 latches [4]. Take off the roller holder [1].
- (3) Remove 2 bushings [2] and 2 springs [5].

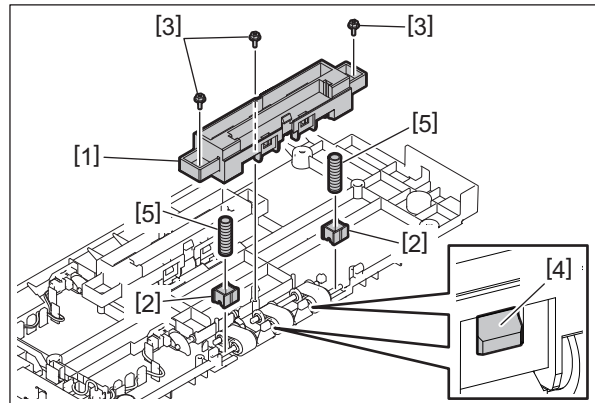

Fig. 4-46

- (4) Remove 1 actuator [6] and 1 spring [7].

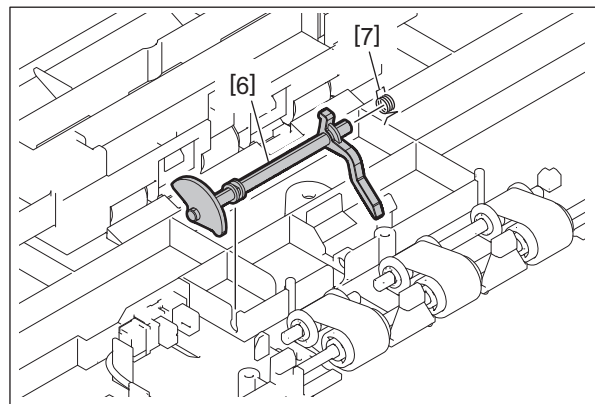

Fig. 4-47

- (5) Disconnect 1 connector [8] and take off the 3rd drawer paper feed sensor [9].

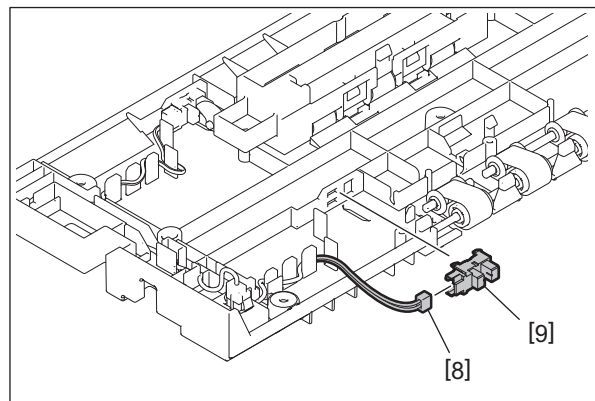

Fig. 4-48

4.8.5 4th drawer paper feed sensor (S2)

- (1) Take off the guide.
P. 4-21 "4.8.3 Guide"
- (2) Remove 3 screws [3] and release 2 latches [4]. Take off the roller holder [1].
- (3) Remove 2 bushings [2] and 2 springs [5].

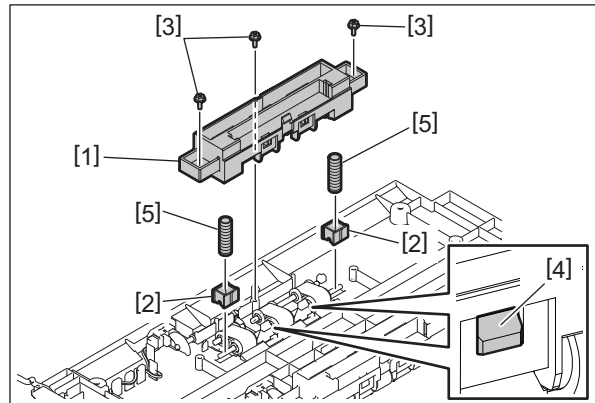

Fig. 4-49

- (4) Remove 1 actuator [6] and 1 spring [7].

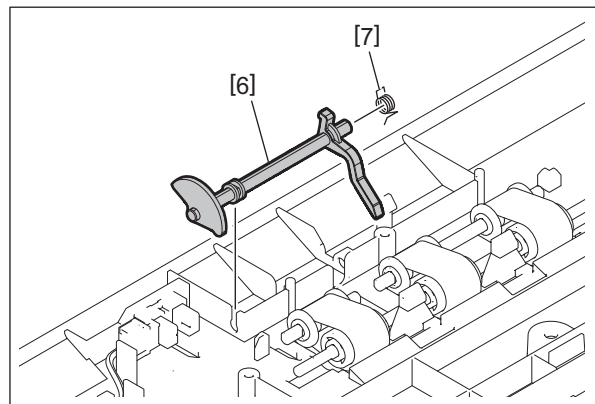

Fig. 4-50

- (5) Disconnect 1 connector [8] and take off the 4th drawer paper feed sensor [9].

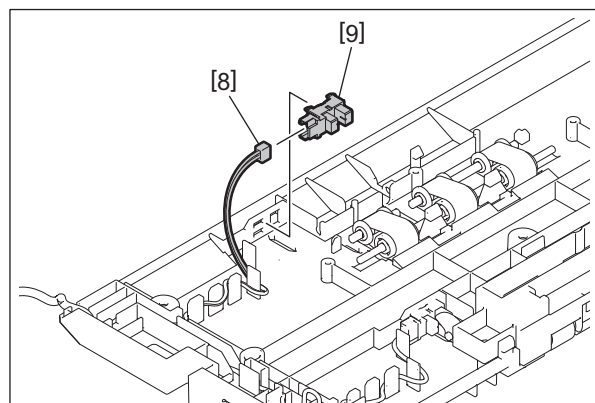

Fig. 4-51

4.8.6 Side cover opening/closing switch (SW1)

- (1) Take off the guide.
📖 P. 4-21 “4.8.3 Guide”
- (2) Disconnect 1 connector [2], release the latch and take off the side cover opening/closing switch [1].

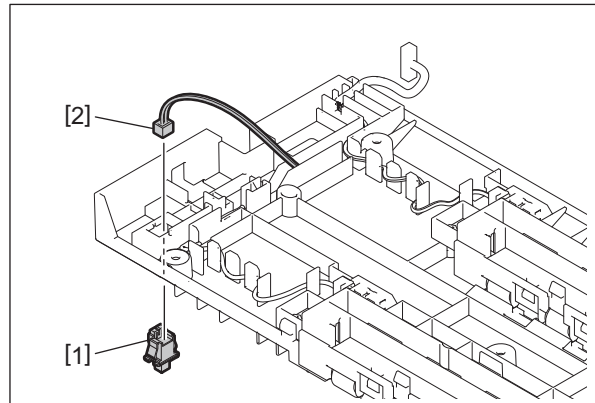

Fig. 4-52

4.8.7 3rd drawer detection switch (SW6), 4th drawer detection switch (SW7)

- (1) Pull out the drawer.
- (2) Take off the rear cover.
📖 P. 4-2 “4.1.2 Rear cover”
- (3) Take off the bracket of the paper feed gear.
📖 P. 4-12 “4.5 Paper Feed Clutch”
- (4) Take off the harness cover [1].
- (5) Disconnect 1 connector of the drawer detection switch [2] of each drawer.
- (6) Release the latch and take off the drawer detection switch [2] from the front side of each drawer.

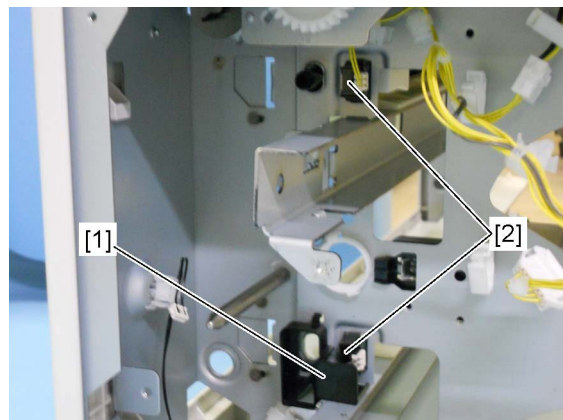

Fig. 4-53

4.8.8 3rd drawer paper width detection switch (SW2), 3rd drawer paper length detection switch (SW3)

- (1) Pull out the drawer.
- (2) Take off the rear cover.
📖 P. 4-2 "4.1.2 Rear cover"
- (3) Disconnect 2 connectors.
- (4) Remove 1 spring [1] and take off the 3rd drawer paper size detection switch holder [2].

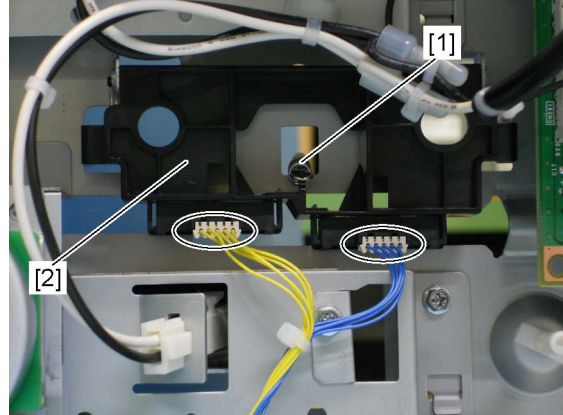

Fig. 4-54

- (5) Release the latch of each switch and take off the 3rd drawer paper width detection switch [4] and 3rd drawer paper length detection switch [3].

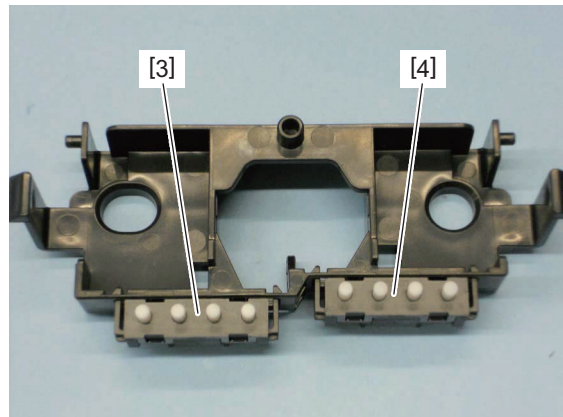

Fig. 4-55

4.8.9 4th drawer paper width detection switch (SW4), 4th drawer paper length detection switch (SW5)

- (1) Pull out the drawer.
- (2) Take off the rear cover.
📖 P. 4-2 "4.1.2 Rear cover"
- (3) Disconnect 2 connectors.
- (4) Remove 1 spring [1] and take off the 4th drawer paper size detection switch holder [2].

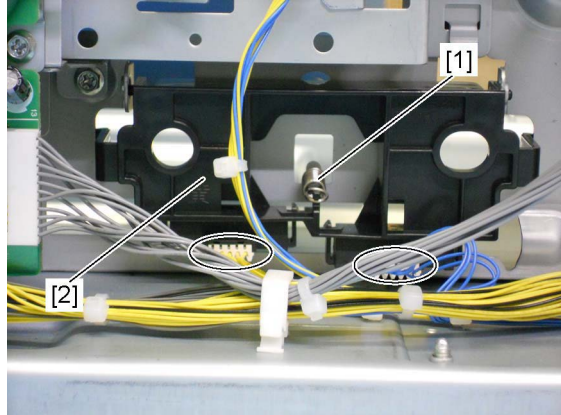

Fig. 4-56

- (5) Release the latch of each switch and take off the 4th drawer paper width detection switch [4] and 4th drawer paper length detection switch [3].

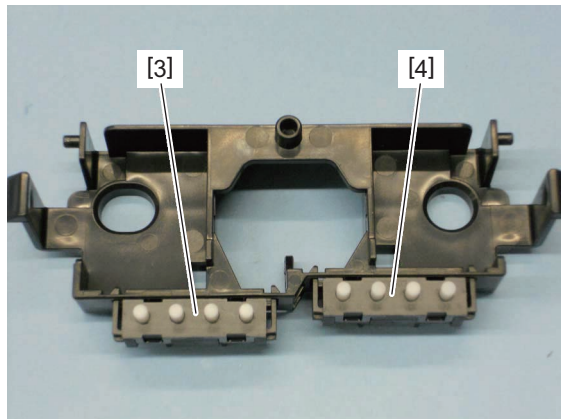

Fig. 4-57

4.9 Soft-close Unit (KD-2019 only)

4.9.1 Soft-close Unit

- (1) Pull out the drawer.
- (2) Take off the rear cover.
☞ P. 4-2 “4.1.2 Rear cover”
- (3) Remove the belt.
☞ P. 4-11 “4.4 Belt”
- (4) Remove 6 screws [1] and take off the soft-close units [2], [3].

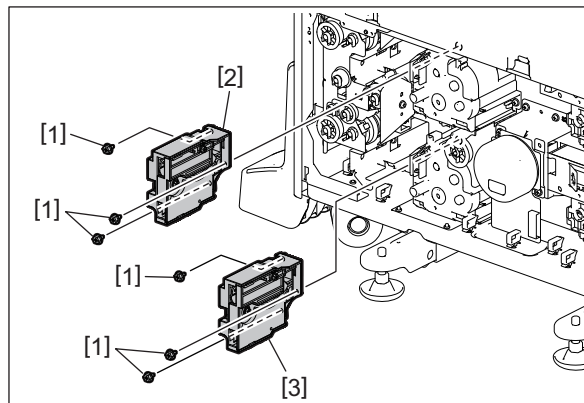

Fig. 4-58

Notes:

- Do not disassemble the soft-close units since a spring with a strong force is used and this will be dangerous.
- When the soft-close unit is replaced, perform the operation described in the following reference.
☞ P. 4-27 “4.9.2 Operation when replacing the soft-close unit for the first time (KD-2019 only)”

4.9.2 Operation when replacing the soft-close unit for the first time (KD-2019 only)

- (1) Take off the paper feed cover.
☞ P. 4-3 “4.1.4 Paper feed cover”
- (2) Insert the drawer [1] or [2] with the soft-close unit replaced all the way in.
- (3) Check if the drawer is automatically inserted by removing and then reinstalling it.

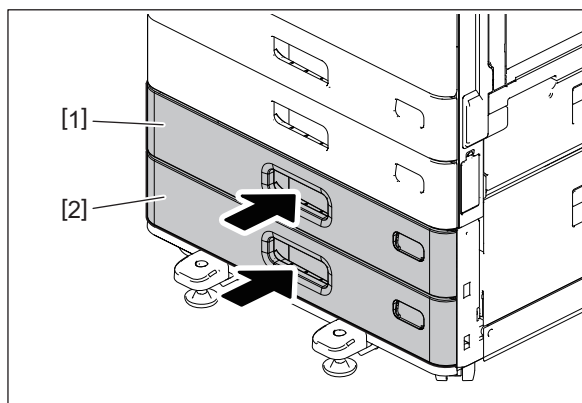



Fig. 4-59

4.10 3rd drawer damp heater (DH1), 4th drawer damp heater (DH2) (KD-2019 only)

Notes:

- Damp heaters have the possibility of causing burns at high temperature. Therefore, care must be taken when handling them.
- Be sure to unplug the power cable of the MFP before starting this work.

- (1) Pull out the drawer.
- (2) Take off the rear cover.
 P. 4-2 "4.1.2 Rear cover"
- (3) Remove 2 screws from the rear side and take off the damp heater unit by sliding it toward the left side.

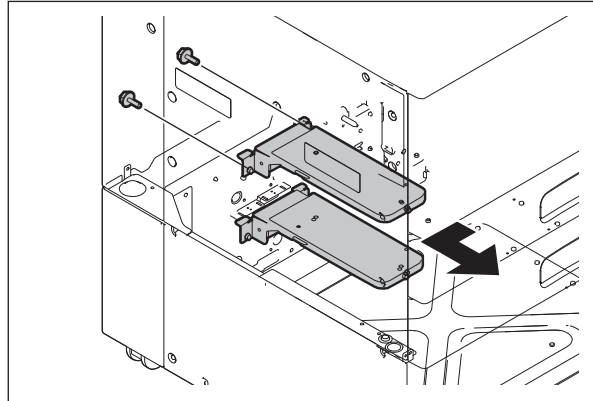

Fig. 4-60

- (4) Disconnect 1 connector.

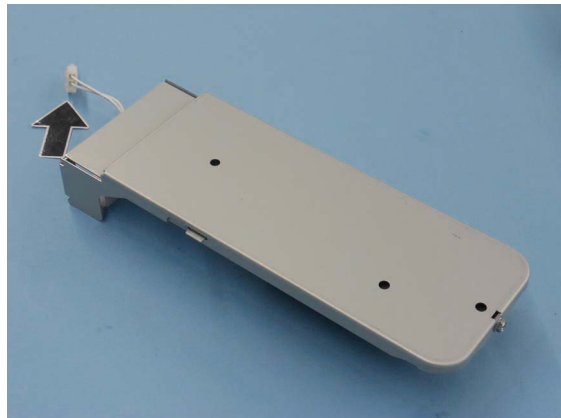

Fig. 4-61

(5) Remove 1 screw and take off the case by sliding it in the direction indicated by the arrow.



Fig. 4-62

(6) Remove 1 screw and take off the damp heater.



Fig. 4-63

5. ELECTRIC CIRCUIT

5.1 Harness Diagram

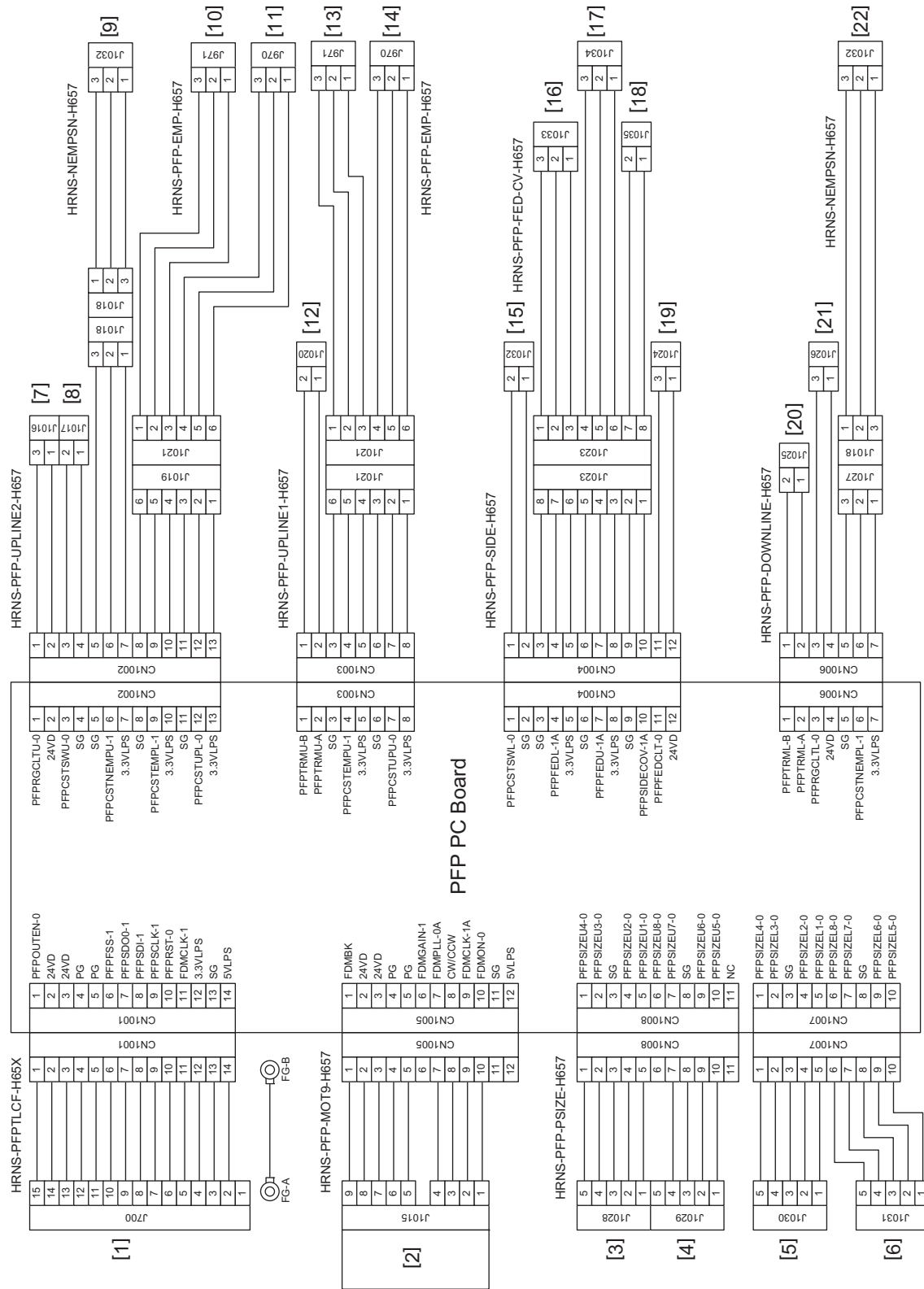

Fig.5-1

[1]	Relay connector for connecting the MFP	[12]	3rd drawer tray-up motor
[2]	PFP motor	[13]	3rd drawer paper empty sensor
[3]	3rd drawer paper size length detection switch	[14]	3rd drawer tray-up sensor
[4]	3rd drawer paper size width detection switch	[15]	4th drawer detection switch
[5]	4th drawer paper size length detection switch	[16]	4th drawer paper feed sensor
[6]	4th drawer paper size width detection switch	[17]	3rd drawer paper feed sensor
[7]	3rd drawer paper feed clutch	[18]	Side cover opening/closing switch
[8]	3rd drawer detection switch	[19]	Transport clutch
[9]	3rd drawer paper remaining detection sensor	[20]	4th drawer tray-up motor
[10]	4th drawer paper empty sensor	[21]	4th drawer paper feed clutch
[11]	4th drawer tray-up sensor	[22]	4th drawer paper remaining detection sensor

6. ADJUSTMENT

6.1 Adjustment of the clearance of the paper and side guide

If the clearance between the paper and the side guide is too wide, it can be adjusted to between 0 and 1 mm using the following procedure.

- (1) Pull out the drawer.
- (2) Move the side guide [1] and loosen 1 screw.

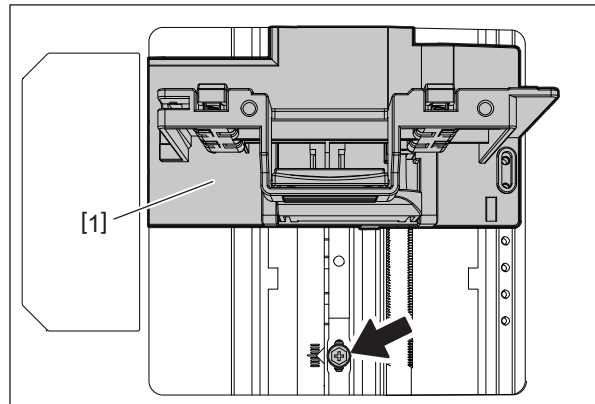

Fig.6-1

- (3) Move the side guide lock adjustment piece [2] to the front and tighten the screw.

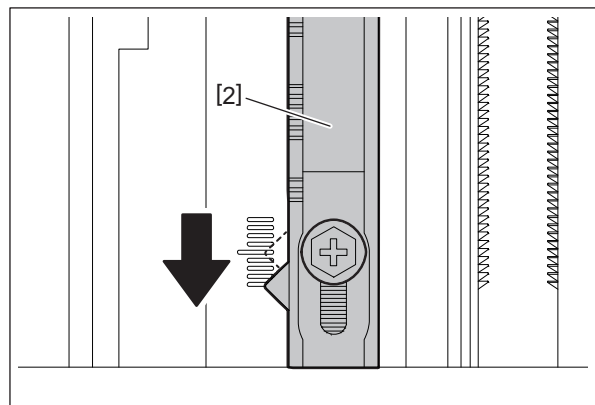

Fig.6-2

6.2 Drawer separation roller pressure force adjustment

If abnormal paper feeding or multiple paper feeding has occurred frequently before the preventive maintenance time of the separation roller, this may be improved by adjusting the pressure force of the separation roller.

Notes:

- Before performing this adjustment, take a memo of the pre-adjustment setting position.
- By performing the adjustment, the occurrence of abnormal paper feeding or multiple paper feeding will increase. If necessary, give sufficient explanation to the users.
- Perform the adjustment carefully depending on the paper.

(1) Remove the paper feed unit.

 P. 4-18 "4.7.1 Drawer Paper Feed Unit"

(2) Remove 1 screw and then attach it temporarily into the oblong hole next to it.

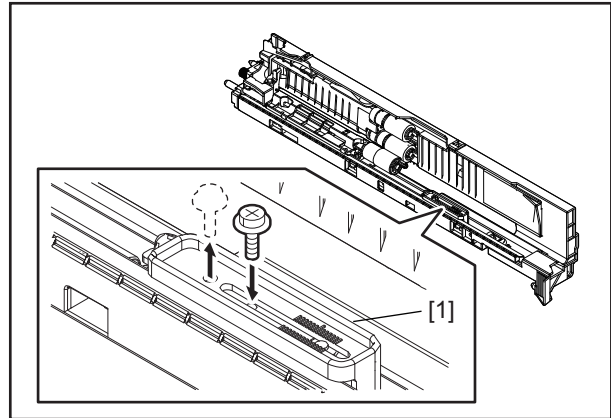

Fig.6-3

Notes:

Make a mark for the installation position of the holder [1] in advance.

(3) Move the holder [1] and perform the adjustment as below.

- To solve multiple paper feeding: Move the holder [1] to the rear side (A). (Abnormal paper feeding tends to occur.)
- To solve abnormal paper feeding: Move the holder [1] to the front side (B). (Multiple feeding tends to occur.)

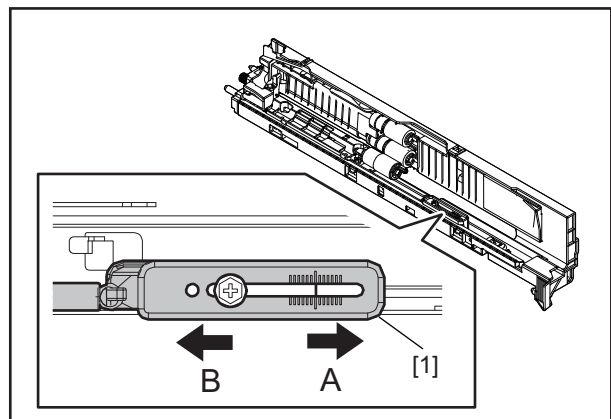

Fig.6-4

Notes:

The recommended moving distance of the holder [1] is within 1 or 2 scale marks.

7. PERIODIC MAINTENANCE

Symbols and values used in the checklist

Item	Explanation
Cleaning	A: Clean with alcohol B: Clean with a soft pad, cloth or vacuum cleaner
Lubrication/Coating	W1: White grease (Molykote EM-30L)
Replacement	Value: Replacement cycle R3: Replace if deformed or damaged
Operation check	O: After cleaning or replacement, confirm there is no problem.

Notes:

Cleaning and lubrication should be performed at the time of the preventive maintenance of the MFP. Lubricate the replacement parts according to the replacement cycle.

The replacement cycle of the parts in the feeding section equals to the number of sheets fed from each paper source.

Be careful not to put oil on the rollers, belts and belt pulleys when lubricating.

The column "P-I" shows the page and item number in the parts list.

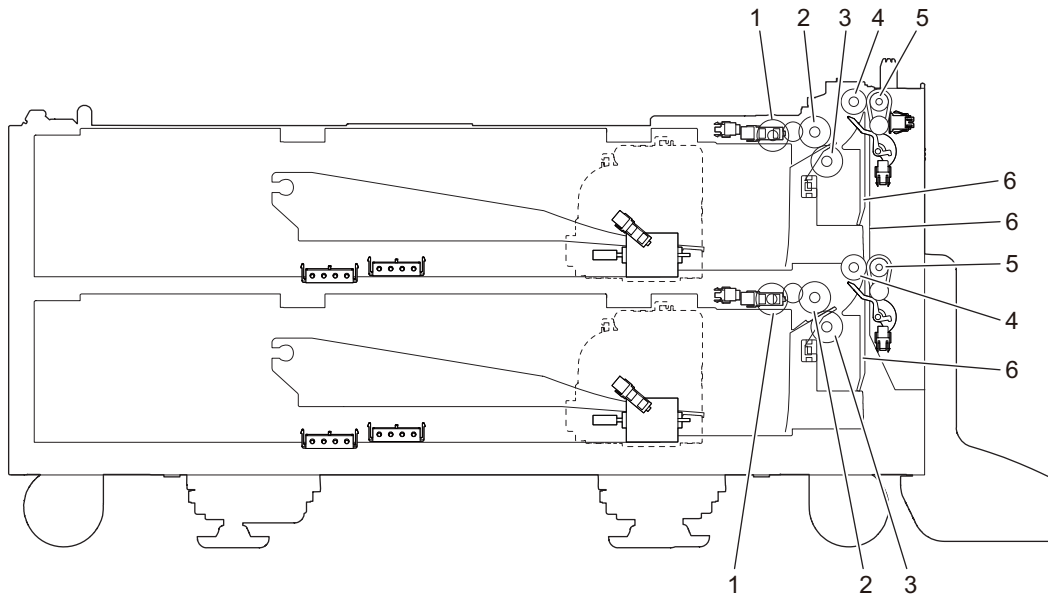

Fig. 7-1

Item	Cleaning	Lubrication/Coating	Replacement		Operation check	<P-I>
			(x 1,000 sheets)	(x 1,000 drive counts)		
1	3rd drawer pickup roller, 4th drawer pickup roller	A		80 or every 2.5 years		5-26
2	3rd drawer paper feed roller, 4th drawer paper feed roller	A		80 or every 2.5 years		5-36
3	3rd drawer separation roller, 4th drawer separation roller	A		80 or every 2.5 years		5-30
4	Upper transport roller, Lower transport roller	A		R3		2-35 2-40
5	Upper idling roller, Lower idling roller (Clean the inner diameter and shaft.)	A	W1			4-2

Item		Cleaning	Lubrication/ Coating	Replacement		Operation check	<P-I>
				(x 1,000 sheets)	(x 1,000 drive counts)		
6	Paper guide	B					4-1 4-11

REVISION RECORD

Ver00

Ver00 <2021/12/22>	
Page	Contents
	Initial release

TOSHIBA

Toshiba Tec Corporation

1-11-1, OSAKI, SHINAGAWA-KU, TOKYO, 141-8562, JAPAN