

Model Da-P1

**Machine Code:
M187**

Field Service Manual

January, 2015

Important Safety Notices

Important Safety Notices

Prevention of Physical Injury

1. Before disassembling or assembling parts of the main machine and peripherals, make sure that the power cord of the main machine is unplugged.
2. The wall outlet should be near the machine and easily accessible.
3. Note that some components of the machine and the paper tray unit are supplied with electrical voltage even if the main power switch is turned off.
4. If any adjustment or operation check has to be made with exterior covers off or open while the main switch is turned on, keep hands away from electrified or mechanically driven components.
5. The inside and the metal parts of the fusing unit become extremely hot while the machine is operating. Be careful to avoid touching those components with your bare hands.

WARNING

- To prevent a fire or explosion, keep the machine away from flammable liquids, gases, and aerosols.

Health Safety Conditions

1. Toner and developer is non-toxic, but if you get either of them in your eyes by accident, it may cause temporary eye discomfort. Immediately wash eyes with plenty of water. If unsuccessful, get medical attention.
2. This machine, which uses a high voltage power source, can generate ozone gas. High ozone density is harmful to human health. Therefore, the machine must be installed in a well-ventilated room.

Observance of Electrical Safety Standards

1. This machine and its peripherals must be serviced by a customer service representative who has completed the training course on those models.
2. The NVRAM on the system control board has a lithium battery which can explode if replaced incorrectly. Replace the NVRAM only with an identical one. The manufacturer recommends replacing the entire NVRAM. Do not recharge or burn this battery. Used NVRAM must be handled in accordance with local regulations.

Handling Toner

- Work carefully when removing paper jams or replacing toner bottles or cartridges to avoid spilling toner on clothing or the hands.
- If toner is inhaled, immediately gargle with large amounts of cold water and move to a well ventilated location. If there are signs of irritation or other problems, seek medical attention.
- If toner gets on the skin, wash immediately with soap and cold running water.
- If toner gets into the eyes, flush the eyes with cold running water or eye wash. If there are signs of irritation or other problems, seek medical attention.
- If toner is swallowed, drink a large amount of cold water to dilute the ingested toner. If there are signs of any problem, seek medical attention.
- If toner spills on clothing, wash the affected area immediately with soap and cold water. Never use hot water! Hot water can cause toner to set and permanently stain fabric.
- Always store toner and developer supplies such as toner and developer packages, cartridges, and bottles (including used toner and empty bottles and cartridges) out of the reach of children.
- Always store fresh toner supplies or empty bottles or cartridges in a cool, dry location that is not exposed to direct sunlight.

WARNING







- Do not use a vacuum cleaner to remove spilled toner (including used toner). Vacuumed toner may cause a fire or explosion due to sparks or electrical contact inside the cleaner. However, it is possible to use a cleaner designed to be dust explosion-proof. If toner is spilled over the floor, sweep up spilled toner slowly and clean up any remaining toner with a wet cloth.

Safety and Ecological Notes for Disposal

1. Do not incinerate toner bottles or used toner. Toner dust may ignite suddenly when exposed to an open flame.
2. Dispose of used toner, the maintenance unit which includes developer or the organic photoconductor in accordance with local regulations. (These are non-toxic supplies.)
3. Dispose of replaced parts in accordance with local regulations.
4. When keeping used lithium batteries in order to dispose of them later, do not put more than 100 batteries per sealed box. Storing larger numbers or not sealing them apart may lead to chemical reactions and heat build-up.

Symbols, Abbreviations and Trademarks

This manual uses several symbols and abbreviations. The meaning of those symbols and abbreviations are as follows:

Symbol	What is means
	Screw
	Shoulder screw
	Connector
	Clip ring
	Clamp
	Timing belt
	Spring
SEF	Short Edge Feed
LEF	Long Edge Feed

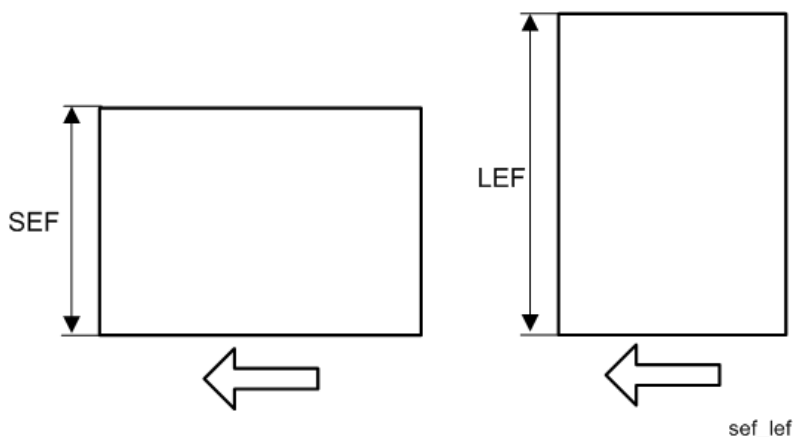

Trademarks

Adobe, Acrobat, PostScript, PostScript 3, and Reader are either registered trademarks or trademarks of Adobe Systems Incorporated in the United States and/or other countries.

Mac OS, OS X, and Safari are trademarks of Apple Inc., registered in the United States and other countries.

Firefox® is a registered trademark of the Mozilla Foundation.

Java is a registered trademark of Oracle and/or its affiliates.

JAWS® is a registered trademark of Freedom Scientific, Inc., St. Petersburg, Florida and/or other countries.

Microsoft®, Windows®, Windows Server®, Windows Vista®, and Internet Explorer® are either registered trademarks or trademarks of Microsoft Corporation in the United States and/or other countries.

Monotype is a registered trademark of Monotype Imaging Inc.

NetWare, IPX, IPX/SPX, NCP, and NDS are either registered trademarks or trademarks of Novell, Inc.

PCL® is a registered trademark of Hewlett-Packard Company.

The proper name of Internet Explorer 6 is Microsoft® Internet Explorer® 6.

The proper name of Internet Explorer 8 is Windows® Internet Explorer® 8.

The proper names of the Windows operating systems are as follows:

- The product names of Windows XP are as follows:

Microsoft® Windows® XP Professional Edition

Microsoft® Windows® XP Home Edition

Microsoft® Windows® XP Media Center Edition

Microsoft® Windows® XP Tablet PC Edition

- The product names of Windows Vista are as follows:

Microsoft® Windows Vista® Ultimate

Microsoft® Windows Vista® Business

Microsoft® Windows Vista® Home Premium

Microsoft® Windows Vista® Home Basic

Microsoft® Windows Vista® Enterprise

- The product names of Windows 7 are as follows:

Microsoft® Windows® 7 Home Premium

Microsoft® Windows® 7 Professional

Microsoft® Windows® 7 Ultimate

Microsoft® Windows® 7 Enterprise

- The product names of Windows 8 are as follows:

Microsoft® Windows® 8

Microsoft® Windows® 8 Pro

Microsoft® Windows® 8 Enterprise

- The product names of Windows 8.1 are as follows:

Microsoft® Windows® 8.1

Microsoft® Windows® 8.1 Pro

Microsoft® Windows® 8.1 Enterprise

- The product names of Windows Server 2003 are as follows:

Microsoft® Windows Server® 2003 Standard Edition

Microsoft® Windows Server® 2003 Enterprise Edition

- The product names of Windows Server 2003 R2 are as follows:

Microsoft® Windows Server® 2003 R2 Standard Edition

Microsoft® Windows Server® 2003 R2 Enterprise Edition

- The product names of Windows Server 2008 are as follows:

Microsoft® Windows Server® 2008 Standard

Microsoft® Windows Server® 2008 Enterprise

- The product names of Windows Server 2008 R2 are as follows:

Microsoft® Windows Server® 2008 R2 Standard

Microsoft® Windows Server® 2008 R2 Enterprise

- The product names of Windows Server 2012 are as follows:

Microsoft® Windows Server® 2012 Foundation

Microsoft® Windows Server® 2012 Essentials

Microsoft® Windows Server® 2012 Standard

- The product names of Windows Server 2012 R2 are as follows:

Microsoft® Windows Server® 2012 R2 Foundation

Microsoft® Windows Server® 2012 R2 Essentials

Microsoft® Windows Server® 2012 R2 Standard

Other product names used herein are for identification purposes only and might be trademarks of their respective companies. We disclaim any and all rights to those marks.

Microsoft product screen shots reprinted with permission from Microsoft Corporation.

TABLE OF CONTENTS

Important Safety Notices.....	1
Important Safety Notices.....	1
Prevention of Physical Injury.....	1
Health Safety Conditions.....	1
Observance of Electrical Safety Standards.....	1
Handling Toner.....	2
Safety and Ecological Notes for Disposal.....	2
Symbols, Abbreviations and Trademarks.....	3
Trademarks.....	3
1. Product Information	
Product Overview.....	15
Component Layout.....	15
Paper Path.....	16
Drive Layout.....	17
Machine Codes and Peripheral Configuration.....	18
Machine Codes and Peripheral Configuration.....	18
Specifications.....	21
2. Installation	
Installation Requirements.....	23
Environment.....	23
Machine Space Requirements.....	24
Machine Dimensions.....	24
Power Requirements.....	25
Main Machine Installation.....	26
Accessory Check.....	26
Instructions for the Customers.....	26
Moving the Machine.....	26
Security Settings.....	28
Changing an Administrator's Password.....	28
Configuring SSL/TLS.....	28
Paper Feed Unit TK2010.....	29
Component Check.....	29
Installation Procedure.....	29

USB Device Server Option Type M12.....	31
Component Check.....	31
Interface Board Surface.....	31
Installation Procedure.....	32
What Do the LED Indications Mean?.....	35
Notes for Energy Save Mode Setting.....	36
IP Address Setting.....	36
SD Card Appli Move.....	39
Overview.....	39
Notes on Using the SD Merge Function.....	39
SD Card Applications.....	40
Move Exec.....	40
Undo Exec.....	42
Settings for @Remote Service.....	44
Check points before making @Remote settings.....	44
Execute the @Remote Settings.....	44
3. Preventive Maintenance	
Preventive Maintenance Tables.....	49
Preventive Maintenance Tables.....	49
Image Quality Standards.....	50
Image Quality Standards.....	50
Paper Transfer Quality Standards.....	51
Paper Transfer Quality Standards.....	51
4. Replacement and Adjustment	
General Cautions.....	53
Notes on the Main Power Switch.....	53
Characteristics of the Push Switch (DC Switch).....	53
Shutdown Method.....	54
Forced Shutdown.....	55
Special Tools	56
Exterior Covers.....	57
Front Cover.....	57
Left Cover.....	58

Right Cover.....	60
Rear Cover, Rear Lower Cover.....	63
By-pass Tray.....	66
Upper Cover.....	67
Operation Panel.....	68
LED Optics.....	72
LED Unit.....	72
PCDU.....	78
PCDU.....	78
Toner Cartridge.....	79
Toner Cartridge.....	79
Image Transfer.....	81
Image Transfer Roller.....	81
Drive Unit.....	83
Main Motor.....	83
Exit/Reverse Motor.....	84
Registration Clutch.....	86
Paper Feed Clutch.....	86
By-pass Feed Clutch.....	87
By-pass Bottom Plate Clutch.....	89
Drive Unit.....	89
Gear Unit.....	89
Toner Supply Clutch.....	92
Relay Clutch.....	93
Duplex Clutch.....	94
Junction Gate Solenoid.....	95
Fusing.....	96
Fusing Unit.....	96
Upper Fusing Unit, Lower Fusing Unit.....	98
Fusing Pressure Roller.....	99
Fusing Lamp, Hot Roller.....	100
Thermostat.....	104
Thermistor.....	104

Hot Roller Stripper.....	106
Paper Feed.....	107
Paper Feed Tray.....	107
Paper Feed Roller.....	107
Friction Roller, Torque Limiter.....	108
Paper End Sensor.....	109
By-pass Feed Unit.....	110
By-pass Feed Roller.....	112
By-pass Friction Pad.....	114
By-pass Paper End Sensor.....	115
By-pass Bottom Plate HP Sensor.....	116
Paper Size Detection Switch.....	117
Paper Transport.....	119
Paper Exit Unit.....	119
Paper Exit Sensor.....	121
Paper Overflow Sensor.....	121
Duplex Reverse Sensor.....	121
Duplex Entrance Sensor.....	123
Registration Roller (Driven).....	123
Registration Roller (Drive).....	126
Registration Sensor.....	128
Electrical Components.....	130
Controller Box.....	130
PSU.....	131
Controller Board.....	134
Before replacing the controller board in the model without HDD.....	134
Replacement Procedure.....	134
After installing the controller board.....	136
NVRAM on the Controller Board.....	136
BCU.....	137
EEPROM on the BCU.....	138
Toner End Sensor.....	139
HVPS.....	140

HVPS with Bracket.....	140
PCDU Cooling Fan.....	141
PCDU Cooling Fan with Duct.....	141
PSU Cooling Fan.....	142
DC Switch.....	142
Front Cover Interlock Switch.....	143
Front Cover Interlock Switch with Bracket.....	144
Rear Cover Interlock Switch.....	144
DIMM.....	145
Temp Humid Sensor.....	147
Envelope Lever Detection Switch.....	147

5. System Maintenance

Service Program Mode.....	149
SP Tables.....	149
Enabling and Disabling Service Program Mode.....	149
Entering SP Mode.....	149
Exiting SP Mode.....	149
Types of SP Modes.....	150
Service Mode Lock/Unlock.....	150
Updating the Firmware.....	151
Overview.....	151
Type of Firmware.....	151
Updating Firmware.....	152
Before You Begin.....	152
Preparation.....	153
Updating Procedure.....	153
Firmware Update Error.....	156
Recovery after Power Loss.....	156
Handling Firmware Update Errors.....	157
Uploading/Downloading NVRAM Data.....	162
Uploading Content of NVRAM to an SD Card.....	162
Downloading an SD Card to NVRAM.....	163
Capturing Log to SD card.....	164

Overview.....	164
Security of the Operation Log.....	165
Retrieving the Debug Logs.....	165
Procedure for Retrieving the Debug Log.....	166
Address Book Upload/Download.....	167
Information List.....	167
Upload (Backup) to SD Card.....	167
Download (Restore) to Machine.....	168
Erasing the Backup Data.....	168
6. Troubleshooting	
Self-Diagnostic Mode.....	169
Self-Diagnostic Mode at Power On.....	169
Service Call.....	170
Summary.....	170
When a Level "D" SC code occurs.....	170
SC100.....	171
SC200 (LED Optics).....	171
SC300 (Image Processing – 1).....	173
SC400 (Image Processing – 2).....	175
SC500 (Paper Feed and Fusing).....	176
SC600 (Device Communication).....	185
SC700 (Peripherals).....	196
SC800 (Controller).....	197
SC900 (Others).....	262
Jam Detection.....	269
Jam Displays.....	269
Jam History.....	269
Sensor Position Layout.....	270
Sensor Position.....	270
Main Machine.....	271
Optional Bank.....	272
Troubleshooting.....	273
Test Pattern Printing.....	273

Image Position Adjustment.....	274
Registration Adjustment.....	274
Print Area.....	274
Adjustment Reference Values.....	275
Adjustment Procedure.....	275
Image Problem.....	275
Problem at Regular Intervals.....	275
When Vertical Banding is Generated.....	277
When Black Spots are Generated on Print Image.....	277
When Toner Smears Appear on the Backside of the Printouts.....	278
Paper Feed (Skew).....	279
Recycled or Thin Paper Is Severely Curled after Printing.....	279
Electrical Component Defects.....	280
Electrical Components.....	280
Fuses.....	281
BCU.....	281
PSU.....	283

7. Energy Save

Energy Save.....	285
Energy Saver Modes.....	285
Sleep Mode Setting.....	285
Weekly Timer.....	286
Eco Night Mode.....	286
Fusing Off Mode.....	289
Fusing Heater Off on Stndby.....	290
Return to Stand-by Mode.....	290
Recommendation.....	290
Energy Save Effectiveness.....	291
Paper Save.....	293
Effectiveness of Duplex/Combine Function.....	293
1. Duplex:.....	293
2. Combine mode:.....	293
3. Duplex + Combine:.....	294

Recommendation.....294



1. Product Information

Product Overview

1

Component Layout

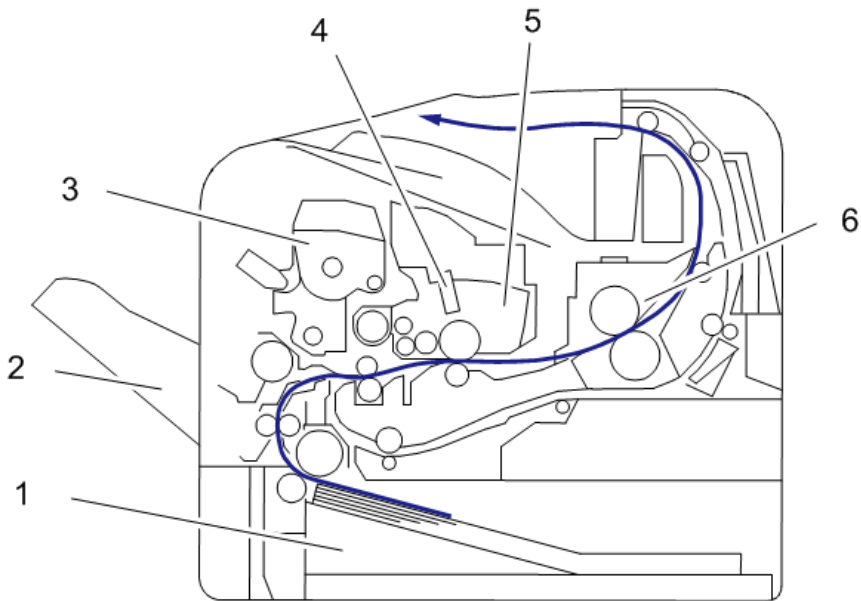

m187z1001

No.	Description	No.	Description
1	Paper Feed Unit	4	LED Head
2	By-pass Tray	5	PCDU
3	Toner Cartridge	6	Fusing Unit

Paper Path

1

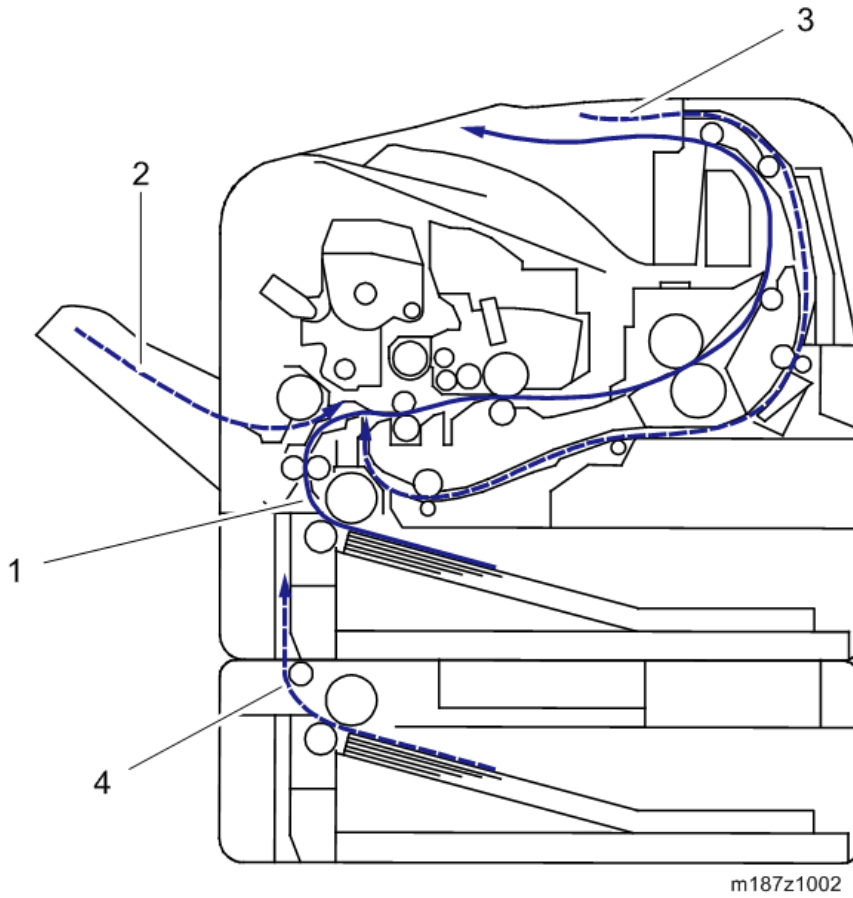

No.	Description	No.	Description
1	Main Machine Paper Feed Path	3	Duplex Paper Feed Path
2	By-pass Paper Feed Path	4	Optional Tray Paper Feed Path

Drive Layout

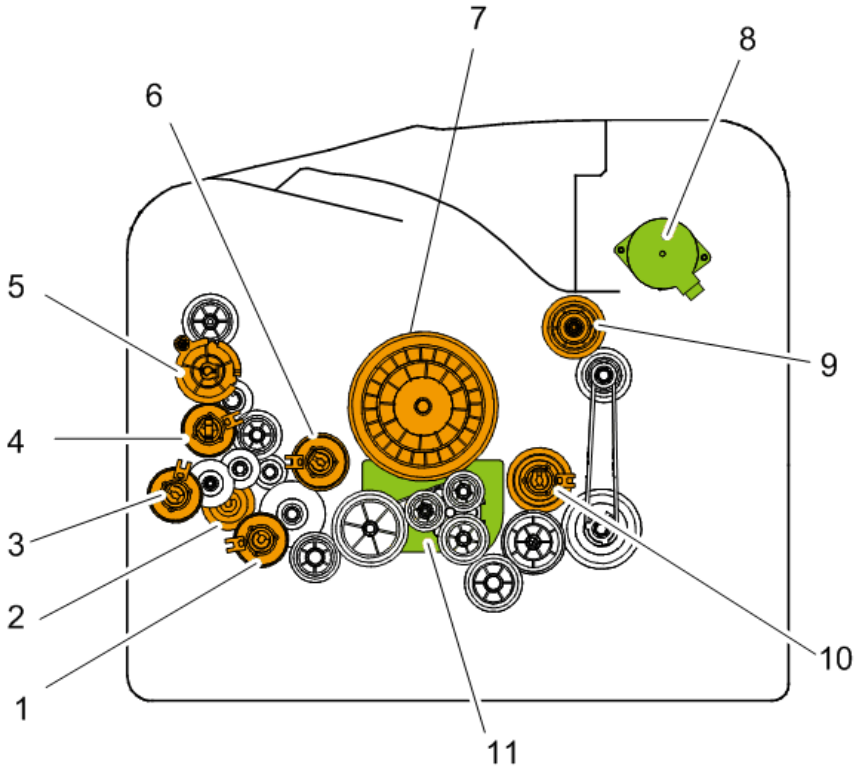

m187z1003

No.	Description	No.	Description
1	Paper feed clutch	7	Drum Gear
2	Replay Clutch	8	Exit/Reverse Motor
3	By-pass Bottom Plate Clutch	9	Fusing Drive Gear
4	By-pass Feed Clutch	10	Duplex Clutch
5	Toner Supply Clutch	11	Main Motor
6	Registration Clutch		

Machine Codes and Peripheral Configuration

Machine Codes and Peripheral Configuration

Main Frame

Item	Machine Code	Remarks
SP 6430DN	M187-17 (NA)	NEW
	M187-27 (EU/AA)	NEW
	M187-21 (CHN)	NEW

External Options

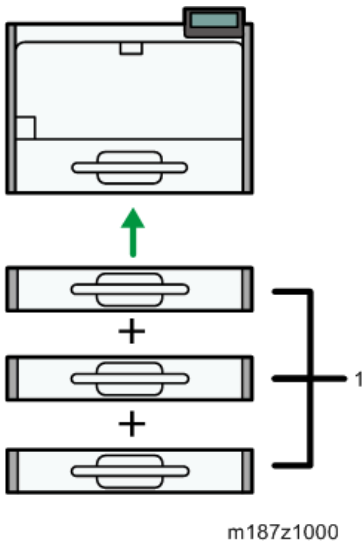

No.	Item	Machine Code	Remarks
1	Paper Feed Unit TK2010	M456-17	NEW

Internal Options

Item	Machine Code	Remarks
IPDS Unit Type P4	M444-50 (NA)	
	M444-51 (EU)	
	M444-52 (AA/CHN)	

Item	Machine Code	Remarks
XPS Direct Print Option Type P4	M444-49	
VM CARD Type W * 1	M417-19 (NA)	
	M417-20 (EU)	
	M417-21 (AA/CHN)	
Memory Unit Type N	M417-03	
SD card for NetWare printing Type P4	M444-55	
Hard Disk Drive Option Type P4	M444-42	
IEEE802.11 Interface Unit Type O	M417-06 (NA)	
USB Device Server Option Type M12	D3A7-28 (NA)	
	D3A7-29 (EU/AA/CHN)	
IEEE1284 Interface Board Type A	B679-17	

* 1: To install this, Memory Unit Type N and Hard Disk Drive Option Type P4 must first be installed.

Consumables for M187

Item	Machine Code	Remarks	Yield
Print Cartridge SP 6430A	M915-17 (NA)	NEW	10,000 pages (ISO)
Print Cartridge SP 6430E	M915-27 (EU)		
Print Cartridge SP 6430S	M915-20 (AA)		
Print Cartridge SP 6430C	M915-21 (CHN)		
Drum Unit SP 6430	M919-17		25,000 pages (3P/J)
Maintenance Kit SP 6430	M920-17 (NA)		90,000 pages (3P/J)
	M920-27 (EU)		

 **Note**

- (ISO): The number of printable pages is based on pages that are compliant with ISO/IEC 19752 with the image density set as the factory default. ISO/IEC 19752 is an international standard for measurement of printable pages, set by the International Organization for Standardization.
- (6%, 3P/J): A4/Letter 6% test chart, 3 pages/job.
- (3P/J): A4/Letter, 3 pages/job.

Specifications

See "Appendices" for the following information:

- General Specifications
- Supported Paper Sizes
- Software Accessories
- Optional Equipment

2. Installation

Installation Requirements

Environment

2

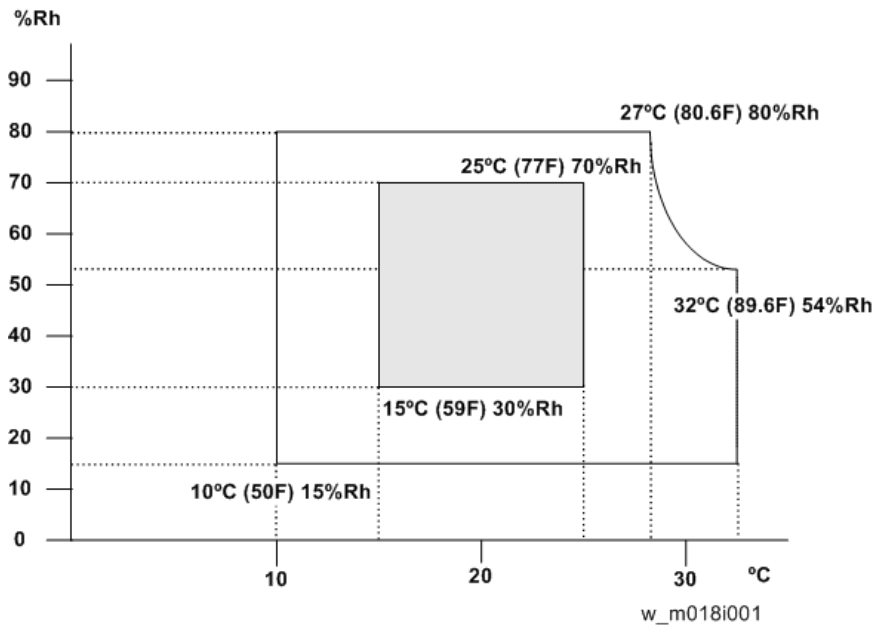

1. Temperature Range: 10°C to 32°C (50°F to 89.6°F)
2. Humidity Range: 15% to 80% RH
3. Ambient Illumination: Less than 1,500 lux (do not expose to direct sunlight)
4. Ventilation: More than 3 times/hr/person
5. Do not install the machine at locations over 2,000 m (6,562 ft.) above sea level.

Machine Space Requirements

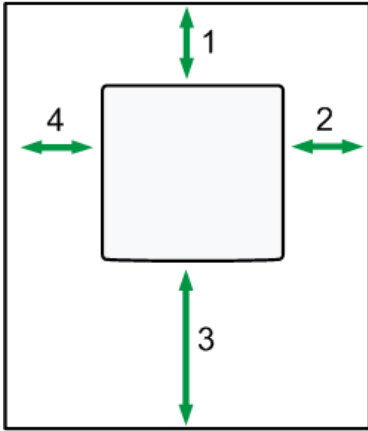

m1600239

1	Rear	Over 20 cm (7.9 inches)
2	Right	Over 10 cm (3.9 inches)
3	Front	Over 55 cm (21.7 inches)
4	Left	Over 10 cm (3.9 inches)

Machine Dimensions

Width	<ul style="list-style-type: none"> Printer only: 459 mm (18.07 inches) With an optional hard disk cover: 475 mm (18.70 inches) With Intake louver: 464 mm (18.27 inches)
Depth	<ul style="list-style-type: none"> 392 mm (15.4 inches) With paper feed tray handle: 412 mm (16.22 inches) With controller screw: 396.4 mm (15.61 inches)
Height	<ul style="list-style-type: none"> Printer Only: 347.5 mm (13.68 inches) With optional paper feed trays (TK2010×3): 719.5 mm (28.33 inches)

Power Requirements

CAUTION

- Make sure that the plug is firmly inserted in the outlet.
- Avoid multi-wiring.
- Be sure to ground the machine.
- Never place anything on the power cord.

1. Input voltage level:

Destination	Power supply voltage	Frequency	Rated current consumption
NA	120 V to 127 V	60 Hz	More than 10 A
EU/AP/CHN	220 V to 240V	50 Hz/60 Hz	5.3 A

2. Permissible voltage fluctuation:

Destination	For printing images	For operating
NA	+8.66 / -10%	+8.66 / -15%
EU/AP/CHN	±10%	±15%

Main Machine Installation

★ Important

- The M187 models are for installation by users.

2

Accessory Check

Description	Q'ty
Power cord	1

Instructions for the Customers

Provide instructions on the following matters to customers. For detailed procedures, see the user manuals.

- Operating the printer function
- Installing consumables and loading paper
- Operating the main power switch
- Removing jammed paper
- Registering/changing/deleting data in the address book
- Providing precautions on use
- Connecting to computers (such as configuring the port setting)
- Giving a brief outline of the tabs in the drivers

Moving the Machine

⚠ CAUTION

- It is dangerous to handle the power cord plug with wet hands. Doing so could result in electric shock.

⚠ CAUTION

- Unplug the power cord from the wall outlet before you move the machine. While moving the machine, take care that the power cord is not damaged under the machine. Failing to take these precautions could result in fire or electric shock.

⚠ CAUTION

- If you have to move the machine when the optional paper tray unit is attached, do not push on the main unit's top section. Doing so can cause the optional paper tray unit to detach, possibly resulting in injury.

⚠ CAUTION

- When disconnecting the power cord from the wall outlet, always pull the plug, not the cord. Pulling the cord can damage the power cord. Use of damaged power cords could result in fire or electric shock.

⚠ CAUTION

- The machine weighs approximately 22.5 kg (49.6 lb.). When moving the machine, use the inset grips on both sides, and lift slowly in pairs. The machine will break or cause injury if dropped.

⚠ CAUTION

- Do not hold the control panel while moving the machine. Doing so may damage the control panel, cause a malfunction, or result in injury.

★ Important

- Be careful when moving the machine. Take the following precautions:
- Close all covers and trays, including the front cover and by-pass tray.
- If optional paper feed units are attached, remove them from the machine and move them separately.
- Keep the machine level and carry it carefully, taking care not to jolt or tip it. Rough handling may cause a malfunction or damage the hard disk or memory, resulting in loss of stored files.

1. Be sure to check the following:

The main power switch is turned off.

The power cord is unplugged from the wall outlet.

The interface cable is unplugged from the machine.

2. If any external options are attached, remove them.**3. Lift the machine using the inset grips on both sides of the machine. And then move it horizontally to the place where you want to use it.****4. If you removed options, reattach them.****↓ Note**

- Be sure to move the machine horizontally. To prevent toner from scattering, move the machine slowly.

Security Settings

Changing an Administrator's Password

You will be prompted to enter the password when logging in to the printer. No password is set by default. We strongly recommend you to change the factory default password immediately to prevent information leakage and unauthorized operations by others.

 **Note**

- For details, see the user manuals. User manual "Security Guide".

Configuring SSL/TLS

To prevent unauthorized viewing, analysis or modification of the data during its transmission, enable SSL/TLS as required.

 **Note**

- For details, see the user manuals. User manual "Security Guide".

Paper Feed Unit TK2010

CAUTION

- When lifting the machine, use the inset grips on both sides. The machine could break or cause an injury if dropped.

2

Component Check

To attach two lower paper trays at the same time, first stack them one upon the other, and then attach them as a single tray.

Check the quantity and condition of the accessories against the following list.

Paper Feed Unit TK2010 (500 Sheets M456)

No.	Description	Q'ty
1	Installation Procedure	1
2	Manufacturer Information / Authorized Representative Information (Paper)	1

Installation Procedure

CAUTION

- Turn off the main power switch of the copier and unplug the power cord before you start the installation procedure.

Important

- To attach two lower paper trays at the same time, first stack them one upon the other, and then attach them as a single unit.

1. Remove the packaging from the lower paper tray.
2. Lift the machine slowly using the inset grips on both sides, and then position it immediately above the lower paper tray.

3. There are three upright pins on the optional lower paper tray. Align them with the holes on the underside of the machine, and then carefully lower the machine.

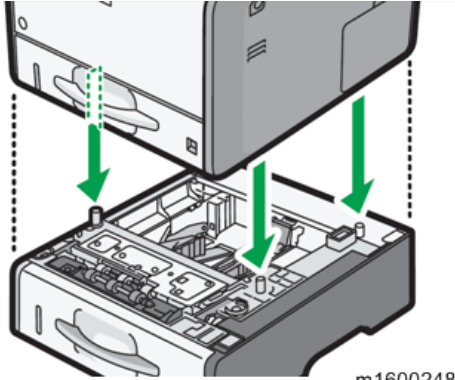

4. Plug in the power cord, and then turn on the machine.
5. Print the configuration page to confirm that the tray was attached correctly.

Note

- Check "Attached Equipment" on the configuration page. If the tray is attached correctly, "Tray 2", "Tray 3", and "Tray 4" appear.

USB Device Server Option Type M12

Component Check

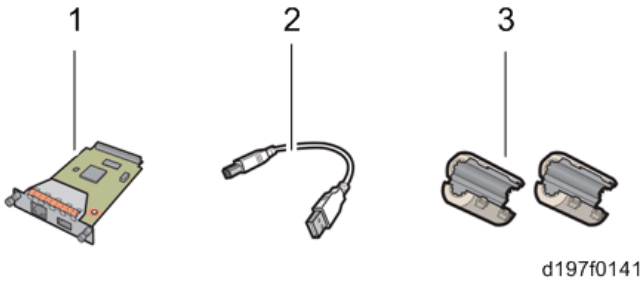

No	Items	Q'ty
1	Interface board	1
2	USB connector	1
3	Ferrite cores	2

Note

- An Ethernet cable, which is not packed with this option, is required.

Interface Board Surface

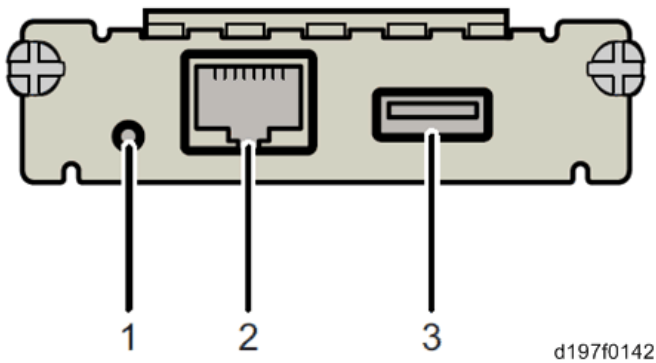

No.	Item	Description
1	Switch	Used to reset to the factory settings.

No.	Item	Description
2	Ethernet port	Used to connect the Ethernet cable.
3	USB port	Used to connect this option to the main machine. Do not use with other options.

Installation Procedure

★ Important

- When you install this option to the main machine for the first time, the interface board must be connected directly to your PC to set up the IP address and other network settings.
1. Turn off the main power switch, and unplug the power cord from the wall socket.
 2. Remove the interface slot cover. (🔩×2)

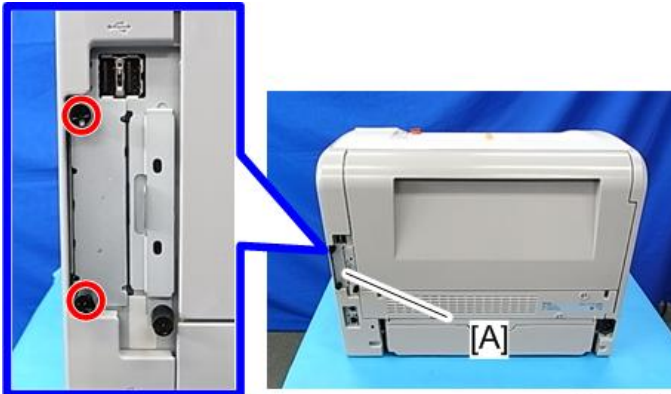

m187z2000

3. Insert the interface board into the interface slot [A] (④×2).



m187z2001

4. Insert the USB connector into the USB port on this option.

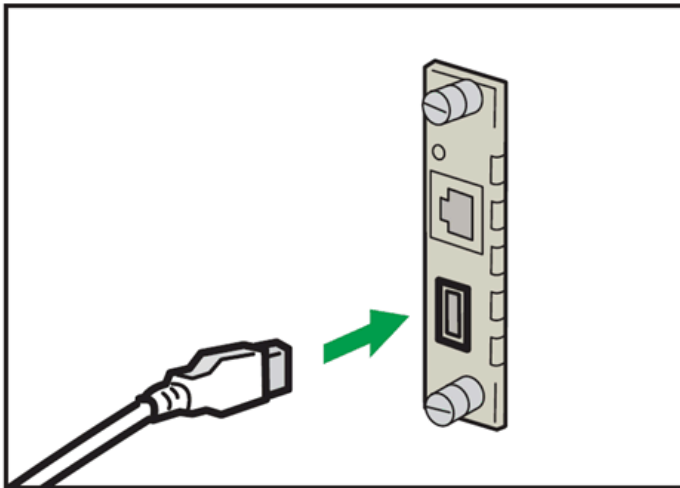

d197f0145

5. Insert the other side of the USB connector into the USB port B on the main machine.

Note

- The machine shape and/or USB port location differs depending on the machine.

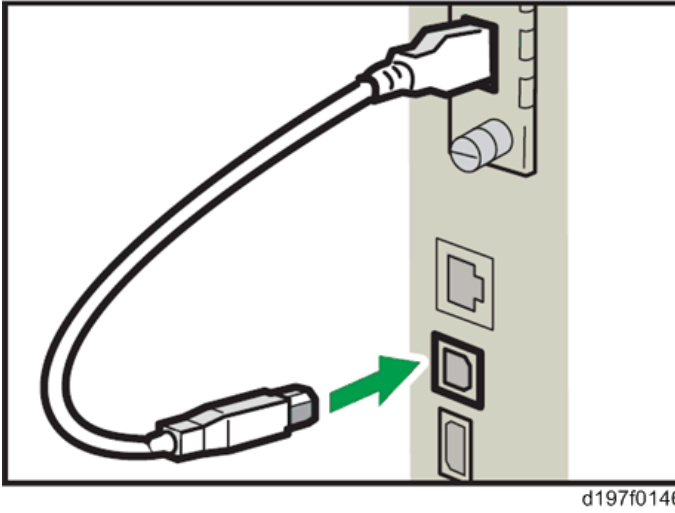

6. Mount the ferrite cores on the Ethernet cable, while looping the cable at 3 cm (approx. 1.2 inch) [A] from the each end of the cable.

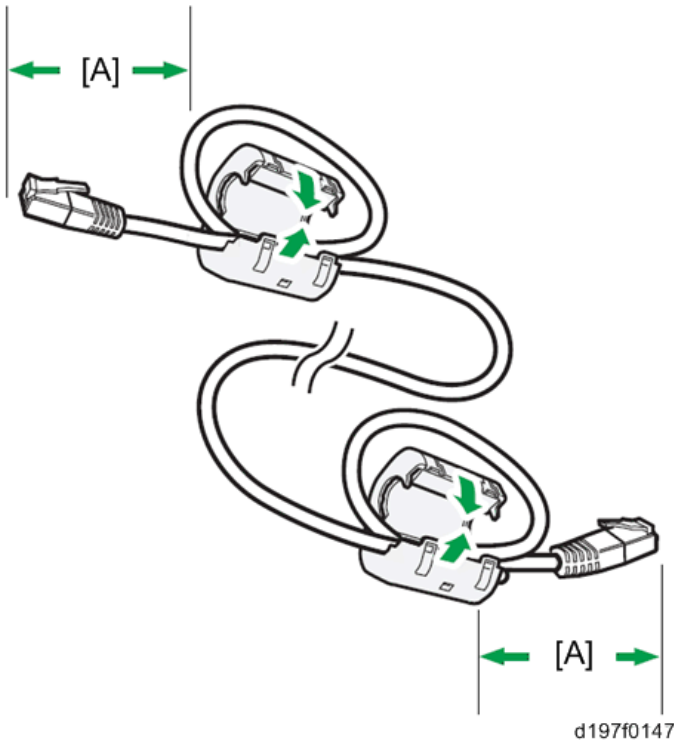

7. Insert the Ethernet cable into the Ethernet board on this option.

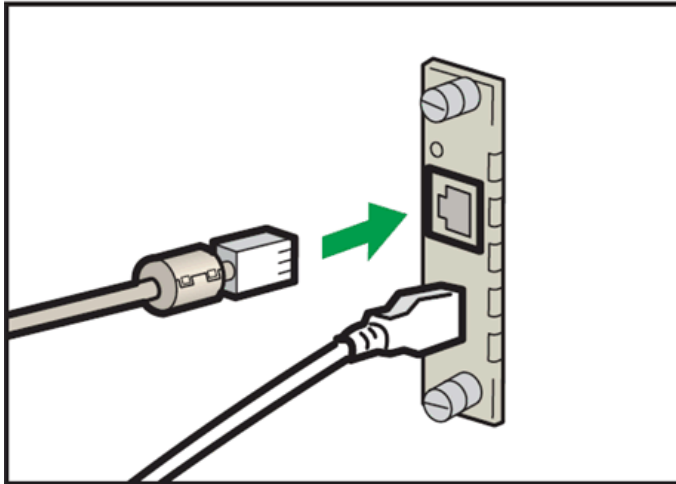

d197f0148

RTB 14
Step added

8. Insert the other end of the Ethernet cable to a PC for network setting.

9. Plug the power cord into the wall socket and turn on the main power switch.

Note

- Do not unplug the USB connector while the machine is recognizing this option. It may take between 30 seconds to 1 minute to finish recognizing it (the LEDs by the connector light up when finished; see below). If unplugged, connect the cable again.

RTB 14
Steps added

What Do the LED Indications Mean?

When this option is properly installed and recognized by the main machine, the LED indicators light up under the following conditions.

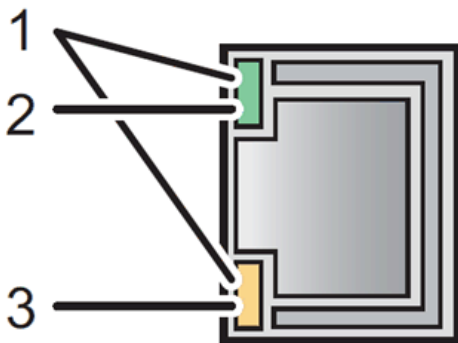

d197f0149

No.	Light Color	Lights Up When:
1	Green and Yellow	1000BASE-T operates
2	Green	10BASE-T operates
3	Yellow	100BASE-TX operates

Notes for Energy Save Mode Setting

If the machine that has this option enters into the energy save mode, you cannot print because there will be a communication error. Follow the instructions below to set the machine to disable entering into the energy save mode.

1. Press [Features Settings] on the operation panel.
2. Press [Administrator Tools] in [System Settings].
3. Press [Energy Saver Mode to Disable Print Server].
4. Press [Disable Mode].
5. Press [OK].
6. Press [Features Settings].

IP Address Setting

This section describes how to set an IP address on this option manually. Note that you can set an IP address which is not only on the same network segment but also on a different network segment to share a single printer with devices in multiple networks.

★ Important

- You cannot change the IP address for this option from the operation panel of the main machine. The setting must be done from a web browser on your PC.
- The network setting of this option is initially assigned as follows:
IP address: 192.168.100.100 / Subnet mask: 255.255.255.0
- The network setting of your PC must be in the same network segment to change the network setting of this option.

1. Make a note of the current network settings of your PC.
2. Change the IP address on your PC to [192.168.100.xxx (*0 - 255)].
3. Change the subnet mask on your PC to [255.255.255.0].
4. Open a web browser.
5. Type [http://192.168.100.100/] in the address bar.

RTB 14
Replace this
procedure

6. Press the Enter key.

Note

- The setting screen for this option appears.

7. Click [Network Setting].

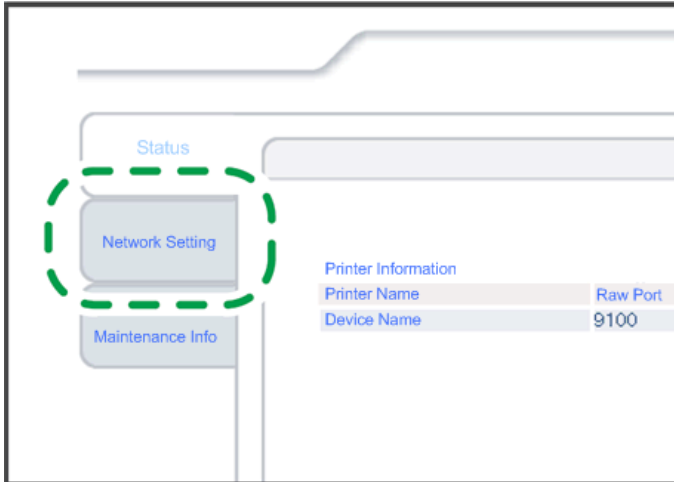

d197f0134

8. Type [root] in the user name textbox and click [OK].

9. Input [IP Address], [Subnet Mask] and [Default Gateway].

Host Name	XXXXXXXXXX
USER/ROOT	ENABLE
IP Address	192.168.100.100
Subnet Mask	255.255.255.0
Default Gateway	0.0.0.0
Network PnP	ENABLE ▾
mDNS	ENABLE ▾
mDNS Service Name	XXXXXXXXXX
LAN Interface	AUTO ▾

d197f0135

10. Set other items if needed.

11. Press [Set].

12. Close the web browser.

13. Disconnect the Ethernet cable from the PC.
14. Connect the Ethernet cable to a network device (e.g. switching hub).
15. Set the IP address of this option in the printer driver that you use.

SD Card Appli Move

Overview

Since there are only two SD card slots (one of them is a service slot), three or more SD card applications cannot be used simultaneously.

However, if multiple SD card applications are merged, three or more SD card options can be used.

This function is referred to as the "SD card merge function."

The "SD card merge function" is a function which enables the use of three or more functions within the capacity of two SD cards by physically transferring the function of one SD card to other SD cards (all SD card options can be stored in two SD cards).

However, SD card applications are under license, therefore, since an SD card license after merge is transferred to the target SD card, it cannot be used even if it is moved to the target machine.

Also, a process to prevent illegal copying is performed.

The service program "SD Card Appli Move" (SP5-873) lets you move application programs from one SD card to another SD card.

Notes on Using the SD Merge Function

- The data necessary for authentication is transferred with the application program from an SD card to another SD card. Authentication fails if you try to use the SD card after you move the application program from one card to another card.
- Do not use the SD card if it has been used before for other purposes. Normal operation is not guaranteed when such an SD card is used.
- An SD card, which becomes empty after moving the data in it to another card, cannot be reused.
- After moving the data in an SD card to another card so that the source card becomes empty, keep the empty card in place by, for example, affixing it near the SD card slot with adhesive tape. This is done for the following reasons:
 - The SD card can be the only proof that the user is licensed to use the application program.
 - You may need to check the SD card and its data to solve a problem in the future.

SD Card Applications

SD Card Option	Card Size Capacity	Movable to another SD card	Target SD card	Remarks
IPDS Unit Type P1	128M	Yes	Yes	Available for use in Slot 1 (Upper) and Slot 2 (Lower)
SD card for NetWare printing Type P1	128M	Yes	Yes	
XPS Direct Print Option Type P1	128M	Yes	Yes	
Browser Unit Type P1	128M	Yes	Yes	
VM Card Type W	512M	No	Yes	Available for use only in Slot 1 (Upper)

- Both Slots 1 and 2 are vacant when the machine is shipped from the factory.
- VM Card Type W cannot be moved to another SD card.

Move Exec

The menu "Move Exec" (SP5-873-001) lets you move application programs from the original SD card to another SD card.

★ Important

- Do not turn ON the write protect switch of the system SD card or application SD card on the machine. If the write protect switch is ON, a download error (e.g. Error Code 44) occurs during a firmware upgrade or application merge.

1. Turn the main power switch off.

2. SD card slot cover [A].

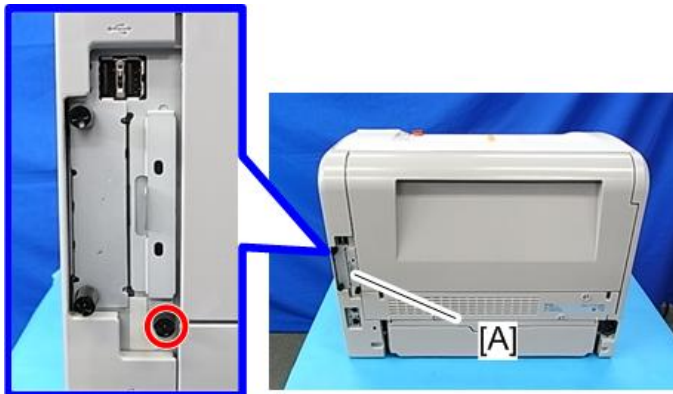

m187z2002

3. Make sure that a target SD card is in SD Card Slot 1 [A]. The application program is moved to this SD card.

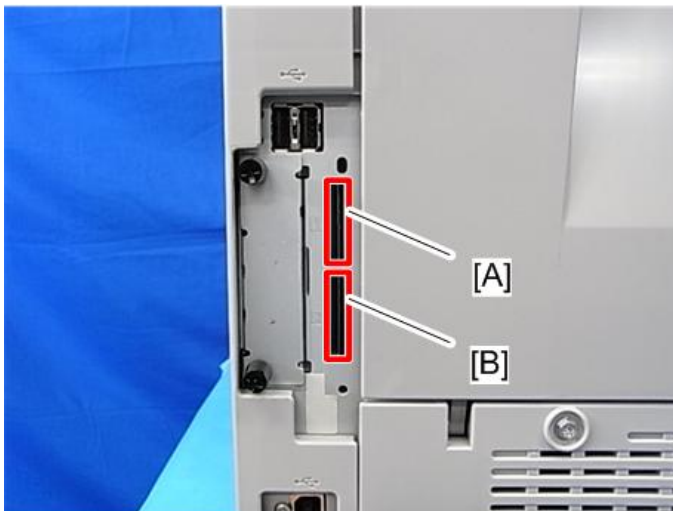

m187z2003

4. Insert the source SD card with the application program in SD Card Slot 2 [B]. The application program is copied from this source SD card.
5. Turn the main power switch on.
6. Start the SP mode.
7. Select SP5-873-001 "Move Exec".
8. Follow the messages shown on the operation panel.
9. Turn the main power switch off.
10. Remove the source SD card from SD Card Slot 2 [B].
11. Attach the SD card slot cover.

12. Turn the main power switch on.
13. Check that the application programs run normally.

Undo Exec

2

"Undo Exec" (SP5-873-002) lets you move back application programs from an SD card in SD Card Slot 1 (upper) to the original SD card in SD Card Slot 2 (lower). You can use this program when, for example, you have mistakenly copied some programs by using Move Exec (SP5-873-001).

★ Important

- Do not turn ON the write protect switch of the system SD card or application SD card on the machine. If the write protect switch is ON, a download error (e.g. Error Code 44) occurs during a firmware upgrade or application merge.
1. Turn the main power switch off.
 2. SD card slot cover [A].

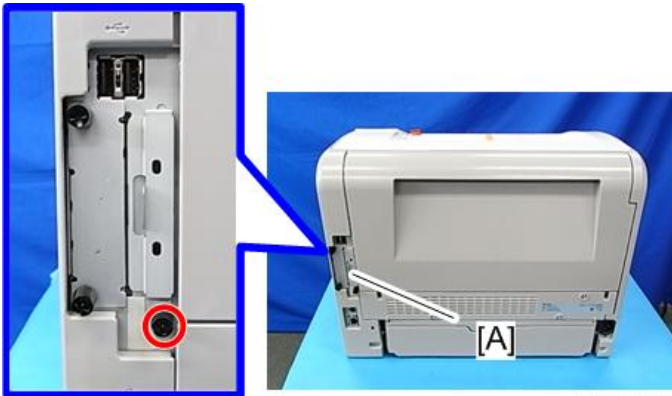

m187z2002

3. Insert the integrated SD card in Slot 1 [A].

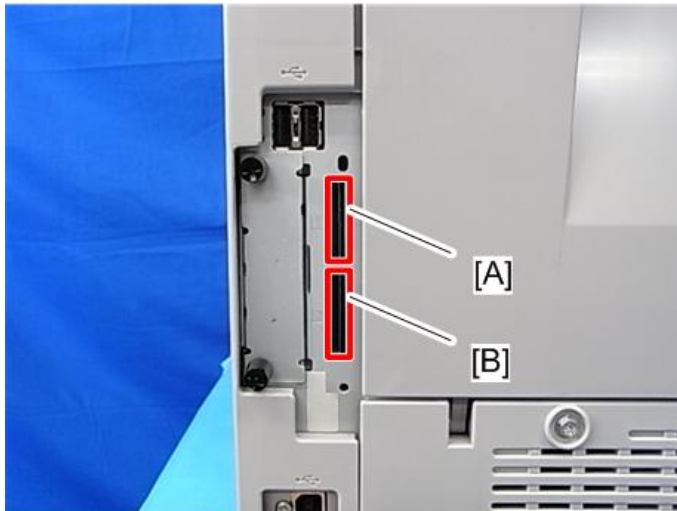

m187z2003

4. Insert the SD card which became empty after integration in Slot 2 [B].
5. Turn the main power switch on.
6. Start the SP mode.
7. Select SP5-873-002 "Undo Exec."
8. Follow the messages shown on the operation panel.
9. Exit the SP mode.
10. Remove the SD card from SD Card Slot 2 [B].
11. Turn the main power switch off.
12. Attach the SD card slot cover.
13. Turn the main power switch on.
14. Check that the application has been deleted.

Settings for @Remote Service

Note

- Prepare and check the following check points before you visit the customer site. For details, ask the @Remote key person.

2

Check points before making @Remote settings

1. The setting of SP5-816-201 in the mainframe must be "0".
2. Print the SMC with SP5-990-002 and then check if a device ID2 (SP5-811-003) must be correctly programmed.
 - 6 spaces must be put between the 3-digit prefix and the following 8-digit number (e.g. xxx____xxx).
3. The following settings must be correctly programmed.
4. If a proxy server is available, configure the following SP settings.
 - Use Proxy (SP5-816-062) Set to "1: Enable".
 - Proxy server IP address (SP5-816-063)
 - Proxy server Port number (SP5-816-064)
 - Proxy User ID (SP5-816-065)
 - Proxy Password (SP5-816-066)
5. Get a Request Number.

Execute the @Remote Settings

1. Enter the SP mode.
2. Input the Request number which you have obtained from @Remote Center GUI, and then enter [OK] with SP5-816-202.
3. Confirm the Request number, and then click [EXECUTE] with SP5-816-203.
4. Check the confirmation result with SP5-816-204.

Value	Meaning	Solution/ Workaround
0	Succeeded	-
3	Communication error (proxy enabled)	Check the network condition.

Value	Meaning	Solution/ Workaround
4	Communication error (proxy disabled)	Check the network condition.
5	Proxy error (authentication error)	Check Proxy user name and password.
6	Communication error	Check the network condition.
8	Other error	See "SP5-816-208 Error Codes" below this.
9	Request number confirmation executing	Processing... Please wait.
11	Already registered	-
12	Parameter error	-
20	Dial-up authentication error	* These errors occur only in the modems that support @Remote.
21	Answer tone detection error	
22	Carrier detection error	
23	Invalid setting value (modem)	
24	Low power supply current	
25	unplugged modem	
26	Busy line	

5. Make sure that the screen displays the Location Information with SP5-816-205 only when it has been input at the Center GUI.
6. Click [EXECUTE] to execute the registration with SP5-816-206.
7. Check the registration result with SP5-816-207.

Value	Meaning	Solution/ Workaround
0	Succeeded	-
2	Already registered	Check the registration status.
3	Communication error (proxy enabled)	Check the network condition.
4	Communication error (proxy disabled)	Check the network condition.

Value	Meaning	Solution/ Workaround
5	Proxy error (Authentication error)	Check Proxy user name and password.
8	Other error	See "SP5-816-208 Error Codes" below this.
9	Request number confirmation executing	Processing... Please wait.
11	Already registered	-
12	Parameter error	-
20	Dial-up authentication error	* These errors occur only in the modems that support @Remote.
21	Answer tone detection error	
22	Carrier detection error	
23	Invalid setting value (modem)	
24	Low power supply current	
25	unplugged modem	
26	Busy line	

8. Exit the SP mode.

SP5-816-208 Error Codes

Cause	Code	Meaning	Solution/ Workaround
Operation Error, Incorrect Setting	-1200 2	Inquiry, registration attempted without acquiring Request No.	Obtain a Request Number before attempting the Inquiry or Registration.
	-1200 3	Attempted registration without execution of a confirmation and no previous registration.	Perform Confirmation before attempting the Registration.
	-1200 4	Attempted setting with illegal entries for certification and ID2.	Check ID2 of the mainframe.
	-1200 5	@Remote communication is prohibited. The device has an Embedded RC gate-related problem.	Make sure that "Remote Service" in User Tools is set to "Do not prohibit".
	-1200 6	A confirmation request was made after the confirmation had been already completed.	Execute registration.
	-1200 7	The request number used at registration was different from the one used at confirmation.	Check Request No.
	-1200 8	Update certification failed because mainframe was in use.	Check the mainframe condition. If the mainframe is in use, try again later.
	-1200 9	The ID2 in the NVRAM does not match the ID2 in the individual certification.	Check ID2 of the mainframe.
	-1201 0	The certification area is not initialized.	Initialize the certification area.

Cause	Code	Meaning	Solution/ Workaround
Error Caused by Response from GW URL	-2385	Other error	
	-2387	Not supported at the Service Center	
	-2389	Database out of service	
	-2390	Program out of service	
	-2391	Two registrations for the same mainframe	Check the registration condition of the mainframe
	-2392	Parameter error	
	-2393	External RCG not managed	
	-2394	Mainframe not managed	
	-2395	Box ID for external RCG is illegal.	
	-2396	Mainframe ID for external RCG is illegal.	
	-2397	Incorrect ID2 format	Check the ID2 of the mainframe.
	-2398	Incorrect request number format	Check the Request No.

3. Preventive Maintenance

Preventive Maintenance Tables

Preventive Maintenance Tables

See "Appendices" for the following information:

- Preventive Maintenance Items

Image Quality Standards

Image Quality Standards

Engine

Item	Specification	Remarks
Assured Image Area	Leading edge: 4.2 mm (1/6 inches) Left/Right: 4.2 mm (1/6 inches) Trailing edge: 4.2 mm (1/6 inches)	
Magnification Error	±0.75% or less	
Perpendicularity	±0.7 mm / 100 mm	DLT: 1.75/200 mm or less
Linearity	±0.25 mm / 100 mm	
Parallelism	±1.8 mm or less	DLT: ±2.0 mm or less

Note

- To check whether the problem is with the image or is due to another issue, print the test pattern.

Paper Transfer Quality Standards

Paper Transfer Quality Standards

Engines

Item	Specification	Remarks
Margin position	<p>Single Side: Main Scan: 0 ± 2.0 mm Sub Scan: 0 ± 1.5 mm</p> <p>Back of the paper when performing duplex printing: Main Scan: 0 ± 2.0 mm Sub Scan: 0 ± 1.5 mm</p>	
Skew	<p>Single Side: ± 1.2 mm / 200 mm or less (B5 SEF or more) ± 1.0 mm / 100 mm or less (Less than B5 SEF)</p> <p>Duplex: ± 1.0 mm/100 mm or less (B5 SEF or more) ± 1.5 mm/100 mm or less (Less than B5 SEF)</p>	
Curling after fusing	<p>25 mm or less from leading and trailing edges</p> <p>60 mm or less (* applicable for printed forms over 90 kg in weight)</p>	In an office environment

These standards are determined using standard paper under standard conditions.

Values may vary depending on environmental conditions such as temperature, humidity, use of used paper, etc.

4. Replacement and Adjustment

General Cautions

Notes on the Main Power Switch

The main power button of this machine has been changed to a push-button switch (push button) from the conventional rocker switch. The push switch has characteristics and specifications different from the rocker switch. Care must be taken when replacing and adjusting parts.

Characteristics of the Push Switch (DC Switch)

Power is supplied to the machine even when the main power switch is turned OFF.

The push switch in this machine uses DC (direct current). Therefore, if the AC power cord is connected to an electrical outlet, power is supplied to the controller board, the operation unit and other modules even when the main power is turned OFF. When replacing the controller board and the operation unit in this state, not only these boards, it will damage other electrical components.

So, when performing maintenance work such as replacing parts, in addition to turning off the main power with the push switch, always unplug the AC power cord.

When you disconnect the power cord from the AC wall outlet, inside the machine there is still residual charge.

When you disconnect the power cord from the AC wall outlet, inside the machine for a while there is still residual charge. Therefore, if you remove boards in this state, it can cause a blown fuse or memory failure.

-- How to remove the residual charge inside the machine--

After you unplug the power cord from the AC wall outlet, in order to remove the residual charge from inside the machine, be sure to press the main power switch. Thus, the charge remaining in the machine is released, and it is possible to remove boards.

When you reconnect the AC power cord into an AC wall outlet, the machine will start automatically.

In order to remove the residual charge, push the main power switch while you disconnect the AC power cord. At that time, the power ON flag inside the machine is set. Therefore, after you finish work on the machine and reconnect the power cord to the AC, even if you do not press the main power switch, the machine will start automatically and the moving parts will begin to move. When working on moving parts, be careful that fingers or clothes do not get caught.

Note

- Automatic restart deals with cases when you accidentally unplugged the AC power cord or unexpected power outages. By keeping the power flag ON, after the resumption of power, the machine will start up automatically.

In rare cases, when you reconnect the AC power cord to a power outlet, the machine does not start automatically. In this case, the machine has not failed. The cause is due to the timing of releasing the residual charge. If you press the main power switch while the residual charge was already released, the power ON flag will not be set. At this time, start the machine manually by pressing the main power switch.

4

Shutdown Method

1. Press the main power switch [A] on the left side of the machine.

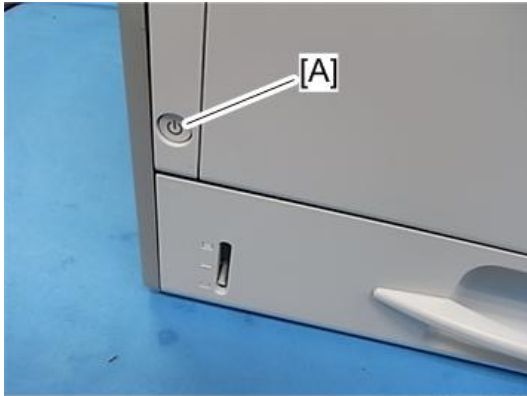

m187z4212

After the shutdown process, the main power is turned off automatically.

When the shutdown is complete

Operation panel LED: Off

2. Take out the power cord.
3. Wait 3 minutes (this is the time required if you will remove the rear cover and access the interior of the machine, to take out the controller board for example).

Note: If some LEDs on any of the boards are blinking or lit, current is still flowing.

How to start from shutdown

To start the machine, press the main power switch. However, if you press the main power switch between the beginning and the end of a shutdown, the machine will not start.

Forced Shutdown

In case normal shutdown does not complete for some reason, the machine has a forced shutdown function.

To make a forced shutdown, press and hold the main power switch for 6 seconds.

In general, do not use the forced shutdown.

Important

- Forced shutdown may damage the hard disk and memory, and can cause damage to the machine. Use a forced shutdown only if it is unavoidable.

Special Tools

Part Number	Description	Q'ty
B6455010	SD Card 128MB	1
B6455020	SD Card 1GB	1

Note

- A PC (Personal Computer) is required for creating the Encryption key file on an SD card when replacing the controller board for a model in which HDD encryption has been enabled.

Exterior Covers

Front Cover

1. Paper Feed Tray (page 107)
2. By-pass tray (page 66)
3. Push the release button to open the front cover [A].



m187z4500

4. Hanging wire [A]



m187z4101

5. Release the hinges at both ends, and detach the front cover [A].

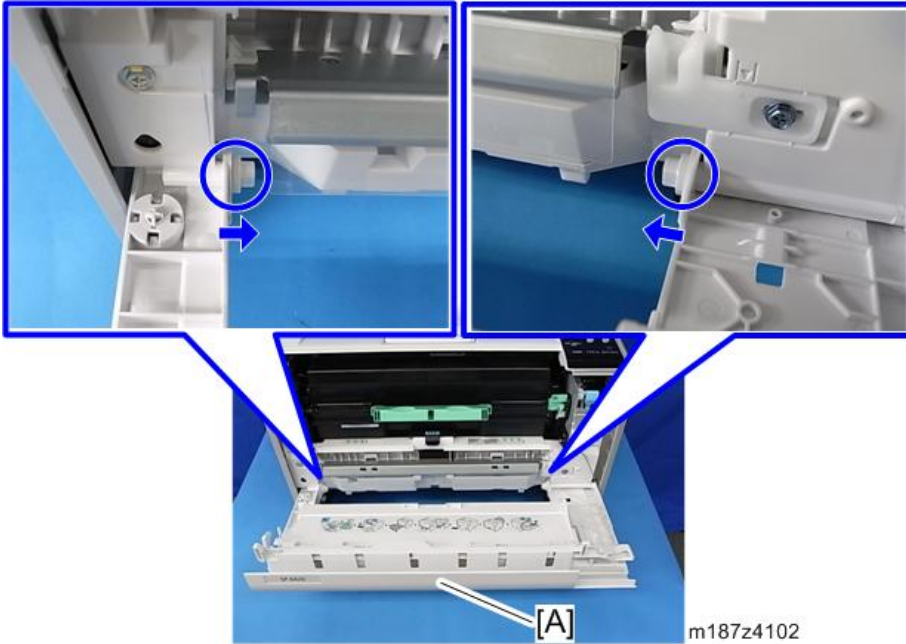

4

↓ Note

- To remove the front cover, lift the left hinge first to release while raising the front cover upwards.
- The left hinge is C-cut.

Left Cover

↓ Note

- There is a tab on the back of the left cover. Refer to the picture below.

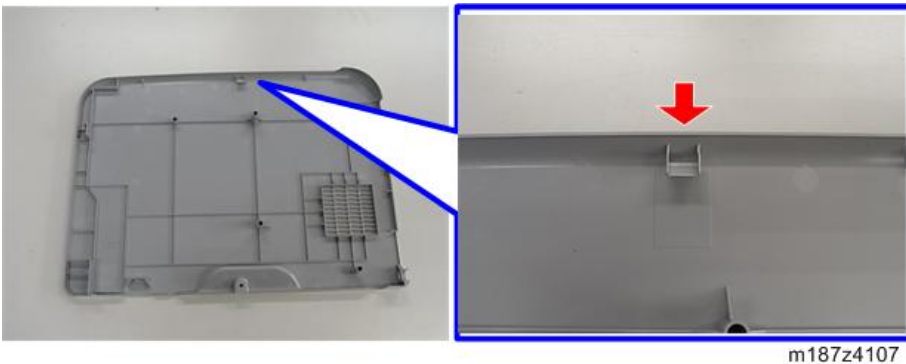

1. Open the front cover [A].



m187z4103

2. Two screws securing the front side of the left cover [A] (⚙️×2)

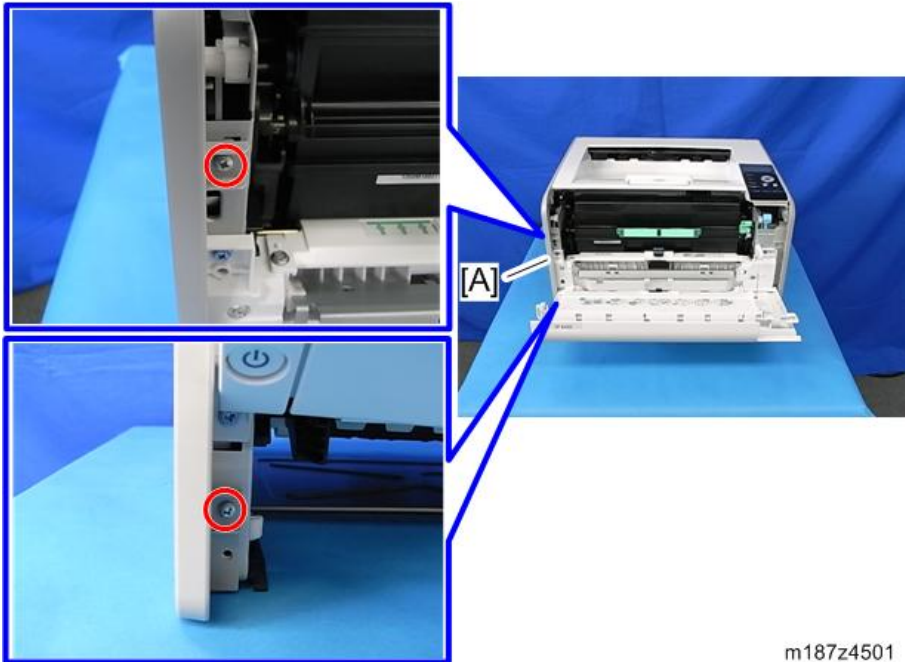

m187z4501

3. Open the rear cover [A].

4. Two screws securing the rear side of the left cover [B] (🔩×2)

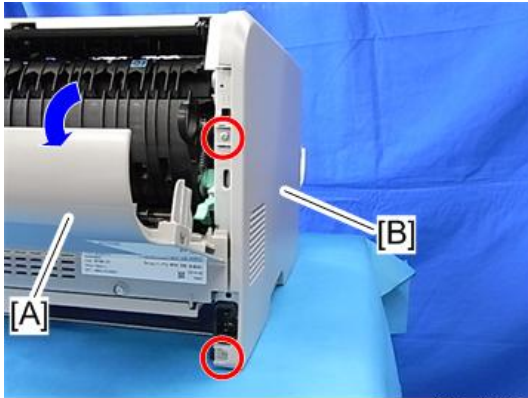

m187z4105

5. One screw to detach the left cover (🔩×1)

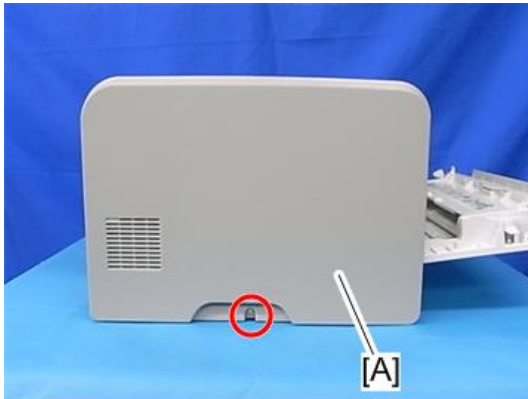

m187z4106

Right Cover

↓ Note

- There is a tab on the back of the right cover. Refer to the picture below.

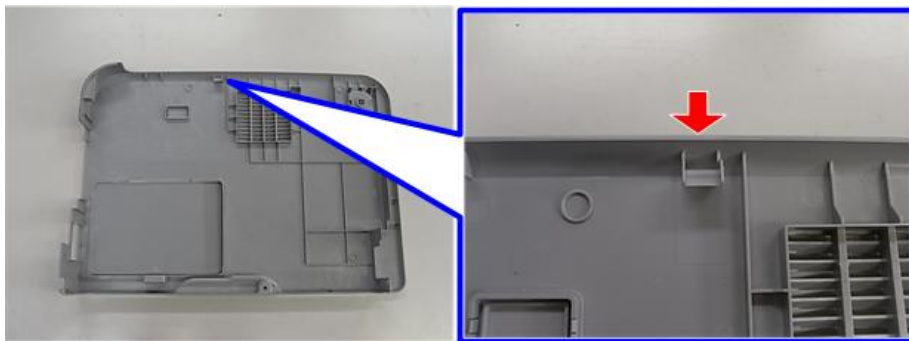

m187z4112

1. Open the front cover [A].



m187z4103

2. Two screws securing the front side of the right cover [A] (🔩 ×2)

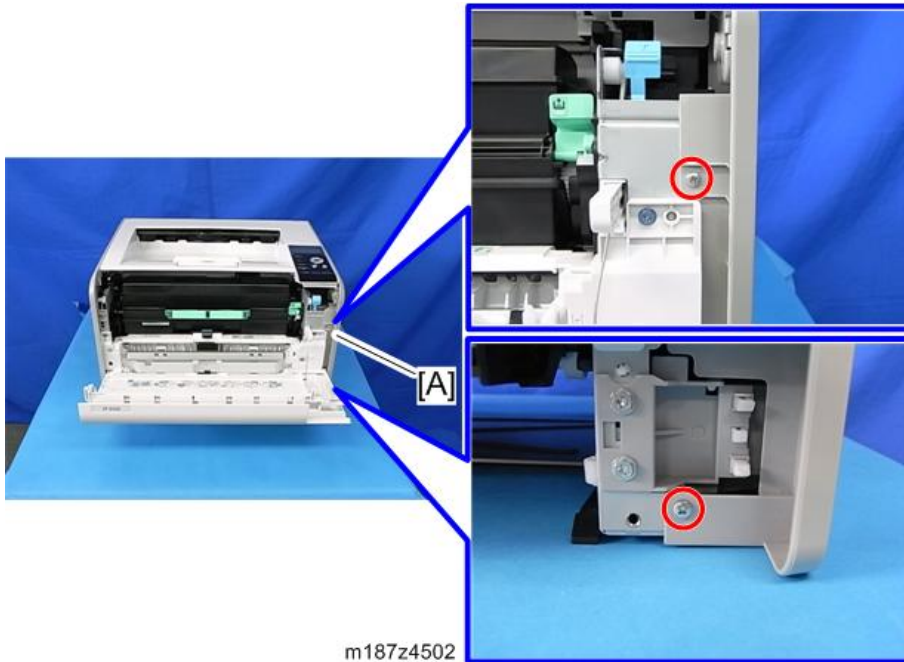

3. Open the rear cover [A].

4. Two screws securing the rear side of the right cover [B] (🔩 ×2)

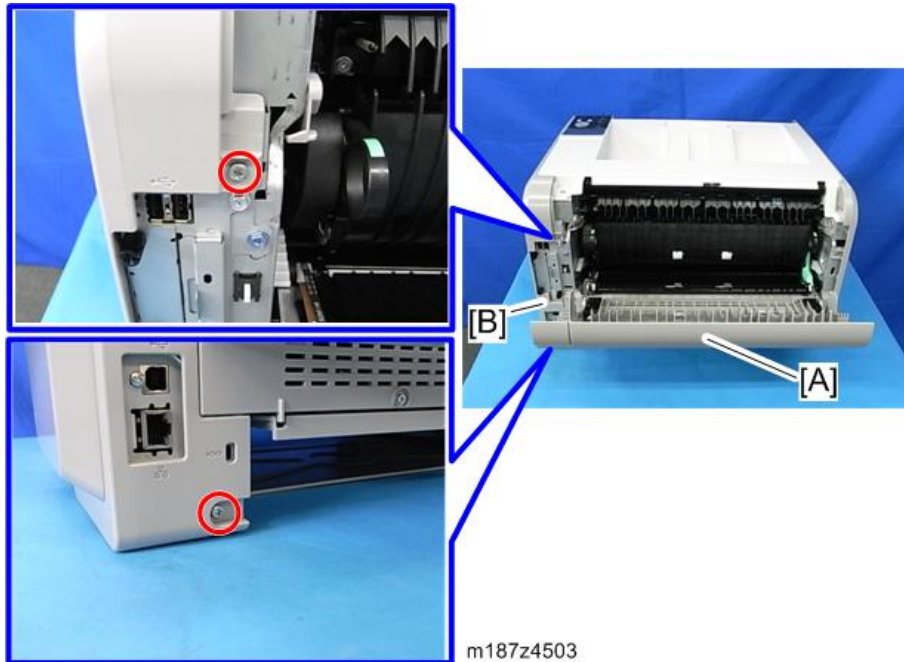

5. Right cover [A] (🔩 ×1)

6. Memory cover [B]

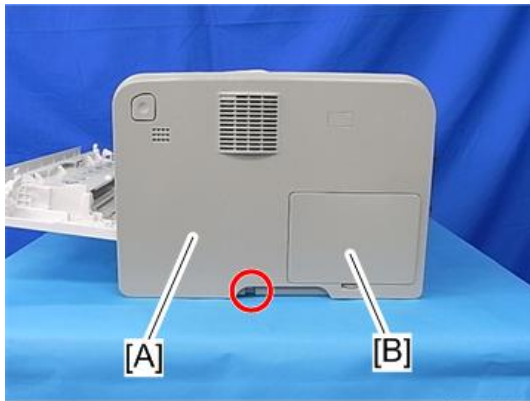

m187z4111

4

Rear Cover, Rear Lower Cover

1. Left cover (page 58)
2. Right cover (page 60)
3. Open the rear cover [A].

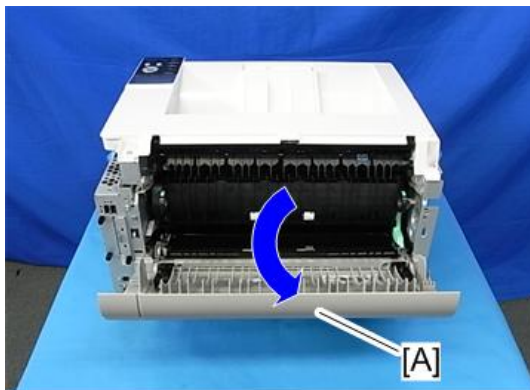

m187z4113

4. Screw (🔩×1)

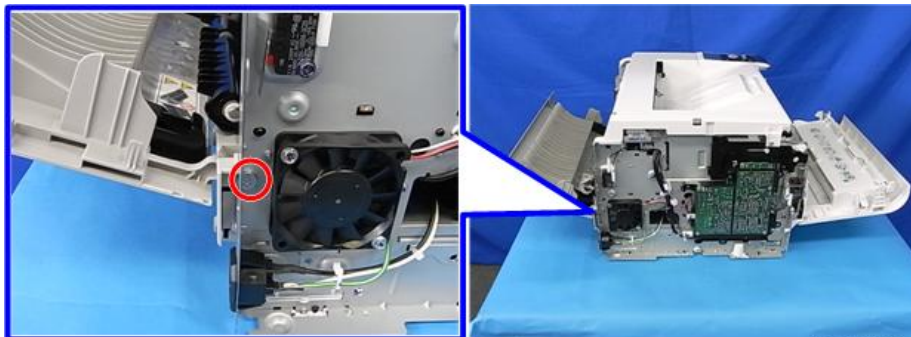

m187z4114

4

5. Release the stopper [A].

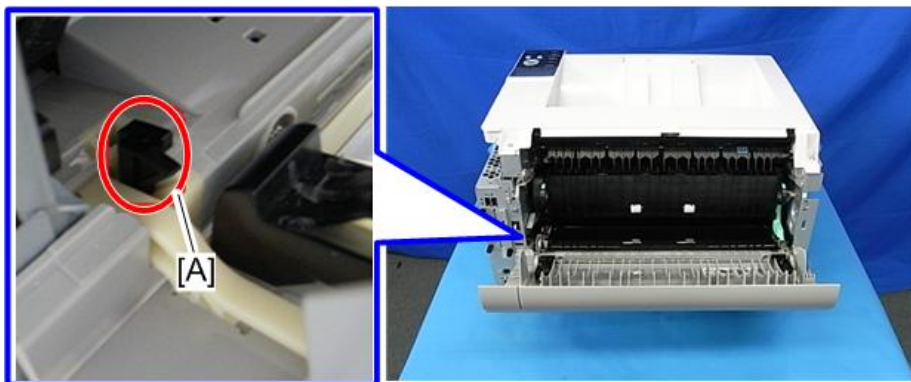

m187z4540

6. Release the hinges at both ends to detach the rear cover [A].

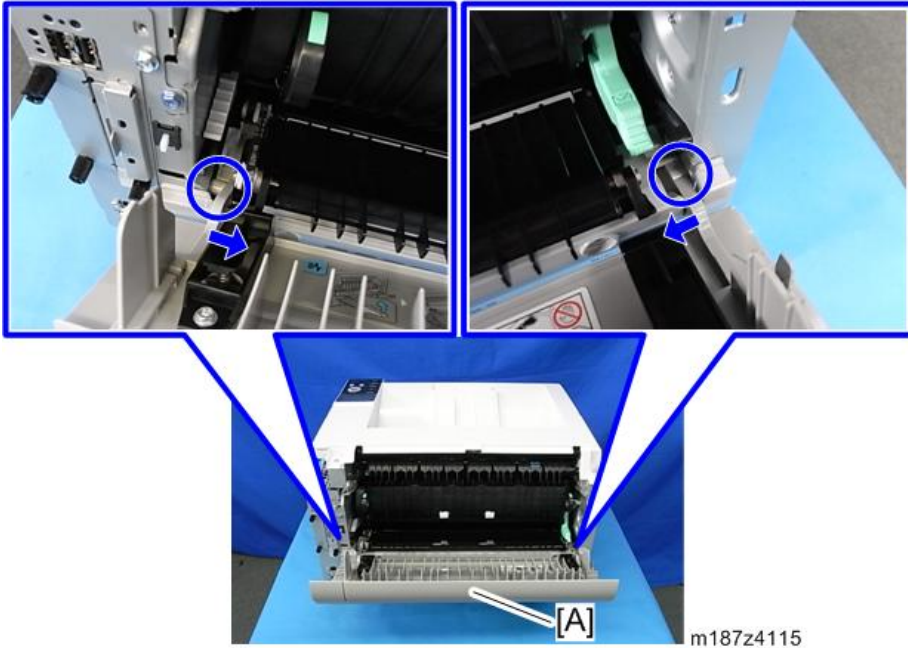

Note

- To release the hinges, push the left hinge inside with your finger while holding the rear cover [A] open at angle of approx. 10°. The right hinge is removed spontaneously when the left hinge is released.

7. Rear lower cover [A] (⌀ ×4)

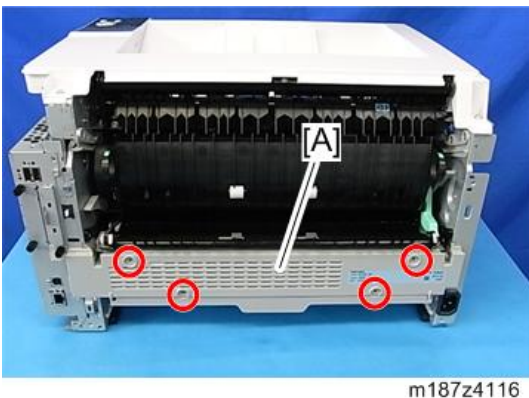

By-pass Tray

1. Open the by-pass tray [A].



m187z4160

2. Release the hinges at both ends.

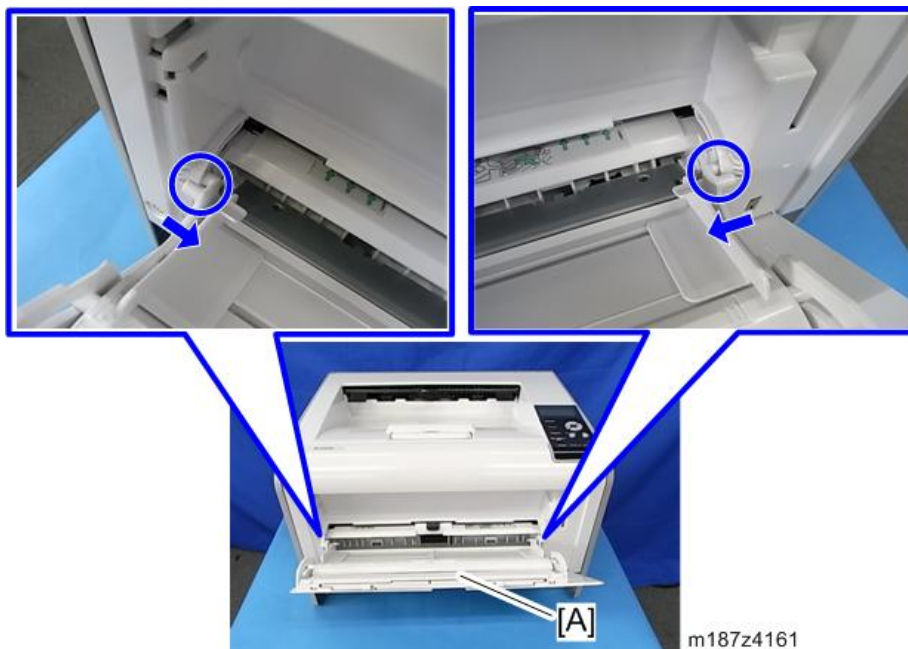

m187z4161

3. Release the hinges at both ends of by-pass tray [A] to detach it.

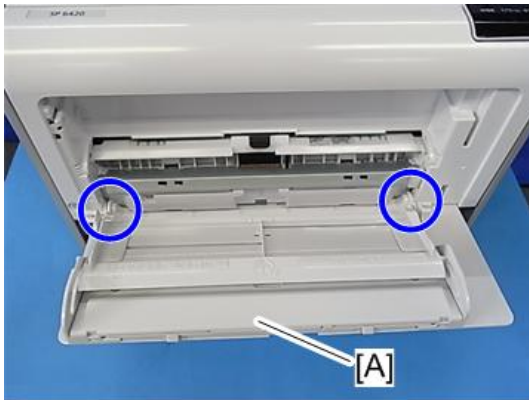

m187z4162

Note

- To remove the by-pass tray, lift the left hinge first to release while raising the by-pass tray upwards.
- The left hinge is C-cut.

Upper Cover

1. Left cover (page 58)
2. Right cover (page 60)
3. Operation panel (page 68)

4. Upper cover [A] (⌀ ×4)



4

Operation Panel

1. Open the front cover [A].



2. Release the tabs of the operation panel [A] (Tab×2).

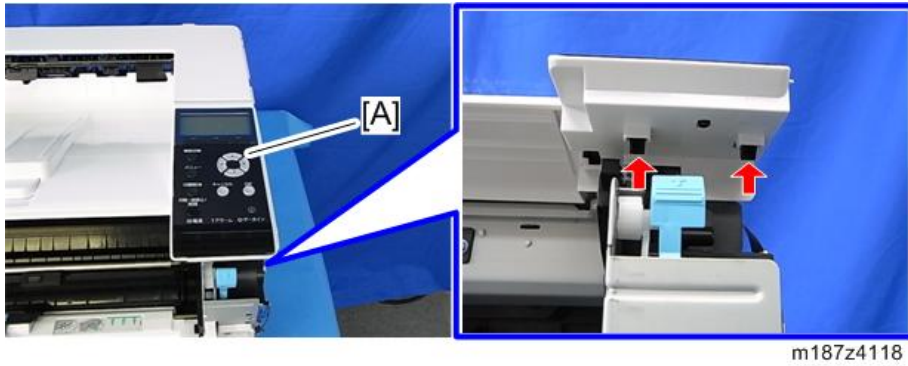

3. The connector on the back of the operation panel [A] (🔌 ×2)



4. Remove the screws and connector (🔩 ×5, 📡 ×1).

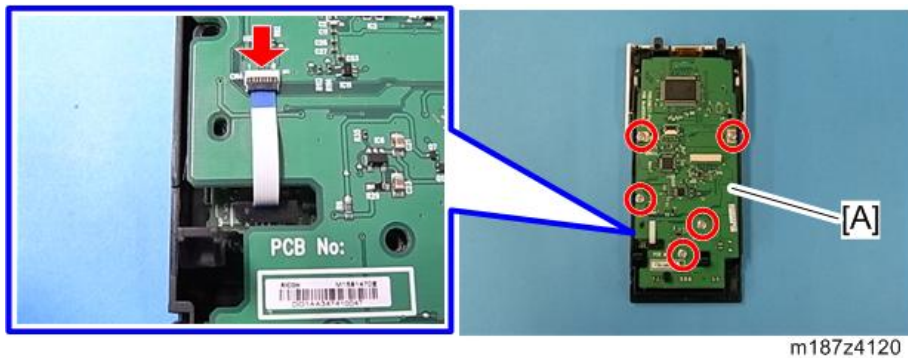

5. OPU board [A] (📦 ×1)

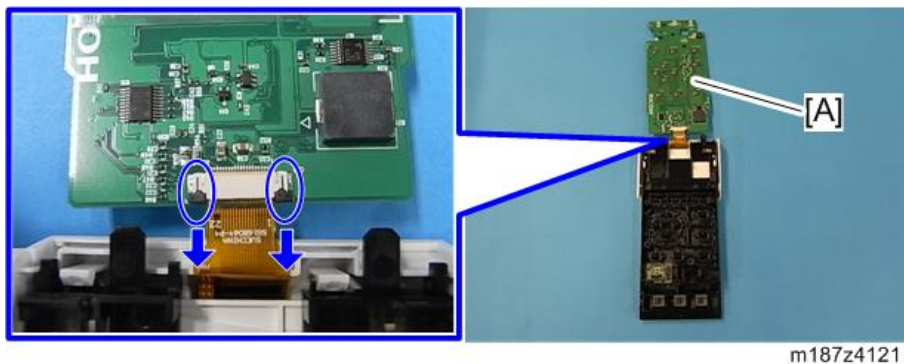

4

6. Board cover [A] (Tab×2)

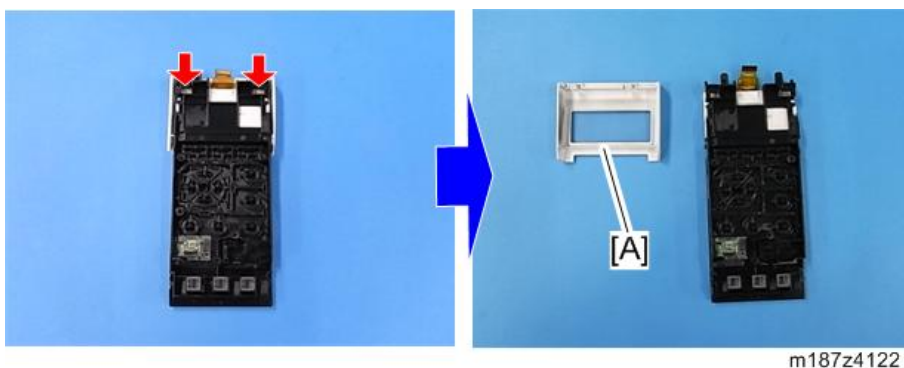

7. Panel [A]



8. Eco night sensor [A]

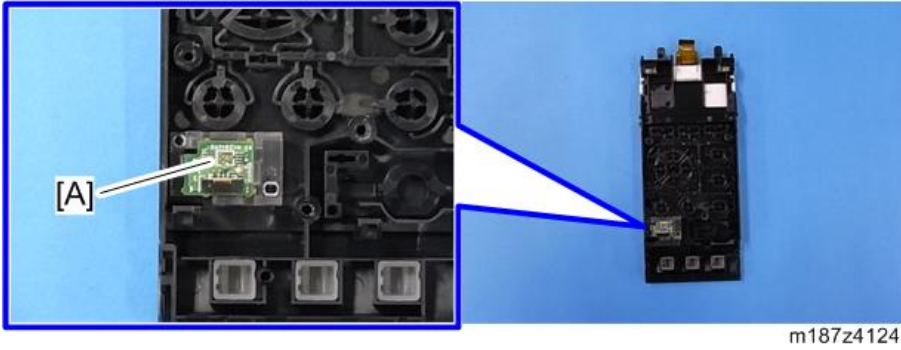

m187z4124

LED Optics

⚠ CAUTION

- Turn off the main power switch and disconnect the power cord before you start any of the procedures in this section. (page 53)

LED Unit

★ Important

- Be sure to clean the lens of the LED head after replacing the LED unit or if you inadvertently touch the lens when replacing another unit.
1. PCDU (page 78)
 2. Upper Cover (page 67)
 3. LED cover [A] (⊙ ×2, Tab ×3)

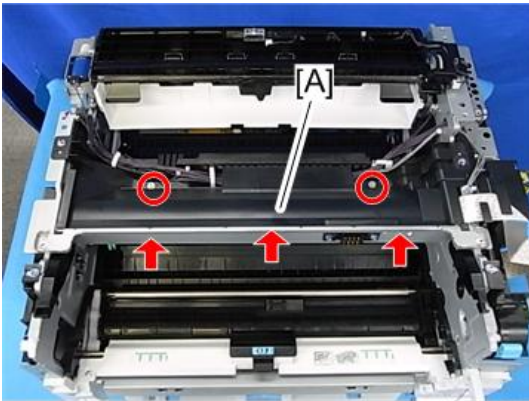

m187z4164

4. Rotate the LED unit [A] until locked.

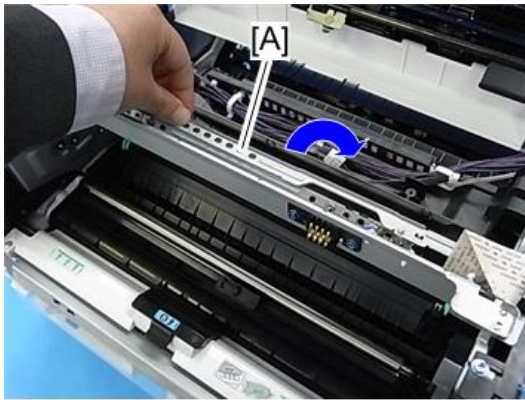

m187z4165

5. Ground wire [A] and FFC [B] from the LED unit.

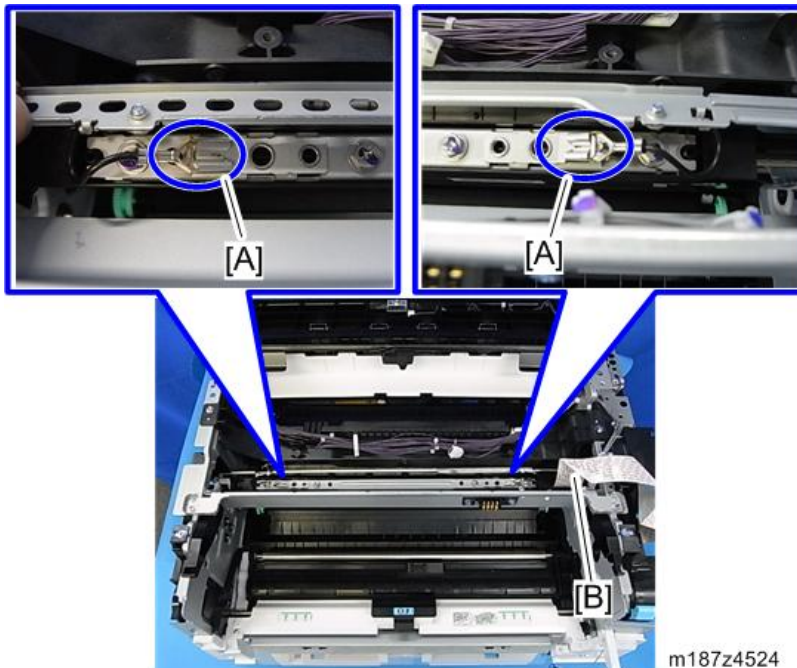

m187z4524

- 6. Unlock the levers at both ends of the LED unit, and rotate the LED unit [A] back to the original position.

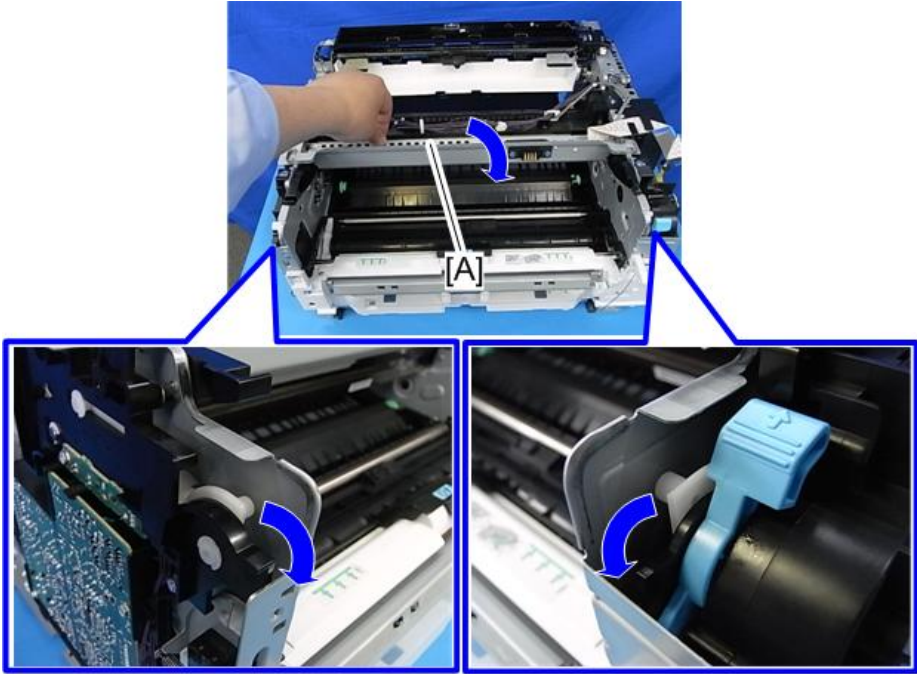

m187z4168

- 7. Spacer [A] from the LED unit.

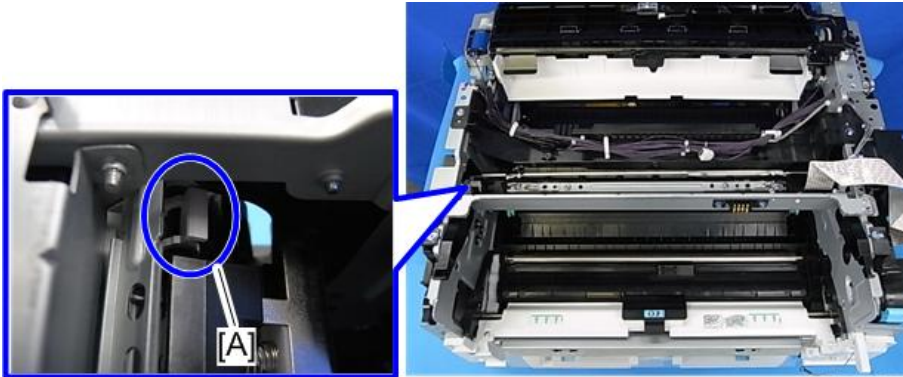

m187z4539

8. Two screws that secure the front stay [A] (⑤ ×2).

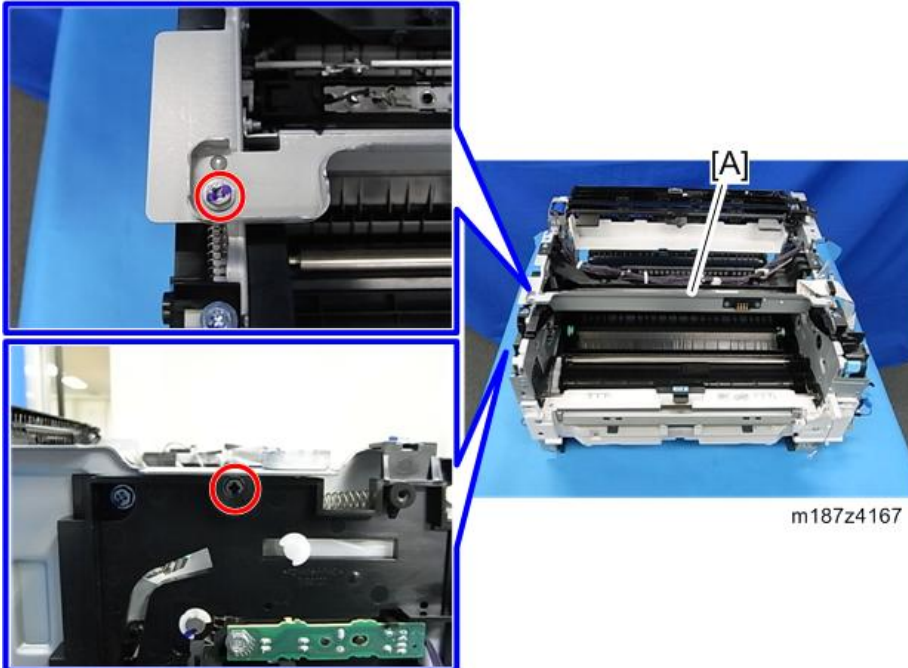

9. Widen the side plate slightly and pull out the LED unit [A] from the main machine.

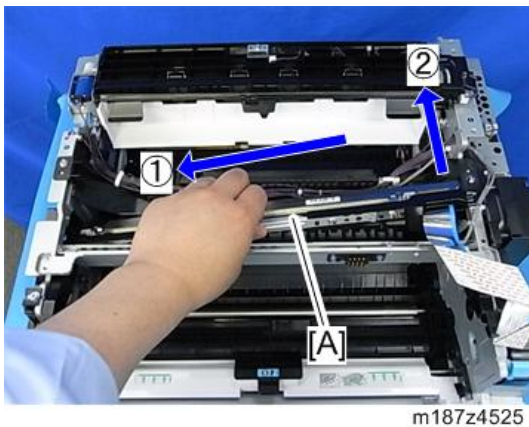

★ Important

- When installing the LED unit, fit the shaft (upper) of the LED unit into the holes of the LED unit holder.

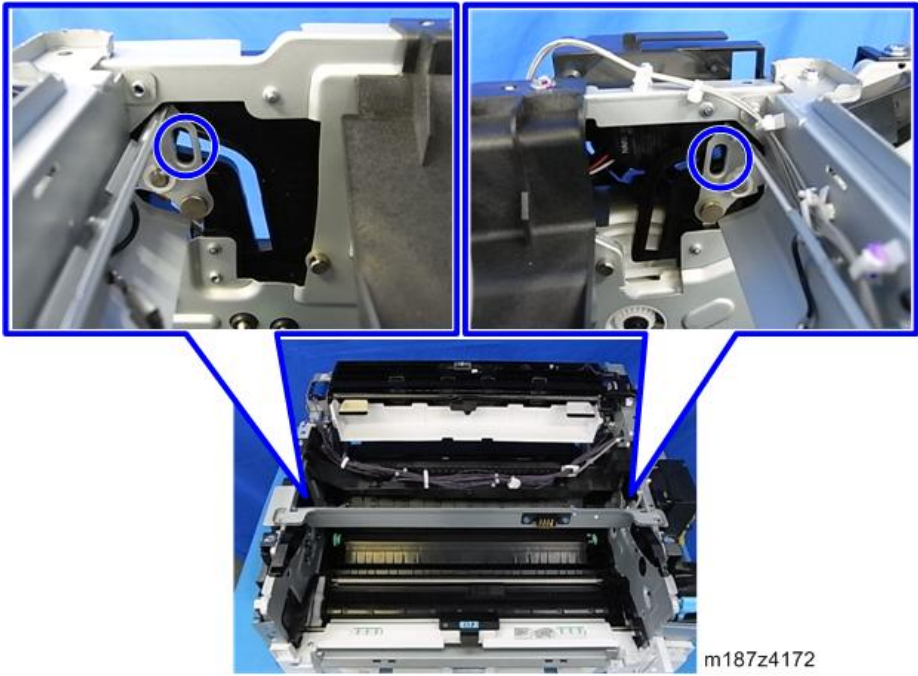

4

10. Bend the stay [A] to release the left and right tabs, and then separate the stay from the LED head [B] (Tab ×4).

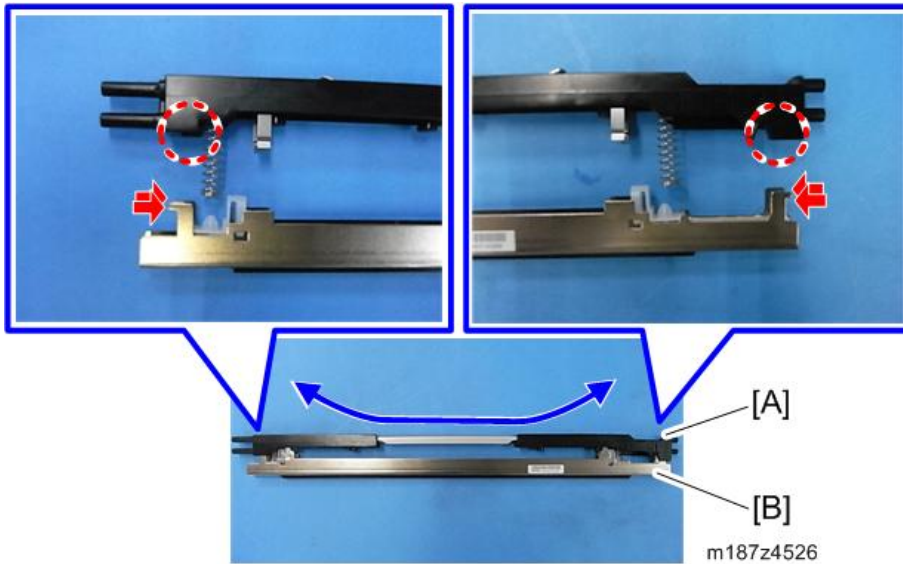

11. Pull out two spring holders from the LED head [A].

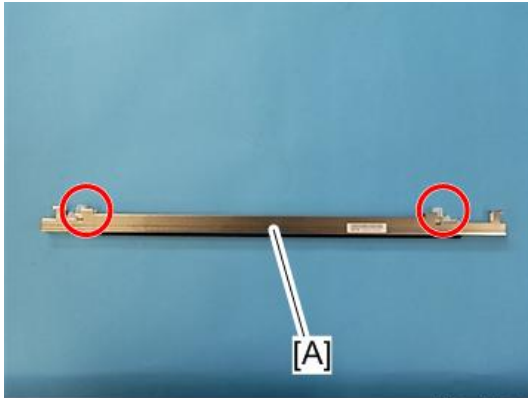

m187z4171

PCDU

PCDU

1. Press the release button and open the front cover [A].

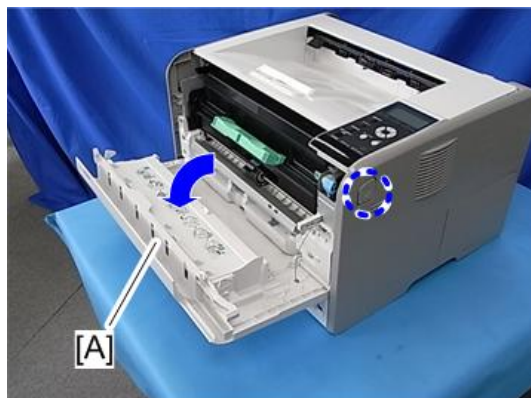

m187z4129

2. Hold the grip to pull the PCDU [A] out.



m187z4130

Toner Cartridge

Toner Cartridge

1. Open the front cover [A].

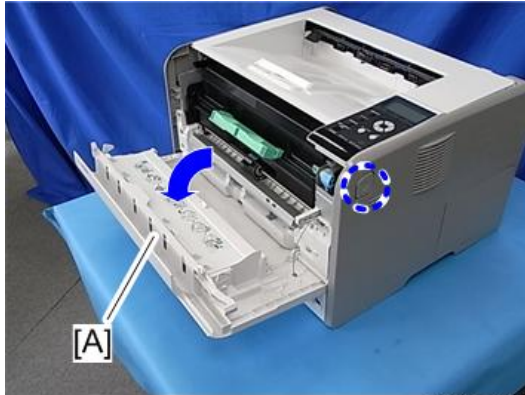

m187z4129

2. Push down the release lever [A] of the toner cartridge.

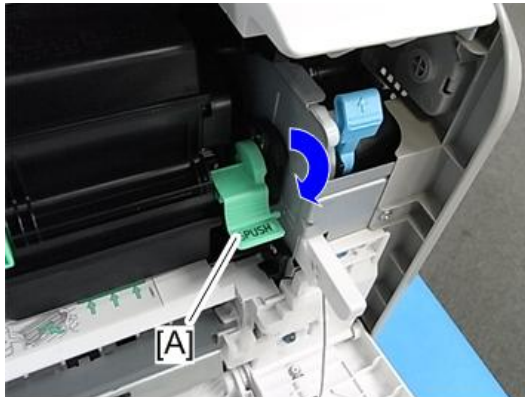

m187z4131

↓ Note

- The release lever works in two steps. To release the lock, push down the release lever to the horizontal position.



3. Hold the grip to pull the toner cartridge [A] out.



Image Transfer

Image Transfer Roller

1. PCDU (page 78)
2. Pinch both green ends of the guide [A] and pull it towards you.



3. Image transfer roller [A]

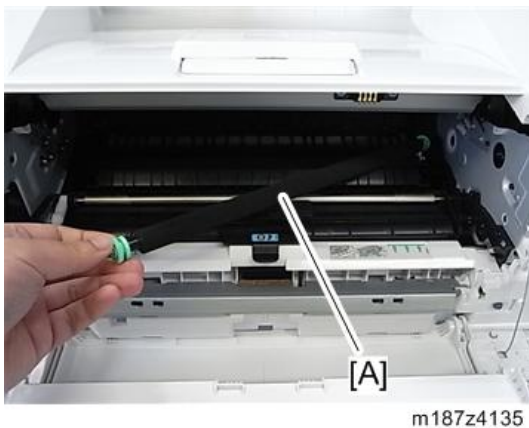

Note

- When installing the image transfer roller, do the following procedure:

1. Attach the image transfer roller to the fitting points at both ends of the guide plate [A].

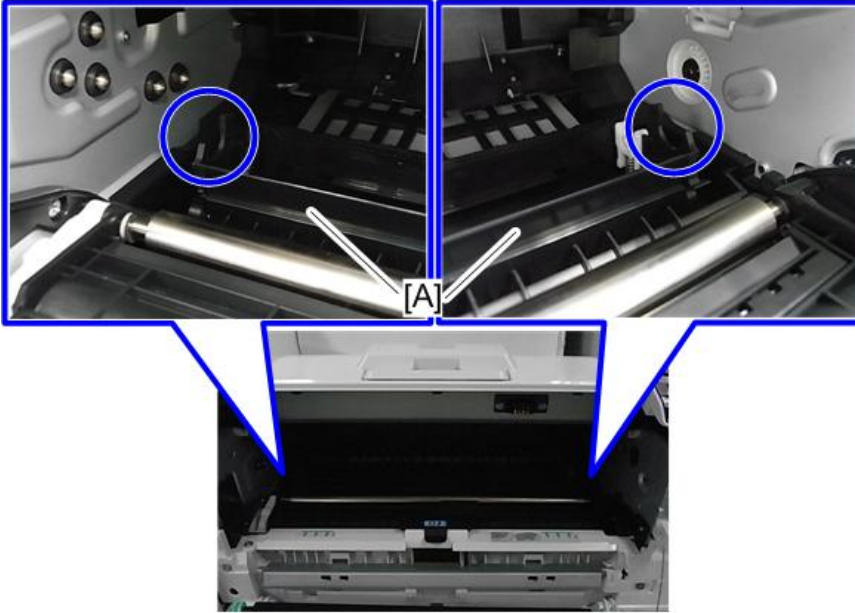

2. Lay down the guide plate [B], on which the image transfer roller [A] is installed, until it clicks into place.

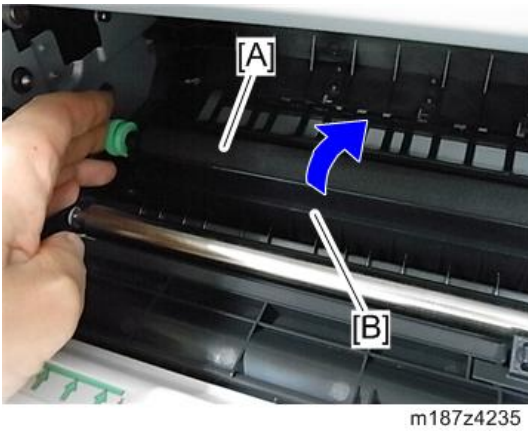

Drive Unit

⚠ CAUTION

- Turn off the main power switch and disconnect the power cord before you start any of the procedures in this section (page 53).

Main Motor

The main motor is located behind the drive unit.

1. BCU (page 137)
2. Drive Unit (page 89)
3. Bracket [A] (🔩×3)

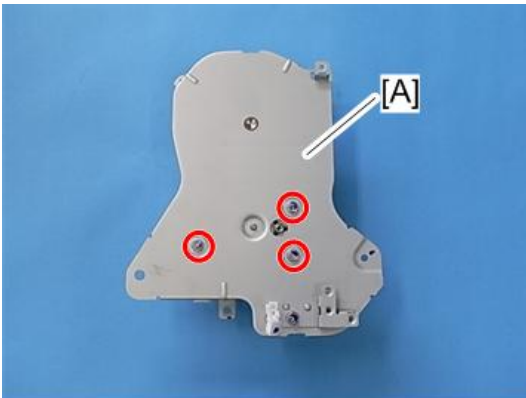

m187z4019

4. Four gears [A]

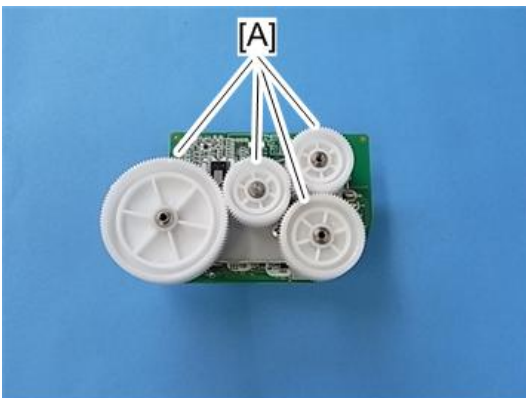

m187z4020

5. Main Motor [A] (⚙️×3)

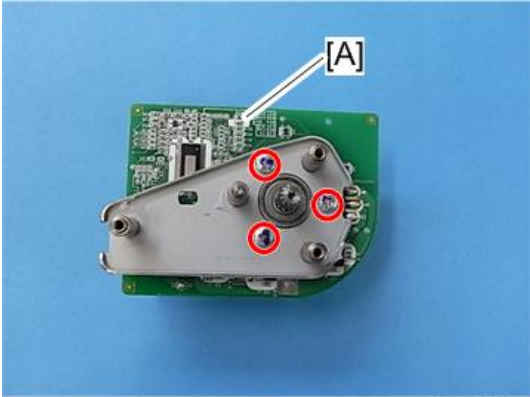

m187z4021

4

Exit/Reverse Motor

1. Upper Cover (page 67)
2. Controller Board (page 134)
3. Bracket [A] (⚙️×4)

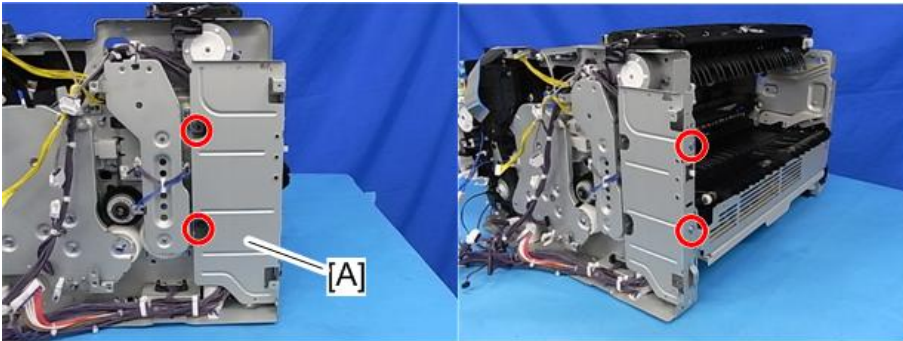

m187z4015

4. Harness guide [A] (🌀×1, 📦×1, Tab×2)

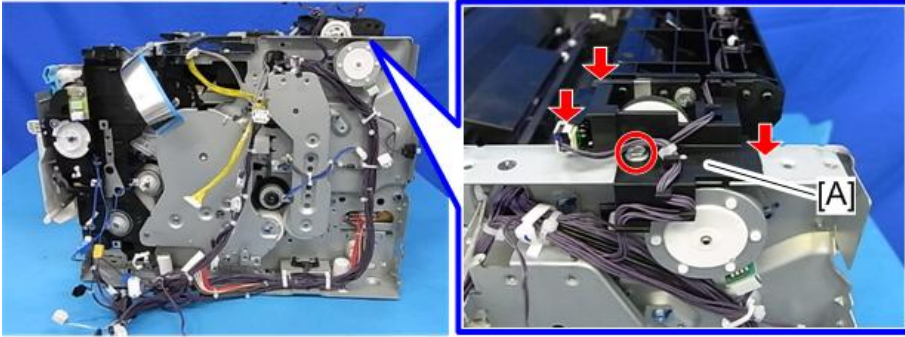

m187z4001

5. Exit/Reverse Motor [A] (🌀×2, 📦×1, 🌀×1)

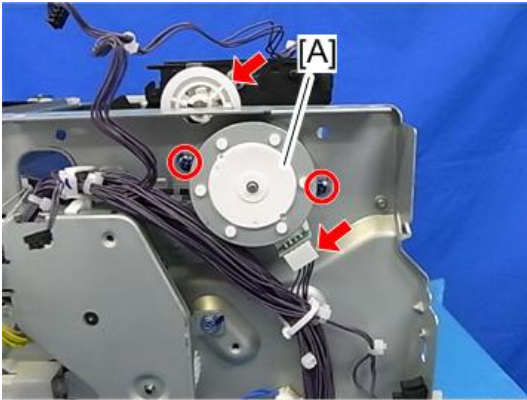

m187z4002

⬇️ Note

- Slide the exit/reverse motor towards the right side, and then pull out the motor.



m187z4225

Registration Clutch

1. BCU (page 137)
2. Registration Clutch [A] (📦 ×1, ⚙️ ×1, 🛠️ ×2)

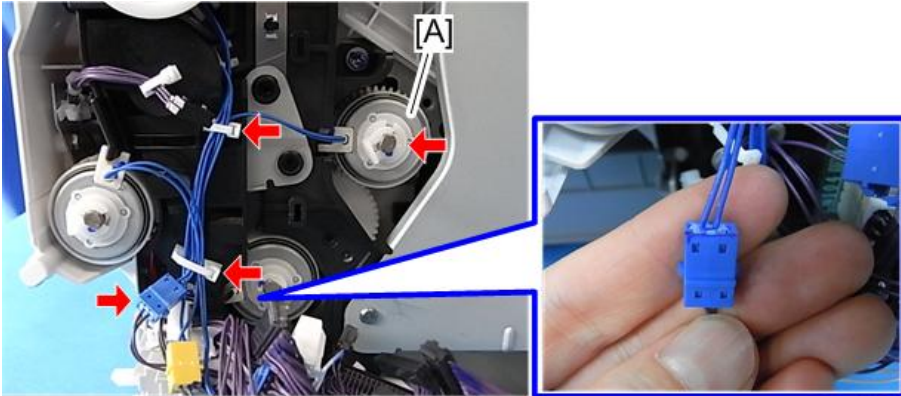

m187z4005

Paper Feed Clutch

1. BCU (page 137)
2. Harness Guide [A] (📦 ×1, 🛠️ ×3)

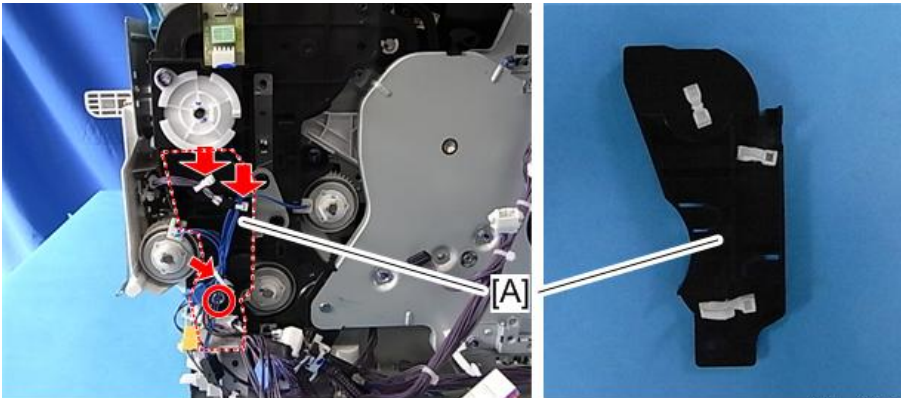

m187z4522

↓ Note

- When installing the harness guide, clamp the harness at the same positions as before removal.

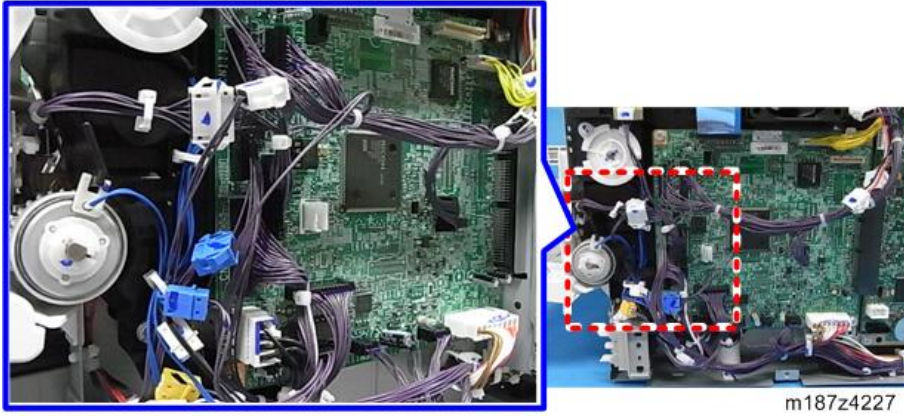

3. Paper feed clutch [A] (🌀 ×1, 📦 ×1)

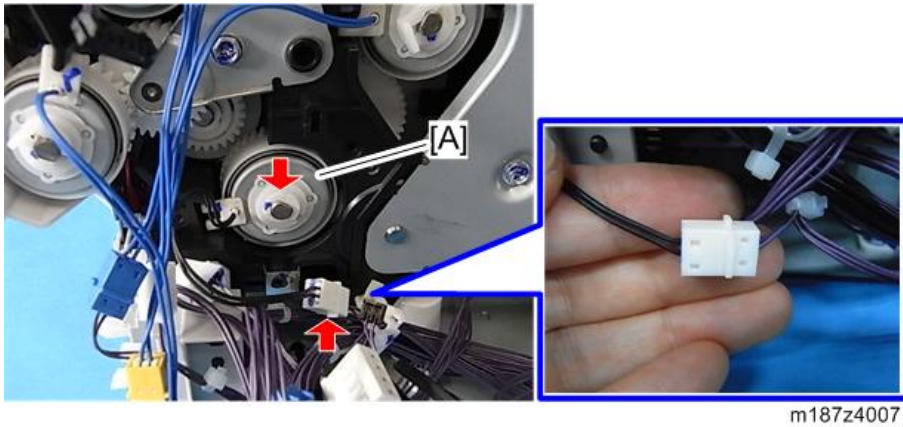

By-pass Feed Clutch

1. Right Cover (page 60)

2. Harness Guide [A] (🔗×1, 📦×3)

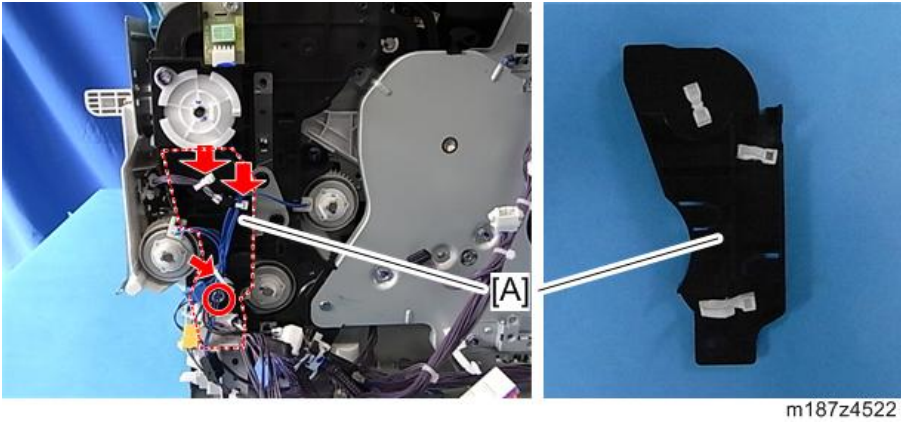

↓ Note

- When installing the harness guide, clamp the harness at the same positions as before removal.

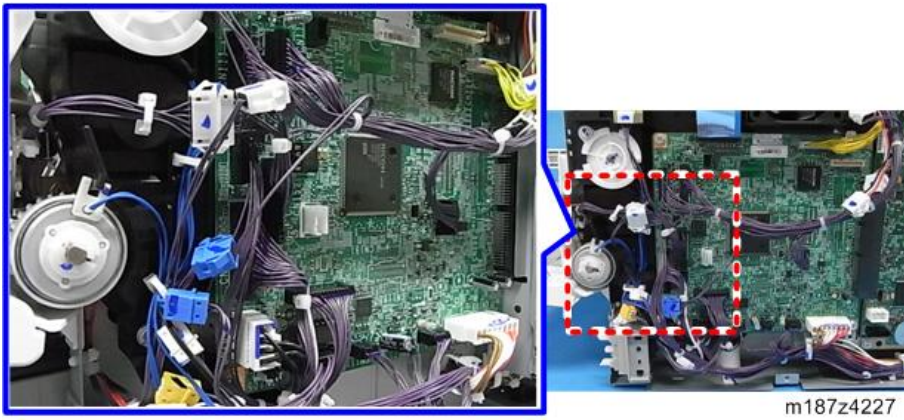

3. By-pass Feed Clutch [A] (🔗×1, 📦×1)

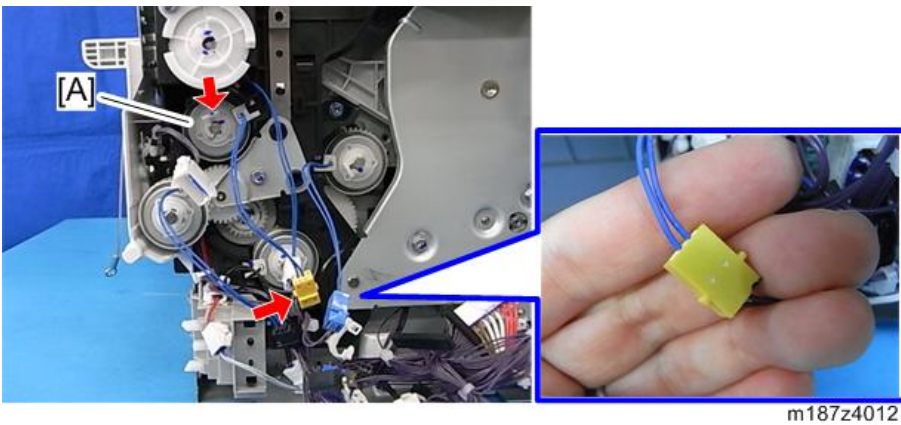

By-pass Bottom Plate Clutch

1. Right Cover (page 60)
2. By-pass Bottom Plate Clutch [A] (⚙️×1, ⚙️×1, 📦×1)

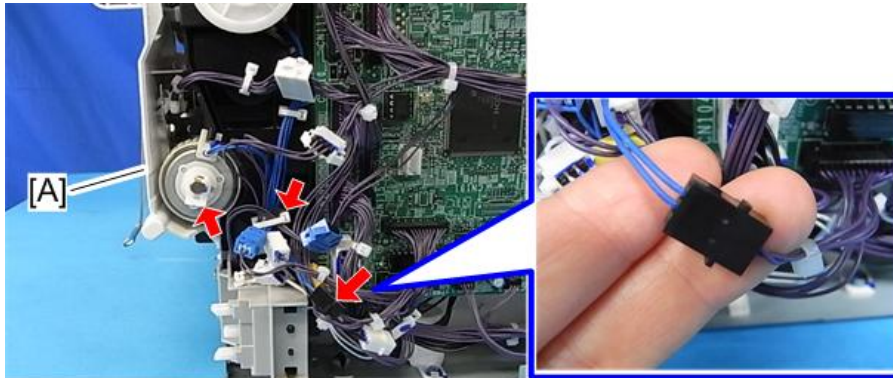

m187z4017

4

Drive Unit

1. BCU (page 137)
2. PCDU cooling fan with duct (page 141)
3. Drive Unit [A] (⚙️×4, 📦×1, ⚙️×1)

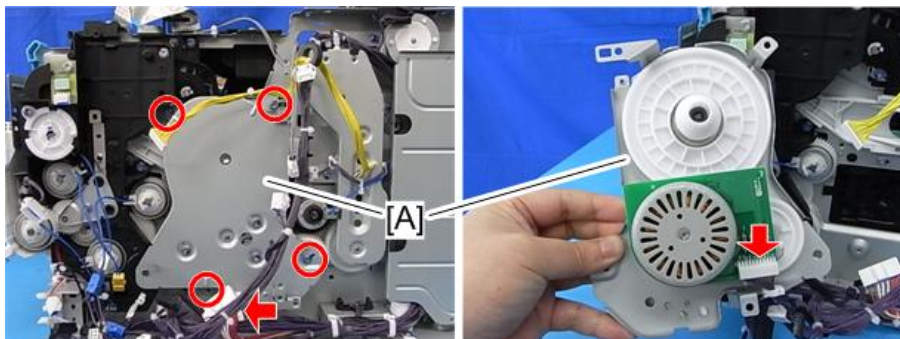

m187z4223

Gear Unit

1. BCU (page 137)
2. Registration clutch (page 86)
3. By-pass bottom plate clutch (page 89)
4. Paper feed clutch (page 86)

- 5. By-pass feed clutch (page 87)
- 6. Drive unit (page 89)
- 7. Paper Size Detection Switch (page 117)
- 8. Temp Humid Sensor (page 147)
- 9. Gear bracket [A] (🔩×1)

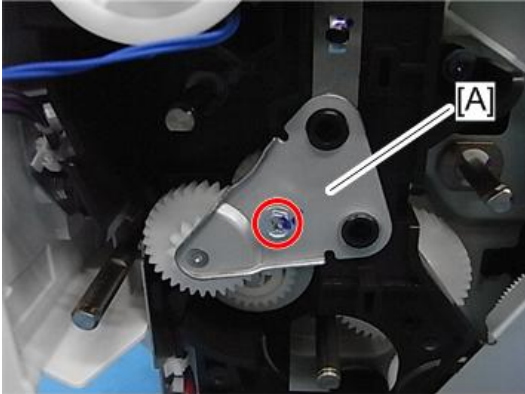

m187z4013

10. Gear [A]

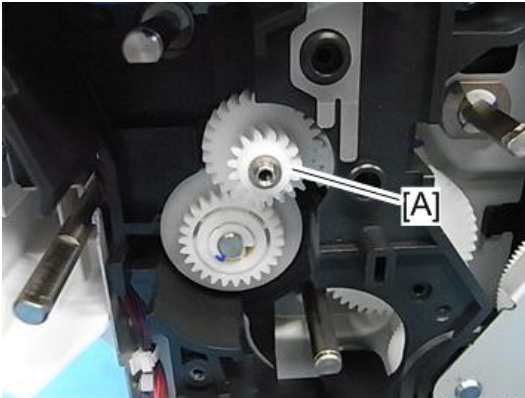

m187z4226

11. Gear Unit [A] (⚙️×4, Ground plate [B], 📦×1, 📦×1)

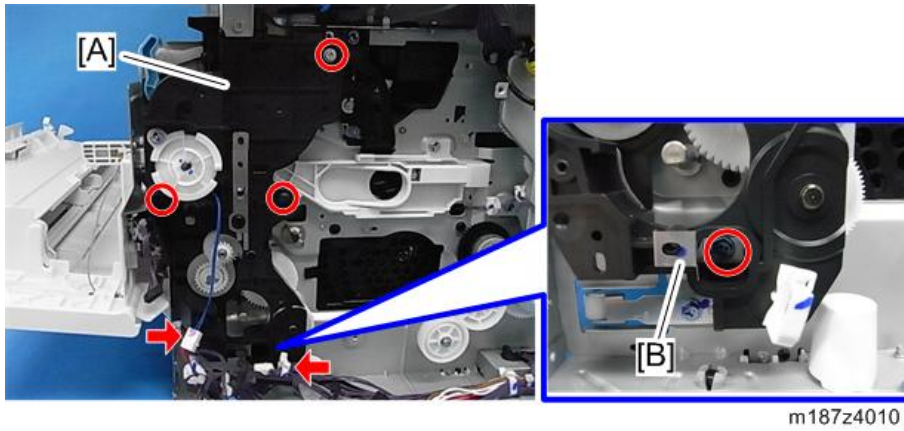

↓ Note

- Gears Arrangement:



★ Important

- Note when reassembling the gear unit [A]:
Close the front cover first, and then fit the boss [B] of the front cover arm into the opening [C].

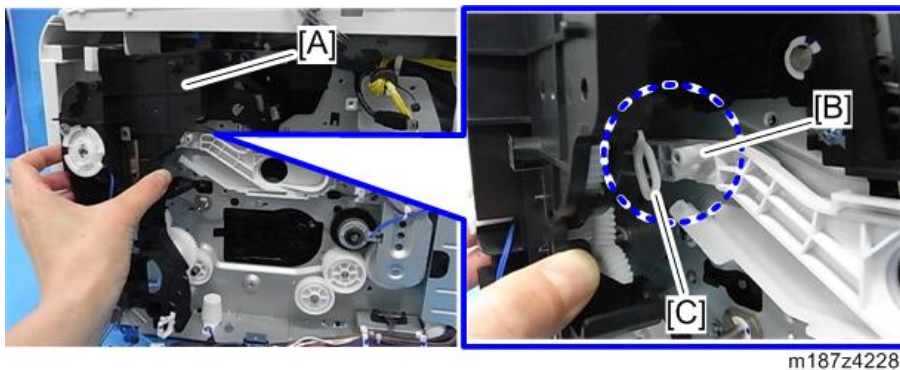

4

Toner Supply Clutch

1. Gear Unit (page 89)
2. Clip ring (🔧×1)



3. Gear [A]

4. Toner Supply Clutch [B] with shaft

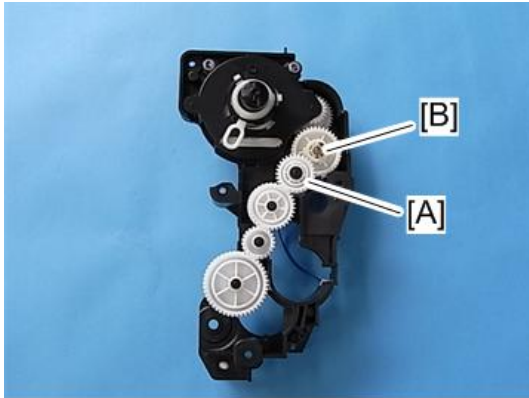

m187z4521

5. Toner supply clutch [A] (Gear ×1, Shaft ×1)

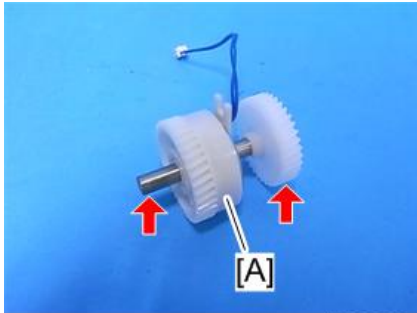

m1600231

4

Relay Clutch

1. Gear Unit (page 89)

2. Relay Clutch [A] (⚙️×1, 📦×1, ⚙️×1)

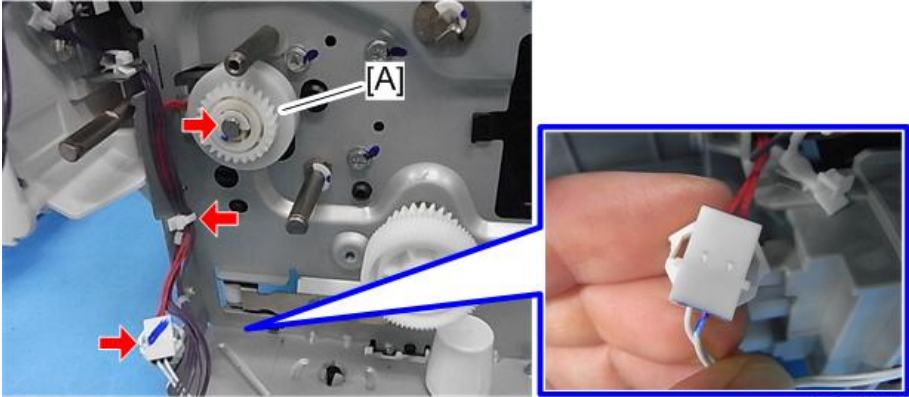

m187z4014

Duplex Clutch

- 1. Controller Board (page 134)
- 2. Bracket [A] (🔩×4)

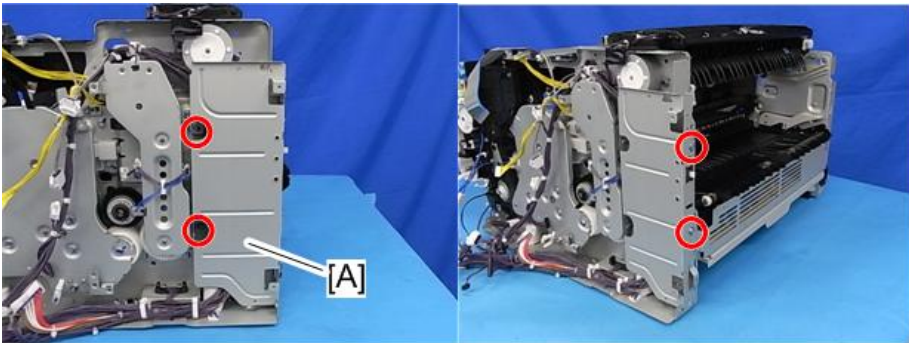

m187z4015

3. Duplex Clutch [A] (⚙️×1, ⚙️×2, 📦×1)

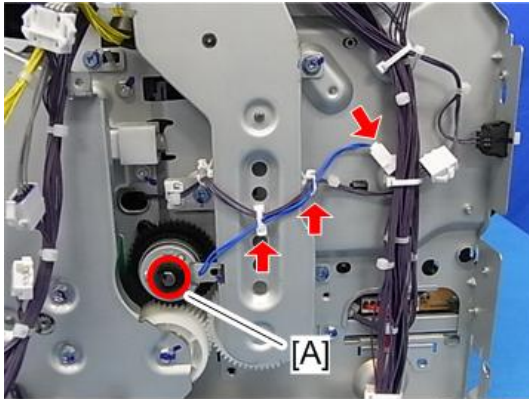

m187z4016

4

Junction Gate Solenoid

1. Upper Cover (page 67)
2. Junction gate solenoid [A] (⚙️×2, 🌀×1, 📦×1)

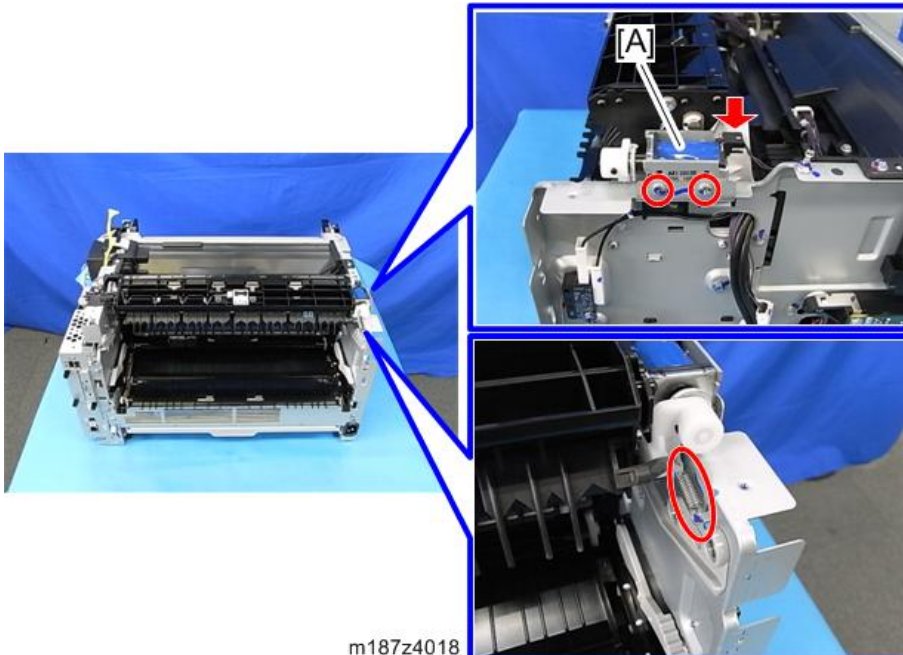

m187z4018

Fusing

⚠ CAUTION

- Because there is a danger of burns on contact with hot parts of the fusing unit, start work when the temperature drops to a low enough temperature.
- Turn off the main power switch and disconnect the power cord before you start any of the procedures in this section (page 53).

Fusing Unit

4

1. Open the rear cover [A].



m187z4173

2. Release the lock levers [A].

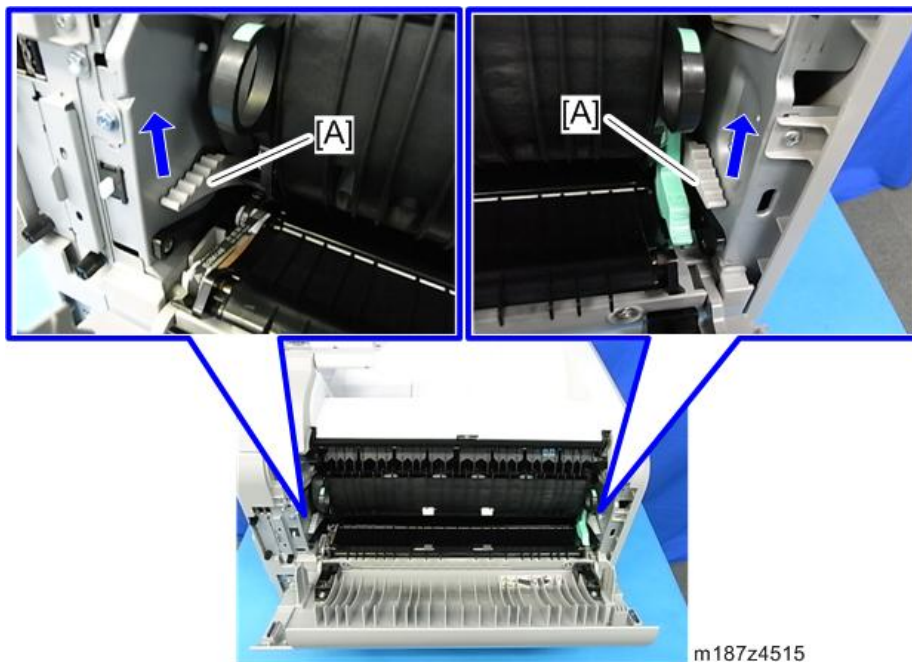

3. Fusing Unit [A]

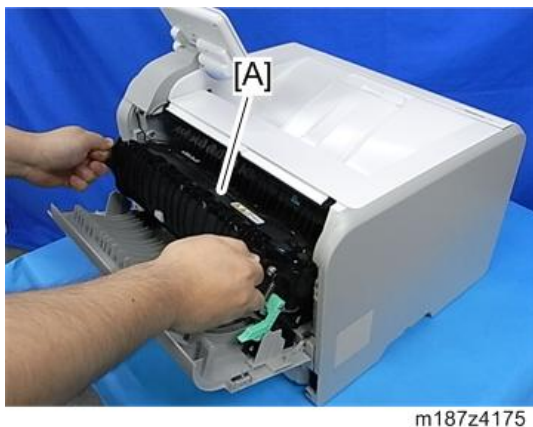

↓ Note

- If replacing a used fusing unit for Emergency Maintenance (EM), **you must** reset the PM counter. Be sure to use a fusing unit that does not include the new-unit detection.
- For Preventive Maintenance (PM), use a fusing unit that includes the new-unit detection. The PM counter is reset automatically and is not inherited after replacement. Also, the counters for image transfer roller, paper feed roller and friction pad are reset by the new-unit detection.

Upper Fusing Unit, Lower Fusing Unit

1. Fusing Unit (page 96)
2. Four screws of the fusing unit [A] (🔩 ×4)

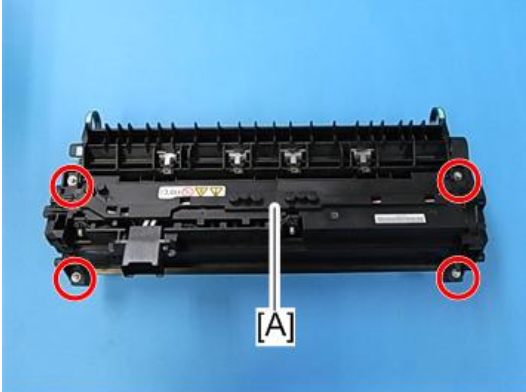

m187z4517

3. Cover [A] (🔩 ×1)



m187z4516

4. Separate the fusing unit into the lower [B] and upper [C] fusing units.



m187z4177

Note

- Insert the flat nut [A]. Be sure not to drop them during disassembly.

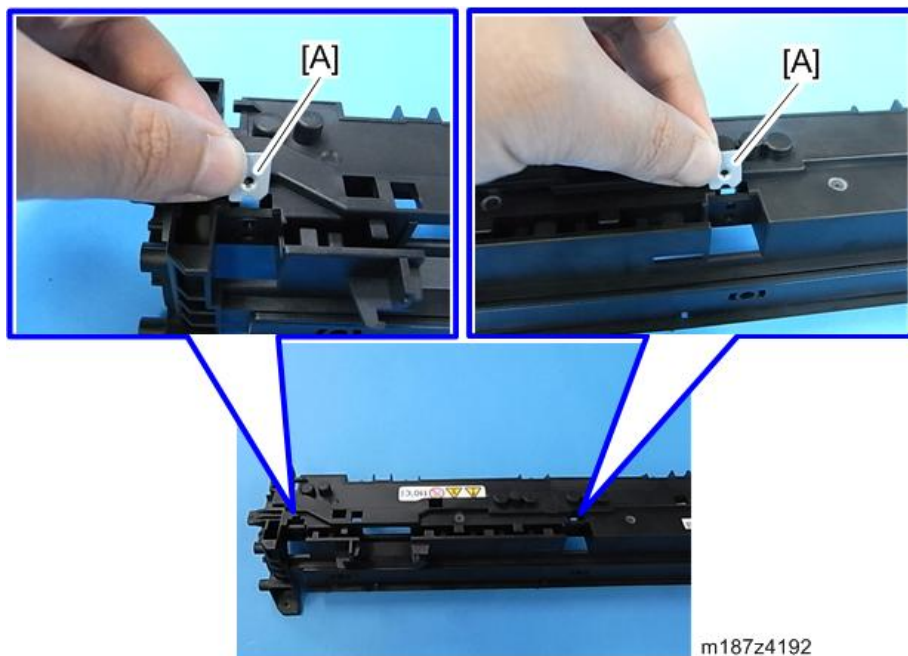

m187z4192

Fusing Pressure Roller

1. Separate the fusing unit into the upper and lower fusing units (page 98).

2. Guide [A] (🔩×3)

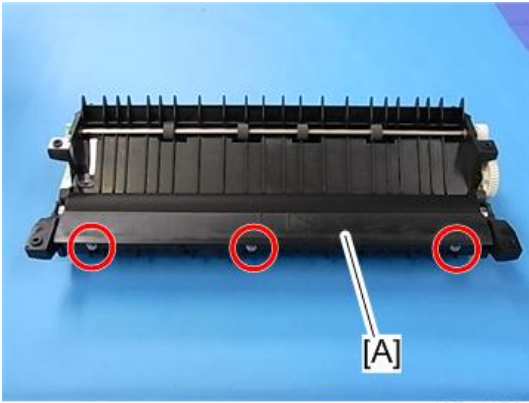

m187z4179

4

3. Fusing Pressure Roller [A]

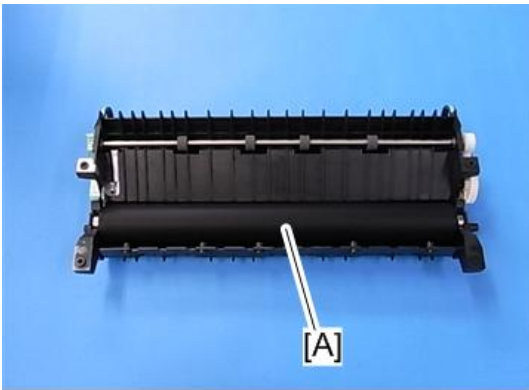

m187z4180

Fusing Lamp, Hot Roller

★ Important

- Be careful not to break the fusing lamp when removing/attaching screws. Insert a pin or jeweller's screwdriver into the service hole (see the lower red circle in the photo below), and hold the flat nut with your finger (see the upper red circle in the photo). Otherwise, the lamp secured together with the flat nut moves with rotation of the screw, which causes a lamp breakage.

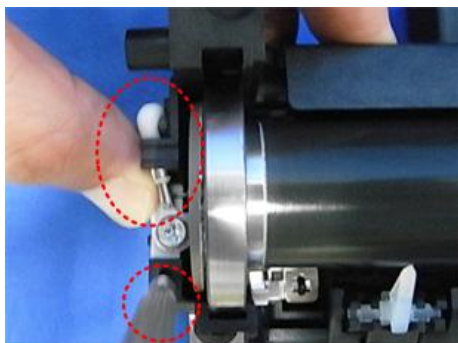

m173m0118

1. Separate the fusing unit into the upper and lower fusing units (page 98).
2. Guide [A]

↓ **Note**

- There is a C-shaped cutout at the right side of the guide.



m187z4181

3. Cover [A] (Ⓢ×1)



m187z4182

4. Screws of the fusing lamp (🔑 x3)

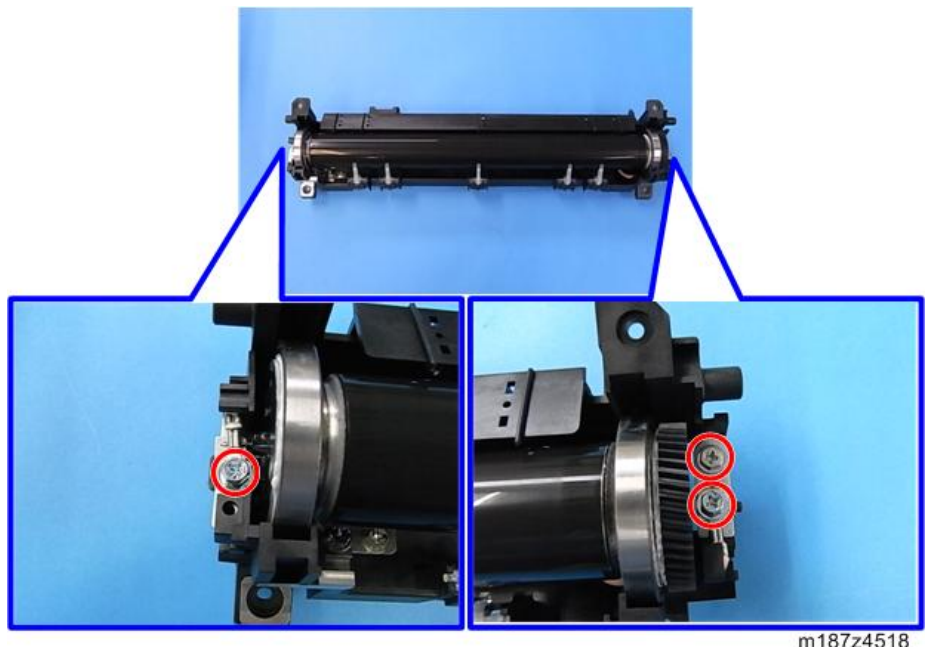

m187z4518

5. Two brackets [A]

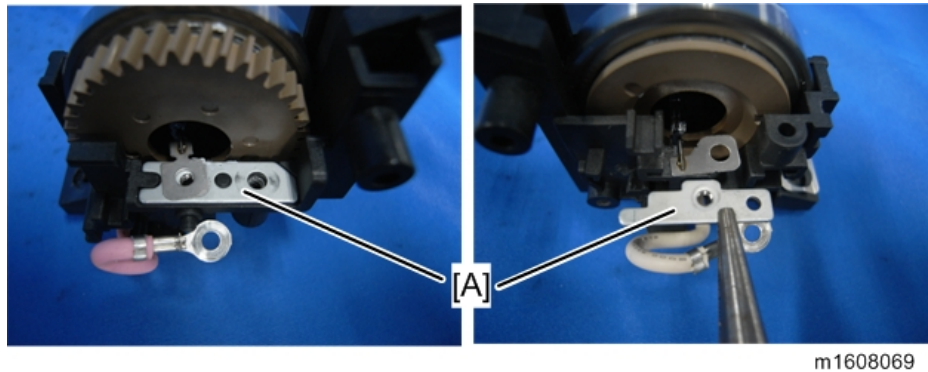

m1608069

6. Pull out the fusing lamp [A].

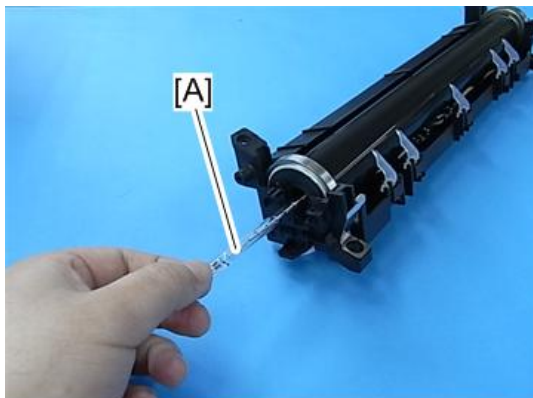

m187z4184

7. Hot Roller [A].

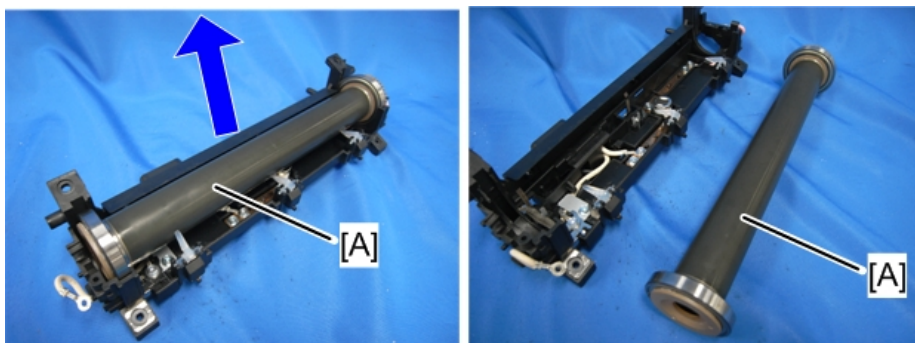

m1608071

↓ Note

- When installing a new hot roller, removing the guide [A] helps you install the hot roller more easily.

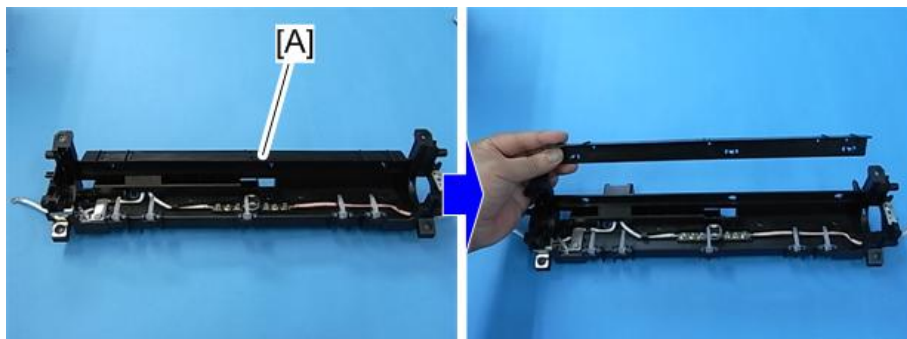

m187z4186

Thermostat

1. Separate the fusing unit into the upper and lower fusing units (page 98).
2. Hot Roller (page 100)
3. Thermostat [A] (🔩 x2)

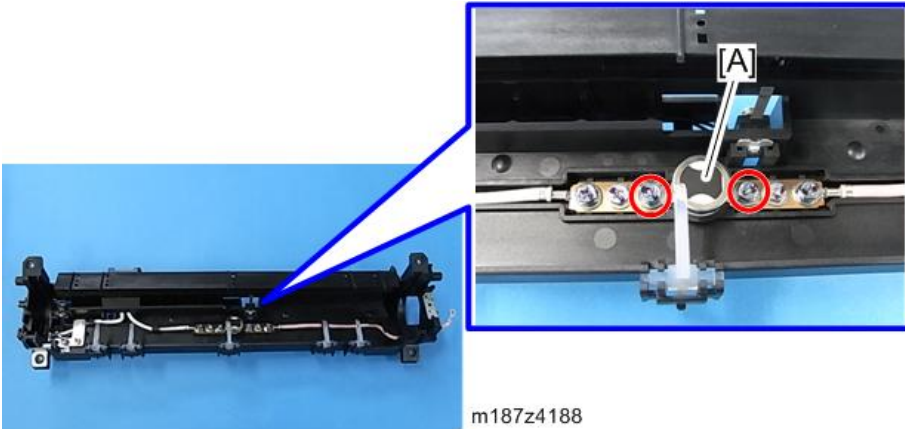

Thermistor

↓ Note

- The thermistor is integrated with the drawer connector.
1. Separate the fusing unit into the upper and lower fusing units (page 98).
 2. Hot Roller (page 100)
 3. Screws of the harness (🔩 x3)



4. Three screws to remove drawer connector [A] (🔩 x3)

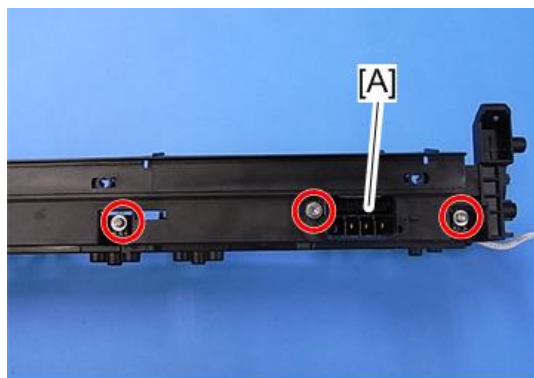

m187z4519

5. Thermistor [A] (📦 x1)



m187z4191

⬇ Note

- Insert the flat nut [A]. Be sure not to drop them during disassembly.

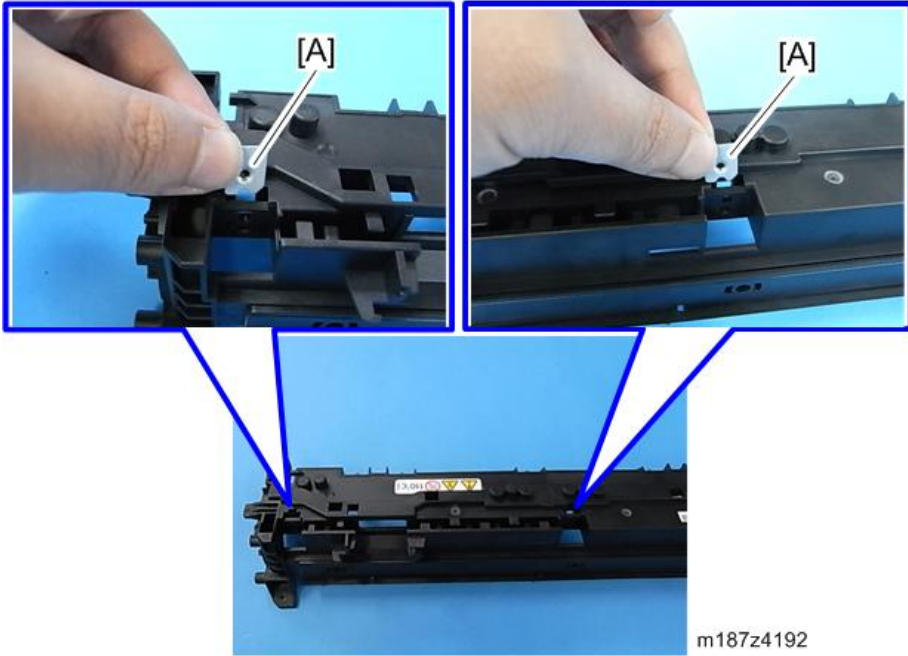

4

Hot Roller Stripper

1. Separate the fusing unit into the upper and lower fusing units (page 98).
2. Hot Roller Stripper [A] (🌀x 1)

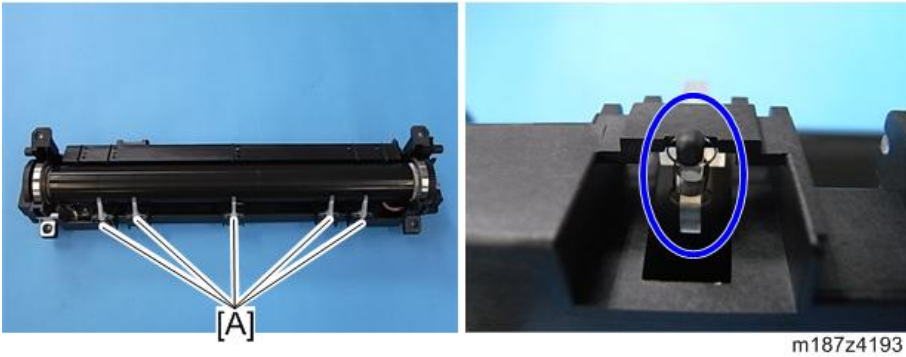

Paper Feed

⚠ CAUTION

- Turn off the main power switch and disconnect the power cord before you start any of the procedures in this section (page 53).

Paper Feed Tray

1. Pull the paper feed tray [A] out completely to detach it.



m187z4133

4

Paper Feed Roller

1. Paper Feed Tray (page 107)
2. Slide the lever [B] to the left to detach the paper feed roller [A].

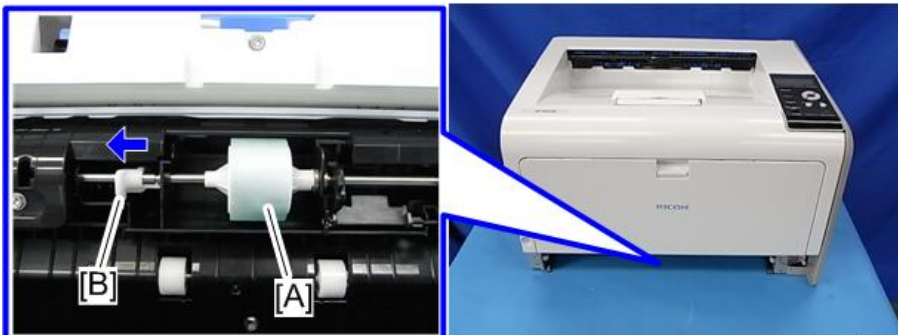

m187z4136

Friction Roller, Torque Limiter

1. Paper Feed Tray (page 107)
2. Paper feed tray handle [A] (🔩×2)

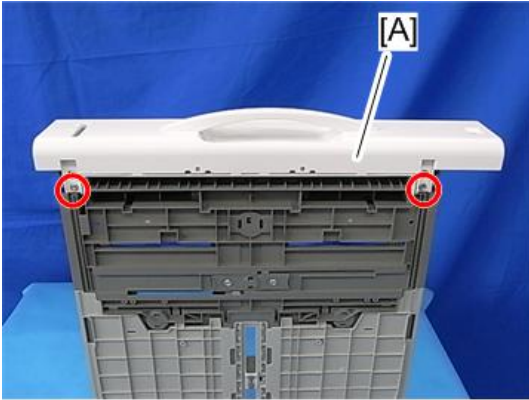

m187z4137

3. Friction roller unit [A] (🔩×2)

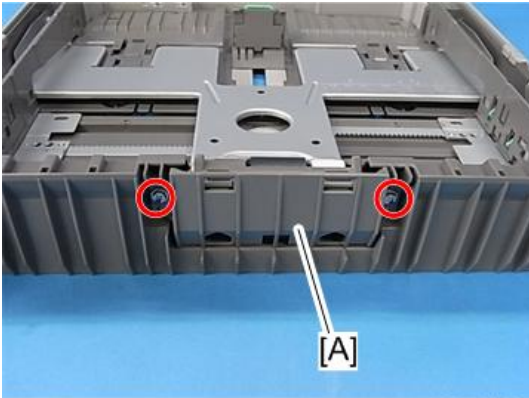

m187z4138

4. Friction roller guide [A] (Release the tabs.)

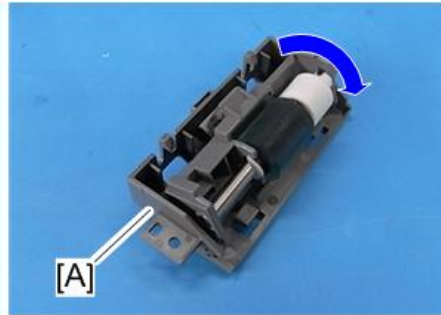
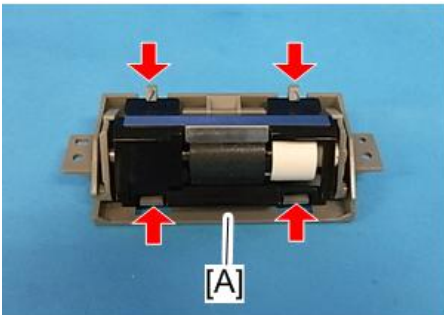

m187z4532

5. Friction roller [A] and torque limiter [B] (⚙️×2, Shaft ×2)

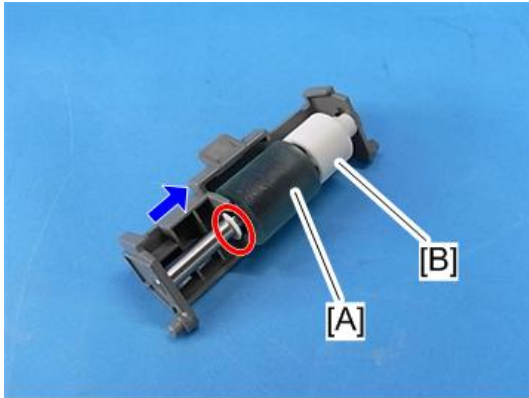

m187z4140

Paper End Sensor

1. By-pass Feed Unit (page 110)
2. Guide plate [A] (⚙️×2)

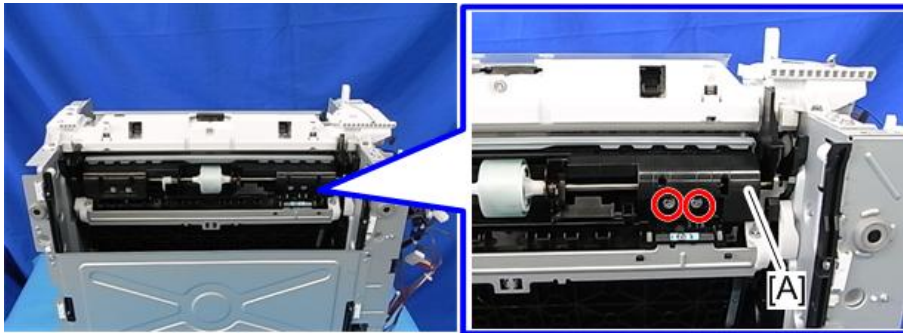

m187z4141

3. Paper End Sensor [A] (🔧 ×1, Release the tab.)

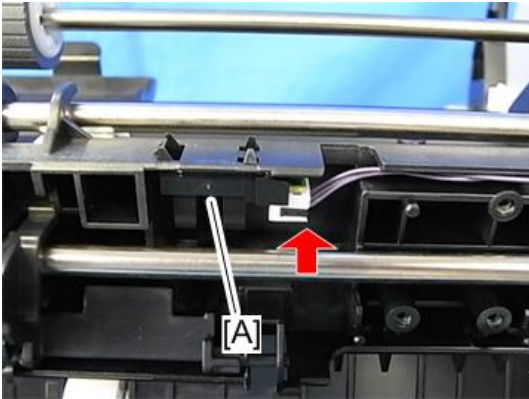

m187z4142

4

By-pass Feed Unit

1. Front Cover (page 57)
2. Left Cover (page 58)
3. Right Cover (page 60)
4. By-pass Bottom Plate Clutch (page 89)
5. Guide plate [A] (🔧 ×1).

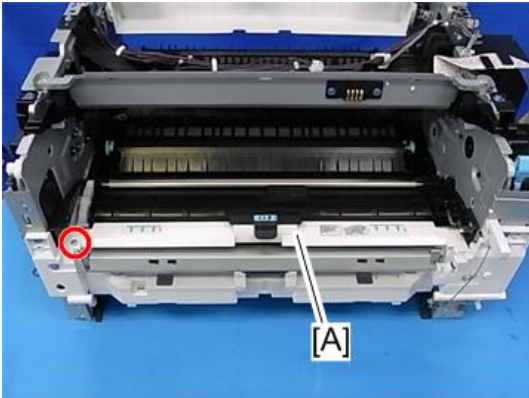

m187z4149

6. Clamp and connector (🔧×1, 📦×1)



m187z4146

7. By-pass bottom plate clutch [A] (🔧×1)

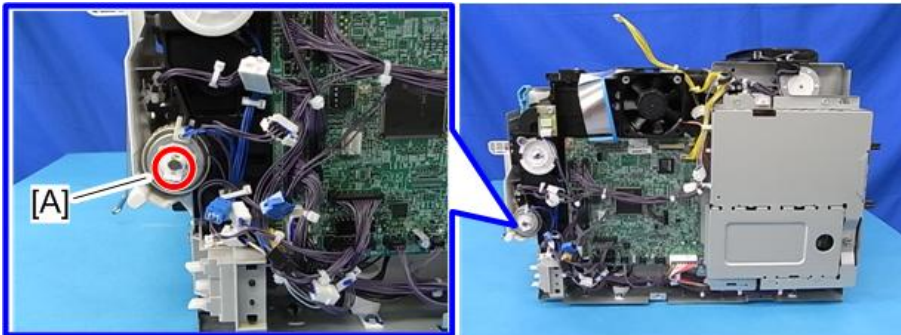

m187z4504a

8. Connector and clamp (🔧×1, 📦×1)

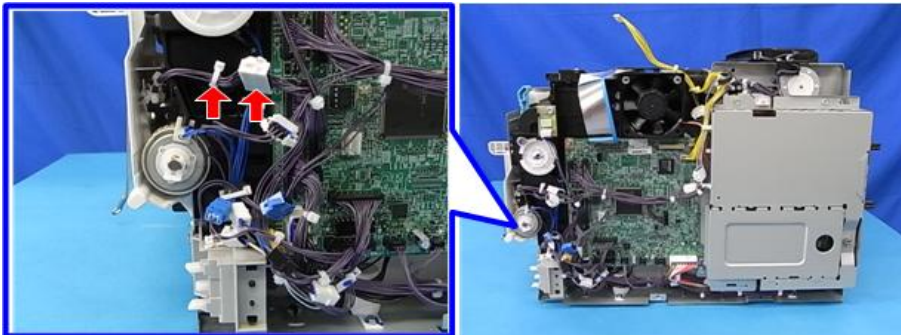

m187z4505

9. By-pass Feed Unit [A] (🔩×4)

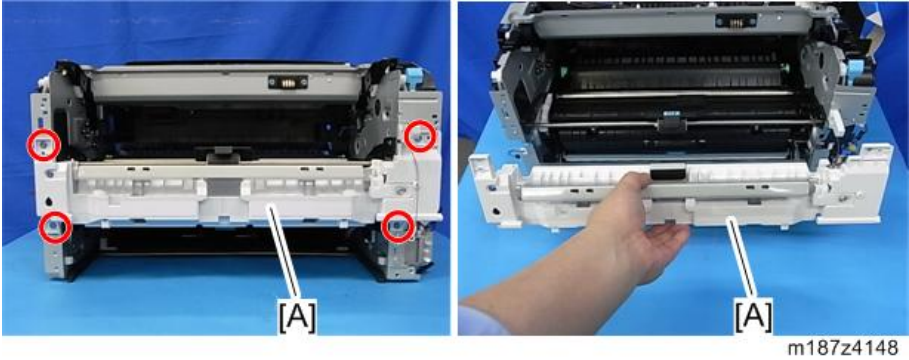

By-pass Feed Roller

1. By-pass Feed Unit (page 110)
2. Gear Unit (page 89)
3. Front cover interlock switch with its bracket (page 144)
4. Bearing and clip attached on both sides of the by-pass feed roller (🔩×1, bearing ×1: at each side)

Right Side

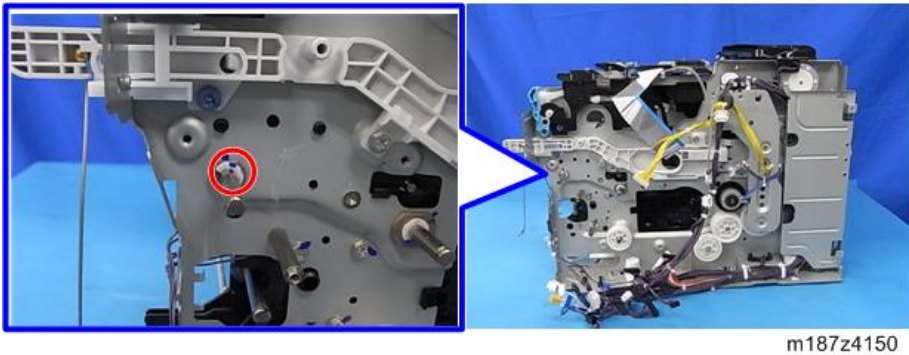

Left Side



m187z4151

- Slide and detach the by-pass feed roller [A] with its shaft.

4

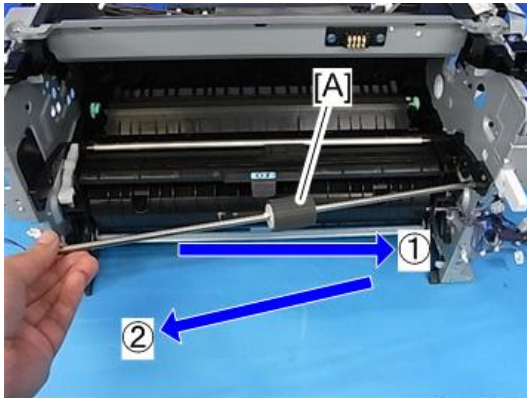

m187z4152

- Release the tab to remove the by-pass paper feed roller [A].

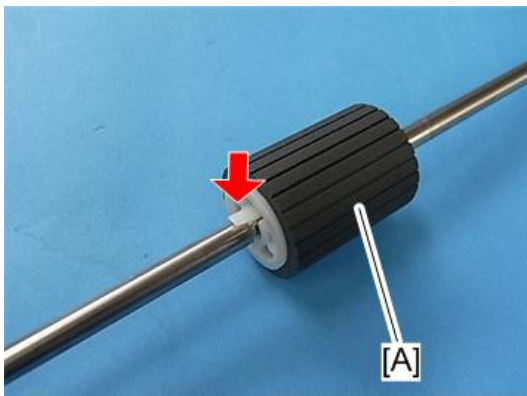

m187z4153

By-pass Friction Pad

1. By-pass Feed Unit (page 110)
2. Bottom Plate [A]

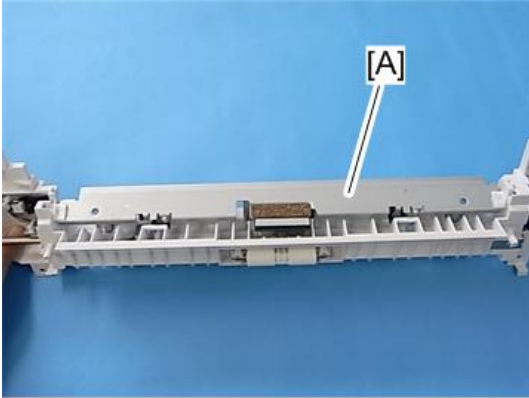

m187z4154

Note

- If you cannot remove the bottom plate because the bottom plate link [A] prevents the cam [B] from releasing, rotate the shaft [C] to let the cam [B] avoid the bottom plate link [A].

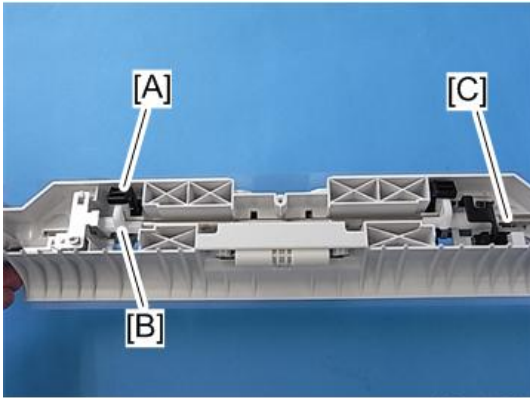

m187z4156

3. Push the friction pad [A] down to detach it (🔩×1).

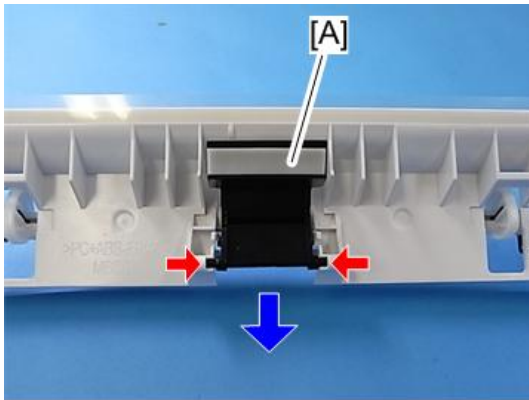

m187z4155

4

By-pass Paper End Sensor

1. By-pass Feed Unit (page 110)
2. Bracket of the front side of the by-pass feed unit [A] (🔩×1)

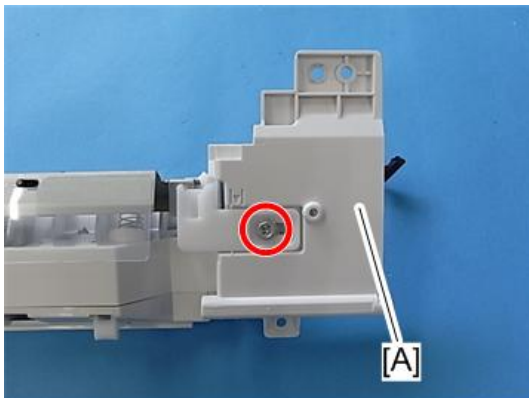

m187z4506

3. By-pass paper end sensor [A] with its bracket (🔩×2, 🛠️×2, 📦×1)

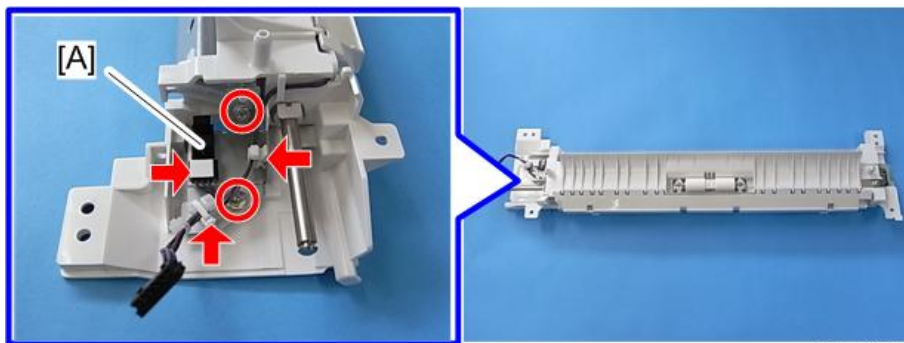

m187z4507

- 4
4. By-pass Paper End Sensor [A] from the bracket (Release the tab.)

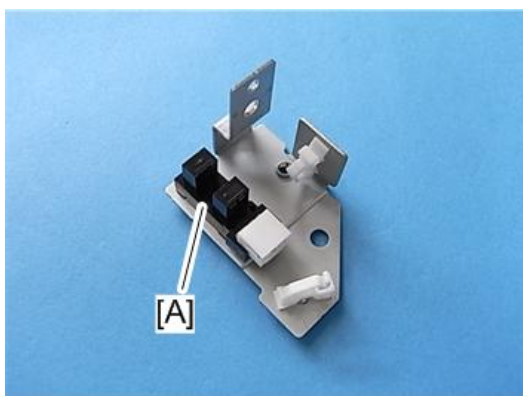

m187z4508

By-pass Bottom Plate HP Sensor

1. By-pass Feed Unit (page 110)

2. By-pass Feed Lower Cover [A] (🔩×3)

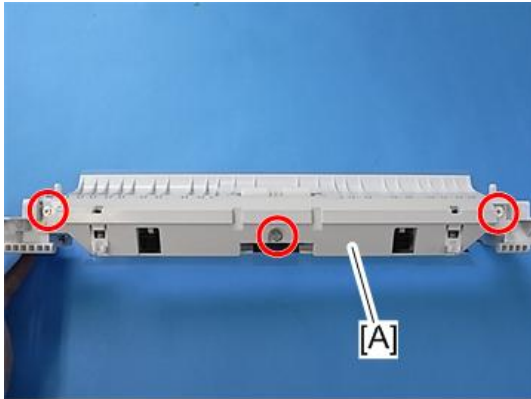

m187z4158

3. By-pass Bottom Plate HP Sensor [A] (🔧×1, Release the tab.)

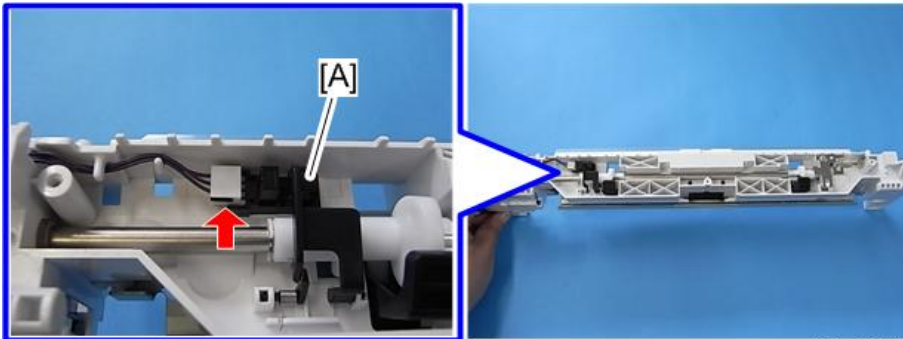

m187z4159

Paper Size Detection Switch

1. Paper Feed Tray (page 107)
2. Right Cover (page 60)

3. Paper Size Detection Switch [A] with its bracket (⚙️×2, 🛠️×1, 📦×1)

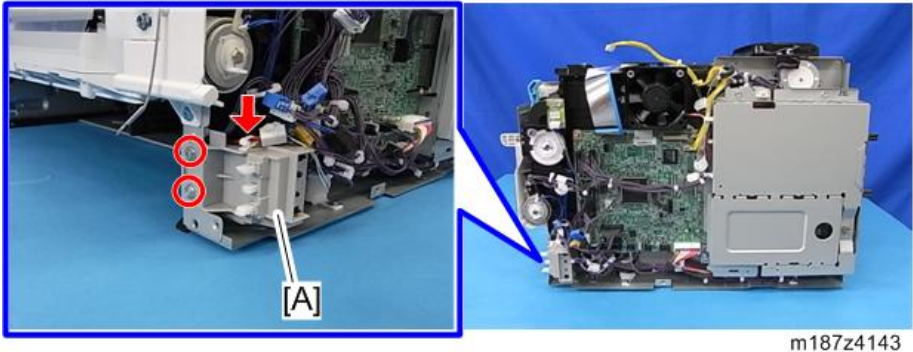

4

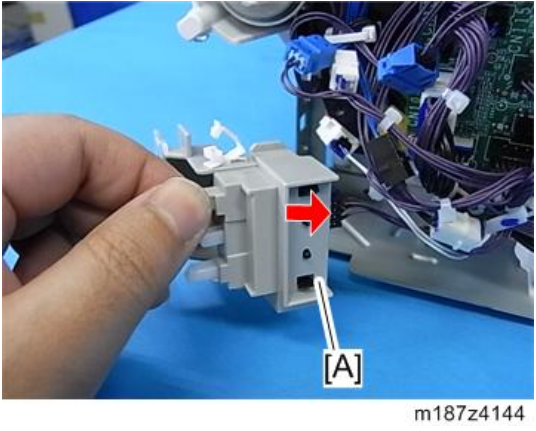

4. Paper Size Detection Switch [A] from the bracket (tab×2)

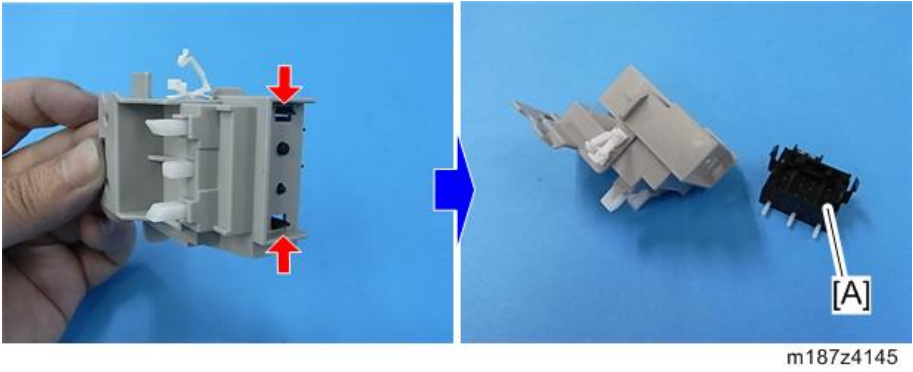

Paper Transport

⚠ CAUTION

- Turn off the main power switch and disconnect the power cord before you start any of the procedures in this section (page 53).

Paper Exit Unit

1. Upper Cover (page 67)
2. Fusing Unit (page 96)
3. Junction gate solenoid (page 95)
4. Release the connector to remove the harness guide [A] (🔩 ×1, 📦 ×2).

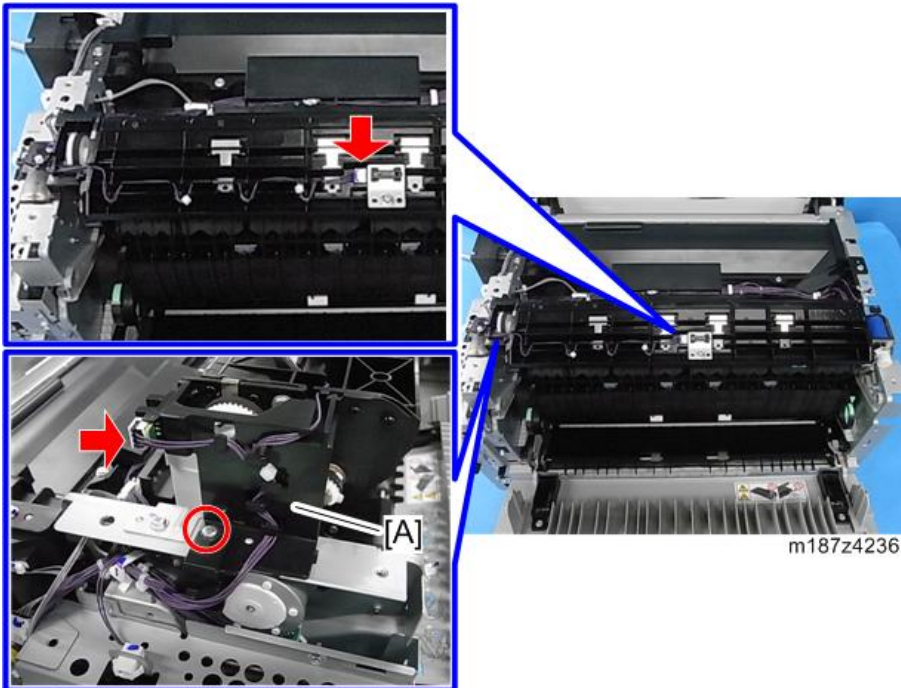

5. Remove the belt and screw at the right side of the paper exit unit [A] (🔩×1, 🌀×1).

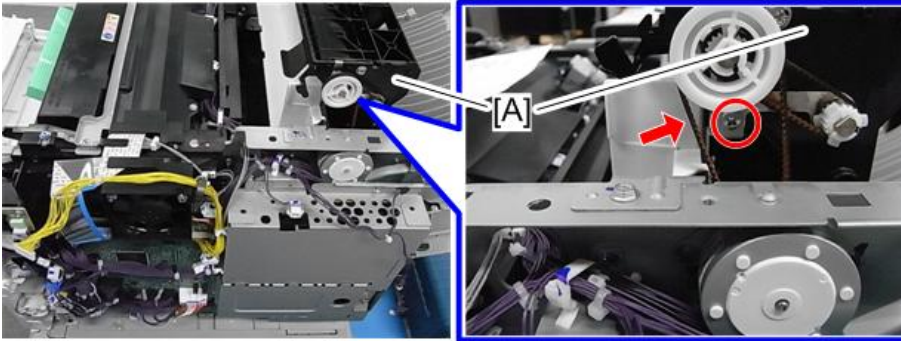

m187z4237

4

6. Remove the screw at the rear side of the paper exit unit [A] (🔩×1).

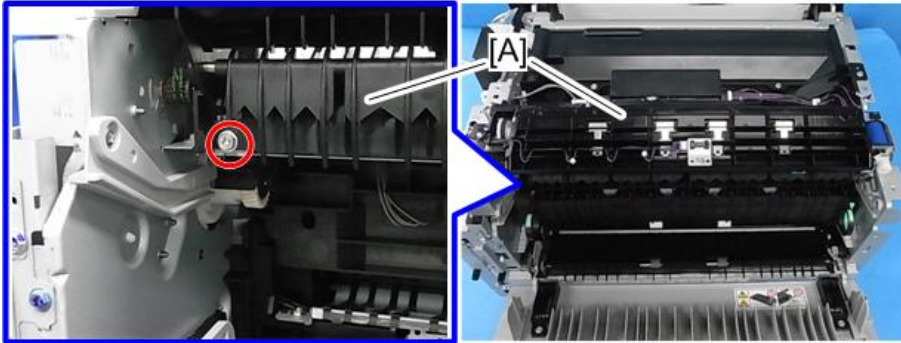

m187z4232

7. Release the connector in the back of the paper exit unit [A] to remove the paper exit unit [A] (📦×1).

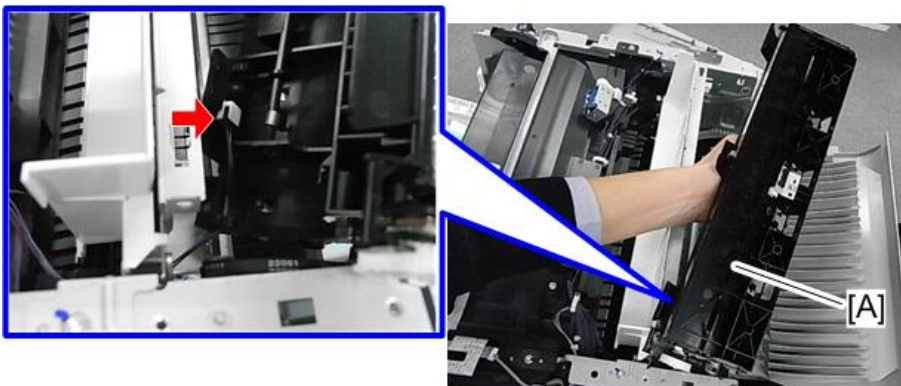

m187z4238

Paper Exit Sensor

1. Paper Exit Unit (page 119)
2. Paper Exit Sensor [A] (Tab)



4

Paper Overflow Sensor

1. Upper Cover (page 67)
2. Paper Overflow Sensor [A] (📦 ×1, Tab)

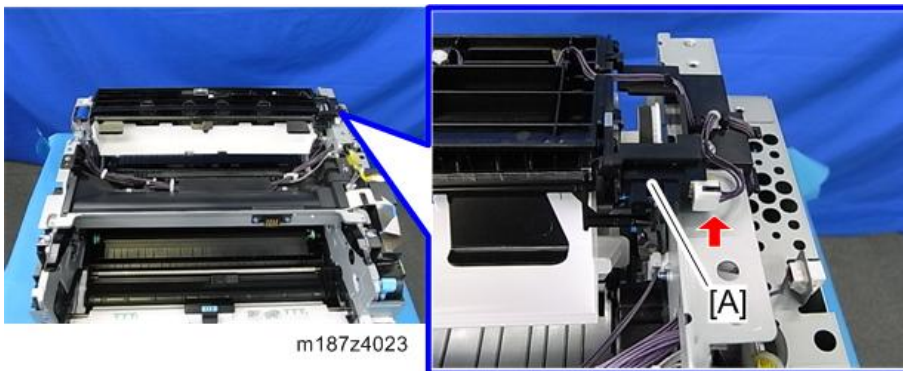

Duplex Reverse Sensor

1. Upper Cover (page 67)

2. Duplex reverse sensor [A] with its bracket (📦 x1)

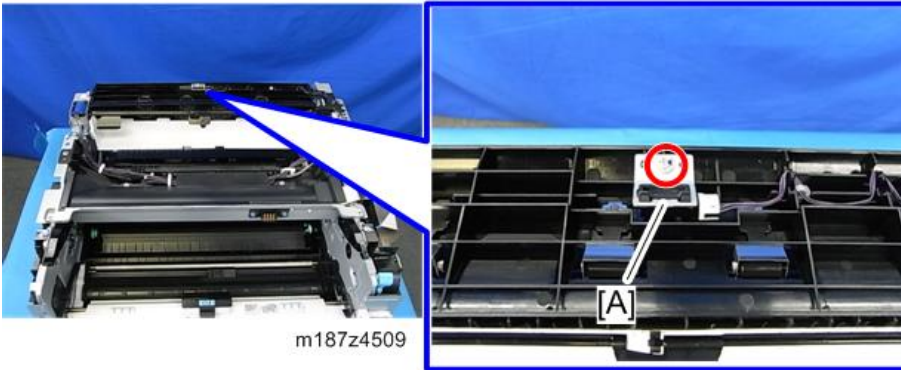

4

3. Stopper [A]

↓ Note

- The stopper is attached to the harness cover with double-sided tape.

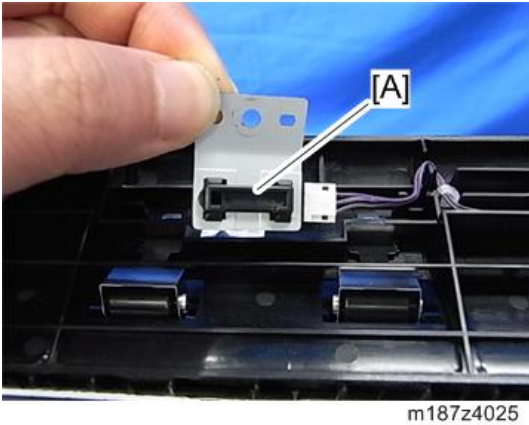

4. Duplex reverse sensor [A] (📦 x1, Tab)

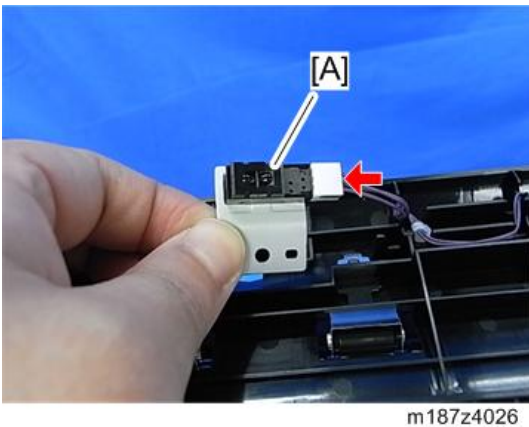

Duplex Entrance Sensor

1. Fusing unit (page 96)
2. Duplex entrance sensor with its bracket (🔩×1)

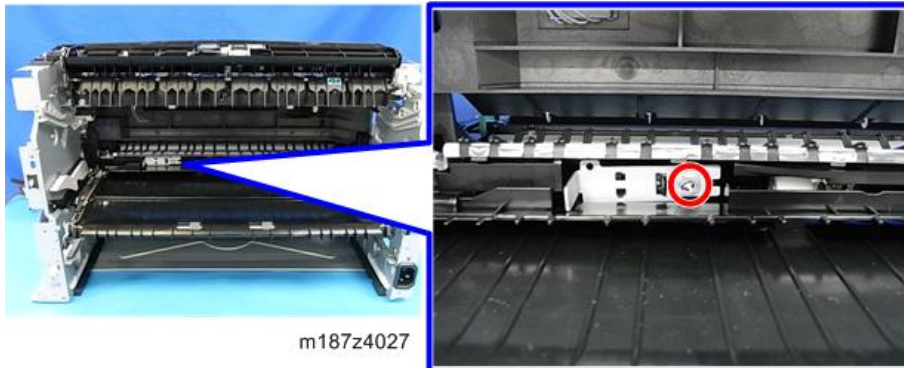

3. Duplex entrance sensor (🔑×1, Tab)

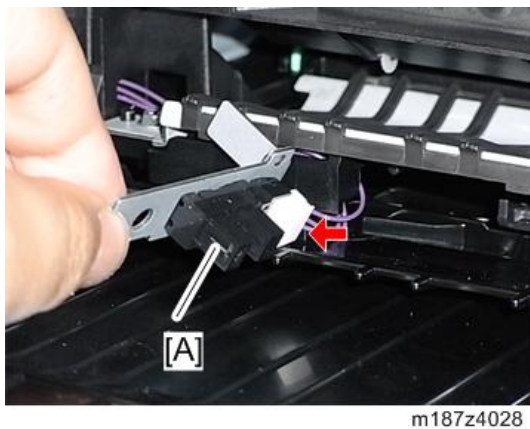

Registration Roller (Driven)

1. Gear Unit (page 89)
2. Registration Sensor (page 128)

3. Guide [A]

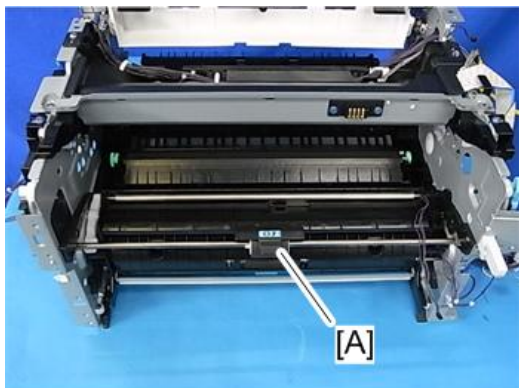

m187z4029

4

↓ Note

- There is a C-shaped cutout at both ends of the guide plate.

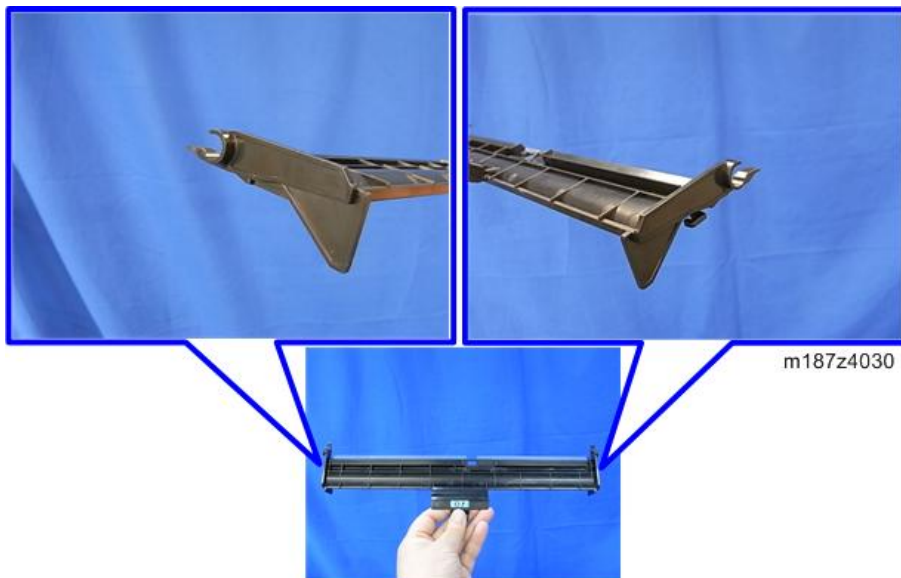

m187z4030

4. E-ring at both sides of the registration roller (driven) (④x2)

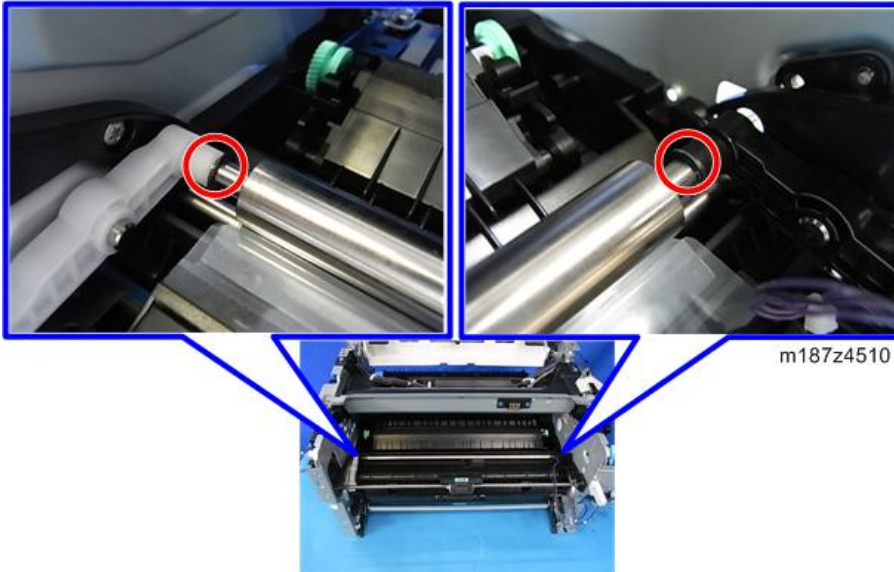

5. Remove the spring of the arm [A], slide the arm [A] to the right, and detach the registration roller (driven).

Right Side

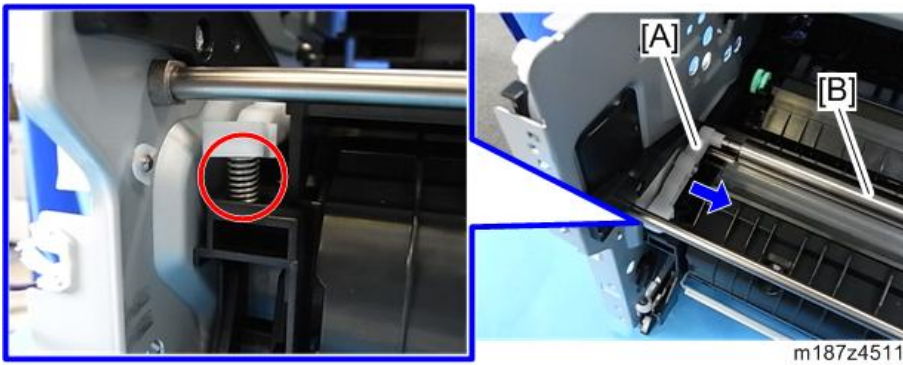

Left Side

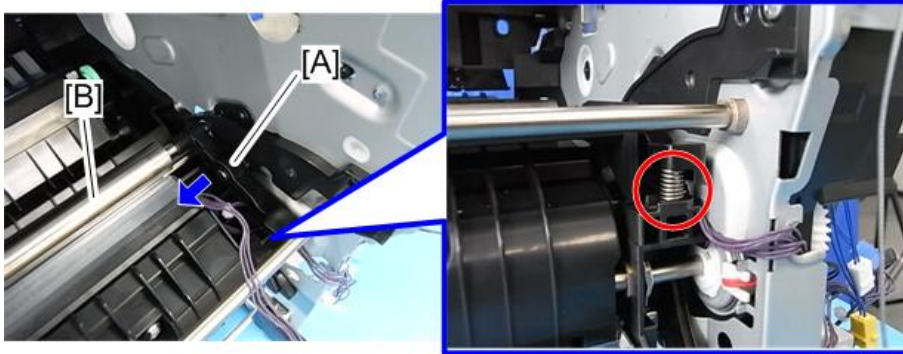

m187z4512

4

6. Arm [B] from the registration roller (driven) [A]

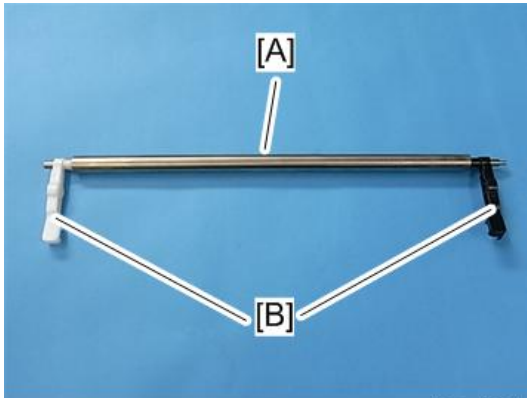

m187z4034

Registration Roller (Drive)

1. Registration Roller (Driven) (page 123)

2. Bearing and clip at both ends of the registration roller (drive) (Bearing ×1,  ×1)

Right Side

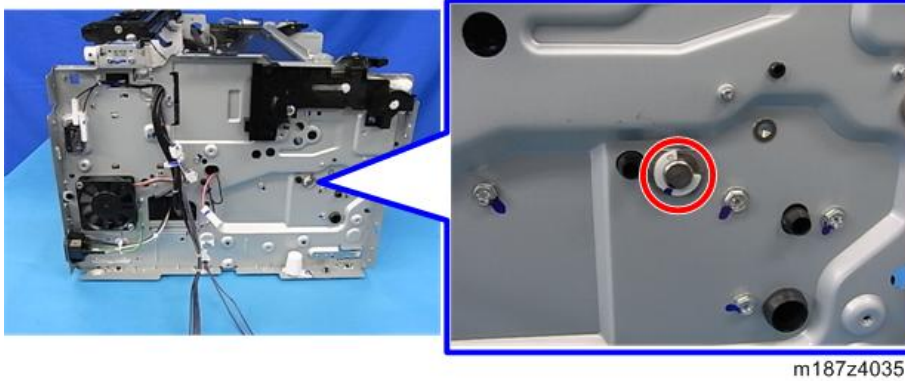

Left Side

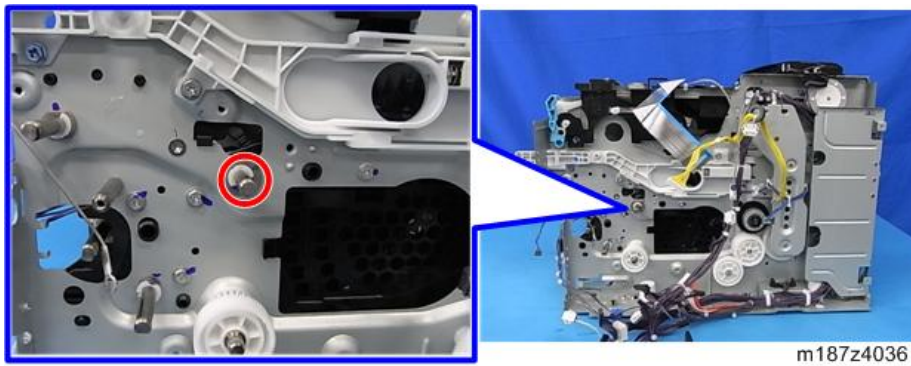

3. Slide the registration roller (drive) [A] to the right to remove it.

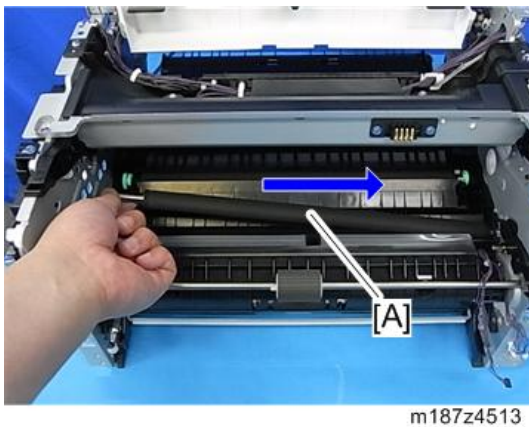

Registration Sensor

1. PCDU (page 78)
2. Harness cover [A]

Note

- There are several tabs on the harness cover. Release these tabs carefully with a jeweller's screwdriver when removing.



m187z4514

3. Stopper [A]

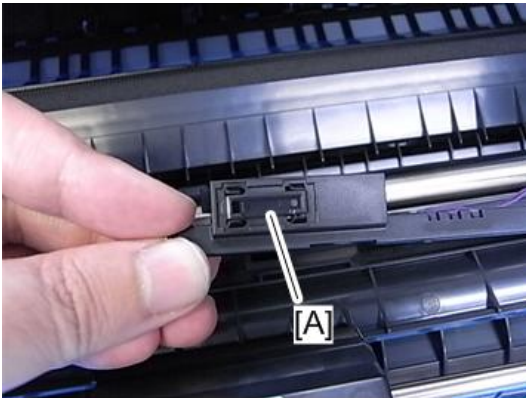

m187z4039

Note

- The stopper is attached to the harness cover with double-sided tape.

4. Registration sensor [A] (Tab,  x1)



m187z4099

Electrical Components

⚠ CAUTION

- Turn off the main power switch and disconnect the power cord before you start any of the procedures in this section (page 53).

Controller Box

1. Right Cover (page 60)
2. Two masking plates [A] [B] (coin screw ×3)

4

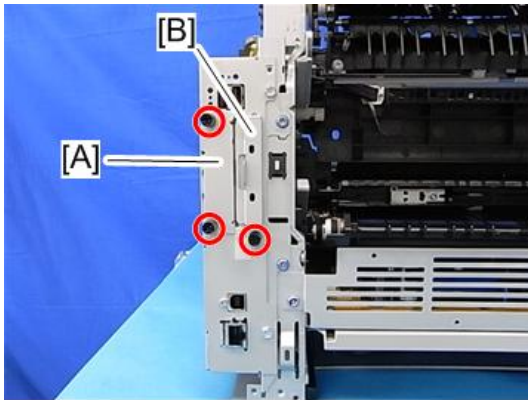

m187z4040

3. Three screws at the rear side of the controller box [A] (⌀ ×3)

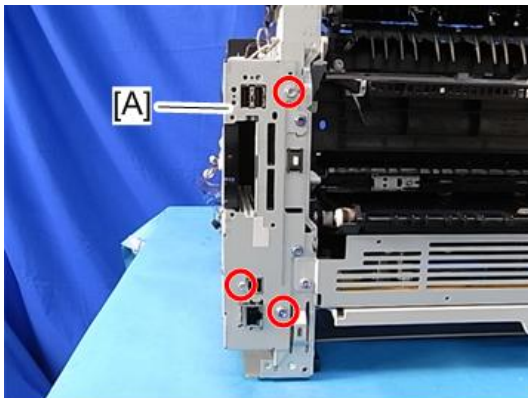

m187z4041

4. Release the two clamps on the controller box [A], and disconnect the harness (🔧×2, 📦×1).

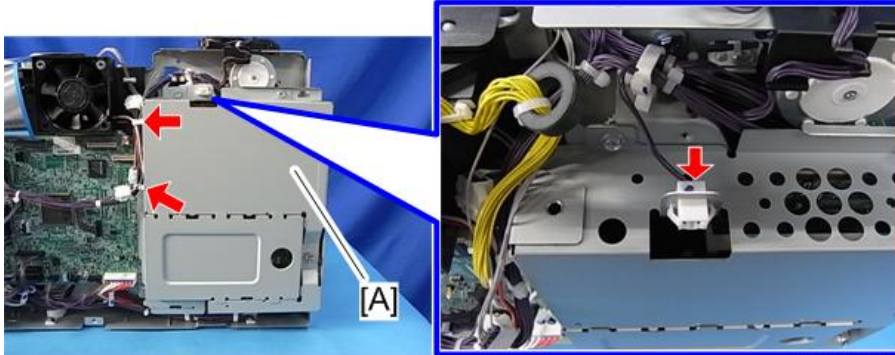

m187z4042

5. Controller box [A] (🔧×4)

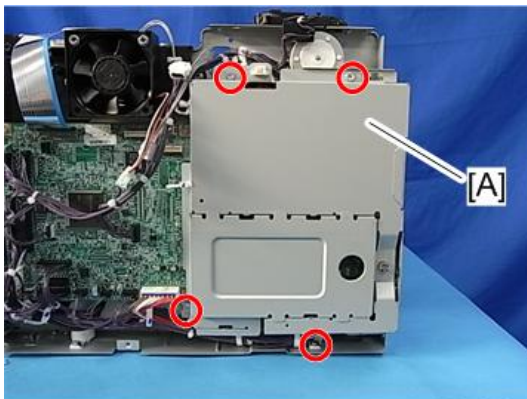

m187z4043

PSU

1. Left Cover (page 58)
2. Rear Cover, Rear Lower Cover (page 63)
3. Controller Board (page 134)
4. Screws and clamp of the PSU.

Left Side (🔧×2):

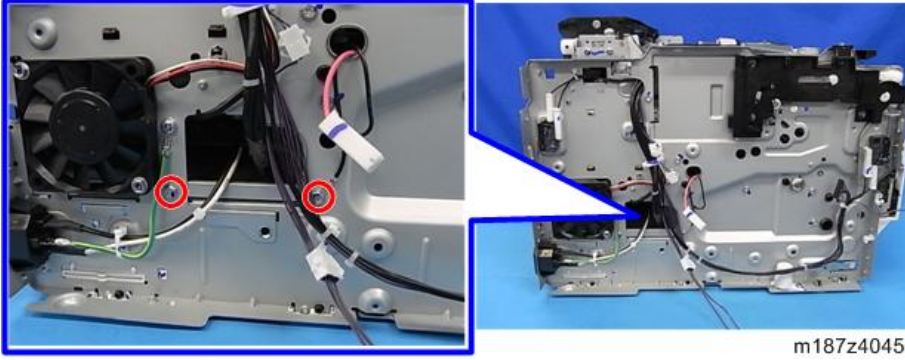

Right Side (🔩×1, 🛠️×1):

4

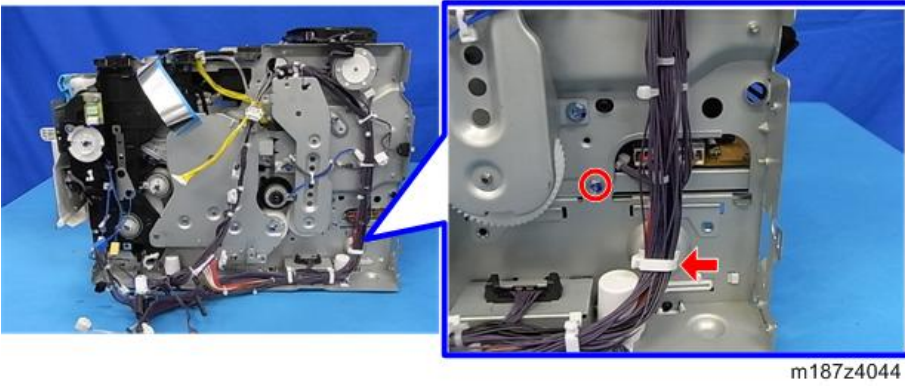

Rear Side (🔩×2):



5. Pick the guide plate [A] up and slightly pull the PSU [B] to disconnect the connector (🔌 x1).

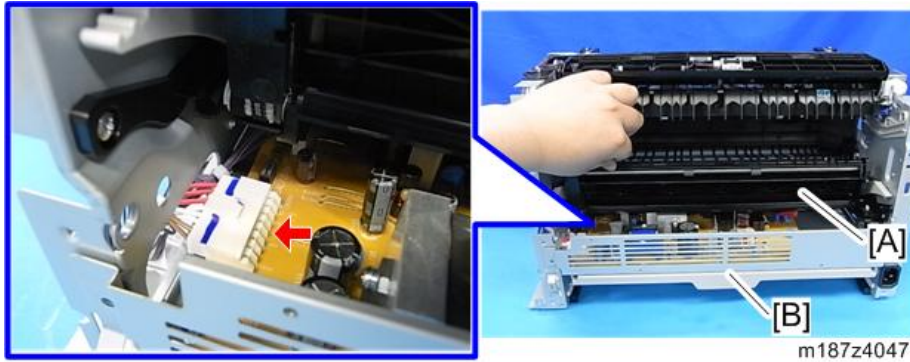

6. PSU [A] with its bracket (🔌 x3)

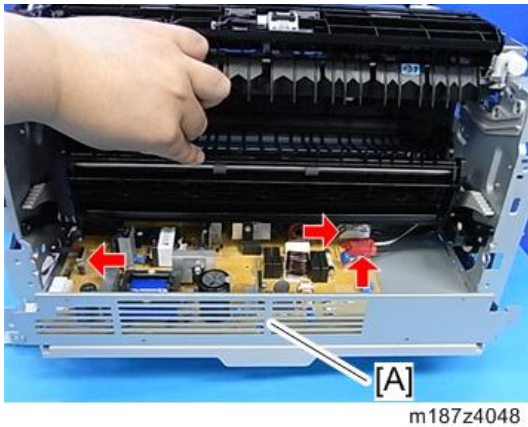

7. Turn the PSU back to detach the cover [A] (🌀 x1).

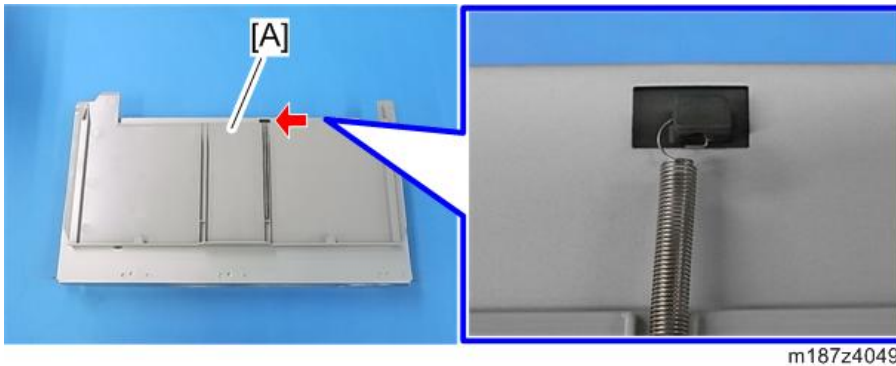

8. PSU [A] from the bracket (⚙️*6)

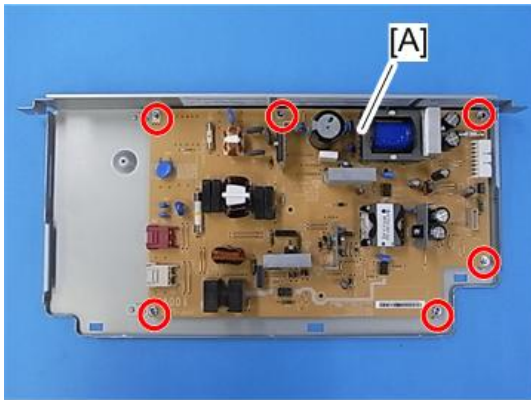

m187z4051

RTB 15

Some parts retain a charge a long while after disconnection. See the RTB for places that can retain this charge.

Controller Board

★ Important

- If you intend to replace the NVRAM, upload its contents to an SD card with SP5-824 before you remove NVRAM and replace it with a new one. Never remove the NVRAM until after you have uploaded its contents.

Before replacing the controller board in the model without HDD

When you replace the controller board in a model without a HDD, address book data can be copied from an old controller board to a new controller board using an SD card.

Copy the address book data to an SD card from the flash ROM on the controller board with SP5-846-051 if possible.

Replacement Procedure

1. Right Cover (page 60)
2. Controller Box (page 130)

3. Sliding the controller board [A] to the right to detach it (🔑 ×4, 📦 ×1).

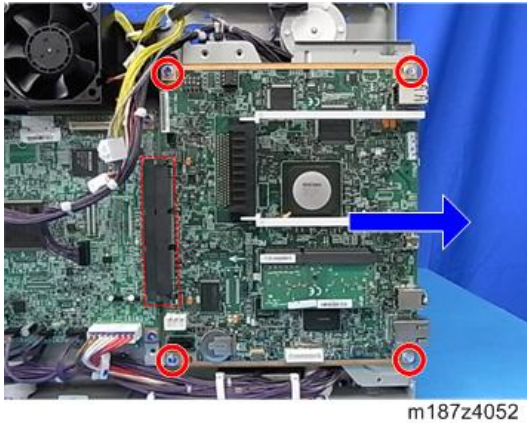

4. NVRAM [C], the upper brace [A] and the lower brace [B].

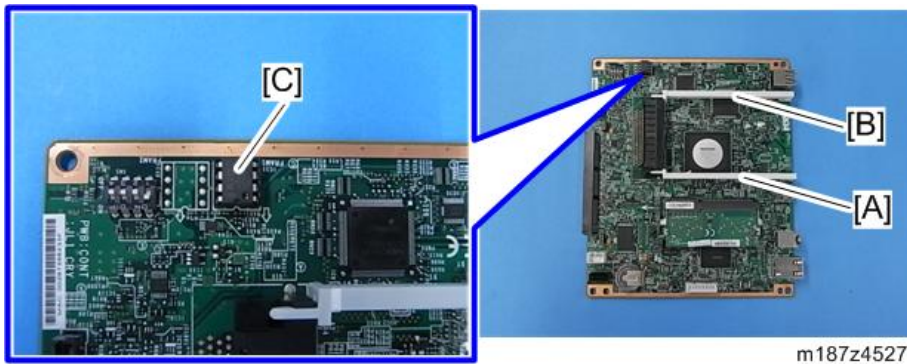

↓ **Note**

- Before removing the NVRAM, back up data.
- When replacing the controller board, remove the NVRAM from the old controller board. Then install it at the same position on the new controller board. Install so that the indentation [C] on NVRAM [A] is facing the direction of the arrow [B] that is printed on the controller board.

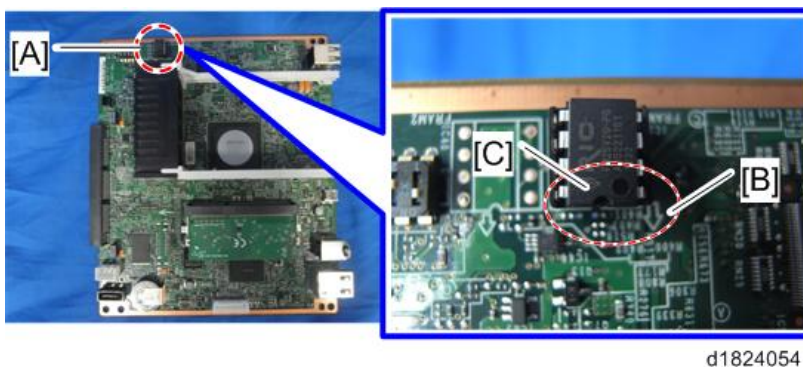

After installing the controller board

1. If the customer is using the data encryption feature, the encryption key must be restored.
 - If the message “SD card for restoration is required.” appears after the controller replacement, the encryption key should be restored.
2. Turn the main power switch off and on.

NVRAM on the Controller Board

4

1. Make sure that you have the SMC report (factory settings). This report comes with the machine.
2. Output the SMC data (“ALL”) using SP5-990-001. (SP5-990-001)
3. Turn off the main power switch.
4. Insert a blank SD card into slot #2, and then turn on the main switch.
5. Upload the NVRAM data to the blank SD card using SP5-824-001 (NVRAM Data Upload).
6. Turn off the main power switch, and then unplug the AC power cord.
7. Remove the SD card containing the NVRAM data from slot #2.
8. Replace the NVRAM on the controller board with a new one.
9. Plug in the AC power cord, and then turn on the main power switch.

↓ Note

- When you do this, SC995-02 (Defective NVRAM) is displayed. However, DO NOT turn off the main power switch. Continue with this procedure.

10. Re-insert the SD card that you removed in step 5 back into slot #2.
11. Download the old NVRAM data from the SD card onto the new NVRAM using SP5-825-001 (NVRAM Data Download).

↓ Note

- This will take about 2 or 3 minutes.

12. Turn off the main power switch, and then remove the SD card from slot #2.
13. Turn on the main power switch.
14. Output the SMC data (“ALL”) using SP5-990-001, and make sure that it matches the SMC data you printed out in step 2 above (except for the value of the total counter).

↓ Note

- When an old NVRAM is replaced to a service NVRAM, the counters are set as follows:
- Total counter: 1000

- Other counters: 0

★ Important

- Do all of the following if SP5-824-001 (NVRAM Data Upload) and SP5-825-001 (NVRAM Data Download) cannot be performed for some reason.
 1. Manually enter all data on the SMC report (factory settings).
 2. Install the Security function (Data Overwrite Security and HDD Encryption unit) again.

BCU

1. Controller Board (page 134)
2. All the connectors connecting to the BCU to detach the BCU (🔧 ×all, 🛠️ ×4).



m187z4055

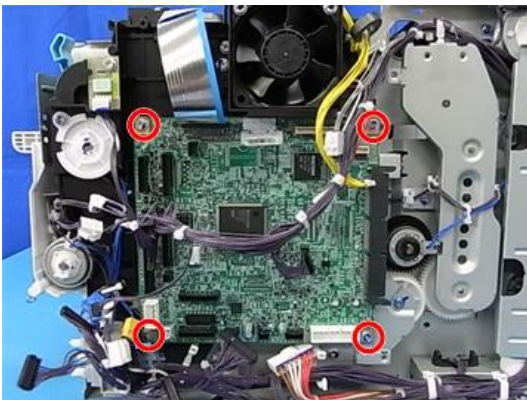

m187z4056

3. Remove the EEPROM [A] from the old board and install it on the new board.

Install so that the indentation [B] on EEPROM is facing the direction of the dent [C] that is printed on the BCU board.

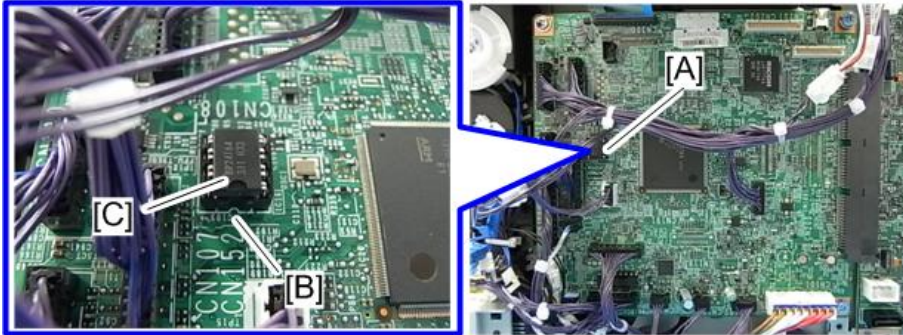

m187z4531

4

4. Install the new BCU in the machine.
5. Turn the main power switch on.
6. Enter the machine's serial number into the BCU (SP5-811-004).

Note

- If the machine's serial number is not entered correctly into the new BCU, SC995-01 (serial number entry error) appears.

7. Turn the main power switch off and on.

Note

- If the serial number is not entered correctly, SC995-01 (serial number entry error) appears.

EEPROM on the BCU

CAUTION

- Keep EEPROM away from any objects that can cause static electricity. Static electricity can damage EEPROM data.
1. Make sure that you have the SMC report (factory settings). This report comes with the machine.
 2. Print out the SMC data (SP5-990-001).
 3. Turn the main power switch off.
 4. Install an SD card into SD card slot 2. Then turn the main power on.
 5. Copy the EEPROM data to an SD card (SP5-824-001) onto the SD card.
 6. Turn off the main power switch. Then unplug the power cord.
 7. Replace the EEPROM on the BCU and reassemble the machine.
 8. Plug in the power cord. Then turn the main power switch on.

When you do this, SC995 will be displayed. However, DO NOT turn off the main power switch. Continue with this procedure.

9. Enter the machine serial number (SP-811-001).

↓ Note

- For information on how to configure SP5-811-001, contact your supervisor or support center.

10. Set the machine state destination (SP-996-001).

↓ Note

- For information on how to configure SP5-996-001, contact your supervisor or support center.

11. Turn the main power switch off and on.

↓ Note

- If the BCU serial number is not entered correctly, SC995-01 (serial number entry error) appears.

12. Execute SP5-825-001 to download the EEPROM data in the SD onto the new EEPROM.

13. Turn off the main power switch.

14. Remove the SD card from SD card slot 2.

15. Turn the main power switch on.

16. In accordance with SMC data, specify the UP and SP mode settings.

Toner End Sensor

1. Left Cover (page 58)

2. Toner End Sensor [A] (⚙️ ×1, 📏 ×1, Tab×1)

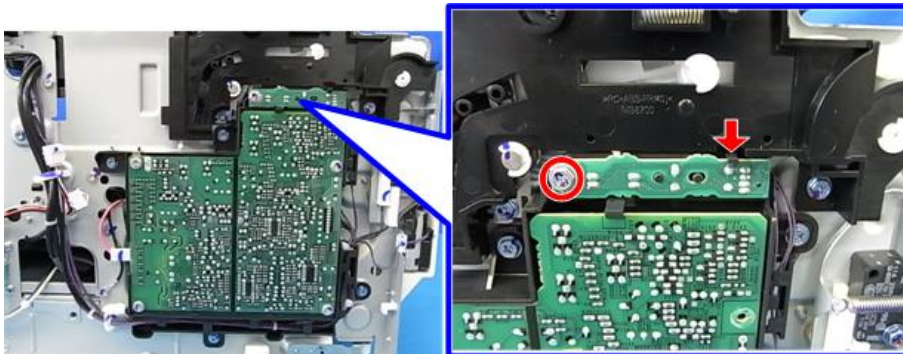

m187z4062

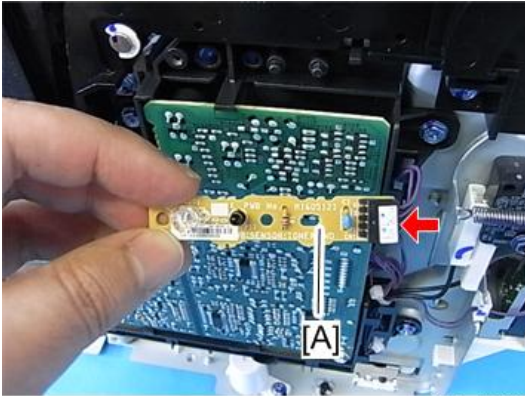

m187z4063

4

HVPS

1. Left Cover (page 58)
2. HVPS [A] (⊙x4, ⊞x2, Tabx1)

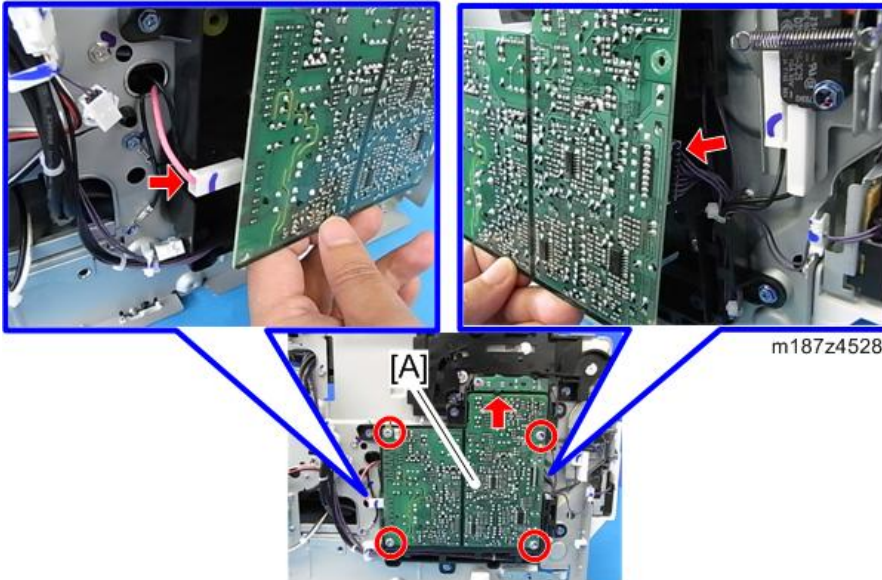

m187z4528

HVPS with Bracket

1. Left Cover (page 58)

2. HVPS [A] and Toner End Sensor [B] with Bracket (🔩×5, 📦×3, 🛠️×1)

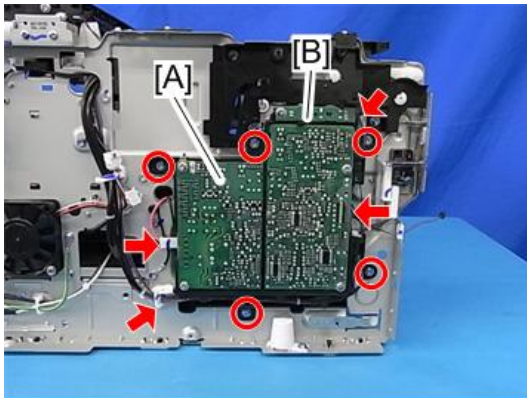

m187z4529

4

PCDU Cooling Fan

1. Right Cover (page 60)
 2. PCDU Cooling Fan [A] (🛠️×2, 🔩×2, 📦×1)

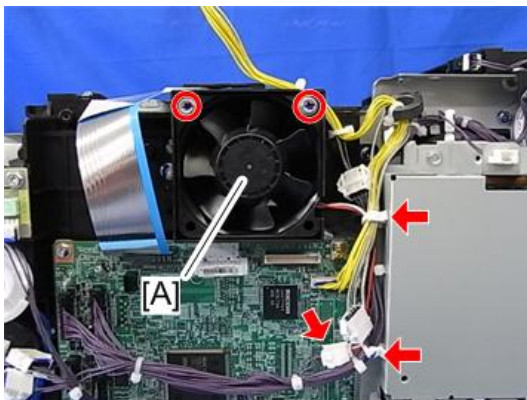

m187z4066

⬇️ Note

- When you reattach the PCDU Cooling Fan, attach it correctly (as shown above, the face of the fan with the sticker is on the outside).

PCDU Cooling Fan with Duct

1. Right Cover (page 60)

2. PCDU Cooling Fan with its duct [A] (🔩×2, 🌀×2 📦×1)

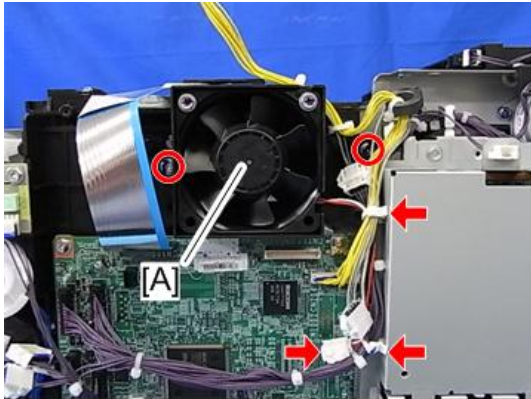

m187z4067

PSU Cooling Fan

1. Left Cover (page 58)
2. PSU Cooling Fan [A] (🔩×1, 🌀×2 📦×1)

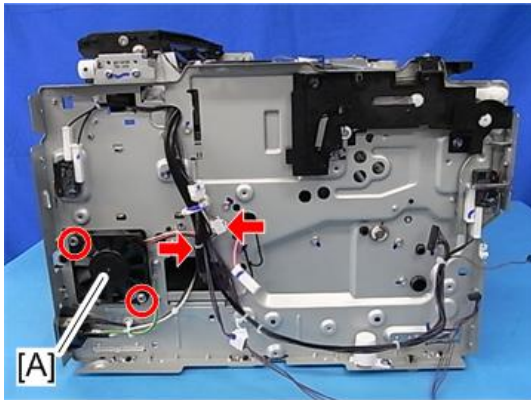

m187z4068

⬇️ Note

- When you reattach the PSU cooling fan, the face of the fan with the sticker must be on the inside.

DC Switch

1. By-pass Feed Unit (page 110)

2. DC Switch [A] with Bracket (Ⓜ × 2)

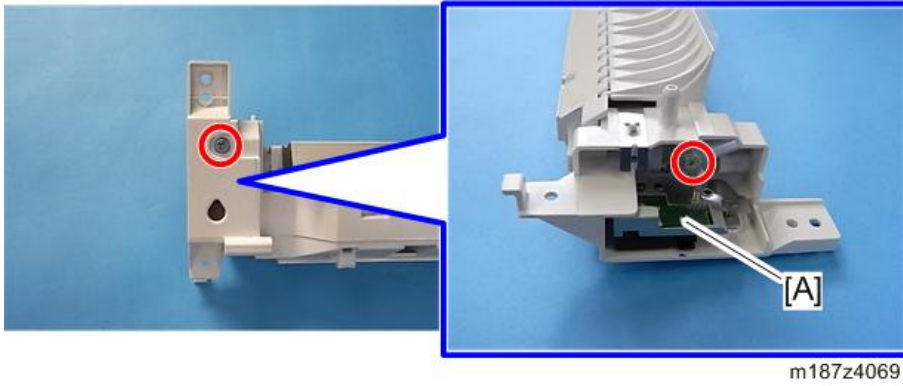

3. Disassemble the DC Switch from the bracket [A] (Ⓜ × 1).

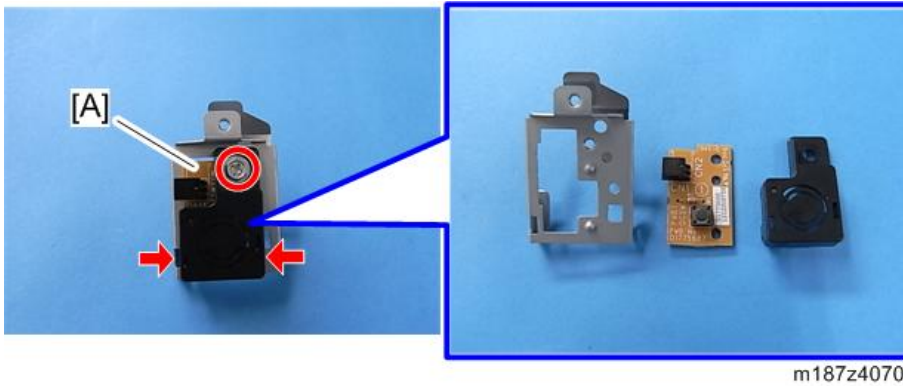



Front Cover Interlock Switch

1. Left Cover (page 58)

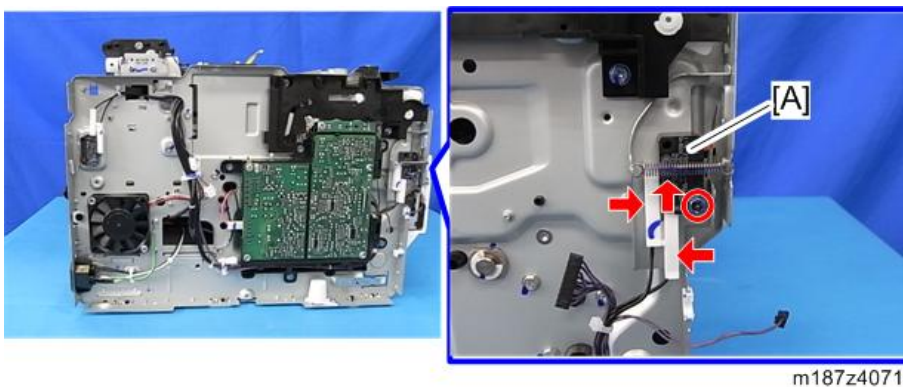
2. Front Cover Interlock Switch [A] (Ⓜ × 1, ⓧ × 2)



Front Cover Interlock Switch with Bracket

1. Left Cover (page 58)
2. Front door interlock switch with its bracket [A] ( ×1,  ×2,  ×1)

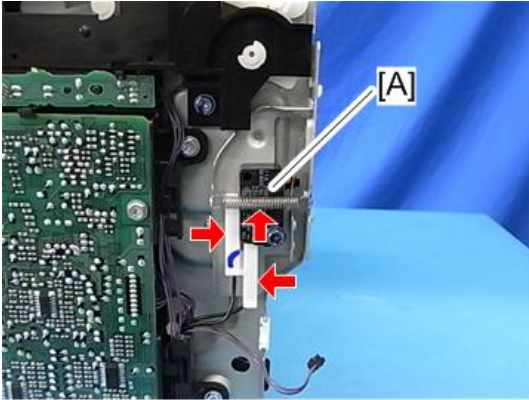

m187z4072

Inside



m187z4073

Rear Cover Interlock Switch

1. Left Cover (page 58)

2. Rear Cover Interlock Switch [A] (🔩×1, 📦×2)



DIMM

1. Memory cover [A]



2. Shield [A] (🔩×1)

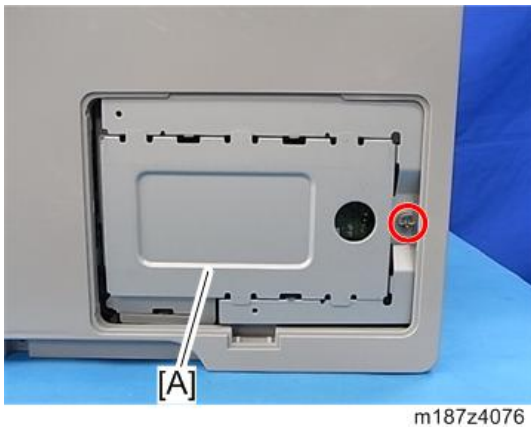

3. DIMM [A] (Release the tab.)

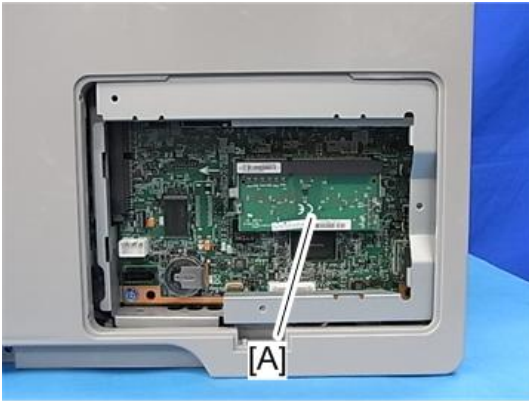

m187z4077

4

↓ Note

- If an optional HDD is installed, remove the HDD first as shown in the following procedure, because it is blocking access to the DIMM:

1. Remove the memory cover [A].

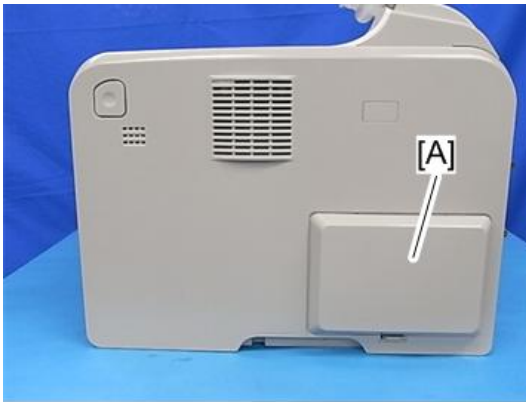

m187z4058

2. Remove the HDD with the bracket [A] (🔩×3, 📦×2).



m187z4059

Temp Humid Sensor

4

1. Right Cover (page 60)
2. Temp Humid Sensor [A] (⊙ ×1, ⊞ ×1).

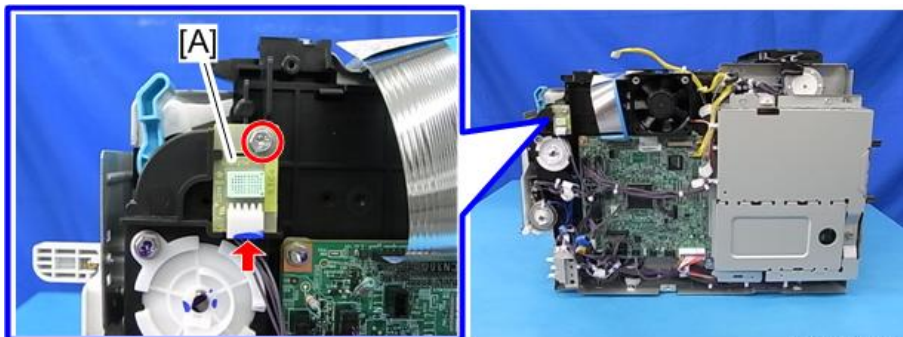

m187z4530

Envelope Lever Detection Switch

1. Fusing unit (page 96)

2. Release two tabs of the Envelope lever detection Switch [A].

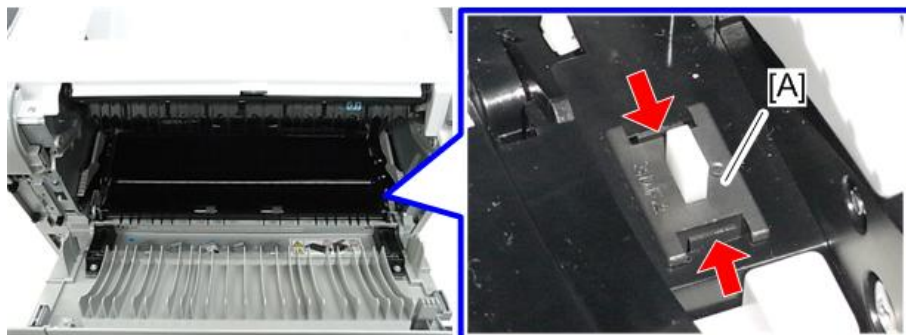

m187z4537

4

3. Envelope lever detection switch [A] (☞ ×1)

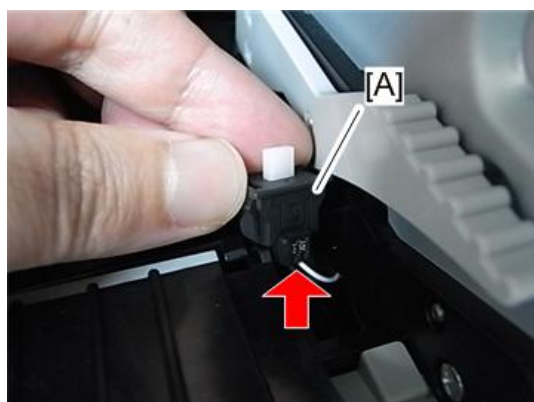

m187z4538

5. System Maintenance

Service Program Mode

CAUTION

- Make sure that the data-in LED is not on before you go into the SP mode. This LED indicates that some data is coming to the machine. When the LED is on, wait for the printer to process the data.
- Do not let the user access the SP mode. Only service representatives are allowed to access the SP mode. The machine quality or its operation is NOT guaranteed if persons other than service representatives access the SP mode.

SP Tables

See "Appendices" for the following information:

- Service SP Tables
- Main SP Tables-1
- Main SP Tables-2
- Main SP Tables-3
- Main SP Tables-5
- Main SP Tables-7
- Main SP Tables-8

5

Enabling and Disabling Service Program Mode

Entering SP Mode

For details, ask your supervisor.

Exiting SP Mode

Select "End" from the service mode main menu, than press the "OK" key.

Note

- To make the settings effective, turn the main power switch off and on after exiting service mode.

Types of SP Modes

Type	Description
Service SP	SP modes related to the controller/printer functions
Engine SP	SP modes related to the engine functions

Select one of the Service Program modes (Service, or Engine) with "**▲/▼**" keys, and then push the "OK" key.



5

Service Mode Lock/Unlock

At locations where the machine contains sensitive data, the customer engineer cannot operate the machine until the Administrator turns the service mode lock off. This function makes sure that work on the machine is always done with the permission of the Administrator.

- 1. If you cannot go into the SP mode, ask the Administrator to log in with the User Tool and then set "Service Mode Lock" to OFF after he or she logs in:**

Menu > Security Options > Service Mode Lock > OFF

- This unlocks the machine and lets you get access to all the SP codes.
- The CE can service the machine and turn the machine off and on. It is not necessary to ask the Administrator to log in again each time the machine is turned on.

- 2. Go into the SP mode and set SP5169 to "1" if you must use the printer bit switches.**

- 3. After machine servicing is completed:**

- Change SP5169 from "1" to "0".
- Turn the machine off and on. Tell the administrator that you have completed servicing the machine.
- The Administrator will then set the "Service Mode Lock" to ON.

Updating the Firmware

Overview

To update the firmware for this machine, you must have the new version of the firmware downloaded onto an SD (Secure Digital) Card. The SD Card is inserted into SD Card Slot 2 (lower) on the left rear side of the controller box.

Type of Firmware

There are several types of firmware as shown below.

Type of firmware	Function	Location of firmware	Message shown
Engine	Printer engine control	BCU Flash ROM	Engine
System	Operating system	Flash ROM on the controller board	System
Lcdc	Panel control	Operation Panel	Lcdc
Bank	Bank control	Bank	Bank
NIB/DESS	Network interface/ Security control	Flash ROM on the controller board	Network Support
Security & Encryption	HDD encryption / Data Overwrite	Flash ROM on the controller board	HDD Format Option
RPCS	Page description Language (RPCS for XPS driver data process)	Flash ROM on the controller board	RPCS
PS3/PDF Adobe	Page description language (PostScript3)	Flash ROM on the controller board	PS/PDF
PCL/ PCLXL	Page description language (PCL)	Flash ROM on the controller board	PCL/PCL XL
MediaPrint: JPEG/ TIFF	MediaPrint control	Flash ROM on the controller board	MediaPrint: JPEG/ TIFF

Type of firmware	Function	Location of firmware	Message shown
Summary Font	Summary fonts	Flash ROM on the controller board	Font
PCL Font	PCL fonts	Flash ROM on the controller board	FONT1
PS Font	PostScript3 fonts	Flash ROM on the controller board	FONT2
Netfile Application	Feature application	Flash ROM on the controller board	NetworkDocBox
Printer Application	Feature application	Flash ROM on the controller board	Printer
WebSys	Web Service application	Flash ROM on the controller board	Web Support
WebDocBox	Document server application	Flash ROM on the controller board	Web Uapl
Java VM	Java VM platform	Java VM card Option	SDK1

Updating Firmware

Before You Begin

An SD card is a precision device. Always observe the following precautions when you handle SD cards:

- Always switch the machine off before you insert an SD card. Never insert the SD card into the slot with the power on.
- Do not remove the SD card from the service slot after the power has been switched on.
- Never switch the machine off while the firmware is downloading from the SD card.
- Keep SD cards in a safe location where they are not exposed to high temperature, high humidity, or exposure to direct sunlight.
- Always handle SD cards with care. Do not bend or scratch them. Do not let the SD card get exposed to shock or vibration.
- Make sure that the write protection of an SD card is unlocked when you download an application to it. If not, downloading fails and a download error (e.g. Error Code 44) occurs during a firmware upgrade.

- Keep the following points in mind when you use the firmware update software:
 - "Upload" means to send data from the machine to the SD card. "Download" means to send data from the SD card to the machine.
 - To select an item on the LCD, touch the appropriate button on the soft touch-screen of the LCD.
 - Disconnect the Ethernet interface cable, IEEE1284 interface cable and remove the Wireless LAN interface board before you start the firmware update procedure. Make sure that the machine is disconnected from the network to prevent a print job for arriving while the firmware update is in progress.

Preparation

- If the SD card is blank, copy the entire "romdata" folder onto the SD card.
- If the card already contains the "romdata" folder, copy the "M187" folder onto the card.
- If the card already contains folders up to "M187", copy the necessary firmware files (e.g. M187xxxx.fwu) into this folder.

Note

- Do not put multiple machine firmware programs on the same SD card. Copy the only model firmware you want.

Updating Procedure

1. Turn the main power switch off.
2. Remove the slot cover [A] (👉 × 1).
3. Insert the SD card into SD Card Slot 2 [B].

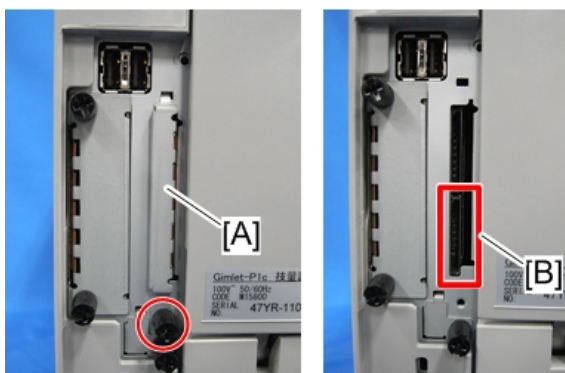

m158m0075

Note

- Make sure the label on the SD card faces the front side of the machine.

- Slowly push the SD card into the slot so it locks in place. You will hear it click. Make sure the SD card locks in place.
- To remove the SD, push it in to unlock the spring lock. Then release it so it pops out of the slot.

4. Disconnect the network cable if the machine is connected to a network.

5. Turn the main power switch on.

After a few seconds, the initial version update screen appears on the LCD in English.

6. On the screen, press the corresponding key (▲, ▼) to select the update file that you want to update.



w_m158m0094

ROM/NEW	What it means
ROM:	Tells you the number of the module and name of the version currently installed.
NEW:	Tells you the number of the module and name version on the SD card.

Note

- You can change the module name screen or module version screen by using ◀, ▶ keys.
- Controller and engine firmware cannot be updated at the same time. It is recommended to update firmware modules one by one.

7. Press the "OK" key after selecting the item that you want to update.

The "UpDate" button appears.

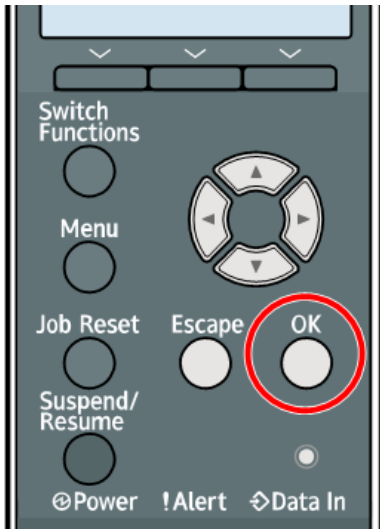

w_m158m0095

8. Press the "UpDate" key to start the update.

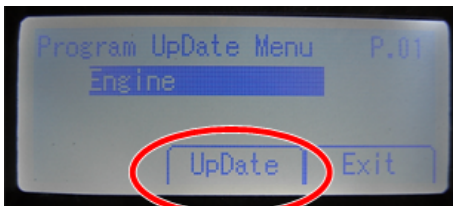

w_m158m0096

Note

- The progress bar appears on the operation panel.

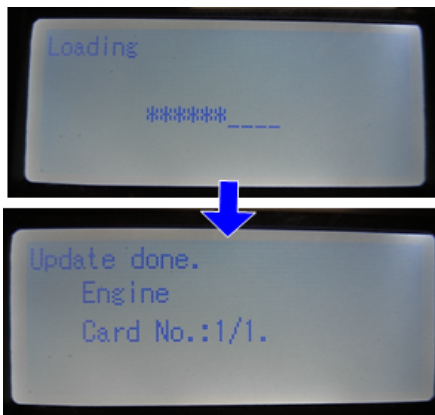

w_m158m0097

9. The "Update Done" message appears after completing the updating.

The message differs depending on the firmware that has been updated.

10. Turn the main power off and on. Then, select the items that you updated, and then push the [Verify] button.

This is to check that the modules were updated correctly. Press in the SD card to release it. Then remove it from the slot.

11. If you see "Verify Error" in the first bar on the screen, then you must do the procedure again for the module shown in the bottom bar.

Note

- The "Verify" procedure is not necessary but it is strongly recommended.

12. After the firmware is correctly updated, turn the main power switch off, and then switch the machine on for normal operation.

Firmware Update Error

5

If firmware update fails, an error code appears.

An error message shows in the first line if an error occurs during the download.

The error code consists of the letter "E" and a number (for example, "E36", "E50"). For details, refer to the Error Message Table. (page 157 in this section)

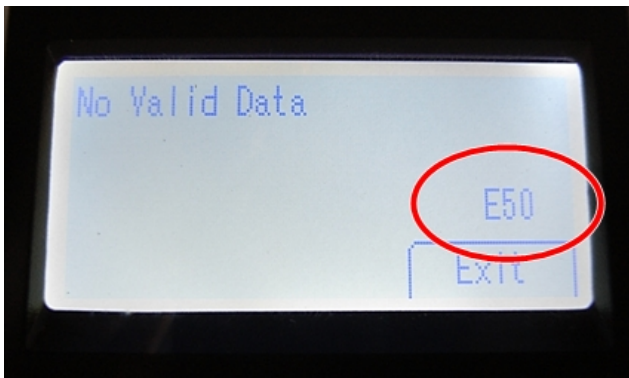

w_m158m2015

Recovery after Power Loss

If the ROM update is interrupted as a result of accidental loss of power while the firmware is updating, then the correct operation of the machine cannot be guaranteed after the machine is switched on again. If the ROM update does not complete successfully for any reason, then in order to ensure the correct operation of the machine, the ROM update error will continue to show until the ROM is updated successfully.

In this case, insert the card again and switch on the machine to continue the firmware download automatically from the card without the menu display.

Handling Firmware Update Errors

Error Message Table

Code	Meaning	Solution
01	The module data does not match.	<ul style="list-style-type: none"> • Cycle the machine off/on. • If the update cannot be made even if you insert the correct SD card, there is a possibility that the SD card is broken. Retry again with a different SD card. • If you cannot resolve the problem with the above steps, replace the controller board.
02	An error occurred while initializing the update program.	<ul style="list-style-type: none"> • Cycle the machine off/on. • If you cannot resolve the problem with the above steps, replace the controller board.
03	The ROM data to be rewritten is missing.	<ul style="list-style-type: none"> • Cycle the machine off/on. • Turn the power off, switch DIPSW-1 on the controller to ON, and then turn the power back on to force the ROM data to be rewritten. • Reset the ROM-DIMM. • If you cannot resolve the problem with the above steps, replace the controller board.
04	Failed to check the GNU ZIP data.	<ul style="list-style-type: none"> • Cycle the machine off/on. • Turn the power off, switch DIPSW-1 on the controller to ON, and then turn the power back on to force the ROM data to be rewritten. • Replace the ROM-DIMM. • If you cannot resolve the problem with the above steps, replace the controller board.
05	A device error occurred while rewriting data.	<ul style="list-style-type: none"> • Cycle the machine off/on. • Turn the power off, switch DIPSW-1 on the controller to ON, and then turn the power back on to force the ROM data to be rewritten. • Reset the ROM-DIMM. • If you cannot resolve the problem with the above steps, replace the controller board.

Code	Meaning	Solution
06	CPU clock error	<ul style="list-style-type: none"> • Turn the power off, switch DIPSW-1 on the controller to ON, and then turn the power back on to force the ROM data to be rewritten. • If you cannot resolve the problem with the above steps, replace the controller board.
10	A startup option error has occurred.	<ul style="list-style-type: none"> • Restore the SD card for installation.
11	An error occurred while waiting to read the installed SD card.	<ul style="list-style-type: none"> • Cycle the machine off/on. • Restore the SD card for installation. • Retry again with a different SD card. • If you cannot resolve the problem with the above steps, replace the controller board.
12	Configuration file error	<ul style="list-style-type: none"> • Cycle the machine off/on. • Restore the SD card for installation. • Retry again with a different SD card.
13	The memory is insufficient to install the data.	<ul style="list-style-type: none"> • Reduce the number of module files to be installed.
14	Failed to execute system call.	<ul style="list-style-type: none"> • Cycle the machine off/on. • Restore the SD card for installation. • Retry again with a different SD card. • If you cannot resolve the problem with the above steps, replace the controller board.
15	Failed to execute self-update.	<ul style="list-style-type: none"> • Cycle the machine off/on. • Restore the SD card for installation. • Retry again with a different SD card. • If you cannot resolve the problem with the above steps, replace the controller board.

Code	Meaning	Solution
19	Schedule data error	<ul style="list-style-type: none"> • Turn the power off, switch DIPSW-1 on the controller to ON, and then turn the power back on to force the ROM data to be rewritten. • If you cannot resolve the problem with the above steps, replace the controller board.
20	Cannot map logical address	<ul style="list-style-type: none"> • Cycle the machine off/on. • If the program starts in the SD card, reinsert the SD card. • If you cannot resolve the problem with the above steps, replace the controller board.
21	Not enough memory for downloading	<ul style="list-style-type: none"> • Cycle the machine off/on. • If you cannot resolve the problem with the above steps, replace the controller board.
22	Cannot decompress compressed data	<ul style="list-style-type: none"> • Cycle the machine off/on. • Replace the SD card that was used to update • If you cannot resolve the problem with the above steps, replace the controller board.
24	SD card access error	<ul style="list-style-type: none"> • Cycle the machine off/on. • Make sure SD card inserted correctly, or use another SD card. • If you cannot resolve the problem with the above steps, replace the controller board.
31	<p>An error to continue downloading has occurred.</p> <p>When using two or more SD cards to download data, the data from the second or later SD card was incompatible.</p>	<ul style="list-style-type: none"> • Install the SD card containing the subsequent program(s), and then turn the power off and then back on to resume downloading. • Retry again with a different SD card. • If the problem persists even if you try to install the subsequent data using another SD card, turn the power off, switch DIPSW-1 on the controller to ON, and then turn the power back on to force the ROM data to be rewritten. • If forcing the data to be rewritten fails, replace the controller board.

Code	Meaning	Solution
32	Different SD card between download interruption and download resumption	<ul style="list-style-type: none"> Setting the SD card was interrupted. Cycle the machine off/on. If the update cannot be made even if you insert the correct SD card, there is a possibility that the SD card is broken. Retry again with a different SD card. If you cannot resolve the problem with the above steps, replace the controller board. If the program is in the SD card, reinsert the SD card. If you updated engine, FCU, or operating unit, replace each board.
33	Incorrect version data in the SD card	<ul style="list-style-type: none"> Acquire correct update data then install again.
34	Module error - Correct module (destination) is not in the SD card.	<ul style="list-style-type: none"> Acquire the correct data (Japan, Overseas, OEM, etc.) then install again.
35	Module error – Module in the SD card is not for this machine	<ul style="list-style-type: none"> Acquire correct update data then install again.
36	Module error – The machine does not have the program that you are trying to download.	<ul style="list-style-type: none"> Install the correct program in advance. Make sure SD card inserted correctly. If the update cannot be made even if you insert the correct SD card, there is a possibility that the SD card is broken. Retry again with a different SD card.
38	Program version is not allowed to update	<ul style="list-style-type: none"> Acquire correct update data then install again.
40	Engine module download failed	<ul style="list-style-type: none"> Cycle the machine off/on. If the download failed again, replace the controller board.
44	Controller module download failed (access error)	<ul style="list-style-type: none"> Cycle the machine off/on. If the program is in the SD card, replace the SD card. If the program is in the controller board, replace the controller board.
49	Firmware update is prohibited	<ul style="list-style-type: none"> Firmware update is disabled in the administrator settings. Retry by changing the settings to allow firmware update.

Code	Meaning	Solution
50	Digital certificate check result of updating data was NG.	<ul style="list-style-type: none">• Acquire correct update data then install again.

Uploading/Downloading NVRAM Data

Uploading Content of NVRAM to an SD Card

Do the following procedure to upload SP code settings from NVRAM to an SD card.

↓ Note

- All data that is stored in NV-RAM of the engine and controller is subject to update.

↓ Note

- This data should always be uploaded to an SD card before the NVRAM is replaced.
- Make sure that the write protection of an SD card is unlocked.

1. Do SP5-990 (SMC Print) before you switch the machine off. You will need a record of the NVRAM settings if the upload fails.
2. Turn the machine main power switch off.
3. Remove the SD slot cover [A] (🔩 x 1).
4. Insert the SD card into SD card slot [B].

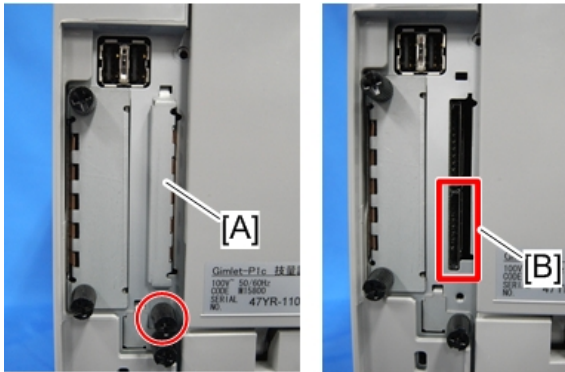

m158m0075

5. Then turn the machine on.
6. Execute SP5-824-001 (NVRAM Data Upload) and then press the “Execute” key.
7. The following files are copied to an NVRAM folder on the SD card when the upload procedure is finished. The file is saved to the following path and filename:
NVRAM\`<serial number>.NV`
Here is an example with Serial Number “K5000017114”:
NVRAM\`K5000017114.NV`
8. In order to prevent an error during the download, be sure to mark the SD card that holds the uploaded data with the number of the machine from which the data was uploaded.

Note

- You can upload NVRAM data from more than one machine to the same SD card.

Downloading an SD Card to NVRAM

Do the following procedure to download SP data from an SD card to the NVRAM in the machine.

Note

- The NVRAM data download may fail if the SD card with the NVRAM data is damaged, or if the connection between the controller and BCU is defective.
- Do the download procedure again if the download fails.
- Do the following procedure if the second attempt fails:
- Enter the NVRAM data manually using the SMC print you created before uploading the NVRAM data.

1. Turn the machine main power switch off.
2. Remove the SD slot cover [A] (🔩 x 1).
3. Insert the SD card with the NVRAM data into SD Card Slot [B].

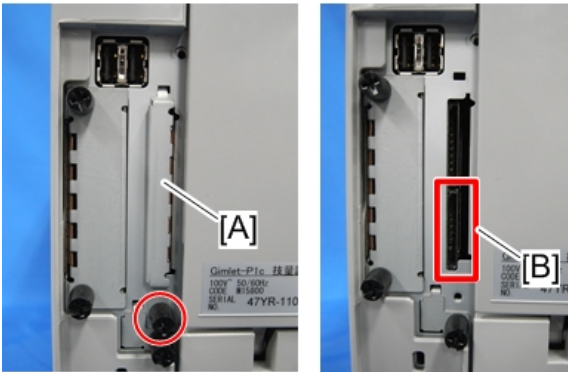

4. Turn the machine main power switch on.
5. Do SP5-825-001 (NVRAM Data Download) and press the “Execute” key.

Note

- The serial number of the file on the SD card must match the serial number of the machine for the NVRAM data to download successfully. The download fails if the serial numbers do not match.

The following data cannot be downloaded to the NVRAM:

- Total Counters
- Charging Counters

Capturing Log to SD card

Overview

★ Important

- This function is not available on machines without a hard disk.

With this feature, you can save debug logs that are stored in the machine (HDD) on an SD card. It allows the Customer Engineer to save and retrieve error information for analysis.

The Capturing Log feature saves debug logs for the following two.

- Controller debug log
- Engine debug log

★ Important

- In older models, a technician enabled the logging tool after a problem occurred. After that, when the problem had been reproduced, the technician was able to retrieve the debug log.
- However, this feature saves the debug logs at the time that problems occur. Then you can copy the logs to an SD card.
- You can retrieve the debug logs using an SD card without a network.
- Analysis of the debug log is effective for problems caused by the software. Analysis of the debug log is not valid for the selection of defective parts or problems caused by hardware.

Types of debug logs that can be saved

Type	Storage Timing	Destination (maximum storage capacity)
Controller debug log (GW debug log)	<ul style="list-style-type: none"> • Saved at all times 	HDD (4 GB) Compressed when written to an SD card from the HDD (from 4 GB to about 300 MB)
Engine debug log	<ul style="list-style-type: none"> • When an engine SC occurs • When paper feeding/output stop by jams • When the machine doors are opened during normal operation 	HDD (Up to 300 times)

Note

- Debug logs are not saved in the following conditions:
 - When there is no optional HDD
 - While erasing all memory
 - While data encryption equipment is installed
 - While changing the firmware configuration
 - Forced power OFF (accidentally disconnecting the outlet)
 - Engine debug log in shutdown
 - When the power supply to the HDD is off because of energy saving (engine OFF mode /STR mode)

Security of the Operation Log

- User ID
- Password
- IP address
- Telephone number
- Encryption key
- Transition to SP mode

Also the following operation logs are not saved.

- Number keys (0 to 9) on the operation panel
- Soft keyboard on the touch panel display
- External keyboard

Retrieving the Debug Logs

★ Important

- Retrieve debug logs to identify the date of occurrence of the problems and to find details of the problems
- e.g.: At around 8:00 am on March 10, an engine stall occurred. The operation panel does not respond. Turn the main power supply off / on.
- You need to retrieve the debug logs dating back three days from the date of the problem.
- Analysis of the debug log is effective for problems caused by the software. Analysis of the debug log is not valid for the selection of defective parts or problems caused by hardware.

Procedure for Retrieving the Debug Log

1. Insert the SD card into the Service Slot 2 (lower) on the back of the machine.
2. Enter SP mode.
3. Set the start date of the log with SP5-857-101 (Start date of debug log output)
e.g.: March 28, 2013: input 20130328 (yyyymmdd)
 - Set the date three days earlier than the occurrence of the problems.
4. Set the end date of the log with SP5-857-102 (End date of debug log output)
e.g.: March 31, 2013: input 20130331 (yyyymmdd)
5. Execute SP5-857-103 (Get a debug log of all) to write the debug log to the SD card.
6. If the transfer is finished successfully, 'completed' is displayed on the panel display.

↓ Note

- The approximate time it takes to transfer the debug log is as follows. Transfer time may be affected by the type or format of the SD card. (It is recommended that you format the SD card using the Panasonic SD Formatter (freeware)).
- Controller debug log (GW debug log): 2 - 20 minutes
- Engine debug log: 2 minutes
- Operation panel debug log: 2 - 20 minutes

7. Make sure that the SD card access LED is off, and then remove the SD card.

↓ Note

- If 'failed' appears on the touch panel display, turn the power off, and then recover from step 1 again.

The debug logs are saved with the following file names.

Controller debug log (GW debug log)	/LogTrace/machine number/watching/ yyyymmdd_hhmmss_unique identification number.gz
Engine debug log	/LogTrace/machine number/engine/yyyymmdd_hhmmss.gz

Address Book Upload/Download

Information List

The following information can be uploaded and downloaded.

Information	
<ul style="list-style-type: none"> • Registration No. • User Code • Group Name • Key Display 	<ul style="list-style-type: none"> • Select Title • Local Authentication • Account ACL

5

Upload (Backup) to SD Card

1. Prepare a formatted SD card.
2. Make sure that the write-protection on the SD card is off.
3. Turn off the main power switch.
4. Remove the SD card slot cover [A] (🔑 x 1), and then install the SD card into the SD card slot 2 [B] (for service use).

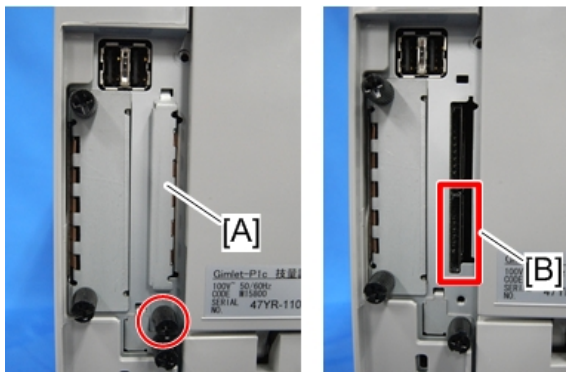

m158m0075

5. Turn on the main power switch.
6. Enter the SP mode, and then execute SP5-846-051 (Backup All Addr Book).
7. Exit from the SP mode, and then turn off the main power switch.
8. Remove the SD card from the SD card slot 2.
9. Install the SD card slot cover.

Note

- If the capacity of SD card is not enough to store the local user information, an error message is displayed.
- Carefully handle the SD card, which contains user information. Do not take it back to your location.

Download (Restore) to Machine

1. Turn off the main power switch.
2. Remove the SD card slot cover [A] (👉 x 1), and then install the SD card, in which the data has been uploaded, into the SD card slot 2 [B].

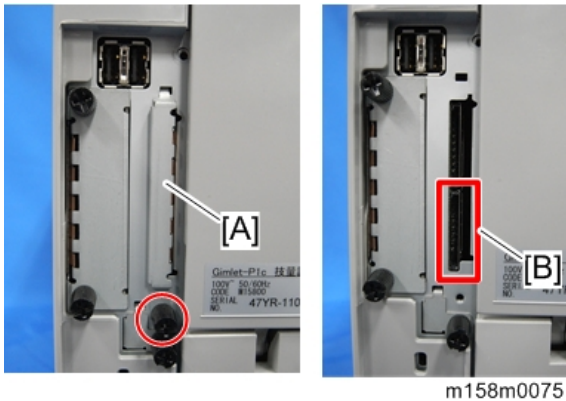

3. Turn on the main power switch.
4. Enter the SP mode, and then execute SP5-846-052 (Restore All Addr Book).
5. Exit from the SP mode, and then turn off the main power switch.
6. Remove the SD card from the SD card slot 2.
7. Install the SD card slot cover.
8. Turn on the main power, and then check that the address book has been restored.

Note

- The counter in the user code information is initialized after uploading.
- The information of an administrator and supervisor cannot be downloaded nor uploaded.
- If there is no data of address book information in the SD card, an error message is displayed.

Erasing the Backup Data

After restoring the data, execute SP5-846-053 (Clear Backup Info) to erase the address book data stored in the SD card.

6. Troubleshooting

Self-Diagnostic Mode

Self-Diagnostic Mode at Power On

As soon as the main machine is powered on, the controller waits for the initial settings of the copy engine to take effect and then starts an independent self-diagnostic test program.

The self-diagnostic test checks the CPU, memory, HDD, and so on. An SC code is displayed if the self-diagnostic program detects any malfunction or abnormal condition. In the case of the error that can start the machine, record it in System Error Log.

Service Call

Summary

Level	Definition	Reset Procedure
A	To prevent damage to the machine, the main machine cannot be operated until the SC has been reset by a service representative (see the note below).	Enter SP mode, go into SP5-810-001, press [Execute], and turn the main power off/on.
B	SCs that disable only the features that use the defective item. Although these SCs are not shown to the user under normal conditions, they are displayed on the operation panel only when the defective feature is selected.	Turn the main power off/on.
C	The SC history is updated. The machine can be operated as usual.	The SC will not be displayed. Only the SC history is updated.
D	Turning the main power off then on resets SCs displayed on the operation panel. These are re-displayed if the error occurs again.	Turn the main power off/on.

When a Level "D" SC code occurs

When a Level D SC occurs, a screen opens on the operation panel to tell the operator:

- An error occurred
- The job in progress will be erased
- The machine will reboot automatically after approximately 30 seconds.

The operator can wait until the machine reboots automatically or touch "Reset" on the screen to reset the machine immediately and go back to the copy screen.

If the operator does not touch "Reset"

The next message tells the operator that the machine will reset automatically and that the previous job was lost and must be started again. After reading the message, the operator touches "Confirm" on the screen. The next screen shows the number and title of the SC code, and stops until the operator turns the machine off and on.

If the operator touches "Reset"

If the operator touches "Reset" to bypass the 30-second interval for the machine to reboot, the machine reboots immediately and the operation panel displays the copy screen.

★ Important

- Do not try to use the operation panel during an automatic reboot. If the Remote Service System is in use, the SC code is sent immediately to the Service Center.

SC100

SC No.	Level	Error Name/Error Condition/Major Cause/Solution
SC195-00	D	Machine serial number error
		Comparison of the product identification code in the machine serial number (11 digits).
		The product identification code in the machine serial number (11 digits) does not match.
		Re-enter the machine serial number.

6

SC200 (LED Optics)

SC No.	Level	Error Name/Error Condition/Major Cause/Solution
SC230-00	D	FGATE ^{*1} : Does not turn ON.
		GPIO ^{*2} has not been asserted, although the specified time (200 ms) elapsed after setting JOB to be started and reaching the FGAT assert time.
		Control Board
		Turn the main power off/on.

(*1)FGATE: Signals used between the controller and the engine in order to send the information about the sub scan length of the page to be printed.

(*2)GPIO: A type of input/output terminal

SC No.	Level	Error Name/Error Condition/Major Cause/Solution
SC231-00	D	FGATE ^{*1} : Does not turn OFF.
		GPIO ^{*2} has not been negated, although the specified time (200 ms) elapsed after detecting GPIO* assert and then reaching the expected FGATE negate time.
		* This is an I/O pin. Such I/O pins can be used for a variety of applications, depending on the setting.
		<ul style="list-style-type: none"> • Turn the main power off/on.

(*1)FGATE: Signals used between the controller and the engine in order to send the information about the sub scan length of the page to be printed.

(*2)GPIO: A type of input/output terminal

SC No.	Level	Error Name/Error Condition/Major Cause/Solution
SC270-00	D	Write ASIC communication error
		<ul style="list-style-type: none"> • When the engine board could not read the Unique ID of the Writing ASIC properly when starting this machine. • When an Error bit occurred in the communication between the engine board and the Writing ASIC.
		The unique ID of the write ASIC was not read normally.
		<ul style="list-style-type: none"> • Turn the main power off/on.

SC No.	Level	Error Name/Error Condition/Major Cause/Solution
SC277-00	D	LEDA communication error
		The head type data was read three times in succession
		<ul style="list-style-type: none"> • Defective LEDA • Defective FFC for LEDA • Defective the engine board (Defective interface b/w Write ASIC - LEDA)
		<ul style="list-style-type: none"> • Turn the main power off/on.

SC No.	Level	Error Name/Error Condition/Major Cause/Solution
SC277-10	D	LEDA communication error: other
		The head type data was read three times in succession
		<ul style="list-style-type: none"> Defective engine board (LEDA Power Error: Broken FU7) Defective harness between PSU – engine board PSU fault (5V Fuse broken) Defective controller (Defective engine interface)
		<ul style="list-style-type: none"> Turn the main power off/on.

SC300 (Image Processing – 1)

SC No.	Level	Error Name/Error Condition/Major Cause/Solution
SC302-00	D	High voltage output error: Charge unit /Development unit
		This SC is issued if the engine board detects a short in the power pack 10 times consecutively.
		Open circuit (+) / Short circuit (-)
		<ul style="list-style-type: none"> Turn the main power off/on. Replace the board. Check the connector connection.

SC332
RTB 17

SC No.	Level	Error Name/Error Condition/Major Cause/Solution
SC332-00	D	Toner supply transfer lock
		This SC is issued if the error that the toner is not supplied is detected n times consecutively (n: SP2-931-005) on the condition that the toner cartridge is not in end
		<ul style="list-style-type: none"> • Overload on the toner transferring part (clogging of toner) • Screw for detecting PCDDU does not turn • Detector element (sensor) defective: light leak • Supplying pick does not engage • Defective Supplying clutch • Defective Drive mechanism of screw for supplying toner cartridge
		<ul style="list-style-type: none"> • Turn the main power off/on.

6

SC No.	Level	Error Name/Error Condition/Major Cause/Solution
SC364-00	D	Toner End Sensor output count error
		When the average value of the toner end sensor output count is 0 n times consecutively (n: SP2-931-003)
		<ul style="list-style-type: none"> • Connector contact failure/disconnected/broken • Detector element (sensor) does not emit light • Detecting surface inside the developing device is stained
		<ul style="list-style-type: none"> • Turn the main power off/on.

SC400 (Image Processing – 2)

SC No.	Level	Error Name/Error Condition/Major Cause/Solution
SC440-00	D	High voltage output error: Transfer unit
		This SC is issued if the engine board detects a short in the power pack 10 times consecutively.
		Open circuit (+) / Short circuit (-)
		<ul style="list-style-type: none"> • Turn the main power off/on. • Replace the board • Check the connector connection.

SC No.	Level	Error Name/Error Condition/Major Cause/Solution
SC460-00	D	High voltage output error: Paper separation
		This SC is issued if the engine board detects a short 10 times consecutively during PWM signal output of the paper separation.
		Short Circuit
		<ul style="list-style-type: none"> • Turn the main power off/on. • Replace the board. • Check the connector connection.

SC No.	Level	Error Name/Error Condition/Major Cause/Solution
SC498-00	C	Temp Humid Sensor error
		<ul style="list-style-type: none"> • Temperature Sensor output error: Out of range between 0.76 V and 2.90 V • Humidity Sensor output error: 2.4 V or more
		<ul style="list-style-type: none"> • Unmounted Sensor (Unset connector or broken wire) • Failed Sensor
		<ul style="list-style-type: none"> • Check that the connector is set. • Replace the Sensor.

SC500 (Paper Feed and Fusing)

SC No.	Level	Error Name/Error Condition/Major Cause/Solution
SC508-00	B	By-pass bottom plate operation error
		The signal from the by-pass bottom plate HP Sensor has not changed (that is, the signal has not changed from ON to OFF or vice versa) for 4 seconds or more after the start of reverse Paper Feed Unit rotation. If the error is detected three times in succession, the appropriate SC number is displayed on the operation panel unit.
		<ul style="list-style-type: none"> • By-pass bottom plate HP sensor connector disconnected or other error • By-pass bottom plate HP sensor feeler stuck or other error
		<ul style="list-style-type: none"> • Check and replace the by-pass bottom plate HP sensor connector connection. • Replace the by-pass bottom plate HP sensor feeler. • Replace the harness. • Replace the engine board.

SC No.	Level	Error Name/Error Condition/Major Cause/Solution
SC520-00	D	Main motor error
		When the main motor is driven, the lock (state of rotation) signal is checked every 100 milliseconds. If the machine detects the lock signal in the High status 20 times in succession, it reports this error.
		<ul style="list-style-type: none"> • The main motor incurs too much load from a defective unit. • The main motor is defective.
		<ul style="list-style-type: none"> • Turn the main power off/on. • Replace the defective unit or the motor.

SC No.	Level	Error Name/Error Condition/Major Cause/Solution
SC525-01	D	Tray 2 paper feed motor error
		When the machine has an optional tray, the lock signal from the paper feed motor in the tray 2 is received.
		<ul style="list-style-type: none"> • Paper feed motor in the tray defective • Connector broken or disconnected • Board failure • Mechanical, excessive load against tray driving
		<ul style="list-style-type: none"> • Replace the paper feed motor of the tray. • Replace the harness. • Replace the board. • Replace the tray
SC525-02	D	Tray 2 paper feed motor error
		When the machine has two optional trays, the lock signal from the paper feed motor in the tray 2 is received.
		<ul style="list-style-type: none"> • Paper feed motor in the tray defective • Connector broken or disconnected • Board failure • Mechanical, excessive load against tray driving
		<ul style="list-style-type: none"> • Replace the paper feed motor of the tray. • Replace the harness. • Replace the board. • Replace the tray.

SC No.	Level	Error Name/Error Condition/Major Cause/Solution
SC525-03	D	Tray 2 paper feed motor error
		When the machine has three optional trays, the lock signal from the paper feed motor in the tray 2 is received.
		<ul style="list-style-type: none"> • Paper feed motor in the tray defective • Connector broken or disconnected • Board failure • Mechanical, excessive load against tray driving
		<ul style="list-style-type: none"> • Replace the paper feed motor of the tray. • Replace the harness. • Replace the board. • Replace the tray.

SC No.	Level	Error Name/Error Condition/Major Cause/Solution
SC526-01	D	Tray 3 paper feed motor error
		When the machine has two optional trays, the lock signal from the paper feed motor in the tray 3 is received.
		<ul style="list-style-type: none"> • Paper feed motor in the tray defective • Connector broken or disconnected • Board failure • Mechanical, excessive load against tray driving
		<ul style="list-style-type: none"> • Replace the paper feed motor of the tray. • Replace the harness. • Replace the board. • Replace the tray.

SC No.	Level	Error Name/Error Condition/Major Cause/Solution
SC526-02	D	Tray 3 paper feed motor error
		When the machine has three optional trays, the lock signal from the paper feed motor in the tray 3 is received.
		<ul style="list-style-type: none"> • Paper feed motor in the tray defective • Connector broken or disconnected • Board failure • Mechanical, excessive load against tray driving
		<ul style="list-style-type: none"> • Replace the paper feed motor of the tray. • Replace the harness. • Replace the board. • Replace the tray.

SC No.	Level	Error Name/Error Condition/Major Cause/Solution
SC527-01	D	Tray 4 paper feed motor error
		When the machine has three optional trays, the lock signal from the paper feed motor in the tray 4 is received.
		<ul style="list-style-type: none"> • Paper feed motor in the tray defective • Connector broken or disconnected • Board failure • Mechanical, excessive load against tray driving
		<ul style="list-style-type: none"> • Replace the main motor of the tray. • Replace the harness. • Replace the board. • Replace the tray.

SC No.	Level	Error Name/Error Condition/Major Cause/Solution
SC531-00	D	PCDU Cooling fan error
		The fan motor lock (rotating state) signal is sampled at 100 ms intervals and the machine fails to receive the lock signal 50 times in succession.
		<ul style="list-style-type: none"> Failed fan motor Disconnected connector
		<ul style="list-style-type: none"> Replace the fan motor. Check the connector. Replace the harness. Replace the engine board.

SC No.	Level	Error Name/Error Condition/Major Cause/Solution
SC532-00	D	PSU Cooling fan error
		The fan motor lock (rotating state) signal is sampled at 100 ms intervals and the machine fails to receive the lock signal 50 times in succession.
		<ul style="list-style-type: none"> Failed fan motor Disconnected connector
		<ul style="list-style-type: none"> Replace the fan motor. Check the connector. Replace the harness. Replace the engine board.

SC No.	Level	Error Name/Error Condition/Major Cause/Solution
SC541-00	A	Broken fusing (Center) thermistor wire
		The condition whereby the temperature is -20°C or less for 5 seconds has been detected 10 times or more.
		<ul style="list-style-type: none"> Broken thermistor wire Bad connector contact
		Clear the SP: fusing SC.

SC No.	Level	Error Name/Error Condition/Major Cause/Solution
SC542-01	A	Fusing lamp (Center) thermistor not reloaded 1
		The heater thermistor has increased by less than 2.0 degrees in 1.5 seconds 5 times in a row.
		<ul style="list-style-type: none"> Deformed or floating thermistor Input voltage out of range
		Clear the SP: fusing SC.

SC No.	Level	Error Name/Error Condition/Major Cause/Solution
SC542-02	A	Fusing lamp (Center) thermistor not reloaded 2
		The heater (Center) thermistor does not reach the reload temperature 50 seconds after the start of motor rotation.
		<ul style="list-style-type: none"> Fusing lamp Disconnected The over temperature prevention mechanism started working
		Clear the SP: fusing SC.

SC No.	Level	Error Name/Error Condition/Major Cause/Solution
SC543-00	A	Fusing (Center) thermopile high-temperature detected (software)
		The temperature is detected to stay at 245°C or higher for one second.
		<ul style="list-style-type: none"> Shorted triac Failed the engine board
		Clear the SP: fusing SC.

SC No.	Level	Error Name/Error Condition/Major Cause/Solution
SC544-00	A	Fusing (Center) thermopile high-temperature detected (hardware)
		The hardware high-temperature error Sensor flag is detected.
		<ul style="list-style-type: none"> • Damaged triac (shorted) • Failed the engine board • Failed fusing thermistor • Abnormal fusing control software behavior
		<ul style="list-style-type: none"> • Clear the SP: fusing SC. • Replace PSU when triac is blown. • Replace engine board and/or fusing thermistor.

SC No.	Level	Error Name/Error Condition/Major Cause/Solution
SC545-00	A	Fusing (Center) heater stay ON
		The thermistor (center) has not detected the target temperature, even after the fusing heater stays ON for more than 30 seconds after reloading.
		<ul style="list-style-type: none"> • Deformed or floating thermistor • Broken fusing lamp wire • The overtemperature prevention mechanism started working.
		Clear the SP: fusing SC.

SC No.	Level	Error Name/Error Condition/Major Cause/Solution
SC547-01	D	Zero-crossing error (adhered relay contact)
		When the fusing relay is in an OFF state, a "zero-crossing interrupt request" occurs in 50 ms.
		Damaged fusing relay (adhered contact) Failed fusing relay driving circuit
		<ul style="list-style-type: none"> • Turn the main power off/on. • Replace the PSU when fusing relay is broken. • Check the connection between PSU – engine board. • Replace the board and/or harness

SC No.	Level	Error Name/Error Condition/Major Cause/Solution
SC547-02	D	Zero-crossing error (bad relay contact)
		If a "zero-crossing interrupt request" does not occur when the fusing relay is in an ON state, an error results.
		<ul style="list-style-type: none"> • Damaged fusing relay (open contact) • Failed fusing relay drive circuit • PSU fuse (24VS) blown
		<ul style="list-style-type: none"> • Turn the main power off/on. • Replace the PSU when fusing relay is broken. • Check the connection between PSU – engine board. • Replace the board and/or harness. • Replace the PSU fuse (24VS) if it is blown

SC No.	Level	Error Name/Error Condition/Major Cause/Solution
SC547-03	D	Zero-crossing error (low frequency error)
		The number of zero-crossing interrupts does not reach a certain value in 500 ms.
		The frequency of the commercial power supply line is unstable.
		<ul style="list-style-type: none"> • Turn the main power off/on. • Check the connection of commercial power supply line • Check the connection between PSU – engine board. • Replace the board and/or harness

SC No.	Level	Error Name/Error Condition/Major Cause/Solution
SC551-00	A	Thermistor broken (Edge)
		While a fusing heater works, temperatures of -20°C or less during a consecutive 9 seconds are detected more than 10 times.
		<ul style="list-style-type: none"> • Thermistor broken • Connector contact failure
		Clear the SP: fusing SC

SC No.	Level	Error Name/Error Condition/Major Cause/Solution
SC553-00	A	Fusing (Edge) thermistor high-temperature detected (software)
		While a fusing heater works, temperatures of 255°C or more are detected during 1 second.
		Resistor failure: Thermistor (Center)
		Clear the SP: fusing SC

SC No.	Level	Error Name/Error Condition/Major Cause/Solution
SC554-00	A	Fusing (Edge) thermistor high-temperature detected (Hardware)
		Temperatures of 257°C or more are detected.
		<ul style="list-style-type: none"> • Damaged triac (shorted) • Failed engine control board • Failed fusing thermopile • Failed fusing thermistor • Abnormal fusing control software behavior • The PWM signal is continuously supplied from the IH inverter (due to a software or temperature Sensor error).
		Clear the SP: fusing SC. Replace PSU when triac is blown. Replace engine board and/or fusing thermistor.

SC No.	Level	Error Name/Error Condition/Major Cause/Solution
SC557-00	C	Zero-crossing frequency exceeded
		The number of zero-crossing interrupts exceeds a certain value in 500 ms.
		The frequency of the commercial power supply line is unstable or noise occurs.
		None

SC No.	Level	Error Name/Error Condition/Major Cause/Solution
SC559-00	A	Fusing jam detected 3 times in succession
		Fusing jam is detected three times in succession.
		Paper is wrapped around the fusing roller.
		Clear the SP: fusing SC.

SC600 (Device Communication)

SC No.	Level	Error Name/Error Condition/Major Cause/Solution
SC636-01	D	IC Card Error (Expanded authentication module error)
		<p>Issued when expanded authentication management is set to "ON" but either of the following occur.</p> <ul style="list-style-type: none"> • There is no expanded authentication module in the machine. • The SD card or the file of the expanded authentication module is broken. • There is no DESS module in the machine.
		<ul style="list-style-type: none"> • There is no DESS module in the machine (models on which the function is optional). • There is no expanded authentication module in the machine. • The SD card or the file of the expanded authentication module is broken.
		<ul style="list-style-type: none"> • Set a working SD card/expanded authentication module file. • Install the DESS module. • In the SSP mode set SP5-401-160 to 0. • In the SSP mode, set SP5-401-161 to 0. • Replace the NVRAM.

SC No.	Level	Error Name/Error Condition/Major Cause/Solution
SC636-02	D	IC Card Error (Version error)
		The version of the expanded authentication module is not correct.
		Incorrect module version
		Install the correct file of the expanded authentication module.

SC No.	Level	Error Name/Error Condition/Major Cause/Solution
SC636-11	D	IC Card Error (OSM user code file error)
		<ul style="list-style-type: none"> The correct "usercode" file could not be found in the root folder of the SD card. The "usercode" file on the SD card could not be read.
		<ul style="list-style-type: none"> The "usercode" file does not exist on the SD card. The "usercode" file on the SD card is an invalid file. Data in the "usercode" file on the SD card is invalid. "usercode" file was not moved when moving the application to another SD card
		Use the user code configuration tool for OSM users (ldissuer.exe) to create the "usercode" and store it in the root folder of the SD card containing the IC card module (eccm.mod).

SC No.	Level	Error Name/Error Condition/Major Cause/Solution
SC637-01	D	Tracking Information Notification Error (Tracking application error)
		Tracking information was lost.
		<ul style="list-style-type: none"> Tracking SDK application error Internal notification error
		Turn the main power off/on.

SC No.	Level	Error Name/Error Condition/Major Cause/Solution
SC637-02	D	Tracking Information Notification Error (Management server error)
		Tracking information was lost.
		Communication with tracking management server failed. <ul style="list-style-type: none"> • Network error • tracking management server error • Tracking SDK application error
		Turn the main power off/on.

SC No.	Level	Error Name/Error Condition/Major Cause/Solution
SC641-01	D	Engine serial communication error (Time-out)
		No response over the specified time. <ul style="list-style-type: none"> • Controller board or software failure • Connection failure may exist between controller board and engine board • Engine board or software failure
		<ul style="list-style-type: none"> • Check the connection between controller board and engine board. • Turn the main power off/on.
SC641-02	D	Engine serial communication error (Retry-Over)
		When commands are sent in the normal mode (ESIF_LECI_NORMAL), communication fails over the upper limit numbers (3 times) of command byte retry.
		<ul style="list-style-type: none"> • Controller board or software failure • Connection failure may exist between controller board and engine board • Engine board or software failure
		<ul style="list-style-type: none"> • Check the connection between controller board and engine board. • Turn the main power off/on.

SC No.	Level	Error Name/Error Condition/Major Cause/Solution
SC641-03	D	Engine serial communication error (Download Error)
		In the download command mode (ESIF_LECI_DLCOM) or download data mode (ESIF_LECI_DLDAT), a communication error is returned from engine.
		<ul style="list-style-type: none"> • Controller board or software failure • Connection failure may exist between controller board and engine board • Engine board or software failure
		<ul style="list-style-type: none"> • Check the connection between controller board and engine board. • Turn the main power off/on.
SC641-04	D	Engine serial communication error (UART Error)
		UART receive errors (Break condition, Framing, Parity or Overrun error) are detected.
		<ul style="list-style-type: none"> • Controller board or software failure • Connection failure may exist between controller board and engine board • Engine board or software failure
		<ul style="list-style-type: none"> • Check the connection between controller board and engine board. • Turn the main power off/on.

SC No.	Level	Error Name/Error Condition/Major Cause/Solution
SC650-01	B	Remote Service Modem Communication Error (Dialup authentication failure)
		<ul style="list-style-type: none"> An error related to communication (dialup connection, modem board etc.) using the RC Gate Type M was detected or an error that prevents RC Gate operation was detected at power on. Displayed only when an error is detected while RC Gate is operating. SC is not issued if an error occurs during RC Gate installation (because it can be referenced using SP).
		Dialup authentication failure
		Check the following SPs. <ul style="list-style-type: none"> SP5-816-156 SP5-816-157

SC No.	Level	Error Name/Error Condition/Major Cause/Solution
SC650-04	B	Remote Service Modem Communication Error (dialup failing because of incorrect modem configuration)
		<ul style="list-style-type: none"> An error related to communication (dialup connection, modem board etc.) using the RC Gate Type M was detected or an error that prevents RC Gate operation was detected at power on. Displayed only when an error is detected while RC Gate is operating. SC is not issued if an error occurs during RC Gate installation (because it can be referenced using SP).
		Dialup failing because of incorrect modem configuration
		Check if the setting of SP5-816-160 is correct. If it is correct, then there is a software bug.

SC No.	Level	Error Name/Error Condition/Major Cause/Solution
SC650-05	B	Remote Service Modem Communication Error (insufficient current or connection fault)
		<ul style="list-style-type: none"> An error related to communication (dialup connection, modem board etc.) using the RC Gate Type M was detected or an error that prevents RC Gate operation was detected at power on. Displayed only when an error is detected while RC Gate is operating. SC is not issued if an error occurs during RC Gate installation (because it can be referenced using SP).
		Insufficient current or connection fault
		The line is not supported and nothing can be done.

SC No.	Level	Error Name/Error Condition/Major Cause/Solution
SC650-13	B	Remote Service Modem Communication Error (RC Gate Type M was installed but modem is not present (detected during operation))
		<ul style="list-style-type: none"> An error related to communication (dialup connection, modem board etc.) using the RC Gate Type M was detected or an error that prevents RC Gate operation was detected at power on. Displayed only when an error is detected while RC Gate is operating. SC is not issued if an error occurs during RC Gate installation (because it can be referenced using SP).
		RC Gate Type M was installed but modem is not present (detected during operation)
		<ul style="list-style-type: none"> If a modem board is not installed, install it. Check again if the modem driver configurations (SP5-816-160, SP5-816-165 to 171 and SP5-816-165 to 171) are correct. If the problem is not solved, replace the modem.

SC No.	Level	Error Name/Error Condition/Major Cause/Solution
SC650-14	B	Remote Service Modem Communication Error (RC Gate Type N was installed but modem is present or wired/wireless LAN is not working correctly)
		<ul style="list-style-type: none"> • An error related to communication (dialup connection, modem board etc.) using the RC Gate was detected or an error that prevents RC Gate operation was detected at power on. • Displayed only when an error is detected while RC Gate is operating. • SC is not issued if an error occurs during RC Gate installation (because it can be referenced using SP).
		RC Gate Type N was installed but modem is present or wired/wireless LAN is not working correctly
		<ul style="list-style-type: none"> • If a modem board is attached, remove it. • Check if wired/wireless LAN works.

SC No.	Level	Error Name/Error Condition/Major Cause/Solution
SC651-01	C	Illegal Remote Service Dial-up (Chat program parameter error)
		An unexpected error occurred when RC Gate Type M dialed up the NRS Center.
		Software bug
		Logging only.

SC No.	Level	Error Name/Error Condition/Major Cause/Solution
SC651-02	C	Illegal Remote Service Dial-up (Chat program execution error)
		An unexpected error occurred when RC Gate dialed up the NRS Center.
		Software bug
		Logging only.

SC No.	Level	Error Name/Error Condition/Major Cause/Solution
SC652-00	D	Remote service ID2 mismatching
		There was an authentication mismatch between ID2 for @Remote, the controller board, and NVRAM.
		<ul style="list-style-type: none"> • Used controller board installed • Used NVRAM installed (such action is not allowed.)
		<ul style="list-style-type: none"> • If this occurs during RC Gate installation: Check the validity of the certificate and the NVRAM, check the machine serial number, write the common certificate, and then begin installation again. • If this occurs after RC Gate installation: Clear the RC Gate install status, check the validity of the certificate and the NVRAM, check the machine serial number, write the common certificate, and then begin installation again.

SC No.	Level	Error Name/Error Condition/Major Cause/Solution
SC653-00	D	Incorrect remote service ID2
		ID2 stored in the NVRAM has either of the following problems. <ul style="list-style-type: none"> • Number of characters is not 17. • Includes a character that cannot be printed. • All spaces • NULL
		Replace the NVRAM.
		Clear the RC Gate install status, write the common certificate, and then begin installation again.

SC No.	Level	Error Name/Error Condition/Major Cause/Solution
SC670-00	D	Engine start up error
		<ul style="list-style-type: none"> • Case 1 <ul style="list-style-type: none"> • /ENGRDY signal was not asserted when the machine was turned on or returned from energy saver mode. • /IPURDY signal was not asserted when the machine was turned on or returned from energy saver mode. • The EC response from the engine was not received within the specified time after turning on the main power. • The PC response from the engine was not received within the specified time after turning on the power. • The SC response from the engine was not received within the specified time after turning on the power (MFP models only). • Writing to Rapi driver failed (the other party not found through PCI). • Case 2 <ul style="list-style-type: none"> • Unexpected down status was detected after /ENGRDY assertion.
		<ul style="list-style-type: none"> • Case 1 <ul style="list-style-type: none"> • Engine board does not start up. • Case 2 <ul style="list-style-type: none"> • Engine board reset unexpectedly.
		<p>Check the connection between the engine board and the controller board.</p> <ul style="list-style-type: none"> • If this problem always occurs, replace the engine board. If the problem persists, consider replacing the controller board or other boards between them. • If this problem occasionally occurs, multiple causes are to be considered, such as the software, engine board, controller board, and PSU.

SC No.	Level	Error Name/Error Condition/Major Cause/Solution
SC674-01	D	Transfer error: M2P
		The video transfer error has occurred on the controller board. If image data transfer to the engine fails for some reason, an SC occurs.
		<ul style="list-style-type: none"> Defective Controller Board/software
		<ul style="list-style-type: none"> Turn the main power off/on.

SC No.	Level	Error Name/Error Condition/Major Cause/Solution
SC674-02	D	Transfer error: PCI
		The video transfer error has occurred on the controller board. A PCI error interrupt is generated by the expanded engine ASIC (SELENE, SELENE2).
		The expanded engine ASIC has failed in its attempt to access another PCI device. The PCI error may occur simultaneously with the M2P error (SC674-01). If this happens, the PCI error takes priority when the SC is displayed.
		<ul style="list-style-type: none"> Defective Controller Board/software
		<ul style="list-style-type: none"> Turn the main power off/on.

SC No.	Level	Error Name/Error Condition/Major Cause/Solution
SC681-**	D	Device ID is not identified (toner cartridge)
		An error is notified during the ID identification after three retries.
		681 - 1 Device ID error (Incorrect ID)
		681 - 6 Channel error
		681 - 11 Device ID error (No ID chip)
		681 - 16 Communication Error
		681 - 21 Communication timeout
		681 - 26 The device has stopped its operation
		681 - 31 The requested buffer is full
681 - 36 EEPROM SRAM OPEN: Verification error		
		<ul style="list-style-type: none"> • Turn the main power off/on. • Replace the toner cartridge (ID chip error)

SC No.	Level	Error Name/Error Condition/Major Cause/Solution
SC682-**	D	Device ID is not identified (PCDU)
		An error is notified during the ID identification after three retries.
		682 - 1 Device ID error (Incorrect ID)
		682 - 6 Channel error
		682 - 11 Device ID error (No ID chip)
		682 - 16 Communication Error
		682 - 21 Communication timeout
		682 - 26 The device has stopped its operation
		682 - 31 The requested buffer is full
682 - 36 EEPROM SRAM OPEN: Verification error		
		<ul style="list-style-type: none"> • Turn the main power off/on. • Replace the PCDU (ID chip error)

SC No.	Level	Error Name/Error Condition/Major Cause/Solution
SC687-00	D	RAPI-PER receipt failure
		Even though 120 seconds have elapsed after RAPI -PES (request for image transfer) is issued, a RAPI-PER receipt is not received from the controller board.
		<ul style="list-style-type: none"> • Defective controller board • Noise
		<ul style="list-style-type: none"> • Turn the main power off/on. • Replace the controller board.

SC No.	Level	Error Name/Error Condition/Major Cause/Solution
SC688-00	D	PRREQ signal not asserted
		The print request signal (PRREQ) signal is not asserted within the prescribed time after paper reaches the registration stand-by position,
		<ul style="list-style-type: none"> • Noise • Engine board error
		<ul style="list-style-type: none"> • Turn the main power off/on. • Replace the engine board.

SC700 (Peripherals)

SC No.	Level	Error Name/Error Condition/Major Cause/Solution
SC790-00	D	Maximum number of banks (paper tray units) exceeded error
		When the main power is turned ON, the machine detects that more than three paper tray units are mounted.
		The number of mounted paper tray units exceeds the specifications.
		Reduce the number of mounted paper tray units according to the specifications.

SC800 (Controller)

SC No.	Level	Error Name/Error Condition/Major Cause/Solution
SC816-00	[0x0000]	Energy save I/O subsystem error
SC816-01	D	Subsystem error
SC816-02	D	Sysarch (LPUX_GET_PORT_INFO) error
SC816-03	D	Transition to STR was denied.
SC816-04	D	Interrupt in kernel communication driver
SC816-05, 06	D	Preparation for transition to STR failed.
SC816-07	D	Sysarch (LPUX_GET_PORT_INFO) error
SC816-08	D	Sysarch (LPUX_ENGINE_TIMERCTRL) error
SC816-09	D	Sysarch (LPUX_RETURN_FACTOR_STR) error
SC816-10	D	Sysarch (LPUX_GET_PORT_INFO) error
SC816-11	D	Sysarch (LPUX_GET_PORT_INFO) error
SC816-12	D	Sysarch (LPUX_GET_PORT_INFO) error
SC816-13	D	open() error
SC816-14	D	Memory address error
SC816-15	D	open() error
SC816-16	D	open() error
SC816-17	D	open() error
SC816-18	D	open() error
SC816-19	D	Double open() error
SC816-20	D	open() error
SC816-22	D	Parameter error
SC816-23	D	read() error
SC816-24	D	read() error

SC No.	Level	Error Name/Error Condition/Major Cause/Solution
SC816-25	D	read() error
SC816-26	D	write() communication retry error
SC816-27	D	write() communication retry error
SC816-28	D	write() communication retry error
SC816-29	D	write() communication retry error
SC816-30	D	write() communication retry error
SC816-35	D	read() error
SC816-36 to94	D	Subsystem error
		<p>Energy save I/O subsystem detected some abnormality.</p> <ul style="list-style-type: none"> • Energy save I/O subsystem defective • Energy save I/O subsystem detected a controller board error (non-response). • Error was detected during preparation for transition to STR. <ul style="list-style-type: none"> • Turn the main power off/on. • Replace the controller board.

SC No.	Level	Error Name/Error Condition/Major Cause/Solution
SC818-00	D	Watchdog timer error
		<ul style="list-style-type: none"> • The system program fell into a bus-hold state or an endless loop of the program interruption occurred, causing other process to stop.
		<ul style="list-style-type: none"> • System program defective • Controller board defective • Optional board defective
		<ul style="list-style-type: none"> • Turn the main power off/on. • Replace the controller board.

SC No.	Level	Error Name/Error Condition/Major Cause/Solution
SC819-00	D	Fatal kernel error [XXXX]: Detailed error code
		Due to a control error, a RAM overflow occurred during system processing. One of the following messages was displayed on the operation panel.
		<ul style="list-style-type: none"> • System program defective • Controller board defective • Optional board defective
		Replace controller firmware
[0x5032]		HAIC-P2 error
		HAIC-P2 decompression error (An error occurred in the ASIC compression/decompression module.)
[0x6261]		HDD defective
		6261 6420 6469 7200 00 → "bad dir"
[0x696e]		gwinit process ending
		x69742064 → "init died"
[0x766d]		VM is full
		0x5f706167 → "vm_pageout: VM is full"
----		Others
		Error in the OS
		Others
		"init died", "vm_pageout: VM is full", "Cache Error"

SC No.	Level	Error Name/Error Condition/Major Cause/Solution
SC820-00	D	Self-diagnostics error: CPU [XXXX]: Detailed error code

SC No.	Level	Error Name/Error Condition/Major Cause/Solution
[0001] to [06FF] [0801] to [4005]		<p>CPU error</p> <p>During the self-diagnosis, the controller CPU detects an error. There are 47 types of error code (0001 to 4005) depending on the cause of the error. The CPU detects an error and displays the specific error code with the program address where the error occurs.</p>
		<ul style="list-style-type: none"> • System firmware problem • Defective controller
		<ol style="list-style-type: none"> 1. Turn the main power off/on. 2. Reinstall the controller system firmware. 3. Replace the controller. <p>When the problem cannot be fixed with the above procedure, the following information displayed on the screen needs to be reported to the technical support center.</p> <ul style="list-style-type: none"> - SC code - Detailed error code - Program address
[0701] to [070A]		<p>CPU/Memory Error</p>
		<ul style="list-style-type: none"> • System firmware problem • Defective RAM-DIMM • Defective controller
		<ul style="list-style-type: none"> • Reinstall the controller system software. • Replace the RAM-DIMM. • Replace the controller board.

SC No.	Level	Error Name/Error Condition/Major Cause/Solution
SC821-00	D	<p>Self-diagnostics error: ASIC</p> <p>[XXXX]: Detailed error code</p>

SC No.	Level	Error Name/Error Condition/Major Cause/Solution
[0B00]		ASIC register check error
		The write-&-verify check has occurred in the ASIC.
		Defective ASIC device
		Replace the controller board.
[0B06]		ASIC detection error
		The I/O ASIC for system control is not detected.
		<ul style="list-style-type: none"> Defective ASIC Defective North Bridge and PCII/F
		Replace the controller board.
[50A2]		Video bridge device (ASIC) register error 1
		The CPU detects the video bridge device, but detects error data from the video bridge device.
		Defective I/F between the video bridge device and controller
		Replace the controller board.

SC No.	Level	Error Name/Error Condition/Major Cause/Solution
SC823-00	B	Self-diagnostics error: NIC [XXXX]: Detailed error code
[6101]		MAC address check sum error
		The result of the MAC address check sum does not match the check sum stored in ROM.
		<ul style="list-style-type: none"> Defective SEEP ROM Defective I2C bus (connection)
		Replace the controller board.

SC No.	Level	Error Name/Error Condition/Major Cause/Solution
[6104]		PHY IC error
		The PHY IC on the controller cannot be correctly recognized.
		<ul style="list-style-type: none"> Defective PHY chip Defective ASIC MII I/F
		Replace the controller board.
[6105]		PHY IC loop-back error
		An error occurred during the loop-back test for the PHY IC on the controller.
		<ul style="list-style-type: none"> PHY chip Defective MAC of ASIC (SIMAC/COMIC/CELLO) Defective I/F with the PHY board Defective solder on the PHY board
		Replace the controller board.

SC No.	Level	Error Name/Error Condition/Major Cause/Solution
SC824-00	D	Self-diagnostics error: NVRAM (resident) [XXXX]: Detailed error code
[1401]		NVRAM verify error
		NVRAM device is missing or NVRAM device is damaged.
		<ul style="list-style-type: none"> The NVRAM device is missing The NVRAM device is damaged NVRAM backup battery exhausted NVRAM socket damaged
		Replace the NVRAM device.

SC No.	Level	Error Name/Error Condition/Major Cause/Solution
SC827-00	D	Self-diagnostic error: Standard SDRAM DIMM [XXXX]: Detailed error code

SC No.	Level	Error Name/Error Condition/Major Cause/Solution
[0201]		Verification error
		Error detected during a write/verify check for the standard RAM (SDRAM DIMM).
		<ul style="list-style-type: none"> Loose connection Defective SDRAM DIMM Defective controller
[0202]		Resident memory error
		The SPD values in all RAM DIMM are incorrect or unreadable.
		<ul style="list-style-type: none"> Defective RAM DIMM Defective SPD ROM on RAM DIMM Defective 12C bus
		Replace the RAM DIMM.

SC No.	Level	Error Name/Error Condition/Major Cause/Solution
SC828-00	D	Self-diagnostic error: ROM [XXXX]: Detailed error code
[0101]		Check sum error 1
		The boot monitor and OS program stored in the ROM DIMM is checked. If the check sum of the program is incorrect, this SC code is displayed.
		Replace the controller board.

SC No.	Level	Error Name/Error Condition/Major Cause/Solution
SC829-00	D	Self-diagnostic error: Optional RAM [XXXX]: Detailed error code

SC No.	Level	Error Name/Error Condition/Major Cause/Solution
[0301] [0401]		Verification error (Optional RAM slot)
		Error detected during a write/verify check for the optional RAM (SDRAM DIMM).
		<ul style="list-style-type: none"> • Loose connection • Defective SDRAM DIMM • Defective controller
		<ul style="list-style-type: none"> • Turn the main power off/on. • Replace the SDRAM DIMM. • Replace the controller.
[0302] [0402]		Memory structure data error (Optional RAM slot)
		The memory structure data error for the optional RAM (SDRAM DIMM) is detected during self-diagnosis.
		<ul style="list-style-type: none"> • Defective RAM DIMM • Defective SPD ROM on RAM DIMM • Defective I2C bus
		Replace the RAM DIMM.

SC No.	Level	Error Name/Error Condition/Major Cause/Solution
SC835-00	B	Self-diagnostic error: Standard SDRAM DIMM [XXXX]: Detailed error code
[1102]		The loopback connector is connected but check results is an error.
		<ul style="list-style-type: none"> • IEEE1284 connector error • Centronic loopback connector is defective
		Replace the controller board.

SC No.	Level	Error Name/Error Condition/Major Cause/Solution
[110C]		The loopback connector is connected but check results is an error.
		<ul style="list-style-type: none"> • ASIC device error • IEEE1284 connector error • Centronic loopback connector is defective
		Replace the controller board.
[1120]		Centronic loopback connector is not connected for detailed self-diagnostic test.
		<ul style="list-style-type: none"> • Centronic loopback connector not connected correctly • Centronic loopback connector is defective • ASIC device is defective
		Replace the controller board.

SC No.	Level	Error Name/Error Condition/Major Cause/Solution
SC838-00	D	Self-diagnostic Error: Clock Generator [XXXX]: Detailed error code
[2701]		A verify error occurred when setting data was read from the clock generator via the I2C bus.
		<ul style="list-style-type: none"> • Defective clock generator • Defective I2C bus • Defective I2C port on the CPU
		Replace the controller board.

SC No.	Level	Error Name/Error Condition/Major Cause/Solution
SC839-00	D	Self-diagnostic Error: Serial Flash [XXXX]: Detailed error code
[9001]		USB NAND Flash ROM cannot be read.
		Defective controller board

SC No.	Level	Error Name/Error Condition/Major Cause/Solution
SC840-00	D	EEPROM access error
		While executing I/O to the EEPROM, an error is detected: <ul style="list-style-type: none"> • When a read error still occurs even after three attempts; • When a write error has occurred.
		EEPROM is defective or has reached its end of life.
		-

SC No.	Level	Error Name/Error Condition/Major Cause/Solution
SC841-00	D	Error in data read from the EEPROM
		When mirrored data read from three different regions in the EEPROM differ each other.
		For some reason, the data stored in a particular region of the EEPROM has been overwritten.
		-

SC No.	Level	Error Name/Error Condition/Major Cause/Solution
SC842-00	C	Verification error in the NAND-Flash update
		When updating the remote ROM and the ROM, SCS encountered an error in writing to the NAND-Flash memory that holds the module data.
		Defective NAND-Flash memory.
		Turn the main power off/on.

SC No.	Level	Error Name/Error Condition/Major Cause/Solution
SC842-01	B	Verification error during NAND-Flash update
		When starting-up the machine or re-starting it from the energy saving, the machine reads the state of the NAND-Flash and detects that there are defective blocks whose amount exceeds the threshold. This means that the life of the NAND-Flash is near-end.
		Near-end Life of NAND-Flash
		Replace the controller board as soon as possible.

SC No.	Level	Error Name/Error Condition/Major Cause/Solution
SC842-02	B	NAND-Flash Block-deletion Excess-error
		When starting-up the machine or re-starting it from the energy saving, the machine reads the state of the NAND-Flash and detects that there are block-deletions whose amount exceeds the threshold. This means that the life of the NAND-Flash is near-end.
		Near-end Life of NAND-Flash
		Replace the controller board as soon as possible.

SC No.	Level	Error Name/Error Condition/Major Cause/Solution
SC853-00	B	Bluetooth device connection error
		When a Bluetooth hardware device (USB type) is connected after startup.
		A Bluetooth hardware device (USB type) has been connected after startup.
		Connect the Bluetooth hardware device (USB type) before turning on the main power.

SC No.	Level	Error Name/Error Condition/Major Cause/Solution
SC854-00	B	Bluetooth device removal error
		When a Bluetooth hardware device (USB type) is removed after startup.
		A Bluetooth hardware device (USB type) has been removed after startup.
		Connect the Bluetooth hardware device (USB type) before turning on the main power.

SC No.	Level	Error Name/Error Condition/Major Cause/Solution
SC855-01	B	Wireless LAN board error (driver attachment failure)
		Wireless LAN board error (wireless LAN card: 802.11 is covered)
		<ul style="list-style-type: none"> Defective wireless LAN board Loose connection
		<ul style="list-style-type: none"> Turn the main power off/on. Replace wireless LAN board

SC No.	Level	Error Name/Error Condition/Major Cause/Solution
SC855-02	B	Wireless LAN board error (driver initialization failure)
		Wireless LAN board error (wireless LAN card: 802.11 is covered)
		<ul style="list-style-type: none"> Defective wireless LAN board Loose connection
		<ul style="list-style-type: none"> Turn the main power off/on. Replace wireless LAN board

SC No.	Level	Error Name/Error Condition/Major Cause/Solution
SC857-00	B	USB driver error
		USB I/F is not available due to USB driver error.
		<ul style="list-style-type: none"> Make sure that the USB is connected correctly. Replace the controller board.

SC No.	Level	Error Name/Error Condition/Major Cause/Solution
SC858-00	A	Data encryption conversion error (Key error)
		A serious error occurred during an attempt to update the encryption key.
		<ul style="list-style-type: none"> • Data in the USB Flash etc. is corrupted. • Communication error because of electromagnetic interference etc. • Controller board is defective
		Replace the controller board.

SC No.	Level	Error Name/Error Condition/Major Cause/Solution
SC858-01	A	Data encryption conversion error (HDD Key Setting Error)
		A serious error occurred during an attempt to update the encryption key.
		<ul style="list-style-type: none"> • Data in the USB Flash etc. is corrupted. • Communication error because of electromagnetic interference etc. • Controller board is defective
		Replace the controller board.

SC No.	Level	Error Name/Error Condition/Major Cause/Solution
SC858-02	A	Data encryption conversion error (NVRAM read/write error)
		A serious error occurred after data conversion during an attempt to update the encryption key.
		NVRAM is defective
		Replace the controller board.

SC No.	Level	Error Name/Error Condition/Major Cause/Solution
SC858-30	A	Data encryption conversion error (NVRAM Before Replace error)
		A serious error occurred after data conversion during an attempt to update the encryption key.
		Software error such as conversion parameters being invalid.
		Replace the controller board.

SC No.	Level	Error Name/Error Condition/Major Cause/Solution
SC858-31	A	Data encryption conversion error (Other Error)
		A serious error occurred after data conversion during an attempt to update the encryption key.
		Controller board is defective.
		Replace the controller board.

SC No.	Level	Error Name/Error Condition/Major Cause/Solution
SC859-01	B	Data encryption conversion HDD conversion error (HDD check error)
		HDD was not converted correctly during an attempt to update the encryption key. Only an error screen is displayed and no SC is issued during conversion. This SC is issued after machine restarts.
		<ul style="list-style-type: none"> • HDD conversion was selected in the Encryption key update function but the machine was turned on with the HDD removed. • Power failure occurred during encryption key update. • HDD was not successfully converted during encryption key update due to HDD errors or cable noises.
		<ul style="list-style-type: none"> • Check HDD connection. • Format the HDD. • If there is a problem with the HDD, it has to be replaced.

SC No.	Level	Error Name/Error Condition/Major Cause/Solution
SC859-02	B	Data encryption conversion HDD conversion error (Power failure during conversion)
		HDD was not converted correctly during an attempt to update the encryption key. Only an error screen is displayed and no SC is issued during conversion. This SC is issued after machine restarts. Details: NVRAM/HDD conversion is incomplete.
		Power failure occurred during encryption key update.
		None
		The display after the restarting instructs the user to format the HDD.

SC No.	Level	Error Name/Error Condition/Major Cause/Solution
SC859-10	B	Data encryption conversion HDD conversion error (Data read/write command error)
		HDD was not converted correctly during an attempt to update the encryption key. Only an error screen is displayed and no SC is issued during conversion. This SC is issued after machine restarts. Details: Abnormal DMAC return value has been received two or more times (DMAC timeout, serial communication error etc.)
		HDD was not successfully converted during encryption key update due to HDD errors or cable noises.
		<ul style="list-style-type: none"> • Check HDD connection. • Format the HDD. • If there is a problem with the HDD, it has to be replaced.

SC No.	Level	Error Name/Error Condition/Major Cause/Solution
SC860-00	B	Hard disk startup error at power-on

SC No.	Level	Error Name/Error Condition/Major Cause/Solution
		<p>A hard disk is connected, but the driver detected the following errors:</p> <p>SS_NOT_READY (-2) The HDD is not ready.</p> <p>SS_BAD_LABEL (-4) Incorrect partition type.</p> <p>SS_READ_ERROR (-5) An error occurred while reading or checking labels.</p> <p>SS_WRITE_ERROR (-6) An error occurred while writing or checking labels.</p> <p>SS_FS_ERROR (-7) Failed to restore filesystem.</p> <p>SS_MOUNT_ERROR (-8) Failed to mount filesystem.</p> <p>SS_COMMAND_ERROR (-9) The driver does not respond to the command.</p> <p>SS_KERNEL_ERROR (-10) Internal kernel error.</p> <p>SS_SIZE_ERROR: (-11) The drive is too small.</p> <p>SS_NO_PARTITION: (-12) The specified partition does not exist.</p> <p>SS_NO_FILE No device file exists.</p> <p>Tried to obtain the information about the status of the hard disk from the driver, but no response has been returned for more than 30 seconds.</p>
		<ul style="list-style-type: none"> • The hard disk has not yet initialized. • Broken label data • Defective hard disk
		Initialize the hard disk from SP mode.

SC No.	Level	Error Name/Error Condition/Major Cause/Solution
SC863-01	D	HDD data read failure
		The data written to the HDD cannot be read normally.
		Bad sectors were generated during operation. (An error occurred in an area that does not belong to a partition, such as the disklabel area.)
		<p>Guide for when to replace the HDD</p> <ol style="list-style-type: none"> 1. When SC863 has occurred ten times or more <ul style="list-style-type: none"> • The interval is short. • Repeatedly occurs in the same situation (At power-on, etc.). • Startup takes a long time when the main power is turned on. 2. It takes a long time after main power on for the operation panel to become ready. <p>HDD access may be consuming time. Normal HDD access time after main power on is about 5 seconds. If the machine is not waiting for the engine to be ready and it still takes 20 to 30 seconds or more, the HDD may be the cause. If there is a problem with the HDD, HDD-related SCs such as SC860 and SC863 will occur frequently. Print the SC log data and check them.</p>

SC No.	Level	Error Name/Error Condition/Major Cause/Solution
SC863-02	D	HDD data read failure
		The data written to the HDD cannot be read normally.
		Bad sectors were generated during operation. (An error occurred in partition "a".)
		<p>Guide for when to replace the HDD</p> <ol style="list-style-type: none"> 1. When SC863 has occurred ten times or more <ul style="list-style-type: none"> • The interval is short. • Repeatedly occurs in the same situation (At power-on, etc.). • Startup takes a long time when the main power is turned on. 2. It takes a long time after main power on for the operation panel to become ready. <p>HDD access may be consuming time. Normal HDD access time after main power on is about 5 seconds. If the machine is not waiting for the engine to be ready and it still takes 20 to 30 seconds or more, the HDD may be the cause. If there is a problem with the HDD, HDD-related SCs such as SC860 and SC863 will occur frequently. Print the SC log data and check them.</p>

SC No.	Level	Error Name/Error Condition/Major Cause/Solution
SC863-03	D	HDD data read failure
		The data written to the HDD cannot be read normally.
		Bad sectors were generated during operation. (An error occurred in partition "b".)
		<p>Guide for when to replace the HDD</p> <ol style="list-style-type: none"> 1. When SC863 has occurred ten times or more <ul style="list-style-type: none"> • The interval is short. • Repeatedly occurs in the same situation (At power-on, etc.). • Startup takes a long time when the main power is turned on. 2. It takes a long time after main power on for the operation panel to become ready. <p>HDD access may be consuming time. Normal HDD access time after main power on is about 5 seconds. If the machine is not waiting for the engine to be ready and it still takes 20 to 30 seconds or more, the HDD may be the cause. If there is a problem with the HDD, HDD-related SCs such as SC860 and SC863 will occur frequently. Print the SC log data and check them.</p>

SC No.	Level	Error Name/Error Condition/Major Cause/Solution
SC863-04	D	HDD data read failure
		The data written to the HDD cannot be read normally.
		Bad sectors were generated during operation. (An error occurred in partition "c".)
		<p>Guide for when to replace the HDD</p> <ol style="list-style-type: none"> 1. When SC863 has occurred ten times or more <ul style="list-style-type: none"> • The interval is short. • Repeatedly occurs in the same situation (At power-on, etc.). • Startup takes a long time when the main power is turned on. 2. It takes a long time after main power on for the operation panel to become ready. <p>HDD access may be consuming time. Normal HDD access time after main power on is about 5 seconds. If the machine is not waiting for the engine to be ready and it still takes 20 to 30 seconds or more, the HDD may be the cause. If there is a problem with the HDD, HDD-related SCs such as SC860 and SC863 will occur frequently. Print the SC log data and check them.</p>

SC No.	Level	Error Name/Error Condition/Major Cause/Solution
SC863-05	D	HDD data read failure
		The data written to the HDD cannot be read normally.
		Bad sectors were generated during operation. (An error occurred in partition "d".)
		<p>Guide for when to replace the HDD</p> <ol style="list-style-type: none"> 1. When SC863 has occurred ten times or more <ul style="list-style-type: none"> • The interval is short. • Repeatedly occurs in the same situation (At power-on, etc.). • Startup takes a long time when the main power is turned on. 2. It takes a long time after main power on for the operation panel to become ready. <p>HDD access may be consuming time. Normal HDD access time after main power on is about 5 seconds. If the machine is not waiting for the engine to be ready and it still takes 20 to 30 seconds or more, the HDD may be the cause. If there is a problem with the HDD, HDD-related SCs such as SC860 and SC863 will occur frequently. Print the SC log data and check them.</p>

SC No.	Level	Error Name/Error Condition/Major Cause/Solution
SC863-06	D	HDD data read failure
		The data written to the HDD cannot be read normally.
		Bad sectors were generated during operation. (An error occurred in partition "e".)
		<p>Guide for when to replace the HDD</p> <ol style="list-style-type: none"> 1. When SC863 has occurred ten times or more <ul style="list-style-type: none"> • The interval is short. • Repeatedly occurs in the same situation (At power-on, etc.). • Startup takes a long time when the main power is turned on. 2. It takes a long time after main power on for the operation panel to become ready. <p>HDD access may be consuming time. Normal HDD access time after main power on is about 5 seconds. If the machine is not waiting for the engine to be ready and it still takes 20 to 30 seconds or more, the HDD may be the cause. If there is a problem with the HDD, HDD-related SCs such as SC860 and SC863 will occur frequently. Print the SC log data and check them.</p>

SC No.	Level	Error Name/Error Condition/Major Cause/Solution
SC863-07	D	HDD data read failure
		The data written to the HDD cannot be read normally.
		Bad sectors were generated during operation. (An error occurred in partition "F".)
		<p>Guide for when to replace the HDD</p> <ol style="list-style-type: none"> 1. When SC863 has occurred ten times or more <ul style="list-style-type: none"> • The interval is short. • Repeatedly occurs in the same situation (At power-on, etc.). • Startup takes a long time when the main power is turned on. 2. It takes a long time after main power on for the operation panel to become ready. <p>HDD access may be consuming time. Normal HDD access time after main power on is about 5 seconds. If the machine is not waiting for the engine to be ready and it still takes 20 to 30 seconds or more, the HDD may be the cause. If there is a problem with the HDD, HDD-related SCs such as SC860 and SC863 will occur frequently. Print the SC log data and check them.</p>

SC No.	Level	Error Name/Error Condition/Major Cause/Solution
SC863-08	D	HDD data read failure
		The data written to the HDD cannot be read normally.
		Bad sectors were generated during operation. (An error occurred in partition "g".)
		<p>Guide for when to replace the HDD</p> <ol style="list-style-type: none"> 1. When SC863 has occurred ten times or more <ul style="list-style-type: none"> • The interval is short. • Repeatedly occurs in the same situation (At power-on, etc.). • Startup takes a long time when the main power is turned on. 2. It takes a long time after main power on for the operation panel to become ready. <p>HDD access may be consuming time. Normal HDD access time after main power on is about 5 seconds. If the machine is not waiting for the engine to be ready and it still takes 20 to 30 seconds or more, the HDD may be the cause. If there is a problem with the HDD, HDD-related SCs such as SC860 and SC863 will occur frequently. Print the SC log data and check them.</p>

SC No.	Level	Error Name/Error Condition/Major Cause/Solution
SC863-09	D	HDD data read failure
		The data written to the HDD cannot be read normally.
		Bad sectors were generated during operation. (An error occurred in partition "h".)
		<p>Guide for when to replace the HDD</p> <ol style="list-style-type: none"> 1. When SC863 has occurred ten times or more <ul style="list-style-type: none"> • The interval is short. • Repeatedly occurs in the same situation (At power-on, etc.). • Startup takes a long time when the main power is turned on. 2. It takes a long time after main power on for the operation panel to become ready. <p>HDD access may be consuming time. Normal HDD access time after main power on is about 5 seconds. If the machine is not waiting for the engine to be ready and it still takes 20 to 30 seconds or more, the HDD may be the cause. If there is a problem with the HDD, HDD-related SCs such as SC860 and SC863 will occur frequently. Print the SC log data and check them.</p>

SC No.	Level	Error Name/Error Condition/Major Cause/Solution
SC863-10	D	HDD data read failure
		The data written to the HDD cannot be read normally.
		Bad sectors were generated during operation. (An error occurred in partition "i".)
		<p>Guide for when to replace the HDD</p> <ol style="list-style-type: none"> 1. When SC863 has occurred ten times or more <ul style="list-style-type: none"> • The interval is short. • Repeatedly occurs in the same situation (At power-on, etc.). • Startup takes a long time when the main power is turned on. 2. It takes a long time after main power on for the operation panel to become ready. <p>HDD access may be consuming time. Normal HDD access time after main power on is about 5 seconds. If the machine is not waiting for the engine to be ready and it still takes 20 to 30 seconds or more, the HDD may be the cause. If there is a problem with the HDD, HDD-related SCs such as SC860 and SC863 will occur frequently. Print the SC log data and check them.</p>

SC No.	Level	Error Name/Error Condition/Major Cause/Solution
SC863-11	D	HDD data read failure
		The data written to the HDD cannot be read normally.
		Bad sectors were generated during operation. (An error occurred in partition "j".)
		<p>Guide for when to replace the HDD</p> <ol style="list-style-type: none"> 1. When SC863 has occurred ten times or more <ul style="list-style-type: none"> • The interval is short. • Repeatedly occurs in the same situation (At power-on, etc.). • Startup takes a long time when the main power is turned on. 2. It takes a long time after main power on for the operation panel to become ready. <p>HDD access may be consuming time. Normal HDD access time after main power on is about 5 seconds. If the machine is not waiting for the engine to be ready and it still takes 20 to 30 seconds or more, the HDD may be the cause. If there is a problem with the HDD, HDD-related SCs such as SC860 and SC863 will occur frequently. Print the SC log data and check them.</p>

SC No.	Level	Error Name/Error Condition/Major Cause/Solution
SC863-12	D	HDD data read failure
		The data written to the HDD cannot be read normally.
		Bad sectors were generated during operation. (An error occurred in partition "k".)
		<p>Guide for when to replace the HDD</p> <ol style="list-style-type: none"> 1. When SC863 has occurred ten times or more <ul style="list-style-type: none"> • The interval is short. • Repeatedly occurs in the same situation (At power-on, etc.). • Startup takes a long time when the main power is turned on. 2. It takes a long time after main power on for the operation panel to become ready. <p>HDD access may be consuming time. Normal HDD access time after main power on is about 5 seconds. If the machine is not waiting for the engine to be ready and it still takes 20 to 30 seconds or more, the HDD may be the cause. If there is a problem with the HDD, HDD-related SCs such as SC860 and SC863 will occur frequently. Print the SC log data and check them.</p>

SC No.	Level	Error Name/Error Condition/Major Cause/Solution
SC863-13	D	HDD data read failure
		The data written to the HDD cannot be read normally.
		Bad sectors were generated during operation. (An error occurred in partition "I".)
		<p>Guide for when to replace the HDD</p> <ol style="list-style-type: none"> 1. When SC863 has occurred ten times or more <ul style="list-style-type: none"> • The interval is short. • Repeatedly occurs in the same situation (At power-on, etc.). • Startup takes a long time when the main power is turned on. 2. It takes a long time after main power on for the operation panel to become ready. <p>HDD access may be consuming time. Normal HDD access time after main power on is about 5 seconds. If the machine is not waiting for the engine to be ready and it still takes 20 to 30 seconds or more, the HDD may be the cause. If there is a problem with the HDD, HDD-related SCs such as SC860 and SC863 will occur frequently. Print the SC log data and check them.</p>

SC No.	Level	Error Name/Error Condition/Major Cause/Solution
SC863-14	D	HDD data read failure
		The data written to the HDD cannot be read normally.
		Bad sectors were generated during operation. (An error occurred in partition "m".)
		<p>Guide for when to replace the HDD</p> <ol style="list-style-type: none"> 1. When SC863 has occurred ten times or more <ul style="list-style-type: none"> • The interval is short. • Repeatedly occurs in the same situation (At power-on, etc.). • Startup takes a long time when the main power is turned on. 2. It takes a long time after main power on for the operation panel to become ready. <p>HDD access may be consuming time. Normal HDD access time after main power on is about 5 seconds. If the machine is not waiting for the engine to be ready and it still takes 20 to 30 seconds or more, the HDD may be the cause. If there is a problem with the HDD, HDD-related SCs such as SC860 and SC863 will occur frequently. Print the SC log data and check them.</p>

SC No.	Level	Error Name/Error Condition/Major Cause/Solution
SC863-15	D	HDD data read failure
		The data written to the HDD cannot be read normally.
		Bad sectors were generated during operation. (An error occurred in partition "n".)
		<p>Guide for when to replace the HDD</p> <ol style="list-style-type: none"> 1. When SC863 has occurred ten times or more <ul style="list-style-type: none"> • The interval is short. • Repeatedly occurs in the same situation (At power-on, etc.). • Startup takes a long time when the main power is turned on. 2. It takes a long time after main power on for the operation panel to become ready. <p>HDD access may be consuming time. Normal HDD access time after main power on is about 5 seconds. If the machine is not waiting for the engine to be ready and it still takes 20 to 30 seconds or more, the HDD may be the cause. If there is a problem with the HDD, HDD-related SCs such as SC860 and SC863 will occur frequently. Print the SC log data and check them.</p>

SC No.	Level	Error Name/Error Condition/Major Cause/Solution
SC863-16	D	HDD data read failure
		The data written to the HDD cannot be read normally.
		Bad sectors were generated during operation. (An error occurred in partition "o".)
		<p>Guide for when to replace the HDD</p> <ol style="list-style-type: none"> 1. When SC863 has occurred ten times or more <ul style="list-style-type: none"> • The interval is short. • Repeatedly occurs in the same situation (At power-on, etc.). • Startup takes a long time when the main power is turned on. 2. It takes a long time after main power on for the operation panel to become ready. <p>HDD access may be consuming time. Normal HDD access time after main power on is about 5 seconds. If the machine is not waiting for the engine to be ready and it still takes 20 to 30 seconds or more, the HDD may be the cause. If there is a problem with the HDD, HDD-related SCs such as SC860 and SC863 will occur frequently. Print the SC log data and check them.</p>

SC No.	Level	Error Name/Error Condition/Major Cause/Solution
SC863-17	D	HDD data read failure
		The data written to the HDD cannot be read normally.
		Bad sectors were generated during operation. (An error occurred in partition "p".)
		<p>Guide for when to replace the HDD</p> <ol style="list-style-type: none"> 1. When SC863 has occurred ten times or more <ul style="list-style-type: none"> • The interval is short. • Repeatedly occurs in the same situation (At power-on, etc.). • Startup takes a long time when the main power is turned on. 2. It takes a long time after main power on for the operation panel to become ready. <p>HDD access may be consuming time. Normal HDD access time after main power on is about 5 seconds. If the machine is not waiting for the engine to be ready and it still takes 20 to 30 seconds or more, the HDD may be the cause. If there is a problem with the HDD, HDD-related SCs such as SC860 and SC863 will occur frequently. Print the SC log data and check them.</p>

SC No.	Level	Error Name/Error Condition/Major Cause/Solution
SC863-18	D	HDD data read failure
		The data written to the HDD cannot be read normally.
		Bad sectors were generated during operation. (An error occurred in partition "q".)
		<p>Guide for when to replace the HDD</p> <ol style="list-style-type: none"> 1. When SC863 has occurred ten times or more <ul style="list-style-type: none"> • The interval is short. • Repeatedly occurs in the same situation (At power-on, etc.). • Startup takes a long time when the main power is turned on. 2. It takes a long time after main power on for the operation panel to become ready. <p>HDD access may be consuming time. Normal HDD access time after main power on is about 5 seconds. If the machine is not waiting for the engine to be ready and it still takes 20 to 30 seconds or more, the HDD may be the cause. If there is a problem with the HDD, HDD-related SCs such as SC860 and SC863 will occur frequently. Print the SC log data and check them.</p>

SC No.	Level	Error Name/Error Condition/Major Cause/Solution
SC863-19	D	HDD data read failure
		The data written to the HDD cannot be read normally.
		Bad sectors were generated during operation. (An error occurred in partition "r".)
		<p>Guide for when to replace the HDD</p> <ol style="list-style-type: none"> 1. When SC863 has occurred ten times or more <ul style="list-style-type: none"> • The interval is short. • Repeatedly occurs in the same situation (At power-on, etc.). • Startup takes a long time when the main power is turned on. 2. It takes a long time after main power on for the operation panel to become ready. <p>HDD access may be consuming time. Normal HDD access time after main power on is about 5 seconds. If the machine is not waiting for the engine to be ready and it still takes 20 to 30 seconds or more, the HDD may be the cause. If there is a problem with the HDD, HDD-related SCs such as SC860 and SC863 will occur frequently. Print the SC log data and check them.</p>

SC No.	Level	Error Name/Error Condition/Major Cause/Solution
SC863-20	D	HDD data read failure
		The data written to the HDD cannot be read normally.
		Bad sectors were generated during operation. (An error occurred in partition "s".)
		<p>Guide for when to replace the HDD</p> <ol style="list-style-type: none"> 1. When SC863 has occurred ten times or more <ul style="list-style-type: none"> • The interval is short. • Repeatedly occurs in the same situation (At power-on, etc.). • Startup takes a long time when the main power is turned on. 2. It takes a long time after main power on for the operation panel to become ready. <p>HDD access may be consuming time. Normal HDD access time after main power on is about 5 seconds. If the machine is not waiting for the engine to be ready and it still takes 20 to 30 seconds or more, the HDD may be the cause. If there is a problem with the HDD, HDD-related SCs such as SC860 and SC863 will occur frequently. Print the SC log data and check them.</p>

SC No.	Level	Error Name/Error Condition/Major Cause/Solution
SC863-21	D	HDD data read failure
		The data written to the HDD cannot be read normally.
		Bad sectors were generated during operation. (An error occurred in partition "r".)
		<p>Guide for when to replace the HDD</p> <ol style="list-style-type: none"> 1. When SC863 has occurred ten times or more <ul style="list-style-type: none"> • The interval is short. • Repeatedly occurs in the same situation (At power-on, etc.). • Startup takes a long time when the main power is turned on. 2. It takes a long time after main power on for the operation panel to become ready. <p>HDD access may be consuming time. Normal HDD access time after main power on is about 5 seconds. If the machine is not waiting for the engine to be ready and it still takes 20 to 30 seconds or more, the HDD may be the cause. If there is a problem with the HDD, HDD-related SCs such as SC860 and SC863 will occur frequently. Print the SC log data and check them.</p>

SC No.	Level	Error Name/Error Condition/Major Cause/Solution
SC863-22	D	HDD data read failure
		The data written to the HDD cannot be read normally.
		Bad sectors were generated during operation. (An error occurred in partition "u".)
		<p>Guide for when to replace the HDD</p> <ol style="list-style-type: none"> 1. When SC863 has occurred ten times or more <ul style="list-style-type: none"> • The interval is short. • Repeatedly occurs in the same situation (At power-on, etc.). • Startup takes a long time when the main power is turned on. 2. It takes a long time after main power on for the operation panel to become ready. <p>HDD access may be consuming time. Normal HDD access time after main power on is about 5 seconds. If the machine is not waiting for the engine to be ready and it still takes 20 to 30 seconds or more, the HDD may be the cause. If there is a problem with the HDD, HDD-related SCs such as SC860 and SC863 will occur frequently. Print the SC log data and check them.</p>

SC No.	Level	Error Name/Error Condition/Major Cause/Solution
SC863-23	D	HDD data read failure
		The data written to the HDD cannot be read normally.
		Bad sectors were generated during operation. (An error occurred in partition "v".)
		<p>Guide for when to replace the HDD</p> <ol style="list-style-type: none"> When SC863 has occurred ten times or more <ul style="list-style-type: none"> The interval is short. Repeatedly occurs in the same situation (At power-on, etc.). Startup takes a long time when the main power is turned on. It takes a long time after main power on for the operation panel to become ready. <p>HDD access may be consuming time. Normal HDD access time after main power on is about 5 seconds. If the machine is not waiting for the engine to be ready and it still takes 20 to 30 seconds or more, the HDD may be the cause. If there is a problem with the HDD, HDD-related SCs such as SC860 and SC863 will occur frequently. Print the SC log data and check them.</p>

SC No.	Level	Error Name/Error Condition/Major Cause/Solution
SC864-00	D	HDD data CRC error
		While reading data from the HDD or storing data in the HDD, data transmission fails.
		Defective HDD
		<ul style="list-style-type: none"> Format the HDD. Replace the HDD.

SC No.	Level	Error Name/Error Condition/Major Cause/Solution
SC864-01	D	HDD data CRC error
		During HDD operation, the HDD returned a CRC error.
		Bad sectors were generated during operation. (An error occurred in an area that does not belong to a partition, such as the disklabel area.)
		<ul style="list-style-type: none"> • Format the HDD. • Replace the HDD.

SC No.	Level	Error Name/Error Condition/Major Cause/Solution
SC864-02	D	HDD data CRC error
		During HDD operation, the HDD returned a CRC error.
		Bad sectors were generated during operation. (An error occurred in partition "a".)
		<ul style="list-style-type: none"> • Format the HDD. • Replace the HDD.

SC No.	Level	Error Name/Error Condition/Major Cause/Solution
SC864-03	D	HDD data CRC error
		During HDD operation, the HDD returned a CRC error.
		Bad sectors were generated during operation. (An error occurred in partition "b".)
		<ul style="list-style-type: none"> • Format the HDD. • Replace the HDD.

SC No.	Level	Error Name/Error Condition/Major Cause/Solution
SC864-04	D	HDD data CRC error
		During HDD operation, the HDD returned a CRC error.
		Bad sectors were generated during operation. (An error occurred in partition "c".)
		<ul style="list-style-type: none"> • Format the HDD. • Replace the HDD.

SC No.	Level	Error Name/Error Condition/Major Cause/Solution
SC864-05	D	HDD data CRC error
		During HDD operation, the HDD returned a CRC error.
		Bad sectors were generated during operation. (An error occurred in partition "d".)
		<ul style="list-style-type: none"> • Format the HDD. • Replace the HDD.

SC No.	Level	Error Name/Error Condition/Major Cause/Solution
SC864-06	D	HDD data CRC error
		During HDD operation, the HDD returned a CRC error.
		Bad sectors were generated during operation. (An error occurred in partition "e".)
		<ul style="list-style-type: none"> • Format the HDD. • Replace the HDD.

SC No.	Level	Error Name/Error Condition/Major Cause/Solution
SC864-07	D	HDD data CRC error
		During HDD operation, the HDD returned a CRC error.
		Bad sectors were generated during operation. (An error occurred in partition "f".)
		<ul style="list-style-type: none"> • Format the HDD. • Replace the HDD.

SC No.	Level	Error Name/Error Condition/Major Cause/Solution
SC864-08	D	HDD data CRC error
		During HDD operation, the HDD returned a CRC error.
		Bad sectors were generated during operation. (An error occurred in partition "g".)
		<ul style="list-style-type: none"> • Format the HDD. • Replace the HDD.

SC No.	Level	Error Name/Error Condition/Major Cause/Solution
SC864-09	D	HDD data CRC error
		During HDD operation, the HDD returned a CRC error.
		Bad sectors were generated during operation. (An error occurred in partition "h".)
		<ul style="list-style-type: none"> • Format the HDD. • Replace the HDD.

SC No.	Level	Error Name/Error Condition/Major Cause/Solution
SC864-10	D	HDD data CRC error
		During HDD operation, the HDD returned a CRC error.
		Bad sectors were generated during operation. (An error occurred in partition "i".)
		<ul style="list-style-type: none"> • Format the HDD. • Replace the HDD.

SC No.	Level	Error Name/Error Condition/Major Cause/Solution
SC864-11	D	HDD data CRC error
		During HDD operation, the HDD returned a CRC error.
		Bad sectors were generated during operation. (An error occurred in partition "j".)
		<ul style="list-style-type: none"> • Format the HDD. • Replace the HDD.

SC No.	Level	Error Name/Error Condition/Major Cause/Solution
SC864-12	D	HDD data CRC error
		During HDD operation, the HDD returned a CRC error.
		Bad sectors were generated during operation. (An error occurred in partition "k".)
		<ul style="list-style-type: none"> • Format the HDD. • Replace the HDD.

SC No.	Level	Error Name/Error Condition/Major Cause/Solution
SC864-13	D	HDD data CRC error
		During HDD operation, the HDD returned a CRC error.
		Bad sectors were generated during operation. (An error occurred in partition "l".)
		<ul style="list-style-type: none"> • Format the HDD. • Replace the HDD.

SC No.	Level	Error Name/Error Condition/Major Cause/Solution
SC864-14	D	HDD data CRC error
		During HDD operation, the HDD returned a CRC error.
		Bad sectors were generated during operation. (An error occurred in partition "m".)
		<ul style="list-style-type: none"> • Format the HDD. • Replace the HDD.

SC No.	Level	Error Name/Error Condition/Major Cause/Solution
SC864-15	D	HDD data CRC error
		During HDD operation, the HDD returned a CRC error.
		Bad sectors were generated during operation. (An error occurred in partition "n".)
		<ul style="list-style-type: none"> • Format the HDD. • Replace the HDD.

SC No.	Level	Error Name/Error Condition/Major Cause/Solution
SC864-16	D	HDD data CRC error
		During HDD operation, the HDD returned a CRC error.
		Bad sectors were generated during operation. (An error occurred in partition "o".)
		<ul style="list-style-type: none"> • Format the HDD. • Replace the HDD.

SC No.	Level	Error Name/Error Condition/Major Cause/Solution
SC864-17	D	HDD data CRC error
		During HDD operation, the HDD returned a CRC error.
		Bad sectors were generated during operation. (An error occurred in partition "p".)
		<ul style="list-style-type: none"> • Format the HDD. • Replace the HDD.

SC No.	Level	Error Name/Error Condition/Major Cause/Solution
SC864-18	D	HDD data CRC error
		During HDD operation, the HDD returned a CRC error.
		Bad sectors were generated during operation. (An error occurred in partition "q".)
		<ul style="list-style-type: none"> • Format the HDD. • Replace the HDD.

SC No.	Level	Error Name/Error Condition/Major Cause/Solution
SC864-19	D	HDD data CRC error
		During HDD operation, the HDD returned a CRC error.
		Bad sectors were generated during operation. (An error occurred in partition "r".)
		<ul style="list-style-type: none"> • Format the HDD. • Replace the HDD.

SC No.	Level	Error Name/Error Condition/Major Cause/Solution
SC864-20	D	HDD data CRC error
		During HDD operation, the HDD returned a CRC error.
		Bad sectors were generated during operation. (An error occurred in partition "s".)
		<ul style="list-style-type: none"> • Format the HDD. • Replace the HDD.

SC No.	Level	Error Name/Error Condition/Major Cause/Solution
SC864-21	D	HDD data CRC error
		During HDD operation, the HDD returned a CRC error.
		Bad sectors were generated during operation. (An error occurred in partition "t".)
		<ul style="list-style-type: none"> • Format the HDD. • Replace the HDD.

SC No.	Level	Error Name/Error Condition/Major Cause/Solution
SC864-22	D	HDD data CRC error
		During HDD operation, the HDD returned a CRC error.
		Bad sectors were generated during operation. (An error occurred in partition "u".)
		<ul style="list-style-type: none"> • Format the HDD. • Replace the HDD.

SC No.	Level	Error Name/Error Condition/Major Cause/Solution
SC864-23	D	HDD data CRC error
		During HDD operation, the HDD returned a CRC error.
		Bad sectors were generated during operation. (An error occurred in partition "v".)
		<ul style="list-style-type: none"> • Format the HDD. • Replace the HDD.

SC No.	Level	Error Name/Error Condition/Major Cause/Solution
SC865-00	D	HDD access error
		During HDD operation, the HDD returned an error.
		The HDD returned an error that does not constitute SC863 (bad sector) or SC864 (CRC error).
		Replace the HDD.

SC No.	Level	Error Name/Error Condition/Major Cause/Solution
SC865-01	D	HDD access error
		During HDD operation, the HDD returned an error.
		The HDD returned an error that does not constitute SC863 (bad sector) or SC864 (CRC error). (An error occurred in an area that does not belong to a partition, such as the disklabel area.)
		Replace the HDD.

SC No.	Level	Error Name/Error Condition/Major Cause/Solution
SC865-02	D	HDD access error
		During HDD operation, the HDD returned an error.
		The HDD returned an error that does not constitute SC863 (bad sector) or SC864 (CRC error). (An error occurred in partition "a".)
		Replace the HDD.

SC No.	Level	Error Name/Error Condition/Major Cause/Solution
SC865-03	D	HDD access error
		During HDD operation, the HDD returned an error.
		The HDD returned an error that does not constitute SC863 (bad sector) or SC864 (CRC error). (An error occurred in partition "b".)
		Replace the HDD.

SC No.	Level	Error Name/Error Condition/Major Cause/Solution
SC865-04	D	HDD access error
		During HDD operation, the HDD returned an error.
		The HDD returned an error that does not constitute SC863 (bad sector) or SC864 (CRC error). (An error occurred in partition "c".)
		Replace the HDD.

SC No.	Level	Error Name/Error Condition/Major Cause/Solution
SC865-05	D	HDD access error
		During HDD operation, the HDD returned an error.
		The HDD returned an error that does not constitute SC863 (bad sector) or SC864 (CRC error). (An error occurred in partition "d".)
		Replace the HDD.

SC No.	Level	Error Name/Error Condition/Major Cause/Solution
SC865-06	D	HDD access error
		During HDD operation, the HDD returned an error.
		The HDD returned an error that does not constitute SC863 (bad sector) or SC864 (CRC error). (An error occurred in partition "e".)
		Replace the HDD.

SC No.	Level	Error Name/Error Condition/Major Cause/Solution
SC865-07	D	HDD access error
		During HDD operation, the HDD returned an error.
		The HDD returned an error that does not constitute SC863 (bad sector) or SC864 (CRC error). (An error occurred in partition "f".)
		Replace the HDD.

SC No.	Level	Error Name/Error Condition/Major Cause/Solution
SC865-08	D	HDD access error
		During HDD operation, the HDD returned an error.
		The HDD returned an error that does not constitute SC863 (bad sector) or SC864 (CRC error). (An error occurred in partition "g".)
		Replace the HDD.

SC No.	Level	Error Name/Error Condition/Major Cause/Solution
SC865-09	D	HDD access error
		During HDD operation, the HDD returned an error.
		The HDD returned an error that does not constitute SC863 (bad sector) or SC864 (CRC error). (An error occurred in partition "h".)
		Replace the HDD.

SC No.	Level	Error Name/Error Condition/Major Cause/Solution
SC865-10	D	HDD access error
		During HDD operation, the HDD returned an error.
		The HDD returned an error that does not constitute SC863 (bad sector) or SC864 (CRC error). (An error occurred in partition "i".)
		Replace the HDD.

SC No.	Level	Error Name/Error Condition/Major Cause/Solution
SC865-11	D	HDD access error
		During HDD operation, the HDD returned an error.
		The HDD returned an error that does not constitute SC863 (bad sector) or SC864 (CRC error). (An error occurred in partition "j".)
		Replace the HDD.

SC No.	Level	Error Name/Error Condition/Major Cause/Solution
SC865-12	D	HDD access error
		During HDD operation, the HDD returned an error.
		The HDD returned an error that does not constitute SC863 (bad sector) or SC864 (CRC error). (An error occurred in partition "k".)
		Replace the HDD.

SC No.	Level	Error Name/Error Condition/Major Cause/Solution
SC865-13	D	HDD access error
		During HDD operation, the HDD returned an error.
		The HDD returned an error that does not constitute SC863 (bad sector) or SC864 (CRC error). (An error occurred in partition "l".)
		Replace the HDD.

SC No.	Level	Error Name/Error Condition/Major Cause/Solution
SC865-14	D	HDD access error
		During HDD operation, the HDD returned an error.
		The HDD returned an error that does not constitute SC863 (bad sector) or SC864 (CRC error). (An error occurred in partition "m".)
		Replace the HDD.

SC No.	Level	Error Name/Error Condition/Major Cause/Solution
SC865-15	D	HDD access error
		During HDD operation, the HDD returned an error.
		The HDD returned an error that does not constitute SC863 (bad sector) or SC864 (CRC error). (An error occurred in partition "n".)
		Replace the HDD.

SC No.	Level	Error Name/Error Condition/Major Cause/Solution
SC865-16	D	HDD access error
		During HDD operation, the HDD returned an error.
		The HDD returned an error that does not constitute SC863 (bad sector) or SC864 (CRC error). (An error occurred in partition "o".)
		Replace the HDD.

SC No.	Level	Error Name/Error Condition/Major Cause/Solution
SC865-17	D	HDD access error
		During HDD operation, the HDD returned an error.
		The HDD returned an error that does not constitute SC863 (bad sector) or SC864 (CRC error). (An error occurred in partition "p".)
		Replace the HDD.

SC No.	Level	Error Name/Error Condition/Major Cause/Solution
SC865-18	D	HDD access error
		During HDD operation, the HDD returned an error.
		The HDD returned an error that does not constitute SC863 (bad sector) or SC864 (CRC error). (An error occurred in partition "q".)
		Replace the HDD.

SC No.	Level	Error Name/Error Condition/Major Cause/Solution
SC865-19	D	HDD access error
		During HDD operation, the HDD returned an error.
		The HDD returned an error that does not constitute SC863 (bad sector) or SC864 (CRC error). (An error occurred in partition "r".)
		Replace the HDD.

SC No.	Level	Error Name/Error Condition/Major Cause/Solution
SC865-20	D	HDD access error
		During HDD operation, the HDD returned an error.
		The HDD returned an error that does not constitute SC863 (bad sector) or SC864 (CRC error). (An error occurred in partition "s".)
		Replace the HDD.

SC No.	Level	Error Name/Error Condition/Major Cause/Solution
SC865-21	D	HDD access error
		During HDD operation, the HDD returned an error.
		The HDD returned an error that does not constitute SC863 (bad sector) or SC864 (CRC error). (An error occurred in partition "t".)
		Replace the HDD.

SC No.	Level	Error Name/Error Condition/Major Cause/Solution
SC865-22	D	HDD access error
		During HDD operation, the HDD returned an error.
		The HDD returned an error that does not constitute SC863 (bad sector) or SC864 (CRC error). (An error occurred in partition "u".)
		Replace the HDD.

SC No.	Level	Error Name/Error Condition/Major Cause/Solution
SC865-23	D	HDD access error
		During HDD operation, the HDD returned an error.
		The HDD returned an error that does not constitute SC863 (bad sector) or SC864 (CRC error). (An error occurred in partition "v".)
		Replace the HDD.

SC No.	Level	Error Name/Error Condition/Major Cause/Solution
SC866-00	B	SD card authentication error
		When a correct license for digital authentication is not found in an SD card application.
		The SD card contains the wrong program data.
		Store the correct program data on the SD card.

SC No.	Level	Error Name/Error Condition/Major Cause/Solution
SC867-00	D	SD card removal detection
		When an application SD card is removed from the slot while the application is being activated.
		An application SD card has been removed from the slot (from the mount point /mnt/sd0).
		Turn the main power off/on.

SC No.	Level	Error Name/Error Condition/Major Cause/Solution
SC867-01	D	SD card removal detection
		When an application SD card is removed from the slot while the application is being activated.
		An application SD card has been removed from the slot (from the mount point /mnt/sd1).
		Turn the main power off/on.

SC No.	Level	Error Name/Error Condition/Major Cause/Solution
SC868-00	D	SD card access error
		The SD controller returned an error during operation. (An error occurred at the mount point of /mnt/sd0)
		<ul style="list-style-type: none"> • SD card is defective • SD controller is defective
		<ul style="list-style-type: none"> • Reformat the SD card (using the "SD Formatter" made by Panasonic).* • Check the SD card insertion status. • Replace the SD card. • Replace the controller board.

* Do not format the SD card supplied with the main machine or sold as an option. You may only format SD cards used for Firmware Update by the Customer Engineer.

SC No.	Level	Error Name/Error Condition/Major Cause/Solution
SC868-01	D	SD card access error
		The SD controller returned an error during operation. (An error occurred at the mount point of /mnt/sd1)
		<ul style="list-style-type: none"> • SD card is defective • SD controller is defective
		SD card used for starting an application <ul style="list-style-type: none"> • Turn the main power off and check the SD card insertion status. <ul style="list-style-type: none"> • If no problem is found, insert the SD card and turn the main power on. • If an error occurs, replace the SD card. • SD card for users <ul style="list-style-type: none"> • In case of a file system error, reformat the SD card (using the "SD Formatter" made by Panasonic).* • In case of a device access error, turn the main power off and check the SD card insertion status. • If no problem is found, insert the SD card and turn the main power on. • If an error occurs, use another SD card. • If the error persists even after replacing the SD card, replace the controller board.

* Do not format the SD card supplied with the main machine or sold as an option. You may only format SD cards used for Firmware Update by the Customer Engineer.

SC No.	Level	Error Name/Error Condition/Major Cause/Solution
SC870-00	B	Address Book data error (Anytime: Address Book Error.)
SC870-01	B	Address Book data error (On startup: Media required for storing the Address Book is missing.)
SC870-02	B	Address Book data error (On startup: encryption is configured but the module required for encryption (DESS) is missing.)
SC870-03	B	Address Book data error (Initialization: Failed to generate a file to store internal Address Book.)

SC No.	Level	Error Name/Error Condition/Major Cause/Solution
SC870-04	B	Address Book data error (Initialization: Failed to generate a file to store delivery sender.)
SC870-05	B	Address Book data error (Initialization: Failed to generate a file to store delivery destination.)
SC870-06	B	Address Book data error (Initialization: Failed to generate a file to store information required for LDAP search.)
SC870-07	B	Address Book data error (Initialization: Failed to initialize entries required for machine operation.)
SC870-08	B	Address Book data error (Machine configuration: HDD is present but the space for storing the Address Book is unusable.)
SC870-09	B	Address Book data error (Machine configuration: Inconsistency in the NVRAM area used for storing settings required for Address Book configuration.)
SC870-10	B	Address Book data error (Machine configuration: Cannot make a directory for storing the Address Book in the SD/USB FlashROM.)
SC870-11	B	Address Book data error (On startup: Inconsistency in Address Book entry number.)
SC870-20	B	Address Book data error (File I/O: Failed to initialize file.)
SC870-21	B	Address Book data error (File I/O: Failed to generate file.)
SC870-22	B	Address Book data error (File I/O: Failed to open file.)
SC870-23	B	Address Book data error (File I/O: Failed to write to file.)
SC870-24	B	Address Book data error (File I/O: Failed to read file.)
SC870-25	B	Address Book data error (File I/O: Failed to check file size.)
SC870-26	B	Address Book data error (File I/O: Failed to delete data.)
SC870-27	B	Address Book data error (File I/O: Failed to add data.)
SC870-30	B	Address Book data error (Search: Failed to obtain data from cache when searching in the machine Address Book. delivery destination/sender.)
SC870-31	B	Address Book data error (Search: Failed to obtain data from cache during LDAP search.)

SC No.	Level	Error Name/Error Condition/Major Cause/Solution
SC870-41	B	Address Book data error (Cache: failed to obtain data from cache.)
SC870-50	B	Address Book data error (On startup: Detected abnormality of the Address Book encryption status.)
SC870-51	B	Address Book data error (Encryption settings: Failed to create directory required for conversion between plaintext and encrypted text.)
SC870-52	B	Address Book data error (Encryption settings: Failed to convert from plaintext to encrypted text.)
SC870-53	B	Address Book data error (Encryption settings: Failed to convert from encrypted text to plaintext.)
SC870-54	B	Address Book data error (Encryption settings: Detected data inconsistency when reading the encrypted Address Book.)
SC870-55	B	Address Book data error (Encryption settings: Failed to delete file when changing encryption setting.)
SC870-56	B	Address Book data error (Encryption settings: Failed to erase the file that records the encryption key during an attempt to change the encryption setting.)
SC870-57	B	Address Book data error (Encryption settings: Failed to move a file during an attempt to change the encryption setting.)
SC870-58	B	Address Book data error (Encryption settings: Failed to delete a directory during an attempt to change the encryption setting.)
SC870-59	B	Address Book data error (Encryption settings: Detected a resource shortage during an attempt to change the encryption setting.)
SC870-60	B	Address Book data error (Unable to obtain the on/off setting for administrator authentication (06A and later).)

SC No.	Level	Error Name/Error Condition/Major Cause/Solution
		When an error related to the Address Book is detected during startup or operation.
		<ul style="list-style-type: none"> • Software bug • Inconsistency of Address Book source location (machine/delivery server/LDAP server) • Inconsistency of Address Book encryption setting or encryption key (NVRAM or HDD was replaced individually without formatting the Address Book) • Address Book storage device (SD/HDD) was temporarily removed or hardware configuration does not match the application configuration. • Address Book data corruption was detected.
		<ul style="list-style-type: none"> • Check the HDD connection. • Initialize all UCS settings and address/authentication information (SP5-846-046). • Initialize the Address Book partition (SP5-832-006).

SC No.	Level	Error Name/Error Condition/Major Cause/Solution
		HDD mail received data error
		An error is detected in the HDD at machine power-on.
		<ul style="list-style-type: none"> • Defective HDD • Power failure while accessing the HDD
SC872-00	B	<ul style="list-style-type: none"> • Use SP5-832-007 to initialize the HDD (HDD-related: Format: Mail received data). • Replace the HDD.

SC No.	Level	Error Name/Error Condition/Major Cause/Solution
SC873-00	B	HDD mail transfer error
		An error is detected in the HDD at machine power-on.
		<ul style="list-style-type: none"> Defective HDD Power failure while accessing the HDD
		<ul style="list-style-type: none"> Use SP5-832-008 to initialize the HDD (HDD-related: Format: Mail transfer data). Replace the HDD.

SC No.	Level	Error Name/Error Condition/Major Cause/Solution
SC874-05	D	Delete All Error (Delete data area): Read Error
SC874-06	D	Delete All Error (Delete data area): Write Error
SC874-09	D	Delete All Error (Delete data area): Drive No Response
SC874-10	D	Delete All Error (Delete data area): Kernel Error
SC874-12	D	Delete All Error (Delete data area): No Specific Partition
SC874-13	D	Delete All Error (Delete data area): No Device File
SC874-14	D	Delete All Error (Delete data area): Incorrect Boot Option
SC874-15	D	Delete All Error (Delete data area): No Specific Sector
SC874-16	D	Delete All Error (Delete data area): hdderase Execution Error
SC874-41	D	Delete All Error (Delete data area): Other Fatal Error
SC874-42	D	Delete All Error (Delete data area): Abort
SC874-61 to -65	D	Delete All Error (Delete data area): Incorrect Return Value: Libraly
SC874-66	D	Delete All Error (Delete data area): Not Available
SC874-67	D	Delete All Error (Delete data area): Delete Not End
SC874-68	D	Delete All Error (Delete data area): HDD Format Failure (Normal)
SC874-69	D	Delete All Error (Delete data area): HDD Format Failure (Error)

SC No.	Level	Error Name/Error Condition/Major Cause/Solution
SC874-70	D	Delete All Error (Delete data area): Incorrect Return Value: Libraly
SC874-99	D	Delete All Error (Delete data area): Other Error
		<p>An error regarding data erase is detected.</p> <ul style="list-style-type: none"> • Error detected in HDD data delete program • Error detected in NVRAM data delete program • The "Delete All" option was not set <ul style="list-style-type: none"> • Turn the main power off and back on, and then execute "Erase All Memory" under UP mode again. (However, if there is a defective sector or other problem with the hard disk, the error will persist even after trying the above.) • "If the "Delete All" option is not installed when this error occurs, install the option.

SC No.	Level	Error Name/Error Condition/Major Cause/Solution
SC875-**	D	Delete All error (HDD)
		An error is detected before executing HDD Erase.
		<p>875-01</p> <ul style="list-style-type: none"> • Error occurred at "hddchack -l". <p>875-02</p> <ul style="list-style-type: none"> • Data erase failed.
		Turn the main power off/on.

SC No.	Level	Error Name/Error Condition/Major Cause/Solution
SC876-01	D	Log Data Error 1
		An error was detected in the acquisition or configuration of the log data at power on or during machine operation.
		Damaged log data file
		Initialize the HDD (SP5-832-004).

SC No.	Level	Error Name/Error Condition/Major Cause/Solution
SC876-02	D	Log Data Error 2
		An error was detected in the acquisition or configuration of the log data at power on or during machine operation.
		Log encryption is enabled but encryption module is not installed.
		<ul style="list-style-type: none"> • Replace or set again the encryption module. • Disable the log encryption setting.

SC No.	Level	Error Name/Error Condition/Major Cause/Solution
SC876-03	D	Log Data Error 3
		An error was detected in the acquisition or configuration of the log data at power on or during machine operation.
		Inconsistency of encryption key between NVRAM and HDD.
		<ul style="list-style-type: none"> • Disable the log encryption setting. • Initialize LCS memory (SP5-801-019). • Initialize the HDD (SP5-832-004).

SC No.	Level	Error Name/Error Condition/Major Cause/Solution
SC876-04	D	Log Data Error 4
		An error was detected in the acquisition or configuration of the log data at power on or during machine operation.
		<ul style="list-style-type: none"> • Log encryption key is disabled but the log data file is encrypted. (NVRAM data corruption) • Log encryption key is enabled but the log data file is not encrypted. (NVRAM data corruption)
		<ul style="list-style-type: none"> • Initialize the HDD (SP5-832-004).

SC No.	Level	Error Name/Error Condition/Major Cause/Solution
SC876-05	D	Log Data Error 5
		An error was detected in the acquisition or configuration of the log data at power on or during machine operation.
		<ul style="list-style-type: none"> • Only the NVRAM has been replaced with one previously used in another machine. • Only the HDD has been replaced with one previously used in another machine.
		<ul style="list-style-type: none"> • Attach the original NVRAM. • Attach the original HDD. • With the configuration that caused the SC, initialize the HDD (SP5-832-004).

SC No.	Level	Error Name/Error Condition/Major Cause/Solution
SC876-99	D	Log Data Error 99
		An error was detected in the acquisition or configuration of the log data at power on or during machine operation.
		Other causes
		-

SC No.	Level	Error Name/Error Condition/Major Cause/Solution
SC877-00	B	Data Overwrite Security card error
		The "Auto Erase Memory" function of the Data Overwrite Security is enabled but it cannot be executed.
		<ul style="list-style-type: none"> • Data Overwrite Security option SD card is broken. • Data Overwrite Security option SD card has been removed.
		<ul style="list-style-type: none"> • If the SD card is broken, prepare a new Data Overwrite Security option SD card and replace the NVRAM. • If the SD card has been removed, turn the main power off and reinstall a working Data Overwrite Security option SD card.

SC No.	Level	Error Name/Error Condition/Major Cause/Solution
SC878-00	D	TPM electronic authentication error
		The machine failed TPM electronic authentication. System hash registered in the TPM did not match the data on the USB flash.
		<ul style="list-style-type: none"> System module was updated in an unauthorized manner. USB flash is not working correctly.
		Replace the controller board.

SC No.	Level	Error Name/Error Condition/Major Cause/Solution
SC878-01	D	USB Flash error
		USB Flash file system error
		USB Flash file system has been destroyed.
		Replace the controller board.

SC No.	Level	Error Name/Error Condition/Major Cause/Solution
SC878-02	D	TPM error
		An error occurred in the TPM or TPM driver.
		TPM is defective
		Replace the controller board.

SC No.	Level	Error Name/Error Condition/Major Cause/Solution
SC878-03	D	TCSD error
		An error occurred in TPM software stack.
		<ul style="list-style-type: none"> Unable to start TPM Necessary files missing from the TPM.
		Replace the controller board.

SC No.	Level	Error Name/Error Condition/Major Cause/Solution
SC881-01	D	Management area error
		Defective software has been detected.
		Abnormal accumulation of authentication information in the software
		Turn the main power off/on.

SC No.	Level	Error Name/Error Condition/Major Cause/Solution
SC899-00	D	Software performance error (signal reception end)
		-
		Occurs when an internal program behaves abnormally.
		In case of a hardware defect <ul style="list-style-type: none"> • Replace the hardware. In case of a software error <ul style="list-style-type: none"> • Turn the main power off/on. • Try updating the firmware.

SC900 (Others)

SC No.	Level	Error Name/Error Condition/Major Cause/Solution
SC900-00	D	Electronic counter error
		The value provided by the electronic total counter is outside the normal range.
		<ul style="list-style-type: none"> • Unexpected NVRAM installed • Defective NVRAM • NVRAM data corruption • Data is stored in an unexpected area due to external causes. • The count requests made by SRM upon receiving the PRT have not yet been processed.
		Install an NVRAM device designed specifically for the model.

SC No.	Level	Error Name/Error Condition/Major Cause/Solution
SC920-00	B	Printer application error (No response when PM started)
SC920-01	B	Printer application error (Time-out during PM)
SC920-02	B	Printer application error (Work memory acquisition failed)
SC920-03	B	Printer application error (Filter process start up error)
SC920-04	B	Printer application error (The filter process was aborted)
		A serious application error that stops the machine from operating is detected.
		<ul style="list-style-type: none"> • The software's bug • Unexpected hardware configuration such as insufficient memory
		Turn the main power off/on.

SC No.	Level	Error Name/Error Condition/Major Cause/Solution
SC921-00	B	Printer font error
		A font that is usually included as the standard font was not found when the printer application was started.
		The standard font file is missing.
		Turn the main power off/on.

SC No.	Level	Error Name/Error Condition/Major Cause/Solution
SC925-00	B	Net File function error
		The Net File storage area on the HDD is not available, or the management file used for handling the Net File data is broken. As a result, access to the Net File data cannot be continued.

SC No.	Level	Error Name/Error Condition/Major Cause/Solution
		<ul style="list-style-type: none"> • Defective HDD • HDD inconsistency caused by switching the machine off while writing to HDD • Software bug • When HDD error-related service calls (SC860-SC865) are issued at the same time: <p>This error can be caused by a defective HDD. Therefore, take the necessary countermeasures specified for SC860, etc.</p> <ul style="list-style-type: none"> • When other HDD error-related service calls (SC860-SC865) are NOT issued at the same time: <ol style="list-style-type: none"> 1) Turn the main power off/on. 2) If it cannot be restored by taking the above measure, initialize the Net File partition in the HDD. <p>Note, however, that this may delete stored data such as documents remaining in the Fax transmission queue and those waiting for capture. Therefore, you must obtain the consent of your customer before executing the initialization. Note that after executing commands including Plumeria/Palm2, the job history will also be cleared.</p> 3) If the error persists even after taking the above step, initialize all of the partitions in the HDD in accordance with SP5-832-001, then turn the main power off and then on again. <p>Note, however, that this step will clear all of the data stored on the HDD including various documents, address book data, and so on. Therefore, again you must obtain the prior consent of your customers. Note that saved received Fax documents will be protected, but the receiving order may not be maintained.</p> 4) If the error still cannot be restored, replace the HDD.

SC No.	Level	Error Name/Error Condition/Major Cause/Solution
SC990-00	D	Software performance error
		The software attempted to make an unexpected operation.
		<ul style="list-style-type: none"> • Incorrect argument • Incorrect internal parameter • Insufficient working memory • Abnormal performance caused by an error that cannot be detected in normal SC detection due to hardware specifications.
		<ul style="list-style-type: none"> • Turn the main power off/on. • Reinstall the software of the controller board. • Reinstall the software of the engine board.

SC No.	Level	Error Name/Error Condition/Major Cause/Solution
SC991-00	C	Software continuity error
		The software has attempted to perform an unexpected operation. (However, the process can continue running if recovery processing is carried out.)
		<ul style="list-style-type: none"> • Incorrect argument • Incorrect internal parameter • Insufficient working memory • May have resulted from an error that cannot be detected by the hardware using normal SC detection.
		Logging only.

SC No.	Level	Error Name/Error Condition/Major Cause/Solution
SC992-00	D	Undefined SC error
		An error that is not controlled by the system occurred (the error does not come under any other SC code).
		A SC code used in the previous machine was applied erroneously.
		Turn the main power off/on.

SC No.	Level	Error Name/Error Condition/Major Cause/Solution
SC994-00	C	Operation error caused by abnormalities that are normally undetectable.
		An error occurred because the number of records exceeded the limit for images managed in the service layer of the firmware.
		This can occur if there are too many application screens open on the operation panel.
		Logging only.

SC No.	Level	Error Name/Error Condition/Major Cause/Solution
SC995-01	D	CPM setting error
		Machine serial number (11 digits) or machine identification code does not match.
		<ul style="list-style-type: none"> Machine serial number cannot be identified because of BCU replacement or malfunction. Machine serial number cannot be identified because of NVRAM replacement.
		<ul style="list-style-type: none"> Input the machine serial number with SP5-811, and turn the main power off/on. Reinstall the NVRAM that was previously used.

SC No.	Level	Error Name/Error Condition/Major Cause/Solution
SC995-02	D	CPM setting error
		Machine serial number (11 digits) or machine identification code does not match.
		Machine serial number cannot be identified because of NVRAM replacement or malfunction.
		<ul style="list-style-type: none"> Reinstall the NVRAM that was previously used. Using SP5-825, download data onto the NVRAM for replacement, and turn the main power off and on.

SC No.	Level	Error Name/Error Condition/Major Cause/Solution
SC995-03	D	CPM setting error
		Machine serial number (11 digits) or machine identification code does not match.
		Machine serial number cannot be identified because of controller replacement or malfunctioning.
		<ul style="list-style-type: none"> • Replace the controller board with the correct type.

SC No.	Level	Error Name/Error Condition/Major Cause/Solution
SC995-04	D	CPM setting error
		Machine serial number (11 digits) or machine identification code does not match.
		-
		<ul style="list-style-type: none"> • Return the parts to the original configuration, and then replace them according to the manual.

SC No.	Level	Error Name/Error Condition/Major Cause/Solution
SC997-00	B	Application function selection error
		<ul style="list-style-type: none"> • The application has not responded to the set command created by SCS within a certain period of time. • The application selected ended abnormally.
		Software bug
		<ul style="list-style-type: none"> • Check whether an option required by the application (RAM, DIMM, board) is installed properly. • Check whether downloaded applications are correctly configured. <p>(Take necessary countermeasures specific to the application in which the error occurs. In some applications, the logs can be taken from the monitor. If this option is available, analyze the logs.)</p>

SC No.	Level	Error Name/Error Condition/Major Cause/Solution
SC998-00	D	Application start error
		<ul style="list-style-type: none"> • After power on, no application program is registered to the system within a predetermined period of time. (No application starts or ends normally.) • Even if they are started, all applications have become unable to be rendered due to an unknown defect.
		<ul style="list-style-type: none"> • Software bug • An option required by the application (RAM, DIMM, board) is not installed properly
		<ul style="list-style-type: none"> • Turn the main power off/on. • Check whether an option required by the application (RAM, DIMM, board) is installed properly. • Check whether downloaded applications are correctly configured. • Replace the controller board.

Jam Detection

Jam Displays

The operation panel of this model has a four-line display which shows only the message indicating the paper jam location. (e.g. "%r (A1)", "%r (B)")

Jam History

SP7-507 shows the paper jam history.

```
CODE :011
SIZE  :05h
TOTAL:000034
DATE  :Fri Feb 15 11:44:50 2006
```

- CODE: Indicates the jam code.
- SIZE: Indicates the paper Size Code.
- TOTAL: Indicates the total counter (SP7-502-001).
- DATE: indicates the date when the jam occurred.

↓ Note

- The 10 latest printer jams are displayed.
- Initial jams are not recorded.

Sensor Position Layout

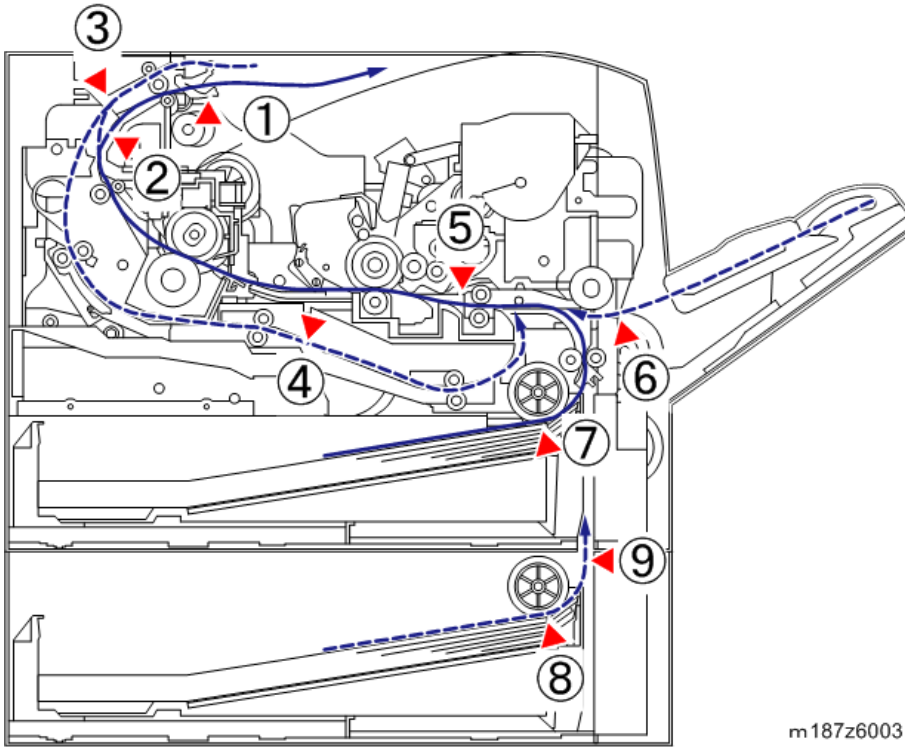

1. Paper Overflow Sensor
2. Paper Exit Sensor
3. Duplex Reverse Sensor
4. Duplex Entrance Sensor
5. Registration Sensor
6. By-pass Paper End Sensor
7. Paper End Sensor (Main Machine)
8. Paper End Sensor (Optional Bank)
9. Vertical Transport Sensor (Optional Bank)

Sensor Position

↓ Note

- Jam code: Shows the cause of a jam. Appears in the log data.
- Position code: Shows the location of a jam. Appears on the operation panel.

These are lists of jam codes for the main machine and peripheral devices. Please note:

- **Late jam.** The paper has failed to arrive within the prescribed time due to a jam that has occurred upstream of the referenced sensor.
- **Lag jam.** The paper has failed to leave the location of the referenced sensor within the prescribed time due to a jam downstream of the referenced sensor.

Main Machine

Jam Code	Jam Type	Position Code
1	Registration Sensor Jam	B
1	Paper Exit Sensor Jam	B Z1
1	Duplex Reverse Sensor Jam	Z1
1	Duplex Entrance Sensor Jam	Z3
3	Tray 1 : No Paper Feeding	A1
8	By-pass Tray : No Paper Feeding	A2
9	Duplex : No Paper Feeding	Z2
17	Registration Sensor: Late Jam	A1
20, 23	Paper Exit Sensor: Late Jam	B C
57	Registration Sensor: Lag Jam	B
60	Paper Exit Sensor: Lag Jam	B Z1
63	Duplex Reverse Sensor: Lag Jam	Z1
26	Duplex Entrance Sensor: Late Jam	Z1
66	Duplex Entrance Sensor: Lag Jam	Z3

Optional Bank

Jam Code	Jam Type	Position Code
4	Tray 2 : No Paper Feeding	Y1
13	Tray 2 Relay Sensor (Vertical Transport Sensor) : Late Jam	Y2
53	Tray 2 Relay Sensor (Vertical Transport Sensor) : Lag Jam	A1 Y1
1	Tray 2 Relay Sensor (Vertical Transport Sensor) Jam	Y1
5	Tray 3 No Paper Feeding	Y2
54	Tray 3 Relay Sensor (Vertical Transport Sensor) : Lag Jam	A1 Y1 Y2
1	Tray 3 Relay Sensor (Vertical Transport Sensor) Jam	Y2
6	Tray 4 No Paper Feeding	Y3
55	Tray 4 Relay Sensor (Vertical Transport Sensor) : Lag Jam	A1 Y1 Y2 Y3
1	Tray 4 Relay Sensor (Vertical Transport Sensor) Jam	Y3
14	Tray 3 Relay Sensor (Vertical Transport Sensor) : Late Jam	Y3

Troubleshooting

Test Pattern Printing

Follow the test pattern print procedure below to print a test pattern.

Note

- Do not operate the machine until the test pattern has been printed. Otherwise, an SC occurs.

1. Enter the SP mode, and then select SP2-109-001.
2. Select the pattern number, and then press [OK].
3. Do the following SP to print the test pattern.

SP	
SP2-109-002	Test Printing 1 Sheet
SP2-109-003	Test Printing Cont. Printing (On: Continue /Off: Stop)
SP2-109-004	Test Printing Print Side Select

4. Check the test pattern.

Pattern number

No.	Pattern	No.	Pattern
0	None	9	Slanting Grid 20mm Pitch
1	Vertical Line (1 dot)	10	Independent Pattern (1 dot)
2	Horizontal Line (1 dot)	11	Independent Pattern (2 dot)
3	Vertical Line (2 dot)	12	Independent Pattern (4 dot)
4	Horizontal Line (2 dot)	13	Full Dot Pattern
5	Grid Vertical Line	14	Band
6	Grid Horizontal Line	15	Gray 10mm Pitch
7	Grid 20mm Pitch	16	Gray 20mm Pitch
8	Slanting Grid	17	Trimming Area

Image Position Adjustment

Note

- Adjust the blank margin width only if it cannot be adjusted by registration (leading edge/side-to-side). First adjust C and D; then A and B.

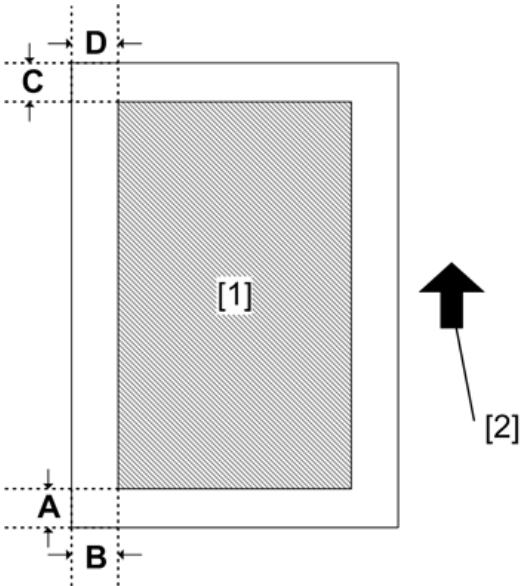

- [1]: Print area
- [2]: Paper feed direction

- Enter the SP mode, and then print the test pattern (17: Trimming Area) with SP2-109-001.
- Adjust the blank margin width of the image with SP2-103-(001-004).
 - Leading edge: 2.7 to 9.9 mm (Default: 3.0 mm)
 - Trailing edge: 0.0 to 9.9 mm (Default: 2.0 mm)
 - Left: 0.0 to 9.9 mm (Default: 2.0 mm)
 - Right: 0.0 to 9.9 mm (Default: 2.0 mm)

Registration Adjustment

Print Area

Check that the adjustment meets the product specification.

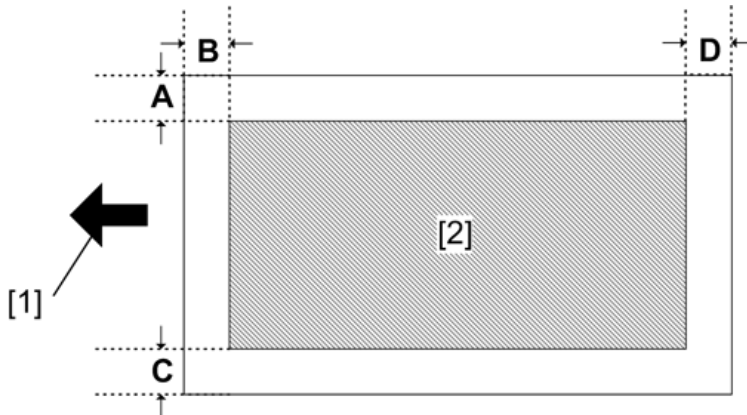

- [1]: Paper feed direction
- [2]: Print area

Adjustment Reference Values

- B: Leading edge (Sub scanning direction): 3.0 ± 1.5 mm
- D: Trailing edge (Sub scanning direction): 3.0 mm
- C: Left (Main scanning direction): 2.0 ± 1.5 mm
- A: Right (Main scanning direction): 2.0 mm

6

Adjustment Procedure

1. Enter the SP mode, and then print the test pattern (17: Trimming Area) with SP2-109-001.

↓ Note

- Print the test pattern, and then adjust the leading edge registration in the SP mode to the optimum value.
2. Do SP1-002-(001,002,003,004,005,006) to check and adjust the registration.
 3. Check the side-to-side registration for each paper feed trays.

Image Problem

Problem at Regular Intervals

Image problems may appear at regular intervals that depend on the circumference of certain components.

The following diagram shows the possible symptoms (black or white dots at regular intervals or other problems).

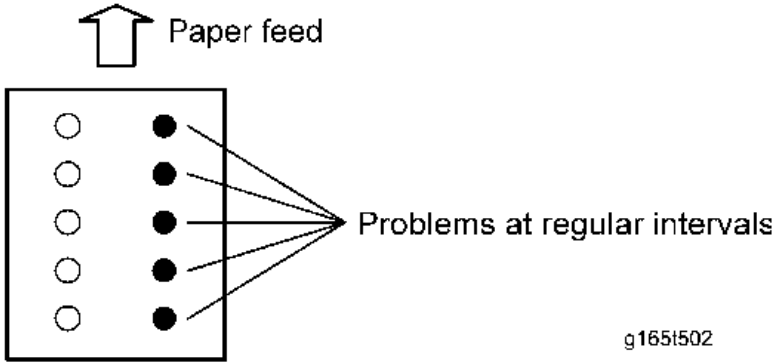

Problems	Intervals	Defective parts
Problems with the printed result (other than black or white dots)	29.9 mm	Charge roller
	50.0 mm	Registration roller
	25.1 mm	Image transfer roller
	106.8 mm	Fusing pressure roller
	108.9 mm	Fusing roller
	113.0 mm	Paper feed roller
Black or white dots	50.2 mm	Development roller
	94.4 mm	Drum

The LED head contains 37 LED chips, each covering a line 8 mm wide. If a line 8 mm wide extending in the paper feed direction appears, an LED chip may be damaged. If so, replace the LED head.

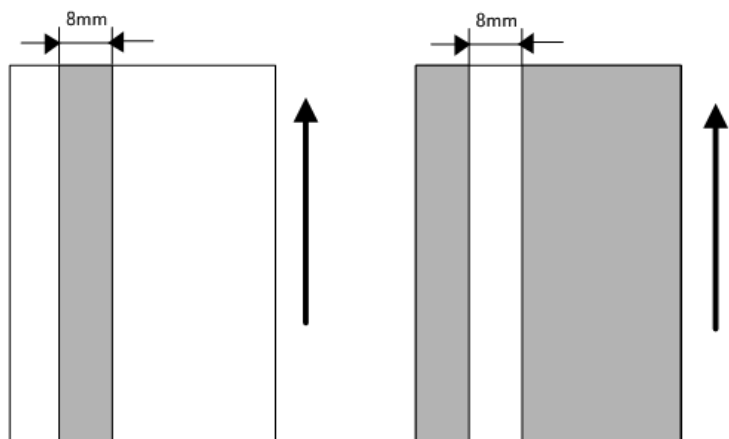

w_m1093070

When Vertical Banding is Generated

The vertical banding on a print image may be improved by the [Drum Rotation] function.

1. Select a drum rotation level.

Menu > Maintenance > Quality Maintenance > Drum Rotation

2. Select a drum rotation level from the following 2 levels: Level 1 (Normal) and Level 2 (Strong).

<Operation>

- Level1 : Photo conductor idles for 55 seconds
- Level2 : Photo conductor idles for 30 seconds (for black and white vertical banding)

<Effectively Prevented Phenomena>

- Level1 : Pieces of white banding (for half tone or continuous printing)
- Level2 : White vertical banding (for half tone), black vertical banding, and black horizontal banding

↓ Note

- If the [Drum Rotation] function is performed many times, the life of the drum unit may be shortened.

When Black Spots are Generated on Print Image

The black spots on a print image may be improved by the [Fusing Roller Cleaning].

1. Load a paper (A4 or LT size plain paper) to the by-pass tray.

2. Perform the [Fusing Roller Cleaning] (toners are consumed).

Menu > Maintenance > Quality Maintenance > Fusing Roller Cleaning

3. A paper is fed and images are printed on both sides of the paper.

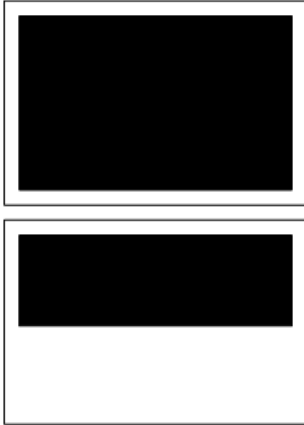

m1608086

4. Check that the black spots do not appear any more.

Note

- The effectiveness of the fusing cleaning varies depending on the types of images printed or papers used until now. Therefore, the problem may be improved by performing the [Fusing Roller Cleaning] several times, which consumes the toners.

When Toner Smears Appear on the Backside of the Printouts

When you keep printing using sheets of paper such as A4 SEF or A5, which is narrower than the maximum printable paper this machine supports, and then keep printing using sheets of paper such as A4 LEF or A3 SEF, which is wider than those used in the previous print job, toner smears may appear on the backside of the printouts depending on your environment or usage.

Specifying this setting prevents the fusing unit temperature from becoming too high, so that the consistent print quality can be maintained.

Specifying [Quality Priority] takes longer than normal printing. Also, printing may stop for approximately 40 seconds as the machine cools down before the next print job starts.

1. Select [Quality Priority].

Menu > Maintenance > Quality Maintenance > Fusing Unit Ctrl Priority

If toner smears also appear when you consecutively print a small size paper, do the following procedure.

1. Enter SP mode.
2. Set SP-1-990-001 (Speed Change 0:LOW 1:HIGH) to 0.

Paper Feed (Skew)

Use the following flowchart to determine the cause and deal with the problem.

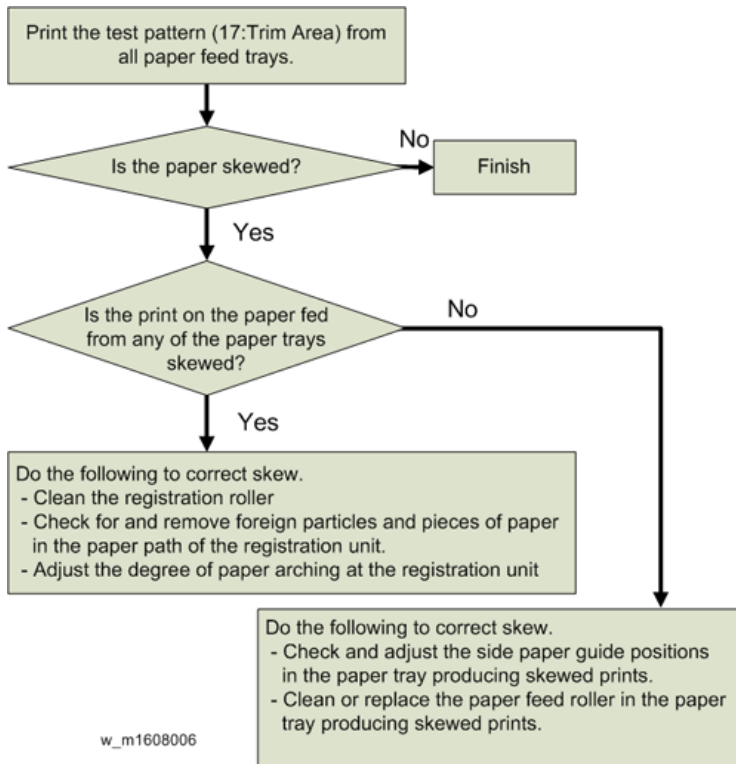

Recycled or Thin Paper Is Severely Curled after Printing

If the delivered paper is curled, it cannot be stacked properly. In such a case, raise the paper stop on the output tray and remove the delivered paper frequently. You can also configure [Curl Prevention] in the UP mode

- Menu > Maintenance > Quality Maintenance > Curl Prevention

If you set [Curl Prevention] to [Active], the machine idles for 20 seconds before it starts printing. By adding the idle time before printing, it takes longer to print, but paper curling can be reduced. To stop the 20-second idling, set [Curl Prevention] to [Inactive].

Electrical Component Defects

Electrical Components

6

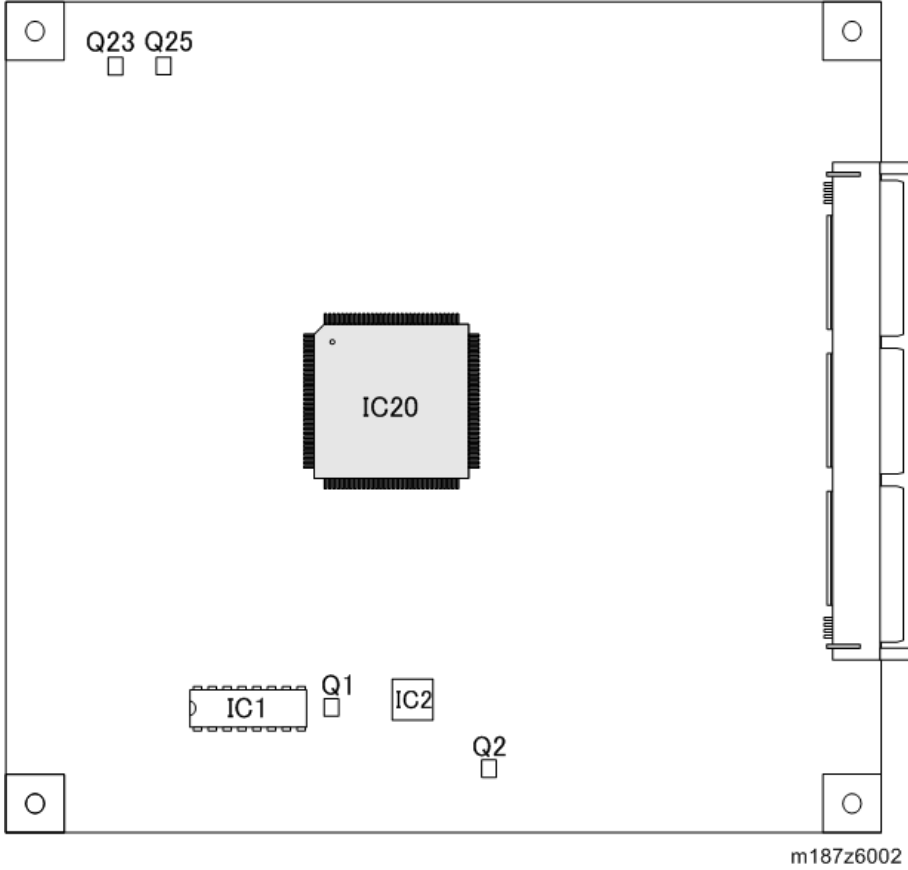

m187z6002

IC No.	Component
IC20	Main motor
IC2	Reverse Motor
Q1	Junction Gate Solenoid
IC1	Paper Feed Clutch
IC1	Registration Clutch
IC1	Relay Clutch

IC No.	Component
IC1	Duplex Clutch
IC1	By-pass Feed Clutch
IC1	By-pass Bottom Plate Clutch
IC1	Toner Supply Clutch
Q23, Q25	PCDU Cooling Fan
Q2	PSU Cooling Fan

Fuses

BCU

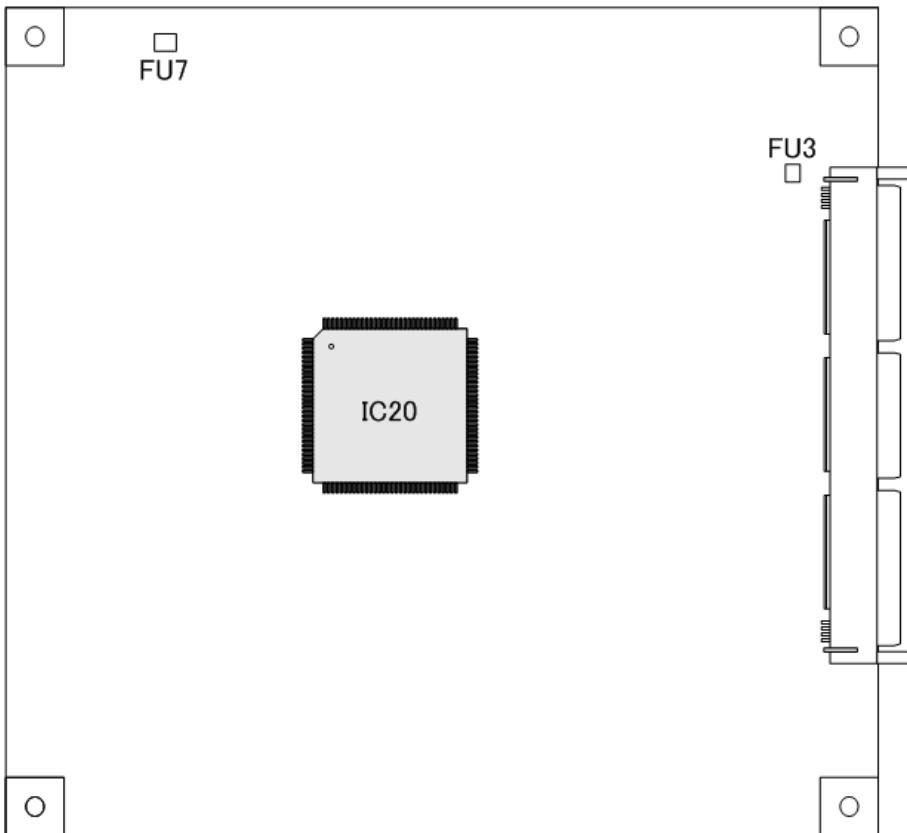

m187z6000

No.	Type	Description	Symptom / Possible Cause / Troubleshooting Procedures
FU3	Micro Fuse	Protects the operation panel from overcurrent	<p>Symptom:</p> <ul style="list-style-type: none"> Although the power is applied to the main machine, the operation panel does not work <p>Possible Cause:</p> <ul style="list-style-type: none"> Fuse blown out due to a short to ground <p>Troubleshooting Procedures:</p> <ul style="list-style-type: none"> Replace the operation panel Replace EGB
FU7	Micro Fuse	Protects the LEDA power source from overcurrent	<p>Symptom:</p> <ul style="list-style-type: none"> An LEDA-related error occurs. <p>Possible Cause:</p> <ul style="list-style-type: none"> FFC is not connected properly. <p>Troubleshooting Procedures:</p> <ul style="list-style-type: none"> Replace EGB Replace FFC Replace LEDA

PSU

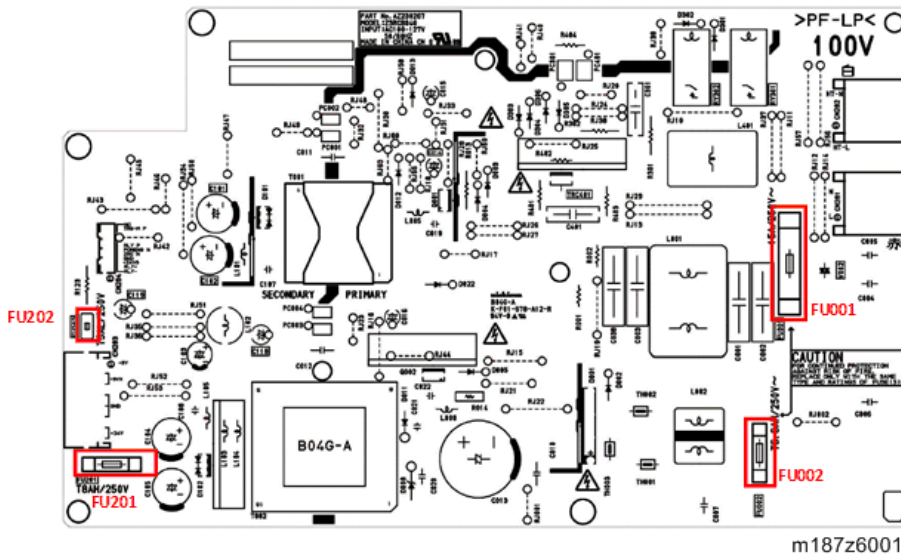

No.	Type	Description	Symptom / Possible Cause / Troubleshooting Procedures
FU001	Ceramic Fuse	Input overcurrent protection	<p>Symptom:</p> <ul style="list-style-type: none"> The main power cannot be turned on <p>Possible Cause:</p> <ul style="list-style-type: none"> The primary circuit of PSU shorts out or broken <p>Troubleshooting Procedures:</p> <ul style="list-style-type: none"> Replace the PSU
FU002	Ceramic Fuse	Protects DC power supply circuit from overcurrent	
FU201	Ceramic Fuse	24 V output overcurrent protection	<p>Symptom:</p> <ul style="list-style-type: none"> Although the power is applied to the main machine, the engine does not work <p>Possible Causes:</p> <ul style="list-style-type: none"> The PSU overcurrent protection does not work 24 V output shorts out to ground <p>Troubleshooting Procedures:</p> <ul style="list-style-type: none"> Replace the PSU

No.	Type	Description	Symptom / Possible Cause / Troubleshooting Procedures
FU202	Micro Fuse	5 V output for LPS	<p>Symptom:</p> <ul style="list-style-type: none"> • Although the power is applied to the main machine, the engine does not work <p>Possible Causes</p> <ul style="list-style-type: none"> • The PSU overcurrent protection does not work • 5 V output shorts out to ground <p>Troubleshooting Procedures:</p> <ul style="list-style-type: none"> • Replace the PSU

7. Energy Save

Energy Save

Energy Saver Modes

Customers should use energy saver modes properly, to save energy and protect the environment.

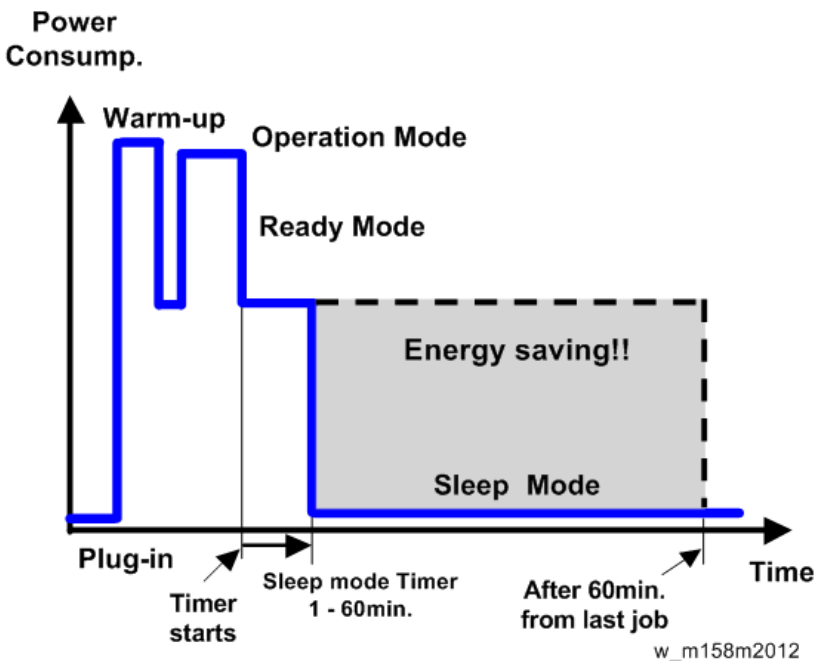

The area shaded grey in this diagram represents the amount of energy that is saved when the timers are at the default settings. If the timers are changed, then the energy saved will be different. For example, if the timers are all set to 60 min., the grey area will disappear, and no energy is saved before 60 min. expires.

Sleep Mode Setting

Sleep Mode

(Menu > System > Sleep Mode > Sleep Mode Timer)

The user can specify the duration the printer waits before entering Sleep mode. The printer enters Sleep mode if no user input has been made during the specified duration. When the printer is in Sleep mode, it takes longer to start printing.

Default: [1 minute]

- 1 minute
- 5 minutes
- 15 minutes
- 30 minutes
- 45 minutes
- 60 minutes

Weekly Timer

Weekly Timer

(Menu > System > Weekly Timer)

The user can set the timer for the printer to turn off and on the main power or enter and exit Sleep mode every day or on specified days of the week. Detailed settings for Weekly Timer, such as setting the day or time to enable Weekly Timer, can be configured using Web Image Monitor.

Default: [Inactive]

- Daily (Web Preset Time)
- Day of Week(Preset Time)
- Inactive

Weekly Timer Code

(Menu > System > Weekly Timer Code)

The user can set a password (up to eight digits) for Weekly Timer. Once the password is set, the screen requiring the password is displayed while the printer is turned off or in Sleep mode by Weekly Timer. Enter the password to turn on the printer or recover the printer from Sleep mode.

If you set Weekly Timer Code to [Off], you do not need to enter a password to recover the printer.

Default: [Off]

Eco Night Mode

Menu > System > Eco Night Sensor



m187z9001

The ECO Night Sensor [A] (ambient light sensor) enables the printer to automatically turn off and on the main power when changes in the ambient light level are detected.

The user can specify how the printer performs when the ECO Night Sensor detects changes in the ambient light level.

When Weekly Timer is set to [Daily] or [Day of the Week], the printer does not turn on even if [ECO Night Sensor] is set to [Auto Power Off and On] and the time for turning on the main power specified in [Timer to Turn On] elapses.

Default: [Auto Power Off Only]

- Auto Power Off Only

The printer turns off the main power when the ECO Night Sensor detects a low ambient light level.

- Auto Power Off and On

The printer turns off the main power when a decrease in the ambient light level is detected. It turns on the main power when an increase in the ambient light level is detected.

- Inactive

The ECO Night Sensor is disabled.

Timer to Turn Off

Specify how long the printer waits to turn off the main power when the ECO Night Sensor detects a low ambient light level.

The timer is reset when:

- The sensor detects changes in the ambient light level.
- Any key on the control panel is pressed or printing is performed.
- The main power switch is turned on.
- The printer configuration screen is displayed on the control panel.
- The printer settings are changed using Web Image Monitor.
- The printer settings are imported or exported.

- A program is downloaded.
- The printer resumes Fusing Unit Off mode.
- The printer enters Sleep mode.

Default: [120 minutes]

- 1 minute
- 5 minutes
- 30 minutes
- 60 minutes
- 120 minutes

Timer to Turn On

Specify how long the printer waits before it turns on the main power when the ECO Night Sensor detects an increase in the ambient light level.

The timer is reset when:

- The sensor detects changes in the ambient light level.
- The ECO Night Sensor setting is changed.
- The main power is turned on.
- The printer enters Sleep mode.

Default: [1 minute]

- 1 minute
- 5 minutes
- 30 minutes
- 60 minutes
- 120 minutes

Brightness Sensor Level

Brightness Sensor Level to Turn Off

Set the brightness threshold for the sensor to turn off the main power.

Default: 0

0 (Dark) - 15 (Bright)

Level 0 (Very dark): Equivalent to a moonlit night

Level 5 (Dark): Equivalent to a dimly-lit room

Level 7 (Dim): Equivalent to a room at sunset

Level 9 (Bright): Equivalent to a brightly lit room at night

Level 15 (Very bright): Equivalent to a sunlit room

Brightness Sensor Level to Turn On

Set the brightness threshold for the sensor to turn on the main power.

Default: 8

0 (Dark) - 15 (Bright)

Level 0 (Very dark): Equivalent to a moonlit night

Level 5 (Dark): Equivalent to a dimly-lit room

Level 7 (Dim): Equivalent to a room at sunset

Level 9 (Bright): Equivalent to a brightly lit room at night

Level 15 (Very bright): Equivalent to a sunlit room

Fusing Off Mode

Menu > System > Fusing Off Mode(EnSav)On/Off

The user can specify whether the printer enters Fusing Unit Off mode or not.

Default: [Off]

- On

Turn on Fusing Unit Off mode. This setting further reduces power consumption, but the printer may take longer to recover from Fusing Unit Off mode.

- Off

Turn off Fusing Unit Off mode.

Exit Fusing Unit Off Mode

Specify the condition for the printer to exit Fusing Unit Off mode.

Default: [On Printing]

- On Printing

The printer exits Fusing Unit Off mode when printing is performed.

- On Operating Control Panel

The printer exits Fusing Unit Off mode when any key on the control panel is pressed.

Fusing Unit Off Mode Timer

Specify the period of time the printer waits before entering Fusing Unit Off mode.

The timer is reset if any key on the control panel is pressed or printing is performed.

Default: [10 seconds]

- 10 seconds
- 30 seconds
- 1 minute

- 15 minutes
- 30 minutes
- 60 minutes
- 120 minutes
- 240 minutes

The Fusing Unit Off Mode Timer is reset when:

- A print is performed
- A cover is opened when [Exit Fusing Unit Off Mode] is set to [On Printing]
- Any key on the operating panel is pressed when [Exit Fusing Unit Off Mode] is set to [On Operating Control Panel]

Fusing Heater Off on Stndby

Menu > System > Fusng Heater Off on Stndby)

The user can specify whether or not to turn off the fusing heater automatically when Sleep mode timer is set to 30 minutes or longer or Fusing Unit Off mode is disabled and the printer remains in standby mode for 30 minutes or longer. The printer consumes less energy when the fusing heater is turned off than when the printer is in standby mode.

Default: [Auto Turn Off]

- Auto Turn Off
- Do not Auto Turn Off

Return to Stand-by Mode

Sleep Mode

Recovery time: 9 sec.

Recommendation

We recommend that the default settings should be kept.

- If the customer requests that these settings should be changed, please explain that their energy costs could increase, and that they should consider the effects on the environment of extra energy use.
- If it is necessary to change the settings, please try to make sure that the Sleep Mode timer is not too long. Try with a shorter setting first, such as 5 min., then go to a longer one (such as 15 min.) if the customer is not satisfied.

- If the Sleep Mode timer is all set to the maximum value, the machine will not begin saving energy until 60 minutes has expired after the last job. This means that after the customer has finished using the machine for the day, energy will be consumed that could otherwise be saved.
- If you change the settings, the energy consumed can be measured using SP8-941, as explained below.

Energy Save Effectiveness

SP 8-941 (Machine Status) keeps a record of the amount of time that the machine spends in each mode.

- SP8-941-001: Operating mode
- SP8-941-002: Standby mode
- SP8-941-003: Panel off mode (Not used in this model)
- SP8-941-004: Sleep mode (Fusing off mode)
- SP8-941-005: Off mode

With this data, and the power consumption values from the specifications, we can estimate the amount of energy that is used by the machine.

This should only be used as a reference value, because the power consumption specifications are measured in a controlled environment with a constant power supply.

To get an exact measurement at the customers site, a watt meter must be used to measure the actual energy consumed.

To use SP8-941 to calculate the energy consumed:

- At the start of the measurement period, read the values of SP8-941-001 to 005.
- At the end of the measurement period, read the values of SP8-941-001 to 005 again.
- Find the amount of time spent in each mode (subtract the earlier measurement from the later measurement).
- Multiply this by the power consumption spec for each mode.
- Convert the result to kWh (kilowatt hours)

Here is an example calculation.

Machine Date	Power Consumption (W): Data: a	SP8941: Machine Status	Start Time: (min.) Data: b	End Time: (min.) Data: c	Time Differences (Data:b - Data: c) (min.) Data: d	Power Consumption (Data:a x Data:d) (Wmin.) Data: e

Operating mode	NA: 543W EU: 565W	001: Operating Time	21089	21386	21386	NA: 161271 EU: 167805
Ready mode (stand by)	51W	002: Standby Time	306163	308046	308046	96033
Energy mode (Panel off)	1W or less	003: Energy Save Time	0	0	0	0
Low power mode	20W or less	004: Low power Time	71386	71386	75111	74500
Sleep mode	1W or less	005: Off mode Time	508776	508776	520377	11601
Total Time of Data: d (min.)					17506	
Total Time of Data: d/60min. (Hour)					291.7667	
Total Power Consumption of Data: e (Wmin.)						NA: 343405 EU: 349939
Total Power Consumption of Data: e /60min./1000W (KWH)						NA: 5.72342 EU: 5.83232

Paper Save

Effectiveness of Duplex/Combine Function

Duplexing and the combine functions reduce the amount of paper used. This means that less energy overall is used for paper production, which improves the environment.

1. Duplex:

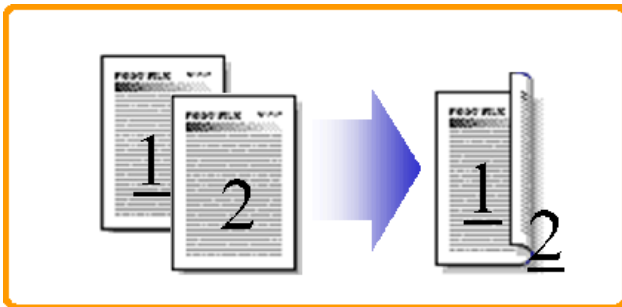

d062d102

Reduce paper volume in half!

7

2. Combine mode:

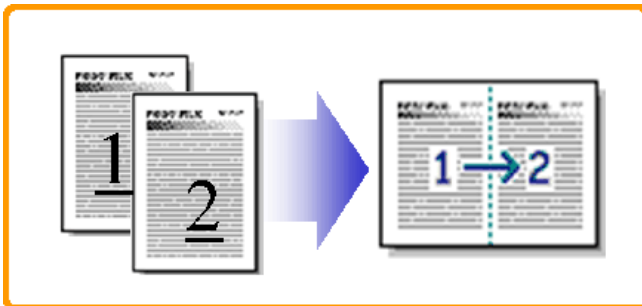

d062d100

Reduce paper volume in half!

3. Duplex + Combine:

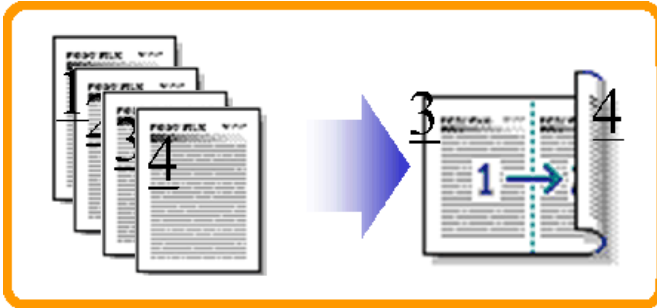

d062d101

Using both features together can further reduce paper volume by 1/4!

To check the paper consumption, look at the total counter and the duplex counter.

The total counter counts all pages printed.

- For one duplex page, the total counter goes up by 2.
- For a duplex job of a three-page original, the total counter goes up by 3.
- The duplex counter counts pages that have images on both sides.
- For one duplex page, the duplex counter goes up by 1.
- For a duplex job of a three-page original, the duplex counter will only increase by 1, even though two sheets are used.

7

Recommendation

Please explain the above features to the customers, so that they can reduce their paper usage.

- Total counter: SP8-581-001
- Duplex counter: SP8-411-001
- Single-sided with combine mode: SP8-421-004
- Duplex with combine mode: SP8-421-005

The following table shows paper savings and how the counters increase for some simple examples of single-sided and duplex jobs

Duplex mode:

Originals	Simplex Sheet used	Duplex Sheets used	Paper Saved	Total counter SP8-581-001	Duplex counter SP8-411-001
1	1	1	0	1	0
2	2	1	1	2	1

Originals	Simplex Sheet used	Duplex Sheets used	Paper Saved	Total counter SP8-581-001	Duplex counter SP8-411-001
3	3	2	1	3	1
4	4	2	2	4	2
5	5	3	2	5	2
10	10	5	5	10	5
20	20	10	10	20	10

If combine mode is used, the total and duplex counters work in the same way as explained previously. The following table shows paper savings and how the counters increase for some simple examples of duplex/combine jobs.

2 in 1 mode:

Originals	Simplex Sheet used	Duplex Sheets used	Paper Saved	Total counter SP8-581-001	Single-sided with combine mode SP8-421-004
1	1	1	0	1	1
2	2	1	1	1	1
3	3	2	1	2	2
4	4	2	2	2	2
5	5	3	2	3	2
10	10	5	5	5	5
20	20	10	10	10	10

Duplex + 2 in 1 mode:

Originals	Simplex Sheet used	Duplex Sheets used	Paper Saved	Total counter SP8-581-001	Duplex with combine mode SP8-421-005
1	1	1	0	1	0
2	2	1	1	1	0

Originals	Simplex Sheet used	Duplex Sheets used	Paper Saved	Total counter SP8-581-001	Duplex with combine mode SP8-421-005
3	3	1	2	2	1
4	4	1	3	2	1
5	5	2	3	3	1
6	6	2	4	3	1
7	7	2	5	4	2
8	8	2	6	4	2
9	9	3	6	5	2
10	10	3	7	5	2
11	11	3	8	6	3
12	12	3	9	6	3

Model Da-P1

**Machine Code:
M187**

Appendices

February, 2015

TABLE OF CONTENTS

1. Appendices: Specifications

- General Specifications..... 3
 - Mainframe..... 3
 - Printer..... 6
- Software Accessories..... 7
 - Printer Drivers..... 7
 - Utility Software..... 8
- Optional Equipment..... 9
 - Paper Feed Unit TK2010..... 9

2. Appendices: Preventive Maintenance Tables

- Preventive Maintenance Tables..... 11
 - Maintenance Tables..... 11
 - Mainframe..... 11
 - Paper Feed Tray TK2010..... 12
 - Other..... 12

3. Appendices: SP Mode Tables

- Service Program Mode..... 13
 - Enabling and Disabling Service Program Mode..... 13
 - Service Table Key..... 13
- Main SP Tables-1..... 14
 - SP1-XXX (Feed)..... 14
- Main SP Tables-2..... 24
 - SP2-XXX (Drum)..... 24
- Main SP Tables-3..... 42
 - SP3-XXX (Process)..... 42
- Main SP Tables-5..... 44
 - SP5-XXX (Mode)..... 44
- Main SP Tables-7..... 98
 - SP7-XXX (Data Log)..... 98
- Main SP Tables-8..... 115
 - Overview..... 115
 - SP8-XXX (Data Log 2)..... 117
- Input and Output Check..... 131

Input Check Table.....	131
Output Check Table.....	133
Printer Service Mode.....	136
SP1-XXX (Service Mode).....	136
Test Pattern Printing.....	151
Test Pattern Printing.....	151

1. Appendices: Specifications

General Specifications

Mainframe

Items	Specification
Type	Desktop
CPU	533MHz
Memory	Standard: 512MB Extension: 1GB
Hard Disk	320GB (Optional)
Photosensitivity Type	OPC Drum
Copy System	LED alley and electro-photographic printing
Development System	Non-magnetic one-component development system
Fusing System	Thin, hard heating roller fusing system
Scanning Method	One-dimensional solid scanning system through CCD
Warm-up Time	19 seconds or less (23°C, rated voltage) Warm-up may take a minute or two for image adjustment.
First Print Time	6.5 seconds or less (A4, LT SEF)

Items	Specification	
Paper Size (*Dial setting is required)	Std. Tray	<p>NA</p> <p>A3(*SEF), B4(*SEF), A4(*SEF/LEF), B5(*SEF/*LEF), A5(*SEF/*LEF), B6(*SEF), A6(*SEF), DLT(SEF), LG(SEF), LT(SEF/LEF), G LT(*SEF/*LEF), HLT(*SEF), Exective(*SEF/*LEF), Com10(*LEF), Eng Quatro(*SEF/*LEF), F/GL(*SEF), C5(*LEF), DL Env(*LEF), F(*SEF), Foolscap(SEF), Folio(*SEF), 8K(*SEF), 16K(*SEF/*LEF)</p> <p>Custom size*: Min. 90mm x 297mm (3.5" x 11.7"), Max. 148mm x 432mm (5.8" x 17")</p>
		<p>EU/CHN</p> <p>A3(SEF), B4(*SEF), A4(SEF/LEF), B5(*SEF/*LEF), A5(*SEF/LEF), B6(*SEF), A6(*SEF), DLT(*SEF), LG(*SEF), LT(SEF/LEF), G LT(*SEF/*LEF), HLT(*SEF), Exective(*SEF/*LEF), Com10(*LEF), Eng Quatro(*SEF/*LEF), F/GL(*SEF), C5(*LEF), DL Env(*LEF), F(*SEF), Foolscap(*SEF), Folio(*SEF), 8K(*SEF), 16K(*SEF/*LEF)</p> <p>Custom size*: Min. 90mm x 297mm (3.5" x 11.7"), Max. 148mm x 432mm (5.8" x 17")</p>

Items	Specification	
	By-pass Tray	<p>A3(*SEF), B4(*SEF), A4(*SEF/*LEF), B5(*SEF/*LEF), A5(*SEF/*LEF), B6(*SEF/*LEF), A6(*SEF), DLT(*SEF), LG(*SEF), LT(*SEF/*LEF), G LT(*SEF/*LEF), HLT(*SEF/*LEF), Exective(*SEF/*LEF), Com10(*SEF/*LEF), Eng Quatro(*SEF/*LEF), F/GL(*SEF), C5(*SEF/*LEF), C6(*SEF/*LEF), DL Env(*SEF/*LEF), Monarch(*SEF), F(*SEF), Foolscap(*SEF), Folio(*SEF), 8K(*SEF), 16K(*SEF/*LEF)</p> <p>Custom size: Min. 60mm x 297mm (2.4" x 11.7"), Max. 127mm x 1260mm (5" x 49.6")</p>
	Op. Paper Tray	<p>A3(SEF), B4(*SEF), A4(SEF/LEF), B5(*SEF/*LEF), A5(*SEF/*LEF), B6(*SEF), A6(*SEF), DLT(SEF), LG(*SEF), LT(SEF/LEF), G LT(*SEF/*LEF), HLT(*SEF), Exective(*SEF/*LEF), Com10(*SEF), Eng Quatro(*SEF/*LEF), F/GL(*SEF), F(*SEF), Foolscap(*SEF), Folio(*SEF), 8K(*SEF), 16K(*SEF/*LEF)</p> <p>Custom size*: Min. 100mm x 297mm (3.9" x 11.7"), Max. 148mm x 432mm (5.8" x 17")</p>
Paper Thickness	<ul style="list-style-type: none"> • Tray1: 52 - 220g/m² • Bypass: 52 - 220g/m² • Duplex: 52 - 162g/m² 	
Paper Feed Capacity	<p>Max. 2100 sheets</p> <p>Standard: 500 sheets (Main) + 100 sheets (Bypass tray)</p> <p>Option: 500 sheet tray x 3</p>	
Power Source	NA	120 – 127V, 60 Hz
	EU/AP/CHN	220 – 240V, 50 – 60 Hz
Max Power Consumption	1073 W or less	
Dimensions (W × D × H)	<p>475 x 416.4 x 347.5 mm (18.7 x 16.3 x 13.6 inches): including projections</p> <p>The height increases by 124 mm as an optional 500-sheets paper feed tray is installed.</p>	

Items	Specification
Space for Main Unit	W×D: 459 x 392 mm (18.0 x 15.4 inches)
Weight	Approx. 22.5 kg (49.6 lb.)

Printer

Items	Specification
Print Size	<ul style="list-style-type: none"> Fixed: Max. A3: SEF: 257×364mm, DLT: SEF: 279×431.8mm Custom: Max.297 × 1260mm (Bypass tray)
Continuous Printing Speed	<p>One-side printing: 38 ppm (A4 LEF / LT LEF)</p> <p>Two-side printing: 29 ppm (A4 LEF / LT LEF)</p>
Resolution	300/600/1200dpi
Printer Language	<ul style="list-style-type: none"> Standard: RPCS, PCL5e/6, Postscript3, PDF Direct Option: XPS, IPDS
Interface	<ul style="list-style-type: none"> Standard: Ethernet(1000BASE-T, 100BASE-TX, 10BASE-T), USB2.0 (Type A), USB2.0 (Type B), SD card Option: IEEE1284, IEEE802.11a/b/g/n (Wireless LAN), NIC (Print server)
Protocol	TCP/IP (IPv4, IPv6), AppleTalk, IPX/SPX, SNMP, MIB, WSM, IPP
Compatible OS	<ul style="list-style-type: none"> WindowsXP/Vista/7/8/Server2003/2008/2012 MacOS (X10.5 or later) *PS only, Citrix/CPS/XenApp, Novell Netware(v 6.5 or later) *Need Netware option
Resident Fonts	<p>PCL: 45 fonts + International fonts 13 fonts</p> <p>PS: 136 fonts</p> <p>IPDS: 108 fonts (Option)</p>

Software Accessories

The printer drivers and utility software are provided on one CD-ROM. An auto-run installer lets you select the components you want to install.

Printer Drivers

For printing, install a printer driver on your computer. The following drivers are included on the CDROM:

Operating System *1	Printer Drivers		
	PCL 5c/5e	PCL 6	PostScript 3
Windows XP *2	A	A	A
Windows Vista *3	A	A	A
Windows 7 *4	A	A	A
Windows 8 *5	A	A	A
Windows Server 2003 *6	A	A	A
Windows Server 2008 *7	A	A	A
Windows Server 2012 *8	A	A	A
Mac OS X *9	-	-	A

A : Supported

- : Not Supported

*1 Printer drivers support both 32-bit and 64-bit Windows.

*2 Microsoft Windows XP Professional Edition/Microsoft Windows XP Home Edition

*3 Microsoft Windows Vista Ultimate/Microsoft Windows Vista Enterprise/Microsoft Windows Vista Business/Microsoft Windows Vista Home Premium/Microsoft Windows Vista Home Basic

*4 Microsoft Windows 7 Home Premium/Microsoft Windows 7 Professional/Microsoft Windows 7 Ultimate/Microsoft Windows 7 Enterprise

*5 Microsoft Windows 8/Microsoft Windows 8 Pro/Microsoft Windows 8 Enterprise

*6 Microsoft Windows Server 2003 Standard Edition/Microsoft Windows Server 2003 Enterprise Edition/ Microsoft Windows Server 2003 R2 Standard Edition/Microsoft Windows Server 2003 R2 Enterprise Edition

*7 Microsoft Windows Server 2008 Standard/Microsoft Windows Server 2008 Enterprise/Microsoft Windows Server 2008 R2 Standard/Microsoft Windows Server 2008 R2 Enterprise

*8 Microsoft Windows Server 2012 Foundation/Microsoft Windows Server 2012 Essentials/Microsoft

Windows Server 2012 Standard

*9 Mac OS X 10.5 or later

Utility Software

The following utilities are available.

No.	Utility	Support Status	Note
1	Printer Utility for Mac	No	Bundled utilities
2	Font Manager 2000	YES	
3	Web Image Monitor (embedded web server)	YES	
4	DeskTopBinder Professional	YES	Optional utilities
5	Desk Top Binder Lt	YES	
6	Remote Communication Gate S Pro	YES	
7	SmartDeviceMonitor for Admin Accounting Report Package	YES	

Optional Equipment

Paper Feed Unit TK2010

1

Item	Description
Paper feed method	Roller Friction (RF) Method
Paper size	<ul style="list-style-type: none"> • Selected by the paper size dial A3 (SEF), A4 (SEF), A4 (LEF), DLT (SEF), Letter (SEF), Letter (LEF) • Set the paper size dial on the tray to “*” and select the paper size with the operation panel A5 (SEF/LEF), A6 (SEF), B4 (SEF), B5 (SEF/LEF), B6 (SEF), Legal (SEF), Foolscap (SEF), GovernmentLG (SEF), Folio (SEF), F/GL (SEF), G LT (SEF/LEF), Eng Quatro (SEF/LEF), Executive (SEF/LEF), Half Letter (SEF), 8K (SEF), 16K (SEF/LEF), 11×15 (SEF), 11×14 (SEF), 10×15 (SEF), 10×14 (SEF) • Custom size Vertical: 148.0 – 432.0 mm (5.83 – 17.00 inch) Horizontal: 100.0 – 297.0 mm (3.94 – 11.69 inch)
Paper weight	52 g/m ² – 220 g/m ²
Power consumption	15 W or less (Power is supplied from the main unit)
Dimensions (W × D × H)	459 × 392 × 124 mm (Without handle)
Weight	Approx. 6 kg (13.22 lb.)
Interface	Three-line parallel to serial conversion system
Power source	Draw from main unit
Operational life	12.5 W or less

2. Appendices: Preventive Maintenance Tables

Preventive Maintenance Tables

Maintenance Tables

Chart: A4 (LT)/5%

Mode: 3 prints/job

Ratio: 50%

Environment: Normal temperature and humidity

Yield may change depending on circumstances and print conditions.

Symbol keys: C: Clean, R: Replace

Mainframe

Item	25K	90K	180K	EM	Remarks
LED Lens	C				<ul style="list-style-type: none"> Customers perform this concurrently with PCDU replacement Use the LED lens cleaner packed with the unit or mainframe
Image Transfer Roller		R			<ul style="list-style-type: none"> Replace to the maintenance kit
Fusing Unit		R			<ul style="list-style-type: none"> Replace to the maintenance kit
Paper Feed Roller				C	<ul style="list-style-type: none"> Wipe with a damp cloth
Friction Roller				C	<ul style="list-style-type: none"> Wipe with a damp cloth
By-pass Feed Roller				C	<ul style="list-style-type: none"> Wipe with a damp cloth
By-pass Friction Pad				C	<ul style="list-style-type: none"> Wipe with a damp cloth

Item	25K	90K	180K	EM	Remarks
Registration Roller				C	<ul style="list-style-type: none"> Wipe with a damp cloth
Registration Sensor				C	<ul style="list-style-type: none"> Remove paper dusts
Duplex Entrance Roller, Duplex Relay Roller, Duplex Exit Roller				C	<ul style="list-style-type: none"> Wipe with a damp cloth
Paper Exit Roller, Duplex Reverse Roller				C	<ul style="list-style-type: none"> Wipe with a damp cloth
Duplex Reverse Sensor				C	<ul style="list-style-type: none"> Remove paper dusts

Paper Feed Tray TK2010

Item	25K	90K	180K	EM	Remarks
Paper Feed Roller				C	<ul style="list-style-type: none"> Wipe with a damp cloth
Separation Roller				C	<ul style="list-style-type: none"> Wipe with a damp cloth
Vertical Transport Roller				C	<ul style="list-style-type: none"> Wipe with a damp cloth
Vertical Transport Sensor				C	<ul style="list-style-type: none"> Remove paper dusts

Other

	Yield (Page)	Condition
High Yield Toner	10,000	ISO
Start-up Toner	6,000	ISO
PCDU	25,000	3P/J
Maintenance Kit	90,000	3P/J

3. Appendices: SP Mode Tables

Service Program Mode

Enabling and Disabling Service Program Mode

Note

- The Service Program Mode is for use by service representatives only. If this mode is used by anyone other than service representatives for any reason, data might be deleted or settings might be changed. In such case, product quality cannot be guaranteed any more.

Entering SP Mode

For details, ask your supervisor.

Service Table Key

The following symbols are used in the SP mode tables.

Notation	What it means
[range / default / step]	Example: [-9 to +9 / 0 / 0.1 mm/step]. The setting can be adjusted in the range ± 9 , value reset to +3.0 after an NVRAM reset, and the value can be changed in 0.1 mm steps with each key press.
ENG	Engine SP
CTL	Controller SP
*	An asterisk (*) to the left side of ENG/CTL column means that this mode is stored in the NVRAM. If you do a RAM clear, this SP mode will be reset to the default value. "ENG" and "CTL" show which NVRAM contains the data. <ul style="list-style-type: none">• *ENG: NVRAM on the BCU board• *CTL: NVRAM on the controller board
DFU	Denotes "Design or Factory Use". Do not change this value.
SSP	This denotes a "Special Service Program" mode.

Main SP Tables-1

SP1-XXX (Feed)

3

1001	[User LeadEdge Reg]		
	Adjusts the leading edge registration by changing the registration motor operation timing for each mode.		
	<ul style="list-style-type: none"> Increasing a value: an image is moved to the trailing edge of paper. Decreasing a value: an image is moved to the leading edge of paper. 		
	1-001-001	By-pass	ENG*
	1-001-002	Tray 1	ENG*
	1-001-003	Tray 2	ENG*
	1-001-004	Tray 3	ENG*
1-001-005	Tray 4	ENG*	
1-001-006	Duplex	ENG*	[-4.0 to 4.0 / 0.0 / 0.1 mm/step]

1002	[User S-to-S Reg]		
	Adjusts the printing side-to-side registration from each paper feed station, using the Trimming Area Pattern.		
	<ul style="list-style-type: none"> To move the start position to the right, increase the value (+). To move the start position to the left, decrease the value (-). 		
	1-002-001	By-pass	ENG*
	1-002-002	Tray 1	ENG*
	1-002-003	Tray 2	ENG*
	1-002-004	Tray 3	ENG*
1-002-005	Tray 4	ENG*	
1-002-006	Duplex	ENG*	[-4.0 to 4.0 / 0.0 / 0.1 mm/step]

1003	[Paper Buckle]			
	This SP eliminates the amount of buckle at the registration roller.			
	<ul style="list-style-type: none"> When paper is fed from the paper cassette, before the registration rollers start to rotate the leading edge of the paper stops and hits the nip of the registration rollers and stops. The registration rollers remain idle long enough to stop the paper from skewing in the paper path. This SP adjusts the amount of time that the registration rollers remain idle to reduce paper buckle. Raise this setting to lengthen the amount of time that the paper pauses at the nip of the registration rollers if you notice a large amount of skew in printouts. 			
	1-003-011	By-pass: Plain	ENG*	
	1-003-012	By-pass: Thick	ENG*	
	1-003-013	By-pass: Envelope	ENG*	
	1-003-021	Tray1: Plain	ENG*	[-5 to 5 / 0 / 1 mm/step]
	1-003-022	Tray1: Thick	ENG*	
	1-003-023	Tray1: Envelope	ENG*	
	1-003-031	Tray2: Plain	ENG*	
	1-003-032	Tray2: Thick	ENG*	
	1-003-041	Tray3: Plain	ENG*	
	1-003-042	Tray3: Thick	ENG*	
	1-003-051	Tray4: Plain	ENG*	
1-003-052	Tray4: Thick	ENG*		
1-003-061	Duplex: Plain	ENG*		
1-003-062	Duplex: Thick	ENG*		
1101	[Flicker Control]			
	Sets the flicker control (0: Disable, 1: Enable).			

1-101-001	Flicker Control	ENG*	[0 or 1 / 0 / 1/step] 0: Disabled 1: Enabled
-----------	-----------------	------	---

1105	[PrintTargetTemp] Adjusts the target fusing temperature for each paper type. "C" indicates the center of the roller.		
1-105-001	C: Plain1	ENG*	[120 to 200 / 160 / 1 deg/step]
1-105-003	C: Plain2	ENG*	[120 to 200 / 167 / 1 deg/step]
1-105-005	C: Thick1	ENG*	[120 to 200 / 172 / 1 deg/step]
1-105-007	C: Thick2	ENG*	[120 to 200 / 172 / 1 deg/step]
1-105-009	C: Thick3	ENG*	[120 to 200 / 176 / 1 deg/step]
1-105-011	C: Thin	ENG*	[120 to 200 / 150 / 1 deg/step]
1-105-013	C: Envelope	ENG*	[120 to 200 / 190 / 1 deg/step]
1-105-015	C: Card	ENG*	[120 to 200 / 175 / 1 deg/step]
1-105-017	C: Transparency	ENG*	[120 to 200 / 163 / 1 deg/step]
1-105-019	C: Special	ENG*	[120 to 200 / 185 / 1 deg/step]

1105	[CurlDecMode]		
1-105-021	Mode Display	ENG*	[0 or 1 / 0 / 1/step] Enables or disables the CurlDecMode
1-105-022	PreprtRotTime	ENG*	[500 to 60000 / 500 / 1 msec/step] Sets the pre-print rotation time for reducing curls.

1105	[PrintTargetTemp] Specifies the heating roller target temperature for coated paper (Center) during printing.		
1-105-023	C:Mid	ENG*	[120 to 200 / 167 / 1 deg/step]
1-105-025	C:Plain2:Mid	ENG*	[120 to 200 / 160 / 1 deg/step]

1-105-026	C:Plain2:Low	ENG*	[120 to 200 / 150 / 1 deg/step]
1-105-027	C:Mid:Thick	ENG*	[120 to 200 / 155 / 1 deg/step]
1-105-028	C:Thin:Low	ENG*	[120 to 200 / 140 / 1 deg/step]
1-105-029	C:Plain:Low	ENG*	[120 to 200 / 145 / 1 deg/step]
1-105-030	C:Thick1:Low	ENG*	[120 to 200 / 160 / 1 deg/step]
1-105-031	FuserOffMode	ENG*	[0 or 1 / 1 / 1/step] The switch that turns the fuser off after the idle process runs over 30 minutes.
1-105-033	PPMdownTemp	ENG*	[200 to 255 / 250 / 1 deg/step] Specifies the starting temperature for a forced PPM down
1-105-034	FuserCleaning	ENG*	[140 to 200 / 140 / 1 deg/step]

1106	[FusingTempDisp] Displays the hot roller and pressure roller temperatures.		
1-106-001	RollerCenter	ENG	[-20 to 250 / 0 / 1 deg/step] Displays the current fusing thermistor temperature (Center).
1-106-002	RollerEnds	ENG	[-20 to 250 / 0 / 1 deg/step] Displays the current fusing thermistor temperature (Ends).
1-106-003	MachinePowerOn	ENG	[-20 to 250 / 0 / 1 deg/step] Displays the external temperature measured at power ON, which is detected with the temperature and humidity sensor.

1110	[FusingCoolDown]		
1-110-001	OFF/ON	ENG*	[0 or 1 / 0 / 1/step]

1135	[Inrush Control] Enables or disables the setting of Inrush control (0: Disabled, 1: Enabled)		
	1-135-001	Inrush control	ENG* [0 or 1 / 0 / 1/step]

1152	[NipWidthMeasuring] Checks the fusing nip band.		
	1-152-001	0:OFF 1:ON	ENG [0 or 1 / 0 / 1/step]

1159	[FusingJamDetect] Disables or enables the consecutive jam error for the fusing unit. When set to "1" (on) this SC code is issued after the 3rd consecutive jam in the fusing unit.		
	1-152-001	SCdisplay	ENG* [0 or 1 / 0 / 1/step] 0: Not detects SC 1: Detects SC

1801	[Motor Speed Adj] Adjusts the speed of the motor. The motor speed can be adjusted to correct images that appear scratchy or of uneven density. This can occur when:		
	<ul style="list-style-type: none"> • Copying originals with large quantities of black. • Copying originals with a large quantity of black near the trailing edge. • Printing multiple copies of positive/negative (reverse) images. 		
	1-801-001	MainMotor:High	ENG*
	1-801-002	MainMotor:Mid	ENG*
	1-801-003	MainMotor:Low	ENG*
	[-4.0 to 4.0 / 0 / 0.01%/step]		
	1-801-011	Exit Reverse	ENG* [-4.0 to 4.0 / 0.0 / 0.1%/step]
	1-801-012	Exit Reverse Mid	ENG* [-9.0 to 9.0 / 0 / 0.1%/step]
1-801-013	Exit Reverse Low	ENG* Makes it faster (+) or slower (-) than the default.	

1907	[Paper Timing Adj] Adjusts the timing of paper feed. (A "+" setting broadens paper feed interval, a "-" setting narrows paper feed interval.)		
1-907-005	Reverse Stop Posi	ENG*	[-10 to 10 / 0 / 1mm/step] Adjusts the reverse stop timing of the range from the Registration Sensor OFF to the Paper Exit Inverter motor. Makes it slower (+) or faster (-) than the default.
1-907-015	Re-Feed Stop Posi	ENG*	[-10 to 10 / 0 / 1mm/step] Adjusts the reverse stop timing of the range from the duplex entrance sensor ON to the duplex clutch. Makes it slower (+) or faster (-) than the default.
1-907-035	Bank1 Feed CLON	ENG*	[-10 to 10 / 0 / 1mm/step]
1-907-036	Bank2 Feed CLON	ENG*	Adjusts the sheet interval to feed a next sheet.
1-907-037	Bank3 Feed CLON	ENG*	Makes it wider (+) or narrower (-) than the default.
1-907-038	BNKWaitAdj Before	ENG*	[-10 to 10 / 0 / 1mm/step] Adjusts the sheet interval to execute the paper waiting command. Makes it wider (+) or narrower (-) than the default.
1-907-039	BNKWaitAdj After	ENG*	[-10 to 10 / 0 / 1mm/step] Adjusts the interval to execute the paper waiting command. Makes it wider (+) or narrower (-) than the default.
1908	[Paper Timing Adj] Adjusts the timing of paper feed. (A "+" setting broadens paper feed interval, a "-" setting narrows paper feed interval.)		

1-908-015	Junc Gate SOL:ON	ENG*	[-10 to 10 / 0 / 1mm/step]
1-908-017	Junc Gate SOL:OFF	ENG*	

1921	[Fact LeadEdge Reg]			
	<ul style="list-style-type: none"> Increasing a value: an image is moved to the trailing edge of paper. Decreasing a value: an image is moved to the leading edge of paper. 			
	1-921-011	By-Pass: Plain	ENG*	[-4.0 to 4.0 / 0.0 / 0.1 mm/step] Reflects adjustment values with no change.
	1-921-012	By-Pass: Thick	ENG*	[-4.0 to 4.0 / 0.0 / 0.1 mm/step] Adds on to the adjusted values of the Plain paper.
	1-921-013	By-Pass: Envelope	ENG*	[-4.0 to 4.0 / 0.0 / 0.1 mm/step] Adds on to the adjusted values of the Plain paper.
	1-921-021	Tray1: Plain	ENG*	[-4.0 to 4.0 / 0.0 / 0.1 mm/step] Reflects adjustment values with no change.
	1-921-022	Tray1: Thick	ENG*	[-4.0 to 4.0 / 0.0 / 0.1 mm/step] Adds on to the adjusted values of the Plain paper.
	1-921-023	Tray1: Envelope	ENG*	[-4.0 to 4.0 / 0.0 / 0.1 mm/step] Adds on to the adjusted values of the Plain paper.
	1-921-031	Tray2: Plain	ENG*	[-4.0 to 4.0 / 0.0 / 0.1 mm/step] Reflects adjustment values with no change.
	1-921-032	Tray2: Thick	ENG*	[-4.0 to 4.0 / 0.0 / 0.1 mm/step] Adds on to the adjusted values of the Plain paper.

1-921-041	Tray3: Plain	ENG*	[-4.0 to 4.0 / 0.0 / 0.1 mm/step] Reflects adjustment values with no change.
1-921-042	Tray3: Thick	ENG*	[-4.0 to 4.0 / 0.0 / 0.1 mm/step] Adds on to the adjusted values of the Plain paper.
1-921-051	Tray4: Plain	ENG*	[-4.0 to 4.0 / 0.0 / 0.1 mm/step] Reflects adjustment values with no change.
1-921-052	Tray4: Thick	ENG*	[-4.0 to 4.0 / 0.0 / 0.1 mm/step] Adds on to the adjusted values of the Plain paper.
1-921-061	Duplex: Plain	ENG*	[-4.0 to 4.0 / 0.0 / 0.1 mm/step] Reflects adjustment values with no change.
1-921-062	Duplex: Thick	ENG*	[-4.0 to 4.0 / 0.0 / 0.1 mm/step] Adds on to the adjusted values of the Plain paper.

1922	[Fact S-to-S Reg]		
	Reflects adjustment values with no change. <ul style="list-style-type: none"> To move the start position to the right, increase the value (+). To move the start position to the left, decrease the value (-). 		
1-922-001	By-pass	ENG*	[-4.0 to 4.0 / 0.0 / 0.1 mm/step]
1-922-002	Tray 1	ENG*	
1-922-003	Tray 2	ENG*	
1-922-004	Tray 3	ENG*	
1-922-005	Tray 4	ENG*	

1-922-006	Duplex	ENG*	[-4.0 to 4.0 / 0.0 / 0.1 mm/step] The value of this SP adds on to the adjusted values of the front page of each tray.
-----------	--------	------	---

1950	[Fan Cooling Time]		
	Specifies the operating time of fans after printing.		
1-950-002	PCDU Fan	ENG*	[0 to 600 / 0 / 1 sec/step]
1-950-003	PSU Fan	ENG*	[0 to 600 / 0 / 1 sec/step]

1951	[Fan Stop Time]		
	Specifies the stop time of fans in Engine-Off mode.		
1-951-002	PCDU Fan	ENG*	[0 to 600 / 70 / 1 sec/step]
1-951-003	PSU Fan	ENG*	[0 to 600 / 70 / 1 sec/step]

1952	[Fan Low Mode Time]		
	Specifies the sustaining time of Engine-Off mode when the machine returns from the Engine-Off mode.		
1-952-001	-	ENG*	[0 to 60 / 13 / 1 min/step]

1953	[FanLowNoiseMode OFF/ON]		
	Enables or disables the fan low noise mode.		
1-953-001	OFF/ON	ENG*	[0 or 1 / 0 / 1/step]

1990	[SpeedCange]		
	Specifies the printing speed for when printing a small-size plain paper 2.		
1-990-001	0:LOW 1:HIGH	ENG*	[0 or 1 / 0 / 1/step]

1998	[Reserve SP]		
------	---------------------	--	--

1-998-001	reserve01	ENG*	[0 to 255 / 0 / 1/step]
1-998-002	reserve02	ENG*	
1-998-003	reserve03	ENG*	
1-998-004	reserve04	ENG*	
1-998-005	reserve05	ENG*	
1-998-006	reserve06	ENG*	[0.00 to 10.00 / 80 / 0.01%/step]
1-998-007	reserve07	ENG*	[227 to 500 / 227 / 1g/step]
1-998-008	reserve08	ENG*	[0 to 65535 / 0 / 1/step]
1-998-009	reserve09	ENG*	[0 to 65535 / 0 / 1/step]
1-998-010	reserve10	ENG*	[0 to 65535 / 0 / 1/step]

Main SP Tables-2

SP2-XXX (Drum)

2001	[C biasControl]		
2-001-001	C setting	ENG *	<p>[-1350 to -900 / -1020 / 1V/step]</p> <p>C: bias value.</p> <p>Note</p> <ul style="list-style-type: none"> This setting is available when the bias control is OFF.
2-001-002	C(low) setting	ENG *	<p>[-400 to -200 / -350 / 50V/step]</p> <p>C(low): The value of C(low) output.</p>
2-001-011	Pot_ref_low_Lc1	ENG *	<p>[-450 to -250 / -320 / 5V/step]</p> <p>Displays or adjusts the target dark potential (Vd) in the Env Division, low humidity.</p> <p>Note</p> <ul style="list-style-type: none"> This setting is available when the bias control is ON.
2-001-012	Pot_ref_low_Lc2	ENG *	<p>[-450 to -250 / -315 / 5V/step]</p> <p>Displays or adjusts the target dark potential (Vd) in the Env Division, mid humidity.</p> <p>Note</p> <ul style="list-style-type: none"> This setting is available when the bias control is ON.
2-001-013	Pot_ref_low_Lc3	ENG *	<p>[-450 to -250 / -310 / 5V/step]</p> <p>Displays and adjusts the target dark potential (Vd) in the Env Division, high humidity.</p> <p>Note</p> <ul style="list-style-type: none"> This setting is available when the bias control is ON.

2-001-014	Pot_ref_mid_Lc1	ENG*	[-450 to -250 / -350 / 5V/step] Displays and adjusts the target background potential, Pot, in the Env Division, high humidity.
2-001-015	Pot_ref_mid_Lc2	ENG*	[-450 to -250 / -330 / 5V/step] Displays and adjusts the target background potential, Pot, in the Env Division, high humidity.
2-001-016	Pot_ref_mid_Lc3	ENG*	[-450 to -250 / -300 / 5V/step] Displays and adjusts the target background potential, Pot, in the Env Division, high humidity.
2-001-017	Pot_ref_high_Lc1	ENG*	[-450 to -250 / -410 / 5V/step] Displays and adjusts the target background potential, Pot, in the Env Division, high humidity.
2-001-018	Pot_ref_high_Lc2	ENG*	[-450 to -250 / -365 / 5V/step] Displays and adjusts the target background potential, Pot, in the Env Division, high humidity.
2-001-019	Pot_ref_high_Lc3	ENG*	[-450 to -250 / -305 / 5V/step] Displays and adjusts the target background potential, Pot, in the Env Division, high humidity.
2-001-100	F:Coefficient:a0	ENG*	[-500 to -350 / -350 / 1/step] Displays and adjusts the coefficient a0 used for the C-calculated function F (Vd, AH, D). Note <ul style="list-style-type: none"> This setting is available when the bias control is ON.

2-001-101	F:Coefficient:a1	ENG*	<p>[0.80 to 1.20 / 1.00 / 0.01/step]</p> <p>Displays and adjusts the coefficient a1 used for the C-calculated function F (Vd, AH, D).</p> <p>Note</p> <ul style="list-style-type: none"> This setting is available when the bias control is ON.
2-001-102	F:Coefficient:a2	ENG*	<p>[0.0 to 10.0 / 5.0 / 0.1/step]</p> <p>Displays and adjusts the coefficient a2 that is of the C-calculated function F (Vd, AH, D).</p> <p>Note</p> <ul style="list-style-type: none"> This setting is available when the bias control is ON.
2-001-103	F:Coefficient:a3	ENG*	<p>[-20 to 0 / -9.9 / 0.1/step]</p> <p>Displays and adjusts the coefficient a3 that is of the C-calculated function F (Vd, AH, D).</p> <p>Note</p> <ul style="list-style-type: none"> This setting is available when the bias control is ON.
2-001-104	Pot_line1	ENG*	<p>[0 to 10000000 / 200000 / 1000 mm/step]</p> <p>Displays and adjusts the threshold of the running distance for line-1 with the configuration table for target background potential.</p>
2-001-105	Pot_line2	ENG*	<p>[0 to 10000000 / 500000 / 1000 mm/step]</p> <p>Displays and adjusts the threshold of the running distance for line-1 with the configuration table for target background potential.</p>

2101	[Reg Correct] The amount of the correction for the main scan position.		
2-101-001	Main Dot	ENG *	[-300 to 300 / 0 / 1dot/step]

2102	[Magnification Adj] Sub Scan Magnification Adjustment		
2-102-002	Sub Mag.:N	ENG *	[-1.0 to 1.0 / 0.0 / 0.1%/step]
2-102-003	Sub Mag.:M	ENG *	
2-102-004	Sub Mag.:L	ENG *	

2103	[Erase Margin Adj] Image Erase Margin Adjustment Adjusts the erase margin by deleting image data at the margins.		
2-103-001	Lead Edge Width	ENG *	[2.7 to 9.9 / 3.0 / 0.1 mm/step]
2-103-002	Trail. Edge Width	ENG *	[0.0 to 9.9 / 2.0 / 0.1 mm/step]
2-103-003	Left	ENG *	
2-103-004	Right	ENG *	
2103	[Erase Margin Adj] Image Erase Margin Adjustment: Back side		
2-103-005	Duplex:Lead	ENG *	[0.0 to 4.0 / 0.0 / 0.1 mm/step]
2-103-006	Duplex:Trail.	ENG *	
2-103-007	Duplex:Left Width	ENG *	
2-103-008	Duplex:RightWidth	ENG *	

2104	[Exposure energy]		
2-104-010	Normal Print	ENG *	[0.23 to 0.98 / 0.50 / 0.01 uJ/cm ² /step] LEDA light emission energy: Normal printing Bk: Display/Setting

2-104-011	Nomal Discharge	ENG*	[0.23 to 0.98 / 0.70 / 0.01 uJ/ cm ² / step] LEDA light emission energy: Quenching pattern Normal speed: Display/Setting
2-104-012	Low Discharge	ENG*	[0.23 to 0.98 / 0.70 / 0.01uJ/ cm ² / step] LEDA light emission energy: Quenching pattern Low speed: Display/Setting

2105	[LED Emit Time Adj] Adjusts the LEDA Light emission time.		
2-105-001	Normal Speed	ENG*	[50 to 200 / 100 / 1%/step]
2-105-002	Mid Speed	ENG*	
2-105-003	Low Speed	ENG*	

2106	[LEDA Emit Time] LEDA Light emission time.		
2-106-021	Print:Normal	ENG	[1000 to 12500 / 3000 / 1ns/step]
2-106-022	Print:Mid	ENG	
2-106-023	Print:Low	ENG	
2-106-024	Quenching:Normal	ENG	
2-106-025	Quenching:Mid	ENG	
2-106-026	Quenching:Low	ENG	

2107	[Exposure Width]		
2-107-001	Erase Left D	ENG*	[0.0 to 20.0 / 5.0 / 0.1mm/step]
2-107-002	Erase Right E	ENG*	

2109	[Test Printing]		
-------------	------------------------	--	--

2-109-001	Pattern Selection	ENG	[0 to 17 / 0 / 1/step] See the selections below. See also page 151 "Test Pattern Printing" for checking the procedure.
2-109-002	1 Sheet Printing	ENG	[0 or 1 / 0 / 1/step] Prints one sheet of a selected test pattern.
2-109-003	Cont. Printing	ENG	[0 or 1 / 0 / 1/step] Continuously prints multiple sheet of a selected test pattern.
2-109-004	Print Side Select	ENG	[0 or 1 / 0 / 1/step] Selects the print side(s) for test pattern printing. 0: One side 1: Both sides

Selections for SP2109

0	None	9	Arg. Grid20mm
1	Vert. (1 dot)	10	Indep. (1 dot)
2	Hori. (1 dot)	11	Indep. (2dot)
3	Vert/ (2dot)	12	Indep. (4dot)
4	Hori. (2dot)	13	Full
5	Grid Vert.	14	Band
6	Grid Hori.	15	Gray 10mm
7	Grid 20mm	16	Gray 20mm
8	Arg. Grid	17	Trim Area

2201	[DV bias Control]		
2-201-001	DV(-)_setting	ENG*	[-350 to -10 / -150 / 1v/step]
2-201-002	DV(+)_offset	ENG*	[-100 to 0 / 0 / 25v/step]

2-201-003	DV(-)_offset	ENG*	[-75 to 75 / 0 / 25v/step]
2-201-011	Line1:L1	ENG*	[500000 to 950000 / 500000 / 50000mm/step]
2-201-012	Line2:L2	ENG*	[1000000 to 1950000 / 1000000 / 50000mm/step]
2-201-013	Line3:L3	ENG*	[2000000 to 2950000 / 3000000 / 50000mm/step]
2-201-014	Line4:L4	ENG*	[4000000 to 7950000 / 5000000 / 50000mm/step]
2-201-015	Line5:L5	ENG*	[8000000 to 19950000 / 8000000 / 50000mm/step]
2-201-016	Line6:L6	ENG*	[20000000 to 29950000 / 20000000 / 50000mm/step]
2-201-017	Line7:L7	ENG*	[30000000 to 39950000 / 33000000 / 50000mm/step]
2-201-204	Coefficient:a4	ENG*	[0.00 to 0.50 / 0.13 / 0.01/step]
2-201-205	Coefficient:a5	ENG*	[0.0 to 5.0 / 0.0 / 0.1/step]
2-201-206	Coefficient:a6	ENG*	[-200 to 0 / 0 / 1/step]

2211	[PcuReverse] Switches the PCU reverse on / off.		
2-211-001	On/Off	ENG*	[0 or 1 / 1 / 1/step] 0: Switch Off 1: Switch On with the reverse rotation sheet counts
2-211-002	Cold Mode	ENG*	[0 or 1 / 0 / 1/step] Switches the PCU Reverse Cold mode. 0: Normal 1: Cold Mode

2212	[ReverseThreshold]		
-------------	---------------------------	--	--

2-212-001	Sheets:Interrupt	ENG*	[1 to 999 / 50 / 1 / page] Specifies the cumulative sheet count threshold from which the previous drum PCU reverse (forced interrupt) is performed.
2-212-002	Sheets:JobEnd	ENG*	[1 to 999 / 10 / 1 / page] Specifies the cumulative sheet count threshold from which the previous drum PCU reverse is performed (Job end).
2-212-003	Dist:Interrupt	ENG*	[1 to 999 / 15 / 1 / m] Specifies the cumulative running distance from which the previous drum PCU reverse (forced interrupt) is performed.
2-212-004	Dist:JobEnd	ENG*	[1 to 999 / 3 / 1 / m] Specifies the cumulative running distance from which the previous drum PCU reverse (job end) is performed.
2-212-005	Sheets Counter	ENG*	[0 to 999 / 0 / 1 / page] Specifies the cumulative sheet count from the previous drum PCU reverse.
2-212-006	Dist Counter	ENG*	[0 to 999999999 / 0 / 1 / mm] Displays the drum running distance from the previous drum PCU reverse.
2-212-007	Sheets:Interupt2	ENG*	[1 to 999 / 20 / 1 / page] Specifies the cumulative sheet count threshold from which the previous drum PCU reverse (forced interrupt) is performed. Note <ul style="list-style-type: none"> * Available only when PCU Cold Mode is ON in LL environment.

2-212-008	Sheets:JobEnd2	ENG*	<p>[1 to 999 / 3 / 1 / page]</p> <p>Specifies the cumulative sheet count threshold from which the previous drum PCU reverse is performed (Job end).</p> <p>Note</p> <ul style="list-style-type: none"> * Available only when PCU Cold Mode is ON in LL environment.
2-212-009	Dist:Interrupt2	ENG*	<p>[1 to 999 / 6 / 1 / m]</p> <p>Note</p> <ul style="list-style-type: none"> * Available only when PCU Cold Mode is ON in LL environment.
2-212-010	Dist:JobEnd2	ENG*	<p>[1 to 999 / 3 / 1 / m]</p> <p>Specifies the cumulative running distance from which the previous drum PCU reverse (job end) is performed.</p> <p>Note</p> <ul style="list-style-type: none"> * Available only when PCU Cold Mode is ON in LL environment.

2221	[LEDA Data:Display] Displays LEDA data.		
2-221-005	Serial No.	ENG	[- / - / -]
2-221-009	Power Error	ENG	[0 or 1 / 0 / 1/step]

2301	<p>[T bias Control]</p> <p>Transfer Bias Control</p> <p>Use these SP's to adjust the power output and power coefficient used to transfer the toner image from drum to paper. Four separate voltages are applied before the leading edge, at the leading edge of the paper, across the image area and at the trailing edge of the paper.</p> <p>Notes:</p> <ul style="list-style-type: none"> The coefficient adjustment should be done before the power output. The amount of voltage applied to each area can be set independently in each area for the type of paper in use. 		
-------------	--	--	--

2-301-002	T(+)_2_FaceOffset	ENG*	[-15 to 15 / 0 / 0.5uA/step] Displays the setting of the offset amount of transfer constant current level during creating an image on the face page.
2-301-003	T(+)_2_BackOffset	ENG*	[-15 to 15 / 0 / 0.5uA/step] Displays the setting of the offset amount of transfer constant current level during creating an image on the back page.
2-301-101	Used Adjust A2	ENG*	[0 to 100 / 80 / 1%/step] Output adjustment for the value of the transfer output table which is to be a basis when the transfer paper count is in the range of 15K and 30K.
2-301-102	Used Adjust A3	ENG*	[0 to 100 / 70 / 1%/step] Output adjustment for the value of the transfer output table which is to be a basis when the transfer paper count is in the range of 30K and 60K.
2-301-103	Used Adjust A4	ENG*	[0 to 100 / 65 / 1%/step] Output adjustment for the value of the transfer output table which is to be a basis when the transfer paper count is in the range of 60K and 90K.
2-301-104	Used Adjust A5	ENG*	[0 to 100 / 60 / 1%/step] Output adjustment for the value of the transfer output table which is to be a basis when the transfer paper count is over 90K.

2401	[Timing Control]		
2-401-003	T[rotation print]	ENG*	[730 to 9900 / 730 / 10msec/step]
2-401-004	T[rotation WU]	ENG*	[730 to 9900 / 5000 / 10msec/step]

2411	[envi_section] Displays and adjusts the absolute temperature threshold under low and high humidity on the Env Division in the Environment Correction Control.		
2-411-001	AH_LM	ENG*	[0.0 to 30.0 / 5.5 / 0.5g/m ³ /step]
2-411-002	AH_MH	ENG*	[0.0 to 30.0 / 15.0 / 0.5g/m ³ /step]

2451	[Separation ctrl]		
2-451-001	bias offset	ENG*	[-2000 to 2000 / 0 / 10V/step]
2-451-002	On/Off	ENG*	[0 or 1 / 0 / 1/step] Switches the separation control. 0: OFF 1: ON

2924	[Supply Speed] For circulating the time to supply certain amount		
2-924-001	Remaining H:178	ENG*	[0.01 to 1.00 / 0.28 / 0.01g/sec/ step]
2-924-002	Remaining M:178	ENG*	[0.01 to 1.00 / 0.25 / 0.01g/sec/ step]
2-924-003	Remaining L:178	ENG*	[0.01 to 1.00 / 0.21 / 0.01g/sec/ step]
2-924-004	Remaining H:160	ENG*	[0.01 to 1.00 / 0.25 / 0.01g/sec/ step]
2-924-005	Remaining M:160	ENG*	[0.01 to 1.00 / 0.22 / 0.01g/sec/ step]
2-924-006	Remaining L:160	ENG*	[0.01 to 1.00 / 0.19 / 0.01g/sec/ step]
2-924-007	Remaining H:130	ENG*	[0.01 to 1.00 / 0.20 / 0.01g/sec]
2-924-008	Remaining M:130	ENG*	[0.01 to 1.00 / 0.18 / 0.01g/sec]
2-924-009	Remaining L:130	ENG*	[0.01 to 1.00 / 0.15 / 0.01g/sec]

2925	[Toner Supply]		
2-925-001	consumed amount	ENG*	[0.0 to 100000.0 / 0.0 / 0.1mg/step] Counter for judging to supply toner during printing.

2-925-002	Supply Threshold	ENG*	[0.1 to 100000.0 / 300.0 / 0.1 mg/step] Threshold for judging to supply toner during printing.
2-925-003	Sup-CoefficientLL	ENG*	[0.0 to 10.0 / 2.0 / 0.1/step] Coefficient for calculating toner amount to supply during printing in LL environment.
2-925-004	Sup-CoefficientMM	ENG*	[0.0 to 10.0 / 1.3 / 0.1/step] Coefficient for calculating toner amount to supply during printing in MM environment.
2-925-005	Sup-CoefficientHH	ENG*	[0.0 to 10.0 / 1.0 / 0.1/step] Coefficient for calculating toner amount to supply during printing in HH environment.

2926	[Recovery Supply]		
2-926-001	Recovery Amount	ENG*	[0 to 300 / 3 / 1g/step] Specifies the toner supply amount per recovery supply.
2-926-002	Mixing Time	ENG*	[0 to 300 / 10 / 1 sec/step] Idle time to mix after Recovery Supply.
2-926-003	Recovery Count	ENG*	[0 to 10000 / 0 / 1 count/step] Total count of executed Recovery Supply
2-926-004	Self-Recovery	ENG	[- / - / -] [Execute] Forcibly executes one time Recovery Supply.

2927	[Initial Supply]		
2-927-001	Initial Amount	ENG*	[1 to 50 / 3 / 1g/step] Specifies the target toner amount for the quantitative toner supply.

2-927-002	Initial Mixing T	ENG *	[0 to 300 / 10 / 1 sec/step] Specifies the idle time to mix after completing the quantitative toner supply.
2-927-003	Ini-Coefficient	ENG *	[0.0 to 10.0 / 5.0 / 0.1/step] Specifies the supply coefficient for initial toner supply.
2-927-004	Initial Flag	ENG *	[0 or 1 / 0 / 1/step] Determines whether to perform the initial supply.
2-927-005	Exchange Count	ENG *	[0 to 1000 / 0 / 1 count/step] Counter of toner cartridge exchange.

2930	[Detection]		
2-930-001	Cleaner Count	ENG *	[1 to 20 / 5 / 1 cycle/step] Specifies the rotating count of the cleaner component to calculate the number of detection count.
2-930-002	stabilization T	ENG *	[0.0 to 3.0 / 0.0 / 0.1sec/step] Specifies the time to stabilize the Toner End Sensor.
2-930-003	Upper n cycle	ENG *	[0 to 20 / 1 / 1/step] Upper counter to exclude from the obtained result when toner remaining in the developer detected.
2-930-004	Lower m cycle	ENG *	[0 to 20 / 1 / 1/step] Lower counter to set it aside from the obtained result if toner remaining in the developer detected.
2-930-005	HH:178 Upper	ENG *	[0 to 100 / 35 / 1 count/step] Counter for judging the upper limit when toner remaining in the developer detected.

2-930-006	HH: 178 Lower	ENG*	[0 to 100 / 40 / 1 count/step] Counter for judging the lower limit when toner remaining in the developer detected.
2-930-007	MM: 178 Upper	ENG*	[0 to 100 / 35 / 1 count/step] Counter for judging the upper limit when toner remaining in the developer detected.
2-930-008	MM: 178 Lower	ENG*	[0 to 100 / 40 / 1 count/step] Counter for judging the lower limit when toner remaining in the developer detected.
2-930-009	LL: 178 Upper	ENG*	[0 to 100 / 40 / 1 count/step] Counter for judging the upper limit when toner remaining in the developer detected.
2-930-010	LL: 178 Lower	ENG*	[0 to 100 / 45 / 1 count/step] Counter for judging the lower limit when toner remaining in the developer detected.
2-930-011	HH: 160 Upper	ENG*	[0 to 100 / 39 / 1 count/step] Counter for judging the upper limit when toner remaining in the developer detected.
2-930-012	HH: 160 Lower	ENG*	[0 to 100 / 44 / 1 count/step] Counter for judging the lower limit when toner remaining in the developer detected.
2-930-013	MM: 160 Upper	ENG*	[0 to 100 / 39 / 1 count/step] Counter for judging the upper limit when toner remaining in the developer detected.
2-930-014	MM: 160 Lower	ENG*	[0 to 100 / 44 / 1 count/step] Counter for judging the lower limit when toner remaining in the developer detected.
2-930-015	LL: 160 Upper	ENG*	[0 to 100 / 44 / 1 count/step] Counter for judging the upper limit when toner remaining in the developer detected.

2-930-016	LL: 160 Lower	ENG*	[0 to 100 / 50 / 1 count/step] Counter for judging the lower limit when toner remaining in the developer detected.
2-930-017	HH:130 Upper	ENG*	[0 to 100 / 48 / 1 count/step] Counter for judging the upper limit when toner remaining in the developer detected.
2-930-018	HH:130 Lower	ENG*	[0 to 100 / 55 / 1 count/step] Counter for judging the lower limit when toner remaining in the developer detected.
2-930-019	MM:130 Upper	ENG*	[0 to 100 / 48 / 1 count/step] Counter for judging the upper limit when toner remaining in the developer detected.
2-930-020	MM:130 Lower	ENG*	[0 to 100 / 55 / 1 count/step] Counter for judging the lower limit when toner remaining in the developer detected.
2-930-021	LL:130 Upper	ENG*	[0 to 100 / 55 / 1 count/step] Counter for judging the upper limit when toner remaining in the developer detected.
2-930-022	LL:130 Lower	ENG*	[0 to 100 / 62 / 1 count/step] Counter for judging the lower limit when toner remaining in the developer detected.
2-930-023	Average Count	ENG*	[0 to 255 / 0 / 1 count/step] Result of remaining detection in the developer.
2-930-024	Sensor Standard V	ENG*	[0.0 to 3.3 / 1.5 / 0.1V/step] Threshold for judging the detection result of toner end sensor.
2-930-025	Self- Detection	ENG	[- / - / -] [Execute] Executes the self detection.

2-930-026	Self-Mixing Time	ENG*	[0 to 300 / 10 / 1 sec/step] Required time for mixing prior to forcibly execute remaining detection.
-----------	------------------	------	--

2931	[Supply Error]		
2-931-002	0 count	ENG*	[0 to 10000 / 0 / 1 count/step] Counter for detecting the SC364.
2-931-003	0 count Threshold	ENG*	[1 to 50 / 30 / 1 count/step] Threshold for detecting the SC364.
2-931-004	Lower Count	ENG*	[0 to 10000 / 0 / 1 count/step] Counter for detecting the SC332.
2-931-005	Lower Threshold	ENG*	[1 to 10 / 10 / 1 count/step] Threshold for detecting the SC332.
2-931-006	SC332 Count	ENG*	[0 to 10 / 0 / 1 count/step] Counts that continuously detected the SC332.

2932	[End Detection]		
2-932-001	End Count	ENG*	[0 to 10000 / 0 / 1 count/step] Specifies the lower limit count used to determine the toner end.
2-932-002	End Threshold	ENG*	[1 to 10 / 5 / 1 count/step] Specifies the threshold of the lower limit count used to determine the toner end.

2940	[Remain Control]		
2-940-001	Remaining Amount	ENG*	[0.0 to 30.0 / 0.0 / 0.1g/step] Specifies the amount of supplied toner which is to be carried over.
2-940-002	Remaining Time	ENG*	[0 to 300 / 0 / 1 sec/step] Specifies the remaining time of idle for mixing.

2941	[Related Control]		
2-941-001	closing count	ENG*	[0 to 10000 / 0 / 1 count/step] Counter for the front cover open/close.
2-941-002	closing count:Upper	ENG*	[0 to 100 / 0 / 1 count/step] Counter for door open/close, being used to determine to execute the toner supply on door open/close.

2950	[Refresh Mode]		
2-950-001	Mode select	ENG*	[0 to 7 / 3 / 1/step] 1,3,5,7: For low coverage: ON 2,3,6,7: Fixed quantity: ON 4,5,6,7: For small paper: ON

2952	[Toner Input] Displays the drum running distance at the previous refresh.		
2-952-001	Runnging Distance	ENG*	[0 to 999999999 / 0 / 1mm/step]

2953	[S_PaperRefresh]		
2-953-001	InputCoefficient	ENG*	[1000 to 3000 / 1884 / 1/step] Specifies the cleaning toner amount (K) for toner refresh in small size paper.
2-953-002	ThresholdDist	ENG*	[2010 to 7500 / 2100 / 10mm/step] Specifies the threshold (Ls) of drum running distance for toner refresh in small size paper.

2961	[CleaningOperation]		
2-961-001	Level 1	ENG	[0 or 1 / 0 / 1 / step]
2-961-002	Level 2	ENG	[0 or 1 / 0 / 1 / step].

2990	[Duty Control]		
-------------	-----------------------	--	--

2-990-001	Counter	ENG*	[0 to 65535 / 0 / 1 count/step] Held counter value used for calculating
2-990-002	Lower	ENG*	[2000 to 60000 / 14400 / 1 count/step] Lower threshold in the forced stopped condition
2-990-003	Upper	ENG*	[2000 to 60000 / 15000 / 1 count/step] Upper threshold in the forced stopped condition
2-990-004	OFF/ON	ENG*	[0 to 1 / 1 / 1/step] Enables or disables the duty control during cooling the development.

2997	[PCDU STOP]		
2-997-001	End Mgn Distance	ENG*	[100000 to 960000000 / 9250000 / 10000mm/step]

2998	[Timing Control]		
2-998-001	T:ReverseRotation	ENG*	[1 to 100 / 35 / 1msec/step] Adjusts the reverse rotation time of PCU reverse rotation.
2-998-002	T:MotorStop	ENG*	[550 to 1000 / 550 / 50msec/step] Adjusts the stop rotation time of PCU reverse rotation.
2-998-003	T:NormalRotation	ENG*	[1 to 100 / 22 / 1msec/step] Adjusts the normal rotation time of PCU reverse rotation.
2-998-004	T:NormalRotation2	ENG*	[1 to 200 / 100 / 1msec/step] Adjusts the normal rotation time of PCU reverse rotation.

Main SP Tables-3

SP3-XXX (Process)

3

3098	[Days Before End] Switches the near end timing: days before end toner		
3-098-001	Toner	ENG *	[0 to 2 / 1 / 1/step] 0: earlier 1: normal 2: later
3501	[Dev Bias Control] Development Bias Control: On/Off designation.		
3-501-001	On/Off	ENG *	[0 or 1 / 1 / 1-/step] 0: Off 1: On
3502	[C Bias Control] C bias Control: On/Off designation		
3-502-001	On/Off	ENG *	[0 or 1 / 1 / 1/step] 0: Off 1: On
3800	[Days Before End] Switches the near end timing: days before end toner		
3-800-001	Waste Toner	ENG *	[0 to 2 / 1 / 1/step] 0: earlier 1: normal 2: later
3920	[Density Adjust]		

3-920-002	Mode select	ENG*	[0 or 1 / 0 / 1/step]
-----------	-------------	------	-----------------------

Main SP Tables-5

SP5-XXX (Mode)

5024	[mm/inch Display Selection] Selects whether mm or inches are used in the display. Note: After selecting the number, you must turn the main power switch off and on.		
5-024-001	0:mm 1:inch	CTL*	[0 or 1 / 1 / 1/step] 0: mm (Europe/Asia) 1: inch (USA)
5051	[Refill Toner Display] Enables or disables the toner refill detection display.		
5-051-001	-	CTL*	[0 or 1 / 0 / 1/step] 0: ON 1: OFF
5055	[DisplayIPAddress] Display or does not display the IP address on the operation panel.		
5-055-001	-	CTL*	[0 or 1 / 0 / 1/step] 0: OFF 1: ON
5074	[Home Key Custom] Sets the application that appears when the home key is pressed.		
5-074-002	Login Setting	CTL*	[00000000 to 11111111 (00H to ffH) / 00000000 / 1 hex/step] Bit0:0=On, 1=Off Bit1 to Bit7: Not used Sets the log-in operation mode of the home menu.

5-074-091	Function Setting	CTL*	[0 to 2 / 0 / 1/step] 0: Function disable 1: SDK application 2: MFP browser application Selects the application to show up when pressed the home key.
5-074-092	Product ID	CTL*	[0x00 to 0xFFFF FFFF / 0h / 1/step] Sets the Application product ID.
5-074-093	Application Screen ID	CTL*	[0 to 255 / 0 / 1/step] Not used in this model.

5083	[LED Light Switch] Specifies whether the alert LED is lit or not when toner near end condition is detected. (This does not change the toner near end condition indication in the operation panel LCD.)		
5-083-001	-	CTL*	[0 or 1 / 1 / 1/step] 0: OFF 1: ON

5104	[Counter Size Setting]		
5-104-001	A3/DLT Double Count	CTL*	[- / - / -]
5-104-002	Bypass Paper Size Undetection	CTL*	[- / - / -]

5169	[CE Login] If you will change the printer bit switches, you must "log in" to service mode with this SP before you go into the printer SP mode.		
5-169-001	-	CTL*	[0 or 1 / 0 / 1/step] 0: Disabled 1: Enabled

5191	[Power Setting] Shifts to the power save mode or not.		
5-191-001	Power Str	CTL*	[0 or 1 / 1 / 1/step] 0: OFF 1: ON

5195	[Limitless Sw] Sets limitless paper feed.		
5-195-001	-	CTL*	[0 or 1 / 0 / 1/step]

5302	[Set Time] Adjusts the RTC (real time clock) time setting for the local time zone. Examples: For Japan (+9 GMT), enter 540 (9 hours x 60 min.) JP: +540 (Tokyo) NA: -300 (New York) EU: + 60 (Paris) CH: +480 (Peking) TW: +480 (Taipei) AS: +480 (Hong Kong) KO: +540 (Korea)		
5-302-002	Time Difference	CTL*	[-1440 to 1440 / -300 / 1 min./step]

5305	[Auto Off Set] Auto Off Limit Set		
5-305-101	Auto Off Limit Set	CTL*	[0 or 1 / 0 / 1/step]

5307	[Daylight Saving Time]		
-------------	-------------------------------	--	--

5-307-001	Setting	CTL*	<p>[0 or 1 / - / 1/step]</p> <p>0: Disabled</p> <p>1: Enabled</p> <p>(Default)</p> <p>1: NA and EUR</p> <p>0: ASIA and others</p> <p>Enables or disables the summer time mode.</p> <p>Note</p> <ul style="list-style-type: none"> Make sure that both SP5-307-3 and -4 are correctly set. Otherwise, this SP is not activated even if this SP is set to "1".
5-307-003	Rule Set(Start)	CTL*	<p>[- / 3200210h / -]</p> <p>Specifies the start setting for the summer time mode.</p> <p>There are 8 digits in this SP. For months 1 to 9, the "0" cannot be input in the first digit, so the eight-digit setting for -2 or -3 becomes a seven-digit setting.</p> <p>1st and 2nd digits: The month. [1 to 12]</p> <p>3rd digit: The week of the month. [1 to 5]</p> <p>4th digit: The day of the week. [0 to 6 = Sunday to Saturday]</p> <p>5th and 6th digits: The hour. [00 to 23]</p> <p>7th digit: The length of the advanced time. [0 to 9 / 1 hour /step]</p> <p>8th digit: The length of the advanced time. [0 to 5 / 10 minutes /step]</p> <ul style="list-style-type: none"> The digits are counted from the left. Make sure that SP5-307-1 is set to "1". <p>For example: 3500010 (EU default)</p> <p>The timer is advanced by 1 hour at am 0:00 on the 5th Sunday in March</p>

5-307-004	Rule Set(End)	CTL*	<p>[- / 11100200h / -]</p> <p>Specifies the end setting for the summer time mode.</p> <p>There are 8 digits in this SP.</p> <p>1st and 2nd digits: The month. [1 to 12]</p> <p>3rd digit: The week of the month. [0 to 5]</p> <p>4th digit: The day of the week. [0 to 7 = Sunday to Saturday]</p> <p>5th and 6th digits: The hour. [00 to 23]</p> <p>The 7th and 8 digits must be set to "00".</p> <ul style="list-style-type: none"> • The digits are counted from the left. • Make sure that SP5-307-1 is set to "1".
-----------	---------------	------	--

5401	[Access Control] DFU		
5-401-104	Authentication Time	CTL*	[0 to 255 / 0 / 1sec/step]
5-401-162	Extend Certification Detail	CTL*	<p>[00000000 to 11111111 (00H to ffH) / 00000000 / 1/step]</p> <p>0: On or Enable</p> <p>1: Off or Disable</p> <p>Bit0: Logout with removing card</p> <p>Bit1: Logout with detecting card</p> <p>Bit2: Return from standby with detecting card</p> <p>Bit3: Password manual entry</p> <p>Bit4: Password manual entry</p> <p>Bit5: PIN entry with alphanumeric characters</p> <p>Bit6: Card reading Control</p> <p>Bit7: Locking screen failed logout</p>
5-401-200	SDK1 UniqueID	CTL*	[0 to 255 / 0 / 1sec/step]
5-401-201	SDK1 Certification Method	CTL*	[0 to 255 / 0 / 1sec/step]

5-401-210	SDK2 UniqueID	CTL*	[- / 0 / -]
5-401-211	SDK2 Certification Method	CTL*	
5-401-220	SDK3 UniqueID	CTL*	
5-401-221	SDK3 Certification Method	CTL*	
5-401-230	SDK Cert	CTL*	
5-401-240	Detail Option	CTL*	

5402	<p>[Accsss Control] Bit0: SDKJ Authentication -0: Panel Type -1: Remote Type Bit1: Using user code setup -0: OFF, 1: ON Bit2: Using key-counter setup -0: OFF, 1: ON Bit3: Using external billing device setup -0: OFF, 1: ON Bit4: Using extended external billing device setup -0: OFF, 1: ON Bit5-6: Not used Bit7: Using extended function J limit users -0: OFF, 1: ON</p>		
	5-402-101 to -130	SDKJ1 to 30 Limit Setting	CTL* [- / 0x00 / 0x01/step]

5402	<p>[Accsss Control] Sets limited uses for SDKJ application data.</p>		
	5-402-141 to -170	SDKJ1 to 30 ProductID	CTL* [0 to 0xffffffff / 0 / 1/step]

5404	[User Code Count Clear] Clears the counts for the user codes assigned by the key operator to restrict the use of the machine. Press [Execute] to clear.		
5-404-001	-	CTL	[- / - / -] [Execute]

3

5411	[LDAP-Certification]		
5-411-004	Simplified Authentication	CTL*	[0 or 1 / 1 / 1/step] 0: OFF 1: ON Determines whether easy LDAP certification is done.
5-411-005	Password Null Not Permit	CTL*	[0 or 1 / 1 / 1/step] 0: Password NULL permitted. 1: Password NULL not permitted. This SP is referenced only when SP5411-4 is set to "1" (On).
5-411-006	Detail Option	CTL*	[- / 00000000 / 0x01/step] Bit0: 0: Anonymous certification OFF 1: Anonymous certification ON Bit1 to Bit7: Not used in this model

5412	[Krb-Certification] Sets the level of Kerberos Certification.		
-------------	---	--	--

5-412-100	Encrypt Mode	CTL*	[00000000 to 11111111 (00H to ffH) / 00000000 / 1/step] 0x01:AES256-CTS-HMAC-SHA1-96 0x02:AES128-CTS-HMAC-SHA1-96 0x04:DES3-CBC-SHA1 0x08:RC4-HMAC 0x10:DES-CBC-MD5 0xFF(0x1F):ALL
-----------	--------------	------	--

5413	[Lockout Setting] Sets the lockout setting for local address book.		
5-413-001	Lockout On/Off	CTL*	[0 or 1 / 0 / 1/step] 0: OFF 1: ON Switches on/off the lock on the local address book account.
5-413-002	Lockout Threshold	CTL*	[1 to 10 / 5 / 1time/step] Sets a limit on the frequency of lockouts for account lockouts.
5-413-003	Cancel On/Off	CTL*	[0 or 1 / 0 / 1/step] 0: OFF (lockout not cancelled) 1: ON (system waits, cancels lockout if correct user ID and password are entered) Determines whether the system waits the prescribed.
5-413-004	Cancel Time	CTL*	[1 to 9999 / 60 / 1min./step] Determines the length of time that the system waits for correct input of the user ID and password after a lockout has occurred. This setting is used only if SP5413-3 is set to "1" (on).
5414	[Access Mitigation]		

5-414-001	Mitigation On/Off	CTL *	[0 or 1 / 0 / 1/step] 0: OFF 1: ON Switches on/off masking of continuously used IDs and passwords that are identical.
5-414-002	Mitigation Time	CTL *	[0 to 60 / 15 / 1 min./step] Sets the length of time for excluding continuous access for identical user IDs and passwords.

5415	[Password Attack]		
5-415-001	Permission Number	CTL *	[0 to 100 / 30 / 1 time/step] Sets the number of attempts to attack the system with random passwords to gain illegal access to the system.
5-415-002	Detect Time	CTL *	[1 to 10 / 5 / 1 sec/step] Sets the time limit to stop a password attack once such an attack has been detected.

5416	[Access Information]		
5-416-001	User Max Num	CTL *	[50 to 200 / 200 / 1 users/step] Limits the number of users used by the access exclusion and password attack detection functions.
5-416-002	Password Max Num	CTL *	[50 to 200 / 200 / 1 users/step] Limits the number of passwords used by the access exclusion and password attack detection functions.
5-416-003	Monitor Interval	CTL *	[1 to 10 / 3 / 1 sec/step] Sets the processing time interval for referencing user ID and password information.

5417	[Access Attack]		
-------------	------------------------	--	--

5-417-001	Permissible Number	CTL *	[0 to 500 / 100 / 1 time/step] Sets a limit on access attempts when an excessive number of attempts are detected for MFP features.
5-417-002	Attack Detect Time	CTL *	[10 to 30 / 10 / 1 sec/step] Sets the length of time for monitoring the frequency of access to MFP features.
5-417-003	Cert Waite	CTL *	[0 to 9 / 3 / 1 sec/step] Sets the wait time to slow down the speed of certification when an excessive number of access attempts have been detected.
5-417-004	Attack Max Num	CTL *	[50 to 200 / 200 / 1/step] Sets a limit on the number of requests received for certification in order to slow down the certification speed when an excessive number of access attempts have been detected.

5420	<p>[User Auth] These settings should be done with the System Administrator.</p> <p> Note</p> <ul style="list-style-type: none"> • These functions are enabled only after the user access feature has been enabled. 		
5-420-041	Printer	CTL *	[0 or 1 / 0 / 1/step] 0: Authentication ON 1: Authentication OFF Determines whether certification is required before a user can use the printer applications.
5-420-051	SDK1	CTL *	[0 or 1 / 0 / 1/step] 0: Authentication ON 1: Authentication OFF Determines whether certification is required before a user can use the SDK application.
5-420-061	SDK2	CTL *	
5-420-071	SDK3	CTL *	

5481	[Authentication Error Code] Determines how the authentication failures are displayed.		
5-481-001	System Log Disp	CTL *	[0 or 1 / 0 / 1/step] 0: Display OFF 1: Display ON Determines whether an error code appears in the system log after a user authentication failure occurs.

5501	[PM Alarm Interval] -		
5-501-001	Printout	CTL *	[0 to 9999 / 0 / 1/step] 0: Alarm off 1 to 9999: Alarm goes off when Value (1 to 9999) x 1000 > PM counter

5504	[Jam Alarm]		
5-504-001	-	CTL *	[0 to 3 / 3 / 1/step] 0: Zero (Off) 1: Low (2.5K jams) 2: Medium (3K jams) 3: High (6K jams) Sets the alarm to sound for the specified jam level (document misfeeds are not included).

5505	[Error Alarm] Sets the error alarm level. The error alarm counter counts "1" when any SC is detected. However, the error alarm counter decreases by "1" when an SC is not detected during a set number of copied sheets (for example, default 700 sheets). The error alarm occurs when the SC error alarm counter reaches "5".		
-------------	--	--	--

5-505-001	-	CTL *	[0 to 255 / NA/AA/CHN:15, EU:17 / 1 hundred/step] 0: Alarm Off
-----------	---	-------	---

5507	[Supply/CC Alarm] Enables or disables the notifying a supply call via the @Remote.		
5-507-001	Paper Size	CTL *	[0 or 1 / 0 / 1/step] Switches the control call on/off for the paper supply. DFU 0: No alarm 1: Sets the alarm to sound for the specified number transfer sheets for each paper size (A3, A4, B4, B5, DLT, LG, LT, HLT)
5-507-003	Toner	CTL *	[0 or 1 / 1 / 1/step] Switches the control call on/off for the stapler installed in the finisher. DFU If you select "1" the alarm will sound when the copier detects toner end. 0: Off 1: On
5-507-004	Maintenance Kit	CTL *	[0 to 2 / 1 / 1/step] 0: OFF 1: Supply call Enable 2: CC call Enabled
5-507-005	Drum	CTL *	[0 or 1 / 1 / 1/step] 0: OFF 1: ON
5-507-080	Toner Call Timing	CTL *	[0 or 1 / 0 / 1/step] 0: At replacement 1: AtLessThanThresh Changes the timing of the "Toner Supply Call" via the @Remote, when the following conditions occur.

5-507-081	Toner Call Thresh	CTL *	[10 to 90 / 10 / 10%/step]
5-507-128	Interval: Others	CTL *	[250 to 10000 / 1000 / 1page/step] The "Paper Supply Call Level: nn" SPs specify the paper control call interval for the referenced paper sizes. DFU
5-507-132	Interval: A3	CTL *	
5-507-133	Interval: A4	CTL *	
5-507-134	Interval: A5	CTL *	
5-507-141	Interval: B4	CTL *	
5-507-142	Interval: B5	CTL *	
5-507-160	Interval: DLT	CTL *	
5-507-164	Interval: LG	CTL *	
5-507-166	Interval: LT	CTL *	
5-507-172	Interval: HLT	CTL *	

5515	<p>[SC/Alarm Setting]</p> <p>With NRS (New Remote Service) in use, these SP codes can be set to issue an SC call when an SC error occurs. If this SP is switched off, the SC call is not issued when an SC error occurs.</p>
-------------	---

5-515-001	SC Call	CTL *	[0 or 1 / 1 / 1/step] 0: OFF 1: ON
5-515-002	Service Parts Near End Call	CTL *	
5-515-003	Service Parts End Call	CTL *	
5-515-004	User Call	CTL *	
5-515-006	Communication Test Call	CTL *	
5-515-007	Machine Information Notice	CTL *	
5-515-008	Alarm Notice	CTL *	
5-515-009	Non Genuine Tonner Ararm	CTL *	
5-515-010	Supply Automatic Ordering Call	CTL *	
5-515-011	Supply Management Report Call	CTL *	
5-515-012	Jam/Door Open Call	CTL *	

5517	[Get Machine Info] When SMC info collect is interrupt, retries during the time between receiving Request for obtaining SMC info, to value set with this setting.		
5-517-031	SMCInf:RtryInt	CTL *	[10 to 255 / 10 / 1 min/step]

5731	[Counter Effect] Converts the paper count to the combine count for MK-1 counter.		
5-731-001	MK1 Paper>Combine	CTL *	[0 or 1 / 0 / 1/step]

5745	[DeemedPowerConsumption] Displays the deemed power consumption of each condition.		
-------------	---	--	--

5-745-211	Contoroller Standby	CTL *	[0 to 9999 / 0 / 1/step]
5-745-212	STR	CTL *	
5-745-213	Main Power Off	CTL *	
5-745-214	Scanning and Printing	CTL *	
5-745-215	Printng	CTL *	
5-745-216	Scanning	CTL *	
5-745-217	Engine Standby	CTL *	
5-745-218	Low Power Consumption	CTL *	
5-745-219	Silent condition	CTL *	
5-745-220	Heater Off	CTL *	

5749	[Import/Export] Imports and exports preference information.		
5-749-001	Export	CTL *	[- / - / -]
5-749-101	Import	CTL *	[Execute]

5751	[Key Event Encryption Setting] Specifies the key to encrypt the key information.		
5-751-001	Password	CTL *	[Letters (Up to 31) / NULL / -]

5801	[Memory Clear]		
5-801-001	All Clear	CTL *	[- / - / -] [Execute] Initializes items 002 to 027. Take a memo of the settings prior to execute this SP
5-801-002	Engine	ENG	[0 or 1 / 0 / 1/step] Initializes all registration settings for the engine and copy process settings.

5-801-003	SCS	CTL	[- / - / -] [Execute] Initializes default system settings, SCS (System Control Service) settings, operation display coordinates, and ROM update information.
5-801-004	IMH Memory Clr	CTL	[- / - / -] [Execute]
5-801-005	MCS	CTL	[- / - / -] [Execute] Initializes the Mcs settings.
5-801-008	Printer	CTL	[- / - / -] [Execute] The following service settings: <ul style="list-style-type: none"> • Bit switches • Gamma settings (User & Service) • Toner Limit The following user settings: <ul style="list-style-type: none"> • Tray Priority • Menu Protect • System Setting except for setting of Energy Saver • I/F Setup (I/O Buffer and I/O Timeout) • PCL Menu
5-801-010	GWWS	CTL	[- / - / -] [Execute] Deletes the network file application management files and thumbnails, and initializes the job login ID.

5-801-011	NCS	CTL	[- / - / -] [Execute] All setting of Network Setup (User Menu) (NCS: Network Control Service)
5-801-014	Clear DCS Setting	CTL	[- / - / -] [Execute] Initializes the DCS (Delivery Control Service) settings.
5-801-015	Clear UCS Setting	CTL	[- / - / -] [Execute] Initializes the UCS (User Information Control Service) settings.
5-801-016	MIRS Setting	CTL	[- / - / -] [Execute] Initializes the MIRS (Machine Information Report Service) settings.
5-801-017	CCS	CTL	[- / - / -] [Execute] Initializes the CCS (Certification and Charge-control Service) settings.
5-801-018	SRM Memory Clr	CTL	[- / - / -] [Execute] Initializes the SRM (System Resource Manager) settings.
5-801-019	LCS	CTL	[- / - / -] [Execute]
5-801-021	ECS	CTL	[- / - / -] [Execute] Initializes the ECS settings.

5-801-025	websys	CTL	[- / - / -] [Execute]
5-801-026	PLN	CTL	
5-801-027	SAS	CTL	

5803	[INPUT Check] See page 131 "Input Check Table"		
-------------	--	--	--

5804	[OUTPUT Check] See page 133 "Output Check Table"		
-------------	--	--	--

5810	[SC Reset] Cancel SC of the CE cancellation.		
5-810-001	Fusing SC Reset	ENG	[- / - / -] [Execute]

5811	[MachineSerial]		
5-811-002	Display	ENG	[0 to 255 / 0 / 1/step] Displays the machine serial number.
5-811-004	BCU	ENG	[0 to 255 / 0 / 1/step] Inputs the serial number.

5812	[Service TEL]		
5-812-001	Telephone	CTL*	[up to 16 / - / 1/step] Sets the telephone number for a service representative. This number is printed on the Counter List, which can be printed with the user's "Counter" menu. This can be up to 20 characters (both numbers and alphabetic characters can be input).

5-812-002	Facsimile	CTL*	<p>[up to 16 / - / 1/step]</p> <p>Sets the fax or telephone number for a service representative. This number is printed on the Counter List.</p> <p>This can be up to 20 characters (both numbers and alphabetic characters can be input).</p>
-----------	-----------	------	--

3

5816	[NRS Function]		
5-816-001	I/F Setting	CTL*	<p>[0 to 2 / 2 / 1/step]</p> <p>0: Remote service off</p> <p>1: CSS remote service on</p> <p>2: NRS remote service on</p> <p>Selects the remote service setting.</p>
5-816-002	CE Call	CTL*	<p>[0 or 1 / 0 / 1/step]</p> <p>0: Start of the service</p> <p>1: End of the service</p> <p>Performs the CE Call at the start or end of the service.</p> <p>Note: This SP is activated only when SP5816-001 is set to "1".</p>
5-816-003	Function Flag	CTL*	<p>[0 or 1 / 0 / 1/step]</p> <p>0: Disabled</p> <p>1: Enabled</p> <p>Enables or disables the remote service function.</p> <p>NOTE: This SP setting is changed to "1" after @Remote register has been completed.</p>

5-816-007	SSL Disable	CTL *	<p>[0 or 1 / 0 / 1/step]</p> <p>0: No. SSL used.</p> <p>1: Yes. SSL not used.</p> <p>Controls if RCG (Remote Communication Gate) confirmation is done by SSL during an RCG send for the @Remote over a network interface.</p>
5-816-008	RCG Connect T/O	CTL *	<p>[1 to 90 / 30 / 1second/step]</p> <p>Sets the length of time (seconds) for the timeout when the RCG (Remote Communication Gate) connects during a call via the @Remote network.</p>
5-816-009	RCG Write Timeout	CTL *	<p>[0 to 100 / 60 / 1second/step]</p> <p>Sets the length of time (seconds) for the timeout when sent data is written to the RCG during a call over the @Remote network.</p>
5-816-010	RCG Read Timeout	CTL *	<p>[0 to 100 / 60 / 1second/step]</p> <p>Sets the length of time (seconds) for the timeout when sent data is written from the RCG during a call over the @Remote network.</p>
5-816-011	Port 80	CTL *	<p>[0 or 1 / 0 / 1/step]</p> <p>0: No. Access denied</p> <p>1: Yes. Access granted</p> <p>Controls if permission is given to get access to the SOAP method over Port 80 on the @Remote network.</p>

5816

[Remote Service]

5-816-013	RFU Timing	CTL *	<p>[0 or 1 / 1 / 1/step]</p> <p>0: RFU is executed whenever update request is received.</p> <p>1: RFU is executed only when the machine is in the sleep mode.</p> <p>Selects the timing for the remote firmware updating.</p>
5-816-014	RCG Error Cause	CTL *	<p>[0 or 1 / 0 / 1/step]</p> <p>0: Initial state, normal condition</p> <p>1: Error</p> <p>Displays RCG connection error. cause</p>
5-816-021	Function Flag	CTL *	<p>[0 or 1 / 0 / 1/step]</p> <p>0: Initial state, normal condition</p> <p>1: Error</p> <p>Displays the Embedded RC Gate installation end flag.</p>
5-816-023	Connect Type(N/M)	CTL *	<p>[0 or 1 / 0 / 1/step]</p> <p>0: Initial state, normal condition</p> <p>1: Error</p> <p>Displays/selects the Embedded RC Gate connection method.</p>
5-816-061	NotiTime ExpTime	CTL *	<p>[- / 0 / -]</p> <p>Proximity of the expiration of the certification.</p>
5-816-062	HTTP Proxy use	CTL *	<p>[- / - / -]</p> <p>Determines if the proxy server is used when the machine communicates with the service center.</p>

5-816-063	HTTP Proxy Host	CTL *	<p>[up to 127 / - / 1/step]</p> <p>This SP sets the address of the proxy server used for communication between the RCG device and the gateway. Use this SP to set up or display the customer proxy server address.</p> <p>The address is necessary to set up the embedded RCG-N.</p> <p>Note</p> <ul style="list-style-type: none"> The address display is limited to 128 characters. Characters beyond the 128 character are ignored. This address is customer information and is not printed in the SMC report.
5-816-064	HTTP Proxy Port	CTL *	<p>[0 to 0xffff / 0 / 1/step]</p> <p>This SP sets the port number of the proxy server used for communication between the embedded RCG-N and the gateway. This setting is necessary to set up the embedded RC Gate-N.</p> <p>Note</p> <ul style="list-style-type: none"> This port number is customer information and is not printed in the SMC report.
5-816-065	HTTP Proxy AutUsr	CTL *	<p>[up to 31 / - / 1/step]</p> <p>This SP sets the HTTP proxy certification user name.</p> <p>Note</p> <ul style="list-style-type: none"> The length of the name is limited to 31 characters. Any character beyond the 31st character is ignored. This name is customer information and is not printed in the SMC report.

5-816-066	HTTP Proxy AuthPass	CTL *	<p>[up to 31 / - / 1/step]</p> <p>This SP sets the HTTP proxy certification password.</p> <p>Note</p> <ul style="list-style-type: none"> • The length of the password is limited to 31 characters. Any character beyond the 31st character is ignored. • This name is customer information and is not printed in the SMC report.
-----------	---------------------	-------	---

5-816-067	Cer Updt Cond		CTL*	[- / - / -] Displays the status of the certification update.
	0	The certification used by Embedded RC Gate is set correctly.		
1	The certification request (setAuthKey) for update has been received from the GW URL and certification is presently being updated.			
2	The certification update is completed and the GW URL is being notified of the successful update.			
3	The certification update failed, and the GW URL is being notified of the failed update.			
4	The period of the certification has expired and new request for an update is being sent to the GW URL.			
11	A rescue update for certification has been issued and a rescue certification setting is in progress for the rescue GW connection.			
12	The rescue certification setting is completed and the GW URL is being notified of the certification update request.			
13	The notification of the request for certification update has completed successfully, and the system is waiting for the certification update request from the rescue GW URL.			
14	The notification of the certification request has been received from the rescue GW controller, and the certification is being stored.			
15	The certification has been stored, and the GW URL is being notified of the successful completion of this event.			
16	The storing of the certification has failed, and the GW URL is being notified of the failure of this event.			
17	The certification update request has been received from the GW URL, the GW URL was notified of the results of the update after it was completed, but a certification error has been received, and the rescue certification is being recorded.			
18	The rescue certification of No. 17 has been recorded, and the GW URL is being notified of the failure of the certification update.			

5-816-068	Cer Abnml Cause		CTL *	[- / - / -] Displays a number code that describes the reason for the request for update of the certification.
	0	Normal. There is no request for certification update in progress.		
	1	Request for certification update in progress. The current certification has expired.		
	2	An SSL error notification has been issued. Issued after the certification has expired.		
	3	Notification of shift from a common authentication to an individual certification.		
	4	Notification of a common certification without ID2.		
	5	Notification that no certification was issued.		
6	Notification that GW URL does not exist.			
5-816-069	Cer Updt ReqID		CTL *	[- / - / -] The ID of the request for certification.
5-816-083	Firm Updating		CTL *	[- / - / -] Displays the status of the firmware update.
5-816-085	Firm UpUsr Conf		CTL *	[- / - / -] Determines if the operator can confirm the previous version of the firmware before the firmware update execution. If the option to confirm the previous version is selected, a notification is sent to the system manager and the firmware update is done with the firmware files from the URL.
5-816-086	Firmware Size		CTL *	[- / - / -] Allows the service technician to confirm the size of the firmware data files during the firmware update execution.
5-816-087	CERT:MacroVsn		CTL *	[- / - / -] Displays the macro version of the @Remote certification.

5-816-088	CERT:PAC Vsn	CTL *	[- / - / -] Displays the PAC version of the @Remote certification.
5-816-089	CERT:ID2 Code	CTL *	[- / - / -] Displays ID2 for the @Remote certification. Spaces are displayed as underscores (_). Asterisks (*) indicate that no @Remote certification exists. "000000_____" indicates "Common certification".
5-816-090	CERT:Subject	CTL *	[- / - / -] Displays the common name of the @Remote certification subject. CN = the following 17 bytes. Spaces are displayed as underscores (_). Asterisks (*) indicate that no @Remote certification exists. "000000_____" indicates "Common certification".
5-816-091	CERT:SeriNum	CTL *	[- / - / -] Displays serial number for the @Remote certification. Asterisks (*) indicate that no @Remote certification exists.
5-816-092	CERT:Issuer	CTL *	[- / - / -] Displays the common name of the issuer of the @Remote certification. CN = the following 30 bytes. Asterisks () indicate that no @Remote certification exists.
5-816-093	CERT:St ExpTime	CTL *	[- / - / -] Displays the start time of the period for which the current @Remote certification is enabled.
5-816-094	CERT:End ExpTime	CTL *	[- / - / -] Displays the end time of the period for which the current @Remote certification is enabled.

5-816-102	CERT:Encrypt Lv	CTL *	[- / 1 / -] Displays cryptic strength of the NRS certification.
5-816-200	Poling Man Exc	CTL *	[- / - / -] [Execute] Executes the center polling manually.
5-816-201	Instl:Condition	CTL *	[0 to 4 / 0 / 1/step] Displays a number that indicates the status of the @Remote service device. 0: Neither the @Remote device nor Embedded RCG Gate is set. 1: The Embedded RCG Gate is being set. Only Box registration is completed. In this status, @Remote device cannot communicate with this device. 2: The Embedded RCG Gate is set. In this status, the @Remote device cannot communicate with this device. 3: The @Remote device is being set. In this status the Embedded RCG Gate cannot be set. 4: The @Remote module has not started.
5-816-202	Instl:ID #	CTL *	[- / - / -] Allows entry of the request number needed for the Embedded RCG Gate.
5-816-203	Instl:Reference	CTL *	[- / - / -] [Execute] Executes the confirmation request to the @Remote Gateway.

5-816-204	Instl:Ref Rslt	CTL *	<p>[0 to 255 / 0 / 1/step]</p> <p>Displays a number that indicates the result of the inquiry executed with SP5816-203.</p> <p>0: Succeeded</p> <p>1: Inquiry number error</p> <p>3: Proxy error (proxy enabled)</p> <p>4: Proxy error (proxy disabled)</p> <p>5: Proxy error (Illegal user name or password)</p> <p>6: Communication error</p> <p>8: Other error</p> <p>9: Inquiry executing</p>
5-816-205	Instl:Ref Section	CTL *	<p>[- / - / -]</p> <p>Displays the result of the notification sent to the device from the GW URL in answer to the inquiry request. Displayed only when the result is registered at the GW URL.</p>
5-816-206	Instl:Rgstltn	CTL *	<p>[- / - / -]</p> <p>[Execute]</p> <p>Executes "Embedded RCG Registration".</p>
5-816-207	Instl:Rgstltn Rst	CTL *	<p>[0 to 255 / 0 / 1/step]</p> <p>Displays a number that indicates the registration result.</p> <p>0: Succeeded</p> <p>1: Inquiry number error</p> <p>2: Registration in progress</p> <p>3: Proxy error (proxy enabled)</p> <p>4: Proxy error (proxy disabled)</p> <p>5: Proxy error (Illegal user name or password)</p> <p>8: Other error</p> <p>9: Registration executing</p>

5-816-208	Instl:ErrorCode	CTL *	[-2147483647 to 2147483647 / -]
	Cause	Code	Meaning
	Illegal Modem Parameter	-11001	Chat parameter error
		-11002	Chat execution error
		-11003	Unexpected error
		-11004	Cutting process occurred during modem communication.
		-11005	NCS reboot occurred during modem communication.
		-12002	Inquiry, registration attempted without acquiring device status.
		-12003	Attempted registration without execution of an inquiry and no previous registration.
		-12004	Attempted setting with illegal entries for certification and ID2.
		-12005	@Remote communication is prohibited. The device has an Embedded RC gate-related problem.
	Operation Error, Incorrect Setting	-12006	A confirmation request was made after the confirmation had been already completed.
		-12007	The request number used at registration was different from the one used at confirmation.
		-12008	Update certification failed because mainframe was in use.
		-12009	D2 mismatch between an individual certification and NVRAM.
		-12010	Certification area is not initialized.

		-2385	Attempted dial up overseas without the correct international prefix for the telephone number.
		-2387	Not supported at the Service Center
		-2389	Database out of service
		-2390	Program out of service
		-2391	Two registrations for same device
		-2392	Parameter error
		-2393	Basil not managed
		-2394	Device not managed
		-2395	Box ID for Basil is illegal
		-2396	Device ID for Basil is illegal
		-2397	Incorrect ID2 format
		-2398	Incorrect request number format
5-816-209	Instl Clear	CTL	[- / - / -] [Execute] Releases the machine from its embedded RCG setup.
5-816-240	CommErrorTime	CTL	
5-816-241	CommErrorCode 1	CTL	[- / - / -]
5-816-242	CommErrorCode 2	CTL	[Execute]
5-816-243	CommErrorCode 3	CTL	
5-816-244	CommErrorState 1	CTL	
5-816-245	CommErrorState 2	CTL	[- / - / -] [Execute]
5-816-246	CommErrorState 3	CTL	
5-816-247	SSL Error Count	CTL*	
5-816-248	Other Err Count	CTL*	[- / 0 / -]

5-816-250	Print Com Log	CTL	[- / - / -] [Execute]
-----------	---------------	-----	--------------------------

5821	[Remote Service Address]		
5-821-002	RCG IP Address	CTL*	[00000000h to FFFFFFFFh / 00000000h / 1/step] Sets the IP address of the RCG (Remote Communication Gate) destination for call processing at the remote service center.
5-821-003	RCG Port	CTL*	[0 to 65535/ 443 / 1/step] Sets the port number of the RCG (Remote Communication Gate) destination for call processing at the remote service center.
5-821-004	RCG URL Path	CTL*	[0 to 16 characters (half characters) Default /RCG/services/ -]

5824	[NV-RAM Upload]		
5-824-001	-	CTL	[- / - / -] [Execute] Uploads the NVRAM data to an SD card. Push Execute. Note: When uploading data in this SP mode, the front door must be open.

5825	[NV-RAM Download] Downloads data from an SD card to the NVRAM in the machine. After downloading is completed, remove the card and turn the machine power off and on.		
5-825-001	-	CTL	[- / - / -] [Execute]

5828	[Network Setting] Job spool settings/ Interface selection for Ethernet and wireless LAN		
-------------	---	--	--

5-828-050	1284 Compatibility (Centro)		CTL *	[- / - / -]
5-828-052	ECP (Centro)		CTL *	[- / - / -]
5-828-065	Job Spooling		CTL *	[0 or 1 / 0 / 1 /step] Switches the job spooling on and off. 0: No spooling 1: Spooling enabled
5-828-066	Job Spooling Clear: Start Time		CTL *	[0 or 1 / 1 / 1 /step] Determines whether the job interrupted at power off is resumed at the next power on. This SP operates only when SP5828-065 is set to "1". 0: ON 1: OFF
5-828-069	Job Spooling (Protocol)		CTL *	[0 or 1 / 1 / 1 /step] Determines whether job spooling is enabled or disabled for each protocol. This is an 8-bit setting.
	0	LPR	4	BMLinks (Japan Only)
	1	FTP (Not Used)	5	DIPRINT
	2	IPP	6	Reserved (Not Used)
	3	SMB	7	Reserved (Not Used)

5-828-087	Protocol usage	CTL*	<p>[- / - / -]</p> <p>Shows which protocols have been used with the network.</p> <p>0: Off (Not used the network with the protocol.)</p> <p>1: On (Used the network with the protocol once or more.)</p> <p>bit0: IPsec, bit1: IPv6, bit2: IEEE 802. 1X, bit3: Wireless LAN,</p> <p>bit4: Security mode level setting, bit5: Appletalk, bit6: DHCP,</p> <p>bit7: DHCPv6, bit8: telnet, bit9: SSL, bit10: HTTPS,</p> <p>bit11: BMLinkS printing, bit12: diprint printing, bit13: LPR printing,</p> <p>bit14: ftp printing, bit15: rsh printing, bit16: SMB printing,</p> <p>bit17: WSD-Printer, bit18: WSD-Scanner, bit19: Scan to SMB,</p> <p>bit20: Scan to NCP, bit21: Reserve, bit22: Bluetooth,</p> <p>bit23: IEEE 1284, bit24: USB printing, bit25: Dynamic DNS,</p> <p>bit26: Netware printing, bit27: LLTD, bit28: IPP printing,</p> <p>bit29: IPP printing (SSL), bit30: ssh, bit31: sftp</p>
5-828-090	TELNET(0:OFF 1:ON)	CTL*	<p>[0 or 1 / 1 / 1/step]</p> <p>Enables or disables the Telnet protocol.</p> <p>0: Disable, 1: Enable</p>
5-828-091	Web (0:OFF 1:ON)	CTL*	<p>[0 or 1 / 1 / 1/step]</p> <p>Enables or disables the Web operation.</p> <p>0: Disable, 1: Enable</p>

5-828-145	Active IPv6 Link Local Address	CTL*	<p>[- / - / -]</p> <p>This is the IPv6 local address link referenced on the Ethernet or wireless LAN (802.11b) in the format:</p> <p>"Link Local Address" + "Prefix Length"</p> <p>The IPv6 address consists of a total 128 bits configured in 8 blocks of 16 bits each.</p>
5-828-147	Active IPv6 Stateless Address 1	CTL*	<p>[- / - / -]</p> <p>These SPs are the IPv6 status addresses (1 to 5) referenced on the Ethernet or wireless LAN (802.11b) in the format:</p> <p>"Status Address" + "Prefix Length"</p> <p>The IPv6 address consists of a total 128 bits configured in 8 blocks of 16 bits each.</p>
5-828-149	Active IPv6 Stateless Address 2	CTL*	
5-828-151	Active IPv6 Stateless Address 3	CTL*	
5-828-153	Active IPv6 Stateless Address 4	CTL*	
5-828-155	Active IPv6 Stateless Address 5	CTL*	
5-828-156	IPv6 Manual Address	CTL*	<p>[- / - / -]</p> <p>This SP is the IPv6 manually set address referenced on the Ethernet or wireless LAN (802.11b) in the format:</p> <p>"Manual Set Address" + "Prefix Length"</p> <p>The IPv6 address consists of a total 128 bits configured in 8 blocks of 16 bits each.</p>
5-828-158	IPv6 Gateway Address	CTL*	<p>[- / - / -]</p> <p>This SP is the IPv6 gateway address referenced on the Ethernet or wireless LAN (802.11b). The IPv6 address consists of a total 128 bits configured in 8 blocks of 16 bits each.</p>
5-828-161	IPv6 Stateless Auto Setting	CTL*	<p>[0 or 1 / 1 / 1 /step]</p> <p>Enables or disables the automatic setting for IPv6 stateless.</p> <p>0: Disable, 1: Enable</p>

5-828-236	Web Item visible	CTL *	[0x0000 to 0xffff / FFFh / 0x0001/step] Displays or does not display the Web system items. bit0: Net RICOH bit1: Consumable Supplier bit2-15: Reserved (all)
5-828-237	Web shop Link	CTL *	[0 or 1 / 1 / 1 /step] Displays or does not display the link to Net RICOH on the top page and link page of the web system. 0: Not display 1: Display
5-828-238	Web Supplies link visible	CTL *	[0 or 1 / 1 / 1 /step] Displays or does not display the link to Consumable Supplier on the top page and link page of the web system. 0: Not display 1: Display
5-828-239	Web link1 Name	CTL *	[- / - / -] Confirms or changes the URL1 name on the link page of the web system. The maximum characters for the URL name are 31 characters.
5-828-240	Web link1 URL	CTL *	[- / - / -] Confirms or changes the link to URL1 on the link page of the web system. The maximum characters for the URL are 127 characters.
5-828-241	Web link1 visible	CTL *	[0 or 1 / 1 / 1 /step] Displays or does not display the link to URL1 on the top page of the web system.
5-828-242	Web link2 Name	CTL *	[- / - / -] Same as "-239"

5-828-243	Web Link2 URL	CTL*	[- / - / -] Same as "-240"
5-828-244	Web Link2 visible	CTL*	[- / 1 / -] Same as "-241"
5-828-249	DHCPv6 DUID	CTL*	[- / - / -]

5832	[HDD] Initializes the hard disk. Use this SP mode only if there is a hard disk error.		
5-832-001	Formatting (ALL)	CTL	[- / - / -] [Execute]

5840	[IEEE 802.11]		
5-840-006	Channel MAX	CTL*	[- / 14 / -] DFU
5-840-007	Channel MIN	CTL*	[- / - / -]
5-840-011	WEP Key Select	CTL*	[- / 00000000 / -] Selects the WEP key.
5-840-045	WPA debug Lvl	CTL*	[1 to 3 / 3 / 1/step] Selects the debug level for WPA authentication application. This SP is displayed only when the IEEE802.11 card is installed. 1: Info 2: warning 3: error
5-840-046	11w	CTL*	[0 to 2 / 0 / 1/step]
5-840-047	PSK Set Type	CTL*	[- / - / -]

5842	[GWWS Analysis] This is a debugging tool. It sets the debugging output mode of each Net File process.		
-------------	---	--	--

5-842-001	Setting 1	CTL *	[- / 00000000 / -]
5-842-002	Setting 2	CTL *	

5844	[USB]		
5-844-001	Transfer Rate	CTL*	[- / 0x04 / -] Sets the speed for USB data transmission. 0x01: Full Speed 0x04: Auto Change
5-844-002	Vendor ID	CTL*	[- / 5CAh / -] DFU
5-844-003	Product ID	CTL*	[- / 403h / -] DFU
5-844-004	Device Release Number	CTL*	[- / 100 / -] DFU
5-844-005	Fixed USB Port	CTL*	[0 to 2 / 0 / 1/step] Standardizes for common use the model name and serial number for USB PnP (Plug & Play). It determines whether the driver requires re-installation. 0: OFF 1: Level1 2: Level2
5-844-006	PnP Model Name	CTL*	[up to 20 characters / - / -] Sets the model name to be used by the USB PnP when "Function Enable (Level 2) is set so the USB Serial No. can have a common name (SP5-844-005).

3

5-844-007	PnP Serial Number	CTL*	<p>[- / - / -]</p> <p>Sets the serial number to be used by the USB PnP when "Function Enable (Level 2) set so the USB Serial No. can have a common name (SP5-844-005).</p> <ul style="list-style-type: none"> • Make sure that this entry is the same as the serial number in use. • At initialization the serial number generated from the model name is used, not the setting of this SP code. • At times other than initialization, the value set for this SP code is used.
5-844-008	Mac Supply Level	CTL*	<p>[0 or 1 / 1 / 1/step]</p> <p>0: OFF</p> <p>1: ON</p>
5-844-100	Notify Unsupported	CTL*	[0 or 1 / 1 / 1/step]

5845	[Delivery Srv] These are delivery server settings.		
5-845-003	Retry Interval	CTL*	<p>[0 to 900 / 300 / 1/step]</p> <p>You can configure the interval before the sending of e-mail notification is retried when it fails.</p>
5-845-004	No. of Retries	CTL*	<p>[0 to 99 / 3 / 1/step]</p> <p>You can configure the number of times the sending of e-mail notification is retried when it fails. If this is set to 3, the machine tries to send e-mail notification up to four times.</p>
5-845-022	InstantTrans Off	CTL*	<p>[0 or 1 / 1 / -/step]</p> <p>0: Control disabled</p> <p>1: Control enabled</p> <p>Enables or disables the prevention function for the continuous data sending error.</p>

5846		[UCS Setting]	
5-846-010	LDAP Search TOut	CTL*	[1 to 255 / 60 / 1/step] Sets the length of the timeout for the search of the LDAP server.
5-846-041	AddrB Acl Info	CTL	[- / - / -] [Execute] This SP must be executed immediately after installation of an HDD unit in a basic machine that previously had no HDD. The first time the machine is powered on with the new HDD installed, the system automatically takes the address book from the NVRAM and writes it onto the new HDD. However, the new address book on the HDD can be accessed only by the system administrator at this stage. Executing this SP by the service technician immediately after power on grants full address book access to all users. Procedure <ol style="list-style-type: none"> 1. Turn the machine off. 2. Install the new HDD. 3. Turn the machine on. 4. The address book and its initial data are created on the HDD automatically. 5. However, at this point the address book can be accessed by only the system administrator or key operator. 6. Enter the SP mode and do SP5846-041. After this SP executes successfully, any user can access the address book.

5-846-043	AddrB Media	CTL*	<p>[0 to 30 / 0 / 1 / step]</p> <p>0: Unconfirmed</p> <p>1: SD Slot 1</p> <p>2: SD Slot 2</p> <p>3: SD Slot 3</p> <p>4: USB Flash ROM</p> <p>10: SD Slot 10</p> <p>20: HDD</p> <p>30: Nothing</p>
5-846-047	Ini Local AddrB	CTL	<p>[- / - / -]</p> <p>[Execute]</p> <p>Clears the local address book information, including the user code.</p>
5-846-049	Ini LDAP AddrB	CTL	<p>[- / - / -]</p> <p>[Execute]</p> <p>Clears the LDAP address book information, except the user code.</p>
5-846-050	Ini All AddrB	CTL	<p>[- / - / -]</p> <p>[Execute]</p> <p>Clears all directory information managed by UCS, including all user codes.</p>
5-846-051	Bkup All AddrB	CTL	<p>[- / - / -]</p> <p>[Execute]</p> <p>Uploads all directory information to the SD card.</p>
5-846-052	Restr All AddrB	CTL	<p>[- / - / -]</p> <p>[Execute]</p> <p>Downloads all directory information from the SD card.</p>

<p>5-846-053</p>	<p>Clear Backup Info</p>	<p>CTL</p>	<p>[- / - / -] [Execute] Deletes the address book data from the SD card in the service slot. Deletes only the files that were uploaded from this machine. This feature does not work if the card is write-protected.</p> <p>Note</p> <ul style="list-style-type: none"> After you do this SP, go out of the SP mode, and then turn the power off. Do not remove the SD card until the Power LED stops flashing.
<p>5-846-060</p>	<p>Search Option</p>	<p>CTL *</p>	<p>[0x00 to 0xff / 00001111 / 1/step] This SP uses bit switches to set up the fuzzy search options for the UCS local address book. Bit: Meaning 0: Checks both upper/lower case characters 1: Japan Only 2: Japan Only 3: Japan Only 4 to 7: Not Used</p>

5-846-062	Compl Opt1	CTL*	<p>[0 to 32 / 0 / 1/step]</p> <p>Use this SP to set the conditions for password entry to access the local address book. Specifically, this SP limits the password entry to upper case and sets the length of the password.</p> <p> Note</p> <ul style="list-style-type: none"> • This SP does not normally require adjustment. • This SP is enabled only after the system administrator has set up a group password policy to control access to the address book.
5-846-063	Compl Opt2	CTL*	<p>[0 to 32 / 0 / 1/step]</p> <p>Use this SP to set the conditions for password entry to access the local address book. Specifically, this SP limits the password entry to lower case and defines the length of the password.</p>
5-846-064	Compl Opt3	CTL*	<p>[0 to 32 / 0 / 1/step]</p> <p>Use this SP to set the conditions for password entry to access the local address book. Specifically, this SP limits the password entry to numbers and defines the length of the password.</p>
5-846-065	Compl Opt4	CTL*	<p>[0 to 32 / 0 / 1/step]</p> <p>Use this SP to set the conditions for password entry to access the local address book. Specifically, this SP limits the password entry to symbols and defines the length of the password.</p>
5-846-094	Encryption Stat	CTL*	<p>[0 to 255 / - / 1/step]</p>

5848	<p>[Web Service]</p> <p>Sets the 4-bit switch assignment for the access control setting.</p>
------	---

5-848-004	ac:UD	CTL *	[4bit assign / 00000010 / bit switch]
5-848-009	ac:Job Ctrl	CTL *	[4bit assign / 00000000 / bit switch]
5-848-011	ac:Dev Mng	CTL *	
5-848-022	ac:Uadmin	CTL *	
5-848-024	ac:Log	CTL *	[4bit assign / 0000 / bit switch] 0000: No access control 0001: Access control

5848	[LogTrans] Sets the 4-bit switch assignment for the access control setting.		
5-848-217	Timing	CTL *	[0 to 2 / 0 / 1/step]

5849	[Installation Date] Displays or prints the installation date of the machine.		
5-849-001	Display	CTL *	[- / - / -] Displays the installation date. The installation date is set automatically after test copies are done at the installation site.
5-849-002	Print	CTL *	[0 or 1 / 1 / 1 /step] 0: OFF (No Print) 1: ON (Print) Determines whether the installation date is printed on the printout for the total counter.
5-849-003	Total Counter	CTL *	[0 to 99999999 / 0 / 1/step] Displays the total counts at the installed date (SP5-849-001).

5851	[Bluetooth]		
-------------	--------------------	--	--

5-851-001	Mode	CTL *	[0 or 1 / 0 / 1/step] Sets the operation mode for the Bluetooth Unit. 0: Public 1: Private
-----------	------	----------	---

5856	[Remote ROM Update] Allows reception of firmware data via the local port (IEEE 1284) during a remote ROM update, when the value set to "1". This setting is reset to "0" after the machine is cycled off and on. Allows the technician to upgrade the firmware using a parallel cable.		
5-856-002	Local Port	CTL	[0 or 1 / 0 / 1/step] 0: Disable 1: Enable

5857	[Debug Log Save]		
5-857-001	ON/OFF	CTL *	[0 to 2 / 0 / 1/step] 0: Enables the Log trace 1: Enables the debug log saving 2: OFF Switches on the debug log feature. The debug log cannot be captured until this feature is switched on.
5-857-002	Target (2:HDD 3:SD)	CTL *	[1 to 3 / 2 / 1/step] 1: IC Card 2: HDD 3: SD Card Selects the destination where the debugging information generated by the event selected by SP5-858 will be stored if an error is generated.
5-857-101	Start Date	CTL *	[- / 20120101 / 1/step] Sets start date of the debug log output.

5-857-102	End Date	CTL *	[- / 20371212 / -] Sets end date of the debug log output.
5-857-103	All Logs	CTL *	[- / - / -] [Execute] Obtains all debug logs.
5-857-104	ControllerLogs	CTL *	[- / - / -] [Execute] Obtains controller debug logs.
5-857-105	EngineDebugLogs	CTL *	[- / - / -] [Execute] Obtains engine debug logs.
5-857-107	OpepanelDebugLogs	CTL *	[- / - / -] [Execute] Obtains controller debug logs to the media inserted front I/F.
5-857-120	Make LogTrace Dir	CTL *	[- / - / -] [Execute]

5860	[SMTP/POP3/IMAP4]		
5-860-002	SMTP Srvr Port No	CTL *	[1 to 65535 / 25 / 1 /step] This SP sets the number of the SMTP server port.
5-860-003	SMTP Authentication	CTL *	[0 to 1 / 0 / 1 /step] This setting switches SMTP certification on and off for mail sending. 0: Off 1: On
5-860-006	SMTP Auth. Encryption	CTL *	[0 to 2 / 0 / 1 /step] This setting determines whether the password for SMTP certification is encrypted. 0: Automatic, 1: No encryption done, 2: Encryption done

5-860-007	POP before SMTP	CTL *	<p>[0 to 1 / 0 / 1 / step]</p> <p>This setting determines whether the transmission connects with the POP server first for certification before it connects to the SMTP server for sending.</p> <p>0: Off 1: On</p>
5-860-008	POPtoSMTP Waiting Time	CTL *	<p>[0 to 10000 / 300 / 1 / step]</p> <p>This SP sets the amount of time to allow for the connection to the SMTP server after the transmission has connected to the POP server and been certified during the execution of POP Before SMTP.</p>
5-860-009	Mail Receive Protocol	CTL *	<p>[0 to 3 / 1 / 1 / step]</p> <p>This SP specifies a protocol for the mail reception or switches off receiving.</p> <p>0: No receiving, 1: POP3 protocol 2: IMAP4 protocol, 3: SMTP protocol</p>
5-860-013	POP3/IMAP4 Auth. Encryption	CTL *	<p>[0 to 2 / 0 / 1 / step]</p> <p>This SP specifies whether password encryption is done for POP3/IMAP4 certification.</p> <p>0: Automatic, 1: No encryption done, 2: Encryption done</p>
5-860-014	POP3 Srvr Port No	CTL *	<p>[1 to 65535 / 110 / 1 / step]</p> <p>This SP sets the number of the POP3 server port.</p>
5-860-015	IMAP4 Srvr Port No	CTL *	<p>[1 to 65535 / 143 / 1 / step]</p> <p>This SP sets the number of the IMAP4 server port.</p>
5-860-016	SMTP Rx Port No	CTL *	<p>[1 to 65535 / 25 / 1 / step]</p> <p>This SP sets the number of the port that receives SMTP mail.</p>

5-860-017	Mail Rx Interval	CTL*	[2 to 1440 / 3 / 1 / -] This SP sets the timing for mail received at regular intervals.
5-860-019	Mail Keep Setting	CTL*	[0 to 2 / 0 / 1 /step] This SP setting determines whether received mail is stored on the server. 0: Received mail not stored 1: All received mail stored 2: Stores only mail that generated errors during receiving
5-860-020	ParMail RecTOut	CTL*	[1 or 168 / 72 / 1/step] Sets the amount of time to wait before saving a mail that breaks up during reception. The received mail is discarded if the remaining portion of the mail is not received during this prescribed time.
5-860-021	MDN ResRFC2298	CTL*	[0 or 1 / 1 / 1/step] 0: No 1: Yes Determines whether RFC2298 compliance is switched on for MDN reply mail.
5-860-022	SMTPAut FieldRep	CTL*	[0 or 1 / 0 / 1/step] 0: No 1: Yes If an SMTP authentication such as POP before SMTP and SMTP AUTH processes when sending a mail, determines whether to replace the FROM field of the header with the account for authentication.

5-860-025	SMTPAut DirectSet	CTL*	<p>[- / 00000000 / -]</p> <p>Occasionally, SMTP certification may fail with encryption enabled for the SMTP server. This can occur if the SMTP server does not meet RFC standards. In such cases you can use this SP to set the SMTP certification method directly. However, this SP can be used only encryption has been enabled.</p> <p>Selects the authentication method for SMTP.</p> <p>Bit switch:</p> <p>Bit 0: LOGIN</p> <p>Bit 1: PLAIN</p> <p>Bit 2: CRAM MD5</p> <p>Bit 3: DIGEST MD5</p> <p>Bit 4 to 7: Not used</p>
5-860-026	S/MIME Header	CTL*	<p>[0 to 2 / 0 / 1 /step]</p> <p>Selects the MIME header type of an E-mail sent by S/MIME.</p> <p>0: Microsoft Outlook Express standard</p> <p>1: Internet Draft standard</p> <p>2: RFC standard</p>

5866	[E-Mail Report]		
5-866-001	Report Validity	CTL	<p>[0 or 1 / 0 / 1/step]</p> <p>Enables or disables the E-mail alert function.</p>
5-866-005	Add Date Field	CTL*	<p>[0 or 1 / 0 / 1/step]</p> <p>Adds or does not add the date field to the header of the alert mail.</p> <p>0: Not added</p> <p>1: Added</p>

5869	[RAM Disk Setting]		
	<p>Enables or disables the email sending/receiving function.</p> <p>Although the RAM Disk size for receiving email can be configured with this setting, the system will manage the size because the size (MB) depends on each machine.</p> <p>The RAM Disk will be created during gwinit started, thus it will be applied with the main power OFF/ON after SCS(SP) writes the size on the NVRAM of gwinit.</p>		
5-869-001	Mail Function	CTL	<p>[0 or 1 / 0 / 1/step]</p> <p>0: Enabled</p> <p>1: Disabled</p>

5870	[Common Key Info Writing]		
	<p>Writes to flash ROM the common proof for validating the device for NRS specifications.</p>		
5-870-001	Writing	CTL	<p>[- / - / -]</p> <p>[Execute]</p> <p>Writes the authentication data (used for NRS) in the memory.</p>
5-870-003	Initialize	CTL	<p>[- / - / -]</p> <p>[Execute]</p>
5870	[Com Key Info WR]		
	<p>Writes to flash ROM the common proof for validating the device for NRS specifications.</p>		
5-870-004	Writing: 2048bit	CTL	<p>[- / - / -]</p> <p>[Execute]</p> <p>Writes the authentication data 2048bit (used for NRS) in the memory.</p>

5873	[SD Card Appli Move]		
	<p>Allows you to move applications from one SD card to another.</p>		
5-873-001	MoveExec	CTL	<p>[- / - / -]</p> <p>[Execute]</p> <p>This SP copies the application programs from the original SD card to another.</p>

5-873-002	UndoExec	CTL	[- / - / -] [Execute] This SP copies back the application programs from an SD card to the original SD card. Use this menu when you have mistakenly copied some programs by using "Move Exec" (SP5873-1).
-----------	----------	-----	--

5875	[SC Auto Reboot] Determines whether the machine reboots automatically when an SC error occurs.		
5-875-001	Reboot Mode	CTL *	[0 or 1 / 0 / 1/step] Enables or disables the automatic reboot function when an SC error occurs. The reboot is not executed for Type A or C SC codes. 0: The machine reboots automatically when the machine issues an SC error and logs the SC error code. If the same SC occurs again, the machine does not reboot. 1: The machine does not reboot when an SC error occurs.
5-875-002	Reboot Method	CTL *	[0 or 1 / 1 / 1/step] 0: Manual reboot 1: Automatic reboot Selects the reboot method for SC.

5878	[Option Setup] Enables the Data Overwrite Security option or HDD Encryption Option after installation.		
5-878-001	DataOverwriteSec.	CTL	[- / - / -] [Execute]
5-878-002	HDD Encryption	CTL	[- / - / -] [Execute] Executes the encryption set-up.

5887	<p>[SD GetCounter]</p> <p>This SP sends a text file to an SD card inserted in SD card Slot 2 (lower slot). The operation stores.</p> <p>The file is stored in a folder created in the root directory of the SD card called SD_COUNTER.</p> <p>The file is saved as a text file (*.txt) prefixed with the number of the machine.</p> <p>Insert the SD card in SD card Slot 2 (lower slot).</p> <p>Select SP5887 then touch [EXECUTE].</p> <p>Touch [Execute] in the message when you are prompted.</p> <p>Note</p> <ul style="list-style-type: none"> “SD_COUNTER” folder must be created under the root directory of the SC card before this SP is executed. 		
	5-887-001	-	<p>CTL</p> <p>[- / - / -]</p> <p>[Execute]</p>

5888	<p>[Person. InfoProt.]</p> <p>Selects the protection level for logs.</p>		
5-888-001	-	<p>CTL</p> <p>*</p>	<p>[0 or 1 / 0 / 1/step]</p> <p>0: No authentication, No protection for logs</p> <p>1: No authentication, Protected logs (only an administrator can see the logs)</p>

5893	<p>[SDK Apli Cnt Name]</p> <p>Displays the counter name of each SDK application.</p>		
5-893-001	SDK-1	CTL	<p>[- / - / -]</p> <p>[Display text]</p>
5-893-002	SDK-2	CTL	
5-893-003	SDK-3	CTL	
5-893-004	SDK-4	CTL	<p>[- / - / -]</p> <p>[Display text]</p>
5-893-005	SDK-5	CTL	
5-893-006	SDK-6	CTL	

5894	[ExternalCountSet] Switch the Charge Mode of External Mech Count		
5-894-001	SW Change Mode	ENG *	[0 to 2 / 0 / 1/step]
5907	[Plug & Play] Selects the brand name and the production name for Windows Plug & Play. This information is stored in the NVRAM. If the NVRAM is defective, these names should be registered again. After selecting, press the "Original Type" key and "#" key at the same time. When the setting is completed, the beeper sounds five times.		
5-907-001	-	CTL *	[- / - / -]
5930	[MeterClick Charge]		
5-930-001	Setting	ENG *	[0 or 1 / 0 / 1/step]
5931	[Life Alert Disp.]		
5-931-001	Maintenance Kit	ENG *	[0 or 1 / 0 / 1/step]
5-931-002	PCDU	ENG *	
5-931-002	PCDU STOP	ENG *	
5987	[Mech. Counter] This SP detects that a mechanical counter device is removed. If it is detected, SC610 occurs.		
5-987-001	0:OFF / 1:ON	ENG *	[0 or 1 / 0 / 1/step] 0: OFF. 1: ON
5990	[SP Print Mode] Prints out the SMC sheets.		
5-990-001	All	CTL	[- / - / -] [Execute] Press "Execute" key to start printing the SMC sheets.

5-990-002	SP	CTL	[- / - / -] [Execute] Press "Execute" key to start printing the SMC sheets.
5-990-004	Logging Data	CTL	
5-990-005	Diagnostic Report	CTL	
5-990-006	Non-Default	CTL	
5-990-007	NIB Summary	CTL	
5-990-024	SDK/J Summary	CTL	
5-990-025	SDK/J Appli. Info	CTL	
5-990-026	Printer SP	CTL	

5992	[SP Text Mode] Exports the SMC sheet data to the SD Card. Press "Execute" key to start exporting the SMC data in the SP mode display.		
5-992-001	All	CTL	[- / - / -]
5-992-002	SP	CTL	[Execute]
5-992-004	Logging Data	CTL	[- / - / -] [Execute]
5-992-005	Diagnostic Report	CTL	
5-992-006	Non-Default	CTL	
5-992-007	NIB Summary	CTL	
5-992-024	SDK/J Summary	CTL	[- / - / -] [Execute]
5-992-025	SDK/J Appli. Info	CTL	
5-992-026	Printer SP	CTL	

5997	[PSC] PSC debug SP		
5-997-001	COMMAND	ENG	[0 to 3 / 2 / 1 / step]
5-997-002	DOMAIN_IF	ENG	[0 to 3 / 0 / 1 / step]
5-997-003	RAPI	ENG	[0 to 3 / 0 / 1 / step]

5-997-004	RAPI	ENG	[0 to 3 / 0 / 1 / step]
5-997-005	ENGINE	ENG	[0 to 3 / 0 / 1 / step]
5-997-006	THREAD	ENG	[0 to 3 / 0 / 1 / step]
5-997-007	THREAD_OBJ	ENG	[0 to 3 / 0 / 1 / step]
5-997-008	STS_TREE	ENG	[0 to 3 / 0 / 1 / step]
5-997-009	TREE_INIT	ENG	[0 to 3 / 0 / 1 / step]
5-997-010	EVENT	ENG	[0 to 3 / 0 / 1 / step]
5-997-011	SP	ENG	[0 to 3 / 0 / 1 / step]
5-997-012	OTHER	ENG	[0 to 3 / 0 / 1 / step]
5-997-013	MEMORY	ENG	[0 to 3 / 0 / 1 / step]

Main SP Tables-7

SP7-XXX (Data Log)

3

7401	<p>[Total SC] Stores total SC occurring count. If the same SC codes are detected continuously and total counter is not increasing, it only logs once in case of deleting other SC code logs.</p>		
	7-401-001	SC Counter	CTL *
	7-401-002	Total SC Counter	CTL *
			[0 to 65535 / - / 1/step]

7403	<p>[SC History] Logs and displays the SC codes detected. The 10 most recently detected SC Codes are displayed on the screen, and also can be seen on the SMC (logging) outputs.</p> <p>Note</p> <ul style="list-style-type: none"> If the same SC codes are detected continuously and total counter is not increasing, it only logs once in case of deleting other SC code logs. 		
	7-403-001	Latest	CTL *
	7-403-002	Latest 1	CTL *
	7-403-003	Latest 2	CTL *
	7-403-004	Latest 3	CTL *
	7-403-005	Latest 4	CTL *
	7-403-006	Latest 5	CTL *
	7-403-007	Latest 6	CTL *
	7-403-008	Latest 7	CTL *
	7-403-009	Latest 8	CTL *
	7-403-010	Latest 9	CTL *
			[0 to 65535 / - / 1/step]

7404	[SC990 / SC991 History]			
	Logs and displays the SC990 / SC991 detected.			
	The 10 most recently detected SC.			
	<div style="border: 1px solid blue; border-radius: 10px; padding: 2px; display: inline-block;"> Note </div>			
	<ul style="list-style-type: none"> If the same SC codes are detected continuously and total counter is not increasing, it only logs once in case of deleting other SC code logs. 			
	7-404-001	Latest	CTL *	[- / - / -]
	7-404-002	Latest 1	CTL *	
	7-404-003	Latest 2	CTL *	
	7-404-004	Latest 3	CTL *	
	7-404-005	Latest 4	CTL *	
	7-404-006	Latest 5	CTL *	[- / - / -]
7-404-007	Latest 6	CTL *		
7-404-008	Latest 7	CTL *		
7-404-009	Latest 8	CTL *		
7-404-010	Latest 9	CTL *		

7502	[Total Paper Jam]		
	Displays the total number of jams detected.		
	7-502-001	Jam Counter	CTL *
7-502-002	Total Jam Counter	CTL *	[00000 to 65535 / 0 / 1/step]

7504	[Paper Jam Count by Location]		
	Displays counts for transfer paper jam for each incidence place.		
7-504-001	At Power On	CTL *	<div style="border: 1px solid blue; border-radius: 10px; padding: 2px; display: inline-block;"> Note </div> <ul style="list-style-type: none"> Paper is not fed at power on.

7-504-003	Tray1: On	CTL *	[0000 to 9999 / - / 1/step]
7-504-004	Tray2: On	CTL *	
7-504-005	Tray3: On	CTL *	
7-504-006	Tray4: On	CTL *	
7-504-008	Bypass: On	CTL *	
7-504-009	Duplex: On	CTL *	
7-504-013	Transport 2: On	CTL *	
7-504-014	Transport 3: On	CTL *	
7-504-017	Registration: On	CTL *	
7-504-020	Paper Exit: On	CTL *	[0000 to 9999 / - / 1/step]
7-504-023	Duplex Inverter: On	CTL *	
7-504-026	Duplex Entrance: On	CTL *	
7-504-053	Transport 2: Off	CTL *	
7-504-054	Transport 3: Off	CTL *	
7-504-055	Transport 4: Off	CTL *	
7-504-057	Registration Sensor: Off	CTL *	
7-504-060	Paper Exit: Off	CTL *	
7-504-063	Duplex Inverter: Off	CTL *	
7-504-066	Duplex Entrance: Off	CTL *	

7506	<p>[Jam Count by Paper Size] Displays the number of jams according to the paper size.</p>
-------------	---

7-506-005	A4 LEF	CTL *	[0000 to 9999 / 0 / 1/step]
7-506-006	A5 LEF	CTL *	
7-506-014	B5 LEF	CTL *	
7-506-038	LT LEF	CTL *	
7-506-044	HLT LEF	CTL *	
7-506-132	A3 SEF	CTL *	
7-506-133	A4 SEF	CTL *	
7-506-134	A5 SEF	CTL *	[0000 to 9999 / 0 / 1/step]
7-506-141	B4 SEF	CTL *	
7-506-142	B5 SEF	CTL *	
7-506-160	DLT SEF	CTL *	
7-506-164	LG SEF	CTL *	
7-506-166	LT SEF	CTL *	
7-506-172	HLT SEF	CTL *	
7-506-255	Other	CTL *	

7507	[Dsply-P Jam Hist] Logs and displays the 10 most recent detected transfer paper jams. (CAUSE, SIZE, TOTAL, DATE)		
7-507-001	Latest	CTL *	[0 to 9999 / 0 / 1 sheets/step]
7-507-002	Latest 1	CTL *	
7-507-003	Latest 2	CTL *	
7-507-004	Latest 3	CTL *	
7-507-005	Latest 4	CTL *	

7-507-006	Latest 5	CTL *	[0 to 9999 / 0 / 1 sheets/step]
7-507-007	Latest 6	CTL *	
7-507-008	Latest 7	CTL *	
7-507-009	Latest 8	CTL *	
7-507-010	Latest 9	CTL *	

3

7514	[Paper Jam Count by Location]		
	Total counter of transfer paper jam by each incidence place. Displays occurring count of transfer paper jams by each incidence place.		
7-514-001	At Power On	CTL *	[0000 to 9999 / - / 1/step]
7-514-003	Tray 1: On	CTL *	
7-514-004	Tray 2: On	CTL *	
7-514-005	Tray 3: On	CTL *	
7-514-006	Tray 4: On	CTL *	
7-514-008	Bypass: On	CTL *	
7-514-009	Duplex: On	CTL *	
7-514-013	Transport 2: On	CTL *	[0000 to 9999 / - / 1/step]
7-514-014	Transport 3: On	CTL *	
7-514-017	Registration: On	CTL *	
7-514-020	Paper Exit: On	CTL *	
7-514-023	Duplex Inverter: On	CTL *	
7-514-026	Duplex Entrance: On	CTL *	

7-514-053	Transport 2: Off	CTL *	[0000 to 9999 / - / 1/step]
7-514-054	Transport 3: Off	CTL *	
7-514-057	Transport 4: Off	CTL *	
7-514-060	Registration: Off	CTL *	
7-514-063	Paper Exit: Off	CTL *	
7-514-066	Duplex Inverter: Off	CTL *	

7516	[PaperSize Jam Cnt]		
7-516-005	A4 LEF	CTL *	[0000 to 9999 / - / 1/step]
7-516-006	A5 LEF	CTL *	
7-516-014	B5 LEF	CTL *	
7-516-038	LT LEF	CTL *	
7-516-044	HLT LEF	CTL *	
7-516-132	A3 SEF	CTL *	[0000 to 9999 / - / 1/step]
7-516-133	A4 SEF	CTL *	
7-516-134	A5 SEF	CTL *	
7-516-141	B4 SEF	CTL *	
7-516-142	B5 SEF	CTL *	
7-516-160	DLT SEF	CTL *	
7-516-164	LG SEF	CTL *	
7-516-166	LT SEF	CTL *	[0000 to 9999 / - / 1/step]
7-516-172	HLT SEF	CTL *	
7-516-255	Other	CTL *	

7520	[Update Log]		
-------------	---------------------	--	--

7-520-001	Record1	CTL *	[- / - / -]
7-520-002	Record2	CTL *	
7-520-003	Record3	CTL *	
7-520-004	Record4	CTL *	
7-520-005	Record5	CTL *	
7-520-006	Record6	CTL *	[- / - / -]
7-520-007	Record7	CTL *	
7-520-008	Record8	CTL *	
7-520-009	Record9	CTL *	
7-520-010	Record10	CTL *	

7801	[Memory/Version/PN] Displays all version numbers, part numbers in machine.		
7-801-255	-	CTL	[- / - / -] [9 digit characters]

7803	[PM Counter] Displays the PM counter value.		
7-803-001	Paper	CTL *	[0 to 9999999 / - / -]

7803	[Disp. PM Counter] Displays and sets the Sheets/Distance/Usage counter		
7-803-002	Sheets PCDU	ENG *	[0 to 9999999 / 0 / 1sheet/step]
7-803-003	Sheets Fuser	ENG *	
7-803-004	Sheets Trans.	ENG *	
7-803-005	Sheets Feed	ENG *	
7-803-006	Sheets Fric. Pad	ENG *	

7-803-012	Distance PCDU	ENG*	[0 to 999999999 / 0 / 1mm/step]
7-803-013	Distance Fuser	ENG*	
7-803-014	Distance Trans.	ENG*	
7-803-022	Usage PCDU	ENG*	[0 to 255 / 0 / 1%/step]
7-803-023	Usage Fuser	ENG*	
7-803-024	Usage Trans.	ENG*	
7-803-025	Usage Feed	ENG*	
7-803-026	Usage Fric. Pad	ENG*	

7804	[PM Count.Reset] Resets the PM counter value.		
7-804-001	Paper	CTL*	[- / - / -] [EXECUTE]

7804	[Reset PM Counter] Resets the counter by execution-typed SP.		
7-804-002	PCDU	ENG	[- / - / -] [Execute]
7-804-003	Fuser	ENG	
7-804-004	Trans.	ENG	
7-804-005	Feed	ENG	[- / - / -] [Execute]
7-804-006	Fric. Pad	ENG	
7-804-010	Maintenance Kit	ENG	
7-804-011	All	ENG	

7805	[Counter Continue]		
7-805-001	Setting	ENG	[- / - / -] [Execute]

7-805-002	Distance PCDU	ENG*	[0 to 999999999 / 0 / 1mm/step] Counter for PCDU control.
-----------	---------------	------	--

7806	[FuserUnitLog]		
7-806-001	Cleaning	ENG*	[0 to 9999 / 0 / 1sheet/step]
7-806-002	Cleaning:LastTime	ENG*	[0 to 9999 / 0 / 1sheet/step]

7807	<p>[Reset-SC/Jam] Resets the SC, paper, original, and total jam counters. When the program ends normally, the message "Completed" is displayed.</p> <p> Note</p> <ul style="list-style-type: none"> SP7-807-1 does not reset the following logs: SP7-507 (Display-Paper Jam History) and SP7-508 (Display-Original Jam History). 		
7-807-001	-	CTL	[- / - / -] [Execute]

7832	<p>[Display-Self-Diag] Displays the result of the diagnostics. To scroll the return codes, press the up-arrow key or the down-arrow key.</p>		
7-832-001	-	CTL	[- / - / -] [Execute]

7836	<p>[Resident Memory] Displays the memory capacity of the controller system.</p>		
7-836-001	-	CTL	[- / - / -]

7850	<p>[Toner Counter] Counter resetting by execution SP.</p>		
7-850-001	PCDU Distance	ENG*	[0 to 999999999 / 0 / 1mm/step]
7-850-002	Total Consump	ENG*	[0.0 to 10000000.0 / 0.0 / 0.1mg/step]
7-850-003	Dots	ENG*	[0 to 999999999 / 0 / 100kdot/step]

7-850-004	Refresh Dist.	ENG*	[0 to 999999999 / 0 / 1mm/step]
7-850-005	Toner Input Dist.	ENG*	PCU running distance

7901	[Assert Info.] Displays the detail information of SC990 that occurred lastly.		
7-901-001	File Name	CTL*	[- / - / -]
7-901-002	Number of Lines	CTL*	
7-901-003	Location	CTL*	

7906	[FuserUnitLog]		
7-906-003	Sheet:LastTime	ENG*	[0 to 9999999 / 0 / 1sheet/step]

7910	[ROM No]		
7-910-001	System	CTL*	[- / - / -]
7-910-002	Engine	CTL*	
7-910-018	NetworkSupport	CTL*	
7-910-023	HDD Format Option	CTL*	
7-910-132	NetWare	CTL*	
7-910-150	RPCS	CTL*	[- / - / -]
7-910-151	PS	CTL*	
7-910-152	RPDL	CTL*	
7-910-153	R98	CTL*	
7-910-154	R16	CTL*	

7-910-155	RPGL	CTL*	[- / - / -]
7-910-156	R55	CTL*	
7-910-157	RTIFF	CTL*	
7-910-158	PCL	CTL*	
7-910-159	PCLXL	CTL*	
7-910-160	MSIS	CTL*	[- / - / -]
7-910-162	PDF	CTL*	
7-910-165	PJL	CTL*	
7-910-166	IPDS	CTL*	
7-910-168	MediaPrint:TIFF	CTL*	
7-910-169	XPS	CTL*	[- / - / -]
7-910-180	FONT	CTL*	
7-910-181	FONT1	CTL*	
7-910-182	FONT2	CTL*	
7-910-183	FONT3	CTL*	
7-910-184	FONT4	CTL*	[- / - / -]
7-910-185	FONT5	CTL*	
7-910-200	Factory	CTL*	
7-910-202	NetworkDocBox	CTL*	
7-910-204	Printer	CTL*	
7-910-210	MIB	CTL*	[- / - / -]
7-910-211	Websupport	CTL*	
7-910-213	SDK1	CTL*	
7-910-214	SDK2	CTL*	
7-910-215	SDK3	CTL*	

7911	[Firmware Version]		
7-911-001	System	CTL*	[- / - / -]
7-911-002	Engine	CTL*	
7-911-018	NetworkSupport	CTL*	
7-911-023	HDD Format Option	CTL*	
7-911-132	NetWare	CTL*	
7-911-150	RPCS	CTL*	[- / - / -]
7-911-151	PS	CTL*	
7-911-152	RPDL	CTL*	
7-911-153	R98	CTL*	
7-911-154	R16	CTL*	
7-911-155	RPGL	CTL*	[- / - / -]
7-911-156	R55	CTL*	
7-911-157	RTIFF	CTL*	
7-911-158	PCL	CTL*	
7-911-159	PCLXL	CTL*	
7-911-160	MSIS	CTL*	[- / - / -]
7-911-162	PDF	CTL*	
7-911-165	PJL	CTL*	
7-911-166	IPDS	CTL*	
7-911-168	MediaPrint:TIFF	CTL*	
7-911-169	XPS	CTL*	[- / - / -]
7-911-180	FONT	CTL*	
7-911-181	FONT1	CTL*	
7-911-182	FONT2	CTL*	
7-911-183	FONT3	CTL*	

7-911-184	FONT4	CTL*	[- / - / -]
7-911-185	FONT5	CTL*	
7-911-200	Factory	CTL*	
7-911-202	NetworkDocBox	CTL*	
7-911-204	Printer	CTL*	
7-911-210	MIB	CTL*	[- / - / -]
7-911-211	Websupport	CTL*	
7-911-213	SDK1	CTL*	
7-911-214	SDK2	CTL*	
7-911-215	SDK3	CTL*	

7931	[Toner Info.] Displays the ID chip information in the toner cartridge. Returns "0", if it could not access to the ID chip.		
7-931-001	Machine ID	ENG	[0 to 255 / 0 / 1/step]
7-931-002	Version	ENG	
7-931-003	Brand ID	ENG	
7-931-004	Area ID	ENG	
7-931-005	Class ID	ENG	
7-931-006	Color ID	ENG	
7-931-007	Maintenance ID	ENG	
7-931-008	New AIO	ENG	
7-931-009	Recycle Count	ENG	
7-931-010	EDP Code	ENG	[- / - / -]
7-931-011	Serial No.	ENG	
7-931-012	Remaining Toner	ENG	[0 to 100 / 0 / 20%/step]

7-931-013	Toner End	ENG	[- / - / -]
7-931-014	Refill Flag	ENG	
7-931-015	R:Total Cnt.	ENG	[0 to 999999999 / 0 / 1 sheet/step]
7-931-016	E:Total Cnt.	ENG	
7-931-017	Unit Output Cnt.	ENG	
7-931-018	Install Date	ENG	[- / - / -]
7-931-019	Toner End Date	ENG	
7-931-020	Total Consump	ENG	[0.0 to 10000000.0 / 0.0 / 0.1mg/step]
7-931-021	PCDU Distance	ENG	[0 to 999999999 / 0 / 1mm/step]
7-931-022	Initial Amount	ENG	[0 to 65535 / 0 / 1g/step]
7-931-023	Dot Count	ENG	[0 to 999999999 / 0 / 1mm/step]
7-931-024	Refresh Dist.	ENG	
7-931-025	Toner Input Dist.	ENG	

7932	[PCDU Info.]		
	Displays the ID chip information in the PCDU.		
	Returns "0", if it could not access to the ID chip.		
	7-932-001	Machine ID	ENG
	7-932-002	Class ID	ENG
	7-932-003	Maintenance ID	ENG
	7-932-004	New AIO	ENG
	7-932-005	Serial No.	ENG
	7-932-006	Install Date	ENG
	7-932-007	Sheets	ENG
7-932-008	Distance	ENG	
7-932-009	Usage	ENG	

7-932-010	Control Distance	ENG	[0 to 999999999 / 0 / 1mm/step]
7-932-011	PM Chg Sheets	ENG	[0 to 999999 / 0 / 1sheet/step]
7-932-012	PM Chg Distance	ENG	[0 to 999999999 / 0 / 1mm/step]
7-932-013	Cleaning1Count	ENG	[0 to 65535 / 0 / 1count / step]
7-932-014	Cleaning2Count	ENG	

3

7935	[Toner Info. Log]		
	Displays the ID chip log data in the toner cartridge.		
7-935-001	1:Serial No.	ENG *	[- / - / -]
7-935-002	1:Install Date	ENG *	
7-935-003	1:R:Total Cnt.	ENG *	[0 to 99999999 / 0 / 1/step]
7-935-004	1:Refill Flag	ENG *	[- / - / -]
7-935-005	2:Serial No.	ENG *	
7-935-006	2:Install Date	ENG *	
7-935-007	2:R:Total Cnt.	ENG *	[0 to 99999999 / 0 / 1/step]
7-935-008	2:Refill Flag	ENG *	[- / - / -]
7-935-009	3:Serial No.	ENG *	
7-935-010	3:Install Date	ENG *	
7-935-011	3:R:Total Cnt.	ENG *	[0 to 99999999 / 0 / 1/step]
7-935-012	3:Refill Flag	ENG *	[- / - / -]
7-935-013	4:Serial No.	ENG *	
7-935-014	4:Install Date	ENG *	
7-935-015	4:R:Total Cnt.	ENG *	[0 to 99999999 / 0 / 1/step]
7-935-016	4:Refill Flag	ENG *	[- / - / -]
7-935-017	5:Serial No.	ENG *	
7-935-018	5:Install Date	ENG *	

7-935-019	5:R:Total Cnt.	ENG*	[0 to 99999999 / 0 / 1/step]
7-935-020	5:Refill Flag	ENG*	[- / - / -]
7-935-021	1:Toner End	ENG*	
7-935-022	2:Toner End	ENG*	
7-935-023	3:Toner End	ENG*	
7-935-024	4:Toner End	ENG*	
7-935-025	5:Toner End	ENG*	

7936	[PCDU Log] Displays the ID chip log data in the toner cartridge.		
7-936-001	1:Serial No	ENG*	[0 / 0 / 1/step]
7-936-002	1:Install Date	ENG*	[0 / 0 / 0/step]
7-936-003	2:Serial No	ENG*	[0 / 0 / 1/step]
7-936-004	2:Install Date	ENG*	[0 / 0 / 0/step]
7-936-005	3:Serial No	ENG*	[0 / 0 / 1/step]
7-936-006	3:Install Date	ENG*	[0 / 0 / 0/step]
7-936-007	4:Serial No	ENG*	[0 / 0 / 1/step]
7-936-008	4:Install Date	ENG*	[0 / 0 / 0/step]
7-936-009	5:Serial No	ENG*	[0 / 0 / 1/step]
7-936-010	5:Install Date	ENG*	[0 / 0 / 0/step]

7952	[Days Before End] Switch the timing of the near end: Days until the end.		
7-952-001	Maintenance Kit	ENG*	[0 to 2 / 1 / 1/step] 0: Earlier 1: Normal 2: Later

7-952-002	PCDU	ENG*	[0 to 2 / 1 / 1/step] 0: Earlier 1: Normal 2: Later
-----------	------	------	--

7993	[Total Counter] Sheet number counter: Engine: Total		
7-993-001	-	ENG*	[0 to 99999999 / 0 / 1/step]

Main SP Tables-8

Overview

Most of the SPs in this group are prefixed with a letter that indicates the mode of operation (the mode of operation is referred to as an "application"). Before reading the Group 8 Service Table, make sure that you understand what these prefixes mean.

Since this machine is an LP, this manual does not list prefixes used for MFPs (such as F for fax).

Prefixes	What it means	
T:	Total: (Grand Total).	Grand total of the items counted for all applications.
P:	Print application.	Totals (pages, jobs, etc.) executed for each application when the job was not stored on the document server.
L:	Local storage (document server)	Totals (jobs, pages, etc.) for the document server. The L: counters work differently case by case. Sometimes, they count jobs/pages stored on the document server; this can be in document server mode (from the document server window), or from another mode, such as from a printer driver. Sometimes, they include occasions when the user uses a file that is already on the document server. Each counter will be discussed case by case.
O:	Other applications (external network applications, for example)	Refers to network applications such as Web Image Monitor. Utilities developed with the SDK (Software Development Kit) will also be counted with this group in the future.

Keys and abbreviations in Data Log 2

Abbreviation	What it means
/	"By", e.g. "T:Jobs/Apl" = Total Jobs "by" Application
>	More (2> "2 or more", 4> "4 or more")
AddBook	Address Book
Apl	Application
B/W	Black & White
Bk	Black

Abbreviation	What it means
ColCr	Color Create
ColMode	Color Mode
Comb	Combine
Comp	Compression
Deliv	Delivery
DesApl	Designated Application. The application (Print) used to store the job on the document server, for example.
Dev Counter	Development Count, no. of pages developed.
Dup, Duplex	Duplex, printing on both sides
Emul	Emulation
FIN	Post-print processing, i.e. finishing (punching, stapling, etc.)
Full Bleed	No Margins
GenCopy	Generation Copy Mode
GPC	Get Print Counter. For jobs 10 pages or less, this counter does not count up. For jobs larger than 10 pages, this counter counts up by the number that is in excess of 10 (e.g., for an 11-page job, the counter counts up $11-10=1$)
ImgEdt	Image Edit performed on the original with the copier GUI, e.g. border removal, adding stamps, page numbers, etc.
K	Black
LS	Local Storage. Refers to the document server.
LSize	Large (paper) Size
Mag	Magnification
MC	One color (monochrome)
NRS	New Remote Service, which allows a service center to monitor machines remotely. "NRS" is used overseas, "CSS" is used in Japan.

Abbreviation	What it means
Palm 2	Print Job Manager/Desk Top Editor: A pair of utilities that allows print jobs to be distributed evenly among the printers on the network, and allows files to move around, combined, and converted to different formats.
PC	Personal Computer
PGS	Pages. A page is the total scanned surface of the original. Duplex pages count as two pages, and A3 simplex count as two pages if the A3/DLT counter SP is switched ON.
PJob	Print Jobs
Ppr	Paper
PrtJam	Printer (plotter) Jam
PrtPGS	Print Pages
R	Red (Toner Remaining). Applies to the wide format model A2 only. This machine is under development and currently not available.
Rez	Resolution
SC	Service Code (Error SC code displayed)
Sim, Simplex	Simplex, printing on 1 side.
SMC	SMC report printed with SP5990. All of the Group 8 counters are recorded in the SMC report.
Svr	Server
TonEnd	Toner End
TonSave	Toner Save
TXJob	Send, Transmission

SP8-XXX (Data Log 2)

8381	[T:Total PrtPGS]
8384	[P:Total PrtPGS]

8387	[O:Total PritPGS]		
8-38x-001	Field Number	CTL*	[0 to 99999999 / 0 / 1/step] These SPs count the number of pages printed by the customer. The counter for the application used for storing the pages increments.

- When the A3/DLT double count function is switched on with SP5-104, 1 A3/DLT page is counted as 2.
- When several documents are merged for a print job, the number of pages stored is counted for the application that stored them.
- These counters are used primarily to calculate the amount used of the machine, so the following pages are not counted as printed pages:
 - Blank pages in a duplex printing job.
 - Blank pages inserted as document covers, chapter title sheets, and slip sheets.
 - Reports printed to confirm counts.
 - All reports done in the service mode (service summaries, engine maintenance reports, etc.)
 - Test prints for machine image adjustment.
 - Error notification reports.
 - Partially printed pages as the result of a copier jam.

8391	[LSize PritPGS] This SPs count pages printed on paper sizes A3/DLT and larger. Note: In addition to being displayed in the SMC Report, these counters are also displayed in the User Tools display on the copy machine.		
8-391-001	A3/DLT, Larger	CTL*	[0 to 99999999 / 0 / 1/step]

8411	[Prints/Duplex] This SP counts the amount of paper (front/back counted as 1 page) used for duplex printing. Last pages printed only on one side are not counted.		
8-411-001	-	CTL*	[0 to 99999999 / 0 / 1/step]

8421	[T:PritPGS/Dup Comb] These SPs count by binding and combine, and n-Up settings the number of pages processed for printing. This is the total for all applications.		
-------------	--	--	--

8424	[P:PrtPGS/Dup Comb] These SPs count by binding and combine, and n-Up settings the number of pages processed for printing by the printer application.		
8427	[O:PrtPGS/Dup Comb] These SPs count by binding and combine, and n-Up settings the number of pages processed for printing by Other applications		
8-42x-001	Simplex> Duplex	CTL*	[0 to 99999999 / 0 / 1/step]
8-42x-004	Simplex Combine	CTL*	
8-42x-005	Duplex Combine	CTL*	
8-42x-006	2in1	CTL*	[0 to 99999999 / 0 / 1/step] 2 pages on 1 side (2-Up)
8-42x-007	4 in1	CTL*	[0 to 99999999 / 0 / 1/step] 4 pages on 1 side (4-Up)
8-42x-008	6 in1	CTL*	[0 to 99999999 / 0 / 1/step] 6 pages on 1 side (6-Up)
8-42x-009	8 in1	CTL*	[0 to 99999999 / 0 / 1/step] 8 pages on 1 side (8-Up)
8-42x-010	9 in1	CTL*	[0 to 99999999 / 0 / 1/step] 9 pages on 1 side (9-Up)
8-42x-011	16 in1	CTL*	[0 to 99999999 / 0 / 1/step] 16 pages on 1 side (16-Up)
8-42x-012	Booklet	CTL*	[0 to 99999999 / 0 / 1/step]
8-42x-013	Magazine	CTL*	
8-42x-014	2-in-1 + Booklet	CTL*	
8-42x-015	4-in-1 + Booklet	CTL*	
8-42x-016	6-in-1 + Booklet	CTL*	
8-42x-017	8-in-1 + Booklet	CTL*	
8-42x-018	9-in-1 + Booklet	CTL*	

8-42x-019	2-in-1 + Magazine	CTL*	[0 to 99999999 / 0 / 1/step]
8-42x-020	4-in-1 + Magazine	CTL*	
8-42x-021	6-in-1 + Magazine	CTL*	
8-42x-022	8-in-1 + Magazine	CTL*	
8-42x-023	9-in-1 + Magazine	CTL*	
8-42x-024	16-in-1 + Magazine	CTL*	

- These counts (SP8-421 to SP8-427) are especially useful for customers who need to improve their compliance with ISO standards for the reduction of paper consumption.
- Pages that are only partially printed with the n-Up functions are counted as 1 page.
- Here is a summary of how the counters work for Booklet and Magazine modes:

Booklet		Magazine	
Original Pages	Count	Original Pages	Count
1	1	1	1
2	2	2	2
3	2	3	2
4	2	4	2
5	3	5	4
6	4	6	4
7	4	7	4
8	4	8	4

8441	[T:PrtPGS/Ppr Size] These SPs count by print paper size the number of pages printed by all applications.
8444	[P:PrtPGS/Ppr Size] These SPs count by print paper size the number of pages printed by the printer application.

8447	[O:PrtPGS/Ppr Size]		
	These SPs count by print paper size the number of pages printed by Other applications.		
	8-44x-001	A3	CTL*
	8-44x-002	A4	CTL*
	8-44x-003	A5	CTL*
	8-44x-004	B4	CTL*
	8-44x-005	B5	CTL*
	8-44x-006	DLT	CTL*
	8-44x-007	LG	CTL*
	8-44x-008	LT	CTL*
	8-44x-009	HLT	CTL*
	8-44x-010	Full Bleed	CTL*
	8-44x-254	Other (Standard)	CTL*
	8-44x-255	Other (Custom)	CTL*

[0 to 99999999 / 0 / 1/step]

[0 to 99999999 / 0 / 1/step]

- These counters do not distinguish between LEF and SEF.

8451	[PrtPGS/Ppr Tray]		
	These SPs count the number of sheets fed from each paper feed station.		
	8-451-001	Bypass Tray	CTL*
	8-451-002	Tray 1	CTL*
	8-451-003	Tray 2	CTL*
	8-451-004	Tray 3	CTL*
	8-451-005	Tray 4	CTL*
8-451-006	Tray 5	CTL*	

[0 to 99999999 / 0 / 1/step]

Bypass Tray

[0 to 99999999 / 0 / 1/step]

Copier

[0 to 99999999 / 0 / 1/step]

Paper Tray Unit (Option)

[0 to 99999999 / 0 / 1/step]

LCT (Option)

8-451-007	Tray 6	CTL*	Currently not used.
8-451-008	Tray 7	CTL*	
8-451-009	Tray 8	CTL*	
8-451-010	Tray 9	CTL*	
8-451-011	Tray 10	CTL*	
8-451-012	Tray 11	CTL*	
8-451-013	Tray 12	CTL*	
8-451-014	Tray 13	CTL*	
8-451-015	Tray 14	CTL*	
8-451-016	Tray 15	CTL*	

8461	<p>[T:PrtPGS/Ppr Type]</p> <p>These SPs count by paper type the number pages printed by all applications.</p> <ul style="list-style-type: none"> • These counters are not the same as the PM counter. The PM counter is based on feed timing to accurately measure the service life of the feed rollers. However, these counts are based on output timing. • Blank sheets (covers, chapter covers, slip sheets) are also counted. • During duplex printing, pages printed on both sides count as 1, and a page printed on one side counts as 1. 		
-------------	---	--	--

8464	<p>[P:PrtPGS/Ppr Type]</p> <p>These SPs count by paper type the number pages printed by the printer application.</p>		
-------------	---	--	--

8-46x-001	Normal	CTL*	[0 to 99999999 / 0 / 1/step]
8-46x-002	Recycled	CTL*	
8-46x-003	Special	CTL*	
8-46x-004	Thick	CTL*	

8-46x-005	Normal (Back)	CTL*	[0 to 99999999 / 0 / 1/step]
8-46x-006	Thick (Back)	CTL*	
8-46x-007	OHP	CTL*	
8-46x-008	Other	CTL*	

8521	[T:PrnPGS/FIN] These SPs count by finishing mode the total number of pages printed by all applications.		
8524	[P:PrnPGS/FIN] These SPs count by finishing mode the total number of pages printed by the print application.		
8-52x-001	Sort	CTL*	[0 to 99999999 / 0 / 1/step]
8-52x-002	Stack	CTL*	
8-52x-003	Staple	CTL*	
8-52x-004	Booklet	CTL*	
8-52x-005	Z-Fold	CTL*	[0 to 99999999 / 0 / 1/step]
8-52x-006	Punch	CTL*	
8-52x-007	Other	CTL*	
8-52x-008	Inside Fold	CTL*	[0 to 99999999 / 0 / 1/step] Half-Fold (FM2) (Multi Fold Unit)
8-52x-009	Three-IN-Fold	CTL*	[0 to 99999999 / 0 / 1/step] Letter Fold-in (FM4) (Multi Fold Unit)
8-52x-010	Three-OUT-Fold	CTL*	[0 to 99999999 / 0 / 1/step] Letter Fold-out (FM3) (Multi Fold Unit)
8-52x-011	Four Fold	CTL*	[0 to 99999999 / 0 / 1/step] Double Parallel Fold (FM5) (Multi Fold Unit)
8-52x-012	KANNON-Fold	CTL*	[0 to 99999999 / 0 / 1/step] Gate Fold (FM6) (Multi Fold Unit)

8-52x-013	Perfect-Bind	CTL*	[0 to 99999999 / 0 / 1/step] Perfect Binder
8-52x-014	Ring-Bind	CTL*	[0 to 99999999 / 0 / 1/step] Ring Binder

Note

- If stapling is selected for finishing and the stack is too large for stapling, the unstapled pages are still counted.
- The counts for staple finishing are based on output to the staple tray, so jam recoveries are counted.

3

8551	[T:FIN Books]		
8554	[P:FIN Books]		
8-55x-001	Perfect-Bind	CTL*	Booklet finishing
8-55x-002	Ring-Bind	CTL*	Not used

8561	[T:A Sheet Of Paper]		
8564	[P:A Sheet Of Paper]		
8567	[O:A Sheet Of Paper]		
8-56x-001	Total: Over A3/DLT	CTL*	[0 to 99999999 / 0 / 1/step]
8-56x-002	Total: Under A3/DLT	CTL*	
8-56x-003	Duplex: Over A3/DLT	CTL*	
8-56x-004	Duplex: Under A3/DLT	CTL*	

8581	[T:Counter] These SPs count the total output broken down by color output, regardless of the application used. In addition to being displayed in the SMC Report, these counters are also displayed in the User Tools display on the copy machine.		
8-581-001	Total	CTL*	[0 to 99999999 / 0 / 1/step]
8-581-032	Total (A3)	CTL*	

8591	[O:Counter] These SPs count the totals for A3/DLT paper use, number of duplex pages printed, and the number of staples used. These totals are for Other (O:) applications only.		
8-591-001	A3/DLT	CTL*	[0 to 99999999 / 0 / 1/step]
8-591-002	Duplex	CTL*	

8601	[T:CoverageCounter] These SPs count the total coverage for each color and the total printout pages for each printing mode.		
8-601-001	Cvg: BW	CTL*	[0 to 2147483647 / 0 / 1%/step]
8-601-011	Cvg: BW Pages	CTL*	[0 to 99999999 / 0 / 1/step]

8604	[P:Coverage Counter]		
8-604-001	Cvg: B/W %	CTL*	[0 to 2147483647 / 0 / 1%/step]

8617	[SDK Apli Counter] These SPs count the total printout pages for each SDK application.		
8-617-001 to -006	SDK-1 to -6	CTL*	[0 to 99999999 / 0 / 1/step]

8621	[Func Use Counter]		
8-621-001 to -064	Function-001 to -064	CTL*	[0 to 99999999 / 0 / 1/step]

8771	[Dev Counter] This SP counts the frequency of use (number of rotations of the development rollers) for black and other color toners.		
8-771-001	Total	CTL*	[0 to 99999999 / 0 / 1/step]\

8781	[Toner_Botol_Info.]		
	This SP displays the number of already replaced toner bottles. NOTE: Currently, the data in SP7-833-011 through -014 and the data in SP8-781-001 through -004 are the same.		
8-781-001	BK	CTL*	[0 to 9999999 / 0 / 1/step]

8801	[Toner Remain]		
	This SP displays the percent of toner remaining for each color. This SP allows the user to check the toner supply at any time.		
8-801-001	K	CTL*	[0 to 100 / 0 / 10%/step]

8811	[Eco Counter]		
	This SP displays the number of scanned sheets on which the coverage of each color is from 0% to 10%.		
8-811-001	Eco Total	CTL*	[0 to 99999999 / 0 / 1/step]
8-811-004	Duplex	CTL*	
8-811-005	Combine	CTL*	
8-811-008	Duplex (%)	CTL*	[0 to 100 / 0 / 1%/step]
8-811-009	Combine (%)	CTL*	
8-811-010	Paper Cut (%)	CTL*	
8-811-101	Eco Totalr>Last	CTL*	[0 to 99999999 / 0 / 1/step]
8-811-104	Duplex>Last	CTL*	
8-811-105	Combine>Last	CTL*	
8-811-108	Duplex (%):Last	CTL*	[0 to 100 / 0 / 1%/step]
8-811-109	Combine (%):Last	CTL*	
8-811-110	Paper Cut (%):Last	CTL*	

8851	[Cvr Cnt: 0-10%]		
	These SPs display the number of scanned sheets on which the coverage of each color is from 0% to 10%.		

8-851-011	0 to 2%: BK	CTL *	[0 to 99999999 / 0 / 1/step]
8-851-021	3 to 4%: BK	CTL *	
8-851-031	5 to 7%: BK	CTL *	
8-851-041	8 to 10%: BK	CTL *	

8861	[Cvr Cnt: 11-20%]		
	This SP displays the number of scanned sheets on which the coverage of each color is from 11% to 20%.		
8-861-001	BK	CTL *	[0 to 99999999 / 0 / 1/step]

8871	[Cvr Cnt: 21-30%]		
	This SP displays the number of scanned sheets on which the coverage of each color is from 21% to 30%.		
8-871-001	BK	CTL *	[0 to 99999999 / 0 / 1/step]

8881	[Cvr Cnt: 31%-]		
	This SP displays the number of scanned sheets on which the coverage of each color is 31% or higher.		
8-881-001	BK	CTL *	[0 to 99999999 / 0 / 1/step]

8891	[Page/Toner Bottle]		
	This SP displays the amount of the remaining current toner for each color.		
8-891-001	BK	CTL *	0 to 99999999 / 0 / 1/step]

8901	[Page/Ink_prev1]		
	This SP displays the amount of the remaining previous toner for each color.		
8-901-001	BK	CTL *	[0 to 99999999 / 0 / 1/step]

8911	[Page/Ink_prev2]		
	This SP displays the amount of the remaining 2nd previous toner for each color.		
8-911-001	BK	CTL *	[0 to 99999999 / 0 / 1/step]

8921	[Cvr Cnt/Total] This SP displays the total coverage and total printout number for each color.		
8-921-001	Coverage (%) Bk	CTL*	[0 to 2147483647 / 0 / 1%/step]
8-921-011	Coverage /P: Bk	CTL*	[0 to 99999999 / 0 / 1/step]

8941	[Machine Status] These SPs count the amount of time the machine spends in each operation mode. These SPs are useful for customers who need to investigate machine operation for improvement in their compliance with ISO Standards.		
8-941-001	Operation Time	CTL*	[0 to 99999999 / 0 / 1/step] Engine operation time. Does not include time while controller is saving data to HDD (while engine is not operating).
8-941-002	Standby Time	CTL*	[0 to 99999999 / 0 / 1/step] Engine not operating. Includes time while controller saves data to HDD. Does not include time spent in Energy Save, Low Power, or Off modes.
8-941-003	Energy Save Time	CTL*	[0 to 99999999 / 0 / 10/step] Includes time while the machine is performing background printing.
8-941-004	Low Power Time	CTL*	[0 to 99999999 / 0 / 1/step] Includes time in Energy Save mode with Engine on. Includes time while machine is performing background printing.
8-941-005	Off Mode Time	CTL*	[0 to 99999999 / 0 / 1/step] Includes time while machine is performing background printing. Does not include time machine remains powered off with the power switches.
8-941-006	SC	CTL*	[0 to 99999999 / 0 / 1/step] Total time when SC errors have been staying.

8-941-007	PrtJam	CTL*	[0 to 99999999 / 0 / 1/step] Total time when paper jams have been staying during printing.
8-941-008	OrgJam	CTL*	[0 to 99999999 / 0 / 1/step] Total time when original jams have been staying during scanning.
8-941-009	Supply PM Unit End	CTL*	[0 to 99999999 / 0 / 1/step] Total time when toner end has been staying

8961	[Electricity Status]		
8-961-001	Ctrl Standby Time	CTL*	[0 to 99999999 / 0 / 1/step]
8-961-002	STR Time	CTL*	
8-961-003	Main Power Off Time	CTL*	
8-961-004	Reading and Printing Time	CTL*	
8-961-005	Printing Time	CTL*	
8-961-006	Reading Time	CTL*	
8-961-007	Eng Waiting Time	CTL*	[0 to 99999999 / 0 / 1/step]
8-961-008	Low Power State Time	CTL*	
8-961-009	Silent State Time	CTL*	
8-961-010	Heater Off State Time	CTL*	
8-961-011	LCD on Time	CTL*	

8971	[Unit Control]		
8-971-001	Engine Off Recovery Count	CTL*	[0 to 99999999 / 0 / 1/step]
8-971-002	Power Off Count	CTL*	
8-971-003	Force Power Off Count	CTL*	

8999	[Admin. Counter List]		
-------------	------------------------------	--	--

8-999-001	Total	CTL*	[0 to 99999999 / 0 / 1/step]
8-999-007	Printer:BW	CTL*	
8-999-012	A3DLT	CTL*	
8-999-013	Duplex	CTL*	
8-999-027	Printer: BW(%)	CTL*	[0 to 2147483647/ 0 / 1/step]

Input and Output Check

Input Check Table

5803	[INPUT Check]		
5-803-001	Paper Size	ENG	[0 to 15 / 0 / 1/step] Bit0-3: Paper size Bit4-7: Not used 0:A3T, 1:A4T, 2:A4Y, 3:A5T, 4:A5Y, 5:A6T, 6:DLTT, 7:LGT, 8:LTT, 9:LTY, 10:Custom size, 11:B4T, 12:B5T, 13:B5Y, 14:B6T, 15:No Cassete
5-803-002	Paper End	ENG	[0 or 1 / 0 / 1/step]
5-803-003	Bypass:Paper End	ENG	0: Paper detected 1: Paper not detected
5-803-004	Bypass:Tray	ENG	[0 or 1 / 0 / 1/step] 0: Down, 1: Up
5-803-005	Paper Exit Full	ENG	[0 or 1 / 0 / 1/step] 0: Paper not detected 1: Paper detected
5-803-006	Paper Exit	ENG	[0 or 1 / 0 / 1/step]
5-803-008	Registration	ENG	0: Paper detected 1: Paper not detected
5-803-009	Envelope_Lever	ENG	[0 or 1 / 0 / 1/step] 0: Released 1: Pressed
5-803-010	Duplex:Entrance	ENG	[0 or 1 / 0 / 1/step]
5-803-011	Duplex:Reverse	ENG	0: Paper detected 1: Paper not detected

5-803-012	Rear Interlock	ENG	[0 or 1 / 0 / 1/step]
5-803-013	Front Interlock	ENG	0: Open 1: Closed
5-803-017	Fusing Unit New	ENG	[0 or 1 / 0 / 1/step] 0: Used 1: New
5-803-018	Fusing Unit Set	ENG	[0 or 1 / 0 / 1/step] 0: Set 1: Unset
5-803-019	HVP: SC_C_DV	ENG	[0 or 1 / 0 / 1/step]
5-803-020	HVP: SC_T	ENG	0: Defective 1: Normal
5-803-022	PSU Fan Lock	ENG	[0 or 1 / 0 / 1/step]
5-803-024	Drum Fan Lock	ENG	0: Unlocked 1: Locked
5-803-025	Main Motor Lock	ENG	[0 or 1 / 0 / 1/step] 0: Normal 1: Defective
5-803-026	HVP: SC_D	ENG	[0 or 1 / 0 / 1/step] 0: Defective 1: Normal
5-803-027	BiCU Ver	ENG	[- / 0 / 1/step] Bit0-2: Version Bit3-7: Not used
5-803-083	BANK1: 500 / 250	ENG	[0 or 1 / 0 / 1/step]
5-803-084	BANK2: 500 / 250	ENG	0: 500 sheets
5-803-085	BANK3: 500 / 250	ENG	1: 250 sheets

5-803-087	BANK1:Relay SN	ENG	[0 or 1 / 0 / 1/step] 0: Does not contain paper 1: Contains paper
5-803-088	BANK2:Relay SN	ENG	
5-803-089	BANK3:Relay SN	ENG	
5-803-092	BANK1:Paper End	ENG	
5-803-093	BANK2:Paper End	ENG	
5-803-094	BANK3:Paper End	ENG	
5-803-095	BANK1:Paper Size	ENG	[- / 0 / 1/step] Bit0: SW1 Bit1: SW2 Bit2: SW3 Bit3-7: Not used
5-803-096	BANK2:Paper Size	ENG	
5-803-097	BANK3:Paper Size	ENG	

Output Check Table

5804	[OUTPUT Check]		
5-804-001	All Off	ENG	[0 or 1 / 0 / 1/step]
5-804-002	MainMT:CW:High	ENG	
5-804-003	MainMT:CW:Mid	ENG	
5-804-004	MainMT:CW:Low	ENG	
5-804-005	MainMT:CW:Slow	ENG	
5-804-006	MainMT:CCW:High	ENG	[0 or 1 / 0 / 1/step]
5-804-007	MainMT:CCW:Mid	ENG	
5-804-008	MainMT:CCW:Low	ENG	
5-804-009	MainMT:CCW:Slow	ENG	
5-804-011	PSU Fan	ENG	

5-804-014	Drum Fan: High	ENG	[0 or 1 / 0 / 1/step]
5-804-015	Drum Fan: Low	ENG	
5-804-016	Registration CL	ENG	
5-804-017	Paper Feed CL	ENG	
5-804-018	Feed Connect CL	ENG	
5-804-019	Duplex CL	ENG	[0 or 1 / 0 / 1/step]
5-804-020	Bypass:Feed CL	ENG	
5-804-021	Bypass:Tray CL	ENG	
5-804-022	Toner Supply CL	ENG	
5-804-023	Exit Junc SOL	ENG	
5-804-024	HVP: Charge	ENG	[0 or 1 / 0 / 1/step]
5-804-025	HVP: Development	ENG	
5-804-026	HVP: Transfer: -	ENG	
5-804-027	HVP: Transfer: +	ENG	
5-804-028	BICTL	ENG	
5-804-029	HVP: Divide	ENG	[0 or 1 / 0 / 1/step]
5-804-030	Toner End Sensor	ENG	
5-804-031	ExtRevMt:HOLD	ENG	
5-804-032	ExtRevMt:CW:Hi	ENG	
5-804-033	ExtRevMt:CW:Mid	ENG	
5-804-034	ExtRevMt:CW:Low	ENG	

5-804-035	ExtRevMt:CCW:Hi	ENG	[0 or 1 / 0 / 1/step]
5-804-036	ExtRevMt:CCW:Mid	ENG	
5-804-037	ExtRevMt:CCW:Low	ENG	
5-804-163	BANK1:Motor:High	ENG	
5-804-164	BANK1:Motor:Mid	ENG	
5-804-165	BANK1:Motor:Low	ENG	
5-804-166	BANK2:Motor:High	ENG	[0 or 1 / 0 / 1/step]
5-804-167	BANK2:Motor:Mid	ENG	
5-804-168	BANK2:Motor:Low	ENG	
5-804-169	BANK3:Motor:High	ENG	
5-804-170	BANK3:Motor:Mid	ENG	
5-804-171	BANK3:Motor:Low	ENG	
5-804-172	BANK1:Feed CL	ENG	[0 or 1 / 0 / 1/step]
5-804-173	BANK2:Feed CL	ENG	
5-804-174	BANK3:Feed CL	ENG	
5-804-175	BANK1:Relay CL	ENG	
5-804-176	BANK2:Relay CL	ENG	
5-804-177	BANK3:Relay CL	ENG	

Printer Service Mode

SP1-XXX (Service Mode)

3

1001	[Bit Switch]			
001	Bit Switch 1 Settings		0	1
	bit 0	DFU	-	-
	bit 1	DFU	-	-
	bit 2	DFU	-	-
	bit 3	No I/O Timeout	Disabled	Enabled
	Enables/Disables MFP I/O Timeouts. If enabled, the MFP I/O Timeout setting will have no affect. I/O Timeouts will never occur.			
	bit 4	SD Card Save Mode	Disabled	Enabled
	If this bit switch is enabled, print jobs will be saved to the GW SD slot and not output to paper.			
	bit 5	DFU	-	-
bit 6	DFU	-	-	
bit 7	[RPCS,PCL]: Printable area frame border	Disabled	Enabled	
Prints all RPCS and PCL jobs with a border around the printable area.				

1001	[Bit Switch]
------	---------------------

002	Bit Switch 2 Settings		0	1
	bit 0	DFU	-	-
	bit 1	DFU	-	-
	bit 2	DFU	-	-
	bit 3	[PCL5e/c,PS]: PDL Auto Switching	Enabled	Disabled
		Enables/Disables the MFPs ability to change the PDL processor mid-job. Some host systems submit jobs that contain both PS and PCL5e/c. If Auto PDL switching is disabled, these jobs will not be printed properly.		
	bit 4	DFU	-	-
	bit 5	DFU	-	-
	bit 6	DFU	-	-
bit 7	DFU	-	-	

1001	[Bit Switch]			
003	Bit Switch 3 Settings		0	1
	bit 0	DFU	-	-
	bit 1	DFU	-	-
	bit 2	[PCL5e/c]: Legacy HP compatibility	Disabled	Enabled
		Uses the same left margin as older HP models such as HP4000/HP8000. In other words, the left margin defined in the job (usually "<ESC>*r0A") will be changed to "<ESC>*r1A".		
	bit 3	DFU	-	-
	bit 4	DFU	-	-
	bit 5	DFU	-	-
	bit 6	DFU	-	-
bit 7	DFU	-	-	

1001	[Bit Switch]		
------	---------------------	--	--

004	Bit Switch 4 Settings		0	1
	bit 0	DFU	-	-
	bit 1	DFU	-	-
	bit 2	DFU	-	-
	bit 3	IPDS print-side reversal	Disabled	Enabled
		If enabled, the simplex pages of IPDS jobs will be printed on the front side because of printing on the back side of the page. This might reduce printing speed.		
	bit 4	DFU	-	-
	bit 5	DFU	-	-
	bit 6	DFU	-	-
bit 7	You can enable/disable the port for IPDS printing.	Off	On	

1001	[Bit Switch]
------	--------------

005	Bit Switch 5 Settings		0	1
bit 0	Show "Collate Type", "Staple Type" and "Punch Type" buttons on the operation panel.	Disabled	Enabled	
	<p>If enabled, users will be able to configure a Collate Type, Staple Type, and Punch Type from the operation panel. The available types will depend on the device and configured options.</p> <p>After enabling the function, the settings will appear under: "User Tools > Printer Features > System"</p>			
	Multiple copies if a paper size or type mismatch occurs	Disabled (single copy)	Enabled (multiple)	
<p>If a paper size or type mismatch occurs during the printing of multiple copies, only a single copy is output by default. Using this BitSw, the device can be configured to print all copies even if a paper mismatch occurs.</p>				
bit 2	Prevent SDK applications from altering the contents of a job.	Disabled	Enabled	
	<p>If this switch is enabled, SDK applications will not be able to alter print data. This is achieved by preventing SDK applications from accessing a module called the "GPS Filter".</p> <p>Note: The main purpose of this switch is for troubleshooting the effects of SDK applications on data.</p>			

005	bit 3	[PS] PS Criteria	Pattern3: The larger the pattern number, the greater the number of criterion used.	Pattern 1: A small number of PS tags and headers
	Change the number of PS criterion used by the PS interpreter to determine whether a job is PS data or not.			
	bit 4	Increase max number of the stored jobs.	Disabled (100)	Enabled (750)
	Changes the maximum number of jobs that can be stored on the HDD. The default (disabled) is 100. If this is enabled, the max. will be raised to 750.			
bit 5	DFU	-	-	-
bit 6	Method for determining the image rotation for the edge to bind on.	Disabled	Enabled	
	<p>If enabled, the image rotation will be performed as they were in the specifications of older models for the binding of pages of mixed orientation jobs.</p> <p>The old models are below:</p> <ul style="list-style-type: none"> - PCL: Pre-04A models - PS/PDF/RPCS:Pre-05S models 			
bit 7	Letterhead mode printing	Disabled	Enabled (Duplex)	
	<p>Routes all pages through the duplex unit.</p> <p>If this is disabled, simplex pages or the last page of an odd-paged duplex job, are not routed through the duplex unit. This could result in problems with letterhead/pre-printed pages.</p> <p>Only affects pages specified as Letterhead paper.</p>			
1001	[Bit Switch]			

006	Bit Switch 6 Settings		0	1
	bit 0	DFU	-	-
	bit 1	DFU	-	-
	bit 2	DFU	-	-
	bit 3	DFU	-	-
	bit 4	DFU	-	-
	bit 5	DFU	-	-
	bit 6	DFU	-	-
	bit 7	DFU	-	-

1001	[Bit Switch]			
007	Bit Switch 7 Settings		0	1
	bit 0	DFU	-	-
	bit 1	DFU	-	-
	bit 2	DFU	-	-
	bit 3	DFU	-	-
	bit 4	DFU	-	-
	bit 5	DFU	-	-
	bit 6	DFU	-	-
	bit 7	DFU	-	-

1001	[Bit Switch]		
-------------	---------------------	--	--

008	Bit Switch 8 Settings		0	1
	bit 0	DFU	-	-
	bit 1	DFU	-	-
	bit 2	DFU	-	-
	bit 3	DFU	-	-
	bit 4	DFU	-	-
	bit 5	DFU	-	-
	bit 6	DFU	-	-
	bit 7	DFU	-	-

1001	[Bit Switch]
------	--------------

009	Bit Switch 9 Settings	0	1
bit 0	PDL Auto Detection timeout of jobs submitted via USB or Parallel Port (IEEE 1284).	Disabled (Immediately)	Enabled (10 seconds)
To be used if PDL auto-detection fails. A failure of PDL autodetection doesn't necessarily mean that the job can't be printed. This bit switch tells the device whether to time-out immediately (default) upon failure or to wait 10 seconds.			
bit 1	DFU	-	-
bit 2	Job Cancel	Disabled (Not cancelled)	Enabled (Cancelled)
If this bit switch, all jobs will be cancelled after a jam occurs. Note: If this bit switch is enabled, printing under the following conditions might result in problems: - Job submission via USB or Parallel Port - Spool printing (WIM > Configuration > Device Settings > System)			
bit 3	DFU	-	-
bit 4	Timing of the PDL Status ReadBack (JOB END) when printing multiple collated copies.	Disable	Enable
This switch determines the timing of the PDL USTATUS JOB END sent when multiple collated copies are being printed. 0 (default): JOB END is sent by the device to the client after the first copy has completed printing. This causes the page counter to be incremented after the first copy and then again at the end of the job. 1: JOB END is sent by the device to the client after the last copy has finished printing. This causes the page counter to be incremented at the end of each job.			

009	bit 5	Display UTF-8 text in the operation panel	Enabled	Disabled
	<p>Enabled (=0): Text composed of UTF-8 characters can be displayed in the operation panel.</p> <p>Disabled (=1): UTF-8 characters cannot be displayed in the operation panel.</p> <p>For example, job names are sometimes stored in the MIB using UTF-8 encoded characters. When these are displayed on the operation panel, they will be garbled unless this switch is enabled (=0).</p>			
	bit 6	Disable super option	OFF	ON
<p>Switches super option disable on / off.</p> <p>If this is On, multiple jobs are grouped at LPR port. PJJ settings are enabled even jobs that are specified queue names are sent.</p>				
bit 7	Enable/Disable Print from USB/SD's Preview function		Enabled	Disabled
	<p>Determines whether Print from USB/SD will have the Preview function.</p> <p>Enabled (=0): Print from USB/SD will have the Preview function.</p> <p>Disabled (=1): Print from USB/SD will not have the Preview function.</p>			
1001	[Bit Switch]			

010	Bit Switch A Settings		0	1
	bit 0	DFU	-	-
	bit 1	DFU	-	-
	bit 2	DFU	-	-
	bit 3	DFU	-	-
	bit 4	DFU	-	-
	bit 5	Store and Skip Errored Job locks the queue	Queue is not locked after SSEJ	Queue locked after SSEJ
	If this is 1, then after a job is stored using Store and Skip Errored Job (SSEJ), new jobs cannot be added to the queue until the stored job has been completely printed.			
bit 6	Allow use of Store and Skip Errored Job if connected to an external charge device.	Does not allow SSEJ with ECD	Allows SSEJ with ECD	
	If this is 0, Store and Skip Errored Job (SSEJ) will be automatically disabled if an external charge device is connected. Note: We do not officially support enabling this bitsw (1). Use it at your own risk.			
bit 7	DFU	-	-	
1001	[Bit Switch]			

011	Bit Switch B Settings		0	1
	bit 0	DFU	-	-
	bit 1	Print job interruption	Does not allow interruption	Allow interruption
		<p>0 (default): Print jobs are not interrupted. If a job is promoted to the top of the print queue, it will wait for the currently printing job to finish.</p> <p>1: If a job is promoted to the top of the queue, it will interrupt the currently printing job and start printing immediately.</p>		
	bit 2	Switch for enabling or disabling Limitless Paper Feeding for the Bypass Tray	Enabled	Disabled
<p>When the Bypass Tray is the target of the Auto Tray Select and Any Size/Type is configured for the Tray Setting Priority setting of the Bypass Tray, this BitSwitch can switch the behavior whether or not Limitless Paper Feeding is applied to the Bypass Tray.</p> <p>* Limitless Paper Feeding will try a matching tray of the next highest priority if a job specified to Auto Tray Select as the tray setting is submitted and the tray runs out of paper.</p> <p>Limitations when this BitSwitch is set to "1":</p> <ul style="list-style-type: none"> - The "Paper Tray Priority: Printer" setting must be configured to a tray other than the Bypass Tray. - Jobs that contain more than one paper size cannot be printed. 				
bit 3	DFU	-	-	

	bit 4	Add "Apply Auto Paper Select" is the condition that decides if the device's paper size or paper type should be overwritten.	Disabled	Enabled
	<p>If this BitSwitch is set to "1" (enabled), the "Apply Auto Paper Select" setting will decide if the paper size or paper type that is specified in the device settings should be overwritten by the job's commands when "Tray Setting Priority" is set to "Driver/Command" or "Any Type".</p> <ul style="list-style-type: none"> - Apply Auto Paper Select = OFF: Overwritten (priority is given to the job's commands) - Apply Auto Paper Select = ON: Not overwritten (priority is given to the device settings) 			
	bit 5	DFU	-	-
	bit 6	DFU	-	-
	bit 7	DFU	-	-

1001	[Bit Switch]			
012	Bit Switch C Settings		0	1
	bit 0	DFU	-	-
	bit 1	DFU	-	-
	bit 2	DFU	-	-
	bit 3	DFU	-	-
	bit 4	DFU	-	-
	bit 5	DFU	-	-
	bit 6	DFU	-	-
	bit 7	DFU	-	-

1003	[Clear Setting]		
1-003-001	Initialize Printer System	*CTL	[- / - / -] [Execute]
	Initializes settings in the "System" menu of the user mode.		

1-003-003	Delete Program	*CTL	[- / - / -] [Execute]
1004	[Print Summary]		
	Prints the service summary sheet (a summary of all the controller settings).		
1-004-001	Print Printer Summary	CTL	[- / - / -] [Execute]
1005	[Display Version]		
	1-005-002	-	CTL [- / - / -]
		Displays the version of the controller firmware.	
1007	[Supply Display]		
	Sets displaying remaining supply amount information or not. 0: Displays remaining supply amount information 1: Does not display remaining supply amount information		
1-007-002	PCU	*CTL	[0 or 1 / 1 / 1 /step]
1-007-006	Fuser	*CTL	*The Default setting is 1 but the Factory setting is 0
1111	[All Job Delete Mode]		
	*This bit switch is only for M159 (touch pane model).		
1-111-001	0:excluding New Job 1:including New Job	*CTL	[- / 1 / -]
7910	[PDL Part Munber Info.]		

7-910-***	-	CTL	Returns the part number string. RPCS:150 PS:151 RPDL:152 R98:153 R16:154 RPG:155 R55:156 RTIFF:157 PCL:158 PCLXL:159 MSIS:160 MSIS(OPT) :161 PDF:162 BMLinkS:163 PICTBRIDGE:164 PJL:165 IPDS:166 MediaPrint:JPEG:167 MediaPrint:TIFF:168 XPS:169 FONT:180 FONT1:181 FONT2:182 FONT3:183 FONT4:184 FONT5:185
-----------	---	-----	---

7911

[PDL Version Info.]

<p>7-911-*** -</p>		<p>Returns the version string.</p> <p>RPCS:150</p> <p>PS:151</p> <p>RPDL:152</p> <p>R98:153</p> <p>R16:154</p> <p>RPGL:155</p> <p>R55:156</p> <p>RTIFF:157</p> <p>PCL:158</p> <p>PCLXL:159</p> <p>MSIS:160</p> <p>MSIS(OPT) :161</p> <p>CTL* PDF:162</p> <p>BMLinkS:163</p> <p>PICTBRIDGE:164</p> <p>PJL:165</p> <p>IPDS:166</p> <p>MediaPrint:JPEG:167</p> <p>MediaPrint:TIFF:168</p> <p>XPS:169</p> <p>FONT:180</p> <p>FONT1:181</p> <p>FONT2:182</p> <p>FONT3:183</p> <p>FONT4:184</p> <p>FONT5:185</p>
--------------------	--	--

Test Pattern Printing

Test Pattern Printing

Printing Test pattern: SP2-109

Some of these test patterns are used for copy image adjustments but most are used primarily for design testing.

Note

- Do not operate the machine until the test pattern is printed out completely. Otherwise, an SC occurs.
1. Enter the SP mode and select **SP2-109-001**.
 2. Select the number for the test pattern that you want to print and press [OK].
 3. Print the test pattern with SP2-109

SP2-109-002	1 Sheet Printing
SP2-109-003	Continuous Printing
SP2-109-004	Print Side Select

4. Check the output.

SP2-109-001 Pattern list

0	None	9	Arg. Grid20mm
1	Vert. (1dot)	10	Indep. (1dot)
2	Hori. (1dot)	11	Indep. (2dot)
3	Vert/ (2dot)	12	Indep. (4dot)
4	Hori. (2dot)	13	Full
5	Grid Vert.	14	Band
6	Grid Hori.	15	Gray 10mm
7	Grid 20mm	16	Gray 20mm
8	Arg. Grid	17	Trim Area

MEMO