



RICOH UNIVERSITY

Learning ♦ Knowledge ♦ Performance



M047
SERVICE MANUAL

005630MIU

LANIER RICOH SAVIN



M047
SERVICE MANUAL

LANIER
RICOH
SAVIN



RICOH UNIVERSITY
Learning ♦ Knowledge ♦ Performance

M047

SERVICE MANUAL

00M047MIU

LANIER RICOH SAVIN

WARNING

The Service Manual contains information regarding service techniques, procedures, processes and spare parts of office equipment distributed by Ricoh Americas Corporation. Users of this manual should be either service trained or certified by successfully completing a Ricoh Technical Training Program.

Untrained and uncertified users utilizing information contained in this service manual to repair or modify Ricoh equipment risk personal injury, damage to property or loss of warranty protection.

Ricoh Americas Corporation

LEGEND

PRODUCT CODE	COMPANY			
	GESTETNER	LANIER	RICOH	SAVIN
M047	SP 6330N	LP235N	SP 6330N	MLP235n

DOCUMENTATION HISTORY

REV. NO.	DATE	COMMENTS
*	01/2010	Original Printing

M047

TABLE OF CONTENTS

PRODUCT INFORMATION

1. PRODUCT INFORMATION.....	1-1
1.1 SPECIFICATIONS	1-1
1.2 OVERVIEW.....	1-2
1.2.1 MECHANICAL COMPONENT LAYOUT	1-2
1.2.2 PAPER PATH	1-3
Printer.....	1-3
Printer with optional units	1-4
1.3 MACHINE CONFIGURATION	1-5
1.3.1 MODEL M047	1-5

INSTALLATION

2. INSTALLATION	2-1
2.1 INSTALLATION REQUIREMENTS.....	2-1
2.1.1 ENVIRONMENT	2-1
2.1.2 MACHINE LEVEL	2-1
2.1.3 MACHINE SPACE REQUIREMENT	2-2
2.1.4 POWER SUPPLY	2-2
2.2 MACHINE INSTALLATION	2-3
2.2.1 MAIN UNIT AND OPTION UNIT	2-3
2.2.2 PRINTER OPTION	2-3
2.2.3 SD CARD APPLI MOVE	2-3
Overview	2-3
Move Exec.....	2-4
Undo Exec.....	2-5

PREVENTIVE MAINTENANCE

3. PREVENTIVE MAINTENANCE	3-1
3.1 USER MAINTENANCE	3-1
3.2 SERVICE MAINTENANCE	3-2
3.2.1 MAIN	3-2
3.2.2 PAPER FEED UNIT (OPTION)	3-3

REPLACEMENT AND ADJUSTMENT

4. REPLACEMENT AND ADJUSTMENT	4-1
4.1 GENERAL	4-1
4.1.1 PRECAUTIONS ON DISASSEMBLY	4-1
Laser unit	4-1
Transfer Roller	4-2
Fusing	4-2
Paper Feed	4-2
4.1.2 RELEASING PLASTIC LATCHES	4-2
4.1.3 AFTER SERVICING THE MACHINE	4-3
4.2 SPECIAL TOOLS	4-4
4.3 EXTERIOR COVERS	4-5
4.3.1 OPERATION PANEL	4-5
4.3.2 REAR COVER	4-6
4.3.3 UPPER COVER	4-6
4.3.4 BY-PASS TRAY	4-7
4.3.5 LEFT COVER	4-8
4.3.6 FRONT DOOR	4-9
4.3.7 RIGHT COVER	4-10
Tab Locations on the Right Cover	4-11
4.4 LASER UNIT	4-12
4.4.1 CAUTION DECAL LOCATION	4-12
4.4.2 POLYGON MIRROR MOTOR	4-13
4.4.3 LASER UNIT	4-14
When reinstalling the laser unit	4-15
4.4.4 LASER DIODE UNIT	4-16
When installing the LD Unit:	4-16
4.4.5 LASER BEAM PITCH ADJUSTMENT	4-17

4.5 IMAGE TRANSFER	4-18
4.5.1 TRANSFER ROLLER	4-18
4.5.2 TONER END SENSOR.....	4-19
4.6 FUSING	4-20
4.6.1 FUSING UNIT	4-20
4.6.2 HOT ROLLER AND FUSING LAMP	4-21
4.6.3 PRESSURE ROLLER.....	4-24
When reassembling the fusing unit	4-25
4.6.4 THERMISTOR AND THERMOSTAT	4-26
Thermostat	4-26
Thermistor	4-26
4.6.5 HOT ROLLER STRIPPERS.....	4-28
4.7 PAPER FEED	4-29
4.7.1 PAPER FEED ROLLER	4-29
4.7.2 FRICTION PAD.....	4-30
When reinstalling the friction pad follow this order	4-30
4.7.3 PAPER END SENSOR	4-31
4.7.4 REMAINING PAPER SENSORS	4-32
4.8 BY-PASS FEED.....	4-33
4.8.1 BY-PASS FEED UNIT	4-33
4.8.2 BY-PASS FEED ROLLER.....	4-34
4.8.3 BY-PASS FRICTION PAD	4-35
4.8.4 BY-PASS PAPER SET SENSOR	4-37
4.9 PAPER EXIT	4-38
4.9.1 PAPER EXIT SENSOR.....	4-38
4.9.2 OVERFLOW SENSOR	4-38
4.9.3 PAPER EXIT UNIT	4-39
4.9.4 FUSING EXIT SENSOR	4-40
4.10 ELECTRICAL COMPONENTS.....	4-41
4.10.1 PRINTER CONTROLLER BOARD	4-41
4.10.2 ENGINE BOARD	4-42
4.10.3 MAIN MOTOR.....	4-43
4.10.4 RELAY CLUTCH.....	4-43
4.10.5 PAPER FEED CLUTCH.....	4-44
4.10.6 REGISTRATION CLUTCH	4-46
4.10.7 REGISTRATION SENSOR	4-47

4.10.8	POWER SUPPLY BOARD AND HIGH VOLTAGE SUPPLY BOARD	4-48
4.10.9	FUSING PRESSURE SENSOR	4-50
4.10.10	FUSING FAN	4-51
4.10.11	PSU FAN	4-51
4.11	IMAGE ADJUSTMENT	4-52
4.11.1	REGISTRATION ADJUSTMENT	4-52
4.11.2	PARALLELOGRAM IMAGE ADJUSTMENT	4-52

SYSTEM MAINTENANCE REFERENCE

5.	SYSTEM MAINTENANCE REFERENCE	5-1
5.1	SERVICE PROGRAM MODE	5-1
5.1.1	SP TABLES	5-1
	Before accessing the service menu, do the following:	5-1
5.1.2	INPUTTING A VALUE OR SETTING FOR A SERVICE PROGRAM	5-1
5.1.3	EXITING SERVICE MODE	5-2
5.2	UPDATING THE FIRMWARE	5-3
5.2.1	TYPE OF FIRMWARE	5-3
5.2.2	PRECAUTIONS	5-4
	Handling SD Cards	5-4
	Upload/Download	5-4
	Network Connection	5-4
5.2.3	MACHINE FIRMWARE UPDATE	5-5
5.2.4	ERROR RECOVERY	5-7
	Controller	5-7
	Engine	5-8
5.3	POWER-ON SELF TESTS	5-9
5.4	DIP SWITCHES	5-10
5.4.1	CONTROLLER BOARD	5-10

TROUBLESHOOTING

6. TROUBLESHOOTING	6-1
6.1 SERVICE CALL CONDITIONS	6-1
6.2 ELECTRICAL COMPONENT DEFECTS	6-2
6.2.1 SENSORS	6-2
6.2.2 SWITCHES	6-4
6.2.3 BLOWN FUSE CONDITIONS	6-5
6.2.4 LEDS	6-5
7. ENERGY SAVING	7-1
7.1 ENERGY SAVE	7-1
7.1.1 ENERGY SAVER MODES	7-1
Energy Saver Mode Setting	7-1
Return to Standby Mode	7-2
7.2 PAPER SAVE	7-3
7.2.1 EFFECTIVENESS OF DUPLEX/COMBINE FUNCTION	7-3
1. Duplex:	7-3
2. Combine mode:	7-3
3. Duplex + Combine:	7-4
Recommendation	7-4
Duplex Mode Tables	7-5

G806(DUPLEX UNIT TYPE AD610)

SEE SECTION G806 FOR DETAILED TABLE OF CONTENTS

M374 (PAPER FEED UNIT PB3090)

SEE SECTION M374 FOR DETAILED TABLE OF CONTENTS

PRODUCT INFORMATION

APPENDIX: SPECIFICATIONS

TAB
POSITION 1

INSTALLATION

APPENDIX: TROUBLESHOOTING GUIDE

M374 (Paper Feed Unit PB3090)

TAB
POSITION 2

PREVENTIVE MAINTENANCE

APPENDIX: SP MODE TABLES

TAB
POSITION 3

REPLACEMENT AND ADJUSTMENT

TAB
POSITION 4

SYSTEM MAINTENANCE REFERENCE

G806 (Duplex Unit Type AD610)

TAB
POSITION 5

TROUBLESHOOTING

TAB
POSITION 6

ENERGY SAVING

TAB
POSITION 7

TAB
POSITION 8

Read This First

Safety Notices

Important Safety Notices

Prevention of Physical Injury

1. Before disassembling or assembling parts of the machine and peripherals, make sure that the machine power cord is unplugged.
2. The wall outlet should be near the machine and easily accessible.
3. If any adjustment or operation check has to be made with exterior covers off or open while the main switch is turned on, keep hands away from electrified or mechanically driven components.
4. The machine drives some of its components when it completes the warm-up period. Be careful to keep hands away from the mechanical and electrical components as the machine starts operation.
5. The inside and the metal parts of the fusing unit become extremely hot while the machine is operating. Be careful to avoid touching those components with your bare hands.

Health Safety Conditions

Toner is non-toxic, but if you get either of them in your eyes by accident, it may cause temporary eye discomfort. Try to remove with eye drops or flush with water as first aid. If unsuccessful, get medical attention.

Observance of Electrical Safety Standards

The machine and its peripherals must be serviced by a customer service representative who has completed the training course on those models.

CAUTION

- The Controller board on this machine contains a lithium battery. The danger of explosion exists if a battery of this type is incorrectly replaced. Replace only with the same or an equivalent type recommended by the manufacturer. Discard batteries in accordance with the manufacturer's instructions and local regulations.

Safety and Ecological Notes for Disposal

1. Do not incinerate toner bottles or used toner. Toner dust may ignite suddenly when exposed to an open flame.
2. Dispose of used toner, the maintenance unit which includes developer or the organic photoconductor in accordance with local regulations. (These are non-toxic supplies.)
3. Dispose of replaced parts in accordance with local regulations.

WARNING

- To prevent a fire or explosion, keep the machine away from flammable liquids, gases, and aerosols. A fire or an explosion might occur.

Handling Toner





- Work carefully when removing paper jams or replacing toner bottles or cartridges to avoid spilling toner on clothing or the hands.
- If toner is inhaled, immediately gargle with large amounts of cold water and move to a well ventilated location. If there are signs of irritation or other problems, seek medical attention.
- If toner gets on the skin, wash immediately with soap and cold running water.
- If toner gets into the eyes, flush the eyes with cold running water or eye wash. If there are signs of irritation or other problems, seek medical attention.
- If toner is swallowed, drink a large amount of cold water to dilute the ingested toner. If there are signs of any problem, seek medical attention.
- If toner spills on clothing, wash the affected area immediately with soap and cold water. Never use hot water! Hot water can cause toner to set and permanently stain fabric.
- Always store toner and developer supplies such as toner and developer packages, cartridges, and bottles (including used toner and empty bottles and cartridges) out of the reach of children.
- Always store fresh toner supplies or empty bottles or cartridges in a cool, dry location that is not exposed to direct sunlight.

Laser Safety

The Center for Devices and Radiological Health (CDRH) prohibits the repair of laser-based optical units in the field. The optical housing unit can only be repaired in a factory or at a location with the requisite equipment. The laser subsystem is replaceable in the field by a qualified Customer Engineer. The laser chassis is not repairable in the field. Customer engineers are therefore directed to return all chassis and laser subsystems to the factory or service depot when replacement of the optical subsystem is required.





WARNING

- Use of controls, or adjustment, or performance of procedures other than those specified in this manual may result in hazardous radiation exposure.

 WARNING	
WARNING: Turn off the main switch before attempting any of the procedures in the Laser Unit section. Laser beams can seriously damage your eyes.	
CAUTION MARKING:	
 CAUTION VORSICHT >PS<	 CAUTION-CLASS 3B INVISIBLE LASER RADIATION WHEN OPEN AVOID EXPOSURE TO THE BEAM VORSICHT-UNSICHTBARE LASERSTRAHLUNG KLASSE 3B, WENN ABDECKUNG GEÖFFNET NICHT DEM STRAHL AUSSETZEN
	 CAUTION-CLASS 3B INVISIBLE LASER RADIATION WHEN OPEN AVOID EXPOSURE TO THE BEAM VORSICHT-UNSICHTBARE LASERSTRAHLUNG KLASSE 3B, WENN ABDECKUNG GEÖFFNET NICHT DEM STRAHL AUSSETZEN PS 3b_laser

Conventions and Trademarks

Conventions

Symbol	What it means
	Refer to section number
	Screw
	Connector
	E-ring
	C-ring

The following notations are used in text to describe the direction of paper feed: lengthwise and sideways. The annotations "SEF" and "LEF" denote "Short Edge Feed" and "Long Edge Feed." (The arrows indicate the direction of paper feed.)

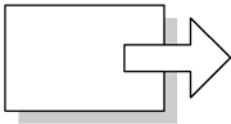

Short Edge Feed (SEF)

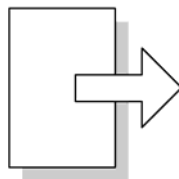

Long Edge Feed (LEF)

Trademarks

Microsoft[®], Windows[®], and MS-DOS[®] are registered trademarks of Microsoft Corporation in the United States and /or other countries.

PostScript[®] is a registered trademark of Adobe Systems, Incorporated.

PCL[®] is a registered trademark of Hewlett-Packard Company.

Ethernet[®] is a registered trademark of Xerox Corporation.

PowerPC[®] is a registered trademark of International Business Machines Corporation.

Other product names used herein are for identification purposes only and may be trademarks of their respective companies. We disclaim any and all rights involved with those marks.

This manual uses several symbols and some simple abbreviations.

PRODUCT INFORMATION

REVISION HISTORY		
Page	Date	Added/Updated/New
		None

1. PRODUCT INFORMATION

1.1 SPECIFICATIONS

See "Appendices" for the "General Specifications."

1.2 OVERVIEW

1.2.1 MECHANICAL COMPONENT LAYOUT

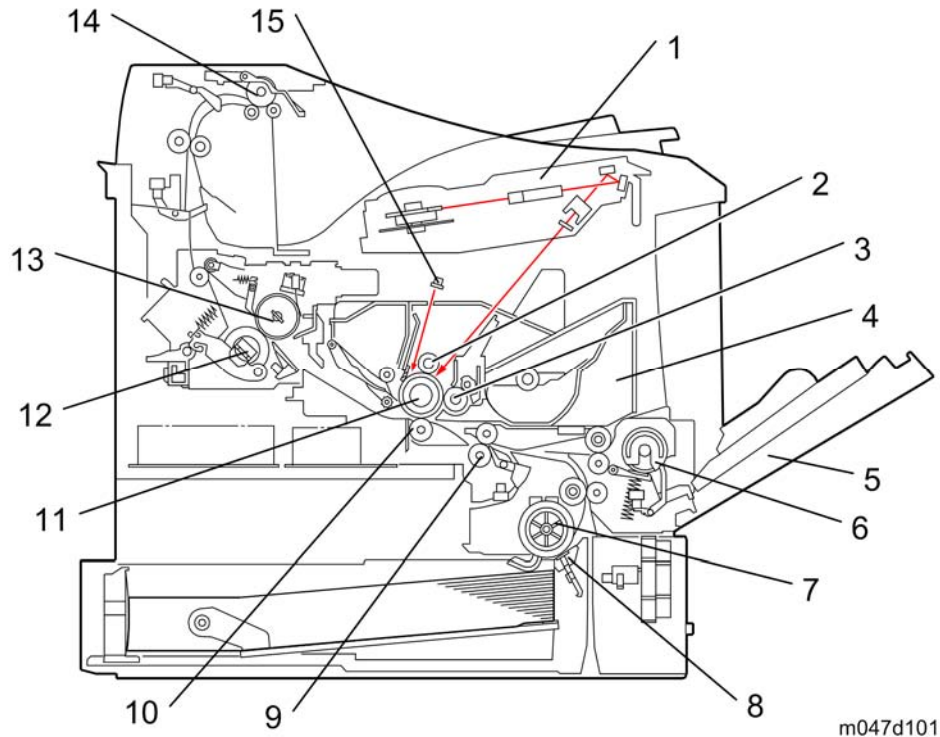

1: Laser unit	9: Registration roller
2: Charge roller	10: Transfer roller
3: Development roller	11: Drum
4: Cartridge (AIO-type)	12: Pressure roller
5: By-pass feed tray	13: Hot roller
6: By-pass feed roller	14: Paper exit roller
7: Paper feed roller	15: Quenching lamp
8: Friction pad	

1.2.2 PAPER PATH

Printer

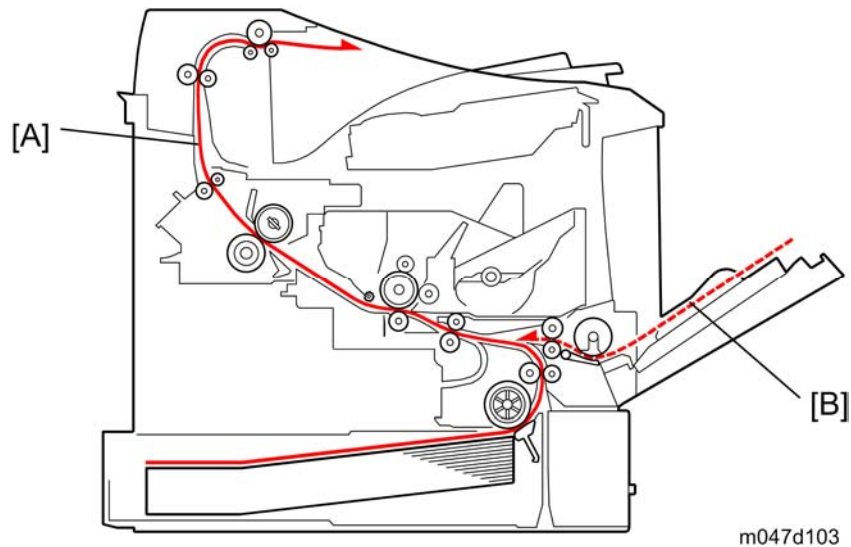

[A]: Paper path from the paper tray (main)

[B]: Paper path from the by-pass tray (main)

Note

- If both optional paper tray units are installed, the envelope feeder must go in the top tray.

Overview

Printer with optional units

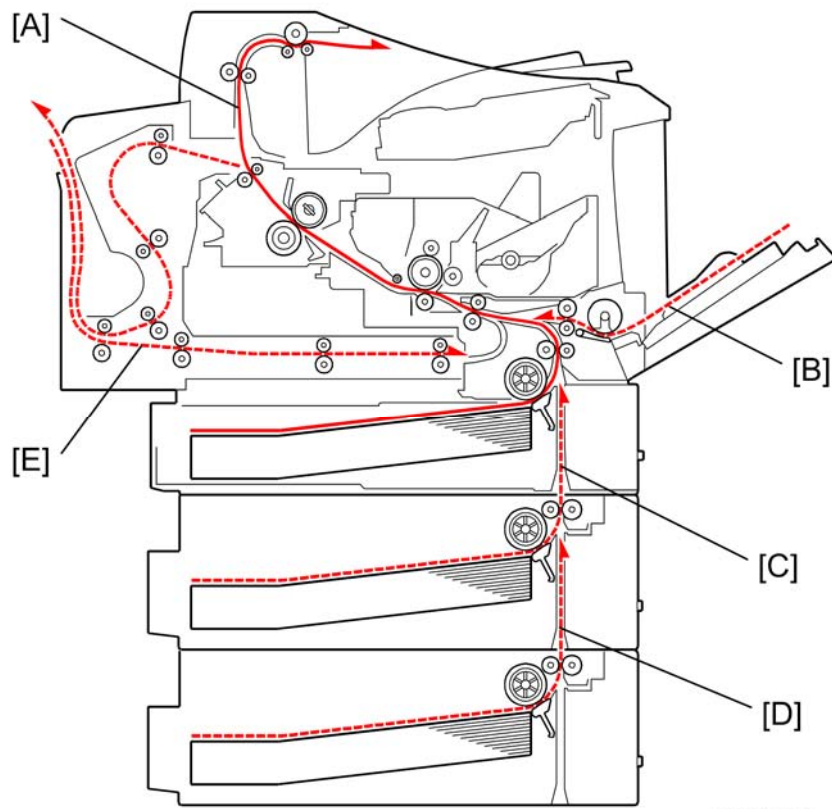

m047d104

- [A]: Paper path from the paper tray (main)
- [B]: Paper path from the by-pass tray (main)
- [C]: Paper path from the paper tray 2 (option)
- [D]: Paper path from the paper tray 3 (option)
- [E]: Paper path from the duplex unit (option)

1.3 MACHINE CONFIGURATION

1.3.1 MODEL M047

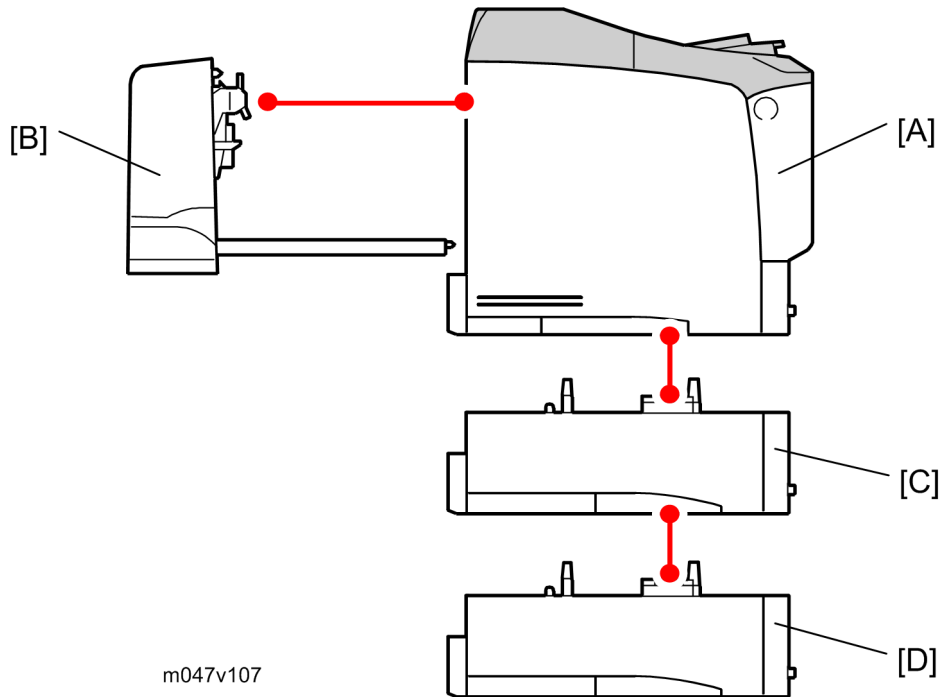

Item	Machine Code	No.	Remarks
Main Unit	M047	A	NIB is standard.
Optional Units			
Duplex Unit	G806	B	
Paper Tray Unit	M374	C, D	Up to two tray units can be installed.
Envelope Feeder	G807	C	If both optional paper trays are installed, the envelope feeder must go in the top tray.

INSTALLATION

REVISION HISTORY		
Page	Date	Added/Updated/New
		None

2. INSTALLATION

2.1 INSTALLATION REQUIREMENTS

2.1.1 ENVIRONMENT

CAUTION

- This machine, which uses high voltage power sources, can generate ozone gas. High ozone density is harmful to human health. Therefore, the machine must be installed in a well-ventilated room.
1. Temperature Range: 10°C to 32°C (50°F to 89.6°F)
 2. Humidity Range: 15 % to 89 % RH
 3. Ambient Illumination: Less than 2,000 lux (do not expose to direct sunlight).
 4. Ventilation: 3 times/hr/person
 5. Avoid areas that are exposed to sudden temperature changes. This includes:
 - Areas directly exposed to cool air from an air conditioner.
 - Areas directly exposed to heat from a heater.
 6. Do not install this machine in an area where it will be exposed to corrosive gases.
 7. Do not install the machine at locations over 2,000 m (6,562 ft.) above sea level.
 8. Put the machine on a strong and level base. Inclination on any side should not exceed 5 mm.
 9. Do not put the machine where it may be subjected to strong vibrations.

2.1.2 MACHINE LEVEL

Front to back: Within 5 mm. (0.2 inches) of level.

Right to left: Within 5 mm. (0.2 inches) of level.

Installation Requirements

2.1.3 MACHINE SPACE REQUIREMENT

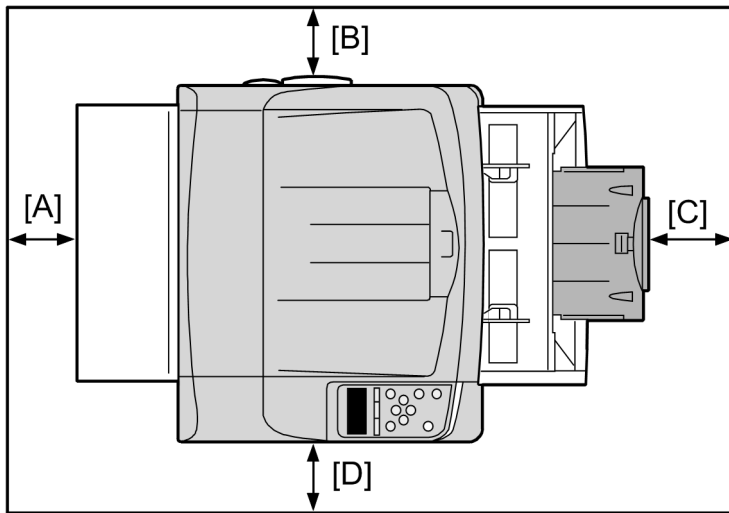

m047i500

Place the machine near the power source, providing the clearance as shown below:

- A: Over 10 cm (4 inches)
- B: Over 10 cm (4 inches)
- C: Over 10 cm (4 inches)
- D: Over 10 cm (4 inches)

2.1.4 POWER SUPPLY

⚠ CAUTION

- Make sure the plug is firmly inserted in the outlet.
- Avoid multi-wiring.
- Be sure to ground the machine.

Input voltage level	120 volts, 60 Hz: More than 10 A
	220-240 volts, 50 Hz/60Hz: More than 6 A
Permissible voltage	Fluctuation: $\pm 10\%$
Do not set anything on the power cord	

2.2 MACHINE INSTALLATION

2.2.1 MAIN UNIT AND OPTION UNIT

Refer to the "Hardware Guide" for M041 model about the machines installation.

2.2.2 PRINTER OPTION

Refer to the "Hardware Guide" for M041 model about the machines installation. If more than two optional applications are supposed to be installed, do "SD Card Appli Move" described below.

★ Important

- IPDS option requires optional memory (128 MB or 256 MB). Install optional memory first before installing the IPDS option. Otherwise, the machine may stall when large print job data is sent to the machine.

2.2.3 SD CARD APPLI MOVE

Overview

The service program "SD Card Appli Move" (SP5-873) lets you to copy application programs from one SD card to another SD card.

Slot 1 and Slot 2 are used to store application programs. However, more than two optional applications are supplied for this machine. In that case, you can move application programs from Slot 2 to Slot 1 with the following procedure.

Obey these precautions during the SD Card Appli move procedure:

- The authentication data is moved with the application program from an SD card to the other SD card. Authentication fails if you try to use the SD card after you move the application program from this card to another SD card.
- Do not use an SD card if it has been used for some other work, for example, on a computer. Normal operation is not guaranteed when such SD card is used.
- Store the original SD card in a safe location after the procedure. The original SD card cannot be used but it must be saved because (1) the original card is the only proof that the user is licensed to use the application program, and (2) you may need to check the SD card and its data to solve a problem in the future.

Move Exec

"Move Exec" (SP5873 1) moves application programs from the original SD card to another SD card. The application programs are moved from Slot 2 to Slot 1.

1. Turn off the main power switch.

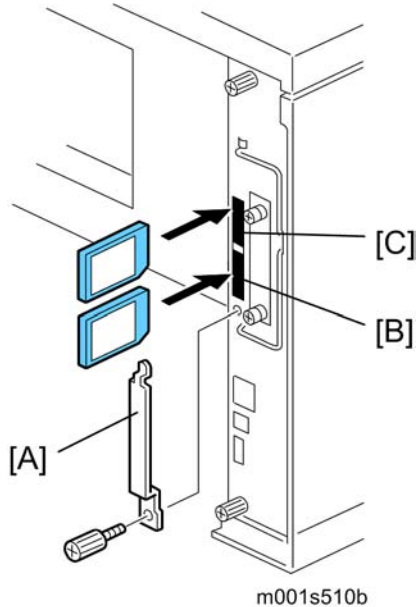

2. Remove the SD card slot cover [A] (🔪 x 1).
3. Insert the original SD card with the application in Slot 2 [B] (lower slot).
4. Insert the SD card to receive the application in Slot 1 [C] (upper slot).
5. Turn on the main power switch.
6. Enter the SP mode and do SP5873 1 "Move Exec."
7. Follow the messages on the operation panel to complete the procedure.
8. Exit the SP mode.
9. Turn off the main power switch.
10. Remove the original SD card from Slot 2.
11. Leave the other SD card in Slot 1.
12. Turn on the main power switch.
13. Confirm that the application program runs normally.
14. Tell the customer to store the original SD card in a safe place.

Undo Exec

"Undo Exec" (SP5873 2) restores an application to its original SD card. The application is moved from Slot 1 to Slot 2.

1. Turn off the main power switch.

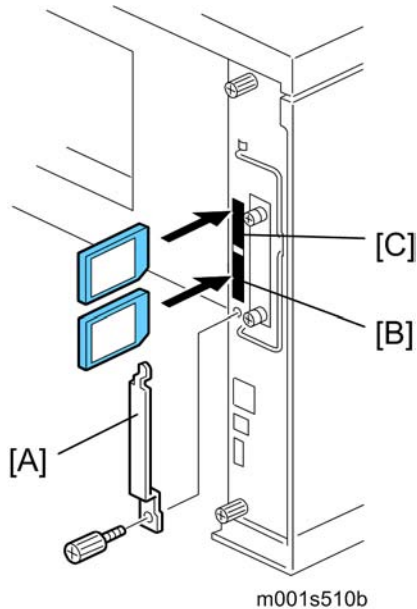

2. Remove the SD card slot cover [A] (⚙️ x 1).
3. Insert the SD card that currently holds the application in Slot 1 [B].
4. Insert the original SD card to receive the restored application in Slot 2 [C].
5. Turn on the main power switch.
6. Enter the SP mode and do SP5873 "Undo Exec."
7. Follow the messages on the operation panel to complete the procedure.
8. Exit the SP mode.
9. Turn off the main power switch.
10. Remove both SD cards.
11. Insert the SD card with the restored application in Slot 1.
12. Turn on the main power switch.
13. Confirm that the application operates normally.

PREVENTIVE MAINTENANCE

REVISION HISTORY		
Page	Date	Added/Updated/New
		None

3. PREVENTIVE MAINTENANCE

3.1 USER MAINTENANCE

The customer can do all PM items with the Maintenance Kit.

Meter-charge mode must be set to "disabled" (engine SP mode 5930).

Cross-reference: "Engine service mode" in the Appendices.

The Operation panel shows "Replace Maintenance Kit" when the PM counter gets to 90K.

After the user replaces the fusing unit in the maintenance kit, the machine automatically resets the PM counter.

Item	Quantity	Remarks
Fusing unit	1	
Transfer roller	1	
Paper feed roller	3	For standard and optional tray(s)
Friction pad	3	For standard and optional tray(s)
PSU Fan Filter	1	

3.2 SERVICE MAINTENANCE

To enable the machine for maintenance by the service technician, the meter-charge mode must be set to "1: Yes" with SP5930-001.

The table below shows the PM items serviced by the service technician.

After completing a PM procedure, reset the PM counter for the replaced part with SP7-804.

- 7-804-2: Transfer roller
- 7-804-3: Paper feed roller
- 7-804-4: Fusing unit.

3.2.1 MAIN

Symbol keys: C: Clean/ R: Replace/ L: Lubricate/ I: Inspect

Item	90K	EM	Quantity	Remarks
Paper Feed				
Paper Feed Roller	R	C	1	Clean with water
Friction Pad	R	C	1	Clean with water
Registration Roller	C	C	1	Clean with water
Bottom Plate Pad	C	C	1	Clean with water
Around the Drum				
Transfer Roller	R		1	
Fusing Unit and Paper Exit				
Hot Roller	R		1	
Pressure Roller	R		1	
Hot Roller Strippers	R		5	
Fusing Thermistor	R	C	1	Clean with alcohol if necessary.
Bushings - Hot Roller	R		2	

Item	90K	EM	Quantity	Remarks
Bushings - Pressure Roller	R		2	
Fusing Entrance and Exit Guide Plates	C		1 each	Clean with water or alcohol
Fusing Unit	R		1	
Other				
PSU Fan Filter	R		1	

3.2.2 PAPER FEED UNIT (OPTION)

Symbol keys: C: Clean/ R: Replace/ L: Lubricate/ I: Inspect

Item	90K	EM	Quantity	Remarks
Paper Feed				
Paper Feed Roller	R	C	1	Clean with water
Friction Pad	R	C	1	Clean with water
Bottom Plate Pad	C	C	1	Clean with water

REPLACEMENT AND ADJUSTMENT

REVISION HISTORY		
Page	Date	Added/Updated/New
		None

4. REPLACEMENT AND ADJUSTMENT

4.1 GENERAL

CAUTION

- Turn off the main power switch and unplug the machine before attempting any of the procedures in this section.

4.1.1 PRECAUTIONS ON DISASSEMBLY

Use extreme caution when removing and replacing components. The cables in the machine are located very close to moving parts; proper routing is a must.

After components have been removed, any cables that have been displaced during the procedure must be restored as close as possible to their original positions. Before removing any component from the machine, note any cable routings that may be affected.

Before servicing the machine:

1. Verify that documents are not stored in memory.
2. Remove the toner cartridge before you remove parts.
3. Unplug the power cord.
4. Work on a flat and clean surface.
5. Replace with authorized components only.
6. Do not force plastic material components.

Make sure all components are returned to their original positions.

Laser unit

1. Do not loosen or adjust the screws securing the LD drive board on the LD unit. Doing so will throw the LD unit out of adjustment.
2. Do not adjust the variable resistors on the LD unit, as these are permanently adjusted at the factory. If replacement of the LD drive board is necessary, replace the entire LD unit.
3. Keep the polygon mirror and toroidal lens free of dust. Laser performance is very sensitive to dust on these components.
4. Do not touch the shield glass or the surface of the polygon mirror with bare hands.
5. Do not adjust the Laser Synchronization detector on the LD unit, as these are permanently adjusted at the factory. If the position of the Laser Synchronization detector has changed from the factory set position, SC 322 will be shown.

General

Transfer Roller

1. Never touch the surface of the transfer roller with bare hands.
2. Be careful not to scratch the transfer roller, as the surface is easily damaged.

Fusing

1. After installing the fusing thermistor, make sure that it is in contact with the hot roller and that the roller can rotate freely.
2. Be careful to avoid damage to the hot roller stripper pawls and their tension springs.
3. Do not touch the fusing lamp and rollers with bare hands.
4. Make sure that the fusing lamp is positioned correctly and that it does not touch the inner surface of the hot roller.

Paper Feed

1. Do not touch the surface of paper feed rollers.
2. To avoid misfeeds, the side and end fences in each paper tray must be positioned correctly so as to align with loaded paper size.

4.1.2 RELEASING PLASTIC LATCHES

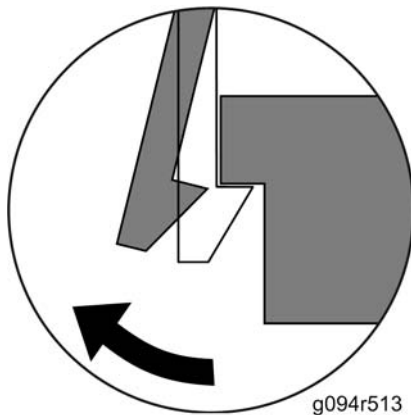

Many of the parts are held in place with plastic latches. The latches break easily, so release them carefully.

To remove such parts, press the hook end of the latch away from the part to which it is latched.

4.1.3 AFTER SERVICING THE MACHINE

1. Make sure all parts that require grounding are properly grounded.
2. Make sure the interlock switch is functioning.
3. Do not leave unused solder or parts inside the machine.
4. Do not leave any tools inside the machine.
5. Make sure all wires are properly connected and routed.
6. Make sure wires are not jammed between parts of the machine.

4.2 SPECIAL TOOLS

Part Number	Description	Q'ty	Remarks
B6455010	SD Card	1	Used in common with other printers.
B6456705	SD Card Adapter	1	Used in common with other printers.
B6456830	USB Reader/Writer	1	Used in common with other printers.
A0069104	Scanner Positioning Pin (4 pieces/set)	1	Used for LD Unit positioning. Used in common with the model K-P series and other models.

4.3 EXTERIOR COVERS

4.3.1 OPERATION PANEL



m047r026

1. Press the button [A], and then open the front door [B].

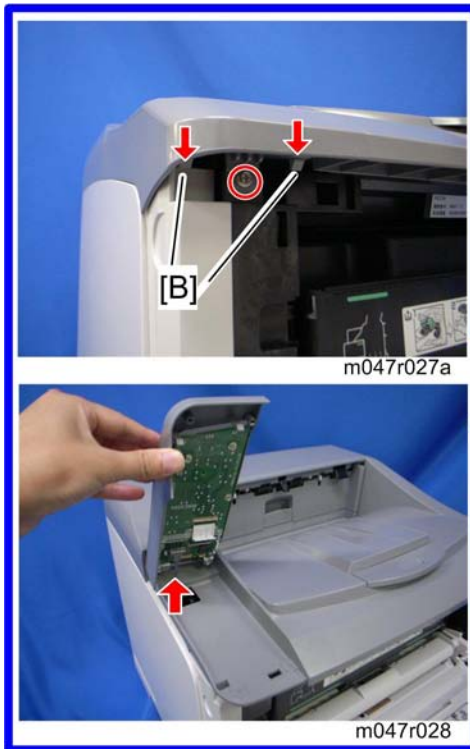

m047r027a

m047r028



m047r027

2. Operation panel [A] (🔩 x 1, hooks [B], 📏 x 1)

Exterior Covers

4.3.2 REAR COVER

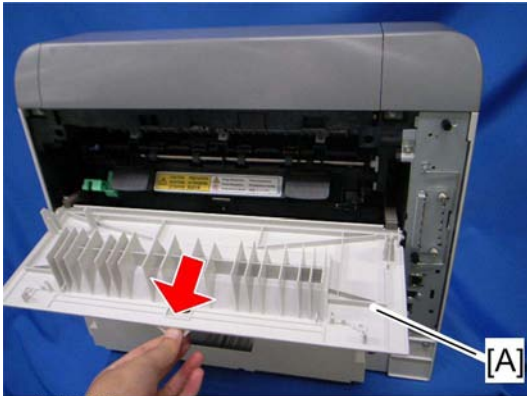

m047r030

1. Rear cover [A]

4.3.3 UPPER COVER

1. Remove the AIO.
2. Rear cover (☛ p.4-6)
3. Operation panel (☛ p.4-5)

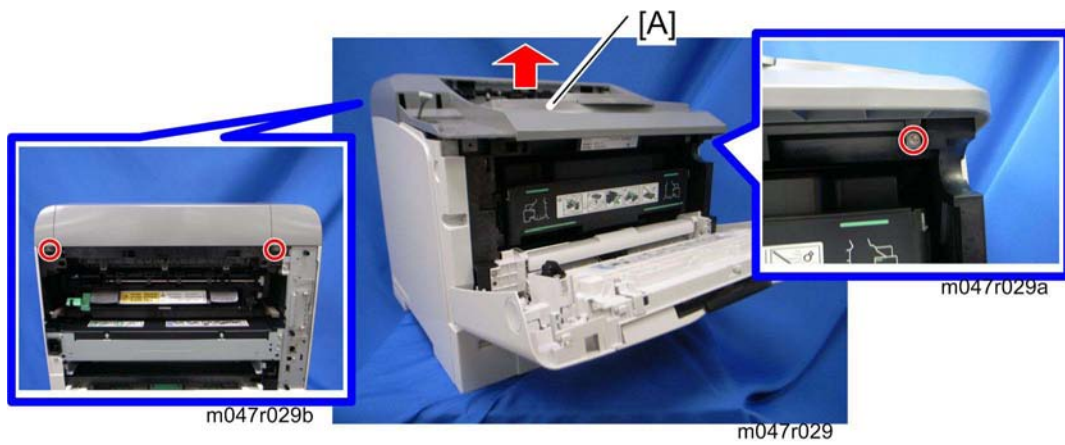

4. Upper cover [A] (☛ x 3)

4.3.4 BY-PASS TRAY

1. Open the front door.



2. Release the both rails [A] (right and left) on the by-pass tray.
3. Close the by-pass tray cover [B].

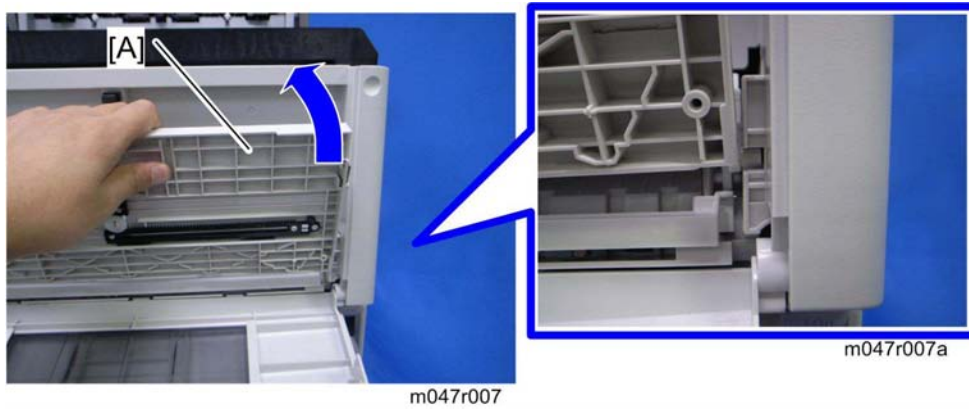

4. Lift the right edge of the by-pass tray cover [A], and then pull the by-pass tray cover to the front.



5. By-pass tray [A].

Exterior Covers

4.3.5 LEFT COVER

↓ Note

- To remove the left cover, separate the machine from the optional paper feed unit first.

1. Upper cover (🔑 p.4-6)

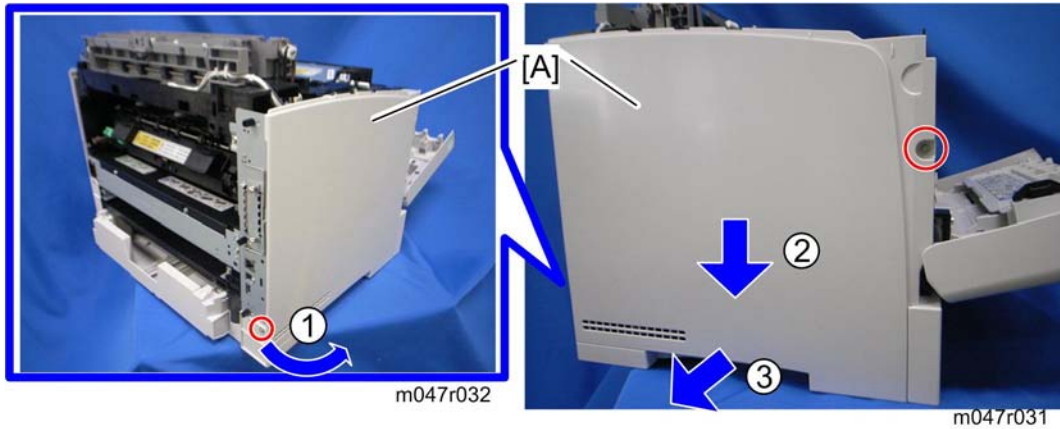

2. Left cover [A] (🔑 x 2)

- [1]: First release the rear left part of the left cover.
- [2]: Pull down the left cover
- [3]: Then remove it.

4.3.6 FRONT DOOR

1. Remove the paper tray.
2. Upper cover (☛ p.4-6)
3. Left cover (☛ p.4-8)
4. By-pass tray (☛ p.4-7)

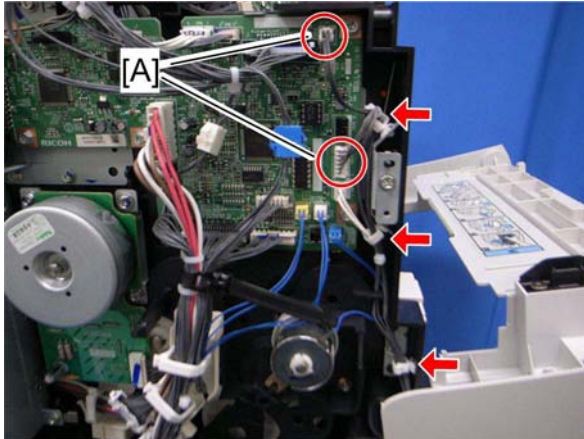

m047r009

5. Disconnect two connectors (CN7, CN17) [A] (☛ x 3).

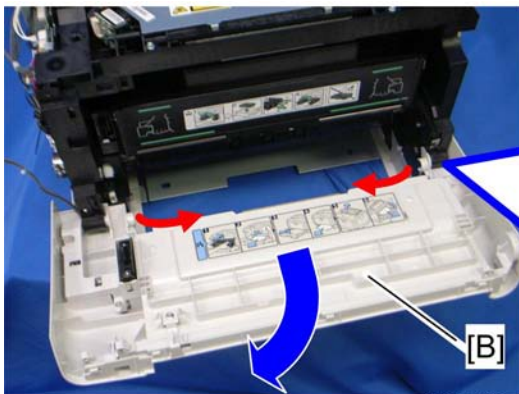

m047r010

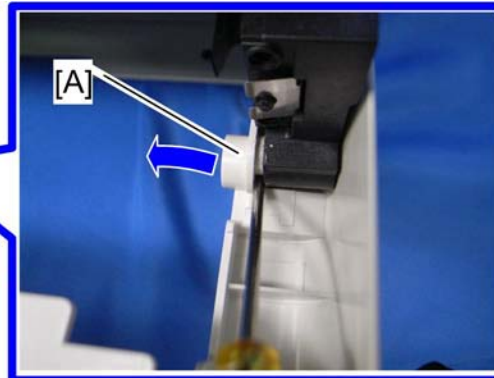

m047r010a

6. Release the right hinge [A] of the front door.
7. Release the left hinge of the front door, and then remove the front door [B].

4.3.7 RIGHT COVER

↓ Note

- To remove the right cover, separate the machine from the optional paper feed unit first.

1. Upper cover (☛ p.4-6)
2. Left cover (☛ p.4-8)
3. By-pass tray (☛ p.4-7)
4. Front door (☛ p.4-9)

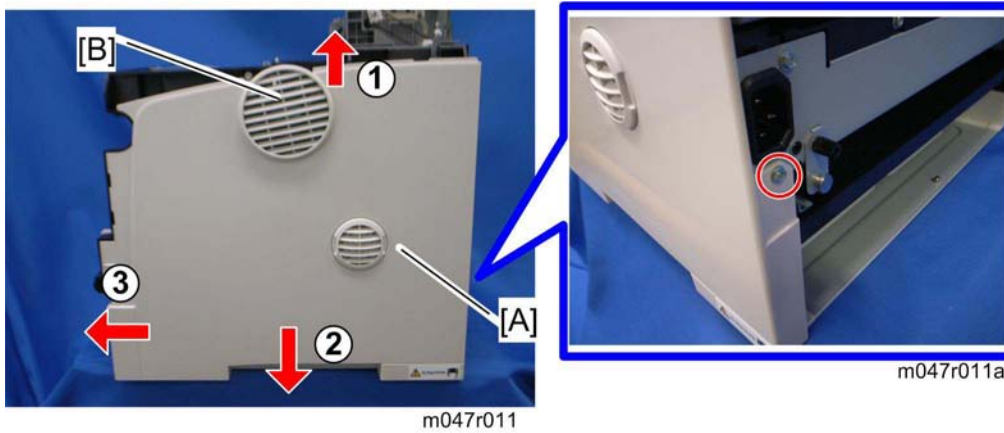

5. Lift the right cover [A], and then pull the top edge of the right cover slightly (☛ x 1, 3 tabs)
6. Slide the right cover to the front with pulling down the right cover (4 tabs).

↓ Note

- The fan cover [B] falls after detaching the right cover from the machine. It is because that the fan cover is held only by the right cover.

Tab Locations on the Right Cover



m047r012

There are seven tabs on the right cover. Each arrow shows the direction of the tab.

Replacement
and
Adjustment

4.4 LASER UNIT

WARNING

- Turn off the main power switch and unplug the machine before attempting any of the procedures in this section. Laser beams can seriously damage your eyes.

4.4.1 CAUTION DECAL LOCATION

Caution decals are attached as shown below.

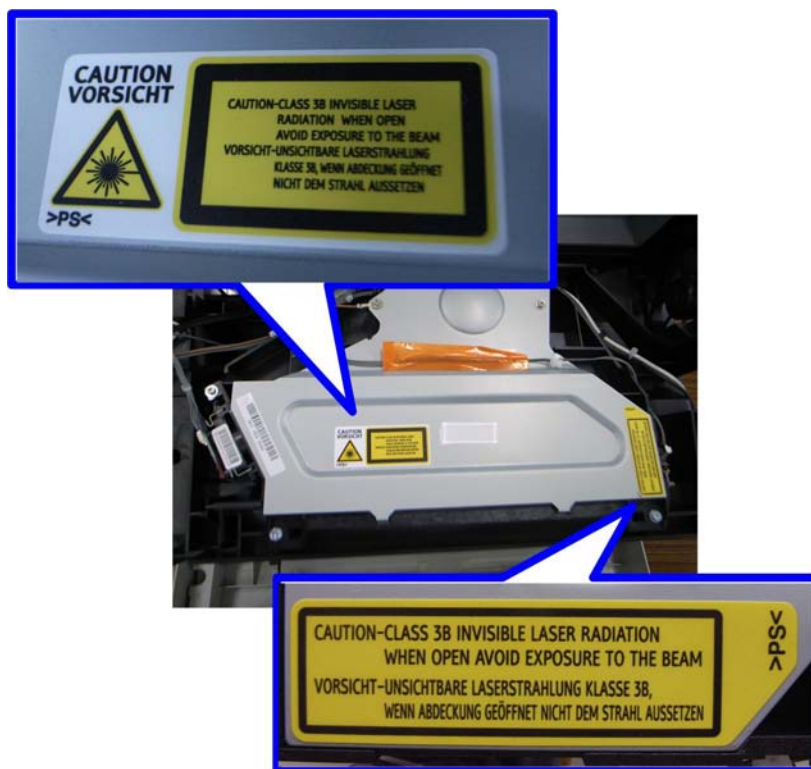

m047r500

WARNING

- Be sure to turn off the main power switch and disconnect the power plug from the power outlet before beginning any disassembly or adjustment of the laser unit. This machine uses a class IIIb laser beam with a wavelength of 785 nm and an output of 6.2 mW. The laser can cause serious eye injury.

4.4.2 POLYGON MIRROR MOTOR



WARNING

- Turn off the main switch and unplug the machine before attempting any of the procedures in this section. Laser beams can seriously damage your eyes.

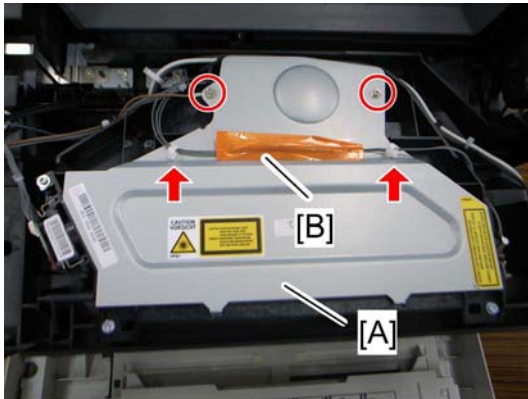
- Upper cover ( p.4-6)





m047r510

- Polygon mirror cover [A] ( x 2, tape [B] x 1,  x 2)



m047r511

- Polygon mirror motor [A] ( x 4,  x 1)

Note

- Do not touch the surface of the mirror with bare hands.

Laser Unit

4.4.3 LASER UNIT

1. Open the front door.
2. Operation panel (🔧 p.4-5)
3. Upper cover (🔧 p.4-6)
4. Left cover (🔧 p.4-8)

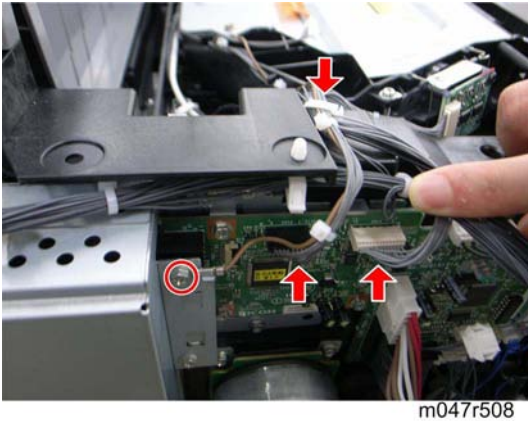

5. Disconnect the two harness (🔧 x 1) at the left side.
6. Remove the ground cable (🔧 x 1).

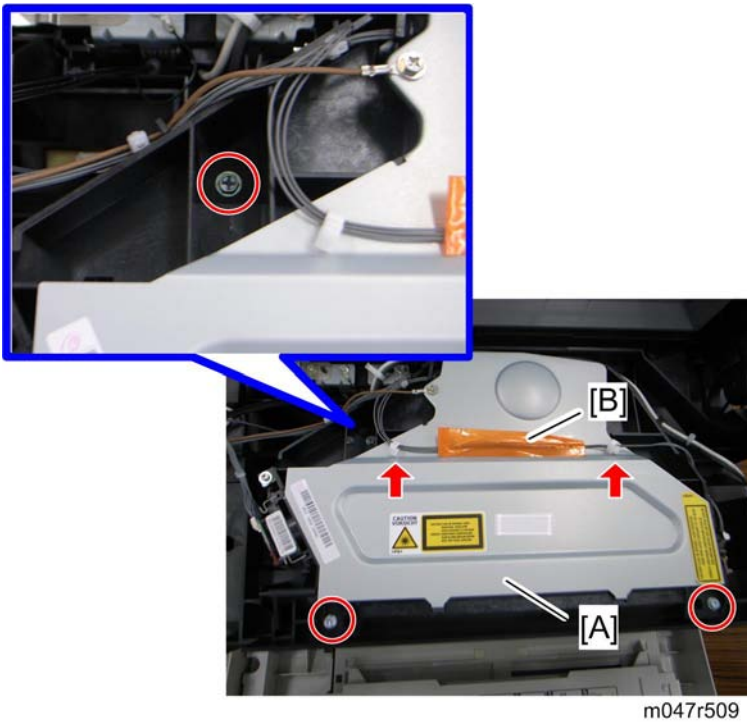

7. Laser unit [A] (🔧 x 3, tape [B] x 1, 📏 x 2)

When reinstalling the laser unit

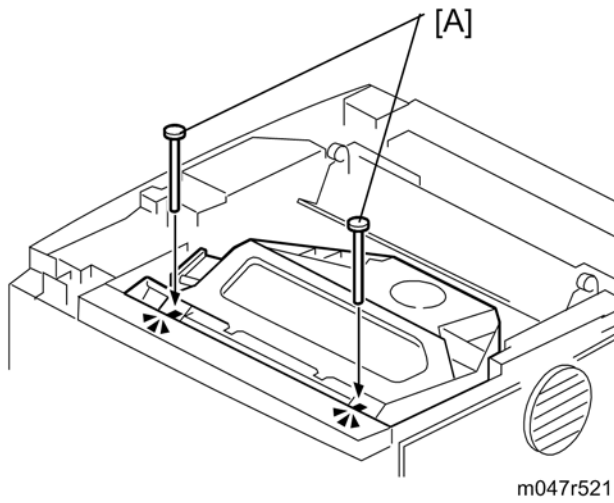

Use the scanner positioning pins (P/N: A0069104) to reinstall the unit.
Set the positioning pins [A] as shown above. Then secure the laser unit.

4.4.4 LASER DIODE UNIT

1. Laser Unit (🔧 p.4-14)

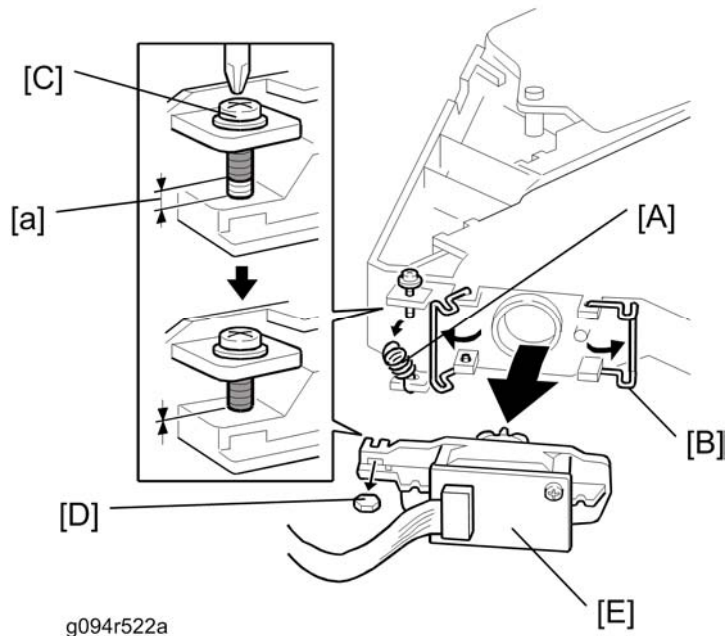

2. Spring [A]
3. LD unit holders [B] (x 2)
4. Loosen the screw [C].
5. Nut [D]
6. LD Unit [E] (🔧 x 1)

⚠ Note

- Do not remove the screws that secure the LD board.
- Do not touch any variable resistors on the LD board.

When installing the LD Unit:

Tighten the screw [C] until the unpainted portion of the screw [a] is not visible.

After installing the LD unit, check the test pattern for the final adjustment (see the following procedure).

4.4.5 LASER BEAM PITCH ADJUSTMENT

1. Print out the following test patterns (A4 LEF or A3):
 - Select the test pattern "10.Stitch" with SP 5902-3.
 - After selecting a pattern, use SP 5902-1 to print one test pattern.
 - After completing the adjustment, reset SP 5902-3 to "NoPattern."

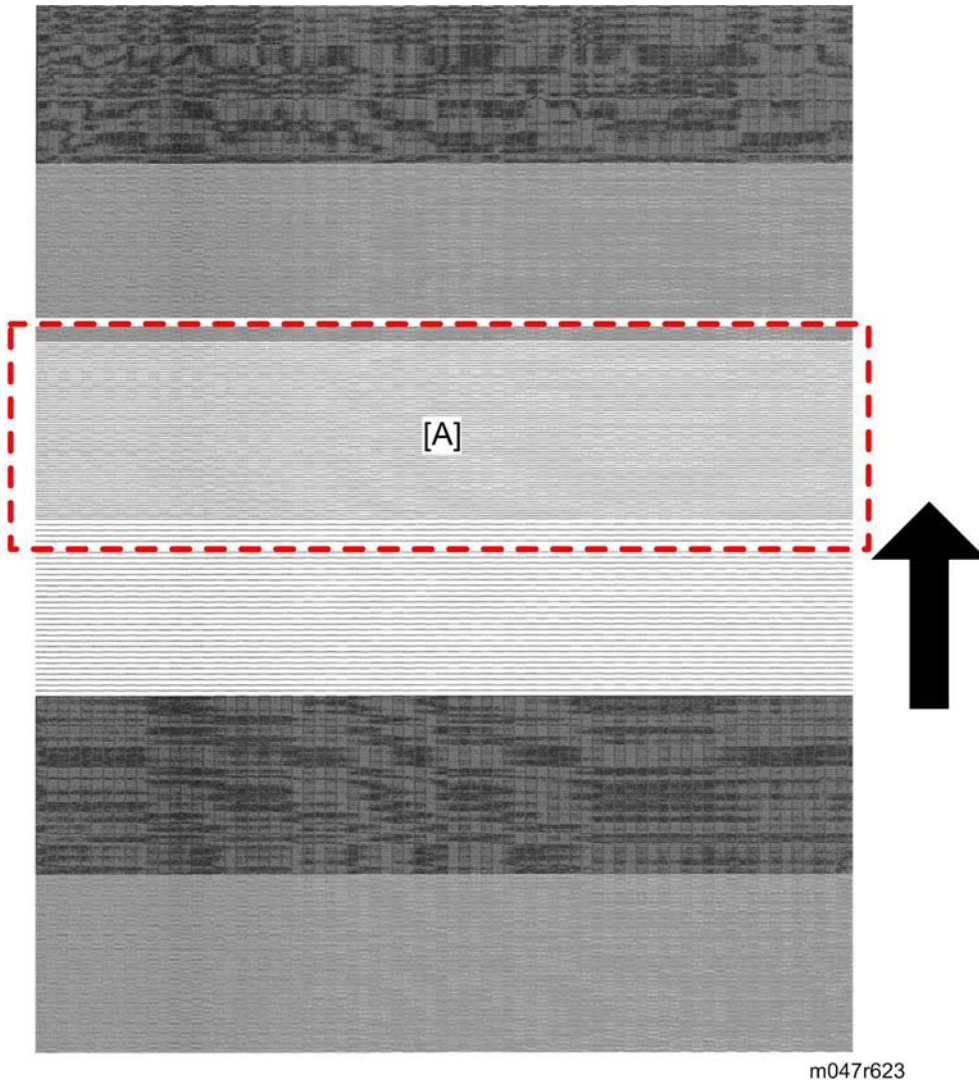

2. Check a test pattern. If the laser beam pitch is not correct, the images are as follows.
 - Third stripe [A] from the leading edge: Vertical black strips seem to appear.
3. Adjust the LD unit holder position: Tighten or loosen the screw [C] (see the previous page) until the printout appears as follows.
 - Third stripe [A] from the leading edge: The thin lines are of uniform thickness (no striping effect should appear on the printout).

4.5 IMAGE TRANSFER

4.5.1 TRANSFER ROLLER

1. Open the front door.
2. Remove the AIO.

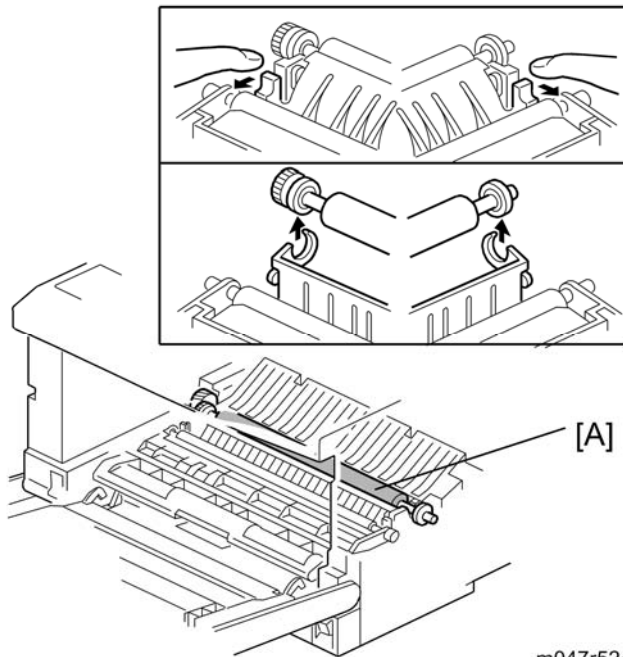

m047r524

3. Transfer roller [A]

Note

- Do not touch the transfer roller surface.

4.5.2 TONER END SENSOR

1. Open the front door.
2. Remove the AIO.

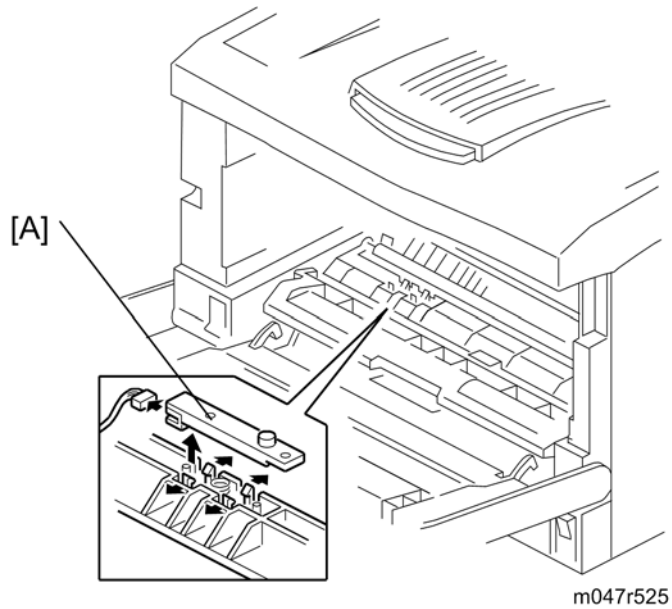

3. Toner end sensor [A] (4 hooks,  x 1)

Fusing

4.6 FUSING

CAUTION

- Allow time for the unit to cool before doing the following procedure.

4.6.1 FUSING UNIT

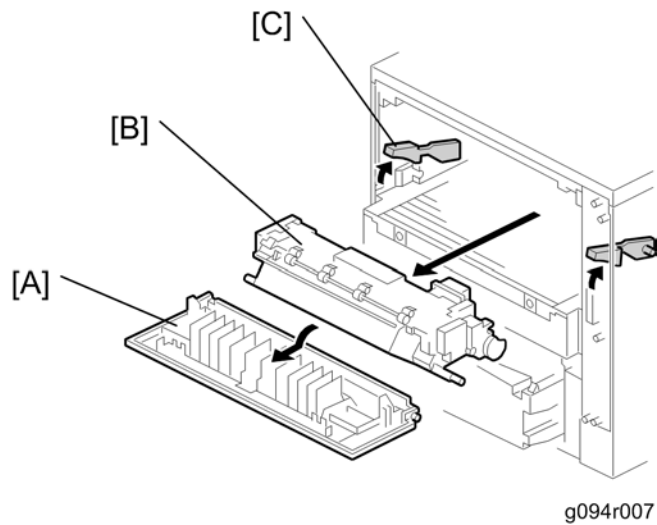

1. Rear cover [A]
2. Fusing unit [B] (2 hooks [C])

Note

- Lift both hooks before attempting to remove the fusing unit from the machine.

4.6.2 HOT ROLLER AND FUSING LAMP

1. Fusing unit (🔧 p.4-20)

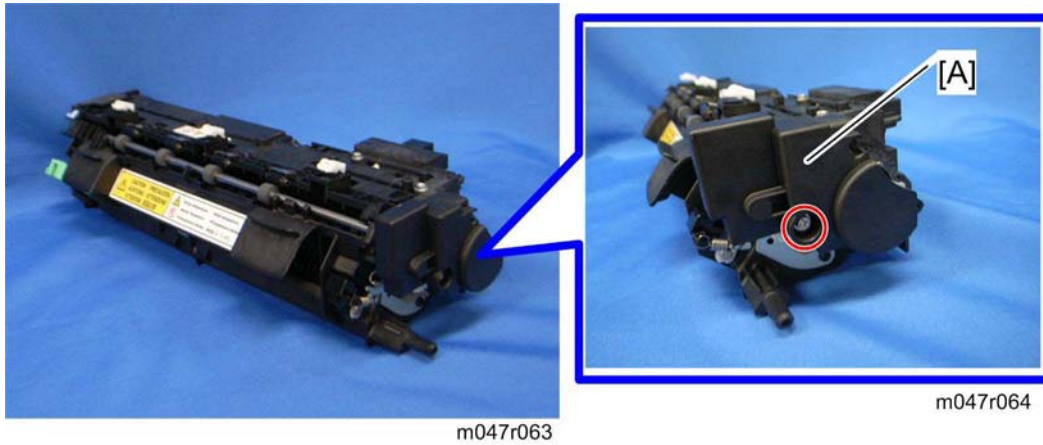

2. Left cover [A] (🔧 x 1)

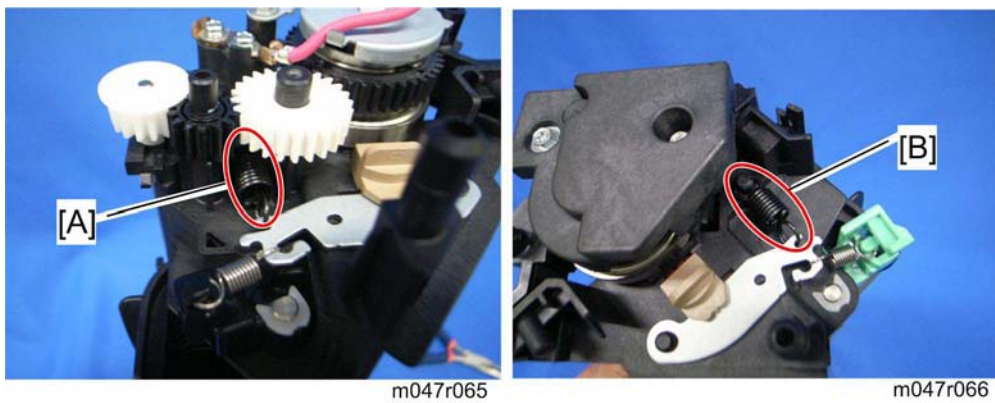

3. Release the fusing tension springs (left [A] and right [B]).

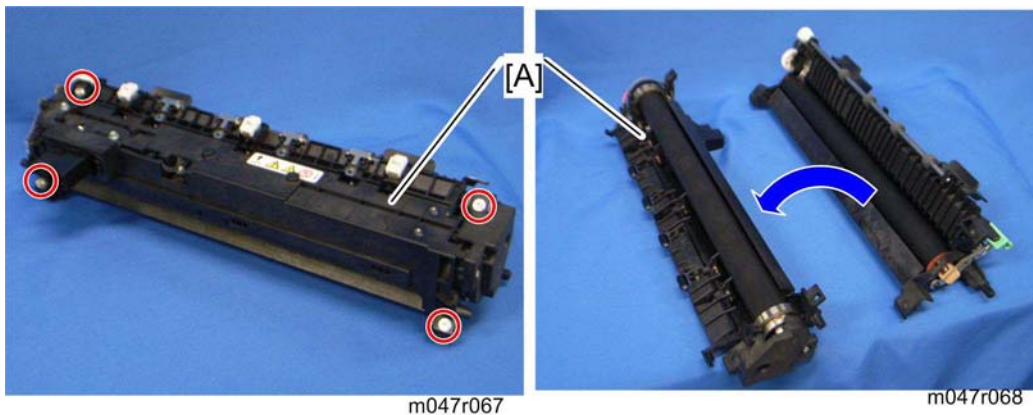

4. Upper fusing unit assembly [A] (🔧 x 4)

Fusing

↓ Note

- Remove both springs before taking apart the fusing unit assembly. The reason for this is to relieve pressure on the unit.
- When reinstalling the fusing unit assembly, install both springs last. The reason for this is to reset the springs back to their default position.



5. Upper guide plate [A] (hooks)
6. Right cover [B] (⚙ x 1)

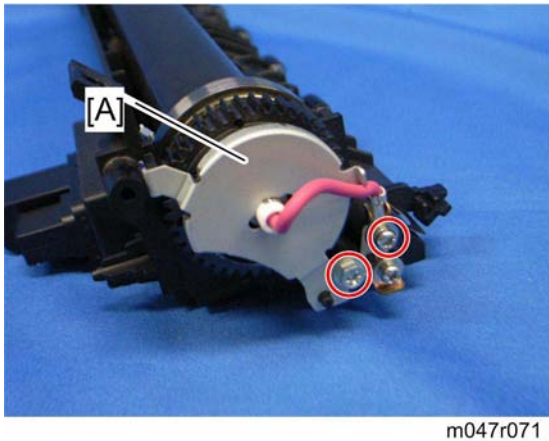

7. Left lamp holder [A] (⚙ x 2)

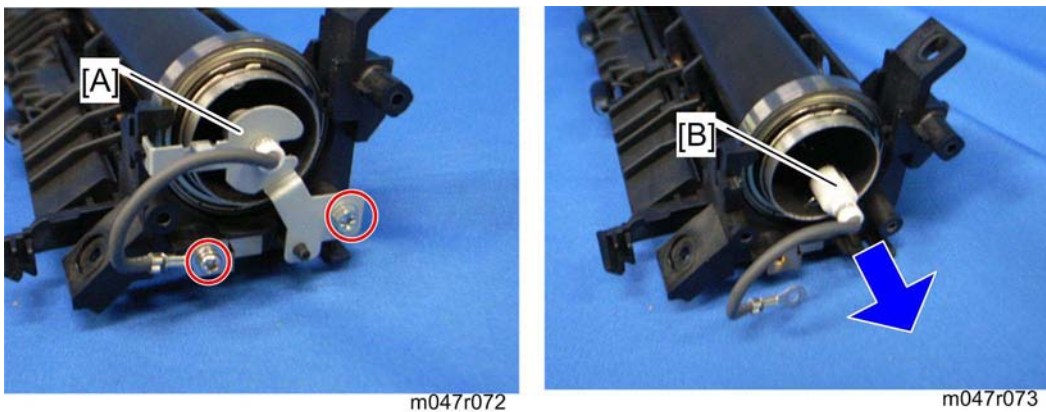

8. Right lamp holder [A] (⚙️ x 2)
9. Fusing Lamp [B]

↓ Note

- The colored cable must be at the hot roller gear side.

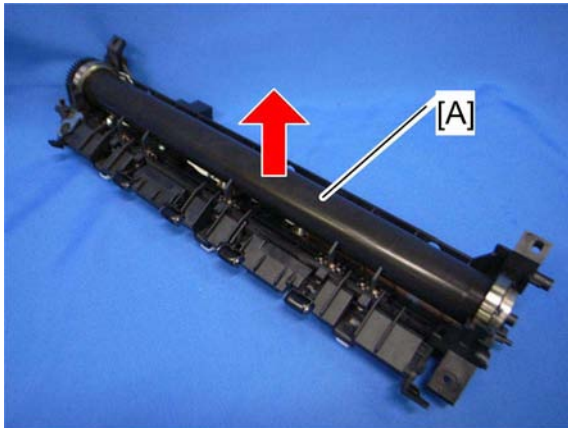

m047r074

10. Hot roller assembly [A]



m047r076

m047r077

m047r075

11. Remove the gear and bearings (left and right) (ring pin x 2)
12. Hot roller [A]

↓ Note

- Before installing the new hot roller, peel off 3 cm (1 inch) from both ends of the protective sheet on the new hot roller. Make sure to remove the rest of the paper before starting the machine.

Fusing

4.6.3 PRESSURE ROLLER

1. Fusing unit (☛ p.4-20)
2. Upper fusing unit assembly (☛ p.4-21 "Hot Roller and Fusing Lamp")

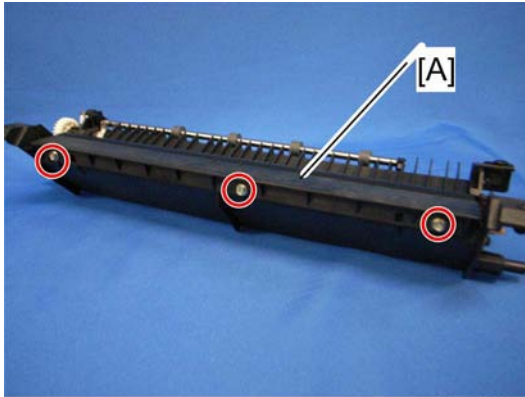

m047r082

3. Lower guide plate [A] (☛ x 3)



m047r079

m047r078

m047r080

4. Pressure roller levers [A] (spring x 1 each)
5. Bushings [B]

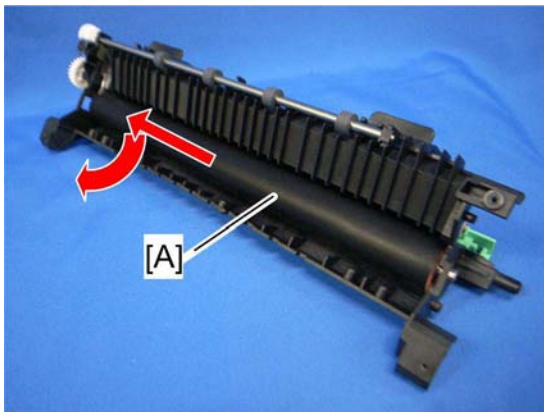

m047r081

6. Pressure roller [A]

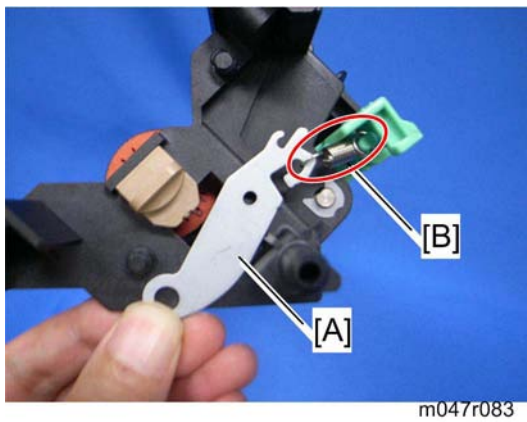
When reassembling the fusing unit

When attaching the pressure roller lever to the lower fusing unit assembly, attach the spring between the pressure roller lever and fusing unit first. If you try to attach the spring after attaching the pressure roller lever to the fusing unit, it is difficult to install the spring.

Fusing

4.6.4 THERMISTOR AND THERMOSTAT

Thermostat

1. Upper fusing unit assembly (☛ p.4-21 "Hot Roller and Fusing Lamp")

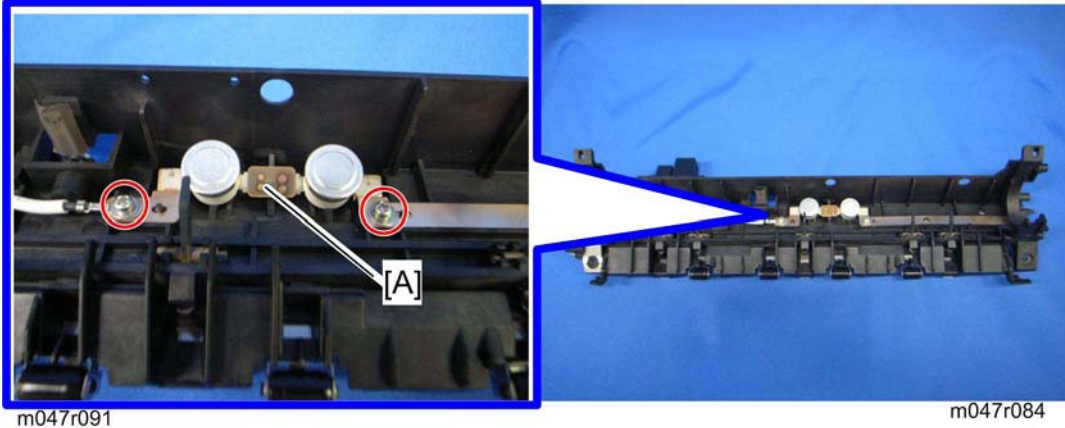

2. Thermostat [A] (☛ x 2)

↓ Note

- Do not touch the thermostat with your hands.
- Do not re-use a thermostat that is already opened. Safety is not guaranteed if you do this.

Thermistor

1. Upper fusing unit assembly (☛ p.4-21 "Hot Roller and Fusing Lamp")

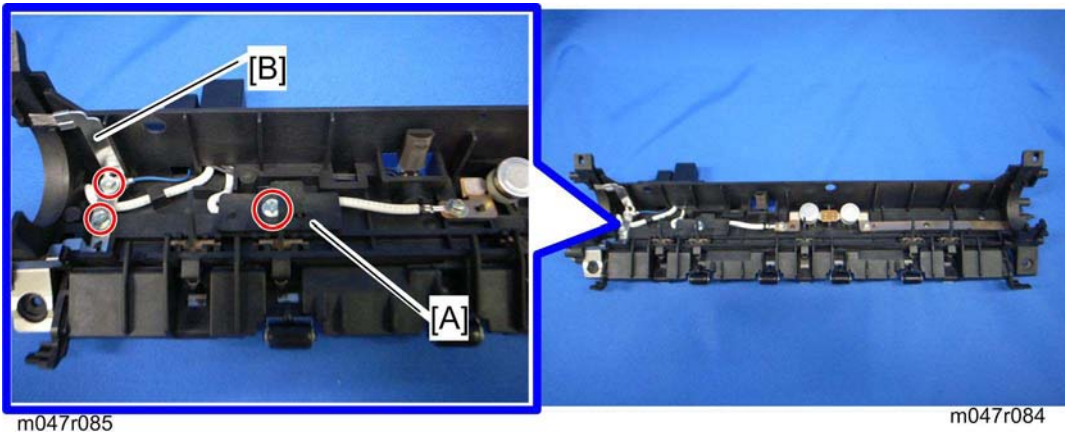

2. Inner wire cover [A] (☛ x 1)
3. Grounding plate [B] (☛ x 2, 1 wire)

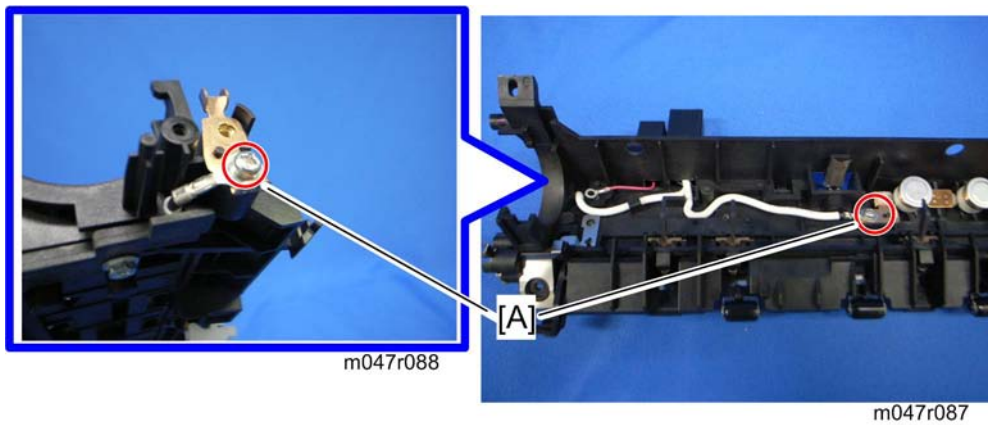

4. Remove two screws [A] of the fusing unit connector.

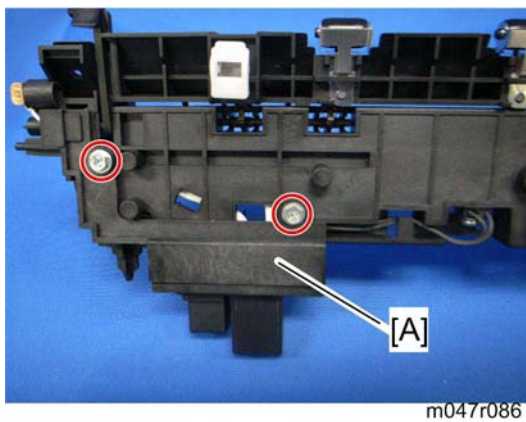

5. Upper wire cover [A] on the top of the fusing upper unit assembly (🔩 x 2)

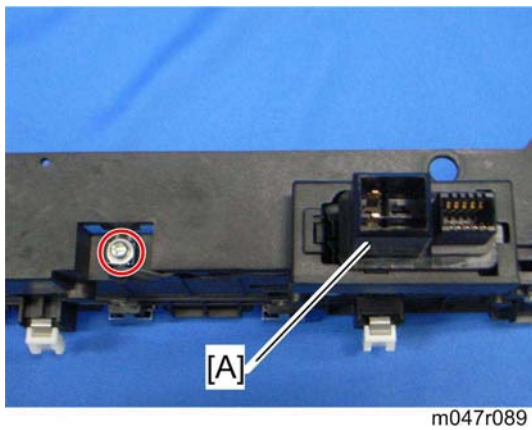

6. Fusing unit connector [A] (🔩 x 1, 2 hooks)

Replacement and Adjustment

Fusing

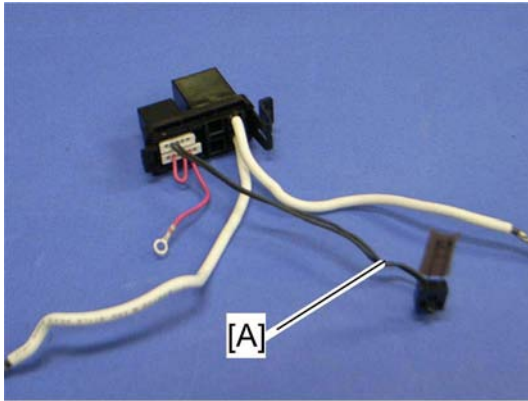

m047r090

7. Thermistor [A] (🔧 x 1, 1 harness)

↓ Note

- When removing the thermistor, remove the entire unit first and then separate it into two parts.

4.6.5 HOT ROLLER STRIPPERS

1. Hot roller (🔧 p.4-21 "Hot Roller and Fusing Lamp")

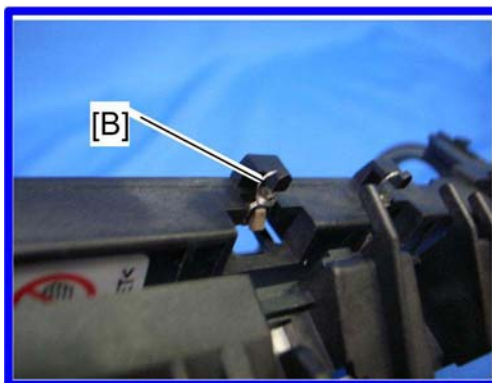

m047r093

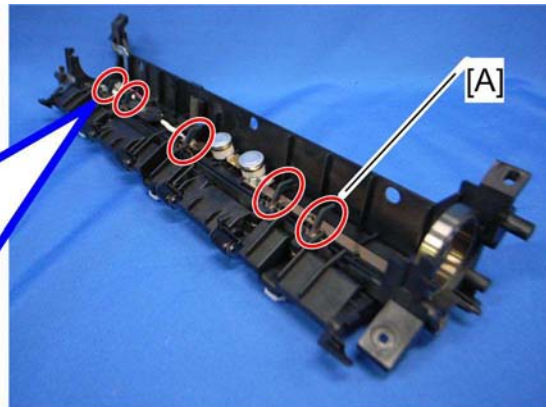

m047r092

2. Hot roller strippers [A] (1 spring each [B])

4.7 PAPER FEED

4.7.1 PAPER FEED ROLLER

1. Pull out the paper tray.

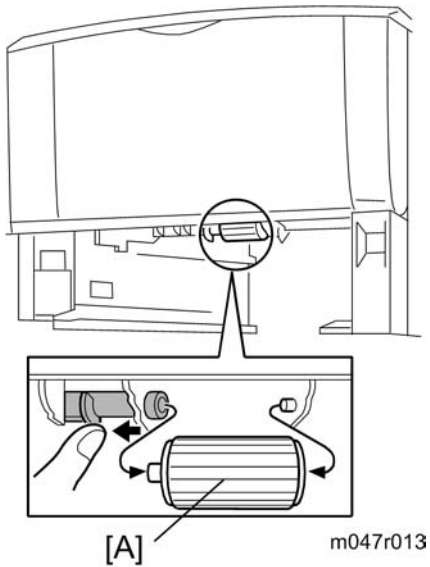

2. Paper feed roller [A]

4.7.2 FRICTION PAD

1. Pull out the paper tray.

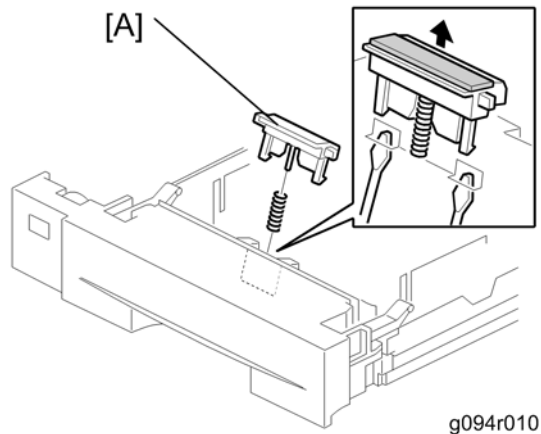

2. Friction pad [A] (2 hooks, 1 spring)

Note

- Remove the paper tray unit from the machine before removing the friction pad.

When reinstalling the friction pad follow this order

1. Replace the spring.
2. Insert the right side of the friction pad first followed by the left side.
3. Gently push the friction pad down into the slot and then pull forward very slightly.

4.7.3 PAPER END SENSOR

1. Pull out the paper tray.

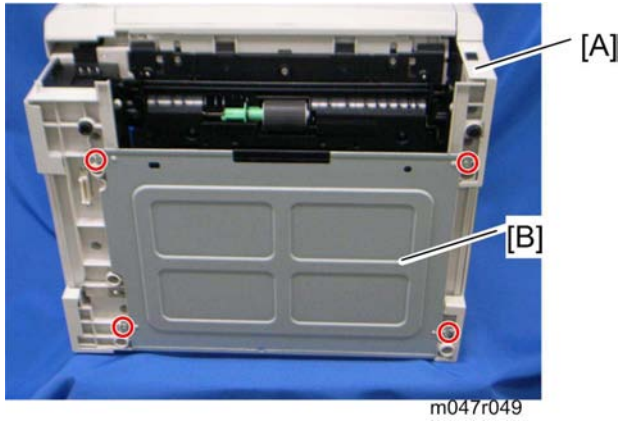

2. Set the machine [A] on the table with the rear side facing down.
3. Bottom plate [B] (🔩 x 4)

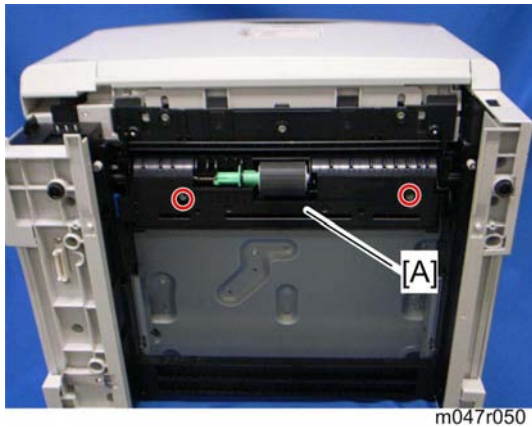

4. Paper feed guide plate [A] (🔩 x 2)

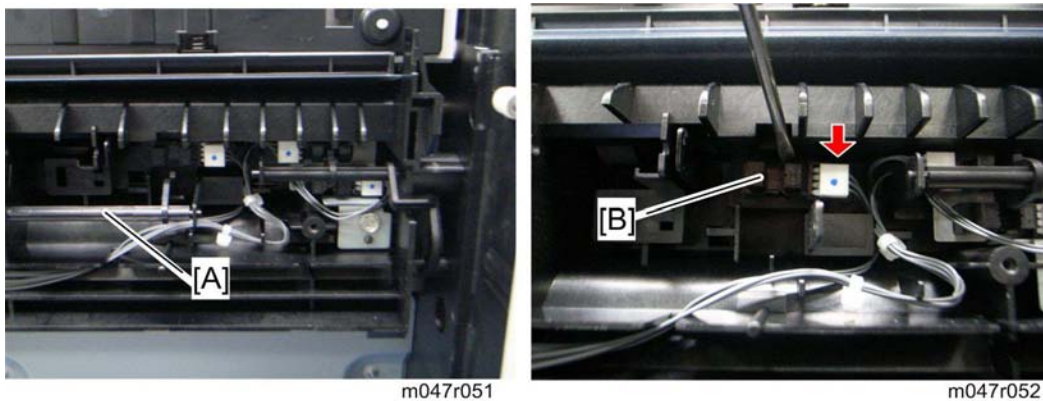

5. Paper end feeler [A]
6. Paper end sensor [B] (hooks, 📌 x 1)

4.7.4 REMAINING PAPER SENSORS

1. Pull out the paper tray.
2. Bottom plate (☛ p.4-31 "Paper End Sensor")
3. Paper feed guide plate (☛ p.4-31 "Paper End Sensor")

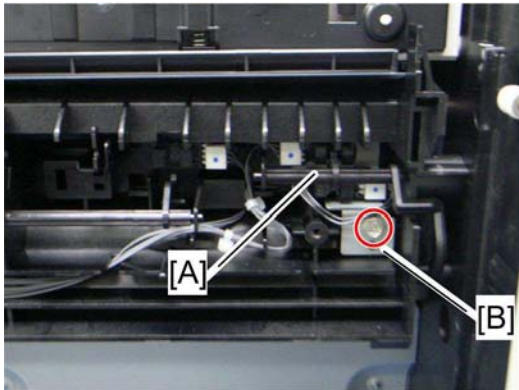

m047r051a

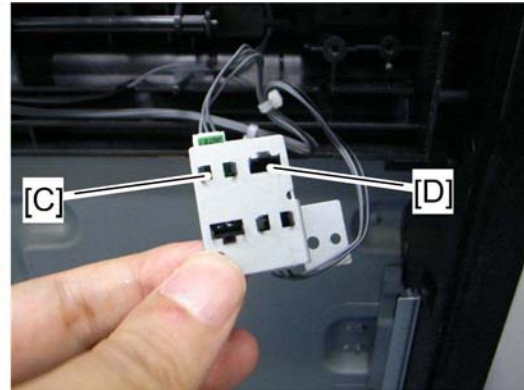

m047r053

4. Paper remaining feeler [A]
5. Sensor bracket [B] (☛ x 1)
6. Remaining paper sensor 1 [C] (hooks, ☛ x 1)
7. Remaining paper sensor 2 [D] (hooks, ☛ x 1)

4.8 BY-PASS FEED

4.8.1 BY-PASS FEED UNIT

1. Upper cover (🔧 p.4-6)
2. Left Cover (🔧 p.4-8)
3. Front door (🔧 p.4-9)

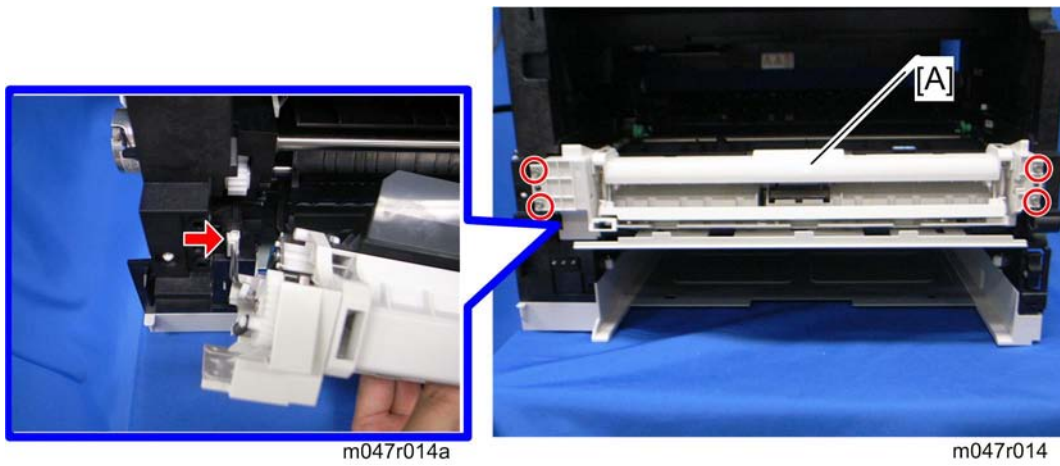

4. By-pass feed unit [A] (🔧 x 4, 📦 x 1)

By-pass Feed

4.8.2 BY-PASS FEED ROLLER

1. By-pass feed unit (☛ p.4-33)

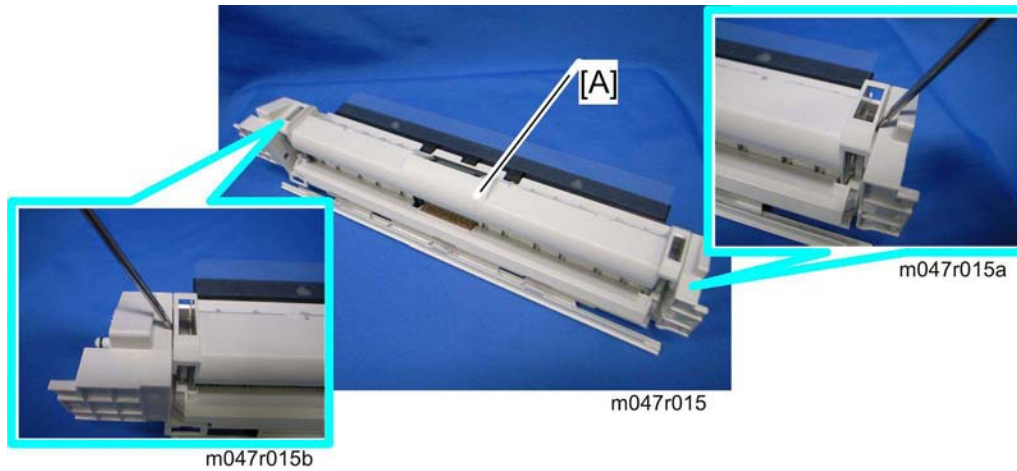

2. By-pass feed upper cover [A].

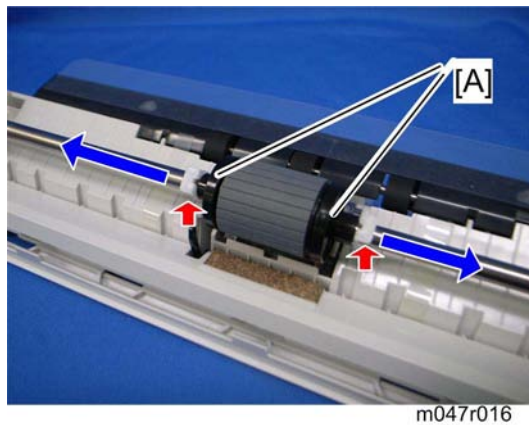

3. Slide the by-pass feed roller holders [A] to the both edges (☞ x 1 each).

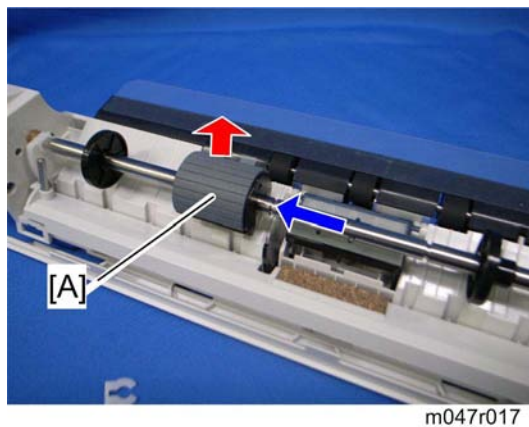

4. Slide the by-pass feed roller [A] to the left, and then remove it.

4.8.3 BY-PASS FRICTION PAD

1. By-pass feed unit (☛ p.4-33)
2. By-pass feed roller (☛ p.4-34)

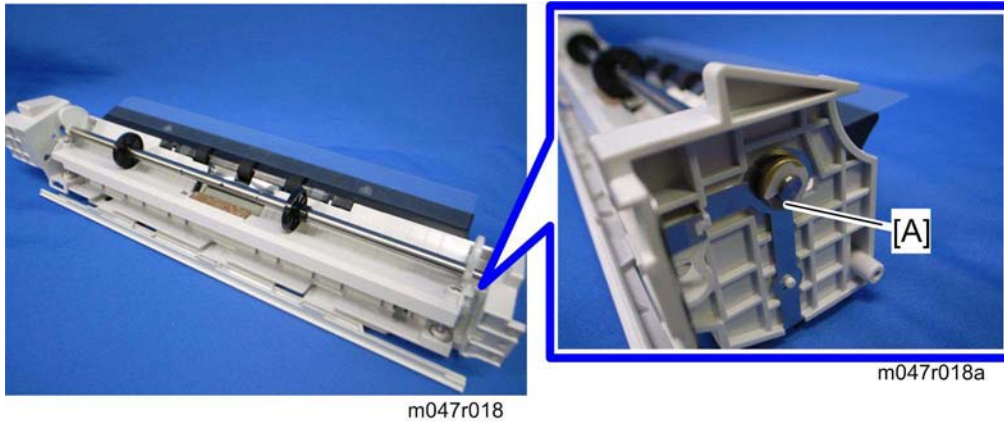

3. Bushing [A] at the right edge of the by-pass feed roller shaft (Clip x 1)

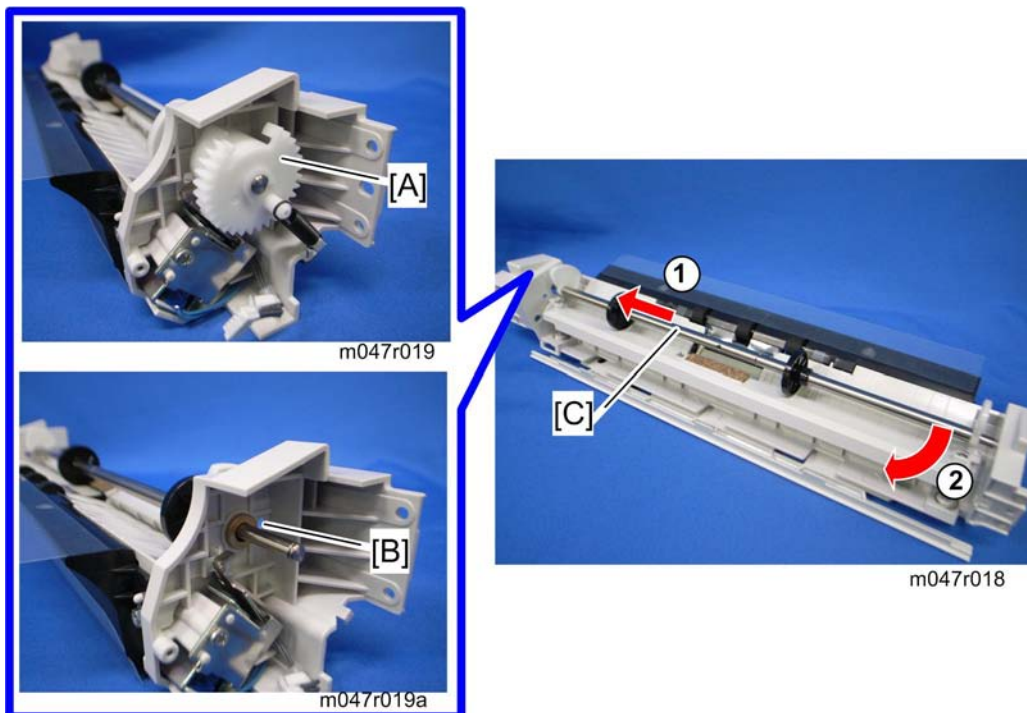

4. By-pass feed gear [A] (spring x 1, clip x 1)
5. Bushing [B] at the left edge of the by-pass feed roller shaft
6. Slide the by-pass feed roller shaft [C] to the left, and then remove it.

By-pass Feed

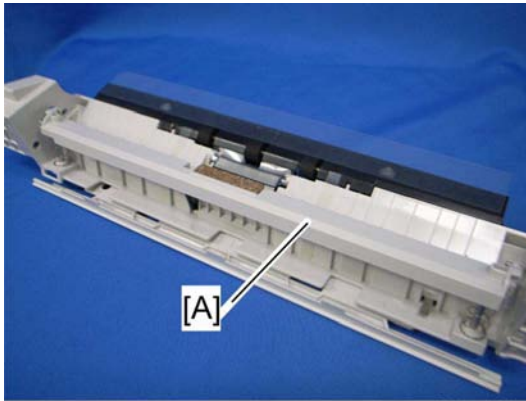

m047r020

7. Bottom bar [A] with two springs

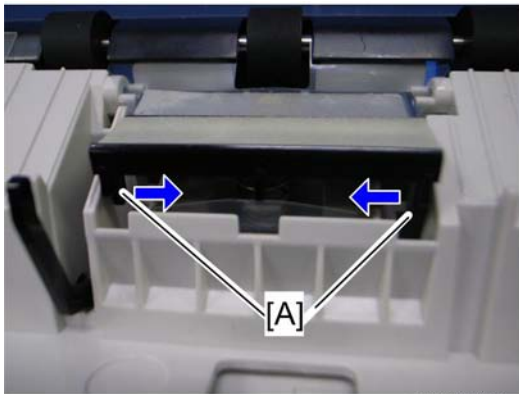

m047r021

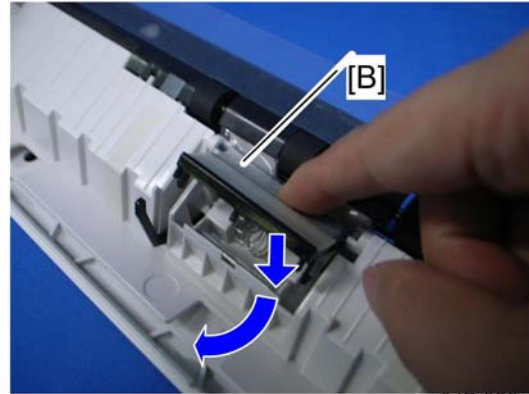

m047r022

8. Release the two hooks [A].
9. Press down the by-pass friction pad [B], and then pull it out (spring x 1).

4.8.4 BY-PASS PAPER SET SENSOR

1. By-pass feed unit (☛ p.4-33)

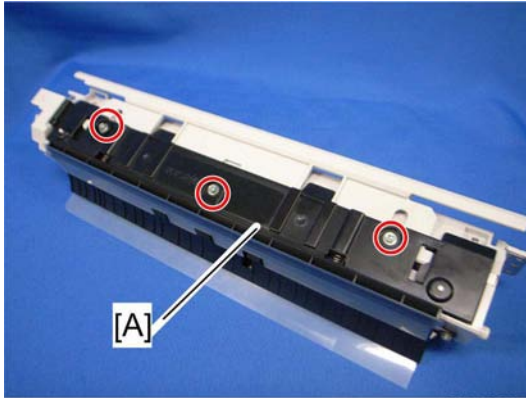

m047r023

2. By-pass guide plate [A] (☛ x 3)

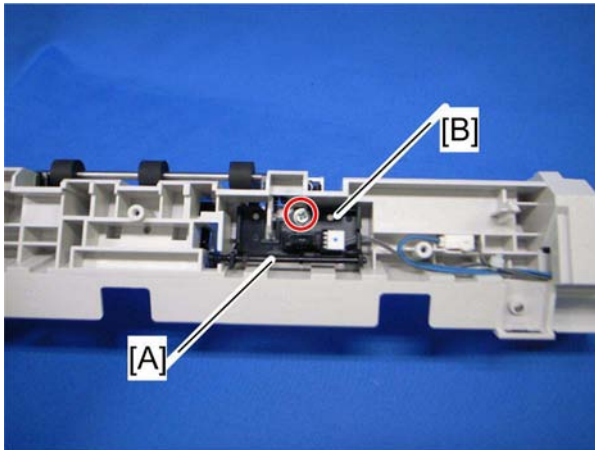

m047r024

3. Feeler [A]
4. Sensor base [B] (☛ x 1)

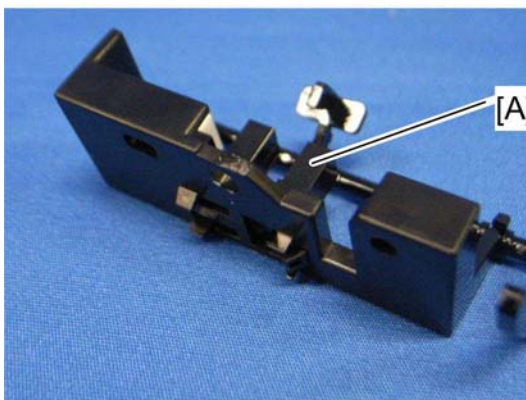

m047r025

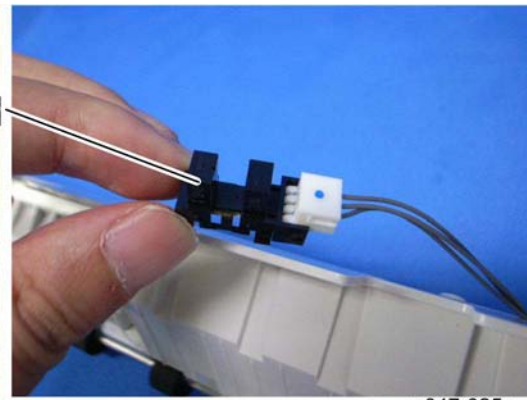

m047r025a

5. By-pass paper set sensor [A] (hook x 3, ☛ x 1)

Paper Exit

4.9 PAPER EXIT

4.9.1 PAPER EXIT SENSOR

1. Upper cover (🔑 p.4-6)

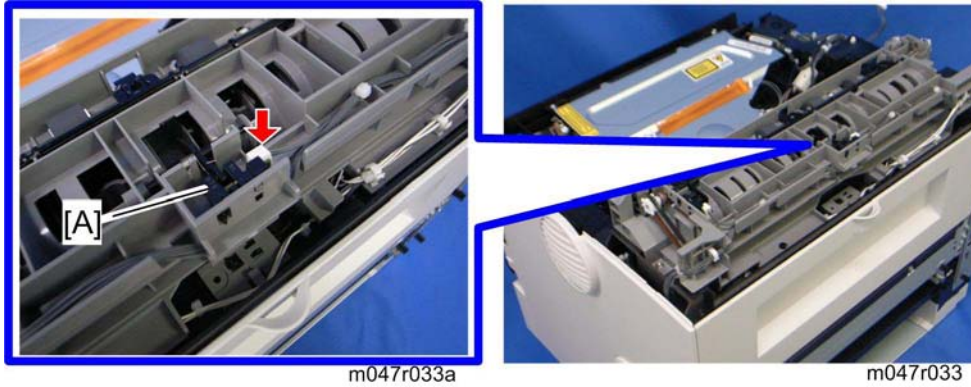

2. Paper exit sensor [A] (hooks, 📌 x 1)

4.9.2 OVERFLOW SENSOR

1. Upper cover (🔑 p.4-6)

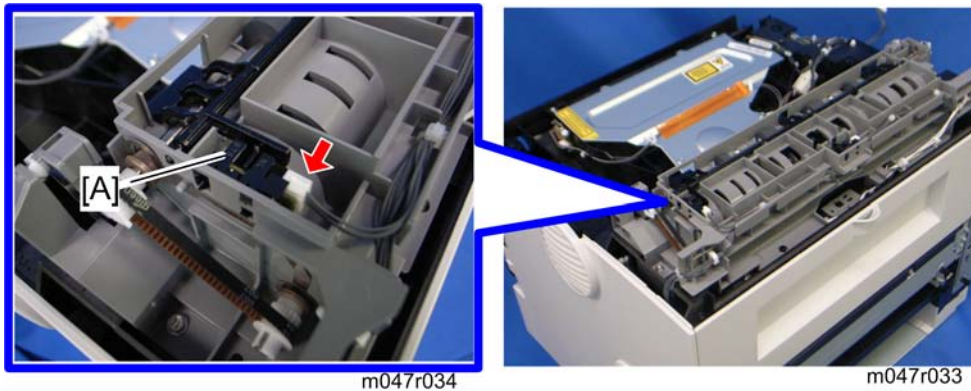

2. Overflow sensor [A] (hooks, 📌 x 1)

4.9.3 PAPER EXIT UNIT

1. Upper cover (☛ p.4-6)

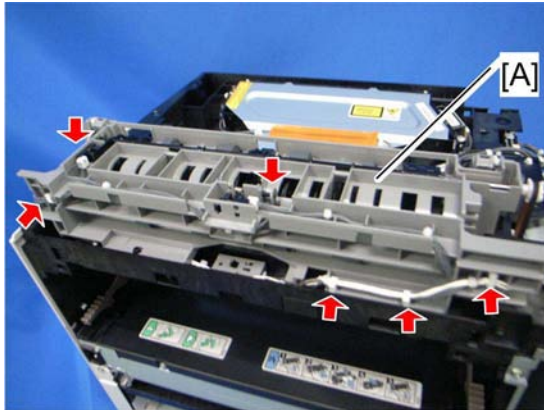

m047r035

2. Disconnect two connectors and release four clamps.
3. Take aside the harnesses on the paper exit unit [A].

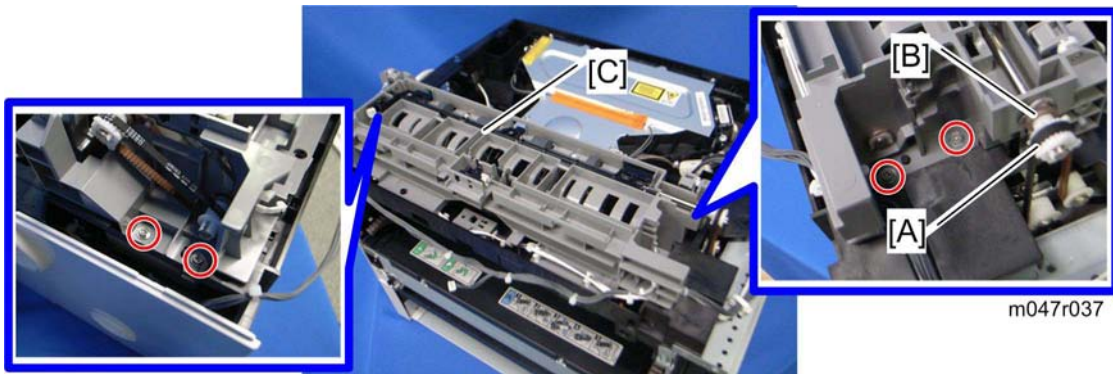

m047r037a

m047r036

m047r037

4. Remove four screws on the paper exit unit.
5. Remove the gear [A] (hook) and bushing [B].

↓ Note

- This gear is engaged with other drive gears through the timing belt. Check if the timing belt is correctly installed after installing the paper exit unit.

6. Paper exit unit [C]

Paper Exit

4.9.4 FUSING EXIT SENSOR

1. Upper cover (🔧 p.4-6)
2. Paper exit unit (🔧 p.4-39)



3. Sensor box [A] (hooks)

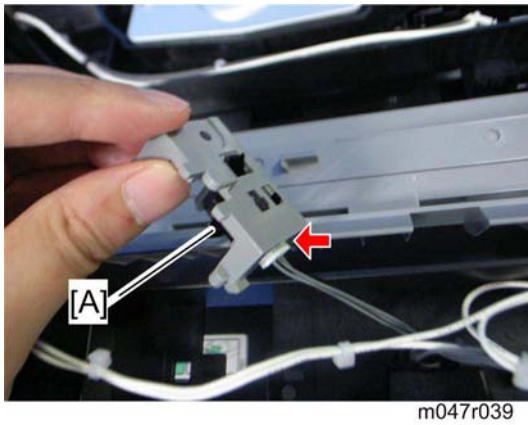

4. Fusing exit sensor [A] (hooks, 🖨️ x 1)

4.10 ELECTRICAL COMPONENTS

4.10.1 PRINTER CONTROLLER BOARD

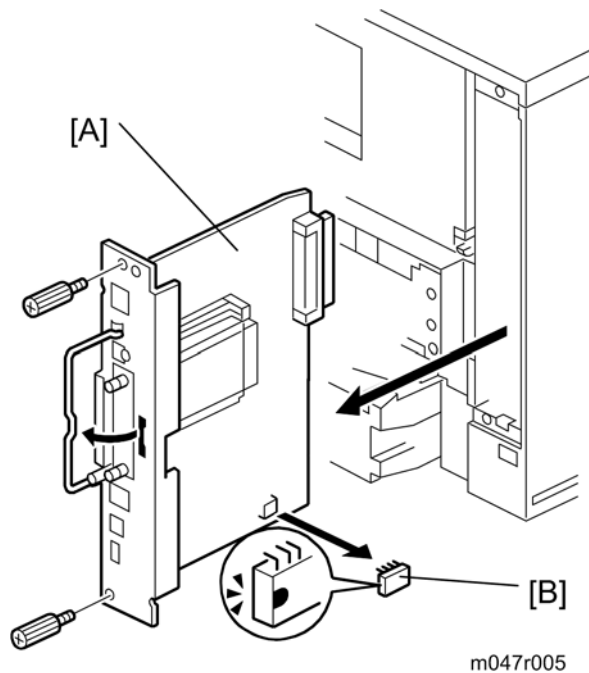

1. Printer controller board [A] (⚙️ x 2)
2. NVRAM [B]

↓ Note

- Remove the NVRAM from the old printer controller board and insert it on the new board.

↓ Note

- Remove the Duplex Unit before you remove the controller board.
- The screws on the printer controller board are hand screws. Gently turn these screws when removing the printer control board.
- Pull on the handle to remove the printer controller board from the machine.

4.10.2 ENGINE BOARD

1. Left cover (☛ p.4-8)
2. Printer controller board (☛ p.4-41)

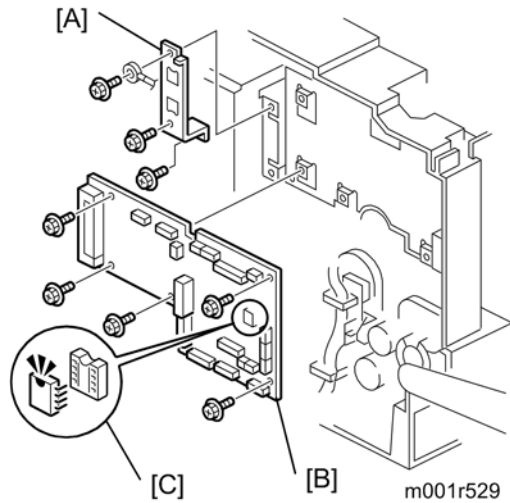

3. Bracket [A] (☛ x 2, 1 grounding wire)
4. Engine board [B] (☛ x 5, all connectors)

↓ Note

- Remove the NVRAM [C] from the old engine board and insert it on the new board.

4.10.3 MAIN MOTOR

1. Left cover (🔧 p.4-8)

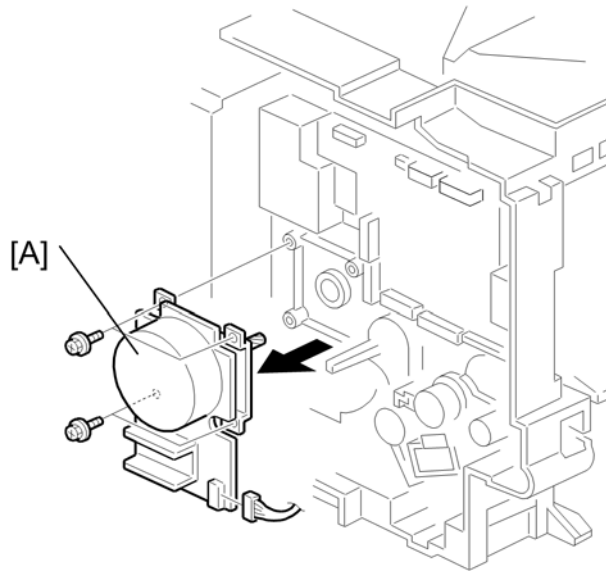

g094r530

2. Main motor [A] (🔧 x 4, 📦 x 1)

4.10.4 RELAY CLUTCH

1. Left cover (🔧 p.4-8)

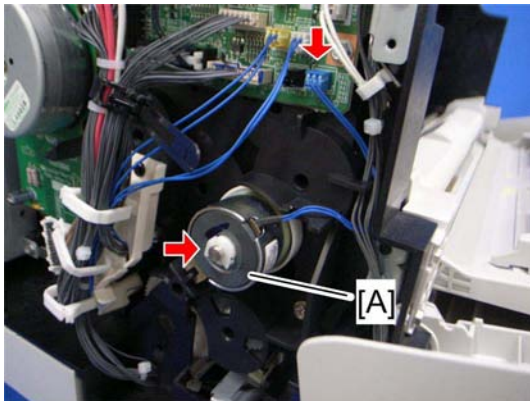

m047r056

2. Relay clutch [A] (📦 x 1, 📦 x 1)

4.10.5 PAPER FEED CLUTCH

1. Left cover (🔩 p.4-8)

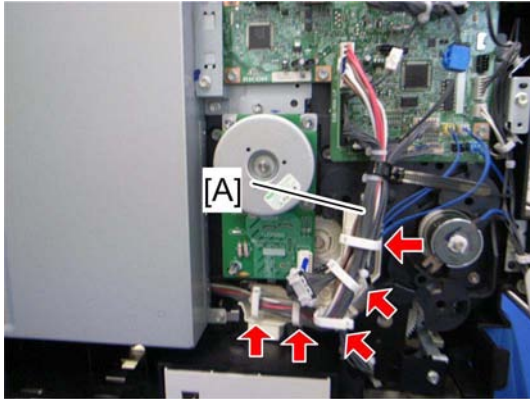

m047r058

2. Release the harness [A] (🔩 x 5, all connectors)

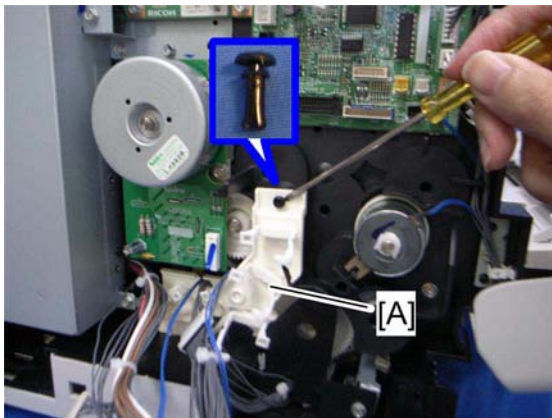

m047r057

3. Harness guide [A] (Rivet screw x 1)

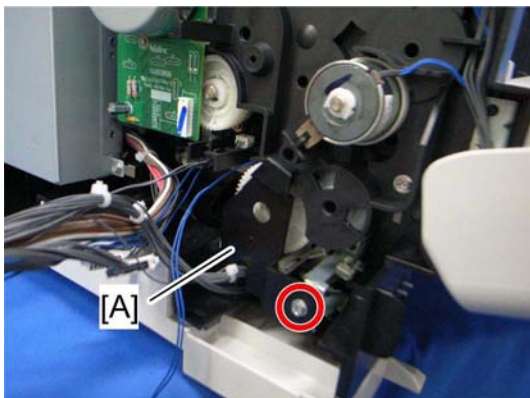

m047r059

4. Clutch cover [A] (🔩 x 1)

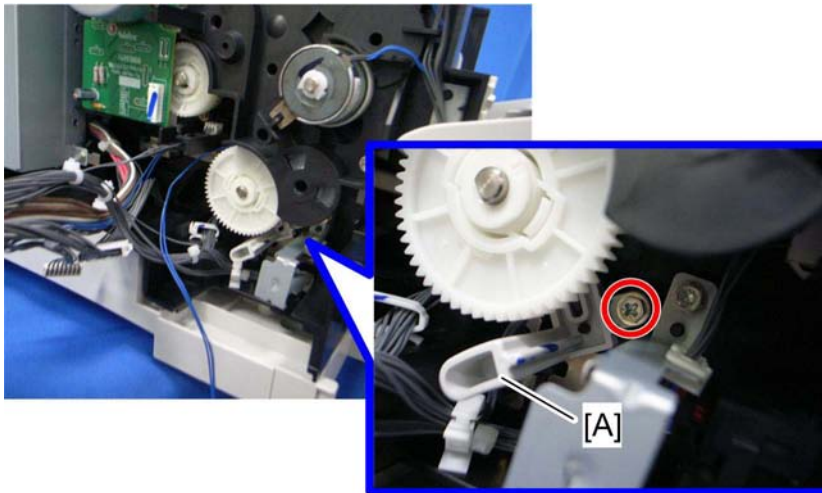

m047r060

- 5. Clutch holder [A] (x 1)

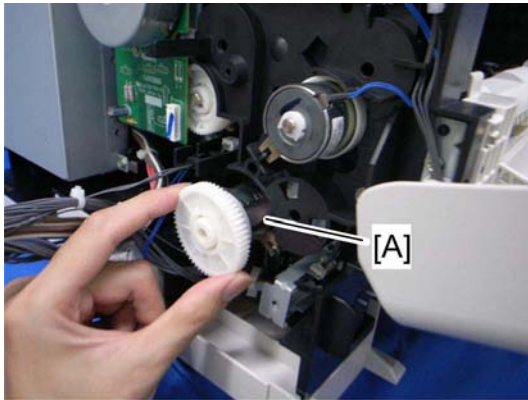

m047r061

- 6. Paper feed clutch [A]

Replacement
and
Adjustment

4.10.6 REGISTRATION CLUTCH

1. Left cover (🔧 p.4-8)
2. Main motor (🔧 p.4-43)
3. Harness guide (🔧 p.4-44 "Paper Feed Clutch")

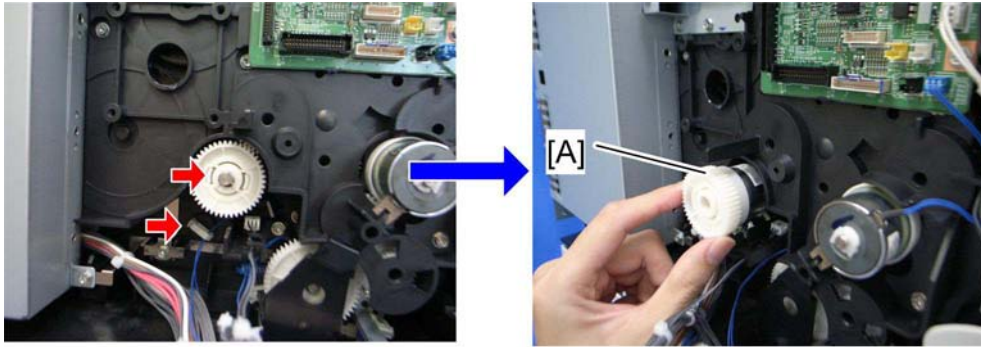

m047r062

4. Registration clutch [A] (🔧 x 1, 🌀 x 1)

4.10.7 REGISTRATION SENSOR

1. Left cover (🔧 p.4-8)
2. Harness guide (🔧 p.4-44)

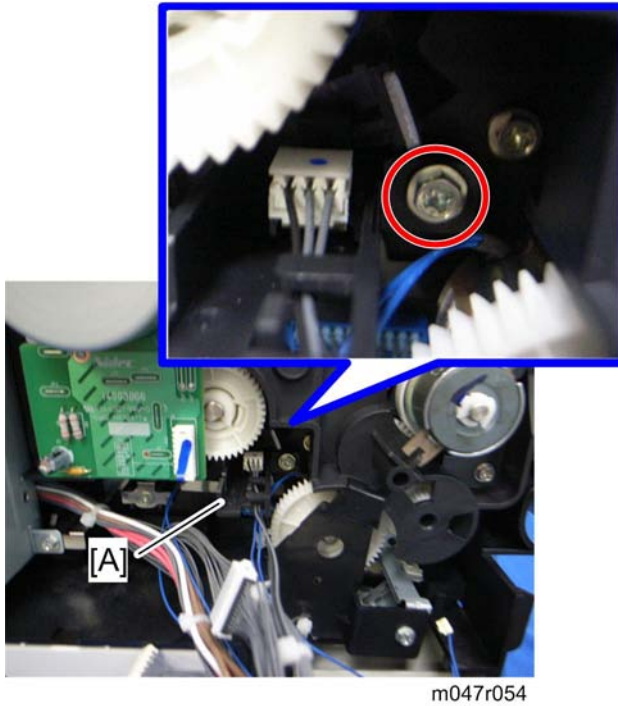

3. Sensor holder [A] (🔧 x 1)

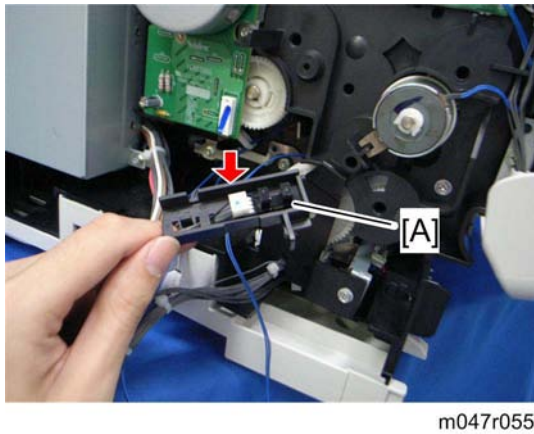

4. Registration sensor [A] (hooks, 🧰 x 1)

Replacement
and
Adjustment

4.10.8 POWER SUPPLY BOARD AND HIGH VOLTAGE SUPPLY BOARD

1. Left cover (🔧 p.4-8)
2. Fusing unit (🔧 p.4-20)

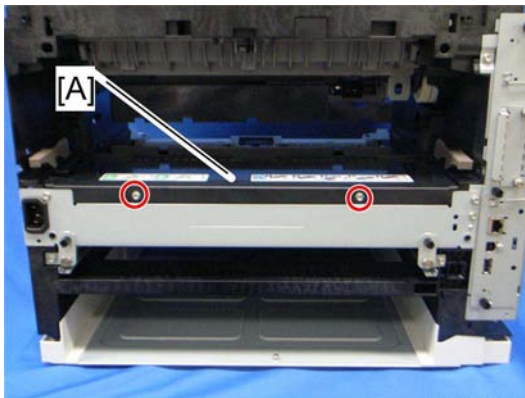

m047r042

3. PSU cover [A] (🔧 x 2)

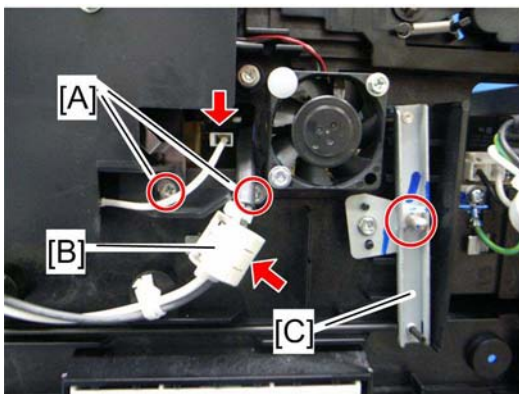

m047r040

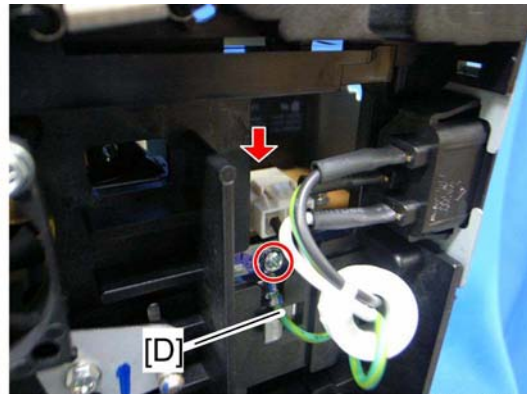

m047r041

4. Remove the two screws [A] at the left of the machine.
5. Disconnect three cables (pointed by arrow mark).
 - Disconnect the cable [B] from the rear of the machine.
6. Main switch link [C] (🔧 x 1)
7. Ground cable [D] (🔧 x 1: washer screw)

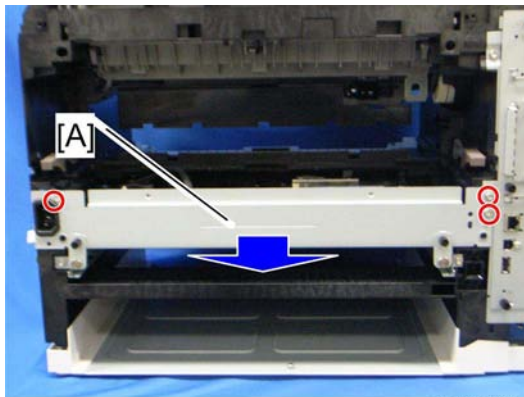

m047r043

8. PSU assembly [A] (🔧 x 3, 🛠️ x 3, all connectors)

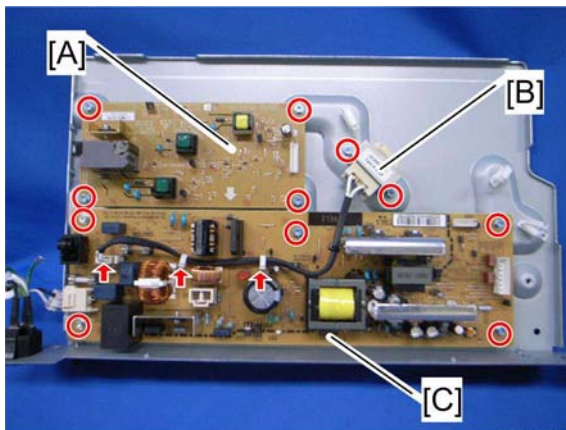

m047r044

9. High voltage supply board [A] (🔧 x 4)
 10. Choke coil [B] (🔧 x 2, 🛠️ x 2, 🛠️ x 1)
 ▪ The choke coil [B] is only for EU model.
 11. Power supply board [C] (🔧 x 5)

4.10.9 FUSING PRESSURE SENSOR

1. Right cover (🔧 p.4-10)

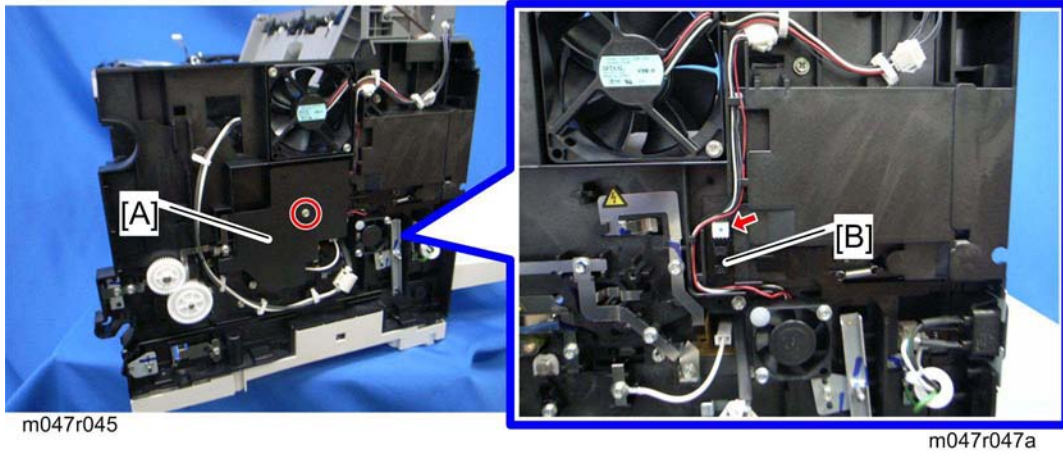

2. Terminal cover [A] (🔧 x 1)
3. Fusing pressure sensor [B] (hooks, 📏 x 1)

4.10.10 FUSING FAN

1. Right cover (🔧 p.4-10)

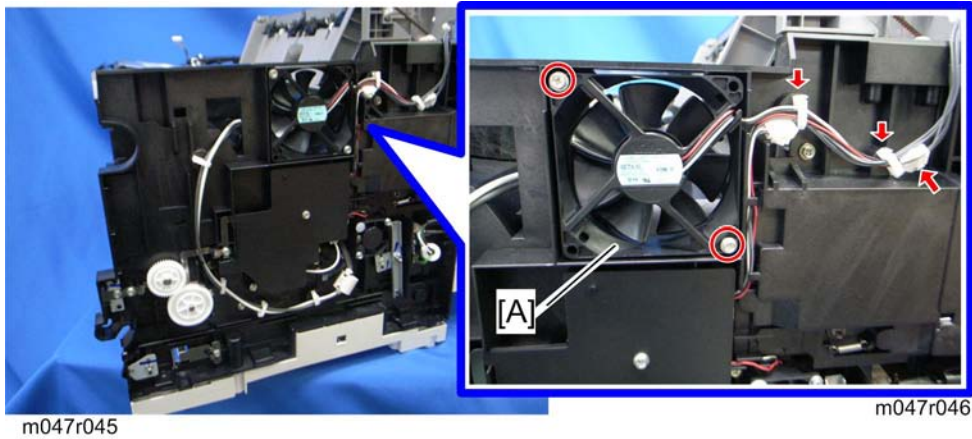

2. Fusing fan [A] (🔧 x 2, 📡 x 2, 📡 x1)

↓ Note

- The fusing fan must be reinstalled with the decal facing right. Do not reinstall the fusing fan opposite to the original position.

4.10.11 PSU FAN

1. Right cover (🔧 p.4-10)

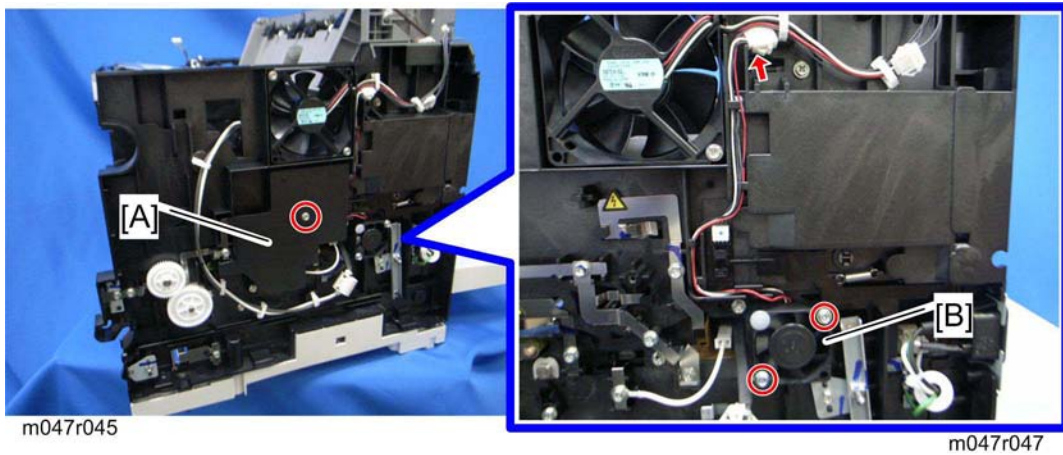

2. Terminal cover [A] (🔧 x 1)
3. PSU fan [B] (🔧 x 2, 📡 x 1)

↓ Note

- The PSU fan must be reinstalled with the decal facing left. Do not reinstall the PSU fan opposite to the original position.

Replacement and Adjustment

4.11 IMAGE ADJUSTMENT

4.11.1 REGISTRATION ADJUSTMENT

The registration is adjusted using the user mode; "Maintenance-Registration." For details, see the Printer Reference operation manual.

4.11.2 PARALLELOGRAM IMAGE ADJUSTMENT

Note

- Use the scanner positioning pin (P/N: A0069104) for the adjustment.
- Do the following procedure if a parallelogram is printed while adjusting the printing registration using a trimming pattern.

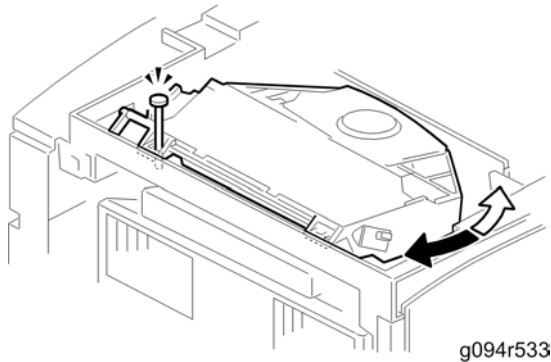

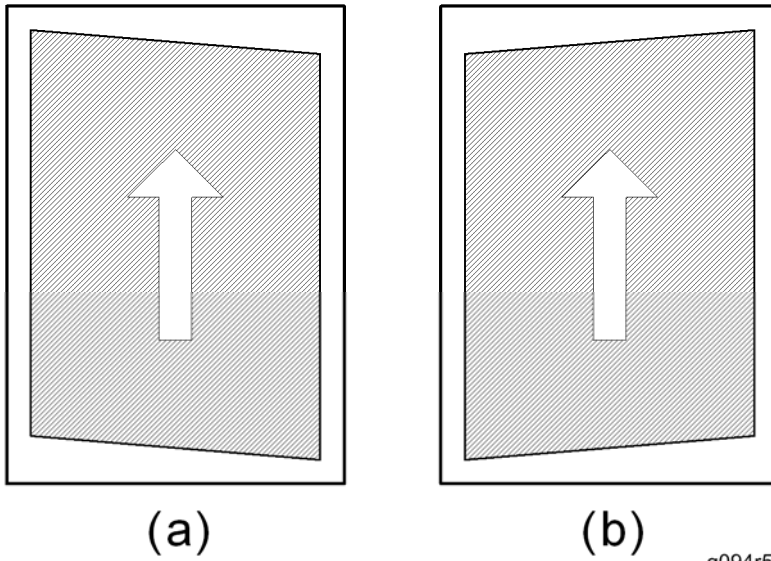

g094r500

1. Remove the upper cover (☛ p.4-6)
2. Put a positioning pin in one of the holes.
3. Loosen four screws and move the laser unit.
4. Tighten the laser unit.
5. Print the trimming area pattern to check the image. If it is still the same, repeat steps 3 to 5.

SYSTEM MAINTENANCE REFERENCE

REVISION HISTORY		
Page	Date	Added/Updated/New
		None

5. SYSTEM MAINTENANCE REFERENCE

5.1 SERVICE PROGRAM MODE

5.1.1 SP TABLES

See "Appendices" for the following information:

- Printer Controller Service Mode Tables
- Engine Mode Tables

⚠ CAUTION

Before accessing the service menu, do the following:

- Confirm that there is no print data in the printer buffer (the Data In LED must not be lit or blinking).
- If there is some data in the buffer, wait until all data has been printed.

5.1.2 INPUTTING A VALUE OR SETTING FOR A SERVICE PROGRAM

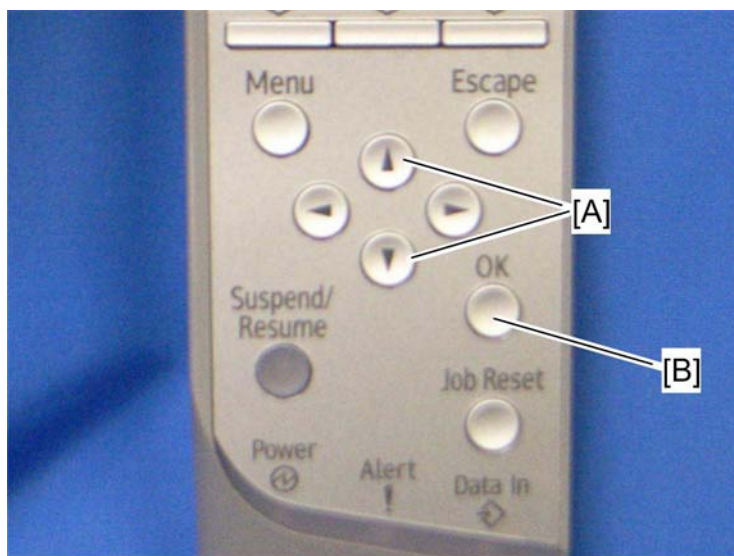

m047s509

Enter the required program mode as explained above. The setting appearing on the display is the current setting.

Select the required setting using the "Up/Down arrow" keys [A], then press the "OK" key [B]. The previous value remains if the "OK" key [B] is not pressed.

Service Program Mode

5.1.3 EXITING SERVICE MODE

Select "3. End" from the service mode main menu, then press the "OK" key.

5.2 UPDATING THE FIRMWARE

CAUTION

- Never turn off the machine while downloading the firmware.

5.2.1 TYPE OF FIRMWARE

The table lists the firmware programs used by the machine. All programs can fit on one SD card.

Program	What It Updates
Engine	Printer engine control
Network DocBox	Document server firmware
Printer	Printer feature applications
System	Printer management
Network Support	Network application
Update Mode Err.	Displays if an error occurs.
Verify Data	Verifies that the update executed successfully.

5.2.2 PRECAUTIONS

Handling SD Cards

Observe these precautions when handling SD cards:

- Always turn off the main power switch before you insert or remove an SD card. Data on an SD card can be corrupted if you insert or remove an SD card while the main power switch is on.
- Never turn off the main power switch during downloading.
- Keep SD cards in a safe location. Never store SD cards in locations where they will be exposed to:
 - High temperature, high humidity
 - Direct sunlight
 - Strong vibrations
 - Magnetic fields generated by machines or electronic devices
- Handle SD cards carefully to avoid dropping them, bending, scratching, etc.

Upload/Download

In this service manual, "upload" and "download" have these meanings:

- Upload: Copying data from the printer to the SD card
- Download: Copying data from the SD card to the printer

Network Connection

A print job sent to the machine during firmware update will interrupt the procedure. Before you start the firmware update procedure tell the operator:

- The machine must be disconnected from the network.
- The machine cannot be used during firmware update.

5.2.3 MACHINE FIRMWARE UPDATE

Each program must be updated one a time. Follow the procedure below to update one program.

1. Prepare a card that contains the required program.
2. If the machine is on, switch it off.

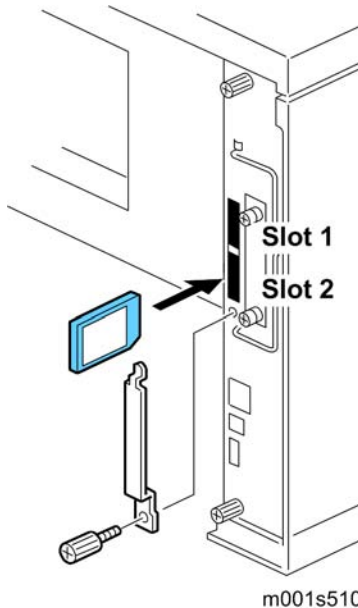

3. Remove the SD card cover (🔩 x 1).
4. Insert the SD card into Slot 2.
5. Turn on the power.
6. "Please Wait" appears, then you will see "Preparing to Start Firmware Update...."
7. Firmware names are displayed on the LCD.
8. Scroll to the program to upgrade, then press [OK].
9. Press the [UPDATE] to start the upgrade.

Loading

Update done
xxxxxxx

10. "Update done" appears on the LCD after completing the firmware updating.
11. Turn off the power, remove the SD card from Slot 2, and turn on the power.

Updating the Firmware

-or-

If you intend to update another program, leave the SD card in Slot 2 and turn off and on the power.

↓ Note

- The firmware has not updated successfully if the "Update done" message does not appear. If this occurs, turn the machine power off/on and repeat the procedure.

5.2.4 ERROR RECOVERY

Controller

If an error occurs during updating the controller firmware, use the following procedure. This procedure will force the controller to boot from the firmware SD card.

1. Prepare an SD card with the required controller firmware version.
2. Turn off the machine and remove the controller.

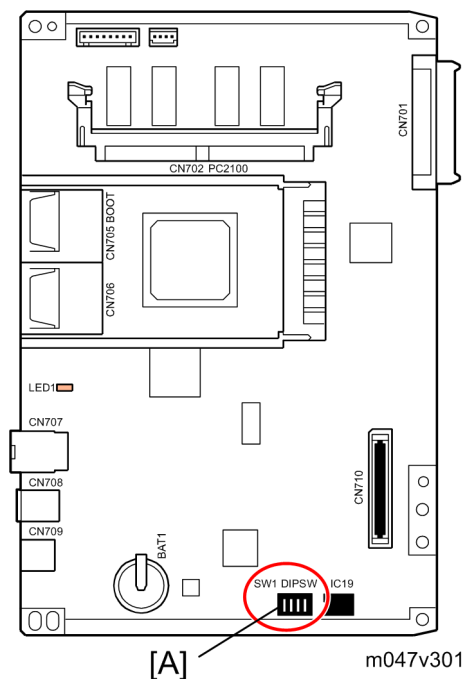

3. Change the DIP Switch 1 [A] - No.1 setting to "OFF."
4. Put back the controller
5. Insert the SD card into the SD slot 2 (lower) on the controller.
6. Turn on the machine. The machine automatically starts to download the software.
7. When downloading is finished, "Updated" is displayed.
8. Turn off the machine, then remove the card.
9. Reset the DIP Switch 2 - No.1 setting to "ON" and then put back the controller.

↓ Note

- You must perform steps 5 to 8 for all three firmware cards.
 - The default settings of the DIP Switches are as followed; "No.1: ON" and "No. 2 to 4: OFF."
10. Turn on the machine, and print the service summary report.

Updating the Firmware

Engine

If a download attempt failed, try downloading the new firmware again using the normal firmware download procedure described in "Machine Firmware Update."

5.3 POWER-ON SELF TESTS

The controller tests the following devices at power-on. If an error is detected, an error code is stored in the controller board.

- CPU, ASIC and clock
- Flash ROM
- Resident and optional SDRAM
- NIB
- IEEE 802.11a/g, Gigabit Ethernet or IEEE1284 (if installed)
- NVRAM
- Optional HDD (if installed)

To check the error codes, use engine SP 7832.

Refer to "Controller Error" for details about the error codes.

5.4 DIP SWITCHES

5.4.1 CONTROLLER BOARD

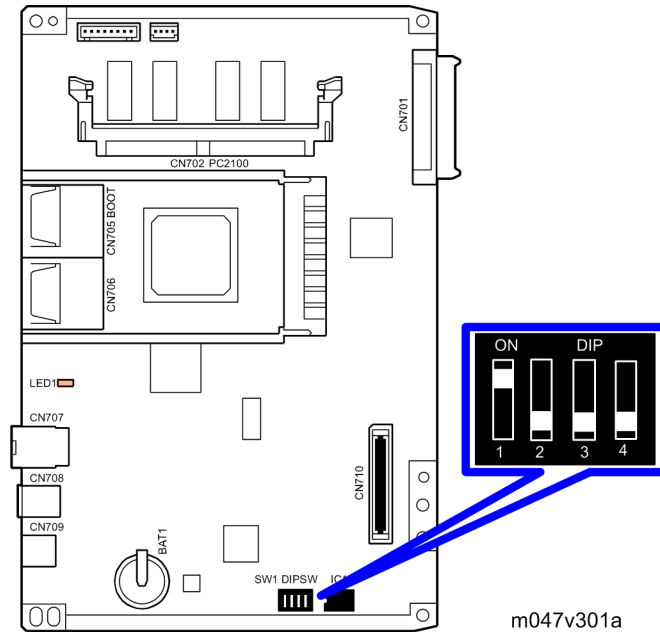

DIP Switch 1 (Bit 1) on the controller board is used for the error recovery after the firmware updating procedure failed.

↓ Note

- The default settings of the DIP Switches are as followed; "No.1: ON" and "No. 2 to 4: OFF ."

TROUBLESHOOTING

REVISION HISTORY		
Page	Date	Added/Updated/New
		None

6. TROUBLESHOOTING

6.1 SERVICE CALL CONDITIONS

For "Service Call Conditions" information, see "Appendices."

6.2 ELECTRICAL COMPONENT DEFECTS

6.2.1 SENSORS

Component	CN	Condition	Symptom
Paper Exit	CN14-20	Open	The Paper Jam indicator will light whenever a print is made.
		Shorted	The Paper Jam indicator lights even if there is no paper.
Paper Overflow	CN4-30	Open	The paper overflow message is not displayed even when a paper overflow condition exists.
		Shorted	The paper overflow message is displayed.
Fusing Exit	CN5-25	Open	The Paper Jam indicator will light whenever a print is made.
		Shorted	The Paper Jam indicator lights even if there is no paper.
Registration	CN14-35	Open	The Paper Jam indicator will light whenever a print is made.
		Shorted	The Paper Jam indicator lights even if there is no paper.
Remaining paper sensor 1	CN14-26	Open	The Paper End indicator lights even if paper is placed in the 1st paper tray.
		Shorted	The Paper End indicator does not light even if there is no paper in the 1st paper tray.

Component	CN	Condition	Symptom
Remaining paper sensor 2	CN14-29	Open	The machine cannot determine the paper near-end condition properly.
		Shorted	
Paper End	CN14-23	Open	The Paper End indicator lights even if paper is placed in the 1st paper tray.
		Shorted	The Paper End indicator does not light even if there is no paper in the 1st paper tray.
Toner End	CN14-33	High	Toner near-end (toner end) is not detected.
		Low	The add toner message is displayed.
Fusing Pressure Sensor	CN5-19	Open	Envelop mode is not selected even if the pressure lever at the fusing unit is set to the envelop mode.
		Shorted	Envelop mode is always selected even if the pressure lever at the fusing unit is set to the other paper mode.

↓ Note

- The CN numbers describe the connector number on the engine board.

6.2.2 SWITCHES

Component	CN	Condition	Symptom
Front Cover Safety	CN8-1/3	Open	The Front Cover Open message is not displayed even if the front cover is opened.
		Shorted	The Front Cover Open message is displayed even if the front cover is closed.
Rear Cover and Paper Exit Cover Safety	CN4-1/5, CN4-3/T2	Open	The Cover Open (Rear Cover or Paper Exit Cover) message is not displayed even if the rear cover or paper exit cover is opened.
		Shorted	The Cover Open (Rear Cover or Paper Exit Cover) message is displayed even if the rear cover or paper exit cover is closed.

 Note

- The CN numbers describe the connector number on the engine board (except for the main switch).

6.2.3 BLOWN FUSE CONDITIONS

CAUTION

- Use a correct rating fuse for the fuse replacement. Never use a wrong rating fuse. If do so, the machine may be damaged.

Fuse	Rating		Symptom when turning on the main switch
	120 V	220 - 240 V	
Power Supply Board			
FU1	15 A/125 V	8A/250V	Machine does not start.
FU2	5.0 A/125 V	3.15 A/250 V	Machine does not start.
FU3	4 A/125 V	4 A/250 V	Machine does not start.
FU4	5 A/125 V	5 A/250 V	Machine does not start.
FU5	6.3V/125V	6.3 A/250V	"Please Wait" is displayed, but machine does not start or SC is issued on the LCD.

6.2.4 LEDS

No LEDs are used for this model.

ENERGY SAVING

REVISION HISTORY		
Page	Date	Added/Updated/New
		None

7. ENERGY SAVING

7.1 ENERGY SAVE

7.1.1 ENERGY SAVER MODES

The customer should use the energy saver mode correctly to save energy and protect the environment.

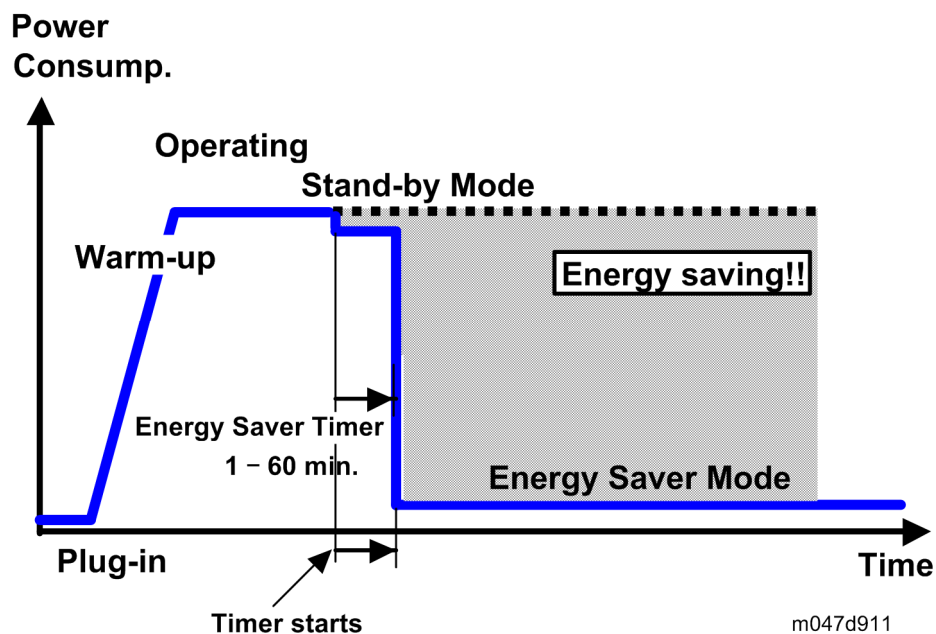

The area shaded grey in this diagram represents the amount of energy that is saved.

Energy Saver Mode Setting

"Energy Saver" mode settings can be adjustable with User Mode (Menu > System > Energy Saver).

Energy Saver On/Off

You can specify whether or not to switch Energy Saver.

- On (Default)
- Off

Energy Save

Energy Saver Timer

Specify time for entering the Energy Saver mode.

- 1 minute (Default)
- 5 minutes
- 15 minutes
- 30 minutes
- 45 minutes
- 60 minutes

Return to Standby Mode

The machine returns to standby mode from energy saver mode after 10 sec.

7.2 PAPER SAVE

7.2.1 EFFECTIVENESS OF DUPLEX/COMBINE FUNCTION

Duplexing and the combine functions reduce the amount of paper used. This means that less energy overall is used for paper production, which improves the environment.

1. Duplex:

Reduce paper volume in half!

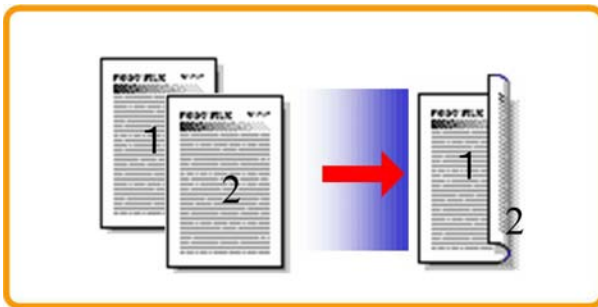

j018d102

2. Combine mode:

Reduce paper volume in half!



j018d100

Paper Save

3. Duplex + Combine:

Using both features together can further reduce paper volume by 3/4!

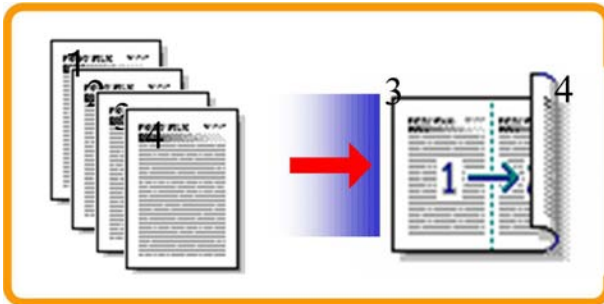

j018d101

To check the paper consumption, look at the total counter and the duplex counter.

The total counter counts all pages printed.

- For one duplex page, the total counter goes up by 2.
- For a duplex job of a three-page original, the total counter goes up by 3.

The duplex counter counts pages that have images on both sides.

- For one duplex page, the duplex counter goes up by 1.
- For a duplex job of a three-page original, the duplex counter will only increase by 1, even though two sheets are used.

Recommendation

Please explain these features to the customers so they can reduce their paper usage.

Duplex Mode Tables

The following table shows paper savings and how the counters increase for some simple examples of single-sided and duplex jobs

Duplex mode:

Originals	Simplex Sheet used	Duplex Sheets used	Paper Saved	Total counter	Duplex counter
1	1	1	0	1	0
2	2	1	1	2	1
3	3	2	1	3	1
4	4	2	2	4	2
5	5	3	2	5	2
10	10	5	5	10	5
20	20	10	10	20	10

If combine mode is used, the total and duplex counters work in the same way as explained previously. The following table shows paper savings and how the counters increase for some simple examples of duplex/combine jobs.

Paper Save

2 in 1 mode:

Originals	Simplex Sheet used	Duplex Sheets used	Paper Saved	Total counter	Duplex counter
1	1	1	0	1	1
2	2	1	1	1	1
3	3	2	1	2	2
4	4	2	2	2	2
5	5	3	2	3	2
10	10	5	5	5	5
20	20	10	10	10	10

Duplex + 2 in 1 mode:

Originals	Simplex Sheet used	Duplex Sheets used	Paper Saved	Total counter	Duplex counter
1	1	1	0	1	1
2	2	1	1	1	1
3	3	1	2	2	2
4	4	1	3	2	2
5	5	2	3	3	3
6	6	2	4	3	3
7	7	2	5	4	4
8	8	2	6	4	4
9	9	3	6	5	5
10	10	3	7	5	5
11	11	3	8	6	6
12	12	3	9	6	6

M047

SERVICE MANUAL APPENDICES

M047 APPENDICES

TABLE OF CONTENTS

1. APPENDIX: SPECIFICATIONS	1-1
1.1 GENERAL SPECIFICATIONS	1-1
1.1.1 MAINFRAME	1-1
1.1.2 CONTROLLER	1-4
1.1.3 OPERATION PANEL LED SPECIFICATIONS	1-6
1.1.4 SUPPORTED PAPER SIZES	1-7
2. APPENDIX: TROUBLESHOOTING GUIDE	2-1
2.1 SERVICE CALL CONDITIONS	2-1
2.1.1 SUMMARY	2-1
2.1.2 SC CODE DESCRIPTIONS	2-2
Engine SC	2-2
Controller SC	2-7
3. APPENDIX: SP MODE TABLES	3-1
3.1 SP TABLES	3-1
3.1.1 PRINTER CONTROLLER SERVICE MODE	3-1
Service Mode Menu ("1. Service Menu")	3-1
Bit Switch Programming	3-8
3.1.2 PRINTER ENGINE SERVICE MODE	3-9
Service Mode Table	3-9
SP1-xxx: Feed	3-10
SP2-xxx: Drum	3-16
SP3-xxx: Process	3-18
SP5-xxx: Mode	3-20
SP7-xxx: Data Log	3-76
SP8XXX: Data Log 2	3-89

APPENDIX: SPECIFICATIONS

REVISION HISTORY		
Page	Date	Added/Updated/New
		None

1. APPENDIX: SPECIFICATIONS

1.1 GENERAL SPECIFICATIONS

1.1.1 MAINFRAME

Configuration	Desktop	
Paper size	DLT – A6 SEF	
Technology	Laser beam scanning (Laser class: Class 1) & Electro photographic printing Dual component toner development AIO is used	
Print Resolution	300/600/1200 dpi	
Smoothing	Yes (on, off)	
Continuous Print Speed	LEF A4 Mono 35 ppm	
	LT Mono 35 ppm	
Duplex Print Speed (A4-LEF)	32 ppm from standard tray	
	32 ppm from first optional paper tray	
	27 ppm from second optional paper tray	
First Print Speed	6.8 seconds or less (A4/LT, LEF from standard tray)	
Copy Paper Weight	Paper Tray	60-216 g/m ² (16-57 lb.)
	By-pass tray	52-216 g/m ² (14-57 lb.)
	Optional PFU	60-216 g/m ² (16-57 lb.)
	Duplex	64-105 g/m ² (17-28 lb.)
Warm-up Time	19 seconds or less from power on (23°C, 73°F)	
	12 seconds or less from energy saver mode	

General Specifications

Paper Input Size	Standard tray	A3/DLT – A5
	By-pass tray	A3/DLT – A6, Free size
	By-pass tray-Custom size paper	Length: 148 - 432 mm (5.8" - 17"), Width: 64 - 305 mm (2.5" - 12"), Com#10, C5, C6, DL. Monarch
	Optional Envelope Feeder	Com#10, C5, C6, DL. Monarch
	Optional paper tray unit Up to 2 units can be installed.	A3/DLT – A5
Paper Input Capacity	Standard tray and Optional paper trays	500 sheets (80 g/m ² , 20 lb.)
	By-pass tray	100 sheets (80 g/m ² , 20 lb.)
	Optional Envelope feeder	60 envelopes
	Maximum paper input	1600 sheets
Output Capacity (Face down)	A3: 250 sheets A4 LEF: 500 sheets	
Total Counter	Electric Counter	
Environmental Standard	Energy Star Tier 2 or Ver. 1.1	

Power Source	North America: 120 V, 8.4 A or more, 60 Hz		
	Europe: 220 - 240 V, 4.5 A or more, 50/60 Hz		
Power Consumption NA	NA	Main Unit (including NIB)	Full system
	Maximum	870 W or less	880 W or less
	Energy Saver	3.9 W or less	7.5 W or less

General Specifications

Power Consumption EU	EU		Main Unit (including NIB)	Full system
	Maximum		910 W or less	940 W or less
	Energy Saver		3.9 W or less	7.5 W or less
Noise Emission			Mainframe Only	Full System
	Printing		67 dB or less	71 dB or less
	Stand-by		40 dB or less	40 dB or less
	Energy Saver		40 dB or less	40 dB or less
Sound Pressure Level	Printing	55dB or less (Operating position)		
	Energy Saver	30dB or less (Operating position)		
Weight	22.5 Kg. 49.6 lb. (including Paper Tray and AIO)			
Dimensions (W x D x H)	Excluding standard tray		478 x 410 x 404 (mm). 18.8 x 16.1 x 15.9 (inch)	
	Including standard tray		478 x 437 x 404 (mm). 18.8 x 17.2x 15.9 (inch)	

General Specifications

1.1.2 CONTROLLER

CPU	RM7035 466 MHz	
Printer Languages	Standard	PCL5e/ XL, IRIPS PS3/ PDF, RPCS
	Option	IPDS
Resolution	RPCS	300/600/1200 dpi
	PCL6	600/1200 dpi
	PCL5e	300/600 dpi
	PS3	300/600/1200 dpi
Resident Fonts	PCL	45 fonts + 13 International fonts
	PS	80 fonts (Type 2:24, Type 14:112)
	Font Manager and 31 additional fonts for PCL to be loaded to the PC, Euro currency ok.	
	Optional	OCR, Barcode
Drivers	RPCS	Windows 2000/XP/Server2003/Vista/Server2008(32bit) Windows XP/Server2003/Vista/Server2008(64bit)
	PCL6	Windows 2000/XP/Server2003/Vista/Server2008(32bit) Windows XP/Server2003/Vista/Server2008(64bit)
	PCL5e	Windows 2000/XP/Server2003/Vista/Server2008(32bit) Windows XP/Server2003/Vista/Server2008(64bit)

	PS3	Windows 2000/XP/Server2003/Vista/Server2008(32bit) Windows XP/Server2003/Vista/Server2008(64bit)
	Mac OS 8.6.0 or later, Mac OSX (10.1 or later)	
ROM	NAND Flash: 128 MB NOR Flash: 4MB	
RAM	Standard	256 MB
	Maximum	512 MB (with optional memory)
HDD	Option: 80 GB	
Interface	Standard	USB 2.0, USB Host 10BASE-T/100BASE-TX
	Optional	Bi-directional IEEE1284, Gigabit Ethernet, IEEE802.11a/g
Firmware Update	SD card. One SD card holds all programs	
	RFU (Remote Firmware Update)	
Network Protocol	TCP/IP (including IPP), IPX/SPX, SMBI, Apple Talk	
NRS	Supported	
DESS	Supported	

 Note

- The machine has a maximum memory capacity of 512 MB. You must install the optional memory (256 MB) in the machine if you want to increase the machine memory.

1.1.3 OPERATION PANEL LED SPECIFICATIONS

LED	Color	Appearance	Meaning
Power	Blue	Off	Power off or in Energy Saver mode
		Flashing	Warming up
		On	Power on and not in Energy Saver mode
Data In	Blue	Off	No data
		Flashing	Data being received or processed or the printer is spooling
		On	Data being received or processed; more data coming
Suspend/ Resume	Blue	Off	Printer off-line
		Flashing	Going off-line
		On	Ready to print
Alert	Red/ Yellow	Off	No messages or error conditions requiring attention
	Yellow	Flashing	Requiring service maintenance soon
	Red	On	Printer requires service

1.1.4 SUPPORTED PAPER SIZES

Paper	Size (W x L)	Paper Trays Main Unit/Option		Bypass Tray	Env. Feeder	Duplex
		NA	EU/Asia			
A3	297 x 420 mm	Y#/Y	Y/Y	Y#	N	Y
B4	257 x 364 mm	Y#/Y#	Y#/Y#	Y#	N	Y
A4 SEF	210 x 297 mm	Y#/Y	Y/Y	Y#	N	Y
A4 LEF	297 x 210 mm	Y/Y	Y/Y	Y#	Y	Y
B5 SEF	182 x 257 mm	Y#/Y#	Y#/Y#	Y#	N	Y
B5 LEF	257 x 182 mm	Y#/Y#	Y#/Y#	Y#	N	Y
B6 SEF	128 x 182 mm	YC	YC	YC	N	N
A5 SEF	148 x 210 mm	Y#	Y#	Y#	N	Y
A5 LEF	210 x 148 mm	Y#/N	Y/N	Y#	N	Y
A6 SEF	105 x 148 mm	N	N	YC	N	N
Ledger	11 x 17"	Y/Y	Y#/Y	Y#	N	Y
Legal	8.5 x 14"	Y/Y	Y#/Y	Y#	N	Y
Letter SEF	8.5 x 11"	Y/Y	Y/Y	Y#	N	Y
Letter LEF	11 x 8.5"	Y/Y	Y/Y	Y#	N	Y
Half Letter SEF	5.5 x 8.5"	N	N	Y#	N	N
Half Letter LEF	8.5 x 5.5"	N	N	N	N	N
Executive SEF	7.25 x 10.5"	Y#/Y#	Y#/Y#	Y#	N	N
Executive LEF	10.5 x 7.25"	Y#/Y#	Y#/Y#	Y#	N	Y
F	8 x 13"	Y#/Y#	Y#/Y#	Y#	N	Y

General Specifications

Paper	Size (W x L)	Paper Trays Main Unit/Option		Bypass Tray	Env. Feeder	Duplex
		NA	EU/Asia			
Foolscap	8.5 x 13"	Y/Y#	Y#/Y#	Y#	N	Y
Folio	8.25 x 13"	Y#/Y#	Y#/Y#	Y#	N	Y
Com10 Env.	4.125 x 9.5"	N	N	Y#	Y#	N
Monarch Env.	3.875 x 7.5"	N	N	Y#	Y#	N
C6 Env.	114 x 162 mm	N	N	Y#	Y#	N
C5 Env.	162 x 229 mm	N	N	Y#	Y#	N
DL Env.	110 x 220 mm	N	N	Y#	Y#	N
8K	267 x 390 mm	Y#/Y#	Y#/Y#	Y#	N	Y
16K SEF	195 x 267 mm	Y#/Y#	Y#/Y#	Y#	N	Y
16K LEF	267 x 195 mm	Y#/Y#	Y#/Y#	Y#	N	Y
Custom	Minimum: 90 x 148 mm Maximum: 305 x 432 mm	N/YC	N/YC	YC	N	N

- Y: Supported. The paper size sensor detects the paper size.
- Y#: Supported. The user has to select the correct paper size for the tray.
- YC: Supported. The user has to enter the width and length of the paper.
- N: Not supported.

APPENDIX:

TROUBLESHOOTING GUIDE

REVISION HISTORY		
Page	Date	Added/Updated/New
		None

2. APPENDIX: TROUBLESHOOTING GUIDE

2.1 SERVICE CALL CONDITIONS

2.1.1 SUMMARY

There are 2 levels of service call conditions.

Level	Definition	Reset Procedure
A	Only a service representative can reset this SC. This will prevent damage to the machine. You cannot use the machine.	Enter engine SP mode 5810 and press "#". When 'execute' is displayed, press "#" again. Then press 'Escape'. Then turn the main power off/on.
B	The SC can be reset by turning the operation switch off and on, if the SC was caused by a sensor error.	Set the main power off and on.
C	SCs that are not shown on the operation panel. They are internally logged.	Logging only

↓ Note

- If the problem is with electrical circuit boards, disconnect the connectors first. Then reconnect the connectors before you replace the PCBs.
- If the problem is with a motor lock, first examine the mechanical load. Then replace motors or sensors.

2.1.2 SC CODE DESCRIPTIONS

Engine SC

Code No.		Symptom	Possible Cause
202	B	Polygon motor error	
		The polygon motor does not reach its operating speed within 10 seconds after the polygon motor on signal, or the lock signal is not detected for more than a certain time during operation.	<ul style="list-style-type: none"> ▪ Polygon motor ▪ Polygon motor cable
220	B	1st laser synchronization error	<ul style="list-style-type: none"> ▪ Laser synchronization detector board out of position ▪ Laser synchronization detector board or cable defective ▪ Laser synchronization mirror out of position ▪ LD unit defective ▪ Engine board defective
		The laser synchronization detector cannot detect the laser synchronization signal for more than 5 consecutive 100 ms intervals.	
221	B	2nd laser synchronization error	<ul style="list-style-type: none"> ▪ Laser synchronization detector board out of position ▪ LD unit defective ▪ Engine board defective
		The 1st LD1 is already on, but the laser synchronization detector cannot detect the laser synchronization signal from the 2nd LD for more than 5 consecutive 100 ms intervals.	

Code No.		Symptom	Possible Cause
230	B	FGATE error	<ul style="list-style-type: none"> ▪ Engine board defective ▪ Controller board defective ▪ Harness broken
		<p>The FGATE signal cannot be detected for 1 second after the machine has sent a start trigger.</p> <p>The FGATE signal is still detected for 13 seconds after the machine has detected the FGATE signal.</p>	
240	C	LD error	<ul style="list-style-type: none"> ▪ Worn-out LD unit ▪ Disconnected or broken harness of the LD unit ▪ LD unit defective
		The machine detects LDB error a few times consecutively when LDB unit turns on after LDB initialization.	
300	B	Charge roller current leak	<ul style="list-style-type: none"> ▪ Cartridge (charge roller) defective ▪ High voltage supply board defective
		60% or more of the PWM duty output is detected for 0.2 seconds when the charge bias is generated by the charge roller.	
330	B	Development bias leak	<ul style="list-style-type: none"> ▪ Cartridge (development roller) defective ▪ High voltage supply board defective
		60% or more of the PWM duty output is detected for 0.2 seconds when the development bias is generated by the development roller.	
520	B	Main motor lock	<ul style="list-style-type: none"> ▪ Main motor defective ▪ Harness broken ▪ Too much load on the drive mechanism
		A main motor lock signal is not detected for more than 700 ms after the main motor starts to rotate, or the lock signal is not detected for more than a certain time during rotation after the last signal.	

Service Call Conditions

Code No.		Symptom	Possible Cause
530	B	Fusing fan error	<ul style="list-style-type: none"> ▪ Poor connection of the fusing fan ▪ Fusing fan defective
		The CPU detects the fusing fan lock signal for more than 3 seconds.	
531	B	PSU fan error	<ul style="list-style-type: none"> ▪ Poor connection of the PSU fan ▪ PSU fan defective
		The CPU detects the PSU fan lock signal for more than 3 seconds.	
541	A	Thermistor error	<ul style="list-style-type: none"> ▪ Thermistor defective
		The fusing temperature detected by the thermistor is 0°C for 7 seconds after the fusing relay has been turned on.	
542	A	Fusing temperature warm-up error	<ul style="list-style-type: none"> ▪ Thermistor defective or deformed ▪ Fusing lamp open ▪ Fusing thermostat open
		The fusing temperature does not increase by 7°C for 10 seconds.	
		The fusing temperature does not reach more than 135°C for 24 seconds after the main switch is turned on.	
543	A	Fusing overheat error: Software	<ul style="list-style-type: none"> ▪ Fusing thermistor defective ▪ Power supply board defective
		A fusing temperature of over 235°C is detected for 0.5 seconds by the fusing thermistor.	
544	A	Fusing overheat error: Software	<ul style="list-style-type: none"> ▪ Fusing control out of control ▪ Power supply board defective
		The machine detects an overheat error of the hardware.	

Code No.		Symptom	Possible Cause
545	A	Fusing lamp stays on	<ul style="list-style-type: none"> ▪ Fusing thermistor defective ▪ Power supply board defective ▪ Defective connection of the fusing unit
		The fusing lamp stays on more than 12 seconds after the main motor has been turned off.	
547	B	Zero cross signal malfunction	<ul style="list-style-type: none"> ▪ Power supply board defective ▪ Unstable main power supply condition
		Zero cross signals are already detected for 0.15 seconds before the fusing relay-on.	
		Zero cross signals are not detected for 3 seconds or the machine cannot detect a frequency.	
559	A	Fusing jam error: 3 counts	<ul style="list-style-type: none"> ▪ Obstacle in the paper transport path ▪ Fusing unit installed incorrectly ▪ Fusing unit defective
		At the fusing exit sensor the paper jam is detected late for three pulse counts (lag error) when SP1913-001 is set to "1: Yes".	
620	B	Communication error - GAVD	<ul style="list-style-type: none"> ▪ Engine board defective
		The engine board detects an unknown device.	
622	B	Communication error - PFU	<ul style="list-style-type: none"> ▪ Noise ▪ Harness connection disconnected between the machine and PFU
		Three consecutive errors are detected during polling after the PFU is successfully detected by the machine.	

Service Call Conditions

Code No.		Symptom	Possible Cause
669	B	EEPROM error	<ul style="list-style-type: none"> ▪ EEPROM not installed or incorrectly installed ▪ EEPROM defective
		The EEPROM error is detected at reading the prefix of the EEPROM address after power-on or recovery from the energy saver mode.	
687	B	PER-command error	<ul style="list-style-type: none"> ▪ Controller board defective
		The machine does not receive PAPI-PER command for s10 seconds after PAPI-PES has been issued.	
688	B	Ready notification error of image data transmission	<ul style="list-style-type: none"> ▪ Controller board defective ▪ Communication error
		The controller does not send a ready notification of image data transmission after a sheet of paper has stopped at the registration roller.	

Controller SC

The following table describes the controller error codes. These codes are displayed at power-on, or after the power-on self test, if an error occurs.

Code	Description	Required Action
641	Engine to controller communication error (no answer).	<ul style="list-style-type: none"> ▪ Examine the connection between the controller and the engine board. ▪ Replace the engine board if the error is frequent.
670	Engine response error	<ul style="list-style-type: none"> ▪ Engine board installed incorrectly ▪ Engine board defective ▪ Controller board defective
819	Kernal end error	<ul style="list-style-type: none"> ▪ HDD error ▪ Software application error ▪ RAM shortage
820	Controller CPU error	<ul style="list-style-type: none"> ▪ Replace the controller if the error is frequent.
833	Self-diagnostic error: Engine I/F ASIC	<p>Replace the engine board.</p> <ul style="list-style-type: none"> ▪ ASIC for system control could not be detected. After the PCI configuration, the device ID for the ASIC could not be checked. <p>Replace the mother board or check the harness connection.</p> <ul style="list-style-type: none"> ▪ Could not initialize or read the bus connection. ▪ Value of the SSCG register is incorrect.
851	IEEE1394 interface error	<ul style="list-style-type: none"> ▪ Replace the controller if the error is frequent.
853	Wireless LAN Error: Card Error 1	<ul style="list-style-type: none"> ▪ Wireless LAN card not inserted into the wireless LAN board

Service Call Conditions

Code	Description	Required Action
854	Wireless LAN Error: Card Error 2	<ul style="list-style-type: none"> Wireless LAN card has been removed
855	Wireless LAN Error: Card Error 3	<ul style="list-style-type: none"> Wireless LAN card defective Wireless card connection not tight
856	Wireless LAN Error 4: Board	<ul style="list-style-type: none"> Wireless LAN card board defective PCI connector loose
857	USB I/F Error	<ul style="list-style-type: none"> The USB driver can generate three types of errors: RX, CRC, and STALL errors. Only the STALL error can generate this SC code. Defective controller board
858	HDD Encryption unit error 1	<p>A serious error occurs when data is encrypted to update an encryption key with the HDD encryption unit. [Number] shows a suffix number of SC code.</p> <ul style="list-style-type: none"> [0], [1], [30]: Replace the controller board. [2]: Replace the NVRAM.
859	HDD Encryption unit error 2	<p>A serious error occurs when the HDD data is encrypted to update an encryption key with the HDD encryption unit. [Number] shows a suffix number of SC code.</p> <ul style="list-style-type: none"> [8]: Install the HDD correctly or initialize the HDD. [9]: Initialize the HDD. [10]: Replace the HDD or replace the controller board.
860	HDD start-up error	<ul style="list-style-type: none"> Turn off the machine and turn it back on. Examine the connection between the HDD and the controller. Replace the HDD if the error is frequent.

Code	Description	Required Action
861	HDD: Reboot error	<ul style="list-style-type: none"> ▪ Loose connection of HDD ▪ Defective cables of HDD ▪ Defective HDD ▪ Defective controller
863	HDD data unable to read	<ul style="list-style-type: none"> ▪ Replace the HDD if the error is frequent.
864	HDD data access error	
865	HDD access error	
866	SD card authentication error	<p>SD-card data is corrupted.</p> <ul style="list-style-type: none"> ▪ Store correct data in the SD card.
867	SD card error	<p>The SD card is ejected from the slot.</p> <ul style="list-style-type: none"> ▪ Install the SD card.
868	SD card access error	<p>-13 to -3 (sub-code): File system error</p> <ul style="list-style-type: none"> ▪ Format the SD card on your PC. ▪ Replace the SD card. ▪ Replace the controller. <p>Other number (sub-code): Device error</p> <ul style="list-style-type: none"> ▪ Turn off and on the machine.
870	Address book error	<p>Defective software program</p> <p>Defective HDD</p> <p>Incorrect path to the server</p> <ul style="list-style-type: none"> ▪ Initialize the address book data (SP5-846-050). ▪ Initialize the HDD (SP5-832-001). ▪ Replace the HDD.
872	HDD mail data error	<p>Defective HDD</p> <p>Power failure during an access to the HDD</p> <ul style="list-style-type: none"> ▪ Initialize the HDD (SP5-832-001). ▪ Replace the HDD.
873	HDD mail transfer error	Defective HDD

Service Call Conditions

Code	Description	Required Action
		Power failure during an access to the HDD <ul style="list-style-type: none"> ▪ Initialize the HDD (SP5-832-001). ▪ Replace the HDD.
874	Delete All error 1: HDD	Data Overwrite Security Unit (SD card) not installed Defective HDD <ul style="list-style-type: none"> ▪ Install the Data Overwrite Security Unit (D377). ▪ Replace the HDD.
875	Delete All error 2: Data area	<ul style="list-style-type: none"> ▪ The logical format for the HDD fails.
876	Log Data Error	
	<p>Log Data Error 1 Damaged log data file in the HDD</p> <ul style="list-style-type: none"> ▪ Initialize the HDD with SP5832-001. <p>Log Data Error 2 An encryption module not installed</p> <ul style="list-style-type: none"> ▪ Disable the log encryption setting with SP9730-004 ("0" is off.) ▪ Install the DESS module. <p>Log Data Error 3 Invalid log encryption key due to defective NVRAM data</p> <ul style="list-style-type: none"> ▪ Initialize the HDD with SP5832-001. ▪ Disable the log encryption setting with SP9730-004 ("0" is off.) <p>Log Data Error 4 Unusual log encryption function due to defective NVRAM data</p> <ul style="list-style-type: none"> ▪ Initialize the HDD with SP5832-004. <p>Log Data Error 5 Installed NVRAM or HDD which is used in another machine</p> <ul style="list-style-type: none"> ▪ Reinstall the previous NVRAM or HDD. ▪ Initialize the HDD with SP5832-001. <p>Log Data Error 99 Other than the above causes</p> <ul style="list-style-type: none"> ▪ Ask your supervisor. 	

Code	Description	Required Action
877	HDD Data Overwrite Security SD card error	<p>Defective SD card (M352) SD card (M352) not installed</p> <ul style="list-style-type: none"> ▪ Replace the NVRAM and then install the new SD card (M352). ▪ Check and reinstall the SD card (M352).
878	TPM system authentication error	<p>Incorrect updating for the system firmware Defective flash ROM on the controller board</p> <ul style="list-style-type: none"> ▪ Replace the controller board.
900	Controller counter error	<ul style="list-style-type: none"> ▪ Replace the NVRAM if the error is frequent.
920	Printer application error	<p>Defective software Unexpected hardware resource (e.g., memory shortage)</p> <ul style="list-style-type: none"> ▪ Software defective; switch off/on, or change the controller firmware if the problem is not solved ▪ Insufficient memory
921	Printer font error	<p>A necessary font is not found in the SD card. The SD card data is corrupted.</p> <ul style="list-style-type: none"> ▪ Check that the SD card has the correct data.
990	Software performance error	<ul style="list-style-type: none"> ▪ Software defective; reboot the machine ▪ Internal parameter incorrect ▪ Insufficient working memory ▪ When this SC occurs, the file name, address, and data will be stored in NVRAM. <p>Note the above data and the situation in which this SC occurs. Then report the data and conditions to your technical control center.</p>

Service Call Conditions

Code	Description	Required Action
991	Software continuity error	<ul style="list-style-type: none">▪ Software bug; reboot the machine▪ Internal parameter incorrect▪ Insufficient working memory
992	Undefined error	<p>Defective software program</p> <ul style="list-style-type: none">▪ An error undetectable by any other SC code occurred
998	Application start error	<ul style="list-style-type: none">▪ Software defective; change the firmware for the application that failed▪ An option required by the application (RAM, DIMM, board) is not installed

APPENDIX:

SP MODE TABLES

REVISION HISTORY		
Page	Date	Added/Updated/New
		None

3. APPENDIX: SP MODE TABLES

3.1 SP TABLES

3.1.1 PRINTER CONTROLLER SERVICE MODE

Service Mode Menu ("1. Service Menu")

1001	Bit Switch			
001	Bit Switch 1		0	1
	bit 0	DFU	-	-
	bit 1	DFU	-	-
	bit 2	DFU	-	-
	bit 3	No I/O Timeout	0: Disable	1: Enable
		Enable: The MFP I/O Timeout setting will have no effect. I/O Timeouts will never occur.		
	bit 4	SD Card Save Mode	0: Disable	1: Enable
		Enable: Print jobs will be saved to an SD Card in the GW SD slot.		
	bit 5	DFU	-	-
	bit 6	DFU	-	-
bit 7	[RPCS,PCL]: Printable area frame border	0: Disable	1: Enable	
	Prints all RPCS and PCL jobs with a border around the printable area.			

SP Tables

1001	Bit Switch			
002	Bit Switch 2		0	1
	bit 0	DFU	-	-
	bit 1	DFU	-	-
	bit 2	DFU	-	-
	bit 3	[PCL5e/c,PS]: PDL Auto Switching	0: Enable	1: Disable
		Disable: The MFPs ability to change the PDL processor mid-job. Some host systems submit jobs that contain both PS and PCL5e/c. If Auto PDL switching is disabled, these jobs will not be printed properly.		
	bit 4	DFU	-	-
	bit 5	DFU	-	-
	bit 6	DFU	-	-
bit 7	DFU	-	-	

1001	Bit Switch			
003	Bit Switch 3		0	1
	bit 0	DFU	-	-
	bit 1	DFU	-	-
	bit 2	[PCL5e/c]: Legacy HP compatibility	0: Disable	1: Enable
		Enable: Uses the same left margin as older HP models such as HP4000/HP8000. In other words, the left margin defined in the job (usually "<ESC>*r0A") will be changed to "<ESC>*r1A"		
	bit 3	DFU	-	-
bit 4	DFU	-	-	

	bit 5	DFU	-	-
	bit 6	DFU	-	-
	bit 7	DFU	-	-

1001	Bit Switch			
004	Bit Switch 4 DFU		0	1
	bit 0	DFU	-	-
bit 1	DFU	-	-	
bit 2	DFU	-	-	
bit 3	IPDS print-side reversal	0: Disable	1: Enable	
		If enabled, the simplex pages of IPDS jobs will be printed on the front side because of printing on the back side of the page. This might reduce printing speed.		
bit 4	DFU	-	-	
bit 5	DFU	-	-	
bit 6	DFU	-	-	
bit 7	DFU	-	-	

SP Tables

1001	Bit Switch		
005	Bit Switch 5	0	1
	bit 0	DFU	-
	bit 1	Multiple copies if a paper size or type mismatch occurs	0: Disable (Single copy)
		1: Enable (Multiple copy)	
		If a paper size or type mismatch occurs during the printing of multiple copies, only a single copy is output by default. Using this BitSw, the device can be configured to print all copies even if a paper mismatch occurs.	
	bit 2	Prevent SDK applications from altering the contents of a job.	0: Disable
			1: Enable
		If this BitSw is enabled, SDK applications will not be able to alter print data. This is achieved by preventing SDK applications from accessing a module called the "GPS Filter". Note: The main purpose of this BitSw is for troubleshooting the effects of SDK applications on data.	
	bit 3	[PS] PS Criteria	0: Pattern3
			1: Pattern1
		Change the number of PS criterion used by the PS interpreter to determine whether a job is PS data or not. Pattern3: includes most PS commands. Pattern1: A small number of PS tags and headers	
	bit 4	Increase max number of the stored jobs to 1000 jobs.	0: Disable (100)
			1: Enable (1000)
		Enable: Changes the maximum number of jobs that can be stored on the HDD via Job Type settings to 1000. The default is 100.	
	bit 5	DFU	-
	bit 6	Method for determining the image rotation for the edge to bind on.	0: Disable
			1: Enable

		<p>If enabled, the image rotation will be performed as they were in the specifications of older models for the binding of pages of mixed orientation jobs.</p> <p>The old models are below:</p> <ul style="list-style-type: none"> - PCL: Pre-04A models - PS/PDF/RPCS:Pre-05S models 		
	bit 7	Letterhead mode printing	0: Disable	1: Enable (Duplex)
		<p>Routes all pages through the duplex unit.</p> <p>If this is disabled, simplex pages or the last page of an odd-paged duplex job, are not routed through the duplex unit. This could result in problems with letterhead/pre-printed pages.</p> <p>Only affects pages specified as Letterhead paper.</p>		

1001	Bit Switch			
006	Bit Switch 6		0	1
	bit 0 to 5	DFU	-	-
		PDL Auto Detection timeout of jobs submitted via USB or Parallel Port (IEEE 1284).	0: Disable (Immediately)	1: Enable (10 seconds)
	bit 6	To be used if PDL auto-detection fails. A failure of PDL autodetection doesn't necessarily mean that the job can't be printed. This bit switch tells the device whether to time-out immediately (default) upon failure or to wait 10 seconds.		
	bit 7	DFU	-	-

SP Tables

1001	Bit Switch		
007	Bit Switch 7	0	1
		Print path	0: Disable 1: Enable
	bit 0	If enabled, simplex pages (in mixed simplex/duplex PS/PCL5 jobs only) and the last page of an odd paged duplex job (PS, PCL5, PCL6), are always routed through the duplex unit. Not having to switch paper paths increases the print speed slightly.	
	bit 1 to 7	DFU	- -

1001	Bit Switch		
008	Bit Switch 8 DFU	-	-

1003	Clear Setting	
001	Init. System	Initializes settings in the System menu of the user mode.
003	Delete Program	DFU

1004	Print Summary	
001	Service Summary	
	Touch [Execute] to print the printer summary sheets.	

1005	Display Version.
	Printer Version
	Displays the version of the controller firmware.

1007	Supply Display	
	Enables or disables the display for information on each consumable supply.	
001	Development	[0 or 1 / 1 / 1 /step] 0: OFF, 1: ON
002	PCU	
003	Transfer	
004	Int. Transfer	
005	Transfer Roller	
006	Fuser	
007	Fuser Oil	

Bit Switch Programming

↓ Note

- Currently, the bit switches are not being used.

```
Service Menu
BitSW
```

m047s501

1. Enter the SP mode, select "Service Menu", then press [Enter] twice.

```
BitSW
<BitSW#1>
```

m047s502

2. Select #1, #2, #3, or #4 for the desired bit switch, then press [Enter].
 - [▲] [▼]: Move to the next switch.

```
Sw#1  00000000
Bit0   _____
```

m047s503

3. Adjust the bit switch using the following keys.
 - [▲] [▼]: Move to the next bit.
 - [Escape]: Exit without saving changes.
 - [Enter]: Exit and save changes.

↓ Note

- The left digit on the display is bit 7 and the right digit is bit 0.
4. Press [Enter] to save changes and exit.

3.1.2 PRINTER ENGINE SERVICE MODE

Service Mode Table

Notation	What it means
[range / default / step]	Example: [-9 to +9 / 3.0 / 0.1 mm step]. The setting can be adjusted in the range ± 9 , value reset to +3.0 after an NVRAM reset, and the value can be changed in 0.1 mm steps with each key press.
Bold	Comments added for reference.
DFU	Denotes "Design or Factory Use". Do not change this value.
Japan only	The feature or item is for Japan only. Do not change this value.

SP1-xxx: Feed

1001	Lead Edge Regist	
	Adjusts the printing leading edge registration for feeding from the trays and duplex tray using the trimming area pattern (SP5-902-003 No.9). Push [▲] or [▼] to select the settings (plus or minus). The specification is 4±2 mm	
1001 1	BypassTray Plain	[-40 to +40 / 0 / 1 mm]
1001 2	BypassTray Thick	
1001 3	BypassTray Thick2	
1001 4	MainTray Plain	
1001 5	MainTray Thick	
1001 6	MainTray Thick2	
1001 7	BankTray Plain	
1001 8	BankTray Thick	
1001 9	BankTray Thick2	
1001 10	Duplex	

1002	Side to Side Reg	
	Adjusts the printing side-to-side registration from the 1st paper feed station using the trimming area pattern (SP2-902 No.12). Push [▲] or [▼] to select the settings (plus or minus). Specification: 0 ±2.0 mm.	
1002 1	BypassTray	[-40 to +40 / 0 / 1 mm]
1002 2	MainTray1	
1002 3	MainTray2	
1002 4	BankTray1	
1002 5	BankTray2	
1002 6	Duplex	

1003	Regist sag	
	Adjusts the relay clutch timing at registration. Relay clutch timing determines the amount of paper buckle at registration. (A "+" setting causes more buckling.)	
1003 1	BypassTray Plain	[-8 to 8 / 0 / 1 mm step]
1003 2	BypassTray Thick	
1003 3	BypassTray Thick2	
1003 4	MainTray Plain	
1003 5	MainTray Thick	
1003 6	MainTray Thick2	
1003 7	BankTray Plain	
1003 8	BankTray Thick	
1003 9	BankTray Thick2	

SP Tables

1003 10	Duplex	
---------	--------	--

1104	Fusing control	0: Normal , 1: Phase control
	Use phase control if the room lights flicker when the fusing lamp starts. Defaults: North America – Normal (On/off control), Europe – Phase	

1105	Fusing Temp.	
	Adjusts the fusing temperatures for printing and standby mode.	
1105 1	Plain	[150 to 200 / 170 / 5 deg.] DFU
	Adjusts the fusing temperature for printing on normal paper.	
1105 2	Thick2	[150 to 195 / 185 / 5 deg.] DFU
	Adjusts the fusing temperature for printing on thick 2 paper.	
1105 3	Standby Temp	[140 to 175 / 168 / 1 deg.] DFU
	Adjusts the fusing temperature for standby mode.	

1106	Fusing Temp Disp	
1106 1	Displays the current fusing temperature.	

1901	OP LoopBackCheck	
	Displays the result of the optional loop back checking at power on.	
1901 1	Summary	Displays the error status for each option. 0: Normal, 1: Error
	bit 0: Bank (paper feed) unit error bit 1: Bin unit error (Not used) bit 2: Duplex unit error	
1901 2	BankTray	[0 to 255 / 0 / 1 step.]
	Displays the error status for the optional paper feed unit.	
	0: Checking is correctly done. 1: D5 is not "High". 2: D5 is not "Low". 3: X2FCL is not "ON". 4: X2FCL is not "OFF". 5: X2MOTOR is not "ON". 6: X2 MOTOR is not "OFF".	7: X3FCL is not "ON". 8: X3FCL is not "OFF". 9: X3MOTOR is not "ON". 10: X3 MOTOR is not "OFF". 11: D4 is not "Low". 255: Loop back connector is not connected.
1901 4	Duplex	[0 to 255 / 0 / 1 step.]
	Displays the error status for the optional duple unit. 0: Checking is correctly done. 1: Serial number communication fails. 2: DPXSET is not "Low". 255: Loop back connector is not connected.	

SP Tables

	Curl Control	Curl Reduction
<p>1911</p>	<p>Thin paper has a tendency to jam or wrinkle, especially during duplex printing. When this SP code is switched on:</p> <ul style="list-style-type: none"> ▪ The machine ignores the fusing temperature set for SP1105. ▪ When the machine is powered on or recovers from the low power mode the machine requires about 20 sec. to warm up (this is longer than normal). <p>[0 or 1 / 0 / -] 0: No (Normal) 1: Yes (Curl Control)</p>	

	SC559 Detect	Fusing Jam SC Setting
<p>1913</p>	<p>This SP setting determines whether SC559 is issued after three paper late jams occur in the fusing unit. After this SP code is turned on, a counter monitors the number of paper late jams that occur in the fusing unit. After the 3rd occurrence of a fusing jam, SC559 is issued and the machine cannot be used until the service technician releases the error.</p> <p>Note: Switching the machine off/on does not reset this jam counter. The counter is reset after the cause of the jam has been removed and a sheet of paper successfully passes the fusing exit sensor.</p> <p>[0 to 1 / 0 / 1] 0: No 1: Yes</p>	

1914	Nip Measure (Fusing Nip Width Measurement)		
1914 001	Measure Exe.	-	-
	Performs the nip width measurement. This is for by-pass tray and used OHP type.		

1915	Envelope Flap		
	JPN use only		

SP2-xxx: Drum

2001	Charge Rol Bias	
	Adjusts the voltage applied to the charge roller for printing.	
2001 1	Charge (1)	[1000 to 2000 / -1650V / 5V step] DFU
2001 2	Charge (2)	[1000 to 2000 / -1675V / 5V step] DFU

2112	Mainscan Mag	
	Adjusts the main scan magnification.	
2112 1	Mainscan (1)	[-0.5% to 0.5% / 0 / 0.1% step]
2112 2	Mainscan (2)	[-0.5% to 0.5% / 0 / 0.1% step]

2113	Subscan Mag	
	Adjusts the sub scan magnification.	
2113 1	Subscan (1)	[-0.5% to 0.5% / 0 / 0.1% step]
2113 2	Subscan (2)	[-0.5% to 0.5% / 0 / 0.1% step]

2201	Developer Bias	
	Adjusts the development bias for printing.	
2201 1	Developer (1)	[200 to 800 / 700V / 10V step] DFU
2201 2	Developer (2)	[200 to 800 / 750V / 10V step] DFU

2213	Toner End Count	[50 to 200 / 200 / 50 sheets/step]
	Adjusts the number of prints the machine can make after it detects toner near-end.	

2301	Trans Current	
	Adjusts the correction current applied to the transfer roller.	
2301 1	Trans (1)	[-5 to 5 / 0 / 1 μ A/step]
	Adjusts the correction value for the transfer current in 120.8 mm/sec line speed.	
2301 2	Trans (2)	[-5 to 5 / 0 / 1 μ A/step]
	Adjusts the correction value for the transfer current in 161.4 mm/sec line speed.	

2910	Thermistor Adjust	0: Yes, 1: No DFU
	If this is "Yes", the machine automatically adjusts the charge roller voltage and transfer current in response to the temperature within the machine.	

2911	PreRotate Time	
2911 2	Curl Reduction	[0 to 40 / 20 / 5 sec/step]
	Specifies the pre-rotation time at power-on or recovery from the energy saver mode.	
2911 3	LowTemp PreRotate	[0 to 40 / 20 / 5 sec/step]
	Specifies the pre-rotation time at power-on or recovery from the energy saver mode in low temperature environment (less than -15°C).	

2980	Waste Toner Count	
	Displays the waste toner counter in the engine board.	

SP3-xxx: Process

3910	Ab Chrg Thermist	[0 to 2 / 0 / 1 /step]
	Displays the result of the charge thermister check (temperature) monitored by the loop back connector. 0: Normal 1: Low temperature limit 2: High temperature limit	

3920	Density Adjust	
3920 1	Density (1)	[-6 to 3 / 0 / 1 /step]
	Adjusts the image density level in 120.8 mm/sec. line speed. +3: Darkest/ -6: Lightest	
3920 2	Density (2)	[-6 to 3 / 0 / 1 /step]
	Adjusts the image density level in 161.4 mm/sec. line speed. +3: Darkest/ -6: Lightest	

3923	WasteTonerLimiter	[0 or 1 / 1 /-]
	Turns on or off the waste toner limiter. The waste toner limiter is executed by the threshold time of the PCU rotation. 0: No (Off), 1: Yes (On)	

3924	Toner End Sensor	
3924 1	Toner Near-end	[100 to 1000 / 200 / 100 ms step] DFU
	Threshold adjustment for toner near-end detection.	
3924 2	Toner End	[250 to 1050 / 550 / 50 ms step] DFU
	Threshold adjustment for toner end detection	

3927	Toner End Judge	
	<p>This SP code determines whether the machine disables printing when the machine detects toner end.</p> <ul style="list-style-type: none"> ▪ Even when toner end is detected, there is a small amount of toner left in the AIO. If a user wants to print with the AIO until all toner is used up, then set this SP to 1. But then, there is no toner end detection, and the user must watch the print quality and change the AIO when prints become too pale. <p>[0 or 1 / 0 / -]</p> <p>0: Yes (Printing stops when toner end is detected.)</p> <p>1: No (Printing can continue even after toner end is detected.)</p>	

SP Tables

SP5-xxx: Mode

5001	All Indicators On	
	Turns on or off the all indicators on the operation panel.	

5024	mm/inch Selection	0: Europe/Asia (mm), 1: North America (inch)
	Selects the unit of measurement. After selection, turn the main power switch off and on.	

5051	Refill Toner Disp	Toner Refill Detect Display
	This SP switches on/off the message that prompts the operator when it is necessary to replenish toner in the machine. 0: ON (Message displayed (Default)) 1: OFF (Message not displayed)	

5055	Display IP address	Display IP Address
	Switches the banner display of the IP address off and on. [0 to 1/ 0 /1] 0= No, 1= Yes For example, if this SP is switched on, the IP address will be displayed below "Ready" while the printer is in standby mode: Ready 169.254.187.055	

5056	Coverage Counter	
	Display or does not display the coverage counter on the LCD. [0 to 1 / 0 / 1] 0: Not displayed, 1: Displayed	

<p>5104</p>	<p>A3 Double Count</p>	<p>Specifies whether the counter is doubled for A3/11" x 17" paper. If "Yes" is selected, the total counter counts up twice when A3/11" x 17" paper is used. Yes (double count), No (single count)</p>
--------------------	------------------------	---

<p>5169</p>	<p>CE Login</p>	
	<p>If you will change the printer bit switches, you must 'log in' to service mode with this SP before you go into the printer SP mode. [0 to 1 / 0 / 1] 0: Off. Printer bit switches cannot be adjusted. 1: On. Printer bit switches can be adjusted.</p>	

<p>5195</p>	<p>Limitless SW</p>	
	<p>DFU</p>	

<p>5302</p>	<p>Set Time</p>	
<p>002</p>	<p>Time Difference</p>	
	<p>Sets the time clock for the local time. This setting is done at the factory before delivery. The setting is GMT expressed in minutes. [-1440 to 1440 / - / 1 min.] Japan: +540 (Tokyo) NA: -300 (NY) EU: +60 (Paris) CH: +480 (Peking) TW: +480 (Taipei) AS: +480 (Hong Kong) KO: +540 (Korea)</p>	

SP Tables

5307	Summer Time		
	<p>Lets you set the machine to adjust its date and time automatically with the change to Daylight Savings time in the spring and back to normal time in the fall. This SP lets you set these items:</p> <p>Day and time to go forward automatically in April.</p> <p>Day and time to go back automatically in October.</p> <p>Set the length of time to go forward and back automatically.</p> <p>The settings for 002 and 003 are done with 8-digit numbers:</p>		
	Digits	Meaning	
1st, 2nd		Month. 4: April, 10: October (for months 1 to 9, the first digit of 0 cannot be input, so the eight-digit setting for 002 or 003 becomes a seven-digit setting)	
3rd		Day of the week. 0: Sunday, 1: Monday	
4th		The number of the week for the day selected at the 3rd digit. If "0" is selected for "Sunday", for example, and the selected Sunday is the start of the 2nd week, then input a "2" for this digit.	
5th, 6th		The time when the change occurs (24-hour as hex code). Example: 00:00 (Midnight) = 00, 01:00 (1 a.m.) = 01, and so on.	
7th		The number of hours to change the time. 1 hour: 1	
8th		If the time change is not a whole number (1.5 hours for example), digit 8 should be 3 (30 minutes).	
	001	ON/OFF	<p>Enables/disables the settings for 002 and 003.</p> <p>[0 or 1 / 1 (NA/EU), 0 (AA/CHN) / -]</p> <p>0: OFF</p> <p>1: ON</p>

003	Start	The start of summer time.	
004	End	The end of summer time.	

5401	Access Control		
	Determines whether the machine adds new user codes in the User Management Tool in Smart Net Monitor.		
5401 104	Authentication Time	[0 to 255 / 0 / 1 second]	
	Specifies the time for the authentication timeout. 0 = 60 seconds, 1 to 255 = displayed time (seconds)		
5401 162	ExtAuth Detail		
	Selects the log out type for the extend authentication device. Bit 0: Log-out without an IC card 0 : Not allowed (default) 1: Allowed		
5401 200	SDK1 UniqueID	"SDK" is the "Software Development Kit". This data can be converted from SAS (VAS) when installed or uninstalled. (DFU)	
5401 201	SDK1 Certification Method		
5401 210	SDK2 UniqueID		
5401 211	SDK2 Certification Method		
5401 220	SDK3 UniqueID		
5401 221	SDK3 Certification Method		
5401 230	SDK Certification Device		

SP Tables

5401 240	Detail Option	
	<p>Enables or disables the log out confirmation option.</p> <ul style="list-style-type: none"> ▪ Bit 0: Log out confirmation option 0: Enable (default), 1: Disable Selects the automatic log out time. ▪ Bit 1 and 2: Automatic log out timer reduction 00: 60 seconds (default), 01: 10 seconds, 10: 20 seconds, 11: 30 seconds 	

5404	User Code Clear	
	<p>Clears the counts for the user codes assigned by the key operator to restrict the use of the machine. Press [#Enter] to clear.</p>	

5411	LDAP-Certification	
5411 4	Easy Certification	
	<p>Determines whether easy LDAP certification is done. [0 to 1 / 1 / 1] 1: On, 0: Off</p>	
5411 5	Password Null Not Permit	
	<p>This SP is referenced only when SP5411-4 is set to "1" (On). [0 to 1 / 0 / 1] 0: Password NULL not permitted. 1: Password NULL permitted.</p>	

5413	Lock Setting	
001	Lockout On/Off	[0 to 1 / 0 / 1] 0: OFF, 1:ON
	Turns on or off the account lock for the local address book account.	
002	Lockout Threshold	[1 to 10 / 5 / 1]
	Sets the maximum trial times for accessing the address book account.	

003	Cancellation On/Off	[0 to 1 / 0 / 1] 0: OFF (Lockout is not cancelled.) 1: ON (Lockout is cancelled if a user ID and password are correctly entered after the lockout function has been executed and a specific time has passed.)
	Turns on or off the cancellation function of the account lockout.	
004	Cancellation Time	[1 to 9999 / 60 / 1 min]
	Sets the interval of the retry for accessing the local address book account after the lockout function has been executed. This setting is enabled only if SP5413-3 is set to "1" (ON).	

5414	Access Mitigation	
001	Mitigation On/Off	
	Permits or does not permit consecutive access to the machine with the same ID and password. [0 to 1 / 0 / 1] 0: Off (Permitted) 1: On (Not permitted)	
002	Mitigation Time	
	Sets the prohibiting time for consecutive access to the machine with the same ID and password. [0 to 60 / 15 / 1 min]	

SP Tables

5415	Password Attack	
001	Permissible Number	[0 to 100 / 30 / 1 times]
	Sets the threshold number of attempts to attack the system with random passwords to gain illegal access to the system.	
002	Detect Time	[0 to 10 / 5 / 1 sec]
	Sets a detection time to count a password attack.	

5416	Access Information	
001	User Max Num	[50 to 200 / 200 / 1]
	Sets the number of users for the access exclusion and password attack detection function.	
002	Password Max Num	[50 to 200 / 200 / 1]
	Sets the number of passwords for the access exclusion and password attack detection function.	
003	Monitor interval	[1 to 10 / 3 / 1 sec]
	Sets the interval of watching out for user information and passwords.	

5417	Access Attack	
001	Permission Num	[0 to 500 / 100 / 1]
	Sets a limit on access attempts to prevent password cracking.	
002	Attack Detect Time	[10 to 30 / 10 / 1 sec]
	Sets a detection time to count password cracking.	
003	Cert Wait	[0 to 9 / 3 / 1 sec]
	Sets the wait time to slow down the speed of certification when an excessive number of access attempts have been detected.	

004	Attack Max Num	[50 to 200 / 200 / 1]
	Sets a limit on the number of requests received for certification in order to slow down the certification speed when an excessive number of access attempts have been detected.	

5420	User Authentication	
	These settings should be done with the System Administrator.  Note <ul style="list-style-type: none"> These functions are enabled only after the user access feature has been enabled. 	
041	Printer	[0 or 1 / 0 / 1] 0: ON. 1: OFF Determines whether certification is required before a user can use the printer application.
051	SDK1	[0 or 1 / 0 / 1] 0: ON. 1: OFF Determines whether certification is required before a user can use the SDK application.
061	SDK2	
071	SDK3	

5481	Auth. Error Code	
	This SP code determines how the authentication failures are displayed.	
001	System Log Disp	[0 or 1 / 0 / -] 0: OFF [Default], 1: ON Determines whether an error code appears in the system log after a user authentication failure occurs.

SP Tables

5501	PM Alarm Interval
001	Printout
	[0 to 9999 / 0 / 1 step] 0: Alarm off 1 to 9999: Alarm goes off when Value (1 to 9999) >= PM counter

5504	Jam Alarm
	Sets the alarm to sound for the specified jam level (document misfeeds are not included). [0 to 3/ 3 /1 step] 0: Zero (Off) 1: Low (2.5K jams) 2: Medium (3K jams) 3: High (6K jams)

5505	Error Alarm DFU
	Sets the error alarm level. [0 to 255 / 25 / 100 copies/ 1 step]

5507	Supply Alarm	
5507 001	Paper Supply Ala(r)m	Switches the control call on/off for the paper supply. DFU 0: Off, 1: On 0: No alarm. 1: Sets the alarm to sound for the specified number transfer sheets for each paper size (A3, A4, B4, B5, DLT, LG, LT, HLT)
5507 004	MaintenanceKit	When switched on this function informs the @Remote supply center that the maintenance kit requires servicing.

		[0: OFF/1: ON]
5507 009	Cartridge Alarm	When switched on this function informs the @Remote supply center that the toner cartridge is almost empty (near-end). [0: OFF/1: ON]
5507 080	Toner Call Timing	Selects the timing of the toner supply call for @Remote. [0: At Replacement/ 1: At nearend]
5507 128	Interval: Others	The "Paper Supply Call Level: nn" SPs specify the paper control call interval for the referenced paper sizes. DFU [00250 to 10000/ 1000 /1 Step]
5507 132	Interval: A3	
5507 133	Interval: A4	
5507 134	Interval: A5	
5507 141	Interval: B4	
5507 142	Interval: B5	
5507 160	Interval: DLT	
5507 164	Interval: LG	
5507 166	Interval: LT	
5507 172	Interval: HLT	

	SC/Alarm Setting	
5515*	With @Remote in use, these SP codes can be set to issue an SC call when an SC error occurs. If this SP is switched off, the SC call is not issued when an SC error occurs.	
001	SC Call	[0 or 1 / 1 / 1] 0: OFF 1: ON
002	Service Parts Near End Call	[0 or 1 / 0 / 1] 0: OFF 1: ON
003	Service Parts End Call	

SP Tables

004	User Call	[0 or 1 / 1 / 1] 0: OFF 1: ON
006	Communication Information Test Call	
007	Machine Information Notice	
008	Alarm Notice	[0 or 1 / 0 / 1] 0: OFF 1: ON
009	Non Genuine Toner	[0 or 1 / 1 / 1] 0: OFF 1: ON
010	Supply Automatic Ordering Call	
011	Supply Management Report Call	

5801	Memory Clear	
	Resets NVRAM data to the default settings. Before executing any of these SP codes, print an SMC Report.	
5801 001	All Clear	Initializes items 2 to 15 below.
5801 002	Engine	Initializes all registration settings for the engine and process settings.
5801 003	SCS	Initializes default system settings, SCS (System Control Service) settings, operation display coordinates, and ROM update information.
5801 004	IMH Memory Clr	Initializes the image file system. (IMH: Image Memory Handler)
5801 005	MCS	Initializes the automatic delete time setting for stored documents. (MCS: Memory Control Service)
5801 008	Printer	Initializes the printer defaults, programs registered, the printer SP bit switches, and the printer CSS counter.

5801 010	GWWS/ NFA	Deletes the Netfile (NFA) management files and thumbnails, and initializes the Job login ID. Netfiles: Jobs to be printed from the document server using a PC and the DeskTopBinder software
5801 011	NCS	Initializes the system defaults and interface settings (IP addresses also), the SmartNetMonitor for Admin settings, WebStatusMonitor settings, and the TELNET settings. (NCS: Network Control Service)
5801 014	Clear DCS Setting	Initializes the DCS (Delivery Control Service) settings.
5801 015	Clr UCS Setting	Initializes the UCS (User Information Control Service) settings.
5801 016	MIRS Setting	Initializes the MIRS (Machine Information Report Service) settings.
5801 017	CCS	Initializes the CCS (Certification and Charge-control Service) settings.
5801 018	SRM Memory Clr	Initializes information in non-volatile RAM.
5801 019	LCS	Initializes information in non-volatile RAM.
5801 021	ECS	Initializes the ECS settings.

5802	Free run
	The machine performs a free run. Press [ON] to start. Press [OFF] to stop. Please note that the machine will not stop immediately after the [Enter] key is pressed.

SP Tables

5803	Input check	
	Displays signals received from sensors and switches. NOTE: SP Modes other than those listed in this table, are not used in the machine.	
	Operation Panel	Component Name
5803 1	Cover Info	Front and rear cover safety switches 0: Close, 1: Open Front door open: bit 0 Paper exit door: bit 1 and 0 Rear cover: bit 2, 1 and 0
5803 2	Main Motor Lock	Main Motor Lock
5803 3	Polygon Motor Lock	Polygon Motor Lock
5803 4	Fan High	Fusing fan; 0: Stop, 1: Lock
5803 5	Fan Lock	Fusing fan; 0: Stop, 1: Lock
5803 6	PSU Fan Lock	PSU fan; 0: Stop, 1: Lock
5803 7	Destination	0: NA model, 1: EU model
5803 8	AIO Unit Set	0: Not set, 1: Set
5803 9	Fuser Temp Error	0: Normal, 1: Error
5803 10	Toner End Sensor	0: Not end, 1: End
5803 11	Paper Full Sensor	0: Not full, 1: Full
5803 12	Carry Sensor	Paper exit sensor; 0: Paper not detected, 1: Paper detected
5803 13	Regist Sensor	0: Paper not detected, 1: Paper detected
5803 14	Exit Sensor	Fusing exit sensor; 0: Paper not detected, 1: Paper detected

5803 15	Fuser Pressure	Fusing pressure sensor; 0: Plain paper, 1: Thick paper
5803 16	Bypass PaperEnd	By-pass Paper Set Sensor; 0: Not end, 1: End
5803 17	Tray1 PaperEnd	0: Not end, 1: End
5803 18	Tray1 RestSensor	Remaining Paper Sensors; bit 1 and 0 00: 1 to 49 sheets 01: 50 to 249 sheets 11: 250 to 449 sheets 10: 450 to 500 sheets
5803 19	Tray2 PaperEnd	Not used
5803 20	Tray1 PaperSize	Paper size switch (Tray 1); bit 2, 1 and 0 000: Tray 1 not set 001: A4 LEF/ LG SEF 010: LT LEF/ 8 _{1/2} " x 13" 011: A4 SEF/ LT LEF 100: Not used 101: LT SEF/ A4 LEF 110: A5 LEF/ LT SEF 111: A3 SEF/ DLT SEF
5803 21	Tray2 PaperSize	Not used
5803 22	Test Mode	0: Normal mode, 1: Test mode
5803 23	Test Print	0: Normal mode, 1: Test print
5803 24	Trans Thermistor	
5803 25	Fuser Thermistor	
5803 26	Fuser Unit Set	
5803 27	Trans Feedback	

SP Tables

5803 28	Charge Feedback	
5803 29	DeveloperFeedback	
5803 30	Bank1 CarrySensor	Paper feed sensor (PFU 1); 0: Paper not detected, 1: Paper detected
5803 31	Bank1 PaperEnd	Paper end sensor (PFU 1); 0: Paper not detected, 1: Paper detected
5803 32	Bank1 RestSensor	Paper remaining sensors (PFU 1); bit 1 and 0 00: 1 to 49 sheets 10: 50 to 249 sheets 11: 250 to 449 sheets 01: 450 to 500 sheets
5803 33	Bank1 PaperSize	Paper size switch (PFU 1); bit 2, 1 and 0 000: Tray 1 not set 001: A4 LEF 010: LG SEF 011: A4 SEF 100: LT LEF 101: Not used 110: DLT SEF 111: A3 SEF
5803 34	Bank2 CarrySensor	Same as SP5803-30
5803 35	Bank2 PaperEnd	Same as SP5803-31
5803 36	Bank2 RestSensor	Same as SP5803-32
5803 37	Bank2 PaperSize	Same as SP5803-33
5803 38	Duplex Cover	0: Close, 1: Open
5803 39	Duplex Unit Set	0: Not set, 1: Set
5803 40	Dplx Ent Sensor	Duplex entrance sensor;

		0: Paper not detected, 1: Paper detected
5803 41	Dplx Exit Sensor	Duplex exit sensor; 0: Paper not detected, 1: Paper detected
5803 42	Dplx Turn Sensor	Duplex inverter sensor; 0: Paper not detected, 1: Paper detected

5804	Output check	
	Turns on electrical components individually for test purposes. NOTE: SP Modes other than those listed in this table, are not used in the machine.	
5804 1	Main Motor: L	
5804 2	Main Motor: H	
5804 3	Middle Clutch	
5804 4	Tray1 Clutch	
5804 5	Tray2 Clutch	
5804 6	Regist Clutch	
5804 7	Bypass Solenoid	
5804 8	Fan High	
5804 9	LD1 Compulsion	
5804 10	LD2 Compulsion	
5804 11	LD1+2 Compulsion	
5804 12	Polygon Motor: L	
5804 13	Polygon Motor: H	
5804 16	Fuser Fuse Cut	
5804 17	QL	



SP Tables

5804 18	Charge Bias	
5804 19	Developer Bias	
5804 20	Trans Plus	
5804 21	Trans Minus	
5804 22	Bank1 Motor: L	
5804 23	Bank1 Motor: H	
5804 24	Bank2 Motor: L	
5804 25	Bank2 Motor: H	
5804 26	Bank1 Clutch	
5804 27	Bank2 Clutch	
5804 28	Dplx Mtr Normal: L	
5804 29	Dplx Mtr Normal: H	
5804 30	Dplx Mtr Revers: L	
5804 31	Dplx Mtr Revers: H	
5804 32	Dplx Mtr Long: L	
5804 33	Dplx Mtr Long: H	
5804 34	Dplx Split SOL	

5807	CLT Dest. Code
	DFU

5810	Fusing Err Clr
	Resets a service call condition (for fusing unit errors). After using this SP mode, turn the main switch off and on.

5811	Machine No. Setting DFU	
	<p>Used to input the machine serial number. This is normally done at the factory.</p> <p>If you want to know the serial number, print the system parameter list. Press  and then input "A".</p>	

5812	Service TEL	
	<p>Use these SP modes to input service and support telephone numbers. Enter the number and press  Key.</p> <p>Press the  key to input a pause. Press the "Clear modes" key to delete the telephone number.</p>	
5812 1	Telephone	Use this to input the telephone number of the CE printed on the SP print mode printout.
5812 2	Facsimile	Use this to input the fax number of the CE printed on the SP print mode printout.

5816	NRS Function	
5816 001	I/F Setting	
	<p>Selects the remote service setting.</p> <p>[0 or 2 / 2 / 1 /step]</p> <p>0: OFF (Remote service off)</p> <p>2: Network (@Remote remote service on)</p>	
5816 002	CE Call	
	<p>Performs the CE Call at the start or end of the service.</p> <p>[0 or 1 / 0 / 1 /step]</p> <p>0: Start of the service</p> <p>1: End of the service</p> <p>NOTE: This SP is activated only when SP 5816-001 is set to "2".</p>	

SP Tables

5816 003	Function Flag	
	<p>Enables or disables the remote service function. [0 to 1 / 0 / 1 /step] 0: Disabled 1: Enabled</p>	
5816 007	SSL Disable	
	<p>Uses or does not use the RCG certification by SSL when calling the RCG. [0 to 1 / 0 / 1 /step] 0: Uses the RCG certification 1: Does no use the RCG certification</p>	
5816 008	RCG Connect T/O	
	<p>Specifies the connect timeout interval when calling the RCG. [1 to 90 / 30 / 1 second /step]</p>	
5816 009	RCG Write Timeout	
	<p>Specifies the write timeout interval when calling the RCG. [1 to 100 / 60 / 1 second /step]</p>	
5816 010	RCG Read Timeout	
	<p>Specifies the read timeout interval when calling the RCG. [1 to 100 / 60 / 1 second /step]</p>	
5816 011	Port 80	-
	<p>Enables/disables access via port 80 to the SOAP method. [0 or 1 / 0 / -] 0: Disabled 1: Enabled</p>	

5816 013	RFU Timing	
	Selects the RFU (Remote Firmware Update) timing. [0 or 1 / 1 / -] 0: RFU is executed whenever update request is received. 1: RFU is executed only when the machine is in the sleep mode.	
5816 021	Function Flag	
	This SP displays the embedded RCG installation end flag. 0 : Installation not completed 1: Installation completed	
5816 022	Install Status	
	This SP displays the external RCG installation status. 0 : External RCG not registered 1: External RCG registered 2: Device registered	
5816 023	Connect Mode (N/M)	
	This SP displays and selects the embedded RCG connection method. [0 or 1 / 0 / 1 /step] 0: Internet connection 1: Dial-up connection	
5816 061	NotiTime ExpTime DFU	Proximity of the expiration of the certification.
5816 062	HTTP Proxy use	
	This SP setting determines if the proxy server is used when the machine communicates with the service center. [0 or 1 / 0 / 1 /step] 0: HTTP Proxy not used 1: HTTP Proxy used	

SP Tables

5816 063	HTTP Proxy Host
	<p>This SP sets the address of the proxy server used for communication between embedded RCG-N and the gateway. Use this SP to set up or display the customer proxy server address. The address is necessary to set up embedded RCG-N.</p> <p>Note: The address display is limited to 128 characters. Characters beyond the 128 character are ignored.</p> <p>This address is customer information and is not printed in the SMC report.</p>
5816 064	HTTP Proxy Port
	<p>This SP sets the port number of the proxy server used for communication between embedded RCG-N and the gateway. This setting is necessary to set up embedded RCG-N.</p> <p>Note: This port number is customer information and is not printed in the SMC report.</p>
5816 065	HTTP Prox AutUsr
	<p>This SP sets the HTTP proxy certification user name.</p> <p>Note:</p> <ul style="list-style-type: none"> ▪ The length of the name is limited to 31 characters. Any character beyond the 31st character is ignored. ▪ This name is customer information and is not printed in the SMC report.
5816 066	HTTP Prox AutPass
	<p>This SP sets the HTTP proxy certification password.</p> <ul style="list-style-type: none"> ▪ The length of the name is limited to 31 characters. Any character beyond the 31st character is ignored. ▪ This name is customer information and is not printed in the SMC report.

5816 067	Cer Updt Cond	
	Displays the status of the certification update.	
	0	The certification used by embedded RCG is set correctly.
	1	The certification request (setAuthKey) for update has been received from the GW URL and certification is presently being updated.
	2	The certification update is completed and the GW URL is being notified of the successful update.
	3	The certification update failed, and the GW URL is being notified of the failed update.
	4	The period of the certification has expired and new request for an update is being sent to the GW URL.
	11	A rescue update for certification has been issued and a rescue certification setting is in progress for the rescue GW connection.
	12	The rescue certification setting is completed and the GW URL is being notified of the certification update request.
	13	The notification of the request for certification update has completed successfully, and the system is waiting for the certification update request from the rescue GW URL.
	14	The notification of the certification request has been received from the rescue GW controller, and the certification is being stored.
	15	The certification has been stored, and the GW URL is being notified of the successful completion of this event.
	16	The storing of the certification has failed, and the GW URL is being notified of the failure of this event.
	17	The certification update request has been received from the GW URL, the GW URL was notified of the results of the update after it was completed, but an certification error has been received, and the rescue certification is being recorded.

SP Tables

	18	The rescue certification of No. 17 has been recorded, and the GW URL is being notified of the failure of the certification update.
5816 068	Cer Abnml Cause	
	Displays a number code that describes the reason for the request for update of the certification.	
	0	Normal. There is no request for certification update in progress.
	1	Request for certification update in progress. The current certification has expired.
	2	An SSL error notification has been issued. Issued after the certification has expired.
	3	Notification of shift from a common authentication to an individual certification.
	4	Notification of a common certification without ID2.
	5	Notification that no certification was issued.
	6	Notification that GW URL does not exist.
5816 069	Cer Updt ReqID	The ID of the request for certification.
5816 083	Firm Updating	Displays the status of the firmware update.
5816 085	Firm UpUsr Conf	This SP setting determines if the operator can confirm the previous version of the firmware before the firmware update execution. If the option to confirm the previous version is selected, a notification is sent to the system manager and the firmware update is done with the firmware files from the URL.
5816 086	Firmware Size	Allows the service technician to confirm the size of the firmware data files during the firmware update execution.

5816 087	CERT: MacroVsn	Displays the macro version of the @Remote certification.
5816 088	CERT: PAC Vsn	Displays the PAC version of the @Remote certification.
5816 089	CERT: ID2 Code	Displays ID2 for the @Remote certification. Spaces are displayed as underscores (_). Asterisks (***) indicate that no @Remote certification exists.
5816 090	CERT: Subject	Displays the common name of the @Remote certification subject. CN = the following 17 bytes. Spaces are displayed as underscores (_). Asterisks (***) indicate that no DESS exists.
5816 091	CERT: SeriNum	Displays serial number for the @Remote certification. Asterisks (***) indicate that no DESS exists.
5816 092	CERT: Issuer	Displays the common name of the issuer of the @Remote certification. CN = the following 30 bytes. Asterisks (***) indicate that no DESS exists.
5816 093	CERT: St ExpTime	Displays the start time of the period for which the current @Remote certification is enabled.
5816 094	CERT: Valid End	Displays the end time of the period for which the current @Remote certification is enabled.
5816 200	Polling Man Exc	
	Executes manual polling. Cumin periodically polls the @Remote Gateway by HTTPS. This is called "center polling". Use this SP at any time to poll the @Remote supply center.	

SP Tables

5816 201	Instl: Condition	
	<p>Displays a number that indicates the status of the @Remote service device.</p> <p>0: Neither the registered device by the embedded RCG nor embedded RCG device is set.</p> <p>1: The embedded RCG device is being set. Only Box registration is completed. In this status the external RCG unit cannot answer a polling request.</p> <p>2: The embedded RCG device is set. In this status the external RCG unit cannot answer a polling request.</p> <p>3: The registered device by the embedded RCG is being set. In this status the embedded RCG device cannot be set.</p> <p>4: The registered module by the embedded RCG has not started.</p>	
5816 202	Instl: ID #	Allows entry of the number of the request needed for the embedded RCG device.
5816 203	Instl: Reference	Executes the inquiry request to the @Remote GateWay URL.
5816 204	Instl Ref Result	
	<p>Displays a number that indicates the result of the inquiry executed with SP5816 203.</p> <p>0: Succeeded</p> <p>1: Inquiry number error</p> <p>2: Registration in progress</p> <p>3: Proxy error (proxy enabled)</p> <p>4: Proxy error (proxy disabled)</p> <p>5: Proxy error (Illegal user name or password)</p> <p>6: Communication error</p> <p>7: Certification update error</p> <p>8: Other error</p> <p>9: Inquiry executing</p>	

5816 205	Instl: Ref Section	
	Displays the result of the notification sent to the device from the GW URL in answer to the inquiry request. Displayed only when the result is registered at the GW URL.	
5816 206	Instl: Rgsltln	Executes Embedded RCG Registration.
5816 207	Instl: Rgsltln Rst	
	<p>Displays a number that indicates the registration result.</p> <p>0: Succeeded</p> <p>2: Registration in progress</p> <p>3: Proxy error (proxy enabled)</p> <p>4: Proxy error (proxy disabled)</p> <p>5: Proxy error (Illegal user name or password)</p> <p>6: Communication error</p> <p>7: Certification update error</p> <p>8: Other error</p> <p>9: Registration executing</p>	

SP Tables

5816 208	Instl: Error Code		
	Displays a number that describes the error code that was issued when either SP5816-204 or SP5816-207 was executed.		
	Cause	Code	Meaning
	Illegal Modem Parameter	-11001	Chat parameter error
		-11002	Chat execution error
		-11003	Unexpected error
	Operation Error, Incorrect Setting	-12002	Inquiry, registration attempted without acquiring device status.
		-12003	Attempted registration without execution of an inquiry and no previous registration.
		-12004	Attempted setting with illegal entries for certification and ID2.
		-12005	@Remote communication is prohibited. The device has an Embedded RC gate-related problem.
		-12006	A confirmation request was made after the confirmation had been already completed.
		-12007	The request number used at registration was different from the one used at confirmation.
		-12008	Update certification failed because mainframe was in use.
	Error Caused by Response from GW URL	-2385	Attempted dial up overseas without the correct international prefix for the telephone number.

		-2387	Not supported at the Service Center
		-2389	Database out of service
		-2390	Program out of service
		-2391	Two registrations for same device
		-2392	Parameter error
		-2393	External RCG not managed
		-2394	Device not managed
		-2395	Box ID for External RCG is illegal
		-2396	Device ID for External RCG is illegal
		-2397	Incorrect ID2 format
		-2398	Incorrect request number format
5816 209	Instl Clear	Releases the machine from its embedded RCG setup.	
5816 250	Print Comm Log	Prints the communication log.	

5821	NRS Address		
5821 2	RCG IP Address	Sets the IP address of the RCG (Remote Communication Gate) destination for call processing at the remote service center. [00000000h to FFFFFFFFh/00000000h/	

SP Tables

5824	NVRAM Upload	
	<p>Uploads the UP and SP mode data (except for counters and the serial number) from NVRAM on the control board to a flash memory card.</p> <p>While using this SP mode, always keep the front cover open. This prevents a software module accessing the NVRAM during the upload.</p>	

5825	NVRAM Download	
	<p>Downloads the content of a flash memory card to the NVRAM on the control board.</p>	

5828	Network Setting	
	<p>This machine supports both Internet Protocols IPv4 and IPv6. IPv6 is the next generation protocol designed by the IETF to replace IPV4. IPv6 adds many improvements such as routing and network auto-configuration.</p>	
5828 050	1284 Compatible	<p>Enables and disables bi-directional communication on the parallel connection between the machine and a computer.</p> <p>[0 to 1 / 1 / -]</p> <p>0:Off, 1: On</p>
5828 052	ECP	<p>Disables and enables the ECP feature (1284 Mode) for data transfer.</p> <p>[0 to 1 / 1 / -]</p> <p>0: Disabled</p> <p>1: Enabled</p>
5828 065	Job Spooling	<p>Switches job spooling spooling on and off.</p> <p>0: No spooling, 1: Spooling enabled</p>

5828 066	Job Spooling Clear	<p>This SP determines whether the job interrupted at power off is resumed at the next power on. This SP operates only when SP5828 065 is set to 1.</p> <p>1: OFF (Resumes printing spooled jog.) 0: ON (Clears spooled job.)</p>
5828 069	JobSpooling Protocl	
	<p>This SP determines whether job spooling is enabled or disabled for each protocol. This is a 8-bit setting.</p> <p>0: LPR/ 1: FTP (Not Used)/ 2: IPP/ 3: SMB/ 4: BMLinks (Japan Only)/ 5: DIPRINT/ 6: Reserved (Not Used)/ 7: Reserved (Not Used)</p>	
5828 090	TELNET	<p>Disables or enables Telnet operation. If this SP is disabled, the Telnet port is closed.</p> <p>[0to1 / 1 /-] 0: OFF 1: ON</p>
5828 091	Web	<p>Disables or enables the Web operation.</p> <p>[0to1 / 1 /-] 0: OFF 1: ON</p>
5828 145	Active IPv6 Link Local	<p>This is the IPv6 local address referenced on the Ethernet or wireless LAN (802.11) in the format: "Link-Local address" + "Prefix Length"</p> <p>The IPv6 address consists of a total 128 bits configured in 8 blocks of 16 bits each. These notations can be abbreviated. See "Note: IPV6 Addresses " below this table.</p>

SP Tables

5828 147	Active IPv6 Stat 1	<p>These SPs are the IPv6 stateless addresses (1 to 5) referenced on the Ethernet or wireless LAN (802.11) in the format: "Stateless Address" + "Prefix Length"</p> <p>The IPv6 address consists of a total 128 bits configured in 8 blocks of 16 bits each.</p>
5828 149	Active IPv6 Stat 2	
5828 151	Active IPv6 Stat 3	
5828 153	Active IPv6 Stat 4	
5828 155	Active IPv6 Stat 5	
5828 156	IPv6Manual Address	<p>This SP is the IPv6 manually set address referenced on the Ethernet or wireless LAN (802.11) in the format: "Manual Set Address" + "Prefix Length"</p> <p>The IPv6 address consists of a total 128 bits configured in 8 blocks of 16 bits each. These notations can be abbreviated. See "Note: IPV6 Addresses" below this table.</p>
5828 158	IPv6 Gateway Address	<p>This SP is the IPv6 gateway address referenced on the Ethernet or wireless LAN (802.11). The IPv6 address consists of a total 128 bits configured in 8 blocks of 16 bits each. These notations can be abbreviated. See "Note: IPV6 Addresses " below this table.</p>
5828 161	IPv6 Stateless Auto	<p>Enables or disables the IPv6 Stateless Auto setting on the Ethernet or wireless LAN (802.11). 0: Off, 1: On</p>

Note: IPV6 Addresses

Ethernet and the Wireless LAN (802.11) reference the IPV6 "Link-Local address + Prefix Length". The IPV6 address consists of 128 bits divided into 8 blocks of 16 bits:

aaaa:bbbb:cccc:dddd:eeee:ffff:gggg:hhhh:

The prefix length is inserted at the 17th byte (Prefix Range: 0x0to0x80). The initial setting is 0x40(64).

For example, the data:

2001123456789012abcdef012345678940h

is expressed:

2001:1234:5678:9012:abcd:ef01:2345:6789: prefixlen 64

However, the actual IPV6 address display is abbreviated according to the following rules.

Rules for Abbreviating IPV6 Addresses

1. The IPV6 address is expressed in hexadecimal delimited by colons (:) with the following characters:
0123456789abcdefABCDEF
2. A colon is inserted as a delimiter every 4th hexadecimal character.
fe80:0000:0000:0207:40ff:0000:340e
3. The notations can be abbreviated by eliminating zeros where the MSB and digits following the MSB are zero. The example in "2" above, then, becomes:
fe80:0:0:0207:40ff:0:340e
4. Sections where only zeros exist can be abbreviated with double colons (::). This abbreviation can be done also where succeeding sections contain only zeros (but this can be done only at one point in the address). The example in "2" and "3" above then becomes: fe80::207:40ff:0:340e (only the first null sets zero digits are abbreviated as "::")
-or-
fe80:0:0:0:207:40ff::340e (only the last null set before "340e" is abbreviated as "::")

SP Tables

236	Web Item visible
	Displays or does not display the Web system items. [0 x 0000 to 0 x ffff / 0 x ffff] 0: Not displayed, 1: Displayed bit0: Net RICOH bit1: Consumable Supplier bit2-15: Reserved (all)
237	Web shop Link
	Displays or does not display the link to Net RICOH on the top page and link page of the web system. [0 to 1 / 1 / 1] 0: Not display, 1:Display
238	Web supplies Link
	Displays or does not display the link to Consumable Supplier on the top page and link page of the web system. [0 to 1 / 1 / 1] 0: Not display, 1:Display
239	Web Link1 Name
	This SP confirms or changes the URL1 name on the link page of the web system. The maximum characters for the URL name are 31 characters.
240	Web Link1 URL
	This SP confirms or changes the link to URL1 on the link page of the web system. The maximum characters for the URL are 127 characters.
241	Web Link1 visible
	Displays or does not display the link to URL1 on the top page of the web system. [0 to 1 / 1 / 1] 0: Not display, 1:Display

242	Web Link2 Name	Same as "-239"
243	Web Link2 URL	Same as "-240"
244	Web Link2 visible	Same as "-241"

5832	HDD
001	Formatting (ALL)
	Initializes the hard disk. Use this only if there is a hard disk error.

5837	Prog checksum
	Displays the checksum for the engine firmware.

SP Tables

5840	IEEE 802.11	
006	Channel max	
	<p>Sets the maximum range of the bandwidth for the wireless LAN. This bandwidth setting varies for different countries.</p> <p>[1 to 14 / 11 (NA), 13 (EU), 14 (JPN) / 1]</p> <p>JPN: 1 to 14, NA: 1 to 11, EU: 1 to 13</p>	
007	Channel min	
	<p>Sets the minimum range of the bandwidth for operation of the wireless LAN. This bandwidth setting varies for different countries.</p> <p>[1 to 14 / 1 / 1]</p> <p>JPN: 1 to 14, NA: 1 to 11, EU: 1 to 13</p>	
008	Transmission speed	[0 x 00 to 0 x FF / 0 x FF to Auto / -]
	<p>0 x FF to Auto [Default]</p> <p>0 x 11 - 55M Fix</p> <p>0 x 10 - 48M Fix</p> <p>0 x 0F - 36M Fix</p> <p>0 x 0E - 18M Fix</p> <p>0 x 0D - 12M Fix</p> <p>0 x 0B - 9M Fix</p> <p>0 x 0A - 6M Fix</p>	<p>0 x 07 - 11M Fix</p> <p>0 x 05 - 5.5M Fix</p> <p>0 x 08 - 1M Fix</p> <p>0 x 13 - 0 x FE (reserved)</p> <p>0 x 12 - 72M (reserved)</p> <p>0 x 09 - 22M (reserved)</p>
011	WEP Key Select	
	<p>Selects the WEP key.</p> <p>Bit 1 and 0</p> <p>00: Key1, 01: Key2 (Reserved),</p> <p>10: Key3 (Reserved), 11: Key4(Reserved)</p> <p>This SP is displayed only when the IEEE802.11 card is installed.</p>	

042	Fragment Thresh
	Adjusts the fragment threshold for the IEEE802.11 card. [256 to 2346 / 2346 / 1] This SP is displayed only when the IEEE802.11 card is installed.
043	11g CTS to self
	Determines whether the CTS self function is turned on or off. [0 to 1 / 1 / 1] 0: Off, 1: On This SP is displayed only when the IEEE802.11 card is installed.
044	11g Slot Time
	Selects the slot time for IEEE802.11. [0 to 1 / 0 / 1] 0: 20 μm, 1: 9 μm This SP is displayed only when the IEEE802.11 card is installed.
045	WPA Debug Lvl
	Selects the debug level for WPA authentication application. [1 to 3 / 3 / 1] 1: Info, 2: warning, 3: error This SP is displayed only when the IEEE802.11 card is installed.

SP Tables

5842	GWWS Analysis (DFU)		
	This is a debugging tool. It sets the debugging output mode of each Net File process. Bit SW 0011 1111	Bit	Groups
		0	System & other groups (LSB)
		1	Capture related
		2	Certification related
		3	Address book related
		4	Machine management related
		5	Output related (printing, delivery)
	6	Repository related	
001	Setting 1	Default: 00000000 – do not change Netfiles: Jobs to be printed from the document server using a PC and the DeskTopBinder software	
002	Setting 2	Adjusts the debug program mode setting. Bit7: 5682 mmseg-log setting 0: Date/Hour/Minute/Second 1: Minute/Second/Msec. 0 to 6: Not used	

5844	USB	
5844 1	Transfer rate	0 x 01 [Full Speed], 0 x 04 [Auto Change]
	Sets the speed for USB data transmission.	
5844 2	Vendor ID	DFU
5844 3	Product ID	DFU
5844 4	Device Release Number	DFU

5845	Delivery Srv	
	Provides items for delivery server settings.	
5845 3	Retry Interval	[60to900 / 300 / 1 sec]
	Determines the time interval between retries before the machine returns to standby after an error occurs during an image transfer with the delivery scanner or SMTP server.	
5845 4	Number of Retries	[0to99 / 3 / 1]
	Determines the number of retries before the machine returns to standby after an error occurs during an image transfer with the delivery or SMTP server.	
5845 22	Instant Trans Off	[0 to 1 / 0 / -] 0: Disable, 1: Enable
	Enables or disables the prevention function for the continuous data sending error.	



SP Tables

5846	UCS Setting	
010	LDAP Search Timeout	
	Sets the length of the time-out for the search of the LDAP server. [1 to 255 / 60 /1 step]	
041	AddrB Acl Info.	
	<p>This SP must be executed immediately after installation of an HDD unit in a basic machine that previously had no HDD. The first time the machine is powered on with the new HDD installed, the system automatically takes the address book from the NVRAM and writes it onto the new HDD. However, the new address book on the HDD can be accessed only by the system administrator at this stage. Executing this SP by the service technician immediately after power on grants full address book access to all users.</p> <p>Procedure</p> <ol style="list-style-type: none"> 1. Turn the machine off. 2. Install the new HDD. 3. Turn the machine on. 4. The address book and its initial data are created on the HDD automatically. However, at this point the address book can be accessed by only the system administrator or key operator. 5. Enter the SP mode and do SP5846 041. After this SP executes successfully, any user can access the address book. 	
043	Addr Book Media	
	Displays the slot number where an address book data is in. [0 to 30 / - /1]	
	0: Unconfirmed 1: SD Slot 1 2: SD Slot 2 4: USB Flash ROM	20: HDD 30: Nothing

047	Ini Local AddrB
	Clears all of the address information from the local address book of a machine managed with UCS.
049	Ini LDAP AddrB
	Push [Execute] to delete all items (this does not include user codes) in the LDAP address book that is controlled by UCS.
050	Ini All AddrB
	Clears everything (including users codes) in the directory information managed by UCS. However, the accounts and passwords of the system administrators are not deleted.
051	Backup All AddrB
	Copies all directory information to the SD card. Do this SP before replacing the controller board or HDD. The operation may not succeed if the controller board or HDD is damaged.
052	Restore All AddrB
	Copies back all directory information from the SD card to the flash ROM or HDD. Upload the address book from the old flash ROM or HDD with SP5846-51 before removing it. Do SP5846 52 after installing the new HDD.
053	Clear Backup Info.
	Deletes the address book uploaded from the SD card in the slot 2. Deletes only the files uploaded for that machine. This feature does not work if the card is write-protected. Note: After you do this SP, go out of the SP mode, turn the power off. Do not remove the SD card until the Power LED stops flashing.

SP Tables

060	Search Option	
	This SP uses bit switches to set up the fuzzy search options for the UCS local address book.	
	Bit	Meaning
	0	Checks both upper/lower case characters
	1	Japan Only
	2	
	3	
	4	--- Not Used ---
	5	--- Not Used ---
	6	--- Not Used ---
7	--- Not Used ---	
062	Complexity Option 1	
	<p>Use this SP to set the conditions for password entry to access the local address book. Specifically, this SP limits the password entry to upper case and sets the length of the password.</p> <p>[0 to 32 / 0 / 1step]</p> <p> Note</p> <ul style="list-style-type: none"> ▪ This SP does not normally require adjustment. ▪ This SP is enabled only after the system administrator has set up a group password policy to control access to the address book. 	

063	Complexity Option 2
	<p>Use this SP to set the conditions for password entry to access the local address book. Specifically, this SP limits the password entry to lower case and defines the length of the password.</p> <p>[0 to 32 / 0 / 1step]</p> <p> Note</p> <ul style="list-style-type: none"> ▪ This SP does not normally require adjustment. ▪ This SP is enabled only after the system administrator has set up a group password policy to control access to the address book.
064	Complexity Option 3
	<p>Use this SP to set the conditions for password entry to access the local address book. Specifically, this SP limits the password entry to numbers and defines the length of the password.</p> <p>[0 to 32 / 0 / 1step]</p> <p> Note</p> <ul style="list-style-type: none"> ▪ This SP does not normally require adjustment. ▪ This SP is enabled only after the system administrator has set up a group password policy to control access to the address book.
065	Complexity Option 4
	<p>Use this SP to set the conditions for password entry to access the local address book. Specifically, this SP limits the password entry to symbols and defines the length of the password.</p> <p>[0 to 32 / 0 / 1step]</p> <p> Note</p> <ul style="list-style-type: none"> ▪ This SP does not normally require adjustment. ▪ This SP is enabled only after the system administrator has set up a group password policy to control access to the address book.

SP Tables

094	Encryption Start
	Shows the status of the encryption function of the address book on the LDAP server. [0 to 255 / 1] No default

5848	WebService	
5848 004	ac:UD	Switches access control on and off. 0000: OFF, 0001: ON
5848 009	ac:Job Ctrl	
5848 011	ac:Dev Mng	
5848 022	ac:Vadmin	
5848 210	Log Type:Job 1 DFU	Note: These SP codes are for display only; they cannot be changed.
	[0 to 0xFFFFFFFF/0/1]	
5848 211	Log Type:Job 2 DFU	
	[0 to 0xFFFFFFFF/0/1]	
5848 212	Log Type Access DFU	
	[0 to 0xFFFFFFFF/0/1]	
5848 213	PrimarySrv DFU	
5848 214	Secondary Srv DFU	
5848 215	StartTime DFU	
	[0 to 0xFFFFFFFF/0/1]	
5848 216	IntervalTime DFU	
	[1 to 100/1/1]	

5848 217	Timing DFU	
	[0 to 2/0/1] 0: Transmission off 1: Transmission 1 by 1 2: Periodic transmission	

5849	Installation Date	
	Displays or prints the installation date of the machine.	
5849 001	Display	Displays the installation date of the machine.
5849 002	Switch to Print	Determines whether the installation date is printed on the printout for the total counter. [0 to 1 / 1 / -] 0: OFF (No Print) 1: ON (Print)
5849 003	Total Counter	Displays the total counter of the machine installation's day.

5851	Bluetooth	
	Sets the Bluetooth security mode. [0: Public] / [1: Private]	

5856	Remote Program Update: Local port.	
	When set to "enable" allows reception of firmware data via the local port (IEEE 1284) during a remote ROM update. 0: Disallow , 1: Allow This setting is reset to "disable" after the machine is cycled off and on.	

SP Tables

5857	Debug Log Save
	On/Off (1:ON 0:OFF)
001	Switches on the debug log feature. The debug log cannot be captured until this feature is switched on. [0 to 1 / 0 / 1] 0: OFF, 1: ON
	Target (2: HDD 3: SD)
002	Selects the destination where the debugging information generated by the event selected by SP5858 will be stored if an error is generated [2 to 3 / 2 / 1] 2: HDD, 3: SD Card
	Save to HDD
005	Specifies the decimal key number of the log to be written to the hard disk.
	Save to SD Card
006	Specifies the decimal key number of the log to be written to the SD Card.
	HDD to SD Card Latest
009	Takes the most recent 4 MB of the log written to the hard disk and copies them to the SD Card. A unique file name is generated to avoid overwriting existing file names on the SD Card. Up to 4MB can be copied to an SD Card. 4 MB segments can be copied one by one to each SD Card.
	HDD to SD Any
010	Takes the log of the specified key from the log on the hard disk and copies it to the SD Card. A unique file name is generated to avoid overwriting existing file names on the SD Card. Up to 4 MB can be copied to an SD Card. 4 MB segments can be copied one by one to each SD Card. This SP does not execute if there is no log on the HDD with no key specified.

011	Erase HDD Debug
	Erases all debug logs on the HDD
012	Erase SD Card Debug
	Erases all debug logs on the SD Card. If the card contains only debugging files generated by an event specified by SP5858, the files are erased when SP5857 010 or 011 is executed. To enable this SP, the machine must be cycled off and on.
013	Dsply-SD Space
	Displays the amount of space available on the SD card.
014	SD to SD Latest
	Copies the last 4MB of the log (written directly to the card from shared memory) onto an SD card.
015	SD to SD Any
	This SP copies the log on an SD card (the file that contains the information written directly from shared memory) to a log specified by key number.
016	Make HDD Debug File
	This SP creates a 32 MB file to store a log on the HDD.
017	Make SD Debug File
	This SP creates a 4 MB file to store a log on an SD card.

SP Tables

5858	Debug Log Save: SC	
	<p>These SPs select the content of the debugging information to be saved to the destination selected by SP5857-002.</p> <p>SP5858-003 stores one SC specified by number.</p>	
001	Engine SC (0:OFF 1:ON)	Stores SC codes generated by copier engine errors.
002	Controller SC (0:OFF 1:ON)	Stores SC codes generated by GW controller errors.
003	Any SC	[0 to 65535 / 0 / 1step]
004	Jam (0:OFF 1:ON)	Stores jam errors.

5859	Debug Log Save Key	
001	Key 1	<p>These SPs allow you to set up to 10 keys for log files for functions that use common memory on the controller board.</p> <p>[-9999999 to 9999999 / - / 1]</p>
002	Key 2	
003	Key 3	
004	Key 4	
005	Key 5	
006	Key 6	
007	Key 7	
008	Key 8	
009	Key 9	
010	Key 10	

5860	SMTP/POP3/IMAP4	
5860 2	SMTP Svr Port no.	Input the SMTP server port number.
5860 3	SMTP Auth	SMTP authentication enable/disable
5860 6	SMTP Auth Encryp	Encryption mode for SMTP authentication enable/disable (Only valid if 5860 3 is set to "enable")
5860 7	POP before SMTP	Enable/disable POP before SMTP. If the SMTP server does not have authentication, you can enable POP before SMTP, then POP authentication is available (SP 5860 13)
5860 8	POP to SMTP Waiting	When using POP before SMTP, this SP mode determines the maximum wait time between POP authentication and connection with SMTP. Communication stops if this time is exceeded.
5860 9	Mail Receive Protocol	Selects the protocol for the mail reception. [0 to 3 / 1 / 1] 0: No reception 1: POP3 2: IMAP4 3: SMTP
5860 13	POP3/IMAP4 Auth.	If POP before SMTP is enabled, then you can use this SP to enable or disable encryption mode for POP authentication [0 to 2 / 0 / 1] 0: Auto 1: Off 2: On
5860 14	POP Serv Port No.	Input the POP server port number.

SP Tables

5860 15	IMAP4 Srvr Port	Input the IMAP4 server port number.
5860 16	SMTP Rx Port No.	Input the SMTP port for the mail reception.
5860 17	Mail Rx Interval	Specifies the interval for the mail reception.
5860 19	Mail Keep Setting	Selects the mail saving setting. [0 to 2 / 0 / 1] 0: Not saved in the mail server 1: All saved in the mail server 2: Only error mails saved in the mail server
5860 20	Par Mail Rec Out	
	[1 to 168 / 72 / 1 hour] Sets the amount of time to wait before saving a mail that breaks up during reception. The received mail is discarded if the remaining portion of the mail is not received during this prescribed time.	
5860 21	MDN Res RFC2298	
	Determines whether RFC2298 compliance is switched on for MDN reply mail. [0 to 1 / 1 / 1] 0: No, 1: Yes	
5860 22	IMAP4Aut FieldRep	If SMTP authentication is enabled, this SP mode determines which name is included in the e-mail header. [0 or 1 / 0 / -] 0: Normal sender name 1: User name used by the authentication feature

5860 025	SMTP Auth Direct Set DFU	
	<p>Select the authentication method for SMPT.</p> <p>Bit 0: LOGIN</p> <p>Bit 1: PLAIN</p> <p>Bit 2: CRAM_MD5</p> <p>Bit 3: DIGEST_MD5</p> <p>Bit 4 to Bit 7: Not Used</p> <p> Note</p> <ul style="list-style-type: none"> This SP is activated only when SMTP authentication is enabled by UP mode. 	
5860 026	S/MIME: MIME Header Setting	
	<p>Selects the MIME header type of an E-mail sent by S/MIME.</p> <p>[0 to 2 / 0 / 1]</p> <p>0: Microsoft Outlook Express standard</p> <p>1: Internet Draft standard</p> <p>2: RFC standard</p>	

5866	E-Mail Report	
001	Report Validity	Enables or disables the E-mail alert function. [0 or 1 / 0 / -] 0: Enabled, 1: Disabled
005	Add Date Field	Adds or does not add the date field to the header of the alert mail. [0 or 1 / 0 / -] 0: Not added, 1: Added

5869	RAM disk setting	DFU
-------------	------------------	------------

SP Tables

5870	Common KeyInfo Writing	
	Writes to flash ROM the common proof for validating the device for @Remote specifications. Note: <ul style="list-style-type: none"> ▪ These SP settings are required to connect @Remote or must also be set after the board is replaced. ▪ Even if @Remote is not connected, these settings are used for Web validation, so at least SP5870 003 must be enabled. 	
5870 001	Writing	Writes the authentication data (used for NRS) in the memory.
5870 003	Initialize	Initializes the authentication data in the memory.

5873	SDCardAppliMove	
	Allows you to move applications from one SD card another. For more, please refer to the "SD Card Application Move" section.	
5873 001	MoveExec	Executes the move from one SD card to another.
5873 002	UndoExec	This is an undo function. It cancels the previous execution.

5878	Option Setup	
001	Data Overwrite Security	Press [Execute] to initialize the Data Overwrite Security option for the printer. For more, see "DataOverwriteSecurity Unit" in the chapter "Installation".
002	HDD Encryption	Press [Execute] to initialize the HDD Encryption option for the printer. For more, see "HDD Encryption" in the chapter "Installation".

5888	Person. Info Prot.
	Selects the protection level for logs. [0 to 1 / 0 / 1] 0: No authentication, No protection for logs 1: No authentication, Protected logs (only an administrator can see the logs)

5893	SDK Application Counter
	Displays the counter name of each SDK application.
5893 001	SDK-1
5893 002	SDK-2
5893 003	SDK-3
5893 004	SDK-4
5893 005	SDK-5
5893 006	SDK-5

5902	Test Print
	Prints the test pattern that you selected with SP 5902-003.
5902 001	1 Sheet Print
	Prints one test pattern
5902 002	Continuous Print
	Prints consecutive copies of the test pattern

SP Tables

5902 003	Print Pattern
	Selects a printer test pattern. Use SP 5902 to print either one test pattern (5902-1) or more than one pattern. (5902-2).
	Pattern:
	0: Not Specified
	1: Vertical Line (1dot)
	2: Vertical Line (2dot)
	3: Horizontal (1dot)
	4: Horizontal (2dot)
	5: Grid pattern Small
	6: Grid pattern Large
	7: Argyle Pattern Small
	8: Argyle Pattern Large
	9: Trimming Area
	10: Horizontal Stitch
11: Checker Flag	

5907	Plug & Play
	<p>Sets the brand name and the production name for Windows Plug & Play. This information is stored in NVRAM. If the NVRAM is defective or has been replaced, these names should be registered again.</p> <p>To set the plug and play model name, enter the model number, and then press ⊕.</p>

5924	SDK Apli Display
001	<p>Selects the display mode for SDK application.</p> <p>[0 or 1 / 0 / -]</p> <p>0: Not displayed 1: Displayed</p>

5930	Meter Click Charge
5930 001	Setting
	<p>Switches the meter-click charge mode on and off.</p> <p>[0: No], [1: Yes]</p> <p>Important: Turn the main switch off/on after changing this setting.</p> <p>No: Meter charge mode disabled (default). This setting is for machines where the operator is responsible for replacing the AIO and the Maintenance Kit.</p> <ul style="list-style-type: none"> ▪ Alert messages are displayed on the operation panel when the AIO or PM parts reach the limit of their yield. ▪ The PM counter resets automatically after the user replaces the fusing unit. <p>Yes: Meter charge mode enabled. This setting is for machines where the service technician has responsibility for servicing the machine.</p> <ul style="list-style-type: none"> ▪ Alert messages are not displayed when the AIO or PM parts reach the limits of their yield. ▪ Pressing the [Menu] button displays the meter charge count. ▪ The service technician must reset the PM counter after completing machine maintenance.

SP Tables

5930 002	<p>Life Alert Display</p> <hr/> <p>Switches the PM alerts on and off. [0: No], [1: Yes] No: Maintenance Kit alerts will not display. Yes: Maintenance Kit alerts will display. Important:</p> <ul style="list-style-type: none"> ▪ The setting of SP5930 002 is ignored unless SP5930 001 is set to "Yes". ▪ In order for the PM alerts to display both SP5930 001 and SP5930 002 must be set to "Yes".
5930 003	<p>Pcon. Life Alert</p> <hr/> <p>This SP switches the near-end and end alerts on/off for the service life of the OPC (not toner), based on the accumulated operation time of the main motor. Note: "Pcon" (photoconductor) means OPC drum. [0: No], [1: Yes] No: Near-end and end alerts will not display. Yes: Near-end and end alerts will display. Important:</p> <ul style="list-style-type: none"> ▪ The setting of SP5930 003 is ignored unless SP5930 001 is set to "Yes". ▪ In order for the OPC alerts to display (near-end, end of service life) for the AIO, both SP5930 001 and SP5930 003 must be set to "Yes".

5990	SP Print Mode	
5990 1	All (Data List)	Prints summary sheet for the item selected.
5990 2	SP (Mode Data List)	
5990 4	Logging Data	
5990 5	Diagnostic Report	
5990 6	Non-Default	
5990 7	NIB Summary	

5997	debug: PSC DFU	
5997 1	COMMAND	

SP Tables

SP7-xxx: Data Log

7001	Operation time
	Displays the total number of engine rotation cycles made so far. However, this counter also includes idle rotations. This counter is not reset at PM.

7401	Total SC Counter	Displays the total number of service calls that have occurred. Display range: 0000 to 9999
-------------	------------------	---

7403	SC History	
7403 001	Latest	Displays the most recent service calls successive groups of 10.
7403 002	Latest 1	
7403 003	Latest 2	
7403 004	Latest 3	
7403 005	Latest 4	
7403 006	Latest 5	
7403 007	Latest 6	
7403 008	Latest 7	
7403 009	Latest 8	
7403 010	Latest 9	

7502	Counter-Paper Jam	Displays the total number of jams. Display range: 0000 to 9999
-------------	-------------------	---

7504	Paper Jam Loc	
	<p>Displays the total number of jams by location.</p> <p>A "Paper Late" error occurs when the paper fails to activate the sensor at the precise time. A "Paper Lag" paper jam occurs when the paper remains at the sensor for longer than the prescribed time.</p> <p>Display range: 0000 to 9999</p>	
	Error No.	Error
7504 001	1	At Power On
7504 017	17	PFU1: Trans. SN: OFF
7504 018	18	PFU2: Trans. SN: OFF
7504 019	19	Regist Bypass: OFF
7504 020	20	Regist T1: OFF
7504 021	21	Regist T2: OFF
7504 022	22	Regist PFU: OFF
7504 023	23	Regist Duplex: OFF
7504 024	24	Regist SN: ON
7504 025	25	Paper Exit SN: OFF
7504 032	32	Paper Exit SN: ON
7504 049	49	Dup Entrance: OFF
7504 050	50	Dup Entrance: ON
7504 051	51	Dup Inverter: OFF
7504 052	52	Dup Inverter: ON
7504 053	53	Duplex Exit: OFF
7504 054	54	Duplex Exit: ON

SP Tables

7506	Paper Jam/ Size	
7506 005	A4 LEF	Displays the total number of jams by paper size
7506 006	A5 LEF	
7506 014	B5 LEF	
7506 038	LT LEF	
7506 044	HLT LEF	
7506 132	A3 SEF	
7506 133	A4 SEF	
7506 134	A5 SEF	
7506 141	B4 SEF	
7506 142	B5 SEF	
7506 160	DLT SEF	
7506 164	LG SEF	
7506 166	LT SEF	
7506 172	HLT SEF	
7506 255	Others	

7507	Dsply-P Jam Hist	
	Displays the copy jam history in groups of 10, starting with the most recent 10 jams. Display contents are as follows: CODE is the SP7-504-nnn number. SIZE is the ASAP paper size (hexadecimal). TOTAL is the total jam error count (SP7-003) DATE is the date the jams occurred.	
7507 001	Latest	Sample Display: CODE: 007 TOTAL: 0000334
7507 002	Latest 1	
7507 003	Latest 2	
7507 004	Latest 3	
7507 005	Latest 4	
7507 006	Latest 5	
7507 007	Latest 6	
7507 008	Latest 7	
7507 009	Latest 8	
7507 010	Latest 9	

SP Tables

Paper Size	Code (hex)	Paper Size	Code (hex)
A4 LEF	05	B4 SEF	8D
A5 LEF	06	B5 SEF	8E
B5 LEF	0E	DLT SEF	A0
LT LEF	26	LG SEF	A4
HLT LEF	2C	LT SEF	A6
A3 SEF	84	HLT SEF	AC
A4 SEF	85	Others	FF
A5 SEF	86		

7801	Memory/ Version/ PN
	Displays the firmware version (system, engine, and duplex).
7801 255	Memory/ Version/ PN

7803	PM Counter
	Displays the PM counter. This is not a page counter. It estimates the page count using the engine rotation cycle count. It counts up one page when the engine has made the average number of rotations that is required for one page of a three-page job.
7803 1	Paper
7803 2	Trans Roller
7803 3	Paper Feed Roller
7803 4	Fusing unit

7804	PM Count. Reset
	Resets the PM counter. Important: If a technician replaces the PM items, reset this counter after replacing these items.
7804 1	Paper
7804 2	Trans Roller
7804 3	Paper Feed Roller
7804 4	Fusing unit

7807	Reset-SC/Jam
	Resets the SC and jam counters. To reset, press [#Enter]. Note: This SP does not reset the jam history counter: SP7-507

7832	Display-Self-Diag
	Press # to display a list of error codes. Nothing is displayed if no errors have occurred.

7836	Resident Memory
	Displays the memory capacity of the controller system.

7853	Replacement Cnt
7853 15	Fusing Unit
	Displays the number of replacement for the fusing unit.

SP Tables

7901	Assert Info DFU (Used for debugging.)	
7901 1	File Name	DFU
7901 2	Number of Lines	DFU
7901 3	Location	DFU

7904	Supply Near-end	
7904 1	Fusing Unit	
	<p>Selects the near end display for the fusing unit.</p> <p>[0 to 2 / 0 / 1]</p> <p>0: Sooner</p> <p>1: Normal</p> <p>2: Later</p>	

7931	Cartridge info		
	<p>Displays information about the cartridge.</p> <ul style="list-style-type: none"> ▪ Returns a value of "0" if the number stored in the cartridge is not recognized. ▪ This is information on the AIO ID Chip so if the cartridge is not installed, if the AIO is not set properly, or if the front door is open, no value will be displayed because the machine cannot communicate with the AIO. 		
	7931 001	Machine ID	Identification number of the machine (Model Name)
	7931 002	Version	Cartridge version number
7931 003	Brand ID	Displays the OEM brand 1: Ricoh	

7931 004	Area ID	Displays the area ID 1: DOM (Japan) 2: NA (North America) 3: EU (Europe) 4: Asia
7931 005	Kind ID	Displays the part code number 1: 6K 3: 15K
7931 006	Color ID	Displays "1" for the color of the toner (Black), this is the only setting for this machine.
7931 007	Maintenance ID	Displays the maintenance ID 1: Printer (no maintenance contract) 3: Accessories
7931 008	New AIO	Displays the conditions of AIO 0: Normal 64: New AIO
7931 009	Recycle Count	0 to 3
7931 010	EDP Code	Displays the toner order code, the code is a string of ASCII characters.
7931 011	Serial No	Displays an ASCII string that identifies the manufacturer Note: <ul style="list-style-type: none"> ▪ This data is originally entered as BCD and changes into a 16-character string in order to convert it to ASCII. ▪ However, only 10 bytes can be used to communicate with the controller, so the 16 bytes are truncated to 10 bytes.

SP Tables

7931 012	Remaining Toner	Displays "0" to "100" (the percentage of toner remaining in the cartridge)
7931 013	Toner End	N: Toner near end E: Toner end
7931 014	Refill Flag	Displays "RF" when the cartridge requires refilling
7931 015	R:Total Counter	Displays a number in the range "0" to "99999999", this is the total count at toner remaining.
7931 016	E:Total Counter	Displays a number in the range "0" to "99999999", this is the total count at toner end.
7931 017	Unit Counter	Displays a number in the range "0" to "99999999", this is the total number of pages output by the AIO unit. Counter adds once for each sheet output.
7931 018	Install Date	Displays Year-Month-Date of installation for the AIO unit, this setting updates automatically through a serial interface with the machine when the new unit is installed.
7931 019	Toner End Date	Displays Year-Month-Date when toner end occurred
7931 020	Pcon Rotation Time 1	Displays a number in the range "0" to "00000000", this is the count for OPC rotation.
7931 021	Pcon Rotation Time 2	<p>Note:</p> <ul style="list-style-type: none"> ▪ This information resides at four locations (020, 021, 022, 023). The recycle count determines where the value is written. ▪ The counter increments by "1" for every 6 sec. of drum rotation time. ▪ To calculate the actual time in sec., multiply the displayed value by 6.
7931 022	Pcon Rotation Time 3	
7931 023	Pcon Rotation Time 4	

7932	Pconductor Info
7932 001	Rotation Time
	Displays the rotation time 1 of the photoconductor (AIO). Actual rotation time = displayed time x 6 (sec)
7932 002	Pre Rotation Time
	Displays the rotation time 2 of the photoconductor (AIO). Actual rotation time = displayed time x 6 (sec)
7932 003	Alert Condition
	Displays the current alert condition of the each part in the AIO. This SP is displayed with hexadecimal number. bit 0: Toner near end bit 1: Toner end bit 2: Waste toner near end bit 3: Waste toner end bit 4: Toner near end bit 5: Photoconductor near end bit 6: Photoconductor end
7932 004	Pre Alert Condition
	Displays the previous alert condition of the each part in the AIO. This SP is displayed with hexadecimal number. bit 0: Toner near end bit 1: Toner end bit 2: Waste toner near end bit 3: Waste toner end bit 4: Toner near end bit 5: Photoconductor near end bit 6: Photoconductor end

SP Tables

7932 005	Kind ID
	<p>Displays the kind ID of the AIO. This SP is displayed with hexadecimal number.</p> <p>01: 3K life 02: 6K life 03: 15K life 04: 20K life</p>
7932 006	Pre Kind ID
	<p>Displays the previous kind ID of the AIO. This SP is displayed with hexadecimal number.</p> <p>01: 3K life 02: 6K life 03: 15K life 04: 20K life</p>
7932 007	RF Rotation Time
	<p>Displays the rotation time of the photoconductor (AIO) after refilled AIO has been detected. Actual rotation time = displayed time x 6 (sec)</p>
7932 008	Remaining Time
	<p>Displays the rest of photoconductor life. [0 to 100 / - / 1 %]</p> <p>NOTE: "0 %" may be displayed if the machine is turned on or recovered from the energy saver with the door opened.</p>

7935	Cartridge Log	
7935 001	1 Serial No.	Saves the serial number of the previous AIO.
7935 002	1 Install Date	Saves the installation date of the previous AIO.
7935 003	1 R: Total Counter	Saves the total counter of the previous AIO.
7935 004	1 Refill Flag	Saves the refill flag (RF) of the previous AIO.
7935 005	2 Serial No.	Saves the serial number of the 2nd previous AIO.
7935 006	2 Install Date	Saves the installation date of the 2nd previous AIO.
7935 007	2 R: Total Counter	Saves the total counter of the 2nd previous AIO.
7935 008	2 Refill Flag	Saves the refill flag (RF) of the 2nd previous AIO.
7935 009	3 Serial No.	Saves the serial number of the 3rd previous AIO.
7935 010	3 Install Date	Saves the installation date of the 3rd previous AIO.
7935 011	3 R: Total Counter	Saves the total counter of the 3rd previous AIO.
7935 012	3 Refill Flag	Saves the refill flag (RF) of the 3rd previous AIO.
7935 013	4 Serial No.	Saves the serial number of the 4th previous AIO.
7935 014	4 Install Date	Saves the installation date of the 4th previous AIO.
7935 015	4 R: Total Counter	Saves the total counter of the 4th previous AIO.
7935 016	4 Refill Flag	Saves the refill flag (RF) of the 4th previous AIO.
7935 017	5 Serial No.	Saves the serial number of the 5th previous AIO.
7935 018	5 Install Date	Saves the installation date of the 5th previous AIO.
7935 019	5 R: Total Counter	Saves the total counter of the 5th previous AIO.
7935 020	5 Refill Flag	Saves the refill flag (RF) of the 5th previous AIO.

SP Tables

7993	Total counter
	Displays the engine total counter. It counts up for all prints, including service reports.

SP8XXX: Data Log 2

The SPs in this group are prefixed with a letter that indicates the mode of operation. The mode of operation is referred to as an 'application'. Before reading the Group 8 Service Tables, make sure that you understand what these prefixes mean.

Prefix	Application	What It Means
T:	Total	Grand total of the items counted for all applications (C, F, P, etc.).
P:	Print	Totals (pages, jobs, etc.) executed for each application when the job was not stored on the document server.
O:	Other	Other applications (external network applications, etc.). Refers to network applications such as Web Image Monitor. Utilities developed with the SDK (Software Development Kit) are also counted.

Group 8 SP codes are limited to 17 characters, forced by the necessity of displaying them on the small LCDs of printers and faxes that also use these SPs.

 Note

- All of the Group 8 SPs are reset with SP5 801 1 Memory All Clear.

8381	T:Total PrtPGS	These SPs count the number of pages printed by the customer. The counter for the application used for storing the pages increments. [0 to 9999999/0/1]
8384	P:Total PrtPGS	
8387	O:Total PrtPGS	

- When the A3/DLT double count function is switched on with SP5104, 1 A3/DLT page is counted as 2.
- When several documents are merged for a print job, the number of pages stored are counted for the application that stored them.
- These counters are used primarily to calculate charges on use of the machine, so the following pages are not counted as printed pages:
- Blank pages in a duplex printing job.

SP Tables

- Reports printed to confirm counts.
- All reports done in the service mode (service summaries, engine maintenance reports, etc.)
- Test prints for machine image adjustment.
- Error notification reports.
- Partially printed pages as the result of a jam.

8391	LSize PrtPGS	
	These SPs count pages printed on paper sizes A3/DLT and larger. [0 to 9999999/0/1]	

8411	Prints/Duplex	
	This SP counts the amount of paper (front/back counted as 1 page) used for duplex printing. Last pages printed only on one side are not counted. [0 to 9999999/0/1]	

8421	T:PrtPGS/Dup Comb	
	These SPs count by binding and combine, and n-Up settings the number of pages processed for printing. This is the total for all applications. [0 to 9999999/0/1]	
8424	P:PrtPGS/Dup Comb	
	These SPs count by binding and combine, and n-Up settings the number of pages processed for printing by the printer application. [0 to 9999999/0/1]	
8427	O:PrtPGS/Dup Comb	
	These SPs count by binding and combine, and n-Up settings the number of pages processed for printing by Other applications [0 to 9999999/0/1]	
842x 1	Simplex> Duplex	
842x 4	Simplex Combine	

842x 5	Duplex Combine	
842x 6	2>	2 pages on 1 side (2-Up)
842x 7	4>	4 pages on 1 side (4-Up)
842x 8	6>	6 pages on 1 side (6-Up)
842x 9	8>	8 pages on 1 side (8-Up)
842x 10	9>	9 pages on 1 side (9-Up)
842x 11	16>	16 pages on 1 side (16-Up)
842x 12	Booklet	
842x 13	Magazine	

- These counts are especially useful for customers who need to improve their compliance with ISO standards for the reduction of paper consumption.
- Pages that are only partially printed with the n-Up functions are counted as 1 page.

SP Tables

8441	T:PrtPGS/Ppr Size	
	These SPs count by print paper size the number of pages printed by all applications. [0 to 9999999/0/1]	
8444	P:PrtPGS/Ppr Size	
	These SPs count by print paper size the number of pages printed by the printer application. [0 to 9999999/0/1]	
8447	O:PrtPGS/Ppr Size	
	These SPs count by print paper size the number of pages printed by Other applications. [0 to 9999999/0/1]	
844x 1	A3	
844x 2	A4	
844x 3	A5	
844x 4	B4	
844x 5	B5	
844x 6	DLT	
844x 7	LG	
844x 8	LT	
844x 9	HLT	
844x 10	Full Bleed	
844x 254	Other (Standard)	
844x 255	Other (Custom)	

- These counters do not distinguish between LEF and SEF.

8451	PrtPGS/PPr Tray	
	These SPs count the number of sheets fed from each paper feed station. [0 to 9999999/0/1]	
001	Bypass Tray	Bypass Tray
002	Tray 1	Main Machine
003	Tray 2	Paper Tray Unit (Option)
004	Tray 3	Paper Tray Unit (Option)
005	Tray 4	Currently not used.
006	Tray 5	
007	Tray 6	
008	Tray 7	
009	Tray 8	
010	Tray 9	

SP Tables

8461	T:PrtPGS/Ppr Type
	[0 to 9999999/0/1] These SPs count by paper type the number pages printed by all applications. <ul style="list-style-type: none"> ▪ These counters are not the same as the PM counter. The PM counter is based on feed timing to accurately measure the service life of the feed rollers. These counts are based on output timing. ▪ Blank sheets (covers, chapter covers, slip sheets) are also counted. ▪ During duplex printing, pages printed on both sides count as 1, and a page printed on one side counts as 1.
8464	P:PrtPGS/Ppr Type
	These SPs count by paper type the number pages printed by the printer application.
846x 1	Normal
846x 2	Recycled
846x 3	Special
846x 4	Thick
846x 5	Normal (Back)
846x 6	Thick (Back)
846x 7	OHP
846x 8	Other

8521	T:PrtPGS/FIN
	[0 to 9999999/0/1] These SPs count by finishing mode the total number of pages printed by all applications.
8524	P:PrtPGS/FIN

	These SPs count by finishing mode the total number of pages printed by the Print application. [0 to 99999999/0/1]
852x 1	Sort
852x 2	Stack
852x 3	Staple
852x 4	Booklet
852x 5	Z-Fold
852x 6	Punch
852x 7	Other
852x 8	Inside-Fold
852x 9	Three-IN-Fold
852x 10	Three-OUT-Fold
852x 11	Four-Fold

- If stapling is selected for finishing and the stack is too large for stapling, the unstapled pages are still counted.
- The counts for staple finishing are based on output to the staple tray, so jam recoveries are counted.

SP Tables

8581	T:Counter	
	<p>These SPs count the total output broken down by color output, regardless of the application used. In addition to being displayed in the SMC Report, these counters are also displayed</p> <p>[0 to 9999999/0/1]</p>	

8591	O:Counter	
	<p>These SPs count the totals for A3/DLT paper used, number of duplex pages printed, and the number of staples used. These totals are for Other (O:) applications only.</p> <p>[0 to 9999999/0/1]</p>	
8591 001	A3/DLT	
8591 002	Duplex	

8601	Cvg Counter	
	<p>These counts correspond to the total counts recorded with the mechanical counter.</p>	
8601 001	Cvg: BW %	Coverage: BW Pages
8601 011	Cvg: BW Pages	Coverage: BW Percent

8617	SDK Apli Counter	*CTL	[0 to 9999999/ 0 / 1]
	These SPs count the total printout pages for each SDK applicaion.		
8617 1	SDK-1		
8617 2	SDK-2		
8617 3	SDK-3		
8617 4	SDK-4		
8617 5	SDK-5		
8617 6	SDK-6		

8621	Func Use Counter DFU		
	This SP counts the number of development roller rotations for development. [0 to 9999999/0/1]		
1 to 64	Function-1 to -64		

8771	Dev Counter		
	This SP counts the number of development roller rotations for development. [0 to 9999999/0/1]		

8781	Toner_Botol_Info.		
	This SP displays the count for the number of toner bottles used. The count is done based on the assumption that one toner bottle yields about 1,000 printed pages.		

SP Tables

8801	Toner Remain	
	<p>This SP displays (as a percentage) the amount of toner remaining. This precise method of measuring remaining toner supply (1% steps) is better than other machines in the market that can only measure in increments of 10 (10% steps).</p> <p>[0 to 100/0/1]</p>	

8851	Cvr Cnt: 0-10%	
	<p>These SPs count the percentage of dot coverage for K toner.</p> <p>[0 to 9999999]</p>	
8851 011	0 to 2%:BK	
8851 021	3 to 4%:BK	
8851 031	5 to 7%:BK	
8851 041	8 to 10%:BK	

8861	Cvr Cnt: 11-20%	
	<p>This SP counts the number of prints that had a percentage of black dot coverage in the range 11-20%.</p> <p>[0 to 9999999]</p>	

8871	Cvr Cnt: 21-30%	
	<p>This SP counts the number of prints that had a percentage of black dot coverage in the range 21-30%.</p> <p>[0 to 9999999]</p>	

8881	Cvr Cnt: 31%-
	This SP counts the number of prints that had a percentage of black dot coverage in the range above 31%. [0 to 9999999]

8891	Page/ Toner Bottle
8901	Page/ Ink Prev1
8911	Page/ Ink Prev1

8921	Cvr Cnt/Total	
	These counters count the percentage of dot coverage for K toner. (This machine uses only black toner)	
8921 001	Coverage (%):BK	
8921 011	Coverage/P:BK	

SP Tables

8941	Machine Status	
	<p>These SPs count the amount of time the machine spends in each operation mode. These SPs are useful for customers who need to investigate machine operation for improvement in their compliance with ISO Standards. [0 to 9999999/0/1]</p>	
8941 001	Operation Time	Engine operation time. Does not include time while controller is saving data to HDD (while engine is not operating).
8941 002	Standby Time	Engine not operating. Includes time while controller saves data to HDD. Does not include time spent in Energy Save mode.
8941 003	Energy Save Time	Includes time while the machine is performing background printing.
8941 004	Low Power Time	Includes time in Energy Save mode with Engine on. Includes time while machine is performing background printing.
8941 005	Off Mode Time	Includes time while machine is performing background printing. Does not include time machine remains powered off with the power switches.
8941 006	SC	Total down time due to SC errors.
8941 007	PrtJam	Total down time due to paper jams during printing.
8941 008	OrgJam	Total down time due to original paper jams.
8941 009	Supply PM Unit End	Total down time due to toner end.

	AdminCounter	Machine Administration Counter
8999	<p>This SP displays the counts for the items listed below. Use this SP as a quick reference to see the total counts of the corresponding SP codes listed below.</p> <p>Note: This machine supports K printing only, so the counts for 015 and 017 are identical.</p>	
8999 001	Total (SP8381 001)	Total output (sheets fed out)
8999 007	Printer: BW	Total output for black & white
8999 012	A3/DLT	Total output for A3/DLT paper
8999 013	Duplex (SP8411 001)	Total output of duplexed sheets
8999 015	Cvg:BW% (SP8601 001)	Total output of K pages
8999 017	Cvg:BW Pages (SP8601 011)	Total output of K pages

