

M158/M159 POINT TO POINT DIAGRAM (1 / 2)

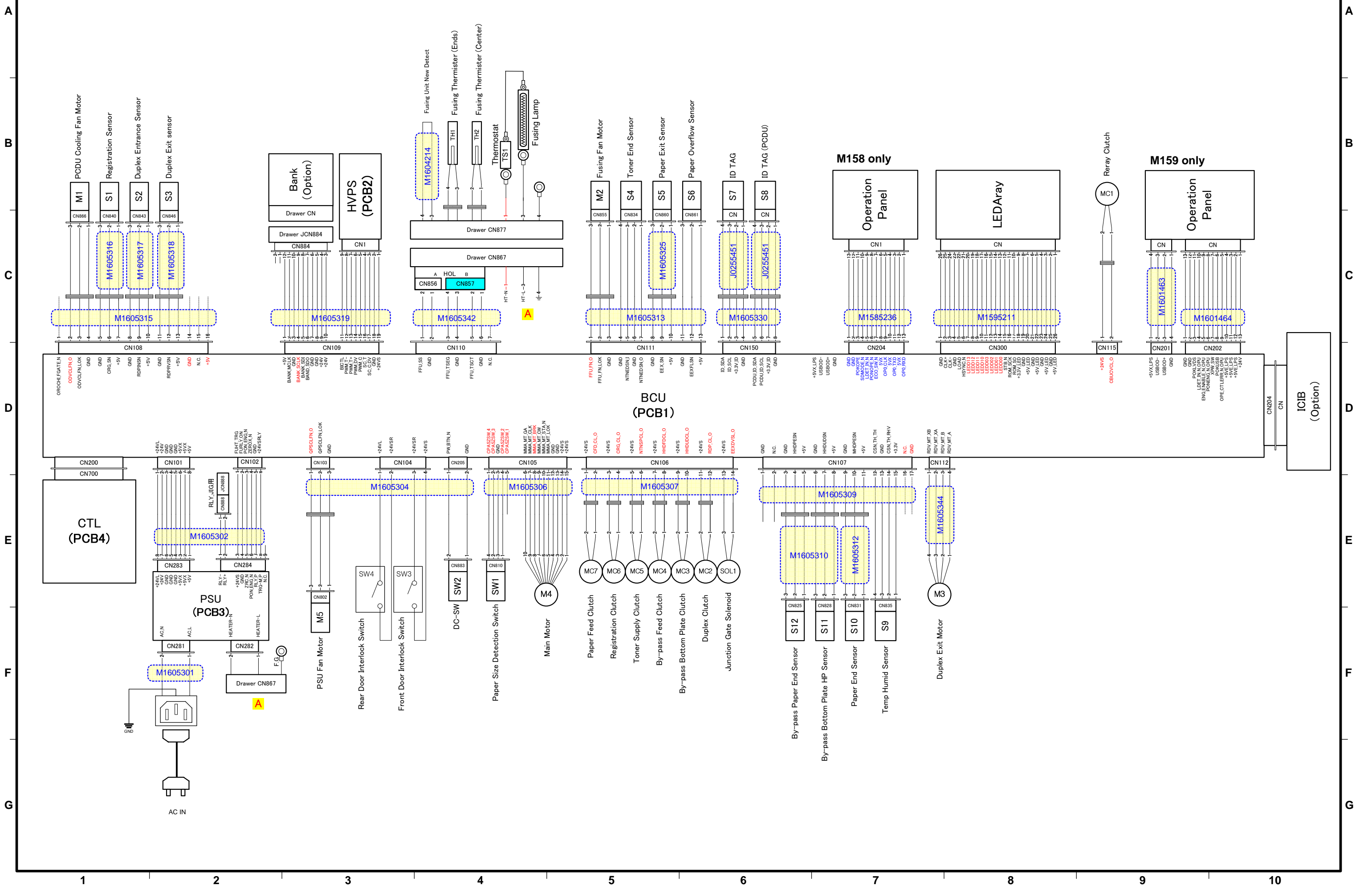

M158/M159 POINT TO POINT DIAGRAM (2 / 2)

M158

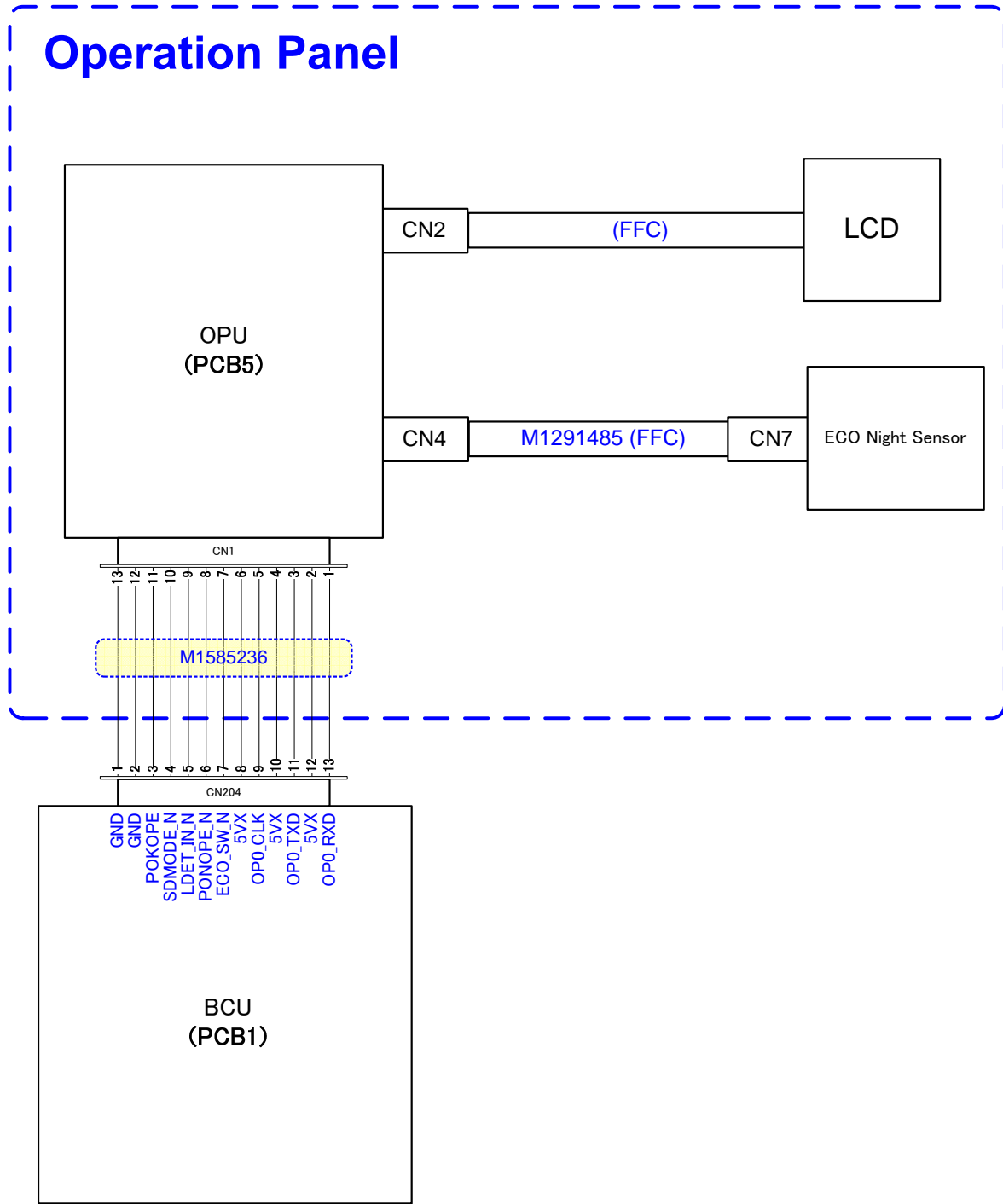

M159

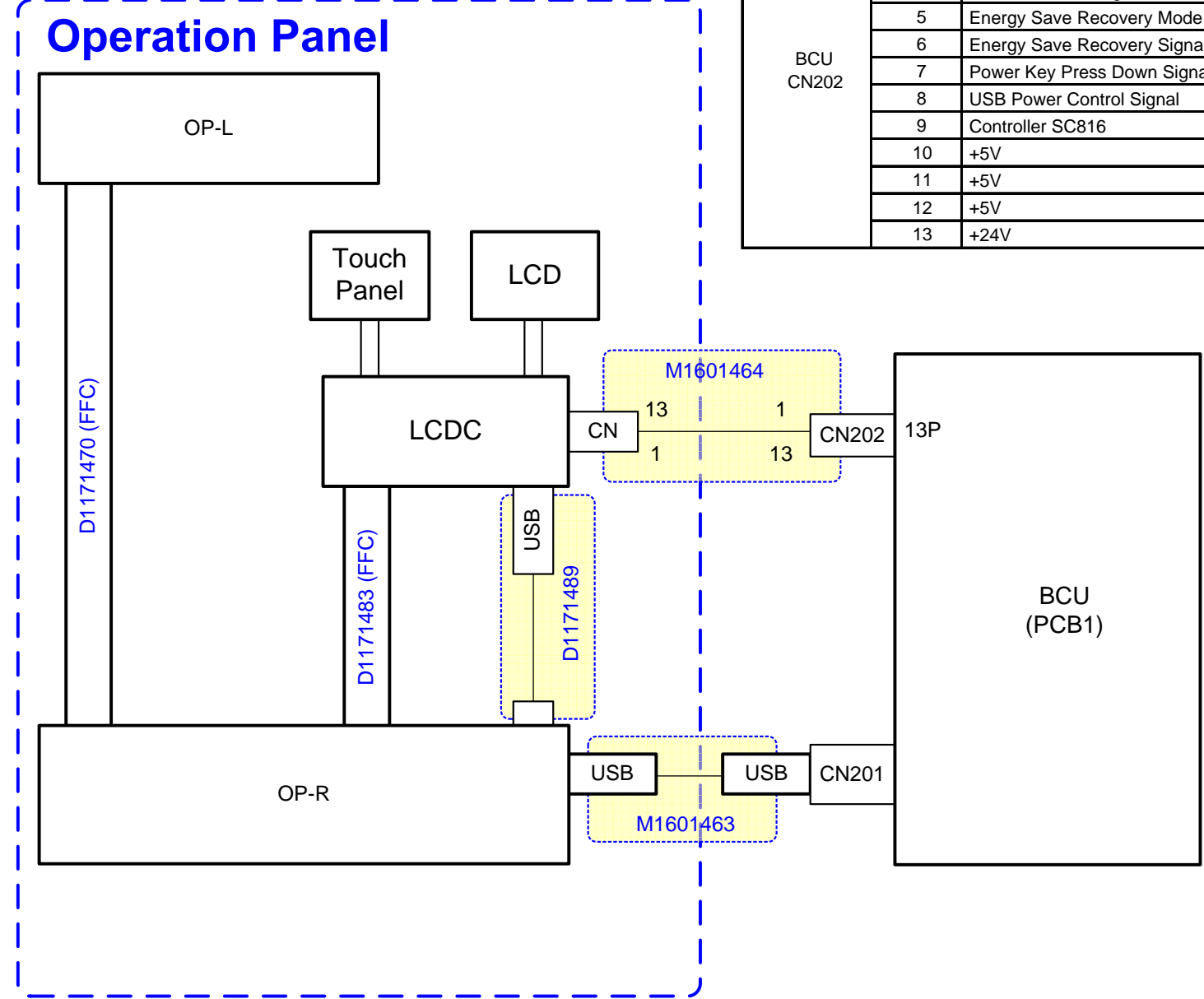

Destination	PIN No	Signal Name
BCU CN202	1	GND
	2	GND
	3	+5VE_LPS Power
	4	Write Detection Signal
	5	Energy Save Recovery Mode Signal
	6	Energy Save Recovery Signal
	7	Power Key Press Down Signal
	8	USB Power Control Signal
	9	Controller SC816
	10	+5V
	11	+5V
	12	+5V
	13	+24V

M158/M159 ELECTRICAL COMPONENT LAYOUT

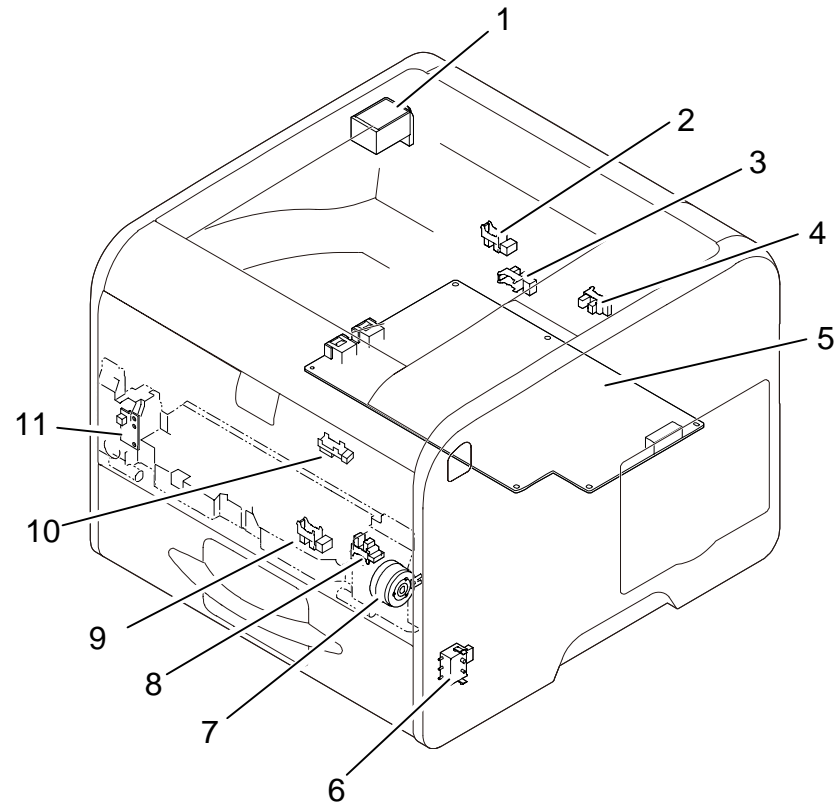

Fig. 1

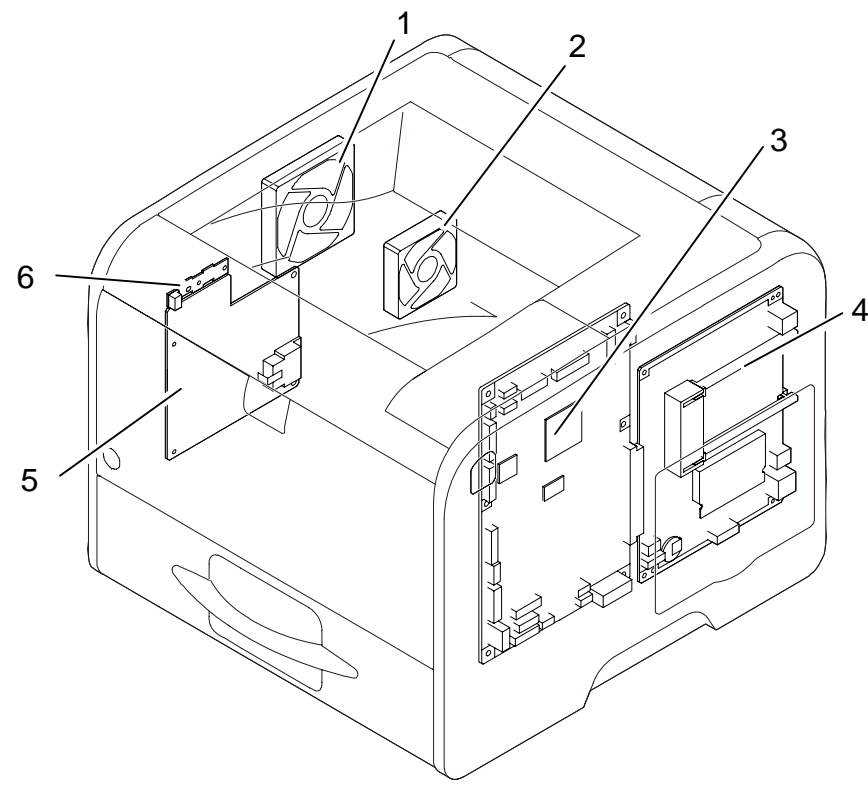

Fig. 2

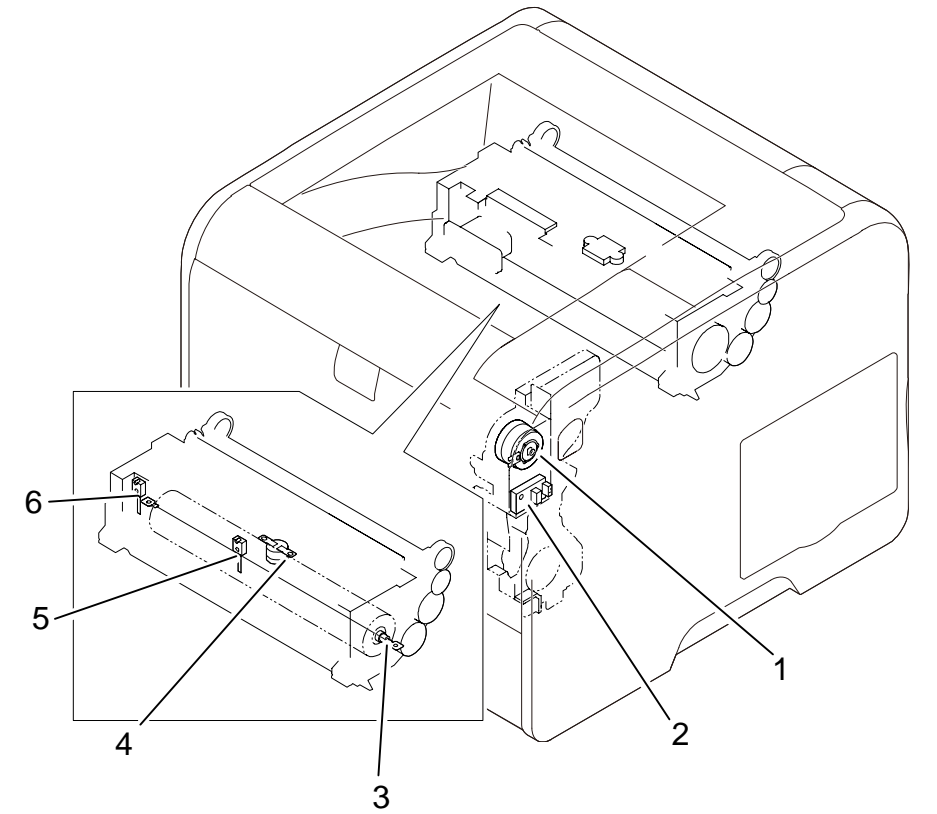

Fig. 3

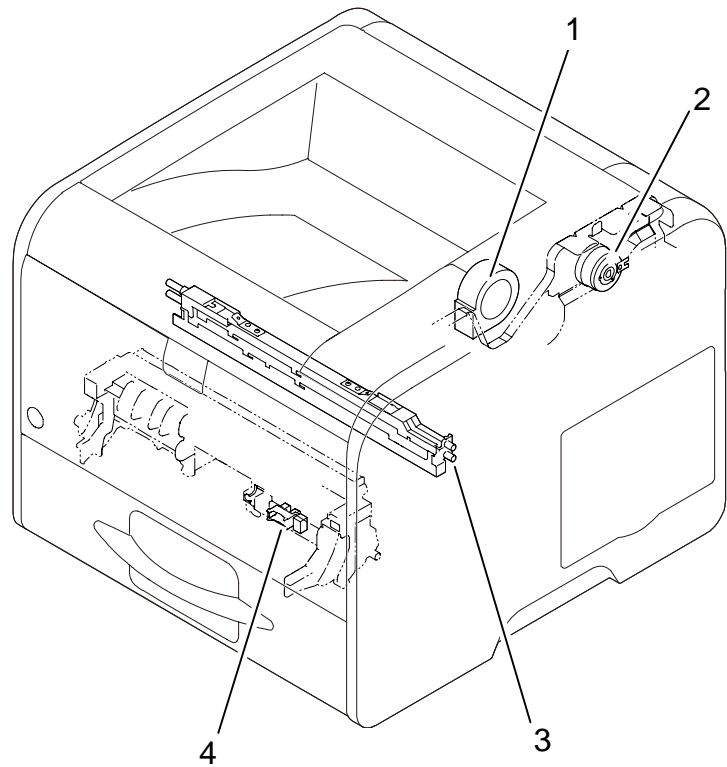
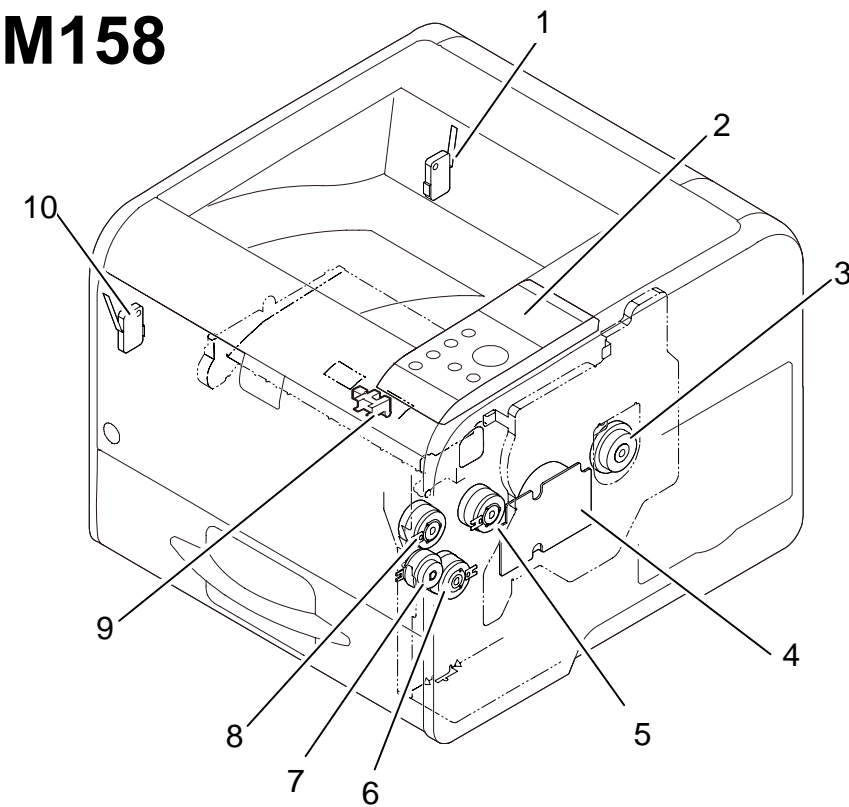

Fig. 4

M158



M159

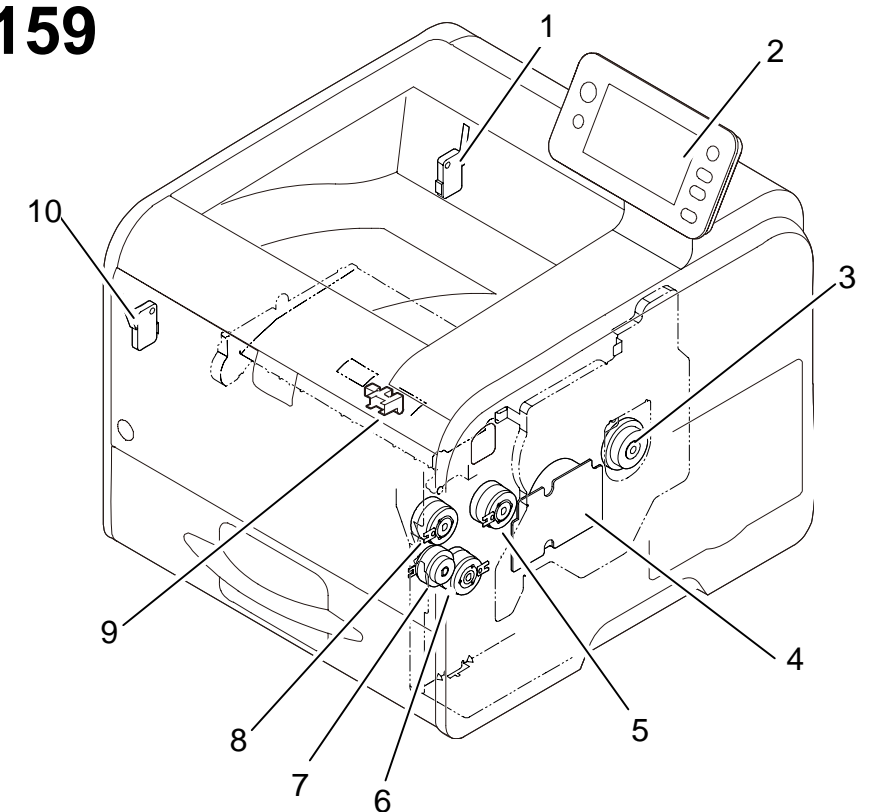

Fig. 5

