



SP 3500SF/SP 3510SF

Operating Instructions

User Guide

TABLE OF CONTENTS

1. Guide to the Machine

- Introduction..... 11
- Manuals for This Machine..... 12
- Notice..... 14
 - Important..... 14
- How to Read This Manual..... 15
 - Symbols..... 15
 - Names of Major Items..... 15
 - Notes..... 15
 - About IP Address..... 16
- Laws and Regulations..... 17
 - Legal Prohibition..... 17
- Model-Specific Information..... 18
- List of Option..... 20
- Using Manuals..... 21
 - Installing Manuals on Your Computer..... 21
 - Opening Manuals..... 22
 - Removing Manuals from Your Computer..... 23
- Feature Highlights..... 24
 - Using the Machine as a Printer..... 24
 - Using the Machine as a Copier..... 26
 - Using the Machine as a Scanner..... 29
 - Using the Machine as a Fax Machine..... 33
- Guide to Components..... 36
 - Exterior: Front View (Type 2 model)..... 36
 - Exterior: Front View (Type 1 model)..... 37
 - Exterior: Rear View..... 38
 - Interior..... 39
 - Control Panel..... 39

2. Getting Started

- Installing the Machine..... 43
 - Where to Put the Machine..... 43
 - Unpacking..... 46

Turning the Power on.....	55
Initial Setup.....	58
Changing Operation Modes.....	59
Saving Energy.....	60
Multi-access.....	61
Connecting the Machine.....	66
Connecting with a Computer Using a USB Cable.....	66
Connecting with a Network Cable.....	66
Connecting to a Telephone Line.....	67
Configuring the Machine.....	70
Configuring the IPv4 Address Settings.....	70
Configuring the IPv6 Address Settings.....	72
Configuring the Ethernet Speed.....	75
Configuring Telephone Network Settings.....	76
Sharing the Printer on a Network.....	80
Installing Option.....	81
Installing the Paper Feed Unit (Tray 2).....	81
Paper and Other Media.....	84
Supported Paper for Each Tray.....	84
Specifications of Paper Types.....	86
Unsupported Types of Paper.....	93
Paper Storage Precautions.....	94
Printable Area.....	94
Loading Paper.....	96
Loading Paper in Tray 1.....	96
Loading Paper in Tray 2.....	105
Loading Paper in the Bypass Tray.....	108
Loading Envelopes.....	110
Specifying Paper Type and Paper Size.....	113
Placing Originals.....	117
About Originals.....	117
Placing Originals.....	119
Entering Characters.....	123

Restricting Machine Functions According to User.....	125
Enabling the User Restriction Settings.....	125
When Machine Functions are Restricted.....	129

3. Using the Printer Function

Configuring Option and Paper Settings.....	131
Windows.....	131
Mac OS X 10.3.....	132
Mac OS X 10.4.....	132
Mac OS X 10.5/10.6.....	132
Accessing the Printer Properties.....	134
Accessing the Printer Properties from the [Devices and Printers] Window.....	134
Accessing the Printer Properties from an Application.....	134
Basic Operation in Printer Mode.....	136
If a Paper Mismatch Occurs.....	136
Canceling a Print Job.....	137
Printing Confidential Documents.....	139
Storing a Locked Print file.....	139
Printing a Locked Print file.....	140
Deleting a Locked Print file.....	141
Checking which Locked Print File Jobs Have Been Canceled.....	142
Manual Duplex Printing (Type 1 model).....	145
Using Various Print Functions.....	147
Print Quality Functions.....	147
Print Output Functions.....	148

4. Using the Copier Function

The Screen in Copier Mode.....	151
Basic Operation in Copier Mode.....	153
Canceling a Copy.....	155
Making Enlarged or Reduced Copies.....	156
Combining Pages and Making 2-sided Copies.....	158
Copying Both Sides of an ID Card onto One Side of Paper.....	167
Making 2-sided Copies Manually (Type 1 model).....	169
Specifying Scan Settings.....	170

Adjusting Image Density.....	170
Selecting the Document Type According to Original.....	171

5. Using the Scanner Function

The Screen in Scanner Mode.....	173
Registering Scan Destinations.....	175
Modifying Scan Destinations.....	181
Deleting Scan Destinations.....	181
Scanning Using the Control Panel.....	183
Basic Operation for Scan to E-mail/FTP/Folder.....	183
Basic Operation for Scan to USB.....	188
Specifying the Scan Settings.....	191
Scanning from a Computer.....	195
Basic Operation for TWAIN Scanning.....	195

6. Using the Fax Function

The Screen in Fax Mode.....	199
Setting the Date and Time.....	201
Registering Fax Destinations.....	203
Registering Fax Destinations Using the Control Panel.....	203
Registering Fax Destinations Using Web Image Monitor.....	206
Sending a Fax.....	209
Selecting Transmission Mode.....	209
Internet Fax Transmission Overview.....	210
Basic Operation for Sending a Fax.....	211
Specifying the Fax Destination.....	214
Useful Sending Functions.....	220
Specifying the Scan Settings.....	222
Using the Fax Function from a Computer (LAN-Fax).....	226
Configuring the LAN-Fax Address Book.....	226
Basic Operation for Sending Faxes from a Computer.....	233
Editing a Fax Cover Sheet.....	235
Configuring Transmission Settings.....	237
Receiving a Fax.....	240
Selecting Reception Mode.....	240

Receiving an Internet Fax.....	243
Forwarding or Storing Faxes in Memory.....	244
Printing Out Faxes Stored in Memory.....	246
Receiving or Rejecting Faxes from Special Senders.....	248
When the Machine Prints a Power Failure Report.....	250

7. Configuring the Machine Using the Control Panel

Basic Operation Using the Menu Screen.....	251
Menu Chart.....	253
Copy Settings.....	257
Changing Copy Settings.....	257
Copy Setting Parameters.....	258
Scanner Settings.....	263
Changing Scanner Settings.....	263
Scanner Setting Parameters.....	264
Fax Transmission Settings.....	267
Changing Fax Transmission Settings.....	267
Fax Transmission Setting Parameters.....	268
Fax Feature Settings.....	270
Changing Fax Feature Settings.....	270
Fax Feature Setting Parameters.....	270
Fax Address Book Settings.....	277
Registering Fax Destinations in Fax Quick Dial/Speed Dial.....	277
Fax Address Book Parameters.....	277
System Settings.....	279
Changing System Settings.....	279
System Setting Parameters.....	279
Network Settings.....	287
Changing Network Settings.....	287
Network Setting Parameters.....	287
Printing Lists/Reports.....	291
Printing the Configuration Page.....	291
Types of Lists/Reports.....	291
Reading the Configuration Page.....	292

Reading the Fax Journal.....	295
Reading the TX/RX Standby File List.....	296
Reading the Scanner Journal.....	297
Administrator Settings.....	298
Changing Administrator Settings.....	298
Administrator Setting Parameters.....	298
Printer Feature Settings.....	304
Changing Printer Feature Settings.....	304
Printer Feature Setting Parameters.....	304

8. Configuring the Machine Using Web Image Monitor

Using Web Image Monitor.....	309
Displaying Top Page.....	311
Changing the Interface Language.....	312
Checking the System Information.....	313
Checking the Status Information.....	313
Checking the Counter Information.....	314
Checking the Machine Information.....	316
Configuring the System Settings.....	317
Configuring the Sound Volume.....	317
Configuring the Paper Settings.....	318
Specifying the Size of Paper for Printing Copies.....	320
Configuring the Fax Settings.....	320
Specifying the Priority Tray.....	323
Configuring the Toner Saving Setting.....	324
Configuring the I/O Timeout Settings.....	325
Configuring the Shortcut to Function Key Settings.....	325
Registering Destinations.....	327
Registering Fax Special Senders.....	328
Restricting Machine Functions According to User.....	329
Configuring the Network Settings.....	330
Checking the Network Status.....	330
Configuring the IPv6 Settings.....	331
Configuring the Network Application Settings.....	332

Configuring the DNS Settings.....	333
Configuring the Auto E-mail Notification Settings.....	334
Configuring the SNMP Settings.....	335
Configuring the SMTP Settings.....	337
Configuring the POP3 Settings.....	338
Configuring the Internet Fax Settings.....	339
Configuring the LDAP Server Settings.....	341
Configuring the LDAP Authentication Settings.....	341
Programming/Changing/Deleting the LDAP Server.....	341
Configuring the IPsec Settings.....	345
Configuring the IPsec Global Settings.....	345
Configuring the IPsec Policy.....	346
Printing Lists/Reports.....	351
Configuring the Administrator Settings.....	353
Configuring the Administrator Password and E-mail Address.....	353
Resetting the Machine's Settings.....	354
Backing Up the Machine's Settings.....	355
Restoring the Machine's Settings from a Backup File.....	356
Configuring the Date and Time Settings.....	357
Configuring the Energy Saver Mode Settings.....	358

9. Troubleshooting

Overview.....	361
Common Problems.....	362
Paper Feed Problems.....	363
Removing Printing Jams.....	365
Removing Scanning Jams (Type 2 model).....	375
Removing Scanning Jams (Type 1 model).....	379
Print Quality Problems.....	384
Checking the Condition of the Machine.....	384
Printer Problems.....	385
Changing the Printer Driver Settings.....	386
Print Positions Do Not Match Display Positions.....	387
Adjusting Printing Position.....	387

Copier Problems.....	390
Scanner Problems.....	392
Fax Problems.....	393
Error and Status Messages on the Screen.....	399
Replacing the Print Cartridge.....	409

10. Maintenance

Cleaning.....	415
Cautions to Take When Cleaning.....	415
Cleaning the Friction Pad and Paper Feed Roller.....	416
Cleaning the Exposure Glass.....	418
Cleaning the ARDF or ADF.....	419
Moving the Machine.....	420
Moving over a Short Distance.....	421
Moving over a Long Distance.....	421
Disposal.....	423
If the Machine is Not Going to Be Used for a Long Time.....	424
Preparing the Machine for a Long Period of Inactivity.....	424
Using the Machine Again After It Has Been Inactive for a Long Period.....	426
Where to Inquire.....	429
Consumables.....	430
Print Cartridge.....	430

11. Appendix

Functions and Network Settings Available in an IPv6 Environment.....	431
Available Functions.....	431
Transmission Using IPsec.....	433
Encryption and Authentication by IPsec.....	433
Security Association.....	434
Encryption Key Exchange Settings Configuration Flow.....	435
Specifying Encryption Key Exchange Settings.....	435
Specifying IPsec Settings on the Computer.....	436
Enabling and Disabling IPsec Using the Control Panel.....	438
Using the LDAP Authentication and Address Search Functions.....	439
Programming the LDAP Server.....	440

When LDAP Authentication is Specified.....	444
Specifying the LDAP Address Search Conditions.....	446
Specifications of the Machine.....	449
General Function Specifications.....	449
Printer Function Specifications.....	451
Copier Function Specifications.....	452
Scanner Function Specifications.....	452
Fax Function Specifications.....	454
Specifications of Options.....	457
Paper Feed Unit TK1080.....	457
Electromagnetic Interference.....	458
Copyright Information about Installed Applications.....	459
expat.....	459
JPEG LIBRARY.....	459
OpenLDAP 2.1.....	459
OpenSSL 0.9.8g.....	460
Trademarks.....	463
INDEX	465



1. Guide to the Machine

This chapter provides basic information about the product and this manual.

Introduction

This manual contains detailed instructions and notes on the operation and use of this machine. For your safety and benefit, read this manual carefully before using the machine. Keep this manual in a handy place for quick reference.

Manuals for This Machine

Several manuals are provided with this machine. Select the manual that contains the information you require.

Important

- Media differ according to manual.
- The printed and electronic versions of a manual have the same contents.
- Adobe® Acrobat® Reader®/Adobe Reader must be installed in order to view the manuals as PDF files.
- A Web browser must be installed in order to view the HTML manuals.

Safety Information

Provides information on safe usage of this machine.

To avoid injury and prevent damage to the machine, be sure to read this.

Quick Installation Guide

Contains procedures for removing the machine from its box and connecting it to a computer.

Initial Guide for Scanner and Fax

Provides installation and operation procedures for the machine's scanner and fax functions. Details about these functions that are not included in this manual are provided in User Guide.

User Guide

Provides information about general operation and covers the topics listed below.

- Installing options
- Suitable paper types
- Procedures to use the printer, copier, scanner, and fax functions
- Configuring the machine
- Troubleshooting problems and fixing paper jams
- Replacing consumables
- Checking the status of the machine using Web Image Monitor
- Information about maintenance

This manual is stored in the manual CD-ROM supplied with the machine.

Quick Guide

Provides information about troubleshooting and basic operations for making photocopies, scanning, and sending faxes.

This manual is stored in the manual CD-ROM supplied with the machine.

Driver Installation Guide

Contains procedures for installing the printer drivers (PCL6 and PostScript 3) and scanner driver (TWAIN).

This manual is stored in the driver CD-ROM supplied with the machine.

Notice

1

Important

In no event will the company be liable for direct, indirect, special, incidental, or consequential damages as a result of handling or operating the machine.

For good output quality, the manufacturer recommends that you use genuine toner from the manufacturer.

The manufacturer shall not be responsible for any damage or expense that might result from the use of parts other than genuine parts from the manufacturer with your office products.

How to Read This Manual

Symbols

This manual uses the following symbols:

Important

Indicates points to pay attention to when using the machine, and explanations of likely causes of paper misfeeds, damage to originals, or loss of data. Be sure to read these explanations.

Note

Indicates supplementary explanations of the machine's functions, and instructions on resolving user errors.

Reference

This symbol is located at the end of sections. It indicates where you can find further relevant information.

[]

Indicates the names of keys on the machine's display or control panels.

 **Region A** (mainly Europe and Asia)

 **Region B** (mainly North America)

Differences in the functions of Region A and Region B models are indicated by two symbols. Read the information indicated by the symbol that corresponds to the region of the model you are using. For details about which symbol corresponds to the model you are using, see p.18 "Model-Specific Information".

Names of Major Items

Major items of this machine are referred to as follows in this manual:

- Auto Document Feeder (Auto Reverse Scanning) → ARDF
- Auto Document Feeder (1 Side Scanning) → ADF

Notes

Contents of this manual are subject to change without prior notice.

Some illustrations in this manual might be slightly different from the machine.

Certain options might not be available in some countries. For details, please contact your local dealer.

About IP Address

In this manual, "IP address" covers both IPv4 and IPv6 environments. Read the instructions that are relevant to the environment you are using.

Laws and Regulations

Legal Prohibition

1

Do not copy or print any item for which reproduction is prohibited by law.

Copying or printing the following items is generally prohibited by local law:

bank notes, revenue stamps, bonds, stock certificates, bank drafts, checks, passports, driver's licenses.

The preceding list is meant as a guide only and is not inclusive. We assume no responsibility for its completeness or accuracy. If you have any questions concerning the legality of copying or printing certain items, consult with your legal advisor.

Model-Specific Information

This section explains how you can identify the model type and region of your machine.

This machine comes in two models which vary in what type of auto document feeder (ADF) they are equipped with: ADF (capable of 1 Side Scanning) or ARDF (capable of Auto Reverse Scanning).

When describing procedures that are model-specific, this manual refers to the different machine models as Type 1 or Type 2. The following table describes the model types.

Model types

Model type	Model name	Type of ADF
Type 1	SP 3500SF	ADF
Type 2	SP 3510SF	ARDF

Furthermore, there is a label on the right side of the machine, located in the position shown below. The label contains details that identify the region your machine belongs to. Read the label.

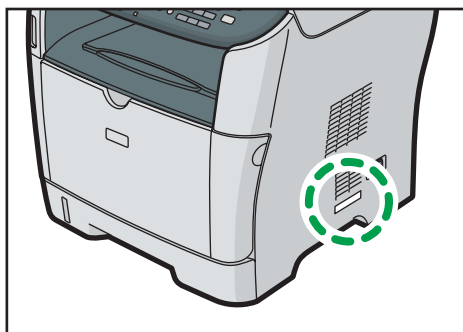

CMF003

The following information is region-specific. Read the information under the symbol that corresponds to the region of your machine.

 **Region A** (mainly Europe and Asia)

If the label contains the following, your machine is a region A model:

- CODE XXXX -22, -27
- 220-240V

 **Region B** (mainly North America)

If the label contains the following, your machine is a region B model:

- CODE XXXX -17
- 120 V

Note

- Dimensions in this manual are given in two units of measure: metric and inch. If your machine is a Region A model, refer to the metric units. If your machine is a Region B model, refer to the inch units.

List of Option

1

This section provides a list of option for this machine, and how it is referred to as in this manual.

Option List	Referred to as
Paper Feed Unit TK1080	Paper feed unit

Reference

- For details about the specifications of this option, see p.457 "Specifications of Options".

Using Manuals

Be sure to read this section before any other part of this manual.

- This manual uses procedures based on Windows 7 as an example, unless otherwise specified. Procedures and screens might vary depending on the operating system you are using.

Installing Manuals on Your Computer

The manual CD-ROM provided with the machine contains manuals in HTML format and PDF. Follow the instructions below to install it.

Important

- **System requirements for installing the HTML manual:**
 - Operating system: Windows XP/Vista/7, Windows Server 2003/2003 R2/2008/2008 R2
 - Minimum display resolution: 800 × 600 pixels
- **Recommended browsers for viewing the HTML manual:**
 - Internet Explorer 6 or later
 - Firefox 3.5 or later
 - Safari 4.0 or later
- **Applications for viewing the PDF manuals:**
 - Adobe Acrobat Reader or Adobe Reader
- The following procedure is based on Windows 7 as an example. If you are using another operating system, the procedure might vary slightly.

1. Quit all applications currently running.

2. Insert the manual CD-ROM into the CD-ROM drive.

If you are using a computer running a Macintosh operating system, open "Manuals.htm" from the CD-ROM root directory.

3. Select a language for the interface, and then click [OK].

4. Click [Install manuals].

5. Follow the instructions on the screen to complete the installation.

6. Click [Finish] when the installation is completed.

7. Click [Exit].

Note

- If you are using a computer running a Windows operating system, the CD-ROM opens automatically. However, AutoRun may not work under certain operating system settings. If this is the case, launch "setup.exe" from the CD-ROM root directory.

Opening Manuals

This section describes how to open the manuals. There are three ways to view the manuals.

Opening from the desktop icon

Follow the procedure below to open the manuals from the desktop icon.

1. **Double-click the manual icon on your desktop.**



The manual opens.

Opening from the [Start] menu

Follow the procedure below to open the manual from the [Start] menu.

Important

- The following procedure is based on Windows 7 as an example. If you are using another operating system, the procedure might vary slightly.
1. **On the [Start] menu, point to [All Programs], point to [Product Name], and then click [Manual Name].**

The manual opens.

Note

- The menu options may appear differently, depending on the options chosen during installation.

Opening from the CD-ROM

Follow the procedure below to open the manual from the CD-ROM.

Important

- The following procedure is based on Windows 7 as an example. If you are using another operating system, the procedure might vary slightly.

1. **Insert the manual CD-ROM into the CD-ROM drive.**

If you are using a computer running a Macintosh operating system, open "Manuals.htm" from the CD-ROM root directory.

2. **Select a language for the interface, and then click [OK].**

3. **Click [Read HTML manuals] or [Read PDF manuals], and then select the manual you want to read.**

The manual opens.

 **Note**

- If you are using a computer running a Windows operating system, the CD-ROM opens automatically. However, AutoRun may not work under certain operating system settings. If this is the case, launch "setup.exe" from the CD-ROM root directory.

Removing Manuals from Your Computer

Follow the procedure below to remove manuals from your computer.

 **Important**

- The following procedure is based on Windows 7 as an example. If you are using another operating system, the procedure might vary slightly.
1. **On the [Start] menu, point to [All Programs], point to [Product Name], and then click [Uninstall].**
 2. **Follow the instructions to remove the manual.**
 3. **Click [Finish].**

 **Note**

- The menu options may appear differently, depending on the options chosen during installation.

Feature Highlights

This section provides information about basic usage and some useful functions of the machine.

★ Important

- Certain functions require special machine configuration.
- This machine is compatible with certain other network environments and operating systems in addition to Windows and Mac OS X. For details, contact your sales or service representative, or visit the product Web site.

Using the Machine as a Printer

To use this machine as a printer, two types of connection methods are available:

- USB connection
- Network connection

Connecting via USB

You can connect this machine directly to a computer using a USB cable.

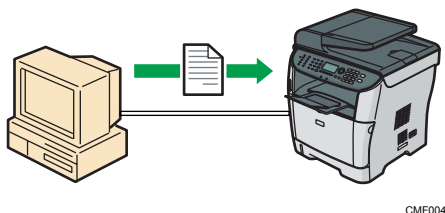

Preparation for printing via USB

To use this machine as a printer via USB connection:

1. Connect the machine to a computer using a USB cable, and install the printer driver on the computer.

For details, see p.66 "Connecting with a Computer Using a USB Cable" and the instructions provided on the driver CD-ROM.

Connecting via a network

You can connect this machine to a network and use it as a network printer.

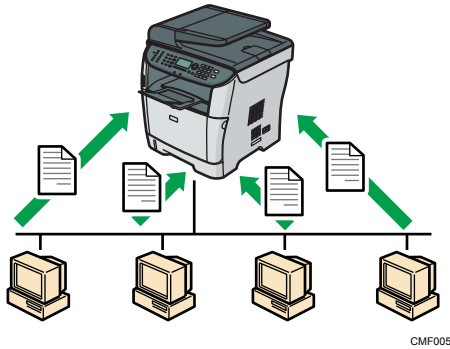

Preparation for printing via a network

To use this machine as a printer via network connection:

1. Connect the machine to a network.
For details, see p.66 "Connecting with a Network Cable".
2. Specify the network settings, such as the machine's IP address.
For details, see p.70 "Configuring the Machine".
3. Install the printer driver on a computer.
For details, see the instructions provided on the driver CD-ROM.

Printing confidential documents

If you use the Locked Print function, you can password protect your print job.

This means that your job is printed only after you enter the password using the machine's control panel.

This function prevents unauthorized users seeing sensitive documents at the printer.

★ Important

- This function is only available when using the PCL6 printer driver, and printing from a computer running a Windows operating system.

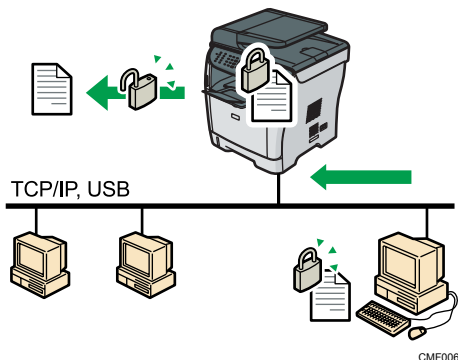

Printing confidential documents

1. Use the printer driver to send a print job as a Locked Print file from a computer.
For details, see p.139 "Storing a Locked Print file".
2. Enter the password using the control panel to print the file.
For details, see p.140 "Printing a Locked Print file".

Using the Machine as a Copier

This section describes some useful functions of this machine when used as a copier.

Making enlarged or reduced copies

This machine has preset ratios for scaling originals, to make it easy to convert documents between different standard sizes.

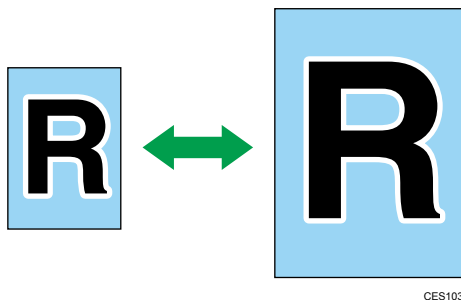

Preparation for making enlarged or reduced copies

To always enlarge or reduce copies:

1. Configure the machine's default [Reduce/Enlarge] setting.
For details, see p.257 "Copy Settings".

To use this function for the current job only:

1. Configure the setting using the [Reduce/Enlarge] key before starting the current job.
For details, see p.156 "Making Enlarged or Reduced Copies".





Making combined copies and 2-sided copies

You can combine multiple pages (2 or 4 pages) of an original onto a single page. Also, with the Type 2 model, you can scan 2-sided originals and make 2-sided copies.

★ Important

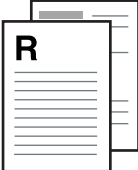





- This function is only available when the original is set in the ARDF or ADF, not when it is set on the exposure glass.

Example of combined copying

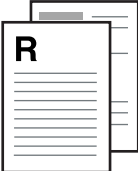
	Original	Copy
Portrait		
Landscape		

CMF250

Example of 2-sided copying

	Original	Copy	
Portrait		<p>Top to Top</p> 	<p>Top to Bottom</p> 
Landscape		<p>Top to Top</p> 	<p>Top to Bottom</p> 

CMF261

You can either set this machine to always make combined/2-sided copies, or use this function only when necessary.

Preparation for making combined/2-sided copies

To always make combined/2-sided copies:

1. Configure the machine's default [Duplex/Combine] setting.

For details, see p.257 "Copy Settings".

To use this function for the current job only:

1. Configure the setting by pressing [Dup/Comb] before starting the current job.

For details, see p.158 "Combining Pages and Making 2-sided Copies".

↓ Note

- You can make 2-sided copies manually with the Type 1 model.

📖 Reference

- For details about how to make 2-sided copies using the Type 1 model, see p.169 "Making 2-sided Copies Manually (Type 1 model)".

Copying both sides of an ID card onto one side of paper

You can copy the front and back sides of an ID card, or other small document, onto one side of a sheet of paper.

★ Important

- This function is only available when the original is set on the exposure glass, not when it is set in the ARDF or ADF.

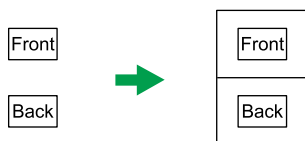

CES165

You can either set this machine to always make photocopies in ID card copy mode, or use this function only when necessary.

Preparation for copying an ID card

To always make photocopies in ID card copy mode:

1. Configure the machine's default [Reduce/Enlarge] setting.

For details, see p.257 "Copy Settings".

To use this function for the current job only:

1. Press the [Shortcut to Func.] key (to which the ID card copy mode is assigned) before starting the current job.

For details, see p.167 "Copying Both Sides of an ID Card onto One Side of Paper".

↓ Note

- To use the [Shortcut to Func.] key to set ID card copy mode for the current job, [Shortcut to Function] under administrator settings must be set to [ID Card Copy Mode].

📖 Reference

- For details about [Shortcut to Function], see p.298 "Administrator Settings".

Sorting the output paper

When making multiple copies of multiple pages, you can configure the machine to sort the output pages into sets.

★ Important

- This function is only available when the original is set in the ARDF or ADF, not when it is set on the exposure glass.

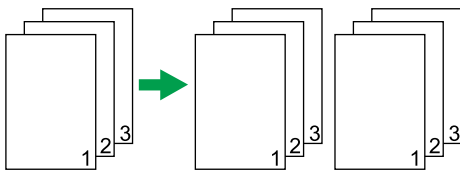

CES104

Preparation for sorting the output paper

1. Enable the [Sort] setting under copy settings.

For details, see p.257 "Copy Settings".

Using the Machine as a Scanner

There are two scanning methods: scanning from the computer (TWAIN scanning) and scanning using the control panel.

Scanning from the computer

TWAIN scanning allows you to operate the machine from your computer and scan originals into your computer directly.

TWAIN scanning can be performed using a TWAIN-compliant application.

TWAIN scanning is available with both USB and network connections.

Scanning using the control panel

Scanning using the control panel allows you to send scanned files via e-mail (Scan to E-mail), to an FTP server (Scan to FTP), or to the shared folder of a computer on a network (Scan to Folder), or to a USB flash disk (Scan to USB).

The Scan to E-mail, Scan to FTP, and Scan to Folder functions are available only through a network connection. No network connection is required for the Scan to USB function; you can send scanned files directly to a USB flash disk inserted into the front of the machine.

Note

- The machine supports WIA scanning, an additional method of scanning originals from your computer, for USB connection. WIA scanning is possible if your computer is running Windows operating system and a WIA-compatible application. For more information, see the manual for your application.

Scanning from a computer

You can operate the machine from your computer and scan originals into your computer directly.

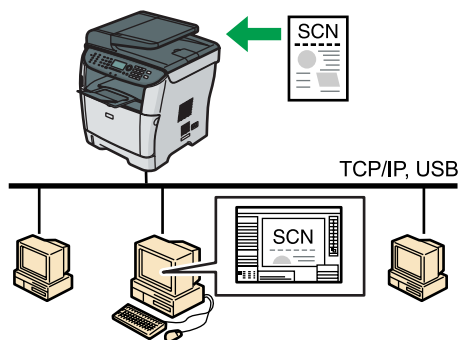

CMF007

Preparation for scanning from a computer with USB connection

1. Connect the machine to the computer using a USB cable, and install the scanner driver on the computer.
For details, see p.66 "Connecting with a Computer Using a USB Cable" and the instructions provided on the driver CD-ROM.
2. If no TWAIN-compliant application is installed on the computer, install one.
For details, see the manual of the application.

Preparation for scanning from a computer with network connection

1. Connect the machine to the network.
For details, see p.66 "Connecting with a Network Cable".
2. Specify the network settings, such as the machine's IP address.

For details, see p.70 "Configuring the Machine".

3. Install the scanner driver on the computer.

For details, see the instructions provided on the driver CD-ROM.

4. If no TWAIN-compliant application is installed on the computer, install one.

For details, see the manual of the application.

↓ Note

- A CD-ROM containing a TWAIN-compliant application (Presto! PageManager) is provided with the machine. For details, see the manual of Presto! PageManager.

Sending scanned files via e-mail

You can send scanned files via e-mail using the control panel.

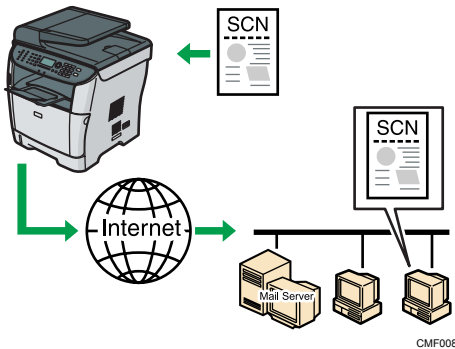

Preparation for sending scanned files via e-mail

1. Connect the machine to the network.
For details, see p.66 "Connecting with a Network Cable".
2. Specify the network settings, such as the machine's IP address.
For details, see p.70 "Configuring the Machine".
3. Configure the DNS and SMTP settings using Web Image Monitor.
For details, see p.333 "Configuring the DNS Settings" and p.337 "Configuring the SMTP Settings".
4. Register the destinations to the Address Book using Web Image Monitor.
For details, see p.175 "Registering Scan Destinations".

Sending scanned files to an FTP server

You can send scanned files to an FTP server using the control panel.

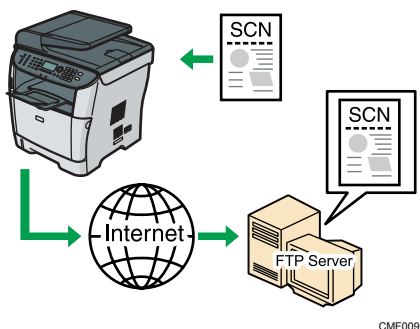

CMF009

Preparation for sending scanned files to an FTP server

1. Connect the machine to the network.
For details, see p.66 "Connecting with a Network Cable".
2. Specify the network settings, such as the machine's IP address.
For details, see p.70 "Configuring the Machine".
3. Register the destinations to the Address Book using Web Image Monitor.
For details, see p.175 "Registering Scan Destinations".

Sending scanned files to a computer's shared folder

You can send scanned files to the shared folder of a computer on a network using the control panel.

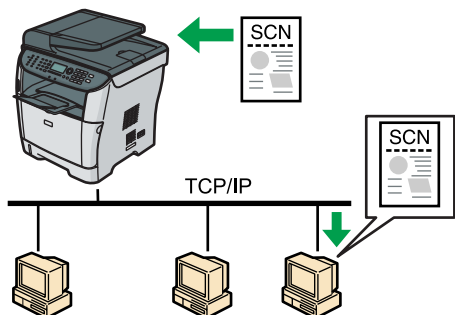

CMF010

Preparation for sending scanned files to a computer's shared folder

1. Connect the machine to the network.
For details, see p.66 "Connecting with a Network Cable".
2. Specify the network settings, such as the machine's IP address.
For details, see p.70 "Configuring the Machine".
3. Create a destination folder on the computer's hard disk drive, and configure it as a shared folder.
For details, see your operating system's documentation.

4. Register the destinations to the Address Book using Web Image Monitor.
For details, see p.175 "Registering Scan Destinations".

Sending scanned files to a USB flash disk

You can send and store scanned files on a USB flash disk using the control panel.

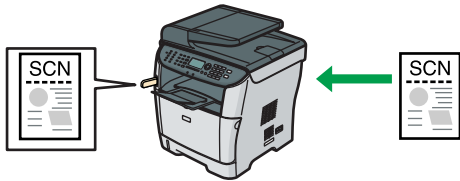

CMF011

Preparation for sending scanned files to a USB flash disk

1. Insert a USB flash disk in the machine.
For details, see p.188 "Basic Operation for Scan to USB".

Using the Machine as a Fax Machine

This section describes basic procedures for using this machine as a fax machine.

Using as a fax machine

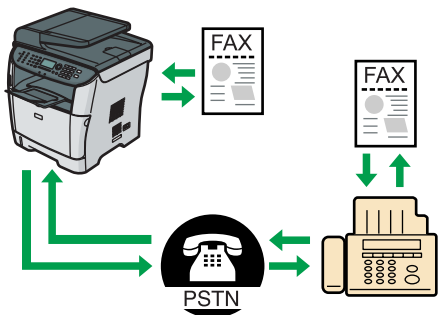

CMF012

Preparation for using as a fax machine

1. Connect the machine to the telephone line.
For details, see p.67 "Connecting to a Telephone Line".
2. Configure the telephone network settings.
For details, see p.76 "Configuring Telephone Network Settings".

3. Configure the time and date.

For details, see p.201 "Setting the Date and Time".

4. Register the destinations to the Address Book using the control panel or Web Image Monitor.

For details, see p.203 "Registering Fax Destinations".

Note

- Make sure to register the user fax number and user name during Initial Setup. For details, see p. 58 "Initial Setup".

Using the machine with an external telephone

You can use this machine as a fax machine and also use the same telephone line for voice calls.

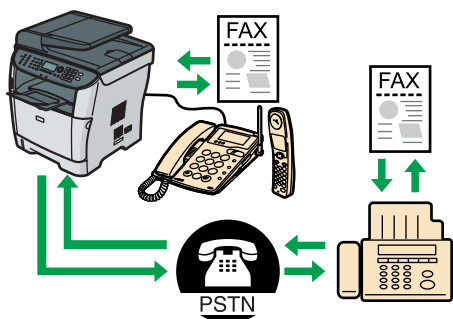

CMF013

Preparation for using the machine with an external telephone

1. Connect an external telephone to the machine.

For details, see p.67 "Connecting to a Telephone Line".

2. Select the fax reception mode.

For details, see p.240 "Receiving a Fax".

Sending faxes from a computer (LAN-Fax)

You can send a document directly from a computer through this machine to another fax machine, without printing the document.

Important

- This function is supported by Windows XP/Vista/7, and Windows Server 2003/2003 R2/2008/2008 R2. Mac OS X does not support this function.

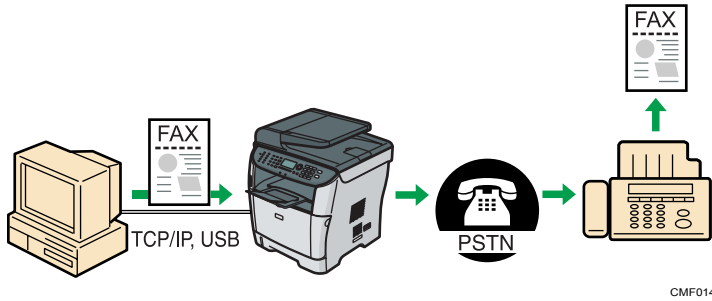

Preparation for sending faxes from a computer connected via USB

1. Connect the machine to a computer using a USB cable.
For details, see p.66 "Connecting with a Computer Using a USB Cable".
2. Install the LAN-Fax driver on the computer.
For details, see the instructions provided on the driver CD-ROM.
3. Register LAN-Fax destinations in the LAN-Fax Address Book.
For details, see p.226 "Configuring the LAN-Fax Address Book".

Preparation for sending faxes from a computer connected via network

1. Connect the machine to the network.
For details, see p.66 "Connecting with a Network Cable".
2. Specify the network settings, such as the machine's IP address.
For details, see p.70 "Configuring the Machine".
3. Install the LAN-Fax driver on the computer.
For details, see the instructions provided on the driver CD-ROM.
4. Register LAN-Fax destinations in the LAN-Fax Address Book.
For details, see p.226 "Configuring the LAN-Fax Address Book".

Guide to Components

This section lists the names and functions of the parts of this machine.

1

Exterior: Front View (Type 2 model)

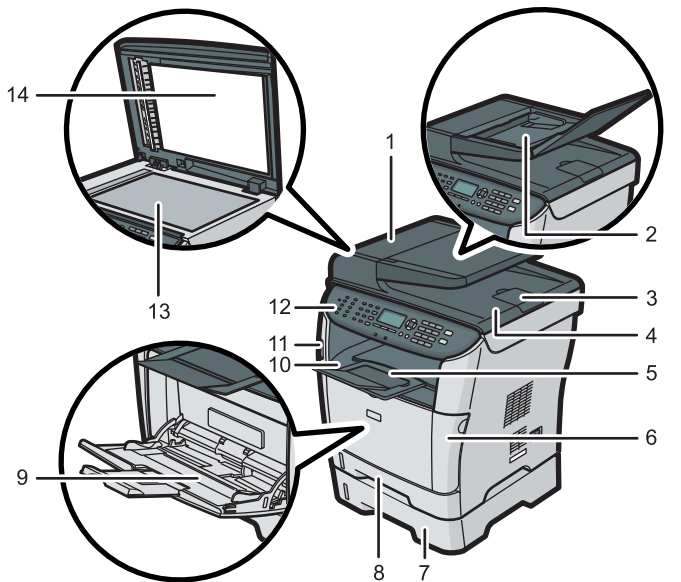

CMF015

1. ARDF (Auto Reverse Document Feeder) Cover

Open this cover to remove originals jammed in the ARDF.

2. Input Tray for the ARDF

Open the cover and place stacks of originals here. They will feed in automatically. This tray can hold up to 50 sheets of plain paper.

3. Extender for the ARDF output tray

Extend this when placing paper longer than A4 in the input tray for ARDF.

4. Output Tray for the ARDF

Originals scanned with the ARDF are output here.

5. Stop Fences

Raise this fence to prevent paper from falling off.

6. Front Cover

Open this cover to replace the print cartridge or remove jammed paper.

7. Tray 2 (option)

This tray can hold up to 250 sheets of plain paper.

8. Tray 1

This tray can hold up to 250 sheets of plain paper.

9. Bypass Tray

This tray can hold up to 50 sheets of plain paper.

10. Output Tray

Printed paper is output here. Up to 125 sheets of plain paper can be stacked here.

11. USB Flash Disk Port

Insert a USB flash disk to store scanned files using the Scan to USB function.

12. Control Panel

Contains a screen and keys for machine control.

13. Exposure Glass

Place originals here sheet by sheet.

14. Cover for the Exposure Glass

Open this cover to place originals on the exposure glass.

Exterior: Front View (Type 1 model)

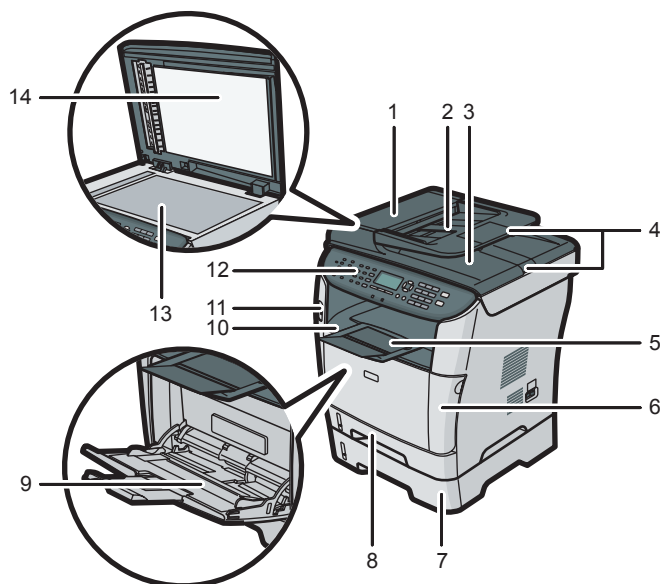

CMF052

1. ADF (Auto Document Feeder) Cover

Open this cover to remove originals jammed in the ADF.

2. Input Tray for the ADF

Place stacks of originals here. They will feed in automatically. This tray can hold up to 35 sheets of plain paper.

3. Output Tray for the ADF

Originals scanned with the ADF are output here.

4. Extender for the ADF Trays

Extend these when placing paper longer than A4 in the input tray for ADF.

5. Stop Fences

Raise this fence to prevent paper from falling off.

6. Front Cover

Open this cover to replace the print cartridge or remove jammed paper.

7. Tray 2 (option)

This tray can hold up to 250 sheets of plain paper.

8. Tray 1

This tray can hold up to 250 sheets of plain paper.

9. Bypass Tray

This tray can hold up to 50 sheets of plain paper.

10. Output Tray

Printed paper is output here. Up to 125 sheets of plain paper can be stacked here.

11. USB Flash Disk Port

Insert a USB flash disk to store scanned files using the Scan to USB function.

12. Control Panel

Contains a screen and keys for machine control.

13. Exposure Glass

Place originals here sheet by sheet.

14. Cover for the Exposure Glass

Open this cover to place originals on the exposure glass.

Exterior: Rear View

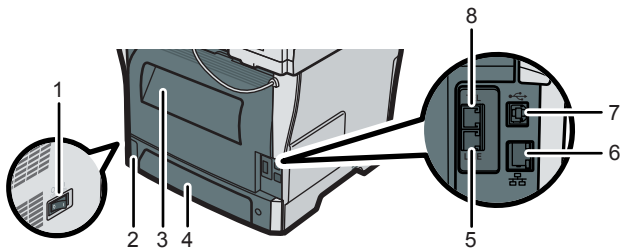

CMF016

1. Power Switch

Use this switch to turn the power on or off.

2. Power Socket

For connecting the power cord to the machine.

3. Rear Cover

Open this cover to remove jammed paper or when printing on envelopes.

4. Tray 1 Rear Cover

Remove this cover when loading paper longer than A4 in tray 1.

5. G3 (analog) Line Interface Connector

For connecting a telephone line.

6. Ethernet Port

For connecting the machine to the network using a network interface cable.

7. USB Port

For connecting the machine to a computer using a USB cable.

8. External Telephone Connector

For connecting an external telephone.

Interior

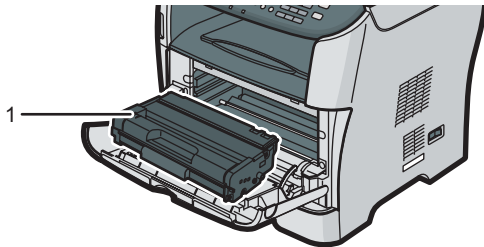

CMF017

1. Print Cartridge

Messages appear on the screen when the print cartridge needs to be replaced, or a new cartridge needs to be prepared.

Reference

- For details about the messages that appear on the screen when consumables need to be replaced, see p.399 "Error and Status Messages on the Screen".

Control Panel

This section describes the names and usage of the parts of the control panel.

★ Important

- The actual control panel may look different from the illustration below, depending on the country of use.
- If the machine remains turned off for a certain period of time (for example, when the power switch is turned off or when there is a power failure), all documents stored in memory will be lost. If the Fax Received indicator is lit or flashing, make sure to print out the stored documents before turning off the power (for example, prior to relocating the machine).

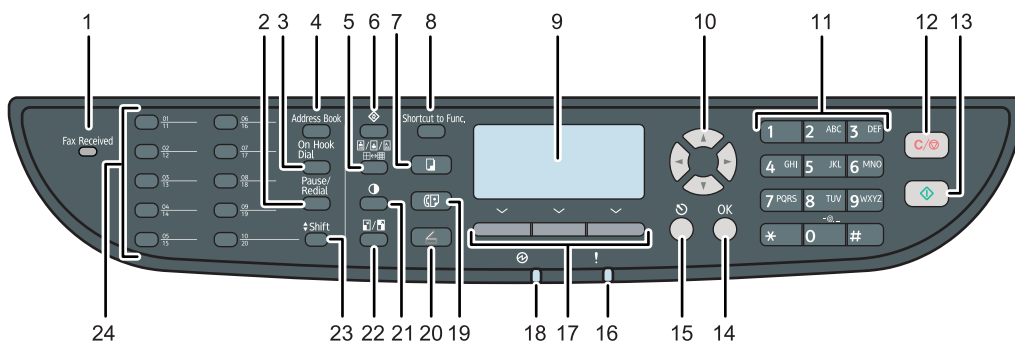

CMF130

1. Fax Received indicator

Lights up when received faxes that have not been printed out exist in the machine's memory. Flashes when the machine is unable to print out the faxes due to machine errors such as an empty paper tray or a paper jam.

2. [Pause/Redial] key

- Pause
Press to insert a pause in a fax number. The pause is indicated by "P".
- Redial
Press to display the last used scan or fax destination.

3. [On Hook Dial] key

Press to use on-hook dialing to check the destination's status when sending a fax.

4. [Address Book] key

Press to select a scan or fax destination from the Address Book.

5. [Image Quality] key

Press to select scan quality for the current job.

- Copier mode: select Text, Photo, or Mixed.
- Scanner mode: select the resolution.
- Fax mode: select Standard, Detail, or Photo.

6. [User Tools] key

Press to display the menu for configuring the machine's system settings.

7. [Copy] key

Press to switch to copier mode. The key stays lit while the machine is in copier mode.

8. [Shortcut to Func.] key

Press to use the function pre-assigned for this key. Depending on the setting, one of the following functions can be used by one-touch:

- Activate ID card copy mode for the current job
- Enter the [Print Received File] menu under fax feature settings
- Enter the [Immediate TX] menu under fax transmission settings
- Open the scanner Address Book (for Scan to E-mail/FTP/Folder)
- Enter the combined/2-sided copy menu for the current job

9. Screen

Displays current status and messages.

10. Scroll keys

Press to move the cursor in the directions indicated by each scroll key.

Pressing the [◀][▶] keys while the machine is in standby mode will display the menu for configuring the settings of the machine's current operation mode (copier, scanner, or fax).

11. Number keys

Use to enter numerical values when specifying settings such as fax numbers and copy quantities, or enter letters when specifying names.

12. [Clear/Stop] key

- While the machine is processing a job: press to cancel the current job.
- While configuring the machine: press to cancel the current setting and return to standby mode.
- While in standby mode: press to cancel temporary settings such as image density or resolution.

13. [Start] key

Press to scan, copy, or send a fax.

14. [OK] key

Press to confirm settings or enter the next level of the menu tree.

15. [Escape] key

Press to cancel the last operation or exit to the previous level of the menu tree.

16. Alert indicator

Flashes yellow when the machine will require maintenance soon (such as replacing a print cartridge), or lights up red when a machine error occurs.

When an alert is issued, check the messages on the screen and follow the instructions as provided in "Error and Status Messages on the Screen".

17. Selection keys

Press the key that corresponds to an item shown on the bottom line of the screen to select it.

18. Power indicator

Remains lit while the power is on. It is unlit when the power is off.

19. [Facsimile] key

Press to switch to fax mode. The key stays lit while the machine is in fax mode.

20. [Scanner] key

Press to switch to scanner mode. The key stays lit while the machine is in scanner mode.

21. [Density] key

Press to adjust image density for the current job.

- Copier mode: select from 5 levels of density.
- Scanner mode: select from 5 levels of density.
- Fax mode: select from 3 levels of density.

22. [Reduce/Enlarge] key

- Copier mode: press to specify the reduction or enlargement ratio for the current job.
- Scanner mode: press to specify the scanning size according to the current original.

23. [Shift] key

Press to use the Quick Dial numbers 11 to 20 when specifying a scan or fax destination using the One Touch buttons.

24. One Touch buttons

Press to select a scan or fax Quick Dial destination.

Note

- The backlight of the screen is turned off when the machine is in Energy Saver mode.
- When the machine is processing a job, you cannot display the menu for configuring the machine. You can confirm the machine's status by checking messages on the screen. If you see messages such as "Printing...", "Copying...", or "Processing...", wait until the current job is finished.
- A sticker for the control panel may be included, depending on the country of use. If included, apply the stickers appropriate for your language to the control panel. Note that if the control panel is covered with a protective sheet, be sure to remove it before applying the stickers.

Reference

- For details about how to configure the [Shortcut to Func.] key, see p.298 "Administrator Settings".
- For details about what to do when the Alert indicator is flashing or lit, see p.399 "Error and Status Messages on the Screen".
- For details about what to do when the Fax Received indicator is flashing or lit, see p.246 "Printing Out Faxes Stored in Memory".

2. Getting Started

This chapter describes procedures for installing and configuring the machine, connecting options to the machine, and handling paper.

Installing the Machine

This section describes steps required to install the machine and prepare it for use.

Where to Put the Machine

The machine's location should be carefully chosen because environmental conditions greatly affect its performance.

⚠ WARNING

- Do not use flammable sprays or solvents in the vicinity of this machine. Doing so could result in fire or electric shock.

⚠ WARNING

- Do not place vases, plant pots, cups, toiletries, medicines, small metal objects, or containers holding water or any other liquids, on or close to this machine. Fire or electric shock could result from spillage or if such objects or substances fall inside this machine.

⚠ CAUTION

- Keep the machine away from humidity and dust. Otherwise a fire or an electric shock might occur.

⚠ CAUTION

- Do not place the machine on an unstable or tilted surface. If it topples over, an injury might occur.

⚠ CAUTION

- Do not place heavy objects on the machine. Doing so can cause the machine to topple over, possibly resulting in injury.

⚠ CAUTION

- Keep the machine in an area that is within optimum environmental conditions. Operating the machine in an environment that is outside the recommended ranges of humidity and temperature can cause an electrical fire hazard. Keep the area around the socket free of dust. Accumulated dust can become an electrical fire hazard.

⚠ CAUTION

- Make sure the room where you are using the machine is well ventilated and spacious. Good ventilation is especially important when the machine is used heavily.

⚠ CAUTION

- Do not obstruct the machine's vents. Doing so risks fire caused by overheated internal components.

⚠ CAUTION

- Keep the machine away from salt-bearing air and corrosive gases. Also, do not install the machine in places where chemical reactions are likely (laboratories, etc.), as doing so will cause the machine to malfunction.

Space Required for Installation

The recommended (minimum) space requirements are as follows:

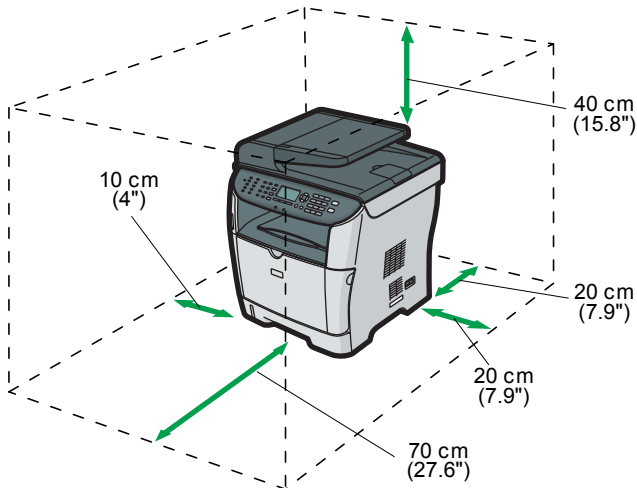

CMF019

Optimum Environmental Conditions

Permissible and recommended temperature and humidity ranges are as follows:

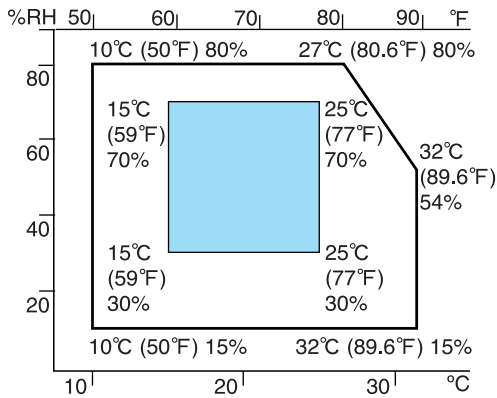

CER119

- White area: Permissible Range
- Blue area: Recommended Range

To avoid possible build-up of ozone, locate this machine in large well ventilated room that has an air turnover of more than 30m³/hr/person.

Environments to Avoid

★ Important

- Areas exposed to direct sunlight or strong light
- Dusty areas
- Areas with corrosive gases
- Areas that are excessively cold, hot, or humid
- Areas directly exposed to currents of hot, cold, or room-temperature air from air conditioners
- Areas directly exposed to radiant heat from heaters
- Locations near air conditioners, heaters, or humidifiers
- Locations near other electronic equipment
- Locations subject to frequent strong vibration

Ventilation

When you use this machine in a confined space without good ventilation for a long time or print large quantities, you might detect an odd smell.

This might cause the output paper to also have an odd smell.

When you detect an odd smell, regularly ventilate in order to keep the workplace comfortable.



- Set up the machine so that it does not directly ventilate towards people.
- Ventilation should be more than 30 m³/hr/person.

New machine smell

When a machine is new, it might have a unique smell. This smell will subside in about one week.

When you detect an odd smell, sufficiently ventilate and circulate the air in the room.

Power Source

-  **Region A**: 220-240 V, 5 A, 50/60 Hz (when fully equipped)
-  **Region B**: 120 V, 10 A, 60 Hz (when fully equipped)

Please be sure to connect the power cord to a power source as above.

Unpacking

To protect it from shock and vibration during transit, this machine comes packaged in cushioning foam and secured with tape. Remove these protective materials after bringing the machine to where it will be installed.

WARNING

- Be sure to locate the machine as close as possible to a wall outlet. This will allow easy disconnection of the power cord in the event of an emergency.

WARNING

- If the machine emits smoke or odours, or if it behaves unusually, you must turn off its power immediately. After turning off the power, be sure to disconnect the power cord plug from the wall outlet. Then contact your service representative and report the problem. Do not use the machine. Doing so could result in fire or electric shock.

WARNING

- If metal objects, or water or other fluids fall inside this machine, you must turn off its power immediately. After turning off the power, be sure to disconnect the power cord plug from the wall outlet. Then contact your service representative and report the problem. Do not use the machine. Doing so could result in fire or electric shock.

WARNING

- Do not touch this machine if a lightning strike occurs in the immediate vicinity. Doing so could result in electric shock.

WARNING

- The following explains the warning messages on the plastic bag used in this product's packaging.
 - Keep the polythene materials (bags, etc.) supplied with this machine away from babies and small children at all times. Suffocation can result if polythene materials are brought into contact with the mouth or nose.

⚠ WARNING

- Do not incinerate toner (new or used) or toner containers. Doing so risks burns. Toner will ignite on contact with naked flame.

⚠ WARNING

- Do not store toner (new or used) or toner containers anywhere near naked flames. Doing so risks fire and burns. Toner will ignite on contact with naked flame.

⚠ WARNING

- Do not use the cleaner to suck spilled toner (including used toner). Sucked toner may cause firing or explosion due to electrical contact flickering inside the cleaner. However, it is possible to use the cleaner designed for dust explosion-proof purpose. If toner is spilled over the floor, sweep up spilled toner slowly and clean remainder with wet cloth.

⚠ CAUTION

- Do not crush or squeeze toner containers. Doing so can cause toner spillage, possibly resulting in dirtying of skin, clothing, and floor, and accidental ingestion.

⚠ CAUTION

- Store toner (new or used), toner containers, and components that have been in contact with toner out of reach of children.

⚠ CAUTION

- If toner or used toner is inhaled, gargle with plenty of water and move into a fresh air environment. Consult a doctor if necessary.

⚠ CAUTION

- If toner or used toner gets into your eyes, flush immediately with large amounts of water. Consult a doctor if necessary.

⚠ CAUTION

- If toner or used toner is swallowed, dilute by drinking a large amount of water. Consult a doctor if necessary.

⚠ CAUTION

- When moving the machine, use the inset grips on both sides. The machine will break or cause injury if dropped.

⚠ CAUTION

- Do not look into the lamp. It can damage your eyes.

⚠ CAUTION

- During operation, rollers for transporting the paper and originals revolve. A safety device has been installed so that the machine can be operated safely. But take care not to touch the machine during operation. Otherwise, an injury might occur.

★ Important

- Removed tape is dirty. Be careful not to let it touch your hands or clothes.
- Leave the protective materials in place while moving the machine.
- Lower the machine slowly and carefully to prevent trapping your hands.
- Do not grip on the tray area when lifting the machine.
- Do not allow paper clips, staples, or other small objects to fall inside the machine.
- Keep uncovered print cartridge away from direct sunlight.
- Do not touch the print cartridge's photo conductor unit.

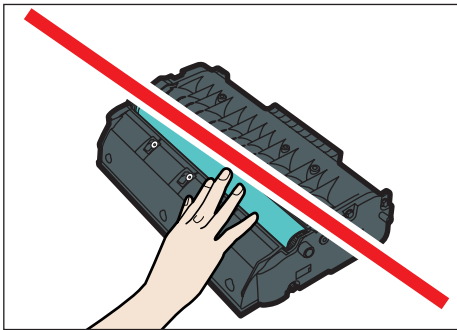

CMC013

- Do not touch the ID chip on the side of the print cartridge as indicated in the illustration below.

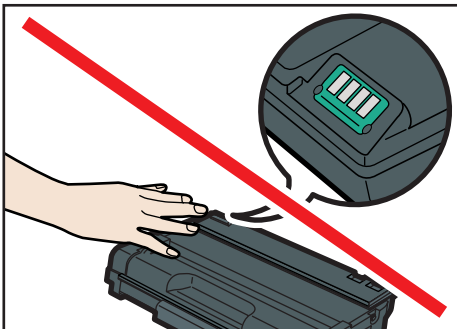

CMC014

1. Remove the plastic bag.

2. Lift the machine by using the inset grips on both sides of the machine.

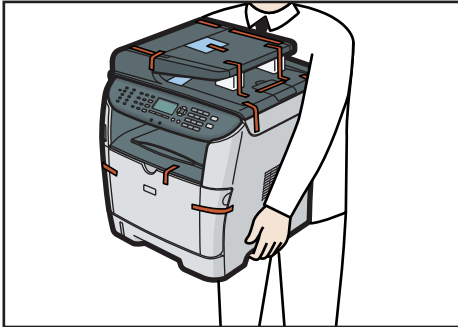

CMF053

3. Remove the protective materials attached on the machine's exterior.

Be sure to also remove the protective sheet on the control panel.

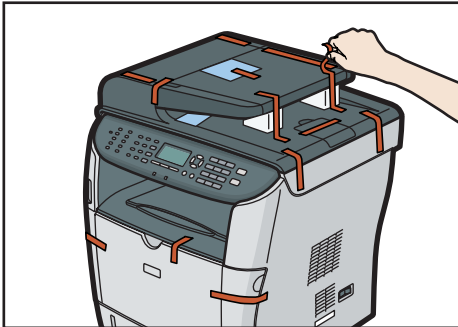

CMF107

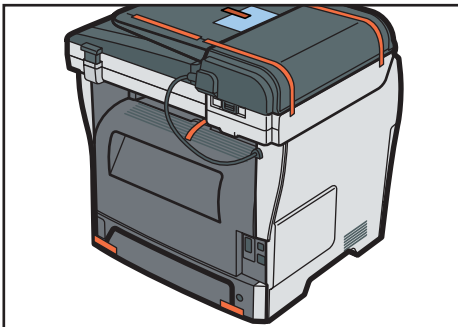

CMF108

The actual machine may come with protective materials attached in different positions. Make sure to check the machine's exterior for all protective materials, and remove them completely.

4. Open the ADF cover.

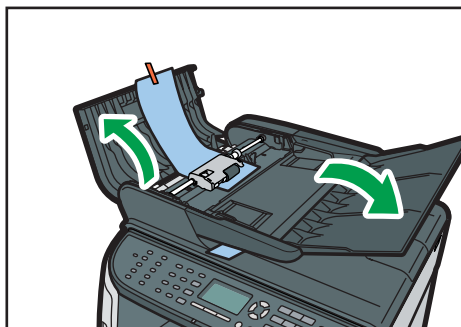

CMF109

5. Gently pull the protective sheet to remove it.

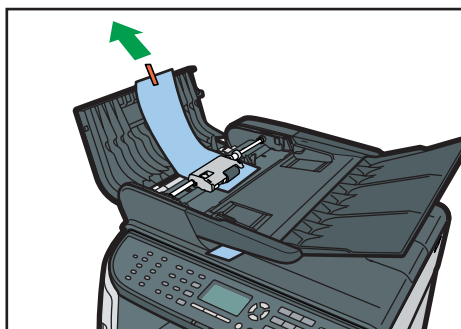

CMF110

6. Close the ADF cover.

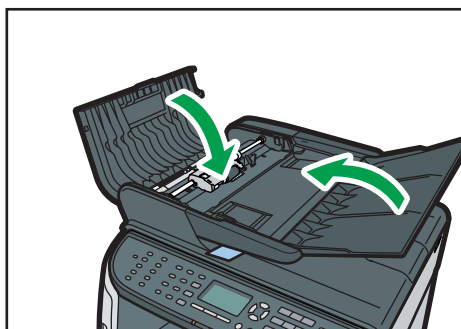

CMF111

7. Remove the protective sheet and materials.

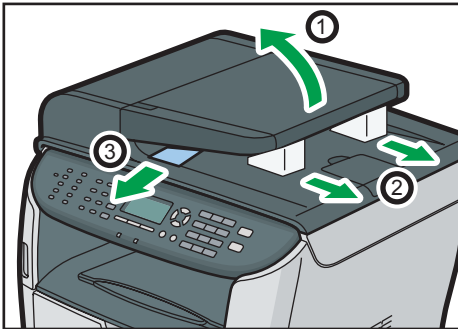

CMF112

8. Open the rear cover, and then peel off the tape on both sides of the machine.

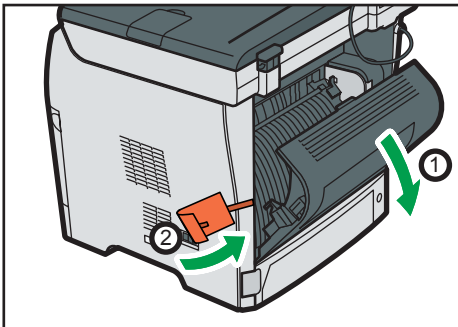

CMF113

9. Pull out the tapes and remove the protective materials. Doing so will pull up the levers on both sides.

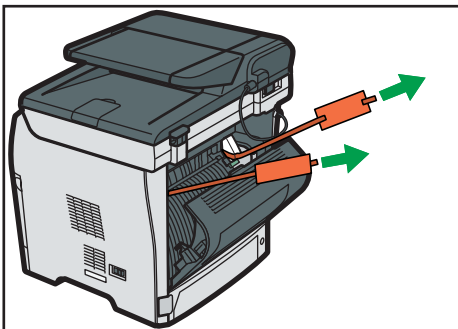

CMF114

10. Check that the levers have been pulled up to the positions indicated with . If not, pull them up completely manually.

Leaving the levers lowered or not pulled up completely may affect the print quality, as toner may be insufficiently fused.

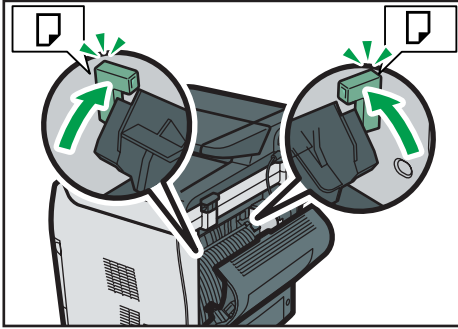

CMF115

11. Close the rear cover.

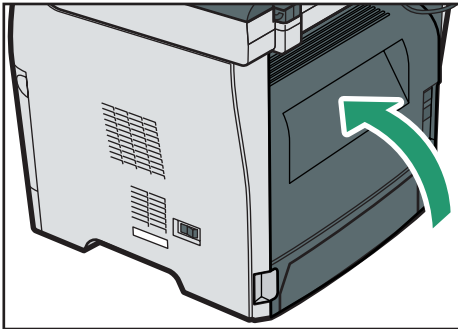

CMF076

12. Push the side button to open the front cover, and then carefully lower it.

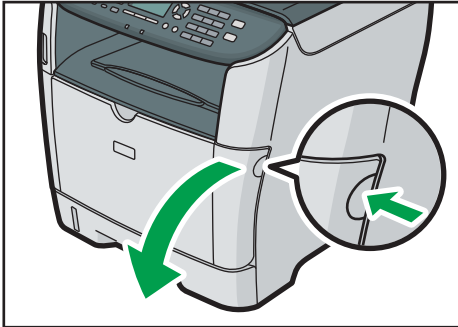

CMF020

13. Remove the protective material attached inside the machine.

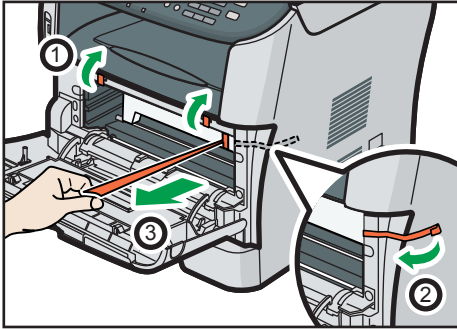

CMF060

14. Unpack the print cartridge. Then, place it on a flat surface, and remove the protection sheet.

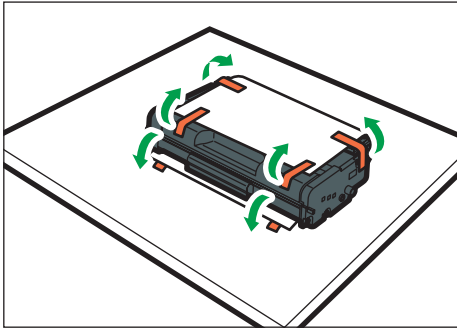

CMC019

Shake the print cartridge from side to side five or six times.

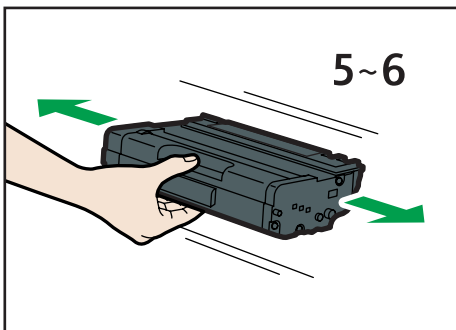

CMC020

15. Slide the print cartridge in horizontally. When the cartridge can go no further, raise it slightly and push it fully in. Then push down on the cartridge until it clicks into place.

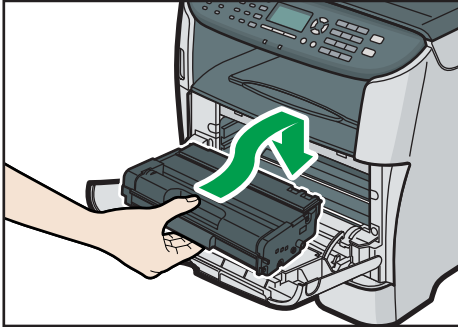

CMF021

16. Using both hands, carefully push up the front cover until it closes.

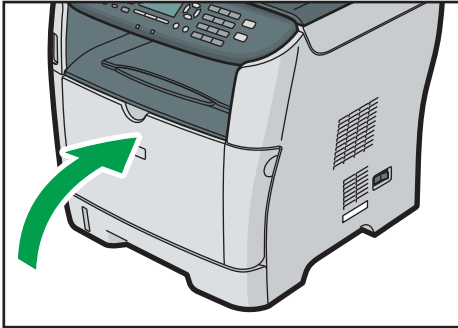

CMF022

17. Carefully pull tray 1, and then pull out with both hands.

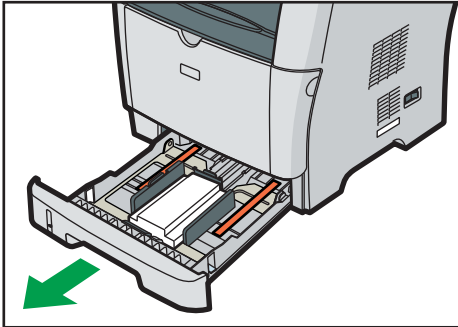

CMF023

Place the tray on a flat surface.

18. Remove the protective material attached inside the tray.

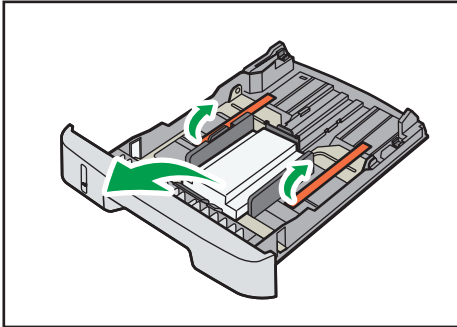

CMF061

19. Carefully push tray 1 straight into the machine.

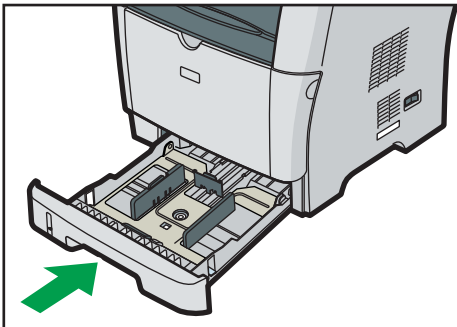

CMF024

20. Pull out and raise the stop fence.

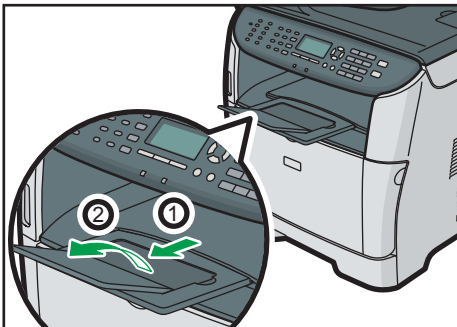

CMF025

Turning the Power on

This section describes how to turn on the machine.

⚠ WARNING

- Do not use any power sources other than those that match the specifications shown in this manual. Doing so could result in fire or electric shock.

⚠ WARNING

- Do not use any frequencies other than those that match the specifications shown. Doing so could result in fire or electric shock.

⚠ WARNING

- Do not use multi-socket adaptors. Doing so could result in fire or electric shock.

⚠ WARNING

- Do not use extension cords. Doing so could result in fire or electric shock.

⚠ WARNING

- Do not use power cords that are damaged, broken, or modified. Also, do not use power cords that have been trapped under heavy objects, pulled hard, or bent severely. Doing so could result in fire or electric shock.

⚠ WARNING

- Touching the prongs of the power cable's plug with anything metallic constitutes a fire and electric shock hazard.

⚠ WARNING

- The supplied power cord is for use with this machine only. Do not use it with other appliances. Doing so could result in fire or electric shock.

⚠ WARNING

- It is dangerous to handle the power cord plug with wet hands. Doing so could result in electric shock.

⚠ CAUTION

- Be sure to push the plug of the power cord fully into the wall outlet. Partially inserted plugs create an unstable connection that can result in unsafe buildup of heat.

⚠ CAUTION

- If this machine is not going to be used for several days or longer at a time, disconnect its power cord from the wall outlet.

⚠ CAUTION

- When performing maintenance on the machine, always disconnect the power cord from the wall outlet.

★ Important

- Make sure that the power cord is plugged securely into the wall outlet before turning the power on.
- Make sure that the power is off when plugging or unplugging the power cord.
- Do not turn off the power switch until initializing is completed. Doing so results in malfunction.

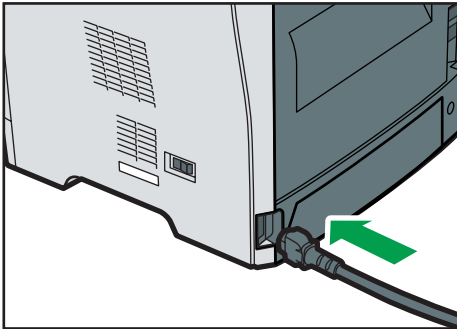
1. Plug in the power cord.

CMF026

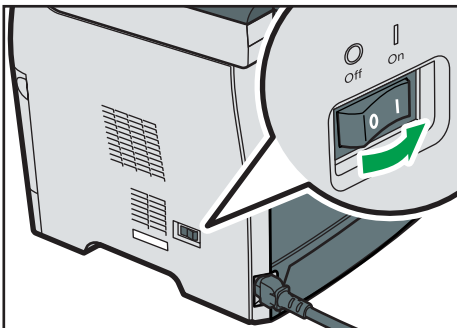
2. Insert the plug of the power cord into the wall socket securely.**3. Turn the power switch to "I On".**

CMF027

The Power indicator lights up, and then the [Copy] key on the control panel lights up.

Note

- Depending on the [Function Priority] setting under [Admin. Tools], the [Facsimile] or [Scanner] key may light up instead of the [Copy] key.
- The machine may make a noise while initializing. This noise does not indicate a malfunction.
- To turn off the power, turn the power switch to "○ Off".

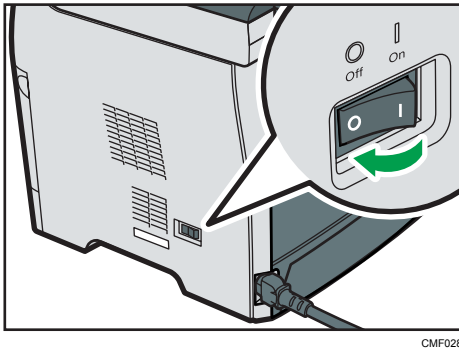

Reference

- For details about [Function Priority], see p.298 "Administrator Settings".

Initial Setup

When you turn on the machine for the first time, a menu for configuring the settings described below will appear on the display. This section describes how to complete the Initial Setup.

★ Important

- **Region B:** The fax number code is required by international law. You cannot legally connect a fax machine to the telephone system if the fax number code is not programmed. Also, the fax header code and the date and time of transmission must be included in the header of all pages faxed to, from, or within the United States.
- Make sure to select the correct code for the country of use. Selecting the wrong country code may cause failures in fax transmissions.

Display language

The language selected here is used for the display.

User fax number

The number entered here is used as the fax number of the machine. The user fax number can contain 0 to 9, space, and "+".

User name

The name entered here is used as the name of the fax sender.

Country code

The country code selected here is used for configuring the time and date display formats, and the settings related to fax transmissions with appropriate default values for the country of use.

1. Press the [▲] [▼] keys to select the required language, and then press the [OK] key.
2. Press the [▲] [▼] keys to select [Number:], and then enter the user fax number (up to 20 digits).
3. Press the [▲] [▼] keys to select [Name:], enter the user name (up to 20 characters), and then press the [OK] key.
4. Press the [▲] [▼] keys to select the required country code, and then press the [OK] key.

Note

- You can change the settings configured during the Initial Setup later under [Admin. Tools]. In addition, you can set the machine's time and date under [Admin. Tools].
- When the [Print Fax Header] setting under fax transmission settings is turned on, the registered user fax number, user name, and time and date of transmission appear on the header of every fax you send.

Reference

- For details about entering characters, see p.123 "Entering Characters".
- For details about [Admin. Tools], see p.298 "Administrator Settings".
- For details about [Print Fax Header], see p.267 "Fax Transmission Settings".

Changing Operation Modes

You can switch between copier, scanner, and fax modes by pressing the corresponding keys.

Copier mode

Press the [Copy] key to activate copier mode. While in copier mode, the [Copy] key lights up.

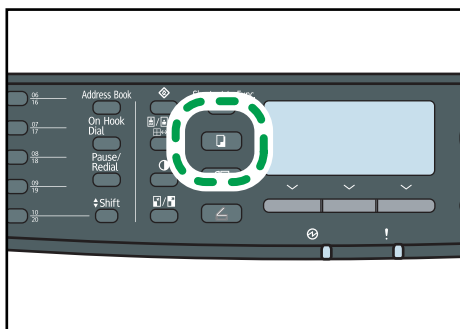

CMF131

Scanner mode

Press the [Scanner] key to activate scanner mode. While in scanner mode, the [Scanner] key lights up.

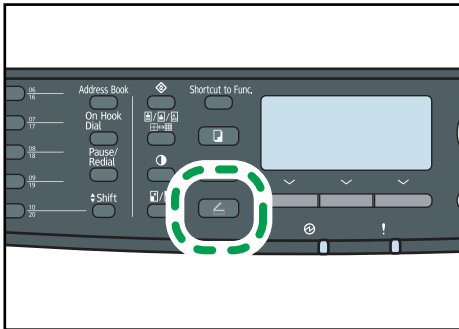

CMF132

Fax mode

Press the [Facsimile] key to activate fax mode. While in fax mode, the [Facsimile] key lights up.

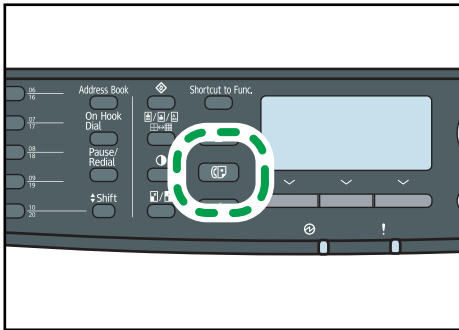

CMF133

Function Priority

By default, copy mode is selected when the machine is turned on, or if the preset [System Auto Reset Timer] time passes with no operation while the initial screen of the current mode is displayed. You can change the selected mode using [Function Priority] under [Admin. Tools].

Reference

- For details about [System Auto Reset Timer] or [Function Priority], see p.298 "Administrator Settings".

Saving Energy

This machine is equipped with the following Energy Saver modes: Energy Saver mode 1 and Energy Saver mode 2. If the machine has been idle for a certain period of time, the machine automatically enters Energy Saver mode.

The machine recovers from Energy Saver mode when it receives a print job, prints a received fax, or when the [Copy] or [Start] key is pressed.

Energy Saver mode 1

If [EnergySaverMode 1] under [Admin. Tools] is enabled, the machine enters Energy Saver mode 1 if the machine has been idle for about 30 seconds. When the machine is in Energy Saver mode 1, "Energy Saver Mode 1" appears on the screen. It takes less time to recover from Energy Saver mode 1 than from power-off state or Energy Saver mode 2, but power consumption is higher in Energy Saver mode 1 than in Energy Saver mode 2.

Energy Saver mode 2

If [EnergySaverMode 2] under [Admin. Tools] is enabled, the machine enters Energy Saver mode 2 after the period of time specified for this setting is passed. When the machine is in Energy Saver mode 2, the screen turns off while the Power indicator remains lit. Power consumption is lower in Energy Saver mode 2 than in Energy Saver mode 1, but it takes longer to recover from Energy Saver mode 2 than from Energy Saver mode 1.

↓ Note

- Even if Energy Saver mode 2 is enabled, the machine will not enter Energy Saver mode 2 for two hours if [Low Humidity Mode] under [System Settings] is enabled. However, the machine will enter Energy Saver mode 1 as normal (even when Energy Saver mode 1 is not enabled).

📖 Reference

- For details about Energy Saver modes, see p.298 "Administrator Settings".
- For details about [Low Humidity Mode], see p.279 "System Settings".

Multi-access

This machine can perform multiple jobs using different functions, such as copying and faxing, at the same time. Performing multiple functions simultaneously is called "Multi-access".

The following table shows the functions that can be performed simultaneously.

Current job	Job that you want to execute simultaneously
Copying	<ul style="list-style-type: none"> • Fax memory transmission • Fax memory reception • Internet Fax reception (no printing) • Receiving a print job from a computer (the actual printing starts after copying is finished) • Receiving a LAN-Fax job from a computer • LAN-Fax transmission

Current job	Job that you want to execute simultaneously
Scanning	<ul style="list-style-type: none"> • Fax memory transmission • Fax immediate printing • Fax memory reception • Printing a fax received in the machine's memory • Internet Fax reception • Printing • Receiving a LAN-Fax job from a computer • LAN-Fax transmission
Scanning a fax into the machine's memory before transmission	<ul style="list-style-type: none"> • Fax memory transmission • Fax immediate printing • Fax memory reception • Printing a fax received in the machine's memory • Internet Fax reception • Printing • Receiving a LAN-Fax job from a computer • LAN-Fax transmission
Fax immediate transmission (scanning an original and sending it simultaneously)	<ul style="list-style-type: none"> • Printing a fax received in the machine's memory • Internet Fax reception • Printing • Receiving a LAN-Fax job from a computer
Fax memory transmission (sending a fax that has already been stored in the machine's memory)	<ul style="list-style-type: none"> • Copying • Scanning • Scanning a fax into the machine's memory before transmission • Internet Fax transmission • Printing a fax received in the machine's memory • Internet Fax reception • Printing • Receiving a LAN-Fax job from a computer

Current job	Job that you want to execute simultaneously
Internet Fax transmission	<ul style="list-style-type: none"> • Fax memory transmission • Fax immediate printing • Fax memory reception • Printing a fax received in the machine's memory • Printing • Receiving a LAN-Fax job from a computer • LAN-Fax transmission
Fax immediate printing (receiving a fax and printing it simultaneously)	<ul style="list-style-type: none"> • Scanning * 1 • Scanning a fax into the machine's memory before transmission • Internet Fax transmission • Internet Fax reception (no printing) • Receiving a LAN-Fax job from a computer
Fax memory reception (storing a received fax into the machine's memory)	<ul style="list-style-type: none"> • Copying • Scanning • Scanning a fax into the machine's memory before transmission • Internet Fax transmission • Internet Fax reception (no printing) • Receiving a LAN-Fax job from a computer
Printing a fax received in the machine's memory	<ul style="list-style-type: none"> • Scanning * 1 • Scanning a fax into the machine's memory before transmission • Fax immediate transmission • Fax memory transmission • Internet Fax transmission • Internet Fax reception (no printing) • Receiving a LAN-Fax job from a computer • LAN-Fax transmission

Current job	Job that you want to execute simultaneously
Internet Fax reception	<ul style="list-style-type: none"> • Copying (except when printing out the received Internet Fax) • Scanning • Scanning a fax into the machine's memory before transmission • Fax immediate transmission • Fax memory transmission • Fax immediate printing (except when printing out the received Internet Fax) • Fax memory reception (except when printing out the received Internet Fax) • Printing a fax received in the machine's memory (except when printing out the received Internet Fax) • Printing (except when printing out the received Internet Fax) • Receiving a LAN-Fax job from a computer • LAN-Fax transmission
Printing	<ul style="list-style-type: none"> • Scanning • Scanning a fax into the machine's memory before transmission • Fax immediate transmission • Fax memory transmission • Internet Fax transmission • Internet Fax reception (no printing) • LAN-Fax transmission
Receiving a LAN-Fax job from a computer	<ul style="list-style-type: none"> • Copying • Scanning • Fax immediate printing • Fax memory reception • Printing a fax received in the machine's memory • Internet Fax reception • LAN-Fax transmission

Current job	Job that you want to execute simultaneously
LAN-Fax transmission	<ul style="list-style-type: none"> • Copying • Scanning • Scanning a fax into the machine's memory before transmission • Internet Fax transmission • Printing a fax received in the machine's memory • Internet Fax reception • Printing • Receiving a LAN-Fax job from a computer

* 1 Fax printing may take longer than normal if you scan using the control panel at the same time, especially when scanning multiple pages using the exposure glass.

Note

- If you try to use a function that cannot be performed simultaneously, you will hear a beep sound from the machine or see a failure message pop up on your computer screen. In this case, try again after the current job is finished.

Connecting the Machine

This section describes connecting the machine to a computer and a telephone line.

Connecting with a Computer Using a USB Cable

★ Important

- USB 2.0 interface cable is not supplied. Obtain a USB cable that is correct for the computer you are using.
- USB connection with a Macintosh is only possible via the computer's standard USB port.

1. Connect the square-shaped connector of the USB 2.0 cable to the USB port.

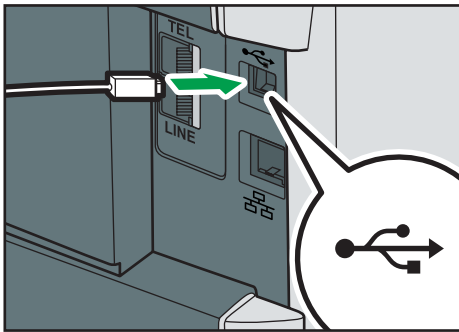

2. Connect the opposite end's flat connector to your computer's USB interface or USB hub.

📖 Reference

- For details about installing printer drivers for USB connection, see the instructions provided on the driver CD-ROM.

Connecting with a Network Cable

Follow the procedure below to connect the machine to a computer through a network.

Prepare the hub and other network devices before connecting the 10BASE-T or 100BASE-TX cable to the machine's Ethernet port.

⚠ CAUTION

- Do not connect the Ethernet port of the machine to a network that may supply excess voltage, such as a telephone line. Doing so may result in fire or electric shock

★ Important

- The Ethernet cable is not supplied with this machine. Select your cable according to the network environment.

1. Connect the Ethernet cable to the Ethernet port.

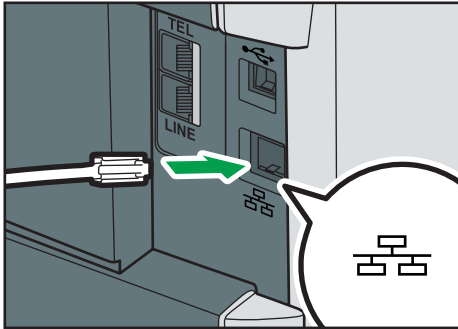

CMF030

2. Connect the other end of the cable to the network (e.g., a network hub).

📖 Reference

- For details about network environment settings, see p.70 "Configuring the Machine".
- For details about installing printer drivers for network connection, see the instructions provided on the driver CD-ROM.

Reading the LED lamps

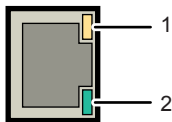

CMF062

1. Yellow: flashes when 100BASE-TX/RX or 10BASE-TX/RX is being used.
2. Green: comes on when the machine is properly connected to the network.

Connecting to a Telephone Line

You can connect the machine to the public switched telephone network (PSTN) directly or through a private branch exchange (PBX).

Also, you can connect an external telephone to use the same telephone line for voice calls.

⚠ CAUTION

- To reduce the risk of fire, use only No. 26 AWG or larger telecommunication line cord.

🌐 Region **B**

⚠ ATTENTION

- Pour réduire le risque d'incendie, utiliser uniquement des conducteurs de télécommunications 26 AWG ou de section supérieure.

★ Important

- 🌐 Region **B**: By law in the United States, you must program your phone number identification (your fax number) into your machine before you can connect to the public phone system.
- Make sure the connector is the correct type before you start.

1. Connect a telephone line cord to LINE.

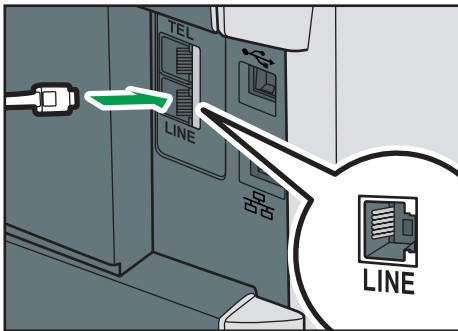

CMF032

2. If using an external telephone, connect the telephone to TEL.

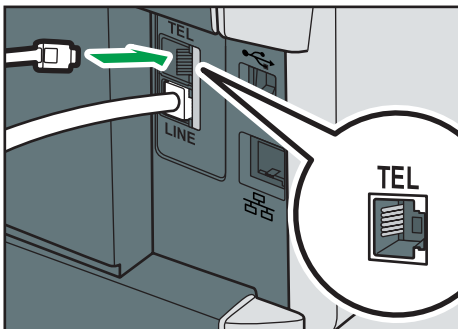

CMF033

↓ Note

- After connecting the machine to the telephone line, configure the telephone network settings and fax reception mode.

- If your telephone has functions that are not compatible with this machine, those functions will not be usable.
- Confirm that you have registered user fax number and user name during Initial Setup. You can check the registered information in [Program Fax Information] under [Admin. Tools].

Reference

- For details about registering fax sender information, see p.298 "Administrator Settings".
- For details about configuring the telephone network settings, see p.76 "Configuring Telephone Network Settings".
- For details about configuring fax reception mode, see p.240 "Selecting Reception Mode".
- For details about [Program Fax Information], see p.298 "Administrator Settings".

Configuring the Machine

This section describes configuring the settings required to use the machine on a network and as a fax machine.

2

Configuring the IPv4 Address Settings

The procedure for configuring network settings differs depending on whether IPv4 address information is assigned automatically by the network (DHCP), or manually.

Setting the machine to receive an IPv4 address automatically

★ Important

- A DHCP server is required on the network for the machine to receive an IPv4 address automatically.

1. Press the [User Tools] key.

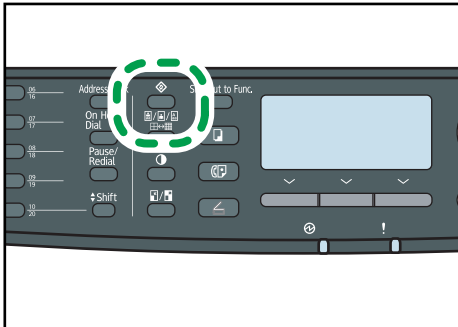

2. Press the [▲] [▼] keys to select [Network Settings], and then press the [OK] key.
3. If you are requested to enter a password, enter the password using the number keys, and then press the [OK] key.
4. Press the [▲] [▼] keys to select [IPv4 Configuration], and then press the [OK] key.
5. Press the [▲] [▼] keys to select [DHCP], and then press the [OK] key.
6. Press the [▲] [▼] keys to select [Active], and then press the [OK] key.
7. Press the [User Tools] key to return to the initial screen.
8. If you are requested to restart the machine, turn off the machine, and then turn it back on.
9. Print the configuration page to confirm the setting.

The IPv4 address setting will appear under "TCP/IP" on the configuration page.

↓ Note

- You can press the [Escape] key to exit to the previous level of the menu tree.
- A password for accessing the [Network Settings] menu can be specified in [Admin. Tools Lock].
- If your network environment requires a specific transmission speed that is not automatically detected, set the transmission speed in [Set Ethernet Speed] under [Network Settings].
- When [DHCP] is activated, manually configured IPv4 address settings are not used.

📖 Reference

- For details about turning the machine on and off, see p.55 "Turning the Power on".
- For details about printing the configuration page, see p.291 "Printing the Configuration Page".
- For details about [Admin. Tools Lock], see p.298 "Administrator Settings".
- For details about [Set Ethernet Speed], see p.75 "Configuring the Ethernet Speed".

Assigning the machine's IPv4 address manually

★ Important

- The IPv4 address assigned to the machine must not be used by any other device on the same network.

1. Press the [User Tools] key.

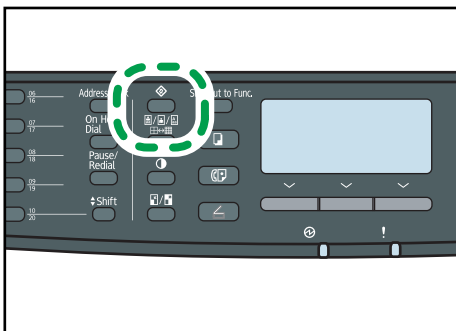

CMF134

2. Press the [▲] [▼] keys to select [Network Settings], and then press the [OK] key.
3. If you are requested to enter a password, enter the password using the number keys, and then press the [OK] key.
4. Press the [▲] [▼] keys to select [IPv4 Configuration], and then press the [OK] key.
5. Press the [▲] [▼] keys to select [DHCP], and then press the [OK] key.
6. Press the [▲] [▼] keys to select [Inactive], and then press the [OK] key.
7. Press the [▲] [▼] keys to select [IP Address], and then press the [OK] key.

The current IPv4 address is shown.

8. Enter the machine's IPv4 address using the number keys, and then press the [OK] key.

Press the [◀] [▶] keys to move between fields.

9. Press the [▲] [▼] keys to select [Subnet Mask], and then press the [OK] key.

The current subnet mask is shown.

10. Enter the subnet mask using the number keys, and then press the [OK] key.

Press the [◀] [▶] keys to move between fields.

11. Press the [▲] [▼] keys to select [Gateway Address], and then press the [OK] key.

The current gateway address is shown.

12. Enter the gateway address using the number keys, and then press the [OK] key.

Press the [◀] [▶] keys to move between fields.

13. Press the [User Tools] key to return to the initial screen.

14. If you are requested to restart the machine, turn off the machine, and then turn it back on.

15. Print the configuration page to confirm the setting.

The IPv4 address setting will appear under "TCP/IP" on the configuration page.

Note

- You can press the [Escape] key to exit to the previous level of the menu tree.
- A password for accessing the [Network Settings] menu can be specified in [Admin. Tools Lock].
- If your network environment requires a specific transmission speed that is not automatically detected, set the transmission speed in [Set Ethernet Speed] under [Network Settings].
- When [DHCP] is activated, manually configured IPv4 address settings are not used.

Reference

- For details about turning the machine on and off, see p.55 "Turning the Power on".
- For details about printing configuration page, see p.291 "Printing the Configuration Page".
- For details about [Admin. Tools Lock], see p.298 "Administrator Settings".
- For details about [Set Ethernet Speed], see p.75 "Configuring the Ethernet Speed".

Configuring the IPv6 Address Settings

The procedure for configuring network settings differs depending on whether IPv6 address information is assigned automatically by the network (DHCP), or manually.

Setting the machine to receive an IPv6 address automatically

★ Important

- A DHCP server is required on the network for the machine to receive an IPv6 address automatically.

1. Press the [User Tools] key.

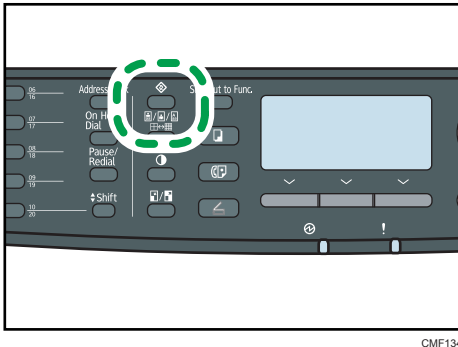

CMF134

2. Press the [▲] [▼] keys to select [Network Settings], and then press the [OK] key.
3. If you are requested to enter a password, enter the password using the number keys, and then press the [OK] key.
4. Press the [▲] [▼] keys to select [IPv6 Configuration], and then press the [OK] key.
5. Press the [▲] [▼] keys to select [DHCP], and then press the [OK] key.
6. Press the [▲] [▼] keys to select [Active], and then press the [OK] key.
7. Press the [User Tools] key to return to the initial screen.
8. If you are requested to reboot the machine, turn off the machine, and then turn it back on.
9. Print the configuration page to confirm the setting.

The IPv6 address setting will appear under "IPv6 Configuration" on the configuration page.

↓ Note

- You can press the [Escape] key to exit to the previous level of the menu tree.
- A password for accessing the [Network Settings] menu can be specified in [Admin. Tools Lock].
- When [DHCP] is activated, manually configured IPv6 address settings are not used.

📖 Reference

- For details about turning the machine on and off, see p.55 "Turning the Power on".
- For details about printing configuration page, see p.291 "Printing the Configuration Page".
- For details about [Admin. Tools Lock], see p.298 "Administrator Settings".

Assigning the machine's IPv6 address manually

★ Important

- The IPv6 address assigned to the machine must not be used by any other device on the same network.

1. Press the [User Tools] key.

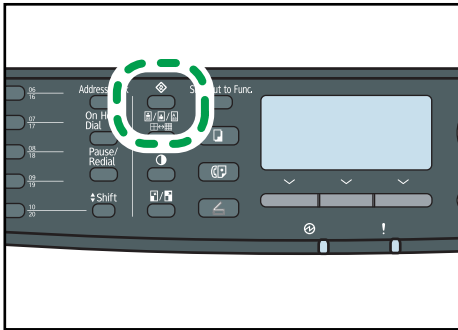

CMF134

2. Press the [▲] [▼] keys to select [Network Settings], and then press the [OK] key.
3. If you are requested to enter a password, enter the password using the number keys, and then press the [OK] key.
4. Press the [▲] [▼] keys to select [IPv6 Configuration], and then press the [OK] key.
5. Press the [▲] [▼] keys to select [DHCP], and then press the [OK] key.
6. Press the [▲] [▼] keys to select [Inactive], and then press the [OK] key.
7. Press the [▲] [▼] keys to select [Manual Config. Address], and then press the [OK] key.
8. Press the [▲] [▼] keys to select [Manual Config. Address], and then press the [OK] key.
9. Enter the machine's IPv6 address using the number keys, and then press the [OK] key.
10. Press the [▲] [▼] keys to select [Prefix Length], and then press the [OK] key.
11. Enter the prefix length using the number keys, and then press the [OK] key.
12. Press the [▲] [▼] keys to select [Gateway Address], and then press the [OK] key.
13. Enter the gateway address using the number keys, and then press the [OK] key.
14. Press the [User Tools] key to return to the initial screen.
15. If you are requested to reboot the machine, turn off the machine, and then turn it back on.
16. Print the configuration page to confirm the setting.

The IPv6 address setting will appear under "IPv6 Configuration" on the configuration page.

↓ Note

- You can press the [Escape] key to exit to the previous level of the menu tree.
- A password for accessing the [Network Settings] menu can be specified in [Admin. Tools Lock].

- When [DHCP] is activated, manually configured IPv6 address settings are not used.

Reference

- For details about turning the machine on and off, see p.55 "Turning the Power on".
- For details about printing configuration page, see p.291 "Printing the Configuration Page".
- For details about [Admin. Tools Lock], see p.298 "Administrator Settings".

Configuring the Ethernet Speed

You can set the speed that the machine will use for Ethernet communications.

In most cases, this should be left on the default setting, [Auto Select]. This setting allows two interfaces to automatically determine the optimum speed when they are connected.

Important

- **Connection cannot be established if the selected Ethernet speed does not match your network's transmission speed.**
- **The use of this feature is recommended. To use it, select [Auto Select].**

Router/HUB	Machine				
	[10Mbps Half Duplex]	[10Mbps Full Duplex]	[100Mbps Half Duplex]	[100Mbps Full Duplex]	[Auto Select]
10 Mbps half duplex	<input type="radio"/>	-	-	-	<input type="radio"/>
10 Mbps full duplex	-	<input type="radio"/>	-	-	-
100 Mbps half duplex	-	-	<input type="radio"/>	-	<input type="radio"/>
100 Mbps full duplex	-	-	-	<input type="radio"/>	-
auto-negotiation (auto selection)	<input type="radio"/>	-	<input type="radio"/>	-	<input type="radio"/>

1. Press the [User Tools] key.

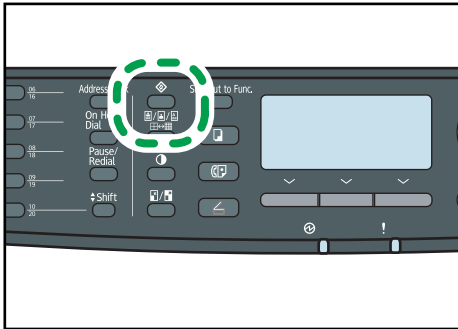

CMF134

2. Press the [▲] [▼] keys to select [Network Settings], and then press the [OK] key.
3. If you are requested to enter a password, enter the password using the number keys, and then press the [OK] key.
4. Press the [▲][▼] keys to select [Ethernet], and then press the [OK] key.
5. Press the [▲][▼] keys to select [Set Ethernet Speed], and then press the [OK] key.
6. Press the [▲][▼] keys to select the Ethernet speed, and then press the [OK] key.
7. Press the [User Tools] key to return to the initial screen.

↓ Note

- You can press the [Escape] key to exit to the previous level of the menu tree.
- A password for accessing the [Admin. Tools] menu can be specified in [Admin. Tools Lock].

📖 Reference

- For details about [Admin. Tools Lock], see p.298 "Administrator Settings".

Configuring Telephone Network Settings

Selecting the telephone line type

Select the telephone line type according to your telephone line service. There are two types: tone and pulse dial.

This function is not available in some regions.

1. Press the [User Tools] key.

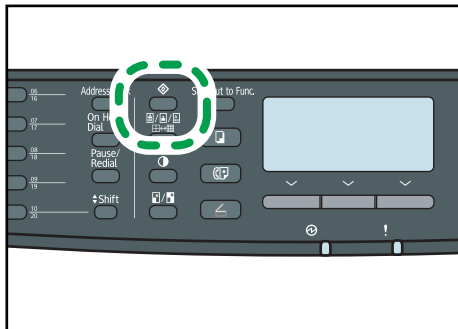

2

2. Press the [▲] [▼] keys to select [Admin. Tools], and then press the [OK] key.
3. If you are requested to enter a password, enter the password using the number keys, and then press the [OK] key.
4. Press the [▲] [▼] keys to select [Dial/Push Phone], and then press the [OK] key.
5. Press the [▲] [▼] keys to select the telephone line type appropriate for your telephone service, and then press the [OK] key.
6. Press the [User Tools] key to return to the initial screen.

↓ Note

- You can press the [Escape] key to exit to the previous level of the menu tree.
- A password for accessing the [Admin. Tools] menu can be specified in [Admin. Tools Lock].

📖 Reference

- For details about [Admin. Tools Lock], see p.298 "Administrator Settings".

Selecting the telephone network connection type

Select the type of connection to the telephone network.

There are two types: public switched telephone network (PSTN) and private branch exchange (PBX).

1. Press the [User Tools] key.

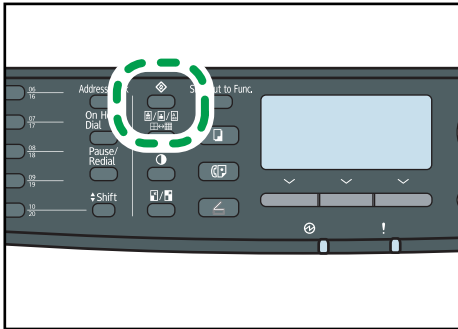

CMF134

2. Press the [▲] [▼] keys to select [Admin. Tools], and then press the [OK] key.
3. If you are requested to enter a password, enter the password using the number keys, and then press the [OK] key.
4. Press the [▲] [▼] keys to select [PSTN / PBX], and then press the [OK] key.
5. Press the [▲] [▼] keys to select [PSTN] or [PBX], and then press the [OK] key.
6. Press the [User Tools] key to return to the initial screen.

Note

- You can press the [Escape] key to exit to the previous level of the menu tree.
- A password for accessing the [Admin. Tools] menu can be specified in [Admin. Tools Lock].

Reference

- For details about [Admin. Tools Lock], see p.298 "Administrator Settings".

Setting the outside line access number

If the machine is connected to the telephone network through a PBX, set the dial number to access the outside line.

Important

- Make sure to set the outside line access number that matches the setting of your PBX. Otherwise, you may not be able to send faxes to outside destinations.

1. Press the [User Tools] key.

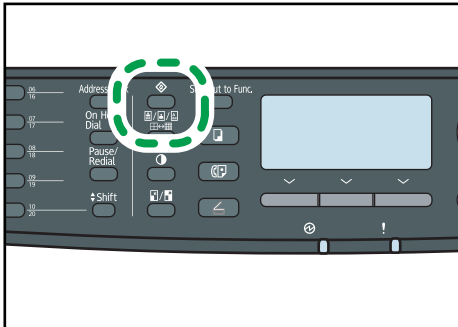

CMF134

2. Press the [▲] [▼] keys to select [Admin. Tools], and then press the [OK] key.
3. If you are requested to enter a password, enter the password using the number keys, and then press the [OK] key.
4. Press the [▲] [▼] keys to select [PBX Access Number], and then press the [OK] key.
5. Enter the outside line access number using the number keys, and then press the [OK] key.
6. Press the [User Tools] key to return to the initial screen.

↓ Note

- You can press the [Escape] key to exit to the previous level of the menu tree.
- A password for accessing the [Admin. Tools] menu can be specified in [Admin. Tools Lock].

📖 Reference

- For details about [Admin. Tools Lock], see p.298 "Administrator Settings".

Sharing the Printer on a Network

This section describes how to configure this machine as a Windows network printer.

The network printer is configured to enable network clients to use it.

★ Important

- To change printer properties, you must have Manage Printers permission (Full Control access authentication under Windows Vista/7). Log on to the file server as an Administrator to acquire this permission.
- The following procedure is based on Windows 7 as an example. If you are using another operating system, the procedure might vary slightly.

1. On the [Start] menu, click [Devices and Printers].
2. Right click the icon of the printer you want to use, and then click [Printer properties].
3. On the [Sharing] tab, click [Share this printer].

To share the printer with users using a different version of Windows, follow steps 4 to 7.

Proceed to step 8 if you have installed an alternative driver by selecting [Share this printer] during the printer driver installation.

4. Click [Additional Drivers...].
5. Select the version of Windows in [Additional Drivers], and then click [OK].
6. Click [Browse...], and select the driver file, and then click [Open].
7. Click [OK].
8. On the [Advanced] tab, click the [Printing Defaults...] button. Specify the default values for the printer driver that will be distributed to client computers, and then click [OK].
9. Click [Apply].
10. Click [OK].

Installing Option

This section describes how to install the optional paper feed unit.

Installing the Paper Feed Unit (Tray 2)

2

WARNING

- Touching the prongs of the power cable's plug with anything metallic constitutes a fire and electric shock hazard.

WARNING

- It is dangerous to handle the power cord plug with wet hands. Doing so could result in electric shock.

CAUTION

- Before installing or removing options, always disconnect the power cord plugs from the wall outlet and allow time for the main unit to fully cool. Failing to take these precautions could result in burns.

CAUTION

- The machine weighs approximately 18.4 kg (40.6 lb.). When moving the machine, use the inset grips on both sides, and lift slowly. The machine will break or cause injury if dropped.

CAUTION

- Lifting the paper feed unit carelessly or dropping may cause injury.

CAUTION

- Before moving the machine, unplug the power cord from the wall outlet. If the cord is unplugged abruptly, it could become damaged. Damaged plugs or cords can cause an electrical or fire hazard.

Important

- Tray 1 is required to print using the optional paper feed unit. Without Tray 1, paper jams will occur.
- Do not grip the tray areas when moving the machine.

1. Check that the package contains paper feed unit.

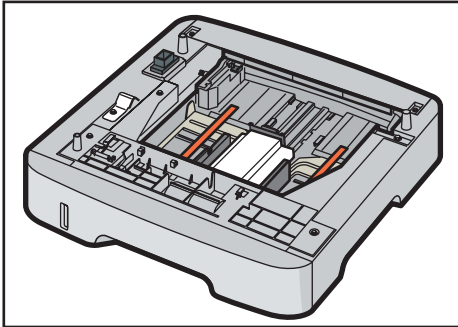

CMC030

2. Turn off the power, and then unplug the machine's power cord from the wall outlet.
3. Carefully pull the tray, and then pull it out with both hands.
Place the tray on a flat surface.
4. Remove the protective material attached inside the tray.

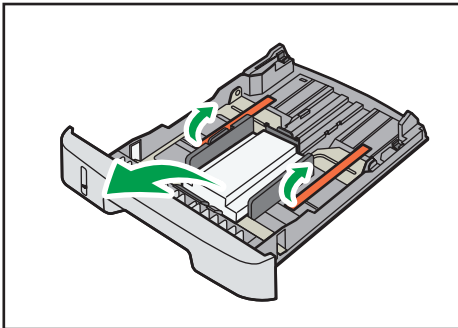

CMF061

5. Carefully push the tray straight into the optional paper feed unit.
6. Lift the machine using the inset grips on both sides.



CMF034

7. There are three upright pins on the optional paper feed unit. Align them with the holes on the underside of the machine, and then carefully lower the machine onto them.

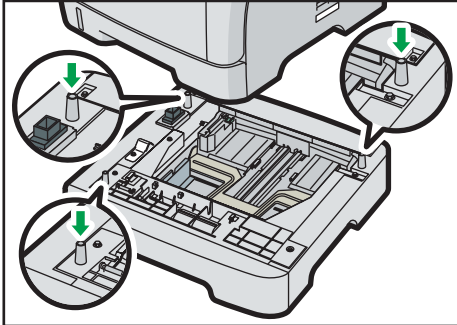

CMF035

8. Plug the machine's power cord back into the wall outlet, and then turn on the power.
9. After installing the option, print the configuration page to confirm the installation.

If it is installed properly, "Tray 2" will appear under "Paper Input" on the configuration page.

↓ Note

- After installing the optional paper feed unit, select tray 2 in the printer driver. For details, see the printer driver Help.
- If the optional paper feed unit is not installed properly, reinstall it following this procedure. If you cannot install it properly even after attempting reinstallation, contact your sales or service representative.

📖 Reference

- For details about printing configuration page, see p.291 "Printing the Configuration Page".
- For details about loading paper in tray 2, see p.105 "Loading Paper in Tray 2".

Paper and Other Media

This section describes supported and unsupported paper, paper precautions, details of each paper type and the printable area.

Note

- All paper must be set vertically, regardless of the paper size.

Supported Paper for Each Tray

This section describes the type, size, and weight of paper that can be loaded in each tray. The capacity of each paper tray is also provided.

Tray 1

Type	Size	Weight	Capacity
Thin paper	A4	52 to 162 g/m ²	250
Plain paper	B5 JIS	(13.8 to 43.0 lb.)	(80 g/m ² , 20 lb.)
Thick paper 1, 2	A5		
Recycled paper	B6 JIS		
Color paper	A6		
Preprinted paper	Legal (8 ¹ / ₂ " × 14")		
Prepunched paper	Letter (8 ¹ / ₂ " × 11")		
Letterhead	Half Letter (5 ¹ / ₂ " × 8 ¹ / ₂ ")		
Bond paper	Executive (7 ¹ / ₄ " × 10 ¹ / ₂ ")		
Cardstock	8" × 13"		
Label paper	8 ¹ / ₂ " × 13"		
	Folio (8 ¹ / ₄ " × 13")		
	16K (195 × 267 mm)		
	Custom size:		
	100 to 216 mm in width,		
	148 to 356 mm in length		
	(3.94 to 8.50 inches in width,		
	5.83 to 14.02 inches in length)		

Tray 2 (option)

Type	Size	Weight	Capacity
Thin paper	A4	60 to 105 g/m ²	250
Plain paper	B5 JIS	(16.0 to 28.0 lb.)	(80 g/m ² , 20 lb.)
Thick paper 1	A5		
Recycled paper	Legal (8 ¹ / ₂ " × 14")		
Color paper	Letter (8 ¹ / ₂ " × 11")		
Preprinted paper	Half Letter (5 ¹ / ₂ " × 8 ¹ / ₂ ")		
Prepunched paper			
Letterhead			

Bypass tray

Type	Size	Weight	Capacity
Thin paper	A4	52 to 162 g/m ²	50
Plain paper	B5 JIS	(13.8 to 43.0 lb.)	(80 g/m ² , 20 lb.)
Thick paper 1, 2	A5		
Recycled paper	B6 JIS		
Color paper	A6		
Preprinted Paper	Legal (8 ¹ / ₂ " × 14")		
Prepunched paper	Letter (8 ¹ / ₂ " × 11")		
Letterhead	Half Letter (5 ¹ / ₂ " × 8 ¹ / ₂ ")		
Bond paper	Executive (7 ¹ / ₄ " × 10 ¹ / ₂ ")		
Cardstock	16K (195 mm × 267 mm)		
Label paper	Com 10 (4 ¹ / ₈ " × 9 ¹ / ₂ ")		
OHP transparencies	Monarch (3 ⁷ / ₈ " × 7 ¹ / ₂ ")		
Envelope	C5 Env (162 × 229 mm) C6 Env (114 × 162 mm) DL Env (110 × 220 mm) Custom size: 90 to 216 mm in width, 140 to 356 mm in length (3.54 to 8.50 inches in width, 5.51 to 14.02 inches in length)		

Note

- The number of sheets that can be printed in one minute may become lower than normal when printing on Legal size paper.
- If you print with the resolution set at 1200 × 1200 dpi, the following conditions apply:
 - Available paper tray: tray 1 and bypass tray
 - Available paper size: A4, B5 JIS, or Letter (8¹/₂ " × 11 ")
 - Available paper type: plain paper
 - Duplex printing: not available

Specifications of Paper Types

The following tables describe the types of paper that can be used with this machine.

★ Important

- Depending on the paper type, the toner may take a while to dry. Before handling, make sure printed sheets have fully dried. Otherwise, the toner may smudge.
- Print quality can be guaranteed only if recommended paper is used. For more information about recommended paper, contact your sales or service representative.

Thin paper

Item	Description
Paper thickness	52 to 64 g/m ² (13.8 to 17.0 lb.)
Supported paper tray	Any input tray can be used.
Duplex supported size	A4, Legal (8 ¹ / ₂ " × 14 "), Letter (8 ¹ / ₂ " × 11 ")
Notes	Tray 2 only supports paper weighing 60 to 64 g/m ² (16.0 to 17.0 lb.).

Plain paper

Item	Description
Paper thickness	65 to 99 g/m ² (17.1 to 26.5 lb.)
Supported paper tray	Any input tray can be used.
Duplex supported size	A4, Legal (8 ¹ / ₂ " × 14 "), Letter (8 ¹ / ₂ " × 11 ")

Thick paper 1

Item	Description
Paper thickness	100 to 130 g/m ² (26.6 to 34.6 lb.)
Supported paper tray	Any input tray can be used.
Duplex supported size	A4, Legal (8 ¹ / ₂ " × 14 "), Letter (8 ¹ / ₂ " × 11 ")
Notes	<ul style="list-style-type: none"> • Tray 2 only supports thick paper weighing 100 to 105 g/m² (26.6 to 28.0 lb). • Duplex printing is only possible with thick paper weighing 100 to 105 g/m² (26.6 to 28.0 lb). • The number of sheets that can be printed in one minute is approximately half that of plain paper. • The number of sheets that can be printed in one minute may become lower than normal when printing on paper of the following sizes: A4, Legal (8¹/₂ " × 14 "), Letter (8¹/₂ " × 11 "), 8 " × 13 ", 8¹/₂ " × 13 ", Folio (8¹/₄ " × 13 "), or 16K (195 × 267 mm).

Thick paper 2

Item	Description
Paper thickness	131 to 162 g/m ² (34.7 to 43.0 lb.)
Supported paper tray	Tray 1 and bypass tray
Duplex supported size	None
Notes	<ul style="list-style-type: none"> • The number of sheets that can be printed in one minute is approximately half that of plain paper. • The number of sheets that can be printed in one minute may become lower than normal when printing on paper of the following sizes: A4, Legal (8¹/₂ " × 14 "), Letter (8¹/₂ " × 11 "), 8 " × 13 ", 8¹/₂ " × 13 ", Folio (8¹/₄ " × 13 "), or 16K (195 × 267 mm). • When using 135 g/m² (35.9 lb.) or heavier paper, prints may be output with strong curls. • When using 135 g/m² (35.9 lb.) or heavier paper, take prints from the output tray frequently.

Recycled paper

Item	Description
Paper thickness	75 to 90 g/m ² (20.0 to 24.0 lb.)
Supported paper tray	Any input tray can be used.
Duplex supported size	A4, Legal (8 ¹ / ₂ " × 14 "), Letter (8 ¹ / ₂ " × 11 ")
Notes	If the paper thickness is outside the specified range, select [Thin Paper], [Thick Paper 1], or [Thick Paper 2].

Color paper

Item	Description
Paper thickness	75 to 90 g/m ² (20.0 to 24.0 lb.)
Supported paper tray	Any input tray can be used.
Duplex supported size	A4, Legal (8 ¹ / ₂ " × 14 "), Letter (8 ¹ / ₂ " × 11 ")
Notes	If the paper thickness is outside the specified range, select [Thin Paper], [Thick Paper 1], or [Thick Paper 2].

Preprinted paper

Item	Description
Paper thickness	75 to 90 g/m ² (20.0 to 24.0 lb.)
Supported paper tray	Tray 1 and tray 2
Duplex supported size	A4, Legal (8 ¹ / ₂ " × 14 "), Letter (8 ¹ / ₂ " × 11 ")
Notes	If the paper thickness is outside the specified range, select [Thin Paper], [Thick Paper 1], or [Thick Paper 2].

Prepunched paper

Item	Description
Paper thickness	75 to 90 g/m ² (20.0 to 24.0 lb.)
Supported paper tray	Any input tray can be used.
Duplex supported size	A4, Legal (8 ¹ / ₂ " × 14 "), Letter (8 ¹ / ₂ " × 11 ")

Item	Description
Notes	If the paper thickness is outside the specified range, select [Thin Paper], [Thick Paper 1], or [Thick Paper 2].

Letterhead

Item	Description
Paper thickness	100 to 130 g/m ² (26.6 to 34.6 lb.)
Supported paper tray	Any input tray can be used.
Duplex supported size	A4, Legal (8 ¹ / ₂ " × 14"), Letter (8 ¹ / ₂ " × 11")
Notes	<ul style="list-style-type: none"> • Tray 2 only supports letterhead weighing 100 to 105 g/m² (26.6 to 28.0 lb). • Paper that has a thickness outside the specified range cannot be printed onto.

Bond paper

Item	Description
Paper thickness	105 to 160 g/m ² (28.0 to 42.6 lb.)
Supported paper tray	Tray 1 and bypass tray
Duplex supported size	None
Notes	<ul style="list-style-type: none"> • The number of sheets that can be printed in one minute is approximately half that of plain paper. • When using 135 g/m² (35.9 lb.) or heavier paper, prints may be output with strong curls. • When using 135 g/m² (35.9 lb.) or heavier paper, take prints from the output tray frequently. • If the paper thickness is outside the specified range, select [Plain Paper] or [Thick Paper 1].

Cardstock

Item	Description
Paper thickness	105 to 160 g/m ² (28.0 to 42.6 lb.)
Supported paper tray	Tray 1 and bypass tray

Item	Description
Duplex supported size	None
Notes	<ul style="list-style-type: none"> The number of sheets that can be printed in one minute is approximately half that of plain paper. When using 135 g/m² (35.9 lb.) or heavier paper, prints may be output with strong curls. When using 135 g/m² (35.9 lb.) or heavier paper, take prints from the output tray frequently. Paper thicker than 160 g/m² cannot be printed onto.

Label paper

Item	Description
Supported paper tray	Tray 1 and bypass tray
Duplex supported size	None
Notes	<ul style="list-style-type: none"> The number of sheets that can be printed in one minute is approximately half that of plain paper. Avoid using adhesive label paper on which glue is exposed. Glue may stick to the inner parts of the machine, which can cause paper feed problems, deterioration in print quality, or premature wear of the print cartridge's photo conductor unit.

OHP transparencies

Item	Description
Supported paper tray	Bypass tray
Duplex supported size	None

Item	Description
Notes	<ul style="list-style-type: none"> • When loading OHP transparencies, take care not to load them upside down. Doing so may cause a malfunction. • It is recommended to place one sheet at a time. • Make sure to fan OHP transparencies every time before printing. Leaving OHP transparencies loaded in the bypass tray may cause them to stick together and result in a misfeed. • If multiple OHP transparencies are fed at the same time, load them one by one. • When printing on OHP transparencies, remove the transparencies one by one as they are output. • When printing on OHP transparencies that have a print side, load them with the print side over on the bypass tray. Not taking this precaution may cause them to stick to the fusing unit and cause misfeeds.

Envelope

Item	Description
Supported paper tray	Bypass tray
Duplex supported size	None

Notes

- The number of envelopes that can be printed in one minute is approximately half that of plain paper.
- Paper can be loaded only up to the lower of the two paper limit marks of the tray.
- If printed envelopes come out badly creased, load the envelopes in the opposite direction. Also, configure the printer driver to rotate the print object 180 degrees. For details about changing the loading orientation, see the printer driver Help.
- Environmental factors can degrade the print quality on both recommended and non-recommended envelopes.
- If envelopes are severely curled after printing, flatten them by bending them back against the curl.
- After printing, envelopes sometimes have creases along their long edges and toner smear on their unprinted sides. Their print images might also be blurred. When printing large, black-solid areas, striping can occur as a result of the envelopes overlapping.
- To correctly specify the length of an envelope whose flap opens along its short edge, be sure to include the open flap when measuring.

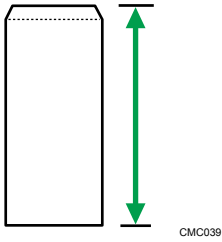

- Fan envelopes, and then align their edges before loading.

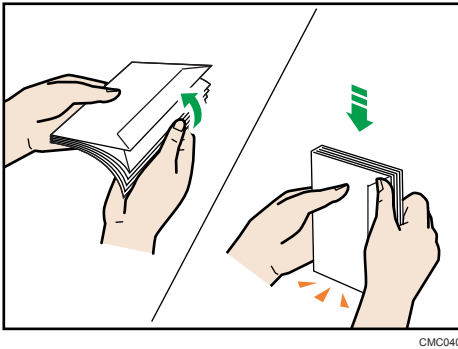

- When fanning envelopes, make sure they are not stuck together. If they are stuck together, separate them.
- When fanning envelopes, make sure the envelope flaps are not stuck together. If they are stuck together, separate them.
- Before loading envelopes, flatten them out so that their curl does not exceed that shown in the illustration below.

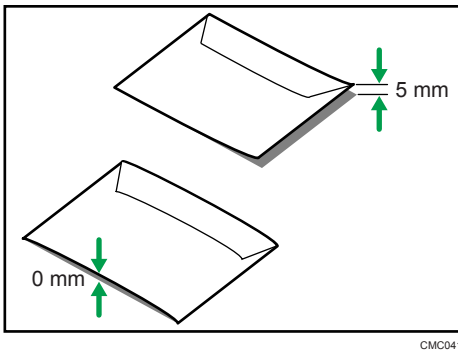

- If the curl is severe, flatten out the envelopes using your fingers, as shown in the illustration below.

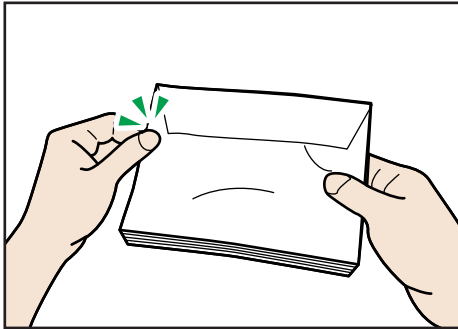

Unsupported Types of Paper

Avoid using the following paper as they are not supported by this machine.

- Paper meant for an ink-jet printer
- Bent, folded, or creased paper
- Curled or twisted paper
- Torn paper
- Wrinkled paper
- Damp paper
- Dirty or damaged paper
- Paper that is dry enough to emit static electricity
- Paper that has already been printed onto, except a preprinted letterhead.
Malfunctions are especially likely when using paper printed on by other than a laser printer (e.g. monochrome and color copiers, ink-jet printers, etc.)
- Special paper, such as thermal paper, aluminum foil, carbon paper and conductive paper
- Paper that is heavier or lighter than the specified limitations
- Paper with windows, holes, perforations, cutouts, or embossing
- Adhesive label paper on which the adhesive under-layer or base paper is exposed
- Paper with clips or staples
- Do not use ink-jet printer paper because it may stick to the fusing unit and cause a paper jam.
- Do not use paper that has already been printed onto by other printers.

↓ Note

- When loading paper, take care not to touch the surface of the paper.
- Even supported types of paper may cause paper jams or malfunctions if the paper is not in good condition.

Paper Storage Precautions

Paper should always be stored properly. Improperly stored paper might result in poor print quality, paper jams, or printer damage.

Recommendations are as follows:

- Avoid storing paper in areas that are excessively cold, hot, humid, or dry.
- Avoid exposing paper to direct sunlight.
- Store on a flat surface.
- Keep paper in its original packaging.

Printable Area

The following diagrams show the areas of paper that the machine can print onto.

Be sure to set the print margins correctly using the settings of the application in which it was created.

Paper

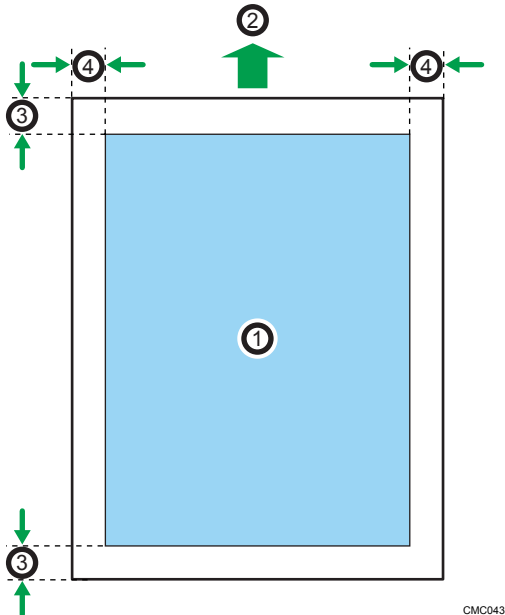

CMC043

1. Print area
2. Feed direction
3. Approximately 4.2 mm (0.17 inches)
4. Approximately 4.2 mm (0.17 inches)

Envelope

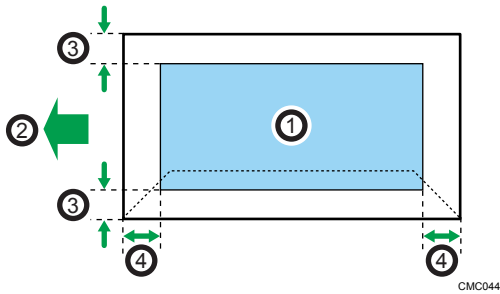

1. Print area
2. Feed direction
3. Approximately 10 mm (0.39 inches)
4. Approximately 15 mm (0.59 inches)

↓ Note

- The print area may vary depending on the paper size, printer language and printer driver settings.
- For better envelope printing, we recommend you set the right, left, top, and bottom print margins to at least 15 mm (0.59 inches) each.

Loading Paper

This describes how to load paper into the paper tray and bypass tray.

⚠ CAUTION

- Do not pull out the paper tray forcefully. If you do, the tray might fall and cause an injury.

⚠ CAUTION

- When loading paper, take care not to trap or injure your fingers.

Loading Paper in Tray 1

The following example explains loading procedure for the standard paper tray (Tray 1).

★ Important

- Before printing on paper other than envelopes, make sure to pull up the levers on the machine rear, inside the rear cover. Leaving the levers lowered can cause print quality problems when printing on paper other than envelopes.
- Make sure paper is not stacked above the limit mark inside the tray. Misfeeds might occur.
- After loading paper in the tray, specify the paper type and size using the control panel to avoid printing problems. This machine does not detect the paper size automatically.
- Do not mix different types of paper in the same paper tray.
- Do not move the side paper guides forcefully. Doing so can damage the tray.
- Do not move the end paper guide forcefully. Doing so can damage the tray.
- When inserting the tray, make sure it is not slanted. Inserting it at a slant can damage the machine.
- Curled paper may jam. Straighten curled paper before loading.

1. Pull out tray 1 carefully with both hands.

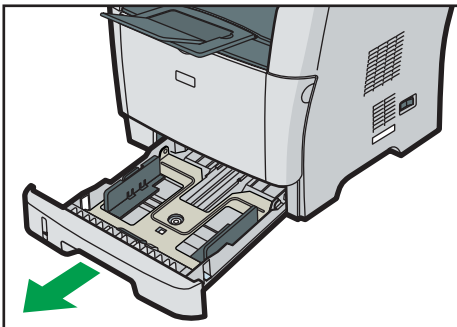

CMF036

Place the tray on a flat surface.

2. Pinch the clip on the side paper guide and slide it to match the standard size.

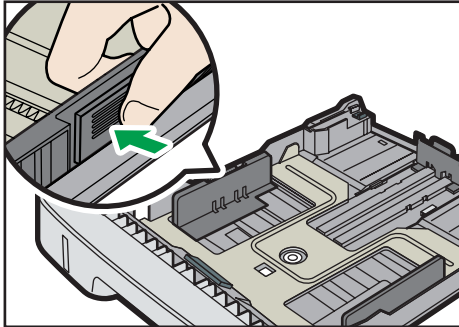

CMC046

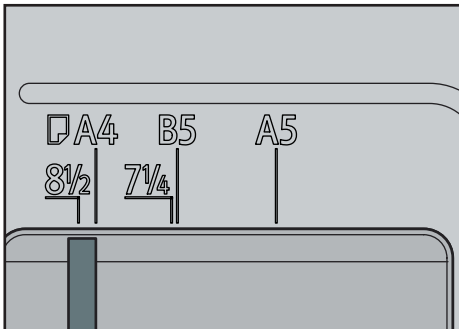

CMC047

When loading custom size paper, position the paper guide slightly wider than the actual paper size.

3. Pinch the end paper guide and slide it inward to match the standard size.

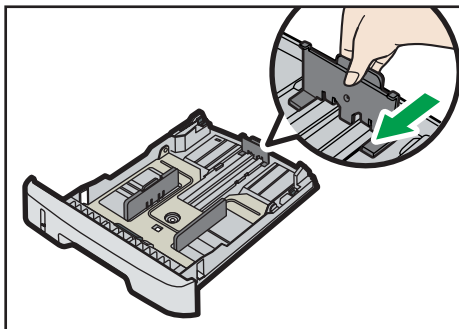

CMC048

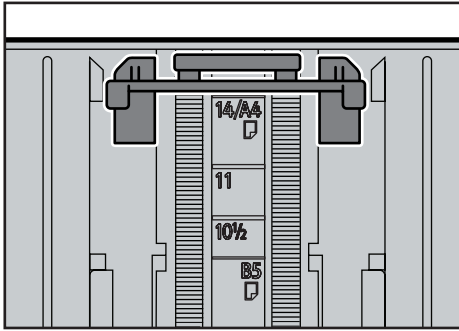

CMC049

When loading custom size paper, position the paper guide slightly wider than the actual paper size.

4. Load the new paper stack print side down.

Make sure paper is not stacked higher than the upper limit marked inside the tray.

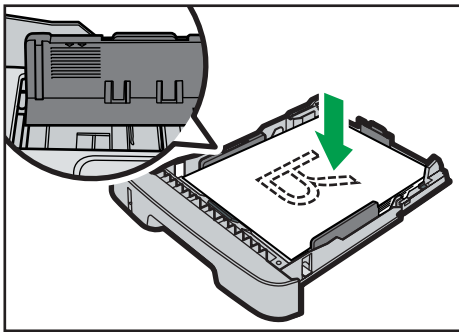

CMC050

Slide the guides inward, until they are flush against the paper's sides.

Make sure the paper is not stacked higher than the projection on the side paper guides.

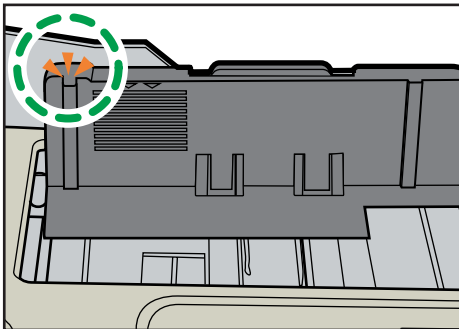

CMC051

5. Check there are no gaps between the paper and the paper guides; both side and end paper guides.

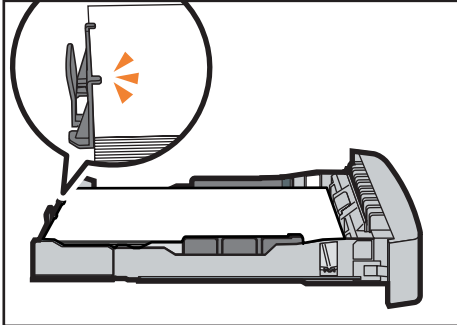

CMC052

If there is a gap between the paper and the end paper guide, as in the example below, the paper might not feed in correctly.

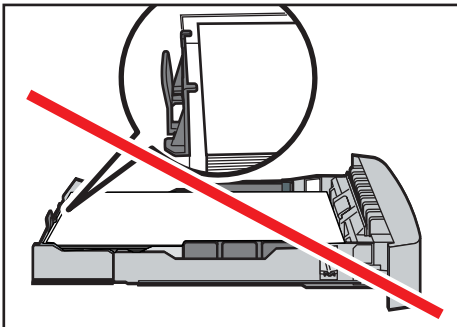

CMC058

6. Carefully push tray 1 straight into the machine.

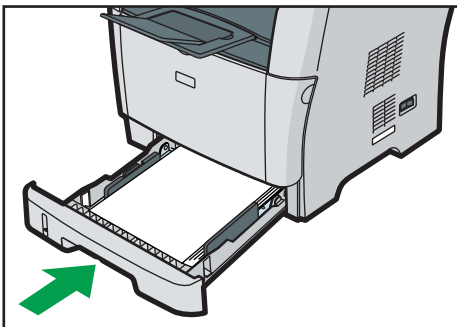

CMF037

To avoid paper jams, make sure the tray is securely inserted.

Note

- The remaining paper indicator on the left front side of the paper tray shows approximately how much paper is remaining.

Reference

- For details about paper types supported by the machine, see p.84 "Paper and Other Media".
- For details about the paper settings, see p.113 "Specifying Paper Type and Paper Size".

Loading paper longer than A4

This section explains how to load paper longer than A4 (297 mm) into the machine.

★ Important

- Before printing on paper other than envelopes, make sure to pull up the levers on the machine rear, inside the rear cover. Leaving the levers lowered can cause print quality problems when printing on paper other than envelopes.
- Make sure paper is not stacked above the limit mark inside the tray. Misfeeds might occur.
- After loading paper in the tray, specify the paper type and size using the control panel to avoid printing problems. This machine does not detect the paper size automatically.
- Do not mix different types of paper in the same paper tray.
- Do not move the side paper guides forcefully. Doing so can damage the tray.
- Do not move the end paper guide forcefully. Doing so can damage the tray.
- When inserting the tray, make sure it is not slanted. Inserting it at a slant can damage the machine.

1. Remove the tray 1 rear cover by pushing its center.

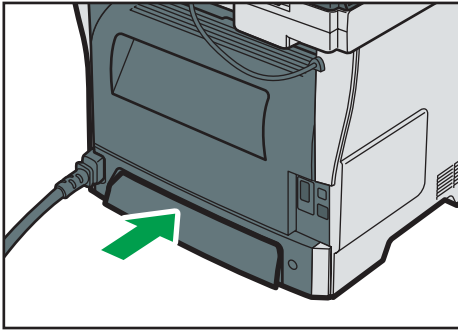

CMF038

2. Pull out tray 1 carefully with both hands.

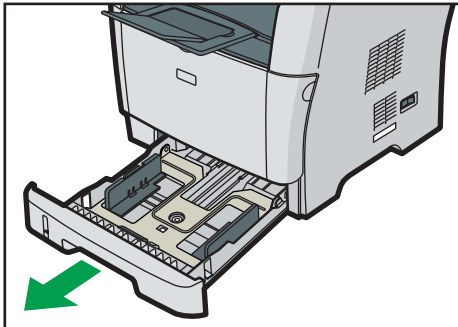

CMF036

Place the tray on a flat surface.

3. Release the extender locks on both sides of the tray, and then pull out the extender until it clicks.

Make sure the extender's inner surface and the scale are aligned.

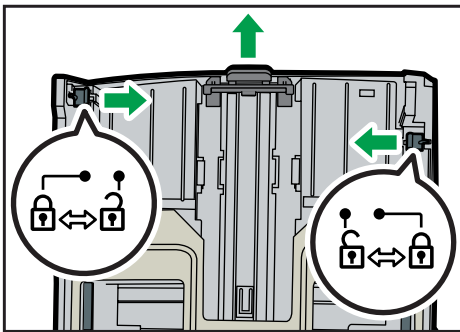

CMC057

4. Lock the extender in the extended position.

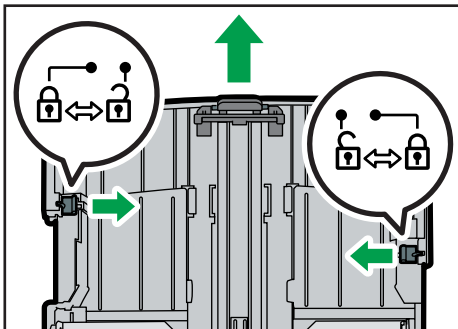

CMC055

5. Pinch the clip on the side paper guide, and then slide it to match the paper size.

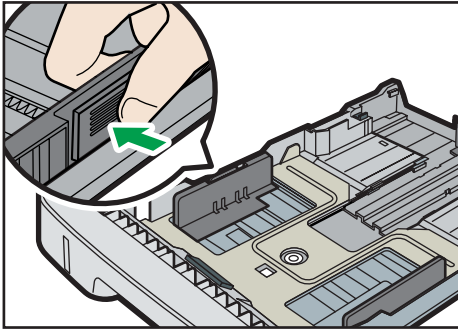

CMC059

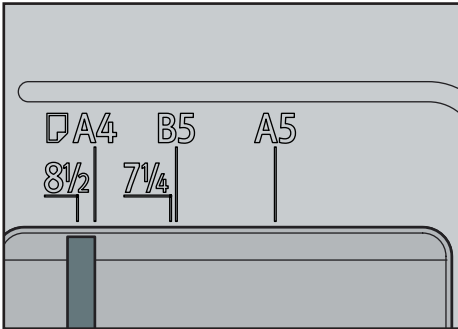

CMC047

6. Pinch the end paper guide and slide it inward to match the paper size.

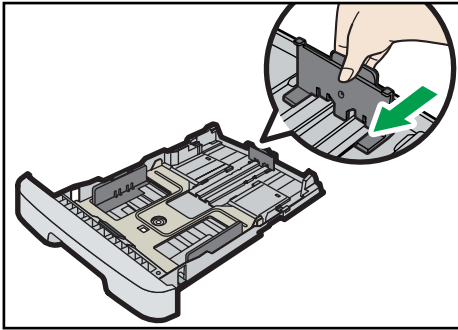

CMC060

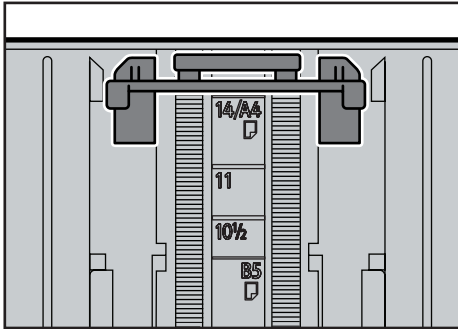

CMC049

7. Load the new paper stack print side down.

Make sure paper is not stacked higher than the upper limit marked inside the tray.

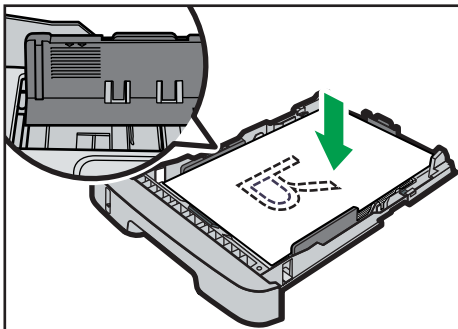

CMC069

Slide the guides inward until they are flush against the paper's sides.

Make sure the paper is not stacked higher than the projection on the side paper guides.

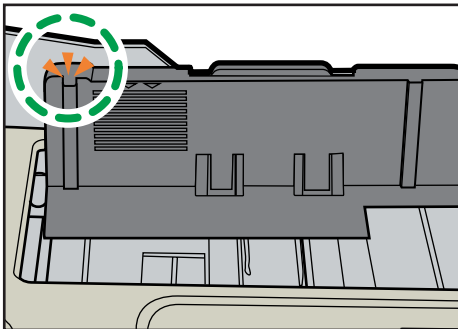

CMC051

8. Check there are no gaps between the paper and the paper guides; both side and end paper guides.

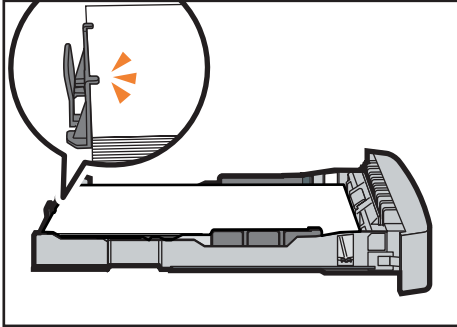

CMC062

If there is a gap between the paper and the end paper guide, as in the example below, the paper might not feed in correctly.

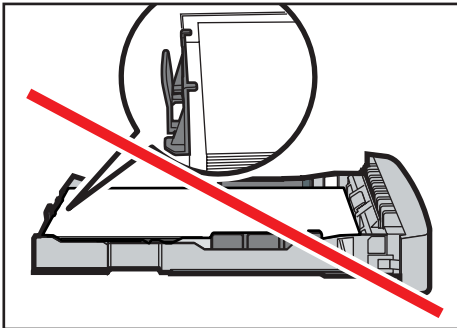

CMC063

9. Carefully push tray 1 straight into the machine.

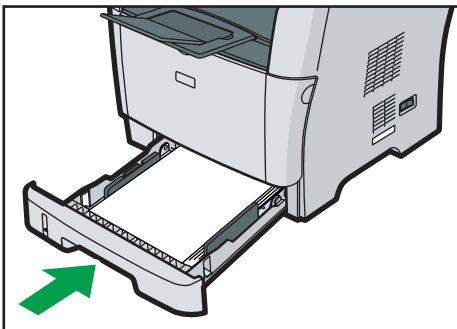

CMF037

To avoid paper jams, make sure the tray is securely inserted.

Note

- To reinsert the extender, you might have to push it with moderate force.
- The remaining paper indicator on the left front side of the paper tray shows approximately how much paper is remaining.

Reference

- For details about paper types supported by the machine, see p.84 "Paper and Other Media".
- For details about the paper settings, see p.113 "Specifying Paper Type and Paper Size".

Loading Paper in Tray 2

2

The following example explains the loading procedure for tray 2.

Important

- Before printing on paper other than envelopes, make sure to pull up the levers on the machine rear, inside the rear cover. Leaving the levers lowered can cause print quality problems when printing on paper other than envelopes.
- Make sure paper is not stacked above the limit mark inside the tray. Misfeeds might occur.
- After loading paper in the tray, specify the paper type and size using the control panel to avoid printing problems. This machine does not detect the paper size automatically.
- Do not mix different types of paper in the same paper tray.
- Do not move the side paper guides forcefully. Doing so can damage the tray.
- Do not move the end paper guide forcefully. Doing so can damage the tray.
- When inserting the tray, make sure it is not slanted. Inserting it at a slant can damage the machine.

1. Pull out tray 2 carefully with both hands.

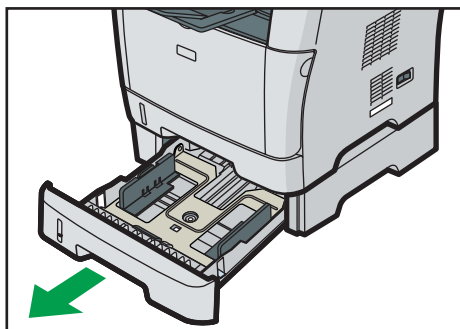

CMF039

Place the tray on a flat surface.

2. Pinch the clips on the side paper guide, and then adjust the guide to the paper size.

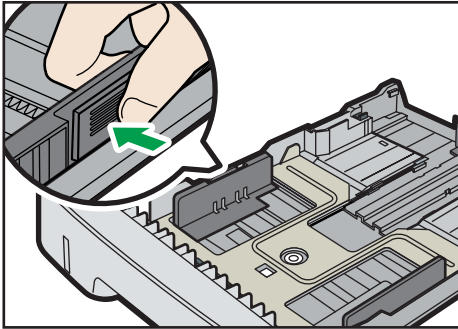

CMC066

3. Pinch the clip on the end paper guide, and slide it inward to match the paper size.

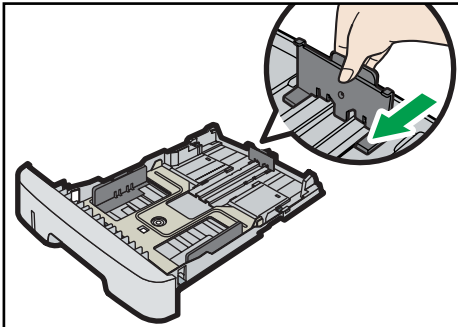

CMC067

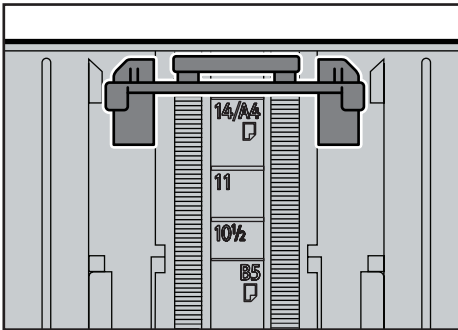

CMC068

4. Load the new paper stack print side down.

Make sure paper is not stacked higher than the upper limit marked inside the tray.

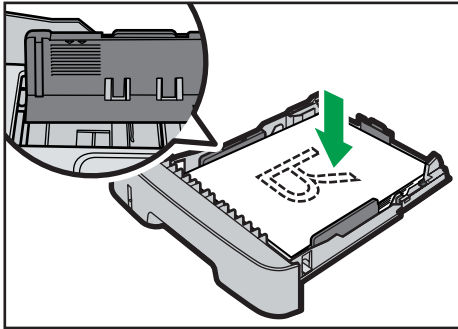

CMC069

Make sure the paper is not stacked higher than the projection on the side paper guides.

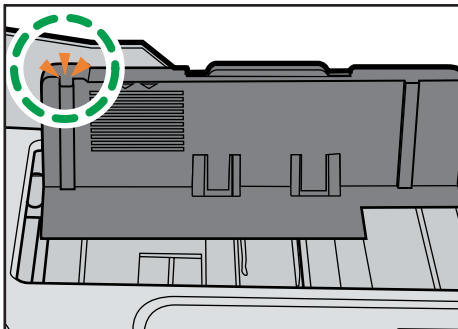

CMC070

5. Check there are no gaps between the paper and the paper guide; both side and end paper guides.

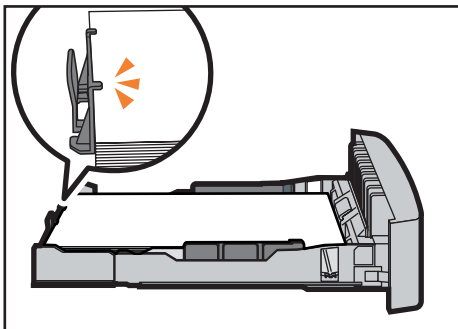

CMC071

6. Carefully push tray 2 straight into the machine.

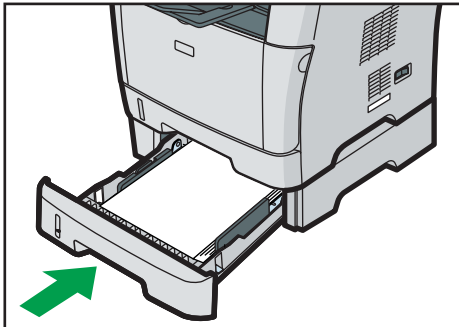

CMF040

To avoid paper jams, make sure the tray is securely inserted.

Note

- The remaining paper indicator on the left front side of the paper tray shows approximately how much paper is remaining.

Reference

- For details about paper types supported by the machine, see p.84 "Paper and Other Media".
- For details about the paper settings, see p.113 "Specifying Paper Type and Paper Size".

Loading Paper in the Bypass Tray

Important

- Before printing on paper other than envelopes, make sure to pull up the levers on the machine rear, inside the rear cover. Leaving the levers lowered can cause print quality problems when printing on paper other than envelopes.
- Make sure paper is not stacked above the paper guides inside the bypass tray.
- After loading paper in the tray, specify the paper type and size using the control panel to avoid printing problems. This machine does not detect the paper size automatically..
- If paper is curled, straighten it before loading, by bending the paper in the opposite direction to the curl, for example.
- Do not load paper while the machine is printing.

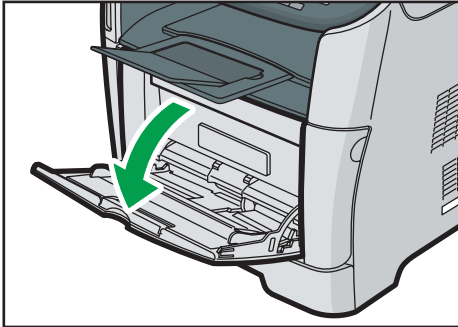
1. Open the bypass tray.

CMF041

If you load A4 (297 mm) or larger size paper, pull out the bypass tray extension.

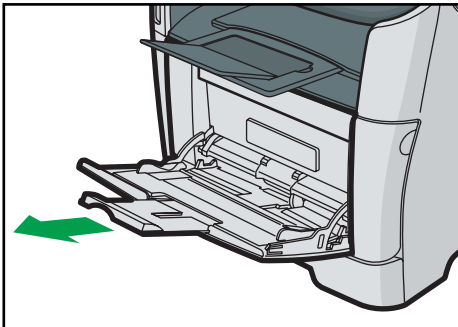

CMF042

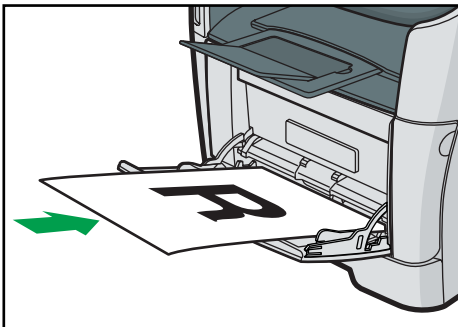
2. Slide the side guides outward, then load paper with the print side up, and push in until it stops against the machine.

CMF043

3. Adjust the side guides to the paper width.

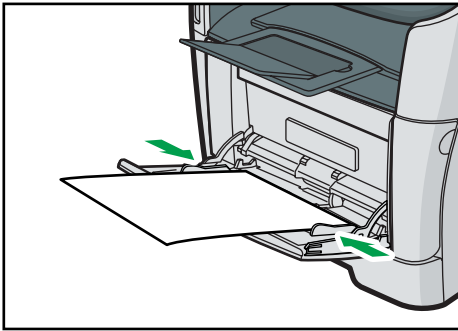

CMF044

↓ Note

- After loading paper in the tray, specify the paper type and size using the control panel. Also, specify the printer driver's paper setting accordingly before printing.

📖 Reference

- For details about supported types of paper, see p.84 "Paper and Other Media".
- For details about specifying the paper type and size, see p.113 "Specifying Paper Type and Paper Size".

Loading Envelopes

⚠ CAUTION

- The inside of this machine becomes very hot. Do not touch the parts labeled "△" (indicating a hot surface).

★ Important

- Before printing on envelopes, make sure to lower the levers on the machine rear, inside the rear cover, to avoid envelopes coming out creased. Also, pull up the levers back to their original positions after printing. Leaving the levers lowered can cause print quality problems when printing on paper other than envelopes.
- Avoid using self-adhesive envelopes. They may cause machine malfunctions.
- Check there is no air in the envelopes before loading.
- Envelopes whose flaps are open must be printed with the flaps open, and envelopes whose flaps are closed must be printed with the flaps closed.
- Load only one size and type of envelope at a time.
- Before loading envelopes, flatten their leading edges (the edge going into the machine) by running a pencil or ruler across them.

- Some kinds of envelope might cause misfeeds, wrinkles or print poorly.
- Print quality on envelopes may be uneven if parts of an envelope have different thicknesses. Print one or two envelopes to check print quality.
- In a hot and humid environment, the envelope might be output creased or improper printing quality.
- After loading envelopes in the tray, specify the paper type and size using the control panel to avoid printing problems. This machine does not detect the paper size automatically.

1. Open the bypass tray.

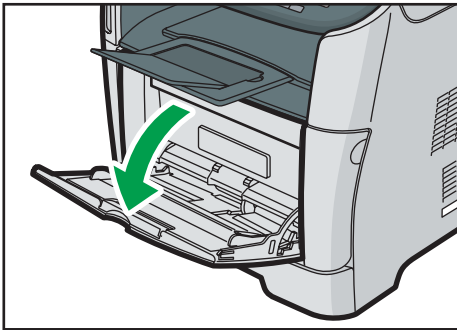

CMF041

2. Slide the side guides outward, then load envelopes with the print side up, and push in until it stops against the machine.

Envelopes whose flaps are open must be printed with the flaps open, and envelopes whose flaps are closed must be printed with the flaps closed. Before loading envelopes, make sure they are as flat as possible.

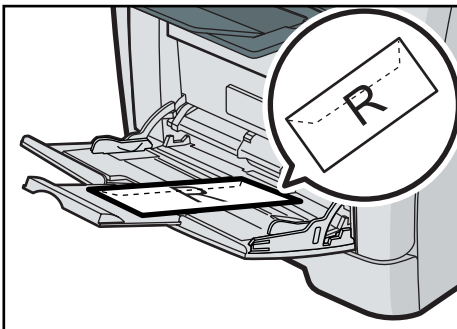

CMF045

3. Adjust the side guides to the envelope width.

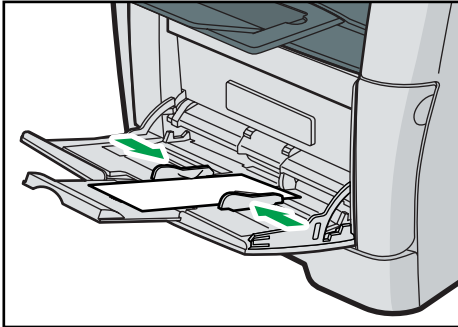

CMF046

4. Open the rear cover.

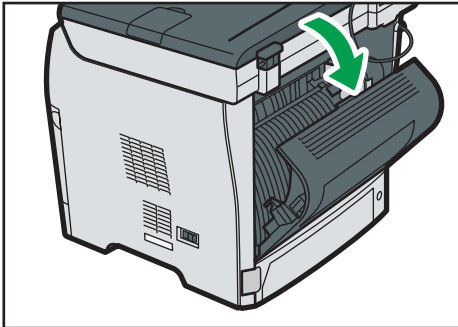

CMF095

5. Lower the levers for printing envelopes on both sides to the position indicated with an envelope mark.

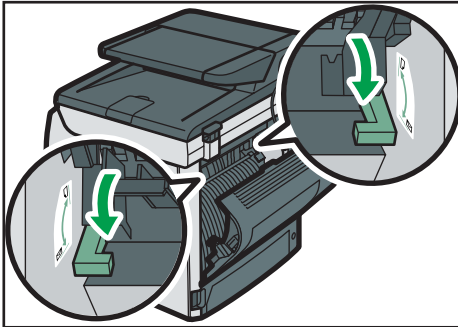

CMF047

Make sure to pull up the levers back to their original positions after printing.

6. Close the rear cover.

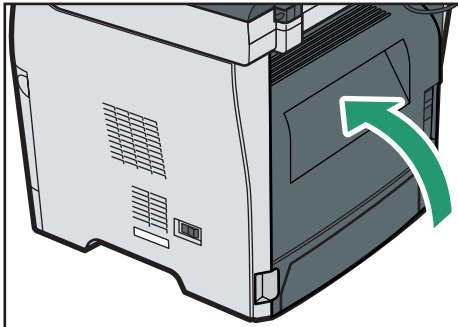

CMF076

↓ Note

- After loading envelopes in the tray, specify the paper type and size using the control panel. Also, specify the printer driver's paper setting accordingly before printing.
- Be sure to load envelopes so that their flaps are on the left. If you do not, the envelopes will become creased.
- If printed envelopes come out badly creased, load the envelopes in the opposite direction, and then rotate the print object by 180 degrees using the printer driver before printing. For details, see the printer driver Help.

📖 Reference

- For details about supported types of paper, see p.84 "Paper and Other Media".
- For details about specifying the paper type and size, see p.113 "Specifying Paper Type and Paper Size".

Specifying Paper Type and Paper Size

This section describes how to specify the paper size and paper type using the control panel.

↓ Note

- Paper type and size can also be specified using the printer driver. For details, see the printer driver Help.
- For prints from the bypass tray, you can select to print according to either the printer driver settings or the control panel settings with [Bypass Tray Priority] under system settings.
- If [Auto Continue] under system settings is enabled, printing stops temporarily if a paper type/size error is detected. The printing restarts automatically with the settings made with the control panel after about ten seconds.

📖 Reference

- For details about [Bypass Tray Priority], see p.279 "System Settings".

- For details about [Auto Continue], see p.279 "System Settings".

Specifying the paper type

This section describes how to specify the paper type.

2

1. Press the [User Tools] key.

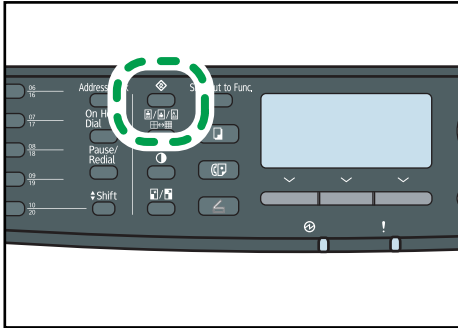

CMF134

2. Press the [▲] [▼] keys to select [System Settings], and then press the [OK] key.
3. Press the [▲] [▼] keys to select [Tray Paper Settings], and then press the [OK] key.
4. Press the [▲] [▼] keys to select the paper type setting for the desired tray, and then press the [OK] key.
5. Press the [▲] [▼] keys to select the desired paper type, and then press the [OK] key.
6. Press the [User Tools] key to return to the initial screen.

↓ Note

- You can press the [Escape] key to exit to the previous level of the menu tree.

Specifying the standard paper size

This section describes how to specify the standard paper size.

1. Press the [User Tools] key.

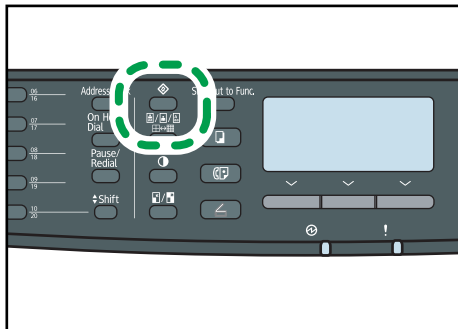

CMF134

2. Press the [▲] [▼] keys to select [System Settings], and then press the [OK] key.
3. Press the [▲] [▼] keys to select [Tray Paper Settings], and then press the [OK] key.
4. Press the [▲] [▼] keys to select the paper size setting for the desired tray, and then press the [OK] key.
5. Press the [▲] [▼] [◀] [▶] keys to select the desired paper size, and then press the [OK] key.
6. Press the [User Tools] key to return to the initial screen.

↓ Note

- You can press the [Escape] key to exit to the previous level of the menu tree.

Specifying a custom paper size

This section describes how to specify a custom paper size.

★ Important

- Custom size paper cannot be loaded in tray 2.
- When you perform printing, make sure that the paper size specified with the printer driver matches the paper size specified with the control panel. If a paper size mismatch occurs, a message appears on the display. To ignore the error and print using mismatched paper, see "If a Paper Mismatch Occurs".

1. Press the [User Tools] key.

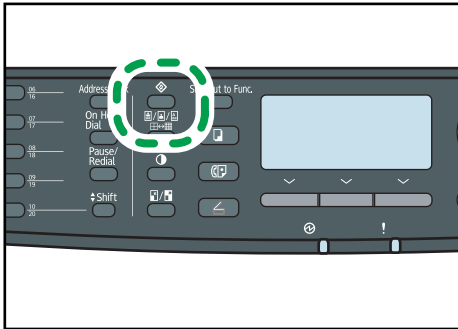

CMF134

2. Press the [▲] [▼] keys to select [System Settings], and then press the [OK] key.
3. Press the [▲] [▼] keys to select [Tray Paper Settings], and then press the [OK] key.
4. Press the [▲] [▼] keys to select the paper size setting for the desired tray, and then press the [OK] key.
5. Press the [▲] [▼] [◀] [▶] keys to select [Custom Size], and then press the [OK] key.
6. Press the [▲] [▼] keys to select [mm] or [inch], and then press the [OK] key.
7. Enter the width using number keys, and then press the [OK] key.
To enter a decimal point, press [✱].
8. Enter the length using number keys, and then press the [OK] key.
To enter a decimal point, press [✱].
9. Press the [User Tools] key to return to the initial screen.

↓ Note

- You can press the [Escape] key to exit to the previous level of the menu tree.

📖 Reference

- For details about printing using mismatched paper, see p.136 "If a Paper Mismatch Occurs".

Placing Originals

This section describes the types of originals you can set and how to place them.

About Originals

This section describes the types of originals that can be placed and the parts of the original that are unscannable.

2

Recommended size of originals

This section describes the recommended size of the original.

Exposure glass

Up to 216 mm (8.5") in width, up to 297 mm (11.7") in length

ARDF/ADF

- Paper size: 140 to 216 mm (5¹/₂" to 8¹/₂") in width, 140 to 356 mm (5¹/₂" to 14") in length
- Paper weight: 52 to 105 g/m² (13.8 to 28.0 lb.)

↓ Note

- Only 1 sheet of an original can be placed on the exposure glass at a time.
- In the ARDF or ADF, up to 50 sheets or 35 sheets of originals can be placed at once, respectively (when using paper weighing 80 g/m², 20 lb.).

Types of originals not supported by the ARDF or ADF

If placed in the ARDF or ADF, the following types of original might be damaged or become jammed, or result in gray or black lines appearing on prints:

- Originals larger or heavier than recommended
- Stapled or clipped originals
- Perforated or torn originals
- Curled, folded, or creased originals
- Pasted originals
- Originals with any kind of coating, such as thermal fax paper, art paper, aluminum foil, carbon paper, or conductive paper
- Originals with perforated lines
- Originals with indexes, tags, or other projecting parts

- Sticky originals such as translucent paper
- Thin, highly flexible originals
- Thick originals such as postcards
- Bound originals such as books
- Transparent originals such as OHP transparencies or translucent paper
- Originals that are wet with toner or white out

Unscannable image area

Even if you correctly place originals in the ARDF or ADF or on the exposure glass, margins of a few millimeters on all four sides of the original might not be scanned.

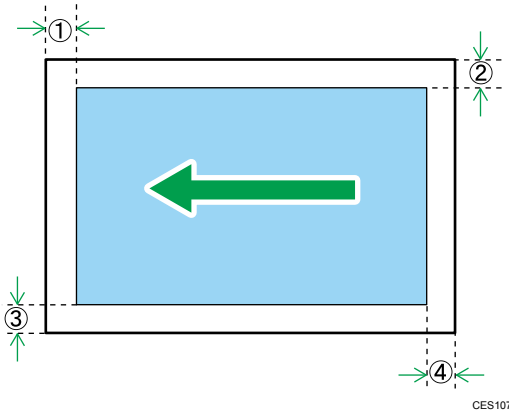

Margins when using exposure glass

	In copier mode	In scanner mode	In fax mode
① Top	4 mm	0 mm	1 mm
② Right	3 mm	0 mm	1 mm
③ Left	3 mm	0 mm	1 mm
④ Bottom	4 mm	0 mm	2 mm

Margins when using ARDF or ADF

	In copier mode	In scanner mode	In fax mode
① Top	4 mm	0 mm	0 mm
② Right	3 mm	0 mm	1 mm

	In copier mode	In scanner mode	In fax mode
③ Left	3 mm	0 mm	1 mm
④ Bottom	4 mm	0 mm	2 mm

Placing Originals

2

This section describes the procedure for placing originals on the exposure glass and in the ARDF or ADF.

★ Important

- Do not place originals before any correction fluid and toner has completely dried. Doing so may make marks on the exposure glass that will appear on copies.
- The original in the ARDF or ADF takes precedence over the original on the exposure glass if you place originals both in the ARDF/ADF and on the exposure glass.

↓ Note

- Because colors made by marker or highlighter pen on originals are difficult to reproduce, they might not appear on copies.

Placing originals on the exposure glass

The exposure glass enables you to scan and send documents that cannot be fed into the ARDF or ADF.

★ Important

- Do not lift the ARDF or ADF forcefully. Otherwise, the cover of the ARDF or ADF might open or be damaged.

1. Lift the ARDF or ADF.

Be careful not to hold the input tray when lifting the ARDF or ADF, for the tray might be damaged.

2. Place the original face down on the exposure glass. The original should be aligned to the rear left corner.

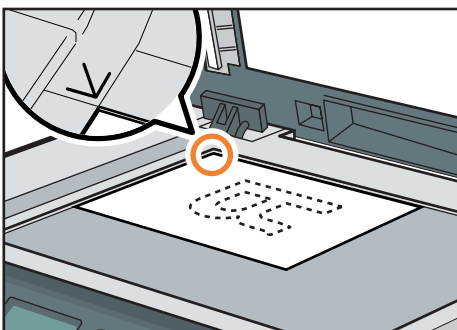

CMF048

3. Lower the ARDF or ADF.

Hold down the ARDF or ADF with your hands when using thick, folded, or bound originals and the ARDF or ADF cannot be lowered completely.

Placing originals in the ARDF (Type 2 model)

2

By using the ARDF, you can scan multiple pages at once. Also, you can scan both sides of original with the ARDF.

★ Important

- Do not place different size originals in the ARDF at once.
- Straighten curls in the originals before placing them in the ARDF.
- To prevent multiple sheets from being fed at once, fan the pages of your original before placing them in the ARDF.
- Place the original squarely.

1. Open the cover of the ARDF.

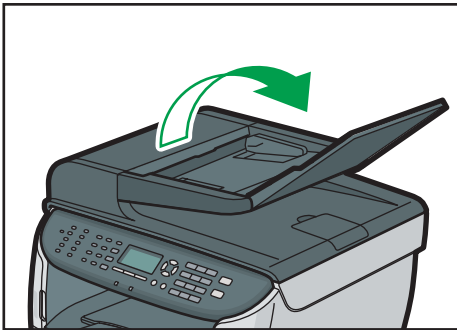

CMF049

2. Adjust the guides according to the size of the original.

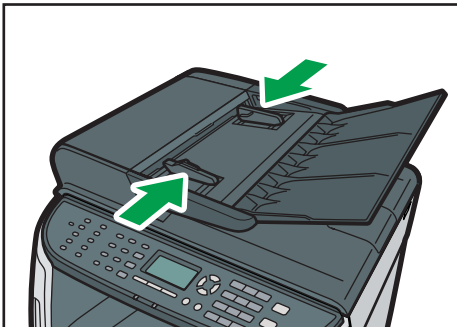

CMF050

3. Place the aligned originals face up in the ARDF. The last page should be on the bottom.

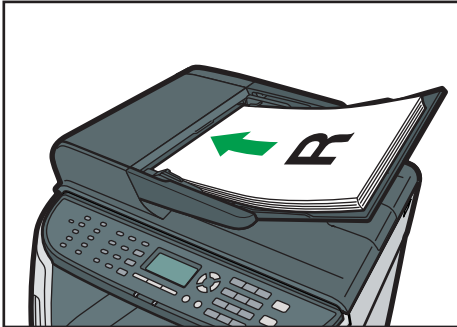

CMF051

Note

- When placing originals longer than A4, pull out the ARDF output tray's extender.

Placing originals in the ADF (Type 1 model)

By using the ADF, you can scan multiple pages at once.

Important

- Do not place different size originals in the ADF at once.
- Straighten curls in the originals before placing them in the ADF.
- To prevent multiple sheets from being fed at once, fan the pages of your original before placing them in the ADF.
- Place the original squarely.

1. Adjust the guides according to the size of the original.

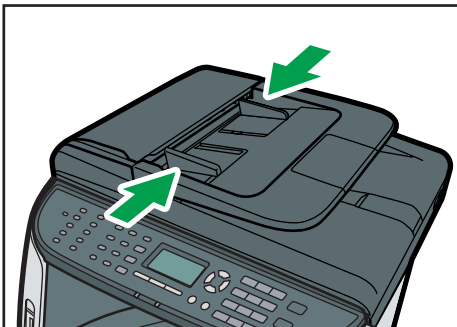

CMF063

2. Place the aligned originals face up in the ADF. The last page should be on the bottom.

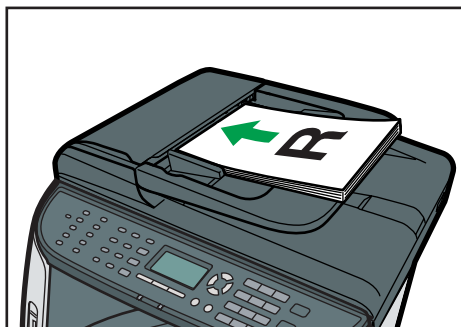

CMF064

Note

- When placing originals longer than A4, pull out the ADF tray's extenders.

Entering Characters

This section describes how to enter characters using the control panel when configuring the machine's settings.

Use the keys as follows to enter characters.

To enter a digit

Press a number key.

To delete a character

Press the [◀] key.

To enter a fax number

- To enter a number
Use the number keys.
- To enter characters other than digits
"✳": Press [✳].
"#": Press [#].
"+": Press [✳].

Pause: Press the [Pause/Redial] key. "P" appears on the screen.

Space: Press the [▶] key.

To enter a name

Letters, numbers, and symbols can be entered using the number keys.

To enter two characters that use the same number key successively, wait briefly after entering the first character.

Number key	Number of key press																												
	1	2	3	4	5	6	7	8	9	10	11	12	13	14	15	16	17	18	19	20	21	22	23	24	25	26	27	28	29
1	1																												
2	A	Ã	Ä	Å	Æ	B	C	Ç	a	à	á	â	ã	ä	æ	b	c	ç	2										
3	D	E	É	F	d	e	è	é	ê	ë	f	3																	
4	G	H	I	g	h	i	í	î	ï	4																			
5	J	K	L	j	k	l	5																						
6	M	N	Ñ	O	Ö	Ø	Œ	m	n	ñ	o	ò	ó	ô	õ	ø	œ	6											
7	P	Q	R	S	ß	p	q	r	s	7																			
8	T	U	Ü	V	t	u	ù	ú	ü	v	8																		
9	W	X	Y	Z	w	x	y	ÿ	z	9																			
0	0	-	.	!	"	,	;	:	^	'	_	=	/		'	?	\$	@	%	&	+	()	[]	{	}	<	>
✳	✳																												
#	#																												

CMF106

 **Note**

- Characters you can enter depend on the setting you are configuring.
- If the number you entered is too large or too small for the setting, it will not be accepted. If you press the [OK] key, the machine will increase or decrease the number to the minimum or maximum value for the setting.

Restricting Machine Functions According to User

You can set the machine to require a user code when someone tries to use certain machine functions.

★ Important

- When print jobs are restricted, you can only authenticate through the PCL6 printer driver. Printing from the PostScript 3 printer driver will not be possible.
- User restriction settings can be used in combination with LDAP authentication, except for printing using the PCL6 printer driver and sending LAN-Faxes. Under LDAP authentication, users will only be able to authenticate for PCL6 printing and LAN-Faxes using user names and passwords for the LDAP server, not user codes for the user restriction settings.

Use of the following functions can be restricted:

- Copying
- Sending faxes
- Scan to E-mail/FTP/Folder
- Scan to USB
- Printing
- Sending faxes via LAN-Fax

To enable this setting, you must first configure the machine via Web Image Monitor.

📖 Reference

- For details about LDAP authentication, see p.439 "Using the LDAP Authentication and Address Search Functions".

Enabling the User Restriction Settings

This section describes how to set the machine to permit only authorized users to use certain machine functions.

Using Web Image Monitor, enable user restriction for all or some of the functions listed below, and then register users who can use those functions.

- Copying
- Sending faxes
- Scan to E-mail/FTP/Folder
- Scan to USB
- Printing
- Sending faxes via LAN-Fax

For each user, you can specify which functions are available upon authentication. A maximum of 30 users can be registered.

1. Start the Web browser, and access the machine by entering its IP address.
2. Click [Restrict Available Functions].
3. Enter the administrator password if required.
4. Click [Apply].

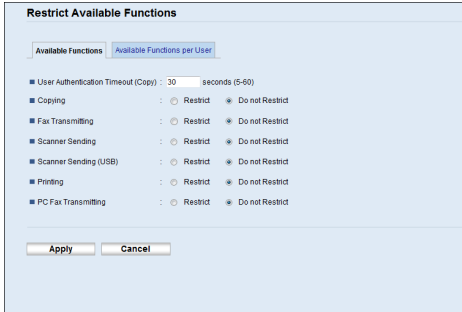

5. Under "Available Functions", enter the timeout value in seconds (5 to 60, the default is 30) in [User Authentication Timeout (Copy)].

Within the time specified here, user stays authenticated after paper is output when copying with the exposure glass. Note that authentication for other functions will expire immediately after using that function.

6. Select [Restrict] for the functions you want to restrict, and then click [Apply].

Select [Do not Restrict] for the functions you do not want to restrict.

The user restriction setting is enabled for the selected function. Proceed to the following steps to register users.

7. Click [Available Functions per User].

A list of currently registered user entries appears.

No.	User Name	Copying	Fax Transmitting	Scanner Sending	Scanner Sending (USB)	Printing	PC Fax Transmitting	Page Counter (Copy, Printing)
01		<input checked="" type="checkbox"/>	<input checked="" type="checkbox"/>	<input checked="" type="checkbox"/>	<input checked="" type="checkbox"/>	<input checked="" type="checkbox"/>	<input checked="" type="checkbox"/>	
02		<input type="checkbox"/>	<input type="checkbox"/>	<input type="checkbox"/>	<input type="checkbox"/>	<input type="checkbox"/>	<input type="checkbox"/>	
03		<input checked="" type="checkbox"/>	<input checked="" type="checkbox"/>	<input checked="" type="checkbox"/>	<input checked="" type="checkbox"/>	<input checked="" type="checkbox"/>	<input checked="" type="checkbox"/>	
04		<input type="checkbox"/>	<input type="checkbox"/>	<input type="checkbox"/>	<input type="checkbox"/>	<input type="checkbox"/>	<input type="checkbox"/>	
05		<input checked="" type="checkbox"/>	<input checked="" type="checkbox"/>	<input checked="" type="checkbox"/>	<input checked="" type="checkbox"/>	<input checked="" type="checkbox"/>	<input checked="" type="checkbox"/>	
06		<input type="checkbox"/>	<input type="checkbox"/>	<input type="checkbox"/>	<input type="checkbox"/>	<input type="checkbox"/>	<input type="checkbox"/>	
07		<input checked="" type="checkbox"/>	<input checked="" type="checkbox"/>	<input checked="" type="checkbox"/>	<input checked="" type="checkbox"/>	<input checked="" type="checkbox"/>	<input checked="" type="checkbox"/>	
08		<input type="checkbox"/>	<input type="checkbox"/>	<input type="checkbox"/>	<input type="checkbox"/>	<input type="checkbox"/>	<input type="checkbox"/>	
09		<input checked="" type="checkbox"/>	<input checked="" type="checkbox"/>	<input checked="" type="checkbox"/>	<input checked="" type="checkbox"/>	<input checked="" type="checkbox"/>	<input checked="" type="checkbox"/>	
10		<input type="checkbox"/>	<input type="checkbox"/>	<input type="checkbox"/>	<input type="checkbox"/>	<input type="checkbox"/>	<input type="checkbox"/>	
11		<input checked="" type="checkbox"/>	<input checked="" type="checkbox"/>	<input checked="" type="checkbox"/>	<input checked="" type="checkbox"/>	<input checked="" type="checkbox"/>	<input checked="" type="checkbox"/>	

8. Select a user entry, and then click [Change].

The screenshot shows a dialog box titled "Available Functions". It has a dropdown menu for "No" with a downward arrow. Below it are two input fields: "User Name" and "User Code". Underneath is a section labeled "Available Functions" with six checkboxes: "Copying", "Fax Transmitting", "Scanner Sending", "Scanner Sending (USB)", "Printing", and "PC Fax Transmitting". At the bottom of the dialog are two buttons: "Apply" and "Cancel".

9. Type a unique user name in [User Name] using up to 16 alphanumeric characters.

10. Type a unique user code in [User Code] using up to 8 digits.

The user code will be used to authenticate users when they try to use a restricted function.

11. Select the functions you want to make available for the user upon authentication.

Unselected functions will be unavailable to users authenticated under this user code.

12. Click [Apply].

13. Close the Web browser.

↓ Note

- You must enter both a user name and user code to register a user entry.
- No two user entries can have the same user name or user code.
- Under "Available Functions per User", you will see counter information for prints made by the copier and printer functions on a user basis.
- The counter resets to 0 in the following cases:
 - When you select a user and click [Clear Counter (Copy)] or [Clear Counter (Printer)]
 - When the user code is changed (not the user name)
 - When the setting is cleared with [Reset Settings of Available Functions] under [Administrator Tools].

📖 Reference

- For details about using Web Image Monitor, see p.309 "Using Web Image Monitor".
- For details about [Reset Settings of Available Functions], see p.353 "Configuring the Administrator Settings".

Modifying user entries

This section describes how to modify user entries.

1. Start the Web browser, and access the machine by entering its IP address.

2. Click [Restrict Available Functions].
3. Enter the administrator password if required.
4. Click [Apply].
5. Click [Available Functions per User].

A list of currently registered user entries appears.

6. Select the entry to modify, and then click [Change].
7. Modify settings as necessary.
8. Click [Apply].
9. Close the Web browser.

Reference

- For details about using Web Image Monitor, see p.309 "Using Web Image Monitor".

Deleting user entries

This section describes how to delete user entries.

1. Start the Web browser, and access the machine by entering its IP address.
2. Click [Restrict Available Functions].
3. Enter the administrator password if required.
4. Click [Apply].
5. Click [Available Functions per User].
A list of currently registered user entries appears.
6. Select the entry to delete, and then click [Delete].
7. Confirm that the entry you have selected is the entry that you want to delete.
8. Click [Apply].
9. Close the Web browser.

Reference

- For details about using Web Image Monitor, see p.309 "Using Web Image Monitor".

When Machine Functions are Restricted

When a machine function is restricted, only authorized users are able to use that function.

Depending on the restricted function, users will be authenticated from the machine's control panel or in the printer/LAN-Fax driver.

★ Important

- When print jobs are restricted, you can only authenticate through the PCL6 printer driver. Printing from the PostScript 3 printer driver will not be possible.
- User restriction settings can be used in combination with LDAP authentication, except for printing using the PCL6 printer driver and sending LAN-Faxes. Under LDAP authentication, users will only be able to authenticate for PCL6 printing and LAN-Faxes using user names and passwords for the LDAP server, not user codes for the user restriction settings.

The table below shows the functions that can be restricted, and how users can be authenticated to use those functions.

Restricted function	Authentication method
<ul style="list-style-type: none"> • Copying • Sending faxes • Scan to E-mail/FTP/Folder • Scan to USB 	<p>The machine requests for a user code when a user presses the [Start] key.</p> <p>The user must enter a valid user code from the control panel.</p>
<ul style="list-style-type: none"> • Printing • Sending faxes via LAN-Fax 	<p>The user must enter a valid user code in the printer or LAN-Fax driver before executing a print command.</p>

Authenticating through the control panel

1. When the machine requests for a user code, enter a user code (within 30 seconds) using the number keys.

If you enter a wrong user code 3 times, the machine beeps and denies the authentication.

2. Press the [OK] key.

Authenticating through the printer or LAN-Fax driver

1. Open the file you want to print on your computer.
2. Open the printer driver's properties.
3. Click the [Valid Access] tab (PCL6 printer driver) or check the [User Code] check box. (LAN-Fax driver).
4. Type the user code using 1 to 8 digits, and then click [OK].

5. Execute a print command.

If an incorrect user code is entered, the job will be canceled automatically.

↓ Note

- You cannot enter the user code if the [User Authentication] (PCL6 printer driver) or [User authentication] (LAN-Fax driver) check box on the [Advanced Options] tab of the driver's properties is checked. Clear the check box if necessary.

📖 Reference

- For details about LDAP authentication, see p.439 "Using the LDAP Authentication and Address Search Functions".

3. Using the Printer Function

This chapter describes the printer functions.

Configuring Option and Paper Settings

Configure the printer driver according to the machine's option and paper settings.

★ Important

- **Manage Printers permission is required to change the printer properties. Log on as an Administrators group member to acquire this permission.**
- **We recommend that bidirectional communication between the machine and the computer be enabled whenever possible. Bidirectional communication allows the computer to retrieve the machine's paper settings, current status, and other information.**

Conditions for Bidirectional Communication

To establish bidirectional communication, the following conditions must be met:

- Operating system of the computer: Windows XP/Vista/7, and Windows Server 2003/2003 R2/2008/2008 R2
- When connected via a network
The machine is connected via a standard TCP/IP port, and the default port name must not be changed.
[Enable bidirectional support] in the [Ports] tab of the printer properties is selected.
- When connected via USB
The machine is connected to the computer's USB port using a USB interface.
[Enable bidirectional support] in the [Ports] tab of the printer properties is selected.

Windows

The following procedure is based on Windows 7 as an example.

1. On the [Start] menu, click [Devices and Printers].
2. Right click the icon of the printer you want to use, and then click [Printer properties].
3. Click the [Accessories] tab.
4. Click [Update Now].
If bidirectional communication is not established, select the installed option manually.
5. Click the [Paper Size Settings] tab.

6. Select the tray you want to use under [Input Tray:], select the paper size under [Paper Size:], and then click [Update Now].

If bidirectional communication is not established, select the tray and paper size manually.

7. Click [OK] to close the printer properties dialog box.

Mac OS X 10.3

1. From the Apple menu, select [System Preferences...].
2. Under "Hardware", click [Print & Fax].
3. Click the [Set Up Printers...].
4. Select the machine from "Printer List", and then click [Show Info].
5. In the [Printer Info] dialog box, select [Installable Options] from the list.
6. Check the tray 2 configuration, and then click [Apply Changes].
7. Click the close button at the upper left corner to close the [Printer Info] dialog box.
8. Click the close button at the upper left corner to close the [Printer List] dialog box.
9. From the [System Preferences] menu, click [Quit System Preferences].

Mac OS X 10.4

1. From the Apple menu, select [System Preferences...].
2. Under "Hardware", click [Print & Fax].
3. Select the machine from "Printer", and then click [Printer Setup...].
4. In the [Printer Info] dialog box, select [Installable Options] from the list.
5. Check the tray 2 configuration, and then click [Apply Changes].
6. Click the close button at the upper left corner to close the [Printer Info] dialog box.
7. From the [System Preferences] menu, click [Quit System Preferences].

Mac OS X 10.5/10.6

1. From the Apple menu, select [System Preferences...].
2. Under "Hardware", click [Print & Fax].
3. Select the machine from "Printers", and then click [Options & Supplies...].
4. Click the [Driver] tab.
5. Check the tray 2 configuration, and then click [OK].

6. From the [System Preferences] menu, click [Quit System Preferences].

Accessing the Printer Properties

This section describes accessing the printer properties. For details about settings, see the printer driver Help.

Accessing the Printer Properties from the [Devices and Printers] Window

★ Important

- To change the printer default settings including option configuration settings, log on using an account that has Manage Printers permission. Members of the Administrators group have Manage Printers permission by default.
- You cannot change the printer default settings for each user. Settings configured in the printer properties dialog box are applied to all users. Procedures and screens might vary depending on the operating system you are using.
- The following procedure is based on Windows 7 as an example. If you are using another operating system, the procedure might vary slightly.

1. On the [Start] menu, click [Devices and Printers].
2. Right click the icon of the printer you want to use, and then click [Printer properties].

The printer properties dialog box appears.

↓ Note

- The settings you configure here are used as the default settings for all applications.
- When accessing the PostScript3 printer properties, do not change settings for [Form to Tray Assignment].

Accessing the Printer Properties from an Application

Windows

You can configure printer settings for a specific application.

To configure printer settings for a specific application, open the printer's properties in that application.

The following procedure explains how to configure settings for the WordPad application provided with Windows 7.

1. Open the file you want to print.
2. On the [File] menu, click [Print...].

The [Print] dialog box appears.

3. Select the printer you want to use in the [Select Printer] list, and then click [Preferences].**↓ Note**

- The procedure to open the printer's properties dialog box may vary depending on the application. For details, see the manuals provided with the application.
- Any settings you configure in the procedure above are valid for the current application only.
- General users can configure the settings displayed in the printer's properties dialog box of an application. The settings configured here are used as defaults when printing from that application.

Mac OS X

1. Open the file you want to print.
2. On the [File] menu, click [Print...].
3. In the [Printer:] list, select the printer you want to use.

Basic Operation in Printer Mode

The following procedure explains how to perform basic printing.

1. **Open the printer properties dialog box in your document's application.**
2. **Set printing options as necessary, and then click [OK].**
The printer properties dialog box closes.
3. **Click [OK].**

Note

- If printing is restricted, you must enter a user code in the printer driver's properties before sending a print job to the machine.
- If LDAP authentication is specified, you must enable user authentication and enter a user name and password in the printer driver's properties before sending a print job to the machine.
- If tray 2 is installed and automatic tray selection is specified for the print job, you can select the tray the machine uses first in [Paper Tray Priority] under system settings.
- If a paper jam occurs, printing stops after the current page has been printed out. After the jammed paper is removed, printing restarts from the jammed page automatically.
- After printing on envelopes, make sure to pull up the levers for printing on envelopes back to their original positions. Leaving the levers lowered can cause print quality problems when printing on paper other than envelopes.

Reference

- For details about accessing the printer properties, see p.134 "Accessing the Printer Properties from an Application".
- For details about entering a user code, see p.129 "When Machine Functions are Restricted".
- For details about enabling user authentication and entering a user name and password, see p.444 "When LDAP Authentication is Specified".
- For details about [Paper Tray Priority], see p.279 "System Settings".
- For details about how to remove the jammed paper, see p.365 "Removing Printing Jams".
- For details about the levers for printing on envelopes, see p.110 "Loading Envelopes".

If a Paper Mismatch Occurs

If the paper size or type does not match the print job's settings, the machine reports an error. There are two ways to resolve this error:

Continue printing using mismatched paper

Use the form-feed function to ignore the error and print using mismatched paper.

Reset the print job

Cancel printing.

Note

- If [Auto Continue] under system settings is enabled, the machine ignores the paper type and size settings and prints on whatever paper is loaded. Printing stops temporarily when the error is detected, and restarts automatically after about ten seconds using the settings made on the control panel.

Reference

- For details about [Auto Continue], see p.279 "System Settings".

3

Continuing printing using mismatched paper

1. While the error message is displayed, press [FormFeed].

Printing resumes on whatever paper is loaded.

Note

- If the paper is too small for the print job, the printed image will be cropped.

Resetting the print job

1. When the error message is displayed, press [JobReset].

Printing is canceled.

Canceling a Print Job

You can cancel print jobs using either the machine's control panel or your computer, depending on the status of the job.

Canceling a print job before printing has started

Cancel the print job from the computer.

Windows

1. Double-click the printer icon on the task bar of your computer.
2. Select the print job you want to cancel, click the [Document] menu, and then click [Cancel].

Mac OS X 10.3

1. From the Apple menu, select [System Preferences...].
2. Under "Hardware", click [Print & Fax].
3. Click [Set Up Printers...].
4. Double-click the machine from "Printer List".
5. Select the print job you want to cancel, and then click [Delete].

Mac OS X 10.4

1. From the Apple menu, select [System Preferences...].
2. Under "Hardware", click [Print & Fax].
3. Double-click the machine from "Printer".
4. Select the print job you want to cancel, and then click [Delete].

Mac OS X 10.5/10.6

1. From the Apple menu, select [System Preferences...].
2. Under "Hardware", click [Print & Fax].
3. Double-click the machine from "Printers".
4. Select the print job you want to cancel, and then click [Delete].

↓ Note

- If the printer is shared by multiple computers, be careful not to cancel the print job of another user.
- If you cancel a print job that has already been processed, printing may continue for a few pages before being canceled.
- You can also open the print job queue window by double-clicking the printer icon in the [Printers] window.
- If you cancel a Locked Print job, the machine might have already stored some pages of the job as a Locked Print file. If this happens, use the control panel to delete the Locked Print file.
- It may take a while to cancel a large print job.

📖 Reference

- For details about deleting a Locked Print file, see p.141 "Deleting a Locked Print file".

Canceling a print job while printing

Cancel the print job using the control panel.

1. Press the [Clear/Stop] key.

Printing Confidential Documents

If you use the Locked Print function, you can password protect your print job.

This means that your job is printed only after you enter the password using the machine's control panel.

This function prevents unauthorized users seeing sensitive documents at the machine.

★ Important

- This function is only available when using the PCL6 printer driver, and printing from a computer running a Windows operating system.

3

Storing a Locked Print file

This section describes how to store a Locked Print file in the machine using the printer driver.

1. Open the file you want to print on your computer.
2. Open the printer driver's properties.
3. Click the [Setup] tab, and then select [Locked Print].

The [Password:] and [User ID:] text boxes become available.

The [User ID:] text box contains the login user name of your computer account or the user code that you used for the previous Locked Print job.

4. Type the password (containing 4 to 8 digits) and user ID (containing 1 to 9 alphanumeric characters), and then click [OK].

The user code will be used to identify your Locked Print file on the machine's control panel.

5. Execute a print command.

The print job is stored in the machine as a Locked Print file. You can print the file by entering the password using the control panel.

↓ Note

- The Locked Print file is automatically erased from the machine's memory when it is printed out, or when the machine's power is turned off.
- The machine can store a maximum of 5 jobs or 5 MB of Locked Print data at a time.
- Even if the machine cannot store any more Locked Print files, the machine holds a new Locked Print file for the period of time specified in [Locked Print] under system settings before canceling the job. Within this time, you can print or delete the new Locked Print file. You can also print or delete an existing Locked Print file so that the new Locked Print file can be stored in the machine.
- When a Locked Print job is canceled, the machine automatically records the cancellation in a log. You can use this log to identify which Locked Print jobs have been canceled.

Reference

- For details about [Locked Print], see p.279 "System Settings".

Printing a Locked Print file

When there is a Locked Print file stored in the machine, "Locked Print Job Press User Tools key" appears on the machine's control panel display when the machine is in the copier mode.

3

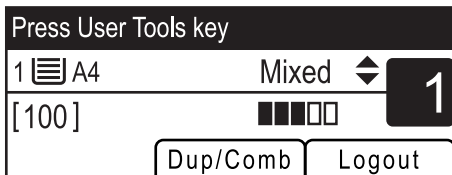
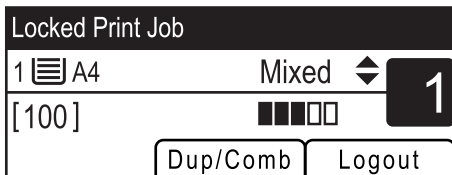

Use the following procedure to unlock and print the Locked Print file.

1. When the Locked Print message is displayed, press the [User Tools] key.

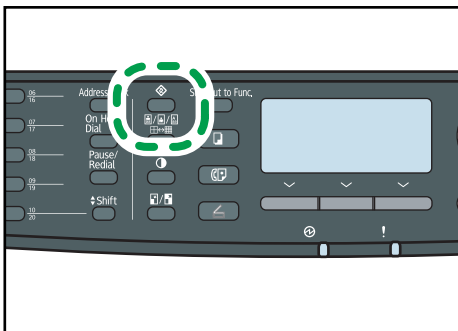

CMF134

2. Press the [▲][▼] keys to select the file you want to print, and then press the [OK] key.

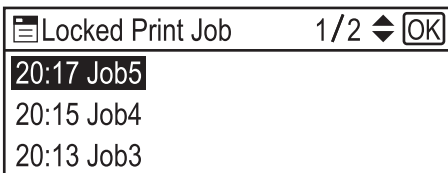

Identify the Locked Print file by checking its time stamp and user ID.

3. Press [Print].

4. Enter the password using the number keys, and then press the [OK] key.

The Locked Print file is printed.

↓ Note

- You can press the [Escape] key to exit to the previous level of the menu tree.
- To enter the menu for changing the machine's settings, press the [Scanner] key or the [Facsimile] key, and then press the [User Tools] key. To print a Locked Print file, press the [Copy] key to return to the copier mode.
- If the machine is currently printing, you cannot print a Locked Print file. The machine beeps if you try to do so.
- While in the Locked Print menu, the machine cannot receive new print jobs.
- The Locked Print file is automatically erased from the machine's memory when it is printed out or canceled, or when the machine's power is turned off.

3

Deleting a Locked Print file

When there is a Locked Print file stored in the machine, "Locked Print Job Press User Tools key" appears on the machine's control panel display when the machine is in the copier mode.

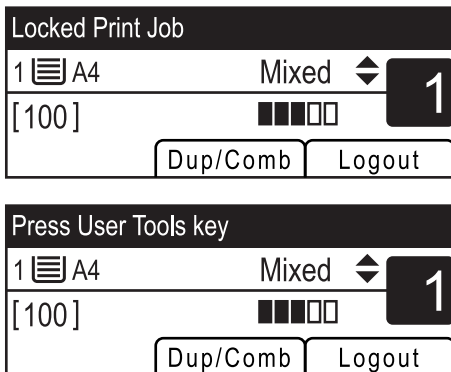

Use the following procedure to delete a Locked Print file. You do not need to enter a password to delete a Locked Print file.

1. When the Locked Print message is displayed, press the [User Tools] key.

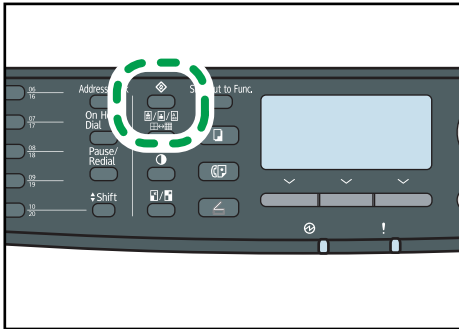

CMF134

2. Press the [▲][▼] keys to select the file you want to delete, and then press the [OK] key.

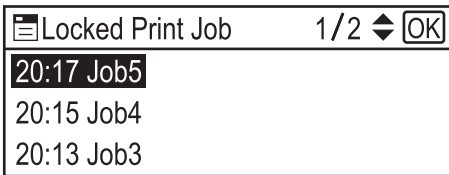

Identify the Locked Print file by checking its time stamp and user ID.

3. Press [Delete].

The Locked Print file is deleted.

If there are Locked Print files/logs remaining in the machine, the display returns to the list of Locked Print files/logs. If there are none remaining, the display returns to the initial screen.

Note

- You can press the [Escape] key to exit to the previous level of the menu tree.
- To enter the menu for changing the machine's settings, press the [Scanner] key or the [Facsimile] key, and then press the [User Tools] key. To delete a Locked Print file, press the [Copy] key to return to the copier mode.

Checking which Locked Print File Jobs Have Been Canceled

When a Locked Print job is canceled, the machine automatically records the cancellation in a log. If the machine has created a cancellation log, "Locked Print Job Deleted Press User Tools key" will appear on the control panel display when the machine is in the copier mode.

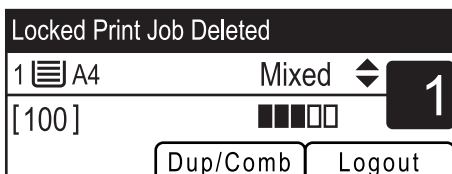

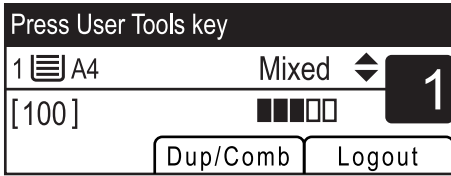

Use the following procedure to check which Locked Print file jobs have been canceled.

1. When the Locked Print message is displayed, press the [User Tools] key.

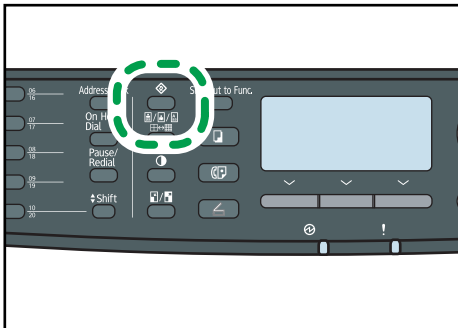

CMF134

2. Press the [▲][▼] keys to find a file whose name starts with an "!" mark.

The "!" mark indicates that the job has been canceled.

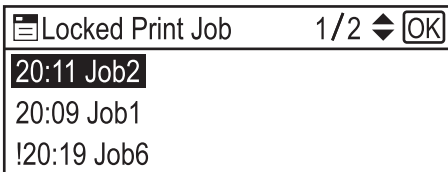

Identify the Locked Print file by checking its time stamp and user ID.

To delete the log entry, proceed to the following steps.

3. Press the [OK] key.
4. Press [Delete].

The log is deleted.

If there are Locked Print logs/files remaining in the machine, the display returns to the list of Locked Print logs/files. If there are none remaining, the display returns to the initial screen.

Note

- You can press the [Escape] key to exit to the previous level of the menu tree.
- To enter the menu for changing the machine's settings, press the [Scanner] key or the [Facsimile] key, and then press the [User Tools] key. To check the Locked Print log, press the [Copy] key to return to the copier mode.

- The machine keeps a log of the 10 most recent canceled jobs. If a Locked Print file is canceled when the machine's log is already full, the oldest log will be deleted automatically.
- The message "Locked Print Job Deleted Press User Tools key" disappears when all log entries are cleared.
- The log will be cleared when the machine is turned off.

Manual Duplex Printing (Type 1 model)

To print on both sides of paper using the Type 1 model, use the Manual Duplex function.

In Manual Duplex printing, the machine prints only even pages of a document first, asks you to reload the output paper turned upside down into the machine, and then prints odd pages on the back sides of the paper.

★ Important

- This function is only available when printing from a computer running a Windows operating system using the PCL6 printer driver.
- The machine always uses tray 1 to print on the back sides of paper, regardless of the tray you selected with the printer driver. Make sure that the paper settings of the trays that will be used match the paper settings of the print job to avoid paper mismatch errors.

1. Open the file you want to print on your computer.
2. Open the printer driver's properties.
3. On the [Setup] tab, select [Long edge bind (to left/top)] or [Short edge bind (to top/left)] from the [Duplex:] list.

Manual duplex printing requires that [Zoom %] be set at 100% and [Print On] be checked on the [Paper] tab. If not, a dialog box appears to inform you that the setting must be changed; clicking [OK] will automatically change the settings.

4. Configure printing preferences according to your needs, and then click [OK] twice.

A Manual Duplex guidance screen appears on your computer showing the subsequent procedure, and the machine starts printing even pages.

When all even pages are printed out, "Set Bck Side in Tray1" appears on the machine's control panel display.

5. Reload the output paper into tray 1 with the printed side up.

If paper orientation is portrait, put the top of paper towards you for [Long edge bind (to left/top)] or towards the machine rear for [Short edge bind (to top/left)].

If paper orientation is landscape, put the top of paper to the right for [Long edge bind (to left/top)] or to the left for [Short edge bind (to top/left)].

6. Press [Continue].

Odd pages will then be printed.

↓ Note

- When you print a document whose page count is an odd number, a blank page is printed last. This blank page is the last page of the document. When you start printing on the other side of the paper, include this blank page in the bundle of paper.

 **Reference**

- For details about loading paper in the trays, see p.96 "Loading Paper".
- For details about printer driver operation, see the printer driver Help.

Using Various Print Functions

This section briefly describes various print functions that you can configure with the printer driver to make printouts appropriate for your purposes.

Print Quality Functions

Print quality and color tone can be adjusted to suit the print data. Some of the print quality settings you can configure are described below.

3

Changing the image printing method

You can select to print with priority on print quality or print speed. When printing images, the higher the resolution of images, the longer the time required for printing.

Changing the graphics mode

You can send graphic information to the machine as either all raster or a mixture of vector and raster images. Most geometric shapes or patterns print faster as vector images than as raster images. However, if certain graphics do not print as they appear on the screen, try to print them as raster images.

Saving toner when printing

You can save toner by printing with lower toner consumption. While this increases the life of the print cartridge, the output appears slightly lighter.

Changing the printable area

You can change the printable area when printing a document printed on a single page with one machine is printed on two separate pages with another machine, or vice-versa.

Changing the method of downloading TrueType fonts to the machine

When you print documents that contain characters in TrueType fonts, garbled or distorted characters may be printed. Changing the method of downloading TrueType fonts may help to solve the problem.

Changing the dither pattern

A dither pattern is a pattern of dots used to simulate a color or shade of an image. If the pattern is changed, the characteristics of the image will also change. You can select a pattern suitable for the image to be printed.

Note

- Some of the functions described above might not be available depending on the printer driver or operating system. For details, see the printer driver Help.

Print Output Functions

You can specify the form of print outputs according to your purposes. This section briefly describes some of the settings that you can specify.

Printing multiple sets of a document

You can print multiple sets of the same document.

Collating the output in document batches

You can print complete sets of a multiple-page document one set at a time (P1, P2, P1, P2 ...). If this function is not used when printing multiple sets, prints will be output in page batches (P1, P1, P2, P2 ...). This function is useful when, for example, making presentation materials.

Changing orientation or rotating the image

You can change the orientation of an image to portrait or landscape. You can also rotate the image by 180 degrees. Use rotation to prevent an image from being printed upside down when using paper that a predefined top and bottom (such as letterhead paper).

Printing multiple pages per sheet

You can print multiple pages onto one sheet of paper.

When using this function, a suitable reduction ratio is selected automatically based on the paper size and the number of pages you want to fit on each sheet.

Printing on both sides of paper (duplex printing)

You can print on both sides of paper.

Duplex printing using the Type 2 model can be done automatically, and available binding options include booklet.

Duplex printing using the Type 1 model requires manually reloading paper.

Reducing or enlarging the document

You can reduce or enlarge documents by a specific ratio, from 25% to 400% in 1% increments.

You can also reduce or enlarge documents automatically to fit a specific paper size. This function is useful, for example, when printing Web pages.

If the [Enable Large Papers] option is selected, A3/11" × 17"/B4/8K documents can be scaled to a size that the machine supports, so it can then be printed out.

Suppressing printing of blank pages

If a print job contains blank pages, they can be prevented from being printed.

Note that the printer driver's setting has higher priority than [Blank Page Print] under printer feature settings of the control panel.

Printing with a cover page

You can add a cover page to the print job.

You can select to leave the cover page blank, or print the first page of the document on the cover page. If a cover page is inserted into a duplex job, you can print on its back side also.

Paper for the cover page can either be the same as or different from the remaining pages.

Printing on custom size paper

You can print using non-standard size paper by specifying the size of the paper as custom size.

To specify a non-standard paper size, select [Custom Paper Size] from the [Document Size:] list, and then click the [Custom Paper Size...] button in the lower part of the dialog box to configure the paper size.

Superimposing text on prints (watermark)

You can superimpose watermark text on prints. Various predefined watermarks are provided. You can also create your own watermarks.

Note

- Some of the functions described above might not be available depending on the printer driver or operating system. For details, see the printer driver Help.

Reference

- For details about [Blank Page Print], see p.304 "Printer Feature Settings".

4. Using the Copier Function

This chapter describes the copier functions.

The Screen in Copier Mode

This section provides information about the screen when the machine is in copier mode.

By default, the display shows the copier screen when the machine is turned on.

If the scanner or fax screen is shown on the display, press the [Copy] key on the control panel to switch to the copier screen.

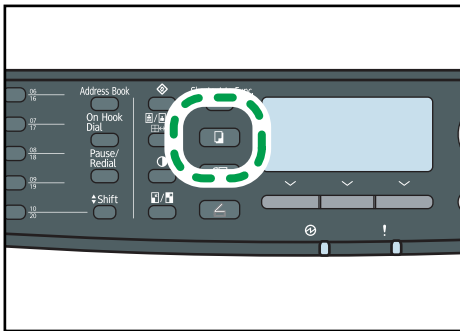

CMF131

Screen in standby mode

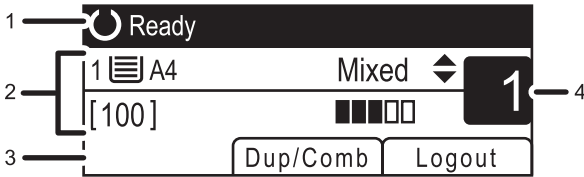

CMF100

1. Current status or messages

Displays the current status or messages.

2. Current settings

Displays the current tray, reproduction ratio, and scan settings.

3. Selection key items

Displays the functions you can use by pressing the corresponding selection keys.

4. Copy quantity

Displays the current copy quantity. You can change the copy quantity using the number keys.

↓ Note

- The start-up mode can be specified in the [Function Priority] setting under [Admin. Tools].

- If LDAP authentication is specified, you must first log in to the machine by entering a user name and password.

Reference

- For details about [Function Priority], see p.298 "Administrator Settings".
- For details about how to log in to the machine, see p.444 "When LDAP Authentication is Specified".

Basic Operation in Copier Mode

This section describes the basic procedure for making photocopies.

★ Important

- The original in the ARDF or ADF takes precedence over the original on the exposure glass if you place originals both in the ARDF/ADF and on the exposure glass.

1. Press the [Copy] key.

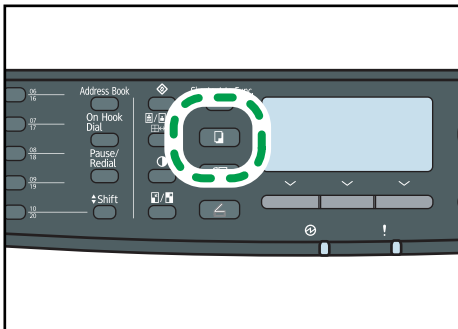

CMF131

2. Place the original on the exposure glass or in the ARDF/ADF.

If necessary, configure advanced photocopy settings.

3. To make multiple copies, enter the number of copies using the number keys.

4. Press the [Start] key.

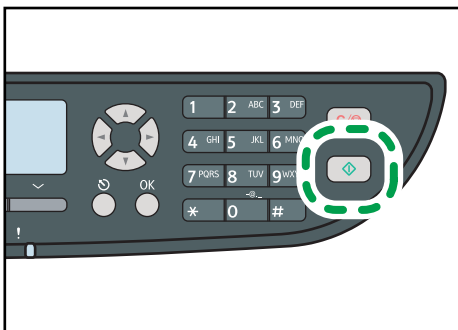

CMF141

If you are using the Type 2 model, depending on the machine's settings, "Set Back Side" appears on the screen when using the exposure glass.

- If you want to copy the back side of the original, proceed to the next step.
- If you want to end the job, press [#]. A copy will be output.

5. Turn over the original on the exposure glass, and then press the [Start] key.

A 2-sided copy will be output, and "Set Front Side" appears on the screen.

- If you want to copy the front side of the original again, turn over the original on the exposure glass, and then return to step 4.
- If you want to end the job, press [#].

 **Note**

- The maximum number of copies is 99.
- You can change the paper tray for the current job by pressing the [▲][▼] keys. You can also select to change the paper tray automatically according to the paper size (A4 or Letter).
- You can select the paper tray for printing out copies in [Select Paper] under copy settings. If you set the machine to switch between tray 1 and 2 automatically depending on the paper size in this setting, you can also specify the tray the machine uses first in [Paper Tray Priority] under system settings.
- When making multiple copies of a multi-page document, you can select whether copies are output in collated sets, or in page batches in the [Sort] setting under copy settings.
- If [Manual 2 Sided Scan Mode], which is available only with the Type 2 model, is enabled, you can copy both sides of original with the exposure glass and make a 2-sided copy.
- If the time specified in [System Auto Reset Timer] under administrator settings passes without any operation while "Set Back Side" or "Set Front Side" is shown on the screen, the copying will finish automatically.
- To enable this function for the current job only, press [Dup/Comb] and select [Manual 2 Sided Scan Mode]. To use it as the machine's default setting, configure [Duplex/Combine] under copy settings.
- If a paper jam occurs, printing stops after the current page has been printed out. After the jammed paper is removed, printing restarts from the jammed page automatically.
- If a scanning jam occurs in the ARDF or ADF, copying is canceled immediately. In this case, copy the originals again starting from the jammed page.

 **Reference**

- To place the original, see p.119 "Placing Originals".
- To make reduced or enlarged copies, see p.156 "Making Enlarged or Reduced Copies".
- To make combine or 2-sided copies, see p.158 "Combining Pages and Making 2-sided Copies".
- To make copies of an ID card, see p.167 "Copying Both Sides of an ID Card onto One Side of Paper".
- To make advanced scan settings, see p.170 "Specifying Scan Settings".
- For details about [Select Paper] or [Sort], see p.257 "Copy Settings".
- For details about [Paper Tray Priority], see p.279 "System Settings".
- For details about [Manual 2 Sided Scan Mode], see p.257 "Copy Settings".
- For details about [System Auto Reset Timer], see p.298 "Administrator Settings".

- For details about how to remove the jammed paper, see p.365 "Removing Printing Jams", or p. 375 "Removing Scanning Jams (Type 2 model)" or p.379 "Removing Scanning Jams (Type 1 model)".

Canceling a Copy

Follow the procedure below to cancel copying.

While scanning the original

If copying is canceled while the machine is scanning the original, copying is cancelled immediately and there is no printout.

When the original is set in the ARDF or ADF, scanning stops immediately but pages that have already been scanned completely will be copied.

While printing

If copying is canceled during printing, the photocopy process is canceled after the current page has been printed out.

1. Press the [Copy] key.

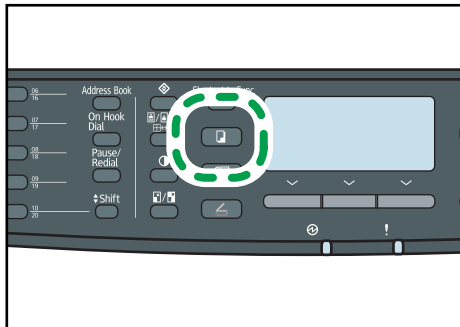

CMF131

2. Press the [Clear/Stop] key.

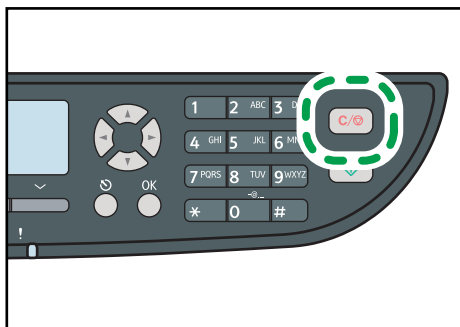

CMF135

Making Enlarged or Reduced Copies

This section describes how to specify the reduction or enlargement ratio for the current job.

Scaling

There are two ways to set the scaling ratio: using a preset ratio or manually specifying a customized ratio.

- Preset ratio

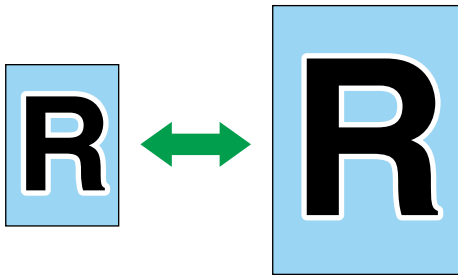

CES103

Region A

50%, 71%, 82%, 93%, 122%, 141%, 200%, 400%

Region B

50%, 65%, 78%, 93%, 129%, 155%, 200%, 400%

- Custom ratio



CES106

25% to 400% in 1% increments.

Use this procedure to specify the reduction or enlargement ratio for the current job.

1. Press the [Reduce/Enlarge] key.

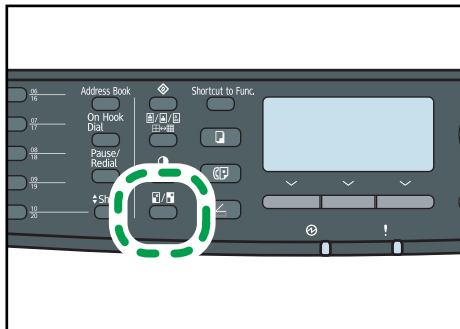

CMF136

2. Press [Reduce], [Enlarge], or [Zoom].

3. For [Reduce] or [Enlarge], press the [▲][▼][◀][▶] keys to select the desired ratio. For [Zoom], specify the desired ratio using the number keys.

4. Press the [OK] key.

↓ Note

- You can press the [Escape] key to exit to the previous level of the menu tree.
- You can change the machine's default [Reduce/Enlarge] setting to always make photocopies in the specified ratio.
- Temporary job settings are cleared in the following cases:
 - When no input is received for the period of time specified in [System Auto Reset Timer] while the initial screen is displayed.
 - When the [Clear/Stop] key is pressed while the initial screen is displayed.
 - When the machine's mode is changed.
 - When the power is turned off.
 - When the machine's default for the same setting is changed.

📖 Reference

- For details about [Reduce/Enlarge], see p.257 "Copy Settings".
- For details about [System Auto Reset Timer], see p.298 "Administrator Settings".

Combining Pages and Making 2-sided Copies

This section describes how to set the machine to combine multiple pages (2 or 4 pages) of an original onto a single page. Also, with the Type 2 model, you can scan 2-sided originals and make 2-sided copies.

★ Important

- This function is only available when the original is set in the ARDF or ADF, not when it is set on the exposure glass.
- For combine and 2-sided copying, the paper size must be A4, Letter or Legal.
- For 2-sided copying, the paper type must be thin, plain, recycled, color, preprinted, prepunched, thick paper 1, or letterhead.





4

There are following copy modes. Select a copy mode according to your original and how you want the copy outputs to appear.

Combined copy on 1 side

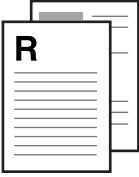





In this mode, copy will be made on 1 side, on which 2 or 4 pages of an original will be printed.

- 1Sd 2Orig->Comb 2on1 1Sd

	Original	Copy
Portrait		
Landscape		





CMF250

- 1Sd 4Orig->Comb 4on1 1Sd





	Original	Copy	
Portrait		Left to Right 	Top to Bottom 
Landscape		Left to Right 	Top to Bottom 

CMF251

- 2Sd 1Orig->Comb 2on1 1Sd (Type 2 model only)







	Original	Copy
Portrait		Top to Top 
		Top to Bottom 

CMF252







	Original	Copy
Landscape		Top to Top 
		Top to Bottom 

CMF263

- 2Sd 2Orig->Comb 4on1 1Sd (Type 2 model only)

	Original	Copy	
Portrait		Left to Right, Top to Top 	Top to Bottom, Top to Top 
		Left to Right, Top to Bottom 	Top to Bottom, Top to Bottom 

CMF253





	Original	Copy	
Landscape		Left to Right, Top to Top 	Top to Bottom, Top to Top 
		Left to Right, Top to Bottom 	Top to Bottom, Top to Bottom 

CMF254

Combined copy on 2 sides (Type 2 model only)

In this mode, copy will be made on 2 sides, on each of which 2 or 4 pages of an original will be printed.

- 1Sd 4Orig->Comb 2on1 2Sd

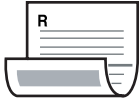
	Original	Copy	
Portrait		Top to Top 	Top to Bottom 
Landscape		Top to Top 	Top to Bottom 

CMF255

- 1Sd8Orig->Comb 4on1 2Sd

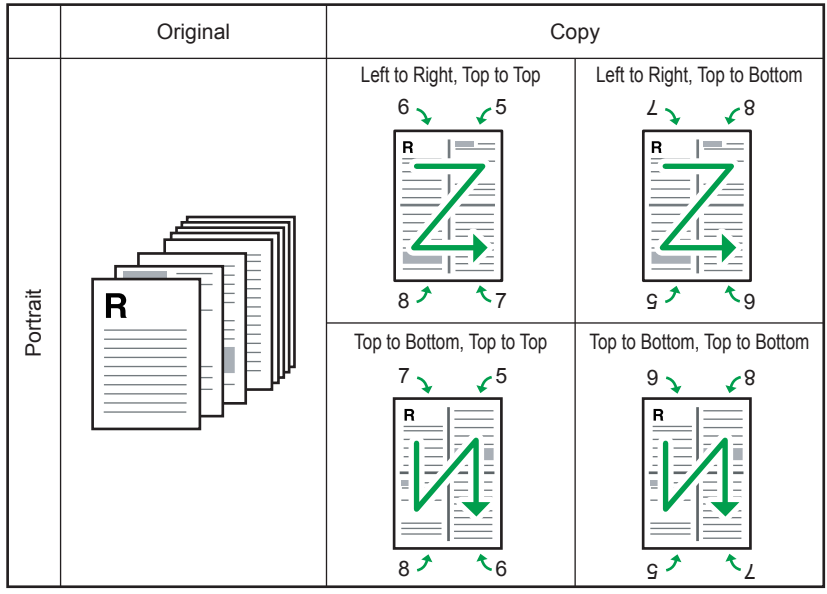



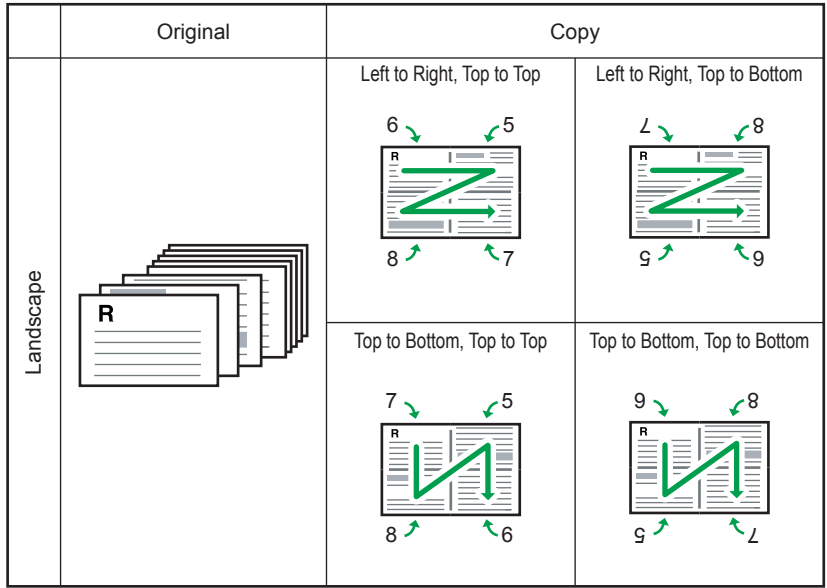

CMF256







CMF257

- 2Sd 2Orig->Comb 2on1 2Sd

	Original	Copy
Portrait		<p>Top to Top</p> 
		<p>Top to Bottom</p> 

CMF258

	Original	Copy
Landscape		<p>Top to Top</p> 
		<p>Top to Bottom</p> 

CMF264

- 2Sd 4Orig->Comb 4on1 2Sd

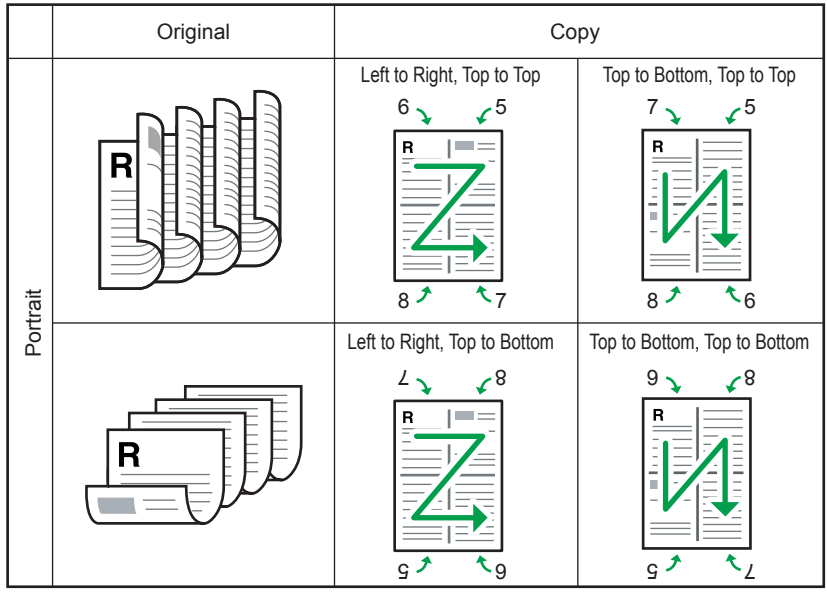

CMF259

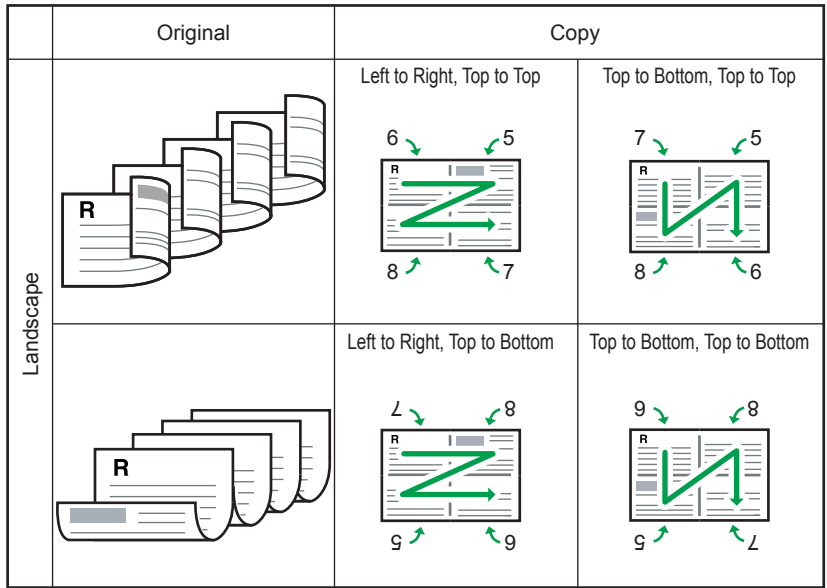





CMF260

Copy on 2 sides (Type 2 model only)

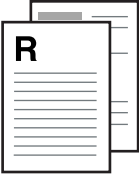

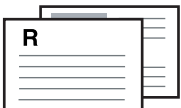

In this mode, copy will be made on 2 sides, on each of which a single page of an original will be printed.

- 1 Sided Orig->2 Sided Copy

	Original	Copy	
Portrait		Top to Top 	Top to Bottom 
Landscape		Top to Top 	Top to Bottom 

CMF261

- 2 Sided Orig->2 Sided Copy

	Original	Copy
Portrait		
Landscape		

CMF262

Use this procedure to set copy mode for the current job.

1. Press [Dup/Comb].

Alternatively, you can press the [Shortcut to Func.] key if [Shortcut to Function] under administrator settings is set to [Dup/Comb Copy].

2. Press the [▲][▼] keys to select the desired copy mode, and then press the [OK] key.

3. Press the [▲][▼] keys to select page and binding orientations, and then press the [OK] key.

The screen will show the selected copy mode.

Note

- You can press the [Escape] key to exit to the previous level of the menu tree.
- You can change the machine's default [Duplex/Combine] setting to always make photocopies in combine/2-sided mode.
- Setting combined/2-sided copying automatically disables the [ID Card Copy] setting.
- Temporary job settings are cleared in the following cases:
 - When no input is received for the period of time specified in [System Auto Reset Timer] while the initial screen is displayed.
 - When the [Clear/Stop] key is pressed while the initial screen is displayed.
 - When the machine's mode is changed.
 - When the power is turned off.
 - When the machine's default for the same setting is changed.

Reference

- For details about [Shortcut to Function], see p.298 "Administrator Settings".
- For details about [Duplex/Combine], see p.257 "Copy Settings".
- For details about [System Auto Reset Timer], see p.298 "Administrator Settings".
- To make 2-sided copies with the Type 1 model, perform manual duplex copying. See p.169 "Making 2-sided Copies Manually (Type 1 model)".

Copying Both Sides of an ID Card onto One Side of Paper

This section describes how to copy the front and back sides of an ID card, or other small document, onto one side of a sheet of paper.

When copying onto A4 size paper, you can copy documents that are smaller than A5 size. Likewise, when copying onto a Letter size paper, you can copy documents that are smaller than Half Letter size.

★ Important

- This function is only available when the original is set on the exposure glass, not when it is set in the ARDF or ADF.
- To use this function, the paper size used for printing copies must be set to A4 or Letter.
- To use the [Shortcut to Func.] key to set ID card copy mode for the current job, [Shortcut to Function] under administrator settings must be set to [ID Card Copy Mode].

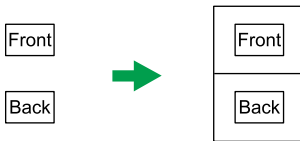

CES165

To use this function, first switch to ID card copy mode for the current job, and then perform ID card copy.

1. Press the [Shortcut to Func.] key.

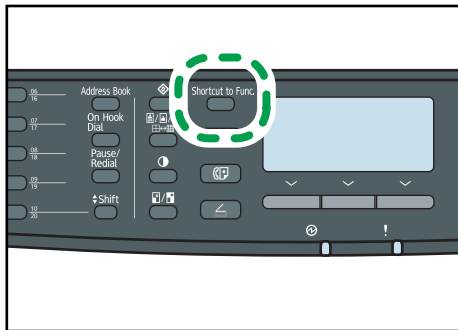

CMF137

The machine is now in ID card copy mode. Proceed to the following steps to perform the ID card copy.

2. Place the original front side down and top to the machine rear on the exposure glass.

Place the original in the center of the A5/Half Letter scan area.

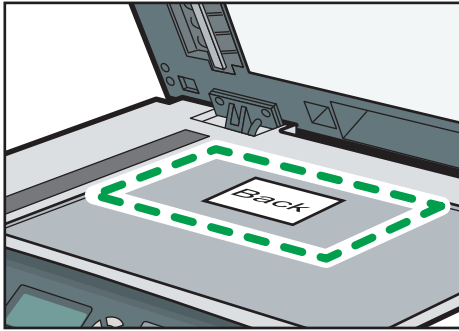

CMF065

3. Press the [Start] key.

A message prompting you to place the original back side down on the exposure glass appears on the display.

4. Within 30 seconds, place the original back side down and top to the machine rear on the exposure glass, and then press the [Start] key again.

↓ Note

- You can press the [Escape] key to exit to the previous level of the menu tree.
- Regardless of the machine's reduction or enlargement ratio setting, an ID card copy will always be made at 100%.
- You can change the machine's default [Reduce/Enlarge] setting to always make photocopies in ID card copy mode. In addition, if the [Shortcut to Func.] key is not set to [ID Card Copy Mode], you must configure the machine's default setting to perform ID card copy.
- Setting this function for the current job temporarily disables combined/2-sided copying automatically. However, after the temporary job setting is cleared, the combined/2-sided copying will be enabled again automatically.
- Temporary job settings are cleared in the following cases:
 - When no input is received for the period of time specified in [System Auto Reset Timer] while the initial screen is displayed.
 - When the [Clear/Stop] key is pressed while the initial screen is displayed.
 - When the machine's mode is changed.
 - When the power is turned off.
 - When the machine's default for the same setting is changed.

📖 Reference

- For details about [Shortcut to Function], see p.298 "Administrator Settings".
- For details about [Reduce/Enlarge], see p.257 "Copy Settings".
- For details about [System Auto Reset Timer], see p.298 "Administrator Settings".

Making 2-sided Copies Manually (Type 1 model)

This section describes how to make 2-sided copies by copying single-sided documents onto the front and back sides of each sheet using the Type 1 model.

Perform duplex copying manually with the Type 1 model. It does not support automatic duplex copying.

1. Place the odd-numbered pages of the original in the ADF.
2. Press the [Copy] key.
3. Press the [Start] key.
4. Load the output paper into the current tray.

If using tray 1 or tray 2, reload the paper with the blank side down; if using the bypass tray, sort the output paper in reverse order, and then load the paper with the blank side up.

Make sure to load paper with the top and bottom sides oriented correctly to avoid misprints.

5. Place the even-numbered pages of the original in the ADF.
6. Press the [Start] key.

Note

- When making 2-sided copies, confirm which tray is used to feed paper from for making copies, by checking the [Select Paper] setting under copy settings.
- If the [System Auto Reset Timer] under administrator setting is enabled, temporary job settings may be cleared during the operation. Make sure to reconfigure the settings if they are cleared.

Reference

- To place the original, see p.119 "Placing Originals".
- To load paper in the trays, p.96 "Loading Paper".
- For details about [Select Paper], see p.257 "Copy Settings".
- For details about [System Auto Reset Timer], see p.298 "Administrator Settings".

Specifying Scan Settings

This section describes how to specify image density and quality for the current job.

Adjusting Image Density

This section describes how to adjust image density for the current job.

There are five image density levels. The higher the density level, the darker the printout.

1. Press the [Density] key.

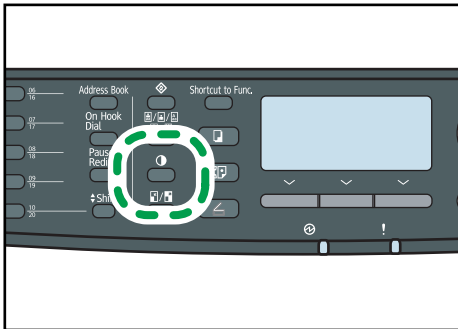

CMF138

2. Press the [◀][▶] keys to select the desired density level, and then press the [OK] key.

↓ Note

- Press the [Escape] key to discard the current change and return to the initial screen.
- You can change the machine's default [Density] setting to always make copies with a specific density level.
- Temporary job settings are cleared in the following cases:
 - When no input is received for the period of time specified in [System Auto Reset Timer] while the initial screen is displayed.
 - When the [Clear/Stop] key is pressed while the initial screen is displayed.
 - When the machine's mode is changed.
 - When the power is turned off.
 - When the machine's default for the same setting is changed.

📖 Reference

- For details about [Density], see p.257 "Copy Settings".
- For details about [System Auto Reset Timer], see p.298 "Administrator Settings".

Selecting the Document Type According to Original

This section describes how to select the best document type for the original that you are scanning.

There are three document types:

Mixed

Select this when the original contains both text and photographs or pictures.

Text

Select this when the original contains only text and no photographs or pictures.

Photo

Select this when the original contains only photographs or pictures. Use this mode for the following types of original:

- Photographs
- Pages that are entirely or mainly photographs or pictures, such as magazine pages.

1. Press the [Image Quality] key.

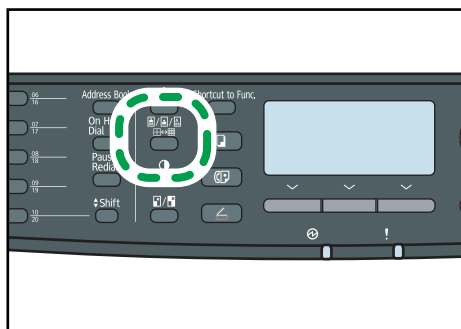

CMF139

2. Press the [▲][▼] keys to select the desired document type, and then press the [OK] key.

Note

- Press the [Escape] key to discard the current change and return to the initial screen.
- You can change the machine's default [Original Type] setting to always make copies with a specific document type.
- Temporary job settings are cleared in the following cases:
 - When no input is received for the period of time specified in [System Auto Reset Timer] while the initial screen is displayed.
 - When the [Clear/Stop] key is pressed while the initial screen is displayed.
 - When the machine's mode is changed.
 - When the power is turned off.
 - When the machine's default for the same setting is changed.

 **Reference**

- For details about [Original Type], see p.257 "Copy Settings".
- For details about [System Auto Reset Timer], see p.298 "Administrator Settings".

5. Using the Scanner Function

This chapter describes the scanner functions.

There are two scanning methods: scanning using the control panel and scanning from the computer (TWAIN scanning).

The Screen in Scanner Mode

This section provides information about the screen in scanner mode.

By default, the display shows the copier screen when the machine is turned on. If the copier or fax screen is shown on the display, press the [Scanner] key on the control panel to switch to the scanner screen.

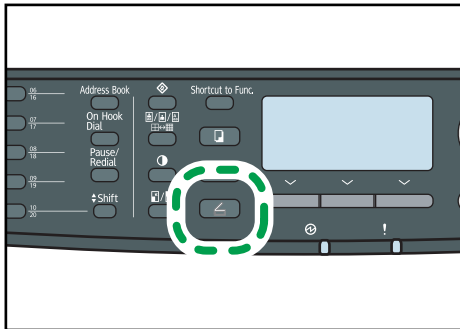

CMF132

Screen in standby mode

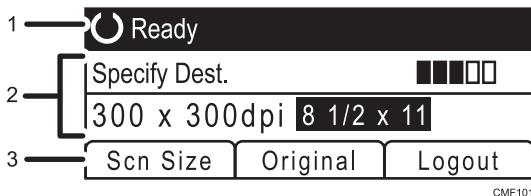

CMF101

1. Current status or messages

Displays the current status or messages.

2. Current settings

Displays the current scanning mode and scan settings.

- When "Specify Dest." is displayed:
Scan to E-mail, Scan to FTP, or Scan to Folder functions can be used.
- When "Save Scn Data to USB" is displayed:
A USB flash disk is inserted in the machine, and the Scan to USB function can be used.

3. Selection key items

Displays the functions you can use by pressing the corresponding selection keys.

Note

- The machine's default mode at power on can be specified in the [Function Priority] setting under [Admin. Tools].
- If LDAP authentication is specified, you must first log in to the machine by entering a user name and password.

Reference

- For details about [Function Priority], see p.298 "Administrator Settings".
- For details about how to log in to the machine, see p.444 "When LDAP Authentication is Specified".

Registering Scan Destinations

This section describes how to register scan destinations in the Address Book. To send scanned files to an e-mail address (Scan to E-mail), FTP server (Scan to FTP), or a shared folder on a network computer (Scan to Folder), you must first register the destination in the Address Book using Web Image Monitor.

★ Important

- **The Address Book data could be damaged or lost unexpectedly. The manufacturer shall not be responsible for any damages resulting from such data loss. Be sure to create backup files of the Address Book data periodically.**
- **Depending on your network environment, the Scan to FTP and Scan to Folder functions may require a user name and password to be correctly entered in the destination information. In such cases, after registering destinations, check that the user name and password are correctly entered by sending test documents to those destinations.**

The Address Book can contain up to 100 entries, including 20 Quick Dial entries.

Destinations registered as Quick Dial entries can be selected by pressing the corresponding One Touch button.

1. **Start the Web browser, and access the machine by entering its IP address.**
2. **Click [Quick Dial Destination] or [Scan Destination].**
3. **From the [Destination Type] list, select [E-mail Address], [FTP] or [Folder].**
4. **Register information as necessary.**

The information you must register varies depending on the destination type. For details, see the tables below.

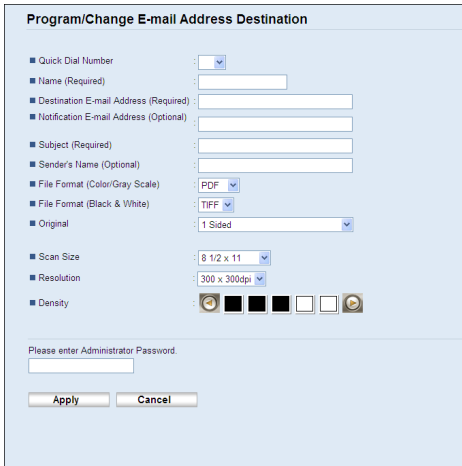

5. **Enter the administrator password if required.**
6. **Click [Apply].**
7. **Close the Web browser.**

Scan to E-mail Settings



5



Item	Setting	Description
Quick Dial Number	Optional	Select when setting the destination as a Quick Dial entry.
Name	Required	Name of the destination. The name specified here will be shown on the screen when selecting a scan destination. Can contain up to 16 characters.
Destination E-mail Address	Required	E-mail address of the destination. Can contain up to 64 characters.
Notification E-mail Address	Optional	E-mail address to which a notification is sent after transmission. Can contain up to 64 characters.
Subject	Required	Subject of the e-mail. Can contain up to 64 characters.
Sender's Name	Optional	Name of e-mail sender. The name specified here will be shown under "From" or a similar field of the recipient's email application. Can contain up to 32 characters.
File Format (Color/Gray Scale)	Required	File format of the scanned file when scanning in color. PDF or JPEG can be selected. PDF supports multiple pages in a document, but JPEG does not.
File Format (Black & White)	Required	File format of the scanned file when scanning in black and white. PDF or TIFF can be selected. Both formats support multiple pages in a document.

Item	Setting	Description
Original (Type 2 model only)	Required	Select the sides of the original (1 side or 2-sides) to scan according to the page and binding orientation. Note that if 2-sided scanning is specified, you must use the ARDF (scanning will not be possible with the exposure glass).
Scan Size	Optional	Select the scanning size for the original from A5, B5, A4, Executive, Half Letter, Letter, Legal, or custom size. If you select custom size, select [mm] or [Inch], and then specify the width and length.
Resolution	Optional	Select the scan resolution from 100×100, 150×150, 200×200, 300×300, 400×400, or 600×600 dpi.
Density	Optional	Specify the image density by clicking the right or left buttons.  is the lightest, and  is the darkest.

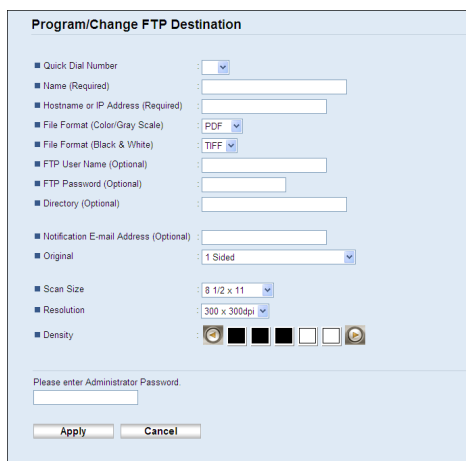
Scan to FTP Settings



Item	Setting	Description
Quick Dial Number	Optional	Select when setting the destination as a Quick Dial entry.
Name	Required	Name of the destination. The name specified here will be shown on the screen when selecting a scan destination. Can contain up to 16 characters.

Item	Setting	Description
Hostname or IP Address	Required	Name or IP address of the FTP server. Can contain up to 64 characters.
File Format (Color/Gray Scale)	Required	File format of the scanned file when scanning in color. PDF or JPEG can be selected. PDF supports multiple pages in a document, but JPEG does not.
File Format (Black & White)	Required	File format of the scanned file when scanning in black and white. PDF or TIFF can be selected. Both formats support multiple pages in a document.
FTP User Name	Optional	User name for logging in to the FTP server. Can contain up to 32 characters.
FTP Password	Optional	Password for logging in to the FTP server. Can contain up to 32 characters.
Directory	Optional	Name of the FTP server directory where scanned files are stored. Can contain up to 64 characters.
Notification E-mail Address	Optional	E-mail address to which a notification is sent after transmission. Can contain up to 64 characters.
Original (Type 2 model only)	Required	Select the sides of the original (1 side or 2-sides) to scan according to the page and binding orientation. Note that if 2-sided scanning is specified, you must use the ARDF (scanning will not be possible with the exposure glass).
Scan Size	Optional	Select the scanning size for the original from A5, B5, A4, Executive, Half Letter, Letter, Legal, or custom size. If you select custom size, select [mm] or [Inch], and then specify the width and length.
Resolution	Optional	Select the scan resolution from 100×100, 150×150, 200×200, 300×300, 400×400, or 600×600 dpi.
Density	Optional	Specify the image density by clicking the right or left buttons.  is the lightest, and  is the darkest.



Scan to Folder Settings

The screenshot shows a dialog box titled "Program/Change Folder Destination". It has several sections of settings:

- Quick Dial Number:** A dropdown menu.
- Name (Required):** A text input field.
- Service Name (Required):** A text input field with a hint: "For example: \\Computer_name_or_IPShare_Folder".
- Domain (Optional):** A text input field.
- Login User Name (Optional):** A text input field.
- Login Password (Optional):** A text input field.
- Directory (Optional):** A text input field.
- Notification E-mail Address (Optional):** A text input field.
- File Format (Color/Gray Scale):** A dropdown menu set to "PDF".
- File Format (Black & White):** A dropdown menu set to "TIFF".
- Original:** A dropdown menu set to "1 Sided".
- Scan Size:** A dropdown menu set to "8 1/2 x 11".
- Resolution:** A dropdown menu set to "300 x 300dpi".
- Density:** A set of radio buttons for different density options.

At the bottom, there is a field for "Please enter Administrator Password" and two buttons: "Apply" and "Cancel".

Item	Setting	Description
Quick Dial Number	Optional	Select when setting the destination as a Quick Dial entry.
Name	Required	Name of the destination. The name specified here will be shown on the screen when selecting a scan destination. Can contain up to 16 characters.
Service Name	Required	Path to the directory where scanned files will be stored. Consists of the IP address or name of the destination computer (can contain up to 64 characters), and name of the shared folder (can contain up to 32 characters).
Domain	Optional	Specify the name of the domain to which the computer belongs. Can contain up to 15 characters.
Login User Name	Optional	User name for logging in to the destination computer. Can contain up to 32 characters.
Login Password	Optional	Password for logging in to the destination computer. Can contain up to 32 characters.
Directory	Optional	Directory within the shared folder for storing scanned files. Can contain up to 64 characters.
Notification E-mail Address	Optional	E-mail address to which a notification is sent after transmission. Can contain up to 64 characters.

Item	Setting	Description
File Format (Color/Gray Scale)	Required	File format of the scanned file when scanning in color. PDF or JPEG can be selected. PDF supports multiple pages in a document, but JPEG does not.
File Format (Black & White)	Required	File format of the scanned file when scanning in black and white. PDF or TIFF can be selected. Both formats support multiple pages in a document.
Original (Type 2 model only)	Required	Select the sides of the original (1 side or 2-sides) to scan according to the page and binding orientation. Note that if 2-sided scanning is specified, you must use the ARDF (scanning will not be possible with the exposure glass).
Scan Size	Optional	Select the scanning size for the original from A5, B5, A4, Executive, Half Letter, Letter, Legal, or custom size. If you select custom size, select [mm] or [Inch], and then specify the width and length.
Resolution	Optional	Select the scan resolution from 100×100, 150×150, 200×200, 300×300, 400×400, or 600×600 dpi.
Density	Optional	Specify the image density by clicking the right or left buttons.  is the lightest, and  is the darkest.

Note

- To send files via e-mail, SMTP and DNS settings must be configured properly.
- If you are using the Scan to E-mail function, select a time zone according to your geographic location to send email with correct transmission date and time.
- To send files to an FTP server or computer, the user name, password, and directory must be configured properly.
- On a network that uses a DNS server, specify a computer name in [Service Name] and the name of the domain to which the computer belongs in [Domain]. In this case, also configure the DNS related settings using Web Image Monitor.
- The Scan to Folder destination must operate on one of the following operating systems: Windows XP/Vista/7, Windows Server 2003/2003 R2/2008/2008 R2, or Mac OS X.
- Scan destinations cannot be registered using the control panel.
- The Scan to USB function does not require destinations registered in the Address Book.

Reference

- To test sending files to a Scan to FTP or Scan to Folder destination, see p.183 "Basic Operation for Scan to E-mail/FTP/Folder".
- For details about creating backup files, see p.355 "Backing Up the Machine's Settings".
- For details about SMTP and DNS settings, see p.333 "Configuring the DNS Settings" and p.337 "Configuring the SMTP Settings".
- For details about the time zone setting, see p.337 "Configuring the SMTP Settings".
- For details about using Web Image Monitor, see p.309 "Using Web Image Monitor".

Modifying Scan Destinations

This section describes how to modify the information of registered destinations.

1. Start the Web browser, and access the machine by entering its IP address.
2. Click [Scan Destination].
3. Click the [E-mail Address], [FTP], or [Folder] tab.
4. Select the entry to modify, and then click [Change].
5. Modify settings as necessary.
6. Enter the administrator password if required.
7. Click [Apply].
8. Close the Web browser.

Note

- You can unassign a Quick Dial entry from a One-touch button from the [Quick Dial Destination] page. To do this, select the desired entry, click [Delete], and then click [Apply] again on a confirmation page.
- The machine will notify you if the destination you want to modify is set as a forwarding destination of received faxes.

Reference

- For details about using Web Image Monitor, see p.309 "Using Web Image Monitor".
- For details about fax forwarding settings, see p.320 "Configuring the Fax Settings".

Deleting Scan Destinations

This section describes how to delete registered destinations.

1. Start the Web browser, and access the machine by entering its IP address.

2. Click [Scan Destination].
3. Click the [E-mail Address], [FTP], or [Folder] tab.
4. Select the entry to delete, and then click [Delete].
5. Confirm that the entry you have selected is the entry that you want to delete.
6. Enter the administrator password if required.
7. Click [Apply].
8. Close the Web browser.

 **Note**

- The machine will notify you if the destination you want to delete is set as a forwarding destination of received faxes. If you delete the destination anyway, reconfigure the fax forwarding setting.

 **Reference**

- For details about using Web Image Monitor, see p.309 "Using Web Image Monitor".
- For details about fax forwarding settings, see p.320 "Configuring the Fax Settings".

Scanning Using the Control Panel

Scanning using the control panel allows you to send scanned files via e-mail (Scan to E-mail), to an FTP server (Scan to FTP), or to the shared folder of a computer on a network (Scan to Folder), or to a USB flash disk (Scan to USB).

The Scan to E-mail, Scan to FTP, and Scan to Folder functions are available only through a network connection. No network connection is required for the Scan to USB function; you can send scanned files directly to a USB flash disk inserted into the front of the machine.

Basic Operation for Scan to E-mail/FTP/Folder

This section describes the basic operation for sending scanned files via E-mail, to an FTP server, or to a computer. The scanned file is sent via E-mail, to an FTP server, or a computer, depending on the specified destination.

★ Important

- The original in the ARDF or ADF takes precedence over the original on the exposure glass if you place originals both in the ARDF/ADF and on the exposure glass.
- When using the Scan to E-mail, Scan to FTP or Scan to Folder function, you must first register the destination in the Address Book using Web Image Monitor.
- If a USB flash disk is inserted in the machine, scanning functions other than Scan to USB are not possible from the control panel. Make sure there is no USB flash disk inserted in the machine.

1. Place the original on the exposure glass or in the ARDF/ADF.
2. Press the [Scanner] key, and then press the [Address Book] key.

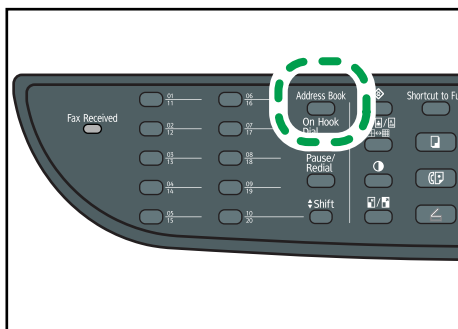

CMF140

Alternatively, you can press the [Shortcut to Func.] key if [Shortcut to Function] under administrator settings is set to [Select Scanner Dest.].

3. Press the [▲][▼] keys to select [Search Address Book], and then press the [OK] key.

If you want to search for a specific entry by its name, enter the first letters of the name using the number keys, and then press the [OK] key. Each time you enter a character, the display changes to show the matching name.

4. Search for the desired destination by pressing the [▲][▼] keys to scroll the Address Book, and then press the [OK] key.

When you specify a scan destination, the machine's scan settings change automatically according to the information registered for that destination in the Address Book. If necessary, you can change the scan settings using the control panel.

5. Press the [Start] key.

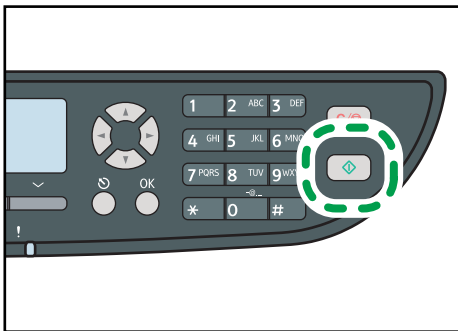

CMF141

Depending on the machine's settings, you may see the following screen on the display when scanning from the exposure glass.



If you see this screen, proceed to the next step.

6. If you have more originals to scan, place the next original on the exposure glass, and then press [Yes]. Repeat this step until all originals are scanned.

7. When all originals have been scanned, press [No] to start sending the scanned file.

↓ Note

- To cancel scanning, press the [Scanner] key, and then press the [Clear/Stop] key. The scan files are discarded.
- You can configure the machine to scan documents in black and white, color, or grayscale by changing the [Scanning Mode] setting under scanner settings.
- You can also specify a destination using the One Touch buttons, [Pause/Redial] key, or from an LDAP server.

- If the [Limitless Scan] setting under scanner settings is enabled, you can place originals on the exposure glass repeatedly in a single scan procedure.
- If [File Type] under scanner settings is set to [Multi-page], you can scan multiple pages to create a single PDF or TIFF file containing all pages. However, if the file format is JPEG, a single-page file will be created for every page scanned.
- If paper is jammed in the ARDF or ADF, the scan job will be discarded. Remove the jammed paper and scan the entire originals again.

Reference

- For details about [Shortcut to Function], see p.298 "Administrator Settings".
- To place the original, see p.119 "Placing Originals".
- To configure advanced scan settings, see p.191 "Specifying the Scan Settings".
- For details about specifying the scan destination, see p.185 "Specifying the scan destination using the One Touch buttons or [Pause/Redial] key".
- For details about specifying the scan destination from an LDAP server, see p.186 "Specifying the scan destination from an LDAP server".
- For details about [Scanning Mode], [File Type], or [Limitless Scan], see p.263 "Scanner Settings".
- For details about how to remove the paper jammed in the ARDF or ADF, see p.375 "Removing Scanning Jams (Type 2 model)" or p.379 "Removing Scanning Jams (Type 1 model)".

Specifying the scan destination using the One Touch buttons or [Pause/Redial] key

This section describes how to specify a destination using the following keys:

- One Touch buttons
Use these to specify destinations registered as Quick Dial entries.
- [Pause/Redial] key
Press this to specify the last used destination as the destination for the current job.

Using the One Touch buttons

Press the One Touch button to which the desired Quick Dial entry is registered.

Press the [Shift] key to use the Quick Dial entries Nos. 11 to 20.

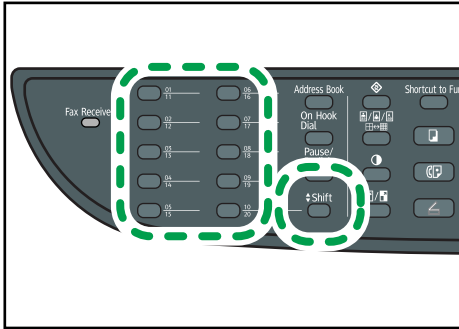

CMF142

Using the [Pause/Redial] key

Press the [Pause/Redial] key to select the last used destination.

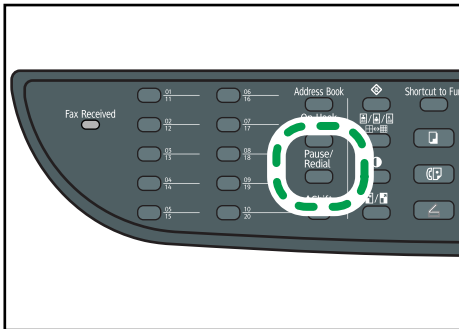

CMF143

5

↓ Note

- When you specify a scan destination, the machine's scan settings change automatically according to the information registered for that destination in the Address Book. If necessary, you can change the scan settings using the control panel.
- The [Pause/Redial] key is not effective for the first scan job after the machine is turned on.
- To select destinations not registered as Quick Dial entries, use the [Address Book] key.

📖 Reference

- For details about how to specify destinations using the [Address Book] key, see p.183 "Basic Operation for Scan to E-mail/FTP/Folder".

Specifying the scan destination from an LDAP server

This section describes how to select a destination registered on the LDAP server.

★ Important

- To search for a destination from an LDAP server, the LDAP server must be registered in advance, and [LDAP Search] must be enabled under the LDAP server settings.

- You can search Scan to E-mail destinations from the LDAP server (not Scan to FTP or Scan to Folder destinations).

1. Press the [Scanner] key.

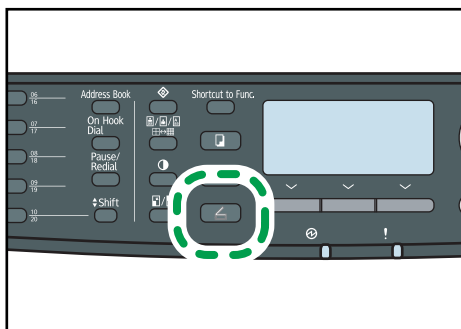

CMF132

2. Press the [Address Book] key.

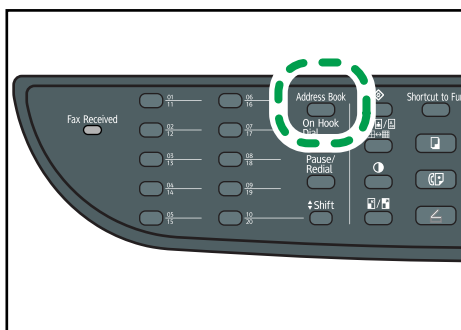

CMF140

3. Press the [▲][▼] keys to select [Search LDAP], and then press the [OK] key.
4. Press the [▲][▼] keys to select [Start LDAP Search], and then press the [OK] key.
A list of destinations that match the search conditions appears on the display (up to 50).
5. Press the [▲][▼] keys to scroll through the search result, and then press [▶] to select the desired destination.

You can select multiple destinations. A check mark will appear for the selected destinations. To deselect a destination, press [▶] again.

Note

- The search result will contain destinations that match the predefined search conditions.
- To send scanned files to the destinations specified from the LDAP server, you must select the file format after pressing the [Start] key to execute scanning. The file format depends on the [Scanning Mode] setting under scanner settings:
 - When in black-and-white scanning mode: TIFF or PDF
 - When in color or gray scale scanning mode: JPEG or PDF

- The scanned files to the destinations specified from the LDAP server will be created with the machine's current scan settings. If necessary, configure the scan settings before executing scanning.
- If a record that has been found contains multiple destinations, the first of those destinations will be used.

Reference

- For details about registering LDAP servers, see p.440 "Programming the LDAP server".
- For details about specifying the search conditions, see p.446 "Specifying the LDAP Address Search Conditions".
- For details about [Scanning Mode], see p.263 "Scanner Settings".
- To configure advanced scan settings, see p.191 "Specifying the Scan Settings".

Basic Operation for Scan to USB

5

This section describes the basic operation for sending scanned files to a USB flash disk.

Important

- The original in the ARDF or ADF takes precedence over the original on the exposure glass if you place originals both in the ARDF/ADF and on the exposure glass.
- This machine does not support the use of USB flash disks connected to external USB hubs. Insert your USB flash disk directly into the USB flash disk port located at the top left corner of the machine.
- Certain types of USB flash disks cannot be used.
- If [Save Scn Data to USB] under administrator settings is disabled, this function cannot be used.

1. Insert your USB flash disk into the USB flash disk port.

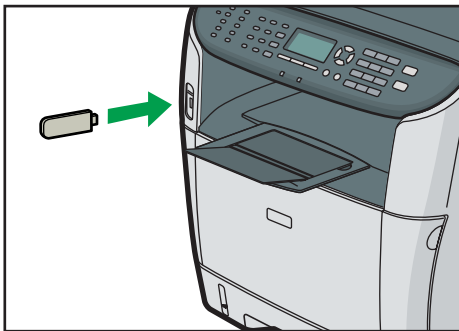

CMF066

2. Press the [Scanner] key.

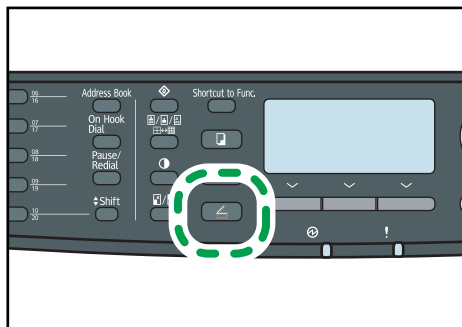

CMF132

"Loading..." appears on the display. Wait until the display changes to show "Save Scn Data to USB" (the duration depends on your USB flash disk).

3. Place the original on the exposure glass or in the ARDF/ADF.

If necessary, configure advanced scan settings.

4. Press the [Start] key.

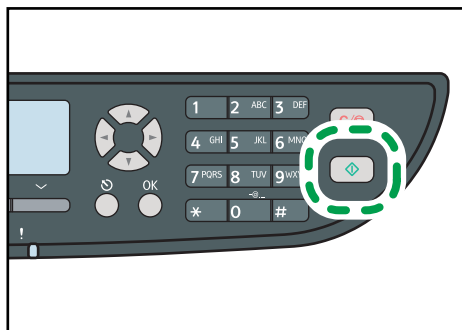

CMF141

Depending on the machine's setting, you will see the following screen on the display.

- When in black-and-white scanning mode:

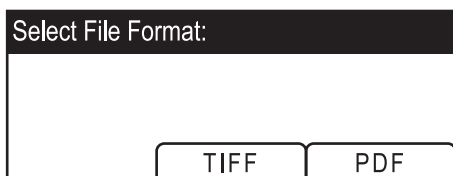

- When in color or gray scale scanning mode:

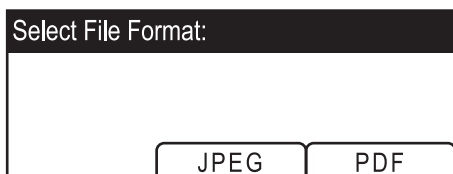

5. Press the appropriate selection key according to the desired file format.

Depending on the machine's settings, you may see the following screen on the display when scanning from the exposure glass.



If you see this screen, proceed to the next step. If not, proceed to step 8.

6. If you have more originals to scan, place the next original on the exposure glass, and then press [Yes]. Repeat this step until all originals are scanned.

7. When all originals have been scanned, press [No] to start sending the scanned file.

8. Confirm that "Ready" appears on the display.

The scanned file is created in the root directory of the USB flash disk.

9. Remove the USB flash disk from the machine.

Note

- To cancel scanning, press the [Scanner] key, and then press the [Clear/Stop] key. The scan files are discarded.
- You can configure the machine to scan documents in black and white, color, or grayscale by changing the [Scanning Mode] setting under scanner settings.
- If the [Limitless Scan] setting under scanner settings is enabled, you can place originals on the exposure glass repeatedly in a single scan procedure.
- If the [File Type] setting under scanner settings is enabled, you can scan multiple pages to create a single PDF or TIFF file containing all pages. However, if the file format is JPEG, a single-page file will be created for every page scanned.
- If paper is jammed in the ARDF/ADF or an access error to the USB flash disk occurs, the scan job will be discarded. Remove the jammed paper and scan the entire originals again.

Reference

- For details about [Save Scn Data to USB], see p.298 "Administrator Settings".
- To place the original, see p.119 "Placing Originals".
- To configure advanced scan settings, see p.191 "Specifying the Scan Settings".
- For details about [Scanning Mode], [Limitless Scan], or [File Type], see p.263 "Scanner Settings".
- For details about how to remove the paper jammed in the ARDF or ADF, see p.375 "Removing Scanning Jams (Type 2 model)" or p.379 "Removing Scanning Jams (Type 1 model)".

Specifying the Scan Settings

This section describes how to specify the scanning size, image density, and resolution for the current job.

When a scan destination is specified

When you specify a scan destination, the machine's scan settings change automatically according to the information registered for that destination in the Address Book.

This allows you to send scanned files without having to reconfigure the scan settings according to each destination. If necessary, you can change the scan settings using the control panel.

↓ Note

- The machine maintains the preset scan settings for the current destination until the machine returns to standby mode.
- Changing the preset scan settings for the current destination does not change the information registered in the Address Book.
- If you specify the last used destination, the preset scan settings become effective again, even if you have changed the settings for the previous job.

5

Specifying the scanning size according to the size of the original

This section describes how to specify the scanning size according to the size of the current original.

1. Press the [Reduce/Enlarge] key or [Scn Size].

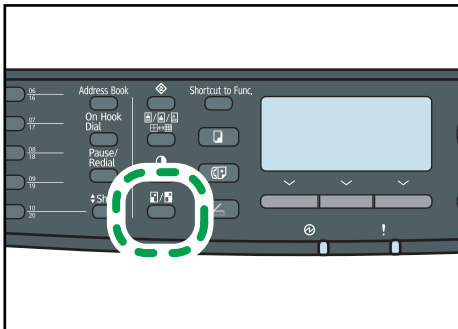

CMF136

2. Press the [▲][▼] keys to select the size of the original, and then press the [OK] key.
If you selected anything other than [Custom Size], you do not need to perform the remaining steps of the procedure.
3. Press the [▲][▼] keys to select [mm] or [inch], and then press the [OK] key.
4. Enter the width using the number keys, and then press the [OK] key.
To enter a decimal point, press [*].

5. Enter the length using the number keys, and then press the [OK] key.

To enter a decimal point, press [*****].

↓ Note

- You can press the [Escape] key to exit to the previous level of the menu tree.
- You can change the machine's default [Scan Size] setting to always scan originals with a specific scanning size.
- Temporary job settings are cleared in the following cases:
 - When no input is received for the period of time specified in [System Auto Reset Timer] while the initial screen is displayed.
 - When the [Clear/Stop] key is pressed while the initial screen is displayed.
 - When the machine's mode is changed.
 - When the power is turned off.
 - When the machine's default for the same setting is changed.

📖 Reference

- For details about [Scan Size], see p.263 "Scanner Settings".
- For details about [System Auto Reset Timer], see p.298 "Administrator Settings".

Adjusting image density

This section describes how to adjust image density for the current job.

There are five image density levels. The higher the density level, the darker the scanned image.

1. Press the [Density] key.

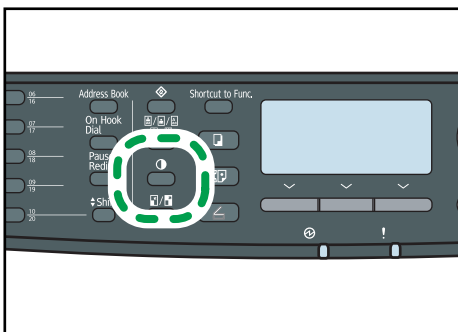

CMF138

2. Press the [◀][▶] keys to select the desired density level, and then press the [OK] key.

↓ Note

- Press the [Escape] key to discard the current change and return to the initial screen.
- You can change the machine's default [Density] setting to always scan with a specific density level.

- Temporary job settings are cleared in the following cases:
 - When no input is received for the period of time specified in [System Auto Reset Timer] while the initial screen is displayed.
 - When the [Clear/Stop] key is pressed while the initial screen is displayed.
 - When the machine's mode is changed.
 - When the power is turned off.
 - When the machine's default for the same setting is changed.

Reference

- For details about [Density], see p.263 "Scanner Settings".
- For details about [System Auto Reset Timer], see p.298 "Administrator Settings".

Specifying resolution

This section describes how to specify the scan resolution for the current job.

There are six resolution settings. The higher the resolution, the higher the quality but greater the file size.

1. Press the [Image Quality] key.

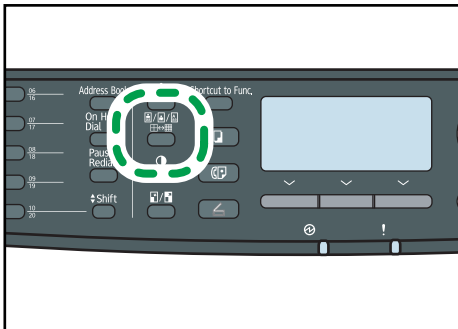

CMF139

2. Press the [▲][▼][◀][▶] keys to select the desired resolution, and then press the [OK] key.

Note

- Press the [Escape] key to discard the current change and return to the initial screen.
- You can change the machine's default [Resolution] setting to always scan with a specific resolution level.
- Temporary job settings are cleared in the following cases:
 - When no input is received for the period of time specified in [System Auto Reset Timer] while the initial screen is displayed.
 - When the [Clear/Stop] key is pressed while the initial screen is displayed.
 - When the machine's mode is changed.

- When the power is turned off.
- When the machine's default for the same setting is changed.

Reference

- For details about [Resolution], see p.263 "Scanner Settings".
- For details about [System Auto Reset Timer], see p.298 "Administrator Settings".

Specifying the scanning side according to the original (Type 2 model)

If you are using the Type 2 model, you can specify the machine to scan both sides of original automatically using the ARDF.

This section describes how to specify the scanning side according to the current original.

1. Press [Original].

2. Press the [^][v] keys to select the desired scanning method, and then press the [OK] key.

Select the sides of the original (1 side or 2-sides) to scan. When scanning 2-sides, select the page and binding orientations according to the original.

Note

- You can press the [Escape] key to exit to the previous level of the menu tree.
- If 2-sided scanning is specified, you must use the ARDF (scanning will not be possible with the exposure glass).
- You can change the machine's default [Original] setting to always scan specific sides of originals.
- Temporary job settings are cleared in the following cases:
 - When no input is received for the period of time specified in [System Auto Reset Timer] while the initial screen is displayed.
 - When the [Clear/Stop] key is pressed while the initial screen is displayed.
 - When the machine's mode is changed.
 - When the power is turned off.
 - When the machine's default for the same setting is changed.

Reference

- For details about [Original], see p.263 "Scanner Settings".
- For details about [System Auto Reset Timer], see p.298 "Administrator Settings".

Scanning from a Computer

Scanning from a computer (TWAIN scanning) allows you to operate the machine from your computer and scan originals into your computer directly.

TWAIN scanning is available with both USB and network connections.

Basic Operation for TWAIN Scanning

You can perform TWAIN scanning by using a TWAIN-compatible application.

If no TWAIN-compatible application is installed on your computer, install one.

Note

- A CD-ROM containing a TWAIN-compliant application (Presto! PageManager) is provided with the machine. For details, see the manual of Presto! PageManager.

Settings you can configure in the TWAIN dialog box

This section describes the settings you can configure in the TWAIN dialog box.

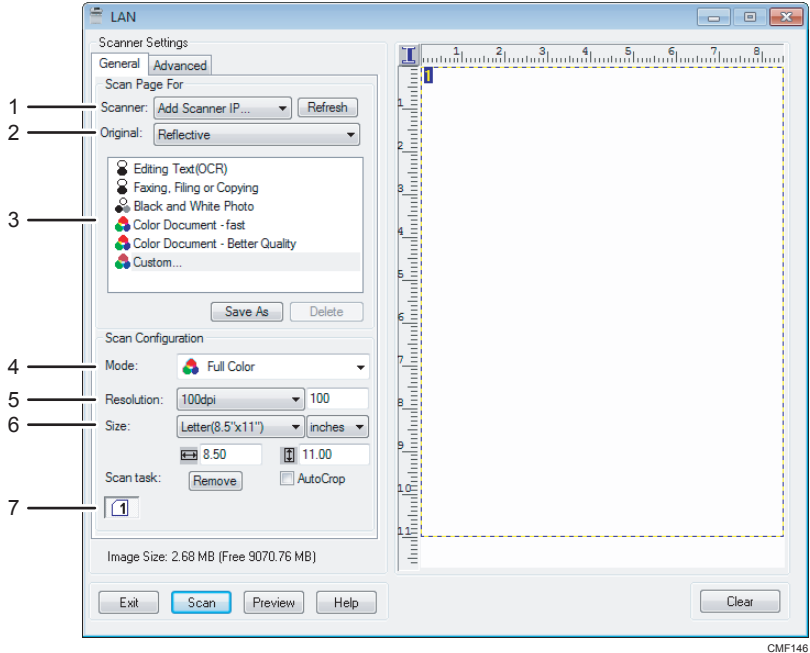

1. Scanner:

Select the scanner you want to use. The scanner you select becomes the default scanner. Click [Refresh] to discover all available scanners connected via USB or the network.

2. Original:

Select [Reflective] to scan from the exposure glass, or [Automatic Document Feeder] to scan from the ARDF or ADF.

3. Original type

According to your original, select a setting from the list of options detailed below, or select [Custom...] to configure your own scan settings.

- When using the exposure glass:

[Editing Text(OCR)]

Select this to scan business letters, contracts, memos, or other documents in editable form.

[Faxing, Filing or Copying]

Select this to scan newspaper and magazine articles, receipts, forms, or other printed text material.

[Black and White Photo]

Select this to scan black and white photographs as grayscale images.

[Color Document - fast]

Select this to scan originals with many graphics, originals with both text and graphics, line art, or color photographs in fast scan mode.

[Color Document - Better Quality]

Select this to scan originals with many graphics, originals with both text and graphics, line art, or color photographs in high-resolution scan mode.

[Custom...]

Select this to configure your own scan settings. You can save or delete your custom scan settings by clicking [Save As] or [Delete], respectively.

- When using the ARDF or ADF:

[ADF-Faster]

Select this to scan originals with many graphics, originals with both text and graphics, line art, or color photographs in fast scan mode.

[ADF-Better]

Select this to scan originals with many graphics, originals with both text and graphics, line art, or color photographs in high-resolution scan mode.

[ADF-gray]

Select this to scan originals with many graphics, originals with both text and graphics, line art, or color photographs as grayscale images.

[Custom...]

Select this to configure your own scan settings. You can save or delete your custom scan settings by clicking [Save As] or [Delete], respectively.

4. Mode:

Select from color, grayscale, or black-and-white.

5. Resolution:

Select a resolution from the list. If you select [User defined], enter a resolution value directly in the edit box. Note that increasing the resolution also increases the file size and scanning time.

Selectable resolutions vary depending on where the original is set.

- When using the exposure glass:
75, 100, 150, 200, 300, 400, 500, 600, 1200, 2400, 4800, 9600, 19200 dpi, User defined
- When using the ARDF or ADF:
75, 100, 150, 200, 300, 400, 500, 600 dpi, User defined

6. Size:

Select the scanning size. If you select [User defined], enter the scanning size directly in the edit box. Also, you can change the scanning size with your mouse in the preview area. You can select the unit of measure from [cm], [inches], or [pixels].

7. Duplex or Scan task:

- Duplex (when using the ARDF, Type 2 model only)

Select this to scan both sides of an original using the ARDF. To use this function, also select paper and binding orientations according the original.

- [2 Sided Portrait: Top to Top]: for portrait original with top-to-top binding
- [2 Sided Portrait: Top to Bottom]: for portrait original with top-to-bottom binding
- [2 Sided Landscape: Top to Top]: for landscape original with top-to-top binding
- [2 Sided Landscape: Top to Bottom]: for landscape original with top-to-bottom binding
- Scan task: (when using the exposure glass)

Displays a maximum of 10 previously used scan areas. To remove a scan task, select the number of the task, and then click [Remove]. You can select [AutoCrop] to let the scanner automatically detect the size of your original.

↓ Note

- If the scan data is larger than the memory capacity, an error message appears and scanning is canceled. If this happens, specify a lower resolution and scan the original again.

6. Using the Fax Function

This chapter describes the fax functions.

The Screen in Fax Mode

This section provides information about the screen in fax mode.

By default, the display shows the copier screen when the machine is turned on.

If the copy or scanner screen is shown on the display, press the [Facsimile] key on the control panel to switch to the fax screen.

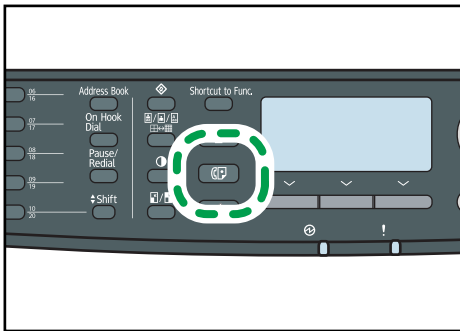

CMF133

Screen in standby mode

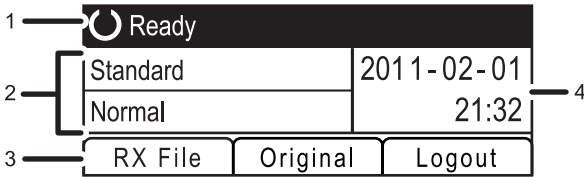

CMF102

1. Current status or messages

Displays the current status or messages.

2. Current settings

Displays the current density and resolution settings.

3. Selection key items

Displays the functions you can use by pressing the corresponding selection keys.

4. Current date and time

Shows the current date and time.

Note

- The machine's default mode at power on can be specified in the [Function Priority] setting under [Admin. Tools].

- The display format for time and date can be specified in [Set Date/Time] under [Admin. Tools].
- If LDAP authentication is specified, you must first log in to the machine by entering a user name and password.

 **Reference**

- For details about [Function Priority], see p.298 "Administrator Settings".
- For details about setting the date and time, see p.201 "Setting the Date and Time".
- For details about how to log in to the machine, see p.444 "When LDAP Authentication is Specified".

Setting the Date and Time

This section describes how to set the time and date for the machine's internal clock, and how to select the display format.

- **Date**
Year, month, date, and date format (Month/Day/Year, Day/Month/Year, or Year/Month/Day)
- **Time**
Hour, minute, time format (12- or 24-hour), and AM/PM stamp (when 12-hour time format is selected)

1. Press the [User Tools] key.

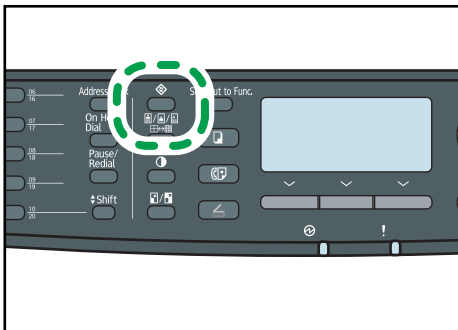

CMF134

2. Press the [▲][▼] keys to select [Admin. Tools], and then press the [OK] key.
3. If you are requested to enter a password, enter the password using the number keys, and then press the [OK] key.
4. Press the [▲][▼] keys to select [Set Date/Time], and then press the [OK] key.
5. Press the [▲][▼] keys to select [Set Date], and then press the [OK] key.
6. Press the [▲][▼] keys to select the desired date format, and then press the [OK] key.
7. Enter the current date using the number keys, and then press the [OK] key.
You can press the [◀][▶] keys to move between fields.
8. Press the [▲][▼] keys to select [Set Time], and then press the [OK] key.
9. Press the [▲][▼] keys to select the desired time format, and then press the [OK] key.
10. Enter the current time using the number keys, and then press the [OK] key.
If you selected [12-hour Format], press the [▲][▼] keys to select [AM] or [PM].
You can press the [◀][▶] keys to move between fields.
11. Press the [User Tools] key to return to the initial screen.

↓ Note

- You can press the [Escape] key to exit to the previous level of the menu tree.

- A password for accessing the [Admin. Tools] menu can be specified in [Admin. Tools Lock].
- If an incorrect time or date is input, the machine automatically corrects it to the nearest valid time or date.

 **Reference**

- For details about [Admin. Tools Lock], see p.298 "Administrator Settings".

Registering Fax Destinations

This section describes how to register fax destinations in the Address Book using the control panel or Web Image Monitor. The Address Book allows you to specify fax destinations quickly and easily.

★ Important

- **The Address Book data could be damaged or lost unexpectedly. The manufacturer shall not be responsible for any damages resulting from such data loss. Be sure to create backup files of the Address Book data periodically.**

The Address Book can contain up to 220 entries (20 Quick Dial entries and 200 Speed Dial entries).

Quick Dial entries

Destinations registered as Quick Dial entries can be selected by pressing the corresponding One Touch button.

Speed Dial entries

Destinations registered as Speed Dial entries can be selected from the Address Book. Press the [Address Book] key, select [Search Address Book], and then select the desired entry using the [▲] [▼] keys.

📖 Reference

- For details about creating backup files, see p.355 "Backing Up the Machine's Settings".

Registering Fax Destinations Using the Control Panel

This section describes how to register destinations using the control panel.

1. Press the [User Tools] key.

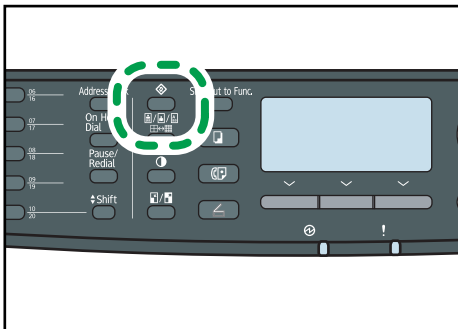

2. Press the [▲][▼] keys to select [Address Book], and then press the [OK] key.
3. If you are requested to enter a password, enter the password using the number keys, and then press the [OK] key.

4. Press the [▲][▼] keys to select [Quick Dial Dest.] or [Fax Speed Dial Dest.], and then press the [OK] key.
5. Press the [▲][▼] keys to select [No.], and then enter the desired Quick Dial number (1 to 20) or Speed Dial number (1 to 200) using the number keys.
If a destination is already registered for the input number, the fax number and fax name registered for that number appear.
6. Press the [▲][▼] keys to select [Fax No.], and then enter the fax number (up to 40 characters).
7. Press the [▲][▼] keys to select [Name], and then enter the fax name (up to 20 characters).
8. Confirm the setting, and then press the [OK] key.
9. Press the [User Tools] key to return to the initial screen.

 **Note**

- You can press the [Escape] key to exit to the previous level of the menu tree.
- A fax number can contain 0 to 9, pause, "✳", "#", and space.
- If necessary, insert a pause in the fax number. The machine pauses briefly before it dials the digits following the pause. You can specify the length of the pause time in the [Pause Time] setting under fax transmission settings.
- To use tone services on a pulse-dialing line, insert "✳" in the fax number. "✳" switches the dialing mode from pulse to tone temporarily.
- If the machine is connected to the telephone network through a PBX, make sure to enter the outside line access number specified in [PBX Access Number] before the fax number.
- Use Web Image Monitor to register an Internet Fax destination (an e-mail address).
- A password for accessing the [Address Book] menu can be specified in [Admin. Tools Lock].

 **Reference**

- For details about entering characters, see p.123 "Entering Characters".
- For details about [Pause Time], see p.267 "Fax Transmission Settings".
- For details about [PBX Access Number], see p.298 "Administrator Settings".
- For details about registering an Internet Fax destination, see p.206 "Registering Fax Destinations Using Web Image Monitor".
- For details about [Admin. Tools Lock], see p.298 "Administrator Settings".

Modifying fax destinations

This section describes how to modify the information of registered destinations.

1. Press the [User Tools] key.

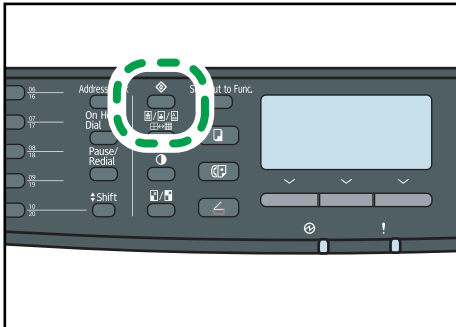

CMF134

2. Press the [▲][▼] keys to select [Address Book], and then press the [OK] key.
3. If you are requested to enter a password, enter the password using the number keys, and then press the [OK] key.
4. Press the [▲][▼] keys to select [Quick Dial Dest.] or [Fax Speed Dial Dest.], and then press the [OK] key.
5. Press the [▲][▼] keys to select [No.], and then enter the desired Quick Dial number (1 to 20) or Speed Dial number (1 to 200) using the number keys.
The fax number and fax name registered for that number appear.
6. Press the [▲][▼] keys to select [Fax No.], and then modify the fax number (up to 40 characters).
7. Press the [▲][▼] keys to select [Name], and then modify the fax name (up to 20 characters).
8. Confirm the setting, and then press the [OK] key.
9. Press the [User Tools] key to return to the initial screen.

↓ Note

- You can press the [Escape] key to exit to the previous level of the menu tree.
- A password for accessing the [Address Book] menu can be specified in [Admin. Tools Lock].

📖 Reference

- For details about [Admin. Tools Lock], see p.298 "Administrator Settings".
- For details about entering characters, see p.123 "Entering Characters".

Deleting fax destinations

This section describes how to delete registered destination.

1. Press the [User Tools] key.

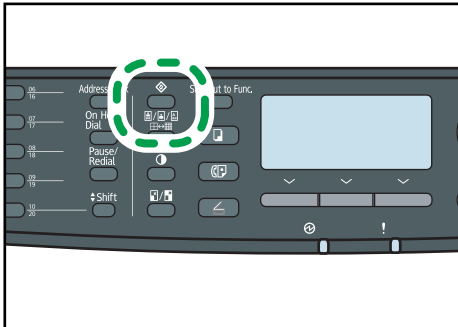

CMF134

2. Press the [▲][▼] keys to select [Address Book], and then press the [OK] key.
3. If you are requested to enter a password, enter the password using the number keys, and then press the [OK] key.
4. Press the [▲][▼] keys to select [Quick Dial Dest.] or [Fax Speed Dial Dest.], and then press the [OK] key.
5. Press the [▲][▼] keys to select [No.], and then enter the desired Quick Dial number (1 to 20) or Speed Dial number (1 to 200) using the number keys.
The fax number and fax name registered for that number appear.
6. Press the [▲][▼] keys to select [Fax No.], and then press the [◀] key repeatedly until the current number is deleted.
7. Press the [▲][▼] keys to select [Name], and then press the [◀] key repeatedly until the current name is deleted.
8. Confirm the setting, and then press the [OK] key.
9. Press the [User Tools] key to return to the initial screen.

↓ **Note**

- You can press the [Escape] key to exit to the previous level of the menu tree.
- A password for accessing the [Address Book] menu can be specified in [Admin. Tools Lock].

📖 **Reference**

- For details about [Admin. Tools Lock], see p.298 "Administrator Settings".

Registering Fax Destinations Using Web Image Monitor

This section describes how to register destinations using Web Image Monitor.

1. Start the Web browser and access the machine by entering its IP address.
2. Click [Quick Dial Destination] or [Fax Speed Dial Destination].

3. From the [Destination Type] list, select [Fax].
4. Select [Quick Dial Number] or [Speed Dial Number], and then select the registration number from the list.
5. Register information as necessary.
6. Enter the administrator password if required.
7. Click [Apply].
8. Close the Web browser.

Fax destination settings

Item	Setting	Description
Quick Dial Number / Speed Dial Number	Required	Select the number to which you want to register Quick Dial or Speed Dial destination.
Name	Optional	Name of the destination. The name specified here will be shown on the screen when selecting a fax destination. Can contain up to 20 characters.
Fax Number	Optional	Fax number of the destination. Can contain up to 40 characters. If the machine is connected to the telephone network through a PBX, make sure to enter the outside line access number specified in [PBX Access Number] before the fax number.
E-mail Address	Optional	E-mail address of the destination of the Internet Fax. Can contain up to 64 characters.

Note

- A fax number can contain 0 to 9, "P" (pause), "*#", "-", and space.
- If necessary, insert a pause in the fax number. The machine pauses briefly before it dials the digits following the pause. You can specify the length of the pause time in the [Pause Time] setting under fax transmission settings.

- To use tone services on a pulse-dialing line, insert "*" in the fax number. "*" switches the dialing mode from pulse to tone temporarily.

Reference

- For details about [Pause Time], see p.267 "Fax Transmission Settings".
- For details about [PBX Access Number], see p.298 "Administrator Settings".
- For details about using Web Image Monitor, see p.309 "Using Web Image Monitor".

Modifying fax destinations

This section describes how to modify the information of registered destinations.

1. Start the Web browser and access the machine by entering its IP address.
2. Click [Quick Dial Destination] or [Fax Speed Dial Destination].
If you modify the Speed Dial entry, proceed to step 4.
3. Click [Fax Quick Dial Destination].
4. Select the entry to modify, and then click [Change].
5. Modify settings as necessary.
6. Enter the administrator password if required.
7. Click [Apply].
8. Close the Web browser.

Deleting fax destinations

This section describes how to delete registered destination.

1. Start the Web browser and access the machine by entering its IP address.
2. Click [Quick Dial Destination] or [Fax Speed Dial Destination].
If you delete the Speed Dial entry, proceed to step 4.
3. Click [Fax Quick Dial Destination].
4. Select the entry to delete, and then click [Delete].
5. Confirm that the entry you have selected is the entry that you want to delete.
6. Enter the administrator password if required.
7. Click [Apply].
8. Close the Web browser.

Sending a Fax

This section describes the transmission modes and the basic operations for sending a fax.

★ Important

- It is recommended that you call the receiver and confirm with them when sending important documents.

Selecting Transmission Mode

This section describes how to select the transmission mode.

There are two transmission modes: Memory Transmission and Immediate Transmission.

Memory Transmission

In this mode, the machine scans several originals into memory and sends them all at once. This is convenient when you are in a hurry and want to take the document away from the machine. In this mode, you can send a fax to multiple destinations.

Select this mode when scanning 2-sides of original and send them using the ARDF with the Type 2 model.

Immediate Transmission

In this mode, the machine scans the original and faxes it simultaneously, without storing it in memory. This is convenient when you want to send an original quickly. In this mode, you can only specify one destination.

Note that if the machine is in this mode, only one side of the original is scanned using the ARDF regardless of the ARDF original setting for the Type 2 model.

1. Press the [Facsimile] key, and then press the [◀][▶] keys.

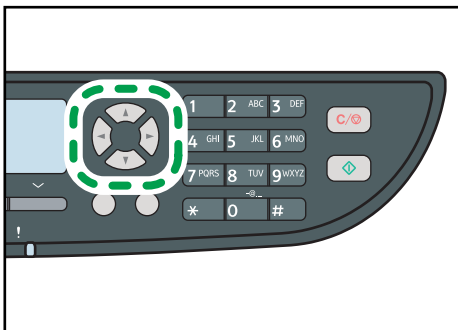

CMF144

Alternatively, you can press the [Shortcut to Func.] key if [Shortcut to Function] under administrator settings is set to [Fax Immediate TX].

2. Press the [▲][▼] keys to select [Immediate TX], and then press the [OK] key.

3. Press the [▲][▼] keys to select [Off], [On], or [Next Fax Only], and then press the [OK] key.

For Memory Transmission, select [Off].

For Immediate Transmission, select [On] or [Next Fax Only].

4. Press the [User Tools] key to return to the initial screen.

Note

- You can press the [Escape] key to exit to the previous level of the menu tree.

Reference

- For details about [Shortcut to Function], see p.298 "Administrator Settings".

Internet Fax Transmission Overview

You can send faxes over the Internet. When you send faxes to Internet Fax destinations, the machine converts scanned images to TIFF-F format files and send them as attachments to e-mail.

Important

- **The level of security for Internet communications is low. It is recommended that you use the telephone network for confidential communications.**
- **Internet Fax delivery might be delayed due to network congestion. Use a public telephone line if the fax needs to be delivered in a timely manner.**

Note

- The Internet Fax function supported by this machine is compliant with ITU-T Recommendation T.37 (Simple Mode).
- To use the Internet Fax function, network settings must be configured properly.
- Internet Fax transmission may take some time before it starts. The machine needs a certain amount of time to convert data in memory prior to transmission.
- Depending on e-mail environment conditions, you may not be able to fax large images.
- The "Photo" resolution is not available for Internet Faxes. Faxes will be sent using "Detail" resolution if "Photo" resolution has been specified.
- If the faxes are received on a computer, a viewer application needs to be installed in order to view the documents.

Reference

- For details about network settings, see p.330 "Configuring the Network Settings".

Basic Operation for Sending a Fax

This section describes the basic operation for sending a fax.

★ Important

- The original in the ARDF or ADF takes precedence over the original on the exposure glass if you place originals both in the ARDF/ADF and on the exposure glass.

1. Press the [Facsimile] key.

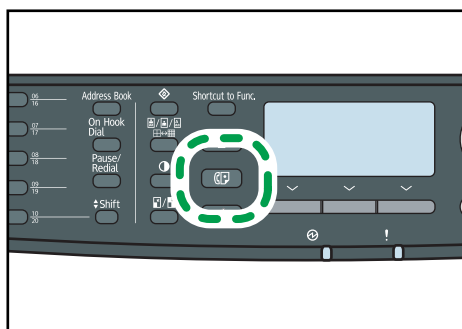

2. Place the original on the exposure glass or in the ARDF/ADF.

If necessary, configure the advanced scan settings.

3. Enter the fax number (up to 40 characters) using the number keys, or specify a destination using the One Touch buttons or Speed Dial function.

- If the machine is connected to the telephone network through a PBX, make sure to enter the outside line access number specified in [PBX Access Number] before the fax number.
- To specify an Internet Fax destination, use the One Touch buttons or Speed Dial function.

4. Press the [Start] key.

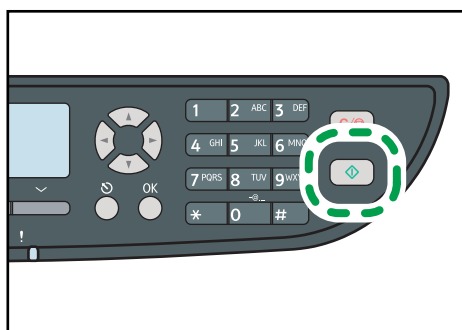

- Depending on the machine's settings, you may be prompted to enter the fax number again if you manually entered the destination fax number. In this case, re-enter the number within 30

seconds, press [OK], and then press the [Start] key. If the fax numbers do not match, go back to step 3.

- When using the exposure glass in Memory Transmission mode, you will be prompted to place another original. In this case, proceed to the next step.

5. If you have more originals to scan, press [Yes] within 60 seconds, place the next original on the exposure glass, and then press [OK]. Repeat this step until all originals are scanned.

If you do not press [Yes] within 60 seconds, the machine will start to dial the destination.

6. When all originals have been scanned, press [No] to start sending the fax.

Note

- A fax number can contain 0 to 9, pause, "*", "#", and space.
- If necessary, insert a pause in a fax number. The machine pauses briefly before it dials the digits following the pause. You can specify the length of the pause time in the [Pause Time] setting under fax transmission settings.
- To use tone services on a pulse-dialing line, insert "*" in a fax number. "*" switches the dialing mode from pulse to tone temporarily.
- You can also specify a destination from an LDAP server or with the [Pause/Redial] key.
- You can specify multiple destinations and broadcast the fax you are sending.
- The machine prompts you to enter the fax number twice only when you dial the destination manually. Destinations specified using the One Touch buttons, Speed Dial function, or [Pause/Redial] key need not be confirmed.
- When in Memory Transmission mode, you can enable the [Auto Redial] setting under fax transmission settings to set the machine to automatically redial the destination if the line is busy or an error occurs during transmission.
- When in Memory Transmission mode, the machine's memory may become full while scanning the originals. In this case, the screen prompts you to cancel the transmission or to send only the pages that have been scanned successfully.
- If you specify an Internet Fax destination in Immediate Transmission mode, the mode switches to Memory Transmission mode temporarily.
- If paper is jammed in the ARDF or ADF, the jammed page has not been scanned properly. When the machine is in Immediate Transmission mode, resend the fax starting from the jammed page. When in Memory Transmission mode, scan the entire originals again.

Reference

- For details about entering characters, see p.123 "Entering Characters".
- To place the originals, see p.119 "Placing Originals".
- To configure advanced scan settings, see p.222 "Specifying the Scan Settings".
- For details about [PBX Access Number], see p.298 "Administrator Settings".

- For details about specifying destinations using the One Touch buttons, Speed Dial function, LDAP server, or [Pause/Redial] key, see p.214 "Specifying the Fax Destination".
- For details about broadcasting a fax, see p.214 "Specifying the Fax Destination".
- For details about fax number confirmation, see p.298 "Administrator Settings".
- For details about [Auto Redial] or [Pause Time], see p.267 "Fax Transmission Settings".
- For details about how to remove the paper jammed in the ADF or ARDF, see p.375 "Removing Scanning Jams (Type 2 model)" or p.379 "Removing Scanning Jams (Type 1 model)".

Canceling a fax

Follow the procedure below to cancel sending a fax.

When in Immediate Transmission mode

If you cancel sending a fax while the machine is scanning the original, the fax transmission process is canceled immediately. In this case, an error is displayed on the other party's machine.

When in Memory Transmission mode

If you cancel sending a fax while the machine is scanning the original, the machine will not send the document.

If you cancel sending a fax during transmission, the fax transmission process is canceled immediately. In this case, an error is displayed on the other party's machine.

1. Press the [Facsimile] key.

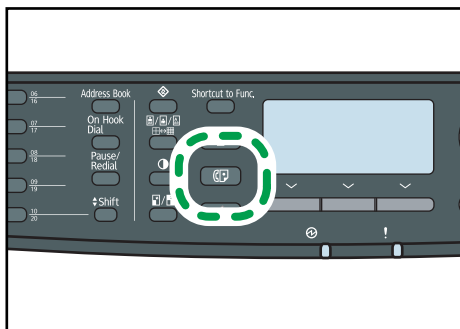

CMF133

2. Press the [Clear/Stop] key.

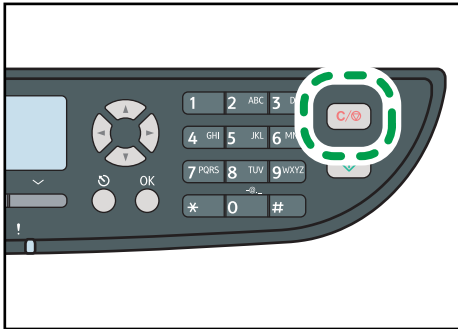

CMF135

Note

- If you cancel sending a fax while broadcasting, only the fax to the current destination is canceled. The fax will be sent to the subsequent destinations as normal.

Reference

- For details about the broadcasting function, see p.218 "Specifying the destination using the broadcast function".

Specifying the Fax Destination

This section describes how to specify the destination when sending a fax.

Other than entering the destination fax number using the number keys, you can specify destinations using the following functions:

- Using the One Touch buttons
- Using Speed Dial
- Using the LDAP server search function
- Using the Broadcast function
- Using the Redial function

Specifying the destination using the One Touch buttons

This section describes how to select a destination registered as a Quick Dial entry using One Touch buttons.

1. Press the [Facsimile] key.

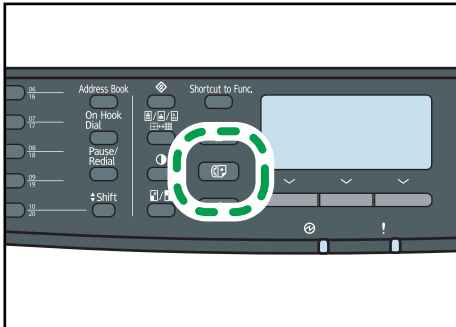

CMF133

2. Press the One Touch button to which the desired Quick Dial entry is registered.

Press the [Shift] key if you want to use Quick Dial entries Nos. 11 to 20 before pressing a One Touch button.

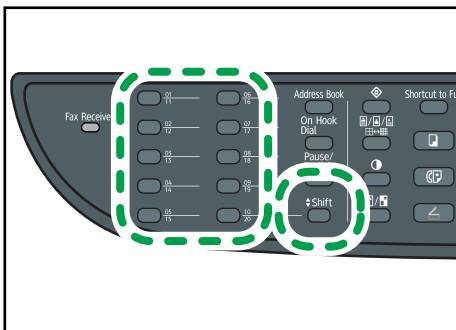

CMF142

↓ Note

- You can check the registered names and fax numbers by printing a report.

📖 Reference

- For details about registering the Quick Dial entries, see p.203 "Registering Fax Destinations".
- For details about printing the Quick Dial list, see p.291 "Printing Lists/Reports".

Specifying the destination using Speed Dial

This section describes how to select a destination registered as a Speed Dial entry.

1. Press the [Facsimile] key.

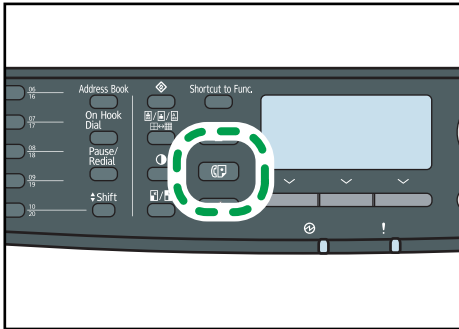

CMF133

2. Press the [Address Book] key.

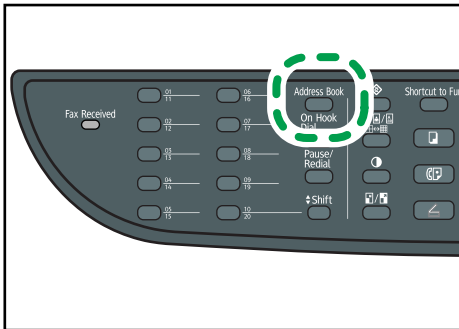

CMF140

3. Press the [▲][▼] keys to select [Search Address Book], and then press the [OK] key.

If you want to search for a specific entry by its registration number or name, use the following procedure:

- Searching by the registration number
Press the [Address Book] key again, enter the number using the number keys, and then press the [OK] key.
- Searching by the name
Enter the first letters of the name using the number keys, and then press the [OK] key. Each time you enter a character, the display changes to show the matching name.

4. Press the [▲][▼] keys to select the desired Speed Dial entry, and then press the [OK] key.

↓ Note

- The Address Book shows only the Speed Dial entries. Use the One Touch buttons to specify Quick Dial destinations.
- You can check the registered names and fax numbers by printing a report.

☰ Reference

- For details about registering the Speed Dial entries, see p.203 "Registering Fax Destinations".

- For details about printing the Speed Dial list, see p.291 "Printing Lists/Reports".

Specifying the destination from an LDAP server

This section describes how to select a destination registered on the LDAP server.

★ Important

- To search for a destination from an LDAP server, the LDAP server must be registered in advance, and [LDAP Search] must be enabled under the LDAP server settings.

1. Press the [Facsimile] key.

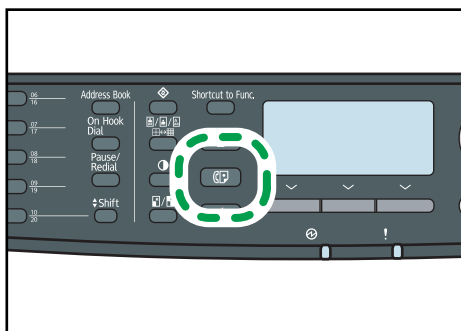

CMF133

2. Press the [Address Book] key.

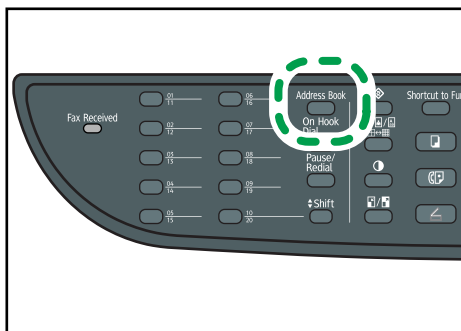

CMF140

3. Press the [▲][▼] keys to select [Search LDAP], and then press the [OK] key.
4. Press the [▲][▼] keys to select [Start LDAP Search], and then press the [OK] key.
A list of destinations that match the search conditions appears on the display (up to 50).
5. Press the [▲][▼] keys to scroll through the search result, and then press [▶] to select the desired destination.

You can select multiple destinations. A check mark will appear for the selected destinations. To deselect a destination, press [▶] again.

Note

- The search result will contain destinations that match the predefined search conditions.
- If a record that has been found contains multiple destinations, the first of those destinations will be used.

Reference

- For details about registering LDAP servers, see p.440 "Programming the LDAP server".
- For details about specifying the search conditions, see p.446 "Specifying the LDAP Address Search Conditions".

Specifying the destination using the broadcast function

You can send a fax to multiple destinations simultaneously. You can broadcast faxes to a maximum of 100 destinations (including both normal fax destinations and Internet Fax destinations).

Faxes are sent to destinations in the order they were specified.

1. Press the [Facsimile] key.

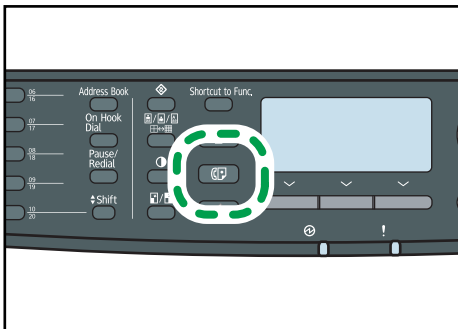

CMF133

2. Add a destination by using one of the following methods:

- To add a Quick Dial destination: press a corresponding One Touch button.
- To add a Speed Dial destination: press the [Address Book] key, select [Search Address Book], select a destination, and then press the [OK] key.
- To add a manually-specified destination: confirm that [No.key] is pressed, and then enter the destination fax number using the number keys.
- To add a destination from an LDAP server: follow the procedure in "Specifying the destination from an LDAP server".

3. Press the [OK] key.

Press [List] to see the list of destinations that have been added so far.

Go back to step 2 to add further destinations.

Note

- While specifying multiple destinations, you can press the [Clear/Stop] key to clear all destinations.
- If you specify multiple destinations in Immediate Transmission mode, the mode switches to Memory Transmission mode temporarily.
- If the destinations contain both normal fax destinations and Internet Fax destinations, the fax will be sent to the Internet Fax destinations first.
- While broadcasting, pressing the [Clear/Stop] key cancels the fax to the current destination only.

Reference

- For details about specifying a destination from an LDAP server, see p.217 "Specifying the destination from an LDAP server".

Specifying the destination using the redial function

You can specify the last used destination as the destination for the current job.

This function saves time when you are sending to the same destination repeatedly, as you do not have to enter the destination each time.

1. Press the [Facsimile] key.

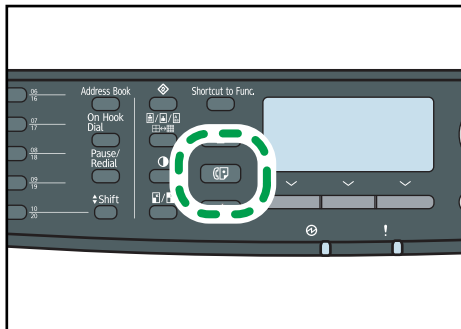

CMF133

2. Press the [Pause/Redial] key.

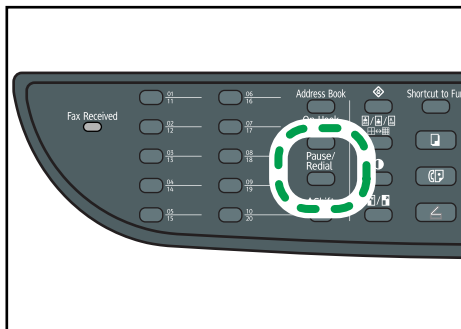

CMF143

Useful Sending Functions

This section explains some useful fax functions.

You can confirm the status of the other party's machine easily before sending a fax by using the On Hook Dial function. If you have an extra telephone, you can talk and send a fax in one call.

★ Important

- This function is available in Immediate Transmission mode only.
- This function is not available with Internet Fax.

📖 Reference

- For details about selecting the transmission mode, see p.209 "Selecting Transmission Mode".

Sending a fax using On Hook Dial

The On Hook Dial function allows you to check the destination's status while listening to the tone from the internal speaker. This function is useful when you want to ensure that the fax will be received.

★ Important

- The On Hook Dial function cannot be used when [Fax Number Confirmation] under administrator settings is enabled.

1. Place the original.
2. Press the [Facsimile] key.

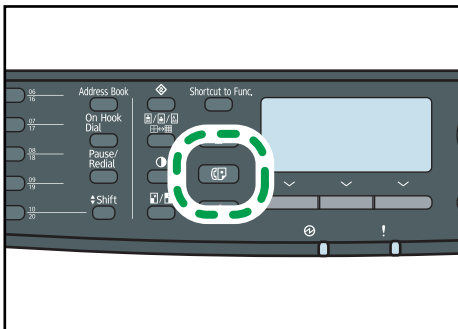

CMF133

3. Press the [On Hook Dial] key.

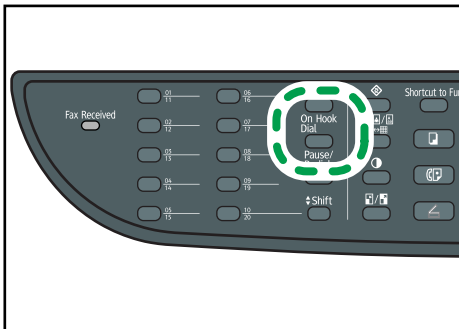

CMF145

"On Hook" appears on the screen.

4. Specify the destination using the number keys.
5. If you hear a high pitched tone, press the [Start] key.

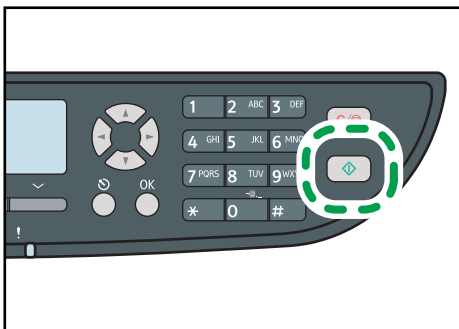

CMF141

6. Press [TX], and then press the [Start] key.

Reference

- For details about [Fax Number Confirmation], see p.298 "Administrator Settings".

Sending a fax after a conversation

An external telephone allows you to send a fax after finishing your conversation, without having to disconnect and redial. This function is useful when you want to ensure that the fax will be received.

1. Place the original.

2. Press the [Facsimile] key.

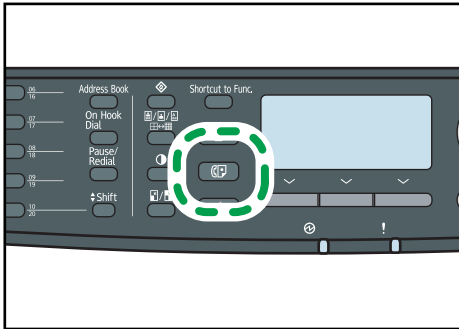

CMF133

3. Pick up the handset of the external telephone.
4. Specify the destination using the external telephone.
5. When the other party answers, ask them to press their fax start button.
6. If you hear a high pitched tone, press the [Start] key.

6

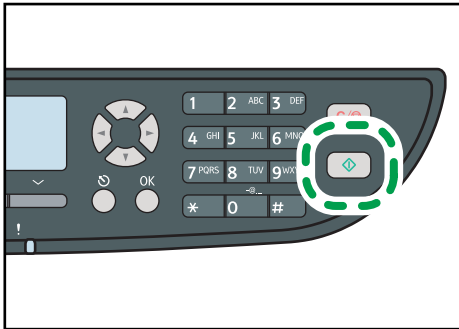

CMF141

7. Press [TX], and then press the [Start] key.
8. Replace the handset.

Reference

- For details about connecting an external telephone, see p.67 "Connecting to a Telephone Line".

Specifying the Scan Settings

This section describes how to specify image density and resolution for the current scan job.

Adjusting image density

This section describes how to adjust image density for the current job.

There are three image density levels. The darker the density level, the darker the printout.

1. Press the [Density] key.

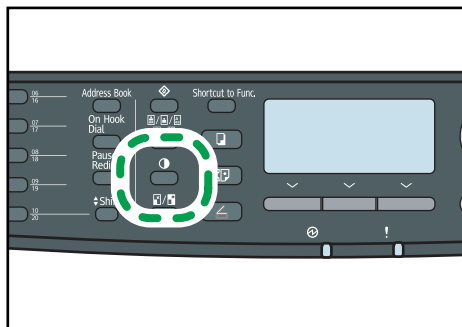

CMF138

2. Press the [▲][▼] keys to select the desired density level, and then press the [OK] key.

↓ Note

- Press the [Escape] key to discard the current change and return to the initial screen.
- You can change the machine's default [Density] setting to always scan with a specific density level.
- Temporary job settings are cleared in the following cases:
 - When no input is received for the period of time specified in [System Auto Reset Timer] while the initial screen is displayed.
 - When the [Clear/Stop] key is pressed while the initial screen is displayed.
 - When the machine's mode is changed.
 - When the power is turned off.
 - When the machine's default for the same setting is changed.

📖 Reference

- For details about [Density], see p.267 "Fax Transmission Settings".
- For details about [System Auto Reset Timer], see p.298 "Administrator Settings".

Specifying the resolution

This section describes how to specify the scan resolution for the current job.

There are three resolution settings:

Standard

Select this when the original is a printed or typewritten document with normal-sized characters.

Detail

Select this when the original is a document with small print.

Photo

Select this when the original contains images such as photographs or shaded drawings.

1. Press the [Image Quality] key.

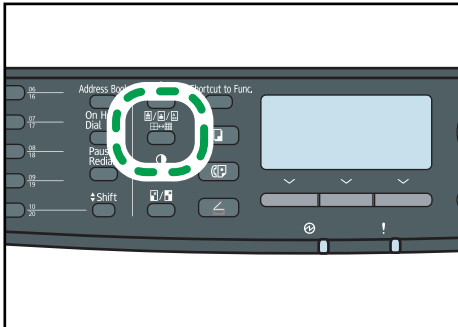

CMF139

2. Press the [▲][▼] keys to select the desired resolution setting, and then press the [OK] key.

↓ Note

- Press the [Escape] key to discard the current change and return to the initial screen.
- You can change the machine's default [Resolution] setting to always scan with a specific resolution level.
- The "Photo" resolution is not available for Internet Faxes. Faxes will be sent using "Detail" resolution if "Photo" resolution has been specified.
- Temporary job settings are cleared in the following cases:
 - When no input is received for the period of time specified in [System Auto Reset Timer] while the initial screen is displayed.
 - When the [Clear/Stop] key is pressed while the initial screen is displayed.
 - When the machine's mode is changed.
 - When the power is turned off.
 - When the machine's default for the same setting is changed.

📖 Reference

- For details about [Resolution], see p.267 "Fax Transmission Settings".
- For details about [System Auto Reset Timer], see p.298 "Administrator Settings".

Specifying the scanning side according to the original (Type 2 model)

If you are using the Type 2 model, you can specify the machine to scan both sides of original automatically using the ARDF.

This section describes how to specify the scanning side according to the current original.

★ Important

- If the machine is in Immediate Transmission mode, this function is not available.

1. Press [Original].**2. Press the [▲][▼] keys to select the desired scanning method, and then press the [OK] key.**

Select the sides of the original (1 side or 2-sides) to scan. When scanning 2-sides, select the page and binding orientations according to the original.

Note

- Press the [Escape] key to discard the current change and return to the initial screen.
- If 2-sided scanning is specified, you must use the ARDF (scanning will not be possible with the exposure glass).
- You can change the machine's default [Original] setting to always scan specific sides of originals.
- Temporary job settings are cleared in the following cases:
 - When no input is received for the period of time specified in [System Auto Reset Timer] while the initial screen is displayed.
 - When the [Clear/Stop] key is pressed while the initial screen is displayed.
 - When the machine's mode is changed.
 - When the power is turned off.
 - When the machine's default for the same setting is changed.

Reference

- For details about [Original], see p.267 "Fax Transmission Settings".
- For details about [System Auto Reset Timer], see p.298 "Administrator Settings".

Using the Fax Function from a Computer (LAN-Fax)

This section describes how to use the fax function of the machine from a computer.

You can send a document directly from a computer through this machine to another fax machine, without printing the document.

★ Important

- This function is supported by Windows XP/Vista/7, and Windows Server 2003/2003 R2/2008/2008 R2. Mac OS X does not support this function.

Configuring the LAN-Fax Address Book

This section describes the LAN-Fax Address Book. Configure the LAN-Fax Address Book on the computer. The LAN-Fax Address Book allows you to specify LAN-Fax destinations quickly and easily.

The LAN-Fax Address Book can contain up to 1000 entries, including individual destinations and groups of destinations.

↓ Note

- You can configure separate LAN-Fax Address Books for each user account on your computer.
- You can import and export the LAN-Fax Address Book as required.

Opening the LAN-Fax Address Book

This section describes how to open the LAN-Fax Address Book.

★ Important

- The following procedure is based on Windows 7 as an example. If you are using another operating system, the procedure might vary slightly.
1. On the [Start] menu, click [Devices and Printers].
 2. Right-click the icon of the LAN-Fax driver, and then click [Printing Preferences].

3. Click the [Address Book] tab.

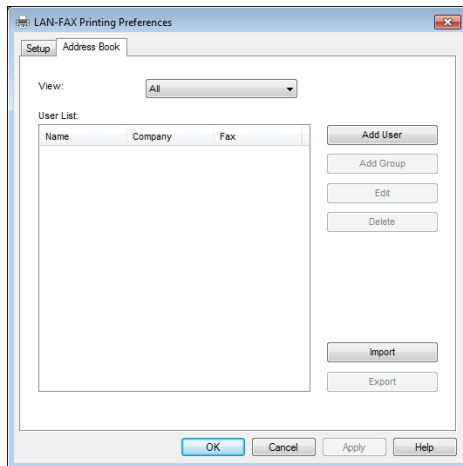

Note

- From the [View:] list, you can select the type of destinations to display.
 - [All]: Displays all destinations.
 - [Group]: Displays groups only.
 - [User]: Displays individual destinations only.

Registering destinations

This section describes how to register destinations in the LAN-Fax Address Book.

1. Open the LAN-Fax Address Book, and then click [Add User].

2. Register the required information and click [OK].

For details, see the table below.

Setting LAN-Fax destinations

Item	Setting	Description
Name	Required	Name of the destination. Can contain up to 32 characters.
Company	Optional	Company name of the destination. Can contain up to 64 characters. You can select from registered data.
Department	Optional	Department name of the destination. Can contain up to 64 characters. You can select from registered data.
Telephone	Optional	Telephone number of the destination. Can contain up to 40 characters.
Fax	Required	Fax number of the destination. Can contain up to 40 characters.

Note

- A telephone number or fax number can contain 0 to 9, "P" (pause), "*", "#", "-" and space.
- If necessary, insert a pause in a fax number. The machine pauses briefly before it dials the digits following the pause. You can specify the length of the pause time in the [Pause Time] setting under fax transmission settings.
- To use tone services on a pulse-dialing line, insert "*" in a fax number. "*" switches the dialing mode from pulse to tone temporarily.
- A message appears if the name you specified already exists in the LAN-Fax Address Book. To register the destination under a different name, click [No] and enter a different name. Clicking [Yes] allows you to register it under the same name.
- You can partly modify an existing destination and register it as a new one with similar information.

Reference

- For details about [Pause Time], see p.267 "Fax Transmission Settings".
- For details about how to register a new destination similar to an existing one, see p.228 "Modifying destinations".

Modifying destinations

This section describes how to modify registered destinations.

1. Open the LAN-Fax Address Book, select the destination you want to modify from the [User List:], and then click [Edit].

The 'Edit User' dialog box has the following fields and controls:

- *Name: User 1
- Company: Company A
- Department: Department A
- Telephone: (empty)
- *Fax: 111222333
- Buttons: Save as new User, OK, Cancel
- Note: * Required item

2. Modify information as necessary, and then click [OK].

Click [Save as new User] if you want to register a new destination with similar information. This is useful when you want to register a series of destinations that contain similar information. To close the dialog box without modifying the original destination, click [Cancel].

Note

- A message appears if the name you specified already exists in the LAN-Fax Address Book. To register the destination under a different name, click [No] and enter a different name. Clicking [Yes] allows you to register it under the same name.

Registering groups

This section describes how to register groups of destinations.

A group can contain up to 100 individual destinations.

1. Open the LAN-Fax Address Book, and then click [Add Group].

The 'Add Group' dialog box contains the following elements:

- Group Name: (empty text box)
- List of Group Members: (empty table with columns Name, Company, Fax)
- User List:

Name	Company	Fax
User 1	Company A	111222333
User 2	Company B	222333444
- Buttons: Add, Delete from List, OK, Cancel

2. Enter the group name in [Group Name].

3. Select the destination you want to include in the group from [User List:], and then click [Add].

To delete a destination from a group, select the destination you want to delete from [List of Group Members:], and then click [Delete from List].

4. Click [OK].

↓ Note

- A group must contain at least one destination.
- A group name must be specified for a group. No two groups can have the same group name.
- A single destination can be included in more than one group.

Modifying groups

This section describes how to modify registered groups.

1. Open the LAN-Fax Address Book, select the group you want to modify from the [User List:], and then click [Edit].

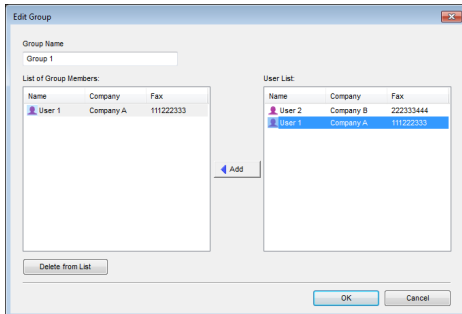

2. To add a destination to the group, select the destination you want to add from [User List:] and click [Add].
3. To delete a destination from the group, select the destination you want to delete from [List of Group Members:], and then click [Delete from List].
4. Click [OK].

↓ Note

- A message appears if the name you specified already exists in the LAN-Fax Address Book. Click [OK] and register it under a different name.

Deleting individual destinations or groups

This section describes how to delete individual destinations or groups from the LAN-Fax Address Book.

1. Open the LAN-Fax Address Book, select the destination you want to delete from [User List:], and then click [Delete].

A confirmation message appears.

2. Click [Yes].

Note

- A destination is automatically deleted from a group if that destination is deleted from the LAN-Fax Address Book. If you are deleting the last destination from a group, a message asking you to confirm the deletion appears. Click [OK] if you want to delete the group.
- Deleting a group does not delete the destinations it contains from the LAN-Fax Address Book.

Exporting/Importing LAN-Fax Address Book data

This section describes how to export or import LAN-Fax Address Book data.

Important

- The following procedure is based on Windows 7 as an example. If you are using another operating system, the procedure might vary slightly.

Exporting LAN-Fax Address Book data

LAN-Fax Address Book data can be exported to a file in CSV (Comma Separated Values) format. Follow this procedure to export LAN-Fax Address Book data.

1. Open the LAN-Fax Address Book, and then click [Export].
2. Navigate to the location to save the LAN-Fax Address Book data, specify a name for the file, and then click [Save].

Importing LAN-Fax Address Book data

LAN-Fax Address Book data can be imported from files in CSV format. You can import address book data from other applications if the data is saved as a CSV file.

Follow this procedure to import LAN-Fax Address Book data. To import address book data from other applications, you must select the appropriate items to import.

1. Open the LAN-Fax Address Book, and then click [Import].
2. Select the file containing the address book data, and then click [Open].

A dialog box for selecting the items to import appears.

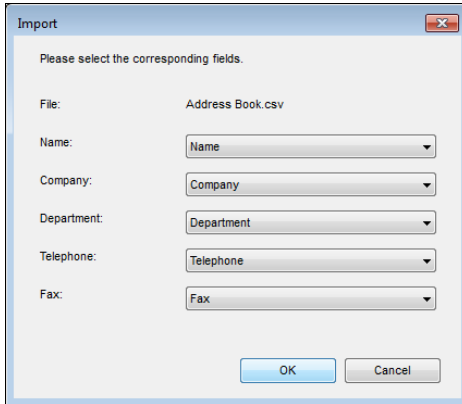

3. For each field, select an appropriate item from the list.

Select [*empty*] for fields for which there is no data to import. Note that [*empty*] cannot be selected for [Name] or [Fax].

4. Click [OK].

If a destination with the same name is found during the import process, select one of the following operations:

- [Skip]: Skips the destination, and imports the remaining data.
- [Save as new User]: Imports the current destination as a separate destination under the same name as an existing destination.
- [Save All as new User]: Imports the current and subsequent destinations as separate destinations under the same names as existing destinations.
- [Overwrite]: Imports the destination, overwriting the data in the LAN-Fax Address Book.
- [Overwrite All]: Imports the current and subsequent destinations under the same names as existing destinations, overwriting the data in the LAN-Fax Address Book.
- [Cancel]: Cancels the import operation.

If a destination does not contain a name, or invalid characters are used in the telephone number or fax number, select one of the following operations:

- [Skip]: Skips the destination, and imports the remaining data.
- [Save]: Imports the destination as is.
- [Save All]: Imports the current and subsequent destinations as is.
- [Cancel]: Cancels the import operation.

↓ Note

- CSV files are exported using Unicode encoding.
- LAN-Fax Address Book data can be imported from CSV files whose character encoding is Unicode or ASCII.

- Group data cannot be exported or imported.
- Up to 1000 destinations can be registered in the LAN-Fax Address Book. If this limit is exceeded during importing, the remaining destinations will not be imported.

Basic Operation for Sending Faxes from a Computer

This section describes the basic operation for sending faxes from a computer.

You can select the destination from the LAN-Fax Address Book or enter the fax number directly. You can send faxes to up to 100 destinations at one time.

★ Important

- Before sending a fax, the machine stores all the fax data in memory. If the machine's memory becomes full while storing this data, the fax transmission will be canceled. If this happens, lower the resolution or reduce the number of pages and try again.
- The following procedure is based on Windows 7 as an example. If you are using another operating system, the procedure might vary slightly.

1. Open the file you want to send.
2. On the [File] menu, click [Print...].
3. Select the LAN-Fax driver as the printer, and then click [Print].

If necessary, configure the transmission settings in the LAN-Fax driver's properties before clicking [Print].

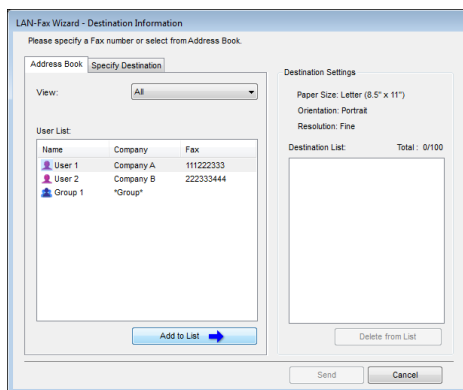

4. To specify a destination from the LAN-Fax Address Book, select a destination from [User List:], and then click [Add to List].

Repeat this step to add more destinations.

5. To directly enter a fax number, click the [Specify Destination] tab, enter a fax number (up to 40 digits) in [Fax Number:], and then click [Add to List].

Repeat this step to add more destinations.

6. If you want to attach a fax cover sheet, click [Edit Cover Sheet] on the [Specify Destination] tab, and then select the [Attach a Cover Sheet] check box.

Edit the cover sheet as necessary, and then click [OK].

7. Click [Send].

Note

- A fax number can contain 0 to 9, "P" (pause), "*#", "-", and space.
- If necessary, insert a pause in a fax number. The machine pauses briefly before it dials the digits following the pause. You can specify the length of the pause time in the [Pause Time] setting under fax transmission settings.
- To use tone services on a pulse-dialing line, insert "*" in a fax number. "*" switches the dialing mode from pulse to tone temporarily.
- To delete an entered destination, select the destination in the [Destination List:], and then click [Delete from List].
- You can register the fax number you entered in the [Specify Destination] tab in the LAN-Fax Address Book. Click [Save to Address Book] to open the dialog box for registering a destination.
- From the [View:] list, you can select the types of destinations to display.
 - [All]: Displays all destinations.
 - [Group]: Displays groups only.
 - [User]: Displays individual destinations only.
- If sending faxes via LAN-Fax is restricted, you must enter a user code in the LAN-Fax driver's property before sending a fax.
- If LDAP authentication is specified, you must enable user authentication and enter a user name and password in the LAN-Fax driver's properties before sending a fax job to the machine.

Reference

- For details about configuring the transmission settings, see p.237 "Configuring Transmission Settings".
- For details about [Pause Time], see p.267 "Fax Transmission Settings".
- For details about editing a fax cover sheet, see p.235 "Editing a Fax Cover Sheet".
- For details about entering a user code, see p.129 "When Machine Functions are Restricted".
- For details about enabling user authentication and entering a user name and password, see p.444 "When LDAP Authentication is Specified".

Canceling a fax

You can cancel sending a fax using either the machine's control panel or your computer, depending on the status of the job.

Canceling while the machine is receiving a fax from the computer

Cancel the fax from the computer.

If the machine is shared by multiple computers, be careful not to cancel the fax of another user.

1. Double-click the printer icon on the task bar of your computer.
2. Select the print job you want to cancel, click the [Document] menu, and then click [Cancel].
3. Click [Yes].

Canceling while sending a fax

Cancel the fax using the control panel.

1. Press the [Facsimile] key.

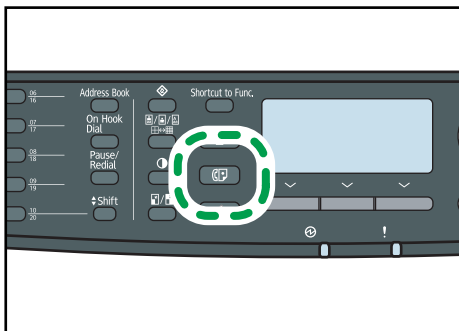

CMF133

2. Press the [Clear/Stop] key.

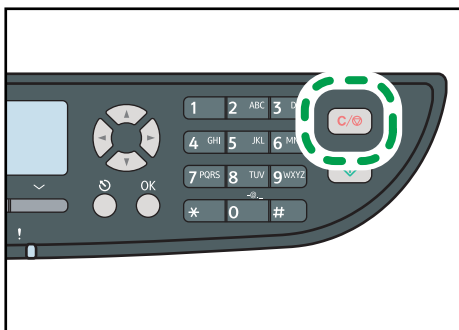

CMF135

Editing a Fax Cover Sheet

This section describes how to edit a fax cover sheet in the LAN-Fax driver's properties.

1. On the [File] menu, click [Print...].
2. Select the LAN-Fax driver as the printer, and then click [Print].

3. Click the [Specify Destination] tab, and then click [Edit Cover Sheet].
4. Configure settings as necessary, and then click [Print].

Reference

- For details about settings, see p.236 "Settings you can configure for the fax cover sheets".

Settings you can configure for the fax cover sheets

This section describes the settings you can configure for the fax cover sheets.

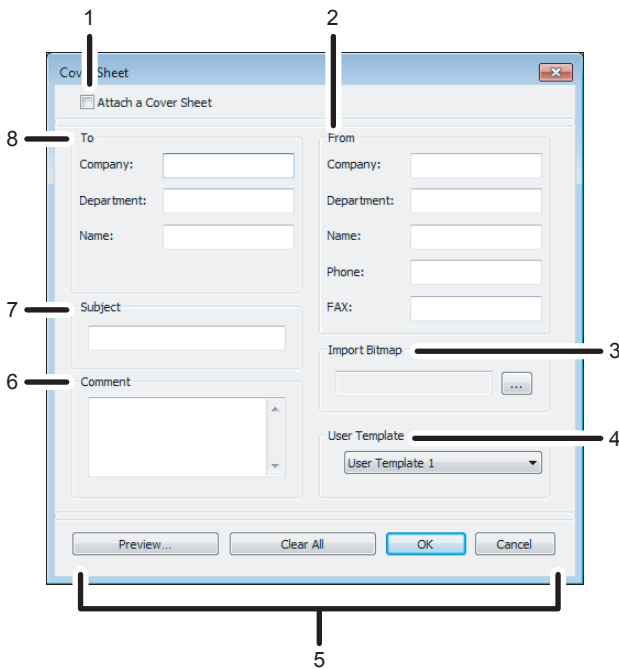

CMF128

1. Attach a Cover Sheet

Check this to send a fax with a cover sheet.

2. From

Enter the sender information. Items left blank will not appear on the cover sheet.

- **Company:**
Enter your company name. Can contain up to 64 characters.
- **Department:**
Enter your department name. Can contain up to 64 characters.
- **Name:**
Enter your name. Can contain up to 64 characters.
- **Phone:**
Enter your telephone number. Can contain up to 64 characters.

- **FAX:**
Enter your fax number. Can contain up to 64 characters.

3. Import Bitmap

Specify a bitmap image you want to show on the cover sheet. The image will be shown in the position as follows: Left=180, Right=800, Top=50, Bottom=180 (pixel). If the image is larger than this area, excess part is trimmed.

4. User Template

Select the template for the cover sheet. There are three templates.

5. Buttons

- **Preview...**
Click to preview the cover sheet before sending the fax.
- **Clear All**
Click to clear all information you entered.
- **OK**
Click to finish editing the fax cover sheet.
- **Cancel**
Click to discard the fax cover sheet.

6. Comment

Enter a comment for the fax. Can contain up to 256 characters.

7. Subject

Enter the subject of the fax. Can contain up to 64 characters.

8. To

Enter the destination information. Items left blank will not appear on the cover sheet.

- **Company:**
Enter the destination company name. Can contain up to 64 characters.
- **Department:**
Enter the destination department name. Can contain up to 64 characters.
- **Name:**
Enter the destination name. Can contain up to 64 characters.

Configuring Transmission Settings

This section describes how to configure transmission settings in the LAN-Fax driver's properties.

Properties are set separately for each application.

1. On the [File] menu, click [Print...].

2. Select the LAN-Fax driver as the printer, and then click a button such as [Preferences] or [Properties] to open the driver's properties.

LAN-Fax driver properties dialog box appears.

3. Click the [Setup] tab.
4. Configure settings as necessary, and then click [OK].

↓ Note

- For details about settings, see p.238 "Settings you can configure in the LAN-Fax driver's properties".

Settings you can configure in the LAN-Fax driver's properties

This section describes the settings you can configure in the LAN-Fax driver's properties.

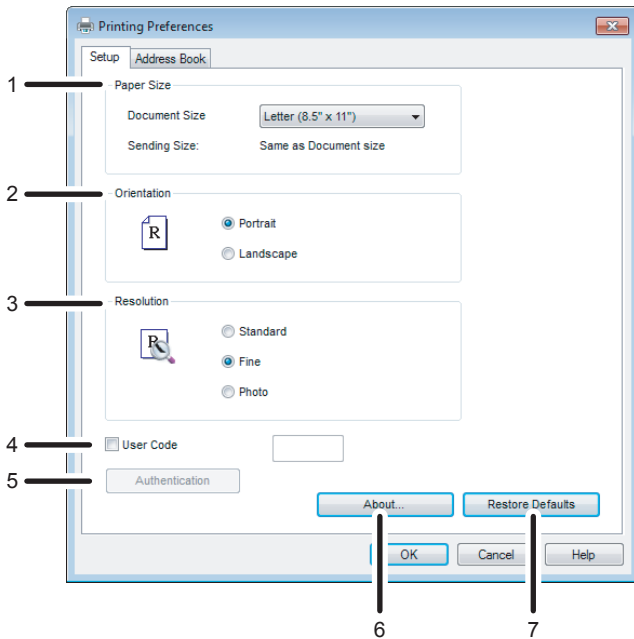

CMF129

1. Paper Size

Specifies the paper size.

- Document Size

Specifies the paper size of the document you are sending. If a paper size is specified in the application, that paper size will be used. Otherwise, the paper size specified here will be used.
- Sending Size:

Displays the actual paper size of the fax that is sent. The actual size of the fax will be A4, if the size of the document being faxed is A3, B4, or smaller than A4. A3/B4 documents will be reduced to sending size automatically.

2. Orientation

Specifies the page orientation.

3. Resolution

Specifies the resolution.

- Standard
Select this for a document with normal-sized characters.
- Fine
Select this for a document with small print.
- Photo
Select this for a document with images such as photographs or shaded drawings.

4. User Code

If sending faxes via LAN-Fax is restricted, select this check box and enter a user code before sending a fax.

5. Authentication

If LDAP authentication is specified, click this button to enable user authentication and enter a user name and password before sending a fax job to the machine.

6. About...

Displays the version of the LAN-Fax driver.

7. Restore Defaults

Restores the settings to their factory defaults.

↓ Note

- The settings configured here are applicable for the current application only.

Receiving a Fax

This section describes fax reception functions.

★ Important

- When receiving an important fax, we recommend you confirm the contents of the received fax with the sender.
- The machine may not be able to receive faxes when the amount of free memory space is low.

↓ Note

- An external telephone is required to use this machine as a telephone.
- Only A4, Letter, or Legal size paper can be used for printing faxes.

📖 Reference

- For details about connecting an external telephone with this machine, see p.67 "Connecting to a Telephone Line".

Selecting Reception Mode

This section describes how to select the reception mode.

The reception modes are as follows:

When using the machine only as a fax machine

Select the following mode when no external telephone or telephone answering device is connected:

- Fax Only mode (auto reception)

In this mode, the machine is used only as a fax machine and receives faxes automatically.

When using the machine with an external device

Select one of the following modes when an external telephone or telephone answering device is connected:

- FAX/TEL Manual mode (manual reception)

In this mode, you must answer calls with an external telephone. If a call is a fax call, you have to start the fax reception manually.

- Fax Only mode (auto reception)

In this mode, the machine automatically answers all incoming calls in fax reception mode.

- FAX/TEL Automatic mode (auto reception)

In this mode, you can answer phone calls with an external telephone and receive faxes automatically.

- FAX/TAD mode (auto reception)

In this mode, you can use the machine with an external telephone answering device.

1. Press the [User Tools] key.

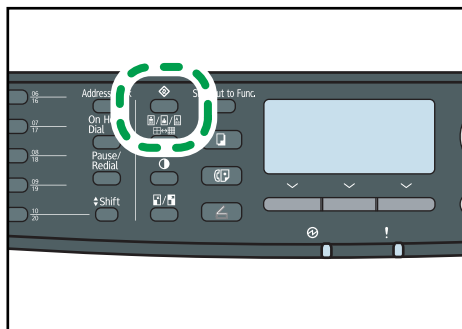

CMF134

2. Press the [▲][▼] keys to select [Fax Features], and then press the [OK] key.
3. Press the [▲][▼] keys to select [Reception Settings], and then press the [OK] key.
4. Press the [▲][▼] keys to select [Switch Reception Mode], and then press the [OK] key.
5. Press the [▲][▼][◀][▶] keys to select the desired reception mode, and then press the [OK] key.
6. Press the [User Tools] key to return to the initial screen.

↓ Note

- You can press the [Escape] key to exit to the previous level of the menu tree.
- In FAX/TAD mode, the machine automatically starts to receive faxes after the external telephone answering device rings the number of times specified in [Total No. of Rings (TAD)] under [Fax Features]. Make sure to set the external telephone answering device to answer calls before the machine starts to receive faxes.

📖 Reference

- For details about [Total No. of Rings (TAD)], see p.270 "Fax Feature Settings".
- For details about receiving Internet Faxes, see p.243 "Receiving an Internet Fax".

Receiving a fax in FAX/TEL Manual mode

This section describes the basic operation for receiving a fax when the reception mode is set to FAX/TEL Manual mode.

1. Pick up the handset of the external telephone to answer the call.

A normal telephone call starts.

2. When you hear a fax calling tone or no sound, press the [Facsimile] key, and then press the [Start] key.
3. Press [RX].

4. Press the [Start] key.
5. Replace the handset.

Receiving a fax in Fax Only mode

When the reception mode is set to Fax Only mode, the machine automatically answers all incoming calls in fax reception mode.

↓ Note

- You can specify the number of times the machine rings before answering a call in the [Number of Rings] setting under [Fax Features].
- If you answer a call with the external telephone while the machine is ringing, a normal telephone call starts. If you hear a fax calling tone or no sound, receive the fax manually.

📖 Reference

- For details about [Number of Rings], see p.270 "Fax Feature Settings".
- For details about manually receiving a fax, see p.241 "Receiving a fax in FAX/TEL Manual mode".

Receiving a fax in FAX/TEL Automatic mode

When the reception mode is set to FAX/TEL Automatic mode, the machine receives a fax automatically if the incoming call is a fax call and rings when it receives voice calls.

1. When there is an incoming call, the machine tries to detect a fax calling tone for five seconds.
If a fax calling tone is detected, the machine starts to receive the fax automatically.
2. If a fax calling tone is not detected, the machine starts to ring, and continues to try to detect a fax calling tone for the period of time specified in [RX Mode Auto Switch Time] under [Fax Features].
 - If a fax calling tone is detected, or if you do not pick up the handset, the machine starts to receive the fax automatically.
 - To start a normal telephone call, pick up the handset, press the [Facsimile] key, and then press the [Clear/Stop] key. If you hear a fax calling tone or no sound, receive the fax manually.
 - If you pick up the handset but the time specified in [RX Mode Auto Switch Time] passes before a normal telephone call starts, the machine starts to receive the fax automatically.

↓ Note

- After you pick up the handset to answer a call, make sure to press the [Facsimile] key to activate fax mode before pressing the [Clear/Stop] key. If the machine is not in fax mode, pressing the [Clear/Stop] key will not let you start a normal telephone call.

📖 Reference

- For details about [RX Mode Auto Switch Time], see p.270 "Fax Feature Settings".

- For details about manually receiving a fax, see p.241 "Receiving a fax in FAX/TEL Manual mode".

Receiving a fax in FAX/TAD mode

When the reception mode is set to FAX/TAD mode, the external telephone answering device answers and records messages when the machine receives telephone calls. If the incoming call is a fax call, the machine receives the fax automatically.

1. When there is an incoming call, the external telephone answering device rings the number of times specified in [Total No. of Rings (TAD)] under [Fax Features].
If the external telephone answering device does not answer, the machine starts to receive the fax automatically.
2. If the external telephone answering device answers, the machine monitors silence on the line for 30 seconds (silence detection).
 - If a fax calling tone or no sound is detected, the machine starts to receive the fax automatically.
 - If a voice is detected, a normal telephone call starts. The external telephone answering device records messages.

Note

- You can manually receive a fax during silence detection.
- Silence detection does not terminate for 30 seconds even if the external telephone answering device goes on-hook, unless you press the [Clear/Stop] key and disconnect the call.

Reference

- For details about [Total No. of Rings (TAD)], see p.270 "Fax Feature Settings".
- For details about manually receiving a fax, see p.241 "Receiving a fax in FAX/TEL Manual mode".

Receiving an Internet Fax

You can set the machine to periodically check for e-mails (Internet Faxes) and receive them automatically, or you can manually check and receive them.

Important

- Specify the e-mail address of this machine for receiving Internet Faxes in [User Account] under POP3 settings of Web Image Monitor.
- This machine may not be able to receive e-mails in HTML format.

Automatic reception

When [Automatic POP] under Internet Fax settings of Web Image Monitor is enabled, the machine periodically connects to the POP3 server, as specified in [POP Interval (minutes)], to check for new e-mails. The machine will download them if there are any.

Manual reception

When [Automatic POP] is disabled, use the control panel to manually connect to the POP3 server and check for new e-mails.

1. Press the [User Tools] key.

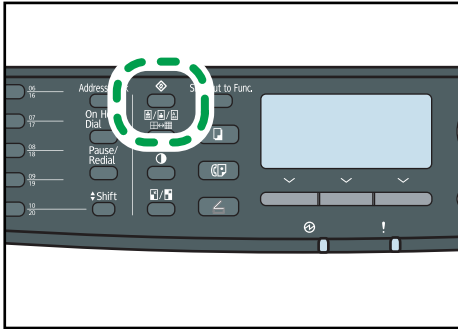

CMF134

2. Press the [▲][▼] keys to select [Fax Features], and then press the [OK] key.

3. Press the [▲][▼] keys to select [Reception Settings], and then press the [OK] key.

4. Press the [▲][▼] keys to select [Manual POP], and then press the [OK] key.

5. In the confirmation screen, press [Yes].

The machine checks for new e-mails and downloads them if there is any.

↓ Note

- If the e-mail reception fails and [Error Notification E-mail] under Internet Fax settings of Web Image Monitor is enabled, an error notification e-mail will be sent to the original sender.
- If [Error Notification E-mail] is disabled or the error notification e-mail failed, the machine will print out an error report.

📖 Reference

- For details about settings of Web Image Monitor, see p.338 "Configuring the POP3 Settings" and p.339 "Configuring the Internet Fax Settings".

Forwarding or Storing Faxes in Memory

To prevent unauthorized users from seeing sensitive faxes, you can set the machine to forward received faxes to a preset destination, or store them in memory without printing them out.

Configuring the forwarding conditions

To specify the forwarding conditions for received faxes, configure the machine as follows:

1. Select [Forward] for [Reception File Setting] under fax feature settings to forward received faxes.

2. Configure what to do after forwarding in [Print Forwarded File] under fax feature settings:
 - [On]: Store the faxes in memory for printing.
 - [Off]: Delete the faxes from memory.
3. Configure the print setting for faxes stored in memory in [Print Received File] under fax feature settings.
 - [On]: Automatically print out the received faxes and delete from memory.
 - [Off]: Store the received faxes in memory for later manual printing.
4. Configure the e-mail notification setting [Notify Forward Status] under fax feature settings:
 - [Active]: Send an e-mail notification after forwarding. E-mail notification destination depends on how the forwarding destination is configured.
 - [Inactive]: An e-mail notification is not sent.
5. Specify the forwarding destination in [Forwarding Destination] under fax settings using Web Image Monitor.

Note

- The table below shows what happens after forwarding succeeds or fails depending on the machine's configuration.

Forwarding	[Print Forwarded File]	[Print Received File]	Results
Success	Off	Not applicable	The machine deletes the fax from memory.
Success	On	On	The machine prints out the fax and deletes it from memory.
Success	On	Off	The machine stores the fax in memory for later manual printing.
Failure	Off	Not applicable	The machine prints out a forwarding failure report and deletes the fax from memory.
Failure	On	On	The machine prints out a forwarding failure report, prints out the fax, and then deletes it from memory.
Failure	On	Off	The machine prints out a forwarding failure report and stores the fax in memory for later manual printing.

- If the machine is unable to print out a fax due to machine errors such as an empty paper tray or a paper jam, the fax will remain in memory and the Fax Received indicator will flash. The remaining pages will start printing as soon as the problem is resolved.
- The number of forwarding attempts and the attempt interval time can be specified using Web Image Monitor.

Reference

- For details about the control panel settings, see p.270 "Fax Feature Settings".
- To manually print out received faxes stored in memory, see p.246 "Printing Out Faxes Stored in Memory".
- For details about the forwarding destination, forwarding trials and interval settings, see p.320 "Configuring the Fax Settings".

Configuring the storing conditions

To specify the storing conditions for received faxes, configure the machine as follows:

1. Select [Print] for [Reception File Setting] under fax feature settings to store received faxes in memory for printing.
2. Configure the print setting for faxes stored in memory in [Print Received File] under fax feature settings.
 - [On]: Automatically print out the received faxes and delete from memory.
 - [Off]: Store the received faxes in memory for later manual printing.

Note

- When the fax is successfully printed out, it will be deleted from memory.
- If the machine is unable to print out a fax due to machine errors such as an empty paper tray or a paper jam, the fax will remain in memory and the Fax Received indicator will flash. The remaining pages will start printing as soon as the problem is resolved.

Reference

- For details about the control panel settings, see p.270 "Fax Feature Settings".
- To manually print out received faxes stored in memory, see p.246 "Printing Out Faxes Stored in Memory".

Printing Out Faxes Stored in Memory

This section describes how to print out received faxes stored in the machine's memory.

★ Important

- If the machine remains turned off for a certain period of time (for example, when the power switch is turned off or when there is a power failure), all documents stored in memory will be lost. If the Fax Received indicator is lit or flashing, make sure to print out the stored documents before turning off the power (for example, prior to relocating the machine).

When the Fax Received indicator is lit, there is a fax stored in machine's memory. Follow the procedure below to print the fax.

1. Press the [Facsimile] key, and then press [RX File].

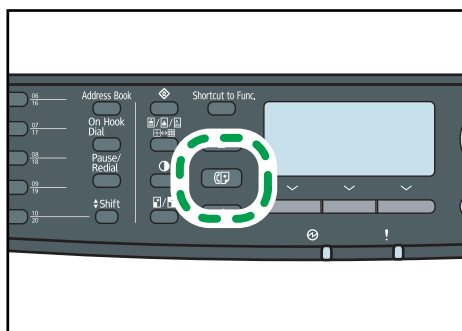

Alternatively, you can press the [Shortcut to Func.] key if [Shortcut to Function] under administrator settings is set to [Fax Auto Print Setting].

2. Press the [▲][▼] keys to select [On], and then press the [OK] key.

The machine prints out the stored fax and deletes it from memory.

↓ Note

- You can press the [Escape] key to exit to the previous level of the menu tree.
- Selecting [On] here will enable [Print Received File] under fax feature settings. If you do not want to print out subsequent faxes automatically, set it back to [Off].
- If tray 2 is installed, you can select which tray to feed paper from in [Select Paper Tray] under fax feature settings. If you set the machine to switch between tray 1 and 2 automatically in this setting, you can also specify the tray the machine uses first in [Paper Tray Priority] under system settings.
- If the Fax Received indicator is flashing, there is a received fax in the machine's memory that could not be printed out due to machine errors such as an empty paper tray or a paper jam. The printing will start as soon as the problem is resolved.

📖 Reference

- For details about [Shortcut to Function], see p.298 "Administrator Settings".
- For details about [Print Received File], see p.270 "Fax Feature Settings".
- For details about [Select Paper Tray], see p.270 "Fax Feature Settings".
- For details about [Paper Tray Priority], see p.279 "System Settings".

Receiving or Rejecting Faxes from Special Senders

You can set the machine to receive (or reject) faxes only from the registered Special Senders. This helps you screen out unwanted documents, such as junk faxes, and prevents the wasting of fax paper.

To use this function, you must first register Special Senders using Web Image Monitor, and then select whether to accept or reject faxes from them.

★ Important

- This function is not available with Internet Fax.

Registering the Special Senders

This section describes how to register Special Senders.

A maximum of 30 Special Senders can be registered.

1. Start the Web browser, and access the machine by entering its IP address.
2. Click [Special Sender].

No.	Special Sender Number
<input type="radio"/> 01	
<input type="radio"/> 02	
<input type="radio"/> 03	
<input type="radio"/> 04	
<input type="radio"/> 05	
<input type="radio"/> 06	
<input type="radio"/> 07	

3. From the [Destination Type] list, select [Special Sender].

4. Select the Special Sender number from the list (1 to 30).
5. Enter the Special Sender's fax number (up to 20 characters).
6. Enter the administrator password if required.

7. Click [Apply].
8. Close the Web browser.

↓ Note

- A fax number can contain 0 to 9, "+", and space.

Limiting the incoming faxes

This section describes how to set the machine to receive (or reject) faxes only from the programmed Special Senders.

1. Start the Web browser, and access the machine by entering its IP address.
2. Click [System Settings].
3. Click the [Fax] tab.

The screenshot shows the 'System Settings' web interface with the 'Fax' tab selected. The settings are organized into several sections:

- Select Paper Tray:** A dropdown menu set to 'Tray 1'.
- Fax Received File Processing:**
 - Received File Processing: Print, Forward
 - Print Automatically: Active, Inactive
 - Print Forwarded File: Active, Inactive
 - Notify Forward Status: Active, Inactive
- Forwarding Destination:**
 - E-mail Address: [Text input field]
 - Scan Destination: Please select (dropdown menu)
 - Number of Trials of Forwarding (time): 145 (range 1-255)
 - Interval of Forwarding Trial (min.): 30 (range 1-255)
- Authorized Reception:**
 - Authorized Reception: Active, Inactive
 - Receive Conditions: Special Sender, Other Than Special Sender

At the bottom, there is a text input field labeled 'Please enter Administrator Password' and two buttons: 'OK' and 'Cancel'.

4. For [Authorized Reception], click [Active].
5. For [Receive Conditions], click [Special Sender] or [Other Than Special Sender].
 - Special Sender
 - Select this to receive faxes from the Special Senders and reject faxes from all other senders.
 - Other Than Special Sender
 - Select this to reject faxes from the Special Senders and receive faxes from all other senders.
6. Enter the administrator password if required.
7. Click [OK].
8. Close the Web browser.

When the Machine Prints a Power Failure Report

If the power supply for this machine is cut off while sending or receiving a fax (due to a power failure, etc.), the fax communication will fail. Also, if the machine remains turned off for about an hour, all documents stored in memory will be lost.

If there was a fax transmission or reception failure, or any fax was lost from the memory, the machine prints a power failure report as soon as the power is restored. The report can be used to identify such faxes.

If there was a fax that was not sent, send it again.

If there was a fax that was not received, request the sender to send it again.

Note

- After the power failure report is printed, keep the machine turned on for about 24 hours to recharge its internal battery. With the battery fully charged, the machine is able to maintain faxes stored in the memory for about one hour in the event of another power failure.

Reference

- For details about turning the machine on, see p.55 "Turning the Power on".

7. Configuring the Machine Using the Control Panel

This chapter describes how to configure and adjust the machine's operational settings using the control panel.

The machine can be operated using its default, but the configuration can be changed depending on the needs of the user. Changes to settings are stored even if the machine is turned off.

Basic Operation Using the Menu Screen

This section describes the basic procedure for specifying and changing the machine's settings.

If you want to configure the machine's system settings, press the [User Tools] key. If you want to configure the settings of machine's current operation mode, press the [◀][▶] keys.

The procedure for changing the copy quality setting is provided as an example.

1. Press the [Copy] key.

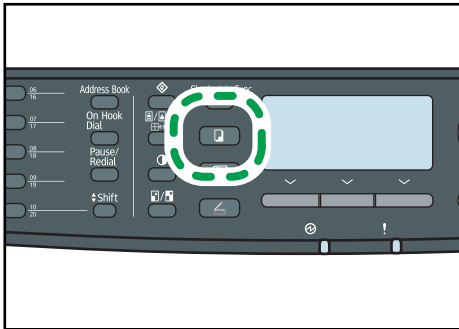

CMF131

2. Press the [◀][▶] keys.

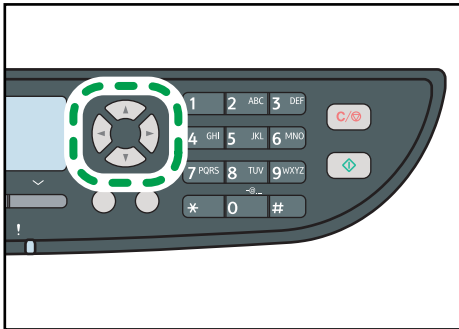

CMF144

3. Press the [▲][▼] keys to select [Original Type], and then press the [OK] key.

4. Press the [▲][▼] keys to select the document type of the original, and then press the [OK] key.
5. Press the [User Tools] key to return to the initial screen.

 **Note**

- You can press the [Escape] key to exit to the previous level of the menu tree.
- If LDAP authentication is specified, you must first log in to the machine by entering a user name and password.

 **Reference**

- For details about how to log in to the machine, see p.444 "When LDAP Authentication is Specified".

Menu Chart

This section lists the parameters included in each menu.

★ Important

- Some items might not appear depending on the model type or machine's configuration.
- Some items can also be configured using Web Image Monitor.

Copy Settings ([◀][▶] key setting)

Select Paper
Sort
Original Type
Density
Reduce/Enlarge
Duplex/Combine

Scan Settings ([◀][▶] key setting)

Scan Size
Scanning Mode
Max. E-mail Size
Density
Resolution
Compression (Colour)
Limitless Scan
File Type
Original

Fax Transmission Settings ([◀][▶] key setting)

Immediate TX
Resolution
Density

Pause Time
Auto Redial
Print Fax Header
Original

Fax Feature Settings ([User Tools] key setting)

Reception Settings
Select Paper Tray
Delete TX Standby File
Communication Settings
Report Print Settings

Fax Address Book Settings ([User Tools] key setting)

Quick Dial Dest.
Fax Speed Dial Dest.

System Settings ([User Tools] key setting)

Adjust Sound Volume
Tray Paper Settings
I/O Timeout
Auto Continue
Toner Saving
Supplies Status
Scanner Carriage
Printer Registration
Scan Warm-up Time
Low Humidity Mode
Image Density

Network Settings ([User Tools] key setting)

Ethernet
IPv4 Configuration
IPv6 Configuration

Printing Lists/Reports ([User Tools] key setting)

Configuration Page
Fax Journal
TX/RX Standby File List
Quick Dial Dest. List
Fax Speed Dial Dest. List
Scanner Dest. List
Scanner Journal
Maintenance Page
Special Sender List

Administrator Settings ([User Tools] key setting)

Set Date/Time
Program Fax Information
Dial/Push Phone
PSTN / PBX
PBX Access Number
Function Priority
System Auto Reset Timer
Energy Saver Mode
Language
Country
Reset Settings

Shortcut to Function
Admin. Tools Lock
IPsec
Fax Number Confirmation
Save Scn Data to USB

Printer Feature Settings ([User Tools] key setting)

List/Test Print
System
PCL Menu
PS Menu

Reference

- For details about configuring the machine using Web Image Monitor, see p.309 "Using Web Image Monitor".

Copy Settings

This section describes how to configure the copy settings.

Changing Copy Settings

The procedure for changing the sort copy setting is provided as an example.

1. Press the [Copy] key.

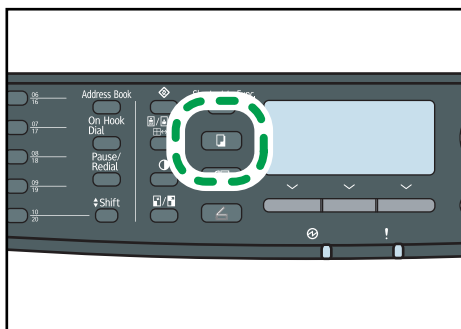

CMF131

2. Press the [◀][▶] keys.

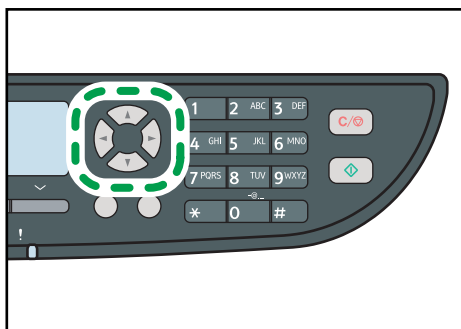

CMF144

3. Press the [▲][▼] keys to select [Sort], and then press the [OK] key.
4. Press the [▲][▼] keys to select [On] or [Off], and then press the [OK] key.
5. Press the [User Tools] key to return to the initial screen.

↓ Note

- You can press the [Escape] key to exit to the previous level of the menu tree.

Copy Setting Parameters

This section describes the copy setting parameters.

Select Paper

Specifies the paper size used for printing copies.

When a tray is selected, the machine prints from that tray only.

When a paper size is selected, the machine checks the trays for the paper of the specified size in the order of priority as set in [Paper Tray Priority] under system settings.

If multiple trays contain valid paper, the first tray the machine finds will be used for printing; when that tray runs out of paper, the machine automatically switches to the next tray to continue printing.

[Tray 2] appears only when tray 2 is installed.

Default: [Tray 1]

- Tray 1
- Tray 2
- Bypass Tray
- A4
- 8 1/2 × 11

Sort

Configures the machine to sort the output pages into sets when making multiple copies of a multi-page document (P1, P2, P1, P2...).

Default: [Off]

- On
- Off

Original Type

Specifies the content of originals, to optimize copy quality.

Default: [Mixed]

- Mixed

Select this when the original contains both text and photographs or pictures.

- Text

Select this when the original contains only text and no photographs or pictures.

- Photo

Select this when the original contains photographs or pictures. Use this mode for the following types of original:

- Photographs

- Pages that are entirely or mainly photographs or pictures, such as magazine pages.

Density

Specifies the image density for photocopying.









Default: 

-  (Lightest)
- 
- 
- 
-  (Darkest)

Reduce/Enlarge

Specifies the percentage by which copies are enlarged or reduced. Also, ID card copying can be specified.

Default: [100%]

- 50%
- 65% ( Region B model only)
- 71% ( Region A model only)
- 78% ( Region B model only)
- 82% ( Region A model only)
- 93%
- 100%
- 122% ( Region A model only)
- 129% ( Region B model only)
- 141% ( Region A model only)
- 155% ( Region B model only)
- 200%
- 400%
- ID Card Copy

Sets the machine to copy the front and back sides of an ID card, or other small document, onto the front of a single sheet of paper.

Note that enabling this setting automatically disables combined/2-sided copying.

- Zoom 25-400%

Duplex/Combine

Specifies combined/2-sided copying. Select a copy mode according to your original and how you want the copy outputs to appear. For more details, see p.158 "Combining Pages and Making 2-sided Copies".

Note that enabling combined/2-sided copying automatically disables ID card copying.

Default: [Off]

- Off
- 1Sd 2Orig->Comb 2on1 1Sd
Copy will be made on 1 side, on which 2 pages of 1-sided original will be printed.
 - Portrait
 - Landscape
- 1Sd 4Orig->Comb 4on1 1Sd
Copy will be made on 1 side, on which 4 pages of 1-sided original will be printed.
 - Portrait: L to R
 - Portrait: T to B
 - Landscape: L to R
 - Landscape: T to B
- 1 Sided Orig->2 Sided Copy (Type 2 model only)
Copy will be made on 2 sides, on each of which 1 page of 1-sided original will be printed.
 - Portrait: T to T
 - Portrait: T to B
 - Landscape: T to T
 - Landscape: T to B
- 1Sd 4Orig->Comb 2on1 2Sd (Type 2 model only)
Copy will be made on 2 sides, on each of which 2 pages of 1-sided original will be printed.
 - Portrait: T to T
 - Portrait: T to B
 - Landscape: T to T
 - Landscape: T to B
- 1Sd8Orig->Comb 4on1 2Sd (Type 2 model only)
Copy will be made on 2 sides, on each of which 4 pages of 1-sided original will be printed.
 - Portrait: L to R, T to T
 - Portrait: L to R, T to B
 - Portrait: T to B, T to T

- Portrait: T to B, T to B
 - Landscape: L to R, T to T
 - Landscape: L to R, T to B
 - Landscape: T to B, T to T
 - Landscape: T to B, T to B
- 2Sd 1Orig->Comb 2on1 1Sd (Type 2 model only)
Copy will be made on 1 side, on each of which 2 pages of 2-sided original will be printed.
 - Portrait: T to T
 - Portrait: T to B
 - Landscape: T to T
 - Landscape: T to B
- 2Sd 2Orig->Comb 4on1 1Sd (Type 2 model only)
Copy will be made on 1 side, on each of which 4 pages of 2-sided original will be printed.
 - Portrait: L to R, T to T
 - Portrait: L to R, T to B
 - Portrait: T to B, T to T
 - Portrait: T to B, T to B
 - Landscape: L to R, T to T
 - Landscape: L to R, T to B
 - Landscape: T to B, T to T
 - Landscape: T to B, T to B
- 2 Sided Orig->2 Sided Copy (Type 2 model only)
Copy will be made on 2 sides, on each of which 2 pages of 2-sided original will be printed.
- 2Sd 2Orig->Comb 2on1 2Sd (Type 2 model only)
Copy will be made on 2 sides, on each of which 2 pages of 2-sided original will be printed.
 - Portrait: T to T
 - Portrait: T to B
 - Landscape: T to T
 - Landscape: T to B
- 2Sd 4Orig->Comb 4on1 2Sd (Type 2 model only)
Copy will be made on 2 sides, on each of which 4 pages of 2-sided original will be printed.
 - Portrait: L to R, T to T
 - Portrait: L to R, T to B

- Portrait: T to B, T to T
- Portrait: T to B, T to B
- Landscape: L to R, T to T
- Landscape: L to R, T to B
- Landscape: T to B, T to T
- Landscape: T to B, T to B
- Manual 2 Sided Scan Mode
 - Enables the machine to scan both sides of an original and make a 2-sided copy using the exposure glass. When this setting is enabled, you will be asked to turn over the original on the exposure glass after scanning one side is complete.
 - This setting is only available with the Type 2 model.

Scanner Settings

This section describes how to configure the scanner settings.

Changing Scanner Settings

The procedure for changing the file type setting is provided as an example.

1. Press the [Scanner] key.

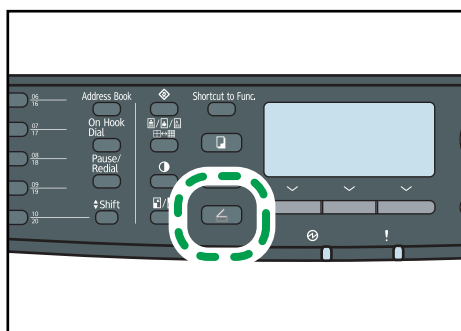

CMF132

2. Press the [◀][▶] keys.

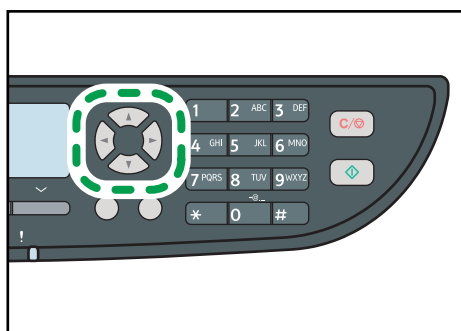

CMF144

3. Press the [▲][▼] keys to select [File Type], and then press the [OK] key.
4. Press the [▲][▼] keys to select [Multi-page] or [Single Page], and then press the [OK] key.
5. Press the [User Tools] key to return to the initial screen.

↓ Note

- You can press the [Escape] key to exit to the previous level of the menu tree.

Scanner Setting Parameters

This section describes the scanner setting parameters.

Scan Size

Specifies the scanning size according to the size of the original.

Default:  Region A [A4],  Region B [8 1/2 × 11]

- 8 1/2 × 14, 8 1/2 × 11, 8 1/2 × 5 1/2, 7 1/4 × 10 1/2, A4, B5, A5, Custom Size

Scanning Mode

Specifies the scanning mode using the control panel.

Default: [Colour]

- B&W
The machine creates 1-bit black-and-white images. Images contain only black and white colors.
- Colour
The machine creates 8-bit color images. Images are full color.
- Grey Scale
The machine creates 8-bit black-and-white images. Images contain black and white, and intermediate gray colors.

Max. E-mail Size

Specifies the maximum size of a file that can be sent by e-mail.





Default: [1 MB]

- 1 MB
- 2 MB
- 3 MB
- 4 MB
- 5 MB
- No Limit

Density

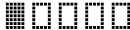
Specifies the image density for scanning originals.

Default: 

-  (Lightest)
- 
- 
- 

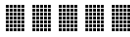
-  (Darkest)

Resolution

Specifies the resolution for scanning the original.

Default: [300 × 300dpi]

- 100 × 100dpi
- 150 × 150dpi
- 200 × 200dpi
- 300 × 300dpi
- 400 × 400dpi
- 600 × 600dpi

Compression (Colour)

Specifies the color compression ratio for JPEG files. The lower the compression ratio, the higher the quality but greater the file size.

Default: [Medium]

- Low
- Medium
- High

Limitless Scan

Sets the machine to request next originals when scanning with the exposure glass.

Default: [Off]

- On
- Off

File Type

Specifies whether to create a multi-page file containing all pages or separate single-page files when scanning multiple pages.

Note that a scanned file can contain multiple pages only when the file format is PDF or TIFF. If the file format is JPEG, a single-page file is created for each scanned page.

Default: [Multi-page]

- Multi-page
- Single Page

Original

Sets the machine to scan both sides of original automatically when using the ARDF.

When using this function, specify the page and binding orientations according to those of the originals.

This setting appears only for the Type 2 model.

Default: [1 Sided]

- 1 Sided
- 2 Sided Portrait: T to T
- 2 Sided Portrait: T to B
- 2 Sided Landscape: T to T
- 2 Sided Landscape: T to B

Fax Transmission Settings

This section describes how to configure the fax transmission settings.

Changing Fax Transmission Settings

The procedure for setting the resolution for scanning the original is provided as an example.

1. Press the [Facsimile] key.

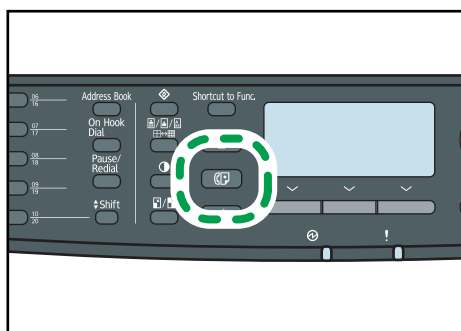

CMF133

2. Press the [◀][▶] keys.

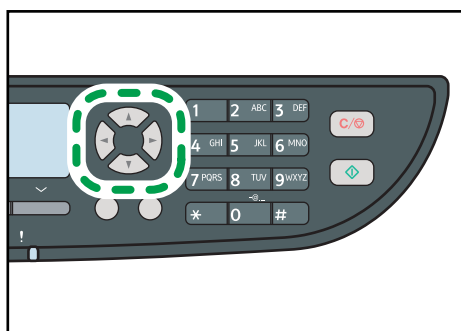

CMF144

3. Press the [▲][▼] keys to select [Resolution], and then press the [OK] key.
4. Press the [▲][▼] keys to select the desired resolution, and then press the [OK] key.
5. Press the [User Tools] key to return to the initial screen.

↓ Note

- You can press the [Escape] key to exit to the previous level of the menu tree.

Fax Transmission Setting Parameters

This section describes fax transmission setting parameters.

Immediate TX

Sets the machine to send a fax immediately when the original is scanned.

Default: [Off]

- Off
Select this when using Memory Transmission.
- On
Select this when using Immediate Transmission.
- Next Fax Only
Select this when using Immediate Transmission for the next transmission only.

Resolution

Specifies the resolution to use for scanning originals.

The "Photo" resolution is not available for Internet Faxes. Faxes will be sent using "Detail" resolution if "Photo" resolution has been specified.

Default: [Standard]

- Standard
Select this when the original is a printed or typewritten document with normal-sized characters.
- Detail
Select this when the original is a document with small print.
- Photo
Select this when the original contains images such as photographs or shaded drawings.

Density

Specifies the image density to use for scanning originals.

Default: [Normal]

- Light
- Normal
- Dark

Pause Time

Specifies the length of pause time when a pause is inserted between the digits of a fax number.

Default: **3** seconds

- 1 to 15 seconds

Auto Redial

Sets the machine to redial the fax destination automatically when the line is busy or a transmission error occurs, if the machine is in Memory Transmission mode. The number of redial attempts is preset to two or three times, depending on the [Country] setting under [Admin. Tools], in five-minute intervals.

Default: [On]

- Off
- On

Print Fax Header

Sets the machine to add a header to every fax you send. The header includes the current date and time, user fax name and fax number of the machine, job ID, and page information.

Default: [On]

- Off
- On

Original

Specifies the sides of the original (1 side or 2-sides) for scanning when using the ARDF in Memory Transmission mode.

When scanning 2-sides of original, specify the page and binding orientations according to those of the originals.

This setting only appears when the machine is in Memory Transmission mode for the Type 2 model.

Default: [1 Sided]

- 1 Sided
- 2 Sided Portrait: T to T
- 2 Sided Portrait: T to B
- 2 Sided Landscape: T to T
- 2 Sided Landscape: T to B

Fax Feature Settings

This section describes how to configure the fax feature settings.

Changing Fax Feature Settings

The procedure for setting the tray for printing faxes is provided as an example.

1. Press the [User Tools] key.

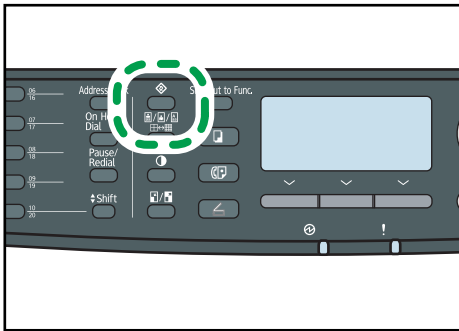

CMF134

7

2. Press the [▲][▼] keys to select [Fax Features], and then press the [OK] key.
3. Press the [▲][▼] keys to select [Select Paper Tray], and then press the [OK] key.
4. Press the [▲][▼] keys to select the desired tray, and then press the [OK] key.
5. Press the [User Tools] key to return to the initial screen.

Note

- You can press the [Escape] key to exit to the previous level of the menu tree.

Fax Feature Setting Parameters

This section describes fax feature setting parameters.

Important

- Some items might not appear, depending on the model type you are using.

Reception Settings

Specifies the settings for receiving a fax.

- Switch Reception Mode
Specifies the reception mode.
Default: [Fax Only]

- Fax Only
The machine automatically answers all incoming calls in fax reception mode.
- FAX/TEL(Mnl.)
The machine rings when it receives incoming calls. The machine receives faxes only when you manually receive faxes.
- FAX/TAD
The machine receives faxes automatically when a fax call is received. Otherwise, the connected telephone answering device answers the call.
- FAX/TEL(Auto)
The machine receives faxes automatically when a fax call is received. Otherwise, the machine starts to ring.
- Total No. of Rings (TAD)
Specifies the number of times the external telephone answering device rings before the machine starts to receive faxes in FAX/TAD mode.
Default: **5** times
 - 1 to 20 times, in increments of 1
- Auto Reduction
Sets the machine to reduce the size of a received fax if it is too large to print on a single sheet of paper.
Note that the machine only reduces the size down to 74%. If further reduction is required to fit the fax on a single sheet, it will be printed on separate sheets without being reduced.
Default: [On]
(Default may be [Off] depending on the [Country] setting under [Admin. Tools].)
 - Off
 - On
- Number of Rings
Specifies the number of times the machine rings before it starts to receive faxes in Fax Only mode.
Default: **3** times
 - 3 to 5 times
- RX Mode Auto Switch Time
Specifies the length of time the machine tries to detect the fax calling tone in FAX/TEL Automatic mode.
Default: **15** seconds
 - 5 to 99 seconds

- Authorized Reception

Sets the machine to receive (or reject) faxes only from the programmed Special Senders. This helps you screen out unwanted documents, such as junk faxes, and prevents the wasting of fax paper.

Default: [Inactive]

- Active
- Inactive

- Auth.RX: Receive Conditions

Specifies whether to receive or reject faxes from the programmed Special Senders.

This setting is available when [Authorized Reception] is enabled.

Default: [Special Sender]

- Special Sender
Receive faxes from the Special Senders and reject faxes from all other senders.
- Other Than Special Sender
Reject faxes from the Special Senders and receive faxes from all other senders.

- Reception File Setting

Sets the machine to store received faxes into memory for printing or forward them to a preset destination.

Use Web Image Monitor to specify the forwarding destination (for details, see p.320 "Configuring the Fax Settings").

Default: [Print]

- Print
- Forward

- Print Received File

Sets the machine to automatically print the faxes received into memory or store them for later manual printing.

Default: [On]

- On
Automatically print out the received faxes and delete from memory.
- Off
Store the received faxes in memory for manual printing.

- Print Forwarded File

Sets the machine to store the faxes in memory for printing or delete them after forwarding.

Default: [Off]

- On
Store the faxes in memory for printing after forwarding.
- Off
Delete the faxes from memory after forwarding.
- Notify Forward Status
Sets the machine to send e-mail notifications after faxes are forwarded. The e-mail notification destination depends on how the forwarding destination is configured using Web Image Monitor (for details, see p.320 "Configuring the Fax Settings").
Default: [Inactive]
 - Active
 - Inactive
- Manual POP
Connects to the POP3 server to receive e-mail messages manually.
Press [Yes] to connect to the POP3 server and receive e-mail messages. Press [No] to exit to the previous level of the menu tree without connecting to the POP3 server.

Select Paper Tray

Specifies the tray for printing received faxes. Note that only A4, Letter, or Legal size paper can be used for printing faxes. Make sure to select a tray that contains paper of the valid size.

If tray 2 is not installed, only [Tray 1] appears.

Default: [Auto]

- Auto
The machine uses tray 1 and tray 2 if they contain paper of the same size. In this case, the machine starts to print from the tray specified as the priority tray in [Paper Tray Priority] under system settings. If that tray runs out of paper, the machine automatically switches to the other tray to continue printing.
- Tray 1
- Tray 2

Delete TX Standby File

Deletes unsent fax jobs remaining in the machine's memory. The machine can store up to 5 unsent fax jobs.

This function is only performed when selected.

- Delete Selected File
To delete a fax job, select the desired job, and then select [Yes]. Selecting [No] exits to the previous level of the menu tree without deleting the fax job.
- Delete All Files

To delete the fax jobs, select [Yes]. Selecting [No] exits to the previous level of the menu tree without deleting the fax job.

Communication Settings

- **ECM Transmission**

Sets the machine to automatically resend parts of the data that are lost during transmission. This function is not available with Internet Fax transmission.

Default: [On]

 - Off
 - On
- **ECM Reception**

Sets the machine to automatically receive parts of the data that are lost during reception. This function is not available with Internet Fax reception.

Default: [On]

 - Off
 - On
- **Dial Tone Detect**

Sets the machine to detect a dial tone before the machine begins to dial the destination automatically.

Default: [Detect]

 - Detect
 - Not Detect
- **Transmission Speed**

Specifies the transmission speed for the fax modem.

Default: [33.6 Kbps]

 - 33.6 Kbps
 - 14.4 Kbps
 - 9.6 Kbps
 - 7.2 Kbps
 - 4.8 Kbps
 - 2.4 Kbps
- **Reception Speed**

Specifies the reception speed for the fax modem.

Default: [33.6 Kbps]

 - 33.6 Kbps

- 14.4 Kbps
- 9.6 Kbps
- 7.2 Kbps
- 4.8 Kbps
- 2.4 Kbps
- JBIG

Enables transmission and reception of JBIG-compressed images, which require less communication time than MMR-/MR-/MH-compressed images.

Note that to use this function, [ECM Transmission] and [ECM Reception] must also be enabled.

This function is not available with Internet Fax.

Default: [Active]

- Active
- Inactive

Report Print Settings

- Print TX Status Report

Sets the machine to print a transmission report automatically after a fax transmission.

When the machine is in Immediate Transmission mode, the image of the original will not be reproduced on the report, even if [Error Only (Image Attached)] or [Every TX (Image Attached)] is selected.

Note that if a memory error occurs for LAN-Fax transmission, a transmission report will always be printed regardless of this setting.

The transmission report will be printed on A4 or Letter size paper.

Default: [Every TX (Image Attached)]

- Error Only
 - Prints a report when a transmission error occurs.
- Error Only (Image Attached)
 - Prints a report with an image of the original when transmission error occurs.
- Every TX
 - Prints a report for every fax transmission.
- Every TX (Image Attached)
 - Prints a report with an image of the original for every fax transmission.
- Do not Print
- Print Fax Journal

Sets the machine to print a fax journal automatically for every 50 fax jobs (both sent and received).

The fax journal will be printed on A4 or Letter size paper.

Default: [Auto Print]

- Auto Print
- Do not Auto Print

Fax Address Book Settings

This section describes the fax Quick Dial/Speed Dial settings.

Registering Fax Destinations in Fax Quick Dial/Speed Dial

Register fax destinations in the Address Book using this menu.

↓ Note

- A password for accessing the [Address Book] menu can be specified in [Admin. Tools Lock].

📖 Reference

- For details about the procedure for registering fax destinations, see p.203 "Registering Fax Destinations Using the Control Panel".
- For details about [Admin. Tools Lock], see p.298 "Administrator Settings".

Fax Address Book Parameters

Quick Dial Dest.

Specifies the fax number and name for Quick Dial entries. You can register up to 20 Quick Dial entries.

- No.
Specifies the Quick Dial number.
- Fax No.
Specifies the fax number for Quick Dial entries. The fax number can contain up to 40 characters, including 0 to 9, pause, "*", "#", and space.
- Name
Specifies the name for Quick Dial entries. The name can contain up to 20 characters.

Fax Speed Dial Dest.

Specifies the fax number and name for Speed Dial entries. You can register up to 200 Speed Dial entries.

- No.
Specifies the Speed Dial number.
- Fax No.
Specifies the fax number for Speed Dial entries. The fax number can contain up to 40 characters, including 0 to 9, pause, "*", "#", and space.
- Name

Specifies the name for Speed Dial entries. The name can contain up to 20 characters.

System Settings

This section describes the machine's operational settings.

Changing System Settings

The procedure for changing the volume of the panel key sound is provided as an example.

1. Press the [User Tools] key.

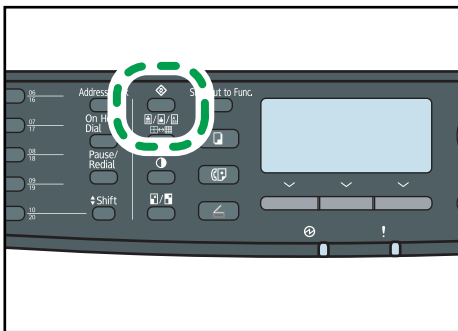

CMF134

2. Press the [▲][▼] keys to select [System Settings], and then press the [OK] key.
3. Press the [▲][▼] keys to select [Adjust Sound Volume], and then press the [OK] key.
4. Press the [▲][▼] keys to select [Panel Key Sound], and then press the [OK] key.
5. Press the [▲][▼] keys to change the volume, and then press the [OK] key.
6. Press the [User Tools] key to return to the initial screen.

Note

- You can press the [Escape] key to exit to the previous level of the menu tree.

System Setting Parameters

This section describes the system setting parameters.

★ Important

- Some items might not appear, depending on the model type you are using.

Adjust Sound Volume

Specifies the volume of the sounds produced by the machine.

Default: [Low] for [Panel Key Sound], and [Middle] for other parameters.

- Panel Key Sound

Specifies the volume of the beep that sounds when a key is pressed.

- Off
- Low
- Middle
- High
- Ring Volume

Specifies the volume of the ring when a call is received.

- Off
- Low
- Middle
- High
- On Hook Mode

Specifies the volume of the sound from the speaker during on hook mode.

- Off
- Low
- Middle
- High
- Job End Tone

Specifies the volume of the beep that sounds when a job is complete.

- Off
- Low
- Middle
- High
- Job Error Tone

Specifies the volume of the beep that sounds when a fax transmission error occurs.

- Off
- Low
- Middle
- High
- Alarm Volume

Specifies the volume of the alarm that sounds when an operation error occurs.

- Off
- Low

- Middle
- High

Tray Paper Settings

- Paper Type: Tray 1

Specifies the paper type for tray 1.

Default: [Plain Paper]

Thin Paper, Plain Paper, Recycled Paper, Colour Paper, Letterhead, Preprinted Paper, Prepunched Paper, Label Paper, Bond Paper, Cardstock, Thick Paper 1, Thick Paper 2

- Paper Type: Tray 2

Specifies the paper type for tray 2.

This setting appears only when tray 2 is installed.

Default: [Plain Paper]

Thin Paper, Plain Paper, Recycled Paper, Colour Paper, Letterhead, Preprinted Paper, Prepunched Paper, Thick Paper 1

- Paper Type: Bypass Tray

Specifies the paper type for bypass tray.

Default: [Plain Paper]

Thin Paper, Plain Paper, Recycled Paper, Colour Paper, Letterhead, Preprinted Paper, Prepunched Paper, Label Paper, Bond Paper, Cardstock, Envelope, Thick Paper 1, Thick Paper 2, OHP

- Paper Size: Tray 1

Specifies the paper size for tray 1.

Default:  Region A [A4],  Region B [8 1/2 × 11]

A4, B5 JIS, A5, B6 JIS, A6, 8 1/2 × 14, 8 1/2 × 11, 5 1/2 × 8 1/2, 7 1/4 × 10 1/2, 8 × 13, 8 1/2 × 13, 8 1/4 × 13, 16K, Custom Size

- Paper Size: Tray 2

Specifies the paper size for tray 2.

This setting appears only when tray 2 is installed.

Default:  Region A [A4],  Region B [8 1/2 × 11]

A4, 8 1/2 × 11, B5 JIS, A5, 8 1/2 × 14, 5 1/2 × 8 1/2

- Paper Size: Bypass Tray

Specifies the paper size for bypass tray.

Default:  Region A [A4],  Region B [8 1/2 × 11]

A4, B5 JIS, A5, B6 JIS, A6, 8 1/2 × 14, 8 1/2 × 11, 5 1/2 × 8 1/2, 7 1/4 × 10 1/2, 16K, 4 1/8 × 9 1/2, 3 7/8 × 7 1/2, C5 Env, C6 Env, DL Env, Custom Size

- Bypass Tray Priority

Specifies how print jobs using the bypass tray are handled.

Default: [Machine Setting(s)]

- Machine Setting(s)

The machine prints all print jobs according to the machine's settings.

An error will occur if the paper size/type settings of the machine and printer driver do not match.

- Any Size/Type

The machine prints all print jobs according to the printer driver's settings.

Printing proceeds even if the paper size/type settings of the machine and printer driver do not match. However, if the paper is too small for the print job, the printed image will be cropped.

- Any Custom Size/Type

The machine prints custom size print jobs according to the printer driver's settings and prints standard size print jobs according to the machine's settings.

For custom size print jobs, printing proceeds even if the paper size/type settings of the machine and printer driver do not match. However, if the paper is too small for the print job, the printed image will be cropped.

For standard size print jobs, an error will occur if the paper size/type settings of the machine and printer driver do not match.

- Paper Tray Priority

Specifies the tray that the machine checks first for paper that can be used for the job when a tray is set to be selected automatically.

If multiple trays contain valid paper, the first tray the machine finds will be used for printing; when that tray runs out of paper, the machine automatically switches to the next tray to continue printing.

[Tray 2] appears only when tray 2 is installed.

Default for all functions: [Tray 1]

- Printer

Select a tray to check first when automatic tray selection is specified for the print job.

- Tray 1
- Tray 2
- Bypass Tray

- Copier

Select a tray to check first when [A4] or [8 1/2 × 11] is selected for [Select Paper] under copy settings.

- Tray 1
- Tray 2
- Bypass Tray
- Facsimile

Select a tray to check first when [Auto] is selected for [Select Paper Tray] under fax feature settings.

- Tray 1
- Tray 2

I/O Timeout

- USB

Specifies how many seconds the machine waits for print data, if the data is interrupted while it is being sent from the computer via USB. If the machine does not receive any more data within the time specified here, the machine only prints the data it has received. If printing is frequently interrupted by data from other ports, increase the timeout period.

Default: [60 sec.]

- 15 sec.
- 60 sec.
- 300 sec.

- Network

Specifies how many seconds the machine waits for print data, if the data is interrupted while it is being sent from the computer via network. If the machine does not receive any more data within the time specified here, the machine only prints the data it has received. If printing is frequently interrupted by data from other ports, increase the timeout period.

Default: [60 sec.]

- 15 sec.
- 60 sec.
- 300 sec.

- Locked Print

Specifies how many seconds the machine holds a new Locked Print file, when the machine cannot store any more Locked Print files. Within this time, you can print or delete the new Locked Print file. You can also print or delete an existing Locked Print file so that the new Locked Print file can be stored in the machine.

Default: **60** seconds

- 0 to 300 seconds
- Fixed USB Port

Specifies whether the same printer/LAN-Fax driver can be used for multiple machines or not under USB connection.

Default: [Off]

- On

The same printer/LAN-Fax driver you have installed in your computer can be used with any machine other than the one originally used for installation, if the machine is of the same model.

- Off

You must install the printer/LAN-Fax driver separately for individual machines, because the machine other than the original will be recognized as a new device upon USB connection.

Auto Continue

Sets the machine to ignore an error with paper size or type and continue printing. The printing stops temporarily when an error is detected, and restarts automatically after about ten seconds using the settings made on the control panel.

Default: [Off]

- On
- Off

Toner Saving

Sets the machine to print using a reduced amount of toner (for prints made by the copier function only).

Default: [Off]

- On
- Off

Supplies Status

Displays information about consumables. To replace the fusing unit, transfer roller, or paper feed roller, contact your sales or service representative.

- Print Cart.:

Displays the remaining amount of toner.

■■■■■■■ (New), ■■■■■■, ■■■■■■, ■■■■■■, ■■■■■■, ■■■■■■
(Needs replacing)

- Fusing Unit:

Displays the remaining life of the fusing unit.

■■■■■■■ (New), ■■■■■■, ■■■■■■, ■■■■■■, ■■■■■■, ■■■■■■
(Needs replacing)

- Transfer Roller:

Displays the remaining life of the transfer roller.

■■■■■■■ (New), ■■■■■■□, ■■■■■□□, ■■■□□□, ■□□□□, □□□□□
(Needs replacing)

- Paper Feed Roller

Displays the remaining life of the paper feed roller.

■■■■■■■ (New), ■■■■■■□, ■■■■■□□, ■■■□□□, ■□□□□, □□□□□
(Needs replacing)

Scanner Carriage

- Lock Scnr. Carriage

Returns the scanning unit inside the machine to its original position. Before transporting the machine, use this function to return the scanning unit to its original position.

Press [Yes] to return the scanning unit to its original position. Press [No] to exit to the previous level of the menu tree without returning the scanning unit to its original position.

Printer Registration

Adjust the registration of each tray if necessary. You can adjust the registration value between -1.5 and +1.5 (that is, -1.5 and +1.5 mm, in 0.1 mm increments).

[Horiz.: Tray 2] and [Vert.: Tray 2] appear only when tray 2 is installed.

[Horiz.: Duplex: Back] and [Vert.: Duplex: Back] appear only for the Type 2 model.

Default: **0** for all parameters

- Horiz.: Tray 1
Select this to adjust the tray 1 registration horizontally.
- Vert.: Tray 1
Select this to adjust the tray 1 registration vertically.
- Horiz.: Tray 2
Select this to adjust the tray 2 registration horizontally.
- Vert.: Tray 2
Select this to adjust the tray 2 registration vertically.
- Horiz.: Bypass Tray
Select this to adjust the bypass tray registration horizontally.
- Vert.: Bypass Tray
Select this to adjust the bypass tray registration vertically.
- Horiz.: Duplex: Back
Select this to adjust the duplex back side registration horizontally.
- Vert.: Duplex: Back

Select this to adjust the duplex back side registration vertically.

Scan Warm-up Time

If the machine is used in a room where the temperature is low, the machine may not be able to scan originals clearly. Selecting [Long] for this setting may improve the scanning quality.

Default: [Normal]

- Normal

Select this if the room temperature is about 19 °C (66.2 °F) or higher.

- Long

Select this if the room temperature is about 18 °C (64.4 °F) or lower. This prolongs the warm-up time for the machine's scanning unit by about 10 seconds.

Low Humidity Mode

If the machine is used in a room where humidity level is low, black lines of a few millimeters thick may appear on printouts with 75-millimeter spaces in between. Selecting [On] for this setting may prevent these lines from appearing (wait for about one day until this setting becomes effective).

Note that when this setting is enabled, the machine automatically performs self-maintenance in every 10 minutes.

Default: [Off]

- On
- Off

Image Density

Adjusts the density of images on prints.

Default: 0

- -3 to +3

Network Settings

This section describes the network settings.

Changing Network Settings

The procedure for changing the network speed is provided as an example.

1. Press the [User Tools] key.

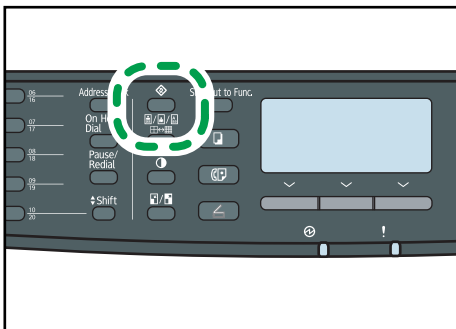

CMF134

2. Press the [▲][▼] keys to select [Network Settings], and then press the [OK] key.
3. If you are requested to enter a password, enter the password using the number keys, and then press the [OK] key.
4. Press the [▲][▼] keys to select [Ethernet], and then press the [OK] key.
5. Press the [▲][▼] keys to select [Set Ethernet Speed], and then press the [OK] key.
6. Press the [▲][▼] keys to select the network speed, and then press the [OK] key.
7. Press the [User Tools] key to return to the initial screen.

Note

- A password for accessing the [Network Settings] menu can be specified in [Admin. Tools Lock].
- You can press the [Escape] key to exit to the previous level of the menu tree.

Reference

- For details about [Admin. Tools Lock], see p.298 "Administrator Settings".

Network Setting Parameters

This section describes the network setting parameters.

Ethernet

- MAC Address

Displays the machine's MAC address.

- Ethernet Speed

Displays the current Ethernet speed setting.

- 100Mbps Full Duplex
- 100Mbps Half Duplex
- 10Mbps Full Duplex
- 10Mbps Half Duplex
- Ethernet Unavailable

Appears when a network cable is not connected.

- Set Ethernet Speed

Specifies the speed for Ethernet communication. Select a speed that matches your network environment.

For most networks, the default setting is the optimum setting.

Default: [Auto Select]

- Auto Select
- 100Mbps Full Duplex
- 100Mbps Half Duplex
- 10Mbps Full Duplex
- 10Mbps Half Duplex

IPv4 Configuration

- DHCP

Sets the machine to receive its IPv4 address, subnet mask, and default gateway address automatically from a DHCP server.

Default: [Active]

- Active
- Inactive

- IP Address

Specifies the machine's IPv4 address when DHCP is not used.

Use this menu to check the current IP address when DHCP is used.

Default: **XXX.XXX.XXX.XXX**

The numbers represented by "X" vary according to your network environment.

- Subnet Mask

Specifies the machine's subnet mask when DHCP is not used.

Use this menu to check the current subnet mask when DHCP is used.

Default: **XXX.XXX.XXX.XXX**

The numbers represented by "X" vary according to your network environment.

- Gateway Address

Specifies the machine's default gateway address when DHCP is not used.

Use this menu to check the current default gateway address when DHCP is used.

Default: **XXX.XXX.XXX.XXX**

The numbers represented by "X" vary according to your network environment.

- IP Address Method

Displays the IP address acquisition method.

- DHCP
- Auto IP
- Manual Config.
- Default IP

IPv6 Configuration

- IPv6

Select whether to enable or disable IPv6.

Default: [Active]

- Active
- Inactive

- DHCP

Sets the machine to receive its IPv6 address from a DHCP server.

Default: [Inactive]

- Active
- Inactive

- IP Address (DHCP)

Displays the IPv6 address obtained from a DHCP server.

- Manual Config. Address

- Manual Config. Address

Specifies the machine's IPv6 address when DHCP is not used. Can contain up to 39 characters.

For details about entering characters, see p.123 "Entering Characters".

- Prefix Length

Specifies the prefix length, using a value between 0 and 128.

- Gateway Address
Specifies the IPv6 address of the default gateway. Can contain up to 39 characters.
For details about entering characters, see p.123 "Entering Characters".
- Stateless Address
Displays the IPv6 stateless addresses obtained from a Router Advertisement.
 - Stateless Address 1
 - Stateless Address 2
 - Stateless Address 3
 - Stateless Address 4
- Link-local Address
Displays the IPv6 link local address.

 **Note**

- Contact your network administrator for information about the network configuration.

Printing Lists/Reports

This section describes the types of reports that can be printed.

Printing the Configuration Page

Follow the procedure below to print the configuration page.

1. Press the [User Tools] key.

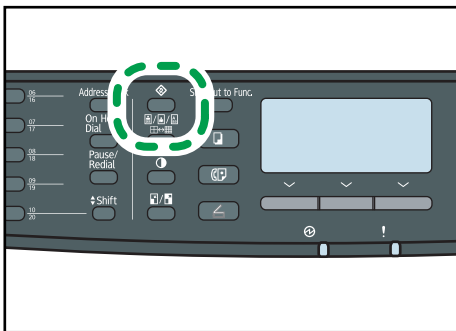

CMF134

2. Press the [▲][▼] keys to select [Print List/Report], and then press the [OK] key.
3. Press the [▲][▼] keys to select [Configuration Page], and then press the [OK] key.
4. Press [Yes] in the confirmation screen.

The configuration page is printed.

Note

- You can press the [Escape] key to exit to the previous level of the menu tree.

Types of Lists/Reports

Configuration Page

Prints general information and the current configurations of the machine.

Fax Journal

Prints a fax transmission and reception journal for the last 50 jobs.

TX/RX Standby File List

Prints a list of fax jobs remaining in the machine's memory to be printed, sent, or forwarded.

Quick Dial Dest. List

Prints a list of scan and fax Quick Dial entries.

Fax Speed Dial Dest. List

Prints a list of Speed Dial entries.

- Sort by Speed Dial No.
Prints the list with the entries sorted by Speed Dial registration number.
- Sort by Name
Prints the list with the entries sorted by name.

Scanner Dest. List

Prints a list of scan destinations.

Scanner Journal

Prints a scanner journal for the last 100 Scan to E-mail, Scan to FTP, and Scan to Folder transmissions.

Maintenance Page

Prints the maintenance page.

Special Sender List

Prints a list of fax Special Senders.



Note

- Reports will be printed on A4 or Letter size paper. Load one of these sizes of paper into the tray before printing reports.



Reference

- For details about loading paper, see p.96 "Loading Paper".

Reading the Configuration Page

System Reference

- Model Name
Shows the machine model name.
- Machine ID
Shows the serial number assigned to the machine by the manufacturer.
- Total Memory
Shows the total amount of memory installed on the machine.
- Bootloader Version
Shows the version of the machine's bootloader.
- Firmware Version
Shows the version of the machine's firmware.

- Engine FW Version
Shows the version of firmware for the machine engine.

Paper Input

Information about tray 2 appears only when it is installed.

- Tray 1
Shows paper size and type settings.
- Tray 2
Shows paper size and type settings.
- Bypass Tray
Shows paper size and type settings.
- Tray Priority
Shows the fax, printer, and copy priority tray settings.
- Bypass Tray Priority
Shows the bypass tray priority settings.

Counter

Shows counter information.

- Total Counter
- Printer
- Scanner
- Facsimile
- Copier
- Duplex

Supplies Status

Shows information about supply levels.

- Print Cartridge
- Fusing Unit
- Paper Feed Roller
- Transfer Roller

System Settings

Shows the system settings.

Admin Tools

Shows the administrator settings.

Copy Settings

Shows the copy settings.

Scan Settings

Shows the scanner settings.

Internet Fax (T.37)

Shows the Internet Fax settings.

- SMTP Server Address
- E-mail Address
- POP Server Address
- POP Account
- Admin. E-mail Address
- Automatic POP
- POP Interval
- Auth.(Internet Fax TX)
- Auth.(Internet Fax RX)
- Internet Fax TX
- Error Notification E-mail
- POP Server: E-mail Recept.Set.
- Insert System-fixed Text

Fax Features

Shows the fax settings.

Network Settings

Shows the settings for the following items:

- MAC Address
- Set Ethernet Speed
- TCP/IP
- SNMP
- E-mail

IPv6 Configuration

Shows the IPv6 settings.

- IPv6
- DHCP
- IP Address

- Stateless Address
- Link-local Address
- Manual Address
- Prefix Length
- DNS Method
- Primary DNS Server
- Secondary DNS Server
- Domain Name
- Default Gateway
- Gateway (Manual Addr.)

LDAP Configuration

Shows the LDAP settings.

- LDAP Server Address 1
- LDAP Server Address 2
- LDAP Server Address 3
- LDAP Server Address 4
- LDAP Server Address 5
- Authentication
- Search Timeout

Reading the Fax Journal

No.

Shows the job number.

Date/Time

Shows the transmission start date and time for fax transmission.

Shows the reception date and time for fax reception.

Comm. Type

Shows the following information:

- TX: a fax was sent.
- RX: a fax was received.
- LAN-Fax: a fax was sent by LAN-Fax.
- I-Fax TX: a fax was sent via Internet Fax.
- I-Fax RX: a fax was received via Internet Fax.

- Forwarding: a fax was forwarded.

Duration

Shows the time taken for fax transmission or reception to complete.

Sender/Destination

For a received fax, shows the fax number registered by the sender or an e-mail address if the fax was received via Internet Fax.

For a fax that was sent, shows the following information according to the transmission method:

- If an external telephone was used: shows the fax number registered by the receiving party.
- If a Quick Dial/Speed Dial was used: shows the name registered for the destination; if a name was not programmed, shows the destination's fax number.
- If a fax number was input using the control panel number keys: shows the dialed fax number.
- If the fax was sent from the computer (LAN-Fax): shows the dialed fax number.
- If the fax was sent via Internet Fax: shows the destination e-mail address.

Pages

Shows the number of pages transmitted or received.

Results

Shows the result of a fax transmission or reception. If an error occurred during the fax communication, shows an error code.

 **Reference**

- For details about the error codes, see p.393 "Fax Problems".

Reading the TX/RX Standby File List

No.

Shows the job number.

Date/Time

Shows the date and time at which a fax was stored in memory.

Type

Shows the following information:

- Redial: sending was done by automatic redial.
- Broadcast: sending was done by broadcast.
- LAN-Fax: sending was done by LAN-Fax.
- Forwarding: sending was done by forwarding.
- Memory TX: sending was done by any other method.

- RX: a fax was received.

Sender/Destination

For a received fax, shows the fax number registered by the sender or an e-mail address if the fax was received via Internet Fax.

For a fax that was sent, shows the following information according to the transmission method:

- If an external telephone was used: shows the fax number registered by the receiving party.
- If a Quick Dial/Speed Dial was used: shows the name registered for the destination; if a name was not programmed, shows the destination's fax number.
- If a fax number was input using the control panel number keys: shows the dialed fax number.
- If the fax was sent from the computer (LAN-Fax): shows the dialed fax number.
- If the fax was sent via Internet Fax: shows the destination e-mail address.

Pages

Shows the number of pages a fax contained.

Reading the Scanner Journal

No.

Shows the job number.

Date

Shows the date of a transmission.

Time

Shows the time at which a transmission was completed.

Type

Shows the transmission method.

Destination

Shows the scan destination.

Files

Shows the number of files created.

Color

Shows the color mode in which the scanning was performed.

Format

Shows the file format.

Results

Shows whether the transmission successfully ended or failed.

Administrator Settings

This section describes administrator settings.

Changing Administrator Settings

The procedure for changing the start-up mode after power-on is provided as an example.

1. Press the [User Tools] key.

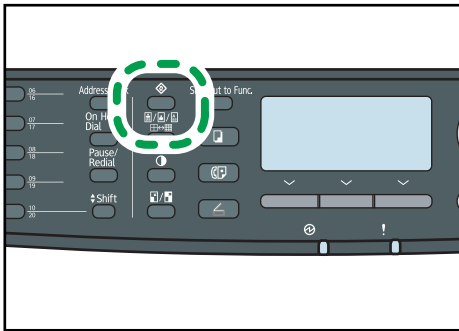

CMF134

7

2. Press the [▲][▼] keys to select [Admin. Tools], and then press the [OK] key.
3. If you are requested to enter a password, enter the password using the number keys, and then press the [OK] key.
4. Press the [▲][▼] keys to select [Function Priority], and then press the [OK] key.
5. Press the [▲][▼] keys to select the desired mode, and then press the [OK] key.
6. Press the [User Tools] key to return to the initial screen.

Note

- A password for accessing the [Admin. Tools] menu can be specified in [Admin. Tools Lock].
- You can press the [Escape] key to exit to the previous level of the menu tree.

Reference

- For details about [Admin. Tools Lock], see p.298 "Administrator Settings".

Administrator Setting Parameters

This section describes administrator setting parameters.

Set Date/Time

Sets the date and time of the machine's internal clock.

- Set Date

Specifies the date of the machine's internal clock.

Only dates that correspond with the year and month can be set. Incompatible dates will be refused.

Default date format:  **Region A** [Day/Month/Year],  **Region B** [Month/Day/Year]

- Date format: Month/Day/Year, Day/Month/Year, or Year/Month/Day



Year: 2000 to 2099

Month: 1 to 12

Day: 1 to 31

- Set Time

Sets the time of the machine's internal clock.

Default time format:  **Region A** [24-hour Format],  **Region B** [12-hour Format]

- Time format: 12-hour Format, 24-hour Format

AM/PM stamp: AM, PM (for 12-hour Format)

Hour: 0 to 23 (for 24-hour Format), or 1 to 12 (for 12-hour Format)

Minute: 0 to 59

Program Fax Information

Specifies the fax name and fax number of the machine.

- Number:

Specifies the fax number of the machine using up to 20 characters, including 0 to 9, space, and "+".

- Name:

Specifies the fax name of the machine using up to 20 alphanumeric characters and symbols.

Dial/Push Phone

Specifies the line type of the telephone line.

To configure this setting, contact your telephone company and select the setting based on your telephone line. Selecting a wrong setting may cause failures in fax transmissions.

[Dial Phone (20PPS)] may not appear depending on the country setting of the machine.

Default: [Push Phone]

- Push Phone
- Dial Phone (10PPS)
- Dial Phone (20PPS)

PSTN / PBX

Sets the machine to connect to the public switched telephone network (PSTN) or a private branch exchange (PBX).

Default: [PSTN]

- PSTN
- PBX

PBX Access Number

Specifies the dial number to access the outside line when the machine is connected to a PBX.

Make sure that this setting matches the setting of your PBX. Otherwise, you may not be able to send faxes to outside destinations.

Default: 9

- 0 to 999

Function Priority

Specifies the mode that is activated when the power is turned on, or if the time specified for [System Auto Reset Timer] elapses without activity while the initial screen of the current mode is displayed.

Default: [Copier]

- Copier
- Facsimile
- Scanner

System Auto Reset Timer

Sets the machine to return to the mode specified in [Function Priority].

Default: [On] (30 seconds)

- On (30 sec., 1 min., 2 min., 3 min., 5 min., 10 min.)
- Off

Energy Saver Mode

Sets the machine to enter Energy Saver mode, Energy Saver mode 1 or Energy Saver mode 2, to reduce power consumption. The machine recovers from Energy Saver mode when it receives a print job, prints a received fax, or when the [Copy] or [Start] key is pressed.

- EnergySaverMode 1

The machine enters Energy Saver mode 1 if the machine has been idle for about 30 seconds. It takes less time to recover from Energy Saver mode 1 than from power-off state or Energy Saver mode 2, but power consumption is higher in Energy Saver mode 1 than in Energy Saver mode 2.

Default: [Off]

- Off
- On (30 seconds)
- EnergySaverMode 2

The machine enters Energy Saver mode 2 after the period of time specified for this setting is passed. The machine consumes less power in Energy Saver mode 2 than in Energy Saver mode 1, but it takes longer to recover from Energy Saver mode 2 than from Energy Saver mode 1.

Default: [On] (1 minute)

- On (1 to 240 minutes)
- Off

Language

Specifies the language used on the screen and in reports.

The default value for this setting is the language you have specified during the Initial Setup, which is required after turning on the machine for the first time.

Country

Selects the country in which the machine is used. The country code you specify determines the time and date display format and the default values of the fax transmission-related settings.

Make sure to select the country code correctly. Selecting a wrong country code may cause failures in fax transmissions.

The default value for this setting is the country code you have specified during the Initial Setup, which is required after turning on the machine for the first time.

Reset Settings

Be sure not to clear the settings by mistake.

- Reset All Settings

Resets the machine's settings to their defaults except the following:

- Network settings
- Fax destinations and Special Sender list
- [Printer Registration], [Low Humidity Mode], and [Image Density] settings under system settings
- Scan destinations (configured using Web Image Monitor)
- User restriction settings (configured using Web Image Monitor)
- IPsec settings (configured using Web Image Monitor)

Press [Yes] to execute. Press [No] to exit to the previous level of the menu tree without clearing the settings.

- Reset Network Settings

Resets the network settings to their defaults.

Press [Yes] to execute. Press [No] to exit to the previous level of the menu tree without clearing the settings.

- Clear Address Book

Clears the fax Quick Dial/Speed Dial destinations and Special Sender list.

Press [Yes] to execute. Press [No] to exit to the previous level of the menu tree without clearing the destinations.

Shortcut to Function

Assigns one of the following functions to the [Shortcut to Func.] key on the control panel.

Default: [ID Card Copy Mode]

- ID Card Copy Mode
- Fax Auto Print Setting
- Fax Immediate TX
- Select Scanner Dest.
- Dup/Comb Copy

Admin. Tools Lock

Specifies a four-digit password for accessing the [Address Book], [Network Settings], and [Admin. Tools] menus.

Do not forget this password.

- On (0000 to 9999)
- Off

IPsec

Selects whether to enable or disable IPsec.

This function appears only when a password is specified under [Admin. Tools Lock].

Default: [Inactive]

- Active
- Inactive

Fax Number Confirmation

Sets the machine to require a fax number to be entered twice when specifying a destination manually.

When this function is enabled, you cannot use the On Hook Dial function.

This function appears only when a password is specified under [Admin. Tools Lock].

Default: [Off]

- On
- Off

Save Scn Data to USB

Selects whether to enable or disable the Scan to USB function.

Note that if you change this setting while a USB flash disk is inserted in the machine, the change will not take effect immediately. You must remove and re-insert the USB flash disk to make the change effective.

This function appears only when a password is specified under [Admin. Tools Lock].

Default: [Active]

- Active
- Inactive

Printer Feature Settings

This section describes the printer feature settings.

Changing Printer Feature Settings

The procedure for changing the setting for duplex printing is described as an example.

1. Press the [User Tools] key.

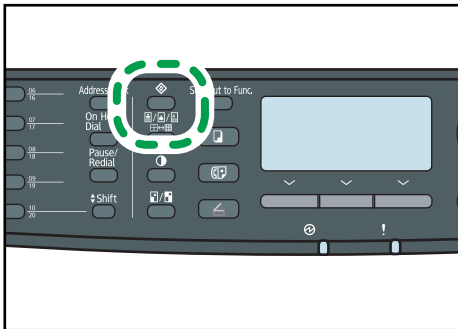

CMF134

7

2. Press the [▲][▼] keys to select [Printer Features], and then press the [OK] key.
3. Press the [▲][▼] keys to select [System], and then press the [OK] key.
4. Press the [▲][▼] keys to select [Duplex], and then press the [OK] key.
5. Press the [▲][▼] keys to select [None], [Long Edge Bind], or [Short Edge Bind], and then press the [OK] key.
6. Press the [User Tools] key to return to the initial screen.

↓ Note

- You can press the [Escape] key to exit to the previous level of the menu tree.

Printer Feature Setting Parameters

This section describes the printer feature setting parameters.

★ Important

- Some items might not appear, depending on the model type you are using.

List/Test Print



Prints lists showing configurations on the machine.

[Duplex Test Page] appears only for the Type 2 model.

The lists will be printed on A4 or Letter size paper.

- **Config. Page**
Prints general information and the current configurations of the machine.
- **Menu List**
Prints the machine's function menus.
- **Test Page**
Prints a test page for checking the single-sided printing condition. The test page contains network settings.
- **PCL Font List**
Prints installed PCL font list.
- **PS Font List**
Prints installed PostScript font list.
- **Duplex Test Page**
Prints a test page for checking the duplex printing condition. The test page contains network settings.

System

- **Copies**
Sets the machine to print the specified number of sets.
This setting is disabled if the number of pages to print is specified by the printer driver.
Default: 1
 - 1 to 999
- **Sub Paper Size**
Sets the machine to print onto paper of another size if the specified paper is not loaded in any tray. Alternative sizes are preset to A4 and Letter.
Default: [Off]
 - Auto
 - Off
- **Default Page Size**
Specifies the paper size to be used when the paper size is not specified in the print job.
Default:  **Region A** [A4],  **Region B** [8 1/2 × 11]
 - A4, B5 JIS, A5, B6 JIS, A6, 8 1/2 × 14, 8 1/2 × 11, 5 1/2 × 8 1/2, 7 1/4 × 10 1/2, 8 × 13, 8 1/2 × 13, 8 1/4 × 13, 16K, 4 1/8 × 9 1/2, 3 7/8 × 7 1/2, C5 Env, C6 Env, DL Env
- **Duplex**
Sets the machine to print on both sides of paper according to the specified binding method.

Default: [None]

- None
 - Long Edge Bind
 - Short Edge Bind
- Blank Page Print

Sets the machine to print blank pages.

When cover sheet printing is enabled from the printer driver, cover sheets are inserted even if you select [Off].

Note that this setting has lower priority than the printer driver's blank page setting ([Do not Print Blank Pages] on the [Setup] tab of the PCL6 printer driver, or [Print Blank Pages] under [Printer Features] of the PostScript 3 printer driver).

Default: [On]

- On
 - Off
- Print Error Report

Sets the machine to print an error page when the machine detects a printer or memory error.

Default: [Off]

- On
- Off

7

PCL Menu

Specifies conditions when using PCL for printing.

- Orientation

Specifies the page orientation.

Default: [Portrait]

- Portrait
- Landscape

- Form Lines

Specifies the number of lines per page.

Default:  Region **A** 64,  Region **B** 60

- 5 to 128

- Font Number

Specifies the ID of the default font you want to use.

Default: 0

- 0 to 89

- **Point Size**

Specifies the point size for the default font.

This setting is effective only for a variable-space font.

Default: **12.00** points

 - 4.00 to 999.75 (you can use the [▲][▼] keys to change the value in 0.25 increments)
- **Font Pitch**

Specifies the number of characters per inch for the default font.

This setting is effective only for fixed-space fonts.

Default: **10.00** pitch

 - 0.44 to 99.99
- **Symbol Set**

Specifies the character set for the default font. The following sets are available:

Default: [PC-8]

 - Roman-8, Roman-9, ISO L1, ISO L2, ISO L5, PC-8, PC-8 D/N, PC-850, PC-852, PC-858, PC8-TK, Win L1, Win L2, Win L5, Desktop, PS Text, VN Intl, VN US, MS Publ, Math-8, PS Math, VN Math, Pifont, Legal, ISO 4, ISO 6, ISO 11, ISO 15, ISO 17, ISO 21, ISO 60, ISO 69, Win 3.0, MC Text, ISO L6, ISO L9, PC-775, PC-1004, Win Baltic
- **Courier Font**

Specifies a courier-type font.

Default: [Regular]

 - Regular
 - Dark
- **Ext. A4 Width**

Sets the machine to extend the width of the printable area of A4 size paper, reducing side margin width.

Default: [Off]

 - On
 - Off
- **Append CR to LF**

Sets the machine to append a CR code to each LF code to print text data clearly.

Default: [Off]

 - On
 - Off

- Resolution

Specifies the print resolution in dots per inch.

Default: [600 × 600 dpi]

- 600 × 600 dpi

PS Menu

Specifies conditions when using PostScript for printing.

- Resolution

Specifies the print resolution in dots per inch.

Default: [600 × 600 dpi]

- 600 × 600 dpi
- 1200 × 600 dpi
- 1200 × 1200 dpi

8. Configuring the Machine Using Web Image Monitor

You can check the machine's status or change its settings by accessing the machine directly using Web Image Monitor.

Using Web Image Monitor

★ Important

- Some items might not appear, depending on the model type you are using.
- Some items can also be configured using the control panel.

Available operations

The following operations can be performed remotely using Web Image Monitor on a computer:

- Displaying the machine's status or settings
- Configuring the machine's settings
- Registering the scan and fax destinations
- Registering the fax Special Senders
- Configuring the user restriction settings
- Configuring the network settings
- Configuring the LDAP settings
- Configuring the IPsec settings
- Printing reports
- Setting the administrator password and e-mail address
- Resetting the machine's configuration to the factory default
- Creating backup files of the machine's configuration
- Restoring the machine's configuration from backup files
- Configuring the machine's date and time
- Configuring the machine's Energy Saver mode setting

Supported Web browsers

- Internet Explorer 6 or later
- Firefox 3.0 or later
- Safari 3.0 or later

 **Note**

- To operate the machine via Web Image Monitor, you must first configure the machine's TCP/IP settings.

 **Reference**

- For details about configuring the machine using the control panel, see p.251 "Basic Operation Using the Menu Screen".
- For details about TCP/IP settings, see p.70 "Configuring the Machine".

Displaying Top Page

When you access the machine using Web Image Monitor, the top page appears in your browser's window.

1. Launch the Web browser.
2. In the Web browser's address bar, enter "http://(machine's IP address)/" to access the machine.

If a DNS or WINS server is used and the machine's host name has been specified, you can enter the host name instead of the IP address.

The top page of Web Image Monitor appears.

Top page

Every Web Image Monitor page is divided into the following areas:

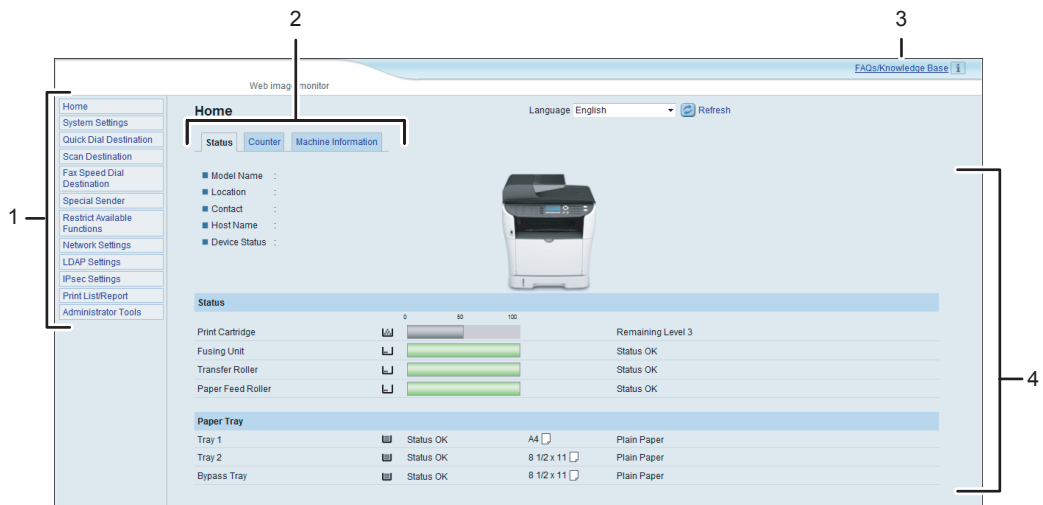

CMF099

1. Menu area
Clicking a menu shows its contents in the main area.
2. Tab area
Contains tabs for switching between information and settings you want to see or configure.
3. FAQs/Knowledge Base
Provides answers to frequently asked questions and other useful information about using this machine.
An internet connection is required to view this information.
4. Main area
Displays the contents of the item selected in the menu area.

Information in the main area is not automatically updated. Click [Refresh] at the upper-right in the main area to update the information. Click the Web browser's [Refresh] button to refresh the entire browser screen.

Note

- If you use an older version of a supported Web browser or the Web browser has JavaScript and cookies disabled, display and operation problems may occur.
- If you are using a proxy server, configure the Web browser settings as necessary. For details about the settings, contact your network administrator.
- The previous page may not appear even if the back button of the Web browser is clicked. If this happens, click the refresh button of the Web browser.
- The FAQs (Frequently Asked Questions)/Knowledge Base are not available in certain languages.

Changing the Interface Language

Select the desired interface language from the [Language] list.

Checking the System Information

Click [Home] to display the main page of Web Image Monitor. You can check the current system information on this page.

This page contains three tabs: [Status], [Counter], and [Machine Information].

Checking the Status Information

Click the [Status] tab on the main page to display system information, paper tray status and toner levels.

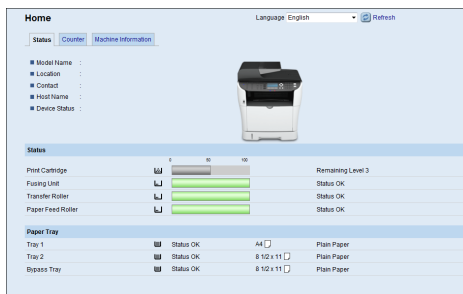

Item	Description
Model Name	Shows the name of the machine.
Location	Shows the location of the machine as registered on the [SNMP] page.
Contact	Shows the contact information of the machine as registered on the [SNMP] page.
Host Name	Shows the host name specified in [Host Name] on the [DNS] page.
Device Status	Shows the current messages on the machine's display.

Status

Item	Description
Print Cartridge	Shows the amount of toner remaining.
Fusing Unit	Shows the remaining life of the fusing unit, as "Status OK", "Replacement Required Soon" or "Replacement Required". For replacing, contact your sales or service representative.

Item	Description
Transfer Roller	Shows the remaining life of the transfer roller, as "Status OK", "Replacement Required Soon" or "Replacement Required". For replacing, contact your sales or service representative.
Paper Feed Roller	Shows the remaining life of the paper feed roller, as "Status OK", "Replacement Required Soon" or "Replacement Required". For replacing, contact your sales or service representative.

Paper Tray

Item	Description
Tray 1	Shows the current state and paper size/type setting of tray 1.
Tray 2	Shows the current state and paper size/type setting of tray 2.
Bypass Tray	Shows the current state and paper size/type setting of the bypass tray.

Note

- The information about tray 2 appears only when it is installed.
- If a non-genuine print cartridge is installed, toner life cannot be reliably indicated.

Reference

- For details about the machine’s location and contact information, see p.335 "Configuring the SNMP Settings".
- For details about the machine’s host name, see p.333 "Configuring the DNS Settings".

Checking the Counter Information

Click the [Counter] tab on the main page to check the counter information.

The screenshot shows a web interface with a 'Home' header and three tabs: 'Status', 'Counter', and 'Machine Information'. The 'Counter' tab is active. Below the tabs, there are two main sections: 'Page Counter' and 'Print Counter'.

Page Counter

	Total	Color	Black
Printer	120	0	120
Scanner	34	32	2
Copier	144	0	144

	Total	Reception	Transmission
Fax	14	4	10

Print Counter

- Page Total: 394

Duplex

- Duplex Total Page: 63

Page Counter

Item	Description
Printer	Shows the following for pages printed using the printer function: <ul style="list-style-type: none"> • Total number of pages printed using the printer function, and lists/reports printed from the [List/Test Print] menu under [Printer Features] • Number of color pages (always shows 0) • Number of black-and-white pages printed using the printer function
Scanner	Shows the following for pages scanned using the scanner function: <ul style="list-style-type: none"> • Total number of pages • Number of color pages • Number of black-and-white pages
Copier	Shows the following for pages printed using the copier function: <ul style="list-style-type: none"> • Total number of pages • Number of color pages (always shows 0) • Number of black-and-white pages
Fax	Shows the following for public telephone line faxes: <ul style="list-style-type: none"> • Total number of pages sent and received • Number of pages sent • Number of pages received

Print Counter

Item	Description
Page Total	Shows the total number of all prints from the machine: <ul style="list-style-type: none"> • Pages printed using the printer, copy, and fax functions • Lists/Reports printed from the [Print List/Report] menu • Lists/Reports printed from the [List/Test Print] menu under [Printer Features]

Duplex

Item	Description
Duplex Total Page	Shows the total number of sheets printed on both sides.

Note

- Duplex counter appears for the Type 2 model only.
- A sheet printed on both sides counts as two printed pages.

Checking the Machine Information

Click the [Machine Information] tab on the main page to display machine information.

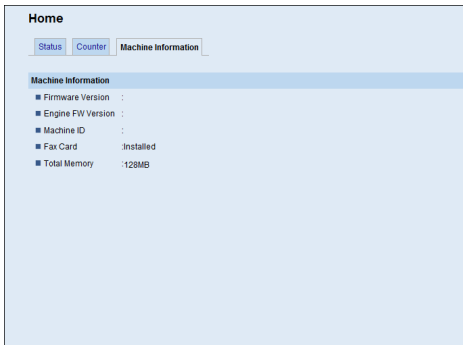

Machine Information

Item	Description
Firmware Version	Shows the version of firmware installed on the machine.
Engine FW Version	Shows the version of firmware for the machine engine.
Machine ID	Shows the identification number of the machine.
Fax Card	Shows that a fax card is installed.
Total Memory	Shows the total memory installed on the machine.

Configuring the System Settings

Click [System Settings] to display the page for configuring the system settings.

This page contains the following tabs: [Sound Volume Adjustment], [Tray Paper Settings], [Copier], [Fax], [Priority Tray], [Toner Saving], [I/O Timeout], and [Shortcut to Function].

Configuring the Sound Volume

Click the [Sound Volume Adjustment] tab on the system settings page to configure the sound volume settings.

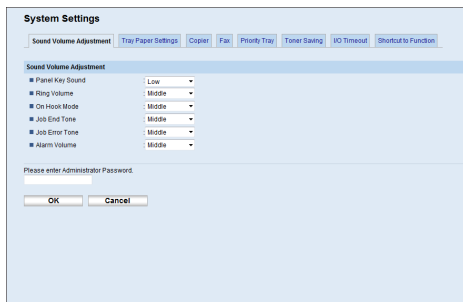

Sound Volume Adjustment

Item	Description
Panel Key Sound	Select the volume of the beep that sounds when a key is pressed from [Off], [Low], [Middle], or [High].
Ring Volume	Select the volume of the ring when a call is received from [Off], [Low], [Middle], or [High].
On Hook Mode	Select the volume of the sound from the speaker during on hook mode from [Off], [Low], [Middle], or [High].
Job End Tone	Select the volume of the beep that sounds when a job is complete from [Off], [Low], [Middle], or [High].
Job Error Tone	Select the volume of the beep that sounds when a fax transmission error occurs from [Off], [Low], [Middle], or [High].
Alarm Volume	Select the volume of the alarm that sounds when an operation error occurs from [Off], [Low], [Middle], or [High].

Configuring the Paper Settings

Click the [Tray Paper Settings] tab on the system settings page to configure the paper settings.

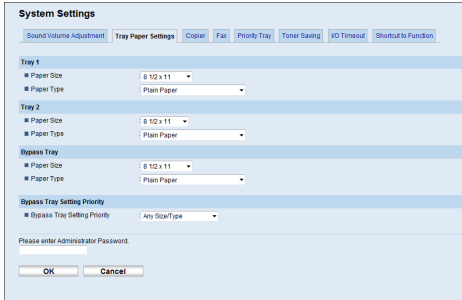

Tray 1

Item	Description
Paper Size	Select the paper size for tray 1 from the following: A4, B5 JIS, A5, B6 JIS, A6, 8 1/2 × 14, 8 1/2 × 11, 5 1/2 × 8 1/2, 7 1/4 × 10 1/2, 8 × 13, 8 1/2 × 13, 8 1/4 × 13, 16K, Custom Size
Paper Type	Select the paper type for tray 1 from the following: Thin Paper (52 to 64g/m2), Thick Paper 1 (100 to 130g/m2), Thick Paper 2 (131 to 162g/m2), Plain Paper, Recycled Paper, Color Paper, Preprinted Paper, Prepunched Paper, Letterhead, Bond Paper, Cardstock, Label Paper

Tray 2

Item	Description
Paper Size	Select the paper size for tray 2 from the following: A4, B5 JIS, A5, 8 1/2 × 14, 8 1/2 × 11, 5 1/2 × 8 1/2
Paper Type	Select the paper type for tray 2 from the following: Thin Paper (52 to 64g/m2), Thick Paper 1 (100 to 130g/m2), Plain Paper, Recycled Paper, Color Paper, Preprinted Paper, Prepunched Paper, Letterhead

Bypass Tray

Item	Description
Paper Size	Select the paper size for the bypass tray from the following: A4, B5 JIS, A5, B6 JIS, A6, 8 1/2 × 14, 8 1/2 × 11, 5 1/2 × 8 1/2, 7 1/4 × 10 1/2, 16K, 4 1/8 × 9 1/2, 3 7/8 × 7 1/2, C5 Env, C6 Env, DL Env, Custom Size
Paper Type	Select the paper type for the bypass tray from the following: Thin Paper (52 to 64g/m ²), Thick Paper 1 (100 to 130g/m ²), Thick Paper 2 (131 to 162g/m ²), Plain Paper, Recycled Paper, Color Paper, Preprinted Paper, Prepunched Paper, Letterhead, Bond Paper, Cardstock, Label Paper, Envelope, OHP

Bypass Tray Setting Priority

Item	Description
Bypass Tray Setting Priority	Select how print jobs using the bypass tray are handled. <ul style="list-style-type: none"> • System Settings The machine prints all print jobs according to the machine's settings. An error will occur if the paper size/type settings of the machine and printer driver do not match. • Any Size/Type The machine prints all print jobs according to the printer driver's settings. Printing proceeds even if the paper size/type settings of the machine and printer driver do not match, but if the paper is too small for the print job, the printed image will be cropped. • Any Custom Size/Type The machine prints custom size print jobs according to the printer driver's settings and prints standard size print jobs according to the machine's settings. For custom size print jobs, printing proceeds even if the paper size/type settings of the machine and printer driver do not match, but if the paper is too small for the print job, the printed image will be cropped. For standard size print jobs, an error will occur if the paper size/type settings of the machine and printer driver do not match.

Note

- The information about tray 2 appears only when it is installed.

Specifying the Size of Paper for Printing Copies

Click the [Copier] tab on the system settings page to specify the size of paper for printing copies.

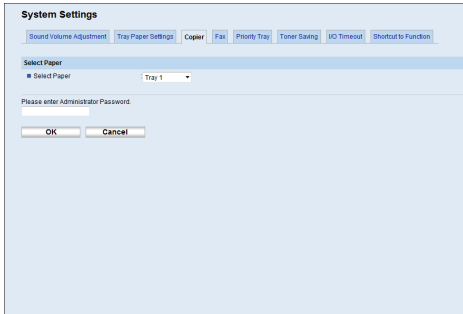

Select Paper

Item	Description
Select Paper	Select the paper size used for printing copies from the following: [Tray 1], [Tray 2], [Bypass Tray], [A4], or [8 1/2 × 11]. When a tray is selected, the machine prints from that tray only. When a paper size is selected, the machine checks the trays for the paper of the specified size in the order of priority as set in [Copier] in the [Priority Tray] page. If multiple trays contain valid paper, the first tray the machine finds will be used for printing; when that tray runs out of paper, the machine automatically switches to the next tray to continue printing.

Note

- [Tray 2] appears only when tray 2 is installed.

Reference

- For details about the priority tray settings, see p.323 "Specifying the Priority Tray".

Configuring the Fax Settings

Click the [Fax] tab on the system settings page to configure the fax settings.

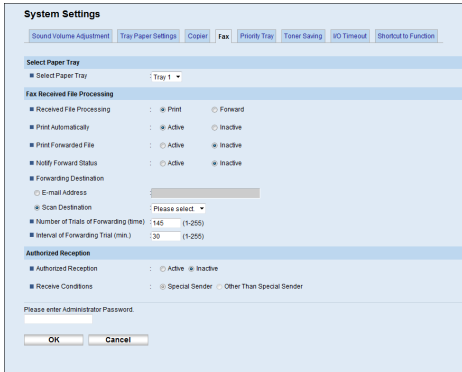

Select Paper Tray

Item	Description
Select Paper Tray	<p>Select the tray for printing faxes from the following: [Auto], [Tray 1], or [Tray 2].</p> <p>If [Auto] is selected, the machine uses tray 1 and tray 2 if they contain paper of the same size. In this case, the machine starts to print from the tray specified as the priority tray for [Fax] in the [Priority Tray] page. If that tray runs out of paper, the machine automatically switches to the other tray to continue printing.</p> <p>Only A4, Letter, or Legal size paper can be used for printing faxes. Make sure to select a tray that contains paper of the valid size.</p> <p>If tray 2 is not installed, only [Tray 1] appears.</p>

Fax Number Confirmation

Item	Description
Fax Number Confirmation	<p>Enable this setting to configure the machine to require a fax number to be entered twice when specifying a destination manually.</p> <p>This setting appears only when the administrator password is set in the [Administrator] page.</p>

Fax Received File Processing

Item	Description
Received File Processing	<p>Select whether received faxes are stored into the machine's memory for printing or forwarded to a destination specified for [Forwarding Destination].</p>

Item	Description
Print Automatically	Select whether the faxes received into the machine's memory are printed automatically or stored for later manual printing.
Print Forwarded File	Select whether the forwarded faxes are printed or not.
Notify Forward Status	Select whether e-mail notifications are sent after forwarding faxes or not. E-mail notification destination depends on how [Forwarding Destination] is specified: <ul style="list-style-type: none"> • If specified with [E-mail Address]: the notification will be sent to the administrator e-mail address specified in [Administrator E-mail Address] in the [Administrator] page. • If specified with [Scan Destination]: the notification will be sent to the notification destination specified for the selected scan destination. <p>Note that if a destination e-mail address is not specified, no notification will be sent even if this setting is enabled.</p>
Forwarding Destination	Specifies the forwarding destination. <ul style="list-style-type: none"> • [E-mail Address]: Enter a destination e-mail address. Can contain up to 64 characters. • [Scan Destination]: Select a scan destination as a forwarding destination.
Number of Trials of Forwarding (time)	Specifies how many times the machine attempts to forward a fax (1 to 255 times).
Interval of Forwarding Trial (min.)	Specifies how many minutes the machine waits between forwarding attempts (1 to 255 minutes).

Authorized Reception

Item	Description
Authorized Reception	Enable this setting to set the machine to receive (or reject) faxes only from the programmed Special Senders. This helps you screen out unwanted documents, such as junk faxes, and prevents the wasting of fax paper. Special Senders can be programmed in the [Special Sender] page.

Item	Description
Receive Conditions	<p>Specifies whether to receive or reject faxes from the programmed Special Senders.</p> <ul style="list-style-type: none"> • Special Sender Receive faxes from the Special Senders and reject faxes from all other senders. • Other Than Special Sender Reject faxes from the Special Senders and receive faxes from all other senders.

Reference

- For details about the priority tray settings, see p.323 "Specifying the Priority Tray".
- For details about the administrator e-mail address and password, see p.353 "Configuring the Administrator Password and E-mail Address".
- For details about programming Special Senders, see p.248 "Registering the Special Senders".

Specifying the Priority Tray

Click the [Priority Tray] tab on the system settings page to specify the priority tray.

The screenshot shows the 'System Settings' dialog box with the 'Priority Tray' tab selected. Under the 'Priority Tray' heading, there are three rows: 'Printer', 'Copier', and 'Fax'. Each row has a dropdown menu currently set to 'Tray 1'. Below these settings is a text input field labeled 'Please enter Administrator Password' and two buttons: 'OK' and 'Cancel'.

Priority Tray

Item	Description
Printer	<p>Select the tray that the machine checks first for paper that can be used for the job from [Tray 1], [Tray 2], or [Bypass Tray].</p> <p>If automatic tray selection is specified for the print job and multiple trays contain valid paper, the first tray the machine finds will be used for printing; when that tray runs out of paper, the machine automatically switches to the next tray to continue printing.</p>

Item	Description
Copier	<p>Select the tray that the machine checks first for paper that can be used for the job from [Tray 1], [Tray 2], or [Bypass Tray].</p> <p>If [A4] or [8 1/2 × 11] is selected for [Select Paper] in the [Copier] page and multiple trays contain valid paper, the first tray the machine finds will be used for printing; when that tray runs out of paper, the machine automatically switches to the next tray to continue printing.</p>
Fax	<p>Select the tray that the machine checks first for paper that can be used for the job from [Tray 1] or [Tray 2].</p> <p>If [Auto] is selected for [Select Paper Tray] in the [Fax] page and multiple trays contain valid paper, the first tray the machine finds will be used for printing; when that tray runs out of paper, the machine automatically switches to the next tray to continue printing.</p>

Note

- [Tray 2] appears only when tray 2 is installed.

Reference

- For details about copy paper selection, see p.320 "Specifying the Size of Paper for Printing Copies".
- For details about fax tray selection, see p.320 "Configuring the Fax Settings".

Configuring the Toner Saving Setting

Click the [Toner Saving] tab on the system settings page to configure the toner saving setting.

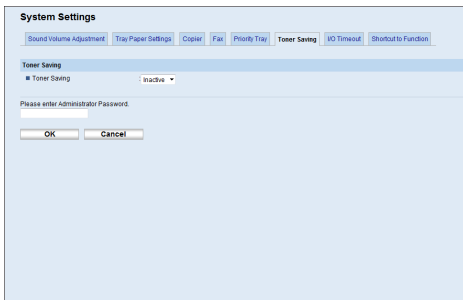

Toner Saving

Item	Description
Toner Saving	Enable this setting to print using a reduced amount of toner when printing out copies.

Configuring the I/O Timeout Settings

Click the [I/O Timeout] tab on the system settings page to configure the I/O timeout settings.

The screenshot shows the 'System Settings' dialog box with the 'I/O Timeout' tab selected. The 'Fixed USB Port' section has two radio buttons: 'Active' (selected) and 'Inactive'. Below it, the 'Locked Print Timeout (seconds)' is set to '00' with a range of '(0-300)'. There is a text input field for 'Please enter Administrator Password' and 'OK' and 'Cancel' buttons at the bottom.

I/O Timeout

Item	Description
Fixed USB Port	<p>Specifies whether the same printer/LAN-Fax driver can be used for multiple machines or not under USB connection.</p> <p>If this setting is enabled, the same printer/LAN-Fax driver you have installed in your computer can be used with any machine other than the one originally used for installation, if the machine is of the same model.</p> <p>If disabled, you must install the printer/LAN-Fax driver separately for individual machines, because the machine other than the original will be recognized as a new device upon USB connection.</p>
Locked Print Timeout (seconds)	<p>Specifies how many seconds the machine holds a new Locked Print file, when the machine cannot store any more Locked Print files (0 to 300 seconds). Within this time, you can print or delete the new Locked Print file. You can also print or delete an existing Locked Print file so that the new Locked Print file can be stored in the machine.</p>

Configuring the Shortcut to Function Key Settings

Click the [Shortcut to Function] tab on the system settings page to configure the Shortcut to Function key settings.

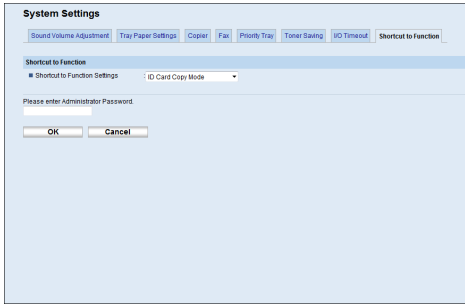

Shortcut to Function

Item	Description
Shortcut to Function Settings	Assigns one of the following functions to the [Shortcut to Func.] key on the control panel. <ul style="list-style-type: none"> • [ID Card Copy Mode] • [Fax Auto Print Setting] • [Fax Immediate TX] • [Select Scanner Destination] • [Duplex/Combine Copy]

Registering Destinations

Scan and fax destinations can be registered using Web Image Monitor.

A maximum of 100 scan destinations and 220 fax destinations (20 Quick Dial and 200 Speed Dial destinations) can be registered. See the scan and fax sections for more information on registering destinations.

Reference

- For details about registering scan destinations, see p.175 "Registering Scan Destinations".
- For details about registering fax destinations using Web Image Monitor, see p.206 "Registering Fax Destinations Using Web Image Monitor".

Registering Fax Special Senders

Fax Special Senders can be registered using Web Image Monitor.

A maximum of 30 Special Senders be registered.

E Reference

- For details about registering Special Senders, see p.248 "Receiving or Rejecting Faxes from Special Senders".

Restricting Machine Functions According to User

You can set the machine to require a user code when someone tries to use certain machine functions.

★ Important

- When print jobs are restricted, you can only authenticate through the PCL6 printer driver. Printing from the PostScript 3 printer driver will not be possible.
- User restriction settings can be used in combination with LDAP authentication, except for printing using the PCL6 printer driver and sending LAN-Faxes. Under LDAP authentication, users will only be able to authenticate for PCL6 printing and LAN-Faxes using user names and passwords for the LDAP server, not user codes for the user restriction settings.

Using Web Image Monitor, enable user restriction for all or some of the functions listed below, and then register users who can use those functions.

- Copying
- Sending faxes
- Scan to E-mail/FTP/Folder
- Scan to USB
- Printing
- Sending faxes via LAN-Fax

For each user, you can specify which functions are available upon authentication. A maximum of 30 users can be registered.

📖 Reference

- For details about configuring the user restriction settings, see p.125 "Restricting Machine Functions According to User".
- For details about LDAP authentication, see p.439 "Using the LDAP Authentication and Address Search Functions".

Configuring the Network Settings

Click [Network Settings] to display the page for configuring the network settings.

This page contains the following tabs: [Network Status], [IPv6 Configuration], [Network Application], [DNS], [Auto E-mail Notification], [SNMP], [SMTP], [POP3], and [Internet Fax].

Checking the Network Status

Click the [Network Status] tab on the network settings page to display network information.

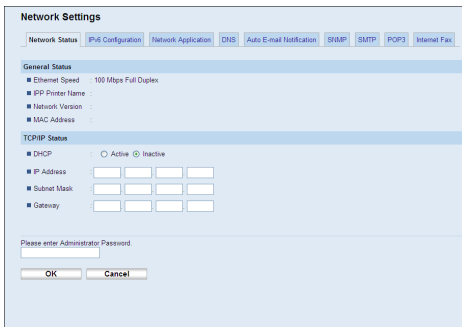

General Status

Item	Description
Ethernet Speed	Shows the type and speed of the network connection.
IPP Printer Name	Shows the name used to identify the machine on the network.
Network Version	Shows the version of the machine's network module (a part of the machine firmware).
MAC Address	Shows the MAC address of the machine.

TCP/IP Status

Item	Description
DHCP	Select whether the machine should receive a dynamic IPv4 address automatically using DHCP. To use DHCP, select [Active]. When enabled, the items below cannot be configured.
IP Address	Enter the IPv4 address for the machine.
Subnet Mask	Enter the subnet mask of the network.

Item	Description
Gateway	Enter the IPv4 address of the network gateway.

Configuring the IPv6 Settings

Click the [IPv6 Configuration] tab on the network settings page to configure the IPv6 settings.

IPv6

Item	Description
IPv6	Select whether to enable or disable IPv6. You cannot disable IPv6 using Web Image Monitor if the machine is currently in use in an IPv6 environment. In this case, use the control panel to disable [IPv6] under network settings. When disabled, [DHCP], [Manual Configuration Address], [Prefix Length], and [Gateway Address] below cannot be configured.

IPv6 Address

Item	Description
DHCP	Select whether or not the machine obtains its IPv6 address from a DHCP server.
IP Address (DHCP)	Displays the IPv6 address obtained from the DHCP server when [DHCP] is set to [Active].
Stateless Address	Displays up to four stateless auto addresses.
Gateway Address	Displays the machine's default gateway address.
Link-local Address	Displays the link local address of the machine. The link local address is an address that is valid only inside the local network (local segment).

Item	Description
Manual Configuration Address	Enter the machine's IPv6 address. Can contain up to 39 characters.
Prefix Length	Enter the prefix length, using a value between 0 and 128.
Gateway Address	Enter the default gateway's IPv6 address. Can contain up to 39 characters.

Reference

- For details about [IPv6], see p.287 "Network Settings".

Configuring the Network Application Settings

Click the [Network Application] tab on the network settings page to configure the network application settings.

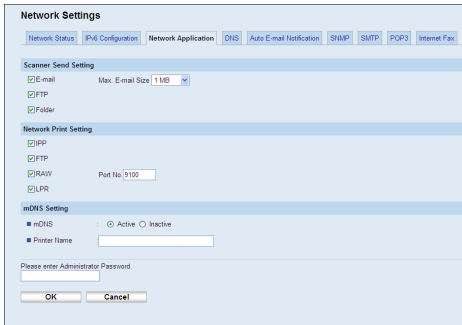

Scanner Send Setting

Item	Description
E-mail	Select to enable the Scan to E-mail feature.
Max. E-mail Size	Select the maximum size of scan files that can be attached to an e-mail message (1 to 5 MB, or no limit).
FTP	Select to enable the Scan to FTP feature.
Folder	Select to enable the Scan to Folder feature.

Network Print Setting

Item	Description
IPP	Select to enable network printing using Internet Print Protocol (via TCP port 631/80).
FTP	Select to enable network printing using an embedded FTP server in the machine (via TCP port 20/21).
RAW	Select to enable network raw printing.
Port No.	Enter the TCP port number to use for raw printing. The valid range is 1024 to 65535, except 53550 and 49999 (default is 9100).
LPR	Select to enable network printing using LPR/LPD (via TCP port 515).

mDNS Setting

Item	Description
mDNS	Select to enable Multicast DNS (via UDP port 5353). If disabled, the item below cannot be configured.
Printer Name	Enter the name of the machine. Can contain up to 32 characters.

Configuring the DNS Settings

Click the [DNS] tab on the network settings page to configure the DNS settings.

The screenshot shows the 'Network Settings' dialog box with the 'DNS' tab selected. The dialog has several tabs at the top: Network Status, IPv6 Configuration, Network Application, DNS (selected), Auto Email Notification, SNMP, SMTP, POP3, and Internet Fax. The DNS section contains the following settings:

- DNS Method:** Radio buttons for 'Auto' (selected) and 'Specify'.
- Primary DNS Server:** A text input field.
- Secondary DNS Server:** A text input field.
- Domain Name:** A text input field.
- IPv6 DNS Method:** Radio buttons for 'Auto' (selected) and 'Specify'.
- Primary IPv6 DNS Server:** A text input field.
- Secondary IPv6 DNS Server:** A text input field.
- IPv6 Domain Name:** A text input field.
- DNS Resolve Priority:** Radio buttons for 'IPv4' (selected) and 'IPv6'.
- DNS Timeout (seconds):** A text input field with '20' entered.
- Host Name:** A text input field.

At the bottom, there is a field for 'Please enter Administrator Password' and 'OK' and 'Cancel' buttons.

DNS

Item	Description
DNS Method	Select whether to specify domain name servers manually or receive DNS information from the network automatically. When set to [Auto], [Primary DNS Server], [Secondary DNS Server], and [Domain Name] below become unavailable.
Primary DNS Server	Enter the IPv4 address of the primary DNS.
Secondary DNS Server	Enter the IPv4 address of the secondary DNS.
Domain Name	Enter the IPv4 domain name for the machine. Can contain up to 32 characters.
IPv6 DNS Method	Select whether to specify the domain server manually or have the machine obtain its DNS information automatically. When set to [Auto], [Primary IPv6 DNS Server], [Secondary IPv6 DNS Server], and [IPv6 Domain Name] below become unavailable.
Primary IPv6 DNS Server	Enter the IPv6 address of the primary IPv6 DNS server. Can contain up to 39 characters.
Secondary IPv6 DNS Server	Enter the IPv6 address of the secondary IPv6 DNS server. Can contain up to 39 characters.
IPv6 Domain Name	Enter the IPv6 domain name of the machine. Can contain up to 32 characters.
DNS Resolve Priority	Select whether to give priority to IPv4 or IPv6 for DNS name resolution.
DNS Timeout (seconds)	Enter the number of seconds the machine waits before considering a DNS request to have timed out (1 to 999 seconds).
Host Name	Enter a host name for the machine. Can contain up to 15 characters.

Configuring the Auto E-mail Notification Settings

Click the [Auto E-mail Notification] tab on the network settings page to configure the e-mail notification settings.

E-mail Notification 1/E-mail Notification 2

Item	Description
Display Name	Enter a sender name for notification e-mail. Can contain up to 32 characters.
E-mail Address	Enter the address of the recipient of the alert email. Can contain up to 64 characters.
Paper Misfeed	Select to send an alert e-mail to the specified address if a paper jam occurs.
Out of Paper	Select to send an alert e-mail to the specified address if paper runs out.
Replace Print Cartridge Soon	Select to send an alert e-mail to the specified address if toner becomes low.
Call Service	Select to send an alert e-mail to the specified address if the machine requires servicing.
Replace Print Cartridge	Select to send an alert e-mail to the specified address if toner runs out.
Cover Open	Select to send an alert e-mail to the specified address if a cover is open.

Configuring the SNMP Settings

Click the [SNMP] tab on the network settings page to configure the SNMP settings.

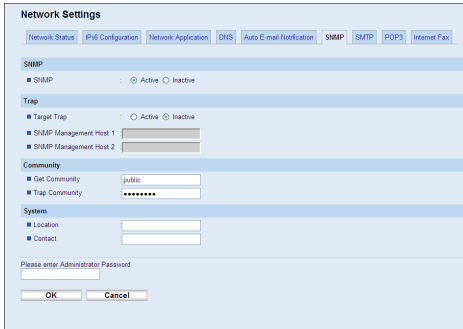

SNMP

Item	Description
SNMP	Select whether to enable the machine to use SNMP services.

Trap

Item	Description
Target Trap	Select whether to enable the machine to send traps to the management host (NMS). When disabled, [SNMP Management Host 1] and [SNMP Management Host 2] below become unavailable.
SNMP Management Host 1	Enter the IP address or host name of a management host. Can contain up to 64 characters.
SNMP Management Host 2	Enter the IP address or host name of a management host. Can contain up to 64 characters.

Community

Item	Description
Get Community	Enter the community name to use for authentication of Get requests. Can contain up to 32 characters.
Trap Community	Enter the community name to use for authentication of Trap requests. Can contain up to 32 characters.

System

Item	Description
Location	Enter the location of the machine. The location entered here is displayed on the main page. Can contain up to 64 characters.

Item	Description
Contact	Enter the contact information of the machine. The contact information entered here is displayed on the main page. Can contain up to 64 characters.

Configuring the SMTP Settings

Click the [SMTP] tab on the network settings page to configure the SMTP settings.

SMTP

Item	Description
Primary SMTP Server	Enter the IP address or host name of the SMTP/POP3 server. Can contain up to 64 characters.
Port No.	Enter the port number for SMTP (1 to 65535).
Authentication Method	Select an authentication method from the following: [Anonymous]: The user name and password are not necessary. [SMTP]: The machine supports NTLM and LOGIN authentication. [POP before SMTP]: The POP3 server is used for authentication. When sending e-mails to an SMTP server, you can enhance the SMTP server security level by connecting to the POP server for authentication.
User Name	Enter the user name for logging in to the SMTP server. Can contain up to 32 characters.
Password	Enter the password for logging in to the SMTP server. Can contain up to 32 characters.

Item	Description
Device E-mail Address	Enter the machine's e-mail address. This address is used as the sender's address of e-mail messages sent from this machine, such as notification e-mails and Internet Faxes. Can contain up to 64 characters.
Server Timeout (seconds)	Enter the number of seconds the machine waits before considering an SMTP operation to have timed out (1 to 999).
Time Zone	Select a time zone according to your geographic location. Selecting a different time zone may cause transmission date and time to be incorrect for email sent by the Scan to E-mail function, even when the machine's clock is set correctly.

Configuring the POP3 Settings

Click the [POP3] tab on the network settings page to configure the POP3 settings.

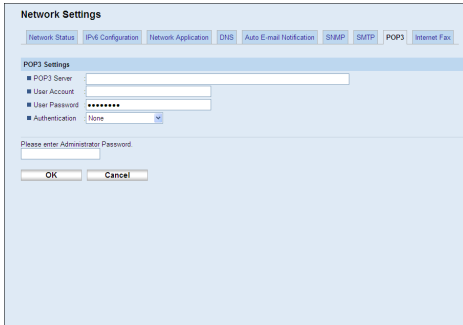

POP3 Settings

Item	Description
POP3 Server	Enter the IP address or host name of the POP3 server for e-mail reception. The POP3 server specified here will be used for [POP before SMTP]. Can contain up to 64 characters.
User Account	Enter the user name for logging in to the POP3 server. Can contain up to 32 characters. If an e-mail address is entered here, the address will be used as the e-mail address for receiving Internet Faxes.
User Password	Enter the password for logging in to the POP3 server. Can contain up to 32 characters.

Item	Description
Authentication	Select an authentication method from the following: [None]: Password will not be encrypted. [APOP Authentication]: Password will be encrypted. [Auto]: Password will be encrypted or not encrypted according to the POP3 server's settings.

Configuring the Internet Fax Settings

Click the [Internet Fax] tab on the network settings page to configure the Internet Fax settings.

The screenshot shows the 'Network Settings' window with the 'Internet Fax' tab selected. Under 'Internet Fax Settings', the following options are visible:

- Internet Fax Transmission: Active, Inactive
- Error Notification E-mail: Yes, No
- Insert System-fixed Text: Yes, No
- Automatic POP: Active, Inactive
- POP Server: E-mail Reception Setting: To
- POP Interval (minutes): 15 (0-1440)

At the bottom, there is a field for 'Please enter Administrator Password' and 'OK' and 'Cancel' buttons.

Internet Fax Settings

Item	Description
Internet Fax Transmission	Select whether to enable or disable the Internet Fax function.
Error Notification E-mail	Select whether to send a notification e-mail to the sender of the Internet Fax or not when e-mail reception fails. The text will include the machine's host name (as set in the DNS settings page), model name, and contact e-mail address (as set in the administrator settings page).
Insert System-fixed Text	Select whether to include system-fixed text in the body of the e-mail or not when sending Internet Faxes. The text will include the machine's host name (as set in the DNS settings page), model name, and contact e-mail address (as set in the administrator settings page).
Automatic POP	Select whether to automatically connect to the POP3 server to check for new e-mails or not. If this setting is enabled, the connection will be made at an interval specified in [POP Interval (minutes)].

Item	Description
POP Server: E-mail Reception Setting	Select whether to leave or delete e-mails in the POP3 server after receiving them. [No]: Delete e-mails from the server after receiving them. [Save E-mail]: Leave e-mails on the server after receiving them. [Save Only Error Info]: Delete e-mails that are successfully received from the server only.
POP Interval (minutes)	Specifies how many minutes the machine waits between automatic connections to the POP3 server to acquire new e-mails (2 to 1440 minutes).

Reference

- For details about the DNS settings, see p.333 "Configuring the DNS Settings".
- For details about the administrator settings, see p.353 "Configuring the Administrator Password and E-mail Address".

Configuring the LDAP Server Settings

Click [LDAP Settings] to display the page for configuring the LDAP settings.

This page contains the following tabs: [LDAP Authentication] and [Program/Change/Delete LDAP Server].

Configuring the LDAP Authentication Settings

Click the [LDAP Authentication] tab on the LDAP settings page to configure the LDAP authentication settings.

Item	Description
Authentication	Select whether to enable or disable LDAP authentication.
Auto Logout Time (seconds)	Enter the number of seconds until the authentication expires (60 to 999 or 0, which is no limit).

Programming/Changing/Deleting the LDAP Server

Click the [Program/Change/Delete LDAP Server] tab on the LDAP settings page to display the list of programmed LDAP servers.

LDAP Server	Identification Name
1	Not Programmed
2	Not Programmed
3	Not Programmed
4	Not Programmed
5	Not Programmed

Item	Description
LDAP Search	Select whether to enable or disable LDAP search to retrieve addresses for scanner and fax destinations.
LDAP Search Timeout	Enter the number of seconds before the machine considers the LDAP search to have timed out (1 to 60).

To configure LDAP server settings, select the desired LDAP server from the list under "Program/Change/Delete", and then click [Change] to open the "Edit LDAP Server" page. The following settings can be made on that page.

LDAP Settings

Item	Description
Identification Name (Required)	Enter the LDAP server's name. Can contain up to 32 characters.
Server Name (Required)	Enter the LDAP server's host name or IP address. Can contain up to 64 characters.
Search Base (Required)	Enter the position within the LDAP directory's structure from which to start user searches. Can contain up to 128 characters.
Port Number (Required)	Enter the port number used to connect to the LDAP server. The valid range is from 1 to 65535 (default is 389 when [SSL] is [Inactive], or 636 when [SSL] is [Active]).
SSL	Select whether or not to use SSL to communicate with the LDAP server. Select [Active] to encrypt communication between the machine and LDAP server; select [Inactive] for communication without encryption.

Item	Description
Authentication	<p>Select whether or not to perform authentication when the machine connects to the LDAP server.</p> <ul style="list-style-type: none"> • [Inactive]: Anonymous (no authentication) • [Active]: Cleartext authentication • [High Security]: CRAM-MD5 authentication <p>If [Active] or [High Security] is selected, you must also set [Login Name Attribute], [User Name (Optional)], and [Password (Optional)].</p>
Login Name Attribute	<p>Specify the user name prefix or login name attribute of Bind DN, such as "uid" or "cn", according to the LDAP server. Can contain up to 16 characters.</p> <p>If [Authentication] is [Active] or [High Security], you cannot leave this setting blank.</p>
User Name (Optional)	<p>Enter the user name to log in to the LDAP server. Can contain up to 128 characters.</p> <p>If [Authentication] is [Active] or [High Security], you cannot leave this setting blank.</p>
Password (Optional)	<p>Enter the password to log in to the LDAP server. Can contain up to 128 characters.</p> <p>If [Authentication] is [Active] or [High Security], you cannot leave this setting blank.</p>
Japanese Character Code Set (Required)	Select the character code the LDAP server uses.
Connection Test	Click [Start] to see whether or not connection to the LDAP server is possible using the settings made.

Search Conditions

Item	Description
Identification Name (Required)	Enter an attribute type by which the user name can be distinguished. Can contain up to 16 characters.
Email Address (Required)	Enter an attribute type by which the user e-mail address can be distinguished. Can contain up to 16 characters.
Fax Number (Required)	Enter an attribute type by which the user fax number can be distinguished. Can contain up to 32 characters.

Item	Description
Company Name (Required)	Enter an attribute type by which the user's company (or organization) name can be distinguished. Can contain up to 16 characters.
Department Name (Required)	Enter an attribute type by which the user's department name can be distinguished. Can contain up to 16 characters.

Search Options

Item	Description
Attribute (Optional)	<p>Enter an attribute type by which the user can be distinguished. Can contain up to 16 characters.</p> <p>If you set this item, also set [Key Display (Optional)].</p>
Key Display (Optional)	<p>Enter the name shown on the machine's control panel, which is used for LDAP search to search a user based on the attribute type specified in [Attribute (Optional)]. Can contain up to 20 characters.</p> <p>If you set this item, also set [Attribute (Optional)].</p>

Configuring the IPsec Settings

Click [IPsec Settings] to display the page for configuring the IPsec settings.

This page contains the following tabs: [IPsec Global Settings] and [IPsec Policy List].

★ Important

- This function is available only when an administrator password is specified.

Configuring the IPsec Global Settings

Click the [IPsec Global Settings] tab on the IPsec settings page to configure the IPsec global settings.

The screenshot shows the 'IPsec Settings' page with the 'IPsec Global Settings' tab selected. The settings are as follows:

- IPsec Function:** Active Inactive
- Default Policy:** Allow Drop
- Broadcast and Multicast Bypass:** DHCPv4 DHCPv6 SNMP mDNS
- All ICMP Bypass:** Active Inactive

Below the settings is a text input field labeled 'Please enter Administrator Password:' and two buttons: 'Apply' and 'Cancel'.

Item	Description
IPsec Function	Select whether to enable or disable IPsec.
Default Policy	Select whether to allow for the default IPsec policy.
Broadcast and Multicast Bypass	Select the services that you do not want to apply IPsec from the following: [DHCPv4], [DHCPv6], [SNMP], [mDNS], [NetBIOS], [UDP Port 53550]
All ICMP Bypass	Select whether to apply IPsec to ICMP packets (IPv4 and IPv6) from the following: [Active]: All ICMP packets will be bypassed without IPsec protection. "ping" command (echo request and echo reply) is not encapsulated by IPsec. [Inactive]: Some ICMP message types will be bypassed without IPsec protection.

Note

- For details about which ICMP message types will be bypassed when setting [All ICMP Bypass] to [Inactive], see Web Image Monitor Help.

Configuring the IPsec Policy

Click the [IPsec Policy List] tab on the IP security settings page to display the list of registered IPsec policies.

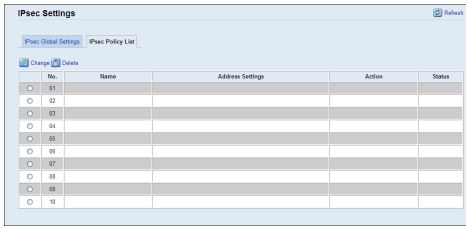

Item	Description
No.	IPsec policy number.
Name	Displays the name of the IPsec policy.
Address Settings	Displays the IP address filter of the IPsec policy as below: Remote address/Prefix length
Action	Displays the action of the IPsec policy as "Allow", "Drop", or "Require Security".
Status	Displays the status of the IPsec policy as "Active" or "Inactive".

To configure IPsec policies, select the desired IPsec policy, and then click [Change] to open the "IPsec Policy Settings" page. The following settings can be made on the "IPsec Policy Settings" page.

IP Policy Settings

Item	Description
No.	Specify a number between 1 and 10 for the IPsec policy. The number you specify will determine the position of the policy in the IPsec Policy List. Policy searching is performed according to the order of the list. If the number you specify is already assigned to another policy, the policy you are configuring will take the number of the earlier policy, and the earlier policy and any subsequent policies will be renumbered accordingly.
Activity	Select whether to enable or disable the policy.
Name	Enter the name of the policy. Can contain up to 16 characters.
Address Type	Select IPv4 or IPv6 as the type of IP address to be used in IPsec communication.
Local Address	Displays the IP address of this printer.
Remote Address	Enter the IPv4 or IPv6 address of the device with which to communicate. Can contain up to 39 characters.
Prefix Length	Enter the prefix length of the Remote Address, using a value between 1 and 128. If this setting is left blank, "32" (IPv4) or "128" (IPv6) will be automatically selected.

Item	Description
Action	<p>Specify how the IP packets are processed from the following:</p> <ul style="list-style-type: none"> • [Allow]: IP packets are both sent and received without IPsec applied to them. • [Drop]: IP packets are discarded. • [Require Security]: IPsec is applied to IP packets that are both sent and received. <p>If you have selected [Require Security], you must configure [IPsec Settings] and [IKE Settings].</p>

IPsec Settings

Item	Description
Encapsulation Type	<p>Specify the encapsulation type from the following:</p> <ul style="list-style-type: none"> • [Transport]: Select this mode to secure only the payload section of each IP packet when communicating with IPsec compliant devices. • [Tunnel]: Select this mode to secure every section of each IP packet. We recommend this type for communication between security gateways (such as VPN devices).
Security Protocol	<p>Select the security protocol from the following:</p> <ul style="list-style-type: none"> • [AH]: Establishes secure communication that supports authentication only. • [ESP]: Establishes secure communication that supports both authentication and data encryption. • [ESP&AH]: Establishes secure communication that supports both data encryption and authentication of packets, including packet headers. Note that you cannot specify this protocol when [Tunnel] is selected for [Encapsulation Type].
Authentication Algorithm for AH	<p>Specify the authentication algorithm to be applied when [AH] or [ESP&AH] is selected for [Security Protocol] from the following: [MD5], [SHA1]</p>
Encryption Algorithm for ESP	<p>Specify the encryption algorithm to be applied when [ESP] or [ESP&AH] is selected for [Security Protocol] from the following: [None], [DES], [3DES], [AES-128], [AES-192], [AES-256]</p>

Item	Description
Authentication Algorithm for ESP	Specify the authentication algorithm to be applied when [ESP] is selected for [Security Protocol] from the following: [MD5], [SHA1]
Life Time	Specify the life time of the IPsec SA (Security Association) as a time period or data volume. The SA will expire when the time period you specify elapses or the volume of data you specify reaches the volume carried. If you specify both a time period and a data volume, the SA will expire as soon as either is reached, and a new SA will then be obtained by negotiation. To specify the life time of the SA as a time period, enter a number of seconds. To specify the life time of the SA as a data volume, enter a number of KBs.
Key Perfect Forward Secrecy	Select whether to enable or disable PFS (Perfect Forward Secrecy).

IKE Settings

Item	Description
IKE Version	Displays the IKE version.
Encryption Algorithm	Specify the encryption algorithm from the following: [DES], [3DES], [AES-128], [AES-192], [AES-256]
Authentication Algorithm	Specify the authentication algorithm from the following: [MD5], [SHA1]
IKE Life Time	Specify the life time of the ISAKMP SA as a time period. Enter a number of seconds.
IKE Diffie-Hellman Group	Select the IKE Diffie-Hellman Group to be used in the generation of the IKE encryption key from the following: [DH1], [DH2]
Pre-Shared Key	Specify the PSK (Pre-Shared Key) to be used for authentication of a communicating device. Can contain up to 32 characters.
Key Perfect Forward Secrecy	Select whether to enable or disable PFS (Perfect Forward Secrecy).

 **Reference**

- For details about IPsec, see p.433 "Transmission Using IPsec".

Printing Lists/Reports

Click [Print List/Report] to display the page for printing reports. Then, select an item and click [Print] to print out information for that item.



Print List/Report

Item	Description
Configuration Page	Prints general information about the machine and its current configuration.
Fax Journal	Prints a fax transmission and reception journal for the last 50 jobs.
Fax TX/RX Standby File List	Prints a list of fax jobs remaining in the machine's memory to be printed, sent, or forwarded.
Quick Dial Destination List	Prints a list of Quick Dial entries.
Fax Speed Dial Destination List	Prints a list of Speed Dial entries.
Scanner Destination List	Prints a list of scan destinations.
Scanner Journal	Prints a scanner journal for the last 100 Scan to E-mail, Scan to FTP, and Scan to Folder transmissions.
Maintenance Page	Prints the maintenance page.

Note

- Reports cannot be printed via Web Image Monitor if other jobs are printing. Before printing reports, confirm that machine is not printing.
- Reports will be printed on A4 or Letter size paper. Load one of these sizes of paper into the tray before printing reports.

Reference

- For details about automatic fax journal printing, see p.270 "Fax Feature Settings".
- For details about loading paper, see p.96 "Loading Paper".

Configuring the Administrator Settings

Click [Administrator Tools] to display the page for configuring the administrator settings.

This page contains the following tabs: [Administrator], [Reset Settings], [Backup Setting], [Restore Setting], [Set Date/Time], and [Energy Saver Mode].

Configuring the Administrator Password and E-mail Address

Click the [Administrator] tab on the administrator settings page to configure the administrator password and e-mail address.

Administrator Settings

Item	Description
Change Password	Check this to configure the administrator password.
New Password	Enter the new administrator password. Can contain up to 16 characters.
Confirm New Password	Enter the same password again, to confirm.
Change E-mail Address	Check this to configure the administrator e-mail address.
Administrator E-mail Address	Enter the administrator e-mail address. If the machine's e-mail address is not configured in the [SMTP] page, this address will be used as the sender's address of e-mails sent from this machine, such as notification e-mails and Internet Faxes. Can contain up to 64 characters.

Reference

- For details about the SMTP settings, see p.337 "Configuring the SMTP Settings".

Resetting the Machine's Settings

Click the [Reset Settings] tab on the administrator settings page to reset the machine's settings.

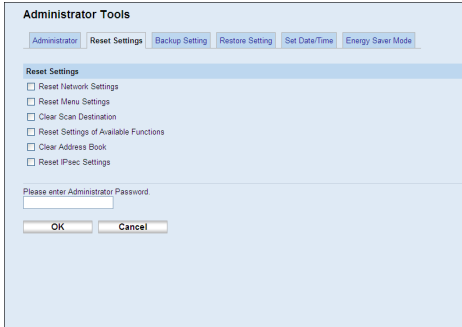

Reset Settings

Item	Description
Reset Network Settings	Select to restore the following settings to their defaults: <ul style="list-style-type: none"> • Settings under [Network Settings] • Settings under [LDAP Server] • Settings under the [Administrator] tab of [Administrator Tools]
Reset Menu Settings	Select to restore the settings other than the following to their defaults: <ul style="list-style-type: none"> • Network settings • Scan destinations • User restriction settings • Fax destinations and Special Sender list • IPsec settings • [Printer Registration], [Low Humidity Mode], and [Image Density] settings under system settings of the control panel setting menu
Clear Scan Destination	Select to clear the scan destinations.
Reset Settings of Available Functions	Select to clear the user restriction settings and counter information for each user.
Clear Address Book	Select to clear the fax destinations and Special Sender list.
Reset IPsec Settings	Select to clear the IPsec settings.

Note

- [Reset IPsec Settings] appears only when the administrator password is specified.

Backing Up the Machine's Settings

Click the [Backup Setting] tab on the administrator settings page to create backup files containing the machine's configuration settings. If necessary, these backup files can be used to restore previous configurations.

★ Important

- When sending the machine for repair, it is important that you create backup files in advance. The machine's settings are returned to the default after repair.

Backup Setting

Item	Description
Back up Network Settings	<p>Backs up the following settings to a file:</p> <ul style="list-style-type: none"> • Settings under [Network Settings] • Settings under [LDAP Server] • Settings under the [Administrator] tab of [Administrator Tools] <p>Note that, however, [Max. E-mail Size] setting under [Network Application] will not be backed up here; it will be backed up by [Back up Menu Settings] instead.</p>
Back up Menu Settings	<p>Backs up the settings other than the following to a file:</p> <ul style="list-style-type: none"> • Network settings • Scan destinations • User restriction settings • Fax destinations and Special Sender list • IPsec settings • [Printer Registration], [Low Humidity Mode], and [Image Density] settings under system settings of the control panel setting menu

Item	Description
Back up Scan Destination	Backs up scan destinations to a file.
Back up Settings of Available Functions	Backs up user restriction settings and counter information for each user to a file.
Back up Address Book	Backs up fax destinations and Special Sender list to a file.
Back up IPsec Settings	Backs up the IPsec settings to a file.

Follow the procedure below to create configuration backup files.

1. Select the radio button for the type of data you wish to back up.
2. Enter the administrator password if required.
3. Click [OK].
4. Click [Save] in the confirmation dialog box.
5. Navigate to the location to save the backup file.
6. Specify a name for the file, and click [Save].

Note

- [Back up IPsec Settings] appears only when the administrator password is specified.

Restoring the Machine's Settings from a Backup File

Click the [Restore Setting] tab on the administrator settings page to restore the machine's settings from a previously created backup file.

Important

- When the machine is returned from repair, it is important that you restore the machine's settings from the backup files. The machine's settings are returned to the default after repair.

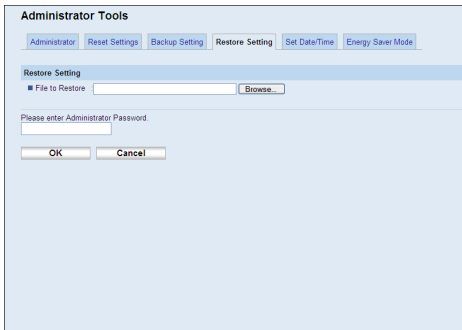

Restore Setting

Item	Description
File to Restore	Enter the path and name of the file to restore, or click [Browse...] to select the file.

Follow the procedure below to restore configuration backup files.

1. Click [Browse...].
2. Navigate to the directory containing the backup file to restore.
3. Select the backup file, and click [Open].
4. Enter the administrator password if required.
5. Click [OK].

↓ Note

- If the settings are not restored successfully, an error message appears. Try again to restore the file completely.

Configuring the Date and Time Settings

Click the [Set Date/Time] tab on the administrator settings page to configure the date and time settings.

The screenshot shows the 'Administrator Tools' dialog box with the 'Set Date/Time' tab selected. The 'Set Date' section includes dropdown menus for Year (2011), Month (7), Day (31), and Date Format (DD/MM/YYYY). The 'Set Time' section includes dropdown menus for Time Format (24-hour Format), hour (15), and min (24). Below these fields is a text input for 'Please enter Administrator Password' and 'OK' and 'Cancel' buttons.

Set Date

Item	Description
Year	Enter the current year (2000 to 2099).
Month	Enter the current month (1 to 12).
Day	Enter the current day (1 to 31).

Item	Description
Date Format	Select the date format from [MM/DD/YYYY], [DD/MM/YYYY], or [YYYY/MM/DD].

Set Time

Item	Description
Time Format	Select 24- or 12-hour time format.
Time (AM/PM)	Select [AM] or [PM] if 12-hour time format is selected.
hour (0-23)	Enter the current hour if 24-hour time format is selected (0-23).
hour (1-12)	Enter the current hour if 12-hour time format is selected (1-12).
min. (0-59)	Enter the current minute (0-59).

Configuring the Energy Saver Mode Settings

Click the [Energy Saver Mode] tab on the administrator settings page to set the machine to enter Energy Saver mode, Energy Saver mode 1 or Energy Saver mode 2, to reduce power consumption.

8

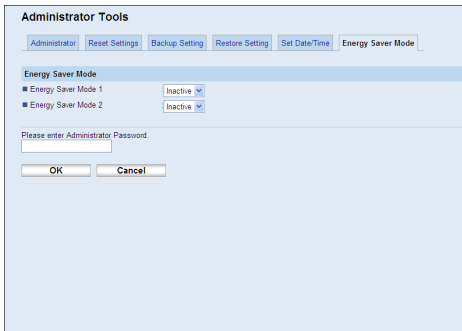

Energy Saver Mode

Item	Description
Energy Saver Mode 1	Select [Active] to set the machine to enter Energy Saver mode 1 if the machine has been idle for about 30 seconds. It takes less time to recover from Energy Saver mode 1 than from power-off state or Energy Saver mode 2, but power consumption is higher in Energy Saver mode 1 than in Energy Saver mode 2.

Item	Description
Energy Saver Mode 2	<p>Select [Active] to set the machine to enter Energy Saver mode 2 after the period of time specified for [Waiting Time (1-240)] is passed (1 to 240 minutes).</p> <p>The machine consumes less power in Energy Saver mode 2 than in Energy Saver mode 1, but it takes longer to recover from Energy Saver mode 2 than from Energy Saver mode 1.</p>

Note

- The machine recovers from Energy Saver mode when it receives a print job, prints a received fax, or when the [Copy] or [Start] key is pressed.

9. Troubleshooting

This chapter provides a guide for solving problems in operating the machine.

Overview

Troubleshooting is divided into the following sections:

- p.362 "Common Problems"
- p.363 "Paper Feed Problems"
- p.384 "Print Quality Problems"
- p.385 "Printer Problems"
- p.390 "Copier Problems"
- p.392 "Scanner Problems"
- p.393 "Fax Problems"
- p.399 "Error and Status Messages on the Screen"
- p.409 "Replacing the Print Cartridge"

Common Problems

This section describes how to troubleshoot common problems that may occur while operating the machine.

Problem	Possible cause	Solution
The machine does not turn on.	The power cord is not connected properly.	<ul style="list-style-type: none"> Make sure that the power plug is firmly inserted into the wall outlet. Make sure that the wall outlet is not defective by connecting another working device.
An error message is shown on the machine's screen.	An error has occurred.	See p.399 "Error and Status Messages on the Screen".
Pages are not printed.	The machine is warming up or receiving data.	Wait until "Printing..." appears on the screen. If "Processing..." is displayed on the screen, the machine is receiving data.
Pages are not printed.	The interface cable is not connected correctly.	<ul style="list-style-type: none"> Reconnect the cable. Check that the interface cable is the correct type.
Strange noise is heard.	The supplies or options are not properly installed.	Confirm that the supplies or options are properly installed.
The volume of the sounds produced by the machine is too loud.	The volume is set to the high level.	Adjust the volume of the beep, ring, speaker, and alarm sounds. For details, see p.279 "System Settings".
The volume of the sounds produced by the machine is too quiet.	The volume is muted or set to the low level.	Adjust the volume of the beep, ring, speaker, and alarm sounds. For details, see p.279 "System Settings".

↓ Note

- If any of these problems persist, turn off the power, pull out the power cord, and contact your sales or service representative.

Paper Feed Problems

If the machine is operating but paper will not feed or paper jams occur frequently, check the condition of the machine and paper.

Problem	Solution
Paper does not feed smoothly.	<ul style="list-style-type: none"> • Use supported types of paper. See p.84 "Supported Paper for Each Tray". • Load paper correctly, making sure that the paper guides are properly adjusted. See p.96 "Loading Paper". • If the paper is curled, straighten the paper. • Take out the paper from tray and fan it well. Then, reverse the top and bottom of the paper, and put it back in the tray.
Paper jams occur frequently.	<ul style="list-style-type: none"> • If there are gaps between the paper and the paper guides, adjust the paper guides to remove the gaps. • Avoid printing on both sides of paper when printing images that contain large solid areas, which consume a lot of toner. • Use supported types of paper. See p.84 "Supported Paper for Each Tray". • Load paper only as high as the upper limit markings on the paper guide. • Make sure that the friction pads and paper feed rollers are clean. See p.416 "Cleaning the Friction Pad and Paper Feed Roller".

Problem	Solution
<p>Multiple sheets of paper are fed at one time.</p>	<ul style="list-style-type: none"> • Fan the paper well before loading. Also make sure that the edges are even by tapping the stack on a flat surface such as a desk. • Make sure that the paper guides are in the right position. • Use supported types of paper. See p.84 "Supported Paper for Each Tray". • Load paper only as high as the upper limit markings on the paper guide. • Make sure that the friction pads and paper feed rollers are clean. See p.416 "Cleaning the Friction Pad and Paper Feed Roller". • Check that paper was not added while there was still some left in the tray. Only add paper when there is none left in the tray.
<p>Paper gets wrinkles.</p>	<ul style="list-style-type: none"> • Paper is damp. Use paper that has been stored properly. See p.84 "Paper and Other Media". • Paper is too thin. See p.84 "Paper and Other Media". • If there are gaps between the paper and the paper guides, adjust the paper guides to remove the gaps.
<p>The printed paper is curled.</p>	<ul style="list-style-type: none"> • Load the paper upside down in the paper tray. • If the paper curl is severe, take prints from the output tray more frequently. • Paper is damp. Use paper that has been stored properly. See p.84 "Paper and Other Media".
<p>Images are printed diagonally to the pages.</p> 	<p>If there are gaps between the paper and the paper guides, adjust the paper guides to remove the gaps.</p>

Removing Printing Jams

If a paper jam occurs, one of the following messages appears on the screen:

- "Misfeed: Bypass Tray"
- "Misfeed: Dup. Unit Remove Paper"
- "Internal Misfeed"
- "Misfeed: Stnd. Tray"
- "Misfeed: Tray 1"
- "Misfeed: Tray 2"

Important

- Jammed paper may be covered in toner. Be careful not to get toner on your hands or clothes.
- Toner on prints made immediately after clearing a paper jam may be insufficiently fused and can smudge. Make test prints until smudges no longer appear.
- Do not forcefully remove jammed paper, as it may tear. Torn pieces remaining inside the machine will cause further jams and possibly damage the machine.
- Paper jams can cause pages to be lost. Check your print job for missing pages and reprint any pages that did not print out.

Removing internal/tray 1/tray 2 jam

If "Internal Misfeed", "Misfeed: Tray 1", "Misfeed: Tray 2" appears on the display, follow the procedure below to remove it.

CAUTION

- The inside of this machine becomes very hot. Do not touch the parts labeled "△" (indicating a hot surface).

CAUTION

- Some of this machine's internal components get very hot. For this reason, take care when removing misfed paper. Not doing so could result in burns.

CAUTION

- When removing jammed paper, make sure not to trap or injure your fingers.

1. Pull tray 1 halfway out, and check for jammed paper. If there is jammed paper, remove it carefully.

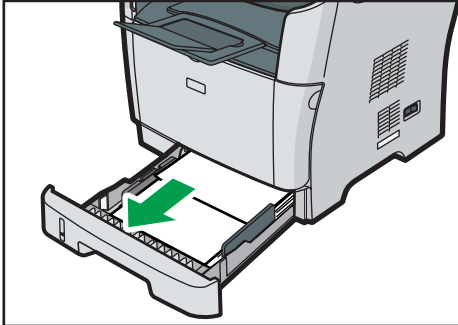

CMF067

2. Carefully slide tray 1 back in until it stops.
3. If paper is loaded in the bypass tray, remove the paper.
4. Close the bypass tray.
5. Push the side button to open the front cover, and then carefully lower it.

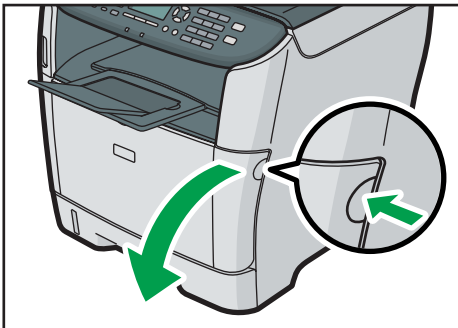

CMF068

6. Carefully pull out the print cartridge horizontally, holding its center.

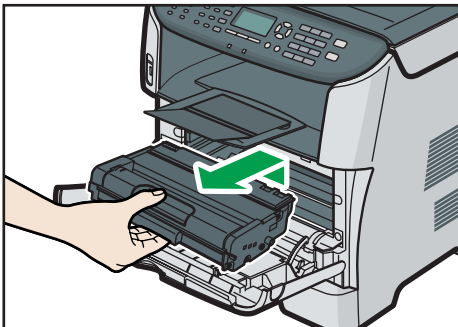

CMF069

- Do not shake the removed print cartridge. Doing so can cause remaining toner to leak.
- Place the print cartridge on paper or similar material to avoid dirtying your workspace.

7. Lifting the guide plate, remove the jammed paper carefully.

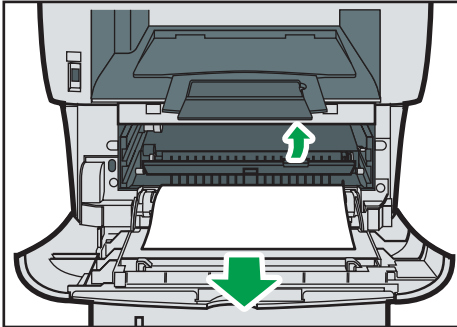

CMF070

8. Slide the print cartridge in horizontally. When the cartridge can go no further, raise it slightly and push it fully in. Then push down on the cartridge until it clicks into place.

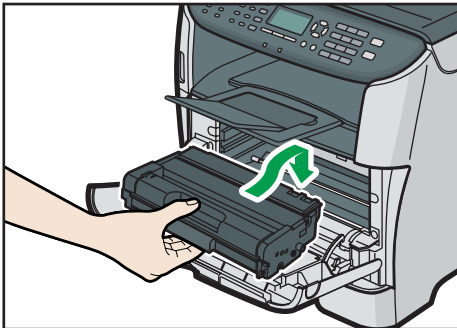

CMF071

9. Using both hands, carefully push up the front cover until it closes.

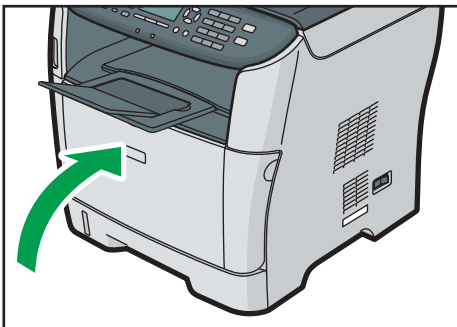

CMF072

Note

- If paper is jammed in tray 2 but is difficult to locate, pull out tray 2 to remove it. After removing the paper, carefully push tray 2 all the way back inside the machine.
- When closing the front cover, push the upper area of the cover firmly. After closing the cover, check that the error is cleared.

Removing bypass tray jam

If "Misfeed: Bypass Tray" appears on the display, follow the procedure below to remove it.

⚠ CAUTION

- The inside of this machine becomes very hot. Do not touch the parts labeled "⚠" (indicating a hot surface).

⚠ CAUTION

- Some of this machine's internal components get very hot. For this reason, take care when removing misfed paper. Not doing so could result in burns.

⚠ CAUTION

- When removing jammed paper, make sure not to trap or injure your fingers.

1. If paper is jammed in the bypass tray input area, remove the jammed paper carefully.

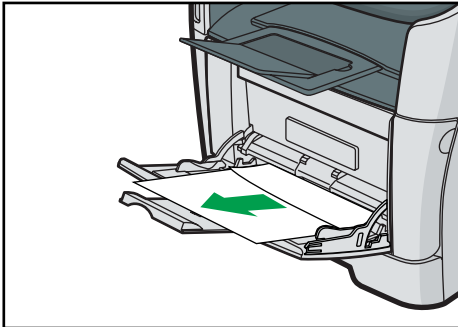

CMF073

2. Close the bypass tray.

3. Push the side button to open the front cover, and then carefully lower it.

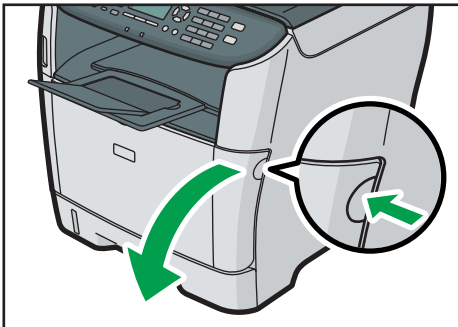

CMF068

- Carefully pull out the print cartridge horizontally, holding its center.

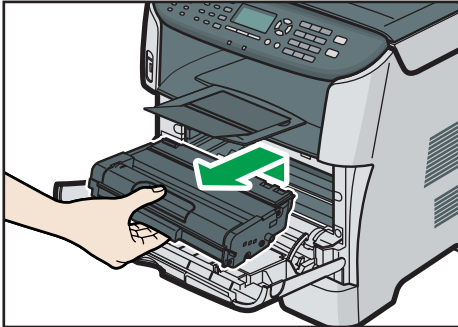

CMF069

- Do not shake the removed print cartridge. Doing so can cause remaining toner to leak.
- Place the print cartridge on paper or similar material to avoid dirtying your workspace.

- Lifting the guide plate, remove the jammed paper carefully.

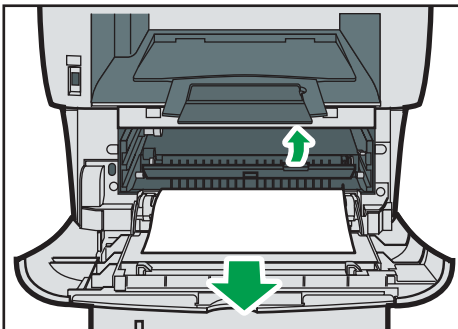

CMF070

- Slide the print cartridge in horizontally. When the cartridge can go no further, raise it slightly and push it fully in. Then push down on the cartridge until it clicks into place.

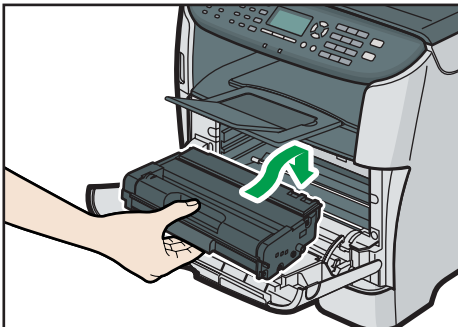

CMF071

7. Using both hands, carefully push up the front cover until it closes.

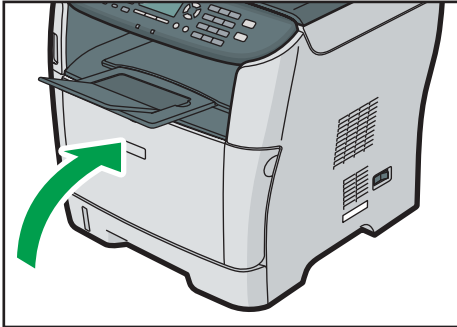

CMF072

Note

- When closing the front cover, push the upper area of the cover firmly. After closing the cover, check that the error is cleared.

Removing standard tray/ duplex unit jam

If "Misfeed: Stnd. Tray" or "Misfeed: Dup. Unit Remove Paper" appears on the display, follow the procedure below to remove it.

CAUTION

- The inside of this machine becomes very hot. Do not touch the parts labeled "△" (indicating a hot surface).

CAUTION

- Some of this machine's internal components get very hot. For this reason, take care when removing misfed paper. Not doing so could result in burns.

CAUTION

- When removing jammed paper, make sure not to trap or injure your fingers.

1. Open the rear cover.

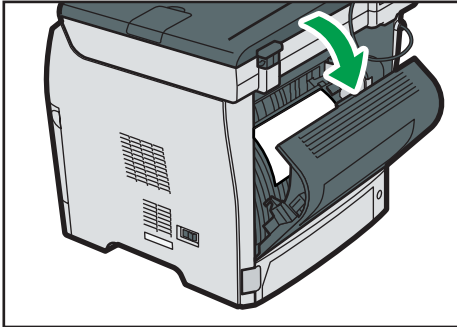

CMF074

2. Remove the jammed paper carefully.

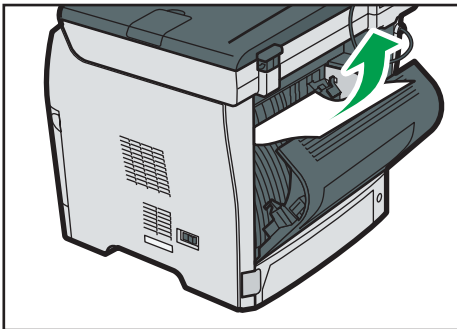

CMF075

3. Close the rear cover.

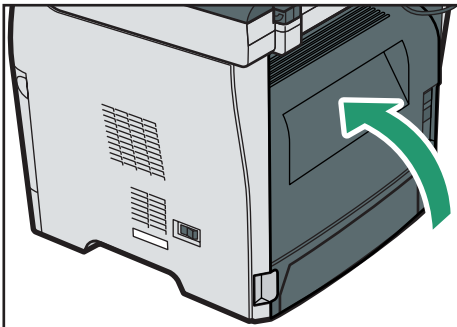

CMF076

4. Pull tray 1 halfway out, and check for jammed paper. If there is jammed paper, remove it carefully.

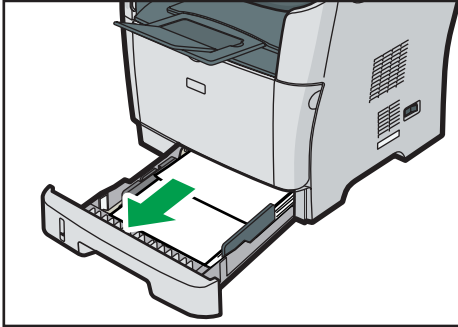

CMF067

5. Pull tray 1 out completely with both hands.

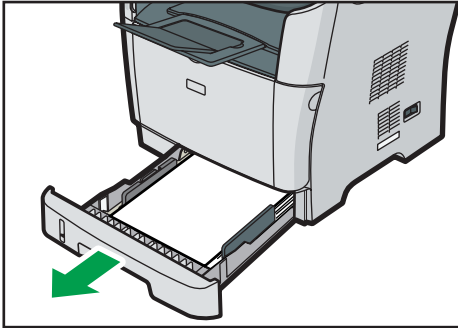

CMF077

Place the tray on a flat surface.

6. Push the lever.

Pushing the lever lowers the duplex transport unit.

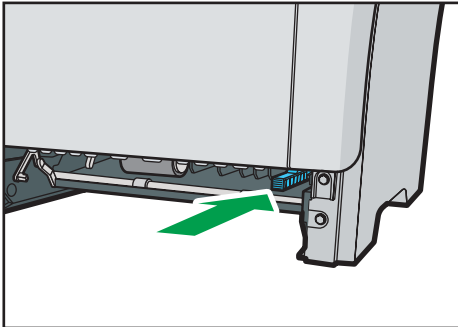

CMF078

7. If there is jammed paper, carefully remove it.

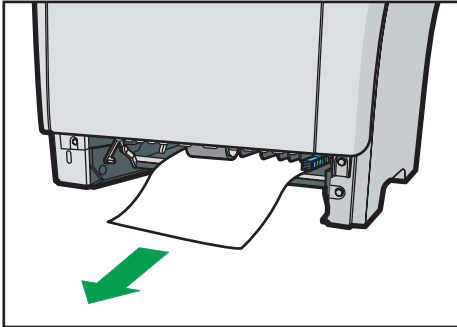

CMF079

8. With the duplex transport unit still lowered, carefully slide tray 1 back in until it stops.

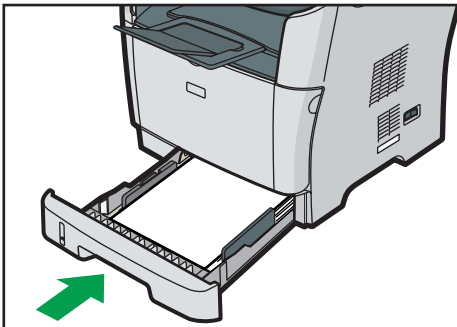

CMF080

9. If paper is loaded in the bypass tray, remove the paper and close the bypass tray.
10. Push the side button to open the front cover, and then carefully lower it.

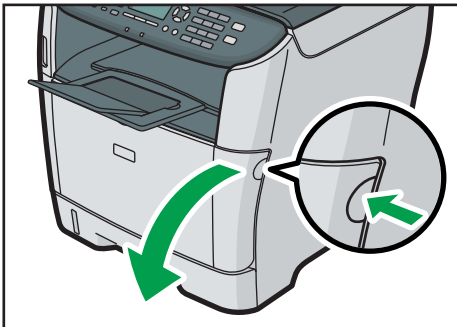

CMF088

11. Carefully pull out the print cartridge horizontally, holding its center.

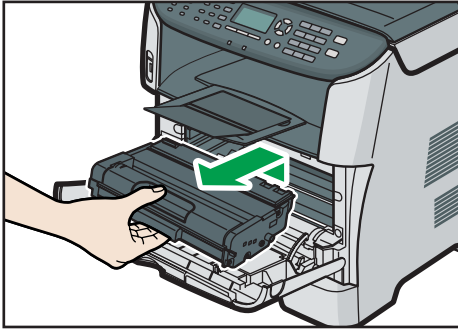

CMF069

- Do not shake the removed print cartridge. Doing so can cause remaining toner to leak.
- Place the print cartridge on paper or similar material to avoid dirtying your workspace.

12. Lifting the guide plate, remove the jammed paper carefully.

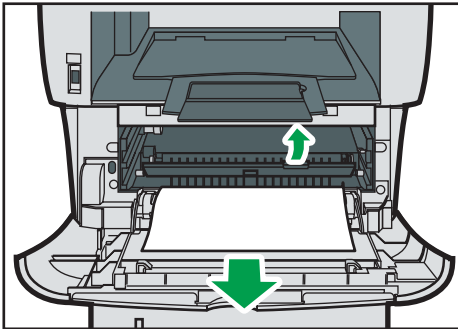

CMF070

9

13. Slide the print cartridge in horizontally. When the cartridge can go no further, raise it slightly and push it fully in. Then push down on the cartridge until it clicks into place.

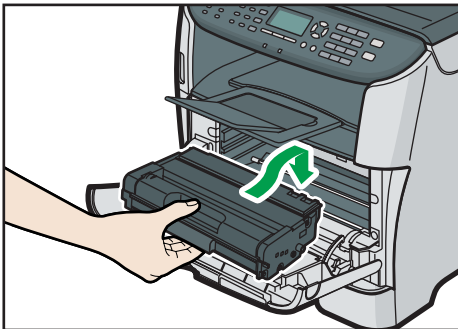

CMF071

- Using both hands, carefully push up the front cover until it closes.

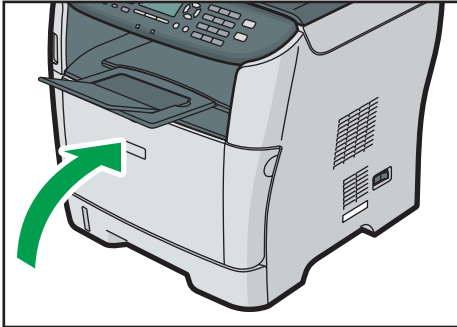

CMF072

Note

- When closing the covers, push the covers firmly. After closing the covers, check that the error is cleared.

Removing Scanning Jams (Type 2 model)

When the following message appears on the screen, follow the procedure below to remove the original jammed in the ARDF:

- "ADF Orig. Misfeed Open ADF Cover and remove paper."

CAUTION

- When removing jammed paper, make sure not to trap or injure your fingers.

- Open the ARDF cover.

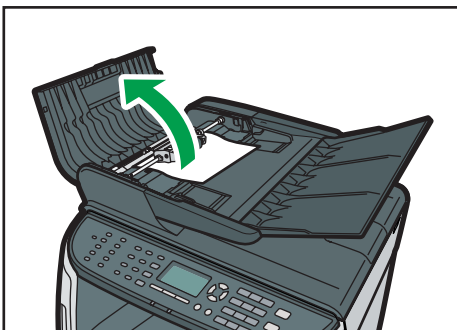

CMF081

2. Gently pull the jammed original to remove it. Be careful not to pull the original too hard, as it may rip.

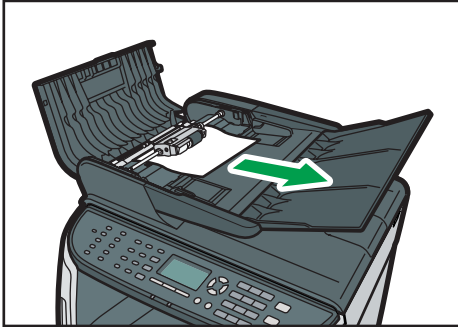

CMF082

3. If you cannot pull out the jammed original easily, move the lever slightly to the machine rear, and then raise it to unlock the paper feed roller.

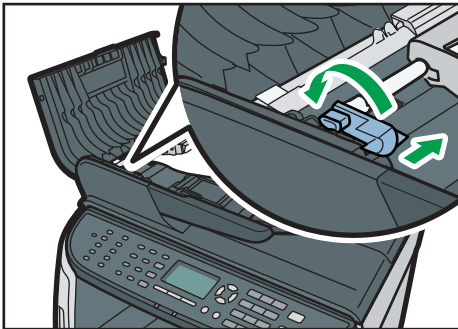

CMF083

4. Lift the paper feed roller slightly and pull it out toward you.

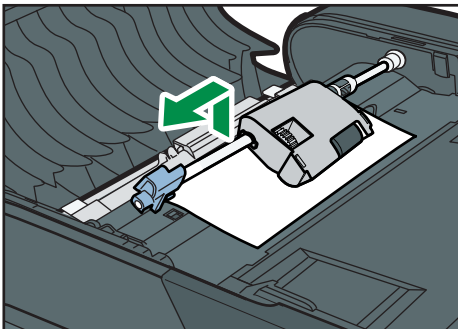

CMF116

5. Gently pull the jammed original to remove it.

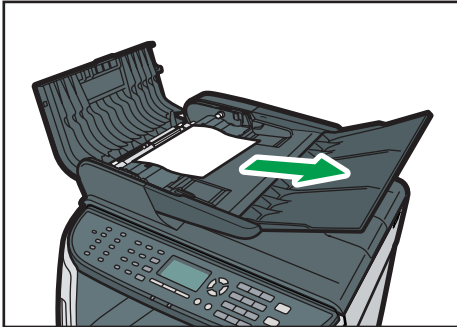

CMF085

6. If you cannot pull out the jammed original easily, raise the input tray to see if the original is jammed in the output area.

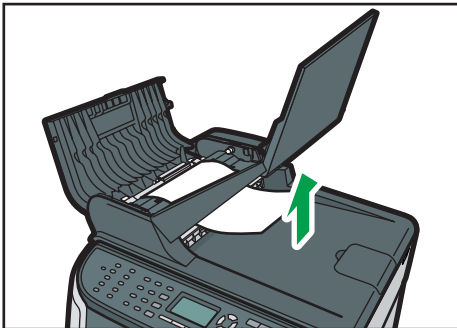

CMF086

7. Gently pull the jammed original to remove it.

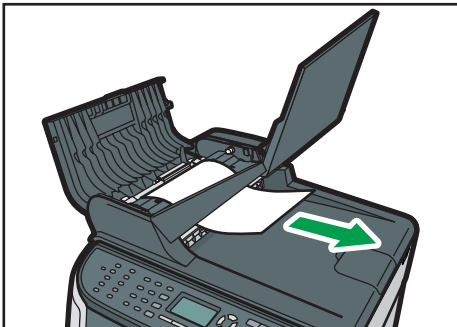

CMF087

8. Put the paper feed roller back in with the roller part facing downwards.

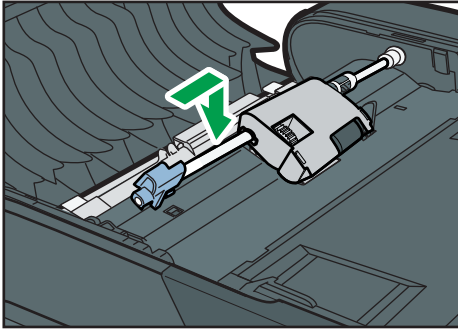

CMF117

9. Lower the lever to lock the paper feed roller.

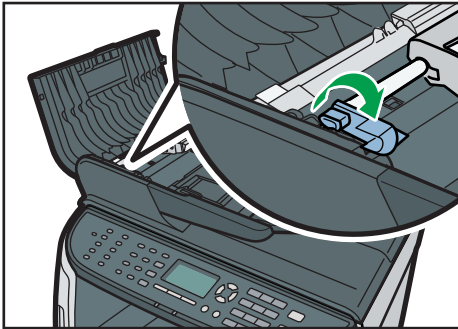

CMF089

10. Close the ARDF cover.

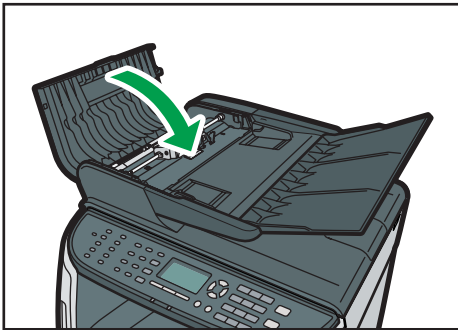

CMF090

11. Lift the ARDF, and if there is original remaining in the ARDF, gently pull the jammed original to remove it.

Be careful not to hold the input tray when lifting the ARDF, for the tray might be damaged.

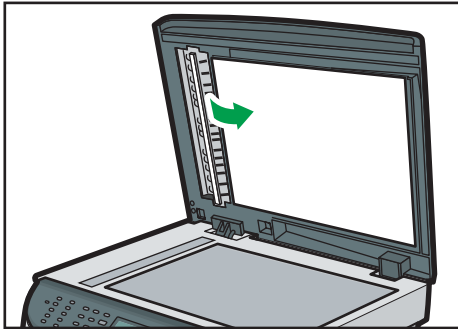

CMF091

12. Close the ARDF.

Removing Scanning Jams (Type 1 model)

When the following message appears on the screen, follow the procedure below to remove the original jammed in the ADF:

- "ADF Orig. Misfeed Open ADF Cover and remove paper."

⚠ CAUTION

- When removing jammed paper, make sure not to trap or injure your fingers.

1. Open the ADF cover.

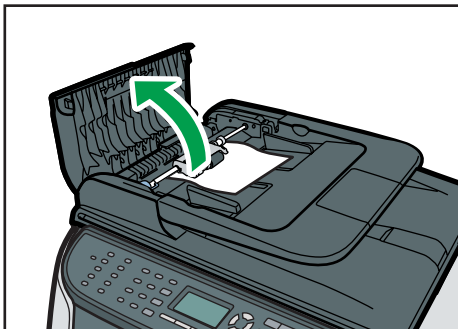

CMF118

2. Gently pull the jammed original to remove it. Be careful not to pull the original too hard, as it may rip.

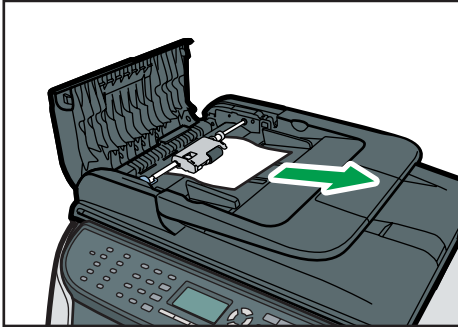

CMF119

3. If you cannot pull out the jammed original easily, move the lever slightly to the machine rear, and then raise it to unlock the paper feed roller.

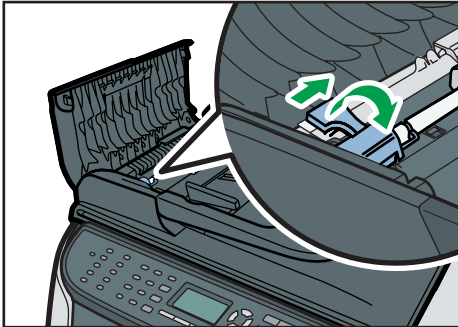

CMF120

4. Lift the paper feed roller slightly and pull it out toward you.

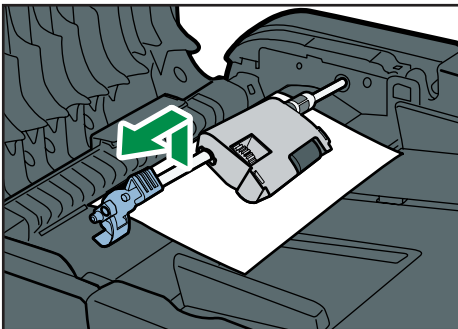

CMF084

5. Gently pull the jammed original to remove it.

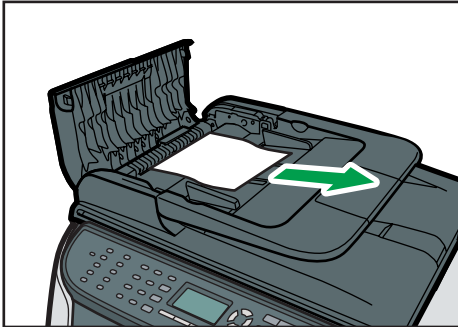

CMF121

6. If you cannot pull out the jammed original easily, raise the input tray to see if the original is jammed in the output area.

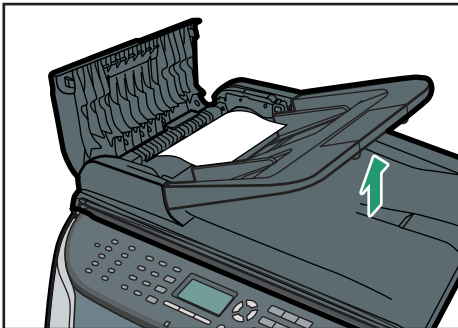

CMF122

7. Gently pull the jammed original to remove it.

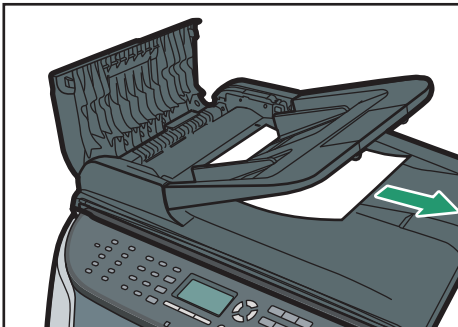

CMF123

- Put the paper feed roller back in with the roller part facing downwards.

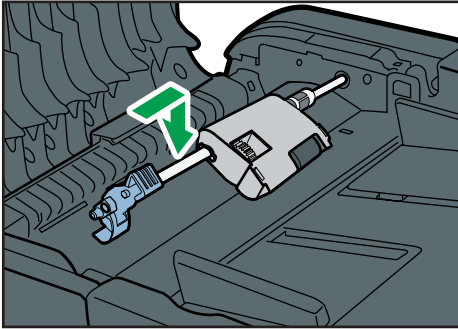

CMF088

- Lower the lever to lock the paper feed roller.

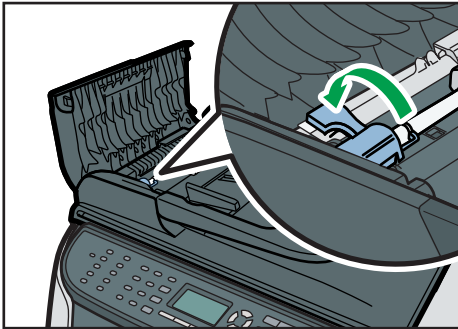

CMF124

- Close the ADF cover.

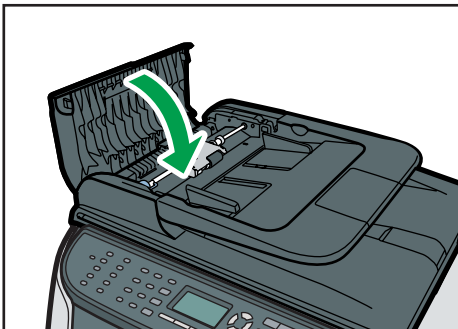

CMF125

- Lift the ADF, and if there is original remaining in the ADF, gently pull the jammed original to remove it.

Be careful not to hold the input tray when lifting the ADF, for the tray might be damaged.

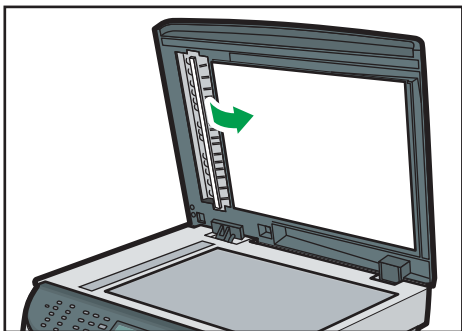

CMF126

12. Close the ADF.

Print Quality Problems

This section describes likely causes of and possible solutions for problems with print quality.

Checking the Condition of the Machine

If there is a problem with the quality of printing, first check the condition of the machine.

Possible Cause	Solution
There is a problem with the machine's location.	Make sure that the machine is on a level surface. Place the machine where it will not be subject to vibration or shock.
Unsupported types of paper is used.	Make sure that the paper being used is supported by the machine. See p.84 "Supported Paper for Each Tray".
The paper type setting is incorrect.	Make sure that the paper type setting of the printer driver matches the type of paper loaded. See p.113 "Specifying Paper Type and Paper Size".
A non-genuine print cartridge is being used.	Refilled or non-genuine print cartridge reduces print quality and can cause malfunctions. Use genuine print cartridge only. See p.430 "Consumables".
An old print cartridge is being used.	Print cartridge should be opened before their expiration date and used within six months of being opened.
The machine is dirty.	See p.415 "Cleaning", and clean the machine as required.
Humidity level surrounding the machine may be too low.	Using the machine in a room where humidity level is too low may cause black lines of a few millimeters thick appearing on printouts with 75-millimeter spaces in between. Selecting [On] for [Low Humidity Mode] under system settings may help to prevent these lines from appearing. See p.279 "System Settings".

Printer Problems

This section describes printing problems and possible solutions.

Problem	Solution
An error occurs.	<p>If an error occurs when printing, change the computer or printer driver settings.</p> <ul style="list-style-type: none"> • Check the printer icon name does not exceed 32 alphanumeric characters. If it does, shorten it. • Check whether other applications are operating. Close any other applications, as they may be interfering with printing. If the problem is not resolved, close unneeded processes too. • Check that the latest printer driver is being used.
A print job is canceled.	<p>If [I/O Timeout] under [System Settings] is set to 15 seconds, increase the time period. A print job may be canceled if printing is frequently interrupted by data from other ports, or if printing data is large and takes time for processing. For details, see p.279 "System Settings".</p>
A Locked Print file is canceled.	<ul style="list-style-type: none"> • The machine already has 5 jobs or 5 MB of Locked Print data. Print or delete an existing Locked Print file. For details, see p.140 "Printing a Locked Print file" or p.141 "Deleting a Locked Print file". • Even if the machine cannot store any more Locked Print files, the machine holds the new Locked Print file for the period of time specified in [Locked Print] under system settings before canceling that file. Within this time, you can print or delete the new Locked Print file. You can also print or delete an existing Locked Print file so that the new Locked Print file can be stored in the machine. For details about [Locked Print], see p.279 "System Settings". • The Locked Print file has too many pages or it is too large. Reduce the number of pages to print, or print with a lower setting for [Resolution] in [Print Quality]. For details, see the printer driver Help.

Problem	Solution
There is considerable delay between the print start command and actual printing.	<ul style="list-style-type: none"> • Processing time depends on data volume. High volume data, such as graphics-heavy documents, take longer to process. • If "Processing..." is displayed on the screen, the machine is receiving data. Wait for a while. • To speed up printing, reduce the printing resolution using the printer driver. For details, see the printer driver Help.
Prints fall in front of the machine when they are output.	Raise the stop fence. See p.46 "Unpacking".
Prints do not stack properly.	<ul style="list-style-type: none"> • Paper is damp. Use paper that has been stored properly. See p.84 "Paper and Other Media". • Raise the stop fence. See p.46 "Unpacking"
The whole printout is blurred.	<ul style="list-style-type: none"> • Paper is damp. Use paper that has been stored properly. See p.84 "Paper and Other Media". • If you enable [Toner Saving] under [System Settings], printing is generally less dense. • Toner is almost depleted. If "Replacement Required: Print Cartridge" appears on the screen, replace the print cartridge. • Condensation may have collected. If rapid change in temperature or humidity occurs, use this machine only after it has acclimatized.
The toner is powdery and comes away from the paper, or the printed image has a matt appearance.	Check if the levers for printing on envelopes inside the rear cover are properly set. Pull up the levers.
Printed envelopes come out creased.	Check if the levers for printing on envelopes inside the rear cover are properly set. Lower the levers.

Changing the Printer Driver Settings

You may eliminate certain problems by changing the printer driver settings as described below.

Possible Cause	Solution
Cannot print properly when using a certain application, or cannot print image data properly.	<ul style="list-style-type: none"> • Increase the print quality settings. • Adjust the image density. • Set the document to print in gray-scale.
Some characters are printed faintly or not printed.	<ul style="list-style-type: none"> • Increase the print quality settings. • Set the document to print in gray-scale.

Print Positions Do Not Match Display Positions

If the position of items on the printed page differs from the position displayed on the computer screen, the cause may be one of the following.

Possible Cause	Solution
Page layout settings have not been configured.	Check that the page layout settings are properly configured in the application.
The paper size setting does not match the paper loaded.	Make sure the paper size selected in the printer properties dialog box matches the size of the paper loaded. For details, see the printer driver Help.
The printable area has been changed.	Set the printable area to maximum. For details, see the printer driver Help.

Adjusting Printing Position

You can adjust the printing position of each tray. Use the following procedure to adjust the printing position.

★ Important

- A test page for checking the printing position will be output from the tray specified as a priority tray for [Printer] in [Paper Tray Priority] under system settings. Check that the tray you want to adjust is set as a priority tray before you perform the following procedure.

1. Press the [User Tools] key.

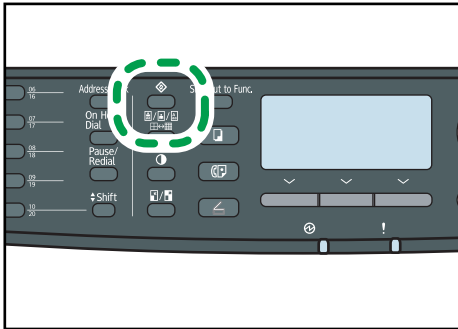

CMF134

2. Press the [▲] [▼] keys to select [Printer Features], and then press the [OK] key.
3. Press the [▲] [▼] keys to select [List/Test Print], and then press the [OK] key.
4. Press the [▲] [▼] keys to select [Test Page] or [Duplex Test Page], and then press the [OK] key.

Print a duplex test page to adjust duplex printing position (Type 2 model only).

5. Press [Yes] to print the test page to preview the settings.

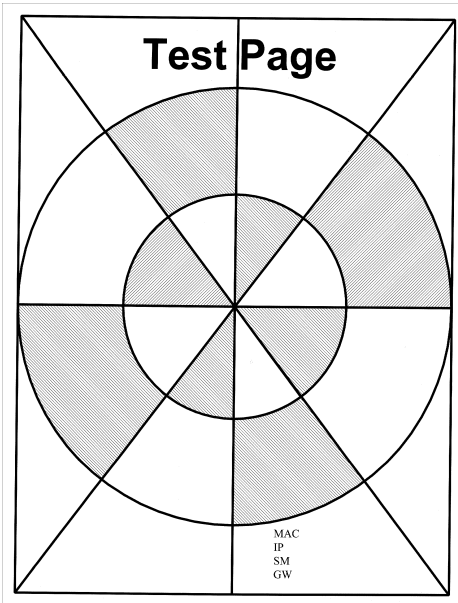

6. Press the [User Tools] key.
7. Press the [▲] [▼] keys to select [System Settings], and then press the [OK] key.
8. Press the [▲] [▼] keys to select [Printer Registration], and then press the [OK] key.
9. Press the [▲] [▼] keys to select the registration you want to adjust, and then press the [OK] key.

10. Press the [▲] [▼] keys to set the registration value from -15 to +15 (that is, from -1.5 to +1.5 mm, in 0.1 mm increments), and then press the [OK] key.

Increase the value to shift the print area in the positive direction, and decrease to shift in the negative direction. Adjust the margins of the test page so that they are equal in size.

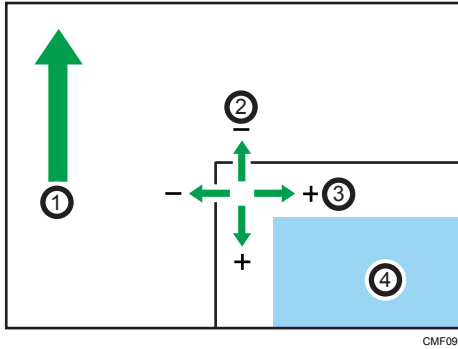

1. Feed Direction
2. Vertical Adjustment
3. Horizontal Adjustment
4. Print Area

11. Press the [User Tools] key to return to the initial screen.
12. Repeat steps 1 to 5 to confirm the adjustment result.
13. Press the [User Tools] key.

Reference

- For details about [Paper Tray Priority], see p.279 "System Settings".

Copier Problems

This section describes photocopy problems and possible solutions.

Problem	Solution
Photocopied pages are not in correct order.	On the control panel, change the [Sort] setting under copy settings to collate pages as you require. For details about [Sort], see p.257 "Copy Settings".
Photocopied paper is blank.	The original is not set correctly. When using the exposure glass, place originals copy side down. When using the ARDF or ADF, place them copy side up. See p.119 "Placing Originals".
The wrong original was copied.	If copying from the exposure glass, make sure that there are no originals in the ARDF or ADF.
Copied pages come out too light.	Low room temperature may have caused the machine to scan originals unclearly. Selecting [Long] for [Scan Warm-up Time] under system settings may help to improve the scanning quality. See p.279 "System Settings".
Copied pages are too dark or too light.	Adjust the image density. See p.170 "Adjusting Image Density".
Copied pages do not look the same as the originals.	Select the correct scan mode according to the type of original. See p.171 "Selecting the Document Type According to Original".
Black spots appear when photocopying a photographic print.	The original may have stuck to the exposure glass due to high humidity. Place the original on the exposure glass, and then place two or three sheets of white paper on top of it. Leave the ARDF or ADF open when copying.
A moire pattern is produced. 	The original probably has heavily lined or dotted areas. Switching the setting for image quality between [Photo] and [Mixed] may eliminate the moire pattern. See p.171 "Selecting the Document Type According to Original".

Problem	Solution
Photocopied paper is dirty.	<ul style="list-style-type: none">• Image density is too high. Adjust the image density. See p. 170 "Adjusting Image Density".• Toner on the printed surface is not dry. Do not touch printed surfaces immediately after copying. Remove freshly printed sheets one by one, taking care not to touch printed areas.• The exposure glass or ARDF or ADF is dirty. See p.415 "Cleaning".• Before placing originals on the exposure glass, make sure that toner or correction fluid is dry.
When copying from the exposure glass, the print area of the copy is out of alignment with the original.	Place the original copy side down, making sure that it is aligned to the rear left corner and pressed flat against the exposure glass.

Scanner Problems

This section describes scanner problems and possible solutions.

Problem	Solution
The machine does not start scanning.	The ARDF/ADF or its cover is open. Close the ARDF/ADF or its cover.
The scanned image is dirty.	<ul style="list-style-type: none"> The exposure glass or ARDF/ADF is dirty. See p.415 "Cleaning". Before placing originals on the exposure glass, make sure that toner or correction fluid is dry.
The scanned image is distorted or out of position.	The original was moved during scanning. Do not move the original during scanning.
The scanned image is upside down.	The original was placed upside down. Place the original in the correct orientation. See p.119 "Placing Originals".
The scanned image is blank.	The original was placed with the front and back reversed. When using the exposure glass, place originals copy side down. When using the ARDF or ADF, place originals copy side up. See p.119 "Placing Originals".
The scanned image comes out too light.	Low room temperature may have caused the machine to scan originals unclearly. Selecting [Long] for [Scan Warm-up Time] under system settings may help to improve the scanning quality. See p.279 "System Settings".
The scanned image is too dark or too light.	Adjust the image density. See p.192 "Adjusting image density".
The Scan to E-mail, Scan to FTP, or Scan to Folder function does not work.	Check if a USB flash disk is inserted into the machine. If a USB flash disk is inserted, scanning functions other than Scan to USB are not possible from the control panel.

Fax Problems

This section describes fax problems and possible solutions.

When an error code appears on the fax journal or transmission status report

The table below describes the meaning of error codes that appear under "Results" on the fax journal or transmission status report, and what to do when a particular error code appears.

"X" indicates a number in an error code that appear differently depending on a specific situation.

Error Code	Solution
1XXX11	<p>An original has been jammed inside the ARDF or ADF while sending a fax in Immediate Transmission mode.</p> <ul style="list-style-type: none"> Remove jammed originals, and then place them again. See p.375 "Removing Scanning Jams (Type 2 model)" or p.379 "Removing Scanning Jams (Type 1 model)". Check the originals are suitable for scanning. See p.119 "Placing Originals".
1XXX21	<p>The line could not be connected correctly.</p> <ul style="list-style-type: none"> Confirm that the telephone line is properly connected to the machine. Disconnect the telephone line from the machine, and connect a standard telephone in its place. Confirm that you can make calls using the telephone. If you cannot make calls this way, contact your telephone company. If the problem persists, contact your sales or service representative.
1XXX22 to 1XXX23	<p>Dial fails when trying to send faxes.</p> <ul style="list-style-type: none"> Confirm that the fax number you dialed is correct. Confirm that the destination is a fax machine. Confirm that the line is not busy. You may need to insert a pause between dial digits. Press the [Pause/Redial] key after, for example, the area code. Confirm that [PSTN / PBX] under [Admin. Tools] is set properly for your connection method to the telephone network. See p.298 "Administrator Settings".

Error Code	Solution
1XXX32 to 1XXX84	<p>An error occurred while sending a fax.</p> <ul style="list-style-type: none"> • Confirm that the telephone line is properly connected to the machine. • Disconnect the telephone line from the machine, and connect a standard telephone in its place. Confirm that you can make calls using the telephone. If you cannot make calls this way, contact your telephone company. • If the problem persists, contact your sales or service representative.
2XXX14	<p>The machine was not able to print the received fax, or the machine's memory reached capacity while receiving a fax because the document was too large.</p> <ul style="list-style-type: none"> • The paper tray was empty. Load paper in the paper tray. See p.96 "Loading Paper". • The tray set for [Select Paper Tray] under [Fax Features] did not contain A4, Letter, or Legal size paper. Load valid size paper in the tray, and configure the paper size settings under [System Settings] accordingly. • A cover or tray was open. Close the cover or tray. • There was a paper jam. Remove the jammed paper. See p.365 "Removing Printing Jams". • A print cartridge was empty. Replace the print cartridge. See p.409 "Replacing the Print Cartridge". • The received fax was too large. Ask the sender to re-send the document in parts as several smaller individual faxes, or to send at a lower resolution.
2XXX32 to 2XXX84	<p>An error occurred while receiving a fax.</p> <ul style="list-style-type: none"> • Confirm that the telephone line is properly connected to the machine. • Disconnect the telephone line from the machine, and connect a standard telephone in its place. Confirm that you can make calls using the telephone. If you cannot make calls this way, contact your telephone company. • If the problem persists, contact your sales or service representative.

Error Code	Solution
3XXX11	<p>Connection to the server failed while sending an Internet Fax.</p> <ul style="list-style-type: none"> • Confirm that the network cable is properly connected to the machine. • Confirm that the network settings such as IP address, DNS, and SMTP settings have been configured properly (make sure that no double-byte character is used). See p.330 "Configuring the Network Settings".
3XXX12	<p>E-mail transmission failed while sending an Internet Fax.</p> <ul style="list-style-type: none"> • There was an error in the header of the e-mail. Confirm that the network settings such as IP address, DNS, and SMTP settings have been configured properly (make sure that no double-byte character is used). See p.330 "Configuring the Network Settings".
3XXX13	<p>E-mail transmission failed while sending an Internet Fax.</p> <ul style="list-style-type: none"> • There was an error in the part header of the e-mail. Confirm that the network settings such as IP address, DNS, and SMTP settings have been configured properly (make sure that no double-byte character is used). See p.330 "Configuring the Network Settings".
3XXX14	<p>E-mail transmission failed while sending an Internet Fax.</p> <ul style="list-style-type: none"> • There was an error in the converted TIFF file. Confirm that the network settings such as IP address, DNS, and SMTP settings have been configured properly (make sure that no double-byte character is used). See p.330 "Configuring the Network Settings".
3XXX33	<p>The machine memory reached capacity while sending an Internet Fax.</p> <ul style="list-style-type: none"> • The fax was too large. Resend the document in parts as several smaller individual faxes, or send at a lower resolution.

Error Code	Solution
4XXX21	Connection to the server failed while receiving an Internet Fax. <ul style="list-style-type: none"> • Confirm that the network cable is properly connected to the machine. • Confirm that the network settings such as IP address, DNS, and POP3 settings have been configured properly (make sure that no double-byte character is used). See p.330 "Configuring the Network Settings".
4XXX22	E-mail reception failed while receiving an Internet Fax. <ul style="list-style-type: none"> • LIST command to the POP3 server failed. Ask the sender to check the e-mail settings.
4XXX23	E-mail reception failed while receiving an Internet Fax. <ul style="list-style-type: none"> • There was an error in the header of the e-mail. Ask the sender to check the e-mail settings.
4XXX24	E-mail reception failed while receiving an Internet Fax. <ul style="list-style-type: none"> • There was an error in the part header of the e-mail. Ask the sender to check the e-mail settings. • The e-mail had an invalid Content-Type, or an unsupported type of file (such as PDF or JPEG) was received. Ask the sender to check the file type.
4XXX25	E-mail reception failed while receiving an Internet Fax. <ul style="list-style-type: none"> • There was an error in the text part of the part body of the e-mail. Ask the sender to check the e-mail settings.
4XXX26	E-mail reception failed while receiving an Internet Fax. <ul style="list-style-type: none"> • There was an error in the received TIFF file (which resulted from a condition not indicated by the error codes 4XXX43 to 4XXX45). Ask the sender to check the TIFF file.
4XXX42	E-mail reception failed while receiving an Internet Fax. <ul style="list-style-type: none"> • There was an error in the part header of the e-mail. Ask the sender to check the e-mail settings.

Error Code	Solution
4XXX43	A TIFF file could not be received via Internet Fax properly. <ul style="list-style-type: none"> The compression method of the received TIFF file was other than MH/MR/MMR. Ask the sender to check the TIFF file.
4XXX44	A TIFF file could not be received via Internet Fax properly. <ul style="list-style-type: none"> The resolution of the TIFF file was not supported, or the width of the TIFF file was A3 or B4. Ask the sender to check the TIFF file.
4XXX45	A TIFF file could not be received via Internet Fax properly. <ul style="list-style-type: none"> The format of the TIFF file was other than TIFF-S/F. Ask the sender to check the TIFF file.
4XXX46	The machine memory reached capacity while receiving an Internet Fax. <ul style="list-style-type: none"> The fax was too large. Ask the sender to resend the document in parts as several smaller individual faxes, or send at a lower resolution.

When other problems occur

The table below describes how to troubleshoot problems that do not produce an error code.

Problem	Solution
Cannot send faxes.	<ul style="list-style-type: none"> See the solutions provided for errors 1XXX32 to 1XXX84 in the above table. The machine cannot accept a new fax job because there are 5 unsent faxes in memory already. Wait until any of those faxes is transmitted completely, or use the [Delete TX Standby File] function to delete unnecessary faxes. For details, see p.270 "Fax Feature Settings".
Cannot receive faxes.	See the solutions provided for errors 2XXX32 to 2XXX84 in the above table.

Problem	Solution
Cannot receive faxes even when sending them is possible.	<ul style="list-style-type: none"> • A print cartridge is empty. Replace the print cartridge. See p.409 "Replacing the Print Cartridge". • The paper tray is empty. Load paper in the paper tray. See p.96 "Loading Paper". • If fax reception mode is FAX/TEL Manual mode, you must receive the fax manually. See p.240 "Receiving a Fax".
Cannot print received faxes.	<ul style="list-style-type: none"> • The paper tray is empty. Load paper in the paper tray. See p.96 "Loading Paper". • The paper tray does not contain paper of the right size. Load paper of the right size in the paper tray.
Faxes you sent appear spotty or dirty when received.	<ul style="list-style-type: none"> • The exposure glass or ARDF/ADF is dirty. See p.415 "Cleaning". • Before placing originals on the exposure glass, make sure that ink or correction fluid is dry.
A fax you sent appears blank when received.	The original was placed upside down. Place the original in the correct orientation. See p.119 "Placing Originals".
The background of received images is dirty, or images from the rear side of the originals are visible.	Image density is too high. Adjust the image density. See p.222 "Adjusting image density".
Faxes you sent come out too light on the receiving end.	<p>Low room temperature may have caused the machine to scan originals unclearly. Selecting [Long] for [Scan Warm-up Time] under system settings may help to improve the scanning quality.</p> <p>See p.279 "System Settings".</p>
Dial fails when trying to send faxes.	See the solutions provided for errors 1XXX22 to 1XXX23 in the above table.

Error and Status Messages on the Screen

This section describes the meaning of messages that appear on the screen and what to do when a particular message appears.

Messages are listed in alphabetical order in the table below.

"X" indicates the parts of the messages that appear differently depending on a specific situation, such as the paper sizes, paper types, or tray names.

Message	Causes	Solutions
2XXX14	The machine was not able to print the received fax, or the machine's memory reached capacity while receiving a fax because the document was too large.	<ul style="list-style-type: none"> • The paper tray was empty. Load paper in the paper tray. See p.96 "Loading Paper". • The tray set for [Select Paper Tray] under [Fax Features] did not contain A4, Letter, or Legal size paper. Load valid size paper in the tray, and configure the paper size settings under [System Settings] accordingly. • A cover or tray was open. Close the cover or tray. • There was a paper jam. Remove the jammed paper. See p.365 "Removing Printing Jams". • A print cartridge was empty. Replace the print cartridge. See p.409 "Replacing the Print Cartridge". • The received fax was too large. Ask the sender to resend the document in parts as several smaller individual faxes, or to send at a lower resolution.
ADF Cover Open Close ADF Cover	The ARDF/ADF cover is open.	<ul style="list-style-type: none"> • Close the cover completely.

Message	Causes	Solutions
<p>ADF Orig. Misfeed Open ADF Cover and remove paper.</p>	<p>An original has been jammed inside the ARDF or ADF.</p>	<ul style="list-style-type: none"> Remove jammed originals, and then place them again. See p.375 "Removing Scanning Jams (Type 2 model)" or p.379 "Removing Scanning Jams (Type 1 model)". Check the originals are suitable for scanning. See p.117.
<p>Available: 2 Sided Copy A4/LG/LT</p>	<p>2-sided copy could not be performed because the tray does not contain the valid size paper, which are A4, Letter, or Legal.</p>	<ul style="list-style-type: none"> Specify the tray containing the A4, Letter, or Legal size paper in the [Select Paper] setting. See p.257 "Copy Settings". Specify A4, Letter, or Legal for the tray selected for printing copies. See p.279 "System Settings".
<p>Available: IDCard Copy A4 or 8 1/2 x 11</p>	<p>ID card copy could not be performed because the tray does not contain the valid size paper, which are A4 or Letter size.</p>	<ul style="list-style-type: none"> Set the machine to print copies using the A4 or Letter size paper in the [Select Paper] setting. See p.257 "Copy Settings". Specify the A4 or Letter size paper for the tray selected for printing copies. See p.279 "System Settings".
<p>Busy</p>	<p>Fax transmission could not be completed because the destination's line was busy.</p>	<p>Wait for a while and send the fax again.</p>
<p>Cannot Copy This Setting Comb.: 2 on 1 / 4 on 1</p>	<p>Combined copying could not be performed because the tray does not contain the valid size paper, which are A4, Letter, or Legal size.</p>	<ul style="list-style-type: none"> Set the machine to print copies using the A4, Letter, or Legal size paper in the [Select Paper] setting. See p.257 "Copy Settings". Specify the A4, Letter, or Legal size paper for the tray selected for printing copies. See p.279 "System Settings".

Message	Causes	Solutions
Cannot copy. Set original to ADF.	Combined copying/2-sided copying could not be performed because the originals were not placed in the ARDF or ADF.	<ul style="list-style-type: none"> • Use the ARDF or ADF, even when copying a single sheet. • If you need to use the exposure glass, turn off combined copying/2-sided copying in [Duplex/Combine] under copy settings, and then try again. See p.257 "Copy Settings".
Check Paper Size	The paper size set for the document differs from the size of the paper in the indicated tray.	Press [FormFeed] to begin printing, or press [JobReset] to cancel the job.
Check Paper Type	The paper type set for the document differs from the type of the paper in the indicated tray.	Press [FormFeed] to begin printing, or press [JobReset] to cancel the job.
Connection Failed	The line could not be connected correctly.	<ul style="list-style-type: none"> • Confirm that the telephone line is properly connected to the machine. • Disconnect the telephone line from the machine, and connect a standard telephone in its place. Confirm that you can make calls using the telephone. If you cannot make calls this way, contact your telephone company.
Cover open	A cover is open.	Close the cover completely.
Dest. is not Programmed	No Quick Dial entry is associated with the One Touch button you pressed.	<ul style="list-style-type: none"> • Press a different One Touch button. • Assign a registered destination to the One Touch button. See p.175 "Registering Scan Destinations".

Message	Causes	Solutions
Dial Failed	The fax could not be sent.	<ul style="list-style-type: none"> • Confirm that the fax number you dialed is correct. • Confirm that the destination is a fax machine. • Confirm that the line is not busy. • You may need to insert a pause between dial digits. Press the [Pause/Redial] key after, for example, the area code.
Exceeded Max.E-mail Size	The scan file exceeds the size limit for files that can be sent through e-mail.	<ul style="list-style-type: none"> • Configure [Resolution] under scanner settings to reduce the scanning resolution. See p.263 "Scanner Settings". • Configure [Max. E-mail Size] under scanner settings to increase the allowed size. See p.263 "Scanner Settings".
Failed to Access File Press Clear key	The Scan to USB function failed because the machine could not access the USB flash disk properly.	Use a USB flash disk that is not password- or write-protected.
Failed to Create File Press Clear key	The Scan to USB function failed because there was not enough memory on the USB flash disk.	Use a USB flash disk with enough memory.
Fax Job Memory Overflow	The number of fax jobs in memory (unsent or unprinted faxes) has reached maximum, so new jobs cannot be stored.	Wait until pending jobs have been transmitted or printed.
I-Fax POP3 fails	Connection to the POP3 server failed.	<ul style="list-style-type: none"> • Confirm that the network cable is properly connected to the machine. • Confirm that the network settings such as IP address, DNS, and POP3 settings have been configured properly (make sure that no double-byte character is used). See p.330 "Configuring the Network Settings".

Message	Causes	Solutions
Indep.Sply.Prt.Cart.	A non-supported print cartridge is installed.	Remove and replace it with a print cartridge specified by an authorized dealer.
Internal Misfeed	Paper has been jammed in the machine.	Remove the jammed paper. See p.365 "Removing Printing Jams".
Memory Almost Full	Memory has almost reached capacity during sort copy.	If several originals are still to be scanned, it is recommended to start printing now, and copy the remaining originals separately. If originals are being scanned from the ARDF or ADF, remove any remaining pages from the ARDF or ADF.
Memory Overflow	<ul style="list-style-type: none"> The data is too large or complex to print. If you try to print a Locked Print file stored in the machine with the printer driver's [Resolution] set to [1200 × 600 dpi] or higher in the [Print Quality] tab, printing may be canceled depending on the machine's current memory usage. 	<ul style="list-style-type: none"> Select [600 × 600 dpi] in [Resolution] under [Printer Features] to reduce the size of data. See p.304 "Printer Feature Settings". If using the PCL6 printer driver, set [Resolution] in [Print Quality] to [600 × 600 dpi]. If using the PostScript 3 printer driver, set [Print Quality:] in [Graphics] to [600 × 600 dpi]. Print or delete other Locked Print files in the machine, and then print the Locked Print file that the machine failed to print. Alternately, resend the Locked Print file to the machine with [Resolution] set to [600 × 600 dpi], and then print the Locked Print file.

Message	Causes	Solutions
Memory Overflow	<ul style="list-style-type: none"> • The machine's memory reached capacity while scanning the first page of the original to store a fax job in memory before transmission. • The machine's memory reached capacity while sending a fax via LAN-Fax. • The machine's memory reached capacity while storing a fax in memory in Memory Transmission mode. 	Resend the fax in parts as several smaller individual faxes, or send at a lower resolution.
Memory Overflow TX Cancel	Memory has reached capacity while scanning the second or later pages of the original when trying to send a fax in Memory Transmission mode.	Press [TX] to send only the pages that have been scanned in memory, or press [Cancel] to cancel.
Misfeed: Bypass Tray	Paper has been jammed in the bypass tray.	Remove the jammed paper. See p.365 "Removing Printing Jams".
Misfeed: Dup. Unit Remove Paper	Paper has been jammed in the duplex unit.	Remove the jammed paper. See p.365 "Removing Printing Jams".
Misfeed: Stnd. Tray	Paper has been jammed in the paper exit area.	Remove the jammed paper. See p.365 "Removing Printing Jams".
Misfeed: Tray 1	Paper has been jammed in the tray 1 paper input area.	Remove the jammed paper. See p.365 "Removing Printing Jams".
Misfeed: Tray 2	Paper has been jammed in the tray 2 paper input area.	Remove the jammed paper. See p.365 "Removing Printing Jams".
Net Communication Error	Connection with the server was lost while sending or receiving data.	Contact the network administrator.

Message	Causes	Solutions
Network is not Ready	A scanned file could not be sent because the machine has not received IP address information from the DHCP server completely.	Wait until the machine receives the IP address information completely, and then try the operation again.
On Hook or Stop key	The machine has been off-hook for an extended period of time.	Put down the handset or press the [Clear/Stop] key.
Out of Paper: X	The indicated tray has run out of paper.	Load paper to the indicated tray. See p.96 "Loading Paper".
Please Restart Machine	The machine needs to be restarted.	Turn off the power, and then turn it back on.
Print Cart. Set Error	The print cartridge has not been installed or has not been installed correctly.	Reinstall the print cartridge. See p.409 "Replacing the Print Cartridge".
Remove Paper: Bypass Tray	The machine failed to proceed with the print job, because tray 1 or tray 2 was specified as the input tray but paper was set in the bypass tray.	Remove paper from the bypass tray.
Replace Required Soon: Print Cartridge	The print cartridge is almost empty.	Prepare a new print cartridge.
Replacement Required: Fusing Unit	The fusing unit is no longer usable, and must be replaced.	Contact your sales or service representative.
Replacement Required: Paper Feed Roller	The paper feed roller is no longer usable, and must be replaced.	Contact your sales or service representative.
Replacement Required: Print Cartridge	The machine has run out of toner.	Replace the print cartridge. See p.409 "Replacing the Print Cartridge".

Message	Causes	Solutions
Replacement Required: Transfer Roller	The transfer roller is no longer usable, and must be replaced.	Contact your sales or service representative.
RX Comm. Error	A reception error occurred, and the fax could not be received correctly.	If possible, contact the sender of the fax and ask them to resend it.
Scan (NW) Disconnected	A scanned file could not be sent because the Ethernet cable was not connected properly.	Reconnect the Ethernet cable properly, and then try the operation again.
Scan (USB) Disconnected	The USB cable was disconnected while scanning from a computer.	Reconnect the USB cable properly, and then try the operation again.
Server Connection Failed	A scanned file could not be sent because the destination could not be reached.	Confirm that the destination is registered correctly, and then try the operation again.
Server Response Error	An error occurred in communication with the server before beginning transmission.	Confirm that the destination is registered correctly, and then try the operation again. If the problem could not be solved, contact the network administrator.
Service call - X	A fatal hardware error has occurred, and the machine cannot function.	Contact your sales or service representative.
Set Correct Paper	The tray set for [Select Paper Tray] under [Fax Features] does not contain A4, Letter, or Legal size paper.	While the message is displayed, press the [OK] key. A menu for changing the paper size of the current tray appears. Load A4/Letter/ Legal size paper in the tray, and then select the corresponding paper size using [▲][▼] keys and press the [OK] key. The machine will then print out the fax. Note that the paper size setting for the tray under system settings will be changed. See p.279 "System Settings".

Message	Causes	Solutions
Set Original to ADF Cannot use exposure glass with set. in [Scan Size].	Scanning could not be performed because the originals were not placed in the ARDF or ADF, even though the machine is set to scan originals larger than A4/Letter size.	<ul style="list-style-type: none"> Use the ARDF or ADF, even when scanning A4/Letter or smaller size originals. If you need to use the exposure glass, set A4/Letter or smaller size in [Scan Size] under scanner settings, and then try again. See p.263 "Scanner Settings".
Sort Copy was Cancelled	The machine's memory reached capacity while originals were being scanned from the ARDF or ADF to perform sort copying.	Press [Exit] to print the originals that were successfully scanned into memory. Then, copy again the originals left in the ARDF or ADF.
TX Comm. Error	A transmission error occurred, and the fax could not be transmitted correctly.	If the [Auto Redial] setting is enabled, the machine will redial the number and try again. If all attempts fail, or if the machine is in Immediate Transmission mode, the fax will not be transmitted. Try the operation again.
Unavailable Paper Type	2-sided copy could not be performed because the tray does not contain the valid type paper, which are thin, plain, recycled, color, preprinted, prepunched, thick paper 1, or letterhead.	<ul style="list-style-type: none"> Specify the tray containing the valid type paper in the [Select Paper] setting. See p.257 "Copy Settings". Specify the valid paper type for the tray selected for printing copies. See p.279 "System Settings".
Unsupported Device Please Remove	The Scan to USB function failed because a USB device other than a USB flash disk or a USB flash disk with an unsupported file system was used.	Use a USB flash disk that is compatible with the Scan to USB function.
Unsupported Device Press Clear key	The Scan to USB function failed because a USB device other than a USB flash disk or a USB flash disk with an unsupported file system was used.	Use a USB flash disk that is compatible with the Scan to USB function.

Message	Causes	Solutions
Unsupported USB Hub Please Remove	The Scan to USB function failed because a USB device other than a USB flash disk or a USB flash disk with an unsupported file system was used.	Use a USB flash disk that is compatible with the Scan to USB function.
USB Disconnected Press Clear key	The Scan to USB function failed because the USB flash disk was removed before the operation could be completed.	Check that the USB flash disk is securely inserted in the machine. Do not pull out the USB flash disk until "Ready" appears on the display.
USB Memory Overflow Press Clear key	The Scan to USB function failed because there was not enough memory on the USB flash disk.	Use a USB flash disk with enough memory.
Write Protect Press Clear key	The Scan to USB function failed because the machine could not access the USB flash disk properly.	Use a USB flash disk that is not password- or write-protected.

Replacing the Print Cartridge

WARNING

- Do not incinerate toner (new or used) or toner containers. Doing so risks burns. Toner will ignite on contact with naked flame.

WARNING

- Do not store toner (new or used) or toner containers anywhere near naked flames. Doing so risks fire and burns. Toner will ignite on contact with naked flame.

WARNING

- The following explains the warning messages on the plastic bag used in this product's packaging.
 - Keep the polythene materials (bags, gloves, etc.) supplied with this machine away from babies and small children at all times. Suffocation can result if polythene materials are brought into contact with the mouth or nose.

WARNING

- Do not use the cleaner to suck spilled toner (including used toner). Sucked toner may cause firing or explosion due to electrical contact flickering inside the cleaner. However, it is possible to use the cleaner designed for dust explosion-proof purpose. If toner is spilled over the floor, sweep up spilled toner slowly and clean remainder with wet cloth.

CAUTION

- Do not crush or squeeze toner containers. Doing so can cause toner spillage, possibly resulting in dirtying of skin, clothing, and floor, and accidental ingestion.

CAUTION

- Store toner (new or used), toner containers, and components that have been in contact with toner out of reach of children.

CAUTION

- If toner or used toner is inhaled, gargle with plenty of water and move into a fresh air environment. Consult a doctor if necessary.

CAUTION

- When removing jammed paper or replacing toner, avoid getting toner (new or used) on your clothing. If toner comes into contact with your clothing, wash the stained area with cold water. Hot water will set the toner into the fabric and make removing the stain impossible.

CAUTION

- When removing jammed paper or replacing toner, avoid getting toner (new or used) on your skin. If toner comes into contact with your skin, wash the affected area thoroughly with soap and water.

CAUTION

- If toner or used toner gets into your eyes, flush immediately with large amounts of water. Consult a doctor if necessary.

CAUTION

- If toner or used toner is swallowed, dilute by drinking a large amount of water. Consult a doctor if necessary.

CAUTION

- The inside of this machine becomes very hot. Do not touch the parts labeled "△" (indicating a hot surface).

Important

- Store print cartridge in a cool dark place.
- Actual printable numbers vary depending on image volume and density, number of pages printed at a time, paper type and size, and environmental conditions such as temperature and humidity. Toner quality degrades over time. Early replacement of the print cartridge might be necessary. Therefore, we recommend you always keep a new print cartridge ready.
- For good print quality, the manufacturer recommends that you use genuine toner from the manufacturer.
- The manufacturer shall not be responsible for any damage or expense that might result from the use of parts other than genuine parts from the manufacturer with your office products.

Messages on the screen

- Replace the print cartridge when "Replacement Required: Print Cartridge" appears on the screen.
- Prepare a new print cartridge when "Replace Required Soon: Print Cartridge" appears on the screen.

★ Important

- Do not allow paper clips, staples, or other small objects to fall inside the machine.
- Do not expose the print cartridge without its cover to direct sunlight for a long time.
- Do not touch the print cartridge's photo conductor unit.

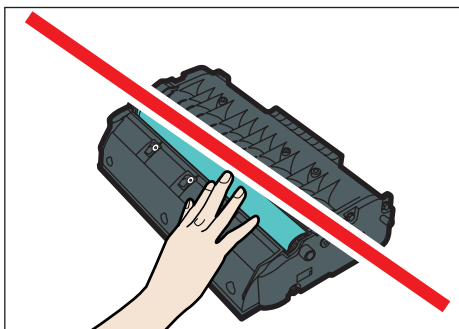

CMC013

- Do not touch the ID chip on the side of the print cartridge as indicated in the illustration below.

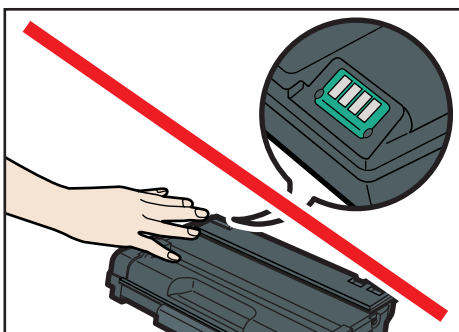

CMC014

- If toner runs out, you cannot print until the print cartridge is replaced.
1. If paper is loaded in the bypass tray, remove the paper and close the bypass tray.
 2. Push the side button to open the front cover, and then carefully lower it.

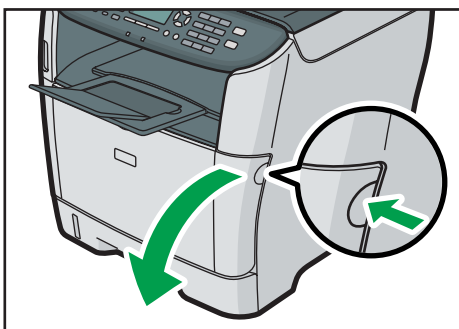

CMF068

3. Carefully pull out the print cartridge horizontally, holding its center.

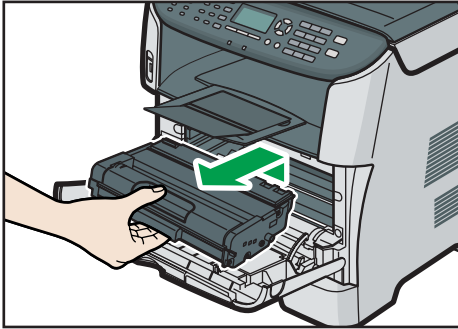

CMF069

- Do not shake the removed print cartridge. Doing so can cause remaining toner to leak.
- Place the old print cartridge on paper or similar material to avoid dirtying your workspace.

4. Take the new print cartridge out of the box, and then take it out of the plastic bag.

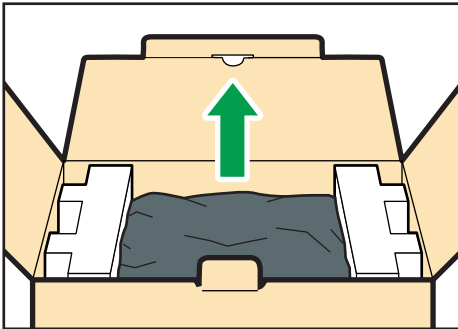

CMC081

9

5. Place the print cartridge on a flat surface, and then remove the protection sheet.

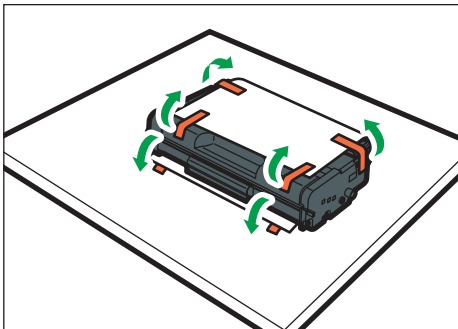

CMC019

6. Hold the print cartridge and shake it from side to side five or six times.

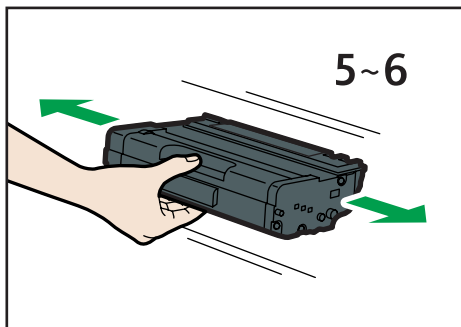

CMC020

Even distribution of toner within the bottle improves print quality.

7. Slide the print cartridge in horizontally. When the cartridge can go no further, raise it slightly and push it fully in. Then push down on the cartridge until it clicks into place.

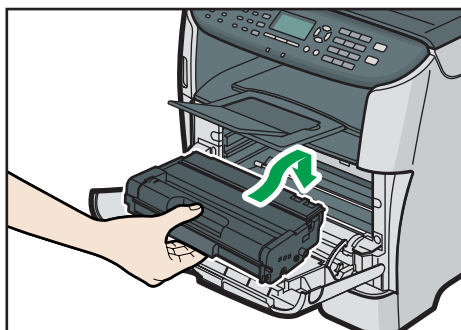

CMF071

8. Carefully push up the front cover until it closes. Be careful not to hurt your fingers. After closing the front cover, wait until the initial screen is displayed.

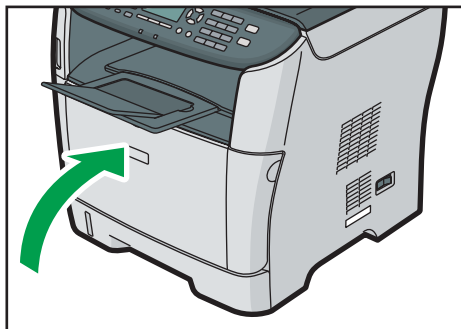

CMF072

9. Put the protective sheet you removed in step 5 on the old print cartridge. Then, put the old print cartridge into the bag, and then put it into the box.

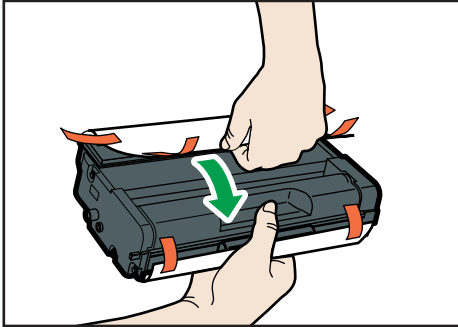

CMC083

Note

- Make sure to cover the old print cartridge with the protective cover for recycling and environmental purposes.
- Comply with the print cartridge Recycling Program, whereby used print cartridges are collected for processing. For details, ask your sales or service representative.

10. Maintenance

This chapter describes how to maintain the machine.

Cleaning

Cautions to Take When Cleaning

WARNING

- Do not remove any covers or screws other than those explicitly mentioned in this manual. Inside this machine are high voltage components that are an electric shock hazard and laser components that could cause blindness. Contact your sales or service representative if any of the machine's internal components require maintenance, adjustment, or repair.
- Do not attempt to disassemble or modify this machine. Doing so risks burns and electric shock. Note again that exposure to the laser components inside this machine risks blindness.

WARNING

- Be sure to disconnect the plug from the wall outlet at least once a year.
 - There are burn marks on the plug.
 - The prongs on the plug are deformed.
- If any of the above conditions exist, do not use the plug and consult your dealer or service representative. Use of the plug could result in fire or electric shock.

WARNING

- Be sure to disconnect the power cord from the wall outlet at least once a year.
 - The power cord's inner wires are exposed, broken, etc.
 - The power cord's coating has a crack or dent.
 - When bending the power cord, the power turns off and on.
 - Part of the power cord becomes hot.
 - The power cord is damaged.
- If any of the above conditions exist, do not use the power cord and consult your dealer or service representative. Use of the power cord could result in fire or electric shock.

CAUTION

- The inside of this machine becomes very hot. Do not touch the parts labeled "△" (indicating a hot surface).

⚠ CAUTION

- Be sure to disconnect the plug from the wall outlet and clean the prongs and the area around the prongs at least once a year. Allowing dust to build up on the plug constitutes a fire hazard.

Clean the machine periodically to maintain high print quality.

Dry wipe the exterior with a soft cloth. If dry wiping is not enough, wipe with a soft, damp cloth that is wrung out well. If you still cannot remove the stain or grime, use a neutral detergent, wipe over the area with a well-wrung damp cloth, and then dry wipe the area and allow it to dry.

★ Important

- To avoid deformation, discoloration, or cracking, do not use volatile chemicals, such as benzine and thinner, or spray insecticide on the machine.
- If there is dust or grime inside the machine, wipe with a clean, dry cloth.
- You must disconnect the plug from the wall outlet at least once a year. Clean away any dust and grime from the plug and outlet before reconnecting. Accumulated dust and grime pose a fire hazard.
- Do not allow paper clips, staples, or other small objects to fall inside the machine.

Cleaning the Friction Pad and Paper Feed Roller

If the friction pad or paper feed roller is dirty, a multi-feed or jam might occur. In this case, clean the friction pad and paper feed roller as follows:

⚠ CAUTION

- Unplug the power cord from the wall outlet before you move the machine. While moving the machine, take care that the power cord is not damaged under the machine. Failing to take these precautions could result in fire or electric shock.

⚠ CAUTION

- Do not pull out the paper tray forcefully. If you do, the tray might fall and cause an injury.

⚠ CAUTION

- Do not put your hands inside the machine when the input tray is removed. Some internal parts become hot and are a burn hazard.

★ Important

- Do not use chemical cleaning fluids or organic solvents such as thinner or benzene.

1. Turn off the power.

2. Unplug the power cord from the wall outlet. Remove all the cables from the machine.
3. Pull out tray 1 carefully with both hands.

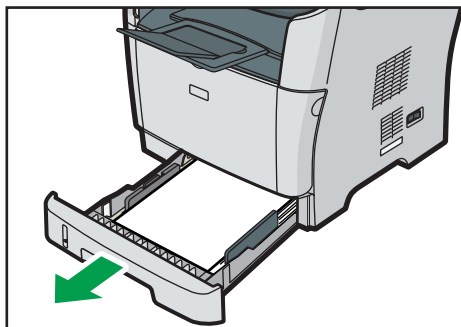

CMF077

Place the tray on a flat surface. If there is paper in the tray, remove it.

4. Wipe the friction pads with a damp cloth.

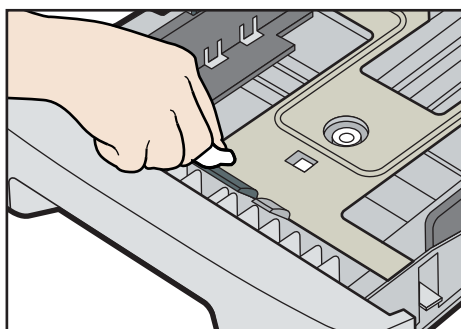

CMC084

5. Wipe the rubber part of the roller with a soft damp cloth. After that, wipe it with a dry cloth to remove the moisture.

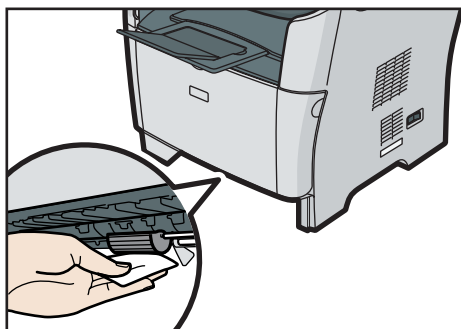

CMF092

6. Reload the removed paper into the tray, and then push the tray carefully into the machine until it clicks into place.

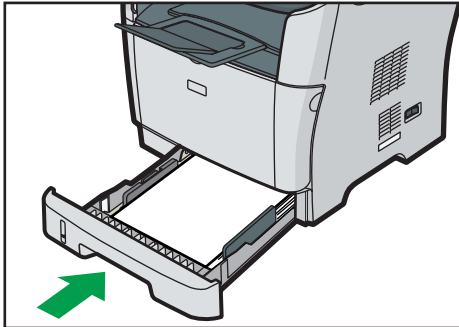

7. Insert the plug of the power cord into the wall socket securely. Connect all the interface cables that were removed.
8. Turn on the power.

Note

- If jams or multi-sheet feeds occur after cleaning the friction pad, contact your sales or service representative.
- If the optional tray 2 is installed, clean its friction pad and paper feed roller in the same way as you did for tray 1.

Cleaning the Exposure Glass

The following procedure describes how to clean the exposure glass.

1. Lift the ARDF or ADF.

Be careful not to hold the input tray when lifting the ARDF or ADF, for the tray might be damaged.

2. Clean the parts indicated with arrows with a soft damp cloth and then wipe the same parts with a dry cloth to remove any remaining moisture.

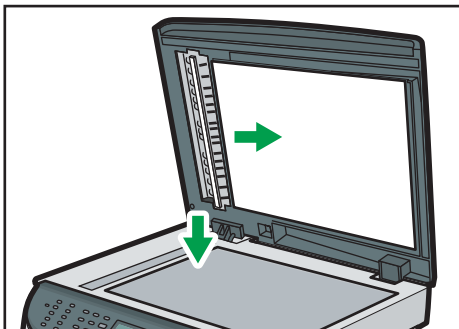

Cleaning the ARDF or ADF

The following procedure describes how to clean the ARDF or ADF.

1. Lift the ARDF or ADF.

Be careful not to hold the input tray when lifting the ARDF or ADF, for the tray might be damaged.

2. Clean the parts indicated with arrows with a soft damp cloth and then wipe the same parts with a dry cloth to remove any remaining moisture.

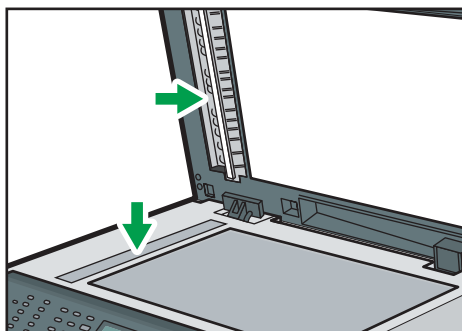

CMF094

Moving the Machine

This section provides cautions that you must follow when moving the machine both short and long distances.

CAUTION

- If you have to move the machine when the optional paper tray unit is attached, do not push on the main unit's top section. Doing so can cause the optional paper tray unit to detach, possibly resulting in injury.

CAUTION

- The machine weighs approximately 18.4 kg (40.6 lb.). When moving the machine, use the inset grips on both sides, and lift slowly. The machine will break or cause injury if dropped.

CAUTION

- Unplug the power cord from the wall outlet before you move the machine. While moving the machine, take care that the power cord is not damaged under the machine. Failing to take these precautions could result in fire or electric shock.

CAUTION

- When disconnecting the power cord from the wall outlet, always pull the plug, not the cord. Pulling the cord can damage the power cord. Use of damaged power cords could result in fire or electric shock.

CAUTION

- When moving the machine after use, do not take out the toner to prevent toner spill inside the machine.

10

Repack the machine in its original packing materials when moving it a long distance.

Important

- Be sure to disconnect all cables from the machine before transporting it.
- The machine is a precision piece of machinery. Be sure to handle it carefully when moving it.
- Make sure to move the machine horizontally. Take extra caution when carrying the machine up or down stairs.
- If tray 2 is installed, remove it from the machine, and move them separately.
- Do not hold onto the tray area when lifting the machine.

Moving over a Short Distance

★ Important

- Do not remove the print cartridge when moving the machine.
1. Be sure to check the following points:
 - The power switch is turned off.
 - The power cord is unplugged from the wall outlet.
 - All other cables are unplugged from the machine.
 2. If tray 2 is installed, remove it.
 3. Return the scanning unit inside the machine to its original position using [Scanner Carriage] under [System Settings].
 4. Lift the machine using the inset grips on both sides of the machine, and then move it horizontally to the place where you want to use it.



CMF034

5. If you have removed tray 2, reinstall it.

↓ Note

- Be sure to hold the machine level while carrying it. To prevent toner from spilling, move the machine carefully.

📖 Reference

- For details about [Scanner Carriage], see p.279 "System Settings".

Moving over a Long Distance

If you intend to move the machine over a long distance, you must pack it well. Empty all the paper trays, but do not remove the print cartridge. Take care not to tip or tilt the machine during transit.

★ Important

- Do not remove the print cartridge when moving the machine.

1. Be sure to check the following points:

- The power switch is turned off.
- The power cord is unplugged from the wall outlet.
- All other cables are unplugged from the machine.
- All paper trays are empty.

2. If tray 2 is installed, remove it.

3. Return the scanning unit inside the machine to its original position using [Scanner Carriage] under [System Settings].

↓ Note

- Toner might spill inside the machine if the machine is not kept level during transit.
- For more information about moving the machine, contact your sales or service representative.

📖 Reference

- For details about [Scanner Carriage], see p.279 "System Settings".

Disposal

Ask your sales or service representative for information about correct disposal of this machine.

If the Machine is Not Going to Be Used for a Long Time

If the machine is going to be inactive for a long time, follow the procedure shown here.

⚠ WARNING

- It is dangerous to handle the power cord plug with wet hands. Doing so could result in electric shock.

⚠ CAUTION

- The inside of this machine becomes very hot. Do not touch the parts labeled "△" (indicating a hot surface).

⚠ CAUTION

- Unplug the power cord from the wall outlet before you move the machine. While moving the machine, take care that the power cord is not damaged under the machine. Failing to take these precautions could result in fire or electric shock.

Preparing the Machine for a Long Period of Inactivity

Use this procedure to prepare the machine for a long period of inactivity with its power switch turned off.

Note that not using the following procedure could result in unusual noises when use of this machine is resumed.

★ Important

- Do not switch off the machine during printing.

1. Turn off the power switch.

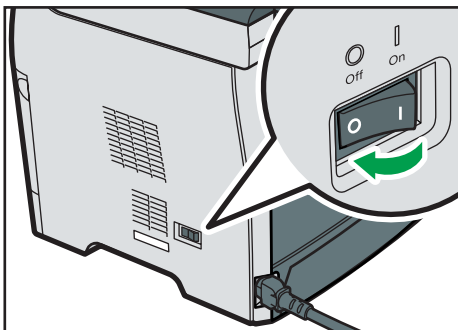

CMF028

2. Pull out the plug from the socket.

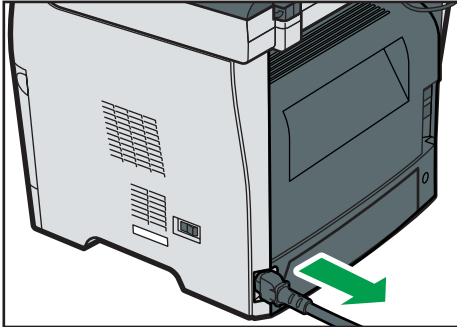

CMF097

3. Open the rear cover.

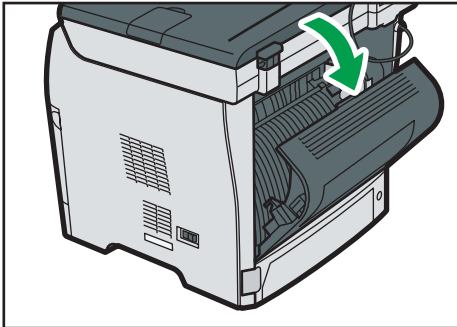

CMF095

4. Lower the levers for printing envelopes on both side to the position indicated with an envelope mark.

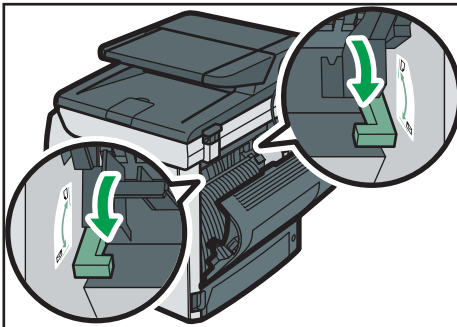

CMF047

5. Close the rear cover.

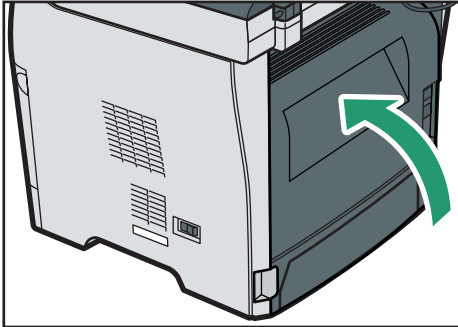

CMF076

Note

- This step is not necessary if the machine's power switch is on but the machine has been inactive for a long time.

Using the Machine Again After It Has Been Inactive for a Long Period

Use the following procedure to start using the machine again after it has been inactive for a long period.

1. Plug in the power cable.

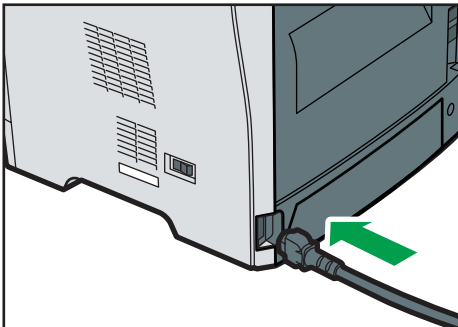

CMF026

2. Open the rear cover.

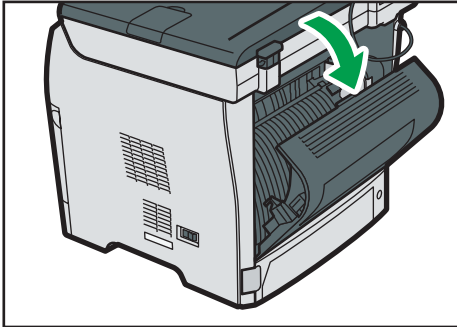

CMF095

3. Pull up the levers for printing envelopes on both sides to the position indicated with a paper mark.

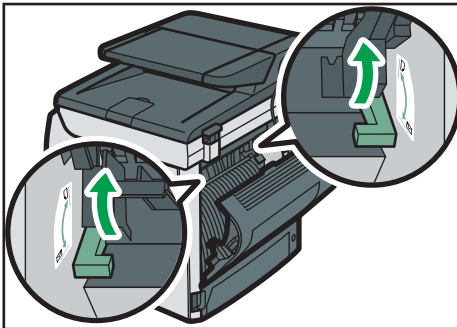

CMF096

4. Close the rear cover.

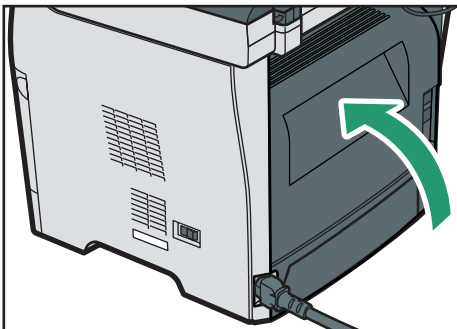

CMF127

5. Turn the power switch to "I On".

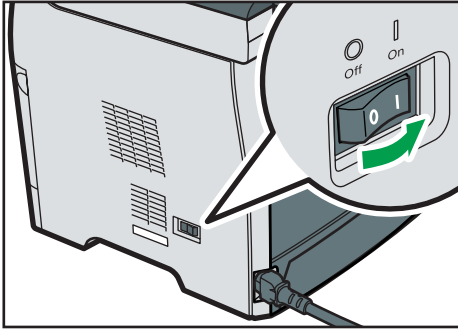

CMF027

Where to Inquire

Contact your sales or service representative for further information about topics covered in this manual or to inquire about topics not covered in this manual.

Consumables

CAUTION

- Our products are engineered to meet high standards of quality and functionality, and we recommend that you use only the expendable supplies available at an authorized dealer.

Print Cartridge

Print cartridge	Average printable number of pages per cartridge ^{*1}
Black	2,500 pages, 5,000 pages

*1 The printable number of pages is based on pages that are compliant with ISO/IEC 19752 and the image density set as the factory default. ISO/IEC 19752 is an international standard on measurement of printable pages, set by the International Organization for Standardization.

Note

- If print cartridge is not changed when necessary, printing will become impossible. For easy replacement, we recommend you purchase and store extra print cartridges.
- The actual number of printable pages varies depending on the image volume and density, number of pages printed at a time, paper type and paper size used, and environmental conditions such as temperature and humidity.
- Print cartridge may need to be changed sooner than indicated above due to deterioration over the period of use.
- Print cartridge (consumable) is not covered by warranty. However, if there is a problem, contact the store where they were purchased.
- When you first use this machine, use the print cartridge packaged with the machine.
- The supplied cartridge is good for approximately 1,500 pages.

11. Appendix

Functions and Network Settings Available in an IPv6 Environment

The functions and network settings of this machine that are available in an IPv6 environment differ from those available in an IPv4 environment. Make sure the functions you use are supported in an IPv6 environment, and then configure the necessary network settings.

Reference

- For details about specifying the IPv6 settings, see p.287 "Network Settings" or p.330 "Configuring the Network Settings".

Available Functions

Print via FTP

Prints documents via FTP using the EPRT and EPSV commands. Windows Vista/7 and an FTP application that supports IPv6 are required to use these commands.

Printer

Prints documents using the printer driver.

Scan to FTP

Delivers files that have been scanned using the control panel to an FTP server.

Scan to E-mail

Sends files scanned using the control panel via e-mail.

Scan to Folder

Sends files scanned using the control panel to a shared folder on a computer on the network.

This function is not available on Mac OS X.

Network TWAIN Server

Controls the scanning function from a computer on the network, and delivers scanned data to the computer directly. This function is available only to computers that have a TWAIN-supporting application. The IP address of the multi-cast group supported by IPv6 is ff12::fb88:1.

Bonjour

Allows the machine to communicate with Bonjour protocol-supported computers on the network. The IP address of the multi-cast group supported by IPv6 is ff02::fb.

LAN-Fax

Sends a document created in an application as a fax and without printing it.

Web Image Monitor

Allows you to check the machine's status and configure its settings using a Web browser.

Configuration Page

Prints a configuration page that shows you the machine's configuration, IP address, and other details.

Internet Fax

Transmission and reception of Internet Faxes.

Transmission Using IPsec

For securer communications, this machine supports the IPsec protocol. When applied, IPsec encrypts data packets at the network layer using shared key encryption. The machine uses encryption key exchange to create a shared key for both sender and receiver. To achieve even higher security, you can also renew the shared key on a validity period basis.

★ Important

- IPsec is not applied to data obtained through DHCP, DNS, or WINS.
- IPsec compatible operating systems are Windows XP SP2, Windows Vista/7, Windows Server 2003/2003 R2/2008/2008 R2, Mac OS X 10.4.8 and later, Red Hat Enterprise Linux WS 4.0, and Solaris 10. However, some setting items are not supported depending on the operating system. Make sure the IPsec settings you specify are consistent with the operating system's IPsec settings.
- If you cannot access Web Image Monitor due to IPsec configuration problems, disable IPsec under [Admin. Tools] on the control panel, and then access Web Image Monitor.

E Reference

- For details about specifying the IPsec settings using Web Image Monitor, see p.345 "Configuring the IPsec Settings".
- For details about enabling and disabling IPsec using the control panel, see p.438 "Enabling and Disabling IPsec Using the Control Panel".

Encryption and Authentication by IPsec

IPsec consists of two main functions: the encryption function, which ensures the confidentiality of data, and the authentication function, which verifies the sender of the data and the data's integrity. This machine's IPsec function supports two security protocols: the ESP protocol, which enables both of the IPsec functions at the same time, and the AH protocol, which enables only the authentication function.

ESP Protocol

The ESP protocol provides secure transmission through both encryption and authentication. This protocol does not provide header authentication.

- For successful encryption, both the sender and receiver must specify the same encryption algorithm and encryption key. The encryption algorithm and encryption key are specified automatically.
- For successful authentication, the sender and receiver must specify the same authentication algorithm and authentication key. The authentication algorithm and authentication key are specified automatically.

AH Protocol

The AH protocol provides secure transmission through authentication of packets only, including headers.

- For successful authentication, the sender and receiver must specify the same authentication algorithm and authentication key. The authentication algorithm and authentication key are specified automatically.

AH Protocol + ESP Protocol

When combined, the ESP and AH protocols provide secure transmission through both encryption and authentication. These protocols provide header authentication.

- For successful encryption, both the sender and receiver must specify the same encryption algorithm and encryption key. The encryption algorithm and encryption key are specified automatically.
- For successful authentication, the sender and receiver must specify the same authentication algorithm and authentication key. The authentication algorithm and authentication key are specified automatically.

↓ Note

- Some operating systems use the term "Compliance" in place of "Authentication".

Security Association

This machine uses encryption key exchange as the key setting method. With this method, agreements such as the IPsec algorithm and key must be specified for both sender and receiver. Such agreements form what is known as an SA (Security Association). IPsec communication is possible only if the receiver's and sender's SA settings are identical.

The SA settings are auto configured on both parties' machines. However, before the IPsec SA can be established, the ISAKMP SA (Phase 1) settings must be auto configured. When this is done, the IPsec SA (Phase 2) settings, which allow actual IPsec transmission, will be auto configured.

Also, for further security, the SA can be periodically auto updated by applying a validity period (time limit) for its settings. This machine only supports IKEv1 for encryption key exchange.

Multiple settings can be configured in the SA.

Settings 1-10

You can configure ten separate sets of SA details (such as different shared keys and IPsec algorithms).

IPsec policies are searched through one by one, starting at [No.1].

Encryption Key Exchange Settings Configuration Flow

This section explains the procedure for specifying encryption key exchange settings.

Machine	PC
1. Set the IPsec settings on Web Image Monitor.	1. Set the same IPsec settings as the machine on PC.
2. Enable IPsec settings.	2. Enable IPsec settings.
3. Confirm IPsec transmission.	

Note

- After configuring IPsec, you can use "ping" command to check if the connection is established correctly. Because the response is slow during initial key exchange, it may take some time to confirm that transmission has been established.
- If you cannot access Web Image Monitor due to IPsec configuration problems, disable IPsec on the control panel, and then access Web Image Monitor.

Reference

- For details about disabling IPsec using the control panel, see p.438 "Enabling and Disabling IPsec Using the Control Panel".

Specifying Encryption Key Exchange Settings

1. Start the Web browser, and access the machine by entering its IP address.
2. Click [IPsec Settings].
3. Click the [IPsec Policy List] tab.
4. Select the number of the setting you want to modify in the list, and then click [Change].
5. Modify the IPsec related settings as necessary.
6. Enter the administrator password, and then click [Apply].
7. Click the [IPsec Global Settings] tab, and then select [Active] in [IPsec Function].
8. If necessary, specify [Default Policy], [Broadcast and Multicast Bypass], and [All ICMP Bypass] also.
9. Enter the administrator password, and then click [Apply].

Specifying IPsec Settings on the Computer

Specify exactly the same settings for IPsec SA settings on your computer as are specified for the IPsec Settings on the machine. Setting methods differ according to the computer's operating system. The following procedure is based on Windows 7 in an IPv4 environment as an example.

1. On the [Start] menu, click [Control Panel], [System and Security], and then click [Administrative Tools].
2. Double-click [Local Security Policy], and then click [IP Security Policies on Local Computer].
3. In the "Action" menu, click [Create IP Security Policy...].

The IP Security Policy Wizard appears.

4. Click [Next].
5. Enter a security policy name in "Name", and then click [Next].
6. Clear the "Activate the default response rule (earlier versions of Windows only)." check box, and then click [Next].
7. Select "Edit properties", and then click [Finish].
8. In the "General" tab, click [Settings...].
9. In "Authenticate and generate a new key after every", enter the same validity period (in minutes) that is specified on the machine in [IKE Life Time], and then click [Methods...].
10. Confirm that the Encryption Algorithm ("Encryption"), Hash Algorithm ("Integrity"), and IKE Diffie-Hellman Group ("Diffie-Hellman Group") settings in "Security method preference order" all match those specified on the machine in [IKE Settings].
If the settings are not displayed, click [Add...].
11. Click [OK] twice.
12. Click [Add...] in the "Rules" tab.
The Security Rule Wizard appears.
13. Click [Next].
14. Select "This rule does not specify a tunnel", and then click [Next].
15. Select the type of network for IPsec, and then click [Next].
16. Click [Add...] in the IP Filter List.
17. In [Name], enter an IP Filter name, and then click [Add...].
The IP Filter Wizard appears.
18. Click [Next].

19. In [Description:], enter a name or a detailed explanation of the IP filter, and then click [Next].

You may click [Next] and proceed to the next step without entering any information in this field.

20. Select "My IP Address" in "Source address", and then click [Next].
21. Select "A specific IP Address or Subnet" in "Destination address", enter the machine's IP address, and then click [Next].
22. For the IPsec protocol type, select "Any", and then click [Next].
23. Click [Finish], and then click [OK].
24. Select the IP filter that you have just created, and then click [Next].
25. Click [Add...] in the Filter Action.

The Filter Action Wizard appears.

26. Click [Next].
27. In [Name], enter a Filter Action name, and then click [Next].
28. Select "Negotiate security", and then click [Next].
29. Select one of options for computers allowed to communicate with, and then click [Next].
30. Select "Custom" and click [Settings...].
31. When [ESP] is selected for the machine in [Security Protocol] under [IPsec Settings], select [Data integrity and encryption (ESP)], and configure the following settings:

Set the value of [Integrity algorithm] to the same value as the [Authentication Algorithm for ESP] specified on the machine.

Set the value of [Encryption algorithm] to the same value as the [Encryption Algorithm for ESP] specified on the machine.

32. When [AH] is selected for the machine in [Security Protocol] under [IPsec Settings], select [Data and address integrity without encryption (AH)], and configure the following settings:

Set the value of [Integrity algorithm] to the same value as the [Authentication Algorithm for AH] specified on the machine.

Clear the [Data integrity and encryption (ESP)] check box.

33. When [ESP&AH] is selected for the machine in [Security Protocol] under [IPsec Settings], select [Data and address integrity without encryption (AH)], and configure the following settings:

Set the value of [Integrity algorithm] under [Data and address integrity without encryption (AH)] to the same value as [Authentication Algorithm for AH] specified on the machine.

Set the value of [Encryption algorithm] under [Data integrity and encryption (ESP)] to the same value as [Encryption Algorithm for ESP] specified on the machine.

34. In the **Session key settings**, select **"Generate a new key every"**, and enter the same validity period (in seconds or Kbytes) as that specified for **[Life Time]** on the machine.
35. Click **[OK]**, and then click **[Next]**.
36. Click **[Finish]**.

If you are using IPv6 under Windows Vista or a newer version of Windows, you must repeat this procedure from step 12 and specify ICMPv6 as an exception. When you reach step 22, select [58] as the protocol number for the "Other" target protocol type, and then set **[Negotiate security]** to **[Permit]**.

37. Select the filter action that you have just created, and then click **[Next]**.
38. Select one of options for an authentication method, and then click **[Next]**.
39. Click **[Finish]**, and then click **[OK]** twice.

The new IP security policy (IPsec settings) is specified.

40. Select the security policy that you have just created, right click on it, and then click **[Assign]**.

IPsec settings on the computer are enabled.

↓ Note

- To disable the computer's IPsec settings, select the security policy, right click, and then click **[Unassign]**.

Enabling and Disabling IPsec Using the Control Panel

1. Press the **[User Tools]** key.
2. Press the **[^][▼]** key to select **[Admin. Tools]**, and then press the **[OK]** key.
3. If you are requested to enter a password, enter the password using the number keys, and then press the **[OK]** key.
4. Press the **[^][▼]** keys to select **[IPsec]**, and then press the **[OK]** key.
5. Press the **[^][▼]** keys to select **[Active]** or **[Inactive]**, and then press the **[OK]** key.
6. Press the **[Clear/Stop]** key to return to the initial screen.

↓ Note

- A password for accessing the **[Admin. Tools]** menu can be specified in **[Admin. Tools Lock]**.
- You can press the **[Escape]** key to exit to the previous level of the menu tree.

📖 Reference

- For details about **[Admin. Tools Lock]**, see p.298 "Administrator Settings".

Using the LDAP Authentication and Address Search Functions

By configuring the LDAP settings, you will be able to use the LDAP authentication and address search functions.

LDAP authentication

LDAP authentication enables you to prevent unauthorized access to the machine, by limiting its use to users who can log in to the machine with correct login user names and passwords.

The table below shows the functions that require users to log in and functions that will be disabled under LDAP authentication.

Function	Details
<ul style="list-style-type: none"> Entering the [User Tools] menu 	<p>Without logging in, users can only check supplies status. The user must log in to the machine from the control panel.</p>
<ul style="list-style-type: none"> Copier function Scanner function Fax function 	<p>No operation is possible without logging in. The user must log in to the machine from the control panel.</p>
<ul style="list-style-type: none"> Printing (using the PCL6 printer driver) Sending faxes via LAN-Fax TWAIN scanning 	<p>No job will be processed without logging in. The user must log in to the machine from the printer, LAN-Fax, or TWAIN driver.</p>
<ul style="list-style-type: none"> Printing (using the PostScript 3 printer driver) WIA scanning 	<p>Will be disabled at all times.</p>

LDAP address search

LDAP address search allows you to retrieve addresses from the server when using the scanner or fax functions.

Note

- LDAP authentication and user restriction settings can be used in combination, except for printing using the PCL6 printer driver and sending LAN-Faxes. Under LDAP authentication, users will only be able to authenticate for PCL6 printing and LAN-Faxes using user names and passwords for the LDAP server, not user codes for the user restriction settings.

Reference

- For details about how to log in to the machine when LDAP authentication is specified, see p.444 "When LDAP Authentication is Specified".
- For details about supplies status information, see p.279 "System Settings".
- For details about user restriction settings, see p.125 "Restricting Machine Functions According to User".

Programming the LDAP Server

This section describes how to specify the LDAP server settings.

Use Web Image Monitor to program the LDAP server settings.

Operational requirements

To program the LDAP server settings, the following requirements must be met:

- The network configuration must allow the machine to detect the presence of the LDAP server.
- When SSL is being used, TLSv1 or SSLv2 can function on the LDAP server.
- The LDAP server must be registered in the machine.
- This machine does not support LDAPv2.

Reference

- For details about individual items related to LDAP server settings, see p.341 "Configuring the LDAP Server Settings".

Programming the LDAP server

This section describes how to program the LDAP server.

Important

- Enter the user's login user name using up to 128 characters, and then enter the user's login password using up to 128 characters.

1. Start the Web browser, and access the machine by entering its IP address.

2. Click [LDAP Settings].

3. Under "LDAP Authentication", select [Active] for [Authentication] to enable LDAP authentication.

If necessary, also configure [Auto Logout Time (seconds)].

4. Enter the administrator password if required.

5. Click [Apply].

6. Click [Program/Change/Delete LDAP Server].

	LDAP Server	Identification Name
<input type="radio"/>	1	Not Programmed
<input type="radio"/>	2	Not Programmed
<input type="radio"/>	3	Not Programmed
<input type="radio"/>	4	Not Programmed
<input type="radio"/>	5	Not Programmed

7. Select [Active] for [LDAP Search] to enable LDAP address search.

If necessary, also configure [LDAP Search Timeout].

8. Under "Program/Change/Delete", select the LDAP server you want to configure, and then click [Change].

"Edit LDAP Server" page appears.

9. Enter the server's name in [Identification Name (Required)].

10. Enter the server's host name or IP address in [Server Name (Required)].

11. Enter the position within the LDAP directory's structure from which to start user searches in [Search Base (Required)].

For example, if the search target is the sales department of ABC company, enter "dc=sales department, o=ABC". (In this example, the description is for an active directory. "dc" is for the organization unit, and "o" is for the company.)

Search base registration may be required depending on your server environment. When registration is required, unspecified searches will result in error.

Check your server environment and enter any required specifications.

12. Enter the port number used to connect to the LDAP server in [Port Number (Required)].

Specify a port according to your environment.

13. Select whether or not to use SSL with the LDAP server in [SSL].

Select [SSL] to encrypt communication between the machine and LDAP server; select [Inactive] for communication without encryption.

The port number will automatically change depending on this setting: it will be 389 when set to [None], or 636 when set to [SSL].

14. Select the authentication method in [Authentication].

Authentication setting must comply with your server's authentication settings. Check your server settings before setting this machine.

If you select [Active], authentication is Cleartext, in which a password is sent to the LDAP server without any encryption processing.

If you select [High Security], authentication is CRAM-MD5.

If [Active] or [High Security] is selected, you must proceed to the next steps to set [Login Name Attribute], [User Name (Optional)], and [Password (Optional)].

15. Enter the user name prefix or login name attribute of Bind DN, such as "uid" or "cn" in [Login Name Attribute].

The attribute value may change depending on the server environment.

16. Enter the user name to log in to the LDAP server in [User Name (Optional)].

17. Enter the password to log in to the LDAP server in [Password (Optional)].

18. Select the character code the LDAP server uses for [Japanese Character Code Set (Required)].

19. Click the [Start] button for connection test.

Access the LDAP server to check that the proper connection is established. Check authentication works according to the authentication settings.

20. Confirm the result of the connection test.

If the connection test fails, check your settings and try again.

This function does not check search conditions or the search base.

21. Under "Search Conditions", enter an attribute type by which the user can be distinguished in the following: [Identification Name (Required)], [Email Address (Required)], [Fax Number (Required)], [Company Name (Required)], and [Department Name (Required)].

You can enter an attribute as a typical search keyword. Using the entered attribute, the function searches the LDAP server's Address Book.

22. Under "Search Options", enter an attribute type by which the user can be distinguished in [Attribute (Optional)].

The attribute value may change depending on the server environment.

23. Enter the name shown on the machine's control panel, which is used for LDAP search to search a user based on the attribute type specified in [Attribute (Optional)], in [Key Display (Optional)].
24. Enter the administrator password if required.
25. Click [Apply].
26. Close the Web browser.

Changing the LDAP server

This section describes how to change the programmed LDAP server.

1. Start the Web browser, and access the machine by entering its IP address.
2. Click [LDAP Settings].
3. Click [Program/Change/Delete LDAP Server].
4. Under "Program/Change/Delete", select the LDAP server you want to change, and then click [Change].

"Edit LDAP Server" page appears.

5. Change the settings as necessary.
6. Enter the administrator password if required.
7. Click [Apply].
8. Close the Web browser.

Deleting the LDAP server

This section describes how to delete the programmed LDAP server.

1. Start the Web browser, and access the machine by entering its IP address.
2. Click [LDAP Settings].
3. Click [Program/Change/Delete LDAP Server].
4. Under "Program/Change/Delete", select the LDAP server you want to delete, and then click [Delete].

Current configuration of the selected LDAP server appears.

5. Enter the administrator password if required.
6. Click [Apply].

7. Close the Web browser.

When LDAP Authentication is Specified

When LDAP authentication is specified, only the users who can log in to the machine with correct user name and password can use the machine.

If you want to enter the [User Tools] menu or use the copier, scanner, or fax functions, you must enter a valid user name and password to log in to the machine. When you are finished with using the machine, be sure to log out to prevent unauthorized users from using the machine.

If you want to print using the PCL6 printer driver, send LAN-Faxes, or perform TWAIN scanning, you must log in to the machine through respective drivers.

Note

- If [Auto Logout Time (seconds)] under LDAP settings is specified with Web Image Monitor, the machine automatically logs you off if you do not use the control panel within a given time.
- You will not need to log out from the machine if you logged in through printer, LAN-Fax, or TWAIN driver.
- Under LDAP authentication, PostScript 3 printing and WIA scanning will always be disabled.

Reference

- For details about [Auto Logout Time (seconds)], see p.341 "Configuring the LDAP Authentication Settings".

Logging in using the control panel

Use the following procedure to log in to the machine using the control panel.

1. In [User Name:], enter the user name (up to 128 characters).
2. Press the [▲][▼] keys to select [Password:], and then enter the password using the number keys (up to 128 characters).
3. Press the [OK] key.

If authentication is successful, the initial screen of the priority function will be displayed.

Reference

- For details about entering characters, see p.123 "Entering Characters".

Logging out using the control panel

When you are finished with using the machine, be sure to log out to prevent unauthorized users from using the machine.

1. Press [Logout] in the standby screen.
2. Press [Yes].

Logging in using the printer, LAN-Fax, TWAIN driver

When LDAP authentication is specified, make sure the user authentication settings are made on the printer, LAN-Fax, or TWAIN driver.

★ Important

- To configure printer or LAN-Fax driver's default settings, log on using an account that has Manage Printers permission. Members of the Administrators group have Manage Printers permission by default.
- You cannot change the printer or LAN-Fax driver's default settings for each user. Settings configured in the properties dialog box are applied to all users. Procedures and screens might vary depending on the operating system you are using.
- The following procedure is based on Windows 7 as an example. If you are using another operating system, the procedure might vary slightly.
- You can log in to the machine through the TWAIN driver only when using a computer running a Windows operating system.

PCL6 printer driver, LAN-Fax driver

1. On the [Start] menu, click [Devices and Printers].
2. Right click the icon of the printer you want to use, and then click [Printer properties].
3. Click the [Advanced Options] tab.
4. Select the [User Authentication] (PCL6 printer driver) or [User authentication] (LAN-Fax driver) check box.
5. Click [Apply].
6. Click the [General] tab, and then click [Preferences...].
7. Click [Authentication...] on the [Valid Access] tab (PCL6 printer driver) or [Authentication] (LAN-Fax driver).
8. In a dialog box that appears, enter the login user name (up to 128 characters) and login password (up to 128 characters).

With the PCL6 printer driver, you need to enter the same password for confirmation.

9. Click [OK] three times.

TWAIN driver

1. Perform the scanning operation.

2. In a dialog box that appears, enter the login user name (up to 128 characters) and login password (up to 128 characters).
3. Click [OK].

Reference

- For details about TWAIN scanning operation, see p.195 "Scanning from a Computer".

Specifying the LDAP Address Search Conditions

LDAP address search allows you to retrieve addresses from the server when using the scanner or fax functions.

To search for specific destinations from the programmed LDAP servers, you can configure search conditions using the control panel.

Important

- To configure the search conditions, [LDAP Search] must be enabled under the LDAP server settings of Web Image Monitor.

1. Press the [Scanner] key or [Facsimile] key.

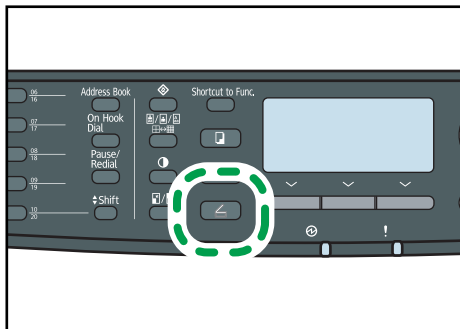

CMF132

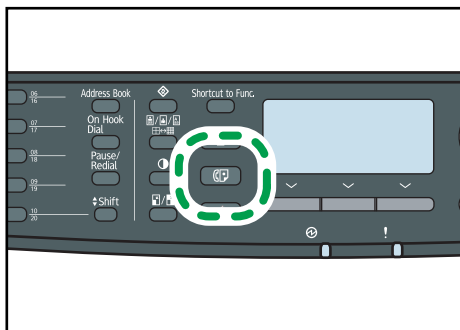

CMF133

2. Press the [Address Book] key.

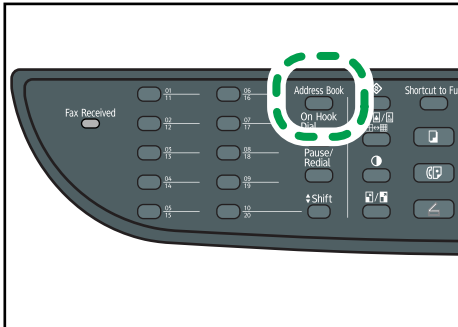

CMF140

3. Press the [▲][▼] keys to select [Search LDAP], and then press the [OK] key.
4. To select a specific LDAP server, press the [▲][▼] keys to select [Select Server], and then press the [OK] key.
5. Press the [▲][▼] keys to select the desired LDAP server, and then press the [OK] key.
6. To specify specific search conditions, press the [▲][▼] keys to select [Search Condition], and then press the [OK] key.
7. Press the [▲][▼] keys to scroll through the list of search options, press [▶] to select the desired item, and then press the [OK] key.

You can select [Identification Name], [Email Address], [Fax Number], [Company Name], [Department Name], or any other item you have defined in [Key Display (Optional)] under "Search Options" using Web Image Monitor.

To deselect a search option, press [▶] again.

8. Enter a string of characters that will be used for searching using the number keys, and then press the [OK] key.
9. Press the [▲][▼][◀][▶] keys to select the search criteria, and then press the [OK] key.
 - [Include]: Search for strings that include the specified string.
Example: To search for "ABC", enter "A", "B", or "C".
 - [First Word]: Search for strings that start with the specified string.
Example: To search for "ABC", enter "A".
 - [Exact Match]: Search for strings that fully match the specified string.
Example: To search for "ABC", enter "ABC".
 - [Exclude]: Search for strings that do not include the specified string.
Example: To search for "ABC", enter "D".
 - [Last Word]: Search for strings that end with the specified string.
Example: To search for "ABC", enter "C".
 - [Fuzzy Search]: Search for strings that are close to the specified string.

The result of fuzzy search depends on the search method implemented in the LDAP server.

To specify more search options, return to step 7.

10. Press the [User Tools] key to return to the initial screen.

Note

- If you perform LDAP address search without any specific search conditions, the search result will contain all destinations registered in the LDAP servers.

Reference

- For details about entering characters, see p.123 "Entering Characters".
- For details about LDAP server settings of Web Image Monitor, see p.341 "Configuring the LDAP Server Settings".

Specifications of the Machine

This section lists the machine's specifications.

General Function Specifications

Configuration

Desktop

Print process

Laser electrostatic transfer

Maximum paper size for scanning

- Exposure glass
A4, Letter (8¹/₂ " × 11 ")
- ARDF/ADF
Legal (8¹/₂ " × 14 ")

Maximum paper size for printing

Legal (8¹/₂ " × 14 ")

Warm-up time

Less than 30 seconds (23 °C, 71.6 °F)

Paper sizes

- Standard paper sizes
A4, B5 JIS, A5, A6, Legal (8¹/₂ " × 14 "), Letter (8¹/₂ " × 11 "), Half Letter (5¹/₂ " × 8¹/₂ "), Executive (7¹/₄ " × 10¹/₂ "), 8 " × 13 ", B6 JIS, 8¹/₂ " × 13 ", Folio (8¹/₄ " × 13 "), 16K (195 × 267 mm), Com 10 (4¹/₈ " × 9¹/₂ "), Monarch (3⁷/₈ " × 7¹/₂ "), C5 Env (162 × 229 mm), C6 Env (114 × 162 mm), DL Env (110 × 220 mm)
- Custom size
 - Tray 1
100 to 216 mm (3.94 to 8.50 inches) in width, 148 to 356 mm (5.83 to 14.02 inches) in length
 - Bypass Tray
90 to 216 mm (3.54 to 8.50 inches) in width, 140 to 356 mm (5.51 to 14.02 inches) in length
- Duplex supported paper sizes
A4, Legal (8¹/₂ " × 14 "), Letter (8¹/₂ " × 11 ")

Paper output capacity (80 g/m², 20 lb.)

Standard 125 sheets

Paper input capacity (80 g/m², 20 lb.)

- Tray 1
250 sheets
- Tray 2 (option)
250 sheets
- Bypass tray
50 sheets

ARDF/ADF capacity (80 g/m², 20 lb.)

- ARDF
50 sheets
- ADF
35 sheets



Paper weight

- Tray 1
52 to 162 g/m² (14 to 43.1 lb.)
- Tray 2 (option)
60 to 105 g/m² (16.0 to 28.0 lb.)
- Bypass tray
52 to 162 g/m² (14 to 43.1 lb.)



Memory

128 MB

Power requirements

-  **Region A**
220-240 V, 5 A, 50/60 Hz (when fully equipped)
-  **Region B**
120 V, 10 A, 60 Hz (when fully equipped)

Power consumption

- Maximum power consumption
 **Region A**: 895 W
 **Region B**: 850 W
- Energy Saver mode 1

70 W

- Energy Saver mode 2

10 W

Machine dimensions (Width × Depth × Height)

- Type 2 model

420 × 397 × 463 ^{*1} mm (16.6 × 15.7 × 18.3 ^{*1} inches)

- Type 1 model

420 × 397 × 442 ^{*1} mm (16.6 × 15.7 × 17.4 ^{*1} inches)

*1 If tray 2 is installed, the height increases by 89 mm (3.5 inches).

Weight (machine body with consumables)

- Type 2 model

Approximately 18.4 kg (40.6 lb.)

- Type 1 model

Approximately 16.9 kg (37.3 lb.)

Printer Function Specifications

Printing speed (600 dpi)

28 pages per minute (A4)/30 pages per minute (Letter)

Resolution

600 dpi (Maximum: 1200 × 1200 dpi)

First print speed

8 seconds or less (A4/Letter, 600 × 600 dpi)

Interface

- Ethernet (10BASE-T, 100BASE-TX)
- USB 2.0

Printer language

PCL6, PostScript 3

Fonts

80 fonts

Network protocol

TCP/IP, IPP

Copier Function Specifications

Maximum resolution (scanning and printing)

- Exposure glass
Scanning: 600 × 600 dpi
Printing: 600 × 600 dpi
- ARDF/ADF
Scanning: 600 × 300 dpi
Printing: 600 × 600 dpi

Gradation

Scanning: 256 levels (1 dot)
Printing: Two-value (1 dot)



First copy speed (A4/Letter, at 25 °C, 77 °F)

12 seconds or less

Multiple copy speed

28 pages per minute

Reproduction ratio

-  **Region A**
Fixed ratio: 50%, 71%, 82%, 93%, 122%, 141%, 200%, 400%
Zoom ratio: 25 to 400% (600 × 300 dpi, 600 × 600 dpi)
-  **Region B**
Fixed ratio: 50%, 65%, 78%, 93%, 129%, 155%, 200%, 400%
Zoom ratio: 25 to 400% (600 × 300 dpi, 600 × 600 dpi)

Copy quantity

99

Scanner Function Specifications

Maximum scanning area (horizontal × vertical)

- Exposure glass
216 × 297 mm (8.5 × 11.7 inches)
- ARDF/ADF
216 × 356 mm (8.5 × 14.1 inches)

Maximum resolution when scanning from the control panel (Scan to E-mail, Scan to FTP, Scan to Folder, Scan to USB)

- Exposure glass
600 × 600 dpi
- ARDF/ADF
600 × 600 dpi

Maximum resolution when scanning from a computer (TWAIN)

- Exposure glass
19200 × 19200 dpi
- ARDF/ADF
600 × 600 dpi

Maximum resolution when scanning from a computer (WIA)

- Exposure glass
600 × 600 dpi
- ARDF/ADF
600 × 600 dpi

Gradation

Input: 16 bit color processing

Output: 8 bit color processing

Scanning time (600 dpi)

Black and white: 5 seconds or less

Color: 10 seconds or less

Not including transfer time.

ARDF/ADF throughput (300 dpi)

Black and white: 120 mm per second

Color: 60 mm per second

Interface

- Scanning from the control panel
Ethernet (10BASE-T, 100BASE-TX), USB2.0 (Scan to USB)
- Scanning from a computer
Ethernet (10BASE-T, 100BASE-TX), USB 2.0

Sendable file formats

TIFF, JPEG, PDF

Address book

Maximum 100 items

Number of redials: 1

Fax Function Specifications

Fax transmission and reception

Access line

- Public switched telephone networks (PSTN)
- Private branch exchange (PBX)

Transmission mode

ITU-T Group 3 (G3)

Scan line density

8 dots per mm × 3.85 line per mm (200 × 100 dpi)

8 dots per mm × 7.7 line per mm (200 × 200 dpi)

Transmission time

3–4 seconds (8 dots per mm × 3.85 line per mm, 33.6 kbps, MMR, ITU-T # 1 chart)

Transfer rate

33.6 kbps to 2400 bps (auto shift down system)

Data compression method

MH, MR, MMR, JBIG

Memory capacity

More than 100 sheets (8 dots per mm × 3.85 line per mm)

Address book

- Speed dial
200 items
- Quick dial
20 items
- Number of redials for Fax
1

Internet Fax transmission and reception

Interface

Ethernet (10BASE-T, 100BASE-TX)

Communication protocols

- Transmission
SMTP, TCP/IP
- Reception
POP3, TCP/IP

Transmission function

E-mail

E-mail format

Single/Multi-part, MIME Conversion

Attached file forms (transmission): TIFF-S (MH encoding)

Attached file forms (reception): TIFF-S/TIFF-F (MH/MR/MMR encoding)

Authentication method

SMTP-AUTH, POP before SMTP, A-POP

Original size

A4 (Length is up to 356 mm)

Scan line density

8 dots per mm × 3.85 line per mm (200 × 100 dpi)

8 dots per mm × 7.7 line per mm (200 × 200 dpi)

Destination machine specifications

- Communication protocols
 - Transmission
SMTP, TCP/IP
 - Reception
POP3, TCP/IP
- E-mail format
 - Format
MIME, Base64
 - Content-Type
Image/tiff
Multipart/mixed (text/plain, Image/tiff (attached file forms))

- Data format
 - Profile
TIFF-S
 - Encoding
MH
 - Original size
A4
 - Resolution (dpi)
200 × 100, 200 × 200

Specifications of Options

This section lists the specifications of the various options.

Paper Feed Unit TK1080

Paper capacity

250 sheets

Paper size

A4, B5 JIS, A5, Legal ($8\frac{1}{2}$ " \times 14"), Letter ($8\frac{1}{2}$ " \times 11"), Half Letter ($5\frac{1}{2}$ " \times $8\frac{1}{2}$ ")

Dimensions (Width \times Depth \times Height)

420 \times 397 \times 89 mm (16.6 \times 15.6 \times 3.5 inches)

Paper weight

60 to 105 g/m² (16.0 to 28.0 lb.)

Weight

Less than 2.4 kg (5.3 lb.)

Electromagnetic Interference

If this machine is located close to another electronic device, both devices may malfunction due to electromagnetic interference.

Televisions and radios may produce noise if located too close to this machine. If this happens, do the following:

- Move the television or radio as far as possible from the machine.
- Change the position of the antenna of the television or radio.
- Use a different wall outlet on a different circuit.

Copyright Information about Installed Applications

expat

Copyright (c) 1998, 1999, 2000 Thai Open Source Software Centre, Ltd. and Clark Cooper.

Copyright (c) 2001, 2002 Expat maintainers.

Permission is hereby granted, free of charge, to any person obtaining a copy of this software and associated documentation files (the "Software"), to deal in the Software without restriction, including without limitation the rights to use, copy, modify, merge, publish, distribute, sublicense, and/or sell copies of the Software, and to permit persons to whom the Software is furnished to do so, subject to the following conditions:

The above copyright notice and this permission notice shall be included in all copies or substantial portions of the Software.

THE SOFTWARE IS PROVIDED "AS IS", WITHOUT WARRANTY OF ANY KIND, EXPRESS OR IMPLIED, INCLUDING BUT NOT LIMITED TO THE WARRANTIES OF MERCHANTABILITY, FITNESS FOR A PARTICULAR PURPOSE AND NONINFRINGEMENT. IN NO EVENT SHALL THE AUTHORS OR COPYRIGHT HOLDERS BE LIABLE FOR ANY CLAIM, DAMAGES OR OTHER LIABILITY, WHETHER IN AN ACTION OF CONTRACT, TORT OR OTHERWISE, ARISING FROM, OUT OF OR IN CONNECTION WITH THE SOFTWARE OR THE USE OR OTHER DEALINGS IN THE SOFTWARE.

JPEG LIBRARY

- The software installed on this product is based in part on the work of the Independent JPEG Group.

OpenLDAP 2.1

<http://www.openldap.org/software/download>

The OpenLDAP Public License

Version 2.8, 17 August 2003

Redistribution and use of this software and associated documentation ("Software"), with or without modification, are permitted provided that the following conditions are met:

1. Redistributions in source form must retain copyright statements and notices,
2. Redistributions in binary form must reproduce applicable copyright statements and notices, this list of conditions, and the following disclaimer in the documentation and/or other materials provided with the distribution, and

3. Redistributions must contain a verbatim copy of this document.

The OpenLDAP Foundation may revise this license from time to time.

Each revision is distinguished by a version number. You may use this Software under terms of this license revision or under the terms of any subsequent revision of the license.

THIS SOFTWARE IS PROVIDED BY THE OPENLDAP FOUNDATION AND ITS CONTRIBUTORS "AS IS" AND ANY EXPRESSED OR IMPLIED WARRANTIES, INCLUDING, BUT NOT LIMITED TO, THE IMPLIED WARRANTIES OF MERCHANTABILITY AND FITNESS FOR A PARTICULAR PURPOSE ARE DISCLAIMED. IN NO EVENT SHALL THE OPENLDAP FOUNDATION, ITS CONTRIBUTORS, OR THE AUTHOR(S) OR OWNER(S) OF THE SOFTWARE BE LIABLE FOR ANY DIRECT, INDIRECT, INCIDENTAL, SPECIAL, EXEMPLARY, OR CONSEQUENTIAL DAMAGES (INCLUDING, BUT NOT LIMITED TO, PROCUREMENT OF SUBSTITUTE GOODS OR SERVICES; LOSS OF USE, DATA, OR PROFITS; OR BUSINESS INTERRUPTION) HOWEVER CAUSED AND ON ANY THEORY OF LIABILITY, WHETHER IN CONTRACT, STRICT LIABILITY, OR TORT (INCLUDING NEGLIGENCE OR OTHERWISE) ARISING IN ANY WAY OUT OF THE USE OF THIS SOFTWARE, EVEN IF ADVISED OF THE POSSIBILITY OF SUCH DAMAGE.

The names of the authors and copyright holders must not be used in advertising or otherwise to promote the sale, use or other dealing in this Software without specific, written prior permission. Title to copyright in this Software shall at all times remain with copyright holders.

OpenLDAP is a registered trademark of the OpenLDAP Foundation.

Copyright 1999-2003 The OpenLDAP Foundation, Redwood City, California, USA.

All Rights Reserved.

Permission to copy and distribute verbatim copies of this document is granted.

OpenSSL 0.9.8g

<http://www.openssl.org/source>

LICENSE ISSUES

The OpenSSL toolkit stays under a dual license, i.e. both the conditions of the OpenSSL License and the original SSLeay license apply to the toolkit. See below for the actual license texts. Actually both licenses are BSD-style Open Source licenses. In case of any license issues related to OpenSSL please contact openssl-core@openssl.org.

OpenSSL License

Copyright (c) 1998-2011 The OpenSSL Project. All rights reserved.

Redistribution and use in source and binary forms, with or without modification, are permitted provided that the following conditions are met:

1. Redistributions of source code must retain the above copyright notice, this list of conditions and the following disclaimer.

2. Redistributions in binary form must reproduce the above copyright notice, this list of conditions and the following disclaimer in the documentation and/or other materials provided with the distribution.
3. All advertising materials mentioning features or use of this software must display the following acknowledgment:
 "This product includes software developed by the OpenSSL Project for use in the OpenSSL Toolkit. (<http://www.openssl.org/>)"
4. The names "OpenSSL Toolkit" and "OpenSSL Project" must not be used to endorse or promote products derived from this software without prior written permission. For written permission, please contact openssl-core@openssl.org.
5. Products derived from this software may not be called "OpenSSL" nor may "OpenSSL" appear in their names without prior written permission of the OpenSSL Project.
6. Redistributions of any form whatsoever must retain the following acknowledgment:
 "This product includes software developed by the OpenSSL Project for use in the OpenSSL Toolkit (<http://www.openssl.org/>)"

THIS SOFTWARE IS PROVIDED BY THE OpenSSL PROJECT "AS IS" AND ANY EXPRESSED OR IMPLIED WARRANTIES, INCLUDING, BUT NOT LIMITED TO, THE IMPLIED WARRANTIES OF MERCHANTABILITY AND FITNESS FOR A PARTICULAR PURPOSE ARE DISCLAIMED. IN NO EVENT SHALL THE OpenSSL PROJECT OR ITS CONTRIBUTORS BE LIABLE FOR ANY DIRECT, INDIRECT, INCIDENTAL, SPECIAL, EXEMPLARY, OR CONSEQUENTIAL DAMAGES (INCLUDING, BUT NOT LIMITED TO, PROCUREMENT OF SUBSTITUTE GOODS OR SERVICES; LOSS OF USE, DATA, OR PROFITS; OR BUSINESS INTERRUPTION) HOWEVER CAUSED AND ON ANY THEORY OF LIABILITY, WHETHER IN CONTRACT, STRICT LIABILITY, OR TORT (INCLUDING NEGLIGENCE OR OTHERWISE) ARISING IN ANY WAY OUT OF THE USE OF THIS SOFTWARE, EVEN IF ADVISED OF THE POSSIBILITY OF SUCH DAMAGE.

This product includes cryptographic software written by Eric Young (ey@cryptsoft.com).

This product includes software written by Tim Hudson (tjh@cryptsoft.com).

Original SSLeay License

Copyright (C) 1995-1998 Eric Young (ey@cryptsoft.com)

All rights reserved.

This package is an SSL implementation written by Eric Young (ey@cryptsoft.com).

The implementation was written so as to conform with Netscapes SSL.

This library is free for commercial and non-commercial use as long as the following conditions are aheared to. The following conditions apply to all code found in this distribution, be it the RC4, RSA, lhash, DES, etc., code; not just the SSL code. The SSL documentation included with this distribution is covered by the same copyright terms except that the holder is Tim Hudson (tjh@cryptsoft.com).

Copyright remains Eric Young's, and as such any Copyright notices in the code are not to be removed.

If this package is used in a product, Eric Young should be given attribution as the author of the parts of the library used.

This can be in the form of a textual message at program startup or in documentation (online or textual) provided with the package.

Redistribution and use in source and binary forms, with or without modification, are permitted provided that the following conditions are met:

1. Redistributions of source code must retain the copyright notice, this list of conditions and the following disclaimer.
2. Redistributions in binary form must reproduce the above copyright notice, this list of conditions and the following disclaimer in the documentation and/or other materials provided with the distribution.
3. All advertising materials mentioning features or use of this software must display the following acknowledgement:

"This product includes cryptographic software written by Eric Young (eay@cryptsoft.com)"

The word 'cryptographic' can be left out if the routines from the library being used are not cryptographic related :-).

4. If you include any Windows specific code (or a derivative thereof) from the apps directory (application code) you must include an acknowledgement:

"This product includes software written by Tim Hudson (tjh@cryptsoft.com)"

THIS SOFTWARE IS PROVIDED BY ERIC YOUNG "AS IS" AND ANY EXPRESS OR IMPLIED WARRANTIES, INCLUDING, BUT NOT LIMITED TO, THE IMPLIED WARRANTIES OF MERCHANTABILITY AND FITNESS FOR A PARTICULAR PURPOSE ARE DISCLAIMED. IN NO EVENT SHALL THE AUTHOR OR CONTRIBUTORS BE LIABLE FOR ANY DIRECT, INDIRECT, INCIDENTAL, SPECIAL, EXEMPLARY, OR CONSEQUENTIAL DAMAGES (INCLUDING, BUT NOT LIMITED TO, PROCUREMENT OF SUBSTITUTE GOODS OR SERVICES; LOSS OF USE, DATA, OR PROFITS; OR BUSINESS INTERRUPTION) HOWEVER CAUSED AND ON ANY THEORY OF LIABILITY, WHETHER IN CONTRACT, STRICT LIABILITY, OR TORT (INCLUDING NEGLIGENCE OR OTHERWISE) ARISING IN ANY WAY OUT OF THE USE OF THIS SOFTWARE, EVEN IF ADVISED OF THE POSSIBILITY OF SUCH DAMAGE.

The licence and distribution terms for any publically available version or derivative of this code cannot be changed. i.e. this code cannot simply be copied and put under another distribution licence [including the GNU Public Licence.]

Trademarks

Adobe, Acrobat, PostScript, and Reader are either registered trademarks or trademarks of Adobe Systems Incorporated in the United States and/or other countries.

Apple, Bonjour, Macintosh, Mac OS, TrueType, and Safari are trademarks of Apple Inc., registered in the U.S. and other countries.

Firefox® is a registered trademark of the Mozilla Foundation.

Java is a registered trademark of Oracle and/or its affiliates.

LINUX® is the registered trademark of Linus Torvalds in the U.S. and other countries.

Microsoft®, Windows®, Windows Server®, Windows Vista®, and Internet Explorer® are either registered trademarks or trademarks of Microsoft Corporation in the United States and/or other countries.

PCL® is a registered trademark of Hewlett-Packard Company.

"Presto! PageManager" and "NewSoft" are trademarks and/or registered trademarks of NewSoft Technology Corporation subject to trademark protection of domestic trademark laws and international trademark conventions.

Red Hat is a registered trademark of Red Hat, Inc.

Other product names used herein are for identification purposes only and might be trademarks of their respective companies. We disclaim any and all rights to those marks.

The proper name of Internet Explorer 6 is Microsoft® Internet Explorer® 6.

The proper names of the Windows operating systems are as follows:

- The product names of Windows XP are as follows:
 - Microsoft® Windows® XP Professional Edition
 - Microsoft® Windows® XP Home Edition
 - Microsoft® Windows® XP Professional x64 Edition
- The product names of Windows Vista are as follows:
 - Microsoft® Windows Vista® Ultimate
 - Microsoft® Windows Vista® Business
 - Microsoft® Windows Vista® Home Premium
 - Microsoft® Windows Vista® Home Basic
 - Microsoft® Windows Vista® Enterprise
- The product names of Windows 7 are as follows:
 - Microsoft® Windows® 7 Starter
 - Microsoft® Windows® 7 Home Premium
 - Microsoft® Windows® 7 Professional

Microsoft® Windows® 7 Ultimate

Microsoft® Windows® 7 Enterprise

- The product names of Windows Server 2003 are as follows:

Microsoft® Windows Server® 2003 Standard Edition

Microsoft® Windows Server® 2003 Enterprise Edition

Microsoft® Windows Server® 2003 Web Edition

Microsoft® Windows Server® 2003 Datacenter Edition

- The product names of Windows Server 2003 R2 are as follows:

Microsoft® Windows Server® 2003 R2 Standard Edition

Microsoft® Windows Server® 2003 R2 Enterprise Edition

Microsoft® Windows Server® 2003 R2 Datacenter Edition

- The product names of Windows Server 2008 are as follows:

Microsoft® Windows Server® 2008 Foundation

Microsoft® Windows Server® 2008 Standard

Microsoft® Windows Server® 2008 Enterprise

Microsoft® Windows Server® 2008 Datacenter

Microsoft® Windows Server® 2008 for Itanium-based Systems

Microsoft® Windows® Web Server 2008

Microsoft® Windows® HPC Server 2008

- The product names of Windows Server 2008 R2 are as follows:

Microsoft® Windows Server® 2008 R2 Foundation

Microsoft® Windows Server® 2008 R2 Standard

Microsoft® Windows Server® 2008 R2 Enterprise

Microsoft® Windows Server® 2008 R2 Datacenter

Microsoft® Windows Server® 2008 R2 for Itanium-based Systems

Microsoft® Windows® Web Server 2008 R2

Microsoft® Windows® HPC Server 2008 R2

 **Note**

- PostScript® 3 in this manual stands for "Adobe PostScript 3 Emulation".

INDEX

2-sided copy.....26, 158
2-sided copy (manual).....169

A

Address book.....175, 277
Address book (LAN-Fax).....226, 227, 228, 229,
230, 231
Address Book key.....39
ADF (Auto Document Feeder)....37, 117, 121, 419
Adjust sound volume.....279
Admin. tools lock.....298
Administrator e-mail address.....353
Administrator password.....353
Administrator settings.....298, 353
Alert indicator.....39
ARDF (Auto Reverse Document Feeder)....36, 117,
120, 419
Authentication.....433
Authorized reception.....248, 249, 320, 328
Auto continue.....279
Auto document feeder.....15
Auto e-mail notification settings.....334
Auto redial.....268
Auto reverse document feeder.....15

B

Backup settings.....355
Bidirectional communication.....131, 132
Bond paper.....86
Broadcast.....218
Bypass tray.....36, 37, 108
Bypass tray setting priority.....318

C

Cancel fax.....213, 234
Cancel print job.....137, 138
Cardstock.....86
Characters.....123
Cleaning.....415, 416, 418, 419
Clear/Stop key.....39
Color paper.....86
Combined copy.....26, 158
Communication settings.....270

Community.....335
Compression (Colour).....264
Confidential document.....139
Configuration page.....291, 292, 351
Consumables.....430
Control panel.....36, 37, 39
Copier function.....26, 452
Copier mode.....151
Copy key.....39, 59, 151
Copy settings.....257
Copyright information.....459
Counter information.....314
Country.....298
Cover for the exposure glass.....36, 37
Cover sheet.....235, 236

D

Date and time settings.....357
Date setting.....201, 298, 357
Default settings.....354
Delete TX standby file.....270
Density.....170, 192, 222, 258, 264, 268
Density key.....39
Destinations.....203
DHCP.....70, 73
Dial/Push phone.....298
Disposal.....423
DNS setting.....333
Document type.....171
Duplex.....314
Duplex/Combine.....258

E

E-mail notification 1.....334
E-mail notification 2.....334
Electromagnetic interference.....458
Encryption.....433
Encryption key exchange.....435
Energy saver mode.....60, 298, 358
Enlarged copy.....26, 156
Envelope.....86, 110
Error messages.....399
Escape key.....39
Ethernet.....66, 287

Ethernet port.....	38, 66
Ethernet speed.....	75
expat.....	459
Exposure glass.....	36, 37, 119, 418
Extender for the ADF tray.....	37
Extender for the ARDF output tray.....	36
Exterior.....	36, 37, 38
External telephone.....	34, 220, 221
External telephone connector.....	38

F

Facsimile key.....	39, 59, 199
Fax destinations.....	203, 204, 205, 206, 208, 214, 327
Fax feature settings.....	270
Fax function.....	33, 454
Fax journal.....	291, 295, 351
Fax mode.....	199
Fax number confirmation.....	298, 320
Fax only mode.....	242
Fax printing.....	246
Fax received file processing.....	320
Fax Received indicator.....	39
Fax reception.....	240
Fax Speed Dial Dest.....	277
Fax Speed Dial destination list.....	291, 351
Fax transmission.....	209, 211
Fax transmission settings.....	267
Fax TX/RX standby file list.....	351
FAX/TAD mode.....	243
FAX/TEL automatic mode.....	242
FAX/TEL manual mode.....	241
Feature highlights.....	24
File type.....	264
Forwarding.....	244
Friction pad.....	416
Front cover.....	36, 37
Function priority.....	59, 298

G

G3 (analog) line interface connector.....	38
Gateway.....	287
General status.....	330
Group (LAN-Fax).....	229

H

How to read this manual.....	15
------------------------------	----

I

I/O timeout.....	279, 325
ID card copy.....	28, 167
IKE settings.....	346
Image density.....	279
Image quality.....	171
Image Quality key.....	39
Immediate transmission.....	209
Immediate TX.....	268
Initial setup.....	58
Input tray for the ADF.....	37
Input tray for the ARDF.....	36
Inquiry.....	429
Installing the machine.....	43
Interior.....	39
Internet Fax.....	210, 243, 455
Internet Fax settings.....	339
IP address.....	16, 70, 287
IPsec.....	298
IPsec global settings.....	345
IPsec policy settings.....	346
IPsec settings.....	345, 346
IPsec transmission.....	433
IPv4 configuration.....	287
IPv6 configuration.....	287
IPv6 environment.....	431
IPv6 settings.....	331

J

JPEG LIBRARY.....	459
-------------------	-----

L

Label paper.....	86
LAN-Fax.....	34, 226, 233, 237
LAN-Fax driver properties.....	238
Language.....	298, 312
Laws and regulations.....	17
LDAP address search.....	186, 217, 439
LDAP address search conditions.....	446
LDAP authentication.....	439, 444, 445
LDAP authentication settings.....	341

LDAP server.....	341, 440, 443
LDAP settings.....	341, 440, 443
LED lamps.....	67
Legal prohibition.....	17
Legal size.....	100
Letterhead.....	86
Limitless scan.....	264
List of option.....	20
List/Test print.....	304
Lists.....	291, 351
Loading paper.....	96, 105, 108
Locked Print.....	25, 139, 140, 141, 142
Log in.....	444, 445
Log out.....	444
Long period of inactivity.....	424, 426
Low humidity mode.....	279

M

Mac OS X.....	132, 134
Machine information.....	316
Machine location.....	43
Maintenance page.....	291, 351
Manual 2 sided scan mode.....	258
Manual duplex copying.....	169
Manual duplex printing.....	145
Manual IP address.....	71, 74
Manuals.....	12, 21, 22, 23
Max. e-mail size.....	264
mDNS setting.....	332
Memory reception.....	244, 246
Memory transmission.....	209
Menu chart.....	253
Menu screen.....	251
Missing image area.....	118
Model types.....	18
Model-specific information.....	18
Moving.....	420, 421
Multi-access.....	61

N

Names and functions.....	36
Names of major items.....	15
Network application.....	332
Network connection.....	24, 66

Network print setting.....	332
Network printer.....	80
Network settings.....	70, 72, 287, 330
Network status.....	330
Note.....	15
Notice.....	14
Number keys.....	39

O

OHP transparencies.....	86
OK key.....	39
On Hook Dial.....	220
On Hook Dial key.....	39
One Touch buttons.....	39, 185, 214
OpenLDAP.....	459
OpenSSL.....	460
Operation modes.....	59
Options.....	81, 457
Original.....	117, 119, 194, 224, 264, 268
Original type.....	258
Output tray.....	36, 37
Output tray for the ADF.....	37
Output tray for the ARDF.....	36
Outside line access number.....	78

P

Page counter.....	314
Paper capacity.....	84
Paper feed roller.....	416
Paper Feed Unit TK1080.....	81, 457
Paper jam.....	365, 368, 370, 375, 379
Paper mismatch.....	136, 137
Paper recommendations.....	117
Paper registration.....	279
Paper settings.....	318
Paper size.....	84, 113, 114, 115
Paper storage.....	94
Paper tray.....	313
Paper type.....	84, 86, 93, 113, 114
Paper weight.....	84
Pause time.....	268
Pause/Redial key.....	39, 185
PBX.....	67, 77, 78
PBX access number.....	298

PCL menu.....	304
Plain paper.....	86
POP3 settings.....	338
Power cord.....	55
Power failure report.....	250
Power indicator.....	39
Power off.....	55
Power on.....	55
Power socket.....	38
Power switch.....	38, 55
Preprinted paper.....	86
Prepunched paper.....	86
Print cartridge.....	39, 409, 430
Print counter.....	314
Print fax header.....	268
Print functions.....	147
Print output functions.....	148
Print quality functions.....	147
Printable area.....	94
Printer feature settings.....	304
Printer function.....	24, 136, 451
Printer properties.....	134
Printing position.....	387
Priority tray.....	323
Program fax information.....	298
PS menu.....	304
PSTN.....	67, 77
PSTN/PBX.....	298

Q

Quick Dial.....	203, 204, 205, 206, 208, 214, 277
Quick Dial Dest.....	277
Quick Dial destination list.....	291, 351

R

Rear cover.....	38
Reception mode.....	240
Reception settings.....	270
Recycled paper.....	86
Redial.....	219
Reduce/Enlarge.....	258
Reduce/Enlarge key.....	39, 156
Reduced copy.....	26, 156
Region A model.....	18

Region B model.....	18
Report print settings.....	270
Reports.....	291, 351
Reset settings.....	298, 354
Resolution.....	193, 223, 264, 268
Restore settings.....	356
Restrict user function.....	125, 127, 128, 129, 329

S

SA (Security Association).....	434
Save scn data to USB.....	298
Scan destinations.....	175, 181, 185, 186, 327
Scan settings.....	170, 191, 222
Scan size.....	191, 264
Scan to E-mail.....	31, 175, 183
Scan to Folder.....	32, 175, 183
Scan to FTP.....	31, 175, 183
Scan to USB.....	33, 188
Scan warm-up time.....	279
Scanner carriage.....	279
Scanner destination list.....	291, 351
Scanner function.....	29, 452
Scanner journal.....	291, 297, 351
Scanner key.....	39, 59, 173
Scanner mode.....	173
Scanner send setting.....	332
Scanner settings.....	263
Scanning from a computer.....	195
Scanning mode.....	264
Scanning using the control panel.....	183
Screen.....	39
Scroll keys.....	39
Search conditions.....	341
Search options.....	341
Select paper.....	258, 320
Select paper tray.....	270, 320
Selection key.....	39
Set date.....	357
Set date/time.....	298
Set time.....	357
Shift key.....	39
Shortcut to Func. key.....	39, 325
Shortcut to function.....	298, 325
SMTP settings.....	337

SNMP settings.....	335
Sort.....	29, 258
Sound volume adjustment.....	317
Special sender list.....	291
Special senders.....	248, 328
Specifications.....	449, 451, 452, 454, 455
Speed Dial.....	203, 204, 205, 206, 208, 215, 277
Start key.....	39
Status information.....	313
Status messages.....	399
Stop fences.....	36, 37
Subnet mask.....	287
Supplies status.....	279
Symbols.....	15
System.....	304, 335
System auto reset timer.....	298
System information.....	313
System settings.....	279, 317

T

TCP/IP status.....	330
Telephone line.....	67, 76
Telephone network.....	67, 76
Thick paper 1.....	86
Thick paper 2.....	86
Thin paper.....	86
Time setting.....	201, 298, 357
Toner.....	409
Toner saving.....	279, 324
Top page.....	311
Trademarks.....	463
Transmission mode.....	209
Trap.....	335
Tray 1.....	36, 37, 96
Tray 1 rear cover.....	38
Tray 2.....	36, 37, 81, 105
Tray paper settings.....	279
Troubleshooting.....	362, 363, 384, 385, 386, 387, 390, 392, 393, 399
TWAIN scanning.....	30, 195
TX/RX standby file list.....	291, 296
Type 1 model.....	18
Type 2 model.....	18

U

Unpacking.....	46
USB connection.....	24, 66
USB flash disk port.....	36, 37
USB port.....	38, 66
User code.....	129
User Tools key.....	39

W

Web Image Monitor.....	309
WIA scanning.....	30, 195

MEMO

MEMO

MEMO

