



RICOH UNIVERSITY

Learning ♦ Knowledge ♦ Performance



B286/B289
SERVICE MANUAL

003165MIU

LANIER RICOH SAVIN



B286/B289
SERVICE MANUAL

LANIER
RICOH
SAVIN®



RICOH UNIVERSITY
Learning ♦ Knowledge ♦ Performance

B286/B289

SERVICE MANUAL

003165MIU

LANIER RICOH SAVIN

It is the reader's responsibility when discussing the information contained within this document to maintain a level of confidentiality that is in the best interest of Ricoh Corporation and its member companies.

NO PART OF THIS DOCUMENT MAY BE REPRODUCED IN ANY FASHION AND DISTRIBUTED WITHOUT THE PRIOR PERMISSION OF RICOH CORPORATION.

All product names, domain names or product illustrations, including desktop images, used in this document are trademarks, registered trademarks or the property of their respective companies.

They are used throughout this book in an informational or editorial fashion only and for the benefit of such companies. No such use, or the use of any trade name, or web site is intended to convey endorsement or other affiliation with Ricoh products.

WARNING

The Service Manual contains information regarding service techniques, procedures, processes and spare parts of office equipment distributed by Ricoh Corporation. Users of this manual should be either service trained or certified by successfully completing a Ricoh Technical Training Program.

Untrained and uncertified users utilizing information contained in this service manual to repair or modify Ricoh equipment risk personal injury, damage to property or loss of warranty protection.

Ricoh Corporation

LEGEND

PRODUCT CODE	COMPANY			
	Gestetner	LANIER	RICOH	SAVIN
B286	GWD2004	LW324	MPW2400	2404WD
B289	GWD2006	LW336	MPW3600	2406WD

DOCUMENTATION HISTORY

REV. NO.	DATE	COMMENTS
*	07/2007	Original Printing

B286/B289

TABLE OF CONTENTS

INSTALLATION

1. INSTALLATION	1-1
1.1 PREPARATION	1-1
1.1.1 ENVIRONMENT	1-1
1.1.2 MINIMUM SPACE REQUIREMENTS	1-2
1.1.3 MACHINE LEVEL	1-2
1.1.4 POWER SOURCE	1-2
1.1.5 INSTALLATION OVERVIEW	1-3
Installation Flow.....	1-3
SP and User Tool Settings Required for Installation	1-4
1.2 MAIN MACHINE INSTALLATION (B286)	1-7
1.2.1 ACCESSORY CHECK.....	1-7
1.2.2 MACHINE INSTALLATION PROCEDURE	1-8
Removing the Shipping Material.....	1-8
Set the Operation Panel Position	1-9
Setting the Main Machine on the Roll Feeder (B851/B852) or Table (B854)	1-9
Leveling the Main Machine and Attaching Leg Covers.....	1-14
Developer	1-16
Toner Cartridge Installation	1-17
Enter Developer Lot Numbers	1-19
Mix Developer and Initialize ID Sensor.....	1-19
1.2.3 MAIN MACHINE FINAL INSTALLATION	1-21
Select the Tray Paper Size and Type.....	1-21
Testing the Main Machine Circuit Breaker.....	1-21
Main Machine Accessories.....	1-22
Roll Feeder, Table Accessories.....	1-23
Copy Check.....	1-25
Enable Onboard NIB, USB Functions	1-25
1.2.4 MOVING THE MACHINE.....	1-25

1.3 ORIGINAL HANGER (D311)	1-27
1.3.1 ACCESSORY CHECK	1-27
1.3.2 INSTALLATION	1-27
1.4 ROLL FEEDER (B851/B852)	1-28
1.4.1 ACCESSORY CHECK	1-28
1.4.2 ROLL FEEDER INSTALLATION PROCEDURE	1-29
Setting the Main Machine on the Roll Feeder	1-29
Opening the Roll Feeder and Removing Shipping Material	1-30
Leveling the Main Machine and Attaching Leg Covers	1-35
Connecting the Main Machine and Roll Feeder	1-37
Attaching the Narrow Mylars to the Main Machine	1-40
Attaching the Wide Mylars to the Back of the Roll Feeder	1-41
Securing the Power Cord	1-42
Installing the Paper Rolls	1-42
Attaching the Lower Output Tray, Exit Guide Plates	1-43
Entering the Cut Length Adjustment	1-44
Setting Paper Sizes/Types for the Tray 1 (1 st Roll), Tray 2 (2 nd Roll)	1-44
1.5 PAPER CASSETTE (B853)	1-45
1.5.1 ACCESSORY CHECK	1-45
1.5.2 PAPER CASSETTE INSTALLATION PROCEDURE	1-45
1.6 TABLE (B854)	1-48
1.6.1 ACCESSORY CHECK	1-48
1.6.2 INSTALLATION PROCEDURE	1-49
Setting the Main Machine on the Table	1-49
Leveling the Main Machine and Attaching Leg Covers	1-50
Attaching the Guide Plate	1-50
Connecting the Main Machine and Table	1-50
Attach the Narrow Mylars to the Main Machine	1-52
Attach the Wide Mylars to the Back of the Table	1-53
Attaching the Stopper Brackets	1-54
Table Accessories	1-54
1.7 INSTALLATION OF MFP OPTIONS	1-56
1.7.1 OVERVIEW	1-56
1.7.2 ENABLING THE ONBOARD FEATURES	1-57
1.7.3 USING SD CARDS	1-58
Removing the SD Card Slot Cover	1-58

SD Card Slot Assignments	1-58
Restrictions and Precautions on the Use of SD Cards	1-59
Application Move	1-60
Undo Exec.....	1-60
1.7.4 PRINTER OPTION TYPE W3600 (D320).....	1-61
Accessories	1-61
Installation	1-62
1.7.5 SCANNER OPTION TYPE W3600 (D321)	1-63
Accessories	1-63
Installation	1-63
1.7.6 FILE FORMAT CONVERTER TYPE C (B609-04)	1-64
Accessories	1-64
Installation	1-64
1.7.7 INTERFACE PCB (D329)	1-67
Accessories	1-67
Installation	1-67
1.7.8 IEEE802.11B INTERFACE UNIT TYPE H (G813-45)/TYPE I (G874-39)	
1-69	
Accessories	1-69
Installation	1-69
1.7.9 GIGABIT ETHERNET BOARD TYPE A (G874-01)	1-70
Accessories	1-70
Installation	1-70
1.7.10 DATA OVERWRITE SECURITY UNIT TYPE D (B735-18) ...	1-72
Accessories	1-72
Before You Begin.....	1-72
Seal Check and Removal	1-72
Installation	1-72
Check Operation of the DOS Application	1-74
1.7.11 USB HOST INTERFACE UNIT TYPE 7300 (G819-01)	1-75
Accessories	1-75
Installation	1-75

1.7.12	BROWSER UNIT TYPE C (B828-03)	1-76
	Accessories	1-76
	Installation	1-76
1.7.13	VM CARD TYPE E (D338-01, -02, -03)	1-77
	Accessories	1-77
	Installation	1-77
1.8	REAR STACKER (D312)	1-79
	1.8.1 ACCESSORIES	1-79
	1.8.2 INSTALLATION	1-80

PREVENTIVE MAINTENANCE

2.	PREVENTIVE MAINTENANCE	2-1
2.1	PM TABLE	2-1
	2.1.1 MAIN MACHINE (B286).....	2-1
	2.1.2 ROLL FEEDER (B851/B852).....	2-4
	2.1.3 PAPER CASSETTE (B853)	2-5
	2.1.4 FOLDER FD/MANUAL FEEDER (D889)	2-5
	2.1.5 MANUAL FEEDER (D333).....	2-6
2.2	CLEANING THE ENTRANCE SPURS.....	2-6
2.3	LUBRICATION POINTS.....	2-7
	2.3.1 DEVELOPMENT SECTION.....	2-7
	2.3.2 FUSING GEARS.....	2-7

REPLACEMENT AND ADJUSTMENT

3. REPLACEMENT AND ADJUSTMENT	3-1
3.1 COMMON PROCEDURES	3-1
3.1.1 BEFORE WORKING ON THE MAIN MACHINE	3-1
3.1.2 SIDE COVERS	3-2
3.1.3 REAR COVER	3-3
3.1.4 PAPER EXIT UNIT	3-3
3.1.5 UNLOCKING, OPENING THE ORIGINAL UNIT	3-4
3.1.6 REMOVING THE ORIGINAL FEED UNIT	3-5
3.1.7 RAISING AND LOCKING THE SCANNER UNIT	3-6
3.1.8 TONER HOPPER COVER	3-7
3.1.9 IDLE REGISTRATION ROLLER PANEL	3-7
3.1.10 MANUAL FEED TABLE, ORIGINAL FEED SENSOR COVER ...	3-8
3.1.11 DRAWER FRONT COVER	3-9
3.2 SCANNER	3-10
3.2.1 ORIGINAL WIDTH SENSORS, ORIGINAL SET SENSOR, SCANNER SWITCH	3-10
3.2.2 ORIGINAL FEED UNIT ROLLERS	3-11
3.2.3 EXPOSURE GLASS	3-12
3.2.4 CIS	3-13
3.2.5 SMDB, VDB	3-14
3.2.6 SIB, CGB POWER PACK	3-15
3.3 AROUND THE DRUM	3-16
3.3.1 CHARGE CORONA WIRE, GRID WIRE, WIRE CLEANER	3-16
3.3.2 QUENCHING LAMPS	3-17
3.3.3 LPH (LED PRINT HEAD)	3-18
3.3.4 TRANSFER CORONA, SEPARATION CORONA WIRES	3-19
3.4 DEVELOPMENT	3-21
3.4.1 DEVELOPMENT UNIT	3-21
3.4.2 DEVELOPER	3-22
3.4.3 PAPER SET SENSOR, REGISTRATION SENSOR	3-24
3.4.4 TONER SUPPLY CLUTCH	3-25
3.4.5 DEVELOPMENT FILTER	3-25

3.4.6 USED TONER COLLECTION BOTTLE, TONER OVERFLOW SENSOR	
3-26	
3.5 DRUM	3-27
3.5.1 DRUM UNIT	3-27
3.5.2 CLEANING BLADE	3-29
3.5.3 ID SENSOR, PICK-OFF PAWLS, PICK-OFF PAWL SOLENOID ...	3-30
3.6 PAPER FEED	3-31
3.6.1 REGISTRATION CLUTCH, REGISTRATION ROLLER.....	3-31
3.6.2 ROLL 1 PAPER FEED CLUTCH, FEED ROLLER.....	3-33
3.6.3 ROLL 2 PAPER CLUTCH, FEED ROLLER	3-34
3.6.4 RF EXIT SENSOR	3-35
3.6.5 ROLL FEED MOTOR.....	3-35
3.6.6 CUTTER MOTOR, HP SENSORS.....	3-36
3.6.7 ROLL PAPER END SENSORS	3-37
3.6.8 CASSETTE FEED ROLLER	3-38
3.6.9 CASSETTE RELAY SENSOR, CASSETTE END SENSOR.....	3-38
3.6.10 CASSETTE FEED MOTOR, CASSETTE OPEN SENSOR.....	3-39
3.6.11 CASSETTE FEED CLUTCH	3-40
3.7 FUSING	3-41
3.7.1 PRESSURE SPRING ADJUSTMENT	3-41
3.7.2 HOT ROLLER STRIPPERS.....	3-42
3.7.3 FUSING EXIT SENSOR	3-42
3.7.4 PRESSURE ROLLER THERMISTORS	3-43
3.7.5 PRESSURE ROLLER STRIPPERS.....	3-44
3.7.6 EXIT UNIT SWITCH	3-44
3.7.7 FUSING UNIT	3-45
3.7.8 FUSING CLEANING ROLLER.....	3-46
3.7.9 FUSING LAMP	3-47
3.7.10 HOT ROLLER	3-48
3.7.11 PRESSURE ROLLER	3-48
3.7.12 HOT ROLLER THERMISTOR, THERMOSTATS	3-49
3.8 MOTORS	3-50
3.8.1 SCANNER MOTOR	3-50
3.8.2 DRUM MOTOR.....	3-51
3.8.3 FUSING MOTOR, MAIN MOTOR.....	3-51
3.8.4 USED TONER BOTTLE MOTOR	3-53

3.9	BOARDS	3-54
3.9.1	MCU/IPU/MB	3-54
3.9.2	PSU/CIRCUIT BREAKER	3-58
3.9.3	CONTROLLER BOARD	3-60
3.9.4	NVRAM	3-63
	NVRAM Upload	3-63
	NVRAM Download	3-63
3.9.5	T&S POWER PACK	3-64
3.9.6	RFDB (ROLL FEEDER DRIVE BOARD)	3-65
3.9.7	SFDB (SHEET FEED DRIVE BOARD)	3-65
3.10	OTHERS	3-67
3.10.1	HDD	3-67
3.10.2	COOLING FAN, OZONE FILTER	3-68
3.11	SP ADJUSTMENTS	3-70
3.11.1	IMAGE ADJUSTMENT WITH SP CODES	3-70
	Step 1: Magnification for Paper Type: Plain	3-70
	Step 2: Scanning Magnification	3-71
	Step 3: Magnification for Paper Type: Translucent	3-71
	Step 4: Magnification for Paper Type: Film	3-72
	Step 5: Scanner Mask Setting	3-72
	Step 6: Erase Margins	3-72
	Step 7: Printer: Leading Edge, Side-to-Side Registration	3-73
	Step 8: Scanner Mask Setting	3-74
	Step 9: Erase Margins	3-74
	Step 10: Scanner Registration	3-75
	Step 11: Printer: Cut Length	3-75
	Step 12: Synchro Cut (Trailing Edge Registration)	3-76
3.11.2	CIS ADJUSTMENT WITH SP CODES	3-77
	To Print the CIS Adjustment Pattern	3-77
	To Adjust the Image at the CIS Joints	3-78
3.11.3	LPH ADJUSTMENT WITH SP CODES	3-80
	Doing SP Adjustment Settings for a Replacement LPH	3-80
	To Print Pattern IPU Test Pattern 10	3-81
	Main Scan Adjustment: White, Black Vertical Lines	3-82
	Main Scan Adjustment: LED Light Level at LPH Joints	3-83
	Adjusting LPH Alignment	3-83

3.11.4 LPH DENSITY ADJUSTMENT WITH SP CODES	3-85
To Print the IPU Test Pattern 2	3-85
To Correct Pattern Density	3-86

TROUBLESHOOTING

4. TROUBLESHOOTING	4-1
4.1 SERVICE CALL CONDITIONS.....	4-1
4.2 SC CODE DESCRIPTIONS.....	4-3
4.2.1 SC1XXX.....	4-3
4.2.2 SC2XXX.....	4-3
4.2.3 SC3XXX.....	4-4
4.2.4 SC4XXX.....	4-5
4.2.5 SC5XXX.....	4-6
4.2.6 SC6XXX.....	4-11
4.2.7 SC7XXX.....	4-14
4.2.8 SC8XXX.....	4-16
4.2.9 SC9XXX.....	4-23
4.3 JAM CODE TABLES.....	4-28
4.3.1 OVERVIEW.....	4-28
4.3.2 SCANNER JAMS.....	4-29
Scanner Standby Jams	4-29
Scanner Late Jams	4-31
Scanner Lag Jams	4-31
4.3.3 PLOTTER (PRINTER) JAMS.....	4-31
Plotter Standby Jams	4-31
Plotter Late Jams	4-32
Plotter Lag Jams	4-32
4.3.4 FOLDER UNIT JAMS	4-33
Folder Unit Standby Jams	4-33
Folder Unit Late Jams	4-34
Folder Unit Lag Jams	4-35
4.4 COVER OPEN	4-36
4.5 FUSES.....	4-37
4.6 IMAGE PROBLEM TROUBLESHOOTING.....	4-38

4.6.1 FLOW CHART	4-38
4.6.2 SCANNING	4-39
4.6.3 PRINTING	4-41
4.6.4 DENSITY CHANGES AT CIS JOINTS	4-43
4.6.5 OTHER PROBLEMS	4-44
4.7 BOARD LEDS	4-45
4.7.1 PSU, MCU, IPU	4-45
PSU LEDs	4-45
MCU LEDs	4-46
IPU LEDs.....	4-47
4.7.2 SIB, VDB.....	4-48
VDB LEDs	4-48
SIB LEDs.....	4-49
GW Controller Board	4-49

SERVICE TABLES

5. SERVICE TABLES.....	5-1
5.1 USING THE SP MODE	5-1
5.1.1 DIRECT ENTRY	5-1
Normal Direct Entry	5-1
Rapid Direct Entry	5-2
5.2 FIRMWARE UPDATE	5-3
5.2.1 OVERVIEW.....	5-3
5.2.2 UPDATING FIRMWARE	5-3
5.3 USER TOOLS	5-6
5.3.1 USER TOOL SUMMARY	5-6
System Settings	5-6
Copier/Document Server Features.....	5-9
Espanol	5-12
Inquiry	5-12
Counter	5-12
5.4 INPUT CHECK.....	5-13
5.5 OUTPUT CHECK.....	5-19
5.6 SP TABLE KEY	5-21

5.7 SP1-XXX FEED	5-22
5.7.1 PAPER THICKNESS DEFAULT SELECTION.....	5-36
5.8 SP2-XXX DRUM	5-56
5.8.1 TEST PATTERN PRINTING	5-72
5.9 SP3-XXX PROCESS CONTROL	5-73
5.10 SP4-XXX SCANNER	5-74
5.11 SP5-XXX MODE	5-97
5.12 SP6-XXX PERIPHERALS.....	5-160
5.13 SP7-XXX DATA LOG.....	5-185
5.14 SP8-XXX DATA LOG 2.....	5-196

DETAILS

6. DETAILS	6-1
6.1 OVERVIEW.....	6-1
6.1.1 MACHINE GENERAL LAYOUT	6-1
6.1.2 MECHANICAL COMPONENT LAYOUT	6-3
6.1.3 DRIVE LAYOUT.....	6-5
6.1.4 ORIGINAL/COPY PAPER PATHS.....	6-6
6.2 SCANNER	6-8
6.2.1 OVERVIEW.....	6-8
6.2.2 SCANNER LAYOUT	6-9
6.2.3 ORIGINAL WIDTH DETECTION	6-10
6.2.4 ORIGINAL DRIVE MECHANISM	6-11
6.2.5 ORIGINAL FEED SPEED	6-11
6.2.6 SCANNING MECHANISM	6-12
CIS Structure.....	6-12
Printed Image.....	6-13
6.2.7 AUTO IMAGE DENSITY CORRECTION	6-13
6.3 IMAGE PROCESSING.....	6-15
6.3.1 GENERAL IMAGE PROCESSING FLOWCHART	6-15
6.3.2 ORIGINAL MODES.....	6-16
Overview	6-16
Drawing Mode	6-17
Text Mode	6-18

Text/Photo Mode	6-19
Photo Mode	6-19
Background Lines Mode	6-20
Patched Original Mode	6-21
Generation Mode	6-22
6.4 AROUND THE DRUM	6-23
6.4.1 OVERVIEW	6-23
6.4.2 DRUM DRIVE	6-24
6.4.3 CHARGE CORONA UNIT	6-25
6.4.4 CORONA WIRE CLEANING	6-26
6.4.5 DRUM CLEANING	6-27
6.4.6 COLLECTING USED TONER	6-28
6.4.7 QUENCHING	6-29
6.4.8 DRUM ANTI-CONDENSATION HEATERS	6-30
6.5 IMAGE WRITING	6-31
6.6 DEVELOPMENT	6-32
6.6.1 OVERVIEW	6-32
6.6.2 DEVELOPMENT DRIVE MECHANISM	6-33
6.6.3 TONER SUPPLY MECHANISM	6-34
6.6.4 DEVELOPER CROSS-MIXING	6-35
6.6.5 DEVELOPMENT BIAS	6-36
6.6.6 ID SENSOR	6-37
6.6.7 WARMUP CONTROL (VSG CORRECTION)	6-38
6.6.8 TONER DENSITY CONTROL	6-39
Overview	6-39
Supply Modes	6-39
Detect Supply Mode	6-40
Fixed Supply Mode	6-41
Toner Supply Clutch Operation	6-41
6.6.9 TONER END/NEAR-END DETECTION	6-43
Toner Near End	6-43
Toner End	6-43
Toner End Recovery	6-43
6.7 PAPER FEED AND REGISTRATION	6-45
6.7.1 OVERVIEW	6-45
Layout Diagrams	6-45

Feed Station Overview	6-47
Manual Feed Table	6-48
Roll Feeder.....	6-48
Paper Cassette.....	6-48
Paper Width and Type Settings.....	6-48
6.7.2 MANUAL FEED MECHANISM.....	6-49
6.7.3 ROLL FEED MECHANISM	6-50
Drive	6-50
Roll Pre-feeding.....	6-51
Roll Paper Feed	6-53
6.7.4 ROLL FEEDER PAPER HOLDERS.....	6-54
6.7.5 ROLL PAPER CUTTING MECHANISM.....	6-55
6.7.6 ROLL END DETECTION	6-56
6.7.7 PAPER CASSETTE MECHANISM	6-58
6.7.8 PAPER CASSETTE FEED	6-59
Cassette Paper Path	6-59
Paper Cassette Pre-Feeding.....	6-60
6.7.9 PAPER CASSETTE PAPER END DETECTION.....	6-61
6.7.10 CONDENSATION PREVENTION	6-62
6.7.11 PAPER REGISTRATION	6-63
6.8 IMAGE TRANSFER AND SEPARATION.....	6-64
6.8.1 OVERVIEW.....	6-64
Transfer Corona Unit.....	6-64
Separation Corona Unit.....	6-65
6.8.2 PICK-OFF PAWL OPERATION	6-65
6.9 FUSING UNIT	6-66
6.9.1 OVERVIEW.....	6-66
6.9.2 PAPER FEED THROUGH THE FUSING UNIT	6-67
6.9.3 FUSING PRESSURE CONTROL MECHANISM	6-68
6.9.4 HOT ROLLER THERMISTORS AND THERMOSTATS	6-69
6.9.5 TEMPERATURE CONTROL	6-69
Paper Thickness Setting	6-69
Zero-Cross Control Test.....	6-71
Switching on the Fusing Lamp Power	6-71
Fusing Temperature Control: Warm-up Sequence.....	6-72
Fusing Temperature Control: Temperature Feedback During Copying.....	6-74

Pressure Roller Temperature Feedback	6-76
Fusing Temperature Control: Inching	6-79
Fusing Temperature Control: CPM Down	6-79
6.9.6 HOT ROLLER CLEANING	6-80
6.9.7 FUSING UNIT DRIVE MECHANISM	6-81
6.9.8 WRINKLE PREVENTION	6-82
Motor Speed Control	6-82
Inching Control	6-82
6.10 PAPER EXIT	6-83
6.10.1 OVERVIEW	6-83
Upper Exit.....	6-83
Rear Exit.....	6-84
Jam Detection	6-84
6.10.2 SWITCHING THE PAPER EXIT.....	6-84
Upper Exit.....	6-84
Rear Exit.....	6-85
6.10.3 PAPER EXIT DRIVE	6-86
6.11 ELECTRICAL COMPONENTS.....	6-87
6.11.1 OVERVIEW	6-87
Overall System	6-87
IPU Board Details.....	6-89
6.11.2 DESCRIPTION OF ELECTRICAL COMPONENTS	6-90
6.11.3 MCU, IPU	6-100
MCU (Main Control Unit)	6-100
IPU (Image Processing Unit).....	6-101
6.11.4 PSU	6-101
6.11.5 SMDB, VDB, SIB.....	6-102
SMDB (Scanner Motor Drive Board)	6-102
VDB (Video Drive Board)	6-102
SIB (Scanner Interface Board)	6-102
CIS I/F (1 to 5).....	6-102
6.11.6 RFDB, SFDB	6-103
RFDB (Roll Feed Drive Board)	6-103
SFDB (Sheet Feed Drive Board).....	6-103
6.11.7 GW CONTROLLER BOARD.....	6-104

SPECIFICATIONS

7. SPECIFICATIONS.....	7-1
7.1 MAIN MACHINE (B286/B289)	7-1
7.2 OPTIONS	7-6
7.2.1 ROLL FEEDER B851/B852	7-6
7.2.2 FOLDER (D889)	7-7
7.2.3 MANUAL FEEDER D333	7-8
7.2.4 PAPER CASSETTE B853.....	7-9
7.3 MAIN MACHINE CONFIGURATION.....	7-10

INSTALLATION

TAB
POSITION 1

PREVENTIVE MAINTENANCE

TAB
POSITION 2

REPLACEMENT AND ADJUSTMENT

TAB
POSITION 3

TROUBLESHOOTING

TAB
POSITION 4

SERVICE TABLES

TAB
POSITION 5

DETAILED DESCRIPTIONS

TAB
POSITION 6

SPECIFICATIONS

TAB
POSITION 7

TAB
POSITION 8

Read This First

Safety, Conventions, Trademarks

Safety

PREVENTION OF PHYSICAL INJURY

1. Before disassembling or assembling parts of the machine and peripherals, make sure that they are unplugged.
2. The plug should be near the machine and easily accessible.
3. Note that some components of the machine and the paper tray unit are supplied with electrical voltage even if the main power switch is turned off.
4. If any adjustment or operation check has to be made with exterior covers off or open while the main switch is turned on, keep hands away from electrified or mechanically driven components.
5. If the [Start] key is pressed before the machine completes the warm-up period (the [Start] key starts blinking red and green), keep hands away from the mechanical and the electrical components as the machine starts making copies as soon as the warm-up period is completed.
6. The inside and the metal parts of the fusing unit become extremely hot while the machine is operating. Be careful to avoid touching those components with your bare hands.

HEALTH SAFETY CONDITIONS

1. Never operate the machine without the ozone filters installed.
2. Always replace the ozone filters with the specified types at the proper intervals.
3. Toner and developer are non-toxic, but if you get either of them in your eyes by accident, it may cause temporary eye discomfort. Try to remove with eye drops or flush with water as first aid. If unsuccessful, get medical attention.

OBSERVANCE OF ELECTRICAL SAFETY STANDARDS

1. The machine and its peripherals must be installed and maintained by a customer service representative who has completed the training course on those models.

SAFETY AND ECOLOGICAL NOTES FOR DISPOSAL

1. Do not incinerate toner bottles or used toner. Toner dust may ignite suddenly when exposed to an open flame.
2. Dispose of used toner, developer, and organic photoconductors in accordance with local regulations. (These are non-toxic supplies.)







3. Dispose of replaced parts in accordance with local regulations.
4. When keeping used lithium batteries in order to dispose of them later, do not put more than 100 batteries per sealed box. Storing larger numbers or not sealing them apart may lead to chemical reactions and heat build-up.

CAUTION

- The danger of explosion exists if a battery of this type is incorrectly replaced. Replace only with the same or an equivalent type recommended by the manufacturer. Discard used batteries in accordance with the manufacturer's instructions.

Conventions and Trademarks

Conventions

Symbol	What it means
	Core Tech Manual
	Screw
	Connector
	E-ring
	C-ring
	Harness clamp

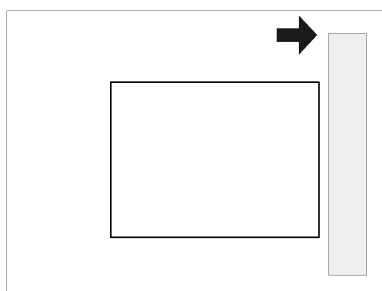

SEF (Short Edge Feed)

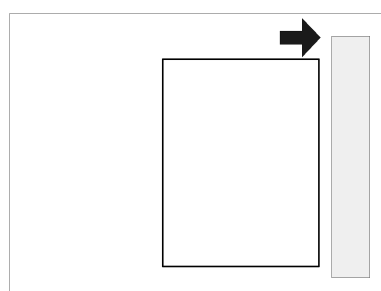

LEF (Long Edge Feed)

The notations “SEF” and “LEF” describe the direction of paper feed. The arrows indicate the direction of paper feed.

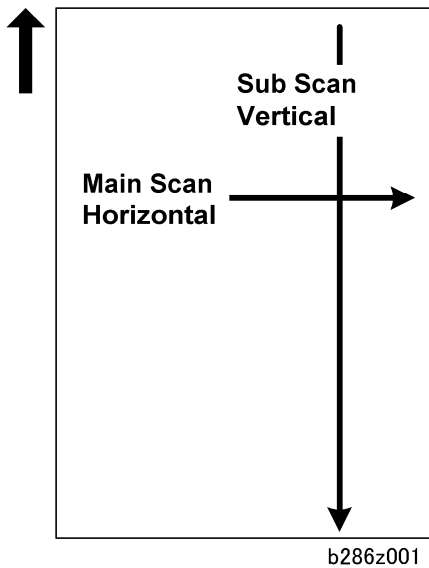

In this manual “Horizontal” means the “Main Scan Direction” and “Vertical” means the “Sub Scan Direction” relative to the paper feed direction.

Warnings, Cautions, Notes

In this manual, the following important symbols and notations are used.

WARNING

- A Warning indicates a potentially hazardous situation. Failure to obey a Warning could result in death or serious injury.

CAUTION

- A Caution indicates a potentially hazardous situation. Failure to obey a Caution could result in minor or moderate injury or damage to the machine or other property.

Important

- Obey these guidelines to avoid problems such as misfeeds, damage to originals, loss of valuable data and to prevent damage to the machine

Note

- This information provides tips and advice about how to best service the machine.

Trademarks

- Microsoft[®], Windows[®], and MS-DOS[®] are registered trademarks of Microsoft Corporation in the United States and /or other countries.
- PostScript[®] is a registered trademark of Adobe Systems, Incorporated.
- PCL[®] is a registered trademark of Hewlett-Packard Company.
- Ethernet[®] is a registered trademark of Xerox Corporation.
- PowerPC[®] is a registered trademark of International Business Machines Corporation.

- Other product names used herein are for identification purposes only and may be trademarks of their respective companies. We disclaim any and all rights involved with those marks.

INSTALLATION

1. INSTALLATION

1.1 PREPARATION

1.1.1 ENVIRONMENT

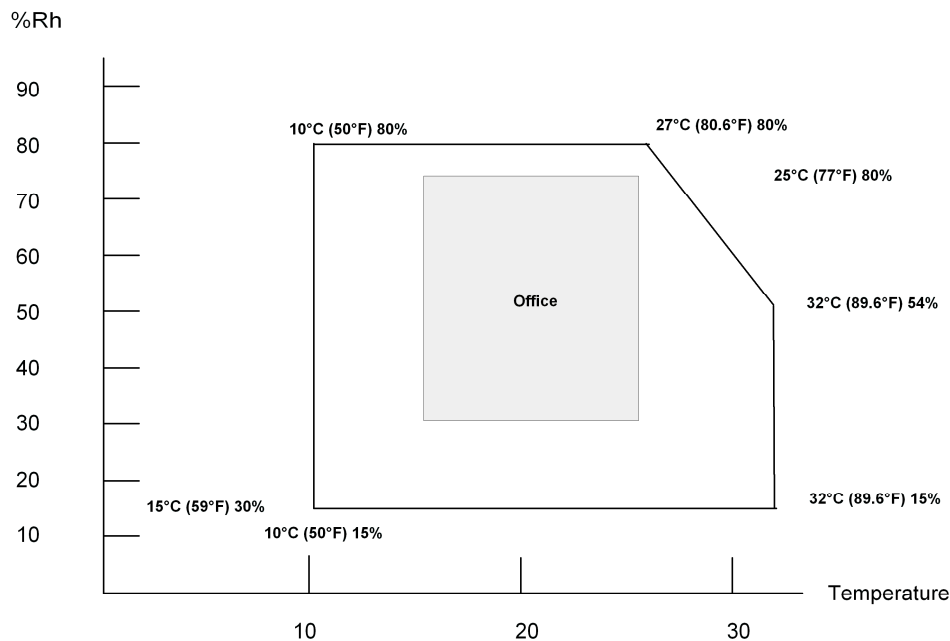

b286i900

1. Temperature Range: 10 °C to 30 °C (50 °F to 86 °F)
2. Humidity Range: 15% to 90% RH
3. Ambient Illumination: Less than 1,500 Lux (do not expose the machine directly to light from the sun).
4. Ventilation: More than 30 m³/hr/person in the work area
5. Ambient Dust: Less than 0.10 mg/m³
6. If the installation area has air-conditioners or heaters, put the machine in a location where:
 - There are no sudden temperature changes from low to high, or high to low.
 - The machine will not be directly exposed to cool air from an air conditioner in the summer.
 - The machine will not be directly exposed to reflected heat from a space heater in the winter.
7. Do not install the machine in an area filled with gases that can cause corrosion.
8. Do not install the machine in areas higher than 2,000 m (6,600 ft) above sea level.

Preparation

- Put the machine on a strong and level surface.

★ Important

- The floor must be able to support a load of more than 2.94 kPa (300 kgf/m²).
- Do not install the machine in an area where there are frequent strong vibrations.

1.1.2 MINIMUM SPACE REQUIREMENTS

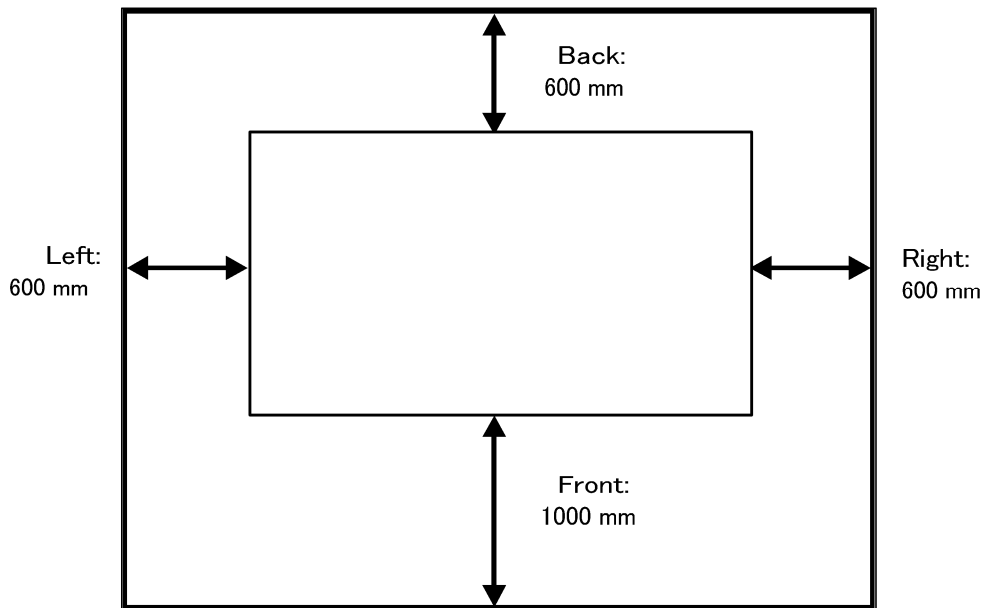

b286i520

- Front: 1000 mm (40")
- Back: 600 mm (23")
- Right: 600 mm (23")
- Left: 600 mm (23")

1.1.3 MACHINE LEVEL

- Front to back: Not more than 5 mm from level
- Right to left: Not more than 0.15/1000 mm from level.

1.1.4 POWER SOURCE

⚠ WARNING

- This machine is provided with a circuit breaker that cuts the power supply to the main machine in case of a current overload or short circuit. The machine must be installed in a building where circuit breakers (and equivalent devices) can operate properly.
- Input Voltage Level:
 - 120V, 60 Hz, 15 A or more

- 220-240V, 50/60 Hz, 10A or more
- 2. Permissible Voltage Fluctuation: $\pm 10\%$
- 3. Do not set objects on the power cord.

↓ Note

- Make sure the plug is firmly inserted in the outlet.
- Do not connect the machine to a power source that is shared with other equipment.

1.1.5 INSTALLATION OVERVIEW

Installation Flow

This copier has these options.

- **Roll feeder.** You can install a roll feeder with one roll or two rolls. You can also install a universal Paper Cassette in the roll feeder. You cannot install the paper cassette without the roll feeder.
- **Table.** Used as an alternative to the roll feeder, it contains only the lower stacker.

Here is a summary of the sequence recommended for installation of all these options together.

Installation Flow Diagram

Copier Pre-Installation	
Remove the copier from its box. Remove all packing material and tape. Put the copier on the roll feeder or the table.	
▼	
Roll Feeder (or Table) Installation	
▼	
Install Paper Cassette	
▼	
SP and User Tool Settings for Installation	
Do all the SP and User Tool settings for the copier and the installed options.	
▼	
Copier Final Installation	
Complete the installation of the copier after you put it on the roll feeder or table, and after	

Preparation

you install all options. Do some sample copies to check the operation of the copier and installed options.	
▼	
Printer/Scanner, Other MFP Options Install the printer/scanner options and do a function check. For installation instructions, refer to the installation manual for the Printer/Scanner controller.	
▼	
Folder Unit Install the Folder Unit last. The MFP options must be installed before the folder unit because the folder unit will block access to the board and SD card slots.	

SP and User Tool Settings Required for Installation

This is a summary of the important SP and User Tool settings that are necessary for this installation.

Main Machine Installation

2801-2	Lot Number 1	Enter the toner lot numbers at installation before doing SP2801-1
2801-3	Lot Number 2	
2801-1	Developer Initial Setting	Mixes developer and initializes the ID sensor.
2923-1	Execute Cleaning Blade Replace Mode	Applies a thin layer of toner to the drum. This prevents scratches on the drum when the machine power comes on for the first time.
3001	ID Sensor Initial Setting - Initialization	Initializes the ID sensor after toner has been applied to the drum.
User Tool	System Settings> Tray Paper Settings> Tray Paper Size: Tray n	Sets the paper size for each tray: <ul style="list-style-type: none"> ▪ Tray 1: Roll 1 ▪ Tray 2: Roll 2 ▪ Tray 3: Cassette ▪ Bypass

User Tool	System Settings> Tray Paper Setting> Paper Type> Next> Paper Type: Tray n	Sets the paper type for each tray: <ul style="list-style-type: none"> ▪ Tray 1: Roll 1 ▪ Tray 2: Roll 2 ▪ Tray 3: Cassette ▪ Bypass
User Tool	System Settings> Timer Settings> Set Date, Set Time	Check the date and time setting. If they are not correct, set the correct date and time.

Roll Feeder Installation

SP	Adjustment	
1920	Cut Length Adjustment	
	Sets the cut length settings for the rolls installed in the roll feeder. These settings are different for each machine. The settings are on a label attached to the right side of the roll feeder drawer.	
1920-111	Cut Length Adjustment: 1 st Roll:297 mm:Plain Paper	Adjust for B851/B852, 1 st Roll
1920-115	Cut Length Adjustment: 1 st Roll:1189 mm:Plain Paper	Adjust for B851/B852, 1 st Roll
1920-211	Cut Length Adjustment: 2 nd Roll:297 mm:Plain Paper	Adjust for B852, 2 nd Roll
1920-215	Cut Length Adjustment: 2 nd Roll:1189 mm:Plain Paper	Adjust for B852, 2 nd Roll
1001-1	Leading Edge Registration – 1 st Roll	Adjust B851/B852, 1 st roll.
1001-2	Leading Edge Registration – 2 nd Roll	Adjust for B852, 2 nd roll.
1002-1	Side-to-Side Registration – 1 st Roll	Adjust for B851/B852, 1 st roll

Preparation

SP	Adjustment	
1002-2	Side-to-Side Registration – 2 nd Roll	Adjust for B852, 2 nd roll.

Paper Cassette

1001-3	Leading Edge Registration – Cassette	Adjust for Paper Cassette B853.
1002-3	Side-to-Side Registration – Cassette	

MFP Options

5985-1	Device Setting – On Board NIC	Both SP codes must be set to “1” to enable these features.
5985-2	Device Setting – On Board USB	

1.2 MAIN MACHINE INSTALLATION (B286)

↓ Note

- Always have this Service Manual with you. The installation procedures are not shipped with the main machine.

CAUTION

- Never turn the main machine off when the main power LED is lit or flashing. To avoid damaging the hard disk or memory, press the operation power switch on the operation panel to turn the power off, wait for the power LED to go off, then turn the main power switch off.

1.2.1 ACCESSORY CHECK

Check the accessories and their quantities against the table below.

No.	Description	Q'ty
1	Flat Brush (Fusing Unit Guide Spurs)	1
2	Original Output Guides	6
3	Upper Output Stacker	2
4	Upper Output Guide	1
5	Original Tray	1
6	Operating Instructions (-17, -21)	3
7	Studs	2
8	Panel: Logo	1
9	Cloth – Exposure Glass	1
10	Copy Exit Selection Lever	1
11	Operation Panel Anchor Screws	3
12	Operating Instruction Holder	1
13	Ferrite Core (For Network Cable)	1

Main Machine Installation (B286)

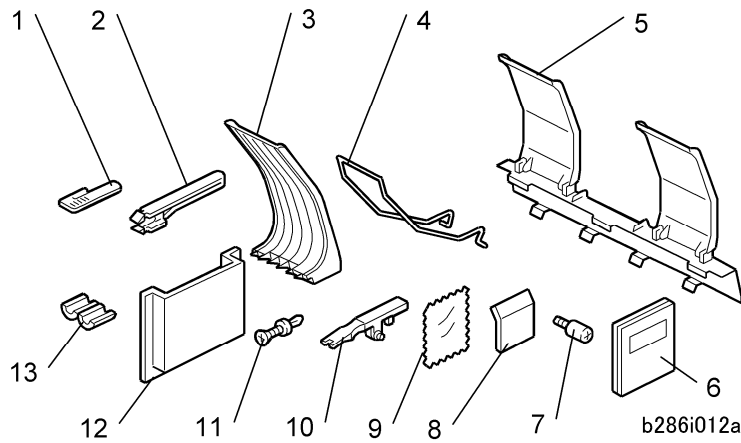

1.2.2 MACHINE INSTALLATION PROCEDURE

Removing the Shipping Material

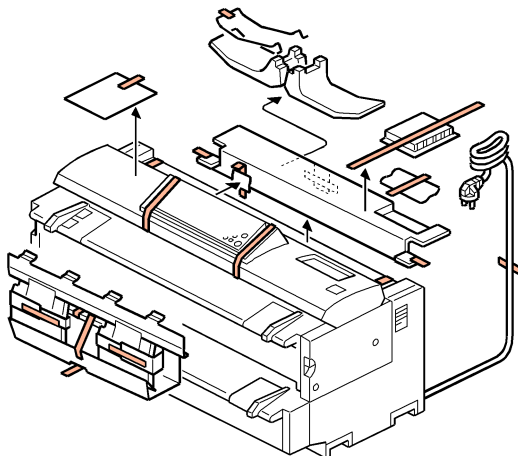

b286i013

CAUTION

- Do not connect the power cord to the power source during these installation procedures until the procedure tells you to do this.

1. Remove all the orange filament tape and packing materials from the main machine (front and back).

Note

- Use a clean cloth moistened with alcohol to remove any tape adhesive that remains on the main machine after tape removal.

Set the Operation Panel Position

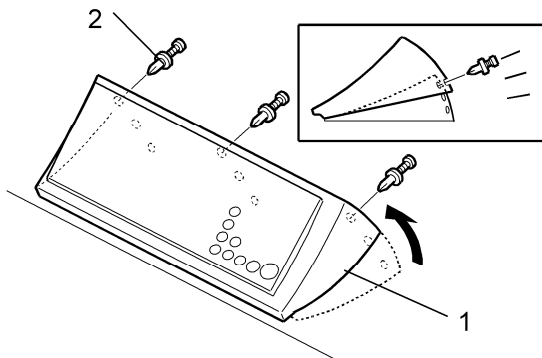

b286i006

You can adjust the position of the operation panel to decrease bright reflections from the operation panel display..

1. Lift or lower the operation panel [1] to one set of the three sets of holes to set the panel at the desired angle.
2. Push each anchor screw [2] into its hole (⌀ x 3).

↓ Note

- It is not necessary to tighten the screws.

Setting the Main Machine on the Roll Feeder (B851/B852) or Table (B854)

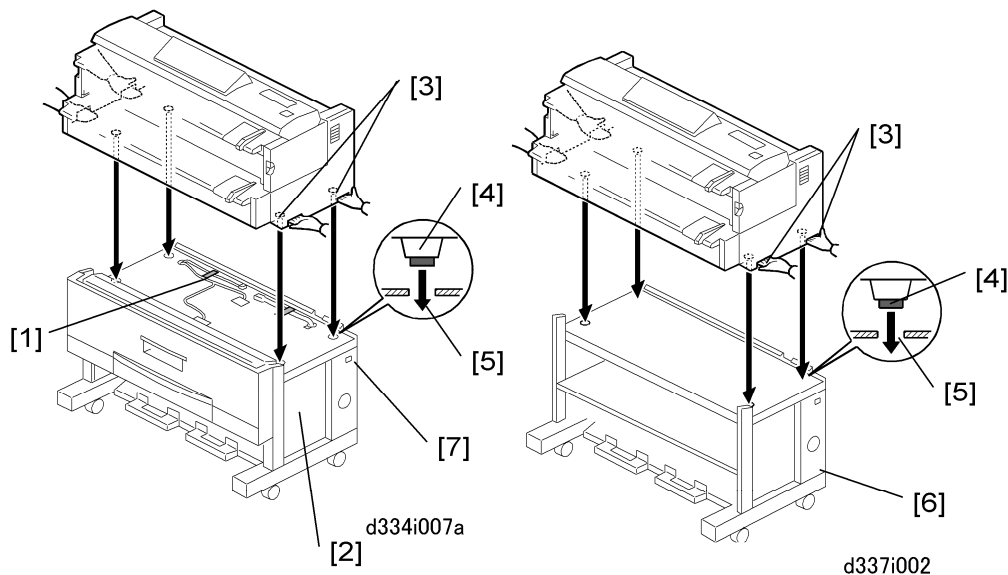

1. Do not remove the shipping tape from the connectors [1] of the roll feeder [2]. This prevents damage to the connectors when the main machine is put on top of the roll feeder.

Main Machine Installation (B286)

CAUTION

- The main machine weighs 107 kg (235 lb.).
 - There are two handles in recesses on each side of the main machine. To prevent injury or damage to the main machine, always use these handles [3] to lift the main machine.
 - Two or more service technicians are necessary to lift the main machine and set it on the roll feeder or table.
2. Lift the main machine, and set its rubber feet [4] into the holes [5] on the top of the roll feeder or table [6].

Note

- With one person at each end of the main machine, use the two handles on each end of the main machine to lift it.
3. Make sure that you put the rubber feet of the main machine into the holes on top of the roll feeder or table.
4. Check the dehumidifier switch [7] of the roll feeder. Make sure that it is OFF. If it is ON, set it to OFF.

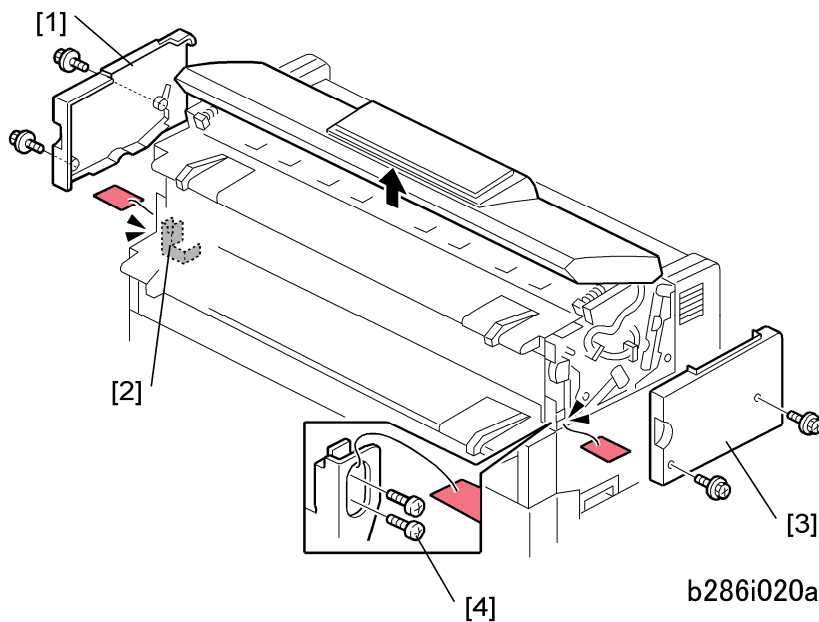

5. Remove the covers and screws:
- [1] Left upper cover (⌀ x 2)
 - [2] Left screws (⌀ x 2)
 - [3] Right upper cover (⌀ x 2)
 - [4] Right screws (⌀ x 2)

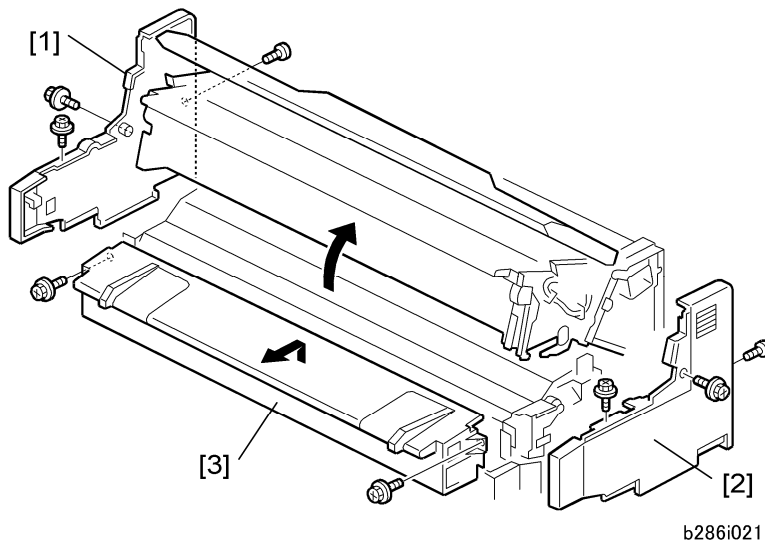

b286i021

6. Open the upper unit.
7. Remove:
 - [1] Left cover (⚙ x 3)
 - [2] Right cover (⚙ x 3)
 - [3] Manual feed table (⚙ x 2). Open the drawer of the roll feeder before removing if the roll feeder is installed.

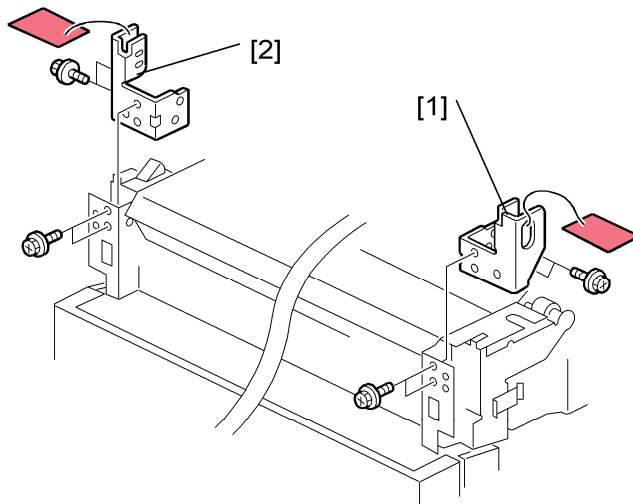

b286i022

8. Remove the right transport lock plate [1] (⚙ x 4).
9. Remove the left transport lock plate [2] (⚙ x 4).

Main Machine Installation (B286)

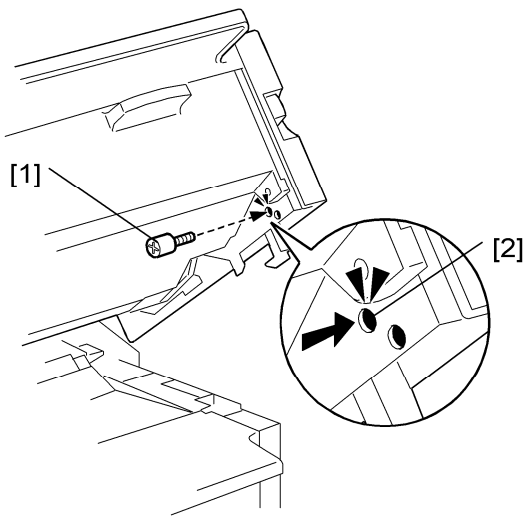

b286i016

10. Install the studs [1] on the right side and the left side.



- You must fasten each stud in the upper hole [2] on both sides.

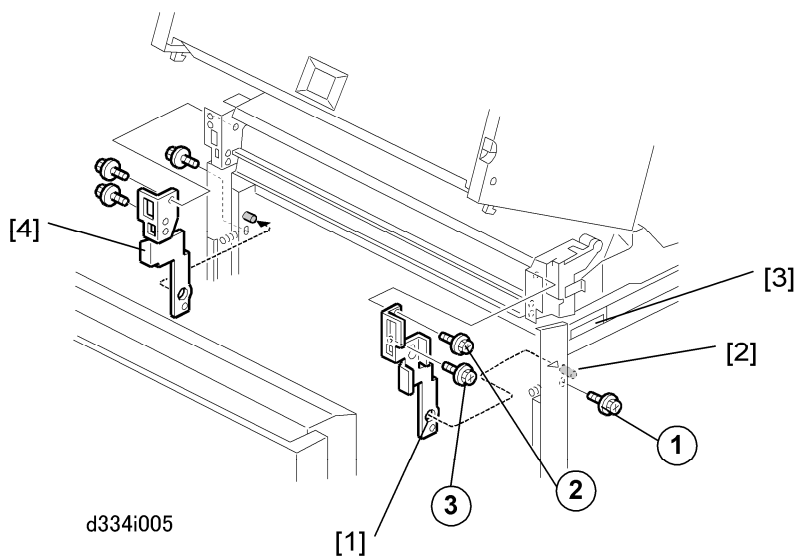

11. Attach the right joint bracket [1] (the spindle [2] must go through the hole). At the same time, align the plate with the holes for the three screws (blue).



- The joint brackets and screws are provided as accessories with either the Roll Feeder (B851/B852) or Table (B854).

12. Attach screws ①, ② but do not tighten them.

13. While you lift the main machine by its handle [3], set screw ③ in the lower hole of the keyhole cutout and tighten it.

14. Tighten screws ① and ②.

15. Do the above procedure again for the left joint bracket [4].

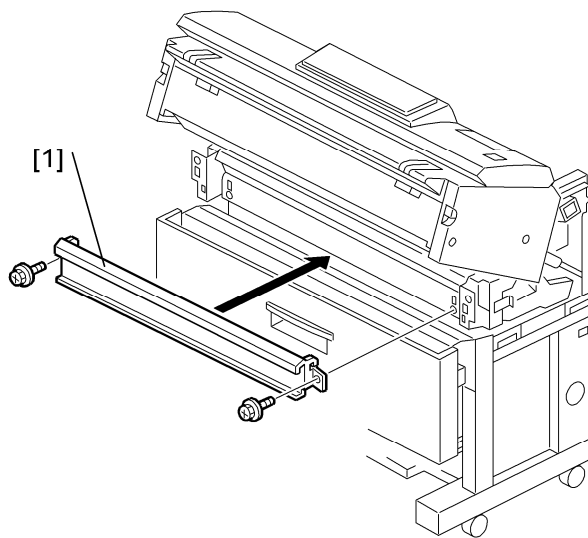

d334i004a

↓ Note

- The guide plate and screws are provided as accessories with either the Roll Feeder (B851/B852) or Table (B854).

16. Install the guide plate [1] (⌀ x 2 Blue). Hang the hooks on each end; this puts the plate in the correct position to be installed.

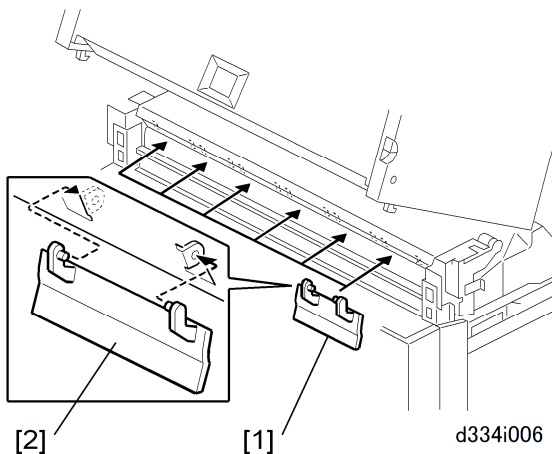

d334i006

↓ Note

- The movable guide plates are provided as accessories with either the Roll Feeder (B851/B852) or Table (B854).

17. Attach the movable guide plates [1] (x6).

- Each plate is the same. It is not possible to install a plate in the incorrect position.
- Attach each plate with the ribbed side down.
- Move the hinges [2] a small distance apart. This allows the tabs to attach easily

Main Machine Installation (B286)

into the holes.

18. Lift each plate and let it fall, to make sure that they move smoothly on the hinges.
19. Reattach the manual feed table.
20. Reattach the left and right covers.

↓ Note

- The flat-head screw must be attached at the rear side of each cover.

21. Close the upper unit.

Leveling the Main Machine and Attaching Leg Covers

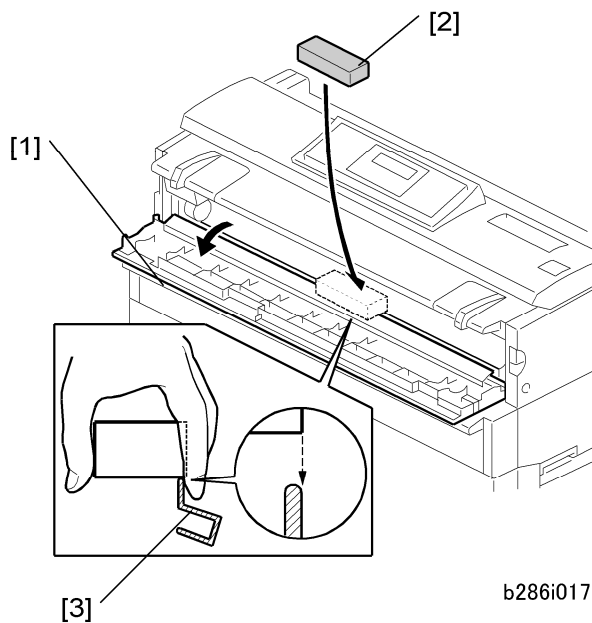

b286i017

1. Open the toner hopper cover [1].
2. Set a level [2] on the plate [3] of the development unit.

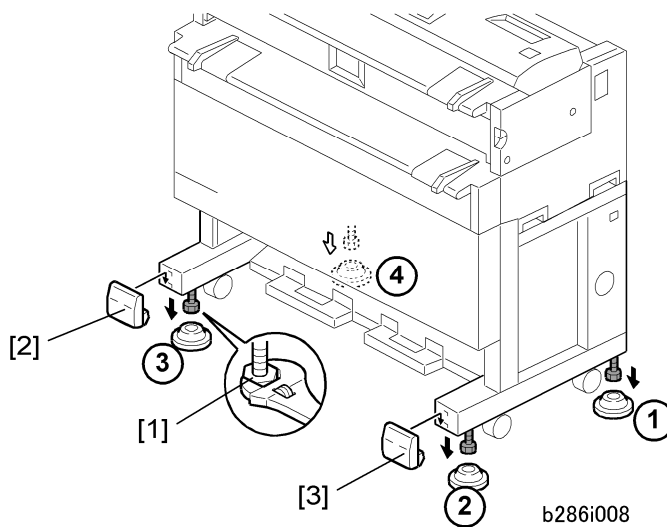

b286i008

3. Set the shoes ①, ②, ③, ④ under the main machine.

4. Use a wrench to adjust the nuts [1] on each foot to raise or lower the main machine at each corner.

↓ Note

- The main machine must be level side-to-side within $\pm 0.15/m$.

5. Attach the left leg cover [2] and the right leg cover [3].

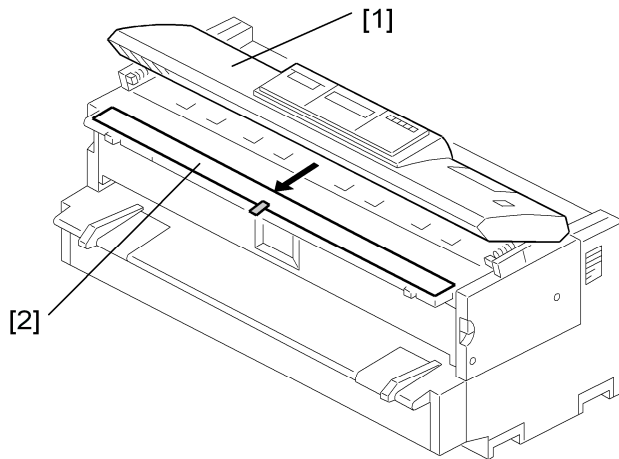

b286i003

6. Raise the original feed unit [1].
7. Remove the protective sheet and tape [2].

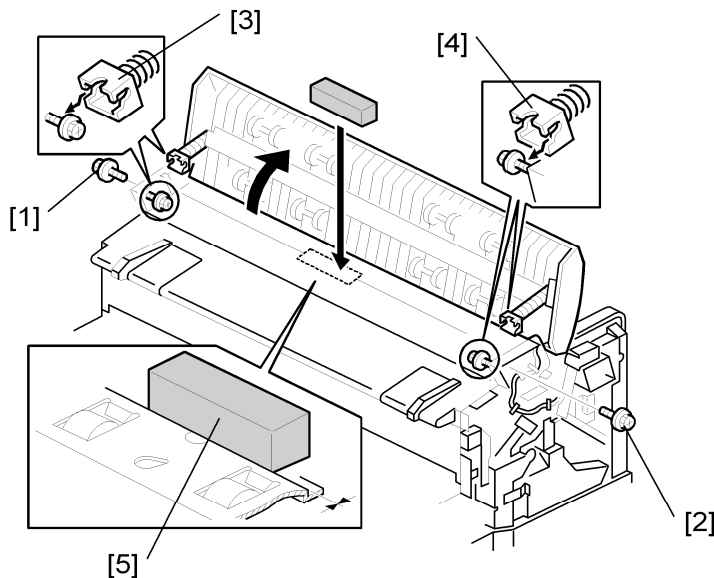

b286i010

8. Remove the lock screws [1], [2] ($\frac{1}{4}$ " x 2)
9. Lift the left hinge [3] and right hinge [4] off their support screws then lift the unit to the vertical position. (Do not remove the support screws.)
10. Put the level [5] on the exposure glass.

Main Machine Installation (B286)

11. Reattach the hinges and fasten the lock screws removed in Step 8.

Developer

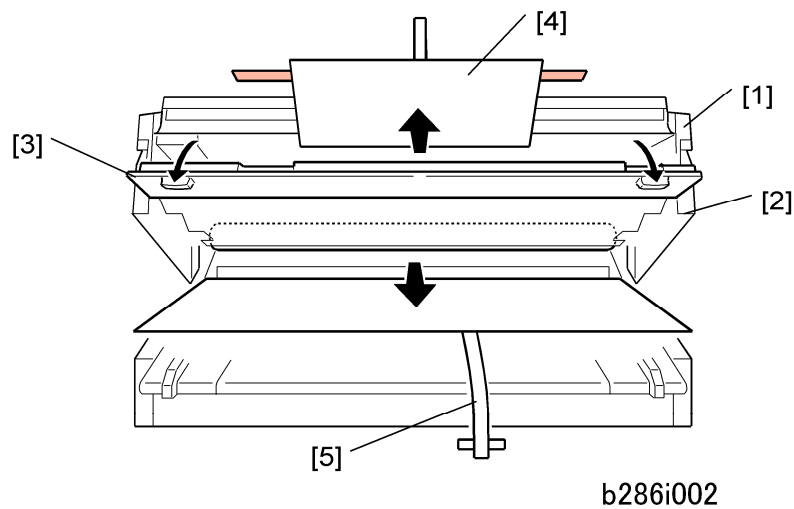

1. Push up the buttons [1] to release the upper unit. Then open the upper unit [2].
2. Open the toner hopper cover [3].
3. Remove all tape and packing materials [4] in the upper unit.
4. Slowly pull out the drum protection sheet [5].

★ Important

- A developer lot number is embossed on the top edge of each package. Save these top edges after you open each developer package. You will need these numbers when you enter them later with SP2801-2 and -3.

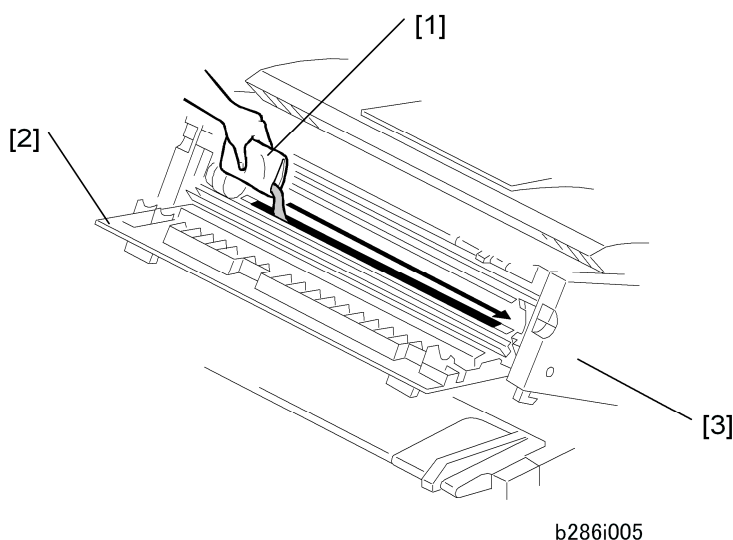

5. Open a 1 kg pack of developer and pour it into the development unit.

★ Important

- Do not add the second pack at this time.
 - Open the first pack of developer [1].
 - Slowly add the developer from the first pack into the development unit, as you move the pack from left to right until the pack is empty.
 - An equal amount of developer must be spread along the entire open slot of the development unit.
6. Close the toner hopper cover [2].
 7. Close the upper unit [3].
 8. Connect the power supply cord. Switch the main power switch on. The main motor switches on and distributes the developer evenly inside the development unit.
 9. Wait about 10 sec.
 10. Turn the main power switch off.
 11. Disconnect the power cord.
 12. Open the upper unit.
 13. Open the toner hopper cover.
 14. Open the second 1 kg pack of developer, then slowly add it to the development unit.
Move the pack from left to right until it is empty.
 15. Use a clean cloth to clean the edges around the slot of the development unit.
 16. Close the upper unit.

Toner Cartridge Installation

To prepare a toner cartridge for installation

Main Machine Installation (B286)

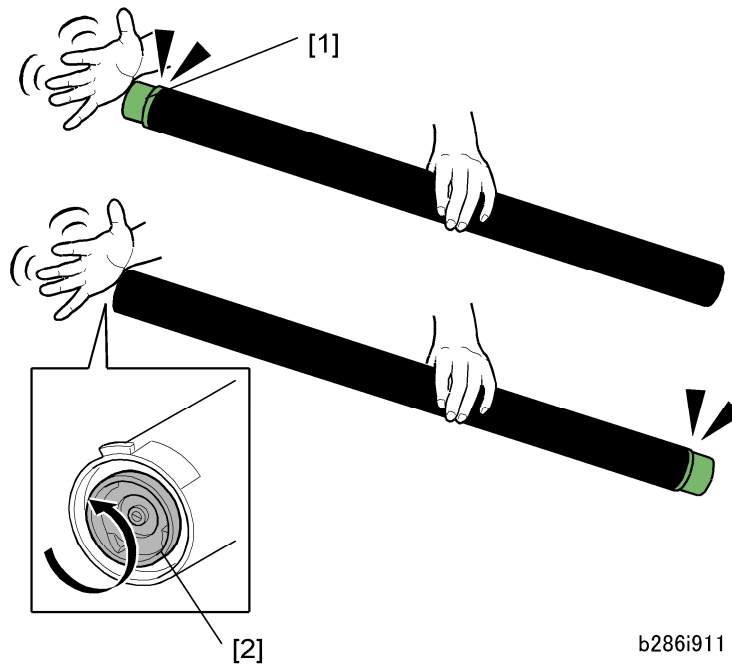

b286i911

1. Remove the cartridge from its package.
2. Gently tap the capped end of the cartridge [1] 4 or 5 times.
3. Tap the other end of the cartridge 4 or 5 times.
4. Shake the cartridge from side to side 4 or 5 times so the toner moves freely inside the cartridge.
5. Rotate the joint [2] to confirm that it rotates easily. If the joint does not rotate easily, tap the ends of the cartridge and shake it again.

★ Important

- Show the operators this procedure so that they know how to load the cartridge properly.
- If the toner is not loosened inside the cartridge before it is installed, the operator may hear a rattling noise when the main machine is switched on. (The noise is caused by agitators inside the cartridge that disengage if compacted toner prevents them from rotating.)
- Show the operators how to store unused toner cartridges properly. Cartridges must be stored horizontally on a flat surface to prevent toner from clumping together at one end of the cartridge. A toner cartridge should never be stored standing on one end.

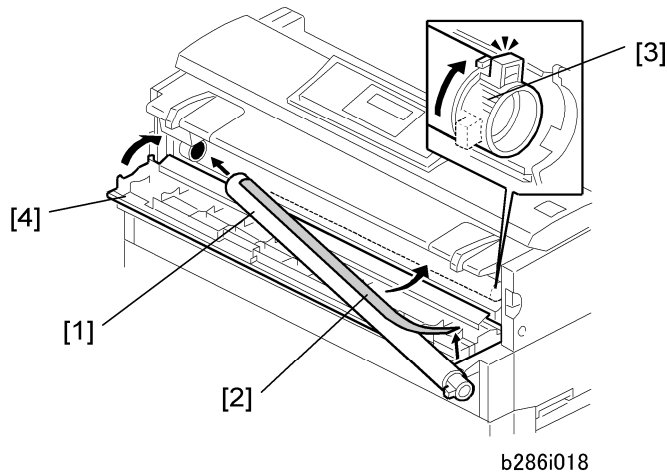
To install a toner cartridge

1. Set the toner cartridge [1] in the main machine.
2. Pull up the tape [2] then pull it across the toner cartridge from right to left to remove the tape.
3. On the right end of the toner cartridge, push the knob [3] up until it stops.
4. Close the toner hopper cover [4].
5. Switch the main power switch on.

Enter Developer Lot Numbers

1. Go into the SP mode.
2. Do SP2801-2 and 3 to enter the lot numbers.

Note

- Use the soft keyboard on the display panel to enter the lot numbers. (The lot numbers are embossed on the top edge of each developer pack.) If the numbers are the same, enter the same number twice.

Important

- You must enter the lot numbers with SP2801-2 and -3 before doing SP2801-1. The main machine will return an error ("Failed") if you attempt to do SP2801-1 before SP2801-2 and -3.

Mix Developer and Initialize ID Sensor

1. Next, do SP2801-1 to mix the developer (and initialize the ID sensor). This takes about 5 minutes.
2. Do SP2923. This applies a thin layer of toner to the bare drum.

Main Machine Installation (B286)

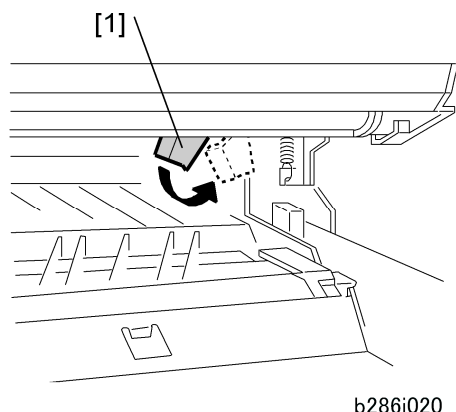

3. Open the upper unit.
4. Push the cleaning-blade release lever [1] to the right.

↓ Note

- The cleaning-blade release lever keeps the cleaning blade away from the drum during transportation. To prevent damage to the drum, before you move the main machine to a different location, be sure to push this lever to the left.

5. Close the upper unit.
6. Do SP3001-2 to initialize the ID sensor again. Initialization takes about 15 sec.

↓ Note

- The ID sensor must be initialized again after the cleaning blade has been lowered onto the drum.

7. Exit the SP mode and turn off the main power switch.
8. If you will install one or more of the following options, do these installations at this time:
 - **Roll Feeder, Paper Cassette** See section 1.4 “Roll Feeder (B851/B852)”, section 1.5 “Paper Cassette (B853)”
 - **Table:** See section 1.6 “Table (B854)”
 - **MFP Options.** See section 1.10 “Installation of MFP Options.”
 - After installing all options (other than the folder unit/manual feeder), complete main machine installation. See section 1.2.3 “Main Machine Final Installation.”
 - **Folder Unit, Manual Feed.** See section 1.7 “Folder Unit (B889)”, section 1.9 “Manual Feeder (D333).”

★ Important

- The Folder Unit and Manual Feed Unit must be installed after the main machine has been completely installed and leveled.

1.2.3 MAIN MACHINE FINAL INSTALLATION

Select the Tray Paper Size and Type

1. Push [User Tools] > “System Settings” > “Tray Paper Settings.”

Note

- Selections are shown only for installed options. If you installed all the options, you will see “Tray Paper Size: Tray 1” (1st Roll), “Tray Paper Size: Tray 2” (2nd Roll), and “Tray Paper Size: Tray 3” (Cassette).
2. Select the paper size for each tray and bypass tray.
 3. Select the paper type for each tray and bypass tray.

Testing the Main Machine Circuit Breaker

Important

- Follow the procedure below to test the operation of the circuit breaker. This must be done at installation and at least once a year after installation.
1. Plug the main machine power cord into its power source and make sure that the main machine power is off.

Important

- Do not turn on the main machine. The main machine must be off.

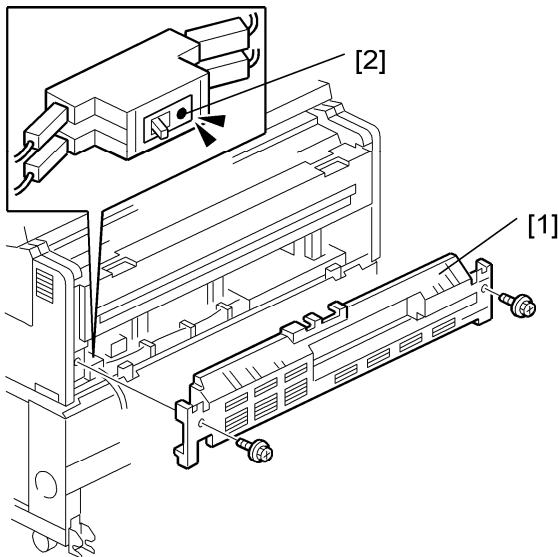

b286r151

2. Remove the rear cover [1] (⚙️x2)
3. Use the tip of a small screwdriver to depress the breaker test button.
 - The breaker switch should flip from “I” to “O.” This indicates that the breaker switch is operating normally.
 - If the breaker switch does not flip to “O”, the switch must be replaced.

Main Machine Installation (B286)

4. Push the breaker lever to display “I” again and reset the main machine for normal operation.

★ Important

- The main machine power will not turn on if the switch [2] remains at “O.”

5. Reattach the rear cover.

Main Machine Accessories

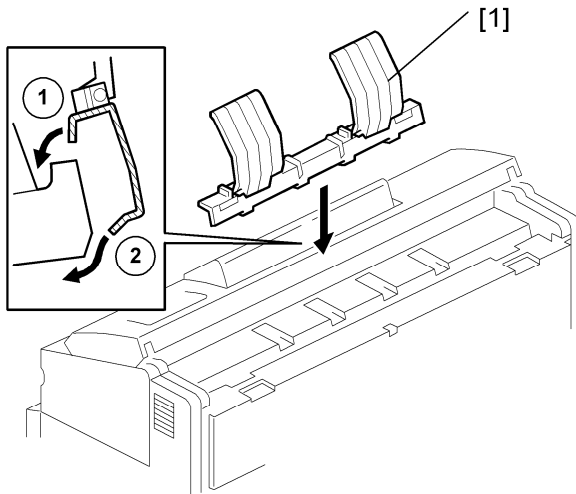

b286i007a

1. To attach the original tray [1], attach the top ① first, then the bottom ② as shown.
2. Make sure the four tabs ② (x4) are completely engaged.

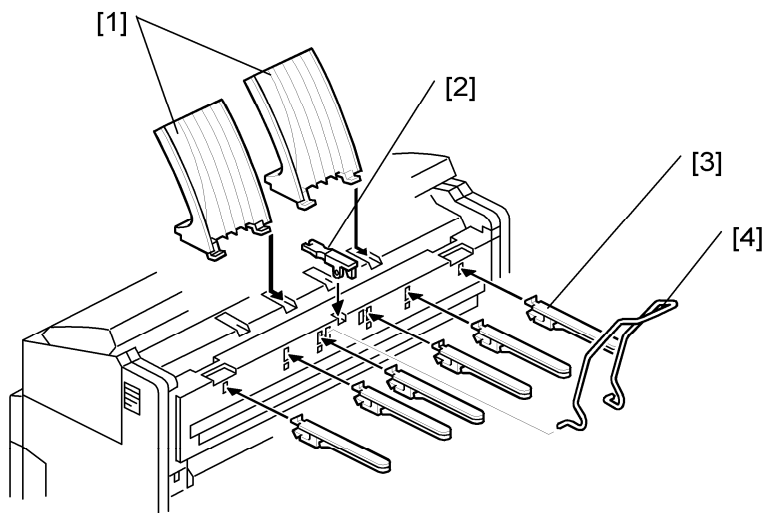

b286i007

3. Attach both upper output stackers [1].
4. Attach the copy exit selection lever [2].
5. Attach the original output guides [3] (x6).
6. Attach the upper output guide [4].

7. Keep the copy-exit selection lever at the vertical position for normal operation.
 - When the lever is up, the user can push the “Upper Copy Output” key to feed copies out of the main machine at the top or straight-through out the rear.
 - When the lever is down, the “Upper Copy Output” key is disabled and copies always feed out straight-through at the rear of the main machine.
 - To enable the “Upper Copy Output” selector key again, lift the lever to the vertical position.

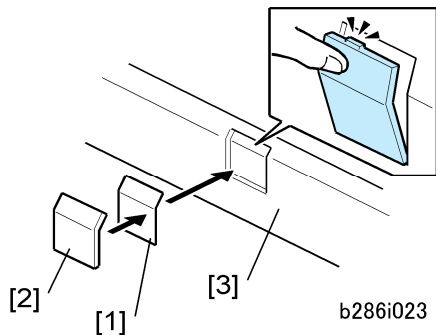

8. Attach the emblem [1] and panel [2] to the toner hopper cover [3].

↓ Note

- Push the panel in until the emblem and panel move into their positions with an audible click.

Roll Feeder, Table Accessories

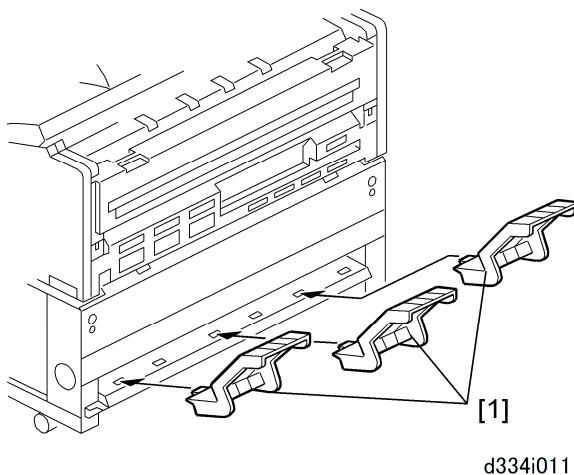

1. Attach the lower output trays [1] to the lower rear of the roller feeder or table (x 3).

Main Machine Installation (B286)

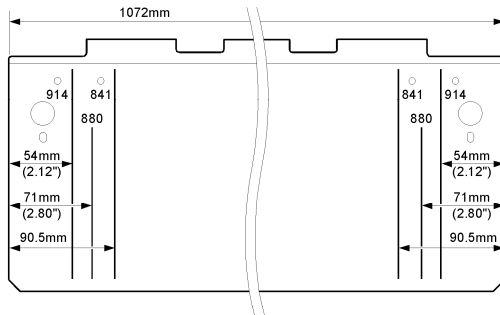

d334i031a

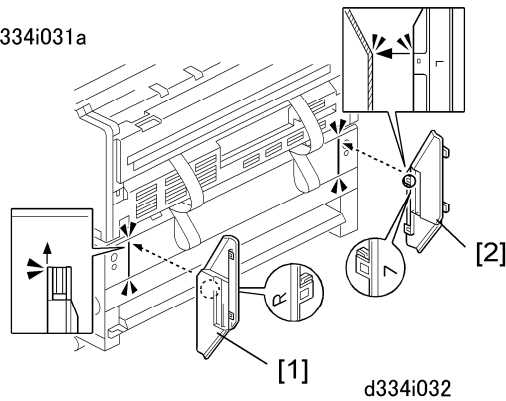

Note

- The lines and numbers embossed on the back of the main machine (see the upper left of the above diagrams) show where to position the exit guide plates for different paper widths.
2. Position the right exit guide plate [1] as shown, then attach it with its magnet.
 3. Position the left exit guide plate [2] as shown, then attach it with its magnet.

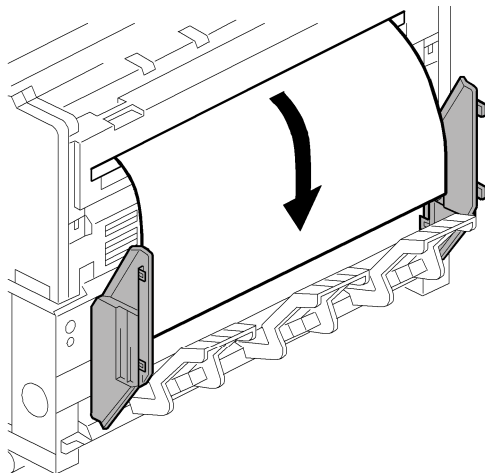

d334i033

4. Do a test print to confirm that the paper exits the main machine straightly and smoothly between the guide plates.

Copy Check

Scan an original to confirm that the main machine operates correctly.

1. Set an original or test pattern face down on the original feed tray.
2. After about 1 second, the main machine pulls the original, stops for 1 second, then starts to feed it.
3. Do a sample copy from the roller feeder and paper cassette if these options are installed.
4. If the copied image is not in the correct position, do SP2941 (IPU Test Pattern) and print pattern 11. For instructions on leading edge and side-to-side adjustments, see section 3.11 “SP Adjustments.”

Paper Roll Adjustments

SP No.	Name	Comment
1001-1	Leading Edge Registration – 1 st Roll	B851/B852
1001-2	Leading Edge Registration – 2 nd Roll	B852
1002-1	Side-to-Side Registration – 1 st Roll	B851/B852
1002-2	Side-to-SideRegistration – 2 nd Roll	B852

Paper Cassette Adjustments

SP No.	Name
1001-3	Leading Edge Registration – Cassette (B853)
1002-3	Side-to-Side Registration – Cassette (B853)

Enable Onboard NIB, USB Functions

Do SP5985 (Device Setting) to enable the onboard NIB and USB features built into the GW Controller board.

↓ Note

- The default setting of SP5985 is “0” (Disable). This SP must be set to “1” in order to use the built-in NIB and USB functions.

1.2.4 MOVING THE MACHINE

- If you will move the main machine to a different building, open the paper feed section

Main Machine Installation (B286)

and push the cleaning blade lever to the left. This keeps the cleaning blade away from the drum while you move the main machine.

- If you will move the main machine to a different location in the same building, it is not necessary to set the lever to the left, and it is not necessary to disconnect the main machine from the roll feeder or table.

★ Important

- Always push low on the roll feeder or table to move the main machine. If you do not do this, you can twist and possibly cause damage to the main machine. Do not push on the main machine while it is installed on top of the roll feeder or table.
- To prepare the main machine for transport to a different building, disconnect the main machine and the roller feeder (or table). Attach the drawer to the frame with tape, or the roll feeder drawer will fall out of the table frame.
- Lift the main machine with one person on each end of the main machine. Be sure to use the handles in recesses on the sides of the main machine.
- To prevent developer and toner spill, never tilt the main machine more than 30° from the horizontal.

1.3 ORIGINAL HANGER (D311)

The optional original hanger is attached to the bypass feed table on the front of the main machine.

1.3.1 ACCESSORY CHECK

Check the accessories and their quantities against the table below.

No.	Description	Q'ty
1	Original Hangers	2

1.3.2 INSTALLATION

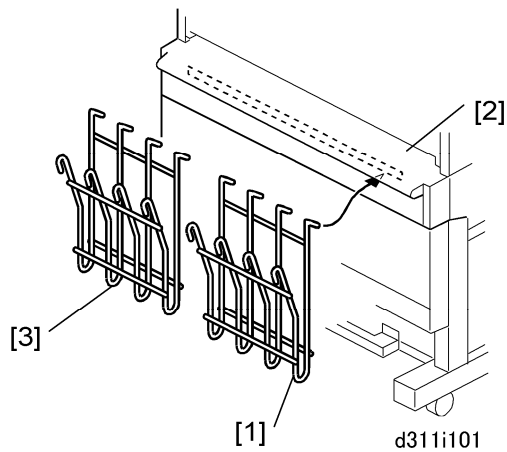

1. Attach one original hanger [1] to the bypass feed table [2].
2. Attach the other original hanger [3] to the bypass feed table.

Roll Feeder (B851/B852)

1.4 ROLL FEEDER (B851/B852)



- The Roll Feeder (B851/B852) is required in order to use the Printer Option (D320/D344).

1.4.1 ACCESSORY CHECK

Check the accessories and their quantities against the table below.

No.	Description	Q'ty
1	Lower Output Trays	3
2	Leg Covers	2
3	Movable Guides	6
4	Shoes	4
5	Joint Brackets (Left, Right)	2
6	Exit Guide Plates	2
7	Screws (Cosmetic Silver)	4
8	Screws (Blue)	9
9	Harness Brackets	2
10	Mylars – Wide	2
11	Mylars – Narrow	2
12	Nylon clamp	1
13	Harness clamp	1
14	Ferrite Core (for B275)	1
15	Guide Plate	1

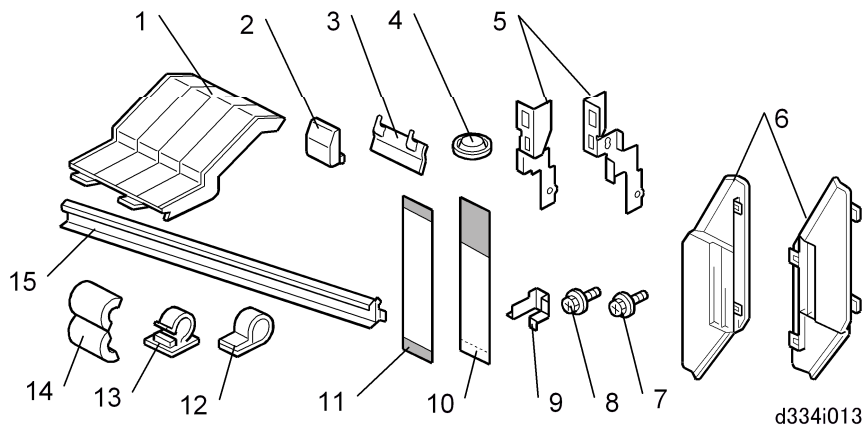

1.4.2 ROLL FEEDER INSTALLATION PROCEDURE

Setting the Main Machine on the Roll Feeder

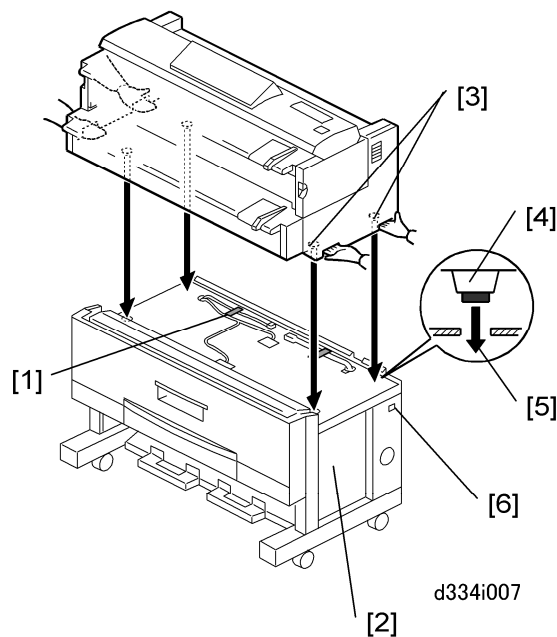

1. Do not remove the shipping tape from the connectors [1] of the roll feeder [2]. This prevents damage to the connectors when the main machine is put on top of the roll feeder.

CAUTION

- The main machine weighs 107 kg (235 lb.).
- There are two handles in recesses on each side of the main machine. To prevent injury or damage to the main machine, always use these handles [3] to lift the main machine.
- Two or more service technicians are necessary to lift the main machine and

Roll Feeder (B851/B852)

set it on the roll feeder.

2. Lift the main machine, and set its rubber feet [4] into the holes [5] on the top of the roll feeder.

↓ Note

- With one person at each end of the main machine, use the two handles on each end of the main machine to lift it.
3. Make sure that you put the rubber feet of the main machine into the holes on top of the roll feeder.
 4. Check the dehumidifier switch [6] of the roll feeder. Make sure that it is OFF. If it is ON, set it to OFF.

Opening the Roll Feeder and Removing Shipping Material

★ Important

- The drawer of the roll feeder is locked and cannot be opened until the main machine is set on top of the roll feeder.
- Do not try to open the drawer of the roll feeder until after you set the main machine on top of the roll feeder.

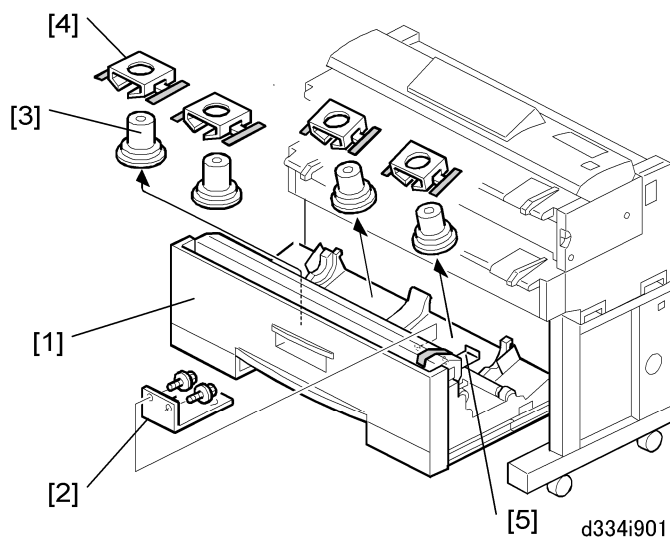

1. Open the drawer [1] of the roll feeder.
2. Remove the spring lock plate [2] (🔧 x 2).
3. Remove the roll paper holders [3] and cardboard packing [4].

↓ Note

- Roll Feeder B851 has 2 holders, and Roll Feeder B852 has 4 holders (shown above).
4. Remove other tape or packing material in the roll feeder.
 5. Remove the shipping lock plate [5] (🔧 x 2).

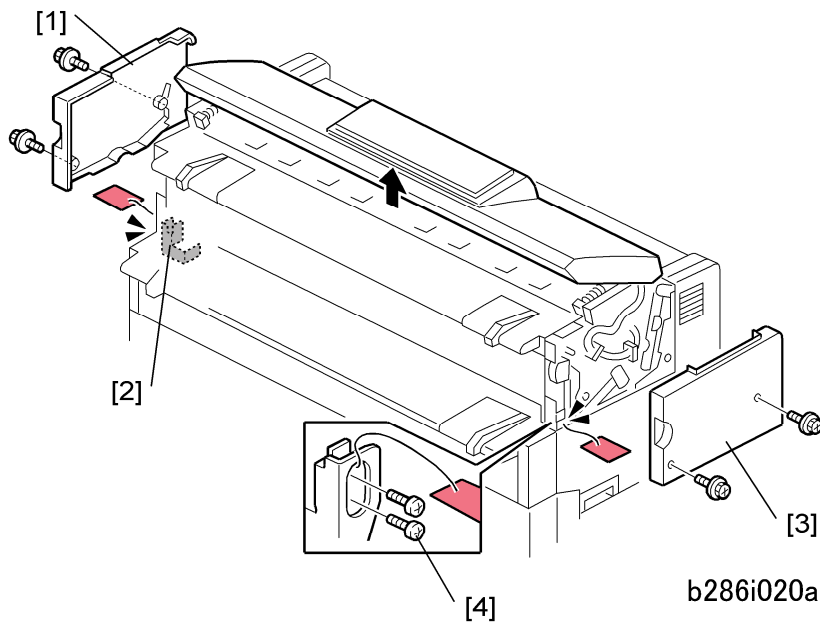

6. Remove the covers and screws:

- [1] Left upper cover (⌀ x 2)
- [2] Left screws (⌀ x 2)
- [3] Right upper cover (⌀ x 2)
- [4] Right screws (⌀ x 2)

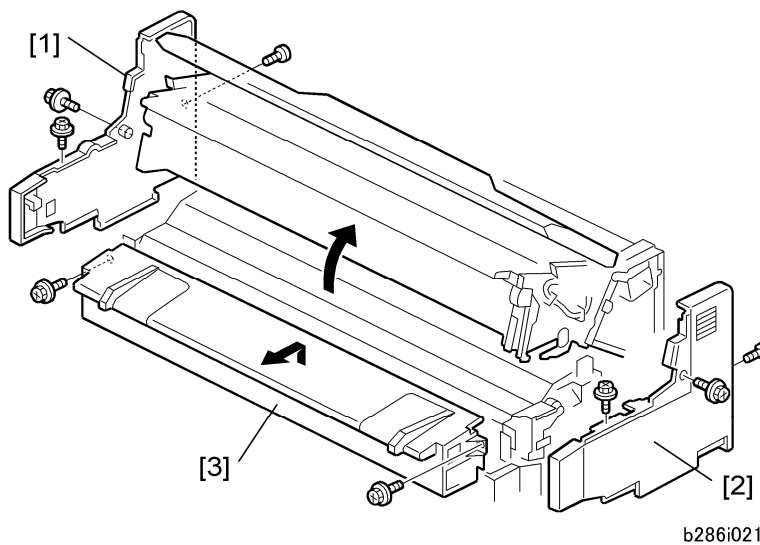

7. Open the upper unit.

8. Remove:

- [1] Left cover (⌀ x 3)
- [2] Right cover (⌀ x 3)
- [3] Manual feed table (⌀ x 2).

Roll Feeder (B851/B852)

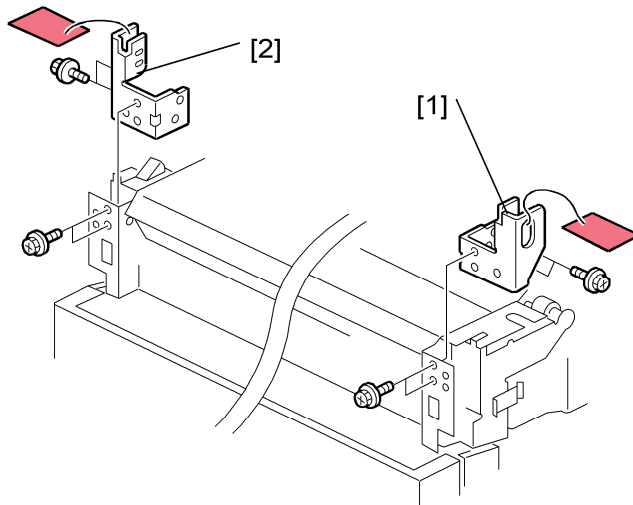

b286i022

9. Remove the right transport lock plate [1] (⚙ x 4).
10. Remove the left transport lock plate [2] (⚙ x 4).

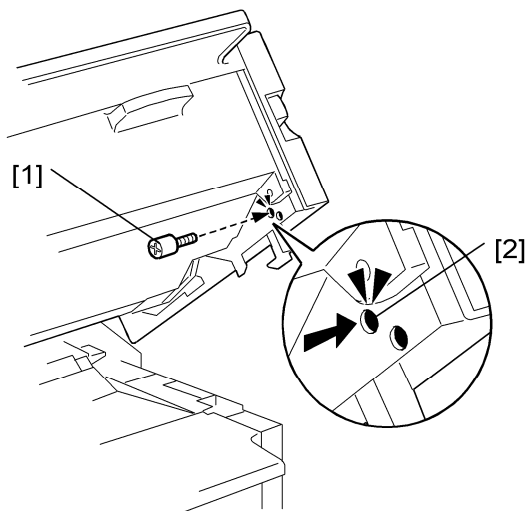

b286i016

11. Install the studs [1] on the right side and the left side.

Note

- You must fasten each stud in the upper hole [2] on both sides.

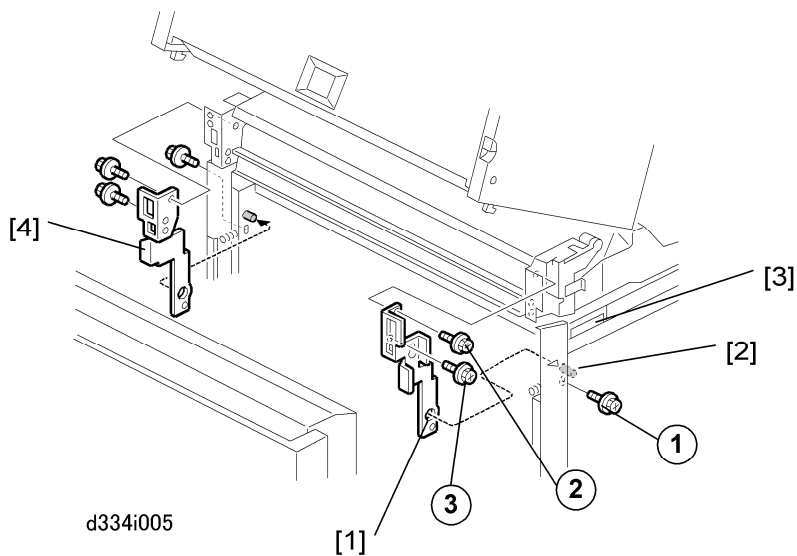

12. Attach the right joint bracket [1] (the spindle [2] must go through the hole). At the same time, align the plate with the holes for the three screws (blue).

↓ Note

- The joint brackets and screws are provided as accessories with the roll feeder.

13. Attach screws ①, ② but do not tighten them.
14. While you lift the main machine by its handle [3], set screw ③ in the lower hole of the keyhole cutout and tighten it.
15. Tighten screws ① and ②.
16. Do the above procedure again for the left joint bracket [4].

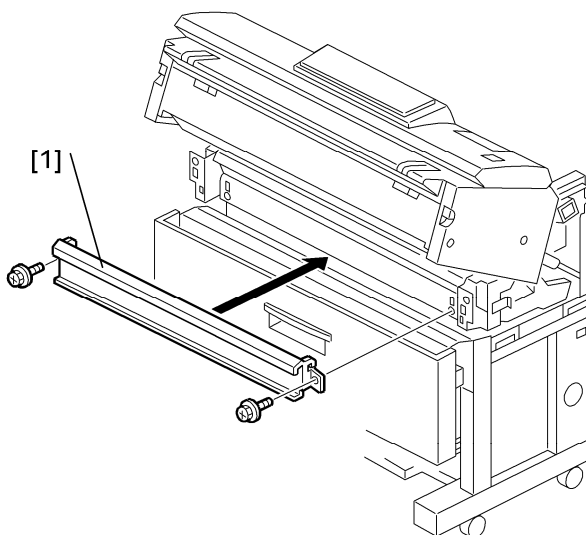

↓ Note

- The guide plate and screws are provided as accessories with the roll feeder.

Roll Feeder (B851/B852)

17. Install the guide plate [1] (x 2 Blue). Hang the hooks on each end; this puts the plate in the correct position to be installed.

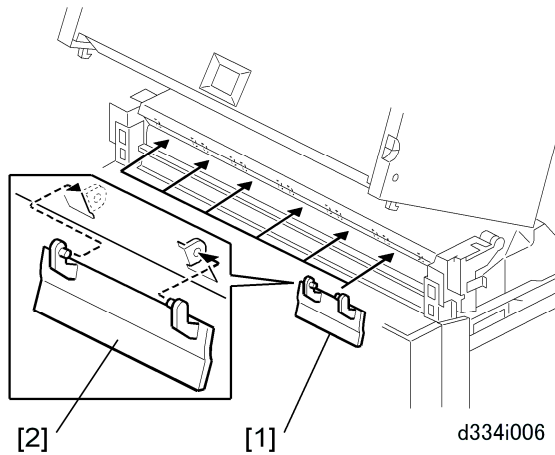

↓ Note

- The movable guide plates are provided as accessories with the roll feeder.

18. Attach the movable guide plates [1] (x6).
 - Each plate is the same. It is not possible to install a plate in the incorrect position.
 - Attach each plate with the ribbed side down.
 - Move the hinges [2] a small distance apart. This allows the tabs attach easily into the holes.
19. Lift each plate and let it fall, to make sure that they move smoothly on the hinges.
20. Reattach the manual feed table.
21. Reattach the left and right covers.

↓ Note

- The flat-head screw must be attached at the rear side of each cover.

22. Close the upper unit.

Leveling the Main Machine and Attaching Leg Covers

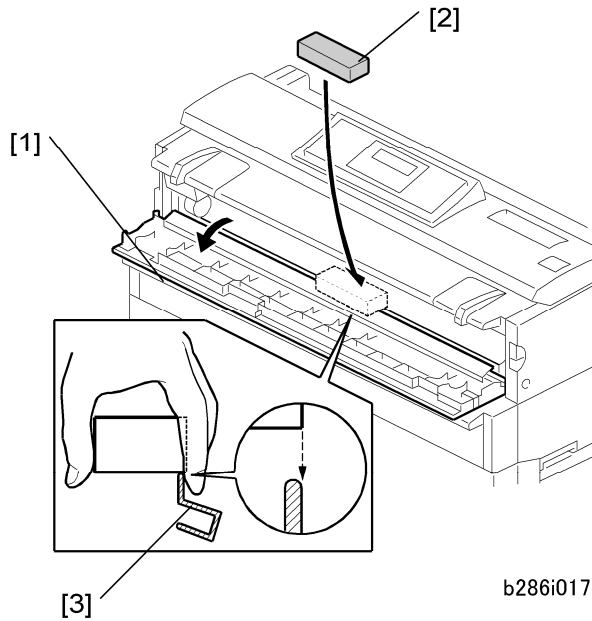

b286i017

1. Open the toner hopper cover [1].
2. Set a level [2] on the plate [3] of the development unit.

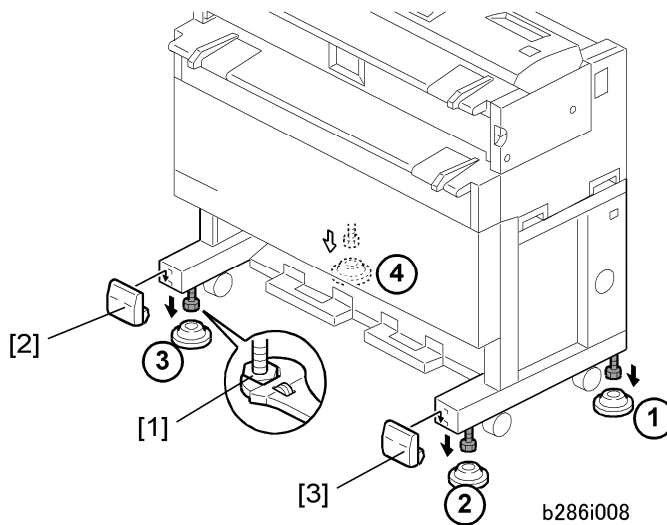

b286i008

3. Set the shoes ①, ②, ③, ④ under the main machine.
4. Use a wrench to adjust the nuts [1] on each foot to raise or lower the main machine at each corner.

↓ Note

- The main machine must be level side-to-side within $\pm 0.15/m$.
5. Attach the left leg cover [2] and the right leg cover [3].

Roll Feeder (B851/B852)

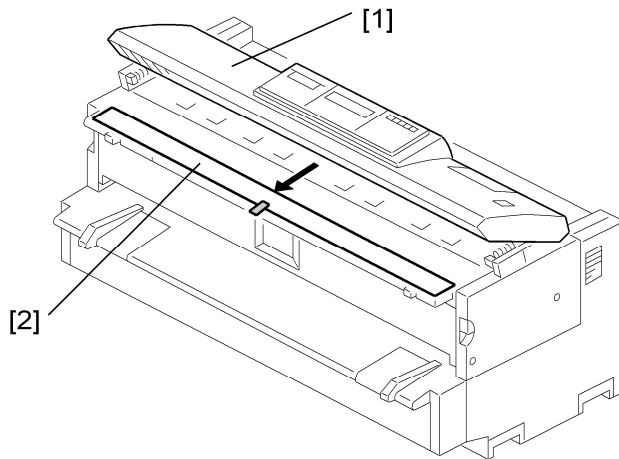

b286i003

6. Raise the original feed unit [1].
7. Remove the protective sheet and tape [2].

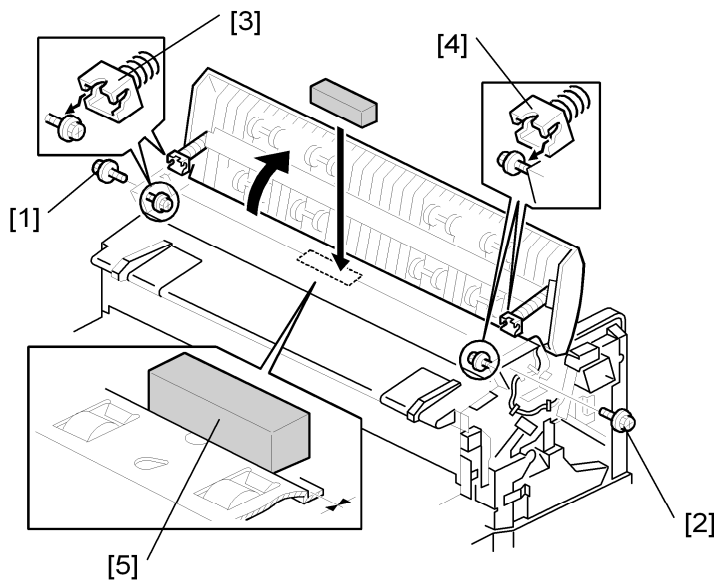

b286i010

8. Remove the lock screws [1], [2] ($\frac{1}{4}$ x 2)
9. Lift the left hinge [3] and right hinge [4] off their support screws then lift the unit to the vertical position. (Do not remove the support screws.)
10. Put the level [5] on the exposure glass.
11. Use a wrench to adjust the nuts on each foot to lift or lower the main machine at each corner.

↓ Note

- The main machine must be level side-to-side within $\pm 0.15/m$.

12. Reattach the hinges and fasten the lock screws removed in Step 8.

Connecting the Main Machine and Roll Feeder

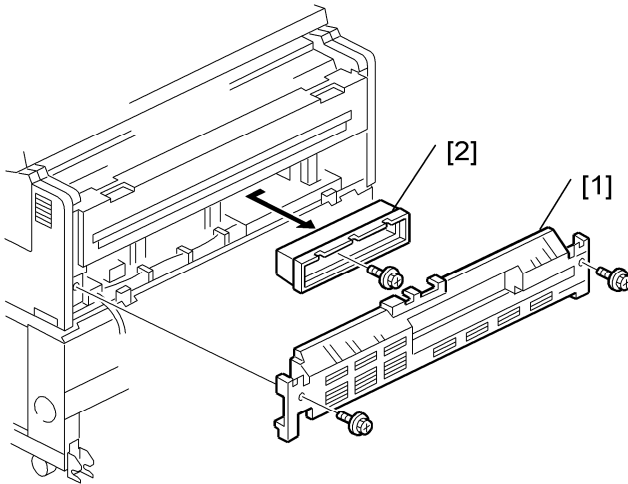

b286i914a

1. Remove the rear cover [1] of the main machine (⌀x2).
2. Remove the cover of the controller unit [2] (⌀x1).

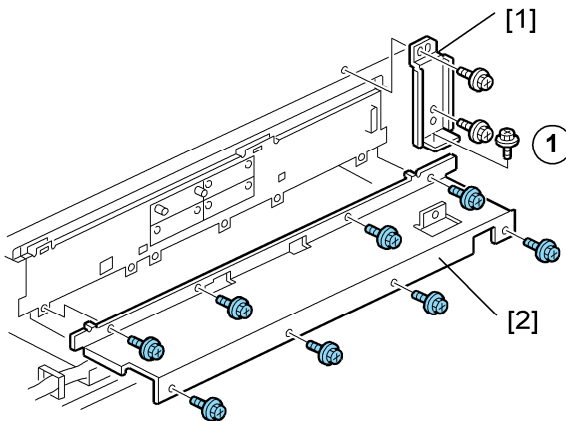

b889i105

3. Remove the ground plate [1] (⌀ x 3).

↓ Note

- Open the paper exit cover (C1) and paper exit unit (C2) together to remove screw ① (the vertical screw).
4. Remove the shield cover [2] (⌀ x 8).

Roll Feeder (B851/B852)

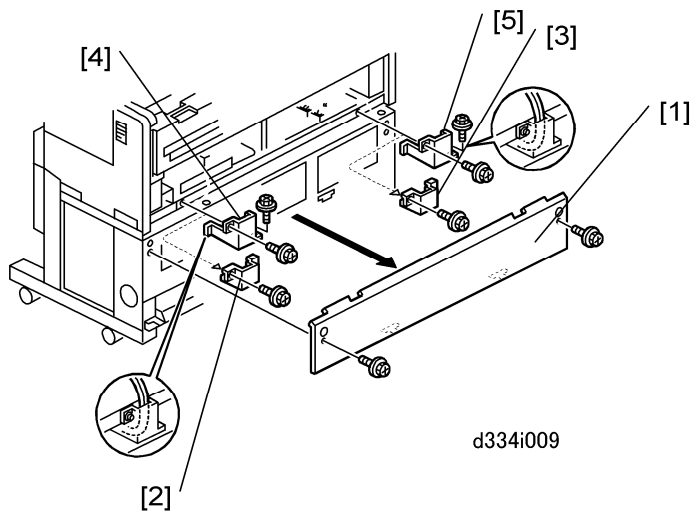

5. Remove the rear plate [1] of the roll feeder (⚙ x 2).
6. Remove the metal brackets [2], [3] (⚙ x 1 each). Discard these brackets and screws.
7. Remove the shipping tape from the roll feeder harnesses between the bottom of the main machine and top of the roll feeder.
8. Route the harness (⚙ x 1) through bracket [4] then attach the bracket (⚙ x 2). (Use one screw from the accessories.)
9. Route the harness (⚙ x 2) through bracket [5] and then attach the bracket (⚙ x 2). (Use one screw from the accessories).

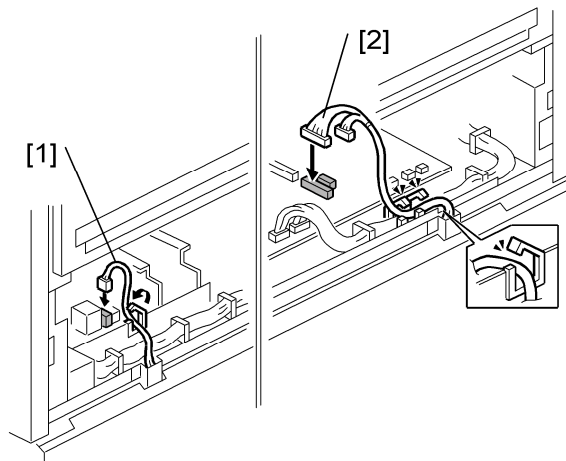

10. Connect the left harness [1] to **CN103** on the PSU (⚙ x 1, ⚙ x 1).
11. Connect the right harness [2] to **CN220** and **CN221** on the MCU (⚙ x 2, ⚙ x 3).

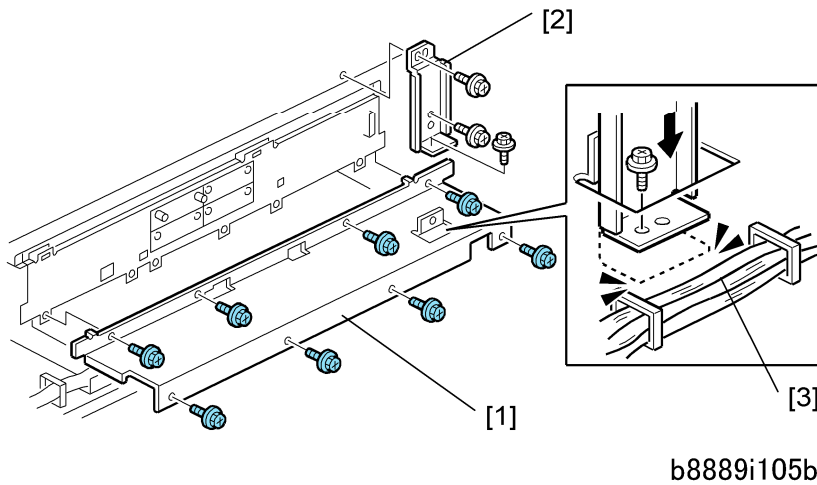

12. Reattach:

- [1] Shield cover (🔩 x 8)
- [2] Ground plate (🔩 x3)
- Roll feeder rear plate(🔩 x 2)

⚠ CAUTION

- When you reattach the ground plate, make sure that the harness wires [3] below are not pinched between the bottom of the frame and bottom of the ground plate.

13. Reattach:

- Controller box cover
- Rear cover

★ Important

- Open and close the paper exit cover C1 and paper exit unit C2 together to confirm that the rear cover is installed correctly. If the paper exit cover does not open properly, remove the rear cover and install it again.

Attaching the Narrow Mylars to the Main Machine

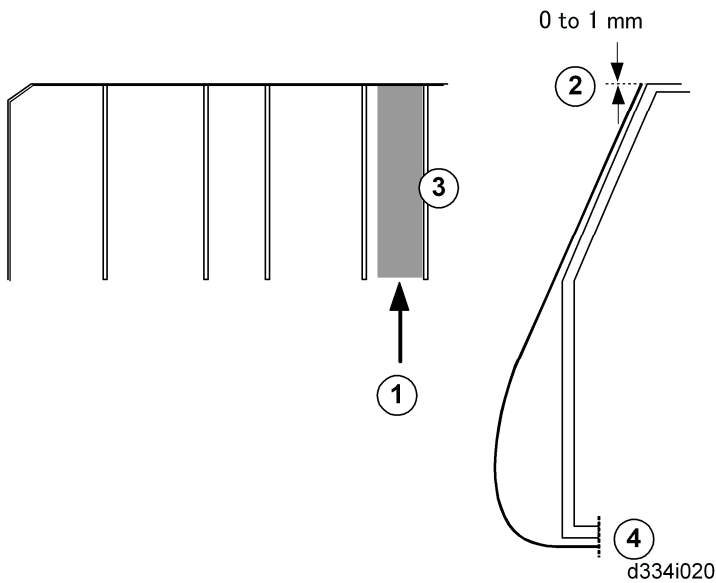

1. Find the 5th space ① from the left end of the rear cover.
2. Use a clean cloth, moistened with a small amount of alcohol, to clean this area and the bottom edge of the cover.
3. Remove the tape from each end of one of the narrow mylars.
4. Attach one end to the top edge of the cover ②.

↓ Note

- The top edge must be flat and parallel to the edge of the cover. The right edge of the mylar must be parallel to ridge ③.
5. Attach the other end of the mylar to the bottom edge of the cover ④.
 6. Do this procedure again to attach the other narrow mylar to the right side of the cover.

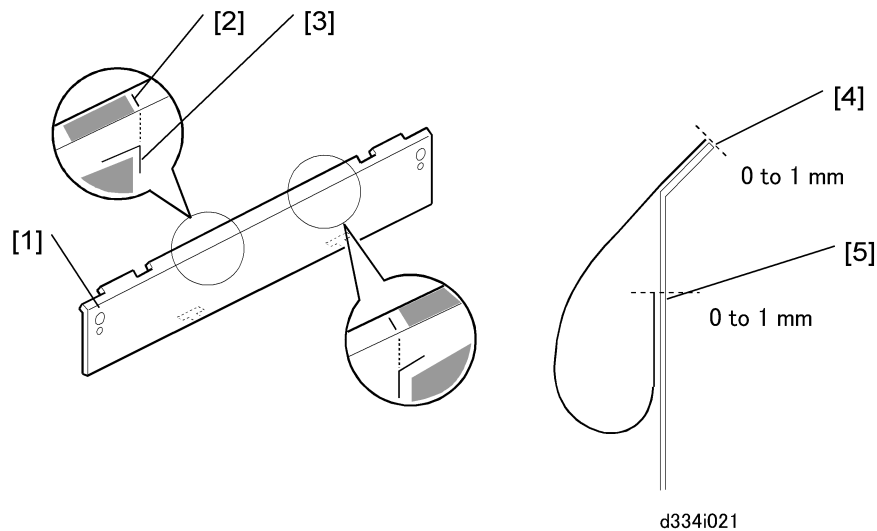
Attaching the Wide Mylars to the Back of the Roll Feeder

d334i021

1. On the left side of the rear plate [1], find the straight line [2] and \sqcap , \sqsubset patterns [3].
2. Use a clean cloth, moistened with a small amount of alcohol, to clean this area and the bottom edge of the cover.
3. Remove the tape from each end of one of the wide mylars.
4. Align the end with the narrow tape with the top edge [4] of the rear plate. Make sure that the right edge is parallel to the vertical lines on the plate, then push down.
5. Turn the end with the wide tape against the plate, and align its corner [5] with the inverted "L" pattern embossed on the plate, then push it against the rear plate.
6. Make sure that the tape surfaces are pushed fully against the rear plate.
7. Reattach the rear cover of the main machine (⚙ x 2).

Roll Feeder (B851/B852)

Securing the Power Cord

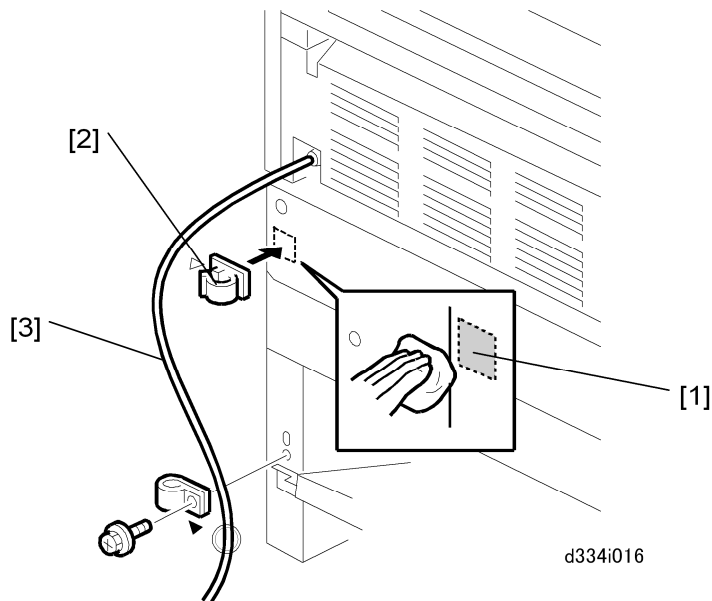

1. Clean the rear plate [1] with alcohol.
2. Attach the harness clamp [2].
3. Clamp the power cord [3] to the roll feeder (⚙ x 1).

Installing the Paper Rolls

If you will install the optional paper cassette (see section 1.5 “Paper Cassette (B853)”), do this before you install the paper rolls.

If you do not install the paper cassette first, you must remove Roll 2 before you can install the optional paper cassette.

↓ Note

- To install the paper rolls, follow the instructions on the decal on the top edge of the roll feeder drawer.

Attaching the Lower Output Tray, Exit Guide Plates

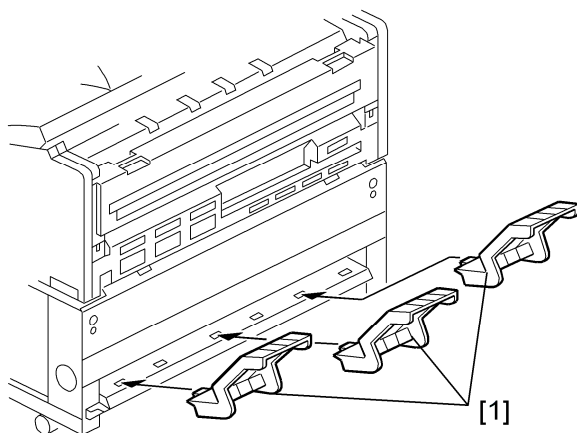

d334i011

1. Attach the lower output trays [1] to the lower rear of the roll feeder (x 3).

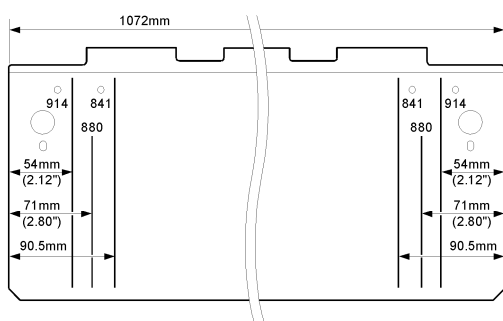

d334i031a

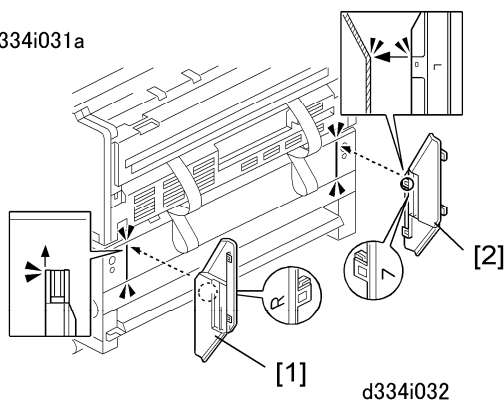

d334i032

Note

- The lines and numbers embossed on the back of the main machine (see the upper left of the above diagrams) show where to position the exit guide plates for different paper widths.
2. Position the right exit guide plate [1] as shown then attach it with its magnet.
 3. Position the left exit guide plate [2] as shown then attach it with its magnet.

Roll Feeder (B851/B852)

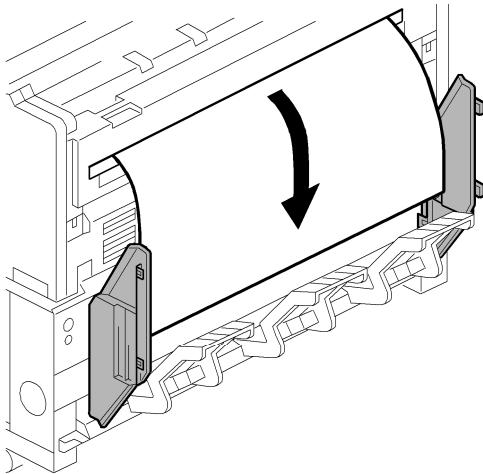

d334i033

4. Do a test print to confirm that the paper exits the main machine straightly and smoothly between the guide plates.

Entering the Cut Length Adjustment

1. Do the settings for SP1920. These are the cut length SP settings for the rolls (there are two settings for each roll).
2. Check the label on the right side of the roll feeder drawer. Do the settings written on the label.

Roll	SP No.	Name
Roll 1	1920-111	Cut Length Adjustment: 1 st Roll:297 mm:Plain Paper
Roll 1	1920-115	Cut Length Adjustment: 1 st Roll:1189 mm:Plain Paper
Roll 2	1920-211	Cut Length Adjustment: 2 nd Roll:297 mm:Plain Paper
Roll 2	1920-215	Cut Length Adjustment: 2 nd Roll:1189 mm:Plain Paper

3. Switch the main power switch off, then switch it on again.

Setting Paper Sizes/Types for the Tray 1 (1st Roll), Tray 2 (2nd Roll)

1. Push [User Tools]> “System Settings”> “Tray Paper Settings”> “Tray Paper Size: Tray 1”, “Tray Paper Size: Tray 2.”
2. Select the paper size for Tray 1 and Tray 2.
3. Push “Next”> “Paper Type: Tray 1”, “Paper Type: Tray2
4. Select the paper type for Tray 1 and Tray 2.

1.5 PAPER CASSETTE (B853)

★ Important

- The Paper Cassette (B853) is installed in the Roll Feeder (B851/B852).

1.5.1 ACCESSORY CHECK

Check the accessories and their quantities the table below.

No.	Description	Q'ty
1	Paper Cassette Unit	1
2	Screws	4
3	Harness Clamps	4
4	Paper Cassette (Universal Type)	1

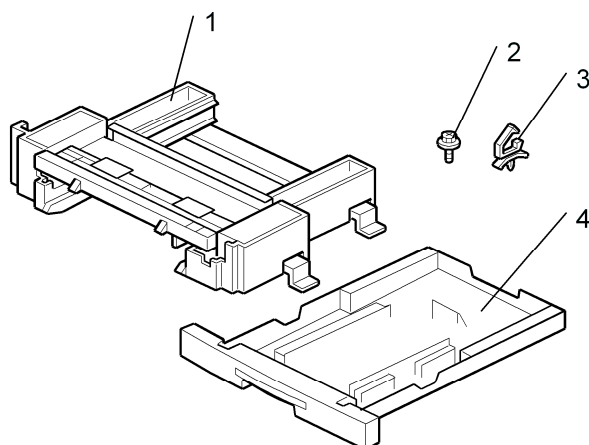

d336i003

1.5.2 PAPER CASSETTE INSTALLATION PROCEDURE

⚠ CAUTION

- Confirm that the machine is switched off and that the power cord is disconnected from the power source before doing this procedure.

Paper Cassette (B853)

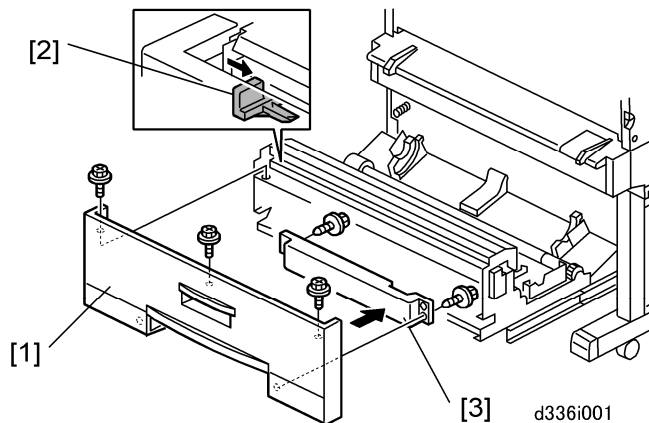

1. Open the drawer of the roll feeder.
2. Remove the front cover [1] of the roll feeder (⚙ x 3)

↓ Note

- If you cannot see the screw on the left or right side of the front cover, push the cutter [2] away from the top of the screw.
3. Remove the knockout [3] (⚙ x 2).
 4. If Roll 2 is installed, remove it.
 5. Remove the paper cassette from the paper cassette unit.

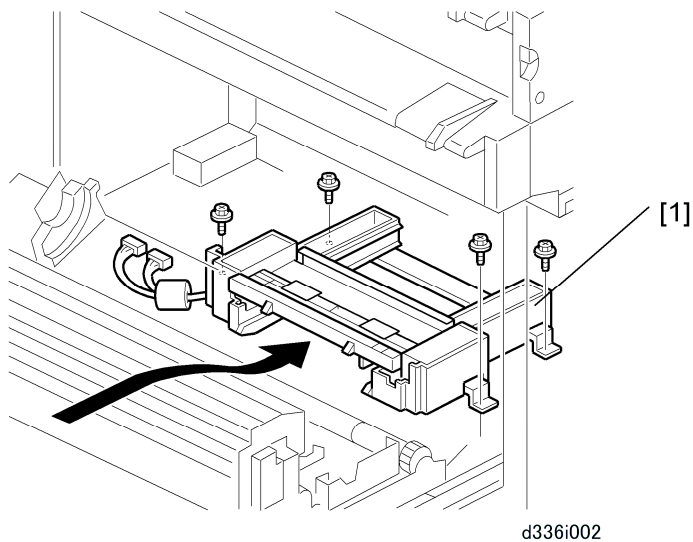

6. Remove the rear plate of the roll feeder (⚙ x 2).
7. Put the cassette unit [1] in the roll feeder. The bosses must go through the holes in the flanges of the cassette unit. Then, attach the cassette unit (⚙ x 4).

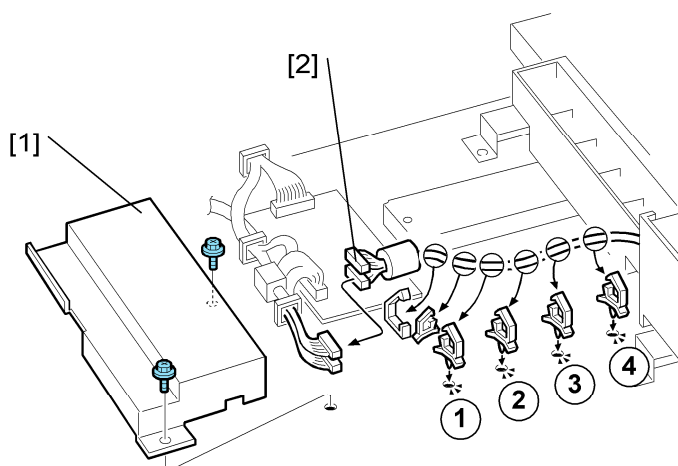

d336i004

8. From the front, remove the board cover [1] (⚙ x 2).
9. Connect the paper-cassette-unit connectors [2] (🔌 x 2) to the roll feeder.
10. From the front, attach the harness clamps ①, ②, ③, ④.
11. Route the connector cable through the open clamps, then close the clamps (🔒 x6).
12. Reattach the board cover, front cover, and rear plate of the roll feeder.
13. Reinstall the paper rolls, and close the drawer of the roll feeder.
14. Put the paper cassette in the paper cassette unit.
15. Set the Paper Size and Type for the Paper Cassette
 - Push [User Tools]> “System Settings”> “Tray Paper Settings”> “Tray Paper Size: Tray 3”
 - Select the paper size for the paper cassette..
 - Push “Next”> “Paper Type: Tray 3”
 - Select the paper type for the paper cassette. (Default: Plain Paper).

Table (B854)

1.6 TABLE (B854)

1.6.1 ACCESSORY CHECK

Check the accessories and their quantities the table below.

No.	Description	Q'ty
1	Lower Output Trays	3
2	Leg Covers	2
3	Shoes	4
4	Joint Brackets (Left, Right)	2
5	Exit Guide Plates	2
6	Screws	9
7	Mylars – Wide	2
8	Mylars – Narrow	2
9	Guide Plate	1
10	Nylon Clamp	1
11	Harness Clamp	1
12	Stopper Bracket (for inch paper sizes)	1

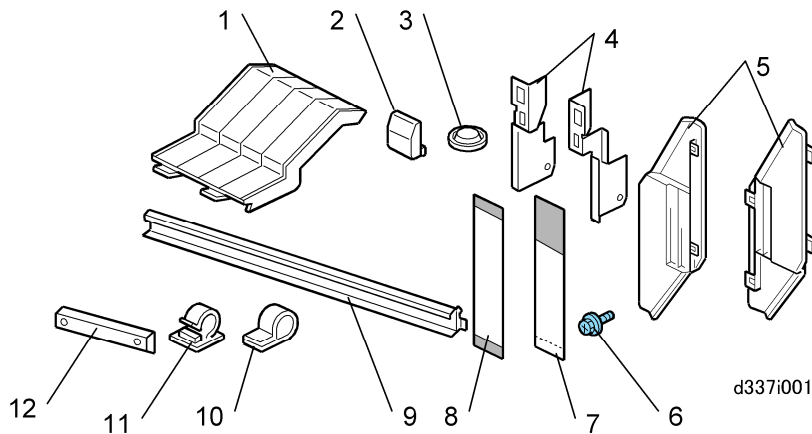

1.6.2 INSTALLATION PROCEDURE

⚠ CAUTION

- Confirm that the machine is switched off and that the power cord is disconnected from the power source before doing this procedure.

Setting the Main Machine on the Table

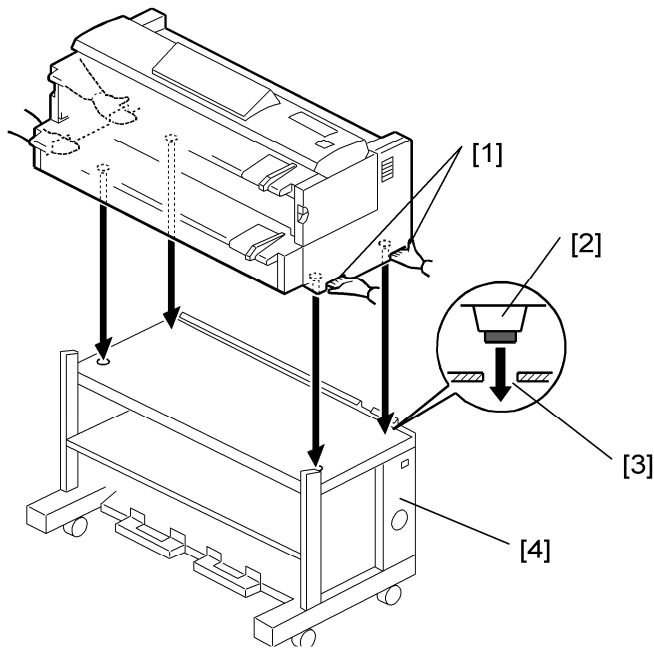

d337i002

⚠ CAUTION

- The main machine weighs 107 kg (235 lb.).
 - There are two handles in recesses on each side of the main machine. To prevent injury or damage to the main machine, always use these handles [1] to lift the main machine.
 - Two or more service technicians are necessary to lift the main machine and set it on the table.
1. Lift the main machine, and set its rubber feet [2] into the holes [3] on the top of the table [4].

↓ Note

 - With one person at each end of the main machine, use the two handles on each end of the main machine to lift it.
 2. Make sure that you put the rubber feet of the main machine into the holes on top of the table.

Table (B854)

Leveling the Main Machine and Attaching Leg Covers

Make the main machine level. Attach the leg covers. Follow the instructions in “Leveling the Main Machine and Attaching Leg Covers.”

Attaching the Guide Plate

⚠ CAUTION

- Keep the power cord disconnected while you do this procedure.

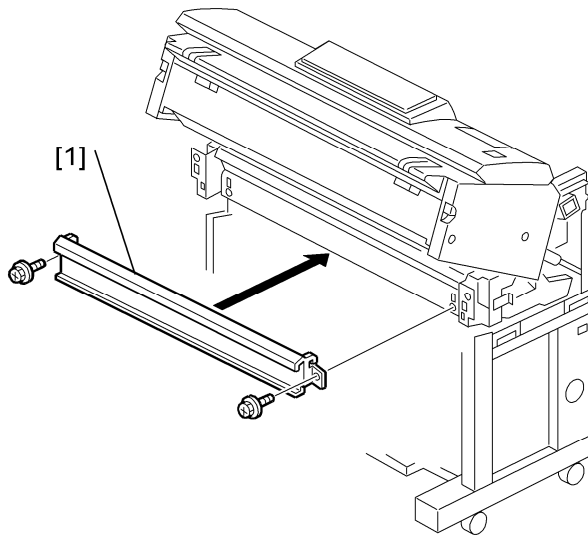

d337i004

1. Install the guide plate [1] (2 Blue). Hang the hooks on each ends; this puts the plate in the correct position to be installed.

Connecting the Main Machine and Table

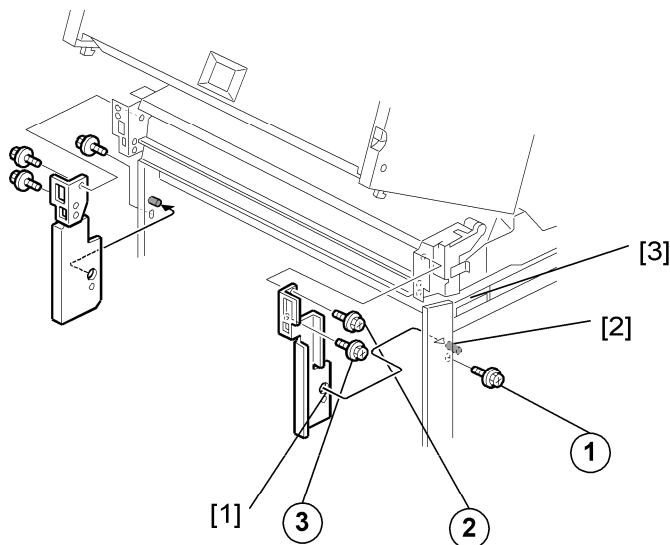

d337i003

Table (B854)

1. Attach the right joint bracket [1] (the spindle [2] must go through the hole). At the same time, align the plate with the holes for the three screws (blue).
2. Attach screws ①, ② but do not tighten them.
3. While you lift the main machine by its handle [3], set screw ③ in the lower hole of the keyhole cutout and tighten it.
4. Tighten screws ①, ②.
5. Do the above procedure again for the left joint bracket.
6. Reattach the manual feed table (⚙ x 2).
7. Reattach the left and right covers (⚙ x 3 each)

↓ Note

- Make sure that you attach the longer screws with the fine threads at the rear sides of the covers.

8. Close the upper unit.

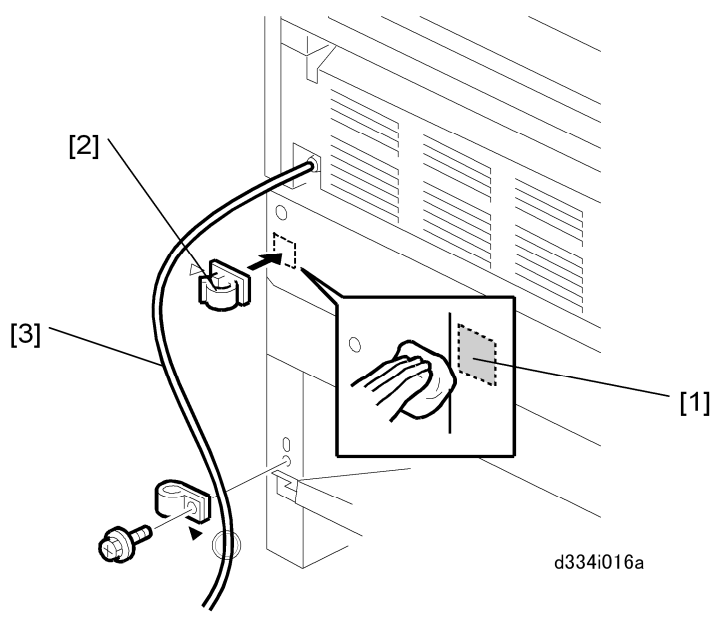

9. Clean the rear plate [1] of the table with alcohol.
10. Attach the harness clamp [2].
11. Clamp the power cord [3] to the table (⚙ x 1).

Table (B854)

Attach the Narrow Mylars to the Main Machine

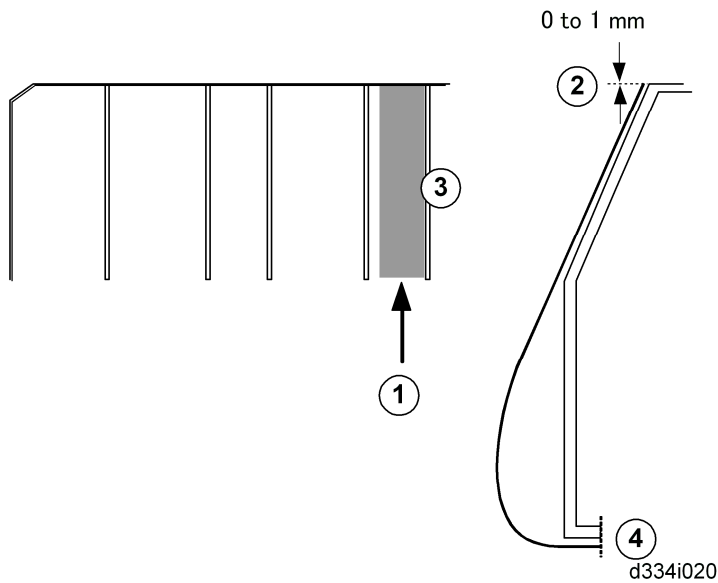

1. If the rear cover is attached to the main machine, remove it (🔧 x 2).
2. Find the 5th space ① from the left end of the rear cover.
3. Use a clean cloth, moist with a small quantity of alcohol, to clean this area and the bottom edge of the cover.
4. Remove the tape from each end of one of the narrow mylars.
5. Attach one end to the top edge of the cover ②.

↓ Note

- The top edge must be flat and parallel to the edge of the cover. The right edge of the mylar must be parallel to ridge ③.
6. Attach the other end of the mylar to the bottom edge of the cover ④.
 7. Do this procedure again to attach the other narrow mylar to the right side of the cover.
 8. Reattach the cover to the back of the main machine (🔧 x 2).

Attach the Wide Mylars to the Back of the Table

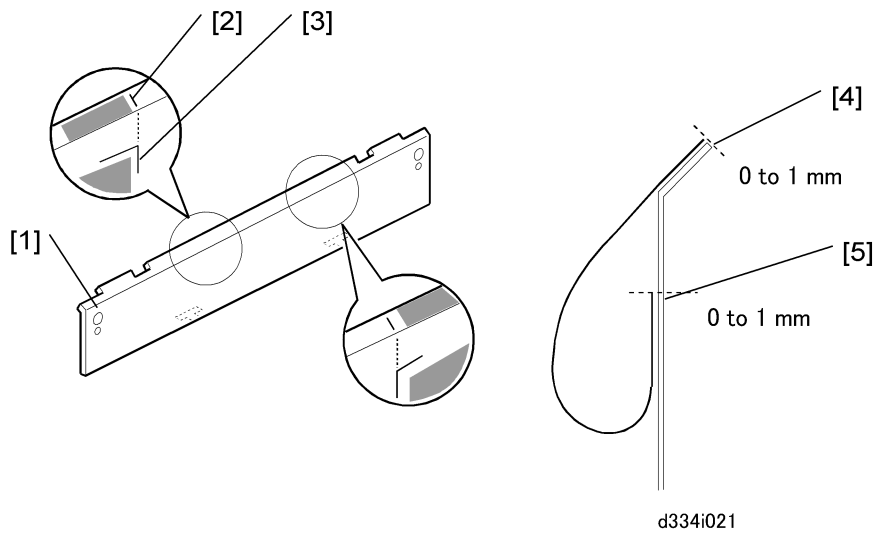

1. On the left side of the rear plate [1], find the straight line [2] and, \lrcorner \llcorner patterns [3].
2. Use a clean cloth, moistened with a small amount of alcohol, to clean this area and the bottom edge of the cover.
3. Remove the tape from each end of one of the wide mylars.
4. Align the end with the narrow tape with the top edge [4] of the rear plate. Make sure that the right edge is parallel to the vertical lines on the plate, then push down.
5. Turn the end with the wide tape against the plate, and align its corner [5] with the inverted "L" pattern embossed on the plate, then push it against the rear plate.
6. Make sure that the tape surfaces are pushed fully against the rear plate.

Table (B854)

Attaching the Stopper Brackets

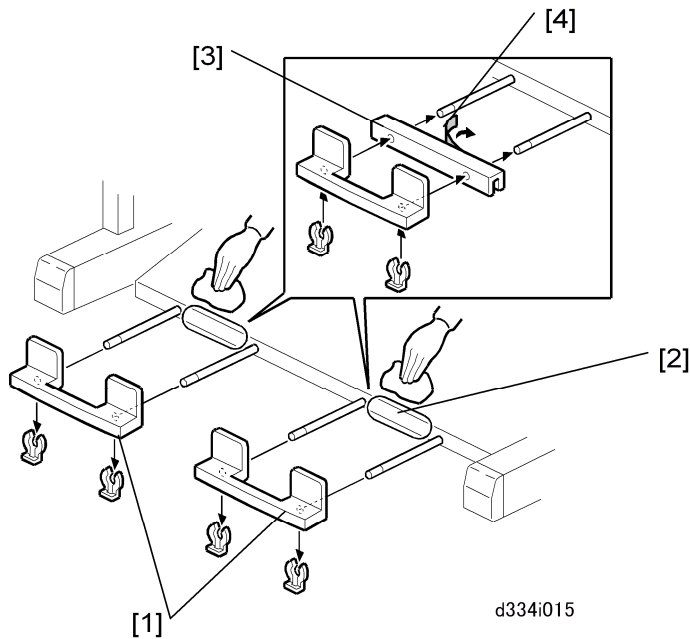

d334i015

Note

- This stopper bracket is only for machines in North America that use inch paper sizes.

1. Remove the stoppers [1] (Ⓢ x 2 each).
2. Use a clean cloth soaked in alcohol to clean the surfaces [2] where the stopper brackets [3] will be attached.
3. Remove the double-sided tape [4] from the rear of each bracket.
4. Install each bracket and stopper on the arms.
5. Lock each stopper in the correct position (Ⓢ x 2 each).

Table Accessories

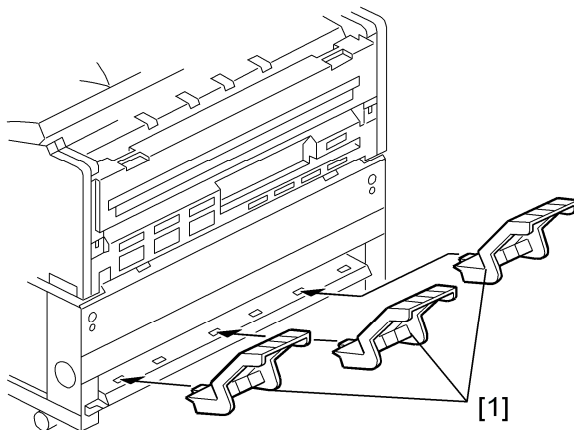

d334i011

1. Attach the lower output trays [1] to the bottom rear of the table (x 3).

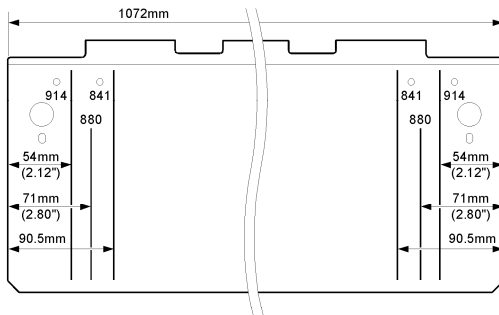

d334i031a

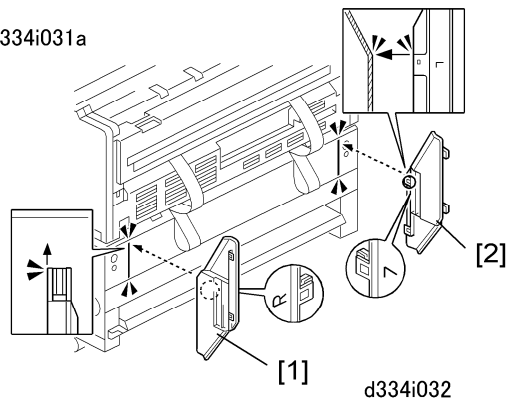

↓ Note

- The lines and numbers embossed on the back of the main machine (see the upper left of the above diagram) show where to position the exit guide plates for different paper widths.
2. Position the right exit guide plate [1] as shown then attach it with its magnet.
 3. Position the left exit guide plate [2] as shown then attach it with its magnet.

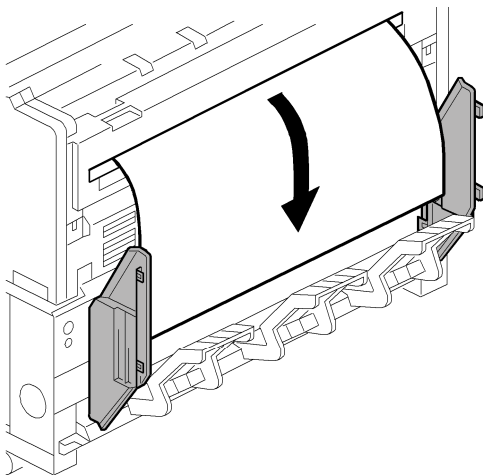

d334i033

4. Do a test print to confirm that the paper exits the main machine straightly and smoothly between the guide plates.

1.7 INSTALLATION OF MFP OPTIONS

1.7.1 OVERVIEW

Three slots for boards (A, B, C) and three slots for SD cards (3, 2, 1) are provided on the controller box. Each board or SD card must be inserted into its assigned slot. The slot assignments of boards and SD cards are written on a decal on the controller box cover.

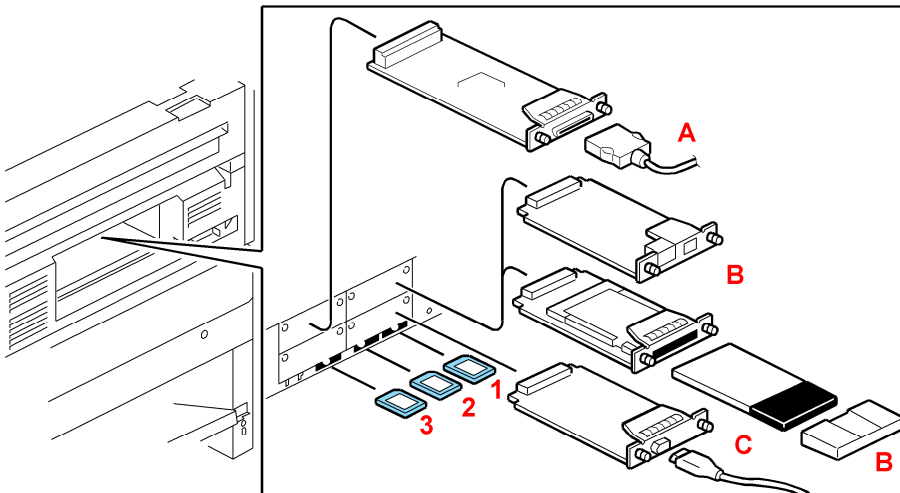
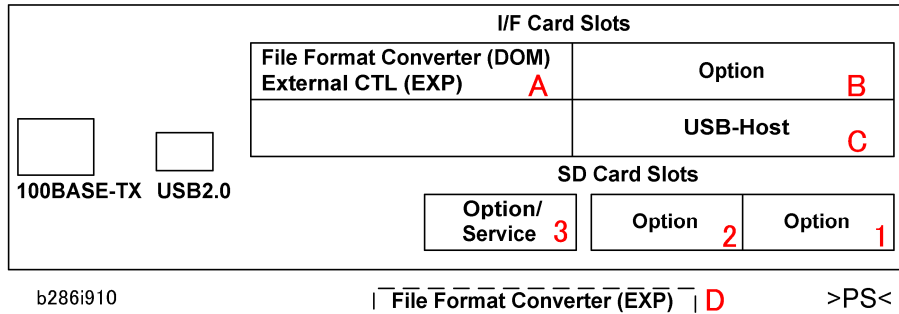

MFP Option Board Slot/SD Card Assignments

Slot	Option Name	Move?
A	Interface PCB Type W3600 (D329)	---
B	Gigabit Ethernet Board Type A (G874-01)	---
	IEEE 802.11b Interface Type H (G813-45)/Type I (G874-39)	---
C	USB Host Interface Unit Type 7300 (G819-01)	---
D	File Format Converter Type C (B609-04)	---

Slot	Option Name	Move?
1	Printer Option Type W3600 (D320)	Yes
	Scanner Option Type W3600 (D321)	Yes
	Data Overwrite Security Unit Type D (B735-18)	Yes
2	Printer Option Type W3600 (D320): TIFF/GL Filter	No* ¹
	Browser Unit Type C (B828-03)	No
	VM Card Type E (D338-01, -02, -03)	No
3	Service <ul style="list-style-type: none"> ▪ Firmware Update ▪ NVRAM Data Download/Upload ▪ Application Move/Undo 	
	Browser Unit Type C (B828-03)	No
	VM Card Type E (D338-01, -02, -03)	No

*1: Due to copyright restrictions, these options cannot be moved to another SD card

1.7.2 ENABLING THE ONBOARD FEATURES

The NIB and USB support features are built into the GW controller board. However, these features cannot be used until they have been enabled with SP5985 (Device Setting).

Before installing any other options in this section, do SP5985 and make sure each item is set to "1."

1.7.3 USING SD CARDS

Removing the SD Card Slot Cover

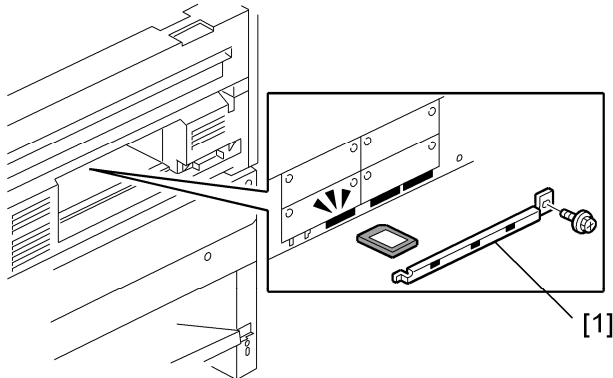

b286i161

The SD card slot cover [1] is fastened by one screw. Remove this cover to insert SD cards. Always reattach this cover after removing or inserting SD Cards.

SD Card Slot Assignments

The machine has three SD card slots:

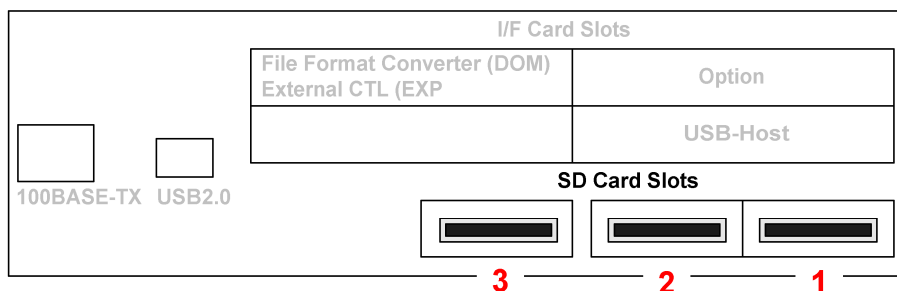

b286i912

- SD card slots 2 and 1 are for application programs.
- Slot 3 is used for machine servicing and application program installation (firmware updates, NVRAM upload and download, application move and undo).
- If the service technician needs to use Slot 3 for servicing and there is an SD card in Slot 3, the application SD card must be removed.
- If the customer needs more than three applications, one or more application must be moved to one SD card with SP5873-1.

Application	Slot			Comment
	1	2	3	
Printer Option Type W3600 (D320)	Yes	No	No	
Scanner Option Type W3600 (D321)	Yes	No	No	Can move to D320
Data Overwrite Security Type D (B735-18)	Yes	No	No	Can move to D320 or D321
Printer Option Type W3600 (B320): TIFF/GL Filter	No	Yes	No	
Browser Unit Type C (B828-03)	No	Yes	Yes	Either Slot
VM Card Type E (D338-01, 02, -03)	No	Yes	Yes	
Service: <ul style="list-style-type: none"> ▪ Firmware update ▪ NVRAM Data Download/Upload ▪ Application Move/Undo 	No	No	Yes	

Restrictions and Precautions on the Use of SD Cards

- When an application is moved from one SD card to another SD card, the authentication data is transferred with the application program to the target SD card.
- Do not use an SD card if it has been used with a computer or other device. (The SD card may not operate correctly.)
- The original SD card received with purchase of the application program is the only evidence that the customer is licensed to use the application. For this reason, the original SD card should be stored at the work site as proof of purchase by the customer. Also, the service technician may occasionally need to check the dates and version numbers SD cards during troubleshooting.
- After an SD card has been used to combine applications on one card, it cannot be used for any other purpose.
- Always make sure that the write-protect switch is OFF before uploading data to an SD card. It is very easy to accidentally turn on the write-protect switch when inserting and removing an SD card.
- To remove an SD card from its slot, push it in gently to release it then pull it out of its slot.

Installation of MFP Options

Application Move

“Move Exec” (SP5873-1) moves one application program from the original SD card to another SD card. The application program is moved from Slot 3 to Slot 1 (or Slot 2).

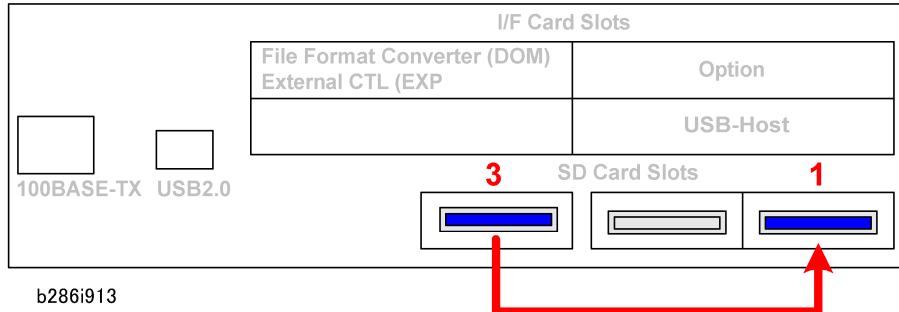

1. Turn off the main power switch.
2. Remove the SD card slot cover (🔑x1).
3. Insert the original SD card with the application in Slot 3.
4. Insert the SD card to receive the application in Slot 1.

↓ Note

- The SD card to receive the moved application can be set in Slot 2, but in this case Slot 1 must be empty. (The application always moves the application to Slot 1 by default if there are SD cards in both Slot 1 and Slot 2.)
5. Turn on the main power switch.
 6. Enter the SP mode and do SP5873-1 “Move Exec.”
 7. Follow the messages on the operation panel to complete the procedure.
 8. Exit the SP mode.
 9. Turn off the main power switch.
 10. Remove the original SD card from Slot 3.
 11. Leave the other SD card in Slot 1 or Slot 2.
 12. Turn on the main power switch.
 13. Check that the application program runs normally.
 14. Tell the customer to store the original SD card in a safe place.

Undo Exec

“Undo Exec” (SP5873-2) restores an application to its original SD card. The application is moved from Slot 3 to Slot 1 (or Slot 2).

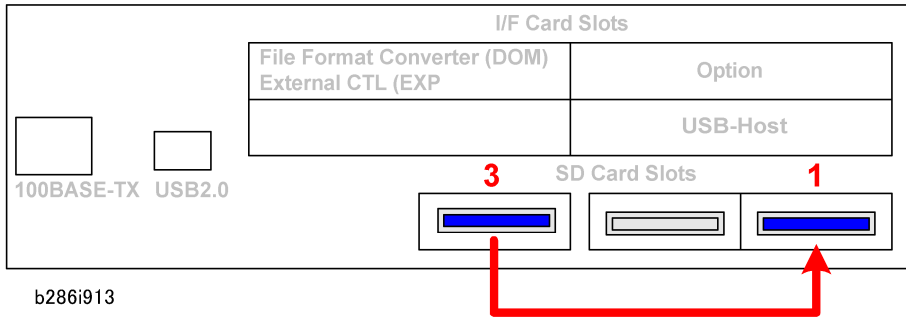

1. Turn off the main power switch.
2. Remove the SD card slot cover (x1).
3. Insert the SD card that currently holds the application in Slot 3.
4. Insert the original SD card to receive the restored application in Slot 1.

Note

- The SD card to receive the restored application can be set in Slot 2, but in this case Slot 1 must be empty. (The application always moves to Slot 1 by default if there are SD cards in both Slot 1 and Slot 2.)

5. Turn on the main power switch.
6. Enter the SP mode and do SP5873-2 “Undo Exec.”
7. Follow the messages on the operation panel to complete the procedure.
8. Exit the SP mode.
9. Turn off the main power switch.
10. Remove both SD cards.
11. Insert the SD card with the restored application in Slot 1 or 2.
12. Turn on the main power switch.
13. Check that the application operates normally.

1.7.4 PRINTER OPTION TYPE W3600 (D320)

Important

- The Roll Feeder (B851/B852) is required in order to use the Printer Option (D320).

Accessories

Check the accessories and their quantities against the table below.

Description	Qt'y
1. SD Card: Printer	1
1. SD Card: TIFF/GL Filter	1

Installation of MFP Options

Description	Qt'y
1. Keytop	1
1. Decal: PS3	1

Installation

CAUTION

- Before doing the procedure, turn off the main power switch and unplug the machine from its power source.
1. Make sure that the machine is switched off and disconnected from its power source.
 2. Remove the SD card slot cover (ⓘx1).
 3. Insert the Printer Option (D320) SD Card in Slot 1.
 4. Insert the Printer Option (D320) SD Card: TIFF/GL Filter in Slot 2.
 5. Reattach the SD card slot cover.

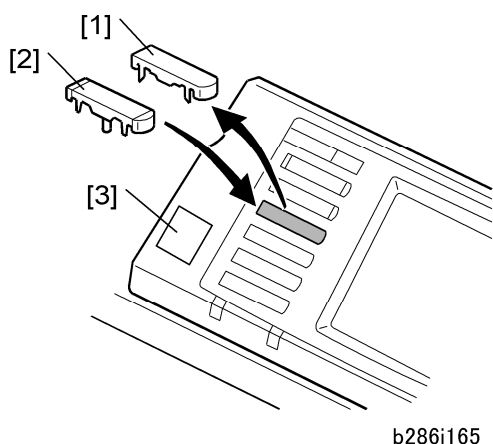

6. On the operation panel, remove the dummy keytop [1] and replace it with the “Printer” keytop [2].
7. Attach the “PS3” decal [3].
8. Reconnect the machine to its power source and turn the main power switch on.
9. Enter the SP mode and set SP5985-1 to “1” (Device Setting: Onboard NIB).
10. Set SP5985-2 (USB) to “1.”
11. Turn the machine power off/on.
12. Print a Configuration Page to make sure that the machine recognizes the installed board:
User Tools> Printer Features> List/Test Print> Configuration Page
13. Contact the system administrator then do the network settings in the User Tools mode

(IP address, subnet mask, etc.)

★ Important

- If the customer intends to use the Ratio external controller from the PC side, this GW controller printer SD card must be removed from the main machine.

1.7.5 SCANNER OPTION TYPE W3600 (D321)

Accessories

Check the accessories and their quantities against the table below.

Description	Qt'y
1. SD Card: Scanner	1
1. Keytop	1

Installation

⚠ CAUTION

- Before doing the procedure, turn off the main power switch and unplug the machine from its power source.
1. Make sure that the machine is switched off and disconnected from its power source.
 2. Remove the SD card slot cover (🔧x1).
 3. Insert the scanner SD card into Slot 1.

★ Important

- If the printer SD card is in Slot 1, do SP5873-1 to move the scanner application to the printer application SD card.
4. Reattach the SD card slot cover (🔧x1).

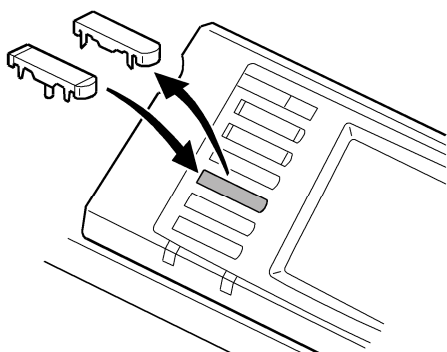

b286i166

5. On the operation panel, remove the dummy keytop and replace it with the “Scanner” keytop.

Installation of MFP Options

6. Reconnect the machine to its power source and turn the main power switch on.
7. Enter the SP mode and set SP5985-1 to "1" (Device Setting: Onboard NIB).
8. Set SP5985-2 (Device Setting: Onboard USB) to "1."
9. Turn the machine power off/on.
10. Print a Configuration Page to make sure that the machine recognizes the installed board:

User Tools> Printer Features> List/Test Print> Configuration Page

Important

- If the customer intends to use the Ratio external controller from the PC side, the GW controller scanner option can be used and does not need to be removed from the main machine.
- If the GW printer option has been moved to the scanner SD card, be sure to remove the printer option SD card.

1.7.6 FILE FORMAT CONVERTER TYPE C (B609-04)

Accessories

Check the accessories and their quantities against the table below.

Description	Q'ty
1. File Format Converter PCB	1

Installation

CAUTION

- Before doing the procedure, turn off the main power switch and unplug the machine from its power source.
1. Make sure that the machine is switched off and disconnected from its power source.
 2. If the folder unit is installed, disconnect it and pull it away from the main machine.

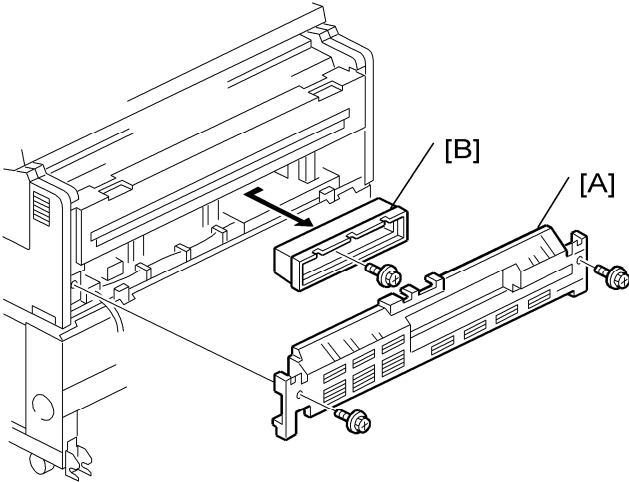

b286r914

3. Remove:

- [A] Rear cover (⌀x2)
- [B] Controller cover (⌀x1)

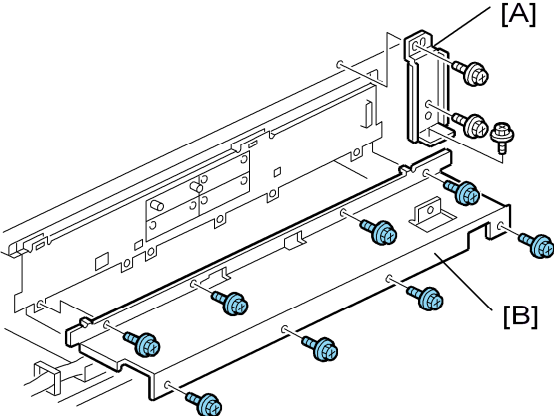

b889i105a

4. Remove:

- [A] Ground plate (⌀x3)

↓ Note

- Open covers **C1** and **C2** together to remove the vertical screw.
- [B] PCB shield cover (⌀x8)

Installation of MFP Options

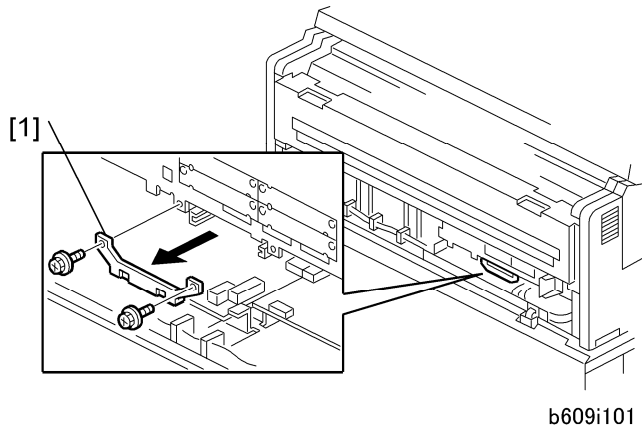

5. Remove bracket [1] (\varnothing x2). Keep these screws.

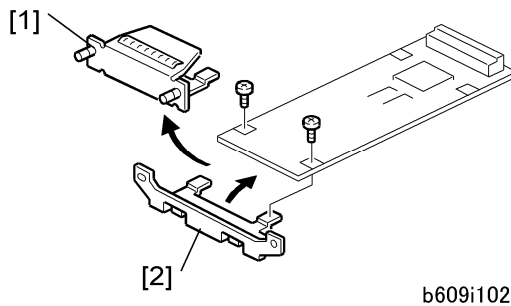

6. Remove cover [1] and discard it (\varnothing x2). Keep the screws.
7. Attach the bracket [2] removed in Step 5 to the PCB (\varnothing x2).

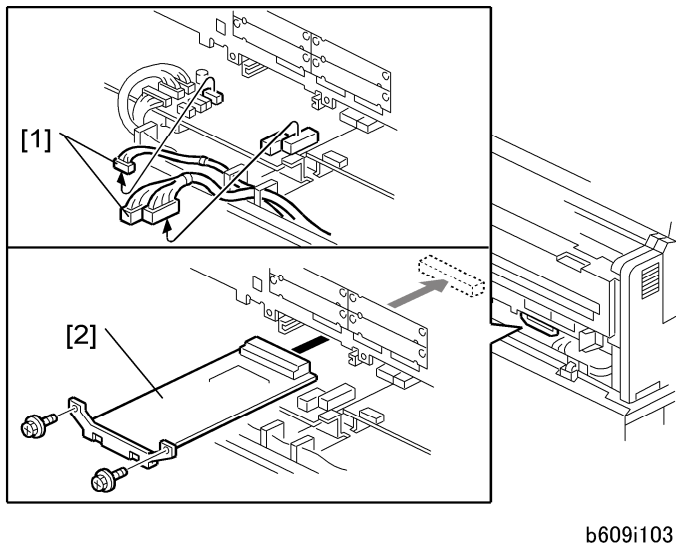

8. Disconnect the connectors [1] (\varnothing x3).
9. Slowly insert the board [2] then fasten it (\varnothing x2).

Reinstallation

- Be sure to reconnect the connectors (\varnothing x3).

- After reattaching the rear cover, open the covers C1 and C2 to confirm that they open smoothly. If C1 and C2 do not open smoothly, the rear cover is not installed correctly. Remove it and reinstall it.

1.7.7 INTERFACE PCB (D329)

 **Important**

- The Interface PCB (D329) is required in order to use the external printer option (D344).

Accessories

Check the accessories and their quantities against the table below.

Description	Qt'y
1. Interface PCB	1
1. Interface Cable	1
1. Nylon Clamp	1
1. Harness Clamp	1
1. Screws (M4x8)	1

Installation

 **CAUTION**

- Before doing the procedure, turn off the main power switch and unplug the machine from its power source.
1. Make sure that the machine is switched off and disconnected from its power source.

Installation of MFP Options

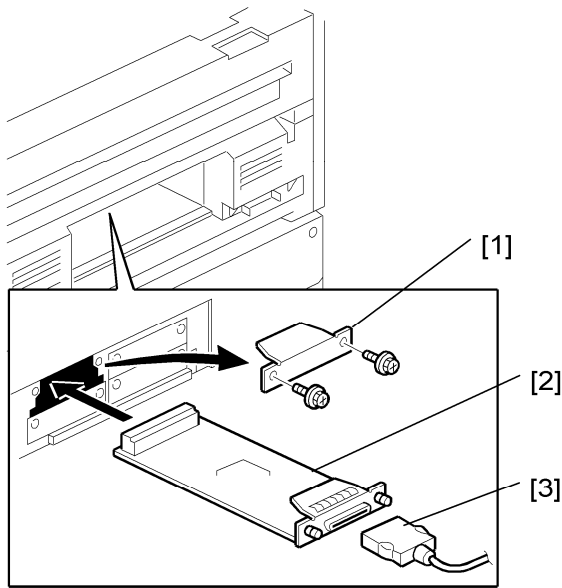

d329i101

2. Remove cover of Slot A [1] (⚙️x2).
3. Insert the interface PCB [2] (Knob screws x2).
4. Connect the interface cable [3].

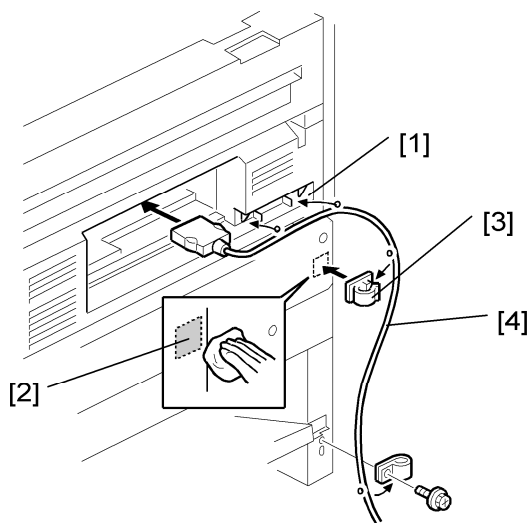

d329i102

5. Attach the interface cable to the back of the main unit [1] (Cable hooks x2)
6. Clean the rear plate [2] with alcohol.
7. Attach harness clamp [3].
8. Close the clamp round the harness cable [4].
9. Connect the other end of the interface cable to the server PC (Printer Controller RW3600).



- The GW printer option cannot be used while this interface PCB is installed in the main machine.

1.7.8 IEEE802.11B INTERFACE UNIT TYPE H (G813-45)/TYPE I (G874-39)

Accessories

Check the accessories and their quantities against the table below.

Description	Qt'y
1. Wireless LAN Card	1
1. Adapter Board	1
1. Cover Cap	1

Installation

⚠ CAUTION

- Before doing the procedure, turn off the main power switch and unplug the machine from its power source.

1. Make sure that the machine is switched off and disconnected from its power source.

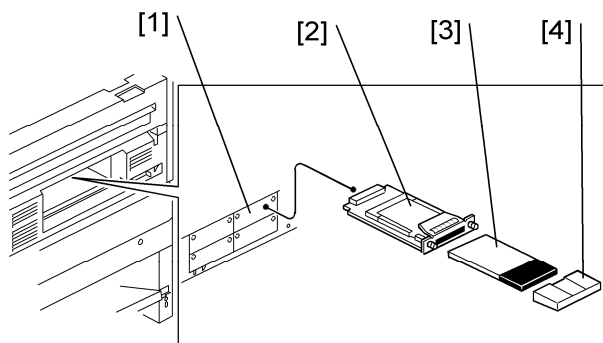

b286i162a

2. Remove the cover [1] of Slot B (⚙ x 2).
3. Insert the adapter board [2] into Slot B (Knob ⚙ x 2).
4. Insert the wireless LAN card [3] into the adapter board [2].
5. Attach the cap [4].
6. Reconnect the machine to the power source and turn the main power switch on.
7. Print a Configuration Page to confirm correct installation:
User Tools> Printer Features> List/Test Print> Configuration Page

1.7.9 GIGABIT ETHERNET BOARD TYPE A (G874-01)

Accessories

Check the accessories and their quantities against the table below.

Description	Qt'y
1. Gigabit Ethernet Board	1
1. Ferrite Core	1
1. Standard USB Connector Cap	1
1. Standard LAN Connector Cap	1

Note

- To use the Gigabit Ethernet Board, SP5985-2 must be set to “1” to enable the NIC and USB functions.

Important

- When the Gigabit Ethernet Board is installed, the standard Ethernet board and standard USB board can no longer be used. Two caps are provided to cover the standard Ethernet and USB connectors. This prevents accidental reconnection of the cables while the Gigabit Ethernet board is installed in the machine.
- Touch a metal surface to discharge any static electricity from your hands before you handle the board.

Installation

CAUTION

- Before doing the procedure, turn off the main power switch and unplug the machine from its power source.
1. Make sure that the machine is switched off and disconnected from its power source.

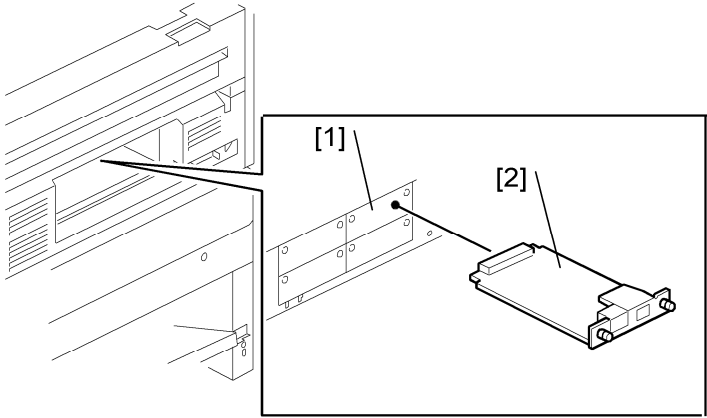

b286i162b

2. Disconnect the cables of the standard Ethernet board and standard USB board.
3. Cover the standard connection points with the caps to prevent accidental reconnection of the standard cables.
4. Remove the cover of Slot B [1] (⚙ x 2).
5. Insert the Gigabit Ethernet Board [2] into Slot B (Knob ⚙ x 2).

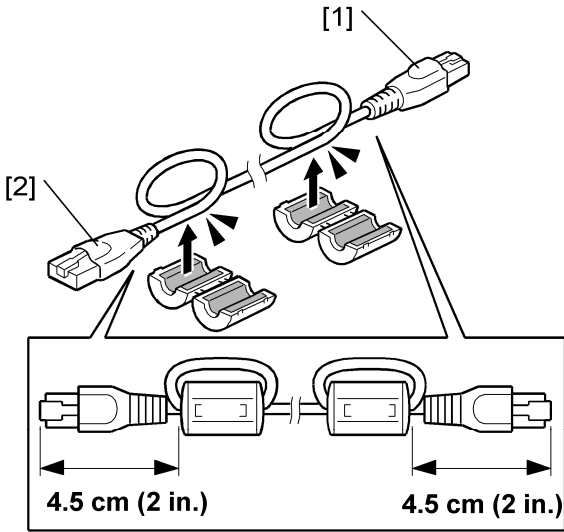

g874i151

6. Attach the ferrite core provided with the Gigabit Ethernet Board to the end of the cable [1] to be attached to the network.
7. Attach the ferrite core provided with the main machine to the end of the cable [2] to be attached to the main machine.

↓ Note

- Attach both cores 4.5 cm (about 2 in.) from each end of the cord.

8. Reconnect the machine to its power source and turn the main power switch on.
9. Do SP5985-2 and set to “1” to enable the NIC and USB functions.

Installation of MFP Options

10. Turn the machine's power off/on.
11. Print a Configuration Page to make sure that the machine recognizes the installed board for USB2.0:

User Tools > Printer Features > List/Test Print > Configuration Page

1.7.10 DATA OVERWRITE SECURITY UNIT TYPE D (B735-18)

Accessories

Check the accessories and their quantities against the table below.

Description	Qt'y
1. Data Overwrite Security SD Card	1
1. Operating Instructions CD-ROM	1

Before You Begin...

1. Make sure that the Data Overwrite Security unit SD card is the correct type for the machine. The correct type for this machine is type "D."

★ Important

- Do this now. If you install any version other than type "D", you will have to replace the NVRAM and do this installation procedure again.
2. Make sure that the following items are not at the factory default settings:
 - Supervisor login password
 - Administrator login name
 - Administrator login password

★ Important

- These settings must be set up by the customer before the Data Overwrite Security unit can be installed.
3. Make sure that "Admin. Authentication" is on:
[User Tools]> "System Settings"> "Administrator Tools"> "Administrator Authentication Management"> "Admin. Authentication"> "On"
If this setting is "Off", tell the customer that this setting must be "On" before you can do the installation procedure.
 4. Make sure that "Administrator Tools" is selected and enabled:
[User Tools] > "System Settings" > "Administrator Tools"> "Administrator Authentication Management"> "Available Settings

↓ Note

- “Available Settings” is not displayed until Step 2 is done. If this setting is not selected, tell the customer that this setting must be selected before you can do the installation procedure.

Seal Check and Removal

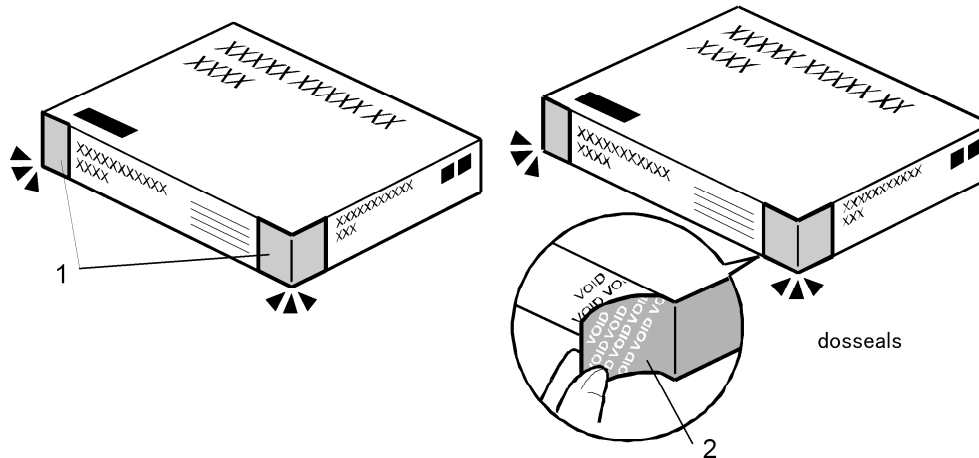

1. Turn off the main power switch and disconnect the power supply cord.
2. Check the two box seals [1] on the corners of the box.
 - Make sure that the seals are attached at both corners.
 - The surfaces of the tapes must be blank.
 - If you see “VOID” on the tapes, do not install the components in the box, contact your sales division.
3. If the surfaces of the tapes do not show “VOID”, remove them from the corners of the box.

★ Important

- Do not install the application if you see “VOID.” The “VOID” marks [2] become visible only after the tape is removed. This guarantees that the box has not been opened since it was shipped.

Installation

⚠ CAUTION

- Before doing the procedure, turn off the main power switch and unplug the machine from its power source.
1. Make sure that the machine is switched off and disconnected from its power source.
 2. Disconnect the network cable.
 3. Turn the main power switch on.
 4. Turn the operation switch and main power switch off.

Installation of MFP Options

5. Remove the SD card slot cover (🔧x1).

★ Important

- Make sure that the number and “Type” are correct (B735 Type D). If you install the incorrect version of this application, the NVRAM must be replaced.
6. Insert the DOS SD card into Slot 1.
 7. Reconnect the network cable.
 8. Turn the main power switch on.
 9. Do SP5878 and push [EXECUTE].
 10. Go out of the SP mode.
 11. Turn the operation switch off, then turn the main power switch off.
 12. Do SP5990-5 to print the Self Diagnosis Test.
 13. Check the diagnostic report.
 - Under [ROM No./Firmware Version] you should see “B7355060/0.03” displayed for “HDD Format Option.”
 - Under [Loading Program] you should see “GW1a_zoffy: B7355060/0.03”

Important

- The numbers in the report must match. (The ROM number and firmware version number change after the firmware has been upgraded.)
- If the ROM numbers or version numbers do not match, this means that the DOS unit type was incorrect (not “Type D”),
- If this occurs:
 - (1) Obtain the correct SD card.
 - (2) Replace the NVRAM on the controller board.
 - (3) Insert the Type D DOS unit SD card in Slot 1
 - (4) Do the DOS unit installation procedure again.

Check Operation of the DOS Application

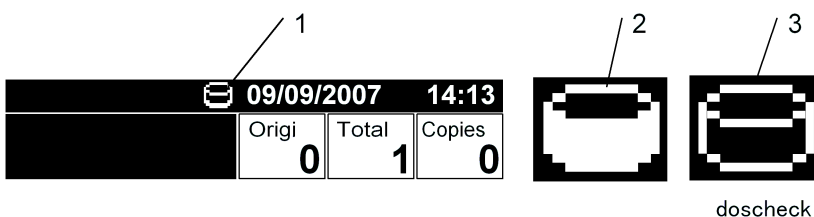

1. Turn "Auto Erase Memory Setting" on:
[User Tools]> "System Settings"> "Administrator Tools"> "Auto Erase Memory Setting"> "On"
2. Exit User Tools.
3. Check the display and make sure that the overwrite erase icon [1] is displayed.
4. Make a Sample Copy.
5. Check the overwrite erase icon.
 - The icon [2] changes to [3] when job data is stored in the hard disk.
 - The icon resumes its normal shape [2] after a data overwrite has completed.

1.7.11 USB HOST INTERFACE UNIT TYPE 7300 (G819-01)

Accessories

Check the accessories and their quantities against the table below.

Description	Qt'y
1. USB Host Interface Board	1



Installation

CAUTION

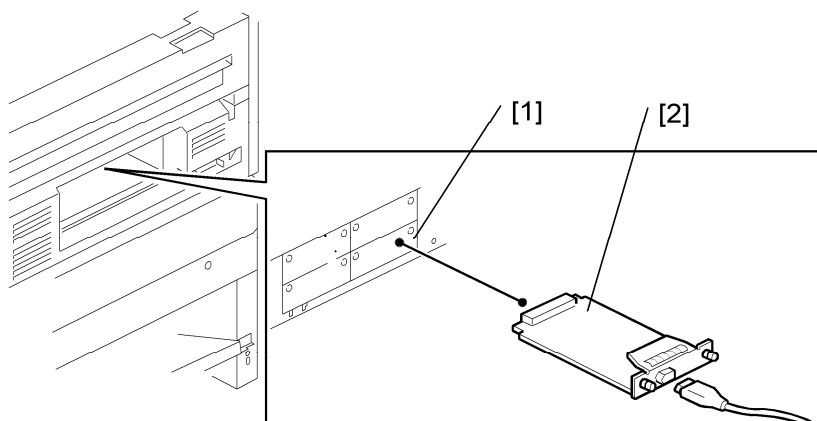
- Before doing the procedure, turn off the main power switch and unplug the machine from its power source.
1. Make sure that the machine is switched off and disconnected from its power source.



b286i162c

2. Remove the cover of Slot C [1] ( x 2).
3. Insert the board [2] into Slot C (Knob  x 2).
4. Reconnect the machine to its power source and turn the main power switch on.
5. Print a Configuration Page to make sure that the machine recognizes the installed

Installation of MFP Options

board:

User Tools> Printer Features> List/Test Print> Configuration Page

1.7.12 BROWSER UNIT TYPE C (B828-03)

Accessories

Check the accessories and their quantities against the table below.

Description	Qt'y
1. Browser Unit Type C SD Card	1
1. Keytops (EU/NA)	2

Installation

CAUTION

- Before doing the procedure, turn off the main power switch and unplug the machine from its power source.
1. Make sure that the machine is switched off and disconnected from its power source.
 2. Remove the SD card slot cover (1x1).
 3. Insert the SD card into Slot 2 or 3.
-  Note
- If you push in the SD Card, this releases it for removal. Make sure that the SD Card is inserted and locked in place. If it is partially out of the slot, push it in gently until it locks.
4. Reconnect the machine and turn it on.
 5. Push [User Tools].
 6. Push [Login/Logout] on the operation panel
 7. Login with the administrator user name and password.
 8. Touch [Extended Feature Settings].
 9. Touch [Extended Feature Settings] again.
 10. Touch [SD Card].
 11. Touch the [Browser] line.
 12. Under “Install to:” touch [Machine HDD] then touch [Next]
 13. When you see “Ready to Install”, check the information on the screen to confirm the previous selection.
 14. Touch [OK]. You will see “Installing...” then “Completed.”
 15. Touch [Exit] twice to return to the copy screen.

16. Turn the machine power off/on.

★ Important

- Do not remove the SC card from Slot C3.

17. Open the Browser screen from the “Extended Feature Settings” in User Tools.

A message appears if the installation was successful: “The MFP Browser was successfully installed.”

18. Turn the main machine off.

19. Remove the SD card for the Browser unit from Slot 2 or 3, then reattach the SD card slot cover.

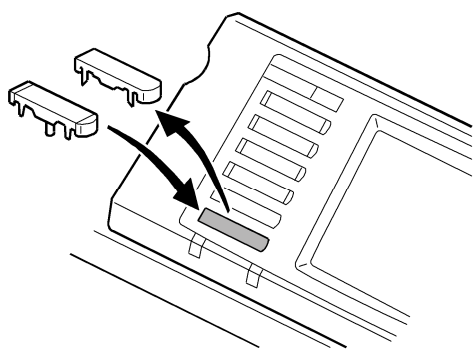

b286i163

20. On the operation panel remove the dummy keytop and replace it with the “Others” keytop.

1.7.13 VM CARD TYPE E (D338-01, -02, -03)

Accessories

Check the accessories and their quantities against the table below.

Description	Qt'y
VM Card	1
Decal	1

Installation

⚠ CAUTION

- Before doing the procedure, turn off the main power switch and unplug the machine from its power source.

- Remove SD card slot cover (🔧x1).
- Insert the SD card into SD card slot 2 or 3.

Installation of MFP Options

↓ Note

- If you push in the SD Card, this releases it for removal. Make sure that the SD Card is inserted and locked in place. If it is partially out of the slot, push it in gently until it locks.
3. Switch the machine on.

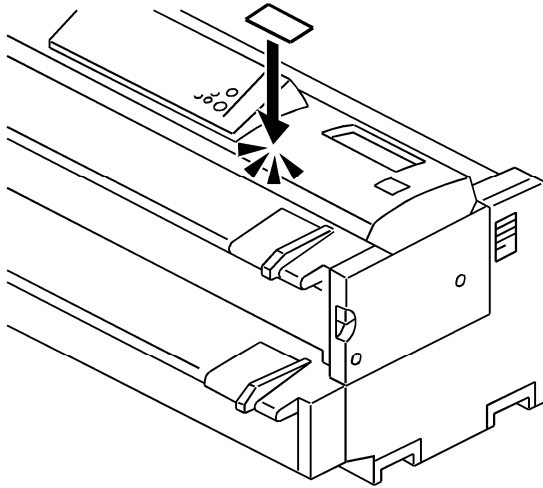

b286i164

4. Attach the decal.

1.8 REAR STACKER (D312)

The rear stacker is an optional device installed on the back of the unit (B286/B289).

1.8.1 ACCESSORIES

Check the accessories and their quantities against the table below.

No.	Description	Qty
1.	Copy Tray Holder	1
2.	Guide Mylar	1
3.	Rear Copy Tray	3
4.	Screws (M4x8)	4

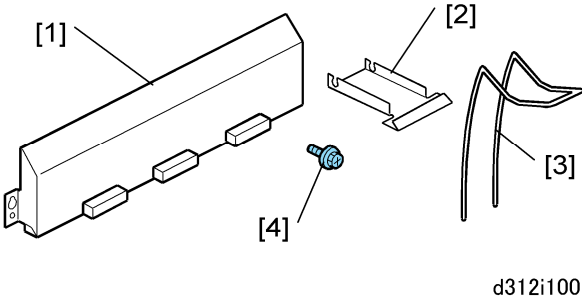

Rear Stacker (D312)

1.8.2 INSTALLATION

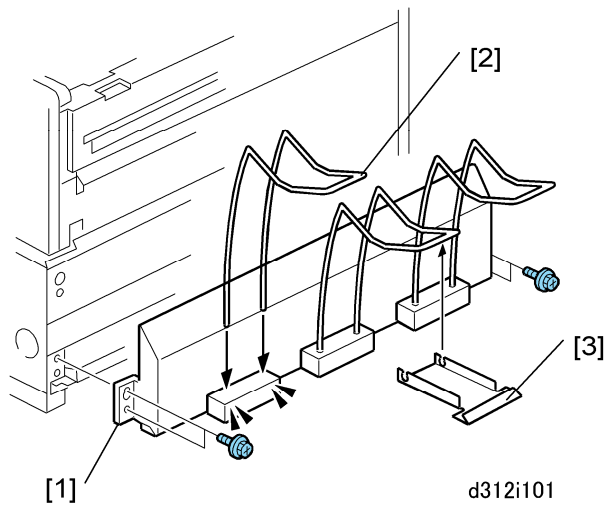

5. Attach:

- [1] Copy tray holder (4x4)
- [2] Rear copy tray (x3)
- [3] Guide mylar (x1)) to center of copy tray

PREVENTIVE MAINTENANCE

2. PREVENTIVE MAINTENANCE

2.1 PM TABLE

Key for the PM Table

A = Adjust, C = Clean, I = Inspect, L = Lubricate, R = Replace

Note

- Units of measure in the PM Interval column: Metric: 1,000 meters, Feet: 1,000 feet

2.1.1 MAIN MACHINE (B286)

Description	Q'ty	PM Interval		PM	Comments
		Metric	Feet		
Scanner					
Original Feed Rollers		5.5	18.0	C	Damp cloth
Original Exit Rollers		5.5	18.0	C	
Platen Plate		5.5	18.0	C	
Original Width, Set, Registration, Exit Sensors		33.0	108.0	C	Blower brush
Exposure Glass		5.5	18.0	C	Damp cloth or glass cleaner
CIS Surfaces		5.5	18.0	C	Alcohol or lens paper
Development					
Developer (1,000 g)	2	27.5	90.0	R	Replace if necessary.
Development Filter		5.5	18.0	C	Dry cloth or vacuum cleaner
Development Roller Gear		5.5	18.0	I	
Development Lower Casing		5.5	18.0	C	Dry

PM Table

Description	Q'ty	PM Interval		PM	Comments
		Metric	Feet		
Cleaning					
Cleaning Blade	1	11.0	36.0	I/R	Replace if necessary.
Cleaning Entrance Seal		11.0	36.0	C	Lens paper or dry cloth.
Side Seals		11.0	36.0	C	
Inside Cleaning Unit		11.0	36.0	I	Dry cloth or vacuum cleaner
Used Toner Bottle		5.5	18.0	C	Empty used toner
Registration					
Registration Rollers		5.5	18.0	C	Damp cloth
Paper Registration Sensor		5.5	18.0	C	Blower brush
Around the Drum					
Charge Corona Wire		11.0	36.0	R	Lens paper
Corona Wire Cleaner	1	5.5	18.0	R	
Charge Corona Casing		5.5	18.0	C	Damp cloth
Grid Wires		5.5	18.0	C	Lens paper
Transfer Corona Wire	1	11.0	36.0	R	
Separation Corona Wire	1	11.0	36.0	R	
T&S Unit Casing and Guides		5.5	18.0	C	Lens paper or dry cloth.
Quenching Lamp		5.5	18.0	C	Lens paper or dry cloth
ID Sensor		5.5	18.0	C	Dry cloth; do SP3001 2 to initialize the sensor after you clean it.
Pick-off Pawl		5.5	18.0	C	

Description	Q'ty	PM Interval		PM	Comments
		Metric	Feet		
LPH (LED Print Heads)		5.5	18.0	C	Lens paper or alcohol. After cleaning, touch to discharge static. Important: Use no other chemical cleaners.
Fusing Unit					
Hot Roller	1	27.5	90.0	R	Replace if necessary.
Fusing Cleaning Roller	1	27.5	90.0	R	Always replace with hot roller.
Hot Roller Bushings	1	27.5	90.0	R	Always replace with hot roller. Lubricate.
Pressure Roller	1	33.0	108.0	R	Replace if necessary.
Hot Roller Strippers		5.5	18.0	C	Dry cloth.
Pressure Roller Strippers		5.5	18.0	C	
Hot Roller Thermistor		11.0	36.0	C	
Pressure Roller Thermistor		11.0	36.0	C	
Fusing Exit Guide Plate		5.5	18.0	C	
Paper Junction Gate		5.5	18.0	C	
Fusing Entrance Guide Spurs		5.5	18.0	C	Cleaner brush Alcohol, dry cloth at every visit. (See section 2.2 "Cleaning the Entrance Spurs")
Fusing Exit Rollers		11.0	36.0	C	Damp cloth
Fusing Exit Sensor		5.5	18.0	C	Blower brush

PM Table

Description	Q'ty	PM Interval		PM	Comments
		Metric	Feet		
Fusing Gears		5.5	18.0	L	Barrierta – S552R
Mechanical Drive Section					
Drum Drive Gears		5.5	18.0	L	Silicone Grease G501.
Development Drive Gears		5.5	18.0	L	
Fusing Drive Gears		5.5	18.0	L	
Others					
Ozone Filter	1	5.5	18.0	R	
Line Speed & Magnification Adjustments				A	Adjust after replacing rollers. For details, see section 3.11 "SP Adjustments."
Circuit Breaker	The circuit breaker should be tested once a year. See section 1.2.3 "Main Machine Final Installation."				

2.1.2 ROLL FEEDER (B851/B852)

Description	Q'ty	PM Interval		PM	Comments
		Metric	Feet		
Cutter unit		5.5	18.0	C	Blower brush, dry cloth. (Estimated service life: 127 K cuts)
Feed Rollers		5.5	18.0	C	Damp cloth
Exit Rollers		5.5	18.0	C	
Exit Sensor		11.0	36.0	C	Blower brush or dry cloth
Roll End Sensors 3, 4		11.0	36.0	C	

Description	Q'ty	PM Interval		PM	Comments
		Metric	Feet		
(EXP)					

2.1.3 PAPER CASSETTE (B853)

Description	Q'ty	PM Interval	PM	Comments
		K Prints		
Feed Roller	1	40	C/R	Replace if necessary
Friction Pad	1		C/R	
Grip Rollers			C	Blower brush or dry cloth
Relay Sensor			C	

2.1.4 FOLDER FD/MANUAL FEEDER (D889)

Description	Q'ty	PM Interval		PM	Comments
		Metric	Feet		
Fan Fold Sensors		11.0	36.0		
Fan Fold Rollers		11.0	36.0	C	Damp cloth
Fan Fold Sensors		11.0	36.0	C	Blower brush or dry cloth
Circuit Breaker	The circuit breaker should be tested once a year. See section 1.7.3 under "Checking the Circuit Breaker" in the folder installation procedure.				

PM Table

2.1.5 MANUAL FEEDER (D333)

Description	Q'ty	PM Interval		PM	Comments
		Metric	Feet		
Paper Width Sensors		11	36		Blower brush or dry cloth
Bypass Relay Sensor		11	36		Blower brush or dry cloth

2.2 CLEANING THE ENTRANCE SPURS

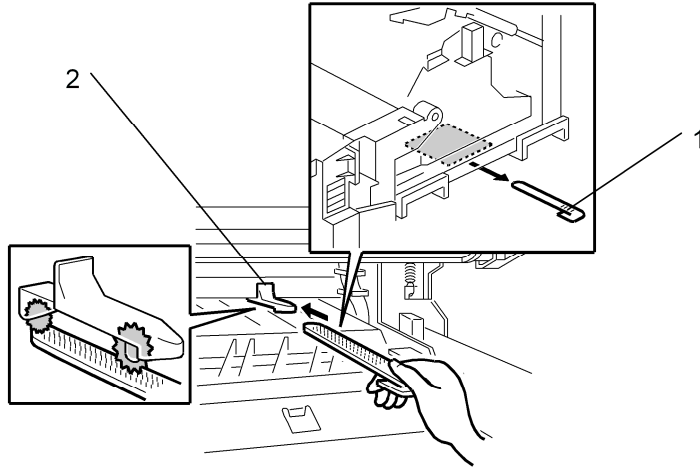

b286p901

1. Open the upper unit.
2. Retrieve the flat brush from [1] from its storage location.
3. Use the flat brush to clean the 5 entrance spurs [2].

★ Important

- Be sure to return the flat brush to its storage location when you are finished.

2.3 LUBRICATION POINTS

2.3.1 DEVELOPMENT SECTION

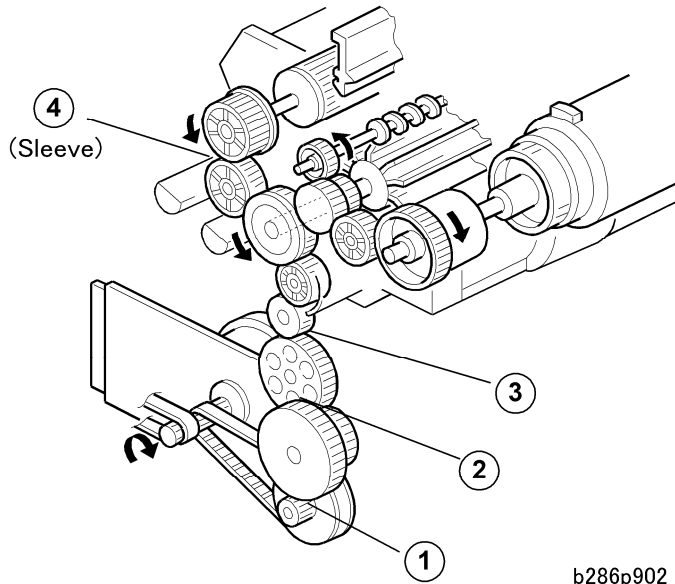

Development Unit Gears: (Silicone Grease G501).
Apply at the points shown by the numbers in the drawing.

2.3.2 FUSING GEARS

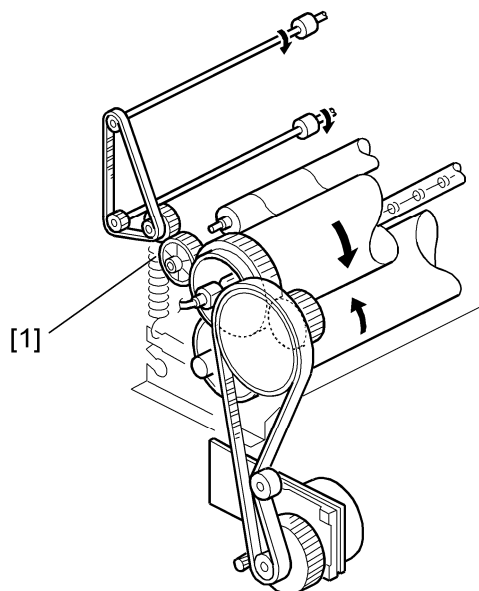

[1]: Fusing Gears (Barrieta S552R). Apply to the surface of the rim.

REPLACEMENT AND ADJUSTMENT

3. REPLACEMENT AND ADJUSTMENT

3.1 COMMON PROCEDURES

3.1.1 BEFORE WORKING ON THE MAIN MACHINE

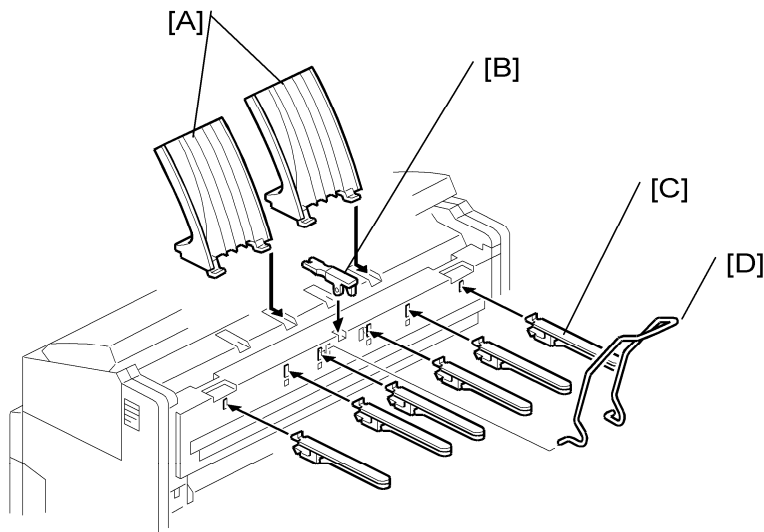

b286r913

Always remove these items before you start work on the machine:

- [A]: Upper output stackers (x 2)
- [B]: Copy exit selection lever (x 1)
- [C]: Original output guides (x 6)
- [D]: Upper output guide (x 1)
- Lower output trays (x 3) (not shown)

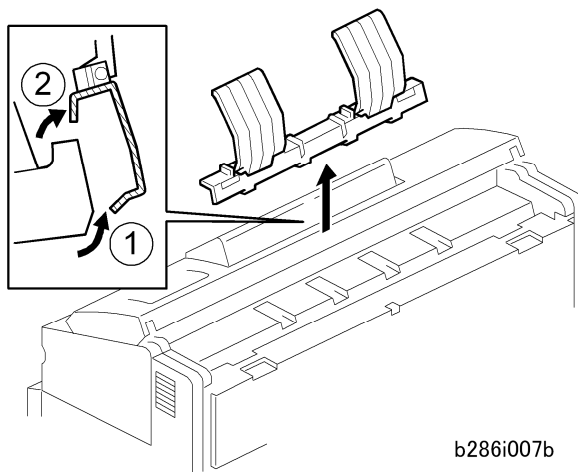

b286i007b

Attach the upper output stacker as shown above. Attach the bottom first ① then the top

Common Procedures

②.

Reinstallation

- The copy-exit selection lever must be up. In this position, the user can set the paper feed exit on the operation panel with the “Upper Copy Output” key. This key is disabled with the lever down and the copies always feed out at the rear.

3.1.2 SIDE COVERS

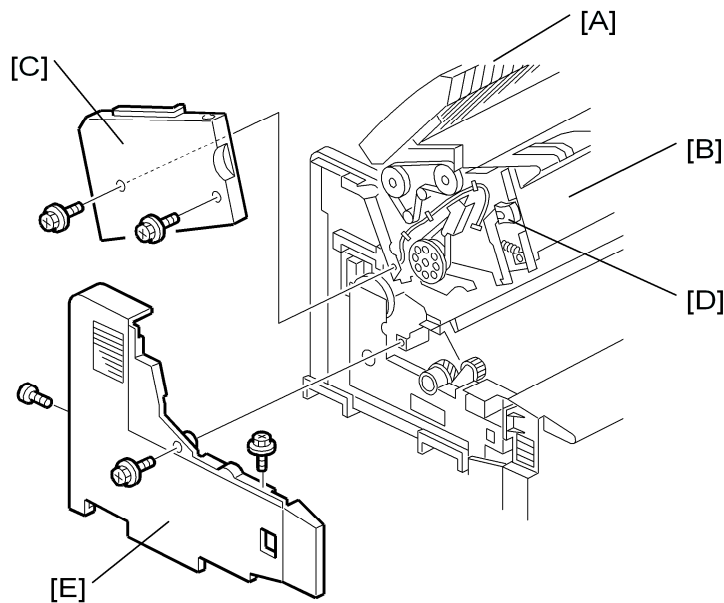

b286r502

1. Open the original feed unit [A].
2. Open the upper unit [B].
3. Remove the left upper cover [C] (⌀ x 2).



- If necessary, push in the release button [D] to remove the cover.
4. Remove the left cover [E] (⌀ x 3).
 5. Do Steps 3 and 4 to remove the right upper cover and right cover.

Reinstallation

- Make sure the original feed unit and upper unit are open.
- Always install the lower covers before the upper covers.
- If necessary, push in the upper unit release buttons [D] when you attach the upper covers.

3.1.3 REAR COVER

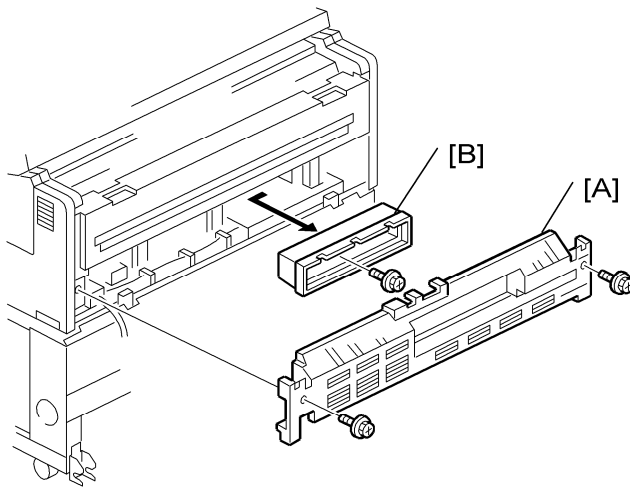

b286r914

1. Rear cover (⚙ x 2) [A]
2. Controller cover [B] (⚙ x 1)

3.1.4 PAPER EXIT UNIT

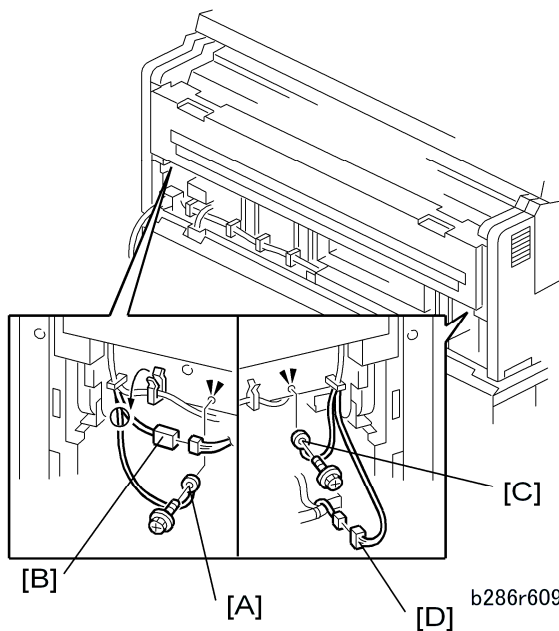

b286r609

1. Disconnect the ground wire [A] and connector [B] on the left (⚙ x 1, ⚙ x 1, ⚙ x 1).
2. Disconnect the ground wire [C] and connector [D] on the right (⚙ x 1, ⚙ x 1, ⚙ x 1).
3. Remove the rear cover (⚙ x 2). (See section 3.1.3 “Rear Cover.”)

Replacement and Adjustment

Common Procedures

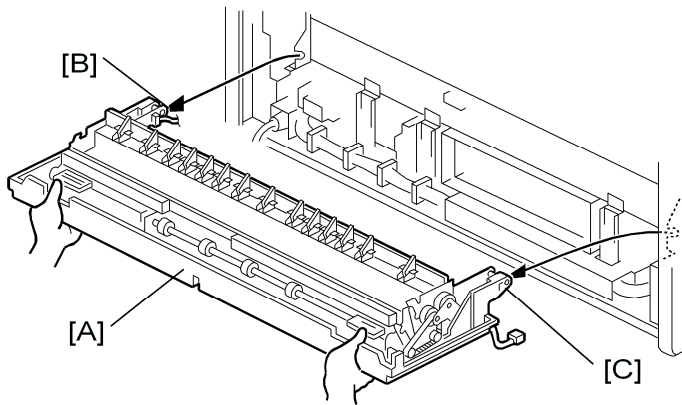

b286r609a

4. Raise the paper exit [A] unit approximately 30° from horizontal.
5. Pull the unit away from the left [B] and right [C] hinges.

3.1.5 UNLOCKING, OPENING THE ORIGINAL UNIT

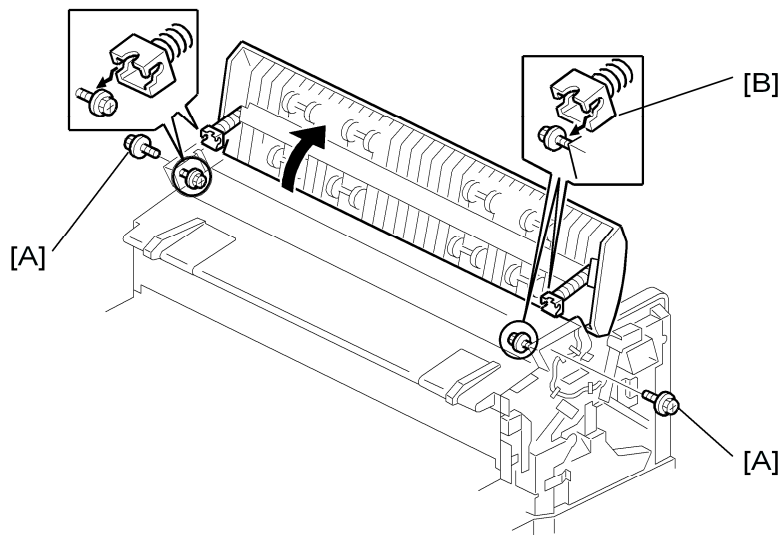

b286r105

1. Open the upper unit.
2. Remove the lock screws [A] (⌀ x 2).
3. On the left and right sides, lift the hinges [B] off the support screws and lift the unit to the vertical position. (Do not remove the support screws.)

3.1.6 REMOVING THE ORIGINAL FEED UNIT

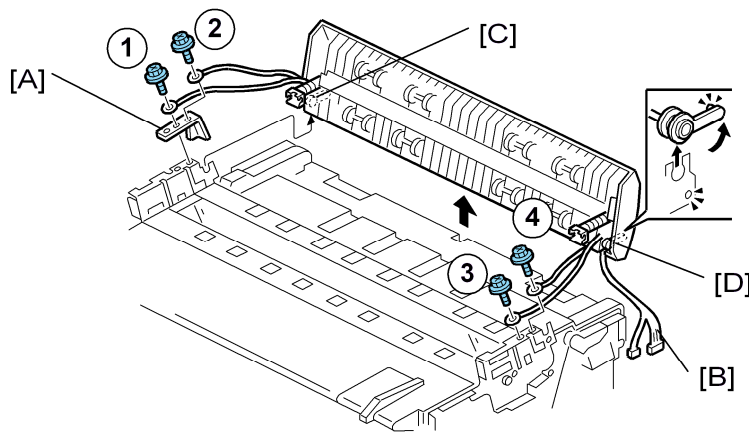

b286r106

1. Unlock the original unit and lift it. (see section 3.1.5 “Unlocking, Opening the Original Unit”)
2. Remove the plate [A] and disconnect the 2 ground wires ①, ② (⚙ x 2).
3. On the right side, disconnect the ground wires ③, ④ (x2) (⚙ x 2).
4. Disconnect the connectors [B] (⚙ x 4, ⚙ x 3, ⚙ x 1 with clamp).
5. On the ends of the original unit shaft, move the Teflon arms [C] and [D] out of the holes and lift them until they are horizontal.
6. Hold the Teflon arms up. At the same time, lower the original feed unit in your direction. When it is approximately 70° from the vertical, lift it off the top of the machine.
7. Be sure to remove the Teflon arms from the ends of the shaft.

3.1.7 RAISING AND LOCKING THE SCANNER UNIT

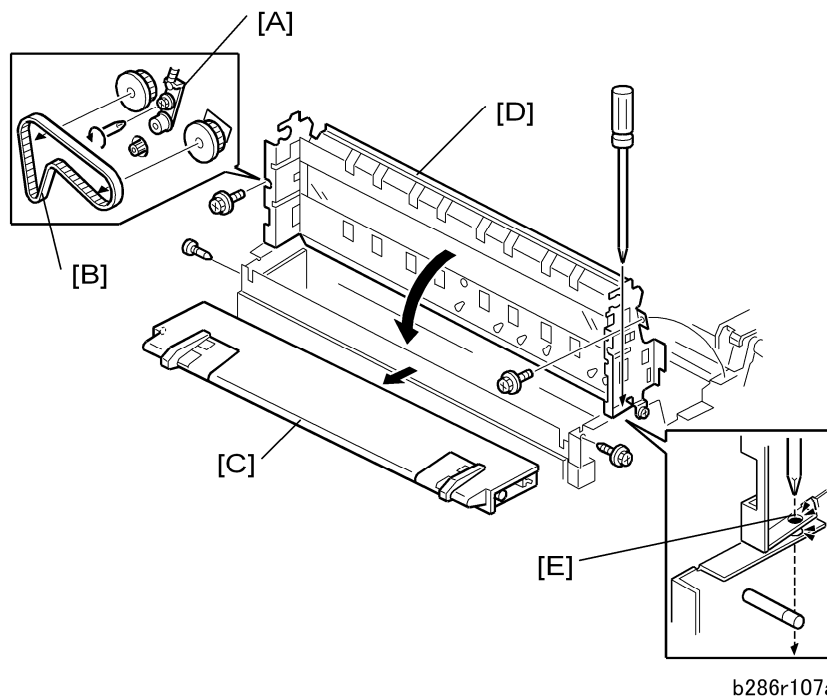

1. Remove the original feed unit. (See section 3.1.6 “Removing the Original Feed Unit.”)
2. Loosen the spring [A] and remove the scanner motor belt [B].
3. Tighten the screw again to make sure that the screw and spring do not fall off.
4. Remove the original table ([C] $\times 2$).
5. Lift the scanner unit [D]
6. Put a long screwdriver [E] through the holes to lock the scanner unit in the “up position.”

★ Important

- Always lock the scanner with a screwdriver when it is in the “up position.”

3.1.8 TONER HOPPER COVER

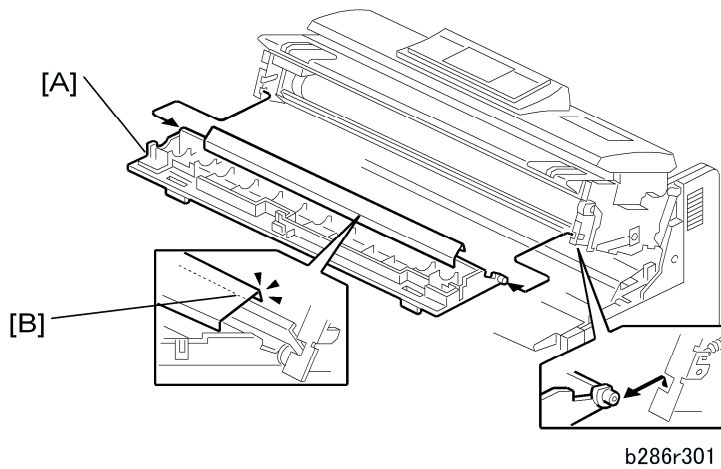

1. Side covers. (See section 3.12 “Side Covers.”)
2. Toner hopper cover [A].

Reinstallation

- Make sure that the bent edge of the mylar [B] is attached around the edge of the plate.

3.1.9 IDLE REGISTRATION ROLLER PANEL

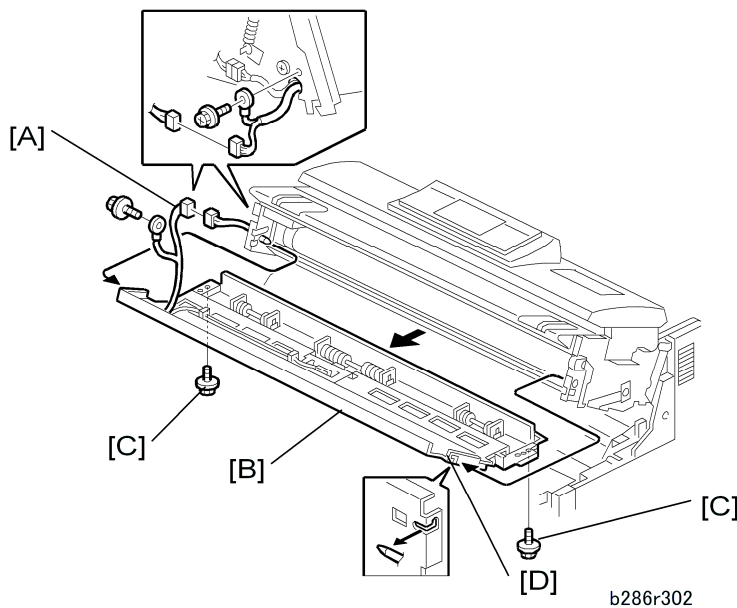

1. Open the upper unit.
2. Side covers. (See section 3.1.2 “Side Covers.”)
3. Toner hopper cover (See section 3.18 “Toner Hopper Cover.”)
4. Disconnect the connector and ground wire [A] (⌀ x 1, ⌀ x 1).
5. Idle registration roller panel [B] (⌀ x 2)
 - Remove the two rear screws [C] first and let the panel come down. Use a very

Common Procedures

short screwdriver to remove the rear screws.

- Disconnect the panel from the stud screw on the right side first [D], then the left side. Do not remove the stud screws.

3.1.10 MANUAL FEED TABLE, ORIGINAL FEED SENSOR COVER

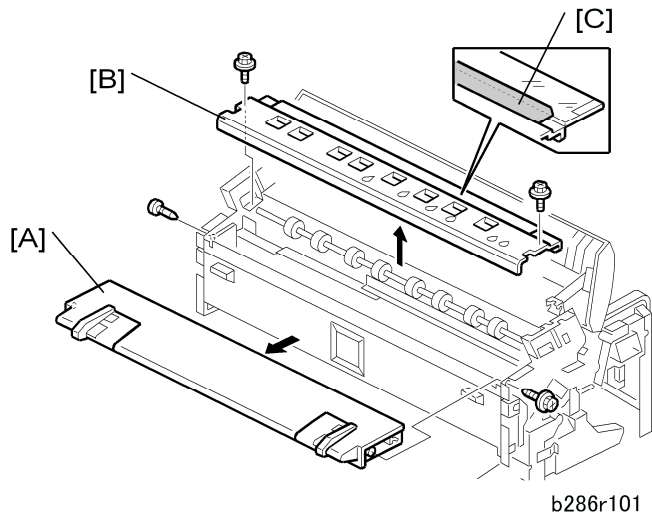

1. Unlock and lift the original feed unit. (See section 3.1.5 "Unlocking, Opening the Original Unit.")
2. Open the upper unit.
3. Side covers (See section 3.1.2 "Side Covers.")
4. Manual feed table [A] (⌘ x 2)
5. Original feed sensor cover [B] (⌘ x 2)

Reinstallation

- Make sure that the mylar [C] is on the front edge of the exposure glass.

3.1.11 DRAWER FRONT COVER

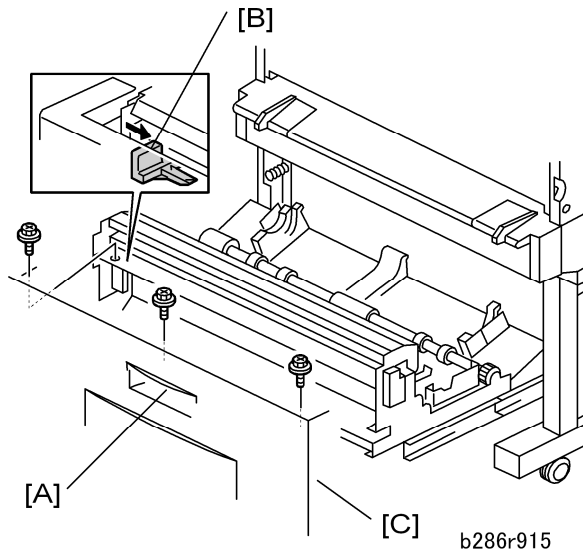

1. Open the front drawer of the roll feeder [A].
2. Push the cutter [B] to the right.
3. Front cover [C] (⚙ x 3)

3.2 SCANNER

3.2.1 ORIGINAL WIDTH SENSORS, ORIGINAL SET SENSOR, SCANNER SWITCH

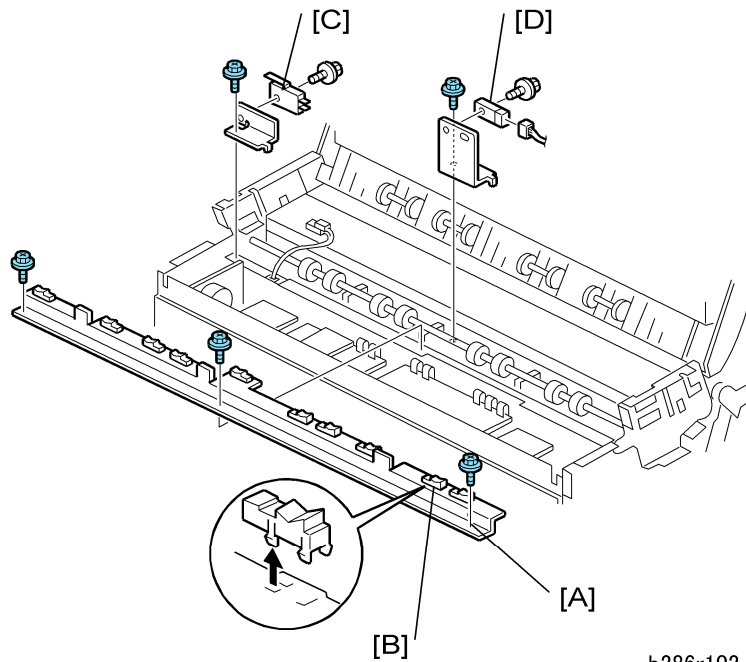

1. Manual feed table, original feed sensor cover (See section 3.1.10 "Manual Feed Table, Original Feed Sensor Cover.")
2. Original width sensor bracket [A] (🔧 x 3, 🛠️ x 3)
3. Original width sensors [B] (🔧 x 1 each)
4. Scanner switch [C] (🔧 x 1, 🛠️ x 2)
5. Registration sensor [D] (🔧 x 1, 🛠️ x 2)

3.2.2 ORIGINAL FEED UNIT ROLLERS

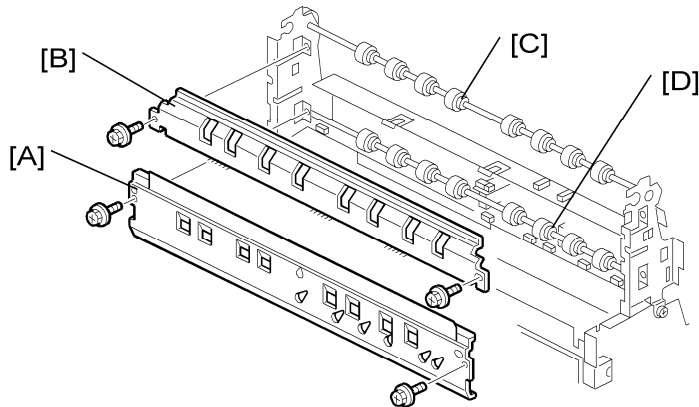

b286r108

1. Lift and lock the scanner unit. (See section 3.1.7 “Raising and Locking the Scanner Unit”)
2. Original width sensor cover [A]
3. Original exit roller cover (2) [B]
4. Original exit rollers (1, bushings x 2, hex 1) [C]
5. Original feed rollers (2, bushings x 2) [D]

Reinstallation

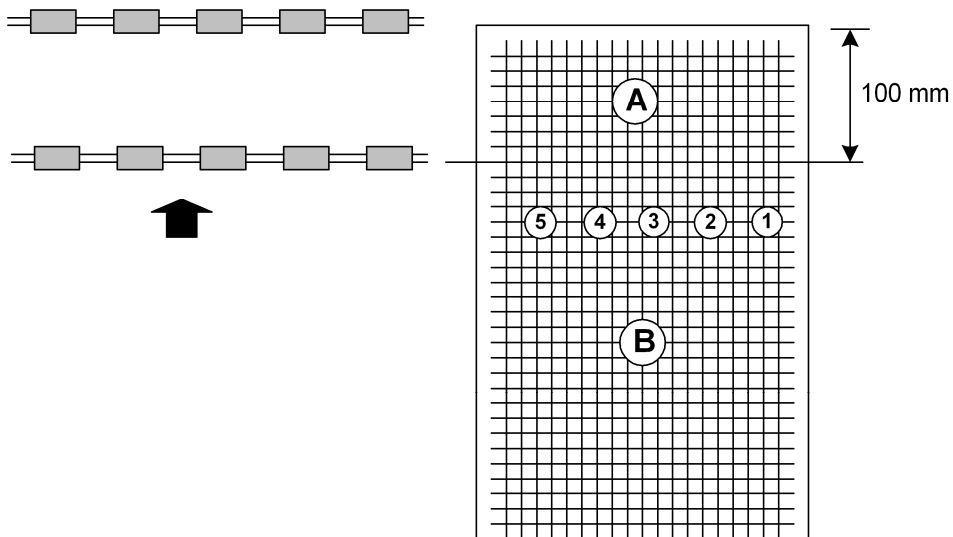

b286r911

- After you replace the original feed roller or the original exit roller, do the CIS sub scan test and adjustment as follows.
 1. Do SP2902-2 (IPU Test Pattern) and print Pattern 11.
 2. Make a copy of the Pattern 11 output that you made in step 1.
 3. On the copy, first, check Area “B.”

Scanner

- If the lines at all the joints are correct (not broken), go to the next step. The joints are labeled 1 to 5 in the diagram; these joints are at the same locations as the joints between segments of the CIS.
- If the lines are broken at a joint, do SP4972 to adjust them. Then go to the next step.

4. Next, check Area "A."



- Area A (100 mm) is the distance that the original is fed by only the feed roller, until the original exit roller gets and feeds the original.
- If the lines at the joints in Area A are correct (not broken), the procedure is completed.
- If the lines are broken at a joint, do SP4965 to adjust them (adjust by trial and error). Then go back to step 3 and check again.

3.2.3 EXPOSURE GLASS

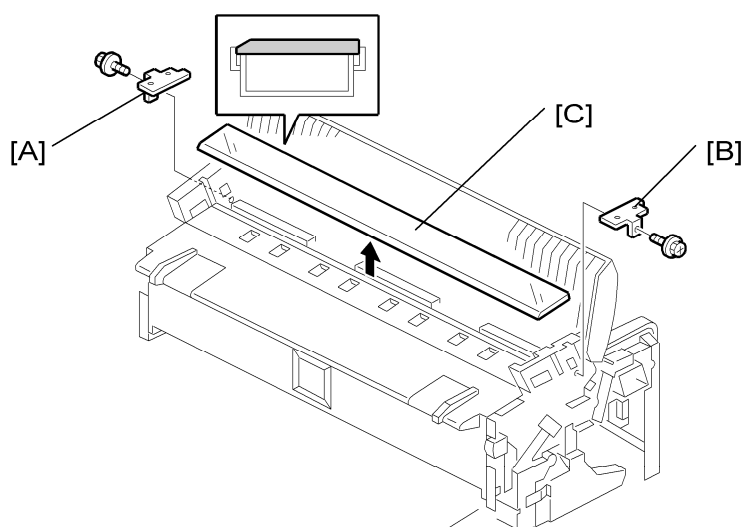

b286r113

1. Unlock and lift the original feed unit. (See section 3.1.6 "Removing the Original Feed Unit.")
2. Side covers (See Side Covers.)
3. Left exposure glass plate [A] (🔧 x 1)
4. Right exposure glass plate [B] (🔧 x 1)
5. Exposure glass [C]



- The exposure glass is very long and thin. It is very easy to break.

Reinstallation

- Make sure that the mylar is on top of the beveled edge of the exposure plate.
- Make sure that the black seal is below the rear edge of the exposure glass. The rear edge of the exposure glass must be on its metal supports and not in front of them.

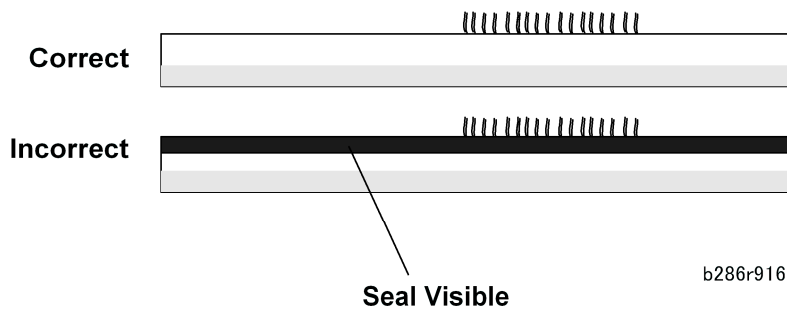

3.2.4 CIS

1. Lift and lock the scanner unit. (See section 3.1.7 “Raising and Locking the Scanner Unit”)
2. Remove the following.
 - Original width sensor cover (See section 3.2.2 “Original Feed Unit Rollers.”)
 - Original exit roller cover (See section 3.2.2 “Original Feed Unit Rollers.”)
 - Exposure glass (See section 3.2.3 “Exposure Glass.”)

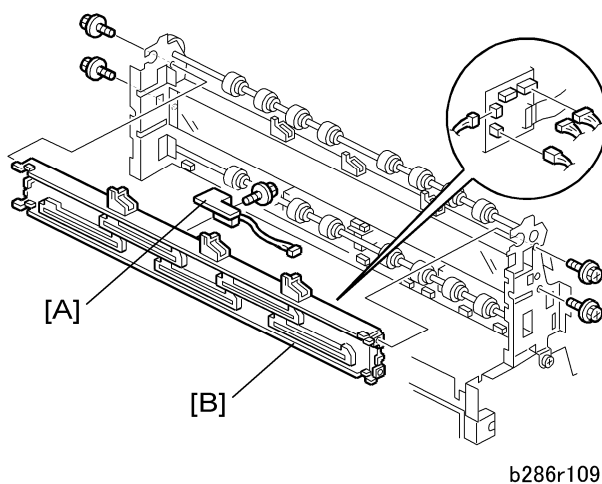

3. Remove the original exit sensor (⚙️ x2, ⚙️ x1, ⚙️ x1)
4. CIS unit [B] (⚙️ x 19, ⚙️ x2)

↓ Note

- Be sure to disconnect each ferrite core.

Reinstallation

After you replace the CIS, do the following procedure:

Scanner

1. Read the values for SP4972 that are printed on the label attached to the CIS replacement unit.



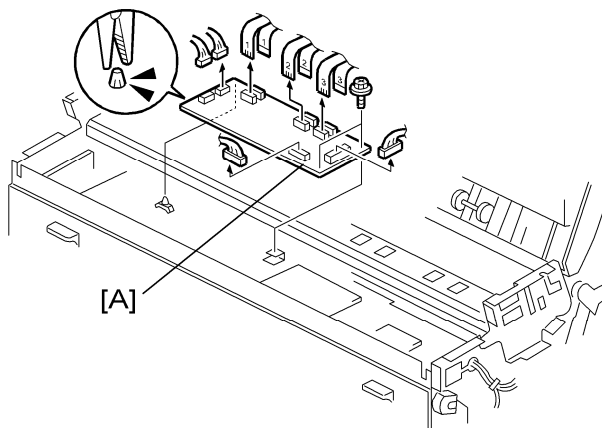

- The label is attached to replacement CIS units only.
2. Do SP4972 and input the 8 values.
 3. Do SP2902-2 and print Pattern 11 to check the CIS.
 4. Adjust if necessary. (See section 311.2 “CIS Adjustment with SP Codes”)

3.2.5 SMDB, VDB



b286r104a

1. Side covers (See section 3.1.2 “Side Covers.”)
2. Manual feed table, original feed sensor cover (See section 3.1.10 “Manual Feed Table, Original Feed Sensor Cover.”)
3. VDB [A] (FFC x 6,  x 4,  x2, Standoff x2)

3.2.6 SIB, CGB POWER PACK

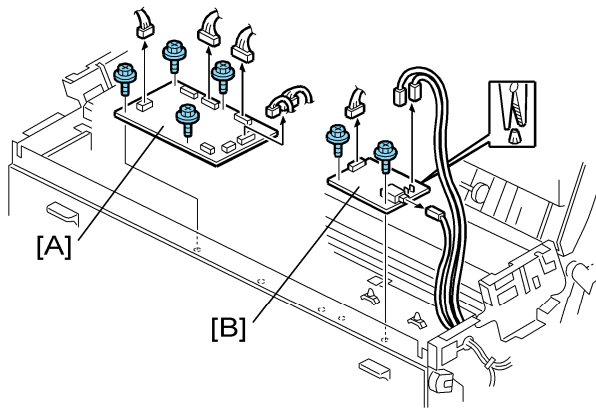

b286r103

1. Side covers (See section 3.1.2 “Side Covers.”)
2. Remove (See section 3.1 “Common Procedures”):
 - Manual feed table
 - Original feed sensor cover
3. SIB [A] (⌘x9, ⌘x4, Standoff x2)
4. CGB power pack [B] (⌘ x 4, ⌘ x 2, standoffs x 2)

3.3 AROUND THE DRUM

3.3.1 CHARGE CORONA WIRE, GRID WIRE, WIRE CLEANER

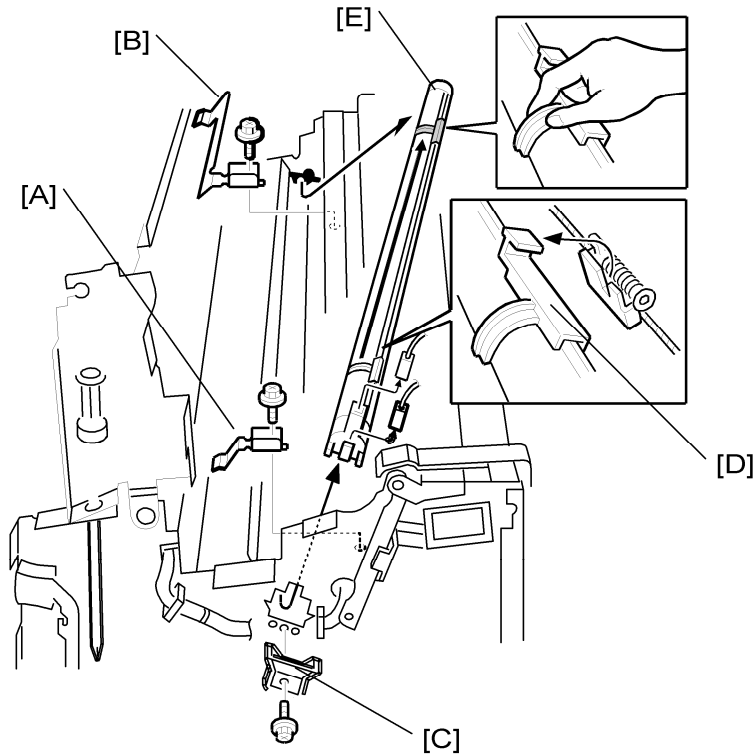

b286r307

1. Lift and lock the scanner unit (See section 3.1.7 “Raising and Locking the Scanner Unit.”)
2. Remove the scanner motor (See section 3.8.1 “Scanner Motor.”)
3. Leaf spring [A] (🔩 x 1)
4. Leaf spring [B] (🔩 x 1)
5. End plate [C] (🔩 x 1)
6. Disconnect the cleaning pad [D] and then move it to the left.
7. Charge corona unit [E] (🔩 x 2)

Reinstallation

- Put the left end into the hole on the left first (viewed from the rear of the machine). Then, put the right end into the hole on the right.
- Attach the right plate, then the left plate. Make sure the T-bar of the cleaning pad [D] is connected to the guide wire.
- After you replace the charge corona wire, do SP2803 (Corona Wire Cleaning) to clean the new corona wire.

Disassembling the Charge Corona Unit

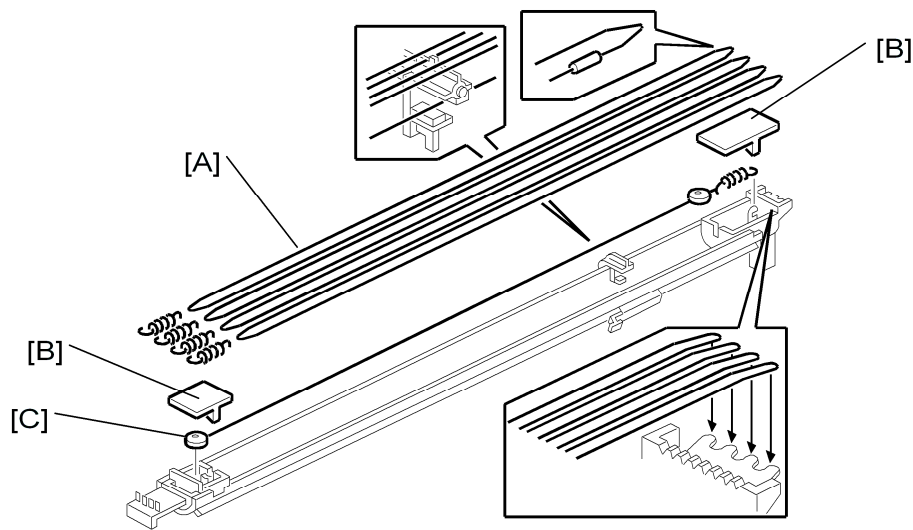

b286r308

8. Grid wires [A] (Spring x 1 each)
9. Two cover plates [B] (pressure release)
10. Charge corona wire [C] (x1)

3.3.2 QUENCHING LAMPS

1. Remove
 - OPC drum unit (See section 3.5 “Drum Unit.”)
 - Charge corona unit (See section 3.3.1 “Charge Corona Wire, Grid Wire, Wire Cleaner.”)

Around the Drum

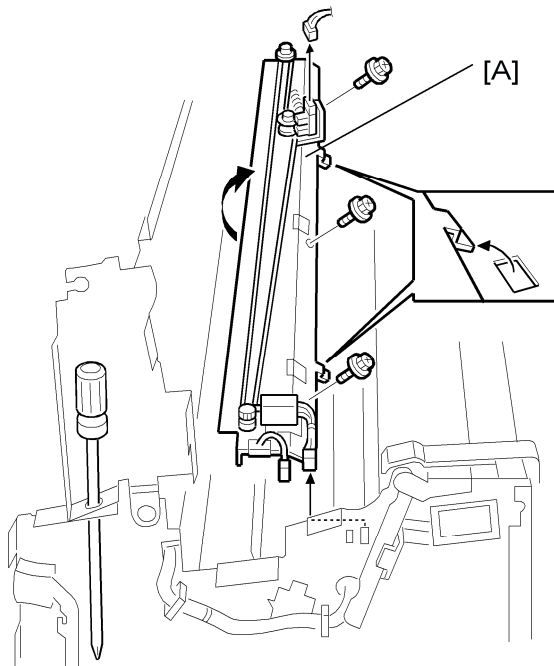

b286r115

2. Quenching lamp unit [A] (☞ x 3, ⚙ x 3)

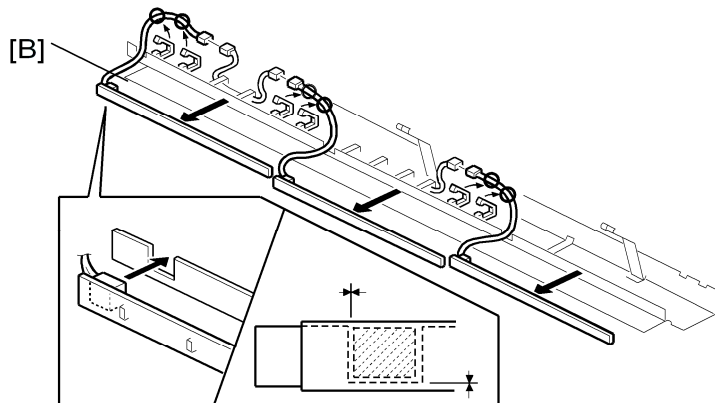

b286r116

3. Quenching lamps (x3) [B] (☞ x all, ☞ x 3)

↓ Note

- The quenching lamps are attached to the plate with double-sided tape.

3.3.3 LPH (LED PRINT HEAD)

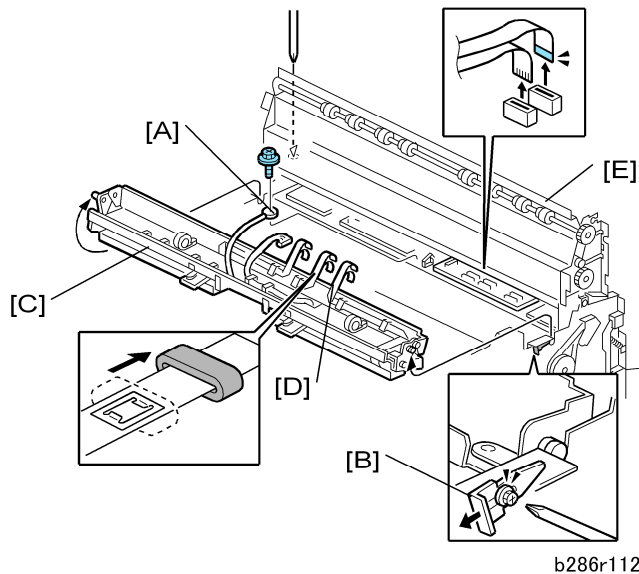

1. Original feed unit (See section 3.1.6 “Removing the Original Feed Unit”)
2. Lift and lock the scanner unit (See section 3.1.7 “Raising and Locking the Scanner Unit.”)
3. Ground wire [A] (⌘ x 1)
4. On each side of the machine, loosen the screws and move the plates [B] to the rear as shown.
5. LPH [C] (⌘ x 2, ⌘ x 1)
6. LPH (⌘ x 6 ribbons [D]). Connect the 3 ribbon connectors with the blue tabs at the rear.
7. Lower the scanning unit [E] to prevent damage to the OPC drum.

Reinstallation

1. Adjust the position of the LPH until it is level.
2. Set the plates [B] lightly against the studs on each side. Then tighten the screws.

★ Important

Do not push the plates forward with force against the LPH studs. If the studs are pushed forward, this could cause the LPH to move out of position and cause images to be too dark.

1. Do SP2943 and input the values that are printed on the label attached to the replacement unit. (See section 3.11.3 “LPH Adjustment with SP Codes.”)
2. Do SP2952 and input the values that are printed on the label attached to the replacement unit. (See section 3.11.3 “LPH Adjustment with SP Codes.”)
3. Make a test print and adjust if necessary. (See section 3.11.3 “LPH Adjustment with SP Codes.”)

3.3.4 TRANSFER CORONA, SEPARATION CORONA WIRES

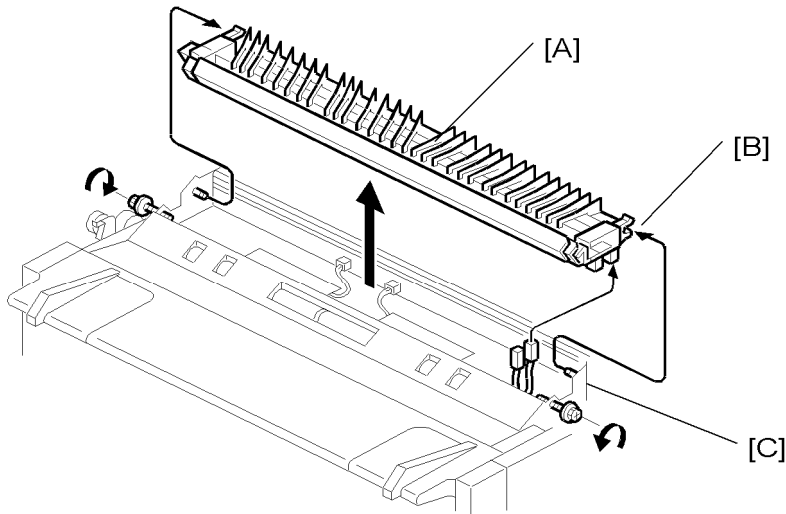

b286r406

1. Open the upper unit.
2. Side covers (See section 3.1.2 “Side Covers.”)
3. Transfer unit [A] (⌘ x 2, ⌘ x 2)

Reinstallation

- At each end of the unit, make sure that the tabs [B] are fully engaged with the studs [C].
- When the tabs are engaged correctly, the caps on the end are fully level.

Disassembling the Transfer Unit

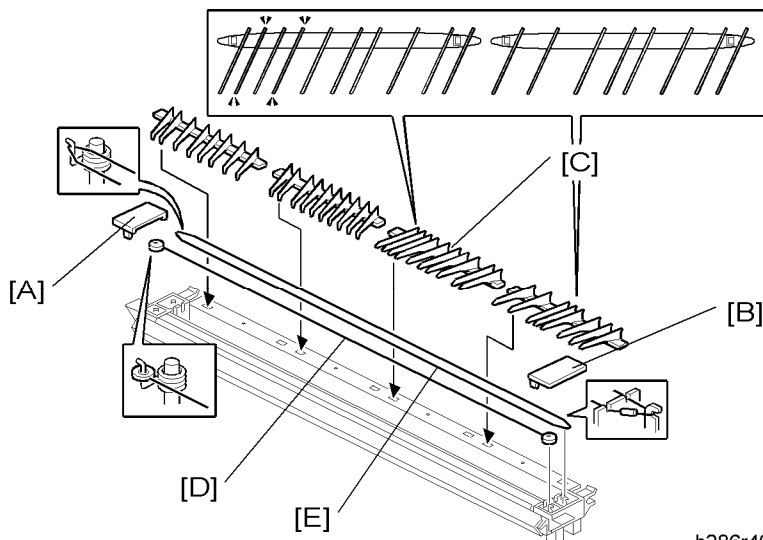

b286r407

1. Left cap [A] (tab release)
2. Right cap [B] (tab release)

↓ Note

- To remove a paper guide, lift it a small distance and move it in the direction of the center. Make a note of the position of each guide. Each guide must be installed at its original position.
3. Paper guides [C] (x4)
 4. Transfer wire [D]
 5. Separation wires [E]

Reinstallation

- Each paper guide pair must be installed at its original position.
- For each pair, the high guide is set on the outer side and the low guide is set on the inner side.
- If each guide is not installed at its original position, this will cause paper to wrinkle.

3.4 DEVELOPMENT

3.4.1 DEVELOPMENT UNIT

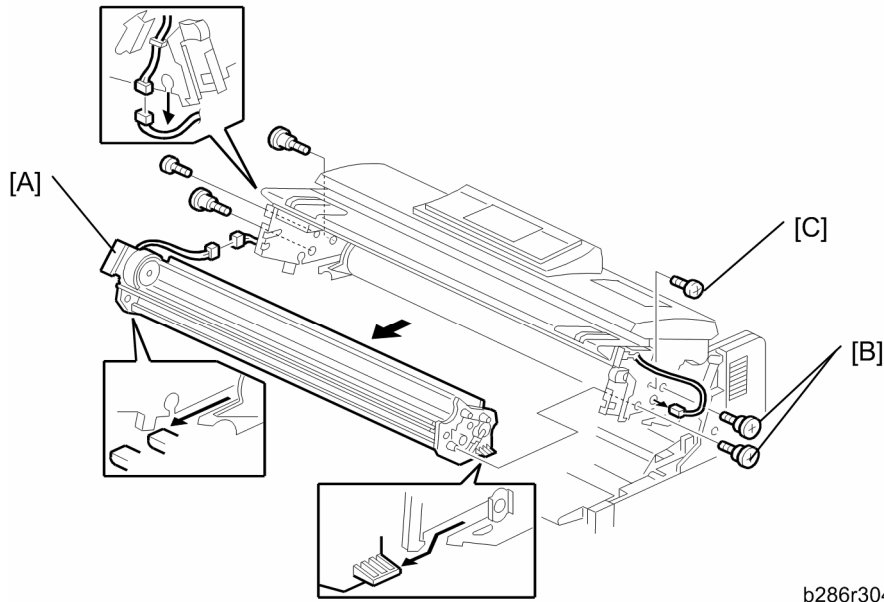

b286r304

1. Lift the upper unit.
2. Side covers (See section 3.1.2 “Side Covers”)
3. Manual feed table (See section 3.1.10 “Manual Feed Table, Original Feed Sensor Cover”)
4. Toner hopper cover (See section 3.1.8 “Toner Hopper Cover”)
5. Idle registration roller panel (See section 3.1.9 “Idle Registration Roller Panel”)
6. Toner cartridge
7. Development unit [A] (☞ x 2, ☞ x 6)

CAUTION

- The development unit is very heavy. Pull it out slowly.

Reinstallation

- Attach the large shoulder screws [B] on each side first, then attach the flat-head screws [C].

3.4.2 DEVELOPER

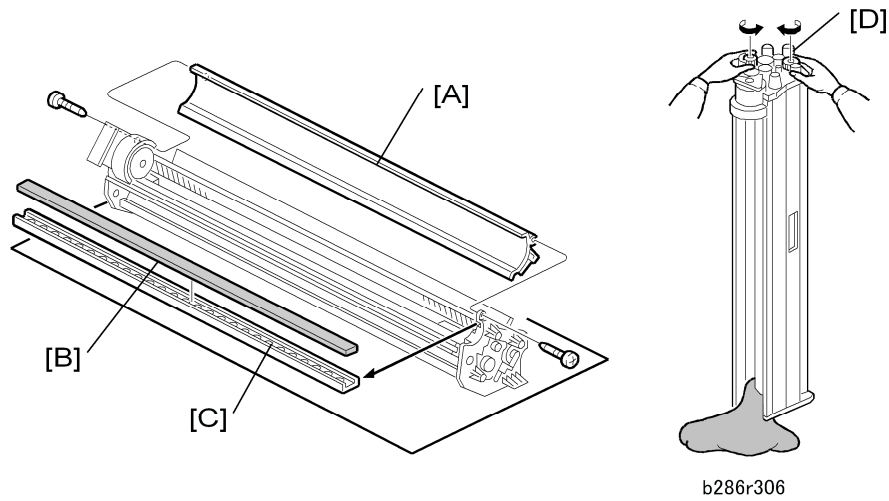

1. Remove the development unit (See section 3.4.1“Development Unit.”)



- Do not bend the bias terminal.

2. Put the development unit on a large sheet of paper.
3. Remove the casing [A] for the toner supply unit (⌀ x 2)
4. Remove the development filter [B] and bracket [C].
5. Hold the development unit above the paper with the gears up.
6. Turn the paddle roller knob [D] clockwise until all developer is out of the unit.
7. Clean the development unit (especially the right end), the development filter, and development filter bracket.

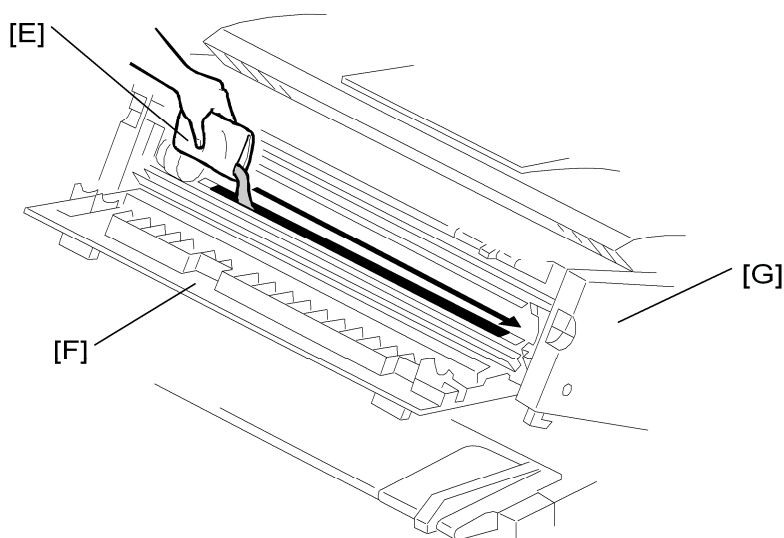

Development

8. Add one (1 kg) pack of developer. Do not add the second pack at this time.

- Open the first developer pack [E].

 Note

- Save the top of the pack. You will need the number to enter the lot number with SP2801.
- Slowly add the first pack of developer to the development unit. Move the pack from left to right until it is empty.
- Make sure that the developer is applied equally across the slot of the development unit.

9. Close the toner hopper cover [F].

10. Close the upper unit [G].

11. Connect the power supply cord. Switch the main power switch on.

12. Do SP5804-32 to start the main motor. This supplies developer to the development unit.

13. Push “ON” to start the motor and let it operate for 30 seconds.

14. Push “OFF” to stop the motor.

15. Switch the main power switch off.

16. Open the upper unit.

17. Open the toner hopper cover.

18. Open the second 1 kg pack of developer and slowly add it to the development unit. Move the pack from left to right until it is empty.

 Note

- Save the top of the pack. You will need the number to enter the lot number with SP2801.

19. Use a clean cloth to clean the edges around the slot of the development unit.

20. Install the development unit in the machine and close the toner hopper cover.

21. Close the upper unit. Make sure that the upper unit locks on each side.

22. Switch the main power switch on.

23. Go into the SP mode, enter the developer lot numbers, then mix the developer and initialize the ID sensor.

- First, do SP2801-2 and -3 and use the soft keyboard on the display panel to enter the lot numbers to enter the lot numbers of both developer packs.

 Important

- You must enter the lot numbers with SP2801-2 and -3 before doing SP2801-1. The machine will return an error (“Failed”) if you attempt to do SP2801-1 before SP2801-2 and -3.

- If the lot numbers are the same, just enter the same number twice.
- Do SP2801-1 to mix the developer and initialize the ID sensor.

3.4.3 PAPER SET SENSOR, REGISTRATION SENSOR

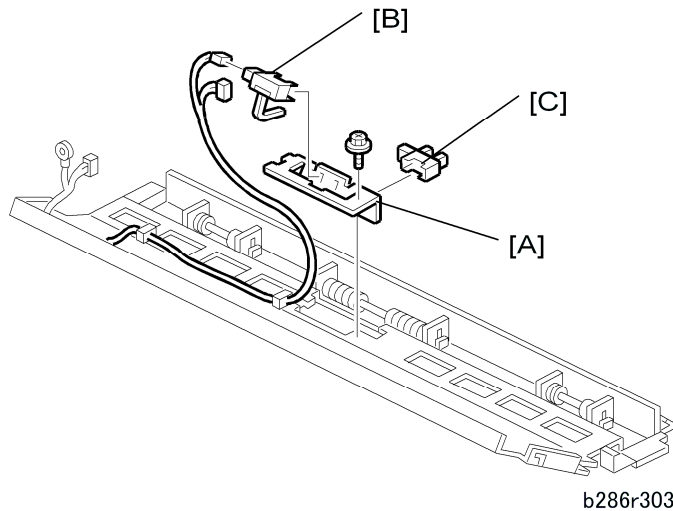

1. Idle registration roller panel (See section 3.1.9 “Idle Registration Roller Panel.”)
2. Sensor bracket [A] (🔩 x 1)
3. Paper set sensor [B] (🔌 x 1)
4. Registration sensor [C] (🔌 x 1)

3.4.4 TONER SUPPLY CLUTCH

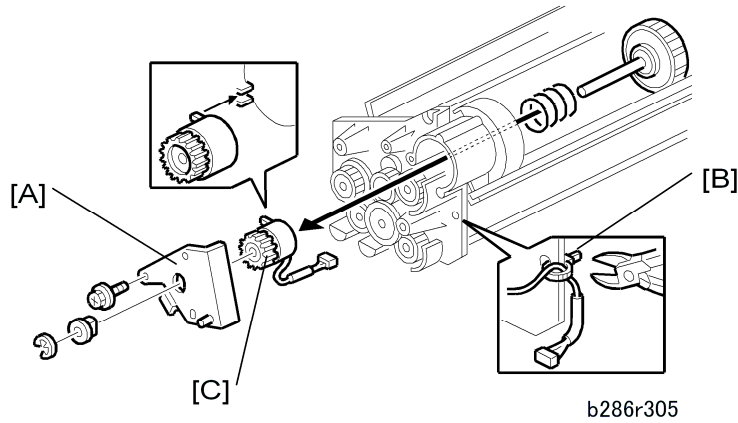

1. Remove the development unit (See section 3.4.1 “Development Unit.”)
2. Plate [A] (⌀ x 1, Ⓢ x 1)
3. Cut the harness clamp [B].
4. Toner supply clutch [C] (Bushing x 1)

Note

- The stopper is spring-loaded and will come out suddenly after you remove the e-ring.

3.4.5 DEVELOPMENT FILTER

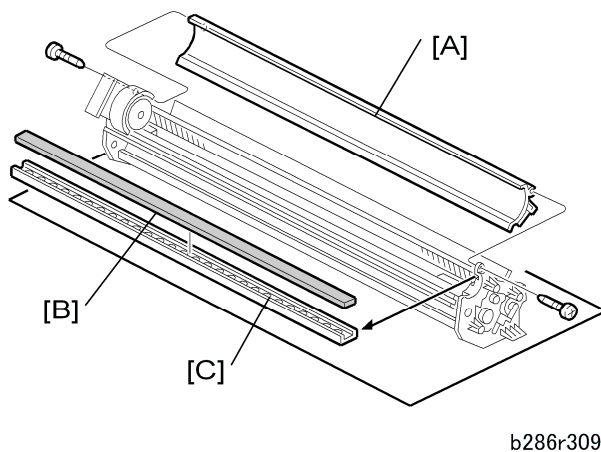

1. Remove the development unit (See section 3.4.1 “Development Unit.”)
2. Development unit casing [A] (⌀ x 2)
3. Filter rack [B]
4. Filter [C]

3.4.6 USED TONER COLLECTION BOTTLE, TONER OVERFLOW SENSOR

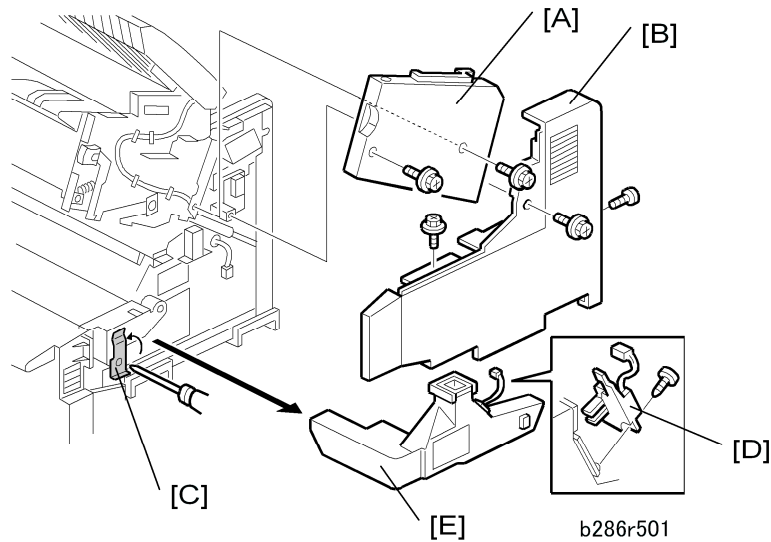

1. Lift the original feed unit.
2. Lift the upper unit.
3. Right upper cover [A] (⚙️ x 2)
4. Right cover [B] (⚙️ x 3)
5. Loosen the leaf spring [C] and lift it.
6. Toner overflow sensor [D] (🔌 x 1, ⚙️ x 1)
7. Toner collection bottle [E]

Drum

3.5 DRUM

3.5.1 DRUM UNIT

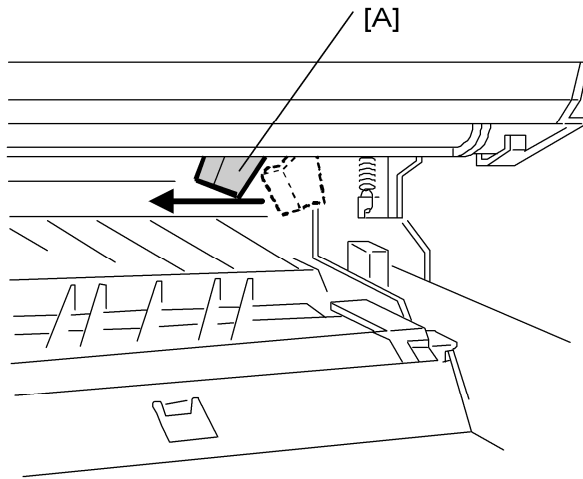

b286r901

1. Open the upper unit and set the cleaning blade release lever [A] to the left.

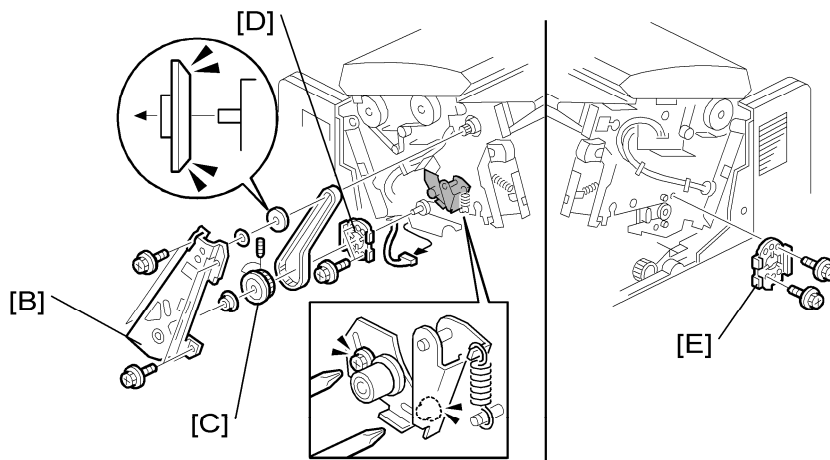

b286r401

2. Development unit (See section 3.4.1 "Development Unit.")
3. Drive belt plate [B], drive belt (⌀ x 4)
4. Use the long end of a hexagonal wrench to remove drum gear [C] (⌀ x 2).
5. Left hub [D] of drum shaft (⌀ x 2)
6. Right hub [E] of drum shaft (⌀ x 2)

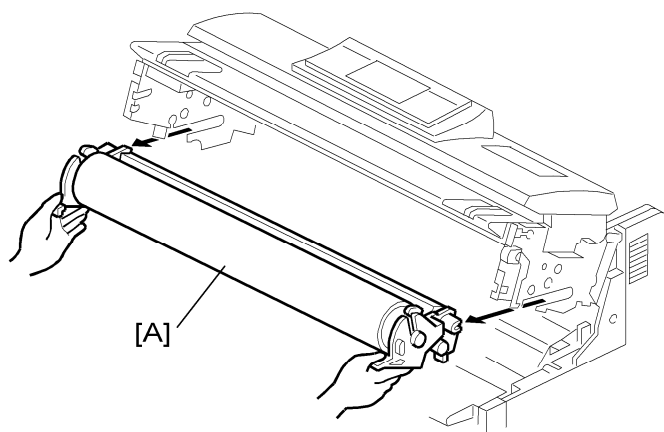

b286r402

7. Drum unit [A]

⚠ CAUTION

- The drum unit is very heavy. Pull it out slowly.

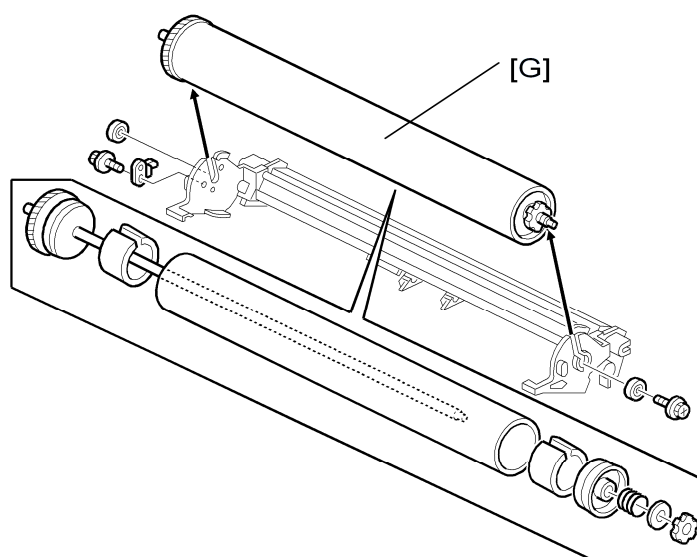

b286r403

★ Important

- Do not touch the surface of the drum.

8. Drum [G] (⌀ x 2. bushings x 2, plate x 1)

Reinstallation

After you replace the drum:

- Do SP2923 (Cleaning Blade Replace Mode). This applies toner to the drum and blade to decrease friction between the drum and the cleaning blade. If you do this, scratches on the drum or a bent cleaning blade are less possible to occur.
- Do SP3001-2 to initialize the ID sensor.
- Be sure to tighten the hexagonal lock screws in the drum gear.

Drum

- Set the cleaning-blade release lever to the right.

3.5.2 CLEANING BLADE

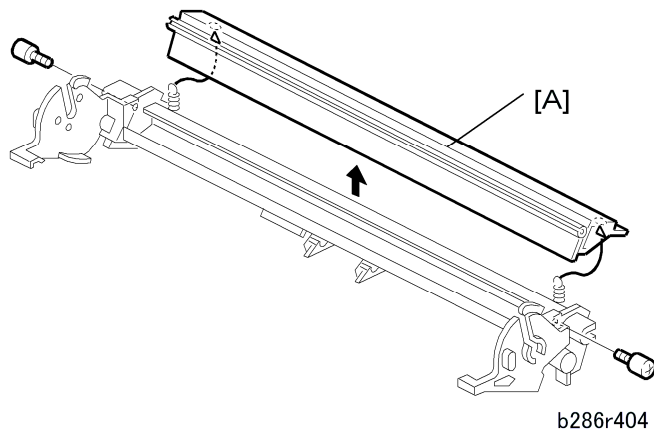

1. Cleaning blade [A] (⚙ x 2, springs x 2)

Reinstallation

After you replace the cleaning blade:

- Do SP2923 (Cleaning Blade Replace Mode). This applies toner to the drum and blade to decrease friction between the drum and the cleaning blade. If you do this, scratches on the drum or a bent cleaning blade are less possible to occur.

3.5.3 ID SENSOR, PICK-OFF PAWLS, PICK-OFF PAWL SOLENOID

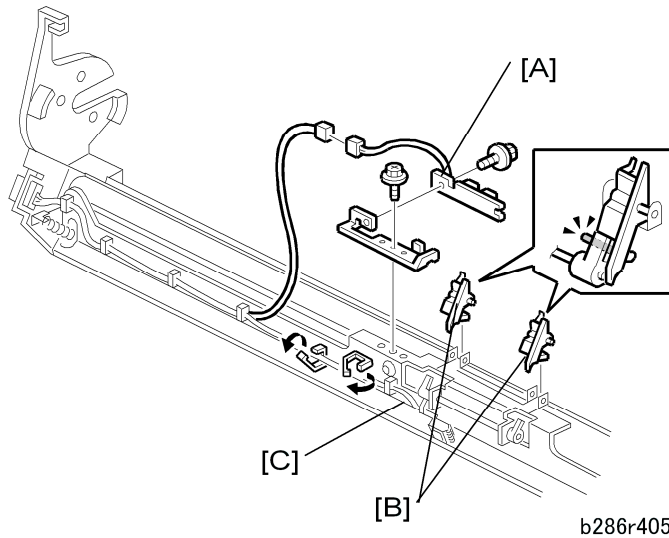

1. Drum (See section 3.5.1 “Drum Unit.”)
2. Cleaning blade (See section 3.5.2 “Cleaning Blade”)
3. ID sensor [A] (🔧 x 3, 🛠️ x 1, 🔩 x 1)
4. Pick-off pawls (x2) [B] (pressure release).
5. Pick-off pawl solenoid [C] (🛠️ x 2, 🔩 x 1)

Reinstallation

- After replacing or cleaning the ID sensor, do SP3001-2 to initialize the new ID sensor.
- If the ID sensor is damaged and cannot be replaced immediately, set SP2208-3 (Toner Supply Setting – Toner Supply Mode) to “1.” Then the customer can continue to use the machine until a new ID sensor is available. After you install a new ID sensor, reset this SP to 0.

3.6 PAPER FEED

3.6.1 REGISTRATION CLUTCH, REGISTRATION ROLLER

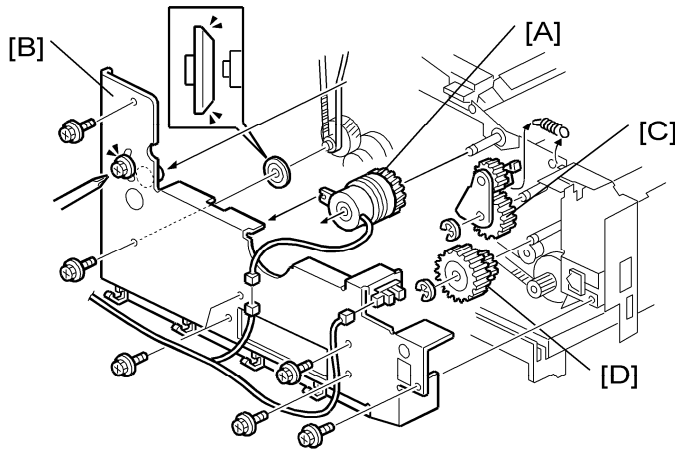

b286r507

1. Side covers (See section 3.1.2 “Side Covers.”)
2. Registration clutch [A] (⚙️ x 1, ⚙️ x 1)
3. Gear cover plate [B] (🔩 x 7, cap x 1, drive belt x 1)
4. Gear [C] (⚙️ x 1, spring x 1)
5. Gear [D] (⚙️ x 1)

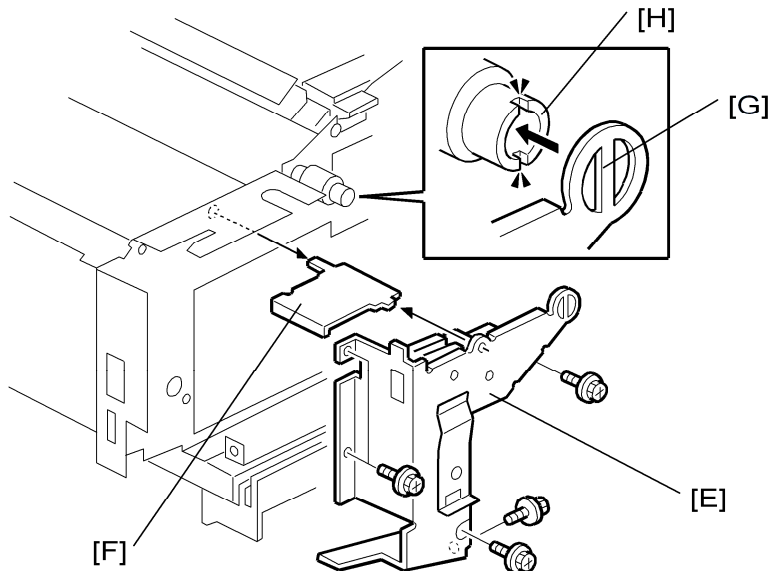

b286r506

6. Used toner collection bottle (See section 3.4.6 “Used Toner Collection Bottle, Toner Overflow Sensor”)

7. Cover plate [E] (⌀ x 5)
8. Switch pressure plate [F]

↓ Note

- At reinstallation, make sure that the vertical brace [G] is locked in the cutouts in the ceramic clutch [H] (see illustration above).

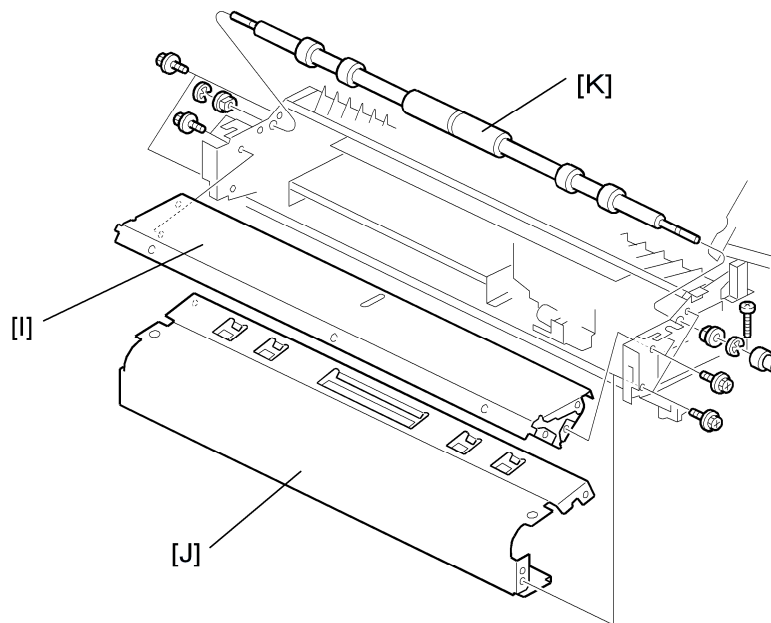

b286r508

9. Front plate [I] (⌀ x 6)
10. Transport roller dust cover [J] (⌀ x 4)
11. Registration roller [K] (⊕ x 2, bushings x 2, torque limiter x 1, ⌀ x 1)

Paper Feed

3.6.2 ROLL 1 PAPER FEED CLUTCH, FEED ROLLER

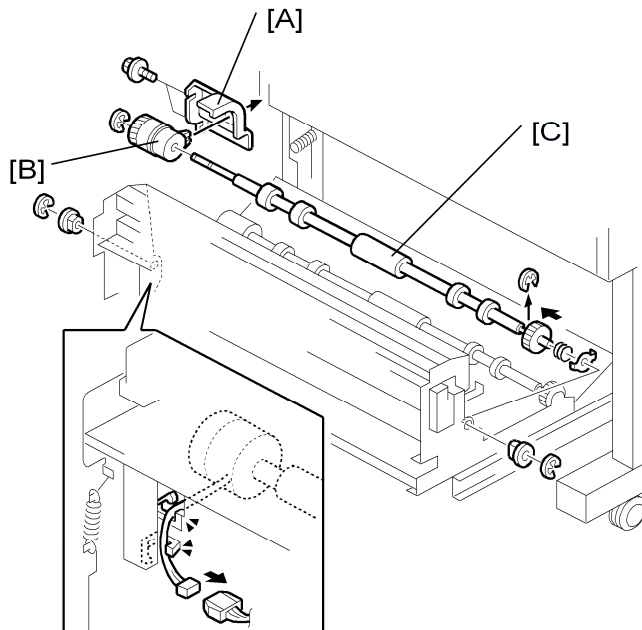

b286r918

1. Open the roll feeder drawer.
2. Remove the paper rolls.
3. Roll 1 feed clutch cover [A] (🔩 x 2)
4. Roll 1 feed clutch [B] (🔩 x 1, Ⓢ x 1)
5. Roll 1 feed rollers [C] (Ⓢ x 3, bushings x 2)
6. After you replace the roller or the clutch, adjust the cut length with SP1920-111 and SP 1920-115. (See section 3.11.1 “Image Adjustment with SP Codes.”)

3.6.3 ROLL 2 PAPER CLUTCH, FEED ROLLER

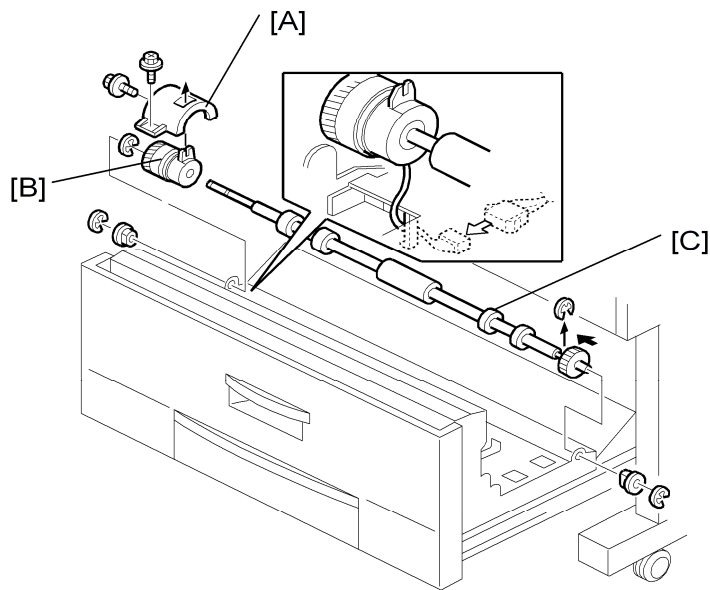

b286r919

Note

- The procedure is for the B642 only.
1. Open the roll feeder drawer.
 2. Remove paper roll 2 (at the rear).
 3. Roll 2 feed clutch cover [A] (🔑 x 2)
 4. Roll 2 feed clutch [B] (🔧 x 1, Ⓢ x 1)
 5. Roll 2 feed rollers [C] (Ⓢ x 3, bushings x 2)
 6. After you replace the roller or the clutch, adjust the cut length with SP 1920-211 and SP 1920-215. (See section 3.11.1 “Image Adjustment with SP Codes.”)

3.6.4 RF EXIT SENSOR

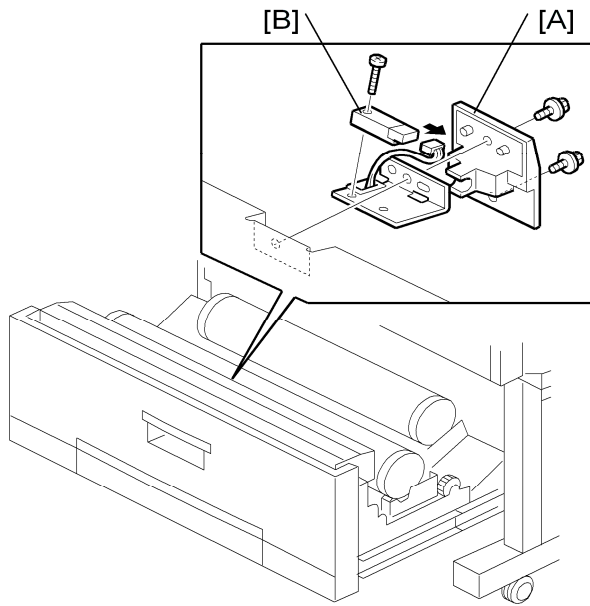

b286r920

1. Open the drawer of the roll feeder.
2. Plate [A] (🔩 x 2)
3. RF exit sensor [B] (🔩 x 1, 🛠️ x 1)

3.6.5 ROLL FEED MOTOR

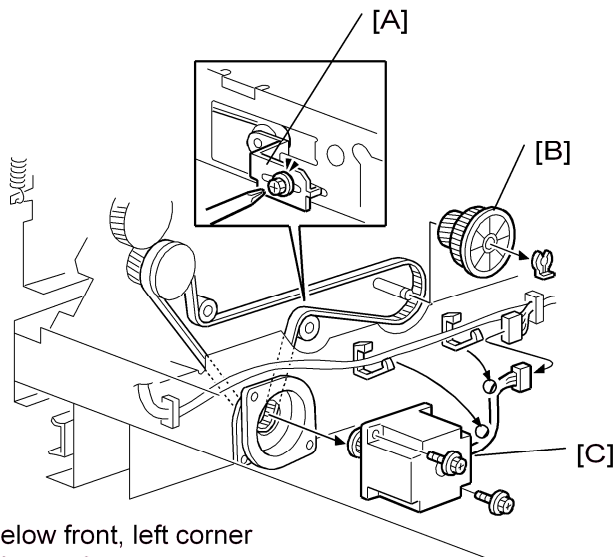

Below front, left corner
of roller feeder

b286r921

1. Open the roll feeder drawer.
2. Drawer front cover (See section 3.1.11 “Drawer Front Cover.”)
3. Loosen belt tension bracket [A].

4. Gear [B] (⚙️ x1)
5. Roll feeder motor [C] (🔌 x 2, 🛠️ x 1, 🛠️ x 2)

3.6.6 CUTTER MOTOR, HP SENSORS

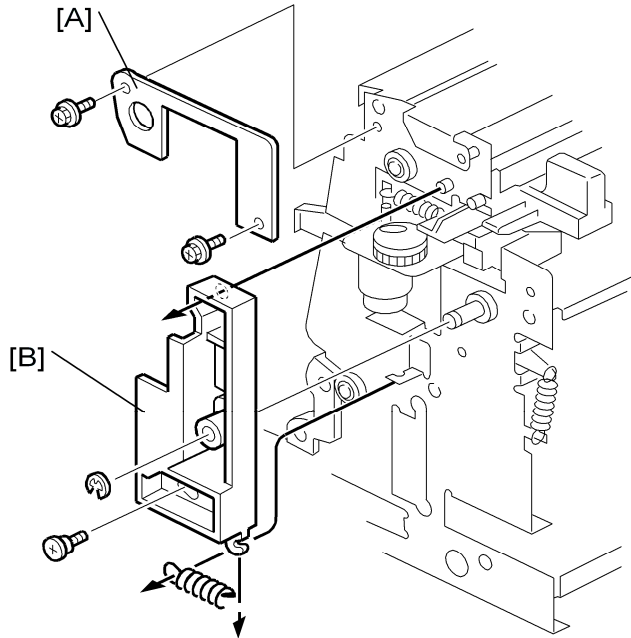

b286r922

1. Open the roller feeder drawer.
2. Drawer front cover (See section 3.1.11 “Drawer Front Cover”)
3. Upper bracket [A] (🛠️ x 2)
4. Lower bracket [B] (spring x 1, 🛠️ x 1, Ⓢ x 1)

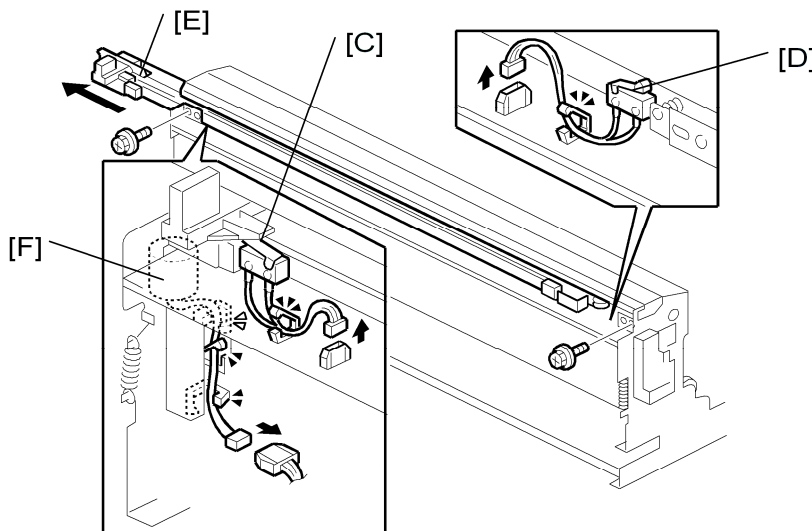

b286r923

Paper Feed

5. Right cutter HP switch [C] (⚙️ x 1, 🛠️ x 1)
6. Left cutter HP switch [D] (⚙️ x 1, 🛠️ x 1)
7. Cutter, race, and motor assembly [E] (⚙️ x 3, 🛠️ x 1, 🔩 x 2)
8. Cutter motor [F] (🔩 x 2)

3.6.7 ROLL PAPER END SENSORS

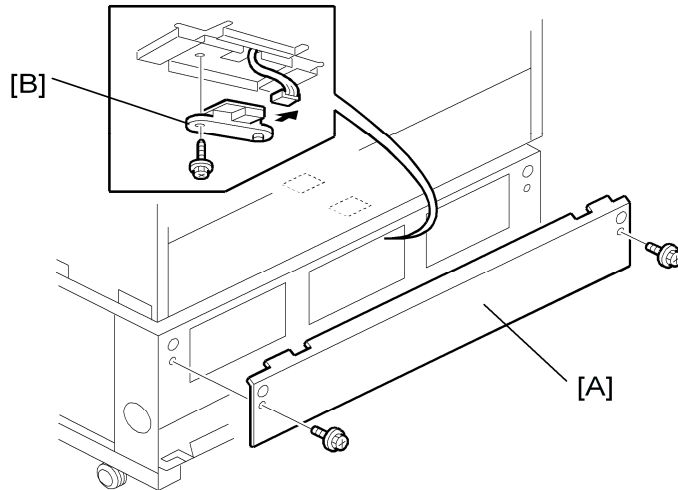

b286r924

1. Open the roll feeder drawer.
2. Roll feeder back plate [A] (🔩 x 2)
3. Roll end sensors [B] (🛠️ x 1, 🔩 x 1 each)

⚠️ Note

- The Roll Feeder B641 has one roll end sensor, and the Roll Feeder B642 has two roll end sensors.

3.6.8 CASSETTE FEED ROLLER

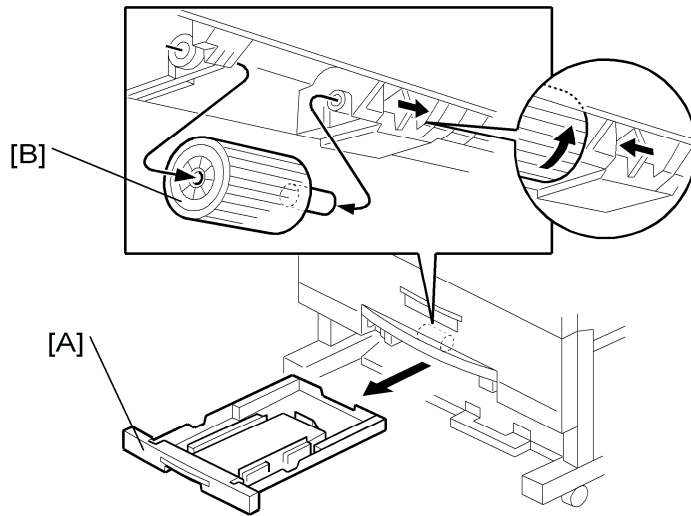

b286r925

1. Paper cassette [A]
2. Cassette feed roller [B]

3.6.9 CASSETTE RELAY SENSOR, CASSETTE END SENSOR

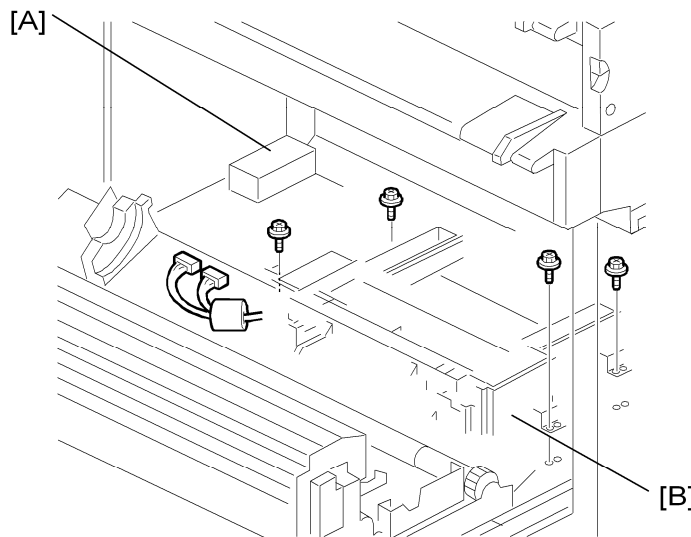

b286r926

1. Open the roll feeder drawer and remove the paper cassette.
2. Roll feeder rear plate (⚙ x 2 Blue)
3. RFDB shield plate [A] (⚙ x 2 Blue).
4. Paper cassette unit [B] (⚙ x 6, ⚙ x 2, ⚙ x 4 Blue)

↓ Note

Paper Feed

- Pull the unit to the rear, then remove it from the front.

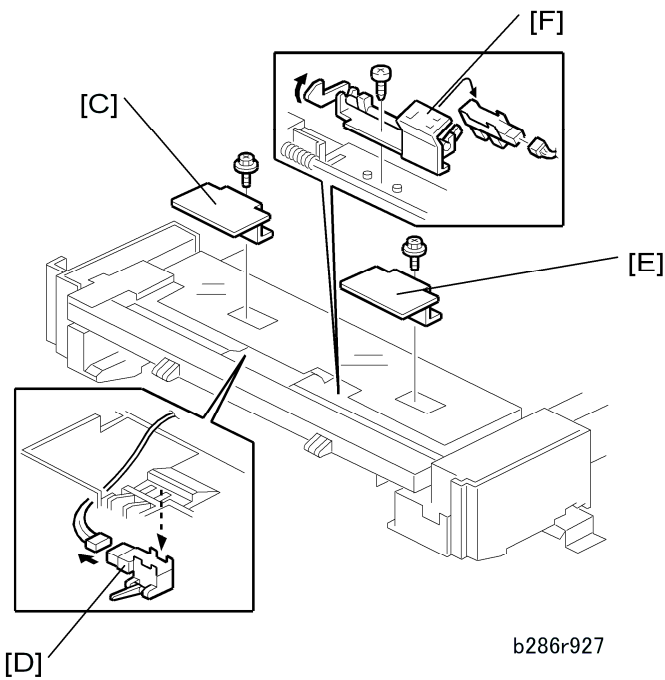

5. Relay sensor plate [C] (⚙️ x 1 Blue)
6. Relay sensor [D] (🔌 x 1, pinch release x 2)
7. Cassette end sensor plate [E] (⚙️ x 1 Blue)
8. Cassette end sensor [F] (🔌 x 1, ⚙️ x 1, pinch release x 3)

3.6.10 CASSETTE FEED MOTOR, CASSETTE OPEN SENSOR

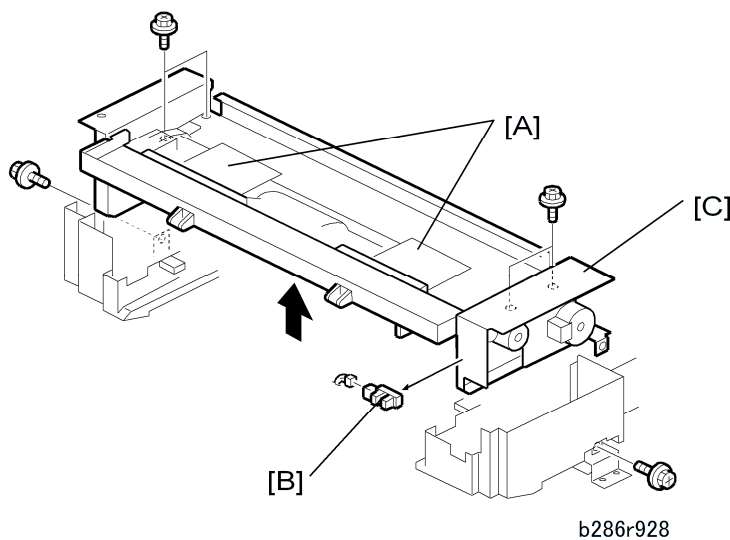

1. Open the roll feeder drawer and remove the paper cassette unit.
2. Relay sensor plate, cassette end sensor plate [A] (⚙️ x 1 each)

3. Cassette open sensor [B] (🔌 x 1, pinch release x 2)
4. Paper cassette feed assembly [C] (🔩 x 6)

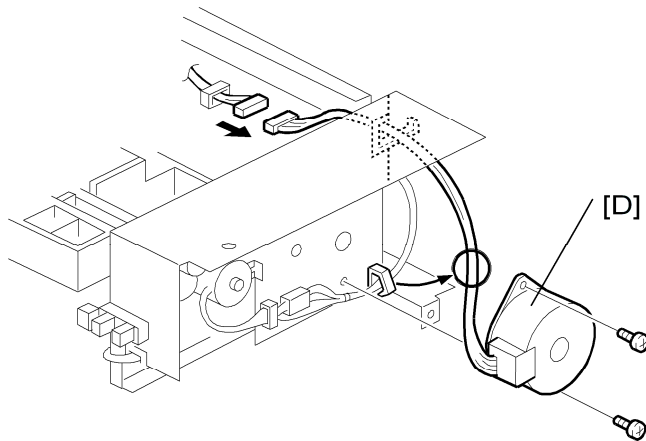

b286r929

5. Paper cassette motor [D] (🔩 x 2, 🔌 x 1, 🔩 x 2)

3.6.11 CASSETTE FEED CLUTCH

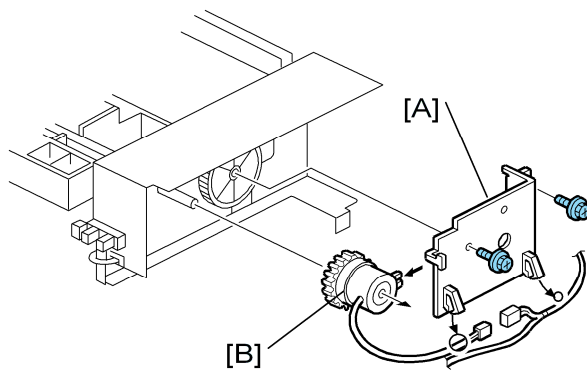

b286r930

1. Cassette feed motor (See section 3.6.10 “Cassette Feed Motor, Cassette Open Sensor”)
2. Motor mount plate [A] (🔩 x 2)
3. Cassette feed clutch [B] (🔩 x 1, 🔌 x 1)

3.7 FUSING

3.7.1 PRESSURE SPRING ADJUSTMENT

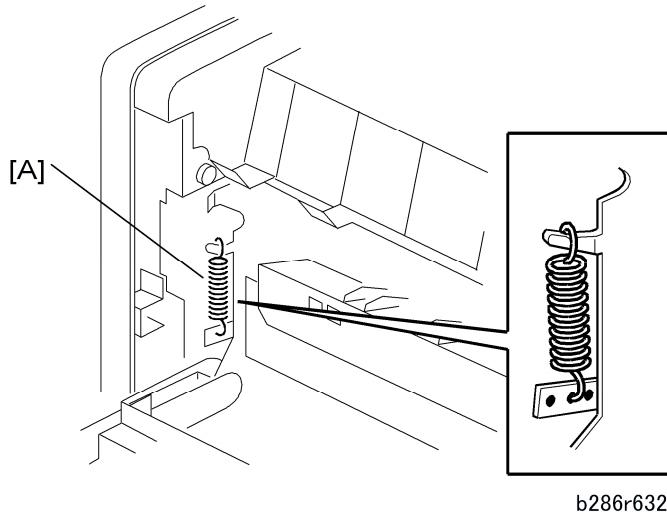

b286r632

1. Open the exit cover and exit unit together.
2. To adjust the pressure, disconnect the spring [A] and connect it to a different hole.
 - Center: Standard tension, standard pressure.
 - Left: Less tension, less pressure. Set to this position to decrease wrinkling
 - Right: More tension, more pressure. Can give better fusing with thick paper.

↓ Note

- Wrinkling occurs more frequently with some types of paper or film. Adjust the tension of the spring only when necessary.

3.7.2 HOT ROLLER STRIPPERS

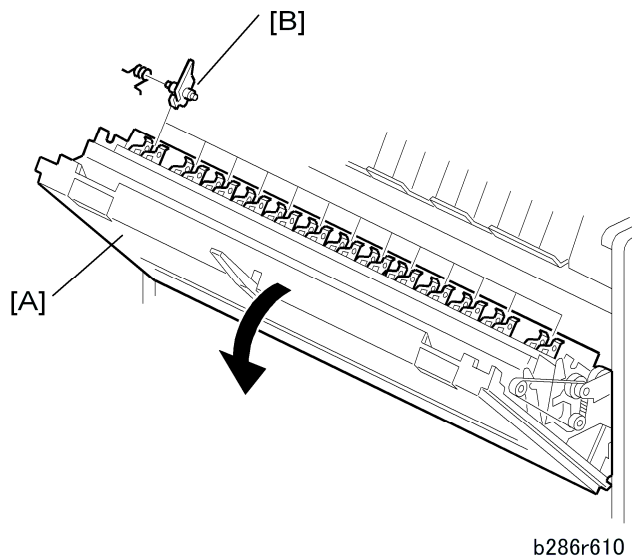

1. Open the paper exit cover and paper exit unit together [A].
2. Hot roller strippers [B] (pressure release, spring x 1 each)

3.7.3 FUSING EXIT SENSOR

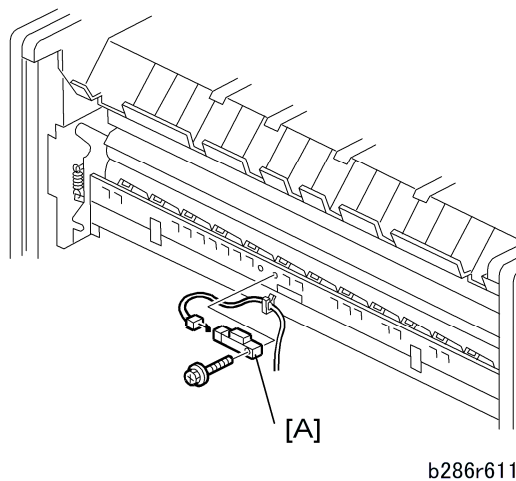

1. Remove:
 - Rear cover (See section 3.1.2 “Side Covers”)
 - Paper exit unit (See section 3.1.4 “Paper Exit Unit”)
2. Remove fusing exit sensor [A] (⌘ x 1, ⚙ x 1)

3.7.4 PRESSURE ROLLER THERMISTORS

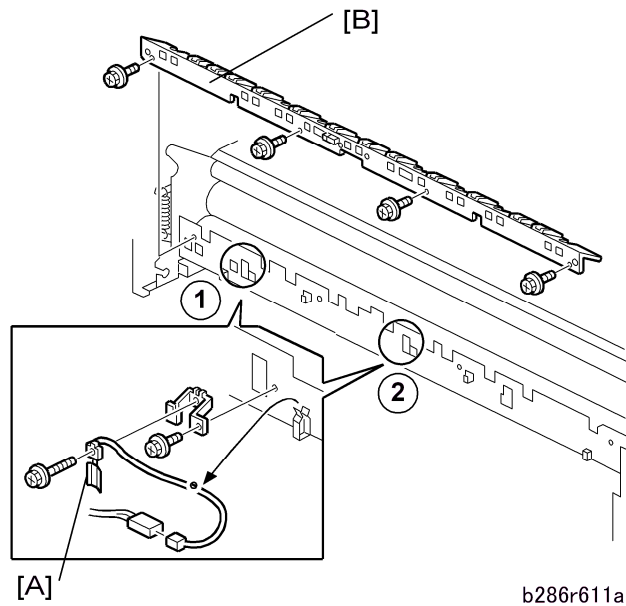

1. Remove:
 - Rear cover (See section 3.1.3 “Rear Cover”)
 - Paper exit unit (See section 3.1.4 “Paper Exit Unit”)
2. Remove pressure roller thermistors [A] (⚙ x 1, ⚙ x 2, ⚙ x1).
 - The end roller thermistor is at ①.
 - The center roller thermistor is at ②.

↓ Note

- You must first remove the stripper unit [B] in order to remove the center thermistor ②.

3.7.5 PRESSURE ROLLER STRIPPERS

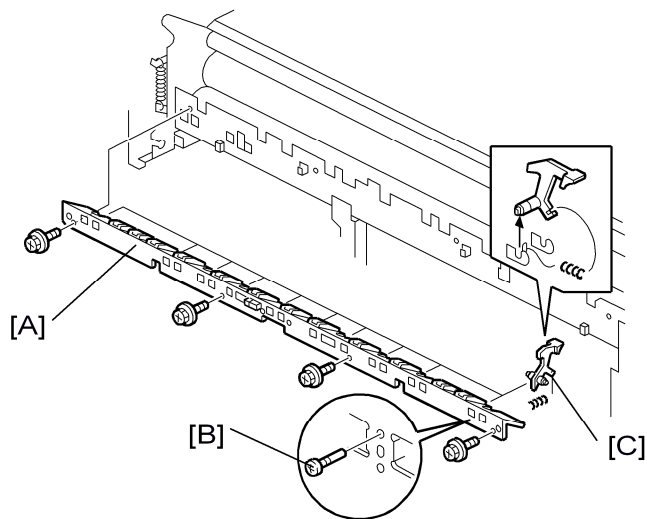

b286r612

1. Remove:
 - Rear cover (🔩 x 2). See section 3.1.3 “Rear Cover”
 - Paper exit unit and exit cover (🔩 x 4, 📄 x 1) See section 3.1.4 “Paper Exit Unit”
2. Remove:
 - Pressure roller stripper unit [A] (🔩 x 4)
 - Stopper screw [B] (🔩 x 1 ea.)
 - Pressure roller strippers [C] (Spring x 1 each)

↓ Note

- There are 11 pressure roller strippers. To remove them, push back and pull out.

3.7.6 EXIT UNIT SWITCH

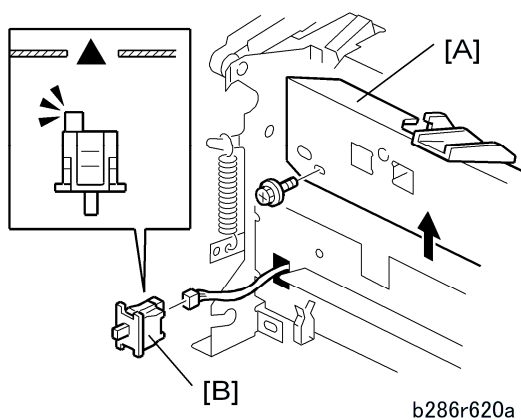

b286r620a

1. Remove the pressure roller stripper unit [A]. (See section 3.7.5 “Pressure Roller Strippers”).

Fusing

2. Remove the exit unit switch [B].



- Use tips of two small flat-head screwdrivers to release the tabs at the top and bottom of the switch to release it, then pull it out.

3.7.7 FUSING UNIT

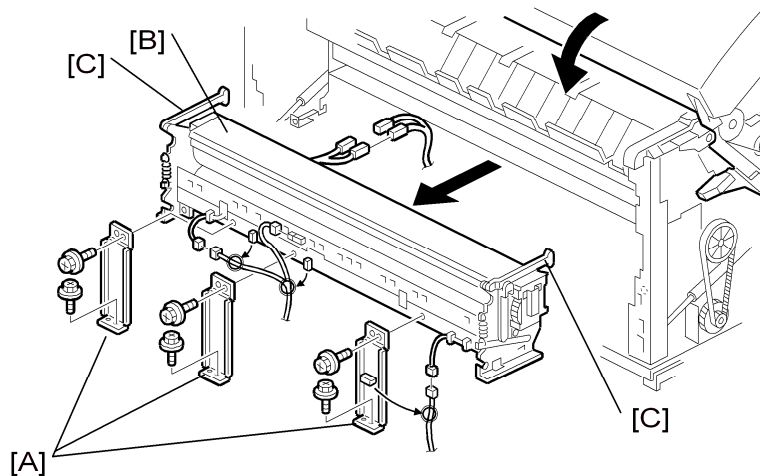



b286r613

CAUTION

- Switch the main power switch off. Then disconnect the machine from its power source. Let the fusing unit become cool for 10 minutes or more before you remove it.

1. Open the upper unit.
2. Paper exit unit (See section 3.1.4 “Paper Exit Unit.”)
3. Pressure roller thermistor, fusing exit sensor (See section 3.7.4 “Pressure Roller Thermistors.”)
4. Fusing Exit Sensor (See section 3.7.3 “Fusing Exit Sensor”)
5. Braces (x 3) [A] ( x 2 each)



- Install the brace with attached harness clamp in the center.
6. Fusing unit [B] ( x 2,  x 2)
 7. Push down the levers [C] when you remove the fusing unit.

CAUTION

- The fusing unit is heavy. Pull it out slowly.

Reinstallation

- Make sure that the upper unit is open when you install the fusing unit.
- Push down on the levers [C] while you set the fusing unit in the machine.

- Connect the color coded connectors correctly:
Europe: Blue - Blue, White - White
North America: Red - Red, White - White

3.7.8 FUSING CLEANING ROLLER

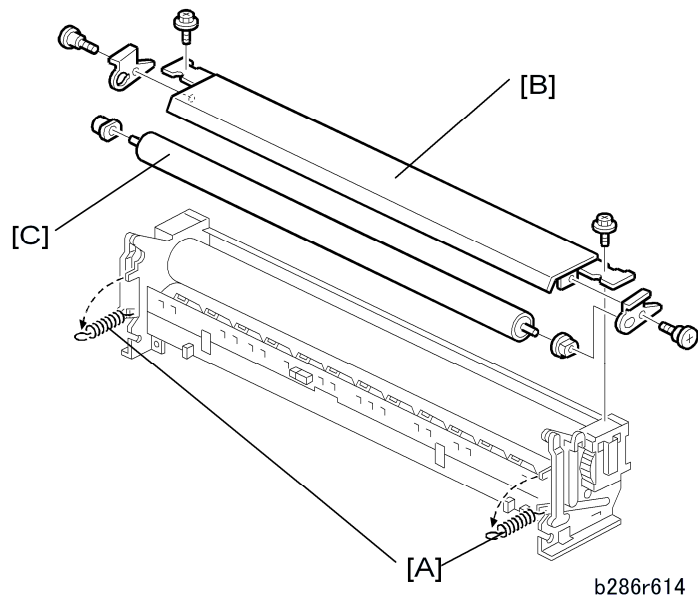

1. Fusing unit (See section 3.7.7 "Fusing Unit")
2. Springs [A] (x 2)
3. Felt plate [B] (1 x 2)
4. Fusing cleaning roller [C] (1 x 2, bushings x 2)

↓ Note

- The brown bushing is on the right; the white bushing is on the left.

Fusing

3.7.9 FUSING LAMP

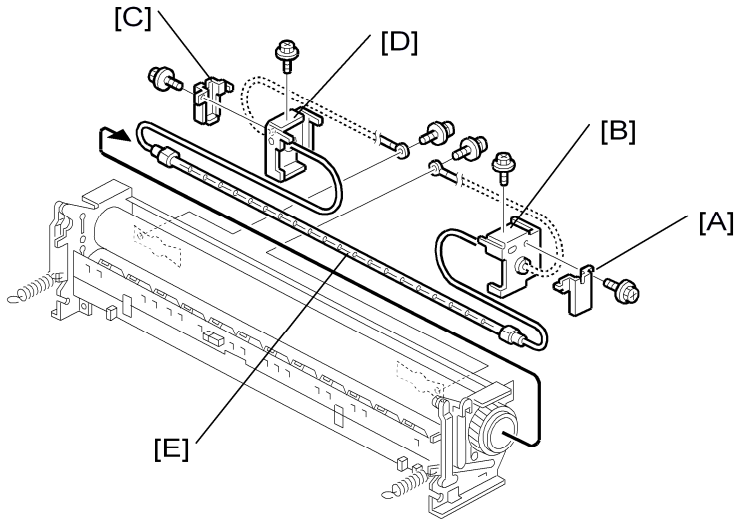

b286r615

1. Fusing cleaning roller (See section 3.7.8 “Fusing Cleaning Roller.”)
2. Right plate [A] (⚙ x 1)
3. Right support [B] (⚙ x 1)
4. Left plate [C] (⚙ x 1)
5. Left support [D] (⚙ x 1)

↓ Note

- This is the support with the anti-static brush.

6. Fusing lamp [E] (⚡ x 2, metal harness clamps x 2)

Reinstallation

- Make sure that the ends of the fusing lamp are given support by the rubber grommets of the right support [B] and left support [D].

3.7.10 HOT ROLLER

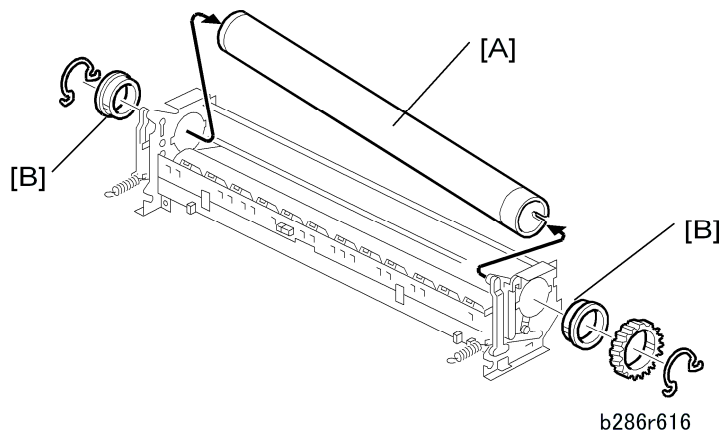

1. Fusing lamp (See section 3.7.9 “Fusing Lamp.”)
2. Hot roller [A] (springs x 2, sleeve bearings x 2, gear x 1)
3. Lubricate [B] with Barrierta – S552R (x 2)

3.7.11 PRESSURE ROLLER

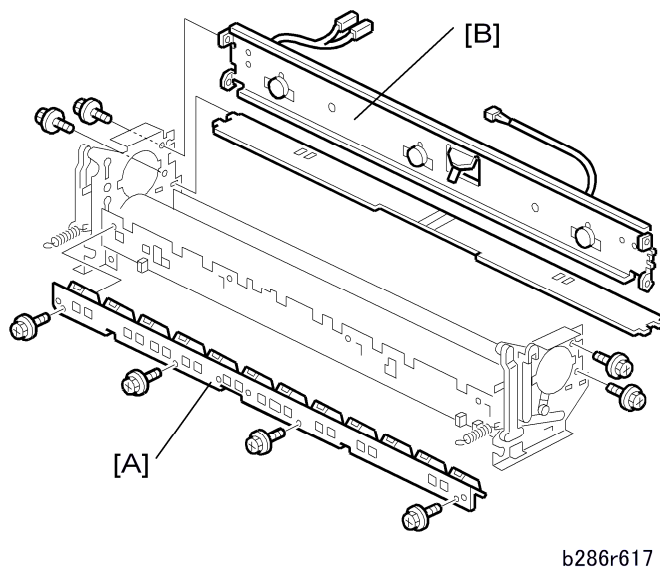

1. Hot roller (See section 3.7.10 “Hot Roller.”)
2. Pressure roller plate [A] (⌀ x 4)
3. Thermistor/Thermostat plate [B] (⌀ x 4)

Fusing

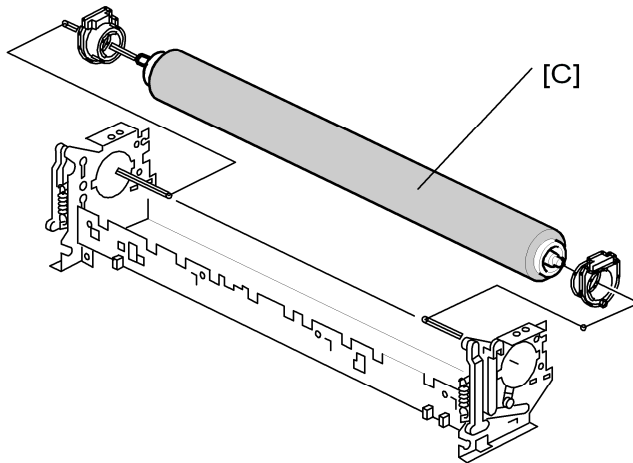

b286r618

4. Pressure roller [C] (sleeve bearings x 2)

3.7.12 HOT ROLLER THERMISTOR, THERMOSTATS

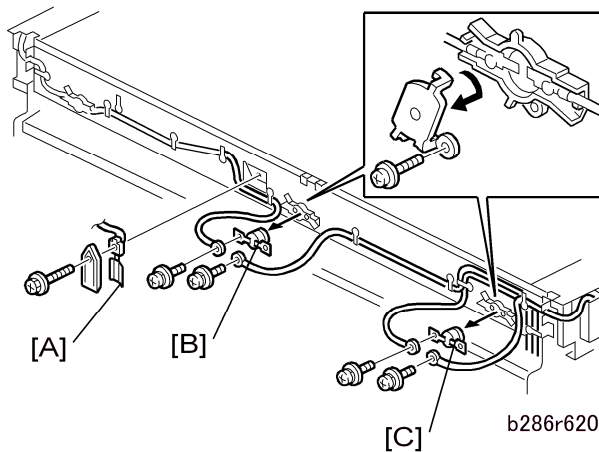

b286r620

1. Fusing unit (See section 3.7.7 “Fusing Unit.”)
2. Hot roller thermistor [A] (x1) (⌀ x 1)
3. Thermostat 2 – 199 °C [B] (⌀ M3x6 x 2)
4. Thermostat 1 – 200 °C [C] (⌀ M3x6 x 2)

Reinstallation

- The thermostats (199 °C and 200 °C) must be installed at [B] and [C]. “199” and “200” are clearly shown on the edge of each thermostat.

3.8 MOTORS

3.8.1 SCANNER MOTOR

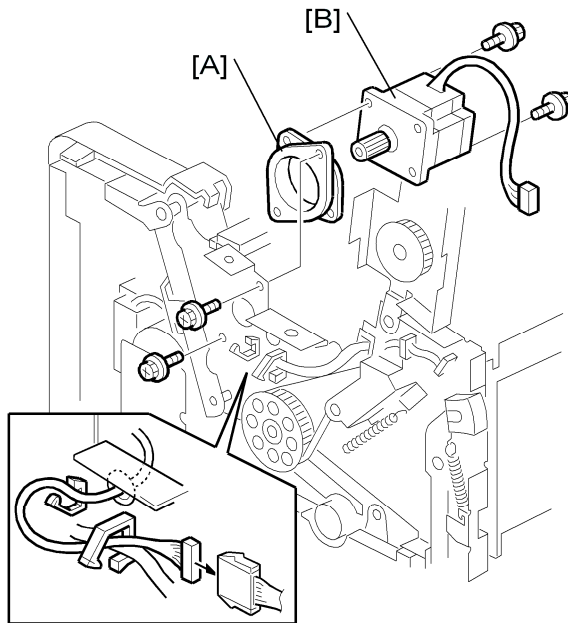

b286r114

1. Original feed unit (See section 3.1.6 “Removing the Original Feed Unit.”)
2. Lift and lock the scanning unit (See section 3.1.7 “Raising and Locking the Scanner Unit.”)
3. Scanner motor assembly [A] (⚙️ x 2, ⚙️ x 1, ⚙️ x 2)
4. Scanner motor [B] (⚙️ x 2)

3.8.2 DRUM MOTOR

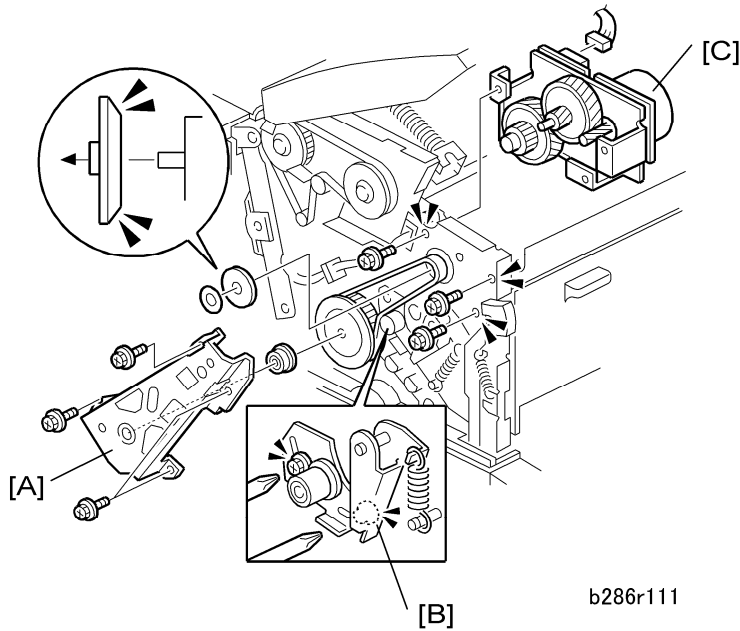

1. Original feed unit (See section 3.1.6 “Removing the Original Feed Unit.”)
2. Lift and lock the scanning unit (See section 3.1.7 “Raising and Locking the Scanner Unit.”)
3. Cover [A] (⌘x4)
4. Belt tension plate [B] (⌘ x 2, Spring x 1)
5. Drum motor [C] (⌘ x 1, ⌘ x 3)

3.8.3 FUSING MOTOR, MAIN MOTOR

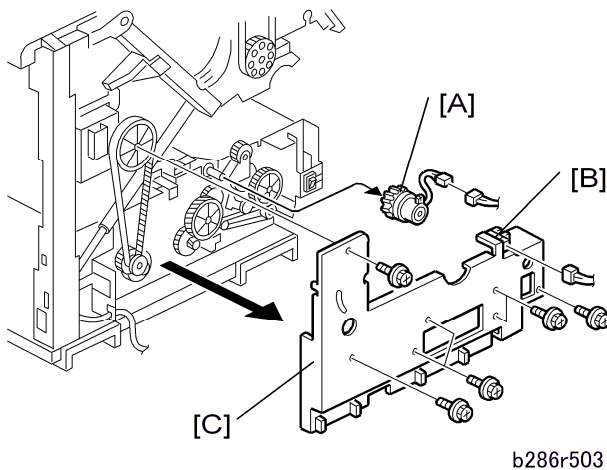

1. Open the upper unit.
2. Side covers (See section 3.1.2 “Side Covers.”)
3. Registration clutch [A] (⌘ x 1, ⌘ x 1)

4. Upper unit sensor [B] (⌚ x 1, ⌚ x 4)
5. Gear cover plate [C] (⌚ x 4, ⌚ x 7)

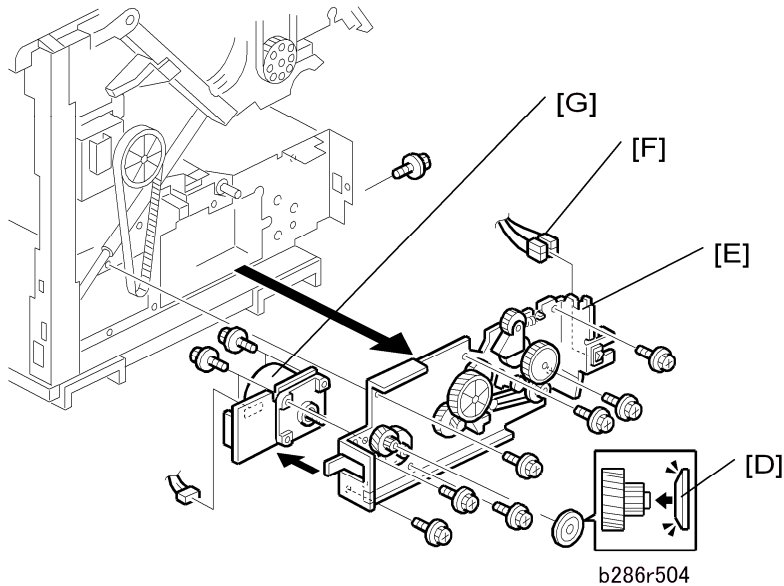

6. Timing belt and cap [D]
7. Motor mount plate [E] (⌚ x 8)
8. Main power switch connector [F] (⌚ x 1, ⌚ x 1).
9. Fusing motor [G] (⌚ x 1, ⌚ x 4)

Reinstallation

If it is not easy to connect the connector at the rear of the motor when you install the motor mount plate:

- Remove the rear cover.
- At the left rear corner of the main machine, open two or three harness clamps to release the motor harnesses. This will decrease the tension in the harnesses.

Motors

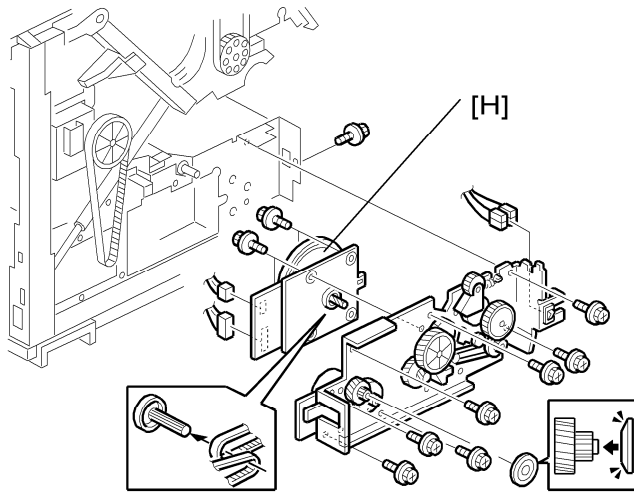

b286r505

10. Remove the gear cover plate and motor mount plate. (Please refer to the two pages before this one.)
11. Main motor [H] (⌘ x 2, drive belts x 2, ⚙ x 4)

3.8.4 USED TONER BOTTLE MOTOR

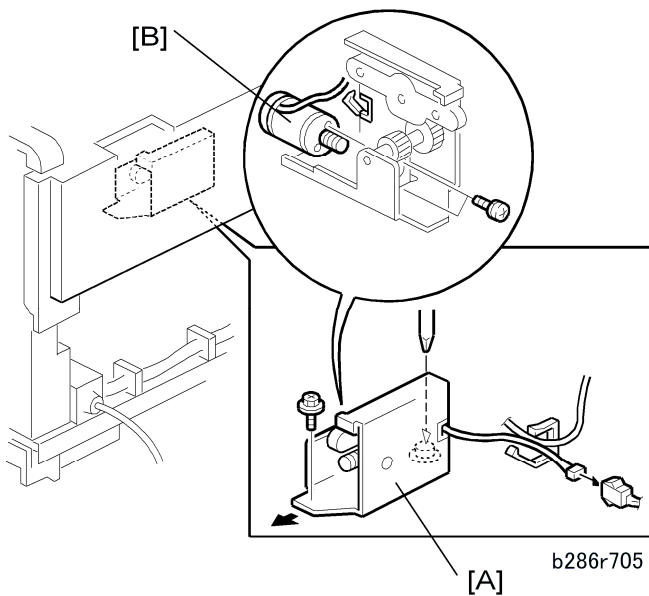

b286r705

1. PSU (See section 3.9.1 "PSU/Circuit Breaker.")
2. Toner collection bottle (See section 3.4.6 "Used Toner Collection Bottle, Toner Overflow Sensor.")
3. T&S power pack (See section 3.9.5 "T&S Power Pack.")
4. Motor plate [A] (⌘ x 1, ⌘ x 1, ⚙ x 2)
5. Motor [B] (⚙ x 2)

3.9 BOARDS

3.9.1 MCU/IPU/MB

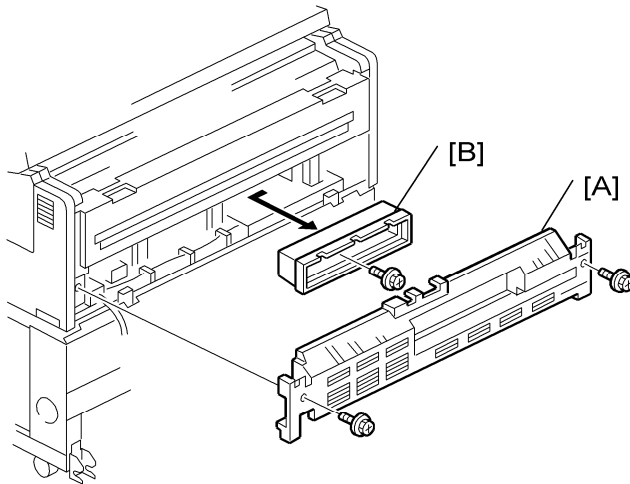

b286r914

1. Remove:

- [A] Rear cover (⌀x2)
- [B] Controller cover (⌀x1)

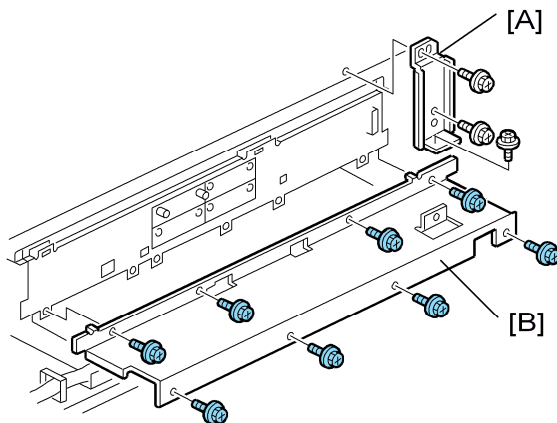

b889i105a

2. Remove:

- [A] Ground plate (⌀x3)
- [B] PCB shield cover (⌀x8)

Boards

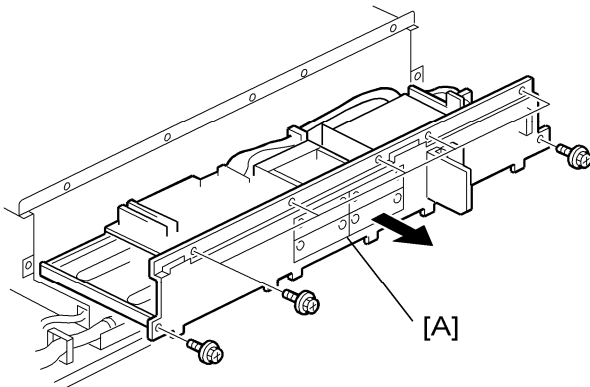

b286r908e

3. If there are any optional boards installed on the controller Unit [A], remove them before removing the controller board (⌀x2 each).

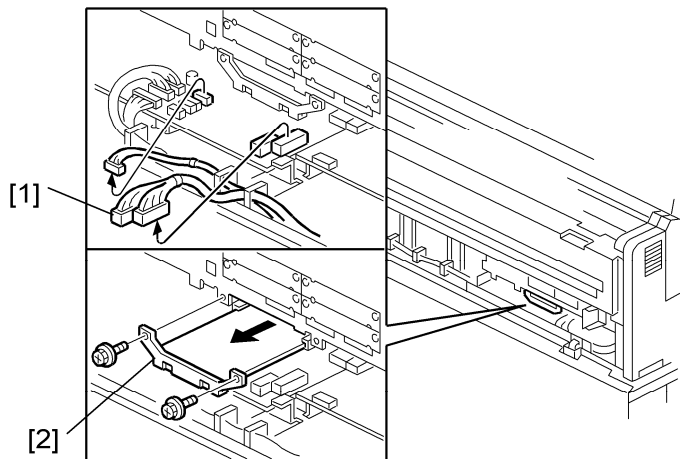

b286r950

★ Important

- Always remove the File Format Converter under the controller board, before pulling the controller board out of the machine.

4. Remove the file format converter board.
 - [1] Connectors (⌀x3)
 - [2] File format converter board (⌀x2).

★ Important

- Slide the board out slowly to avoid snagging the board on any connector harnesses below the board.

5. Remove the controller unit (⌀x7).

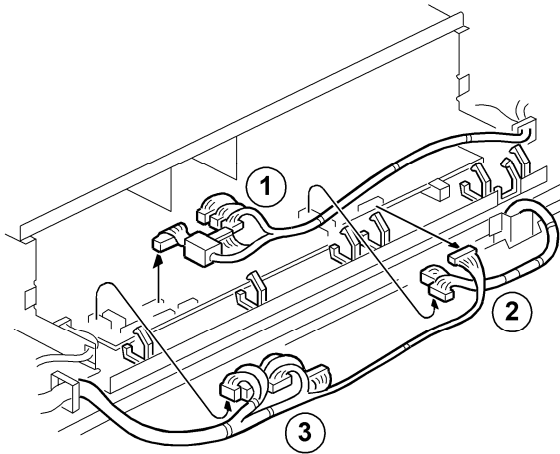

b286r701d

6. Disconnect the IPU and MCU harnesses ①, ②, ③ (🔌x7, 📡x all).

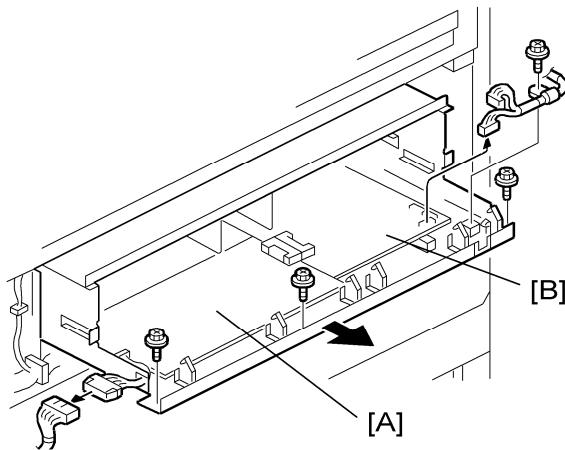

b286r701a

7. Disconnect the MCU/IPU bracket.
- [A] MCU side (🔌x2, 📡x1)
 - [B] IPU side (🔌x2, 📡x2)
8. Pull the controller housing out of the machine.

Boards

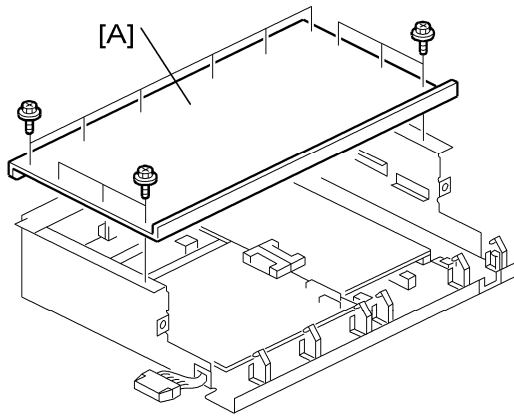

b286r702

9. Remove the shield cover [A] (⚙️x12).

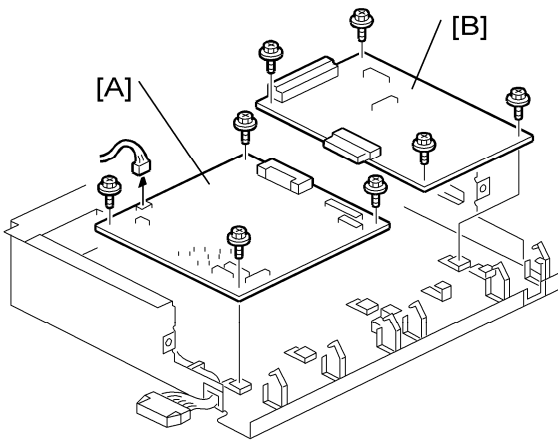

b286r702a

10. Remove:

- [A] MCU (⚙️x4, 📏x1)
- [B] IPU (⚙️x4)

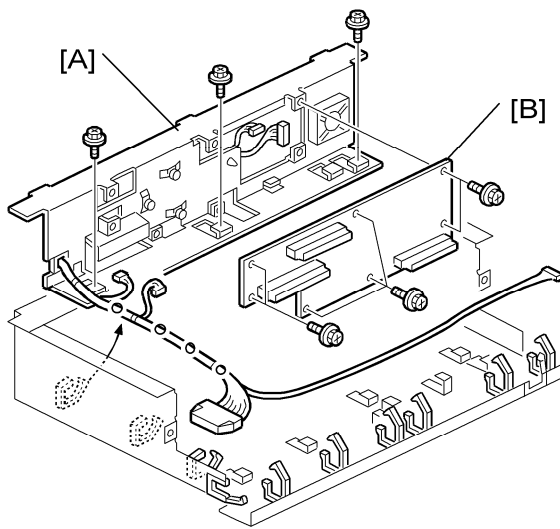

b286r702b

11. Remove:

- [A] Motherboard bracket (⚙️x3, 🛠️x3, 🛠️x1)
- [B] Motherboard (⚙️x7)

↓ Note

- If you install a new MCU board, do SP3001 2 to initialize the ID sensor.

3.9.2 PSU/CIRCUIT BREAKER

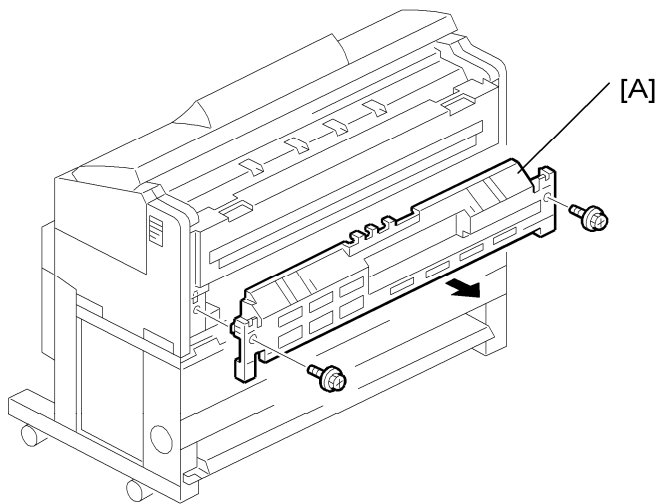

b286r991

1. Remove the rear cover [A] (⚙️x2).

Boards

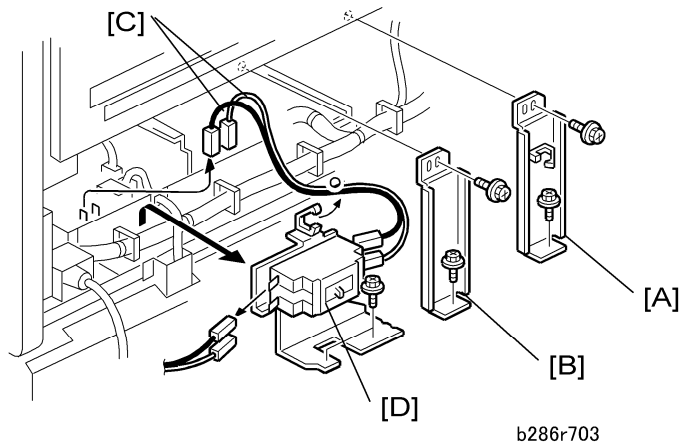

2. Remove:
 - [A] Earth plate (⚙️x2)
 - [B] Earth plate (⚙️x2)
3. Disconnect the white and black harnesses [C] (🔌x2).
4. Remove the circuit breaker [D] (⚙️x2, 🔌x4).

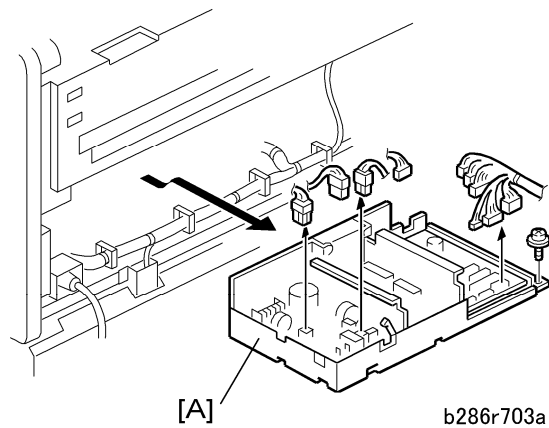

5. Remove the PSU [A] (⚙️x1, 🔌x10, 📦x all)

3.9.3 CONTROLLER BOARD

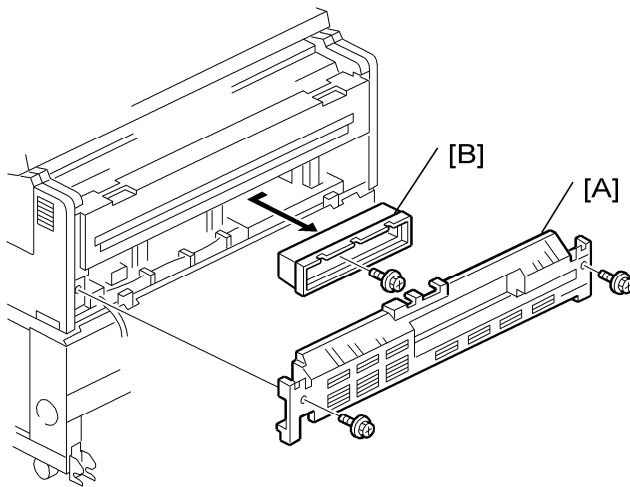

b286r914

1. Remove:

- [A] Rear cover (⌀x2)
- [B] Controller cover (⌀x1)

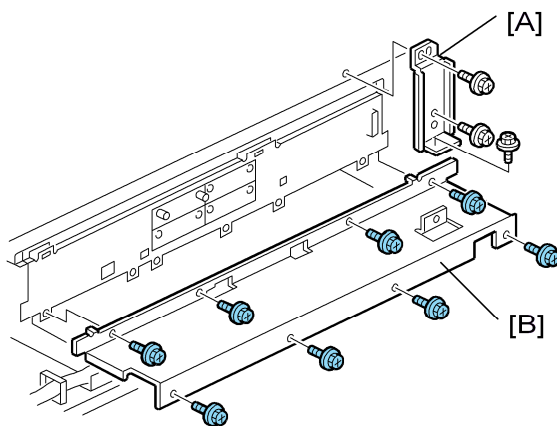

b889i105a

2. Remove:

- [A] Ground plate (⌀x3)
- [B] PCB shield cover (⌀x8)

Boards

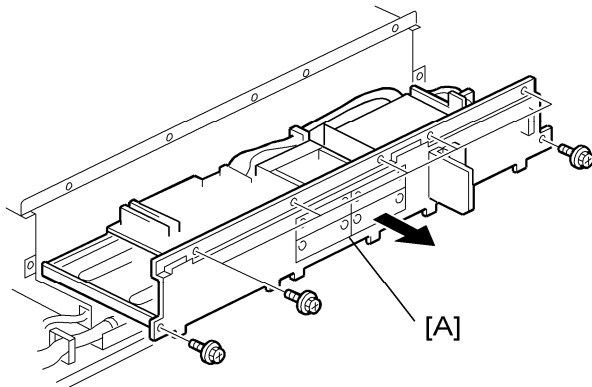

b286r908e

3. If there are any optional boards installed on the controller unit [A], remove them before removing the controller board (⌀x2 each).

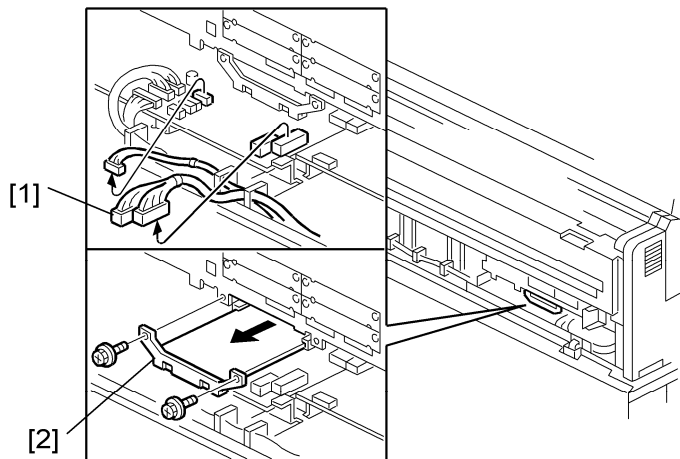

b286r950

★ Important

- Always remove the File Format Converter under the controller board, before pulling the controller board out of the machine.

4. Remove the file format converter board.
 - [1] Connectors (⌀x3)
 - [2] File format converter board (⌀x2).

★ Important

- Slide the board out slowly to avoid snagging the board on any connector harnesses below the board.

5. Remove the controller unit (⌀x7).

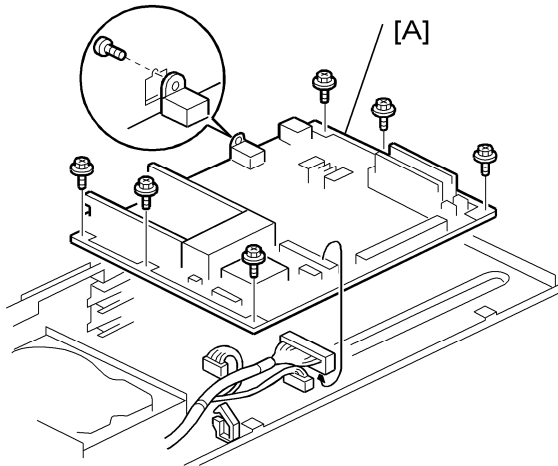

b286r908b

6. Remove the controller board [A] (⚙️x7, 🗑️x3).

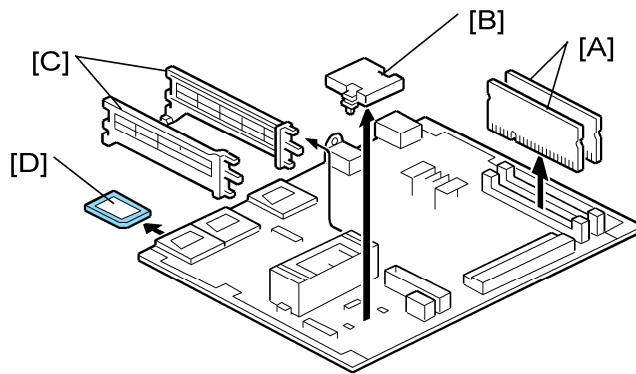

b286r908c

- [A] Memory chips
- [B] NVRAM (if you change the controller board, put the old NVRAM on the new board)
- [C] Rails
- [D] SD card (if installed)

3.9.4 NVRAM

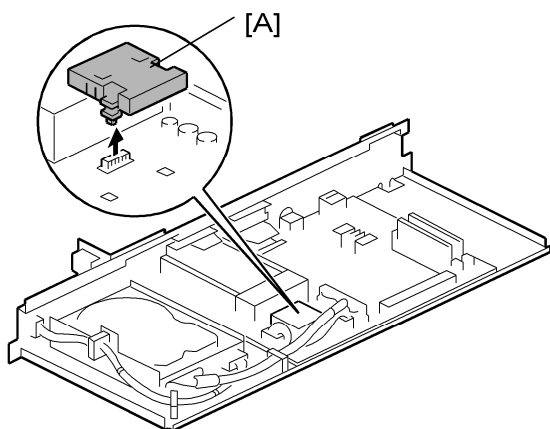

b286r908a

1. Remove the controller board (See section 3.9.3 “Controller Board”)
2. Remove the NVRAM [A]

NVRAM Upload

Do this procedure to upload the NVRAM data from NVRAM to an SD card. Do this procedure before replacing the NVRAM.

1. Switch the machine off.
2. Insert an SD card in SD card Slot 3.
3. Switch the machine on.
4. Go into the SP mode and do SP5824 (Upload NVRAM Data).
5. When you see “Completed!”, switch the machine off.

NVRAM Download

Do this procedure to download the NVRAM data from an SD card to the NVRAM in the machine.

1. Switch the main power switch off.
2. If a new NVRAM is to be installed, do SP5801-2 to make sure that the new NVRAM is clear.

★ Important

- After clearing the NVRAM, confirm that the total counter has been reset to 0:
[User Tools]> [Counter].
3. Do SP5811 (Machine Serial Number) to set the serial number.
 4. Insert the SD card with the NVRAM data in SD card Slot 3.
 5. Switch the main power switch on.
 6. Go into SP mode and do SP5825 (Download NVRAM Data).

7. Follow the instructions on the operating panel display to execute the download.
8. Switch the main power switch off.
9. Switch the main power switch on.
10. If the Data Overwrite Security Unit Type D (B735-18) has been installed, it must be installed again.
11. Do SP3001 2 to initialize the ID sensor.

3.9.5 T&S POWER PACK

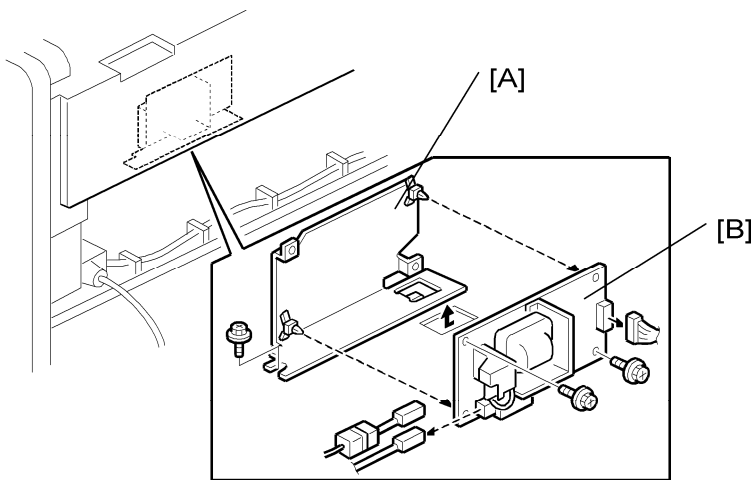

b286r704

Remove:

- PSU (See section 3.9.2 “PSU/Circuit Breaker”)
- [A] T&S power pack mounting plate (⌘ x 2, ⌘ x 3, ⌘ x 1)
- [B] T&S power pack (⌘ x 1)

3.9.6 RFDB (ROLL FEEDER DRIVE BOARD)

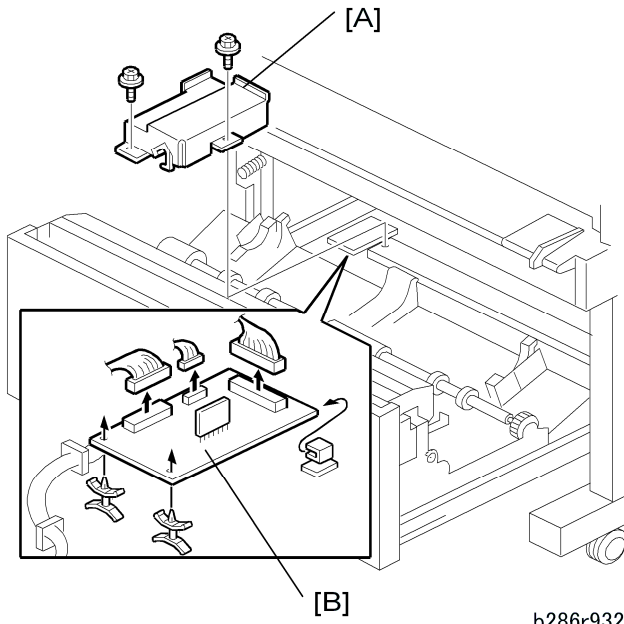

1. Open the roll feeder drawer.
2. Remove the rear plate of the roll feeder (☞ x 2 blue)
 - [A] Shield plate (☞ x 2)
 - [B] RFDB (☞ x 3, standoffs x 2)

3.9.7 SFDB (SHEET FEED DRIVE BOARD)

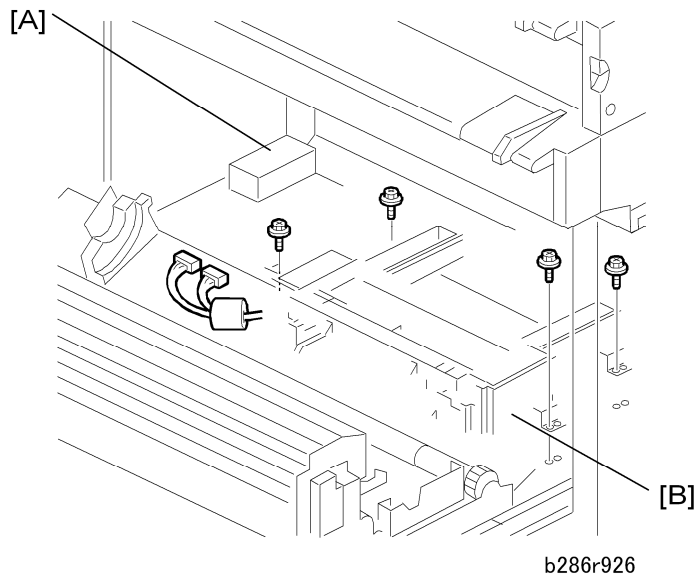

1. Open the roll feeder drawer and remove the paper cassette.

2. Remove Roll feeder rear plate (⚙️ x 2 Blue) (See section 3.6.7 “Roll Paper End Sensors”)

[A] RFDB shield plate [A] (⚙️ x 2).

[B] Paper cassette unit [B] (⚙️ x 4, ⚙️ x 2, ⚙️ x 4)

↓ Note

- Pull the unit to the rear, remove it from the front.

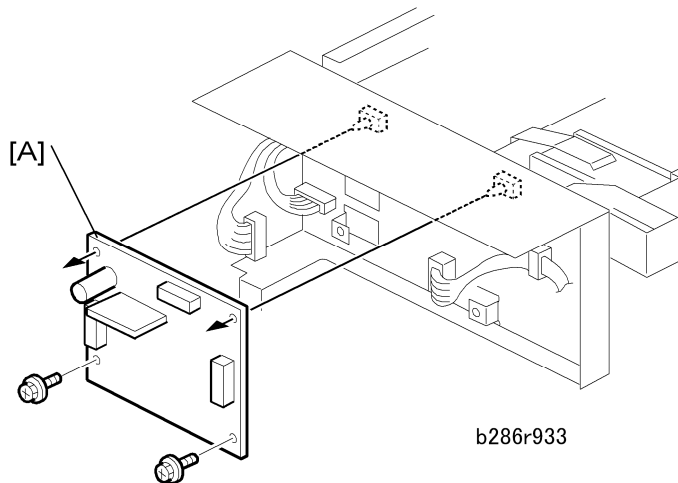

3. Remove the SFDB [A] (⚙️ x 2, ⚙️ x 2, standoffs x 2)

Others

3.10 OTHERS

3.10.1 HDD

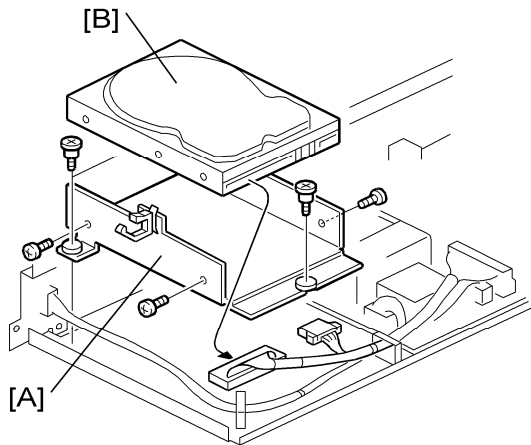

b286r908d

1. Remove the controller board (See section 3.9.3 “Controller Board”)
2. Remove:
 - [A] HDD bracket (⚙️x3, 🛠️x1, 🛠️x2)
 - [B] HDD (⚙️x4)

Reinstallation

- Do SP5832-1 (HDD Formatting - All) to format the new HDD.
- Do SP5853 (Stamp Data Download) to download the fixed stamp data from ROM to the hard disk.

★ Important

- A new hard disk should always be formatted with SP5832-1, even if it has already been formatted.
- The fixed stamp data, the files for fixed stamps such as “Confidential”, “Urgent”, etc. should always be downloaded from ROM with SP5853 after the HDD is replaced or reformatted.

3.10.2 COOLING FAN, OZONE FILTER

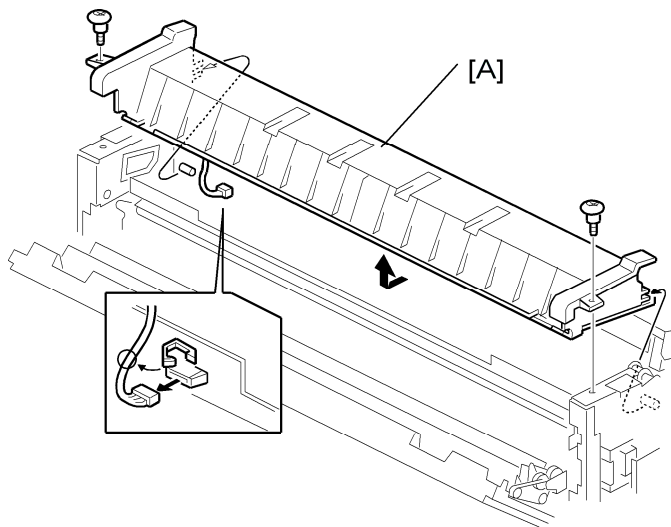

b286r310

1. Remove:

- Side covers (See section 3.1.2 Side Covers”)
- [A] Rear top cover (⚙️ x 1, 🔩x1, 🛠️ x 2)

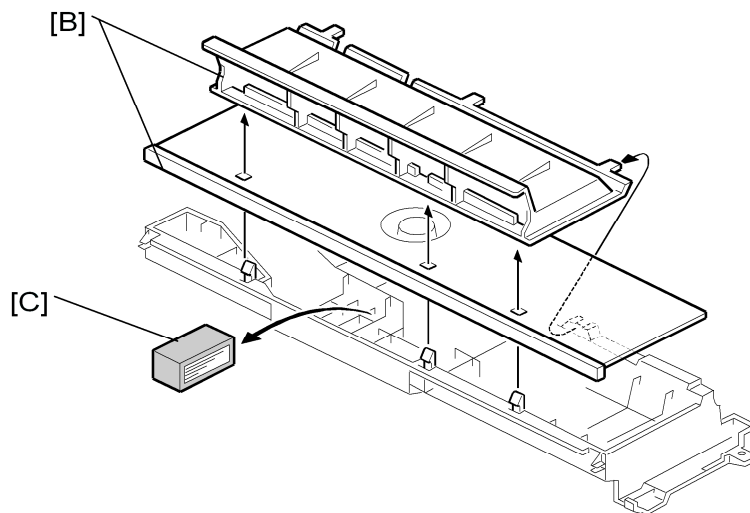

b286r311

2. Remove the plates [B] (press release)
3. Remove the ozone filter [C]

Others

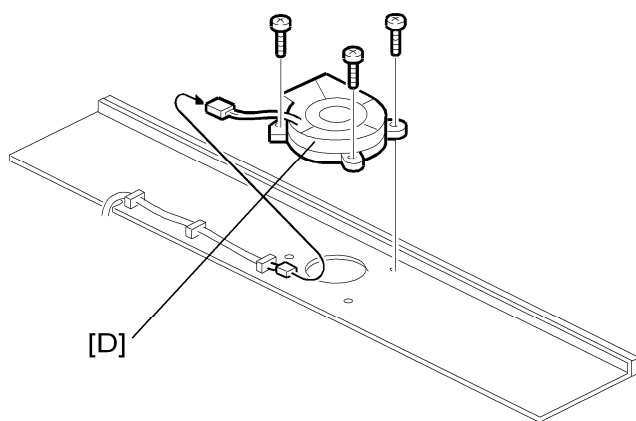

b286r312

4. Remove the cooling fan [D] (🔧 x 1, 🛠️ x 3)

3.11 SP ADJUSTMENTS

3.11.1 IMAGE ADJUSTMENT WITH SP CODES

Do these adjustments if output is unsatisfactory. Before you start measurements and adjustments, let the test print output cool for five minutes.

Note

- Do each adjustment in the order described below. Be sure to turn the main machine's power off/on after each SP adjustment to enable the new setting.

Step 1: Magnification for Paper Type: Plain

- Go into the SP mode.
- Do SP2902-2, select pattern 11 (Grid Pattern), then touch "OK."
- Touch "COPY Window."
- Select the paper size.
- Set a blank sheet of A1 SEF paper in the original tray.
- Press [Start] to print a test pattern.
- Print two more test patterns (you need three grid pattern prints).
- Refer to the diagram and instruction table below to do the SP magnification corrections (if needed).

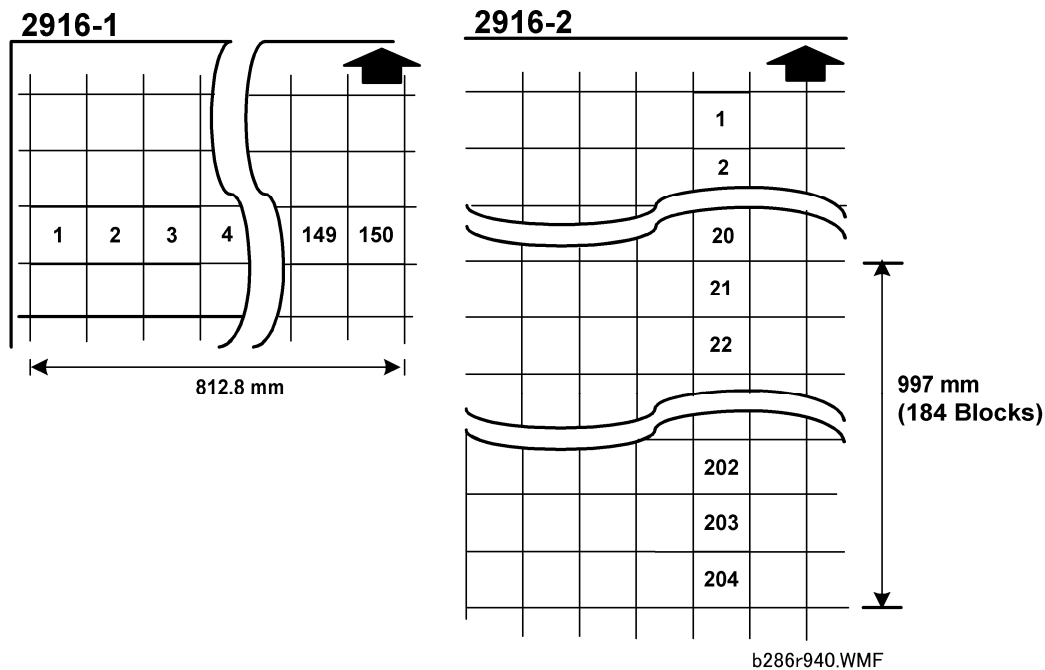

SP Adjustments

SP	Comments
2916-1	On each grid pattern measure the width from block 1 to block 150 (150 blocks) then average the three measurements. The width must be 812.8 mm. If the average measured width is not 812.8 mm, adjust this SP until the width is 812.8 mm.
2916-2	On each grid pattern measure the length from block 21 to block 204 (184 blocks) then average the three measurements. The length must be 997 mm. If the measured length is not 997 mm, adjust this SP until the length is 997 mm.

Step 2: Scanning Magnification

1. Make a 1:1 copy of the A0 SEF Magnification Chart with plain roll paper.



- You can use a different test chart, if it has lines 1000 mm long in the sub-scan direction and 700 mm long in the main-scan direction.

2. Measure the length and width of the images on the original and the copy.
3. Do these SPs in the sequence shown in this table, if the measurements are not in the standard range:

SP	Standard	Comments
4008	Less than ± 0.5	Scanner Sub Scan Magnification
4101	Less than ± 0.5	Scanner Main Scan Magnification

Step 3: Magnification for Paper Type: Translucent

1. Make a 1:1 copy of the A0 SEF Magnification Chart with translucent (tracing) paper.



- You can use a different test chart, if it has lines 1000 mm long in the sub-scan direction and 700 mm long in the main-scan direction.

2. Measure the length and width of the images on the original and the copy.
3. Do the same measurements that you did for “Step 1: Magnification for Paper Type: Plain.”
4. Do these SPs in the sequence shown in this table, if the measurements are not in the

standard range:

SP	Standard	Comments
2916-3	Less than ± 0.5	Fine Magnification – Translucent: Mode 1-4: Horiz
2916-4	Less than ± 0.5	Fine Magnification – Translucent: Mode 1-4: Vert

Step 4: Magnification for Paper Type: Film

1. Make a 1:1 copy of the A0 SEF Magnification Chart with film.



- You can use a different test chart if it has lines 1000 mm long in the sub-scan direction and 700 mm long in the main-scan direction.

2. Measure the length and width of the images on the original and the copy.
3. Do the same measurements for “Magnification for Paper Type: Plain.”
4. Do these SPs in the sequence shown in this table, if the measurements are not in the standard range:

SP	Standard	Comments
2916-5	Less than ± 0.5	Fine Magnification – Film: Mode 1-4: Horiz
2916-6	Less than ± 0.5	Fine Magnification – Film: Mode 1-4: Vert

Step 5: Scanner Mask Setting

SP	Set To:	Comments
4012-5	0	Scanner Erase Margin DF – LEdge
4012-6	0	Scanner Erase Margin DF – TEdge
4012-7	0	Scanner Erase Margin DF – Left
4012-8	0	Scanner Erase Margin DF – Right

Step 6: Erase Margins

Set these SPs to “5” to make measurement easier:

SP Adjustments

SP	Set To:	Comments
2101-1	5	Print Erase Margin – Leading Edge
2101-2	5	Print Erase Margin – Trailing Edge
2101-3	5	Print Erase Margin – Left Edge
2101-4	5	Print Erase Margin – Right Edge

Step 7: Printer: Leading Edge, Side-to-Side Registration

- Use a sheet of blank plain paper to print the IPU Printing test pattern (SP2902-2, Pattern 11) for each paper feed station installed on the machine:
 - Manual feed (bypass)
 - Roll Feeder Roll 1
 - Roll Feeder Roll 2
 - Paper Cassette
- Measure the gaps for the leading edge and side-to-side registration.

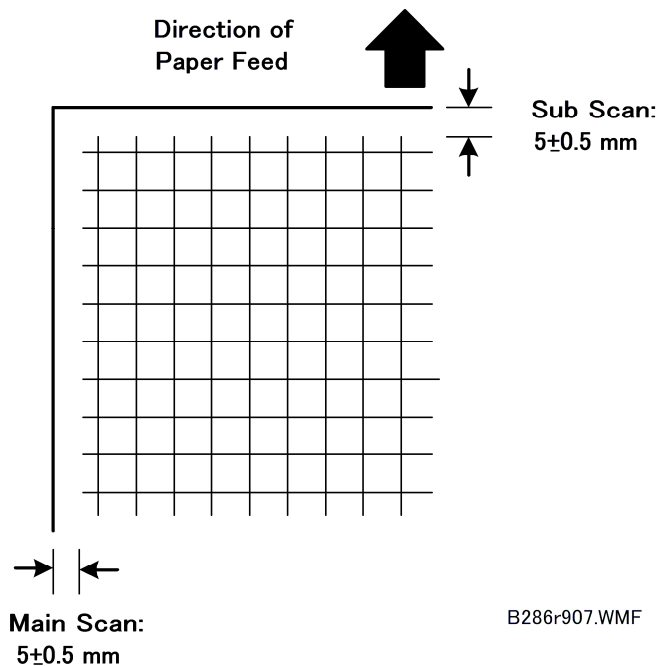

- Touch “SP Mode” and adjust these SPs if a measurement is not in the standard range.

SP	Standard:	Comments
----	-----------	----------

SP	Standard:	Comments
1001-1	5 ±0.5 mm	Leading Edge Registration – 1 st Roll
1001-2		Leading Edge Registration – 2 nd Roll
1001-3		Leading Edge Registration –Cassette
1001-5		Leading Edge Registration – By-pass Feed
1002-1		Side-to-Side Registration – 1 st Roll
1002-2		Side-to-Side Registration – 2 nd Roll
1002-3		Side-to-Side Registration –Cassette
1002-5		Side-to-Side Registration – By-pass Feed

Step 8: Scanner Mask Setting

Do these SPs to replace the “0” settings done in Step 5.

SP	Set To:	Comments
4012-5	1.5	Scanner Erase Margin DF – LEdge
4012-6		Scanner Erase Margin DF – TEdge
4012-7		Scanner Erase Margin DF – Left
4012-8	0.5	Scanner Erase Margin DF – Right

Step 9: Erase Margins

Do these SPs to replace the settings done in Step 6.

SP	Set To:	Comments
2101-1	2	Print Erase Margin – Leading Edge
2101-2		Print Erase Margin – Trailing Edge
2101-3		Print Erase Margin – Left Edge
2101-4	0.5	Print Erase Margin – Right Edge

SP Adjustments

Step 10: Scanner Registration

1. Use the A1 LEF Test Chart to make a 1:1 copy on plain A1 LEF paper.
2. On the copy, measure the gap between the chart image and the leading edge and left edge.
3. Adjust these SPs if necessary:

SP	Standard	Comments
4010-1	±3 mm	Scanner Sub Scan Reg – Leading Edge
4011	±2.8 mm	Scanner Main Scan Reg

Step 11: Printer: Cut Length

The following SPs are necessary for this step:

SP	
1920-111	Cut Length Adjustment-1 st Roll:297 mm (11" or 12"):Plain Paper
1920-115	Cut Length Adjustment-1 st Roll:1189 mm (44" or 48"):Plain Paper
1920-211	Cut Length Adjustment-2 nd Roll:297 mm (11" or 12"):Plain Paper
1920-215	Cut Length Adjustment-2 nd Roll:1189 mm (44" or 48"):Plain Paper

Note

- The cut length adjustment is done for all paper sizes after these settings are done.
- After these settings are done you may still need to do fine adjustments for each paper size.
- SP1920-1 to 238 (Cut Length Adjustment)
 1. Use the Preset Cut feature to make standard cuts of plain paper for these sizes:

Size	Orientation
A3	Sideways
A1	Lengthways

Size	Orientation
A0	Lengthways
A	Sideways (Eng. 11")
B	Sideways (Eng. 17")
D	Lengthways (Eng. 34")
E	Lengthways (Eng. 44")

2. Measure the cuts and check them against the standards of this table.

Cut Length (mm)	Cut Tolerance (mm)
Less than 297	±3
420 to 1189	±5
to 2000	±6
=3000	±11
to 4000	±14

3. If a measurement is not in the standard range of the "Cut Tolerance" in the table above, adjust SP1920-1 to -238 for each roll, paper width, and paper type.

Step 12: Synchro Cut (Trailing Edge Registration)

The following SPs are necessary for this step:

- SP4961-1 (Original Adjustment – Synchro Cut Adjustment 210 mm)
- SP4961-2 (Original Adjustment – Synchro Cut Adjustment 1000 mm)
- SP4961-3 (Original Adjustment – Original Length Display)

1. Prepare two originals
 - 1 original 210 mm long (A4 LEF)
 - 1 original 1000 mm long (measure and cut)
2. Go into the SP mode and do SP4961-1.
3. Touch "COPY Window" and copy the 210 mm sheet that you prepared in Step 1.
4. Touch "SP Mode" to go back to the SP mode.

SP Adjustments

5. Do SP4961-3 to check the original scan length.
6. If the display is different, adjust with SP4961-1.
7. Do SP4961-2.
8. Touch “COPY Window” and scan the 1000 mm sheet that you prepared in Step 1.
9. Touch “SP Mode” to go back to the SP mode.
10. Do SP4961-3 to check the scan length.
11. If the display is different, adjust with SP4961-2.

Cut Length (mm)	Cut Tolerance (mm)
Less than 297	±4.50
to 594	±5.00
to 841	±6.00
to 1189	±8.50
to 2000	±18.0
to 3000	±27.0
to 3600	±33.0

3.11.2 CIS ADJUSTMENT WITH SP CODES

To Print the CIS Adjustment Pattern

1. Open the roll feeder drawer and cut off a sheet manually from a roll. (Turn the manual feed knob to feed the paper, then push the cutter from side to side to cut.)
2. Close the roll feeder drawer.
3. Go into the “Copy SP” mode.
4. Do SP2902-2, select Pattern 11, then touch “OK.”
5. Touch “COPY Window” to go to the main screen.
6. On the operation panel, select one of the rolls for paper feed.
7. Put the blank sheet of paper on the original feed tray and feed it into the original feed unit. Pattern 11 (grid pattern) prints.
8. Touch “SP Mode” to return to the SP mode.
9. Open SP4973, push [1] on the operation panel to change the setting from “0” to “1”, then push [#]

10. Touch "Exit" twice to leave the SP mode.
11. Select the paper roll size, then copy the grid pattern that you printed in Step 7 above.

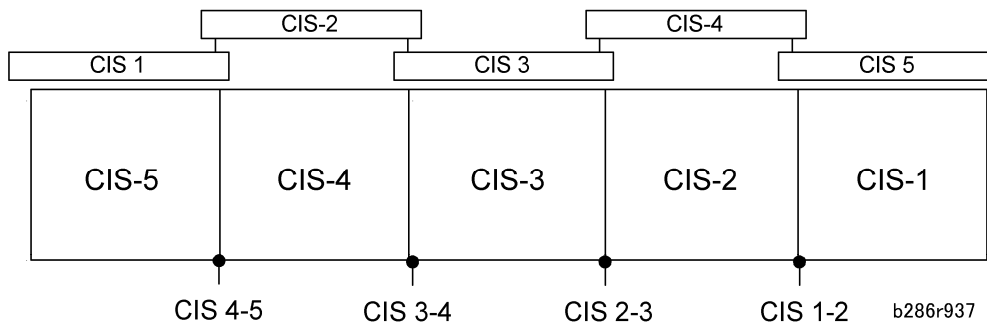

Note

- When you look at the printed pattern, the number sequence of the CIS joints is opposite, with CIS-5 on the left through CIS-1 on the right as shown in the diagram above.

Important

- After completing the CIS adjustments, be sure to reset SP4973 to "0."

To Adjust the Image at the CIS Joints

1. Check the printed pattern to find if the dots are aligned at CIS 1-2.
2. If they are aligned correctly, no adjustment is necessary.
 - or-

If they are not aligned correctly, do the next step.

Here are two samples where the outputs are not aligned correctly.

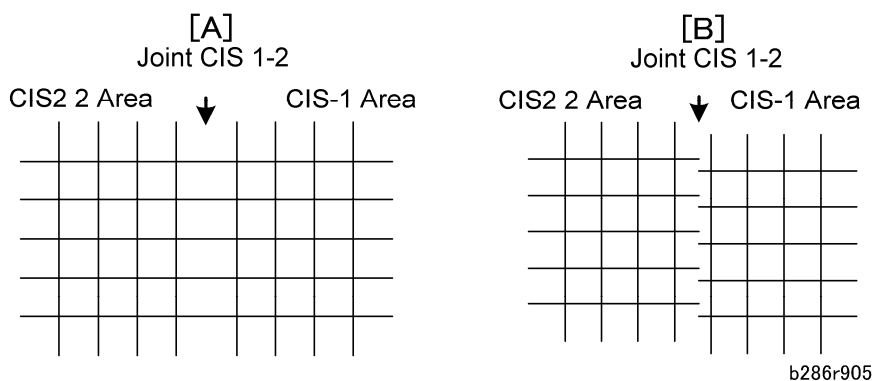

- [A]: Distance between the lines at CIS 1-2 is wider than usual (as shown above). If the distance between these lines is wider or narrower than the other lines, adjust the main scan offset at CIS 1-2 with SP4972-1 (CIS Joint Adjustment –CIS 1-2 Main Scan) as described below.
- [B]: The lines at CIS 1-2 are broken. If the output from CIS 1 is lower (as shown above) or higher, adjust the sub scan offset at CIS 1-2 with SP4972-11 (CIS Joint

Replacement and Adjustment

SP Adjustments

Adjustment – CIS 1-2 Sub Scan) as described below.

To adjust the main scan offset for Example [A]

Problem: Output from CIS 1 is too far to the right.

1. Do SP4972-1 and adjust the setting.
 - Adjust the position of CIS 1. The position of CIS 2 does not move.
 - If the area at the joint is too wide, set a smaller value.
 - If the area at the joint is too narrow, set a larger value.
 - In the example [A], you must set a smaller value.

To adjust the sub scan offset for Example [B]

Problem: Output from CIS 1 is lower than the output from CIS 2.

1. Do SP4972-11 and adjust the setting.
 - Adjust the position of CIS 1. The position of CIS 2 does not move.
 - If the CIS 1 area is higher than the CIS 2 area, set a larger value.
 - If the CIS 1 area is lower than the CIS 2 area, set a smaller value.
 - In the example shown [B], you must decrease the value for CIS 1.

After adjusting

1. Print one more pattern and check CIS 1-2.
2. Repeat these procedures until the image at CIS 1-2 is correct.
3. Do these procedures for the other joints (CIS 2-3, CIS 3-4, CIS 4-5)

Note

- The “Effect” column in the table below tells you which area moves with the adjustment, and which area does not move.

SP4972	CIS Main/Sub Scan Offset Adjustment [0 to 2047/638/1]		
	Problem	Joint	Effect
1	Main Scan Offset: Interval 1-2	CIS 1-2	CIS 1 moves. CIS 2 does not move.
2	Main Scan Offset: Interval 2-3	CIS 2-3	CIS 3 moves. CIS 2 does not move.
3	Main Scan Offset :Interval 3-4	CIS 3-4	CIS 4 moves. CIS 3 does not move.
4	Main Scan Offset: Interval 4-5	CIS 4-5	CIS 5 moves. CIS 4 does not move.
11	Sub Scan Offset: Interval 1-2	CIS 1-2	CIS 1 moves. CIS 2 does not move.
12	Sub Scan Offset: Interval 2-3	CIS 2-3	CIS 3 moves. CIS 2 does not move.
13	Sub Scan Offset: Interval 3-4	CIS 3-4	CIS 4 moves. CIS 3 does not move.
14	Sub Scan Offset: Interval 4-5	CIS 4-5	CIS 5 moves. CIS 4 does not move.

★ Important

- After completing the CIS adjustments, be sure to reset SP4973-3 to “0.”

3.11.3 LPH ADJUSTMENT WITH SP CODES

Doing SP Adjustment Settings for a Replacement LPH

1. Remove the replacement LPH from its box.
2. Read the label attached to the replacement LPH and note of the settings for SP2952 and SP2943.

↓ Note

- This label is attached to the replacement LPH only.
3. Remove the old LPH and install the new LPH unit. (See section 3.3.3 “LPH (LED Print Head)”))

SP Adjustments

4. Do SP2952-1, -2 and enter the settings you read from the label attached to the LPH replacement unit.
5. Do SP2943-1, -2, -3 and enter the settings you read from the label attached to the replacement unit.
6. Print a test print in the IPU Test Pattern mode to make sure that the LPH joints are aligned correctly. (See below.)
7. Do SP2902-2 to print IPU Test Pattern 10 to confirm that the LPH is functioning normally (see the procedure below).

To Print Pattern IPU Test Pattern 10

1. Open the roll feeder drawer. Cut off a sheet manually from a roll.
2. Close the roll feeder drawer.
3. Go into the SP mode.
4. Do SP2902-2 (IPU Test Pattern. Press "Set" twice, select Pattern "10" then press "OK."
5. Touch "COPY Window" to go to the copy display.
6. Select one of the rolls for paper feed.
7. Feed a blank sheet of paper into the machine then press [Start] print Pattern 10.
8. Check the printed pattern:
 - If you see vertical white or black lines, do the vertical line adjustments (See the next section, "Main Scan Adjustment: White, Black Vertical Lines").
 - If you see the areas are not aligned, do the misalignment adjustments (See below, "To Adjust the LPH for Misalignment").
 - If you see vertical white/black lines and misalignment, do the vertical line adjustment first.

Main Scan Adjustment: White, Black Vertical Lines

1. Check the printed pattern at LPH 1-2 for white or black lines.
2. If there are no lines, no adjustment is necessary.

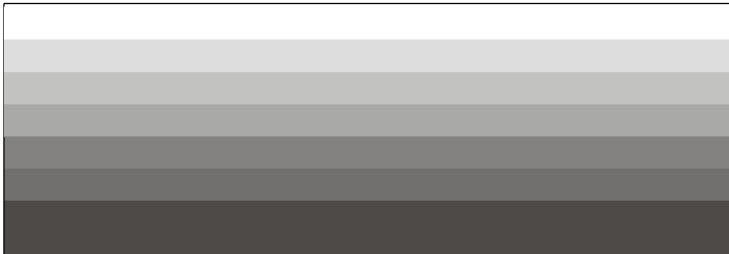

Normal Pattern

b286r561

If you see white or black lines at LPH 1-2, go to the next step.

- White lines occur if too few LEDs come on at the joint.
- Black lines occur if too many LEDs come on at the joint.

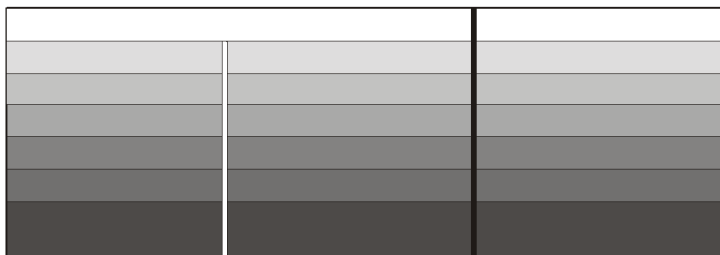

Abnormal Pattern

b286r562

3. Left line:
 - If the left line is **white**, adjust SP2952-1 to a smaller value.
 - If the left line is **black**, adjust SP2952-1 to a larger value.
4. Right line:
 - If the right line is **white**, adjust SP2952-2 to a smaller value.
 - If the right line is **black**, adjust SP2952-2 to a larger value.
5. After the adjustment, feed the blank sheet again to print one more pattern.
6. Check the results of the adjustment.
7. Do the adjustment again until the lines appear faint.

↓ Note

- The lines cannot be completely erased.

SP Adjustments

Main Scan Adjustment: LED Light Level at LPH Joints

After you do the previous procedure to adjust the main scan at the LPH joints, you can do a fine adjustment on this area. To do this, you increase or decrease the intensity of the light from the four LEDs at the joints.

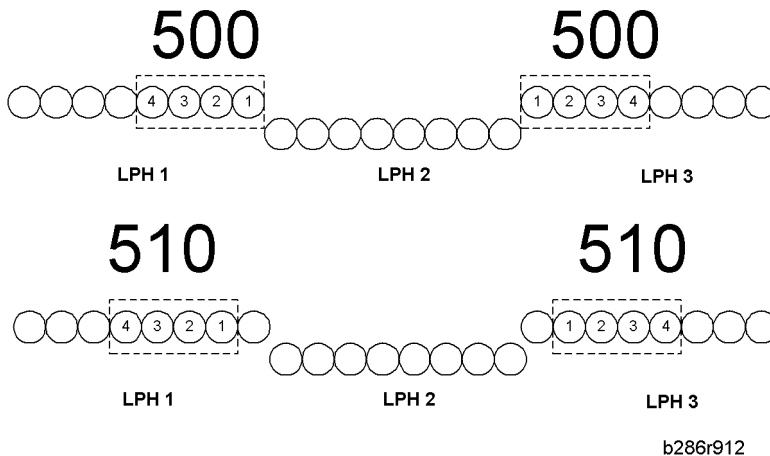

“500” is the default setting for LPH 1-2 and LPH 2-3.

- If you change the 2nd digit of the value for LPH 1-2 (500 to **510**) with SP2952-1, this moves the four LEDs by one position to the **left**.
- If you change the 2nd digit of the value for LPH 2-3 (500 to **510**) with SP2952-2, this moves the four LEDs by one position to the **right**.
- If you change the 3rd digit of LPH 1-2 or LPH 2-3 (510 to **512**, for example), this increases the quantity of light from LEDs 1, 2, 3, 4 in the illustration.

The quantity of light can be adjusted for each LED independently with SP2953 (Power Correction). But, this fine adjustment is usually not necessary in the field.

Adjusting LPH Alignment

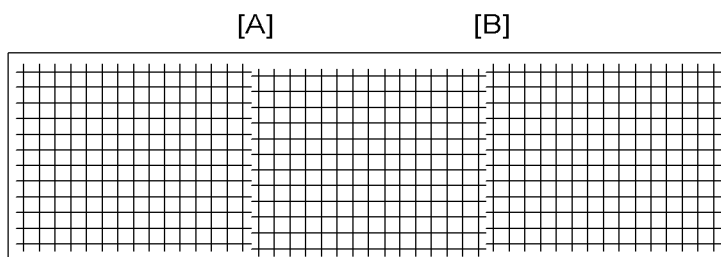

Broken lines [A] or [B] in the IPU Test Pattern (SP2902-2, Pattern 11) indicate incorrect sub-scan timing at one or both joints.

1. Go into the SP mode, and do SP2952-11 for LPH 1-2
 - Adjust the position of LPH 2 (LPH 1 does not move).

- If LPH 2 is higher than LPH 1, set a larger value.
 - If LPH 2 is lower than LPH 1, set a smaller value.
2. Print one more pattern with SP2952-11) and check the alignment at the joints.
 3. Do this procedure again until the pattern at the joint is correct.
 4. Do SP2952-12 for LPH 2-3
 - Adjust the position of LPH 3 to LPH 2 (LPH 2 is the standard).
 - If LPH 3 is higher than LPH 2, set a larger value.
 - If LPH 3 is lower than LPH 2, set a smaller value.
 5. Do this procedure again until the pattern at the joint is correct.

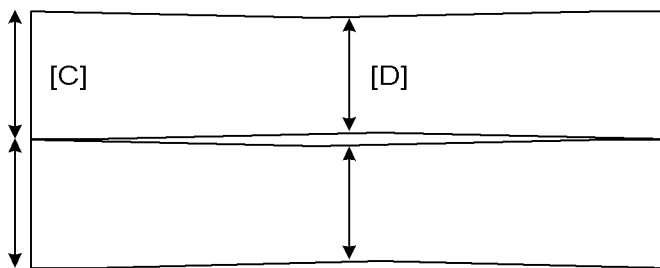

b286r939

The hot roller and pressure roller have a slight spindle shape. The circumference at the ends of the rollers [C] is slightly larger than the circumference at the centers [D]. This arrangement ensures that there is always sufficient pressure on the paper between the roller ends.

However, this difference in circumference also causes a small difference in the speed of paper feed. The paper transport speed at the ends is slightly faster than at the center. Because the centers of the rollers bend in slightly, this also increases the risk of slippage at the center with paper narrower than 420 mm.

- For operators who frequently use paper wider than 420 mm, do the sub scan adjustments for the LPH joints with SP2952-11, -12.
- For operators who frequently use paper that is less than 420 mm wide, do the sub scan adjustments for the LPH joints with SP2952-51, -52 after you input the values of SP 2952-11 and -12 from the decal.

3.11.4 LPH DENSITY ADJUSTMENT WITH SP CODES

To Print the IPU Test Pattern 2

1. Open the roll feeder drawer. Cut off a sheet manually from a roll.
2. Close the roll feeder drawer.
3. Go into the SP mode.
4. Do 2902-2, select Pattern "2", then touch "OK."
5. Touch "COPY Window" to show the main screen.
6. On the operation panel, select one of the rolls for paper feed.



- You must select Tray 1 (1st Roll) or Tray 2 (2nd Roll). You cannot use "Auto Paper Select." If you select "Auto Paper Select" the pattern will not print.
7. Set the blank sheet of paper on the original feed tray.
 8. Press [Start]. The pattern prints.
 9. Touch "SP Mode" to return to the SP mode.
 10. Check the density of the patterns in LPH 1, LPH 2, and LPH 3.
If density is equal for all areas, no adjustment is necessary. If the density is not equal, do the next procedure.



B286r906

To Correct Pattern Density

1. Do SP2943-1, -2, and -3
 - This SP makes the output of each LPH block brighter or darker.
2. Adjust the density for LPH 1 with SP2943-1.
 - If the density is too dark, set a smaller value.
 - If the density is too light, set a larger value.
3. Do SP2902-2, select Pattern #10, touch [OK], then print the pattern by feeding the blank sheet and check the density.
4. Do this procedure for LPH2 and LPH3 until the density is the same in each of the three sections.
 - LPH2: SP2943-2
 - LPH3: SP2943-3

TROUBLESHOOTING

4. TROUBLESHOOTING

4.1 SERVICE CALL CONDITIONS

There are 4 levels of service call conditions

Level	Definition	Reset Procedure
A	Fusing unit SC codes shown on the operation panel. The machine is disabled. The user cannot reset the SC.	Go into the SP mode. Cycle the machine off/on with the main power switch.
B	These SC codes disable only the features that use the defective item. The user does not see these SC codes in usual conditions. But, they are shown on the operation panel when the defective feature is used.	Cycle the machine off/on with the main power switch.
C	SC codes that are not shown on the operation panel. They are recorded internally.	Recorded only.
D	These SC codes are shown on the operation panel. To reset these SC codes, turn the operation switch or main power switch off and on. These SC codes are shown again if the error occurs again.	Set the operation switch or the main power switch to "off" then to "on."

Preliminary Instructions

- If the problem is in an electrical circuit board, disconnect then connect the board connectors again before you replace the PCB.
- If the problem is a motor lock, check the mechanical load before you replace a motor or sensor.
- When a Level A or Level B SC occurs while the machine is in the SP mode, the SC number will not be shown. If this occurs, check the SC number after the machine goes out from the SP mode. This does not include Level B codes.
- Many SC codes contain more than one level (SC303-1, SC303-2, SC303-3, and others). Some SC codes can show a "-1," even if there is only one level.

Service Call Conditions

The following abbreviations are used in these SC tables:

- (F) means “Front”
- (R) means “Rear”

4.2 SC CODE DESCRIPTIONS

4.2.1 SC1XXX

143	C	Scanner Automatic Adjustment Error	
		Automatic adjustment of the CIS failed at power on.	<ul style="list-style-type: none"> ▪ Standard white strips dirty or not platen plate installed improperly ▪ CIS LED defective and not lighting ▪ CIS-to-PSU harness connector loose, disconnected, or defective ▪ CIS-to-MCU harness connector loose, disconnected, or defective ▪ CIS defective ▪ MCU defective

144	D	SIB Communication Error	
		SIB serial transmission did not begin within 1 sec. after power on. No communication with SIB.	<ul style="list-style-type: none"> ▪ MCU defective ▪ SIB defective ▪ SIB-to-MCU harness connector loose, disconnected, or defective

4.2.2 SC2XXX

There are no Group 2 SC codes for this machine

SC Code Descriptions

4.2.3 SC3XXX

Group 3 SC codes are related to image making.

300	D	Charge Corona Output Error	
		<p>After sampling at 10 ms intervals, the charge-corona feedback voltage remained less than 0.5 V for more than 200 ms.</p>	<ul style="list-style-type: none"> ▪ Charge corona unit defective ▪ High voltage cable defective ▪ Corona wire dirty or defective ▪ CGB power pack fuse, connections loose, broken, or defective ▪ CGB power pack defective

305	D	Charge Corona Wire Cleaner Error	
		<p>The charge wire cleaner did not: (1) come from the home position within 5 s, or (2) did return to the home position within 3.75 s due to wire cleaner overload.</p>	<ul style="list-style-type: none"> ▪ Cleaner unit blocked or damaged ▪ Until replacement parts become available, set SP2804 to "0" to disable the charge-corona cleaning function so the machine can operate.

392	D	Development Bias Error	
		<p>The development bias feedback voltage was less than 0.3 V for longer than 200 ms while the PWM duty value was more than 5% (indicating a development bias leak).</p>	<ul style="list-style-type: none"> ▪ Bias terminal damaged ▪ High voltage cable damaged, defective ▪ CGB power pack defective

4.2.4 SC4XXX

Group 4 SC codes are also related to image making.

400	D	ID Sensor Auto Adjustment Error	
		Vsg did not reach 4 ± 0.2 V when the ID sensor was initialized with SP3001-2.	<ul style="list-style-type: none"> ▪ ID sensor dirty ▪ ID sensor harness, connector loose, disconnected, damaged, defective ▪ ID sensor defective ▪ MCU defective ▪ Development unit defective ▪ CGB power pack defective

401	D	ID Sensor Vsg Error	
		<p>The Vsg level was twice detected lower than 2.5 V.</p> <p>-or-</p> <p>The Vsg level was once detected higher than 4.8V.</p>	<ul style="list-style-type: none"> ▪ ID sensor dirty ▪ ID sensor harness, connector loose, disconnected, damaged, defective ▪ ID sensor defective ▪ MCU defective ▪ CGB power pack defective

402	D	ID Sensor Vsp Error	
		The Vsp level was twice detected at 0V or at more than 2.5 V.	<ul style="list-style-type: none"> ▪ Under the left upper cover, make sure that the hex screw of the main drum drive gear is tight ▪ ID sensor dirty ▪ ID sensor harness, connector loose, disconnected, damaged, defective ▪ ID sensor defective ▪ MCU defective ▪ Development unit defective ▪ CGB power pack defective

Trouble-shooting

SC Code Descriptions

440	D	Transfer Output Error	
		A high voltage feedback voltage of less than 0.5 V was detected for 200 ms.	<ul style="list-style-type: none"> ▪ High voltage cable disconnected, damaged ▪ T/S power pack defective

460	D	DC Separation Corona Output Error	
		A dc separation feedback voltage of less than 0.5 V was detected after more than 200 ms.	<ul style="list-style-type: none"> ▪ High voltage cable disconnected, damaged ▪ T/S power pack defective

4.2.5 SC5XXX

508	B	Cutter Error	
		The left and right cutter HP sensors remained on or off more than 2 sec.	<ul style="list-style-type: none"> ▪ HP sensors on the left and right side loose, disconnected, defective ▪ Cutter motor harness damaged, defective ▪ HP sensors defective ▪ Cutter motor defective <p>Note: Paper can be fed from the bypass table if the roll feeder or paper cassette is not operating.</p>

520	D	Main Motor Error	
		After the motor started, the main motor lock signal remained HIGH for 5 sec.	<ul style="list-style-type: none"> ▪ Physical obstruction blocking motor ▪ Motor harness damaged, defective ▪ Motor defective

SC Code Descriptions

521	D	Drum Motor Error	
		After the motor started, the drum motor lock signal remained HIGH for 5 sec.	<ul style="list-style-type: none"> ▪ Physical obstruction blocking motor ▪ Motor harness damaged, defective ▪ Motor defective

522	D	Fusing Unit Drive Motor Error	
		After the motor started, the fusing motor lock signal remained HIGH for 5 sec.	<ul style="list-style-type: none"> ▪ Physical obstruction blocking motor ▪ Motor harness damaged, defective ▪ Motor defective

530	D	Fusing Unit Ventilation Fan Error	
		After the motor started, the fan motor lock signal remained HIGH for 5 sec.	<ul style="list-style-type: none"> ▪ Physical obstruction blocking motor ▪ Motor harness damaged, defective ▪ Motor defective

541	A	Fusing Thermistor Errors	
		The thermistor measured the hot roller temperature every 1 sec. for 30 sec. and the temperature remained below 5°C (54°F).	<ul style="list-style-type: none"> ▪ Thermistor positioned incorrectly ▪ Thermistor cable loose, disconnected, damaged ▪ Thermistor defective

Trouble-shooting

SC Code Descriptions

542	A	Fusing Temperature Warm-up Error	
		<p>The hot roller did not reach the ready temperature within 4 min. 30 sec. after power on.</p> <p>-or-</p> <p>After 5 sec. and 5 rotations of the hot roller, the machine detected that the temperature rise was less than 3°C .</p>	<ul style="list-style-type: none"> ▪ Fusing lamp connections loose, broken, defective ▪ Fusing lamp defective ▪ Thermistor not touching the hot roller ▪ Thermistor defective ▪ MCU defective
		<p>The ready temperature is determined by the state of the machine at recovery:</p> <ul style="list-style-type: none"> ▪ Ready Temp. = Target Fusing Temp. (if power on or recovery starts when the hot roller is 80°C or higher). ▪ Ready Temp. = Target Fusing Temp. – 10°C (SP1105-1 default) if power on or recovery starts when the hot roller is less that 80°C. ▪ Ready Temp. = Target Fusing Temp. – 20°C (SP1937-3 default) if power on or recovery starts with pressure roller inching control on. 	

543	A	Fusing Lamp Overheated: Error 1	
		<p>The circuit on the MCU that monitors the temperature of the board detected a fusing temperature of 230°C (446°F) for longer than 2 sec.</p>	<ul style="list-style-type: none"> ▪ MCU defective

545	A	Fusing Lamp Overheated: Error 2	
		<p>After the hot roller reached the ready temperature, the fusing lamp stayed on at full power for 50 sec. while the hot roller was not rotating.</p>	<ul style="list-style-type: none"> ▪ Hot roller thermistor not positioned correctly ▪ Fusing lamp harness loose, disconnected, defective ▪ MCU defective

546	A	Fusing Temperature Errors	
		The machine detected that the fusing temperature was fluctuating out of range for more than 60 sec. (7 readings detected temperature fluctuating more than $\pm 20^{\circ}\text{C}$)	<ul style="list-style-type: none"> ▪ Thermistor connection loose, disconnected, defective ▪ Hot roller thermistor not positioned correctly ▪ Fusing lamp connections loose, disconnected, defective ▪ MCU defective

547	D	Zero-Cross Signal Errors	
		<p>This error occurs if the machine fails to detect 50/60 Hz on the power supply line.</p> <p>Note: The zero-cross signal from the ac power supply generates a trigger pulse to control the power supply of power. (It automatically detects 50/60 Hz.)</p>	<ul style="list-style-type: none"> ▪ Check that the frequency of the power supply to the machine is correct ▪ PSU defective ▪ MCU defective

551	A	Pressure roller center thermistor error 1	
		During the hot roller temperature control sequence, or while the hot roller and pressure roller were rotating, the pressure roller center thermistor measured a value higher than 3.3V 10 consecutive times at 600 ms intervals.	<ul style="list-style-type: none"> ▪ Pressure roller center thermistor not positioned properly ▪ Pressure roller center thermistor connector loose, broken, defective ▪ Pressure roller center thermistor defective ▪ MCU defective

Trouble-shooting

SC Code Descriptions

553	A	Pressure roller center thermistor error 2	
		<p>During the hot roller temperature control sequence, the pressure roller center thermistor measures a value lower than 0.2V.</p>	<ul style="list-style-type: none"> ▪ Pressure roller center thermistor not positioned properly ▪ Pressure roller center thermistor connector loose, broken, defective ▪ Pressure roller center thermistor defective ▪ MCU defective

557	C	Applied zero-cross waveform error	
		<p>The applied power ac frequency was detected less than 66 Hz more than 10 times.</p>	<ul style="list-style-type: none"> ▪ Noise on the ac power supply line

559	A	Fusing paper jam errors	
		<p>Three consecutive paper jam errors occurred in the fusing unit. Note: This SC code is not issued unless SP1159 is switched on.</p>	<ul style="list-style-type: none"> ▪ Paper jam in fusing unit ▪ Pick-off pawl defective ▪ Paper scraps in fusing unit ▪ Exit sensor defective

561	A	Pressure roller end thermistor error 1	
		<p>During the hot roller temperature control sequence, or while the hot roller and pressure roller were rotating, the end thermistor on the pressure roller returned a digital reading of more than 3.3V.</p>	<ul style="list-style-type: none"> ▪ Pressure roller end thermistor not positioned properly ▪ Pressure roller end thermistor connector loose, broken, defective ▪ Pressure roller end thermistor defective ▪ MCU defective

563	A	Pressure roller end thermistor error 2	
		During the hot roller temperature control sequence, the end thermistor on the pressure roller returned a digital reading of less than 0.2V.	<ul style="list-style-type: none"> ▪ Pressure roller end thermistor connector loose ▪ Pressure roller end thermistor short circuit, defective ▪ MCU defective

4.2.6 SC6XXX

628	D	Fan fold unit communication error 1	
		The machine failed to detect within 100 ms a response to a data frame sent to the fan fold unit. Three consecutive retries failed, resulting in a timeout.	<ul style="list-style-type: none"> ▪ Cable harness between the main machine and fan fold unit broken or defective ▪ Connector loose, disconnected, or defective

632	B	Key/card counter device error 1	
		After 1 data frame is sent to the device, an ACK signal is not received within 100 ms, and is not received after 3 retries.	<ul style="list-style-type: none"> ▪ Serial line from the device to the main machine is unstable, disconnected, or defective.

633	B	Key/card counter device error 2	
		During communication with the device, the MCU received a break (Low) signal.	<ul style="list-style-type: none"> ▪ Serial line from the device to the main machine is unstable, disconnected, or defective

Trouble-shooting

SC Code Descriptions

634	B	Key/card counter device error 3	
		The backup battery of the counter device RAM is low.	<ul style="list-style-type: none"> ▪ RAM backup battery exhausted ▪ Counter device defective

635	B	Key/card counter device error 4	
		After installation of the device a message alerts user to a battery voltage abnormal error.	<ul style="list-style-type: none"> ▪ Device control board defective ▪ Device control board backup battery defective

650	B	@Remote communication error 1	
		A dial-up or modem error occurred during @Remote operation. (This error occurs only during @Remote operation.)	<ul style="list-style-type: none"> ▪ Modem line disconnected ▪ Modem board missing or not properly installed

651	C	@Remote communication error 2	
		An illegal dial-up to the service center was attempted by @Remote.	<ul style="list-style-type: none"> ▪ Software bug

670	D	Engine startup error	
		The MCU failed to respond within the prescribed time when the machine was turned on.	<ul style="list-style-type: none"> ▪ Connections between MCU and controller board are loose, disconnected, or damaged ▪ MCU defective ▪ Controller board defective

SC Code Descriptions

672	D	Controller startup error	
		<p>After power on, the line between the controller and the operation panel did not open for normal operation.</p> <p>-or-</p> <p>After normal startup, communication with the controller stopped.</p>	<ul style="list-style-type: none"> ▪ Controller installed incorrectly ▪ Controller board defective ▪ Operation panel harness disconnected or defective

690	D	VDB communication error	
		<p>There was no serial communication with the VDB within 1 sec. after power on.</p>	<ul style="list-style-type: none"> ▪ VDB-to-MCU harness or connectors broken, loose, defective ▪ VDB defective ▪ MCU defective

Trouble-shooting

4.2.7 SC7XXX

720	D	Fan folder transport motor error	
		A transport motor lock signal was detected for more than 5 sec. while the motor was running.	<ul style="list-style-type: none"> ▪ Transport motor harness connector loose, disconnected, broken ▪ Motor overload due to an obstruction ▪ Transport motor defective ▪ Fan folder unit MCU defective

762	D	Front fold plate HP sensor error	
		The state (on/off, off/on) of the front fold plate HP sensor in the fan fold unit did not change 1 sec. after the plate started to move.	<ul style="list-style-type: none"> ▪ Fold plate motor (F) harness connector loose, disconnected, broken ▪ Front fold plate HP sensor harness connector loose, disconnected, broken ▪ Fold plate motor (F) defective ▪ Front fold plate HP sensor defective ▪ Undetected paper is jamming the action of the motor or fold plate ▪ Fan folder unit MCU defective

763	D	Rear fold plate HP sensor error	
		The state (on/off, off/on) of the rear fold plate HP sensor in the fan fold unit did not change 1 sec. after the plate started to move.	<ul style="list-style-type: none"> ▪ Fold plate motor (R) arness connector loose, disconnected, broken ▪ Rear fold plate HP sensor harness connector loose, disconnected, broken ▪ Fold plate motor (R) defective ▪ Rear fold plate HP sensor defective ▪ Undetected paper is jamming the action of the motor or fold plate ▪ Fan folder unit MCU defective

790	D	PCB fan error: Folder Unit	
		<p>The machine detected a continuous lock signal from the PCB cooling fan on the PSU for 20 sec.</p>	<ul style="list-style-type: none"> ▪ Fan harness connector loose, disconnected, broken ▪ Overload on the fan motor due to physical obstruction such as undetected paper, etc. ▪ Fan defective ▪ MCU folder unit defective

4.2.8 SC8XXX

819	C	Fatal kernel error	
		Due to a control error, a RAM overflow occurred during system processing.	<ul style="list-style-type: none"> ▪ Controller board defective ▪ Insufficient memory ▪ Expanded memory defective

Note: For more details about this SC code error, execute SP5990 to print an SMC report so that you can read the error code. The error code is not displayed on the operation panel.

		Self-Diagnostic Error: CPU	
820	D	The CPU returned an unexpected error during the self-diagnostic test.	<ul style="list-style-type: none"> ▪ Controller board defective ▪ Insufficient memory ▪ Expanded memory defective

		Self-diagnostic error 2: ASIC	
821	D	The ASIC provides the central point for the control of bus arbitration for CPU access, for option bus and SDRAM access, for SDRAM refresh, and for management of the internal bus gate.	<ul style="list-style-type: none"> ▪ Controller board defective

Note: For more details about this SC code error, execute **SP5990** to print an SMC report so that you can read the error code. The error code is not displayed on the operation panel.

822	B	Self-diagnostic error 3: HDD	
		An error occurred when the self-check was performed when the machine was switched on after the HDD was replaced. (The diagnostic command was issued to the HDD device but the result was an error).	<ul style="list-style-type: none"> ▪ HDD defective ▪ HDD harness disconnected, defective ▪ Controller board defective

823	B	Self-diagnostic Error: NIB	
		The network interface board returned an error during the self-diagnostic test.	<ul style="list-style-type: none"> ▪ Network interface board defective ▪ Controller board defective

824	D	Self-diagnostic error 4: NVRAM	
		Error occurred because: <ul style="list-style-type: none"> ▪ NVRAM device does not exist ▪ NVRAM device is damaged ▪ NVRAM socket damaged 	<ul style="list-style-type: none"> ▪ NVRAM defective

826	D	Self-diagnostic Error 5: RTC/Optional NVRAM	
		The NVRAM or optional NVRAM returned an error during the self-diagnostic test.	<ul style="list-style-type: none"> ▪ Make sure NVRAM is seated correctly in its socket ▪ Replace the NVRAM on the controller board

827	D	Self-diagnostic error 6: Resident RAM	
		The resident RAM returned a verify error during the self-diagnostic test.	<ul style="list-style-type: none"> ▪ Controller board defective ▪ Replace RAM DIMM

828	D	Self-diagnostic error 8: ROM	
		Measuring the CRC for the boot monitor and operating system program resulted in an error.	<ul style="list-style-type: none"> ▪ Software defective ▪ Controller board defective

Trouble-shooting

SC Code Descriptions

829	B	Self-diagnostic Error 9: Optional RAM	
		The optional RAM returned an error during the self-diagnostic test.	<ul style="list-style-type: none"> ▪ Replace the optional memory board ▪ Controller board defective

838	D	Self-diagnostic Error 10: Clock Generator	
		A verify error occurred when setting data was read from the clock generator via the I2C bus.	<ul style="list-style-type: none"> ▪ Replace the controller board

853	B	Wireless LAN Error 1	
		During machine start-up, the machine can access the board that holds the wireless LAN, but not to the wireless LAN card.	<ul style="list-style-type: none"> ▪ Wireless LAN card missing (was removed)

854	B	Wireless LAN Error 2	
		During machine operation, the machine can get access to the board that holds the wireless LAN, but not to the wireless LAN card (802.11b or Bluetooth).	<ul style="list-style-type: none"> ▪ Wireless LAN card missing (was removed)

855	B	Wireless LAN error 3	
		An error was detected on the wireless LAN card.	<ul style="list-style-type: none"> ▪ Wireless LAN card defective ▪ Wireless LAN card connection incorrect

856	B	Wireless LAN error 4	
		An error was detected on the wireless LAN board.	<ul style="list-style-type: none"> ▪ Wireless LAN board defective ▪ PCI connector to MB loose

857	B	USB I/F Error	
		The USB driver is not stable and caused an error.	<ul style="list-style-type: none"> ▪ Poor USB card connection ▪ Replace the controller board

860	B	HDD startup error at power on	
		<p>HDD is connected but a driver error is detected.</p> <p>-or-</p> <p>The driver does not respond with the status of the HDD within 30 s.</p>	<ul style="list-style-type: none"> ▪ HDD is not initialized ▪ Level data corrupted ▪ HDD is defective

861	D	HDD re-try failure	
		At power on the HDD was detected. Power supply to the HDD was interrupted after the system entered the energy save mode, but after the HDD was awakened from the energy save mode it did not return to the ready status within 30 sec.	<ul style="list-style-type: none"> ▪ Harness between HDD and controller board disconnected, defective ▪ HDD power connector disconnected ▪ HDD defective ▪ Controller board defective

Trouble-shooting

SC Code Descriptions

863	D	HDD data read failure	
		The data written to the HDD cannot be read normally, due to bad sectors generated during operation.	<ul style="list-style-type: none"> ▪ HDD defective

Note:

- If the bad sectors are generated at the image partition, the bad sector information is written to NVRAM.
- The next time the HDD is accessed, these bad sectors will not be accessed for read/write operation. The HDD will probably require replacement soon.

864	D	HDD data CRC error	
		During HDD operation, the HDD cannot respond to a CRC error query. Data transfer did not execute normally while data was being written to the HDD.	<ul style="list-style-type: none"> ▪ HDD defective

865	D	HDD access error	
		HDD responded to an error during operation for a condition other than those for SC863, 864.	<ul style="list-style-type: none"> ▪ HDD defective

866	B	SD card error 1: Confirmation error	
		The machine detected an electronic license error in the application on the SD card in the controller slot immediately after the machine was turned on.	<ul style="list-style-type: none"> ▪ Program missing from the SD card

867	D	SD card error 2: SD card removed	
		The SD card in the boot slot when the machine was turned on was removed while the machine was on.	<ul style="list-style-type: none"> ▪ Insert the SD card ▪ Turn the machine's power off/on

868	D	SD card error 3: SD card access	
		An error occurred while an SD card was used.	<ul style="list-style-type: none"> ▪ SD card not inserted correctly ▪ SD card defective ▪ Controller board defective ▪ To reformat the SC card, use SD Formatter Ver 1.1.

870	B	Address book data error	
		Address book data on the hard disk was detected as abnormal when it was accessed from either the operation panel or the network. The address book data cannot be read from the HDD or SD card where it is stored, or the data read from the media is defective.	<ul style="list-style-type: none"> ▪ Turn the machine power off/on. If this does not solve the problem, do the Procedure below. ▪ HDD defective
		<p>Procedure</p> <ol style="list-style-type: none"> 1. Do SP5846-50 (UCS Settings – Initialize all Directory Info.) to reset all address book data. 2. After 3 sec. reset the user information with SP5832-6 (HDD Formatting– User Information). 3. Turn the main power switch off/on. 	

Trouble-shooting

SC Code Descriptions

873	B	HDD mail send data error	
		<p>An error was detected on the HDD immediately after the machine was turned on, or power was turned off while the machine used the HDD.</p>	<ul style="list-style-type: none"> ▪ Do SP5832 (Format HDD – Mail TX Data) to initialize the HDD ▪ Replace the HDD

874	D	Delete All error 1: HDD	
		<p>A data error was detected for the HDD/NVRAM after the Delete All option was used.</p> <p>Note: The source of this error is the Data Overwrite Security Unit B735 running from the DOS SD card.</p>	<ul style="list-style-type: none"> ▪ Turn the main switch off/on, do the operation again. ▪ Install the Data Overwrite Security Unit again. ▪ HDD defective

875	D	Delete All error 2: Data area	
		<p>An error occurred when the machine deleted data from the HDD.</p> <p>Note: The source of this error is the Data Overwrite Security Unit B735 running from the DOS SD card.</p>	<ul style="list-style-type: none"> ▪ Turn the main switch off/on and try the operation again.

880	B	File Format Converter (MLB) error	
		<p>A request to access the MLB was not answered within the specified time (60 sec.).</p>	<ul style="list-style-type: none"> ▪ File format converter board defective

4.2.9 SC9XXX

900	D	Electrical total counter error	
		The total counter contains something that is not a number.	<ul style="list-style-type: none"> ▪ NVRAM incorrect type ▪ NVRAM defective ▪ NVRAM data scrambled ▪ Unexpected error from external source

901	D	Mechanical Total Counter	
		The mechanical counter is not connected.	<ul style="list-style-type: none"> ▪ Mechanical counter connection loose, broken, defective ▪ Replace the mechanical counter

910	B	External controller error 1	
911	B	External controller error 2	
912	B	External controller error 3	
913	B	External controller error 4	
914	B	External controller error 5	
		The external controller alerted the machine about an error.	<ul style="list-style-type: none"> ▪ Refer to the instructions for the external controller

919	D	External controller error 6	
		While EAC (External Application Converter), the conversion module, was operating normally, the receipt of a power line interrupt signal from the FLUTE serial driver was detected, or BREAK signal from the other station was detected.	<ul style="list-style-type: none"> ▪ Controller RW3600 power outage ▪ Controller RW3600 rebooted ▪ Connection to Controller RW3600 loose

Trouble-shooting

SC Code Descriptions

920	B	Printer error 1	
		An internal application error was detected and operation cannot continue.	<ul style="list-style-type: none"> ▪ Software defective ▪ Turn the machine power off/on, or change the controller firmware ▪ Insufficient memory

921	B	Printer Error 2	
		When the printer application started, the font designated for use could not be found on the SD card.	<ul style="list-style-type: none"> ▪ The font is not on the SD card

953	B	Scanner start error	
		The job was ready to start with the selected image processing mode, but the program did not receive a start signal from the IPU.	<ul style="list-style-type: none"> ▪ Firmware bug ▪ Update the scanner firmware ▪ IPU defective

954	D	Printer Image Setting Error	
		The settings that are required for image processing using the printer controller are not sent from the IPU.	<ul style="list-style-type: none"> ▪ Firmware bug ▪ IPU defective

955	D	Memory Setting Error	
		The settings that are required for image processing using the memory are not sent from the IPU.	<ul style="list-style-type: none"> ▪ Firmware bug ▪ Hard disk unit defective ▪ Controller defective ▪ MCU defective ▪ IPU defective

SC Code Descriptions

964	D	Scanner Start Error	
		During scanned image processing, another command to start scanning was received.	<ul style="list-style-type: none"> ▪ Scanner firmware defective ▪ Update scanner firmware

965	D	Print Start Error	
		During print processing, another command to start printing was received.	<ul style="list-style-type: none"> ▪ Printer firmware defective ▪ Update printer firmware

967	D	Image write start error	
		The paper stopped at the registration sensor and roller for buckle adjustment but the signal to start image writing was not received within 60 sec.	<ul style="list-style-type: none"> ▪ Printer firmware defective ▪ Update printer firmware ▪ Check the connections between the LPH sections (x3) and the VDB ▪ LPH defective ▪ VDB defective ▪ MCU defective

Trouble-shooting

SC Code Descriptions

990	D	Software error 1	
		The software performs an unexpected function and the program cannot continue.	<ul style="list-style-type: none"> ▪ Firmware defective: re-boot ▪ Update firmware*¹
991	C	Software error 2	
		The software performs an unexpected function. However, unlike SC990, recovery processing allows the program to continue.	Software defective, re-boot* ¹

*¹: For more information about SC990 and SC991:

1. Execute SP7403 or print an SMC Report (SP5990) to read the history of the 10 most recent logged errors.
2. If you press [0] on the operation panel with the SP selection menu displayed, you will see detailed information about the recently logged SC990 or SC991 errors, including the software file name, line number, and so on. (1) above is the recommended method, because another SC could write over the information for the previous SC.

992	D	Erratic SC error	
		<p>There was an unusual operation by the software because of:</p> <ul style="list-style-type: none"> ▪ An incorrect argument in the program. ▪ An incorrect internal parameter. ▪ Work memory not sufficient. ▪ An error occurred that could not be detected by other SC codes. 	<ul style="list-style-type: none"> ▪ Turn the main power switch off/on. ▪ Go into the SP mode. Do SP7901 to display details about SC992 (software file name, line number, and variable), and inform your supervisor of the results.

997	B	Cannot select application function	
		An application did not start after the user pushed the correct key on the operation panel.	<ul style="list-style-type: none"> ▪ Software bug ▪ A RAM or DIMM option required for the application is not installed or not installed correctly.

998	D	Application cannot start	
		Register processing does not operate for an application within 60 s after the machine power is turned on. No applications start correctly, and all end abnormally.	<ul style="list-style-type: none"> ▪ Software bug ▪ A RAM or DIMM option needed for the application not installed, or not installed correctly ▪ Controller board defective

4.3 JAM CODE TABLES

4.3.1 OVERVIEW

When a jam occurs:

- The jam indicator lights (☞).
- A diagram on the LCD shows the location of the jam with instructions about how to correct the problem.
- The “Code” numbers in the table are also shown. Use SP 7507 (Plotter Jam History) to see the most recent codes.

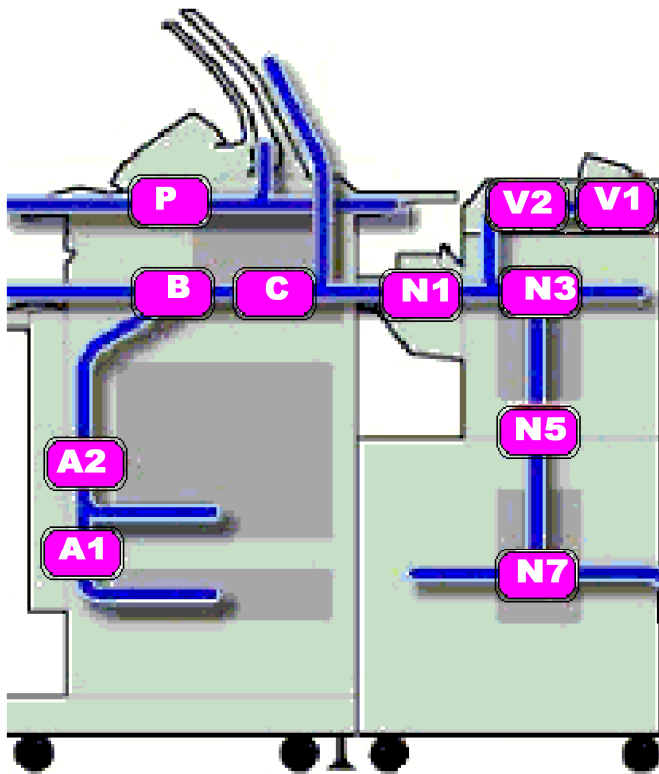

b286d560

Code	Location	Code	Location
A1	Paper Cassette Feed	N3	Folder unit junction gate
A2	Roll Paper Feed	N5	Fan folder entrance
B	Bypass Paper Feed, Paper Registration	N7	Fan folder exit

Code	Location	Code	Location
C	Fusing Unit (Exit)	V1	Manual feeder feed entrance
P	Original feed	V2	Folder unit entrance (from manual feeder)
N1	Folder unit entrance (from main unit)		

- The operator must open and close the upper unit to release a jam in the fusing unit.
- If the operator opens and closes the paper exit cover during copying, this is not recorded in the jam record.
- An original or paper feed jam that occurs just after the main power switch or operation switch comes on is not recorded in the jam record.

4.3.2 SCANNER JAMS

In the tables below “late” and “lag” have the following meanings:

- **Late.** Paper (or original) fails to arrive at the sensor location at the prescribed time.
- **Lag.** Paper (or original) fails to leave the sensor location at the prescribed time.
- **LE.** Leading edge of original or paper.
- **TE.** Trailing edge of original or paper.

Scanner Standby Jams

Code	Location	Display	Comment
001	Initial jam: Original Set Sensor	P	Sensor ON
	Initial jam: Original Registration Sensor	P	Sensor ON
	Initial jam: Original Width Sensor (A0)	P	Sensor ON
	Initial jam: Original Width Sensor (A1)	P	Sensor ON
	Initial jam: Original Width Sensor (A2)	P	Sensor ON

Jam Code Tables

Code	Location	Display	Comment
	Initial jam: Original Width Sensor (A3)	P	Sensor ON
	Initial jam: Original Width Sensor (A4)	P	Sensor ON
	Initial jam: Original Width Sensor (B1)	P	Sensor ON
	Initial jam: Original Width Sensor (B2)	P	Sensor ON
	Initial jam: Original Width Sensor (B3)	P	Sensor ON
	Initial jam: Original Width Sensor (B4)	P	Sensor ON
	Initial jam: Original Width Sensor (914)	P	Sensor ON
	Initial jam: Original Exit Sensor	P	Sensor ON
008	Next Original Time Limit	P	Next original was set on the original feed table too early. Original set sensor detected the trailing edge of the first original. The paper set sensor detected the leading edge of the next original (before the IPU received the scan end signal).
006	Original Stop	P	[Scanner Stop] button was pushed to remove the original.

Scanner Late Jams

Code	Location	Display	Comment
002	Registration Jam	P	Registration sensor not ON
003	Registration Jam	P	Registration sensor OFF
007	Exit Jam	P	Fusing exit sensor not ON

Scanner Lag Jams

Code	Location	Display	Comment
004	Registration Jam (Sensor not OFF)	P	
005	Registration Jam	P	

4.3.3 PLOTTER (PRINTER) JAMS**Plotter Standby Jams**

Code	Location	Display	Comment
001	Initial Jam: Registration Sensor	B	
	Initial Jam: Paper Set Sensor	B	
	Initial Jam: Fusing Exit Sensor	C	

Jam Code Tables

Plotter Late Jams

Code	Location	Display	Comment
003	Roll 1 Non-Feed Jam	A2	
004	Roll 2 Non-Feed Jam	A2	
005	Paper cassette Non-Feed Jam	A1	
008	Roll Feeder Exit Jam	A1	RF exit sensor not ON
013	Registration Jam	B	Registration sensor not ON
016	Fusing Exit Jam	C	Fusing exit sensor not ON.
034	Bypass Non-Feed	B	Paper set not ON.

Plotter Lag Jams

Code	Location	Display	Comment
053	Roll 1 Feed Lag	A2	Roll paper failed to feed
054	Roll 2 Feed Lag	A2	Roll paper failed to feed
055	Paper Cassette Lag	A1	Cut sheets failed to feed
058	Roll Feeder Exit Jam	A2	RF exit sensor failed to go OFF
063	Registration Jam	B	Paper registration sensor failed to go OFF.
066	Fusing Exit Jam	C	Fusing exit sensor failed to go OFF.
084	Bypass Jam	B	Paper set sensor failed to go OFF.

4.3.4 FOLDER UNIT JAMS

Folder Unit Standby Jams

Code	Location	Display	Comment
100	Initial Jam: Folder Entrance	N1	Folder entrance sensor
	Initial Jam: Relay Sensor	N5	Relay sensor 1
	Initial Jam: Fan Folder Entrance	N7	Fan folder entrance sensor
	Initial Jam: Fan Folding (Front)	N7	Fan fold LED (F1), fan fold sensor (F2) pair
	Initial Jam: Fan Folding (Rear)	N7	Fan fold LED (R1), fan fold sensor (R2) pair
	Initial Jam: Folder Unit Exit	N7	Folder unit exit sensor
	Initial Jam: Straight-Through Exit	N3	Straight-Through Sensor
	Initial Jam: Manual Feeder Entrance	V1	Bypass Entrance Sensor
	Initial Jam: Folder Unit Entrance (from Manual Feed unit)	V2	Bypass Relay Sensor
	Initial Jam: Bypass Entrance	V1	Paper Width Sensor (880)
	Initial Jam: Bypass Entrance	V1	Paper Width Sensor (841)
	Initial Jam: Bypass Entrance	V1	Paper Width Sensor (594)
	Initial Jam: Bypass Entrance	V1	Paper Width Sensor (420)
	Initial Jam: Bypass Entrance	V1	Paper Width Sensor (297)
	Initial Jam: Bypass Entrance	V1	Paper Width Sensor (30 in.)
Initial Jam: Bypass Entrance	V1	Paper Width Sensor (B4)	

Jam Code Tables

Code	Location	Display	Comment
	Initial Jam: Bypass Entrance	V1	Paper Width Sensor (B3)
	Initial Jam: Bypass Entrance	V1	Paper Width Sensor (B2)
	Initial Jam: Bypass Entrance	V1	Paper Width Sensor (B1)

Folder Unit Late Jams

Code	Location	Display	Comment
130	Bypass LE Relay ON Check	V2	Bypass relay sensor
132	Junction Gate LE Exit ON Check	N3	Relay Sensor 1
134	Fan Folder LE Relay ON Check	N5	Relay Sensor 2
138	Fan Folder LE Entrance ON Check	N7	Fan folder entrance sensor
140	Front Fan Fold LE Detect ON Check	N7	Fan fold LED (F1), Fan fold sensor (F2)
141	Rear Fan Fold LE Detect ON Check	N7	Fan fold LED (R1), Fan fold sensor (R2)
143	Fan Fold Exit LE Detect ON Check	N7	Folder unit exit sensor
145	Minimum Length Bypass Check	V2	Bypass Relay Sensor

Folder Unit Lag Jams

Code	Location	Display	Comment
131	Bypass TE Relay OFF Check	V2	Bypass relay sensor
133	Junction Gate TE Exit OFF Check	N3	Relay Sensor 1
135	Fan Folder TE Relay OFF Check	N5	Relay Sensor 2
139	Fan Folder TE Entrance OFF Check	N7	Fan folder entrance sensor
142	Rear Fan Fold TE Detect OFF Check	N7	Fan fold LED (R1), Fan fold sensor (R2)
144	Fan Fold Exit TE Detect OFF Check	N7	Folder unit exit sensor
146	Fold Count Limit	N7	Front/Rear Fold Sensor Pairs

4.4 COVER OPEN

Location	Shuts Off Lines	Display
Drawer Connector	Roll feed motor, cutter motor, roll feed clutches (24 V dc line)	Cover Open
Exit Cover Sensor	Cooling fan, paper junction gate solenoid, quenching lamp, pick-off pawl solenoid, fusing motor, T&S power pack (24 V dc line), fusing lamp (power relay/ac line)	
Exit Cover Switch		
Exit Unit Switch		
Scanner Switch	Scanner motor (24 dc line)	
Toner Hopper Cover Switch	Toner supply clutch, paper registration clutch, drum motor, main motor, CGB power pack (24 V dc line)	
Upper Unit Sensor	Toner supply clutch, paper registration clutch, drum motor, main motor, CGB power pack, cooling fan, paper junction gate solenoid, quenching lamp, pick-off pawl solenoid, fusing motor, T&S power pack (24 V dc line), fusing lamp (power relay/ac line)	
Upper Unit Switch		

4.5 FUSES

The fuses differ slightly with geographic location.

Main Machine Fuse Table

No.	No.	Area	Part No.	Specification
PSU	CP101	120V	11071079	15A 125Vac/250ac
		220 - 240V	11070957	8A 125Vac/250ac
	FU001	120V	11070629	15A 125Vac
		220 - 240V	11071054	T6.3AH 250ac
	FU002	120V, 220 - 240V	11071095	T2A 250Vac
	FU101	120V	11070016	T10AH 250Vac
		220 - 240V	11071054	T6.3AH 250Vac
	FU301	120V, 220 - 240V	11071067	T6.3AL 250Vac
	FU302		11071067	T6.3AL 250Vac
	FU303		11071067	T6.3AL 250Vac
	RFDB	FU501	120V, 220 - 240V	
SFDB	FU601	120V, 220 - 240V		T1 A/250V

4.6 IMAGE PROBLEM TROUBLESHOOTING

4.6.1 FLOW CHART

Follow this flow chart to determine the cause of an image problem. Use SP2902 to print the VDB/IPU test patterns.

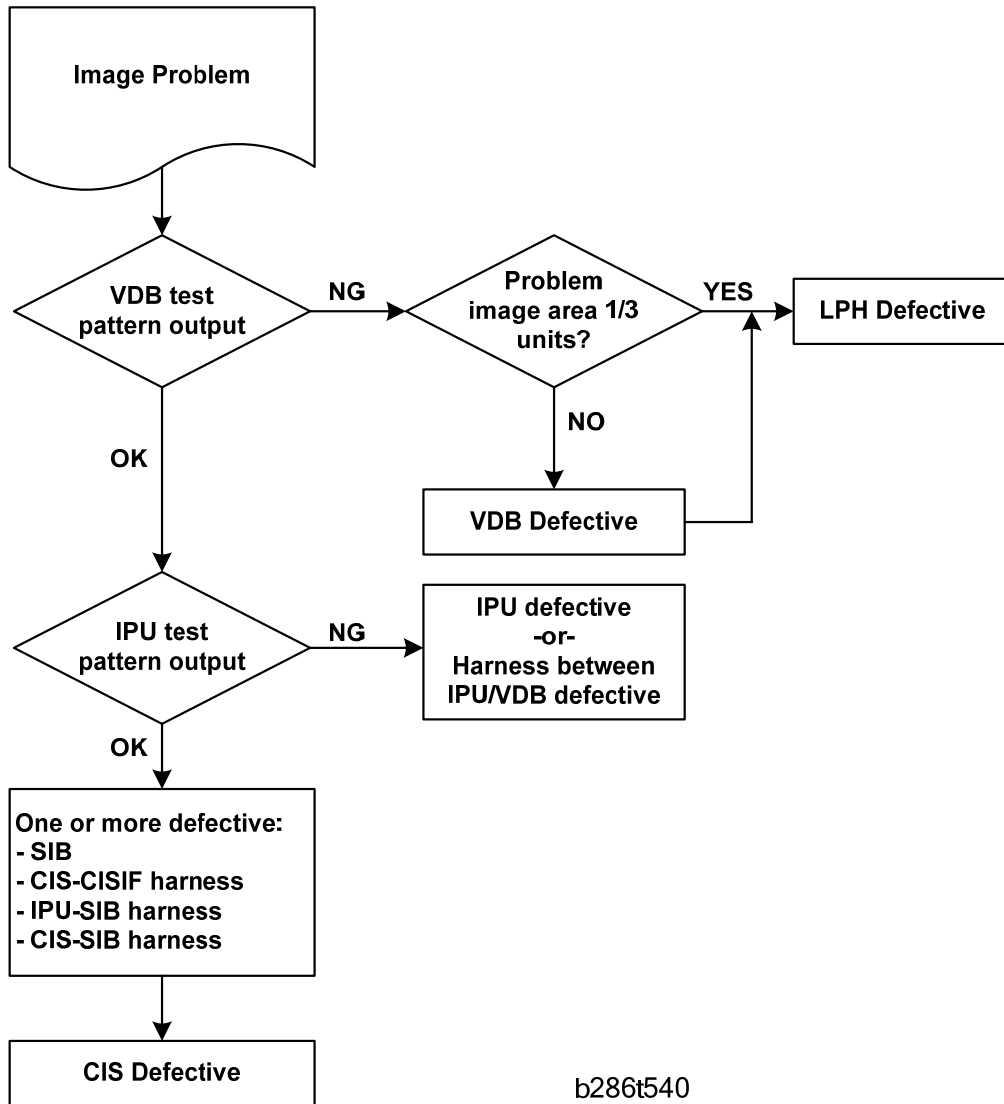

b286t540

4.6.2 SCANNING

1. No image (or no image with only vertical black lines on the output)

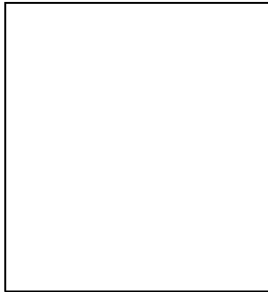

b286t541

Possible causes:

- Connection problem between CIS and IPU.
- CIS defective

2. No image (solid black copy/print, or no image with only vertical white lines on the output)



b286t542

Possible causes:

- Connection problem between CIS and IPU.
- CIS defective

3. Light image

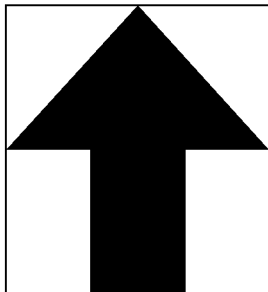

b286t543

Possible causes:

- Low CIS output
- IPU board defective

Image Problem Troubleshooting

4. Vertical black lines

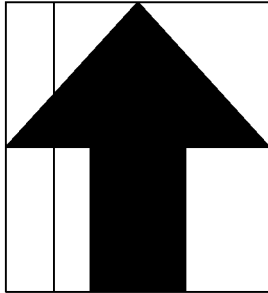

b286t544

Possible causes:

- Dirty exposure glass
- CIS defective

5. Vertical white lines

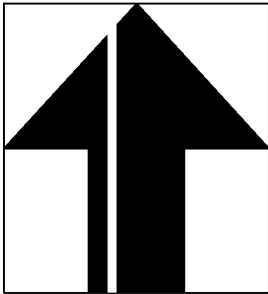

b286t545

Possible causes:

- Dirty exposure glass
- Dirt or scratches on the white plate above the CIS
- CIS defective

6. Black or white bands with no image-width 1/8 A0 (E) size

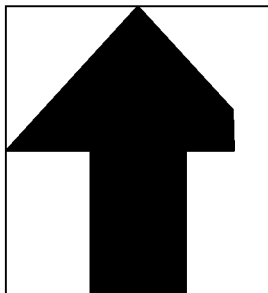

b286t546

Possible causes:

- Connection problem between CIS and IPU
- CIS output error
- IPU board adjustment error

7. White lines every 1mm pitch in halftone areas

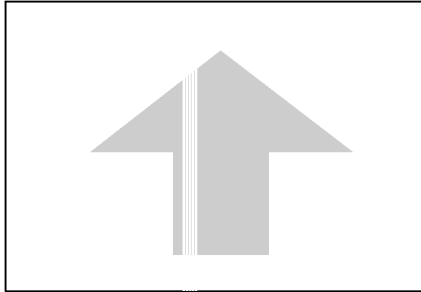

b286t547

Possible causes:

- CIS defective

8. Bands/lines every 8mm pitch in halftone areas

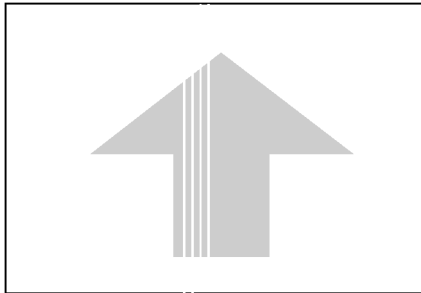

b286t548

Possible causes:

- LPH defective

4.6.3 PRINTING

1. No Image (blank copy/print)



b286t549

Possible causes:

- VDB board defective
- IPU board defective
- LPH (LED head) defective

Image Problem Troubleshooting

2. Band with no image-width 1/3 of image

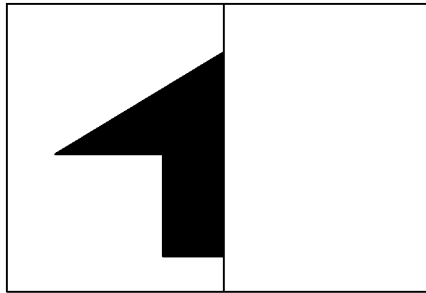

b286t550

Possible causes:

- Connection problem between VDB and LPH
- LPH head defective

3. Bands with no image-width 1/8 A0 (E) size

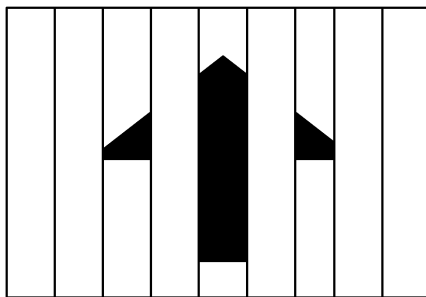

b286t571

Possible causes:

- VDB board defective

4. Vertical white and black line at 150 mm from center.

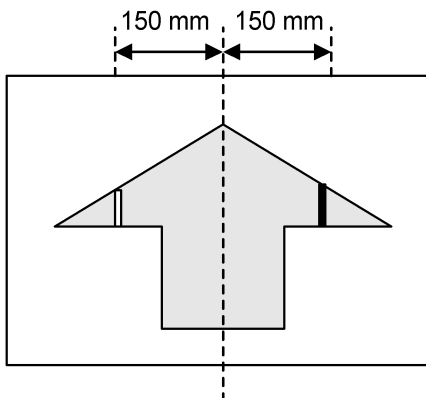

b286t572

Possible causes:

- LPH Joints adjustment error

5. Horizontal line broken at 150 mm from center.

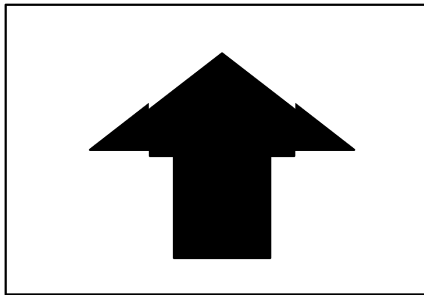

b286t573

Possible causes:

- LPH subscan timing error at joint position

4.6.4 DENSITY CHANGES AT CIS JOINTS

Case 1: Dark image density at CIS1, CIS3, and CIS5.

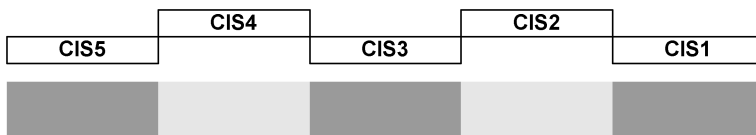

b286t574

Possible causes:

- The main machine is installed near a window. Direct sunlight is hitting the CIS units inside the scanner unit.

Case 2: Dark image density at CIS2 and CIS4.

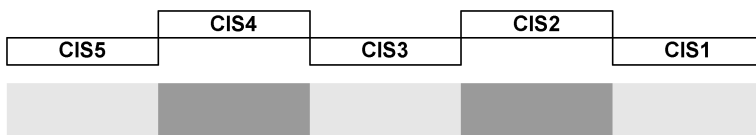

d286t575

Possible causes:

- The white plate is not flat against the original.

Trouble-shooting

4.6.5 OTHER PROBLEMS

1. Excessive curl

Possible causes:

- When a paper roll reaches its end, the paper closest to the core tends to have excessive curl.
- There is no way to correct this. Operators should be instructed to use cut sheets if possible.

2. Shrinkage of areas in incomplete images

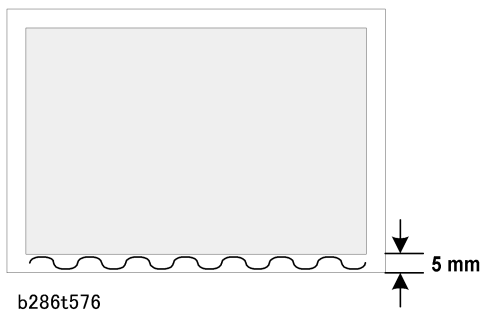

Possible causes:

- Some customers complained about loss of borderlines at the trailing edge of copies when an A1 original is reduced to A3.
- This problem has not been corrected.

4.7 BOARD LEDS

This section describes the functions of the LEDs on the most important PCBs.

4.7.1 PSU, MCU, IPU

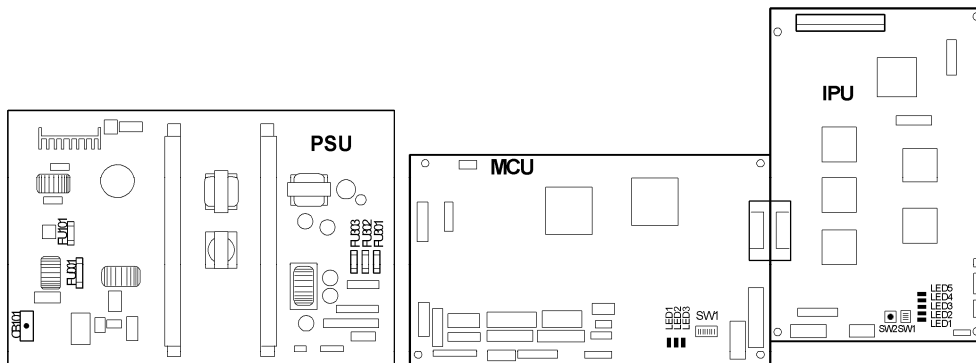

b286t981

PSU LEDs

The PSU supplies dc current to electrical components and also controls the flow of ac current to the fusing lamp, dehumidifiers (x4), and anti-condensation heaters (x2).

No.	Color	Meaning	
Vaa +24 V	GREEN	ON	Normal
		OFF	<ul style="list-style-type: none"> PSU defective, or the +24 V system has shorted or is defective.
Vca2 -12 V	GREEN	ON	Normal
		OFF	<ul style="list-style-type: none"> PSU defective, or the -12 V system has shorted or is defective.
Vca2 +12 V	GREEN	ON	Normal
		OFF	<ul style="list-style-type: none"> PSU defective, or the +12 V system (HDD) has shorted or is defective.
Vcc +5.1 V	GREEN	ON	Normal
		OFF	<ul style="list-style-type: none"> PSU defective, or the +5.1 system (Vcc2) has

Board LEDS

No.	Color	Meaning	
			shorted or is defective.
Vcc1 +5.1 V	GREEN	ON	Normal. Also remains on in auto off mode.
		OFF	<ul style="list-style-type: none"> ▪ PSU defective, or the +5.1 system (Vcc1) has shorted or is defective.

MCU LEDs

The MCU (Main Control Unit) performs system control, base engine control, scanner control, and also controls the IPU. The MCU also controls:

- I/O for the base engine (high voltage power supply, motors, sensors, solenoids, clutches, fusing temperature, customer support systems, etc.)
- Scanning signals (sensors, motors)
- Power supply
- Scanner motor output

MCU LED 1 to 4

No.	Color	Operation	LED Action
LED 1	GREEN	Firmware update	Flashes rapidly
		End of firmware update, normal operation	Flashes slowly
LED 2	GREEN	Firmware update	On
		End of firmware update, normal operation	Off
LED 3	ORANGE	Firmware update	Flashes rapidly
		End of firmware update, normal operation	Flashes slowly
LED 4	ORANGE	Firmware update	On
		End of firmware update, normal operation	Off

IPU LEDs

The IPU (Image Processing Unit) processes the image data. After the scan data from the CIS has been processed, the data is sent via the VDB to the LPH for image writing.

No.	Color	Operation	LED Action
LED 1	Green	Image Processing 1	Flashes
LED 2	Green	Image Processing 1	Flashes
LED 3	Green	Image Processing 1	Flashes
LED 4	Green	Image Processing 1	Flashes
LED 5	Green	Image Processing 1 (while data is transferring)	On

4.7.2 SIB, VDB

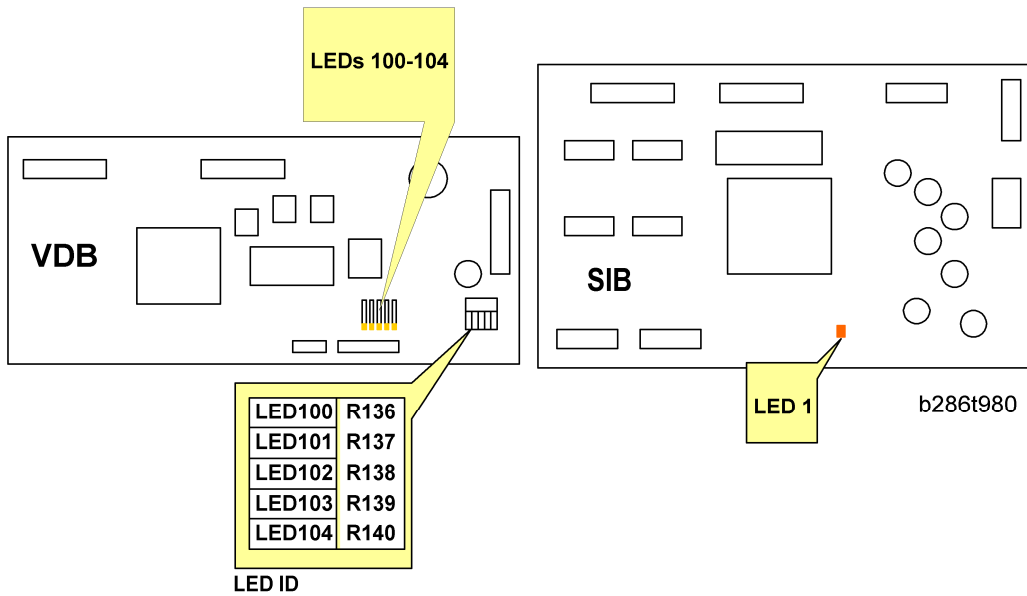

VDB LEDs

The VDB (Video Drive Board) controls the LPH (LED Print Head). The VDB receives the image processed data from the IPU and sends it to the LPH.

No.	Color	Operation	LED Action
LED 100	GREEN	Timer	Flashes
LED 101	YELLOW	During image writing (RFGATE signal)	ON
LED 102	GREEN	Outputting LPH 2 print data (1-bit)	ON
LED 103	YELLOW	Outputting ID sensor sampling	ON
LED 104	GREEN	Calibrating amount of LPH light	ON

SIB LEDs

The SIB (Scanner Interface Board) controls and processes the analog-to-digital (AD) conversion of the image scanned with the CIS.

No.	Color	Operation	LED Action
LED 1	RED	Confirming that the control circuits on the SIB are operating normally.	Flashes

GW Controller Board

The controller board interfaces with the IPU and accesses all the expansion applications provided on boards and SD cards installed in the slots of the controller board.

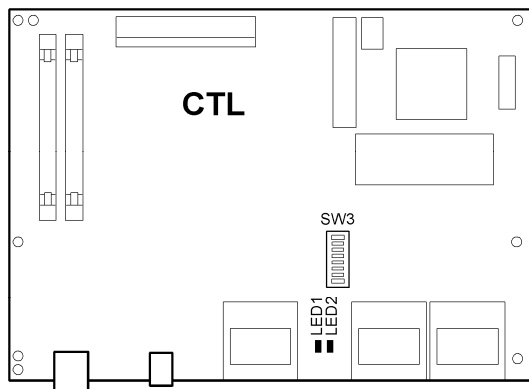

b286t982

Controller Board LEDs

No.	Color	Operation	LED Action
LED 1	RED	Normal operation	Off
		During firmware update	Alternates flashes with LED 2
		At completion of firmware update	On
LED 2	RED	Normal operation	Flashes
		During firmware update	Alternates flashes with LED 1
		At completion of firmware update	On

Board LEDS

Controller Board DIP SW3

Bit	Application	Setting
0	Boot mode selection	On: FlashROM (Default) Off: SD Card
1	Not Used	---
2	Not Used	---
3	Not Used	---
4	Not Used	---
5	Not Used	---
6	Not Used	---
7	HDD Power Control	On: HDD OFF in CTL_OFF mode (Default) Off: HDD ON in CTL_OFF mode

SERVICE TABLES

5. SERVICE TABLES

5.1 USING THE SP MODE

5.1.1 DIRECT ENTRY

Normal Direct Entry

1. Go into the SP mode.
 - Push [Clear] (⊗).
 - Push [1] [0] [7].
 - Push and hold [Clear/Stop] (Ⓢ) for 3 seconds.

The initial SP mode screen appears.

2. Touch “Copy SP.”

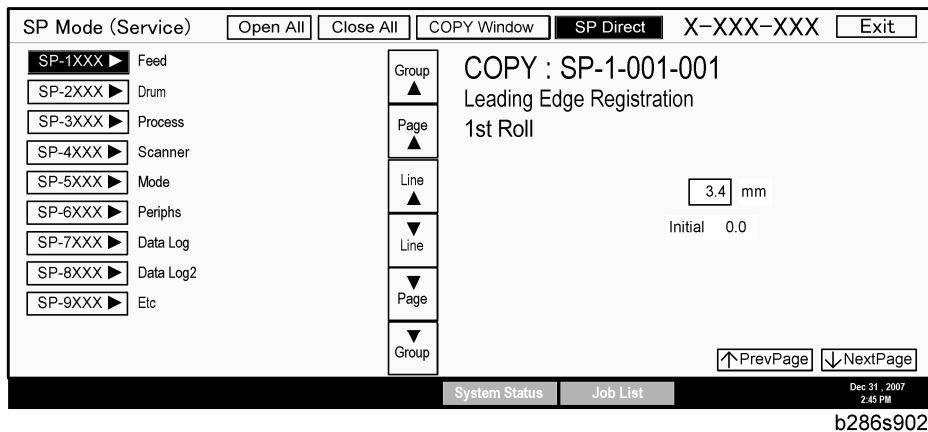



3. When the SP mode is opened it is in direct entry mode (SP Direct). Input the full number of the SP code. Then push [#].

When you input the number:

- Do not input a hyphen (-) between the first 4 digits and the last 3 digits.
 - If the 2nd half of the SP code is only 1 or 2 digits, input the zeros that are in front. For example, if the 2nd number is 1 or 12, push [0] [0] [0] or [0] [1] [2].
 - If you input only the first 4 digits of an SP that has sub levels, the first SP code (001) will be shown. Push the key below “PrevMenu” or “NextMenu” to show the SP. Then push the key below “Set” or push [#].
4. Set the adjustment value.
 - If a minus sign (-) is necessary, push (⊖) to change the +/- sign.
 - If a decimal point is necessary, do not push the decimal point button. For example,

Using the SP Mode



to input “-1.3”, push  for the minus sign, then push [1] [3].

- If you make an error, push  to reset the setting, then try again. You cannot correct it with a new entry.
5. Push the key below “Set” on the LCD, or push [#] to enable the setting you have just input.
 6. To go out of SP mode, push the key on the operation panel below “Exit” one or more times until you see the initial copy screen.
 7. Switch the main power switch off. Then switch it on again.

Note

- You must switch the main power switch off then on again to enable the SP codes that you have just input.

Rapid Direct Entry

1. Refer to the “Service Tables” in this section to find the SP code.
2. Go into the SP mode.
 - Push [Clear] ().
 - Push [1] [0] [7].
 - Push and hold [Clear/Stop] () for 3 seconds.
3. Input the group number. Then input the full number to go directly to the SP code screen. It is not necessary to stop until the screens show.

Examples

[1] (Copy) [2001002]	Shows the setting screen for SP2001-2.
[1] (Copy) [2001]	Shows the setting screen for the first level below SP2001 (1). Note: To see the level before or after, push “PrevMenu” or “NextMenu.” With SP2001-xxx on the display, input the full number again to go directly to 2001-2.

5.2 FIRMWARE UPDATE

5.2.1 OVERVIEW

The MCU (Main Control Unit) board flash-memory contains the software for this machine. To upgrade the software, one SD card is necessary. This card contains the SCU and ECU firmware.

★ Important

- Always turn the main power switch off before you insert or remove an SD card.
- Keep the main switch on during software installation.
- Store and handle SD cards carefully to protect them from heat, humidity, and sunlight.

5.2.2 UPDATING FIRMWARE

1. Turn the main power switch off.

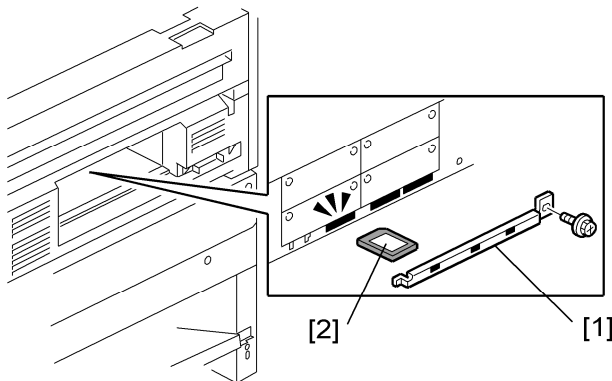

b286i161a

2. Remove the SD slot cover [1].
3. Insert the SD card [2] with the firmware in SD card Slot 3. (If there is an SD card in Slot 3, remove it.)

Firmware Update

- Turn on the main power switch. "Please wait" appears on the operation panel display. After approximately 90 sec. the initial firmware update screen appears.

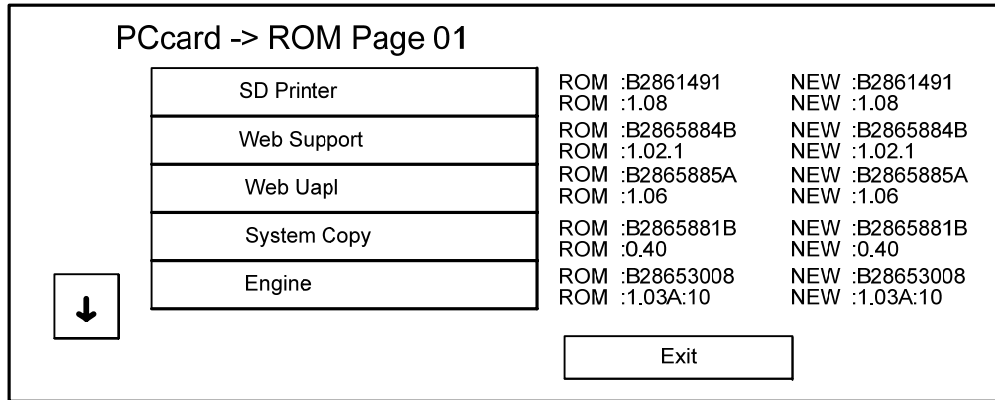

b286s941

- Look at the numbers in the right (ROM) and left (NEW) columns.
 - If the NEW number is higher than the ROM number the application needs to be updated.
 - If the numbers are the same, the application does not need to be updated.
- Press the down arrow to see the next screen.

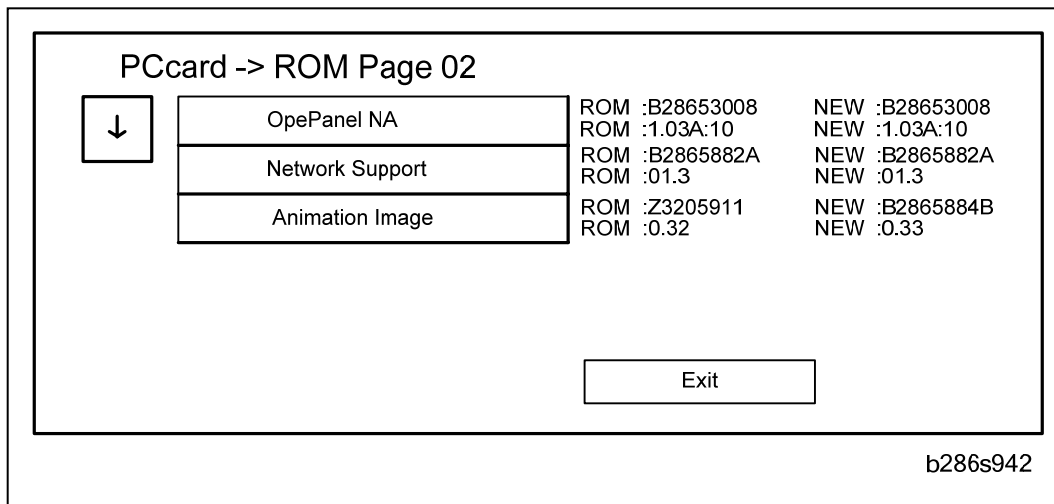

b286s942

- If no application needs to be updated, touch [Exit].

8. To update an application:
 - Touch the name of the application that needs to be updated. The name of the application changes to reverse black and the [Update#] key appears at the lower right corner of the screen.
 - Touch [Update#] to start the update procedure.
 - Follow the instructions on the operation panel to complete the procedure.

 **CAUTION**

- Never switch the machine off while a firmware update is in progress.
9. When the update is finished:
 - Switch the machine off.
 - Remove the SD card from Slot 3.
 - Reattach the SD card slot cover.

Note:

- More than one application can be selected for update, but there are restrictions.
- Controller applications and the operation panel update must be done separately. If you select a controller application and the operation panel for update, the machine will display a message:

Caution!
Controller applications and Op Panel must be installed separately.

5.3 USER TOOLS

5.3.1 USER TOOL SUMMARY

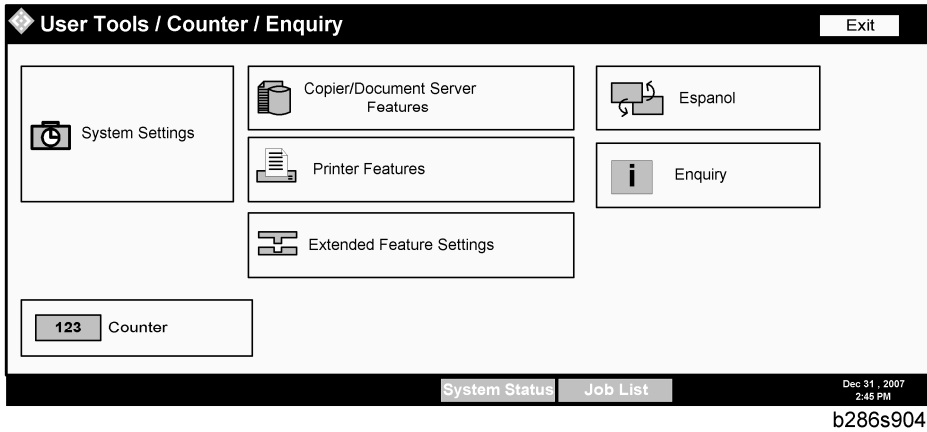

Push [User Tools].

System Settings

Tab	Item	
General Features	Program/Change/Delete User Text	
	Panel Key Sound	On/Off
	Warm Up Beeper	On/Off
	Copy Count Display	Up/Down
	Function Priority	Copier, Document Server
	Print Priority	Display Mode, Copier/Document Server, Interleave, Job Order
	Function Reset Timer	Set Time
	Interleave Printing	Enter the number of sheets...
	Original Feed Delay 1	1 sec.
	Original Feed Delay 2	1 sec.

Tab	Item	
	Feed Start Method	Auto, Press Start Key
▼ Next	Fine Ratio Adjustment: Copier	Plain Paper, Recycled Paper, Translucent Paper, Film
	Adjust Scan Position	NG
	System Status/Job List Display Time	Enter the time...
	Key Repeat	Off, Normal, Repeat Time: Medium, Repeat Time: Long
Tray Paper Settings	Paper Tray Priority: Copier	Tray 1, Tray 2, Tray 3
	Tray Paper Size: Tray 1	Engineering, Architecture, Others
	Tray Paper Size: Tray 2	Engineering, Architecture, Others
	Tray Paper Size: Tray 3	Engineering, Architecture, Others
▼Next	Paper Type: Paper Bypass	No Display, Recycled Paper, Translucent Paper
	Paper Type: Tray 1	
	Paper Type: Tray 2	
	Paper Type: Tray 3	No Display, Recycled Paper
	Paper Thickness: Paper Tray	
	Paper Thickness: Paper Bypass	

User Tools

Paper Thickness: Paper Tray		Cancel	OK		
Select level of thickness for each paper type.					
Paper Type	← Thicker	Thinner →			
▶ Plain Paper	1	2	3	4	5
▶ Recycled Paper	1	2	3	4	5
▶ Translucent Paper	1	2	3	4	5
▶ Film	1	2	3	4	5

b286s905

	Paper Volume	Paper Roll 1, Paper Roll 2
Timer Settings	Auto Off Timer	Enter the time...
	Energy Saver Timer	
	Panel Off Timer	
	System Auto Reset Timer	
	Copier/Document Server Auto Reset Timer	
	Set Date	Enter the date...
	Set Time	Enter the time...
	Auto Logout Timer	
Administrator Tools	Address Book Management	See "Operating Instructions"
	Address Book: Program/Change/Delete Group	
	Address Book: Change Order	
	Address Book: Edit Title	
	Address Book: Switch Title	
	Back Up/Restore Address Book	
	Display/Print Counter	

	Display/Print Counter per User	
▼Next	User Authentication Management	See "Operating Instructions"
	Administrator Authentication Management	
	Program/Change Administrator	
	Key Counter Management	
	External Charge Unit Management	
	Enhanced External Charge Unit Management	
	Extended Security	
	Auto Delete File in Document Server	

Copier/Document Server Features

Tab	Item	
General Features	Auto Image Density Priority	

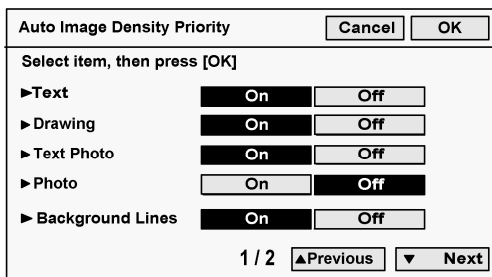

b286s906

	Copy Quality	
--	--------------	--

Service Tables

User Tools

Copier/Document Server Features **Exit**

Copy Quality Cancel OK

Adjust quality for each type then press [OK].

▶Text

▶Drawing

▶Text Photo

▶Photo

▶Background Lines

1 / 2

System Status Job List Dec 31, 2007 2:45 PM

b286s907

	Image Density	
--	---------------	--

Copier/Document Server Features **Exit**

Image Density Cancel OK

Adjust density for each type, then press [OK].

▶Text

▶Drawing

▶Text Photo

▶Photo

▶Background Lines

1 / 2

System Status Job List Dec 31, 2007 2:45 PM

b286s908

	Max Copy Quantity	99 Sheet(s)
	Auto Tray Switches	With Image Rotation, Without Image Rotation, Off
	Job End Call	On/Off
Reproduction Ratio	User Reduce/Enlarge Ratio	Select % ...
	Reproduction Ratio	

	Reduce/Enlarge Ratio Priority	
	Magnification Key Display	Engineering, Architecture

Reproduction Ratio

Select a key to set the ratio.

141.4% A4 → A3 A2 → A1	200.0% A4 → A2 A3 → A1	282.8% A4 → A1 A3 → A0	400.0% A4 → A0
25.0% A0 → A4	35.4% A1 → A4 A0 → A3	50.0% A2 → A4 A1 → A3	70.7% A3 → A4 A1 → A2

b286s909

Edit	Adjust Position	See "Operating Instructions"
	Erase Border Width	
	Erase Original Shadow in Combine	
	Image Repeat Separation Line	
	Double Copies Separation Line	
	Separation Line in Combine	
	Copy Order in Combine	
	Program/Delete Format	
	Margin Adjustment Priority	
	Partial Copy Size	
Stamp	Background Numbering	See "Operating Instructions"
	Preset Stamp	
	User Stamp	
	Date Stamp	
	Page Numbering	

Service Tables

User Tools

Input/Output	Rotate Sort: Auto Paper Continue	See "Operating Instructions"
Administrator Tools	Menu Protect	See "Operating Instructions"

Espanol

Espanol	English	
---------	---------	--

Inquiry

▶ Machine Maintenance/Repair
Telephone No.
[REDACTED]

▶ Serial No. of Machine
B2891700010

Sales Representative
Telephone No.
[REDACTED]

b286s910

Counter

	▶ Total Counter [11] Meters	
	[Print Counter List]	

5.4 INPUT CHECK

You can check the sensors and switches with SP5803. Go into one of the modes in the tables.

In each mode, the display shows an 8-digit number. The digits are given numbers 7 to 0 from left to right. Each bit shows the on/off condition of a sensor or switch with a 0 or 1. For example:

Display	1	1	0	0	0	0	1	0
Bit	7	6	5	4	3	2	1	0

1 Roll Tray	Input	Status	
bit-7	Not used		
bit-6	Not used		
bit-5	Not used		
bit-4	Cassette Set Sensor	0: Close	1: Open
bit-3	Cutter HP switch – Left	0: At HP	1: Not at HP.
bit-2	Cutter HP switch – Right	0: At HP	1: Not at HP
bit-1	Not used		
bit-0	Upper Unit	0: Close	1: Open

2 1 st & 2 nd Roll	Input	Status	
bit-7	Not used		
bit-6	Roll End Sensor 2	0: Paper present	1: Paper out
bit-5	Not used		
bit-4	Roll End Sensor 4 (EXP)	0: No paper	1: Paper present
bit-3	Not used		

Input Check

2 1st & 2nd Roll	Input	Status	
bit-2	Roll End Sensor 2	0: Paper present	1: Paper end
bit-1	Not used		
bit-0	Roll End Sensor 4 (EXP)	0: No paper	1: Paper present

4 Cassette Tray	Input	Status	
bit-7	Not used		
bit-6	Not used		
bit-5	Not used		
bit-4	Not used		
bit-3	Not used		
bit-2	Cassette End Sensor	0: No paper	1: Paper present
bit-1	Not used		
bit-0	Cassette Jam Sensor	0: No paper	1: Paper present

7 Paper Path Sensors	Input	Status	
bit-7	Not used		
bit-6	Not used		
bit-5	Not used		
bit-4	Fusing Exit Sensor	0: No paper	1: Paper present
bit-3	Paper Registration Sensor	0: No paper	1: Paper present
bit-2	Paper Set Sensor	0: No paper	1: Paper present
bit-1	RF Exit Sensor	0: No paper	1: Paper present

7 Paper Path Sensors	Input	Status	
bit-0	Not used		

8 Unit Set Detection	Input	Status	
bit-7	Not used		
bit-6	Key Counter Set	0: Not set	1: Set
bit-5	Key Card Set	0: Not set	1: Set
bit-4	Total Counter Set	0: Not set	1: Set
bit-3	Folder Unit	0: Not connected	1: Connected
bit-2	Paper Cassette	0: Not connected	1: Connected
bit-1	Roll Feeder 2	0: Not connected	1: Connected
bit-0	Roll Feeder 1	0: Not connected	1: Connected

9 Door Open/Motor Lock	Input	Status	
bit-7	Fusing Motor	0: Normal	1: Lock
bit-6	Wire Cleaner Motor	0: Normal	1: Lock
bit-5	Drum Motor	0: Normal	1: Lock
bit-4	Main Motor	0: Normal	1: Lock
bit-3	Exit Cover Sensor (Right)	0: Close	1: Open
bit-2	Toner Hopper Cover SW	0: Close	1: Open
bit-1	Upper Unit SW 1 (Left)	0: Close	1: Open

Input Check

9 Door Open/Motor Lock	Input	Status	
bit-0	Upper Unit SW 2 (Right)	0: Close	1: Open

10 Others	Input	Status	
bit-7	Fusing Unit Cover Switch	0: Close	1: Open
bit-6	Exit Cover Switch (Left) 5V	0: Close	1: Open
bit-5	Cooling Fan	0: Normal	1: Lock
bit-4	Toner Overflow Sensor	0: Not full	1: Full
bit-3	Model Confirm	0: Model A	1: Model B
bit-2	Model Detect	0: Model A	1: Model B
bit-1	Fusing Overheat	0: Normal	1: Overheat
bit-0	Zero Cross	0: Off	1: On

11 Dip Switch 1	Input	Status	
bit-7	DIP SW8	0: Off	1: On
bit-6	DIP SW7	0: Off	1: On
bit-5	DIP SW6	0: Off	1: On
bit-4	DIP SW5	0: Off	1: On
bit-3	DIP SW4	0: Off	1: On
bit-2	DIP SW3	0: Off	1: On
bit-1	DIP SW2	0: Off	1: On
bit-0	DIP SW1	0: Off	1: On

12 Original Size Sensor 1	Input	Status	
bit-7	Not used		
bit-6	Original Width Sensor A1 (22")	0: No paper	1: Paper present
bit-5	Original Width Sensor B2 (18")	0: No paper	1: Paper present
bit-4	Original Width Sensor A2 (17")	0: No paper	1: Paper present
bit-3	Original Width Sensor B3 (12")	0: No paper	1: Paper present
bit-2	Original Width Sensor A3 (11")	0: No paper	1: Paper present
bit-1	Original Width Sensor B4 (9")	0: No paper	1: Paper present
bit-0	Original Set Sensor	0: No paper	1: Paper present

13 Original Size Sensor 2	Input	Status	
bit-7	Not used		
bit-6	Not used		
bit-5	Not used		
bit-4	Not used		
bit-3	Original Width Sensor (30")	0: No paper	1: Paper present
bit-2	Original Width Sensor 914	0: No paper	1: Paper

Input Check

13 Original Size Sensor 2	Input	Status	
	(36")		present
bit-1	Original Width Sensor A0 (34")	0: No paper	1: Paper present
bit-0	Original Width Sensor B1 (24")	0: No paper	1: Paper present

14 Original Feed Unit	Input	Status	
bit-7	Not used		
bit-6	Not used		
bit-5	Original Registration Sensor	0: No paper	1: Paper present
bit-4	Copy Exit Sensor	0: Straight-thru	1: Up
bit-3	Original Exit Sensor	0: No paper	1: Paper present
bit-2	Scanner Stop Key	0: Normal	1: Depressed
bit-1	Scanner Switch	0: Close	1: Open
bit-0	Not used		

5.5 OUTPUT CHECK

You can check the operation of these parts with SP5804.

5804	Output Check	
	Switches each electrical component to test its operation.	
1	Original Feed Motor	
4	CIS LED	
11	Roll Feed Motor 1: Forward	
12	Roll Feed Motor 1: Reverse	
15	1 st Roll Feed Clutch	
16	2 nd Roll Feed Clutch	
19	Cutter 1	
21	Cassette Feed Motor	
25	1 st Cassette Feed Clutch	
31	Registration Motor	
32	Main Motor	
33	Fusing/Exit Motor	
34	Registration Clutch	
35	Paper Junction Gate Solenoid	
36	Used Toner Motor	
41	Charge Corona	
42	Charge Grid: Image Area	
43	Charge Grid: ID Sensor Pattern	
44	Charge Corona/Grid: Image Area	

Output Check

5804	Output Check	
45	Development Bias: Image Area	
46	Development Bias: ID Sensor Pattern	
47	Transfer Corona: Leading Edge	
48	Transfer Corona	
49	Separation Corona: Leading Edge	
50	Separation Corona	
52	Toner Supply Clutch	
53	Quenching Lamp	
54	Pick-off Pawl Solenoid	
55	ID Sensor LED	
66	Charge Corona Wire Cleaner Motor	
67	Recycle Counter	
68	Dehumidifier	

5.6 SP TABLE KEY

Notation	What it means
[range/default step]	Example: [-9 to +9/+3.0/0.1 mm step]. Setting can be adjusted in the range ± 9 , value reset to +3.0 after and NVRAM reset, and the value can be changed in 0.1 mm steps with each key push.
DFU	"Design or Factory Use." Do not change this value. The factory default setting provides optimum performance.
Not Used	<p>These SP's appear in the SP mode menus but these codes are not used because:</p> <ul style="list-style-type: none"> ▪ Currently the feature is not available for the main machine, or its use has been discontinued. ▪ The SP is intended for use with a peripheral that is currently under development but not available at this time. <p>Note: Executing these SP's has no effect on operation of the main machine or any peripheral device.</p>
Japan Only	This feature or item is for Japan only. Do not change this value.

 **Important**

- Always turn the machine power off/on after changing an SP setting.

5.7 SP1-XXX FEED

1001	Leading Edge Registration	
1	1 st Roll	Adjusts the leading edge registration for printing. To move the image down the page, increase the value. [-10.0 to +10.0/ 0 /0.1 mm step]
2	2 nd Roll	
3	Cassette	
5	By-pass Feed	

1002	Side-to-Side Registration	
1	1 st Roll	Adjusts the side-to-side registration for printing. [-10.0 to +10.0/ 0 /0.1 mm step] <ul style="list-style-type: none"> ▪ To move the start position to the right, increase the value (+). ▪ To move the start position to the left, decrease the value (-). Note: If you use paper 914 mm wide, adjust within the range of ± 2 mm. If you set the adjustment outside this range, part of the image will be cut off.
2	2 nd Roll	
3	Cassette	
5	By-pass Feed	

1105	Fusing Temperature Adjustment	
	Be sure to switch the main power switch off and on after adjustment.	
1	Copy Ready Temperature	Sets the copy ready fusing temperature. The setting is the difference from the target fusing temperature that is set with SP1931. DFU [0 to +20/10/1°C] Copying can start at this temperature before the hot roller reaches its target temperature (SP1931).

3	Low Power Mode	Sets the copy ready temperature for low power mode. [80 to 150/90/1°C step]
5	Fusing Temperature Calibration	Calibrates the scale for the fusing temperature settings. DFU [-10 to +10/0/1°C step]
6	Pressure Temperature Calibration: Center	Calibrates the scale for the pressure temperature control at the center of the pressure roller. DFU [-10 to +10/0/1°C step]
7	Pressure Temperature Calibration: Edge	Calibrates the scale for the pressure temperature control at the end of the pressure roller. DFU [-10 to +10/0/1°C step]

1106	Fusing Temperature Display	
	This SP displays the hot roller and pressure roller temperatures.	
1	Hot Roller Temperature	
2	Pressure Roller Temperature: Center	
3	Pressure Roller Temperature: Edge	

Service Tables

SP1-xxx Feed

1159	Fusing Jam SC Setting
	<p>The setting of this SP determines whether the machine issues SC559 after three successive jams occur in the fusing unit.</p> <p>[0-1/0/1]</p> <p>0: Disabled. SC559 not issued after 3 successive jams in the fusing unit.</p> <p>1: Enabled. SC559 issued after 3 successive jams in the fusing unit. The operator cannot restore operation of the machine by cycling the machine off/on. SC559 is a Class "A" SC error. The service technician must restore operation of the machine.</p>

1801	Motor Speed Adjustment DFU
	<p>These SP's adjust the speeds of the feed motor (paper cassette), main motor, and fusing motor. The motor speeds can be adjusted to correct images that appear scratchy or of uneven density. This can occur when:</p> <ul style="list-style-type: none"> ▪ Copying originals with large quantities of black. ▪ Copying originals with a large quantity of black near the trailing edge. ▪ Printing multiple copies of positive/negative (reverse) images.
1	Feed Motor: 1 st Roll DFU
	<p>[-30 to +30/0/1]</p> <p>For every change of "1", speed is adjusted 1/1635 or approximately 0.06%</p> <p>Std: $(70 \text{ MHz}/32)/1635 = 1338 \text{ pps}$</p> <p>Example: If the setting is changed by "+10" then:</p> <p>$(70 \text{ MHz}/32)/(1635-10) =$</p> <p>$(70 \text{ MHz}/32)/(1625) = 1346 \text{ pps}$</p>
2	Feed Motor: 2 nd Roll DFU
	<p>[-30 to +30/0/1]</p> <p>For every change of "1", speed is adjusted 1/1635 or approximately 0.06%</p> <p>Std: $(70 \text{ MHz}/32)/1635 = 1338 \text{ pps}$</p> <p>Example: If the setting is changed by "+10" then:</p> <p>$(70 \text{ MHz}/32)/(1635-10) =$</p> <p>$(70 \text{ MHz}/32)/(1625) = 1346 \text{ pps}$</p>

5	Feed Motor : Cut Paper Tray DFU
	<p>[-30 to +30/0/1] For every change of "1", speed is adjusted 1/1063 or approximately 0.094% Std: $(19.6608 \text{ MHz}/32)/1063 = 578 \text{ pps}$ Example: If the setting is changed by "+10" then: $(19.6608 \text{ MHz}/32)/(1063-10) =$ $(19.6608 \text{ MHz}/32)/(1053) = 583 \text{ pps}$</p>
6	Main Motor DFU
	<p>[-80 to +80/0/1] For every change of "1", speed is adjusted 1/2485 or approximately 0.035%. Std: $(19.6608 \text{ MHz}/8)/2485 = 988.07 \text{ pps}$ Example: If the setting changed by "+10" then: $(19.6608 \text{ MHz}/8)/(2485-10) =$ $(19.6608 \text{ MHz}/8)/(2475) = 992.9 \text{ pps}$</p>
7	Fusing Motor DFU
	<p>[-100 to +100/7/1] For every change of "1", speed is adjusted 1/1848 or approximately 0.054%. Std: $(19.6608 \text{ MHz}/8)/1848 = 1329.97 \text{ pps}$ Example: If the setting changed by "+10" then: $(19.6608 \text{ MHz}/8)/(1848-10) =$ $(19.6608 \text{ MHz}/8)/(1838) = 1337.11 \text{ pps}$</p>

1911	By-pass Feed Start Timing Adj.
	<p>Adjusts the time that the operator has to adjust the paper skew manually when feeding paper manually from the bypass tray. [1.0 to 8.0/2.0/0.1 sec.]</p>

SP1-xxx Feed

1912	Feed Motor Speed Adjustment	
	<p>Adjusts the feed motor speed for the type of print medium in use (plain paper, translucent paper, film).</p> <p>Std: $(70 \text{ MHz}/32)/1635 = 1338 \text{ pps}$</p> <p>For every change of "1", speed is adjusted $1/1635$ or approximately 0.06%.</p> <p>Example: If the setting is changed by "+10" then:</p> <p>$(70 \text{ MHz}/32)/(1635-10) =$</p> <p>$(70 \text{ MHz}/32)/(1625) = 1346 \text{ pps}$</p>	
1	Plain	[-100 to +100/-10/1%]
2	Translucent	[-100 to +100/0/1%]
3	Film	[-100 to +100/-10/%1]

1916	Fusing Motor Speed Adj.	
	<p>SP1916 1 to 013 adjust the basic fusing motor speed and correct the speed for different widths of paper to prevent skew in the paper feed path. Note: The actual adjustment that the machine applies is the sum of the width adjustment (1916 010 to 013) and the paper type adjustment (1916 021 to 045).</p>	
10	Width:611mm more	[-100 to +100/0/1]
11	Width:461-610mm	[-100 to +100/5/1]
12	Width:298-460mm	[-100 to +100/9/1]
13	Width:297mm less	[-100 to +100/18/1]
	<p>Note: "Mode 1 to 5" below refer to the paper thickness set with [User Tools]> "System Settings"> "Tray Paper Settings"> "Paper Thickness: Paper Tray" or "Paper Thickness: Bypass Tray."</p>	
21	Plain:Mode1	[-100 to +100/0/1]
22	Plain:Mode2	
23	Plain:Mode3	

24	Plain:Mode4	
25	Plain:Mode5	[-100 to +100/25/1]
31	Trans.:Mode1	[-100 to +100/21/1]
32	Trans.:Mode2	
33	Trans.:Mode3	
34	Trans.:Mode4	
35	Trans.:Mode5	[-100 to +100/32/1]
41	Film:Mode1	[-100 to +100/23/1]
42	Film:Mode2	
43	Film:Mode3	
44	Film:Mode4	[-100 to +100/41/1]
45	Film:Mode5	[-100 to +100/18/1]
<p>Note: These comments apply to 051 to 053 below. Changes to SP1916-51 to -53 affect the speed of the fusing motor. $(19.6608 \text{ MHz}/8)/(1848) = 1329.97 \text{ pps}$ For every change of "1", speed is adjusted $1/1848 = 0.054\%$. Example: If the setting is changed by "+10", then: $(19.6608 \text{ MHz}/8)/(1848-10) =$ $(19.6608 \text{ MHz}/8)/(1838) = 1337.11 \text{ pps}$</p>		
51	Man:420mm over	[-100 to +100/0/1]
52	Man:420mm less	[-100 to +100/9/1]
53	Cassette	[-100 to +100/0/1]

1918	Fusing/Main Mtr Speed Change	
	<p>These SP modes adjust the rate of the speed reduction between the main motor and the fusing motor. During normal operation, the line speed in the fusing unit is slightly faster than the line speed at registration. This keeps the paper slightly stretched to prevent wrinkling and skewing.</p> <p>However, if the speed of the drum becomes slower as a result of a change in the amount of buckle at the registration roller, the tension on the paper will pull on the drum and rotate it faster than the rotation of the main motor. This can cause image distortion at the two LPH joints.</p> <p>To prevent such distortion, use this SP to decrease the speed of the fusing motor. While this lowers the line speed slightly, it also keeps the correct amount of tension on the paper between the fusing unit and registration roller to prevent skewing and image distortion.</p> <p>Important</p> <ul style="list-style-type: none"> ▪ There are two adjustments for each feed source and paper width: (1) “Chg Timing” and (2) “Chg%.” ▪ Always do the “Chg Timing” adjustment before doing the “%Chg adjustment.” ▪ The “Chg Timing” adjustment sets the length of paper to feed before the speed reduction rate (“Chg%”) takes effect. ▪ The “Chg%” adjustment sets the rate of speed reduction between the main motor and fusing motor. 	
10	Roll/1 st Chg Timing/Plain/Width > 611mm	[0 to 15000/170/1mm]
11	Roll/1 st Chg Timing/Plain/Width 461-610mm	
12	Roll/1 st Chg Timing/Plain/Width 298-460mm	
13	Roll/1 st Chg Timing/Plain/Width < 297mm	
15	Roll/1 st Chg %/Plain/Width > 611mm	[-9.99 to 9.99/-0.2/0.01%]
16	Roll/1 st Chg %/Plain/Width 461-610mm	
17	Roll/1 st Chg %/Plain/Width 298-460mm	[-9.99 to 9.99/-0.4/0.01%]
18	Roll/1 st Chg %/Plain/Width < 297mm	[-9.99 to 9.99/-0.5/0.01%]

20	Roll/1 st Chg Timing/Trans/Width > 611mm	[0 to 15000/170/1mm]
21	Roll/1 st Chg Timing/Trans/Width 461-610mm	
22	Roll/1 st Chg Timing/Trans/Width 298-460mm	
23	Roll/1 st Chg Timing/Trans/Width < 297mm	
25	Roll/1 st Chg %/Trans/Width > 611mm	[-9.99 to 9.99/-0.9/0.01%]
26	Roll/1 st Chg %/Trans/Width 461-610mm	[-9.99 to 9.99/-1.1/0.01%]
27	Roll/1 st Chg %/Trans/Width :298-460mm	
28	Roll/1 st Chg %/Trans/Width < 297mm	[-9.99 to 9.99/-1.4/0.01%]
30	Roll/1 st Chg Timing/Film/Width > 611mm	[0 to 15000/170/1mm]
31	Roll/1 st Chg Timing/Film/Width 461-610mm	
32	Roll/1 st Chg Timing/Film/Width 298-460mm	
33	Roll/1 st Chg Timing/Film/Width < 297mm	
35	Roll/1 st Chg %/Film/Width > 611mm	[-9.99 to 9.99/-1.2/0.01%]
36	Roll/1 st Chg %/Film/Width 461-610mm	[-9.99 to 9.99/-1.3/0.01%]
37	Roll/1 st Chg %/Film/Width 298-460mm	
38	Roll/1 st Chg %/Film/Width < 297mm	[-9.99 to 9.99/-1.5/0.01%]
42	Cassette/1 st Chg Timing/Width /298-460mm	[0 to 15000/170/1mm]
43	Cassette/1 st Chg Timing/Width < 297mm	
47	Cassette/1 st Chg %/Width 298-460mm	[-9.99 to 9.99/-1.0/0.01%]
48	Cassette/1 st Chg %/Width < 297mm	[-9.99 to 9.99/-1.3/0.01%]
50	Bypass/1 st Chg Timing/Width > 611mm	[0 to 15000/170/1mm]
51	Bypass/1 st Chg Timing/Width 461-610mm	
52	Bypass/1 st Chg Timing/Width 298-460mm	

SP1-xxx Feed

53	Bypass/1 st Chg Timing/Width < 297mm	
55	Bypass/1 st Chg %/Width > 611mm	[-9.99 to 9.99/-0.5/0.01%]
56	Bypass/1 st Chg %/Width 461-610mm	
57	Bypass/1 st Chg %/Width 298-460mm	[-9.99 to 9.99/-1.0/0.01%]
58	Bypass/1 st Chg %/Width < 297mm	[-9.99 to 9.99/-1.3/0.01%]
110	Roll/2 nd Chg Timing/Plain/Width > 611mm	[0 to 15000/0/1mm]
111	Roll/2 nd Chg Timing/Plain/Width 461-610mm	
112	Roll/2 nd Chg Timing/Plain/Width 298-460mm	
113	Roll/2 nd Chg Timing/Plain/Width > 297mm	
115	Roll/2 nd Chg %/Plain/Width > 611mm	[-9.99 to 9.99/0/0.01%]
116	Roll/2 nd Chg %/Plain/Width 461-610mm	
117	Roll/2 nd Chg %/Plain/Width 298-460mm	
118	Roll/2 nd Chg %/Plain/Width < 297mm	
120	Roll/2 nd Chg Timing/Trans/Width > 611mm	[0 to 15000/0/1mm]
121	Roll/2 nd Chg Timing/Trans/Width 461-610mm	
122	Roll/2 nd Chg Timing/Trans/Width 298-460mm	
123	Roll/2 nd Chg Timing/Trans/Width < 297mm	
125	Roll/2 nd Chg %/Trans/Width > 611mm	[-9.99 to 9.99/0/0.01%]
126	Roll/2 nd Chg %/Trans/Width 461-610mm	
127	Roll/2 nd Chg %/Trans/Width :298-460mm	
128	Roll/2 nd Chg %/Trans/Width < 297mm	
130	Roll/2 nd Chg Timing/Film/Width > 611mm	[0 to 15000/0/1mm]
131	Roll/2 nd Chg Timing/Film/Width 461-610mm	

132	Roll/2 nd Chg Timing/Film/Width 298-460mm	
133	Roll/2 nd Chg Timing/Film/Width < 297mm	
135	Roll/2 nd Chg %/Film/Width > 611mm	[-9.99 to 9.99/0/0.01%]
136	Roll/2 nd Chg %/Film/Width 461-610mm	
137	Roll/2 nd Chg %/Film/Width 298-460mm	
138	Roll/2 nd Chg %/Film/Width < 297mm	
142	Cassette/2 nd Chg Timing/Width /298-460mm	
143	Cassette/2 nd Chg Timing/Width < 297mm	
147	Cassette/2 nd Chg %/Width 298-460mm	[-9.99 to 9.99/0/0.01%]
148	Cassette/2 nd Chg %/Width < 297mm	
150	Bypass/2 nd Chg Timing/Width > 611mm	[0 to 15000/0/1mm]
151	Bypass/2 nd Chg Timing/Width 461-610mm	
152	Bypass/2 nd Chg Timing/Width 298-460mm	
153	Bypass/2 nd Chg Timing/Width < 297mm	
155	Bypass/2 nd Chg %/Width > 611mm	[-9.99 to 9.99/0/0.01%]
156	Bypass/2 nd Chg %/Width 461-610mm	
157	Bypass/2 nd Chg %/Width 298-460mm	
158	Bypass/2 nd Chg %/Width < 297mm	
210	Roll/3 rd Chg Timing/Plain/Width > 611mm	[0 to 15000/0/1mm]
211	Roll/3 rd Chg Timing/Plain/Width 461-610mm	
212	Roll/3 rd Chg Timing/Plain/Width 298-460mm	
213	Roll/3 rd Chg Timing/Plain/Width < 297mm	
215	Roll/3 rd Chg %/Plain/Width > 611mm	[-9.99 to 9.99/0/0.01%]

SP1-xxx Feed

216	Roll/3 rd Chg %/Plain/Width 461-610mm	
217	Roll/3 rd Chg %/Plain/Width 298-460mm	
218	Roll/3 rd Chg %/Plain/Width < 297mm	
220	Roll/3 rd Chg Timing/Trans/Width > 611mm	
221	Roll/3 rd Chg Timing/Trans/Width 461-610mm	[0 to 15000/0/1mm]
222	Roll/3 rd Chg Timing/Trans/Width 298-460mm	
223	Roll/3 rd Chg Timing/Trans/Width < 297mm	
225	Roll/3 rd Chg %/Trans/Width > 611mm	
226	Roll/3 rd Chg %/Trans/Width 461-610mm	[-9.99 to 9.99/0/0.01%]
227	Roll/3 rd Chg %/Trans/Width :298-460mm	
228	Roll/3 rd Chg %/Trans/Width < 297mm	
230	Roll/3 rd Chg Timing/Film/Width > 611mm	
231	Roll/3 rd Chg Timing/Film/Width 461-610mm	[0 to 15000/0/1mm]
232	Roll/3 rd Chg Timing/Film/Width 298-460mm	
233	Roll/3 rd Chg Timing/Film/Width < 297mm	
235	Roll/3 rd Chg %/Film/Width > 611mm	
236	Roll/3 rd Chg %/Film/Width 461-610mm	[-9.99 to 9.99/0/0.01%]
237	Roll/3 rd Chg %/Film/Width 298-460mm	
238	Roll/3 rd Chg %/Film/Width < 297mm	
250	1 st Chg Speed Min Length	[0 to 300/0/1 mm]

1920	Cut Length Adjustment	
	These SP's adjust the cut length of the paper sizes below.	
111	1 st Roll: 297mm: Plain Paper	[-10 to +10/0/0.1 mm]
112	1 st Roll: 420mm: Plain Paper	
113	1 st Roll: 594mm: Plain Paper	
114	1 st Roll: 841mm: Plain Paper	[-20 to +20/0/0.1 mm]
115	1 st Roll: 1189mm: Plain Paper	[-20.0 to +20.0/0/0.1 mm]
116	1 st Roll: 2000mm: Plain Paper	[-30 to +30/0/1 mm]
117	1 st Roll: 3600mm: Plain Paper	[-30 to +30/0/1 mm]
118	1 st Roll: 6000mm: Plain Paper	
119	1 st Roll: 15000mm: Plain Paper	[-100 to +100/0/ 1 mm]
121	1 st Roll: 297mm: Translucent Paper	[-10.0 to +10.0/0/0.1 mm]
122	1 st Roll: 420mm: Translucent Paper	
123	1 st Roll: 594mm: Translucent Paper	
124	1 st Roll: 841mm: Translucent Paper	[-20 to +20/0/0.1 mm]
125	1 st Roll: 1189mm: Translucent Paper	
126	1 st Roll: 2000mm: Translucent Paper	[-30 to +30/0/1 mm]
127	1 st Roll: 3600mm: Translucent Paper	
128	1 st Roll: 6000mm: Translucent Paper	
129	1 st Roll: 15000mm: Translucent Paper	[-100 to +100/0/ 1 mm]
131	1 st Roll: 297mm: Film	
132	1 st Roll: 420mm: Film	
133	1 st Roll: 594mm: Film	[-10 to +10/0/0.1 mm]

SP1-xxx Feed

134	1 st Roll: 841mm: Film	[-20 to +20/0/0.1 mm]
135	1 st Roll: 1189mm: Film	
136	1 st Roll: 2000mm: Film	[-30 to +30/0.0/1 mm]
137	1 st Roll: 3600mm: Film	
138	1 st Roll: 6000mm: Film	
139	1 st Roll: 15000mm: Film	[-100 to +100/0/ 1 mm]
211	2 nd Roll: 297mm: Plain Paper	[-10 to +10/0/0.1 mm]
212	2 nd Roll: 420mm: Plain Paper	
213	2 nd Roll: 594mm: Plain Paper	
214	2 nd Roll: 841mm: Plain Paper	[-20 to +20/0/0.1 mm]
215	2 nd Roll: 1189mm: Plain Paper	
216	2 nd Roll: 2000mm: Plain Paper	[-30 to +30/0/1 mm]
217	2 nd Roll: 3600mm: Plain Paper	
218	2 nd Roll: 6000mm: Plain Paper	
219	2 nd Roll: 15000mm: Plain Paper	[-100 to +100/0/ 1 mm]
221	2 nd Roll: 297mm: Translucent Paper	[-10 to +10/0/0.1 mm]
222	2 nd Roll: 420mm: Translucent Paper	
223	2 nd Roll: 594mm: Translucent Paper	
224	2 nd Roll: 841mm: Translucent Paper	[-20 to +20/0/0.1 mm]
225	2 nd Roll: 1189mm: Translucent Paper	
226	2 nd Roll: 2000mm: Translucent Paper	[-30 to +30/0/1 mm]
227	2 nd Roll: 3600mm: Translucent Paper	
228	2 nd Roll: 6000mm: Translucent Paper	

229	2 nd Roll: 15000mm: Translucent Paper	[-100 to +100/0/ 1 mm]
231	2 nd Roll: 297mm: Film	[-10 to +10/0/0.1 mm]
232	2 nd Roll: 420mm: Film	
233	2 nd Roll: 594mm: Film	
234	2 nd Roll: 841mm: Film	[-20 to +20/0/1 mm]
235	2 nd Roll: 1189mm: Film	
236	2 nd Roll: 2000mm: Film	[-30 to +30/0/1 mm]
237	2 nd Roll: 3600mm: Film	
238	2 nd Roll: 6000mm: Film	
239	2 nd Roll: 15000mm: Film	[-100 to +100/0/ 1 mm]

1923	Paper Interval Adjustment
	<p>This SP slightly increases the gap between sheets in the paper path. When the machine shifts to the CPM down mode, the paper is fed by whichever interval between sheets is longer, the gap set with this SP or the gap determined by CPM down.</p> <p>[0 to 500/0/1 mm]</p> <p>Note:</p> <ul style="list-style-type: none"> ▪ The “0” (default) setting does not mean that the gap is eliminated. ▪ When set to “0” the standard gap between sheets is maintained (480 mm for the B286 and 168 mm for the B289.)

1925	Cut Length Offset Correction Not Used
------	--



1931	Target Temp: Hot Roller	
	<p>Sets the target fusing temperature of the hot roller. After you adjust these SP's, you must switch the main power switch off and on.</p> <p>Important: Modes "1" to "5" below refer to the paper type and thickness settings selected in User Tools (see "Paper Thickness Default Selection" in this section).</p>	
1	Plain: Mode1	[120 to 220/195/5°C]
2	Plain: Mode2	
3	Plain: Mode3	
4	Plain: Mode4	[120 to 220/185/5°C]
5	Plain: Mode5	[120 to 220/175/5°C]
6	Trans.: Mode1	[120 to 220/205/5°C]
7	Trans.: Mode2	[120 to 220/195/5°C]
8	Trans.: Mode3	
9	Trans.: Mode4	[120 to 220/165/5°C]
10	Trans.: Mode5	[120 to 220/*/5°C]
11	Film: Mode1	[120 to 220/195/5°C]
12	Film: Mode2	[120 to 220/190/5°C]
13	Film: Mode3	[120 to 220/185/5°C]
14	Film: Mode4	
15	Film: Mode5	[120 to 220/175/5°C]
16	Plain: Low Temp Mode	[120 to 220/195/5°C]

Service Tables

SP1-xxx Feed

1932	Target Temp: Press.Roller	
	<p>Sets the target fusing temperature of the pressure roller for plain paper, translucent paper, and film. These temperatures are used for pressure roller feedback. Turn the machine power off/on after changing the settings.</p> <p>Important:</p> <ul style="list-style-type: none"> ▪ Modes “1” to “5” below refer to the paper type and thickness settings selected in User Tools (see “Paper Thickness Default Selection” in this section). ▪ After adjusting these SP’s, you must turn the machine power off/on. 	
1	Plain: Mode1	[60 to 80 /100/5°C]
2	Plain: Mode2	[60 to 80 /85/5°C]
3	Plain: Mode3	[60 to 80 /60/5°C]
4	Plain: Mode4	
5	Plain: Mode5	
6	Trans.: Mode1	[60 to 80 /130/5°C]
7	Trans.: Mode2	[60 to 80 /100/5°C]
8	Trans.: Mode3	[60 to 80 /60/5°C]
9	Trans.: Mode4	
10	Trans.: Mode5	
11	Film: Mode1	
12	Film: Mode2	
13	Film: Mode3	
14	Film: Mode4	
15	Film: Mode5	
16	Plain: Low Temp Mode	[60 to 80 /120/5°C]

1934	Lower Limit Temp: Hot Roller		
	<p>This SP sets the minimum difference in temperature allowed between the actual temperature and the target temperature of the hot roller.</p> <p>Important:</p> <ul style="list-style-type: none"> ▪ Modes “1” to “5” below refer to the paper and thickness settings selected in User Tools (see “Paper Thickness Default Selection” in this section). In order for this SP to operate, SP9952 1 must be at “0” (default) so that the machine can acquire temperature readings (feedback) from the pressure roller thermistors. ▪ The default setting of SP9952 should never be adjusted in the field. 		
1	Plain: Mode1	[0 to 50/20/5]	
2	Plain: Mode2	[0 to 50/15/5]	
3	Plain: Mode3	[0 to 50/25/5]	
4	Plain: Mode4	[0 to 50/20/5]	
5	Plain: Mode5		
6	Trans.: Mode1		
7	Trans.: Mode2		
8	Trans.: Mode3		
9	Trans.: Mode4		
10	Trans.: Mode5		
11	Film: Mode1		
12	Film: Mode2		
13	Film: Mode3		
14	Film: Mode4		
15	Film: Mode5		
16	Plain: Low Temp Mode		[0 to 50/0/5]

Service Tables

SP1-xxx Feed

1935	Pressure FB Control Steps	Pressure Feedback Control Steps
	<p>This SP changes the stepped adjustments of SP1932 (Target Temp: Pressure Roller) by using the sum of the settings of SP1932 (Target Temp: Pressure Roller) +SP1935 (Press FB Control Steps) as the steps.</p> <p>Example</p> <ul style="list-style-type: none"> ▪ If the pressure roller temperature for SP1935-1 is 100°C, the target hot roller temperature is 195°C (“100” is SP1932, “195” is SP1931). ▪ If the pressure roller temperature 120°C (= “100”+”20”, this is SP1932+SP1935), the target hot roller temperature is 175°C (=”195”-”20”, this is SP1931 – SP1934) ▪ If the setting is “0”, the temperature settings of SP1931 do not change. 	
1	Plain: Mode1	[0 to 50/20/5]
2	Plain: Mode2	[0 to 50/25/5]
3	Plain: Mode3	[0 to 50/30/5]
4	Plain: Mode4	[0 to 50/20/5]
5	Plain: Mode5	
6	Trans.: Mode1	
7	Trans.: Mode2	
8	Trans.: Mode3	
9	Trans.: Mode4	
10	Trans.: Mode5	
11	Film: Mode1	
12	Film: Mode2	
13	Film: Mode3	
14	Film: Mode4	
15	Film: Mode5	

16	Plain: Low temp.Mode	[0 to 50/0/5]
----	----------------------	---------------

1936	Lower Limit Temp: Press Roller	
	<p>This SP sets the minimum difference allowed between the actual temperature and the target temperature of the pressure roller.</p> <ul style="list-style-type: none"> ▪ If the setting for the target temperature of the pressure roller is high (SP1932), the temperature of the pressure roller is lowered for continuous printing on plain paper. ▪ At this time, if the temperature is below the temperature set for the pressure roller, paper feed will stop during a long job to perform inching to allow enough time for the pressure roller temperature to rise to the level of the prescribed setting, and then the job will continue. <p>Important:</p> <ul style="list-style-type: none"> ▪ Modes “1” to “5” below refer to the paper and thickness settings selected in User Tools (see “Paper Thickness Default Selection” in this section). ▪ In order for this SP to operate, SP9952-1 must be at “0” (default) so that the machine can acquire temperature readings (feedback) from the pressure roller thermistors. SP9952 should never be adjusted in the field. 	
1	Plain: Mode1	[0 to 50/20/5°C]
2	Plain: Mode2	
3	Plain: Mode3	
4	Plain: Mode4	
5	Plain: Mode5	
6	Trans.: Mode1	[0 to 50/0/5°C]
7	Trans.: Mode2	[0 to 50/20/5°C]
8	Trans.: Mode3	
9	Trans.: Mode4	

Service Tables

SP1-xxx Feed

10	Trans.: Mode5	
11	Film: Mode1	
12	Film: Mode2	
13	Film: Mode3	
14	Film: Mode4	
15	Film: Mode5	

1937	Low Temp Environ Detect Ctrl
	<p>These SP's are used to modify fusing temperature control sequence in a low temperature environment where room temperature is below the optimum room temperature of 20°C (68°F).</p> <p>Note</p> <ul style="list-style-type: none"> ▪ At optimum room temperature, the machine should reach the target fusing temperature within 2 min. ▪ If the hot roller does not reach the target fusing temperature within 2 minutes, the machine issues SC542 (Fusing Temperature Warmup Error).
1	Low Temp Setting
	<p>The machine monitors the time required for the hot roller temperature to reach the critical temperature defined by this SP:</p> <p>Copy Ready Temperature (SP1105-1) - This SP Value (Default: 20°C)</p> <p>In a low temperature environment copying will not begin at the normal copy ready temperature.</p> <p>[0 to 50/20/5]</p>
2	Low Temp Time Setting
	<p>This SP sets the length of time within which the hot roller temperature should reach the target temperature set with SP1937-1. If the hot roller does not reach the SP1937-1 temperature within this time limit, the machine will not allow copying to start when the temperature reaches the ready temperature.</p> <p>[0 to 120/120/1 sec.]</p>

3	Pressure Inching Start: Temp
	<p>If the inching target temperature (set with SP1948) is higher than 65°C, inching will start when the hot roller temperature reaches this target hot roller temperature. If the pressure roller temperature is less than 60°C, inching will start at the ready (reload) temperature.</p> <p>This SP sets the temperature at which inching starts in a low-temperature environment where fusing temperature control is handled with the settings of SP1937.</p> <p>[0 to 50/20/5]</p>
11	Low Temp Mode Setting: Cold Start
	<p>If the hot roller temperature is below the temperature set with this SP at the beginning of a cold start, the machine determines that it is in a low temperature environment</p> <p>[0 to 50/15/1]</p>
12	Low Temp Mode Setting: Cold Start Hold Time
	<p>This SP determines the length of time the machine remains in the low temperature cold start mode after the machine determines that that it has been cold started in a low temperature environment. After this time has elapsed, fusing temperature control will operate with the paper type and thickness settings (see “Paper Thickness Default Selection” in this section).</p> <p>[0 to 20/7/0.5 min.]</p>
13	Low Temp Mode Paper Interval Ratio
	<p>This SP sets the size of the gap between sheets of paper while the machine is in the low temperature environment cold start mode.</p> <p>[1 to 10/3/0.1 mm]</p>

SP1-xxx Feed

1938	Press FB Ctrl Step Width Switch	
	<p>This SP switches step control by width on and off. After this SP has been switched on, the step control by width can be set up with SP1939 002 to 004.</p> <p>Note:</p> <ul style="list-style-type: none"> ▪ These settings can be done for each paper type and thickness mode. ▪ Modes “1” to “5” below refer to the paper and thickness settings selected in User Tools (see “Paper Thickness Default Selection” in this section). 	
1	Plain: Mode1	<p>[0 to 1/0/1]</p> <p>0: Disabled</p> <p>1: Enabled</p>
2	Plain: Mode2	
3	Plain: Mode3	
4	Plain: Mode4	
5	Plain: Mode5	
6	Trans.: Mode1	
7	Trans.: Mode2	
8	Trans.: Mode3	
9	Trans.: Mode4	
10	Trans.: Mode5	
11	Film: Mode1	
12	Film: Mode2	
13	Film: Mode3	
14	Film: Mode4	
15	Film: Mode5	

1939	Press FB Ctrl Step by Width	
	Use these SP's to set up the step control used in the paper type and paper thickness selections done in the User Tools (see "Paper Thickness Default Selection" in this section).	
1	> 611mm	First, use SP1938 to select the paper type and mode where the setting is to apply. Next, select the paper width here. [0 to 30/30/5]
2	461-610mm	
3	298-460mm	
4	> 297mm	

1940	CPM Down Setting	
	CPM down control attempts to achieve optimum fusing of toner to paper. To do this, it automatically adjusts the timing of paper feed, which increases the length of the interval between sheets. A longer interval between sheets creates a short delay, so that the temperature of the hot roller and pressure roller can rise.	
1	Enable	
	Switches CPM down off and on. [0 to 1/1/1] 0: Off 1: On	
11	Temp Differential: Step 1	
	The interval between sheets of paper in the paper path is determined by the temperature readings of the thermistors at the center and end of the pressure roller. This SP sets Step 1 of CPM down mode. If the amount of the difference between the actual temperature and target temperature falls in the range between this SP and SP1940 012, this is judged as Step 1. [0 to 150/50/5]	
12	Temp Differential: Step 2	

Service Tables

SP1-xxx Feed

	<p>This SP sets Step 2 of CPM down mode. If the amount of the difference between the actual temperature and target temperature falls in the range between this SP and SP1940 013, this is judged as Step 2.</p> <p>[0 to 150/75/5]</p>
13	<p>Temp Differential: Step 3</p> <p>This SP sets Step 3 of CPM down mode. If the difference between actual and target temperature is larger than this SP setting, this is judged as Step 3.</p> <p>[0 to 150/100/5]</p>
21	<p>Paper Interval: Step 1</p>
	<p>When the pressure roller center and end thermistor detect a temperature in the Step 1 range (SP1940 011), the setting of this SP is activated to set the length of the interval between sheets in the paper path.</p> <p>[1.0 to 5.0/1.4/0.1]</p> <p>The default setting (1.4) is the variable for Step 1 multiplied by the constant set for Step 1 of the machine:</p> <ul style="list-style-type: none"> ▪ B286: 480 mm. The default interval is 672 mm (1.4 x 480 mm). ▪ B289: 168 mm. The default interval is 235 mm (1.4 x 168 mm). <p>Setting a smaller or larger number decreases or increases the length of the interval with this simple calculation. This standard interval can be modified slightly with SP1923.</p>
22	<p>Paper Interval Step 2</p>
	<p>When the pressure roller center and end thermistor detect a temperature in the Step 2 range (SP1940 012), the setting of this SP is activated to set the length of the interval between sheets in the paper path.</p> <p>[1.0 to 5.0/2.1/0.1]</p> <p>The default setting (2.1) is the variable for Step 2 multiplied by the constant set for Step 2 of the machine:</p> <ul style="list-style-type: none"> ▪ B286: 480 mm. The default interval is 1008 mm (2.1 x 480 mm). ▪ B289: 168 mm. The default interval is 353 mm (2.1 x 168 mm). <p>Setting a smaller or larger number decreases or increases the length of the interval with this simple calculation. This standard interval can be modified slightly with SP1923.</p>

23	Paper Interval Step 3
	<p>When the pressure roller center and end thermistor detect a temperature in the Step 3 range (SP1940 013), the setting of this SP is activated to set the length of the interval between sheets in the paper path.</p> <p>[1.0 to 5.0/3.5/0.1]</p> <p>The default setting (3.5) is the variable for Step 3 multiplied by the constant set for Step 2 of the machine:</p> <ul style="list-style-type: none"> ▪ B286: 480 mm. The default interval is 1680 mm (3.5 x 480 mm). ▪ B289: 168 mm. The default interval is 588 mm (3.5 x 168 mm). <p>Setting a smaller or larger number decreases or increases the length of the interval with this simple calculation. This standard interval can be modified slightly with SP1923.</p>

1941	Press FB Ctrl Switch by Temp Diff
	<p>This SP sets the temperature differential that determines when the machine adjusts for pressure roller feedback control when the difference between the temperatures of the center and end of the pressure roller is greater than 20°C (Default: 20).</p> <p>[0 to 50/20/5]</p> <p>Example</p> <p>If this SP is set to “50”: and there is a difference between the temperatures at the center and end of the pressure roller after more than 50 readings, then pressure roller feedback control shifts to the supplement mode.</p>



SP1-xxx Feed

1942	Press FB Temp Hold Int: Normal	
	<p>This SP sets the interval between temperature samplings for pressure roller feedback control.</p> <p>Note: Modes “1” to “5” below refer to the paper type and thickness settings selected in User Tools (see “Paper Thickness Default Selection” in this section).</p>	
1	Plain: Mode1	[0 to 50/0/5°C]
2	Plain: Mode2	
3	Plain: Mode3	
4	Plain: Mode4	[0 to 50/15/55°C]
5	Plain: Mode5	[0 to 50/0/5 °C]

1943	Press FB Temp High Temp: Special	
	<p>This SP sets the high temperature used by pressure roller feedback temperature control for Custom paper.</p> <p>Note: Modes “1” to “5” below refer to the paper type and thickness settings selected in User Tools (see “Paper Thickness Default Selection” in this section).</p>	
1	Plain: Mode1	[0 to 50/0/5°C]
2	Plain: Mode2	
3	Plain: Mode3	
4	Plain: Mode4	[0 to 50/20/5 °C]
5	Plain: Mode5	[0 to 50/0/5 °C]

1944	Press FB Temp Low Temp: Special	
	<p>This SP sets the low temperature used by pressure roller feedback temperature control for Custom paper.</p> <p>Note: Modes “1” to “5” below refer to the paper type and thickness settings selected in User Tools (see “Paper Thickness Default Selection” in this section).</p>	
1	Plain: Mode1	[0 to 50/0/5°C]
2	Plain: Mode2	
3	Plain: Mode3	
4	Plain: Mode4	[0 to 50/10/5 °C]
5	Plain: Mode5	[0 to 50/5/5 °C]

1945	Length Level Setting	
	<p>These SP's define the Length Levels for the following SP codes:</p> <ul style="list-style-type: none"> ▪ SP1946 Press FB Stop: Target Temp Diff. ▪ SP1947 Press FB Stop: Time Period 	
1	Level 1	[1000 to 15000/1300/1 mm]
2	Level 2	[1000 to 15000/3700/1 mm]
3	Level 3	[1000 to 15000/6100/1 mm]
4	Level 4	[1000 to 15000/9100/1 mm]
5	Level 5	[1000 to 15000/12100/1 mm]

SP1-xxx Feed

1946	Press FB Stop: Target Temp Diff	
	<p>This SP calculates the hot roller target temperature while pressure roller feedback control is stopped. This SP determines the target hot roller temperature while pressure roller feedback control is not operating. The temperature is determined based on the paper type and length of the paper (Length Level). Note: The Length Levels (1 to 5) are defined by SP1945.</p>	
1	Length Level 1: Normal	[0 to 30/15/1°C]
2	Length Level 2: Normal	[0 to 30/10/1°C]
3	Length Level 3: Normal	[0 to 30/7/1°C]
4	Length Level 4: Normal	[0 to 30/5/1°C]
5	Length Level 5: Normal	[0 to 30/3/1°C]
11	Length Level 1: Cold Start	[0 to 30/10/1°C]
12	Length Level 2: Cold Start	[0 to 30/5/1°C]
13	Length Level 3: Cold Start	[0 to 30/3/1°C]
14	Length Level 4: Cold Start	[0 to 30/0/1°C]
15	Length Level 5: Cold Start	
16	Length Level 0: Cold Start	

1947	Press FB Stop: Time Period	
	<p>This SP sets the length of time that pressure roller feedback is suspended for the paper lengths defined by SP1945.</p> <ul style="list-style-type: none"> ▪ Pressure roller feedback control begins when the time set with this SP has elapsed after paper feed starts. ▪ As more paper is fed for a multiple print job, the time setting for succeeding sheets is overwritten. ▪ However, for succeeding sheets where the time prescribed for feedback suspension is "0", the "0" value is not overwritten, but feedback suspension control is maintained until countdown for the multiple copies is finished. 	
1	Length Level 1: Normal	[0 to 300/15/1 sec.]
2	Length Level 2: Normal	[0 to 300/30/1 sec.]
3	Length Level 3: Normal	[0 to 300/45/1 sec.]
4	Length Level 4: Normal	[0 to 300/60/1 sec.]
5	Length Level 5: Normal	[0 to 300/80/1 sec.]
11	Length Level 1: Cold Start	[0 to 300/20/1 sec.]
12	Length Level 2: Cold Start	[0 to 300/35/1 sec.]
13	Length Level 3: Cold Start	[0 to 300/50/1 sec.]
14	Length Level 4: Cold Start	[0 to 300/70/1 sec.]
15	Length Level 5: Cold Start	[0 to 300/100/1 sec.]
16	Length Level 0: Cold Start	
	<p>Normally, pressure roller feedback control does not operate when the paper length is not prescribed (length = 0). But if copying was started while feedback control was not operating, during a cold start for example, then feedback control operates using the setting of this SP code.</p> <p>[0 to 300/15/1 sec.]</p>	

SP1-xxx Feed

17	Length Level 0: False Start
	The target hot roller temperature for a flying start is determined by SP1931. This SP determines the time limit for the hot roller to reach that target hot roller temperature. [0 to 300/20/1 sec.]
18	Standby After Cold Start
	This SP sets a time period that prohibits printing to begin even after the hot roller temperature reaches its target temperature after a cold start. If a job is started during this time period countdown, the countdown changes to the counts for-11 to -17 above. [0 to 300/60/1 sec.]

1948	Press Roller Inching Target Temp	
	<p>This SP determines when inching starts.</p> <ul style="list-style-type: none"> ▪ Inching control is done when the pressure roller temperature is above this setting (65°C for example), but printing is prohibited until the pressure roller temperature reaches its target temperature. ▪ Inching (idle rotation of the rollers) starts after the temperature rises above the hot roller target temperature (SP1937 003). ▪ While the temperature is below 65°C copying (not printing) is possible before the temperature of the pressure roller reaches its target temperature and inching starts. 	
1	Plain: Mode1	[60 to 180/100/5°C]
2	Plain: Mode2	[60 to 180/65/5°C]
3	Plain: Mode3	[60 to 180/60/5°C]
4	Plain: Mode4	
5	Plain: Mode5	
6	Trans.: Mode1	[60 to 180/130/5°C]

7	Trans.: Mode2	[60 to 180/100/5°C]
8	Trans.: Mode3	[60 to 180/60/5°C]
9	Trans.: Mode4	
10	Trans.: Mode5	
11	Film: Mode1	
12	Film: Mode2	
13	Film: Mode3	
14	Film: Mode4	
15	Film: Mode5	
16	Plain Mode: Low Temp Cold Start	
	<p>When the machine determines that a cold start in a low-temperature environment has started, the machine uses this setting to start the machine and ignores the paper thickness mode settings.</p> <ul style="list-style-type: none"> ▪ When the prescribed time has elapsed after a cold start, temperature control returns to the paper type and thickness settings. ▪ However, this low temperature cold start does temperature control for plain paper only, not for either translucent paper or film. <p>[60 to 80/120/5°C]</p>	

SP1-xxx Feed

1949	Press FB Std Temp Coeff
------	-------------------------

$$\text{Press.Roller Ctr Temp.} + \left(\frac{\text{Press.Roller End Temp.} - \text{Press.Roller Ctr Temp.}}{\text{Press.Roller Ctr Temp.}} \right) \times \text{SP1949}^{***} = \text{Press.Roller FB Temp.}$$

b286d920

	<p>The formula above uses the setting of this SP to determine the pressure roller feedback temperature. The result of this calculation is used to calculate the hot roller target temperature.</p> <p>Note:</p> <ul style="list-style-type: none"> ▪ Settings can be selected below for the paper type, mode, and paper length. ▪ Modes “1” to “5” below refer to the paper type and thickness settings selected in User Tools (see “Paper Thickness Default Selection” in this section). 	
11	Normal Mode1: > 611mm	[0 to 1/0/0.1]
12	Normal Mode1: 461-610mm	
13	Normal Mode1: 298-460	
14	Normal Mode1: < 297mm	
21	Normal Mode2: > 611mm	
22	Normal Mode2: 461-610mm	
23	Normal Mode2: 298-460	
24	Normal Mode2: < 297mm	
31	Normal Mode3: > 611mm	
32	Normal Mode3: 461-610mm	
33	Normal Mode3: 298-460	
34	Normal Mode3: < 297mm	
41	Normal Mode4: > 611mm	

42	Normal Mode4: 461-610mm	
43	Normal Mode4: 298-460	
44	Normal Mode4: < 297mm	
51	Normal Mode5: > 611mm	
52	Normal Mode5: 461-610mm	
53	Normal Mode5: 298-460	
54	Normal Mode5: < 297mm	
61	Trans Mode: > 611mm	
62	Trans Mode: 461-610mm	
63	Trans Mode: 298-460	
64	Trans Mode: < 297mm	
111	Film Mode: > 611mm	
112	Film Mode: 461-610mm	
113	Film Mode: 298-460	
114	Film Mode: < 297mm	

1970	Fan Stop Time
	This SP sets the fan stop time. [0 to 30/1/1 min.]

Service
Tables

5.8 SP2-XXX DRUM

2001	Charge Corona Adjustment	
	This SP adjusts the charge corona outputs.	
1	Total Corona Current	Adjusts the charge corona output for total area. DFU [650 to 1530/1220/1 V step]
2	Grid Voltage: Image Area	Adjusts the charge grid output. DFU [162 to 1070/865/1 mA step]
3	Grid Voltage: ID Sensor Pattern	Adjusts the charge grid output for the ID sensor pattern. DFU [162 to 1070/690/1 V step]

2101	Print Erase Margin	
	Adjusts the quantity of erase for copy mode (quantity of white space).	
1	Leading Edge	[0.0 to 10/2/0.1 mm step]
2	Trailing Edge	
3	Left edge	
4	Right edge	[0.0 to 10/0.5/0.5 mm step]

2110	Test Mode dpi DFU
	<p>This SP adjusts the pixel resolution.</p> <p>[0 to 19/8/1]</p> <p>0: 400 x 400 dpi (reduction)</p> <p>4: 300 x 300 dpi (reduction)</p> <p>8: 600 x 600 dpi</p> <p>19: 200 x 200 dpi (reduction)</p>

2201	Development Bias Adjustment	
	This SP sets the development bias to adjust the amount of toner used in the image area.	
1	Image Area	[-56 to -952/-650/1 V step]
2	ID Sensor Pattern: Low Duty Copy Jobs	[-56 to -952/-414/1 V step]
3	ID Sensor Pattern: High Duty Copy Jobs	[56 to 952/453/1 V step]
4	Copy Jobs	[0 to 1/0/1] 0: Low Duty Mode 1: High Duty Mode

2207	Forced Toner Supply	
	Push [Execute] to force toner supply. Make a copy and check the image density. This SP supplies more toner to make light copies darker. Each time this SP is done, toner is supplied one time.	

2208	Toner Supply Setting	
1	Gain	<p>Sets the toner supply capacity for the job load.</p> <p>[0 to 3/1/1]</p> <p>0: L (Low)</p> <p>1: M (Medium)</p> <p>2: H (High)</p> <p>3: HH (Very High)</p>
3	Toner Supply Mode	<p>Sets the toner supply mode.</p> <p>0: Detect Mode (uses ID sensor)</p> <p>1: Fixed Mode</p> <ul style="list-style-type: none"> ▪ If the ID sensor is damaged and cannot be replaced immediately, set this SP to “1.” The operator can continue to use the machine until a new ID sensor becomes available. ▪ After the ID sensor has been replaced, reset this SP to 0.

2301	Transfer Current Adjustment	
	<p>Use these SP's to adjust the coefficient and power output used to develop the image at the center, leading edge, and trailing edge.</p> <p>Note: Always do the coefficient adjustment first, then adjust the power output.</p>	
1	Plain Paper: Img LEdge	<p>Adjusts the transfer output power for plain paper. DFU</p> <p>[0 to 230/60/1 mA]</p>
2	Plain Paper: Img Area	
3	Plain Paper: Img TEdge	
4	Plain Paper: Coefficient	<p>Adjusts the transfer output coefficient for the image at the center, leading edge, and trailing edge on plain paper. DFU</p> <p>[1.0 to 2.0/1.0/0.2 step]</p>
5	Translucent: Img LEdge	<p>Adjusts the transfer output power for</p>

6	Translucent: Img Area	translucent print media. DFU [0 to 230/60/1 mA]
7	Translucent: Img TEdge	
8	Translucent: Coefficient	Adjusts the transfer output coefficient for the image at the center, leading edge, and trailing edge on translucent print media. DFU [1.0 to 2.0/1.0/0.2 step]
9	Film: Img LEdge	Adjusts the transfer output power for film print media. DFU [0 to 230/80/1 mA]
10	Film: Img Area	
11	Film: Img TEdge	
12	Film: Coefficient	Adjusts the transfer output coefficient for the image at the center, leading edge, and trailing edge on film print media. DFU [1.0 to 2.0/1.0/0.2 step]

2401	Separation DC Timing Adjustment	
	Adjusts the separation dc timing. DFU [0 to 300/100/4 mm step]	

2402	Separation AC Current Adjustment	
	Adjusts the separation ac voltage for roll paper and cut sheets.	
1	Roll Paper	[18 to 466/280/1 mA step]
2	Cut Paper	

Service Tables

SP2-xxx Drum

2403	Separation DC Current DFU	
	Adjusts the separation dc current. If this setting is too high, toner from the paper will cling to the drum after transfer. The separation dc current can be set for plain paper, translucent paper, and film for the leading edge, trailing edge, and areas outside the image.	
1	Roll Paper: Plain Paper: Img LEdge	[0.0 to -66/ -25/0.1 mA]
2	Roll Paper: Plain Paper: Outside Img LEdge	[0.0 to -66/ -15/0.1 mA]
3	Roll Paper: Translucent: Img LEdge	[0.0 to -66/ -25/0.1 mA]
4	Roll Paper: Translucent: Outside Img LEdge	[0.0 to -66/ -15/0.1 mA]
5	Roll Paper: Film: Img LEdge	[0.0 to -66/ -25/0.1 mA]
6	Roll Paper: Film: Outside Img LEdge	[0.0 to -66/ -15/0.1 mA]
11	Bypass: Plain Paper: Img LEdge	[0.0 to -66/ -25/0.1 mA]
12	Bypass: Plain Paper: Outside Img LEdge	[0.0 to -66/ -25/0.1 mA]
13	Bypass: Translucent: Img LEdge	[0.0 to -66/ -15/0.1 mA]
14	Bypass: Translucent: Outside Img LEdge	[0.0 to -66/ -15/0.1 mA]
15	Bypass: Film: Img LEdge	[0.0 to -66/ -15/0.1 mA]
16	Bypass: Film: Outside Img LEdge	[0.0 to -66/ -15/0.1 mA]
17	Cassette: Img LEdge	[0.0 to -66/0/0.1 mA]
18	Cassette: Outside Img LEdge	[0.0 to -66/0/0.1 mA]

2801	Initialize Developer	
	<p>This SP mixes the developer and initializes the ID sensor. Use this SP to mix the developer during machine installation or after the developer has been replaced. The machine requires two packs of developer. Two SP codes are provided for entering the lot numbers of both packages.</p> <p>Note:</p> <ul style="list-style-type: none"> Always enter the lot numbers with SP2801-2 and -3 before doing SP2801-1. 	
1	Developer Initial Setting: Execute	Mixes developer and initializes the ID sensor
2	Lot Number 1	Lot number of the 1 st packet.
3	Lot Number 2	Lot number of the 2 nd packet.

2803	Corona Wire: Cleaning Start	
	<p>Do this SP to clean the charge corona wire. This SP also moves the cleaning pad to the home position. The cleaning requires about 20 sec. to complete.</p>	

2804	Corona Wire: Cleaning Interval	
	<p>Sets the interval for charge corona wire cleaning.</p> <p>Note: The wire is cleaned only when the hot roller temperature is below 50 °C (122°F).</p> <p>[0 to 6/3/1 step]</p> <p>0: None (no cleaning)</p> <p>1: After the main switch is turned on.</p> <p>2: After 300 m of copies</p> <p>3: After 600 m of copies</p> <p>4: After 900 m of copies</p> <p>5: After 1200 m of copies</p> <p>6: After 1500 m of copies</p>	

Service Tables

SP2-xxx Drum

2805	Drum Motor Speed DFU	
	This SP adjusts the drum motor speed.	
1	Width:420mm more	
2	Width:420mm less	

2902	Test Pattern	
	Use these SP's to select and print test patterns.	
1	IPU Scanning Test Pattern (See section 5.8.1 Test Pattern Printing for instructions)	
	Select this test pattern if you suspect there is a problem with scanning. Select one of 17 available test patterns (1-17). [0 to 17/0/1]	
	* 0: None	9: Vertical Grayscale (16-level)
	1: Vertical Line (1-dot)	10: Grayscale (16-level)
	2: Vertical Line (2-dot)	11: Cross Pattern
	3: Horizontal Line (1-dot)	12: Argyle Pattern
	4: Horizontal Line (2-dot)	13: Density Patch (256-level)
	5: Independent Dot (1-dot)	14: Density Patch (64-level)
	6: Grid Pattern (1-dot)	15: Trimming Area
	7: Vertical Stripes	16: Bandwidth (Vertical)
	8: Horizontal Gray (16-level)	17: Bandwidth (Horizontal)
2	IPU Printing Test Pattern (See section 5.8.1 Test Pattern Printing for instructions)	
	Select this test pattern if you suspect there is a problem with image printing. Select one of 11 available test patterns (1-11). Refer to "3. Replacement and Adjustment" for more details about how to use these patterns to check these items:	

	<ul style="list-style-type: none"> ▪ Registration line speed (Pattern #11) ▪ Magnification (Pattern #11) ▪ LPH replacement (Pattern #11) ▪ Pattern density (Pattern #10) <p>[0 to 11/0/1]</p>	
	* 0: None	6: Density Patch (64-level)
	1: Independent Dot (1-4 dot)&Solid	7: Cross Pattern
	2: Horizontal Grayscale (16-level)	8: Grid Pattern (96 dot width)
	3: Vertical Grayscale (16-level)	9: Argyle Pattern
	4: Grayscale (16-level)	10: Grayscale Horizontal (8-level & line)
	5: Density Patch (256-level)	11: Grid Pattern (128 dot width)
3	Printing Test Pattern (See section 5.8.1 Test Pattern Printing for instructions)	
	<p>Select this test pattern if you suspect there is a problem with image writing. Select one of 25 available test patterns (1-25). [0 to 25/0/1] 0: None (default)</p>	
	* 0: None	13: Vertical Line (1-dot)
	1: Grid Pattern (1-dot)	14: Vertical Line (2-dot)
	2: Grid Pattern (2-dot)	15: Horizontal Line (1-dot)
	3: Grid Pattern (3-dot)	16: Horizontal Line (2-dot)
	4: Grid Pattern (4-dot)	17: Checkered Flag
	5: Grid Pattern (5-dot)	18: Alternating Dot Pattern (1-dot)
	6: Grid Pattern (6-dot)	19: Alternating Dot Pattern (2-dot)
	7: Argyle Pattern (1-dot)	20: Alternating Dot Pattern (4-dot)
	8: Argyle Pattern (2-dot)	21: Trimming Area

Service Tables

SP2-xxx Drum

	9: Argyle Pattern (3-dot)	22: Full Dot Pattern
	10: Argyle Pattern (4-dot)	23: Black Band (Vertical)
	11: Argyle Pattern (5-dot)	24: Black Band (Horizontal)
	12: Argyle Pattern (6-dot)	25: Blank Image

2909	Main Scan Magnification
	This SP fine adjusts magnification of the copy image in the main scan direction. [-10 to +10/0/0.1%]

2916	Fine Magnification
	Adjusts the magnification for each paper type. These settings are enabled automatically for the paper type when the operator selects a magnification ratio for the copy job. These corrections are done during image processing after the original is scanned. Adjust the setting for a paper type if you consistently notice distortion in magnified images for a particular type. [-10 to +10/0/0.1%] Notes <ul style="list-style-type: none"> ▪ SP2916-1, SP2916-2 should be adjusted at installation of the main machine. In "1. Installation" See section 3.11.
1	Plain Paper: Mode1-4: Horiz
2	Plain Paper: Mode1-4: Vert
3	Translucent: Mode1-4: Horiz
4	Translucent: Mode1-4: Vert
5	Film: Mode1-4: Horiz
6	Film: Mode1-4: Vert
7	Recycled Paper: Mode1-4: Horiz
8	Recycled Paper: Mode1-4: Vert

9	Plain Paper: Mode5: Horiz
10	Plain Paper: Mode5: Vert
11	Translucent: Mode5: Horiz
12	Translucent: Mode5: Vert
13	Film: Mode5: Horiz
14	Film: Mode5: Vert
15	Recycled Paper: Mode5: Horiz
16	Recycled Paper: Mode5: Vert

2923	Execute Cleaning Blade Replace Mode
	<p>Always do this SP after replacing the OPC or cleaning blade.</p> <p>This SP applies a small amount of toner to the drum and blade to reduce friction between the new drum and/or new blade. This prevents scratching the drum or bending the blade.</p>

2924	Developer Mixing: Warmup
	<p>Enables/disables measurement of Vsg during warm-up immediately after the machine is switched on. Vsg sampling is done to ensure good quality for the first copies.</p> <p>[0 to 2/0/1]</p> <p>0: Vsg is read immediately after the machine is switched on with the fusing temperature less than 50°C (122°F).</p> <p>1: Vsg is always read during warm-up immediately after the machine is switched on, regardless of the fusing temperature level.</p> <p>2: Vsg is not read during warm-up.</p>

SP2-xxx Drum

2925	Transfer Current Timing DFU	
	These SP's adjust the transfer current timing.	
1	ON	Adjusts the timing for power on. [0 to 16/6/0.2 mm]
2	Leading Edge	Adjusts the timing for switching from the leading edge to the center. [0 to 30/8/1 mm]
3	Trailing Edge	Adjusts the timing for switching from the center to the trailing edge. [-30 to 0/0/1 mm]

2926	Used Toner Overflow Detect	
	The used toner bottle motor operates a cam. This cam strikes the side of the used toner collection bottle, to create a vibration that levels the used toner inside the bottle.	
1	Used Tnr M (Sensor Detection)	
	Sets the length of time that the used toner bottle motor operates. The motor starts 10 sec. after the main power switch is switched on and if the fusing temperature is less than 50°C (122°F). [0 to 30/20/5] Note: Ten seconds after the machine is switched on, if the machine detects that the toner collection bottle is full, the used toner bottle motor does not operate.	
2	Used Tnr M (TE Recovery)	
	Sets the length of time that the used toner bottle motor operates after TE (toner end). [0 to 80/30/5 sec.]	

3	Used Toner Bottle Full Detect
	Limits the length of paper that can be printed after the machine detects that the used toner collection bottle is full. [1 to 50/15/1 m]

2927	Toner (Near) End Detection DFU	
	These SP's set the levels for the toner near-end and toner end levels.	
1	Near End Level	Sets the level for toner near end detection. ($V_{sp}/V_{sg} = V_{end}$). [0.140 to 0.275/0.145/0.005 V]
3	End Level	Sets the V_{sp}/V_{sg} level for toner end detection. The ID sensor must detect this value three times in succession to detect toner end. The machine stops when toner end is detected. [0.150 to 300/0.165/0.005 V]

2928	Toner End Recovery
	<p>Recovery starts after the toner cartridge is replaced when a toner-end condition exists. [0.130 to 0.215/0.145/0.005 V]</p> <p>In the toner-end recovery process:</p> <ul style="list-style-type: none"> ▪ The machine writes an ID sensor pattern on the surface of the drum. ▪ The ID sensor reads the density of the ID sensor pattern and converts it to an electrical signal (V_{sp}). ▪ The machine compares the V_{sp} value with V_{sg}, which is read from the bare sursection of the drum ($V_{sg}/V_{sg}=V_{ref}$) ▪ If $V_{sp}/V_{sg} < V_{ref}$ (the value of this SP setting), recovery is completed and the machine goes back to normal operation.

2943	LED Duty Adjustment	
	Adjusts the on timing (the “width” or “duty”) of the LEDs in the LPH units to change image exposure. Use this SP if it is necessary to make the output of one LPH block brighter or darker. Raising the setting creates darker pixels, lowering the setting creates lighter pixels.	
1	LPH1	[1.0 to 32.0/12.0/0.1%]
2	LPH2	The optimum LPH settings are printed on the label that is attached to LPH replacement units. Always input these settings immediately after the LPH unit has been replaced.
3	LPH3	

2944	LED Duty Rate DFU	
	This SP adjusts the power to the LPH. [0 to 100/50/1%]	

2952	LPH Joint Adjustment	
	Adjust these settings only after you replace the LPH. For more, refer to “Replacement and Adjustment.”	
1	LPH1-2 Main Scan	Adjusts the LPH joint for main scan between LPH1 and LPH2. [0 to 999/500/1]
2	LPH2-3 Main Scan	Adjusts the LPH joint for main scan between LPH2 and LPH3. [0 to 999/500/1]
11	LPH1-2 Sub Scan	Adjusts sub scanning at LPH 1-2 for paper more than 420 mm wide. [300 to 500/412/1]
12	LPH2-3 Sub Scan	Adjusts sub scanning at LPH 2-3 for paper more than 420 mm wide. [2 to 100/16/1]

51	LPH1-2 Sub Scan: < 420mm	Adjusts sub scanning at LPH 1-2 for paper less than 420 mm wide. This value is calculated automatically. Do not adjust. [-50 to +50/0/1] DFU
52	LPH2-3 Sub Scan: < 420mm	Adjusts sub scanning at LPH 2-3 for paper less than 420 mm wide. This value is calculated automatically. Do not adjust. [-50 to +50/0/1] DFU

2953	LPH Joint Power Corr		
	Adjusts the four LEDs at each end of LPH 2. This fine adjustment is not usually necessary in the field. [-63 to +63/0/1]		
1	1-Dot: Left	011	1-Dot: Right
2	2-Dot: Left	012	2-Dot: Right
3	3-Dot: Left	013	3-Dot: Right
4	4-Dot: Left	014	4-Dot: Right

SP2-xxx Drum

2954	Binary Line Width Corr: Print
	These SP's determine how line processing is handled for vertical lines. Note: This SP has no effect on horizontal lines.
1	Change On/Off
	This SP switches fine line processing by the LPH off and on. [0 to 1/1/1] 0: Disabled 1: Enabled
10	Level Select (for > 2dots)
	This SP selects the level for fine line processing of vertical lines thicker than two dots. [0 to 3/1/1] 0: Strongest processing (thinnest) 1: Normal processing 2: Weaker processing 3: Weakest processing (thickest)

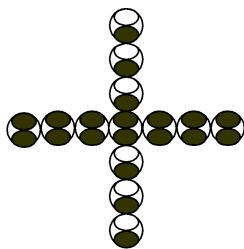

b286s931

The illustration above shows how two elements comprise each dot. This example shows vertical and horizontal 1-dot lines.

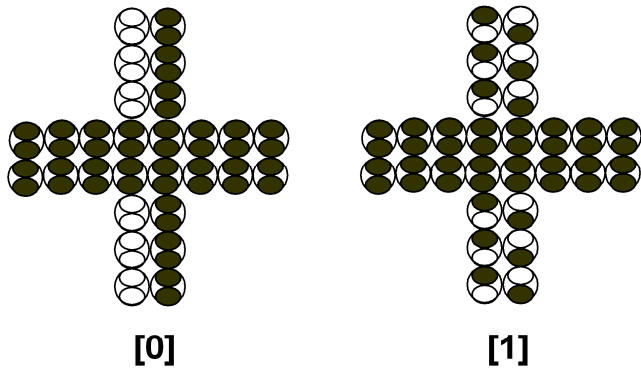

The diagram above illustrates the patterns for the settings SP2954-10 (0 to 3) on a 2-dot vertical line. The settings have no effect on the horizontal line.

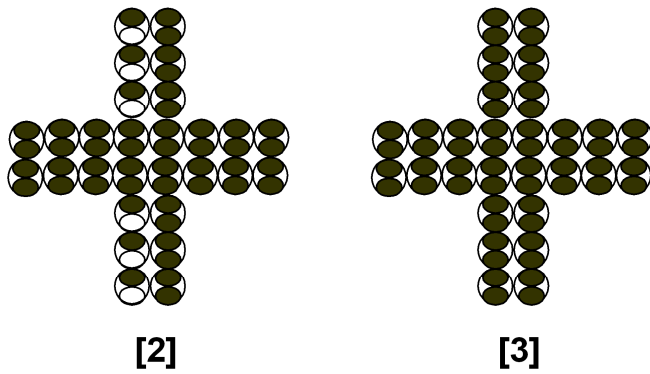

b286s932

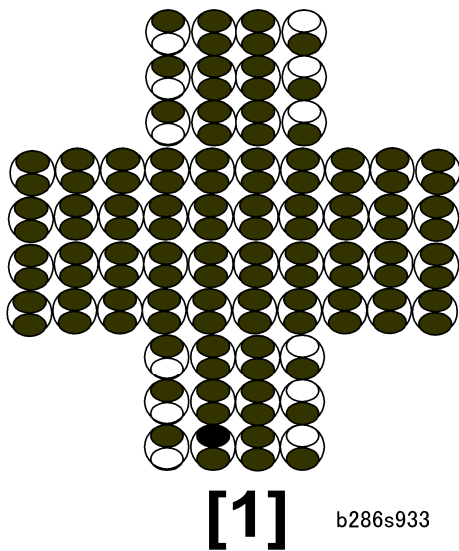

When line thickness more than 2 dots the value selected for SP2954-10 affects only the outer lines. The diagram above shows “1” selected for SP2954-10. The setting does not affect the horizontal line.

2959	Display VDB ID
	This SP displays the 8-bit data that identifies the FPGA version of the VDB (Video Drive Board). The VDB controls the signals sent to the LPH.

5.8.1 TEST PATTERN PRINTING

The following procedure will provide information to access various test patterns and to enable test patterns printing.

1. Open the roll feeder drawer and cut off a sheet manually from a roll. (Turn the manual feed knob to feed the paper, then push the cutter from side to side to cut.) Close the roll feeder drawer.
2. Go into the Copy SP. mode.
3. Select SP2902-1, SP2902-2 or SP2902-3 and then select a test pattern (from those listed in section 5 of the service manual) then press OK.
4. Touch COPY Window. to go to the main screen.
5. On the operation panel, select one of the rolls for paper feed.
6. Put the blank sheet of paper on the original feed tray and feed it into the original feed unit. The pattern selected prints.
7. Touch SP Mode to return to the SP mode list. Then press 0: None and select OK before selecting a different set of patterns or exiting out of the SP mode.

5.9 SP3-XXX PROCESS CONTROL

3001	ID Sensor Initial Setting	
	These SP's do the settings for the ID sensor LED.	
1	PWM	Sets the level of the PWM (Pulse Width Modulation) of the ID sensor LED. DFU [0 to 100/20/0.1%]
2	Initialization	Automatically adjusts the ID sensor with a sensor reading of the bare drum. The initial setting is 4.0V ±0.2. This SP requires about 4 sec. to execute. Always do this SP at installation, and after you replace these components: <ul style="list-style-type: none"> ▪ OPC Drum ▪ ID Sensor ▪ NVRAM ▪ MCU

3103	ID Sensor Output Display	
	This SP displays the current readings of the bare drum surface (Vsg) and the ID sensor pattern (Vsp)	
1	Vsg	Bare drum reflection
2	Vsp	ID sensor pattern reflection

3911	Mix New Developer	
	<p>This SP agitates and mixes developer to raise its triboelectric charge and prevent dirty background on copies. Do this SP only if the machine has not been used for a long time.</p> <p>Note: Execution of this SP is not required at machine installation or after developer replacement.</p>	

Service Tables

5.10 SP4-XXX SCANNER

4008	Scanner Sub Scan Magnification	
	Adjusts magnification in the sub scan direction by changing the speed of the main motor. [-0.9 to +0.9/0/0.1% step]	

4010	Scanner Sub Scan Reg	
1	Leading Edge	Adjusts the time between the sensor-on position and the leading edge of the image. [-10 to +10/0/0.1 mm step]
2	Trailing Edge	Adjusts the time between the sensor-off position and the trailing edge of the image. This sets the timing for the CIS to stop scanning after the trailing edge of the original passes the registration sensor. [-10 to +10/0.0/0.1 mm step]

4011	Scanner Main Scan Reg	
	Adjusts the scan registration. [-4 to +4/0.0/0.1 mm]	

4012	Scanner Erase Margin	
	These SP's define borders around the image area output by the scanner. Each edge can be set independent of the others.	
5	DF: LEdge	[0 to 9/1.5/1 mm]
6	DF: TEdge	
7	DF: Left	
8	DF: Right	[0 to 9/0.5/1 mm]

4013	Scanner Free Run	
	These SP's set up and start the scanner free run operation for testing.	
1	Start	Push [Execute] to start.
2	Page Interval Setting	Sets the interval between prints for the scanner free run. [0 to 25/10/0.1 s]
3	Original Length Setting	Sets the interval between multiple feeds for the DF free run. [0.1 to 15/1.2/0.1 m]

4101	Scanner Main Scan Magnification	
	Adjusts the side- to -side scan magnification. [-0.9 to +0.9/0.0/0.1 %]	

4550	Scanner: Text/Chart	
	<p>These SP's set the MTF (Modular Transfer Function) for scanned text and charts.</p> <ul style="list-style-type: none"> ▪ Always adjust the level (coefficient) before adjusting the strength. ▪ Raising the brightness or contrast level may increase moiré <p>Note: When the original image is converted to electrical signals, the contrast is reduced due to the influence that adjacent white and black pixels have on one another as a result of CIS properties. Typically, you will see very narrow width and spacing between black and white areas. MTF corrects this problem and emphasizes image detail.</p>	
1	MTF Filter Level: Main Scan:0-15	Set the MTF coefficient for main/sub scanning. [0 to 15/8/1] 0: Weak < 8: Default > 15: Strong
2	MTF Filter Level: Sub Scan:0-15	
3	MTF Filter Strength: Main Scan:0-7	Set the MTF strength for main/sub scan directions. [0 to 7/4/1] 0: Weak ← 4: Default → 7: Strong
4	MTF Filter Strength: Sub Scan:0-7	
6	Smoothing Filter:0-7	Selects the level of smoothing for originals that contain dithered images. [0 to 7/0/1] 0: Default (Off) > 7: Strong
7	Brightness:1-255	Sets the overall brightness of the image. [1 to 255/128/1] 1: Weak < 128: Default > 255: Strong
8	Contrast:1-255	Sets the overall contrast of the image. [1 to 255/128/1] 1: Weak < 128: Default > 255: Strong
9	Independent Dot Erase:0-7	Sets the level of independent dot erasure to improve the appearance of background. [0 to 7/0/1] 0: Default (Off) → 7: Strongest

4551	Scanner: Text	
	<p>These SP's set the MTF (Modular Transfer Function) for scanned text.</p> <ul style="list-style-type: none"> ▪ Always adjust the level (coefficient) before adjusting the strength. ▪ Raising the brightness or contrast level may increase moiré <p>Note: When the original image is converted to electrical signals, the contrast is reduced due to the influence that adjacent white and black pixels have on one another as a result of CIS properties. Typically, you will see very narrow width and spacing between black and white areas. MTF corrects this problem and emphasizes image detail.</p>	
1	MTF Filter Level: Main Scan:0-15	Set the MTF coefficient for main/sub scanning. [0 to 15/8/1] 0: Weak < 8: Default > 15: Strong
2	MTF Filter Level: Sub Scan:0-15	
3	MTF Filter Strength: Main Scan:0-7	Set the MTF strength for main/sub scan directions. [0 to 7/4/1] 0: Weak ← 4: Default → 7: Strong
4	MTF Filter Strength: Sub Scan:0-7	
6	Smoothing Filter:0-7	Selects the level of smoothing for originals that contain dithered images. [0 to 7/0/1] 0: Default (Off) > 7: Strong
7	Brightness:1-255	Sets the overall brightness of the image. [1 to 255/128/1] 1: Weak < 128: Default > 255: Strong
8	Contrast:1-255	Sets the overall contrast of the image. [1 to 255/128/1] 1: Weak < 128: Default > 255: Strong
9	Independent Dot Erase:0-7	Sets the level of independent dot erasure to improve the appearance of background. [0 to 7/0/1] 0: Default (Off) → 7: Strongest

4553	Scanner: Text/Photo	
	<p>These SP's set the MTF (Modular Transfer Function) for originals with text and photos on the same area.</p> <ul style="list-style-type: none"> ▪ Always adjust the level (coefficient) before adjusting the strength. ▪ Raising the brightness or contrast level may increase moiré <p>Note: When the original image is converted to electrical signals, the contrast is reduced due to the influence that adjacent white and black pixels have on one another as a result of CIS properties. Typically, you will see very narrow width and spacing between black and white areas. MTF corrects this problem and emphasizes image detail.</p>	
1	MTF Filter Level: Main Scan:0-15	Set the MTF coefficient for main/sub scanning. [0 to 15/8/1] 0: Weak < 8: Default > 15: Strong
2	MTF Filter Level: Sub Scan:0-15	
3	MTF Filter Strength: Main Scan:0-7	Set the MTF strength for main/sub scan directions. [0 to 7/4/1] 0: Weak ← 4: Default → 7: Strong
4	MTF Filter Strength: Sub Scan:0-7	
6	Smoothing Filter:0-7	Selects the level of smoothing for originals that contain dithered images. [0 to 7/0/1] 0: Default (Off) > 7: Strong
7	Brightness:1-255	Sets the overall brightness of the image. [1 to 255/128/1] 1: Weak < 128: Default > 255: Strong
8	Contrast:1-255	Sets the overall contrast of the image. [1 to 255/128/1] 1: Weak < 128: Default > 255: Strong
9	Independent Dot Erase:0-7	Sets the level of independent dot erasure to improve the appearance of background. [0 to 7/0/1] 0: Default (Off) → 7: Strongest

4554	Scanner: Photo	
	<p>These SP's set the MTF (Modular Transfer Function) for photo originals.</p> <ul style="list-style-type: none"> ▪ Always adjust the level (coefficient) before adjusting the strength. ▪ Raising the brightness or contrast level may increase moiré <p>Note: When the original image is converted to electrical signals, the contrast is reduced due to the influence that adjacent white and black pixels have on one another as a result of CIS properties. Typically, you will see very narrow width and spacing between black and white areas. MTF corrects this problem and emphasizes image detail.</p>	
1	MTF Filter Level: Main Scan:0-15	Set the MTF coefficient for main/sub scanning. [0 to 15/8/1] 0: Weak < 8: Default > 15: Strong
2	MTF Filter Level: Sub Scan:0-15	
3	MTF Filter Strength: Main Scan:0-7	Set the MTF strength for main/sub scan directions. [0 to 7/4/1] 0: Weak ← 4: Default → 7: Strong
4	MTF Filter Strength: Sub Scan:0-7	
6	Smoothing Filter:0-7	Selects the level of smoothing for originals that contain dithered images. [0 to 7/0/1] 0: Default (Off) > 7: Strong
7	Brightness:1-255	Sets the overall brightness of the image. [1 to 255/128/1] 1: Weak < 128: Default > 255: Strong
8	Contrast:1-255	Sets the overall contrast of the image. [1 to 255/128/1] 1: Weak < 128: Default > 255: Strong
9	Independent Dot Erase:0-7	Sets the level of independent dot erasure to improve the appearance of background. [0 to 7/0/1] 0: Default (Off) → 7: Strongest

4565	Scanner: Line Drawing	
	<p>These SP's set the MTF (Modular Transfer Function) for line drawing originals.</p> <ul style="list-style-type: none"> ▪ Always adjust the level (coefficient) before adjusting the strength. ▪ Raising the brightness or contrast level may increase moiré <p>Note: When the original image is converted to electrical signals, the contrast is reduced due to the influence that adjacent white and black pixels have on one another as a result of CIS properties. Typically, you will see very narrow width and spacing between black and white areas. MTF corrects this problem and emphasizes image detail.</p>	
1	MTF Filter Level: Main Scan:0-15	Set the MTF coefficient for main/sub scanning. [0 to 15/8/1] 0: Weak < 8: Default > 15: Strong
2	MTF Filter Level: Sub Scan:0-15	
3	MTF Filter Strength: Main Scan:0-7	Set the MTF strength for main/sub scan directions. [0 to 7/4/1] 0: Weak ← 4: Default → 7: Strong
4	MTF Filter Strength: Sub Scan:0-7	
6	Smoothing Filter:0-7	Selects the level of smoothing for originals that contain dithered images. [0 to 7/0/1] 0: Default (Off) > 7: Strong
7	Brightness:1-255	Sets the overall brightness of the image. [1 to 255/128/1] 1: Weak < 128: Default > 255: Strong
8	Contrast:1-255	Sets the overall contrast of the image. [1 to 255/128/1] 1: Weak < 128: Default > 255: Strong
9	Independent Dot Erase:0-7	Sets the level of independent dot erasure to improve the appearance of background. [0 to 7/0/1] 0: Default (Off) → 7: Strongest

4700	Display CIS ASIC ID	
	This SP displays an 8-bit string that identifies the FPGA version of the SIB board.	

4705	CIS Adjustment	
1	Flag Display	Displays a "0" (not adjusted) or a "1" to indicate whether the white level adjustment with SP4705-2 has been successful.
2	Start	Input "1" to adjust the standard white level. Note: Do this SP to correct the problem of uneven density in copies, especially in filled areas.

4713	CIS White Level Adjustment DFU	
	These SP's display the standard white board values after adjustment with SP4705-2.	
1	CIS1	[0 to 511/0/1]
2	CIS2	
3	CIS3	
4	CIS4	
5	CIS5	

SP4-xxx Scanner

4716	CIS White Level Adjustment: Factory DFU	
	These SP's display the standard white board values after adjustment at the factory.	
1	CIS1	[0 to 511/0/1] Note: If "0" is displayed, this means no adjustment has been done.
2	CIS2	
3	CIS3	
4	CIS4	
5	CIS5	

4724	CIS Read Offset Data DFU	
	These SP codes display the black level read data for visual confirmation at power on.	
1	CIS1 : GE(ven)	[0 to 255/0/1]
2	CIS1 : GO(dd)	
3	CIS2 : GE(ven)	
4	CIS2 : GO(dd)	
5	CIS3 : GE(ven)	
6	CIS3 : GO(ven)	
7	CIS4 : GE(ven)	
8	CIS4 : GO(dd)	
9	CIS5 : GE(ven)	
10	CIS5 : GO(dd)	

4732	CIS Gain Adjustment DFU	
	These SP's display the gain data of the analog ASIC (EVEN or ODD) from the CIS after the white level adjustment done immediately after power on. The white level adjustment sets the peak value (shading data peak) for each channel at 240±2 digits.	
1	CIS1 : GE(ven)	[0 to 255/0/1]
2	CIS1 : GO(dd)	
3	CIS2 : GE(ven)	
4	CIS2 : GO(dd)	
5	CIS3 : GE(ven)	
6	CIS3 : GO(dd)	
7	CIS4 : GE(ven)	
8	CIS4 : GO(dd)	
9	CIS5 : GE(ven)	
10	CIS5 : GO(dd)	

4735	CIS Read White Level DFU	
	These SP's display the peak level of the shading data after white level adjustment is done immediately after power on.	
1	CIS1 : GE(ven)	[0 to 255/0/1]
2	CIS1 : GO(dd)	
3	CIS2 : GE(ven)	
4	CIS2 : GO(dd)	
5	CIS3 : GE(ven)	

Service
Tables

SP4-xxx Scanner

6	CIS3 : GO(dd)	
7	CIS4 : GE(ven)	
8	CIS4 : GO(dd)	
9	CIS5 : GE(ven)	
10	CIS5 : GO(dd)	

4741	CIS White Adjust Loop DFU
	This SP displays the number of AGC (gain) adjustment loops performed during white level adjustment.

4745	CIS Adjustment Error Flag DFU												
	<p>This SP displays the flags of any errors that occur at power on during:</p> <ul style="list-style-type: none"> ▪ CIS white level check ▪ Black level check ▪ White level adjustment <p>[0 to 1111 1111b]</p>												
	<table border="1"> <tr> <td>b0</td> <td>Black level adjustment timeout (not used)</td> </tr> <tr> <td>b1</td> <td>White level adjustment timeout. The test did not acquire a value after 20 attempts.</td> </tr> <tr> <td>b2</td> <td>White level 1st check error. The acquired value was judged not within range.</td> </tr> <tr> <td>b3</td> <td>Density adjustment timeout. After 20 attempts a value within range could not be acquired.</td> </tr> <tr> <td>b4</td> <td>Standard white roller adjustment interrupted. Something interrupted the adjustment sequence (jam, upper unit opened, etc.)</td> </tr> <tr> <td>b5</td> <td>Standard white roller density adjustment timeout. The original (T6200) was output before the adjustment completed.</td> </tr> </table>	b0	Black level adjustment timeout (not used)	b1	White level adjustment timeout. The test did not acquire a value after 20 attempts.	b2	White level 1 st check error. The acquired value was judged not within range.	b3	Density adjustment timeout. After 20 attempts a value within range could not be acquired.	b4	Standard white roller adjustment interrupted. Something interrupted the adjustment sequence (jam, upper unit opened, etc.)	b5	Standard white roller density adjustment timeout. The original (T6200) was output before the adjustment completed.
b0	Black level adjustment timeout (not used)												
b1	White level adjustment timeout. The test did not acquire a value after 20 attempts.												
b2	White level 1 st check error. The acquired value was judged not within range.												
b3	Density adjustment timeout. After 20 attempts a value within range could not be acquired.												
b4	Standard white roller adjustment interrupted. Something interrupted the adjustment sequence (jam, upper unit opened, etc.)												
b5	Standard white roller density adjustment timeout. The original (T6200) was output before the adjustment completed.												

4747	CIS Hard Error Flag DFU	
	This SP displays the flags of errors that occur during the CIS communication check done immediately after power on.	
	b0	Serial output port abnormal. Signal at HIGH level became "1."
	b1	Read failure. Failed to read CIS unit version information.
	b2	Write failure. A value was written to the CIS register (AGC_CONT) but it could not be read.

4762	CIS Gain Adjustment Normally DFU	
	These SP's display the gain data of the analog ASIC (EVEN or ODD) from the CIS after the white level adjustment done immediately after power on. The white level adjustment sets the peak value (shading data peak) for each channel at 240±2 digits.	
1	CIS1 : GE(ven)	[0 to 255/0/1]
2	CIS1 : GO(dd)	
3	CIS2 : GE(ven)	
4	CIS2 : GO(dd)	
5	CIS3 : GE(ven)	
6	CIS3 : GO(dd)	
7	CIS4 : GE(ven)	
8	CIS4 : GO(dd)	
9	CIS5 : GE(ven)	
10	CIS5 : GO(dd)	

SP4-xxx Scanner

4765	CIS Standard White Level Adjustment Normally DFU	
	These SP's display the value adjusted for density of the white plate after standard white plate density adjustment	
1	CIS1	[0 to 511/0/1]
2	CIS2	
3	CIS3	
4	CIS4	
5	CIS5	

4781	CIS Gain Adjustment at Factory DFU	
	When SP4705 002 (CIS Adjustment - Start) is executed after SP4705 (CIS Adjustment) returned a "0" (failure to adjust) and standard white plate density adjustment ends successfully. The gain value is stored in NVRAM. This SP retrieves that value and displays it.	
1	CIS1 : GE	[0 to 255/0/1]
2	CIS1 : GO	
3	CIS2 : GE	
4	CIS2 : GO	
5	CIS3 : GE	
6	CIS3 : GO	
7	CIS4 : GE	
8	CIS4 : GO	
9	CIS5 : GE	
10	CIS5 : GO	

4901	Scan Correction DFU	
1	Shading Correction: AEREF Setting	Displays the AEREF value used to supplement shading processing. [0 to 63/0/1]
2	Shading Correction: Shading Data Output	Outputs the shading data used during supplemental shading processing of scanned image data. [0 to 1/0/1] 0: Scanned image after shading processing (normal) 1: Shading data
3	Digital AE: AEREF Setting	Changes the AEREF value used during digital A/E processing of the scanned image. [-63 to +63/0/1]
4	Digital AE: Low Limit	Provides the boundary values to the digital A/E processing address for the scanned image data. [0 to 255/41/1]
5	Digital AE: Start Position	Defines the start position for digital A/E processing of the scanned image data. [0.5 to 10.0/5.0/0.1 mm]

4903	Image Quality Adj.	
	<p>Use this if density is not equal in shaded areas of the copy. The change from high to low density areas in shaded areas must be smooth. Do these SP adjustments if you see “false outlines” in shaded areas of the copy.</p> <ul style="list-style-type: none"> ▪ To increase the effect, use a higher setting. ▪ To decrease the effect, use a lower setting. ▪ The higher settings can make text look better, but can also decrease the quality of the image. 	
	MTF Filter Settings	
1	Text (25.0-55.0%)	

SP4-xxx Scanner

2	Text (55.1-75.0%)	
3	Text (75.1-160.0%)	
4	Text (160.1-400.0%)	
5	Photo: Dithering (25.0-55.0%)	
6	Photo: Dithering (55.1-75.0%)	
7	Photo: Dithering (75.1-160.%)	
8	Photo: Dithering (160.1-400.0%)	
9	Photo: Error Diffusion (25.0-55.0%)	
10	Photo: Error Diffusion (55.1-75.0%)	
11	Photo: Error Diffusion (75.1-160.%)	
12	Photo: Error Diffusion (160.1-400.0%)	
13	Text/Photo (25.0-55.0%)	
14	Text/Photo (55.1-75.0%)	
15	Text/Photo (75.1-160.0%)	
16	Text/Photo (160.1-400.0%)	
21	Generation (25.0-55.0%)	
22	Generation (55.1-75.0%)	
23	Generation (751-160.0%)	
24	Generation (160.1-400.0%)	
25	Drawing (25.0-55.0%)	
26	Drawing (55.1-75.0%)	
27	Drawing (75.1-160.0%)	
28	Drawing (160.1-400.0%)	

29	Patched Original (25.0-55.0%)	
30	Patched Original (55.1-75.0%)	
31	Patched Original (75.1-160.0%)	
32	Patched Original (160.1-400.0%)	
33	Blue Line (25.0-55.0%)	
34	Blue Line (55.1-75.0%)	
35	Blue Line (75.1-160.0%)	
36	Blue Line (160.1-400.0%)	
	Independent Dot Erase	
60	Independent Dot Erase: Text	
61	Independent Dot Erase: Photo	
62	Independent Dot Erase: Text/Photo	
64	Independent Dot Erase: Generation	
65	Independent Dot Erase: Drawing	
66	Independent Dot Erase: Patched Original	
67	Independent Dot Erase: Blue Line	
	Background Erase	
70	Background Erase: Text	
71	Background Erase: Photo	
72	Background Erase: Text/Photo	
74	Background Erase: Generation	
75	Background Erase: Drawing	
76	Background Erase: Patched Original	

SP4-xxx Scanner

77	Background Erase: Blue Line	
	Line Width Correction	
80	Line Width Corr: Text: Mode Select	
81	Line Width Corr: Text: Main Scan	
82	Line Width Corr: Text: Sub Scan	
83	Line Width Corr: Photo: Mode Select	
84	Line Width Corr: Photo: Main Scan	
85	Line Width Corr: Photo: Sub Scan	
86	Line Width Corr: Text/Photo: Mode Select	
87	Line Width Corr: Text/Photo: Main Scan	
88	Line Width Corr: Text/Photo: Sub Scan	
95	Line Width Corr: Drawing: Mode Select	
96	Line Width Corr: Drawing: Main Scan	
97	Line Width Corr: Drawing: Sub Scan	
98	Line Width Corr: Patched Original: Mode Select	
99	Line Width Corr: Patched Original: Main Scan	
100	Line Width Corr: Patched Original: Sub Scan	
101	Line Width Corr: Blue Line: Mode Select	
102	Line Width Corr: Blue Line: Main Scan	
103	Line Width Corr: Blue Line: Sub Scan	

4904	Image Process Setting	
	<p>These SP's set up image processing for each mode.</p> <ul style="list-style-type: none"> ▪ The smoothing level filters remove false outlines. ▪ Line width correction corrects thin vertical lines. 	
2	Process Select: Photo	
	<p>This SP sets the matrix that is used for dithering in the Photo Mode. [1 to 3/0/1] 0: 8 x 8 dithering 1: 6 x 6 dithering 2: 4 x 4 dithering 3: Error diffusion</p>	
3	Density level: Patched Original	[0 to 8/2/1]
10	Smoothing Filter Level: Text	[0 to 3/1/1]
11	Smoothing Filter Level: Photo	[0 to 3/2/1]
12	Smoothing Filter Level: Text/Photo	[0 to 3/1/1]
14	Smoothing Filter Level: Generation	
15	Smoothing Filter Level: Drawing	
16	Smoothing Filter Level: Patched Original	
17	Smoothing Filter Level: Blue Line	

SP4-xxx Scanner

4909	Image Processing Through	
	These SP's check the operation of the scan and print processing modules on the IPU board.	
1	IPU Scan Image Module	
	This SP checks the operations of the scanned image processing modules on the IPU board.	
	(7) 0000 0000 (0)	
	0: Shading correction	4: Independent dot erase
	1: Scanner gamma	5: Gamma (scan path)
	2: Filter	6: Gradation processing (scan path)
	3: Line width correction	7: Scan mask
2	IPU Plotter Image Module	
	This SP checks the operations of the print image processing modules on the IPU board.	
	(7) 0000 0000 (0)	
	0: Print magnification 1: Gamma 2: Gradation processing 4: Print mask	

4961	Original Adjustment	
1	Synchro-cut Adjustment 210mm	Adjusts the synchro-cut position. [-9.9 to +9.9/0.0/0.1 mm] Use the 210-mm position in the sample to check the difference. This setting is used to calculate the motor clock count for adjusting the difference.
2	Synchro-cut Adjustment 1000mm	Adjusts the synchro-cut position. [-9.9 to +9.9/0.0/0.1 mm step] Use the 1000-mm position in the sample to check the difference. This setting is used to calculate the motor clock count for adjusting the difference.
3	Original Length Display	Displays the original length.

4965	Original Speed:LEdge
	<p>The original feed roller tries to adjust for slippage of the feed rollers to allow the machine measure the length of the original accurately. The diameter of the feed roller (32 ±0.05) differs slightly from the diameter of the exit roller (32 ±0.05). The slightly higher speed of the exit roller could cause the original to feed faster than usual, and cause distortion of the image at the joints of the CIS. Use this SP to lower the speed of the original to correct this problem if image distortion at the CIS joints occurs.</p> <p>When to Use This SP</p> <ul style="list-style-type: none"> ▪ Adjust this SP if you see image distortion after replacing the original feed roller or exit roller. ▪ You may also need to adjust this SP if you see image distortion after CIS adjustments with SP4872. <p>For more about how to use SP4865, please refer to “Replacements and Adjustments “ > “Scanner”, “Original Feed Unit Rollers’ for how to use SP 4965. [-1.0 to 0.0/ -0.2 /0.1]</p>

SP4-xxx Scanner

4972	CIS Joint Adjustment	
	These SP's correct the alignment the image scanned by the CIS. For more, see section 3.112 (CIS Adjustment with SP Code)	
1	CIS1-2 Main Scan	[-127 to +127/0/1]
2	CIS2-3 Main Scan	
3	CIS3-4 Main Scan	
4	CIS4-5 Main Scan	
11	CIS1-2 Sub Scan	
12	CIS2-3 Sub Scan	
13	CIS3-4 Sub Scan	
14	CIS4-5 Sub Scan	

4973	CIS Scan Setting
	<p>This SP disables and enables correction of the alignment of the CIS elements with SP4972. For more, see SP Adjustments.</p> <p>[0 to 1/0/1]</p> <p>0: Correction allowed</p> <p>1: Correction not allowed</p>

4974	CIS Power Corr DFU	
	These SP's adjust the level of current to the CIS elements. Adjusting these settings affect LED control. Adjustments can be done separately for Red, Green, and Blue.	
1	R	Corrects the current level for Red. When set to "0", the LED is off. When set to any value other than "0", the LED lights and Red can be adjusted. [+127 to -127/0/1]
11	G	Corrects the current level for Green. This SP is adjusted to change when the scanning with the default settings does not achieve satisfactory results. [+127 to -127/0/1]
21	B	Corrects the current level for Blue. When set to "0", the LED is off. When set to any value other than "0", the LED lights and Blue can be adjusted. [+127 to -127/0/1]

4975	Original Edge Hold	
	This SP determines whether the machine stops and holds the original after the original is fed so that it does not fall. [0 to 1/0/1] *0: Disable, 1: Enable	

Service
Tables

SP4-xxx Scanner

4991	Read Shading (Error) DFU	
	Determines whether the machine uses volatile data for shading correction. [0 to 1/0/1] *0: Disable, 1: Enable	
1	CIS1 : GE(ven)	[0 to 255/255/1]
2	CIS1 : GO(dd)	
3	CIS2 : GE(ven)	
4	CIS2 : GO(dd)	
5	CIS3 : GE(ven)	
6	CIS3 : GO(dd)	
7	CIS4 : GE(ven)	
8	CIS4 : GO(dd)	
9	CIS5 : GE(ven)	
10	CIS5 : GO(dd)	

5.11 SP5-XXX MODE

5024	mm/inch Display Selection	
	0: Europe/Asia (mm), 1: North America (inch)	

5045	Accounting Counter		
	These SP codes set the method and units for counting.		
1	Counter Method		
	Selects the counting method [0 to 1/1/1] 0: Development counter (black prints) 1: Paper counter. Shows the total page counts		
2	Counter Unit		
	[0 to 8/0/1]		
	0	Meters	
	1	Yards	
	2	Feet	
	3	Meters ²	
	4	Yards ²	
	5	Feet ²	
	6	A3=1	Surface area count
	7	0.1 meters	Only for counting devices/meters by user.
	8	01. yards	

Service
Tables

SP5-xxx Mode

5051	Toner Refill Detect Display
	<p>This SP switches on/off the message that prompts the operator when it is necessary to replenish toner in the machine.</p> <p>ON: Message displayed (Default)</p> <p>OFF: Message not displayed</p>

5055	Display IP Address
	<p>Switches the banner display of the IP address off and on. (Default: *Off)</p> <p>[OFF] ON</p> <p>For example, if this SP is switched on, the IP address will be displayed below "Ready" while the printer is in standby mode:</p> <p>Ready</p> <p>169.254.187.055</p>

5056	Coverage Counter Display
	<p>This SP switches the counter list for the system administrator on/off.</p>

5101	Panel Off Level
	<p>This SP sets the level of the low power mode, where the operation panel will switch off after the machine enters low power mode.</p> <p>[0 to 3/3/1]</p> <p>0: Low power level 1</p> <p>1: Low power level 2</p> <p>2: Low power level 3</p> <p>3: Low power level 4</p>

5113	Optional Counter Type
1	Default Optional Counter Type
	<p>Selects the type of counter:</p> <p>0: None</p>

	<p>1: Key Card (RK3, 4) Japan Only</p> <p>2: Key Card Down</p> <p>3: Pre-paid Card</p> <p>4: Coin Rack</p> <p>5: MF Key Card</p> <p>11: Exp Key Card (Add)</p> <p>12: Exp Key Card (Deduct)</p>
2	<p>External Optional Counter Type</p> <p>Enables the SDK application. This lets you select a number for the external device for user access control.</p> <p>Note: "SDK" refers to software on an SD card.</p> <p>[0 to 3/1]</p> <p>0: None</p> <p>1: Expansion Device 1</p> <p>2: Expansion Device 2</p> <p>3: Expansion Device 3</p>

5114	Optional Counter I/F
	<p>This SP code enables the interface for an optional counting device.</p> <p>[0 to 8/0/1]</p> <p>Important Note: Only settings that can be enabled for machines outside Japan are listed here.</p> <p>0: Disabled</p> <p>1: Key Cards (RK2, 3, 4)</p> <p>2: Decrementing keycard</p> <p>11: Incrementing key cards for use outside Japan</p> <p>12: Decrementing key cards for use outside Japan</p>

SP5-xxx Mode

5118	Disable Copying
	Temporarily denies access to the machine. Japan Only [0 to 1/1] 0: Release for normal operation 1: Prohibit access to machine

5120	Mode Clear Count Removal DFU
	For a machine that has a counting device, this SP sets the next action when a copy job stops because the card is removed, the card is expired, or if the paper supply runs out. Japan Only [0 to 2/0/1 step] 0: Yes 1: Stand-by 2: No

5121	Counter Up Timing
	Determines whether the optional key counter counts up at paper feed-in or at paper exit. Japan Only [0 to 1/1] 0: Feed count 1: No feed count

5127	APS Off Mode
	This SP can be used to switch APS (Auto Paper Select) off while a coin lock or pre-paid key card device is connected to the machine. [0 to 1/1] 0: On 1: Off

5162	App. Switch Method
	<p>Determines if the application screen changes with a hardware switch or a software switch.</p> <p>[0 to 1/1]</p> <p>0: Soft Key Set</p> <p>1: Hard Key Set</p>

5169	CE Login
	<p>This SP enables and disables the CE log in mode. With this SP enabled, the machine is in the CE (Customer Engineer/Service Technician) login mode.</p> <p>In the CE login mode:</p> <ul style="list-style-type: none"> ▪ The machine power can be turned off and on in the SP mode, and it will remain in the SP mode after power is restored. ▪ This SP is automatically reset to “0” (disabled) after the service technician closes the SP mode with the [Exit] soft button or after the log out timer expires. <p>Note: The Auto Logout Timer is in the “System Settings” of UserTools.</p> <p>*0: Disable, 1: Enable</p> <p>0: CE login mode disabled.</p> <p>1: CE login mode enabled.</p>

5180	Charge Counter Method Japan Only
	<p>This SP codes sets the charge counter method.</p> <p>[0 to 1/1/1]</p> <p>0: Count number of sheets by paper size</p> <p>1: Count frequency by paper size</p>

5188	Copy NV Version DFU
	<p>This SP displays the NVRAM version to determine whether the NVRAM has been initialized. Used during debugging.</p>

SP5-xxx Mode

5212	Page Numbering Not Used
------	--------------------------------

5302	Set Time DFU
	<p>Sets the time clock for the local time. This setting is done at the factory before delivery. The setting is GMT expressed in minutes. [-1440 to 1440/1 min.]</p> <p>JA: +540 (Tokyo) NA: -300 (NY) EU: +6- (Paris) CH: +480 (Peking) TW: +480 (Taipei) AS: +480 (Hong Kong)</p>

5307	Summer Time	
	<p>Lets you set the machine to adjust its date and time automatically with the change to Daylight Savings time in the spring, and back to normal time in the fall. This SP lets you set these items:</p> <ul style="list-style-type: none"> ▪ Day and time to go forward automatically in April ▪ Day and time to go back automatically in October ▪ Set the length of time to go forward and back automatically ▪ The settings for 2 and 3 are done with 8-digit numbers 	
	Digits	Meaning
	1 st , 2 nd	Month. 4: April, 10: October (for months 1 to 9, the first digit of 0 cannot be input, so the eight-digit setting for 2 or 3 becomes a seven-digit setting)
	3 rd	Day of the week. 0: Sunday, 1: Monday
	4 th	The number of the week for the day selected at the 3 rd digit. If "0" is selected for "Sunday", for example, and the selected Sunday is the start of the 2 nd week, then input a "2" for this digit.
5 th , 6 th	The time when the change occurs (24-hour as hex code). Example: 00:00 (Midnight) = 00, 01:00 (1 a.m.) = 01, and so on.	

	7 th	The number of hours to change the time. 1 hour: 1	
	8 th	If the time change is not a whole number (1.5 hours for example), digit 8 should be 3 (30 minutes).	
	1	Setting	Enables/disables the settings for 2 and 3. [0 to 1/1] 0: Disable 1: Enable
	3	Rule Set (Start)	The start of summer time.
	4	Rule Set (End)	The end of summer time.

5401	Access Control DFU		
	These SP's store settings that limit uses access to SDK (Software Development Kit) application data.		
200	SDK1 Unique ID	"SDK" is the "Software Development Kit." This data can be converted from SAS (VAS) when installed or uninstalled. DFU	
201	SDK1 Certification Method		
210	SDK2 Unique ID		
211	SDK2 Certification Method		
220	SDK3 Unique ID		
221	SDK3 Certification Method		

5404	User Code Count Clear
	Clears the counts for the user codes assigned by the key operator to restrict the use of the machine. Press [Execute] to clear.

SP5-xxx Mode

5501	PM Alarm	
1	PM Alarm Level	[0 to 9999 / 0 / 1 step] 0: Alarm off 1 to 9999: Alarm goes off when Value (1 to 9999) ≥ PM counter
2	Original Count Alarm	0: No alarm sounds 1: Alarm sounds after the number of originals passing through the ARDF ≥ 10,000

5504*	Jam Alarm Japan Only	
	Sets the alarm to sound for the specified jam level (document misfeeds are not included). [0 to 3 / 3 / 1 step] 0: Zero (Off) 1: Low (2.5K jams) 2: Medium (3K jams) 3: High (6K jams)	

5505	Error Alarm	
	Sets the error alarm level. Japan only DFU [0 to 255 / 50 / 100 copies per step]	

5507	Supply Alarm DFU	
1	Paper Supply Alarm (0:Off 1:On)	
	Switches the control call on/off for the paper supply. DFU 0: Off, 1: On 0: No alarm. 1: Sets the alarm to sound for the specified number transfer sheets for each paper size (A3, A4, B4, B5, DLT, LG, LT, HLT)	

3	Toner Supply Alarm (0:Off 1:On)		
	Switches the control call on/off for the toner end. DFU 0: Off, 1: On If you select "1" the alarm will sound when the main machine detects toner end.		
	The "Interval nn" SP's below specify the paper control call interval for the referenced paper sizes. DFU [00250 to 10000 / 1000 / 1 Step]		
97	Interval: 841mm	164	Interval: LG
98	Interval: 594mm	165	Interval: Foolscap
99	Interval: 420mm	166	Interval: LT
100	Interval: 297mm	175	Interval: 12x18
101	Interval: 210mm	225	Interval: 36inch
106	Interval: 728mm	226	Interval: 24inch
107	Interval: 515mm	227	Interval: 18inch
108	Interval: 364mm	228	Interval: 12inch
109	Interval: 257mm	229	Interval: 9inch
128	Interval: Others	234	Interval: 34inch
132	Interval: A3	235	Interval: 22inch
133	Interval: A4	236	Interval: 17inch
141	Interval: B4	237	Interval: 11inch
160	Interval: DLT	238	Interval: 8.5inch

SP5-xxx Mode

5508	CC Call Japan Only	
1	Jam Remains	Enables/disables initiating a call.
2	Continuous Jams	[0 to 1/1] 0: Disable
3	Continuous Door Open	1: Enable
11	Jam Detection: Time Length	Sets the length of time to determine the length of an unattended paper jam. [03 to 30/1] This setting is enabled only when SP5508-1 is enabled (set to 1).
12	Jam Detection Continuous Count	Sets the number of continuous paper jams required to initiate a call. [02 to 10/1] This setting is enabled only when SP5508-2 is enabled (set to 1).
13	Door Open: Time Length	Sets the length of time the door remains opens to determine when to initiate a call. [03 to 30/1] This setting is enabled only when SP5508-3 is enabled (set to 1).

5515	SC Call
1	Determines whether an SC call is issued when an SC error occurs while either CSS (Japan) or @Remote is enabled: [0 to 1/1/1] 1: An SC call is issued when an SC error occurs. 0: An SC call is not issued when an SC error occurs.
2	Service Parts Near End Call
3	Service Parts End Call
4	User Call
6	Communication Test Call
7	Machine Information Notice
8	Alarm Notice
10	Supply Automatic Ordering Call
11	Supply Management Report Call
12	Jam/Door Open Call

5792	MCS Debug SW DFU
------	-------------------------

5793	ECS Debug SW DFU
------	-------------------------

SP5-xxx Mode

5801	Memory Clear	
	Resets NVRAM data to the default settings. Before executing any of these SP's, print an SMC Report.	
1	All Clear	Initializes items 2 to 15 below.
2	Engine Clear	Initializes all registration settings for the engine and copy process settings.
3	SCS	Initializes default system settings, SCS (System Control Service) settings, operation display coordinates, and ROM update information.
4	IMH Memory Clr	Initializes the image file system. (IMH: Image Memory Handler)
5	MCS	Initializes the automatic delete time setting for stored documents. (MCS: Memory Control Service)
6	Copier Application	Initializes all main machine application settings.
8	Printer Application	Initializes the printer defaults, programs registered, the printer SP bit switches, and the printer CSS counter.
9	Scanner Application	Initializes the defaults for the scanner and all the scanner SP modes.
10	Web Service	Deletes the Netfile (NFA) management files and thumbnails, and initializes the Job login ID. Netfiles: Jobs to be printed from the document server using a PC and the DeskTopBinder software
11	NCS	Initializes the system defaults and intersection settings (IP addresses also), the SmartNetMonitor for Admin settings, WebStatusMonitor settings, and the TELNET settings. (NCS: Network Control Service)

14	Clear DCS Setting	Initializes the DCS (Delivery Control Service) settings.
15	Clear UCS Setting	Initializes the UCS (User Information Control Service) settings.
16	MIRS Setting	Initializes the MIRS (Machine Information Report Service) settings.
17	CCS	Initializes the CCS (Certification and Charge-control Service) settings.
18	SRM Memory Clr	Initializes information in non-volatile RAM.
19	LCS Memory Clr	Initializes information in non-volatile RAM.

5802	Printer Free Run
	Does a free run in the mode specified on the operation panel. Push On or Off to switch on or off.

5803	Input Check		
	Displays the signals received from switches and sensors.		
1	Roll Tray	8	Unit Set Detection
2	1 st & 2 nd Roll	9	Door Open/Motor Lock
3	3 rd & 4 th Roll	10	Others
4	Cassette Tray	11	Dip Switch 1
5	1 st Cassette	12	Original Size Sensor 1
6	2 nd cassette	13	Original Size Sensor 2
7	Paper Path Sensors	14	Original Feed unit

SP5-xxx Mode

5804	Output Check	
	Switches each electrical component to test its operation.	
1	Original Feed Motor	
4	CIS LED	
11	Roll Feed Motor 1: Forward	
12	Roll Feed Motor 1: Reverse	
15	1 st Roll Feed Clutch	
16	2 nd Roll Feed Clutch	
19	Cutter 1	
21	Cassette Feed Motor	
25	1 st Cassette Feed Clutch	
31	Registration Motor	
32	Main Motor	
33	Fusing/Exit Motor	
34	Registration Clutch	
35	Paper Junction Gate Solenoid	
36	Used Toner Motor	
41	Charge Corona	
42	Charge Grid: Image Area	
43	Charge Grid: ID Sensor Pattern	
44	Charge Corona/Grid: Image Area	
45	Development Bias: Image Area	
46	Development Bias: ID Sensor Pattern	

47	Transfer Corona: Leading Edge	
48	Transfer Corona	
49	Separation Corona: Leading Edge	
50	Separation Corona	
52	Toner Supply Clutch	
53	Quenching Lamp	
54	Pick-off Pawl Solenoid	
55	ID Sensor LED	
66	Charge Corona Wire Cleaner Motor	
67	Recycle Counter	
68	Dehumidifier	

5811	Machine No. Setting
	This SP presents the screen used to enter the 11-digit number of the machine. The allowed entries are "A" to "Z" and "0" to "9." The setting is done at the factory, and should not be changed in the field.

5812	Service Tel. No. Setting	
	Use these SP modes to input service and support telephone numbers. Enter the number and press Press the  key to input a pause. Press the "Clear modes" key to delete the telephone number.	
1	Service	Service representative telephone number.
2	Facsimile	Fax number of service representative
3	Supply	Supplier of consumables
4	Operation	Operation support

SP5-xxx Mode

5816	Remote Service
	I/F Setting
1	Turns the remote diagnostics off and on. [0 to 2/1] 0: Remote diagnostics off. 1: Serial (CSS or @Remote) remote diagnostics on. 2: Network remote diagnostics on for @Remote
	CE Call
2	Lets the operator engineer start or end of the remote machine check with CSS or @Remote; to do this, push the center report key
	Function Flag
3	Enables and disables remote diagnosis over the @Remote network. [0 to 1/1] 0: Disables remote diagnosis over the network. 1: Enables remote diagnosis over the network.
	SSL Disable
7	Controls if RCG (Remote Communication Gate) confirmation is done by SSL during an RCG send for the @Remote over a network intersection. [0 to 1/1] 0: Yes. SSL not used. 1: No. SSL used.
	RCG Connect Timeout
8	Sets the length of time (seconds) for the time-out when the RCG (Remote Communication Gate) connects during a call via the @Remote network. [1 to 90/1 sec.]
	RCG Write to Timeout
9	Sets the length of time (seconds) for the time-out when sent data is written to the RCG during a call over the @Remote network.

	[0 to 100/1 sec.]
10	RCG Read Timeout Sets the length of time (seconds) for the timeout when sent data is written from the RCG during a call over the @Remote network. [0 to 100/1 sec.]
11	Port 80 Enable Controls if permission is given to get access to the SOAP method over Port 80 on the @Remote network. [0 to 1/1] 0: No. Access denied 1: Yes. Access granted.
12	@Remote Communication Permission Setting DFU NVRAM Offset: NrsCommEnable [0 to 1/1/1] 0: Disable 1: Enable
21	RCG – C Registered This SP displays the Embedded RC Gate installation end flag. 1: Installation completed 2: Installation not completed
22	RCG – C Registered Detail This SP displays the Embedded RC Gate installation status. 0: Basil not registered 1: Basil registered 2: Device registered
23	Connect Type (N/M) This SP displays and selects the Embedded RC Gate connection method. 0: Internet connection 1: Dial-up connection

SP5-xxx Mode

61	Cert. Expire Timing DFU
	Proximity of the expiration of the certification.
62	Use Proxy
	This SP setting determines if the proxy server is used when the machine communicates with the service center.
63	Proxy Host
	This is the address of the HTTP proxy server used to effect communication between Embedded RC Gate-M and the Gateway. The length of the address is limited to 127 characters (characters beyond the 127 th character are ignored).
64	Proxy Port Number
	This is the port number of the HTTP proxy used to effect communication between Embedded RC Gate-N and the Gateway. [0 to 0xffff/0/1]
65	Proxy User name
	This is the user name used for certification of the HTTP proxy. The length of the name is limited to 31 characters (characters beyond the 31 st character are ignored).
66	Proxy Password
	This is the certification password of the HTTP proxy. The length of the password is limited to 31 characters (characters beyond the 31 st character are ignored).

Note: The proxy number, user name, and password comprise proprietary operator information required by the service technician to do the necessary settings for Embedded RC Gate-N. To prevent unauthorized access this information, these SP settings do not appear in the SMC report.

67	CERT: Up State
	Displays the state of the certification update used for Embedded RC Gate. If Embedded RC Gate has not been set up, These SP settings are done automatically as soon as Embedded RC Gate is set up.
0	The certification used by Embedded RC Gate is set correctly.
1	The certification request (SetAuthKey) for update has been received from the GW URL and certification is presently being updated.
2	The certification update is completed and the GW URL is being notified of the successful update.
3	The certification update failed, and the GW URL is being notified of the failed update.
4	The period of the certification has expired and new request for an update is being sent to the GW URL.
11	A rescue update for certification has been issued and a rescue certification setting is in progress for the rescue GW connection.
12	The rescue certification setting is completed and the GW URL is being notified of the certification update request.
13	The notification of the request for certification update has completed successfully, and the system is waiting for the certification update request from the rescue GW URL.
14	The notification of the certification request has been received from the rescue GW URL, and the certification is being stored.
15	The certification has been stored, and the GW URL is being notified of the successful completion of this event.

SP5-xxx Mode

	16	The storing of the certification has failed, and the GW URL is being notified of the failure of this event.
	17	The certification update request has been received from the GW URL, the GW URL was notified of the results of the update after it was completed, but a certification error has been received, and the rescue certification is being recorded.
	18	The rescue certification of No. 17 has been recorded, and the GW URL is being notified of the failure of the certification update.
68	CERT: Error	
	Displays a number code that describes the reason for the notification requesting the certification update.	
	0	Normal. No request for certification update in progress.
	1	Certification update in progress due to expiration of certification.
	2	SSL error has been issued after the certification has expired.
	3	There has been a shift from a common to individual certification.
	4	There has been a common certification without ID2.
	5	No certification has been issued.
6	GW URL does not exist.	
69	CERT: Up ID	
	The ID of the request for certification.	
83	Firm Up Status	
	Displays the status of the firmware update.	
84	Non-HDD Firm Up	
	This setting determines if the firmware can be updated, even without the HDD installed.	

85	Firm Up User Check
	This SP setting determines if the operator can check the previous version of the firmware before the firmware update execution. If the option to check the previous version is selected, a notification is sent to the system manager and the firmware update is done with the firmware files from the URL.
86	Firmware Size
	Allows the service technician to check the size of the firmware data files during the firmware update execution.
87	CERT: Macro Version
	Displays the macro version of the @Remote certification
88	CERT: PAC Version
	Displays the PAC version of the @Remote certification.
89	CERT: ID2 Code
	Displays ID2 for the @Remote certification. Spaces are displayed as underscores (_). Asterisks (****) indicate that no @Remote certification exists.
90	CERT: Subject
	Displays the common name of the @Remote certification subject. CN = the following 17 bytes. Spaces are displayed as underscores (_). Asterisks (****) indicate that no DESS exists.
91	CERT: Serial Number
	Displays serial number for the @Remote certification. Asterisks (****) indicate that no DESS exists.
92	CERT: Issuer
	Displays the common name of the issuer of the @Remote certification. CN = the following 30 bytes. Asterisks (****) indicate that no DESS exists.

SP5-xxx Mode

93	CERT: Valid Start
	Displays the start time of the period for which the current @Remote certification is enabled.
94	CERT: Valid End
	Displays the end time of the period for which the current @Remote certification is enabled.
95	Server CN Check DFU
	[0 to 1/0/1] 0: Thorough check. Set when connected to @Remote gateway. 1: Moderate check. Set when connected to @Remote emulator
96	GW Host DFU
	Used by designers for debugging and evaluation of gateway security devices.
97	GW URL Path DFU
	Used by designers for debugging and evaluation of gateway security devices.
99	Debug Rescue G/W URL Set DFU
	Executing this SP sets "i01/AS" in the rescue gateway URL path. Used for 2-line displays, or when input with lowercase alphanumeric characters is not possible.

	Selection Country DFU	
150	<p>Used only for Embedded RC Gate-M to select a country name. Once the number/country is selected, the following settings are checked:</p> <ul style="list-style-type: none"> ▪ Access point telephone number ▪ Dial-up user name ▪ Modem parameters set for the country <p>[0 to 10/*/1] *: 0: Japan, 1: USA, 3: Europe 0:Japan, 1:USA, 2:Canada, 3:UK, 4:Germany, 5:France, 6:Italy, 7:Netherlands, 8:Belgium, 9:Luxembourg, 10:Spain</p>	
	Line Type Automatic Judgement DFU	
151	<p>Used only for Embedded RC Gate-M to determine whether the dial-up line is for manual rotary or push-button tone dialing.</p> <ul style="list-style-type: none"> ▪ The status of the execution of this SP (dialing in progress, success, failure) is written to SP5816-152. ▪ If the check succeeds, the number (dial or push number) written to SP5816-153 can be used ▪ If the check succeeds, the number of the carrier line written to SP816-154 can be used. 	
	Line Type Judgement Result DFU	
152	Used only for Embedded RC Gate-M to display the status of the execution of SP5816-151 identify the type of line.	
	0	Success
	1	Currently dialing
	2	Line abnormal
	3	Could not confirm external line carrier with automatic detection.
	4	Line disconnected
	5	Power supply insufficient

SP5-xxx Mode

	6	Line determination not supported
	7	Error due to fax transmission in progress.
	8	Other error
	9	Line type identification still in progress. Please wait.
153	Selection Dial/Push DFU	
	Used only for Embedded RC Gate-M to set the telephone number of the dial-up access point of the line checked with SP5816-151. If a number is entered, use that number. If a number is not displayed, use the pre-set value for that country.	
154	Outside Line Outgoing Number DFU	
	Used only for Embedded RC Gate-M to set the number of the PSTN number to dial out where Embedded RC Gate-M is used with a PBX system. If a number is set here, the number will be replaced by the number returned by the successful execution of SP5816-151.	
156	Dial Up User Name DFU	
	This is the user name for dialing at the access point where Embedded RC Gate-M is used. Note: Numbers with spaces or # marks appear enclosed with quotation marks in the user name.	
157	Dial Up Password DFU	
	This is the password for dialing at the access point where Embedded RC Gate-M is used. Note: Numbers with spaces or # marks appear enclosed with quotation marks in the user name.	
161	Local Phone Number DFU	
	This is the number of the local line where Embedded RC Gate-M is connected. This is the line used to communicate with the Call Center.	
162	Connection Timing Adjustment Incoming DFU	

	<p>When the Call Center calls out to the access point where Embedded RC Gate-M is used, the ID tone (*#1#) is sent repeatedly. This SP sets the amount of time to elapse for ID tone output.</p> <p>[0 to 24/1/1 pause count] 1 pause count = 2 sec.</p>
163	<p>Access Point DFU</p>
	<p>This is the dial-up telephone line number of the access point connected to Embedded RC Gate-M. If a number is entered here that number is used. If no number is entered here then the pre-set country setting is used.</p>
164	<p>Line Connecting DFU</p>
	<p>This SP code should be set for the customer using Embedded RC Gate-M, depending on the line usage (whether line is shared with a fax or not).</p> <p>[0 to 1/0/1] 0: Line shared with facsimile 1: Line not shared with facsimile</p>
173	<p>Modem Serial No. DFU</p>
	<p>This SP code displays the serial number of the Embedded RC Gate-M (modem).</p>
174	<p>Retransmission Limit DFU</p>
	<p>Use this SP to manually send a registration update request to Embedded RC Gate-M.</p>
186	<p>RCG-C M Debug Bit SW DFU</p>
	<p>This SP code sets the bit switch for Embedded RC Gate-M to enable debugging.</p> <p>[0 to 1/0/1] 0: Enable 1: Disable</p>

SP5-xxx Mode

187	FAX TX Priority DFU	
	<p>This SP is used with SP5816-164 for users who are using a line shared with a facsimile unit.</p> <p>[0 to 1/0/1]</p> <p>0: Disabled. Embedded RC Gate-M continues to operate if a fax transmission starts on the same line.</p> <p>1: Enabled. Fax transmissions have priority. Embedded RC Gate-M will shut down when a fax transmission begins.</p>	
200	Manual Polling	
	<p>Executes manual polling. Embedded RC Gate periodically polls the @Remote Gateway by HTTPS. This is called "center polling." Use this SP at any time to poll the @Remote supply center.</p>	
201	Regist: Status	
	Displays a number that indicates the status of the @Remote service device.	
	0	Neither the @Remote device nor Embedded RC Gate device are set.
	1	The Embedded RC Gate device is being set. Only Box registration is completed. In this status the Basil unit cannot answer a polling request.
	2	The Embedded RC Gate device is set. In this status the Basil unit cannot answer a polling request.
	3	The @Remote device is being set. In this status the Embedded RC Gate device cannot be set.
4	The @Remote module has not started.	
202	Letter Number	
	Allows entry of the number of the request needed for the Embedded RC Gate device.	

203	Confirm Execute	
	Executes the inquiry request to the @Remote GW URL.	
204	Confirm Result	
	Displays a number that indicates the result of the inquiry executed with SP5816 203.	
	0	Succeeded
	1	Inquiry number error
	2	Registration in progress
	3	Proxy error (proxy enabled)
	4	Proxy error (proxy disabled)
	5	Proxy error (Illegal user name or password)
	6	Communication error
	7	Certification update error
	8	Other error
9	Inquiry executing	
205	Confirm Place	
	Displays the result of the notification sent to the device from the GW URL in answer to the inquiry request. Displayed only when the result is registered at the GW URL.	
206	Register Execute	
	Executes Embedded RC Gate Registration.	

Service Tables

SP5-xxx Mode

207	Register Result		
	Displays a number that indicates the registration result.		
	0	Succeeded	
	2	Registration in progress	
	3	Proxy error (proxy enabled)	
	4	Proxy error (proxy disabled)	
	5	Proxy error (Illegal user name or password)	
	6	Communication error	
	7	Certification update error	
	8	Other error	
9	Registration executing		
208	Error Code		
	Displays a number that describes the error code that was issued when either SP5816 204 or SP5816 207 was executed.		
	Cause	Code	Meaning
	Illegal Modem Parameter	-11001	Chat parameter error
		-11002	Chat execution error
		-11003	Unexpected error
	Operation Error, Incorrect Setting	-12002	Inquiry, registration attempted without acquiring device status.
-12003		Attempted registration without execution of an inquiry and no previous registration.	
-12004		Attempted setting with illegal entries for	

			certification and ID2.
	Error Caused by Response from GW URL	-2385	Attempted dial up overseas without the correct international prefix for the telephone number.
		-2387	Not supported at the Service Center
		-2389	Database out of service
		-2390	Program out of service
		-2391	Two registrations for same device
		-2392	Parameter error
		-2393	Basil not managed
		-2394	Device not managed
		-2395	Box ID for Basil is illegal
		-2396	Device ID for Basil is illegal
		-2397	Incorrect ID2 format
	-2398	Incorrect request number format	
209	Instl Clear		
	Releases a machine from its embedded RCG setup.		
250	CommLog Print		
	Prints the communication log.		

SP5-xxx Mode

5821	Remote Service Address (Japan Only)	
1	CSS PI Device Code	Sets the PI device code. After changing this setting, you must switch the machine off and on.
2	RCG IP Address	Sets the IP address of the RCG (Remote Communication Gate) destination for call processing at the remote service center. [00000000h to FFFFFFFFh/ 00000000h /

5824	NVRAM Data Upload	
	Uploads the UP and SP mode data (except for counters and the serial number) from NVRAM on the control board to a flash memory card. While using this SP mode, always keep the front cover open. This prevents a software module accessing the NVRAM during the upload.	

5825	NVRAM Data Download	
	Downloads the content of a flash memory card to the NVRAM on the control board.	

5828	Network Setting	
65	Job Spool Setting	
	Switches job spooling spooling on and off. 0: No spooling 1: Spooling enabled	
66	Job Spool Clear	
	This SP determines whether the job interrupted at power off is resumed at the next power on. This SP operates only when SP5828065 is set to 1. 1: Resumes printing spooled jog. 0: Clears spooled job.	

69	Job Spool Pro to col			
	This SP 8etermines whether job spooling is enabled or disabled for each pro to col. This is a 8-bit setting.			
0	LPR	4	BMLinks (Japan Only)	
1	FTP (Not Used)	5	DIPRINT	
2	IPP	6	Reserved (Not Used)	
3	SMB	7	Reserved (Not Used)	
84	Setting List Print Settings List			
	Prints a list of the NCS parameter settings.			
90	TELNET Operation Settings: TELNET (0:OFF 1:ON)			
	Disables or enables Telnet operation. If this SP is disabled, the Telnet port is closed. [0 to 1/1] 0: Disable 1: Enable			
91	Web Operation Web (0:OFF 1:ON)			
	Disables or enables the Web operation. [0 to 1/1] 0: Disable 1: Enable			

SP5-xxx Mode

145	Active IPv6 Link Local Address
	<p>This is the IPv6 local address referenced on the Ethernet or wireless LAN (802.11b) in the format: “Link-Local address” + “Prefix Length”</p> <p>The IPv6 address consists of a total 128 bits configured in 8 blocks of 16 bits each. These notations can be abbreviated. See “Note: IPV6 Addresses “ below this table.</p>
147	Active IPv6 Stateless Address 1
149	Active IPv6 Stateless Address 2
151	Active IPv6 Stateless Address 3
153	Active IPv6 Stateless Address 4
155	Active IPv6 Stateless Address 5
	<p>SP codes 147 to 155 are the IPv6 stateless addresses (1 to 5) referenced on the Ethernet or wireless LAN (802.11b) in the format: “Stateless Address” + “Prefix Length”</p> <p>The IPv6 address consists of a total 128 bits configured in 8 blocks of 16 bits each.</p>
156	IPv6 Manual Address
	<p>This SP is the IPv6 manually set address referenced on the Ethernet or wireless LAN (802.11b) in the format: “Manual Set Address” + “Prefix Length”</p> <p>The IPv6 address consists of a total 128 bits configured in 8 blocks of 16 bits each. These notations can be abbreviated. See “Note: IPV6 Addresses” below this table.</p>

158	IPv6 Gateway Address
	This SP is the IPv6 gateway address referenced on the Ethernet or wireless LAN (802.11b). The IPv6 address consists of a total 128 bits configured in 8 blocks of 16 bits each. These notations can be abbreviated. See “Note: IPv6 Addresses “ below this table.

Note: IPV6 Addresses

Ethernet and the Wireless LAN (802.11b) reference the IPV6 “Link-Local address + Prefix Length.” The IPV6 address consists of 128 bits divided into 8 blocks of 16 bits:

aaaa:bbbb:cccc:dddd:eeee:ffff:gggg:hhhh:

The prefix length is inserted at the 17th byte (Prefix Range: 0x0~0x80). The initial setting is 0x40(64).

For example, the data:

2001123456789012abcdef012345678940h

is expressed:

2001:1234:5678:9012:abcd:ef01:2345:6789: prefixlen 64

However, the actual IPV6 address display is abbreviated according to the following rules.

Rules for Abbreviating IPV6 Addresses

1. The IPV6 address is expressed in hexadecimal delimited by colons (:) with the following characters:
0123456789abcdefABCDEF
2. A colon is inserted as a delimiter every 4th hexadecimal character.
fe80:0000:0000:0000:0207:40ff:0000:340e
3. The notations can be abbreviated by eliminating zeros where the MSB and digits following the MSB are zero. The example in “2” above, then, becomes:
fe80:0:0:0207:40ff:0:340e
4. Sections where only zeros exist can be abbreviated with double colons (::). This abbreviation can be done also where succeeding sections contain only zeros (but this can be done only at one point in the address). The example in “2” and “3” above then becomes: fe80::207:40ff:0:340e (only the first null sets zero digits are abbreviated as “::”)
 - or-
fe80:0:0:0:207:40ff::340e (only the last null set before “340e” is abbreviated as “::”)



SP5-xxx Mode

5831	Initial Setting Clear
	This SP clears all the User Tools settings and restores them to their factory default settings.

5832	HDD Formatting
	Enter the SP number for the partition to initialize, then press #. When the execution ends, turn the machine power off and on.
1	HDD Formatting (All)
2	HDD Formatting (IMH)
3	HDD Formatting (Thumbnail)
4	HDD Formatting (Job Log)
5	HDD Formatting (Printer Fonts)
6	HDD Formatting (User Info)
7	Mail RX Data
8	Mail TX Data
9	HDD Formatting (Data for Design)
10	HDD Formatting (Log)
11	HDD Formatting (Ridoc I/F) (for Ridoc DesktopBinder)

5836	Capture Settings	
1	Capture Function	<p>With this function disabled, the settings related to the capture feature cannot be initialized, displayed, or selected. DFU</p> <p>[0 to 1/0/1] 0: Disable 1: Enable</p>
2	Panel Setting	<p>Determines whether each capture related setting can be selected or updated from the initial system screen.</p> <p>[0 to 1/0/1] 0: Disable 1: Enable</p> <p>The setting for SP5836-1 has priority.</p>
3	Print Back-up Function	<p>Determines whether the print back-up function setting can be changed.</p> <p>[0 to 1/0/1] 0: Disable 1: Enable</p>
71	Capture Setting: Resolution Conversion for Color	<p>Determines the resolution conversion ratio when a Color image document is sent to the Document Server via the MLB (Media Link Board).</p> <p>[0 to 2/0/1] 0: 1 x 1: ½ x 2: ¼ x</p>
72	Capture Setting: Resolution Conversion for Copy Text	<p>Determines the resolution conversion ratio when a Copy Text image document is sent to the Document Server via the MLB (Media Link Board).</p> <p>[0 to 2/0/1] 0: 1 x 1: ½ x 2: ¼ x</p>

SP5-xxx Mode

73	Capture Setting: Resolution Conversion for Copy (Others)	Determines the resolution conversion ratio when a Copy image document other than Text mode is sent to the Document Server via the MLB (Media Link Board). [0 to 2/0/1] 0: 1 x 1: ½ x 2: ¼ x
74	Reduction for Printer Color	[0~3/1] 0:1 1:1/2 2:1/3 3:1/4 DFU
75	Capture Setting: Resolution Conversion for Binary Print	Determines the resolution conversion ratio when a binary print image document is sent to the Document Server via the MLB (Media Link Board). [0 to 2/0/1] 0: 1 x 1: ½ x 2: ¼ x
76	Capture Setting: Resolution Conversion for Dither Print (1200 dpi)	Determines the resolution conversion ratio when the Dither print image document is sent to the Document Server via the MLB (Media Link Board). [1 to 3/1/1] 1: ½ x 2: ¼ x 3: 1/8 x
81	Format for Copy Color	[0 to 3/1] 0: JFIF/JPEG, 1: TIFF/MMR, 2: TIFF/MH, 3: TIFF/MR DFU

82	Capture Setting: Format for Copy Text	<p>Determines the image format for Copy Text images sent to the Document Server via the MLB (Media Link Board).</p> <p>[0 to 3/1/1]</p> <p>0: JFIF/JPEG</p> <p>1: TIFF/MMR</p> <p>2: TIFF/MH</p> <p>3: TIFF/MR</p>
83	Capture Setting: Format for Copy (Others)	<p>Determines the image format for Copy (other than text) images sent to the Document Server via the MLB (Media Link Board).</p> <p>[0 to 3/1/1]</p> <p>0: JFIF/JPEG</p> <p>1: TIFF/MMR</p> <p>2: TIFF/MH</p> <p>3: TIFF/MR</p>
85	Capture Setting: Format for Binary Print	<p>Determines the image format for Binary Print images sent to the Document Server via the MLB (Media Link Board).</p> <p>[0 to 3/1/1]</p> <p>0: JFIF/JPEG</p> <p>1: TIFF/MMR</p> <p>2: TIFF/MH</p> <p>3: TIFF/MR</p>
86	Capture Setting: Format for Dither Print (1200dpi)	<p>Determines the image format for Dither Print images sent to the Document Server via the MLB (Media Link Board).</p> <p>[0 to 3/1/1]</p> <p>0: JFIF/JPEG</p> <p>1: TIFF/MMR</p> <p>2: TIFF/MH</p> <p>3: TIFF/MR</p>

SP5-xxx Mode

91	Capture Setting: Page Quality for JPEG	Determines the quality level of JPEG images sent to the Document Server via the MLB (Media Link Board). [5 to 95/50/1]
92	Capture Setting: Page Quality for JPEG (High Quality)	Determines the quality level of JPEG images for high quality sent to the Document Server via the MLB (Media Link Board). [5 to 95/60/1]
93	Capture Setting: Page Quality for JPEG (Low Quality)	Determines the quality level of JPEG images for low quality sent to the Document Server via the MLB (Media Link Board). [5 to 95/40/1]
94	Capture Setting: Format for Backup File	Determines the format of the backup files. [0 to 2/0/1] 0: TIFF 1: JPEG 2: For printing This function can be selected only if SP5836-3 is set to "1."
95	Capture Setting: Resolution Conversion for Backup File	Determines the resolution conversion ratio for the backup files. [0 to 3/2/1] 0: 1x 1: 1/2x 2: 1/3 x 3: 1/4x
96	Default User Name for Backup Files	Allows the user to set the default user name for the backup files created during the copy job. 20 characters are allowed.

97	Capture Setting: Page Quality for JPEG	<p>Determines the quality level of JPEG images for backup files.</p> <p>[0 to 2/0/1]</p> <p>0: Standard quality 1: Low quality 2: High quality</p> <p>This function can be selected only if SP5836-95 is set to "2."</p>
98	Capture Setting: Gamma SW for Backup File	<p>Removes the ghost images transferred from the back sides of double-sided originals.</p> <p>1: Enable 0: Disable</p>

5840	IEEE 802.11b	
6	Channel MAX	<p>Sets the maximum range of the bandwidth for the wireless LAN. This bandwidth setting varies for different countries.</p> <p>[1 to 14/1]</p>
7	Channel MIN	<p>Sets the minimum range of the bandwidth for operation of the wireless LAN. This bandwidth setting varies for different countries.</p> <p>[1 to 14/1]</p>

SP5-xxx Mode

	WEP Key Select
11	<p>Determines how the initiator (SBP-2) handles subsequent login requests. [00 to 11/00/1]</p> <p>Note: There are four settings (binary numbers): 00, 01, 10, 11. These settings are possible only after the wireless LAN card has been installed.</p> <p>00: 1st key. If the initiator receives another login request while logging in, the request is refused.</p> <p>01, 10, 11: 2nd, 3rd, 4th keys are "Reserved."</p>

	Supply Name Setting
5841	Use the soft keyboard of this SP to enter the names and numbers of consumables. These are the names that appear on the display when [Inquiry] is pressed on the User Tools screen.

5842	GWWS Analysis Mode DFU																	
	Setting 1																	
1	<p>This is a debugging tool. It sets the debugging output mode of each Net File process. Bit SW 0011 1111</p>	<table border="1"> <thead> <tr> <th>Bit</th> <th>Groups</th> </tr> </thead> <tbody> <tr> <td>0</td> <td>System & other groups (LSB)</td> </tr> <tr> <td>1</td> <td>Capture related</td> </tr> <tr> <td>2</td> <td>Certification related</td> </tr> <tr> <td>3</td> <td>Address book related</td> </tr> <tr> <td>4</td> <td>Machine management related</td> </tr> <tr> <td>5</td> <td>Output related (printing, delivery)</td> </tr> <tr> <td>6</td> <td>Repository related</td> </tr> </tbody> </table>	Bit	Groups	0	System & other groups (LSB)	1	Capture related	2	Certification related	3	Address book related	4	Machine management related	5	Output related (printing, delivery)	6	Repository related
Bit		Groups																
0		System & other groups (LSB)																
1		Capture related																
2		Certification related																
3		Address book related																
4		Machine management related																
5		Output related (printing, delivery)																
6	Repository related																	

	Setting 2	Bit	
2	This SP codes sets the optional setting for message log time stamp. Bit 7 is the 5682 message log where the following are set:	0-6	Not Used
		7	Message log 1: mm:ss:ms 0: mm:ss (time)

5844	USB
1	Transfer Rate
	Sets the speed for USB data transmission. [Full Speed], [Auto Change]
2	Vendor ID
	Sets the vendor ID: Initial Setting: 0x05A Ricoh Company [0x0000~0xFFFF/1] DFU
3	Product ID
	Sets the product ID. [0x0000~0xFFFF/1] DFU
4	Device Release No.
	Sets the device release number of the BCD (binary coded decimal) display. [0000~9999/1] DFU Enter as a decimal number. NCS converts the number to hexadecimal number recognized as the BCD.

SP5-xxx Mode

5845	Delivery Server Setting	
	Provides items for delivery server settings.	
1	FTP Port No.	[0 to 65535 / 3670 / 1]
	Sets the FTP port number used when image files are sent to the Scan Router Server.	
2	IP Address (Primary)	Range: 000.000.000.000 to 255.255.255.255
	Use this SP to set the Scan Router Server address. The IP address under the transfer tab can be referenced by the initial system setting.	
6	Delivery Error Display Time Netfiles:	[0 to 999 / 300 / 1]
	Use this setting to determine the length of time the prompt message is displayed when a test error occurs during document transfer with the NetFile application and an external device.	
8	IP Address (Secondary)	Range: 000.000.000.000 to 255.255.255.255
	Specifies the IP address assigned to the computer designated to function as the secondary delivery server of Scan Router. This SP allows only the setting of the IP address without reference to the DNS setting.	
9	Delivery Server Model	[0 to 4/ 0 / 1]
	Allows changing the model of the delivery server registered by the I/O device. 0: Unknown 1: SG1 Provided 2: SG1 Package 3: SG2 Provided 4: SG2 Package	

	Delivery Svr Capability
	Changes the capability of the registered that the I/O device registered. [0 to 255 / 0 / 1] (7) [0000 0000] (1)
10	Bit7 = 1 Comment information exists
	Bit6 = 1 Direct specification of mail address possible
	Bit5 = 1 Mail RX confirmation setting possible
	Bit4 = 1 Address book automatic update function exists
	Bit3 = 1 Fax RX delivery function exists
	Bit2 = 1 Sender password function exists
	Bit1 = 1 Function to link MK-1 user and Sender exists
	Bit0 = 1 Sender specification required (if set to 1, Bit6 is set to "0")
	Delivery Svr.Capability (Ext)
11	These settings are for future use. They will let you increase the number of registered devices (in addition to those registered for SP5845-10). There are eight bits (Bit 0 to Bit 7). All are unused at this time.
13	Server Scheme (Primary)
14	Server Port Number (Primary)
15	Server URL Path (Primary)
16	Server Scheme (Secondary)
17	Server Port Number (Secondary)
18	Server URL Path (Secondary)
19	Capture Server Scheme
20	Capture Server Port Number

SP5-xxx Mode

21	Capture Server URL Path
	SP codes 13 to 21 specify the schemes, port numbers, and URL paths of the primary, secondary, and capture servers.
22	Instant Trans Off
	<p>Switches instant transmission off/on. [0 to 1/1/1]</p> <p>0: Off. Instant transmission not possible with network setting errors. 1: On. Instant transmission possible with network setting errors.</p> <p>Note:</p> <ul style="list-style-type: none"> ▪ The machine will continue to transmit over the network, even if the network settings are incorrect. (This causes multiple errors, of course.) ▪ With this SP off, the machine will stop communicating with the network if the settings are wrong. This reduces the amount of spurious network traffic caused by errors due to incorrect settings.

5846	UCS Setting
	Machine ID (for Delivery Server)
1	<p>Displays the unique device ID in use by the delivery server directory. The value is only displayed and cannot be changed.</p> <p>This ID is created from the NIC MAC or IEEE 1394 EUI.</p> <p>The ID is displayed as either 6-byte or 8-byte binary.</p> <p>6-byte %02X.%02X.%02X.%02X.%02X.%02X</p> <p>8-byte %02X.%02X.%02X.%02X.%02X.%02X.%02X.%02X</p>
	Machine ID Clear (Delivery Server)
2	<p>Clears the unique ID of the device used as the name in the file transfer directory. Execute this SP if the connection of the device to the delivery server is unstable. After clearing the ID, the ID will be established again automatically by cycling the machine off and on.</p>

	Maximum Entries
3	Changes the maximum number of entries that UCS can handle. [2000 to 50000/1] If a value smaller than the present value is set, the UCS managed data is cleared, and the data (excluding user code information) is displayed.
	Delivery Server Retry Timer
6	Sets the interval for retry attempts when the delivery server fails to acquire the delivery server address book. [0 to 255/1 s] 0: No retries
	Delivery Server Retry Times
7	Sets the number of retry attempts when the delivery server fails to acquire the delivery server address book. [0 to 255/1]
	Delivery Server Maximum Entries
8	Lets you set the maximum number of account entries and information about the users of the delivery server controlled by UCS. [20000 to 50000/1]
	LDAP Search Timeout
10	Sets the length of the time-out for the search of the LDAP server. [1 to 255/1]

<p>40</p>	<p>Addr Book Migration (SD -> HDD)</p> <p>This SP moves the address book data from an SD card to the HDD. You must turn the machine power off and on after executing this SP.</p> <ol style="list-style-type: none"> 1. Turn the machine off. 2. Install the HDD. 3. Insert the SD card with the address book data in SD card Slot C3. 4. Turn the machine on. 5. Do SP5846-40. 6. Turn the machine off. 7. Remove the SD card from SD card Slot C3. 8. Turn the machine on. <p>Notes:</p> <ul style="list-style-type: none"> ▪ Executing this SP overwrites any address book data already on the HDD with the data from the SD card. ▪ We recommend that you back up all directory information to an SD card with SP5846-51 before you execute this SP. ▪ After the address book data is copied to HDD, all the address book data is deleted from the source SD card. If the operation fails, the data is not erased from the SD card.
<p>41</p>	<p>Fill Addr Acl Info.</p> <p>This SP must be executed immediately after installation of an HDD unit in a basic machine that previously had no HDD. The first time the machine is powered on with the new HDD installed, the system automatically takes the address book from the NVRAM and writes it to the new HDD. However, the new address book on the HDD can be accessed only by the system administrator at this stage. Executing this SP by the service technician immediately after power on grants full address book access to all users.</p> <p>Procedure</p> <ol style="list-style-type: none"> 1. Turn the machine off. 2. Install the new HDD. 3. Turn the machine on. 4. The address book and its initial data are created on the HDD automatically. However, at this point the address book can be accessed by only the

	<p>system administrator or key operator.</p> <p>5. Enter the SP mode and do SP5846-41. After this SP executes successfully, any user can access the address book.</p>
47	<p>Initialize Local Address Book</p> <p>Clears all of the address information from the local address book of a machine managed with UCS.</p>
48	<p>Initialize Delivery Addr Book</p> <p>Push [Execute] to delete all items (this does not include user codes) in the delivery address book that is controlled by UCS.</p>
49	<p>Initialize LDAP Addr Book</p> <p>Push [Execute] to delete all items (this does not include user codes) in the LDAP address book that is controlled by UCS.</p>
50	<p>Initialize All Addr Book</p> <p>Clears everything (including user codes) in the directory information managed by UCS. However, the accounts and passwords of the system administrators are not deleted.</p>
51	<p>Backup All Addr Book</p> <p>Uploads all directory information to the SD card.</p>
52	<p>Restore All Addr Book</p> <p>Downloads all directory information from the SD card.</p>
53	<p>Clear Backup Info.</p> <p>Deletes the address book uploaded from the SD card in the slot. Deletes only the files uploaded for that machine. This feature does not work if the card is write-protected.</p> <p>Note: After you do this SP, go out of the SP mode, turn the power off. Do not remove the SD card until the Power LED stops flashing.</p>

SP5-xxx Mode

60	Search Option	
	This SP uses bit switches to set up the fuzzy search options for the UCS local address book.	
	Bit	Meaning
	0	Checks both upper/lower case characters
	1	Japan Only
	2	
	3	
	4	--- Not Used ---
	5	--- Not Used ---
	6	--- Not Used ---
7	--- Not Used ---	
62	Complexity Option 1	
	<p>Use this SP to set the conditions for password entry to access the local address book. Specifically, this SP limits the password entry to upper case and sets the length of the password. [0 to 32/1]</p> <p>Note: This SP does not normally require adjustment. This SP is enabled only after the system administrator has set up a group password policy to control access to the address book.</p>	

63	<p>Complexity Option 2</p> <p>Use this SP to set the conditions for password entry to access the local address book. Specifically, this SP limits the password entry to lower case and defines the length of the password.</p> <p>[0 to 32/1]</p> <p>Note:</p> <p>This SP does not normally require adjustment.</p> <p>This SP is enabled only after the system administrator has set up a group password policy to control access to the address book.</p>
64	<p>Complexity Option 3</p> <p>Use this SP to set the conditions for password entry to access the local address book. Specifically, this SP limits the password entry to numbers and defines the length of the password.</p> <p>[0 to 32/1]</p> <p>Note:</p> <p>This SP does not normally require adjustment.</p> <p>This SP is enabled only after the system administrator has set up a group password policy to control access to the address book.</p>
65	<p>Complexity Option 4</p> <p>Use this SP to set the conditions for password entry to access the local address book. Specifically, this SP limits the password entry to symbols and defines the length of the password.</p> <p>[0 to 32/1]</p> <p>Note:</p> <p>This SP does not normally require adjustment.</p> <p>This SP is enabled only after the system administrator has set up a group password policy to control access to the address book.</p>
91	<p>FTP Auth. Port Settings</p> <p>Sets the FTP port to get the delivery server address book that is used in the individual authorization mode.</p> <p>[0 to 65535/1]</p>

SP5-xxx Mode

	Encryption Start
94	Shows the status of the encryption function of the address book on the LDAP server. [0 to 255/1] No default

	Rep. Resolution Reduction		
5847	These SP's change the default settings of image data sent externally by the Net File page reference function. [0 to 2/1] Note: <ul style="list-style-type: none"> ▪ "NetFile" refers to jobs to be printed from the document server with a PC and the DeskTopBinder software. ▪ This SP is available only after the File Format Converter (B609) has been installed. 		
2	Rate for Copy B&W Text	[0 to 6/1]	0: 1x
3	Rate for Copy B&W Other		1: 1/2x
5	Rate for Printer B&W		2: 1/3x
7	Rate for Printer B&W 1200 dpi		3: 1/4x
			4: 1/6x
			5: 1/8x
			6: 2/3x1
	Note: "6:" above (2/3x) applies to 3, 5, 6 only.		
	Network Quality Default for JPEG		
21	Sets the default value for the quality of JPEG images sent as NetFile pages. This function is available only with the MLB (Media Link Board) option installed. [5 to 95/1]		

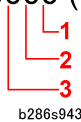
5848	Web Service	
	5847 2 sets the 4-bit switch assignment for the access control setting. Setting of 5848 1 has no effect on access and delivery from Scan Router. 5847 100 sets the maximum size of images that can be downloaded. The default is equal to 1 gigabyte.	
2	Acc. Ctrl.: Repository (only Lower 4 Bits)	0000: No access control 0001: Denies access to DeskTop Binder.
3	Acc. Ctrl.: Doc. Svr. Print (Lower 4 Bits)	Switches access control on and off. 0000: OFF, 0001: ON
4	Acc. Ctrl.: User Directory (Lower 4 Bits)	
5	Acc. Ctrl.: Delivery Input (Lower 4 Bits)	
7	Acc. Ctrl Comm. Log Fax (Lower 4 Bits)	
9	Acc. Ctrl.: Job Control (Lower 4 Bits)	
11	Acc. Ctrl: Device Management (Lower 4 Bits)	
21	Acc. Ctrl: Delivery (Lower 4 Bits)	
22	Acc. Ctrl: User Administration (Lower 4 Bits)	
99	Repository: Download Image Setting DFU	
	<p>This is a bit-switch setting. Only the lower 4 bits are enabled/disabled.</p> <p>(7) 00000000 (0)</p>  <p>Set to "0" (disabled) or "1" (enabled) as needed for image download.</p> <p>(1) Mac OS (2) Windows OS (3) OS other than Mac or Windows</p> <p>Note: This SP is used primarily by designers.</p>	
100	Repository: Download Image Max. Size	[1 to 1024/1 K]

SP5-xxx Mode

210	Setting: Log Type: Job 1 DFU	Note: These SP's are for display only; they cannot be changed.
	[0 to 0xFFFFFFFF/0/1]	
211	Setting: Log Type: Job 2 DFU	
	[0 to 0xFFFFFFFF/0/1]	
212	Setting: Log Type: Access DFU	
	[0 to 0xFFFFFFFF/0/1]	
213	Setting: Primary Srv DFU	
214	Setting: Secondary Srv DFU	
215	Setting: Start Time DFU	
	[0 to 0xFFFFFFFF/0/1]	
216	Setting: Interval Time DFU	
	[1 to 100/1/1]	
217	Setting: Timing DFU	
	[0 to 2/0/1] 0: Transmission off 1: Transmission 1 by 1 2: Periodic transmission	

5849	Installation Date	
	Displays or prints the installation date of the machine.	
1	Display	Displays the installation date. The installation date is set automatically after test copies are done at the installation site.
2	Switch to Print	Determines whether the installation date or total count is printed on the total counter printout. [0 to 1/1] 0: No Print 1: Print
3	Total Counter	Displays the total count starting from the installation date (SP5849-1).

5851	Bluetooth (Not Used)	
	Sets the operation mode for the Bluetooth Unit. Press either key. [0:Public] [1: Private]	

5853	Stamp Data Download	
	<p>Push [Execute] to download the fixed stamp data from the machine ROM onto the hard disk so that these stamps can be used by the system. The customer will not be able to use these stamps (“Confidential”, “Secret”, etc.) until this SP has been executed.</p> <p>Note:</p> <ul style="list-style-type: none"> ▪ This SP must always be executed after the HDD has been reformatted or replaced. ▪ Always switch the machine off and on after executing this SP. 	

SP5-xxx Mode

5856	Remote ROM Update
	<p>When set to “1” allows reception of firmware data via the local port (IEEE 1284) during a remote ROM update. This setting is reset to zero after the machine is cycled off and on.</p> <p>[0 to 1 / 0 / 1]</p> <p>0: Not allowed</p> <p>1: Allowed</p>

5857	Save Debug Log
	On/Off (1:ON 0:OFF)
1	<p>Switches on the debug log feature. The debug log cannot be captured until this feature is switched on.</p> <p>[0 to 1/1]</p> <p>0: OFF</p> <p>1: ON</p>
	Target (2: HDD 3: SD Card)
2	<p>Selects the destination where the debugging information generated by the event selected by SP5858 will be stored if an error is generated</p> <p>[2 to 3 /1]</p> <p>2: HDD</p> <p>3: SD Card</p>
5	Save to HDD
	Specifies the decimal key number of the log to be written to the hard disk.
6	Save to SD Card
	Specifies the decimal key number of the log to be written to the SD Card.

9	Copy HDD to SD Card (Latest 4 MB)
	<p>Takes the most recent 4 MB of the log written to the hard disk and copies them to the SD Card.</p> <p>A unique file name is generated to avoid overwriting existing file names on the SD Card. Up to 4MB can be copied to an SD Card. 4 MB segments can be copied one by one to each SD Card.</p>
10	Copy HDD to SD Card Latest 4 MB Any Key]
	<p>Takes the log of the specified key from the log on the hard disk and copies it to the SD Card.</p> <p>A unique file name is generated to avoid overwriting existing file names on the SD Card. Up to 4 MB can be copied to an SD Card. 4 MB segments can be copied one by one to each SD Card. This SP does not execute if there is no log on the HDD with no key specified.</p>
11	Erase HDD Debug Data
	Erases all debug logs on the HDD
12	Erase SD Card Debug Data
	<p>Erases all debug logs on the SD Card. If the card contains only debugging files generated by an event specified by SP5858, the files are erased when SP5857-10 or -11 is executed.</p> <p>To enable this SP, the machine must be cycled off and on.</p>
13	Free Space on SD Card
	Displays the amount of space available on the SD card.
14	Copy SD to SD (Latest 4MB)
	Copies the last 4MB of the log (written directly to the card from shared memory) on to an SD card.
15	Copy SD to SD (Latest 4MB Any Key)
	This SP copies the log on an SD card (the file that contains the information written directly from shared memory) to a log specified by key number.

Service Tables

SP5-xxx Mode

16	Make HDD Debug
	This SP creates a 32 MB file to store a log on the HDD.
17	Make SD Debug
	This SP creates a 4 MB file to store a log on an SD card.

5858	Debug Save When	
	These SP's select the content of the debugging information to be saved to the destination selected by SP5857-2. SP58583 stores one SC error specified by number. (See "4. Troubleshooting" for descriptions of all SC codes.)	
1	Engine SC Error (0:OFF 1:ON)	Stores SC codes generated by main machine engine errors.
2	Controller SC Error (0:OFF 1:ON)	Stores SC codes generated by GW controller errors.
3	Any SC Error (0:OFF 1:ON)	[0 to 65535 / 0 / 1]
4	Jam (0:OFF 1:ON)	Stores jam errors.

5859	Debug Log Save Function	
1	Key 1	These SP's allow you to set up to 10 keys for log files for functions that use common memory on the controller board. [-9999999 to 9999999 / 0 / 1]
2	Key 2	
3	Key 3	
4	Key 4	
5	Key 5	
6	Key 6	
7	Key 7	
8	Key 8	
9	Key 9	
10	Key 10	

5860	SMTP/POP3/IMAP4
20	Partial Mail Receive Timeout
	[1 to 168/72/1] Sets the amount of time to wait before saving a mail that breaks up during reception. The received mail is discarded if the remaining portion of the mail is not received during this prescribed time.
21	MDN Response RFC2298Compliance
	Determines whether RFC2298 compliance is switched on for MDN reply mail. [0 to 1/1] 0: No 1: Yes
22	SMTP Auth. From Field Replacement
	Determines whether the FROM item of the mail header is switched to the validated account after the SMTP server is validated. [0 to 1/1] 0: No. "From" item not switched. 1: Yes. "From" item switched.
25	SMTP Auth Direct Sending
	Occasionally, all SMTP certifications may fail with SP5860-6 set to "2" to enable encryption during SMTP certification for the SMTP server. This can occur if the SMTP server does not meet RFC standards. In such cases you can use this SP to set the SMTP certification method directly. However, this SP can be used only after SP5860-3 has been set to "1" (On). Bit0: LOGIN Bit1: PLAIN Bit2: CRAM_MD5 Bit3: DIGEST_MD5 Bit4 to Bit 7: Not Used

SP5-xxx Mode

5866	Email Report
1	Report Validity
	Disables and re-enables the email notification feature. [0~1/0/1] 0: Enable 1: Disable
5	Add Date Field
	This SP adds the current date to the date field of an email alert that informs the operator that an error has occurred. [0 to 1/0/1] 0: Date not added 1: Date added
100	Log Format DFU
	This SP sets the output level for the MIRS module (Machine Information Report Service).

5870	Common Key Info Writing	
	Writes to flash ROM the common proof for validating the device for @Remote specifications.	
1	Writing	Note: These SP's are for future use and currently are not used.
3	Initialize	

5873	SD Card Appli Move	
	Moves an application from one SD card to another..	
1	Move Exec	Executes the move from one SD card to another.
2	Undo Exec	This is an undo function. It cancels the previous execution.

5875	SC Auto Reboot
1	Reboot Setting
	<p>Determines whether the machine reboots automatically when an SC error occurs.</p> <p>[0 to 1/0/1]</p> <p>1: The machine does not reboot when an SC error occurs. However, the reboot does not occur for Type "A" SC codes.</p> <p>0: The machine reboots automatically when the machine issues an SC error and logs the SC error code. If the same SC occurs again, the machine does not reboot.</p>
2	Reboot Type
	<p>Selects the reboot method after an SC error occurs.</p> <p>[0 to 1/0/1]</p> <p>0: Manual reboot by operator or technician</p> <p>1: Automatic reboot</p>

5876	Security Clear DFU	
	<p>This SP clears all security data in the NCS area or the UCS area.</p> <p>Note:</p> <ul style="list-style-type: none"> ▪ NCS: Network Control Service ▪ USC: User Information Control Service 	
1	All Clear	Clear all security data for both NCS and UCS.
11	Clear NCS Sec.	Clears all security data for NCS.
15	Clr UCS Security	Clears all security data for UCS.

5878	Option Setup	
	Press [Execute] to initialize the Data Overwrite Security option for the main machine.	

SP5-xxx Mode

5885	WIM Settings		
	This SP determines how access to the Web Image Monitor document server is controlled. These are bit settings where “1” enables and “0” disables.		
		(7) 0000 0000 (0)	
	LSB	0bit	Denies all access to document server
		1bit	Denies all access to User Tools
		2bit	Denies access to printing
		3bit	Denies access to data transfer functions
		4bit	Denis access to scan-to-email
		5bit	Denies access data downloading functions
		6bit	Denies access to data delete functions
	MSB	7bit	(reserved)

5886	ROM Update		
	The setting of this SP allows or prohibits updating the ROM. *0:YES, 1:NO		

5887	Get Counter		
	This SP outputs a text file (*.txt) that lists the counts for the application SD card inserted in to the SD service slot. Before executing this SP, you must first create a folder entitled “SD_COUNTER” in the root direc to ry of the SD card.		

5907	Plug & Play Maker/Model Name
	<p>Selects the brand name and the production name for Windows Plug & Play. This information is stored in the NVRAM. If the NVRAM is defective, these names should be registered again.</p> <p>After selecting, press the “Original Type” key and “#” key at the same time. When the setting is completed, the beeper sounds five times.</p>

5913	Switchover Permission Time
	<p>Sets the length of time to elapse before allowing another application to take control of the display when the application currently controlling the display is not operating because a key has not been pressed.</p> <p>[3~30/3/1 s]</p>

5915	Mechanical Counter Detection
	<p>This SP checks the mechanical counter to confirm whether it is connected. 0: Disconnected 1: Connected 2: Unknown</p> <p>Note:</p> <ul style="list-style-type: none"> ▪ The reading returned by this SP does not change if the mechanical counter is removed while the machine is powered on. ▪ About 3 sec. is required for this SP to return a correct reading after the machine is switched on.

5967	Copy Server: Set Function
	<p>Disables and enables the document server. This is a security measure that prevents image data from being left in the temporary file sector of the HDD. After changing this setting, switch the main switch off and on to enable the new setting.</p> <p>[0 to 1/0/1]</p> <p>0: Enable 1: Disable</p>

SP5-xxx Mode

5974	Cherry Server Japan Only
	<p>Selects which version of the Scan Router application program, “Light” or “Full (Professional)”, is installed.</p> <p>[0 to 1 / 0 / 1 /step]</p> <p>0: Light version (supplied with this machine)</p> <p>1: Full version (optional)</p>

5985	Onboard Device Setting	
	<p>The NIC and USB support features are built into the GW controller. Use this SP to enable and disable these features. In order to use the NIC and USB functions built into the controller board, these SP’s must be set to “1.”</p> <p>[0 to 2/0/1]</p> <p>0: Disable 1: Enable 2: Enable for @Remote</p>	
1	On Board NIC	
2	On Board USB	

5990	SP Print Mode (SMC Printout)	
1	All (Data List)	<p>Prints all of the system parameter lists for the item selected. Input the number for the item that you want to print, and then press [1]: “Execute” on the touch panel.</p>
2	SP (Mode Data List)	
3	User Program	
4	Logging Data	
5	Diagnostic Report	
6	Non-Default	
7	NIB Summary	
8	Capture Log	
21	Copier User Program	
22	Scanner SP	
23	Scanner User Program	

5.12 SP6-XXX PERIPHERALS

6117	Folder Input Check		
	<p>This SP retrieves the SP settings of each bit within 0.5 sec., collects the data into 1-byte, then sends it to the controller. However, undefined sensor information on the Folder unit side is set to “0” without checking the Folder unit.</p> <ul style="list-style-type: none"> ▪ If there is no response from the Folder FD within the prescribed time after it is checked, the 1-byte data (sensor information) is set to “0.” ▪ The requests for engine information stop after this SP screen is closed. 		
	(7) 0000 0000 (1)		
1	Fan Folder 1		
	Bit	Input	Status
	7	Not used	---
	6	Not used	---
	5	Original width sensor	36 in.
	4	Not used	---
	3	Entrance sensor	0: No paper, 1: Paper present
	2	Not used	---
	1	Exit JG sensor	0: No paper, 1: Paper present
	0	Not used	---
2	Fan Folder 2		
	Bit	Input	Status
	7	Original width sensor: 24 in.	0: No paper, 1: Paper present
	6	Original width sensor: 18 in.	0: No paper, 1: Paper present
	5	Original width sensor: 12 in.	0: No paper, 1: Paper present

	4	Original width sensor: 30 in.	0: No paper, 1: Paper present
	3	Original width sensor: 841 mm/34 in.	0: No paper, 1: Paper present
	2	Original width sensor: 594 mm/22 in.	0: No paper, 1: Paper present
	1	Original width sensor: 420 mm/17 in.	0: No paper, 1: Paper present
	0	Original width sensor: 297 mm/11 in.	0: No paper, 1: Paper present
3	Fan Folder 3		
	Bit	Input	Status
	7	Not used	---
	6	Not used	---
	5	Not used	---
	4	Not used	---
	3	Fold plate HP sensor (F)	0: Off, 1: On
	2	Fold plate HP sensor ®	0: Off, 1: On
	1	Fold plate down sensor (F)	0: Off, 1: On
	0	Fold plate down sensor ®	0: Off, 1: On
4	Fan Folder 4		
	Bit	Input	Status
	7	Folder unit entrance sensor	0: No paper, 1: Paper present
	6	Corner fold entrance sensor	0: No paper, 1: Paper present
	5	Fan fold sensors (F)	0: No paper, 1: Paper present
	4	Corner fold sensors (F)	0: No paper, 1: Paper present

SP6-xxx Peripherals

	3	Fan fold sensors ®	0: No paper, 1: Paper present
	2	Corner fold sensors ®	0: No paper, 1: Paper present
	1	Fan fold exit sensor	0: No paper, 1: Paper present
	0	Corner fold exit sensor	0: No paper, 1: Paper present
5	Transport Switching (Not Used: Cross-Folder)		
	Bit	Input	Status
	7	Junction gate entrance sensor	0: No paper, 1: Paper present
	6	Paper exit sensor	0: No paper, 1: Paper present
	5	Paper length sensor	0: No paper, 1: Paper present
	4	Horizontal pressure HP sensor 1	0: No paper, 1: Paper present
	3	Horizontal pressure HP sensor 2	0: No paper, 1: Paper present
	2	Jogger HP sensor	0: No paper, 1: Paper present
	1	Punch registration sensor (H)	0: No paper, 1: Paper present
	0	Punch registration sensor (V)	0: No paper, 1: Paper present
6	Cross Folder (Not Used)		
	Bit	Input	Status
	7	Not used	---
	6	Not used	---
	5	Not used	---
	4	Cross folder entrance sensor	0: No paper, 1: Paper present
	3	Cross folder (U) sensor	0: No paper, 1: Paper present
	2	Cross folder (L) sensor	0: No paper, 1: Paper present
	1	Cross fold plate HP sensor (U)	0: Off, 1: On

	0	Cross fold plate HP sensor (L)	0: Off, 1: On
7	Invert/Rotate (Not Used: Cross-Folder)		
	Bit	Input	Status
	7	Not used	0: No paper, 1: Paper present
	6	Inverter entrance sensor	0: No paper, 1: Paper present
	5	Inverter exit sensor	0: No paper, 1: Paper present
	4	Inverter output sensor	0: No paper, 1: Paper present
	3	Rotate entrance sensor	0: No paper, 1: Paper present
	2	Non-rotate entrance sensor (U)	0: No paper, 1: Paper present
	1	Non-rotate entrance sensor (L)	0: No paper, 1: Paper present
	0	Paper registration sensor	0: No paper, 1: Paper present
8	Shift Tray (Not Used)		
	Bit	Input	Status
	7	Not used	---
	6	Not used	---
	5	Not used	---
	4	Exit sensor	0: No paper, 1: Paper present
	3	Shift tray HP sensor	0: Off, 1: On
	2	Paper sensor	0: No paper, 1: Paper present
	1	Lower limit sensor	0: Off, 1: On
	0	Door Switch	0: Off, 1: On
9	Punch: Horiz (Not Used)		
	Bit	Input	Status

SP6-xxx Peripherals

	7	Not used	---
	6	Not used	---
	5	Not used	---
	4	Not used	---
	3	Not used	---
	2	Not used	---
	1	Punch HP sensor	0: Off, 1: On
	0	Punch hopper full sensor	0: Off, 1: On
10	Punch: Vert (Not Used)		
	Bit	Input	Status
	7	Not used	---
	6	Not used	---
	5	Not used	---
	4	Not used	---
	3	Punch unit HP sensor	0: Off, 1: On
	2	Punch hopper full sensor	0: Off, 1: On
	1	Punch leading edge sensor (V)	0: Off, 1: On
	0	Punch HP sensor (V)	0: Off, 1: On
11	Door 1: Fan Folder		
	Bit	Input	Status
	7	N3 door switch	0: Close, 1: Open
	6	N5 door switch	0: Close, 1: Open
	5	N6 door switch	0: Close, 1: Open

	4	N7 door switch	0: Close, 1: Open
	3	Bypass front cover	0: Close, 1: Open
	2	Bypass rear cover	0: Close, 1: Open
	1	N6 guide switch (U)	0: Close, 1: Open
	0	N6 guide switch (L)	0: Close, 1: Open
12	Door 2: Fan Folder		
	Bit	Input	Status
	7	Not used	---
	6	Not used	---
	5	Not used	---
	4	Not used	---
	3	N1 guide microswitch	0: Close, 1: Open
	2	N3 door microswitch	0: Close, 1: Open
	1	N5 door microswitch	0: Close, 1: Open
	0	Bypass jam door microswitch	0: Close, 1: Open
13	Door 1: Cross Folder		
	Bit	Input	Status
	7	Not used	---
	6	Not used	---
	5	Not used	---
	4	Not used	---
	3	Transport JG door sensor (F)	0: Close, 1: Open
	2	Transport JG door sensor (U)	0: Close, 1: Open

Service
Tables

SP6-xxx Peripherals

	1	Transport JG door sensor ®	0: Close, 1: Open
	0	Cross fold door sensor ®	0: Close, 1: Open
14	Door 2: Cross Folder (Not Used)		
	Bit	Input	Status
	7	Not used	---
	6	Not used	---
	5	Not used	---
	4	Transport JG door microswitch (F)	0: Close, 1: Open
	3	Cross horizontal microswitch 1	0: Close, 1: Open
	2	Cross horizontal microswitch 2	0: Close, 1: Open
	1	Inverter door microswitch	0: Close, 1: Open
	0	Inverter door microswitch	0: Close, 1: Open

6118	Folder Output Check		
	<p>Use this SP to switch on the motors, clutches, and solenoids of the Folder unit B889 to test their operation.</p> <p>Important: After switching on a motor, clutch, or solenoid, be sure to switch it off after you finish your work.</p>		
	1	Transport Motor: Fwd: Fan Folder	
	2	Bypass Feed Clutch: Fan Folder	
	3	Paper Entrance Clutch: Fan Folder	
	4	Output Junction Gate SOL: Fan Folder	
	5	Pre-Fold Motor: SE: Fwd: Fan Folder	
	6	Pre-Fold Motor: LE Fwd: Fan Folder	
	7	Pre-Fold Clutch: SE: Fan Folder	

8	Pre-Fold Clutch: LE: Fan Folder
9	Relay Clutch: Fan Folder
10	Corner Fold Exit Clutch: Fan Folder
11	Front Fold Plate: Fan Folder
12	Rear Fold Plate: Fan Folder
13	Fold Motor: Fwd: Fan Folder
14	Fold Motor: Rev: Fan Folder
16	Front Fold Plate Motor: Fwd: Fan Folder
17	Front Fold Plate Motor: Rev: Fan Folder
18	Rear Fold Plate Motor: Fwd: Fan Folder
19	Rear Fold Plate Motor: Rev: Fan Folder
31	Vert Transport Motor: Fwd: Fan Folder
32	Vert Transport Motor: Rev: Fan Folder
33	Jogger Motor: Fwd: Cross Folder
34	Jogger Motor HP Sensor: Cross Folder
35	Punch Transport JG SOL: Cross Folder
36	Horiz Feed Pressure Motor HP Sensor: Cross Folder
38	Vert Feed Pressure SOL 1-3: Cross Folder
39	Horiz Feed Motor: Fwd: Cross Folder
40	Horiz Feed Motor: Rev: Cross Folder
41	Vert Feed Pres Idle SOL 1: L: Cross Folder
42	Vert Feed Pres Idle SOL 2: C: Cross Folder
43	Vert Feed Pres Idle SOL 3: R: Cross Folder

SP6-xxx Peripherals

44	Fold Motor: Fwd: Cross Folder
45	Fold Motor: Rev: Cross Folder
46	Upper Fold Plate Motor: Fwd: Cross Folder
47	Upper Fold Plate Motor: Rev: Cross Folder
49	Lower Fold Plate Motor: Fwd: Cross Folder
50	Lower Fold Plate Motor: Rev: Cross Folder
51	Fold Plate Motor Position HP Sensor: Cross Folder
52	Inverter Motor: Fwd: Cross Folder
53	Inverter Motor: Rev: Cross Folder
54	Rotate/Transport Motor: Fwd: Cross Folder
55	Inverter Entrance JG SOL: Cross Folder
57	Rotation Sensor SOL: Cross Folder
58	Rotation Entrance Pressure SOL: Cross Folder
59	Rotation Exit Pressure SOL: Cross Folder
60	Rotation Right Pressure SOL: Cross Folder
61	Rotation Left Pressure SOL: Cross Folder
62	Paper Output Motor: Fwd: Cross Folder
63	Shift Tray Motor: Fwd: Cross Folder
64	Tray Lift Motor HP Sensor: Cross Folder
66	Punch Move Motor: Fwd Horiz
67	Punch Move Motor: Rev Horiz
73	Punch Move Motor: Fwd Vert
74	Punch Move Motor: Rev Vert

75	Punch Drive Motor: Horiz
76	Punch Drive Clutch

6961	Trans. Motor Adj.: Fan Folder - Number of Folder Motor Rotations DFU
	<p>This SP adjusts the line-speed of the Folder unit transport motor. The transport motor drives all the timing belts that turn the rollers in the paper feed path.</p> <p>[-10 to +10/0/1%]</p> <p>Note: At “0”, the motor runs at normal speed. Adjustment in the “+” direction increases speed, and in the “-“ direction it decreases speed.</p>

6962	(Fan) Fold Motor Adjustment DFU
	<p>Use these SP’s to adjust the fan motor speed to correct skew and offset at the Folder unit entrance. The fan fold motor drives both pairs of fan fold rollers at the bottom of the Folder unit.</p>
1	Display Paper Length
	<p>This SP displays the length of the paper most recently fed into and folded in the Folder unit.</p> <p>[0 to 32767 mm]</p> <p>One of two sensors detects the leading edge and trailing edge of the paper, and calculates the paper length based on the length of time for the paper to pass below:</p> <ul style="list-style-type: none"> ▪ On line mode. The Folder unit entrance sensor detects the length of the paper fed from the main machine. ▪ Off line mode. The leading edge sensor of the Manual Feeder detects the length of the paper fed directly into the manual feeder.

2	Display Folded Length
	<p>This SP displays the length of the paper most recently folded in the Folder unit. [0 to 32767 mm]</p> <p>One of two sensors detects the leading edge and trailing edge of the paper, and calculates the paper length based on the length of time for the paper to pass below:</p> <ul style="list-style-type: none"> ▪ On line mode. The Folder unit entrance sensor detects the length of the paper fed from the main machine. ▪ Off line mode. The leading edge sensor of the Manual Feeder detects the length of the paper fed directly into the manual feeder.
11	(Fan) Fold Roller Speed
	<p>The SP sets the default speed of the fan fold roller motor when the man machine is turned on. [80 to 160/80/1 mm/s]</p>
21	Skew at Folder Entrance
	<p>This SP can be adjusted to correct the reading of the paper length. The input from SP6962-1 (paper length) and SP6962-22 (paper offset) are used together. After two sheets of different length have passed, the amount of skew and offset are calculated then corrected using this equation:</p> $Y = aX + b$ <p>where:</p> <p>X: Actual paper length Y: Paper length read by machine (SP6962-1) a: Skew correction (SP6962-21) b: Offset correction (SP6962-22) [70 to 130/100/0.1 %]</p>

22	Offset at Folder Entrance
	<p>This SP can be adjusted to correct reading of the paper length. The input from SP6962-1 (paper length) and SP6962-021 (paper skew) are used together. After two sheets of different length have passed, the amount of skew and offset are calculated then corrected using this equation:</p> $Y = aX + b$ <p>where:</p> <p>X: Actual paper length Y: Paper length read by machine (SP6962-1) a: Skew correction (SP6962-21) b: Offset correction (SP6962-22) [70 to 130/100/0.1 %]</p>
31	Offset at Folder Exit
	<p>This SP adjusts the length of the fan folds in the paper to be sent to the cross fold unit. [-10 to +10/0/0.1 mm]</p>
41	Fold Motor Rotation
	<p>This SP adjusts the rotations of the fan fold motor. [-10 to +10/0/0.1 %]</p>

SP6-xxx Peripherals

6963	Fold Plate Adjustment DFU
	Use these SP's to adjust operation of the fold plates inside the fan folder of the Folder unit.
1	Fold Plate Movement : LEdge
	<p>This SP adjusts how far the fold plates descend to guide the leading edge. [-200 to +200/0/1]</p> <p>Note:</p> <ul style="list-style-type: none"> ▪ An adjustment of 1 step is equivalent to 0.191 mm. ▪ An adjustment in the "+" direction moves the fold plates closer to the fan fold rollers, and an adjustment in the "-" direction moves them away from the fan fold rollers.
2	Fold Plate Movement
	<p>This SP adjusts how far the fold plates descend to push the paper between the fan fold rollers to form the folds. [-400 to +400/0/1]</p> <p>Note:</p> <ul style="list-style-type: none"> ▪ An adjustment of 1 step is equivalent to 0.191 mm. ▪ An adjustment in the "+" direction moves the fold plates closer to the fan fold rollers, and an adjustment in the "-" direction moves them away from the fan fold rollers.
11	Fold Plate Halt : LEdge
	<p>This SP adjusts when the fold plates pause on the downstroke at the lowest point near the fan fold rollers after the leading edge of the paper has entered the fan folder mechanism. [-100 to 500/0/10 ms]</p> <p>Note: An adjustment in the "+" direction sets a longer time, and an adjustment in the "-" direction sets a shorter time.</p>

12	Fold Plate Halt : Folding
	<p>This SP adjusts the how long the fold plates pause on the down stroke at its lowest point near the fan fold rollers.</p> <p>[-100 to 500/0/10 ms]</p> <p>Note: An adjustment in the “+” direction sets a longer time, and an adjustment in the “-“ direction sets a shorter time.</p>
21	Fold Plate Timing : LEdge
	<p>This SP adjusts the distance the paper feeds past the fan folder entrance sensor (the sensor goes ON) before the fold plate starts to descend.</p> <p>[-70 to 70/0/0.1 mm]</p> <p>Note: An adjustment in the “+” direction lengthens the distance, and an adjustment in the “-“ direction shortens the distance.</p>
22	Fold Plate Timing: Folding
	<p>This SP adjusts the distance that the paper travels past the fan fold sensor pair before the fold plate starts to descend.</p> <p>[-70 to 70/0/0.1 mm]</p> <p>Note: An adjustment in the “+” direction lengthens the distance, and an adjustment in the “-“ direction shortens the distance.</p>
31	Fold Plate Movement: LEdge Corner Folding
	<p>This SP adjusts the distance that the fan fold plate descends in order to guide the paper into the fan folding unit for the first fold when corner folding and fan folding have been selected for the job.</p> <p>[-200 to +200/0/1 mm]</p> <p>Note:</p> <ul style="list-style-type: none"> ▪ This SP applies only if corner folding the first sheet has been selected for the job. ▪ An adjustment of 1 step is equivalent to 0.191 mm. ▪ An adjustment in the “+” direction moves the fan fold plates closer to the fan fold rollers, and an adjustment in the “-“ direction moves the plate away from the fan fold rollers.

SP6-xxx Peripherals

32	Fold Plate Halt: LEdge Corner Folding
	<p>This SP adjusts the length of time the paper feeds before the fan fold plate starts to ascend when corner folding and fan folding have been selected for the job. [-100 to +500/0/10 mm]</p> <p>Note:</p> <ul style="list-style-type: none"> ▪ This SP applies only if corner folding has also been selected for the job. ▪ An adjustment in the “+” direction lengthens the time, and an adjustment in the “-” direction shortens the time.
33	Fold Plate Timing: LEdge Corner Folding
	<p>This SP adjusts the distance the paper feeds past the fan folder entrance sensor (the sensor goes ON) before the fold plate starts to descend when corner folding is also selected for the job. [-70 to 70/0/0.1 mm]</p> <p>Note:</p> <ul style="list-style-type: none"> ▪ This adjustment applies only after corner folding is also selected for the job. ▪ An adjustment in the “+” direction lengthens the distance, and an adjustment in the “-” direction shortens the distance.
41	Fold Plate Movement: Paper Exit
	<p>This SP adjusts the distance for the fan fold plate to move in order to guide the trailing edge of the last fold out of the fan folder unit. [-200 to +200/0/1 mm]</p> <p>Note:</p> <ul style="list-style-type: none"> ▪ An adjustment of 1 step is equivalent to 0.191 mm. ▪ An adjustment in the “+” direction moves the fan fold plates closer to the fan fold rollers, and an adjustment in the “-” direction moves the plate away from the fan fold rollers.

42	Fold Plate Halt: Paper Exit
	<p>This SP adjusts the length of time that the fan fold plate stops after descending in order to output trailing edge of the folded copy out of the folder unit after the last fold.</p> <p>[-100 to +6000/0/1 msec.]</p> <p>Note: An adjustment in the “+” direction lengthens the time, and an adjustment in the “-“ direction shortens the time.</p>
43	Fold Plate Timing: Paper Exit
	<p>This SP adjusts distance that the paper moves after the fan fold sensor pair detects the trailing edge and switches ON until the fan fold plate starts to move when feeding the copy out of the folder unit after the last fold.</p> <p>[0 to 350/0/1 mm]</p> <p>Note: An adjustment in the “+” direction lengthens the distance, and an adjustment in the “-“ shortens the distance.</p>

6964	Length Adjustment (Folder)
	These SP codes adjust the length of the folds. The summary below describes important terms used in these SP descriptions. For more see the “Folder FD 6500 Service Manual.”

There are two types of folding:

- **Long folding.** The folded copy looks like an accordion with the edges of the folded surfaces aligned.
- **File folding.** The same as long folding but the leading edge of the bottom sheet protrudes from the bottom of the stack. This margin can be used to fasten the leading edge into a flat binder, or it can be punched for filing in a ring binder.

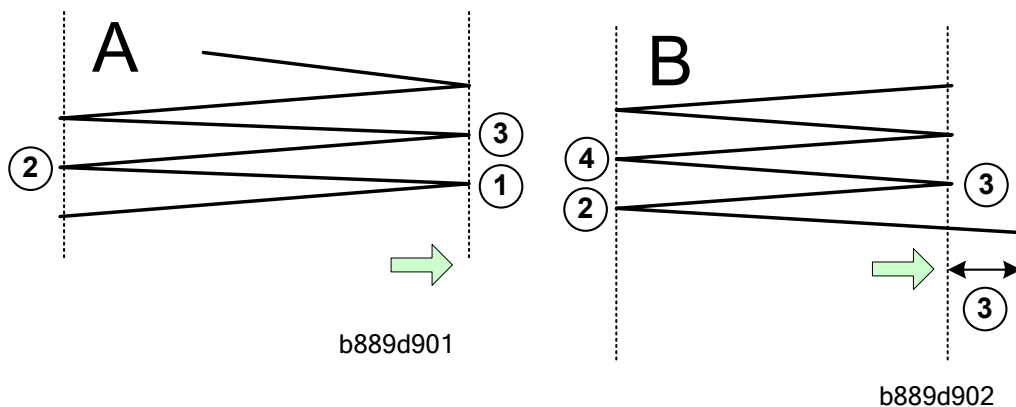

The first example [A] is a long fold. The second example [B] is a file fold. The colored arrows show the direction of paper feed when viewed from the right side of the folder unit. For the sake of convention, the folds on the right sides of the stacks shown above are called “peak folds” and those on the left are “valley folds.” In Stack [A], fold ① is a peak fold, fold ② is a valley fold, ③ is a peak fold, and so on.

- In a “long fold” like Stack [A], the first fold is always a peak fold.
- In Stack [B], ① is the leading edge fed wider than other sections of the stack, ② is a valley fold, ③ is a peak fold, ④ is a valley fold, and so on.
- In a “file fold” like Stack [B], the first fold is always a valley fold (done after creating the longer bottom sheet with the protruding leading edge). To create this difference in length, the fan fold motor feeds the leading edge to the rear slightly farther (about 40 mm) than the other folded sections above.

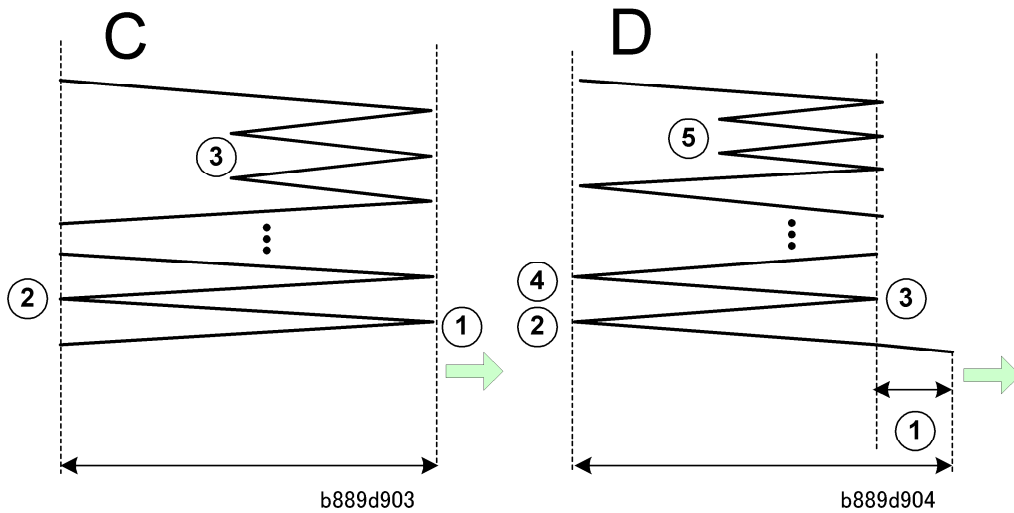

As shown in Stack [A] above, the top flap is slightly shorter than the other folds below which are of uniform size. If this is not desirable, the folding job can be set to calculate how much paper is needed for the last fold to ensure that the top flap is the same length as the other folds below, with folded surfaces of shorter length hidden in the stack. The folds of the paper remaining before the final full-length fold are “adjusted” to create shorter sections that will be covered by the top flap, so that the stack has a neat and uniform appearance. These adjusted folds can be done for either long folds or file folds as shown above.

- Stack [C] is a long fold (the first fold ① is a peak fold). The folds are adjusted at ③ so that the last flap is the same size as the other sections of the stack and long enough to cover the shorter adjusted folds below.
- Stack [D] is a file fold (the first fold is a valley fold). The folds are adjusted at ⑤ so that the last flap is the same size as the other sections of the stack and long enough to cover the short adjusted folds below.

Service
Tables

SP6-xxx Peripherals

1	Fold Length: 1 st Fold Peak
	<p>This SP determines the start of the first peak fold. To do this, it changes the timing of the fan fold sensor (F) that affects how far the paper feeds past this sensor after the first peak fold. This adjustment determines the length of a flap at the first fold wider than the succeeding folds.</p> <p>[-70 to 70/0/0.1 mm]</p> <p>Note:</p> <ul style="list-style-type: none"> ▪ Adjustment in the “-“ or “+” direction decreases or increases the amount of paper that feeds past the sensor. This decreases or increases the length of paper between the first two folds.
2	Fold Length: 1 st Fold Valley
	<p>This SP determines the start of the first valley fold. To do this, it changes the timing of the fan fold sensor (R) that affects how far the paper feeds past this sensor after the first peak fold. This adjustment determines the length of a flap, starting at the leading edge, that is wider than the succeeding folds. (This elongated flap can be used to bind the folded copy.)</p> <p>[-70 to 70/0/0.1 mm]</p> <p>Note: Adjustment in the “-“ or “+” direction decreases or increases amount of paper that feeds past the sensor. This decreases or increases the length of the paper (section) from the leading edge to the first valley fold.</p>
3	Fold Length: 2 nd Fold Peak
	<p>This SP adjusts the operation of the fan fold sensor (F).</p> <ul style="list-style-type: none"> ▪ If the first fold is a peak fold, this SP setting determines the length of even number sections, excluding that of the first section. ▪ If the first fold is a valley fold, this SP setting determines the length of odd sections. <p>Note: Adjustment in the “-“ or “+” direction decreases or increases amount of paper that feeds past the sensor. This decreases or increases the length of the even or odd sections.</p>

4	Fold Length: 2 nd Fold Valley
	<p>This SP adjusts the operation of the fan fold sensor (R).</p> <ul style="list-style-type: none"> ▪ If the first fold is a peak fold, this SP setting determines the length of odd number sections. ▪ If the first fold is a valley fold, this SP setting determines the length of even sections, excluding that of the first section. <p>Note: Adjustment in the “-“ or “+” direction decreases or increases amount of paper that feeds past the sensor. This decreases or increases the length of the even or odd sections.</p>
11	Margin Fold Length: 3 rd Fold: A0 SEF
	<p>This SP adjusts the length of the 3rd section when folding A0 SEF paper. [-20 to +20/-2.5/01. mm]</p> <p>Note: Adjustment in the “-“ or “+” direction decreases or increases the length of the 3rd section.</p>
12	Margin Fold Length: 5 th Fold A0 SEF
	<p>This SP adjusts the length of the 5th section when folding A0 SEF paper. [-20 to +20/-3/01. mm]</p> <p>Note: Adjustment in the “-“ or “+” direction decreases or increases the length of the 5th section.</p>
13	Margin Fold Length: 3 rd Fold: A1 SEF
	<p>This SP adjusts the length of the 3rd section when folding A1 SEF paper. [-20 to +20/-1.5/01. mm]</p> <p>Note: Adjustment in the “-“ or “+” direction decreases or increases the length of the 3rd section.</p>
14	Margin Fold Length: 3 rd Fold: A2 SEF
	<p>This SP adjusts the length of the 3rd section when folding A2 SEF paper. [-20 to +20/-6/01. mm]</p> <p>Note: Adjustment in the “-“ or “+” direction decreases or increases the length of the 3rd section.</p>

SP6-xxx Peripherals

21	Margin Fold Length: 7 th Fold
	<p>This SP adjusts the length of the 6th section in order to complete the 7th (last) section.</p> <p>[-20 to +20/3/01. mm]</p> <p>Note: Adjustment in the “-“ or “+” direction decreases or increases the length.</p>
22	Margin Fold Length: 5 th Fold
	<p>This SP adjusts the length of the 4th section in order to complete the 5th (last) section.</p> <p>[-20 to +20/0/01. mm]</p> <p>Note: Adjustment in the “-“ or “+” direction decreases or increases the length.</p>
23	Margin Fold Length: 3 rd Fold
	<p>This SP adjusts the length of the 2nd section in order to complete the 3rd (last) section.</p> <p>[-20 to +20/-3/01. mm]</p> <p>Note: Adjustment in the “-“ or “+” direction decreases or increases the length.</p>
31	Margin Fold Length: Regular Size
	<p>This SP fine adjusts the length of the sections between folds for copies printed on standard size paper.</p> <p>[-20 to +20/0/0.1]</p> <p>Note: Adjustment in the “-“ or “+” direction decreases or increases the length.</p>
32	Margin Fold Length: Long Print
	<p>This SP adjusts the length of the last section (from last fold to the trailing edge) during long fan folding.</p> <p>[-20 to +20/0/0.1 mm]</p> <p>Note: Adjustment in the “-“ or “+” direction decreases or increases the length.</p>

41	Long Print: 1 st Fold Peak: After 2 nd Fold
	<p>This SP modifies the operation of the fan fold sensor (F) to determine the lengths of the odd and even sections for long fan folding only.</p> <ul style="list-style-type: none"> ▪ If the first fold is a peak fold, this SP setting determines the length of even number sections, excluding the 1st section. ▪ If the first fold is a valley fold, this SP setting determines the length of odd sections. <p>Note: Adjustment in the “-“ or “+” direction decreases or increases the length.</p>
42	Long Print: 1 st Fold Valley: After 2 nd Fold
	<p>This SP modifies the operation of the fan fold sensor (R) to determine the lengths of the odd and even sections for long fan folding.</p> <ul style="list-style-type: none"> ▪ If the first fold is a peak fold, this SP setting determines the length of odd number sections, excluding the 1st section. ▪ If the first fold is a valley fold, this SP setting determines the length of even sections. <p>Note: Adjustment in the “-“ or “+” direction decreases or increases the length.</p>
43	Margin Fold: 1 st Fold Peak: After 4 th Fold
	<p>This SP modifies the operation of the fan fold sensor (F) to determine the lengths of the odd and even sections for long fan folding (including file flap or margin folding).</p> <ul style="list-style-type: none"> ▪ If the first fold is a peak fold, this SP setting determines the length even number sections, excluding the 1st section. ▪ If the first fold is a valley fold, this SP setting determines the length of odd sections. <p>Note: Adjustment in the “-“ or “+” direction decreases or increases the length.</p>
44	Margin Fold: 1 st Fold Valley: After 2 nd Fold

SP6-xxx Peripherals

	<p>This SP modifies the operation of the fan fold sensor (R) to determine the lengths of the odd and even sections for long fan folding) including file flap folding).</p> <ul style="list-style-type: none"> ▪ If the first fold is a peak fold, this SP setting determines the length even number sections. ▪ If the first fold is a valley fold, this SP setting determines the length of odd sections, excluding the 1st section. <p>Note: Adjustment in the “-“ or “+” direction decreases or increases the length.</p>
45	Fold Length: 1 st Fold Peak: A3 SEF
	<p>This SP fine adjusts the length of the sections between folds for copies printed on A3 SEF paper.</p> <p>[-20 to +20/0/0.1]</p> <p>Note: Adjustment in the “-“ or “+” direction decreases or increases the length.</p>
51	Margin Fold Length: File
	<p>This SP fine adjusts the calculated length of the file flap.</p> <p>[-20 to +20/0/0.1]</p>
61	Margin Fold Length: Threshold
	<p>This SP adjusts the threshold variable that the machine uses to calculate when to do adjusted folding.</p> <p>[-70 to +70/0/0.1]</p>
91	Regular Size Fold Switching
	<p>This SP determines whether the lengths of the sections can be adjusted for folding standard paper sizes.</p> <p>[0 to 1/0/1]</p> <p>0: Adjustment allowed 1: Adjustment not allowed</p>
6965	Pre-Fold Adjustment (Corner Folder) Not Used

6966	Fan Fold Selection: Fan Folder Standard Fold Switching
	This SP determines whether fixed pattern printing only is enabled when the Folder unit is online. [0 to 1/0/1] 0: Disable 1: Enable fixed pattern only

6969	Bypass Feed Setting DFU
	This sets the how the bypass feed sensors read paper sizes. [0 to 1/0/1] 0: DOM, EU (Japan, Europe) 1: NA (North America)

6971	Transport Switch Adj (Cross Folder) Not Used
------	---

6972	Cross Fold Adjustment (Cross Folder) Not Used
------	--

6973	Invert/Rotate Adjustment (Cross Folder) Not Used
------	---

6974	Shift Tray Adjustment: Cross Wait Position (Cross Folder) Not Used
------	---

Service
Tables

SP6-xxx Peripherals

6991	Folder Counter	
	These SP's display the operational counts for the functions in the fan fold, cross punch, and transport and folding unit. This SP's display the counts for each item listed below in the range: 0 to 9999 9999,	
1	Fan Folder Sheet Count	Number of sheets through the fan folder (with or without folding)
2	Cross Folder Sheet Count	Number of sheets through the cross folder unit (with or without folding)
3	Fan Fold Count	Number of folds done by fan folder.
4	Corner Fold Count	Number of folds done by corner folder.
5	Cross Fold Count	Number of folds done by cross folder.
6	Punch Count (Vert)	Number of vertical punches (2 holes across direction of feed)
7	Punch Count (Horiz)	Number of vertical punches (2 holes parallel to direction of feed)

5.13 SP7-XXX DATA LOG

7001	Main Motor Operation Time
	Shows the drum-drive-motor operation time (to check the print count and drum operation time.)

7401	Total SC Counter
	Shows the total SC count as a 4-digit number.

7403	SC History	
1	Latest	Display the most recent service calls in their order of occurrence.
2	Latest 1	
3	Latest 2	
4	Latest 3	
5	Latest 4	
6	Latest 5	
7	Latest 6	
8	Latest 7	
9	Latest 8	
10	Latest 9	

7502	Total Paper Jam Counter
	Displays the total number of copy jams. Display range: 0000 to 9999

Service Tables

SP7-xxx Data Log

7503	Total Original Jam Counter
	Displays the total number of original jams. Display range: 0000 to 9999

7504:	Paper Jam Counter by Jam Location	
	Displays the total number of copy jams by location. A "Paper Late" error occurs when the paper fails to activate the sensor at the precise time. A "Paper Lag" paper jam occurs when the paper remains at the sensor for longer than the prescribed time. Display range: 0000 to 9999	
	Main Machine	
	1: At Power On	Main Machine (B286)
	3: Tray 1: No Feed	
	4: Tray 2: No Feed	
	5: Tray 3: No Feed	
	8: RF Exit Sn: Not On	
	13: Reg Sn: Not On	
	16: Exit Sn: Not On	
	34: Bypass: No Feed	
	53: Tray 1: Paper Lag	
	54: Tray 2: Paper Lag	
	55: Tray 3: Paper Lag	
	58: RF Exit Sn: Not Off	
63: Reg Sn: Not Off		
66: Exit Sn: Not Off		

84: Bypass Sn: Not Off	
Folder FD Unit (B889)	
100: Folder: At Power On	
130: Bypass Ent Sn: Not On	
131: Bypass Relay Sn: Not Off	
132: Straight Exit Sn: Not On	
133: Straight Exit Sn: Not Off	
134: Folder Relay Sn: Not On	
135: Folder Relay Sn: Not Off	
136: Corner Folder Exit Sn: Not On	
137: Corner Folder Exit Sn: Not Off	
138: Accordion Folder Ent Sn: Not On	
139: Folder Ent Sn: Not Off	
140: Front Fold Width Sn: Not On	
141: Rear Fold Width Sn: Not On	
142: Rear Fold Width Sn: Not Off	
143: Accordion Folder Exit Sn: Not On	
144: Folder Exit Sn: Not Off	
145: Maximum Paper Length	
146: Fold Count Limit	
Cross Folder	
150: Cross Folder: At Power On	Not used
170: Trans Unit Ent Sn: Not On	Not used

Service
Tables

SP7-xxx Data Log

171: Trans Unit Ent Sn: Not Off	Not used
172: Punch Reg Sn (Vert): Not On	Not used
173: Punch Reg Sn (Horiz): Not On	Not used
174: Trans Uniti Exit Sn: Not On	Not used
175: Paper Exit Sn: Not Off	Not used
176: Long Paper Exit Sn: Not On	Not used
177: Paper Length Sn: Not Off	Not used
178: Cross Folder Ent Sn: Not On	Not used
179: Cross Folder Ent Sn: Not Off	Not used
180: Fold Width Sn (Upper): Not On	Not used
181: Fold Width Sn (Lower): Not On	Not used
182: Folder Width Sn (Up): Not Off	Not used
183: Inverter Ent Sn: Not On	Not used
184: Inverter Ent Sn: Not Off	Not used
185: Inverter Exit Sn: Not On	Not used
186: Inverter Exit Sn: Not Off	Not used
187: Inverter Output Sn: Not Off	Not used
188: Rotation Ent Sn: Not On	Not used
189: Rotation Ent Sn: Not Off	Not used
190: No Rotation Sn	Not used
191: Rotation Exit Sn: Not On	Not used
192: Rotation Exit Sn: Not Off	Not used
193: Cross Folder Exit Sn: Not On	Not used

	194: Cross Folder Exit Sn: Not Off	Not used
	196: Folder Paper Width Error	Not used

7505	Original Jam Detection	
	<p>Displays the total number of original jams by location. These jams occur when the original does not activate the sensors.</p> <p>Display range: 0000 to 9999</p> <p>Note:</p> <ul style="list-style-type: none"> ▪ A “Check In” failure occurs when the paper fails to activate the sensor at the precise time. ▪ A “Check Out” failure occurs when the paper remains at the sensor for longer than the prescribed time and causes a jam. ▪ The 3rd column in the table below tells you the correct component name used in the service manual. 	
	Operation Panel Display	
	1	Org at Power On
	2	Org Reg Sn: Not On
	3	Org Reg Sn/Exit Sn: Both Off
	4	Org Reg Sn: Not Off
	5	Org Exit Sn: Not Off
	6	Org Stop
	7	Org Exit Sn: Not On
8	Org Interval Error	

Service Tables

SP7-xxx Data Log

7506	Jam Count by Paper Size
	This SP displays the counts for the number of jams by paper size. Note: In the paper size notations below, "T" means "SEF" (Short Edge Feed).
97	A0T/A1
98	A1T/A2
99	A2T/A3
100	A3T/A4
101	A4T
106	B1T/B2
107	B2T/B3
108	B3T/B4
109	B4T
225	36x48T/24x36
226	24x36T/18x24
227	18x24T/12x18
228	12x18T/9x12
229	9x12T
234	34x44T/22x34
235	22x34T/17x22
236	17x22T/11x17
237	11x17T/8.5x11
238	8.5x11T
255	Others

7507	Plotter Jam History	
	Displays the copy jam history in groups of 10, starting with the most recent 10 jams. Display contents are as follows: CODE: SP7-505-*** number. SIZE: Paper size code in hex. (See the table below.) TOTAL : Total jam error count (SP7003) DATE: Previous jam occurred	
1	Latest	Sample Display: CODE: 007 SIZE: 05h TOTAL: 0000334 DATE: Mon Mar 15 11:44:50 2000
2	Latest 1	
3	Latest 2	
4	Latest 3	
5	Latest 4	
6	Latest 5	
7	Latest 6	
8	Latest 7	
9	Latest 8	
10	Latest 9	

Service Tables

7508	Original Jam History	
	Displays the original jam history in groups of 10, starting with the most recent 10 jams. Display contents are as follows: CODE: SP7505-*** number. SIZE: Paper size code in hex. (See table below.) TOTAL: Total jam error count (SP7003) DATE: Date the previous jam occurred	
1	Latest	Sample Display: CODE: 007
2	Latest 1	

SP7-xxx Data Log

3	Latest 2	SIZE: 05h TOTAL: 0000334 DATE: Mon Mar 15 11:44:50 2000
4	Latest 3	
5	Latest 4	
6	Latest 5	
7	Latest 6	
8	Latest 7	
9	Latest 8	
10	Latest 9	

Paper Size Hex Codes

These codes are displayed by SP7507 and SP7508.

Paper Size	Code (hex)	Paper Size	Code (hex)
A4 LEF	05	B4 SEF	8D
A5 LEF	06	B5 SEF	8E
LT LEF	26	DLT SEF	A0
A3 SEF	84	LG SEF	A4
A4 SEF	85	LT SEF	A6
A5 SEF	86	Others	FF

7801	ROM Version
	Displays the ROM number, firmware version numbers, and other important information about the machine. Press ▼ or ▲ to see more information.

7803	PM Counter Display
	Displays the PM counter since the last PM.

7804	PM Counter Reset	
	Resets the PM counter. To reset, press [Execute]	
7807	SC/Jam Counter Reset	
	Resets the SC and jam counters. To reset, press [Execute]. This SP does not reset the jam history counters: SP7507, SP7508.	
7826	MF Error Counter Japan Only	
	Displays the number of counts requested of the card/key counter.	
	1 Error Total	A request for the count total failed at power on. This error will occur if the device is installed but disconnected.
	2 Error Staple	The request for a staple count failed at power on. This error will occur if the device is installed but disconnected.
7827	MF Error Counter Clear	
	Press [Execute] to reset the values of SP7826 to "0." Japan Only	
7832	Self-Diagnosis Result Display	
	Opens the "Self-Diagnose Result Display" to view details about errors. Use the keys on in the display to scroll through all the information. If no errors have occurred, you will see "No Error."	
7833	Pixel Coverage	
	Displays the coverage ratio of the output (the ratio of the total pixel area of the image data to the total printable area on the paper).	
	Note <ul style="list-style-type: none"> ▪ This value is not directly proportional to the amount of toner consumed. ▪ It is, however, one factor that affects this amount. 	

SP7-xxx Data Log

	<ul style="list-style-type: none"> Other major factors include: the type, total image area and image density of the original, toner concentration and developer potential. 	
1	Last Page	0% to 100%.
2	Accumulated Average	0% to 100%.
3	Total Toner Cartridges Used	0 to 65,535 copies
4	Previous Toner Bottle	0 to 999,999 copies
5	Toner Bottle Before Previous	0 to 999,999 copies

7834	Coverage Data Clear	
	These SPs clear the counters for the following items.	
1	Last & Average	
2	Total Toner Cartridges Used	
3	Toner Cartridge Count: Last & Before Last	
4	Page Counts	
255	All Clear	

7836	Total Memory Size	
	Displays the memory capacity of the controller system: "1024 MB."	

7901	Assert Info.	
	These SP numbers display the results of the occurrence of the most recent SC code generated by the machine.	
1	File Name	Module name
2	Number of Lines	Lines where error occurred.
3	Location	Component affected by error

7999	Engine Debug Log Switch DFU	
	Allows selection of the log to save with the debug log switch. [0 to 100/0/1]	

5.14 SP8-XXX DATA LOG 2

Here are some Group 8 SP's that when used in combination with others can provide useful information.

SP Numbers	What They Do
SP8211 to SP8216	The number of pages scanned to the document server.
SP8401 to SP8406	The number of pages printed from the document server
SP8691 to SP8696	The number of pages sent from the document server

Specifically, the following questions can be answered:

- How is the document server actually being used?
- What application is using the document server most frequently?
- What data in the document server is being reused?

The SP's in this group are prefixed with a letter that indicates the mode of operation (the mode of operation is referred to as an 'application'). Before reading the Group 8 Service Table, make sure that you understand what these prefixes mean.

Prefix	What It Means	
T:	Total: (Grand Total).	Grand total of the items counted for all applications (C, F, P, etc.)..
C:	Copy application.	Totals (pages, jobs, etc.) executed for each application when the job was not stored on the document server.
P:	Print application.	
S:	Scan application.	

L:	Local storage (document server)	Totals (jobs, pages, etc.) for the document server. The L: counters work differently case by case. Sometimes, they count jobs/pages stored on the document server; this can be in document server mode (from the document server window), or from another mode, such as from a printer driver or by pressing the Store File button in the Copy mode window. Sometimes, they include occasions when the user uses a file that is already on the document server. Each counter will be discussed case by case.
O:	Other applications (external network applications, for example)	Refers to network applications such as Web Image Monitor. Utilities developed with the SDK (Software Development Kit) will also be counted with this group in the future.

The Group 8 SP codes are limited to 17 characters, forced by the necessity of displaying them on the smaller LCD's of copiers, printers and faxes that also use these SP's. Read over the list of abbreviations below and refer to it again if you see the name of an SP that you do not understand.

Key for Abbreviations

Abbreviation	What It Means
/	"By", e.g. "T:Jobs/Apl" = Total Jobs "by" Application
>	More (2> "2 or more", 4> "4 or more")
AddBook	Address Book
Apl	Application
B/W	Black & White
Bk	Black
C	Cyan

Service Tables

SP8-xxx Data Log 2

Abbreviation	What It Means
ColCr	Color Create
ColMode	Color Mode
Comb	Combine
Comp	Compression
Deliv	Delivery
DesApl	Designated Application. The application (Copy, Fax, Scan, Print) used to store the job on the document server, for example.
Dev Counter	Development Count, no. of pages developed.
Dup, Duplex	Duplex, printing on both sides
Emul	Emulation
FC	Full Color
FIN	Post-print processing, i.e. finishing (punching, stapling, etc.)
Full Bleed	No Margins
GenCopy	Generation Copy Mode
GPC	Get Print Counter. For jobs 10 pages or less, this counter does not count up. For jobs larger than 10 pages, this counter counts up by the number that is in excess of 10 (e.g., for an 11-page job, the counter counts up 11-10 =1)
IFax	Internet Fax
ImgEdt	Image Edit performed on the original with the copier GUI, e.g. border removal, adding stamps, page numbers, etc.
K	Black (YMCK)
LS	Local Storage. Refers to the document server.
LSize	Large (paper) Size

Abbreviation	What It Means
Mag	Magnification
MC	One color (monochrome)
NRS	New Remote Service, which allows a service center to monitor machines remotely. "NRS" is used overseas, "CSS" is used in Japan.
Org	Original for scanning
OrgJam	Original Jam
Palm 2	Print Job Manager/Desktop Editor: A pair of utilities that allows print jobs to be distributed evenly among the printers on the network, and allows files to be moved around, combined, and converted to different formats.
PC	Personal Computer
PGS	Pages. A page is the total scanned subsection of the original. Duplex pages count as two pages, and A3 simplex count as two pages if the A3/DLT counter SP is switched ON.
PJob	Print Jobs
Ppr	Paper
PrtJam	Printer (plotter) Jam
PrtPGS	Print Pages
Rez	Resolution
SC	Service Code (Error SC code displayed)
Scn	Scan
Sim, Simplex	Simplex, printing on 1 side.

SP8-xxx Data Log 2

S- to -Email	Scan- to -E-mail
SMC	SMC report printed with SP5990. All of the Group 8 counters are recorded in the SMC report.
Svr	Server
tonEnd	toner End
tonSave	toner Save
TXJob	Send, Transmission
YMC	Yellow, Magenta, Cyan
YMCK	Yellow, Magenta, Cyan, Black

All of the Group 8 SP's are reset with SP5 801 1 Memory All Clear, or the counter reset SP7 808.

8001	T:Total Jobs	These SP's count the number of times each application is used to do a job. [0 to 9999999/ 0 / 1] Note: The L: counter is the total number of times the other applications are used to send a job to the document server, plus the number of times a file already on the document server is used.
8002	C:Total Jobs	
8004	P:Total Jobs	
8005	S:Total Jobs	
8006	L:Total Jobs	

- These SP's reveal the number of times an application is used, not the number of pages processed.
- When an application is opened for image input or output, this counts as one job.
- Interrupted jobs (paper jams, etc.) are counted, even though they do not finish.
- Only jobs executed by the operator are counted. Jobs executed by the operator engineer using the SP modes are not counted.
- When using secure printing (when a password is required to start the print job), the job is counted at the time when either "Delete Data" or "Specify Output" is specified.
- When a copy job on the document server is printed, SP8022 also increments, and when a print job stored on the document server is printed, SP8024 also increments.

- When an original is both copied and stored on the document server, the C: and L: counters both increment.
- When a print job is stored on the document server, only the L: counter increments.
- When the user presses the Document Server button to store the job on the document server, only the L: counter increments.
- When the user enters document server mode and prints data s to red on the document server, only the L: counter increments.
- When an image received from Palm 2 is received and stored, the L: counter increments.
- When the operator prints a report (user code list, for example), the O: counter increments.

8011	T:Jobs/LS	These SP's count the number of jobs stored to the document server by each application, to reveal how local storage is being used for input. [0 to 9999999/ 0 / 1] The L: counter counts the number of jobs stored from within the document server mode screen at the operation panel.
8012	C:Jobs/LS	
8014	P:Jobs/LS	
8015	S:Jobs/LS	
8016	L:Jobs/LS	
8017	O:Jobs/LS	

- When a scan job is sent to the document server, the S: counter increments. When you enter document server mode and then scan an original, the L: counter increments.
- When a print job is sent to the document server, the P: counter increments.
- When a network application sends data to the document server, the O: counter increments.
- When an image from Palm 2 is stored on the document server, the O: counter increments.

SP8-xxx Data Log 2

8021	T:Pjob/LS	<p>These SP's reveal how files printed from the document server were s to red on the document server originally. [0 to 9999999/ 0 / 1]</p> <p>The L: counter counts the number of jobs stored from within the document server mode screen at the operation panel.</p>
8022	C:Pjob/LS	
8024	P:Pjob/LS	
8025	S:Pjob/LS	
8026	L:Pjob/LS	
8027	O:Pjob/LS	

- When a copy job stored on the document server is printed with another application, the C: counter increments.
- When an application like DeskTopBinder merges a copy job that was stored on the document server with a print job that was stored on the document server, the C: and P: counters both increment.
- When a job already on the document server is printed with another application, the L: counter increments.
- When a scanner job stored on the document server is printed with another application, the S: counter increments. If the original was scanned from within document server mode, then the L: counter increments.
- When images stored on the document server by a network application (including Palm 2), are printed with another application, the O: counter increments.
- When a copy job stored on the document server is printed with a network application (Web Image Monitor, for example), the C: counter increments.

8031	T:Pjob/DesApl	<p>These SP's reveal what applications were used to output documents from the document server. [0 to 9999999/ 0 / 1]</p> <p>The L: counter counts the number of jobs printed from within the document server mode screen at the operation panel.</p>
8032	C:Pjob/DesApl	
8034	P:Pjob/DesApl	
8035	S:Pjob/DesApl	
8036	L:Pjob/DesApl	
8037	O:Pjob/DesApl	

- When documents already stored on the document server are printed, the count for the application that started the print job is incremented.
- When the print job is started from a network application (Desktop Binder, Web Image Monitor, etc.) the L: counter increments.

8041	T:TX Jobs/LS	<p>These SP's count the applications that stored files on the document server that were later accessed for transmission over the telephone line or over a network (attached to an e-mail). [0 to 9999999/ 0 / 1]</p> <p>Note:</p> <ul style="list-style-type: none"> ▪ Jobs merged for sending are counted separately. ▪ The L: counter counts the number of jobs scanned from within the document server mode screen at the operation panel.
8042	C:TX Jobs/LS	
8044	P:TX Jobs/LS	
8045	S:TX Jobs/LS	
8046	L:TX Jobs/LS	
8047	O:TX Jobs/LS	

- When a stored copy job is sent from the document server, the C: counter increments.
- When images stored on the document server by a network application or Palm2 are sent as an e-mail, the O: counter increments.

8051	T:TX Jobs/DesApl	<p>These SP's count the applications used to send files from the document server over the telephone line or over a network (attached to an e-mail). Jobs merged for sending are counted separately. [0 to 9999999/ 0 / 1]</p> <p>The L: counter counts the number of jobs sent from within the document server mode screen at the operation panel.</p>
8052	C:TX Jobs/DesApl	
8054	P:TX Jobs/DesApl	
8055	S:TX Jobs/DesApl	
8056	L:TX Jobs/DesApl	
8057	O:TX Jobs/DesApl	

- If the send is started from Desktop Binder or Web Image Monitor, for example, then the O: counter increments.

SP8-xxx Data Log 2

8061	T:FIN Jobs	[0 to 9999999/ 0 / 1]
	These SP's total the finishing methods. The finishing method is specified by the application.	
8062	C:FIN Jobs	[0 to 9999999/ 0 / 1]
	These SP's total finishing methods for copy jobs only. The finishing method is specified by the application.	
8064	P:FIN Jobs	[0 to 9999999/ 0 / 1]
	These SP's total finishing methods for print jobs only. The finishing method is specified by the application.	
8065	S:FIN Jobs	[0 to 9999999/ 0 / 1]
	These SP's total finishing methods for scan jobs only. The finishing method is specified by the application. Note: Finishing features for scan jobs are not available at this time.	
8066	L:FIN Jobs	[0 to 9999999/ 0 / 1]
	These SP's total finishing methods for jobs output from within the document server mode screen at the operation panel. The finishing method is specified from the print window within document server mode.	
8067	O:FIN Jobs Not Used	[0 to 9999999/ 0 / 1]
	These SP's total finishing methods for jobs executed by an external application, over the network. The finishing method is specified by the application.	
806x 1	Sort	Number of jobs started in Sort mode. When a stored copy job is set for Sort and then stored on the document server, the L: counter increments. (See SP8066 1)
806x 2	Stack	Number of jobs started in Sort mode.
806x 3	Staple	Number of jobs started in Staple mode.
806x 4	Booklet	Number of jobs started in Booklet mode. If the machine is in staple mode, the Staple counter also increments.

806x 5	Z-Fold	Number of jobs started In any mode other than the Booklet mode and set for folding (Z-fold).
806x 6	Punch	Number of jobs started in Punch mode. When Punch is set for a print job, the P: counter increments. (See SP8064 6.)
806x 7	Other	Reserved. Not used.

8071	T:Jobs/PGS	[0 to 9999999/ 0 / 1]
	These SP's count the number of jobs broken down by the number of pages in the job, regardless of which application was used.	
8072	C:Jobs/PGS	[0 to 9999999/ 0 / 1]
	These SP's count and calculate the number of copy jobs by size based on the number of pages in the job.	
8074	P:Jobs/PGS	[0 to 9999999/ 0 / 1]
	These SP's count and calculate the number of print jobs by size based on the number of pages in the job.	
8075	S:Jobs/PGS	[0 to 9999999/ 0 / 1]
	These SP's count and calculate the number of scan jobs by size based on the number of pages in the job.	
8076	L:Jobs/PGS	[0 to 9999999/ 0 / 1]
	These SP's count and calculate the number of jobs printed from within the document server mode window at the operation panel, by the number of pages in the job.	
8077	O:Jobs/PGS	[0 to 9999999/ 0 / 1]
	These SP's count and calculate the number of "Other" application jobs (Web Image Monitor, Palm 2, etc.) by size based on the number of pages in the job.	

Service Tables

SP8-xxx Data Log 2

807x 1	1 Page	807x 8	21 to 50 Pages
807x 2	2 Pages	807x 9	51 to 100 Pages
807x 3	3 Pages	807x 10	101 to 300 Pages
807x 4	4 Pages	807x 11	301 to 500 Pages
807x 5	5 Pages	807x 12	501 to 700 Pages
807x 6	6 to ~ Pages	807x 13	701 to 1000 Pages
807x 7	11 ~ 20 Pages	807x 14	1001 to Pages

Example: When a copy job stored on the document server is printed in document server mode, the appropriate L: counter (SP8076 0xx) increments.

- Interrupted jobs (paper jam, etc.) are counted, even though they do not finish.
- If a job is paused and re-started, it counts as one job.
- If the finisher runs out of staples during a print and staple job, then the job is counted at the time the error occurs.
- For copy jobs (SP 8072) and scan jobs (SP 8075), the total is calculated by multiplying the number of sets of copies by the number of pages scanned. (One duplex page counts as 2.)
- The first test print and subsequent test prints to adjust settings are added to the number of pages of the copy job (SP 8072).
- When printing the first page of a job from within the document server screen, the page is counted.

8131	T:S-to-Email Jobs	[0 to 9999999/ 0 / 1]
	These SP's count the total number of jobs scanned and attached to an e-mail, regardless of whether the document server was used or not.	
8135	S:S-to-Email Jobs	
	These SP's count the number of jobs scanned and attached to an e-mail, without storing the original on the document server.	

- These counters count jobs, not pages.
- If the job is stored on the document server, after the job is stored it is determined to be color or black-and-white then counted.
- If the job is cancelled during scanning, or if the job is cancelled while the document is waiting to be sent, the job is not counted.
- If the job is cancelled during sending, it may or may not be counted, depending on what stage of the process had been reached when the job was cancelled.
- If several jobs are combined for sending to the Scan Router, Scan- to -Email, or Scan- to -PC, or if one job is sent to more than one destination. each send is counted separately. For example, if the same document is sent by Scan- to -Email as well as Scan- to -PC, then it is counted twice (once for Scan- to -Email and once for Scan- to -PC).

8141	T:Deliv Jobs/Svr	[0 to 9999999/ 0 / 1]
	These SP's count the total number of jobs scanned and sent to a Scan Router server.	
8145	S:Deliv Jobs/Svr	
	These SP's count the number of jobs scanned and sent to a Scan Router server.	

Service Tables

- These counters count jobs, not pages.
- The jobs are counted even though the arrival and reception of the jobs at the Scan Router server cannot be confirmed.
- If even one color image is mixed with black-and-white images, then the job is counted as a "Color" job.
- If the job is cancelled during scanning, or if the job is cancelled while the document is waiting to be delivered, the job is not counted.
- If the job is cancelled during sending, it may or may not be counted, depending on what stage of the process had been reached when the job was cancelled.
- Even if several files are combined for sending, the transmission counts as one job.

SP8-xxx Data Log 2

8151	T:Deliv Jobs/PC	[0 to 9999999/ 0 / 1]
	<p>These SP's count the total number of jobs scanned and sent to a folder on a PC (Scan- to -PC).</p> <p>Note: At the present time, 8151 and 8155 perform identical counts.</p>	
8155	S:Deliv Jobs/PC	
	<p>These SP's count the total number of jobs scanned and sent with Scan- to -PC.</p>	

- These counters count jobs, not pages.
- If the job is cancelled during scanning, it is not counted.
- If the job is cancelled while it is waiting to be sent, the job is not counted.
- If the job is cancelled during sending, it may or may not be counted, depending on what stage of the process had been reached when the job was cancelled.
- Even if several files are combined for sending, the transmission counts as one job.

8191	T:Total Scan PGS	<p>These SP's count the pages scanned by each application that uses the scanner to scan images.</p> <p>[0 to 9999999/ 0 / 1]</p>
8192	C:Total Scan PGS	
8195	S:Total Scan PGS	
8196	L:Total Scan PGS	

- SP 8191 to 8196 count the number of scanned sides of pages, not the number of physical pages.
- These counters do not count reading user stamp data, or reading color charts to adjust color.
- Previews done with a scanner driver are not counted.
- A count is done only after all images of a job have been scanned.
- Scans made in SP mode are not counted.

Examples

- If 3 B5 pages and 1 A3 page are scanned with the scanner application but not stored, the S: count is 4.
- If both sides of 3 A4 sheets are copied and stored to the document server using the Store File button in the Copy mode window, the C: count is 6 and the L: count is 6.
- If both sides of 3 A4 sheets are copied but not stored, the C: count is 6.
- If you enter document server mode then scan 6 pages, the L: count is 6.

8211	T:Scan PGS/LS	These SP's count the number of pages scanned in to the document server . [0 to 9999999/ 0 / 1]
8212	C:Scan PGS/LS	
8215	S:Scan PGS/LS	The L: counter counts the number of pages stored from within the document server mode screen at the operation panel, and with the Store File but to n from within the Copy mode screen
8216	L:Scan PGS/LS	

- Reading user stamp data is not counted.
- If a job is cancelled, the pages output as far as the cancellation are counted.
- If the scanner application scans and stores 3 B5 sheets and 1 A4 sheet, the S: count is 4.
- If pages are copied but not stored on the document server, these counters do not change.
- If both sides of 3 A4 sheets are copied and stored to the document server, the C: count is 6 and the L: count is 6.
- If you enter document server mode then scan 6 pages, the L: count is 6.



SP8-xxx Data Log 2

8221	ADF Org Feeds	[0 to 99999999/ 0 / 1]
	These SP's count the number of pages fed through the ADF for front and back side scanning.	
1	Front	<p>Number of front sides fed for scanning:</p> <p>With an ADF that can scan both sides simultaneously, the Front side count is the same as the number of pages fed for either simplex or duplex scanning.</p> <p>With an ADF that cannot scan both sides simultaneously, the Front side count is the same as the number of pages fed for duplex front side scanning. (The front side is determined by which side the user loads section up.)</p>
2	Back	<p>Number of rear sides fed for scanning:</p> <p>With an ADF that can scan both sides simultaneously, the Back count is the same as the number of pages fed for duplex scanning.</p> <p>With an ADF that cannot scan both sides simultaneously, the Back count is the same as the number of pages fed for duplex rear-side scanning.</p>

- When 1 sheet is fed for duplex scanning the Front count is 1 and the Back count is 1.
- If a jam occurs during the job, recovery processing is not counted to avoid double counting. Also, the pages are not counted if the jam occurs before the first sheet is output.

8231	Scan PGS/Mode	[0 to 99999999/ 0 / 1]
	These SP's count the number of pages scanned by each ADF mode to determine the work load on the ADF.	
1	Large Volume	Selectable. Large copy jobs that cannot be loaded in the ADF at one time.
2	SADF	Selectable. Feeding pages one by one through the ADF.
3	Mixed Size	Selectable. Select "Mixed Sizes" on the operation panel.
4	Custom Size	Selectable. Originals of non-standard size.
5	Platen	Book mode. Raising the ADF and placing the original directly on the platen.
6	Mixed 1side/2side	Job mixed with printing one/two sides.

- If the scan mode is changed during the job, for example, if the user switches from ADF to Platen mode, the count is done for the last selected mode.
- If the user selects "Mixed Sizes" for copying in the platen mode, the Mixed Size count is enabled.
- In the SADF mode if the user copies 1 page in platen mode and then copies 2 pages with SADF, the Platen count is 1 and the SADF count is 3.

SP8-xxx Data Log 2

8241	T:Scan PGS/Org	[0 to 9999999/ 0 / 1]			
	These SP's count the total number of scanned pages by original type for all jobs, regardless of which application was used.				
8242	C:Scan PGS/Org	[0 to 9999999/ 0 / 1]			
	These SP's count the number of pages scanned by original type for Copy jobs.				
8245	S:Scan PGS/Org	[0 to 9999999/ 0 / 1]			
	These SP's count the number of pages scanned by original type for Scan jobs.				
8246	L:Scan PGS/Org	[0 to 9999999/ 0 / 1]			
	These SP's count the number of pages scanned and stored from within the document server mode screen at the operation panel, and with the Store File button from within the Copy mode screen				
	8241		8242	8245	8246
824x 1: Text	Yes	Yes	Yes	Yes	Yes
824x 2: Text/Photo	Yes	Yes	Yes	Yes	Yes
824x 3: Photo	Yes	Yes	Yes	Yes	Yes
824x 4: GenCopy, Pale	Yes	Yes	Yes	Yes	Yes
824x 5: Map	Yes	Yes	Yes	Yes	Yes
824x 11: Other	Yes	Yes	Yes	Yes	Yes

- If the scan mode is changed during the job, for example, if the user switches from ADF to Platen mode, the count is done for the last selected mode.

8251	T:Scan PGS/ImgEdt	<p>These SP's show how many times Image Edit features have been selected at the operation panel for each application. Some examples of these editing features are:</p> <p>Erase> Border Erase> Center Image Repeat Centering Positive/Negative [0 to 9999999/ 0 / 1]</p> <p>Note: The count totals the number of times the edit features have been used. A detailed breakdown of exactly which features have been used is not given.</p>
8252	C:Scan PGS/ImgEdt	
8254	P:Scan PGS/ImgEdt	
8256	L:Scan PGS/ImgEdt	
8257	O:Scan PGS/ImgEdt	

- The L: counter counts the number of pages stored from within the document server mode screen at the operation panel, and with the Store File button from within the Copy mode screen.

8281	T:Scan PGS/TWAIN	<p>These SP's count the number of pages scanned using a TWAIN driver. These counters reveal how the TWAIN driver is used for delivery functions.</p> <p>[0 to 9999999/ 0 / 1]</p> <p>Note: At the present time, these counters perform identical counts.</p>
8285	S:Scan PGS/TWAIN	

8291	T:Scan PGS/Stamp	<p>These SP's count the number of pages stamped with the stamp in the ADF unit.</p> <p>[0 to 9999999/ 0 / 1]</p>
8295	S:Scan PGS/Stamp	

Service Tables

SP8-xxx Data Log 2

8301	T:Scan PGS/Size	[0 to 9999999/ 0 / 1]	
	These SP's count by size the total number of pages scanned by all applications. Use these totals to compare original page size (scanning) and output (printing) page size [SP 8-441].		
8302	C:Scan PGS/Size	[0 to 9999999/ 0 / 1]	
	These SP's count by size the total number of pages scanned by the Copy application. Use these totals to compare original page size (scanning) and output (printing) page size [SP 8-442].		
8305	S:Scan PGS/Size	[0 to 9999999/ 0 / 1]	
	These SP's count by size the total number of pages scanned by the Scan application. Use these totals to compare original page size (scanning) and output page size [SP 8-445].		
8306	L:Scan PGS/Size	[0 to 9999999/ 0 / 1]	
	These SP's count by size the total number of pages scanned and stored from within the document server mode screen at the operation panel, and with the Store File button from within the Copy mode screen. Use these totals to compare original page size (scanning) and output page size [SP 8-446].		
830x 1	A3	830x 104	B1
830x 2	A4	830x 105	B2
830x 4	B4	830x 106	30x42
830x 6	DLT	830x 107	34x44
830x 8	LT	830x 108	22x34
830x 100	A2	830x 109	17x22
830x 101	B3	830x 254	Other (Standard)
830x 102	A0	830x 255	Other (Custom)

830x 103	A1			
----------	----	--	--	--

8311	T:Scan PGS/Rez	[0 to 9999999/ 0 / 1]		
	These SP's count by resolution setting the total number of pages scanned by applications that can specify resolution settings.			
8315	S:Scan PGS/Rez	[0 to 9999999/ 0 / 1]		
	These SP's count by resolution setting the total number of pages scanned by applications that can specify resolution settings. Note: At the present time, 8311 and 8315 perform identical counts.			
831x 1	1200dpi ~			
831x 2	600dpi ~ 1199dpi			
831x 3	400dpi ~ 599dpi			
831x 4	200dpi ~ 399dpi			
831x 5	~ 199dpi			

- Copy resolution settings are fixed so they are not counted.
- The Fax application does not allow finely-adjusted resolution settings so no count is done for the Fax application.

Service
Tables

SP8-xxx Data Log 2

8381	T:Total PrtPGS	These SP's count the number of pages printed by the operator. The counter for the application used for storing the pages increments. [0 to 99 999 999/ 0 / 1] The L: counter counts the number of pages stored from within the document server mode screen at the operation panel. Pages stored with the Store File button from within the Copy mode screen go to the C: counter.
8382	C:Total PrtPGS	
8384	P:Total PrtPGS	
8385	S:Total PrtPGS	
8386	L:Total PrtPGS	
8387	O:Total PrtPGS	
838x 1	Field Number	Total number of copies (regardless of size)
838x 2	Length (High)	Total length
838x 3	Length (Low)	Total length
838x 4	Area (High)	Total area coverage
838x 5	Area (Low)	Total area coverage
	<p>Note:</p> <ul style="list-style-type: none"> ▪ The values for "Length" are displayed in mm. If a "Length" reading is "42126" this is 42,126 mm (42.126 m). ▪ The values for "Area" are displayed as mm². If an "Area" reading is "33213257" this is 33,213,257 mm² (33,213.257 m²). ▪ The counts for the "Length" and "Area" start with "Low." Once the count exceeds the width of the field on the display the "Low" field will reset to "0" and the count overflows to the "High" SP codes. (This is necessary because the fields of the "Low" SP codes are limited to 8 digits and not wide enough to display the full reading for a reading larger than 8 digits.) ▪ Always check the "Low" SP first. If the "Low" display is zero, check the "High" field. ▪ When the length count reaches "99,999,999" in the "Low" field (8 digits), for example, after the next copy the count will show "1" in the "High" field and "00 000 000" in the "Low." Multiply the "1" in the "High" field by: 1) 10⁸ (100,000,000 mm), 2) 10⁵ (100, 000 m) or 3) 10² (100 kilometers) to determine the accurate count. 	

- When several documents are merged for a print job, the number of pages stored are counted for the application that stored them.
- These counters are used primarily to calculate charges on use of the machine, so the following pages are not counted as printed pages:
 - Blank pages in a duplex printing job.
 - Blank pages inserted as document covers, chapter title sheets, and slip sheets.
 - Reports printed to confirm counts.
 - All reports done in the service mode (service summaries, engine maintenance reports, etc.)
 - Test prints for machine image adjustment.
 - Error notification reports.
 - Partially printed pages as the result of a jam.

8401	T:PrtPGS/LS	These SP's count the number of pages printed from the document server. The counter for the application used to print the pages is incremented. The L: counter counts the number of jobs stored from within the document server mode screen at the operation panel. [0 to 9999999/ 0 / 1]
8402	C:PrtPGS/LS	
8404	P:PrtPGS/LS	
8405	S:PrtPGS/LS	
8406	L:PrtPGS/LS	

- Print jobs done with Web Image Monitor and Desktop Binder are added to the L: count.
- Fax jobs done with Web Image Monitor and Desktop Binder are added to the F: count.

8411	Prints/Duplex	This SP counts the amount of paper (front/back counted as 1 page) used for duplex printing. Last pages printed only on one side are not counted. [0 to 9999999/ 0 / 1]
------	---------------	---

SP8-xxx Data Log 2

8421	T:PrtPGS/Dup Comb	[0 to 9999999/ 0 / 1]
	These SP's count by binding and combine, and n-Up settings the number of pages processed for printing. This is the total for all applications.	
8422	C:PrtPGS/Dup Comb	[0 to 9999999/ 0 / 1]
	These SP's count by binding and combine, and n-Up settings the number of pages processed for printing by the application.	
8424	P:PrtPGS/Dup Comb	[0 to 9999999/ 0 / 1]
	These SP's count by binding and combine, and n-Up settings the number of pages processed for printing by the printer application.	
8425	S:PrtPGS/Dup Comb	[0 to 9999999/ 0 / 1]
	These SP's count by binding and combine, and n-Up settings the number of pages processed for printing by the scanner application.	
8426	L:PrtPGS/Dup Comb	[0 to 9999999/ 0 / 1]
	These SP's count by binding and combine, and n-Up settings the number of pages processed for printing from within the document server mode window at the operation panel.	
8427	O:PrtPGS/Dup Comb	[0 to 9999999/ 0 / 1]
	These SP's count by binding and combine, and n-Up settings the number of pages processed for printing by Other applications	
842x 1	Simplex> Duplex	
842x 2	Duplex> Duplex	
842x 3	Book> Duplex	
842x 4	Simplex Combine	
842x 5	Duplex Combine	
842x 6	2>	2 pages on 1 side (2-Up)

842x 7	4>	4 pages on 1 side (4-Up)
842x 8	6>	6 pages on 1 side (6-Up)
842x 9	8>	8pages on 1 side (8-Up)
842x 10	9>	9 pages on 1 side (9-Up)
842x 11	16>	16 pages on 1 side (16-Up)
842x 12	Booklet	
842x 13	Magazine	

- These counts (SP8421 to SP8427) are especially useful for operators who need to improve their compliance with ISO standards for the reduction of paper consumption.
- Pages that are only partially printed with the n-Up functions are counted as 1 page.
- Here is a summary of how the counters work for Booklet and Magazine modes:

Booklet			Magazine	
Original Pages	Count		Original Pages	Count
1	1		1	1
2	2		2	2
3	2		3	2
4	2		4	2
5	3		5	4
6	4		6	4
7	4		7	4
8	4		8	4

Service
Tables

SP8-xxx Data Log 2

8431	T:PrtPGS/ImgEdt	[0 to 9999999/ 0 / 1]
	These SP's count the total number of pages output with the three features below, regardless of which application was used.	
8432	C:PrtPGS/ImgEdt	[0 to 9999999/ 0 / 1]
	These SP's count the total number of pages output with the three features below with the copy application.	
8434	P:PrtPGS/ImgEdt	[0 to 9999999/ 0 / 1]
	These SP's count the total number of pages output with the three features below with the print application.	
8436	L:PrtPGS/ImgEdt	[0 to 9999999/ 0 / 1]
	These SP's count the total number of pages output from within the document server mode window at the operation panel with the three features below.	
8437	O:PrtPGS/ImgEdt	[0 to 9999999/ 0 / 1]
	These SP's count the total number of pages output with the three features below with Other applications.	
843x 1	Cover/Slip Sheet	Total number of covers or slip sheets inserted. The count for a cover printed on both sides counts 2.
843x 2	Series/Book	The number of pages printed in series (one side) or printed as a book with booklet right/left pagination.
843x 3	User Stamp	The number of pages printed where stamps were applied, including page numbering and date stamping.

8441	T:PrtPGS/Ppr Size	[0 to 9999999/ 0 / 1]
	These SP's count by print paper size the number of pages printed by all applications.	

8442	C:PrtPGS/Ppr Size	[0 to 9999999/ 0 / 1]	
	These SP's count by print paper size the number of pages printed by the copy application.		
8444	P:PrtPGS/Ppr Size	[0 to 9999999/ 0 / 1]	
	These SP's count by print paper size the number of pages printed by the printer application.		
8445	S:PrtPGS/Ppr Size	[0 to 9999999/ 0 / 1]	
	These SP's count by print paper size the number of pages printed by the scanner application.		
8446	L:PrtPGS/Ppr Size	[0 to 9999999/ 0 / 1]	
	These SP's count by print paper size the number of pages printed from within the document server mode window at the operation panel.		
8447	O:PrtPGS/Ppr Size	[0 to 9999999/ 0 / 1]	
	These SP's count by print paper size the number of pages printed by Other applications.		
844x 1	A3	844x 240	841 mm Custom:-A0
844x 2	A4	844x 241	594 mm Custom
844x 4	B4	844x 242	420 mm Custom
844x 6	DLT	844x 243	297 mm Custom
844x 8	LT	844x 244	210 mm Custom
844x 100	A2	844x 245	728 mm Custom
844x 101	B3	844x 246	515 mm Custom
844x 102	A0	844x 247	364 mm Custom
844x 103	A1	844x 248	257 mm Custom
844x 104	B1	844x 249	30/34/36 inch Custom

Service Tables

SP8-xxx Data Log 2

844x 105	B2	844x 250	22 inch Custom
844x 106	30x42	844x 251	17 inch Custom
844x 107	34x44	844x 252	11 inch Custom
844x 108	22x34	844x 253	8.5 inch Custom
844x 109	17x22	844x 254	Other (Standard)
844x 239	841 mm Custom: A0-	844x 255	Other (Custom)

- These counters do not distinguish between LEF and SEF.

8451	PrtPGS/Ppr Tray		[0 to 9999999/ 0 / 1]
	These SP's count the number of sheets fed from each paper feed station.		
1	Bypass	Bypass Table	
2	Tray 1	Copier	
3	Tray 2	Copier	
4	Tray 3	Paper Tray Unit (Option)	
5	Tray 4	Paper Tray Unit (Option)	
6	Tray 5	LCT (Option)	
7	Tray 6	Currently not used.	
8	Tray 7		
9	Tray 8		
10	Tray 9		

8461	T:PrtPGS/Ppr Type	[0 to 9999999/ 0 / 1]
	<p>These SP's count by paper type the number pages printed by all applications.</p> <p>These counters are not the same as the PM counter. The PM counter is based on feed timing to accurately measure the service life of the feed rollers. However, these counts are based on output timing.</p> <p>Blank sheets (covers, chapter covers, slip sheets) are also counted.</p> <p>During duplex printing, pages printed on both sides count as 1, and a page printed on one side counts as 1.</p>	
8462	C:PrtPGS/Ppr Type	[0 to 9999999/ 0 / 1]
	<p>These SP's count by paper type the number pages printed by the copy application.</p>	
8464	P:PrtPGS/Ppr Type	[0 to 9999999/ 0 / 1]
	<p>These SP's count by paper type the number pages printed by the printer application.</p>	
8466	L:PrtPGS/Ppr Type	[0 to 9999999/ 0 / 1]
	<p>These SP's count by paper type the number pages printed from within the document server mode window at the operation panel.</p>	
846x 1	Normal	
846x 2	Recycled	
846x 3	Special	
846x 4	Thick	
846x 5	Normal (Back)	
846x 6	Thick (Back)	
846x 7	OHP	
846x 8	Other	

Service
Tables

SP8-xxx Data Log 2

8471	PrtPGS/Mag	[0 to 9999999/ 0 / 1]
	These SP's count by magnification rate the number of pages printed.	
1	~49%	
2	50%~99%	
3	100%	
4	101%~200%	
5	201%~	

- Counts are done for magnification adjusted for pages, not only on the operation panel but performed remotely with an external network application capable of performing magnification adjustment as well.
- Magnification adjustments done with printer drivers with PC applications such as Excel are also counted.
- Magnification adjustments done for adjustments after they have been stored on the document server are not counted.
- Magnification adjustments performed automatically during Auto Reduce/Enlarge copying are counted.
- The magnification rates of blank cover sheets, slip sheets, etc. are automatically assigned a rate of 100%.

8481	T:PrtPGS/ TonSave	
8484	P:PrtPGS/TonSave	
	<p>These SP's count the number of pages printed with the toner Save feature switched on.</p> <p>Note: These SP's return the same results as this SP is limited to the Print application.</p> <p>[0 to 9999999/ 0 / 1]</p>	

8511	T:PrtPGS/Emul		[0 to 9999999/ 0 / 1]
	These SP's count by printer emulation mode the total number of pages printed.		
8514	P:PrtPGS/Emul		[0 to 9999999/ 0 / 1]
	These SP's count by printer emulation mode the total number of pages printed.		
851x 1	RPCS		
851x 2	RPDL		
851x 3	PS3		
851x 4	R98		
851x 5	R16		
851x 6	GL/GL2		
851x 7	R55		
851x 8	RTIFF		
851x 9	PDF		
851x 10	PCL5e/5c		
851x 11	PCL XL		
851x 12	IPDL-C		
851x 13	BM-Links	Japan Only	
851x 14	Other		

- SP8511 and SP8514 return the same results as they are both limited to the Print application.
- Print jobs output to the document server are not counted.

SP8-xxx Data Log 2

8521	T:PrtPGS/FIN	[0 to 9999999/ 0 / 1]
	These SP's count by finishing mode the total number of pages printed by all applications.	
8522	C:PrtPGS/FIN	[0 to 9999999/ 0 / 1]
	These SP's count by finishing mode the total number of pages printed by the Copy application.	
8524	P:PrtPGS/FIN	[0 to 9999999/ 0 / 1]
	These SP's count by finishing mode the total number of pages printed by the Print application.	
8525	S:PrtPGS/FIN	[0 to 9999999/ 0 / 1]
	These SP's count by finishing mode the total number of pages printed by the Scanner application.	
8526	L:PrtPGS/FIN	[0 to 9999999/ 0 / 1]
	These SP's count by finishing mode the total number of pages printed from within the document server mode window at the operation panel.	
852x 1	Sort	
852x 2	Stack	
852x 3	Staple	
852x 4	Booklet	
852x 5	Z-Fold	
852x 6	Punch	
852x 7	Other	
<p>Note:</p> <ul style="list-style-type: none"> ▪ If stapling is selected for finishing and the stack is too large for stapling, the unstapled pages are still counted. ▪ The counts for staple finishing are based on output to the staple tray, so jam recoveries are counted. 		

8531	Staples	This SP counts the amount of staples used by the machine. [0 to 9999999/ 0 / 1]
------	---------	--

8581	T:Counter	[0 to 9999999/ 0 / 1]
	<p>These SP's count the total output broken down by color output, regardless of the application used. In addition to being displayed in the SMC Report, these counters are also displayed in the User tools display on the copy machine.</p> <p>Note: This SP is expanded for color MFP and color LP machines. For this machine, the count is done for black only.</p>	

8591	O:Counter	[0 to 9999999/ 0 / 1]
	<p>These SP's count the totals for A3/DLT paper use, number of duplex pages printed, and the number of staples used. These totals are for Other (O:) applications only.</p>	

SP8-xxx Data Log 2

8651	T:S-to-Email PGS	[0 to 9999999/ 0 / 1]
	<p>These SP's count by color mode the total number of pages attached to an e-mail for both the Scan and document server applications.</p> <p>Note: This SP is expanded for color MFP and color LP machines. For this machine, the count is done for black only.</p>	
8655	S:S-to-Email PGS	[0 to 9999999/ 0 / 1]
	<p>These SP's count by color mode the total number of pages attached to an e-mail for the Scan application only.</p> <p>Note: This SP is expanded for color MFP and color LP machines. For this machine, the count is done for black only.</p>	

- The count for B/W pages is done after the document is stored on the HDD. If the job is cancelled before it is stored, the pages are not counted.
- If Scan- to -Email is used to send a 10-page document to 5 addresses, the count is 10 (the pages are sent to the same SMTP server together).
- If Scan- to -PC is used to send a 10-page document to 5 folders, the count is 50 (the document is sent to each destination of the SMB/FTP server).
- Due to restrictions on some devices, if Scan- to -Email is used to send a 10-page document to a large number of destinations, the count may be divided and counted separately. For example, if a 10-page document is sent to 200 addresses, the count is 10 for the first 100 destinations and the count is also 10 for the second 100 destinations, for a total of 20.).

8671	T:Deliv PGS/PC	[0 to 9999999/ 0 / 1]
	<p>These SP's count by color mode the total number of pages sent to a folder on a PC (Scan- to -PC) with the Scan and LS applications.</p> <p>Note: This SP is expanded for color MFP and color LP machines. For this machine, the count is done for black only.</p>	
8675	S:Deliv PGS/PC	[0 to 9999999/ 0 / 1]
	<p>These SP's count by color mode the total number of pages sent with Scan-to -PC with the Scan application.</p> <p>Note: This SP is expanded for color MFP and color LP machines. For this machine, the count is done for black only.</p>	

8691	T:TX PGS/LS	<p>These SP's count the number of pages sent from the document server. The counter for the application that was used to store the pages is incremented.</p> <p>[0 to 9999999/ 0 / 1]</p> <p>The L: counter counts the number of pages stored from within the document server mode screen at the operation panel.</p>
8692	C:TX PGS/LS	
8694	P:TX PGS/LS	
8695	S:TX PGS/LS	
8696	L:TX PGS/LS	

- Print jobs done with Web Image Monitor and Desk TopBinder are added to the count.
- If several documents are merged for sending, the number of pages sent are counted for the application that stored them.
- When several documents are sent by a Fax broadcast, the F: count is done for the number of pages sent to each destination.

SP8-xxx Data Log 2

8701	TX PGS/Port		[0 to 9999999/ 0 / 1]
	These SP's count the number of pages sent by the physical port used to send them. For example, if a 3-page original is sent to 4 destinations via ISDN G4, the count for ISDN (G3, G4) is 12.		
1	PSTN-1		
2	PSTN-2		
3	PSTN-3		
4	ISDN (G3,G4)		
5	Network		

8 711	T:Scan PGS/Comp		[0 to 9999999/ 1]
	These SP's count the number of compressed pages scanned in to the document server, counted by the formats listed below.		
1	JPEG/JPEG2000		
2	TIFF (Multi/Single)		
3	PDF		
4	Other		
5	PDF Comp		

8715	S:Scan PGS/Comp	
	These SP's count the number of compressed pages scanned by the scan application, counted by the formats listed below.	
1	JPEG/JPEG2000	[0 to 9999999/ 1]
2	TIFF (Multi/Single)	
3	PDF	
4	Other	
5	PDF Comp	

8741	RX PGS/Port	
	These SP's count the number of pages received by the physical port used to receive them. [0 to 9999999/ 0 / 1]	
1	PSTN-1	
2	PSTN-2	
3	PSTN-3	
4	ISDN (G3,G4)	
5	Network	

8771	Dev Counter	
	These SP's count the frequency of use (number of rotations of the development rollers) for black and other color toners. Note: For machines that do not support color, the Black toner count is the same as the total count. [0 to 9999999/ 0 / 1]	

Service Tables

SP8-xxx Data Log 2

8781	Pixel Coverage Ratio	
	This SP displays the number of toner bottles used. The count is done based on the equivalent of 1,000 pages per bottle.	

8791	LS Memory Remain	
	This SP displays the percent of space available on the document server for storing documents. [0 to 100/ 0 / 1]	

8801	Toner Remain	
	This SP displays the percent of toner remaining for each color. This SP allows the user to check the toner supply at any time. Note: This method of measuring remaining toner supply (1% steps) is more precise better than other machines in the market that can only measure increments of 10 (10% steps). [0 to 100/ 0 / 1]	

8851	Cover Cnt: 0-10%	
	These SP's count the percentage of toner dot coverage. [0 to 9999999]	
11	0~2%	
21	3~4%	
31	5~7%	
41	8~10%	

8861	Cvr Cnt: 11-20%
	This SP counts the number of copies in the toner dot coverage range 11-20% [0 to 9999999]

8871	Cvr Cnt: 21-30%
	This SP counts the number of copies in the toner dot coverage range 21-30% [0 to 9999999]

8881	Cvr Cnt: 31%~
	This SP counts the number of copies in the toner dot coverage range 31% and over. [0 to 9999999]

8891	Page/Toner Bottle	Previous cartridge	Counts that record number of pages per toner cartridge.
8901	Page/Toner_Prev1	Previous but 1	
8911	Page/Toner_Prev2	Previous but 2	

8921	Cvr Cnt Total	
	These SP's display the percent and number of pages for black toner coverage.	
1	Coverage (%): BK	
11	Coverage (/P):BK	

Service Tables

SP8-xxx Data Log 2

8941	Machine Status	
	<p>These SP's count the amount of time the machine spends in each operation mode. These SP's are useful for operators who need to investigate machine operation for improvement in their compliance with ISO Standards.</p> <p>[0 to 99999999 / 0 / 1]</p>	
1	Operation Time	Engine operation time. Does not include time while controller is saving data to HDD (while engine is not operating).
2	Standby Time	Engine not operating. Includes time while controller saves data to HDD. Does not include time spent in Energy Save, Low Power, or Off modes.
3	Energy Save Time	Includes time while the machine is performing background printing.
4	Low Power Time	Includes time in Energy Save mode with Engine on. Includes time while machine is performing background printing.
5	Off Mode Time	Includes time while machine is performing background printing. Does not include time machine remains powered off with the power switches.
6	SC	Total down time due to SC errors.
7	PrtJam	Total down time due to paper jams during printing.
8	OrgJam	Total down time due to original jams during scanning.
9	Supply PM Unit End	Total down time due to toner end.

8951	AddBook Register		
	These SP's count the number of events when the machine manages data registration.		
1	User Code/User ID	User code registrations.	[0 to 9999999/ 0 / 1]
2	Mail Address	Mail address registrations.	
3	Fax Destination	Fax destination registrations.	
4	Group	Group destination registrations.	
5	Transfer Request	Fax relay destination registrations for relay TX.	
6	F-Code	F-Code box registrations.	
7	Copy Program	Copy application registrations with the Program (job settings) feature.	[0 to 255 / 0 / 255]
8	Fax Program	Fax application registrations with the Program (job settings) feature.	
9	Printer Program	Printer application registrations with the Program (job settings) feature.	
10	Scanner Program	Scanner application registrations with the Program (job settings) feature.	

Service Tables

SP8-xxx Data Log 2

8999	Admin. Counter List	
	This SP provides a central point for display of important information for the system administrator.	
1	Total	Print total (copies and prints)
3	Copy: BW	Copy totals (not print jobs)
7	Printer: BW	Print totals (not copy jobs)
15	Coverage: BW(%)	Total coverage (copies/prints)
17	Coverage: BW Print Page (%)	Total coverage (print jobs only)
102	Transmission Total: BW	Jobs sent to document server, scan-to-email.
105	Scanner Transmission: BW	Jobs scanned to document server, scan-to-email.

DETAILS

6. DETAILS

6.1 OVERVIEW

6.1.1 MACHINE GENERAL LAYOUT

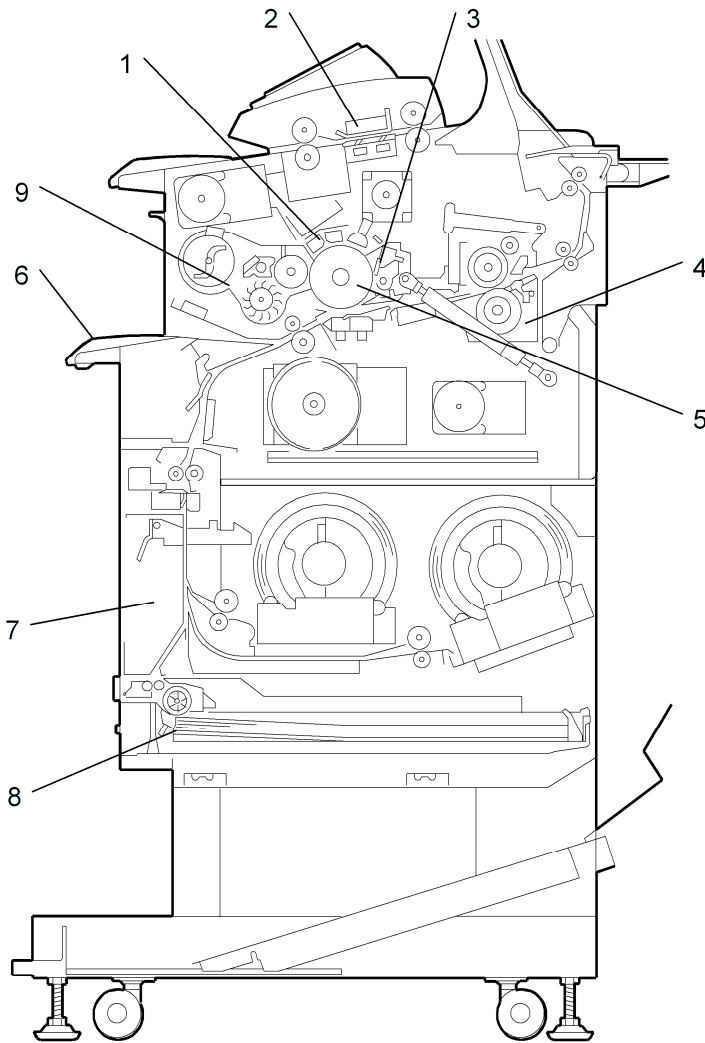

b286r969

1.	Image Writing Unit	Uses an LPH (LED Print Head)
2.	Scanner Unit	Uses a CIS (Contact Image Sensor) unit for scanning. The CIS is made of 5 sensor arrays connected at four joints.

Overview

		The CIS scans the face-down original from below.
3.	Cleaning Unit	A counter blade cleans the drum.
4.	Fusing Unit	The hot roller contains one halogen lamp. The machine uses the applicable fusing temperature for the paper size and paper type that the user input at the operation panel.
5.	OPC Drum	The components around the OPC drum do the charging, image writing, development, transfer, separation, cleaning, and quenching.
6.	Manual Feed Table	The user can feed paper from the manual feed table (this is also referred to as the bypass tray).
7.	Roll Feeder	Paper also feeds from the optional roll feeder with one or two paper rolls installed.
8.	Paper Cassette	Cut sheets are also supplied from the optional paper cassette.
9.	Development Unit	Toner transfers from a magnetic roller to the OPC drum. An ID sensor controls the toner concentration.

6.1.2 MECHANICAL COMPONENT LAYOUT

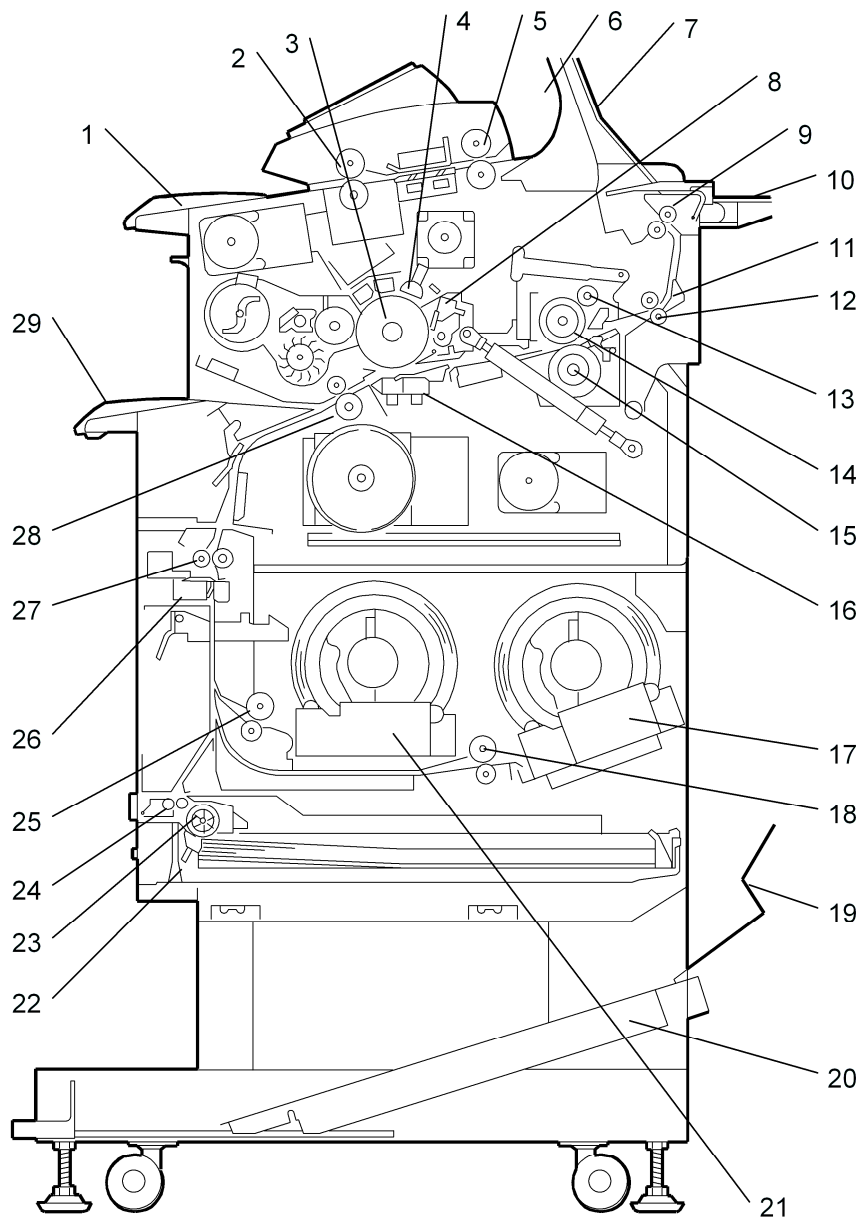

b286d969a

Details

Overview

1. Original Table
2. Original Feed Rollers
3. OPC Drum
4. Charge Corona Unit
5. Original Exit Roller
6. Upper Output Stacker
7. Original Upper Exit Guides
8. Cleaning Unit
9. Upper Exit Rollers
10. Original Exit Guides (Straight-Through)
11. Paper Exit Junction Gate
12. Fusing Exit Rollers
13. Fusing Cleaning Roller
14. Hot Roller
15. Pressure Roller
16. T&S Corona Unit
17. Roll 2 Holders
18. Roll 2 Paper Feed Rollers
19. Lower Output Guide
20. Lower Output Stacker
21. Roll 1 Holder
22. Paper Cassette
23. Paper Cassette Feed Roller
24. Paper Cassette Grip Rollers
25. Roll 1 Paper Feed Rollers
26. Cutter
27. Roll/Cassette Exit Rollers
28. Registration Rollers
29. Manual Feed Table (Bypass)

6.1.3 DRIVE LAYOUT

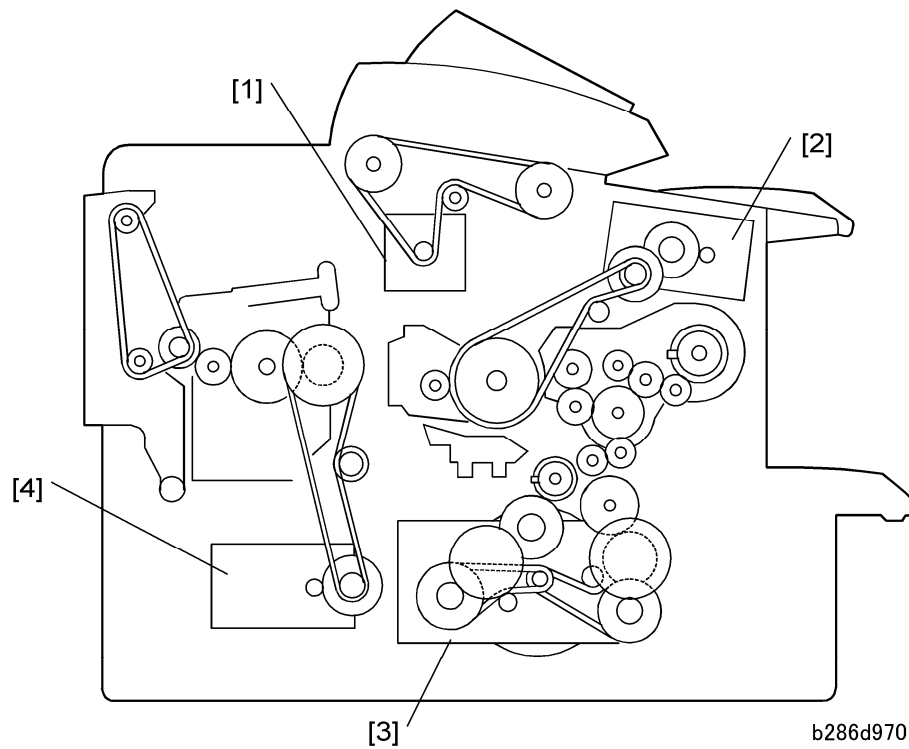

- 1. Scanner Motor
- 2. Drum Motor
- 3. Main Motor
- 4. Fusing Motor

6.1.4 ORIGINAL/COPY PAPER PATHS

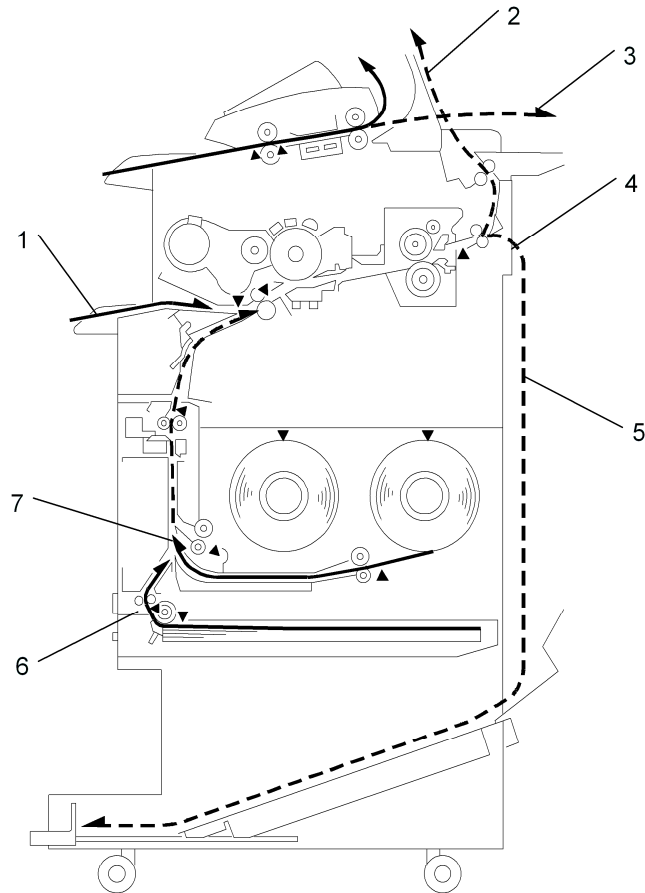

b286d971

1.	Manual Feed (Bypass) Path	
2.	Original Path (Upper)	Upper output stacker installed.
3.	Original Path (Straight-Through)	Upper output stacker removed.
4.	Paper Path (Upper)	Normal (Default)
5.	Paper Path (Rear)	Selectable *1
6.	Paper Path (Paper Cassette)	
7.	Paper Path (Rolls)	B851 (1 Roll), B852 (2 Rolls)

*1: The position of the copy-exit selection lever on the rear top edge of the machine controls where the copy feeds out.

Lever UP	Lever DOWN
<p>The operator touches “Upper” or “Lower” under “Copy Output Location” on the display to select the exit shown in the illustration above:</p> <ul style="list-style-type: none"> ▪ Upper: Copy feeds out at “2.” ▪ Lower: Copy feeds out at “4” 	<p>“Lower” is selected for the “Copy Output Location,” so the copy always feeds out at “4” in the illustration above.</p> <p>“Upper” cannot be selected. If the operator selects “Upper,” a message will prompt the operator that the output destination cannot be selected.</p>

 Note

- For normal operation, the copy exit selection lever must be up, so that the operator always has the option of selecting either “Upper” or “Lower” for copy exit.

6.2 SCANNER

6.2.1 OVERVIEW

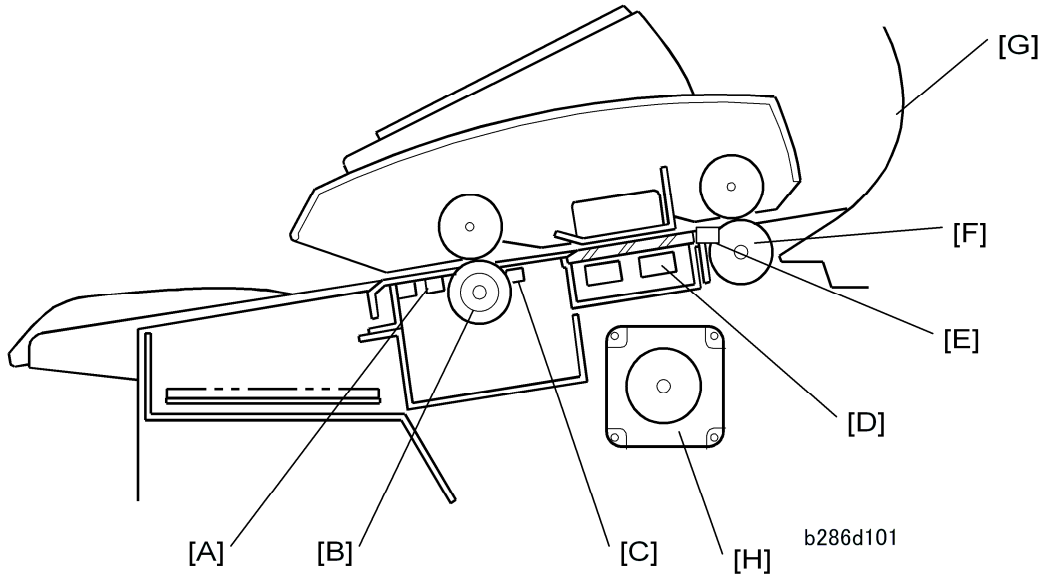

Only one original can be placed face-down on the original table.

Original set sensor [A]: Detects the leading edge of the original. Then the machine stops original feed for 1 second (Delay 1). This gives the user time to put the paper straight. This sensor also functions as a width sensor, with the original width sensors (not shown) below the original feed table.

Note

- Delay 1 can be adjusted. User Tools > System Settings > General Features > Original Feed Delay 1.

Original feed roller [B]: Feeds the original to the registration sensor [C].

Registration sensor [C]: When this detects the leading edge of the original, the machine stops original feed for 1 second (Delay 2). This gives the user time to check that the original is straight. If the original is not straight, the user can push the “Scanner Stop” button to stop original feed, remove the original, and try again.

Note

- Delay 2 can be adjusted. User Tools > System Settings > General Features > Original Feed Delay 2.

CIS (Contact Image Sensor) [D]: Scans the original from below.

Original exit sensor [E]: Detects the leading and trailing edge of the original to make sure that there is no jam.

Original exit rollers [F]: Feed the original out while the scanned image is processed

Upper output tray [G]: Receives the original after scanning. Long originals will curl in the tray.

Note

- If the original output trays are removed, the original feeds in a straight path, out of the rear of the machine. The original feed path through the machine is the same.

Important

- The user should remove the original output trays when scanning thick originals so the original will feed straight out.

Scanner motor [H]: Controls the original feed roller and original exit roller. (See section 6.2.4 “Original Drive Mechanism.”)

6.2.2 SCANNER LAYOUT

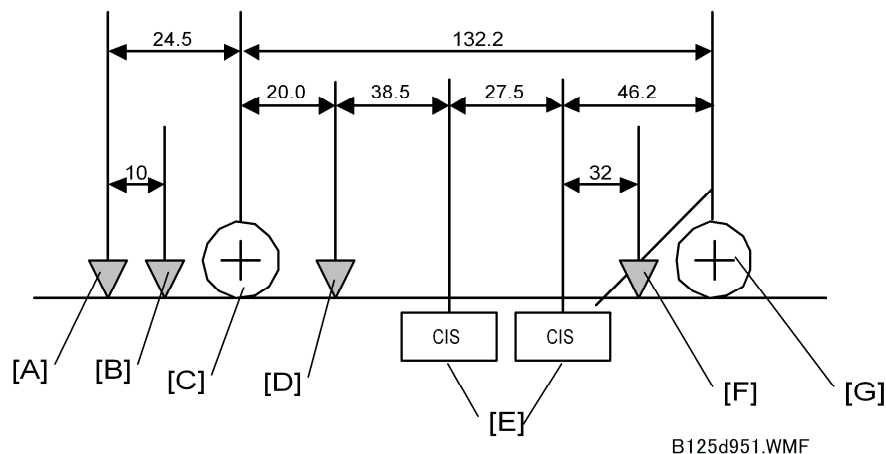

[A]: Original Width Sensors. Detect the width of the original.

[B]: Original Set Sensor. Detects when the original is put on the original feed table.

[C]: Original Feed Roller. Feeds the original to the original registration sensor.

[D]: Original Registration Sensor. Detects the leading edge of the original and stops feed temporarily for the user to align the original manually.

[E]: CIS. Scans the original and sends the image data to the VDB.

[F]: Original Exit Sensor. Detects the leading and trailing edge of the original for job timing.

[G]: Original Exit Roller. Feeds the original out of the machine.

6.2.3 ORIGINAL WIDTH DETECTION

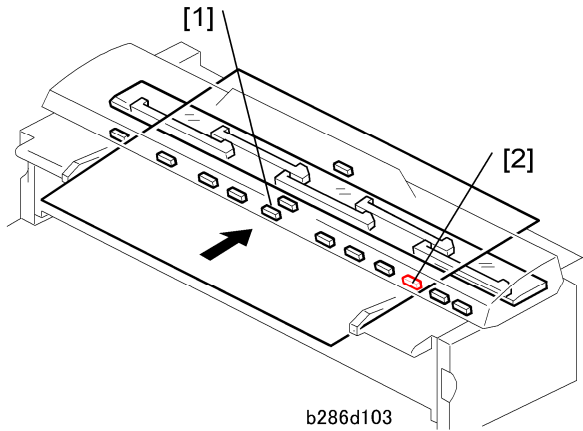

Multiple sensors are used to detect the width of the original when it is set on the original table:

- **Metric.** 10 sensors: 9 original width sensors and the original set sensor [1] which also functions as a width sensor. Sensor [2] above is not in the EU machine.
- **Inch.** 11 sensors: 10 original width sensors and the original set sensor [1] which also functions as a width sensor. Sensor [2] (30") above is included in the NA machine.

Metric

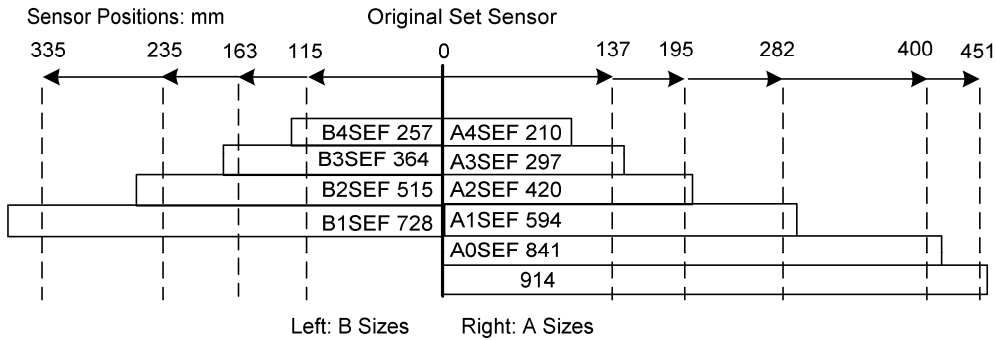

Inch

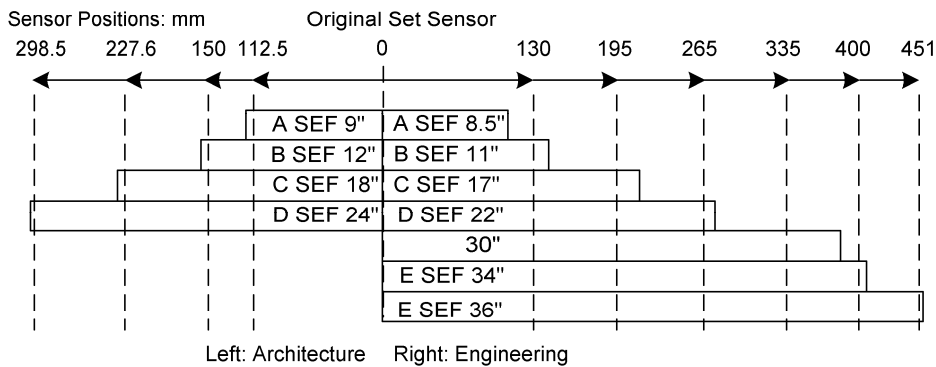

b286d902

The sensors on the left detect B series (Metric) or Architecture (USA) sizes. The sensors on the right detect A series (Metric) or Engineering (USA) sizes.

The original set sensor detects A4 or 8 1/2" "A" size SEF originals. The original width sensors detect the larger sizes.

6.2.4 ORIGINAL DRIVE MECHANISM

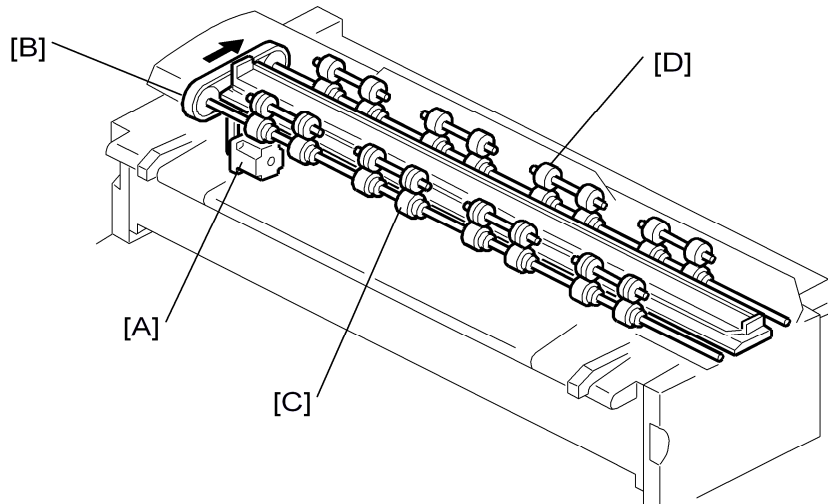

b286d02

The scanner motor [A] (a stepper motor) and timing belt [B] control the original feed rollers [C] and original exit rollers [D]. The signal from the original set sensor controls the on/off timing.

6.2.5 ORIGINAL FEED SPEED

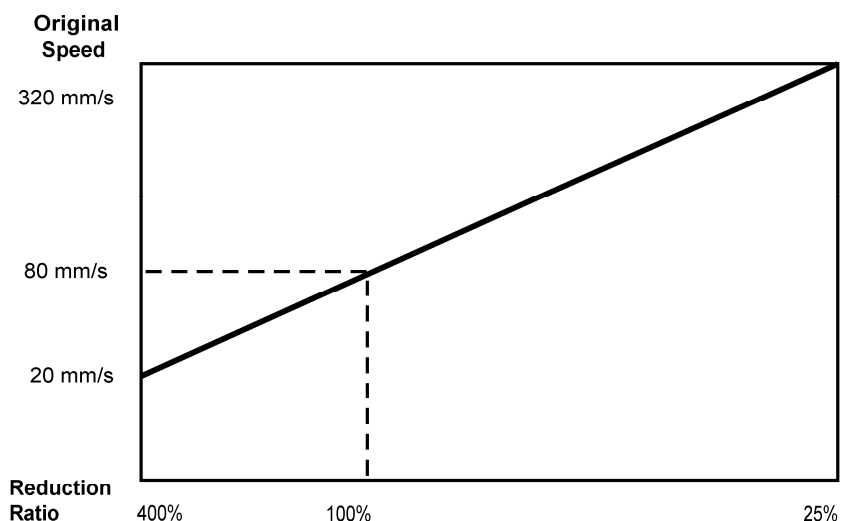

b286d515

The speed of the original is faster if the magnification ratio is lower.

6.2.6 SCANNING MECHANISM

CIS Structure

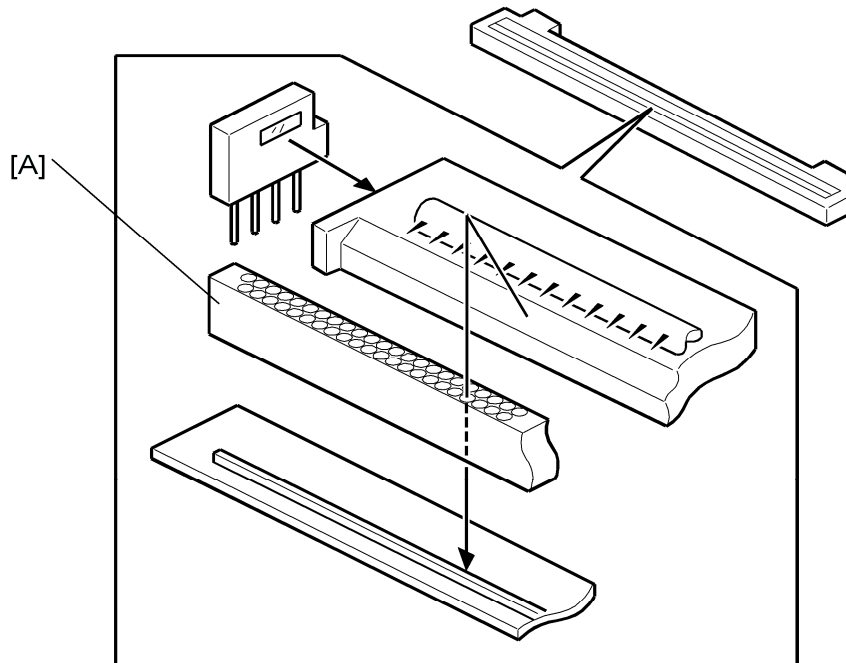

b286d104

This machine uses a contact image sensor [A] (: Digital Processes – Image Processing – Black and White CIS Systems).

The scanning unit is below the original feed path. The CIS scans black and white originals a maximum of 926.5 mm (36 1/2 inches) wide at 600 dpi.

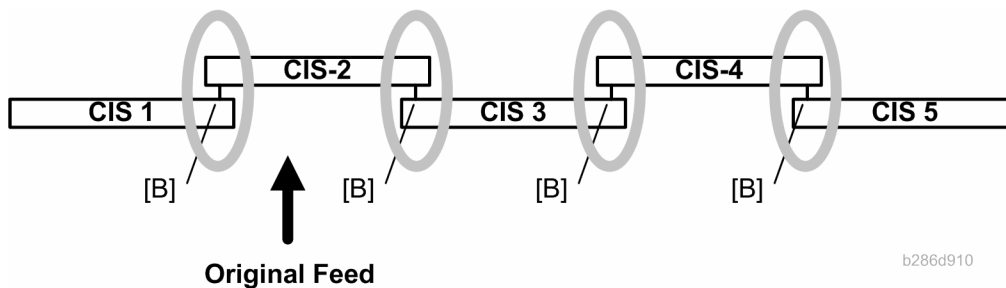

b286d910

The CIS unit is made of 5 sections connected at four joints [B]. If you look from above, the CIS sections are numbered from left to right as CIS-1 to CIS-5.

Printed Image

Abc				
CIS-5	CIS-4	CIS-3	CIS-2	CIS-1

b286d911

When you look at the copy to identify the areas scanned by each section, the numbering is in the opposite sequence, with CIS-5 on the left to CIS-1 on the right.

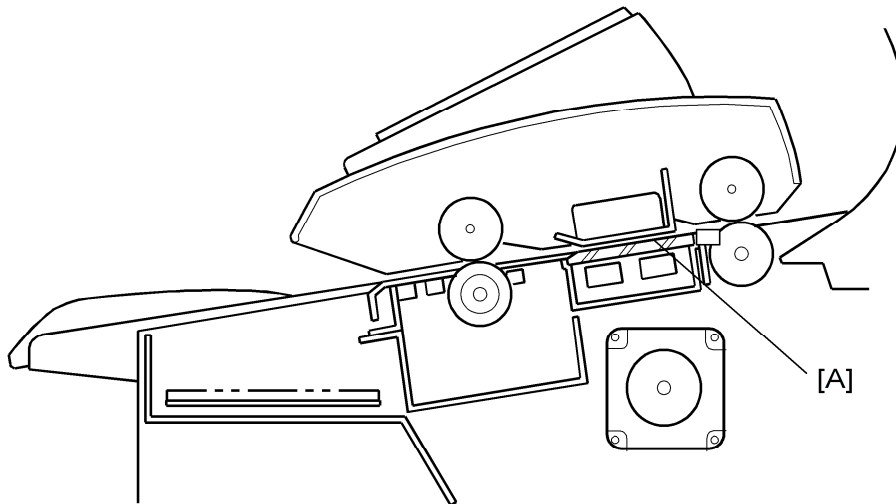
6.2.7 AUTO IMAGE DENSITY CORRECTION

b286d101

Auto Image Density Correction corrects the background density.

First, the CIS reads the surface of the white strips on the platen plate[A]. The machine uses these readings as a reference points for density correction.

Scanner

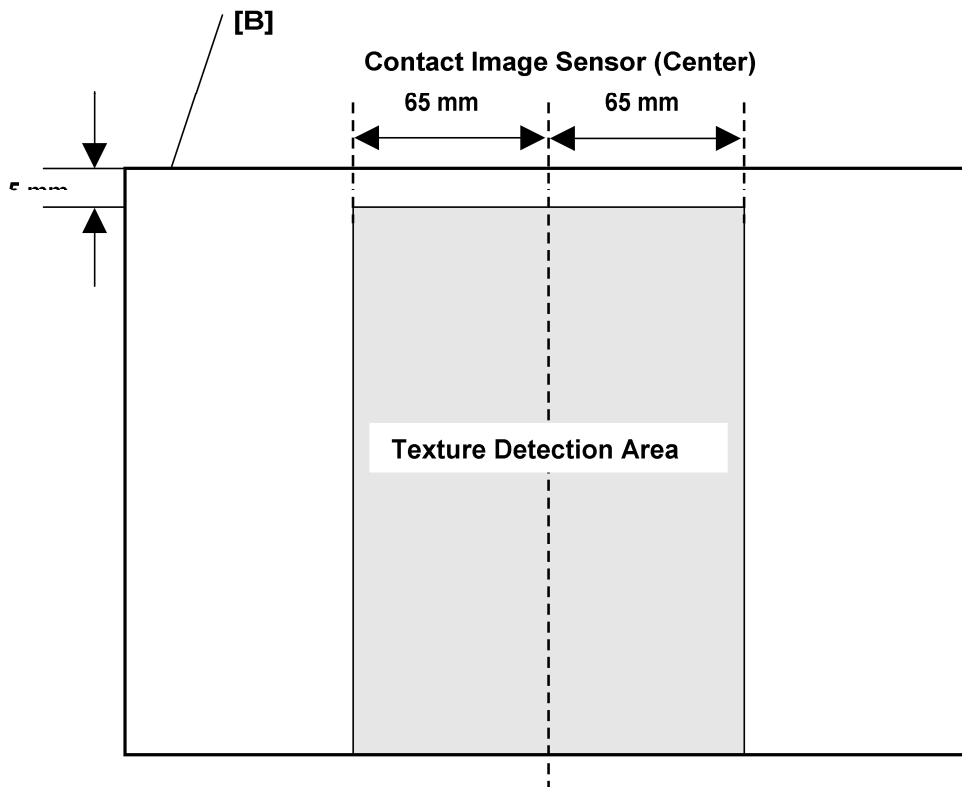

b286d514

Then, during scanning, the CIS corrects the image density line by line. To do this, it starts 5 mm from the leading edge of the original [B], and reads 65 mm to the left and to the right of the center.

6.3 IMAGE PROCESSING

6.3.1 GENERAL IMAGE PROCESSING FLOWCHART

Image processing is done for all seven original image modes on the IPU which handles data compression and decompression.

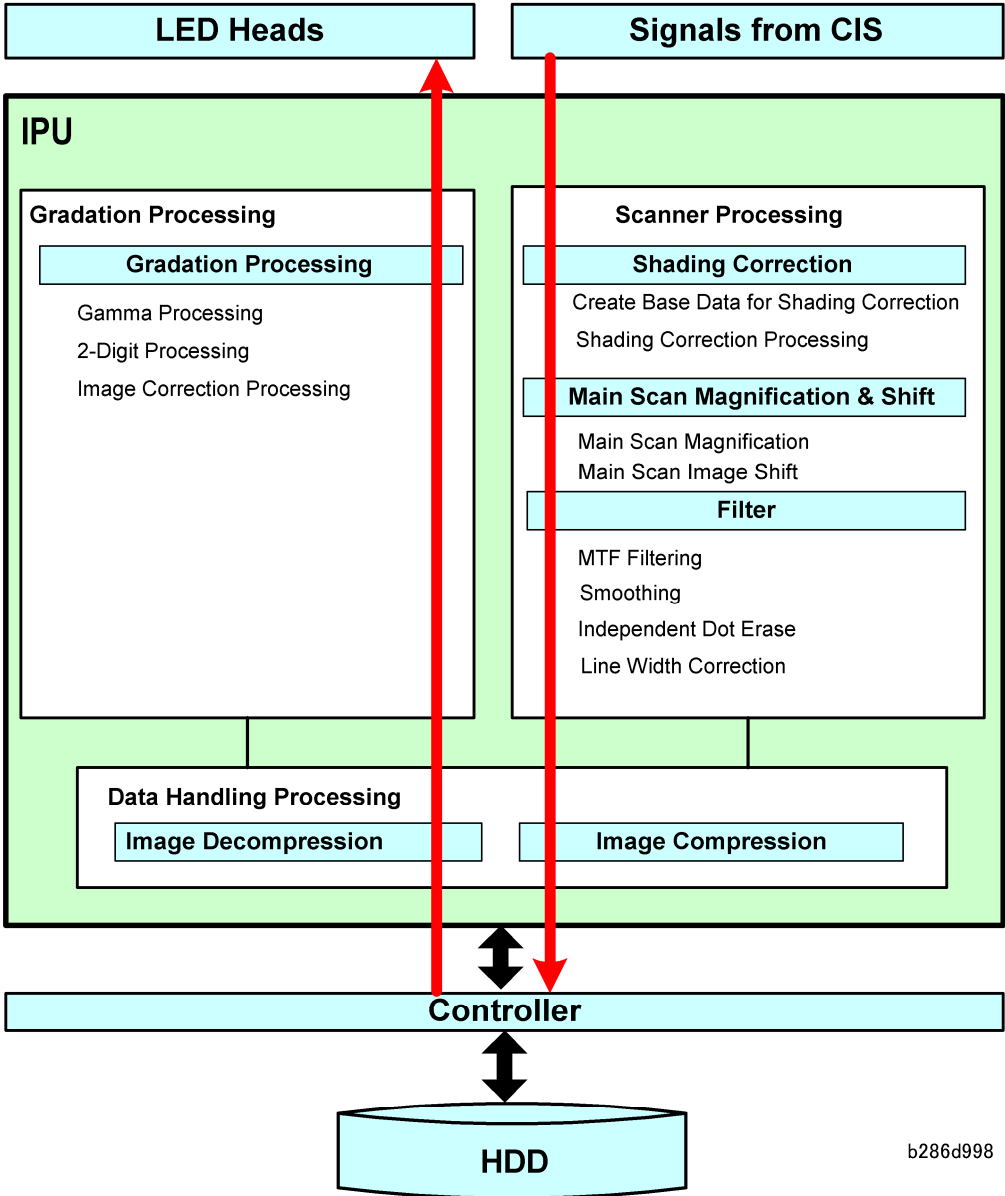

Details

6.3.2 ORIGINAL MODES

Overview

Here is a summary of the seven original modes that the operator can select on the operation panel before scanning the original.

Mode	Function
Drawing	<p>Best reproduction of detailed diagrams, specially for drawings with many thin lines. When Drawing is selected, the auto density feature (ADS) is automatically switched on.</p> <p>Note: This selection can be used to sharpen text.</p>
Text	<p>Best reproduction of text and sharp lines. Text mode does not detect differences between areas of the page that contain text, graphics, or photographs; all the page is processed as a text original. When this mode is selected, the auto image density feature (ADS) is automatically switched on.</p>
Text/Photo	<p>The 2-level error diffusion used in this mode gives the best reproduction for originals with text and photos on the same page. Grayscales are more accurate than those achieved with Text mode. When this mode is selected, the auto image density feature (ADS) is automatically switched on.</p>
Photo	<p>The 2-value dither processing used in this mode removes jagged edges on photo originals. Gives the best reproduction for copied photographs. When this mode is selected, the auto image density feature (ADS) is automatically switched off.</p>
Background Lines	<p>Ignores blue or green lines in the original. For example, the blue grid squares of graph paper, or the markings with a dropout blue pencil do not appear in copies. When this mode is selected, the auto density feature (ADS) is automatically switched on.</p> <p>Note: Some blue or green lines may not drop out if they are very thick or of high density.</p>
Patched Original	<p>Prevents background from appearing in copies of originals where the textures of the backgrounds differ. For example, this mode will even out the backgrounds and eliminate the shadows and lines on page or sheets</p>

Mode	Function
	pasted up for design layout. When this mode is selected, the auto image density feature (ADS) is automatically switched off.
Generation Copy	Almost the same as the Text mode, but tries to decrease the thickness of thick characters, repair thin or broken lines of originals, ignore the background, and erase independent dots that are frequently in copies of originals which are 2 nd , 3 rd , etc. generation copies themselves. When this mode is selected, the auto image density feature (ADS) is automatically switched off.

Drawing Mode

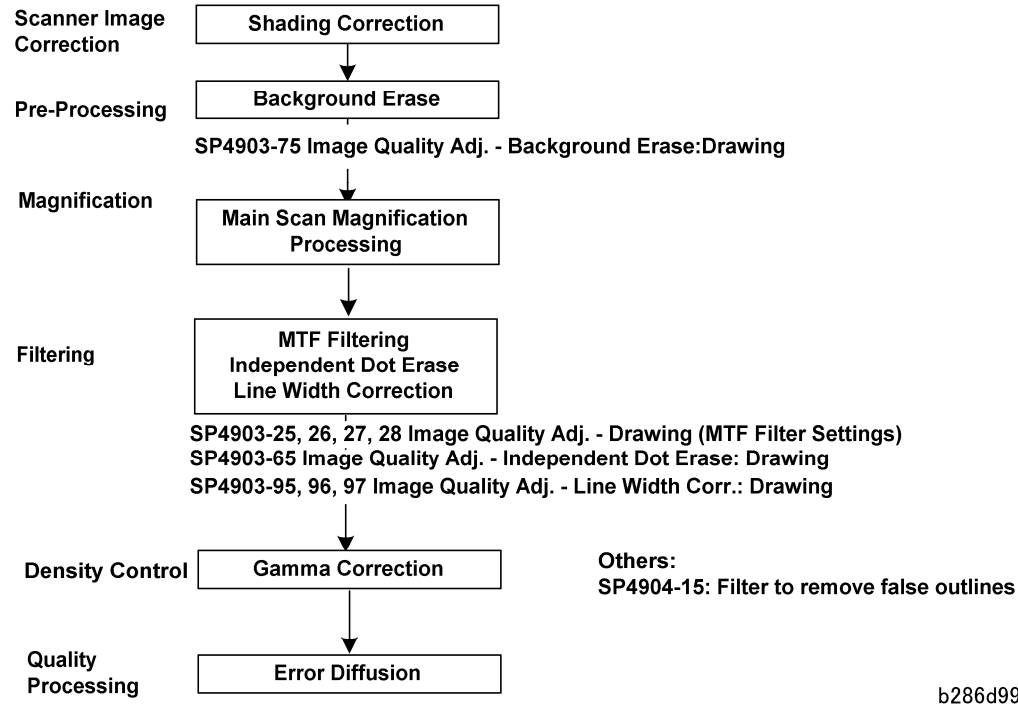

b286d992

Details

Image Processing

Text Mode

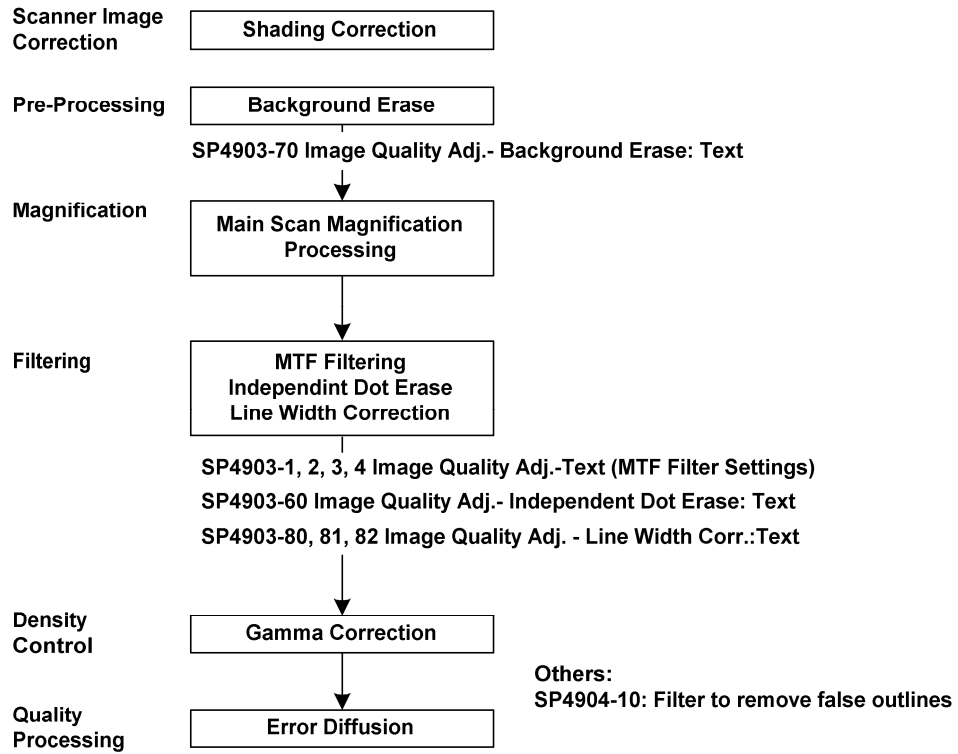

b286d991

Text/Photo Mode

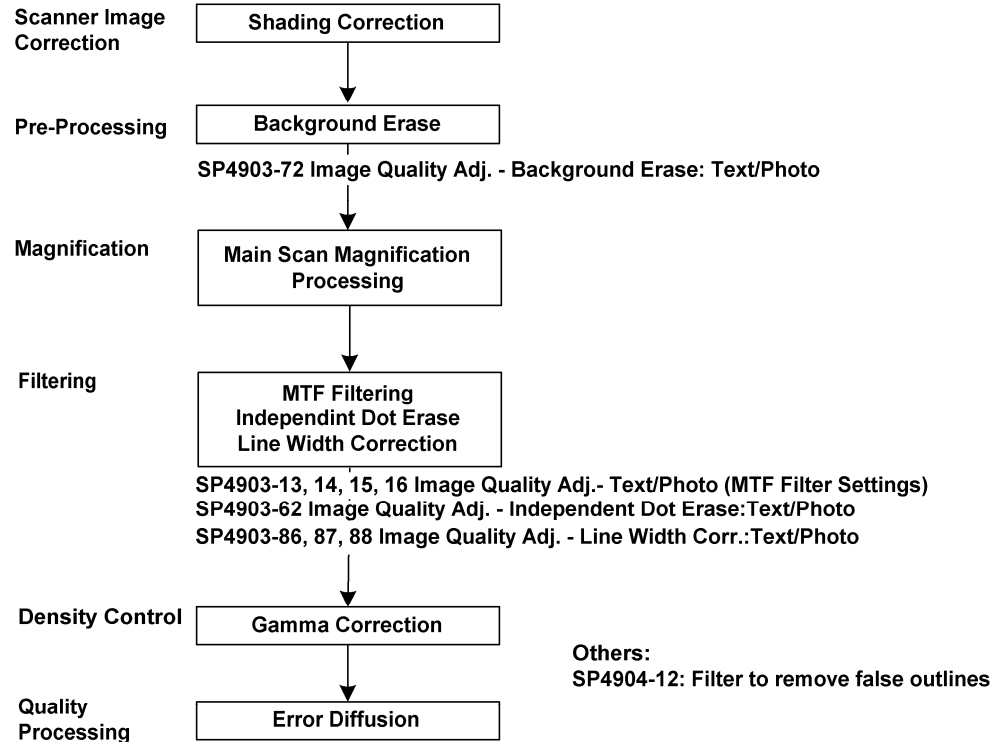

b286d993

Photo Mode

The setting of SP4904-2 (Image Process Setting – Process Select: Photo) determines whether dithering or error diffusion is used at the “Quality Processing” step. Four settings are available:

0:	8 x 8 dithering
1:	6 x 6 dithering
2:	4 x 4 dithering
3:	Error diffusion

- If dithering is selected (0, 1, or 2), this enables the settings of SP4903-5, 6, 7, 8.
- If error diffusion is selected (3), this enables the settings of SP4903-9, 10, 11, 12

Details

Image Processing

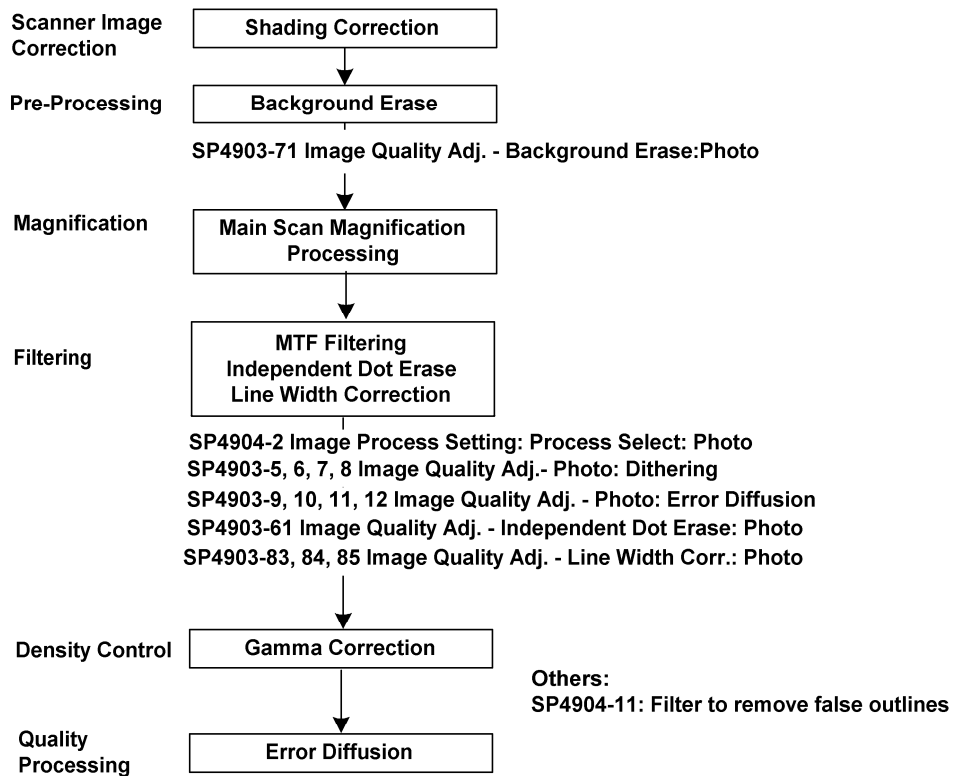

b286d994

Background Lines Mode

In order to prevent the thickening of text in the main scan direction, stronger line width correction is done in the main scan direction.

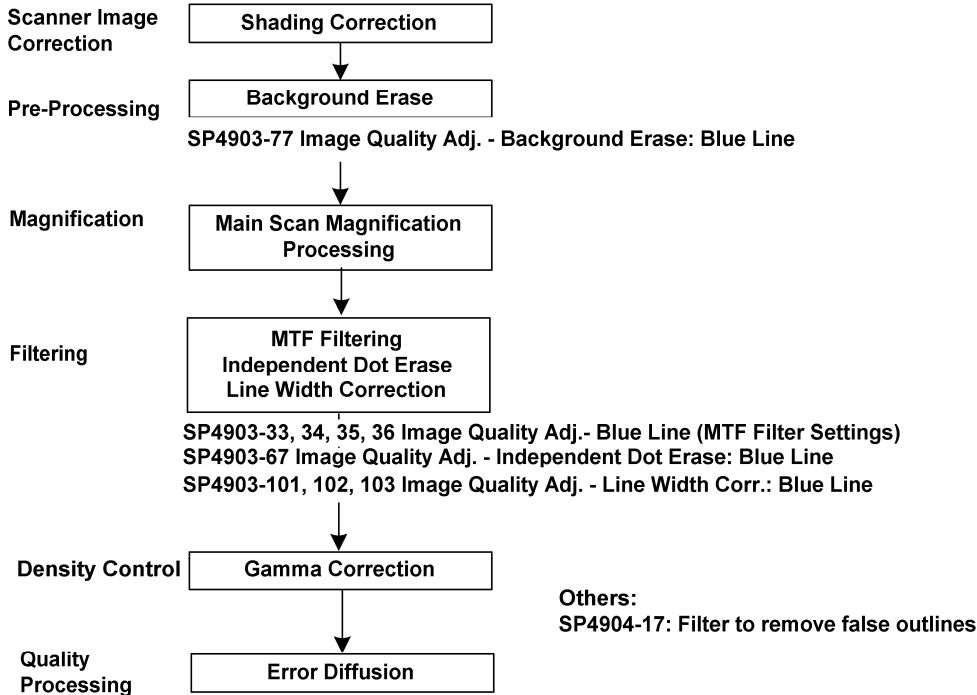

b286d995

Patched Original Mode

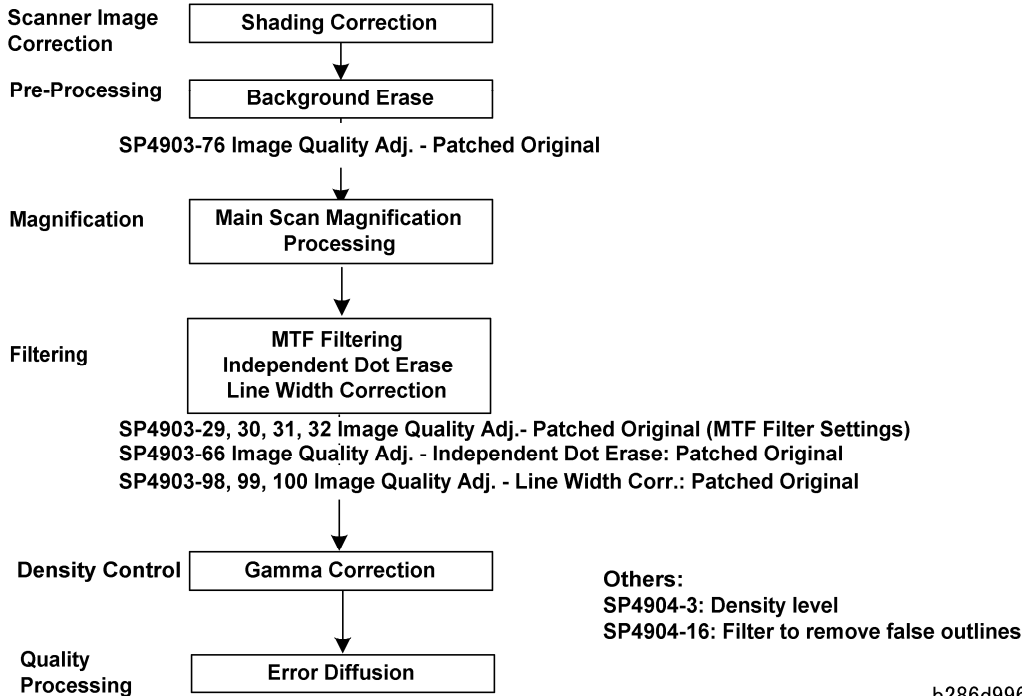

b286d996

Details

Image Processing

Generation Mode

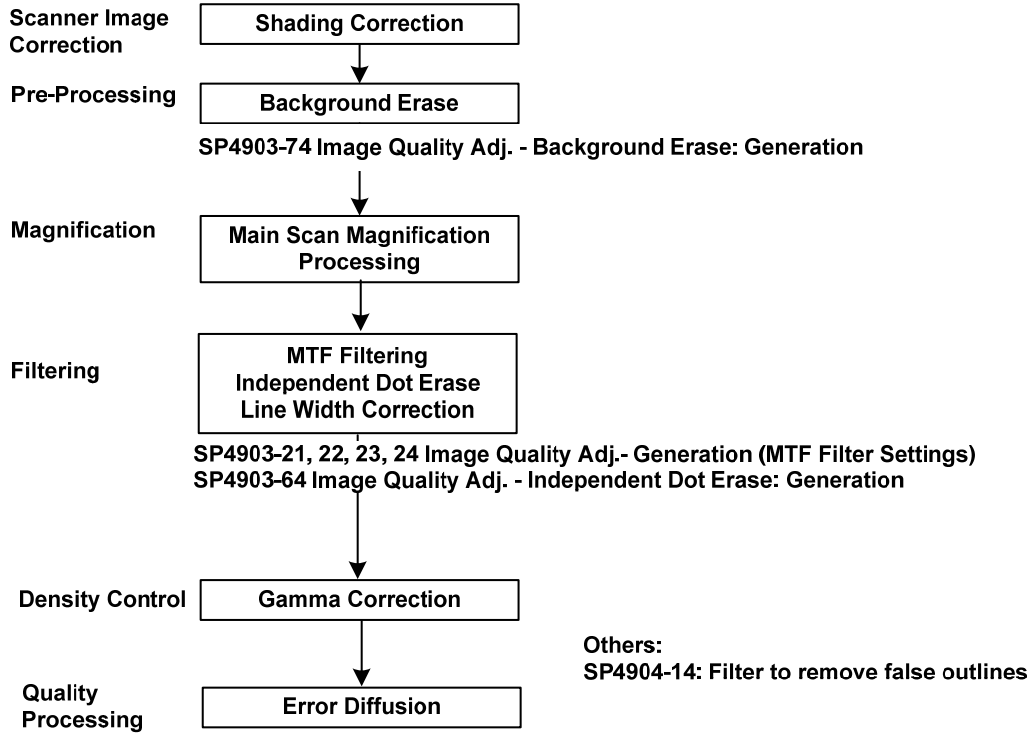

b286d997

6.4 AROUND THE DRUM

6.4.1 OVERVIEW

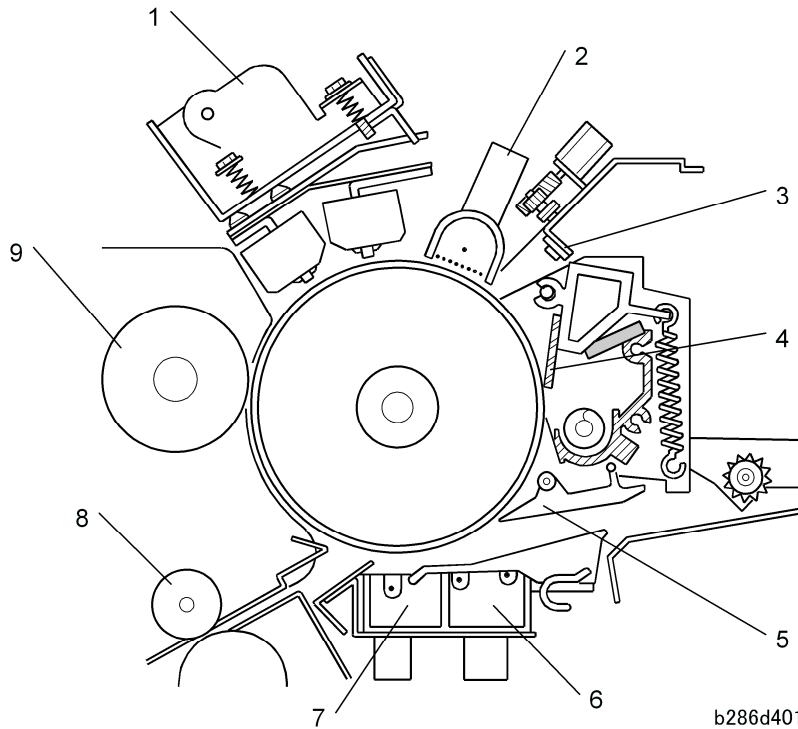

- | | |
|-------------------------------|---------------------------------|
| 1. LPH (LED Print Head) | 6. T&S Unit (Separation Corona) |
| 2. Charge Corona Unit | 7. T&S Unit (Transfer Corona) |
| 3. Quenching Lamp (LED Array) | 8. Registration Rollers |
| 4. Cleaning Blade | 9. Development Roller |
| 5. Pick-off Pawl | |

Drum diameter: 80 mm (3.2")

Drum speed: 80 mm/s

LPH: 3 arrays, each array the same width as one A3 sheet

6.4.2 DRUM DRIVE

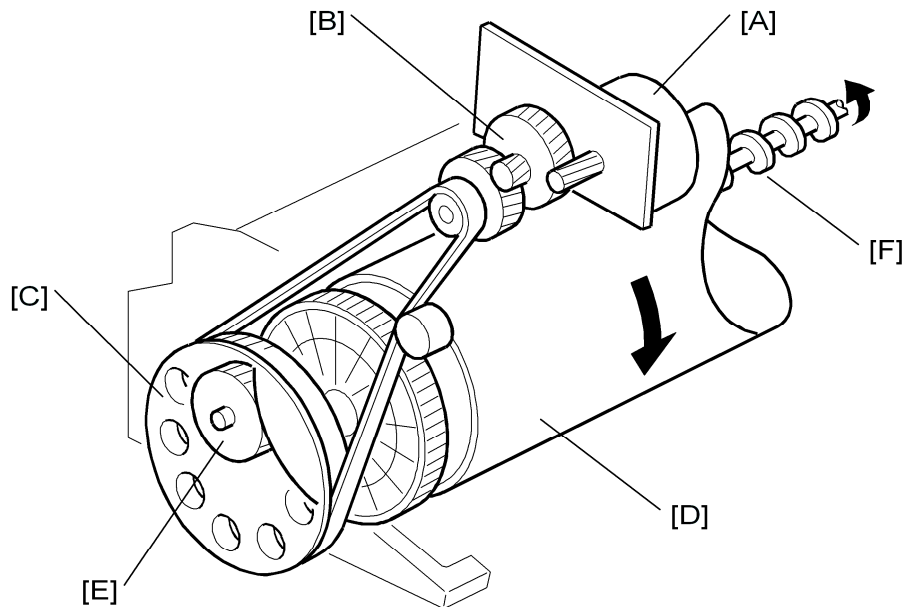

b286d404

The drum motor [A] controls:

- Timing gears [B]
- Timing belt and wheel [C]

This turns the OPC drum [D].

Gear [E] (meshed with the OPC drum) turns the cleaning unit auger [F].

When paper feed starts:

- The drum motor switches on and turns the drum forward.
- While the drum turns forward, the LPH writes the ID sensor pattern on the drum, then the drum turns forward 250 mm more.
- The ID sensor reads the pattern (V_{sp}) and the surface of the drum (V_{sg}) to find V_{sp}/V_{sg} for toner density control.

The drum motor turns the drum in the opposite direction at the end of each job for 0.3 s.

This removes paper dust (caused when the paper roll is cut) from the cleaning blade.

6.4.3 CHARGE CORONA UNIT

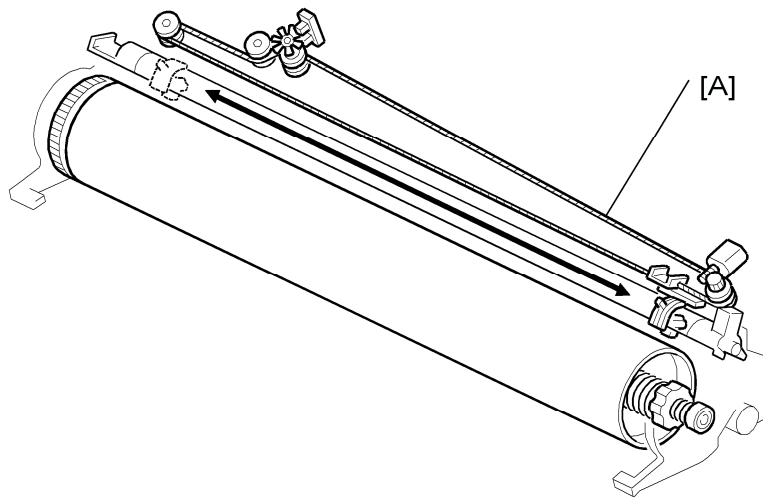

b286d405

The charge corona unit [A], above the OPC drum, uses the Scorotron (Negative) Charge Method (☞ Photocopying Processes – Charge – Corona Charge)

There is one gold-plated charge wire behind some grid wires. The grid wires make sure that the charge on the OPC drum is constant.

Charges used for this machine:

- Grid: -825 V
- Drum surface: -850 V
- Corona wire: About 1200 μ A

6.4.4 CORONA WIRE CLEANING

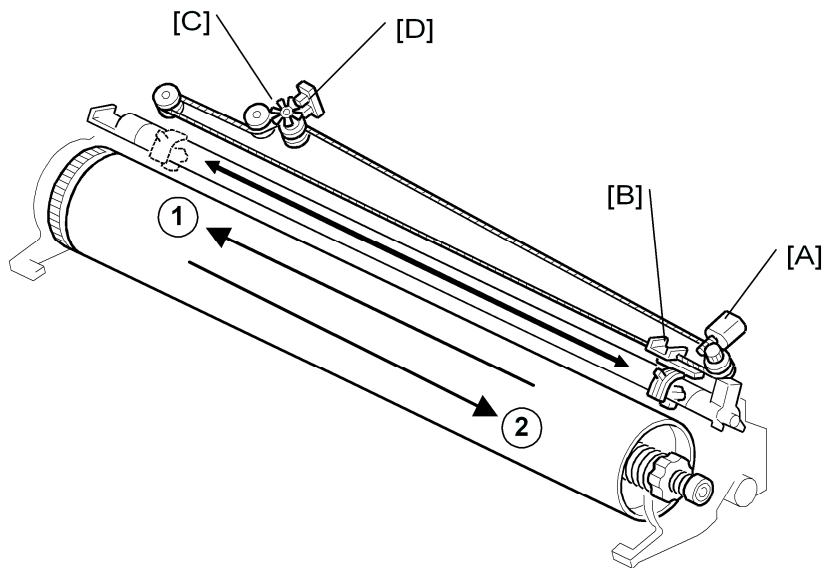

b286405a

The corona wire is cleaned immediately after the main power switch or operation power switch is switched on, if these two conditions occur at the same time:

- 600 m of paper fed through the machine since the last wire cleaning
- The temperature of the hot roller is less than 50°C (122°F).

The interval between automatic wire cleaning (Default: 600 m) can be adjusted with SP2804. This SP can also be set to clean the corona wire immediately after the machine is switched on.

The wire cleaner motor [A] controls the cleaning pad [B].

When the cleaning pad gets to the left side (as shown above), the motor changes direction and pulls the cleaning pad back to the home position on the right.

If the cleaning pad is not at the home position immediately after the main power is switched on, the cleaning pad goes back to home position.

The actuator [C] for the wire cleaner sensor [D] turns while the cleaner moves. The signals from this sensor tell the machine when the cleaning pad moves. If the wire cleaner stops before it gets to the end, or if stops too long at the far left position, the wire cleaner sensor detects an error.

6.4.5 DRUM CLEANING

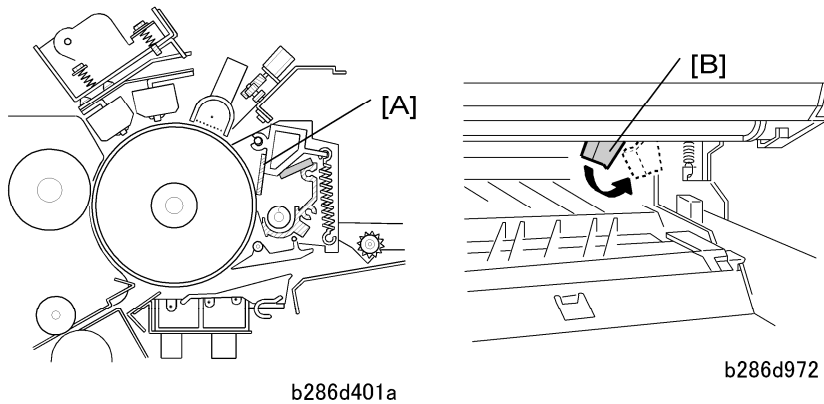

This machine uses a counter blade system to clean toner from the surface of the drum.

( Photocopying Processes – Cleaning – Counter Blade)

The cleaning blade [A] is opposite to the direction that the drum turns.

The counter blade has a lever [B] on the bottom side of the upper unit.

- Set [B] to the right: The blade touches the drum for normal operation.
- Set [B] to the left: The blade is away from the drum.

This lever must be set to the left at the following times:

- Before you remove the OPC drum
- Before you move the machine a long distance

 **Note**

- If you will move the machine to a different location on the same floor, then it is not necessary to move the lever to the left.

6.4.6 COLLECTING USED TONER

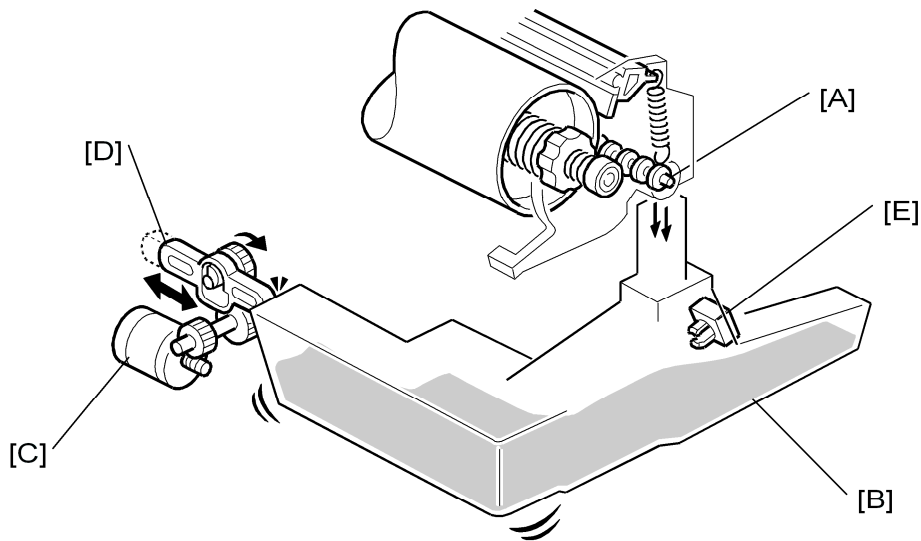

b286d406

The cleaning unit auger [A] pushes toner into the used toner collection bottle [B]. The used toner bottle motor [C] moves a cam [D] from side to side, to hit the side of the used toner collection bottle. This causes a vibration, and this keeps the level of used toner in the bottle flat. The motor never switches on during a job, to prevent this vibration from causing a malfunction.

The motor operation timing is controlled as follows:

- When the used toner overflow sensor detects that the used toner tank is almost full, the motor switches on for 20 seconds at the end of the job (SP2926-1). During the motor operation, printing and scanning cannot be done.
- After a new toner cartridge is installed and the cover is closed, the motor switches on for 30 seconds (SP2926-2).

If the used toner overflow sensor [E] still detects toner after 20 seconds of vibration, the overflow indicator on the operation panel starts to flash:

- Printing can continue until the end of the job. But, if 15 more meters are printed before the end of the job, printing stops at the 15-meter point.
- After 15 meters of copying, or at the end of the job, the overflow indicator stops flashing and stays on. The machine cannot be used until you remove the used toner from the collection bottle.

↓ Note

- The length of paper that can be printed after the toner-bottle-full indication can be made shorter or longer with SP2926-3 (Used Toner Control – Used Toner Overflow Detection).

After you put the empty bottle back in the machine, if toner is not detected by the used toner bottle sensor, then the machine returns to normal operation mode. If toner is detected, the used toner bottle motor turns on for 30 seconds. If toner is still detected, then the machine stops and the bottle must be removed.

6.4.7 QUENCHING

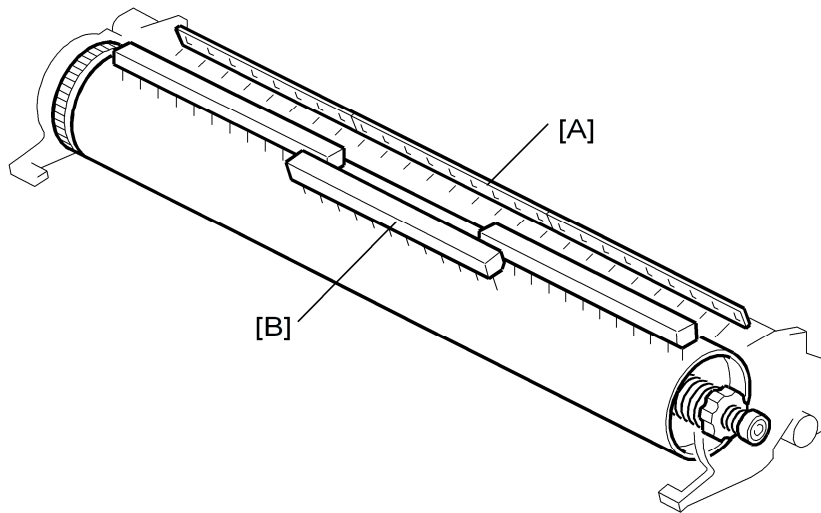

b286d402

The quenching lamp [A], an array of LEDs, is behind the LPH [B]. After the drum [A] is cleaned by the cleaning blade, light from the quenching lamp removes unwanted charge on the drum. This prepares the drum for the subsequent copy cycle. The quenching lamp switches on and off with the drum motor (the lamp stays on while the OPC drum turns).

Around the Drum

6.4.8 DRUM ANTI-CONDENSATION HEATERS

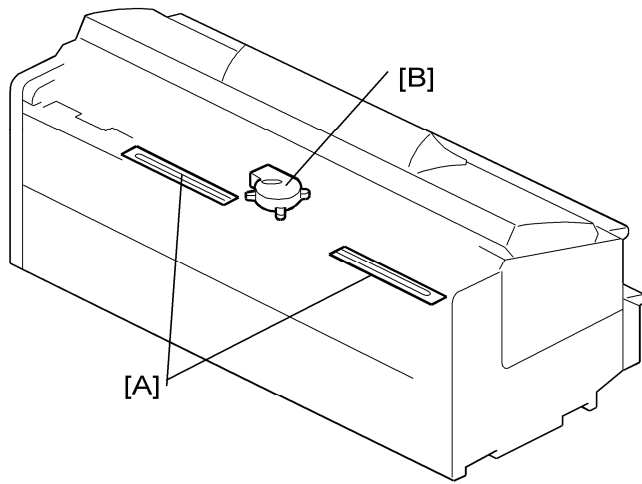

b286d973

The two heaters [A] below the drum prevent condensation around the drum and T&S unit. A cooling fan [B] moves the air.

The on/off timing of these heaters is:

- When the main power switch or operation switch is switched on, the heaters switch off.
- When the main power switch or operation switch is switched off, the heaters switch on.

6.5 IMAGE WRITING

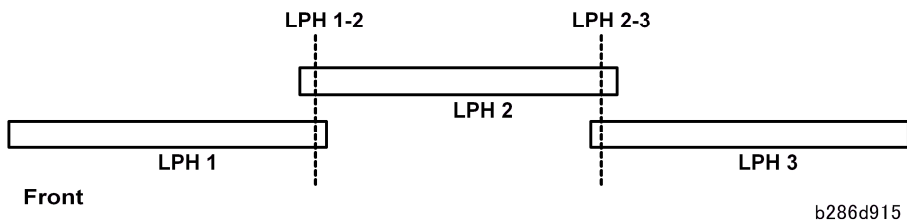
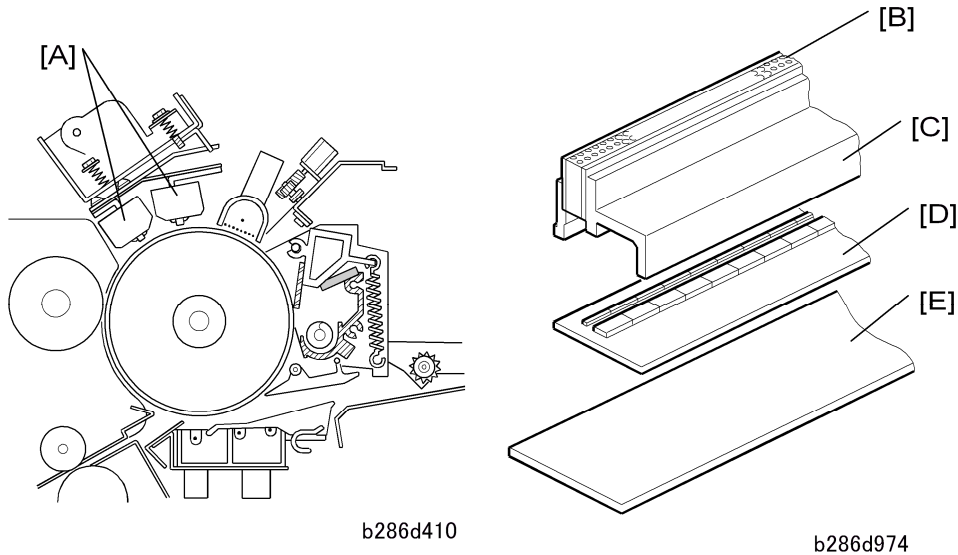

This machine uses an LPH (LED Print Head) [A] that sends light directly to the OPC drum to make a latent image.

The A0-size 600-dpi print head is an array of connected self-focusing lenses [B] above an LED array [C] and drive board [D], and attached to a heat sink [E].

Note

- The maximum printing width of the print head is 914 mm (36”).

The LPH has three sections: LPH 1, LPH 2, and LPH 3. The two joints between the sections are identified as “LPH 1-2” and “LPH-2-3” (see above).

6.6 DEVELOPMENT

6.6.1 OVERVIEW

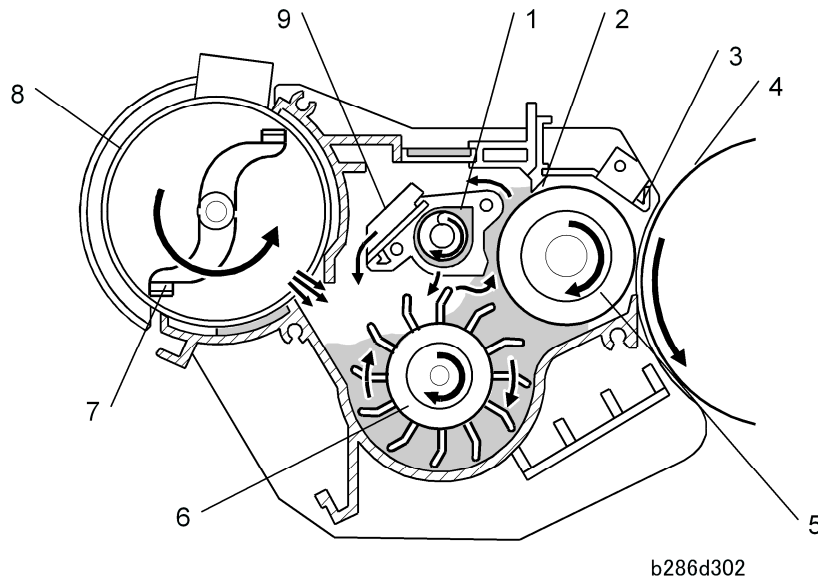

- | | |
|------------------------------|--------------------|
| 1. Auger | 6. Paddle Roller |
| 2. Doctor Blade | 7. Toner Agitator |
| 3. Development Entrance Seal | 8. Toner Cartridge |
| 4. OPC Drum | 9. Separator |
| 5. Development Roller | |

 Note

- The development unit does not have a TD sensor. The machine uses only the ID sensor for toner supply control.

6.6.2 DEVELOPMENT DRIVE MECHANISM

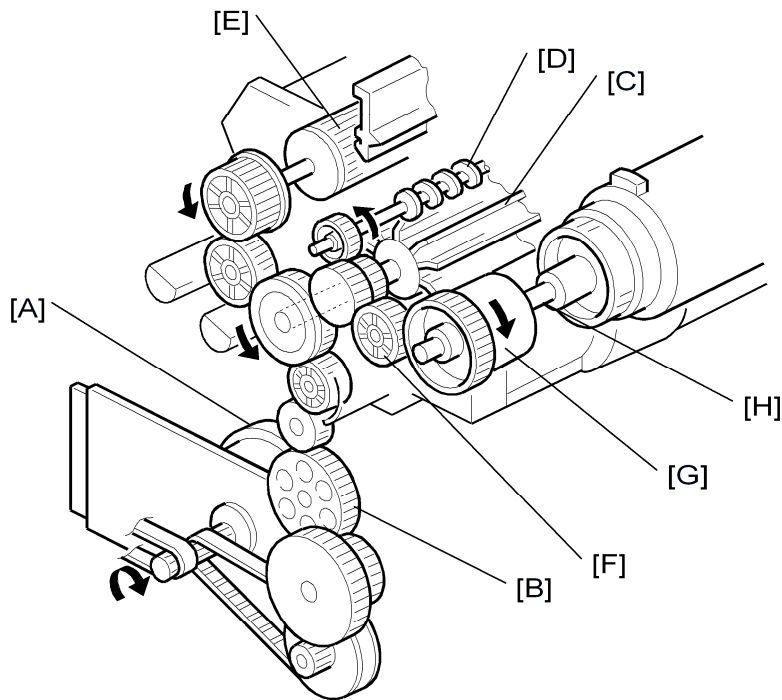

b286d304

- [A]: Timing belt (from the main motor)
- [B]: Gear train
- [C]: Paddle roller
- [D]: Mixing auger
- [E]: Development roller
- [F]: Gear
- [G]: Toner supply clutch
- [H]: Toner agitator shaft (controlled by the toner supply clutch)

The toner supply clutch engages only when toner density control switches on the clutch to supply toner from the toner cartridge.

The main motor:

- Switches on 1.25 s after the drum motor switches on.
- Turns the development roller at 60 mm/s, to be the same speed as the drum.
- Stops 83 ms (approx. 5 mm turned) after the ID sensor pattern is written during the initial rotation of the drum motor.

6.6.3 TONER SUPPLY MECHANISM

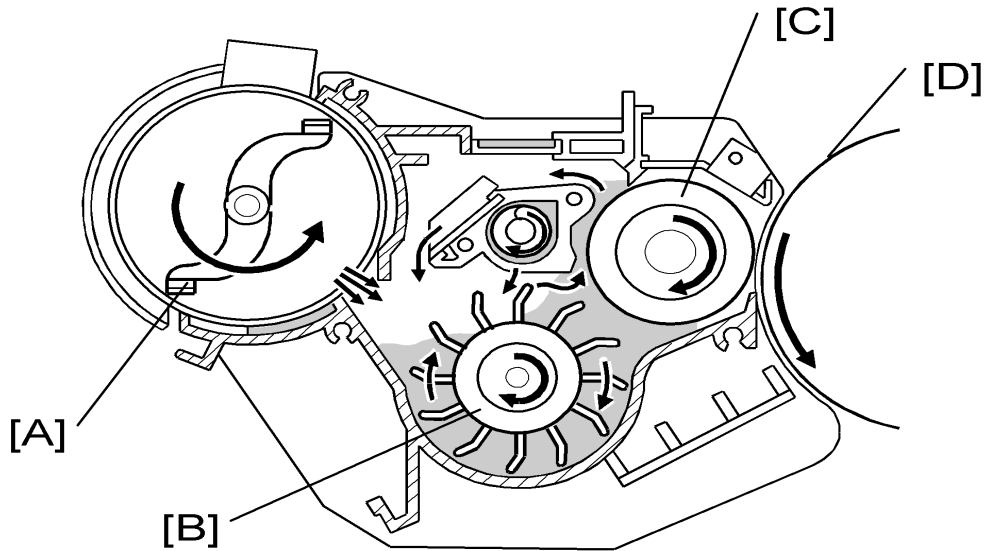

b286d302a

This machine uses dual-component development with toner concentration control. The toner agitator [A] turns in the center of the toner cartridge to move toner to the paddle roller [B] in the development unit. Toner then goes to the development roller [C] and the drum [D]. To control the quantity of toner that is supplied to the development unit, the machine switches the toner supply clutch on and off. The output from the ID sensor controls the clutch on/off timing. This development unit does not have a TD sensor.

6.6.4 DEVELOPER CROSS-MIXING

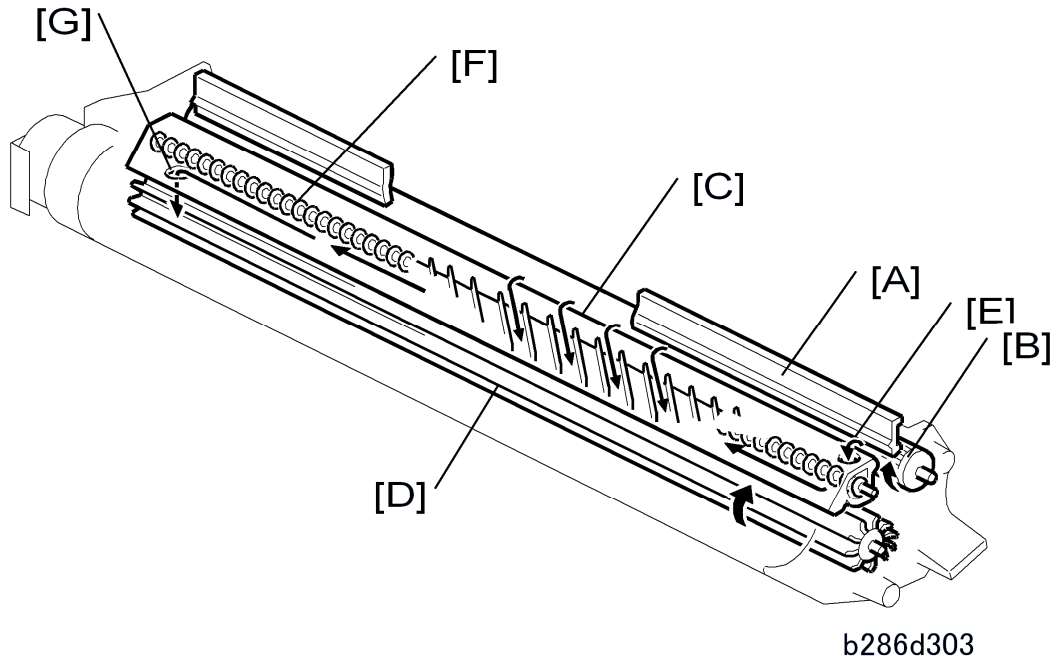

( Photocopying Processes – Development – Crossmixing)

[A]: Doctor blade

[B]: Development roller

[C]: Backspill plate

[D]: Paddle roller

[E]: Auger inlet

[F]: Mixing auger

[G]: Paddle roller inlet

6.6.5 DEVELOPMENT BIAS

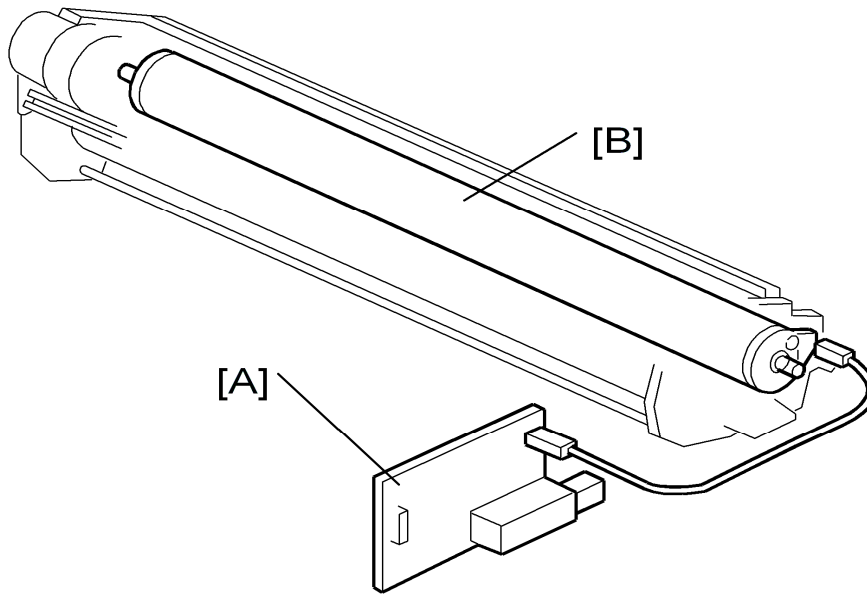

b286d904

The CGB power pack [A] applies a negative bias (-650V) to the development roller [B], slightly higher than the remaining charge on the drum.

The development bias during copying is set by SP 2201-1 (Development Bias Adjustment – Image Area).

6.6.6 ID SENSOR

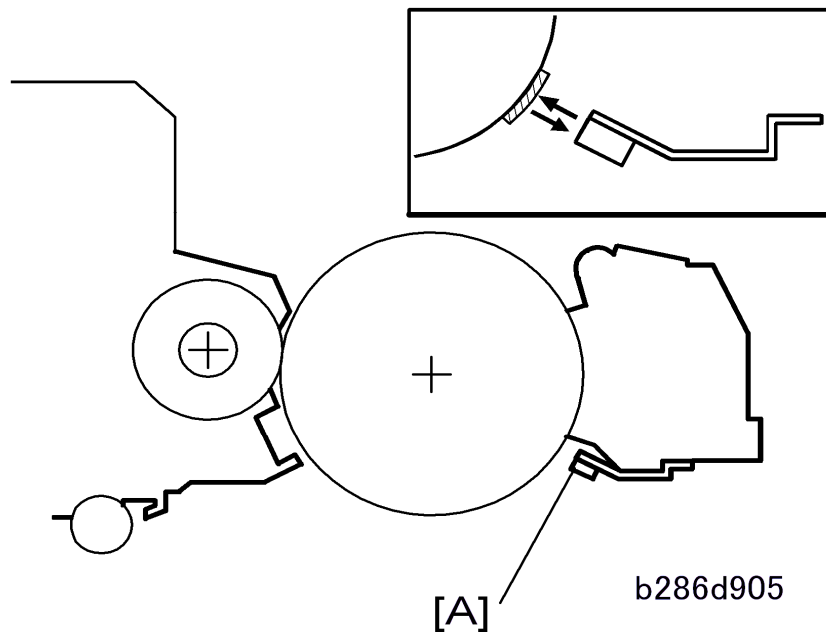

The ID sensor [A] regularly reads two areas of the drum:

- **Bare surface of the drum.** The ID sensor measures the reflectivity of the bare drum, converts this reading to a voltage, and stores this value (V_{sg}) in NVRAM.
- **ID sensor pattern.** The LPH writes an ID sensor pattern on the drum. The ID sensor reads the density of this pattern, converts it to a voltage, and stores this value (V_{sp}) in NVRAM.

The machine makes an ID sensor pattern to read V_{sp} after each copy.

But, the machine reads V_{sg} only one time. This is done during machine warm-up (see the next section).

6.6.7 WARMUP CONTROL (VSG CORRECTION)

In order to prevent the occurrence of dirty background on the first copy after the machine warms up, the value of Vsg is checked after the upper unit is closed and after the machine is turned on (or returns from low power mode).

After Closing the Upper Unit

The machine measures Vsg after the upper unit is closed, and recalibrates the ID sensor if necessary.

- If the machine detects Vsg < 2.5 V twice, the machine issues SC401 (ID Sensor Vsg Error).
- If the machine detects Vsg > 2.5 V, it will perform adjustments or issue SC401 as shown below, based on the value of the Vsg reading. (See the “ID Sensor Recalibration Table” below.)

After Power On

If the fusing temperature is below 50°C (122°F) after the machine is powered on (or returns from the low power mode), the machine measures Vsg. The machine compares this Vsg reading with the PWM value that was stored when the ID sensor was initialized, in order to determine if the current Vsg value is correct.

- If the machine detects Vsg < 2.5 V twice, the machine issues SC401 (ID Sensor Vsg Error).
- If the machine detects Vsg > 2.5 V, it will perform adjustments or issue SC401 as shown below, based on the value of the Vsg reading.

ID Sensor Recalibration

Readings (V)	How the ID Sensor is Recalibrated
Vsg < 3.9	PWM value +0.5%
Vsg = 3.9 to 4.10	ID sensor is re-calibrated automatically with the stored PWM value.
Vsg = 4.1 to 4.2	PWM value -0.2%
Vsg = 4.2 to 4.5	PWM value -0.5%
Vsg = 4.5 to 4.8	PWM value -1.0%
Vsg > 4.8	SC401 occurs (ID Sensor Vsg Error). For more details see section 4.2 “SC Code Descriptions.”

 Note

- If SP2804 is set to clean the charge corona wire during warm-up, Vsp/Vsg is measured after the wire is cleaned.
- The machine measures Vsg after the machine is powered on or returns from the low power mode, if SP2924 is set to “0” or “1.” (The default is “0”, which means that the machine measures Vsg after power on when the fusing temperature is below 50°C.) For more, refer to “Service Tables.”
- If the machine is switched off and on after the warm-up sequence when Vsg is less than 2.5V, the warm-up sequence is done, and the setting of SP2924 (Warm-up Control) is ignored.

6.6.8 TONER DENSITY CONTROL

Overview

This machine uses an ID sensor to control:

- Toner density
- Toner near end detection
- Toner end detection

The machine uses the ratio of Vsg/Vsp to find the quantity of toner that must be supplied to the drum.

To supply toner, the machine switches on the toner supply clutch to feed toner from the toner cartridge to the development unit.

SP3103 (ID Sensor Output Display) shows the most recent values of Vsg and Vsp that were stored in the NVRAM (Range: 0.00 ~ 5.00 V).

Supply Modes

There are two supply modes

- Detect Supply Mode
- Fixed Supply Mode

During normal operation, the machine uses detect supply mode.

Detect supply mode has two sub-modes (referred to as “tables”).

- Main table: Used during copying
- Length table: The machine switches to this table during copying if the length of the copy becomes more than 1189 mm (46.8”).

If an ID sensor problem occurs during the job, the machine stops the end of the job. The machine does not go into fixed supply mode automatically. The technician must repair the machine. If the machine cannot be repaired, the technician must put the machine into fixed supply mode with SP 2208-3.

Development

In fixed supply mode, the machine supplies a set quantity of toner per page.

After the technician repairs the machine, the machine must be put back in detect supply mode with SP 2208-3.

Detect Supply Mode

- **Main Table -**

The machine uses this table from the start of the page until the length of the printed page gets to 1189 mm (46.8”).

The machine uses these two parameters to control the rate of toner supply:

- Vsg/Vsp
- The toner supply level set with SP2208-1

Vsp/Vsg	Toner Supply Level (SP 2208 001)			
	L	M	H	HH
Less than 10%	None	None	None	None
10% to 12%	15%	20%	30%	40%
More than 12%	40%	50%	60%	70%
Toner Near-End	100%	100%	100%	100%

- **Length Table -**

If the page becomes longer than 1189 mm (46.8”), the machine changes to the Length Table for the remaining part of the page.

But, if no toner was supplied before the start of the copy job, the quantity of toner was sufficient at that time. Because of this, the machine does not change to the Length Table.

The Length Table ignores the Vsp/Vsg ratio. Toner is supplied at a set rate. This rate is controlled by the toner supply level set with SP 2208-1.

Length Table

Toner supply rate	Toner Supply Level (SP 2208-1)			
	L	M	H	HH
	4%	8%	12%	20%

Fixed Supply Mode

When the technician switches the machine to fixed supply mode, toner is supplied as shown in this table.

Toner supply rate	Toner Supply Level (SP 2208-1)			
	L	M	H	HH
	4%	8%	10%	12%

Toner Supply Clutch Operation

The toner supply clutch turns the toner agitator shaft to supply toner from the toner cartridge to the development unit.

The toner supply rates in these three tables control the on/off timing of the toner supply clutch.

When the toner supply clutch switches on, it stays on for 0.4 second. The length of the intervals when the clutch is off is set by the percentage values shown in the diagram on the next page.

Development

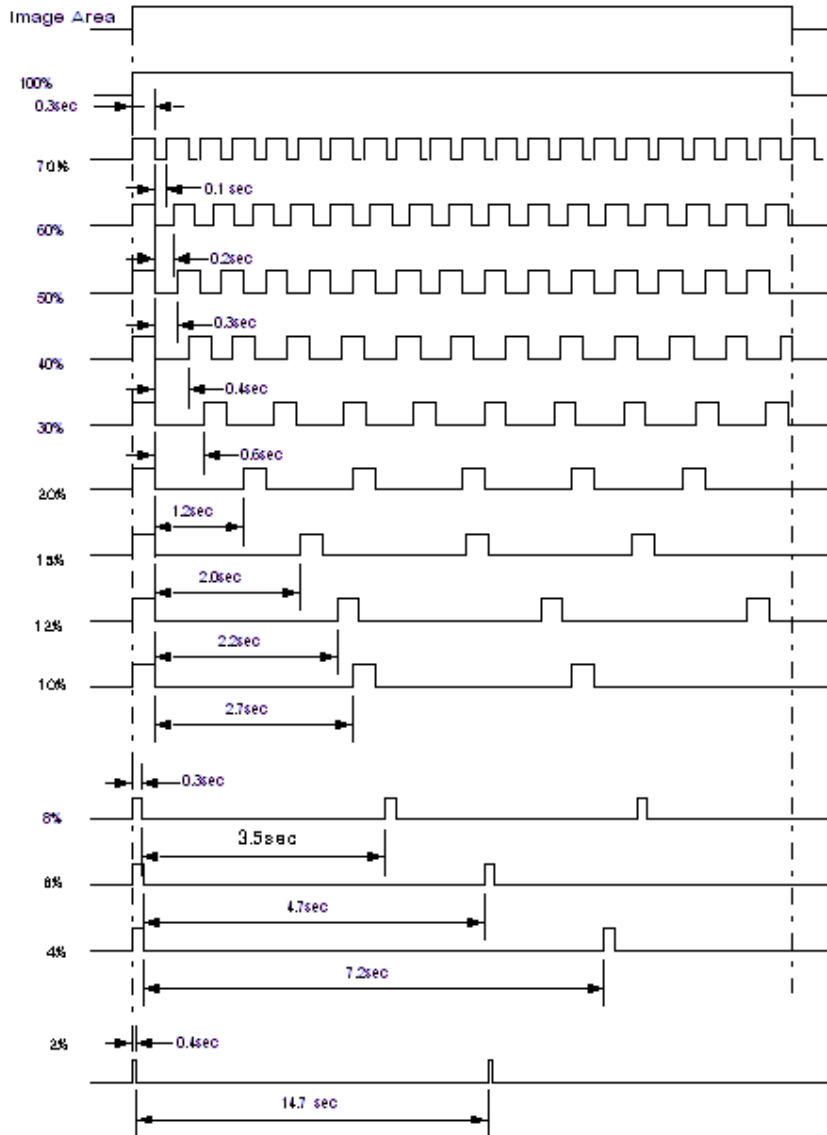

The percentage values in this chart correspond to the percentages listed in the Main, Length, and Abnormal ID Sensor Tables. For example, if the value is 10%, the toner supply clutch is on for 10% of the time; it switches on for 0.3 second at 3.0 second intervals

6.6.9 TONER END/NEAR-END DETECTION

The machine compares V_{sp}/V_{sg} with two SP settings to find when the toner cartridge is almost empty (Toner Near End) or fully empty (Toner End).

- SP2927-1: Toner near-end
- SP2927-3: Toner end

Toner Near End

When V_{sp}/V_{sg} is larger than SP2927-1 three times in sequence, the machine shows a toner near-end indication. The default is 0.145. If the setting is higher, the quantity of toner in the cartridge becomes less before toner near-end occurs. This can cause paler images at the end of the toner cartridge's life. When toner near-end occurs, the toner near-end indicator lights on the operation panel.

Toner End

When V_{sp}/V_{sg} is larger than the setting for SP2927-3 (Default: 0.165) three pages in a row, the machine prints one more page and then stops immediately.

When toner end occurs, the toner end indicator lights on the operation panel and copying stops. The machine cannot be used until:

- A new toner cartridge is installed.
- The machine recovers from toner end.

Toner End Recovery

The flow chart on the next page shows the recovery sequence when a new toner cartridge is installed after toner end occurs. After toner end occurs, toner end recovery starts if you open and close the toner hopper cover.

The machine makes an ID sensor pattern to detect if a supply of toner is available. If V_{sp}/V_{sg} is less than V_{ref} , then the machine detects recovery from toner end, and goes out from the toner end condition. If V_{sp}/V_{sg} is more than V_{ref} 5 times, then the machine stays in the toner end condition, and it cannot be used. In some conditions, the machine recovers from toner end if you switch the machine off and on.

Development

Toner End Recovery Flow Chart

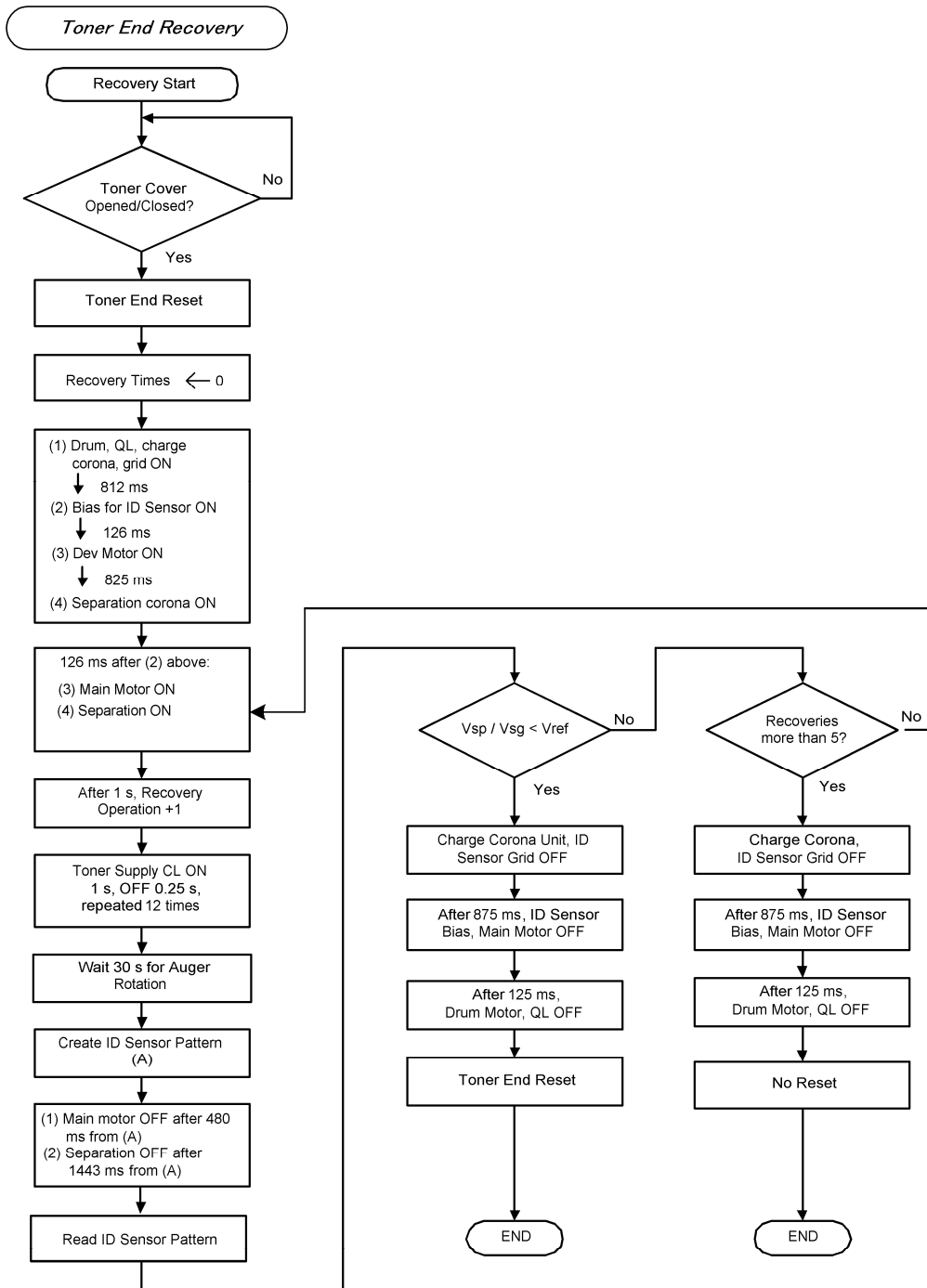

b286d917

6.7 PAPER FEED AND REGISTRATION

6.7.1 OVERVIEW

Layout Diagrams

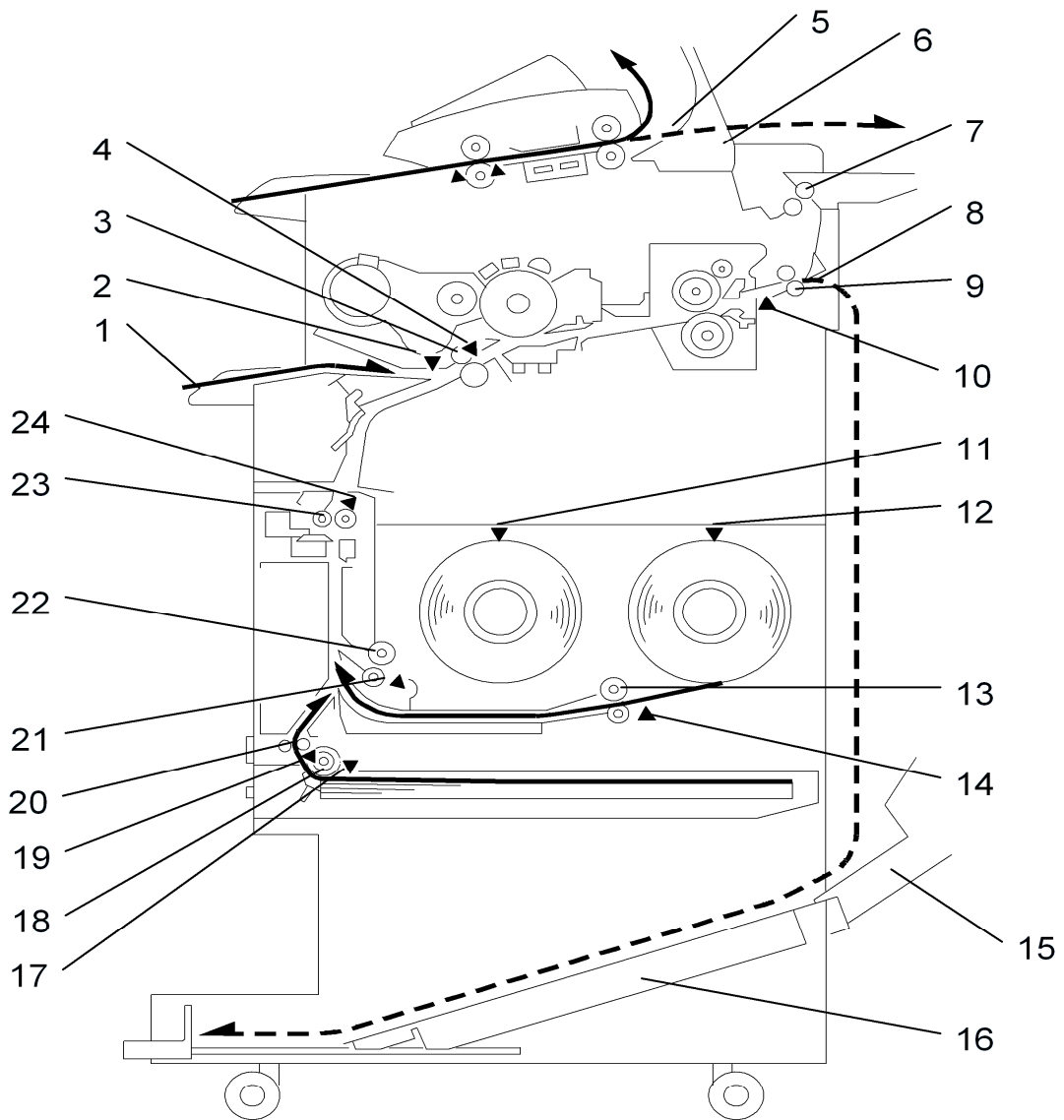

Details

b286d975

Paper Feed and Registration

1. Manual Feed Table (Bypass)
2. Paper Set Sensor
3. Registration Rollers
4. Registration Sensor
5. Upper Exit
6. Paper Junction Gate
7. Upper Exit Rollers
8. Rear Exit
9. Fusing Exit Rollers
10. Exit Sensor
11. Roll 1 End Sensor
12. Roll 2 End Sensor
13. Feed Rollers (Roll 2)
14. Roll 2 Paper End Sensor
15. Lower Output Tray
16. Lower Output Stacker
17. Paper Cassette Paper End Sensor
18. Paper Cassette Feed Roller
19. Relay Sensor (Cut Sheet)
20. Grip Rollers
21. Roll 1 Paper End Sensor
22. Feed Rollers (Roll 1)
23. RF Exit Rollers
24. RF Exit Sensor

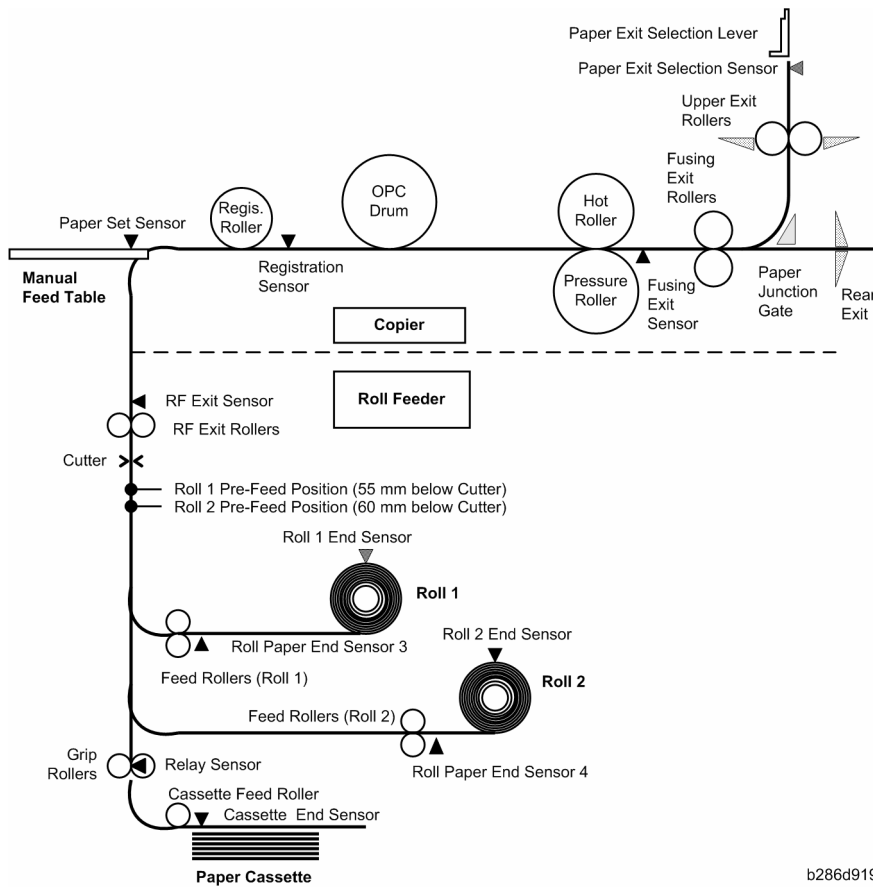

b286d919

This diagram shows all the rollers and sensors used during paper transport. The diagram is not in scale.

Feed Station Overview

The machine can feed paper from the manual feed table or the optional roll feeder. With all options installed, there are four paper feed sources:

- Manual Feed Table (bypass tray)
- Roll 1: Front roll in the Roll Feeder (Roll Feeder B851 has the front roll only)
- Roll 2: Rear roll in the Roll Feeder (Roll Feeder B852 has the front and rear rolls).
- Paper Cassette (installed in the bottom of the Roll Feeder)

The user sets one of these paper feed sources at the operation panel.

When the machine detects the original, the feed motor and the registration motor start, and paper feed starts. The paper goes into the machine from the paper supply source, goes through the RF exit rollers, and then to the registration rollers.

The registration rollers stop temporarily for paper skew correction, and then start again to feed the paper to the drum.

Details

Paper Feed and Registration

Manual Feed Table

The manual feed table (bypass tray) is the main station for paper supply for this machine. (The roll feeder and paper cassette are options.) Because of this, the manual feed table is not a “bypass” tray, although the name for the manual feed table is “bypass tray” in the User Tools menus.

The manual feed table feeds one pre-cut sheet.

Roll Feeder

The cutter cuts the paper after the machine feeds the specified paper length. The RF exit sensor monitors paper feed.

The start time of the cutter is controlled by the cutting mode set by the user at the operation panel:

- Preset 1. Cuts a preset SEF length. The size of the original is ignored.
- Preset 2. Cuts a preset LEF length. The size of the original is ignored.
- Synchro. Cuts the copy paper to the same length as the original.
- Variable. Cuts the copy to the length that was input at the operation panel.

After the last cut of a job, the feed roller changes direction and feeds the leading edge of the paper to its home position. This makes sure that the paper path is not blocked when paper feed starts for the next job.

Paper Cassette

The optional universal-type paper cassette, installed in the bottom of the roll feeder, feeds cut sheets.

Paper Width and Type Settings

After a roll is installed, the width of the paper and the type of paper must be set. For more, see section 1.2 “Main Machine Installation (B286).”

6.7.2 MANUAL FEED MECHANISM

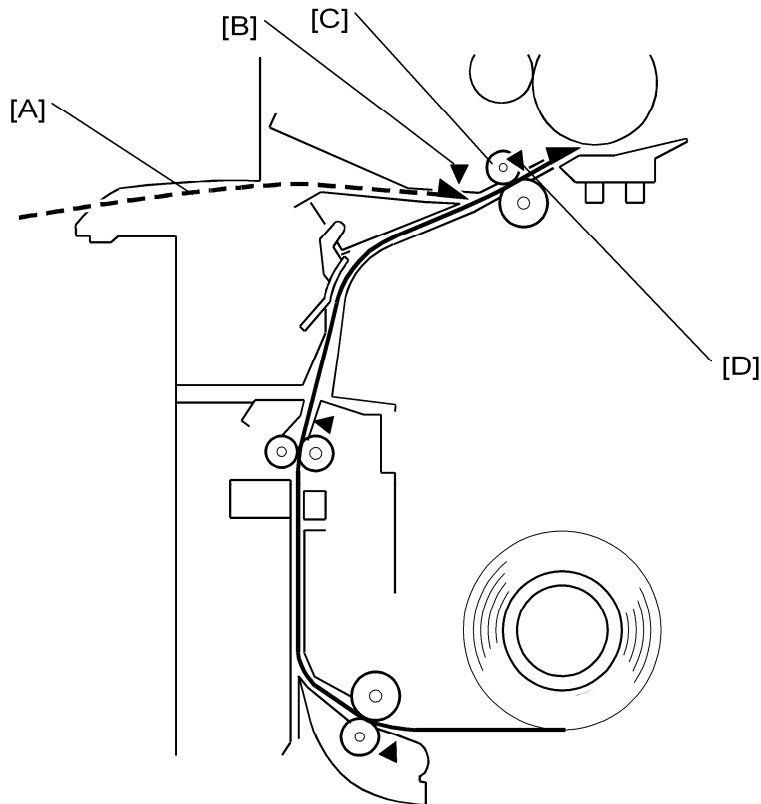

b286d203

The user puts a cut sheet [A] on the manual feed table (also known as the bypass tray). The paper set sensor [B] detects the leading edge of the sheet. This switches on the drum motor, main motor, and registration clutch.

The registration clutch engages the registration roller [C] which feeds the sheet.

The registration sensor [D] detects the edge of the sheet and the registration clutch switches off for 2 seconds. This gives the user time to adjust the position of the paper to make it straight.

The 2-second interval can be adjusted with SP1911 (By-Pass Feed Start Timing Adj.).

6.7.3 ROLL FEED MECHANISM

Drive

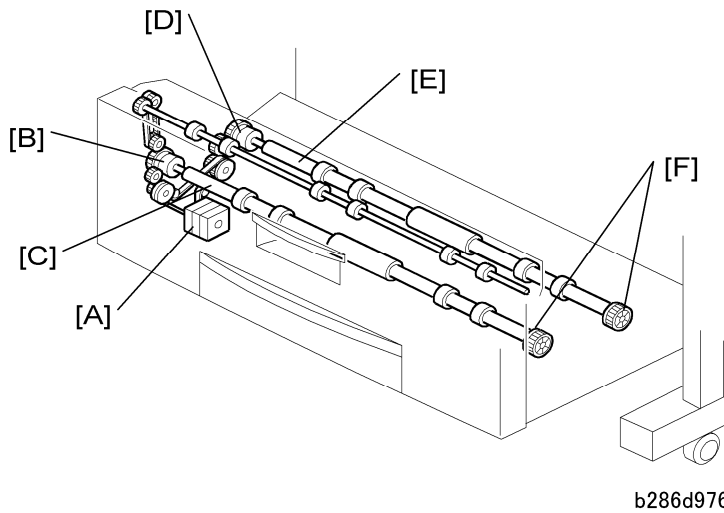

One roll feed motor [A] controls the two feed rollers:

The clutch [B] engages to transfer power from the motor to the feed roller [C] for Roll 1.

• or-

The clutch [D] engages to transfer power from the motor to the feed roller [E] for Roll 2.

There is a plastic knob [F] at the end of each feed roller. After a new roll is installed, or after a paper jam is removed, the user turns these knobs to feed the paper manually to the cutting position.

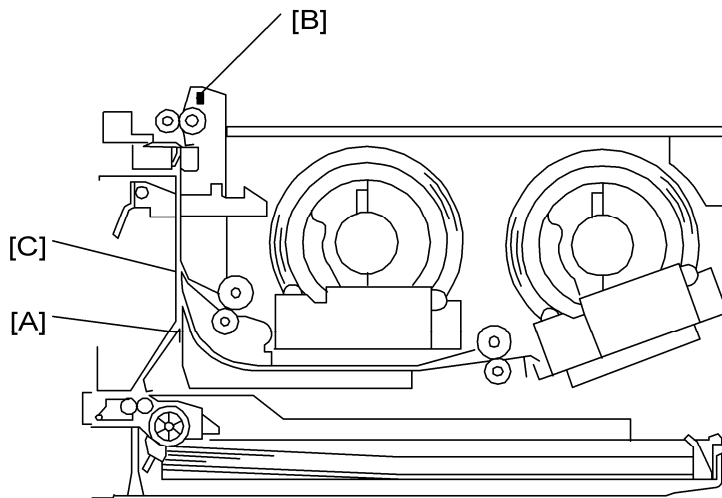
Roll Pre-feeding

b286d952

Check Before Pre-Feeding

The machine does a pre-feed control check:

- Immediately after the main power switch or operation switch is switched on.
- Immediately after the roll feeder drawer is closed.
- At the end of a copy job.

During the pre-feed check, the cutter moves to home position:

- The machine checks if the left or right cutter HP switch is ON.
- If the two cutter sensors are OFF, the machine moves the cutter to the left home position. This makes sure that the spring-loaded paper holder opens to let paper feed. (See section 6.7.5 “Roll Paper Cutting Mechanism.”)

The machine pre-feeds paper from each roll after the pre-feed check completes without error. Pre-feeding is done for Roll 1 first.

Paper Feed and Registration

Roll 1 Pre-Feeding

- Roll feed clutch 1 engages and turns the Roll 1 feed roller.
- The leading edge of the sheet feeds past the RF exit sensor [A].
- Feed stops.
- The roll feed motor pulls back the leading edge of the sheet until it is **55 mm** below the cutter. Then it stops. This is the pre-feed position [B] for Roll 1.

Roll 2 Pre-Feeding

- The machine pre-feeds the sheet from Roll 2.
- The roll feed motor pulls back the leading edge of the sheet until it is **60 mm** below the cutter and then stops. This is the pre-feed position [C] for Roll 2.

The two sheets stay at their pre-feed positions for the start of the next copy job. There are no rollers in this part of the paper path. As a result, when the two rolls are at the pre-feed positions, one can easily feed, and the other does not move.

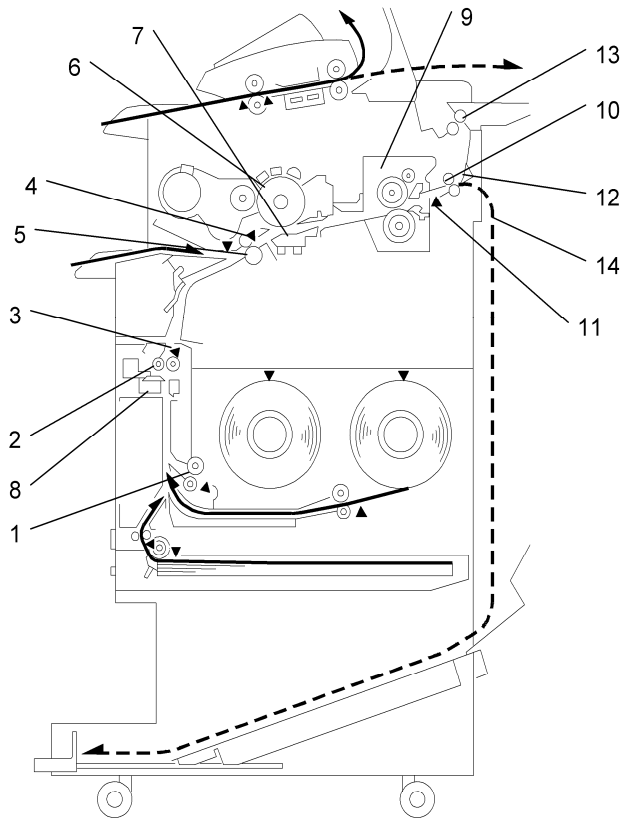
Roll Paper Feed

b286d977

Roll paper feed starts from the pre-feed position.

- The roll feed motor engages roll feed clutch 1 and turns the feed rollers [1].
- The RF exit rollers [2] feed the paper past the roll exit sensor [3] to the registration roller. The RF exit sensor checks that the leading and trailing edges of the sheet go by at the correct time.
- The registration sensor [4] stops the registration roller [5] to correct skew. Then, the registration roller feeds the paper to the drum [6] and through the T&S unit [7].
- The cutter [8] cuts the paper at the length specified for the job. (See section 6.7.5 “Roll Paper Cutting Mechanism.”)
- The rollers in the fusing unit [9] feed the sheet to the exit rollers [10].
- The exit sensor [11] checks that the leading and trailing edges of the sheet go by at the correct time.
- The exit rollers feed the sheet to the paper junction gate [12].
- The paper junction gate sends the paper to the upper exit rollers [13] or sends it out the rear [14] of the machine. (see section 6.10.2 “Switching the Paper Exit.”)

6.7.4 ROLL FEEDER PAPER HOLDERS

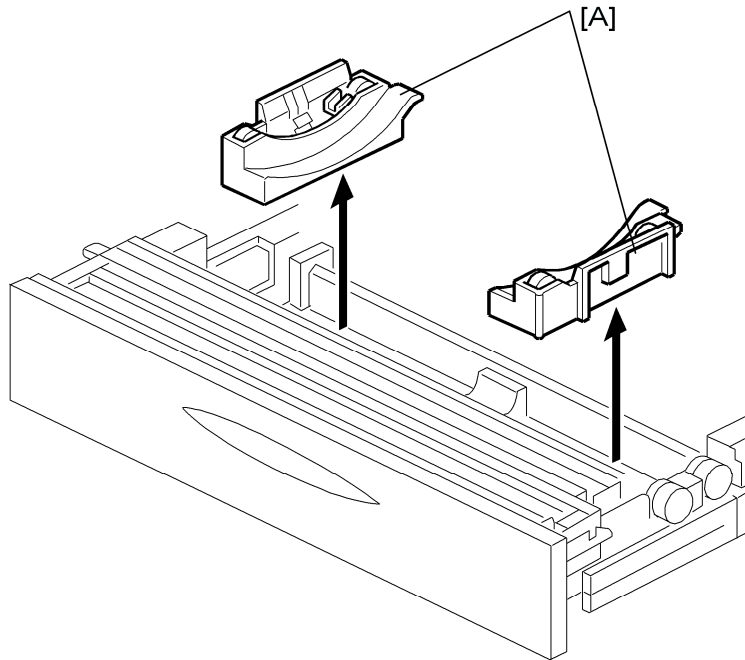

b286d907

The racks [A] hold the rolls that are adjustable. This lets the user install paper rolls of different widths.

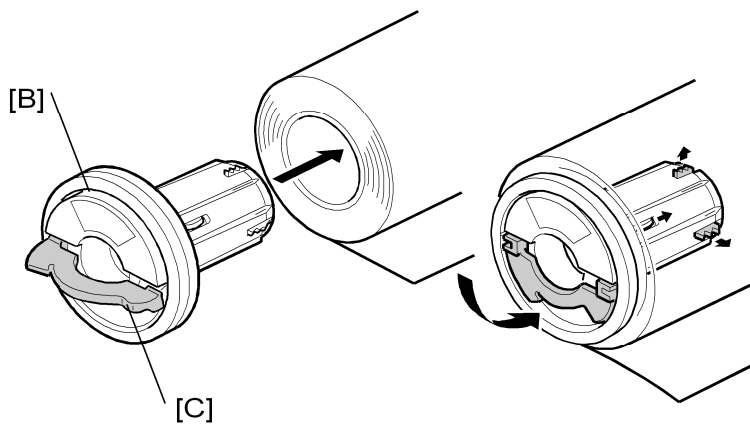

b286d711

A roll stopper [B] is put in each end of a roll. The roll lever [C] locks the stoppers in their position after they are put in the ends of a roll. The roll is put on the rack with each stopper locked in its position.

6.7.5 ROLL PAPER CUTTING MECHANISM

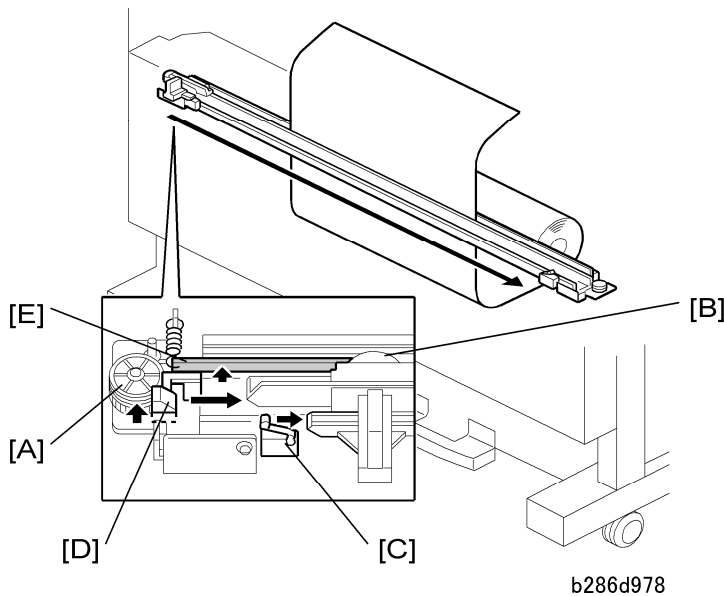

Immediately before cutting, the registration roller continues to turn at normal speed, but the roll feed motor speed increases by a small quantity. This causes the paper to buckle slightly between the registration roller and the top of the cutter, and this gives the machine time to cut the paper.

The cutter motor below the drive gear [A] switches on and moves the rotary cutter [B] and its handle across the width of the paper. The switch [C] on the left or right end detects when to stop the cutter motor. The cutter cuts from left to right, or from right to left. It does not come back after cutting the paper, until it is time to cut the next page. In the illustration, the cutter starts a cut from left to right.

The tab [D] on the bottom of the handle releases the spring-loaded paper holder [E]. This holder holds the paper for cutting when the cutter moves across the paper.

The tab opens and locks the paper holder when the cutter gets to the home position on the other side after cutting. This keeps the paper path open for the next sheet.

The registration roller continues to turn during cutting.

- This removes the tension between the registration roller and the cutter.
- It also lets paper feed past the drum at the same speed during cutting.

After you install a roll of paper, push the cutter with your hand fully to the left or right side.

6.7.6 ROLL END DETECTION

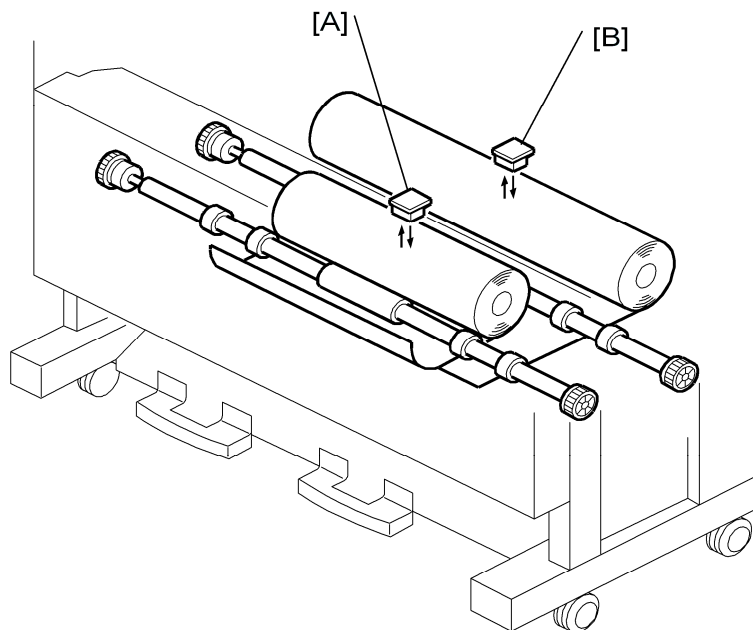

b286d980

To detect roll end, these two reflective photo-sensors detect the black core of an empty roll:

- Roll end sensor 1 [A], above Roll 1
- Roll end sensor 2 [B], above Roll 2

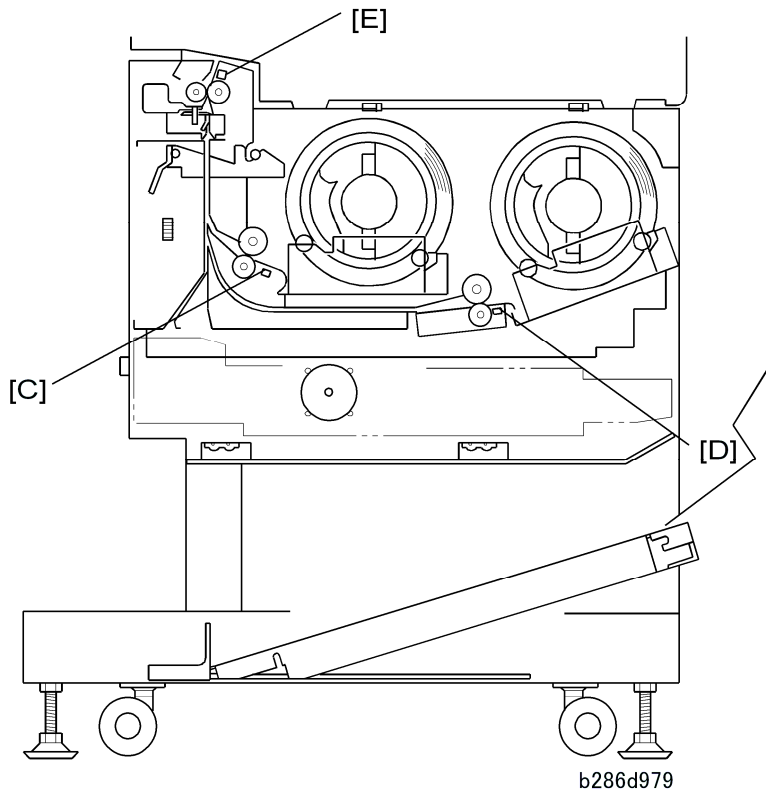

Also, two other sensors detect roll end if the core of the paper roll is a color other than black:

- Roll end sensor 3 (EXP) [C] detects the trailing edge of the roll when roll 1 has no more paper.
- Roll end sensor 4 (EXP) [D] detects the trailing edge of the roll when roll 2 has no more paper.

The machine also detects roll end if the RF exit sensor [E] does not detect a leading edge after paper feed starts.

- If the leading edge of the sheet does not get to the paper exit sensor from Roll 1 in 3.2 seconds or less, the machine detects paper end (or roll not installed).
- If the leading edge of the sheet does not get to the paper exit sensor from Roll 2 in 6.7 seconds or less, the machine detects paper end (or roll not installed).

6.7.7 PAPER CASSETTE MECHANISM

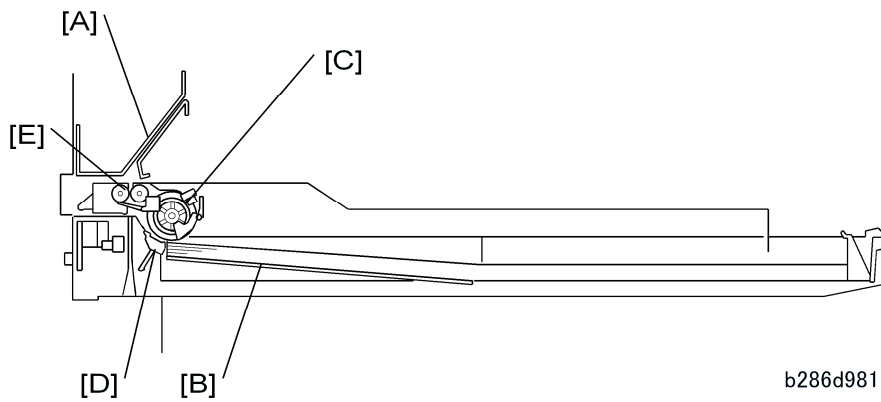

Support arms [A] on each side of the paper cassette go in grooves on each side when the paper cassette is set in the roll feeder.

The grooves lift the supports and pull the springs attached to the bottom plate [B] of the paper cassette. This gives sufficient tension to keep the stack of paper on the bottom plate at the correct height for paper feed.

The cassette feed motor turns the cassette feed roller [C] to feed paper from the top of the stack.

A friction pad [D] below the feed roller gives sufficient friction to stop sheets from double feeding.

The grip rollers [E] (also driven by the cassette feed motor), pull the paper into the paper feed path and feed it up to the RF exit rollers.

6.7.8 PAPER CASSETTE FEED

Cassette Paper Path

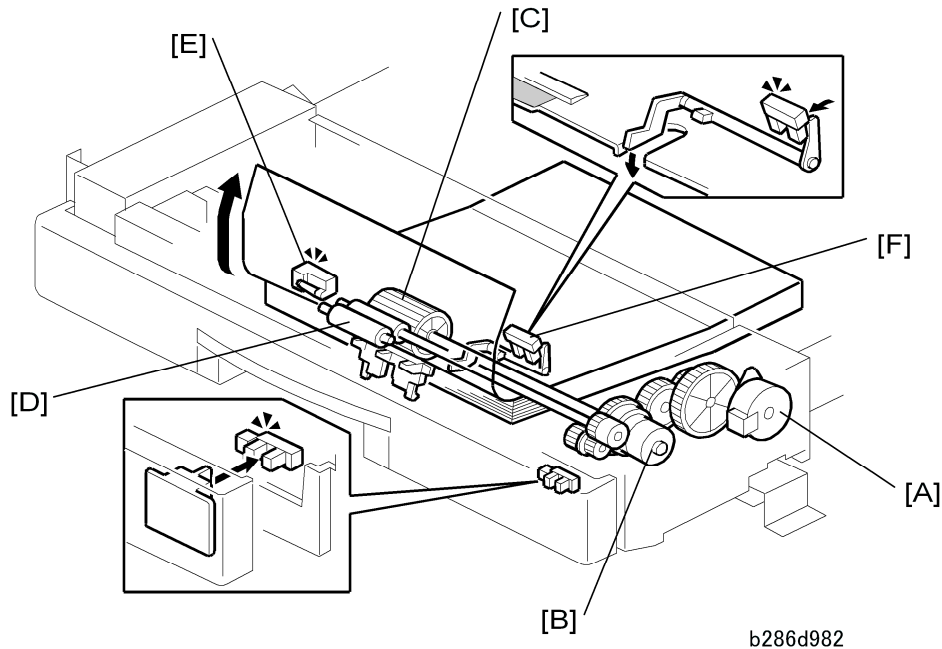

b286d982

Paper feeds from the paper cassette when the copy job starts.

The cassette feed motor [A] switches on, and the cassette feed clutch [B] engages to turn the cassette feed roller [C] and the grip rollers [D].

The cassette relay sensor [E]:

- Detects the leading edge of the sheet.
- Switches off the cassette feed clutch.
- The grip rollers [D] continue to turn, and they feed the paper into the same paper path used by roll feed.
- The cassette relay sensor also detects paper jams.

↓ Note

- After the cassette feed clutch switches off, the cassette feed roller continues to touch the paper. But, the pressure is very weak. Because of this, the grip rollers can pull the paper out easily.

After the grip rollers pull the paper out of the paper cassette, the transport sequence is the same as the roll paper path (the paper is not cut). Refer to the previous page.

The cassette set sensor [F] detects paper after the paper cassette is pulled out or is not correctly locked in its position.

Paper Feed and Registration

Paper Cassette Pre-Feeding

Paper does not pre-feed from the cassette before the copy job starts. The machine pre-feeds paper from the cassette only between pages of multi-page copy jobs.

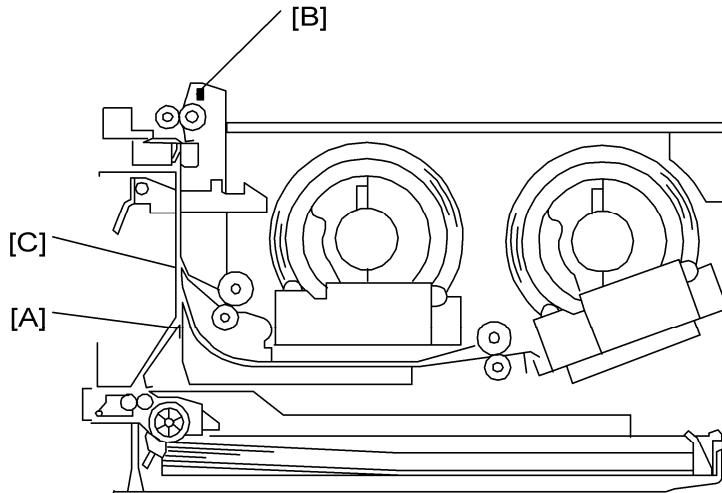

b286d952

There are two pre-feed positions for the leading edge of cut sheets after the first sheet of a multi-page copy job. The length of the paper in the cassette controls the pre-feed position.

- Pre-feed position 1 [A] is 234.8 mm below the RF exit sensor [B]. This is for cut sheets 18.7 inches (457.2 mm) long. (This is the maximum length for the paper cassette.)
- Pre-feed position 2 [C] is 184.4 mm below the RF exit sensor. This is for cut sheets less than 18.7 inches long.

Position 1 (lower than Position 2) is used for longer paper. This prevents overlap between the leading edge of a sheet and the trailing edge of the sheet before it.

6.7.9 PAPER CASSETTE PAPER END DETECTION

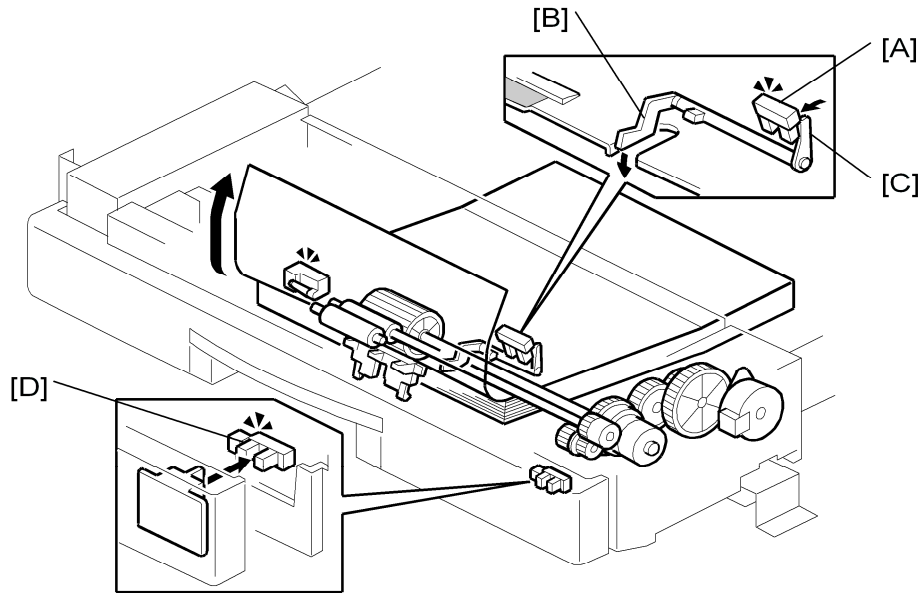

b286d983

The paper end sensor [A] is above the paper cassette.

The feeler [B] falls through a hole in the cassette plate after the last sheet feeds from the cassette. The actuator [C] moves forward away from the sensor and the machine detects paper end.

The cassette sensor [D] detects when the paper cassette is set and locked in its position.

6.7.10 CONDENSATION PREVENTION

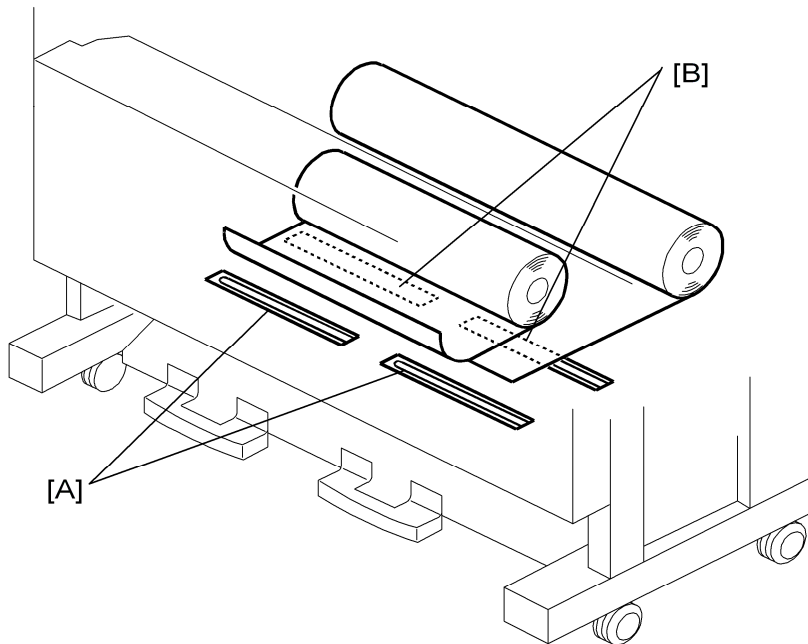

b286d984

There are four dehumidifiers, two at the front [A] and two at the rear [B], for the roll feeder. The dehumidifier switch on the right side of the roll feeder controls the operation of these dehumidifiers.

Note

- The dehumidifier switch appears on the decal as “anti-humidity heater.”

Dehumidifier Switch	Operation
ON	The dehumidifiers stay on unless the fusing lamp is on. When the fusing lamp switches on, the dehumidifiers switch off. When the fusing lamp switches off, the dehumidifiers switch on again.
OFF	The dehumidifiers always stay off.

6.7.11 PAPER REGISTRATION

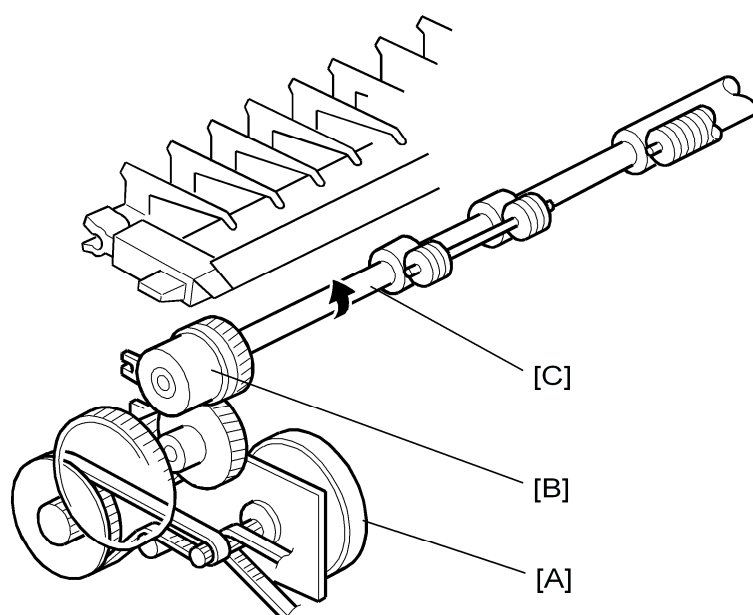

b286d202

The main motor [A] and registration clutch [B] control the registration roller [C].

The registration clutch switches off temporarily for roll paper or cut sheets from the paper cassette.

- When paper is fed from the roll feeder or paper cassette, the paper buckles paper against the roller to remove skew.
- When paper is fed from the manual feed table, feed stops for 2 seconds to let the user correct the paper position, to prevent skew (see section 6.7.2 “Manual Feed Mechanism”). The 2-second interval can be adjusted with SP1911 (By-Pass Feed Start Timing Adj.).

Then the registration clutch switches on again to feed the paper to the drum.

6.8 IMAGE TRANSFER AND SEPARATION

6.8.1 OVERVIEW

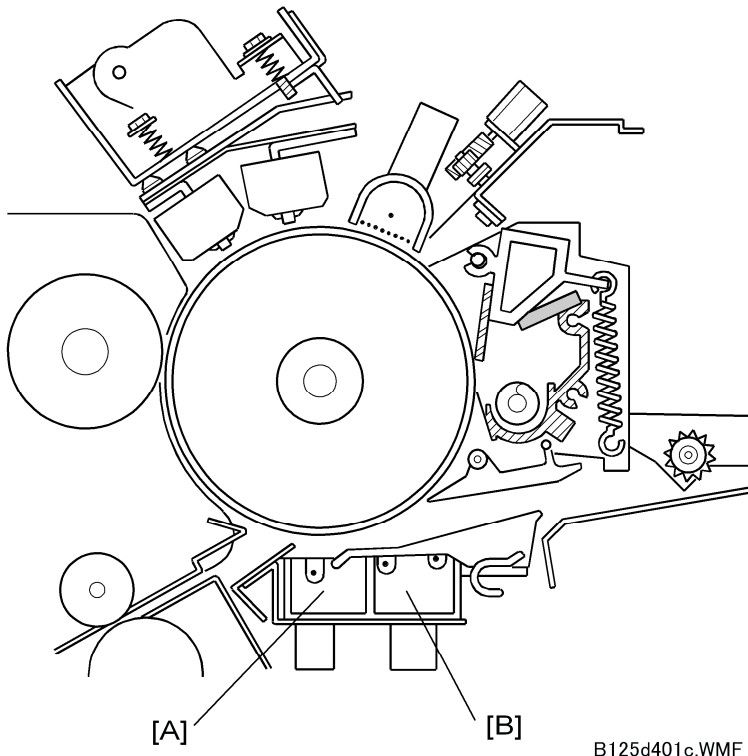

The T&S unit contains two parts:

[A] Transfer corona unit

[B] Separation corona unit

Transfer Corona Unit

Uses a tungsten wire (diameter 80 μm) 9.6 mm below the drum. This wire applies approx. 60 μA to transfer toner from the drum to the paper.

Transfer method:	Scorotron charger
Entrance guides:	2 Guide plates: The first is a conductive mylar and guide plate, and the second is a conductive mylar and leaf spring. They are 0.85 mm above the drum.

Separation Corona Unit

Applies approx. ac 280 μ A and dc -25 μ A to pull the paper off the drum.

Separation method:	Wide angle AC Scorotron charger
Backup separation:	Pick-off pawl, pick-off pawl solenoid

6.8.2 PICK-OFF PAWL OPERATION

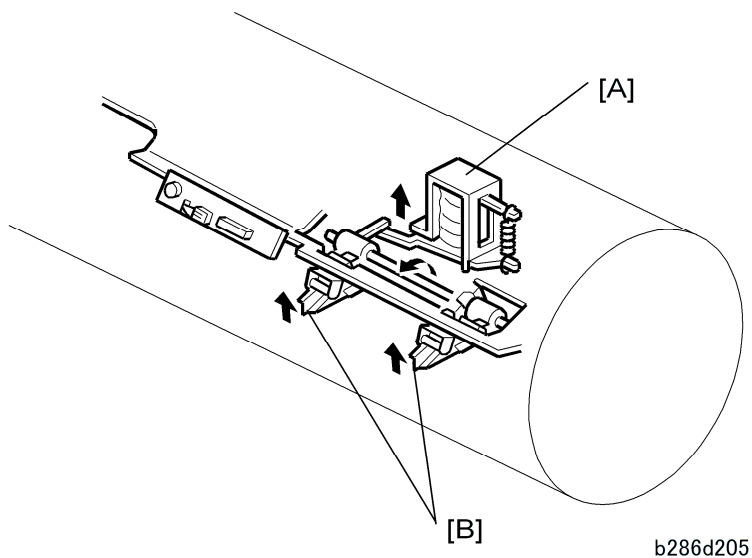

The pick-off pawls separate paper from the drum if the separation corona does not separate the paper fully.

The pick-off pawl solenoid [A] moves the pick-off pawls [B] until they touch the drum. When the leading edge of the paper on the drum goes into the separation corona unit, the solenoid switches on. About 198 mm (7.8") of the paper touches the drum. The pick-off pawl shaft starts to turn, and the pawls on the shaft are held against the drum by a spring.

6.9 FUSING UNIT

6.9.1 OVERVIEW

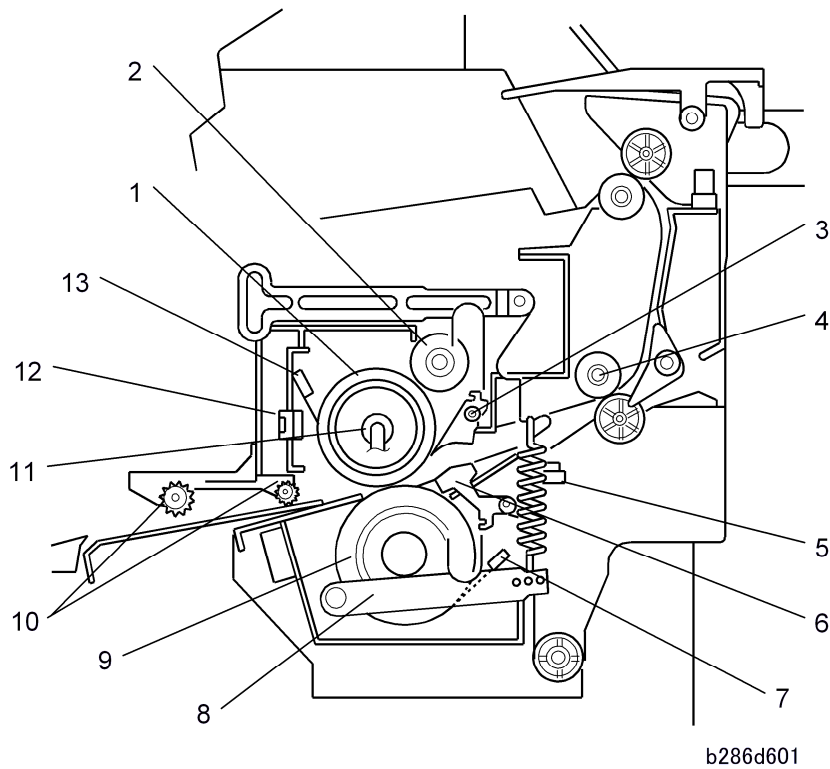

- | | |
|--|---------------------------|
| 1. Hot Roller | 8. Pressure Release Lever |
| 2. Fusing Cleaning Roller | 9. Pressure Roller |
| 3. Hot Roller Strippers | 10. Entrance Spurs |
| 4. Fusing Exit Rollers | 11. Fusing Lamp |
| 5. Fusing Exit Sensor | 12. Thermostats |
| 6. Pressure Roller Strippers | 13. Hot Roller Thermistor |
| 7. Pressure Roller Thermistors (Center, End) | |

The hot roller wall thickness is 1.3 mm. As a result, warm-up time is short (less than 120 s from 23°C).

6.9.2 PAPER FEED THROUGH THE FUSING UNIT

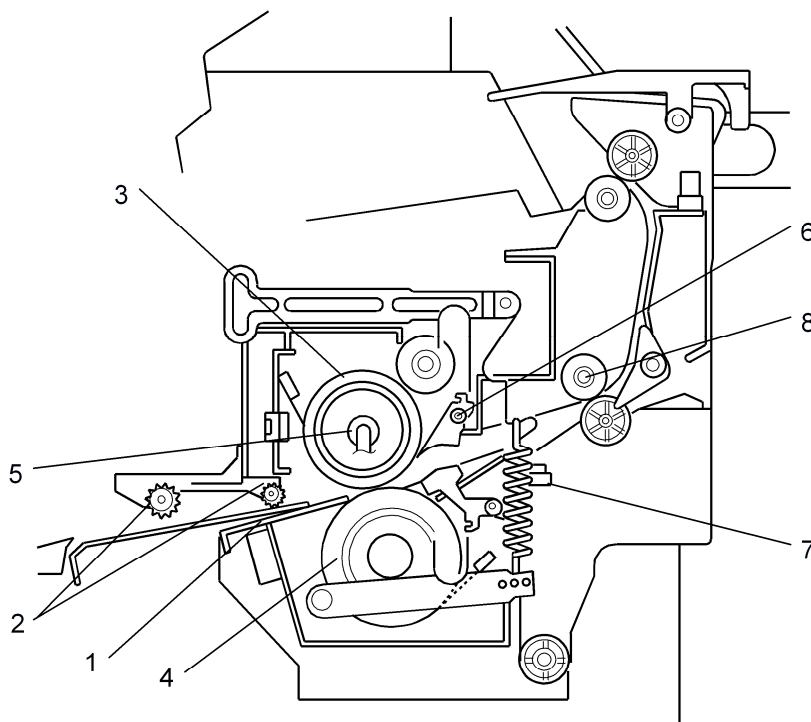

b286d601a

After separation from the drum:

- The paper feeds to the transport plate [1].
- The 5 sets of spurs [2] at the entrance hold the paper against the transport plate
- The heat and pressure of the hot roller [3] against the pressure roller [4] fuse the image to the paper.
- The fusing lamp [5] in the center of the hot roller is pre-heated to the correct temperature. (It switches on and off to keep the rollers at the correct operating temperature.)
- The hot roller strippers [6] pull the copy off the hot roller.
- The fusing exit sensor [7] detects the leading edge and trailing edge of the sheet, and checks the timing to detect paper jams.
- The fusing exit rollers [8] feed the paper out of the fusing unit.

6.9.3 FUSING PRESSURE CONTROL MECHANISM

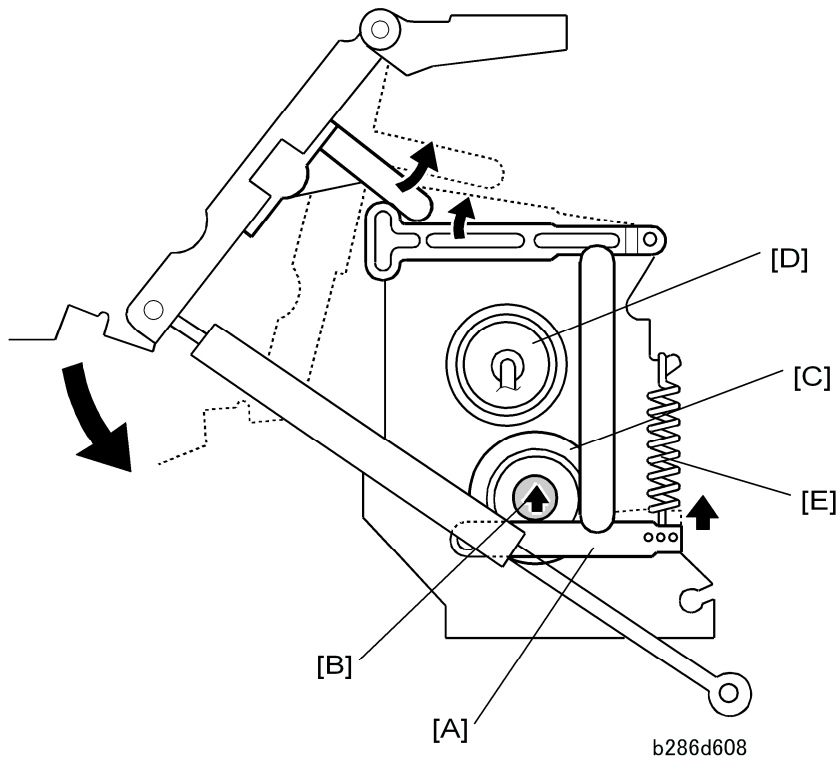

The spring-loaded pressure levers [A] are attached to the pressure roller shaft [B]. The pressure of the springs pushes the pressure roller [C] (a silicone-rubber roller) against the hot roller [D].

To adjust the position of the pressure spring [E], change the position of the lower attachment point:

- Center: Standard tension (60 N on each spring), standard pressure.
- Left: Less tension, less pressure. Set to this position to decrease wrinkling
- Right: More tension, more pressure. Can make better fusing with thick paper.

Note

- Wrinkling occurs more frequently for some types of media (plain, translucent, film, thick paper).

6.9.4 HOT ROLLER THERMISTORS AND THERMOSTATS

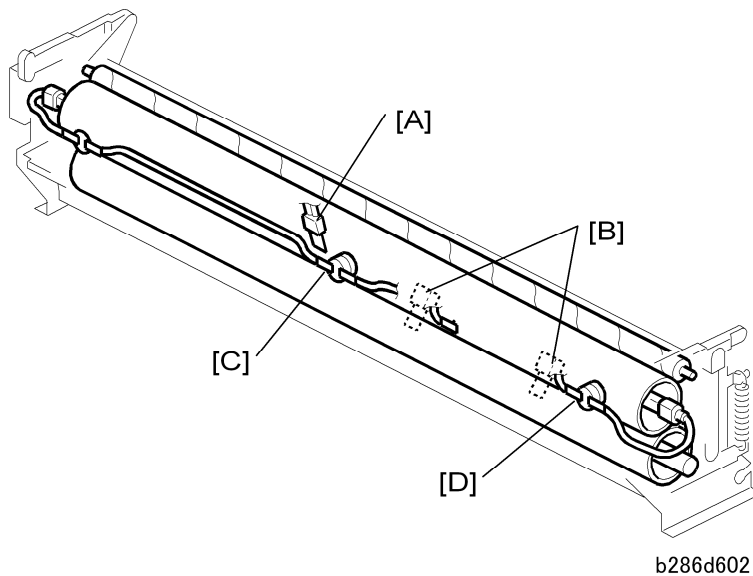

Three thermistors monitor the temperature of the hot roller and pressure roller:

- Thermistor [A] monitors the temperature of the hot roller.
- Two thermistors [B] monitor the temperature of the pressure roller. One thermistor is at the center of the pressure roller and the other is near the end of the pressure roller.

Thermostat [C] (199°C) and thermostat [D] (200°C) give emergency heat protection. If one of the thermistors breaks, one of the thermostats will cut power to the fusing lamp. Also, interlock switches cut power to the fusing circuit when a cover is opened.

6.9.5 TEMPERATURE CONTROL

Paper Thickness Setting

To achieve and maintain optimum fusing, the operator must select on the operation panel the proper setting for the thickness of the paper. This ensures that the machine sets and maintains the correct target temperatures for the hot roller and pressure roller during the job.

★ Important

- Strict control of the fusing temperature is necessary to prevent wrinkling that can occur at high temperatures with different types of paper.

Changing the paper thickness default setting can improve results if copy images are blurred or wrinkled. The paper thickness default setting screen can be opened by the operator with the User Tool:

[User Tools] > “System Settings” > “Tray Paper Settings” > “Paper Thickness” > “Paper Tray” or “Bypass.”

Fusing Unit

Paper Thickness: Paper Tray						
					Cancel	OK
Select level of thickness for each paper type.						
Paper Type	← Thicker		Thinner →			
▶ Plain Paper	1	2	3	4	5	
▶ Recycled Paper	1	2	3	4	5	
▶ Translucent Paper	1	2	3	4	5	
▶ Film	1	2	3	4	5	

b286s905

Note

- The numbers displayed in reverse are the default settings.

There are 5 modes available for each paper type. The table below shows paper weights and their recommended mode selections.

Fusing Mode Selection Table: Europe/Asia

Paper Type	Mode (g/m ² /lb.)				
	1	2	3	4	5
Plain	110 g/m ²	90 g/m ²	70 g/m²	60 g/m ²	50 g/m ²
Translucent	70-90 g/m ²	70-80 g/m²	70-80 g/m ²	50-70 g/m ²	50-60 g/m ²
Film	0.07 to 0.095 g/m²				

Fusing Mode Selection Table: NA

Paper Type	Mode (g/m ² /lb.)				
	1	2	3	4	5
Plain	29.3 lb	23.9 lb	18.6 lb	15.9 lb	13.3 lb
Translucent	18.6-29.3 lb	18.6-21.3 lb	18.6-21.3 lb	13.3-18.6 lb	13.3-15.9 lb
Film	2.8-3.7 mil				

Important Points and Recommendations

- When plain paper is used in a low temperature environment (10°C (50°F), 15% rh), change the thickness level from 3 > 2.
- If wrinkling occurs on translucent paper with Mode 2 selected, select Mode 1.
- Fusing conditions can be affected by low temperature, humidity, the length of the print job, continuous printing, etc. To improve toner fusing, shift the mode selections down: 3 > 2 > 1.
- To eliminate wrinkling or blurred images, shift the mode selection up: 3 > 4 > 5.
- If the selection is changed from Mode 1 or 2 for translucent paper to another setting (plain, film), the machine may take longer (up to 2 min.) to reach the copy ready temperature.
- During long print jobs, the interval between copies may increase. This slows down printing. The machine does this automatically (CPM down) to maintain the correct fusing temperature.

Zero-Cross Control Test

Before the machine switches on the fusing lamp, the zero-cross control test determines whether the power supply is 50 Hz or 60 Hz.

If the frequency does not fall in the necessary range after 10 attempts, then:

- If the frequency is too low, SC547 (Zero-Cross Signal Errors) occurs.
- If the frequency is too high, SC557 (Applied Zero Cross Waveform Over) occurs.
- After power is switched on, if there are no zero-cross interrupt signals for more than 3 seconds with the power relay on (other than when the upper unit is open), then SC547 occurs.

If the upper unit or exit unit is open at power on, the test is not done until after the upper unit or exit unit is closed.

Switching on the Fusing Lamp Power

When the fusing lamp is switched on, the applied voltage is added in steps. This “soft start” prevents problems that can be caused by voltages that fluctuate rapidly.

Fusing Unit

Fusing Temperature Control: Warm-up Sequence

Here is an example of the sequence of events for cold start, with the temperature below 15°C (SP 1937-11) and the hot roller and pressure roller target temperatures are as shown below.

	Target Temp.	SP Code	Comment
Hot Roller	195°C	SP1931	Default settings
Pressure Roller	60°C	SP1932	

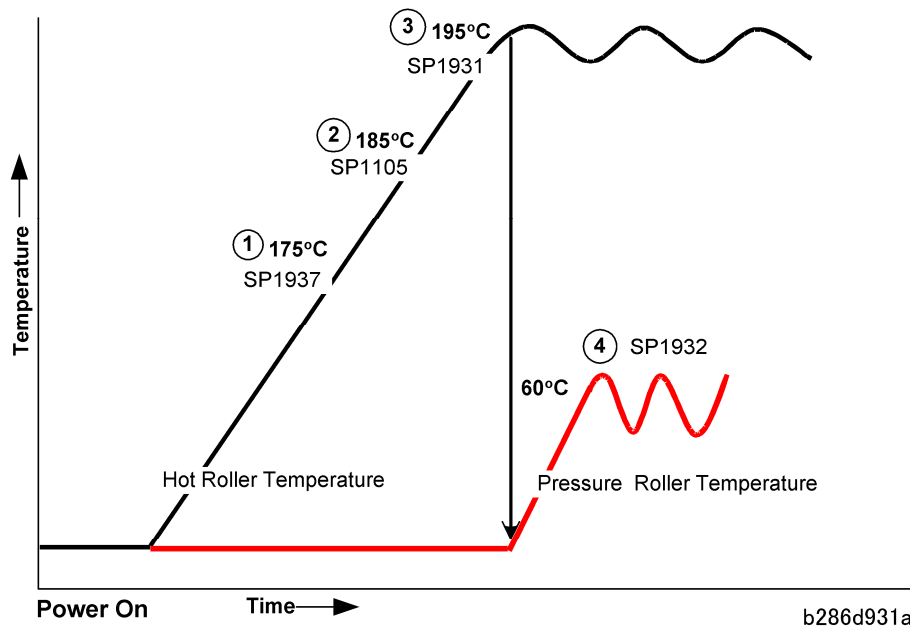

Step	What Happens
Power On	Room Temperature
<p>① Low temperature environment detection</p>	<p>175°C = ③ - 20°C (SP1937-1) b286d941</p> <p>From when the main machine is switched on until fusing temperature reaches 175°C, the time required to reach the copy ready temperature is determined by SP1937-2 (Default: 2 min.) This is the “prescribed time” to reach the target hot roller temperature..</p> <ul style="list-style-type: none"> ▪ If hot roller reaches the target temperature within the time prescribed by SP1937-2., copy ready temperature is at ②. ▪ If hot roller does not reach the target temperature within the time prescribed by SP1937-2, copy ready temperature is not set at ②. Rather, after the temperature reaches ③, inching starts with rotation of the pressure roller. When the pressure roller reaches 60°C at ④, this is the copy ready temperature.
<p>② Ready-1</p>	<p>185°C = ③ - 10°C (SP1105-1) b286d942</p> <p>If warm-up reaches the target fusing temperature within the prescribed time (SP1937-2), this is the copy ready temperature.</p>
<p>③ Reach target hot roller temperature</p>	<p>195°C (SP1931-3) b286d943</p> <p>Temperature of the hot roller is monitored and controlled within ±5°C of target hot roller temperature.</p>
<p>④ Reach target pressure roller temperature</p>	<p>60°C (SP1932-3) b286d944</p> <p>Temperature of the pressure roller is monitored and controlled within ±5°C target pressure roller temperature.</p>

Fusing Unit

Note:

If the target pressure roller temperature is set for 65°C, inching with rotation of the pressure roller and hot roller starts, then the copy ready temperature is set when both temperatures at ③ and ④ are reached.

- Inching Start Temperature = ③ SP1937-3
- Pressure roller target temperature for inching control: ④ SP1948

Fusing Temperature Control: Temperature Feedback During Copying

This machine uses the feedback of the hot roller thermistor and two pressure roller thermistors, one at the center and one at the end of the pressure roller, to control the fusing temperature. The SP codes settings shown in the tables and illustrations below determine how fusing temperature is controlled for the paper thickness modes (Mode 1 to 5) for each type of paper.

Here is a quick summary of the SP codes that are used to maintain optimum fusing temperature.

Important

- These SP codes are set at the factory and normally should not require adjustment in the field.

1931	Target Temp: Hot Roller	Sets the target temperature of the hot roller.
1932	Target Temp: Press Roller	Sets the target temperature of the pressure roller
1934	Lower Limit Temp: Hot Roller	Sets the minimum difference in temperature allowed between the actual temperature and the target temperature of the hot roller
1935	Pressure FB Control Steps	Changes the stepped adjustments of SP1932 (Target Temp: Pressure Roller) by using the sum of the settings of SP1932 (Target Temp: Pressure Roller) +SP1935 (Press FB Control Steps).
1941	Press FB Ctrl Switch by Temp Diff	Sets the temperature differential that determines when the machine switches to the supplement mode for pressure roller feedback control. (See description below.)

1942	Press FB Temp Hold Int: Normal	Sets the interval between temperature samplings for pressure roller feedback control.
1943	Press FB Temp High Temp: Special	This SP sets the high temperature used by pressure roller feedback temperature control for Custom paper.
1944	Press FB Temp Low Temp: Special	Sets the low temperature used by pressure roller feedback temperature control for Custom paper.
1948	Press Roller Inching Target Temp	This SP determines when inching starts.

Here are more details about the settings of these SP codes.

SP No.	Range	Initial Setting					
		Mode	1	2	3	4	5
1931-1 to 5	120 to 220	Plain	195	195	195	185	175
-6 to 10	120 to 220	Translucent	205	195	195	165	165
-11 to 15	120 to 220	Film	195	190	185	185	175
1932-1 to 5	60 to 180	Plain	100	85	60	60	60
-6 to 10	60 to 180	Translucent	130	100	60	60	60
-11 to 15	60 to 180	Film	60	60	60	60	60
1934-1 to 5	0 to 50	Plain	20	15	25	20	20
-6 to 10	0 to 50	Translucent	20	20	20	20	20
-11 to 15	0 to 50	Film	20	20	20	20	20
1935-1 to -5	0 to 50	Plain	20	25	30	20	20
-6 to 10	0 to 50	Translucent	20	20	20	20	20
-11 to 15	0 to 50	Film	20	20	20	20	20

Fusing Unit

1941-1	0 to 50	Plain	20				
1942-1 to 5*¹	0 to 50	Plain	0	0	5	15	0
1943-1 to 5*¹	0 to 50	Plain	0	0	20	20	0
1944-1 to -5	0 to 50	Plain	0	0	10	5	0
1948-1 to 5	60 to 180	Plain	100	65	60	60	60
-6 to 10	60 to 180	Translucent	130	100	60	60	60
-11 to x15	60 to 180	Film	60	60	60	60	60

*¹ SP1942, SP1943, SP1944 do not operate if they are set to "0."

Pressure Roller Temperature Feedback

The graph and descriptions below (Plain Paper, Mode 3 selected) show how the temperature of the hot roller is controlled using the difference in the temperatures of the center and end of the pressure roller.

The temperature readings are fed back by the pressure roller thermistors (one at the end and one at the center of the pressure roller). These difference between these readings are compared with the value set for SP1941 (Press FB Ctrl Switch by Temp Diff).

	Difference between Center, End Temperatures	
< SP1941 (20°C)	> SP1941 (20°C)	
Hot Roller Control Temp.	SP1931 to SP1935 (Black Line)	SP1942 to SP1944 (Blue Line)

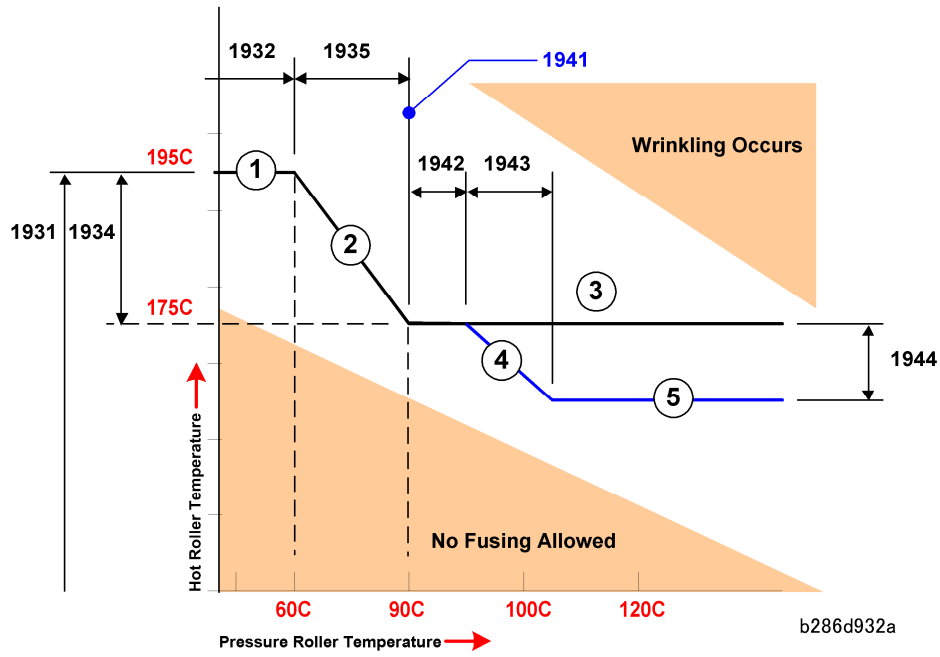

Note

- In the table below “PR” is the “Pressure Roller” and “HR” is the “Hot Roller.”

Fusing Unit

	PR (°C)	HR (°C)	Controlling SP Codes	
< SP1941(20°C)	①	60	195	HR:SP1931 PR:SP1932
	②	61-90	194-175	HR:SP1931-SP1934 PR:SP1932+SP1935
	③	> 96	175	
> SP1941 (20°C)	①	< 60	195	HR:SP1931 PR:SP1932
	②	61-90	194-175	HR:SP1931-SP1934 PR:SP1932+SP1935
	③	91-95	175	PR:SP1942 (91°C to 95°C) HR:SP1931-SP1934 PR:SP1932+SP1935
	④	96-120	174-165	HR:SP1931+(SP1934+SP1944) PR:SP1932+(SP1935+SP1943)
	⑤	< 121	165	

Fusing Temperature Control: Inching

The default setting for this machine is for inching control to always remain on.

★ Important

- This inching control on/off setting (controlled by SP9952) should never be switched off.

During inching control:

- When the temperature of the hot roller falls to 20°C (SP1937-3) below its target temperature, the fusing motor switches on and idling starts.
- When the pressure roller reaches its target temperature, the fusing motor switches off and idling stops.

↓ Note

- The target temperature of the pressure roller is controlled by the settings of SP1932 (Target Temperature: Pressure Roller) for each paper type.

Fusing Temperature Control: CPM Down

During a long copy job on narrow width paper, the difference in the temperatures between the center and end of the pressure roller increases. The temperature at the center decreases and the temperatures at the ends increase. In order to prevent this, CPM down control automatically adjusts the timing of paper feed. This increases the length of the interval between sheets in the paper path.

A longer interval between sheets creates a short delay between feeds to the fusing unit. This extra time allows slightly more time so that the temperature of the hot roller and pressure roller can rise.

- The operation of CPM down is controlled by SP1940-1 (CPM Down Setting). This SP code should remain on.
- For more about adjusting these settings see the description of SP1940 in “Service Tables.”

Fusing Unit

6.9.6 HOT ROLLER CLEANING

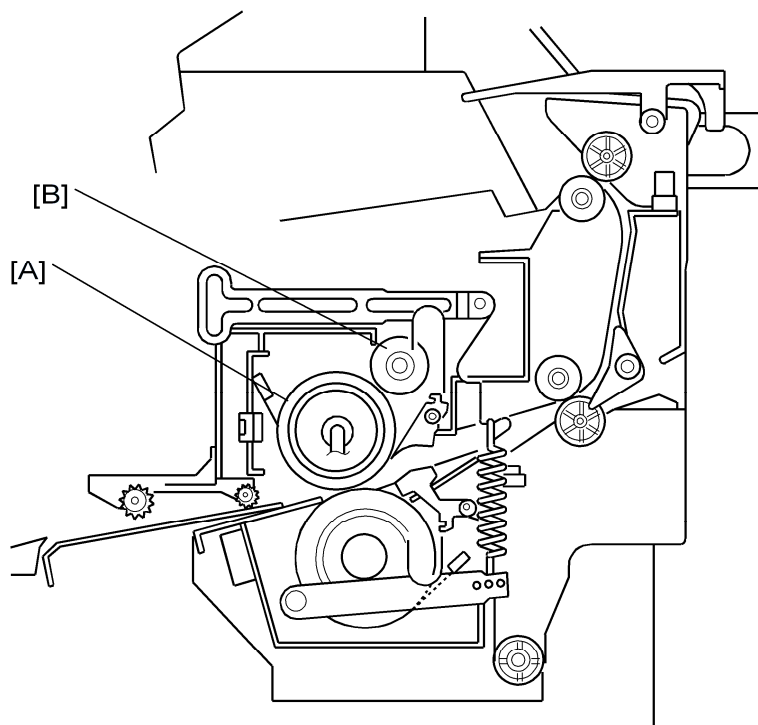

b286d601b

The cleaning roller [B] (parallel to the hot roller) always touches the hot roller [A] with a low pressure. The cleaning roller has a layer of material that is soaked with silicone oil. Each time the fusing motor switches on, it reverses for 400 ms (at line speed 30 mm/s) to clean the hot roller.

6.9.7 FUSING UNIT DRIVE MECHANISM

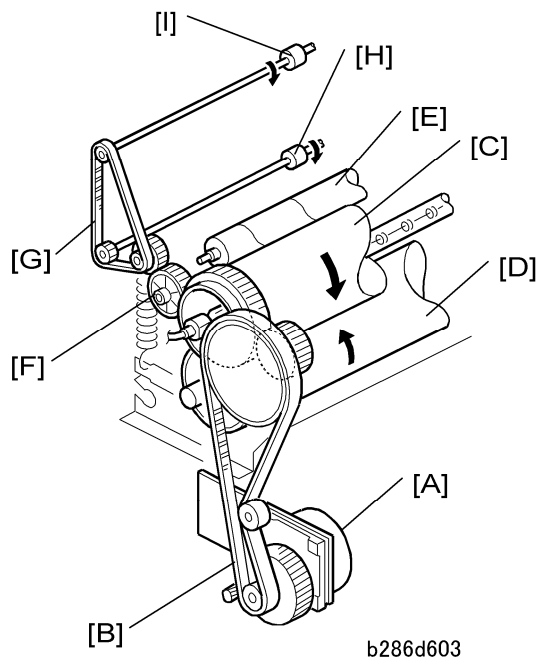

The fusing motor [A] (a stepper motor) controls the gears and timing belt [B] that turn the hot roller [C]

The pressure of the hot roller against the pressure roller [D] and cleaning roller [E] turns these rollers in the opposite direction.

An idle gear [F] turns the gears and timing belt [G]. These gears and belts turn the fusing exit roller [H] and upper exit rollers [I] in the same direction as the hot roller.

The speed of the fusing motor is controlled by:

- The paper feed source set by the user (manual feed table, roll feeder paper, and cassette).
- The type of paper set for the paper feed source: plain (not displayed), recycled, translucent, or film, (This is done with the User Tool: System Settings > Paper Type Settings > Paper Type).
- The width of the paper in the feed source that is used. (The width in each feed source is set with the User Tool 1 System Setting > 1 General Features > Tray Paper Size. The feed source for the job is set at the operation panel.)

6.9.8 WRINKLE PREVENTION

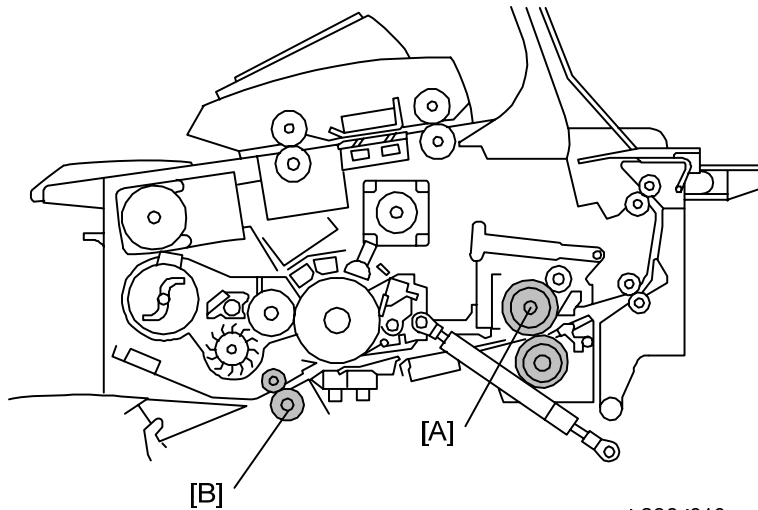

Motor Speed Control

During normal operation, the hot roller [A] (controlled by the fusing motor) is slightly faster than the registration rollers [B] (controlled by the main motor).

This stretches the paper between the registration rollers and the fusing unit to keep the paper from wrinkling inside the fusing unit.

Inching Control

This machine also has an inching control feature that controls the temperature of the pressure roller to prevent wrinkling. (See Section 6.9.5 “Temperature Control.”)

6.10 PAPER EXIT

6.10.1 OVERVIEW

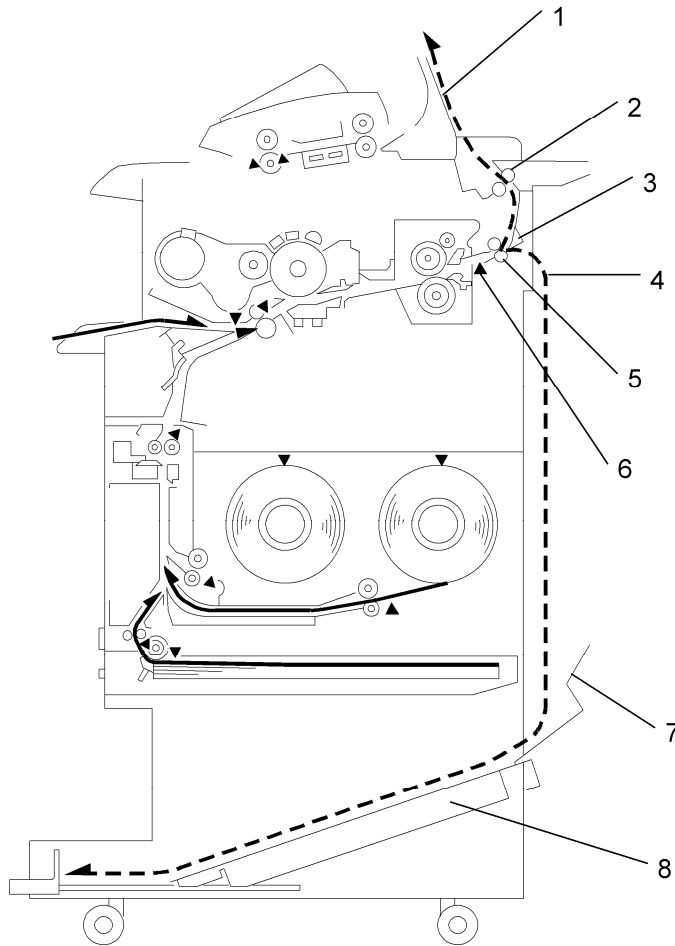

b286d985

The fusing exit rollers [5] send the paper to the paper junction gate [3].

Upper Exit

When the paper junction gate [3] is closed:

- The gate sends the paper to the upper exit rollers [2].
- The upper exit rollers feed the paper out of the upper paper exit [1] to a wire guide on top of the machine. The user can remove this wire guide.
- The wire guide holds the paper against the rear side of the original output tray.

Paper Exit

Rear Exit

When the paper junction gate is open:

- The gate sends the paper to the rear paper exit [4].
- The paper moves past mylars attached on the rear of the machine.
- The paper falls into the lower output tray [7] and then stops in the lower output stacker [8].

Jam Detection

The exit sensor [6] detects paper jams.

6.10.2 SWITCHING THE PAPER EXIT

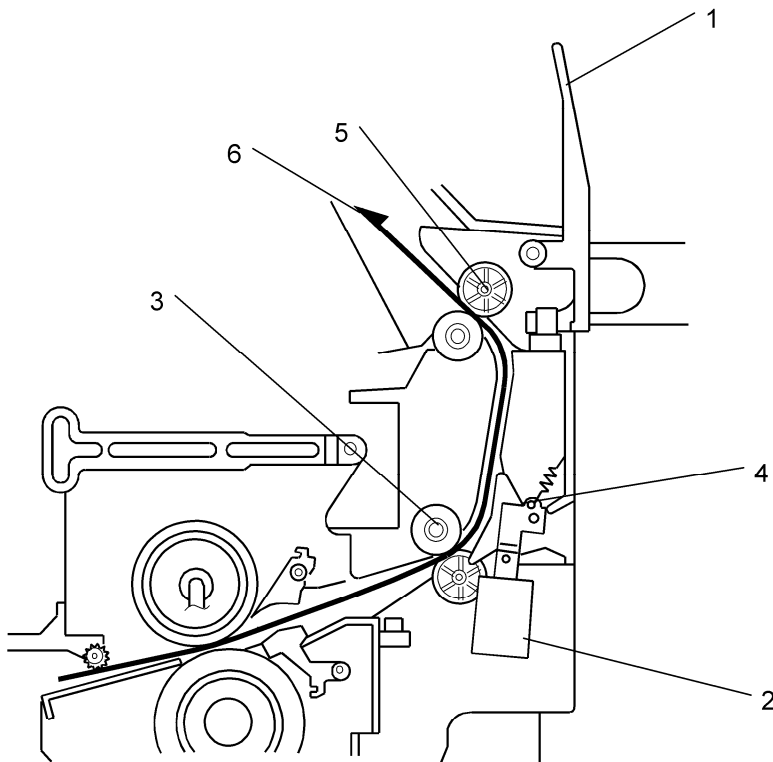

b286d606

Upper Exit

When the “Upper” (Copy Output Location) indicator on the operation panel is ON and the copy exit lever [1] is UP:

- The paper junction gate solenoid [2] stays off.
- The fusing exit rollers [3] send the paper to the paper junction gate [4].
- The closed junction gate sends the paper to the upper exit rollers [5].
- The upper exit rollers feed the paper out of the upper exit [6].

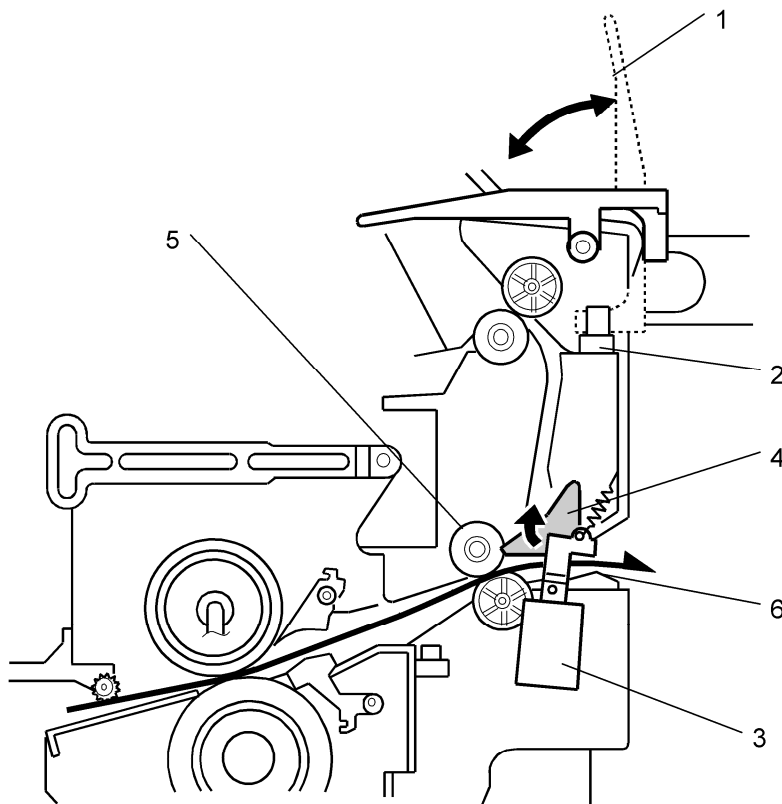
Rear Exit

b286d607

Copy Exit Lever Up (“Upper” and “Lower” Selection Allowed)

With the copy exit lever up, the operator has the option of selecting “Upper” or “Lower” under “Copy Output Location” on the operation panel display. (“Upper” is the default selection.)

With “Upper” selected, the copy exits to the top of the main machine.

If the operator selects “Lower” with the copy exit lever [1] up:

- The paper exit selection sensor [2] detects the lever in the up position.
- The solenoid [3] switches on and opens the paper junction gate [4].
- The fusing exit rollers [5] send the paper past the paper junction gate to the rear paper exit [6].

Paper Exit

Copy Exit Lever Down (“Upper” Selection Not Allowed)

- The paper exit selection sensor [3] detects the lever in the “Lower” (down) position.
- The operator must select “Lower” under “Copy Output Location” on the operation panel display. If the operator selects “Upper” with the lever down, the machine will display a message:

Cannot output to the selected location

Switch copy exit switching lever or paper output location

- After the operator selects “Lower”, the operation sequence is the same as that described above (with the lever up and “Lower” selected).

Keep the copy exit selection lever in the vertical position for normal operation. This allows the operator to select the copy output destination on the operation panel.

6.10.3 PAPER EXIT DRIVE

See Section 6.9.7 “Fusing Unit Drive Mechanism.”

6.11 ELECTRICAL COMPONENTS

6.11.1 OVERVIEW

Overall System

The illustration below shows the configuration of the system components.

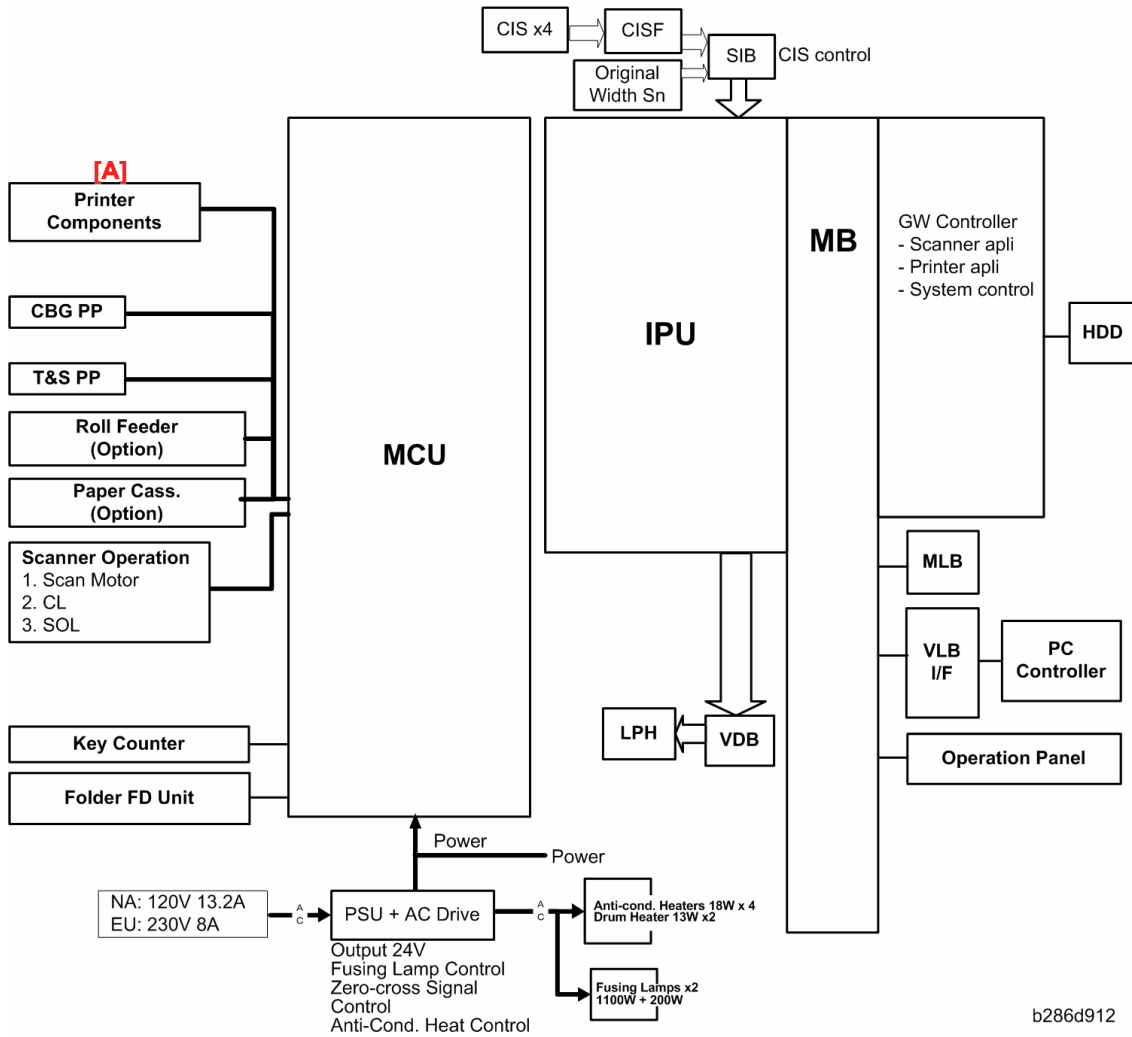

Details

Electrical Components

[A] Printer components:

- | | |
|---------------|--------------------------------------|
| 1. Motors | 4. Thermistors |
| 2. Sensors | 5. Solenoids: Separation, Paper Exit |
| 3. Fan Motors | 6. Clutches: |

Here is a brief description of functions of the important boards:

MCU (Main Control Unit). This is the engine control board. The MCU manages:

- Base engine control, scanning control, image processing control, image writing control.
- Basic I/O function control for the power packs, motors, sensors, solenoids, clutches, and fusing.
- Power supply to scanner components (sensors, motors).

SIB (Scanner Interface Board). Controls the operation of the CIS elements (x5) and does the sub scan correction to compensate for their staggered arrangement. Also manages the A/D conversion of the scanned image data.

IPU (Image Processing Unit). Provided with five RI1001A_BGA components that do every type of processing of the image data received from the SIB. LUPUS contains the Rapi I/F functions. Also manages sending and receiving image data between itself and the GW controller board.

MB (Mother Board). Provides important relay functions 1) for the Rapi Bus I/F between the IPU, GW controller, file format converter, and VLB, and 2) for machine power supply.

VDB (Video Drive Board). Controls operation of the LPH (LED Print Head), including the conversion of video sent to the LPH.

GW controller (Type-Bz2). Performs overall control of all multi-function peripheral (MFP) devices.

IPU Board Details

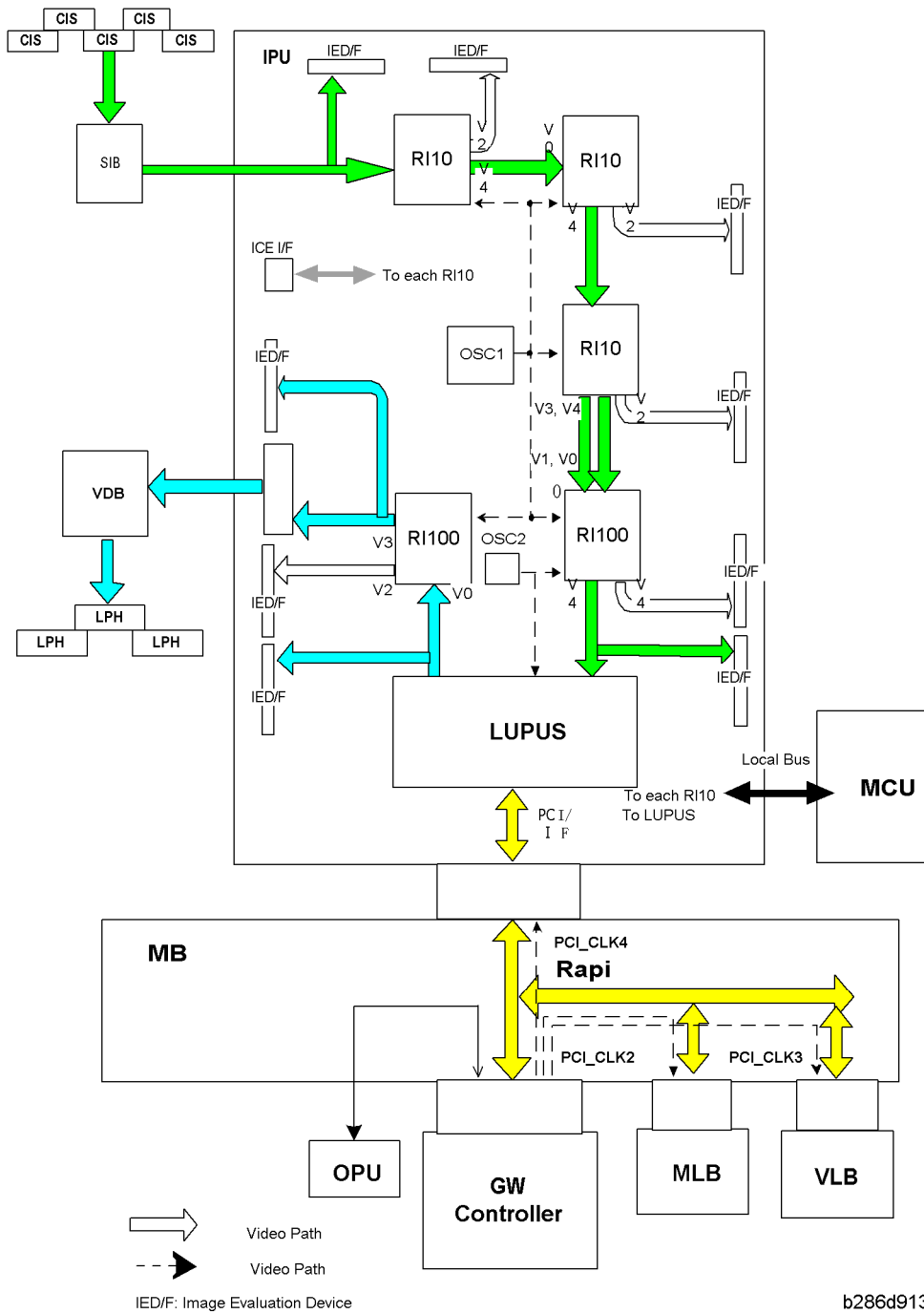

b286d913

Image data scanned by the CIS elements is converted from analog to digital data by the SIB and then sent to the IPU for processing.

Details

6.11.2 DESCRIPTION OF ELECTRICAL COMPONENTS

NUMBER	NAME	DESCRIPTION
CIS		
CIS1 - 5	CIS 1 - 5 (Contact Image Sensor)	Transfer the image signals from the CIS LEDs to the SIB.
Lamp		
L1	Fusing Lamp	One fusing lamp (1100 W) in the hot roller.
LPH		
LPH1-3	LPH1-3 (LED Print Head)	Each section writes a part of the image on the PCB drum. The VDB controls the LPH units.
Magnetic Clutches		
MC1	Cassette Feed Clutch	This transfers power from the cassette feed motor to the feed and grip rollers in the cassette.
MC2	Paper Registration Clutch	This controls the registration roller. It switches off for a short time to stop the registration roller to correct skew in the paper feed path.
MC3	Roll Feed Clutch 1	This transfers power from the roll feed motor to roll 1 in the roll feeder.
MC4	Roll Feed Clutch 2	This transfers power from the roll feed motor to roll 2 in the roll feeder.
MC5	Toner Supply Clutch	This controls the toner supply mechanism.
Motors		
M1	Cassette Feed Motor	This stepper motor controls the paper feed roller in the paper cassette.
M2	Cooling Fan Motor	This is an exhaust fan for the area around the drum.

NUMBER	NAME	DESCRIPTION
M3	Cutter Motor	This controls the cutter in the roll feeder.
M4	Drum Motor	This controls the OPC drum.
M5	Fusing Motor	This controls the hot roller, fusing exit rollers, and upper exit rollers.
M6	Main Motor	This controls the registration roller, development unit, and the agitator in the toner cartridge.
M7	PCB Cooling Fan Motor 1	Cools the IPU, MCU and controller board.
M8	PCB Cooling Fan Motor 2	Cools the IPU, MCU and controller board.
M9	Roll Feed Motor	This controls the feed rollers for roll 1 and roll 2 in the roll feeder.
M10	Scanner Motor	This controls the original feed rollers and original exit rollers.
M11	Used Toner Bottle Motor	This controls the mechanism that keeps the level of used toner in the bottle flat.
M12	Wire Cleaner Motor	This moves the corona wire cleaner to the left and right to clean the charge corona wire.
PCBs		
PCB1	IPU (Image Processing Unit)	This processes image data from the CIS (Contact Image Sensor), and sends it to the VDB (Video Drive Board) and LPH (LED Print Heads). The IPU also controls the HDD unit and the PC interfaces.
PCB2	MCU (Main Control Unit)	This is the machine's main board. It contains the SCU (Scanner Control Unit) and ECU (Engine Control Unit). These units control all parts of the machine, and this includes the print engine, scanner, and image processing.

Electrical Components

NUMBER	NAME	DESCRIPTION
PCB3	Operation Panel	This contains the operation keys, touch-panel LCD, and the LEDs. It is controlled by the MCU.
PCB4	PSU (Power Supply Unit)	This supplies dc power for the machine, heaters, and dehumidifiers in the roll feeder.
PCB5	RFDB (Roll Feed Drive Board)	This is attached to the optional roll feeder. It controls the components of the roll feeder (motor, clutches, sensors, and switches).
PCB6	SFDB (Sheet Feed Drive Board)	This is attached to the optional paper cassette. It controls the components of the paper cassette (motor, clutches, sensors, and switches).
PCB7	SIB (Scanner Interface Board)	This controls the scanner, and is an interface board for the IPU and MCU.
PCB8	Mother Board	Interfaces with the controller, IPU, and optional devices such as interface board for the printer controller.
PCB9	VDB (Video Drive Board)	This controls the image signals that are sent to the LPH (LED Print Head).
PCB10	Controller Board	Controls the memory and all peripheral devices. The GW architecture allows the board to control all applications (copying, printing, and scanning).
PCB11	Interface Board	Option. This relay board must be installed with the external printer controller for interface between the server PC and the copier.
PCB12	File Format Converter (MLB)	Option.

NUMBER	NAME	DESCRIPTION
Power Packs		
PP1	CGB Power Pack	High voltage power supply for the charge corona wire ©, development bias (B), and charge corona grid (G).
PP2	T&S Power Pack	High voltage power supply for the transfer corona wire (T) and the separation corona wire (S) in the T&S (Transfer and Separation) unit.
QL		
QL1 - 3	Quenching Lamp 1 – 3 (1: Left, 2: Center, 3: Right)	This removes remaining electrical charge on the drum immediately after cleaning.
Sensors		
S1	Cassette End Sensor	This sensor is above the paper cassette. It detects paper end after the last sheet feeds.
S2	Cassette Set Sensor	This detects when the cassette is set and locked in its place.
S3	Exit Cover Sensor	This detects if the exit cover on the rear of the machine is open or closed.
S4	Fusing Exit Sensor	This sensor is in front of the fusing exit rollers. It switches on when the leading edge of the copy leaves the fusing unit.
S5	ID Sensor	The machine uses this sensor to control toner supply, toner near-end, and toner end. There is no toner density sensor in this machine.
S6	Original Exit Sensor	This detects the original when it feeds out of the scanner.

Electrical Components

NUMBER	NAME	DESCRIPTION
S7	Original Registration Sensor	(1) Detects the leading edge of the original and stops the original feed roller. The user can then manually straighten the original. (2) Detects the trailing edge of the original, or detects a jam if it does not detect the trailing edge.
S8	Original Set Sensor (A4/8.5")	Detects the leading edge of the original. This starts the scanner motor. This sensor also detects A4 or 8.5" width paper.
S9	Original Width Sensor (A0/8.5")	Detects A0/8.5"-width paper.
S10	Original Width Sensor (A1/34")	Detects A1/34"-width paper.
S11	Original Width Sensor (A2/22")	Detects A2/22"-width paper.
S12	Original Width Sensor (A3/17")	Detects A2/22"-width paper.
S13	Original Width Sensor (914mm/36")	Detects 914mm/36"-width paper.
S14	Original Width Sensor (30")	Detects 30"-width paper. (-17 version only)
S15	Original Width Sensor (B1/24")	Detects B1/24"-width paper.
S16	Original Width Sensor (B2/18")	Detects B2/18"-width paper.
S17	Original Width Sensor (B3/12")	Detects B3/12"-width paper.
S18	Original Width Sensor (B4/9")	Detects B4/9"-width paper.

NUMBER	NAME	DESCRIPTION
S19	Paper Exit Selection Sensor	This detects the position of the paper exit selection lever on the top rear edge of the machine. This sensor on the SIB board.
S20	Paper Registration Sensor	This detects paper at the registration rollers.
S21	Paper Set Sensor	This detects when a cut sheet is placed on the manual feed table (by-pass).
S22	Relay Sensor	This sensor is near the grip rollers, and (1) Detects the leading edge of every cut sheet, switches off the cassette paper feed clutch, and switches on the grip rollers, (2) Detects paper jams where the paper feeds out of the paper cassette.
S23	RF Exit Sensor	(1) Detects the leading edge of the paper from the rolls. (2) Detects the trailing edge of cut sheets from the paper cassette and trailing edges of sheets cut from the paper rolls for paper feed timing and jam detection. (3) If this sensor does not detect a leading edge after feeding from Roll 1 or Roll 2, it also signals paper end for the roll.
S24	RF Set Sensor	This detects if the spring-loaded lock lever of the roll feeder drawer is locked.
S25	Roll End Sensor 1	This reflective photosensor above Roll 1 detects the core of the roll (which is black), after there is no more paper on Roll 1.
S26	Roll End Sensor 2	This reflective photosensor above Roll 2 detects the core of the roll (which is black), after there is no more paper on Roll 2.

Electrical Components

NUMBER	NAME	DESCRIPTION
S27	Roll End Sensor 3	Detects the trailing edge of the roll after there is no more paper on Roll 1. This sensor is included because if the color of the roll core is not black, Roll End Sensor 1 cannot always detect roll end.
S28	Roll End Sensor 4	Detects the trailing edge of the roll after there is no more paper on Roll 2. This sensor is included because if the color of the roll core is not black, Roll End Sensor 2 cannot always detect roll end.
S29	Toner Overflow Sensor	Detects toner overflow in the used toner collection bottle.
S30	Upper Unit Sensor	Detects when the upper unit is open.
S31	Wire Cleaner Sensor	The actuator of this sensor is attached to the wire that moves the transfer cleaner from left to right. This tells the machine when the wire cleaner moves. This sensor is a part of the SIB board.
Solenoids		
SOL1	Paper Junction Gate Solenoid	This controls the paper junction gate in front of the rear paper exit and below the upper exit. When closed, paper feeds out at the top. When open, paper feeds out at the back.
SOL2	Pick-Off Pawl Solenoid	This moves the pick-off pawls until they touch the drum.
Switches		
SW1	Dehumidifier Switch	Switches the dehumidifiers (x4) in the roll feeder on/off.

NUMBER	NAME	DESCRIPTION
SW2	Exit Cover Switch	This detects if the exit cover on the rear of the machine is closed.
SW3	Main Power Switch	This switches the copier on and off.
SW4	Scanner Stop Switch	This is on the operation panel. The user pushes this to stop original feed if there is a problem during scanning.
SW5	Scanner Switch	This interlock switch stops power to the original feed unit when the original feed unit cover is lifted.
SW6	Toner Hopper Cover Switch	This detects if the toner supply cover is open or closed.
SW7	Upper Unit Switch 1	This detects if the upper unit is open on the left side.
SW8	Upper Unit Switch 2	This detects if the upper unit is open on the right side.
SW9	Left Cutter HP Switch	This detects if the cutter in the roller feeder is at the home position at the left side. In this condition, the paper holder of the cutter is locked open (the paper feed path is open).
SW10	Right Cutter HP Switch	This detects if the cutter in the roller feeder is at the home position at the right side. In this condition, the paper holder of the cutter is locked open (the paper feed path is open).

Electrical Components

NUMBER	NAME	DESCRIPTION
SW11	Exit Unit Switch	<p>Detects whether the fusing unit cover is open or closed. SC559 is issued after 3 consecutive jams occur in the fusing unit.</p> <p>Note: SC559 is not issued unless SP1159 is switched on (Default: "0" off).</p> <p>The fusing unit cover must always be opened and closed after this SC occurs to restore the machine to full operation. This ensures that the operator has opened and closed the cover to check for paper and/or paper scraps around the hot roller. Loose paper around the hot roller is a fire hazard.</p>
Others		
CO1	Recycle Counter	A mechanical counter that measures the total length in meters of paper that the machine feeds. It starts from the first copy.
H1	Dehumidifier 1 (Front/Right)	One of four dehumidifiers that keeps the roll feeder drawer free of moisture.
H2	Dehumidifier 2 (Front/Left)	
H3	Dehumidifier 3 (Rear/Right)	
H4	Dehumidifier 4 (Rear/Left)	
H5	Anti-Condensation Heater (Left)	These are below the OPC drum. They keep the copier free of moisture, which could cause problems with paper feed and fusing.
H6	Anti-Condensation Heater (Right)	
HDD1	HDD	
TH1	Hot Roller Thermistor	The CPU uses this thermistor to monitor the temperature of the hot roller.

NUMBER	NAME	DESCRIPTION
TH2	Pressure Roller Thermistor 1 (Edge)	The CPU uses this thermistor to monitor the temperature of the pressure roller.
TH3	Pressure Roller Thermistor 2 (Center)	
TS1	Thermostat 1 (Center)	199°C. This safety device prevents overheating if the temperature control circuit fails.
TS2	Thermostat 2 (End)	200°C. This safety device prevents overheating if the temperature control circuit fails.
CB1	Circuit Breaker	Breaks the main power supply to the machine if there is an overload or short circuit. Located on the back of the machine, this switch is set manually. This breaker switch must be at the down position for the machine to operate. For more, see section 1.2.3 "Main Machine Final Installation."

6.11.3 MCU, IPU

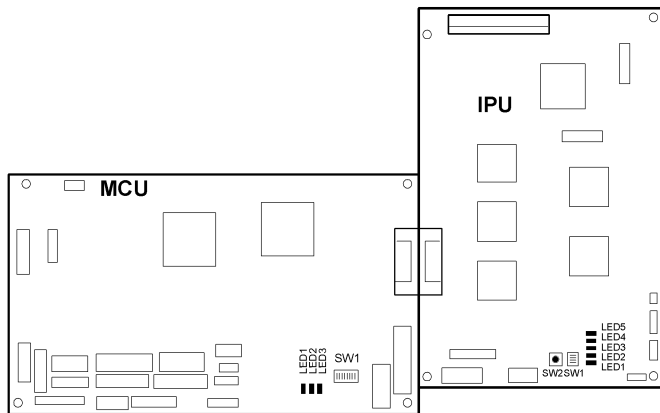

b286v301

MCU (Main Control Unit)

This is the main control board of the machine. It does the following:

- System control
- Base engine control
- Scanner control
- Image processing

The MCU also sends load signals and supplies power to:

- Base engine (high voltage power pack, motors, sensors, solenoid, clutches, fusing unit, RSS, etc.)
- Scanner (sensors, motors, etc.)

The MCU contains two large blocks, connected by a UART: SCU and ECU.

- **SCU:** (System & Scanner Control Unit). Does overall system and scanner control.
- **ECU:** (Engine Control Unit). Does print engine and image processing control.

Note

- The MCU DIP switches must always be OFF (default) and they must not be changed in the field.

IPU (Image Processing Unit)

The IPU (Image Processing Unit) holds the ASIC and memory for image processing. It processes image data from the CIS (Contact Image Sensors), sends it to the VDB (Video Drive Board), and then sends it to the LPH (LED Print Heads). The IPU also controls the HDD unit and the printer board, and the printer/scanner interface functions.

Note

- The IPU DIP switches must always be OFF (default) and they must not be changed in the field.

6.11.4 PSU

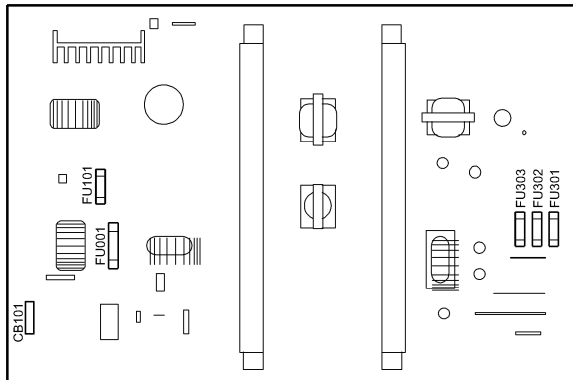

b286v303

The PSU (Power Supply Unit) supplies dc for all electrical components in the machine, and controls ac input to the fusing lamps and anti-condensation lamps.

6.11.5 SMDB, VDB, SIB

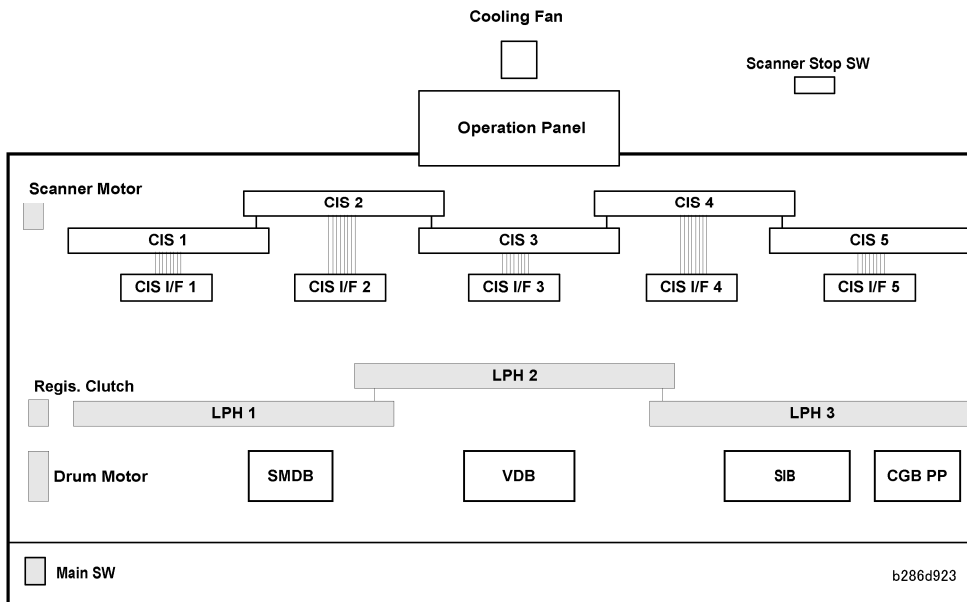

SMDB (Scanner Motor Drive Board)

Controls the scanner motor.

VDB (Video Drive Board)

The VDB controls the LPH and the algorithms to convert video data.

SIB (Scanner Interface Board)

The SIB controls the CIS (Contact Image Sensor) and changes analog data to digital data (A/D) for scanned images.

CIS I/F (1 to 5)

These small PCBs interface between the CIS units and the SIB. This facilitates replacement of the CIS unit.

6.11.6 RFDB, SFDB

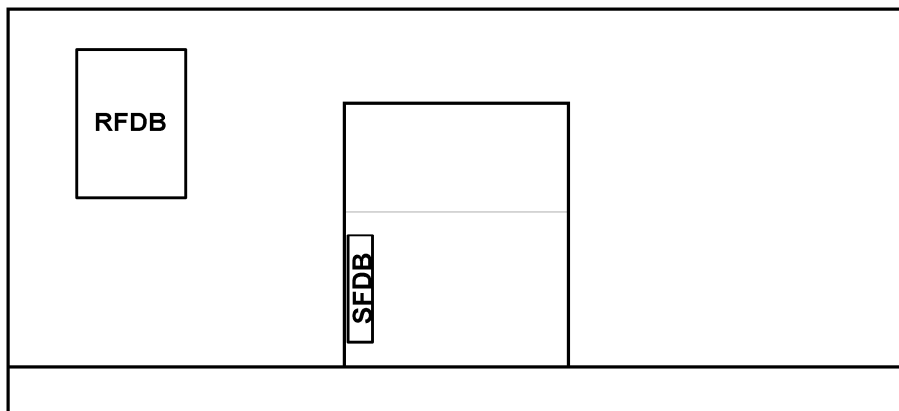

b286d924

The RFDB and SFDB are on the bottom plate of the drawer in the optional roll sheet feeder.

RFDB (Roll Feed Drive Board)

The RFDB, on the floor panel of the roll feeder, controls the motors, solenoids, and clutches for the two paper rolls in the roll sheet feeder.

SFDB (Sheet Feed Drive Board)

The SFDB, on the left side of the paper cassette unit, controls the paper feed mechanisms for the optional paper cassette.

6.11.7 GW CONTROLLER BOARD

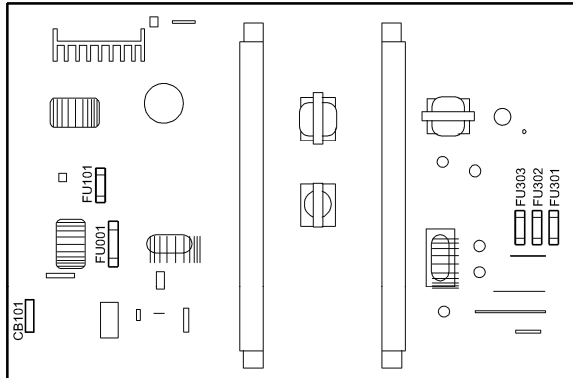

b286v303

The controller board controls the memory and all peripheral devices. The GW architecture allows the board to control all applications, i.e. copying, printing, and scanning. In order to add an option (printer, scanner), the appropriate ROM DIMM must be installed on the controller.

SPECIFICATIONS

7. SPECIFICATIONS

7.1 MAIN MACHINE (B286/B289)

Configuration:	Desktop
Copy Process:	Dry electrostatic transfer system
Originals:	Sheet
Original Image Size (W x L):	<p>Maximum: 914 x 15,000 mm (36" x 590") Minimum: 210 x 182 mm (8.5" x 7")</p> <ul style="list-style-type: none"> ▪ Maximum length copying (15 m) is limited to wide paper. ▪ Copies at maximum length must be done one at a time (multiple copies are not allowed).
Max Original Width:	960 mm (37.7")
Original Weight	<p>18 ~ 135 g/m² 35 μm ~ 1.0 mm</p> <p>Note: Less than 70 μm must be used with carrier sheet.</p>
Copy Paper Size (W x L):	<p>Maximum: Manual feed: 914 x 2,000 mm (36" x 78") Roll Feed: 914 x 15,000 mm (36" x 590") Paper Cassette: 297 x 420mm (12" x 18")</p> <p>Minimum: Manual Feed: 210 x 257 mm (8½" x 10") Roll Feed: 210 x 280 mm (8½" x 11") Paper Cassette: 210 x 297 mm (8½" x 11")</p>
Copy Paper Weight	<p>52.3 ~ 110 g/m² (13.9 ~ 29.3 lb) 68 ~ 148 μm (Plain paper, Translucent) 3 ~ 4 mils (Film)</p>
Copying Speed (cpm):	B286: 2 cpm (A0/E SEF), 4 cpm (A1/D LEF)

Main Machine (B286/B289)

copies/minute):	B289: 3 cpm (A0/E SEF), 6 cpm (A1/D LEF)
Photoconductor:	Organic photoconductor drum
Reduction/Enlargement:	<p>Inch Version, Engineering: Reduction: 25.0, 32.4, 50.0, 64.7% Enlargement: 129.4, 200.0, 258.8, 400.0%</p> <p>Inch Version, Architecture: Reduction: 25.0, 33.3, 50.0, 66.7% Enlargement: 133.3, 200.0, 266.7, 400.0%</p> <p>Metric Version Reduction: 25.0, 35.4, 50.0, 70.7% Enlargement: 141.4, 200.0, 282.8, 400.0%</p>
Zoom:	25 to 400% (1%/step) 200.1 to 400% (1%/step)
Resolution:	Scanning 600 dpi, Printing 600 dpi
Gradation:	Scanning: 256 levels Printing: 2 levels
Warm-up Time:	Less than 2 minutes Room temperature 23°C, Plain Paper mode AC 120V/220-240V
First Copy Time:	1 st Roll Feed: 18 s (A1/LEF/D LEF) Cassette: 19 s (A3 LEF/B LEF) Manual Feed: 31 s (A1/LEF/D LEF)
Copy Number Input:	Ten-key pad, 1 to 99 (standard sizes only)

Copy Paper Capacity:	Bypass Feed: 1 sheet Roll Feed: Max. Diameter: 175 mm (6.9") Max. Length: 150 m (16.4 yd) Roll Core Diameter: 76.4 ±0.25 mm (about 3") Paper Cassette: 250 sheets
Output Tray Capacity:	Upper Output Stacker Plain paper: 50 sheets (maximum A1/D LEF) Translucent: 10 sheets (maximum A1/D LEF) Roll Feeder or Table Plain paper: 40 sheets (A1/D or A0/E) Translucent: 1 sheet
Original Stacker	1 original
Memory Capacity:	DDR-DIMM: 1 GB (512 MB x 2) HDD: More than 80
Toner Replenishment:	Cartridge exchange (800 g/cartridge)
Toner Yield:	2,200 copies (A1 LEF, 6% full black, 1 to 99 copying, Text mode)
Power Source:	-17 Version: AC 120V, 60 Hz, 15 A or more -21, -27 Version: AC 220-240 V, 50/60 Hz, 10 A or more

Main Machine (B286/B289)

Power Consumption* ¹	AC120V Version		
		B286	B289
	Warm-up	1.4 kW	
	Ready* ²	0.090 kW	
	During Copying	0.94 kW	0.96 kW
	Maximum	1.5 kW	
	AC220-240V Version		
		B286	B289
	Warm-up	1.4 kW	
	Ready* ²	0.110 kW	
	During Copying	0.92 kW	0.94 kW
	Maximum	1.5 kW	

*¹ **Full System:** Main Machine with Roll Feeder (2 rolls), Paper Cassette, Interface PCB, USB Host Interface Unit and Gigabit Ethernet Board.

*² **Ready:** Dehumidifiers switched off.

Noise Emission:	The measurements were made in accordance with ISO 7779 at the operator position Sound Power Level, Full System Stand-by: 40.0 dB (A) Copying: 68.0 dB (A) Copying (from memory): 68.0 dB (A)
Max. Power Consumption:	North America: Less than 1.44 kW Europe/Asia: Less than 1.5 kW
Dimensions (w x d x h):	1,080 x 637 x 580 mm (43" x 25" x 23")

Weight:	Less than 107 kg (235.9 lb)
Optional Equipment:	<ul style="list-style-type: none"> ▪ Roll Feeder Type 240A/B (B851/B852) ▪ Paper Cassette Type 240 (B853) ▪ Table Type 240 (B854) ▪ Original Hanger (D311) ▪ Rear Stacker (D312) ▪ Interface PCB Type 240 (D329) ▪ Printer Option Type W3600 (D320) ▪ Scanner Option Type W3600 (D321) ▪ VM Card Type E (D338) ▪ Printer Controller RW3600 (D344) ▪ Roll Holder Type A (B394) ▪ Data Overwrite Security Unit Type D (B73518) ▪ IEEE802.11b Interface Unit Type H (G813) ▪ USB Host Interface Unit Type 7300 (G819) ▪ Gigabit Ethernet Board Type A (G874)

Options

7.2 OPTIONS

7.2.1 ROLL FEEDER B851/B852

Copy Paper Size: (W x L)	Maximum: 914 x 15,000 mm (36" x 590") Minimum: 210 x 280 mm (8.5" x 11")
Copy Paper Weight	52.3 to 104.7g/m ² (13.9 ~ 27 lb.)
Copy Paper Capacity:	Max. Diameter: 175 mm (6.9") Max. Length: 150 m (137.6") Roll Core Diameter: 76.4 ± 0.25 mm (about 3")
Power Source:	From main frame
Dimensions (w x d x h)	1,080 x 720 x 700 mm (43" x 28" x 27")
Weight:	B851: 70 kg (154 lb.) B852: 72 kg (158.4 lb)

7.2.2 PAPER CASSETTE B853

Type	Universal Cassette (installed in Roll Feeder B641/B642)
Paper Separation	Friction Pad
Paper Capacity:	250 sheets
Copy Paper Size	A3 SEF, A4 SEF, B4 SEF LT SEF, LG SEF, DLT SEF, 8.5 x 13 SEF, 12 x 18 SEF
Copy Paper Weight	64 to 105 g/m ² (17 to 28 lb)
Power Source	From Roll Feeder
Weight	6 kg (13.2 lb)

7.3 MAIN MACHINE CONFIGURATION

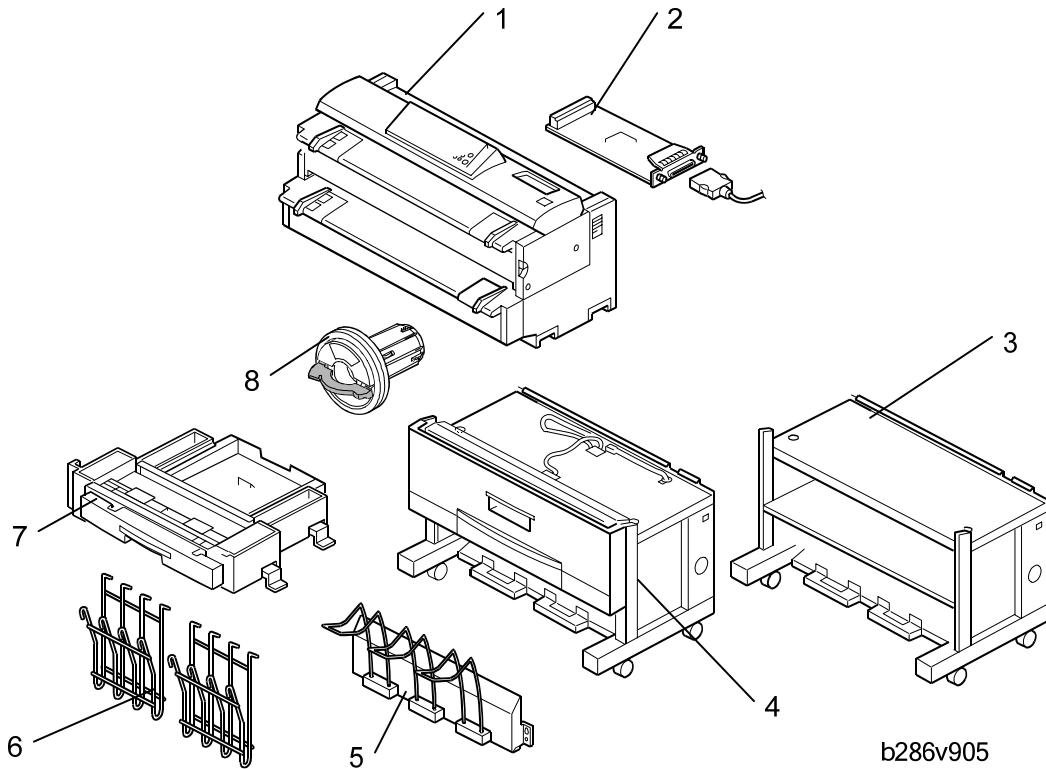

No.	Item	Machine Code
1	Main Machine	B286
2	Interface PCB Type 3600	D329
3	Table Type 240	B854
4	Roll Feeder Type 240A/B	B851/B852
5	Rear Stacker (Option for copies)	D312
6	Original Hanger (Option for originals)	D311
7	Paper Cassette Type 240	B853
8	Roll Holder Type A	B394