

**MP C3004, C3504, C4504, C5504,  
C6004, C3004ex, C3504 ex, C4504  
ex, C5504ex, C6004ex,MP C501SP  
Machine Code:D238, D239, D240,  
D241, D242, D0AC, D0AD, D0AE,  
D0AF, D0AG D0BH**

**Fax**

**Ver 1.0**

**Latest Release: July, 2018  
Initial Release: July, 2018  
(c) 2018 Ricoh Co.,Ltd.**



## Table of Contents

1. Models Covered by This Service Manual.....	4
2. Installation.....	5
Fax Option Type M20 (D3BT-01, -02, -03) / Fax Option Type M39 (D0BH-01, -02).....	5
Accessory Check.....	5
Installation Procedure.....	5
Adding Fax Application Icons to the Home Screen.....	11
Notes for Connecting the Telephone Line.....	14
Fax Option Type M19 (D3BV-01, -02, -03).....	16
Accessory Check.....	16
Installation Procedure.....	16
Adding Fax Application Icons to the Home Screen.....	21
Notes for Connecting the Telephone Line.....	25
G3 Interface Unit Type M20 (D3BT-07, -08, -12).....	27
Accessory Check.....	27
Installation Procedure.....	27
Notes for Connecting the Telephone Line.....	37
G3 Interface Unit Type M19 (D3BV-07, -08, -12).....	38
Accessory Check.....	38
Installation Procedure.....	38
Notes for Connecting the Telephone Line.....	48
Fax Unit Options.....	49
Fax Memory Unit Type M19 64MB (D3BZ).....	49
Handset HS3020 (D739).....	54
Fax Connection Unit.....	57
Accessory Check.....	57
Installation Procedure.....	57
3. Replacement and Adjustment.....	62
FCU.....	62
SRAM Data Transfer Procedure.....	62
4. Troubleshooting.....	72
Error Codes.....	72
Error Codes.....	72
Fax Connection Unit Error Codes.....	89
Fax Connection Unit Error Code List.....	89
IFAX Troubleshooting.....	91
IFAX Troubleshooting.....	91
IP-Fax Troubleshooting.....	93

IP-Fax Transmission.....	93
IP-Fax Reception.....	95
5. Service Tables.....	98
Cautions.....	98
Service Program Tables.....	99
SP1-XXX (BIT Switches).....	99
SP2-XXX (RAM).....	100
SP3-XXX (Machine Set).....	100
SP4-XXX (ROM Versions).....	102
SP5-XXX (RAM Clear).....	102
SP6-XXX (Reports).....	102
SP7-XXX (Tests).....	104
Bit Switches – 1.....	106
System Switches.....	106
Bit Switches – 2.....	117
I-Fax Switches.....	117
Printer Switches.....	122
Bit Switches – 3.....	129
Communication Switches.....	129
Bit Switches – 4.....	137
G3 Switches.....	137
Bit Switches – 5.....	145
G3-2 and G3-3 Switches.....	145
G4 Internal Switches.....	151
G4 Parameter Switches.....	151
Bit Switches – 6.....	152
IP Fax Switches.....	152
NCU Parameters.....	159
NCU Parameters.....	159
Dedicated Transmission Parameters.....	170
Programming Procedure.....	170
Parameters.....	170
Service RAM Addresses.....	177
Service RAM Addresses.....	177
6. Detailed Section Descriptions.....	188
Overview.....	188
Overview.....	188
Boards.....	189
FCU.....	189

SG3 Board .....	190
Video Data Path .....	192
Transmission.....	192
Reception.....	194
Fax Communication Features .....	195
Multi-port.....	195
Document Server.....	195
Internet Mail Communication.....	196
IP-Fax .....	204
What is IP-FAX? .....	204
T.38 Packet Format.....	204
Settings.....	204
7. Specifications.....	205
General Specifications.....	205
FCU.....	205
Capabilities of Programmable Items .....	207
Capabilities of Programmable Items .....	207
IFAX Specifications .....	208
IFAX Specifications.....	208
IP-FAX Specifications.....	210
IP-FAX Specifications .....	210
Fax Unit Configuration.....	211
G3 Interface Unit Type M19 (for MP C3004/C3504).....	211
G3 Interface Unit Type M20 (for MP C4504/C5504/C6004 and MP C501SP).....	212

# 1. Models Covered by This Service Manual

---

The following models are covered by this manual:

- MP C3004/C3504/C4504/C5504/C6004 series\*1
- MP C3004ex/C3504ex/C4504ex/C5504ex/C6004ex series\*1
- MP C501SP

\* If descriptions are provided according to different models in this manual, “ex” models are also included unless described otherwise. For example, “MP C3004/C3504 only” also includes MP C3004ex/C3504ex.

## 2. Installation

### Fax Option Type M20 (D3BT-01, -02, -03) / Fax Option Type M39 (D0BH-01, -02)

Fax Option Type M20: For MP C4504/C5504/C6004.

Fax Option Type M39: For MP C501SP.

#### Accessory Check

Check the quantity and condition of the accessories against the following list.

No.	Description	Q'ty	Remarks
1	FCU	1	
2	Ferrite Core	1	For NA, this ferrite core is attached to the telephone cable [4].
3	Screw: M3x6	4	
4	Telephone Cable with ferrite core	1	NA only
5	Serial number decal	1	
-	FCC Decal	1	NA only
-	EMC Address Decal	1	EU only
-	Telephone Jack Cap	1	TWN only

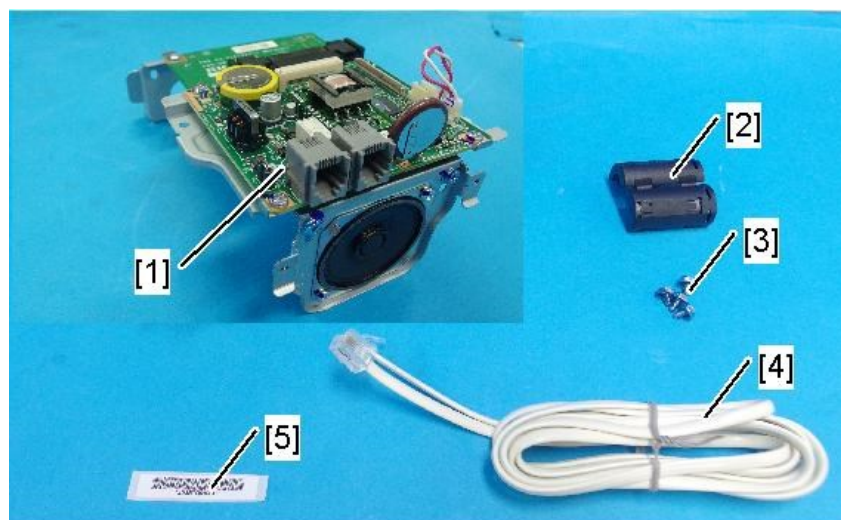

d238m0703a

#### Installation Procedure

#### **⚠ CAUTION**

- Before installing this fax unit, print out all data in the printer buffer. Turn the main power to OFF and disconnect the power cord and the network cable.

## 2. Installation

1. Remove the I/F cover [A].

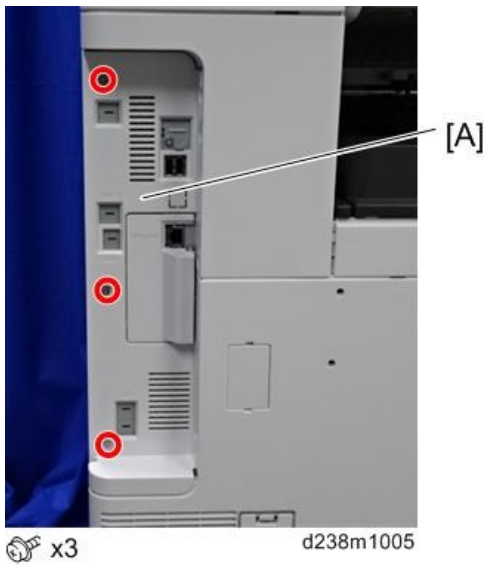

2. Remove the rear cover [A].

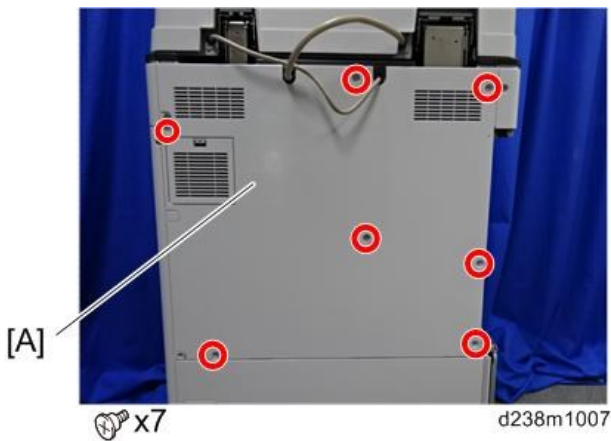

3. Remove the controller box cover [A].

Red circle: remove

Blue circle: loosen

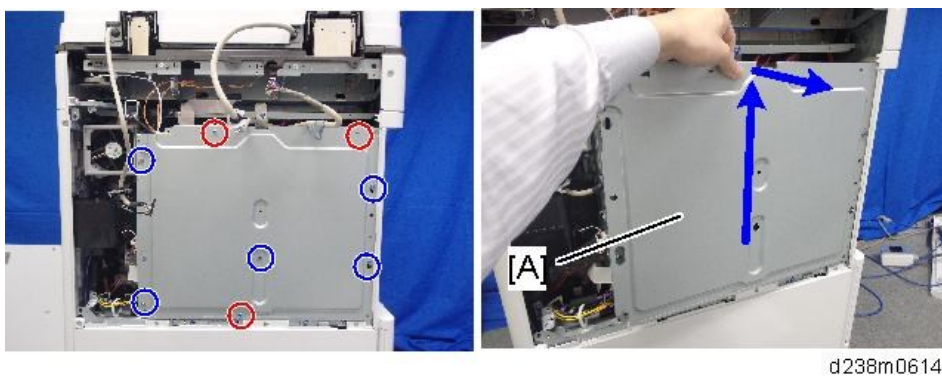



- 4.** Remove the "TEL" [A] and "LINE1" [B] covers using a screwdriver.

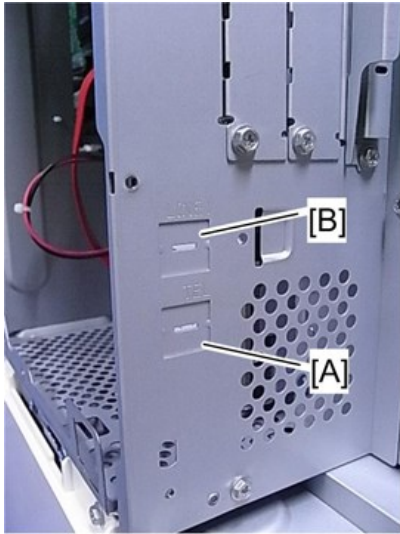

d1670001

- 5.** Switch the battery jumper switch [A] to the "ON" position.

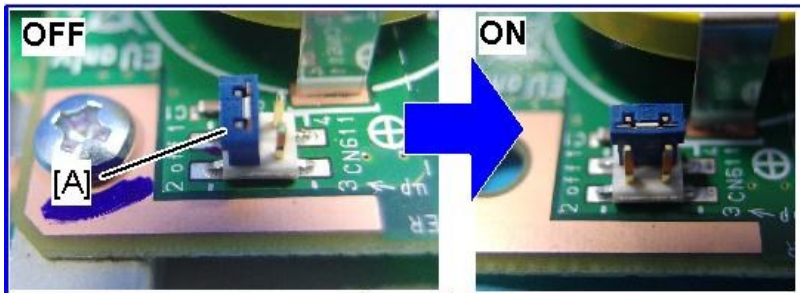

d238m0704a



**Note**

- If the battery jumper switch is not in the correct position, SC820 will occur.

- 6.** Install the FCU [A] on the controller board.  
Make sure that both connectors [B] are connected.

## 2. Installation

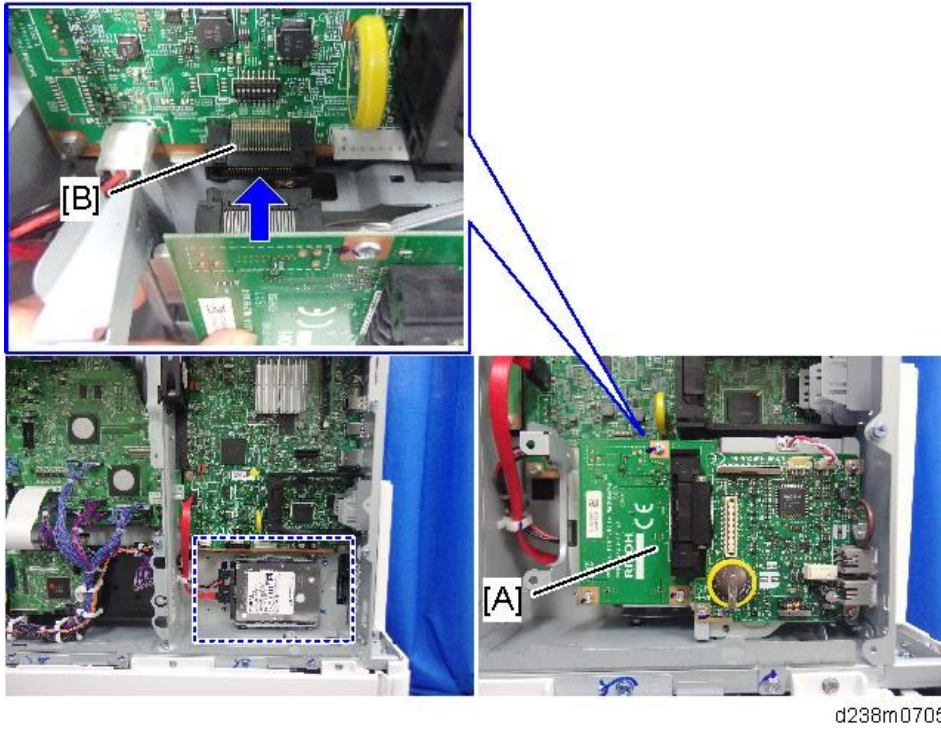

- Insert the tabs [A] of the FCU bracket into the cutouts on the left of the controller box.

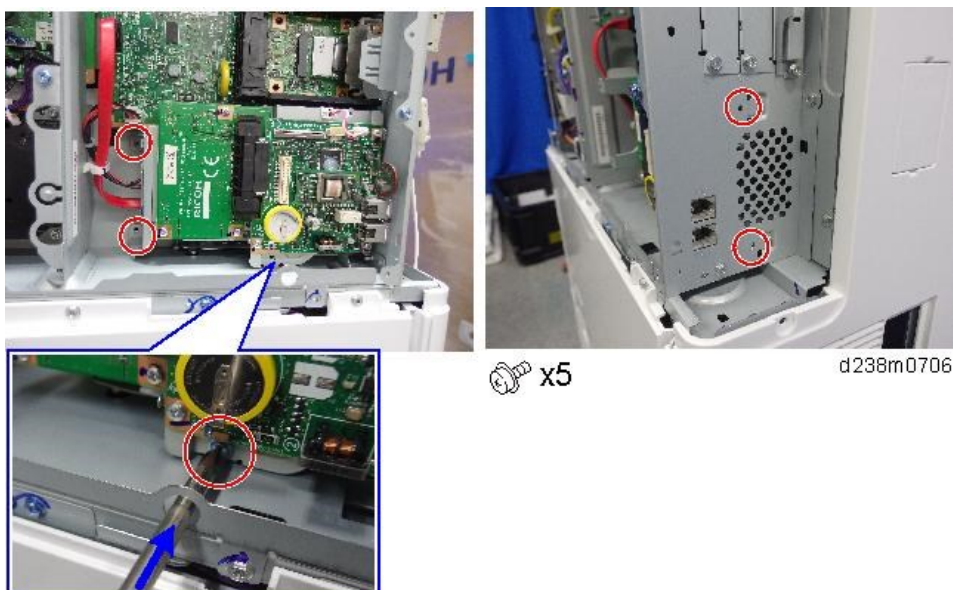
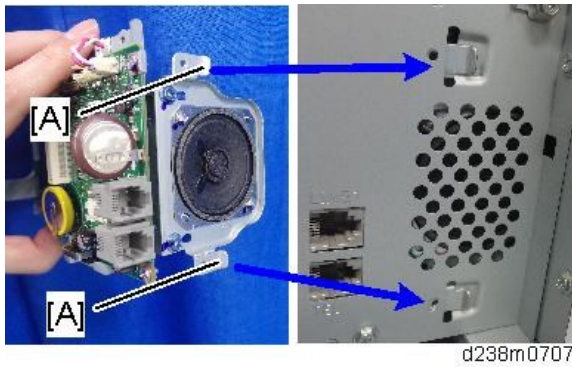

**7.** Reinstall the rear cover and controller box cover.

- 8.** Attach the handset support bracket and handset bracket to the machine. To install the handset, connect the handset cord with the ferrite core to the "TEL" jack.

**Note**

- For details about installation, refer to [Handset HS3020 \(D739\)](#).

Taiwan only: Install the telephone jack cap in the "TEL" jack if the handset is not installed on the machine.

- 9.** Make one loop with the telephone cord, and then attach the ferrite core [A] (this step is not needed for NA).

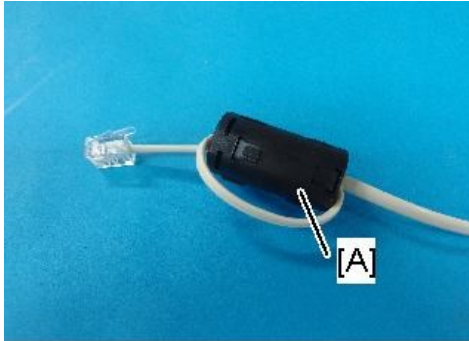

d238m0916

- 10.** Connect the telephone cord to the "LINE 1" jack.

- 11.** Attach the clamps [A] to the rear cover of the optional paper feed unit, and then hold the telephone line with the clamps as shown below.

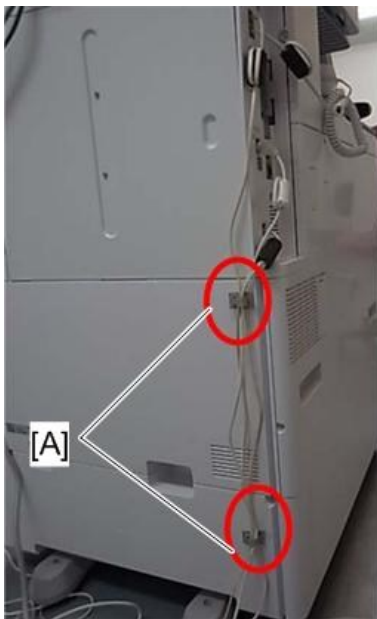

d163z0001

- 12.** Attach the serial number decal under the machine serial number decal on the rear cover of the machine.

- 13.** Attach the FCC decal to the rear cover of the machine (NA only).

- 14.** Insert the power plug into the outlet. Turn ON the main power of the machine.

**Note**

- Make sure that the outlet is grounded.

## 2. Installation

- "SRAM formatted" is displayed on the operation panel after the main power is turned ON.  
Turn the main power OFF and then ON again for normal use.

**15.** Make sure that the date and time are correctly set.

**16.** Execute SP3-102-000 in the fax SP mode and enter the serial number for the fax unit.

**17.** Enter the correct country code with SP1101-016(SYS OF): Country/area code for functional setting.

### Fax Stamp Installation

This procedure is only for machines with ARDF DF3090.

**1.** Open the ARDF original cover and stamp holder [A].

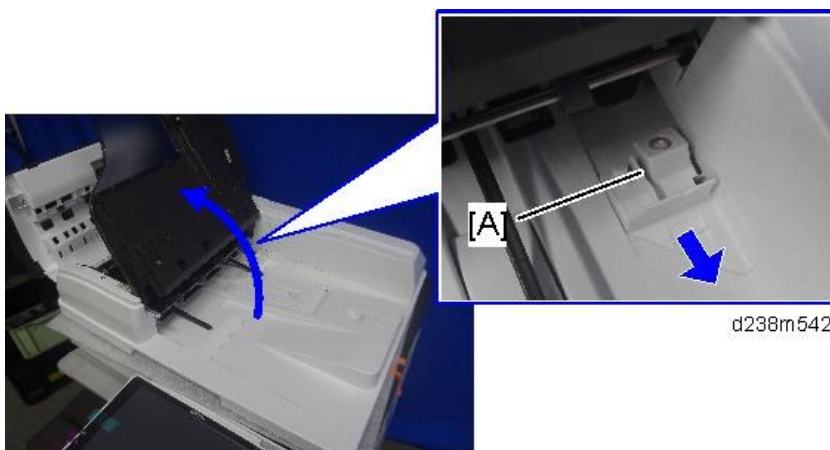

**2.** Install the fax stamp [A] provided with the machine.

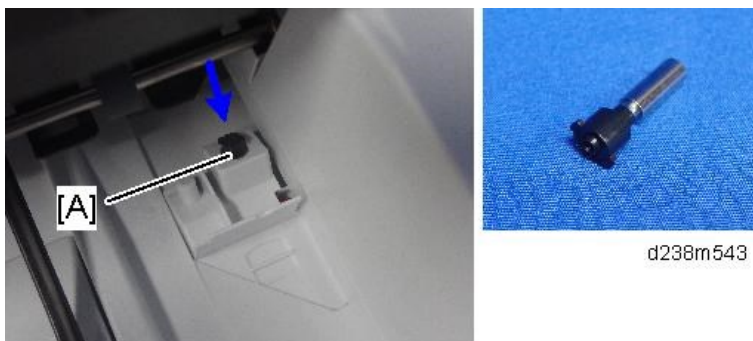

**3.** Close the holder.

Make sure that the holder is pushed into the position where the marks on the holder and the exterior cover face each other. If not, jam detection (J001) will occur.

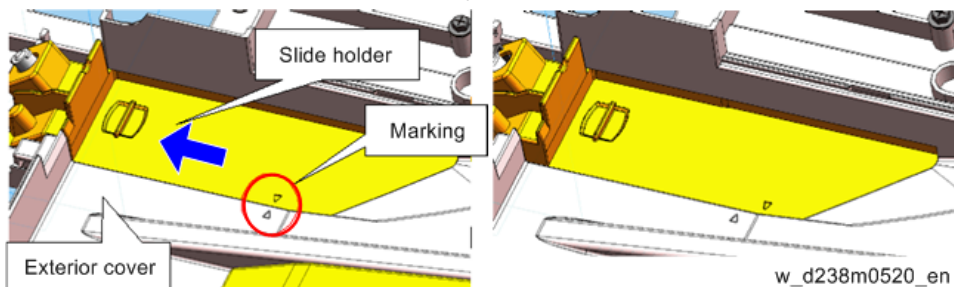

**4.** Close the ARDF.

**5.** As an operation test, place an original on the ARDF tray, and send it with the memory sending/fax

stamp function ON.

- Set the sending time to a time when nobody uses the machine (such as 11 PM).
- Check if the fax stamp is marked on the trailing edge of the original.

---

## Adding Fax Application Icons to the Home Screen

---

The fax application icon is normally added automatically. However, if it is missing from the Home screen, add it as follows:

1. Press the [Application List] key [A].



d238m0743

2. Press and hold the Fax application from the app list.



d238m0744

3. Drag and position the application on the home screen.



d238m0745

---

## Registering Function Keys

---

By registering a fax application to a function key on the Home screen, you can open the application from any page. Specify the setting as required.

Function Keys 1, 2, and 3 are from the left, as shown:

## 2. Installation

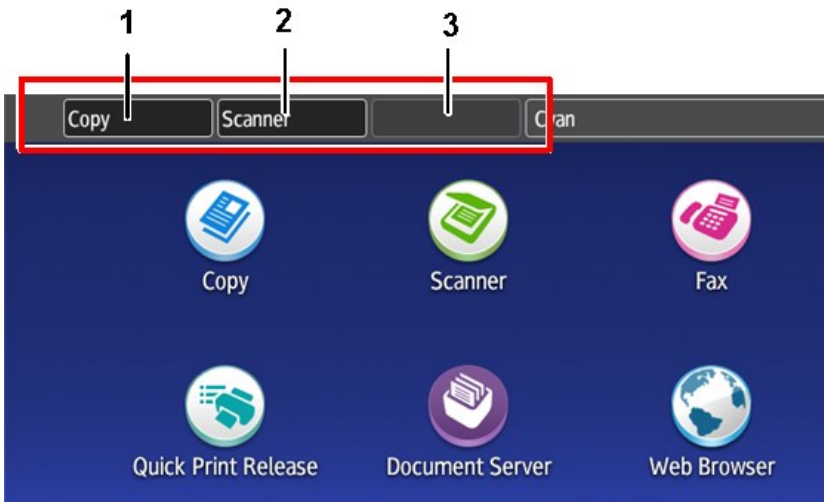

d238m0991e

Allocate an application to a function key as follows:

1. Login as the machine administrator
2. Press "User Tools" icon > "Screen Features".
3. Press [Screen Device Settings].

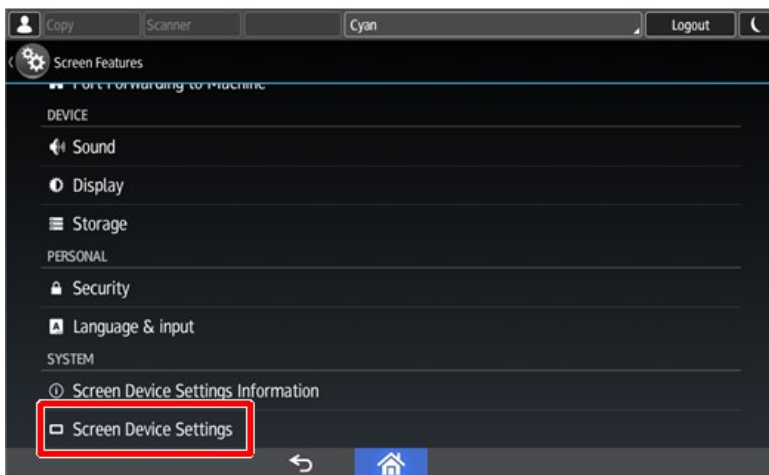

d238m0988e

4. Press [Function Key Settings].

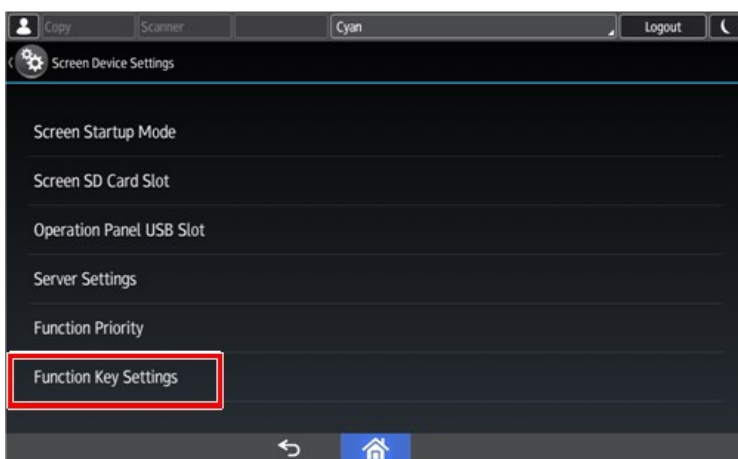

d238m0994e

**5.** Select the key to register.

To disable a function key, deselect the corresponding function key check box.

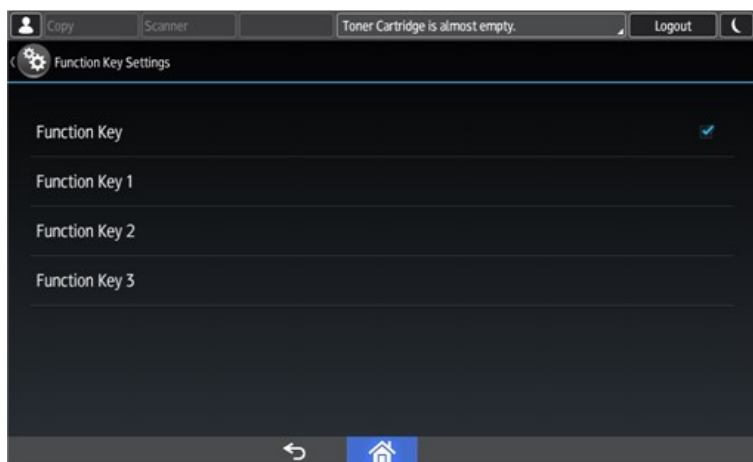

d238m0992e

**6.** Press [Allocated Function], and then select the fax application.

In [Display Name], you can change the name of the icon on the Home screen (using up to 64 characters).

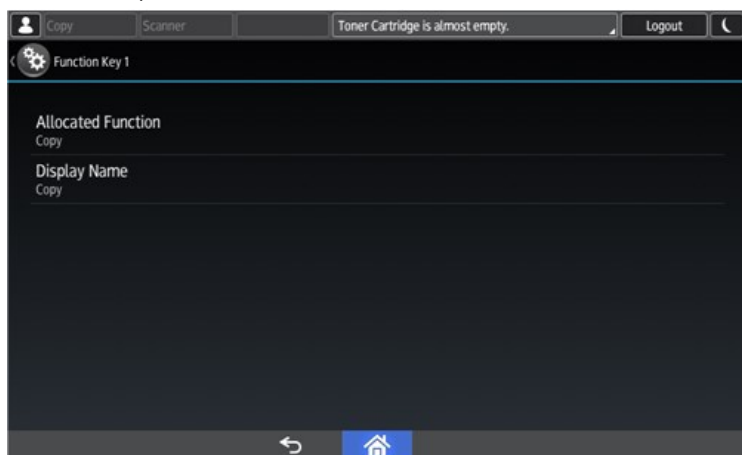

d238m0993e

### Function Priority Setting

---

You can specify whether the fax application appears on the operation panel just after turning the power on or just after the system is reset automatically.

- 1.** Login as the machine administrator
- 2.** Press “User Tools” icon > “Screen Features”.

## 2. Installation

### 3. Press [Screen Device Settings].

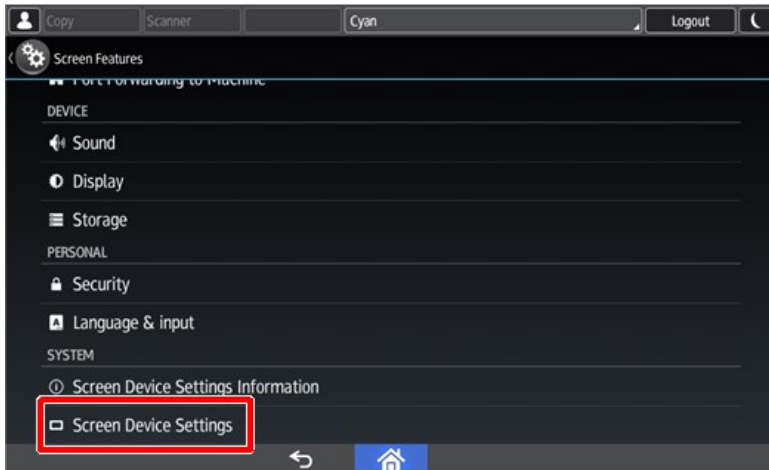

d238m0988e

### 4. Press [Function Priority].

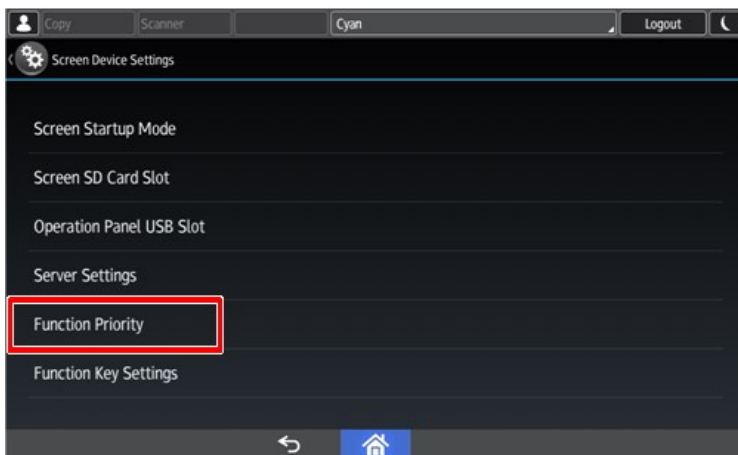

d238m0989e

### 5. Select the fax application.

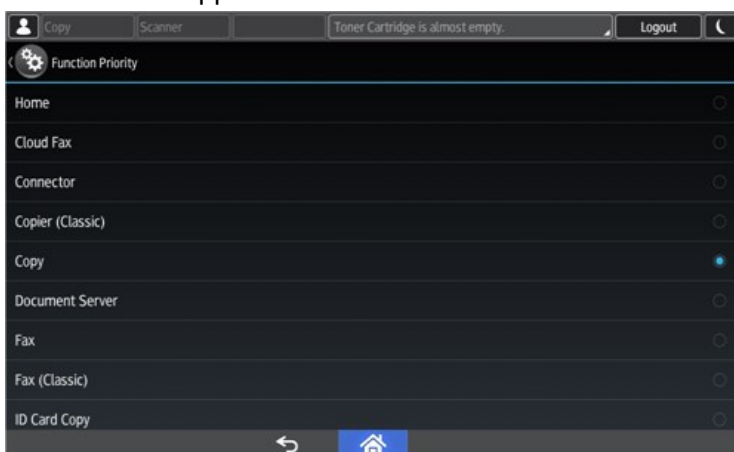

d238m0990e

---

## Notes for Connecting the Telephone Line

---

Checking the following before connecting the telephone line:

If a phone line dedicated to business phones is connected to the MFP, the fax board may be damaged.



Make sure that the connecting phone line is for fax.

### Reasons why the Fax Board may be damaged

---

Business phones have various functions. To operate those functions, a high current is supplied to a business phone line. This may damage components on the Fax board.

## Fax Option Type M19 (D3BV-01, -02, -03)

This fax option is for C3004/C3504 models only.

### Accessory Check

Check the quantity and condition of the accessories against the following list.

No.	Description	Q'ty	Remarks
1	Shield	1	
2	FCU	1	
3	Speaker Bracket	1	
4	Ferrite Core	1	For NA, this ferrite core is attached to the telephone cable [4].
5	Serial Number Decal	1	
6	Clamp	2	
7	FCU Screw: M3x6	4	
8	Screw	2	Not used for this machine
9	Telephone Cable with ferrite core	1	NA only
-	FCC Decal	1	NA only
-	EMC Address Decal	1	EU Only
-	Telephone Jack Cap	1	TWN only

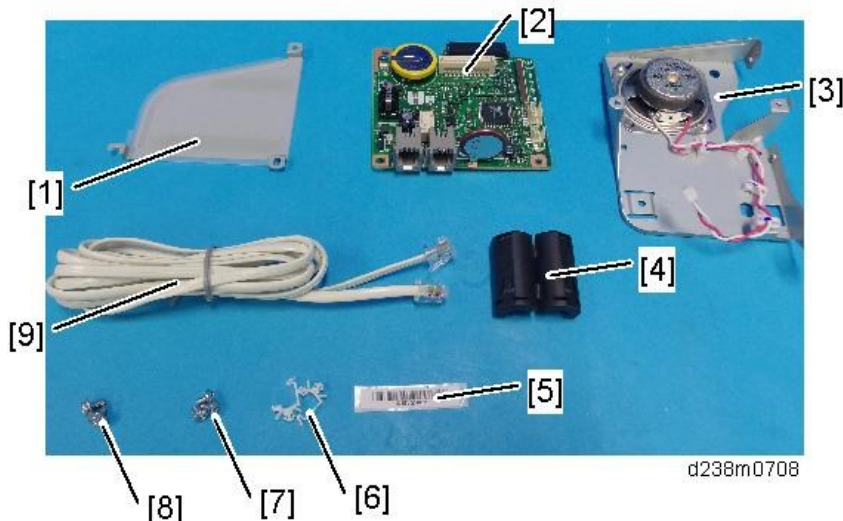

### Installation Procedure

#### **⚠ CAUTION**

- Before installing this fax unit, print out all data in the printer buffer. Turn the main power to OFF and disconnect the power cord and the network cable.

1. Remove the I/F cover [A].

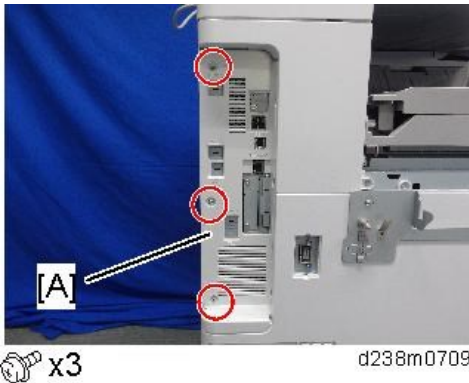

2. Remove the interface slot cover [A] (🔩 x 2).

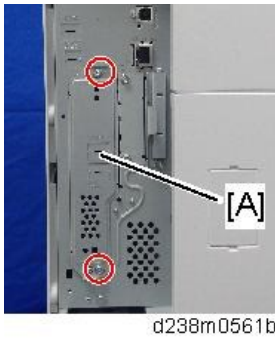

3. Remove the "TEL" [A] and "LINE1" [B] covers on the interface slot cover using a screwdriver.

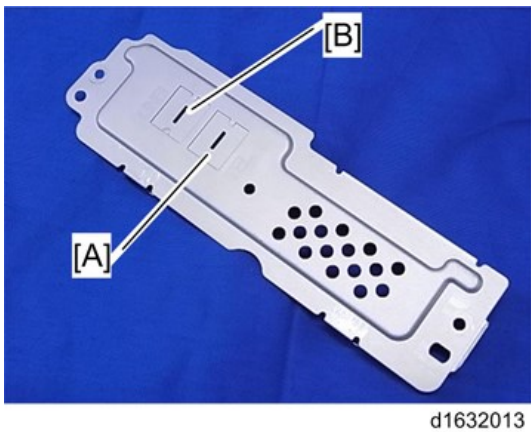

2.Installation

4. Switch the battery jumper switch [A] to the "ON" position.

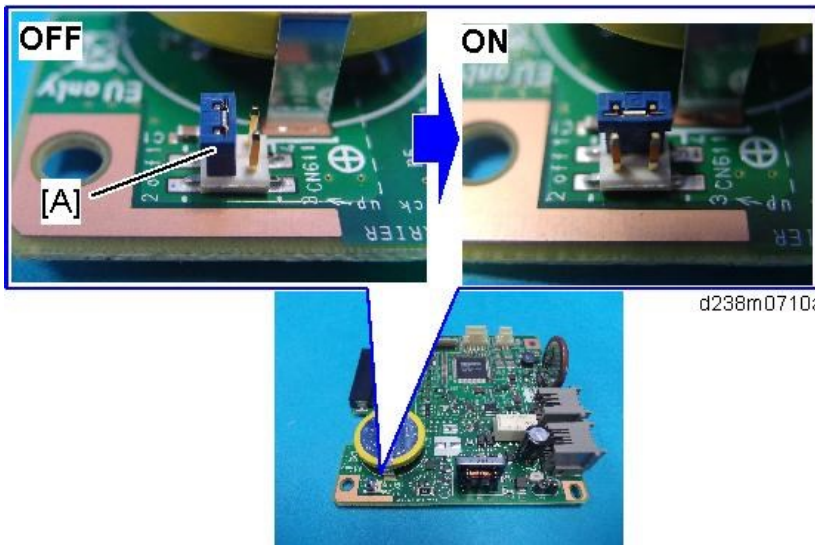

5. Connect the speaker bracket [A] to the FCU [B].

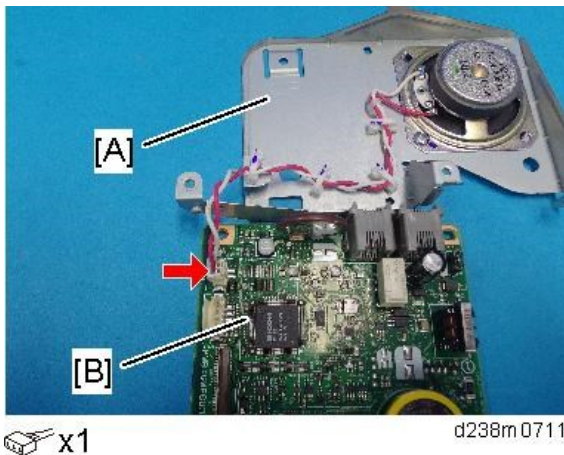

6. Attach the shield [A], FCU [B], and speaker bracket [C] together.

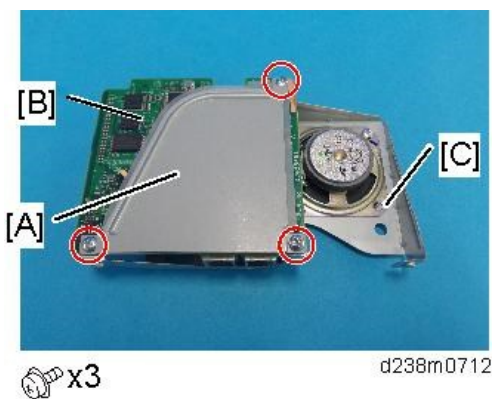

- 7.** Insert the FCU [A] completely into the interface slot.



- 8.** Reattach the interface slot cover [A].  
Blue circle: Use supplied screws (for the FCU)

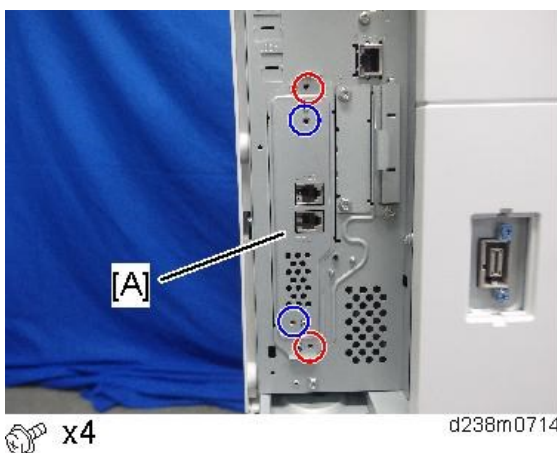

- 9.** Reinstall the I/F cover (🔩 x 3).  
**10.** Attach the handset support bracket and handset bracket to the machine. To install the handset, connect the handset cord with the ferrite core to the "TEL" jack.

**Note**

- For details about installation, refer to [Handset HS3020 \(D739\)](#).

Taiwan only: Install the telephone jack cap in the "TEL" jack if the handset is not installed on the machine.

- 11.** Make one loop with the telephone cord, and then attach the ferrite core [A] (this step is not needed for NA).

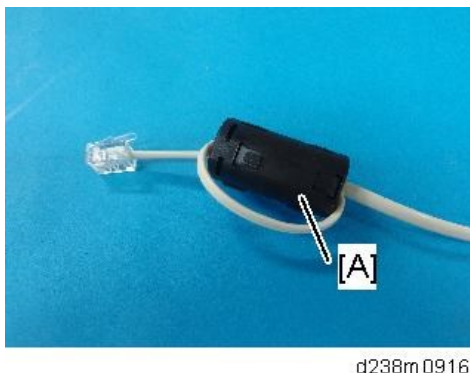

- 12.** Connect the telephone cord to the "LINE 1" jack.

## 2. Installation

- 13.** Attach the clamps [A] to the rear cover of the optional paper feed unit, and then hold the telephone line with the clamps as shown below.

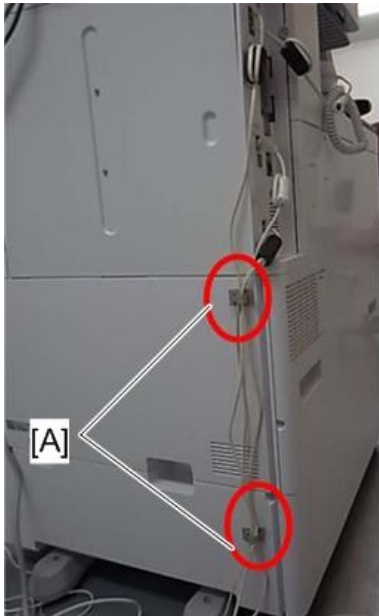

d163z0001

- 14.** Attach the serial number decal under the machine serial number decal on the rear cover of the machine.
- 15.** Attach the FCC decal to the rear cover of the machine (NA only).
- 16.** Insert the power plug into the outlet. Turn ON the main power of the machine.

### Note

- Make sure that the outlet is grounded.
- "SRAM formatted" is displayed on the operation panel after the main power is turned ON. Turn the main power OFF and then ON again for normal use.

- 17.** Make sure that the date and time are correctly set.
- 18.** Execute SP3-102-000 in the fax SP mode and enter the serial number for the fax unit.
- 19.** Enter the correct country code with SP1101-016(SYS OF): Country/area code for functional setting.

### Fax Stamp Installation

---

This procedure is needed only for machines with ARDF DF3090.

1. Open the ARDF original cover and stamp holder [A].

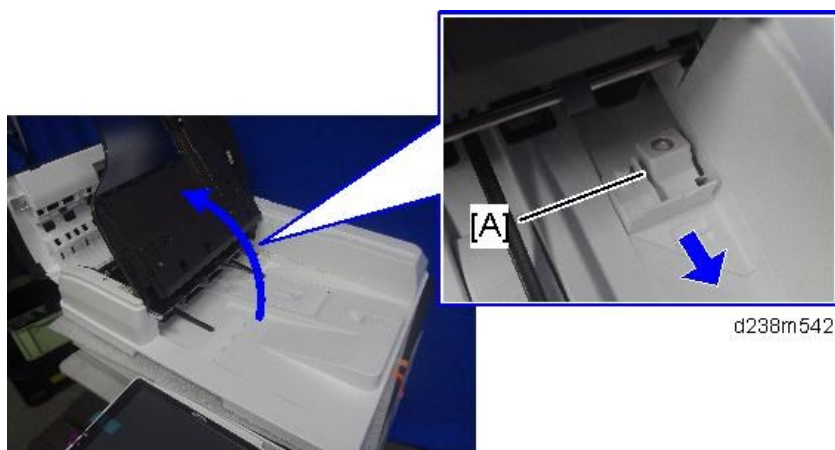

2. Install the fax stamp [A] provided with the machine.

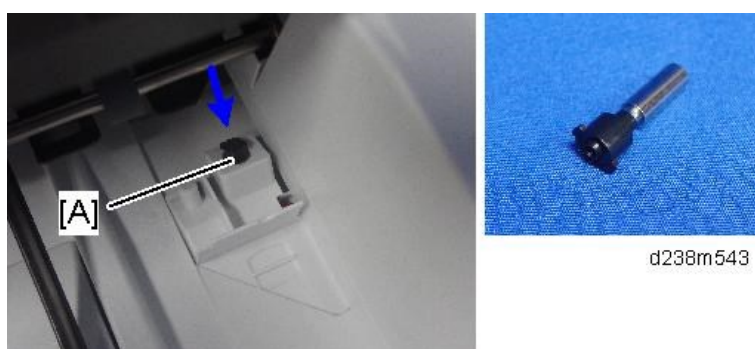

3. Close the holder.

Make sure that the holder is pushed into the position where the marks on the holder and the exterior cover face each other. If not, jam detection (J001) will occur.

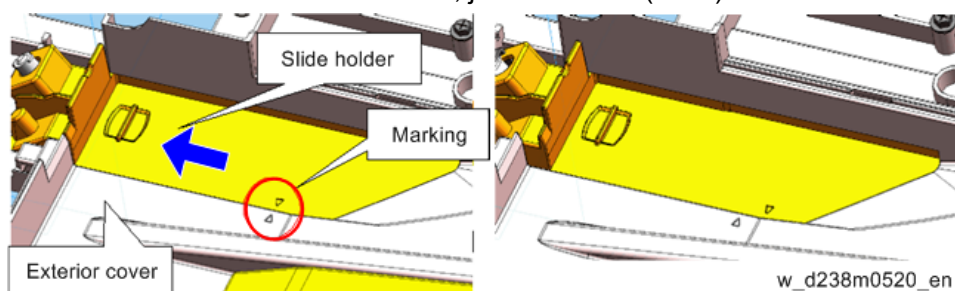

4. Close the ARDF.

5. As an operation test, place the original on ARDF tray, and send it with the memory sending/fax stamp function ON.

- Set the sending time to a time when nobody uses the machine (such as 11 PM).
- Check if the fax stamp is marked on the trailing edge of the original.

---

## Adding Fax Application Icons to the Home Screen

---

The fax application icon is normally added automatically. However, if it is missing from the Home screen, add it as follows:

## 2. Installation

1. Press the [Application List] key [A].



d238m0743

2. Press and hold the Fax application from the app list.

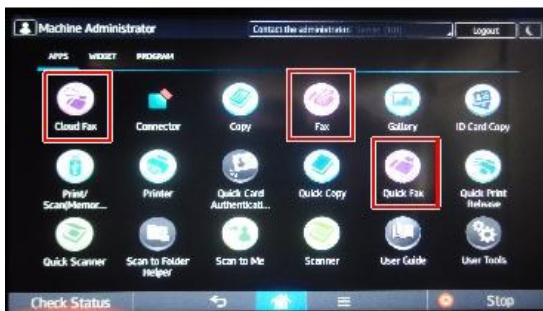

d238m0744

3. Drag and position the application on the home screen.



d238m0745

## Registering the Function key

By registering a fax application to a function key on the Home screen, you can open the application from any page. Specify the setting as required.

Function Keys 1, 2, and 3 are from the left, as shown:



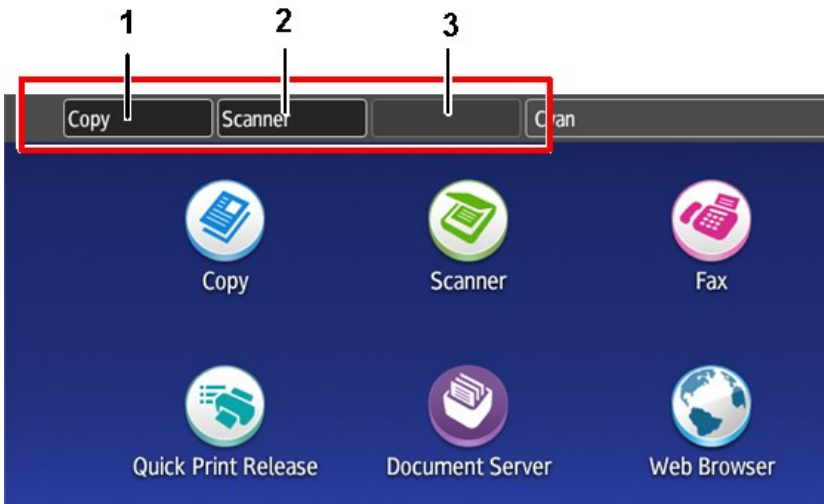

d238m0991e

Allocate an application to a function key as follows:

1. Login as the machine administrator
2. Press “User Tools” icon > “Screen Features”.
3. Press [Screen Device Settings].

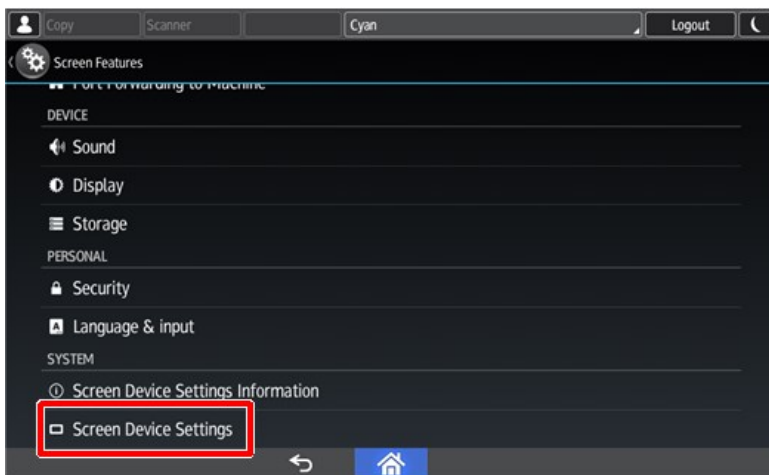

d238m0988e

4. Press [Function Key Settings].

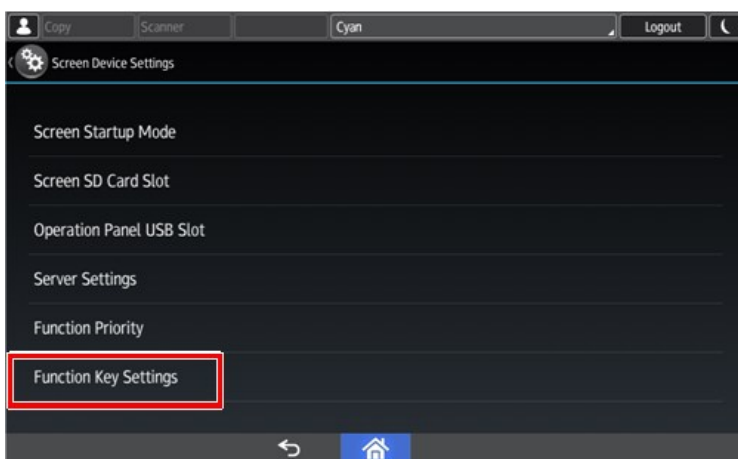

d238m0994e

## 2.Installation

### 5. Select the key to register.

To disable a function key, deselect the corresponding function key check box.

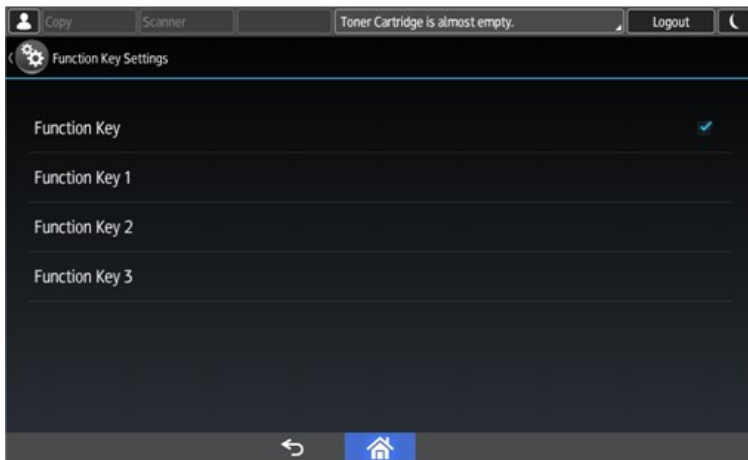

d238m0992e

### 6. Press [Allocated Function], and then select the fax application.

In [Display Name], you can change the name of the icon on the Home screen (using up to 64 characters).

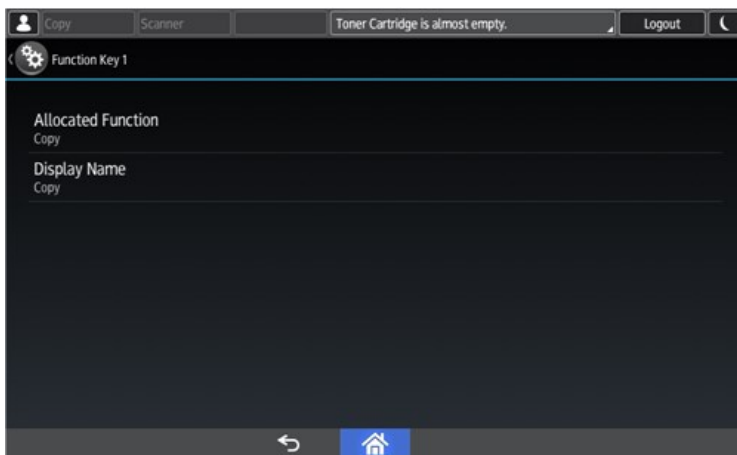

d238m0993e

## Function Priority Setting

---

You can specify whether the fax application appears on the operation panel just after turning the power on or just after the system is reset automatically.

1. Login as the machine administrator
2. Press "User Tools" icon > "Screen Features".

**3.** Press [Screen Device Settings].

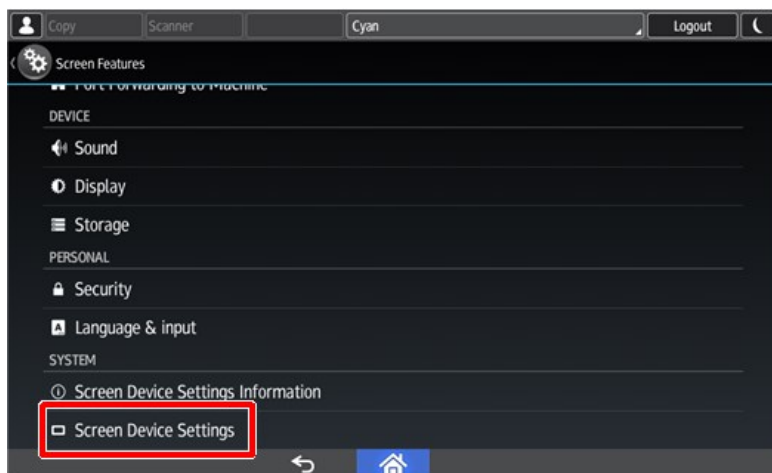

d238m0988e

**4.** Press [Function Priority].

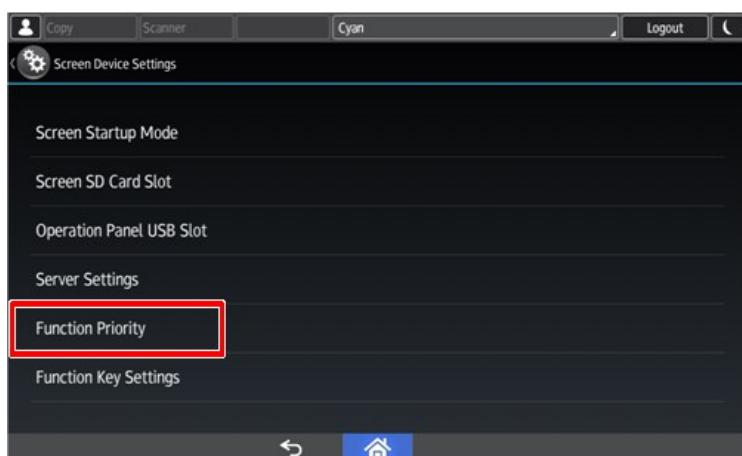

d238m0989e

**5.** Select the fax application.

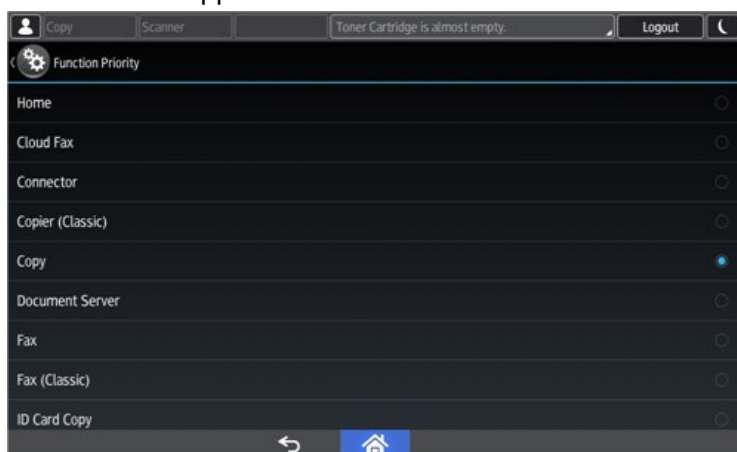

d238m0990e

---

## Notes for Connecting the Telephone Line

---

Checking the following before connecting the telephone line:

If a phone line dedicated to business phones is connected to the MFP, the fax board may be damaged.

## 2. Installation

Make sure that the connecting phone line is for fax.

### Reasons why the Fax Board may be damaged

---

Business phones have various functions. To operate those functions, a high current is supplied to a business phone line. This may damage components on the Fax board.

## G3 Interface Unit Type M20 (D3BT-07, -08, -12)

This G3 interface unit option is for Fax Option Type M20/M39.

### Accessory Check

Check the quantity and condition of the accessories against the following list.

No.	Description	Q'ty	Remarks
1	SG3 Interface Unit	1	
2	FFC	1	
3	Ferrite Core	1	
4	Screw: M3x6	3	
5	Telephone Cable	1	NA only
6	FFC Holder	1	
-	FCC Decal	1	NA only
-	EMC Address Decal	1	EU only

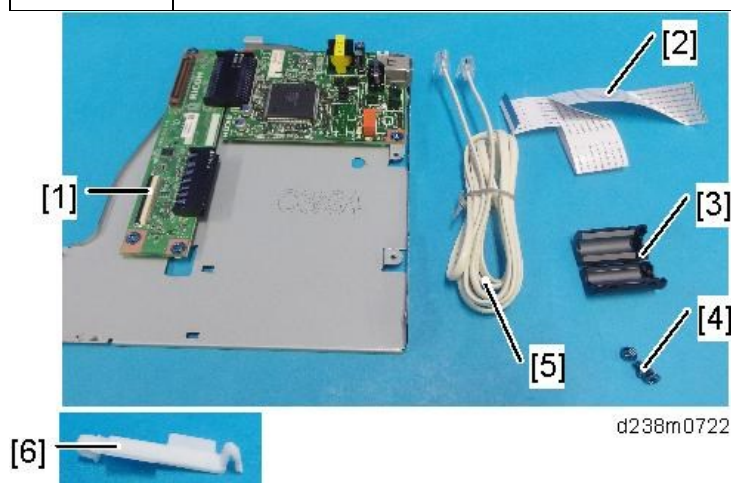

### Installation Procedure

#### **⚠ CAUTION**

- Before installing this fax unit, print out all data in the printer buffer. Turn the main power to OFF and disconnect the power cord and the network cable.

An additional two SG3 boards can be added for this model. Follow the procedures for installing a single SG3 board or double SG3 board as required.

#### Single G3 Board

##### **?** Preparation

- If Fax Option Type M20/M39 is not installed in the machine, install the Fax Option Type M20/M39 first ([Fax Option Type M20 \(D3BT-01, -02, -03\)](#) / [Fax Option Type M39 \(D0BH-01, -02\)](#)).

## 2. Installation

1. Remove the I/F cover [A].

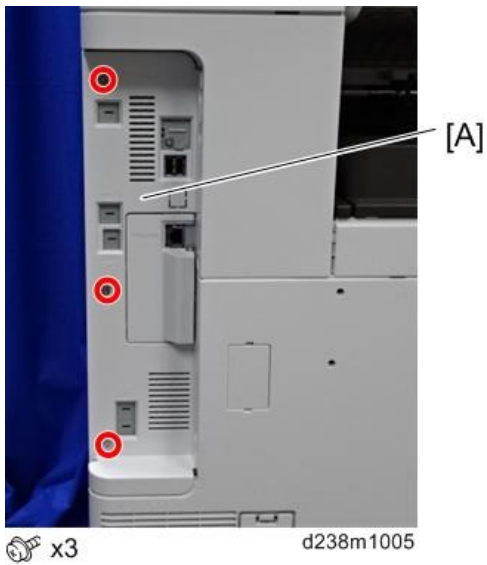

2. Remove the rear cover [A].

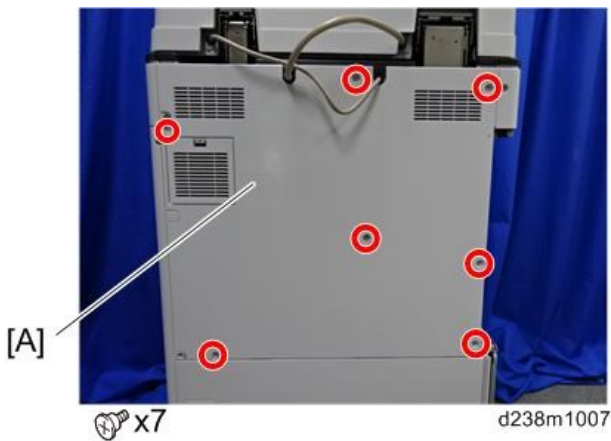

3. Remove the controller box cover [A].

Red circle: remove

Blue circle: loosen

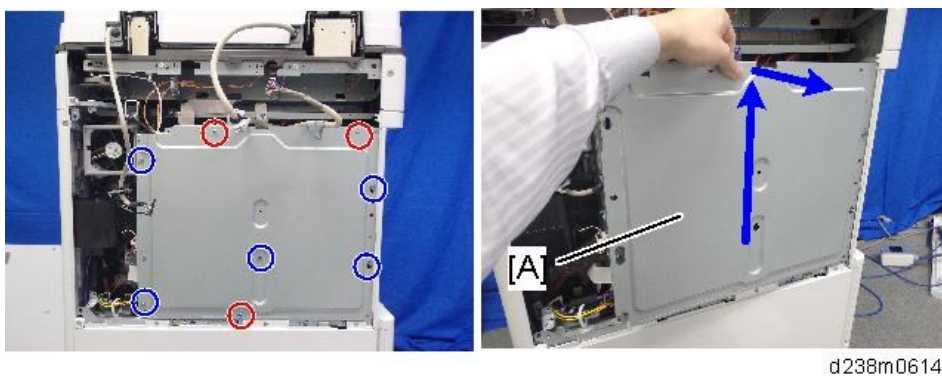

- 4.** Remove the "LINE2" [A] cover using a screwdriver.



- 5.** Install the SG3 interface unit [A].

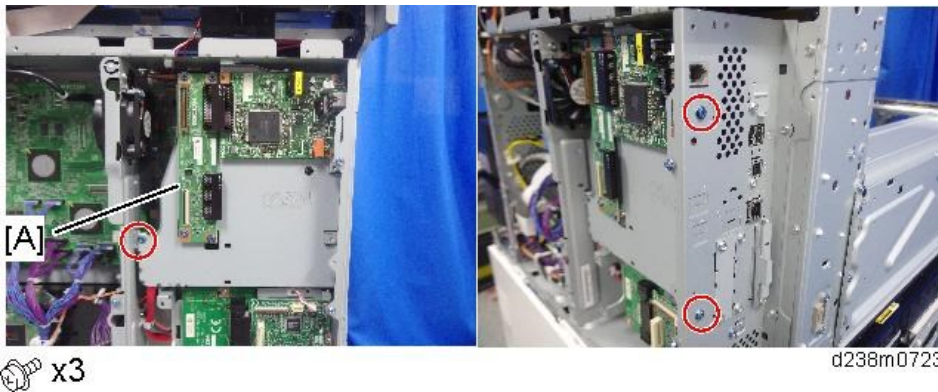

- Insert the tab [B] of the SG3 interface unit bracket in the cutout [C] on the top of the controller box.

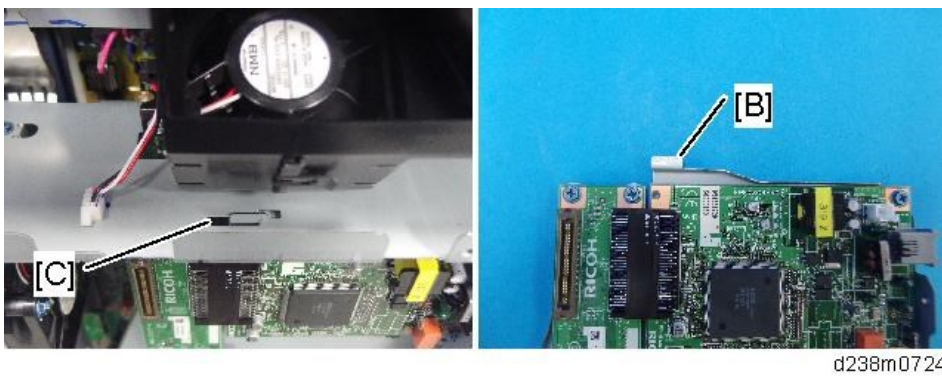

- Insert the tab [D] of the controller box in the cutout [E] of the SG3 interface unit.

## 2. Installation

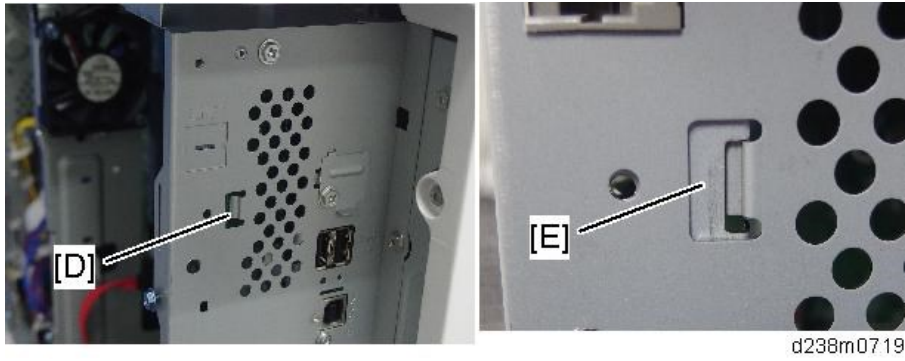

### 6. Connect the FFC [A] to the FCU.

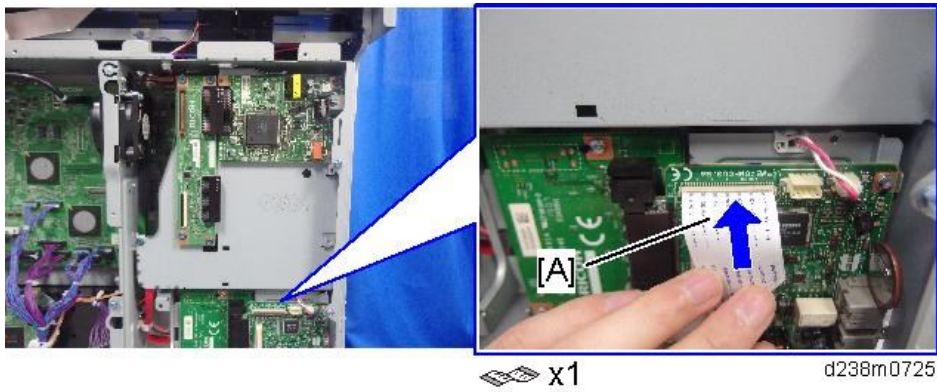

- Release the connector lock [B] and connect the FFC, and then lock the FFC.

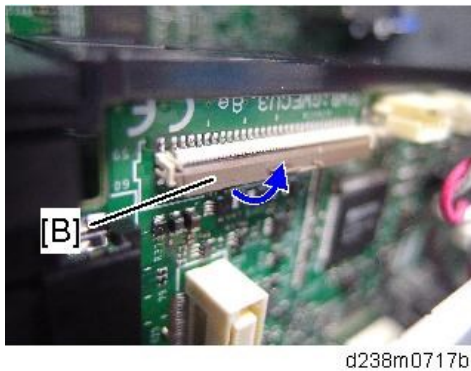

### 7. Attach the other end of the flat cable to the connector [A] on the CCU interface unit.

- Make sure that the blue tapes of the flat cable face outward.





- 8.** Attach the FFC Holder [A] to secure the FFC.

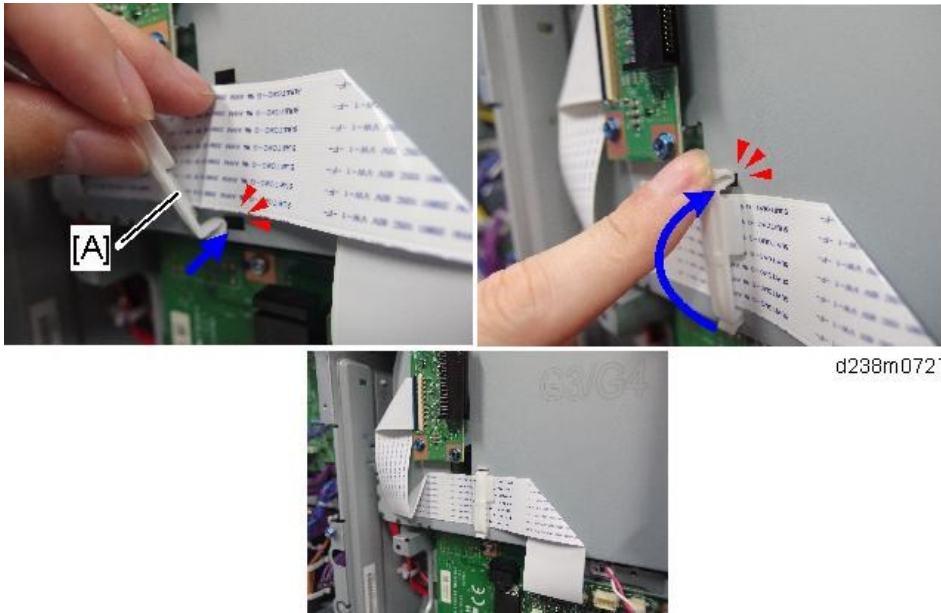

d238m0727

- 9.** Reinstall the controller box cover, rear cover and I/F cover.  
**10.** Make two loops with the telephone cord, and then attach the ferrite core [A].

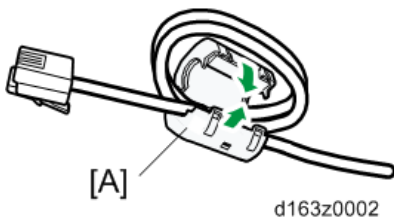

d163z0002

- 11.** Connect the telephone cord to the "LINE 2" jack.  
**12.** Attach the clamps [A] to the rear cover of the optional paper feed unit, and then hold the telephone line with the clamps as shown below.

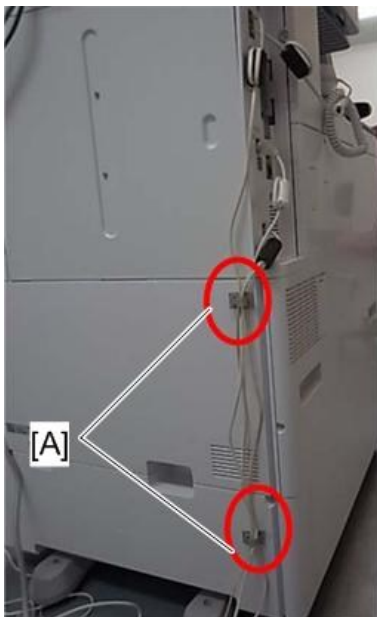

d163z0001

- 13.** Insert the power plug into the outlet. Turn ON the main power of the machine.

## 2. Installation

**14.** Enter the service mode. Set Bit 1 of Communication Switch 16 to "1" (SP1-104-023).

**15.** Exit the service mode.

**16.** Turn OFF then ON the main power.

**17.** Print out the system parameter list. Check that "G3" is displayed as an option.

**18.** Set up and program the items required for PSTN-2 communications.

### Double G3 Boards

---

#### Preparation

- If the Fax Option Type M20/M39 is not installed in the machine, install the Fax Option Type M20/M39 first (Fax Option Type M20 (D3BT-01, -02, -03) / Fax Option Type M39 (D0BH-01, -02)).

**1.** Remove the I/F cover [A].

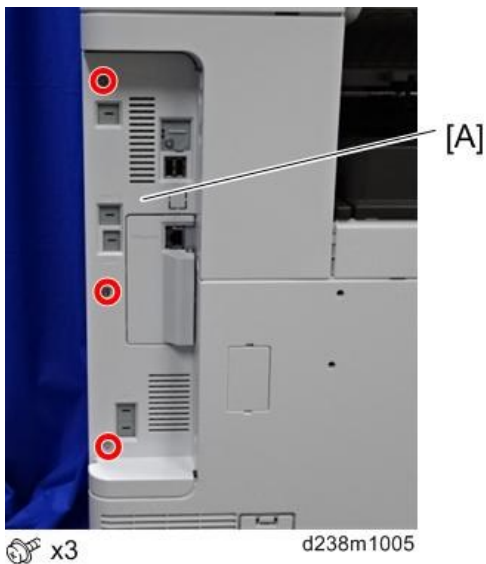

**2.** Remove the rear cover [A].

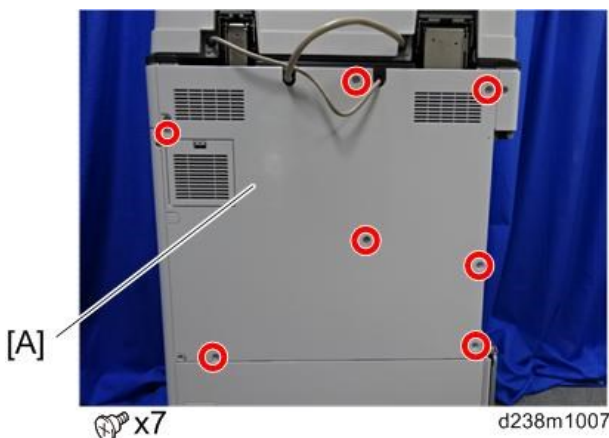

**3.** Remove the controller box cover [A].

Red circle: remove

Blue circle: loosen

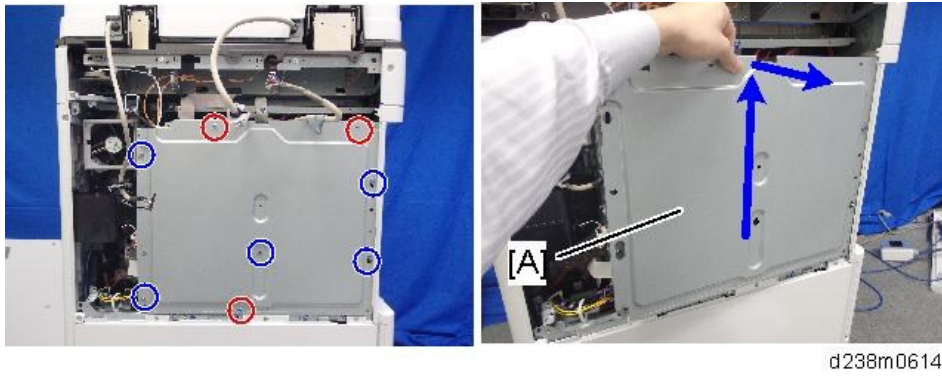

- 4.** Remove the "LINE2" [A] and "LINE3" [B] covers using a screwdriver.

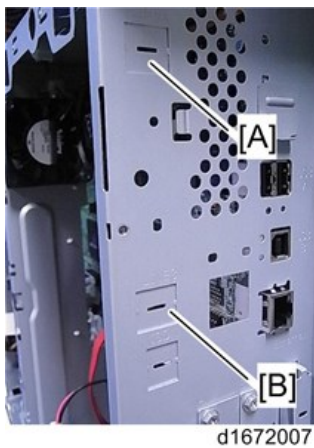

- 5.** Remove the CCU I/F board and SG3 board [A] from the SG3 interface unit. Repeat the same procedure for the second SG3 interface unit.

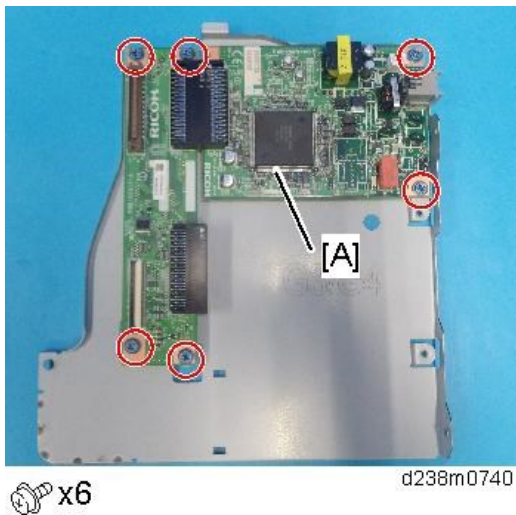

- 6.** Remove the SG3 board [A] from one of the CCU I/F and SG3 board assemblies removed in step 5.

## 2. Installation

**7.** Attach the SG3 board removed in step 6 to the other CCU I/F and SG3 board assembly [B].

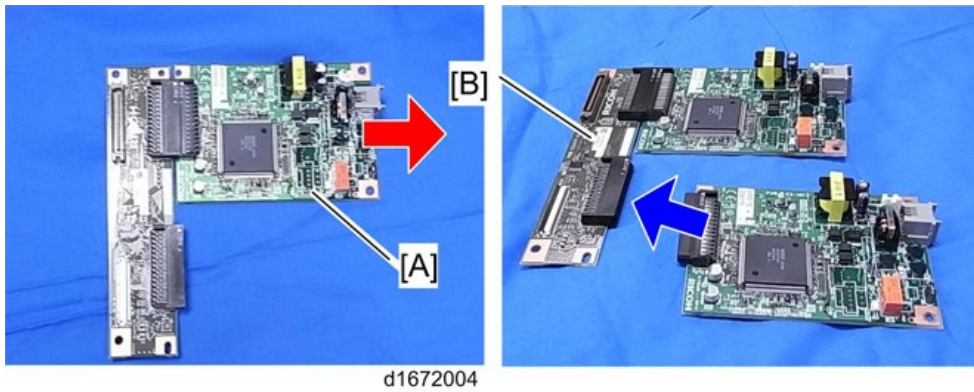

**8.** Attach the boards (CCU I/F board and two SG3 boards) to the SG3 interface unit bracket.

- Use two screws from the eight screws removed in step 5



**9.** Install the SG3 interface unit [A].

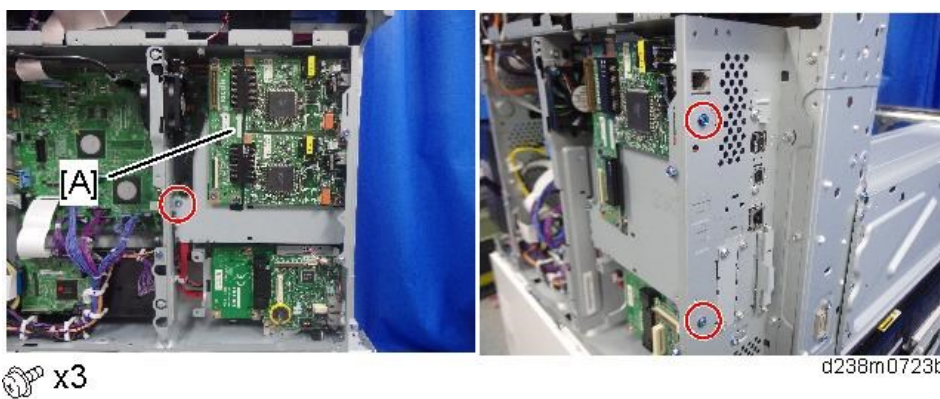

- Insert the tab [B] of the SG3 interface unit bracket in the cutout [C] on the top of the controller box.

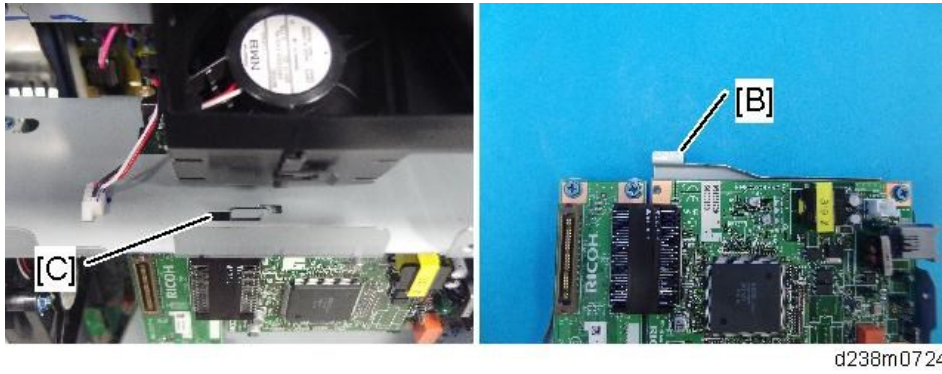

- Insert the tab [D] of the controller box in the cutout [E] of the SG3 interface unit.

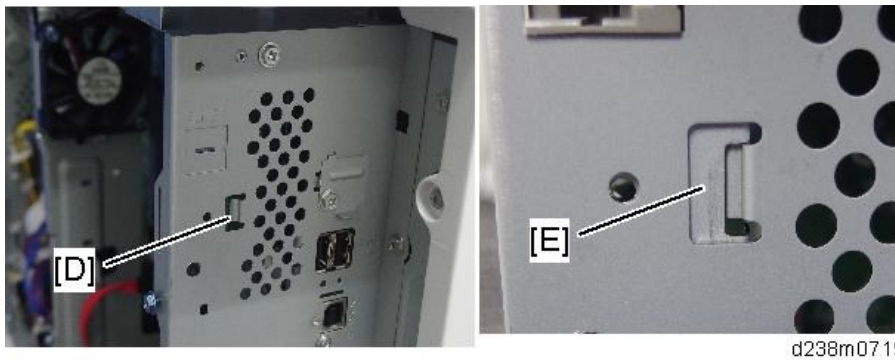

**10.** Connect the FFC [A] to the FCU.

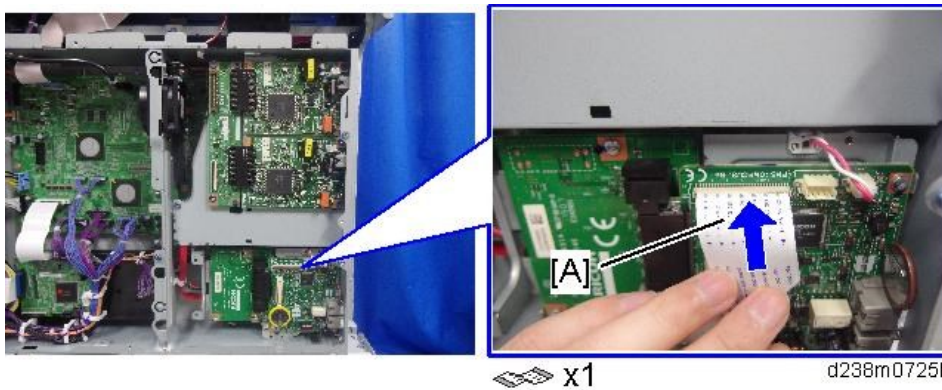

- Release the connector lock [B] and connect the FFC, and then lock the FFC.

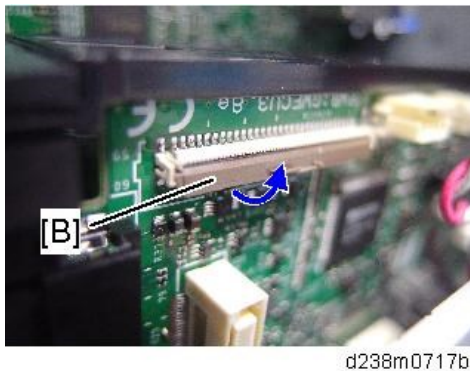

**11.** Attach the other end of the flat cable to the connector [A] on the CCU interface unit.

## 2. Installation

- Make sure that the blue tapes of the flat cable face outward.

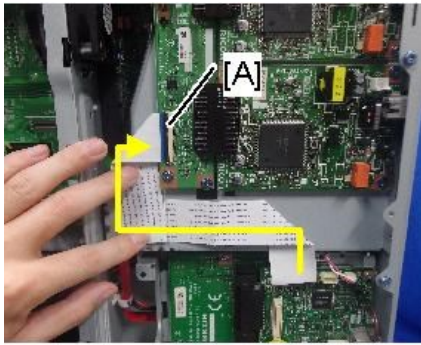

d238m0726b

- 12.** Attach the FFC Holder [A] to secure the FFC.

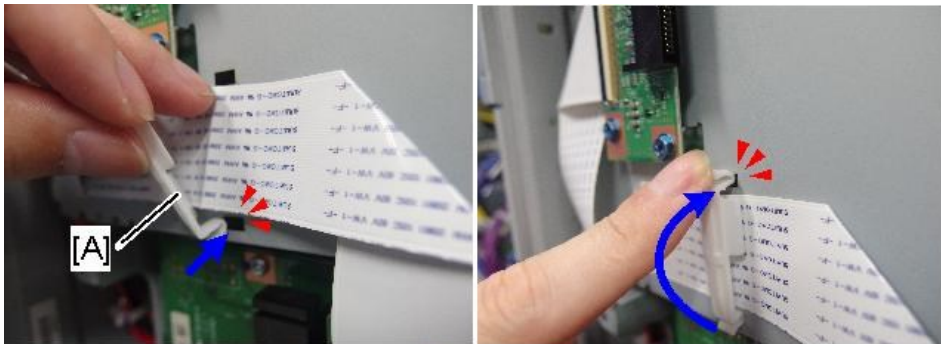

d238m0727



- 13.** Reinstall the controller box cover, rear cover and I/F cover.

- 14.** Make two loops with the telephone cord for each telephone line (LINE2, LINE3). Attach the ferrite core [A] to each telephone line.

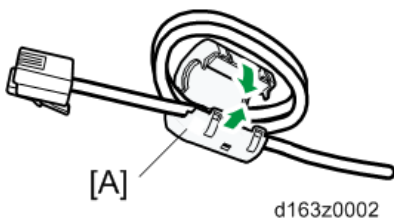

d163z0002

- 15.** Connect the telephone cords to the "LINE2" and "LINE3" jacks.

- 16.** Attach the clamps [A] to the rear cover of the optional paper feed unit, and then hold the telephone lines with the clamps as shown below.

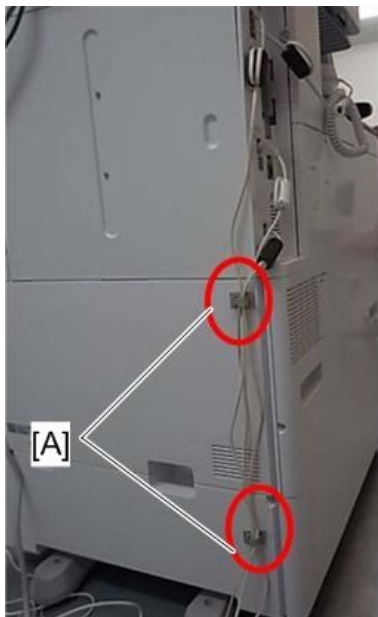

d163z0001

- 17.** Insert the power plug into the outlet. Turn ON the main power of the machine.
- 18.** Enter the service mode. Set Bit 1 of Communication Switch 16 to "1" (SP1-104-023).
- 19.** Set Bit 3 of Communication Switch 16 to "1" (SP1-104-023).
- 20.** Exit the service mode.
- 21.** Turn ON then OFF the main power.
- 22.** Print out the system parameter list. Check that "G3" is displayed as an option.
- 23.** Set up and program the items required for PSTN-2 communications.

---

### Notes for Connecting the Telephone Line

---

Checking the following before connecting the telephone line:

If a phone line dedicated to business phones is connected to the MFP, the fax board may be damaged. Make sure that the connecting phone line is for fax.

### Reasons why the Fax Board may be damaged

---

Business phones have various functions. To operate those functions, a high current is supplied to a business phone line. This may damage components on the Fax board.

## G3 Interface Unit Type M19 (D3BV-07, -08, -12)

This G3 interface unit option is for Fax Option Type M19.

### Accessory Check

Check the quantity and condition of the accessories against the following list.

No.	Description	Q'ty	Remarks
1	SG3 Interface Unit	1	
2	Telephone Cable	1	NA only
3	Ferrite Core	1	
4	FFC	1	
5	FFC Holder	1	
6	Screw: M3x6	3	
-	EMC Address Decal	1	EU only
-	FCC Decal	1	NA only

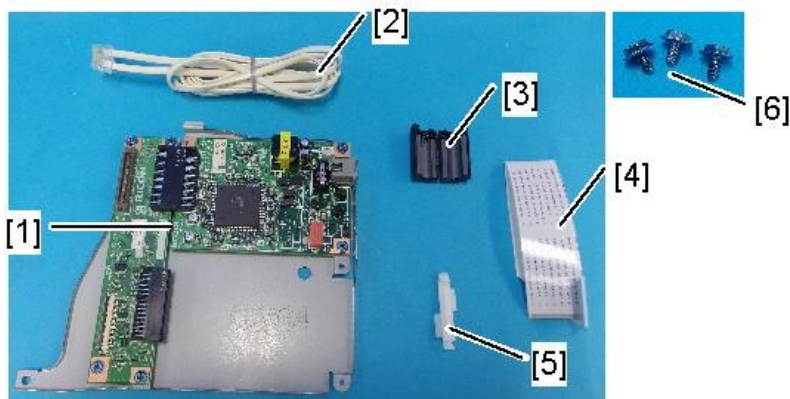

d238m0715

### Installation Procedure

#### **⚠ CAUTION**

- Before installing this fax unit, print out all data in the printer buffer. Turn the main power to OFF and disconnect the power cord and the network cable.

An additional two SG3 boards can be added for this model. Follow the procedures for installing a single SG3 board or double SG3 board as required.

#### Single G3 Board

##### **🔧 Preparation**

- If the Fax Option Type M19 is not installed in the machine, install the Fax Option Type M19 first ([Fax Option Type M19 \(D3BV-01, -02, -03\)](#)).



- 1.** Remove the I/F cover [A].

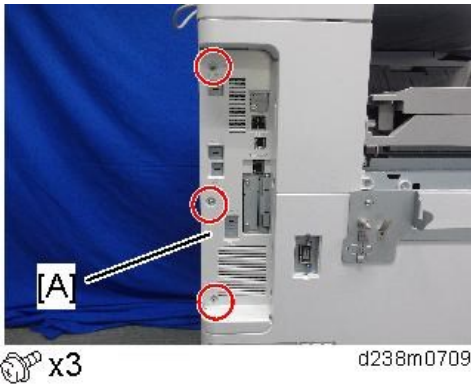

- 2.** Remove the rear cover [A].

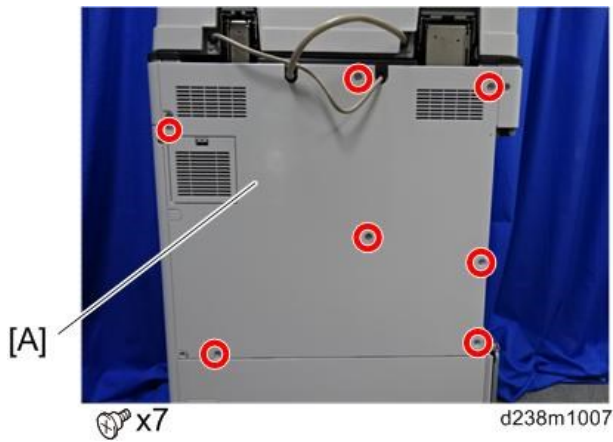

- 3.** Remove the controller box cover [A].

Red circle: remove

Blue circle: loosen

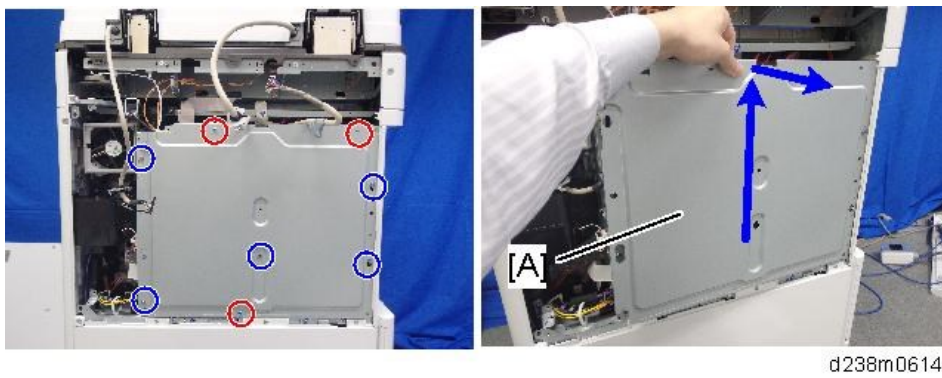

## 2. Installation

- 4.** Remove the "LINE2" [A] cover using a screwdriver.



- 5.** Connect the FFC [A] to the FCU.

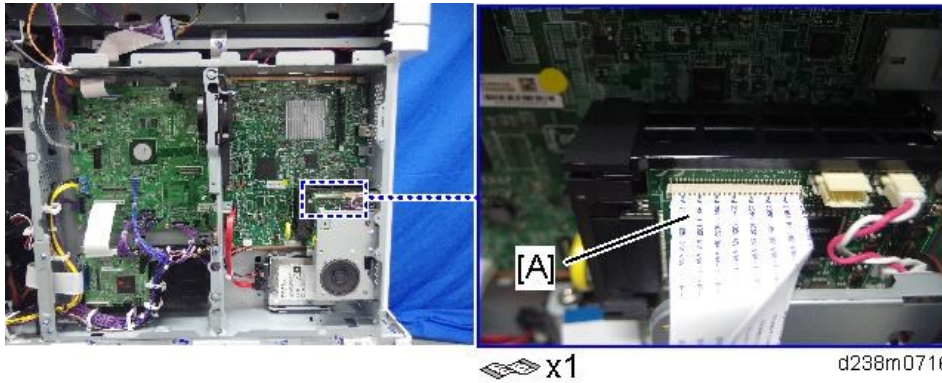

- Release the connector lock [B] and connect the FFC, and then lock the FFC.
- Connect the folded side [C] as shown below.

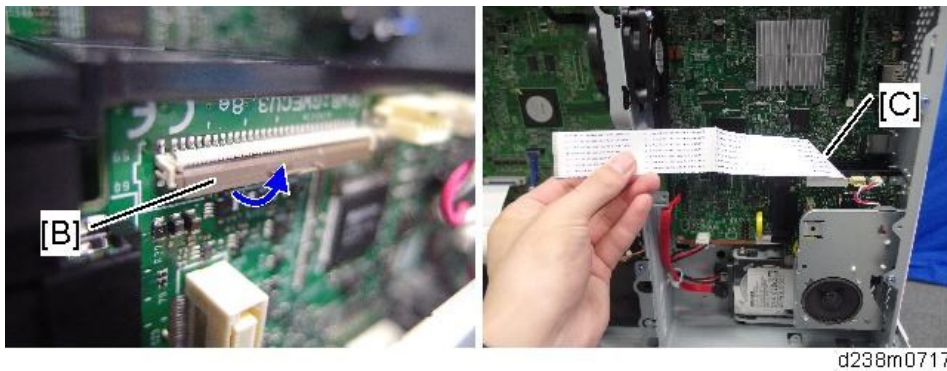

- 6.** Install the SG3 interface unit [A].

- Insert the tab [C] of the controller box into the cutout [B] of the SG3 interface unit.

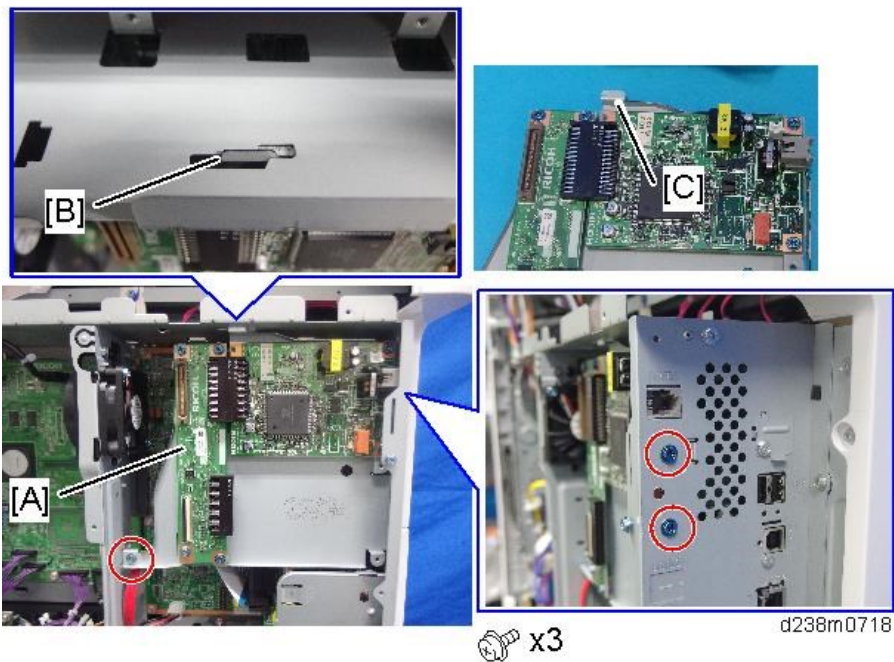

- Insert the tab [D] of the controller box into the cutout of the SG3 interface unit [E].

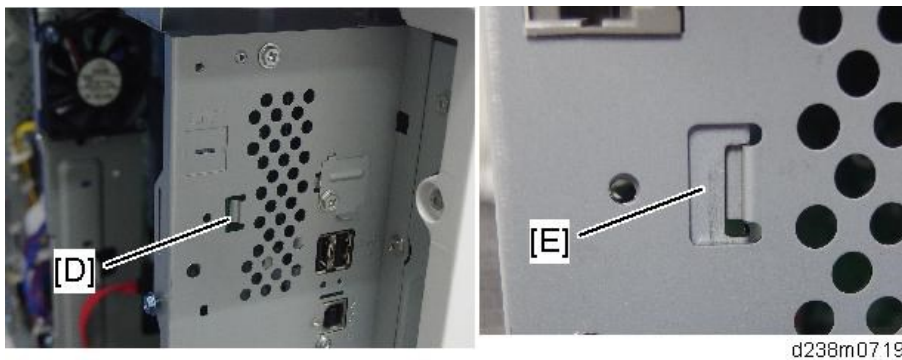

7. Take the FFC [A] out and connect the CCU interface board connector [B].

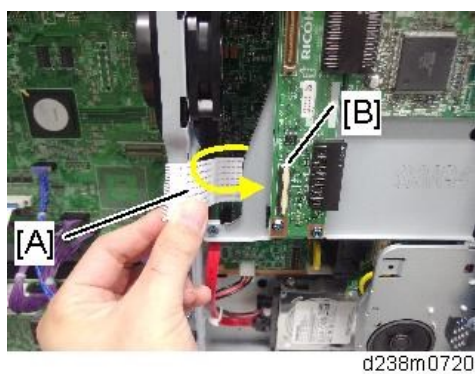

8. Secure the FFC [B] with the supplied clamp [A].  
Make sure that there is no FFC deflection.

## 2. Installation

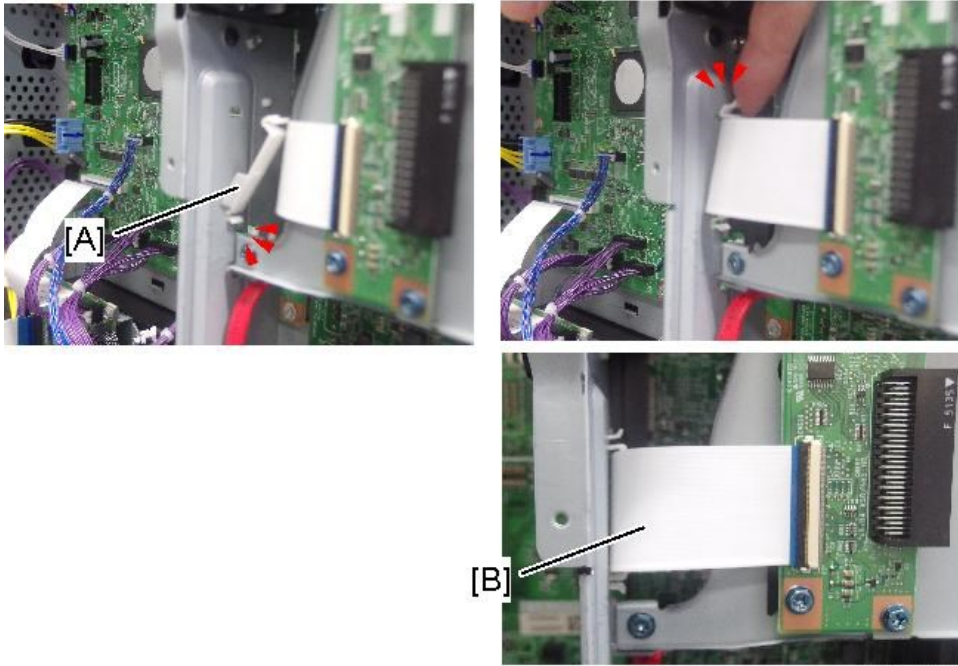

d238m0738

**9.** Reinstall the controller box cover, rear cover and I/F cover.

**10.** Make two loops with the telephone cord, and then attach the ferrite core [A].

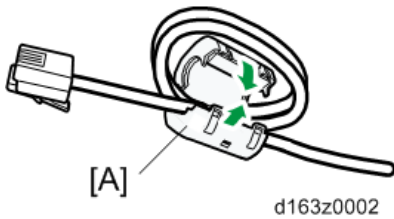

d163z0002

**11.** Connect the telephone cord to the "LINE 2" jack.

**12.** Attach the clamps [A] to the rear cover of the optional paper feed unit, and then hold the telephone line with the clamps as shown below.

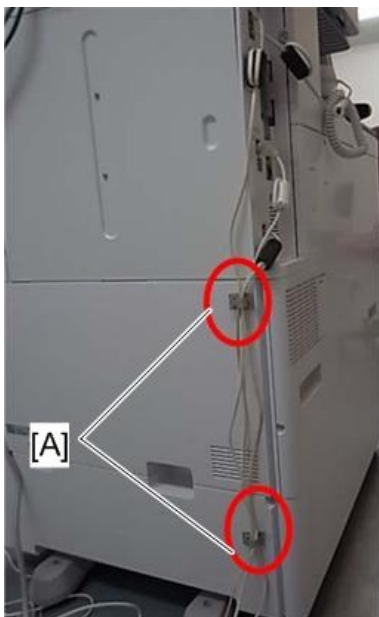

d163z0001

- 13.** Insert the power plug into the outlet. Turn ON the main power of the machine.
- 14.** Enter the service mode. Set Bit 1 of Communication Switch 16 to "1" (SP1-104-023).
- 15.** Exit the service mode.
- 16.** Turn OFF then ON the main power.
- 17.** Print out the system parameter list. Check that "G3" is displayed as an option.
- 18.** Set up and program the items required for PSTN-2 communications.

### Double G3 Boards

---

#### Preparation

- If the Fax Option Type M19 is not installed in the machine, install the Fax Option Type M19 first. (Fax Option Type M19 (D3BV-01, -02, -03))

- 1.** Remove the I/F cover [A].

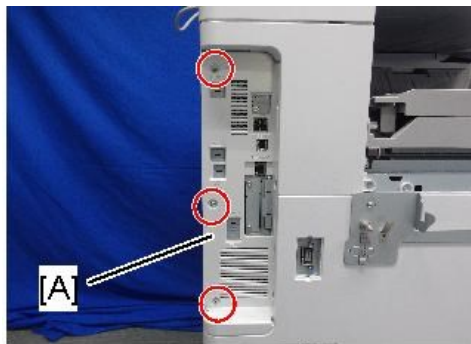

 x3

d238m0709

- 2.** Remove the rear cover [A].

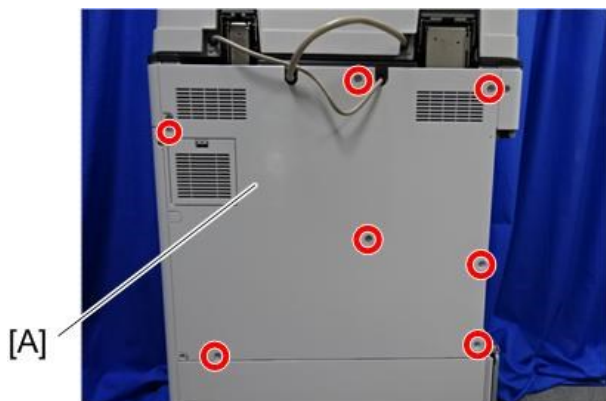

 x7

d238m1007

- 3.** Remove the controller box cover [A].

Red circle: remove

Blue circle: loosen

## 2. Installation

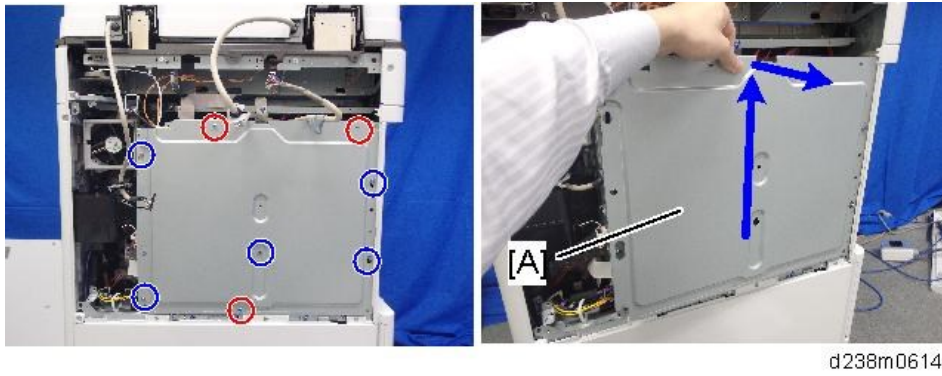

- 4.** Remove the "LINE2" [A] and "LINE3" [B] covers using a screwdriver.

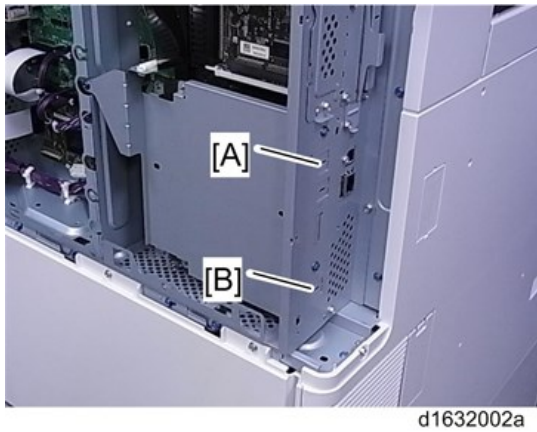

- 5.** Remove the CCU I/F board and SG3 board [A] from the SG3 interface unit. Repeat the same procedure for the second SG3 interface unit.

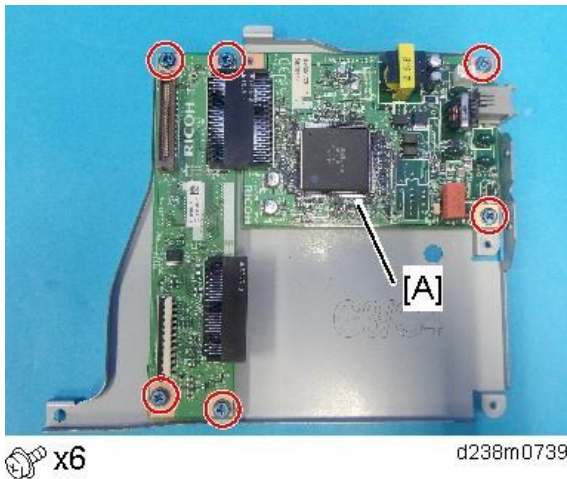

- 6.** Remove the SG3 board [A] from one of the CCU I/F and SG3 board assemblies removed in step 5.

**7.** Attach the SG3 board removed in step 6 to the other CCU I/F and SG3 board assembly [B].

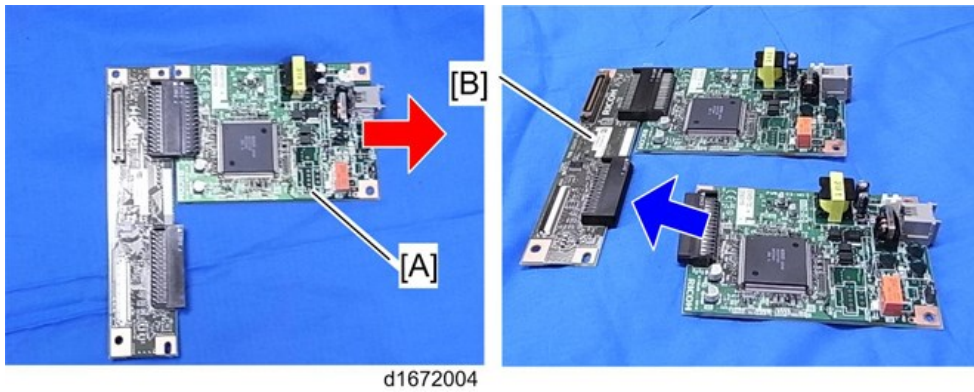

**8.** Attach the boards (CCU I/F board and two SG3 boards) to the SG3 interface unit bracket.

- Use two screws from the six screws removed in step 5.

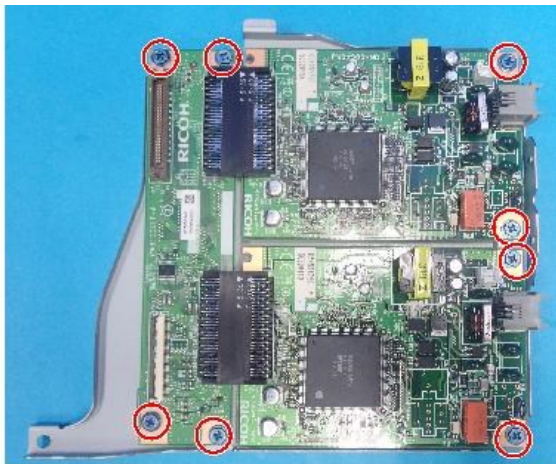

 x8

**9.** Connect the FFC [A] to the FCU.

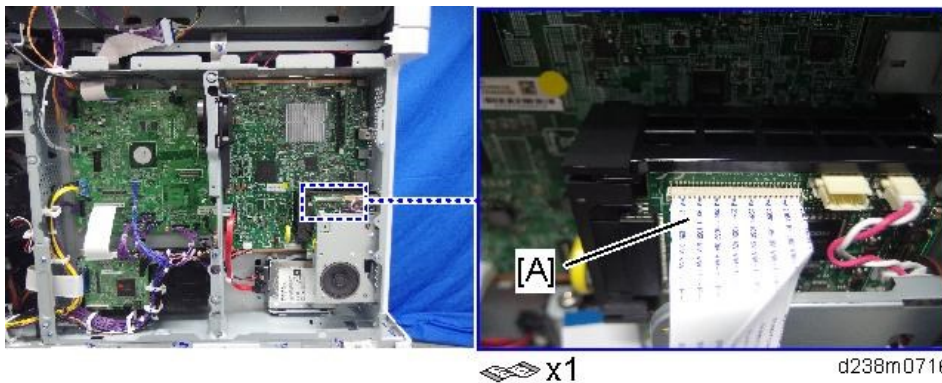

 x1

- Release the connector lock [B] and connect the FFC, and then lock the FFC.

## 2. Installation

- Connect the folded side [C] as shown below.

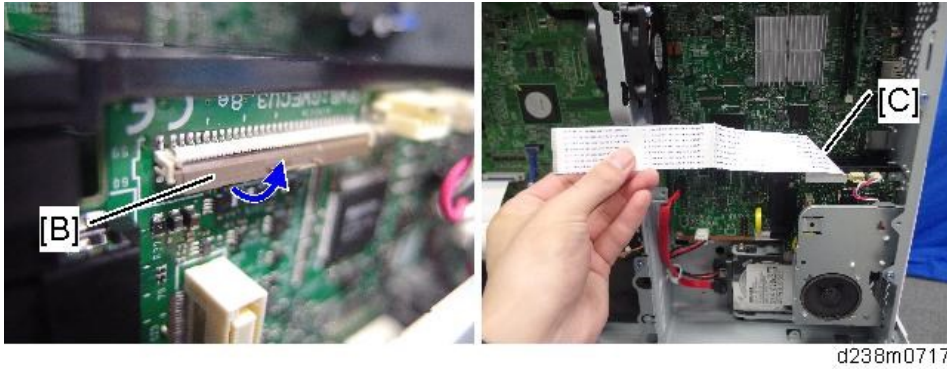

### 10. Install the SG3 interface unit [A].

- Insert the tab [C] of the controller box into the cutout [B] of the SG3 interface unit.

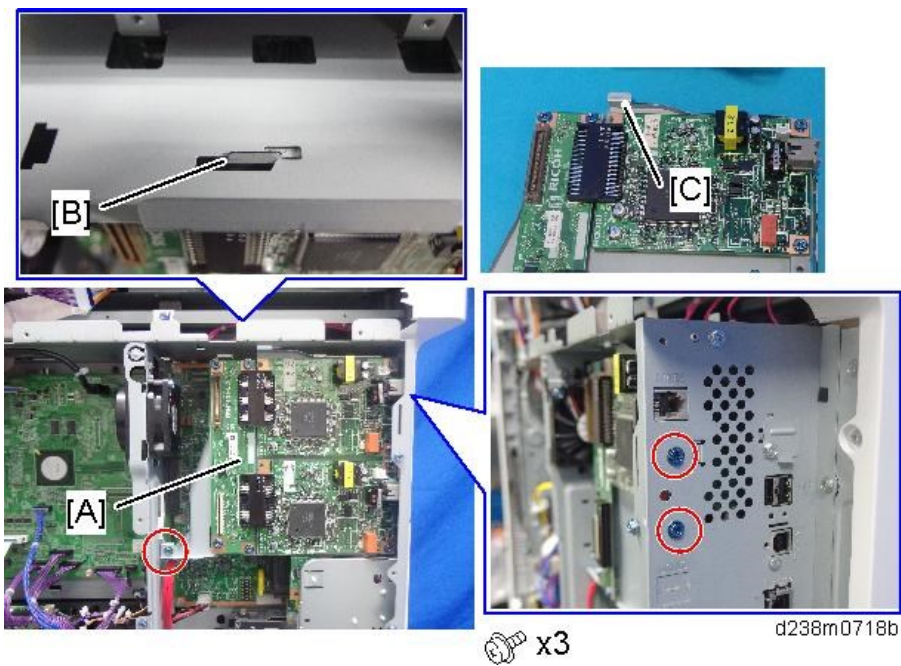

 x3

- Insert the tab [D] of the controller box into the cutout of the SG3 interface unit [E].

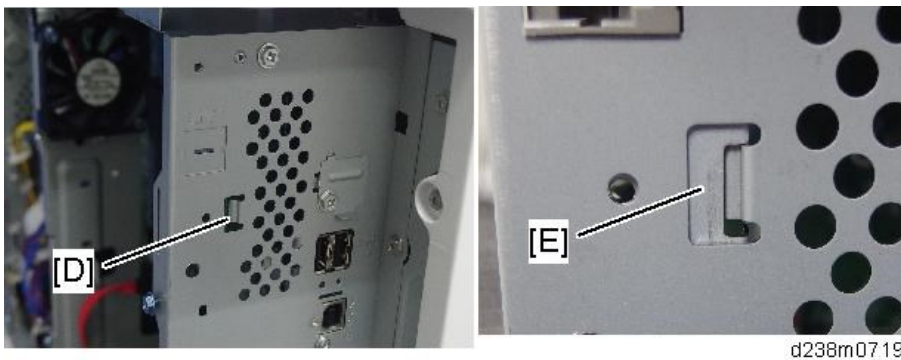



- 11.** Take the FFC [A] out and connect the CCU interface board connector [B].

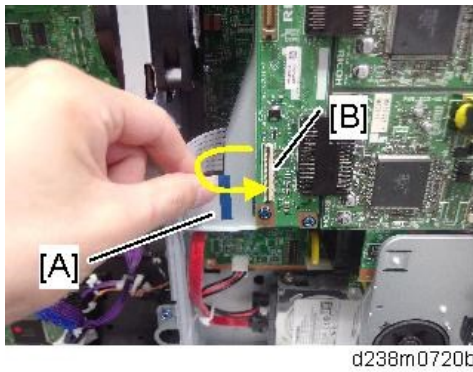

- 12.** Secure the FFC [B] with a supplied clamp [A].  
Make sure that there is no FFC deflection.

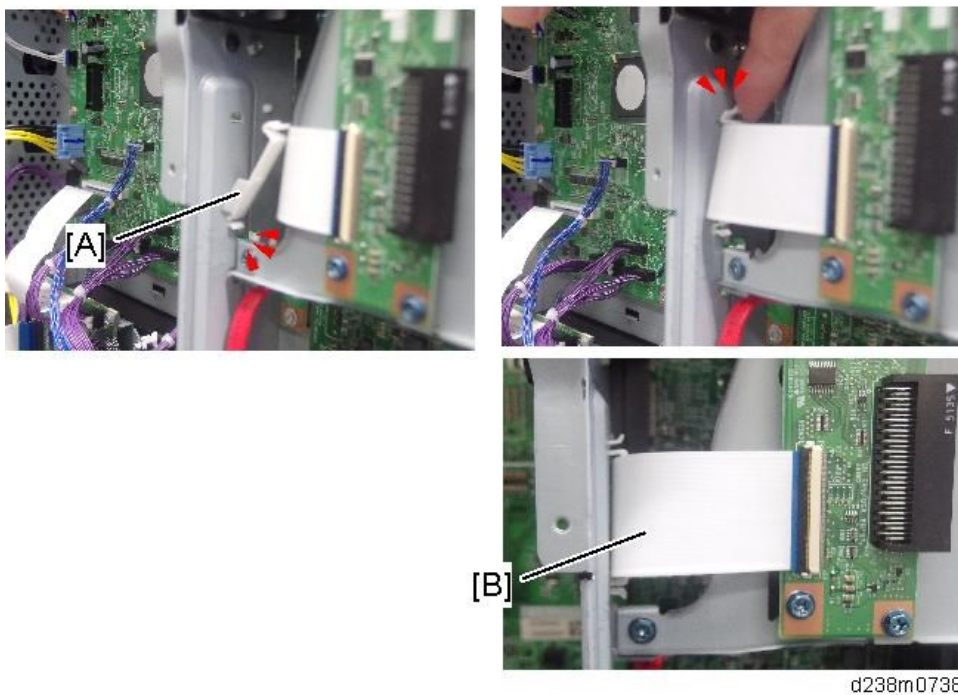

- 13.** Reinstall the controller box cover, rear cover and I/F cover.  
**14.** Make two loops with the telephone cord for each telephone line (LINE2, LINE3). Attach the ferrite core [A] to each telephone line.

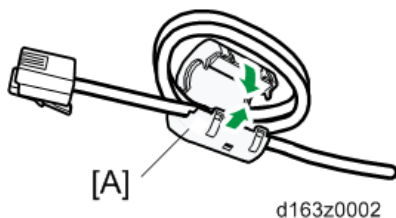

- 15.** Connect the telephone cords to the "LINE2" and "LINE3" jacks.

## 2. Installation

- 16.** Attach the clamps [A] to the rear cover of the optional paper feed unit, and then hold the telephone lines with the clamps as shown below.

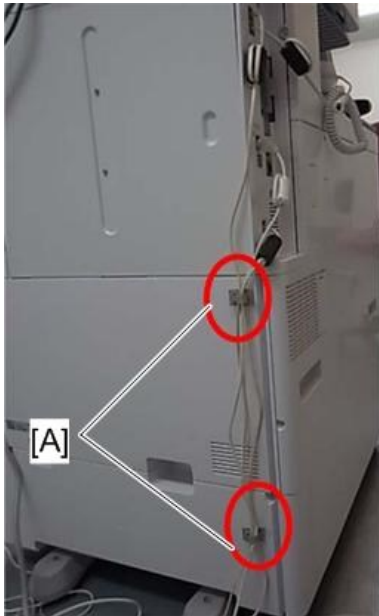

d163z0001

- 17.** Insert the power plug into the outlet. Turn ON the main power of the machine.
- 18.** Enter the service mode. Set Bit 1 of Communication Switch 16 to "1" (SP1-104-023).
- 19.** Set Bit 3 of Communication Switch 16 to "1" (SP1-104-023).
- 20.** Exit the service mode.
- 21.** Turn ON then OFF the main power.
- 22.** Print out the system parameter list. Check that "G3" is displayed as an option.
- 23.** Set up and program the items required for PSTN-2 communications.

---

### Notes for Connecting the Telephone Line

---

Checking the following before connecting the telephone line:

If a phone line dedicated to business phones is connected to the MFP, the fax board may be damaged. Make sure that the connecting phone line is for fax.

#### Reasons why the Fax Board may be damaged

---

Business phones have various functions. To operate those functions, a high current is supplied to a business phone line. This may damage components on the Fax board.

## Fax Unit Options

### Fax Memory Unit Type M19 64MB (D3BZ)

#### Accessory Check

Check the quantity and condition of the accessories against the following list.

No.	Description	Q'ty	Remarks
1	Bracket	1	For MP C4504/C5504/C6004 and MP C501SP
2	Memory unit	1	
3	Screws M3x6	2	For MP C4504/C5504/C6004 and MP C501SP
4	Screws	1	For MP C4504/C5504/C6004 and MP C501SP
5	Clamp	1	For MP C3004/C3504

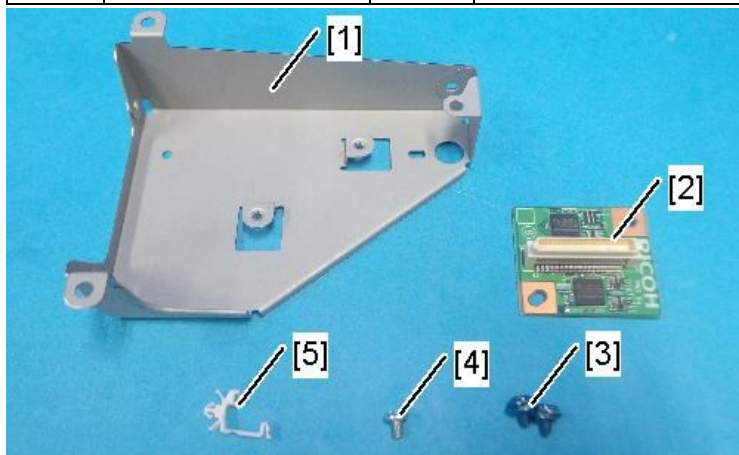

d238m0729

For MP C4504/C5504/C6004 and MP C501SP models

1. Attach the memory unit [A] to the bracket [B].

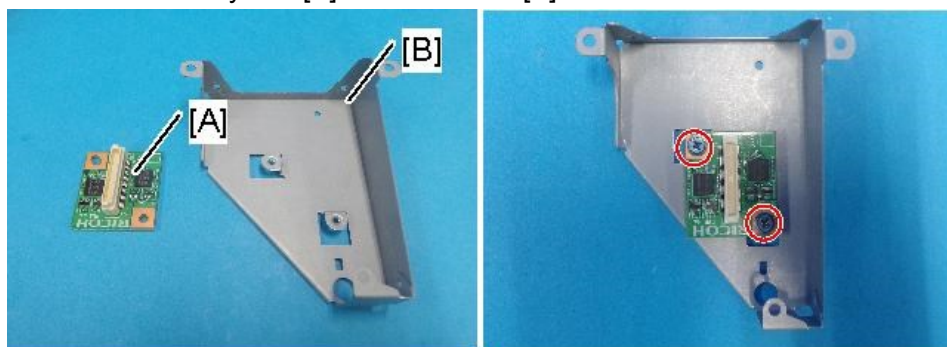

 x2

d238m0730

## 2. Installation

### 2. Remove the I/F cover [A].

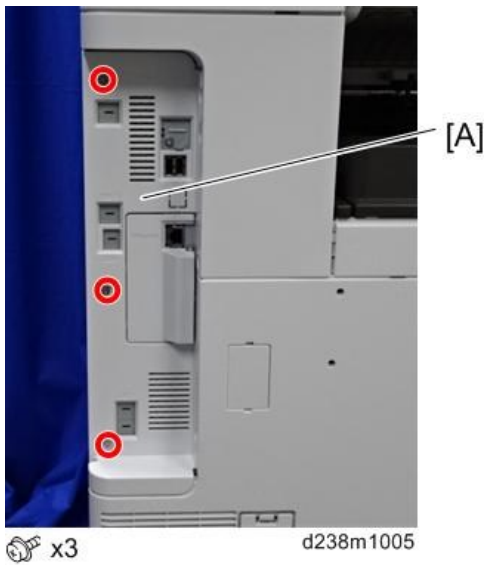

### 3. Remove the rear cover [A].

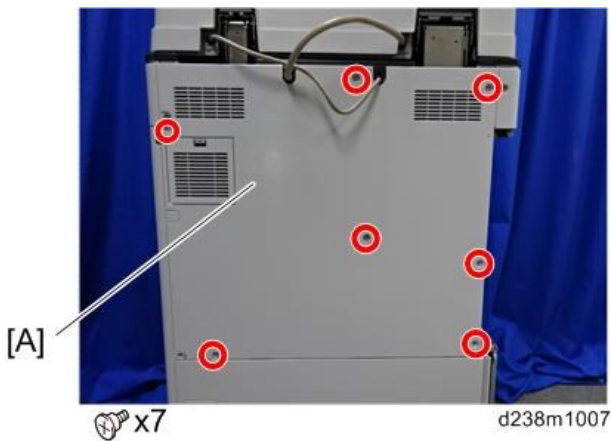

### 4. Remove the controller box cover [A].

Red circle: remove

Blue circle: loosen

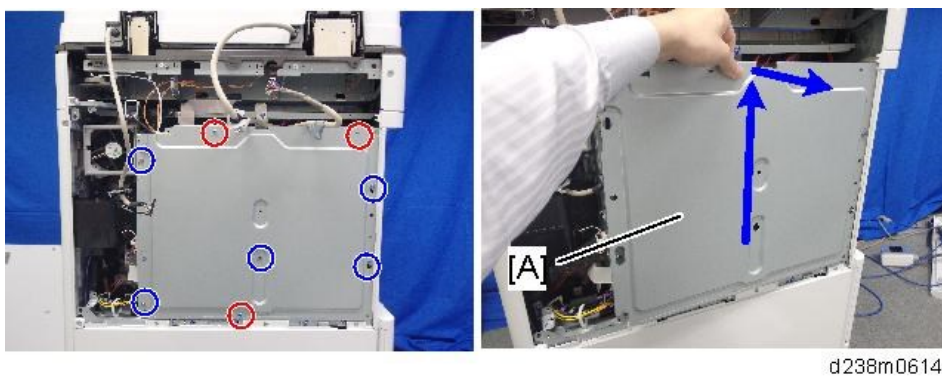

- 5.** To attach the memory unit [A], remove the two screws of the FCU.

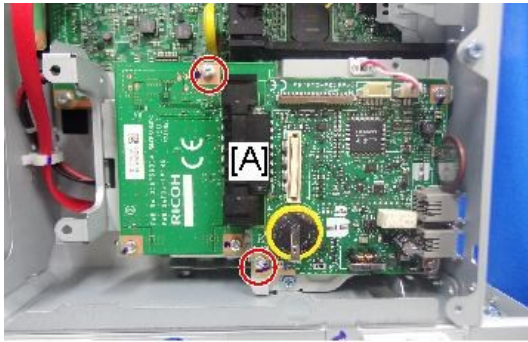

 x2

d238m0731

- 6.** Connect the memory unit connector [A] to the FCU [B].

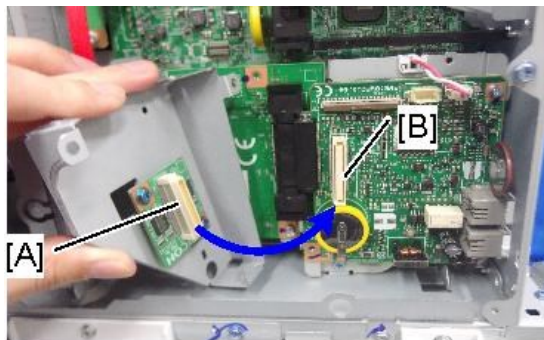

d238m0732

- 7.** Secure the bracket [A].

Red circle: Use screws removed in the previous step.

Blue circle: Use supplied screws.

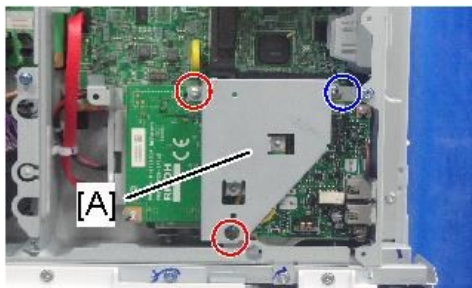

 x3

d238m0733

## 2. Installation

### 8. Re-assemble the machine.

#### Note

- To install the G3 interface unit with this option, install the FFC before attaching the bracket. Otherwise, the bracket blocks the FFC connector [A].

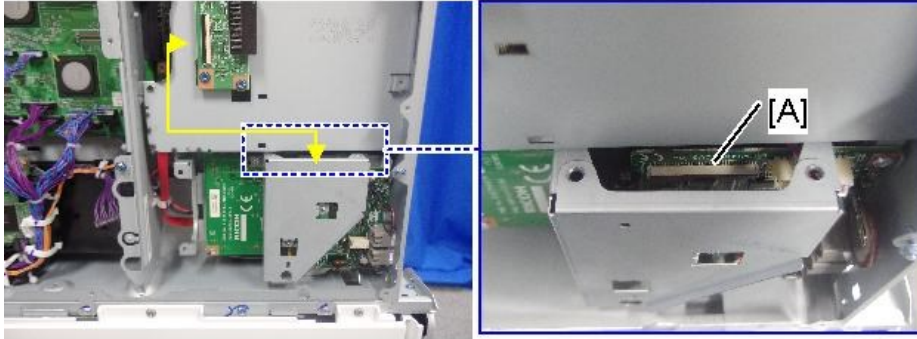

d238m0734

For MP C3004/C3504 models

### 1. Remove the fax option unit [A] (Fax Option Type M19 (D3BV-01, -02, -03)).

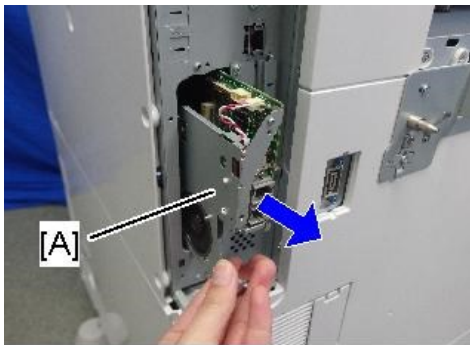

d238m0713b

### 2. Separate the shield [A], FCU [B], and speaker bracket [C].

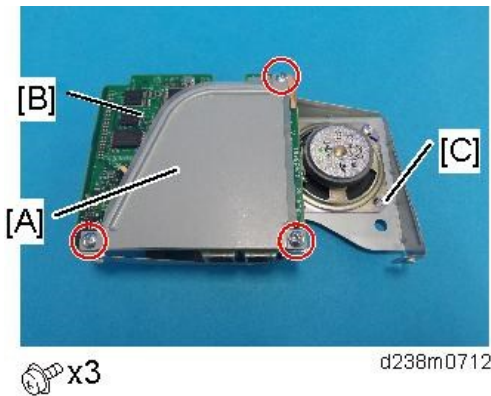

d238m0712

- 3.** Attach the supplied clamp [B] to the speaker Bracket [A].

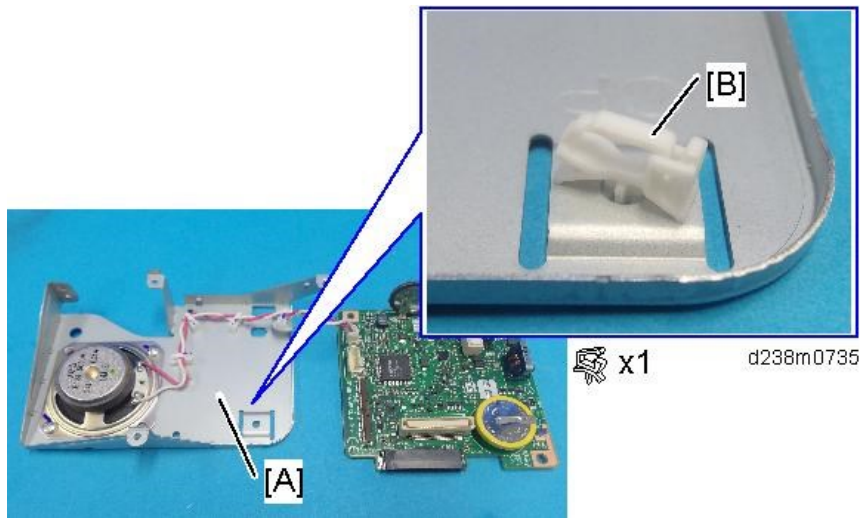

- 4.** Attach the memory unit [B] to the FCU connector [A]

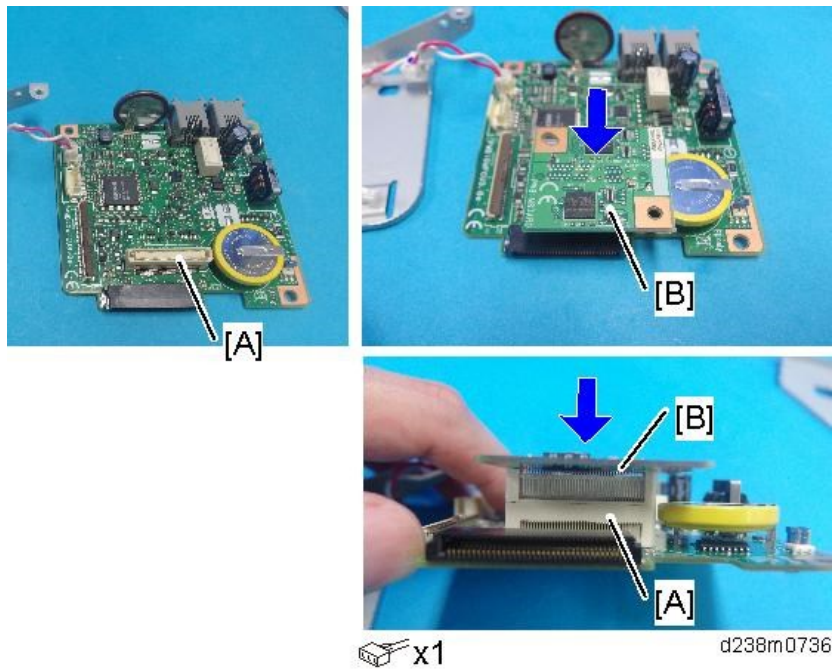

- 5.** Re-assemble the shield [A], FCU [B], and speaker bracket [C].

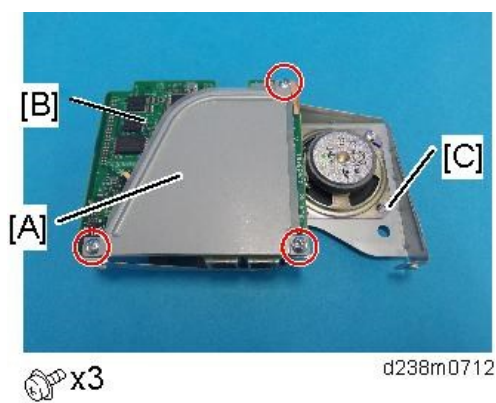

## 2. Installation

### Note

- Make sure that the clamp [B] is pressing the memory unit [A] and holding it in place.

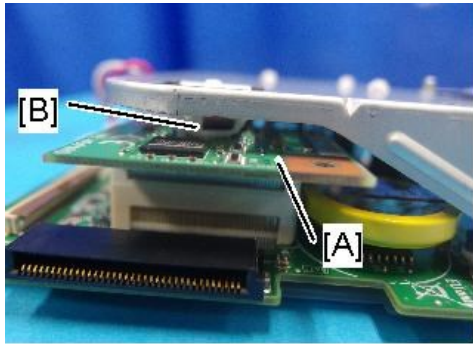

d238m0737

6. Reinstall the FCU in the interface slot.
7. Re-assemble the machine.

---

## Handset HS3020 (D739)

---

The optional handset is available for NA only.

1. Remove the scanner front cover [A] (🔧 x2).



d1462302

2. Remove the scanner left cover [A] (🔧 x 3).

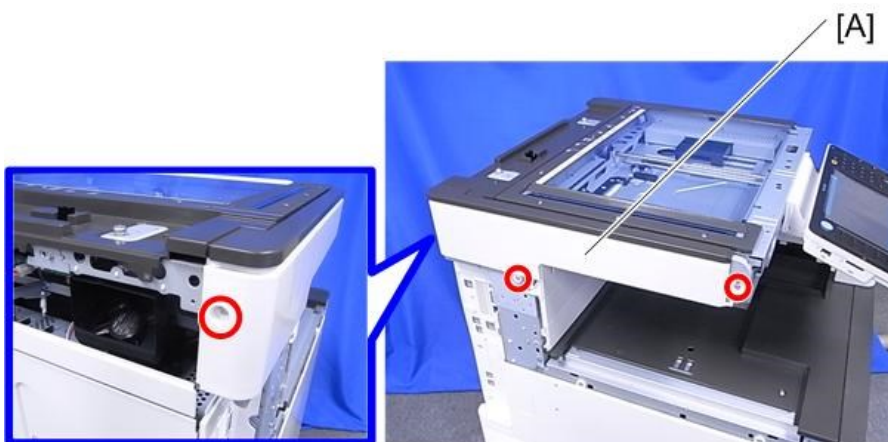

d1462303



- 3.** Make two holes in the scanner left cover.

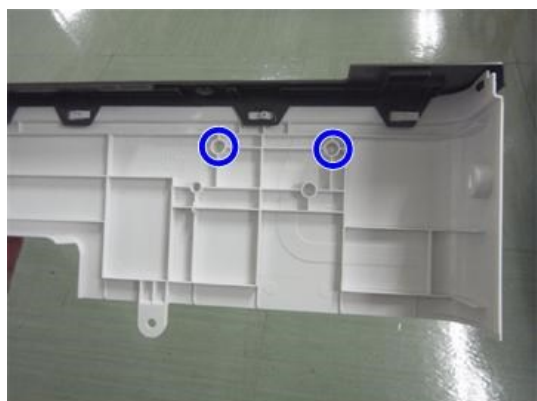

d1463050

- 4.** Reattach the scanner left cover (Ⓜ x 3).

- 5.** Re-assemble the machine.

- 6.** Attach the bracket [A] enclosed with the fax unit (Ⓜ x 2: M3 x 12) as shown.

For machines with the single pass ADF, the bracket can be attached slanted using the hole [B].

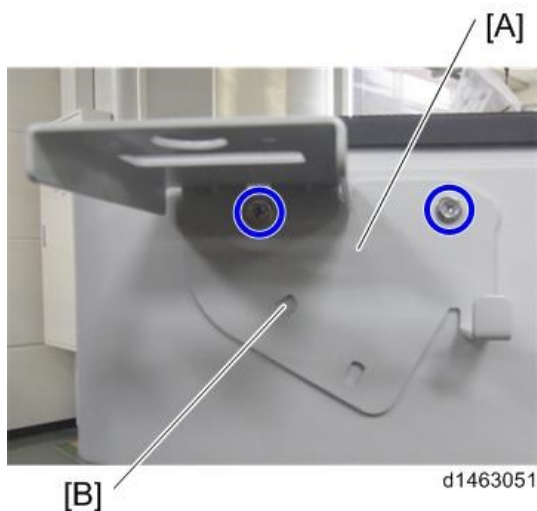

d1463051

- 7.** Attach the cradle [A] to the handset bracket (Ⓜ x 2).



d1463052

## 2. Installation

- 8.** Make two loops with the telephone cord, and then attach the ferrite core [A] to the cable.



- 9.** Connect the cable to the "TEL" jack on the left side of the controller box.

## Fax Connection Unit

Fax Connection Unit Type M19 (D3BD-01, -02, -03) is for MP C3004/C3504

Fax Connection Unit Type M20 (D3BC-01, -02, -03) is for MP C4504/C5504/C6004 and MP C501SP

---

### Accessory Check

---

Check the quantity and condition of the accessories against the following list.

No.	Description	Q'ty	Remarks
1	Fax Connection Unit SD card	1	

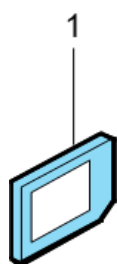

d595i900b

---

### Installation Procedure

---

This unit allows a machine without the fax unit installed (client machine) to send and receive faxes via a machine with the fax unit installed (remote machine).

#### Requirements

- Up to six machines can be registered as the client machines.
- Machines that already have a fax unit installed cannot be used as client machines.
- Only one machine can be registered as the remote machine.
- Firmware for this unit: "aics" (software number: D1655759 for Type M3/ D1665759 for Type M4)
- Remote Fax transmission is possible using a G3 line.
- The Remote Fax function does not support User Code Authentication. Disable the User Code Authentication on the remote machine.
- Use this function to check the contents of a file that is stored in memory and not yet sent. Also, use this function to cancel a transmission from the client machine.

#### Order of installation

---

1. Install the Fax Connection Unit in the remote machine (fax unit already installed).
2. Install the Fax Connection Unit in the client machine (no fax unit is installed).
3. Register the client machine on the remote machine.

#### ★ Important

- Do not register the remote machine before the client machine is registered on the remote machine. Otherwise, the remote machine cannot be registered.

## 2. Installation

### 4. Register the remote machine in the client machine.

#### Installing the fax connection unit

---

##### ↓ Note

- Before starting this procedure, connect the network cable to the target machine(s), and then configure the network settings.
- When installing more than one SD card, perform the merge operation. For details about how to merge, refer to “Card Appli Move” in the field service manual for the main frame.

#### 1. Remove the SD card slot covers [A] [B].

##### MP C4504/C5504/C6004 and MP C501SP



##### MP C3004/3504:

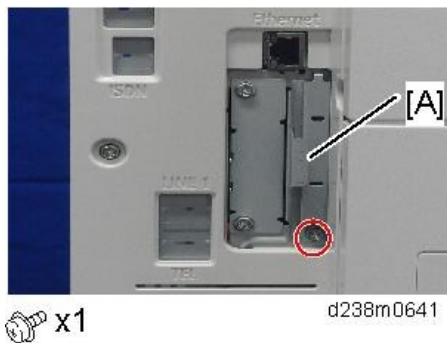

#### 2. Insert the Fax Connection Unit SD card into SD card slot 1 [A: Upper Slot].

- Type M19 is for MP C3004/3504.
- Type M20 is for MP C4504/C5504/C6004 and MP C501SP.

**MP C4504/C5504/C6004 and MP C501SP:**

d238m0639

**MP C3004/3504:**

d238m0640

- 3.** Reattach the SD-card slot cover (🔩 x 1).
- 4.** Turn ON the main power.
- 5.** Make sure that the machine can recognize the option (See 'Self-Diagnosis Report' and check whether the aics (D1655759 for Type M3/ D1665759 for Type M4) is listed in [Loading Program].)

---

 Registering the client machine(s)
 

---

**Note**

- Before starting this procedure, connect the network cable to the target machine(s), and then configure the network settings.

- 1.** On the remote machine, press the [User Tools/Counter] key on the operation panel.
- 2.** Press [System Settings].
- 3.** Press [Administrator Tools].
- 4.** Press [Program/Change/Delete Remote machine].
- 5.** Enter the IP address or host name of the client machines.

**Note**

- Up to six machines can be registered as the client machines.

- 6.** Press [OK] to set after "connection test".
- 7.** Press the [User Tools/Counter] key on the operation panel to terminate System Settings.

---

 Registering the remote machine
 

---

**Note**

- Only one machine can be registered as the remote machine.

## 2. Installation

- Before starting this procedure, connect the network cable to the target machine(s), and then configure the network settings.

- 1.** On the client machine, press the [User Tools/Counter] key on the operation panel
- 2.** Press [System Settings].
- 3.** Press [Administrator Tools].
- 4.** Press [Program/Change/Delete Remote machine].
- 5.** Enter the IP address or host name of the remote machine.
- 6.** Press [OK] to set after "connection test".
- 7.** Press [Exit].

### Configuring the Remote Reception Settings

---

Perform the following procedure to enable the client machine(s) to receive faxes via the remote machine. You can forward or route received documents per line or to a specific sender.

#### Note

- Before starting this procedure, connect the network cable to the target machine(s), and then configure the network settings.
- By performing procedures #1-3 above, the client machines can send faxes via the remote machine. The procedures shown below are necessary to enable the client machines to receive faxes.

**This procedure is performed on the remote machine.**

#### Using "Remote Reception Setting per Line"

- 1.** Press [Facsimile Features].
- 2.** Press [Remote Reception Setting per Line] in [Reception Settings].
- 3.** Enter an IP address or a host name of the client-side machine to connect.
- 4.** Press [Set], and [Exit] to exit from the setting.

#### Using "Remote Reception per Sender"

- 1.** Press [Facsimile Features].
- 2.** Press [Program Special Sender] in [Reception Settings].

**3.** Select the Special Sender.

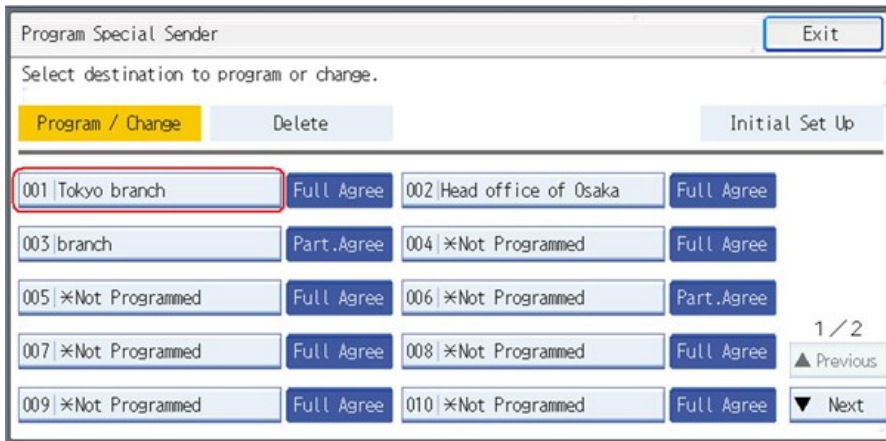

d1661001

**4.** Press [Remote Reception Setting per Sender].

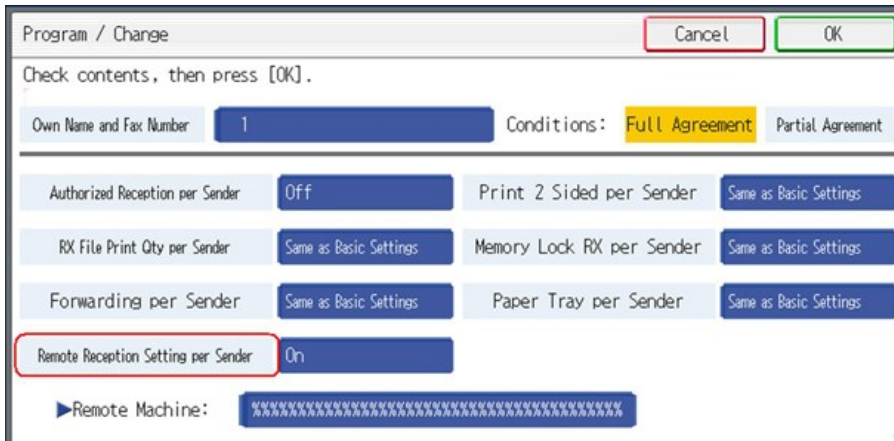

d1661002

**5.** Press [On] and [Remote machine].

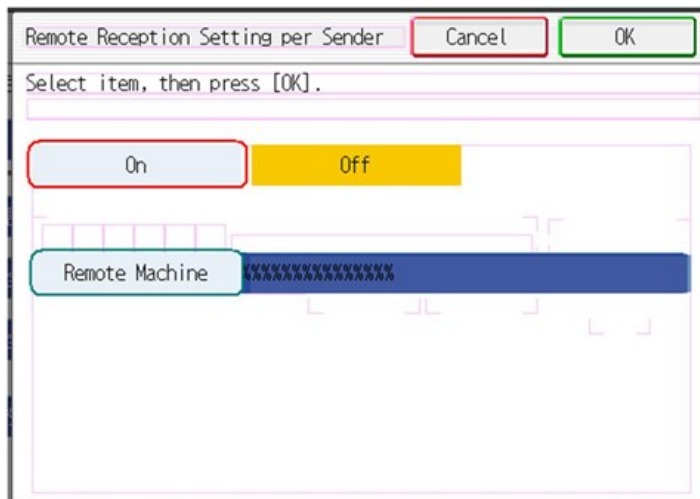

d1661003

**6.** Enter an IP address or a host name of the client machine to connect.

**7.** Press [OK] to exit from the setting.

## 3. Replacement and Adjustment

### FCU

#### ⚠ CAUTION

- When removing the FFC, lift the lever [A] to release the lock.

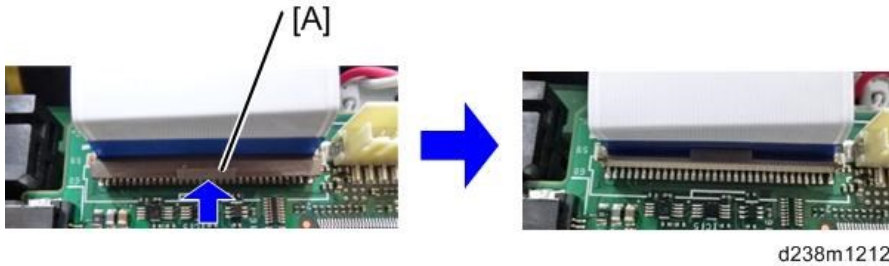

### SRAM Data Transfer Procedure

When you replace the FCU board, transfer the SRAM data from the old FCU board to the new FCU board. Do the following procedure to back up the SRAM data.

#### ⓘ Note

- The following data can be transferred: TTI, RTI, CSI, Fax bit switch settings, RAM address settings, NCU parameter settings.

For MP C4504/5504/6004 and MP C501SP models

1. Remove the controller cover [A].

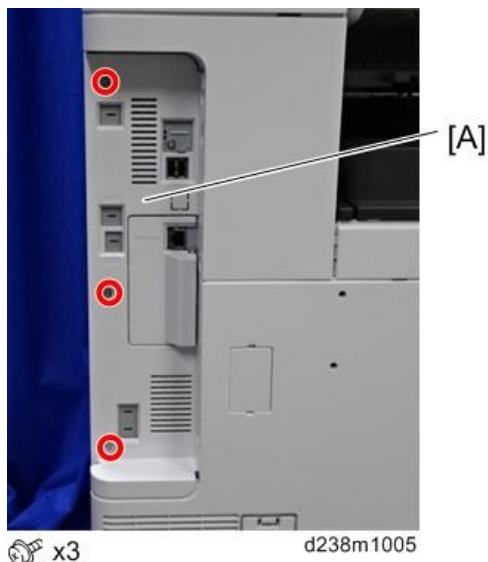



2. Remove the rear cover [A].

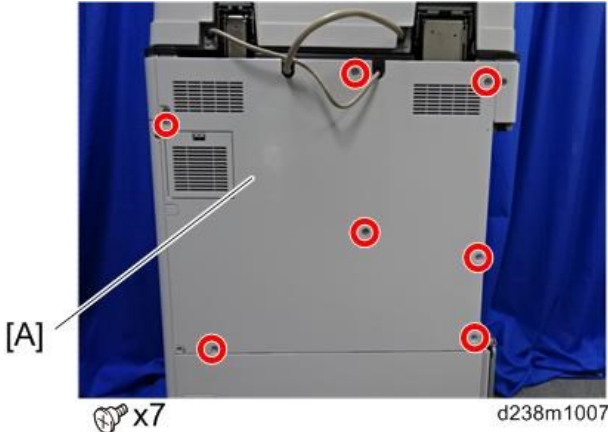

3. Remove the controller box cover [A].

Red circle: remove  
Blue circle: loosen

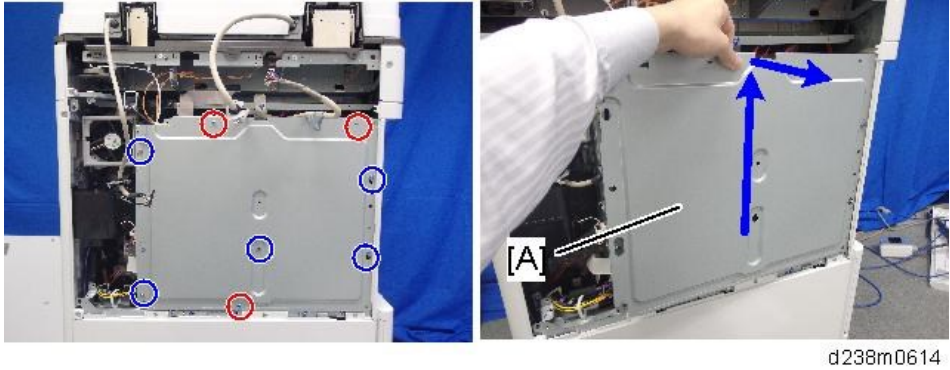

4. Disconnect the FFC [A] if connected.

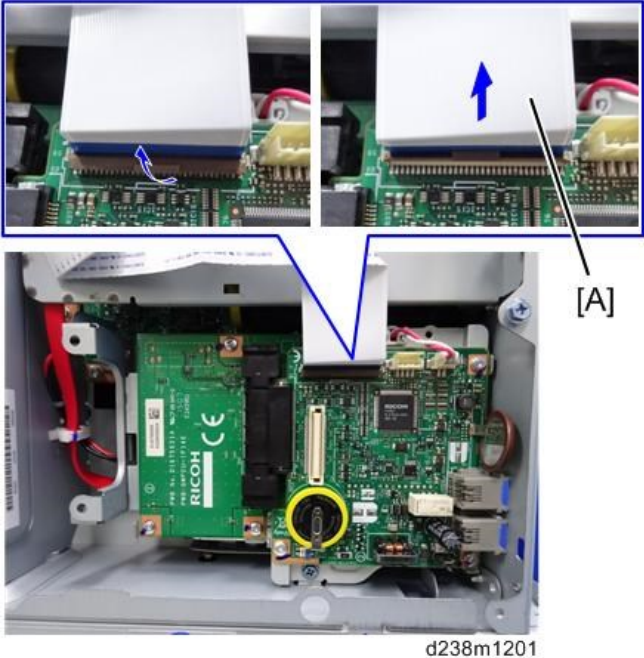

### 3.Replacement and Adjustment

5. Remove the FCU board [A].

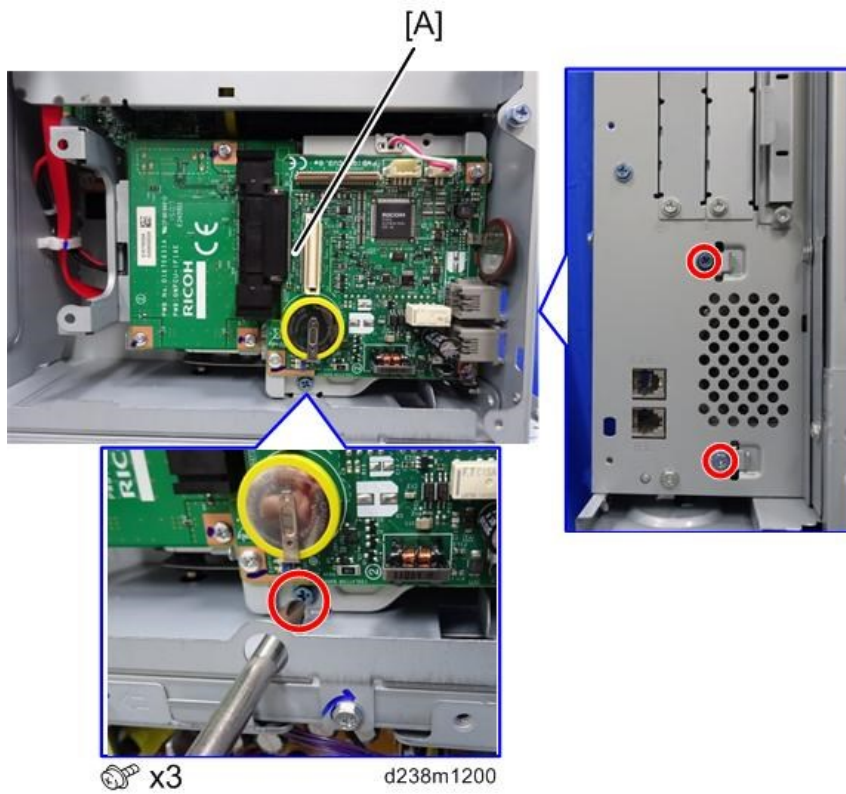

6. Change the orientation of the battery jumper switch [A] on the removed FCU board, and then attach the battery jumper switch [B] on the FCU board to switch to the Restore mode. The battery jumper switch [B] is supplied with the new FCU board.

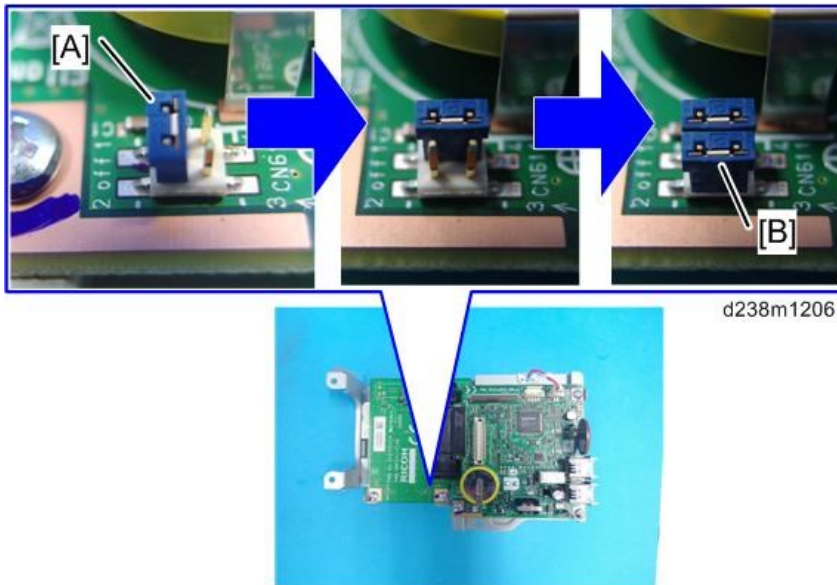

- 7.** Switch the battery jumper switch [A] of the new fax unit to the "ON" position before installing.

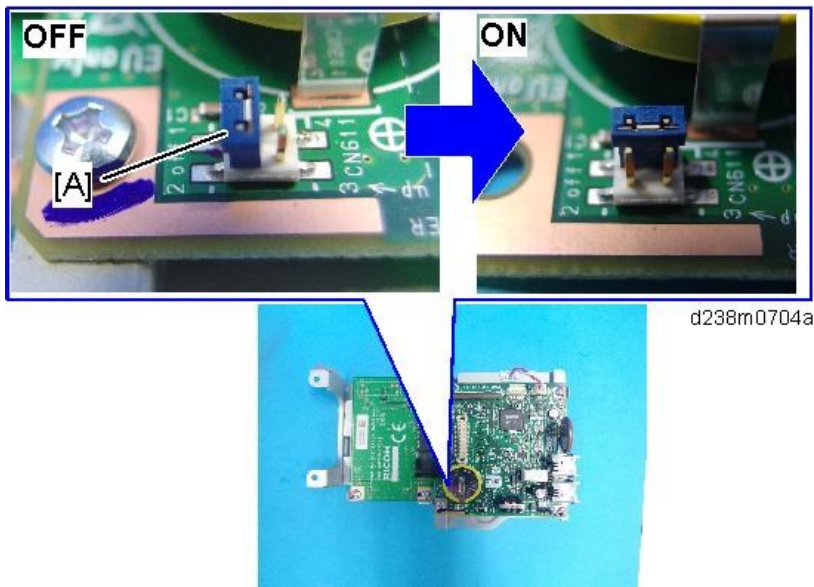

**Note**

- If the battery jumper switch is not in the correct position, SC820 will occur.

- 8.** Install the new fax unit (🔩 x 3).  
**9.** Attach the flat cable [A] to CN603 of the new fax unit.

Make sure that the blue tape of the flat cable faces outward.

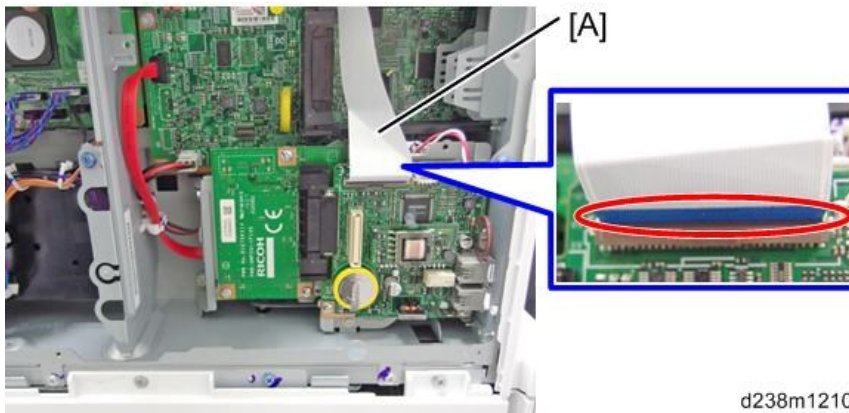

- 10.** Attach the removed FCU board [A] to the center frame of the controller box (🔩 x 1). Then attach the flat cable to CN603 of the removed FCU board.  
 Make sure that the blue tape of the flat cable faces outward.

### 3.Replacement and Adjustment

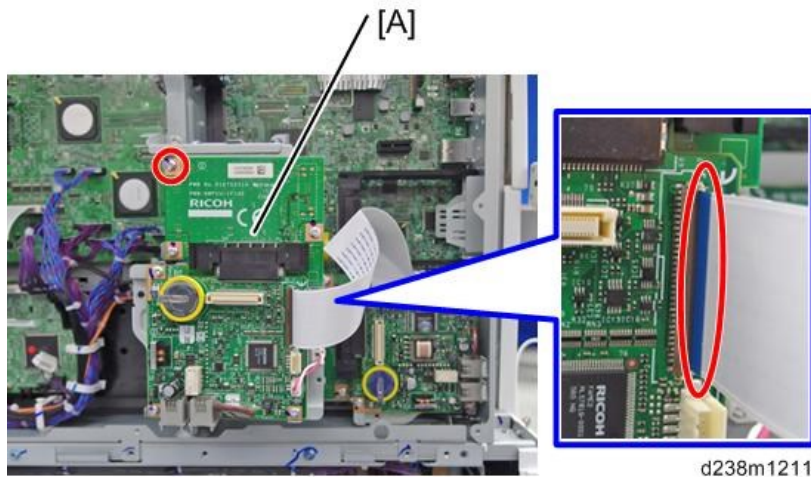

#### **⚠ CAUTION**

- Keep the removed FCU board away from the metal frames. Otherwise, the removed FCU board may have a short circuit.

#### **11.** Turn ON the main power.

SRAM data transmission starts. When the transmission is completed, you will hear a beeper sound.

#### **Note**

- The beeper sound is at the same volume as the speaker sound.
- The beeper sounds even if the speaker sound is turned off.
- If the beeper does not sound, repeat main power OFF/ON until the beeper sounds, and then perform the transmission procedure. If the data cannot be transmitted, repeat transmission 2 or 3 times.
- If the beeper does not sound after turning the main power OFF/ON 3 times, you need to input the settings stored in SRAM memory manually.

#### **12.** When “Ready” is displayed on the display panel, turn the main power OFF. Disconnect the flat cable from the removed FCU board.

#### **13.** Remove the removed FCU board (🔧 x 1).

#### **14.** Remove the bracket from the center frame of the controller box (🔧 x 1).

#### **15.** Disconnect the flat cable from the new FCU board.

#### **16.** Re-assemble the machine.

#### **17.** Turn ON the main power. Execute SP6-101 to print the system parameter list.

#### **18.** Check the system parameter list to make sure that the data is transferred correctly.

#### **19.** Set the correct date and time with the User Tools: User Tools > System Settings > Timer Setting > Set Date/Time.

#### **Note**

- If any of the SRAM data was not transferred, input those settings manually.

For MP C3004/3504 models

**Preparation**

- Remove the G3 Unit and disconnect the FFC connection. (See the installation of "G3 Interface Unit Type M19"[G3 Interface Unit Type M19 \(D3BV-07, -08, -12\)](#))

Check "LINE2" to see if the 3G unit is installed.

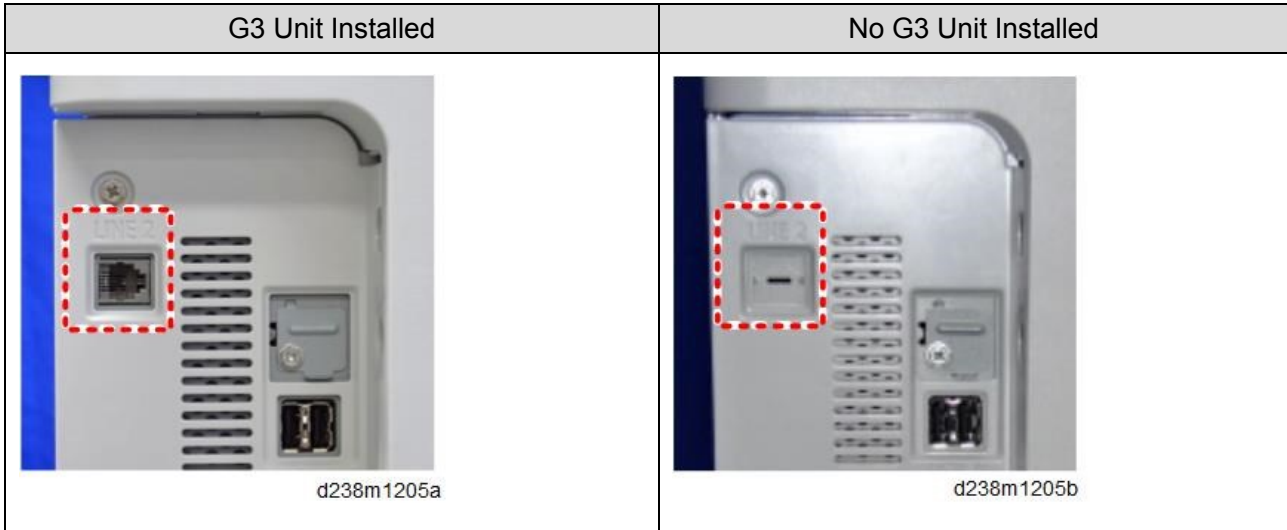

1. Remove the controller box cover [A].

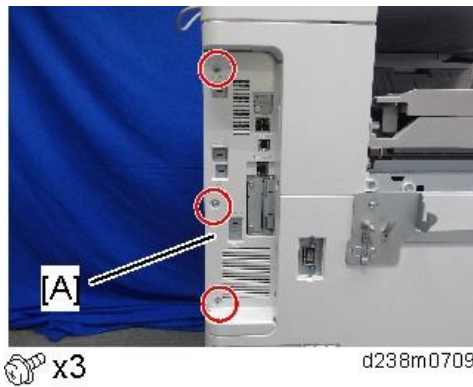

2. Remove the interface slot cover [A] ( x 2).

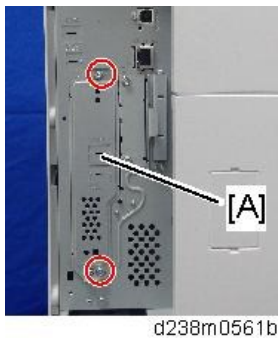

### 3.Replacement and Adjustment

- 3.** Pull out the FCU [A] from the interface slot.



- 4.** Switch the battery jumper switch [A] of the new fax unit to the "ON" position before installing.

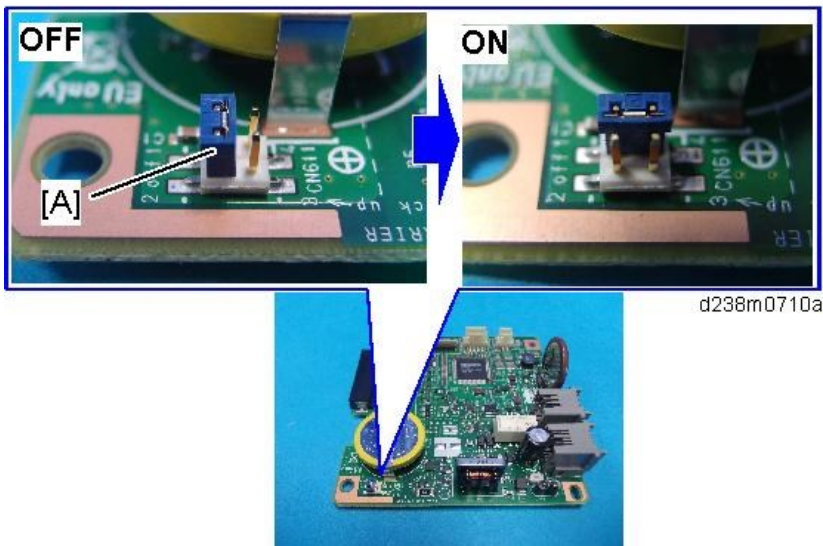

**Note**

- If the battery jumper switch is not in the correct position, SC820 will occur.

- 5.** Replace the installed FCU board [A] with a new FCU board [B].

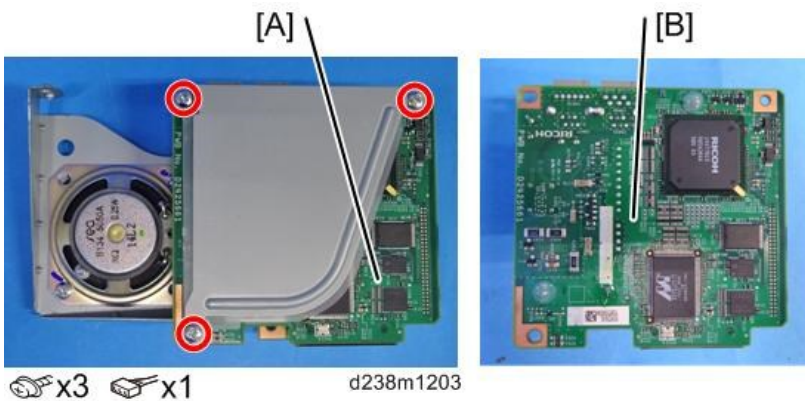

- 6.** Change the orientation of the battery jumper switch [A] on the removed FCU board, and then attach the battery jumper switch [B] on the FCU board to switch to the Restore mode. The battery jumper switch [B] is supplied with the new FCU board.

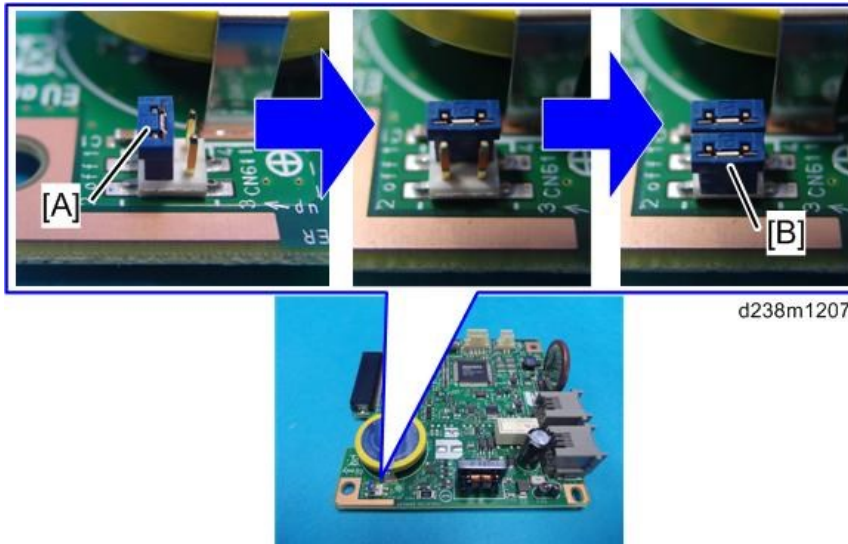

- 7.** Reinstall the new fax unit, and then the slot cover (Ⓜ x 2).
- 8.** Remove the rear cover [A].

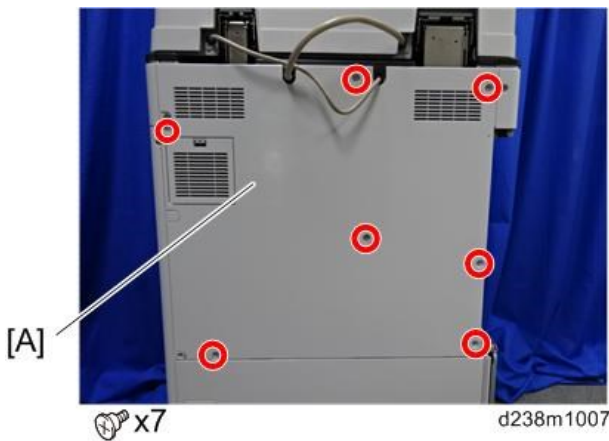

- 9.** Remove the controller box cover [A].
- Red circle: remove  
Blue circle: loosen

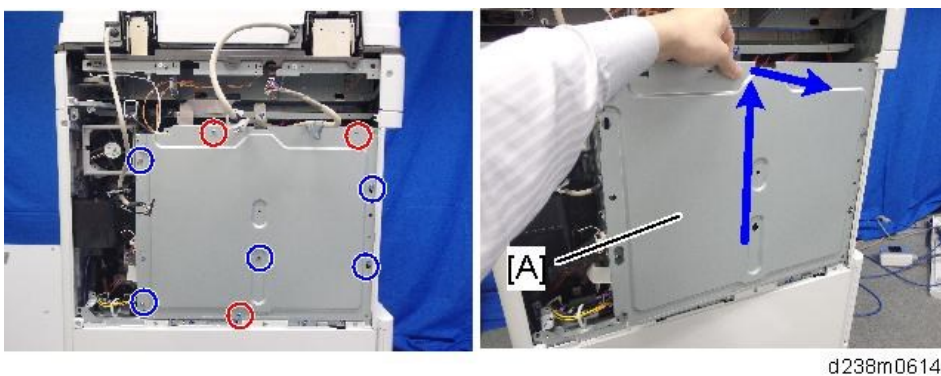

- 10.** Attach the flat cable [A] to CN603 of the new fax unit.
  - When inserting the cable, make sure that it is not slanted.
  - Make sure that the blue tapes of the flat cable face outward.

### 3.Replacement and Adjustment

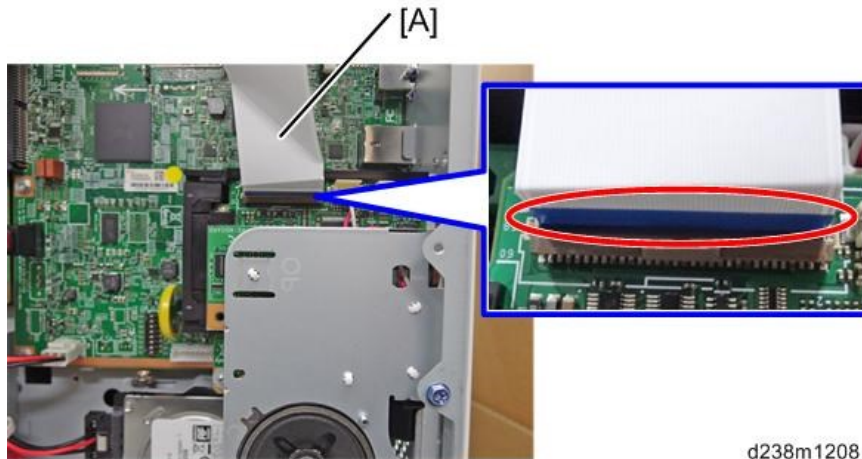

- 11.** Attach the removed FCU board [A] to the center frame of the controller box (⊙ x 1). Then attach the flat cable to CN603 of the removed FCU board. Make sure that the blue tape of the flat cable faces outward.

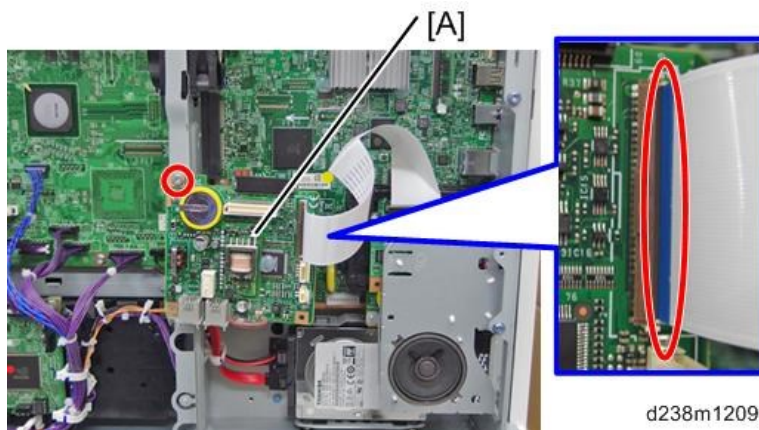

#### **⚠ CAUTION**

- Keep the removed FCU board away from the metal frames. Otherwise, the removed FCU board may have a short circuit.

- 12.** Turn ON the main power.  
SRAM data transmission starts. When the transmission is completed, you will hear a beeper sound.

#### **↓ Note**

- The beeper sound is at the same volume as the speaker sound.
- The beeper sounds even if the speaker sound is turned off.
- If the beeper does not sound, repeat main power OFF/ON until the beeper sounds, and then perform the transmission procedure. If the data cannot be transmitted, repeat transmission 2 or 3 times.

- 13.** When “Ready” is displayed on the display panel, turn OFF the main power. Disconnect the flat cable from the removed FCU board.
- 14.** Remove the removed FCU board (⊙ x 1).
- 15.** Remove the bracket from the center frame of the controller box (⊙ x 1).
- 16.** Disconnect the flat cable from the new FCU board.



- 17.** Re-assemble the machine.
- 18.** Turn ON the main power. Execute SP6-101 to print the system parameter list.
- 19.** Check the system parameter list to make sure that the data is transferred correctly.
- 20.** Set the correct date and time with the User Tools: User Tools > System Settings > Timer Setting > Set Date/Time.

## 4. Troubleshooting

### Error Codes

#### Error Codes

If an error code is displayed, retry communication. If the same problem occurs, try to fix the problem as suggested below.

**Note**

- Error codes appear in the error code display and on the service report.

Code	Meaning	Suggested Cause/Action
0-00	DIS/NSF not detected within 40 s of Start being pressed	<ul style="list-style-type: none"> <li>• Check the connection.</li> <li>• The other party may be incompatible.</li> <li>• Replace the FCU.</li> <li>• Check for DIS/NSF with an oscilloscope.</li> <li>• If the RX signal is weak, there may be a bad connection.</li> </ul>
0-01	DCN received unexpectedly	<ul style="list-style-type: none"> <li>• The other party is out of paper or has a paper jam.</li> <li>• The other party pressed the Stop button during communication.</li> </ul>
0-03	Incompatible modem at the other end	The other party is incompatible.
0-04	CFR or FTT not received after modem training	<ul style="list-style-type: none"> <li>• Check the connection.</li> <li>• Try changing the TX level and/or cable equalizer settings.</li> <li>• Replace the FCU.</li> <li>• The other machine may be defective. Try sending to another machine.</li> <li>• If the RX signal is weak or defective, there may be a bad connection.</li> </ul> <p><b>Reference:</b></p> <ul style="list-style-type: none"> <li>• TX level: NCU Parameter 01 (PSTN)</li> <li>• Cable equalizer: G3 Switch 07 (PSTN)</li> <li>• Dedicated TX parameters in Service Program Mode</li> </ul>
0-05	Modem training fails even G3 shifts down to 2400 bps.	<ul style="list-style-type: none"> <li>• Check the connection.</li> <li>• Try adjusting the TX level and/or cable equalizer.</li> <li>• Replace the FCU.</li> </ul>

Code	Meaning	Suggested Cause/Action
		<ul style="list-style-type: none"> <li>• Check for line problems.</li> </ul> <p><b>Reference:</b> See error code 0-04.</p>
0-06	The other terminal did not reply to DCS	<ul style="list-style-type: none"> <li>• Check the connection.</li> <li>• Try adjusting the TX level and/or cable equalizer settings.</li> <li>• Replace the FCU.</li> <li>• The other end may be defective or incompatible; try sending to another machine.</li> <li>• Check for line problems.</li> </ul> <p><b>Reference:</b> See error code 0-04.</p>
0-07	No post-message response from the other end after a page was sent	<ul style="list-style-type: none"> <li>• Check the connection.</li> <li>• Replace the FCU.</li> <li>• The other party is out of paper or has a paper jam.</li> <li>• The other party may have disconnected the call.</li> <li>• Check for a bad line.</li> <li>• The other machine may be defective. Try sending to another machine.</li> </ul>
0-08	The other end sent RTN or PIN after receiving a page, because there were too many errors	<ul style="list-style-type: none"> <li>• Check the connection.</li> <li>• Replace the FCU.</li> <li>• The other end may have jammed, or run out of paper or memory space.</li> <li>• Try adjusting the TX level and/or cable equalizer settings.</li> <li>• The other end may have a defective modem/FCU; try sending to another machine.</li> <li>• Check for line problems and noise.</li> </ul> <p><b>Reference:</b></p> <ul style="list-style-type: none"> <li>• TX level: NCU Parameter 01 (PSTN)</li> <li>• Cable equalizer: G3 Switch 07 (PSTN)</li> <li>• Dedicated TX parameters in Service Program Mode</li> </ul>
0-14	Non-standard post message response code received	<ul style="list-style-type: none"> <li>• Incompatible or defective remote terminal; try sending to another machine.</li> <li>• Noisy line; resend.</li> <li>• Try adjusting the TX level and/or cable equalizer</li> </ul>

#### 4.Troubleshooting

Code	Meaning	Suggested Cause/Action
		<p>settings.</p> <ul style="list-style-type: none"> <li>• Replace the FCU.</li> </ul> <p><b>Reference:</b> See error code 0-08.</p>
0-15	The other terminal is not capable of specific functions.	<p>The other party is unable to accepting the following functions, or the other party's memory is full.</p> <ul style="list-style-type: none"> <li>• Confidential RX</li> <li>• Transfer function</li> <li>• SEP/SUB/PWD/SID</li> </ul>
0-16	CFR or FTT not detected after modem training in confidential or transfer mode	<ul style="list-style-type: none"> <li>• Check the connection.</li> <li>• Replace the FCU.</li> <li>• Try adjusting the TX level and/or cable equalizer settings.</li> <li>• The other machine may have disconnected, or it may be defective. Try sending to another machine.</li> <li>• If the ax signal level is too low, there may be a line problem.</li> </ul> <p><b>Reference:</b> See error code 0-08.</p>
0-17	Communication was interrupted by pressing the Stop key	<p>If the Stop key was not pressed and this error keeps occurring, replace the operation panel or the operation panel drive board.</p>
0-20	Facsimile data not received within 6 s of retraining	<ul style="list-style-type: none"> <li>• Check the connection.</li> <li>• Replace the FCU.</li> <li>• Check for line problems.</li> <li>• Try calling another fax machine.</li> <li>• Try adjusting the reconstruction time for the first line and/or RX cable equalizer setting.</li> </ul> <p><b>Reference:</b> Reconstruction time - G3 Switch 0A, Bit 6 Rx cable equalizer - G3 Switch 07 (PSTN)</p>
0-21	EOL signal (end-of-line) from the other end not received within 5 s of the previous EOL signal	<ul style="list-style-type: none"> <li>• Check the connection between the FCU and line.</li> <li>• Check for line noise or other line problems.</li> <li>• Replace the FCU.</li> <li>• The remote machine may be defective or may have been disconnected.</li> </ul>

Code	Meaning	Suggested Cause/Action
		<b>Reference:</b> Maximum interval between EOLs and between ECM frames - G3 Bit Switch 0A, Bit 4
0-22	The signal from the other end was interrupted for more than the acceptable modem carrier drop time (default: 200 ms)	<ul style="list-style-type: none"> <li>• Check the connection.</li> <li>• Replace the FCU.</li> <li>• The remote machine may be defective.</li> <li>• Check for line noise or other line problems.</li> <li>• Try adjusting the acceptable modem carrier drop time.</li> </ul> <b>Reference:</b> Acceptable modem carrier drop time: G3 Switch 0A, Bits 0 and 1
0-23	Too many errors during reception	<ul style="list-style-type: none"> <li>• Check the connection.</li> <li>• Replace the FCU.</li> <li>• The remote machine may be defective.</li> <li>• Check for line noise or other line problems.</li> <li>• Try asking the other party to adjust their TX level.</li> <li>• Try adjusting the RX cable equalizer setting and/or RX error criteria.</li> </ul> <b>Reference:</b> Rx cable equalizer: G3 Switch 07 (PSTN) Rx error criteria: Communication Switch 02, Bits 0 and 1
0-29	Data block format failure in ECM reception	<ul style="list-style-type: none"> <li>• Check for line noise or other line problems.</li> <li>• Check the FCU - NCU connectors.</li> <li>• Replace the NCU or FCU.</li> </ul>
0-30	The other terminal did not reply to NSS(A) in AI short protocol mode	<ul style="list-style-type: none"> <li>• Check the connection.</li> <li>• Try adjusting the TX level and/or cable equalizer settings.</li> <li>• The other terminal may not be compatible.</li> </ul> <b>Reference:</b> Dedicated TX parameters - Section 4
0-32	The other terminal sent a DCS, which contained functions that the receiving machine cannot handle.	<ul style="list-style-type: none"> <li>• Check the protocol dump list.</li> <li>• Ask the other party to contact the manufacturer.</li> </ul>
0-33	The data reception (not ECM) is not completed within 10 minutes.	<ul style="list-style-type: none"> <li>• Check the connection.</li> <li>• The other terminal may have a defective</li> </ul>

#### 4.Troubleshooting

Code	Meaning	Suggested Cause/Action
		modem/FCU.
0-52	Polarity changed during communication	<ul style="list-style-type: none"> <li>Check the connection.</li> <li>Retry communication.</li> </ul>
0-55	FCU does not detect the SG3.	<ul style="list-style-type: none"> <li>FCU firmware or board defective.</li> <li>SG3 firmware or board defective.</li> </ul>
0-56	The stored message data exceeds the capacity of the mailbox in the SG3.	SG3 firmware or board defective.
0-70	The communication mode specified in CM/JM was not available (V.8 calling and called terminal)	<ul style="list-style-type: none"> <li>The other terminal did not have a compatible communication mode (e.g., the other terminal was a V.34 data modem and not a fax modem.)</li> <li>A polling TX file was not ready at the other terminal when polling RX was initiated from the calling terminal.</li> </ul>
0-74	The calling terminal fell back to T.30 mode, because it could not detect ANSam after sending CI.	<ul style="list-style-type: none"> <li>The calling terminal could not detect ANSam due to noise, etc.</li> <li>ANSam was too short to detect.</li> <li>Check the connection. and condition.</li> <li>Try making a call to another V.8/V.34 fax.</li> </ul>
0-75	The called terminal fell back to T.30 mode, because it could not detect a CM in response to ANSam (ANSam timeout).	<ul style="list-style-type: none"> <li>The terminal could not detect ANSam.</li> <li>Check the connection. and condition.</li> <li>Try receiving a call from another V.8/V.34 fax.</li> </ul>
0-76	The calling terminal fell back to T.30 mode, because it could not detect a JM in response to CM (CM timeout).	<ul style="list-style-type: none"> <li>The called terminal could not detect a CM due to noise, etc.</li> <li>Check the connection. and condition.</li> <li>Try making a call to another V.8/V.34 fax.</li> </ul>
0-77	The called terminal fell back to T.30 mode, because it could not detect a CJ in response to JM (JM timeout).	<ul style="list-style-type: none"> <li>The calling terminal could not detect a JM due to noise, etc.</li> <li>A network that has narrow bandwidth cannot pass JM to the other end.</li> <li>Check the connection. and condition.</li> <li>Try receiving a call from another V.8/V.34 fax.</li> </ul>
0-79	The called terminal detected CI while waiting for a V.21 signal.	<ul style="list-style-type: none"> <li>Check for line noise or other line problems.</li> <li>If this error occurs, the called terminal falls back to T.30 mode.</li> </ul>
0-80	The line was disconnected due to a timeout in V.34 phase 2 – line	<ul style="list-style-type: none"> <li>The guard timer expired while starting these phases. Serious noise, narrow bandwidth, or low</li> </ul>

Code	Meaning	Suggested Cause/Action
	probing.	signal level can cause these errors.
0-81	The line was disconnected due to a timeout in V.34 phase 3 – equalizer training.	If these errors happen at the transmitting terminal: <ul style="list-style-type: none"> <li>• Try making a call later.</li> <li>• Try using V.17 or a slower modem using dedicated TX parameters.</li> </ul>
0-82	The line was disconnected due to a timeout in the V.34 phase 4 – control channel start-up.	<ul style="list-style-type: none"> <li>• Try increasing the TX level.</li> <li>• Try adjusting the TX cable equalizer setting.</li> </ul>
0-83	The line was disconnected due to a timeout in the V.34 control channel restart sequence.	If these errors happen at the receiving terminal: <ul style="list-style-type: none"> <li>• Try adjusting the RX cable equalizer setting.</li> <li>• Try increasing the TX level.</li> <li>• Try using V.17 or a slower modem if the same error is frequent when receiving from multiple senders.</li> </ul>
0-84	The line was disconnected due to abnormal signaling in V.34 phase 4 – control channel start-up.	<ul style="list-style-type: none"> <li>• The signal did not stop within 10 s.</li> <li>• Turn off the main power switch, and then turn it back on.</li> <li>• If the same error is frequent, replace the FCU.</li> </ul>
0-85	The line was disconnected due to abnormal signaling in V.34 control channel restart.	<ul style="list-style-type: none"> <li>• The signal did not stop within 10 s.</li> <li>• Turn off the main power switch, and then turn it back on.</li> <li>• If the same error is frequent, replace the FCU.</li> </ul>
0-86	The line was disconnected because the other terminal requested a data rate using MPh that was not available in the currently selected symbol rate.	<ul style="list-style-type: none"> <li>• The other terminal was incompatible.</li> <li>• Ask the other party to contact the manufacturer.</li> </ul>
0-87	The control channel started after an unsuccessful primary channel.	<ul style="list-style-type: none"> <li>• The receiving terminal restarted the control channel because data reception in the primary channel was not successful.</li> <li>• This does not result in an error communication.</li> </ul>
0-88	The line was disconnected because PPR was transmitted/received 9 (default) times within the same ECM frame.	<ul style="list-style-type: none"> <li>• Try using a lower data rate at the start.</li> <li>• Try adjusting the cable equalizer setting.</li> </ul>
2-11	Only one V.21 connection flag was received	<ul style="list-style-type: none"> <li>• Replace the FCU.</li> </ul>
2-12	Modem clock irregularity	<ul style="list-style-type: none"> <li>• Replace the FCU.</li> </ul>
2-13	Modem initialization error	<ul style="list-style-type: none"> <li>• Turn off the machine, and then turn it back on.</li> </ul>

#### 4.Troubleshooting

Code	Meaning	Suggested Cause/Action
		<ul style="list-style-type: none"> <li>Update the modem ROM.</li> <li>Replace the FCU.</li> </ul>
2-22	Counter overflow error of JBIG chip	If error occurs frequently, change the settings for resolution, paper size, and compression type.
2-23	JBIG compression or reconstruction error	Turn off the machine, and then turn it back on.
2-24	JBIG ASIC error	<ul style="list-style-type: none"> <li>Turn off the machine, and then turn it back on.</li> </ul>
2-25	JBIG data reconstruction error (BIH error)	<ul style="list-style-type: none"> <li>JBIG data error</li> <li>Check the sender's JBIG function.</li> </ul>
2-26	JBIG data reconstruction error (Float marker error)	<ul style="list-style-type: none"> <li>Update the FCU ROM.</li> </ul>
2-27	JBIG data reconstruction error (End marker error)	
2-28	JBIG data reconstruction error (Timeout)	
2-29	JBIG trailing edge maker error	<ul style="list-style-type: none"> <li>FCU defective</li> <li>Check the destination device.</li> </ul>
2-50	The machine resets itself for a fatal FCU system error	<ul style="list-style-type: none"> <li>If this is frequent, update the ROM, or replace the FCU.</li> </ul>
2-51	The machine resets itself because of a fatal communication error	<ul style="list-style-type: none"> <li>If this is frequent, update the ROM, or replace the FCU.</li> </ul>
2-53	Snd msg() in the manual task is an error because the mailbox for the operation task is full.	<ul style="list-style-type: none"> <li>The user did the same operation many times, and this gave too much load to the machine.</li> </ul>
4-01	Line current was cut	<ul style="list-style-type: none"> <li>Check the line connector.</li> <li>Check for line problems.</li> <li>Replace the FCU.</li> </ul>
4-10	Communication failed because of an ID Code mismatch (Closed Network) or Tel. No./CSI mismatch (Protection against Wrong Connections)	<ul style="list-style-type: none"> <li>Get the ID Codes the same and/or the CSIs programmed correctly, and then resend.</li> <li>The machine at the other end may be defective.</li> </ul>
5-00	Data reconstruction not possible	Replace the FCU.
5-10	DCR timer expired	<ul style="list-style-type: none"> <li>Replace the FCU.</li> </ul>
5-20	Storage impossible because of a lack of memory	<ul style="list-style-type: none"> <li>Temporary memory shortage.</li> <li>Test the SAF memory.</li> </ul>
5-21	Memory overflow	
5-23	Print data error when printing a	<ul style="list-style-type: none"> <li>Test the SAF memory.</li> </ul>



Code	Meaning	Suggested Cause/Action
	substitute RX or confidential RX message	<ul style="list-style-type: none"> <li>Ask the other end to resend the message.</li> </ul>
5-25	SAF file access error	<ul style="list-style-type: none"> <li>Replace an SD card or HDD.</li> <li>Replace the FCU.</li> </ul>
6-00	G3 ECM - T1 time out during reception of facsimile data	<ul style="list-style-type: none"> <li>Try adjusting the RX cable equalizer.</li> <li>Replace the FCU.</li> </ul>
6-01	G3 ECM - no V.21 signal was received	
6-02	G3 ECM - EOR was received	
6-04	G3 ECM - RTC not detected	<ul style="list-style-type: none"> <li>Check the connection.</li> <li>Check for a bad line or defective remote terminal.</li> <li>Replace the FCU.</li> </ul>
6-05	G3 ECM - facsimile data frame not received within 18 s of CFR, but there was no line fail	<ul style="list-style-type: none"> <li>Check the connection.</li> <li>Check for a bad line or defective remote terminal.</li> <li>Replace the FCU.</li> <li>Try adjusting the RX cable equalizer</li> </ul> <p><b>Reference:</b></p> <ul style="list-style-type: none"> <li>RX cable equalizer - G3 Switch 07 (PSTN)</li> </ul>
6-06	G3 ECM - coding/decoding error	<ul style="list-style-type: none"> <li>Defective FCU.</li> <li>The other terminal may be defective.</li> </ul>
6-08	G3 ECM - PIP/PIN received in reply to PPS.NULL	<ul style="list-style-type: none"> <li>The other end pressed Stop during communication.</li> <li>The other terminal may be defective.</li> </ul>
6-09	G3 ECM - ERR received	<ul style="list-style-type: none"> <li>Check for a noisy line.</li> <li>Adjust the TX levels of the communicating machines.</li> <li>See code 6-05.</li> </ul>
6-10	G3 ECM - error frames still received at the other end after all communication attempts at 2400 bps	<ul style="list-style-type: none"> <li>Check for line noise.</li> <li>Adjust the TX level (use NCU parameter 01 or the dedicated TX parameter for that address).</li> <li>Check the connection.</li> <li>Defective remote terminal.</li> </ul>
6-21	V.21 flag detected during high speed modem communication	<ul style="list-style-type: none"> <li>The other terminal may be defective or incompatible.</li> </ul>
6-22	The machine resets the sequence	<ul style="list-style-type: none"> <li>Check for line noise.</li> </ul>

#### 4.Troubleshooting

Code	Meaning	Suggested Cause/Action
	because of an abnormal handshake in the V.34 control channel	<ul style="list-style-type: none"> <li>If the same error occurs frequently, replace the FCU.</li> <li>Defective remote terminal.</li> </ul>
6-99	V.21 signal not stopped within 6 s	Replace the FCU.
13-17	SIP user name registration error	<ul style="list-style-type: none"> <li>Double registration of the SIP user name.</li> <li>Capacity for user-name registration in the SIP server is not sufficient.</li> </ul>
13-18	SIP server access error	<ul style="list-style-type: none"> <li>Incorrect initial setting for the SIP server.</li> <li>Defective SIP server.</li> </ul>
13-24	SIP authentication error	<ul style="list-style-type: none"> <li>Registered password in the device does not match the password in the SIP server.</li> </ul>
13-25	Network I/F setting error	<ul style="list-style-type: none"> <li>IPV4 is not active in the active protocol setting.</li> <li>IP address of the device is not registered.</li> </ul>
13-26	Network I/F setting error at power on	<ul style="list-style-type: none"> <li>Active protocol setting does not match the I/F setting for SIP server.</li> <li>IP address of the device is not registered.</li> </ul>
13-27	IP address setting error	<ul style="list-style-type: none"> <li>IP address of the device is not registered.</li> </ul>
14-00	SMTP Send Error	<ul style="list-style-type: none"> <li>Error occurred during sending to the SMTP server. Occurs for any error other than 14-01 to 16. For example, the mail address of the system administrator is not registered.</li> </ul>
14-01	SMTP Connection Failed	<ul style="list-style-type: none"> <li>Failed to connect to the SMTP server (timeout) because the server could not be found.</li> <li>The PC is not ready to transfer files.</li> <li>SMTP server not functioning correctly.</li> <li>The DNS IP address is not registered.</li> <li>Network not operating correctly.</li> <li>Destination folder selection not correct.</li> </ul>
14-02	No Service by SMTP Service (421)	<ul style="list-style-type: none"> <li>SMTP server operating incorrectly or the destination for direct SMTP sending is not correct.</li> <li>Contact the system administrator and check that the SMTP server has the correct settings and operates correctly.</li> <li>Contact the system administrator for direct SMTP sending and check the sending destination.</li> </ul>

Code	Meaning	Suggested Cause/Action
14-03	Access to SMTP Server Denied (450)	<ul style="list-style-type: none"> <li>• Failed to access the SMTP server because the access is denied.</li> <li>• SMTP server operating incorrectly. Contact the system administrator to determine if there is a problem with the SMTP server and to check that the SMTP server settings are correct.</li> <li>• Folder send destination is incorrect. Contact the system administrator to determine that the SMTP server settings and path to the server are correct.</li> <li>• Device settings incorrect. Confirm that the user name and password settings are correct.</li> <li>• Direct SMTP destination incorrect. Contact the system administrator to determine if there is a problem at the destination and that the settings at the destination are correct.</li> </ul>
14-04	Access to SMTP Server Denied (550)	<ul style="list-style-type: none"> <li>• SMTP server operating incorrectly</li> <li>• Direct SMTP sending not operating correctly</li> </ul>
14-05	SMTP Server HDD Full (452)	<ul style="list-style-type: none"> <li>• Failed to access the SMTP server because the HDD on the server is full.</li> <li>• Insufficient free space on the HDD of the SMTP server. Contact the system administrator and check the amount of space remaining on the SMTP server HDD.</li> <li>• Insufficient free space on the HDD where the destination folder is located. Contact the system administrator and check the amount of space remaining on the HDD where the target folder is located.</li> <li>• Insufficient free space on the HDD at the target destination for SMTP direct sending. Contact the system administrator. Check the amount of space remaining on the target HDD or check if the mail size setting is the default value (2MB).</li> <li>• Check the size of the original data. For example, if the original has too many pages, the data size can be too big to send.</li> </ul>
14-	User Not Found on SMTP Server	<ul style="list-style-type: none"> <li>• The designated user does not exist.</li> </ul>

#### 4.Troubleshooting

Code	Meaning	Suggested Cause/Action
06	(551)	<ul style="list-style-type: none"> <li>The designated user does not exist on the SMTP server.</li> <li>The designated address is not for use with direct SMTP sending.</li> </ul>
14-07	Data Send to SMTP Server Failed (4XX)	<ul style="list-style-type: none"> <li>Failed to access the SMTP server because the transmission failed.</li> <li>PC not operating correctly.</li> <li>SMTP server operating incorrectly</li> <li>Network not operating correctly.</li> <li>Destination folder setting incorrect.</li> <li>Direct SMTP sending not operating correctly.</li> </ul>
14-08	Data Send to SMTP Server Failed (5XX)	<ul style="list-style-type: none"> <li>Failed to access the SMTP server because the transmission failed.</li> <li>SMTP server operating incorrectly</li> <li>Destination folder setting incorrect.</li> <li>Direct SMTP sending not operating correctly.</li> <li>Software application error.</li> </ul>
14-09	Authorization Failed for Sending to SMTP Server	<ul style="list-style-type: none"> <li>POP-Before-SMTP or SMTP authorization failed.</li> <li>Incorrect setting for file transfer</li> </ul>
14-10	Addresses Exceeded	<ul style="list-style-type: none"> <li>Number of broadcast addresses exceeded the limit for the SMTP server.</li> </ul>
14-11	Buffer Full	<ul style="list-style-type: none"> <li>The send buffer is full so the transmission could not be completed. Buffer is full due to using Scan-to-Email while the buffer is being used send mail at the same time.</li> </ul>
14-12	Data Size Too Large	<ul style="list-style-type: none"> <li>Transmission was cancelled because the detected size of the file was too large.</li> </ul>
14-13	Send Cancelled	<ul style="list-style-type: none"> <li>Processing is interrupted because the user pressed Stop.</li> </ul>
14-14	Security Locked File Error	<ul style="list-style-type: none"> <li>Update the software because of the defective software.</li> </ul>
14-15	Mail Data Error	<ul style="list-style-type: none"> <li>The transmitting a mail is interrupted via DCS due to the incorrect data.</li> <li>Update the software because of the defective software.</li> </ul>
14-16	Maximum Division Number Error	<ul style="list-style-type: none"> <li>When a mail is divided for the mail transmission and the division number of a mail are more than the specified number, the mail transmission is</li> </ul>

Code	Meaning	Suggested Cause/Action
		interrupted. <ul style="list-style-type: none"> <li>Update the software because of the defective software.</li> </ul>
14-17	Incorrect Ticket	<ul style="list-style-type: none"> <li>Update the software because of the defective software.</li> </ul>
14-18	Access to MCS File Error	<ul style="list-style-type: none"> <li>The access to MCS file is denied due to the no permission of access.</li> <li>Update the software because of the defective software.</li> </ul>
14-20	SMTP Authentication error	Make sure the administrator's e-mail address is same as the SMTP authentication address or POP before SMTP address.
14-21	Transmission error of S/MIME	Register the correct user certificate and device certificate.
14-30	MCS File Creation Failed	Failed to create the MCS file because: <ul style="list-style-type: none"> <li>The number of files created with other applications on the Document Server has exceeded the limit.</li> <li>HDD is full or not operating correctly.</li> <li>Software error.</li> </ul>
14-31	UFS File Creation Failed	UFS file could not be created: <ul style="list-style-type: none"> <li>Not enough space in UFS area to handle both Scan-to-Email and IFAX transmission.</li> <li>HDD full or not operating correctly.</li> <li>Software error.</li> </ul>
14-32	Cancelled the Mail Due to Error Detected by NFAX	<ul style="list-style-type: none"> <li>Error detected with NFAX and send was cancelled due to a software error.</li> </ul>
14-33	No Mail Address For the Machine	<ul style="list-style-type: none"> <li>Neither the mail address of the machine nor the mail address of the network administrator is registered.</li> </ul>
14-34	Address designated in the domain for SMTP sending does not exist	<ul style="list-style-type: none"> <li>Operational error in normal mail sending or direct SMTP sending.</li> <li>Check the address selected in the address book for SMTP sending.</li> <li>Check the domain selection.</li> </ul>
14-50	Mail Job Task Error	Due to an FCU mail job task error, the send was cancelled: <ul style="list-style-type: none"> <li>Address book was being edited during creation</li> </ul>

#### 4.Troubleshooting

Code	Meaning	Suggested Cause/Action
		<p>of the notification mail.</p> <ul style="list-style-type: none"> <li>• Software error.</li> </ul>
14-51	UCS Destination Download Error	<p>Not even one return notification can be downloaded:</p> <ul style="list-style-type: none"> <li>• The address book was being edited.</li> <li>• The number for the specified destination does not exist (it was deleted or edited after the job was created).</li> </ul>
14-60	Send Cancel Failed	<ul style="list-style-type: none"> <li>• The cancel operation by the user failed to cancel the send operation.</li> </ul>
14-61	Notification Mail Send Failed for All Destinations	<ul style="list-style-type: none"> <li>• All addresses for return notification mail failed.</li> </ul>
14-62	Transmission Error due to the existence of zero line page	<ul style="list-style-type: none"> <li>• When the 0 line page exists in received pages with G3 communication, the transmission is interrupted.</li> </ul>
14-63	Fax Communication Unit: Transmission Error	<p>Check the followings.</p> <ul style="list-style-type: none"> <li>• Name of SMTP server</li> <li>• Port number of SMTP</li> <li>• DNS setting</li> <li>• Server name (FTP)</li> <li>• Path name (computer name and shared folder name at SMTP/ NCP)</li> <li>• Active protocol setting (Netware/ NCP)</li> <li>• NW flame type (NCP)</li> <li>• Log-on mode (NDS tree/ bindery)</li> </ul>
-		<p>Check the SMTP server.</p> <ul style="list-style-type: none"> <li>• Check if the SMTP server works normally and is connected to the network.</li> <li>• Check if the settings of the SMTP are correct.</li> </ul>
-		<p>Check the DNS server.</p> <ul style="list-style-type: none"> <li>• Check if the DNS server works normally and is connected to the network.</li> <li>• Check if the settings of the DNS server are correct.</li> </ul>
-		<p>Check the network.</p> <ul style="list-style-type: none"> <li>• Check if the LAN works normally.</li> <li>• Check if the no firewall exists.</li> </ul>
-		<p>Check the destination folder for the data transfer.</p> <ul style="list-style-type: none"> <li>• Check if the destination folder works normally.</li> </ul>

Code	Meaning	Suggested Cause/Action
		<ul style="list-style-type: none"> <li>• Check if the settings of the destination folder are correct.</li> </ul>
-		<p>Ask an administrator of the direct SMTP server in which the data is supposed to be transferred.</p> <ul style="list-style-type: none"> <li>• Check if the destination SMTP server works normally.</li> <li>• Check if the settings of the destination SMTP server are correct.</li> </ul>
15-01	POP3/IMAP4 Server Not Registered	<ul style="list-style-type: none"> <li>• At startup, the system detected that the IP address of the POP3/IMAP4 server has not been registered in the machine.</li> </ul>
15-02	POP3/IMAP4 Mail Account Information Not Registered	<ul style="list-style-type: none"> <li>• The POP3/IMAP4 mail account has not been registered.</li> </ul>
15-03	Mail Address Not Registered	<ul style="list-style-type: none"> <li>• The mail address has not been registered.</li> </ul>
15-10	DCS Mail Receive Error	<ul style="list-style-type: none"> <li>• Error other than 15-11 to 15-18.</li> </ul>
15-11	Connection Error	<p>The DNS or POP3/IMAP4 server could not be found:</p> <ul style="list-style-type: none"> <li>• The IP address for DNS or POP3/IMAP4 server is not stored in the machine.</li> <li>• The DNS IP address is not registered.</li> <li>• Network not operating correctly.</li> </ul>
15-12	Authorization Error	<p>POP3/IMAP4 send authorization failed:</p> <ul style="list-style-type: none"> <li>• Incorrect IFAX user name or password.</li> <li>• Another device, such as the PC, attempted access.</li> <li>• POP3/IMAP4 settings incorrect.</li> </ul>
15-13	Receive Buffer Full	<ul style="list-style-type: none"> <li>• Occurs only during manual reception. Transmission cannot be received due to insufficient buffer space. The buffer is being used for mail send or Scan-to-Email.</li> </ul>
15-14	Mail Header Format Error	<ul style="list-style-type: none"> <li>• The mail header is not standard format. For example, the Date line description is incorrect.</li> </ul>
15-15	Mail Divide Error	<ul style="list-style-type: none"> <li>• The e-mail is not in standard format. There is no boundary between parts of the e-mail, including the header.</li> </ul>
15-16	Mail Size Receive Error	<ul style="list-style-type: none"> <li>• The mail cannot be received because it is too large.</li> </ul>

#### 4.Troubleshooting

Code	Meaning	Suggested Cause/Action
15-17	Receive Timeout	<ul style="list-style-type: none"> <li>May occur during manual receiving only because the network is not operating correctly.</li> </ul>
15-18	Incomplete Mail Received	<ul style="list-style-type: none"> <li>Only one portion of the mail was received.</li> </ul>
15-31	Final Destination for Transfer Request Reception Format Error	<ul style="list-style-type: none"> <li>The format of the final destination for the transfer request was incorrect.</li> </ul>
15-39	Send/Delivery Destination Error	<p>The transmission cannot be delivered to the final destination:</p> <ul style="list-style-type: none"> <li>Destination file format is incorrect.</li> <li>Could not create the destination for the file transmission.</li> </ul>
15-41	SMTP Receive Error	<ul style="list-style-type: none"> <li>Reception rejected because the transaction exceeded the limit for the "Auth. E-mail RX" setting.</li> </ul>
15-42	Off Ramp Gateway Error	<ul style="list-style-type: none"> <li>The delivery destination address was specified with Off Ramp Gateway OFF.</li> </ul>
15-43	Address Format Error	<ul style="list-style-type: none"> <li>Format error in the address of the Off Ramp Gateway.</li> </ul>
15-44	Addresses Over	<ul style="list-style-type: none"> <li>The number of addresses for the Off Ramp Gateway exceeded the limit of 30.</li> </ul>
15-61	Attachment File Format Error	<ul style="list-style-type: none"> <li>The attached file is not TIFF format.</li> </ul>
15-62	TIFF File Compatibility Error	<p>Could not receive transmission due to:</p> <ul style="list-style-type: none"> <li>Resolution error</li> <li>Image of resolution greater than 200 dpi without extended memory.</li> <li>Resolution is not supported.</li> <li>Page size error</li> <li>The page size was larger than A3.</li> <li>Compression error</li> <li>File was compressed with other than MH, MR, or MMR.</li> </ul>
15-63	TIFF Parameter Error	<p>The TIFF file sent as the attachment could not be received because the TIFF header is incorrect:</p> <ul style="list-style-type: none"> <li>The TIFF file attachment is a type not supported.</li> <li>The TIFF file attachment is corrupted.</li> <li>Software error.</li> </ul>
15-	TIFF Decompression Error	<p>The file received as an attachment caused the TIFF</p>



Code	Meaning	Suggested Cause/Action
64		decompression error: <ul style="list-style-type: none"> <li>• The TIFF format of the attachment is corrupted.</li> <li>• Software error.</li> </ul>
15-71	Not Binary Image Data	<ul style="list-style-type: none"> <li>• The file could not be received because the attachment was not binary image data.</li> </ul>
15-73	MDN Status Error	<ul style="list-style-type: none"> <li>• The disposition line in the header of the Return Receipt could not be found, or there is a problem with the firmware.</li> </ul>
15-74	MDN Message ID Error	<ul style="list-style-type: none"> <li>• Could not find the Original Message ID line in the header of the Return Receipt, or there is a problem with the firmware.</li> </ul>
15-80	Mail Job Task Read Error	<ul style="list-style-type: none"> <li>• Could not receive the transmission because the destination buffer is full and the destination could not be created (this error may occur when receiving a transfer request or a request for notification of reception).</li> </ul>
15-81	Repeated Destination Registration Error	<ul style="list-style-type: none"> <li>• Could not repeat receive the transmission because the destination buffer is full and the destination could not be created (this error may occur when receiving a transfer request or a request for notification of reception).</li> </ul>
15-91	Send Registration Error	Could not receive the file for transfer to the final destination: <ul style="list-style-type: none"> <li>• The format of the final destination or the transfer destination is incorrect.</li> <li>• Destinations are full so the final and transfer destinations could not be created.</li> </ul>
15-92	Memory Overflow	<ul style="list-style-type: none"> <li>• Transmission could not be received because memory overflowed during the transaction.</li> </ul>
15-93	Memory Access Error	<ul style="list-style-type: none"> <li>• Transaction could not complete due to a malfunction of SAF memory.</li> </ul>
15-94	Incorrect ID Code	<ul style="list-style-type: none"> <li>• The machine rejected an incoming e-mail for transfer request, because the ID code in the incoming e-mail did not match the ID code registered in the machine.</li> </ul>
15-95	Transfer Station Function	<ul style="list-style-type: none"> <li>• The machine rejected an incoming e-mail for transfer because the transfer function was unavailable.</li> </ul>

#### 4.Troubleshooting

Code	Meaning	Suggested Cause/Action
16-00	No IP address registered	<ul style="list-style-type: none"> <li>The machine does not get an IP address because the DNS server has not been registered for the remote machine or IP address of the remote machine has not been registered.</li> <li>Register the DNS server for the remote machine or configure an IP address of the remote machine.</li> </ul>
22-00	Original length exceeded the maximum scan length	<ul style="list-style-type: none"> <li>Divide the original into more than one page.</li> <li>Check the resolution used for scanning. Lower the scan resolution if possible.</li> <li>Add optional page memory.</li> </ul>
22-01	Memory overflow while receiving	<ul style="list-style-type: none"> <li>Wait for the files in the queue to be sent.</li> <li>Delete unnecessary files from memory.</li> <li>Transfer the substitute reception files to another fax machine, if the machine's printer is busy or out of order.</li> <li>Add an optional SAF memory card or hard disk.</li> </ul>
22-02	TX or RX job stalled due to line disconnection at the other end	<ul style="list-style-type: none"> <li>The job started normally but did not finish normally; data may or may not have been received fully.</li> <li>Restart the machine.</li> </ul>
22-04	The machine cannot store received data in the SAF	<ul style="list-style-type: none"> <li>Update the ROM</li> <li>Replace the FCU.</li> </ul>
22-05	No G3 parameter confirmation answer	<ul style="list-style-type: none"> <li>Defective FCU board or firmware.</li> </ul>
23-00	Data read timeout during construction	<ul style="list-style-type: none"> <li>Restart the machine.</li> <li>Replace the FCU.</li> </ul>
25-00	The machine software resets itself after a fatal transmission error occurred	<ul style="list-style-type: none"> <li>Update the ROM</li> <li>Replace the FCU.</li> </ul>
F0-xx	V.34 modem error	<ul style="list-style-type: none"> <li>Replace the FCU.</li> </ul>
F6-xx	SG3 modem error	<ul style="list-style-type: none"> <li>Update the SG3 modem ROM.</li> <li>Replace the SG3 board.</li> <li>Check for line noise or other line problems.</li> <li>Try communicating another V.8/V.34 fax.</li> </ul>

## Fax Connection Unit Error Codes

### Fax Connection Unit Error Code List

#### MACHINE

Error Code	Possible Causes	Troubleshooting Procedures
01(1)	IPv4/IPv6 not enabled	Enable IPv4 and IPv6
01(3)	“Cancel” is pressed by user.	-
01(4)	A false connection ID is being used.	Check that the network is established.
01(5)	Network is disconnected because of no response within a specified time.	
01(14)	<ul style="list-style-type: none"> <li>Either this machine or the machine at the other end has entered SP or Initial settings.</li> <li>An established connection exists.</li> </ul>	<ul style="list-style-type: none"> <li>Exit SP or initial settings.</li> <li>Wait until the connection has finished.</li> </ul>

#### MACHINE

Error Code	Possible Causes	Troubleshooting Procedures
02(5)	<ul style="list-style-type: none"> <li>Wrong IP address/host name was used.</li> <li>The main power of the other machine at destination is OFF.</li> <li>LAN cable is disconnected.</li> <li>Network is rebooting.</li> </ul>	<ul style="list-style-type: none"> <li>Enter the correct IP address/host name</li> <li>Turn ON the main power.</li> <li>Connect the LAN cable</li> <li>Wait until rebooting has finished.</li> </ul>

#### MACHINE

Error Code	Possible Causes	Troubleshooting Procedures	
03	<ul style="list-style-type: none"> <li>No user authentication (i.e. Basic/Windows/LDAP/Custom Auth.) applies to fax application.</li> <li>Settings other than user authentication are applied to the fax application.</li> </ul>	Configure the user authentication setting for client and remote machines as follows:	
		Client Machine	Remote Machine
		OFF	OFF
		ON	OFF
		ON	ON

#### 4.Troubleshooting

##### MACHINE

Error Code	Possible Causes	Troubleshooting Procedures
04	Although the same user is registered on the remote machine and client machine, the user name and login password do not match.	<ul style="list-style-type: none"> <li>Register the same user to both the remote machine and client machine.</li> <li>Make sure to match the username and login password.</li> </ul>

##### MACHINE

Error Code	Possible Causes	Troubleshooting Procedures
05	An unauthorized user tried to connect.	Authorize the user to use fax connection.

##### MACHINE

Error Code	Possible Causes	Troubleshooting Procedures
06	Timeout error on the node authentication	Adjust the value of SP5-741-001 to prolong the timeout for node authentication.

##### MACHINE

Error Code	Possible Causes	Troubleshooting Procedures
07	Multiple destinations are set in the client machine.	On the client machine, execute SP5-801-021 to clear AICS memory

##### MACHINE

Error Code	Possible Causes	Troubleshooting Procedures
08(1)	<ul style="list-style-type: none"> <li>A client machine connects to another client machine.</li> <li>The client machine is not registered on the remote machine as destinations.</li> </ul>	<ul style="list-style-type: none"> <li>Connect to the remote machine.</li> <li>Register the client machine to the remote machine as a destination.</li> </ul>
08(2)	<ul style="list-style-type: none"> <li>A remote machine connects to another Remote Machine.</li> <li>The wrong remote machine is registered on the client machine.</li> </ul>	<ul style="list-style-type: none"> <li>Connect to the client machine.</li> <li>Check the remote machine registered on the client machine.</li> </ul>

## IFAX Troubleshooting

### IFAX Troubleshooting

Use the following procedures to determine whether the machine or another part of the network is causing the problem.

Communication Route	Item	Troubleshooting Procedures
General LAN	1. Connection with the LAN	<ul style="list-style-type: none"> <li>• Check that the LAN cable is connected to the machine.</li> <li>• Check that the LEDs on the hub are lit.</li> </ul>
	2. LAN activity	Check that other devices connected to the LAN can communicate through the LAN.
Between IFAX and PC	1. Network settings on the PC	<ul style="list-style-type: none"> <li>• Check the network settings on the PC.</li> <li>• Check with the network administrator for the IP address. (Is the IP address registered in the TCP/IP properties in the network setup correct?)</li> </ul>
	2. Check that PC can connect with the machine	<p>Use the “ping” command on the PC to contact the machine.</p> <p>At the MS-DOS prompt, type ping then the IP address of the machine, then press Enter.</p>
	3. LAN settings in the machine	<ul style="list-style-type: none"> <li>• Check the LAN parameters</li> <li>• Check if there is an IP address conflict with other PCs.</li> </ul> <p>Use the “Network” function in the User Tools. If there is an IP address conflict, inform the administrator.</p>
Between machine and e-mail server	1. LAN settings in the machine	<ul style="list-style-type: none"> <li>• Check the LAN parameters</li> <li>• Check if there is an IP address conflict with other PCs.</li> </ul> <p>Use the “Network” function in the User Tools. If there is an IP address conflict, inform the administrator.</p>
	2. E-mail account on the server	<ul style="list-style-type: none"> <li>• Make sure that the machine can log into the e-mail server.</li> <li>• Check that the account and password stored in the server are the same as in the machine.</li> </ul> <p>Ask the administrator to check.</p>

#### 4.Troubleshooting

Communication Route	Item	Troubleshooting Procedures
	3. E-mail server	<p>Make sure that the client devices which have an account in the server can send/receive e-mail.</p> <p>Ask the administrator to check.</p> <p>Send a test e-mail with the machine's own number as the destination. The machine receives the returned e-mail if the communication is performed successfully.</p>
Between e-mail server and internet	1. E-mail account on the Server	<ul style="list-style-type: none"> <li>• Make sure that the PC can log into the e-mail server.</li> <li>• Check that the account and password stored in the server are the same as in the machine.</li> </ul> <p>Ask the administrator to check.</p>
	2. E-mail server	<p>Make sure that the client devices which have an account in the server can send/receive e-mail.</p> <p>Ask the administrator to check.</p> <p>Send a test e-mail with the machine's own number as the destination. The machine receives the returned e-mail if the communication is performed successfully.</p>
	3. Destination e-mail address	<ul style="list-style-type: none"> <li>• Make sure that the e-mail address is actually used.</li> <li>• Check that the e-mail address contains no incorrect characters such as spaces.</li> </ul>
	4. Router settings	<ul style="list-style-type: none"> <li>• Use the "ping" command to contact the router.</li> <li>• Check that other devices connected to the router can sent data over the router.</li> </ul> <p>Ask the administrator of the server to check.</p>
	5. Error message by e-mail from the network of the destination.	<ul style="list-style-type: none"> <li>• Check whether e-mail can be sent to another address on the same network, using the application e-mail software.</li> <li>• Check the error e-mail message.</li> </ul> <p>Inform the administrator of the LAN.</p>

## IP-Fax Troubleshooting

### IP-Fax Transmission

#### Cannot send by IP Address/Host Name

Check Point		Troubleshooting Procedures
1	LAN cable connected?	Check the LAN cable connection.
2	Specified IP address/hostname correct?	Check the IP address/host name.
3	Firewall/NAT installed?	The firewall cannot be breached. Send by another method (Fax, Internet Fax)
4	Transmission sent manually?	Manual sending not supported.
5	IP address of local machine registered?	Register the IP address.
6	Remote terminal port number setting other than 1720 (when using H.323) or 5060 (when using SIP)?	Send by specifying the port number.
7	Specified port number correct?	Confirm the port number of the remote fax.
8	DNS server registered when host name specified?	Contact the network administrator.
9	Remote fax a T.38 terminal?	Check whether the remote fax is a T38 terminal.
10	Remote fax switched off or busy?	Check that the remote fax is ON.
11	Network bandwidth too narrow?	Request the network administrator to increase the bandwidth.
		Raise the delay level. (IPFAX SW 01 Bit 0 to 3)
		IP-Fax bandwidth is the same as the DCS speed. Set IP-Fax SW00 Bit 6 to 1.
12	Remote fax cancelled transmission?	Check whether the remote fax cancelled the transmission.

#### Cannot send via VoIP Gateway

Check Point		Troubleshooting Procedures
1	LAN cable connected?	Check the LAN cable connection.
2	VoIP Gateway T.38 standard?	Contact the network administrator.
3	VoIP Gateway installed correctly?	Contact the network administrator.
4	VoIP Gateway power switched on?	Contact the network administrator.
5	Is the IP address/host name of the specified Gateway correct?	Check the IP address/host name.
6	Number of the specified fax correct?	Check the remote fax number.

#### 4.Troubleshooting

7	Firewall/NAT installed?	The firewall cannot be breached. Send by another method (Fax, Internet Fax)
8	Transmission sent manually?	Manual sending not supported.
9	IP address of local fax registered?	Register the IP address.
10	DNS registered when host name specified?	Contact the network administrator.
11	Remote fax a G3 fax?	Check that the remote fax is a G3 fax.
12	G3 fax connected to VoIP gateway?	Check that G3 fax is connected.
13	Remote G3 fax turned ON?	Check that G3 fax is ON.
14	Network bandwidth too narrow?	Request the network administrator to increase the bandwidth.
		Raise the network delay level. (IPFAX SW 01 Bit 0 to 3)
		IP-Fax bandwidth is the same as the DCS speed. Set IP-Fax SW00 Bit 6 to 1.

#### Cannot send by Alias Fax number.

Check Point		Troubleshooting Procedures
1	LAN cable connected?	Check the LAN cable connection.
2	Number of specified Alias fax correct?	Confirm the Alias of the remote fax. Error Code: 13-14
3	Firewall/NAT installed?	The firewall cannot be breached. Send by another method (Fax, Internet Fax)
4	Transmission sent manually?	Manual sending not supported.
5	Gatekeeper/SIP server installed correctly?	Contact the network administrator.
6	Gatekeeper/SIP server power turned ON?	Contact the network administrator.
7	IP address/host name of Gatekeeper/SIP server correct?	Check the IP address/host name.
8	DNS server registered when Gatekeeper/SIP server host name specified?	Contact the network administrator.
9	Enable H.323/Enable SIP SW is set to on?	Check the settings. See User Parameter SW 34 Bit 0/SW 34 Bit 1
10	IP address of local fax registered?	Register the IP address of the local fax.
11	Alias number of local fax registered?	Register the Alias number of the local fax.
12	Remote fax registered in Gatekeeper?	Contact the network administrator.
13	Remote fax a T.38 terminal?	Check whether the remote fax is a T38 terminal.
14	Remote fax switched off or busy?	Contact the network administrator.



15	Network bandwidth too narrow?	Request the system administrator to increase the bandwidth.
		Raise the delay level. (IPFAX SW 01 Bit 0 to 3)
		Lower the modem transmission baud rate. (IPFAX SW 05)
16	Remote fax cancelled transmission?	Check whether the remote fax cancelled the transmission.

## IP-Fax Reception

Cannot receive via IP Address/Host Name.

Check Point		Troubleshooting Procedures
1	LAN cable connected?	Check the LAN cable connection.
2	Firewall/NAT installed?	The firewall cannot be breached. Send by another method (Fax, Internet Fax)
3	IP address of local fax registered?	Register the IP address.
4	Port number specified at remote sender fax (if required)?	Request the sender to specify the port number.
5	Specified port number correct (if required)?	Request the sender to check the port number.
6	DNS server registered when host name specified on sender side?	Contact the network administrator. <b>Note</b> <ul style="list-style-type: none"> <li>The sender machine displays this error code if the sender fax is a Ricoh model.</li> </ul>
7	Network bandwidth too narrow?	Request the system administrator to increase the bandwidth.
		Lower the start modem reception baud rate on the receiving side. (IPFAX SW06)
8	Remote fax cancelled transmission?	Check whether the remote fax cancelled the transmission.

Cannot receive by VoIP Gateway.

Check Point		Troubleshooting Procedures
1	LAN cable connected?	Check the LAN cable connection.
2	Firewall/NAT installed?	The firewall cannot be breached. Send by another method (Fax, Internet Fax)
3	VoIP Gateway installed correctly?	Contact the network administrator.

#### 4.Troubleshooting

4	VoIP Gateway power turned ON?	Contact the network administrator.
5	IP address/host name of specified VoIP Gateway correct on sender's side?	Request the remote fax to check the IP address/host name.
6	DNS server registered when host name specified on sender side?	Contact the network administrator.
7	Network bandwidth too narrow?	Request the network administrator to increase the bandwidth.
8	G3 fax connected?	Check that G3 fax is connected.
9	G3 fax power turned ON?	Check that G3 fax is ON.

#### Cannot receive by Alias Fax number.

Check Point		Troubleshooting Procedures
1	LAN cable connected?	Check the LAN cable connection.
2	Firewall/NAT installed?	The firewall cannot be breached. Send by another method (Fax, Internet Fax)
3	Gatekeeper/SIP server installed correctly?	Contact the network administrator. <b>Note</b> <ul style="list-style-type: none"> <li>The sender machine displays this error code when the sender fax is a Ricoh model.</li> </ul>
4	Power to Gatekeeper/SIP server turned ON?	Contact the network administrator. <b>Note</b> <ul style="list-style-type: none"> <li>The sender machine displays this error code when the sender fax is a Ricoh model.</li> </ul>
5	IP address/host name of Gatekeeper/SIP server correct on the sender's side?	Request the sender to check the IP address/host name. <b>Note</b> <ul style="list-style-type: none"> <li>The sender machine displays this error code when the sender fax is a Ricoh model.</li> </ul>
6	DNS server registered when Gatekeeper/SIP server host name specified on sender's side?	Contact the network administrator. <b>Note</b> <ul style="list-style-type: none"> <li>The sender machine displays this error code when the sender fax is a Ricoh model.</li> </ul>
7	Enable H.323/Enable SIP SW set to on?	Request the sender to check the settings. User Parameter SW 34 Bit 0/SW 34 Bit 1

		<p><b>Note</b></p> <ul style="list-style-type: none"> <li>Only if the remote sender fax is a Ricoh fax.</li> </ul>
8	Local fax IP address registered?	Register the IP address.
9	Local fax Alias number registered?	Register the Alias number.
10	Network bandwidth too narrow?	Request the system administrator to increase the bandwidth.
		Lower the start modem reception baud rate on the receiving side. (IPFAX SW06)
11	Remote fax cancelled transmission?	Check whether the remote fax cancelled the transmission.
12	Local fax registered in Gatekeeper/SIP server?	Contact the network administrator.
		<p><b>Note</b></p> <ul style="list-style-type: none"> <li>The sender machine displays this error code when the sender fax is a Ricoh model.</li> </ul>

## 5. Service Tables

---

### Cautions

**★ Important**

- Never turn off the main power switch when the power LED is lit or flashing. To avoid damaging the hard disk or memory, press the operation power switch to switch the power off, wait for the power LED to go off, and then switch the main power switch off.

**↓ Note**

- The main power LED lights or flashes while the platen cover or ARDF is open, while the main machine is communicating with a facsimile or the network server, or while the machine is accessing the hard disk or memory for reading or writing data.

## Service Program Tables

### SP1-XXX (BIT Switches)

1	Mode No.		Function
101	System Switch		
	001 – 032	00 – 1F	Change the bit switches for system settings for the fax option "Bit Switches - 1" : "System Switches"
102	I-fax Switch		
	001 – 016	00 – 0F	Change the bit switches for internet fax settings for the fax option "Bit Switches - 2" : "I-Fax Switches"
103	Printer Switch		
	001 – 016	00 – 0F	Change the bit switches for printer settings for the fax option "Bit Switches - 2": "Printer Switches"
104	Communication Switch		
	001 – 032	00 – 1F	Change the bit switches for communication settings for the fax option "Bit Switches - 3" : "Communication Switches"
105	G3-1 Switch		
	001 – 016	00 – 0F	Change the bit switches for the protocol settings of the standard G3 board "Bit Switches - 4" : "G3 Switches"
106	G3-2 Switch		
	001 – 016	00 – 0F	Change the bit switches for the protocol settings of the optional G3 board "Bit Switches - 5" : "G3-2 and G3-3 Switches"
107	G3-3 Switch		
	001 – 016	00 – 0F	Change the bit switches for the protocol settings of the optional G3 board "Bit Switches - 5": "G3-2 and G3-3 Switches"
108	G4 Internal Switch		
	001 – 032	00 – 1F	<b>Not used</b> (Do not change the bit switches)
109	G4 Parameter Switch		
	001 – 016	00 – 0F	<b>Not used</b> (Do not change the bit switches)
111	IP fax Switch		
	001 – 016	00 – 0F	Change the bit switches for optional IP fax parameters "Bit Switches - 6" : "IP Fax Switches"

## SP2-XXX (RAM)

2	Mode No.	Function
101	RAM Read/Write	
	001	Change RAM data for the fax board directly. "Service RAM Addresses"
102	Memory Dump	
	001	G3-1 Memory Dump Print out RAM data for the fax board. "Service RAM Addresses"
	002	G3-2 Memory Dump Print out RAM data for the optional SG3 board.
	003	G3-3 Memory Dump Print out RAM data for the optional SG3 board.
	004	G4 Memory Dump Not used
103	G3-1 NCU Parameters	
	001 – 023	CC, 01 – 22 NCU parameter settings for the standard G3 board. "NCU Parameters"
104	G3-2 NCU Parameters	
	001 – 023	CC, 01 – 22 NCU parameter settings for the optional G3 board. "NCU Parameters"
105	G3-3 NCU Parameters	
	001 – 023	CC, 01 – 22 NCU parameter settings for the optional G3 board. "NCU Parameters"

## SP3-XXX (Machine Set)

3	Mode No.	Function
101	Service Station	
	001	Fax Number Enter the fax number of the service station.
	002	Select Line Select the line type.
102	Serial Number	
	000	Enter the fax unit's serial number.
103	PSTN-1 Port Settings	
	001	Select Line Select the line type setting for the G3-1 line. If the machine is installed on a PABX line, select "PABX", "PABX (GND)" or "PABX (FLASH)".
	002	PSTN Access Number Enter the PSTN access number for the G3-1 line.
	003	Memory Lock Not used

		Disabled	
104	PSTN-2 Port Settings		
	001	Select Line	Select the line setting for the G3-2 line. If the machine is installed on a PABX line, select "PABX", "PABX (GND)" or "PABX (FLASH)".
	002	PSTN Access Number	Enter the PSTN access number for the G3-2 line.
	003	Memory Lock Disabled	Not used
	004	Transmission Disabled	If you turn this SP on, the machine does not send any fax messages on the G3-2 line.
105	PSTN-3 Port Settings		
	001	Select Line	Select the line setting for the G3-3 line. If the machine is installed on a PABX line, select "PABX", "PABX (GND)" or "PABX (FLASH)".
	002	PSTN Access Number	Enter the PSTN access number for the G3-3 line.
	003	Memory Lock Disabled	Not used
	004	Transmission Disabled	If you turn this SP on, the machine does not send any fax messages on the G3-3 line.
106	ISDN Port Settings		
	001	Select Line	<b>Not used</b> (Do not change the settings.)
	002	PSTN Access Number	
	003	Memory Lock Disabled	
	004	Transmission Disabled	
107	IPFAX Port Settings		
	001	H323 Port	Sets the H323 port number.
	002	SIP Port	Sets the SIP port number.
	003	RAS Port	Sets the RAS port number.
	004	Gatekeeper port	Sets the Gatekeeper port number.
	005	T.38 Port	Sets the T.38 port number.
	006	SIP Server Port	Sets the SIP port number.
	007	IPFAX Protocol Priority	Select "H323" or "SIP".

## 5. Service Tables

201	FAX SW	
	001 – 032	00 – 1F

### SP4-XXX (ROM Versions)

4	Mode No.	Function
101	001	FCU ROM Version Displays the FCU ROM version.
102	001	Error Codes Displays the latest 64 fax error codes.
103	001	G3-1 ROM Version Displays the G3-1 modem version.
104	001	G3-2 ROM Version Displays the G3-2 modem version.
105	001	G3-3 ROM Version Displays the G3-3 modem version.
106	001	G4 ROM Version <b>Not used</b> (Do not change the settings.)

### SP5-XXX (RAM Clear)

5	Mode No.	Function
101	Initialize SRAM (except Secure)	
	000	Initializes the bit switches and user parameters, user data in the SRAM, files in the SAF memory, and clock.
102	Erase All Files	
	000	Erases all files stored in the SAF memory.
103	Reset Bit Switches (except Secure)	
	000	Resets the bit switches and user parameters.
104	Factory Setting	
	000	Resets the bit switches and user parameters, user data in the SRAM and files in the SAF memory.
105	Reset All Bit Switches	
	000	Resets all the current bit switch settings.
106	Reset Security Bit Switches	
	000	Resets only the security bit switches. If you select automatic output/display for the user parameter switches, the security settings are initialized.

### SP6-XXX (Reports)

6	Mode No.	Function
101	System Parameter List	
	000	- Touch the "ON" button to print the system parameter list.
102	Service Monitor Report	



	000	-	Touch the "ON" button to print the service monitor report.
103	G3 Protocol Dump List		
	001	G3 All Communications	Prints the protocol dump list of all communications for all G3 lines.
	002	G3-1 (All Communications)	Prints the protocol dump list of all communications for the G3-1 line.
	003	G3-1 (1 Communication)	Prints the protocol dump list of the last communication for the G3-1 line.
	004	G3-2 (All Communications)	Prints the protocol dump list of all communications for the G3-2 line.
	005	G3-2 (1 Communication)	Prints the protocol dump list of the last communication for the G3-2 line.
	006	G3-3 (All Communications)	Prints the protocol dump list of all communications for the G3-3 line.
	007	G3-3 (1 Communication)	Prints the protocol dump list of the last communication for the G3-3 line.
104	G4 Protocol Dump List		
	001	Dch + Bch 1	<b>Not used</b> (Do not change the settings.)
	002	Dch	
	003	Bch 1 Link Layer	
	004	Dch Link Layer	
	005	Dch +Bch 2	
	006	Bch 2 Link Layer	
105	All Files print out		
	000	-	Prints out all the user files in the SAF memory, including confidential messages.  <b>Note</b> <ul style="list-style-type: none"> <li>Do not use this function, unless the customer is having trouble printing confidential messages or recovering files stored using the memory lock feature.</li> </ul>
106	Journal Print out		
	001	All Journals	The machine prints all the communication records on the report.
	002	Specified Date	The machine prints all communication records after the specified date.
107	Log List Print out		
	001	All log files	These log print out functions are for designer use only.

## 5. Service Tables

	002	Printer	
	003	SC/TRAP Stored	
	004	Decompression	
	005	Scanner	
	006	JOB/SAF	
	007	Reconstruction	
	008	JBIG	
	009	Fax Driver	
	010	G3CCU	
	011	Fax Job	
	012	CCU	
	013	Scanner Condition	
108	IP Protocol Dump List		
	001	All Communications	Prints the protocol dump list of all communications for the IP fax line.
	002	1 Communication	Prints the protocol dump list of the last communication for the IP fax line.

---

## SP7-XXX (Tests)

---

These are the test modes for PTT approval.

7	Function
101	G3-1 Modem Tests
102	G3-1 DTMF Tests
103	Ringer Test
104	G3-1 V34 (S2400baud)
105	G3-1 V34 (S2800baud)
106	G3-1 V34 (S3000baud)
107	G3-1 V34 (S3200baud)
108	G3-1 V34 (S3429baud)
109	Recorded Message Test
110	G3-2 Modem Tests
111	G3-2 DTMF Tests
112	G3-2 V34 (S2400baud)
113	G3-2 V34 (S2800baud)
114	G3-2 V34 (S3000baud)
115	G3-2 V34 (S3200baud)
116	G3-2 V34 (S3429baud)
117	G3-3 Modem Tests

118	G3-3 DTMF Tests
119	G3-3 V34 (S2400baud)
120	G3-3 V34 (S2800baud)
121	G3-3 V34 (S3000baud)
122	G3-3 V34 (S3200baud)
123	G3-3 V34 (S3429baud)
124	IG3-1 Modem Tests - <b>Not used</b>
125	IG3-1 DTMF Tests - <b>Not used</b>
126	IG3-1 V34 (S2400baud) - <b>Not used</b>
127	IG3-1 V34 (S2800baud) - <b>Not used</b>
128	IG3-1 V34 (S3000baud) - <b>Not used</b>
129	IG3-1 V34 (S3200baud) - <b>Not used</b>
130	IG3-1 V34 (S3429baud) - <b>Not used</b>
131	IG3-2 Modem Tests - <b>Not used</b>
132	IG3-2 DTMF Tests - <b>Not used</b>
133	IG3-2 V34 (S2400baud) - <b>Not used</b>
134	IG3-2 V34 (S2800baud) - <b>Not used</b>
135	IG3-2 V34 (S3000baud) - <b>Not used</b>
136	IG3-2 V34 (S3200baud) - <b>Not used</b>
137	IG3-2 V34 (S3429baud) - <b>Not used</b>

## Bit Switches - 1

**★ Important**

- Do not adjust a bit switch or use a setting that is described as "Not used", as this may cause the machine to malfunction or to operate in a manner that is not accepted by local regulations. Such bits are for use only in other areas, such as Japan.

Default settings for bit switches are not listed in this manual. Refer to the System Parameter List printed by the machine.

### System Switches

System Switch 00 (SP No. 1-101-001)		
No	Function	Comments
0	Dedicated transmission parameter programming 0: Disabled 1: Enabled	Set this bit to 1 before changing any dedicated transmission parameters.  This setting is automatically reset to "0" after turning off and on.
1	Not used	Do not change this setting.
2	Technical data printout on the journal 0: Disabled 1: Enabled	1: Instead of the personal name, the following data are listed in the journal for each G3 communication.
	<p>Example:</p> <p><b>0000 32V34 288/264 L0100 03 04</b>                      (1) (2)(3) (4) (5) (6) (7) (8)</p> <p>(1): EQM value (Line quality data). A larger number means more errors.                      (2): Symbol rate (V.34 only)                      (3): Final modem type used                      (4): Starting data rate (for example, 288 means 28.8 kbps)                      (5): Final data rate                      (6): RX level (see below for how to read the RX level)                      (7): Total number of error lines that occurred during non-ECM reception.                      (8): Total number of burst error lines that occurred during non-ECM reception.</p> <p><b>↓ Note</b></p> <ul style="list-style-type: none"> <li>EQM and RX level are fixed at "FFFF" in TX mode.</li> <li>The seventh and eighth numbers are fixed at "00" for transmission records and ECM reception records.</li> </ul>	
	RX level calculation Example:	

	<b>0000 32V34 288/264 L0100 03 04</b> (1) (2)(3) (4) (5) (6) (7) (8)	
	<p>The four-digit hexadecimal value (N) after "L" indicates the RX level.</p> <p>The <b>high</b> byte is given first, followed by the <b>low</b> byte. Divide the decimal value of N by -16 to get the RX level.</p> <p>In the above example, the decimal value of N (= 0100 [H]) is 256.</p> <p>So, the actual RX level is <math>256/-16 = -16</math> dB</p>	
3	Not used	Do not change this setting.
4	Line error mark print 0: OFF, 1: ON (print)	When "1" is selected, a line error mark is printed on the printout if a line error occurs during reception. This shows error locations when ECM is turned off.
5	G3 communication parameter display 0: Disabled 1: Enabled	This is a fault-finding aid. The LCD shows the key parameters (see "G3 Communication Parameters" below this table). This is normally disabled because it cancels the CSI display for the user. Be sure to reset this bit to "0" after testing.
6	Protocol dump list output after each communication 0: Off 1: On	This is only used for communication troubleshooting. It shows the content of the transmitted facsimile protocol signals. Always reset this bit to 0 after finishing testing.  If system switch 09 bit 6 is at "1", the list is only printed if there was an error during the communication.
7	Not used	Do not change the setting.

### G3 Communication Parameters

Modem rate	336: 33600 bps      168: 16800 bps 312: 31200 bps      144: 14400 bps 288: 28800 bps      120: 12000 bps 264: 26400 bps      96: 9600 bps 240: 24000 bps      72: 7200 bps 216: 21600 bps      48: 4800 bps 192: 19200 bps      24: 2400 bps
Resolution	S: Standard (8 x 3.85 dots/mm) D: Detail (8 x 7.7 dots/mm) F: Fine (8 x 15.4 dots/mm) SF: Superfine (16 x 15.4 dots/mm) 21: Standard (200 x 100 dpi) 22: Detail (200 x 200 dpi) 44: Superfine (400 x 400 dpi)
Compression mode	MMR: MMR compression MR: MR compression MH: MH compression

## 5. Service Tables

	JBO: JBIG compression (Optional mode) JBB: JBIG compression (Basic mode)
Communication mode	ECM: With ECM NML: With no ECM
Width and reduction	A4: A4 (8.3"), no reduction B4: B4 (10.1"), no reduction A3: A3 (11.7"), no reduction
I/O rate	0: 0 ms/line 5: 5 ms/line 10: 10 ms/line 20: 20 ms/line 25: 2.5 ms/line 40: 40 ms/line  <div style="border: 1px solid blue; border-radius: 5px; padding: 2px; display: inline-block;"> <span style="color: blue;">↓</span> <b>Note</b> </div> <ul style="list-style-type: none"> <li>• "40" is displayed while receiving a fax message using AI short protocol.</li> </ul>

**System Switch 01** - Not used (Do not change the factory settings.)

### System Switch 02 (SP No. 1-101-003)

No	Function	Comments
0-1	Not used	Do not change these settings.
2	Forced reset after transmission stalls 0: Off 1: On	With this setting on, the machine resets itself automatically if a transmission stalls and fails to complete the job.
3	Not used	Do not change these settings.
4	File retention time 0: Depends on User Parameter 24 [18(H)] 1: No limit	1: A file that had a communication error will not be erased unless the communication is successful.
5-7	-	Do not change this setting

**System Switch 03** - Not used (Do not change the factory settings.)

### System Switch 04 (SP No. 1-101-005)

No	Function	Comments
0- 2	Not used	Do not change these settings.
3	Printing dedicated TX parameters on Quick/Speed Dial Lists 0: Disabled 1: Enabled	1: Each Quick/Speed dial number on the list is printed with the dedicated TX parameters (10 bytes each). The first 10 bytes of data are the programmed dedicated TX parameters; 34 bytes of data are printed (the other 24 bytes have no use for service technicians).
4- 7	Not used	Do not change these settings.

<b>System Switch 05</b> - Not used (Do not change the factory settings.)
<b>System Switch 06</b> - Not used (Do not change the factory settings.)
<b>System Switch 07</b> - Not used (Do not change the factory settings.)
<b>System Switch 08</b> - Not used (Do not change the factory settings.)

<b>System Switch 09 (SP No. 1-101-010)</b>		
No	Function	Comments
0	Addition of image data from confidential transmissions on the transmission result report 0: Disabled 1: Enabled	If this feature is enabled, the top half of the first page of confidential messages will be printed on transmission result reports.
1	Print timing of communication reports on the Journal when no image data was exchanged. 0: After DCS/NSS communication (default), 1: After polling	0: The Journal is printed only when image data is sent. 1: The Journal is printed when any data is sent.
2	Automatic error report printout 0: Disabled 1: Enabled	0: Error reports will not be printed. 1: Error reports will be printed automatically after failed communications.
3	Printing of the error code on the error report 0: No 1: Yes	1: Error codes are printed on the error reports. This can be used for detecting an error which occurs rarely.
4	Not used	Do not change this setting.
5	Power failure report 0: Disabled 1: Enabled (default)	1: A power failure report will be automatically printed after the power is turned ON if a fax message disappeared from the memory when the power was

5. Service Tables

		turned off last. <b>NOTE:</b> If "0" is selected, no reports are printed and no one may recognize that fax data is gone due to a power failure.
6	Conditions for printing the protocol dump list 0: Print for all communications 1: Print only when there is a communication error	This switch becomes effective only when system switch 00 bit 6 is set to 1. 1: Set this bit to 1 when you wish to print a protocol dump list only for communications with errors. <b>NOTE:</b> The memory size is limited. Use this bit switch only when some log reports are necessary.
7	Not used	Do not change this setting.

<b>System Switch 0A (SP No. 1-101-011)</b>		
No	Function	Comments
0	Automatic port selection 0: Disabled, 1: Enabled	When "1" is selected, a suitable port is automatically selected if the selected port is not used. <b>NOTE:</b> This bit is useful if all communication lines at a customer site are not the same quality
1-3	Not used	Do not change these settings.
4	Dialing on the ten-key pad when the external telephone is off-hook 0: Disabled 1: Enabled	0: Prevents dialing from the ten-key pad while the external telephone is off-hook. Use this setting when the external telephone is not by the machine, or if a wireless telephone is connected as an external telephone. 1: The user can dial on the machine's ten-key pad when the handset is off-hook.
5	On hook dial 0: Disabled 1: Enabled	0: On hook dial is disabled.
6-7	Not used	Do not change these settings

<b>System Switch 0B</b> - Not used (Do not change the factory settings.)
<b>System Switch 0C</b> - Not used (Do not change the factory settings.)
<b>System Switch 0D</b> - Not used (Do not change the factory settings.)

<b>System Switch 0E (SP No. 1-101-015)</b>		
No	Function	Comments
0-	Not used	Do not change the settings.



1		
2	Enable/disable for direct sending selection 0: Direct sending off 1: Direct sending on	Direct sending cannot operate when the capture function is on during sending. Setting this switch to "1" enables direct sending without capture. Setting this switch to "0" masks the direct sending function on the operation panel so direct sending with ScanRouter cannot be selected.
3	Action when the external handset goes off-hook 0: Manual TX and RX operation 1: Memory TX and RX operation (the display remains the same)	0: Manual TX is possible while the external handset is off-hook. However, manual TX during handset off-hook may not be sent to a correct direction. Manual TX is not possible. 1: The display stays in standby mode even when the external handset is used, so that other people can use the machine for memory TX operation. Note that manual TX and RX are not possible with this setting.
4-7	Not used	Do not change these settings.

<b>System Switch 0F (SP No. 1-101-016)</b>		
<b>No</b>	<b>Function</b>	<b>Comments</b>
0	Country/area code for functional settings (Hex)	This country/area code determines the factory settings of bit switches and RAM addresses. However, it has no effect on the NCU parameter settings and communication parameter RAM addresses. Cross reference NCU country code: SP No. 2-103-001 for G3-1 SP No. 2-104-001 for G3-2 SP No. 2-105-001 for G3-3
7	00: France    12: Asia	
	01: Germany    13: Japan	
	02: UK    14: Hong Kong	
	03: Italy    15: South Africa	
	04: Austria    16: Australia	
	05: Belgium    17: New Zealand	
	06: Denmark    18: Singapore	
	07: Finland    19: Malaysia	
	08: Ireland    1A: China	
	09: Norway    1B: Taiwan	
	0A: Sweden    1C: Korea	

## 5. Service Tables

0B: Switz.	1D: Brazil	
0C: Portugal	20: Turkey	
0D: Holland	21: Greece	
0E: Spain	22: Hungary	
0F: Israel	23: Czech	
10: ---	24: Poland	
11: USA		

System Switch 10 (SP No. 1-101-017)		
No	Function	Comments
0-7	Threshold memory level for parallel memory transmission	Threshold = N x 128 KB + 256 KB N can be between 00 - FF(H) Default setting: 02(H) = 512 KB

System Switch 11 (SP No. 1-101-018)		
No	Function	Comments
0	TTI printing position 0: Superimposed on the page data 1: Printed before the data leading edge	Change this bit to 1 if the TTI overprints information that the customer considers to be important (G3 transmissions). <b>NOTE:</b> If "1" is selected, it is possible that sent data is printed on two sheets of paper.
1-2	Not used	Do not change these settings.
3	TTI used for broadcasting 0: The TTIs selected for each Quick/Speed dial are used 1: The same TTI is used for all destinations	1: The TTI (TTI_1 or TTI_2) which is selected for all destinations during broadcasting.
4-7	Not used	Do not change these settings.

System Switch 12 (SP No. 1-101-019)		
No	Function	Comments
0-7	TTI printing position in the main scan direction	TTI: 08 to 92 (BCD) mm Input even numbers only. This setting determines the print start position for the TTI from the left edge of the paper. If the TTI is moved too far to the right, it may overwrite the file

	number which is on the top right of the page. On an A4 page, if the TTI is moved over by more than 50 mm, it may overwrite the page number.
--	---

<b>System Switch 13</b> - Not used (do not change these settings)
<b>System Switch 14</b> - Not used (do not change these settings)

<b>System Switch 15 (SP No. 1-101-022)</b>				
No	Function		Comments	
0	Not used		Do not change the settings.	
1	Going into the Energy Saver mode automatically 0: Enabled 1: Disabled		1: The machine will restart from the Energy Saver mode quickly, because the +5V power supply is active even in the Energy Saver mode. The LED of the operation switch is flashing instead of entering Energy Saver mode. Use this setting if an external telephone has to be used when the machine is in the Energy Saver mode.	
2- 3	Not used		Do not change these settings.	
4- 5	Interval for preventing the machine from entering Energy Saver mode if there is a pending transmission file.		If there is a file waiting for transmission, the machine does not go to Energy Saver mode during the selected period. After transmitting the file, if there is no file waiting for transmission, the machine goes to the Energy Saver mode.	
	Bit 5	Bit 4		Setting
	0	0		1 min
	0	1		30 min
	1	0		1 hour
	1	1	24 hours	
6- 7	Not used		Do not change	

<b>System Switch 16 (SP No. 1-101-023)</b>		
No	Function	Comments
0	Parallel Broadcasting 0: Disabled 1: Enabled	1: The machine sends messages simultaneously using all available ports during broadcasting. <b>NOTE:</b> If a customer wants to keep a line available for fax reception or other reasons, select "0" (Disable).
1	Priority setting for the G3 line. 0: PSTN-1 > PSTN-2 or 3	This function allows the user to select the default G3 line type. The optional SG3 units are required to use the PSTN-2 or 3 setting.

## 5. Service Tables

	1: PSTN-2 or 3 > PSTN-1	
2- 7	Not used	Do not change these settings.

**System Switch 17** - Not used (do not change these settings)

**System Switch 18** - Not used (do not change these settings)

### System Switch 19 (SP No. 1-101-026)

No	Function	Comments
0- 5	Not used	Do not change the settings.
6	Extended scanner page memory after memory option is installed 0: Disabled 1: Enabled	0: After installing the memory expansion option, the scanner page memory is extended to 4 MB from 2 MB. 1: If this bit is set to 1 after installing the memory expansion option, the scanner page memory is extended to 12 MB. But the SAF memory decreases to 18 MB.
7*	Special Original mode 0: Disabled 1: Enabled	1: If the customer frequently wishes to transmit a form or letterhead which has a colored or printed background, change this bit to "1". "Original 1" and "Original 2" can be selected in addition to the "Text", "Text/Photo" and "Photo" modes.

\* This setting can be used for the client machine which has no FCU.

### System Switch 1A (SP No. 1-101-027)

No	Function	Comments
0 to 7	LS RX memory capacity threshold setting 00-FF (0-1020 Kbyte: Hex)	Sets the value to x4KB. When the amount of available memory drops below this setting, RX documents are printed to conserve memory. Initial setting 0x80 (512 KB)  <b>Note</b> <ul style="list-style-type: none"> <li>If a customer wants available memory size to be larger, decrease this threshold.</li> </ul>

**System Switch 1B** - Not used (do not change these settings)

**System Switch 1C** - Not used (do not change these settings)

### System Switch 1D (SP No. 1-101-030)

No	Function	Comments
0	RTI/CSI/CPS code	0: RTI, CSI, CPS codes are displayed on the top line of the LCD panel

	display 0: Enable 1: Disable	during communication. 1: Codes are switched off (no display)
1-7	Not used	Do not change these settings.

System Switch 1E (SP No. 1-101-031)		
No	Function	Comments
0	Communication after the Journal data storage area has become full 0: Impossible 1: Possible	0: When this switch is on and the journal history becomes full, the next report prints. If the journal history is not deleted, the next transmission cannot be received. This prevents overwriting communication records before the machine can print them. 1: If the buffer memory of the communication records for the Journal is full, fax communications are still possible. But the machine will overwrite the oldest communication records. <b>Note</b> <ul style="list-style-type: none"> <li>This setting is effective only when Automatic Journal printout is enabled but the machine cannot print the report (e.g., no paper).</li> </ul>
1*	Action when the SAF memory has become full during scanning 0: The current page is erased. 1: The entire file is erased.	0: If the SAF memory becomes full during scanning for a memory transmission, the successfully scanned pages are transmitted. 1: If the SAF memory becomes full during scanning for a memory transmission, the file is erased and no pages are transmitted. <b>Note</b> <ul style="list-style-type: none"> <li>This setting is effective only when Automatic Journal printout is enabled but the machine cannot print the report (e.g., no paper).</li> </ul>
2	RTI/CSI display priority 0: RTI 1: CSI	This bit determines which identifier, RTI or CSI, is displayed on the LCD while the machine is communicating in G3 non-standard mode.
3	File No. printing 0: Enabled 1: Disabled	1: File numbers are not printed on any reports. <b>NOTE:</b> The file numbers may not be printed in the sequential order. If a customer does not like this numbering, select "0".
4	Action when authorized reception is enabled but authorized RTIs/CSIs are not	0: If the user has stored no acceptable sender RTIs or CSIs, the user can select "ON" in the authorized reception setting but the setting becomes invalid ("OFF"). The machine will not

## 5. Service Tables

	<p>yet programmed</p> <p>0: All fax reception is disabled</p> <p>1: Faxes can be received if the sender has an RTI or CSI</p>	<p>be able to receive any fax messages.</p> <p>If the customer wishes to receive messages from any sender that includes an RTI or CSI, and to block messages from senders that do not include an RTI or CSI, change this bit to "0", then enable Authorized Reception.</p> <p>Otherwise, keep this bit at "1 (default setting)".</p>
5-7	Not used	Do not change the settings

\* This setting can be used for the client machine which has no FCU.

<b>System Switch 1F (SP No. 1-101-032)</b>		
<b>No</b>	<b>Function</b>	<b>Comments</b>
0	Not used	Do not change the settings.
1	<p>Report printout after an original jam during SAF storage or if the SAF memory fills up</p> <p>0: Enabled</p> <p>1: Disabled</p>	<p>0: When an original jams, or the SAF memory overflows during scanning, a report will be printed.</p> <p>Change this bit to "1" if the customer does not want to have a report in these cases.</p> <p>Memory TX – Memory storage report</p> <p>Parallel memory TX – Transmission result report</p>
2	Not used	Do not change the settings.
3	<p>Received fax print start timing (G3 reception)</p> <p>0: After receiving each page</p> <p>1: After receiving all pages</p>	<p>0: The machine prints each page immediately after the machine receives it.</p> <p>1: The machine prints the complete message after the machine receives all the pages in the memory.</p>
4-6	Not used	Do not change the factory settings.
7	<p>Action when a fax SC has occurred</p> <p>0: Automatic reset</p> <p>1: Fax unit stops</p>	<p>0: When the fax unit detects a fax SC code other than SC1201 and SC1207, the fax unit automatically resets itself.</p> <p>1: When the fax unit detects any fax SC code, the fax unit stops.</p> <p><b>Reference:</b></p> <p>For fax SC codes, see "Troubleshooting".</p>

## Bit Switches - 2

### ★ Important

- Do not adjust a bit switch or use a setting that is described as "Not used", as this may cause the machine to malfunction or to operate in a manner that is not accepted by local regulations. Such bits are for use only in other areas, such as Japan.

Default settings for bit switches are not listed in this manual. Refer to the System Parameter List printed by the machine.

### I-Fax Switches

I-fax Switch 00 (SP No. 1-102-001)		
No	Function	Comments
Original Width of TX Attachment File		This setting sets the maximum size of the original that the destination can receive. (Bits 3 to 6 are reserved for future use or not used.)
0	A4	-
1	B4	
2	A3	
3-6	Reserved	
7	Not used	
<p>0: Off (not selected), 1: On (selected)</p> <p>If more than one of these three bits is set to "1", the larger size has priority. For example, if both Bit 2 and Bit 1 are set to "1" then the maximum size is "A3" (Bit 2).</p> <p>When mail is sent, there is no negotiation with the receiving machine at the destination, so the sending machine cannot make a selection for the receiving capabilities (original width setting) of the receiving machine. The original width selected with this switch is used as the RX machine's original width setting, and the original is reduced to this size before sending. The default is A4.</p> <p>If the width selected with this switch is higher than the receiving machine can accept, the machine detects this and this causes an error.</p>		

I-fax Switch 01 (SP No. 1-102-002)		
No	Function	Comments
Original Line Resolution of TX Attachment File		These settings set the maximum resolution of the original that the destination can receive.
0	200x100 Standard	0: Not selected
1	200x200 Detail	1: Selected
2	200x400 Fine	If more than one of these three bits is set to "1", the higher resolution has priority. For example, if both Bit 0 and Bit 2 are set to "1" Then The Resolution is set for "Bit 2 200 x 400.
3	300 x 300 Reserve	
4	400 x 400 Super	

5. Service Tables

	Fine	
5	600 x 600 Reserve	
6	Reserve	
7	mm/inch	
	<p>This setting selects mm/inch conversion for mail transmission.            0: Off (No conversion), 1: On (Conversion)</p> <p>When on (set to "1"), the machine converts millimeters to inches for sending mail. There is no switch for converting inches to millimeters.</p> <p>Unlike G3 fax transmissions which can negotiate between sender and receiver to determine the setting, mail cannot negotiate between terminals; the mm/inch selection is determined by the sender fax.</p> <p>When this switch is Off (0):</p> <ul style="list-style-type: none"> <li>• Images scanned in inches are sent in inches.</li> <li>• Images scanned in mm are sent in mm.</li> <li>• Images received in inches are transmitted in inches.</li> <li>• Images received in mm are transmitted in mm.</li> </ul> <p>When this switch is On (1):</p> <ul style="list-style-type: none"> <li>• Images scanned in inches are sent in inches.</li> <li>• Images scanned in mm are converted to inches.</li> <li>• Images received in inches are transmitted in inches.</li> <li>• Images received in mm are converted to inches.</li> </ul>	

<b>I-fax Switch 02 (SP No. 1-102-003)</b>		
<b>No</b>	<b>Function</b>	<b>Comments</b>
0	RX Text Mail Header Processing	<p>This setting determines whether the header information is printed with text e-mails when they are received.</p> <p>0: Prints only text mail.            1: Prints mail header information attached to text mail.</p> <p>When a text mail is received with this switch On (1), the "From" address and "Subject" address are printed as header information.</p> <p>When a mail with only binary data is received (a TIFF-F file, for example), this setting is ignored and no header is printed.</p>
1	Output from Attached Document at E-mail TX Error	<p>This setting determines whether only the first page or all pages of an e-mail attachment are printed at the sending station when a transmission error occurs. This allows the customer to see which documents have not reached their intended destinations if sent to the wrong e-mail addresses, for example.</p> <p>0: Prints 1st page only.</p>



	1: Prints all pages.
2-3	Text String for Return Receipt This setting determines the text string output for the Return Receipt that confirms the transmission was received normally at the destination.
	00: "Dispatched" Sends from PC mail a request for a Return Receipt. Receives the Return Receipt with "dispatched" in the 2nd part: Disposition: Automatic-action/MDN-send automatically; dispatched The "dispatched" string is included in the Subject string. 01: "Displayed" Sends from PC mail a request for a Return Receipt. Receives the Return Receipt with "displayed" in the 2nd part: Disposition: Automatic-action/MDN-send automatically; displayed The "displayed" string is included in the Subject string. 10: Reserved 11: Reserved A mail requesting a Return Receipt sent from an IFAX with this switch set to "00" (for "dispatched") received by Microsoft Outlook 2000 may cause an error. If any setting other than "displayed" (01) causes a problem, change the setting to "01" to enable normal sending of the Return Receipt.
4	Media accept feature This setting adds or does not add the media accept feature to the answer mail to confirm a reception. 0: Does not add the media accept feature to the answer mail 1: Adds the media accept feature to the answer mail. Use this bit switch if a problem occurs when the machine receives an answer mail, which contains the media accept feature field.
5-6	Not Used
7	Image Resolution of RX Text Mail This setting determines the image resolution of the received mail. 0: 200 x 200 1: 400 x 400 The "1" setting requires installation of the Memory Unit in order to have enough SAF (Store and Forward) memory to receive images at 400 x 400 resolution.

**I-fax Switch 03** - Not used (do not change these settings)

**I-fax Switch 04 (SP No. 1-102-005)**

5. Service Tables

No	Function	Comments
0	Subject for Delivery TX/Memory Transfer	<p>This setting determines whether the RTI/CSI registered on this machine or the RTI/CSI of the originator is used in the subject lines of transferred documents.</p> <p>0: Puts the RTI/CSI of the originator in the Subject line. If this is used, either the RTI or CSI is used. Only one of these can be received for use in the subject line.</p> <p>1: Puts the RTI/CSI registered on this machine in the Subject line.</p> <p>When this switch is used to transfer and deliver mail to a PC, the information in the Subject line that indicates where the transmission originated can be used to determine automatically the destination folder for each e-mail.</p>
1	Subject corresponding to mail post database	<p>0: Standard subject</p> <p>1: Mail post database subject</p> <p>The standard subject is replaced by the mail post database subject in the following three cases:</p> <ol style="list-style-type: none"> <li>1) When the service technician sets the service (software) switch.</li> <li>2) When memory sending or delivery specified by F code is applied by the SMTP server</li> <li>3) With relay broadcasting (1st stage without the Schmidt 4 function).</li> </ol> <p><b>Note</b></p> <ul style="list-style-type: none"> <li>• This switch does not apply for condition 3) when the RX system is set up for memory sending, delivery by F-code, sending with SMTP RX and when operators are using FOL (to prevent problems when receiving transmissions).</li> </ul>
2-7	Not Used	

I-fax Switch 05 (SP No. 1-102-006)		
No	Function	Comments
0	Mail Addresses of SMTP Broadcast Recipients	<p>Determines whether the e-mail addresses of the destinations that receive transmissions broadcasted using SMTP protocol are recorded in the Journal.</p> <p>For example:</p> <p>"1st destination + Total number of destinations: 9" in the Journal indicates a broadcast to 9 destinations.</p> <p>0: Not recorded</p> <p>1: Recorded</p>
1	IFAXTX Retries	<p>Determines whether the machine retries sending IFAX when connection and transmission fails due to errors.</p> <p>0: Disabled</p> <p>1: Enabled</p>
2-7	Not Used	

<b>I-fax Switch 06</b> - Not used (do not change the settings)
<b>I-fax Switch 07</b> - Not used (do not change the settings)

<b>I-fax Switch 08 (SP No. 1-102-009)</b>		
<b>No</b>	<b>Function</b>	<b>Comments</b>
0-7	Memory Threshold for POP Mail Reception	<p>This setting determines the amount of SAF (Store and Forward) memory. (SAF stores fax messages to send later for transmission to more than one location, and also holds incoming messages if they cannot be printed.) When the amount of SAF memory available falls below this setting, mail can no longer be received; received mail is then stored on the mail server.</p> <p>00-FF (0 to 1024 KB: HEX)</p> <p>The hexadecimal number you enter is multiplied by 4 KB to determine the amount of memory.</p>

<b>I-fax Switch 09 (SP No. 1-102-010)</b>		
<b>No</b>	<b>Function</b>	<b>Comments</b>
0-3	Not used	Do not change the settings
4-7	Restrict TX Retries	<p>This setting determines the number of retries when connection and transmission fails due to errors.</p> <p>01-F (1-15 Hex)</p>

<b>I-fax Switch 0A</b> - Not used (do not change the settings)
<b>I-fax Switch 0B</b> - Not used (do not change the settings)
<b>I-fax Switch 0C</b> - Not used (do not change the settings)

<b>I-fax Switch 0D (SP No. 1-102-014)</b>				
<b>No</b>	<b>Function</b>			<b>Comments</b>
0-1	Not used			Do not change the settings
2-3	Select the signature when sending mail notification of the send results			In response to IEEE2600.1.
	Bit 2	Bit 3	Setting	
	0	0	No sign	
	0	1	No setting	
	<b>1</b>	<b>0</b>	Individual setting	
	1	1	Always sign	
4-	Select the signature when sending mail.			In response to

## 5. Service Tables

5				IEEE2600.1.
	Bit 5	Bit 4	Setting	
	0	0	No sign	
	0	1	No setting	
	1	0	Individual setting	
	1	1	Always sign	
6-7	Not used			Do not change the settings.

**I-fax Switch 0E** - Not used (do not change the settings)

<b>I-fax Switch 0F (SP No. 1-102-016)</b>		
No	Function	Comments
0	Delivery Method for SMTP RX Files	This setting determines whether files received with SMTP protocol are delivered or output immediately. 0: Off. Files received via SMTP are output immediately without delivery. 1: On. Files received via SMTP are delivered immediately to their destinations.
1	Set to select the signature when receiving SMTP mail.	0: No sign 1: Always sign
2	Set to encrypt the data when receiving SMTP mail.	0: No encryption 1: Encryption
3-7	Not used	

## Printer Switches

<b>Printer Switch 00 (SP No. 1-103-001)</b>		
No	Function	Comments
0	Select page separation marks 0: Off 1: On	0: If a 2 page RX transmission is split, [*] is printed in the bottom right corner of the 1st page and only a [2] is printed in the upper right corner of the 2nd page. 1: If a 2 page RX transmission is split into two pages, for example, [*] [2] is printed in the bottom right corner of the 1st page and only a [2] is printed in the upper right corner of the 2nd page. <b>Note</b> • This helps the user to identify pages that have been split

		because the size of the paper is smaller than the size of the document received. (When A5 is used to print an A4 size document, for example.)
1	Repetition of data when the received page is longer than the printer paper 0: Off 1: On	1: Default. 10 mm of the trailing edge of the previous page are repeated at the top of the next page. 0: The next page continues from where the previous page stopped without any repeated text.
2	Prints the date and time on received fax messages 0: Disabled 1: Enabled	This switch is only effective when user parameter 02 - bit 2 (printing the received date and time on received fax messages) is enabled. 1: The machine prints the received and printed date and time at the bottom of each received page.
3-7	Not used	Do not change the settings.

<b>Printer Switch 01 (SP No. 1-103-002)</b>				
<b>No</b>	<b>Function</b>			<b>Comments</b>
0-2	Not used			Do not change the settings.
3-4	Maximum print width used in the setup protocol			These bits are only effective when bit 7 of printer switch 01 is "1".
	Bit 4	Bit 3	Setting	
	0	0	Not used	
	0	1	A3	
	1	0	B4	
	1	1	A4	
5-6	Not used			Do not change the settings.
7	Received message width restriction in the protocol signal to the sender 0: Disabled 1: Enabled			0: The machine informs the transmitting machine of the print width depending on the paper size available from the paper feed stations. Refer to the table on the next page for how the machine chooses the paper width used in the setup protocol (NSF/DIS). 1: The machine informs the transmitting machine of the fixed paper width which is specified by bits 3 and 4

5. Service Tables

	above.
--	--------

**Relationship between available paper sizes and printer width used in the setup protocol**

Available Paper Size	Printer width used in the Protocol (NSF/DIS)
A4 or 8.5" x 11"	297 mm width
B5	256 mm width
A5 or 8.5" x 5.5"	216 mm width
No paper available (Paper end)	216 mm width

Printer Switch 02 (SP No. 1-103-003)		
No	Function	Comments
0*	1st paper feed station usage for fax printing 0: Enabled 1: Disabled	0: The paper feed station can be used to print fax messages and reports. 1: The specified paper feed station will not be used for printing fax messages and reports.
1*	2nd paper feed station usage for fax printing 0: Enabled 1: Disabled	<p><b>Note</b></p> <ul style="list-style-type: none"> <li>Do not disable usage for a paper feed station which has been specified by User Parameter Switch 0F (15), or which is used for the Specified Cassette Selection feature.</li> </ul>
2*	3rd paper feed station usage for fax printing 0: Enabled 1: Disabled	
3*	4th paper feed station usage for fax printing 0: Enabled 1: Disabled	
4*	LCT usage for fax printing 0: Enabled 1: Disabled	
5-7	Not used	

\* This setting can be used for the client machine which has no FCU.

Printer Switch 03 (SP No. 1-103-004)
--------------------------------------

No	Function	Comments
0*	Length reduction of received data 0: Disabled 1: Enabled	0: Incoming pages are printed without length reduction. (Page separation threshold: Printer Switch 03, bits 4 to 7) 1: Incoming page length is reduced when printing. (Maximum reducible length: Printer Switches 04, bits 0 to 4)
1-3	Not used	Do not change the settings
4 to 7	Page separation setting when sub scan compression is forbidden 00-0F (0-15 mm: Hex) Default: 6 mm	Page separation threshold (with reduction disabled with switch 03-0 above). For example, if this setting is set to "10", and A4 is the selected paper size: If the received document is 10 mm or less longer than A4, then the 10 mm are cut and only 1 page prints. If the received document is 10 mm longer than A4, then the document is split into 2 pages.

\* This setting can be used for the client machine which has no FCU.

Printer Switch 04 (SP No. 1-103-005)						
No	Function			Comments		
0 to 4	Maximum reducible length when length reduction is enabled with switch 03-0 above. [Maximum reducible length] = [Paper length] + (N x 5mm) "N" is the decimal value of the binary setting of bits 0 to 4.					
	Bit 4	Bit 3	Bit 2	Bit 1	Bit 0	Setting
	0	0	0	0	0	0 mm
	0	0	0	0	1	5 mm
	0	0	1	0	0	20 mm
	1	1	1	1	1	155 mm
	For A5 sideways and B5 sideways paper [Maximum reducible length] = [Paper length] + 0.75 x (N x 5mm)					
5 to 6	Length of the duplicated image on the next page, when page separation has taken place.					
	Bit 6		Bit 5		Setting	
	0		0		4 mm	
	0		1		10 mm	
	1		0		15 mm	
	1		1		Not used	
7	Not used.			Do not change the setting.		

5. Service Tables

**Printer Switch 05** - Not used (do not change the settings)

<b>Printer Switch 06 (SP No. 1-103-007)</b>		
<b>No</b>	<b>Function</b>	<b>Comments</b>
0*	Printing while a paper cassette is pulled out, when the Just Size Printing feature is enabled. 0: Printing will not start 1: Printing will start if another cassette has a suitable size of paper, based on the paper size selection priority tables.	<b>Reference:</b> Just size printing on/off – User switch 05, bit 5
1-7	Not used.	Do not change the settings.

\* This setting can be used for the client machine which has no FCU.

<b>Printer Switch 07 (SP No. 1-103-008)</b>		
<b>No</b>	<b>Function</b>	<b>Comments</b>
0-3	Not used.	Do not change the settings.
4	Receiver name printed on the transmission result report	Selects the printing target on the transmission result report. 0: All receivers 1: Printing only receivers which have received fax transmission.
5-7	Not used.	Do not change the settings.

- Printer Switch 08** - Not used (do not change the settings)
- Printer Switch 09** - Not used (do not change the settings)
- Printer Switch 0A** - Not used (do not change the settings)
- Printer Switch 0B** - Not used (do not change the settings)
- Printer Switch 0C** - Not used (do not change the settings)

<b>Printer Switch 0E (SP No. 1-103-015)</b>		
<b>No</b>	<b>Function</b>	<b>Comments</b>
0*	Paper size selection priority 0: Width 1: Length	0: A paper size that has the same width as the received data is selected first. 1: A paper size which has enough length to print all the received lines without reduction is selected first.
1*	Paper size selected for printing A4 width fax data	This switch determines which paper size is selected for printing A4 width fax data, when the machine has both A4 and



	0: 8.5" x 11" size 1: A4 size	8.5" x 11" size paper.															
2	Page separation 0: Enabled 1: Disabled	1: If all paper sizes in the machine require page separation to print a received fax message, the machine does not print the message (Substitute Reception is used). After a larger size of paper is set in a cassette, the machine automatically prints the fax message.															
3-4	Printing the sample image on reports <table border="1"> <thead> <tr> <th>Bit 4</th> <th>Bit 3</th> <th>Setting</th> </tr> </thead> <tbody> <tr> <td>0</td> <td>0</td> <td>The upper half only</td> </tr> <tr> <td>0</td> <td>1</td> <td>50% reduction (sub-scan only)</td> </tr> <tr> <td>1</td> <td>0</td> <td>Same size</td> </tr> <tr> <td>1</td> <td>1</td> <td>Not used</td> </tr> </tbody> </table>	Bit 4	Bit 3	Setting	0	0	The upper half only	0	1	50% reduction (sub-scan only)	1	0	Same size	1	1	Not used	"Same size" means the sample image is printed at 100%, even if page separation occurs. User Parameter Switch 19 (13H) bit 4 must be set to "0" to enable this switch. Refer to "Detailed Descriptions" for more details.
Bit 4	Bit 3	Setting															
0	0	The upper half only															
0	1	50% reduction (sub-scan only)															
1	0	Same size															
1	1	Not used															
5-6	Not used	Do not change the settings.															
7	Equalizing the reduction ratio among separated pages (Page Separation) 0: Enabled 1: Disabled	0: When page separation has taken place, all the pages are reduced with the same reduction ratio. 1: Only the last page is reduced to fit the selected paper size when page separation has taken place. Other pages are printed without reduction.															

\* This setting can be used for the client machine which has no FCU.

<b>Printer Switch 0F (SP No. 1-103-016)</b>																			
No	Function			Comments															
0-1*	Smoothing feature <table border="1"> <thead> <tr> <th>Bit 1</th> <th>Bit 0</th> <th>Setting</th> </tr> </thead> <tbody> <tr> <td>0</td> <td>0</td> <td>Disabled</td> </tr> <tr> <td>0</td> <td>1</td> <td>Disabled</td> </tr> <tr> <td>1</td> <td>0</td> <td>Enabled</td> </tr> <tr> <td>1</td> <td>1</td> <td>Not used</td> </tr> </tbody> </table>			Bit 1	Bit 0	Setting	0	0	Disabled	0	1	Disabled	1	0	Enabled	1	1	Not used	(0, 0) (0, 1): Disable smoothing if the machine receives halftone images from other manufacturers fax machines frequently.
Bit 1	Bit 0	Setting																	
0	0	Disabled																	
0	1	Disabled																	
1	0	Enabled																	
1	1	Not used																	
2*	Duplex printing 0: Disabled 1: Enabled			1: The machine always prints received fax messages in duplex printing mode:															
3	Binding direction for Duplex printing			0: Sets the binding for the left edge of the stack. 1: Sets the binding for the top of the stack.															

## 5. Service Tables

	0: Left binding 1: Top binding	
4-7	Not used	Do not change the settings.

\* This setting can be used for the client machine which has no FCU.

## Bit Switches - 3

### ★ Important

- Do not adjust a bit switch or use a setting that is described as "Not used", as this may cause the machine to malfunction or to operate in a manner that is not accepted by local regulations. Such bits are for use only in other areas, such as Japan.

Default settings for bit switches are not listed in this manual. Refer to the System Parameter List printed by the machine.

### Communication Switches

Communication Switch 00 (SP No. 1-104-001)				
No	Function			Comments
0- 1	Compression modes available in receive mode			These bits determine the compression capabilities to be declared in phase B (handshaking) of the T.30 protocol.
	Bit	Bit	Modes	
	1	0		
	0	0	MH only	
	0	1	MH/MR	
	1	0	MH/MR/MMR	
2- 3	Compression modes available in transmit mode			These bits determine the compression capabilities to be used in the transmission and to be declared in phase B (handshaking) of the T.30 protocol.
	Bit	Bit	Modes	
	3	2		
	0	0	MH only	
	0	1	MH/MR	
	1	0	MH/MR/MMR	
1	1	MH/MR/MMR/JBIG		
4	Not used			Do not change the settings.
5	JBIG compression method: Reception 0: Only basic supported 1: Basic and optional both supported			Change the setting when communication problems occur using JBIG compression.
6	JBIG compression method: Transmission 0: Basic mode priority 1: Optional mode priority			Change the setting when communication problems occur using JBIG compression.
7	Closed network (reception)			1: Reception will not go ahead if the polling ID code of the

5. Service Tables

	0: Disabled 1: Enabled	remote terminal does not match the polling ID code of the local terminal. This function is only available in NSF/NSS mode.
--	---------------------------	--

Communication Switch 01 (SP No. 1-104-002)				
No	Function		Comments	
0	ECM 0: Off 1: On		If this bit is set to 0, ECM is switched off for all communications. In addition, V.8 protocol and JBIG compression are switched off automatically.	
1	Not used		Do not change the setting.	
2-3	Wrong connection prevention method		(0,1): The machine will disconnect the line without sending a fax message, if the last 8 digits of the received CSI do not match the last 8 digits of the dialed telephone number. This does not work when manually dialed.  (1,0): The same as above, except that only the last 4 digits are compared.  (1,1): The machine will disconnect the line without sending a fax message, if the other end does not identify itself with an RTI or CSI.  (0,0): Nothing is checked; transmission will always go ahead.	
	Bit 3	Bit 2		Setting
	0	0		None
	0	1		8 digit CSI
	1	0		4 digit CSI
	1	1		CSI/RTI
4-5	Not used		Do not change the setting.	
6-7	Maximum printable page length available		The setting determined by these bits is informed to the transmitting terminal in the pre-message protocol exchange (in the DIS/NSF frames).	
	Bit 7	Bit 6		Setting
	0	0		No limit
	0	1		B4 (364 mm)
	1	0		A4 (297 mm)
	1	1	Not used	

**Note**

- This function does not work when dialing is done from the external telephone.

Communication Switch 02 (SP No. 1-104-003)		
No	Function	Comments
0	G3 Burst error threshold 0: Low 1: High	If there are more consecutive error lines in the received page than the threshold, the machine will send a negative

		response. The Low and High threshold values depend on the sub-scan resolution, and are as follows.
		100 dpi                      6(L) →12(H)
		200 dpi                      12(L) →24(H)
		300 dpi                      18(L) →36(H)
		400 dpi                      24(L) →48(H)
1	Acceptable total error line ratio 0: 5% 1: 10%	If the error line ratio for a page exceeds the acceptable ratio, RTN will be sent to the other end.
2	Treatment of pages received with errors during G3 reception 0: Deleted from memory without printing 1: Printed	0: Pages received with errors are not printed.
3	Hang-up decision when a negative code (RTN or PIN) is received during G3 immediate transmission 0: No hang-up, 1: Hang-up	0: The next page will be sent even if RTN or PIN is received. 1: The machine will send DCN and hang up if it receives RTN or PIN.  This bit is ignored for memory transmissions or if ECM is being used.
4-7	Not used	Do not change these settings.

<b>Communication Switch 03 (SP No. 1-104-004)</b>		
<b>No</b>	<b>Function</b>	<b>Comments</b>
0-7	Maximum number of page retransmissions in a G3 memory transmission	00 - FF (Hex) times.  This setting is not used if ECM is switched on.  Default setting - 03(H)

<b>Communication Switch 04 (SP No. 1-104-005)</b>		
<b>No</b>	<b>Function</b>	<b>Comments</b>
0	Remote mode switch (TEL mode) 0: Disable 1: Enable (Active)	Set this bit to ON when you wish to switch TEL mode to FAX mode remotely.
1	Remote mode switch (FAX mode) 0: Disable 1: Enable (Active)	Set this bit to ON when you wish to turn on the remote mode switch after automatic reception with FAX mode.

5. Service Tables

2	Remote mode switch (AUTO mode) 0: Disable 1: Enable (Active)	Set this bit to ON when you wish to turn on the remote mode switch after automatic reception with AUTO mode.
3-7	Not used	Do not change the settings.

<b>Communication Switch 05 (SP No. 1-104-006)</b>		
No	Function	Comments
0-3	Remote mode switch number 00-09 (0-9:HEX)	Enter the number to switch between TEL/FAX modes using the external phone.
4-7	Not used	Do not change the settings.

<b>Communication Switch 06</b> - Not used (do not change the settings)
<b>Communication Switch 07</b> - Not used (do not change the settings)
<b>Communication Switch 08</b> - Not used (do not change the settings)

<b>Communication Switch 09 (SP No. 1-104-009)</b>		
No	Function	Comments
0-7	Minimum interval between automatic dialing attempts	This value is the minimum time that the machine waits before it dials the next destination.

<b>Communication Switch 0A (SP No. 1-104-011)</b>		
No	Function	Comments
0	Point of resumption of memory transmission upon redialing 0: From the error page 1: From page 1	0: The transmission begins from the page where transmission failed the previous time. 1: Transmission begins from the first page, using normal memory transmission.
1-7	Not used	Do not change these settings.

<b>Communication Switch 0B (SP No. 1-104-012)</b>		
No	Function	Comments
0-3	Not used	Do not change these settings.
4	Printout of the message	When the machine is acting as a Transfer Station, this bit

	when acting as a Transfer Station 0: Disabled, 1: Enabled	determines whether the machine prints the fax message coming in from the Requesting Terminal.
5-7	Not used	Do not change the settings.

**Communication Switch 0C** - Not used (do not change the settings)

**Communication Switch 0D (SP No. 1-104-014)**

No	Function	Comments
0-7	The available memory threshold, below which ringing detection (and therefore reception into memory) is disabled	00 to FF (Hex), unit = 4 Kbytes (e.g., 06(H) = 24 Kbytes) One page is about 24 Kbytes. The machine refers to this setting before each fax reception. If the amount of remaining memory is below this threshold, the machine cannot receive any fax messages. If this setting is kept at 0, the machine will detect ringing signals and go into receive mode even if there is no memory available. This will result in communication failure.

**Communication Switch 0E (SP No. 1-104-015)**

No	Function	Comments
0-7	Minimum interval between automatic dialing attempts	06 to FF (Hex), unit = 2 s (e.g., 06(H) = 12 s) This value is the minimum time that the machine waits before it dials the next destination.

**Communication Switch 0F** – Not used (do not change the settings.)

**Communication Switch 10 (SP No. 1-104-017)**

No	Function	Comments
0-7	Memory transmission: Maximum number of dialing attempts to the same destination	01 – FE (Hex) times

**Communication Switch 11** – Not used (do not change the settings.)

5. Service Tables

<b>Communication Switch 12 (SP No. 1-104-019)</b>		
<b>No</b>	<b>Function</b>	<b>Comments</b>
0-7	Memory transmission: Interval between dialing attempts to the same destination	01 – FF (Hex) minutes

**Communication Switch 13** – Not used (do not change the settings.)

<b>Communication Switch 14 (SP No. 1-104-021)</b>				
<b>No</b>	<b>Function</b>		<b>Comments</b>	
0	Inch-to-mm conversion during transmission 0: Disabled, 1: Enabled		0: In immediate transmission, data scanned in inch format are transmitted without conversion. In memory transmission, data stored in the SAF memory in mm format are transmitted without conversion. Note: When storing the scanned data into SAF memory, the fax unit always converts the data into mm format. 1: The machine converts the scanned data or stored data in the SAF memory to the format which was specified in the set-up protocol (DIS/NSF) before transmission.	
1-5	Not used		Do not change the factory settings.	
6-7	Available unit of resolution in which fax messages are received		For the best performance, do not change the factory settings. The setting determined by these bits is informed to the transmitting terminal in the pre-message protocol exchange (in the DIS/NSF frames).	
	Bit 7	Bit 6		Unit
	0	0		mm
	0	1		inch
	1	0		mm and inch
	1	1	Not used	

**Communication Switch 15** – Not used (do not change the settings)

<b>Communication Switch 16 (SP No. 1-104-023)</b>		
<b>No</b>	<b>Function</b>	<b>Comments</b>
0	Not used	Do not change the settings.
1	Optional G3 unit (G3-2) 0: Not installed 1: Installed	Change this bit to 1 when installing the first optional G3 unit.
2	Not used	



3	Select PSTN connection 0: Off 1: On	This switch enables the G3-2. 0: Off, no connection 1: Recognizes and enables G3-2. This switch can be used only after G3-2 has been installed.
4-7	Not used	Do not change the settings.

<b>Communication Switch 17 (SP No. 1-104-024)</b>		
<b>No</b>	<b>Function</b>	<b>Comments</b>
0	SEP reception 0: Disabled 1: Enabled	0: Polling transmission to another maker's machine using the SEP (Selective Polling) signal is disabled.
1	SUB reception 0: Disabled 1: Enabled	0: Confidential reception to another maker's machine using the SUB (Sub-address) signal is disabled.
2	PWD reception 0: Disabled 1: Enabled	0: Disables features that require PWD (Password) signal reception.
3-4	Not used	Do not change the settings.
5	PSTN dial-in routing setting 0: OFF 1: ON	1: The machine sets multiple PSTN dial-in numbers in the PSTN dial-in line and transfers received data from each PSTN dial-in number to each address.
6	Not used	Do not change the settings.
7	Action when there is no box with an F-code that matches the received SUB code 0: Disconnect the line 1: Receive the message (using normal reception mode)	Change this setting when the customer requires.

<b>Communication Switch 18 (SP No. 1-104-025)</b>		
<b>No</b>	<b>Function</b>	<b>Comments</b>
0-4	Not used	Do not change the settings.
5	IP-Fax dial-in routing selection 0: Off 1: On	1: Transfers received data to each IP-Fax dial-in number. IP-Fax dial-in number is a 4-digit number.
6	PSTN 2 dial-in routing	Enables or disables dial-in routing for the PSTN 2 connection.

5. Service Tables

	0: Off 1: On	
7	PSTN 3 dial-in routing 0: Off 1: On	Enables or disables dial-in routing for the PSTN 3 connection.

<b>Communication Switch 19</b> - Not used (do not change the settings)
<b>Communication Switch 1A</b> - Not used (do not change the settings)

<b>Communication Switch 1B (SP No. 1-104-028)</b>		
No	Function	Comments
0-7	Extension access code (0 to 7) to turn V.8 protocol On/Off 0: On 1: Off	If the PABX does not support V.8/V.34 protocol procedure, set this bit to "1" to disable V.8.  Example: If "0" is the PSTN access code, set bit 0 to 1. When the machine detects "0" as the first dialed number, it automatically disables V.8 protocol. (Alternatively, if "3" is the PSTN access code, set bit 3 to 1.)

<b>Communication Switch 1C (SP No. 1-104-029)</b>		
No	Function	Comments
0-1	Extension access code (8 and 9) to turn V.8 protocol On/Off 0: On 1: Off	Refer to communication switch 1B.  Example: If "8" is the PSTN access code, set bit 0 to 1. When the machine detects "8" as the first dialed number, it automatically disables V.8 protocol. (If "9" is the PSTN access code, use bit 1.)
2-7	Not used	Do not change the settings.

<b>Communication Switch 1D</b> - Not used (do not change the settings)
<b>Communication Switch 1E</b> - Not used (do not change the settings)
<b>Communication Switch 1F</b> - Not used (do not change the settings)

## Bit Switches - 4

### ★ Important

- Do not adjust a bit switch or use a setting that is described as "Not used", as this may cause the machine to malfunction or to operate in a manner that is not accepted by local regulations. Such bits are for use only in other areas, such as Japan.

Default settings for bit switches are not listed in this manual. Refer to the System Parameter List printed by the machine.

### G3 Switches

G3 Switch 00 (SP No. 1-105-001)				
No	Function			Comments
0 1	Monitor speaker during communication (TX and RX)			(0, 0): The monitor speaker is disabled all through the communication.
	Bit 1	Bit 0	Setting	(0, 1): The monitor speaker is on up to phase B in the T.30 protocol.
	0	0	Disabled	(1, 0): Used for testing. The monitor speaker is on all through the communication. Make sure that you reset these bits after testing.
	0	1	Up to Phase B	
	1	0	All the time	
	1	1	Not used	
2	Monitor speaker during memory transmission 0: Disabled 1: Enabled			1: The monitor speaker is enabled during memory transmission.
3- 5	Not used			Do not change the settings.
6	Dedicated G3 line mode selection 0: Off 1: On (Dedicated)			Set this bit to 1 when you wish to dedicate a line for G3.
7	Not used			Do not change this setting.

G3 Switch 01 (SP No. 1-105-002)		
No	Function	Comments
0- 3	Not used	Do not change the settings.
4	DIS frame length 0: 10 bytes 1: 4 bytes	1: The bytes in the DIS frame after the 4th byte will not be transmitted (set to 1 if there are communication problems with PC-based faxes which cannot receive the extended DIS frames).
5	Not used	Do not change the setting.

5. Service Tables

6	Forbid CED/ANSam output 0: Off 1: On (Forbid output)	Do not change this setting (Default: 0: Off), unless communication problem is caused by a CED or ANSam transmission.
7	Not used	Do not change this setting.

<b>G3 Switch 02 (SP No. 1-105-003)</b>		
No	Function	Comments
0	G3 protocol mode used 0: Standard and non-standard 1: Standard only	Change this bit to 1 only when the other end can only communicate with machines that send T.30-standard frames only. 1: Disables NSF/NSS signals (these are used in non-standard mode communication)
1-6	Not used	Do not change the settings.
7	Short preamble 0: Disabled 1: Enabled	Refer to Appendix B in the Group 3 Facsimile Manual for details about Short Preamble.

<b>G3 Switch 03 (SP No. 1-105-004)</b>		
No	Function	Comments
0	DIS detection number (Echo countermeasure) 0: 1 1: 2	0: The machine will hang up if it receives the same DIS frame twice. 1: Before sending DCS, the machine will wait for the second DIS which is caused by echo on the line.
1	Not Used	Do not change the settings.
2	Not Used	Do not change the settings.
3	ECM frame size 0: 256 bytes 1: 64 bytes	Keep this bit at "0" in most cases.
4	CTC transmission conditions 0: After one PPR signal received 1: After four PPR signals received (ITU-T standard)	0: When using ECM in non-standard (NSF/NSS) mode, the machine sends a CTC to drop back the modem rate after receiving a PPR, if the following condition is met in communications at 14.4, 12.0, 9.6, and 7.2 kbps. $\sqrt{N} \text{ Transmit} \leq N \text{ Re send}$

		<p>NTransmit- Number of transmitted frames</p> <p>NResend- Number of frames to be retransmitted</p> <p>1: When using ECM, the machine sends a CTC to drop back the modem rate after receiving four PPRs.</p> <p>PPR, CTC: These are ECM protocol signals.</p> <p>This bit is not effective in V.34 communications.</p>
5	<p>Modem rate used for the next page after receiving a negative code (RTN or PIN)</p> <p>0: No change 1: Fallback</p>	<p>1: The machine's TX modem rate will fall back before sending the next page if a negative code is received. This bit is ignored if ECM is being used.</p>
6	Not used	Do not change the settings
7	<p>Select detection of reverse polarity in ringing</p> <p>0: Off</p> <p>1: On</p>	<p>This switch is used to prevent reverse polarity in ringing on the phone line (applied to PSTN-G3 ringing). Do not change this setting</p> <p>0: No detection</p> <p>1: Detection (Japan and Korea only)</p>

<b>G3 Switch 04 (SP No. 1-105-005)</b>		
No	Function	Comments
0-3	Training error detection threshold	<p>0 - F (Hex); 0 - 15 bits</p> <p>If the number of error bits in the received TCF is below this threshold, the machine informs the sender that training has succeeded.</p>
4-7	Not used	Do not change the settings.

<b>G3 Switch 05 (SP No. 1-105-006)</b>						
No	Function					Comments
0-3	Initial TX modem rate (kbps)					<p>These bits set the initial starting modem rate for transmission.</p> <p>Use the dedicated transmission parameters if you need to change this for specific receivers.</p> <p>If a modem rate 14.4 kbps or slower is selected, V.8 protocol should be disabled manually.</p> <p>Cross reference</p> <p>V.8 protocol on/off - G3 switch 03, bit 2</p>
	Bit 3	Bit 2	Bit 1	Bit 0	kbps	
	0	0	0	1	2.4	
	0	0	1	0	4.8	
	0	0	1	1	7.2	
	0	1	0	0	9.6	
	0	1	0	1	12.0	
	0	1	1	0	14.4	
	0	1	1	1	16.8	

5. Service Tables

	1	0	0	0	19.2	
	1	0	0	1	21.6	
	1	0	1	0	24.0	
	1	0	1	1	26.4	
	1	1	0	0	28.8	
	1	1	0	1	31.2	
	1	1	1	0	33.6	
	Other settings - Not used					
4-5	Initial modem type for 9.6 k or 7.2 kbps.					These bits set the initial modem type for 9.6 and 7.2 kbps, if the initial modem rate is set at these speeds.
	Bit 5	Bit 4	Setting			
	0	0	V.29			
	0	1	V.17			
	1	0	V.34			
	1	1	Not used			
6-7	Not used					Do not change the settings.

G3 Switch 06 (SP No. 1-105-007)						
No	Function					Comments
0-3	Initial RX modem rate(kbps)					These bits set the initial starting modem rate for reception. Use a lower setting if high speeds pose problems during reception. If a modem rate 14.4 kbps or slower is selected, V.8 protocol should be disabled manually. Cross reference V.8 protocol on/off - G3 switch 03, bit2
	Bit 3	Bit 2	Bit 1	Bit 0	kbps	
	0	0	0	1	2.4	
	0	0	1	0	4.8	
	0	0	1	1	7.2	
	0	1	0	0	9.6	
	0	1	0	1	12.0	
	0	1	1	0	14.4	
	0	1	1	1	16.8	
	1	0	0	0	19.2	
	1	0	0	1	21.6	
	1	0	1	0	24.0	
	1	0	1	1	26.4	
	1	1	0	0	28.8	
	1	1	0	1	31.2	
	1	1	1	0	33.6	

	Other settings - Not used				
4-7	<p>Modem types available for reception</p> <p>The setting of these bits is used to inform the transmitting terminal of the available modem type for the machine in receive mode.</p> <p>If V.34 is not selected, V.8 protocol must be disabled manually.</p> <p>Cross reference</p> <p>V.8 protocol on/off - G3 switch 03, bit 2</p>				
	Bit 7	Bit 6	Bit 5	Bit 4	Types
	0	0	0	1	V.27ter
	0	0	1	0	V.27ter, V.29
	0	0	1	1	V.27ter, V.29, V.33
	0	1	0	0	V.27ter, V.29, V.17
	0	1	0	1	V.27ter, V.29, V.17, V.34
	Other settings - Not used				

G3 Switch 07 (SP No. 1-105-008)				
No	Function			Comments
0-1	PSTN cable equalizer (TX mode: Internal)			<p>Use a higher setting if there is signal loss at higher frequencies because of the length of wire between the modem and the telephone exchange.</p> <p>Use the dedicated transmission parameters for specific receivers.</p> <p>Also, try using the cable equalizer if one or more of the following symptoms occurs.</p> <p>Communication error</p> <p>Modem rate fallback occurs frequently.</p> <p><b>Note</b></p> <ul style="list-style-type: none"> <li>This setting is not effective in V.34 communications.</li> </ul>
	Bit 1	Bit 0	Setting	
	0	0	None	
	0	1	Low	
	1	0	Medium	
	1	1	High	
2-3	PSTN cable equalizer (RX mode: Internal)			<p>Use a higher setting if there is signal loss at higher frequencies because of the length of wire between the modem and the telephone exchange.</p> <p>Also, try using the cable equalizer if one or more of the following symptoms occurs.</p> <p>Communication error with error codes such as 0-20, 0-23, etc.</p> <p>Modem rate fallback occurs frequently.</p> <p><b>Note</b></p> <ul style="list-style-type: none"> <li>This setting is not effective in V.34 communications.</li> </ul>
	Bit 3	Bit 2	Setting	
	0	0	None	
	0	1	Low	
	1	0	Medium	
	1	1	High	
4	PSTN cable equalizer			Keep this bit at "1".

5. Service Tables

	(V.8/V.17 RX mode: External) 0: Disabled 1: Enabled	
5	Not used	Do not change the settings.
6	Parameter selection for dial tone detection 0: Normal parameter 1: Specific parameter	0: This uses the fixed table in the ROM for dial tone detection. 1: This uses the specific parameter adjusted with SRAM (69ECBEH - 69ECDEH). Select this if the dial tone cannot be detected when the "Normal parameter: 0" is selected.
7	Not used	Do not change the settings.

<b>G3 Switch 08</b> - Not used (do not change the settings)
<b>G3 Switch 09</b> - Not used (do not change the settings)

<b>G3 Switch 0A (SP No. 1-105-011)</b>				
No	Function			Comments
0-1	Maximum allowable carrier drop during image data reception			These bits set the acceptable modem carrier drop time. Try a longer setting if error code 0-22 is frequent.
	Bit 1	Bit 0	Value (ms)	
	0	0	200	
	0	1	400	
	1	0	800	
1	1	Not used		
2	Select cancellation of high-speed RX if carrier signal lost while receiving 0: Off 1: On			This switch setting determines if high-speed receiving ends if the carrier signal is lost when receiving during non-ECM mode
3	Not used			Do not change the settings
4	Maximum allowable frame interval during image data reception. 0: 5 s 1: 13 s			This bit set the maximum interval between EOL (end-of-line) signals and the maximum interval between ECM frames from the other end. Try using a longer setting if error code 0-21 is frequent.



5	Not used	Do not change the settings.
6	Reconstruction time for the first line in receive mode 0: 6 s 1: 12 s	When the sending terminal is controlled by a computer, there may be a delay in receiving page data after the local machine accepts set-up data and sends CFR. This is outside the T.30 recommendation. But, if this delay occurs, set this bit to 1 to give the sending machine more time to send data. Refer to error code 0-20. ITU-T T.30 recommendation: The first line should come within 5 s of CFR.
7	Not used	Do not change the settings.

**G3 Switch 0B** Not used (do not change the settings).

**G3 Switch 0E (SP No. 1-105-013)**

No	Function	Comments
0-1	Not used	Do not change these settings.
4-5	Select detection of DTMF/DP detection when using remote switch. 00: DTMF+PSTN (Simultaneous detection) 01: DTMF 10: DP (10 PPS) 11: DP (20 PPS)	This setting determines how to detect the signals from the handset when remote switch is active.

**G3 Switch 0D** Not used (do not change the settings).

**G3 Switch 0E (SP No. 1-105-015)**

No	Function	Comments
0-7	Set CNG send time interval Some machines on the receiving side may not be able to automatically switch the 3-second CNG interval.	
	High order bit	3000-2250ms: 3000-50xNms 3000 – 50 x Nms 0F (3000 ms) <= N <= FF (2250 ms)
	Low order bit	00-0E(3000-3700ms: 3000+50xNms 3000 – 50 x Nms 0F (3000 ms) <= N <= 0F (3700 ms)

**G3 Switch 0F (SP No. 1-105-016)**

## 5. Service Tables

No	Function	Comments
0	Alarm when an error occurred in Phase C or later 0: Disabled 1: Enabled	If the customer wants to hear an alarm after each error communication, change this bit to "1".
1	Alarm when the handset is off-hook at the end of communication 0: Disabled 1: Enabled	If the customer wants to hear an alarm if the handset is off-hook at the end of fax communication, change this bit to "1".
2- 3	Not used	Do not change these settings.
4	Manual calibration setting 0: Off 1: On	1: manually calibrates for communication with a line whose current change occurs such as an optical fiber line.
5- 7	Not used	Do not change the settings.

## Bit Switches - 5

### ★ Important

- Do not adjust a bit switch or use a setting that is described as "Not used", as this may cause the machine to malfunction or to operate in a manner that is not accepted by local regulations. Such bits are for use only in other areas, such as Japan.

Default settings for bit switches are not listed in this manual. Refer to the System Parameter List printed by the machine.

### G3-2 and G3-3 Switches

These switches require an optional G3 interface unit.

G3-3 switches are the same as for G3-2 switches.

<b>G3-2 Switch 00 (SP No. 1-106-001)</b>				
No	Function			Comments
0 1	Monitor speaker during communication (TX and RX)			(0, 0): The monitor speaker is disabled all through the communication.
	Bit 1	Bit 0	Setting	(0, 1): The monitor speaker is on up to phase B in the T.30 protocol.  (1, 0): Used for testing. The monitor speaker is on all through the communication. Make sure that you reset these bits after testing.
	0	0	Disable	
	0	1	Up to Phase B	
	1	0	All the time	
	1	1	Not used	
2	Monitor speaker during memory transmission 0: Disabled 1: Enabled			1: The monitor speaker is enabled during memory transmission.
3- 7	Not used			Do not change the settings.

<b>G3-2 Switch 01 (SP No. 1-106-002)</b>		
No	Function	Comments
0- 3	Not used	Do not change the settings.
4	DIS frame length 0: 10 bytes 1: 4 bytes	1: The bytes in the DIS frame after the 4th byte will not be transmitted (set to 1 if there are communication problems with PC-based faxes which cannot receive the extended DIS frames).
5	Not used	Do not change the setting.
6	Forbid CED/ANSam output	Do not change this setting (Default: 0: Off), unless communication problem is caused by a CED or ANSam transmission.

5. Service Tables

	0: Off 1: On (Forbid output)	
7	Not used	Do not change the setting.

<b>G3-2 Switch 02 (SP No. 1-106-003)</b>		
<b>No</b>	<b>Function</b>	<b>Comments</b>
0	G3 protocol mode used 0: Standard and non-standard 1: Standard only	Change this bit to 1 only when the other end can only communicate with machines that send T.30-standard frames only. 1: Disables NSF/NSS signals (these are used in non-standard mode communication)
1-4	Not used	Do not change the settings.
5	AI modem rate selection 0: OFF, 1: ON	Selects if the AI modem rate is ON or OFF.
6	Not used	Do not change the settings.
7	Short preamble 0: Disabled 1: Enabled	Refer to Appendix B in the Group 3 Facsimile Manual for details about Short Preamble.

<b>G3-2 Switch 03 (SP No. 1-106-004)</b>		
<b>No</b>	<b>Function</b>	<b>Comments</b>
0	DIS detection number (Echo countermeasure) 0: 1 1: 2	0: The machine will hang up if it receives the same DIS frame twice. 1: Before sending DCS, the machine will wait for the second DIS which is caused by echo on the line.
1	Not Used	Do not change the settings.
2	Not Used	Do not change the settings.
3	ECM frame size 0: 256 bytes 1: 64 bytes	Keep this bit at "0" in most cases.
4	CTC transmission conditions 0: After one PPR signal received 1: After four PPR signals received (ITU-T standard)	0: When using ECM in non-standard (NSF/NSS) mode, the machine sends a CTC to drop back the modem rate after receiving a PPR, if the following condition is met in communications at 14.4, 12.0, 9.6, and 7.2 kbps.

		$\sqrt{N_{\text{Transmit}} \leq N_{\text{Resend}}}$ <p> <math>N_{\text{transmit}}</math> = Number of transmitted frames  <math>N_{\text{resend}}</math> = Number of frames to be retransmitted  1: When using ECM, the machine sends a CTC to drop back the modem rate after receiving four PPRs.  PPR, CTC: These are ECM protocol signals.  This bit is not effective in V.34 communications. </p>
5	Modem rate used for the next page after receiving a negative code (RTN or PIN) 0: No change 1: Fallback	1: The machine's TX modem rate will fall back before sending the next page if a negative code is received. This bit is ignored if ECM is being used.
6	Not used	Do not change the settings
7	Select detection of reverse polarity in ringing 0: Off 1: On	This switch is used to prevent reverse polarity in ringing on the phone line (applied to PSTN-G3 ringing). Do not change this setting 0: No detection 1: Detection (Japan and Korea only)

<b>G3-2 Switch 04 (SP No. 1-106-005)</b>		
No	Function	Comments
0-3	Training error detection threshold	0 - F (Hex); 0 - 15 bits If the number of error bits in the received TCF is below this threshold, the machine informs the sender that training has succeeded.
4-7	Not used	Do not change the settings.

<b>G3-2 Switch 05 (SP No. 1-106-006)</b>						
No	Function					Comments
0-3	Initial TX modem rate (kbps)					These bits set the initial starting modem rate for transmission. Use the dedicated transmission parameters if you need to change this for specific receivers. If a modem rate 14.4 kbps or slower is selected, V.8 protocol should be disabled manually. Cross reference V.8 protocol on/off - G3 switch 03, bit 2
	Bit 3	Bit 2	Bit 1	Bit 0	kbps	
	0	0	0	1	2.4	
	0	0	1	0	4.8	
	0	0	1	1	7.2	
	0	1	0	0	9.6	
	0	1	0	1	12.0	

5. Service Tables

	0	1	1	0	14.4	
	0	1	1	1	16.8	
	1	0	0	0	19.2	
	1	0	0	1	21.6	
	1	0	1	0	24.0	
	1	0	1	1	26.4	
	1	1	0	0	28.8	
	1	1	0	1	31.2	
	Other settings - Not used					
4-5	Initial modem type for 9.6 k or 7.2 kbps.					These bits set the initial modem type for 9.6 and 7.2 kbps, if the initial modem rate is set at these speeds.
	Bit 5	Bit 4	Setting			
	0	0	V.29			
	0	1	V.17			
	1	0	V.34			
	1	1	Not used			
6-7	Not used					Do not change the settings.

G3-2 Switch 06 (SP No. 1-106-007)						
No	Function					Comments
0-3	Initial RX modem rate(kbps)					These bits set the initial starting modem rate for reception. Use a lower setting if high speeds pose problems during reception. If a modem rate 14.4 kbps or slower is selected, V.8 protocol should be disabled manually. Cross reference V.8 protocol on/off - G3 switch 03, bit2
	Bit 3	Bit 2	Bit 1	Bit 0	kbps	
	0	0	0	1	2.4	
	0	0	1	0	4.8	
	0	0	1	1	7.2	
	0	1	0	0	9.6	
	0	1	0	1	12.0	
	0	1	1	0	14.4	
	0	1	1	1	16.8	
	1	0	0	0	19.2	
	1	0	0	1	21.6	
	1	0	1	0	24.0	
	1	0	1	1	26.4	
	1	1	0	0	28.8	
	1	1	0	1	31.2	

	Other settings - Not used			
4-7	<p>Modem types available for reception</p> <p>The setting of these bits is used to inform the transmitting terminal of the available modem type for the machine in receive mode.</p> <p>If V.34 is not selected, V.8 protocol must be disabled manually.</p> <p>Cross reference</p> <p>V.8 protocol on/off - G3 switch 03, bit 2</p>			
	Bit 7	Bit 6	Bit 5	Bit 4
	0	0	0	1
	0	0	1	0
	0	0	1	1
	0	1	0	0
	0	1	0	1
	Other settings - Not used			

G3-2 Switch 07 (SP No. 1-106-008)				
No	Function			Comments
0-1	PSTN cable equalizer (TX mode: Internal)			<p>Use a higher setting if there is signal loss at higher frequencies because of the length of wire between the modem and the telephone exchange.</p> <p>Use the dedicated transmission parameters for specific receivers.</p> <p>Also, try using the cable equalizer if one or more of the following symptoms occurs.</p> <p>Communication error</p> <p>Modem rate fallback occurs frequently.</p> <p><b>Note</b></p> <ul style="list-style-type: none"> <li>This setting is not effective in V.34 communications.</li> </ul>
	Bit 1	Bit 0	Setting	
	0	0	None	
	0	1	Low	
	1	0	Medium	
	1	1	High	
2-3	PSTN cable equalizer (RX mode: Internal)			<p>Use a higher setting if there is signal loss at higher frequencies because of the length of wire between the modem and the telephone exchange.</p> <p>Also, try using the cable equalizer if one or more of the following symptoms occurs.</p> <p>Communication error with error codes such as 0-20, 0-23, etc.</p> <p>Modem rate fallback occurs frequently.</p> <p><b>Note</b></p> <ul style="list-style-type: none"> <li>This setting is not effective in V.34 communications.</li> </ul>
	Bit 3	Bit 2	Setting	
	0	0	None	
	0	1	Low	
	1	0	Medium	
	1	1	High	

5. Service Tables

4	PSTN cable equalizer (V.8/V.17 RX mode: External) 0: Disabled 1: Enabled	Keep this bit at "1".
5-7	Not used	Do not change the settings.

<b>G3-2 Switch 08</b> - Not used (do not change the settings)
<b>G3-2 Switch 09</b> - Not used (do not change the settings)

<b>G3-2 Switch 0A (SP No. 1-106-011)</b>				
No	Function			Comments
0-1	Maximum allowable carrier drop during image data reception			These bits set the acceptable modem carrier drop time. Try a longer setting if error code 0-22 is frequent.
	Bit 1	Bit 0	Value (ms)	
	0	0	200	
	0	1	400	
	1	0	800	
	1	1	Not used	
2-3	Not used			Do not change the settings
4	Maximum allowable frame interval during image data reception. 0: 5 s 1: 13 s			This bit set the maximum interval between EOL (end-of-line) signals and the maximum interval between ECM frames from the other end. Try using a longer setting if error code 0-21 is frequent.
5	Not used			Do not change the settings.
6	Reconstruction time for the first line in receive mode 0: 6 s 1: 12 s			When the sending terminal is controlled by a computer, there may be a delay in receiving page data after the local machine accepts set-up data and sends CFR. This is outside the T.30 recommendation. But, if this delay occurs, set this bit to 1 to give the sending machine more time to send data. Refer to error code 0-20. ITU-T T.30 recommendation: The first line should come within 5 s of CFR.
7	Not used			Do not change the settings.



<b>G3-2 Switch 0B</b> - Not used (do not change the settings)
<b>G3-2 Switch 0C</b> - Not used (do not change the settings)
<b>G3-2 Switch 0E</b> - Not used (do not change the settings)
<b>G3-2 Switch 0F</b> - Not used (do not change the settings)

---

#### G4 Internal Switches

---

The G4 internal switches (SW00 to 1F) are displayed but do not change these settings.

---

#### G4 Parameter Switches

---

The G4 parameter switches (SW00 to 0F) are displayed but do not change these settings.

## Bit Switches - 6

### ★ Important

- Do not adjust a bit switch or use a setting that is described as "Not used", as this may cause the machine to malfunction or to operate in a manner that is not accepted by local regulations. Such bits are for use only in other areas, such as Japan.

Default settings for bit switches are not listed in this manual. Refer to the System Parameter List printed by the machine.

### IP Fax Switches

IP Fax Switch 00 (SP No. 1-111-001)		
No.	Function	Comments
0	Not used	Do not change this setting.
1	IP Fax Transport 0: TCP, 1: UDP	Selects TCP or UDP protocol for IP-Fax
2	IP Fax single port selection 0: OFF, 1: ON (enable)	Selects single data port.
3	IP Fax double ports (single data port) selection 0: OFF, 1: ON (enable)	Selects whether IP-Fax uses a double port.
4	IP Fax Gatekeeper 0: OFF, 1: ON (enable)	Enables/disables the gatekeeper for IP-Fax.
5	IP Fax T30 bit signal reverse 0: LSB first, 1: MSB first	Reverses the T30 bit signal.
6	IP Fax max bit rate setting 0: Not affected, 1: Affected	When "0" is selected, the max bit rate does not affect the value of the DIS/DCS. When "1" is selected, the max bit rate affects the value of the DIS/DCS.
7	IP Fax received telephone number confirmation 0: No confirmation, 1:	When "0" is selected, fax data is received without checking the telephone number. When "1" is selected, fax data is received only when confirming that the telephone number from the sender matches the registered

	Confirmation	telephone number in this machine. If this confirmation fails, the line is disconnected.
--	--------------	---

IP Fax Switch 01 (SP No. 1-111-002)						
No.	Function				Comments	
0-3	IP Fax delay level setting				Selects the acceptable delay level. Level 0 is the highest quality Default is "0000" (level 0).	
	Bit 3	Bit 2	Bit 1	Bit 0		
	0	0	0	0		Level 0
	0	0	0	1		Level 1
	0	0	1	0		Level 2
	0	0	1	1	Level 3	
4-7	IP Fax preamble wait time setting				Selects the preamble wait time. [00 to 0f] There are 16 values in this 4-bit binary switch combination. Waiting time: set value level x 100 ms Max: 0f (1500 ms) Min: 00 (No wait time) The default is "0000" (00H).	

IP Fax Switch 02 (SP No. 1-111-003)		
No.	Function	Comments
0	IP Fax bit signal reverse setting 0: Maker code setting 1: Internal bit switch setting	When "0" is selected, the bit signal reverse method is decided by the maker code. When "1" is selected, the bit signal reverse method is decided by the internal bit switch. (When communicating between IP Fax devices, LSB first is selected.)
1	IP Fax transmission speed setting 0: Modem speed 1: No limitation	Selects the transmit speed for IP Fax communication.
2	SIP transport setting 0: TCP 1: UDP	This bit switch sets the transport that has priority for receiving IP Fax data. This function is activated only when the sender has both TCP and UDP.
3	CCM connection	When "1" is selected, only the connection call message with

## 5. Service Tables

	0: No CCM connection 1: CCM connection	H.323 or no tunneled H.245 is transmitted via CCM.
4	Message reception selection from non-registered SIP server 0: Answer 1: Not answer	0: This answers the INVITE message from the SIP server not registered for the machine. 1: This does not receive the INVITE message from the SIP server not registered for the machine and send a refusal message.
5	ECM communication setting 0: No limit for image compression 1: Limit for image compression	0: This does not limit the type of the image compression with ECM communication. 1: When the other end machine is Cisco, this permits the image compression other than JBIG or MMR with ECM communication.
6-7	Not used	Do not change these settings.

<b>IP Fax Switch 03 (SP No. 1-111-004)</b>		
<b>No.</b>	<b>Function</b>	<b>Comments</b>
0	Effective field limitation for G3 standard function information 0: OFF, 1: 4byte (DIS)	Limits the effective field for standard G3 function information.
1	Switching between G3 standard and G3 non standard 0: Enable switching 1: G3 standard only	Enables/disables switching between G3 standard and G3 non-standard.
2	Not used	Do not change this setting.
3	ECM frame size selection at transmitting 0: 256byte, 1: 64byte	Selects the ECM frame size for sending.
4	DIS detection times for echo prevention 0: 1 time, 1: 2 times	Sets the number of times for DIS to detect echoes.
5	CTC transmission selection 0: PPRx1 1: PPRx4	When "0" is selected, the transmission condition is decided by error frame numbers. When "1" is selected, the transmission condition is based on the ITU-T method.
6	Shift down setting at receiving negative code 0: OFF, 1: ON	Selects whether to shift down when negative codes are received.
7	Not used	Do not change this setting.

IP Fax Switch 04 (SP No. 1-111-005)		
No.	Function	Comments
0-3	TCF error threshold	Sets the TCF error threshold level. [00 to 0f] The default is "1111" (0fH).
4-7	Not used	Do not change these settings.

IP Fax Switch 05 (SP No. 1-111-006)						
No.	Function					Comments
0-3	Modem bit rate setting for transmission (kbps)					Sets the modem bit rate for transmission. The default is "0110" (14.4K bps).
	Bit 3	Bit 2	Bit 1	Bit 0	kbps	
	0	0	0	1	2.4	
	0	0	1	1	4.8	
	0	0	1	1	7.2	
	0	1	0	0	9.6	
	0	1	0	1	12.0	
	0	1	1	0	14.4	
4-5	Modem setting for transmission					Sets the modem type for transmission. The default is "00" (V29).
	Bit 5	Bit 4		Types		
	0	0		V29		
	0	1		V17		
	1	0		Not used		
1	1		Not used			
6-7	Not used					Do not change these settings.

IP Fax Switch 06 (SP No. 1-111-007)					
No.	Function				Comments
0-3	Modem bit rate setting for reception				Sets the modem bit rate for reception. The default is "0110" (14.4K bps).
4-7	Modem setting for reception				
	Sets the modem type for reception. The default is "0100" (V27ter, V29, V17).				
	Bit 7	Bit 6	Bit 5	Bit 4	Types
	0	0	0	1	V.27ter
	0	0	1	0	V.27ter, V.29
	0	0	1	1	V.27ter, V.29, V.33
	0	1	0	0	V.27ter, V.29, V.17/V.33
Other settings - Not used					

5.Service Tables

IP Fax Switch 07 (SP No. 1-111-008)		
No.	Function	Comments
0	TSI information 0: Not added, 1: Added	Adds or does not add TSI information to NSS(S).
1	DCN transmission setting at T1 timeout 0: Not transmitted 1: Transmitted	Transmits or does not transmit DCN at T1 timeout.
2	Not used	Do not change this setting.
3	Hang up setting at DIS reception disabled 0: No hang up 1: Hang up after transmitting DCN	Sets whether the machine disconnects after DIS reception.
4	Number of times for training 0: 1 time, 1: 2 times	Selects the number of times training is done at the same bit rate.
5	Space CSI transmission setting at no CSI registration 0: Not transmitted 1: Transmitted	When "0" is selected, frame data is enabled. When "1" is selected, the transmitted data is all spaces.
6-7	Not used	Do not change these settings.

IP Fax Switch 08 (SP No. 1-111-009)				
No.	Function			Comments
0-1	T1 timer adjustment			Adjusts the T1 timer. The default is "00" (35 seconds).
	Bit 1	Bit 0		
	0	0	35 s	
	0	1	40 s	
	1	0	50 s	
	1	1	60 s	
2-3	T4 timer adjustment			Adjust the T4 timer. The default is "00" (3 seconds).
	Bit 3	Bit 2		
	0	0	3 s	
	0	1	3.5 s	
	1	0	4 s	
	1	1	5 s	
4-5	T0 timer adjustment			Adjusts the fail safe timer. This timer sets the interval between "setup" data transmission and T.38 phase decision. If your destination return is late on the network or G3 fax return is late, adjust the longer interval
	Bit 5	Bit 4		
	0	0	75 s	

	0	1	120 s	timer. The default is "00" (75 seconds).
	1	0	180 s	
	1	1	240 s	
6-7	Not used		Do not change these settings.	

IP Fax Switch 09 (SP No. 1-111-010)				
No.	Function			Comments
0	Network I/F setting for SIP connection 0: IPv4 1: IPv6.			Selects the connection type (IPV4 or IPV6) to connect to the SIP server.
1	Network I/F setting for Fax communication 0: Same setting as SIP server connection 1: Automatic setting			0: The I/F setting for fax communication follows the setting for SIP server connection. 1: The negotiation between the SIP server and the device decides whether IPv4 or IPv6 is used for the I/F setting for fax communication.
2	Record-route setting 0: Disable 1: Enable			0: Disables the record-route function of the SIP server. 1: Enables the record-route function of the SIP server.
3-4	re-INVITE transmission delay timer setting			This changes the interval for transmit re-INVITE after receiving the ACK message transmitted by T.38 device.
	Bit 4	Bit 3		
	0	0	No delay	
	0	1	1 sec	
	1	0	2 sec	
	1	1	3 sec	
5	SIP-IPFAX: Adding vender information selection 0: Declare T38VendorInfo=RICOH 1: Not declare T38VendorInfo=RICOH			0: Use this setting normally. 1: This setting is used only when a customer wants to connect the machine with SIP server + VOIP-GW provided by AVAYA Inc.
6-7	Not used.			Do not change these settings.

**IP Fax Switch 0A** - Not used (do not change the settings)

5. Service Tables

<b>IP Fax Switch 0B</b> - Not used (do not change the settings)
<b>IP Fax Switch 0C</b> - Not used (do not change the settings)
<b>IP Fax Switch 0D</b> - Not used (do not change the settings)

<b>IP Fax Switch 0E (SP No. 1-111-013)</b>		
<b>No.</b>	<b>Function</b>	<b>Comments</b>
0-1	SIP: IP-FAX port mode (UDP) 00: 3 port mode 01: 2 port mode 10: 1 port mode	Switch the port mode for IP-FAX (T38 transport: UDP) at SIP call control.
2-3	SIP: IP-FAX port mode (TCP) 00: 3 port mode 01: 2 port mode 10: 1 port mode	Switch the port mode for IP-FAX (T38 transport: TCP) at SIP call control.
4-7	Not used.	Do not change these settings.



## NCU Parameters

### NCU Parameters

The following tables give the RAM addresses and the parameter calculation units that the machine uses for ringing signal detection and automatic dialing. The factory settings for each country are also given. Most of these must be changed by RAM read/write (SP2-102), but some can be changed using NCU Parameter programming (SP2-103, 104 and 105); if SP2-103, 104 and 105 can be used, this will be indicated in the Remarks column. The RAM is programmed in hex code unless (BCD) is included in the Unit column.

#### ↓ Note

- The following addresses describe settings for the standard NCU.
- Change the fourth digit from "5" to "6" (e.g. 680500 to 680600) for the settings for the first optional G3 interface unit and from "5" to "7" (e.g. 680700) for the settings for the second optional G3 interface unit.

Address	Function					
680500	Country/Area code for NCU parameters					
	Use the Hex value to program the country/area code directly into this address, or use the decimal value to program it using SP2-103-001					
	<b>Country /Area</b>	<b>Decimal</b>	<b>Hex</b>	<b>Country /Area</b>	<b>Decimal</b>	<b>Hex</b>
	France	00	00	Asia	18	12
	Germany	01	01	Japan	19	13
	UK	02	02	Hong Kong	20	14
	Italy	03	03	South Africa	21	15
	Austria	04	04	Australia	22	16
	Belgium	05	05	New Zealand	26	17
	Denmark	06	06	Singapore	24	18
	Finland	07	07	Malaysia	25	19
	Ireland	08	08	China	26	1A
	Norway	09	09	Taiwan	27	1B
	Sweden	10	0A	Korea	28	1C
	Switzerland	11	0B	Brazil	29	1D
	Portugal	12	0C	Turkey	32	20
	Holland	13	0D	Greece	33	21
Spain	14	0E	Hungary	34	22	
Israel	15	0F	Czech	35	23	
USA	17	11	Poland	36	24	

5. Service Tables

Address	Function	Unit	Remarks
680501	Line current detection time	20 ms	Line current detection is disabled.
680502	Line current wait time		Line current is not detected if 680501 contains FF.
680503	Line current drop detect time		
680504	PSTN dial tone frequency upper limit (high byte)	Hz (BCD)	If both addresses contain FF (H), tone detection is disabled.
680505	PSTN dial tone frequency upper limit (low byte)		
680506	PSTN dial tone frequency lower limit (high byte)	Hz (BCD)	If both addresses contain FF (H), tone detection is disabled.
680507	PSTN dial tone frequency lower limit (low byte)		
680508	PSTN dial tone detection time	20 ms	If 680508 contains FF (H), the machine pauses for the pause time (address 68050D / 68050E). Italy: See Note 2.
680509	PSTN dial tone reset time (LOW)		
68050A	PSTN dial tone reset time (HIGH)		
68050B	PSTN dial tone continuous tone time		
68050C	PSTN dial tone permissible drop time		
68050D	PSTN wait interval (LOW)		
68050E	PSTN wait interval (HIGH)	-	
68050F	PSTN ring-back tone detection time	20 ms	Detection is disabled if this contains FF.
680510	PSTN ring-back tone off detection time	20 ms	-
680511	PSTN detection time for silent period after ring-back tone detected (LOW)	20 ms	-
680512	PSTN detection time for silent period after ring-back tone detected (HIGH)	20 ms	-
680513	PSTN busy tone frequency upper limit (high byte)	Hz (BCD)	If both addresses contain FF (H), tone detection is disabled.
680514	PSTN busy tone frequency upper limit (low byte)		
680515	PSTN busy tone frequency lower limit (high byte)	Hz (BCD)	If both addresses contain FF (H), tone detection is disabled.
680516	PSTN busy tone frequency lower		

Address	Function	Unit	Remarks	
	limit (low byte)			
680517	PABX dial tone frequency upper limit (high byte)	Hz (BCD)	If both addresses contain FF (H), tone detection is disabled.	
680518	PABX dial tone frequency upper limit (low byte)			
680519	PABX dial tone frequency lower limit (high byte)	Hz (BCD)	If both addresses contain FF (H), tone detection is disabled.	
68051A	PABX dial tone frequency lower limit (low byte)			
68051B	PABX dial tone detection time	20 ms	If 68051B contains FF, the machine pauses for the pause time (680520 / 680521).	
68051C	PABX dial tone reset time (LOW)			
68051D	PABX dial tone reset time (HIGH)			
68051E	PABX dial tone continuous tone time			
68051F	PABX dial tone permissible drop time			
680520	PABX wait interval (LOW)			-
680521	PABX wait interval (HIGH)			-
680522	PABX ringback tone detection time	20 ms	If both addresses contain FF (H), tone detection is disabled.	
680523	PABX ringback tone off detection time	20 ms		
680524	PABX detection time for silent period after ringback tone detected (LOW)	20 ms	If both addresses contain FF (H), tone detection is disabled.	
680525	PABX detection time for silent period after ringback tone detected (HIGH)	20 ms		
680526	PABX busy tone frequency upper limit (high byte)	Hz (BCD)	If both addresses contain FF (H), tone detection is disabled.	
680527	PABX busy tone frequency upper limit (low byte)			
680528	PABX busy tone frequency lower limit (high byte)	Hz (BCD)	If both addresses contain FF (H), tone detection is disabled.	
680529	PABX busy tone frequency lower limit (low byte)			
68052A	Busy tone ON time: range 1	20 ms	-	

5. Service Tables

Address	Function	Unit	Remarks	
68052B	Busy tone OFF time: range 1	20 ms		
68052C	Busy tone ON time: range 2			
68052D	Busy tone OFF time: range 2			
68052E	Busy tone ON time: range 3			
68052F	Busy tone OFF time: range 3			
680530	Busy tone ON time: range 4			
680531	Busy tone OFF time: range 4			
680532	Busy tone continuous tone detection time			
680533	<p>Busy tone signal state time tolerance for all ranges, and number of cycles required for detection (a setting of 4 cycles means that ON-OFF-ON or OFF-ON-OFF must be detected twice).</p> <p>Tolerance (<math>\pm</math>)</p> <p>Bit 1: 0, Bit 0: 0 = 75% Bits 2 and 3 must always be kept at 0.</p> <p>Bit 1: 0, Bit 0: 0 = 50% Bits 2 and 3 must always be kept at 0.</p> <p>Bit 1: 0, Bit 0: 0 = 25%</p> <p>Bit 1: 0, Bit 0: 0 = 12.5%</p> <p>Bits 7, 6, 5, 4 - number of cycles required for cadence detection</p>			
680534	International dial tone frequency upper limit (high byte)	Hz (BCD)	If both addresses contain FF (H), tone detection is disabled.	
680535	International dial tone frequency upper limit (low byte)			
680536	International dial tone frequency lower limit (high byte)	Hz (BCD)	If both addresses contain FF (H), tone detection is disabled.	
680537	International dial tone frequency lower limit (low byte)			
680538	International dial tone detection time	20 ms	<p>If 680538 contains FF, the machine pauses for the pause time (68053D / 68053E).</p> <p>Belgium: See Note 2.</p>	
680539	International dial tone reset time (LOW)			
68053A	International dial tone reset time (HIGH)			
68053B	International dial tone continuous tone time			
68053C	International dial tone permissible drop time			
68053D	International dial wait interval			-

Address	Function	Unit	Remarks
	(LOW)		
68053E	International dial wait interval (HIGH)		
68053F	Country dial tone upper frequency limit (HIGH)	Hz (BCD)	If both addresses contain FF (H), tone detection is disabled.
680540	Country dial tone upper frequency limit (LOW)		
680541	Country dial tone lower frequency limit (HIGH)		
680542	Country dial tone lower frequency limit (LOW)		
680543	Country dial tone detection time	20 ms	If 680543 contains FF, the machine pauses for the pause time (680548 / 680549).
680544	Country dial tone reset time (LOW)		
680545	Country dial tone reset time (HIGH)		
680546	Country dial tone continuous tone time	-	-
680547	Country dial tone permissible drop time	20 ms	-
680548	Country dial wait interval (LOW)		
680549	Country dial wait interval (HIGH)		
68054A	Time between opening or closing the DO relay and opening the OHDI relay	1 ms	See Notes 3, 6 and 8. SP2-103-012 (parameter 11).
68054B	Break time for pulse dialing	1 ms	See Note 3. SP2-103-013 (parameter 12).
68054C	Make time for pulse dialing	1 ms	See Note 3. SP2-103-014 (parameter 13).
68054D	Time between final OHDI relay closure and DO relay opening or closing	1 ms	See Notes 3, 6 and 8. SP2-103-015 (parameter 14). This parameter is only valid in Europe.
68054E	Minimum pause between dialed digits (pulse dial mode)	20 ms	See Note 3 and 8. SP2-103-016 (parameter 15).
68054F	Time waited when a pause is entered at the operation panel		SP2-103-017 (parameter 16). See Note 3.
680550	DTMF tone on time	1 ms	SP2-103-018 (parameter 17).

## 5. Service Tables

Address	Function	Unit	Remarks
680551	DTMF tone off time		SP2-103-019 (parameter 18).
680552	Tone attenuation level of DTMF signals while dialing	-N x 0.5 -3.5 dBm	SP2-103-020 (parameter 19). See Note 5.
680553	Tone attenuation value difference between high frequency tone and low frequency tone in DTMF signals	-dBm x 0.5	SP2-103-021 (parameter 20). The setting must be less than -5dBm, and should not exceed the setting at 680552h above. See Note 5.
680554	PSTN: DTMF tone attenuation level after dialing	-N x 0.5 -3.5 dBm	SP2-103-022 (parameter 21). See Note 5.
680555	ISDN: DTMF tone attenuation level after dialing	-dBm x 0.5	See Note 5
680556	Not used	-	Do not change the settings.
680557	Time between 68054Dh (NCU parameter 14) and 68054Eh (NCU parameter 15)	1 ms	This parameter takes effect when the country code is set to France.
680558	Not used	-	Do not change the setting.
680559	Grounding time (ground start mode)	20 ms	The Gs relay is closed for this interval.
68055A	Break time (flash start mode)	1 ms	The OHD1 relay is open for this interval.
68055B	International dial access code (High)	BCD	For a code of 100: 68055B - F1 68055C - 00
68055C	International dial access code (Low)		
68055D	PSTN access pause time	20 ms	This time is waited for each pause input after the PSTN access code. If this address contains FF [H], the pause time stored in address 68054F is used. Do not set a number more than 7 in the UK.
68055E	Progress tone detection level, and cadence detection enable flags	Bit 7: 0, Bit 6: 0, Bit 5: 0 = -25.0 dBm Bit 7: 0, Bit 6: 0, Bit 5: 1 = -35.0 dBm Bit 7: 0, Bit 6: 1, Bit 5: 0 = -30.0 dBm Bit 7: 1, Bit 6: 0, Bit 5: 0 = -40.0 dBm Bit 7: 1, Bit 6: 1, Bit 5: 0 = -49.0 dBm	

Address	Function	Unit	Remarks
			Bits 2, 0 - See Note 2.
68055F To 680564	<b>Not used</b>	-	Do not change the settings.
680565	Long distance call prefix (HIGH)	BCD	For a code of 0: 680565 – FF 680566 - FF
680566	Long distance call prefix (LOW)	BCD	
680567 to 680571	<b>Not used</b>	-	Do not change the settings.
680572	Acceptable ringing signal frequency: range 1, upper limit	1000/ N (Hz).	SP2-103-003 (parameter 02).
680573	Acceptable ringing signal frequency: range 1, lower limit		SP2-103-004 (parameter 03).
680574	Acceptable ringing signal frequency: range 2, upper limit		SP2-103-005 (parameter 04).
680575	Acceptable ringing signal frequency: range 2, lower limit		SP2-103-006 (parameter 05).
680576	Number of rings until a call is detected	1	SP2-103-007 (parameter 06). The setting must not be zero.
680577	Minimum required length of the first ring	20 ms	See Note 4. SP2-103-008 (parameter 07).
680578	Minimum required length of the second and subsequent rings	20 ms	SP2-103-009 (parameter 08).
680579	Ringing signal detection reset time (LOW)	20 ms	SP2-103-010 (parameter 09).
68057A	Ringing signal detection reset time (HIGH)		SP2-103-011 (parameter 10).
68057B to 680580	<b>Not used</b>	-	Do not change the settings.
680581	Interval between dialing the last digit and switching the Oh relay over to the external telephone when dialing from the operation panel in handset mode.	20 ms	Factory setting: 500 ms
680582	Bits 0 and 1 - Handset off-hook detection time	-	

5. Service Tables

Address	Function	Unit	Remarks
	Bit 1:0, Bit 0: 0 = 200 ms Bit 1:0, Bit 0: 1 = 800 ms Other Not used Bits 2 and 3 - Handset on-hook detection time Bit 3: 0, Bit 2: 0 = 200 ms Bit 3: 0, Bit 2: 1 = 800 ms Other Not used Bits 4 to 7 - <b>Not used</b>		
680583 To 6805A0	<b>Not used</b>	-	Do not change the settings.
6805A1	Acceptable CED detection frequency upper limit (high byte)	BCD (Hz)	If both addresses contain FF (H), tone detection is disabled.
6805A2	Acceptable CED detection frequency upper limit (low byte)		
6805A3	Acceptable CED detection frequency lower limit (high byte)	BCD (Hz)	If both addresses contain FF (H), tone detection is disabled.
6805A4	Acceptable CED detection frequency lower limit (low byte)		
6805A5	CED detection time	20 ms ± 20 ms	Factory setting: 200 ms
6805A6	Acceptable CNG detection frequency upper limit (high byte)	BCD (Hz)	If both addresses contain FF (H), tone detection is disabled.
6805A7	Acceptable CNG detection frequency upper limit (low byte)		
6805A8	Acceptable CNG detection frequency lower limit (high byte)	BCD (Hz)	If both addresses contain FF (H), tone detection is disabled.
6805A9	Acceptable CNG detection frequency lower limit (low byte)		
6805AA	<b>Not used</b>	-	Do not change the setting.
6805AB	CNG on time	20 ms	Factory setting: 500 ms
6805AC	CNG off time	20 ms	Factory setting: 3000 ms
6805AD	Number of CNG cycles required for detection	-	The data is coded in the same way as address 680533.
6805AE	<b>Not used</b>	-	Do not change the settings.
6805AF	Acceptable AI short protocol tone (800Hz) detection frequency	Hz (BCD)	If both addresses contain FF (H), tone detection is disabled.



## 5.Service Tables

Address	Function	Unit	Remarks
	upper limit (high byte)		
6805B0	Acceptable AI short protocol tone (800Hz) detection frequency upper limit (low byte)		
6805B1	Acceptable AI short protocol tone (800Hz) detection frequency lower limit (high byte)	Hz(BCD)	If both addresses contain FF (H), tone detection is disabled.
6805B2	Acceptable AI short protocol tone (800Hz) detection frequency lower limit (low byte)		
6805B3	Detection time for 800 Hz AI short protocol tone	20 ms	Factory setting: 360 ms
6805B4	PSTN: TX level from the modem	-N – 3 dBm	SP2-103-002 (parameter 01).
6805B5	PSTN: 1100 Hz tone transmission level	- N 6805B4 - 0.5N 6805B5 –3.5 (dB) See Note 7.	
6805B6	PSTN: 2100 Hz tone transmission level	- N6805B4 - 0.5N 6805B6 –3 (dB) See Note 7.	
6805B7	PABX: TX level from the modem	- dBm	
6805B8	PABX: 1100 Hz tone transmission level	- N 6805B7 - 0.5N 6805B8 (dB)	
6805B9	PABX: 2100 Hz tone transmission level	- N 6805B7 - 0.5N 6805B9 (dB)	
6805BD	Modem turn-on level (incoming signal detection level)	-37-0.5N (dBm)	
6805BE to 6805C6	<b>Not used</b>	-	Do not change the settings.
6805C7	Bits 0 to 3 – <b>Not used</b> Bit 4 = V.34 protocol dump 0: Simple, 1: Detailed (default) Bits 5 to 7 – <b>Not used.</b>		
6805C8 to 6805D9	<b>Not used</b>	-	Do not change the settings.
6805DA	T.30 T1 timer	1 s	
6805E0 bit 3	Maximum wait time for post message	0: 12 s 1: 30 s	1: Maximum wait time for post message (EOP/EOM/MPS) can be changed to 30 s. Change this bit to “1” if

5. Service Tables

Address	Function	Unit	Remarks
			communication errors occur frequently during V.17 reception.
6805E3	Bits 0 and 1 – DCV (TIP/RING) Voltage Bit 1:0, Bit 0: 0 = 3.1 V Bit 1:0, Bit 0: 1 = 3.2 V Bit 1:1, Bit 0: 0 = 3.35 V Bit 1:1, Bit 0: 1 = 3.5 V Bits 2 and 3 – MINI (minimum loop electric current) Bit 2:0, Bit 3: 0 = 10 mA Bit 2:0, Bit 2: 1 = 12 mA Bit 2:1, Bit 3: 0 = 14 mA Bit 2:1, Bit 3: 1 = 16 mA Bits 6 and 7 – ACIM (AC impedance) Bit 7:0, Bit 6: 0 Bit 5:0, Bit 4: 0= 600 Bit 7:0, Bit 6: 0 Bit 5:1, Bit 4: 0= TBR21		
6805E4	Bit 0 – OHS (on hook speed) 0: OHS=0 1: OHS=1 Bit 1 – SQ (spark quench) 0: SQ=00 1: SQ=11 Bit 2 – RZ (call signal Impedance) 0: RZ=0 (high) 1: RZ=1 (low) Bit 3 – RT (call signal detection level) 0: RT=0 (low) 1: RT=1 (high) Bit 4 – ILIM (DC limitation) 0: ILIM=0 (CTR 21) 1: ILIM=1 (other than CTR 21) Bit 5 –FILTER 0: FILTER=0 (around 5Hz) 1: FILTER=1 (around 200Hz) Bits 6 to 7 – Calibration in off hook state Bit 6:0, Bit 7: 0 = off hook to ACAL:128 ms, off hook to MCAL: 1000 ms Bit 6:1, Bit 7: 0 = off hook to ACAL:128 ms, off hook to MCAL: 500 ms Bit 6:0, Bit 7: 1 = off hook to ACAL:128 ms (no MCAL) Bit 6:1, Bit 7: 1 = off hook to ACAL:8 ms (no MCAL)		

Address	Function	Unit	Remarks
6805E5	Bits 0 to 6 – <b>Not used</b> Bits 7 – Energy saving for DSP, COMBLK, SiDAA 0: Does not save energy 1: Saves energy		

**NOTES**

- If a setting is not required, store FF in the address.
  - Italy and Belgium only  
RAM address 68055E: the lower four bits have the following meaning.  
Bit 2 - 1: International dial tone cadence detection enabled (Belgium)  
Bit 1 - Not used  
Bit 0 - 1: PSTN dial tone cadence detection enabled (Italy)  
If bit 0 or bit 2 is set to 1, the functions of the following RAM addresses are changed.  
680508 (if bit 0 = 1) or 680538 (if bit 2 = 1): tolerance for on or off state duration (%), and number of cycles required for detection, coded as in address 680533.  
68050B (if bit 0 = 1) or 68053B (if bit 2 = 1): on time, hex code (unit = 20 ms)  
68050C (if bit 0 = 1) or 68053C (if bit 2 = 1): off time, hex code (unit = 20 ms)
  - Pulse dial parameters (addresses 68054A to 68054F) are the values for 10 pps. If 20 pps is used, the machine automatically compensates.
  - The first ring may not be detected until 1 to 2.5 wavelengths after the time specified by this parameter.
  - The calculated level must be between 0 and 10.  
The attenuation levels calculated from RAM data are:  
High frequency tone:
    - $-0.5 \times N_{680552/680554} - 3.5$  dBm
    - $-0.5 \times N_{680555}$  dBm
 Low frequency tone:
    - $-0.5 \times (N_{680552/680554} + N_{680553}) - 3.5$  dBm
    - $-0.5 \times (N_{680555} + N_{680553})$  dBm
-  **Note**
- $N_{680552}$ , for example, means the value stored in address 680552(H)
- 68054A: Europe - Between Ds opening and Di opening, France - Between Ds closing and Di opening  
68054D: Europe - Between Ds closing and Di closing, France - Between Ds opening and Di closing
  - Tone signals which frequency is lower than 1500Hz (e.g., 800Hz tone for AI short protocol) refer to the setting at 6805B5h. Tones which frequency is higher than 1500Hz refer to the setting at 6805B6h.
  - 68054A, 68054D, 68054E: The actual inter-digit pause (pulse dial mode) is the sum of the period specified by the RAM addresses 68054A, 68054D, and 68054E.

## Dedicated Transmission Parameters

There are two sets of transmission parameters: Fax and E-mail

Each Quick Dial Key and Speed Dial Code has eight bytes of programmable parameters allocated to it. If transmissions to a particular machine often experience problems, store that terminal's fax number as a Quick Dial or Speed Dial, and adjust the parameters allocated to that number.

The programming procedure will be explained first. Then, the eight bytes will be described.

---

### Programming Procedure

---

1. Set the bit 0 of System Bit Switch 00 to 1.
2. Enter Address Book Management mode ([User Tools]> System Settings> Key Operator> Address Book Management).
3. Select the address book that you want to program.
4. For the fax parameter, select "Fax Dest.", for the E-mail parameter, select "E-mail", then press "Start". Make sure that the LED of the Start button lights green.
5. The settings for the switch 00 are now displayed. Press the bit number that you wish to change.
6. To scroll through the parameter switches, either:
7. Select the next switch: press "Next" or Select the previous switch: "Prev." until the correct switch is displayed. Then go back to step 6.
8. After the setting is changed, press "OK".
9. After finishing, reset bit 0 of System Bit Switch 00 to 0.

---

### Parameters

---

#### Fax Parameters

---

The initial settings of the following fax parameters are all FF (H) - all the parameters are disabled.

<b>Switch 00</b>	
<b>FUNCTION AND COMMENTS</b>	
ITU-T T1 time (for PSTN G3 mode) If the connection time to a particular terminal is longer than the NCU parameter setting, adjust this byte. The T1 time is the value stored in this byte (in hex code), multiplied by 1 second.	
<b>Range:</b> 0 to 120 s (00h to 78h) FFh - The local NCU parameter factory setting is used. Do not program a value between 79h and FEh.	

<b>Switch 01</b>		
<b>No</b>	<b>FUNCTION</b>	<b>COMMENTS</b>
0-	TX level	If communication with a particular remote terminal

4	Bit4	Bit3	Bit2	Bit1	Bit0		<p>often contains errors, the signal level may be inappropriate. Adjust the TX level for communications with that terminal until the results are better.</p> <p>If the setting is "Disabled", the NCU parameter 01 setting is used.</p> <p><b>Note</b></p> <ul style="list-style-type: none"> <li>Do not use settings other than listed on the left.</li> </ul>
	0	0	0	0	0	0	
	0	0	0	0	1	-1	
	0	0	0	1	0	-2	
	0	0	0	1	1	-3	
	0	0	1	0	0	-4	
	↓	↓	↓	↓	↓	↓	
	0	1	1	1	1	-15	
	1	1	1	1	1	Disabled	
5-7	<p>Cable equalizer</p> <p>Bit 7: 0, Bit 6: 0, Bit 5: 0 = None</p> <p>Bit 7: 0, Bit 6: 0, Bit 5: 1 = Low</p> <p>Bit 7: 0, Bit 6: 1, Bit 5: 0 = Medium</p> <p>Bit 7: 0, Bit 6: 1, Bit 5: 1 = High</p> <p>Bit 7: 1, Bit 6: 1, Bit 5: 1 = Disabled</p>					<p>Use a higher setting if there is signal loss at higher frequencies because of the length of wire between the modem and the telephone exchange when calling the number stored in this Quick/Speed Dial.</p> <p>Also, try using the cable equalizer if one or more of the following symptoms occurs.</p> <p>Communication error with error codes such as 0-20, 0-23, etc.</p> <p>Modem rate fallback occurs frequently.</p> <p><b>Note</b></p> <ul style="list-style-type: none"> <li>Do not use settings other than listed on the left.</li> </ul> <p>If the setting is "Disabled", the bit switch setting is used.</p>	

Switch 02						
No	FUNCTION					COMMENTS
0-3	Initial TX modem rate					<p>If training with a particular remote terminal always takes too long, the initial modem rate may be too high. Reduce the initial TX modem rate using these bits.</p> <p>For the settings 14.4 or kbps slower, Switch 04 bit 4 must be changed to 0.</p> <p><b>Note</b></p> <ul style="list-style-type: none"> <li>Do not use settings other than listed on the left. If the setting is "Disabled", the bit switch setting is used.</li> </ul>
	Bit3	Bit2	Bit1	Bit0	bps	
	0	0	0	0	Not used	
	0	0	0	1	2400	
	0	0	1	0	4800	
	0	0	1	1	7200	
	0	1	0	0	9600	
	0	1	0	1	12000	
	0	1	1	0	14400	
	0	1	1	1	16800	
1	0	0	0	19200		

5. Service Tables

	1	0	0	1	21600	
	1	0	1	0	24000	
	1	0	1	1	26400	
	1	1	0	0	28800	
	1	1	0	1	31200	
	1	1	1	0	33600	
	1	1	1	1	Disabled	
	Other settings: <b>Not used</b>					
4-7	<b>Not used</b>					Do not change the settings.

Switch 03		
No	FUNCTION	COMMENTS
0-1	Inch-mm conversion before TX Bit 1: 0, Bit 0: 0 = Inch-mm conversion available Bit 1: 0, Bit 0: 1 = Inch only Bit 1: 1, Bit 0: 0 = Not used Bit 1: 1, Bit 0: 1 = Disabled	If "inch only" is selected on the machine uses inch-based resolutions for scanning, the printed copy may be slightly distorted at the other end if that machine uses mm-based resolutions. If the setting is "Inch-mm conversion available ", Inch-mm conversion become effective to the special senders. If the setting is "Disabled", the bit switch setting is used.
2-3	DIS/NSF detection method Bit 3: 0, Bit 2: 0 = First DIS or NSF Bit 3: 0, Bit 2: 1 = Second DIS or NSF Bit 3: 1, Bit 2: 0 = Not used Bit 3: 1, Bit 2: 1 = Disabled	(0, 1): Use this setting if echoes on the line are interfering with the set-up protocol at the start of transmission. The machine will then wait for the second DIS or NSF before sending DCS or NSS. If the setting is "Disabled", the bit switch setting is used.
4	V.8 protocol 0: Off 1: Disabled	If transmissions to a specific destination always end at a lower modem rate (14,400 bps or lower), disable V.8 protocol so as not to use V.34 protocol. 0: V.34 communication will not be possible.

		If the setting is "Disabled", the bit switch setting is used.
5	Compression modes available in transmit mode 0: MH only 1: Disabled	This bit determines the capabilities that are informed to the other terminal during transmission. If the setting is "Disabled", the bit switch setting is used.
6-7	ECM during transmission Bit 7: 0, Bit 6: 0 = Off Bit 7: 0, Bit 6: 1 = On Bit 7: 1, Bit 6: 0 = Not used Bit 7: 1, Bit 6: 1 = Disabled	For example, if ECM is switched on but is not wanted when sending to a particular terminal, use the (0, 0) setting. <b>Note</b> <ul style="list-style-type: none"> <li>V.8/V.34 protocol and JBIG compression are automatically disabled if ECM is disabled.</li> <li>If the setting is "Disabled", the bit switch setting is used.</li> </ul>

<b>Switch 04 - Not used</b> (do not change the settings)
<b>Switch 05 - Not used</b> (do not change the settings)
<b>Switch 06 - Not used</b> (do not change the settings)
<b>Switch 07 - Not used</b> (do not change the settings)
<b>Switch 08 - Not used</b> (do not change the settings)
<b>Switch 09 - Not used</b> (do not change the settings)

#### E-mail Parameters

The initial settings of the following e-mail parameters are all "0" (all parameters disabled).

<b>Switch 00</b>		
<b>No</b>	<b>FUNCTION</b>	<b>COMMENTS</b>
0	MH Compression mode for e-mail attachments 0: Off 1: On	Switches MH compression on and off for files attached to e-mails for sending.
1	MR Compression mode for e-mail attachments 0: Off 1: On	Switches MR compression on and off for files attached to e-mails for sending.
2	MMR Compression mode for e-mail attachments 0: Off 1: On	Switches MMR compression on and off for files attached to e-mails for sending.
3-	<b>Not used</b>	Do not change these settings.

## 5. Service Tables

6		
7	Designates the bits to reference for compression method of e-mail attachments <b>0</b> : Registered (Bit 0 to 6) <b>1</b> : No registration.	The "0" selection (default) references the settings for Bits 00, 01, 02 above. The "1" selection ignores the selections of Bits 00, 01, 02.

<b>Switch 01</b>		
<b>No</b>	<b>FUNCTION</b>	<b>COMMENTS</b>
0	Original width of e-mail attachment: A4 <b>0</b> : Off <b>1</b> : On	Sets the original width of the e-mail attachment as A4.
1	Original width of e-mail attachment: B4 <b>0</b> : Off <b>1</b> : On	Sets the original width of the e-mail attachment as B4.
2	Original width of e-mail attachment: A3 <b>0</b> : Off <b>1</b> : On	Sets the original width of the e-mail attachment as A3.
3-6	<b>Not used</b>	Do not change these settings.
7	Designates the bits to reference for original size of e-mail attachments <b>0</b> : Registered (Bit 0 to 6) <b>1</b> : No registration.	The "0" selection (default) references the settings for Bits 00, 01, 02 above. The "1" selection ignores the selections of Bits 00, 01, 02.

<b>Switch 02</b>		
<b>No</b>	<b>FUNCTION</b>	<b>COMMENTS</b>
0	Line resolution of e-mail attachment: 200 x 100 <b>0</b> : Off <b>1</b> : On	Sets the line resolution of the e-mail attachment as 200 x 100.
1	Line resolution of e-mail attachment: 200 x 200 <b>0</b> : Off	Sets the line resolution of the e-mail attachment as 200 x 200.



	1: On	
2	Line resolution of e-mail attachment: 200 x 400 <b>0:</b> Off <b>1:</b> On	Sets the line resolution of the e-mail attachment as 200 x 400.
3	Not used	Do not change these settings.
4	Line resolution of e-mail attachment: 400 x 400 <b>0:</b> Off <b>1:</b> On	Sets the line resolution of the e-mail attachment as 400 x 400.
5-6	<b>Not used</b>	Do not change these settings.
7	Designates the bits to reference for original size of e-mail attachments <b>0:</b> Registered (Bit 0 to 6) <b>1:</b> No registration.	The "0" selection (default) references the settings for Bits 00, 01, 02, 04 above. The "1" selection ignores the selections of Bits 00, 01, 02, 04.

**Switch 03 - Not used** (do not change the settings)

<b>Switch 04</b>		
<b>No</b>	<b>FUNCTION</b>	<b>COMMENTS</b>
0	Full mode address selection <b>0:</b> Full mode address <b>1:</b> No full mode (simple mode)	If the other ends have the addresses, which have the full mode function flag ("0"), this machine determines them as full mode standard machines. <ul style="list-style-type: none"> <li>This machine attaches the "demand of reception confirmation" to a message when transmitting.</li> <li>This machine updates the reception capability to the address book when receiving.</li> </ul>
1-7	<b>Not used</b>	Do not change these settings.

<b>Switch 05</b>		
<b>No</b>	<b>FUNCTION</b>	<b>COMMENTS</b>
0	Direct transmission selection to SMTP server <b>0:</b> ON <b>1:</b> OFF	Allows or does not allow the direct transmission to SMTP server.
1-	Not used	Do not change these settings.

## 5. Service Tables

7		
---	--	--

<b>Switch 06 - Not used</b> (do not change the settings)
<b>Switch 07 - Not used</b> (do not change the settings)
<b>Switch 08 - Not used</b> (do not change the settings)
<b>Switch 09 - Not used</b> (do not change the settings)

## Service RAM Addresses

---

### Service RAM Addresses

---

#### ★ Important

- Do not change the settings that are marked as “Not used” or “Read only.”

#### **680001 to 680004(H) - ROM version (Read only)**

680001(H) - Revision number (BCD)

680002(H) - Year (BCD)

680003(H) - Month (BCD)

680004(H) - Day (BCD)

#### **680006 to 680015(H) - Machine's serial number (16 digits - ASCII)**

#### **680016(H) - Language code**

0: Japanese, 1: UK English, 2: US English, 3: French, 4: German, 5: Spanish, 6: Italian, 7: Dutch, 8: Swedish, 9: Norwegian, 10: Danish, 11: Finnish, 12: Czech, 13: Hungarian, 14: Polish, 15: Portuguese, 16: Russian, 17: Traditional Chinese, 18: Simplified Chinese, 19: Korean

#### **680018(H) - Total program checksum (low)**

#### **680019(H) - Total program checksum (high)**

#### **680020 to 68003F(H) - System bit switches**

#### **680050 to 68005F(H) - Printer bit switches**

#### **680060 to 68007F(H) - Communication bit switches**

#### **680080 to 68008F(H) - G3 bit switches**

#### **680090 to 68009F(H) - G3-2 bit switches: Not used**

#### **6800A0 to 6800AF(H) - G3-3 bit switches: Not used**

#### **6800D0(H) - User parameter switch 00 (SWUER\_00): Not used**

#### **6800D1(H) - User parameter switch 01 (SWUSR\_01): Not used**

#### **6800D2(H) - User parameter switch 02 (SWUSR\_02)**

Bit 0: Forwarding mark printing on forwarded messages 0: Disabled, 1: Enabled

Bit 1: Center mark printing on received copies

(This switch is not printed on the user parameter list.)

0: Disabled, 1: Enabled

Bit 2: Reception time printing

(This switch is not printed on the user parameter list.)

0: Disabled, 1: Enabled

Bit 3: TSI print on received messages 0: Disabled, 1: Enabled

Bit 4: Checkered mark printing

(This switch is not printed on the user parameter list.)

0: Disabled, 1: Enabled

Bit 5: Not used

Bit 6: Not used

## 5. Service Tables

Bit 7: Not used

### **6800D3(H) - User parameter switch 03 (SWUSR\_03: Automatic report printout)**

Bit 0: Transmission result report (memory transmissions) 0: Off, 1: On

Bit 1: Not used

Bit 2: Memory storage report 0: Off, 1: On

Bit 3: Polling reserve report (polling reception) 0: Off, 1: On

Bit 4: Polling result report (polling reception) 0: Off, 1: On

Bit 5: Transmission result report (immediate transmissions) 0: Off, 1: On

Bit 6: Not used

Bit 7: Journal 0: Off, 1: On

### **6800D4(H) - User parameter switch 04 (SWUSR\_04: Automatic report printout)**

Bit 0: Not used

Bit 1: Automatic communication failure report and transfer result report output 0: Off, 1: On

Bits 2 to 3: Not used

Bit 4: Indicates the parties 0: Not indicated, 1: Indicated

Bit 5: Include sender's name on reports 0: Off, 1: On

Bit 6: Not used

Bit 7: Inclusion of a sample image on reports 0: Off, 1: On

### **6800D5(H) - User parameter switch 05 (SWUSR\_05)**

Bit 0: Substitute reception when the base copier is in an SC condition

0: Enabled, 1: Disabled

Bits 1 and 2: Condition for substitute RX when the machine cannot print messages (Paper end, toner end, jam, and during night mode)

Bit 2: 0, Bit 1: 0 = The machine receives all the fax messages.

Bit 2: 0, Bit 1: 1 = The machine receives the fax messages with RTI or CSI.

Bit 2: 1, Bit 1: 0 = The machine receives the fax messages with the same ID code.

Bit 2: 1, Bit 1: 1 = The machine does not receive anything.

Bit 3: Not used

Bit 4: Not used

Bit 5: Just size printing 0: Off, 1: On

Bit 6: Not used

Bit 7: Add paper display when a cassette is empty 0: Off, 1: On

### **6800D6(H) - User parameter switch 06 (SWUSR\_06)**

Bit 0:

Bit 1: V8 protocol (G3-1: Super G3) 0: Off, 1: On

Bit 2: V8 protocol (G3-2: Super G3) 0: Off, 1: On

Bit 3: V8 protocol (G3-3: Super G3) 0: Off, 1: On

### **6800D7(H) - User parameter switch 07 (SWUSR\_07)**

Bit 0 Ringing 0: Off, 1: On

Bit1: Automatic answering message 0: Off, 1: On

Bit 2: Parallel memory transmission 0: Off, 1: On

Bits 3 and 4: Not used

Bit 5: Remote control 0: Off, 1: On

Bits 6 and 7: Not used

**6800D8(H) - User parameter switch 08 (SWUSR\_08)**

Bits 0 and 1: Not used.

Bit 2: Authorized reception

0: Only faxes from senders whose RTIs/CSIs are specified for this feature are accepted.

1: Only faxes from senders whose RTIs/CSIs are not specified for this feature are accepted.

Bits 3 to 7: Not used.

**6800D9(H) - User parameter switch 09 (SWUSR\_09):** Not used

**6800DA(H) - User parameter switch 10 (SWUSR\_0A)**

Bits 0 to 2: Not used

Bit 3: Page reduction 0: Off, 1: On

Bits 4 and 5: Not used

Bit 6: Use both e-mail notification and printed reports to confirm the transmission results 0: Off, 1: On

Bit 7: Not used

**6800DB(H) - User parameter switch 11 (SWUSR\_0B)**

Bits 0 and 1: Not used

Bit 2: White original detection 0: Off, 1: On (alarm and alert message on the LCD)

Bit 3: Receive rejection for 1300 Hz transmission 0: Off (receive), 1: On (not receive)

Bit 5: Not used

Bit 6: Printout of messages received while acting as a forwarding station 0: Off, 1: On

Bit 7: Not used

**6800DC(H) - User parameter switch 12 (SWUSR\_0C):** Not used

**6800DD(H) - User parameter switch 13 (SWUSR\_0D):** Not used

**6800DE(H) - User parameter switch 14 (SWUSR\_0E)**

Bit 0: Message printout while the machine is in Night Printing mode 0: On, 1: Off

Bit 1: Maximum document length detection 0: Double letter, 1: Longer than double-letter (well log) – up to 1,200 mm

Bit 2: Not used

Bit 3: Fax mode settings, such as resolution, before a mode key (Copy/Fax/Printer/Scanner) is pressed  
0: Not cleared, 1: Cleared

Bits 4 to 6: Not used

Bit 7: Not used

**6800DF(H) - User parameter switch 15 (SWUSR\_0F)**

(This switch is not printed on the user parameter list.)

Bits 0, 1 and 2: Cassette for fax printout

## 5. Service Tables

Bit 2: 0, Bit 1: 0, Bit 0: 1 = 1st paper feed station

Bit 2: 0, Bit 1: 1, Bit 0: 0 = 2nd paper feed station

Bit 2: 0, Bit 1: 1, Bit 0: 1 = 3rd paper feed station

Bit 2: 1, Bit 1: 0, Bit 0: 0 = 4th paper feed station

Bit 2: 1, Bit 1: 0, Bit 0: 1 = LCT

Other settings Not used

Bits 3 and 4: Not used

Bit 5: Using the cassette specified by bits 0, 1 and 2 above only 0: On, 1: Off

Bits 6 and 7: Not used

### **6800E0(H) – User parameter switch 16 (SWUSR\_10)**

(This switch is not printed on the user parameter list.)

Bits 0 and 1: Not used

Bit 2: Paper size selection priority for an A4 size fax message when A4/LT size paper is not available. 0: A3 has priority, 1: B4 has priority

Bits 3 to 7: Not used

### **6800E1(H) – User parameter switch 17 (SWUSR\_11)**

Bit 0: Not used

Bit 1: Not used

Bit 2: Inclusion of the “Add” button when a sequence of Quick/Speed dials is selected for broadcasting  
0: Not needed, 1: Needed

Bits 3 to 6: Not used

Bit 7: Press “Start” key without an original when using the on hook dial or the external telephone,  
0: displays “Cannot detect original size”. 1: Receives fax messages.

### **6800E2(H) - User parameter switch 18 (SWUSR\_12)**

Bit 0: TTI date 0: Off, 1: On

Bit 1: TTI sender 0: Off, 1: On

Bit 2: TTI file number 0: Off, 1: On

Bit 3: TTI page number 0: Off, 1: On

Bits 4 to 6: Not used

Bit 7: Japan only

### **6800E3(H) - User parameter switch 19 (SWUSR\_13)**

Bit 0: Not used

Bit 1: Journal format

0: The Journal is separated into transmissions and receptions

1: The Journal is separated into G3-1, G3-2, and G3-3 communications

Bit 2: Not used

Bit 3: 90° image rotation during B5 portrait TX (This switch is not printed on the user parameter list.) 0: Off, 1: On

Bit 4: Reduction of sample images on reports to 50% in the main scan and sub-scan directions. (This

switch is not printed on the user parameter list.) 0: Technician adjustment (printer switch 0E bits 3 and 4), 1: 50% reduction

Bit 5: Use of A5 size paper for reports (This switch is not printed on the user parameter list.) 0: Off, 1: On

Bits 6 and 7: Not used

#### **6800E4(H) - User parameter switch 20 (SWUSR\_14)**

Bit 0: Automatic printing of the LAN fax result report 0: Off, 1: On

Bit 1: Not used.

Bits 2 to 5: Store documents in memory, which could not be printed from PC fax (LAN fax) driver

Bit 5	Bit 4	Bit 3	Bit 2	Setting
0	0	0	0	0 min.
0	0	0	1	1 min.
↓	↓	↓	↓	↓
1	1	1	0	14 min.
1	1	1	1	15 min.

Bits 6 and 7: Not used.

#### **6800E5(H) - User parameter switch 21 (SWUSR\_15)**

Bit 0: Print results of sending reception notice request message 0: Disabled (print only when error occurs), 1: Enabled

Bit 1: Respond to e-mail reception acknowledgment request 0: Disabled, 1: Enabled

Bit 2: Not used

Bit 3: File format for forwarded folders 0: TIFF, 1: PDF

Bit 4: Transmit Journal by E-mail 0: Disabled, 1: Enabled

Bit 5: Not used

Bit 6: Network error display 0: Displayed, 1: Not displayed

Bit 7: Transmit error mail notification 0: Enabled, 1: Disabled

#### **6800E6(H) - User parameter switch 22 (SWUSR\_16)**

(This switch is not printed on the user parameter list.)

Bit 0: Dial tone detection (PSTN 1) 0: Disabled, 1: Enabled

Bits 1 to 7: Not used

**6800E7(H) - User parameter switch 23 (SWUSR\_17):** Not used

**6800E8(H) - User parameter switch 24 (SWUSR\_18):** Not used

#### **6800E9(H) - User parameter switch 25 (SWUSR\_19)**

Bit 0: Not used

Bit 1: Reception mode switch timer 0: Off, 1: On (switching Fax or Fax/Tel)

Bit 2: Mode priority switch 0: Fax first, 1: Tel first

Bit 3: Dial in function (Japan Only)

Bit 4: **Do not Change this Bit.**

Bits 5 to 7: Not used

## 5. Service Tables

**6800EA(H) and 6800EB(H) - User parameter switches 26 and 27 (SWUSR\_1A and 1B):** Not used

**6800EC(H) - User parameter switch 28(SWUSR\_1C):** Not used

**6800ED(H) - User parameter switch 29(SWUSR\_1D):** Not used

**6800EE(H) and 6800EF(H) - User parameter switches 30 and 31 (SWUSR\_1E and 1F):** Not used

**6800F0(H) - User parameter switch 32 (SWUSR\_20)**

Bit 0: Quotation priority for a destination when there is no destination of the specified type

0: Paper output priority = Priority order: 1. IP-fax destination, 2. Fax Number, 3. E-mail address, 4.

Folder

1: Electric putout order = Priority order: 1. E-mail address, 2. Folder, 3. IP-fax destination, 4. Fax number

Bits 1 to 7: Not used

**6800F1(H) - User parameter switch 33 (SWUSR\_21):** Not used

**6800F2(H) - User parameter switch 34 (SWUSR\_22)**

Bit 0: Gatekeeper server used with IP-Fax 0: Disabled, 1: Enabled

Bit 1: SIP server used with IP-Fax 0: Disabled, 1: Enabled

Bits 2 to 7: Not used

**6800F3(H) - User parameter switch 35 (SWUSR\_23)**

Redial interval when sending a backup file

**6800F4(H) - User parameter switch 36 (SWUSR\_24)**

Maximum number of redials when sending a backup file

**6800F5(H) - User parameter switch 37 (SWUSR\_25)**

Bit 0: Whether to stop sending a backup file if the destination folder becomes full while the machine is sending or waiting to send a fax or the backup file. 0: No, • 1: Yes

Bit 2 and 3: Backup file is printed along with the TX communication failure report when a backup file transmission failure occurs. 00: Do not print, 01: Print first page only, 10: Print whole file

Bit 4: Display the sender's information in the file name of documents that are forwarded to folder destinations. 0: Disabled, 1: Enabled

Bit 5: Limit the file names of documents that are forwarded to folder destinations to plain characters only. 0: Disabled, 1: Enabled

Bit 6: When using the remote fax function, the sub-machine beeps to let you know when it has printed a received document (If you specify "On", the machine will beep according to the setting of [Panel Key Sound] under [System Settings].) 0: On, 1: Off

Bit 7: Not used

**6800F6(H) - User parameter switch 38 (SWUSR\_26)**

Maximum number of transmissions the machine attempts before determining that a fax cannot be forwarded from a sender (including special senders) to a folder destination

**6800F7(H) - User parameter switch 39 (SWUSR\_27)**

Interval (in minutes) between resend attempts after failing to forward a fax from a sender (including special senders) to a folder destination



**6800F8(H) - User parameter switch 40 (SWUSR\_28)**

Bit 0: When memory space is insufficient, the machine prints and then deletes the oldest faxes, creating memory space for storage of new faxes. 0: Disabled, 1: Enabled

Bit 1 to 7: Not used

**6800FD(H) - User parameter switch 45 (SWUSR\_2D)**

Bit 0 and 1:

Bit 2: File format for files transmitted to e-mail addresses and folders registered as forwarding, destinations of backup file transmission, receivers for Personal Box, or end receivers for Transfer Box.

0: PDF 1: PDF/A

Bit 3:

Bit 4 to 7: Not used

**680100 to 68010F(H)** - G4 Parameter Switches – Not used

**680110 to 68012F(H)** - G4 Internal Switches – Not used

**680130 to 68016F(H)** - Service Switches

**680170 to 68017F(H)** - IFAX Switches

**680180 to 68018F(H)** - IP-FAX Switches

**680190 to 6801A3(H)** - PSTN-1 RTI (Max. 20 characters - ASCII) - See the following note.

**6801A4 to 6801B7(H)** - PSTN-2 RTI (Max. 20 characters - ASCII)

**6801B8 to 6801CB(H)** - PSTN-3 RTI (Max. 20 characters - ASCII)

**6801CF to 68020E(H)** - TTI 1 (Max. 64 characters - ASCII) - See the following note.

**68020F to 68024E(H)** - TTI 2

**68024F to 68028E(H)** - TTI 3

**68028F to 6802CE(H)** - TTI 4

**6802CF to 68030E(H)** - TTI 5

**68030F to 68034E(H)** - TTI 6

**68034F to 68038E(H)** - TTI 7

**68038F to 6803CE(H)** - TTI 8

**6803CF to 68040E(H)** - TTI 9

**68040F to 68044E(H)** - TTI 10

 **Note**

- If the number of characters is less than the maximum (20 for RTI, 32 for TTI), add a stop code (00[H]) after the last character.

**68044F(H)**

Printing format for TTI 1

0: DOM (Japan), 1:EXP (Export)

**680450(H)**

Printing format for TTI 2

0: DOM, 1: EXP

**680451(H)**

## 5. Service Tables

Printing format for TTI 3

0: DOM, 1:EXP

**680452(H)**

Printing format for TTI 4

0: DOM, 1:EXP

**680453(H)**

Printing format for TTI 5

0: DOM, 1:EXP

**680454(H)**

Printing format for TTI 6

0: DOM, 1:EXP

**680455(H)**

Printing format for TTI 7

0: DOM, 1:EXP

**680456(H)**

Printing format for TTI 8

0: DOM, 1:EXP

**680457(H)**

Printing format for TTI 9

0: DOM, 1:EXP

**680458(H)**

Printing format for TTI 10

0: DOM, 1: EXP

**680459 to 68046C(H)** - PSTN-1 CSI (Max. 20 characters - ASCII)

**68046D to 680480(H)** - PSTN-2 CSI (Max.20 characters - ASCII)

**680481 to 680494(H)** - PSTN-3 CSI (Max.20 characters - ASCII)

**680495(H)** - Number of PSTN-1 CSI characters (Hex)

**680496(H)** - Number of PSTN-2 CSI characters (Hex)

**680497(H)** - Number of PSTN-3 CSI characters (Hex)

**6804C6(H)** - Memory Lock ID (BCD)

**6804D2 to 6804D9(H)** - Last power off time (Read only)

6804D2(H) - 01(H) - 24-hour clock, 00(H) - 12-hour clock (AM), 02(H) - 12-hour clock (PM)

6804D3(H) - Year (BCD)

6804D4(H) - Month (BCD)

6804D5(H) - Day (BCD)

6804D6 (H) – Hour

6804D7 (H) – Minute

6804D8(H) – Second

6804D8 (H) - 00: Monday, 01: Tuesday, 02: Wednesday, ///, 06: Sunday

**6804E6(H)** - Optional equipment (Read only – Do not change the settings)

Bit 0: Page Memory 0: Not installed, 1: Installed

Bit 1: SAF Memory (4M) 0: Not installed, 1: Installed

Bit 2: SAF Memory 0: Not installed, 1: Installed

Bits 3 to 7; Not used

**6804E7(H)** - Optional equipment (Read only – Do not change the settings)

Bits 0 to 3: Not used

Bit 4: G3-2 0: Not installed, 1: Installed

Bit 5: G3-3 0: Not installed, 1: Installed

Bit 6 and 7: Not used

**6804EE(H)** - Machine code (Check ram 3)

**680500(H)** - Start address of G3 table for G3-1

**680600(H)** - Start address of G3 table for G3-2

**680700(H)** - Start address of G3 table for G3-3

**680800 to 68081F(H)** - Service station's fax number (SP3-101)

**680820 to 680829(H)** - Own fax PABX extension number – Not used

**68082A to 680833(H)** - Own fax number (PSTN) – Not used

**680834 to 680847(H)** - Own fax number (ISDN G4) – Not used

**680848 to 680853(H)** - The first subscriber number (ISDN G3) – Not used

**680854 to 68085F(H)** - The second subscriber number (ISDN G3) – Not used

**680860 to 68086B(H)** - The first subscriber number (ISDN G4) – Not used

**68086C to 680877(H)** - The second subscriber number (ISDN G4) – Not used

**6808A0 to 6808B7(H)** - G4TID registered information (Max.24 characters - ASCII)

**6808B8 to 6808CB(H)** - ISDN CSI (Max.20 characters - ASCII)

**6808CC(H)** - Number of ISDN CSI characters (Hex)

**6808D1 to 6808D4(H)** - ISDN G3 sub address registered information

**6808D5 to 6808D8(H)** - G4 sub address registered information

**6808DE to 6808E2** – Option G3 board (G3-2) ROM information (Read only)

6808DE(H) - Suffix (BCD)

6808DF(H) - Version (BCD)

6808E0(H) - Year (BCD)

6808E1(H) - Month (BCD)

6808E2(H) - Day (BCD)

**6808E3 to 6808E7** – Option G3 board (G3-3) ROM information (Read only)

6808E3(H) - Suffix (BCD)

6808E4(H) - Version (BCD)

6808E5(H) - Year (BCD)

6808E6(H) - Month (BCD)

6808E7(H) - Day (BCD)

## 5. Service Tables

- 6808E8(H)** - G3-1 Modem ROM version (Read only)
- 6808EA(H)** - G3-2 Modem ROM version (Read only)
- 6808EC(H)** - G3-3 Modem ROM version (Read only)
- 6808F8(H)** - Number of multiple sets print (Read only)
- 68094E(H)** - Time for economy transmission (Not used)
- 68094F(H)** - Time for economy transmission (Not used)
- 68096A(H)** - Transmission monitor volume 00 - 07(H)
- 68096B(H)** - Reception monitor volume 00 - 07(H)
- 68096C(H)** - On-hook monitor volume 00 - 07(H)
- 68096D(H)** - Dialing monitor volume 00 - 07(H)
- 68096E(H)** - Buzzer volume 00 - 07(H)
- 68096F(H)** - Beeper volume 00 - 07(H)
- 680980(H)** - Machine code (Check ram 4)
- 680982(H)** - Machine serial number (ASCII)
- 687178 to 68717B(H)** - Transmission counter (Max.24 characters - ASCII)
- 68717C to 68717F(H)** - Reception counter (Max.24 characters - ASCII)
- 6871E8 to 6871EB(H)** - Mail transmission counter (Max.24 characters - ASCII)
- 6871EC to 6871EF(H)** - Mail reception counter (Max.24 characters - ASCII)
- 6A6DEE(H) to 6A70ED(H)** - SIP server address (Read only)
- 6A6DEE(H) - Proxy server - Main (Max. 128 characters - ASCII)
- 6A6E6E(H) - Proxy server - Sub (Max. 128 characters - ASCII)
- 6A6EEE(H) - Redirect server - Main (Max. 128 characters - ASCII)
- 6A6F6E(H) - Redirect server - Sub (Max. 128 characters - ASCII)
- 6A6FEE(H) - Registrar server - Main (Max. 128 characters - ASCII)
- 6A706E(H) - Registrar server - Sub (Max. 128 characters - ASCII)
- 6A70EE(H)** - Gatekeeper server address - Main (Max. 128 characters - ASCII)
- 6A716E(H)** - Gatekeeper server address - Sub (Max. 128 characters - ASCII)
- 6A71EE(H)** - Alias Number (Max. 128 characters - ASCII)
- 6A726E(H)** - SIP user name (Max. 128 characters - ASCII)
- 6A72EE(H)** - **SIP digest authentication password** (Max. 128 characters - ASCII)
- 6A736E(H)** - Gateway address information (Max. 7100 characters - ASCII)
- 6A8F2A(H)** - NGN initial setting method 0: Simple, 1: Manual
- 6A8F2B(H)** - SIP digest authentication user name (Max. 128 characters - ASCII)
- 6A8FAB(H)** - NGN-SIP domain name (Max. 64 characters - ASCII)
- 6A8FEB(H)** - NGN-home gateway address (Max. 128 characters - ASCII)
- 6A906C(H)** - Stand-by port number for H.323 connection
- 6A906E(H)** - Stand-by port number for SIP connection
- 6A9070(H)** - RAS port number
- 6A9072(H)** - Gatekeeper port number

**6A9074(H)** - Port number of data waiting for T.38

**6A9076(H)** - Port number of SIP server

**6A9078(H)** - Priority for SIP and H.323 0: H.323, 1: SIP

**6A9079(H)** - SIP function 0: Disabled, 1: Enabled

**6A907A(H)** - H.323 function 0: Disabled, 1: Enabled

**6A907B(H)** - **SIP digest authentication function** 0: Disabled, 1: Enabled

**6B3AE4(H) - 6B3B04 (H) - Dial tone detection parameter** (Max. 11 x 3 lines)

This initializes following order. [0x04, 0x40, 0x03, 0x60, 0x64, 0xf4, 0x01,0x64, 0x04, 0xc8, 0x00]

**6B3AE4(H)** – Dial tone detection frequency – Upper limit (High)

Defaults: NA: 06, EU: 06, ASIA: 06

**6B3AE5(H)** – Dial tone detection frequency – Upper Limit (Low)

Defaults: NA: 50, EU: 50, ASIA: 50

**6B3AE6(H)** – Dial tone detection frequency – Lower Limit (High)

Defaults: NA: 03, EU: 02, ASIA: 02

**6B3AE7(H)** – Dial tone detection frequency – Lower Limit (Low)

Defaults: NA: 60, EU: 90, ASIA: 90

**6B3AE8(H)** –Dial tone detection waiting time (20 ms)

Defaults: NA: 64, EU 64, ASIA: 64

**6B3AE9 to 6B3AEA** – Dial tone detection monitoring time (20 ms)

Defaults

Area	6B35A9	6B35AA
NA	F4	01
EU	F4	01
ASIA	F4	01

**6B3AEB(H)** – Dial tone detect judge time (20 ms)

Defaults: NA: 64, EU: 1B, ASIA: 32

**6B3AEC(H)** – Dial tone disconnect permission time (20 ms)

Defaults: NA: 11, EU: 0F, ASIA: 11

## 6. Detailed Section Descriptions

---

### Overview

---

#### Overview

---

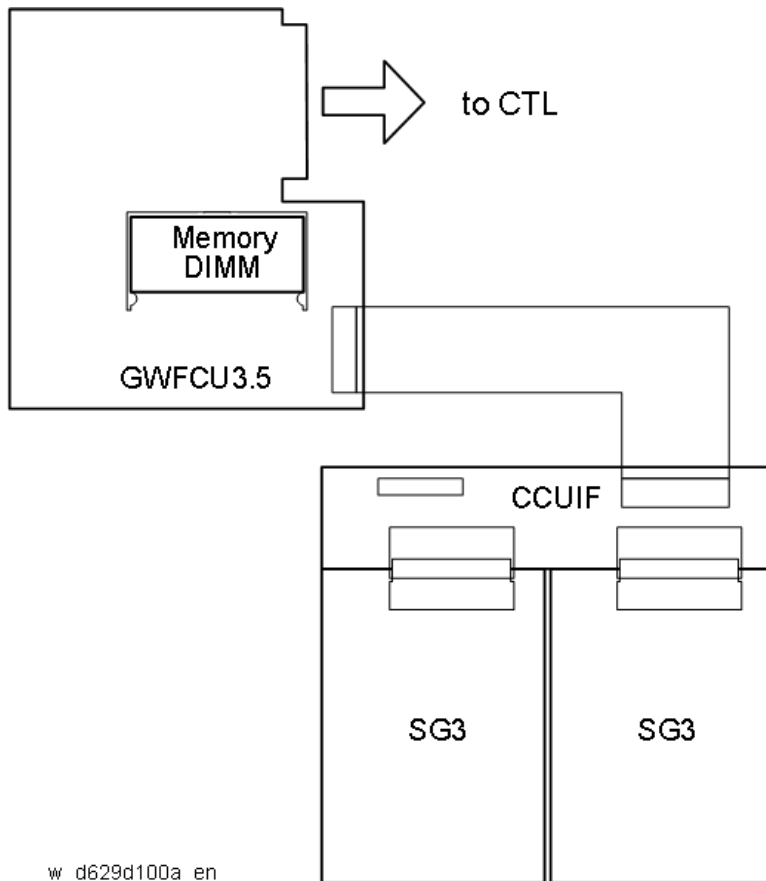

Together with the controller board, the FCU controls all the fax communications and fax features. The FCU also contains the ROM, SRAM and NCU circuits.

#### Fax Options

- Extra G3 Interface option  
This provides one more analog line interface. This allows full dual access. Two extra G3 interface options can be installed.
- Memory Expansion  
This expands the SAF memory and the page memory (used for image rotation); without this expansion, the page memory is not big enough for image rotation at 400 dpi, so transmission at 400 dpi is not possible.

## Boards

### FCU

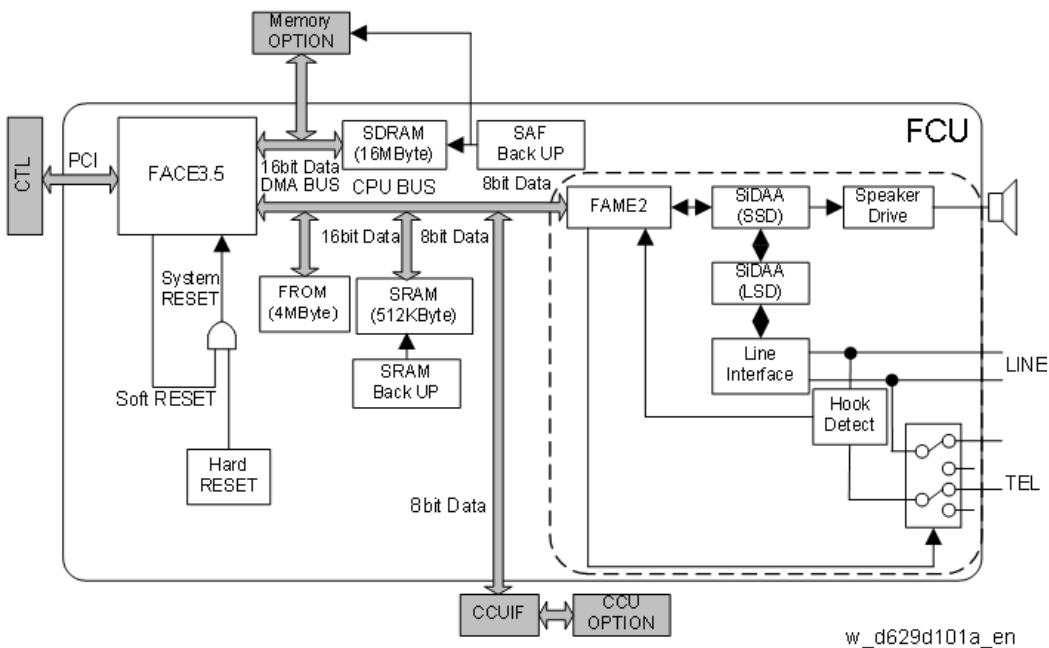

The FCU (Facsimile Control Unit) controls fax communications, the video interface to the base copier's engine, and all the fax options.

#### FACE3.5 (Fax Application Control Engine)

- CPU
- Data compression and reconstruction (DCR)
- DMA control
- Clock generation
- DRAM backup control

#### Modem (FAME2)

- V.34, V33, V17, V.29, V.27ter, V.21, and V.8

#### DRAM

- The 16 MB of DRAM is shared as follows.
  - SAF memory: 4MB
  - Working memory: 4MB
  - Page memory: 8MB
  - The SAF memory is backed up by a rechargeable battery.

#### ROM

- 4MB flash ROMs for system software storage

#### SRAM

- The 512 KB SRAM for system and user parameter storage is backed up by a lithium battery.

#### Memory Back-up

- A rechargeable battery backs up the SAF memory (DRAM) for 12 hours.

## 6. Detailed Section Descriptions

- A lithium battery backs up the system parameters and programmed items in the SRAM, in case the base copier's main switch is turned off.

### Switches

Item	Description
SW1	Switches the SRAM backup battery on/off.

## SG3 Board

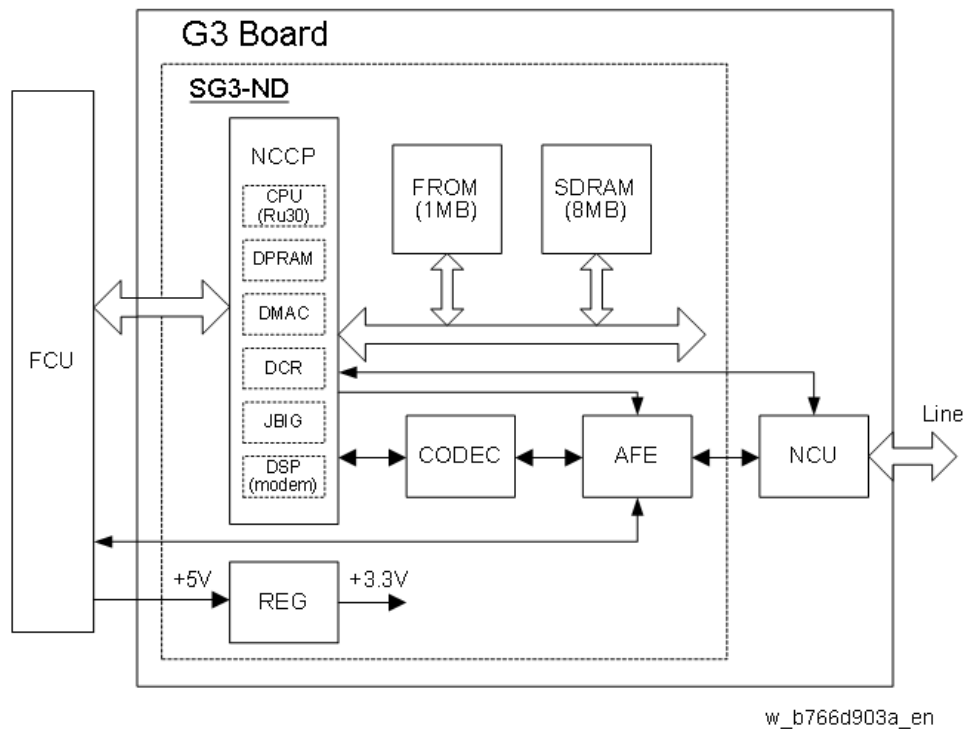

The SG3 board allows up to three simultaneous communications when used in combination with the FCU and optional G3 boards. The NCU is on the same board as the common SG-3 board. This makes the total board structure smaller. But, the specifications of the SG3 board do not change.

### NCCP (New Communication Control Processor)

- Controls the SG3 board.
- CPU (RU30)
- DPRAM (Dual Port RAM): Handshaking with the FCU is done through this block.
- DMA controller
- JBIG
- DSP V34 modem (RL5T892): Includes the DTMF Receiver function
- DCR for MH, MR, MMR, and JBIG compression and decompression

### FROM

- 1Mbyte flash ROM for SG3 software storage and modem software storage

### SDRAM

- 4Mbyte DRAM shared between ECM buffer, line buffer, and working memory

### AFE (Analog Front End)



- Analog processing

**CODEC (COder-DECoder)**

- A/D & D/A conversions for modem

**REG**

- Generates +3.3 V from the +5V from the FCU

## Video Data Path

### Transmission

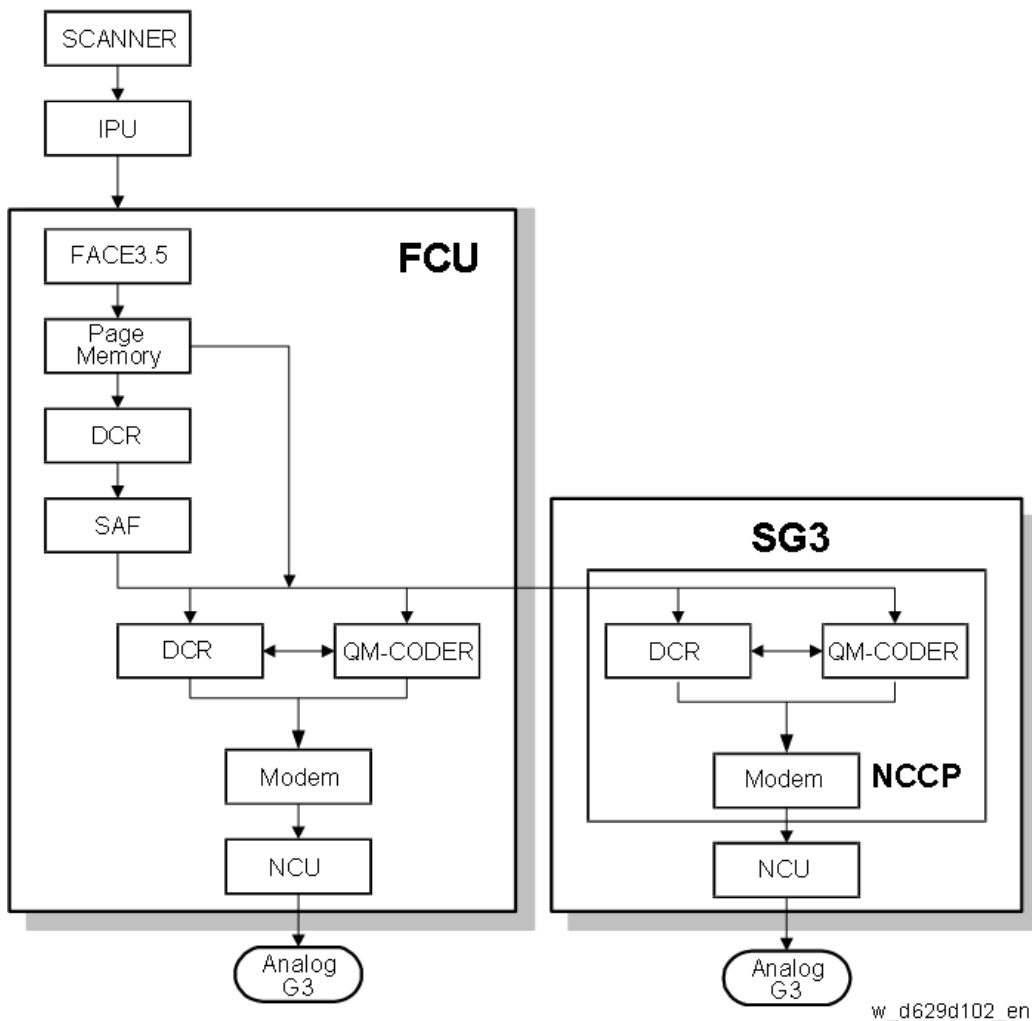

### Memory Transmission and Parallel Memory Transmission

The base copier's scanner scans the original at the selected resolution in inch format. The IPU processes the data and transfers it to the FCU.

**Note**

- When scanning a fax original, the IPU uses the MTF, independent dot erase and thresholding parameter settings programmed in the fax unit's scanner bit switches, not the copier's SP modes.

Then, the FCU converts the data to mm format, and compresses the data in MMR or raw format to store it in the SAF memory. If image rotation will be done, the image is rotated in page memory before compression.

At the time of transmission, the FCU decompresses the stored data, then re-compresses and/or reduces the data if necessary for transmission. The NCU transmits the data to the line.

### Immediate Transmission

---

The base copier's scanner scans the original at the resolution agreed with the receiving terminal. The IPU video processes the data and transfers it to the FCU.

#### Note

- When scanning a fax original, the IPU uses the MTF, independent dot erase and thresholding parameter settings programmed in the fax unit's scanner bit switches, not the copier's SP modes.

Then the FCU stores the data in page memory, and compresses the data for transmission. The NCU transmits the data to the line.

### JBIG Transmission

---

#### **Memory transmission**

If the receiver has JBIG compression, the data goes from the DCR to the QM-Coder. Then the NCU transmits the data to the line. When an optional G3 unit (SG3) is installed and PSTN2 is selected as the line type, JBIG compression is available, but only for the PSTN-2 line.

#### **Immediate transmission**

If the receiver has JBIG compression, the data goes from the page memory to the QM-Coder. Then the NCU transmits the data to the line. When an optional G3 unit (SG3) is installed and PSTN2 is selected as the line type, JBIG compression is available, but only for the PSTN-2 line.

### Adjustments

---

- Priority for the line used for G3 transmissions (PSTN 1/PSTN 2 or 3): System switch 16 bit 1

Reception

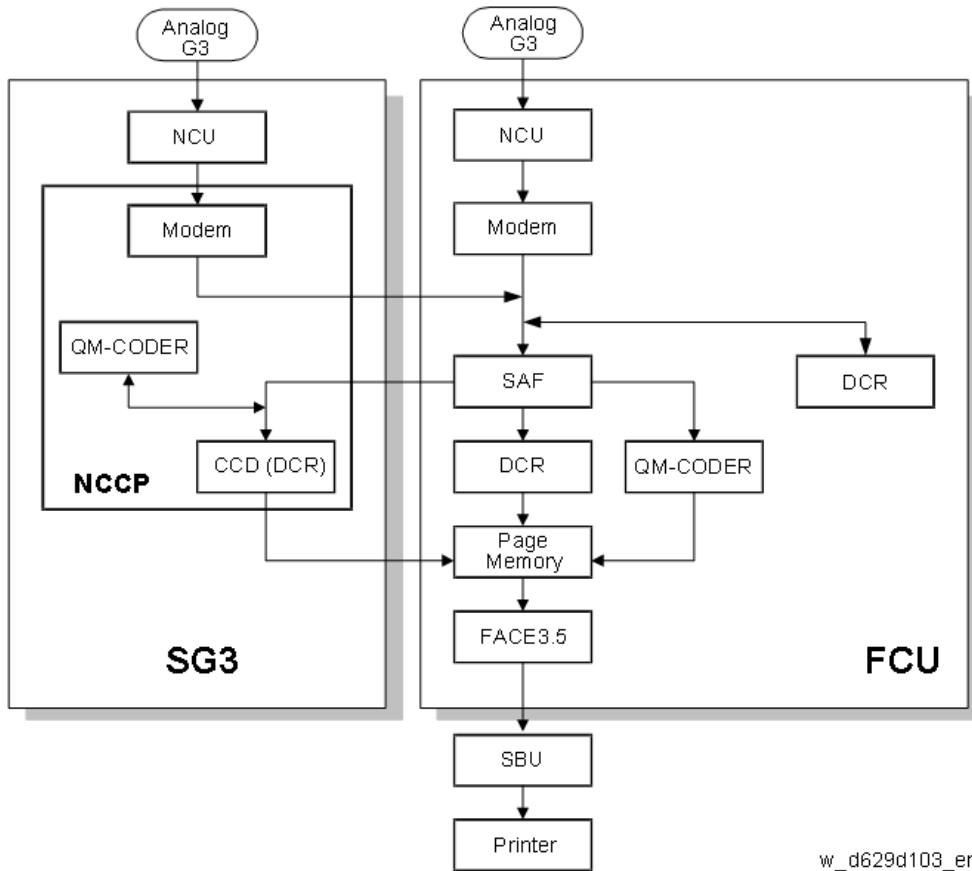

First, the FCU stores the incoming data from either an analog line to the SAF memory. (The data goes to the FACE3 at the same time, and is checked for error lines/frames.)

The FCU then decompresses the data and transfers it to page memory. If image rotation will be done, the image is rotated in the page memory. The data is transferred to the IPU.

If the optional G3 unit is installed, the line that the message comes in on depends on the telephone number dialed by the other party (the optional G3 unit has a different telephone number from the main fax board).

**JBIG Reception**

When data compressed with JBIG comes in on PSTN-1 (the standard analog line), the data is sent to the QM-CODER for decompression. Then the data is stored in the page memory, and transferred to the IPU.

When data compressed with JBIG comes in on PSTN-2 (optional extra analog line), the data is sent to the QM-CODER on the SG3 board for decompression.

## Fax Communication Features

### Multi-port

When the optional extra G3 Interface Unit is installed, communication can take place at the same time through the two or three lines at once.

Option	Available Line Type	Available protocol Combinations
Standard only	PSTN	G3
Extra G3 Interface Unit (single)	PSTN + PSTN	G3 + G3
Extra G3 Interface Unit (double)	PSTN + PSTN +PSTN	G3 + G3 +G3

### Document Server

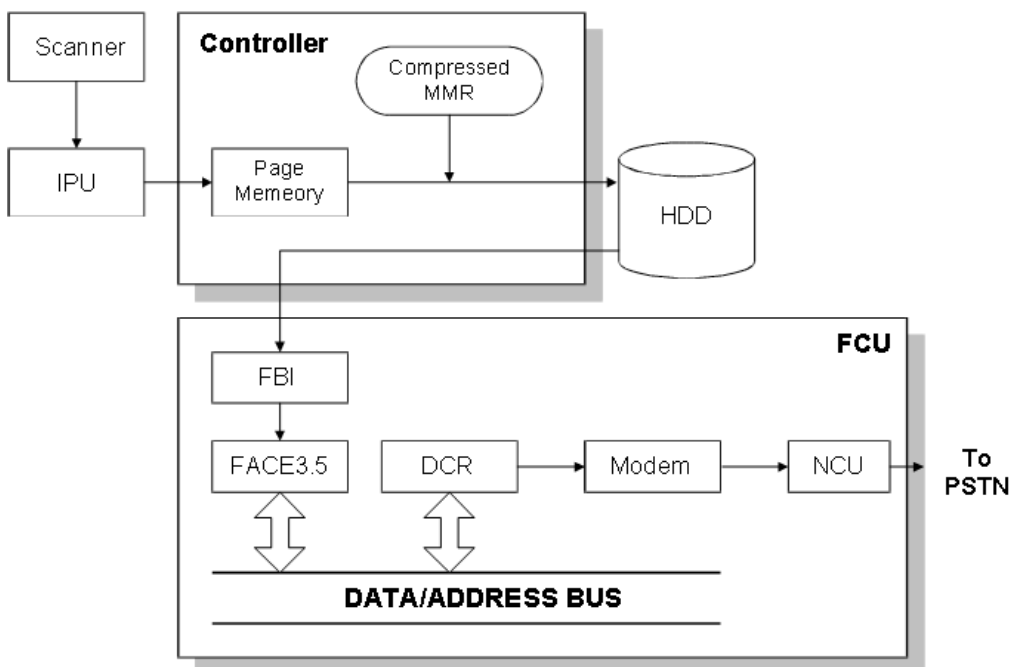

w\_d629d104\_en

The base copier's scanner scans the original at the selected resolution. The IPU video processes the data and transfers it to the controller board.

Then the controller stores the data in the page memory for the copier function, and compresses the data in MMR (by software) to store it in the HDD. If image rotation will be done, the image is rotated in the page memory before compression.

For transmission, the stored image data is transferred to the FCU. The FCU decompresses the image data, then recompresses and/or reduces the data if necessary for transmission. The NCU transmits the data to the line.

The documents can be stored in the HDD (Document Server) from the fax application. The stored documents in the document sever can be used for the fax transmission in many times. More than one document and the scanned document can be combined into one file and then the file can be

## 6.Detailed Section Descriptions

transmitted.

- When using the document server, the SAF memory is not used.
- The document is compressed with MMR and stored.
- Up to 9,000 pages can be stored (1 file: Up to 1,000 pages) from the fax application.
- Only stored documents from the fax application can be transmitted.
- Scanned documents are given a name automatically, such as "FAX001". But it is possible to change the file name, user name and password.
- Up to 30 files can be selected at once.

### Note

- The compression method of the fax application is different from the copy application. The storing time is longer than the copier storing.
- When selecting "Print 1st page", the stored document will be reduced to A4 size.

---

## Internet Mail Communication

---

### Mail Transmission

---

#### T.37 simple and full modes

This machine supports T.37 full mode. (ITU-T Recommendation, RFC2532). The difference between T.37 simple mode and full mode is as follows.

Function	T.37 Simple Mode	T.37 Full Mode
Resolution	200 x 100 200 x 200	200 x100 200 x 200 200 x 400 400 x 400 (if available)
RX Paper Width	A4	A4, B4, A3
RX Data Compression Method	MH	MH (default), MR, MMR,
Signals	Image data transmission only	Image data transmission, exchange of capability information between the two terminals, and acknowledgement of receipt of fax messages

#### Data Formats

The scanned data is converted into a TIFF-F formatted file.

The fields of the e-mail and their contents are as follows:

Field	Content
From	Mail address of the sender
Reply To	Destination requested for reply
To	Mail address of the destination

Field	Content
Bcc	Backup mail address
Subject	From CSI or RTI (Fax Message No. xxxx)
Content Type	Multipart/mixed Attached files: image/tiff
Content Transfer Encoding	Base 64, 7-bit, 8-bit, Quoted Printable
Message Body	MIME-converted TIFF-F (MIME standards specify how files are attached to e-mail messages)

### Direct SMTP Transmission

Internet Fax documents can be sent directly to their destinations without going through the SMTP server. (Internet Faxes normally transmit via the SMTP server.)

For example:

<b>e-mail address:</b>	gts@ricoh.co.jp
<b>SMTP server address:</b>	gts.abcd.com

In this case, this feature destination e-mail address (gts@ricoh.co.jp) is read as the SMTP server address "gts.abcd.com", and the transmissions bypass the SMTP server. This leads to decrease the server load and to reduce the time lag during transferring the mail.

- Requirements for destination server:
  - Supports with Internet FAX (as a destination of Internet FAX)
  - Can receive mails (as a destination of mail)
  - Is installed in the same LAN as this machine
  - Supports with the SMTP mail reception, and the reception protocol is set to SMTP

#### Note

- Set the port number for [SMTP server] to "25" to enable this feature.
- If the sender server sends an Internet FAX or a mail using this feature, the SMTP authentication is disabled even if the server sets it.
- Using this feature, error notification mail will not be sent even if the mail is not properly received.
- Also, error mail will not be sent even if the mail is not sent properly.
- This feature refers to A records (not supported with MX records).

### Selectable Options

These options are available for selection:

- With the default settings, the scan resolution can be either standard or detail. Inch-mm conversion before TX depends on IFAX SW01 Bit 7. Detail resolution will be used if Super Fine resolution is selected, unless Fine resolution is enabled with IFAX SW01.
- The requirements for originals (document size, scan width, and memory capacity) are the same as

## 6.Detailed Section Descriptions

for G3 fax memory TX.

- The default compression is TIFF-F format.
- IFAX SW00: Acceptable paper widths for sending
- IFAX SW09: Maximum number of attempts to the same destination

### Secure Internet Transmission

- SMTP Authentication:  
User Tools> System Settings> File Transfer> SMTP Authentication
- POP Before SMTP:  
User Tools> System Settings> File Transfer> POP Before SMTP

## Mail Reception

---

### Three Types

This machine supports three types of e-mail reception:

- POP3 (Post Office Protocol Ver. 3.)
- IMAP4 (Internet Messaging Access Protocol)
- SMTP (Simple Mail Transfer Protocol)

#### Note

- For details: Core Technology Manual – Facsimile Processes – Faxing from a PC – Internet/LAN Fax Boards – Mail Reception

### POP3/IMAP4 Mail Reception Procedure

The machine automatically picks up e-mail from the server at an interval which is adjustable in the range 2 to 1440 min. in 1-minute steps:

- User Tools> System Settings> File Transfer> E-mail Reception Interval

### SMTP Reception

1. The IFAX must be registered as an SMTP server in the MX record of the DNS server, and the address of the received mail must specify the IFAX.
2. To enable SMTP reception: User Tools> System Settings> File Transfer> Reception Protocol
  - Even if the MX record on the DNS server includes the IFAX, mail cannot be received with SMTP until SMTP reception is enabled:
  - However, if SMTP reception is selected and the machine is not registered in the MX record of the DNS server, then either IMAP4 or POP3 is used, depending on the setting: User Tools> System Settings> File Transfer> Reception Protocol

#### Note

- An error will be issued and error mail will be sent to the mail source when the reception protocol is not set to SMTP even if you configure to enable SMTP reception in the DNS server.
- If the received mail contains error, the reception operation is stopped, the mail is discarded and error report is output. Error mail is also sent to the mail source.



- When a mail is received from SMTP server during sending a mail in the machine, the SMTP server will give a “Busy” response. The SMTP server will usually try to send the mail again later until the time-out is reached.
- This feature cannot be used with the POP server.

### Mail Delivery Conditions: Transferring Mail Received With SMTP

1. The machine must be set up for SMTP mail delivery:
  - User Tools> Facsimile Features> Reception Settings> SMTP RX File Delivery Settings
2. If the user wishes to limit this feature so that the machine will only deliver mail from designated senders, the machine's "Auth. E-mail RX" feature must be set (User Tools> Facsimile Features> Reception Settings> SMTP RX File Delivery Settings).
3. If the "SMTP RX File Delivery Setting" is set to “Off” to prohibit SMTP receiving, and if there is mail designated for delivery, then the machine responds with an error. (User Tools> Facsimile Features> Reception Settings> SMTP RX File Delivery Settings)
4. If the quick dial, speed dial, or group dial entry is incorrect, the mail transmission is lost, and the IFAX issues an error to the SMTP server and outputs an error report.

### Auth. E-mail RX

In order to limit access to mail delivery with IFAX, the addresses of senders must be limited using the Access Limit Entry. Only one entry can be registered.

1. Access Limit Entry

For example, to limit access to @IFAX.ricoh.co.jp:

gts@IFAX.ricoh.co.jp	Matches and is delivered.
gts@IFAX.abcde.co.jp	Does not match and is not delivered.
IFAX@ricoh.co.jp	Does not match and is not delivered.

2. Conditions

- The length of the Access Limit Entry is limited to 127 characters.
- If the Access Limit Entry address and the mail address of the incoming mail do not match, the incoming mail is discarded and not delivered, and the SMTP server responds with an error. However, in this case an error report is not output.
- If the Access Limit Entry address is not registered, and if the incoming mail specifies a delivery destination, then the mail is delivered unconditionally.

### Handling Mail Reception Errors

---

#### Abnormal files

When an error of this type occurs, the machine stops receiving and commands the server to erase the message. Then the machine prints an error report and sends information about the error by e-mail to the sender address (specified in the "From" or "Reply-to" field of the message). If there is an incomplete received message in the machine memory, it will be erased.

## 6.Detailed Section Descriptions

The machine prints an error message when it fails to send the receive error notification after a certain number of attempts.

The following types of files are judged to be abnormal if one or more of the following are detected:

1. Unsupported MIME headers.

Supported types of MIME header

Header	Supported Types
Content-Type	Multipart/mixed, text/plain, message/rfc822 Image/tiff
Charset	US-ASCII, ISO 8859 X. Other types cannot be handled, and some garbage may appear in the data.
Content-Transfer-Encoding	Base 64, 7-bit, 8-bit, Quoted Printable

2. MIME decoding errors
3. File format not recognized as TIFF-F format
4. Resolution, document size, or compression type cannot be accepted

### Remaining SAF capacity error

The machine calls the server but does not receive e-mail if the remaining SAF capacity is less than a certain value (the value depends on IFAX Switch 08. The e-mail will be received when the SAF capacity increases (for example, after substitute reception files have been printed). The error handling method for this type of error is the same as for "Abnormal files".

If the capacity of the SAF memory drops to zero during reception, the machine operates in the same way as when receiving an abnormal file (refer to "Abnormal files" above).

### Secure Internet Reception

---

To enable password encryption and higher level security: User Tools> System Settings> File Transfer> POP3/IMAP4 Settings> Encryption (set to "On")

### Transfer Request: Request By Mail

---

For details: Core Technology Manual – Facsimile Processes – Faxing from a PC – Internet/LAN Fax Boards – Transfer Request

The fields of the e-mail and their contents are as follows:

Field	Content
From	E-mail address of the requesting terminal
To	Destination address (Transfer Station address)
Bcc	Backup mail address
Subject	From TSI (Fax Message No. xxxx)
Content-Type	Multipart/mixed Text/Plain (for a text part), image/tiff (for attached files)
Content-Transfer-Encoding	Base 64, 7-Bit, 8-bit, Quoted Printable

Field	Content
Mail body (text part)	RELAY-ID:- xxxx (xxxx: 4 digits for an ID code) RELAY: #01#*X#*01....
Message body	MIME-converted TIFF-F.

### E-Mail Options (Sub TX Mode)

The following features are available as options for mail sending: entering a subject, designating the level of importance, confirming reception of the mail.

#### Subject and Level of Importance

You can enter a subject message with: TX Mode> Subject

The Subject entry for the mail being sent is limited to 128 characters. The subject can also be prefixed with a "Confidential", "Urgent", "Please phone" or "Copy to corres. Section" notation.

- How the Subject Differs According to Mail Type -

Mail Type	Item 1	Item 2		Item 3
Subject Entry	---	Entry Condition		Fax Message No.
No Subject Entry		1. "CSI" ("RTI")		+ File No.
		2. "RTI"	CSI not registered	
		3. "CSI"	RTI not registered	
		4. None	CSI, RTI not registered	
Confirmation of Reception	From	1. "CSI" ("RTI")		Normal: Return Receipt (dispatched). You can select "displayed" with IFAX SW02 Bits 2 and 3.
		2. "RTI"	CSI not registered	
		3. "CSI"	RTI not registered	Error: Return Receipt (processed/error)
		4. None	CSI, RTI not registered	
Mail delivery, memory transfer, SMTP receiving and delivery	From	RTI or CSI of the station designated for delivery	Mail delivery	Fax Message No. + File Number
		RTI or CSI of sender	Mail sending from G3 memory	
		Mail address of sender	Memory sending	
		Mail address of	SMTP receiving	

## 6.Detailed Section Descriptions

Mail Type	Item 1	Item 2		Item 3
		sender	and delivery (Off Ramp Gateway)	
Mail error notification	---	Error Message No. xxxx From CSI (RTI)		

Items 1, 2, and 3 in the table above are in the Subject.

- Subjects Displayed on the PC -

Sender	Date	Size	Subject
Substation 2	04/25/2002	1,513	Parts List
Substation 2	04/26/2002	1,147	Specifications
Main Station	05/09/2002	33,551	[Urgent] Memo 2041

b766d907

### E-mail Messages

After entering the subject, you can enter a message with: TX Mode> Text

An e-mail message (up to 5 lines) can be pre-registered with: User Tools> System Settings> File Transfer> Program/Change/Delete E-mail Message

- Limitations on Entries -

Item	Maximum
Number of Lines	5 lines
Line Length	80 characters
Name Length	20 characters

### Message Disposition Notification (MDN)

For details: Core Technology Manual – Facsimile Processes – Faxing from a PC – Internet/LAN Fax Boards – E-mail Options

The network system administrator can confirm whether a sent mail has been received correctly or not. This confirmation is done in four steps.

1. Send request for confirmation of mail reception. To enable or disable this request (known as MDN):  
TX Mode> Reception Notice
2. Mail reception (receive confirmation request)
3. Send confirmation of mail reception
4. Receive confirmation of mail reception

The other party's machine will not respond to the request unless the two conditions below are met:

- The other party's machine must be set up to respond to the confirmation request.
- The other party's machine must support MDN (Message Disposition Notification).

- Setting up the Receiving Party -

The receiving party will respond to the confirmation request if:

1. The "Disposition Notification To" field is in the received mail header (automatically inserted in the 4th line in the upper table on the previous page, if MDN is enabled), and

2. Sending the disposition notification must be enabled (User Parameter Setting SW21 (15 [H]) Bit 1 for this model). The content of the response is as follows:

Normal reception:	"Return Receipt (dispatched)" in the Subject line
IFAX SW02 (Bit 2, 3)	"Return Receipt (displayed)" in the Subject line
Error:	"Return Receipt (processed/error)" in the Subject line

### Handling Reports

#### - Sending a Request for a Return Receipt by Mail -

After the mail sender transmits a request for a return receipt, the mail sender's journal is annotated with two hyphens (--) in the Result column and a "Q" in the Mode column.

#### - Mail Receipt (Request for Receipt Confirmation) and Sending Mail Receipt Response -

After the mail receiver sends a response to the request for a return receipt, the mail receiver's journal is annotated with two hyphens (--) in the Result column and an "A" in the Mode column.

#### - Receiving the Return Receipt Mail -

- After the mail sender receives a return receipt, the information in the mail sender's journal about the receipt request is replaced, i.e. the journal is annotated with "OK" in the Result column.
- When the return receipt reports an error, the journal is annotated with an "E" in the Result column.
- The arrival of the return receipt is not recorded in the journal as a separate communication. Its arrival is only reported by the presence of "OK" or "E" in the Result column.
- If the mail address used by the sender specifies a mailing list (i.e., a Group destination; the machine sends the mail to more than one location. See "How to set up Mail Delivery"), the Result column of the Journal is updated every time a return receipt is received. For example, if the mailing list was to 5 destinations, the Result column indicates the result of the communication with the 5th destination only. The results of the communications to the first 4 destinations are not shown.

#### Exceptions:

If one of the communications had an error, the Result column will indicate E, even if subsequent communications were OK.

If two of the communications had an error, the Journal will indicate the destination for the first error only.

#### - Report Sample -

DATE	TIME	ADDRESS	MODE	TIME	PAGE	RESULT
MAY. 5	10:15	fuser_01@dom1g. ricoh. co.	Mail SM	0'09"	2	--
	10:16	fuser_01@dom1g. ricoh. co.	Mail SMQ	0'05"	1	--
	10:17	s_tadashi@dom1g. ricoh. co.	Mail SMQ	0'09"	2	OK
	10:19	m_masataka@dcmlg. ricoh. co.	Mail SMA	0'05"	1	--

b771d506

## IP-Fax

### What is IP-FAX?

For details: Core Technology Manual – Facsimile Processes – Faxing from a PC – Internet/LAN Fax Boards – IP-FAX

### T.38 Packet Format

TCP is selected by default for this machine, but you can change this to UDP with IPFAX SW 00 Bit 1.

### UDP Related Switches

IP-Fax Switch 01						
No.	Function					Comments
0-3	Select IP FAX Delay Level					Raise the level by selecting a higher setting if too many transmission errors are occurring on the network. If TCP/UDP is enabled on the network, raise this setting on the T.30 machine. Increasing the delay time allows the recovery of more lost packets. If only UDP is enabled, increase the number of redundant packets. Level 1~2: 3 Redundant packets Level 3: 4 Redundant packets
	Bit	Bit	Bit	Bit	Level	
	3	2	1	0		
	0	0	0	0	0	
	0	0	0	1	1	
	0	0	1	0	2	
0	0	1	1	3		

### Settings

User parameter switch 34 (22[H]), bit 0

IP-Fax Gate Keeper usage, 0: No, 1: Yes

IP Fax Switches: Various IP-FAX settings (see the bit switch table)

# 7. Specifications

## General Specifications

### FCU

Type:	Desktop type transceiver
Circuit:	PSTN (max. 3ch.) PABX
Connection:	Direct couple
Original Size:	Book (Face down) Maximum Length: 432 mm [17 ins] Maximum Width: 297 mm [11.7 ins] ARDF (Face up) (Single-sided document) Length: 128 - 1200 mm [5.0 - 47.2 ins] Width: 105 - 297 mm [4.1 - 11.7 inch] (Double-sided document) Length: 128 - 432 mm [5.0 - 17 inch] Width: 105 - 297 mm [4.1 - 11.7 inch]
Scanning Method:	Flat bed, with CCD
Resolution:	G3 8 x 3.85 lines/mm (Standard) 8 x 7.7 lines/mm (Detail) 8 x 15.4 line/mm (Fine) See Note1 16 x15.4 line/mm (Super Fine) See Note 1 200 x 100 dpi (Standard) 200 x 200 dpi (Detail) 400 x 400 dpi (Super Fine) See Note 1 <b>Note</b> <ul style="list-style-type: none"> <li>Optional Expansion Memory required</li> </ul>
Transmission Time:	G3: 3 s at 28800 bps; Measured with G3 ECM using memory for an ITU-T #1 test document (Slerexe letter) at standard resolution
Data Compression:	MH, MR, MMR, JBIG
Protocol:	Group 3 with ECM
Modulation:	V.34, V.33, V.17 (TCM), V.29 (QAM),

## 7. Specifications

	V.27ter (PHM), V.8, V.21 (FSK)
Data Rate:	G3: 33600/31200/28800/26400/24000/21600/ 19200/16800/14400/12000/9600/7200/4800/2400 bps Automatic fallback
I/O Rate:	With ECM: 0 ms/line Without ECM: 2.5, 5, 10, 20, or 40 ms/line
Memory Capacity:	SAF Standard: 4 MB With optional Expansion Memory: 28 MB (4 MB+ 24 MB) Page Memory Standard: 8 MB (Print: 4 MB + Scanner: 4 MB) With optional Expansion Memory: 16 MB (8 MB + 8 MB) (Print 8 MB + Scanner: 8 MB)



## Capabilities of Programmable Items

### Capabilities of Programmable Items

The following table shows the capabilities of each programmable items.

Item	Standard
Quick Dial	2000
Groups	100
Destination per Group	500
Destinations dialed from the ten-key pad overall	500
Programs	100
Auto Document	6
Communication records for Journal stored in the memory	200
Specific Senders	30

The following table shows how the capabilities of the document memory will change after the Expansion Memory are installed.

	Without the Expansion Memory	With the Expansion Memory
Memory Transmission file	800	800
Maximum number of page for memory transmission	1000	1000
Memory capacity for memory transmission (Note1)	320	2240

#### ↓ Note

- Measured using an ITU-T #1 test document (Slerexe letter) at the standard resolution, the auto image density mode and the Text mode.

## IFAX Specifications

### IFAX Specifications

<b>Connectivity:</b>	Local area network Ethernet 100base-Tx/10base-T Gigabit Ethernet 1000 Base-T IEEE802.11a/g, g (wireless LAN),
<b>Resolution:</b>	200 × 100 dpi (Standard resolution), 200 × 200 dpi (Detail resolution), 200 × 400 dpi (Fine resolution)*1, 400 × 400 dpi (Super Fine resolution)*1 <b>Note</b> <ul style="list-style-type: none"> <li>To use 200 × 400 dpi and 400 × 400 dpi, IFAX SW01 Bit 2 and/or bit 4 must be set to “1”.</li> </ul>
<b>Transmission Time:</b>	1 s (through a LAN to the server) Condition: ITU-T #1 test document (Selerexe Letter) MTF correction: OFF TTI: None Resolution: 200 x 100 dpi Communication speed: 10 Mbps Correspondent device: E-mail server Line conditions: No terminal access
<b>Document Size:</b>	Maximum Original Size: A3/DLT. <b>Note</b> <ul style="list-style-type: none"> <li>To use B4 and A3 width, IFAX SW00 Bit 1 (B4) and/or Bit 2 (A3) must be set to “1”.</li> </ul>
<b>E-mail File Format:</b>	Single/multi-part MIME conversion Image: TIFF-F (MH, MR, MMR)
<b>Protocol:</b>	<b>Transmission:</b> SMTP, TCP/IP <b>Reception:</b> POP3, SMTP, IMAP4, TCP/IP
<b>Data Rate:</b>	1000 Mbps (1000 Base-T) 100 Mbps (100base-Tx) 10 Mbps (10base-T)
<b>Authentication Method:</b>	SMTP-AUTH POP before SMTP A-POP
<b>Remark:</b>	The machine must be set up as an e-mail client before installation. Any client

	PCs connected to the machine through a LAN must also be e-mail clients, or some features will not work (e.g. Autorouting).
--	--

## IP-FAX Specifications

### IP-FAX Specifications

Network:	Local Area Network Ethernet/10base-T, 100base-TX Gigabit Ethernet/1000 Base-T IEEE802.11a/g, g (wireless LAN)
Scan line density:	8 x 3.85 lines/mm, 200x100dpi (standard character), 8 x 7.7lines/mm, 200x200dpi (detail character), 8 x 15.4lines/mm (fine character: optional expansion memory required), 16 x 15.4lines/mm, 400x400dpi (super fine character: optional expansion memory required)
Maximum Original size:	A3 or 11" x 17" (DLT) Custom: 297mm x 1200mm (11.7" x 47.3")
Maximum scanning size:	297mm x 1200mm (11.7" x 47.3")
Transmission protocol:	Recommended: T.38 Annex protocol, TCP, UDP/IP communication, SIP (RFC 3261 compliant), H.323 v2
Compatible machines:	IP-Fax compatible machines
IP-Fax transmission function:	Specify IP address and send faxes to an IP-Fax compatible fax through a network. Also capable of sending faxes from a G3 fax connected to a telephone line via a VoIP gateway.
IP-Fax reception function:	Receive faxes sent from an IP-Fax compatible fax through a network. Also capable of receiving faxes from a G3 fax connected to a telephone line via a VoIP gateway.

## Fax Unit Configuration

### G3 Interface Unit Type M19 (for MP C3004/C3504)

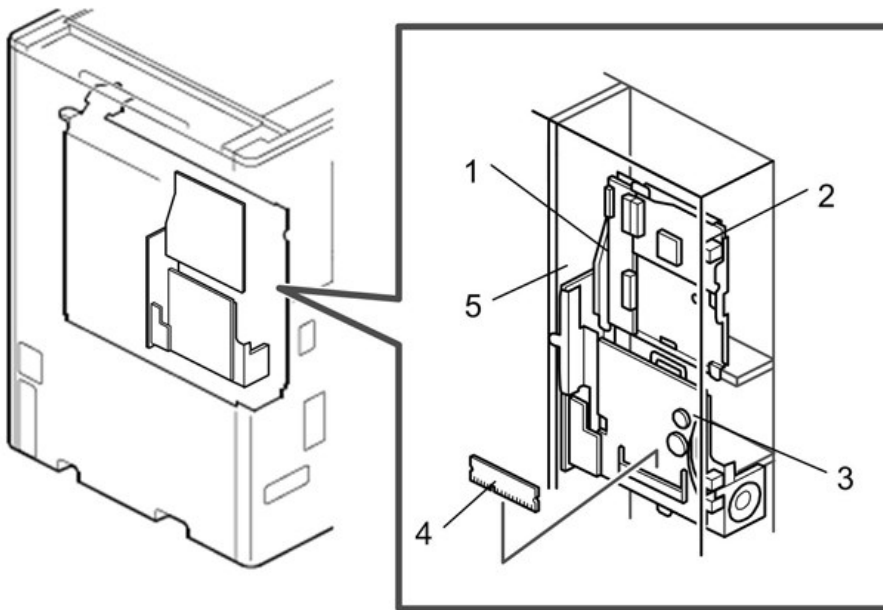

d1673010

Component	Code	No.	Remarks
FCU	D3BV	1	Included with the fax unit
GWFCU I/F		5	
Expansion Memory	D3BZ	2	Optional
SG3 Board	D3BV	3	Included with optional G3 unit
CCU I/F Board		4	

## 7.Specifications

### G3 Interface Unit Type M20 (for MP C4504/C5504/C6004 and MP C501SP)

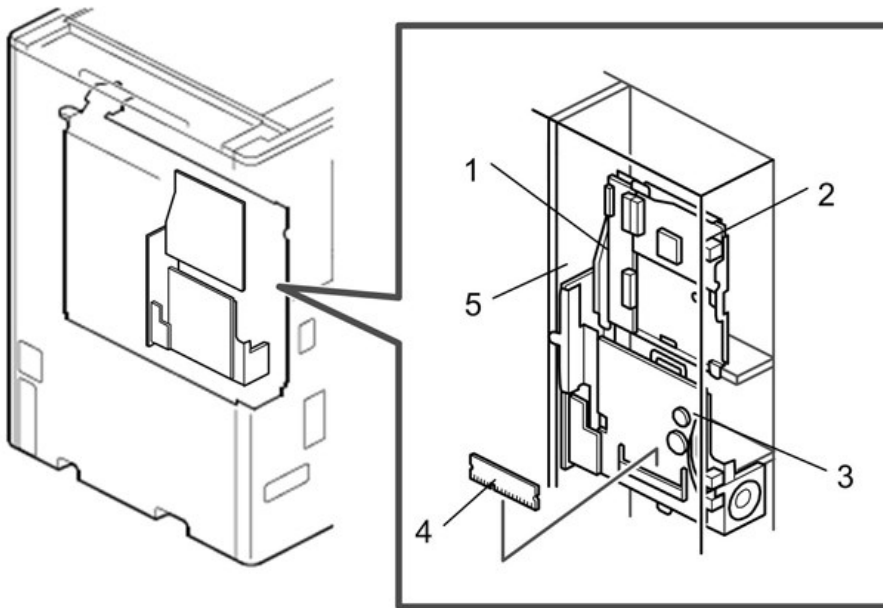

d1673010

Component	Code	No.	Remarks
FCU	D3BT	3	Included with the fax unit
GWFCU I/F		5	
Expansion Memory	D3BZ	4	Optional
SG3 Board	D3BT	2	Included with optional G3 unit
CCU I/F Board		1	